

MARC D. BINDER, NOBUTAKA HIROKAWA AND UWE WINDHORST (Eds.)

# Encyclopedia of Neuroscience

With 1625 Figures\* and 90 Tables

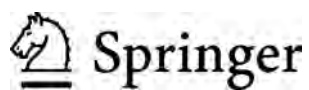

\*For color figures please see our Electronic Reference on [www.springerlink.com](http://www.springerlink.com)

Editors:

**Marc D. Binder**

Department of Physiology & Biophysics  
University of Washington School of Medicine  
Seattle, Washington, USA  
mdbinder@u.washington.edu

**Nobutaka Hirokawa**

Department of Cell Biology and Anatomy  
Graduate School of Medicine  
University of Tokyo  
Hongo, Bunkyo-ku, Tokyo, Japan  
hirokawa@m.u-tokyo.ac.jp

**Uwe Windhorst**

Göttingen, Germany  
siggi.uwe@t-online.de

A C.I.P. Catalog record for this book is available from the Library of Congress

ISBN: 978-3-540-23735-8

This publication is available also as:

Electronic publication under ISBN 978-3-540-29678-2 and

Print and electronic bundle under ISBN 978-3-540-35857-2

Library of Congress Control Number: 2008930846

This work is subject to copyright. All rights are reserved, whether the whole or part of the material is concerned, specifically the rights of translation, reprinting, reuse of illustrations, recitation, broadcasting, reproduction on microfilms or in other ways, and storage in data banks. Duplication of this publication or parts thereof is only permitted under the provisions of the German Copyright Law of September 9, 1965, in its current version, and permission for use must always be obtained from Springer-Verlag. Violations are liable for prosecution under the German Copyright Law.

© Springer-Verlag GmbH Berlin Heidelberg 2009

The use of registered names, trademarks, etc. in this publication does not imply, even in the absence of a specific statement, that such names are exempt from the relevant protective laws and regulations and therefore free for general use.

THIS PARAGRAPH FOR MEDICAL TITLES ONLY: Product liability: The publishers cannot guarantee the accuracy of any information about the application of operative techniques and medications contained in this book. In every individual case the user must check such information by consulting the relevant literature.

Springer is part of Springer Science+Business Media

springer.com

Printed on acid-free paper SPIN: 10 84 69 79 2109 — 5 4 3 2 1 0

## Preface

Neuroscience is a rapidly expanding endeavor devoted to unraveling the structure and function of the nervous system. It relies on, and keeps close relations to, a number of other disciplines, such as mathematics, physics, chemistry, engineering, computer science, genetics, molecular biology, biochemistry, medicine and philosophy. Indeed, many of its recent successes result from the application of ideas, concepts and methods borrowed from these fields. Thus, neuroscience has become the archetype for interdisciplinary undertakings. This convergence of influences accounts for part of its enormous attractiveness and fascination to students, researchers and lay persons from various walks of life or science. Many of neuroscience's most creative and productive investigators have been lured into the field not only by the excitement inherent in the possibility of uncovering the secrets of the human mind, but by the appeal of venturing into a vast unknown land, requiring the development of new tools for its effective cultivation. Far from simply satisfying our intellectual curiosity, however, neuroscience has become ever more important as a theoretical ground for practical applications in medicine, in particular neurology, and other disciplines.

The explosion of neuroscience has made it virtually impossible for individuals to follow all the ramifications and fast developments in the many corners and branches of this science. This *Encyclopedia* has therefore been designed for a wide variety of readers, from members of the lay public to students, practitioners and researchers in biology, medicine, psychology, sociology, philosophy and their associated auxiliary fields. Moreover, it should also prove useful to advanced researchers of biology and neuroscience who wish to stay abreast of current developments outside their immediate areas of expertise.

In the interest of rapid and convenient access to information, this *Encyclopedia* has adopted a new format. The entire complex of neuroscience has been divided into 38 subject fields organized and surveyed by associated Field Editors. Entries, which are in alphabetical order for rapid localization, are of three type: (1) simple and relatively brief definitions and explanations (glossary entries), (2) structured "essays" of a few pages to provide coherent treatments of particularly important topics, and (3) synopses written by the Field Editors as larger overviews of their fields with links to the essays in their field. Extensive cross-references to definitions and essays serve to lead the reader to additional sources of information.

This *Encyclopedia* is available as a print version (5 volumes, more than 4,500 pages, 6,500 entries and 1,000 illustrations), an eReference version (online version), and as a bundle (print plus online) version.

Thanks are due to a vast number of people who have made this ambitious endeavor possible. First and foremost, we are extremely grateful to our 46 Field Editors who accepted the arduous challenge of organizing their fields, soliciting essays and glossary terms from expert authors, editing the submitted texts, and finally writing their own synopses. Second, many thanks also go to our nearly 1,000 authors who wrote essays and glossary terms. Third, Drs. Thomas Mager, Natasja Sheriff, Michaela Bilic and Jana Simniok of Springer-Verlag investigated much effort, initiative, patience and enthusiasm (at times interrupted by outbursts of frustration) into initiating, administering, pushing ahead and keeping alive this project. Many thanks are due to the numerous unnamed support staff in the background: secretaries, copy editors, computer and graphics specialists at *Springer*.

MARC D. BINDER (Seattle)  
NOBUTAKA HIROKAWA (Tokyo)  
UWE WINDHORST (Göttingen)

## **Editor-in-Chief**

Marc D. Binder  
Department of Physiology & Biophysics  
University of Washington School of Medicine  
Seattle, Washington, USA  
mdbinder@u.washington.edu

Nobutaka Hirokawa  
Department of Cell Biology and Anatomy  
Graduate School of Medicine  
University of Tokyo  
Hongo, Bunkyo-ku, Tokyo, Japan  
hirokawa@m.u-tokyo.ac.jp

Uwe Windhorst  
Göttingen, Germany  
siggi.uwe@t-online.de

## **Conceptual Editor**

Martin C. Hirsch  
iAS interActive Systems,  
Marburg, Germany  
martin.hirsch@brainmedia.de

## Section Editors

### Autonomic and Enteric Nervous System

Akio Sato  
(deceased)  
University of Human Arts and Sciences  
Saitama, Japan

Brian Budgell  
Departement de Chiropratique  
Universite du Quebec a Trois-Rivieres  
Quebec, Canada  
budgell@uqtr.ca

Sae Uchida  
Department of the Autonomic Nervous System  
Tokyo Metropolitan Institute of Gerontology  
Tokyo, Japan  
suchida@tmig.or.jp

### Behavior

Hermann Wagner  
Institut für Biologie II  
RWTH Aachen  
Aachen, Germany  
wagner@bio2.rwth-aachen.de

### Biological Rhythms and Sleep

Martha U. Gillette  
Molecular and Integrative Physiology, and  
Neuroscience Program  
Institute for Genomic Biology University of Illinois at  
Urbana-Champaign  
Urbana, IL, USA  
mgillett@uiuc.edu

### Biomechanics

Walter Herzog  
Faculty of Kinesiology  
Human Performance Lab University of Calgary  
Calgary, AB, Canada  
walter@kin.ucalgary.ca

### Central Vision

Uwe Windhorst  
Göttingen, Germany  
siggi.uwe@t-online.de

Andreas K. Engel  
Dept. of Neurophysiology and Pathophysiology  
University Medical Center  
Hamburg-Eppendorf  
Hamburg, Germany  
ak.engel@uke.de

### Cognitive Functions

Fred Mast  
Department of Psychology  
University of Lausanne  
Bâtiment Anthropole  
Lausanne, Switzerland  
Fred.Mast@unil.ch

### Computational Motor Control

Amir Karniel  
Department of Biomedical Engineering  
Ben-Gurion University of the Negev  
Beer Sheva, Israel  
akarniel@bgu.ac.il

### Development

Fujio Murakami  
Laboratory of Neuroscience,  
Graduate School of Frontier Biosciences,  
Graduate School of Engineering Science  
Osaka University  
Suita, Osaka, Japan  
fujiomurakami@gmail.com

### Evolution

Ann B. Butler  
Dept. Molecular Neuroscience  
Krasnow Institute for Advanced Study  
George Mason University  
Fairfax, VA, USA  
abbutler@gmu.edu

### Eye Movements

Adonis K. Moschovakis  
Institute of Applied and Computational Mathematics  
Foundation for Research and Technology - Hellas  
Heraklion, Crete, Greece  
moschov@med.uoc.gr

### Genetics, Molecular Biology

Sarah McFarlane  
Department of Cell Biology and Anatomy  
Hotchkiss Brain Institute,  
Faculty of Medicine  
University of Calgary  
Calgary, Alberta, Canada  
smcfarla@ucalgary.ca

### Hearing

Armin Seidl  
Virginia Merrill Bloedel Hearing Research Center

University of Washington  
Seattle, WA, USA  
armins@u.washington.edu

Edwin W. Rubel  
Virginia Merrill Bloedel Hearing Research Center  
University of Washington  
Seattle, WA, USA  
rubel@u.washington.edu

### **Learning and Memory**

Taketoshi Ono  
Molecular and Integrative Emotional Neuroscience  
Graduate School of Medicine  
University of Toyama  
Sugitani, Toyama, Japan  
onotake@med.u-toyama.ac.jp

### **Limbic System**

Daniel S. Zahm  
Department of Pharmacological and Physiological Science  
Saint Louis University School of Medicine  
St. Louis, MO, USA  
zahmds@slu.edu

Lennart Heimer  
(deceased)  
Department of Neurological Surgery  
University of Virginia  
Charlottesville, VA, USA

### **Magnetic and Electrical Senses**

Wolfgang Wiltschko  
Universität Frankfurt  
Zoologisches Institut Biologie – Campus der  
Universität  
Frankfurt/Main, Germany  
wiltschko@zoologie.uni-frankfurt.de

Bernd Kramer  
Institut für Zoologie  
Animal Behaviour and Behavioural Physiology  
Research Group,  
Universität Regensburg  
Regensburg, Germany  
bernd.kramer@biologie.uni-regensburg.de

### **Membrane Biophysics**

Peter M. Lalley  
Department of Physiology, Medical Sciences Center  
University of Wisconsin School of Medicine and  
Public Health,  
Madison, WI, USA  
pmlalley@facstaff.wisc.edu

Uwe Windhorst  
Göttingen, Germany  
siggi.uwe@t-online.de

### **Muscle**

C.J. Heckman  
Physiology, Physical Medicine and Rehabilitation  
Northwestern University  
Feinberg School of Medicine  
Chicago, IL, USA  
c-heckman@northwestern.edu

### **Muscle Reflexes**

Arthur Prochazka  
Professor, Centre for Neuroscience  
University of Alberta  
Edmonton, AB, USA  
arthur.prochazka@ualberta.ca

### **Neuroanatomy**

Farel R. Robinson  
University of Washington  
Dept. of Biological Structure  
Seattle, WA, USA  
robinsn@u.washington.edu

### **Neuroendocrinology**

Dick F. Swaab  
Netherlands Institute for Neuroscience  
Amsterdam, The Netherlands  
d.f.swaab@nih.knaw.nl

Paul J. Lucassen  
Centre for Neuroscience  
Swammerdam Institute of Life Sciences  
University of Amsterdam  
Amsterdam, The Netherlands  
lucassen@science.uva.nl

### **Neuroimmunology**

John J. Haddad  
Cellular and Molecular Signaling Research Group  
Division of Biological Sciences, Departments of  
Biology and Biomedical Sciences, Faculty of  
Arts and Sciences  
Lebanese International University (LIU)  
Beirut, Lebanon  
john.haddad@liu.edu.lb

### **Neurology**

William J. Spain  
Department of Neurology  
Veterans Affairs Puget Sound Health Care System  
University of Washington  
Seattle, WA, USA  
spain@u.washington.edu

Uwe Windhorst  
Göttingen, Germany  
siggi.uwe@t-online.de

**Neuron Cellular/Molecular**

Naweed I. Syed  
 Dept. Cell Biology and Anatomy  
 Faculty of Medicine  
 University of Calgary  
 Calgary, Alberta, Canada  
 nisyed@ucalgary.ca

**Neuropharmacology**

Paul F. Smith  
 Dept. of Pharmacology and Toxicology  
 School of Medical Sciences  
 University of Otago  
 Medical School  
 Dunedin, New Zealand  
 paul.smith@stonebow.otago.ac.nz

**Neurophilosophy**

Michael Pauen  
 Institut für Philosophie  
 Berlin School of Mind and Brain  
 Humboldt-Universität zu Berlin  
 Berlin, Germany  
 michael.pauen@philosophie.hu-berlin.de

**Neuropsychiatry**

Georg Northoff  
 Department of Psychiatry  
 University of Magdeburg  
 Magdeburg, Germany  
 Georg.Northoff@med.ovgu.de

**Olfaction and Gustation**

Pierre-Marie Lledo  
 Institut Pasteur  
 Perception and Memory Laboratory  
 CNRS Unit - Genes, Synapses & Cognition  
 Paris, Cedex 15, France  
 pmlledo@pasteur.fr

**Pain**

Gerald F. Gebhart  
 Center for Pain Research  
 University of Pittsburgh  
 Pittsburgh, PA, USA  
 gebhartgf@upmc.edu

**Posture**

Fay B. Horak  
 Neurological Sciences Institute  
 Oregon Health and Science University  
 Portland, OR, USA  
 fay.horak@gmail.com

**Proprioception**

Simon Gandevia  
 Prince of Wales Medical Research Institute  
 Sydney, Australia  
 s.gandevia@unsw.edu.au

**Regeneration**

Chizuka Ide  
 Institute of Regeneration and Rehabilitation  
 Department of Occupational Therapy,  
 Faculty of Nursing and Rehabilitation  
 Aino University  
 Ibaraki, Osaka, Japan  
 c-ide@ot-u.aino.ac.jp

**Respiration**

Peter M. Lalley  
 Department of Physiology, Medical Sciences Center  
 University of Wisconsin School of Medicine and  
 Public Health  
 Madison, WI, USA  
 pmlalley@facstaff.wisc.edu

**Retinal Processing**

David Vaney  
 Queensland Brain Institute  
 University of Queensland  
 Brisbane, Queensland, Australia  
 d.vaney@uq.edu.au

W. Rowland Taylor  
 Neurological Sciences Institute  
 Oregon Health and Science University  
 Beaverton, OR, USA  
 and  
 Casey Eye Insititute  
 School of Medicine  
 Oregon Health and Science University  
 Portland, OR, USA  
 taylorw@ohsu.edu

Uwe Windhorst  
 Göttingen, Germany  
 siggi.uwe@t-online.de

**Rhythmic Movements**

Ole Kiehn  
 Department of Neuroscience  
 Karolinska Institute Stockholm  
 Stockholm, Sweden  
 O.Kiehn@ki.se

**Synapse**

Masami Takahashi  
 Department of Biochemistry

Kitasato-University,  
School of Medicine  
Sagamihara-shi, Kanagawa, Japan  
masami@med.kitasato-u.ac.jp

### **Touch**

Yoshiaki Iwamura  
Department of Sensory Science  
Kawasaki University of Medical Welfare  
Okayama, Japan  
iwayoshi@mw.kawasaki-m.ac.jp

### **Vestibular System**

Neal H. Barmack  
Neurological Sciences Institute  
Oregon Health & Science University

Portland, OR, USA  
barmackn@ohsu.edu

Vito Enrico Pettorossi  
Dipartimento di Medicina Interna  
Section of Physiology  
Perugia, Italy  
vitopett@unipg.it

### **Voluntary Movements**

Martha Flanders  
Department of Neuroscience  
University of Minnesota,  
Minneapolis  
MN, USA  
fland001@umn.edu



## Contributors

TERUO ABE  
Department of Cellular Neurobiology  
Brain Research Institute  
Niigata University  
Niigata, Japan  
teruoa@bri.niigata-u.ac.jp

VALERY V. ABRAMOV  
Laboratory of Neuroimmunology  
State Research Institute of Clinical Immunology of SB  
RAMS  
Novosibirsk, Russia  
valery\_abramov@mail.ru

TATJANA YA. ABRAMOVA  
Laboratory of Neuroimmunology  
State Research Institute of Clinical Immunology of SB  
RAMS  
Novosibirsk, Russia

MONICA L. ACOSTA  
Department of Optometry and Vision Science  
University of Auckland  
Auckland, New Zealand

MASAHARU ADACHI  
Department of Electrical and Electronic Engineering,  
School of Engineering  
Tokyo Denki University  
Tokyo, Japan  
adachi@d.dendai.ac.jp

ANTOINE ADAMANTIDIS  
Department of Psychiatry and Behavioral Sciences  
Stanford University  
School of Medicine  
Palo Alto, CA, USA

DANIEL L. ADAMS  
Department of Ophthalmology  
Koret Vision Research Laboratory  
UCSF, San Francisco, CA, USA

FABIENNE AGASSE  
Center for Neuroscience and Cell Biology  
Institute of Biochemistry  
Faculty of Medicine,  
University of Coimbra  
Coimbra, Portugal

KAZUYUKI AIHARA  
Institute of Industrial Science  
The University of Tokyo  
Tokyo, Japan  
aihara@sat.t.u-tokyo.ac.jp

RACHID AIT-HADDOU  
Human Performance Laboratory  
University of Calgary  
Calgary, AB, Canada  
aihara@sat.t.u-tokyo.ac.jp

KATHRYN M. ALBERS  
Department of Medicine  
University of Pittsburgh  
Pittsburgh, PA, USA  
kaa2@pitt.edu

JESSICA ALBRECHT  
Department of Neuroradiology  
Ludwig Maximilian University Munich  
Munich, Germany  
Jessica.albrecht@med.uni-muenchen.de

URS ALBRECHT  
Department of Medicine  
Division of Biochemistry  
University of Fribourg  
Fribourg, Switzerland  
urs.albrecht@unifr.ch

HÅKAN ALDSKOGIUS  
Uppsala University Biomedical Center  
Department of Neuroscience  
Uppsala, Sweden  
Hakan.Aldskogius@neuro.uu.se

GEORGE F. ALHEID  
Department of Physiology  
Feinberg School of Medicine  
Northwestern University  
Chicago, IL, USA  
gfa@northwestern.edu

DOUGLAS W. ALLAN  
Department of Cellular and Physiological Sciences  
University of British Columbia  
Vancouver, BC, Canada  
dwallan@interchange.ubc.ca

MARIANA ALONSO  
Institut Pasteur  
Perception and Memory Laboratory  
Paris, France  
malonso@pasteur.fr

NADJA ALTHAUS  
Centre for Brain and Cognitive Development  
Birkbeck, University of London  
London, UK

WILKO ALTROCK  
Leibniz Institute for Neurobiology  
Department of Neurochemistry and Molecular Biology  
Magdeburg, Germany

SHIMON AMIR  
Center for Studies in Behavioral Neurobiology,  
Department of Psychology  
Concordia University  
Montreal, QC, Canada  
shimon.amir@concordia.ca

BAGRAT AMIRKIAN  
Department of Neuroscience  
University of Minnesota Medical School  
Minneapolis, MN, USA  
amiri001@tc.umn.edu

RAMÓN ANADÓN  
University of Santiago de Compostela  
Campus Sur Santiago de Compostela  
Spain

HOLLEY ANDRÉ  
Centre Européen des Sciences du Goût (CESG)  
CNRS-INRA-Université de Bourgogne  
Dijon, France

HIROYUKI ARAKAWA  
Pacific Biomedical Research Center  
University of Hawaii at Manoa  
Honolulu, HI, USA

JOSEPHINE ARENDT  
Centre for Chronobiology  
Faculty of Health and Medical Sciences  
University of Surrey  
Guildford, Surrey, UK  
arendtjo@aol.com

LARS ARENDT-NIELSEN  
Center for Sensory-Motor Interaction (SMI),  
Department of Health Science and Technology  
Aalborg University  
Aalborg, Denmark  
LAN@hst.aau.dk

PAOLA ARLOTTA  
Center for Regenerative Medicine  
Department of Neurosurgery  
Massachusetts General Hospital  
Harvard Medical  
School  
Boston, MA, USA

PAMELA ARSTIKAITIS  
Department of Psychiatry and the Brain Research  
Centre  
University of British Columbia  
Vancouver, BC, Canada  
parstika@interchange.ubc.ca

HIDEKI ASOH  
Information Technology Research Institute  
National Institute of Advanced Industrial Science and  
Technology  
Tsukuba, Ibaraki, Japan  
h.asoh@aist.go.jp

CLAUDIA BAGNI  
Department of Experimental Medicine and  
Biochemical Sciences, University “Tor Vergata”,  
Rome, Italy  
claudia.bagni@uniroma2.it

NASSER S. BALLANI  
Biomedical Sciences  
Lebanese International University  
Beirut, Lebanon  
nasser.ballani@liu.edu.lb

KLAUS BALLANYI  
Department of Physiology  
Perinatal Research Centre  
Faculty of Medicine & Dentistry  
University of Alberta  
Edmonton, AB, Canada  
klaus.ballanyi@ualberta.ca

JAMES R. BAMBURG  
Molecular, Cellular and Integrative Neurosciences  
Program  
Department of Biochemistry and Molecular Biology  
Colorado State University  
Fort Collins, CO, USA  
jbamburg@lamar.colostate.edu

LAURA BAMERT  
Department of Psychology  
University of Lausanne  
Lausanne, Switzerland

ALBERT J. BANES  
University of North Carolina  
North Carolina State University  
North Carolina, USA  
ajbvault@med.unc.edu

AI-MIN BAO  
Netherlands Institute for Neurosciences  
Meibergdreef, Amsterdam, The Netherlands  
a.bao@nin.knaw.nl

NEAL H. BARMACK  
Neurological Sciences Institute  
Oregon Health & Science University  
Beaverton, OR, USA  
barmackn@ohsu.edu

SCOTT R. BARNUM  
Departments of Microbiology and Neurology  
University of Alabama at Birmingham (UAB)  
Birmingham, AL, USA

RALF BARON  
Division of Neurological Pain Research and Therapy,  
Department of Neurology  
Universitätsklinikum Schleswig-Holstein  
Campus Kiel  
Kiel, Germany  
r.baron@neurologie.uni-kiel.de

ANDRES BARRIA  
Department of Physiology and Biophysics  
University of Washington  
Seattle, WA, USA  
barria@u.washington.edu

DONALD BARTLETT JR.  
Department of Physiology  
Dartmouth Medical School  
Lebanon, NH, USA  
don.bartlett@dartmouth.edu

ALEXANDRA BATTAGLIA-MAYER  
Department of Human Physiology and Pharmacology  
SAPIENZA, University of Rome  
Rome, Italy  
alexandra.battagliamayer@uniroma1.it

PHILIPPA R. BAYLEY  
Neurological Sciences Institute  
Oregon Health and Science University  
Beaverton, OR, USA  
bayleyp@ohsu.edu

CHRISTIAN BEAULÉ  
Department of Biology  
Washington University  
St. Louis, MO, USA  
cbeaule@mac.com

WOLFGANG BECKER  
Sektion Neurophysiologie  
Universität Ulm  
Ulm, Germany  
wolfgang.becker@medizin.uni-ulm.de

FIONA K. BEDFORD  
Department of Anatomy and Cell Biology  
McGill University  
Montreal, QC, Canada  
fiona.bedford@mcgill.ca

GREGORY BELENKY  
Sleep and Performance Research Center  
Washington State University  
Spokane, WA, USA  
Belenky@WSU.edu

HAROLD J. BELL  
Department of Cell Biology and Anatomy  
University of Calgary  
Calgary, AB, Canada  
jbell@math.umbc.edu

HEATHER BELL  
Department of Zoology  
University of Oklahoma  
Norman, OK, USA  
harold.bell@ucalgary.ca

JONATHAN BELL  
University of Maryland  
Baltimore, MD, USA  
jbell@math.umbc.edu

YEHEZKEL BEN-ARI  
INMED, INSERM U29  
Université de la Méditerranée  
Campus de Luminy  
Marseille, France  
ben-ari@inmed.univ-mrs.fr

EDUARDO E. BENARROCH  
Department of Neurology  
Mayo Clinic  
Rochester, MN, USA  
benarroch@mayo.edu

KARIM BENCHENANE  
LPPA  
Collège de France, CNRS  
Paris, France

TIM A. BENKE  
Pediatrics, Neurology, Pharmacology and  
Neuroscience Program  
University of Colorado Health Sciences Center  
The Children's Hospital  
Aurora, CO, USA

TOMASZ BERKOWICZ  
Department of Neurology  
Medical University of Lodz  
Lodz, Poland  
tberkowicz@afazja.am.lodz.pl

LILIANA BERNARDINO  
Center for Neuroscience and Cell Biology  
Institute of Biochemistry  
Faculty of Medicine, University of Coimbra  
Coimbra, Portugal

ANTHONY BERNDT  
Institute of Maternal and Child Health  
Genes and Development Research Group  
Department of Cell Biology and Anatomy  
Faculty of Medicine  
University of Calgary  
Calgary, AB, Canada

SVEN BERNECKER  
Department of Philosophy  
University of California at Irvine  
Irvine, CA, USA  
bernecker@Lrz.uni-muenchen.de

ROMMY VON BERNHARDI  
Department of Neurology  
Faculty of Medicine  
Pontificia Universidad Católica de Chile  
Santiago, Chile  
rvonb@med.puc.cl

DANIEL M. BERNSTEIN  
Department of Psychology  
Kwantlen University College  
Surrey, BC, Canada  
db6@u.washington.edu

LESLIE R. BERNSTEIN  
Department of Neuroscience and Department of  
Surgery  
University of Connecticut Health Center  
Farmington, CT, USA

GABRIEL BERTOLESI  
The Hotchkiss Brain Institute  
Department of Cell Biology and Anatomy  
Faculty of Medicine  
University of Calgary  
Calgary, AB, Canada  
gbertole@ucalgary.ca

MARTIN BIEL  
Department Pharmazie  
Zentrum für Pharmaforschung  
Ludwig-Maximilians-Universität München  
München, Germany  
mbiel@cup.uni-muenchen.de

KLAUS BIELEFELDT  
University of Pittsburgh  
Department of Medicine  
Pittsburgh, PA, USA  
bielefeldtk@dom.pitt.edu

ANDREW A. BIEWENER  
Concord Field Station  
Department of Organismic and  
Evolutionary Biology  
Harvard University  
Cambridge, MA, USA  
biewener@fas.harvard.edu

STUART A. BINDER-MACLEOD  
Department of Physical Therapy  
University of Delaware  
Newark, DE, USA  
sbinder@udel.edu

VERNER P. BINGMAN  
Department of Psychology and J.P. Scott Center for  
Neuroscience, Mind and Behavior  
Bowling Green State University  
Bowling Green, OH, USA  
vbingma@bgnet.bgsu.edu

THOMAS D. BIRD  
Department of Neurology  
UW Medical Center  
Seattle, WA, USA  
tomnroz@u.washington.edu

INGVARS BIRZNIEKS  
Prince of Wales Medical Research Institute  
Sydney, NSW, Australia

ERIC L. BITTMAN  
Department of Biology  
University of Massachusetts  
Amherst, MA, USA  
elb@bio.umass.edu

D. CAROLINE BLANCHARD  
Department of Genetics and Molecular Biology  
John A. Burns School of Medicine  
University of Hawaii at Manoa  
Honolulu, HI, USA

ROBERT J. BLANCHARD  
Department of Psychology  
University of Hawaii at Manoa  
Honolulu, HI, USA  
blanchar@hawaii.edu

OLAF BLANKE  
Laboratory of Cognitive Neuroscience, Brain-Mind  
Institute  
École Polytechnique Fédérale de Lausanne  
Switzerland  
Department of Neurology  
University Hospital  
Geneva, Switzerland  
olaf.blanke@epfl.ch

CLARK M. BLATTEIS  
University of Tennessee Health Science Center  
College of Medicine  
Memphis, TN, USA  
blatteis@physiol.utmem.edu

BAS BLITS  
Netherlands Institute for Neurosciences  
A Research Institute of the Royal Netherlands  
Academy of Arts and Sciences  
Amsterdam, The Netherlands

JAMES R. BLOEDEL  
Department of Biomedical Sciences  
Iowa State University  
Ames, IA, USA  
jbloedel@iastate.edu

JOËL BOCKAERT  
Université de Montpellier, CNRS UMR5203  
Inserm U661, Montpellier, France  
Joel.bockaert@igf.cnrs.fr

ULRICH BOEHM  
Center for Molecular Neurobiology  
Institute for Neural Signal Transduction  
Hamburg, Germany  
Ulrich.Boehm@zmnh.uni-hamburg.de

HEINZ BOEKER  
University Hospital of Psychiatry Zurich  
Hospital for Affective Disorders and General  
Psychiatry Zurich East  
Zurich, Switzerland  
boeker@bli.unizh.ch

KARIN BOEKHOORN  
Neurosignalisation Moleculaire et Cellulaire  
INSERM U706  
Institut du Fer a Moulin  
Paris, France

NIKOLAI BOGDUK  
University of Newcastle  
Newcastle Bone and Joint Institute  
Royal Newcastle Centre  
Newcastle, NSW, Australia

BERNHARD BOGERTS  
Universitätsklinik für Psychiatrie  
Psychotherapie und Psychosomatische Medizin  
Otto-von-Guericke  
Universität Magdeburg  
Magdeburg, Germany  
Bernhard.Bogerts@medizin.uni-magdeburg.de

DONALD C. BOLSER  
Department of Physiological Sciences  
University of Florida College of Veterinary Medicine  
Gainesville, FL, USA

MARTHA M. BOSMA  
Department of Biology  
University of Washington  
Seattle, WA, USA  
martibee@u.washington.edu

ANNETTE BÖLTER  
Universitätsklinikum Magdeburg  
Abteilung für Psychosomatische Medizin und  
Psychotherapie  
Magdeburg, Germany

CONSTANTIN BOURAS  
Department of Psychiatry  
University Hospitals of Geneva  
Geneva, Switzerland  
Constantin.Bouras@medecine.unige.ch

JAMIE D. BOYD  
Department of Biological Sciences  
Simon Fraser University  
Burnaby, BC, Canada

VLASTISLAV BRACHA  
Department of Biomedical Sciences  
Iowa State University  
Ames, IA, USA  
vbracha@iastate.edu

MARK R. BRAFORD JR  
Departments of Biology and Neuroscience  
Oberlin College, Oberlin  
Ohio, OH, USA

CATHERINE BRANDNER  
Université de Lausanne  
Institut de Psychologie  
Lausanne, Switzerland  
Catherine.Brandner@unil.ch

ANNA KATHARINA BRAUN  
Otto von Guericke University Magdeburg  
Institute of Biology  
Faculty for Natural Sciences  
Leibniz Institute of Neurobiology  
Magdeburg, Germany  
katharina.braun@nat.uni-magdeburg.de

CHRISTOPHER B. BRAUN  
Department of Psychology, Hunter College  
Programs in Biopsychology and Behavioral  
Neuroscience, and Ecology Evolution and Behavior,  
Graduate Center  
City University of New York (CUNY)  
NY, USA  
cbraun@hunter.cuny.edu

HEINZ BREER  
University of Hohenheim  
Institute of Physiology  
Stuttgart, Germany  
breer@uni-hohenheim

BJÖRN BREMBS  
Freie Universität Berlin  
Fachbereich Biologie, Chemie Pharmazie  
Institut für Biologie – Neurobiologie  
Berlin, Germany  
bjoern@brembs.net

PETER BRENNAN  
Department of Physiology  
University of Bristol  
Bristol, UK  
p.brennan@bristol.ac.uk

TIMOTHY J. BRENNAN  
Departments of Anesthesia and Pharmacology  
University of Iowa  
Carver College of Medicine  
Iowa City, IA, USA  
tim-brennan@uiowa.edu

LOÏC BRIAND  
Unité Mixte de recherche FLAVIC INRA-ENESAD  
Université de Bourgogne  
Dijon, France  
loic.briand@jouy.inra.fr

DORA BRITES  
Centro de Patogénese Molecular - UBMBE iMed.UL,  
Faculdade de Farmácia  
University of Lisbon  
Lisbon, Portugal  
dbrites@ff.ul.pt

M. A. BRITO  
Centro de Patogénese Molecular - UBMBE iMed.UL,  
Faculdade de Farmácia  
University of Lisbon  
Lisbon, Portugal

ADOLFO M. BRONSTEIN  
Division of Neuroscience  
Imperial College London  
Charing Cross Hospital and the National Hospital for  
Neurology and Neurosurgery  
London, UK  
A.Bronstein@IC.AC.UK

ANNA BROOKS  
Laboratory of Perceptual Processing  
Southern Cross University  
Lismore, NSW, Australia  
anna.brooks@scu.edu.au

NILS BROSE  
Department of Molecular Neurobiology  
Max-Planck-Institute for Experimental Medicine  
Göttingen, Germany  
brose@em.mpg.de

LAURA L. BRUCE  
Department of Biomedical Sciences  
School of Medicine  
Creighton University  
Omaha, NE, USA  
lbruce@creighton.edu

PETER C. BRUNJES  
Department of Psychology  
University of Virginia  
Charlottesville, VA, USA  
brunj@virginia.edu

BRIAN BUDGELL  
Department de Chiropratique  
Universite du Chiropratique  
Universite du Quebec a Trois-Rivieres  
Quebec, Canada  
budgell@uqts.ca

THOMAS N. BUELL  
Department of Neuroscience  
University of Connecticut  
Health Center  
Farmington, CT, USA

RUUD M. BUIJS  
Instituto de Investigaciones Biomedicas  
Department Fisiologia  
Universidad Nacional Autonoma de Mexico  
Mexico City, Mexico  
ruudbuijs@gmail.com

NATHALIE BUONVISO  
Neurosciences Sensorielles, Comportement, Cognition  
Université Claude Bernard Lyon 1  
CNRS – UMR5020 – INFL LYON  
Lyon, France  
buonviso@olfac.univ-lyon1.fr

ROBERT D. BURGOYNE  
The Physiological Laboratory  
School of Biomedical Sciences  
University of Liverpool  
Liverpool, UK  
burgoyne@liv.ac.uk

ROBERT E. BURKE  
Laboratory of Neural Control  
National Institute of Neurological Disorders and Stroke  
National Institutes of Health  
Bethesda, MD, USA  
reburke@helix.nih.gov

RALF BUSSE  
Institut für Philosophie  
Universität Regensburg  
Regensburg, Germany  
ralf.busse@psk.uni-regensburg.de

ANN B. BUTLER  
Department of Molecular Neuroscience  
Krasnow Institute for Advanced Study  
George Mason University  
Fairfax, VA, USA  
abbutler@gmu.edu

RONALD L. CALABRESE  
Department of Biology  
Emory University  
Atlanta, GA, USA  
RCalabre@Biology.EMORY.EDU

MIKE B. CALFORD  
School of Biomedical Sciences and Hunter Medical  
Research Institute

The University of Newcastle  
Newcastle, NSW, Australia  
mike.calford@newcastle.edu.au

ROSE M. CALHOUN-HANEY  
Yerkes National Primate Research Center  
Emory University  
Atlanta, GA, USA  
rcalhou@emory.edu

GEMMA A. CALVERT  
Department of Experimental Psychology  
Oxford University  
Oxford, UK  
g.a.calvert@warwick.ac.uk

ROBERTO CAMINITI  
Department of Human Physiology and Pharmacology  
SAPIENZA, University of Rome  
Rome, Italy

IAIN L. CAMPBELL  
School of Molecular and Microbial Biosciences  
The University of Sydney  
Sydney, NSW, Australia  
icamp@mmb.usyd.edu.au

ANA R. CAMPOS  
Department of Biology  
McMaster University  
Hamilton, ON, Canada  
camposa@univmail.cis.mcmaster.ca

LAURA CANCEDDA  
Department of Neuroscience and Brain Technologies  
The Italian Institute of Technology  
Genoa, Italy  
laura.cancedda@iit.it

LING CAO  
Department of Anesthesiology  
Dartmouth-Hitchcock Medical Center  
Lebanon, NH, USA  
LCao@une.edu

EMILIO CARBONE  
Department of Neuroscience  
NIS Center of Excellence  
CNISM Research Unit  
Torino, Italy  
emilio.carbone@unito.it

ROBERT CARLONE  
Department of Biological Sciences  
Brock University  
St. Catharines, ON, Canada

JOSÉ CARLOS DÁVILA  
Departamento de Biología Celular, Genética y  
Fisiología  
Facultad de Ciencias  
Universidad de Málaga  
Málaga, Spain

BRUCE A. CARLSON  
Department of Biology  
University of Virginia  
Charlottesville, VA, USA  
carlson.bruce@gmail.com

CATHERINE CARR  
Department of Biology  
University of Maryland  
College Park, MD, USA  
cecarr@umd.edu

MATT CARTER  
Department of Psychiatry and Behavioral Sciences  
Stanford University  
School of Medicine  
Palo Alto, CA, USA

PATRIZIA CASACCIA-BONNEFIL  
Robert Wood Johnson Medical School UMDNJ  
Piscataway, NJ, USA

VIVIEN A. CASAGRANDE  
Department of Cell & Developmental Biology  
Vanderbilt University Medical School, U3218  
Learned Lab  
Nashville, TN, USA  
vivien.casagrande@vanderbilt.edu

VIVIEN A. CASAGRANDE  
Department of Psychology and Department of  
Ophthalmology and Visual Sciences  
Nashville, TN, USA  
vivien.casagrande@vanderbilt.edu

TRISTAN CENIER  
Neurosciences Sensorielles, Comportement,  
Cognition  
Université Claude Bernard Lyon 1  
CNRS – UMR5020 – INFL LYON  
Lyon, France

FERNANDO CERVERO  
Anesthesia Research Unit (Faculty of Medicine),  
Faculty of Dentistry and McGill Centre for Research on  
Pain  
McGill University  
QC, Canada  
fernando.cervero@mcgill.ca

JEAN CHAMPAGNAT  
UPR CNRS 2216 Neurobiologie Génétique et  
Intégrative  
FRC CNRS Institut de Neurobiologie Alfred Fessard  
Gif sur Yvette, France  
jean.champagnat@iaf.cnrs-gif.fr

CHRISTINE ELAINE CHAPMAN  
Groupe de Recherche sur le Système Nerveux Central,  
Département de Physiologie & École de Réadaptation,  
Faculté de Médecine  
Université de Montréal  
Montréal, QC, Canada  
c.elaine.chapman@umontreal.ca

MELISSA J. S. CHEE  
Department of Pharmacology and Centre for  
Neuroscience  
University of Alberta  
Edmonton, AB, Canada  
mchee@ualberta.ca

CHIEN-FU CHEN  
Department of Zoology  
University of Oklahoma  
Norman, OK, USA

JEN-YUNG CHEN  
Dept. of Psychology  
Binghamton University  
Binghamton, NY, USA  
happy\_jenyung1@yahoo.com

PAUL CHENEY  
Dept. Molecular and Integrative Physiology  
University of Kansas  
Medical Center  
Kansas City, Kansas, USA  
pcheney@kumc.edu

AMANDA F. P. CHEUNG  
Department of Physiology, Anatomy and Genetics  
University of Oxford  
Oxford, UK

LORENZO CHIARI  
Dipartimento di Elettronica, Informatica e Sistemistica  
Alma Mater Studiorum – Università di Bologna  
Bologna, Italia  
lchiari@deis.unibo.it

JAKOB CHRISTENSEN-DALSGAARD  
Institute of Biology  
University of Southern Denmark  
Odense, Denmark  
jcd@biology.sdu.dk



MACDONALD J. CHRISTIE  
Pain Management Research Institute  
Kolling Institute  
The University of Sydney at Royal North Shore  
Hospital  
St Leonards, NSW, Australia  
macc@med.usyd.edu.au

PAUL CISEK  
Groupe de Recherche Sur le Système Nerveux Central  
Department of Physiology  
University of Montreal  
Montreal, QC, Canada  
cisekp@magellan.unmontreal.ca

MARIA GRAZIA CIUFOLINI  
Department of Infectious, Parasitic and Immune-  
Mediated Diseases  
Istituto Superiore di Sanità  
Rome, Italy  
ciufolin@iss.it

JULIE CHAPUIS  
Laboratoire Systèmes Sensoriels, Comportement et  
Cognition  
UMR 5020 CNRS–UCB Lyon  
IFR19 Lyon, France

ANDREA L. CLARK  
Faculty of Kinesiology and Medicine  
KNB 304  
University of Calgary  
Calgary, AB, Canada  
jgpa.clark@btinternet.com

THOMAS A. CLELAND  
Department of Psychology  
Cornell University  
Ithaca, NY, USA  
tac29@cornell.edu

COLIN W. G. CLIFFORD  
School of Psychology  
University of Sydney  
Sydney, NSW, Australia  
colinc@psych.usyd.edu.au

MAYO CLINIC  
Department of Neurology  
Mayo Foundation  
Rochester, MN, USA

JEAN-FRANÇOIS CLOUTIER  
Department of Neurology and Neurosurgery  
McGill University

Montreal Neurological Institute  
Montréal, QC, Canada  
jf.cloutier@mcgill.ca

DANIEL A. COHEN  
Harvard Medical School, Beth Israel Deaconess  
Medical Center  
Department of Neurology  
Brigham and Women's Hospital  
Division of Sleep Medicine  
Boston, MA, USA  
dcohen2@bidmc.harvard.edu

CAROL L. COLBY  
Department of Neuroscience  
Center for Neural Basis Cognition  
University of Pittsburgh  
Pittsburgh, PA, USA  
colby@cnbc.cmu.edu

JONATHAN COLE  
University of Southampton Clinical Neurological  
Sciences  
Poole Hospital  
Dorset, UK  
jonathan.cole@poole.nhs.uk

MICHAEL A. COLICOS  
Department of Physiology and Biophysics  
Faculty of Medicine  
University of Calgary  
Calgary, AB, Canada  
mcolicos@ucalgary.ca

SHAUN P. COLLIN  
Sensory Neurobiology Group  
School of Biomedical Sciences  
The University of Queensland  
Brisbane, QLD, Australia  
s.collin@uq.edu.au

DAVID F. COLLINS  
Faculty of Physical Education and Recreation  
Centre for Neuroscience  
University of Alberta  
Edmonton, AB, Canada  
dave.collins@ualberta.ca

WILLIAM F. COLMERS  
Department of Pharmacology  
University of Alberta  
Edmonton, AB, Canada  
Centre for Neuroscience  
University of Alberta  
Edmonton, AB, Canada

CHRISTOPHER S. COLWELL  
Department of Psychiatry  
University of California  
Los Angeles, USA  
CColwell@mednet.ucla.edu

RUTH M. COLWILL  
Department of Psychology  
Brown University  
Providence, Rhode Island, USA  
Ruth\_Colwill@Brown.EDU

CHARLES E. CONNOR  
Krieger Mind/Brain Institute and Department of  
Neuroscience  
Johns Hopkins University  
Baltimore, MD, USA  
connor@mail.mb.jhu.edu

JENS R. COORSSEN  
Hotchkiss Brain Institute  
Faculty of Medicine  
University of Calgary  
Calgary, Alberta, Canada  
jcoorsse@ucalgary.ca

GÉRARD COUREAUD  
Ethology and Sensory Psychobiology Group,  
European Center for Taste and Smell  
CNRS/University of Burgundy/INRA  
Dijon, France  
coureaud@cesg.cnrs.fr

ELLEN COVEY  
Department of Psychology  
University of Washington  
Seattle, WA, USA  
ecovey@u.washington.edu

TRINITY B. CRAPSE  
Department of Neuroscience  
The Center for the Neural  
Basis of Cognition, and the Center for Neuroscience  
University of Pittsburgh  
Pittsburgh, PA, USA

SARAH H. CREEM-REGEHR  
Department of Psychology  
University of Utah  
Salt Lake City, UT, USA  
sarah.creem@psych.utah.edu

CLAIRE CREUTZFELD  
Harborview Neurology - Comprehensive Stroke Center  
University of Washington  
School of Medicine  
Seattle, WA, USA

JAVIER CUDEIRO  
Neurosciences and Motor Control Group (Neurocom),  
Department of Medicine-INEF-Galicia  
University de A Coruña  
Campus de Oza, A Coruña, Spain

KATHLEEN E. CULLEN  
Department of Physiology  
Aerospace Medical Research Unit  
McGill University  
Montreal, QC, Canada  
kathleen.cullen@mcgill.ca

WILLIAM E. CULLINAN  
Department of Biomedical Sciences and Integrative  
Neuroscience Research Center  
Marquette University  
Milwaukee, WI, USA  
william.cullinan@marquette.edu

YANNIS DALEZIOS  
Institute of Applied and Computational Mathematics  
Crete, Greece  
dalezios@med.uoc.gr

GOMEZ-MERINO DANIELLE  
Department of Physiology  
Institut de Médecine Aérospatiale du Service de Santé  
des Armées  
Brétigny-sur-Orge, France  
dgomez@imassa.fr

CYNTHIA L. DARLINGTON  
Department of Pharmacology and Toxicology  
School of Medical Sciences  
University of Otago  
Medical School  
Dunedin, New Zealand  
cynthia.darlington@stonebow.otago.ac.nz

FRÉDÉRIQUE DATICHE  
Neurophysiology of Chemoreception Group  
European Center for Taste and Smell  
CNRS/University of Burgundy/INRA  
Dijon, France  
datiche@cesg.cnrs.fr

SUBIMAL DATTA  
Sleep and Cognitive Neuroscience Laboratory,  
Department of Psychiatry  
Boston University  
School of Medicine  
Boston, MA, USA  
subimal@bu.edu

ANDREA D'AVELLA  
Department of Neuromotor Physiology  
Santa Lucia Foundation  
Rome, Italy

FRANÇOIS DAVID  
Neurosciences Sensorielles, Comportement,  
Cognition  
Université Claude Bernard Lyon 1  
CNRS – UMR5020 – INFL LYON  
Lyon, France

SAMUEL DAVID  
Center for Research in Neuroscience  
McGill University Health Center  
Montreal, Canada  
samuel.david@mcgill.ca

STEVE DAVIDSON  
Department of Neuroscience  
University of Minnesota  
Minneapolis, MN, USA  
davi1082@umn.edu

JUSTIN R. DAVIS  
Brain Research Centre  
University of British Columbia  
Vancouver, BC, Canada

RANDALL L. DAVIS  
Neuroinflammation Research Laboratory  
Department of Pharmacology/Physiology  
Oklahoma State University  
Center for Health Sciences  
Tulsa, OK, USA  
randadl@chs.okstate.edu

LUIS DE LECEA  
Department of Psychiatry and Behavioral Sciences  
Stanford University  
School of Medicine  
Palo Alto, CA, USA  
llecea@stanford.edu

PAUL DEAN  
Department of Psychology  
University of Sheffield  
Sheffield, UK

GUSTAVO DECO  
Department of Technology, Computational  
Neuroscience  
Universitat Pompeu Fabra  
Barcelona, Spain  
Gustavo.Deco@upf.edu

CHRISTOPHER A. DEL NEGRO  
The Department of Applied Science  
The College of William and Mary  
Williamsburg, VA, USA  
cadeln@wm.edu

JOYCE A. DELEO  
Department of Pharmacology  
Dartmouth-Hitchcock Medical Center  
Lebanon, NH, USA  
cadeln@wm.edu

JOSÉ M. DELGADO-GARCÍA  
División de Neurociencias  
Universidad Pablo de Olavide  
Sevilla, Spain  
jmdelgar@dex.upo.es

ANNETTE DENZINGER  
Tierphysiologie  
Zoologisches Institut  
Universität Tübingen  
Tübingen, Germany

MARI DEZAWA  
Department of Anatomy and Neurobiology  
Kyoto University Graduate School of Medicine,  
Yoshidakonoe-cho  
Sakyo-ku, Kyoto, Japan  
dezawa@anat2.med.kyoto-u.ac.jp

YASIN Y. DHAHER  
Department of Biomedical Engineering  
McCormick School of Engineering  
Department of Physical Medicine and Rehabilitation,  
Feinberg School of Medicine, Northwestern University,  
Sensory Motor Performance Program  
The Rehabilitation Institute of Chicago  
Chicago, IL, USA  
y-dhafer@northwestern.edu

HASSAN R. DHAINI  
Faculty of Health Sciences  
University of Balamand  
Aschrafieh, Beirut  
hassan.dhaini@balamand.edu.lb

PATRICIA M. DI LORENZO  
Dept. of Psychology  
Binghamton University  
Binghamton, NY, USA  
diloren@binghamton.edu

BETTY DIAMOND  
Department of Medicine  
Columbia University  
Medical Center  
New York, NY, USA  
bd2137@columbia.edu

SULAYMAN D. DIB-HAJJ  
Department of Neurology and Center for Neuroscience  
and Regeneration Research  
Yale University  
School of Medicine  
New Haven, CT, USA  
sulayman.dib-hajj@yale.edu

THOMAS E. DICK  
Division of Pulmonary, Critical Care and Sleep  
Medicine  
Department of Medicine  
Case Western Reserve University  
Cleveland, OH, USA  
thomas.dick@case.edu

URSULA DICKE  
Brain Research Institute  
University of Bremen  
Bremen, Germany

J. DAVID DICKMAN  
Department of Anatomy and Neurobiology  
Washington University  
St. Louis, MO, USA  
ddickman@wustl.edu

ANNE DIDIER  
Neurosciences Sensorielles, Comportement, Cognition  
Université de Lyon, Université  
Claude Bernard Lyon1, Villeurbanne, France  
didier@olfac.univ-lyon1.fr

W. DALTON DIETRICH  
The Miami Project to Cure Paralysis and Neurological  
Surgery  
University of Miami Miller  
School of Medicine  
Miami, FL, USA  
DDietrich@miami.edu

DERK-JAN DIJK  
Surrey Sleep Research Centre  
University of Surrey  
Guildford, Surrey, UK  
d.j.dijk@surrey.ac.uk

CHRISTINE D. DIJKSTRA  
Department of Molecular Cell Biology and  
Immunology  
VUMC  
Amsterdam, The Netherlands  
cd.dijkstra@vumc.nl

PAUL DiZIO  
Ashton Graybiel Spatial Orientation Laboratory  
Brandeis University  
Waltham, MA, USA  
dizio@brandeis.edu

PETER R. DODD  
School of Molecular and Microbial Sciences  
University of Queensland  
Brisbane, Queensland, Australia  
p.dodd@uq.edu.au

RODNEY J. DOUGLAS  
Institute of Neuroinformatics UZH/ETH  
University/ETH  
Zurich, Switzerland

MEGAN J. DOWIE  
Department of Pharmacology and Clinical  
Pharmacology  
University of Auckland  
Auckland, New Zealand

KATI E. DRAPER  
Department of Human Nutrition, Foods and Exercise  
Virginia Polytechnic Institute and State University  
Blacksburg, VA, USA

DAVID DUBAYLE  
CNRS UMR 8119, Neurophysique et Physiologie  
Université René Descartes  
UFR Biomédicale  
Paris, France  
dubayle@biomedicale.univ-paris5.fr

RÉJEAN DUBUC  
Département de Kinanthropologie  
Université du Québec à Montréal  
Montréal, QC, Canada  
Département de Physiologie  
Université de Montréal  
Montréal, QC, Canada  
rejean.dubuc@gmail.com

ELIZABETH DUDKIN  
Penn State University  
Media, PA, USA  
ead9@psu.edu

JAMES DUFFIN  
Department of Anaesthesia and Physiology  
University of Toronto  
Medical Sciences Building  
Toronto, ON, Canada  
j.duffin@utoronto.ca

MAYANK B. DUTIA  
Centre for Integrative Physiology  
Edinburgh University  
Hugh Robson Building  
Edinburgh, UK  
m.b.dutia@ed.ac.uk

MATHIAS DUTSCHMANN  
Department of Neuro and Sensory Physiology  
Georg August University of Göttingen  
Göttingen, Germany  
mdutsch@gwdg.de

FORD EBNER  
Department of Psychology  
Vanderbilt University  
Nashville, TN, USA  
ford.ebner@vanderbilt.edu

VICTOR REGGIE EDGERTON  
Brain Research Institute and Department of  
Physiological Science  
University of California  
Los Angeles, CA, USA

ELISABETH EHLER  
The Randall Division of Cell and Molecular  
Biophysics & The Cardiovascular Division  
King's College London  
London, UK  
elisabeth.ehler@kcl.ac.uk

WALTER H. EHRENSTEIN  
Leibniz Research Center for Working Environment and  
Human Factors  
University of Dortmund  
Dortmund, Germany  
ehrenstein@ifado.de

GÜNTER EHRET  
Department of Neurobiology  
University of Ulm  
Ulm, Germany  
guenter.ehret@biologie.uni-ulm.de

DAVID D. EISENSTAT  
Manitoba Institute of Cell Biology,  
Departments of Pediatrics and Child Health, Human  
Anatomy and Cell Science,  
Ophthalmology, and Biochemistry and  
Medical Genetics,  
Faculty of Medicine  
University of Manitoba  
Winnipeg, MB, Canada

ALAA EL-HUSSEINI  
Department of Psychiatry and the Brain Research  
Centre  
University of British Columbia  
Vancouver, BC, Canada

STACY L. ELLIOTT  
Departments of Psychiatry and Urological Sciences and  
International Collaboration on Repair Discoveries  
University of British Columbia  
Vancouver, BC, Canada  
elliott@icord.org

BERNARD T. ENGEL  
Schulich School of Engineering  
University of Calgary  
Calgary, AB, Canada  
Btere@aol.com

MARCELO EPSTEIN  
Schulich School of Engineering  
University of Calgary  
Calgary, AB, Canada  
mepstein@ucalgary.ca

GERHARD ERNST  
Seminar für Philosophie, Logik und  
Wissenschaftstheorie  
Ludwig-Maximilians-Universität München  
München, Germany  
Gerhard.Ernst@lrz.uni-muenchen.de

MICHAEL ESFELD  
Department of Philosophy  
University of Lausanne  
Lausanne Switzerland  
Michael-Andreas.Esfeld@philo.unil.ch

GREG K. ESSICK  
Department of Prosthodontics and Center for  
Neurosensory Disorders  
School of Dentistry  
University of North Carolina  
Chapel Hill, NC, USA  
essickg@DENTISTRY.UNC.EDU

NAOMI ETHERIDGE  
School of Molecular and Microbial Sciences  
University of Queensland  
Brisbane, Queensland, Australia

THOMAS EULER  
Department of Biomedical Optics  
Max-Planck Institute for Medical Research  
Heidelberg, Germany  
thomas.euler@mpimf-heidelberg.mpg.de

SUSAN E. EVANS  
Research Department of Cell and Developmental  
Biology  
UCL, University College London  
London, UK  
ucgasue@ucl.ac.uk

MANFRED FAHLE  
Bremen University  
Department of Human Neurobiology  
Bremen, Germany  
mfahle@uni-bremen.de

A. S. FALCÃO  
Centro de Patogénese Molecular - UBMBE iMed.UL,  
Faculdade de Farmácia  
University of Lisbon  
Lisbon, Portugal

JAMSHID FARAJI  
Canadian Centre for Behavioural Neuroscience,  
Department of Neuroscience  
University of Lethbridge  
Lethbridge, AB, Canada

DAVID H. FARB  
Laboratory of Molecular Neurobiology  
Department of Pharmacology and Experimental  
Therapeutics  
Boston, MA, USA  
eisensta@cc.umanitoba.ca

NATHAN R. FARRAR  
Department of Biological Sciences  
Brock University  
St. Catharines, ON, Canada

PAUL A. FAURE  
Department of Psychology, Neuroscience & Behavior,  
McMaster University  
Hamilton, ON, Canada  
paul4@mcmaster.ca

PHILIPPE FAURE  
Department of Neurobiology  
Pasteur Institute and CNRS  
Paris, France  
phfaure@pasteur.fr

JAMES W. FAWCETT  
Cambridge University Centre for Brain Repair,  
Robinson Way  
Cambridge, UK  
jf108@cam.ac.uk

ANNA FEJTOVÁ  
Leibniz Institute for Neurobiology  
Department of Neurochemistry and Molecular Biology  
Magdeburg, Germany

URSULA FELDERHOFF-MUESER  
Department of Neonatology  
Charité Universitätsmedizin Berlin,  
Campus Virchow  
Klinikum  
Berlin, Germany

ANATOL G. FELDMAN  
Neurological Science Research Center,  
Department of Physiology  
University of Montreal  
Montreal, QC, Canada  
feldman@med.umontreal.ca

DANIEL J. FELLEMAN  
Department of Neurobiology and Anatomy  
University of Texas  
Medical School-Houston  
Houston, TX, USA

HONORARY FELLOW  
Department of Anatomy and Structural Biology  
University of Otago  
Dunedin, New Zealand  
Daniel.Felleman@uth.tmc.edu

FENG FENG  
Department of Biology  
University of Iowa  
Iowa City, IA, USA

ZHONG-PING FENG  
Department of Physiology  
University of Toronto  
Toronto, ON, Canada  
Zp.feng@utoronto.ca

ANDRÉ A. FENTON  
Department of Physiology and Pharmacology  
The Robert F. Furchgott Center for Neural and  
Behavioral Science,  
State University of New York,  
Downstate Medical Center  
Brooklyn, NY, USA  
afenton@biosignalgroup.com

RUSSELL D. FERNALD  
Department of Biology  
Stanford University  
Stanford, CA, USA

A. FERNANDES  
Centro de Patogénese Molecular - UBMBE iMed.UL,  
Faculdade de Farmácia  
University of Lisbon  
Lisbon, Portugal

JOSEPH R. FETCHO  
Department of Neurobiology and Behavior  
Cornell University  
Ithaca, NY, USA  
jfetcho@notes.cc.sunysb.edu

ARIE FEUER  
Electrical Engineering  
Technion, Israel  
feuer@ee.technion.ac.il

HOWARD L. FIELDS  
Ernest Gallo Clinic and Research Center,  
University of California  
San Francisco, USA  
hlf@phy.ucsf.edu

ROGER B. FILLINGIM  
Department of Community Dentistry and Behavioral  
Science,  
College of Dentistry  
University of Florida and North Florida  
South Georgia  
Veterans Health System  
Gainesville, FL, USA  
RFILLINGIM@dental.ufl.edu

NANNA B. FINNERUP  
Department of Neurology and Danish Pain Research  
Center  
Aarhus University Hospital  
Aarhus, Denmark

MARIA FITZGERALD  
UCL Department of Anatomy and Developmental  
Biology  
University College London  
London, UK  
m.fitzgerald@ucl.ac.uk

MARTHA FLANDERS  
Department of Neuroscience  
University of Minnesota  
Minneapolis, MN, USA  
fland001@umn.edu

TAMAR FLASH  
Department of Computer Science and Applied  
Mathematics  
Weizmann Institute of Science  
Rehovot, Israel  
tamar.flash@weizmann.ac.il

ERICA L. FLETCHER  
Department of Anatomy and Cell Biology  
The University of Melbourne  
Parkville, VI, Australia

ERIC FLIERS  
Dept of Endocrinology and Metabolism,  
Academic Medical Center  
University of Amsterdam  
Amsterdam, The Netherlands  
e.fliers@amc.uva.nl

KEVIN C. FLYNN  
Molecular, Cellular and Integrative Neurosciences  
Program,  
Department of Biochemistry and Molecular Biology  
Colorado State University  
Fort Collins, CO, USA

MÓNICA FOLGUEIRA  
University of A Coruña,  
Campus A Zapateira  
A Coruña, Spain

ALFREDO FONTANINI  
Department of Neurobiology and Behavior  
State University of New York at Stony Brook  
Stony Brook, NY, USA  
afontanini@brandeis.edu

ROBERT D. FOREMAN  
Department of Physiology  
University of Oklahoma Health Sciences Center  
Oklahoma City, OK, USA  
Robert-Foreman@ouhsc.edu

FIONA FRANCIS  
Département Génétique, Développement et Pathologie  
Moléculaire  
INSERM U567, CNRS UMR 8104, Institut Cochin  
Paris, France

CY FRANK  
Department of Surgery,  
University of Calgary  
Calgary, AB, Canada  
cfrank@ucalgary.ca

MARCOS G. FRANK  
Department of Neuroscience  
University of Pennsylvania  
Philadelphia, PA, USA  
mgf@mail.med.upenn.edu

PAUL FRANKEN  
Center for Integrative Genomics  
University of Lausanne  
Lausanne-Dorigny, Switzerland  
paul.franken@unil.ch

PETER FRANSSON  
MR Research Center,  
Cognitive Neurophysiology  
Department of Clinical Neuroscience,  
Karolinska Institute  
Stockholm, Sweden  
Peter.Fransson@ki.se

RALPH D. FREEMAN  
Vision Science, School of Optometry  
Helen Wills Neuroscience Institute,  
University of California  
Berkeley, CA, USA  
freeman@neurovision.berkeley.edu

CURTIS R. FRENCH  
Department of Biological Sciences  
University of Alberta  
Edmonton, AB, Canada

BERND FRITZSCH  
Department of Biomedical Sciences,  
Creighton University  
Omaha, NE, USA  
fritzsch@creighton.edu

JÖRG FROMMER  
Universitätsklinikum Magdeburg,  
Abteilung für Psychosomatische Medizin und  
Psychotherapie  
Magdeburg, Germany  
joerg.frommer@medizin.uni-magdeburg.de

ELIZABETH FRY  
Center for Research in Neuroscience  
McGill University  
Health Center  
Montreal, Canada

TOSHIKATSU FUJII  
Department of Behavioral Neurology and Cognitive  
Neuroscience  
Tohoku University  
Graduated School of Medicine  
Sendai, Japan  
fujii@mail.tains.tohoku.ac.jp

ROBERT S. FUJINAMI  
Department of Pathology  
University of Utah School of Medicine  
Salt Lake City, Utah, USA  
robert.fujinami@hsc.utah.edu

HIDEFUMI FUKUMITSU  
Laboratory of Molecular Biology  
Gifu Pharmaceutical University  
Gifu, Japan  
fukumitsu@gifu-pu.ac.jp

SHINTARO FUNAHASHI  
Kokoro Research Center,  
Kyoto University  
Kyoto, Japan  
h50400@sakura.kudpc.kyoto-u.ac.jp

JOHN B. FURNESS  
Department of Anatomy and Cell Biology and Centre  
for Neuroscience  
University of Melbourne  
Parkville, VIC, Australia  
j.furness@unimelb.edu.au

SHOEI FURUKAWA  
Laboratory of Molecular Biology  
Gifu Pharmaceutical University  
Gifu, Japan  
furukawa@gifu-pu.ac.jp

VOLKER GADENNE  
Department of Philosophy and Theory of Science  
Johannes-Kepler-University Linz  
Linz, Germany  
volker.gadenne@jku.at

MANFRED GAHR  
Department of Behavioural Neurobiology  
Max Planck Institute for Ornithology  
Germany  
gahr@bio.vu.nl

C. GIOVANNI GALIZIA  
Universität Konstanz  
Faculty of Biology  
Konstanz, Germany  
galizia@uni-konstanz.de

MILAGROS GALLO  
Department of Experimental Psychology and  
Physiology of Behavior,  
Institute of Neurosciences  
University of Granada  
Granada, Spain  
mgallo@ugr.es



SIMON GANDEVIA  
Prince of Wales Medical Research Institute  
Sydney, NSW, Australia  
s.gandevia@unsw.edu.au

QIAN GAO  
Section of Comparative Medicine,  
Department of Ob/Gyn & Reproductive Sciences and  
Neurobiology  
Yale University School of Medicine  
New Haven, CT, USA

P. GASQUE  
Brain Inflammation and Immunity Group  
Department of Medical Biochemistry  
Cardiff University  
Cardiff, UK

GARY O. GAUFO  
Department of Biomedical Sciences  
Creighton University  
Omaha, NE, USA

GERARD L. GEBBER  
Department of Pharmacology and Toxicology  
Michigan State University  
East Lansing, MI, USA  
gebber@msu.edu

G. F. GEBHART  
Center for Pain Research  
University of Pittsburgh  
Pittsburgh, PA, USA  
gebhartgf@upmc.edu

KARL R. GEGENFURTNER  
Abteilung Allgemeine Psychologie  
Justus-Liebig-Universität  
Giessen, Germany  
Karl.R.Gegenfurtner@psychol.uni-giessen.de

YURI GEINISMAN  
Department of Cell and Molecular Biology  
Northwestern University's Feinberg School of  
Medicine and Institute of Neuroscience,  
Chicago, IL, USA  
yurig@northwestern.edu

STEFANIE GEISLER  
Behavioral Neuroscience Branch,  
National Institute on Drug Abuse  
Intramural Research Program  
Baltimore, MD, USA  
geislrs@intra.nida.nih.gov

ALAN GELPERIN  
Monell Chemical Senses Center  
Philadelphia, PA, USA  
agelperin@monell.org

MENNO P. GERKEMA  
Department of Chronobiology  
Faculty of Mathematics and Natural Sciences,  
University of Groningen  
Groningen, The Netherlands  
m.p.gerkema@rug.nl

RÉMI GERVAIS  
Laboratoire Systèmes Sensoriels, Comportement et  
Cognition  
UMR 5020 CNRS–UCB Lyon IFR19  
Lyon, France

GILLES GHEUSI  
Pasteur Institut,  
Laboratory of Perception and Memory  
Paris, France  
ggheusi@pasteur.fr

PANTELEIMON GIANNAKOPOULOS  
Department of Psychiatry  
University Hospitals of Geneva  
Geneva, Switzerland

IAN L. GIBBINS  
Department of Anatomy & Histology, and Centre for  
Neuroscience  
Flinders University  
Adelaide, SA, Australia  
ian.gibbins@flinders.edu.au

STAN C. A. M. GIELEN  
Department of Biophysics  
Radboud University Nijmegen  
Nijmegen, The Netherlands  
s.gielen@science.ru.nl

GLENN J. GIESLER JR  
Department of Neuroscience  
University of Minnesota  
Minneapolis, MN, USA  
giesler@umn.edu

ANDREW C. GILES  
Brain Research Centre,  
University of British Columbia  
Vancouver, BC, Canada

MARTHA U. GILLETTE  
Molecular and Integrative Physiology, and  
Neuroscience Program,  
Institute for Genomic Biology  
University of Illinois at Urbana-Champaign  
Urbana, IL, USA  
mgillett@uiuc.edu

KEVIN D. GILLIS  
Department of Biological Engineering,  
Department of Medical Pharmacology and Physiology,  
Dalton Cardiovascular Research Center  
University of Missouri – Columbia  
Columbia, MO, USA  
gillisk@missouri.edu

MARTIN GIURFA  
Research Center on Animal Cognition  
CNRS – University Paul Sabatier  
Toulouse, France  
giurfa@cict.fr

MICHELLE GLASS  
Department of Pharmacology and Clinical  
Pharmacology  
University of Auckland  
Auckland, New Zealand  
m.glass@auckland.ac.nz

BEN GODDE  
Jacobs Center on Lifelong Learning and Institutional  
Development  
Jacobs University Bremen  
Bremen, Germany  
b.godde@iu-bremen.de

MICHAEL S. GOLD  
Department of Medicine, Division of Gastroenterology,  
Hepatology and Nutrition  
University of Pittsburgh School of Medicine  
Pittsburgh, PA, USA  
GoldM@dom.pitt.edu

TIMOTHY GOMEZ  
Department of Anatomy  
University of Wisconsin School of Public Health  
Madison, WI, USA

IRINA A. GONTOVA  
Laboratory of Neuroimmunology  
State Research Institute of Clinical Immunology of SB  
RAMS  
Novosibirsk, Russia

AGUSTÍN GONZÁLEZ  
Dept. Biología Celular, Fac. Biología  
Univ. Complutense  
Madrid, Spain

ANTONY W. GOODWIN  
Department of Anatomy and Cell Biology  
University of Melbourne  
Parkville, VIC, Australia  
a.goodwin@unimelb.edu.au

GRAHAM C. GOODWIN  
ARC Centre for Complex Dynamic Systems and  
Control,  
Department of Electrical and Computer Engineering  
The University of Newcastle  
Callaghan, NSW, Australia

TESSA GORDON  
Centre of Neuroscience,  
Division of Physical Medicine and Rehabilitation,  
Faculty of Medicine and Dentistry  
University of Alberta  
Edmonton, AB, Canada

VERENA GOTTSCHLING  
Department for Philosophy  
York University  
Toronto, ON, Canada

DAVID GOZAL  
Kosair Children's Hospital Research Institute,  
Department of Pediatrics  
University of Louisville  
Louisville, KY, USA

RICHARD H. GRACELY  
Internal Medicine-Rheumatology  
University of Michigan  
Ann Arbor, MI, USA

WERNER M. GRAF  
Department of Physiology & Biophysics  
Howard University College of Medicine  
Washington, DC, USA

ROBERT W. GRANGE  
Department of Human Nutrition, Foods and Exercise  
Virginia Polytechnic Institute and State University  
Blacksburg, VA, USA  
rgrange@vt.edu

ALEXEJ GRANTYN  
Laboratoire de Physiologie de la Perception et de  
l'Action  
C.N.R.S – College de France  
Paris, France

THOMAS GRAVEN-NIELSEN  
Center for Sensory-Motor Interaction (SMI),  
Department of Health Science and Technology  
Aalborg University  
Aalborg, Denmark

JOEL D. GREENSPAN  
Department of Biomedical Sciences  
University of Maryland Dental School  
Baltimore, MD, USA

JOHN J. GREER  
Department of Physiology,  
Centre for Neuroscience  
University of Alberta  
Edmonton, AB, Canada

MICHAEL J. GREY  
Department of Exercise and Sport Science &  
Department of Neuroscience and Pharmacology  
The Panum Institute  
Copenhagen, Denmark  
mgrey@mfi.ku.dk

KENNETH L. GRIEVE  
Faculty of Life Sciences  
University of Manchester  
Manchester, UK  
ken.grieve@manchester.ac.uk

M. GRIFFITHS  
Brain Inflammation and Immunity Group  
Department of Medical Biochemistry  
Cardiff University  
Cardiff, UK

NATASHA L. GRIMSEY  
Department of Pharmacology and Clinical  
Pharmacology  
University of Auckland  
Auckland, New Zealand

WILLIAM C. DE GROAT  
Department of Pharmacology  
University of Pittsburgh Medical School  
Pittsburgh, PA, USA  
degroat@server.pharm.pitt.edu

HENK J. GROENEWEGEN  
Institute for Clinical and Experimental Neurosciences,  
Department of Anatomy and Neurosciences  
VU University medical center  
Amsterdam, The Netherlands  
hj.groenewegen@vumc.nl

CLAUDE GRONFIER  
Department of Chronobiology  
Stem Cell and Brain Research Institute,  
Institut National de la Santé et de la Recherche  
Médicale  
France

TED S. GROSS  
Department of Orthopaedics and Sports Medicine  
University of Washington  
Seattle, WA, USA  
tgross@u.washington.edu

STEPHEN GROSSBERG  
Department of Cognitive and Neural Systems  
Center of Excellence for Learning in Education,  
Science and Technology, Boston University  
Boston, MA, USA  
steve@cns.bu.edu

MURRAY GROSSMAN  
Department of Neurology  
University of Pennsylvania School of Medicine  
Philadelphia, PA, USA  
mgrossma@mail.med.upenn.edu

MATTHEW S. GRUBB  
MRC Centre for Developmental Neurobiology  
King's College London  
London, UK  
matthew.grubb@kcl.ac.uk

EDWARD GRUBERG  
Biology Department  
Temple University  
Philadelphia, PA, USA  
e.gruberg@temple.edu

ULRIKE GRÜNERT  
The National Vision Research Institute of Australia  
Department of Optometry & Vision Sciences  
The University of Melbourne  
Australia  
ugrunert@optometry.unimelb.edu.au

ALAIN GUILLAUME  
Institut des Sciences du Movement  
UMR H6233 CNRS  
Université de la Méditerranée  
Marseille, France

GILLES J. GUILLEMIN  
Centre for Immunology and Department of  
Pharmacology, Faculty of Medicine  
University of New South Wales, NSW  
Australia  
g.guillemine@cfi.unsw.edu.au

SALVADOR GUIRADO  
Departamento de Biología Celular, Genética y  
Fisiología, Facultad de Ciencias  
Universidad de Málaga  
Málaga, Spain  
guirado@uma.es

DANIEL GUITTON  
Montreal Neurological Institute  
McGill University  
Montreal, QC, Canada  
dguitt@mni.mcgill.ca

ECKART D. GUNDELFINGER  
Leibniz Institute for Neurobiology  
Department of Neurochemistry and Molecular Biology  
Magdeburg, Germany  
Gundelfinger@ifn-magdeburg.de

ONUR GÜNTÜRKÜN  
Biopsychology, Institute of Cognitive Neuroscience  
Ruhr-University Bochum  
Bochum, Germany  
onur.guentuerken@ruhr-uni-bochum.de

VICTOR S. GURFINKEL  
Neurological Sciences Institute  
Oregon Health & Science University  
Portland, OR, USA  
gurfinkv@ohsu.edu

SERAP GUR  
Department of Urology  
Tulane University Medical Center  
New Orleans, LA, USA

SUZANNE N. HABER  
Department of Pharmacology and Physiology  
University of Rochester School of Medicine  
Rochester, NY, USA  
suzanne\_haber@urmc.rochester.edu

REZA HABIB  
Department of Psychology,  
Department of Computer Science, and School of  
Medicine  
Southern Illinois University Carbondale  
Carbondale, IL, USA

JOHN J. HADDAD  
Cellular and Molecular Signaling Research Group,  
Division of Biological Sciences,  
Departments of Biology and Biomedical Sciences,  
Faculty of Arts and Sciences,  
Lebanese International University,  
Beirut, Lebanon  
john.haddad@liu.edu.lb

THOMAS HADJISTAVROPOULOS  
Centre on Aging and Health and Department of  
Psychology  
University of Regina  
Regina, SK, Canada  
Thomas.Hadjistavropoulos@uregina.ca

TATSUYA HAGA  
Institute for Biomolecular Science, Faculty of Science  
Gakushuin University  
Tokyo, Japan  
tatsuya.haga@gakushuin.ac.jp

PEJMUN HAGHIGHI  
Department of Physiology  
McGill University  
Montreal, QC, Canada  
pejmun.haghighi@mcgill.ca

AKIRA HAJI  
Laboratory of Neuropharmacology  
School of Pharmacy,  
Aichi Gakuin University  
Chikusa, Nagoya, Japan  
haji@dpc.aichi-gakuin.ac.jp

MIMI HALPERN  
Facultad de Medicina and Centro Regional de  
Investigaciones Biomédicas (CRIB)  
Universidad de Castilla-La Mancha  
Albacete, Spain  
mimi.halpern@downstate.edu

JUNG-SOO HAN  
Department of Biological Sciences  
Konkuk University  
Seoul, South Korea

HERRMANN O. HANDWERKER  
Institut für Physiologie und Pathophysiologie  
Erlangen, Germany  
handwerker@physiologie1.uni-erlangen.de

THORSTEN HANSEN  
Abteilung Allgemeine Psychologie  
Justus-Liebig-Universität  
Giessen, Germany  
Thorsten.Hansen@psychol.uni-giessen.de

JENS HARBECKE  
Department of Philosophy  
University of Witten-Herdecke  
Germany

DEBORAH L. HARRINGTON  
Department of Radiology  
University of California, San Diego and V.A. San Diego  
Healthcare Center  
San Diego, CA, USA  
dharrington@ucsd.edu

RONALD M. HARRIS-WARRICK  
Department of Neurobiology and Behavior  
Cornell University  
Ithaca, NY, USA  
rmh4@cornell.edu

NATHAN S. HART  
School of Biomedical Sciences  
University of Queensland, St. Lucia  
Brisbane, QLD, Australia  
n.hart@uq.edu.au

STEVEN E. HARTE  
Department of Neurology  
University of Michigan  
VA Ann Arbor Health System  
Ann Arbor, MI, USA

CHRISTIAN HARTENECK  
Molekulare Pharmakologie & Zellbiologie  
Charité Universitätsmedizin Berlin  
Berlin, Germany  
Christian.Harteneck@charite.de

YUICHI HASHIMOTO  
Institute for Biomolecular Science,  
Faculty of Science  
Gakushuin University  
Tokyo, Japan

YOSHIO HATA  
Division of Integrative Bioscience  
Tottori University Graduate School of Medical  
Sciences  
Yonago, Japan  
yhata@grape.med.tottori-u.ac.jp

YUTAKA HATA  
Department of Medical Biochemistry,  
Graduate School of Medicine  
Tokyo Medical and Dental University  
Tokyo, Japan  
yuhammch@med.tmd.ac.jp

MEGUMI HATORI  
The Salk  
Institute for Biological Studies  
La Jolla, CA, USA

HANNS HATT  
Department of Cell Physiology  
Ruhr-University Bochum  
Bochum, Germany  
Hanns.Hatt@ruhr-uni-bochum.de

SUSANNE HAUSSELT  
Department of Biomedical Optics  
Max-Planck Institute for Medical Research  
Heidelberg, Germany

JOHN A. HAWLEY  
Exercise Metabolism Group,  
School of Medical Sciences  
RMIT University  
Bundoora, Victoria, Australia  
john.hawley@rmit.edu.au

MICHAEL R. HAYDEN  
Centre for Molecular Medicine and Therapeutics  
University of British Columbia  
Vancouver, Canada  
mrh@cmmt.ubc.ca

JOHN A. HAYES  
The Department of Applied Science  
The College of William and Mary  
Williamsburg, VA, USA

NICHOLAS P. HAYS  
Nutrition, Metabolism, and Exercise Laboratory,  
Donald W. Reynolds Institute on Aging  
University of Arkansas for Medical Sciences  
Little Rock, AR, USA  
HaysNicholasP@uams.edu

DAVID HAZLERIGG  
Jackwat Consulting Services Springview  
NSW, Australia  
jackwat@bigpond.com

C. J. HECKMAN  
Departments of Physiology, Physical Medicine and  
Rehabilitation, and Biomedical Engineering  
Feinberg School of Medicine  
Northwestern University  
Chicago, IL, USA  
c-heckman@nwu.edu

WAYNE G. HELLSTROM  
Department of Pharmacology  
Tulane University Medical Center  
New Orleans, LA, USA

THOMAS HELLWIG-BÜRCEL  
Institute of Physiology,  
University of Lübeck  
Lübeck, Germany  
hellwig@physio.uni-luebeck.de

WAYNE HENING  
Department of Neurology  
University of Medicine and Dentistry of New Jersey  
New Brunswick, NJ, USA  
WAHeningMD@aol.com

MICHAEL HERZOG  
Laboratory of Psychophysics,  
Brain Mind Institute  
Ecole Polytechnique Fédérale de Lausanne  
Lausanne, Switzerland  
michael.herzog@epfl.ch

WALTER HERZOG  
Faculty of Kinesiology  
Human Performance Laboratory  
University of Calgary  
Calgary, AB, Canada  
walter@kin.ucalgary.ca

JUAN HIDALGO  
Institute of Neurosciences and Department of Cellular  
Biology, Physiology and Immunology,  
Animal Physiology Unit,  
Faculty of Sciences,  
Autonomous University of Barcelona  
Bellaterra, Barcelona, Spain

STEPHEN M. HIGHSTEIN  
Department of Otolaryngology and Department of  
Anatomy and Neurobiology  
Washington University  
Medical School  
St. Louis, MO, USA  
highstes@medicine.wustl.edu

OKIHIDE HIKOSAKA  
Laboratory of Sensorimotor Research  
National Eye Institute,  
National Institute of Health  
Bethesda, MD, USA  
oh@lsr.nei.nih.gov

TINA HINTON  
Department of Pharmacology,  
The University of Sydney  
NSW, Australia  
tinah@med.usyd.edu.au

MAKOTO HIRAHARA  
Faculty of Engineering,  
Hosei University  
Tokyo, Japan  
hirahara@hosei.ac.jp

TOMOO HIRANO  
Department of Biophysics  
Graduate School of Science,  
Kyoto University  
Kyoto, Japan  
thirano@neurosci.biophys.kyoto-u.ac.jp

TATSUMI HIRATA  
Division of Brain Function,  
National Institute of Genetics  
Graduate University for Advanced Studies (Sokendai)  
Mishima, Japan  
tathirat@lab.nig.ac.jp

MIYAKAWA HIROYOSHI  
Laboratory of cellular Neurobiology,  
School of Life Sciences  
Tokyo University of Pharmacy and Life Sciences  
Tokyo, Japan  
miyakawa@ls.toyaku.ac.jp

JUDITH A. HIRSCH  
Department of Biological Sciences  
University of Southern California  
Los Angeles, CA, USA  
jhirsch@usc.edu

FRANTISEK HLAVACKA  
Institute of Normal and Pathological Physiology  
Bratislava, Slovakia  
hlavacka@unpf.savba.sk

WILLIAM HODOS  
Department of Psychology  
University of Maryland  
College Park, MD, USA  
whodos@psyc.umd.edu

MARKUS J. HOFER  
School of Molecular and Microbial Biosciences,  
The University of Sydney  
Sydney, NSW, Australia

PATRICK R. HOF  
Department of Neuroscience  
Mount Sinai School of Medicine  
New York, NY, USA  
patrick.hof@mssm.edu

MICHEL A. HOFMAN  
Netherlands Institute for Neuroscience  
Amsterdam, The Netherlands  
M.Hofman@nin.knaw.nl

FRANK HOFMANN  
Philosophisches Seminar  
Universität Tübingen  
Tübingen, Germany  
f.hofmann@uni-tuebingen.de

RALPH L. HOLLOWAY  
Department of Anthropology  
Columbia University  
USA

NICHOLAS P. HOLMES  
Espace et Action  
Bron, France  
nicholas.p.holmes@wolfson.oxon.org

IKUO HOMMA  
Department of Physiology  
Showa University  
School of Medicine  
Tokyo, Japan  
ihomma@med.showa-u.ac.jp

FAY B. HORAK  
Neurological Sciences Institute,  
Oregon Health and Science University  
Portland, OR, USA  
horakf@ohsu.edu

HIDENORI HORIE  
Advanced Research Institute for Biological Science  
Waseda University  
Nishitokyo, Tokyo, Japan

ARATA HORII  
Department of Otolaryngology  
Osaka University School of Medicine  
Suita, Osaka, Japan  
ahorii@ent.med.osaka-u.ac.jp

DAVID E. HORNUNG  
Dana Professor of Biology  
St. Lawrence University  
Canton, NY, USA  
dhornung@stlawu.edu

JONATHAN C. HORTON  
Department of Ophthalmology  
Koret Vision Research Laboratory  
UCSF,  
San Francisco, CA, USA  
hortonj@vision.ucsf.edu

TAMAS HORVATH  
Section of Comparative Medicine,  
Department of Ob/Gyn & Reproductive Sciences and  
Neurobiology  
Yale University School of Medicine  
New Haven, CT, USA  
tamas.horvath@yale.edu

XINTIAN HU  
Laboratory of Sensory Motor Integration  
Kunming Institute of Zoology,  
The Chinese Academy of Sciences  
Kunming, People's Republic of China

GEMA HUESA  
Institute of Neurosciences  
University Aut6noma of Barcelona,  
Campus of Bellaterra  
Bellaterra, Spain  
gema.huesa@uab.es

PETER A. HUIJING  
Research Instituut Faculteit Bewegingswetenschappen  
Vrije Universiteit  
Amsterdam, The Netherlands  
p\_a\_j\_b\_m\_huijing@fbw.vu.nl

INGE HUITINGA  
Netherlands Institute for Neurosciences  
Amsterdam, The Netherlands  
i.huitinga@nin.knaw.nl

PETER HUNTER  
Auckland Bioengineering Institute  
University of Auckland  
Auckland, New Zealand  
p.hunter@auckland.ac.nz

CLOTILDE M. J. I. HUYGHUES-DESPOINTES  
Department of Physiology  
Emory University  
Atlanta, GA, USA

MASUMI ICHIKAWA  
Tokyo Metropolitan Institute for Neuroscience  
Tokyo, Japan  
mich@tmin.ac.jp

CHIZUKA IDE  
Institute of Regeneration and Rehabilitation  
Department of Occupational Therapy  
Faculty of Nursing and Rehabilitation  
Aino University  
Ibaragi, Osaka, Japan  
c-ide@ot-u.aino.ac.jp

JUNKO IIDA  
Department of Medical Biochemistry,  
Graduate School of Medicine  
Tokyo Medical and Dental University  
Tokyo, Japan

KAZUHIRO IKENAKA  
National Institute of Physiology Sciences  
Division of Neurobiology and Bioinformatics  
Myodaiyi, Okazaki, Japan  
ikenaka@nips.ac.jp

KURT R. ILLIG  
Department of Psychology  
University of Virginia Charlottesville  
VA, USA

KAZUHIDE INOUE  
Department of Molecular and System Pharmacology,  
Graduate School of Pharmaceutical Sciences  
Kyushu University,  
Japan  
inoue@nihs.go.JP

ANDREAS A. IOANNIDES  
Laboratory for Human Brain Dynamics  
Brain Science Institute, RIKEN  
Saitama, Japan  
ioannides@postman.riken.jp

DEXTER R. F. IRVINE  
Department of Psychology  
Monash University  
VIC, Australia  
Irvine@med.monash.edu.au

YASUYUKI ISHIKAWA  
Nara Institute of Science and Technology (NAIST)  
Structural Cell Biology  
Nara, Japan

YUTAKA ITOKAZU  
Department of Anatomy and Neurobiology  
Kyoto University Graduate School of Medicine,  
Yoshidakonoe-cho  
Sakyo-ku, Kyoto, Japan

ALEXEY M IVANITSKY  
Group of Human Higher Nervous Activity  
Institute of Higher Nervous Activity and  
Neurophysiology  
Russian Academy of Sciences  
Moscow, Russia  
alivanit@aha.ru

GEORGE A. IVANITSKY  
Laboratory of Human Higher Nervous Activity  
Institute of Higher Nervous Activity and  
Neurophysiology  
Russian Academy of Sciences  
Moscow, Russia

YOSHIKI IWAMURA  
Department of Sensory Science  
Kawasaki University of Medical Welfare  
Okayama, Japan  
iwayoshi@mw.kawasaki-m.ac.jp

DENNIS J. MCFARLAND  
New York State Department of Health  
Laboratory of Nervous System Disorders,  
Wadsworth Center  
Albany, NY, USA

MEHRNAZ JAFARIAN-TEHRANI  
Laboratoire de Pharmacologie (UPRES EA2510)  
Université Paris Descartes - UFR Pharmacie  
Paris, France  
mehrnaz.jafarian@univ-paris5.fr

JOHANNES JAKOBSEN  
Department of Neurology  
Aarhus University Hospital  
Aarhus, Denmark  
jakob@as.aaa.dk

WILFRID JÄNIG  
Department of Physiology  
Physiologisches Institut  
Christian-Albrechts-Universität zu Kiel  
Kiel, Germany  
w.janig@physiologie.uni-kiel.de

ERICH D. JARVIS  
Department of Neurobiology  
Duke University Medical Center  
Durham, NC, USA  
Jarvis@neuro.duke.edu

JOHN JEKA  
Department of Kinesiology  
Neuroscience and Cognitive Science Program,  
Bioengineering Graduate  
Program  
University of Maryland  
MD, USA  
jjeka@umd.edu

TROELS S. JENSEN  
Department of Neurology and Danish Pain Research  
Center  
Aarhus University Hospital  
Aarhus, Denmark  
tsjensen@ki.au.dk

HARRY J. JERISON  
Department of Psychiatry & Bibehavioral Sciences  
UCLA Health Sciences Center  
Santa Monica, CA, USA  
hjerison@ucla.edu

BRETT A. JOHNSON  
Department of Neurobiology and Behavior  
University of California  
Irvine, CA, USA  
bajohnso@uci.edu

BRUCE R. JOHNSON  
Department of Neurobiology and Behavior  
Cornell University  
Ithaca, NY, USA  
brj1@cornell.edu



GRAHAM A. R. JOHNSTON  
Department of Pharmacology  
The University of Sydney  
NSW, Australia  
grahamj@mail.usyd.edu.au

BARBARA E. JONES  
Department of Neurology & Neurosurgery  
McGill University  
Montreal Neurological Institute  
Montreal, QC, Canada  
barbara.jones@mcgill.ca

LYNETTE A. JONES  
Department of Mechanical Engineering  
Massachusetts Institute of Technology  
Cambridge, MA, USA  
ljones@mit.edu

RENÉ J. JORNA  
Professor of Knowledge Management & Cognition  
Faculty of Economics and Business  
University of Groningen  
Groningen, The Netherlands  
r.j.j.m.jorna@bdk.rug.nl

M. J. JOYNER  
Departments of Anesthesiology and Physiology  
Mayo Clinic College of Medicine  
Rochester, MN, USA  
joyner.michael@mayo.edu

JON H. KAAS  
Department of Psychology  
Vanderbilt University  
Nashville, TN, USA  
Jon.H.Kaas@vanderbilt.edu

HIDETO KABA  
Department of Physiology  
Kochi Medical School  
Nankoku, Kochi, Japan  
kabah@med.kochi-u.ac.jp

TORAH M. KACHUR  
Department of Biological Sciences  
University of Alberta  
Edmonton, AB, Canada

PHILIP J. KADOWITZ  
Department of Pharmacology  
Tulane University Medical Center  
New Orleans, LA, USA  
pkadowi@tulane.edu

RYOICHIRO KAGEYAMA  
Institute for Virus Research  
Kyoto University  
Kyoto, Japan  
rkageyam@virus.kyoto-u.ac.jp

MICHAEL KALLONIATIS  
Department of Optometry and Vision Science  
University of Auckland  
Auckland, New Zealand  
m.kalloniatis@auckland.ac.nz

MIHALY KALMAN  
1st Department of Anatomy  
Semmelweis University  
School of Medicine  
Budapest, Hungary  
kalman@ana.sote.hu

ANDRIES KALSBECK  
Netherlands Institute for Neuroscience  
Amsterdam, The Netherlands

BARBARA KALTSCHMIDT  
Department of Cell Biology  
Faculty of Biology  
University of Bielefeld  
Bielefeld, Germany  
b.kaltschmidt@uni-wh.de

CHRISTIAN KALTSCHMIDT  
Department of Cell Biology  
Faculty of Biology  
University of Bielefeld  
Bielefeld, Germany  
C.Kaltschmidt@uni-wh.de

HARUYUKI KAMIYA  
Department of Neurobiology  
Department of Molecular Neuroanatomy  
Hokkaido University School of Medicine  
Sapporo, Japan  
kamiya@med.hokudai.ac.jp

RYOTA KANAI  
Division of Biology  
California Institute of Technology  
Pasadena, CA, USA  
r.kanai@ucl.ac.uk

CHRIS R. S. KANEKO  
Department of Physiology and Biophysics  
Washington National Primate Research Center,  
University of Washington  
Seattle, WA, USA  
kaneko@u.washington.edu

HIROSHI KANNAN  
Department of Physiology  
Faculty of Medicine  
University of Miyazaki  
Miyazaki, Japan  
kannanh@med.miyazaki-u.ac.jp

AMIR KARNIEL  
Department of Biomedical Engineering  
Ben-Gurion University of the Negev  
Beer Sheva, Israel  
akarniel@bgu.ac.il

HARUO KASAI  
Laboratory of structured Physiology  
Center for Disease  
Biology and Integrative Medicine  
University of Tokyo  
Tokyo, Japan  
hkasai@nips.ac.jp

SABINE KASTNER  
Department of Psychology  
Princeton Neuroscience Institute  
Center for the Study of Brain, Mind and Behavior  
Princeton University  
Princeton, NJ, USA  
skastner@Princeton.EDU

YOSHIFUMI KATAYAMA  
Department of Autonomic Physiology  
Medical Research Institute  
Tokyo Medical and Dental University  
Tokyo, Japan  
kataauto@mri.tmd.ac.jp

KAZUO KATO  
Department of Psychology  
Kyushu University  
Fukuoka, Japan  
kaz@hes.kyushu-u.ac.jp

HIROSHI KAWABE  
Department of Molecular Neurobiology  
Max-Planck-Institute for Experimental Medicine  
Göttingen, Germany

YOSHIKO KAWAI  
Department of Physiology  
Shinshu University School of Medicine  
Matsumoto, Japan

MITSUO KAWATO  
ATR Computational Neuroscience Laboratories  
Kyoto, Japan  
kawato@atr.jp

LESLIE M. KAY  
Department of Psychology  
Institute for Mind and Biology  
The University of Chicago  
Chicago, IL, USA  
LKay@uchicago.edu

ROBERT W. KEANE  
Department of Physiology and Biophysics  
University of Miami Miller School of Medicine  
Miami, FL, USA  
rkeane@miami.edu

GEERT KEIL  
Dept. of Philosophy  
RWTH Aachen University  
Aachen, Germany  
geert.keil@rwth-aachen.de

LAURIE A. KELLAWAY  
Division of Neuroscience  
Department of Human Biology  
Faculty of Health Sciences  
University of Cape Town  
Cape Town, South Africa

BERNHARD KELLER  
Department of Neurophysiology  
University of Göttingen  
Göttingen, Germany  
bkeller1@gwdg.de

EDWARD L. KELLER  
Smith-Kettlewell Eye Research Institute  
San Francisco, CA, USA  
elk@ski.org

DANIEL KELLY  
Department of Philosophy  
Purdue University  
West Lafayette, IN, USA

MINEKO KENGAKU  
Laboratory for Neural Cell Polarity  
RIKEN Brain Science Institute  
Wako, Japan  
kengaku@brain.riken.jp

HENRY KENNEDY  
INSERM U846, Stem Cell and Brain Research Institute  
Department of Integrative Neuroscience  
Bron cedex, France  
kennedy@lyon.inserm.fr

ROBERT W. KENTRIDGE  
Psychology Department  
University of Durham  
Durham, UK  
robert.kentrige@durham.ac.uk

ROLAND KERN  
Institut für Psychologie II  
Münster, Germany

DOUGLAS STEVEN KERR  
Department of Pharmacology & Toxicology  
University of Otago School of Medical Sciences  
Dunedin, New Zealand  
steve.kerr@stonebow.otago.ac.nz

DIRK KERZEL  
Faculté de Psychologie et des Sciences de l'Éducation  
Université de Genève  
Genève, Switzerland  
dirk.kerzel@pse.unige.ch

EMILY A. KESHNER  
Department of Physical Therapy  
College of Health  
Professions and Department of Electrical and Computer  
Engineering  
College of Engineering  
Temple University  
Philadelphia, PA, USA  
eak@NORTHWESTERN.EDU

HAIDER ALI KHAN  
Nuclear Medicine Department  
Kuwait Center for Specialized Surgery  
Kuwait

ILYA KHAYTIN  
Department of Cell & Developmental Biology  
Vanderbilt University  
Medical School  
U3218 Learned Lab  
Nashville, TN, USA

YOSHI KIDOKORO  
Institute for Molecular and Cellular Regulation  
Gunma University  
Gunma, Japan  
kidokoro@med.gunma-u.ac.jp

OLE KIEHN  
Mammalian Locomotor Laboratory  
Department of Neuroscience  
Karolinska Institute  
Stockholm, Sweden  
o.kiehn@neuro.ki.se

TIM KIEMEL  
Department of Kinesiology  
University of Maryland  
MD, USA  
iemel@umd.edu

JOANNE S. KIM  
Department of Molecular Genetics  
University of Toronto  
Toronto, ON, Canada

JULIA KIM  
Laboratory of Molecular Neurobiology  
Department of Pharmacology and Experimental  
Therapeutics  
Boston, MA, USA

HIROSHI KIMURA  
Graduate School of Biostudies  
Kyoto University  
Kyoto, Japan

MINORU KIMURA  
Kyoto Prefectural University of Medicine  
Kawaramachi-Hirokoji  
Kamigyo-ku, Kyoto, Japan  
mkimura@koto.kpu-m.ac.jp

ANDREW J. KING  
Department of Physiology, Anatomy and Genetics  
Sherrington Building  
University of Oxford, Oxford, UK

JONATHAN KIPNIS  
The Weizmann Institute of Science  
Rehovot, Israel

JANINA KIRSCH  
Biopsychology, Institute of Cognitive Neuroscience  
Ruhr-University Bochum  
Bochum, Germany

STEPHEN J. KISH  
Human Neurochemical Pathology Laboratory  
Centre for Addiction and Mental Health  
Toronto, ON, Canada

NORIYUKI KISHI  
MGH-HMS Center for Nervous System Repair,  
Departments of Neurosurgery and Neurology, and  
Program in Neuroscience  
Harvard Medical School;  
Nayef Al-Rodhan Laboratories  
Massachusetts General Hospital  
Department of Stem Cell and Regenerative  
Biology, and Harvard Stem Cell Institute  
Harvard University  
Boston, MA, USA  
noriyuki\_kishi@hms.harvard.edu

TOSHIHIRO KITAMA  
Center for Life Science Research  
University of Yamanashi, Yamanashi  
Japan

CHRISTIAN KLÄMBT  
Institut für Neurobiologie  
Münster, Germany

PETER KLAVER  
Department of Psychology  
University of Zurich  
Zurich, Switzerland

ELIZABETH B. KLERMAN  
Division of Sleep Medicine  
Department of Sleep Medicine  
Brigham and Women's Hospital  
Harvard Medical School  
Boston, MA, USA

KEITH R. KLUENDER  
Department of Psychology  
University of Wisconsin  
Madison, WI, USA  
krkluend@wisc.edu

MARKUS KNAUFF  
Center for Cognitive Science  
University of Freiburg  
Freiburg, Germany

KENNETH KNOBLAUCH  
Inserm U846  
Bron, France

MIKAKO KOBAYASHI-WARREN  
Department of Pathology  
University of Utah  
School of Medicine  
Salt Lake City, Utah, USA

H. RICHARD KOERBER  
Department of Neurobiology  
University of Pittsburgh  
Pittsburgh, PA, USA

KIYOMI KOIZUMI  
Department of Physiology and Pharmacology  
State University of New York  
Downstate Medical Center  
Brooklyn, New York, USA

ARLETTE KOLTA  
Faculté de Médecine Dentaire  
Université de Montréal  
Succursale Centre-ville  
Montréal, QC, Canada

PAUL DE KONINCK  
Department of Biochemistry and Microbiology  
Laval University  
Centre de Recherche Université Laval Robert-Giffard  
Quebec, QC, Canada  
paul.dekoninck@crulrg.ulaval.ca

KONRAD KÖRDING  
Institute of Neurology  
London, UK  
konrad@koerding.com

HELEN A. KORNEVA  
Institute for Experimental Medicine  
St. Petersburg, Russia

GIRISH J. KOTWAL  
Inflamed  
Louisville, KY, USA  
gikotw01@yahoo.com

ENIKŐ KÓVARI  
Department of Psychiatry  
University Hospitals of Geneva  
Geneva, Switzerland

VLADIMIR A. KOZLOV  
Laboratory of Neuroimmunology  
State Research Institute of Clinical Immunology of SB  
RAMS  
Novosibirsk, Russia

ACHIM KRAMER  
Laboratory of Chronobiology  
Charité Universitätsmedizin Berlin  
Berlin, Germany  
achim.kramer@charite.de

BERND KRAMER  
Institut für Zoologie  
Animal Behaviour and Behavioural Physiology  
Research Group  
Universität Regensburg  
Regensburg, Germany  
bernd.kramer@biologie.uni-regensburg.de

NINA KRAUS  
Departments of Communication Sciences,  
Neurobiology and Physiology, Otolaryngology  
Northwestern University  
Evanston, IL, USA  
nkraus@northwestern.edu

LEAH KRUBITZER  
Department of Psychology  
University of California  
Davis, CA, USA  
lakrubitzer@ucdavis.edu

JOHN L. KUBIE  
Department of Anatomy and Cell Biology  
State University of New York  
Downstate Medical Center  
Brooklyn, NY, USA

M. FABIANA KUBKE  
Department of Anatomy with Radiology  
Faculty of Medical and Health Sciences  
University of Auckland  
Auckland, New Zealand  
f.kubke@auckland.ac.nz

YOSHIHISA KUDO  
School of Life Science  
Tokyo University of Pharmacy and Life Science  
Tokyo, Japan  
kudoy@ls.toyaku.ac.jp

AMOD P. KULKARNI  
Division of Medical Virology  
Department of Clinical Laboratory Sciences  
Institute of Infectious Disease and Molecular Medicine  
amoduct@gmail.com

SHIGERU KURATANI  
Laboratory for Evolutionary Morphology  
Center for Developmental Biology  
Riken, Kobe, Japan  
saizo@cdb.riken.go.jp

HIROSHI KUROMI  
Institute for Behavioral Sciences  
Gunma University Graduate School of Medicine  
Maebashi, Japan  
kuromi@med.gunma-u.ac.jp

ALEXANDER KUSNECOV  
Rutgers University  
Department of Psychology  
Piscataway, NJ, USA  
kusnecov@rci.rutgers.edu

FRÉDÉRIC LABERGE  
Brain Research Institute  
University of Bremen  
Bremen, Germany

JAMES R. LACKNER  
Ashton Graybiel Spatial Orientation Laboratory  
Brandeis University  
Waltham, MA, USA  
lackner@brandeis.edu

BERND LADWIG  
Otto-Suhr-Institut für Politik-Wissenschaft  
Freie Universität Berlin  
Berlin, Germany  
berndladwig@hotmail.com

HUGO LAGERCRANTZ  
Karolinska Institute  
Astrid Lindgren Children's Hospital  
Stockholm, Sweden  
hugo.lagercrantz@actapaediatrica.se

PETER M. LALLEY  
Department of Physiology  
The University of Wisconsin  
School of Medicine and Public Health  
Medical Sciences Center  
Madison, WI, USA  
pmlalley@wisc.edu

NATHALIE LAMARCHE-VANE  
Department of Anatomy and Cell Biology  
McGill University  
Montreal, Quebec, Canada  
nathalie.lamarche@mcgill.ca

MICHAEL F. LAND  
Department of Biology and Environmental Science  
University of Sussex  
Brighton, UK  
m.f.land@sussex.ac.uk

BASILE NICOLAS LANDIS  
Unité de Rhinologie-Olfactologie  
Clinique de Oto-Rhinologie-Laryngologie et de  
Chirurgie Cervicofaciale  
Hopitaux Universitaires de Genève  
Genève, Switzerland  
Basile.Landis@hcuge.ch

GERALD LANGNER  
Neuroakustik  
Fachbereich Biologie  
TU Darmstadt  
Darmstadt, Germany  
gl@bio.tu-darmstadt.de

ENRIQUE LANUZA  
Depts of Biología Cellular i Parasitologia  
Facultat de Ciències Biològiques  
Universitat de València  
Burjassot, Spain  
enrique.lanuza@uv.es

MARKUS LAPPE  
Psychologisches Institut II  
Westf. Wilhelms-Universität  
Münster, Germany  
mlappe@uni-muenster.de

MARK L. LATASH  
The Pennsylvania State University  
University Park  
PA, USA  
mll11@psu.edu

FRANÇOISE LAZARINI  
Perception and Memory Unit  
Neuroscience Department  
Pasteur Institute  
Paris, France  
lazarini@pasteur.fr

LUIS DE LECEA  
Department of Psychiatry and Behavioral Sciences  
Stanford University  
School of Medicine  
Palo Alto, CA, USA  
llecea@stanford.edu

ANDY K. LEE  
Department of Pharmacology  
Centre for Neuroscience  
University of Alberta  
Edmonton, AB, Canada

SAMUEL C. K. LEE  
Research Department  
Shriners Hospitals for Children  
Philadelphia, PA, USA

TAI SING LEE  
Computer Science Department and Center for Neural  
Basis of Cognition  
Carnegie Mellon University  
Pittsburgh, PA, USA  
tai@cnbc.cmu.edu

TZUMIN LEE  
Department of Neurobiology  
University of Massachusetts  
Medical School  
Worcester, MA, USA  
Tzumin.Lee@umassmed.edu

TANYA L. LEISE  
Department of Mathematics  
Amherst College  
Amherst, MA, USA  
tleise@amherst.edu

JAMES C. LEITER  
Department of Physiology  
Dartmouth Medical School  
Lebanon, NH, USA  
james.c.leiter@dartmouth.edu

MADO LEMIEUX  
Department of Biochemistry and Microbiology,  
Laval University  
Centre de Recherche Université Laval Robert-Giffard  
Quebec, QC, Canada

MICHAEL LEON  
Department of Neurobiology and Behavior  
University of California  
Irvine, CA, USA  
mleon@uci.edu

DAVID A. LEOPOLD  
Unit on Cognitive Neurophysiology and Imaging  
NIH  
Bethesda, MD, USA

SIMON ROCK LEVINSON  
Department of Physiology and Biophysics  
University of Colorado  
School of Medicine  
Aurora, CO, USA  
Rock.Levinson@UCHSC.edu

JOANNE M. LEWOHL  
Genomics Research Centre  
School of Medical Sciences  
Griffith University  
Southport, Queensland, Australia

ALFRED J. LEWY  
Department of Psychiatry  
Oregon Health & Science University  
Portland, OR, USA  
lewy@ohsu.edu

JAN LEXELL  
Department of Clinical Science  
Lund, Division of Rehabilitation Medicine,  
Lund University  
Lund, Sweden  
jan.lexell@skane.se

AIHUA LI  
Department of Physiology  
Dartmouth Medical School  
Lebanon, NH, USA

DAVID W. LI  
Department of Biochemistry and Molecular Biology,  
Department of Ophthalmology and Visual Sciences,  
College of Medicine  
University of Nebraska Medical Center  
Omaha, NE, USA  
davidli@unmc.edu

JANE E. LIBBEY  
Department of Pathology  
University of Utah School of Medicine  
Salt Lake City, Utah, USA

DAVID C. LIN  
Programs in Bioengineering and Neuroscience  
Washington State University  
Pullman, WA, USA  
davidlin@wsn.edu

YOAV LITVIN  
Department of Psychology  
University of Hawaii at Manoa  
Honolulu, HI, USA  
litvin@hawaii.edu

MILOS LJUBISAVLJEVIC  
Department of Neurophysiology  
Institute for Medical Research  
Belgrade, Serbia and Montenegro  
milos@uaeu.ac.ae

PIERRE-MARIE LLEDO  
Pasteur Institute  
Laboratory for Perception and Memory  
Paris Cedex, France  
pmlledo@pasteur.fr

ANNA LOBELL  
Department of Medical Sciences  
Uppsala University  
University Hospital  
Uppsala, Sweden

ELIZABETH F. LOFTUS  
Departments of Psychology and Social Behavior,  
Criminology, Law and Society, Cognitive Sciences  
University of California  
Irvine, CA, USA  
eloftus@uci.edu

CAIRINE LOGAN  
Institute of Maternal and Child Health, Genes and  
Development Research Group  
Department of Cell Biology and Anatomy  
Faculty of Medicine  
University of Calgary  
Calgary, AB, Canada  
clogan@ucalgary.ca

CATHERINE M. F. LOHMANN  
Department of Biology  
University of North Carolina  
Chapel Hill, NC, USA

KENNETH J. LOHMANN  
Department of Biology  
University of North Carolina  
Chapel Hill, NC, USA  
klohmann@email.unc.edu

BARBARA LOM  
Biology Department and Program in Neuroscience  
Davidson College  
Davidson, NC, USA  
balom@davidson.edu

STEPHEN R. LORD  
Prince of Wales Medical Research Institute and  
University of New South Wales  
Sydney, NSW, Australia  
s.lord@unsw.edu.au

PHILLIP A. LOW  
Department of Neurology  
Mayo Foundation  
Rochester, MN, USA  
low.phillip@mayo.edu

E. J. LOWE  
University of Durham  
Durham, United Kingdom  
E.J.Lowe@durham.ac.uk

MADELEINE LOWERY  
Rehabilitation Institute of Chicago  
Department of Physical Medicine and Rehabilitation  
Northwestern University  
Chicago, IL, USA  
m-lowery@northwestern.edu

SYLVIA LUCAS  
Department of Neurology  
University of Washington Medical Center  
Seattle, WA, USA  
lucass@u.washington.edu

PAUL J. LUCASSEN  
Centre for Neuroscience  
Swammerdam Institute of Life Sciences  
University of Amsterdam  
Amsterdam, The Netherlands  
P.J.Lucassen@uva.nl

JAMES P. LUND  
Faculty of Dentistry  
McGill University  
Montréal, QC, Canada  
james.lund@mcgill.ca

GÖRAN LUNDBORG  
Hand Surgery/Department of Clinical Sciences  
Malmö University Hospital  
Lund University  
Lund, Sweden  
Goran.Lundborg@hand.mas.lu.se

HUUB MAAS  
Departments of Physiology, Physical Medicine and  
Rehabilitation, and Biomedical Engineering  
Northwestern University  
Evanston, IL, USA

VAUGHAN G. MACEFIELD  
School of Medicine  
University of Western Sydney  
Sydney, NSW, Australia  
v.macefield@uws.edu.au

JEFFREY D. MACKLIS  
MGH-HMS Center for Nervous System Repair,  
Departments of Neurosurgery and Neurology, and  
Program in Neuroscience  
Harvard Medical School;  
Nayef Al-Rodhan Laboratories  
Massachusetts General Hospital;  
Department of Stem Cell and Regenerative Biology,  
and Harvard Stem Cell Institute  
Harvard University  
Boston, MA, USA  
jeffrey\_macklis@hms.harvard.edu

MERRITT MADUKE  
Department of Molecular and Cellular Physiology  
Stanford University  
School of Medicine  
Stanford, CA  
maduke@stanford.edu

ALEXANDER MAIER  
Unit on Cognitive Neurophysiology and Imaging  
NIH  
Bethesda, MD, USA  
maiera@mail.nih.gov

STEVEN F. MAIER  
University of New Mexico  
Albuquerque, NM, USA

BRIAN E. MAKI  
Centre for Studies in Aging, Sunnybrook and Health  
Sciences Centre  
University of Toronto  
Toronto, Canada  
brian.maki@swri.ca

ADEL MAKLAD  
Department of Biology  
University of Iowa  
Iowa City, IA, USA

JON MALLATT  
School of Biological Sciences  
Washington State University  
Pullman, Washington, WA, USA  
jmallat@mail.wsu.edu

MANUEL S. MALMIERCA  
Auditory Neurophysiology Unit  
Laboratory for the Neurobiology of Hearing  
Faculty of Medicine and Insitute for Neuroscience of  
Castilla y León  
Salamanca, Spain  
msm@usal.es

JOÃO O. MALVA  
Center for Neuroscience and Cell Biology  
Institute of Biochemistry  
Faculty of Medicine,  
University of Coimbra  
Coimbra, Portugal  
jomalva@fmed.uc.pt

TOSHIYA MANABE  
Division of Neuronal Network  
Department of Basic Medical Sciences  
Institute of Medical Science  
University of Tokyo  
Tokyo, Japan  
tmanabe-ky@umin.ac.jp

NATHALIE MANDAIRON  
Neurosciences Sensorielles, Comportement, Cognition  
Université de Lyon, Université  
Claude Bernard Lyon1, Villeurbanne, France

PAUL R. MANGER  
School of Anatomical Sciences  
Faculty of Health Sciences  
University of the Witwatersrand  
Johannesburg, Republic of South Africa  
mangerpr@anatomy.wits.ac.za

ABDELJABBAR EL MANIRA  
Department of Neuroscience Karolinska Institutet  
Stockholm, Sweden  
abdel.elmanira@neuro.ki.se

PAUL B. MANIS  
Otolaryngology/Head and Neck Surgery and Cell and  
Molecular Physiology  
University of North Carolina at Chapel Hill  
NC, USA  
pmanis@med.unc.edu



TADAAKI MANO  
Gifu University of Medical Science  
Seki, Gifu, Japan  
tadaaki.mano@nifty.com

FIONA MANSERGH  
Ocular Genetic Unit, Smurfit Institute of Genetics  
Trinity College Dublin  
Dublin 2, Ireland  
manserghfc@Cardiff.ac.uk

DIEGO MANZONI  
Dipartimento di Fisiologia e Biochimica  
Università degli Studi di Pisa  
Pisa, Italy  
manzoni@dfb.unipi.it

YING-WEI MAO  
Howard Hughes Medical Institute  
Massachusetts Institute of Technology  
Boston, MA, USA

URI MAOZ  
Interdisciplinary Center for Neural Computation  
Hebrew University of Jerusalem  
Jerusalem, Israel

DENIS MARESCHAL  
Centre for Brain and Cognitive Development  
Birkbeck, University of London  
London, UK  
d.mareschal@bbk.ac.uk

OSCAR MARÍN  
Instituto de Neurociencias de Alicante  
Consejo Superior de Investigaciones Científicas and  
Universidad Miguel Hernández  
Alicante, Spain  
o.marin@umh.es

LESLEY MARSON  
Division of Urology  
University of North Carolina at Chapel Hill  
Chapel Hill, NC, USA  
lmarson@med.unc.edu

CLAIRE MARTIN  
Laboratoire Systèmes Sensoriels, Comportement et  
Cognition  
UMR 5020 CNRS–UCB Lyon  
IFR19 Lyon, France

KEVAN A. C. MARTIN  
Institute of Neuroinformatics UZH/ETH  
Winterthurerstrasse  
Zurich, Switzerland  
kevan@ini.phys.ethz.ch

WIESMANN MARTIN  
Department of Neuroradiology  
Ludwig-Maximilians-University Munich  
Germany  
Martin.Wiesmann@med.uni-muenchen.de

PAUL R. MARTIN  
National Vision Research Institute of Australia  
Carlton, VIC, Australia  
prmartin@unimelb.edu.au

LUIS M. MARTINEZ  
Instituto de Neurociencias  
CSIC – Universidad Miguel Hernández  
Alicante, Spain  
l.martinez@umh.es

GIANVITO MARTINO  
Neuroimmunology Unit  
DIBIT-San Raffaele Scientific Institute  
Milano, Italy

FERNANDO MARTÍNEZ-GARCÍA  
Biología Funcional i Antropología Física  
Facultat de Ciències Biològiques  
Universitat de València  
Burjassot, Spain  
fernando.mtnez-garcia@uv.es

ALINO MARTÍNEZ-MARCOS  
Facultad de Medicina and Centro Regional de  
Investigaciones Biomédicas (CRIB)  
Universidad de Castilla-La Mancha  
Albacete, Spain  
Alino.Martinez@uclm.es

SHUNICHI MARUNO  
Department of Psychology  
Kyushu University  
Fukuoka, Japan  
syunedu@mbox.nc.kyushu-u.ac.jp

ANDREW C. MASON  
Integrative Behavior and Neuroscience Group,  
Department of Biological Sciences  
University of Toronto at Scarborough  
Scarborough, ON, Canada

KELBY MASON  
Department of Philosophy  
Rutgers, The State University of New Jersey  
New Brunswick, NJ, USA  
mason@philosophy.rutgers.edu

PEGGY MASON  
Department of Neurobiology, Pharmacology and  
Physiology  
University of Chicago  
Chicago, IL, USA

FRED W. MAST  
Department of Psychology  
University of Lausanne  
Bâtiment Anthropole, Lausanne, Switzerland  
Fred.Mast@unil.ch

ALISTAIR MATHIE  
Medway School of Pharmacy  
Universities of Kent and Greenwich at Medway  
Chatham Maritime, Kent, UK  
a.a.mathie@kent.ac.uk

NAOYA MATSUMOTO  
Department of Anatomy and Neurobiology  
Kyoto University Graduate School of Medicine,  
Yoshidakonoe-cho, Sakyo-ku, Kyoto, Japan

CARLOS MATUTE  
Departamento de Neurociencias  
Universidad del País  
Vasco, Leioa and  
Neurotek-UPV/EHU  
Parque Tecnológico de Bizkaia  
Zamudio, Spain  
carlos.matute@ehu.es

JOHN ROBERT MATYAS  
Faculty of Veterinary Medicine  
University of Calgary  
Calgary, AB, Canada  
jmatyas@ucalgary.ca

J. PATRICK MAYO  
Department of Neuroscience  
The Center for the Neural Basis of Cognition, and the  
Center for Neuroscience  
University of Pittsburgh  
Pittsburgh, PA, USA

LAWRENCE MAYS  
University of North Carolina  
Charlotte, NC, USA  
lmays@uab.edu

DAVID MCALPINE  
UCL Ear Institute and Department of Physiology  
University College London  
London, UK  
d.mcalpine@ucl.ac.uk

CATHERINE A. MCCORMICK  
Departments of Biology and Neuroscience  
Oberlin College  
Oberlin, OH, USA  
catherine.mccormick@oberlin.edu

DONALD R. MCCRIMMON  
Department of Physiology  
Feinberg School of Medicine  
Northwestern University  
Chicago, IL, USA  
dm@northwestern.edu

ALEXANDER J. McDONALD  
Department of Pharmacology, Physiology, and  
Neuroscience  
University of South Carolina  
School of Medicine  
Columbia, SC, USA  
MCDONALD@MED.SC.EDU

SARAH MCFARLANE  
The Hotchkiss Brain Institute  
Department of Cell Biology and Anatomy  
Faculty of Medicine  
University of Calgary  
Calgary, AB, Canada  
smcfarla@ucalgary.ca

DENNIS MCGINTY  
Department of Psychology  
University of California  
Los Angeles, CA, USA  
dmcginty@ucla.edu

PATRICIA A. MCGRATH  
Department of Anaesthesia  
Divisional Centre of Pain Management and Research,  
The Hospital for Sick Children  
Toronto, ON, Canada  
patricia.mcgrath@sickkids.ca

ELSPETH MCLACHLAN  
Prince of Wales Medical Research Institute and the  
University of New South Wales  
Randwick, NSW, Australia  
e.mclachlan@unsw.edu.au

STEPHANIE A. MCMAINS  
Department of Psychology  
Princeton Neuroscience Institute  
Center for the Study of Brain, Mind and Behavior  
Princeton University  
Princeton, NJ, USA  
smcmains@Princeton.EDU

LOWELL T. MCPHAIL  
International Collaboration on Repair Discoveries  
the University of British Columbia  
Vancouver, BC, Canada

LORETA MEDINA  
Department of Experimental Medicine  
Faculty of Medicine  
University of Lleida  
Institut of Biomedical Research of Lleida  
Lleida, Catalonia, Spain  
loreta.medina@cmb.udl.cat

SVYATOSLAV V. MEDVEDEV  
Institute of the Human Brain of the Russian Academy of  
Sciences  
Laboratory of the Positron Emission Tomography  
St-Petersburg, Russia  
Medvedev@ihb.spb.ru

ALFRED R. MELE  
Department of Philosophy  
Florida State University  
Tallahassee, FL, USA  
almele@mailers.fsu.edu

D. MENETREY  
CNRS UMR 8119, Neurophysique et Physiologie  
Université René Descartes  
UFR Biomédicale  
Paris, France

MANUEL MERCIER  
Laboratory of Perceptual Processing  
Southern Cross University  
Lismore, NSW, Australia  
manuel.mercier@epfl.ch

WILLIAM H. MERIGAN  
Eye Institute and Center for  
Visual Sciences  
University of Rochester  
Rochester, NY, USA  
billm@cvs.rochester.edu

MARTHA MERROW  
The University of Groningen  
Haren, The Netherlands  
m.merrow@rug.nl

GERLINDE A. METZ  
Canadian Centre for Behavioural Neuroscience,  
Department of Neuroscience  
University of Lethbridge  
Lethbridge, AB, Canada  
Gerlinde.metz@uleth.ca

WALTER METZNER  
UCLA Department of Physiological Science  
Los Angeles, CA, USA  
metzner@ucla.edu

WOLFGANG MEYERHOF  
Department of Molecular Genetics  
German Institute of Human Nutrition Potsdam-  
Rehbruecke  
Nuthetal, Germany  
meyerhof@dife.de

RAJIV MIDHA  
Division of Neurosurgery  
Department of Clinical Neurosciences  
University of Calgary  
AB, Canada

AKICHIKA MIKAMI  
Primate Research Institute  
Kyoto University  
Inuyama, Japan  
mikami@pri.kyoto-u.ac.jp

ROBERT MILLER  
Department of Anatomy and Structural Biology  
University of Otago  
Dunedin, New Zealand  
robert.miller@stonebow.otago.ac.nz

ERIN D. MILLIGAN  
Department of Kinesiology and Physical Education,  
McGill University  
Montreal, QC, Canada  
erin.milligan@colorado.edu

THEODORE E. MILNER  
School of Kinesiology  
Simon Fraser University  
Burnaby, British Columbia, Canada  
tmilner@sfu.edu

JOSEPH A. MINDELL  
Membrane Transport Biophysics Unit  
Porter Neuroscience Research Center  
National Institute of Neurological Disorders and Stroke  
National Institutes of Health  
Bethesda, MD  
mindellj@ninds.nih.gov

JAN VAN MINNEN  
Department Cell Biology & Anatomy  
University of Calgary  
Calgary, AB, Canada  
Jan.van.minnen@falw.vu.nl

LLOYD B. MINOR  
 Department of Otolaryngology – Head and Neck  
 Surgery  
 The Johns Hopkins University  
 School of Medicine  
 Baltimore, MD, USA  
 lminor@jhmi.edu

RALPH MISTLBERGER  
 Department of Psychology  
 Simon Fraser University  
 Burnaby, BC, Canada  
 mistlber@sfu.ca

TAKAYUKI MITSUHASHI  
 Department of Pediatrics, School of Medicine  
 Keio University  
 Tokyo, Japan

TETSUYA MIZUNO  
 Department of Neuroimmunology  
 Research Institute of Environmental Medicine  
 Nagoya University  
 Furo-cho, Chikusa, Nagoya, Japan  
 tmizuno@riem.nagoya-u.ac.jp

AMALIA MOLINERO  
 Institute of Neurosciences and Department of Cellular  
 Biology, Physiology and Immunology  
 Animal Physiology Unit  
 Faculty of Sciences  
 Autonomous University of Barcelona  
 Bellaterra, Barcelona, Spain  
 Amalia.Molinero@uab.es

DEREK C. MOLLIVER  
 Department of Medicine  
 University of Pittsburgh  
 Pittsburgh, PA, USA

ZOLTÁN MOLNÁR  
 Department of Physiology, Anatomy and Genetics  
 University of Oxford  
 Oxford, UK  
 zoltan.molnar@anat.ox.ac.uk

BRADLEY J. MOLYNEAUX  
 MGH-HMS Center for Nervous System Repair,  
 Departments of Neurosurgery and Neurology, and  
 Program in Neuroscience  
 Harvard Medical School;  
 Nayef Al-Rodhan Laboratories  
 Massachusetts General Hospital  
 Department of Stem Cell and Regenerative  
 Biology, and Harvard Stem Cell Institute  
 Harvard University  
 Boston, MA, USA

BARBARA MONTERO  
 Graduate Center  
 City University of New York  
 New York, NY, USA  
 bmontero@gc.cuny.edu

JEAN-PIERRE MONTMAYEUR  
 Centre des Sciences du Goût  
 Centre National de la Recherche Scientifique  
 Dijon, France  
 montmayeur@cesg.cnrs.fr

ROBERT J. MORECRAFT  
 Division of Basic Biomedical Sciences  
 University of South Dakota  
 School of Medicine  
 Vermillion, SD, USA  
 rmorecra@usd.edu

NEREA MORENO  
 Dept. Biología Celular  
 Fac. Biología  
 Univ. Complutense  
 Madrid, Spain

ALAN MORGAN  
 The Physiological Laboratory  
 School of Biomedical Sciences  
 University of Liverpool  
 Liverpool, UK

CATHERINE W. MORGANS  
 Neurological Sciences Institute  
 Oregon Health and Science University  
 Beaverton, OR, USA  
 morgansc@ohsu.edu

KATRIN E. MORGEN  
 Department of Neurology  
 Giessen University  
 Giessen, Germany  
 Katrin.Morgen@neuro.med.uni-giessen.de

LAWRENCE P. MORIN  
 Department of Psychiatry  
 Stony Brook University  
 Medical Center  
 Stony Brook, NY, USA  
 lawrence.morin@stonybrook.edu

YOSHINORI MORIYAMA  
 Department of Biochemistry  
 Faculty of Pharmaceutical Sciences  
 Okayama University  
 Okayama, Japan  
 moriyama@pheasant.pharm.okayama-u.ac.jp

JUDY L. MORRIS  
Department of Anatomy & Histology, and Centre for  
Neuroscience  
Flinders University  
Adelaide, SA, Australia  
Judy.Morris@flinders.edu.au

KENDALL F. MORRIS  
Department of Molecular Pharmacology and  
Physiology, Neuroscience  
University of South Florida  
College of Medicine  
Tampa, FL, USA  
kmorris@health.usf.edu

JOHN F. B. MORRISON  
Department of Physiology  
Faculty of Medicine and Health Sciences  
UAE University  
Al Ain, UAE  
john.morrison@uaeu.ac.ae

ADONIS MOSCHOVAKIS  
Institute of Applied and Computational Mathematics,  
Foundation of Research and Technology  
University of Crete  
Heraklion, Crete, Greece  
moschov@med.uoc.gr

AURELIE MOURET  
Laboratory for Perception and Memory, CNRS URA  
2182  
Pasteur Institute  
Paris, France  
amouret@pasteur.fr

MACIEJ M. MRUGALA  
Departments of Neurology and Neurosurgery  
University of Washington Medical School  
Fred Hutchinson Cancer Research Center  
Seattle, WA, USA  
mmrugala@u.washington.edu

DEVIN MUELLER  
Department of Psychiatry  
University of Puerto Rico School of Medicine  
San Juan, Puerto Rico  
devin.mueller@gmail.com

S. MÜHLENBROCK-LENTER  
Brain Research Institute  
University of Bremen  
Bremen, Germany

IAN MULLANEY  
School of Pharmacy  
Division of Health Sciences

Murdoch University  
WA, Australia  
I.Mullaney@murdoch.edu.au

MICHAEL MÜLLER  
DFG Research Center Molecular Physiology of the  
Brain  
Department of Neurophysiology  
Georg-August-Universität Göttingen  
Göttingen, Germany

FUJIO MURAKAMI  
Laboratory of Neuroscience  
Graduate School of Frontier Biosciences  
Graduate School of Engineering Science  
Osaka University  
Suita, Osaka, Japan  
murakami@fbs.osaka-u.ac.jp

IKUYA MURAKAMI  
Department of Life Sciences  
University of Tokyo  
Tokyo, Japan  
ikuya@fechner.c.u-tokyo.ac.jp

AKIRA MURATA  
Department of Physiology  
Kinki University  
School of Medicine  
Osaka-sayama, Japan

SUBRAMANYAM N. MURTHY  
Department of Pharmacology  
Tulane University Medical Center  
New Orleans, LA, USA

TOSHITAKA NABESHIMA  
Department of Chemical Pharmacology  
Graduate School of Pharmaceutical Sciences  
Meijo University  
Nagoya, Japan  
tnabeshi@med.nagoya-u.ac.jp

KAZUNORI NAKAJIMA  
Department of Anatomy  
Keio University School of Medicine  
Tokyo, Japan  
kazunori@sc.itc.keio.ac.jp

HARUKAZU NAKAMURA  
Department of Molecular Neurobiology  
Graduate School of Life Sciences and Institute of  
Development,  
Aging; Cancer  
Tohoku University  
Aoba-ku, Sendai, Japan  
nakamura@idac.tohoku.ac.jp

AVINDRA NATH  
Department of Neurology  
Johns Hopkins University School of Medicine  
Baltimore, MD, USA  
anath1@jhmi.edu

EUGENE NATTIE  
Department of Physiology  
Dartmouth Medical School  
Lebanon, NH, USA  
Eugene.E.Nattie.Jr@Dartmouth.EDU

J. W. NEAL  
Department Histopathology  
School of Medicine  
Cardiff University  
Cardiff, UK

ALBERT NEWEN  
Institut für Philosophie  
Ruhr Universität Bodium  
Bodium, Germany  
albert.newen@uni-tuebingen.de

DAVE NICHOLS  
Department of Biology  
University of Texas at San Antonio  
Texas, TX, USA

DAVID E. NICHOLS  
Department of Medicinal Chemistry and Molecular  
Pharmacology  
Purdue University  
West Lafayette, IN, USA  
drdave@pharmacy.purdue.edu

T. RICHARD NICHOLS  
Department of Physiology  
Emory University  
Atlanta, GA, USA  
tm@physio.emory.edu

DANIEL A. NICHOLSON  
Department of Cell and Molecular Biology  
Northwestern University's Feinberg School of  
Medicine and Institute of Neuroscience  
Chicago, IL, USA

TRENT NICOL  
Department of Communication Sciences  
Northwestern University  
Evanston, IL, USA

MIGUEL A. L. NICOLELIS  
Department of Neurobiology  
Center of Neuroengineering  
Department of Biomedical Engineering

Department of Psychology and Neurosciences  
Duke University  
Durham, NC, USA

LOREDANA NICOLETTI  
Department of Infectious, Parasitic and Immune-  
Mediated Diseases  
Istituto Superiore di Sanità  
Rome, Italy

ANDREAS NIEDER  
Primate NeuroCognition Laboratory  
Department of Cognitive Neurology  
Hertie-Institute for Clinical Brain Research  
University of Tuebingen  
Tuebingen, Germany  
andreas.nieder@uni-tuebingen.de

JENS BO NIELSEN  
Department of Exercise and Sport Science &  
Department of Neuroscience and Pharmacology  
The Panum Institute  
Copenhagen, Denmark

TORE A. NIELSEN  
Psychiatry Department  
Université de Montréal  
Montreal, QC, Canada  
tore\_a\_nielsen@yahoo.com

ANDREY R. NIKOLAEV  
Laboratory of Human Higher Nervous Activity  
Institute of Higher Nervous Activity and  
Neurophysiology  
Russian Academy of Sciences  
Moscow, Russia

CHRISTIAN NIMTZ  
Department of Philosophy  
University of Bielefeld  
Bielefeld, Germany  
chn@nimt.net

HIROSHI NISHIMARU  
Neuroscience Research Institute  
National Institute of Advanced Industrial Science and  
Technology (AIST)  
Tsukuba Center, Higashi  
Tsukuba, Ibaraki, Japan  
Hiroshi.Nishimaru@neuro.ki.se

ANTOINE NISSANT  
Laboratory for Perception and Memory  
Pasteur Institute  
Paris Cedex,  
France  
anissant@pasteur.fr

MICHAEL N. NITABACH  
Department of Cellular and Molecular Physiology  
Yale School of Medicine  
New Haven, CT, USA  
michael.nitabach@yale.edu

GEORG NORTHOFF  
Department of Psychiatry  
University of Magdeburg  
Magdeburg, Germany  
Georg.Northoff@Medizin.Uni-Magdeburg.DE

AKINAO NOSE  
Department of Complexity Science and Engineering,  
Graduate School of Frontier Sciences  
University of Tokyo  
Tokyo, Japan  
nose@bio.phys.s.u-tokyo.ac.jp

BOBBY D. NOSSAMAN  
Department of Pharmacology  
Tulane University Medical Center  
New Orleans, LA, USA  
bnossama@tulane.edu

ANTONIO A. NUNEZ  
Department of Psychology and Neuroscience Program  
Michigan State University  
East Lansing, MI, USA

MICHAEL P. NUSBAUM  
Department of Neuroscience  
University of Pennsylvania  
School of Medicine  
Philadelphia, PA, USA  
nusbaum@mail.med.upenn.edu

LARS NYBERG  
Departments of Radiation Sciences (Radiology) and  
Integrative Medical Biology (Physiology)  
Umeå University  
Umeå, Sweden  
Lars.Nyberg@physiol.umu.se

JOHN PHILIP O'DOHERTY  
Computation and Neural Systems Program  
Division of Humanities and Social Sciences  
California Institute of Technology  
Pasadena, CA, USA  
jdoherty@caltech.edu

HISASHI OGAWA  
Department of Neurology  
Kumamoto Kinoh Hospital;  
Department of Sensory and Cognitive Physiology

Kumamoto University  
Honjo, Kumamoto, Japan  
ogawa@juryo.or.jp

TOSHIO OHHASHI  
Department of Physiology  
Shinshu University School of Medicine  
Matsumoto, Japan  
ohhashi@sch.md.shinshu-u.ac.jp

FRANK W. OHL  
BioFuture Research Group  
Leibniz Institute for Neurobiology  
Magdeburg, Germany  
frank.ohl@ifn-magdeburg.de

TAKAKO OHNO-SHOSAKU  
Department of Cellular Neurophysiology  
Graduate School of Medical Science  
Kanazawa University  
Kanazawa, Japan

RYOSUKE OHSAWA  
Institute for Virus Research  
Kyoto University  
Kyoto, Japan

MASAYOSHI OHTA  
Department of Anatomy and Neurobiology and  
Department of Plastic and Reconstructive Surgery  
Kyoto University  
Graduate School of Medicine  
Kyoto, Japan  
ota@kuhp.kyoto-u.ac.jp

TOSHIYUKI OHTSUKA  
Institute for Virus Research  
Kyoto University  
Kyoto, Japan

KOJI OISHI  
Department of Anatomy  
Keio University  
School of Medicine  
Tokyo, Japan

SHIGEO OKABE  
Department of Cellular Neurobiology  
Graduate School of Medicine  
University of Tokyo  
okabe.cbio@tmd.ac.jp

MASATO OKADA  
Graduate School of Frontier Sciences  
The University of Tokyo  
Kashiwa Chiba, Japan

HIDEYUKI OKANO  
Department of Physiology  
School of Medicine  
Keio University  
Tokyo, Japan  
hidokano@sc.itc.keio.ac.jp

ALBINO J. OLIVEIRA-MAIA  
Instituto de Biologia Molecular e Celular  
Faculdade de Medicina  
Universidade do Porto  
Porto, Portugal

DOUGLAS L. OLIVER  
University of Connecticut Health Center  
Department of Neuroscience  
Farmington, CT, USA  
DOliver@neuron.uhc.edu

HIROSHI OMOTE  
Department of Biochemistry  
Faculty of Pharmaceutical Sciences  
Okayama University  
Okayama, Japan

HIROSHI ONIMARU  
Department of Physiology  
Showa University  
School of Medicine  
Tokyo, Japan  
oni@med.showa-u.ac.jp

TAKETOSHI ONO  
Molecular and Integrative Emotional Neuroscience,  
Graduate School of Medicine  
University of Toyama  
Sugitani, Toyama, Japan  
onotake@med.u-toyama.ac.jp

JOHN ORMOND  
Department of Cell & Systems Biology  
University of Toronto  
Toronto, ON, Canada

INMACULADA ORTEGA-PÉREZ  
Laboratory of Perception and Memory  
Institute Pasteur  
Paris, France  
iortega@pasteur.fr

NORIKO OSUMI  
Division of Developmental Neuroscience  
CTAAR  
Tohoku University  
School of Medicine  
Sendai, Japan

RYLAND W. PACE  
The Department of Applied Science  
The College of William and Mary  
Williamsburg, VA, USA

JEFFREY PADBERG  
Center for Neuroscience  
University of California  
Davis, CA, USA

ANN M. PALKOVICH  
Krasnow Institute for Advanced Study  
Department of Sociology and Anthropology  
George Mason University  
Fairfax, VA, USA  
apalkovi@gmu.edu

SATCHIDANANDA PANDA  
The Salk  
Institute for Biological Studies  
La Jolla, CA, USA  
panda@salk.edu

RAÚL G. PAREDES  
Instituto de Neurobiología  
Universidad Nacional Autónoma de México  
Juriquilla, México  
Rparedes@servidor.unam.mx

MAGDA PASSATORE  
Department of Neuroscience – Section of Physiology  
University of Torino  
Torino, Italy  
magda.passatore@unito.it

TOSHAL PATEL  
Eisai London Research Laboratories  
University College London  
London, UK

JULIAN F. R. PATON  
Department of Physiology  
Bristol Heart Institute  
School of Medical Sciences,  
University of Bristol  
Bristol, UK  
Julian.F.R.Paton@Bristol.ac.uk

TADD B. PATTON  
Department of Psychology  
University of South Florida  
Tampa, Florida, USA

MICHAEL PAUEN  
Institut für Philosophie  
Berlin School of Mind and Brain  
Humboldt-Universität zu Berlin  
Berlin, Germany  
m@pauen.com



KEIR PEARSON  
Department of Physiology  
University of Alberta  
Edmonton, AB, Canada  
Keir.pearson@ualberta.ca

JOHN H. PEEVER  
Department of Cell and Systems Biology  
University of Toronto  
Toronto, ON, Canada  
j.duffin@utoronto.ca

LEO PEICHL  
Max Planck Institute for Brain Research  
Frankfurt am Main  
Germany  
peichl@mpih-frankfurt.mpg.de

DENIS PELISSON  
Espace et Action Unité 864  
INSERM/Université Claude Bernard – Lyon  
IFR19 Institut Fédératif des Neurosciences de Lyon  
Bron, France  
pelisson@lyon151.inserm.fr

MILENA PENKOWA  
Department of Medical Anatomy  
The Panum Institute  
University of Copenhagen  
Copenhagen, Denmark

KEITH R. PENNYPACKER  
Departments of Molecular Pharmacology and  
Physiology  
University of South Florida  
College of Medicine  
Tampa, FL, USA

DAVID J. PERKEL  
Departments of Biology & Otolaryngology  
University of Washington  
Seattle, WA  
perkel@u.washington.edu

ERIC J. PERREAULT  
Department of Biomedical Engineering  
Department of Physical Medicine and Rehabilitation  
Northwestern University  
Chicago, IL, USA  
e-perreault@northwestern.edu

ROBERT J. PETERKA  
Neurological Sciences Institute  
Oregon Health & Science University  
Portland, OR, USA  
peterkar@ohsu.edu

ROBERT C. PETERS  
Department of Functional Neurobiology  
Utrecht University  
Utrecht, The Netherlands

RONALD S. PETRALIA  
NIDCD/NIH  
Bethesda, MD, USA  
r.c.peters@bio.uu.nl

RYAN PETRIE  
Department of Anatomy and Cell Biology  
McGill University  
Montreal, Quebec, Canada

VITO E. PETTOROSI  
Department of Internal Medicine  
Section of Human Physiology  
University of Perugia  
Perugia, Italy  
vitopett@unipg.it

AXEL PETZOLD  
Department of Neuroimmunology,  
Institute of Neurology  
University College London  
London, UK  
a.petzold@ion.ucl.ac.uk

PHUC H. PHAM  
Department of Biology  
University of Waterloo  
Waterloo, ON, Canada

ANTHONY G. PHILLIPS  
Department of Psychiatry  
University of British Columbia  
Vancouver, BC, Canada

STEPHEN J. PIAZZA  
Department of Kinesiology  
The Pennsylvania State University  
University Park  
PA, USA  
steve-piazza@psu.edu

HUGH PIGGINS  
Departments of Psychology at Barnard College and at  
Columbia University, Department of Pathology and  
Cell Biology, Columbia Health Sciences, New York,  
NY, USA

DAVE B. PILGRIM  
Department of Biological Sciences  
University of Alberta  
Edmonton, AB, Canada  
dave.pilgrim@ualberta.ca

GILES W. PLANT  
Red's Spinal Cord Research Laboratory  
School of Anatomy and Human Biology  
The University of Western Australia  
Crawley, Perth, WA  
gplant@anhb.uwa.edu.au

STEFANO PLUCHINO  
Neuroimmunology Unit  
DIBIT-San Raffaele Scientific Institute  
Milano, Italy  
pluchino.stefano@hsr.it

HOWARD POIZNER  
Institute for Neural Computation  
University of California  
San Diego, CA, USA  
hpoizner@ucsd.edu

ALEXANDER A. POLLEN  
Department of Physiology, Anatomy and Genetics  
University of Oxford  
Oxford, UK

GLEN POLLOCK  
Pathology and Cell Biology  
University of South Florida  
College of Medicine  
Tampa, FL, USA

FELIX POLYAKOV  
Department of Computer Science and Applied  
Mathematics  
Weizmann Institute of Science  
Rehovot, Israel

MU-MING POO  
Division of Neurobiology  
Department of Molecular and Cell Biology  
HelenWills Neuroscience Institute  
University of California  
Berkeley, CA, USA  
mpoo@uclink.berkeley.edu

MARIA POPESCU  
Department of Psychology  
Vanderbilt University  
Nashville, TN, USA  
maria.v.popescu@Vanderbilt.Edu

JOHN PORRILL  
Department of Psychology  
University of Sheffield  
Sheffield, UK

ALICE SCHADE POWERS  
Department of Psychology  
St. John's University  
Jamaica, NY, USA  
powersa@stjohns.edu

CLAUDE PRABLANC  
Espace et Action Unité 864  
INSERM/Université Claude Bernard – Lyon, IFR19  
Institut Fédératif des Neurosciences de Lyon  
Bron, France

ARTHUR PROCHAZKA  
Centre for Neuroscience  
University of Alberta  
Edmonton, AB, Canada  
Arthur.Prochazka@ualberta.ca

UWE PROSKE  
Department of Physiology  
Monash University  
Melbourne, VIC, Australia  
uwe.proske@med.monash.edu.au

IGNACIO PROVENCIO  
Department of Biology  
University of Virginia  
Charlottesville, VA, USA  
ip7m@virginia.edu

DALE PURVES  
Center for Cognitive Neuroscience and Department of  
Neurobiology  
Duke University  
Durham, NC, USA  
purses@neuro.duke.edu

MARTINA PYRSKI  
Department of Physiology  
University of Saarland  
School of Medicine  
Homburg/Saar, Germany  
martina.pyrski@uks.eu

JORGE N. QUEVEDO  
Department of Physiology, Biophysics and  
Neuroscience  
Centro de Investigación y de Estudios Avanzados del I.  
P.N  
Mexico City, Mexico  
jquevedo@fisio.cinvestav.mx

ALBERT QUINTANA  
Institute of Neurosciences and Department of Cellular  
Biology, Physiology and Immunology  
Animal Physiology Unit  
Faculty of Sciences  
Autonomous University of Barcelona  
Bellaterra, Barcelona, Spain

GREGORY J. QUIRK  
Department of Psychiatry  
University of Puerto Rico  
School of Medicine  
San Juan, Puerto Rico  
gjquirk@yahoo.com

MATT S. RAMER  
International Collaboration on Repair Discoveries  
the University of British Columbia  
Vancouver, BC, Canada  
ramer@icord.org

JAN-MARINO RAMIREZ  
Department of Organismal Biology and Anatomy  
Committees on Neurobiology, Computational  
Neuroscience and Molecular Medicine  
The University of Chicago  
Chicago, IL, USA  
jramire@uchicago.edu

CATHARINE H. RANKIN  
Brain Research Centre  
University of British Columbia  
Vancouver, BC, Canada  
crankin@psych.ubc.ca

YONG RAO  
Centre for Research in Neuroscience  
Department of Neurology and Neurosurgery  
McGill University Health Centre  
Montreal, QC, Canada  
yong.rao@mcgill.ca

THEODORE RAPHAN  
Department of Computer and Information Science  
Institute of Neural and Intelligent Systems, Brooklyn  
College of the City University of New York  
Brooklyn, NY, USA  
raphan@sci.brooklyn.cuny.edu

DANIEL L. RATHBUN  
Center for Neuroscience  
University of California  
Davis, CA, USA

NADINE RAVEL  
Laboratoire Systèmes Sensoriels, Comportement et  
Cognition  
UMR 5020 CNRS-UCB Lyon  
IFR19 Lyon, France  
nadine.ravel@olfac.univ-lyon1.fr

ADRIAN REES  
Auditory Group, Institute of Neuroscience  
Newcastle University  
Newcastle upon Tyne, UK  
adrian.rees@ncl.ac.uk

SANDRA REES  
Department of Anatomy and Cell Biology  
University of Melbourne  
Melbourne, Australia  
SRees@Unimelb.edu.au

KATHRYN M. REFSHAUGE  
Faculty of Health Sciences  
University of Sydney  
Sydney, NSW, Australia  
k.refshauge@fhs.usyd.edu.au

ALFONSO REPRESA  
INMED, INSERM U29  
Université de la Méditerranée  
Campus de Luminy, Marseille, France  
alfonso.represa@inmed.univ-mrs.fr

DIEGO RESTREPO  
University of Colorado at Denver and Health Sciences  
Center  
Aurora, CO, USA  
Diego.Restrepo@uchsc.edu

MARK M. RICH  
Department of Neuroscience, Cell Biology and  
Physiology  
Wright State University  
Dayton, OH, USA  
mmrich@emory.edu

ROBERT C. RICHARDSON  
Department of Philosophy  
University of Cincinnati  
Cincinnati, OH, USA

GEORGE RICHESON  
Department of Neurology  
School of Medicine  
Yale University  
New Haven, CT, USA  
george.richerson@yale.edu

DIETHELM W. RICHTER  
DFG Research Center Molecular Physiology of the  
Brain  
Department of Neurophysiology  
Georg-August-Universität Göttingen  
Göttingen, Germany  
d.richter@gwdg.de

JUSTIN P. RIDGE  
School of Molecular and Microbial Sciences  
University of Queensland  
Brisbane, Queensland, Australia

JAMES K. RILLING  
Department of Anthropology  
Columbia University  
New York, NY, USA

JÜRGEN A. RIPPERGER  
Department of Medicine  
Division of Biochemistry  
University of Fribourg  
Fribourg, Switzerland

CASTO RIVADULLA  
Neurociencias and Motor Control Group (Neurocom),  
Department of Medicine-INEF-Galicia  
University de A Coruña  
Campus de Oza, A Coruña, Spain

CLAUDIO RIVERA  
Institute of Biotechnology  
University of Helsinki  
Helsinki, Finland  
claudio.rivera@helsinki.fi

SILVESTRO ROATTA  
Department of Neuroscience – Physiology Division  
University of Torino  
Raffaello, Torino, Italy  
silvestro.roatta@polito.it

FERNANDO RODRIGUEZ  
Laboratory of Psychobiology  
University of Sevilla  
Sevilla, Spain

VERONICA G. RODRIGUEZ MONCALVO  
Department of Biology  
McMaster University  
Hamilton, ON, Canada

TILL ROENNEBERG  
The University of Munich  
Munich, Germany

MALIN ROHDIN  
Karolinska Institute  
Astrid Lindgren Children's Hospital  
Stockholm, Sweden

URI ROKNI  
Center for Brain Science and Swartz Center for  
Computational Neuroscience  
Harvard  
Cambridge, MA, USA  
rokniu@MIT.EDU

EDMUND T. ROLLS  
Department of Experimental Psychology  
University of Oxford  
Oxford, UK  
Edmund.Rolls@psy.ox.ac.uk

BENNO ROOZENDAAL  
Center for the Neurobiology of Learning and Memory,  
Department of Neurobiology and Behavior  
University of California  
Irvine, CA, USA  
broozend@uci.edu

JONAS ROSE  
Biopsychology  
Institute of Cognitive Neuroscience  
Ruhr-University Bochum  
Bochum, Germany

ANDREW M. ROSEN  
Dept. of Psychology  
Binghamton University  
Binghamton, NY, USA  
andrewri@u.washington.edu

SERGE ROSSIGNOL  
Centre de Recherche en Sciences Neurologiques,  
Department of Physiology  
Pavillon Paul-G.-Desmarais  
Université de Montréal  
Montreal, QC, Canada  
serge.rossignol@unmontreal.ca

GERHARD ROTH  
Brain Research Institute  
University of Bremen  
Bremen, Germany  
gerhard.roth@uni-bremen.de

LOUISE RÖSKA-HARDY  
Kulturwissenschaftliches Institut  
Essen, Germany  
louise.roeska-hardy@kwi-nrw.de

ANDRE T. ROUSSIN  
Dept. of Psychology  
Binghamton University  
Binghamton, NY, USA  
roussinat@yahoo.com

MARK J. ROWE  
Department of Physiology and Pharmacology  
School of Medical Sciences  
The University of New South Wales  
Sydney, NSW, Australia  
M.Rowe@unsw.edu.au

ARIJIT ROY  
Hotchkiss Brain Institute  
Department of Medical  
Physiology and Biophysics  
University of Calgary  
Calgary, AB, Canada

ROLAND R. ROY  
Brain Research Institute and Department of  
Physiological Science  
University of California  
Los Angeles, CA, USA  
rrr@ucla.edu

ARAYA RUANGKITTISAKUL  
Department of Physiology  
Perinatal Research Centre,  
Faculty of Medicine & Dentistry, HMRC  
University of Alberta  
Edmonton, AB, Canada

SILVIA DE RUBEIS  
Department of Biology  
University "Tor Vergata"  
Rome Department of Molecular and Developmental  
Genetics/VIB11,  
Catholic University of Leuven  
Leuven, Belgium

EDWIN W. RUBEL  
Virginia Merrill Bloedel Hearing Research Center  
University of Washington  
Seattle, WA, USA  
rubel@u.washington.edu

MARIO A. RUGGERO  
The Hugh Knowles Center and Institute for  
Neuroscience  
Northwestern University  
Evanston, Illinois, USA  
mruggero@northwestern.edu

JEFFREY A. RUMBAUGH  
Department of Neurology  
Johns Hopkins University  
School of Medicine  
Baltimore, MD, USA

DAVID W. RUSS  
School of Physical Therapy  
Ohio University  
Athens, OH, USA

SHELLEY J. RUSSEK  
Laboratory of Molecular Neurobiology  
Department of Pharmacology and Experimental

Therapeutics  
Boston, MA, USA  
srussek@bu.edu

ILYA A. RYBAK  
Department of Neurobiology and Anatomy  
Drexel University College of Medicine  
Philadelphia, PA, USA  
rybak@drexel.edu

KLAUS SACHS-HOMBACH  
Otto-von-Guericke University Magdeburg  
Magdeburg, Germany  
klaus.sachs-hombach@gse-w.uni-magdeburg.de

WILLIAM M. SAIDEL  
Department of Biology  
Rutgers, the State University of New Jersey  
Camden, NJ,  
saidel@camden.rutgers.edu

TETSUICHIRO SAITO  
Graduate School of Medicine  
Chiba University  
Chiba, Japan  
tesaito@faculty.chiba-u.ac.jp

NORIO SAKAI  
Department of Developmental Medicine (Pediatrics)  
Osaka University  
Graduate School of Medicine  
Yamadaoka, Suita, Osaka, Japan

HIDEO SAKATA  
Department of Administrative Nutrition  
Faculty of Health and Nutrition  
Tokyo, Japan  
sakata@horae.dti.ne.jp

KENJI SAKIMURA  
Department of Cellular Neurobiology  
Brain Research Institute  
Niigata University  
Niigata, Japan  
npsaki01@bri.niigata-u.ac.jp

YOSHIO SAKURAI  
Department of Psychology  
Graduate School of Letters  
Kyoto University  
Sakyo, Kyoto, Japan  
ysakurai@bun.kyoto-u.ac.jp

COSME SALAS  
Department of Psychology and J.P. Scott Center for  
Neuroscience, Mind and Behavior  
Bowling Green State University  
Bowling Green, OH, USA

ERNESTO SALCEDO  
University of Colorado at Denver and Health  
Sciences Center  
Aurora, CO, USA  
Ernesto.Salcedo@uchsc.edu

ALI SAMII  
Department of Neurology  
University of Washington  
Seattle, WA, USA  
asamii@u.washington.edu

WILLIS K. SAMSON  
Department of Pharmacological and Physiological  
Science  
Saint Louis University  
School of Medicine  
St. Louis, MO, USA  
samsonwk@slu.edu

THOMAS SANDERCOCK  
Departments of Physiology, Physical Medicine and  
Rehabilitation, and Biomedical Engineering  
Feinberg School of Medicine  
Northwestern University  
Chicago, IL, USA  
t-sandercock@northwestern.edu

JÜRGEN SANDKÜHLER  
Department of Neurophysiology  
Center for Brain Research  
Medical University of Vienna  
Vienna, Austria  
juergen.sandkuehler@meduniwien.ac.at

J. C. SANDOZ  
Research Center for Animal Cognition  
CNRS UMR 5169  
Paul Sabatier University  
Toulouse Cedex, France  
sandoz@cict.fr

VITTORIO SANGUINETI  
Dipartimento di Informatica, Sistemistica e Telematica  
Università di Genova  
Genova, Italy  
sanguini@dist.unige.it

ROBERT M. SANTER  
School of Biosciences  
Cardiff University  
Cardiff, United Kingdom  
santer@cardiff.ac.uk

SAMUEL SAPORTA  
Pathology and Cell Biology  
University of South Florida College of Medicine  
Tampa, FL, USA  
ssaporta@hsc.usf.edu

YUKA SASAKI  
Harvard Medical School  
Boston, MA, USA

MARCO SASSOÈ-POGNETTO  
Department of Anatomy, Pharmacology and Forensic  
Medicine and National Institute of Neuroscience  
University of Torino  
Torino, Italy  
marco.sassoe@unito.it

MAKOTO SATO  
Division of Cell Biology and Neuroscience,  
Department of Morphological and Physiological  
Sciences, Faculty of Medical Sciences  
University of Fukui  
Matsuoka-Shimoaizuki, Eiheiji, Fukui, Japan  
makosato@fmsrsa.fukui-med.ac.jp

BENOIST SCHAAL  
Centre Européen des Sciences du Goût, CNRS  
Dijon, France  
Schaal@cesg.cnrs.fr

HANS-GEORG SCHAIBLE  
Institute of Physiology  
Friedrich-Schiller-University of Jena  
Jena, Germany  
Hans-Georg.schaible@mti.uni-jena.de

JEFFREY D. SCHALL  
Department of Psychology  
Center for Integrative and Cognitive Neuroscience,  
Vanderbilt Vision Research Center,  
Vanderbilt University  
Nashville, TN, USA  
jeffrey.d.schall@vanderbilt.edu

HENNING SCHEICH  
Leibniz-Institute for Neurobiology  
Magdeburg, Germany

MARC H. SCHIEBER  
Departments of Neurology and of Neurobiology and  
Anatomy

University of Rochester School of Medicine and  
Dentistry  
Rochester, NY, USA  
mhs@cvs.rochester.edu

HANS-ULRICH SCHNITZLER  
Tierphysiologie  
Zoologisches Institut  
Universität Tübingen  
Tübingen, Germany  
hans-ulrich.schnitzler@uni-tuebingen.de

CHRISTOPH E. SCHREINER  
Coleman Memorial Laboratory  
W.M. Keck Center for Integrative Neuroscience  
Department of Otolaryngology-Head and Neck Surgery  
School of Medicine  
University of California  
San Francisco, CA, USA  
chris@phy.ucsf.edu

MARKUS SCHRENK DPHIL  
Research Fellow  
Department Philosophy  
University of Nottingham  
University Park  
Nottingham, UK  
markus.schrenk@ccc.ox.ac.uk

JÜRGEN SCHRÖDER  
University of Karlsruhe  
Heidelberg, Germany

MICHAEL SCHÜTTE  
Institut für Philosophie  
Universität Magdeburg  
Magdeburg, Germany  
Mschuett@philosophie.uni-bielefeld.de

MICHAL SCHWARTZ  
The Weizmann Institute of Science  
Rehovot, Israel  
Charles Scudder  
Portland, OR, USA  
michal.schwartz@weizmann.ac.il

MICHAEL SEAGAR  
INSERM/Université de la Méditerranée, UMR641  
Faculté de Médecine Nord  
Marseille, France  
seagar.m@jean-roche.univ-mrs.fr

ARMIN H. SEIDL  
Virginia Merrill Bloedel Hearing Research Center  
University of Washington  
Seattle, WA, USA  
armins@u.washington.edu

KRZYSZTOF SELMAJ  
Department of Neurology  
Medical University of Lodz  
Lodz, Poland

ALICIA SEMAKA  
Centre for Molecular Medicine and Therapeutics  
University of British Columbia  
Vancouver, Canada

ADRIANO SENATORE  
B1-173, Department of Biology  
University of Waterloo  
Waterloo, ON, Canada

SUSAN R. SESACK  
Departments of Neuroscience and Psychiatry  
University of Pittsburgh  
Pittsburgh, PA, USA  
sesack@bns.pitt.edu

KAARE SEVERINSEN  
Department of Neurology  
Aarhus University Hospital  
Aarhus, Denmark

ROBERT V. SHANNON  
House Ear Institute  
Los Angeles, CA, USA  
bshannon@hei.org

DAVID SHEINBERG  
Department of Neuroscience  
Brown University  
Providence, RI, USA  
David\_Sheinberg@brown.edu

SIMING SHEN  
Robert Wood Johnson Medical School UMDNJ  
Piscataway, NJ, USA

YIRU SHEN  
Department of Physiology  
Yong Loo Lin School of Medicine  
National University of Singapore  
and National Neuroscience Institute  
Seng, Singapore

GORDON M. SHEPHERD  
Department of Neurobiology  
Yale University School of Medicine  
New Haven, CT, USA  
Gordon.shepherd@yale.edu

KIRSTEN SHEPHERD-BARR  
Faculty of English  
Oxford University  
Oxford, UK

CHET C. SHERWOOD  
Department of Anthropology  
The George Washington University  
Washington, DC, USA

SHIGENOBU SHIBATA  
Division of Physiology and Pharmacology  
School of Science and Engineering  
Waseda University  
Tokyo, Japan  
shibatasa@waseda.jp

KENJI SHIMAMURA  
Division of Morphogenesis  
Institute of Molecular Embryology and Genetics  
Kumamoto University  
Kumamoto, Japan  
imamura@kaiju.medic.kumamoto-u.ac.jp

TORU SHIMIZU  
Department of Psychology  
University of South Florida  
Tampa, Florida, USA  
shimizu@cas.usf.edu

NAHUM SHIMKIN  
Department of Electrical Engineering  
Technion – Israel Institute of Technology  
Haifa, Israel  
shimkin@ee.technion.ac.il

RENÉ M. SHINAL  
Department of Community Dentistry and Behavioral  
Science  
College of Dentistry  
University of Florida  
FL, USA  
rshinal@dental.ufl.edu

SOOYOUN SHIN  
Department of Neuroscience  
The Center for the Neural Basis of Cognition, and the  
Center for Neuroscience  
University of Pittsburgh  
Pittsburgh, PA, USA

TOMOMI SHINDOU  
Neurobiology Research Unit  
Okinawa Institute of Science and Technology  
Uruma, Okinawa, Japan

SADAO SHIOSAKA  
Nara Institute of Science and Technology (NAIST)  
Structural Cell Biology  
Nara, Japan  
sshiosak@bs.aist-nara.ac.jp

GILLES SICARD  
Centre Européen des Sciences du Goût  
Dijon, France  
sicard@cesg.cnrs.fr

JEROME M. SIEGEL  
Center for Sleep Research 151A3  
Department of Psychiatry  
UCLA School of Medicine  
Veterans Administration Greater Los Angeles Health  
Care System  
North Hills, CA, USA

JONATHAN SIEGEL  
Department of Communication Sciences and Disorders  
Northwestern University  
Evanston, IL, USA  
jsiegel@ucla.edu

R. F. M. SILVA  
Centro de Patogénese Molecular - UBMBE iMed.UL,  
Faculdade de Farmácia  
University of Lisbon  
Lisbon, Portugal

RAE SILVER  
Departments of Psychology at Barnard College and  
Columbia University, and Department of Pathology and  
Cell Biology  
Columbia Health Sciences Campus  
Columbia University  
New York, NY, USA  
QR@columbia.edu

NARONG SIMAKAJORNBOON  
Cincinnati Children's Hospital Medical Center  
Cincinnati, OH, USA  
Narong.Simakajornboon@cchmc.org

ANDREW SIMMONDS  
Department of Cell Biology  
Faculty of Medicine and Dentistry  
University of Alberta  
Edmonton, AB, Canada

JULIA SIMNER  
School of Philosophy, Psychology and Language  
Sciences  
University of Edinburgh  
Edinburgh, UK  
j.simner@ed.ac.uk

SIDNEY A. SIMON  
Department of Neurobiology  
Duke University  
Durham, NC, USA  
sas@neuro.duke.edu



BURTON SLOTNICK  
Department of Psychology  
University of South Florida  
Tampa, FL, USA  
slotnic@american.edu

LAURA SMALE  
Department of Psychology and Neuroscience Program  
Michigan State University  
East Lansing, MI, USA  
smale@msu.edu

JEFFREY C. SMITH  
Cellular and Systems Neurobiology Section  
National Institute of Neurological Disorders and Stroke  
National Institutes of Health  
Bethesda, MD, USA  
jsmith@helix.nih.gov

PAUL F. SMITH  
Department of Pharmacology and Toxicology  
School of Medical Sciences  
University of Otago  
Medical School  
Dunedin, New Zealand  
paul.smith@stonebow.otago.ac.nz

PETER G. SMITH  
Department of Molecular and Integrative Physiology  
and Kansas Intellectual and Developmental Disabilities  
Research Center  
University of Kansas  
Medical Center  
Kansas City, KS, USA  
psmith@kumc.edu

PHILIP H. SMITH  
Department of Anatomy  
University of Wisconsin  
Medical School – Madison  
Madison, WI, USA  
Smith@Physiology.wisc.edu

TERENCE SMITH  
Eisai London Research Laboratories  
University College London  
London, UK

Kwok-Fai So  
Department of Anatomy  
The University of Hong Kong  
Hong Kong, People's Republic of China  
hrmaskf@hkucc.hku.hk

BEATE SODIAN  
Department of Psychology  
Ludwig-Maximilians-Universität München  
München, Germany  
Beate.Sodian@psy.lmu.de

JOHN F. SOECHTING  
Department of Neuroscience  
University of Minnesota  
Minneapolis, MN, USA  
soech001@umn.edu

U. SHIVRAJ SOHUR  
MGH-HMS Center for Nervous System Repair,  
Departments of Neurosurgery and Neurology, and  
Program in Neuroscience  
Harvard Medical School;  
Nayef Al-Rodhan Laboratories  
Massachusetts General Hospital;  
Department of Stem Cell and Regenerative  
Biology, and Harvard Stem Cell Institute  
Harvard University  
Boston, MA, USA

MARC A. SOMMER  
Department of Neuroscience  
The Center for the Neural Basis of Cognition, and the  
Center for Neuroscience  
University of Pittsburgh  
Pittsburgh, PA, USA  
mas@cnbc.cmu.edu

MARGARET J. SONNENFELD  
Department of Cellular and Molecular Medicine,  
Faculty of Medicine  
University of Ottawa  
Ottawa, ON, Canada  
msonnenf@uottawa.ca

PAMELA SOUZA  
Department of Speech and Hearing Sciences  
University of Washington  
Seattle, WA, USA  
psouza@u.washington.edu

J. DAVID SPAFFORD  
B1-173, Department of Biology  
University of Waterloo  
Waterloo, ON, Canada  
spafford@uwaterloo.ca

WILLIAM J. SPAIN  
Department of Neurology  
University of Washington  
Veterans Affairs Puget  
Sound Health Care System  
Seattle, WA, USA  
spain@u.washington.edu

DAVID L. SPARKS  
Division of Neuroscience  
Baylor College of Medicine  
Houston, TX, USA  
sparks@neusc.bcm.tmc.edu

CHARLES SPENCE  
Department of Psychology  
University of Bath  
Bath, UK  
charles.spence@psy.ox.ac.uk

GAYNOR E. SPENCER  
Department of Biological Sciences  
Brock University  
St. Catharines, ON, Canada  
gspencer@brocku.ca

SIMON G. SPRECHER  
Department of Biology  
Center for Developmental Genetics  
New York University  
New York, NY, USA  
simon.sprecher@gmail.com

JAMES M. STADDON  
Eisai London Research Laboratories  
University College London  
London, UK  
James\_Staddon@eisai.net

PHILIP F. STAHEL  
Department of Orthopaedic Surgery  
Denver Health Medical Center  
University of Colorado  
School of Medicine  
Denver, CO, USA  
Philip.Stahel@dhha.org

ANGELA STARKWEATHER  
Intercollegiate College of Nursing  
Washington State University  
Spokane, WA, USA  
starkweather@comcast.net

ALEXANDER STAUDACHER  
Institut für Philosophie  
Otto-von-Guericke-Universität Magdeburg  
Magdeburg, Germany  
Alexander.Staudacher@gse-w.uni-magdeburg.de

J. VAN DER STEEN  
Department of Neuroscience  
Erasmus MC  
Rotterdam, The Netherlands  
J.vanderSteen@ErasmusMC.nl

PAUL S. G. STEIN  
Department of Biology  
Washington University  
St. Louis, MO, USA  
stein@biology.wustl.edu

YOSSEF STEINBERG  
Electrical Engineering Department  
Technion  
Haifa, Israel

MAIKE STENDEL  
Division of Neurological Pain Research and Therapy,  
Department of Neurology  
Universitätsklinikum Schleswig-Holstein  
Campus Kiel, Kiel, Germany

ACHIM STEPHAN  
Institute of Cognitive Science  
University of Osnabrück  
Lower Saxony, Germany  
achim.stephan@t-online.de

SUSANNE J. STERBING-D'ANGELO  
Department of Psychology  
Vanderbilt University  
Nashville, TN, USA  
susanne.j.sterbing-dangelo@vanderbilt.edu

RICHARD J. STEVENSON  
Department of Psychology  
Macquarie University  
Sydney, NSW, Australia  
Richard.Stevenson@psy.mq.edu.au

RALF STOECKER  
Institut für Philosophie  
Universität Potsdam  
Potsdam, Germany  
Ralf.Stoecker@uni-potsdam.de

ESTHER T. STOECKLI  
Institute of Zoology/Developmental Neuroscience,  
University of Zurich  
Zurich, Switzerland  
esther.stoeckli@zool.uzh.ch

HANS STRAKA  
Laboratoire de Neurobiologie des Réseaux  
CNRS UMR 7060 – Université Paris 5  
Paris Cedex, France

VOLKO A. STRAUB  
Department of Cell Physiology & Pharmacology  
University of Leicester  
Leicester, UK  
vs64@le.ac.uk

ARJEN M. STRIJKSTRA  
Department of Chronobiology  
University of Groningen  
Groningen, The Netherlands  
a.m.strijkstra@rug.nl

JÖRG STROTSMANN  
University of Hohenheim  
Institute of Physiology  
Stuttgart, Germany  
strotman@uni-hohenheim.de

MAKOTO SUGITA  
Department of Oral Physiology  
Graduate School of Biomedical Sciences  
Hiroshima University  
Hiroshima, Japan  
sugisan@hiroshima-u.ac.jp

KYOUNGHO SUK  
Department of Pharmacology  
School of Medicine  
Kyungpook National University  
Daegu, Korea  
ksuk@knu.ac.kr

WILLIAM K. SUMMERS  
Alzheimer's Corporation  
Albuquerque, NM, USA  
acasec@swcp.com

YING YING SUNG  
Department of Physiology  
Yong Loo Lin School of Medicine  
National University of Singapore  
and National Neuroscience Institute  
Seng, Singapore

MAKI SUZUKI  
Division of Cyclotron Nuclear Medicine  
Cyclotron and Radioisotope Center  
Tohoku University  
Sendai, Japan

YOSHIHISA SUZUKI  
Department of Anatomy and Neurobiology and  
Department of Plastic and Reconstructive Surgery  
Kyoto University Graduate School of Medicine  
Kyoto, Japan  
utsubo@kuhp.kyoto-u.ac.jp

AKIO SUZUMURA  
Department of Neuroimmunology  
Research Institute of Environmental Medicine  
Nagoya University  
Nagoya, Japan

DICK F. SWAAB  
Netherlands Institute for Neuroscience  
Meibergdreef, Amsterdam, The Netherlands  
d.f.swaab@nih.knaw.nl

NAWEED I. SYED  
Department of Cell Biology and Anatomy  
Faculty of Medicine  
University of Calgary  
Calgary, AB, Canada  
nisyed@ucalgary.ca

JOHN SYMONS  
Department of Philosophy  
The University of Texas  
El Paso, TX, USA  
jsymons@utep.edu

OLGA V. SYSOEVA  
Laboratory of Human Higher Nervous Activity  
Institute of Higher Nervous Activity and  
Neurophysiology  
Russian Academy of Sciences  
Moscow, Russia

GABRIELLE SZAFRANSKI  
Department of Psychology  
University of South Florida  
Tampa, Florida, USA

RONALD SZYMUSIAK  
Departments of Medicine and Neurobiology  
School of Medicine  
University of California  
Los Angeles, CA, USA  
rszym@ucla.edu

TAMIKO TACHIBANA  
Department of Oral Anatomy  
Iwate Medical University  
School of Dentistry  
Uchimaru, Morioka, Japan  
tetsu@agr.ehime-u.ac.jp

MASAMI TAKAHASHI  
Department of Biochemistry  
Kitasato University  
School of Medicine  
Sagamihara-shi, Kanagawa, Japan  
masami@med.kitasato-u.ac.jp

TAKAO TAKAHASHI  
Department of Pediatrics  
School of Medicine  
Keio University  
Tokyo, Japan  
tata@sc.itc.keio.ac.jp

TERRY TAKAHASHI  
Institute of Neuroscience  
University of Oregon  
Eugene, OR, USA

MASAHARU TAKAMORI  
Neurological Center  
Kanazawa-Nishi Hospital and  
Kanazawa University  
Kanazawa, Ishikawa, Japan  
t-kiyomi@guitar.ocn.ne.jp

SIU LIN TAM  
Centre of Neuroscience  
Division of Physical Medicine and Rehabilitation  
Faculty of Medicine and Dentistry  
University of Alberta  
Edmonton, AB, Canada

ATSUSHI TAMADA  
Laboratory for Neuronal Growth Mechanisms  
RIKEN Brain Science Institute  
Wako, Saitama, Japan  
tamada@brain.riken.go.jp

HIROTAKE TANABE  
Department of Neuropsychiatry, Neuroscience  
Ehime Graduate School of Medicine  
Shitsukawa, Japan  
htanabe@m.ehime-u.ac.jp

HIROKAZU TANAKA  
ATR Computational Neuroscience Laboratories  
Kyoto, Japan  
hirokazu@atr.jp

KOHICHI TANAKA  
Laboratory of Molecular Neuroscience  
School of Biomedical Science and Medical Research  
Institute  
Tokyo Medical and Dental University  
Bunkyo-Ku, Tokyo  
tanaka.aud@mri.tmd.ac.jp

A. TANDON  
Centre for Research in Neurodegenerative Diseases  
Toronto, ON, Canada  
a.tandon@utoronto.ca

ITARU F. TATSUMI  
LD/Dyslexia Centre  
Chiba, Japan  
itaru\_ft@mbp.nifty.com

JANET L. TAYLOR  
Prince of Wales Medical Research Institute and  
University of New South Wales  
Sydney, NSW, Australia  
jl.taylor@unsw.edu.au

HANS J. TEN DONKELAAR  
Department of Neurology  
Radboud University Nijmegen  
Medical Centre  
Nijmegen, The Netherlands  
H.tenDonkelaar@neuro.umcn.nl

HOLM TETENS  
Institut für Philosophie  
Freie Universität Berlin  
Berlin, Germany  
Tetens@zedat.fu-berlin.de

CHARLOTTE E. TEUNISSEN  
Department of Molecular Cell Biology and  
Immunology  
VUMC  
Amsterdam, The Netherlands

FREDÉRIC E. THEUNISSEN  
UC Berkeley  
Department of Psychology and  
Neurosciences Institute  
Berkeley, CA, USA  
theunissen@berkeley.edu

THIERRY THOMAS-DANGUIN  
Flavour Perception Group: Peri-receptor Events and  
Sensory Interactions  
UMR1129 FLAVIC, ENESAD, INRA  
Université de Bourgogne  
Dijon Cedex, France  
Thierry.Thomas-Danguin@dijon.inra.fr

DAGMAR TIMMANN  
Department of Neurology  
University of Duisburg-Essen  
Essen, Germany  
Dagmar.Timmann@uni-essen.de

LENA H. TING  
Laboratory for Neuroengineering  
The W. H. Coulter  
Department of Biomedical Engineering  
Emory University and Georgia Institute of Technology  
Atlanta, GA, USA  
lting@emory.edu

DAVID TIRSCHWELL  
Harborview Neurology - Comprehensive Stroke Center  
University of Washington  
School of Medicine  
Seattle, WA, USA

SHELLEY TISCHKAU  
Department of Pharmacology  
Southern Illinois University  
School of Medicine  
Springfield, IL, USA  
stischkau@siu.edu

GUNNAR TOBIN  
Department of Pharmacology  
The Sahlgrenska Academy  
Göteborg University  
Göteborg, Sweden  
gunnar.tobin@pharm.gu.se

YOAV TOCK  
IBM Haifa Research Laboratory  
University Campus  
Haifa, Israel  
TOCK@il.ibm.com

WILLIAM H. TOLLESON  
Division of Biochemical Toxicology  
National Center for Toxicological Research  
US Food and Drug Administration  
Jefferson, AR, USA  
william.tolleson@fda.hhs.gov

GIANLUCA TOSINI  
Circadian Rhythms and Sleep Disorders Program,  
Neuroscience Institute  
Morehouse School of Medicine  
Atlanta, GA, USA  
gtosini@msm.edu

IRENE TRACEY  
Department of Clinical Neurology and Nuffield  
Department of Anaesthetics  
Centre for Functional Magnetic Resonance Imaging of  
the Brain  
Oxford University  
Oxford, UK  
irene@fmrib.ox.ac.uk

CONSTANTINE TRAHOTIS  
Department of Neuroscience and  
Department of Surgery (Otolaryngology)  
University of Connecticut Health Center  
Farmington, CT, USA  
tino@nso2.uhc.edu

R. ALBERTO TRAVAGLI  
Neuroscience, Pennington Biomedical Research  
Center-LSU System  
Baton Rouge, LA, USA  
Alberto.Travagli@pbr.edu

MATS TRULSSON  
Department of Prosthetic Dentistry  
Institute of Odontology  
Karolinska Institutet  
Sweden

VINZENZ VON TSCHARNER  
Human Performance Laboratory  
University of Calgary  
AB, Canada  
tvvon@ucalgary.ca

AMY TSE  
Department of Pharmacology and Centre for  
Neuroscience  
University of Alberta  
Edmonton, AB, Canada  
Amy.tse@ualberta.ca

FREDERICK W. TSE  
Department of Pharmacology & Centre for  
Neuroscience  
University of Alberta  
Edmonton, AB, Canada  
Fred.tse@ualberta.ca

MINORU TSUKADA  
Brain Science Institute  
Tamagawa University  
Tamagawa-gakuen, Machida, Tokyo, Japan  
tsukada@eng.tamagawa.ac.jp

IKUO TSUNODA  
Department of Pathology  
University of Utah  
School of Medicine  
Salt Lake City, Utah, USA  
Ikuo.Tsunoda@hsc.utah.edu

KEN-ICHIRO TSUTSUI  
Division of Systems Neuroscience  
Graduate School of Life Sciences  
Tohoku University  
Sendai, Japan

A. RUSSELL TUPLING  
Department of Kinesiology  
University of Waterloo  
Waterloo, ON, Canada  
rtupling@healthy.uwaterloo.ca

THOMAS M. TZSCHENTKE  
Grünenthal GmbH  
Research and Development  
Department of Pharmacology  
Aachen, Germany  
Thomas.Tzschentke@grunenthal.de

SAE UCHIDA  
Department of the Autonomic Nervous System  
Tokyo Metropolitan Institute of Gerontology  
Tokyo, Japan  
suchida@tmig.or.jp

YASUMASA UEDA  
Kyoto Prefectural University of Medicine  
Kawaramachi-Hirokoji  
Kamigyo-ku, Kyoto, Japan

TADASHI UEMURA  
Graduate School of Biostudies  
Kyoto University  
Kyoto, Japan  
tauemura@lif.kyoto-u.ac.jp

W. MARTIN USREY  
Center for Neuroscience  
University of California  
Davis, CA, USA  
wmusrey@ucdavis.edu

RICKY VAN DER ZWAN  
Sleep and Performance Research Center  
Washington State University  
Spokane, WA, USA  
rick.vanderzwan@scu.edu.au

P. A. VAN DONGEN  
Sleep and Performance Research Center  
Washington State University  
Spokane, WA, USA  
hvd@wsu.edu

RENE VANDENBOOM  
Faculty of Applied Health Sciences  
Brock University  
St. Catharines, ON, Canada  
boomerene@hotmail.com

TODD W. VANDERAH  
College of Medicine  
Departments of Pharmacology  
and Anesthesiology  
University of Arizona  
Tucson, AZ, USA  
vanderah@email.arizona.edu

FREDERIQUE VAROQUEAUX  
Department of Molecular Neurobiology  
Max-Planck-Institute for Experimental Medicine  
Göttingen, Germany

MICHAEL R. VASKO  
Department of Pharmacology and Toxicology  
Indiana University  
School of Medicine  
Indianapolis, IN, USA  
vaskom@iupui.edu

EMMA L. VEALE  
Medway School of Pharmacy  
Universities of Kent and Greenwich at Medway  
Chatham Maritime, Kent, UK

SIGRID C. VEASEY  
Center for Sleep & Respiratory Neurobiology,  
Department of Medicine  
School of Medicine  
University of Pennsylvania  
Philadelphia, PA, USA  
veasey@mail.med.upenn.edu

ELLY J. F. VEREYKEN  
Department of Molecular Cell Biology and  
Immunology  
VUMC  
Amsterdam, The Netherlands

JOOST VERHAAGEN  
Netherlands Institute for Neurosciences  
A Research Institute of the Royal Netherlands Academy  
of Arts and Sciences  
Amsterdam, The Netherlands  
j.verhaagen@nih.knaw.nl

PHILIPPE VERNIER  
CNRS, Institute of Neurobiology A. Fessard  
Gif sur Yvette Cedex, France  
philippe.vernier@iaf.cnrs-gif.fr

RONALD T. VERRILLO  
Institute for Sensory Research  
Syracuse University  
Syracuse, NY, USA  
ron\_verrillo@isr.syr.edu

EUGENE VLODAVSKY  
Department of Pathology  
Rambam Medical Center,  
and Faculty of Medicine  
Technion-Israel Institute of Technology  
Haifa, Israel  
e\_vlodavsky@rambam.health.gov.il

BRENT A. VOGT  
Department of Neuroscience and Physiology  
State University of New York  
Upstate Medical University  
Syracuse, NY, USA  
vogtb@upstate.edu

TALILA VOLK  
Department of Molecular Genetics  
Weizmann Institute  
Rehovot, Israel  
lgvolk@wicc.weizmann.ac.il

BRUCE T. VOLPE  
Department of Neurology & Neuroscience  
The Burke Medical Research Institute  
Weill Medical College of Cornell University  
White Plains, NY, USA  
bvolpe@burke.org

CATHERINE DE WAELE  
Laboratoire de Neurobiologie des Réseaux  
Sensorimoteurs,  
CNRS  
Paris, France  
Catherine.de-waele@univ-paris.fr

ELAINE WADDINGTON LAMONT  
Institute of Neuroscience  
Carleton University  
Life Sciences Building  
Ottawa, ON, Canada  
ewlamont@mac.com

HERMANN WAGNER  
Institute for Biology II  
RWTH Aachen  
Aachen, Germany  
wagner@bio2.rwth-aachen.de

TUCK WAH SOONG  
Department of Physiology  
Yong Loo Lin School of Medicine  
National University of Singapore  
and National Neuroscience Institute  
Seng, Singapore

DAVID M. WAITZMAN  
University of Connecticut Health Center  
Department of Neurology  
Farmington, CT, USA  
e-waitzman@nso2.uchc.edu

MICHELLE WALL  
Flexcell International Corp.  
North Carolina  
USA

SVEN WALTER  
Department of Philosophy  
University of Saarland  
Saarbruecken, Germany  
s.walter@philosophy-online.de

MARK M. G. WALTON  
Division of Neuroscience  
Baylor College of Medicine  
Houston, TX, USA

NAN WANG  
Department of Pharmacology & Centre for  
Neuroscience  
University of Alberta  
Edmonton, AB, Canada

QIONG WANG  
Department of Human Nutrition, Foods and Exercise  
Virginia Polytechnic Institute and State University  
Blacksburg, VA, USA

MEG WARACZYNSKI  
Department of Psychology  
University of Wisconsin – Whitewater  
Whitewater, WI, USA  
waraczym@uww.edu

SIMON C. WARBY  
Centre for Molecular Medicine and Therapeutics  
University of British Columbia  
Vancouver, Canada

SARAH E. WARNER  
Department of Orthopaedics and Sports Medicine  
University of Washington  
Seattle, WA, USA

ANNE-KATHRIN WARZECHA  
Lehrstuhl Neurobiologie  
Fakultät Biologie  
Universität Bielefeld  
Bielefeld, Germany  
ak.warzecha@uni-bielefeld.de

ANDREW J. WASKIEWICZ  
Department of Biological Sciences  
University of Alberta  
Edmonton, AB, Canada  
aw@ualberta.ca

MASATAKA WATANABE  
Department of Systems Innovation  
Graduate School of Engineering  
The University of Tokyo  
Tokyo, Japan  
watanabe@sk.q.t.u-tokyo.ac.jp

MASUMI WATANABE  
Department of Speech, Language and Hearing Sciences  
Niigata University of Health and Welfare  
Niigata, Japan

SHIGERU WATANABE  
Department of Psychology  
Keio University  
Mita, Minato-Ku  
Tokyo, Japan  
swat@flet.keio.ac.jp

TAKEO WATANABE  
Boston University  
Boston, MA, USA  
takeo@bu.edu

LINDA R. WATKINS  
University of Colorado at Boulder  
Boulder, CO, USA

STEPHEN G. WAXMAN  
Rehabilitation Research Center  
VA Connecticut, USA Healthcare System  
West Haven, CT, USA  
Stephen.Waxman@yale.edu

ELKE WEILER  
Department of Neurophysiology  
Institute of Physiology  
Ruhr-University Bochum  
Bochum, Germany  
weiler@neurop.ruhr-uni-bochum.de

PETER WENDEROTH  
Department of Psychology  
Macquarie University, North Ryde  
Sydney, NSW, Australia  
peterw@vision.psy.mq.edu.au

ROBERT J. WENTHOLD  
NIDCD/NIH  
Bethesda, MD, USA  
wenthold@nidcd.nih.gov

DAVID A. WESTWOOD  
School of Health and Human Performance  
Dalhousie University  
Halifax, NS, Canada  
David.Westwood@Dal.Ca

HEATHER E. WHEAT  
Department of Anatomy and Cell Biology  
University of Melbourne  
Parkville, VIC, Australia

PATRICK J. WHELAN  
Hotchkiss Brain Institute  
University of Calgary  
Calgary, AB, Canada  
whelan@ucalgary.ca

DENNIS WHITCOMB  
Department of Philosophy  
Western Washington University  
Bellingham, Washington, USA  
dporterw@eden.rutgers.edu

KATHLEEN WHITLOCK  
Department of Molecular Biology & Genetics  
Cornell University  
Ithaca, NY, USA  
kew13@cornell.edu

JEFFERY R. WICKENS  
Neurobiology Research Unit  
Okinawa Institute of Science and Technology  
Uruma, Okinawa, Japan  
ysuzuki@oist.jp

DARIUS WIDERA  
Department of Cell Biology  
Faculty of Biology  
University of Bielefeld  
Bielefeld, Germany  
darius.widera@uni-wh.de

SIDNEY WIENER  
LPPA  
Collège de France, CNRS  
Paris, France  
sidney.wiener@college-de-france.fr

WALTER WILCZYNSKI  
Center for Behavioral Neuroscience and Department of  
Psychology  
Georgia State University  
Atlanta, GA, USA  
wwilczynski@gsu.edu

J. MARTIN WILD  
Department of Anatomy with Radiology  
Faculty of Medical and Health Sciences  
University of Auckland  
Auckland, New Zealand  
jm.wild@auckland.ac.nz

WILLEM C. WILDERING  
Department of Biological Sciences  
Faculty of Science and Hotchkiss Brain Institute,  
University of Calgary  
Calgary, AB, Canada  
wilderin@ucalgary.ca



BRIAN O. WILLIAMS  
 Department of Human Nutrition, Foods and Exercise  
 Virginia Polytechnic Institute and State University  
 Blacksburg, VA, USA

TRICIA WILLIAMS  
 Neuroscience and Mental Health Program  
 Research Institute at The Hospital for Sick Children  
 Department of Anaesthesia  
 The University of Toronto  
 Toronto, ON, Canada

DONALD A. WILSON  
 Department of Zoology  
 University of Oklahoma  
 Norman, OK, USA  
 dwilson@ou.edu

MARTIN WILSON  
 Department of Neurobiology, Physiology and  
 Behavior  
 College of Biological Sciences  
 University of California Davis  
 Davis, CA, USA  
 mcwilson@ucdavis.edu

RICHARD J. A. WILSON  
 Hotchkiss Brain Institute  
 Department of Medical Physiology and Biophysics  
 University of Calgary  
 Calgary, AB, Canada  
 wilsonr@ucalgary.ca

WOLFGANG WILTSCHKO  
 Universität Frankfurt  
 Zoologisches Institut Biologie–Campus der Universität  
 Frankfurt am Main, Germany  
 wilschko@zoology.uni-frankfurt.de

UWE WINDHORST  
 Göttingen, Germany  
 siggi.uwe@t-online.de

JEFFERY A. WINER  
 Division of Neurobiology  
 Department of Molecular and Cell Biology  
 University of California at Berkeley  
 Berkeley, CA, USA

MICHAEL WINKLHOFFER  
 Department für Geo- und Umweltwissenschaften –  
 Sektion Geophysik  
 Ludwig-Maximilians-Universität Munich  
 Munich, Germany  
 michael@geophysik.uni-muenchen.de

PHILIP WINN  
 School of Psychology  
 University of St Andrews  
 Fife, UK  
 pw@st-andrews.ac.uk

S. WISLET-GENDEBIEN  
 Centre for Research in Neurodegenerative Diseases  
 Toronto  
 ON, Canada  
 sabine.wislet@utoronto.ca

MARTIN WITT  
 Smell and Taste Clinic  
 Department of Otorhinolaryngology  
 Department of Anatomy  
 University of Technology Dresden  
 Medical School  
 Dresden, Germany  
 martin.witt@mailbox.tu-dresden.de

MENNO P. WITTER  
 Kavli Institute for System Neuroscience  
 Centre for the Biology of Memory  
 Department of Neuroscience  
 Norwegian University of Science and Technology  
 (NTNU),  
 Trondheim, Norway

JOACHIM WITZEL  
 Central State Forensic Psychiatric Hospital of Saxony-  
 Anhalt  
 Uchtspringe, Stendal,  
 Germany  
 j.witzel@salus-lsa.de

RODGER WOLEDGE  
 Institute of Human Performance  
 University College London  
 London, UK  
 r.woledge@ucl.ac.uk

LUKE WOLOSZYN  
 Department of Neuroscience  
 Brown University  
 Providence, RI, USA  
 supawolo@yoshi.neuro.brown.edu

JONATHAN R. WOLPAW  
 New York State Department of Health  
 Laboratory of Nervous System Disorders  
 Wadsworth Center  
 Albany, NY, USA  
 wolpaw@wadsworth.org

STEPHANIE WOO  
Department of Biochemistry, Biophysics  
University of California  
San Francisco, CA, USA

JACKIE D. WOOD  
Department of Physiology and Cell Biology and  
Internal Medicine  
College of Medicine  
The Ohio State University  
Columbus, OH, USA  
wood.13@osu.edu

MELANIE A. WOODIN  
Department of Cell & Systems Biology  
University of Toronto  
Toronto, ON, Canada  
m.woodin@utoronto.ca

MARJORIE WOOLLACOTT  
Department of Human Physiology  
University of Oregon  
Eugene, OR, USA  
mwool@uoregon.edu

MICHAEL WRIDE  
Department of Zoology  
Trinity College Dublin  
Dublin 2, Ireland  
wridema@Cardiff.ac.uk

KENNETH P. WRIGHT JR  
Sleep and Chronobiology Laboratory  
Department of Integrative Physiology  
University of Colorado at Boulder  
Boulder, CO, USA  
Kenneth.Wright@colorado.edu

DANUTA WRONA  
Department of Animal Physiology  
University of Gdansk  
Gdansk, Poland  
wronada@biotech.univ.gda.pl

DAW-AN WU  
Division of Biology  
California Institute of Technology  
Pasadena, CA, USA

F. GREGORY WULCZYN  
Center for Anatomy  
Institute for Cell and Neurobiology  
Charité University Hospital  
Berlin, Germany  
gregory.wulczyn@charite.de

MARIO F. WULLIMANN  
Ludwig-Maximilians-University  
Department of Biology II-Neurobiology  
Planegg-Martinsried, Germany  
wullimann@zi.biologie.uni-muenchen.de

ROBERT H. WURTZ  
Laboratory of Sensorimotor Research  
National Eye Institute  
National Institutes of Health  
Bethesda, MD, USA  
bob@1sr.nei.nih.gov

DOUGLAS R. W. WYLIE  
University Centre for Neuroscience and Department of  
Psychology  
University of Alberta  
Edmonton, AB, Canada

XIAO-MING XU  
Kentucky Spinal Cord Injury Research Center,  
Department of Neurological Surgery  
School of Medicine  
University of Louisville  
Louisville, KY, USA  
xmxu0001@louisville.edu

JAYNE E. YACK  
Department of Biology  
Carleton University  
Ottawa, ON, Canada

HIROYUKI YAGINUMA  
Department of Anatomy  
School of Medicine  
Fukushima Medical University  
Fukushima, Japan  
h-yaginuma@fmu.ac.jp

KIYOFUMI YAMADA  
Laboratory of Neuropsychopharmacology  
Graduate School of Natural Science and Technology  
Kanazawa University  
Kanazawa, Japan  
kyamada@p.kanazawa-u.ac.jp

MASAHITO YAMAGATA  
Department of Molecular and Cellular Biology  
Harvard University  
Cambridge, MA, USA  
yamagatm@mcb.harvard.edu

KAZUHIKO YAMAGUCHI  
Laboratory for Memory and Learning  
Brain Science Institute  
Riken, Japan  
yamaguchi@brain.riken.go.jp

NOBUHIKO YAMAMOTO  
Dept Cellular and Molecular Neurobiology  
Graduate School of Frontier Biosciences  
Osaka University  
Osaka, Japan  
nibuhiko@fbs.osaka-u.ac.jp

TAKASHI YAMAMOTO  
Department of Oral Physiology  
Graduate School of Dentistry  
Osaka University  
Osaka, Japan  
yamamoto@dent.osaka-u.ac.jp

LEI YAN  
Department of Pharmacology & Centre for  
Neuroscience  
University of Alberta  
Edmonton, AB, Canada

QIN YAN  
Key Laboratory of Protein Chemistry and  
Developmental Biology of National Education Ministry  
of China  
College of Life Sciences  
Hunan Normal University  
Changsha, Hunan, China

XIAOHANG YANG  
Institute of Molecular and Cell Biology  
Agency for Science, Technology and Research  
Proteos, Singapore  
mcbyangn@imcb.a-star.edu.sg

BILL J. YATES  
Department of Otolaryngology  
University of Pittsburgh  
School of Medicine  
Eye & Ear Institute Building  
Pittsburgh, PA, USA  
byates@pitt.edu

HIROMU YAWO  
Department of Developmental Biology and  
Neuroscience  
Tohoku University  
Graduate School of Life Sciences  
Sendai, Japan  
yawo@mail.tains.tohoku.ac.jp

VALERIE YEUNG-YAM-WAH  
Department of Pharmacology  
Centre for Neuroscience  
University of Alberta  
Edmonton, AB, Canada

TOM C. T. YIN  
Department of Physiology and Neuroscience Training  
Program  
University of Wisconsin  
Madison, WI, USA  
yin@physiology.wisc.edu

ETI YOLES  
Proneuron Biotechnologies  
Beit-Gamliel, Israel

ELAD YOM-TOV  
IBM Haifa Research Laboratory  
Haifa University Campus  
Haifa, Israel  
YOMTOV@il.ibm.com

MICHIO YOSHIDA  
Division of Morphogenesis  
Institute of Molecular  
Embryology and Genetics  
Kumamoto University  
Kumamoto, Japan  
myoshida@kaiju.medic.kumamoto-u.ac.jp

YOSHIHIRO YOSHIHARA  
RIKEN Brain Science Institute  
Wako, Saitama, Japan  
yoshihara@brain.riken.jp

WILLIAM A. YOST  
Speech and Hearing Science  
Arizona State University  
Tempe, AZ, USA  
wyost@luc.edu

DEBORAH YOUNG  
Department of Molecular Medicine & Pathology,  
Department of Pharmacology & Clinical Pharmacology  
Faculty of Medical & Health Sciences  
University of Auckland  
Auckland, New Zealand  
ds.young@auckland.ac.nz

HUNG-HSIANG YU  
Department of Neurobiology  
University of Massachusetts  
Medical School  
Worcester, MA, USA

LI YU  
Centre for Research in Neuroscience  
Department of Neurology and Neurosurgery  
McGill University Health Centre  
Montreal, QC, Canada

JULIÁN YÁÑEZ  
University of A Coruña  
Campus A Zapateira  
A Coruña, Spain

DANIEL S. ZAHM  
Department of Pharmacological and Physiological  
Science  
Saint Louis University  
School of Medicine  
Saint Louis, MO, USA  
zahmds@slu.edu

LUCIA ZANOTTI  
Neuroimmunology Unit  
DIBIT-San Raffaele Scientific Institute  
Milano, Italy

SEMIR ZEKI  
Department of Imaging Neuroscience  
University College London  
London, UK  
zeki.pa@ucl.ac.uk

DAVID ZENISEK  
Yale University School of Medicine  
New Haven, CT, USA  
shaul.hestrin@stanford.edu

MEI ZHEN  
Department of Molecular Genetics  
University of Toronto

Toronto, ON, Canada  
Samuel Lunenfeld Research Institute  
Mount Sinai Hospital  
Toronto, ON, Canada  
zhen@mshri.on.ca

D. W. ZOCHODNE  
Department of Clinical Neurosciences  
University of Calgary  
Calgary, AB, Canada  
dzochodn@ucalgary.ca

STUART M. ZOLA  
Yerkes National Primate Research Center  
Emory University  
Atlanta, GA, USA  
szola@rmy.emory.edu

FRANK ZUFALL  
Department of Physiology  
University of Saarland School of Medicine  
Homburg/Saar, Germany  
frank.zufall@uks.eu

MICHAËL ZUGARO  
LPPA, Collège de France  
CNRS  
Paris, France  
michael.zugaro@college-de-france.fr

### 3 Splice

#### Definition

One edge of the splicing reaction.

► Alternative Splicing and Glial Maturation

### 5 Untranslated Region (5 UTR)

#### Definition

The 5 region of the mRNA that is not translated into protein. It extends from the transcription start site to the translation ATG start site, and contains regulatory sequences that control mRNA stability and translation efficiency.

### 14-3-3

#### Definition

A large family of acidic adaptor proteins of ~30 kDa that mainly (but not solely) interact with phosphoserine or -threonine sites on target proteins to facilitate their activity. 14-3-3 proteins have 9–10 alpha helices, generally form homo- or heterodimers, and contain a number of common modification sites (e.g. phosphorylation, divalent cation binding, and so forth) to regulate their activities, interactions, and localizations.

► Synaptic Proteins and Regulated Exocytosis

### 65-kDa Synaptic Vesicle Protein

► Calcium Binding Proteins

### 2074v Alpha1-Beta1 and Alpha6-Beta1-Integrin

#### Definition

Integrins are a family of alpha-beta-heterodimers, comprising of different beta chains that associate with different alpha chains. Integrins primarily mediate cell adhesion and recognize a variety of ligands including extracellular matrix proteins, cell surface proteins and plasma proteins.

### A1-A7 Cell Groups (Noradrenergic Cell Groups)

#### Definition

A1-A7 is the original designation for separate catecholamine cell groups located in the brainstem by the use of fluorescent histochemical methods. The numbering began in the medulla and continued into the forebrain. Groups A1-A7 are located only in the medulla, and are noradrenergic.

► Cellulae noradrenergicae/A1 – A7

## A8-A17 Cell Groups (Dopaminergic Cell Groups)

### Definition

A1-A17 is the original designation for separate catecholamine cell groups located in the brain by the use of fluorescent histochemical methods. The numbering began in the medulla and continued into the forebrain. Groups A8-A16 are dopaminergic, and reside primarily in the midbrain and hypothalamus. Another dopaminergic cell type, A17, appears in the retina.

## Abducens Nucleus

### Definition

A nucleus which contains both motoneurons and interneurons. The motoneurons send direct projections to the lateral rectus muscles. The interneurons send projections via the medial longitudinal fasciculus to the contralateral medial rectus motoneurons neurons.

## A $\delta$ -, C-Fibers

### Definition

Small-diameter myelinated (conduction velocity 2–30 m/s, diameter below  $\leq 4 \mu\text{m}$ ) or unmyelinated (conduction velocity  $\lambda\tau$ ; 2 m/s, diameter  $\lambda\tau$  1–2  $\mu\text{m}$ ) afferent nerve fibers.

► Complex Regional Pain Syndromes: Pathophysiological Mechanisms

## Abducens Internuclear Neuron

### Definition

Neurons located within the abducens nucleus which project to the contralateral medial rectus motoneurons to produce conjugate eye movements.

- Accommodation–vergence Interactions
- Near Response Neuron
- Saccade–Vergence Interactions

## Abducens Nerve (VI)

### Synonyms

► N. abducens (N. VI); ► Abducent Nerve (VI)

### Definition

Abducens nerve (VI) has a purely motor function and innervates the lateral rectus muscle of the eyeball, generating an abduction movement of the eyeball (hence the name) Nucleus: nucleus of abducens nerve.

Skull: superior orbital fissure.

Damage to the nerve causes inversion of the ipsilateral eyeball towards the nose. This produces diplopia (double vision), increasingly so the more the two visual axes deviate from each other. Looking in the direction of the respective eye reduces the severity of the diplopia.

► Nerves

## Absence Epilepsy

### Definition

Absence (petit mal) seizures are a group of epileptic syndromes typically starting in childhood or adolescence and characterized by a sudden brief lack of attention (indicated by a stare or cessation of behavior) and mild automatic movements (fluttering of eyelids or facial twitches) for some seconds to minutes. The ► [electroencephalogram](#) shows typical three-per-second spikes and waves. Absence ► [epilepsies](#) are generalized, i.e. the whole ► [neocortex](#) shifts into a state of sleep-like oscillations.

► Electroencephalography

## Absolute Temperature

### Definition

A (positive) temperature scale postulated by the second law of thermodynamics. It is physically related to the laws of ideal gases.

► Mechanics

## Absolute Threshold

### Definition

The lowest intensity of sensory stimulation that can be detected.

- ▶ Sensory Systems

## Abstract Entity

### Definition

Something that exists but is not spatiotemporally located, e.g. universals (whiteness, horseness), numbers or states of affairs.

- ▶ Possible World
- ▶ Property

## Absolute Threshold in Acoustics

### Definition

This characterizes the lowest level of sound that a listener can reliably detect and is sometimes referred to as threshold of audibility. The units are typically reported in dB sound pressure level (SPL).

- ▶ Psychoacoustics

## Abundance of Degrees of Freedom

### Definition

An apparent excess of elemental variables (cf. redundancy); the term assumes that elemental variables (degrees-of-freedom) are not eliminated in voluntary movements, but they are all used to stabilize important task-related performance variables (principle of abundance).

- ▶ Coordination
- ▶ Redundancy

## Absorption (Sound Absorption)

### Definition

Change in sound energy into some other form, usually heat, in passing through a medium or striking a surface.

- ▶ Acoustics

## Abventricular Division

### Definition

Any cell divisions that occur outside the ventricular and subventricular zones.

## Abstinence Syndrome

### Definition

The abstinence syndrome (synonym: withdrawal symptom) is observed after withdrawal of a drug to which a person is addicted. For example, the abstinence syndrome after alcohol withdrawal is characterized by

- ▶ tremor, nausea, tachycardia, sweating and sometimes
- ▶ hallucinations.

## ACC

### Definition

Anterior cingulate cortex.

## Acceleration

### Definition

The time-derivative of the velocity vector of a specific particle. For a material body, at each instant of time there exists an acceleration field, namely an acceleration vector assigned to each particle of the body.

- ▶ Mechanics
- ▶ Measurement Techniques

## Accessory Nerve (XI)

### Synonyms

- ▶ N. accessorius (N.XI)

### Definition

The accessory nerve has two parts:

- Accessory nerve (XI), cranial roots: these fibers arise from nucleus ambiguus and innervate the pharynx and larynx muscles and course together with the vagus nerve (X). Skull: Foramen jugulare.
- Accessory nerve (XI), spinal root: it arises from a nuclear column in the cervical cord (spinal root nucleus of accessory nerve) and innervate the sternocleidomastoid muscle and the trapezius muscle.

Skull: Foramen magnum.

Dysfunction of the accessory nerve (XI) results in accessory paralysis rendering it more difficult to lift the arm above shoulder level (trapezius muscle), and turning the head to the unimpaired side is possible only after having successfully contended with resistance (sternocleidomastoid muscle).

- ▶ Nerves

## Accessory Nucleus of Oculomotor Nerve

### Synonyms

- ▶ Accessorius n. Oculomotorii

### Definition

The accessory nucleus (Edinger-Westphal) is the parasympathetic nuclear component of the oculomotor nucleus.

It contains the somas of the preganglionic parasympathetic fibers and innervates the sphincter muscle of pupil as well as the ciliary muscle. It receives its afferents from the pretectal area of the ipsi- and contralateral side. Its efferents course in the ipsilateral oculomotor nerve to the second neuron in the ciliary ganglion.

- ▶ Mesencephalon

## Accessory Neuromast

### Definition

Supernumary neuromasts found only in teleosts. Most likely sensitive to fluid velocity and may mediate rheotaxis in teleosts.

- ▶ Evolution of the Mechanosensory and Electrosensory Lateral Line Systems

## Accessory Olfactory Bulb

### Definition

Specialized region adjacent to the dorsocaudal main olfactory bulb receiving input from the vomeronasal organ. Axons of vomeronasal sensory neurons are bundled in the vomeronasal nerve and terminate in accessory olfactory bulb glomeruli where they form synapses with the dendrites of mitral cells, the first-order relay neurons in the accessory olfactory system.

Axons from vomeronasal sensory neurons expressing the same vomeronasal receptor converge onto a small number of glomeruli in the accessory olfactory bulb.

- ▶ Accessory Olfactory System
- ▶ Evolution of Olfactory and Vomeronasal Systems
- ▶ Vomeronasal Organ (Jacobson's Organ)



## Accessory Olfactory System

ULRICH BOEHM

Center for Molecular Neurobiology, Institute for Neural Signal Transduction, Hamburg, Germany

### Synonyms

Vomeronasal system; Vomeronasal pathway

### Definition

Second olfactory pathway found in addition to the **▶main olfactory system** in terrestrial vertebrates. Initiating in the neuroepithelium of the vomeronasal organ, the **▶accessory olfactory system** is specialized in the detection of pheromones. The accessory olfactory system converges and synergizes with the main olfactory system to control behaviors and hormonal changes triggered by chemosensory cues.

### Characteristics

#### Vomeronasal Organ

In addition to the main **▶olfactory epithelium (OE)**, a second chemoreceptive structure can be found at the base of the nasal septum in most terrestrial vertebrates. This structure is called **▶vomeronasal** (or Jacobson's) **▶organ (VNO)** and is specialized in the detection of **▶pheromones** [1]. Pheromones are chemical cues that are released by animals and act on members of the same species to regulate populations of animals and their social interactions by eliciting stereotyped behaviors and neuroendocrine alterations.

Pheromonal effects in mammals range from intermale aggression to reproductive behaviors and endocrine changes [1]. In rodents, pheromones can influence the onset of puberty as well as the length of the estrus cycle in females, and cause a surge in serum testosterone levels in males. In the **▶Bruce effect**, implantation failure results from exposure of a female mouse to the urine of a male genetically different from the inseminating male, coupling a pheromone effect with the detection of "individuality cues." Male pheromones can also stimulate female courtship behaviors, as well as receptive posturing (lordosis). Vice versa, female pheromones can act on males to stimulate mounting behavior, increased intromission attempts, and ultrasonic vocalizations associated with courtship. Experimental ablation of the VNO has shown that it contributes to most if not all of these pheromone effects [1].

Due to advances in molecular biology and genetic engineering of mice, the molecular architecture of the mouse VNO in particular has emerged in great detail [2]. The mouse VNO is a bilateral tubular structure contained in a cartilaginous capsule, which is connected to

the nasal cavity via a narrow duct [1] (Figs. 1a and 2b). Stimulus access to the VNO depends on a vascular pumping mechanism that is activated in situations of novelty.

The VNO contains two populations of bipolar **▶vomeronasal sensory neurons (▶VSNs)**, which appear to be specialized in responding to different types of **▶ligands** (Fig. 1) [2]. Each VSN expresses members of two large families of **▶vomeronasal receptors (VRs)**, the V1Rs and V2Rs (Figs. 1b and c). VRs are seven-transmembrane-domain **▶G-protein-coupled receptors (▶GPCRs)** and members of each family are diverse in amino acid sequence, suggesting that they may recognize a variety of different sensory ligands [3]. It appears that each VSN may express only one V1R or V2R gene and that ~500–1000 VSNs express the same VR [2].

Expression of V1Rs and V2Rs is anatomically confined to specific zones in the VNO **▶neuroepithelium** (Fig. 1a). Members of the V1R family are exclusively expressed by VSNs located in the apical zone (Figs. 1a and b) and appear to be specialized in the detection of pheromones [4]. Each of the few mouse pheromones identified so far (Fig. 1b) is detected with high specificity by a unique small subset of VSNs in the apical V1R positive zone (Figs. 3a and b), suggesting that VSNs are very narrowly tuned. However, it is not known whether a given pheromone is recognized by one or multiple VRs, and only one VR-ligand pair has been identified so far [2]. A mouse line lacking a cluster of V1R genes has clearly established their contribution in the detection of some pheromones [5].

In contrast, members of the V2R family are specifically expressed by VSNs located in the basal zone of the epithelium and appear to be specialized in the detection of individuality cues such as peptides (Figs. 1c and 3d, e) [2]. A small number of VSNs respond to two different **▶major histocompatibility complex (MHC)** class I peptides [6] as well as to a sex-specific peptide secreted from exocrine glands [2] (Figs. 1c and 3e) and all of them are located in the basal V2R positive zone (Fig. 3d). MHC class I peptides are fragments of intracellular proteins which are presented on the cell surface by MHC class I molecules. This process is called **▶antigen presentation** and enables cytotoxic T cells to identify and selectively eliminate those cells that are synthesizing foreign or abnormal proteins. MHC-peptide complexes can be shed from the cell surface and their fragments appear in urine and other body fluids, which can get access to the VNO [6]. It has been shown, that MHC peptides can function as individuality signals during social recognition offering a molecular basis to explain the pregnancy block in the Bruce effect [6].

Chemosensory signal transduction in VSNs is distinct from that in **▶olfactory sensory neurons**

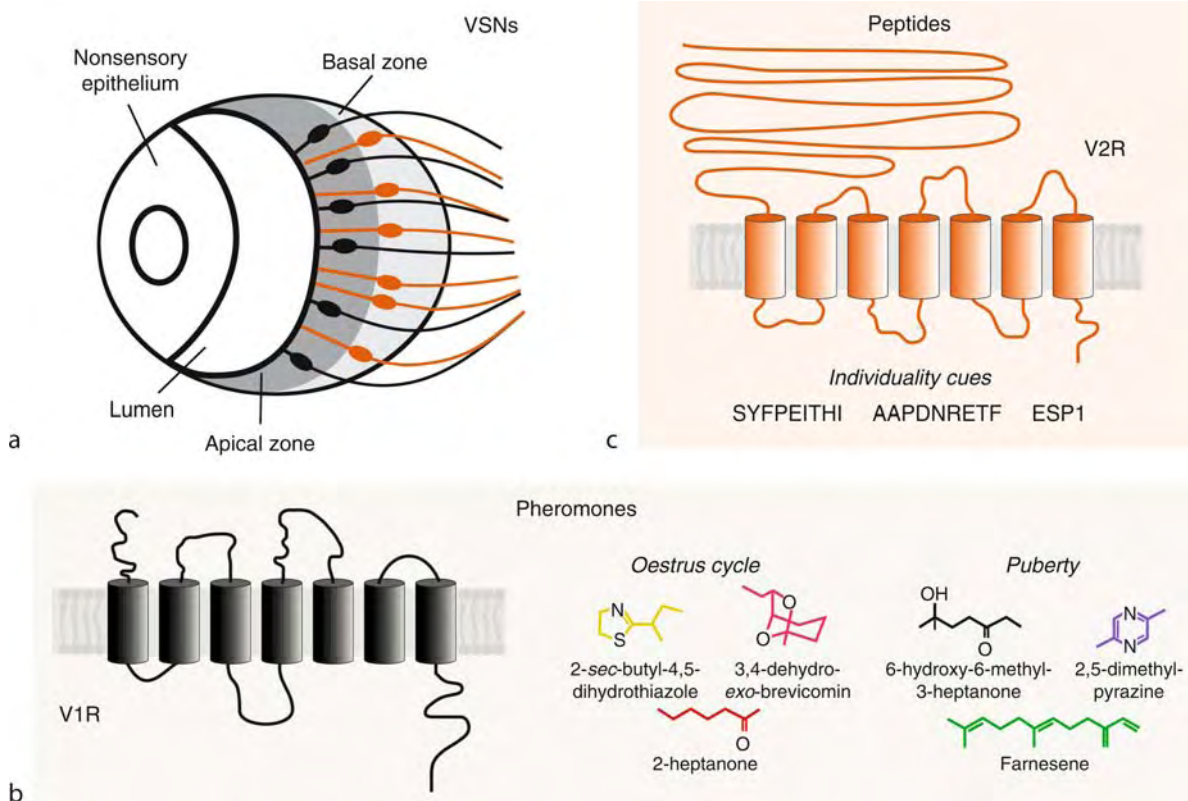

**Accessory Olfactory System. Figure 1** Molecular architecture of the vomeronasal organ. (a) Schematic representation of a rodent vomeronasal organ (coronal view). Vomeronasal receptors of the V1R family (Fig. 1b) are expressed by sensory neurons in the apical zone (black) whereas V2R family members (Fig. 1c) are expressed by sensory neurons in the basal zone of the epithelium (orange). (b) V1Rs are seven-transmembrane-domain GPCRs that appear to be specialized in detecting pheromones (pheromone colors correspond to Fig. 3a and b). (c) V2R GPCRs contain a long N-terminal extracellular domain and appear to be specialized in the detection of peptides such as the mouse strain specific MHC class I peptides SYFPEITHI and AAPDNRETF (see Figs. 3d and e) and exocrine-gland secreting peptide 1 (ESP1).

(►OSNs), but poorly understood. V1R and V2R positive VSNs express different G proteins,  $G_{\alpha_{i2}}$  and  $G_{\alpha_o}$ , respectively, however a direct role in VSN ►sensory transduction still needs to be demonstrated. Signal transduction in VSNs involves a diacylglycerol-activated cation channel, which partially depends on TRPC2, a VNO-specific member of the Trp family of ►calcium channels [7].

#### From Vomeronasal Organ to Accessory Olfactory Bulb: Segregation and Convergence

Each VSN projects one single ►axon to the ►accessory olfactory bulb (►AOB), which is a specialized region adjacent to the dorsocaudal main ►olfactory bulb (MOB). VSN axons are bundled in the vomeronasal nerve and terminate in anatomically discrete synaptic units called ►glomeruli where they form synapses with the ►dendrites of AOB ►mitral cells, the first-order relay neurons in the accessory olfactory system [1].

Neurons that express V1R/ $G_{\alpha_{i2}}$  or V2R/ $G_{\alpha_o}$  synapse in the anterior or posterior part of the AOB, respectively, maintaining the anatomical segregation observed in the VNO [1] (Fig. 2c). This raises the possibility that signals generated by the V1R and V2R families are eventually targeted to brain regions that mediate different behavioral and physiological effects.

Axons from ~500–1000 VSNs expressing the same VR converge onto a small number (6–30) of glomeruli in the AOB [7] (Fig. 2c). This wiring pattern is similar but not identical compared to that in the MOB where axons of olfactory sensory neurons (OSNs) expressing the same ►odorant receptor (OR) converge onto 1 or 2 glomeruli at two specific locations in the MOB [3]. AOB mitral cells can have from one up to six dendrites contacting multiple glomeruli innervated by neurons expressing the same V1R or V2R [2]. Therefore convergence in the AOB is achieved by dendritic convergence of mitral cells.

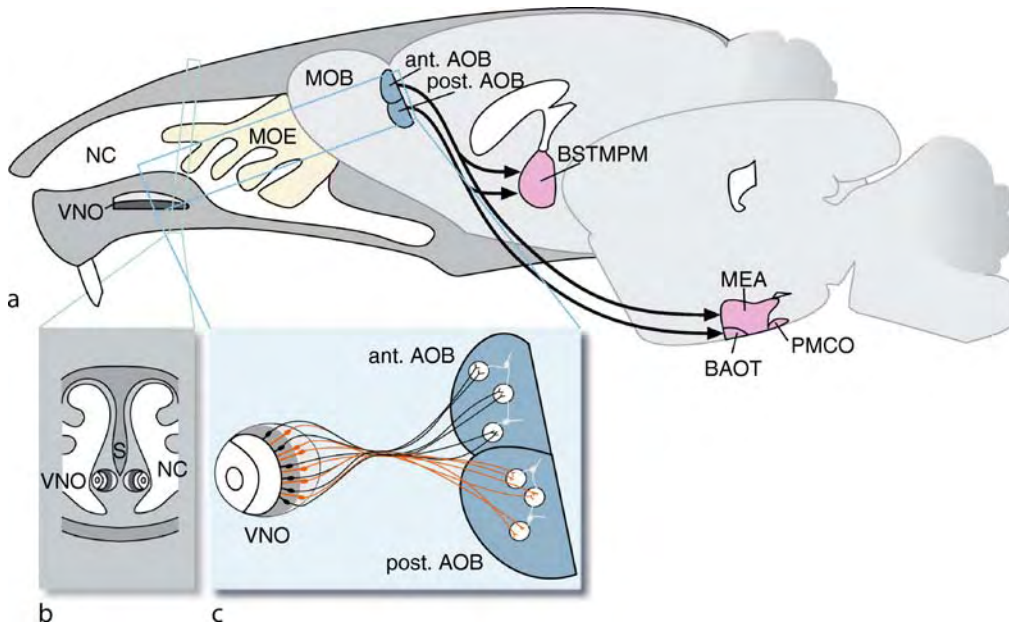

**Accessory Olfactory System. Figure 2** The rodent accessory olfactory system. (a) Schematic representation of a rodent nasal cavity and brain (lateral view). AOB mitral cells project to vomeronasal and extended amygdala. For abbreviations, see text. (b) Schematic representation of a coronal section through a rodent nose. The VNO is a bilateral tubular structure located at the base of the nasal septum. (c) VSNs that express the same V1R or V2R converge on a small number of glomeruli in the accessory olfactory bulb (AOB). The apical layer of the epithelium projects to the anterior part of the AOB whereas the basal layer projects to the posterior part. Adapted from [2].

### Accessory Olfactory System Signaling Beyond the Bulb

Sensory signals generated in the VNO follow neural pathways separate from those that carry odor signals from the OE [1]. OE signals are transmitted to the MOB, and then relayed through the primary **▶olfactory cortex** to higher cortical areas involved in conscious **▶perception** as well as **▶limbic** areas controlling basic drives and **▶emotions** [3]. In contrast, VNO signals are relayed through the AOB to regions of the **▶amygdala** and **▶hypothalamus** implicated in behavioral and physiological effects of pheromones. Although the general projections of the accessory olfactory system are known, the individual cells and neural circuits that mediate pheromonal effects on behavior and physiology have not been identified. Only recently some new techniques using genetically engineered mouse models have started to reveal individual neurons in the hypothalamus that appear to integrate **▶chemosensory information**.

How are signals generated by VSNs relayed beyond the bulb? AOB mitral cells project to the medial amygdaloid nucleus (MEA) and posteromedial cortical amygdaloid area (PMCO; which taken together are referred to as the vomeronasal amygdala), as well as to the bed nucleus of the accessory olfactory tract (BAOT) and the posteromedial bed nucleus of the stria terminalis (BSTMPM, also called “extended amygdala”) (Fig. 2a).

All of these connections are bidirectional suggesting **▶feedback loops** [2].

It is not known whether the V1R/V2R segregation observed in VNO and AOB is preserved in connections beyond the bulb. Although differential projections from the distinct AOB zones to the vomeronasal amygdala were observed in some species, this segregation could not be confirmed in the mouse [1]. Several studies of neural activation in rodents, however, suggest some functional segregation within the vomeronasal amygdala itself [1].

Information from the vomeronasal amygdala to the medial hypothalamus is sent both by direct projections and via a relay in the BSTMPM [1]. Therefore the BSTMPM receives vomeronasal information both by direct innervation from AOB **▶mitral cells** and via a relay in the vomeronasal amygdala, suggesting a prominent role in the integration of accessory olfactory signaling [2]. It is not known whether accessory olfactory signaling involving a particular chemosensory stimulus can bypass any of these relay nodes. The BSTMPM is also a prominent part of a sexually dimorphic forebrain circuit including the MEA and several nuclei in the hypothalamus [2].

It is not yet known if signals relayed by AOB mitral cells representing two different VRs converge onto the same neuron(s) in the vomeronasal amygdala or

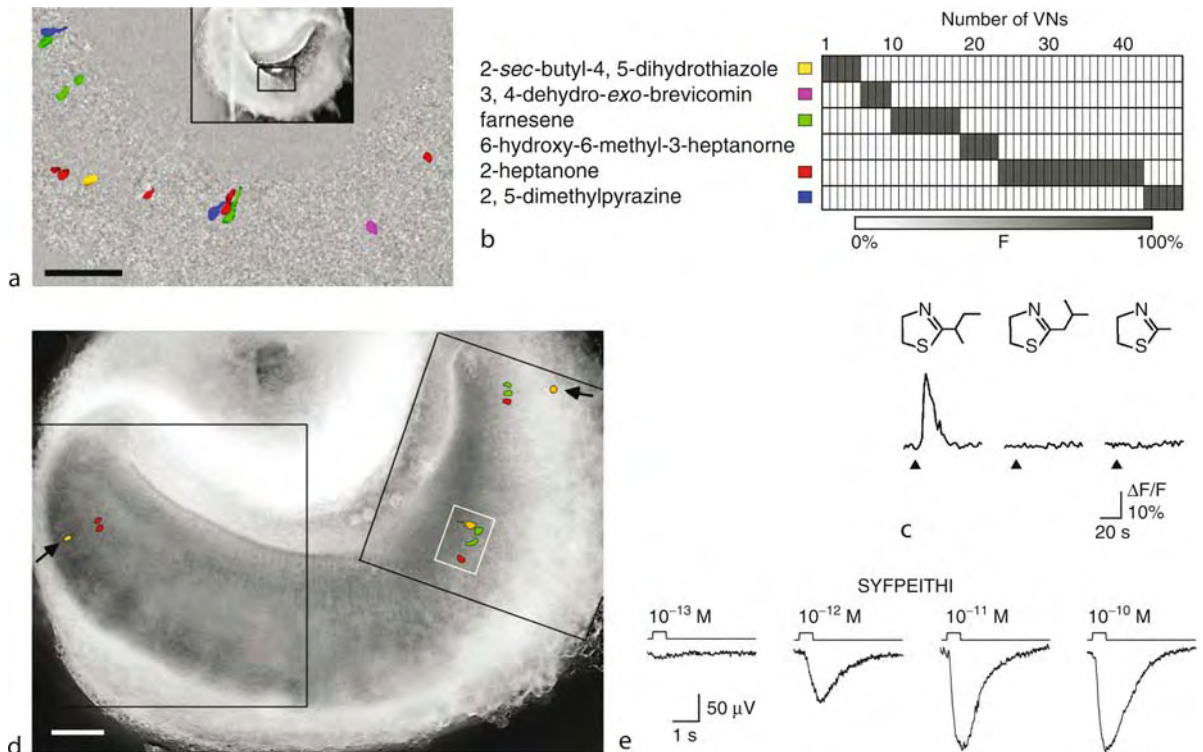

**Accessory Olfactory System. Figure 3** Chemoselectivity of vomeronasal sensory neurons. (a) VSN activation map produced by successive stimulation with each of the six ligands listed in B (each at  $10^{-6}$  M). Each ligand activated a unique, nonoverlapping subset of VSNS. Inset, low-power transmitted light image of the VNO slice; black box, imaged area. Scale bar, 50  $\mu$ m. (b) Summary of the tuning profiles of 47 VSNS responding to the six ligands. For each VSN, the magnitude of the  $\text{Ca}^{2+}$  response was plotted as a percentage of the maximal response to a given chemical. Dark grey, 100%; white 0%. Without exception, VSNS responded to only one of the pheromones tested. Thus, computed tuning curves were identical for all VSNS that responded to the same pheromone. (c) Two structural analogues of 2-sec-butyl-4,5-dihydrothiazole, isobutyl-4,5-dihydrothiazole and methyl-4,5-dihydrothiazole, were unable to evoke a  $\text{Ca}^{2+}$  response in VSNS (each tested at  $10^{-6}$  M). Adapted from [4]. (d) Spatial representation of peptide-induced activity in VNO sensory epithelium using an acute slice preparation. Shown are reconstructed VSN response maps for the MHC class I ligands AAPDNRETf ( $10^{-12}$  M, green) and SYFPEITHI ( $10^{-12}$  M, red). Cells responding to both peptides are shown in yellow. Black arrows indicate peptide-sensitive neurons that are localized at the base of the epithelium. Black boxes: imaged areas. Scale bar, 100  $\mu$ m. (e) Ultrasensitive detection of the MHC class I ligand SYFPEITHI by VSNS. Traces are summed field potentials evoked by brief pulses of increasing concentrations of ligand. Adapted from [6].

BSTMPM or if a stereotyped map represents vomeronasal input in the amygdala.

Ultimately, VNO signals are relayed to specific neurons in the hypothalamus, which initiate and control the behavioral and hormonal responses triggered by pheromones. At the center of hypothalamic control of reproduction are **GnRH neurons**, which regulate the reproductive endocrine status in mammals. Recent studies using **transneuronal tracers** have shown, that GnRH neurons appear to integrate both vomeronasal [8] and main olfactory signals [8,9]. In addition, these studies have revealed feedback loops between the neuroendocrine hypothalamus and both the main and accessory olfactory systems [8], suggesting that the

animal's neuroendocrine status might modulate its susceptibility to chemosensory cues.

### Multiple Level Convergence and Synergism of the Main and Accessory Olfactory Systems

Because the main and accessory olfactory systems consist of anatomically separated chemosensory epithelia (Fig. 2a) with different molecular profiles and parallel largely non-overlapping projections, strict functional dichotomy was postulated with each olfactory system specialized in distinct behavioral domains [1]. However, experimental evidence is accumulating that hints at complementary roles of the two olfactory systems and it is important to point out that accessory

olfactory signaling is not functionally equivalent to pheromone signaling [2].

Several experiments across species have shown that pheromone signals are not exclusively perceived by the VNO, but can also be processed by the main olfactory system [2]. Consistent with this, 2-heptanone (Fig. 1b), the only ligand matched to a particular VR (V1Rb2) so far, is also recognized by an olfactory receptor (mOR912–93; [2]). *Vive versa*, some odorants can also stimulate VSNS [2]. In addition, both the main and the accessory olfactory bulbs are stimulated by both pheromones and general odorants in mice [2]. Furthermore, the two MHC class I peptides recognized by VSNS were recently shown to stimulate OSNs at equally low concentrations, consistent with numerous studies demonstrating participation of the main olfactory system in MHC-related behaviors [2]). Thus, both OE and VNO can contribute to olfactory recognition of pheromones, odorants and peptides.

Convergence of the main and accessory olfactory systems could potentially also occur at different levels in the brain [1,2]. For example, the MEA in hamster has been shown to share extensive bidirectional connections with the cortical nucleus of the amygdala (ACO), which receives information from the MOB but not AOB [1]. In addition, convergence could occur in the hypothalamus, for example in GnRH neurons, which apparently receive information from both olfactory systems [8].

Potential synergism of both olfactory systems is evident in the analysis of reproductive behavior in hamster where complete removal of the olfactory bulbs (bulbectomy) in hamsters completely eliminates mating whereas VNO or OE ablation alone have more subtle effects [1]. Therefore it appears that both olfactory systems can converge and synergize to express reproductive behaviors and hormonal changes triggered by chemosensory cues in rodents.

### Do Humans Have a Functional Accessory Olfactory System?

Fueled by significant public interest, pheromonal communication in humans is controversially debated [7]. Both anatomical and molecular evidence clearly speaks against the existence of a functional human accessory olfactory system. Although an embryonic structure resembling a VNO and a fetal AOB have been identified, they degenerate before birth [1]. A ► **vomer-onasal pit** has been described in some adults, however this structure is not connected to the brain. In addition, no AOB has been found in adults. On the molecular level, hallmarks of the rodent accessory olfactory system are missing in humans. The V2R family is not found in the ► **human genome**, the V1R repertoire is reduced from 150 functional genes in mice to five in humans and the gene encoding the human TRPC2 channel is a ► **pseudogene** [7].

The apparent absence of a functional accessory olfactory system in humans does however not imply that humans do not have pheromonal communication. Some chemosensory effects like synchronized estrus in women living in close proximity are well documented [7]. Presumably these more subtle pheromonal effects in humans are mediated by the main olfactory epithelium. Consistent with this, a family of putative pheromone receptors expressed in the main olfactory epithelium has recently been identified [10].

### ► Evolution of Olfactory and Vomeronasal Systems

### References

- Halpern M, Martinez-Marcos A (2003) Structure and function of the vomeronasal system: an update. *Prog Neurobiol* 70:245–318
- Boehm U (2006) The vomeronasal system in mice: from the nose to the hypothalamus- and back! *Semin Cell Dev Biol* 17:471–479
- Buck LB (2000) The molecular architecture of odor and pheromone sensing in mammals. *Cell* 100:611–618
- Leinders-Zufall T, Lane AP, Puche AC, Ma W, Novotny MV, Shipley MT, Zufall F (2000) Ultrasensitive pheromone detection by mammalian vomeronasal neurons. *Nature* 405:792–796
- Del Punta K, Leinders-Zufall T, Rodriguez I, Jukam D, Wysocki CJ, Ogawa S, Zufall F, Mombaerts P (2002) Deficient pheromone responses in mice lacking a cluster of vomeronasal receptor genes. *Nature* 419:70–74
- Leinders-Zufall T, Brennan P, Widmayer P, SPC, Maul-Pavicic A, Jager M, Li XH, Breer H, Zufall F, Boehm T (2004) MHC class I peptides as chemosensory signals in the vomeronasal organ. *Science* 306:1033–1037
- Dulac C, Torello AT (2003) Molecular detection of pheromone signals in mammals: from genes to behaviour. *Nat Rev Neurosci* 4:551–562
- Boehm U, Zou Z, Buck LB (2005) Feedback loops link odor and pheromone signaling with reproduction. *Cell* 123:683–695
- Yoon H, Enquist LW, Dulac C (2005) Olfactory inputs to hypothalamic neurons controlling reproduction and fertility. *Cell* 123:669–682
- Liberles SD, Buck LB (2006) A second class of chemosensory receptors in the olfactory epithelium. *Nature* 42:645–650

## Accessory Optic System

### Definition

A subcortical visual pathway that is responsible for the analysis of optic flow that results from self-motion.

### ► Optic Flow

## Accessory Subunits of Ion Channels

### Definition

Most of the pores forming subunits of ion channels are complexed with additional, accessory subunits that can influence key properties of ion channels, such as trafficking and targeting of ion channels to specific cell membrane components. Accessory subunits can also modulate channel gating, such as the activation or inactivation properties of voltage-gated ion channels.

► Ion Channels from Development to Disease

## Accommodation of the Lens

### Definition

Increase in the refractive power of the lens of the eye.

## Accommodation–Vergence Interactions

LAWRENCE MAYS

University of North Carolina at Charlotte, NC, USA

### Definition

In this context, accommodation refers to the change in the refractive power of the crystalline lens of the eye. A unit of refractive power is the Diopter, which is the reciprocal of the focal length measured in meters. Positive accommodation decreases the focal length of the lens, allowing near objects to be seen clearly, while negative accommodation or relaxation of accommodation increases the focal length for viewing more distant objects. Vergence, or vergence angle, refers to the angle between the lines of sight of the two eyes in the horizontal plane. Clinically, vergence angle is usually expressed in terms of prism diopters. A prism diopter is the deviation of light by one cm at a distance of one meter, and is  $\sim 0.57^\circ$ . Convergence (► **Convergent eye movement**) is an increase in vergence angle, and occurs when viewing a near object with both eyes. Divergence (► **Divergent eye movement**) is a decrease in vergence angle. Accommodative convergence (AC) is the increase in vergence angle which occurs when the lens

accommodates to view a nearer object. The AC/A ratio is the change in vergence angle for each Diopter of accommodative demand. Convergence accommodation (CA) is the increase in lens accommodation which occurs when the eyes converge. The CA/C ratio is the amount of accommodation (in Diopters) associated with a given change in convergence (usually measured in prism diopters).

### Characteristics

#### Upstream Events/Conditions

The primary stimulus for ► **accommodation of the lens** is optical blur caused by a mismatch between the distance to the object of regard and the refractive power of the lens. Since blur decreases the spatial frequencies of the image, any element in the visual system which is tuned to spatial frequency can be used to detect blur. Indeed, many neurons in the visual cortices show such sensitivity. In operation, accommodation is modeled as a negative feedback system (top half of Fig. 1) the goal of which is to minimize blur [1]. The primary stimulus for horizontal ocular vergence is binocular disparity, which is the difference between the locations of an image on the two retinas. Many neurons in the primary visual cortex, the first point in the geniculostriate system at which inputs from the two eyes are combined [2], are sensitive to absolute horizontal binocular disparity, and so could provide a useful disparity error signal. Single binocular vision requires that binocular disparity be reduced to a fraction of a degree. Like the accommodative system, the vergence system is modeled as a negative feedback system (bottom half of Fig. 1). It is important to note that for both the accommodation and vergence systems, the subtraction of the accommodative or vergence response from the demands imposed by the visual stimulus is geometric and not neural.

#### Interactions Between Systems

The observations that accommodation by itself drives vergence and vergence responses drive accommodation suggest a simple cross linking of these systems, as indicated by the crossed arrows in the Fig. 1. The strengths of these cross-links are given by the AC/A (accommodation to vergence drive) and CA/C (vergence to accommodation drive) ratios. Control system analysis indicates that as long as the product of AC/A and CA/C, measured in equivalent units (Diopters for accommodation and Meter Angles for vergence) is less than unity, the system is stable. Indeed, the accommodative and vergence systems work in a synergistic manner via these cross-links to facilitate responses to changes in the distance of visual objects. Both psychophysical [1] and neurophysiological studies [3] have supported this model.

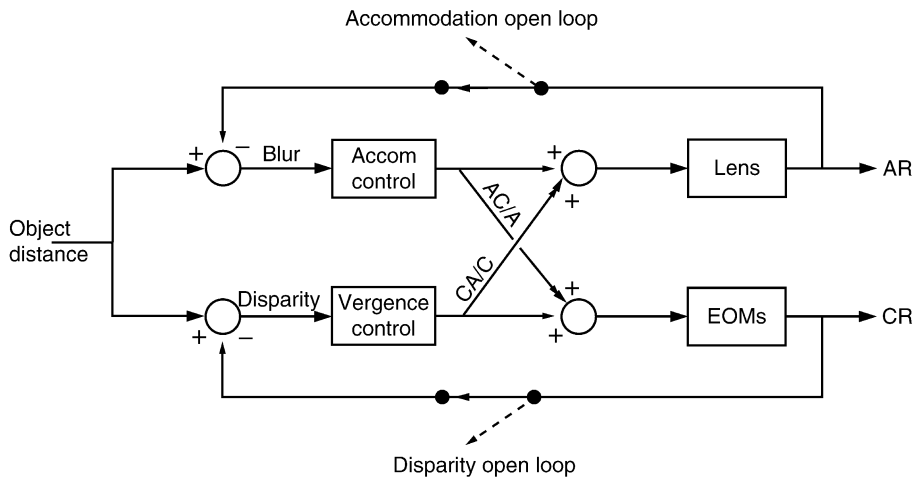

**Accommodation–Vergence Interactions. Figure 1** Representation of the dual-interaction model of accommodation and vergence. Both the accommodation (upper half of figure) and the disparity vergence (lower half) systems are controlled by negative feedback. The input to both controllers is Object Distance. For the accommodative controller, the error signal is optical blur, arises from the mismatch (difference) between Object Distance and the Accommodative Response (AR). The blur-driven accommodative controller (Accom Control) produces an output proportion to this error to drive the neurons controlling the crystalline lens (Lens) and thus changes the AR. The accommodative system can be made open loop by placing pinholes in the optical path which eliminates blur, regardless of the relationship between the Object Distance and the AR. This is shown schematically by a switch represented by the dashed arrow at top. A similar system is used for the disparity vergence system; except that the error signal for the controller (Vergence Control) is binocular disparity, which is the difference between the vergence demand imposed by Object Distance and the Convergence Response (CR). The output of the vergence controller goes to the extraocular muscles (EOMs) which adjust vergence angle. This feedback loop can be opened (dashed arrow at bottom) by any manipulation which eliminates binocular viewing of the target, such as occluding one eye. The accommodation-vergence interaction is due to cross-links by which some fraction of the output of the accommodative controller is added to output of the vergence controller (accommodative convergence, downward angled arrow), and some fraction of the output of the vergence controller is added to the output of the accommodative controller (convergence accommodation, upward angled arrow). The strengths of these cross-links is assessed by the AC/A and CA/C ratios. In order to measure the AC/A ratio, the disparity feedback system must be open loop, and measurement of the CA/C ratio requires that the accommodative feedback system be open loop.

Although not indicated by the Fig. 1, there is some flexibility associated with these cross-links. For example, if a subject is required to binocularly view a target at a given distance through base-out prisms, a greater demand is placed upon the systems to converge than to accommodate. Subjects have some limited ability to dissociate the convergence and accommodative responses. However, if the convergence demand imposed by the prisms is too great, the subjects will experience blurring of the target, caused by the excessive driving of the accommodative system by the vergence systems via the AC/A cross-link. If the change in vergence demand by the prisms is gradual and takes place over a time course of minutes, prism adaptation may occur. Prism adaptation may be considered as a change in the vergence offset or bias in the relationship between accommodation and vergence [4]. Adaptation with base-out prisms causes the eyes to be more converged for a given level of accommodative demand. Prism adaptation is also called phoria adaptation,

because it is measured as a change in the phoria. There is some evidence for adaptation of accommodation when accommodative and vergence demands are mismatched, but the degree of adaptation appears to be modest.

In addition to the changes in bias or offsets, the AC/A and CA/C ratios can be modified. Prolonged viewing of targets using periscopic spectacles which simulate a larger inter-ocular distance results in an increase in the AC/A ratio and a corresponding decrease in the CA/C ratio [5]. Optical manipulations which effectively decrease the inter-ocular distance decrease the AC/A ratio and increase the CA/C ratio, although the observed changes are more modest. For adults, the inter-ocular distance is constant, and so are the AC/A and CA/C ratios for a given individual, although there are differences in the ratios among people. The capacity to increase the AC/A ratio with increasing inter-ocular separation is probably important during childhood growth.

### Downstream Events/Conditions

Although both the vergence and accommodative control systems strive to minimize error, this is rarely realized. Error within the vergence systems is termed binocular disparity. If it is small enough to permit single vision (i.e. less than about  $0.25^\circ$ ) this error is termed “fixation disparity.” Larger binocular disparities lead to double vision, or ►**diplopia**, which generally results in the suppression of one eye’s image by the nervous system. Errors in accommodation seem to be more readily tolerated, and the mismatch between the accommodative demand and the eye’s response is termed “accommodative lag.” With aging, there is a progressive loss of the ability to accommodate (presbyopia), which is believed to be due to the gradual loss of elasticity of the crystalline lens.

### Involved Structures

The neuronal circuits for both accommodation and vergence are believed to be located in the midbrain. Although it seems likely that visual cortical inputs provide the sensory inputs to this mechanism, the pathways are not known. Neuronal signals related to accommodation and vergence are found on midbrain near response cells (►**Near response neurons**). Most near response cells have a firing rate which is proportional to both accommodation and vergence. Many also have a signal related to vergence velocity, and presumably, to accommodation velocity as well. A subset of near response cells has been shown to project to the ►**medial rectus** subdivisions of the oculomotor nucleus, the site of medial rectus motoneurons, which are needed to generate convergence of the eyes [3]. Near response cells may also project to the Edinger-Westphal nucleus to control accommodation, but this has not been demonstrated. Neurons in the abducens nucleus are also involved in ocular vergence, but neither direct nor indirect projections from near response neurons to the abducens nucleus have been shown. Lens accommodation is effected by the action of the ciliary muscle of the eye, which has both parasympathetic and sympathetic inputs. Parasympathetic input, which appears to be more important for accommodation, is relayed from the midbrain Edinger-Westphal nucleus via the ciliary ganglion.

### Methods to Measure This Event/Condition

The most commonly used measure of the interaction between accommodation and vergence is the AC/A ratio. This is measured by first opening the vergence feedback loop (see dashed arrow in lower half of Fig. 1). This is done by dissociating vision in the two eyes, often with a hand-held occluder, so that they do not see the same object at the same time. Typically, a clinician will measure the subject’s phoria while viewing a distant target. The phoria is the deviation of the non-viewing eye from the target. The phoria will

then be re-measured while the subject views a near target. The AC/A is calculated as the ratio of the change in phoria to the change in accommodative demand. A typical AC/A ratio value is 4 prism diopters per Diopter, or about 0.6 Meter Angles (MA) per Diopter. Note that this describes a stimulus AC/A ratio; in that the subject’s accommodative response is not measured. The accommodative response can be measured, but this is rarely done in clinical settings. The CA/C ratio must be determined independently, since it cannot be calculated from the AC/A ratio. To measure the CA/C ratio, it is necessary to open the accommodative feedback loop (dashed arrow on top half of Fig. 1), which can be done by having the subject view a target through optical pinholes. Convergence can be elicited by placing base-out prisms in the optical path as the subject views a target binocularly. The associated change in accommodation, which can be measured using retinoscopy or by means of an optometer, is expressed as a ratio of accommodative change per unit of vergence change. When expressed in equivalent units, the CA/C ratio is usually around 0.7 D/MA. This corresponds to about 0.1 Diopters per prism diopter. Due to the specialized optical equipment needed to measure the CA/C ratio, it is rarely done in clinical settings.

### References

1. Hung GD, Semmlow JL (1980) Static behavior of accommodation and vergence: computer simulation of an interactive dual-feedback system IEEE Trans. BME 27:439–447
2. Freeman RD (2004) Binocular interaction in the visual cortex. In: Chalupa LM, Werner JS (eds) The visual neurosciences. MIT, Cambridge, MA, pp 765–778
3. Zhang Y, Mays LE, Gamlin PDR (1992) Characteristics of near response cells projecting to the oculomotor nucleus. J Neurophysiol 67:944–960
4. Henson DB, North R (1980) Adaptation to prism-induced heterophoria. Am J Physiol Opt 57:129–137
5. Miles FA, Judge SJ, Optican LM (1987) Optically induced changes in the couplings between vergence and accommodation. J Neurosci 7:2576–2589

## Accumbens Nucleus

### Synonyms

►Nucl. Accumbens

### Definition

At the site where the corpus striatum borders on the septal nuclei is situated the accumbens nucleus (septal),



which has a structure similar to the corpus striatum, but has unusually intensive fiber connections to the limbic system and hence is viewed as being a link in emotion/motivation and movement.

- ▶ Telencephalon

## Accuracy Versus Speed Rule

### Definition

- ▶ Fitts' Law.
- ▶ Eye-Hand Coordination

## Acetylation of Nucleosomal Histones

- ▶ Histone Acetylation in the Developing Central Nervous System

## Acetylcholine (ACh)

### Definition

Acetylcholine (ACh) is a classical neurotransmitter found both in the central nervous system (CNS) and the peripheral nervous system (PNS). Cells that produce acetylcholine are referred to as cholinergic. Acetylcholine formed the basis for early studies of synaptic transmission which led to the formation of key principles of chemical neurotransmission. The transfer of the acetyl group from acetyl-coenzyme A to choline is a single step process that forms acetylcholine and is dependent on the enzyme choline acetyltransferase (ChAT). Acetylcholine is inactivated by the enzyme acetylcholinesterase, which converts acetylcholine to choline and acetic acid. Choline is transported back into the presynaptic terminal where it is used to synthesize acetylcholine. Acetylcholine is released from both somatic motor nerve terminals (at the neuromuscular junction) and autonomic preganglionic terminals, as well as at synapses in enteric ganglia and some central synapses. In the central nervous system, cholinergic

neurons are primarily located in the basal forebrain and brainstem. Acetylcholine acts at nicotinic and muscarinic acetylcholine receptors.

- ▶ Acetylcholine Receptors
- ▶ Autonomic Ganglia
- ▶ Basal Forebrain
- ▶ Cholinergic Brainstem
- ▶ Neuromuscular Junction

## Acetylcholinesterase

### Definition

Enzyme that breaks down acetylcholine at the synapse.

- ▶ Evolution of Subpallial Cholinergic Cell Groups

## N-acetyl-5-methoxytryptamine

- ▶ Melatonin

## AchR

### Definition

Acetylcholine Receptor.

- ▶ Acetylcholine

## Achromatopsia

### Definition

Color blindness resulting from damage to cortical visual area V4.

- ▶ Visual Neuropsychology
- ▶ Visual Perception

---

## Acid-Sensing Ion Channels

### Definition

Acid-sensing ion channels (ASICs) are members of the epithelial sodium channel (ENaC)/degenerin (DEG) family, characterized by two transmembrane domains and a large cysteine-rich extracellular domain. ASICs are expressed in neurons, and function as extracellular proton-gated cation channels, preferably permeable to  $\text{Na}^+$ .

► Taste Bud

---

## Acinopterygians

### Definition

The subclass of Osteichthyes, the bony fishes, that comprise the ray-finned fishes. These include five major clades: the cladistians (reedfishes, or bichirs), chondrosteans (paddlefishes and sturgeons), ginglymodi (gars), halecomorphi (the single species *Amia calva*, the bowfin), and teleosts (the very large radiation of bony fishes).

► Evolution of Brain: at Invertebrate–vertebrate Transition

---

## Acoustic Labyrinth

► Cochlea

---

## Acoustic Neuroma

### Definition

Tumor arising from the nerve sheath cells. Other terms to describe this entity include acoustic schwannoma, neurilemoma, acoustic neuroma. This tumor arises on the cranial nerve VIII (acoustic). It is presumably formed by Schwann cells (or their progenitors).

Schwannoma arises eccentrically within the nerve, displacing the axons and sparing the nerve. This feature makes nerve-sparing surgery possible in some cases.

Tissue architecture of the tumor is characterized by dense or loose structures named Antoni A or B respectively. Acoustic schwannoma corresponds histologically to WHO grade I. Malignant progression of acoustic schwannoma is extremely rare. Clinical presentation typically includes tinnitus (ringing in the ear) and hearing loss. Magnetic resonance imaging (MRI) is the study of choice for detection of this tumor and usually reveals well-circumscribed, sometimes cystic and enhancing mass. Treatment modalities employed include observation, surgical resection and/or radiotherapy. Bilateral acoustic schwannomas are the hallmark of a neurogenetic disease Neurofibromatosis type 2.

► Gliomas  
► Schwann Cell

---

## Acoustic Sensillum

► Invertebrate Ears and Hearing

---

## Acoustic Striae

### Definition

Fiber tracts that emerge from the cochlear nucleus containing the axons of neurons projecting to higher auditory centers.

► Cochlear Nucleus

---

## Acusticolateralis Organ

► Electroreceptor Organs

---

## Acusticolateralis System

► Evolution of the Mechanosensory and Electrosensory Lateral Line Systems

## Acoustics

WILLIAM A. YOST

Speech and Hearing Science, Arizona State University,  
Tempe, AZ, USA

### Definition

► **Acoustics** is the study of ► **sound** [1,2]. Sound is produced when an object vibrates causing a pressure wave to propagate through a medium (e.g., air) to a receiver.

### Characteristics

As acoustics is the study of sound [1,2], it is the study of how objects produce sound through vibration. An object must have mass and inertia in order to vibrate. A spring attached to a weight may serve as a model for a vibrating object, with the weight representing the properties of mass and the spring the properties of inertia. When the weight is pulled away from or pushed past its resting point, the spring will cause the weight to vibrate. A force moves the object and the spring applies a restoring force. These forces can be expressed as the moving force,  $F = ma$ , and the restoring force,  $F = -sx$ , where  $m$  is mass,  $s$  is stiffness, and  $a$  and  $x$  are acceleration terms. In a frictionless world with no ► **resistance**, the two forces offset each other when the weight vibrates resulting in  $ma + sx = 0$ . This equation has as one of its solutions  $a(t) = A \text{Sin}[(s/m)t + \theta]$ , where  $s$ ,  $m$  are defined as above,  $a(t)$  is the instantaneous displacement of the weight as a function of time,  $t$  is the time in seconds,  $A$  is the peak distance that the weight moves, and  $\theta$  is the ► **starting phase** (in radians) that describes the position of the start of the vibration relative to the weight's resting position.

Hence, a sinusoidal (sin) function describes the motion of the free vibration of the weight and spring. The formula  $a(t)$  can be rewritten as  $a(t) = A \text{Sin}(2\pi ft + \theta)$ , where  $A$  is the peak amplitude,  $f$  is ► **frequency** (for the mass and spring  $f = 1/[s/m]$ ),  $t$  is the time, and  $\theta$  is the starting phase. Such a sinusoidal vibration produces a ► **simple** or pure-tone sound. The frequency of vibration ( $f$ ) is expressed in ► **Hertz** (► **Hz**), in which “n” Hz means that the object has gone through “n” vibratory ► **cycles** in one second. When friction is included, the sinusoidal pattern of vibration becomes a damped pattern in which the amplitude of vibration decreases over time, at a rate that is proportional to the amount of resistance.

Vibrating objects then impart their pattern of vibration to the molecules within a medium (e.g., air). As air is the medium for sound transmission for most animals, we will consider the transmission of sound through air. Air consists of molecules in constant random motion. When

a vibrating object moves in one direction, air molecules are pushed in the same direction (assuming no frictional forces). The molecules next to the vibrating object are compressed together as the object moves outward from its resting state, creating an area of greater air-molecule density. As the density of air molecules increases, the pressure increases creating an area of ► **condensation**. As the vibrating object moves in the opposite direction (back toward its resting state), the air molecules fill the space vacated by the vibrating object moving in the opposite direction. As the vibrating object moves back past its resting state, an even larger vacated area is generated for the air molecules to fill. Now the density of air molecules has decreased, lowering the pressure, and generating an area of ► **rarefaction**.

The mere presence of molecules in air creates ► **static air pressure**, which is proportional to the density of molecules. The changes in pressure due to the vibrating object are changes in this existing static air pressure. Imagine a photograph of the air molecules taken when the object was vibrating, freezing the density pattern at a moment in time (Fig. 1).

The molecules appear to cluster at some points in space (condensation) and spread farther apart at other places (rarefaction). The molecular motion at a condensation tends to be away from the source, and the motion at a rarefaction tends to be toward the source. As an object vibrates, it causes a sound pressure wave with alternating areas of condensation and rarefactions to radiate out from the source in a spherical

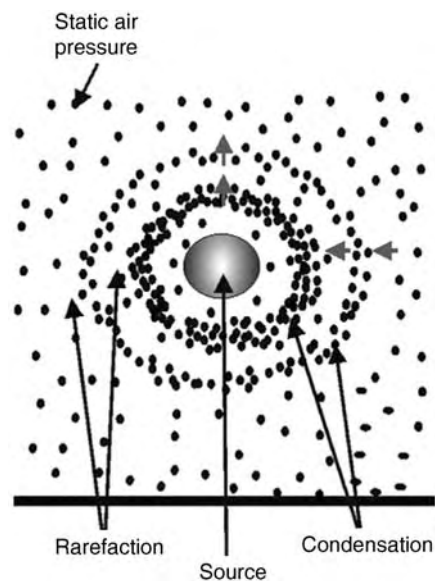

**Acoustics. Figure 1** A depiction of a sound wave and areas of condensation and rarefaction of increased and decreased pressure (above and below the static air pressure) as the wave motion forces the air molecules to move away from and toward the vibrating source.

manner. The distance between successive condensations or rarefactions is the **wavelength** ( $\lambda$ ) of sound;  $\lambda = c/f$ , where  $c$  is the speed of sound in meters/second,  $f$  is the frequency, and  $\lambda$  is expressed in units of distance (e.g., meters). The speed of sound in air is approximately  $345 \text{ m s}^{-1}$ , although it can vary as a function of temperature, density, and humidity.

A propagating wave produces instantaneous changes in pressure  $p(t) = mv / tAr$ , where  $m$  is the mass,  $v$  is the velocity,  $t$  is the time, and  $Ar$  is the area. The root-mean-square (rms) pressure ( $p$ ) describes an average pressure. Since force,  $F = mv / t$ , then,  $p = F / Ar$ . As a vibrating object exerts a force, this means that the force moves an object through some distance. This is a definition of work. Energy ( $E$ ) is the ability to do work. Power ( $P$ ) is the rate at which work is done. Therefore  $P = E/T$ , where  $T$  is the time in seconds over which the work is done. **Sound intensity** ( **$I$** ) is a measure of sound power,  $I = p^2 / p_o c$ ,  $p$  is the rms pressure,  $p_o$  is the density of the medium, and  $c$  is the speed of sound in the medium. Sound pressure is usually expressed in units of micropascal ( $\mu\text{Pa}$ ) and sound intensity in units of watt/cm<sup>2</sup>.

Given the very large range over which sound intensity can vary (especially in terms of the range for hearing), a logarithmic relationship is often used to measure sound **level** in terms of sound intensity and sound pressure. The ratio of two sound intensities ( $I_1$  and  $I_2$ ) expressed in **decibels** (**dB**) is  $10 \log I_1 / I_2$ . As  $I = p^2 / p_o c$ , then the formula for decibels in terms of pressure ( $p$ ) is decibel (dB) =  $10 \log I_1 / I_2 = 20 \log (p_1 / p_2)$ . The decibel (dB), therefore, is 10 times the log of the ratio of two intensities, two powers, or two energies and 20 times the log of the ratio of two pressures. Two conventions are commonly used to define decibels in relative terms. Experiments conducted in the 1930s determined that a pressure of 20  $\mu\text{Pa}$  was the smallest sound pressure required for the average young adult to detect the presence of a mid-frequency pure tone. When decibels are expressed relative to 20  $\mu\text{Pa}$  (i.e.,  $p_2 = 20 \mu\text{Pa}$ ), they are expressed as decibels of **Sound Pressure Level** (dB SPL), and they indicate the decibel level relative to the softest sound that humans can detect. **Sensation Level** (dB SL) is referenced to the least intense sound a particular subject can detect in a particular experimental situation (for example, at a particular frequency). Decibels of **Hearing Loss** (dB HL) is a measure like dB SL, in that dB HL is expressed relative to standardized levels required for listeners with normal hearing to detect tones of different frequencies.

The sound wave propagates out from the source in a spherical manner. Since sound intensity is inversely proportional to area, and the area of a sphere is proportional to its radius squared, sound intensity decreases as function of the square of the distance from

the source. This inverse relationship between sound intensity and distance is referred to as the **inverse-square law**. Thus, for each doubling of the distance from the sound source, sound intensity decreases by a factor of 4, or about 6 dB ( $10 \log 4 = 6.02 \text{ dB}$ ) assuming the sound wave does not encounter any obstacles as it radiates out from the vibrating source.

The sound pressure wave can encounter objects as it travels from its source. The sound wave can be reflected from the object, absorbed at the boundary of the object, transmitted through the medium of the object, or **diffracted** around the object. The amount of reflection depends on the difference between the characteristic **impedance** of the original medium in which the sound wave is traveling and that of the object the sound wave encounters. **Characteristic impedance** ( **$Z_c$** ) is defined as  $Z_c = p_o c$ , where  $p_o$  is the density of the medium and  $c$  is the speed of the sound in the medium. Notice that  $Z_c$  is the same as the denominator of the definition of sound intensity, i.e.,  $I = p^2 / Z_c$ . The greater the characteristic impedance of the object, the greater the magnitude of the sound wave that is reflected from the surface of the object.

Sound is diffracted around objects whose diameters are approximately equal to or less than the wavelength of the sound wave. The level of sound on the side of an object opposite the direction in which the sound travels may be less than that on the side that the sound wave encounters first. That is, objects can produce a sound shadow. Since wavelength is inversely proportional to frequency, the higher the frequency of the sound wave, the greater the amount of attenuation due to the sound shadow.

The reflections of sound waves traveling in enclosed spaces (e.g., in a tube) can produce a pattern of reflections that can both reinforce and cancel the pressure waveform. Under appropriate conditions, a **standing wave** can be created. A standing wave creates areas of increased pressure within the enclosed spaces (**antinodes**), interspaced with areas of decreased pressure (**nodes**). The fundamental frequency ( $f_o$ ) of the standing wave is related to the length of the enclosed space (e.g.,  $f_o = c / (2L)$ , where  $c$  is speed of sound,  $L$  is length of enclosed space, when the enclosed space is closed or opened at both ends).

The reflections from surfaces in enclosed spaces like rooms can reinforce each other and the combined reflected sound wave can last a long time after the originating sound has ceased. In this case, **reverberation** is produced and the time it takes the reverberant sound level to decrease 60 dB from the original sound level is the **reverberation time** of the room. Reverberation time is proportional to the size of the room and inversely proportional to the amount of sound that is absorbed by the surfaces of the room.

Sound may be analyzed in several ways. The time waveform representing the relationship between sound pressure or intensity and time may be converted into a frequency-domain representation using a mathematical procedure known as the ►**Fourier transform**. Using the Fourier transform, any ►**time-domain** waveform can be represented by the sum (or integral) of a set of simple sinusoidal time-domain components.

For ►**periodic** time-domain waveforms, the discrete Fourier transform is

$$f(t) = 1/2A_o + \sum [a_n \cos(n\omega_o t) + b_n \sin(n\omega_o t)]$$

for  $n = 0$  to  $\infty$ ,

where  $f(t)$  is the time-domain waveform,  $A_o$  is a DC shift in the baseline of the time-domain waveform,  $\omega_o = 2\pi f_o$ ,  $f_o$  is the fundamental frequency of the periodic complex time-domain waveform, and  $a_n$  and  $b_n$  are magnitude constants expressed in terms of amplitude or power.

For non-periodic waveforms the Fourier transform is  $f(t) = 1/2\pi \int f(\omega) e^{j\omega t} d\omega$ , over the integral from  $-\infty$  to  $+\infty$ , where  $f(t)$  is the time-domain waveform,  $f(\omega)$  is ►**frequency domain** transform,  $j$  is complex number ( $\sqrt{-1}$ ), and  $\omega = 2\pi f$ . The exponential ( $e^{j\omega t}$ ) is related to a complex form of the trigonometric sinusoidal function.

Thus, either the time-domain or the frequency domain description of the sound waveform provides a unique and complete characterization of the waveform. In the frequency domain, the sinusoidal components are described by ►**spectra**. The ►**magnitude spectrum** indicates the magnitude (pressure or intensity) of each sinusoidal component as a function of its frequency (e.g., for discrete Fourier transforms of “ $n$ ” components, the magnitude spectrum is the relationship between  $C_n = \sqrt{(a_n^2 + b_n^2)}$  and  $n\omega_o$ ). The ►**phase spectrum** indicates the starting phase of each sinusoidal component as a function of its frequency (e.g., for discrete Fourier transforms of “ $n$ ” components, the phase spectrum is the relationship between the arctangent ( $a_n/b_n$ ) and  $n\omega_o$ ). Thus, the magnitude and phase spectra completely and uniquely describe the waveform. If sound is to be described in terms of pressure variations over time, then the time-domain waveform is used. If it is important to know the frequency components of the sound, then the frequency-domain description is used.

Any system that analyzes sound can be described as linear or nonlinear. A ►**linear analysis system** means that the spectrum of the sound would only change in the sense that the amplitudes and starting phase of the input spectrum might change, but the frequency components at the output of the analysis system are the same as those of the input spectrum. In a ►**nonlinear system**, there may be frequency components at the output of the analysis system that were not present in the input.

For instance, if the input to a nonlinear analysis system was a spectrum of two sinusoidal components with frequencies  $f_1$  and  $f_2$  ( $f_1 > f_2$ ), then a nonlinear system of the form  $y = x^n$ , where  $x$  is the sum of the components with frequencies  $f_1$  and  $f_2$ , can produce nonlinear ►**distortion** components at  $mf_1$ ,  $mf_2$ ,  $(m-1)f_1 + (p-1)f_2$ , and  $(m-1)f_1 - (p-1)f_2$ , where  $m = p = 1$  to  $n$ ,  $m \neq p$ . If  $n = 2$ , then the output spectrum would contain frequency components at  $f_1$  and  $f_2$  (the input components),  $2f_1$ ,  $2f_2$  (►**harmonics**),  $f_1 + f_2$  (►**summation tones**), and  $f_1 - f_2$  (►**difference tones**). Since the additional sinusoidal components would be added to the input components, the time-domain description of the output of a nonlinear system is distorted relative to the input.

Filtering may be used to estimate the magnitude spectrum of a complex time-domain waveform. A ►**filter** is a device or function that passes the frequency components of a sound within the ►**passband** of the filter without altering their magnitude. The magnitudes of frequency components with frequencies that lie outside of the passband are attenuated. For instance, a bandpass filter with a 500-Hz to 1,000-Hz passband and a 6-dB/octave ►**roll off** would not change the magnitude of the frequency components with frequencies between 500 and 1,000 Hz. The magnitude of components with frequencies greater than 1,000 Hz, or less than 500 Hz, would be reduced by 6 dB for each ►**octave** (doubling) of the component’s frequency away from 500 or 1,000 Hz (e.g., components at two octaves below 500 Hz, 125 Hz, and two octaves above 1,000 Hz, 4,000 Hz, will have magnitudes at the output of the filter that are 12 dB less than they were at the input to the filter).

In the example above, if a ►**complex sound** input to the filter had frequency components in the range of 500–1,000 Hz, the filter output would be greater in level than if the complex sound only had frequencies above 4,000 Hz. Thus, the output of each filter in a bank of bandpass filters can estimate the relative magnitudes of the frequency components in a complex sound. The accuracy of the estimate depends on the density of filters, the width of the passbands of each filter (the width of the passband is related to the ►**Q of the filter**, where  $Q$  is the ratio of the filter’s center frequency and its bandwidth), and steepness of the roll offs of each filter. Thus, a bank of bandpass filters may be used to estimate the magnitude spectrum of a sound.

The description of sound and its analysis provided above covers the major aspects of sound that affect auditory processing. The auditory system is sensitive to the pressure wave and how any objects that it encounters as it travels from its source to the ears of a listener affect it. Both the time and frequency domain descriptions of sound are coded by the auditory periphery. A filter bank is often used to model the frequency analysis performed by the biomechanics of the inner

ear. The auditory system is nonlinear at almost every stage of processing and is remarkably sensitive to the acoustic properties of vibrating objects.

## References

1. Rossing T (1990) The science of sound, 2nd edn. Addison-Wesley, Reading, MA
2. Yost WA (2007) Fundamentals of hearing: an introduction 5th edn. Academic, San Diego, CA

## Acquisition in Classical Conditioning

### Definition

Learning about the predictive relation between a conditioned stimulus (CS) and an unconditioned stimulus (US) follows a negatively accelerated acquisition curve. A common index of acquisition is the ability of the CS to elicit a conditioned response. Control procedures are used to ensure that the change in behavior to the CS is due to learning about the CS-US relation and not to experience with the events per se. In the unpaired control procedure, the same number of CSs and USs is presented as in the paired condition but they are never contiguous in time; in the random control procedure, the probability of an US is unchanged by the presence or absence of the CS.

► Theory on Classical Conditioning

## Across-Neuron (also: Across-Fiber) Pattern Code

### Definition

Hypothesis stating that neural information is represented by spatiotemporal patterns of activity and amounts of activity in populations of nerve fibers and central neurons rather than in the activity of individual neurons. For example, since the three types of retinal cones respond broadly, albeit differentially, to overlapping ranges of light wavelengths, any individual wavelength is represented by a specific ratio of activities across the different cone types.

- Color Processing
- Photoreceptors
- Sensory Systems

## Actin

### Definition

Actin filaments (microfilament) are a major structural component of the cellular cytoskeleton. The monomeric globular form (G-actin) polymerizes to form long helical filaments (F-actin), 7–9 nm in diameter. All subunits are oriented in the same direction resulting in a structural polarity where the ends of the filament are different. The structural polarity has important functional implications where the barbed end (+ end) of the filament has a faster rate of growth than the pointed (-) end. Actin is also the name of one of the two contractile proteins implicated in muscle contraction. Actin (sometimes also referred to as the thin filament) consists of two chains of serially linked actin globules that are wrapped around each other in a helical fashion. Actin also contains tropomyosin, a long fibrous protein that lies in the groove formed by the actin chains and three sub-units of troponin, troponin T, I and C. Tropomyosin and troponin are regulatory proteins associated with controlling cross-bridge binding to actin.

- Force Depression/Enhancement in Skeletal Muscles
- Molecular and Cellular Biomechanics
- Sliding Filament Theory

## Actin-associating Protein Kinase (Akt)

### Definition

Akt, also known as protein kinase B (PKB) is involved in intracellular signaling. Its roles include glucose metabolism and cell survival. Akt regulates cell survival and metabolism by binding to and regulating downstream effectors such as transcription factors and anti-apoptotic molecules.

- Neurotrophic Factors in Nerve Regeneration

## Actinopterygians

### Definition

Sistergroup of sarcopterygians, include all ray-finned fishes, i.e., bichirs (Polypterus) and the reedfish

(Calamoichthys), together forming the cladistians, the sturgeons (chondrosteans) the gars (*Lepisosteus*; ginglymodes) and the bowfin (*Amia*; halecomorphs), as well as the manifold modern ray-finned fishes, the teleosts.

- ▶ Evolution of the Brain: In Fishes
- ▶ Evolution of the Telencephalon: In Anamniotes

## Action, Action-Theory

RALF STOECKER  
 Institut für Philosophie, Kollegium LER, Universität  
 Potsdam, Potsdam, Germany

### Synonyms

Action; Behavior; Doing; Action-theory; Philosophy of action

### Definition

Usually an action is defined as something which is done by an agent for a reason, where the reason explains the action. But here, at the latest, agreement comes to an end and various action-theories start.

### Description of the Theory

There is no single action-theory but a variety of theories which address a number of closely interrelated topics that shape what is usually called ▶ **philosophy of action**. Although many of these topics had already been discussed in traditional philosophy (notably by Aristotle, Hume, Kant), these discussions were then usually regarded as part of moral philosophy. Philosophy of action as a discipline of its own came up in the middle of the twentieth century (helpful collections of classical papers in action theory are [1,2]).

### The Central Question: What are Actions?

The main target of any action-theory is to give an adequate account of ▶ **what actions are**. An action is something we do, not something that merely happens to us, like rotating with the earth or catching a cold. Yet, not everything done is properly called an action. Warming the seat of a chair or outwearing one's shoes are things we do, but they are not actions. Neither is it an action if someone trembles when he is scared or blinks when something is approaching his eyes. Hence, actions are to be distinguished from things that happen to us and also from mere behavior, particularly reflexive behavior.

In order to account for the difference, actions are usually regarded as events each of one of which is a person's doing something for a reason, where the person's having the reason explains why they did the thing. In ordinary language the term "reason" is used in two different ways to explain actions: reasons are either states of affairs that speak in favor of the action (The reason I phone you is that your uncle died) or reasons are mental states that motivate the action (The reason I phone you is that I want to invite you for dinner). Both kinds of reasons (so called ▶ **external** ▶ **internal reasons**) have been used to specify what actions are.

The idea that reasons basically are external reasons, i.e. states of affairs in the environment of the agent, and that actions are the agent's ▶ **response** to them was proposed, among others, by Georg Henrik von Wright [3]. But this view faces a number of serious problems: First, usually we would only regard such responses as actions if the agent also realizes the specific features of the environment, i.e. if she has the respective internal reason as well. Secondly, we would still take them to be actions even if the features do not in fact obtain, as long as the agent mistakenly assumes that they do. And thirdly, it is not quite clear how an adherent of this approach could account for the explanatory power of reasons.

Because of these problems and because it is initially so plausible that we are agents because we have minds, the received understanding of action in modern action theory is ▶ **mentalistic**, which means that the specific difference between actions and other doings is located in the mental attitudes the agent has towards her doings. Actions are done, because the agent wants, wills or intends them to occur. Mentalistic proposals differ with respect to the mental attitudes they take to be crucial and/or with respect to what they regard as the proper relationship between these attitudes and the respective actions.

The classical mentalistic view is ▶ **volitionalism**, according to which actions have to be preceded by volitions or ▶ **acts of will** that trigger the action. Volitionalism arguably originates in the early Christian adaptation of antique concepts of agency, particularly in the writings of Augustine. However, in recent philosophy of action volitionalism met at least two serious problems: first, there are many everyday, routine actions, which we seem to perform without a preceding act of will, and secondly volitionalism seems to imply that volitions are actions too, which would presuppose that they in turn are preceded by another act of will, and so on, ad infinitum. Despite these difficulties there are still defenders of volitionalism.

The dominant mentalistic alternative to volitionalism is the so-called ▶ **belief-desire thesis**. According to this view it is characteristic of actions that they are

performed because the agent has a desire (or more generally: a pro-attitude) towards doing something and believes that what she does is of the desired kind. The agent might e.g. phone her friend because she wants to invite him for dinner and believes that phoning him is a way to invite him. In the terminology of the leading proponent of this view, Donald Davidson, the belief-desire pair is called the action's ►primary reason [4]. Actions are things done for primary reasons.

However, the belief-desire thesis, too, faces an obvious problem: it seems to account merely for ►intentional actions, leaving all kinds of unintentional, involuntary, inadvertent actions unexplained. If the agent phones her friend because she mistook his number for the number of her parents, she does not act on a primary reason for phoning him, yet her phoning him is neither just something that happened to her nor a mere behavior, it is a mistaken, misguided action. What is therefore needed is a two-step account of actions: they are either intentional (i.e. done for a primary reason) or they are performed by doing something else intentionally.

For some time, roughly between 1970 and 1990, the metaphysical question of how to understand this by-location played an important role in action theory (for an overview see [5]). According to Davidson and others "by" only relates different descriptions of the same, numerically identical action. Hence, in their terminology, actions are intentional only under a certain description (►coarse grained account). According to authors like Alvin Goldman and Jaegwon Kim on the other hand "by" always or at least sometimes relates different, numerically distinct actions (►fine-grained accounts). These views were usually combined with ontological claims as to whether actions are events at all, whether they are restricted to bodily movements or could also comprise some other events, or whether actions should in the last analysis be seen as internal, mental phenomena: e.g. strivings, tryings or decisions.

The ontological debate in action theory also focused on the problem of how to account for so called ►negative actions, i.e. omitting something or letting something happen. On the one hand it seems to be beyond doubt that part of what we intentionally do belongs to this negative kind (e.g. if we abstain from smoking because it is unhealthy), on the other hand negative actions seem to be ontologically unreal, because in a sense the agent is not doing anything at all.

The intentionality of actions also gave rise to the question, whether a pair of beliefs and desires is really sufficient for an action to occur or whether it is necessary to have an ►intention in advance of one's action. The proposal to augment the belief-desire thesis by an additional mental component, the agent's intention or choice, has the advantage to preserve the initial plausibility of volitionalism with a good chance for avoiding some of its difficulties. However, the

proposal it is still faced with the problem that particularly routine acts seem not to be preceded by such an attitude. Yet in any case, even if not all actions presuppose intentions separate from the agent's primary reasons, it is an important task in action theory to account for the role an agent's intentions play, since intentions are crucial for understanding ►planned, ►complex and ►joint actions [6]. Authors disagree though on what intentions are and particularly whether they could be reduced to other kinds of intentional attitudes.

Other mental phenomena also play an important role for agency. Actions are not only performed for reasons or intentions, we also act on e.g. fury, love, fear, or shame. Sometimes we even act just for fun or "for nothing." What this shows is that, at least, action theory has to take into account other mental antecedents of actions that add to action explanations, although some authors go further and regard the existence of such ►arational actions as a refutation of the belief-desire thesis and of its too rationalistic view of actions.

Despite their differences all mentalistic approaches agree in the idea that for a doing to be an action it is not sufficient that the agent has the respective mental antecedents, the doing must also be explained by them. This leads to a second major topic in the philosophy of action, the character of action explanations.

### Action Explanations

Action explanations combine two ideas: first the action is described as, in a sense, being ►adequate (or fitting) to the explanantia, and secondly it is described as happening because of its adequacy.

The first idea is easily illustrated by explanations based on the agent's acts of will, volitions, intentions or decisions. The action fulfils what is expressed in the content of the respective attitude. The agent's phoning her friend fits to her preliminary intention, because phoning him is what she intended to do.

Primary reasons fit the action in showing it as being reasonable, in the sense that the agent could have concluded from the reasons she has that it is somehow favorable to perform the action. The agent's desire to invite her friend together with her belief that this could be done by phoning him speak in favor of phoning him. The idea that reasons allow for a special sort of inference to the respective action goes back to Aristotle who called inferences like these ►practical syllogisms. Obviously there is something to the idea that action explanations have such a quasi-logical structure, but there is widespread disagreement as to whether practical inferences could be valid at all, whether they follow a special kind of (deontic) logic and which form a conclusion of a practical syllogism has. Is it, e.g. a value judgement, an expression of intention or perhaps the action itself?



Moreover, pointing out the primary reason of an action seems to be quite a feeble kind of explanation. Since agents usually have many competing desires which they cannot fulfill simultaneously, simply saying that there was a reason in favor for the agent's action doesn't explain why it was just this desire she satisfied and not any other. So one might wonder why we are at all interested in an agent's reasons.

One way to cope with this question is to regard the agent's intentional states as constituting something like a ►**hierarchical structure**, ordered according to the strength of her desires and the subjective probability of her beliefs. Reason explanations would then carry an implicit presumption that the reasons mentioned were on top of this hierarchy. Seen in this light the agent is a perfectly ►**rational** being and reasons explain an action because from the agent's perspective every action is displayed as the very rational thing to do.

Obviously, this view has difficulties in coping with familiar cases of ►**irrationality**, e.g. instances of weakness of will, and also with agency in dilemmatic cases. Moreover, as Rational Choice Theory and Game Theory have made vivid, it is sometimes awfully complicated to figure out how to behave rationally, hence it would be surprising if every human agent could be regarded as a perfectly rational being.

But besides these difficulties there is the second idea that for an occurrence's being an action it may not be sufficient that it is rational in the light of the agent, but that it also has to be caused by the agent's intention.

When this topic was discussed in the mid twentieth century by, among others, Ludwig Wittgenstein, Gilbert Ryle and G.E.M. Anscombe there was widespread agreement that because reason explanations aim at an ►**interpretation** (or an understanding) of the action they could not at the same time be causal explanations. The most prominent argument for this view was the so called logical connection argument, according to which the connection between a reason for doing something and the resultant action is incompatible with the logical independence requisite for cause and effect.

During the sixties these arguments were criticized very effectively, most prominently by Davidson. Since then it is the received view that reason explanations are a special kind of causal explanations. This causalistic view fits well with different approaches to the mind body problem that were developed in these days in the ►**philosophy of mind**, e.g. identity theory and functionalism. But there are still authors who doubt that reason explanations are causal and defend alternative views (►**interpretative** or ►**teleological approaches**).

One reason for being skeptical about the causalistic approach is that there are cases where although intentional attitudes rationalize as well as cause something the agent does, what she does isn't an action. A student, e.g. who wants to avoid an examination may try so hard

to find a way of getting around it that she absentmindedly runs into a car on the street and spends her time in the hospital instead of being examined. Although the student certainly knows that having a car accident is a suitable means for avoiding an examination, and although her want to avoid the examination also has caused the accident, the accident still was not an intentional act of her. Some authors regard such cases of so called ►**wayward causal chains** as evidence against causalism. What they show in any case is that there is more to the explanatory value of reason explanations than just rationalization and causation. Speaking metaphorically, the causation has to take the right route, and it is a widely discussed topic in today's action theory how to unwrap this metaphor.

### Agents

Another reason for being reluctant to accept the standard causal account of action explanations is that it may threaten our ►**freedom and responsibility** (►**Will, freedom of**). The suspicion that taking reasons to be causes of actions would leave us no real freedom of choice has led some authors (most prominently Roderick Chisholm) to the view (foreshadowed in ancient conceptions of causality) that instead of the agent's intentional attitudes the agent herself should be regarded as the cause of the action.

But although most action theorists are reluctant with regard to such a special kind of ►**agent causality**, many agree that the standard belief-desire thesis underestimates the role of the agent, as far as full-fledged human agency is concerned. What is usually assumed to be missing is some sort of complexity that distinguishes agents like us from simpler (e.g. animal) agents. Moreover most authors agree that the crucial difference is to be found in features that are usually associated with concepts like ►**personality** and ►**autonomy** (►**personal autonomy**). These features in turn are either located in the reflective structure of the intentionality of persons (e.g. Harry Frankfurt's conception of second order volitions in [7]), or in a special capability of valuing (e.g. Charles Taylor's distinction between weak and strong evaluations in [8]).

Parallel to this debate about the characteristics of paradigmatic full-fledged human agents there is also a discussion about borderline cases of ►**non-human agency**. In accordance with common sense most authors agree that at least higher mammals are agents, but some authors are willing to concede agency to lower animals, plants and perhaps even artifacts as well. A rather different and also widely discussed question is concerned with corporate agency. While animals typically raise worries whether they are sophisticated enough for being agents, corporations, in a sense, are obviously very smart, but on the other hand they seem to be too lofty entities for counting them as true agents.

### Why Action Theory?

There are several good reasons for being interested in the results of action theory. Action theory is part of ►[anthropology](#) i.e. the study of human nature. In particular, there are strong connections with the philosophy of mind. On the one hand actions are typically characterized by their mental antecedents, therefore most problems in action theory can only be solved by taking into account the nature of these antecedents. On the other hand, many influential characterizations of mental states in the philosophy of mind refer to their behavioral output (e.g. behaviorism, functionalism), so that presumably any plausible theory of the mind has to offer an account of actions as well (for an overview see [9]).

The findings of action theory also have strong bearings on ►[ethical issues](#). For one thing ethics is obviously interested in the problem of freedom of the will since free will is usually regarded as a prerequisite of moral responsibility, and for another there are some important distinctions in moral theory that rely on corresponding differences in action theory, most prominently the difference between actively doing something and letting something happen or omitting something, which e.g. is at the basis of the distinction in medical ethics between killing a patient and letting him die. Another distinction that is relevant for applied ethics is the one between causing something and merely accepting it as a side effect, which, e.g. is sometimes employed for drawing the line between permitted and forbidden killings of civilians in warfare. Both distinctions have to be elucidated in action theory in order to estimate their ethical impact in moral philosophy [10].

### References

1. White A (ed) (1968) The philosophy of action. Oxford University Press, Oxford
2. Mele A (ed) (1997) The philosophy of action. Oxford University Press, Oxford
3. von Wright GH (1971) Explanation and understanding. Routledge, London
4. Davidson D (2001) Essays on actions and events, 2nd edn. Oxford University Press, Oxford
5. Pfeifer K (1989) Actions and other events. New York, Bern, Frankfurt, Peterlong, Paris
6. Bratman M (1999) Faces of intention. Cambridge University Press, Cambridge
7. Frankfurt H (1988) The importance of what we care about. Cambridge University Press, Cambridge
8. Taylor C (1985) What is human agency? In: Taylor C. Philosophical Papers 1. Cambridge University Press, Cambridge. pp 15–44
9. Kim J (2005) Philosophy of mind, 2nd edn. Harper collins, Boulder
10. Steinbock B, Norcross A (1994) Killing and letting die, 2nd edn. Fordtion University Press, New York

## Action Potential

UWE. WINDHORST<sup>1</sup>, PETER M. LALLEY<sup>2</sup>  
<sup>1</sup>Physiological Institute, University of Göttinger, Göttinger, Germany  
<sup>2</sup>Department of Physiology, The University of Wisconsin School of Medicine, Medical Sciences Center, Madison, Wisconsin, USA

### Synonyms

Discharge; Impulse; Spike

### Definition

The action potential is the active electrical response of an excitable cell membrane to a stimulus, reflected in a fairly stereotyped change in membrane potential from a resting value (negative inside) to a depolarized (either positive or less negative inside) value and back. The durations of action potentials range from a few milliseconds in neurons to hundreds of milliseconds in cardiac, gastric and intestinal cells. The underlying mechanism consists of voltage-dependent opening of Na<sup>+</sup>, Ca<sup>2+</sup> and K<sup>+</sup> channels. The response is initially depolarizing due to opening of Na<sup>+</sup> and/or Ca<sup>2+</sup> channels, and subsequently repolarizing due to delayed opening of K<sup>+</sup> channels.

### Characteristics

The action potential represents membrane mechanisms, that yield an electrical signal, which propagates over long distances. The signal originates from an encoding process that converts graded, non-propagating ►[receptor potentials](#) or synaptic potentials into action potentials (►[Sensory Systems](#)).

Various examples of action potentials (red lines) in different cells are displayed in [Fig. 1](#). Most of them are pulses (also called “impulses” or “spikes”) of fairly short duration, on the order of 1–3 ms ([Fig. 1a, b](#)) except for those in heart or smooth muscle cells ([Fig. 1c, d](#)). A spike ([Fig. 1a](#)) evolves from a ►[resting membrane potential](#) of about –50 to –90 mV, (►[Membrane Potential – Basics](#)), depolarizes at a steep rate and reaches a peak which, depending on the resting potential from which it arises, ranges from a much less negative value than at rest (typically –10 mV to –5 mV) to a positive voltage (►[overshoot](#)). In cardiac Purkinje fibers, myocytes and some cells of the gastro intestinal tract. the action potential has a prolonged plateau phase ([Fig. 1c](#)), while in neurons and skeletal muscle cells, rapid repolarization brings the action potential back close to the resting potential, where a ►[delayed depolarization](#) or protracted ►[afterhyperpolarization](#) (AHP) may follow ([Fig. 1a, b](#)). Some neurons, such as

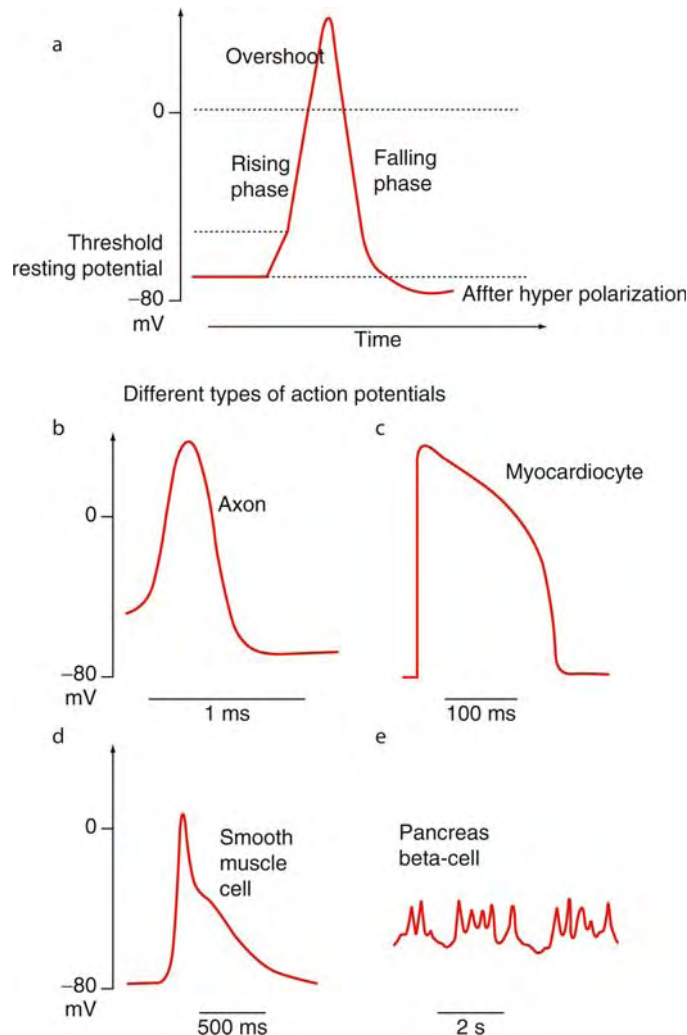

**Action Potential. Figure 1** (a–e) Intracellular records of membrane and action potentials (red lines).

(a) Schematic representation of an action potential with its phases. (b) The action potential measured in a squid axon is a prototype of the fast action potential produced by nerve or muscle fibers. It is about 100 times faster than the action potentials of heart muscle cells. In heart and smooth muscle cells (c,d), the rising phase of the action potential is carried by  $\text{Na}^+$  currents through  $\text{Na}^+$  channels, while the prolonged plateau phase is mediated by  $\text{Ca}^{2+}$  currents through  $\text{Ca}^{2+}$  channels. E: Endocrine cells such as the pancreatic  $\beta$ -cells also produce action potentials, which are mediated by  $\text{Ca}^{2+}$  and trigger exocytosis of the hormone (in this case insulin) (Adapted from ref. [1]).

the ►**motoneurons** innervating skeletal muscle fibers, may have pronounced (several mV deep) and long-lasting (50–200 ms) afterhyperpolarizations.

### The Squid Giant Axon

The basic processes underlying the generation of the axon action potential were studied and described by Hodgkin, Huxley (A.L. Hodgkin, A.F. Huxley, Nobel Prize of Physiology or Medicine 1963) and coworkers, including B. Katz (Nobel Prize of Physiology and Medicine (1970)). The giant axon of the squid turned out to be a favourable structure because its size (diameter 0.5–1 mm) and robustness allowed it to be removed

from the animal, placed in a bath and subjected to varying extracellular compositions. Its size allowed insertion of relatively bulky longitudinal electrodes, and because of membrane durability it was possible to squeeze out the intracellular content and replace it with solutions of varying composition (►**Intracellular Recording**).

### Processes Underlying the Squid-Axon Action Potential Need for Extracellular $\text{Na}^+$

The squid-axon experiments showed that the depolarization (rising phase) of the action potential results from a regenerative increase in  $\text{Na}^+$  conductance, beginning

with the observation that reducing extracellular  $\text{Na}^+$  concentration diminished the amplitude and rate of depolarization. Subsequently, current measurements were made with the ►**voltage-clamp technique**, which identified voltage- and time-dependent properties associated with the action potential.

### Voltage-Dependent Currents

Voltage changes during the action potential are associated with several different currents:

- $\text{Na}^+$  and  $\text{K}^+$  conductances and the ensuing currents show complicated dependencies on both time  $t$  and time-varying membrane potential  $V(t)$ :

$$I_{\text{Na}}(V, t) = g_{\text{Na}}(V, t) [V(t) - E_{\text{Na}}], \quad (1a)$$

$$I_{\text{K}}(V, t) = g_{\text{K}}(V, t) [V(t) - E_{\text{K}}], \quad (1b)$$

These dependencies lead to a fast ionic current  $I_{\text{ion}}(V, t)$  through the membrane, composed of  $\text{Na}^+$  and  $\text{K}^+$  currents:

$$I_{\text{ion}}(V, t) = I_{\text{Na}}(V, t) + I_{\text{K}}(V, t) \quad (2)$$

- Although small and relatively insignificant in the squid axon, a so-called leakage or ►**leak current** through other ion channels must be taken into account, if only for corrective purposes [2]:

$$I_{\text{L}}(V, t) = g_{\text{L}}(V, t) [V(t) - E_{\text{L}}]. \quad (3)$$

- Fast voltage changes during the action potential generate ►**capacitive currents**  $I_{\text{C}}$  due to charging and discharging the membrane capacitance  $C_{\text{m}}$ :

$$I_{\text{C}}(t) = C_{\text{m}} \cdot dV(t)/dt \quad (4)$$

- The total current during the action potential would thus be:

$$I_{\text{tot}}(t) = I_{\text{Na}}(V, t) + I_{\text{K}}(V, t) + I_{\text{L}}(V, t) + I_{\text{C}}(t) \quad (5)$$

The superposition of various time- and voltage-varying currents was difficult to disentangle using the more conventional methods of the time. The invention of the voltage-clamp technique (►**Intracellular recording**) made it possible to separate and analyze voltage- and time-dependent properties of the action potential.

### Voltage Clamp

The basic idea of the voltage-clamp technique is as follows. Rather than studying the naturally occurring action potential with its complicated time- and voltage-dependent currents, abrupt step-like changes in membrane potential from an initial “holding” potential  $V_{\text{h}}$  to a final test potential  $V_{\text{f}}$  are utilized. The fundamental principle is to keep the membrane potential constant before and after the step by injecting, via a second intracellular electrode, currents into the axon. These currents

would, of necessity, have the same magnitude, but the opposite polarity of those elicited by the voltage step.

The method was revolutionary for its time, introducing a number of advantages:

1. The transient capacitive current  $I_{\text{C}}$  (Eq. 4) is isolated because it only occurs during a very brief time (order of microseconds), whereas the slower ionic currents persist and can be measured independently of  $I_{\text{C}}$ .
2. The membrane potential can be “clamped” at various, constant test levels, at which the time course of the voltage-dependent net current  $[I_{\text{net}}(t)]$  can be followed.
3. Varying the voltage-step size reveals the dependency of ion conductances on membrane potential.
4. Conditioning voltage steps and holding potentials permit measurements of time- and voltage-dependent properties of ion channel activation and inactivation.
5. Changes in extra- and intracellular ion concentrations, and/or elimination of specific ion conductances with ion channel neurotoxins, can be used in conjunction with voltage-clamp protocols to elucidate the relative contributions of  $I_{\text{Na}}(t)$  and  $I_{\text{K}}(t)$  to  $I_{\text{net}}(t)$ .
6. The experimental arrangement for voltage-clamping the squid axon has the further advantage of producing a uniform space clamp, because an identical transmembrane potential change is impressed across the entire length of the membrane. The result is that current changes due to longitudinal current spread between regions of different membrane voltage cannot contaminate transmembrane current flow through voltage-gated ion channels.

### $\text{Na}^+$ and $\text{K}^+$ Currents Elicited by Depolarization

An example of a voltage-clamp experiment is shown in Fig. 2. The membrane is abruptly depolarized from an initial holding potential of  $-65$  mV by  $56$  mV to  $-9$  mV (upper trace). This evokes an initial capacitive current (not shown) that is very brief and precedes an inward-outward sequence of slower currents (middle panel, lower trace). Provided this latter sequence is ionic, various manipulations should demonstrate its nature and composition.

Replacing about 90% of the external  $\text{Na}^+$  with choline, an impermeant ion, renders the  $\text{Na}^+$  concentrations inside and outside the axon approximately equal and, according to the Nernst equation (►**Membrane Potential – Basics**), brings  $E_{\text{Na}}$  to about zero. If, after the step, the membrane potential is then held at  $0$  mV, no net  $\text{Na}^+$  current should flow, and the remaining current should be due to  $\text{K}^+$  (Fig. 2, middle panel, blue line labelled “10%  $\text{Na}^+$ ”), as verified by the observation that its magnitude is altered by varying extracellular  $\text{K}^+$

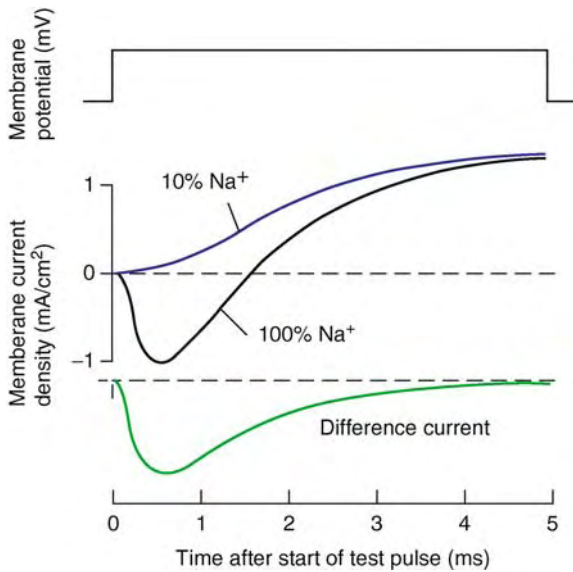

**Action Potential. Figure 2** Classical ion substitution method for studying the ionic basis of voltage-clamp currents. The axon is depolarized from  $-65$  mV by  $56$  mV to  $-9$  mV (top trace). With normal seawater ( $100\%$   $\text{Na}^+$ ), the typical curve (black line in the middle panel) results. Reducing the external  $\text{Na}^+$  concentration to  $10\%$  of normal results in the blue line (labeled “ $10\%$   $\text{Na}^+$ ”) in the middle panel. The difference between these two curves (green line in lower panel) corresponds to the current carried by  $\text{Na}^+$ .  $T = 8.5^\circ\text{C}$  (Adapted from ref. [3]).

concentration (not shown). The  $\text{K}^+$  current is slowly activated by depolarization, directed outward, has a slow time course, and remains activated throughout the depolarization. The difference between the  $\text{K}^+$  current (blue line) and the mixed current (Fig. 2, middle panel, black line labelled “ $100\%$   $\text{Na}^+$ ”) is plotted in the bottom trace (green line labelled “Difference current”) and corresponds to the current carried by  $\text{Na}^+$  (► **Intracellular Recording**). It is an inward current that peaks within  $1$  ms and then decays over a few milliseconds despite continued depolarization. Hence, the  $\text{Na}^+$  current is quickly activated, but subsequently ► **inactivates** automatically (see below).

### Dependence of $\text{Na}^+$ and $\text{K}^+$ Currents and Conductances on Depolarization Amplitude

The precise dependence of these currents on the amplitude of the voltage steps and, hence, the steady state potential, can be established [4] by stepping the membrane from a holding potential (say  $-65$  mV) to various end-potentials. The late  $\text{K}^+$  current increases as the depolarizing steps increase. By contrast, the early  $\text{Na}^+$  current first increases, but subsequently decreases with increasing depolarization, is absent at  $+52$  mV (corresponding approximately to the  $\text{Na}^+$  equilibrium

potential), and is reversed in sign (directed outward) at  $+65$  mV. The  $\text{Na}^+$  and  $\text{K}^+$  currents can be transformed into the underlying conductance changes by using Eqs. 1a, b. Like the currents, these conductance changes depend on the amplitude of the voltage step. While the  $\text{K}^+$  conductance remains elevated with continuing depolarization, the  $\text{Na}^+$  decays on its own. This process is due to ion channel inactivation (see below).

### Pharmacological Identification of $\text{Na}^+$ and $\text{K}^+$ Conductances

The above results indicate that the squid giant axon must possess (at least) two voltage-dependent conductances with different, very specific properties. Indeed, voltage-clamp experiments have shown that they also have very different pharmacological sensitivities. The neurotoxins ► **tetrodotoxin** (TTX) or ► **saxitoxin** (STX) and local anaesthetics such as procaine, cocaine and tetracaine block voltage-gated  $\text{Na}^+$  current but leave the  $\text{K}^+$  current intact. On the other hand, ► **tetraethylammonium** (TEA) as well as cesium ions block  $\text{K}^+$  currents but not sodium currents [5].

### Ion channels that carry $\text{Na}^+$ Current Inactivate during the Time Course of the Action Potential

Voltage-clamp experiments such as those described above pointed to two processes that bring about the fall of the action potential from its peak: inactivation of the  $\text{Na}^+$  conductance and late development of the  $\text{K}^+$  conductance. If both  $\text{Na}^+$  activation and inactivation during an action potential are triggered by depolarization, the two processes must be timed in such a manner as not to cancel each other. Inactivation should have a slower time course that allows it to follow activation. By the same token, any degree of antecedent inactivation should suppress a second activation (see below), and preceding membrane potential changes should influence the amount of  $\text{Na}^+$  activation. These predictions have been confirmed in pulse-conditioning experiments and have functional consequences on discharge properties during bursts of action potentials (see below).

In voltage-clamp experiments on squid giant axons, depolarization from  $-65$  mV to  $-21$  mV elicits the usual inward-outward sequence of currents. However, when the voltage step to  $-21$  mV is preceded by a short-lasting, smaller depolarization of  $14$  mV (conditioning pre-pulse), the inward current is much reduced. Conversely, when a hyperpolarizing pre-pulse of  $31$  mV is applied, the step depolarization elicits a much stronger inward current. A plot of normalized inward current vs. amount of conditioning potential change shows that at the normal resting potential, about one-third of the  $\text{Na}^+$  current is inactivated. The functional consequence is that antecedent membrane hyperpolarization decreases the degree of inactivation and therefore

increases action potential amplitude, while residual membrane depolarization has the opposite effect.

The time course of recovery from  $\text{Na}^+$  inactivation has been worked out in paired depolarizing pulse paradigms, where the pulses are delivered at varied intervals. They show that the  $\text{Na}^+$  system recovers from inactivation with an approximately exponential time course and a time constant on the order of 5 ms, with the time constant depending on the holding potentials [5].

At the peak of an action potential and during the subsequent decline toward resting potential the  $\text{Na}^+$  channels exhibit reduced depolarization-dependent permeability, from which recovery occurs gradually over several milliseconds. This period of reduced channel reactivity characterizes the ►refractory period. At peak membrane depolarization and shortly thereafter,  $\text{Na}^+$  permeability cannot be activated at all, however strong the depolarization. This is called the absolute refractory period. During the subsequent relative refractory period,  $\text{Na}^+$  permeability can be increased by relatively large degrees of membrane depolarization.

Proteolytic enzymes such as pronase or papain applied intracellularly impair or remove  $\text{Na}^+$  inactivation, leading to long-lasting  $\text{Na}^+$  activation during prolonged depolarization [5].

### Consequences of $\text{Na}^+$ Inactivation

The impact of membrane depolarization on both activation and inactivation of  $\text{Na}^+$  conductance has profound functional consequences. The sequence of  $\text{Na}^+$  activation and inactivation:

1. Limits action potential frequency. Since an action potential is followed by an absolute refractory period, there is a minimal interval at which one action potential can follow the preceding one. This minimal interval defines the maximal rate of occurrence of action potentials.
2. Leads to accommodation. When a nerve fiber is slowly depolarized by a ramp-like rather than a step-like waveform, the  $\text{Na}^+$  inactivation may have time enough to develop in step with  $\text{Na}^+$  activation. Slow depolarization – even to very high levels – may thus not elicit action potentials, but rather completely prevent their generation.
3. Has clinical implications. Nerve, muscle and gut paralysis can result from long-lasting depolarization (►depolarization block).

### The Hodgkin–Huxley Model of the Action Potential

Voltage-clamp experiments revealed that the  $\text{Na}^+$  and  $\text{K}^+$  conductances that give rise to the action potential vary with membrane potential and time. A successful attempt at quantitatively describing these dependencies and mathematically model the squid-axon action potential was made by Hodgkin and Huxley [6]. They

were able to reconstruct the shape of the action potential and its underlying ion conductance changes, as shown in Fig. 3. The “HH equations” and variations thereof are still used to model neuron bioelectrical properties.

### Channel Gating Currents

Hodgkin and Huxley [6] suggested that channel opening should be associated with the movement of charged particles within the membrane. This was subsequently demonstrated in voltage-clamp experiments with computer averaging and subtraction techniques [7].

### Single-Channel Currents

Within the last 25 years, it has become possible to voltage-clamp small patches of cell membrane and record single-channel currents with the ►patch-clamp technique (►Intracellular Recording). Single-channel inward currents appear at varying times after step depolarization, but most often close to the beginning. When hundreds of individual recordings are averaged, the average inward current has a time course comparable with that of the inward  $\text{Na}^+$  current shown in Fig. 2 (green line in lower panel: “Difference curve”). Experiments such as these have revealed some interesting properties of single ion channels. They indicate that channel behavior is probabilistic; the current reflects the probability of being open. The  $\text{Na}^+$  current recorded with gross electrodes (Fig. 2) results from the superimposed activity of many  $\text{Na}^+$  channels.

### Action Potentials in Central Neurons

The squid axon is a relatively simple system devoted to conducting action potentials along the axon (►Action Potential Propagation), and probably for this reason can be content with two major ion conductances. Central neurons, however, have much more varied signal-processing functions and therefore express complex repertoires of ion channels, endowing them with a plethora of firing behaviors. Thus, individual neurons in the mammalian brain typically express several subtypes of ►voltage-dependent  $\text{Na}^+$  channels, ►voltage-dependent  $\text{Ca}^{2+}$  channels, ►voltage-dependent  $\text{K}^+$  channels, ► $\text{Ca}^{2+}$ -activated  $\text{K}^+$  channels (►Neuronal potassium channels), ►hyperpolarization-activated, ►non-selective cation channels, and more. The different combinations of channels enable diverse action potential shapes and firing patterns. Action potential amplitude, shape and firing rate are particularly important at presynaptic axon terminals, where they co-determine – via the amount of presynaptic  $\text{Ca}^{2+}$  influx – the amount of released ►neurotransmitter [8].

### Contribution of $\text{Na}^+$ Currents to Action Potentials

In central neurons, very much like in the squid axon, the rising phase of the action potential is generated by very fast activation and inactivation of voltage-dependent

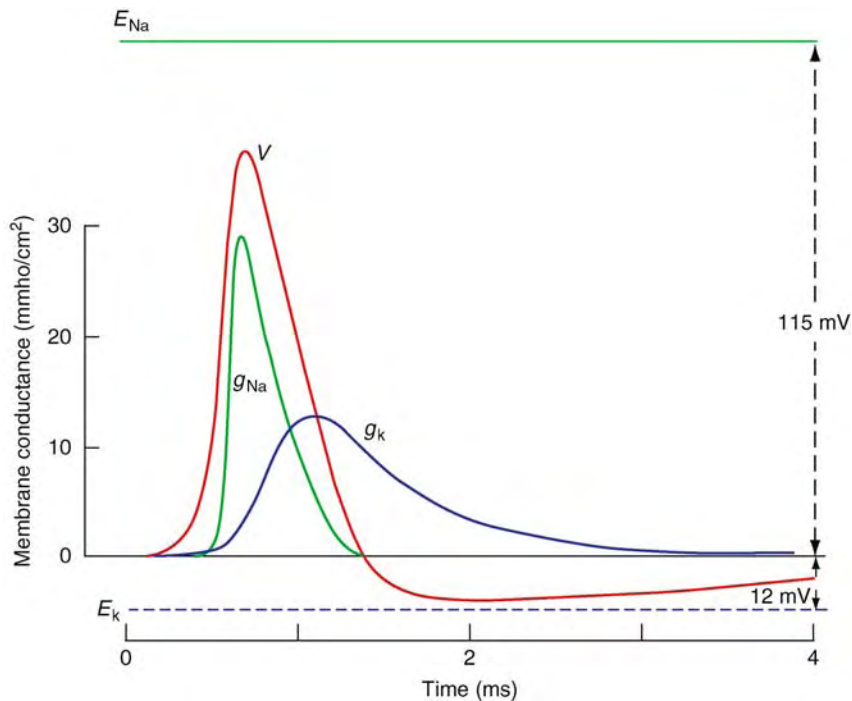

**Action Potential. Figure 3** Reconstruction of the action potential. The time courses of the propagated action potential and underlying ionic conductance changes computed by Hodgkin and Huxley [5] from their voltage-clamp data. The constants used were appropriate to a temperature of 18.5°C. The calculated net entry of Na<sup>+</sup> was 4.33 pmole/cm<sup>2</sup>, and the net exit of K<sup>+</sup> was 4.26 pmole/cm<sup>2</sup>. The calculated conduction velocity was 18.8 m/s (Adapted from ref. [6]).

Na<sup>+</sup> channels, although the detailed kinetics may vary between different types of neuron and even between different parts of a neuron [8].

### Contribution of Ca<sup>2+</sup> Current to Action Potentials

Although individual mammalian neurons typically express at least four or five types of voltage-dependent Ca<sup>2+</sup> channels, inward Ca<sup>2+</sup> currents contribute little to the action potential upstroke because of their slow activation kinetics, whereby they start to be activated near the peak of the action potential and are maximal during the repolarization phase. In addition to initiating intracellular signalling pathways, the action potential-evoked Ca<sup>2+</sup> influx influences action-potential shape and firing pattern. Conversely, since the activation and inactivation kinetics of the Ca<sup>2+</sup> channels are strongly voltage-dependent, the shape and width of the action potential determines the amount of evoked Ca<sup>2+</sup> influx and thereby, at presynaptic terminals, the amount of neurotransmitter released [8].

Among the Ca<sup>2+</sup> channels expressed are low-voltage-activated T-type channels (Cav3 family channels) and high-voltage-activated channels including L-type (Cav1.2 and Cav1.3), P/Q-type channels (Cav2.1), N-type (Cav2.2) and R-type (Cav2.3) channels.

Pharmacological blockade of Ca<sup>2+</sup> channels often broadens the action potential and lengthens discharge duration, because Ca<sup>2+</sup> influx leads to opening of large-conductance Ca<sup>2+</sup>-activated K<sup>+</sup> channels (BK channels) that promote membrane repolarization. Small-conductance Ca<sup>2+</sup>-activated K<sup>+</sup> channels (SK channels) are also coupled to Ca<sup>2+</sup> influx. They activate too slowly to affect action-potential repolarization, but they do contribute to the following afterhyperpolarization (AHP; below) [8].

### Contribution of K<sup>+</sup> Current to Action Potentials

Central neurons express a huge variety of voltage-gated K<sup>+</sup> channels, only a fraction of which activate appreciably during the action potential. Significant contributions to action potential repolarization are commonly made by Kv3 family and Kv4 family channels mediating the A-type current (I<sub>A</sub>). In some fast-spiking neurons (below), Kv3-mediated current appears to be the major current flowing during repolarization. In glutamatergic neurons of hippocampus and cortex, repolarization is mediated by at least three types of K<sup>+</sup> currents: the BK Ca<sup>2+</sup>-activated K<sup>+</sup> current (above), and two purely voltage-dependent currents, I<sub>A</sub> and I<sub>D</sub>. I<sub>A</sub> shows relatively rapid inactivation

and is, in cell bodies and dendrites, mostly mediated by the Kv4 family channels.  $I_D$  is activated by sub-threshold depolarizations, inactivates slowly and is blocked by ▶4-aminopyridine, which broadens action potentials. In some neurons, high rates of firing lead to broadening of action potentials that probably results from cumulative inactivation of  $K^+$  channels, and may facilitate synaptic transmission by increasing  $Ca^{2+}$  influx in presynaptic terminals [8].

### Afterdepolarization

In many neurons (e.g., pyramidal cells of hippocampus and cortex), the fast phase of action potential repolarization is followed by a delayed depolarization, either attached to the fast phase as a slow phase or as a hump intercalated between a fast transient and a subsequent afterhyperpolarization. The origins of ▶afterdepolarization may be passive and/or active. That is, an action potential in the cell soma may recharge the dendritic tree with its large surface area and ▶capacitance (electrical), which takes time. This electrotonic mechanism may be amplified by active dendritic conductances, whose activation is often delayed and slower than that of the somatic conductances. Active ionic currents contributing to afterdepolarization include ▶persistent  $Na^+$  currents, ▶resurgent  $Na^+$  currents, R-type and T-type  $Ca^{2+}$  currents, and currents due to ▶non-selective cation currents [8].

### Afterhyperpolarization (AHP)

While in the squid axon, the afterhyperpolarization (Fig. 3) is generated by the merely slowly inactivating voltage-dependent  $K^+$  conductance activated during the action potential, afterhyperpolarizations in mammalian central neurons are more complex. First, they may show different phases: fast, medium and slow. Second, the contributing  $K^+$  channels include BK and SK channels and Kv7 channels mediating the ▶M-current. BK-channel-mediated afterhyperpolarizations are usually brief, while SK-channel-mediated ones can last up to seconds [8].

### Repetitive Firing

Many central neurons discharge action potential over a wide range of frequencies and with various patterns, to which many factors already discussed may contribute. For example, if the hump-like intermittent afterdepolarization is fast and large enough, it may elicit new spikes and thus burst firing [8]. On the other hand, the depth and duration of afterhyperpolarization (reduced excitability) co-determines the firing pattern, e.g., in skeleto-motoneurons [9].

The rates and patterns of repetitive firing are also influenced by several sub-threshold currents that flow between action potentials and accelerate or slow the approach to threshold. Such currents include the

steady-state “persistent”  $Na^+$  current,  $I_A$  and  $I_D$   $K^+$  currents, the  $I_h$  current carried by ▶hyperpolarization-activated cyclic nucleotide-gated (HCN) channels, and currents carried by low-voltage-activated (T-type)  $Ca^{2+}$  channels [8].

The ▶A-type  $K^+$  current ( $I_A$ ) activates and inactivates at sub-threshold voltages. During the post-spike hyperpolarization,  $I_A$  inactivation is partially removed; during the subsequent depolarization,  $I_A$  first activates and slows the approach to threshold, and then inactivates enabling threshold crossing. The  $I_D$  current plays a similar role but inactivates more slowly [8].

Most central neurons possess TTX-sensitive and insensitive, voltage-dependent, steady-state “persistent” inward  $Na^+$  current flowing at voltages between  $-65$  and  $-40$  mV, which significantly influences sub-threshold membrane potential changes and thus the firing rate and pattern of discharge [8].

One function of low-voltage-gated (T-type)  $Ca^{2+}$  currents is the generation of ▶rebound bursting following hyperpolarization (e.g., after a prolonged inhibitory synaptic input), which removes its inactivation [8].

Many central neurons fire spontaneously (without overt excitatory inputs) and fairly regularly, and are called “▶pacemakers”. In some of these neurons, the “persistent”  $Na^+$  current plays the major role to drive membrane potential to threshold, in others it is the  $I_h$  current. In dopaminergic midbrain neurons, a sub-threshold  $Ca^{2+}$  current appears to drive pacemaker activity [8].

### Fast-Spiking Neurons

Neurons capable of firing at high rates for prolonged periods, e.g., cerebellar ▶Purkinje cells, often possess voltage-gated  $K^+$  channels of the Kv3 family, whose fast and steeply voltage-dependent activation and inactivation kinetics allow them to produce narrow action potentials and short refractory periods suitable for fast repetitive firing. In some types of central neurons, this mechanism may be supported by a special “resurgent”  $Na^+$  current, which activates transiently upon repolarization after inactivation due to strong depolarization and is sensitive to tetrodotoxin (TTX) [8].

### References

1. Ruppertsberg JP (1996) Ion channels in excitable membranes. In: Greger R, Windhorst U (eds) Comprehensive human physiology. From cellular mechanisms to integration. Springer, Berlin Heidelberg, New York, pp 267–282
2. Keynes RD, Aidley DJ (1991) Muscle and nerve, 2nd edn. Cambridge University Press, Cambridge
3. Hodgkin AL (1958) Ionic movements and electrical activity in giant nerve fibres. Proc R Soc Lond B 148:1–37



4. Hodgkin AL, Huxley AF, Katz B (1952) Measurement of current-voltage relations in the membrane of the giant axon of Loligo. *J Physiol (Lond)* 116:424–448
5. Hille B (1992) *Ionic channels of excitable membranes*, 2nd edn. Sinauer Associates, Sunderland, MA
6. Hodgkin AL, Huxley AF (1952) A quantitative description of membrane current and its application to conduction and excitation in nerve. *J Physiol (Lond)* 117:500–544
7. Armstrong CM, Bezanilla F (1974) Charge movement associated with the opening and closing of the activation gates of the Na channel. *J Gen Physiol* 63:533–552
8. Bean BP (2007) The action potential in mammalian central neurons. *Nat Rev Neurosci* 8:451–465
9. Kernell D (1992) Organized variability in the neuromuscular system: a survey of task-related adaptations. *Arch Ital Biol* 130:19–66

## Action Potential Conduction

### ► Action Potential Propagation

## Action Potential Propagation

UWE WINDHORST<sup>1</sup>, PETER M. LALLEY<sup>2</sup>

<sup>1</sup>Physiological Institute, University of Göttingen, Göttingen, Germany

<sup>2</sup>Department of Physiology, The University of Wisconsin School of Medicine, Medical Sciences Center, Madison, Wisconsin, USA

### Synonyms

Action potential conduction

### Definition

Movement of the action potential along the cell surface.

### Characteristics

The evolutionary pressure to develop the ► **action potential** resulted from the inability of graded local membrane potential changes to electronically spread across the cell surface over wide distances (► **Electrotonic Spread**). Self-evidently, the action potential holds its promise to do exactly that, otherwise it would not have evolved. The mechanisms underlying the propagation along muscle fibers and axons are surprisingly simple: amplification of ► **graded potential** changes into much larger, all-or-none action potentials and electrotonic spread. Action potential propagation

along a nerve or muscle fiber occurs automatically as a consequence of the axonal cable structure (► **Cable Theory**).

### Continuous Action Potential Propagation along an Axon or Muscle Fiber

First consider a smooth muscle or nerve fiber. The mechanism, somewhat simplified, is as follows.

#### Propagation Mechanism

Since charging or discharging of a capacitor takes some time, expressed in the time constant, the substantial depolarization-induced ionic ( $\text{Na}^+$ ) currents are delayed. The amount of current needed to unload the membrane capacitor by a certain amount depends on the capacitor's surface, which increases linearly with fiber radius, and so the capacitative current required for depolarization should increase by a given amount. But note that the amount of source current also increases linearly with the fiber radius because the number of opening  $\text{Na}^+$  channels does.

#### Conduction Velocity

In axons like the squid axon, the conduction velocity  $v$  is related to the ► **space constant** (► **Cable Theory**) for electrotonic spread. The reason is simple: The farther the local currents reach out in front at any moment, the more advanced are the membrane regions that are depolarized to threshold for action potential generation the next moment. Thus:

$$v \propto \lambda = \sqrt{R_M/R_i} \quad (1)$$

where  $R_M$  is the membrane resistance and  $R_i$  is the longitudinal resistance of the fiber interior.

Since, with  $r$  being the fiber radius,

$$R_M \propto 1/(2\pi r) \quad R_i \propto 1/(\pi r^2)$$

$$v \propto \sqrt{r} \quad (2)$$

One means of increasing the conduction velocity is therefore to increase the fiber diameter. This means is used especially by invertebrates. For example, the squid giant axon innervates the mantle musculature whose rapid contraction ejects water in the squid's flight reaction. Clearly, a high action potential conduction velocity has a high survival value, and therefore the axon has evolved to reach fiber diameters of 0.5–1 mm and maximal conduction velocities of up to ca.  $20 \text{ m s}^{-1}$  (depending on ambient temperature).

In higher organisms, however, the evolutionary pressure on the complexity and speed of neural information transmission increases dramatically, requiring an ever-increasing number of fast parallel signal channels. For example, the human optic nerve contains about 1 million

nerve fibers, many of them conducting several times faster than the squid giant axon. These values cannot be achieved with the squid solution of producing “giant” axons. Just imagine how the human optic nerve would look like if made up of giant axons of appropriate conduction velocities. The problem for Nature therefore was to invent a more efficient method that would allow for an increase in velocity without a proportional increase in space as well as metabolic and other costs.

### Saltatory Action Potential Propagation along an Axon

Since the conduction velocity is related to cable properties of the axon, a possible solution to the above problem would be to change one or the other cable parameter appropriately. A possible mechanism would be to increase the ►length constant  $\lambda = \sqrt{R_M/R_i}$  by increasing  $R_M$ , that is, by thickening the membrane somehow (►Cable Theory).

### Myelination

The solution Nature came up with is a ►myelinsheath. In the peripheral nervous system, myelin sheaths are built by ►Schwann cells, in the central nervous system they are built by ►oligodendrocytes, this different origin having implications for diseases and restoration of function after injury. A myelin sheath is built by repetitively wrapping the cell membranes of a Schwann cell or oligodendrocyte around an axon, in which process the cytoplasm is squeezed out. Thereby a stretch of axon of 0.5–2 mm length becomes covered by a multi-layered stack of membranes, adjacent stretches being separated by gaps of 1–2  $\mu\text{m}$ . These gaps are called ►nodes of Ranvier and the stretches in between internodes. There may be as many as 100 myelin wrappings between two nodes of Ranvier, producing a sheath as thick as 2  $\mu\text{m}$  [2].

The myelin sheath is a good insulator. With 100 double-membrane layers in the sheath, the Ohmic resistance of the sheath to perpendicular current flow is 200 times higher than that of the single cell membrane. By contrast, because the capacity of a capacitor is inversely proportional to the distance of the plates, the capacity of the myelin sheath and, hence, the amount of charge stored across it for a particular potential difference, is 200 times smaller than that of the single membrane layer. The amount of charge stored on an internodal region of 2 mm length is only about half that stored in a single 1–2  $\mu\text{m}$  ►node of Ranvier [2]. The reduced charge capacity and the higher resistance to transmembrane current flow cause resting and action potentials to be generated only at the nodes.

### Saltatory Conduction

When a node is depolarized during an action potential, local circuit currents depolarize the next one ahead,

without discharging the internodal region. The excitation thus hops from node to node rather than coursing continuously through all membrane regions, this mode of propagation being called ►saltatory conduction (saltare, Latin for to leap, dance). The conduction velocity  $v$  is determined by a number of factors [2], but largely by the length of the ►internode, which is approximately proportional to the fiber diameter. In myelinated nerve fibers, the conduction velocity is linearly correlated with outer fiber diameter, with the proportionality constant (Hursh factor) being about 6 m/s per  $\mu\text{m}$  in cats, where maximal conduction velocities are on the order of 120  $\text{m s}^{-1}$  for a fiber of 20  $\mu\text{m}$  diameter. For comparison, according to the square-root rule (1), an unmyelinated squid axon of 20  $\mu\text{m}$  diameter would have a conduction velocity of 4  $\text{m s}^{-1}$  [2]. It should be noted that conduction velocity in myelinated and unmyelinated fibers also depends directly on temperature, because the operation of channels does.  $\text{Na}^+$  channels, for instance, open more slowly at lower temperatures [2]. This is an experimental means of slowing nerve conduction in human and animal experiments.

Saltatory conduction confers several advantages:

1. Economy of space: A myelinated frog nerve fiber of 10  $\mu\text{m}$  diameter has the same conduction velocity as an unmyelinated squid axon of 500  $\mu\text{m}$  diameter, but 2,500 10- $\mu\text{m}$  fibers can be packed into the volume of a squid giant axon. A mammalian muscle nerve typically contains on the order of 2,000 large-diameter (10–20  $\mu\text{m}$ ) fibers and is about 1 mm thick. If the nerve were composed of the same number of unmyelinated fibers of the same conduction velocities, its diameter would lie between 3.5 and 4 cm [2].
2. Economy of energy expenditure: The ► $\text{Na}^+ - \text{K}^+$  pump that generates and maintains the resting potential is needed only at and close to the nodes of Ranvier, amounting to an immense saving of metabolic energy.
3. High safety factor for conduction: The current density discharging the capacitor at the narrow nodes of Ranvier is so high as to easily secure action potential generation.

In the central nervous system, the “white matter” is characterized by high concentrations of myelinated axons, while the “gray matter” contains lower concentrations of myelin.

### Problems with Myelination

The myelin sheath has been an extremely useful invention of Nature to dramatically enhance information transmission and processing capabilities in the nervous system. However, as all good inventions, it has its drawbacks. These are indicated by limits to regeneration after injury (►Regeneration) and various neurological diseases involving myelin.

### Axon Regeneration and Its Limits

Prerequisites for functional recovery following axonal interruption (axotomy) in the nervous system are [3]:

1. Survival of the injured neuron.
2. Axon regrowth of sufficient length to reach its target.
3. Axon guidance and path-finding such that the appropriate connections are reformed.
4. Formation and maintenance of functional synapses.

Functional recovery following injury differs dramatically in the peripheral and the central nervous system (►Regeneration). If a peripheral nerve is injured so that some or all of its axons are severed, it usually regenerates by sending out new processes. Thus there is a robust growth of injured axons within the peripheral nervous system of vertebrates and in some regions of the central nervous system of lower vertebrates [3]. This is facilitated by the nerve sheath being intact or re-sutured surgically. By contrast, axon regeneration is much less likely in the central nervous system. In the central nervous system of adult mammals and higher vertebrates, neurons that survive axotomy extend their axons only a short distance (approximately 1 mm). The reasons for this are multiple and complex, from physical or molecular barriers built by glial scarring at the lesion site, to the possibility that the normal myelinated environment contains potent growth inhibitors or lacks growth-promoting molecules. However, combined approaches raise the possibility of overcoming these problems [4].

### Demyelination Disorders

The importance of myelin for normal nervous system operation is attested to by a number of demyelination diseases, two of which are the ►Guillain-Barré syndrome and ►Multiple sclerosis.

### Ephaptic Transmission

Demyelination disorders may impair fast action potential propagation, but also lead to non-synaptic contacts between nerve fibers with pathological transfer of electrical impulses.

### Composition of Peripheral Nerves

Peripheral nerves are composed of nerve fibers of different degree of myelination, diameter and conduction velocity. Using both histological and electrophysiological techniques, nerve fibers have been classified as shown in Table 1.

### Back-Propagation of Action Potentials

In many neurons, action potentials originate close to the origin of the centrifugal axon and then not only travel down the efferent axon, but also ‘back-propagate’ retrogradely into the dendritic tree. These back-propagating action potentials are supported by active, ►tetrodotoxin-sensitive, ►voltage-dependent  $\text{Na}^+$  channels and possibly ► $\text{Ca}^{2+}$  channels, and decrease in amplitude but increase in width, the further they travel into the tree. The extent of this decremental back-propagation varies widely between different types of central neurons, different specimens of the same sort, and possibly different dendritic branches of individual cells. Back-propagation depends on cell morphology and densities of dendritic ion channels, modulatory influences provided by excitatory and inhibitory inputs and ►neuromodulators [8].

Several functions have been proposed for back-propagating action potentials, among which are [8]:

1. Short-term changes in ►synaptic efficacy due to the back-propagating action potential’s drastic effects on membrane potential and voltage- and

**Action Potential Propagation. Table 1** Properties of different peripheral nerve fiber groups (Data from [5–7])

Group		Function	Diameter ( $\mu\text{m}$ )	Conduction velocity ( $\text{m s}^{-1}$ )
I	A $\alpha$	Ia afferents from muscle spindle endings (stretch)	ca. 12–20	ca. 70–120
		Ib afferents from Golgi tendon organs (force)		
		Motor efferents to skeletal muscles		
II	A $\beta$	Afferents from cutaneous mechano-receptors (pressure, touch, vibration)	ca. 6–12	ca. 30–70
		Afferents from secondary muscle spindle endings (stretch)		
II	A $\gamma$	Motor efferents to muscle spindle (intrafusal ca. 2–8 muscle fibers)	ca. 2–8	ca. 15–30
III	A $\delta$	Afferents for mechano-, chemo-, thermo- and nociception	ca. 1–5	ca. 5–30
	B	Preganglionic sympathetic efferents	<3	ca. 3–15
IV	C unmyelinated	Afferents for mechano-, chemo-, thermo- and nociception	0.1–1.3	ca. 0.6–2
		Postganglionic sympathetic efferents (motor to glands and smooth muscle)		

time-dependent dendritic ion channels, whereby the properties of synaptic conductances are changed.

2. Long-term changes in synaptic efficacy. It has been proposed that back-propagating action potentials change synaptic efficacy on a long-term time base. Long-term increases in synaptic efficacy often depend on increased  $\text{Ca}^{2+}$  influx, which may elicit a cascade of metabolic events. The rises in intra-dendritic  $\text{Ca}^{2+}$  concentrations occur following (i) activation of ►voltage-dependent  $\text{Ca}^{2+}$  channels due to the back-propagating action potential, (ii) activation of postsynaptic ►N-methyl-D-aspartate (NMDA) channels during depolarization [8]. Thus, nearly coincident pre- and postsynaptic activity and consequent intra-dendritic  $\text{Ca}^{2+}$  increases would be expected to strengthen excitatory synapses.

The extent of action potential back-propagation into the dendritic tree is not invariant, but depends on several variables, such as interactions between synaptic inputs and postsynaptic activity and modulatory factors. Appropriately timed excitatory inputs to distal dendrites may enhance action potential back-propagation, and inhibitory (e.g., GABAergic) inputs suppress it [8]. Locally operating inhibitory inputs may control the routes of action potential propagation through the dendritic tree and thereby the action of action potentials on other synaptic inputs. Depending on where in the soma-dendritic tree the inhibition operates, it may differentially influence the propagation of excitatory synaptic currents to the action potential-generating site. Inhibition at the soma would globally shunt excitation originating in vast spaces of the dendritic tree, while local inhibition in the dendrites would counteract excitation originating peripherally to the site of inhibition. The converse may now hold for back-propagating action potentials. Synaptic inhibition acting at the soma may prevent or attenuate back-propagating action potentials and, hence, quench their effects on synaptic inputs widely distributed in the dendritic tree, while local dendritic inhibition may have subtle and selective local effects.

►Recurrent inhibition in the spinal cord is among the types of inhibition influencing action potential back-propagation in ►motoneurons. It has been proposed that recurrent inhibition might provide a mechanism involved in regulating, calibrating and adapting the patterns and quantitative characteristics of excitatory reflex inputs to motoneurons during the stance phase. It could do so by influencing the degree of retrograde invasion of the motoneuron dendritic trees by back-propagating action potentials [9].

## References

1. Hodgkin AL, Huxley AF (1952) A quantitative description of membrane current and its application to conduction and excitation in nerve. *J Physiol (Lond)* 117:500–544
2. Woodbury JW (1965) Action potential: properties of excitable membranes. In: Ruch TC, Patton HD (eds) *Physiology and biophysics*. W.B. Saunders Comp, Philadelphia London, pp 26–58
3. Zwimpfer TJ, Guest JD (1999) Grafting of peripheral nerves and Schwann cells into the CNS to support axon regeneration. In: Windhorst U, Johansson H (eds) *Modern techniques in neuroscience research*. Springer, Berlin Heidelberg New York, pp 379–409
4. Maier IC, Schwab ME (2007) Sprouting, regeneration and circuit formation in the injured spinal cord: factors and activity. *Philos Trans R Soc Lond B Biol Sci* 361:1611–1634
5. Afifi AK, Bergman RA (1980) *Basic neuroscience*. Urban & Schwarzenberg, Baltimore Munich
6. Boyd IA, Davey MR (1968) *Composition of peripheral nerves*. Livingstone, Edinburgh
7. Stein RB (1980) *Nerve and muscle: membranes, cells and systems*. Plenum, New York
8. Waters J, Schaefer A, Sakmann B (2005) Backpropagating action potentials in neurones: measurement, mechanisms and potential functions. *Prog Biophys Mol Biol* 87:145–170
9. Windhorst U (2007) Muscle proprioceptive feedback and spinal networks. *Brain Res Bull* 73:155–202

## Action Representation

LAURA BAMERT, FRED W. MAST

Department of Psychology, University of Lausanne, Lausanne, Switzerland

### Definition

The brain represents actions and this information is used to prepare and execute voluntary movements. Action representations are also drawn upon when we imagine a movement or when we observe and understand actions of others. As regards the underlying brain structures, action representations involve brain activity in the frontal and parietal lobes.

### Characteristics

#### Different Pathways for Perception and Action

Action and perception mutually depend on one another (e.g. when we look for a pen on our desk we first need to detect it visually before picking it up) and it is not evident that the underlying mechanisms can in fact dissociate. Visual input from the retina first reaches occipital cortex and the visual information is then further processed in the ventral and dorsal streams of the brain. Ungerleider and Mishkin [1] postulate that the dorsal stream, from the occipital primary visual areas to the inferior parietal lobule, is involved in the perception

of where objects are in space, whereas the ventral stream, which ends in the inferior temporal cortex, is associated with the perception and recognition of objects. In line with this view, the dorsal and ventral streams are referred to as the “where-stream” and the “what-stream” respectively. It has been suggested that the two streams differ primarily in terms of the output they provide [2]. Indeed, the output provided by the dorsal stream plays an important role in action related processes. Patients with lesions to the posterior parietal cortex (dorsal stream) have an impaired capacity to execute spatially accurate movements to visual targets despite the preserved capacity to correctly estimate the size of the target (optic ataxia) [3]. Lesions to the ventral stream, however, leave intact the ability to act appropriately whereas perceptual judgments are impaired.

Indeed, appropriate actions need not necessarily rely on a perfect perception of a visual target. Studies on visual illusions provide further evidence, an example of which is the Ebbinghaus-illusion: two identical circles appear different in size when one of them is surrounded by set of larger circles (leading to a relative decrease in perceived size) and the other one is surrounded by a set of smaller circles (leading to a relative increase in perceived size). Interestingly, this visual illusion shows up much weaker when measuring the finger grip as participants prepare to pick up the central circle [4]. Thus, the grip aperture turns out to be more adequate to the real size of the circle and thus depends less on the confounding visual context. The representations guiding our movements are provided by a neural substrate that does not completely overlap with those representations involved in visual perception.

### Action Observation

One of the most remarkable findings in recent neurophysiological research is the discovery of a population of visuo-motor neurons in the ventral premotor cortex [5]. These neurons were discovered in the macaque monkey’s frontal area F5 (corresponds to area 44 in humans) and have been called “▶**mirror neurons**” as they fire when a goal-directed action is executed and during observation of the same action performed by another agent. These findings gave rise to a new view on how actions are represented. It has been suggested that the mere observation of a motor act causes the observer’s motor system to resonate [5]. Motor representations are thus used to understand the meaning of an observed motor action. Moreover, the premotor areas containing mirror neurons are not driven by the visual input alone as they are still activated when the final part of the observed action is hidden. In this context, intended actions are yet another important factor, which was studied by Iacoboni et al. [6]. In that study participants viewed videos displaying grasping

movements. The video clips showed the action of grasping a cup in the absence of any other object, and exactly the same action in the presence of two different situational contexts: (i) displaying filled cups and cookies as before having tea, and (ii) an after tea setting with empty cups and crumbs. It was the context conditions, which specified the intention of the grasping movement (either for drinking or cleaning up). The activity of premotor areas increased in the context conditions, thus indicating that these neurons do not only fire when we recognize an action but they also take into account the goal behind a specific movement. It has been proposed that these neurons specifically code the “why” of an action. Furthermore, the mirror neuron system is not only involved in the understanding of an action per se, but also in the understanding of body postures or faces expressing emotions. It has been suggested that we infer emotions of others on the basis of an internal simulation.

### Imagined Actions

Neuroimaging and behavioral studies on improvements of motor skills showed similar results when participants imagined actions as compared to when the movements were executed (for a review on this topic see [7]). For example, imagined and executed actions are both principally controlled by the contralateral hemisphere and mental practice can improve both the accuracy and the velocity of an action as well as muscular strength. Moreover, heart and respiration rates are also increased during mental rehearsal of an action and this provides further support for the involvement of at least partly the same underlying mechanisms. According to Jeannerod [7] imagined movements can be conceived as covert actions, which involve several action-related mechanisms (with the difference being the non-execution of the action itself). Cerebral lesions provide yet another approach to explore whether and to what extent motor execution and ▶**motor imagery** share the same mechanisms. It has been shown that brain lesions leading to an impaired capacity to execute specific body part movements also affect the capacity to imagine a movement of the same body part. Moreover, the use of mental practice has been shown to improve motor performance after peripheral or cerebral lesions.

Motor representations can also be involved in other mental imagery abilities such as ▶**mental rotation**. For example, when participants have to judge the laterality of pictures of hands shown in different orientations on a screen (is this is a left or right hand?), they mentally rotate a representation of their own hand to line it up with the stimulus hand. In this case, a motor strategy is used automatically to process visual stimuli (pictures of hands).

As regards the underlying neuronal representation it has to be pointed out that not only frontal brain areas

play a role in motor imagery tasks. The parietal cortex is involved in predicting through mental imagery the time necessary to perform an action. Sirigu and colleagues [8] investigated the involvement of the parietal cortex in patients with unilateral lesions. They imagined a thumb-finger sequence with either hand. The patients' ability to mentally represent the sequence was impaired when compared to the actual motor performance. The key role the parietal cortex plays in monitoring motor intentions is also supported by a more recent study comparing patients with parietal and cerebellar lesions [9]. Patients were asked to indicate both the onset of a finger movement, and the moment when they have decided to move. Parietal patients were unable to discriminate the onset of movement from the moment in which they felt the urge to move, whereas cerebellar patients behaved like healthy control subjects. Parietal patients also showed a much less pronounced progressive and negative rise in the cortical potentials originating in contralateral motor areas before motor onset. This is supposed to be the neuronal correlate of the decision to initiate a motor preparation. It has therefore been suggested that the parietal cortex might be involved in a conscious self-monitoring of the motor intentions originating within the prefrontal areas.

### The Self-Other Distinction

It has been claimed that the experience of oneself being the cause of an action and the representation of the ►bodily self are related. Gallagher [10] distinguished between a "sense of ownership" and a "►sense of agency." We refer to the former as the feeling of the body belonging to ourselves. The sense of ownership appears to rely strongly on the afferent sensory input. The sense of agency is based on the ability to recognize oneself as the source of one's own actions, thoughts, and intentions. Therefore, the ►efferent information stream of centrally generated commands plays an important role and constitutes the awareness of having initiated an action. Afferent and efferent information are simultaneously involved when people execute actions and it is therefore not easy to isolate their relative contributions to the representation of a coherent bodily self. Imagine, however, someone grasped your forearm and moved it up and down. There is no reason to doubt that you will still consider yourself being the owner of your forearm even though you are not executing its movement and thus are lacking any sense of agency. Interestingly, it has been shown that the contribution of efferent information helps to better recognize one's own movements when proprioceptive and visual information are not conclusive. Clinical cases suggest dissociations in the reverse direction such as the alien hand syndrome (patients attribute to others their own body parts despite preserved motor functions).

### Acknowledgement

We are grateful to the Swiss National Science Foundation (PDFM1-114406).

### References

1. Ungerleider LG, Mishkin M (1982) Two visual systems. In: Ingle DJ, Goodale MA, Mansfield RJW (eds) Analysis of visual behavior. MIT Press, Cambridge, pp 549–586
2. Milner D, Goodale MA (1995) The visual brain in action, Oxford University Press, Oxford
3. Himmelbach M, Karnath HO (2007) Optic ataxia: a gateway to the human visual action system. In: Mast FW, Jäncke L (eds) Spatial processing in navigation, imagery and perception. Springer, Berlin Heidelberg New York, pp 85–105
4. Haffenden AM, Goodale MA (1998) The effect of pictorial illusion on prehension and perception. *J Cogn Neurosci* 10:122–136
5. Rizzolatti G, Fogassi L, Gallese V (2001) Neurophysiological mechanisms underlying the understanding and imitation of action. *Nat Rev Neurosci* 2:661–670
6. Iacoboni M, Molnar-Szakacs I, Gallese V, Buccino G, Mazziotta JC, Rizzolatti G (2005) Grasping the intentions of others with one's own mirror neuron system. *Plos Biology* 3(3):e79
7. Jeannerod M (2001) Neural Simulation of action: a unifying mechanism for motor cognition. *Neuroimage* 14:103–109
8. Sirigu A, Duhamel JR, Cohen L, Pillon B, Dubois B, Agid Y (1996) The mental representation of hand movements after parietal cortex damage. *Science* 273:1564–1568
9. Sirigu A, Daprati E, Ciancia S, Giraux P, Nighoghossian N, Posada A, Haggard P (2004) Altered awareness of voluntary action after damage to the parietal cortex. *Nat Neurosci* 7:80–84
10. Gallagher II (2000) Philosophical conceptions of the self: implications for cognitive science. *Trends Cogn Sci* 4:14–21

---

## Action Tremor

### Definition

Also called kinetic tremor is a tremor that occurs during voluntary movement.

### ►Essential Tremor

---

## Activation

### ►Ion Channels from Development to Disease

## Activation Gating

### Definition

Specialized molecular regions of the ion channel protein, which undergo sequential conformational changes leading to channel activation (open-conductive configuration). For a voltage-gated channel the activation gate is controlled by a number of charged amino acids (gating charges), which move under the action of the electric field acting across the membrane and opens the channel.

## Activation Studies

### Definition

Studies based on the fact that alteration in neuronal activity in a region correlates with alteration of local cerebral blood flow in the same region during a task performance. Alteration (activation) of a region indicates that it is involved in the maintenance of the task activity.

- ▶ Positron Emission Tomography

## Activational Hormonal Effects

### Definition

Acute changes in structure and/or function of particular anatomic systems; often resulting from natural hormonal fluctuations (e.g. menstrual cycle) or laboratory manipulation (e.g. gonadectomy) of adult organisms.

## Activators

- ▶ Stimulants

## Active Avoidance Learning

### Definition

Active avoidance is a term applied to a class of tasks in which animals are required to actively exhibit certain experimenter-defined responses in order to avoid punishment. Behaviors that are more compatible with natural defensive responses to aversive stimuli (see SDR in glossary) are more easily learned.

- ▶ Aversive Learning
- ▶ Passive Avoidance Learning

## Active Electrolocation

### Definition

The process by which weakly electric fish can sense their surroundings by detecting distortions in their own electric field.

- ▶ Reafferent Control in Electric Communication
- ▶ Temporal Coding in Electrosensation

## Active Touch

CHRISTINE ELAINE CHAPMAN

Groupe de recherche sur le système nerveux central,  
Département de physiologie & École de réadaptation,  
Faculté de médecine, Université de Montréal, Montréal,  
QC, Canada

### Definition

Active touch refers to the act of touching, and implies voluntary, self-generated movements. With active touch, the environment is explored using specialized touch organs (the hand or forepaw, whiskers in rodents) in order to gather information about the properties of surfaces (texture, hardness, temperature) and/or objects (size, shape, weight, location) located in the nearby peripersonal space. In contrast, passive touch, or the act of being touched, implies that the sensory input is generated by an external agent; this type of touch is not generally exploratory in nature (although there can be exceptions in the laboratory situation). For both modes of touch, the

sensory input can be dynamic, implying movement between the skin and the object, or static (no movement). For example, a hand-held object can be identified using a combination of active exploratory movements, turning the object over to examine all of its surfaces (dynamic active touch), combined with periods of static holds (static active touch). A special type of dynamic passive touch, often used in experimental situations, is to displace surfaces, mounted on a drum or a moveable platform, over a single region of skin.

## Characteristics

### Quantitative Description

Active touch is a complex, goal-oriented behavior. A wide range of relatively stereotyped movements accompany tactile exploration, and these are optimized to seek specific sensory information.

### Description of the Process

In humans and other primates, the hand is generally used for active tactile exploration of the surround. Early in development, human infants preferentially use the mouth and perioral region for active tactile exploration; these regions continue to play an important role throughout the life span, but with more restricted roles (appetitive and sexual). Other species use different body parts for active tactile exploration, an important experimental model being the rodent vibrissa system, along with the associated whisking behavior. In all cases, the body regions used for active tactile exploration are characterized by having a high density of peripheral sensory receptors, a correspondingly large cortical representation (both sensory and motor), and high sensory acuity.

One important difference between primates and most other mammals is, however, the fact that the hand is not only a touch organ, but also has highly developed effector functions as witnessed by their ability to make independent finger movements. Indeed, humans are distinguished from other primates because the manipulative functions of the human hand are combined with our unique ability to build and use complex tools. This essay concentrates mainly, but not exclusively, on studies of active touch in humans and non human primates.

### Sources of Feedback During Active Touch

Depending on the exploratory strategy used (see below), active touch can generate both cutaneous and proprioceptive feedback. The specialized skin mechanoreceptors innervated by large fiber myelinated afferents are considered to play a key role in discriminative touch (texture, local shape and pattern recognition). Proprioceptive signals, related to joint movement (▶*kinaesthetic* signals) and position, arise from muscle (muscle spindle,

Golgi tendon organs), joint, and skin mechanoreceptors. Simultaneous cutaneous and proprioceptive feedback is often elicited when actively exploring the shape of an object, and this combined input is called haptic feedback [1]. The term haptic comes from the Greek term *haptesthai*, meaning “able to come into contact with” (OED online, <http://www.oed.com/>). In addition to the sensory feedback generated during active touch, subjects also have knowledge of the motor commands that guide the exploratory movements. Indeed, the ▶*primary somatosensory cortex (S1)* is the only *primary* sensory receiving area to have direct, reciprocal connections with primary motor cortex, the region involved in the execution of active exploratory movements. Thus, S1 is well-placed to provide on-line sensory information critical for controlling the exploratory processes. Additional somatosensory inputs to motor cortex come from other parietal regions (area 5 and the ▶*secondary somatosensory cortex, S2*), and also from the cerebellum via the motor thalamus (ventral lateral posterior nucleus).

### The Exploratory Process

The movements used during active touch have the overriding goal of generating high quality sensory feedback. While tactile information can be gathered through a simple static contact, it is generally acknowledged that tactile perception is better with dynamic stimuli as compared to static stimuli. For example, roughness discrimination thresholds are approximately halved when using dynamic touch as compared to static touch [2]. The superiority of dynamic touch over static touch can be explained by several factors. Dynamic touch recruits rapidly adapting cutaneous mechanoreceptors [RA (▶*RA afferents*) and ▶*PC afferents* or Pacinian afferents] as well as slowly adapting cutaneous mechanoreceptors [SA types I and II (▶*SAI and SAII afferents*)], while static touch only activates SA receptors. Also, the discharge rates for SA afferents are higher for dynamic stimuli than for static stimuli, increasing the signal-to-noise ratio. Finally, S1 neurones show a bias for dynamic as opposed to static stimuli, so that the population of neurones contributing to the processing of the tactile input is potentially larger for dynamic inputs.

During active tactile exploration, the types of movements made are critically dependent on the information sought. In fact, humans use a series of stereotyped movement patterns (also called exploratory procedures) in order to seek specific sensory information (Fig. 1) [3].

*Static contact* alone can provide information about the temperature, volume and global shape of an object, particularly for smaller or local geometric features (corresponding to what can be sensed with the fingertip) as well as providing some information about surface texture. The *pressure* exploratory procedure, essentially poking an object with the finger, gives information about its softness/hardness, along with other surface



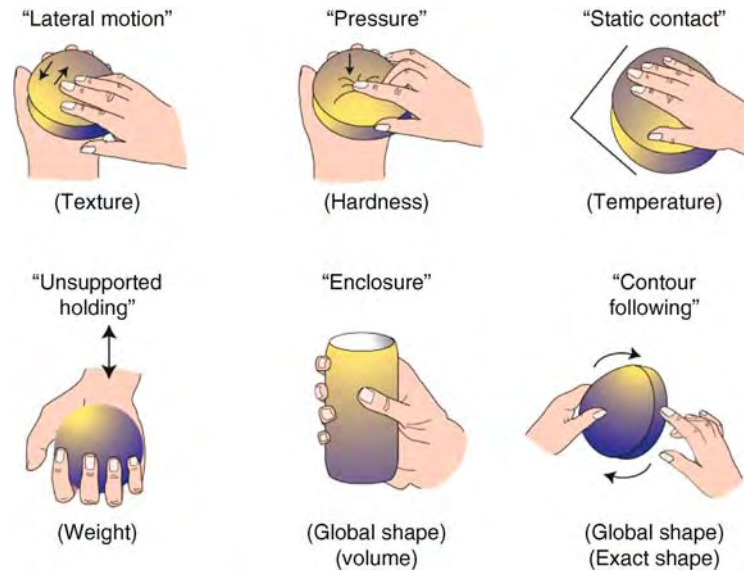

**Active Touch. Figure 1** During active tactile exploration of objects and surfaces, different exploratory procedures are used depending on the property, or properties, sought (in parentheses). (After [3], with permission of the authors and Elsevier Ltd.).

properties (temperature, texture). *Lateral motion*, or rubbing the fingers back and forth over a surface, is important for texture appreciation. The other exploratory procedures are used for extracting information about global object properties. These include *unsupported holding* (object is held in the hand and often hefted; this movement is important for weight estimation), *enclosure* (provides a general appreciation of both the material properties and global shape of objects by enveloping the object closely in the hand; static hold alternates with movements to shift the position of the object in the hand), and *contour following* (trace out the exact shape of objects). The exploratory procedures that are specialized for seeking information about surface properties (texture, temperature, local geometric features) are characterized by the fact that exploration is performed using the most sensitive skin surface of the hand, the fingertips.

Active touch generally employs relatively slow movements. For example, when an otherwise smooth surface is explored to find a small raised square (0.28 mm in height), then average exploration speed is 85 mm/s (range 55–110 mm/s) [4]. To put this into context, fair to good Braille readers scan text at 60–125 mm/s, while excellent Braille readers use faster scans of up to about 190 mm/s. The optimal scanning speed may, however, vary as a function of the task. For example, when subjects evaluate surface texture within the context of a forced-choice texture discrimination task, then higher average speeds are used, 160 mm/s (sinusoidal movements corresponding to the lateral motion exploratory procedure) [2]. The importance of optimizing speed during tactile exploration is

emphasized by observations that perceived roughness shows a modest decline when subjects are asked to adopt very rapid scanning speeds of  $\sim 200$  mm/s; this latter falls outside the very wide range of speeds that subjects voluntarily choose when scaling roughness ( $\sim 10$ – $150$  mm/s). With rapid movements, the stimulus likely becomes less effective, as there is less time for mechanical deformation of the skin as it passes over the textured surface. Finally, movements may slow considerably when the finger encounters a salient feature, presumably to optimize the quality of the sensory feedback elicited during the exploration. Thus, finger movement is very slow (3–4 mm/s) when subjects feel an object in order to estimate its softness or compliance.

The contact forces applied during active exploration with the fingertip are relatively light [4]. For example, average normal forces of  $\sim 0.5$  N are used during tactile search for a small raised element. Most importantly, subjects adopt a strategy of keeping normal force relatively constant for a given tactile exploration task, but this is adapted depending on the goal. If subjects seek a small recessed, rather than an elevated, target, then normal force is slightly increased to  $\sim 0.65$  N presumably to maximize the amount of skin penetrating the recessed square and so to improve detection.

### Lower Level Processes

The mechanisms involved in generating the active movements essential for active touch have been described in another essay. The sensory receptors found in the skin and various deep tissues (muscle, joints),

and that are activated during active touch, have also been described elsewhere.

### Higher Level Processes

#### *Is Perception Equivalent With Active and Passive touch?*

Intuitively, it seems obvious that active touch, in which case the salient sensory inputs are self-generated, should show an advantage over passive touch because the exploration is controlled and optimized by the subject. Indeed, Gibson [1] argued strongly that passive touch, in which the parameters of stimulation are controlled by an external agent, is an unnatural experience. He argued that active touch should be considered an entirely different order of sensory experience since the sensory impressions are directly projected to the environment. For example, during manual exploration of an object like a pencil or a paper clip, it is the object that is perceived and not the areas of skin contacted or the finger movements.

A number of studies have compared perceptual performance using active and passive touch, but these have concentrated almost exclusively on tasks dependent on cutaneous feedback. Their results show that perceptual performance with active and passive touch is similar when exploratory conditions are suitably matched [5]. Equivalence for active and passive touch has been shown for a variety of cutaneous tasks, including the detection of minute surface irregularities, texture discrimination, scaling the roughness of various surfaces, and recognition of raised tactile patterns (letters, Braille characters). Occasionally, investigators have shown an advantage for active touch over passive touch, e.g. recognition of Braille characters, but the findings have not been confirmed in other studies using similar types of pattern recognition tasks.

Few studies have looked at abilities dependent on haptic feedback within the context of the active-passive debate. This is a difficult problem, one that cannot be easily addressed, because the presence of the motor command itself modifies the sensitivity of muscle and joint proprioceptors to limb movements. Coactivation of the gamma motoneurons along with the alpha motoneurons directly modifies muscle spindle sensitivity to stretch; activation of muscles inserting into the joint capsule also modifies joint receptor sensitivity to movement. Thus, the sensory feedback during passive movements is likely substantially different from that associated with active movement (see also below). Despite these reservations, there have been a few attempts to compare active and passive touch, e.g. comparing performance during active and passive tactual exploration of raised line drawings of the type used in reading aids for the blind [5]. This task combined tactile feedback from the exploring index finger along with kinaesthetic feedback from the arm as the image is explored. When exploration time was limited (5 s), then active touch was better than passive;

this advantage disappeared when more time was allowed for passive touch (30 s). These observations suggest that active touch is more efficient than passive touch, but it is not clear whether the task used was truly haptic in nature, since performance depended most critically on the arm trajectory and so kinaesthetic feedback. With technological advances, it is now possible to use a robot arm with added force feedback to generate virtual shapes, and explore these by moving around a manipulandum (kinaesthetic feedback); force feedback is sensed both through the hand grip (cutaneous feedback), and the sense of effort required to perform the exploration. Although not directly tested yet, it appears that discrimination abilities may be similar for active and passive explorations of virtual shapes [6]. This is quite surprising given that the sensory feedback during passive movements is likely different from that during active movement (including no force feedback during the passive testing). If anything, the results argue in favour of considerable redundancy in encoding haptic shape.

To summarize, current evidence indicates that there is perceptual equivalence for active and passive touch in a range of tasks, mostly dependent only on cutaneous inputs. Active touch, on the other hand, likely enjoys an advantage over passive touch in being more efficient: the relevant sensory information is collected, and analyzed, more rapidly. More fundamentally, active, but not passive, touch is used for exploration.

#### *Neuronal Mechanisms of Active and Passive Touch*

As much of the evidence points in favor of similar perceptual abilities with active and passive touch, there has been a tendency to consider that the underlying neuronal mechanisms must be the same. One school of thought believes that sensory inputs are processed in the same fashion, regardless of the mode of touch; another school of thought (above) believes that active touch is more than the sum of its parts (cutaneous and proprioceptive inputs), including as it does a voluntary, intentional component.

During active touch, recordings of neuronal activity in S1 cortex show that the pattern of discharge reflects the expected discharge of the various peripheral mechanoreceptors (cutaneous and proprioceptive) activated during tactile exploration [7], with active touch being inherently noisier than passive touch because of associated discharge related to joint movements. In addition, small numbers of cells are active well in advance of movement onset, possibly reflecting the motor command itself, given the existence of reciprocal connections between motor cortex and S1. A variety of discharge patterns are found during active touch: the discharge frequency of some cells varies with both the stimulus (e.g. surface texture) and the movement parameters (speed, contact force); others show invariant responses to tactile

features, independent of the motor kinematics or kinetics; yet others signal information about the movement parameters alone. In contrast, S1 neuronal responses during passive touch are more focused, reflecting the details of the applied stimulus. As with active touch, a proportion of S1 cells show invariant responses to tactile features during passive touch, independent of the parameters of stimulation, e.g. the speed at which textures are displaced under the finger tips.

The movements that accompany active touch bring an added complication to the central processing of somatic sensory signals since the act of movement modulates the transmission of tactile inputs to S1 cortex. This phenomenon is widely referred to as movement-related gating of sensory transmission [5]. Both the motor command (efference copy) and sensory feedback from the moving limb (movement reafference) contribute. Sensory inputs are most frequently diminished during movement, but there is also evidence that some inputs can be selectively enhanced during active exploration. Much of the evidence showing gating during active movement comes from studies in which externally generated test stimuli (e.g. air puff or electrical stimuli) are applied to the body surface, so corresponding to passive touch [5]. These studies have shown that sensory inputs from the moving limb are diminished prior to, and during, movement (Fig. 2a).

Parallel changes in tactile detection and magnitude estimates are seen. In contrast, the relative differences

between suprathreshold stimuli are preserved (Fig. 2b). This latter observation is particularly important for the active-passive touch debate, because the majority of studies showing similar perceptual abilities for active and passive touch used tactile discrimination tasks, dependent on judgments of the relative differences between suprathreshold inputs, and not the absolute amplitude of the signals. Since relative differences are preserved during movement, performance is similar. This observation helps to explain the paradoxical observation of perceptual equivalence for active and passive touch, in the face of movement-related suppression in the transmission of tactile stimuli to S1 cortex.

Recordings from single S1 cortical neurons, in both monkeys and rats, indicate that even behaviorally relevant inputs during active touch show evidence for the existence of movement-related suppression of their responses: many neuronal evoked responses during active touch are smaller than those evoked during passive touch, consistent with a gating out of tactile inputs during movement [5,8]. Although it is difficult to ensure that stimulation is identical during both modes of touch, some S1 cells signal somatic stimuli equally well during active and passive touch, consistent with relative sparing from movement-related suppressive influences. In addition, the population of cells encoding behaviorally relevant inputs is actually smaller during active touch than passive touch, possibly reflecting some pruning of the inputs so that only cells directly involved

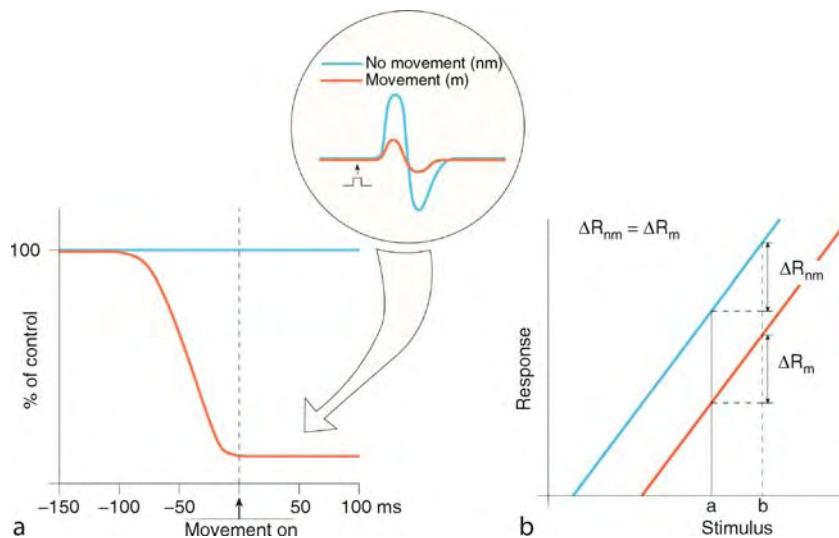

**Active Touch. Figure 2** (a) During movement, there is a decrease in the amplitude of somatosensory evoked potentials (SEPs) recorded from the dorsal column-medial lemniscal pathway that conveys cutaneous and proprioceptive feedback from the periphery to primary somatosensory cortex (S1) (inset). The time-course of gating is identical for both perception (detection of near-threshold tactile stimuli) and SEPs, with the decrease preceding the onset of movement. (b) Psychophysical results suggest that gating is associated with a downward shift of the stimulus-response curve: the perceived magnitude of suprathreshold stimuli is decreased during movement (red curve) while relative differences,  $\Delta R$ , and so the discrimination threshold, are preserved.

in the behavioral task are activated. The functional role of this suppressive mechanism is most likely to reduce the flow of afferent information that can be predicted from the motor command so that the detection of unexpected or novel stimuli is enhanced. Finally, there is evidence that inputs can be selectively gated in during active touch: neurones in monkey area 2 (S1) that lack an obvious peripheral receptive field, discharge in relation to specific shapes actively grasped in the hand [9]. Similarly, no-receptive field neurones in S2 encode surface texture during active touch.

To summarize, there has been a long-standing debate about the perceptual equivalence of active touch and passive touch. The underlying neuronal mechanisms differ, in part, because only active touch involves active voluntary movements. Moreover, apart from laboratory studies, passive touch is not used for exploration. It thus seems unwise to generalize from results obtained using one form of touch to the other. For example, it is conceivable that the motor commands associated with active touch may trigger central mechanisms (e.g. attention) that contribute to enhance neuronal responses to salient inputs during active touch. Finally, active touch enjoys a number of advantages over passive touch: digits can be oriented so that the most sensitive skin areas contact the object and; movement speed can decline at critical times during exploration, so minimizing suppressive gating influences (themselves speed-dependent).

### Function

Active touch allows one to identify salient objects or surfaces in the immediate peri-personal space using the cutaneous and proprioceptive feedback generated during the exploration. One can then act on this information, either to control or interact with the surrounding environment. A typical example might be to search for a key in one's pocket; the key can then be used to unlock a door. This example highlights the use of the hand both as a touch organ and an effector (wielding a tool).

### Pathology

Lesions of the anterior part of the parietal lobe (S1) produce profound deficits in somesthesia, including both simple (light touch, two-point discrimination, position sense, vibration sense) and complex abilities (e.g. tactile object recognition, visuotactile matching). In contrast, patients with lesions of the posterior parietal cortex (posterior S1 and areas 5 and 7) are particularly impaired on complex tasks. Some of these patients also show difficulties in generating exploratory and manipulative finger movements within the context of active touch, although they can imitate the appropriate finger movements [10]. Such observations suggest that posterior parietal cortex plays an important role in generating and executing exploratory movements

within the context of using sensory feedback to choose and execute the appropriate exploratory procedure. This dissociation has been most clearly described in a case report of a patient with a deficit in tactile object recognition using active touch, but not passive touch. The patient had a large infarct that spared S1 but encompassed regions of the infero-posterior part of the parietal lobe (possibly including S2), as well as the temporal lobe and the frontal operculum. Thus, deficits in active touch do not necessarily follow directly from the problems in processing somatosensory information.

Active touch is also critically dependent on the integrity of the somatomotor system, and so lesions of, for example, the hand representation within the primary motor cortex (area 4 of the frontal lobe) result in profound deficits in active hand/digit movements, and so active touch. Even lesions restricted to more proximal parts of the arm representation (elbow, shoulder) can cause difficulties in active tactile exploration because the whole arm is frequently employed (for example, as one searches for a light switch in the dark).

Thus, active touch is critically dependent on the integrity of both the somatosensory cortical regions in the parietal lobe, as well as the various precentral motor cortical regions involved in planning and executing exploratory movements.

### ► Haptics

### References

1. Gibson JJ (1962) Observations on active touch. *Psychol Rev* 69:477–491
2. Morley JW, Goodwin AW, Darian-Smith I (1983) Tactile discrimination of gratings. *Exp Brain Res* 49:291–299
3. Lederman SJ, Klatzky RL (1987) Hand movements: a window into haptic object recognition. *Cogn Psychol* 19:342–368
4. Smith AM, Gosselin G, Houde B (2002) Deployment of fingertip forces in tactile exploration. *Exp Brain Res* 147:209–218
5. Chapman CE (1994) Active versus passive touch: factors influencing the transmission of somatosensory signals to primary somatosensory cortex. *Can J Physiol Pharmacol* 72:558–570
6. Soechting JF, Poizner H (2005) The use of motion cues in the haptic sense of circularity. *Exp Brain Res* 165:413–421
7. Chapman CE, Tremblay F, Ageranioti-Bélanger SA (1996) Role of primary somatosensory cortex in active and passive touch. In: Wing A, Flanagan R, Haggard P (eds) *Hand and brain: neurophysiology and psychology of hand movement*. Academic Press, San Diego, CA, pp 329–347
8. Hentschke H, Haiss F, Schwarz C (2006) Central signals rapidly switch tactile processing in rat barrel cortex during whisker movements. *Cereb Cortex* 16:1142–1156

9. Iwamura Y, Tanaka M (1978) Postcentral neurons in hand region of area 2: their possible role in the form discrimination of tactile objects. *Brain Res* 150:662–666
10. Freund HJ (2003) Somatosensory and motor disturbances in patients with parietal lobe lesions. *Adv Neurol* 93:179–193

## Active Vision

MICHAEL F. LAND

Department of Biology and Environmental Science,  
University of Sussex, Brighton, UK

### Definition

The eyes are not static recorders of the visual surroundings. They scan the scene for new information by making fast eye movements (►saccades) up to 4 times a second. Active vision is the study of the relations of these patterns of fixations to the control of ongoing behavior [1].

### Characteristics

#### Why Move the Eyes?

The human ►fovea, the region of maximum acuity, has a maximum angular diameter of  $2^\circ$ , which means that it covers an area equivalent to a thumb nail at arm's length. Acquiring detailed information from different places thus requires the eyes to move. A second requirement of vision is that, having moved, gaze must remain still until the next eye movement. This is because the ►photoreceptors are slow to respond, and image motion results in blurring at speeds of more than a few degrees per second. As a result our usual method of viewing the world is with a saccade-and-fixate strategy in which we take in information during "snapshots" that typically last about 300 ms. Our eyes are then in rapid motion for about 30 ms, during which we are effectively blind. A major question in active vision is how the sequences of fixations that we make are adapted to the needs of the current task.

#### Patterns of Gaze During Different Activities

The task we are engaged in determines the pattern of fixations that we make. In reading Western languages the eyes move saccadically from left to right taking in about seven characters per fixation [2]. Interestingly this number is almost independent of the size of the type, indicating that the brain can scale saccade size to fit the letter spacing. In sight-reading piano music gaze alternates between the upper and lower staves, reading approximately 3 notes per fixation. In both reading aloud and sight-reading the time between seeing a

note or letter and speaking or playing it is about 1 s. Typing is similar. All three activities operate like conveyor belts. The content of each fixation passes through a processor to produce an appropriate motor act and leaves nothing behind, except meaning in the case of reading. Sight-reading is particularly interesting because the two staves are read serially, but combined in the processor to be emitted simultaneously by the fingers.

In ►locomotory activities such as walking vision is only used to guide the feet if the terrain is rough or there is a need to avoid obstacles. In those cases the point of gaze is about two steps ahead of the next footfall, though not usually exactly on the point of the footfall itself [3]. About twice as many saccades are made as there are footfalls, and the time interval between gaze position and footfall is again about 1 s. When driving the way gaze is deployed on the road varies with the type of road and traffic conditions. On winding country roads where continuous monitoring of curvature is essential many studies have found that drivers' gaze tracks the tangent point on the inside of the bend [4]. This is the moving point on the outward convexity of the road edge (or center line) where the line of sight is tangential to the lane marker. Provided the driver maintains a constant lateral position in the lane, the direction of this point relative to the driver's present direction of travel provides a direct measure of the curvature of the bend ahead, and hence can act as a direct feed-forward control signal for steering. In practice there is a very high correlation between observed tangent point direction and steering wheel angle, after a delay of about 0.8 s. The delay here is necessary because the vehicle has not yet reached the point where the curvature was measured. Town driving is very different. The main problem there is to find a route through parked vehicles, oncoming traffic and other obstacles. Gaze typically alternates between the various hazards, checking their moving locations at a rate of several fixations per second.

In ball games such as cricket gaze does not always follow the ball, but often anticipates its future position. Thus in cricket a batsman watches the bowler's delivery, and from the apparent speed of descent of the ball estimates the location of its bounce point. A gaze saccade is made to this point, reaching it about 100 ms before the ball [5]. In this way the location, time of arrival and behavior of the ball when it bounces can be observed, and from these the time and position of contact with the bat can be obtained. Much the same happens in table tennis, and no doubt lawn tennis as well, although that game is too fast to allow currently available head-mounted eye trackers to be used.

Some of the most interesting patterns of ►eye-hand coordination are seen in such ordinary domestic activities as food preparation [6]. These activities consist of a series of actions based around objects such as kettles, mugs, knives etc. (Fig. 1).

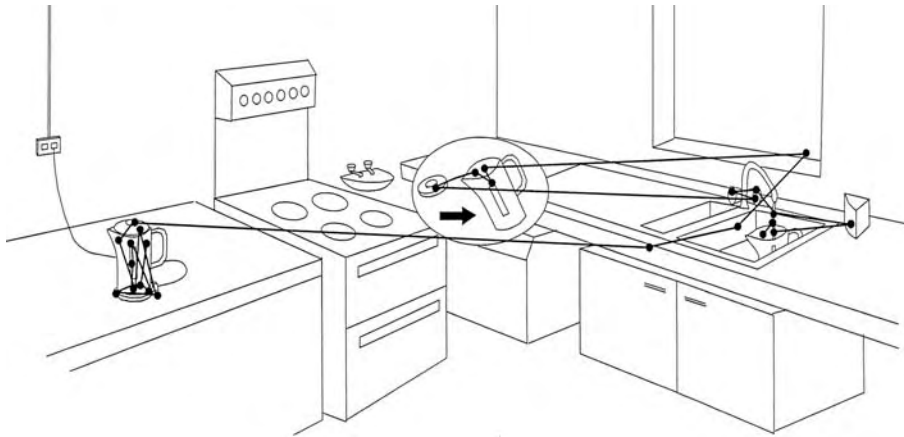

**Active Vision. Figure 1** Eye fixations during the first 10 s of a tea-making video in which the participant inspects the kettle, picks it up, moves it to the sink while removing the lid, positions it under the faucet and turns on the tap. The 26 fixations are almost entirely on the objects involved in the action (the sink tidy on the right is the sole exception). They supply the information required for the task at the time it is needed. From [6].

There are three motor components to these object-related actions. First, if needed, there is a movement of the whole trunk towards the next object; this is followed about half a second later by the first fixation of the eyes on the object, and about half a second after that the hands start to move to perform one or more manipulations on the object. Interestingly, gaze moves on to the next object in the sequence about half a second before manipulation of the present object is complete, implying the existence of a buffer holding whatever information is required to complete the last action. The functions of the different fixations that are made during such actions can be classified into four categories. “Locating” (or “look-ahead”) fixations establish the locations or attributes of objects to be dealt with in the future, with no action occurring at the time. “Directing” fixations accompany actions where an object is fixated prior to a hand movement towards it or gaze moves to position where an object is to be set down. Typically only a single fixation is involved, and gaze usually leaves the object or set-down point before the hand reaches it, so that the act is completed without visual feedback. “Guiding” fixations are concerned with manipulations involving more than one object, for example a kettle and its lid, where both objects have to be guided relative to each other under visual feedback so that they dock in an appropriate way. Most tool use is of this kind (e.g. hammer and nail, spanner and nut). “Checking” fixations determine when some condition is met, for example the kettle is filled, the water boils, or the lid is off the bottle. Such fixations, which may be unusually long if there is a delay before the condition to be met, usually terminate actions and trigger the next one. Interestingly the hands themselves are rarely if ever fixated, nor are objects once they have been

acquired by the hands. It seems that vision is a scarce resource and is only employed when ►proprioceptive and ►haptic information is unavailable.

### General Rules for the Use of Vision During Action

As the preceding paragraphs indicate, gaze is used to obtain the information needed by the action system, and each kind of action has a unique (though not exactly replicable) pattern of fixations associated with it. In other words the fixation sequences are highly task-specific. Early in the study of the subject Ballard [7] and his colleagues suggested two rules that seem to hold for most patterns of eye-hand coordination. The first is the “do it where I’m looking” strategy, which states that the point of fixation is usually very close to the point where action is taking place. Actions are not performed in peripheral vision, nor are they performed from memory when vision is available. The second is the “just in time” rule: actions are usually initiated within a second of the fixation that provides the information for that action. Both rules imply that memory is used frugally. Apart from look-ahead saccades, which do contribute to future action planning, there is little evidence that actions are set up in detail in advance of their execution.

### What Drives Fixation Sequences?

A key question in the study of eye movements is: “What determines where the next saccade will land?” A popular model for the specification of saccade targets involves “►salience” [8]. Certain image features – contrast, color, high spatial frequency content, motion – are said to be salient, and it is argued that saccades are directed to those parts of the visual field where the appropriately weighted sum of such features is greatest. Whilst this may hold when vision is otherwise uncommitted, it certainly

does not hold during active vision. Yarbus [9] demonstrated over 40 years ago that when subjects are asked to look at a picture the pattern of eye movements they make depends crucially on what the experimenter has asked them to look for. Thus there is a very strong “▶top down” control over fixation sequences, as opposed to “bottom up” control by image features. The same is true during visually guided actions. In food preparation, for example, it is very rare to see fixations directed to objects that are not relevant to the action sequence, even though there are distracting objects around which, on a salience basis, should attract gaze more strongly.

What then does determine fixation sequences during active vision? Electrode recordings from monkeys and ▶fMRI scans in humans have provided some information about their neural basis. For complex routines such as tea making it is necessary to assume that it is the overall plan, or script, of the activity which determines what is targeted, and in approximately what sequence. These plans originate in the ▶prefrontal cortex (PFC) in primates and man. They specify to the eye movement system what is the next object to be fixated, and with that provide information about its likely location and appearance. Remarkably, objects are often fixated with a single saccade even when they are in the far periphery, indicating the efficiency of this process. The script must also inform the motor system what action to perform, and the eye movement system what to monitor as the action progresses. Many parts of the brain are involved (Fig. 2).

Output to the ▶brainstem nuclei of the oculomotor system (oculomotor nuclei, ON) which move the eyes comes from the ▶frontal eye fields (FEF) and ▶superior colliculi (SC), with the ▶parietal cortex involved in the coordination of reaching and grasping [10]. The limb motor system also has an input from the parietal lobe and from the ▶somatosensory cortex (SS) and generates its output to the ▶spinal cord via the ▶premotor cortex (PMC) and ▶primary motor cortex (MC). Visual input to both systems comes ultimately from the occipital lobe, and the temporal lobe is also likely to be involved in establishing the identity of objects. The coordination of apparently simple actions is a complex neural operation.

## Conclusions

Although we can direct our gaze direction by an act of will, this rarely happens; for most of the time fixation patterns are automatic and are not available to conscious scrutiny. We are even unaware that we look around the room in a series of discontinuous jerks, rather than a smooth scan. The principal function of the eye movement system in man is to direct gaze to locations where the eyes can provide the executive systems of the brain with the information they need for perception and action. To do this the eye movement system has its own knowledge base—of where to look on a winding road, for example, or

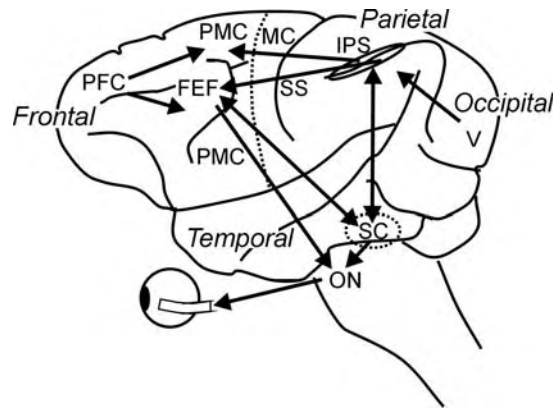

**Active Vision. Figure 2** Drawing of the left-hand side of a macaque brain showing some of the regions and pathways involved in the neural control of reach-and-grasp movements. Details in the text. The names of the four lobes of the cortex are shown. Abbreviations: FEF frontal eye fields; IPS intraparietal sulcus; MC primary motor cortex; ON oculomotor nuclei of the brain stem; PFC prefrontal cortex; PMC premotor cortex; SS somatosensory cortex; SC superior colliculus of the mid brain; V primary and secondary visual areas of the occipital lobe. The cortical output to the limbs originates in the motor cortex (MC) and runs to the spinal cord via the brainstem.

how to read a double stave of music – which we cannot access by introspection. Objective eye-movement recording is the only way to study this hidden information.

## References

1. Findlay JM, Gilchrist ID (2003) Active vision. Oxford, Oxford University Press
2. Rayner K (1998) Eye movements in reading and information processing: 20 years of research. *Psychol Bull* 124:372–422
3. Patla AE, Vickers JN (2003) How far ahead do we look when required to step on specific locations in the travel path during locomotion. *Exp Brain Res* 148:133–138
4. Land MF, Lee DN (1994) Where we look when we steer. *Nature* 369:742–744
5. Land MF, McLeod P (2000) From eye movements to actions: how batsmen hit the ball. *Nat Neurosci* 3:1340–1345
6. Land MF, Hayhoe M (2001) In what ways do eye movements contribute to everyday activities. *Vision Res* 41:3559–3565
7. Ballard DH, Hayhoe MM, Pelz JB (1995) Memory representations in natural tasks. *J Cogn Neurosci* 7:66–80
8. Itti L, Koch C (2000) A saliency-based search mechanism for overt and covert shifts of visual attention. *Vision Res* 40:1489–1506
9. Yarbus A (1967) Eye movements and vision. Plenum Press, New York
10. Jeannerod M (1997) The cognitive neuroscience of action. Blackwell, Oxford

## Active Zone

ECKART D. GUNDELFINGER, WILKO ALTROCK,  
ANNA FEJTOVÁ

Leibniz Institute for Neurobiology, Department of  
Neurochemistry and Molecular Biology, Magdeburg,  
Germany

### Synonyms

Site of regulated neurotransmitter release

### Definition

Physiologically, the active zone is defined as the restricted area of the presynaptic plasma membrane, at which ►synaptic vesicles can fuse and regulated neurotransmitter release can occur. The active zone, as defined here, consists of two major parts, the active zone plasma membrane and the associated cytoskeletal matrix, which is called presynaptic dense projection, presynaptic grid, presynaptic particle web or ►CAZ (cytomatrix assembled at the active zone) [1,2].

The general description given here refers to conventional chemical synapses of the central nervous system. It should be noted that different types of chemical synapses display differential adaptations of their active zones and the associated cytomatrices to their specific function. Of these specializations, we will briefly consider here the active zone of vertebrate ►neuromuscular junctions and of so-called ►ribbon synapses, i.e. specialized excitatory high-throughput synapses occurring, for example, in ►photoreceptor cells or bipolar cells in the retina or in ►inner ear hair cells.

### Characteristics

#### Quantitative Description

Typically, the active zone has a diameter of several hundred nanometers. For representative conventional synapses in mouse hippocampus and piriform cortex, average surface areas of  $\sim 0.04 \mu\text{m}^2$  (square microns) and  $\sim 0,095 \mu\text{m}^2$  have been determined, respectively [3]. Active zones rarely exceed an area of  $0.4 \mu\text{m}^2$ , and large synaptic boutons would rather form multiple active zones than exceed this upper “limit.” On average, these active zones accommodate one docking site for synaptic vesicles per  $3800\text{--}6200 \text{ nm}^2$  [3].

Specialized synapses have active zones of different sizes and shapes adapted to their particular function. At the vertebrate neuromuscular synapse, for example the frog’s ►neuromuscular junction, the active zone is frequently  $1\text{--}2 \mu\text{m}$  (microns) long and  $\sim 75 \text{ nm}$  wide [4].

#### Higher Level Structures

The active zone is a component of the neurotransmission apparatus of chemical synapses. It is part of the

plasma membrane of presynaptic boutons [1]. The active zone faces the synaptic cleft and is surrounded by (and tightly linked to) an endocytic zone, where synaptic vesicles that have fused with the active zone membrane are retrieved by clathrin-mediated endocytosis [5,6]. The active zone is precisely aligned with the region of postsynaptic membrane that harbors the neurotransmitter reception apparatus, and is defined by the ►postsynaptic density (PSD). The PSD is particularly prominent in excitatory brain synapses.

### Lower Level Components

#### Ultra-Structure of the Active Zone

In the electron microscope, the CAZ or presynaptic grid appears as a more or less regular array of electron-dense cone-shaped particles, which extend  $\sim 50 \text{ nm}$  into the cytoplasm. A meshwork of cytoskeletal filaments connects the  $50 \text{ nm}$  particles [2]. Additionally, filamentous strands extend  $100 \text{ nm}$  and more from the active zone plasma membrane into the presynaptic bouton (Fig. 1a).

At the frog neuromuscular junction, active zone material extends  $50\text{--}75 \text{ nm}$  into the cytoplasm of the terminal and has a regularly arranged ultra-structure consisting of “pegs,” “ribs” and “beams” as revealed by electron microscope tomography [4]. The molecular composition of these structures is currently unknown (Fig. 1b).

►Synaptic ribbons in nerve terminals of ►retinal photoreceptors are horseshoe-shaped specializations of the CAZ, which extend  $300\text{--}500 \text{ nm}$  into the presynaptic cytoplasm and tether ►synaptic vesicles. They are connected to the active zone plasma membrane via a specialized structure called arciform density [7].

#### Proteins of the Active Zone Plasma Membrane

Plasma membrane proteins present in the active zone primarily include ion channels and receptor proteins that are required for synaptic function, and cell adhesion molecules (CAMs) involved in adhesion and alignment of pre- and postsynaptic membranes as well as in trans-synaptic regulation of plasticity [8]. Most importantly, voltage-gated  $\text{Ca}^{2+}$  channels (N-type [ $\text{Ca}_v2.2$ ], P/Q-type [ $\text{Ca}_v2.1$ ]) mediate the influx of  $\text{Ca}^{2+}$  upon arrival of a depolarizing ►action potential, the trigger for synaptic vesicle exocytosis. Basically, all super-families of CAMs, including immunoglobulin superfamily members, integrins and cadherins, are represented at synaptic junctions and are involved in synaptic function and plasticity. Alpha- and beta-neurexins seem to be specific CAMs of the active zone membrane. Beta-neurexins make asymmetric contacts with postsynaptic neuroligins, while alpha-neurexins couple  $\text{Ca}^{2+}$  channels to synaptic vesicle exocytosis in a manner that is not yet understood. Active zone and opposite PSD are surrounded by a belt



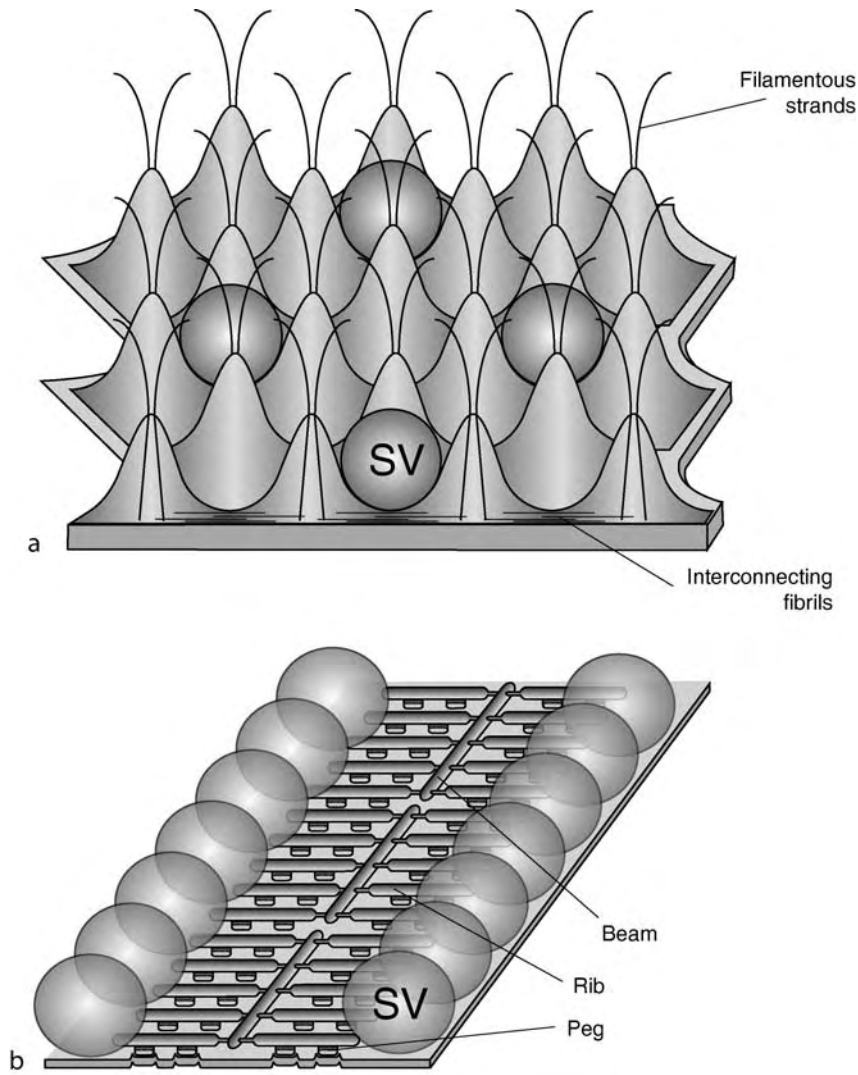

**Active Zone. Figure 1** Ultra-structure of the cytomatrix assembled at the active zone. (a) Schematic depiction of the presynaptic grid at conventional brain synapses. A more or less regular array of 50-nm cone-shaped particles is thought to define docking sites for synaptic vesicles (SV). Cones appear to be interconnected by fibrils. In addition, filamentous strands extend 100 nm and more from the active zone plasma membrane into the presynaptic bouton [3]. (b) Cartoon of the active zone at the frog neuromuscular junction as revealed by electron microscope tomography [5].

of cadherin/beta-catenin complexes. Additional cell membrane proteins thought to reside within the active zone include ephrin ligand-receptor systems and receptor tyrosine phosphatases, as well as a variety of metabotropic receptors.

#### **Molecular Organization of the CAZ**

Only few CAZ-specific proteins have been identified to date [9]. These include the Munc13 synaptic vesicle priming factors; the ►RIM (Rab3-interacting molecules), multi-domain proteins that can interact with multiple other active zone proteins; ►Bassoon and Piccolo (►Piccolo/Aczonin), two very large CAZ scaffolding proteins; as well as ►CAST/ERC (CAZ-Associated

Structural Protein Or Elks/Rab6-Interacting Protein/CAST), another family of CAZ-specific structural proteins. In addition, SH3 domain-bearing RIM-binding proteins (RIM-BPs) and alpha-liprins, which also bind RIMs and the receptor tyrosine phosphatase LAR, have been described as bona fide or potential CAZ components. These molecules are thought to form the scaffold of the CAZ, which links proteins of the active zone plasma membrane to the actin/spectrin-based cortical cytoskeleton and components of the synaptic vesicle cycle. Scaffolding molecules of the CAZ can physically integrate additional effector proteins that are involved in the organization and regulation of the synaptic vesicle cycle as listed in 1 and illustrated in (Fig. 2).

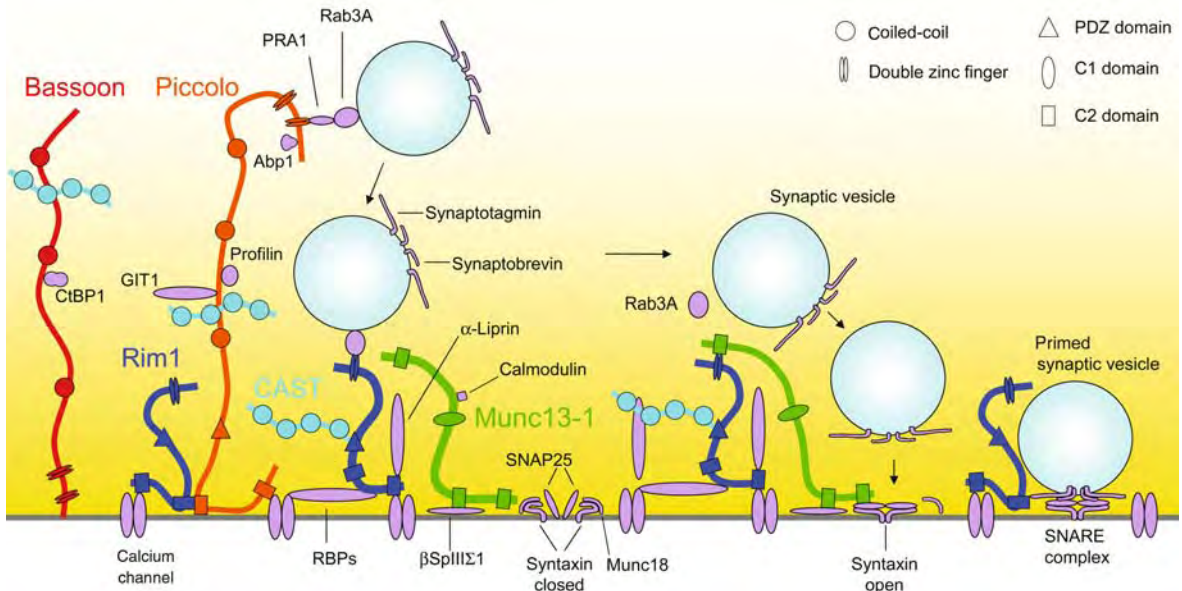

**Active Zone. Figure 2** Molecular organization of the CAZ. The CAZ-specific multi-domain proteins RIMs, Bassoon and Piccolo and the CAST/ERC proteins are thought to act as major scaffolding proteins of the presynaptic cytomatrix. They can recruit a variety of effector proteins to the CAZ and thereby organize presynaptic processes functionally and topologically. The CAZ-specific protein Munc13 serves as a priming factor for synaptic vesicles (for further details and the definition of abbreviations see Table 1). The figure was adapted from Dresbach, Altrrock and Gundelfinger (2003), *Neuroforum* 3.03, pp 79–86.

Moreover structural components of the CAZ, such as Piccolo, may serve as a physical link between the exocytic and endocytic machineries that have to cooperate precisely in presynaptic boutons [5]. In addition, a trimeric complex consisting of the membrane-associated guanylate kinase homolog CASK and the adaptor proteins Veli/Lin7 and Mint (Munc18/Sec1-interactor), which interacts with active zone membrane proteins such as beta-neurexins and voltage-gated  $\text{Ca}^{2+}$  channels, has been reported to occur at the active zone [9].

#### Specialization of the CAZ – Synaptic Ribbons

The photoreceptor ribbon synapse is a unique type of chemical synapse, structurally and functionally specialized for the tonic release of neurotransmitter in the dark. Basically, all scaffolding proteins present in the CAZ of conventional synapses can be found in synaptic ribbons. In addition, a ribbon-specific protein, RIBEYE, has been identified as a major component of synaptic ribbons [7]. Interestingly, CAZ proteins fall into two groups: those that are associated with the actual ribbon (RIBEYE, Piccolo, RIM1 and the Kinesin KIF3A), and those that associate with the active zone membrane and/or the arciform density (Munc13–1, RIM2, CAST1/ERC2). Bassoon seems to be involved in anchoring the ribbon to the arciform density [7]. Major constituents of photoreceptor ribbons including

RIBEYE, Piccolo and Bassoon are also present at inner hair cell ribbons.

#### Higher Level Processes

The active zone is integrated into the process of synaptic transmission. In this context, it serves an essential function in regulated neurotransmitter release and the organization of the underlying membrane trafficking cycle (synaptic vesicle cycle).

#### Lower Level Processes

At the active zone, processes of regulated exocytosis of neurotransmitter from synaptic vesicles, as well as refilling of synaptic vesicles (“kiss-and-stay”) or their local recycling (“kiss-and-run” mode), takes place [5,6]. Components of the active zone plasma membrane and the associated CAZ are involved in the performance and regulation of these processes. Processes localized at the active zone include docking and priming of synaptic vesicles, entry and sensing of  $\text{Ca}^{2+}$  ions, control of membrane fusion and retrieval as well as regulation of efficiency and fidelity of stimulus-secretion coupling.

#### Process Regulation

##### Presynaptic Plasticity

At the active zone, arriving action potentials trigger exocytosis. Incoming signals can be modulated as

**Active Zone. Table 1** Proposed protein–protein Interactions of CAZ proteins

Protein (Synonyms)	Domains/Motifs	Interaction partners (Literature)	Proposed function for the interaction
Rab3 interacting molecules (RIMs: primarily RIM1 $\alpha$ ; RIM2 $\alpha$ )	Zn finger	Rab3 <sup>1</sup>	SV tethering?, Regulation of SV exocytosis?
	PDZ	Munc13–1 <sup>2</sup>	SV priming
	C2A	ubMunc13–2 <sup>2</sup>	SV priming
	Proline-rich sequence (PRS)	CAST1/ERC2 <sup>3,4</sup>	Scaffolding
	C2B	Piccolo <sup>5</sup>	Scaffolding
		N-type voltage-dependent Ca <sup>2+</sup> channel <sup>6</sup>	Channel anchoring
		Synaptotagmin, SNAP-25 <sup>6</sup>	Ca <sup>2+</sup> sensing
		RIM-BPs <sup>7</sup>	Scaffolding
		$\alpha$ -Liprin <sup>8</sup>	Scaffolding
	N-type voltage-dependent Ca <sup>2+</sup> channel <sup>6</sup>	Channel anchoring	
	Synaptotagmin, SNAP-25 <sup>6</sup>	Ca <sup>2+</sup> sensing	
Munc13s	N-term region of Munc13–1 and ubMunc13–2	RIM1 $\alpha$ <sup>2</sup>	Scaffolding, Rab3 effector
	Conserved R region of Munc13s	Calmodulin <sup>9</sup>	Ca-dependent plasticity
	C-term region of Munc13–1	DOC2 $\alpha$ (double C2 domain protein) <sup>10</sup>	Unknown
		Spectrin $\beta$ -spIII $\Sigma$ <sup>11</sup>	Cytoskeleton anchoring
		msec7–1 ARF-GEF <sup>12</sup>	Cytoskeleton regulation
Bassoon	Zn fingers	CtBP1/BARS-50 (Lysophosphatidic acid acyl transferase, LPAAT) <sup>14</sup>	Membrane trafficking? Regulation of membrane curvature?
	N-terminal of CC2	Ribeye/CtBP2 (LPAAT) <sup>14</sup>	Membrane trafficking?, Scaffolding
	CC3	CAST/ERC <sup>15</sup>	Scaffolding
Piccolo (Aczonin)	Q domain	Actin-binding protein Abp1 <sup>16</sup>	Actin binding, link to endocytosis
	Zn fingers	PRA1 <sup>17</sup>	Unknown
	PRS	GIT (ARF-GAP) <sup>18</sup>	GTPase regulation, membrane trafficking
	PRS	Profilin (actin binding protein) <sup>19</sup>	Actin regulation
	CC3	CAST/ERC <sup>15</sup>	Scaffolding
	PDZ	cAMP-GEFII <sup>5</sup>	GTPase regulation
	C2A	RIM2 <sup>5</sup>	Scaffolding, Rab3 effector
	C2B	Piccolo <sup>5</sup>	Scaffolding
CAZ-associated structural proteins (CASTs, ERCs)	Coiled-coil regions	Bassoon, Piccolo <sup>15</sup>	Scaffolding
	C-term PDZ binding motif	$\alpha$ -Liprin <sup>20</sup>	Scaffolding, Transport?
		RIMs <sup>3</sup>	Scaffolding

**Active Zone. Table 1** Proposed protein–protein Interactions of CAZ proteins (Continued)

Protein (Synonyms)	Domains/Motifs	Interaction partners (Literature)	Proposed function for the interaction
RIM binding proteins (RIM-BPs)	SH3 domains (one of 3)	RIMs <sup>7</sup>	Scaffolding
	SH3 domains (one of 3)	Ca <sup>2+</sup> channels Ca <sub>v</sub> 2.2 (N-type), Ca <sub>v</sub> 1.3 (L-type) <sup>21</sup>	Channel anchoring
α-Liprins (SYD-2)	N-term CC region	CAST/ERC <sup>20</sup>	Scaffolding, Transport?
	C-term SAM domains	KIF1A (kinesin motor) <sup>22</sup>	Transport
		LAR (receptor tyrosine phosphatase) <sup>23</sup>	Receptor anchoring
		GRIP <sup>24</sup>	Receptor clustering

<sup>1</sup>Wang Y, Okamoto M, Schmitz F, Hofmann K, Sudhof TC (1997) *Nature* 388:593.

<sup>2</sup>Betz A et al. (2001) *Neuron* 30:183.

<sup>3</sup>Ohtsuka T et al. (2002) *J Cell Biol* 158:577.

<sup>4</sup>Wang Y, Liu X, Biederer T, Sudhof TC (2002) *Proc Natl Acad Sci USA* 99:14464.

<sup>5</sup>Shibasaki T, Sunaga Y, Fujimoto K, Kashima Y, Seino S (2003) *J Biol Chem*.

<sup>6</sup>Coppola T et al. (2001) *J Biol Chem* 276:32756.

<sup>7</sup>Wang Y, Sugita S, Sudhof TC (2000) *J Biol Chem* 275:20033.

<sup>8</sup>Schoch S et al. (2002) *Nature* 415:321.

<sup>9</sup>Junge HJ et al. (2004) *Cell* 118:389.

<sup>10</sup>Orita S et al., *J Biol Chem* 272:16081.

<sup>11</sup>Sakaguchi G et al. (1998) *Biochem Biophys Res Commun* 248:846.

<sup>12</sup>Neeb A, Koch H, Schurmann A, Brose N (1999) *Eur J Cell Biol* 78:533.

<sup>13</sup>Betz A, Okamoto M, Benseler F, Brose N (1997) *J Biol Chem* 272:2520.

<sup>14</sup>Tom Dieck S et al. (2005) *J Cell Biol* 168:825.

<sup>15</sup>Takao-Rikitsu E et al. (2004) *J Cell Biol* 164:301.

<sup>16</sup>Fenster SD et al. (2003) *J Biol Chem* 278:20268.

<sup>17</sup>Fenster SD et al. (2000) *Neuron* 25:203.

<sup>18</sup>Kim S et al. (2003) *J Biol Chem* 278:6291.

<sup>19</sup>Wang X et al. (1999) *J Cell Biol* 147:151.

<sup>20</sup>Ko J, Na M, Kim S, Lee JR, Kim E (2003) *J Biol Chem* 278:42377.

<sup>21</sup>Hibino H et al. (2002) *Neuron* 34:411.

<sup>22</sup>Shin H et al. (2003) *J Biol Chem* 278:11393.

<sup>23</sup>Pulido R, Serra-Pagez C, Tang M, Streuli M, Proc Natl Acad Sci USA 92:11686.

<sup>24</sup>Wyszynski M et al. (2002) *Neuron* 34:39.

a function of the history of previous presynaptic activation (presynaptic plasticity). The major signal mediator, both for neurotransmitter release and its modulation is the bivalent Ca<sup>2+</sup> ion. Two parameters are thought to determine presynaptic plasticity, i.e. the conversion of an action potential to a Ca<sup>2+</sup> current and the conversion of a Ca<sup>2+</sup> signal to exocytosis [6]. Components of the active zone essentially govern processes of presynaptic plasticity. Recently, two CAZ proteins, RIM and Munc13, have been implicated in the regulation of presynaptic plasticity [6,10]. Regulation of the synaptic vesicle priming factor Munc13 by the ubiquitous calcium sensor calmodulin may be a long-sought for molecular mechanism for Ca<sup>2+</sup>-dependent presynaptic plasticity. In addition, Munc13's function is regulated by the second messenger diacylglycerol [10]. RIM1alpha knock-out mice display deficits both in short-term plasticity of conventional synapses and in long-term potentiation of mossy fiber

boutons of the hippocampal CA3 region [6,9]. As RIM1a and Munc13s can physically interact, it is conceivable that they fulfill their modulatory effect on presynaptic function in a concerted manner.

#### **Developmental Assembly of the Active Zone**

During brain development, the active zone is assembled from distinct pre-formed packages in a quantal manner [8]. Assembly of the major components of the active zone including membrane proteins, such as N-type Ca<sup>2+</sup> channels, cadherins and the target SNARE protein syntaxin, as well as bona fide CAZ components, like Bassoon, Piccolo, RIMs and Munc13, occurs inside the neurons, probably at the trans-Golgi complex. According to the “active zone transport vesicle” hypothesis these pre-assembled complexes bud off the Golgi membrane, are transported into the axon along microtubules, and fuse with the presynaptic membrane in response to a yet unknown signal. Dense-core active

zone transport vesicles have a diameter of  $\sim 80$  nm, and are found in axonal growth cones and along axons before synaptogenesis. This mode of assembly may explain the speed and efficiency with which new synapses can be formed during development.

### Function

The active zone, including the associated cytoskeletal matrix, is a specialized region of the presynaptic plasma membrane that serves the regulated release of neurotransmitter. Here, incoming action potentials are translated into chemical signals, which can then be detected by the postsynaptic cell. As both basic mechanisms of regulated exocytosis and processes of synaptic plasticity are triggered by calcium [6] (see above), the appropriate placement of voltage-dependent  $\text{Ca}^{2+}$  channels and of  $\text{Ca}^{2+}$ -sensing and -modulating systems is of key importance. Various active zone proteins including Munc13s, RIMs and Piccolo as well as Synaptotagmins, which are thought to act as principal  $\text{Ca}^{2+}$  sensors on synaptic vesicles, harbor multiple C2 domains as phospholipid-dependent  $\text{Ca}^{2+}$ -binding sites.

Proteins assembled at the active zone serve the local restriction as well as the structural and functional organization of the synaptic vesicle cycle [6,9]. They are involved in

- anchoring and clustering active zone membrane proteins, e.g.  $\text{Ca}^{2+}$  channels and CAMs,
- recruiting effector molecules to the active zone,
- docking, priming, fusion and retrieval of synaptic vesicles,
- the local integration and regulation of the actin/spectrin-based cortical cytoskeleton
- linkage to the endocytic apparatus.

Proposed functions for individual CAZ components and their interaction partners are summarized in Table 1.

### Pathology

Mutations in CAZ genes may result in altered presynaptic plasticity, epilepsy and impaired vision and hearing. For example, RIM1 $\alpha$  knock-out mice display a decreased probability of neurotransmitter release and impaired short-term and long-term synaptic plasticity [9]. Mice mutant for Bassoon suffer from rapidly generalizing epileptic seizures [9]. Moreover, in these mice, anchoring of synaptic ribbons to the active zone is impaired in retinal photoreceptors and cochlear inner hair cells [7] resulting in dramatic deficiencies in vision and hearing. To date, no corresponding genetic defects have been reported for humans. On the other hand, mutations in presynaptic calcium channels can result in episodic or spinocerebellar ataxia, familial hemiplegic migraine or idiopathic generalized epilepsy.

## References

1. Dresbach T et al. (2001) The presynaptic cytomatrix of brain synapses. *Cell Mol Life Sci* 58(1):94–116
2. Phillips GR et al. (2001) The presynaptic particle web: ultrastructure, composition, dissolution, and reconstitution. *Neuron* 32(1):63–77
3. Schikorski T, Stevens CF (1999) Quantitative fine-structural analysis of olfactory cortical synapses. *Proc Natl Acad Sci USA* 96(7):4107–4112
4. Harlow ML et al. (2001) The architecture of active zone material at the frog's neuromuscular junction. *Nature* 409(6819):479–484
5. Gundelfinger ED, Kessels MM, Qualmann B (2003) Temporal and spatial coordination of exocytosis and endocytosis. *Nat Rev Mol Cell Biol* 4(2):127–139
6. Sudhof TC (2004) The synaptic vesicle cycle. *Annu Rev Neurosci* 27:509–547
7. Tom Dieck S, Brandstatter JH (2006) Ribbon synapses of the retina. *Cell Tissue Res* 362(2):339–346
8. Ziv NE, Garner CC (2004) Cellular and molecular mechanisms of presynaptic assembly. *Nat Rev Neurosci* 5(5):385–399
9. Schoch S, Gundelfinger ED (2006) Molecular organization of the presynaptic active zone. *Cell Tissue Res* 362(2):379–19
10. Rosenmund C, Rettig J, Brose N (2003) Molecular mechanisms of active zone function. *Curr Opin Neurobiol* 13(5):509–519

## Activity Phase

### Definition

Portion of the behavioral circadian cycle where the organism is active. In diurnal organism, the activity phase occurs during the daytime, in nocturnal organisms, during the nighttime.

- ▶ Arrhythmicity/Rhythmicity
- ▶ Circadian Cycle

## Activity-dependent Synaptic Competition

### Definition

A refinement process of neural circuitry to select stronger synaptic inputs among multiple inputs converging on the same target while the other weaker inputs are eliminated. This process is referred to as

“competition” because the relative strength of each synaptic input is evaluated.

- ▶ Activity-dependent Synaptic Plasticity
- ▶ Synaptic Elimination

---

## Activity-dependent Synaptic Modification

### Definition

Synaptic depression or facilitation induced by special patterns of activation of the synapse. Higher-frequency activation often causes synaptic facilitation, and lower-frequency activation gives rise to synaptic depression.

- ▶ Associative Long-Term Potentiation (LTP)
- ▶ Memory, Molecular Mechanisms

---

## Acquired Immunodeficiency Syndrome (AIDS)

### Definition

Illness and associated conditions caused by infection with the ▶ **human immunodeficiency virus (HIV)**, a retrovirus. The syndrome may include neurological symptoms resulting from the combined degeneration (vacuolar ▶ **myelopathy**) of the ▶ **corticospinal tract** and the ▶ **dorsal columns**.

- ▶ Human Immunodeficiency Virus (HIV)

---

## Activity-Dependent Synaptic Plasticity

MICHAEL A. COLICOS

Department of Physiology and Biophysics, Faculty of Medicine, University of Calgary, Calgary, AB, Canada

### Synonyms

Neuronal plasticity

### Definition

The ability of the connections between neurons (the synapses) to change in strength in response to activity.

### Characteristics

#### Introduction

Central to the function of the nervous system is its ability to change dynamically in response to sensory input. The process of learning and the formation of memories allow the individual to adapt to and function in its environment. In order to accomplish this, the connectivity between the neurons must be able to change. Rather than occurring randomly, these changes must be guided by the information that flows through the neuronal network. Thus, activity dependent synaptic plasticity is an essential mechanism by which the cognitive function of the central nervous system is achieved. There are two tiers to the alteration of synaptic connectivity: changes that take place very rapidly, which allow immediate response to dynamic input; and more long-term changes that can consolidate memories for up to the life of the organism. As one would expect a mechanistic commonality between these two tiers exists, and short-term changes, if emphasized and repeated, will eventually become permanent.

#### Foundations

At the end of the nineteenth century the Spanish neuroanatomist Santiago Ramón y Cajal suggested that since no new neurons are created in the brain during the life of an individual, memories might be formed by improving the strength of the connections between them [1]. In the middle of the twentieth century Donald Hebb suggested a mechanism by which this strengthening could occur, postulating that through repeated and persistent stimulation of a neuron there is an increase in its efficacy of communication, arising from either a metabolic change in the cell or the activation of the growth process [2]. It is now generally accepted that the connectivity between neurons determines how information will be processed by the brain, and the ability to modify these connections in response to activity underlies learning and memory. The brain can change its information processing pathways in response to input by two basic mechanisms: by forming new connections or by strengthening the existing ones. Memory can be generally classified as being either short-term or long-term. While some forms of altered synaptic strength can last for extended periods of time (up to days or weeks), it is generally thought that short-term memory is associated with changes in synaptic efficacy, whereas long-term memory involves a structural change in the connectivity between neurons. These long-term changes can be expected to last for years. Of key importance to the function of the nervous system is that these changes in the strength of neuronal

connections arise in response to activity. This reflects an important aspect of how the brain functions, in that there is selective strengthening of circuits that are being used. In addition to activity-driven synaptic plasticity, subsequent regulatory plasticity can also occur. This is a slower process which modulates the changes in connectivity themselves, necessary to avoid a loss of stability in the neuronal network.

### **Mechanism of Altered Synaptic Efficacy: Long-Term Potentiation (LTP)**

Long-term potentiation is an experimentally-induced phenomenon by which high frequency activity at a synapse results in an enhancement, or potentiation, of subsequent synaptic transmission. Although demonstration of an identical phenomenon occurring in the intact brain is limited, it is widely accepted as a basic mechanism for learning and memory. LTP was first described by Terje Lømo in 1966, when he observed that stimulation of the perforant pathway into the rabbit hippocampus caused an enhancement of the excitatory postsynaptic potentials induced in the cells of the dentate gyrus [3]. Many types and stages of LTP exist. Two of the most studied are often defined by their dependence on either the NMDA or on the AMPA glutamate receptors. Moreover, multiple durations and phases of LTP rely on different biochemical mechanisms, all of which have been extensively investigated [4]. It is generally believed that LTP is a fundamental mechanism by which short-term changes in synaptic efficacy can be achieved.

### **Long-Term Depression (LTD)**

The counterpart to LTP, long-term depression, is a weakening of synaptic strength which results (in the hippocampus) from either persistent low-frequency stimulation or from an extremely strong synaptic stimulation such as occurs in the cerebellum. From a functional point of view, the presence of long-term depression of synaptic strength is essential. To develop a neural processing system based solely on enhancement of synaptic strengths would result in a general increase in activity in the brain during the life of the individual. The ability to reduce synaptic strength or prune out unwanted synapses is essential for the overall balance. Mechanistically LTD has not been as rigorously studied as LTP, however it is clear that many of the mechanisms are in common between the two, especially calcium influx [5].

### **Spike Timing Dependent Plasticity (STDP)**

Spike timing dependent plasticity illustrates the fine balance between LTP and LTD. A single dendrite of a neuron receives many inputs from multiple axons. The synapses at these junctions most often fire independently,

each following its own rules and dynamics. Consequently, as excitatory postsynaptic potentials are induced and are traveling down a dendrite it is likely that other synaptic input will also be depolarizing the dendrites, causing the two signals to either summate or interfere with each other. Additionally, when a neuron fires there is a back propagating depolarization that arises from the action potential. This back propagating action potential can affect new incoming EPSPs. If neurotransmitter release occurs after a back propagating action potential arrives at the postsynaptic site, LTD can be induced and synaptic strength decreased. Conversely if the back propagating action potential arrives at the synapse after the EPSP, the potential is reinforced, and, LTP can be induced. Thus, the timing of the arrival of depolarizing potentials at the synapse can either strengthen or weaken it. The dependence of such changes in synaptic efficacy on the coincident timing of activity illustrate the ability of the nervous system to respond with a high degree of temporal specificity, and react in a finely tuned manner by changing the strength of the individual synaptic connections [6].

### **Mechanism of Structural Plasticity: Synapse Number**

Perhaps the most direct mechanism of synaptic plasticity is structural change. The strength of the connections between two neurons can be directly altered by either adding or removing synapses. In the 1980s Bailey and Chen demonstrated that the process of habituation in an invertebrate system can alter the number of connections between neurons [7]. This has also been demonstrated in mammalian systems, and researchers hypothesize that by making physical changes such as these in connectivity, permanent changes in the functioning of a neuronal system that last the lifetime of an individual can be achieved. The mechanism of such changes is often assumed to be related to the initial process of synaptogenesis that occurs during embryonic development, which is subsequently reinitiated by activity. If one views the changes in synaptic efficacy as a precursor to more permanent structural change, one would expect common signaling pathways between the two processes. The most studied candidate for this signal is the calcium influx that occurs during synaptic transmission. It can not only play a determinate role in altering synaptic efficacy through mechanisms such as LTP and LTD, but can also induce cytoskeletal changes through mobilization of actin, a requisite for morphological change. Additionally, the nature of the direct change in synaptic connectivity can be related to the information carried by the activity, for example high frequency stimulation will cause an increase in the number of connections, where as low frequencies result in a loss of connectivity. This change in synapse density has been eloquently demonstrated *in vivo*, using high-resolution imaging of neurons from

trained versus untrained animals [8]. Synaptic remodeling has also been observed under more controlled conditions using dissociated hippocampal neuronal cultures [9]. Thus, during learning and memory formation, the brain can encode new information in its structure by directly altering the number of connections between neurons.

### Spine Morphology

In addition to changing the number of presynaptic contacts, the shape and size of the postsynaptic structure can also be altered to modulate synaptic transmission. This can occur by both changing the size of the active zone, as well as by altering the diameter of the spine shaft. Changing the morphology of the postsynaptic spine will modulate the way an incoming depolarization propagates before actually entering the dendrite and proceeding to the cell body. Spine dynamics are also integral to the process of new synapse formation, acting as targets for synaptogenesis [10].

### Summary

Activity-dependent synaptic plasticity describes the change in neuronal connectivity that occurs as a direct result of synaptic transmission. This plasticity can be manifested as either altered synaptic efficacy or as direct physical synaptic change. The process is assumed to provide a mechanism of altering information flow through the neuronal system in a manner which reflects the incoming activity patterns that initiated the change, providing a system for learning and memory.

### References

1. Ramón y Cajal, Santiago (1894) The croonian lecture: la fine structure des centres nerveux. Proc R Soc Lond 55:444–468
2. Hebb DO (1949) Organization of behavior: a neuropsychological theory. Wiley, New York, ISBN 0-471-36727-3
3. Bliss T, Lømo T (1973) Long-lasting potentiation of synaptic transmission in the dentate area of the anaesthetized rabbit following stimulation of the perforant path. J Physiol 232(2):331–356
4. Malenka RC, Bear MF (2004) LTP and LTD: an embarrassment of riches. Neuron 44(1):5–21
5. Dudek SM, Bear MF (1993) Bidirectional long-term modification of synaptic effectiveness in the adult and immature hippocampus. J Neurosci 1993 13(7): 2910–2918
6. Lisman J, Spruston N (2005) Postsynaptic depolarization requirements for LTP and LTD: a critique of spike timing-dependent plasticity. Nat Neurosci 2005 8(7): 839–841
7. Bailey CH, Chen M (1988) Long-term memory in Aplysia modulates the total number of varicosities of single identified sensory neurons. Proc Natl Acad Sci USA 85(7):2373–2377
8. Zito K, Svoboda K (2002) Activity-dependent synaptogenesis in the adult Mammalian cortex. Neuron 35(6): 1015–1017
9. Colicos MA, Collins BE, Sailor MJ, Goda Y (2001) Remodeling of synaptic actin induced by photoconductive stimulation. Cell 107(5):605–616
10. Matus A (2000) Actin-based plasticity in dendritic spines. Science 290(5492):754–758

---

## Activity-dependent Synaptic Rearrangement

### Definition

A refinement process of neural circuitry regulated by the strength of neural activity in the pre- and postsynaptic cells.

► Synaptic Elimination

---

## Actogram

### Definition

An actogram depicts activity patterns of organisms.

Usually, activity on a time base of 24 h is plotted on horizontal lines below each other for consecutive days.

However, also other time bases can be chosen (modulo plots). Activity can be depicted quantitatively or as a state variable. Aligning the same actogram twice so that two consecutive time episodes are plotted one after the other and the second episode is repeated just below the first episode on the successive line is called a double plotted actogram, facilitating the identification of rhythms which cross the time base.

► Circadian Rhythm

► Circannual Rhythms

---

## Actualism

### Definition

The view that everything which exists actually exists; this implies that possible worlds, if they exist at all, have to exist as part of the actual world.

► Possible World



## Actuator

### Definition

An actuator is a device with the capability of transforming one type of energy into another. Actuator differs from sensor in the way it is used. The actuator is used to transform commands of a control algorithm into actions applied to the physical system to affect its behaviour (state).

- ▶ Control

## Acutance

- ▶ Contrast Enhancement

## Acute and Chronic Ataxic Neuropathy

- ▶ Large-Fiber Sensory Neuropathy

## Acute Brain Slice

- ▶ Slice Preparation

## Acute Disseminated Encephalomyelitis

### Definition

ADEM belongs to the group of ▶ idiopathic inflammatory demyelinating diseases (IIDDs) and is an autoimmune disease with multifocal lesions throughout the brain and spinal cord, usually following a febrile viral infection or vaccination, with the highest incidence

during childhood. ADEM is characterized by ▶ encephalopathy and ▶ pyramidal, ▶ cerebellar, and ▶ brainstem signs, bilateral ▶ optic neuritis, transverse ▶ myelitis, and altered consciousness. ▶ Seizures are rare. The pathogenesis is unknown and may be triggered by a T-cell mediated autoimmune response to ▶ myelin basic protein. Treatment includes methylprednisolone, immunoglobulins, plasmapheresis, or cytotoxic drugs.

- ▶ Idiopathic Inflammatory Demyelinating Diseases (IIDDs)

## Acute Pain

- ▶ Incisional/Postoperative Pain

## Acute Sensory Neuropathy Syndrome

### Definition

Acute loss of large myelinated sensory nerves subserving touch and proprioception (see Section on Large-Fiber Sensory neuropathy).

- ▶ Proprioception: Effect of Neurological Disease

## Adaptation of Saccadic Eye Movement

### Definition

The saccadic eye movement or saccade is a rapid eye movement to capture an object in the visual field. When the target is displaced during the saccadic eye movement, it changes so that the target can be captured.

The forward or backward target displacement causes a gradual increase or decrease in the saccade amplitude, respectively. Such a phenomenon is called adaptation of saccade.

- ▶ Saccade, Saccadic Eye Movement
- ▶ Sensory Motor Learning/Memory and Cerebellum

## Adaptation of Sensory Receptors

### Definition

Adaptation is the decline of the electric responses of a receptor neuron over time in spite of the continued presence of an appropriated stimulus of constant strength. This change is apparent as a gradual decrease in the frequency of spikes generated within the receptor neuron. Phasic receptors adapt rapidly and inform, therefore, about the rate of change of a stimulus. Tonic receptors adapt slowly and inform about the presence and strength of a stimulus. Many sensory neurons may unify both response properties and are called phasic-tonic receptors. They usually show a phasic response at stimulus onset, followed by a long-lasting, but lower tonic response.

► Sensory Systems

## Adaptation of Vestibulo-Ocular Reflex

### Definition

The vestibulo-ocular reflex is the eye movement driven by the head motion detected by inner ears. The eyeball turns in the opposite direction of head turn so that the image motion on the retina (retinal slip) is suppressed.

The amplitude of this reflex changes when there is a mismatch between the head and the eye movements.

The change works to reduce the retinal slip, thus it is regarded as adaptive.

- Retinal Slip
- Sensory Motor Learning/Memory and Cerebellum
- Vestibulo-ocular Reflexes

## Adaptation of Visual Perception

### Definition

Adaptation refers to the tendency of a sensory system to change its operating characteristics as a result of prolonged or repeated exposure to a specific type of stimulus. For example, a striped surface (a grating) that appears vertical when presented in isolation (test stimulus) can be made to look tilted if the observer

first stares at (adapts to) a tilted grating for some time (say 60 s) and then looks at the isolated test grating again.

► Visual Illusions

## Adaptive Behavior

### Definition

The ability to adjust behavior to changes in the environment.

► Cognitive Elements in Animal Behavior

## Adaptive Control

ARIE FEUER<sup>1</sup>, GRAHAM C. GOODWIN<sup>2</sup>

<sup>1</sup>Electrical Engineering, Technion, Israel

<sup>2</sup>ARC Centre for Complex Dynamic Systems and Control, Department of Electrical and Computer Engineering, The University of Newcastle, Callaghan, NSW, Australia

### Definition

An “adaptive controller” is a special form of control law (see separate article on “control”). Adaptive controllers have the distinguishing feature that they incorporate some form of inbuilt mechanism for adjusting their characteristics, based on perceived changes in the characteristics of the system or the environment in which the system operates.

One helpful way of thinking about adaptive control is via the concept of internal models (see separate articles on “internal model” and “control”). It can be argued (see article on “control”) that all controllers explicitly or implicitly contain internal models for both the system and the environment in which the system operates. A non-adaptive controller will typically utilize fixed internal models, whereas an adaptive controller will have some mechanism for changing the internal model, based on observations made regarding how the system responds to stimuli provided to the system through the actuators (see separate article on “control”).

There is a helpful example given in the article on internal models regarding lifting a box. Quoting from that article:

When you get ready to pick up a box that you believe to be heavy, you prepare your posture for

generating a large lift force long before you begin lifting. If the box turns out to be empty, it will move unexpectedly fast. One may say that your internal estimate of the dynamics of the object was inaccurate, or that you had the wrong internal model of its properties. Because you used an incorrect internal model of the box to guide your actions, you generated unnecessarily large forces in trying to pick it up.

Continuing this example, if you are asked to pick up the same box a second time, then you will almost certainly use a different posture and apply forces that are more appropriate. In other words, you will have adjusted (or adapted) the internal model for the true system and this will, in turn, have changed (or adapted) your control law.

Based on the above heuristic description, we can see that adaptive control is an interesting and potentially very useful concept. Clearly, there seems to be substantial merit in having control algorithms that are capable of initially designing themselves based on only partial knowledge of the process to be controlled.

Of even greater interest would be control algorithms that were capable of redesigning themselves in the face of significant process variations. The study of adaptive controllers takes on different forms in different areas. In the life sciences, researchers have postulated and studied the presence of adaptive mechanisms in biological control systems. In engineering, researchers

have endeavored to capture the essence of adaptive control to design control laws for use in man-made systems. In both cases, the question arises as to what form of adaptive mechanism results in the overall system behaving in the required fashion. Indeed, it is a non-trivial exercise to specify the adaptive rules so that the resulting controller has desirable properties. Understanding the general rules that lead to stable (or convergent) adaptive behavior has proven to be surprisingly difficult. Indeed, this question has captured the interest of engineers and mathematicians for the past five decades. Many insights have been obtained but the general question remains largely open. In the sequel, we will attempt to give some insights into adaptive controllers from an engineering perspective. We will not attempt to give a precise definition of adaptive control. However, in Fig. 1 we provide a possible conceptual view of an adaptive control system. At the heart of it is a typical feedback control (solid lines in Fig. 1 indicate signal flow in this part of the system), which consists of the controlled physical plant and a controller with a feedback loop. The typical starting point for traditional feedback control design is the availability of a **mathematical model** for the physical plant to be controlled (see companion article on “control”). The model typically consists of structure and parameters and similarly, the design process is aimed at determining the controller structure and parameters. There are many control design methodologies [1]. However,

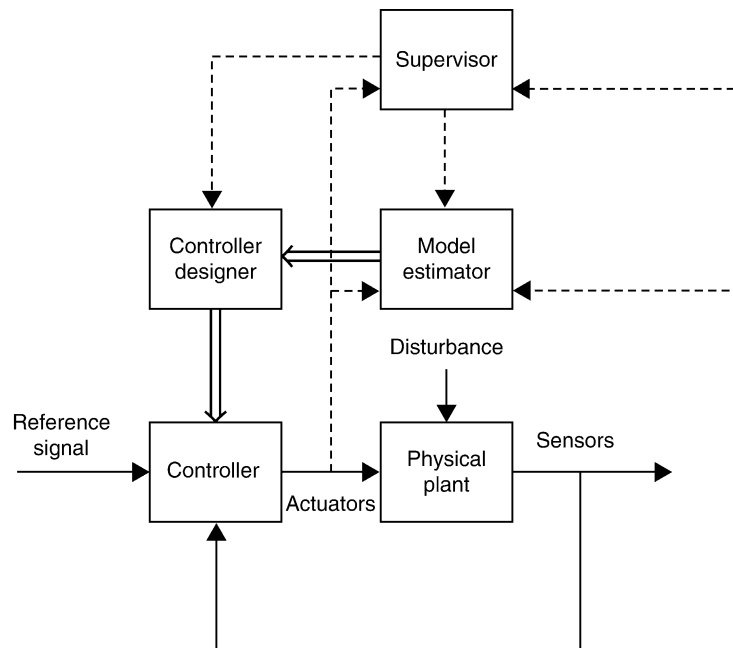

**Adaptive Control. Figure 1** A general adaptive control system.

irrespective of how the control law is designed, in a traditional setting, once the controller has been designed and implemented it stays “fixed.” On the other hand, an adaptive controller has the capacity of changing the control law by adjusting its internal models.

Specifically, an adaptive controller is aimed at providing:

- Capability to estimate the model of the process applicable at the current time – the **►Model Estimator** in Fig. 1
- Capability to redesign the controller (using some underlying design methodology) – the **Controller Designer** in Fig. 1
- Capability to make decisions as to when to re-initiate the processes of model estimation and controller redesign – the **Supervisor** in Fig. 1

Over the past 50 years, the idea of adaptive control has sparked the imagination of many researchers as well as control engineers. This resulted in thousands of papers and tens of books on the subject (see, e.g., [2,3,4,5] and many more). The adaptive controllers reported in the engineering literature (both in theory and in practice) differ in the way each capability is implemented. This will be further discussed below. Ideally, one would like to have an algorithm that was capable of changing the model and controller structure as well as their parameters. The reality, however, is that most adaptive controls in common engineering use, are limited to parameter adaptation only, while the structures of both model and controller are predetermined. As a result, the model estimation used in most contemporary adaptive controllers consists of parameter estimation and the redesign is limited to determination of controller parameters. Hence, a close connection has emerged between the area of system identification [6,7] (which studies how one can estimate model parameters from observations of input–output data) and adaptive control. Basically, one could attempt to combine any identification algorithm with any control design methodology to get an adaptive control scheme.

## Description of the Theory

### Direct and Indirect Adaptive Control

As shown in Fig. 1, estimated parameters are fed to the controller design block, which typically treats them as if they were true system parameters when designing the controller. This idea is called “**►Certainty Equivalence**” [5]. More sophisticated procedures may also try to give a measure of local accuracy of the current model and this can also be used in the control system design procedure.

There are also several ways that one can utilize the updated model information. For example, one could use the current model until one has a high level of confidence

that on-line parameter estimation has led to a better model. In other schemes, every time new estimates reach the design block, the controller is redesigned. Unfortunately, the resulting systems typically turn out to be highly nonlinear and time varying, hence, very difficult to analyze. A stumbling block is often the **Controller Design** block, which introduces much of the nonlinear relationships. In very special types of simple control law design, it is possible to avoid the need for a control design block. In those cases, the system model is manipulated into a form where it is expressed directly in terms of the control law parameters. Namely, the system parameters and the controller parameters are identical. In this case, the control law design phase becomes trivial. These cases have been referred to in the literature as **direct adaptive control** while the other cases where one needs to translate system parameters into control law parameters have been called **indirect adaptive control**. **►Model reference adaptive control** [5] and the **self-tuning regulator** [2] are prime examples of **direct adaptive controllers**.

### Analysis of behavior

An adaptive controller can thus be seen as a special form of nonlinear control law, which incorporates on-line adjustments to a feedback law. Not surprisingly, it is very difficult to analyze the behavior of these algorithms. Initial attempts focused on proving closed loop stability under idealized assumptions.

For the **direct adaptive controllers**, proof exists of stability in the literature (see, e.g., [3,4]) under idealized assumptions. It is also possible to extend these ideas to **indirect adaptive control** at the expense of additional simplifying assumptions [5].

Following these initial results, stability proofs were generated when the system was affected by disturbances and noise. Again, very idealized assumptions were made, e.g., time invariant, linear dynamics, stationary stochastic disturbances, etc.

Ideally, it would be good to have a theory that allowed one to understand the behavior of adaptive controllers in practical scenarios, e.g., when there is noise, non-stationary behavior, non-linearities and unmodeled dynamics. While some preliminary ideas are available in the literature (see for example, [8]), a comprehensive theory of adaptive control has proven to be illusive.

### Two Time Scale Adaptive Controllers

It is well known in the system identification literature, for the parameter estimators to work properly one needs to “shake up” the system to excite all its parts and exhibit its different behavioral patterns [6,7]. On the other hand, a controller typically tries to “calm” the system down. These two contradicting processes are at the core of the problem of adaptive control performance. One idea that has been shown to lead to

interesting properties is the use of two time scales (or, block invariance). The idea is to use different time scales, a fast one for the control law action and data collection for the purposes of identifying the model parameters, and a slow one for the controller redesign. Specifically, a ►sufficiently exciting signal [6,7] is inserted into the system while the controller parameters are kept constant. During this period the identifier improves its estimated parameters. At the end of this predetermined period, the redesign block is triggered, generating a new, improved, controller design. This process is repeated at predetermined fixed intervals. It has been argued (see [9]) that this idea can be applied to many combinations of identification algorithm and control design method leading to convergent behavior.

### Supervised Adaptive Controllers: Switched Control

While, in two time scale adaptive controllers, the controller redesign is “switched on” at predetermined instances, one could readily imagine the incorporation of additional logic that gets all the available information from the system and, based on some mechanism, decides when to switch on the redesign. Currently available configurations for this type of idea in the engineering literature are relatively simple. One idea is to utilize a finite set of fixed, distinct controllers with a supervisor which switches on the “most appropriate” controller at different times (see, e.g., [10]). So far the results in the literature have been limited to establishing stability of the resulting control system with no performance claims.

### Adaptive Controllers in Practice

A comprehensive theory of adaptive control is not yet available. This is perhaps not surprising, given the fact that these controllers are inherently nonlinear and exhibit complex behavior. Nonetheless, the idea of adaptive control is both persuasive and interesting.

Adaptive controllers have frequently been used in practical engineering applications [2]. Indeed, the authors of the current article have used a form of adaptive control in thickness control in rolling mills, where it has proven to be an effective design tool – allowing expensive sensors to be replaced by less expensive “virtual” sensors.

Physiological systems also frequently contain instances of control loops that appear to exhibit adaptive behavior. Indeed, it could be argued that the use of adaptive controllers by engineers is nothing more than a somewhat naïve attempt to mimic behavior which is intrinsic to all biological systems. In summary, adaptive control remains an exciting concept that will undoubtedly continue to attract interest from many fields including engineering and the life sciences.

## References

1. Goodwin GC, Graebe SF, Salgado ME (2001) Control system design. Prentice Hall, New Jersey
2. Astrom KJ, Wittenmark B (1995) Adaptive control, 2nd edn. Addison-Wesley, Reading, MA
3. Feuer F, Morse AS (1978) Adaptive control of single-input, single-output linear systems. *IEEE Trans Automat Contr* 23(4):557–569
4. Goodwin GC, Ramadge PJ, Caines PE (1980) Discrete-time multivariable adaptive control. *IEEE Trans Automat Contr* 25(3):449–456
5. Goodwin GC, Sin KS (1984) Adaptive filtering, prediction and control. Prentice Hall Information and Systems Sciences Series. Prentice Hall, Englewood Cliffs, NJ
6. Goodwin GC, Payne RL (1977) Dynamic system identification: experiment design and data analysis. Academic, New York
7. Ljung L (1987) Identification: theory for the user. Prentice Hall, Englewood Cliffs
8. Morse AS (1990) Towards a unified theory of parameter adaptive control: tunability. *IEEE Trans Automat Contr* 35(9):1002–1012
9. Shimkin N, Feuer A (1988) On the necessity of “block-invariance” for the convergence of adaptive pole-placement with persistently exciting input. *IEEE Trans Automat Contr* 33:775–780
10. Morse AS, Anderson BDO, Bitmead TS, de Bruyne F, Hespanha JP, Liberzon D (2000) Multiple model adaptive control. *Int J Robust Nonlinear Contr* 10:909–929

## Adaptive Controller

### Definition

An Adaptive Controller consists of a controller with changeable parameters combined with an adaptive scheme that changes control parameters based on plant measurements.

### ► Adaptive Control

## Adaptive Immune Responses

### Definition

Also known as acquired immunity that has four characteristic attributes: (i) antigen specificity; (ii) diversity; (iii) immunological memory; and (iv) self/nonself recognition. Adaptive immunity is capable of specifically recognizing and selectively eliminating

foreign micro-organisms and molecules via activated T and B lymphocytes and the factors they release.

Activation of adaptive immunity is directed by the cellular responses in the innate immune response and can be activated faster and more effectively upon re-encounter with the same antigen, known as a memory response. In the central nervous system (CNS), immunity conferred by T and B cells as a result of their specific recognition of certain antigens assists in the recruitment, activation, and regulation of innate immune cells for the purpose of tissue maintenance, repair, renewal, and recovery.

- ▶ Autologous Macrophages for Central Nervous System Repair
- ▶ Immune System and Pain

---

## Adaptive Multi-Layer Systems

### Definition

An architecture of neural networks composed of multiple layers of adaptive neurons. A network normally has one input layer and one output layer.

Other layers are called hidden layers. There may be both inter-layer connections and intra-layer connections between neurons. The networks which have only feed-forward inter-layer connections from input to output are called feed-forward networks. Signals on the input layer are transferred through inter-layer connections to the output layer. By modifying the weight of connections according to an adequate learning rule, desired input-output relations can be acquired.

- ▶ Competitive Learning Theory

---

## Adaptor Protein

### Definition

An accessory protein having a number of different protein-binding modules that facilitate specific protein-protein (or other molecular) interactions. It thus promotes the formation of protein complexes, and plays a role in regulating signal transduction pathways.

- ▶ Synaptic Proteins and Regulated Exocytosis

---

## Addiction

### Definition

Addiction is a neuropsychiatric disorder characterized by compulsive thoughts and actions directed toward obtaining and consumption of pharmacological and natural reward stimuli, with no regard for the potential injury to health, family or society. Casual use of substances such as heroin, cocaine, or methamphetamine does not constitute addictive behavior. Addiction is also characterized as a “chronic-relapsing disorder” which may be triggered by drug-associated cues and environments, or stress, even after long periods of abstinence from drug-seeking behavior. Addictive behaviors often entail “risk-taking” and harmful activity which may constitute a danger to public health.

Repeated exposure to drugs of abuse, excessive sexual activity, or gambling has been shown to activate specific brain systems, most notably dopaminergic and glutamateric pathways converging on the nucleus accumbens and prefrontal cortex. Long-term changes in synaptic plasticity, in the form of long-term potentiation and long-term depression in these pathways are hypothesized to be the neural correlate of addictive behavior, hence the claim that addiction is a brain disease.

- ▶ Learning and Motivation
- ▶ Long-term Depression
- ▶ Long-term Potentiation

---

## ADEM (Acute Demyelinating Encephalomyelitis)

### Definition

ADEM has a monophasic course, occurs more often in children and may follow immunization or infection.

Onset is usually abrupt with rapid progression.

Pathologically, perivenous inflammation with macrophage infiltration and associated demyelination in a sleeve like distribution along the perivenous zones is seen. Magnetic resonance imaging (MRI) shows perivenular inflammation, extensive demyelination and gadolinium enhancement of white matter in the brain and spinal cord and often involve deeper layers of cortical or subcortical structures.

Treatment may be attempted with high-dose corticosteroids or plasma exchange.

## Adenohypophysis

### Definition

- ▶ Diencephalon
- ▶ Anterior Lobe of the Hypophysis

## Adenosine

### Definition

Adenosine is a purine nucleoside that forms adenosine triphosphate (ATP), adenosine diphosphate (ADP) and cyclic adenosine monophosphate (cAMP), which are all important in cell metabolism throughout tissues of the body.

During cellular activity (and formation of ATP from two ADP molecules), free adenosine is released and transported out of cells, including neurons. Extracellular adenosine levels increase with increasing activity or under pathological conditions. Adenosine acts upon different receptors, which are associated with inhibitory (A1 and A3) or excitatory (A2a and A2b) effects on target cells. In the heart, adenosine acts upon A1 receptors to inhibit pacemaker cells and slow heart rate in a manner that is thought to be protective, particularly under conditions of ischemia or hypoxia. In the brain, concentrations of extracellular adenosine increase during prolonged periods of waking and associated neural activity. Acting upon A1 receptors, adenosine can inhibit neurons of the arousal system to promote sleep. Caffeine, well known as one of the major stimulants, acts by blocking A1 receptors.

## Adenylate Cyclase

### Definition

Enzyme that generates cyclic adenosine monophosphate (cAMP) from adenosine triphosphate (ATP).

Adenylate cyclase activity is either inhibited or stimulated by signaling through G-protein coupled receptors. There are nine mammalian adenylate cyclases.

## Adequate Stimulus

### Definition

Adequate stimulus denotes that physico-chemical stimulus, for whose reception a sensory receptor is specialized and responds to at the lowest possible intensity (energy). For example, under optimal conditions, rods in the mammalian retina respond very sensitively to low-intensity light, even single photons (adequate stimulus), while a strong blow to the eye may evoke flashes of light sensations (phosphemes), but at much higher intensity (inadequate stimulus).

- ▶ Sensory Systems

## Adjuvant Analgesics

### Definition

Adjuvant analgesics are drugs with analgesic properties that were initially developed to treat other health problems, such as anticonvulsants and antidepressants.

These drugs have become a cornerstone of pain control for children with chronic pain, especially when pain has a neuropathic component.

- ▶ Pain in Children

## Adolescent Pain

- ▶ Pain in Children

## Adrenal Insufficiency (Addison's Disease)

### Definition

Addison's disease is a condition in which patients excrete copious amounts of dilute urine and drink comparable volumes of water in compensation. The patient may suffer from adrenal tumor or atrophy.

## Adrenaline or Epinephrine

### Definition

Adrenaline is a catecholamine, which is released as a neurotransmitter from neurons in the central nervous system and as a hormone from chromaffine cells in the adrenal gland. Adrenaline is required for increased metabolic and cardiovascular demands during stress. Its cellular actions are mediated via plasma membrane bound G protein-coupled receptors.

## Adrenergic Fiber

### Definition

An adrenergic fiber is an axon of a postganglionic sympathetic neuron that synthesizes noradrenaline (or adrenaline in some amphibians and fish). These fibers are more commonly referred to as noradrenergic fibers when noradrenaline is the neurotransmitter. Adrenergic/noradrenergic fibers travel from sympathetic ganglia to target tissues within bundles, usually mixed with other autonomic and sensory nerve fibers, before they branch extensively and become varicose. Most adrenergic/noradrenergic fibers also contain co-transmitters like ATP or neuropeptide Y.

- ▶ Adrenaline
- ▶ Postganglionic Neurotransmitter
- ▶ Sympathetic Pathways

## Adrenoceptors

### Definition

Adrenoceptors are receptors of the sympathetic nervous system activated by the postganglionic transmitter noradrenaline or by adrenaline. They occur in the main subtypes of  $\alpha_1$ ,  $\alpha_2$ ,  $\beta_1$ ,  $\beta_2$  and  $\beta_3$  and may occur as auto- or heteroreceptors modulating transmitter release.

- ▶ Postganglionic Neurotransmitter
- ▶ Sympathetic Nervous System
- ▶ Sympathetic Pathways

## Adroitness

- ▶ Coordination

## Adult Neurogenesis

INMACULADA ORTEGA-PÉREZ

Laboratory of Perception and Memory, Institute Pasteur, Paris, France

### Synonyms

Neuron production in the adult brain; Secondary neurogenesis; Ongoing neurogenesis

### Definition

Neurogenesis is the process by which new neurons are generated. It encompasses the entire series of events from ▶precursor cell division to survival and functional integration of the neural progeny into the neural network.

### Characteristics

For many years, the idea that the brains of almost all mammals retained a constant structure throughout life and could not generate new neurons prevailed in the field of neuroscience. Reports contradicting this long-standing dogma first emerged in the early 1960s, but it was another 40 years before the notion of the adult brain as a static organ was finally overturned. With the advent of new methods for labeling dividing cells and improvements in imaging techniques, investigators have confirmed that neurogenesis takes place in discrete areas of the central nervous system (CNS) throughout life (reviewed in [1]). Ongoing neurogenesis is now thought to be an important mechanism underlying ▶brain plasticity, enabling organisms to adapt to environmental changes and influencing learning and memory in adulthood.

### Adult Neurogenesis in Mammals

In mammals (including humans), new neurons are added to two main areas of the adult brain: the hippocampus [2] (which is involved in certain types of learning and memory) and the olfactory bulb (OB) [3] (which is involved in the sense of smell).

In the hippocampus, neurons are generated by neural precursor cells located in the dentate gyrus (DG), in a region known as the subgranular zone (SGZ). Neuroblasts generated in the SGZ migrate into the adjacent



granular layer, where they mature into granular neurons. In contrast, new olfactory neurons arise from neural precursors located outside of the olfactory system, in a region lining the border between the striatum and the lateral ventricle, the subventricular zone (SVZ). In this case, neuroblasts cover long distances as they migrate towards the OB along a path known as the rostral migratory stream (RMS). They migrate tangentially in chains, through tubular structures formed by astrocytes. After detaching from these chains and migrating radially from the RMS to the OB, the new neurons mature into olfactory inhibitory interneurons of two main types: granule cells and periglomerular cells. Both cell types make only local contacts in the bulb, directly or indirectly modulating the processing of sensory information by the OB's projection neurons: the mitral and tufted neurons (Fig. 1). Outside these two germinal regions, little or no neurogenesis seems to occur. In both the SGZ and the SVZ, precursor or stem cells reside in specialized niches, providing a local microenvironment that influences the behavior of precursors and their ability to

differentiate into neurons (reviewed in [4]). The transplantation of SVZ precursor cells into the hippocampus results in the generation of hippocampal neurons, whereas the transplantation of SGZ precursor cells into the RMS results in the generation of olfactory interneurons. Conversely, when implanted outside these neurogenic regions, these two types of precursor generate only glia. These observations indicate that neurogenesis depends on the presence of a permissive environment, rather than on regionally different properties of precursor cells [5].

The SVZ is the neurogenic region that generates by far the largest number of new neurons in the adult CNS. However, most of the cells generated in the SVZ die, with only a subset going on to achieve maturation and functional integration. OB neurogenesis appears to involve both neuronal turnover (neuronal replacement) and a net increase in the number of neurons (neuronal addition). The cell types and architecture of the SVZ have been characterized at the ultrastructural level, and four main cell types have been identified: astrocyte-like

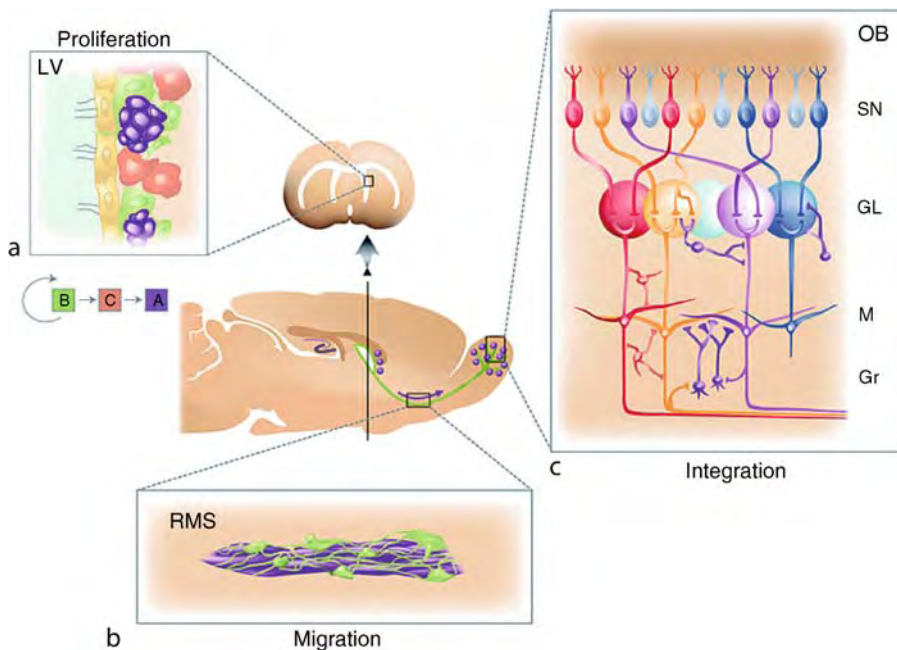

**Adult Neurogenesis. Figure 1** *Neurogenesis in the adult olfactory bulb*: (a) Schematic representation of the SVZ showing the cell types present in this region and their organization. Multi-ciliated ependymal cells (yellow) line the wall between the lateral ventricle and the striatum. Neuroblasts (A, purple), appear forming clusters that are surrounded by astrocytes (B, green) and occasionally for rapidly dividing Type C cells (red). SVZ astrocytes can eventually extend a process to contact the lateral ventricle and exhibit a short single cilium. (b) New-born neuroblasts migrate tangentially along the rostral migratory stream to reach their final destination in the olfactory bulb. Migrating neuroblast group together in chains that are surrounded by tubular structures formed by the process of astrocytes. (c) After reaching the core of the olfactory bulb, neuroblasts detach from the chains and migrate radially to the overlaying layers, where they differentiate into two local interneuron subtypes: granule cells (located in the deeper layer of the olfactory bulb) and periglomerular neurons (located in the most superficial layer). LV: lateral ventricle; RMS: rostral migratory stream; OB: olfactory bulb; SN: sensory neurons; GL: Glomerular layer; M: Mitral layer; Gr: granular layer.

cells (GFAP-positive, with an astrocytic morphology, type B cells), intermediate amplifiers (type C cells), neuroblasts (type A cells), and ependymal cells lining the lateral ventricle (Fig. 1). B cells are thought to be multipotent neural precursors. They divide to generate the neuroblasts, via transit-amplifying C cells, which migrate through the RMS towards the OB. This region also contains a specialized basal lamina, which extends from blood vessels in the SVZ and terminates in small bulbs adjacent to the ependymal cells [4].

In contrast to neurons destined for the OB, which migrate over long distances, DG granule neurons are generated locally in the SGZ. Neurogenesis in the SGZ occurs in foci associated with blood vessels and containing primary precursors (astrocyte-like, type B cells), dividing immature (type D cells) cells that already express markers of neuronal differentiation, newly generated granule neurons and endothelial cells. D cells divide less frequently and are more differentiated than the type C cells of the SVZ [4].

Despite their astrocytic phenotype, not all the astrocytes in the germinal regions of the adult brain seem to act as stem cells. Only some of these cells proliferate slowly, giving rise to mature neurons in the OB or hippocampus. The other astrocytes may act as ►niche cells, possibly providing crucial signals to the diverse stem and progenitor cells in this lineage [6].

### Regulation of Adult Neurogenesis

The molecular mechanisms involved in regulating adult neurogenesis remain unclear. It is currently thought that the process is orchestrated by an intricate, complex network of signals inducing or inhibiting the proliferation of ►precursors, influencing fate choice or favoring migration towards target areas. The transcription factors E2F or Notch 1, and molecules such as ephrins (Eph) and their tyrosine kinase receptors (EphB1–3 and EphA4) provide just a few examples of proteins involved in regulating the proliferative activity of stem cells [7]. The sonic hedgehog (SHH) pathway has also been implicated in ►progenitor cell maintenance during adulthood. A loss of hedgehog signaling results in abnormalities in the DG and OB, whereas stimulation of the pathway induces an increase in the rate of proliferation of adult progenitors. Finally, growth factors, such as brain-derived neurotrophic factor (BDNF), basic fibroblast growth factor (bFGF), insulin growth factor 1 (IGF1) and vascular endothelial growth factor (VEGF) also enhance the proliferation of progenitors in the DG or SVZ, or both [7].

Bone morphogenic protein (BMP) has been shown to induce the differentiation of neural stem cells into glial cells, whereas the local presence of BMP antagonists is associated with the generation of new neurons. Ependymal cells in the SVZ secrete Noggin and astrocytes in the SGZ secrete neurogesin-1, both of which are

BMP antagonists. The Wnt signaling pathway may also guide cells toward a neuronal fate, and it has been shown that the WNT inhibitors sFRP2 and 3 (secreted frizzled-related proteins 2 and 3) partially block astroglial cell-induced neurogenesis in the DG [8]. The transcription factors paired box 6 (Pax6) and oligodendrocyte transcription factor 2 (Olig2) are involved in the mechanisms determining the fate of newborn cells and the timing of this specification along the SVZ-olfactory bulb pathway. Olig2 is produced in the SVZ, but only in transit-amplifying cells. The overproduction of this factor facilitates oligodendrocyte maturation, but represses neural development. By contrast, Pax6 is produced in only small amounts in the SVZ, but its repression is associated with a decrease in neuroblast formation. Pax6 is also produced in large amounts in the migrating neuroblasts along the RMS, providing further evidence of a role for Pax6 in promoting neuronal differentiation [8].

The process of migration is also highly regulated during neurogenesis. The tangential migration of neuroblasts from the SVZ to the OB is modulated by a cohort of factors, including PSA-NCAM, netrins and integrins. Reelin and tenascin-R play a role in radial migration, facilitating the detachment of neuroblasts from the chains. Neuroblasts also respond to ambient GABA levels by modulating their speed of migration [7].

### Adult Neurogenesis Under Pathological Conditions

Neurogenesis is also stimulated in the mammalian brain in response to injury and disease. Experiments in rodents have demonstrated that new cells are generated in response to ischemia or brain trauma. Remarkably, newly generated neurons can migrate to the site of the injury in the cerebral cortex or striatum (where neurogenesis does not normally occur) and differentiate into mature neurons forming connections with neighboring cells [9]. Enhanced neurogenesis has also been reported in degenerative diseases, such as Huntington's chorea and Alzheimer's disease. Although this injury-induced neurogenesis does not lead to recovery, many scientists believe it represents the brain's attempt at self-repair [8]. Neurogenesis also increases in response to seizure activity, but the production of new neurons is not beneficial because these neurons develop, migrate and integrate inappropriately, and actually seems to contribute to recurrent seizures [8]. The functional significance of abnormal neurogenesis in these and other medical conditions is not yet understood, but this area is the focus of intensive research, which may one day yield new treatments for these disorders.

### Functions of Adult Neurogenesis

The precise function of newly generated neurons in the adult brain remains unclear. It has been suggested that neurogenesis in the OB system may be a plastic response coupled to the high turnover of receptor neurons in the

olfactory epithelium. However, another potential role of bulbar granule neurons generated in adulthood has emerged in recent years. An odor-enriched environment enhances neurogenesis and improves olfactory memory, and the genetic disruption of olfactory neurogenesis has been shown to result in a loss of performance in odor discrimination tasks in mice. These observations indicate that newly generated neurons may contribute to perceptual and memory functions in the bulb [7,9]. The hippocampus has been shown to be involved in learning and memory, and it has been suggested that newly generated neurons within the hippocampus contribute to these processes. The conditions impairing adult neurogenesis, such as stress, have also been shown to impair learning. In contrast, conditions promoting the generation of new neurons, such as physical exercise, are often associated with improvements in memory and the learning of tasks dependent on the hippocampus [7,8]. Studies have also shown that learning promotes the survival of new neurons, and better learners seem to retain more new neurons, particularly when trained to perform difficult tasks [9]. Hippocampal neurogenesis may also play a role in various neurological disorders and diseases, including epilepsy and depression, as some of the treatments and drugs successfully used to treat individuals suffering from depression may increase the production of new hippocampal neurons [10]. Furthermore, the beneficial effects of some antidepressants are blocked by the inhibition of neurogenesis, suggesting that low levels of neurogenesis may be an underlying cause of depression.

## References

- Gould E (2007) How widespread is adult neurogenesis in mammals? *Nat Rev Neurosci* 8(6):481–488
- Gage FH (2000) Mammalian neural stem cells. *Science* 287:1433–1438
- Alvarez-Buylla A, Garcia-Verdugo JM (1999) Neurogenesis in adult subventricular zone. *J Neurosci* 22:629–634
- Doetsch F (2003) A niche for adult neural stem cells. *Curr Opin Genet Dev* 13(5):543–550
- Suhonen JO, Peterson DA, Ray J, Gage FH (1996) Differentiation of adult hippocampus-derived progenitors into olfactory neurons in vivo. *Nature* 383(6601):624–627
- Ninkovic J, Gotz M (2007) Signaling in adult neurogenesis: from stem cell niche to neuronal networks. *Curr Opin Neurobiol* 17(3):338–344
- Lledo PM, Grubb M, Alonso M (2006) Adult neurogenesis and functional plasticity in neuronal circuits. *Nat Neurosci Rev* 7:179–193
- Ming GL, Song H. Adult neurogenesis in the mammalian central nervous system. *Annu Rev Neurosci* 28:223–250
- Sohur US, Emsley JG, Mitchell BD, Macklis JD (2006) Adult neurogenesis and cellular brain repair with neural progenitors, precursors and stem cells. *Philos Trans R Soc Lond B Biol Sci* 361(1473):1477–1497
- Malberg JE (2004) Implications of adult hippocampal neurogenesis in antidepressant action. *J Psychiatry Neurosci* 29:196–205

## Advanced Sleep Phase Syndrome (ASPS)

### Definition

Advanced sleep phase syndrome (ASPS) is most common in the elderly. It is characterized by a difficulty in staying awake in the evening and by early morning awakening. Sleep maintenance insomnia is often related to ASPS. This disorder is treated by taking 0.5 mg of melatonin at each awakening during the night after 1 a.m. and a final dose of up to 0.5 mg at final awakening in the morning. Bright light (2,000–10,000 lux) scheduled between 7 and 9 p.m., ending no later than 1 h before desired bedtime is also helpful.

►Circadian Sleep Phase Syndromes

## Aerotaxis

### Definition

Motility in relation to a gradient of oxygen concentration such that the organism migrates to an optimal oxygen concentration in an oxygen gradient.

## Aetiology

### Definition

Causal explanation, the cause of a disease.

## A-Fibers of Dorsal Root of the Spinal Nerve

### Definition

C and A delta fibers innervate primarily nociceptors but also thermo- and some mechanoreceptors. Conversely,

A-beta and A-delta fibers innervate touch receptors of the skin. All these fiber types enter the spinal cord via the dorsal root.

- ▶ Medulla Spinalis

---

## Affect

- ▶ Emotion

---

## Affective Dimension

### Definition

The way an individual feels or experiences emotion in response to a particular setting, process, characteristic, attitude, or sensation. A full description of a particular item would usually include the affective dimension of the item, along with its cognitive and behavioral dimensions (plus sometimes the sensory dimension).

---

## Afferent

### Definition

The term afferent (from Latin “ad” = towards and “ferre” = carry) refers to nerves that carry information towards the central nervous system. Somatic afferent nerves innervate muscles, joints or skin. Visceral afferent nerves innervate body organs and blood vessels.

- ▶ Sensory Systems

---

## Afferent Innervation of the Heart

- ▶ Visceral Afferents

---

## Afferent Input to Rhythm Generating Networks

- ▶ Peripheral Feedback and Rhythm Generation

---

## Afferent Regulation of Locomotion

- ▶ Locomotor Reflexes

---

## AFP

### Definition

Anterior forebrain pathway.

- ▶ Song Learning of Songbirds

---

## Afterdepolarization

### Definition

Afterdepolarization (delayed depolarization) is the depolarization after the fast spike repolarization phase, either appearing as a slow phase of repolarization or as an intermittent depolarization between a fast afterhyperpolarization and a subsequent afterhyperpolarization.

- ▶ Action Potential

---

## Aftereffect in Circadian Rhythm

### Definition

A long-term change in the endogenous circadian period as a result of entrainment to a light-dark cycle. For example, if a mouse with an endogenous period of 23 h

was entrained to a 24.5 h light dark cycle for a period of six months and released into constant darkness, it might show a new endogenous period of 24 h for several weeks to months before eventually returning to a period of approximately 23 h.

► Masking (Positive/Negative)

## Aftereffect Measurement

### Definition

Generally, an aftereffect is measured as follows: An observer judges a test stimulus in isolation (called a pretest trial or baseline measure) and then judges it in isolation again, but this time after prolonged adaptation to an inducing stimulus (called a posttest trial). There is no difference between the stimulus displays in the pretest and posttest because the inducing is removed prior to the posttest. The aftereffect, that is, the effect of the inducing stimulus on the test stimulus, is defined as the algebraic difference between the posttest and pretest judgments. Because the posttest stimulus is judged after the inducer is removed, an aftereffect is a successive effect.

► Visual Illusions

## Afterhyperpolarization (AHP)

### Definition

Afterhyperpolarization (AHP) – hyperpolarization following an (action potential). In the squid axon, the afterhyperpolarization is generated by the slowly inactivating voltage-dependent  $K^+$  conductance activated during the action potential. In mammalian central neurons, AHPs may show different phases: fast, medium and slow, in some cases interrupted by afterdepolarizations. Second, the contributing  $K^+$  channels include BK and SK channels and Kv7 channels mediating the M-current. BK-channel-mediated AHPs are usually brief, while SK-channel-mediated ones can last up to seconds.

► Action Potential

## Ageing

### Definition

Ageing refers to growing old, maturing or exhibiting the effects of the passing of time.

## Ageing of Autonomic/Enteric Function

ROBERT M. SANTER

School of Biosciences, Cardiff University, Cardiff, United Kingdom

### Synonyms

Vegetative nervous function; Visceral nervous function; Gastrointestinal function

### Definition

The ►autonomic nervous system is part of the peripheral nervous system, which is instrumental in maintaining the internal environment of the body in a steady state and in returning the internal environment to a steady state following internal and external stimuli. In order to accomplish this, the autonomic nervous system maintains a controlling influence over the cardiovascular, digestive, thermoregulatory and urinogenital systems. This is achieved by both motor and sensory innervation of the major organ systems together with other structures such as sweat glands and intraocular muscles. Autonomic function is involuntary, and we are not usually conscious of ongoing autonomic activity except at times of increased emotions such as anger or fear, when autonomically induced increases in heart rate or in sweating occur.

The ►enteric nervous system is the intrinsic, local nervous system of the digestive system which controls the processes of digestion such as motility of the gut, secretion of chemicals for the breakdown of food and the absorption of the products of digestion. The enteric nervous system also regulates the flow of blood throughout the gastrointestinal tract. The enteric nervous system can also act autonomously but, like the autonomic nervous system, is under the control of the central nervous system. In old age, there is a tendency for the ability of autonomic and enteric function to be perturbed, such that it is not as capable of maintaining a homeostatic state as it is in the young adult. There is considerable variability in the extent to which different organ systems are affected by ►aging. As advanced health care in the developed world leads to increased longevity of the human population, the

incidence of ►autonomic and enteric dysfunction in the elderly will undoubtedly increase.

## Characteristics

### Quantitative Description

By virtue of the fact that autonomic nerves travel alongside the arteries of the body and within somatic peripheral nerves and their branches, the ►autonomic nervous system is present in all regions of the body. Likewise the ►enteric nervous system extends throughout the digestive system from the oral to the anal cavity.

### Higher Level Structures

The autonomic nervous system is divided into parasympathetic and ►sympathetic divisions, which usually both innervate the same organ but have opposing functions. In general, parasympathetic function is anabolic whilst sympathetic function is catabolic in nature.

The anatomical organization of both the parasympathetic and sympathetic divisions is essentially similar. The efferent (motor) limb is a two neuron chain originating in the central nervous system in which the two neurons synapse in an ►autonomic ganglion in the periphery. The first of these neurons is termed the ►preganglionic neuron, and it has its cell bodies located in the brainstem or spinal cord. The second neuron is termed the ►postganglionic neuron, having its cell body in a ganglion sending its axon to innervate the target organ. The position of the ganglion varies and in consequence so does the length of the axons of preganglionic and postganglionic neurons. In the ►parasympathetic system, the ganglia are located close to, or even within, the innervated organ, with the consequence that the preganglionic axon is relatively long and the postganglionic axon relatively short. Sympathetic ganglia are located closer to the central nervous system and in consequence the preganglionic axon is relatively short and the postganglionic axon relatively long. All preganglionic neurons are under the control of the central nervous system by descending supraspinal pathways or by local interneurons. The afferent (sensory) limb of the autonomic reflex consists of receptor endings in the walls of the viscera, a peripheral process running either in an autonomic or a somatic peripheral nerve trunk, a cell body in a spinal or cranial ganglion and a central process entering the dorsal horn of the spinal cord or grey matter of the brainstem.

The enteric nervous system consists of two networks, or plexuses, of neurons that are located in the wall of the digastric tract. The myenteric plexus (of Auerbach) is located between the outer longitudinal and inner circular layers of the muscularis externa, and is principally concerned with the control of gut motility such that the contents are propelled in an oral to anal direction. The submucous plexus (of Meissner) is located within the submucosa. Its role is to regulate

gastrointestinal blood flow, control the functioning of the epithelial cell lining of the gut and in sensing the chemical composition of the contents of the gut lumen. The enteric nervous system has important connections with the sympathetic and parasympathetic divisions of the autonomic nervous system, and can therefore come under controlling influences of the central nervous system.

### Lower Level Components

The chemical neuroanatomy of the autonomic nervous system is relatively simple and can be summarized as follows:

1. Preganglionic neurons are multipolar and receive glutamergic, glycinergic, monoaminergic, cholinergic and peptidergic afferents.
2. All preganglionic neurons release acetylcholine at the ganglionic synapse.
3. All parasympathetic postganglionic neurons release acetylcholine at their targets but this is often accompanied by the release of vasoactive intestinal polypeptide (VIP), particularly at secretomotor terminals.
4. The majority of sympathetic postganglionic neurons release noradrenaline at their targets, often accompanied by the release of neuropeptide Y (NPY). The exception to this concerns sweat glands where acetylcholine acts as the neurotransmitter.
5. The occurrence of nitric oxide is widespread in both preganglionic and postganglionic autonomic neurons.

In addition to their extrinsic autonomic connections, ►enteric neurons secrete a wide range of neurotransmitters of which acetylcholine, nitric oxide, and many neuropeptides (principally substance P, VIP, NPY, galanin and somatostatin) which occur in different functional types of enteric neuron. The combinations of neurochemicals in enteric neurons have been used to code them and to define their functional characteristics [1,2]. In general terms, enteric neurons can be divided into the following categories:

1. Motor neurons controlling gastrointestinal motility by innervation of the muscularis and secretion from a variety of secretory cell types within the intestine.
2. Sensory neurons receiving information from terminals in the mucosa sensitive to chemical, osmotic thermal and mechanical changes and from terminals in the smooth muscle which are sensitive to stretch.
3. Interneurons responsible for the co-ordination of activity between individual ganglia of the plexuses and between the myenteric and submucous plexus. The co-ordination of descending (oral to anal) reflexes controlling peristaltic function is of special importance in promoting the passage of gut contents.

### Structural Regulation

Neurons of autonomic and enteric ganglia originate in the neural crest and migrate to their final locations. Their axons then grow into their target organs. These neural migrations are guided by a variety of factors such as neurotrophins and glial derived neurotrophic factor as well as constituents of the extracellular matrix. Failure of the ontogenetic process resulting in neurons not migrating into their correct locations results in serious malfunctions: for example, mice whose cardiac neurons have failed to reach the heart die at birth [2], and congenital dysfunctions of the gastrointestinal system such as motility disorders, megacolon and gastric outlet obstruction result from the failure of neuronal migration during development.

### Higher Level Processes

**Cardiovascular System.** Aging is associated with a reduced capability of the autonomic nervous system to maintain hemodynamic stability. A decline in the tonic influence of the parasympathetic system and an increase in sympathetic activity coupled with a change in the structure of the heart and major blood vessels from a supple nature to a more resistant, stiffer nature are characteristic of the elderly. This increased systemic vascular resistance leads to hypertension accompanied by increased systolic pressure and left ventricular hypertrophy. Decreases in cardiac output and stroke volume may be compensated for by reduced metabolic demand in the elderly. Changes with age occur in many cardiovascular reflexes including cardiopulmonary reflexes, respiratory sinus arrhythmia and in the baroreceptor reflex. Baroreceptors are stretch receptors in the carotid sinus and aortic arch, and the increased stiffening of the walls of these vessels with age results in a reduction in the ability of the receptors to respond to changes in blood pressure with a reduction in afferent input to autonomic regulatory centres in the brainstem. This is likely to be a factor in the increased occurrence of orthostatic hypotension in the elderly, a problem that is nowadays also associated with the administration of antihypertensive medication. Postprandial hypotension is also common in the elderly where there is inadequate cardiovascular compensation for the increased blood flow to the gastrointestinal system after a meal.

**Urinogenital System.** In old age, dysfunctions of urinary voiding are common and the frequency of micturition and the amount of urine voided are increased. Changes in the structure of the bladder wall and internal urethral sphincter, changes in the nerve supply of the bladder and changes in the central nervous system control of the micturition are implicated in the development of urinary incontinence. Normally, the smooth muscle of the bladder receives a dual innervation from the parasympathetic and sympathetic nervous systems. Sympathetic activity causes a relaxation of the bladder wall and a

constriction of the base of the bladder, including the internal urethral sphincter allowing the bladder to fill whilst maintaining continence. The parasympathetic effects are directly opposite, thereby inducing a voiding of urine. The sensory innervation of the bladder is a crucial part of the voiding reflex. It is considered that the age-associated changes in micturition are more likely to be due to the neural control of the bladder than to changes in the responsiveness of bladder smooth muscle to adrenergic and cholinergic agonists. The pelvic neurons innervating the lower urinary tract are, in common with those innervating the internal genital organs, sensitive to circulating androgens such as testosterone which also has potent effects on reproductive behaviour. Testosterone affects the ability of these neurons to maintain their morphology, synthesize neurotransmitters and express receptors. The age-associated reduction of plasma testosterone is likely to have serious consequences for the maintenance of pelvic neurons resulting in dysfunction of urinogenital function.

**Enteric Function.** In elderly human beings there is an increased incidence of problems associated with gastrointestinal motility. Dysphagia due to reduced oesophageal peristalsis and relaxation of the oesophageogastric junction, increased transit time of gut contents with the danger of faecal stasis and also faecal incontinence are the most common **▶enteric dysfunctions** which may be attributed to the enteric innervation. Other age-associated dysfunctions include diminished ability to absorb certain constituents of the diet.

### Lower Level Processes

**Cardiovascular System.** Well documented changes occur in the sympathetic innervation of the cardiovascular system with age. There is a reduction in the density of sympathetic innervation of the heart and in many, but not all, arteries and veins, stimulus-induced noradrenaline release increases, beta-adrenoceptor vasoconstrictive responsiveness declines, the re-uptake of noradrenaline by sympathetic nerve terminals declines and there is an increase in the concentration of plasma noradrenaline.

**Urinogenital System.** Investigations of the effects of age on the innervation of the lower urinary tract [3] have revealed that the sympathetic innervation is much more susceptible than is the parasympathetic innervation. This differential susceptibility affects both the preganglionic and postganglionic neurons supplying the bladder but also the descending supraspinal afferents to the preganglionic sympathetic neurons. The supraspinal pathways so far investigated contain glutamate, GABA, substance P and monoamines. Age-associated changes in the sensory innervation of the bladder wall have not been detected. There is some evidence that the neurodegeneration of postganglionic sympathetic pelvic neurons in old age may be

attributable to decreases in calcium binding proteins, leading to raised intracellular calcium concentrations [4].

**Enteric Function.** Neurodegeneration in the enteric nervous system with increasing age is now a well established phenomenon and affects both the myenteric and submucous plexuses [5]. Moreover, thanks to the neurochemical coding of enteric neurons [6], it is now possible to determine which functional types of enteric neuron are susceptible to age-associated neurodegeneration. In summary, there is a significant loss of cholinergic neurons from the myenteric plexus, which is likely to impair the propulsion of gut contents [7] and also of sensory neurons of the submucous plexus, possibly also contributing to reduced gut motility [5]. The postganglionic sympathetic innervation which has an inhibitory effect on the myenteric neurons is also much reduced in old age [8]. The mechanism for age-associated neurodegeneration in the gut may well be the excessive production of reactive oxygen species, as this can be almost totally prevented by caloric restriction [9,10].

### Function

Autonomic and enteric functions are complex, vital processes in the maintenance of ►homeostasis of mammals. Perturbation of these processes during aging will be detrimental to the health of individuals and may eventually be life-threatening, thus influencing the longevity of an individual.

### Pathology

Some of the age-associated effects of the ►ageing autonomic nervous system are similar to those seen in multiple systems atrophy (Shy-Drager syndrome), a progressive disease of the autonomic nervous system, in which there is a ►selective vulnerability of certain brainstem nuclei that control the preganglionic autonomic outflow. This selective vulnerability is also a feature of ageing in autonomic ganglia, in which certain target-specific groups of neurons are affected in old age whereas others are not [9]. This observation is reinforced by neuropathological evidence of neuronal degeneration in sympathetic ganglia of both man and rodents.

### Therapy

Two factors which certain groups of autonomic and enteric neurons require for successful development and maintenance in adult life have been proposed as possible therapeutic agents in instances of autonomic and/or enteric change in old age: neurotrophic factors have possible wide-ranging application and androgens whose potential beneficial effects are restricted to the androgen-sensitive pelvic neurons.

## References

1. Brookes SJH (2001) Classes of enteric nerve cells in the guinea-pig small intestine. *Anat Rec* 262:58–70
2. Young HM, Anderson RB, Anderson CR (2004) Guidance cues in the development of the peripheral autonomic nervous system. *Auton Neurosci* 112:1–14
3. Santer RM, Dering MA, Ranson RN, Waboso HN, Watson AHD (2002) Differential susceptibility to ageing of rat preganglionic neurons projecting to the major pelvic ganglion and of their afferent inputs. *Auton Neurosci* 96:73–81
4. Corns RA, Hidaka H, Santer RM (2001) Decreased neurocalcin immunoreactivity in sympathetic and parasympathetic neurons of the major pelvic ganglion in aged rats. *Neurosci Lett* 297:81–84
5. Wade PR, Cowen T (2004) Neurodegeneration: a key factor in the ageing gut. *Neurogastroenterol Motil* 16 (Suppl 1):19–23
6. Scheman M, Schaaf C, Mäder M (1995) Neurochemical coding of enteric neurons in the guinea-pig stomach. *J Comp Neurol* 353:161–178
7. Phillips RJ, Kieffer EJ, Powley TL (2003) Aging of the myenteric plexus: neuronal loss is specific to cholinergic neurons. *Auton Neurosci* 106:69–83
8. Santer RM, Baker DM (1993) Enteric System. In: Amenta F (ed) *Aging of the Autonomic Nervous System*. CRC, Boca Raton, pp 213–225
9. Cowen T (2002) Selective vulnerability in adult and ageing mammalian neurons. *Auton Neurosci* 96:20–24
10. Cowen T, Johnson RJR, Soubeyre V, Santer RM (2000) Restricted diet rescues rat enteric motor neurones from age related cell death. *Gut* 47:653–660

---

## Agency

### Definition

The property of being an agent. That is, the property of being an entity that acts. Typically, the term “agency” is applied only to agents capable of acting intentionally or purposively.

►Freedom of Will

---

## Agent Causation

### Definition

Agent causation is a relation supposed to hold between a substance, the agent, and its actions. The agent is construed as a prime mover. Agent causation contrasts



with event causation, a relation between events (including a person's motivational and representational states), and is taken by some theorists to be the key for understanding how free will is possible.

- ▶ Freedom of Will
- ▶ Information

## Age-related Macular Degeneration

### Definition

An age-related degeneration of the central retina (macular region). It causes irreversible loss of central vision (see Inherited Retinal Degenerations).

- ▶ Inherited Retinal Degenerations

## Ageusia

### Definition

Ageusia corresponds to the inability to detect and discriminate taste qualities. Most complaints of 'loss of taste' correspond in fact to hyposmia or anosmia, the loss of olfactory capability, since olfaction is essential for flavor perception. True ageusia is rare and hypogeusia, which refers to a diminished, rather than lost, sense of taste, is more common.

Direct damage of the tongue is one of the causes for taste disturbances. It could result from head and neck radiation therapy, inflammation of the tongue (glossitis) or other conditions. Tobacco use and dry mouth (xerostomia), such as that resulting from Sjögren's syndrome, may also have the same effects.

The chorda tympani nerve, a branch of the facial (VIIth) cranial nerve, contains primary sensory neurons that transmit chemosensory information from the anterior two-thirds tongue. The glossopharyngeal (IXth) cranial nerve contains the peripheral taste fibres from the posterior third of the tongue. Damage to any of these nerves, for example due to trauma or surgery (e.g., iatrogenic chorda tympani lesion during otologic surgery) may cause hypogeusia. Ageusia from peripheral neural lesion is unlikely since multiple anatomically distinct nerves would have to be damaged. Central lesions (e.g., trauma, tumor or ischemia of the parietal lobe) may also cause loss of taste in discrete areas of the

taste field. Non-traumatic peripheral or central neurological disorders, such as Bell's palsy or multiple sclerosis, may also affect taste function.

Systemic disturbances may also affect the sense of taste. Vitamin deficiency, endocrine disorders, cancer, renal or hepatic failure and multiple drugs, are known causes of ageusia. Aging is also typically accompanied by loss of taste sensitivity.

- ▶ Gustation

## Aggression

### Definition

Attack and threat; behavior directed to other organisms with the aim to intimidate, hurt or drive another animal away.

## Aging of Tactile Sense

RONALD T. VERRILLO

Institute for Sensory Research, Syracuse University,  
Syracuse, New York, NY, USA

### Definition

#### Characteristics

None of the sensory systems is immune from the deficits in function that occur as a consequence of the natural process of aging. It is a slow process that advances throughout the life span, but does not become noticeable until the mid-40 and 50 decades of life. Most people become aware of this decline when the visual system makes it necessary to wear "reading" glasses in order to bring a printed page into proper focus. The tactile sense (touch) is not exempt from the effects of advancing age. However these effects go largely unnoticed by most people because interaction with the environment is much more salient in vision and hearing and there is no dramatic "end product" such as blindness and deafness. For this reason there has been a paucity of research funding and effort in tactile research as compared to that of vision and hearing. Although these effects have been studied for about 80 years, for the most part the early studies used poorly controlled stimulators such as cotton swabs, hairs and primitive electronic devices. Hardly quantifiable, the

results of these experiments are difficult to interpret. Controlled laboratory experiments using modern technologies for measurement have been used routinely only in the past 35 years.

Studies of the tactile sense usually fall into two broad categories, namely measurements made at ► **threshold** and at ► **suprathreshold** levels of stimulation. Threshold experiments are performed to determine the minimal amount of energy that an observer is able to detect, in this case mechanical displacements (vibration). Suprathreshold experiments are performed in order to determine the observer's judgments and perceptions of energy levels well above the just-detectable level. Research on the effects of aging on the tactile sense has focused on measuring both threshold and suprathreshold responses.

### Threshold

The onset of a loss of sensitivity in the tactile system is measurable at a relatively early age. Between the ages of 10–20 years youngsters show a loss of sensitivity especially at frequencies above 80 Hz [1,2]. Later Verrillo [3] tested a different group of subjects at the age

of 10 and the same subjects again at 23 years of age in a longitudinal study and found the same result. This confirmed that the results of the earlier study were not due to a bias in cross-sectional selection of subjects. All of the frequencies between 40 and 600 Hz were affected; only at 25 Hz was there no change in sensation. The span of ages was expanded further from 10 to 65 years in a series of experiments that determined that the loss of sensitivity was progressive throughout the life span, slow in the younger years but increasing more rapidly after about 55 years of age [4,5] which confirmed an earlier finding that covered approximately the same span of ages (20–70 years) [6]. Figure 1 shows the threshold values for vibrotaction in subjects ranging in age from 10 to 70 years. Increasing threshold values denote a loss of sensitivity.

The data also revealed an effect of gender; beyond 65 years of age in males suffered a greater loss of sensitivity than did females [5]. The loss of sensitivity in all of these studies occurred only at high frequencies from 80 to 250 Hz. At lower frequencies (25–40 Hz) the sensitivity to vibration remained constant through the life span. This suggests that in the ► **vibrotactile**

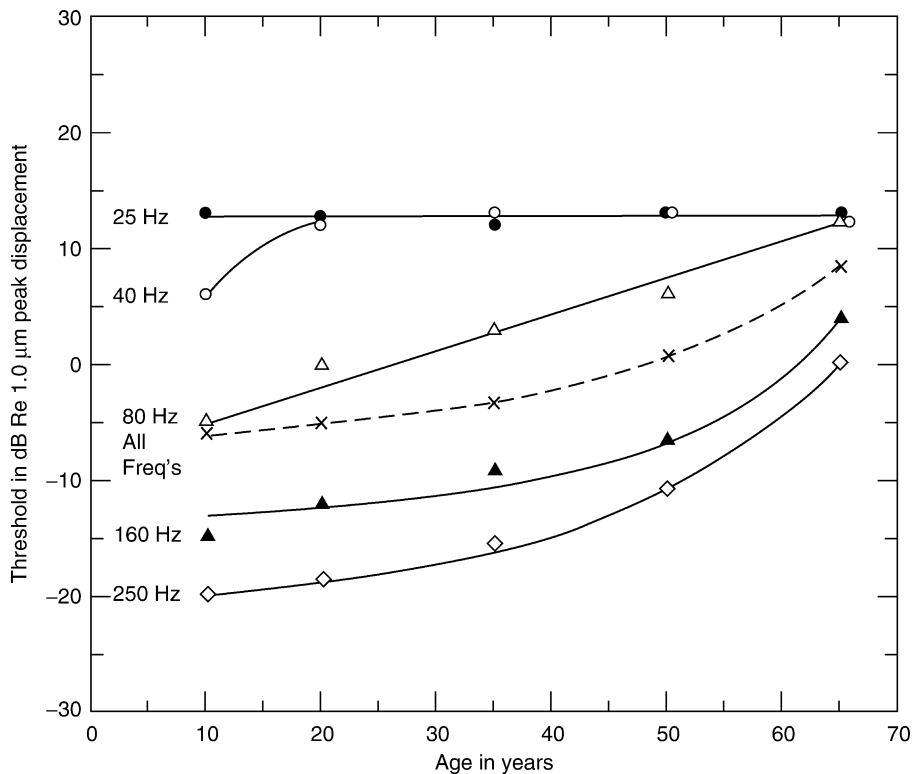

**Aging of Tactile Sense. Figure 1** Detection thresholds of vibrotaction measured at five frequencies plotted as a function of age. The dashed line represents a composite of all frequencies combined. Decreasing sensitivity is indicated by increasing values along the vertical axis. From Verrillo [3].

neural channel subserved by the ►Pacinian-corporuscle receptors, which are activated optimally by high-frequency vibration, there are anatomical and physiological changes in structure and/or biochemical composition that do not occur in non-Pacinian channels. Non-Pacinian receptors respond primarily to low-frequency vibrations. Many explanations have been offered to account for the loss of sensitivity with advancing age including changes in receptor morphology, loss of receptors, decrease of spinal-root fibers, decreased peripheral circulation and dietary deficiency. Throughout the life span, and especially in adulthood, there is a progressive loss of nerve fibers that is steady and continuous. A decrease in the number of receptor end organs accompanies the loss of nerve fibers. The large Pacinian corpuscles decrease in number, change in size and become more complex in structure with advancing years, becoming convoluted in shape, which can affect their ability to respond to mechanical deformations. Once fully developed in infancy, all of the cutaneous nerves and receptor end organs undergo a steady decrease in number and in morphological change that continues throughout the span of life. The rate of change is constant throughout the age span at 80 Hz, at about 3 dB per decade of age. At higher frequencies the loss accelerates at greater age levels. Throughout the span of years tested below the age of 65 there was no difference between men and women in the sensitivity to vibration, but beyond 65 years of age males suffered a greater loss of sensitivity than did females [5]. The loss of sensitivity in all of these studies occurred only at high frequencies from 80 to 250 Hz. At low frequencies (25–40 Hz) the sensitivity to vibration remained constant through the life span. It is likely that no single factor can explain the loss of sensitivity but that a combination of several or many of these is probably responsible.

### Suprathreshold

Because we live in an environment in which we are stimulated by and respond to stimuli that are, for the most part, above the threshold of detection, it is essential that the effects of these higher energy levels be considered. There are a number of psychophysical methods used to measure responses to suprathreshold stimulation, but the method of choice for measuring the relationship between the physical intensity of a stimulus and an observer's subjective impression of that intensity is a technique called Absolute Magnitude Estimation (AME). Subjects are asked to assign a number (greater or less than 1.0) whose magnitude is judged to be a match to that of the stimulation that is perceived. No standard, modulus or range of numbers is suggested by the investigator. The numbers assigned by the subjects are then plotted as a function of

the physical intensities of the stimulus. The subject is free to use any number, large or small that seems an appropriate fit to the perceived intensity of the stimulus. The resultant curve is typically a power function. This method has been used in a number of sensory modalities and along many dimensions of the stimulus. The slope of the curve (exponent) is different for each sense modality, but it is consistent within each modality.

Figure 2 shows the results obtained when a group of 25 year olds was compared to an older group with a mean age of 66 years [7]. They were both tested using the AME method at a frequency of 250 Hz. The shift in the curve of the older group to higher intensities by 16 dB indicates that for the same perceived intensity in assigned numbers, the older group required at least a 16 dB increase in the physical intensity of the vibration. This means that at both threshold (Fig. 1) and at above threshold levels of stimulation there is a loss of vibrotactile sensitivity associated with the process of growing older. The 16 dB difference in threshold values would predict this outcome. However, the slopes of the two curves are identical; both slopes are about 1.0 in the mid-to upper-levels of physical intensity. This suggests that although there is a loss of sensation with age, there is no difference in the rate at which suprathreshold stimuli grow in perceived magnitude. This would imply that in the vibrotactile system the effects of aging are manifested more as a result of changes at central levels of the nervous system (cortical) rather than changes at the periphery.

Judgment of the subjective magnitude of vibration is not the only suprathreshold performance that suffers a deficit with advancing age. From a practical viewpoint the sense of touch has been used as a surrogate channel for both vision and hearing as an aid to communication for the blind and the deaf. The blind have used ►Braille for many years and more recently electromechanical devices to read the printed word with their fingertips. In a parallel effort, for many years researchers have made the effort to develop a method of substituting the tactile sense for hearing as an aid to the profoundly deaf. As the blind and the deaf grow older or develop pathologies such as adult-onset diabetes mellitus, which degrades the sense of touch, their ability to access the world becomes severely limited. The sensory input from the fingertips is a vital link with the world that has become reduced or disrupted. Human speech is the most sophisticated and complex form of communication throughout the animal kingdom. All animals communicate with one another in various ways, but none approaches the subtlety and richness of expression as that of human speech. To render this into a system of tactile stimuli has been a formidable task indeed.

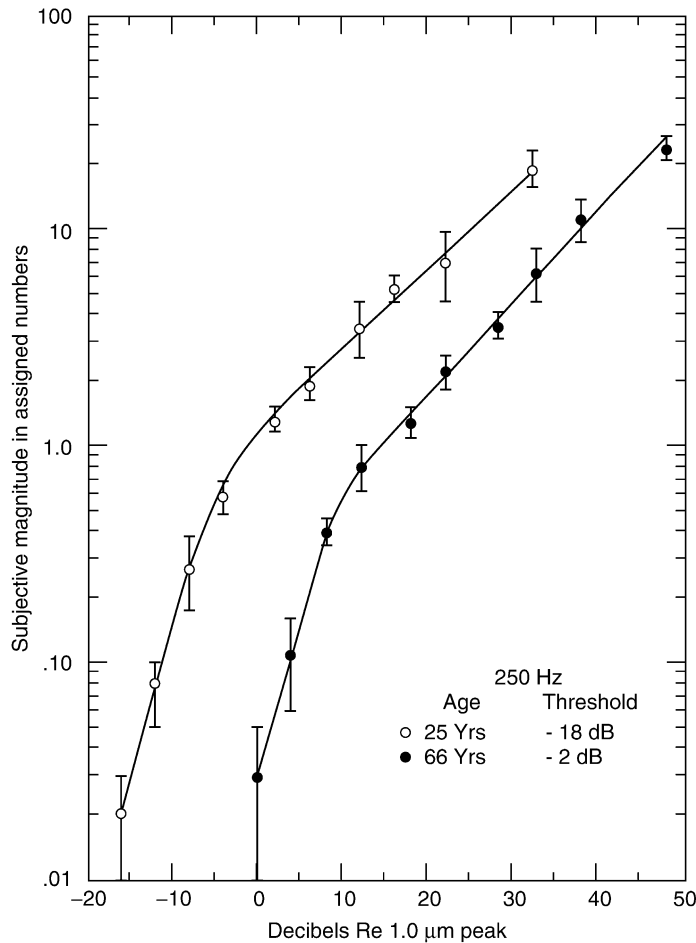

**Aging of Tactile Sense. Figure 2** Absolute magnitude estimation of vibrotaction plotted as a function of the displacement intensity of the vibration. Comparison of a younger group (mean age 25 years) and an older group (mean age 66 years) is shown. From Verrillo [7].

In order to develop tactile sensory aids for the deaf (▶tactile vocoders) investigators have studied a large number of speech parameters so that these elements might be incorporated into the design of a practical tactile device. One of the elements essential in understanding speech is the ability to distinguish rapidly changing temporal sequences of stimuli. In one study a group of subjects 22 years of age was compared to a group of 66 year olds in the ability to distinguish two short bursts of vibration separated by ▶interstimulus intervals of various durations [7]. The younger group was able to detect two bursts separated by as little as 25 ms whereas the older group was unable to make that distinction when the separation of the double burst was less than 150 ms. Older subjects would be at a severe disadvantage in understanding the spoken word by the use of a tactile vocoder unless the design of the device would contain a feature to compensate for this serious limitation.

Another measurement used to assess the ability to understand speech (in the hard-of-hearing) is the test of gap-detection, that is, the ability to detect a silent interval between two long bursts of sound. Similar measurements have been made using the sense of touch [8]. Tests made using subjects between the ages of 8 and 75 years using both bursts of sinusoids and bursts of noise showed that the ability to detect a silent interval was significantly worse in older than in younger subjects. Again this limitation must be compensated for by design features of the tactile aid.

In summary, in every comparison of young and elderly persons tested at suprathreshold levels of stimulation, the performance of the elderly is poorer than that of the young. It is imperative that the designer of a tactile aid for the communication of speech takes these findings into consideration so that the aid can be used successfully by young and old alike. The reader is

referred to Verrillo [10] for a discussion in greater depth of the topics considered here.

## References

1. Verrillo RT (1997) Comparison of child and adult vibrotactile thresholds. *Bull Psychonom Soc* 9:197–200
2. Frisina RD, Gescheider GA (1977) Comparison of child and adult vibrotactile thresholds as a function of frequency and duration. *Percept Psychophys* 22:100–103
3. Verrillo RT (1980) Age related changes in the sensitivity to vibration. *J Gerontol* 35:185–193
4. Verrillo RT (1980) Change in vibrotactile thresholds as a function of age. *Sens Proc* 3:49–59
5. Gescheider GA, Bowlanowski SJ, Hall KL, Hoffman KE, Verrillo RT (1994) Effects of aging on the information processing channels in the sense of touch. I. Absolute sensitivity. *Somatosens Mot Res* 11:345–357
6. Plumb CS, Meigs JW (1961) Human vibration perception. I. Vibration perception at different ages. *Arch Gen Psychiat* 4:611–614
7. Verrillo RT (1982) Effects of aging on the suprathreshold responses to vibration. *Percept Psychophys* 3:61–68
8. VanDoran CL, Gescheider GA, Verrillo RT (1990) Vibrotactile temporal gap detection as a function of age. *J Acoust Soc Am* 87:2201–2206
9. Gescheider GA, Edwards RR, Lackner EA, Bowlanowski SJ, Verrillo RT (1996) The effects of aging on the information-processing channels in the sense of touch. III. Differential sensitivity to changes in stimulus intensity. *Somatosens Mot Res* 13:73–80
10. Verrillo RT (1993) The effects of aging on the sense of touch. In: Verrillo RT (ed) *Sensory research: multimodal perspectives*. Lawrence Erlbaum, Hillsdale, NJ, pp 260–275

## Agmatine or AGB

### Definition

An organic cation that enters cells via cation channels. It is used to label cells secondary to excitatory drive or photoreceptors destined to degenerate.

► [Inherited Retinal Degenerations](#)

## Agnathan(s)

### Definition

Descriptor for all jawless fishes; the two extant groups, lampreys (petromyzontids) and hagfishes (myxinooids)

are not considered monophyletic here, since petromyzontids are more closely related to gnathostomes

- [Evolution of the Brain: In Fishes](#)
- [Evolution of the Telencephalon: In Anamniotes](#)
- [The Phylogeny and Evolution of Amniotes](#)

## Agnosia

### Definition

Inability to recognize visual objects. Agnosias come in various specific forms, for example, color agnosia (► [achromatopsia](#)), motion agnosia (► [akinetopsia](#)), ► [agnosia for form or object](#), agnosia for faces (► [prosopagnosia](#)), agnosia for depth.

- [Achromatopsia](#)
- [Akinetopsia](#)
- [Visual Neuropsychology](#)

## Agnosia of Form or Object

### Definition

Characterized by the difficulty a brain-damaged patient has in identifying an object without being blind. This affliction is also called “psychic or mind blindness”. There are two types of object agnosia. Apperceptive agnosia denotes the problem of putting together pieces of visual information into a coherent percept of objects etc.; the world looks fragmented and chaotic. This syndrome often follows ► [carbon monoxide poisoning](#) causing many small, disseminated brain lesions in the ► [occipital lobe](#). Associative agnosia is the difficulty of associating visual perceptual input with stored information of similar objects. Patients with this disorder can tell whether two objects are the same, but cannot identify them because this would require reference to memory. This syndrome is not uniform and may result from lesions of the ► [temporal lobes](#) or temporo-occipital areas.

## Agonist (Pharmacological)

### Definition

A ligand that binds to a specific cellular receptors and triggers a response in the cell.

## Agouti-related Peptide

### Definition

Hypothalamic neuropeptide that regulates hair color and bodyweight.

- ▶ Neuroendocrinology of Eating Disorders

## Agraphia

### Definition

Disorder of the ability to write.

## Agrin

### Definition

Agrin is a heparin proteoglycan expressed by motor neurons and muscle. The neuronal isoform is important for clustering acetylcholine receptors at synaptic sites.

- ▶ Neuromuscular Junction

## AIDS

### Definition

- ▶ Acquired Immunodeficiency Syndrome

## Air Sickness

- ▶ Anti-Motion Sickness Drugs

## Airways

- ▶ Visceral Afferents

## Akinesia

### Definition

An extension of bradykinesia that implies nearly absent voluntary movement (failure of willed movements to occur). There may be two reasons for akinesia: either the movement is too small to be seen or that the time to generate movement is extremely long, so that the movement never really occurs.

- ▶ Bradykinesia
- ▶ Parkinson's Disease

## Akinetopsia

### Definition

An incapacity to perceive moving visual stimuli, resulting from damage to cortical visual area V5.

- ▶ Visual Neuropsychology
- ▶ Visual Perception

## Alar Plate

### Definition

Dorsal portion of the developing neural tube separated from the ventral, basal plate by the sulcus limitans. In the spinal cord and rhombencephalon, it contains most of the sensory neurons.

- ▶ Neural Tube

## Alcohol

- ▶ Central Nervous System Inflammation: Astroglia and Ethanol

## Alcoholic Brain Damage

- ▶ Effects of Alcohol on the Brain

## Alertness Level

HANS P. A. VAN DONGEN, GREGORY BELENKY  
Sleep and Performance Research Center, Washington  
State University, Spokane, WA, USA

### Synonyms

Arousal; Vigilance; Sleepiness (antonym)

### Definition

The ability to direct and sustain attention. It reflects cortical activation and is modulated by sleep/wake regulatory mechanisms.

### Characteristics

#### Neurophysiologic Regulation of Alertness Level

The regulation of alertness is closely tied to sleep/wake regulation, as is obvious from its antonym ►**sleepiness**. As such, alertness level may be expressed on a scale ranging from wide awake to struggling not to fall asleep. There are two primary neurophysiologic processes of sleep/wake regulation driving dynamic changes in the waking level of alertness across hours and days: a homeostatic process producing a ►**homeostatic sleep drive**, and a circadian process (►**circadian cycle**) producing an opponent circadian wake drive [1]. These two processes have been instantiated in conceptual and mathematical models of sleep/wake regulation and alertness.

The homeostatic sleep drive increases progressively from the time of awakening until the beginning of the next sleep period, and decreases progressively during sleep. The dissipation rate during sleep is greater than the build-up rate during wakefulness, such that the homeostatic sleep drive pattern is stable from day to day for the average person given a typical schedule of 16 h of wakefulness and 8 h of sleep. If wakefulness is extended and/or sleep duration is reduced, the dissipation of the homeostatic sleep drive is incomplete.

In contrast to the homeostatic sleep drive, the circadian wake drive waxes and wanes with time of day regardless of sleep and wake duration, such that wake drive is highest in the early evening and lowest in the early morning. For a normal schedule of daytime wakefulness and nighttime sleep, the result is a sustained high level of alertness through most of the waking period [2]. The reason for this is that while the homeostatic sleep drive increases with time awake, it is also increasingly counteracted by the growing circadian wake drive. As such, the alertness level remains stable from morning to evening, with only a minor mid-afternoon dip observable in some individuals [3].

In the early evening hours, the circadian wake drive is high, such that it would be difficult to fall asleep if

sleeping were attempted. This is known as the wake maintenance zone [2]. Later in the evening, however, the circadian wake drive falls and the homeostatic sleep drive becomes the dominant factor determining the alertness level. Thus, in late evening there is a rapid increase in sleepiness signaling that it is time to go to sleep. Assuming the sleep period is long enough to dissipate the homeostatic sleep drive, this pattern repeats itself the next day. Immediately after awakening there is a brief interval of residual sleepiness known as ►**sleep inertia**, but it quickly subsides to be followed by another daytime period of high, stable alertness.

If sleep is postponed and wakefulness continued into the night – as may occur in ►**shift work** settings – the further increasing of the homeostatic sleep drive and the further waning of the circadian wake drive produce a considerable deterioration of the alertness level. This continues until the next morning. At that time, the circadian wake drive begins to rise again, providing a partial rebound of alertness later in the afternoon and early evening. This is illustrated in Fig. 1.

Just as extending the waking period reduces the alertness level as modulated by the homeostatic process, so does altering the timing of the waking period reduce the alertness level through the action of the circadian process. This can be observed when traveling to another time zone, which results in a temporary misalignment of the circadian cycle with the new local day and night. This yields reduced daytime alertness and difficulty sleeping at night – a phenomenon known as ►**jet lag**. Depending on the number of time zones crossed, it may take several days for ►**entrainment** mechanisms to realign the circadian process with the local time.

In addition to the long-term action of the homeostatic and circadian processes, a variety of short-term neurobiological effects on the alertness level have been reported. For reasons not well understood, sustained attention to perform a task results in progressive declines of alertness while the task is ongoing [4]. This ►**time-on-task effect** is undone by a break from the task – see Fig. 1. The time-on-task effect is thought to be amplified by monotony or boredom, while it may be dampened in tasks that are inherently novel or interesting (although it is not clear what determines the latter). Reductions in alertness may be overcome by motivation (e.g., through incentives), but this effect is likely to be transient. Alertness is also affected by ►**stress**, where the nature of the stress determines whether alertness is increased or decreased. Posture plays a role as well, in that supine positions appear to enhance sleepiness while standing up enhances alertness.

The environment can influence the alertness level as well. Bright light (e.g., sunlight) is known to provide a short-lasting boost of alertness (in addition to its ►**photoperiodic** effect on the circadian cycle). Sound may enhance alertness, but chronic exposure to noise

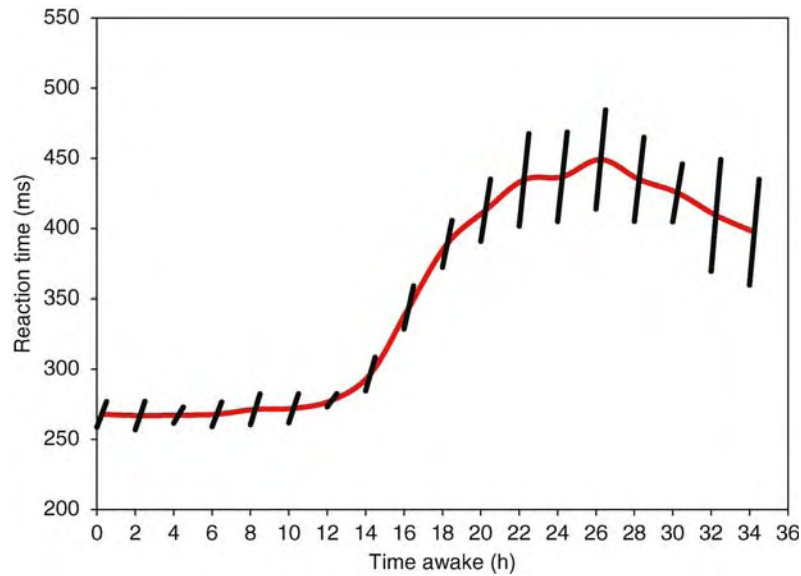

**Alertness Level. Figure 1** Pattern of alertness across 36 h of total sleep deprivation beginning at 10:00 (10 A.M.), as measured by mean reaction time on a 10-min psychomotor vigilance task [5] administered every 2 h in a laboratory (averages shown for ten healthy young adults). The red curve displays the combined effect of the homeostatic sleep drive, which increases progressively across time awake, and the circadian wake drive, which waxes and wanes across the 24 h of the day. The black lines show deterioration of performance (assessed with linear regression) during each 10-min test bout, which is known as the time-on-task effect. The steeper the rise of the line, the greater the time-on-task effect. The time-on-task effect is greatest when the overall alertness level is lowest, revealing an interaction between this effect and the homeostatic and circadian processes. Note also that the breaks between the test bouts provide recuperation from the time-on-task effect.

may have the opposite effect. The effects of tactile and olfactory stimulation on alertness have not been well documented. When measuring the endogenous (neuro-physiologically driven) alertness level, it is important to take these environmental factors into account (e.g., by standardization in a controlled laboratory environment).

### Neurobehavioral and Physiological Correlates

Changes in the alertness level can be observed in a variety of neurobehavioral and physiological variables. Individuals experiencing reduced alertness (e.g., due to sleep deprivation) report elevated feelings of sleepiness and fatigue, negative effects on mood, difficulty concentrating, and greater effort needed to stay awake. They show stereotypical behaviors such as yawning and muscle stretching. They exhibit ►cognitive impairment, ranging from increased ►reaction times and greater numbers of performance errors to ►executive control deficits and poor decision making. Indices of ►attention appear to be particularly affected, with tasks requiring sustained attention showing increased variability in responses. This latter effect has been hypothesized to reflect the episodic intrusion of sleep processes into wakefulness [5].

Indeed, reduced levels of alertness are associated with greater propensity to fall asleep, which translates into reduced sleep latencies – i.e., falling asleep faster – as determined through sleep physiological

recording (►polysomnogram). This phenomenon, which is observed both when sleep is attempted and when it is to be resisted, provides a basis for physiological tests of sleepiness, including the ►multiple sleep latency test and the ►maintenance of wakefulness test. Physiological changes can also be seen before the occurrence of sleep, though. ►Visual evoked potentials and ►auditory evoked potentials show changes indicative of impaired signal processing under conditions of diminished waking alertness. The background waking ►electroencephalogram (EEG) also changes, reflecting enhanced synchronization [6] possibly associated with sleep initiation mechanisms in the brain (drowsiness).

Alertness changes are further reflected in ocular measures, including the appearance of slow-rolling eye movements, changes in blink rate, extended partial or complete eye closures, and variations in pupil diameter. Additionally, cardiovascular indices (heart rate, heart rate variability) have been reported to covary with alertness. These physiologic changes may be mediated by alterations in the tone of the ►autonomic nervous system.

There are considerable inter-individual differences in the effects of alertness-reducing interventions such as sleep deprivation on the various correlates of alertness described above [7]. The expression of these inter-individual differences is found to vary from one correlate of alertness to another. It might be concluded that there is not just a single overall level of alertness,



but that there are several alertness levels depending on which specific measure is considered. However, measures of alertness typically involve other neurophysiologic and neurocognitive systems as well, which contribute to the measurement outcomes in potentially non-trivial and/or person-specific ways. For instance, a cognitive performance measure of alertness is also affected by a person's aptitude for the performance task as well as any practice effects. Understanding such issues is important for the interpretation of alertness measurement data [3].

### Neuroanatomical Structures and Neurotransmitters

Although the neuroanatomical and neurochemical mechanisms underlying the regulation of alertness have only partially been delineated, it is known that there is a strong modulation of the alertness level by the ▶**ascending neuromodulatory projections**. Briefly, this system involves ▶**arousal** of the ▶**cortex** by monoaminergic and cholinergic nuclei in the ▶**brainstem**, ▶**hypothalamus** and ▶**basal forebrain**. These nuclei and their ▶**neurotransmitters** include the ▶**locus coeruleus** (noradrenalin), the ▶**tuberomammillary nucleus** (histamine), the ▶**raphe** (▶**serotonin**), and nuclei in the ▶**tegmentum** (▶**acetylcholine**). The ascending neuromodulatory projections can be blocked by activation of the ▶**ventrolateral preoptic nucleus** (▶**GABA**, galanin), which initiates sleep [8]. It is possible that the activity of this system represents, in part, the homeostatic sleep drive, but definitive evidence is lacking and other pathways, neurotransmitters/▶**neuromodulators** (▶**dopamine**, ▶**adenosine**) and mechanisms are likely involved as well [9]. The source of the circadian wake drive is much better understood. It is driven by the ▶**suprachiasmatic nuclei** (▶**SCN**) in the hypothalamus [1], the functioning of which has been elucidated in considerable detail.

The neurotransmitter systems involved in sleep/wake and alertness regulation are targets of a wide variety of pharmacological substances affecting alertness. These include hypnotics such as benzodiazepine receptor agonists, which reduce alertness and promote sleep; and ▶**stimulants** such as caffeine and amphetamine, which enhance alertness. Hypnotics are particularly useful to improve sleep quality and increase sleep duration as part of the treatment repertoire for clinical sleep disorders. Stimulants are administered to treat excessive sleepiness associated with certain sleep disorders (e.g., narcolepsy), and to maintain optimal (baseline) alertness levels in operational settings [10] (caffeine being the most widely used). With specific stimulants (e.g., amphetamine), it is possible to temporarily raise alertness and enhance performance beyond the baseline level, although this does not necessarily translate into better cognitive/behavioral outcomes and often involves undesirable side effects. The mechanisms of actions of most hypnotics and stimulants have only partially been determined.

## References

1. Edgar DM, Dement WC, Fuller CA (1993) Effect of SCN lesions on sleep in squirrel monkeys: evidence for opponent processes in sleep-wake regulation. *J Neurosci* 13:1065–1079
2. Dijk DJ, Czeisler CA (1994) Paradoxical timing of the circadian rhythm of sleep propensity serves to consolidate sleep and wakefulness in humans. *Neurosci Lett* 166:63–68
3. Van Dongen HPA, Dinges DF (2005) Circadian rhythms in sleepiness, alertness, and performance. In: Kryger MH, Roth T, Dement WC (eds) *Principles and practice of sleep medicine*, 4th edn. Elsevier Saunders, Philadelphia, pp 435–443
4. Bills AG (1937) Fatigue in mental work. *Physiol Rev* 17:436–453
5. Doran SM, Van Dongen HPA, Dinges DF (2001) Sustained attention performance during sleep deprivation: evidence of state instability. *Arch Ital Biol* 139:253–267
6. Strijkstra AM, Beersma DGM, Drayer B, Halbesma N, Daan S (2003) Subjective sleepiness correlates negatively with global alpha (8–12 Hz) and positively with central frontal theta (4–8 Hz) frequencies in the human resting awake electroencephalogram. *Neurosci Lett* 340:17–20
7. Van Dongen HPA, Vitellaro KM, Dinges DF (2005) Individual differences in adult human sleep and wakefulness: leitmotif for a research agenda. *Sleep* 28:479–496
8. Saper CB, Scammell TE, Lu J (2005) Hypothalamic regulation of sleep and circadian rhythms. *Nature* 437:1257–1263
9. Krueger JM, Obál F, Kapás L, Fang J (1995) Brain organization and sleep function. *Behav Brain Res* 69:177–185
10. Penetar D, McCann U, Thorne D, Kamimori G, Galinski C, Sing H, Thomas M, Belenky G (1993) Caffeine reversal of sleep deprivation effects on alertness and mood. *Psychopharmacology* 112:359–365

## Alginate

### Definition

Alginate is derived from brown seaweed. Alginate is a polysaccharide like glycosaminoglycan composed of two monosaccharides,  $\beta$ -D-mannuronic acid and  $\alpha$ -L-guluronic acid.

## Allele

### Definition

Different forms or variants of a gene that occupy a given locus on a chromosome.

## Allocentric Cues

### Definition

Distal and local environmental cues used for navigation.

Distal cues are principally visual and provide information about the distance to landmarks and spatial arrangement among landmarks. Local cues, such as odors on the ground, are also allothetic. Typically contrasted with “idiothetic cues”.

- ▶ Spatial Learning/Memory

## Allocentric Reference Frame

### Definition

Framework centered outside of the body of the subject such as mountain, or individual object.

- ▶ Spatial Memory

## Allocortex

### Definition

“Other” cerebral cortex, referenced against six-layered isocortex.

Allocortex includes cerebral cortical areas, such as the hippocampus and olfactory cortex, which comprise fewer than six-layers.

- ▶ Hippocampus
- ▶ Isocortex
- ▶ Olfactory Cortex

## Allodynia

### Definition

Pain due to a stimulus which does not normally provoke pain (e.g., gentle static pressure, non-painful thermal stimuli).

- ▶ Hyperalgesia and Allodynia

## Allodynia, Hyperalgesia

### Definition

*Hyperalgesia* denotes increased pain generated by a stimulus which is normally painful and excites nociceptors. It has a peripheral (sensitization of nociceptors) and/or a central component (sensitization of central neurons, e.g. in the dorsal horn of the spinal cord). *Allodynia* is pain generated by stimuli which activate low-threshold mechanoreceptors (mechanical allodynia) or cold receptors (cold allodynia). The mechanism of allodynia is central (central sensitization generated by persistent excitation of nociceptors). *Secondary allodynia* is pain elicited by stimulation of low-threshold mechanoreceptors in an area of skin which surrounds a territory with sensitized nociceptors (e.g. generated by inflammation) *Causalgia*.

- ▶ Complex Regional Pain Syndromes: Pathophysiological Mechanisms

## Allografting

### Synonyms

Allotransplantation

### Definition

Transplantation of tissues and organ pieces from one person to another, or from one animal to another of the same species.

## Allometric

### Definition

A scaling relationship, usually exponential, between the size of a part of the body, and the whole body. There is an allometric relationship between brain and body size in the primate order.

- ▶ Evolution of the Brain in Humans – Paleoneurology

## Allometry

### Definition

Measurement and correlation of biological size of organs or organ-systems.

► Evolution and Brain-Body Allometry

## Allophone

### Definition

Phonetic variant of a phoneme; substituting one allophone for another does not change the meaning of a word (e.g., [bath] does not differ in meaning to [bat]; [th] is an aspirated /t/ and [t] is an unaspirated /t/).

► Phoneme

## Allosteric Enzyme

### Definition

An enzyme that alters its three-dimensional conformation as a result of the binding of a smaller molecule (at a site different to its active site), often leading to inhibition or activation of its activity.

## Allosteric Protein

### Definition

A protein that can adopt several conformations. These conformations can be stabilized by different molecules, that bind at the same, or different sites.

## Allothetic Information

### Definition

Stimuli providing information about the environment like visual, olfactory, sound, tactile inputs.

## Alpha (Activity Phase) in Circadian Cycle

### Definition

Alpha is the duration of the active portion of the daily rest-activity cycle.

► Circadian Cycle  
► Rest-activity Cycle

## Alpha Rhythm

### Definition

A neocortical pattern of 8–13 Hz EEG activity characteristic of quiet wakefulness in humans.

► Brain Rhythms

## Alpha Subunit of Gustducin

► Gustducin

## Alpha-gustducin

► Gustducin

## Alpha-internexin

### Definition

A 66 kDa protein encoded on chromosome 10q24.33.

## Alpha-motoneuron

### Definition

A motoneuron that exclusively innervates the large extrafusal striated muscle fibers that make up the bulk of anatomical muscles and that generate output force.

### ► Motor Units

## Alpha-synuclein: From Neurological Disorders to Molecular Pathways

S. WISLET-GENDEBIEN, A. TANDON  
Centre for research in neurodegenerative diseases,  
Toronto, ON, Canada

### Definition

$\alpha$ -Synuclein is a small acidic protein of 140 amino acid residues and a member of a multi-gene synuclein family (Fig. 1a). The N-terminal part has seven imperfect repeats containing the consensus core sequence Lys-Thr-Lys-Glu-Gly-Val, whereas the C-terminal part (residues 96–140) has no recognized structural elements. The central portion of  $\alpha$ -synuclein (residues 61–95) is known as the non-A $\beta$  component of ► amyloid plaques in Alzheimer disease (Fig. 1b). It comprises the highly amyloidogenic part of the molecule that is necessary for  $\alpha$ -synuclein (i) to undergo a conformational change from ► random coil to ► Beta Sheet structure, (ii) to form single cylindrical  $\beta$ -sheets, and (iii) to form protofibrils and fibrils. These features distinguish  $\alpha$ -synuclein from its two close relatives  $\beta$ -synuclein and  $\gamma$ -synuclein that fail to form copolymers with  $\alpha$ -synuclein [1].  $\alpha$ -Synuclein displays an extended unfolded structure and thus belongs to the group of natively unfolded proteins also comprising protein tau.  $\alpha$ -Synuclein exists physiologically in both soluble and membrane-bound states, with an unstructured or alpha-helical conformation, respectively. The function of  $\alpha$ -synuclein is poorly resolved, though it is attributed with wide-ranging roles such as molecular chaperone, axonal transport and turnover of synaptic vesicles [2].

### Characteristics

#### Alpha-Synuclein and Neurological Disorders

Pathological accumulation of  $\alpha$ -synuclein is associated with multiple neurodegenerative diseases that are collectively known as synucleinopathies (Fig. 2). The

most prominent of these is Parkinson's disease (PD), a progressive disorder that impairs movement in nearly 2% of individuals over 65 years. Other disorders include Dementia with ► Lewy bodies (DLB), the second major cause of dementia in the elderly after Alzheimer's disease (AD), the Lewy body variant of Alzheimer's disease, multiple system atrophy, neurodegeneration with brain iron accumulation type 1, familial forms of AD and Down syndrome.  $\alpha$ -Synuclein-containing inclusions are also found in several more disparate neurodegenerative diseases that are not commonly referred to as synucleinopathies [3].

A causative role for  $\alpha$ -synuclein in neurodegeneration was fortified by the identification of three mutations (A30P, A53T and E46K) in the  $\alpha$ -synuclein gene, as well as multiplication of the normal gene that results in increased  $\alpha$ -synuclein protein expression, in families with early-onset PD [4]. Affected family members present clinical and pathological features that are similar to sporadic PD that is clinically characterized by the three cardinal symptoms including muscle rigidity, bradykinesia and resting tremor [5]. These motor impairments are primarily due to degenerating dopaminergic neurons in the substantia nigra and the loss of their dopaminergic projections to the striatum and can be corrected by dopamine-replacement therapy. Moreover, histological analyses of PD brains reveal dense aggregations of insoluble material including  $\alpha$ -synuclein in intracellular inclusions called Lewy bodies (LB).

Development of PD appears to be linked to processes that increase the rate at which  $\alpha$ -synuclein forms aggregates. These processes include increased protein concentration (via either increased expression or reduced turnover), and altered forms of  $\alpha$ -synuclein (such as truncations, missense mutations, or post-translational modifications [6]). Phosphorylated  $\alpha$ -synuclein at Ser-129 has been observed in post-mortem analyses of patients with PD, multiple system atrophy, and neurodegeneration with brain iron accumulation type 1. Under normal physiological conditions, about 4% of  $\alpha$ -synuclein is phosphorylated at Ser-129, but in LB, 89% of  $\alpha$ -synuclein is phosphorylated at this residue. The effects of phosphorylation of Ser-129 on  $\alpha$ -synuclein conformation are not known, but phosphorylation at Ser-129 caused a fourfold increase in insoluble  $\alpha$ -synuclein and inhibited interaction of  $\alpha$ -synuclein with phospholipids and phospholipase D2. Moreover, mutation of Ser-129 to alanine (to prevent phosphorylation) completely suppressed DA neuronal loss produced by expression of human  $\alpha$ -synuclein, and substituting aspartate for Ser-129 (to mimic phosphorylation) significantly enhanced  $\alpha$ -synuclein toxicity.

#### Role of Alpha-Synuclein

$\alpha$ -Synuclein is widely expressed in mammalian CNS, and particularly concentrated in presynaptic terminals,

**a. Synuclein sequence homologies:**

	1	11	21	31	41	51
		Repeat 1	Repeat 2	Repeat 3	Repeat 4	Repeat
$\alpha$ -synuclein	mdvfmkglsk	akegfvaaae	ktkqgvaaea	gktkegvlv	gsktkegvvh	gvatvaeatk
$\beta$ -synuclein	mdvfmkglsm	akegfvaaae	ktkqgvteaa	ektkegvlv	gsktr=gvvq	gvasvaeatk
$\gamma$ -synuclein	mdvfkkgfsi	akegfvgaave	ktkqgvteaa	ektkegvmyv	gaktkenvvq	svtsvaeatk
			p		k	t
	61	71	81	91	101	111
	5		Repeat 6			
$\alpha$ -synuclein	egvtnvggav	vtgvtavaqk	tvegagssiaa	atgfvkkdql	gkneegapqe	giledmpvdp
$\beta$ -synuclein	eqashlggav	fsgagniaaa	tglvkreefp	tdlkpeeva	eaaepliep	lmepegesye
$\gamma$ -synuclein	eqanavseav	vssvntvatk	tveeaeniav	tsgvvrkedl	rpsapqqegv	askekeevaa
$\alpha$ -synuclein	121	131				
$\beta$ -synuclein	dneayempse	egyqdyepa				
$\gamma$ -synuclein	dppqeeyqey	epea				
	Eaqsggd					

**Keys:**

- Residues** - Familial PD associated mutations
- Residues** - conserved sequence between  $\alpha$ -,  $\beta$ - and  $\gamma$ -synuclein
- Residue** - Serine 129
- Residues** - ktkegv imperfect repeats

**b.  $\alpha$ -synuclein Structure:**

$\alpha$ -helicoidal domain (Residues 1-67)	Hydrophobic region (Residues 61-95)	Acidic Rich region (Residues 96-140)
--	--	---

**Alpha-synuclein: From Neurological Disorders to Molecular Pathways. Figure 1**  $\alpha$ -Synuclein homologies and structure. (a) The synuclein family consists of three members:  $\alpha$ -synuclein,  $\beta$ -synuclein and  $\gamma$ -synuclein that range from 127 to 140 amino acids in length and are 55–62% identical in sequence, with a similar domain organization. (b)  $\alpha$ -synuclein structure is divided in three regions: (i) N-terminal domain (residues 1–67) contains two  $\alpha$ -helical regions separated by a short break; (ii) hydrophobic domain (residues 61–95) and (iii) C-terminal domain acidic rich region.

where it is associated with synaptic vesicles and freely-diffusible in the cytoplasm. While the exact functions of normal  $\alpha$ -synuclein remain to be fully elucidated, several studies suggested it may play a role in synaptic plasticity; regulate dopamine (DA) neurotransmission via effects on vesicular DA storage and protecting neurons from neurodegeneration induced by the loss of ►cysteine string protein (Fig. 2; [7]). More recently, it has been suggested that  $\alpha$ -synuclein may be involved in the trafficking of cargo within the endoplasmic reticulum/Golgi network since one of the most profound initial consequences of artificially expressing  $\alpha$ -synuclein in yeast appears to be a disruption of ER-Golgi trafficking [8].

So far, the exact role of  $\alpha$ -synuclein in healthy brain as well as in pathological conditions still remain unclear. However, several protein interactions with  $\alpha$ -synuclein suggest a function in specific molecular pathways. Figure 3 summarizes potential functions associated with

$\alpha$ -synuclein. However, it is unclear if the  $\alpha$ -synuclein binding proteins compete for overlapping binding sites, interact differentially depending on  $\alpha$ -synuclein conformation, or bind in a competitive/allosteric manner. It also remains to be determined if these interacting proteins bind to  $\alpha$ -synuclein in distinct subcellular compartments. Conformational changes in  $\alpha$ -synuclein due to temperature, pH and/or posttranslational modification could alter the protein and ligand binding properties of  $\alpha$ -synuclein as well as its aggregation properties. In addition to lipids, various reports suggest that  $\alpha$ -synuclein is capable of interacting with a variety of proteins including PLD2, UCH-L1, parkin, synphilin, 14-3-3, different PKC isozymes, BAD, Rab3A, Rab5A, Rabphilin, the ELK-1/ERK-2 complex, ERK-1/2, p38MAPK, and SAPK/JNK mitogen activated kinases, A $\beta$ , MAP1B, heterodimeric but not microtubule Tubulin, tau, TBP-1, the DAT, the mitochondrial complex IV enzyme cytochrome oxidase, and TH, and calmodulin [1] (Reviewed by Dalfo et al.,

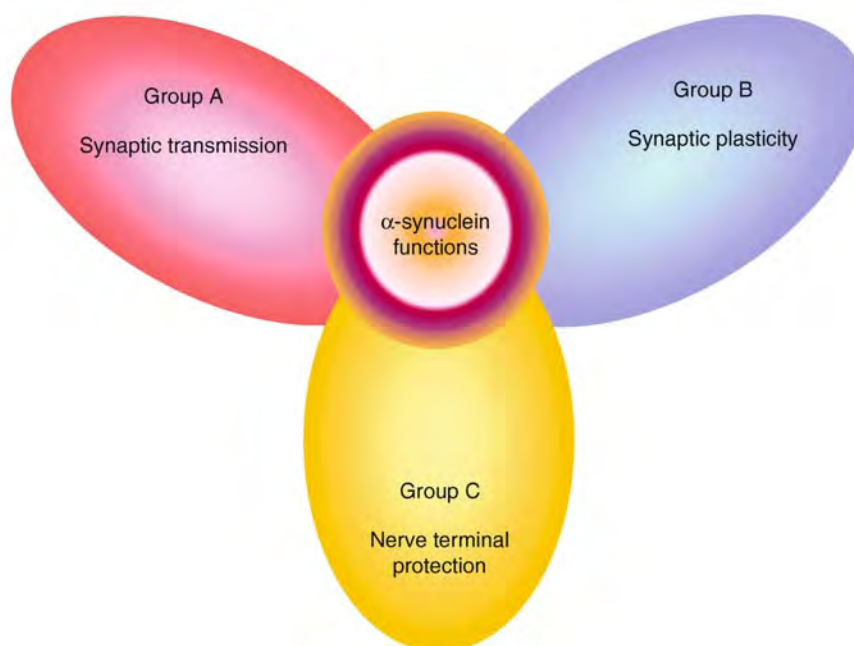

Interacting protein	Role	References
Calmodulin M	Major calcium-binding protein in the brain.	Martinez et al., 2003
TBP-1	Recognized as a component of a 19S regulatory subunit of the 26S proteasome which degrades ubiquitinated proteins	Nakamura et al., 1998
Rab	Small GTPases of the Rab family control timing of vesicle fusion.	Jordens et al. 2005
TH	Enzyme responsible for catalyzing the conversion of the amino acid L-tyrosine to dihydroxyphenylalanine (DOPA)	Sung et al., 2001
HSP90	Important roles in cellular regulation, primarily as a chaperone for a number of key intracellular proteins. Also involved in cell migration.	Sidera et al., 2004
Parkin	E3 ubiquitin ligase and, which ubiquitinates proteins such as CDC rel-1, synphilin-1, the O-glycosylated form of $\alpha$ -synuclein, and parkin-associated endothelin receptor-like receptor to facilitate their proteasomal degradation.	Mukhida et al., 2004
14-3-3	14-3-3 proteins modulate the action of proteins that are involved in cell cycle and transcriptional control, signal transduction, intracellular trafficking and regulation of ion channels.	Berg et al., 2003
MAP1B	Major component of the neuronal cytoskeleton which play a crucial role in neuronal morphogenesis and neurite extension	Takei et al., 1997
Synphilin	The physiological function of the protein is currently unknown, although several protein domains have been defined and are known to be present in a variety of proteins mediating protein-protein interactions	Kruger, 2004
ERK, MAPk, JNK	A large kinase network in which upstream kinases activate downstream kinases that, in response to phosphorylation, translocate to the nucleus and activate transcription factors.	Adams et al., 2000
PKC	C kinases (PKCs) are a family of enzymes essential for the transduction of signals	Kuo et al., 1997
BAD	Bad represents a bridging molecule which interconnects signal transduction pathways from extracellular survival factors with the Bcl-2 intracellular checkpoint upon cell death.	Hong et Wu, 2002
TAU	Tau has a variety of functions, most prominently in microtubule stabilization or neurite outgrowth	Garcia et Cleveland, 2001

**Alpha-synuclein: From Neurological Disorders to Molecular Pathways. Figure 2** Summary of the potential role of  $\alpha$ -synuclein. The exact role of  $\alpha$ -synuclein still needs to be defined, however, it seems that this protein is involved in synaptic transmission as well as protection and plasticity and is reported to interact with different proteins.

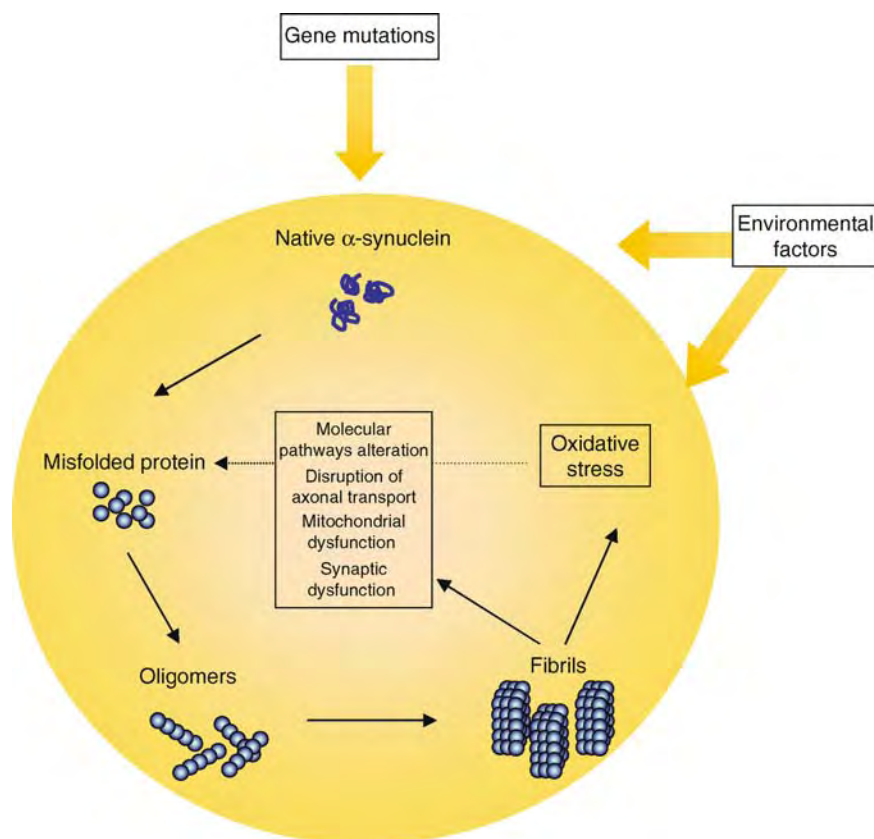

**Alpha-synuclein: From Neurological Disorders to Molecular Pathways. Figure 3** Hypothetical routes for α-synuclein to induce neurodegeneration. α-synuclein gene mutations as well as environmental factors may induce the α-synuclein fibrilization which may lead to changes in cell activity, dysfunction, and cell death. However, it is still unclear if those factors act first on the fibril formation which then induces dysfunction or if the fibrilization is a consequence of the functional dysregulation.

2005). Interaction has been shown also with divalent cations include  $\text{Fe}^{2+}$ ,  $\text{Al}^{3+}$ ,  $\text{Zn}^{2+}$ ,  $\text{Cu}^{2+}$ , and  $\text{Ca}^{2+}$  [1]. For most of these interactions, their relevance to cell physiology and pathophysiology remains to be clarified. Moreover, it is interesting to note that only some of the α-synuclein interacting proteins are found in LB.

6. Shults CW, Barrett JM, Fontaine D (2006) *Neurosci Lett* 405:223–225
7. Chandra S, Gallardo G, Fernandez-Chacon R, Schluter OM, Sudhof TC (2005) *Cell* 123:383–396
8. Lee VM, Trojanowski JQ (2006) *Neuron* 52:33–38
9. Dalfo E, Ferrer I (2005) *Neuroscience Letter* 380:170–175

## References

1. Dev KK, Hofele K, Barbieri S, Buchman VL, van der PH (2003) *Neuropharmacology* 45:14–44
2. Bennett MC (2005) *Pharmacol Ther* 105:311–331
3. Galpern WR, Lang AE (2006) *Ann Neurol* 59:449–458
4. Jain S, Wood NW, Healy DG (2005) *Clin Sci (Lond)* 109:355–364
5. Goedert M (2001) *Nat Rev Neurosci* 2:492–501

## ALS

### Definition

► Amyotrophic Lateral Sclerosis

## Alternative Splicing

YIRU SHEN, YING YING SUNG,  
TUCK WAH SOONG

Department of Physiology, Yong Loo Lin School of Medicine, National University of Singapore, Singapore and National Neuroscience Institute, Seng, Singapore

### Definition

Alternative splicing refers to the post-transcriptional modification process in which coding regions (exons) of a primary transcript are joined in different combinations through the removal or retention of non-coding intervening sequences (introns) to produce distinct mature messenger RNA (mRNA) transcripts.

### Characteristics

#### Mechanisms of Alternative Splicing

One surprising finding stemming from genome analyses is that proteomic diversity of an organism does not correlate with the number of protein-coding genes observed. It was later revealed that alternative splicing provides the major mechanism for increasing transcriptome and proteome complexity. An analogy to explain this idea would be to liken alternative splicing to a glass prism which can disperse white light into a spectrum of colors (Fig. 1).

Through alternative splicing, a single pre-mRNA can generate a diverse array of mRNA splice variants which will be translated into protein isoforms with varying structure and/or function.

Recent genome analyses have estimated that 60–80% of human genes are subjected to alternative splicing and this biological phenomenon is emerging to be of central importance in the nervous system [1,2]. Furthermore, sequence- and microarray-based

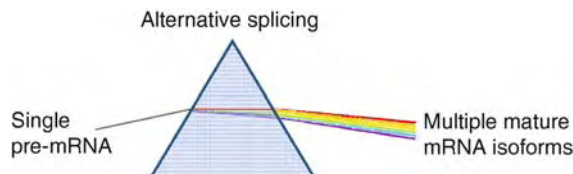

**Alternative Splicing. Figure 1** Analogous to the dispersion of white light into the color spectrum by a glass prism, a single pre-mRNA can generate a diverse array of mature mRNA transcripts through alternative splicing.

analyses have suggested that transcripts from genes expressed in functionally complex tissues, such as that of the brain, undergo alternative splicing at a higher frequency [1].

There are several types of alternative splicing events leading to the generation of distinct transcripts: cassette exon, alternative 5' splice site, alternative 3' splice site, mutually exclusive exons, intron retention, alternative promoter, and alternative polyadenylation site (Fig. 2).

In general, these events occur in a combinatorial manner to produce multiple alternatively spliced isoforms or splice variants. The *Drosophila melanogaster* Down syndrome cell adhesion molecule (*Dscam*) gene is one of the best examples to illustrate this process. The *Dscam* gene, which contains four clusters of exons alternatively spliced in a mutually exclusive fashion (12, 48, 33, and 2 exons respectively), can theoretically give rise to as many as 38,016 different mRNAs by virtue of combinatorial alternative splicing [3]. Remarkably, this number is even greater than the predicted number of genes in the *Drosophila* genome.

Protein variations generated by alternative splicing can range from subtle to drastic [3]. While alternative splicing in the untranslated regions does not alter the protein sequence, it can affect mRNA stability and localization, which in turn influence the expression pattern and subcellular localization of the protein [3]. On the other hand, alternative splicing in the coding region can lead to the addition or removal of a functional motif or domain, or in some cases, bring about frameshifts that introduce premature termination codons that result in truncated, non-functional proteins [3].

### Regulation of Alternative Splicing

Pre-mRNA splicing reaction takes place on a cellular machinery known as the spliceosome, a large complex composed of five small nuclear ribonucleoproteins (snRNPs) (U1, U2, U4, U5, and U6) and many additional proteins. The spliceosome assembles onto the pre-mRNA in a stepwise fashion and catalyzes the removal of introns and ligation of exons. Four conserved sequence elements at both ends of the intron, namely the 5' splice site, the branchpoint, the polypyrimidine tract, and the 3' splice site, act as splicing signals that define the intron-exon boundary. However, additional *cis*-acting elements are required to ensure that the splicing process proceeds with high fidelity and accuracy.

Exonic and intronic splicing enhancers (ESEs and ISEs) and silencers (ESSs and ISSs) are splicing regulatory sequences in the pre-mRNA that facilitate correct splice site recognition [1]. ESEs and ISEs usually enhance the use of weak splice sites and thereby promote inclusion of an alternatively spliced exon; whereas ESSs and ISSs generally inhibit the use of splice sites and in doing so, promote skipping of an



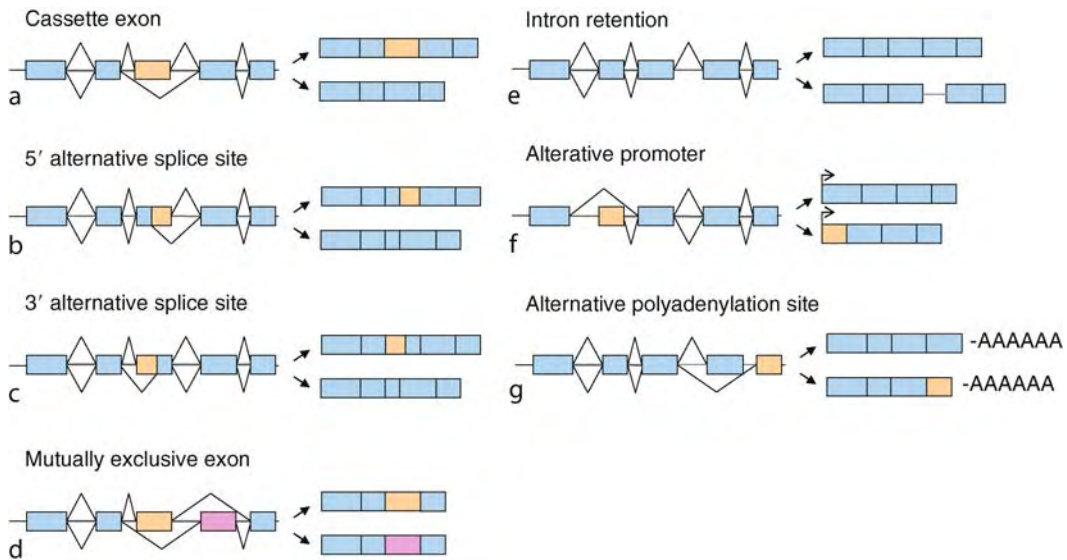

**Alternative Splicing. Figure 2** Schematic illustrations of alternative splicing events. Exons are represented by boxes, while introns are depicted as thick grey lines. Alternative splicing can lead to (a) either the inclusion or exclusion of an exon, (b and c) the use of alternative splice sites, (d) the use of mutually exclusive exons, (e) the retention of an intron, (f) the use of an alternative site for translation initiation, or (g) the use of alternative site for translation termination.

alternatively spliced exon [1]. These sequences are bound by splicing factors, such as members of the serine/arginine-repeat (SR) and heterogeneous nuclear ribonucleoprotein (hnRNP) families of proteins which define the splicing pattern in many cases by either facilitating or blocking spliceosome assembly [1]. Expanding on the simplistic view that SR proteins mostly bind to ESEs and activate splicing, while hnRNP proteins mostly bind to ISSs and repress splicing, a recent global analysis of splicing regulators in *Drosophila* demonstrates that these two families can have both positive and negative effects on splice site choice [2].

Central to the regulation of alternative splicing is the combinatorial interplay of the *cis*-acting sequences with the *trans*-acting splicing factors [1]. A major mechanism used in the regulation of alternative splicing is the differential expression of splicing factors [2]. More specifically, unique alternative splicing patterns across different cell types can be achieved by the tissue-specific expression of splicing factors in one cell type but not others [2]. In addition, expression levels of splicing factors have also been found to vary across different developmental stages [2]. Further regulatory potential is derived from post-translational modifications of the splicing factors [2]. Such modifications can modulate functions of splicing factors by regulating their ability to bind to RNA or interact with other

proteins [2]. For instance, phosphorylation is critical for the protein activity of SR proteins [2]. Recent studies have explored the regulation of alternative splicing events by cellular signaling pathways, and looked into alternative splicing events resulting from genetic polymorphisms and such events are characterized by the production of allele-specific transcript isoforms [2].

In the following sections, the role of alternative splicing in the nervous system will be illustrated with several examples. To truly understand the physiological significance of the utilization of an alternatively spliced exon in a specific excitable cell in the nervous system, however, will require multi-pronged studies. One approach is to determine the cellular or sub-cellular localization of an alternatively spliced exon to provide more defined clues as to its functional importance in the native cells. Another approach is to evaluate the functional diversifications via alternative splicing of cognate protein to provide important predictions of selective requirements for the splice variants in physiology or disease. A third approach is to examine the expression profiles of the alternatively spliced exons in response to physiological or pathophysiological signals to provide evidence for their dynamic roles in adaptation or response to changing cellular conditions or inputs. Finally, it will be of immense interest to genetically delete an alternatively spliced exon from the genome and to assess the physiological significance of its total

exclusion from the cognate protein in a transgenic mouse model.

### Alternative Splicing as a Determinant of Subcellular Localization and Tissue Distribution

Alternative splicing of the calcitonin/calcitonin gene-related peptide (CT/CGRP) is one of the earliest examples of diversification of protein properties and localizations by alternative splicing. In the peptide-hormone system, the inclusion or exclusion of an exon in the final mRNA can alter the biological behavior of a molecule and change the peptide-ligand binding properties. In thyroidal C cells, the majority of the CT/CGRP pre-mRNA is processed to include exon 4 which leads to production of calcitonin peptide [4]. However, in neuronal cells, 99% of the CT/CGRP pre-mRNA is processed to exclude exon 4 and this leads to the production of CGRP peptide [4]. Clearly, through alternative RNA processing, two peptide hormones having completely different structures and functions are generated.

Recent studies indicate that alternative splicing is similarly important for controlling the function of voltage-gated calcium channels ( $Ca_v$ ) in neurons. For instance, the mutually exclusive exons e37a and e37b in the  $Ca_v2$  subfamily exhibit selective cellular or subcellular distribution in neurons (Fig. 3).

The  $Ca_v2$  calcium channels are integrally involved in neurotransmission and pain processing. The N-type  $Ca_v2.2$  calcium channels show specific expression of e37b in the neurons of the brain, while e37a is preferentially expressed in the nociceptive neurons of

the dorsal root ganglia [5]. On the other hand, the pair of e37a/b exons of the P/Q-type  $Ca_v2.1$  calcium channels show differences in subcellular localizations, where e37a is expressed preferentially in the soma, while e37b is found predominantly in the dendrites of the cerebellar Purkinje neurons [6]. Additionally, the e37a/b exons of the  $Ca_v2.1$  calcium channels are developmentally regulated, with a switch in expression from e37b in the fetal brain towards more e37a in the adult brain. In the adult brain, the expression patterns also vary across different regions, where, for example, e37b is expressed at higher levels in the amygdala, and e37a in the thalamus.

Other proteins of the nervous system show similar selective expression patterns. Another example is the  $K_v3$  subfamily of voltage-gated potassium ( $K_v$ ) channels. The  $K_v3$  subunits play an important role in driving fast repolarization of action potentials to enable neurons to fire repetitively at high frequencies. It has been proposed that alternative splicing of the  $K_v3$  subunits mediates differential subcellular targeting and modulation. In neurons of the mouse brain, the  $K_v3.1a$  isoform is localized exclusively on the axons and presynaptic terminals while  $K_v3.1b$  channels are prominently expressed on somatic and proximal dendritic membrane [7]. Interestingly,  $K_v3.1$  channels are co-expressed with  $K_v3.4a$  channels that are found mainly in the globus pallidus neurons, CA1 hippocampal interneurons and subthalamic nucleus neurons that are all fast-spiking.  $K_v3.4a$  channels are, however, absent in the regular-spiking hippocampal, striatal and basal forebrain neurons.

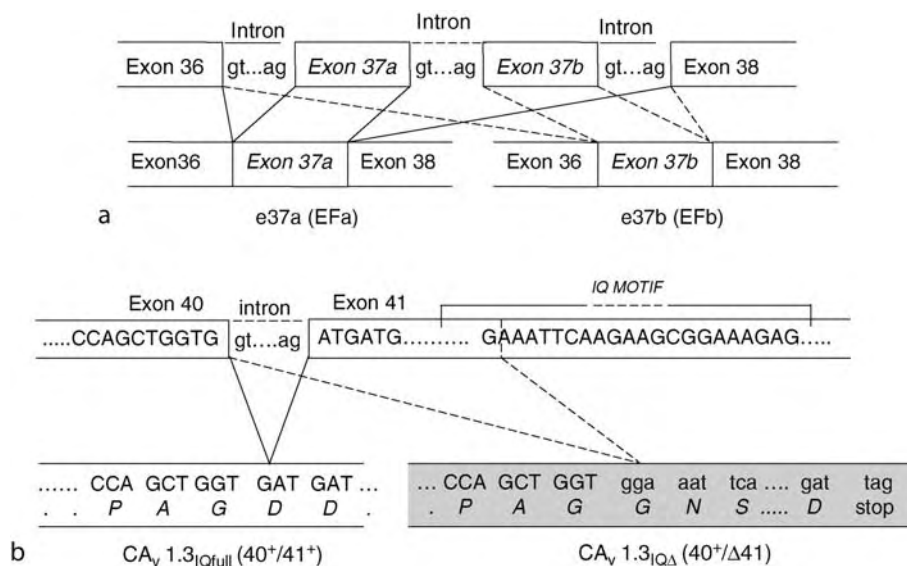

**Alternative Splicing. Figure 3** Postulated mechanism underlying splice variation of both  $\alpha_1$  subunits of  $Ca_v2.1$  and  $Ca_v1.3$  calcium channels. The nucleotide sequences of the relevant exon-intron boundaries are displayed in the top, while the bottom shows the resultant transcript and encoded amino acids of each variant.

### Alternative Splicing as a Molecular Switch for Protein Function

Alternative splicing often results in isoforms with different functional properties. For instance, the e37a- but not the e37b-containing  $Ca_v2.2$  channels allow large currents to flow and are regulated by G-proteins in a voltage-independent manner. Importantly, alternatively spliced exons located at other loci of the  $Ca_v2.2$  channels modify other channel properties or control the trafficking of the channels.

Interestingly, the e37a/b exons of the  $Ca_v2.1$  calcium channels act as an exquisite molecular switch to determine channel function. The e37a-containing  $Ca_v2.1$  calcium channels respond to  $Ca^{2+}$ -dependent regulation by promoting the opening of the channels in a process called  $Ca^{2+}$ -dependent facilitation (CDF). This process may be important in short term plasticity as the increase in  $Ca^{2+}$  influx will result in much greater neurotransmitter release at the CNS synapse [6]. This property is missing from the e37b-containing channels. Similar to  $Ca_v2.2$  calcium channels, the other alternative splicing loci of the  $Ca_v2.1$  calcium channels act to modify channel electrophysiological and pharmacological properties [5,6]. Interestingly, the paralogous pairs of e37a/b exons of the  $Ca_v2.1$  and  $Ca_v2.2$  channels instill dissimilar properties on the channels.

Clearly, alternative splicing can diversify protein functions providing a spectrum of protein isoforms customized to support the complex operations within the central nervous system where information has to be processed rapidly. In this regard, the discovery of the entire suite of alternative splicing loci in a gene, and their coordinated assembly, will provide a compendium essential for reference and for understanding of physiological relevance. Nonetheless, the identification of novel splice variation at single splice locus has been useful to explain discrepancies between observed activity of a protein and the cloned cDNA assayed in a heterologous system. One such example is the observed lack of  $Ca^{2+}$ -dependent inactivation (CDI) of native hair cell  $Ca^{2+}$  currents as compared to robust CDI exhibited by the cloned L-type  $Ca_v1.3$  calcium channel. Recent work showed that a splice variant ( $Ca_v1.3_{IQ\Delta}$ ) missing the IQ-motif that is important for CDI is expressed in the outer hair cells of the cochlea (Fig. 3b) [8]. The  $Ca_v1.3_{IQ\Delta}$  channels expressed in HEK 293 cells showed total lack of CDI that in part explains the behavior of the native  $Ca^{2+}$  currents in the cochlear hair cells.

### Alternative Splicing as a Molecular Switch for Physiological Responses

It is important to understand how cells alter their splicing patterns in response to extracellular stimuli and signaling pathways. Ion channels and neurotransmitter-receptor pre-mRNAs undergo extensive alternative splicing to

generate multiple isoforms. An example is the vertebrate *Slo* (also known as *slowpoke* or *BK*) gene, which encodes a voltage-gated  $Ca^{2+}$  and  $K^+$  channel expressed widely in the nervous system. *Slo* splice variants containing the STREX exon exhibit slow deactivation and enhanced channel activation. Changes in the concentration of stress hormones can modulate STREX (stress axis-regulated exon) exon inclusion in the *Slo* pre-mRNA and evidence suggests that STREX splicing is repressed by depolarization of GH3 pituitary cells and signaling through  $Ca^{2+}$ /calmodulin-dependent protein kinase (CaMK) IV [9].

A good example of how alternative splicing regulates neuronal function is the pattern of expression of the *cSlo* (chicken *Slo* gene) splice variants that correlates well with the tonotopic frequency map along the cochlear basilar membrane [9]. In addition, alternative splicing could remodel synaptic proteins, ion channels or receptors to modify neuronal excitability, synaptic plasticity, and efficacy of synaptic transmission in order to adapt to the myriad of neuronal activities and inputs. For instance, with NMDA receptors neuronal activity influences the choice for the inclusion or exclusion of alternatively spliced exon C2 or C2' possibly to facilitate homeostatic regulation of synaptic plasticity [10].

### Alternative Splicing in Disease and Disorder

Alternative splicing generates phenotypic variations of proteins that impacts the diversity of their biological function. As such, it is not surprising that dysfunction or dysregulation of the splicing machinery can contribute to human diseases. Aberrant splicing of a gene can alter the abundance, spatial and/or temporal expression of a splice variant. Mutations in the tau gene can give rise to frontotemporal dementia with parkinsonism linked to chromosome 17 (FTDP-17), by increasing the levels of proteins with the inclusion of exon 10 [9,10]. This tau isoform, which comprises four microtubule binding motifs, enhances the formation of filamentous tau aggregates in the brain [9,10]. In contrast, a translationally silent C to T nucleotide substitution in the survival of motor neuron protein 2 (*SMN2*) gene of spinal muscular atrophy (SMA) patients results in the skipping of exon 7 and the formation of a non-functional protein [10].

Alternative splicing can also play a role in modifying disease severity as evidenced in Timothy's syndrome, a disorder where patients suffer multi-organ dysfunction that includes lethal arrhythmias, cognitive abnormalities and autism. The severity of the cardiac arrhythmias depends on which mutually exclusive exon, e8 or e8a, carries the G406R mutation on the L-type  $Ca_v1.2$  calcium channel, *CACNA1C*, gene. There is a correlation between the severity of cardiac arrhythmias and the level of expression of the cardiac-selective exon e8a in

the heart. Especially for genes critical for the survival of an organism, hereditary neurological disorders could arise because the genetic mutations were found on alternatively spliced exons or in regions that modulate splicing efficacy.

### Conclusions

Alternative splicing is an exquisite mechanism to customize and diversify protein function to cater and respond to the complexity and immense plasticity of the nervous system. The dynamic regulation of alternative splicing will allow the neurons to respond appropriately to changing conditions in physiology or disease. As such, it is important to evaluate the altered activities of a mutant protein, arising from single genetic mutations, in the backbone of the predominant combinatorial splicing code for that gene. However, answers to fundamental questions as to what directs the specific utilization of an alternatively spliced exon, what is the physiological role of a specific alternatively spliced exon, and how it behaves in the context of different combinatorial arrangements of other alternatively spliced exons will require a wide array of ideas and multidisciplinary approaches.

### References

1. Blencowe BJ (2006) Alternative splicing: new insights from global analyses. *Cell* 126:37–47
2. Soller M (2006) Pre-messenger RNA processing and its regulation: a genomic perspective. *Cell Mol Life Sci* 63:796–819
3. Lee CJ, Irizarry K (2003) Alternative splicing in the nervous system: an emerging source of diversity and regulation. *Biol Psychiat* 54:771–776
4. Lou H, Gagel RF (2001) Alternative ribonucleic acid processing in endocrine systems. *Endocr Rev* 22:205–225
5. Gray AC, Raino J, Lipscombe D (2007) Neuronal calcium channels: splicing for optimal performance. *Cell Calcium*
6. Chaudhuri D, Alseikhan BA, Chang SY, Soong TW, Yue DT (2005) Developmental activation of calmodulin-dependent facilitation of cerebellar P-type  $Ca^{2+}$  current. *J Neurosci* 25:8282–8294
7. Ozaita A, Martone ME, Ellisman MH, Rudy B (2002) Differential subcellular localization of the two alternatively spliced isoforms of the Kv3.1 potassium channel subunit in brain. *J Neurophysiol* 88:394–408
8. Shen Y, Yu D, Hiel H, Liao P, Yue DT, Fuchs PA, Soong TW (2006) Alternative splicing of the Ca(v)1.3 channel IQ domain, a molecular switch for  $Ca^{2+}$ -dependent inactivation within auditory hair cells. *J Neurosci* 26(42):10690–10699
9. Grabowski PJ, Black DL (2001) Alternative RNA splicing in the nervous system. *Prog Neurobiol* 65:289–308
10. Licatalosi DD, Darnell RB (2006) Splicing regulation in neurologic disease. *Neuron* 52:93–101

## Alternative Splicing and Glial Maturation

TALILA VOLK<sup>1</sup>, CHRISTIAN KLÄMBT<sup>2</sup>

<sup>1</sup>Department of Molecular Genetics, Weizmann Institute, Rehovot, Israel

<sup>2</sup>Institut für Neurobiologie, Münster, Germany

### Definition

The number of protein-coding genes in an organism does not always correlate with its overall cellular complexity. Genes may be relatively simple, containing only a single or a small number of exons; some genes, however, may be incredibly complex and can give rise to literally thousands of different protein isoforms. One way to generate a huge variety of different protein variants from a gene with only moderately complex organization is **▶alternative splicing**. This mechanism amplifies the complexity of the 30,000 human genes to astronomic numbers. Furthermore, alternate splicing mechanisms may act on top of an already sophisticated transcriptional control system, and these combined mechanisms enable the development of complex organisms. Here we review how differential splicing regulates glial cell maturation in flies and mammals.

### Characteristics

Several known examples indicate that alternative splicing may result in distinct and even opposite functional consequences, either during embryonic development or in adult life. A prime example has been established for sex specification in *Drosophila*. In this system, the presence of the **▶Sex lethal** splice factor results in the differential **▶3' splice junction** choice that routes an animal towards female (or in its absence, into a male) development [1]. Moreover, sexual dimorphisms in the nervous system are brought about by sex-specific alternative variants of the *fruitless* gene, *fruitless<sup>m</sup>* or *fruitless<sup>f</sup>*, to induce either male or female behavior [2]. Another example is the alternative splicing of Apolipoprotein 2 (Apoer2), which induces an **▶NMDA receptor** isoform at postsynaptic sites that is sensitive to Reelin-dependent phosphorylation, thereby enhancing long term potentiation [3].

Terminal differentiation of cells is most often regulated by transcriptional activity and/or by cell/cell interactions. Interestingly, it was recently shown that differential splicing also plays an important and decisive role in cell differentiation. *Drosophila* glial cell differentiation depends on alternative splicing, which surprisingly, appears to be conserved during evolution. Two major components that control glial cell differentiation in *Drosophila*, Crooked Neck (Crm) and Held Out Wings (HOW) were identified. In mutants lacking either

of these genes, glial cells are correctly specified and initiate their normal migration towards their final destination. However, late glial cell differentiation, manifested by ►axonal wrapping, is impaired. Both Crn and HOW mediate alternative splicing of specific target genes essential for glial cell differentiation [4].

### Crn is a Conserved Splice Factor

The Crooked neck protein is conserved from yeast to humans. Yeast cells show little alternative splicing activity, though the molecular mechanisms underlying the splice reaction are conserved. The role of the yeast Crooked neck-like protein (Clfp1) is to promote assembly of a functional ►spliceosome. The yeast clfp1 mutant has been successfully complemented by the expression of the *Drosophila* Crn protein, demonstrating that the proteins not only share sequence conservation but also exhibit similar functional properties. In addition to its role in yeast, the function of Crn in the regulation of splicing was demonstrated in a number of examples in the *Drosophila* system. Crn proteins do not bind directly to RNA. Rather, through multiple TPR repeats that mediate protein-protein interactions, Crn proteins can function as assembly platforms.

### STAR Proteins Mediate Alternative Splicing in Specific Tissues

Proteins belonging to the ►STAR (►Signal Transduction and Activation of RNA) family of RNA-binding proteins have long been viewed as candidates for mediating alternative splicing decisions. These proteins share a single maxi ►KH domain, which binds to RNA and is highly conserved from *C. elegans* to humans [5]. Members of this family exhibit tissue-specific distribution. For example, *C. elegans* Gld-1 is expressed in the gonads of the nematodes, mammalian Quaking is expressed in ►oligodendrocytes, ►astrocytes and in ►Schwann cells, as well as in the heart, and *Drosophila* HOW is expressed in tendon, glial and muscle cells. Importantly, several members of this family were shown to regulate splicing of specific targets. For example, mammalian Quaking was shown to mediate the alternative splicing of the myelin-associated glycoprotein, MAG [6] in oligodendrocytes of the mouse brain. Thus, viable *quaking* mutants suffer from a severe ►demyelination phenotype.

### The *Drosophila* HOW and Crn Proteins Mediate Alternative Splicing Required for Glial Cell Differentiation

Recently, an association was demonstrated between the *Drosophila* STAR protein, Held Out Wing (HOW), and the splicing factor Crooked Neck (Crn) [4,7]. These two proteins appear to function together to regulate critical differentiation steps of both glia and tendon cells, suggesting that they form part of a general mechanism

that mediates alternative splicing in a tissue specific manner. Similar to other STAR family members, the *how* gene itself produces at least two major protein ►isoforms by alternative splicing, HOW(L) and HOW(S). The nuclear HOW(L) isoform had been shown to mediate mRNA degradation, thereby reducing the levels of specific target mRNAs. In contrast, the HOW(S) isoform shuttles between the nucleus and the cytoplasm where it can interact specifically with the splicing factor, Crn, to induce alternative splicing of specific targets.

The functional link between the HOW-Crn-dependent alternative splicing events and tissue differentiation has been demonstrated recently in two distinct tissues, glia and tendon cells. In a genetic screen, *crooked neck* (*crn*) mutants were identified based on their glial differentiation phenotype. In *crn* mutant embryos, ►peripheral glial cells exhibit aberrant migration and fail to wrap the axons. While *crn* mutants exhibit additional phenotypes in other tissues, overall embryonic development proceeds relatively normally, possibly due to the contribution of maternal *crn* transcript (►maternal transcript). The glial-specific nature of the *crn* phenotype indicates that the process of glial cell maturation and its ability to wrap the axons is hypersensitive to the reduction of Crn levels. Since the general splicing machinery is still intact in the mutant, it is likely that Crn is involved in specific splicing events required for glial cell maturation. Analysis of *how* mutants revealed a glial phenotype similar to that of *crn*, in which the peripheral glia also fails to wrap the axons. Moreover, a genetic interaction between the two gene products was demonstrated. Crn was shown to enhance a gain of function phenotype in the wing following ectopic expression of HOW(S); reducing Crn levels partially rescues the HOW(S)-gain of function phenotype. These and additional experiments strongly suggested that both Crn and HOW form a protein complex in the cytoplasm that functions together to mediate glial cell maturation.

To reveal the basis for the alternative splicing-dependence of glial cell differentiation it was essential to identify glial-specific targets that are spliced in response to Crn-HOW complex formation. The ►HOW-response element (HRE) was recently characterized as a penta-nucleotide sequence (ACUAA), which is unfortunately too short to be used for bioinformatic screening as a tool for target gene identification [8]. Therefore, to find such genes that are differentially expressed in wild type versus *crn* mutants, we followed a ►GFP-exon trap approach. This procedure identified two proteins, NrXIV (Casper homolog) and Nervana2 (beta subunit of the Na<sup>+</sup>/K<sup>+</sup> ATPase), whose expression was greatly reduced in the nervous system of *crn* mutants.

Both NrXIV and Nervana 2 are required for the formation of ►autocellular septate junctions formed by the glial cells that wrap the peripheral axons. Additional experiments strongly support a mechanism by which

*nrxIV* pre mRNA is associated with HOW, and undergoes specific splicing in the presence of both HOW and Crn. Glial specific splicing of *nrxIV* may help to establish tight temporal control of the formation of the autocellular junctions. Transcriptional regulation may provide a pool of pre-mRNAs that, upon an as yet unidentified signal, are processed to form autocellular junctions required to insulate axons at a very specific developmental stage.

### The Mechanisms that may Regulate Glial Specific Crn-HOW-Dependent Alternative Splicing

Taken together, our data suggest a model in which the HOW-Crn protein complex is shuttled from the cytoplasm into the nucleus to regulate the splicing and/or RNA stability of specific mRNAs required for the induction of glial cell differentiation. This process would contribute to the specific gene expression profile characteristic of the mature differentiation state of glial cells.

The mammalian STAR protein, Sam 68, undergoes phosphorylation by the protein tyrosine kinases Src and Fyn, as well as by ERK kinases. These phosphorylation events could affect different aspects of Sam 68 activity as they alter the subcellular distribution of Sam 68 (nuclear versus cytoplasmic) as well as its affinity to RNA. For example, the Sam 68-dependent inclusion of exon5 into the CD44 mRNA is induced upon ERK phosphorylation of Sam 68 [9]. Similarly, HOW-dependent splicing activity could be regulated by ERK-dependent signaling. Recently, it was shown that Fyn, a kinase of the Src family, phosphorylates the STAR protein, Quaking, which is essential for oligodendrocyte maturation [10]. The absence of Fyn activity in oligodendrocytes leads to specific alternative splicing of the Myelin Basic Protein, resulting in ►[hypomyelination](#) in the brain, a phenotype that is shared with viable *quaking* mutants in mice. It remains to be shown that the loss of Fyn-dependent phosphorylation of Quaking is the primary cause for the hypomyelination phenotype. Similarly, HOW phosphorylation may regulate its promotion of splicing in glial cells. These results are consistent with a model in which an external regulatory signal that leads to ERK, or Src-dependent phosphorylation of HOW, promotes the Crn-HOW interaction leading to alternative splicing only when glial cells undergo terminal differentiation.

Control of cellular differentiation needs to be carefully regulated. It makes sense that glial differentiation must not be initiated before all the cells are correctly localized; however, once they are, the signal for differentiation needs to be fast and efficiently executed. We speculate that this is one of the advantages provided by differential splicing. ►[Pre-mRNA](#) molecules can be generated and ready for use, but are rapidly spliced into the correct isoform only upon cells receiving a, still-elusive, signal.

In summary, the identification of the HOW-Crn complex, and its involvement in glial cell differentiation may represent a paradigm for a tissue-specific mechanism of alternative RNA splicing. Future elucidation of the mechanisms involved in the regulation of the HOW-Crn complex formation, and/or the promotion of developmentally-regulated alternative splicing, as well as the identification of glial-specific target mRNAs are essential for understanding how alternative splicing of specific targets is linked to glial cell differentiation.

### References

- Christiansen AE, Keisman EL, Ahmad SM, Baker BS (2002) Sex comes in from the cold: the integration of sex and pattern. *Trends Genet* 18:510–516
- Demir E, Dickson BJ (2005) Fruitless splicing specifies male courtship behavior in *Drosophila*. *Cell* 121:785–794
- Beffert U, Weeber EJ, Durudas A, Qiu S, Masiulis I, Sweatt JD, Li WP, Adelman G, Frotscher M, Hammer RE et al. (2005) Modulation of synaptic plasticity and memory by Reelin involves differential splicing of the lipoprotein receptor Apoer2. *Neuron* 47:567–579
- Edenfeld G, Volohonsky G, Krukkert K, Naffin E, Lammel U, Grimm A, Engelen D, Reuveny A, Volk T, Klämbt C (2006) The splicing factor crooked neck associates with the RNA-binding protein HOW to control glial cell maturation in *Drosophila*. *Neuron* 52:969–980
- Vernet C, Artzt K (1997) STAR, a gene family involved in signal transduction and activation of RNA. *Trends Genet* 13:479–484
- Wu JI, Reed RB, Grabowski PJ, Artzt K (2002) Function of quaking in myelination: regulation of alternative splicing. *Proc Natl Acad Sci USA* 99:4233–4238
- Volohonsky G, Edenfeld G, Klämbt C, Volk T (2007) Muscle-dependent maturation of tendon cells is induced by post-transcriptional regulation of stripeA. *Development* 134:347–356
- Israeli D, Nir R, Volk T (2007) Dissection of the target specificity of the RNA-binding protein HOW reveals *dpp* mRNA as a novel HOW target. *Development* 134:2107–2114
- Matter N, Herrlich P, König H (2002) Signal-dependent regulation of splicing via phosphorylation of Sam 68. *Nature* 420:691–695
- Lu Z, Ku L, Chen Y, Feng Y (2005) Developmental abnormalities of myelin basic protein expression in *fyn* knock-out brain reveal a role of Fyn in posttranscriptional regulation. *J Biol Chem* 280:389–395

## Altricial

### Definition

Altricial refers to animals that are born rather immature.

►[Neural Correlates of Imprinting](#)

## Altruistic Behavior

### Definition

Unselfish behavior; thus, the opposite of selfish behavior. In a strict sense a behavior that decreases the fitness of an animal. If individuals sacrifice their own reproduction for the reproduction of relatives, this is not, in a strict sense altruistic, because it will increase their fitness through kin selection.

## Alveus of Hippocampus

### Synonyms

▶ Alveus hippocampi

### Definition

The efferent fibers of the large pyramidal cells of the hippocampus course on the ventricular surface of the hippocampus. This lamella is called the alveus of hippocampus. It bundles to form the fimbria of the hippocampus and later enters the crus of fornix via which the fibers pass as part of the fornix into the direction of the diencephalon (hypothalamus).

▶ Telencephalon

## Alzheimer's Disease (AD)

### Definition

AD is a disabling neurological disorder that afflicts about 11% of the population over age 65. It involves widespread intellectual impairment, personality changes, sometimes delirium, and culminates in ▶ dementia, the loss of reason and ability to care for oneself. A person with Alzheimer's disease usually dies of some complication that affects bedridden patients, such as pneumonia. Brains of Alzheimer individuals show three distinct structural abnormalities: great loss of neurons in specific regions (e.g., ▶ hippocampus and ▶ cerebral cortex), plaques of abnormal proteins deposited outside neurons (amyloid plaques), tangled protein filaments within neurons (neurofibrillary ▶ tangles). Its causes are unknown, and it has no cure at the

present time, although drugs that inhibit acetylcholinesterase (AChE) mitigate the symptoms in 5% of patients.

▶ Memory and Dementia

## Alzheimer's Disease – Oxidative Injury and Cytokines

WILLIAM K. SUMMERS<sup>1</sup>, HELEN A. KORNEVA<sup>2</sup>

<sup>1</sup>Alzheimer's Corporation, Albuquerque, NM, USA

<sup>2</sup>Institute for Experimental Medicine, St. Petersburg, Russia

### Synonyms

Alzheimer's disease; Senile dementia of the Alzheimer's type; Senile dementia

### Definition

Alzheimer's disease is a progressive dementing illness, typically fatal within eight to ten years due to intercurrent infections such as pneumonia. At autopsy there is generalized shrinking of the brain. Microscopically the hallmarks are  $\beta$ -amyloid laden plaques and tau protein laden tangles. Current belief is that the disease is caused by toxicity from  $\beta$ -amyloid or tau protein.

### Characteristics

#### Alzheimer's Disease is not Caused by $\beta$ -Amyloid

Tomb stones do not kill, unless they fall upon the living. Tomb stones mark where the dead reside. To discover the cause of death, the body needs to be exhumed and analyzed. Even then, the cause of death may not be discovered.

For three decades, scientists pursued plaques ( $\beta$  amyloid) and tangles (tau protein) as causal Alzheimer's disease (AD) [1]. It is not the first time science went in a wrong direction. Plaques and tangles are tombstones. But, evidence has been show that  $\beta$  amyloid and tau protein are toxic to neurons [1,2]. Yes. But this is similar to dropping tomb stones on the living.

What, then, causes AD? When does it start?

A logical hypothesis with substantial support is that various CNS insults initiate oxidative injury with a pathologic immune response resulting in smoldering CNS microlocalized inflammation (mLI) [2]. The mLIs create plaques and tangles. Over two or more decades these pockets of inflammation metastasizes to other areas of the brain. Ultimately this preclinical state is called mild cognitive impairment (MCI). As time

passes, this becomes Alzheimer's which leads down the familiar path to death.

What are the initiating brain insults? The general classes would be mechanical trauma (sports, auto accidents); infections (herpes simplex viruses, cytomegalovirus, HIV, chlamydia pneumoniae, syphilis); anoxia (stroke, cardiac arrest, hemodynamic shock, pulmonary emboli, sleep apnea syndrome); metabolic (diabetes, B12 deficiency, hypothyroidism, obesity, hypertension, homocysteinemia); and toxic (iron, mercury, bismuth) [2,3]. The list of CNS insults that are related to AD is growing.

### The Role of Excitotoxin Neurotransmitters and the Release of Free Radicals

The CNS insult must result in focal neuron death by either necrosis or secondary apoptotic damage. This results in massive release of the excitatory amino acid, glutamate into the extraneuronal space [3]. L-glutamate, the most abundant excitatory neurotransmitter, binds to AMPA and NMDA receptors to precipitate localized neuronal apoptosis. This is accomplished by Na<sup>+</sup> ion influx with acute osmotic damage followed by apoptosis. Or it is accomplished by Ca<sup>2+</sup> influx and delayed apoptosis. Both necrosis and apoptosis release free radicals (ROS/RNS) into the intracellular space. Indeed L-glutamate is a neurotransmitter free radical. However, release of mitochondrial contents injects metals (copper, zinc, iron, etc) into the intracellular space. Homeostasis is threatened. This is where nitric oxide (NO), antioxidants, Beta amyloid and cytokines come into play.

NO is a free radical, but is part of homeostasis [3]. Rapidly formed, it interacts with superoxide radicals (O<sub>2</sub><sup>-</sup>) to form more innocuous products which antioxidant mechanisms can manage.

### Oxidative Injury

Metabolism produces reactive oxygen species (ROS) and reactive nitrogen species (RNS) which is approximately balance by antioxidant defense systems of the body. Anoxia, blunt trauma, infections, and any cause of inflammations create an excess of ROS/RNS. Serious imbalance between production of ROS/RNS and the antioxidant defense results in oxidative injury or disruption of DNA, proteins (enzymes), and lipids.

The brain is uniquely vulnerable to oxidative injury [2]. In the milieu of local necrosis/apoptosis, the free radicals test the ability of the brain to protect lipid membranes. 50–80% of neurons by weight are lipids. The brain has antioxidant methods to protect the neuronal membrane [2,4]. As these local defenses fail, markers of oxidative damage should be evident. Indeed activated NFκB, 8-OHdG, protein carbonyls, nitrotyrosine, 4-HNE, and other markers of oxidative injury are elevated in AD. Further these markers are associated with senile plaques and paired helical filaments [4].

### Cytokines

Concomitant with and as the mLI persists, cytokines come into play. Cytokines are low molecular weight regulatory proteins secreted by cells to orchestrate host immune processes [2,5]. They regulate proliferation, maturation, enhanced inflammation or dampened inflammation. Important properties of cytokines are: (i) pleiotropy (one cytokine has multiple targets and multiple actions) (ii) redundancy (several different cytokines have similar actions) (iii) countervailing actions (one cytokine may stimulate or inhibit production of others) (iv) cytokines precipitate or truncate cascades of other cytokines (v) cytokines increase or decrease receptor sensitivity for other cytokines or even themselves (vi) CNS cytokines stimulate or inhibit both local cytokine response and distant (non-CNS) cytokine response.

Only recently has it been recognized that cytokines are produced by all four major CNS cell groups. These are neurons, oligodendrocytes, astrocytes, and microglia. Over two hundred distinct cytokines identified to date are divided into three groups and 12 sub groups (families) [2,5] Chemokines are a subgroup of 50 small cytokines that are central to mediation of inflammatory responses. Most of these are produced by CNS cells [6]. Some cytokines tend to be proinflammatory and promote apoptosis. Example are TNF-α, IFN-γ, IL1β, IL-6, IL-8, IL-18, MCP-1, MIP-1α, MIP-1β, IP-10, and RANTES. Some CNS cytokines tend to down regulate inflammation and promote growth/ repair. These would include BDNF, β-NGF, GDNF, G-CSF IL-1β, IL-4, IL-10, IL-13, and NT-3, 4/6, 6. This list changes near daily. Further one cytokine may be found to be pro-inflammatory in one region or circumstance, and have an opposite effect under other circumstances. CNS cytokines may stimulate distant response. For example, blood levels of IL-2 correlate with severity of Alzheimer's disease. External application of cytokines can induce CNS patterned responses. For example, administration of IL-2 will induce depressive symptoms.

Sustained elevations of cytokine productions are associated with pathologies. In the case of AD, the key cytokines are IL-1 which induces iNOS expression by astrocytes and then potentiates NMDA – glutamate neurotoxicity [7]. IL-1 may also be neuroprotective. Interleukin-6, produced by neurons, astrocytes and microglia co-localizes with Aβ plaques. Peripherally, IL-6 is a marker of chronic inflammation. Elevated IL-6 is seen in chronic simple anemia, rheumatoid arthritis, Crohn's disease and others [5]. IL-6 is involved in protecting neurons from methylmercury [7]. It is probably involved with Aβ neuroprotection by neutralizing metalloproteins ROS/RNS produced by apoptosis [2,8]. TNF-alpha typically is a harbinger that calls forth other inflammatory cytokines. In AD there is mixed evidence at the present time. Macrophage Colony Stimulating



Factor (MCSF, CSF-1) appears to be involved with upregulated cytokine/iNOS response to A $\beta$  [7]. A growing list of chemokines is involved with AD. Transforming growth factor (TGF- $\beta$ ) cytokine family, which includes the neurotrophin subfamily, are expressed by neurons, astrocytes, and microglia. The neurotrophin subfamily include nerve growth factor (NGF), brain derived neurotrophic factor (BDNF), ciliary neurotrophic factor (CNTF), insulin like growth factor (ILGF), glial derived neurotrophic factor (GDNF), and erythropoietin (EPO) [2,5,9]. These stimulate repair, growth, and neurogenesis [2,10].

### The Role of A $\beta$ in Alzheimer's Disease

Perry, Smith, et al offer a logical explanation [2,8] A $\beta$  is actually part of the brain's efforts to maintain homeostasis. Apoptosis and necrosis resulting from mLI cause release of mitochondrial metalloproteins and metals (iron, zinc, copper, etc) into an acidic extracellular matrix. A $\beta$  is induced by cytokines. A $\beta$  binds copper, zinc, iron and others. A $\beta$  absorbs these ROS/RNS as part of homeostasis. Adequate circulation should allow clearance of the A $\beta$ -metal complexes. When the microglia are activated, and when the ROS/RNS are overwhelming, myeloid-specific enzyme myeloperoxidases (MPO) consume them to produce MPO-H<sub>2</sub>O<sub>2</sub>. This MPO-H<sub>2</sub>O<sub>2</sub> creates cross linkage with A $\beta$  protein to precipitate it into insoluble plaques [2].

With plaque formation, activated microglia, highly reactive ROS (including glutamate) the table is set for distant penumbra effect. The mLI can trigger distant microinflammations by transaxonal/transsynaptic flow, intracellular flow, and vascular dispersion of ROS/RNS. So plaques and tangles develop elsewhere in the CNS, and after decades the victim dies of AD.

### Possible Interventions in Alzheimer's Disease

Use of cytokines, anti-cytokines, cytokine receptor modulators is not a current therapeutic intervention. The pleiotropy, redundancy, and unexplored effects of cytokine cascades would result in unanticipated adverse side effects [2,5]. Down modulating the effects of glutamate is both practical and available. NMDA antagonists memantine and amantadine are available, and by personal experience of the authors effective early in the course of AD [7]. Third, are anti-inflammatory medications. These have been disappointing to date, possibly due to the drawbacks noted for cytokines [1]. Vaccinations against A $\beta$  are fraught with problems, as one is developing immunity against a homeostatic mechanism. Finally there are antioxidants. Inexpensive vitamins and herbals are available and have increasing scientific support [2,4,11]. Traditional medicine discounts these, while pursuing patentable pharmaceuticals. Further research on synergistic combinations of antioxidants may prove effective.

Because the authors were limited to eleven references, the choice was made to cite recent books with a larger number of specific references.

### References

1. Behl C (2002) Neuroprotective strategies in Alzheimer's disease. In: Alzheimer C (ed) *Molecular and cellular biology of neuroprotection in the CNS*. Kluwer Academic/Plenum, New York, pp 475–496
2. Summers WK (2004) Alzheimer's disease, oxidative injury, and cytokines. *J Alzheimers Dis* 6:651–657
3. Gillessen T, Budd SL, Lipton SA (2002) Excitatory amino acid neurotoxicity. In: Alzheimer C (ed) *Molecular and cellular biology of neuroprotection in the CNS*. Kluwer Academic/Plenum, New York, pp 3–40
4. Halliwell B, Gutteridge JMC (2001) *Free radicals in biology and medicine*, 3rd edn. Oxford University Press, Oxford, pp 617–859
5. Vilček J (2006) Cytokines: wherefrom and whereto. In: Ransohoff RM, Benveniste EN (eds) *Cytokines and the CNS*. Taylor & Francis, New York, pp 23–37
6. Dey N, Durden DL, Van Meir EG. Cytokine expression and signaling in brain tumors. In: Ransohoff RM, Benveniste EN (eds) *Cytokines and the CNS*. Taylor & Francis, New York, pp 194–228
7. Murphy GM, Saravanapavan P (2006) Cytokines and neurodegeneration. In: Ransohoff RM, Benveniste EN (eds) *Cytokines and the CNS*. Taylor & Francis, New York, pp 163–191
8. Castellani RJ, Lee H, Perry G, Smith MA (2006) Antioxidant protection and neurodegenerative disease: the role of amyloid- $\beta$  and tau. *Am J Alzheimers Dis Oth Demen* 21:126–130
9. Dechant G, Neumann H. Neurotrophins (2002) In: Alzheimer C (ed) *Molecular and cellular biology of neuroprotection in the CNS*. Kluwer Academic/Plenum, New York, pp 303–334
10. Unsicker K, Kriegstein K (2002) TGF- $\beta$ s and their roles in the regulation of neuron survival. In: Alzheimer C (ed) *Molecular and cellular biology of neuroprotection in the CNS*. Kluwer Academic/Plenum, New York, pp 353–374
11. Packer L, Ong CN, Halliwell (eds) (2004) *Herbal and traditional medicine*. Marcel Dekker, New York

## Amacrine Cell

### Definition

A group of lateral interneurons in the vertebrate retina, interacting with bipolar cells, other amacrine cells and ganglion cells in the inner plexiform layer (synaptic layer).

- ▶ Inherited Retinal Degenerations
- ▶ Retinal Bipolar Cells

- ▶ Retinal Color Vision in Primates
- ▶ Retinal Direction Selectivity and Starburst Amacrine Cells
- ▶ Retinal Ganglion Cells

---

## Ambiens Gyrus

### Definition

The ambiens gyrus borders on the uncus and is partially surrounded by the semilunar gyrus. Both are components of the hippocampus.

- ▶ Telencephalon

---

## Amiculum of Olive

### Synonyms

- ▶ Amiculum olivare

### Definition

Shortly before reaching the dentate nucleus, some afferents of this nucleus form, around the inferior olive, a dense, superficial fiber bundle at the rostral end of the laterodorsal myelencephalon, which is called the amiculum of olive.

- ▶ Myelencephalon

---

## 4-Aminopyridine

### Definition

High-potency blocker of some types of potassium ( $K^+$ ) channels, including those of the Kv3 family and a subset of Kv1 family subunits, and less potent blocker of other  $K^+$  channels, including those of the Kv4 family.

- ▶ Action Potential
- ▶ Neuronal Potassium Channels

---

## Ammons Horn/Cornu Ammonis

- ▶ Hippocampal Formation

---

## Amnesia

ROSE M. CALHOUN-HANEY, STUART M. ZOLA  
Yerkes National Primate Research Center, Emory University, Atlanta, GA, USA

### Synonyms

Memory loss; Memory impairment; Memory dysfunction

### Definition

▶ **Amnesia** refers to an impaired ability to learn new information or recall details from the past.

### Characteristics

The definitive characteristic of amnesia is profound forgetfulness. It can be caused by brain injury, neurological disease, a cardiovascular event (e.g., stroke), as well as by neurodegenerative and psychological disorders. Amnesia can occur simultaneously with impairment in other cognitive domains (e.g., visuospatial, language, attention disorders), or in the absence of additional cognitive deficits. For this reason, patients with amnesia can perform in the average to above average range on intelligence tests (e.g., Wechsler Adult Intelligence Scale – Third Edition), while simultaneously performing in the severely impaired range on tests of memory (e.g., the Wechsler Memory Scale – Third Edition). This impairment in memory can be observed regardless of the sensory modality (e.g., auditory, visual) in which the information is presented. Interestingly, amnesic individuals can retain intact language and social skills, as well as intact memories for the remote past. Immediate memory remains intact as well. This is illustrated by their ability to retain information up to several minutes provided there is no distraction; the presented material does not exceed immediate memory capacity (e.g., eight or more items); and they are able to rehearse the material. These preserved characteristics explain why individuals with amnesia can appear quite normal in casual conversation. It is only when information must be recalled after an extended delay or distraction-filled interval that a memory impairment becomes apparent.

In 1957, Scoville and Milner detailed the discovery of the critical involvement of the medial temporal

lobe in amnesia in a report on famed patient, H.M., who underwent bilateral medial temporal lobe resection, and subsequently suffered severe memory impairment as a result [1]. A great deal has been learned about amnesia from well-studied amnesic patients such as H.M., as well as from the development of the animal models of human amnesia. Methodical work with the non human primate model subsequently revealed the system of medial temporal lobe structures recognized to be crucial for memory. This system consists of the hippocampal region (CA fields, dentate gyrus and subicular complex) and the adjacent perirhinal, entorhinal, and parahippocampal cortices [1,2]. There are continued efforts to try to further elucidate the types of memory properties (e.g., object versus spatial memory) processed by these regions within the medial temporal lobe (Fig. 1) [3].

Regions outside the medial temporal lobe, such as the diencephalon and basal forebrain, are also known to impair memory when injured. The essential structures within each of these areas for memory is still in need of further investigation. Suspected regions include the mediodorsal thalamic nucleus, the anterior nucleus, the internal medullary lamina, the mammillothalamic tract, and the mammillary nuclei. Amnesia resulting

from lesions in medial diencephalic structures (e.g., medio-dorsal thalamic nucleus, mammillary nuclei) is referred to as “►medial diencephalic disorder” or “diencephalic amnesia.” The behavioral presentation of diencephalic amnesia and ►medial temporal lobe amnesia can be similar. Therefore, it is thought that these two regions together perhaps form an anatomically linked, functional system.

### Multiple Memory Systems

Decades of research on amnesia have highlighted the fact that memory is not a single faculty but instead is composed of multiple separate systems (Fig. 2), only one of which is generally impaired in amnesia [5]. Human amnesia impairs the ability to acquire information about facts and events (►declarative memory or ►explicit memory), while typically sparing the capacity for skill learning, probabilistic classification learning, certain kinds of conditioning and habit learning, as well as the phenomenon of priming (collectively referred to as ►nondeclarative memory or ►implicit memory) [2]. Declarative memory is largely dependent upon the integrity of the medial temporal lobe and diencephalon, whereas nondeclarative memory largely relies on

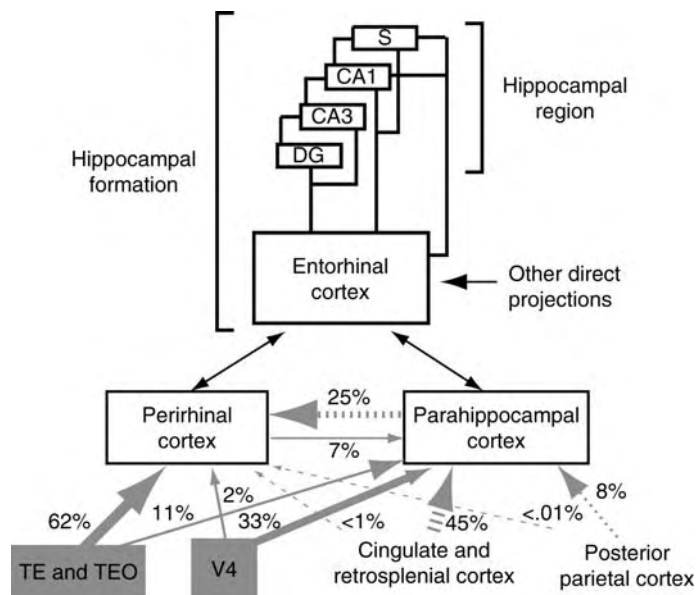

**Amnesia. Figure 1** Schematic view of the medial temporal lobe memory system (adapted from references [3] and [2]) showing the percentage of cortical input from unimodal and polymodal association areas to the perirhinal and parahippocampal cortices in the medial temporal lobe (black boxes). The percentages of cortical input shown on this schematic are from Suzuki and Amaral [4]. The thickness of the lines approximate the relative percentages of cortical input. Buffalo et al. [3] suggest that the perirhinal cortex might be more important for object memory (grey solid lines and boxes) while the parahippocampal cortex might be more important for spatial memory (grey dashed lines and boxes). Additionally, they hypothesize the possibility that the perirhinal cortex is involved in both spatial and object memory due to the large amount of spatial information it receives via the parahippocampal cortex. See also ►Spatial Learning and ►Object recognition, visual. Abbreviations: S, subiculum; CA1, hippocampal field CA1; CA3, hippocampal field CA3; DG, dentate gyrus; TE, inferotemporal cortex area TE; TEO, infero temporal cortex area TEO; V4, visual area V4.

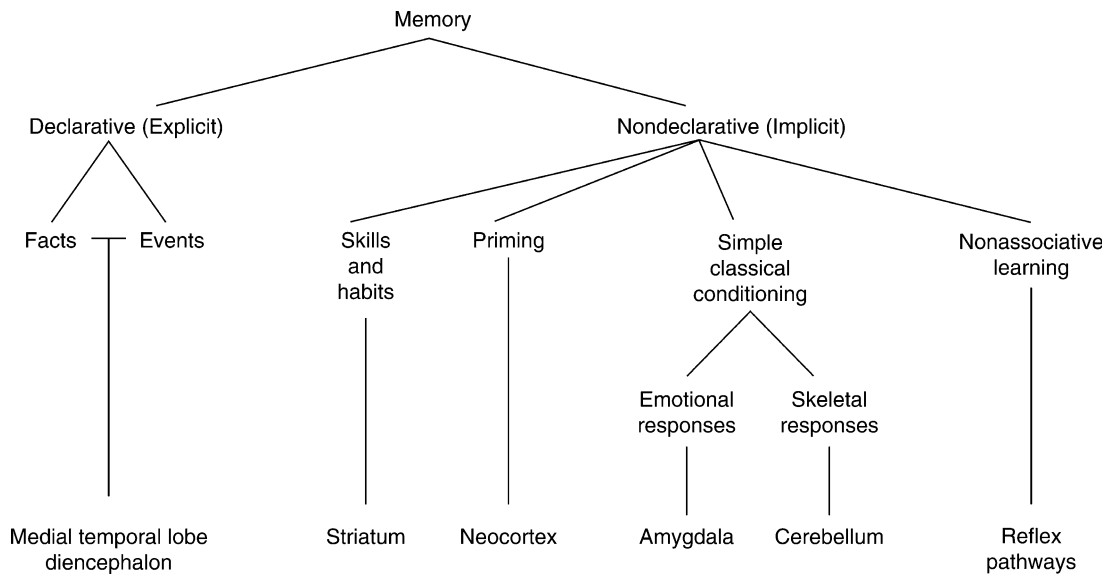

**Amnesia. Figure 2** A taxonomy of long-term memory systems together with specific brain structures involved in each system (adapted from reference [2]).

different brain systems than those damaged in amnesia (Fig. 2) [2].

The label “amnesia” is a broad term that describes the presence of some type of memory impairment. However, there are a variety of amnesic presentations. The following text explains more specifically what particular type of memory difficulties a person with a certain type of amnesia might experience. Additionally, given the majority of research that suggests that nondeclarative memory typically remains preserved in amnesic patients [5], the kinds of amnesia described below concentrate on what could be observed as a result of an impaired declarative memory system.

### Types of Amnesia

► **Anterograde amnesia** refers to an impaired ability to learn new information. An individual who experiences anterograde amnesia can have significant difficulty remembering new people, recent conversations, and new surroundings subsequent to the onset of amnesia. For example, Scoville and Milner [1] described patient H.M. as having severe anterograde amnesia. They detailed an incident where H.M. could not remember meeting a particular physician despite his having had a conversation with the physician only minutes earlier. It is important to note that the degree of severity of anterograde amnesia produced by medial temporal lobe damage is variable. However, research has demonstrated that damage limited to the hippocampus alone is sufficient to produce memory impairment. Additionally, work performed with both amnesic patients and animal models of amnesia suggest that memory impairment is exacerbated when damage

includes cortical regions adjacent to the hippocampus. In other words, the severity of anterograde amnesia can increase as more regions of the medial temporal lobe memory system are involved in the injury.

► **Retrograde amnesia** is characterized by an impaired ability to remember facts or events that occurred prior to the onset of amnesia. It may or may not occur in conjunction with anterograde amnesia. Similar to anterograde amnesia though, the severity of retrograde amnesia can vary as a function of the extent of damage to cortical regions adjacent to and including the hippocampus. Furthermore, although memory for events close in time to the amnesic episode can be significantly impaired (e.g., details of an accident that resulted in head injury), memories for very remote events are typically preserved (e.g., childhood memories). This phenomenon is referred to as ► **temporally graded retrograde amnesia**. Scoville and Milner’s report on H.M. [1] supplies a fine illustration of temporally graded retrograde amnesia. They described H.M. as having very poor memory for events occurring several before and up to his surgery, while retaining relatively intact memories from his youth. This sparing of remote memories is generally attributed to the process of ► **memory consolidation**. This term refers to the cortical processing and reorganization of neural substrates involved when forming memories. Memory formation is initially thought to be dependent on the medial temporal lobe system, but its role appears to diminish as more permanent memory is established elsewhere, presumably in neocortex [6]. Research suggests that memory consolidation processes for remote memories have had a sufficient amount of

time to be completed. Recently acquired memories have not had the same amount of time to undergo reorganization, and are thus more vulnerable to medial temporal lobe injury, whose structures are presumed to be involved in the early stages of memory consolidation [6].

► **Source amnesia** or ► **contextual amnesia** is a phenomenon that occurs when an individual can recall a fact or an idea, but cannot recall when or where the information was learned. In other words, the individual has access to and can recall information previously presented to them, but cannot recall the context in which the information was acquired. Source memory and source amnesia have been associated with frontal lobe function (or dysfunction in the case of source amnesia) due to its suspected processing of spatial-temporal (i.e., where-when) information [7,8]. Source amnesia can be commonly seen in young children as well as in the elderly. This observation has been attributed to the slow maturation of the frontal lobes relative to other brain regions during development, as well as the relatively increased vulnerability of the frontal lobes to the effects of normal aging. Additionally, source amnesia can be observed in normal adults when newly learned information is assessed after long periods of delay. An increase in the duration of the delay before testing corresponds to an increase in frequency of source memory errors [8]. Patients with frontal lobe lesions can often exhibit source memory difficulties. The pattern of deficits on memory tests suggest they fail to employ efficient memory strategies (e.g., semantic clustering) to enhance encoding and retrieval of previously learned information [7]. It is important to note that a person with anterograde amnesia does not necessarily have to also have source amnesia. Its appearance is variable in amnesic patients and seems to be a separate deficit that can occur in addition to impaired declarative memory. The variability of its co-occurrence with anterograde amnesia lends support to the idea that source amnesia is associated with regions outside the medial temporal lobe, such as the frontal lobes [7].

► **Transient global amnesia** is characterized by a sudden onset of both ► **anterograde** and retrograde amnesia, with no other obvious cognitive disturbances present. It can last for a few to several hours, but usually resolves within a day. It is most commonly observed in middle age to elderly individuals. The person experiencing transient global amnesia typically complains of memory impairment, but remains fully conscious and self-aware. Complete recovery is usually expected. However, research has demonstrated persistent mild cognitive deficits after transient global amnesia has resolved [9]. Its etiology is still unknown, although hypothesized causes include focal ischemic lesions, brain tumors, and migraine headaches. The medial temporal lobe is known to be particularly susceptible to the effects of stress, which could suggest its possible role. A recent study involving diffusion-weighted imaging has

demonstrated the involvement of the hippocampus in the pathophysiology of transient global amnesia, providing structural evidence indicative of ischemic dysfunction in this particular brain region [10]. Given the pattern of advance in structural and functional brain imaging procedures, improved methods show promise in providing more substantial evidence of the neuroanatomical substrates involved in transient global amnesia.

► **Mnesitic block syndrome** is sometimes referred to as “functional retrograde amnesia,” or “psychogenic amnesia,” and it is the type of memory disorder with which the average layperson is probably most familiar. It is also this kind of amnesia that has been most popularized by television and film. Mnesitic block syndrome is characterized by a sudden onset of severe retrograde amnesia, in the absence of significant anterograde amnesia. This is reflected by the individual’s memory loss for personal identity and autobiographical detail (e.g., cannot recall name or date of birth), as well as a period of wandering. It can also include impaired ► **semantic memory** and ► **episodic memory**. This collection of symptoms is often referred to as a “fugue state” [5]. Additionally, when a person recovers, he or she may have no recollection of what took place during their amnesic state. The extent of retrograde amnesia experienced by the individual can range from an inability to recall past memories for a limited time period, to complete lack of recollection for most memories prior to amnesic onset. Incidents of mnesitic block syndrome are usually precipitated by premorbid periods of severe psychological stress (e.g., death of loved one, financial collapse, marital discord), hence the term “psychogenic amnesia.” A recently proposed model tries to explain the psychogenic nature of mnesitic block syndrome by hypothesizing an interaction between psychosocial stress factors and brain regions pertinent to autobiographical memory retrieval and personal identity. The model suggests that severe stress can directly inhibit the frontal control/executive brain system, which in turn negatively affects retrieval of memories [5]. Episodes of mnesitic block syndrome generally resolve over a short period of time, but can last anywhere from a few hours to a few months. However, prolonged “fugue states” can raise the suspicion of simulation [5].

## References

1. Scoville WB, Milner B (1957) Loss of recent memory after bilateral hippocampal lesions. *J Neurol Neurosurg Psychiatry* 20:11–21
2. Squire LR, Zola SM (1996) Structure and function of declarative and nondeclarative memory systems. *Proc Natl Acad Sci USA* 93:13515–13522
3. Buffalo E, Bellgowan P, Martin A (2006) Distinct roles for medial temporal lobe structures in memory for objects and their locations. *Learn Mem* 13:638–643

4. Suzuki WA, Amaral DG (1994) Perirhinal and para-hippocampal cortices of the macaque monkey: cortical afferents. *J Comp Neurol* 350:497–533
5. Kopelman M (2002) Disorders of memory. *Brain* 125:2152–2190
6. Squire LR, Stark CEL, Clark RE (2004) The medial temporal lobe. *Annu Rev Neurosci* 27:279–306
7. Baldo J, Shimamura A (2002) Frontal lobes and memory. In: Baddeley A, Kopelman M, Wilson B (eds) *Handbook of memory disorders*, 2nd edn. Wiley & Sons, Inc., Chichester, pp 363–380
8. Schacter D, Harbluk J, MacLachlan D (1984) Retrieval without recollection: an experimental analysis of source amnesia. *J Verbal Learn Verbal Behav* 23:593–611
9. Le Pira F, Giuffrida S, Maci T, Reggio E (2005) Cognitive findings after transient global amnesia: role of prefrontal cortex. *Appl Neuropsychol* 12:212–217
10. Cianfoni A, Tartaglione T, Gaudino S, Pilato F, Saturno E, Tonali P, Di Lazzaro V (2005) Hippocampal magnetic resonance imaging abnormalities in transient global amnesia. *Arch Neurol* 62:1468–1469

---

## Amnesic Aphasia

### Definition

A type of aphasia in which word-finding difficulty in spontaneous speech and in picture or object naming is the predominant symptom, with other language abilities being relatively spared. Despite the name, patients with “amnesic” aphasia do not exhibit amnesia or episodic memory deficits. Synonymous with anomic aphasia.

► Verbal Memory

---

## Amnesic Shellfish Poison

► Domoic Acid Neurotoxicity

---

## Amniote Egg

### Definition

An egg that contains everything needed for the development of an organism on land – protective shell

and membranes (amnion, chorion, allantois), respiratory surfaces, and food and water reserves.

► The Phylogeny and Evolution of Amniotes

---

## Amniotes

### Definition

A group of vertebrates whose embryos develop inside extensive membranes that allow the offspring to be laid as eggs or carried by the female and born live. Early amniotes were known as reptiles, but they are now called early amniotes to distinguish them from the separate lines that led to present-day reptiles and mammals.

► Evolution of the Brain in Reptiles

► Evolution of the Somatosensory System: in Mammals

---

## Amorphosynthesis

### Definition

Inability of patients with ► [Balint's syndrome](#) to construct an internal representation of the external world.

► Visual Neuropsychology

---

## AMPA

### Definition

$\alpha$ -amino-3-hydroxy-5-methylisoxazole-4-propionic acid is an amino acid derivative that binds to the AMPA-type glutamate receptor.

► AMPA Receptors

---

## AMPA Receptors

### Definition

Ionotropic receptors for the excitatory neurotransmitter glutamate. AMPA receptors consist of GluR1

(GluR $\alpha$ 1), GluR2 (GluR $\alpha$ 2), GluR3 (GluR $\alpha$ 3) and GluR4 (GluR $\alpha$ 4) subunits and are localized at the postsynaptic site on the dendritic spine. The composition of the subunits determines the properties of AMPA receptor channels. When glutamate binds to the receptor channel, the channel opens and monovalent cations permeate through the receptor channel. Mainly, sodium ions permeate into the neuron at the resting membrane potential, resulting in the depolarization of the neuron.

- ▶ Associative Long-term Potentiation (LTP)
- ▶ Long-Term Potentiation (LTP)
- ▶ Memory
- ▶ Molecular Mechanisms

## Amperometry

### Definition

A sensitive electro-chemical method to detect the release of transmitters or hormones (e.g. dopamine or adrenaline) that can be catalyzed to undergo a redox reaction by a voltage applied to the tip of an electrode (typically made of a carbon fiber). This method can monitor the rate of release of certain transmitters and hormones from individual vesicles in millisecond timescale.

- ▶ Dopamine
- ▶ Noradrenaline

## Amphibian Cerebral Cortex

- ▶ Evolution of the Pallium: in Amphibians

## Amphibians

- ▶ Evolution of the Brain: Amphibians

## Amphisbenid (Type)

### Definition

Refers to a family (Amphisbaenidae) of burrowing lizards.

- ▶ Evolution of the Brain: At the Reptile-Bird Transition

## Amplification

- ▶ Hearing Aids

## Amplitude Spectrum

### Definition

Most often used in acoustics and the analysis of electrical signals. An amplitude spectrum shows the strength of each frequency over the whole range of all sine and cosine waves of unknown frequencies that make up a signal.

- ▶ Electric Fish

## Ampulla

### Definition

Enlarged portion at the base of each semicircular canal that contains the crista, the cupula and canal receptor hair cells.

- ▶ Ampullar Receptors
- ▶ Semicircular Canals
- ▶ The Peripheral Vestibular Apparatus

## Ampulla of Lorenzini; Tuberous Organ

- ▶ Electroreceptor Organs

## Ampullar Receptors

### Definition

Labyrinthine receptors located over a protrusion of the epithelium (ampullary crista) within the ampullae of semicircular canals. Their cilia are embedded in a gelatinous structure (cupula) having the same density as the endolymph. These receptors are stimulated by the movement of the endolymph within the semicircular canals elicited by head angular accelerations. Opposite directions of fluid motion induce opposite effects on the receptors.

- ▶ Semicircular Canals
- ▶ The Peripheral Vestibular Apparatus

## Ampullary Organs

### Definition

Primitive receptor of the electrosensory system.

Sensitive to weak direct-current (DC) and low-frequency electric fields.

- ▶ Evolution of Mechanosensory and Electrosensory Lateral Line Systems

## Amygdala

ALEXANDER J. McDONALD

Department of Pharmacology, Physiology, and Neuroscience, University of South Carolina School of Medicine, Columbia, SC, USA

### Synonyms

Amygdaloid body; Amygdalar nuclear complex

### Definition

The amygdala (Latin, almond) is a subcortical cluster of brain nuclei located in the temporal lobe of the cerebral hemispheres. It is involved in a wide range of functions, including emotion, biologically based behaviors, attention, memory and learning. It exhibits pathological and pathophysiological changes in several important neurological and psychiatric diseases including temporal lobe epilepsy, Alzheimer's disease, schizophrenia, anxiety disorders and depression.

## Characteristics

### Anatomical Organization

The amygdala is a part of the ▶limbic system located in the temporal lobe of the cerebral hemispheres [1,2] (Figs. 1 and 2).

It is customary to categorize the amygdalar nuclei into groups that exhibit distinctive anatomical or functional characteristics. Traditionally, two major amygdalar nuclear groups were recognized, a superficial "corticomedial" group (including the cortical, medial and central nuclei) and a deeper "basolateral" group (including the lateral, basal and accessory basal nuclei) (Fig. 1). Recent studies however, indicate that the central and medial nuclei exhibit anatomical and histochemical characteristics that are distinct from those of the cortical nucleus. Therefore, it has been suggested that the amygdalar nuclei should be divided into a corticobasolateral nuclear group and a centromedial nuclear group [3]. In addition, attenuated portions of the centromedial nuclear group extend forward to become continuous with a brain region called the bed nucleus of the ▶stria terminalis, which is located in the septal region adjacent to the anterior commissure. The term "▶extended amygdala" has been used to collectively designate the centromedial amygdala and bed nucleus of the stria terminalis [4].

Cell types in the basolateral and cortical nuclei are very similar to each other. Most of the neurons in both groups are termed pyramidal cells because they resemble the pyramidal neurons in the cerebral cortex. The pyramidal cells are the main "projection neurons" of the cortical and basolateral nuclei (i.e. their axons project out of the amygdala and allow the amygdala to activate other brain regions). Pyramidal cells utilize the amino acid ▶glutamate as an excitatory ▶neurotransmitter. The remaining cell types in the basolateral and cortical nuclei are nonpyramidal neurons. The axons of these cells establish synaptic contacts with neighboring amygdalar neurons but do not extend beyond the amygdala (i.e. they are ▶interneurons). They utilize  $\gamma$ -aminobutyric acid (▶GABA) as an inhibitory neurotransmitter.

In contrast to the basolateral and cortical nuclei, neurons of the centromedial nuclei and the bed nucleus of the stria terminalis resemble neurons of the adjacent striatum (part of the ▶basal ganglia) rather than the cerebral cortex. Most of these neurons utilize GABA as an inhibitory neurotransmitter, and many also contain ▶neuropeptides that function as neurotransmitter-like substances.

### Functional Anatomy

In their classic study performed in 1937, Klüver and Bucy [5] found that lesions of the amygdalar region produced a profound loss of fear in monkeys ("▶Klüver-Bucy syndrome"). These animals also exhibited



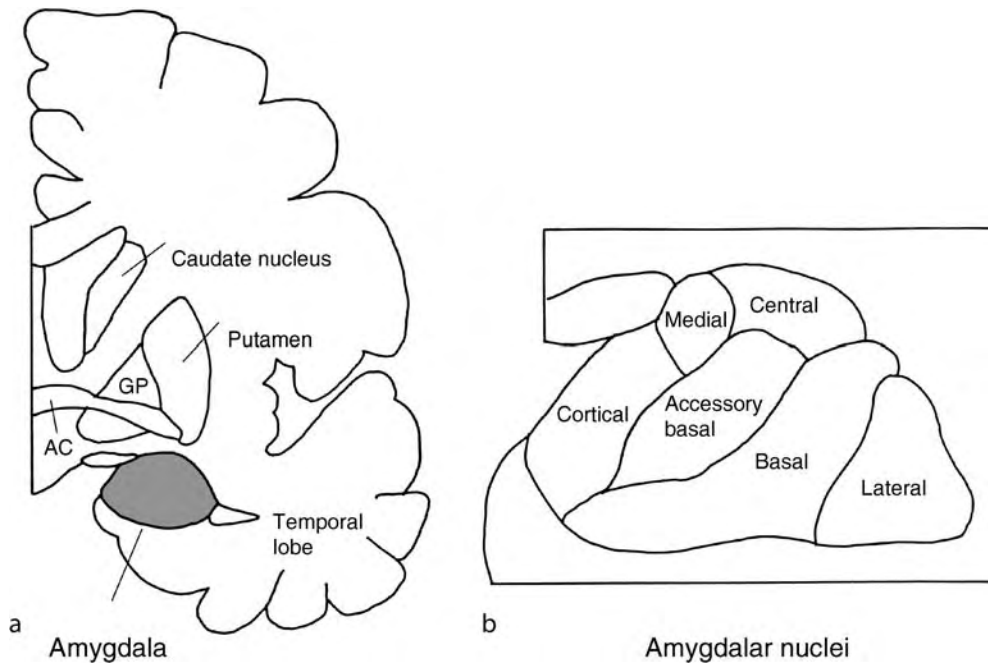

**Amygdala. Figure 1** (a) Coronal section through the human brain at the level of the amygdala (only the right half of the brain is shown; the amygdala is actually found on both sides of the brain). Note that the amygdala (*shaded area*) is located in the anteromedial part of the temporal lobe. (b) Enlargement of the amygdala at the level shown in (a), illustrating the locations of the main amygdalar nuclei. AC anterior commissure; GP globus pallidus. Reprinted from Encyclopedia of the Neurological Sciences with permission from Academic Press.

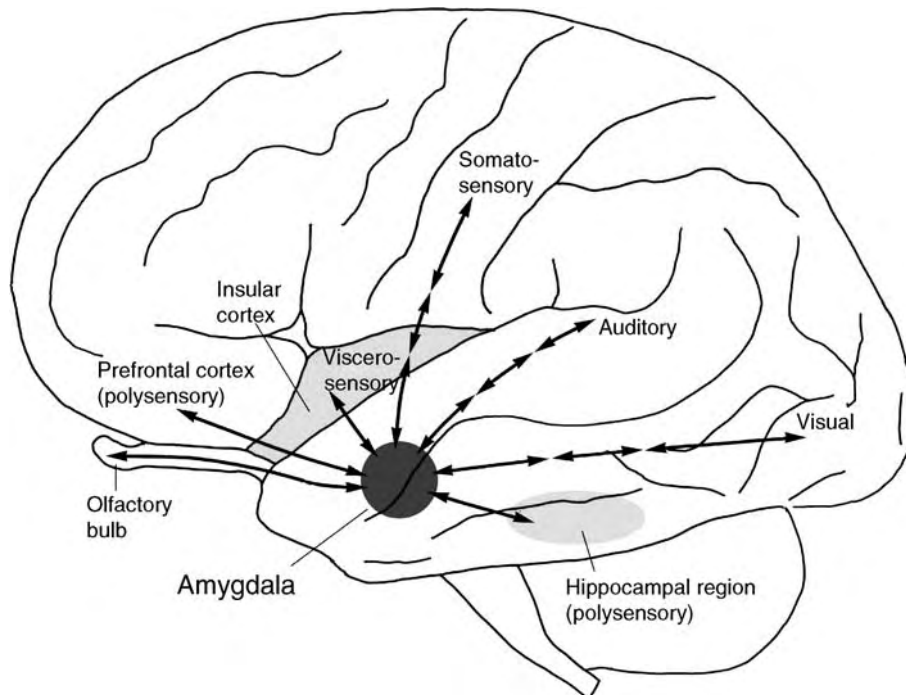

**Amygdala. Figure 2** Lateral view of the human brain illustrating the anatomy of the main cortical pathways conveying sensory information to the amygdala. Note that somatosensory, auditory and visual information is transmitted to the amygdala over polysynaptic cortical pathways; only higher order cortical areas involved in processing the most complex sensory information in these modalities have projections to the amygdala. Reprinted from Encyclopedia of the Neurological Sciences with permission from Academic Press.

inappropriate sexual and feeding behavior. In general, it appeared that these amygdalotomized monkeys were unable to recognize the emotional or behavioral significance of visual stimuli. Subsequent studies revealed that animals with amygdalar lesions also did not respond appropriately to auditory, somatosensory and olfactory cues. Thus, it appears that the amygdala is critical for producing appropriate behavioral responses to biologically relevant sensory stimuli and events in the external world. In fact, the amygdala is thought to constitute an essential link between brain regions that process sensory information (e.g. the ►cerebral cortex and ►thalamus) and brain regions responsible for eliciting emotional and motivational responses (i.e. the ►hypothalamus, ►brainstem and ►striatum). For this reason, the amygdala has been called the “sensory gateway to the emotions.”

The amygdala receives sensory information through its connections with the olfactory bulb and sensory association areas in the cerebral ►cortex (Fig. 2). The cortical and medial nuclei receive olfactory information from the olfactory cortex and from the main and accessory olfactory bulbs. The latter structure is part of the vomeronasal system, which is involved in detecting special odors (pheromones) that are produced by individuals of the same species. Pheromones elicit hormonal and behavioral responses involved in species-specific reproductive and social activities. The amygdala receives visual and auditory information from the temporal lobe, ►somatosensory and viscerosensory (including gustatory) information from the insular lobe and polysensory information from the ►prefrontal cortex and ►hippocampus. These nonolfactory inputs primarily target the basolateral nuclei. The basolateral nuclei also have reciprocal projections back to these same cortical regions. It has been suggested that these amygdalocortical projections may be important for attention to emotionally and behaviorally significant stimuli and for the storage of emotional memories.

Projections from the ►thalamus to the amygdala arise mainly from the midline thalamic nuclei and from the medial part of medial geniculate nucleus and adjacent posterior thalamic nuclei. These projections, which terminate primarily in the basolateral and central amygdalar nuclei, convey auditory, somatosensory, viscerosensory and visual information to the amygdala. Amygdalothalamic projections are more limited and consist of projections from the central nucleus to the midline thalamic nuclei and from the basolateral amygdala to the mediodorsal thalamic nucleus. Since the latter nucleus has extensive reciprocal connections with the prefrontal cortex, it provides an indirect link by which the amygdala can influence the activity of the prefrontal region.

The amygdala produces emotional responses by way of its connections with several subcortical regions,

including the ►hypothalamus, brainstem, striatum and ►basal forebrain. Some of these fibers course in the ►ventral amygdalofugal pathway, which runs (Fig. 3) near the inferior surface of the brain. Others course in a thin fiber bundle termed the ►stria terminalis, which takes a more circuitous route above the thalamus (Fig. 3). There are extensive reciprocal connections between the medial portions of the hypothalamic region and the amygdala, particularly the medial amygdalar nucleus, cortical nuclei and medial portions of the basolateral amygdala. Consistent with these connections, stimulation and lesion studies in experimental animals have shown that the amygdala is involved in behavior related to biological drives and motivation, including arousal, orienting and sleep, fight or flight, feeding and drinking and social, reproductive and maternal behavior. In humans, these behaviors are typically associated with emotional feelings (e.g. fear with flight and anger and rage with fighting and defensive behavior). In each of these affective states, the amygdala appears to elicit a coordinated response consisting of autonomic, endocrine and behavioral components by way of its projections to various subcortical regions, especially the hypothalamus. The endocrine responses produced by amygdalar stimulation are due to its indirect activation of the pituitary via the hypothalamus. Interestingly, many of the hormones secreted by the glands targeted by pituitary hormones can affect the activity of the amygdala via receptors expressed by amygdalar neurons. Thus, there is a very high density of estrogen and androgen receptors in the medial and cortical nuclei. Glucocorticoid receptors, activated during stress, are located in all portions of the amygdala, but particularly high levels are found in the centromedial nuclear group.

Another important subcortical target of the amygdala that is important for producing behavioral responses is the striatum (caudate, putamen and nucleus accumbens) (Fig. 3). This projection mainly originates in the basolateral nuclei and terminates primarily in the ventral and medial portions of the striatum, including the nucleus accumbens. Lesion studies indicate that the projections of the basolateral amygdala to the striatum are important for controlling behavior related to the reinforcing properties of sensory stimuli.

The central nucleus is the main amygdalar region exhibiting connections with the brainstem and basal forebrain. Among these targets are several brainstem areas involved in visceral function, including the parabrachial nucleus, ►dorsal vagal nucleus and ►nucleus solitarius. It also has projections to the ►periaqueductal gray and ►reticular formation, which are important for pain modulation and behavioral responses to stress. In addition, the central nucleus innervates several brain regions that give rise to neurotransmitter specific fiber systems that target the

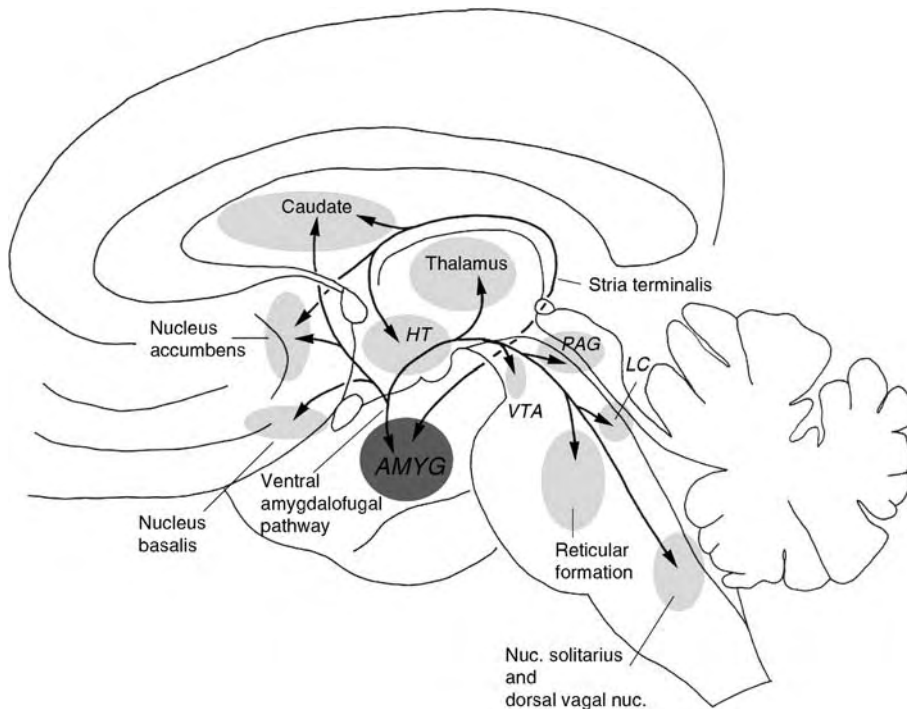

**Amygdala. Figure 3** Medial view of the human brain illustrating the connections of the amygdala (AMYG) with subcortical brain regions. All connections are reciprocal except those to the caudate and nucleus accumbens, which do not have projections back to the amygdala. HT, hypothalamus; LC, locus ceruleus; PAG, periaqueductal gray; VTA, ventral tegmental area. Reprinted from Encyclopedia of the Neurological Sciences with permission from Academic Press.

amygdala and other forebrain areas. These regions include the locus ceruleus (noradrenergic), the substantia nigra and ventral tegmental area (dopaminergic), the raphe nuclei (serotonergic) and the nucleus basalis (▶cholinergic). These transmitter specific systems, also known as ▶ascending modulatory projections, are activated in certain behavioral states, particularly during stress and can modulate amygdalar activities related to emotion, attention and memory.

#### Involvement in Neurological and Psychiatric Diseases

In agreement with the results of animal experiments, recent investigations of the human amygdala have shown that it is critical for the recognition of the emotional significance of auditory, visual and olfactory stimuli, including facial expressions, vocal intonation and expressive body movements. It has also been demonstrated that electrical stimulation of the human amygdala elicits fear, rage or other emotions. In addition, the human amygdala plays an important role in emotional learning, consistent with animal studies showing that the amygdala is essential for classical ▶Pavlovian fear conditioning to simple sensory cues, as well as to complex sensory representations such as the context in which an emotional event has occurred

[6,7]. Studies in both humans and animals have demonstrated that the release of noradrenaline in the amygdala is essential for the formation and recall of memories involving emotional events [8] and that there is over-activation of the amygdala in patients with post-traumatic stress disorder (PTSD).

The amygdala exhibits pathological and pathophysiological changes in several additional neurological and psychiatric diseases including ▶temporal lobe epilepsy, ▶Alzheimer's disease, schizophrenia, ▶anxiety disorders and ▶depression. Temporal lobe epilepsy (TLE) is the most common type of epilepsy and is often characterized by psychiatric disturbances. The amygdala exhibits cell loss in TLE and altered activity has been noted in recording studies. Studies in the rat have shown that the amygdala has the lowest threshold for "▶kindling," a phenomenon that has attracted a considerable amount of interest as a model of TLE. The amygdala is also a major target of the classic neuropathological changes seen in Alzheimer's disease and it has been suggested that degeneration of the amygdala may be responsible for the emotional lability seen in this disease.

There is also amygdalar degeneration in schizophrenia and recording studies have detected abnormal activity in the amygdala in this condition. ▶Dopamine

levels are increased in the amygdala in schizophrenia and this brain region may be one of the main sites of action of atypical ▶antipsychotic drugs such as clozapine. Consistent with numerous rodent studies implicating the amygdala in fear and anxiety, there is evidence that anxiety disorders in humans are associated with excessive activity in the amygdala. Moreover, studies in animals and humans have shown that the amygdala has very high levels of benzodiazepine receptors and is a critical site of action for the anxiolytic effects of these drugs. Recent functional imaging investigations have demonstrated that there is increased activity in the human amygdala in major depression and that administration of ▶antidepressants, which modulate levels of serotonin and noradrenaline in the amygdala, cause a decrease in amygdalar activity that is associated with amelioration of depressive symptoms [9].

## References

1. Aggleton JP (ed) (2000) The amygdala: a functional analysis. Oxford University Press, Oxford, NY
2. Price JL, Russchen FT, Amaral DG (1987) The limbic region. II: the amygdaloid complex. In: Björklund A, Hökfelt T, Swanson LW, (eds) Handbook of chemical neuroanatomy, vol 5. Elsevier, Amsterdam, pp 279–388
3. McDonald AJ (2003) Is there an amygdala and how far does it extend?: an anatomical perspective. *Ann NY Acad Sci* 985:1–21
4. Alheid GF, Heimer L (1988) New perspectives in basal forebrain organization of special relevance for neuropsychiatric disorders: the striatopallidal, amygdaloid, and corticopetal components of substantia innominata. *Neuroscience* 27:1–39
5. Klüver H, Bucy PC (1937) “Psychic blindness” and other symptoms following bilateral temporal lobectomy in rhesus monkeys. *Am J Physiol* 119:352–353
6. Davis M, Falls WA, Campeau S, Kim M (1993) Fear-potentiated startle: a neural and pharmacological analysis. *Behav Brain Res* 58:175–198
7. LeDoux J (1996) The emotional brain. Simon & Schuster, New York
8. McGaugh JL (2004) The amygdala modulates the consolidation of memories of emotionally arousing experiences. *Annu Rev Neurosci* 27:1–28
9. Drevets WC (2003) Neuroimaging abnormalities in the amygdala in mood disorders. *Ann NY Acad Sci* 985:420–444

## Amygdalar Nuclear Complex

▶Amygdala

## Amygdaloid Body

### Synonyms

▶Corpus amygdaloideum

### Definition

The amygdala is a large nuclear complex in the dorsomedial portion of the temporal lobe, at the inferior horn of the lateral ventricle. Reciprocal connections with the rhinencephalon, hypothalamus, thalamus, brainstem and some cortical areas. The amygdaloid body receives highly preprocessed sensory impressions and is responsible for initiation and integration of somatic and autonomic responses, associated with affective behavior.

▶Telencephalon

▶Amygdala

## Amygdalospinal Fibers

### Definition

Fibers, predominantly from the central amygdaloid nucleus which pass further through the brainstem into the spinal cord, where they may be involved in the regulation of autonomic processes.

▶Pathways

## Amyloid Plaques

### Definition

These aggregates of primarily amyloid proteins and other carbohydrates are found in the brains of patients suffering from amyloidopathies, typically in Alzheimer’s disease, and rarely in brain disorders of viral origin such as Acquired Immune Deficiency Syndrome (AIDS). The amyloid plaques can either be well defined or can occur as diffuse plaques, and play an important role in the pathogenesis of neurodegenerative disorders.

▶Alzheimer’s Disease

▶Central Nervous System Disease – Natural Neuroprotective Agents as Therapeutics

## Amyotrophic Lateral Sclerosis (ALS)

### Definition

ALS is also called Lou Gehrig's disease, is ultimately fatal and results from progressive degeneration of cortical neurons giving rise to corticospinal fibers and motor neurons in ►brainstem and ►spinal cord (cause unknown). Amyotrophy here denotes the neurogenic atrophy of skeletal muscle, and lateral sclerosis refers to the hardness of the lateral spinal cord resulting from astrocyte proliferation and scarring consequent to degeneration of the ►corticospinal tracts. ►Tendon reflexes are increased (►hyperreflexia), while sensation is normal.

## Analeptics

►Stimulants

## Analgesia

TODD W. VANDERAH  
University of Arizona, College of Medicine,  
Departments of Pharmacology and Anesthesiology,  
Tucson, AZ, USA

### Synonyms

Antinociception

### Definition

The word analgesia comes from the Greek words of An (negative) and Algesis (►pain) hence not sensing pain. We can think of analgesia as the process in which the sensation of pain is attenuated or inhibited. This is most often accomplished by the use of pharmaceuticals such as opioids that inhibit the activation of the neuronal pathways that relay pain sensations from the periphery to the central nervous system.

### Characteristics

#### Description of Pain and Analgesia

Pain is described as an unpleasant sensation associated with a specific part of the body [1] (►Nociception). It is produced by processes that either damage, or are

capable of damaging, the tissues. Such damaging stimuli are called ►noxious and are detected by specific sensory nerve fibers called ►nociceptors [2]. These nociceptors are free nerve endings with cell bodies in the dorsal root ganglia and terminate in the superficial layers of the dorsal horn of the spinal cord. Here they relay messages of noxious stimulation by releasing neurotransmitters such as glutamate [3], substance P and calcitonin gene related peptide (CGRP) [4,5]. These "pain" neurotransmitters will result in the activation of the second order neurons *via* their corresponding receptors. The second order neurons cross the spinal cord to the contralateral side and travel up the spinothalamic tract until they reach the thalamus. From there the third order neurons are activated, traveling from the thalamus to the somatosensory cortex, hence allowing for the perception of pain. In addition to the activation of second order neurons that ascend *via* the spinothalamic tract, there are second order neurons that activate lower motor neurons in the ventral horn of the spinal cord provoking a reflex withdrawal from the ►noxious stimulus. Likewise, there are enkephalin and endorphin containing interneurons at the level of the spinal cord and brainstem that will modulate the neurotransmission of pain.

### Analgesic Actions Along the Pain Pathways

Several sites for analgesic actions can be identified in the neural processing of noxious signals. Nociceptive afferent fibers are typically pseudounipolar neurons, with a peripheral terminal and a central terminal. Neurotransmitters that are produced within the cell body (i.e. in the dorsal root ganglia) are the same at both the central and peripheral ends of the nerve fiber. The neurotransmitters are released at both ends, participating in the pain signal peripherally and centrally. The release of neurotransmitters from the peripheral terminals of the afferent fibers is actually an "efferent" function of these afferent neurons. Peripheral release of neurotransmitter substances leads to the classic "axon reflex". This reflex leads to peripheral changes which are recognized as indicators of pain – redness, swelling, tenderness [6]. The peripheral terminals have ►opioid receptors on which compounds such as morphine, codeine, fentanyl, etc. or endogenous opioids such as enkephalin and endorphins can act to inhibit the release of such pain neurotransmitters that contribute to the activation of the nociceptors themselves. Opioid receptor activation (G-protein coupled receptors) results in the indirect opening of potassium channels. Potassium with its positive charge flows out of the ►nociceptor leaving the inside of the neuron more negative. The enhanced intracellular negative charge hyperpolarizes the nociceptor, resulting in a decrease in nociceptor activity (i.e. ►analgesia).

The periphery is the site of other analgesics including steroids (i.e. corticosteroids) and the family of

non-steroidal anti-inflammatory drugs (►NSAIDs) (i.e. ibuprofen, indomethacin, aspirin). Steroids and NSAIDs result in ►analgesia by inhibiting the pro-inflammatory and pro-nociceptive family of prostaglandins.

Opioids can act on the presynaptic terminal of the primary afferent nociceptor at the level of the spinal cord *via* the opioid receptor (G-protein coupled receptors) by indirectly blocking voltage gated calcium channels, as well as opening potassium channels. The inhibition of calcium entry into the presynaptic terminal as well as the efflux of potassium (hyperpolarization) results in the inhibition of pain neurotransmitter release from the primary afferent fibers, hence ►analgesia. Opioids have a second site of action at the level of the spinal cord. Opioid receptors on the postsynaptic nerve (the second order neuron), when activated by an opioid, indirectly open potassium channels resulting in hyperpolarization of the second order neuron, producing further ►analgesia.

The inhibition of pain, analgesia, also occurs by the activation of the cortical descending neural system. Activation of the cortical/bulbar/spinal descending pain inhibitory system to further promote ►analgesia is induced by the release of endorphins and, enkephalin, as well as by exogenously administered opioids acting again via opioid receptors. Thus far we know that these systems are activated in and around the periaqueductal gray (PAG) region of the midbrain. Such neurons then project to sites in the medullary reticular formation and the locus ceruleus (the major source of norepinephrine cells in the brain). These neurons that are opioid sensitive are activated through disinhibition - that is, inhibition of a tonically active inhibitory interneuron. Opioids are known to hyperpolarize neurons as detailed above, yet when given into these CNS regions activate neurons by simply attenuating the inhibitory GABAergic neurons (i.e. opioids act to remove the “GABA brake”). These descending fibers then project to the dorsal horn of the spinal cord along a tract called the dorsolateral funiculus (located in the dorsolateral portion of the spinal cord) to synapse with either the incoming primary afferent neuron, the second order pain transmission neuron, or interneurons. These descending pain modulatory neurons either (i) release neurotransmitters in the spinal cord, especially serotonin (5HT) and norepinephrine (NE) or (ii) activate small opioid containing interneurons in the spinal dorsal horn to release endogenous opioid peptides. The released NE and 5HT in the end (i) inhibit the release of pain transmitters from the incoming nociceptive afferent signal, and (ii) inhibit the second order pain transmission cell, hence producing ►analgesia. Activation of the descending pain modulatory system is a good example of why subjects report not feeling pain at all under conditions of stress, or perhaps other situations, where

even though the pain is felt, the degree appears to be greatly modulated [7].

### Summary of Analgesic Sites

We can identify several analgesic sites. (i) activating opioid receptors in the periphery to inhibit the activation of the nociceptors, as well as use NSAIDs or steroids to inhibit the release of inflammatory mediators, (ii) activating opioid receptors at the central terminals of nociceptors to stop the release of pain neurotransmitters in the spinal cord, (iii) activating opioid receptors on the second order pain transmission cells to prevent the ascending transmission of the pain signal, and (iv) activating the opioid receptors in the midbrain and “turning on” the descending pain inhibitory systems (through disinhibition).

### Intracellular Mechanisms of Opioid Analgesia

Recent cloning has identified three distinct genes for the  $\mu$ ,  $\kappa$  and  $\delta$  opioid receptors (this needs to be corrected by the author) [8–11]. All three receptors belong to the G-protein coupled receptor (GPCR) family. Agonist binding to opioid receptors leads to a conformational change in the opioid receptor resulting in the activation of an intracellular protein called a G-protein. The G-protein is made up of three separate protein subunits termed alpha, beta and gamma. The alpha portion of the G-protein associates with guanosine diphosphate (GDP). The alpha portion with its GDP will associate with the beta and gamma subunits and exist as an intracellular trimeric protein. An opioid bound to an opioid receptor undergoes a conformational change in the receptor resulting in the exchange of the GDP for a GTP on the  $G\alpha$  subunit. It is this exchange of GDP for GTP that activates the G-protein complex. Opioid receptors typically couple to a  $G\alpha_i$  subunit and once the exchange of GDP for GTP has occurred, the  $\alpha_i$  subunit will dissociate from the  $\beta\gamma$  subunit and inhibit the activity of adenylate cyclase, a nearby membrane bound enzyme. Under resting conditions, adenylate cyclase converts ATP into cAMP at some basal rate. cAMP acts as a second messenger within the cell resulting in several events including the activation of protein kinases and gene transcription proteins. Opioid receptor activation by an opioid will result in the activation of the  $G\alpha_i$  subunit and inhibit adenylate cyclase enzyme, hence significantly decreasing intracellular basal levels of cAMP. This opioid via opioid receptor-induced decrease in cAMP indirectly results in the inhibition of voltage dependent calcium channels on presynaptic neurons. These voltage dependent calcium channels are important in the release of neurotransmitter and transduction of neuronal communication, in this case pain transmission. Opioid receptors located on the presynaptic terminals of the nociceptive fibers, when

activated by an opioid agonist, will indirectly inhibit voltage dependent calcium channels via decreasing cAMP levels hence blocking the release of pain neurotransmitters such as glutamate, substance P and calcitonin gene related peptide (CGRP) from the nociceptive fibers resulting in ►analgesia.

In addition to the indirect inhibition of voltage gated calcium channels by opioid receptors, the  $\beta\gamma$  subunit of the G-protein will open inward rectifying potassium (GIRK) channels allowing  $K^+$  to flow down its concentration gradient and out of the cell carrying its (+) charge. This results in a more negatively charged environment within the cell termed hyperpolarization. This opioid-induced hyperpolarization results in a decrease in cell excitability hence attenuating neuronal transmission [12] and ►analgesia.

►Development of Nociception

## References

- Melzack R, Katz J (eds) (2006) Pain assessment in adult patients. Textbook of Pain, 5th edn. Elsevier Churchill Livingstone, Edinburgh, UK, pp. 291–304
- Sherington CS (1906) The integrative action of the nervous system. Scribner, New York
- Jeftinija S, Jeftinija K, Liu F, Skilling SR, Smullin DH, Larson AA (1991) Excitatory amino acids are released from rat primary afferent neurons in vitro. *Neurosci Lett* 125:191–194
- Lawson SN, Crepps BA, Perl ER (1997) Relationship of substance p to afferent characteristics of dorsal root ganglion neurons in guinea-pigs. *J Physiol* 505:177–191
- Lawson SN, Crepps BA, Perl ER (2002) Calcitonin gene related peptide immunoreactivity and afferent receptive properties of dorsal root ganglion neurons in guinea-pigs. *J Physiol* 540:989–1002
- Schmelz M, Petersen LJ (2001) Neurogenic inflammation in human and rodent skin. *News Physiol Sci* 16:33–37
- Mayer DJ, Price DD (1976) Central nervous system mechanisms of analgesia. *Pain* 2:379–404
- Evans CJ, Keith DE Jr, Morrison H, Magendzo K, Edwards RH (1992) Cloning of a delta opioid receptor by functional expression. *Science* 258:1952–1955
- Kieffer B, Befort K, Gaveriaux-Ruff C, Hirth C (1992) The delta opioid receptor: isolation of a cDNA by expression cloning and pharmacological characterization. *Proc Natl Acad Sci USA* 89:12048–12052
- Chen Y, Mestek A, Liu Y, Hurley J and Yu L (1993) Molecular cloning and functional expression of a  $\mu$ -opioid receptor from rat brain. *Mol. Pharmacol.* 44:8–12.
- Yasuda K, Raynor K, Kong H, Breder C.D., Takeda J, Reisine T and Bell GI (1993) Cloning and functional comparison of  $\mu$  and  $\delta$  opioid receptors from mouse brain. *Proc Nat Acad Sci USA* 90:6736–6740.
- Jordan B, Devi LA (1998) Molecular mechanisms of opioid receptor signal transduction. *Br J Anaesth* 81:12–19

## Analogous (Phylogenetic)

### Definition

Similar in function, but without phyletic continuity (e.g., human hands and the tongue of a chameleon used for prey catching: they both do the same thing at one time, but their origins are completely different).

## Analytical Behaviorism

►Behaviorism, Logical

## Analytical Functionalism

### Definition

This is a version of functionalism which says that it is a conceptual truth about our folk psychological concepts that every mental state of an organism can be characterized by its causal relations to perceptual input, other internal states, and the behavioral output of that organism.

►Behaviorism  
►Functionalism  
►Logical

## Analytical Mechanics

MARCELO EPSTEIN

Schulich School of Engineering, University of Calgary, Calgary, AB, Canada

### Definition

A formulation of the laws of ►mechanics based on the geometric concept of ►configuration space. In this approach, forces (or, more precisely, generalized forces) are considered as linear operators on vectors tangent to the configuration space (virtual displacements, or virtual velocities).

### Description of the Theory

The concept of *configuration space* is briefly discussed in the article on classical mechanics (q.v.), and the use of *generalized coordinates* has been introduced in the article on the ►[principle of virtual work](#) (q.v.). To effect the transition to ►[analytical mechanics](#) the so-called ►[principle of D'Alembert](#), briefly discussed in the article on statics (q.v.), may be invoked. According to this principle the equations of motion of a system can be regarded as equilibrium equations that include fictitious inertia forces. Applying this idea to the principle of virtual work, the virtual work of the forces of inertia associated with the free motion of a single particle in space may be calculated. Working in an inertial frame, the force of inertia, as defined in the article on statics (q.v.), is equal to  $-\dot{\mathbf{p}}$ . Since the particle is free, any arbitrary virtual displacement  $\delta\mathbf{x}$  is admissible. The virtual work of the force of inertia is, therefore, given by:

$$-\dot{\mathbf{p}} \cdot \delta\mathbf{x} = -m\dot{\mathbf{v}} \cdot \delta\mathbf{x}. \quad (1)$$

According to D'Alembert's principle, the incorporation of this extra term to the virtual work of the applied forces will deliver (by means of the principle of virtual work) the equations of motion of the particle. In fact, in many practical applications, including the derivation of approximate numerical algorithms for finding the motion of a system, this is all that is needed. But analytical mechanics does not stop at this point, since its inspiration came from a philosophical point of view (initially advocated in France during the eighteenth century by, among others, Maupertuis) according to which the laws of Nature must represent in some sense the most efficient possible way for phenomena to take place. This principle has its historical origins in the *principle of least time* of optics (already known for reflected rays to Heron of Alexandria and extended to refraction problems by Fermat), according to which light rays travel in a trajectory that minimizes the time of travel (or, at least, renders it stationary with respect to neighboring trajectories). Maupertuis advocated the existence of a similar principle in mechanics, except that the quantity to be optimized was not necessarily time, but some vaguely defined quantity called *action*. This general idea was further developed and made mathematically precise by Euler, Lagrange and Hamilton. To understand these developments, it is useful to realize that, even in the case of the rays of light, the quantity to be minimized is not an ordinary function of several variables, but rather a *functional*, namely, a function whose independent variables are themselves entire functions. Consider, for example, the trajectory of a ray of light in a refractive medium whose index of refraction varies smoothly from point

to point. The time-minimizing trajectory is, therefore, expected to be a smooth curve (rather than a zigzag of straight pieces). In principle, all smooth trajectories starting at the source and ending at the receptor must be considered in an equal footing. The time of travel is thus a function of the whole trajectory, a function to be evaluated for each candidate curve, namely, a functional given by an integration over a curve of a certain function of the index of refraction and the element of length of the curve. Returning to Eq. 1 for the virtual work of the force of inertia for a single particle and integrating it between an initial time  $t_0$  and a final time  $t_1$ :

$$\begin{aligned} \int_{t_0}^{t_1} -m\dot{\mathbf{v}} \cdot \delta\mathbf{x} dt &= \int_{t_0}^{t_1} -\frac{d}{dt}(m\mathbf{v} \cdot \delta\mathbf{x}) dt + \int_{t_0}^{t_1} m\mathbf{v} \cdot \delta\dot{\mathbf{x}} dt \\ &= -m\mathbf{v} \cdot \delta\mathbf{x} \Big|_{t_0}^{t_1} + \int_{t_0}^{t_1} m\mathbf{v} \cdot \delta\mathbf{v} dt \\ &= -m\mathbf{v} \cdot \delta\mathbf{x} \Big|_{t_0}^{t_1} + \delta \int_{t_0}^{t_1} K dt, \end{aligned} \quad (2)$$

where  $K$  is the ►[kinetic energy](#) of the particle:

$$K = \frac{1}{2} m\mathbf{v} \cdot \mathbf{v}. \quad (3)$$

There are several subtleties involved in the derivation of Eq. 2. One is that the variations  $\delta\mathbf{x}$  are vector-valued *functions of time*. In other words, they consist of entire variations (or perturbations) of a motion between the initial and the final times. So far, these variations have been permitted to be arbitrary, but now they must vanish at the end points. This is tantamount to saying that, although the actual trajectory of the particle is unknown, its positions for the initial and the final times are assumed to be known and that is why a non-zero variation is no longer being allowed at these times. Under these restricted conditions, the integrated virtual work of the force of inertia is exactly equal to the integral of the kinetic energy of the particle between the initial and the final times. Naturally, the kinetic energy depends on the trajectory chosen and thus its integral is not an ordinary function but a functional of the trajectory; for each candidate trajectory (always starting and finishing at specified points) a different value of the integral of the kinetic energy is obtained.

Having calculated the integrated virtual work of the force of inertia, the integrated virtual work of the actual forces impressed on the particle may be calculated. Assume that this force is conservative, namely, it is equal to minus the derivative of a ►[potential energy](#) function  $V$  (see the article on the ►[principle of virtual](#)



work). In that case, the integrated virtual work of the impressed forces is:

$$\int_{t_0}^{t_1} \mathbf{f}^{ext} \cdot \delta \mathbf{x} dt = - \int_{t_0}^{t_1} \delta V dt = - \delta \int_{t_0}^{t_1} V dt. \quad (4)$$

Since, according to D'Alembert's principle, along the actual trajectory of the particle, the total virtual work must vanish at each instant of time, it follows that the integrated virtual work will also vanish identically. Collecting the results of Eqs. 2 and 4, and defining the ► *Lagrangian density*  $L$  as the difference between the kinetic and the potential energies, namely,

$$L = K - V, \quad (5)$$

along the actual trajectory of the particle the variation of the integral of the Lagrangian density must vanish, viz.:

$$\delta \int_{t_0}^{t_1} L dt = 0. \quad (6)$$

This result can be interpreted as follows. Among all the possible trajectories starting and ending at specified points and at specified times, the particle will choose a trajectory that, when compared with any of its neighboring trajectories starting and ending in the same way, renders the integral of the Lagrangian density stationary (for example, minimum).

An in-depth treatment of this important topic is beyond the scope of this article. Nevertheless, the validity of this principle extends to all conservative mechanical systems of a finite number of degrees of freedom with purely geometrical constraints. Systems with so-called ► *non-holonomic constraints* (constraints on the velocities rather than the positions of the system) require a special treatment.

The kinetic energy of a rigid body can be calculated on the basis of Eq. 9 of ► *Newtonian mechanics* (q.v.) as:

$$K = \frac{1}{2} M \dot{\mathbf{x}} \cdot \dot{\mathbf{x}} + \frac{1}{2} \Omega \cdot \mathbf{J} \Omega. \quad (7)$$

The Lagrangian density  $L$  will in general be a function of the generalized coordinates  $q^i$  and of their time-derivatives  $\dot{q}^i$  (or, *generalized velocities*). According to the principles of the *calculus of variations* (the mathematical discipline dealing with the determination of stationary values of functionals), a functional of the type shown in Eq. 6 is stationary if the functions  $q^i(t)$  satisfy the so-called *Euler-Lagrange differential equations*:

$$\frac{\partial L}{\partial q^i} - \frac{d}{dt} \left( \frac{\partial L}{\partial \dot{q}^i} \right) = 0 \quad (8)$$

These equations are not partial but ordinary differential equations. The partial derivatives appearing therein are nothing but indications of the operations to be performed with the Lagrangian density (seen as a function of the  $2n$  independent variables, the generalized coordinates and the generalized velocities) to obtain the equations. The total time-derivative appearing in Eq. 8, on the other hand, needs to be calculated by the chain rule of differentiation, namely, taking into consideration that the generalized coordinates and velocities are ultimately functions of time. The Euler-Lagrange equations represent an alternative procedure for the derivation of the equations of motion of the system. Although they were derived by means of a time-wise global conceptual framework (the stationary value of an integral over time), they ultimately yield a time-wise local result (a system of differential equations). As compared with the derivation of the equations of motion by means of Newtonian mechanics (q.v.) the advantages are clear. In analytical mechanics only the expression of two scalar functions, the kinetic and the potential energy of the system, need be known. The rest is delivered automatically by the calculus of variations, thus avoiding the pitfalls of derivations based on free-body diagrams. These pitfalls are particularly severe in those cases in which extra geometric constraints are imposed whose associated forces are not easily represented in free-body diagrams (for example, a constraint of area preservation of a panel comprised between several bars). Even if these constraints are not easily factored out in the choice of generalized coordinates, the calculus of variations provides techniques for their straightforward incorporation in the formulation of analytical mechanics.

This is an elementary sketch of the so-called *Lagrangian mechanics*. There exists an equivalent formulation known as *Hamiltonian mechanics* in which the primary concept is the so-called *phase space*, rather than the configuration space. In phase space the generalized coordinates and the generalized momenta are given symmetric roles. In spite of the long-standing tradition of these two versions of analytical mechanics, there is still much research being carried out today. The discovery of a strong canonical geometric structure in phase space for example, has given rise to the *symplectic formalism*, which is specially suited to the definition of physically meaningful quantities in a global intrinsic way, rather than in terms of local coordinate expressions. These topics are beyond the scope of this article.

## References

1. Whittaker ET (1947) A treatise on the analytical dynamics of particles and rigid bodies, 4th edn. Cambridge University Press, Cambridge

2. Goldstein H (1950) Classical mechanics. Addison-Wesley, Cambridge
3. Neimark JI, Fufaev NA (1972) Dynamics of nonholonomic systems. In: Translations of Mathematical Monographs, vol 33. American Mathematical Society, Providence
4. Lanczos C (1970) The variational principles of mechanics, 4th edn. Toronto University Press, Toronto
5. Abraham RA, Marsden JE (1982) Foundations of mechanics, 2nd edn. Addison-Wesley, Redwood
6. Arnold VI (1989) Mathematical methods of classical mechanics. In: Graduate texts in mathematics, 2nd edn. vol 60. Springer, New York

---

## Anandamide

### Definition

Anandamide also known as arachidonylethanolamide or AEA, is an endogenous cannabinoid neurotransmitter. It was isolated and its structure was elucidated in the Laboratory of Raphael Mechoulam, at the Hebrew University in Jerusalem in 1992. The name is taken from the Sanskrit word ananda, which means “bliss”. Its structure represents arachidonic acid linked to ethanolamine via an amide linkage.

► Cannabinoids

---

## Anapsida

### Definition

The most ancient, extinct group of Amniota, without temporal openings for the masticatory muscles. Formerly turtles were held the extant representatives of the group. The advanced amniotes have two evolutionary lines: Synapsida, with one large temporal opening, it comprises mammals, and their extinct, reptile-like ancestors, and Diapsida, with two temporal openings: birds, extant reptiles, and extinct groups, like dinosaurs and pterosaurs.

► Evolution of the Brain: At the Reptile-Bird Transition

---

## Anatomical Coordinate System

### Definition

An orthonormal set of coordinate axes attached to a bone, and defined using bony anatomical landmarks

or other points of anatomical significance to the segment.

► Motion Analysis

---

## Anatomy

### Definition

The branch of biology that explores the structure and organization of tissues.

---

## Anatomy and Function in the Respiratory Network

GEORGE F. ALHEID, DONALD R. MCCRIMMON  
Department of Physiology, Northwestern University  
Feinberg School of Medicine, Chicago, IL, USA

### Synonyms

Anatomy of Breathing; Central Respiratory Mechanisms; Models of Respiration

### Definition

Breathing is an automatic somatomotor behavior serving homeostasis for O<sub>2</sub> and CO<sub>2</sub>. The rhythm and pattern of breathing is shaped by an interconnected series of neural modules located mainly in the rhombencephalon (medulla and pons). Breathing is also voluntary in that it can be consciously started or stopped as well as its depth and frequency altered.

### Characteristics

Breathing is an essential homeostatic behavior persisting without significant interruption throughout life. Although it can be voluntarily controlled, respiration is served by highly automated central rhythmic oscillators located in the rhombencephalon. In general, the frequency (rhythm) and volume of respiration is unconsciously adjusted over a wide range. Brainstem reflexes respond to central and peripheral chemosensors monitoring the partial pressures of oxygen (PO<sub>2</sub>) and carbon dioxide (PCO<sub>2</sub>) in the arterial blood and in the brain parenchyma, as well as responding to receptors in the upper airways and lungs monitoring inflation or deflation (stretch receptors) or signaling the presence of toxins or irritants in the airways.

In addition to its vital role in homeostasis, breathing may be arbitrarily altered to serve other non-homeostatic behaviors ranging from walking and talking to postural adjustments. Breathing is also an (involuntary) component of emotional behaviors; it may be enhanced or inhibited relative to orienting and defensive responses, modulated within emotional state and in conditions such as panic disorder where hyperventilation may contribute to the dysphoria experienced by the affected individual. As a basic component of vocalization, the precise control of expiration and muscle contractions in the upper airways (including the larynx and tongue) underlies the

motor output for one of the most complex cognitive activities of the brain.

### Functional Neuroanatomy

The importance of the brainstem in the control of breathing was appreciated relatively early on in the history of neuroscience, Cajal [3] for example, provided a relatively accurate overview of mammalian afferent and efferent pathways regulating breathing (Figs. 1 and 2). These include: (i) ascending sensory information from the airways that travel via the vagus to reach the nucleus of the solitary tract (NTS), (ii) integration by brainstem

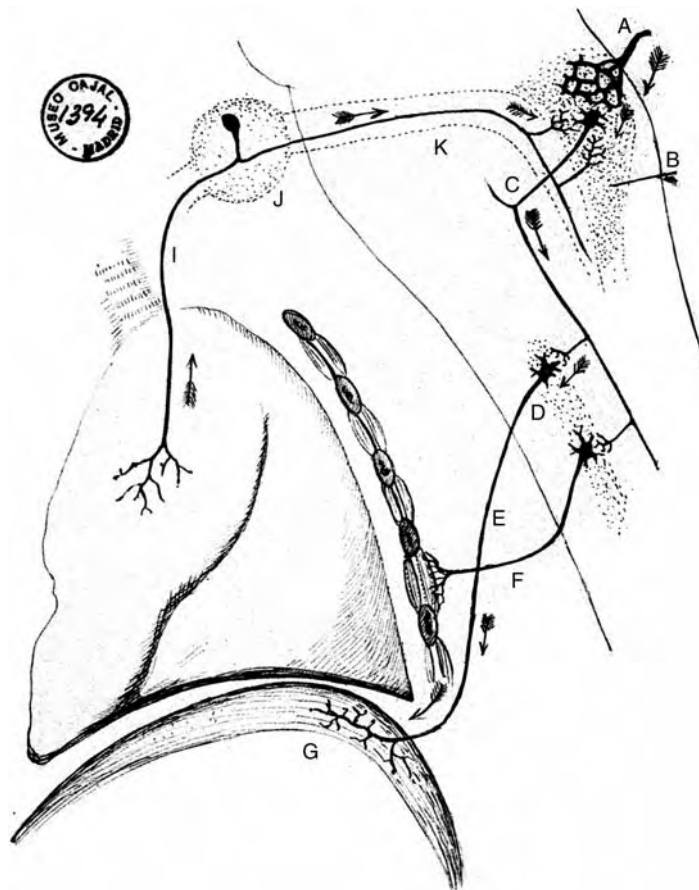

**Anatomy and Function in the Respiratory Network. Figure 1** Diagram of respiratory circuits and the output to inspiratory muscles. This diagram provides an overview of the anatomical circuits controlling breathing, and, in particular, respiratory motor output via inspiratory pump muscles. Specifically, peripheral pulmonary stretch receptors (I, J, K), and peripheral chemoreceptors that monitor arterial  $O_2$  and  $CO_2$  (not shown – see text) provide afferents that terminate centrally in the nucleus of the solitary tract (B). Central chemoreceptors in this nucleus (A, and elsewhere in the brainstem – see Fig. 8) monitor  $CO_2$  levels and brainstem respiratory rhythm generators in the ventrolateral medulla (see Fig. 3) integrate this information with feedback from pulmonary stretch receptors. Respiratory premotor neurons in the medulla (C, and see Fig. 5) give rise to descending axons that innervate inspiratory motoneurons in the cervical spinal cord (D – phrenic nucleus, E – phrenic nerve) and thoracic spinal cord (F) that innervate the inspiratory pump muscles. The latter include the diaphragm (G) and external intercostal muscles (F). From Cajal SR 1897–1899. “Textura del sistema nervioso del hombre y de los vertebrados,” copyright Herederos de Santiago Ramón y Cajal. [English Transl Pasik P & Pasik T, 1999–2002] With the kind permission of Maria Angeles Ramón y Cajal.

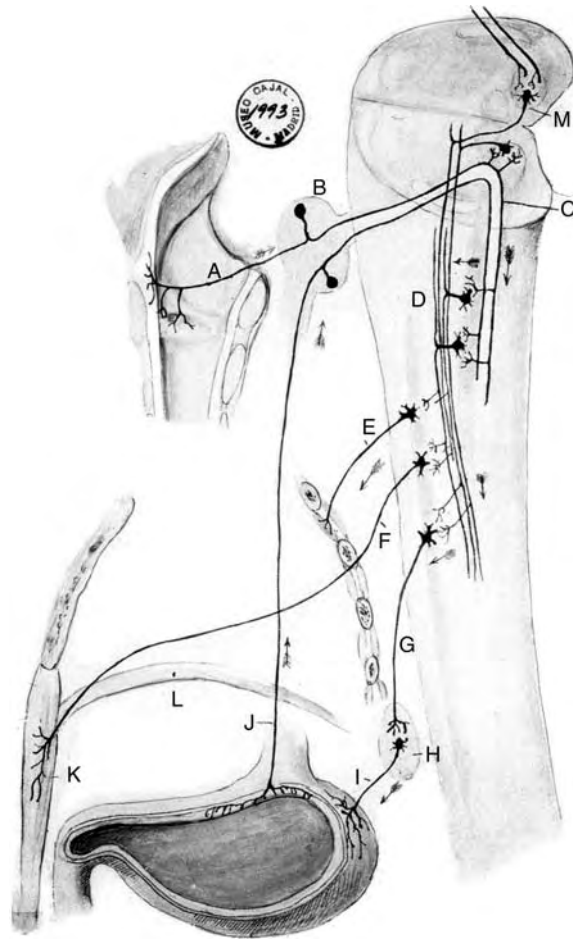

**Anatomy and Function in the Respiratory Network.**  
**Figure 2** Diagram of respiratory circuits and their output to expiratory muscles. This diagram, initially intended to illustrate anatomical circuits involved in coughing and vomiting, also provides an overview of the respiratory motor output via expiratory pump muscles. Airway receptors (A – larynx) and pulmonary stretch receptors (see Fig. 1) provide afferents to the nucleus of the solitary tract (M) which relays this information to respiratory circuits in the medulla (D) and pons (see Fig. 3). The latter circuits provide afferents to spinal projecting expiratory premotor neurons in the medulla (D and Fig. 5) controlling the rhythm and pattern of activity on their axons which terminate on thoracic motoneurons innervating expiratory pump muscles, including abdominal (K) and internal intercostal muscles (E). From Cajal SR 1897–1899. “Textura del sistema nervioso del hombre y de los vertebrados,” copyright Herederes de Santiago Ramón y Cajal. [English Transl Pasik P & Pasik T, 1999–2002 with the kind permission of Maria Angeles Ramón y Cajal.

neurons of vagal respiratory afferent information with the central detection of CO<sub>2</sub> levels, and the control of brainstem premotor neurons. (iii) The latter innervate spinal motoneurons in the phrenic nucleus and thoracic

spinal cord that activate the inspiratory pump muscles (i.e., the diaphragm and external intercostal muscles), and (iv) innervate motoneurons in the thoracic spinal cord that activate the expiratory pump muscles (i.e., internal intercostal and abdominal muscles). Over the past century physiological and anatomical research has resulted in considerable elaboration of this basic outline, including the identification of multiple compartments within the brainstem whose coordinated activity precisely controls breathing.

### Brainstem Respiratory Neurons

Neurons demonstrating bursts of action potentials phase-locked to the respiratory cycle, and dependant on a centrally generated respiratory rhythm are operationally defined as “respiratory neurons.” These are distinguished from non-phasic firing respiratory related neurons, such as neurons in chemosensory pathways providing tonic inputs to respiratory neurons.

Not surprisingly, rhomencephalic respiratory neurons tend to fire in phase with either the inspiratory or expiratory phase of the respiratory cycle. Prominent brainstem collections of respiratory neurons are concentrated in three regions (Fig. 3). The first is located dorsally within the medulla in ventrolateral portions of the NTS and was accordingly designated the “dorsal respiratory group” (DRG). A second region, in the dorsolateral pons in and around the complex formed by the parabrachial and Kölliker-Fuse nuclei, was originally termed the “pontine pneumotaxic region,” but more recently, the “pontine respiratory group” (PRG). The third consists of an elongated column of neurons in the ventrolateral medulla which is termed the “ventral respiratory column” (VRC).

It is argued that three respiratory phases are necessary to characterize the breathing cycle, the inspiratory phase and early and late expiratory phases (Fig. 4). Specifically, activity on the phrenic nerve starts contraction of the diaphragm, expanding the lungs and beginning the inspiratory phase. Following lung inflation, action potentials on the phrenic nerve decline abruptly. At this point, the inherent elastic recoil of the lungs and thorax begin the expiratory phase of respiration. During normal relaxed breathing in humans, expiration generally depends on the passive recoil of the lungs and chest wall with little expiratory muscle contraction (e.g., abdominal and internal intercostal muscles). As the demand for gas exchange increases (for example during running) phasic activation of expiratory muscle activity is recruited. During the early part of expiration, adduction of the larynx slows expiratory airflow. There may also be residual activity on the phrenic nerve. This expiratory activity on a nerve innervating the major inspiratory muscle (the diaphragm) prompted the designation of early expiration as post-inspiration. If activity on expiratory muscles occurs (e.g., abdominal, internal

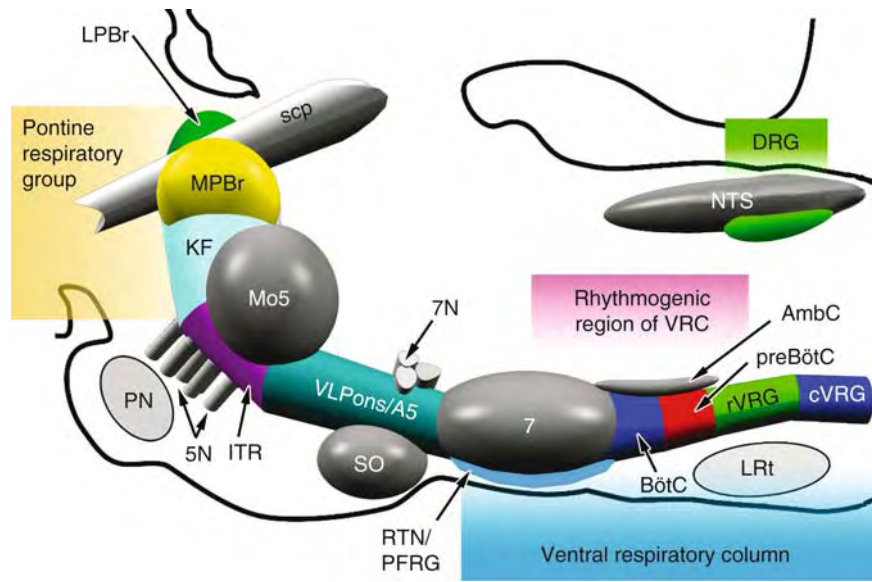

**Anatomy and Function in the Respiratory Network. Figure 3** Brainstem respiratory neurons and compartments. Respiratory related regions of the rhombencephalon (pons + medulla) are diagrammed by colored coded compartments against a parasagittal section of the rat brain (as viewed from the midline). Nearby landmark structures are shaded in gray. Brainstem respiratory neurons are concentrated in three regions: (i) The dorsal respiratory group (DRG) located in the region of the ventral and ventrolateral subnuclei of the solitary tract, (ii) the pontine respiratory group composed of several subdivisions of the parabrachial complex along with the Kölliker-Fuse nucleus, (iii) the ventral respiratory column (VRC) extending from the level of the facial nucleus caudally to the spinal-medullary junction. The VRC is composed of a serial succession of physiologically distinct compartments (see text) which are responsible for the automatic generation of the respiratory rhythm (particularly in the rostral portions of the VRC, see magenta shaded region) and integrating this rhythm with patterned activity on respiratory spinal-projecting premotor neurons (mainly in caudal portions of the VRC, see text and Fig. 5). The VRC is essentially continuous with the PRG, via respiratory-related neurons located along the boundaries of the facial nucleus that recollect in the ventrolateral pons and continue into the intertrigeminal region (ITR) before merging with the Kölliker-Fuse nucleus (KF). Abbreviations: 5N, trigeminal nerve; 7, facial nucleus; 7N, facial nerve; A5, A5 noradrenergic neurons; Ambc, nucleus ambiguus compact part; Botc, Bötzinger complex; cVRG, caudal part of ventral respiratory group; DRG, dorsal respiratory group; ITR, intertrigeminal region; KF, Kölliker-Fuse nucleus; LPBr, lateral parabrachial area; LRT, lateral reticular nucleus; Mo5, motor trigeminal nucleus; NTS, nucleus of the solitary tract; MPBr, medial parabrachial area; PFRG, parafacial respiratory group; preBötC, preBötzinger complex; pRG, pontine respiratory group; RTN, retrotrapezoid nucleus; VRG, rostral part of ventral respiratory group; PN, basilar pontine nuclei; Scp, superior cerebellar peduncle; SO, superior olive; VLPons, ventrolateral pons; VRC, ventral respiratory column.

intercostal muscles) it is usually most prominent during late expiration. It is notable that the extent to which the expiratory muscles participate in breathing varies considerably across the energy demands of the individual.

Individual respiratory neurons tend to fire with particular phase relationships to the respiratory cycle (Fig. 4), and the firing pattern as well as the synaptic interactions of individual respiratory neurons have been used to infer different functional roles. While a standardized nomenclature has not been agreed upon, the basic types include inspiratory (I) and expiratory (E) neurons as well as phase-spanning neurons whose activity spans the temporal limits between inspiration and expiration. Within the inspiratory or expiratory phase of the respiratory cycle, neurons have been

further categorized by their augmenting (Aug), decrementing (Dec), or constant rate (Con) of firing within a specific respiratory phase, and whether the activity of a particular cell occurs in the early or late within the inspiratory or expiratory phase of respiration. Using these qualifications, types of respiratory neurons commonly identified include E-I phase spanning neurons, I-Con, I-Dec, I-Aug, and Late-I neurons, as well as E-Dec (or post-I) and E-Aug neurons. Additionally, a “pre-I” cell type has been described whose activity begins at the end of expiration, is actively inhibited during inspiration, and fires again at the beginning of expiration. The firing patterns of these various types of neurons are generally a result of their circuit interactions within the rhombencephalon

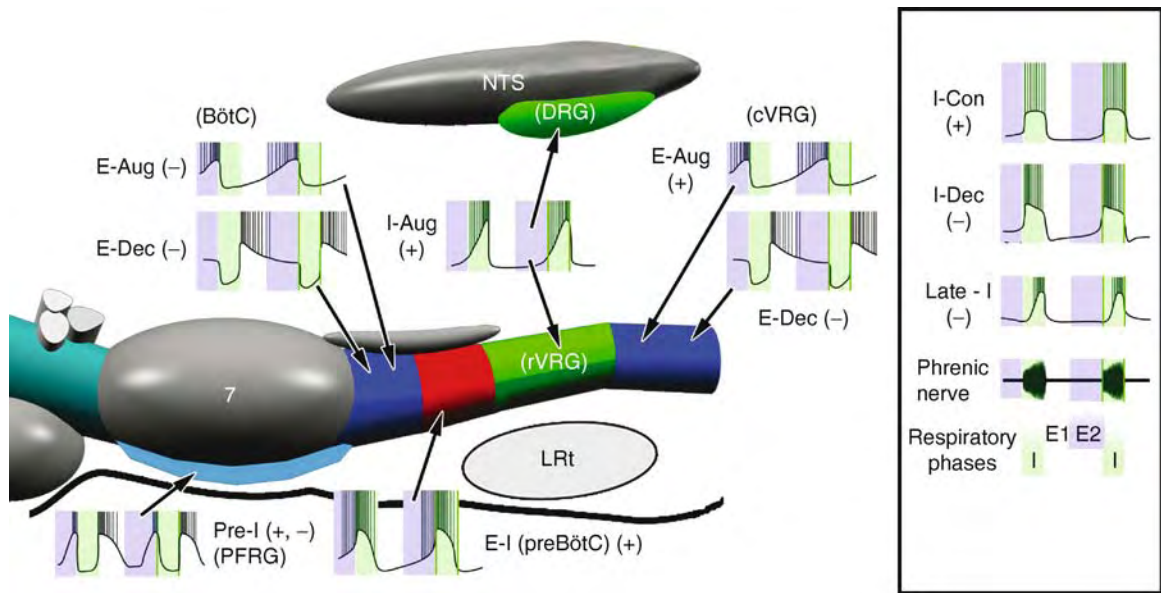

**Anatomy and Function in the Respiratory Network. Figure 4** Medullary respiratory neurons. This figure depicts the activity patterns for a representative sample of respiratory neurons on a parasagittal view of the rat medulla. These neurons are distinguished by the timing of their bursts of action potentials with respect to the inspiratory phase, or with respect to one of the two postulated expiratory phases of the respiratory cycle and the accompanying changes in their membrane potentials, and (when possible) by their axonal projections (see Fig. 5). Most of the respiratory compartments in the VRC are associated with “typical” (but not exclusive) concentrations of particular classes of inspiratory or expiratory neurons; the firing patterns of these neurons are depicted in relation to a sagittal diagram of the VRC and with respect to the DRG. Respiratory neuronal types commonly recorded in the VRC but not readily associated with a particular brainstem compartment are shown in the inset at the right side of the figure along with the “normal” pattern of firing for the phrenic nerve. For all of the respiratory neurons depicted, the inspiratory (I) part of the respiratory cycle is identified by the green shading. The first part of the expiratory phase (E1) is not shaded, while the second part of the expiratory phase (E2) is identified by purple shading. The characteristic excitatory or inhibitory nature of the particular neuronal types is indicated by plus or minus signs. Note that in some instances a single firing pattern may be associated with both inhibitory and excitatory neurons, as is the case for E-Aug neurons in the BötC or cVRG (respectively), or for pre-I neurons in the parafacial region. It should be further noted that the terminology used for respiratory neurons is not entirely uniform between different investigators in this field, and the depicted excitatory and inhibitory bursting patterns do not represent an exhaustive catalog of the possible respiratory neuronal types. Abbreviations: E1, early expiratory phase E2, late expiratory phase; E-Aug, expiratory neurons with an augmenting depolarization string at the begin of E2; E-Dec, expiratory neurons with a decrementing depolarization pattern beginning in E1; E-I, phase-spanning neurons with a depolarization beginning at the end of E2 and continuing into the inspiratory phase; I, inspiratory phase of respiratory cycle; I-Aug, inspiratory neurons with augmenting depolarization and firing pattern; I-Con, inspiratory neurons with a constant depolarization; I-Dec, inspiratory neurons with decrementing depolarization; Late-I, inspiratory neurons depolarizing at later portion of inspiratory phase; Pre-I neurons, phase spanning neurons characterized by depolarization beginning in E2, which are then actively inhibited during inspiration, and subsequently depolarized at the beginning of E1; (other abbreviations as in Figure 3).

and particularly within the medulla. Ultimately, the pattern of activity at motoneurons giving rise to nerves innervating the airways and pump muscles reflects premotor input to these motoneurons from various combinations of brainstem respiratory neurons.

### The Nucleus of the Solitary Tract

The NTS is compartmented and multifunctional, relaying visceral information from various peripheral organs relevant to physiological homeostasis and central

reflexes. Afferents arising from the lung and airways as well as arterial chemoreceptors (carotid and aortic bodies) travel mainly in the vagus and glossopharyngeal nerves, and target neurons in caudal aspects of the NTS. Relative to breathing, pulmonary stretch receptors monitor the level of inflation of the lungs and via inhibitory second order NTS neurons increasingly inhibit inspiration as maximal lung volume is reached. Receptors in the airways additionally detect irritants, and their afferents to the NTS initiate protective reflexes

such as a cough or sneeze. Peripheral chemoreceptors for breathing are located mainly in the carotid body. They are activated by decreases in  $PO_2$  or pH or an increase in  $PCO_2$  of arterial blood and generally facilitate respiration during developing hypoxia or hypercapnia. Evidence suggests that a subset of neurons in the NTS also functions as central chemosensors for  $CO_2$ /pH. The targets of NTS second or higher order sensory relay neurons are predominantly within the VRC and the pontine respiratory group; a subset of these targets includes direct synapses on cranial motoneurons within the region of the VRC. Thus the respiratory related elements of the NTS function as sensory relays, as chemosensors, and as premotor neurons. The topography of respiratory related afferents to the NTS and the central reflexes they serve are discussed in greater detail elsewhere in this volume (*McCrimmon and Alheid, respiratory reflexes*).

### Populations of Respiratory Neurons

#### Dorsal Respiratory Group (DRG; Fig. 3)

The dorsal respiratory group is comprised of “respiratory neurons” (predominantly inspiratory) located mainly in the ventral and ventrolateral NTS. These neurons receive a central respiratory drive that persists in the absence of peripheral afferent input. Interestingly, although they receive vagal and glossopharyngeal afferent input, they do not appear to be required for the production of peripheral reflexes which are relayed largely through neurons in other NTS subregions. Particularly in the cat, significant numbers of these DRG neurons are premotor with terminations in the phrenic nucleus, including monosynaptic input to phrenic motoneurons.

#### The Ventral Respiratory Column (VRC; Fig. 3)

The VRC refers to a succession of six contiguous but physiologically distinctive collections of respiratory neurons in the ventrolateral medulla. This includes the principal neuronal circuits responsible for the intrinsic generation of respiratory rhythm, and for the pattern of respiratory activity on nerves innervating the muscles of the airways as well as on nerves innervating the pump muscles. In the caudal half of the VRC, premotor neurons for spinal respiratory motoneurons are concentrated within a region termed the “ventral respiratory group” (VRG). The VRG is divided into rostral (rVRG) and caudal (cVRG) components reflecting a predominance of inspiratory neurons rostrally and expiratory neurons caudally. The rVRG and cVRG represent the main foci of excitatory (glutamatergic) bulbospinal inspiratory (augmenting; I-Aug) and expiratory (Augmenting; E-Aug) neurons (respectively). They provide the alternating (phasic) central drive mainly responsible for determining the pattern of activity for spinal motoneurons of the respiratory pump muscles (Fig. 5). At least within the

bulbospinal inspiratory neurons of the rVRG, enkephalin appears to be a co-transmitter with glutamate. Neurons in rVRG and cVRG appear to integrate afferents arising from second- or higher-order sensory relay neurons in the NTS as well as from respiratory-related neurons located throughout the ventrolateral medulla and pons (Figs. 6 and 7).

In the rostral half of the VRC, four additional concentrations of respiratory neurons have been identified, each with a distinctive physiological profile. From caudal to rostral, these include the pre-Bötzinger complex (preBötC), the Bötzinger complex (BötC), the retrotrapezoid nucleus (RTN) and the parafacial respiratory group (PFRG). At the most rostral end of the VRC, RTN neurons appear to be chemosensory, increasing their firing rate in proportion to central  $CO_2$  (or inversely proportional to pH) and activating respiratory neurons in the other VRC compartments. The remaining three anterior VRC compartments (PFRG, BötC, preBötC) appear to play a significant role in respiratory rhythm generation. In contrast, spinal premotor neurons in the posterior part of the VRC (rVRG, cVRG) provide the major source of rhythmic excitatory input to pump muscle motoneurons in the spinal cord but do not appear to contribute to the generation of respiratory rhythm. Chemical blockade in the cVRG, for example, blocks respiratory activity at abdominal muscles but does not change the respiratory rate measured on the phrenic nerve. It should be noted, however, that the transition between anterior rhythmogenic and posterior spinal premotor portions of the VRC is not abrupt. This may reflect the fact that the respiratory neuronal types (Fig. 4), characterizing a particular VRC region have distributions whose tails overlap with those of neuronal types typifying adjacent compartments.

#### The Retrotrapezoid Nucleus (and Central Chemosensitive Brainstem Regions)

The RTN consists of a narrow layer of chemoresponsive neurons located near the surface of the brainstem ventral to the facial nucleus (Figs. 3 and 8). Specifically, hypercapnic solutions or acidification of these superficial regions, cause increased firing of glutamatergic neurons that project widely to medullary and pontine areas related to breathing, resulting in increased ventilation. RTN neurons also increase their firing in response to stimulation of peripheral chemoreceptors. This is consistent with the presence of excitatory projections from the commissural NTS, which is the primary target region of peripheral chemoreceptor afferent neurons. Consequently, it has been argued that the RTN integrates peripheral and central chemoreceptor information and provides a drive to respiratory circuits.

In addition to the RTN several other chemosensitive brainstem regions have been identified, including the preBötC, the caudal raphe nuclei (raphe magnus,

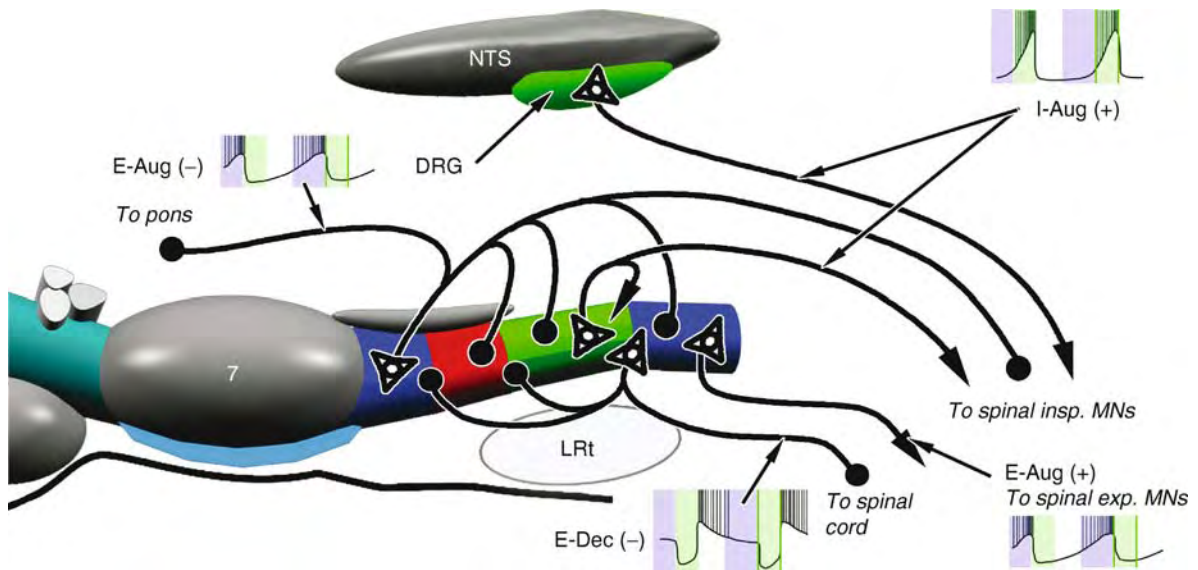

**Anatomy and Function in the Respiratory Network. Figure 5** Bulbospinal respiratory neurons. This parasagittal diagram of the rat medulla depicts various types of respiratory neurons in the VRC and DRG that provide the spinal premotor input that ultimately determines the activity of the respiratory pump muscles. Some of the neurons sending axons to the spinal cord also provide collaterals to the VRC; for I-Aug neurons in the rVRG (see Fig. 3), some of these collaterals appear to target other inspiratory bulbospinal neurons ipsilaterally or contralaterally, while other collaterals of I-Aug neurons appear to target cranial motoneurons (e.g., laryngeal, hypoglossal motoneurons). Also notable is the difference between E-Aug neurons that in the cVRG are excitatory (glutamatergic) and do not have medullary collaterals compared to E-Aug neurons in the BötC which are largely inhibitory and project extensively throughout the VRC and in some instances also send ascending axons to the pons. For the depicted E-Aug and E-Dec neurons the diagram is a summary of the axon collaterals since the individual neurons do not necessarily reach every potential target of these populations. Finally, many neurons in the NTS relay respiratory related afferents to the VRC and pons; these are not shown here but are depicted elsewhere in this volume (McCrimmon & Alheid, *Respiratory Reflexes*). For abbreviations see legends for Figures 3 and 4.

pallidus, and obscurus), the locus coeruleus, the fastigial nucleus of the cerebellum, as well as a subset of NTS neurons (Fig. 8). The occurrence of multiple chemosensitive brainstem sites related to brainstem respiratory circuits may reflect alternative redundant systems for this important function.

Attention has also been focused on the chemosensory role of neurons in the caudal raphe nuclei (raphe magnus, raphe pallidus, and raphe obscurus), by clinical pathology relating aberrations in serotonergic neurons and serotonergic receptors at the ventromedial surface of the brain (in the medullary arcuate nucleus of human brains), to sudden infant death syndrome (SIDS). The caudal raphe nuclei have a diffuse system of projections including the brainstem and spinal cord, and descending serotonergic projections appear to be important both for the tonic activation of motoneurons and for the modulation of sensory afferents. Serotonergic neurons appear to be chemosensitive and are activated by increasing  $\text{CO}_2$ /decreasing pH when tested using cultured neurons or brain slices. In addition to their role as potential central chemoreceptors, serotonergic projections to the phrenic

nucleus are essential for the occurrence of long-term facilitation to intermittent hypoxia, a model of plasticity in central respiratory circuits.

#### **The Parafacial Respiratory Group and the RTN**

Recently, it has been argued that “pre-I” neurons in the vicinity of the RTN function as an expiratory oscillator complementing an inspiratory oscillator located in the preBötC. *In vitro* imaging experiments of neonatal rat brainstems implicated neurons beneath lateral portions of the facial nucleus in the generation of rhythmic respiratory activity [9]. While not entirely separate topographically from the area normally associated with the RTN the term “parafacial respiratory group” (PFRG) has been used to designate this conceptually distinctive functional group.

The PFRG and preBötC are proposed to operate together as mutually inhibitory, coupled oscillators in the generation of the respiratory rhythm [5]. Data derived from *in vitro* and *in vivo* experiments (mainly on neonatal or juvenile rat brains) suggest that PFRG neurons are capable of generating rhythmic activity on



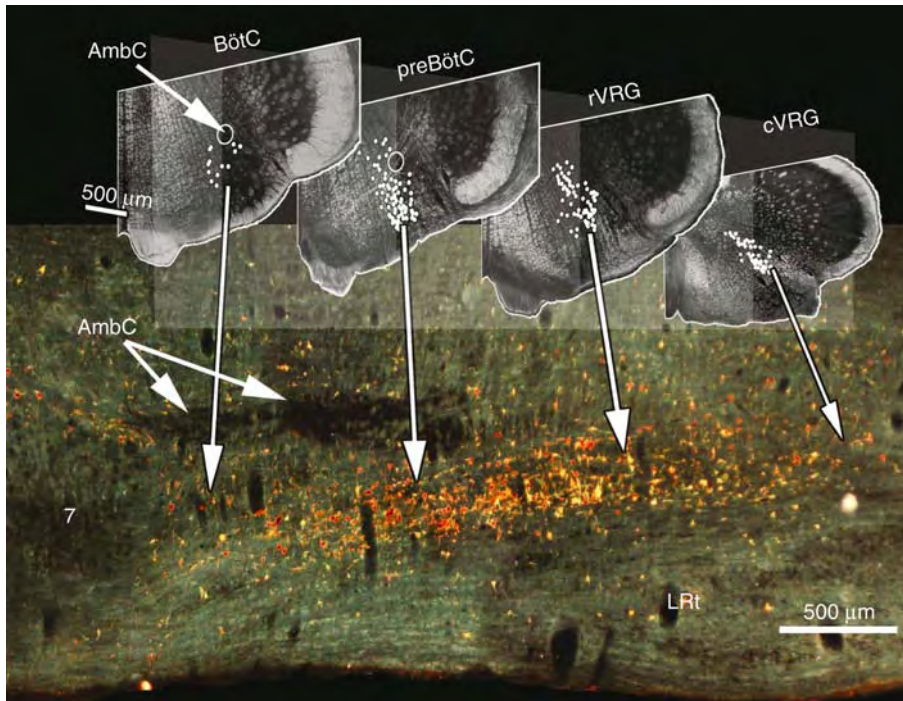

**Anatomy and Function in the Respiratory Network. Figure 6** Retrogradely labeled neurons in the ventral respiratory column of the rat brain. The anatomical location of respiratory neurons in the VRC is depicted after an injection of a retrograde tracer (FluoroGold) in the contralateral rVRG of two brains, one sectioned in the coronal plane (shown in perspective in the upper sections) and one in the parasagittal plane (lower section). Note that retrograde labeling is lighter in the RTN and in the BötC than in the more caudal portions of the VRC since the former regions have projections that preferentially target the ipsilateral side of the medulla. The parasagittal plane depicted is at the lateral level of the compact division of the nucleus ambiguus. This is indicated in the upper (coronal) sections by the parasagittal cutting plane indicated in light gray. In the coronal sections the location of the FluoroGold fluorescent labeling is identified by white dots mapped against darkfield images of the same sections in which the fluorescent cells were observed. In the lower parasagittal section, the FluoroGold labeling was enhanced by detection with an antibody to FluoroGold and a subsequent immunoperoxidase reaction to label the neurons with polymerized diaminobenzidine (DAB). (Color version of monochrome figure published in Alheid et al., *J Neurocytol* 31:693–717, 2002, with kind permission from Springer Science and Business Media). For abbreviations see legends for Figures 3 and 4.

the nerves innervating expiratory pump muscles, even following pharmacological blockade of neuronal activity in the preBötC. Based on *in vitro* experiments the PFRG appears to include both excitatory and inhibitory pre-I neurons. It is not at present clear whether some of the neurons comprising the PFRG are coincident with those cells serving chemosensory functions in the region of the RTN. The latter, however, appear to be exclusively excitatory (glutamatergic). It is also the case that for the adult brainstem, a clear physiological description of PFRG neurons functioning as an expiratory oscillator is still lacking. The concept of a brainstem expiratory oscillator has broad implications for the studies in the neurobiology of breathing. These have been addressed in the context of the evolution of vertebrate respiratory circuits and with respect to the

pre- and post-natal developmental course of respiratory circuits [4]. Consequently, the topic of the PFRG and its persistence in the adult brainstem remains topics under intense scrutiny.

### The Bötzing Complex

The BötC is located in the ventrolateral medulla immediately caudal to the facial nucleus (Fig. 3), and is identified physiologically by its content of expiratory, and mainly inhibitory (glycinergic) neurons (Fig. 4; augmenting or decrementing; E-Aug or E-Dec neurons). These projects widely to other respiratory related regions of the brainstem, and a subset of these neurons also provides descending projections to the spinal cord, including terminations in the phrenic nucleus (Figs. 1 and 5). BötC neurons (together with other inhibitory

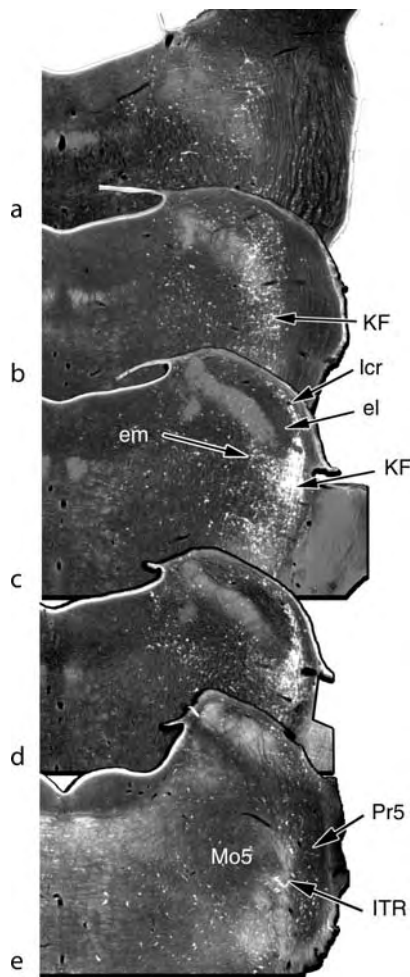

**Anatomy and Function in the Respiratory Network.** **Figure 7** The anatomical distribution in the rat brain of pontine neurons projecting to the VRC shown in coronal sections. Neurons were retrogradely labeled after a tracer (FluoroGold) injected in the ipsilateral rVRG. A, the most rostral section in the series, is located at the mesencephalic-pontine border. The labeling of the neurons was enhanced by immunodetection and conversion to DAB. The darkfield images of the labeled sections were combined with inverted brightfield images of the densely DAB labeled neurons. (From Jiang et al., *Respir Physiol Neurobiol* 143:215–233, 2004, with permission from Elsevier). Abbreviations: DAB, diaminobenzidine; em, external medial subnucleus of the lateral parabrachial complex; el, external lateral subnucleus of the lateral parabrachial complex; lcr, lateral crescent subnucleus of the lateral parabrachial complex; Pr5, principal (sensory) trigeminal nucleus; For other abbreviations see legends for Figures 4 and 5.

expiratory neurons scattered throughout the VRC) presumably account for the pronounced phasic inhibition of inspiratory neurons in the brainstem and spinal cord during the expiratory phase of breathing.

### The PreBötzinger Complex

Interposed between the BötC and the rVRG is the preBötC; this compact region contains excitatory phase-spanning neurons [10] essential for the generation of the respiratory rhythm, and particularly for the expression of rhythmic inspiratory activity. Even when isolated *in vitro* from the remainder of the medulla, neurons in the preBötC are capable of sustaining an inspiratory-like rhythmic bursting activity [5]. The latter derives mainly from excitatory local circuits within the preBötC since its oscillating activity persists after blockade of inhibitory transmitters. Compared to other portions of the VRC the preBötC appears to be distinguished by a particular set of neurons having an expiratory-inspiratory (E-I) pattern of activity, which use glutamate as a transmitter, and which express neurokinin-1 (substance P) and  $\mu$ -opioid receptors. Recent observations in the rat indicate that somatostatin is also present in relatively high concentrations within preBötC neurons and is a likely co-transmitter with glutamate; somatostatin containing neurons are, however, not confined to the preBötC in this area of the medulla. The preBötC has widespread projections to other ipsilateral and contralateral brainstem respiratory regions, but at least in the rat characteristically lacks neurons with spinal projections.

### The Ventral Respiratory Column and Nucleus Ambiguus

Intermingled with or adjacent to VRC neurons are the cranial motoneurons in the dorsal portions of nucleus ambiguus (Fig. 9 and [2]). These include motoneurons of the larynx, pharynx, and esophagus. The activity of these motoneurons is not uniquely tied to respiration and serves a variety of additional behaviors including feeding, drinking, vomiting, and vocalizations. These types of homeostatic, protective, and social orofacial behaviors are served by neural networks in the forebrain and brainstem that are, to some extent, distinct from one another, and from the brainstem circuits underlying rhythmic respiratory activity. Nonetheless, these behaviors are often multiplexed with ongoing respiratory activity at the level of relevant cranial motoneurons. In fact, phasic respiratory activity is generally present on the cranial nerves innervating the airways, such as those supplied by pharyngeal and laryngeal motoneurons. Respiratory activity is also evident on subsets of motoneurons outside of nucleus ambiguus such as in the trigeminal, facial, and hypoglossal nuclei. Accordingly, axon collaterals from subsets of respiratory neurons in the VRC (including both propriobulbar and bulbospinal neurons) contribute premotor input to airway cranial motoneurons. Such connections have been shown for inspiratory bulbospinal neurons in the rVRG which also elaborate axon collaterals locally within the medulla. Similarly, expiratory neurons in the cVRG provide ascending axons that

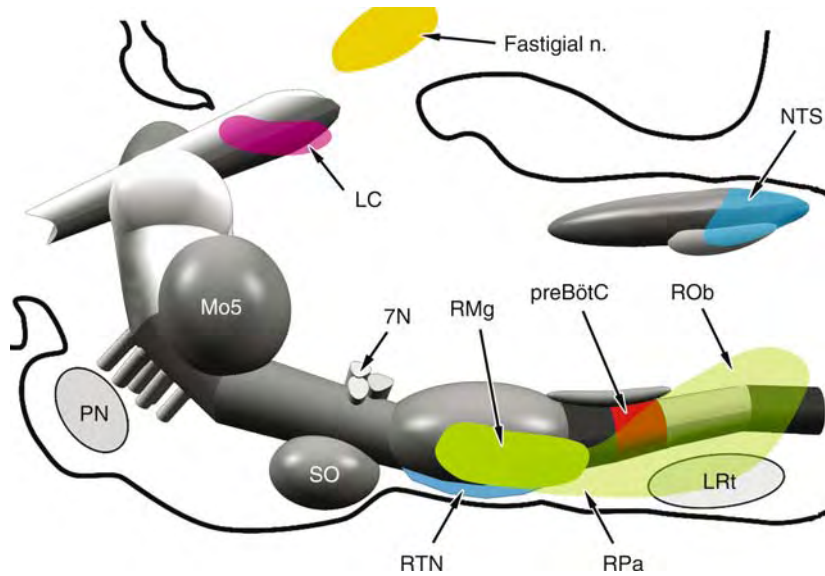

**Anatomy and Function in the Respiratory Network. Figure 8** Chemosensitive regions of the rhombencephalon. A parasagittal view of central chemosensitive regions depicted in color against brainstem regions (gray) related to breathing (see Fig. 3). Chemosensitive regions are identified by neurons with relatively early responses to hypercapnia (excess  $\text{CO}_2$ ) or the accompanying low pH levels. Relative to breathing, a number of candidate regions have been identified in the rhombencephalon that both show chemosensitivity and are interconnected with brainstem or spinal areas involved in respiration. These are the fastigial nucleus (one of the efferent nuclei of the cerebellum), the locus coeruleus (LC; which projects widely throughout the forebrain, brainstem, and spinal cord, the retrotrapezoid nucleus (RTN), the preBötzinger complex (preBötC), the nucleus of the solitary tract (NTS, see text), and the caudal raphe nuclei (RMg, raphe magnus, RPa, raphe pallidus; ROB, raphe obscurus) For other abbreviations see legends for Figures 4 and 5.

innervate laryngeal and pharyngeal motoneurons; such projections may be of particular significance for vocalizations rather than for other laryngeal reflexes, since the latter appear to survive pharmacological inactivation of the cVRG while vocalizations (and the accompanying laryngeal activation) elicited by electrical stimulation of the midbrain periaqueductal gray do not.

In addition to its role in the expiratory phase of respiration, the cVRG, or as it is alternatively termed, “the retroambiguus nucleus,” is identified as an important medullary focus for vocalizations, controlling a significant part of the activity of laryngeal muscles necessary for vocalizations, as well as providing for the activation of abdominal expiratory muscles. Abdominal muscles are involved in a variety of non-respiratory behaviors including vomiting, postural adjustments, and reproductive behaviors such as lordosis, all of which may access abdominal premotor neurons in the cVRG/retroambiguus region. The cVRG is consequently a particularly striking example of a respiratory compartment that is multiplexed with other behaviors. Whether individual cVRG neurons are recruited for multiple functions or whether distinct subgroups of these neurons are specialized for different behaviors is not entirely clear. Populations of “silent” neurons that are only activated under specific functional demands have been observed in cVRG, while some

cVRG neurons with axons reaching the lower segments of the lumbar spinal cord demonstrate expiratory rhythmicity despite the absence of potential motoneuron targets serving respiration.

#### **Pontine Respiratory-Related Circuits**

The brainstem column of neurons related to respiration does not end abruptly with the VRC at the facial nucleus. Neurons related to the control of breathing and connected with the VRC or with airway motoneurons in nucleus ambiguus are scattered around the margins of the facial nucleus, and continue rostral to it, forming an attenuated but essentially continuous and interconnected column in the lateral pons (Fig. 3 and [1]). At its rostral end this column expands into the larger aggregate of neurons in the region of the parabrachial and Kölliker-Fuse nuclei (Fig. 7). As with the VRC, respiratory-related neurons in the lateral pons do not appear to represent a functionally homogeneous column, but may be tentatively divided into distinct compartments. These include the ventrolateral pons/A5 region, the inter-trigeminal region, the Kölliker-Fuse nucleus, and medial and lateral nuclei of the parabrachial complex. As mentioned earlier, respiratory neurons in the parabrachial complex and Kölliker-Fuse nucleus together comprise the area designated as the pontine respiratory group.

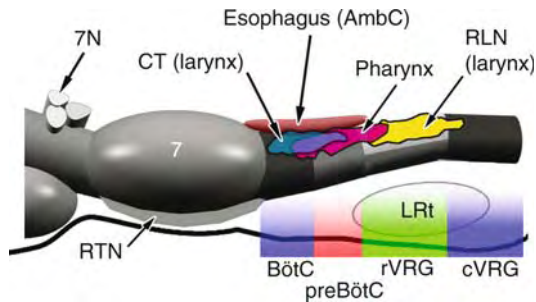

**Anatomy and Function in the Respiratory Network.** **Figure 9** Nucleus ambiguus cranial motoneurons and the ventral respiratory column. This figure depicts the topography of cranial motoneurons of the upper airways and esophagus (colored polygons; based on Fig. 9 in [2]) located in the dorsal portions of nucleus ambiguus and overlapping with the VRC (gray, also see Fig. 3). In addition to spinal motoneurons controlling the pump muscles (see Figs. 1, 2 and 5) the respiratory circuits of the VRC provide afferents to cranial motoneurons of the upper airways. These motoneurons, however, are also activated in a variety of other behaviors (see text) and are not exclusively controlled by the circuits controlling the rhythm and pattern of breathing. The subdivisions of the VRC are indicated by the labeled colored bands. Abbreviations: CT, motoneurons projecting to the crico-thyroid muscles of the larynx; RLN, motoneurons projecting to the larynx via the recurrent laryngeal nerve. For other abbreviations see legends for Figures 4 and 5.

### Ventrolateral Pons/A5 Region

At pontine levels just rostral to the facial nucleus is an area variously referred to as the A5 region and/or the ventrolateral pons (Fig. 3). The A5 noradrenergic cell group is located within the ventrolateral pons near the ventral surface of the brain. A5 neurons are reported to project to the adjacent facial nucleus and to ventrolateral medulla, but also send axons terminating throughout much of the spinal cord including terminations at sympathetic preganglionic neurons in the intermediolateral column of the spinal cord. It is important to note that the major proportion of neurons projecting to the VRC from the ventrolateral pons is not catecholaminergic. A specific role of the ventrolateral pons/A5 region in breathing has not been determined in any detail. Electrical or chemical (glutamatergic) stimulation in this region facilitates expiration (i.e., lengthens expiration time while reducing respiratory frequency). It has additionally been reported that the ventrolateral pons may be a necessary relay for a similar facilitation of expiration evoked by stimulation in the medial parabrachial region.

The ventrolateral pons has also been identified as an important area for vocalizations [7] and some of the

interactions of the ventrolateral pons with the respiratory circuits in the VRC presumably reflect this function. It is argued that neurons in the ventrolateral pontine reticular formation are necessary for the organization of specific voluntary vocalizations (as opposed to emotional vocalizations), particularly including those sets of vocalizations requiring integration with auditory feedback. Consistent with this interpretation, some neurons in the ventrolateral pontine reticular formation both demonstrate a respiratory rhythm and receive auditory input.

### The Intertrigeminal Area

Rostrally and dorsally, the ventrolateral pons merges with the intertrigeminal region (ITR; Figs. 3 and 7). This region consists of neurons located between the pontine principal (sensory) trigeminal nucleus and the motor trigeminal nucleus. Apneas appear to be readily elicited from the ITR with low doses of glutamatergic stimulation. The relevance of this observation for normal breathing is not entirely clear, but are potentially related to upper airway protective reflexes.

### The Pontine Respiratory Group

Neurons in the parabrachial complex and Kölliker-Fuse nucleus are included within the pontine respiratory group (PRG). This region of the pons includes significant populations of respiratory neurons and is designated as the pontine respiratory group. Compared to the on-off firing pattern of most VRC neurons, the PRG has a larger percentage of neurons with tonic activity that is phasically modulated by the respiratory cycle.

### The Kölliker-Fuse Nucleus

The Kölliker-Fuse nucleus is an ill-defined but fairly large aggregate of neurons located at the rostral and lateral boundaries of the pons (Figs. 3 and 7). The Kölliker-Fuse nucleus has the largest aggregate of neurons extrinsic to the medulla that project to the VRC; it densely innervates every compartment of the VRC. Targets include bulbospinal neurons in the rVRG, cranial motoneurons in the ambiguus and hypoglossal nuclei, and phrenic motoneurons in the spinal cord. Despite the extensive knowledge about the circuitry of the Kölliker-Fuse nucleus, its specific functional role remains unclear. It has been suggested that the Kölliker-Fuse nucleus is part of the network coordinating orofacial and/or airway protective reflexes.

### The Parabrachial Complex

The parabrachial complex is composed of several functionally distinct subnuclei characterized by extensive and topographically specific reciprocal connections

with the NTS, as well as providing diverse (and to some extent reciprocated) efferents to the rhombencephalon and basal forebrain. The parabrachial complex surrounds the axons in the superior cerebellar peduncle (a.k.a. “brachium conjunctivum”) as they exit the deep cerebellar nuclei. At its ventral limits the parabrachial complex merges with the dorsal portions of the Kölliker-Fuse nucleus. Only a subset of the multiple compartments that make up the parabrachial complex appear to be directly related to breathing. Based on retrograde labeling, these particularly include the lateral crescent subnucleus, the external medial subnucleus, and rostral portions of the external lateral subnucleus (Fig. 7). Only scattered neurons in the more dorsal parts of the medial parabrachial complex appear to directly target the VRC, and similarly there is only a dispersed field of VRC projecting neurons in the subcoeruleus region located just medial to the medial parabrachial complex and ventral to the locus coeruleus. Projections from the medial parabrachial region may also reach the VRC via relays in the ventrolateral pons.

The parabrachial complex plays a significant role in relaying viscerosensory information (a substantial portion of which originates in the NTS) via ascending axons, to the thalamus, hypothalamus, and basal forebrain. Nociceptive afferents also reach the parabrachial region directly from the spinal cord and from the sensory trigeminal nuclei. Via descending projections, the parabrachial complex in part reciprocates the projections it receives from the NTS but also targets neurons in the caudal pontine reticular formation (medially and laterally), and sends projections to the ventrolateral medulla. Via these descending projections, the parabrachial region appears to function as a relay integrating visceral reflexes with descending forebrain afferents. Together these forebrain afferents and the substantial parabrachial projections to the brainstem form part of the emotional motor system. The latter is responsible for evoking the involuntary motor and visceral responses that accompany strong emotions.

Differential effects on breathing follow stimulation in the medial vs. lateral parabrachial nuclei. When stimulated, the lateral part of the parabrachial complex appears to provide a facilitation of inspiration. In contrast, stimulation in the medial parabrachial region (and to some extent in the adjacent dorsal portions of the Kölliker-Fuse nucleus) leads to a facilitation of expiration. Facilitation of breathing during locomotion, or in response to painful stimuli, appears to involve relays in the lateral part of the parabrachial complex. One parabrachial region that appears to be involved in these responses is the lateral crescent, which receives direct projections relevant to painful stimuli from the dorsal horn of the spinal cord and which sends projections directly to the VRC.

### **Periaqueductal Gray**

Neurons surrounding the central canal in the mesencephalon play an important role as a relay to motor areas of the brainstem for a variety of behaviors originating in the forebrain. These include emotional vocalizations, reproductive reflexes, orienting responses, as well as antinociceptive role presumably related to facilitating adaptive responses in spite of bodily damage. Stimulation in lateral portions of the periaqueductal gray reliably evokes vocalizations that have been related to emotional behavior. Periaqueductal gray neurons directly and indirectly target the VRC and particularly, the cVRG. Respiratory changes occurring during other behaviors such as the orienting response appear to require an obligatory relay from the periaqueductal gray to the parabrachial complex.

### **Higher Order Neurons in the Hypothalamus, Basal Forebrain, and Cortex**

Higher order neurons in the hypothalamus, basal forebrain, and cortex also influence respiration, but with the exception of cortical regions related to vocalizations, most forebrain regions are not exclusively related to breathing. Nonetheless, in addition to vocalizations, the influence of neuroendocrine systems, thermoregulatory systems, locomotor regions, and emotional behaviors on breathing is an important and complex topic. This is, unfortunately, beyond the scope of the present survey of the functional circuitry of respiration.

### **References**

1. Alheid GF, Milsom WK, McCrimmon DR (2004) Pontine influences on breathing: an overview. *Respir Physiol Neurobiol* 143(2–3):105–114
2. Bieger D, Hopkins DA (1987) Viscerotopic representation of the upper alimentary tract in the medulla oblongata in the rat: the nucleus ambiguus. *J Comp Neurol* 262(4):546–562
3. Cajal SR (1897–1899) *Texture of the nervous system of man and the vertebrates*. (transl. by Pasik P, Pasik T, 1999–2002). Springer, Vienna/New York
4. Chatonnet F, Borday C, Wrobel L, Thoby-Brisson M, Fortin G, McLean H, Champagnat J (2006) Ontogeny of central rhythm generation in chicks and rodents. *Respir Physiol Neurobiol*
5. Feldman JL, Del Negro CA (2006) Looking for inspiration: new perspectives on respiratory rhythm. *Nat Rev Neurosci* 7(3):232–242
6. Feldman JL, McCrimmon DR (2002) Neural control of breathing. In: Squire LR, Bloom FE, McConnell SK, Roberts JL, Spitzer NC, Zigmond MJ (eds) (2003) *Fundamental neuroscience*, 2nd edn. Elsevier-Academic Press, San Diego, pp 967–990
7. Hage SR, Jurgens U (2006) Localization of a vocal pattern generator in the pontine brainstem of the squirrel monkey. *Eur J Neurosci* 23(3):840–844

8. McCrimmon DR, Alheid GF. Respiratory reflexes. In: Binder M, Hirokawa N, Martin MC, Winhorst U (eds) *Encyclopedia of Neuroscience*. Springer, Berlin
9. Onimaru H, Homma I (2003) A novel functional neuron group for respiratory rhythm generation in the ventral medulla. *J Neurosci* 23(4):1478–1486
10. Sun QJ, Goodchild AK, Chalmers JP, Pilowsky PM (1998) The pre-Botzinger complex and phase-spanning neurons in the adult rat. *Brain Res* 809(2):204–213

---

## Anatomy of Breathing

- ▶ Anatomy and Function in the Respiratory Network

---

## Andersen Syndrome

### Definition

- ▶ Familial Periodic Paralysis

---

## Anencephaly

### Definition

Lack of encephalon resulting from failure of the

- ▶ neural tube to close.

- ▶ Neural Tube

---

## Angular Gyrus

### Synonyms

- ▶ Gyrus angularis

### Definition

The angular gyrus lies in the parietal lobe, and shaped like an angle, it surrounds the posterior end of the superior temporal sulcus. Functionally, it is between the secondary auditory cortex and the area 18. And indeed the angular gyrus does play an important role in linking visual impulses with linguistic concepts. Damage to the angular gyrus causes alexia and agraphia. Those

affected are often not able to assign objects they see to specified expressions. Instead of using the correct expression, they engage in circumlocutions in which the expression does not occur.

- ▶ Telencephalon

---

## Angular Momentum

### Definition

In classical (particle) mechanics, the angular momentum of a particle with respect to a point is defined as the cross product of the vector joining this point with the particle times the linear momentum of the particle. In continuum mechanics, the angular momentum density with respect to a point in space is obtained in a similar manner, using the linear momentum density. The total angular momentum is then obtained as the integral over the body of the angular momentum density.

- ▶ Mechanics

---

## Angular Vestibulo-Ocular Reflex (aVOR)

### Definition

The angular or rotational vestibulo ocular reflex (aVOR or rVOR) is the compensatory eye movement generated in response to an angular rotation of the head. The reflex is mediated by semicircular canals and the vestibular nuclei.

- ▶ Velocity Storage
- ▶ Vestibulo-Ocular Reflexes

---

## Animal Communication

### Definition

Interaction between two or more animals. A sender encodes and sends out a signal through a channel. A receiver decodes the signals and interprets it. For more information see essay on “Communication in electric fish.”

## Animal Model

### Definition

Species that have been used to study principles of neural and behavioral processing. Synonym: model system. Famous model systems are squids (for the investigation of the mechanisms underlying the action potential), *caenorhabditis* (genetics), *drosophila* (genetics), mouse (genetics), bats (biosonar), electric fish (acetylcholine receptor).

## Animat

### Definition

Artificial animal. Robot or computer simulation with sensors, actuators and nervous system that are directly inspired by actual living organisms.

► Computer-Neural Hybrids

## Anisocoria

### Definition

Pupils of unequal diameter. This is generally indicative of disruption of sensory, central, or lower motor neuronal components of the reflex circuitry.

► Neural Regulation of the Pupil

## Anisotropic

### Definition

Not invariant with respect to direction.

► Anisotropy

## Anisotropy

### Definition

Materials that have properties that change as the material is tested in different orientations are called “anisotropic materials.” For example, if the uniaxial stress-strain behavior of a material is stiffer in one material direction than another (possibly because there is more collagen laid down in that direction), the material is anisotropic.

## Ankle Strategy

### Definition

A fixed support (feet in place) reaction to anteroposterior postural perturbation where the predominant stabilizing action involves active generation of ankle torque. Also commonly referred to as the “early automatic postural response” (APR).

► Postural Strategies

## Anomalous Monism

### Definition

Anomalous monism is the thesis in the philosophy of mind, formulated by D. Davidson, that every event with a mental description, i.e. a mental event, is also physical, i.e. has a physical description, but no strict, precise and exceptionless laws link the mental and the physical. If there are no psychophysical laws relating events under mental descriptions in terms of “believing/desiring/hoping that snow is white” with events under physical descriptions in terms of, say, oscillatory patterns in the brain, then there can be no conceptual reduction of the mental to the physical. Anomalous monism is a form of monism, because it claims that all events are physical, but it is “anomalous” (“a nomos” – not governed by law), because it denies the possibility of strict psychophysical laws, which would allow conceptual reduction of the mental to the physical. It offers a non-reductive conception of the relation of the mental and the physical, which accepts ontological monism, but preserves the autonomy of the mental with its concepts of belief, desire, reasons and actions.

► Theory Theory (Simulation Theory, Theory of Mind)

## Anomia

### Definition

Word-finding difficulty in naming a picture, object, or definition as well as in spontaneous speech. Anomia is found in various pathological cases resulting from brain damage, such as aphasia, Alzheimer's disease, semantic dementia and herpes simplex virus encephalitis (HSVE or HSE).

- ▶ Alzheimer's Disease
- ▶ Aphasia
- ▶ Verbal Memory

## Anorexia Nervosa

### Definition

Serious loss of appetite. The patient becomes greatly emaciated. Neurobiological risk factors are becoming apparent.

- ▶ Neuroendocrinology of Eating Disorders

## Anorgasm

### Definition

Anorgasm refers to difficulty achieving or lack of orgasm.

- ▶ Sexual Reflexes

## Anosmia

### Definition

A temporary or permanent loss of the sense of smell, which may be selective to a small number of odorants or affect detection of all odorants. Acute nasal infection can cause temporary loss of smell. Permanent loss often involves neural damage in the olfactory system, for example due to close head injury damaging the olfactory nerve or brain disease.

- ▶ Smell Disorders

## Anosognosia

### Definition

Denial or unawareness of one's handicap. After stroke or traumatic brain injury, usually with involvement of the non-dominant hemisphere (right side in 95% of people).

- ▶ Stroke

## Anoxic

### Definition

Conditions characterized by the absence of free oxygen.

## Ansa Lenticularis

### Definition

Fiber tract of the subthalamus. The lenticular fasciculus and ansa lenticularis together form the pallidothalamic projection, the biggest efferent of the globus pallidus. The fibers terminate in the ventral lateral thalamic nucleus, which in turn projects to parts of premotor cortex (area 6) and of the supplementary motor area. They arrive at the thalamic nuclei via the thalamic fasciculus.

## Ansa Peduncularis

### Definition

In the ansa peduncularis short tracts project from the amygdaloid body to the hypothalamus and to the medial thalamic nucleus.

## Antagonist Muscle

### Definition

Muscle acting to produce opposite motion or torque at a joint.

- ▶ Impedance Control



## Antagonistic Innervation

### Definition

Antagonistic innervation refers to the case in which an organ is controlled by two different kinds of nerves (double innervation), and the effects of nerves on the organ are antagonistic. An example would be the effect of sympathetic innervation of the heart which is facilitatory versus that of parasympathetic innervation is inhibitory.

## Antennal Lobe

### Definition

First central area of the insect olfactory system. This structure receives input from the olfactory nerve in the antennae and projects to the mushroom body. The architecture is very similar to the vertebrate olfactory bulb.

► Olfactory Information

## Anterior Cerebellar Lobe

### Synonyms

► Lobus cerebelli ant; ► Anterior lobe of cerebellum

### Definition

The anterior lobe is the part of the cerebellum rostral to the primary fissure, and is composed of vermis (lingula, central lobule and culmen) as well as hemispheres (quadrangular lobe, anterior part, and ala lobuli centralis). Functionally this subdivision has practically no significance, since the cerebellum evidences a functional arrangement in a vertical direction (vermis, intermediate part, lateral part).

► Cerebellum

## Anterior Cingulate Cortex

### Definition

The anterior cingulate cortex is the area of the cerebral cortex located in the medial wall of the cerebral

hemispheres, just above the corpus callosum. The anterior cingulate has a major role in behavioral drive and regulation of affective behavior. It has extensive connections with the prefrontal cortex, amygdala, thalamus, and striatum; receives inputs from pain pathways, and contributes to the corticospinal tract.

## Anterior Column

### Synonyms

► Funiculus ant; ► Anterior funiculus

### Definition

The white mater between anterior median fissure and ventral root forms the anterior column, containing:

- Anterior pyramidal tract
- Medial longitudinal fasciculus

► Medulla Spinalis

## Anterior Commissure

### Synonyms

► Commissura ant.

### Definition

The anterior commissure is a bundle of nerve fibers connecting both hemispheres. It crosses the midline anterior to the third ventricle. The anterior commissure runs between parts of the temporal lobes (e.g. parahippocampal gyrus, amygdala) as well as between olfactory areas of the two hemispheres.

► Telencephalon

## Anterior Commissure, Anterior Limb

### Synonyms

► Commissura ant., pars ant; ► Anterior commissure, anterior part

**Definition**

Very narrow branch of the anterior commissure passing to the anterior perforated substance, where it joins the olfactory tract.

► Diencephalon

---

## Anterior Commissure, Posterior Limb

**Synonyms**

► Commissura ant., pars post; ► Anterior commissure, Posterior part

**Definition**

Main part of the anterior commissure passing to the frontal portion of the temporal lobe, hippocampus and amygdaloid body.

► Diencephalon

---

## Anterior Corticospinal Tract

**Synonyms**

► Tractus corticospinalis ant.

---

## Anterior Forceps

**Synonyms**

► Forceps minor; ► Minor forceps

**Definition**

The commissural fibers running in the splenium of the corpus callosum from the occipital lobe embark on a U-shaped course and are shaped like forceps. They are called the posterior forceps. The anterior forceps is formed from similar U-shaped fibers in the frontal lobe.

► Telencephalon

---

## Anterior Gray Commissure

**Synonyms**

► Commissura grisea ant.

**Definition**

In the gray commissure, the nuclear regions, more precisely the intermediate substance, of both halves of spinal cord meet each other. Whereas the anterior gray commissure runs ventrally to the central canal, the posterior gray commissure passes dorsally to the spinal canal.

► Medulla Spinalis

---

## Anterior Group Hox Genes

**Definition**

Hox genes expressed in the anterior region and located toward the 3' end of Hox clusters, this group includes Hoxa1.

► Hox Gene-Related Respiratory Control Disturbance

---

## Anterior Horn

**Synonyms**

► Cornu ant; ► Anterior horn of the spinal cord

**Definition**

In the anterior horn are situated the large alpha motoneurons which innervate the skeletal muscles. But the gamma motoneurons responsible for innervation of intrafusal fibers are also encountered here. They play an important role in the refinement of muscle-spindle sensitivity. The anterior horn evidences a somatotopic arrangement and has two zones:

- Medial motor cells
- Lateral motor cells

► Medulla Spinalis

## Anterior Hypothalamic Nucleus

### Synonyms

► Nucl. ant. hypothalami; ► Anterior nucleus of hypothalamus

### Definition

The anterior hypothalamic nucleus has myriad diverse afferents, e.g. from the limbic system, other hypothalamic nuclei and the Mesencephalon. Efferents go to the surrounding hypothalamic nuclei, but also to the rhomben-cephalic nuclear regions.

Functionally, the nucleus is involved in regulation of body temperature, respiration and cardiovascular tasks (context: affective defense behavior).

► Diencephalon

## Anterior Limb of Internal Capsule

### Synonyms

► Capsula interna, crus ant; ► Anterior limb of internal capsule

### Definition

The internal capsule features the following pathways: posterior limb of internal capsule:

- Pyramidal tract
- Superior thalamic peduncle
- Posterior thalamic peduncle
- Parietopontine tract
- Corticogenital fibers

Anterior limb of internal capsule:

- Frontopontine tract
- Anterior thalamic peduncle

► Telencephalon

## Anterior Lobe of Cerebellum

### Definition

Several classifications are used to subdivide the cerebellum based on anatomical, phylogenetic and

functional (i.e. termination of cerebellar afferents and efferents) findings. Anatomically, both sagittal and horizontal subdivisions can be distinguished. The cerebellum consists of two large lateral parts called the hemispheres and a midline structure, the vermis.

The cerebellum is further subdivided into three major horizontal components, the flocculonodular, anterior and posterior lobes, the latter two forming the corpus cerebelli. The anterior lobe is separated from the posterior lobe by the primary fissure and the flocculonodular lobe is separated from the posterior lobe by the posterolateral fissure.

► Posture Role of Cerebellum

## Anterior Lobe of the Hypophysis

### Synonyms

► Adenohypophysis

### Definition

The glandular tissue of the anterior lobes produce gonadotropic hormones that regulate the secretion of peripheral hormone glands (ACTH → NNR hormones, TSH → thyroid gland hormones, inter alia) but also effector hormones that act directly (PRL → mammary gland, FSH → gonads inter alia). Regulation is effected via releasing and release-inhibiting factors secreted by neurons of the hypothalamus (infundibular nucleus) into the portal system of the gland.

► Diencephalon

## Anterior Median Fissure

### Synonyms

► Fissura mediana ant.

### Definition

Fissure in the ventral side of the spinal cord.

► Medulla Spinalis

## Anterior Occipital Sulcus

### Definition

Relatively constant continuation of the preoccipital notch.

The sulcus could be called a “three-lobe corner,” since here the occipital lobe, parietal lobe and temporal lobe meet.

► Telencephalon

## Anterior Olfactory Cortex

► Anterior Olfactory Nucleus

## Anterior Olfactory Nucleus

PETER C. BRUNJES, KURT R. ILLIG  
Department of Psychology, University of Virginia  
Charlottesville, VA, USA

### Synonyms

Anterior olfactory cortex

### Definition

The primary component of the region of the telencephalon located between the olfactory bulb and the ► piriform cortex.

### Characteristics

The olfactory system is highly developed in vertebrates, particularly in “macrosmic” mammals (such as many rodents) where olfaction is the primary sensory system used to navigate in the world. As olfactory ability has evolved, there has been a concurrent increase in the size and complexity of cortical structures dedicated to encoding and deciphering olfactory information (► cortical circuitry). Below is an overview of one of these cortical regions, the ► anterior olfactory nucleus (AON), which plays a central, though largely uncharted role in olfactory information processing [1].

In vertebrates, odor information is transduced by olfactory receptor neurons that line the nasal cavity (or olfactory rosette in fishes). The information is sent via

the olfactory nerve (Cranial Nerve I) to the olfactory bulb, an evagination of the ventral forebrain that is the rostral-most portion of the telencephalon and is commonly found just behind (or above) the nasal cavity. The general circuitry of the olfactory bulb is similar to that of the retina in that a) incoming sensory information is parsed into separate data streams, and b) it contains two layers of inhibitory interactions to reinforce the differences between these data channels. Axons of the two major output neurons, the mitral and tufted cells, travel caudally and ventrally in the bulb, coalescing to form the lateral olfactory tract (LOT) that courses along the ventrolateral surface of the forebrain.

The area directly behind the olfactory bulb is often referred to as the ► olfactory peduncle (or retrobulbar area, Fig. 1). The peduncle contains the anterior olfactory nucleus (AON) as well as two other much smaller regions, the *tenia tecta* (or dorsal hippocampal rudiment) and the dorsal penduncular cortex. The olfactory peduncle merges caudally with the ► olfactory tubercle on the medial side and with the piriform cortex laterally. The core of the peduncle is formed by a subependymal layer that is continuous with the rostral extension of the lateral ventricle, and comprises the

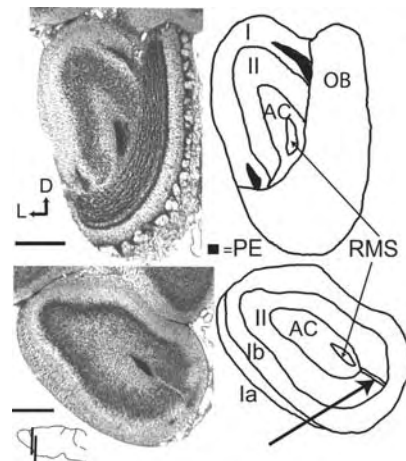

**Anterior Olfactory Nucleus. Figure 1** Left panels: Photomicrographs of coronal Nissl-stained sections at two levels of the rat olfactory peduncle (Small panel on bottom left shows the approximate location of these two sections). Right panels: diagrams of cytoarchitectural features in the left panels. The two top panels show an anterior section that includes *pars externa* (PE). The bottom panels depict a section approximately 600  $\mu\text{m}$  more caudal, where *pars principalis* predominates. Abbreviations: I = Layer I of the AON; Ia, Ib = sublaminae within Layer I; II = Layer II of *pars principalis*; LOT = Lateral olfactory tract; RMS = Rostral migratory stream; AC = Anterior limb of the anterior commissure; OB = Olfactory bulb; D, L = dorsal and lateral. Scale bars = 150  $\mu\text{m}$ .

“rostral migratory stream” that provides new interneurons to the olfactory bulb throughout life. Overlying the rostral migratory stream is the anterior or olfactory limb of the anterior commissure, the source of centrifugal fibers, including some from the medial forebrain bundle, to the region.

### The Anterior Olfactory Nucleus is Comprised of two Separate Structures

The first is a thin ring of cells encircling the rostral end of the olfactory peduncle known as “*pars externa*.” *Pars externa* contains large cells with apical dendrites that have long and thin dendritic spines. Evidence gathered from injections of neuronal tracers suggests that there are topographical projections from the olfactory bulb to *pars externa*: cells in the lateral and medial portions of the bulb project to corresponding regions in *pars externa*. No evidence for patterning in the rostral-caudal dimension has been reported. Axons from *pars externa* travel via the anterior commissure to the contralateral olfactory bulb where they synapse in the internal plexiform layer.

The second and largest region, “*pars principalis*,” appears as a two-layered structure in coronal sections from rodents (Fig. 1). The deepest (Layer II) is a thick ring of cell bodies surrounding the anterior limb of the anterior commissure. Many of the resident neurons are similar to neocortical pyramidal cells with a thick apical dendrite, several basal dendrites, and dense dendritic spines. The outer layer has been subdivided into a superficial zone (Layer Ia, which contains the output axons from the olfactory bulb) and a deeper area (Layer Ib) where these axons synapse with the dendrites of Layer II neurons. The subdivisions of Layer I are easily discernable in Nissl-stained sections based on patterns of glial staining.

Since the only landmark in *pars principalis* is a small, cell-free gap in the ventromedial region of Layer II (Fig. 1), most studies divide the region on the basis of the “compass points,” yielding *pars dorsalis*, *pars ventralis*, *pars medialis*, *pars lateralis*, and *pars posterioralis* (often combined with *pars ventralis* to form “*pars ventroposterioralis*”). However, since there are few obvious ways to make these subdivisions, the boundaries employed are often arbitrary and exhibit wide variations, leading to considerable confusion [2].

*Pars lateralis* is often defined as the area that lies directly under the major portion of the lateral olfactory tract. Caudally, *pars lateralis* merges with the piriform cortex. The transition occurs with the emergence of a deep polymorphic cell layer (Layer III, the “polymorphic cell zone” of the piriform cortex), and the emergence of the pre-endopiriform and endopiriform nuclei.

*Pars medialis* appears in anterior regions caudal to the remnant of the granule cell layer of the olfactory bulb. In posterior regions the structure is replaced by the ventral tenia tecta. The ventral border of the subregion

is the cell-free notch in Layer II, while the dorsal border can be difficult to delineate and is often determined by examining variations in cell size and density.

*Pars dorsalis* is typically defined by exclusion: it is found between *pars lateralis* and *pars medialis* on the dorsal aspect of the AON. The superficial plexiform layer overlying both *pars dorsalis* and *pars medialis* has few myelinated fibers except in the area of transition with *pars lateralis*, reflecting a relatively small innervation by the olfactory bulb. The caudal border of *pars dorsalis* occurs with the emergence of the dorsal peduncular cortex and the transition zone between the AON and the frontal neocortex.

*Pars ventralis* can also be defined by exclusion as the area between *pars lateralis* and *pars medialis* on the ventral surface. It is relatively small, often only slightly larger than *pars medialis* in coronal sections. In caudal areas, *pars ventralis* merges with *pars posterioralis*. In posterior regions this area forms the caudomedial boundary of the AON with the olfactory tubercle.

### Role in the Olfactory Information Processing

The position of the AON in the olfactory circuit suggests that it plays a crucial role in olfactory information flow (Fig. 2). The fact that the region receives a substantial input from the olfactory bulb has been known for a century; indeed, Ramon y Cajal formed his “law of dynamic polarization” (information flows from the axon of one cell to the dendrites of the next) partly by observing the projection of mitral and tufted cell axons onto the dendrites of AON cells. There is a broadly topographical organization in the anterior olfactory peduncle and LOT, with fibers from the dorsal olfactory bulb contacting the dorsal AON, ventral bulb to ventral AON, etc. The LOT continues through the olfactory peduncle to innervate the piriform cortex. The projection appears to be organized in that deep relay cells in the bulb (e.g., mitral cells and the deep tufted cells) send axons all the way to the entorhinal cortex while more superficial tufted cells rarely project caudal to the AON and rostral piriform cortex. Evidence for more specific topographical patterns is difficult to find, indeed, it appears that individual projection neurons innervate broad regions in both the AON and PC.

The AON sends a substantial reciprocal input back to the olfactory bulb. The connections are so widespread that the AON is capable of interacting at nearly every synaptic step in bulb processing. Significant regional differences have been observed these projections. Converging evidence indicates that *pars medialis* fibers are heaviest in the deep granule cell layer of the ipsilateral bulb, while *pars externa* predominately innervates the contralateral internal plexiform layer. The remaining regions have bilateral projections to broader regions.

The AON projects predominantly to the ventromedial portion of anterior piriform cortex (APC), primarily to the region deep to the LOT and extending from the

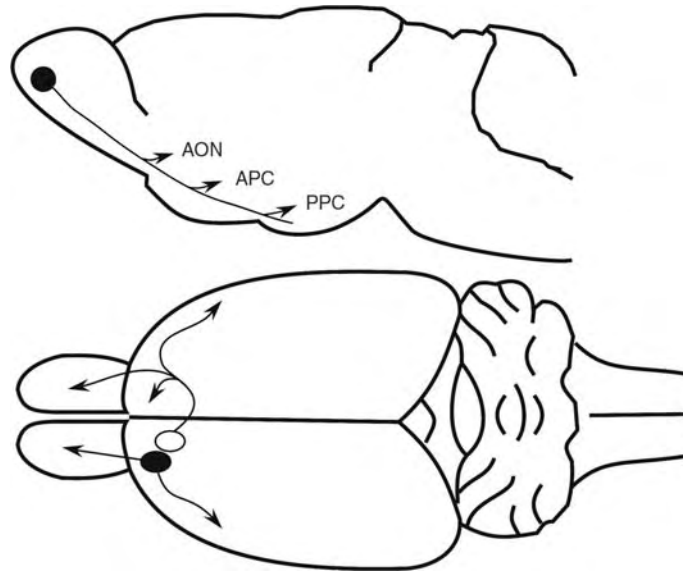

**Anterior Olfactory Nucleus. Figure 2** Schematic view of a mouse or rat brain from the lateral (*top*) and dorsal (*bottom*) sides. Top panel depicts the trajectory of the lateral olfactory tract, leaving the olfactory bulb (*on left*) and distributing information to the anterior olfactory nucleus AON, anterior piriform cortex APC and posterior piriform cortex PPC. Bottom panel shows the ipsilateral (*bottom*) projections of the AON (to the olfactory bulb and anterior piriform cortex) and contralateral (*top*) projections (to opposite AON, olfactory bulb, and APC).

olfactory tubercle laterally to just beyond the border of the LOT. Axons run primarily in deep Layer Ib, adjacent to the compact cell body layer. A broad topography exists, with the heaviest projections from *pars dorsalis*, *pars lateralis* and *pars ventroposterioralis* going to the dorsolateral, central, and ventromedial APC respectively. There is an abrupt decrease in labeled fibers at the boundary with the posterior piriform cortex.

Back-projections from the piriform cortex to the AON are also complex. The APC projects primarily to *pars lateralis*, with a smaller projection to both *pars dorsalis* and *pars ventroposterioralis*, and maintains the broad medial-to-lateral topography displayed in the projections from AON. Interestingly, connections from PPC to the AON are apparently plentiful to all parts of the AON except for *pars externa*.

While much remains to be learned about the precise nature of the projections into and out of the AON, it is obvious that the region is involved in the feedforward regulation of information passing from the bulb to the anterior piriform cortex, and in the feedback regulation of the return circuit. Further, it regulates information flow between the left and right olfactory bulbs via the anterior commissure, and it serves a similar role in distributing information to the left and right piriform cortices.

### Development

AON neurons in the rat are generated during the last week of embryonic development in two distinct

patterns. All divisions exhibit a caudal-to-rostral gradient of neurogenesis similar to that seen in the PC. A second superficial-to-deep gradient is also observed which contrasts with the “inside-out” sequence typical of cortical areas. Patterns of axonal ingrowth from the bulb follow the sequence of cell proliferation. Axonal projections from *pars externa* develop sooner than those from other, deeper AON regions. Similarly, the earliest contralateral projections of *pars lateralis* arise from its caudal- and superficial-most regions, while more rostral, deeper cells send projections 2–3 days later. Finally, three different patterns in the postnatal growth of the subregions of the AON have been reported: a) relatively little expansion (*pars lateralis*), b) moderate growth with overshooting of size and subsequent reduction (*pars medialis*), and c) exuberant growth with subsequent size reduction (*pars dorsalis* and *pars ventroposterior*). Such independent development of the various subregions is compelling evidence that they may serve different functions.

### Anterior Olfactory Nucleus or Anterior Olfactory Cortex?

Several have suggested that the AON would more properly be labeled the anterior ▶**olfactory cortex**. Arguments include the fact that the area is rigidly laminated and populated by pyramidal-shaped cells characteristic of the cerebral cortex, and that it gradually merges with the three-layered piriform cortex. An argument based on functional attributes has been made by Haberly [3], who suggested that the AON shares features with the primary sensory cortices of other

sensory modalities. Haberly split the traditional AON into two functionally distinct areas (the “anterior” and “medial” olfactory cortices), opening the door for further research examining regional differences within the structure. In light of its substantial connections with both the olfactory bulb and the piriform cortex, the AON is likely to play a central role in olfactory information processing; understanding this role will lead to a more complete understanding of vertebrate olfaction.

## References

1. Brunjes PC, Illig KR, Meyer EAA (2005) A field guide to the anterior olfactory nucleus (cortex). *Brain Res Rev* 50:305–335
2. Meyer EAA, Illig KR, Brunjes PC (2006) Differences in chemo- and cytoarchitectural features within *pars principalis* of the rat anterior olfactory nucleus suggest functional specialization. *J Comp Neurol* 498:786–795
3. Haberly LB (2001) Parallel-distributed processing in olfactory cortex: New insights from physiological and morphological analysis of neuronal circuitry. *Chem Senses* 26:551–576

## Anterior Parolfactory Sulcus

### Synonyms

▶ Sulcus parolfactorius ant.

### Definition

The subcallosal area is enclosed by the anterior parolfactory sulcus and posterior parolfactory sulcus.

▶ Telencephalon

## Anterior Peduncle of Thalamus

### Definition

Corticothalamic and thalamocortical fibers together form the thalamic peduncles:

- Anterior peduncle of thalamus: rostral parts of the cerebral cortex and of cingulum
- Inferior peduncle of thalamus: temporal striate cortex, retrosplenial region
- Posterior peduncle of thalamus: occipital lobe without area 17 (striate cortex)

- Superior peduncle of thalamus: precentral gyrus, postcentral gyrus, prefrontal area.

▶ Diencephalon

## Anterior Perforated Substance

### Synonyms

▶ Subst. perforata ant.

### Definition

The anterior perforated substance has a typical, perforated appearance and lies beneath the putamen and globus pallidus, at the site where the olfactory bulb divides into the medial stria and lateral stria (olfactory trigone). It passes laterally in the direction of the limen insula and contains various nuclei of the secondary, olfactory area and limbic system.

▶ Telencephalon

## Anterior Poliomyelitis

### Definition

▶ Polioencephalitis

## Anterior Pyramidal Tract

### Definition

In the pyramidal decussation 70–90% of the fibers cross to the contralateral side forming the lateral pyramidal tract.

The remaining 10–30% continue their ipsilateral course and descend in the anterior pyramidal tract crossing, however, on entering the gray mater of the spinal cord and innervating also the motoneurons. The tract extends only as far as the cervical cord.

▶ Nerves

## Anterior Spinocerebellar Tract

### Synonyms

▶ Tractus spinocerebellum ant

### Definition

This tract conducts proprio- and exteroceptive impulses (skin receptors, muscle spindles, tendon spindles) of the spinal cord (lumbar cord) to the cerebellum without synapsing in the lateral column. They are the only afferent fibers to enter the cerebellum via the superior cerebellar peduncle.

▶ Cerebellum

## Anterior Thalamic Nucleus

### Synonyms

▶ Nuclei ant. thalami; ▶ Anterior nuclei of thalamus

### Definition

This nucleus of the lateral nuclear group is divided into three parts: anteromedial nucleus, anterodorsal nucleus, anteroventral nucleus. Afferents come from the mammillary body, lateral nucleus and the mammillary body, medial nucleus.

In addition, the nucleus has reciprocal connections with the limbic cortex of the cingulate gyrus, the retrosplenial area and the pre- and parasubiculum.

Eunctions in this regions are emotion, motivation and short-term memory.

▶ Diencephalon

## Anterograde Amnesia

### Definition

New memories are not formed following the incident (e.g., trauma), but events prior to the incident can be remembered.

▶ Amnesia

▶ Memory Improvement

## Anterograde Degeneration

### Definition

Anterograde degeneration is the breakdown of fibers (axons) that occurs distal to the point of injury of an axon i.e., away from the cell body. In contrast, retrograde changes take place toward, and can include, the cell body.

## Anterograde Tracing Techniques

### Definition

Neuron tracing techniques take advantage of the fact that axoplasmic transport of materials goes in both directions within the axon. Anterograde transport is away from the cell body, and has fast (400 mm/day) and slow (1–5 mm/day) components that involve the microtubules. Early studies utilized reduced silver techniques or radio autographic methods using labeled amino acids, to outline axons and/or terminals. A variety of immunocytochemical methods are now used to trace and reveal transmitters and other neuron components.

## Anterolateral Column

### Synonyms

▶ Tractus anterolat; ▶ Anterolateral tract

### Definition

The white mater between the ventral root and dorsal root gives rise to the lateral column, containing:

1. anterolateral column with
  - anterolateral fasciculus
  - parts of the anterior spinocerebellar tract.
2. posterolateral column with
  - posterior spinocerebellar tract
  - parts of the anterior spinocerebellar tract
  - lateral pyramidal tract.

▶ Medulla Spinalis



## Anterolateral Fasciculus

### Synonyms

► Lemniscus spinalis; ► Spinal lemniscus

### Definition

Somatotopically organized column of the spinal cord containing somatosensory afferents in the direction of the brain. The following tracts course in this column:

- Spinotectal tract
- Spinothalamic tract
- Spino-anular tract
- Spino-olivary tract

► Medulla Spinalis

## Anterolateral Tract (Pain & Temp Pathway)

► Anterolateral column

► Tractus anterolat.

The fibers in this pathway originate from neuron cell bodies in the dorsal gray of the spinal cord, cross the midline in the anterior commissure at their level of origin, and ascend the spinal cord in its anterolateral quadrant. A portion of the tract, the spinothalamic fibers, ends in the thalamus. Many of the ascending anterolateral quadrant fibers end in the brainstem reticular formation.

## Anti-aliasing Filter

### Definition

A filter placed before a sampling element, designed to prevent frequency components higher than half the sampling frequency entering the sampler. Such

frequency components would be incorrectly sampled according to the Nyquist sampling theorem.

► Nyquist Sampling Theorem

► Signals and Systems

## Anti-amnesic Agents

### Definition

Agents that reverse or ameliorate amnesia.

► Memory Improvement

## Anticipatory Motor Action

### Definition

Skilled action requires that we predict the sensory consequences of our actions, since the sensory signals conveying information about the world and our body are processed too slowly to allow fast, skilled movements.

For example in rapidly reaching for an object, we estimate the distance between our hand and the object and, in an anticipatory, feed-forward manner, compute the time at which we need to activate the appropriate muscles to brake the movement at the proper point in space.

## Anticipatory Postural Adjustment (APA)

### Definition

A predictive motor response that acts to counter, in a preemptive manner, the postural destabilization associated with a forthcoming movement. For forward and backward stepping movements, the APA acts to propel the center of mass of the body toward the stance limb prior to the lifting of the swing foot, so as to counter the tendency of the body to fall laterally toward the unsupported side during the swing phase.

► Anticipatory Postural Responses

► Postural Strategies

## Anticipatory Postural Responses

MARJORIE WOOLLACOTT

Department of Human Physiology, University of Oregon, Eugene, OR, USA

### Synonyms

Feedforward postural control; Preparatory postural adjustments

### Definition

► **Anticipatory postural adjustments** are defined as the activation of postural muscles in a feedforward manner before a voluntary movement begins, in anticipation of the destabilizing forces caused by the movement.

### Characteristics

Investigation of the characteristics of anticipatory postural adjustments was initiated in the 1960s, when researchers in Russia studied the way humans control posture to steady the execution of tasks. This original research showed that when a standing human is asked to raise one arm, postural (leg and trunk) muscles were activated both before and after the activation of the prime mover (arm) muscles. The first part of the postural activity was in preparation for the movement, to compensate in advance for the destabilizing effects of the movement. In this case, leg and trunk muscles were activated more than 50 ms in advance of the prime mover arm muscles. Thus, anticipatory postural adjustments are activated in a feedforward manner, in anticipation of any sensory feedback associated with potential postural instability related to the movement. In addition, the postural muscles were activated after the arm muscles in a feedback manner to stabilize the body further [1,2].

When specific muscle synergies were identified as basic units of reactive postural control, a study was performed to determine if the same muscle synergies used in feedback postural control were also used during anticipatory postural adjustments. Cordo and Nashner [3] asked subjects to perform a task that required anticipatory postural adjustments (pushing or pulling on a handle while standing in a reaction time task) and measured the muscle response organization of the postural muscles activated in advance of the arm muscles (biceps or triceps). Results showed that the very similar postural response synergies used to react to external perturbations to balance control were activated as anticipatory synergies, before the arm flexion or extension movements. Thus, when a participant pulled on the handle in front of him/her, first the gastrocnemius, hamstrings and

trunk extensor muscles were activated, followed by the prime mover the biceps.

To determine the extent to which anticipatory postural synergies adapt to the initial support conditions, researchers compared anticipatory postural responses under two conditions. In the first condition, subjects were asked to stand without additional support, as described above. In the second condition, subjects leaned forward against a horizontal bar at chest height, thus eliminating the efficacy of postural muscle activation in the legs. The research showed that anticipatory postural muscle responses in the legs were reduced or disappeared when subjects were supported. In addition, the voluntary reaction time latencies in the arm were shorter when subjects did not need anticipatory postural muscles in the legs for stability.

These data suggest that there is a preselection of an anticipatory postural muscle synergy associated with each voluntary movement task, as a function of the synergy's contribution to postural stability. This preselection or tuning of sensorimotor systems in anticipation of tasks is often described as "central set." ► *Central set* is defined as a state of the nervous system readiness that is influenced or determined by the context of a task [4]. In the experiment described above, the subject's leaning against a horizontal bar changed the context under which balance would occur during the arm movement task. As a result of the change in context, there was an associated change in central set. A different set of anticipatory postural muscles was selected in advance of the movement, based on their ability to contribute to balance under the new task conditions [5,6].

Anticipatory adjustments are usually discussed in relation to tasks in which postural muscles are activated in advance of prime mover muscles; however, anticipatory control based on central set is also used when postural adjustments to balance threats are scaled in amplitude according to the expected perturbation velocity or size. Experiments designed to test the effect of expectation on postural response characteristics used three platform perturbation contexts: (i) serial versus random conditions, (ii) expected versus unexpected conditions and (iii) practiced versus unpracticed conditions. Results showed that expectation contributed to the modulation of the amplitude of postural responses, with participants giving hypermetric responses when they expected a larger perturbation than they received and hypometric responses when they expected a smaller one. There was also a practice effect, with a reduction in postural response magnitude and in the amplitude of antagonist muscle responses with repeated trials. However, central set did not affect EMG onset latencies. The authors noted that when different perturbations were presented in random order, all scaling disappeared. Results that suggest that scaling

of postural responses is based on prediction of what is needed in a specific context [7,8].

Anticipatory postural adjustments are also used in arm movements in which one arm serves a postural role (holding an object) and the second arm is the prime mover manipulating the object. In experiments examining anticipatory postural adjustments in this context, a 1 kg weight was lifted from the subject's forearm either by the subject or the experimenter. Results indicated that when the subject actively unloaded the arm, there was preparatory biceps muscle inhibition to keep the arm from moving upward during unloading. There was also a coupling between the anticipatory reduction in the biceps EMG of the arm holding the object and the onset of contraction of the biceps of the lifting arm. This inhibition of the biceps activity was not found in the condition in which the experimenter lifted the object (passive unloading) [9].

Animal experiments have been performed to examine the neural circuitry contributing to these anticipatory adjustments [10]. Cats were trained to perform a leg-lifting task that required them to activate postural muscles simultaneously in the other three legs when they lifted the initial leg. Researchers found direct stimulation of the motor cortex or the red nucleus in the area of the forelimb flexors could also produce the leg-lifting movement. When the cortex or red nucleus was stimulated, the leg-lifting movement was accompanied by a postural adjustment in the other limbs, initiated in an anticipatory or feedforward manner. This has led to the hypothesis that postural adjustments are organized at the bulbospinal level and that the pyramidal tract activates these postural response centers as it sends descending commands to the prime mover muscles. In addition to the basic control of postural adjustments occurring at this level, there is also modulation of these responses by other neural sub-systems, including the cerebellum.

## References

1. Belen'kii VY, Gurfinkel VS, Paltsev YI (1967) Elements of control of voluntary movements. *Biofizika* 12:135–141
2. Chong RKY, Horak FB, Woollacott MW (2000) Parkinson's disease impairs the ability to change set quickly. *J Neurol Sci* 175:57–70
3. Cordo P, Nashner L (1982) Properties of postural adjustments associated with rapid arm movements. *J Neurophysiol* 47:287–302
4. Prochazka A (1989) Sensorimotor gain control: a basic strategy of motor systems? *Prog Neurobiol* 33:281–307
5. Horak FB (1996) Adaptation of automatic postural responses. In: Bloedel JR, Ebner TJ, Wise SP (eds) *The acquisition of motor behavior in vertebrates*. MIT, Cambridge, pp 57–85

6. Shumway-Cook A, Woollacott MH (2006) *Motor control: translating research into clinical practice*, 3rd edn. Lippincott Williams & Wilkins, Philadelphia
7. Hansen P, Woollacott MH, Debu B (1988) Responses to sequential postural perturbations. *Exp Brain Res* 73:627–636
8. Horak F, Diener HC, Nashner LM (1989) Influence of central set on human postural responses. *J Neurophysiol* 62:841–853
9. Hugon M, Massion J, Wiesendanger M (1982) Anticipatory postural changes induced by active unloading and comparison with passive unloading in man. *Pflugers Arch* 393:292–296
10. Massion J (1992) Movement, posture and equilibrium: interaction and coordination. *Prog Neurobiol* 38(1):35–36

## Anticonvulsants

TIM A. BENKE

Pediatrics, Neurology, Pharmacology and Neuroscience Program, University of Colorado Health Sciences Center, The Children's Hospital, Aurora, CO, USA

### Synonyms

Anti-seizure medicine; Anti-epileptic medicine

### Definition

Anticonvulsants are medicines used to stop seizures or prevent recurrent seizures in ►epilepsy. Currently, none of the anticonvulsants are known to actually be anti-epileptic in that they do not prevent or cure epilepsy.

### Characteristics Overview

Anticonvulsants are medicines used to stop seizures or prevent recurrent seizures in epilepsy. A single ►seizure may affect 2–4% of the entire population, while recurrent unprovoked seizures or epilepsy may affect 0.5% [1]. Seizures and epilepsy have many causes and are discussed in detail elsewhere, however particular anticonvulsants are often more suited to a particular type of epilepsy. According to the International League Against Epilepsy (<http://www.ilae-epilepsy.org/>), these types are broadly broken down into (i) localization related epilepsy (LRE), (ii) generalized epilepsy, which includes absence epilepsy (GE), (iii) undetermined focal or generalized epilepsy (UE) which includes some

forms of myoclonic epilepsy and (iv) situation-related syndromes. Seizures due to situation-related syndromes (fever, infection, etc) are treated in concert with their underlying cause. Approximately 25% of patients have medically refractory epilepsy that does not respond favorably to two or more medications. Treatment decisions, consequences of seizures, and specific management of seizures and epilepsy are addressed in numerous texts.

A variety of conditions have been treated by anti-convulsant drugs. These have included ►[neuropathic pain](#), migraine, ►[movement disorders](#), sleep disorders and ►[mood and anxiety disorders](#).

### Causes of Seizures and the Basis of Drug Design

Seizures are caused by imbalances between excitation and inhibition in the normal pattern of communication between neurons in the central nervous system. The imbalances lead to abnormal, repetitive discharges that are often sustained by the underlying neuronal circuitry. Typically, the circuit re-excites itself leading to the sustained, repetitive discharges that are the hallmark of seizures. Due to their innate recurrent circuitry, certain regions of the central nervous system are more prone to seizures, such as the ►[hippocampus](#). Abnormal formation of recurrent circuitry due to developmental or other causes can also underlie seizures and epilepsy.

Neuronal communication happens through a combination of electrical and chemical signaling. Communication along a neuron is electrical while communication between neurons is mostly chemical. Neurotransmitters mediate the chemical communication between neurons and ►[gap junctions](#) mediate electrical transmission between neurons. Proteins that mediate the various means of communication are the molecular targets of anticonvulsants. The mechanisms of neuronal communication and the networks that sub-serve them are under the control of developmental as well as environmental influences. Thus, the molecular targets of anticonvulsants vary according to developmental and environmental influences. Achieving the balance of preventing abnormal and preserving normal communication is the ultimate goal of anticonvulsant drug design.

Most anticonvulsants interfere with at least one form of neuronal communication [1–3]. Electrical and chemical communication is either depolarizing or excitatory or hyperpolarizing or inhibitory. ►[Voltage-gated ion channels](#) are proteins that mediate selective ionic fluxes across the neuronal membrane. These channels open in response to the potential, changing or static, of the neuronal membrane around them. ►[Neurotransmitter](#) receptor-channels open in response to the binding of a neurotransmitter. The relative concentration of ions on either side of the membrane, the membrane potential and the relative ion selectivity (e.g., sodium, potassium, calcium, chloride, etc.) of the channel direct the

overall net flux of ions across the neuronal membrane according to the ►[Goldman–Hodgkin–Katz](#) equation. The net flux of ions through the ►[ion channels](#) can result in depolarizing or hyperpolarizing influences that in turn affect neuronal communication.

Neurotransmitter release involves many tightly linked processes. Only specialized structures and regions are involved in neurotransmitter release. Initiation involves either local voltage-gated changes or second messenger systems activated by neurotransmitters themselves. Vesicles, membranous spheres filled with neurotransmitter by pumps within the vesicular membrane, fuse with presynaptic membranes to release neurotransmitter into the ►[synaptic cleft](#) that separates the presynaptic neuron from the postsynaptic neuron. Alternatively, neurotransmitters may be directly pumped into the cleft. Neurotransmitters are either enzymatically ►[degraded](#) in the cleft or pumped back out of the cleft by ►[transporters](#) into the presynaptic terminal, postsynaptic neuron or surrounding ►[glial](#) support cells. From there it is either enzymatically broken down, recycled and shuttled across membranes, resynthesized or pumped backed into vesicles.

While each neuronal communication process (e.g., excitation, neurotransmitter release) can be thought of as “generic”, these must all be differentiated when considering the effects of anticonvulsants and rational drug development and design. Since most anticonvulsants are unable to differentiate between “good” communication and “abnormal” communication (seizures), side effects are the result. In terms of understanding the different types of seizures, epilepsy and anticonvulsants, it must be kept in mind that specific types of neurons in unique anatomical locations use specific subtypes of channels for each individual process. The few characterized genetic epilepsies occur through single gene (often ion channel) defects and therefore rational drug design should seek to directly restore, enhance or limit function (depending on loss or gain of function) of the affected ion channel. In principle, this should be considered even in cases of epilepsies caused by multiple genetic defects.

The ideal anticonvulsant, therefore, should recognize and correct not only specific ion channel dysfunction in a particular brain region, but also recognize that defects are also likely limited to unique aspects of neuronal structure. Neurons are multipolar structures, that is, they have unique compartments designed for unique functions. As part of this, unique subtypes of ion channels are segregated to unique compartments. For example, a particular type of ►[voltage-gated potassium channel](#) (hyperpolarizing) may be segregated to dendrites, while another type (also hyperpolarizing but with different voltage-dependent properties and pharmacological sensitivity) may be segregated specifically to presynaptic terminals. Neurons themselves are also

segregated as inhibitory or excitatory, depending on the type of neurotransmitter(s) they may (predominantly) release. Each class of neuron may also express a unique complement of subtyped ion channels.

### Historical Perspectives of Drug Development

Up until recently, the anticonvulsant drugs in use were developed not only before the genetics of epilepsy were imagined but before the nature of neurotransmission itself was understood. As a result, most drugs were discovered through brute force trial and error in animal models. These animal models typically used injected pro-convulsants or direct electrical stimulation. As such, these often did not directly mimic human seizures or epilepsies, occasionally resulting in a mismatch between model and human efficacy. This has been somewhat improved by the use of different animal models of genetic epilepsies [1]. Effective parent compounds (e.g., carbamazepine) have been used as models for later drugs (oxcarbazine) with better side-effect profiles.

As techniques in neuroscience have advanced, for example the development of ►patch-clamp techniques for recording currents through single ion channels in the early 1980s, the mechanisms of anticonvulsant drugs have more recently become better understood. Despite advances in molecular neuroscience, many anticonvulsants are still classed according to the general types of ion channels that are affected. ►Voltage-gated sodium channels (VGSCs) are somewhat broadly categorized while ►voltage-gated calcium channels (VGCCs) are segregated according to their biophysical properties (T, P/Q, N, and L/HVA-type) due in part to the fact that most anticonvulsant drugs do not themselves segregate the different molecular entities of ion channels.

Similarly, as more detailed descriptions of neurotransmission are presented, it has been found that anticonvulsant drugs can affect chemical neurotransmission at all stages of the process from neurotransmitter synthesis, vesicular fusion, neurotransmitter reuptake as well as neurotransmitter receptors themselves. Inhibitory transmission, primarily mediated by ►GABA-A receptors (GABARs), is often enhanced by anticonvulsants while excitatory transmission, primarily mediated by glutamate receptors, is typically reduced. The effects of anticonvulsants on glutamate receptors are pharmacologically divided into ►AMPA-type (GluRs), ►kainate-type (KARs) and ►NMDA-type (NMDARs) primarily because it is still contentious how their molecular diversity equates to their functional and pharmacological diversity. NMDARs and perhaps KARs, due to their ability to flux the second messenger calcium, hold important distinction because of their role in triggering specific forms of synaptic plasticity and thus may play a role in epileptogenesis. Another class of glutamate receptors that is directly linked to second messenger systems, the

►metabotropic glutamate receptors (mGluRs), has not been demonstrated to be a target of currently used anticonvulsant drugs.

Valproic acid has the broadest pharmacological and clinical spectrum of all of the anticonvulsant drugs [2]. Most of its anticonvulsant effects can be attributed to enhancing GABA-mediated inhibitory transmission. Additional effects, which may play a role in its use as a mood altering drug, include inhibiting excitatory transmission. Valproic acid may have antiepileptogenic effects by its effect on DNA binding proteins with subsequent alteration of gene expression.

Adrenocorticotropin and prednisone are frequently used to treat infantile spasms, a form of myoclonic/UE. The mechanisms for these agents are not entirely understood. Vigabatrin is often used to treat infantile spasms caused by ►Tuberous sclerosis; however lack of FDA approval has prevented its use in the United States (Table 1).

### Rational Drug Development

At present, there are three major thrusts in anticonvulsant rational drug design [3,4]. First, the parent structures of anticonvulsants currently in use are being modified to find drugs with improved efficacy and tolerability. This rational has been used in developing many of the drugs in current use. Second, drugs with specific molecular targets that have been suggested either by discovery in the molecular genetics of epilepsy or advances in neuroscience research are being sought, developed and further modified for efficacy and tolerability. Finally, novel anticonvulsant compounds with possible antiepileptic properties are actively sought. Many potential compounds, especially those targeting NMDARs, have been pursued and subsequently abandoned due to lack of efficacy and poor tolerability. GluR antagonists, due to sedation issues, are likely to be more appropriate for ►status epilepticus. Serendipity continues to play a major role as our understanding of neuroscience, seizures, and epilepsy expands (Table 2).

### Future Directions in Drug Development

The fact that 25% of all epilepsies are drug resistant with only 50% of these potentially amenable to surgical treatment (itself with significant cost and morbidity) dictates that further drug development is necessary. Animal studies have suggested several important lines for future development. Group I mGluR agonists or Group II mGluR antagonists are thought to have both anticonvulsant and antiepileptogenic potential [5]. Since these modulatory receptors do not directly participate in fast excitatory synaptic transmission, it is felt that targeting these receptors would be effective with fewer side effects compared to agents that directly modulate GluRs and NMDARs. Similarly, targeting

**Anticonvulsants. Table 1** Anticonvulsant drugs currently in widespread use

Drug	Date of initiated or pubmed first citation of anticonvulsant use (date synthesized)	Mechanisms of action (in presumed order of efficacy)	LRE	GE	UE	Notes
Phenobarbital	1912 (1911)	GABAR, VGCC-HVA, GluR	+	+		
Phenytoin	1938 (1908)	VGSC	+			Phenytoin, carbamazepine and oxcarbazepine may exacerbate some generalized epilepsies
Ethosuximide	1951 (1927)	VGCC-T-type, VGSC		+		
Carbamazepine	1962 (1953)	VGSC	+			Blocks defective nicotinic acetylcholine receptors in ADNLE
Benzodiazepines (Diazepam)	1964 (1961)	GABAR	+	+	+	
Valproic acid	1973 (1882)	↑GABA turnover, VGSC, VGCC-T-type	+	+	+	
Zonisamide	1982	VGSC, VGCC-T-type	+	+	+	
Vigabatrin	1983 (1977)	↓GABA transaminase (GABA degradation prevented)	+	+	+	Not FDA approved in the United States due to retinal damage associated with long-term use
Lamotrigine	1985	VGSC, VGCC-HVA, I <sub>h</sub>	+	+		
Gabapentin	1987	VGCC-HVA, ↓GABA transaminase	+			
Oxcarbazepine	1987	VGSC	+			
Felbamate	1989	VSCS, GABAR, VGCC-HVA, NMDAR	+	+		Use limited by bone marrow and liver toxicity
Topiramate	1994 (1987)	VGSC, VGCC-HVA, GABAR, KAR/GluR	+	+	+	
Tiagabine	1994 (1988)	blocks GABA reuptake (transporter)	+			
Levetiracetam	1996 (1992)	VGCC-HVA, GABAR, Binds to SV2A (presynaptic vesicle protein)	+	+	+	

See text for most abbreviations. "+" indicates clinical evidence for usage. ADNLE: autosomal dominant nocturnal frontal lobe epilepsy. Modified from [2,3].

KARs [6], which to some extent also modulate fast excitatory transmission, holds promise, as has been shown with topiramate that antagonizes KARs [2]. Other receptor systems (amines, peptides, acetylcholine, etc.) have also been suggested as targets [2].

Targeting potassium channels with anticonvulsive agents that augment their function may be helpful, as suggested by the progression of advanced clinical trials with retigabine. Many additional potassium channels other than the KCNQ-type have been proposed. For instance, I<sub>h</sub>, a potassium channel that modulates dendritic excitability, has been implicated in epilepsy. Long-term alteration of I<sub>h</sub>, resulting in

reduced function of this potassium channel, has been induced by experimental models of seizures and epilepsy [7]. Thus, by attempting to reverse this process, it may be possible to obtain better seizure control as well as reverse epilepsy. It is thought that the primary anticonvulsant mechanism of lamotrigine is to augment I<sub>h</sub> function [2]. Recently it has been shown that the ketogenic diet, used to treat medically refractory epilepsy, may augment function of another type of potassium channel that is sensitive to ATP (K-ATP channels) [8].

Agents that do not target ion channels directly but rather accessory proteins that modulate their

**Anticonvulsants. Table 2** Anticonvulsants in development [4,3]

Drug	Parent structure	Mechanisms of action
Brivaracetam and selectracetam	Levetiracetam	SV2A ligand, similar to levetiracetam?
Valroceamide, valnoctamide, isovaleramide, propylisopropyl acetamide	Valproic acid	Similar to valproate?
Flurofelbamate	Felbamate	Similar to felbamate?
RWJ-333369	Carbamate	Similar to felbamate?
Licarbazepine, BIA 2-093	Oxcarbazepine	Similar to oxcarbazepine?
ELB139	Benzodiazepine	Selective benzodiazepine receptor agonist
Lacosamide	Functionalized amino acid	Unknown
Talampanel	2,3 benzodiazepine	Non-competitive GluR antagonist
NS1209		Competitive GluR antagonists, weak KAR antagonist
Ganaxolone	Neuroactive steroid	GABAR modulator
Retigabine		KCNQ (voltage-gated potassium channel) opener
ICA-27243	Benzanilide	More selective KCNQ opener
Rufinamide	Triazole	Unknown

function are also on the horizon. For instance, it has been shown that the direction of chloride flux through GABARs is developmentally regulated by the expression of specific transporters. Targeting transporters with a diuretic to maintain the “correct” direction of chloride flux has been shown in an animal model to attenuate otherwise medically refractory seizures [9]. Furthermore, aberrant expression of transporters has been found in human epileptic tissue, potentially resulting in “wrong-way” chloride fluxes [10]. Thus targeting these transporters with diuretics that can cross the blood-brain barrier would present a novel therapeutic approach. In the end, targeting either the specific enzymes capable of altering ion channel properties (for instance by ►phosphorylation or de-phosphorylation) or the genetic expression of aberrant channels and transporters are likely to be the key to anticonvulsant and antiepileptogenic drugs of the future. For example, the phosphorylation state of  $I_h$  is critical in regulating dendritic excitability and preventing this may alter the course of epilepsy. Also, targeting the selective activation of ►kinases and phosphatases that underlie the long-term alteration of excitatory synapses (►synaptic plasticity) in the early stages after a first seizure might prevent epilepsy before abnormal synaptic modifications induced by the seizure become “hard-wired”. By targeting these processes early in the course of epilepsy or just after the first seizure, the long-term consequences (of medical refractory epilepsy or learning impairment) could potentially be averted.

## References

- White HS (2003) Preclinical development of antiepileptic drugs: past, present and future directions. *Epilepsia* 44 (Suppl 7):2–8
- Rogawski MA, Loscher W (2004) The neurobiology of antiepileptic drugs. *Nat Rev Neurosci* 5:553–564
- Stefan H, Feuerstein TJ (2007) Novel anticonvulsant drugs. *Pharmacol Ther* 113:165–183
- Rogawski MA (2006) Diverse mechanisms of antiepileptic drugs in the development pipeline. *Epilepsy Res* 69:273–294
- Ure J, Baudry M, Perassolo M (2006) Metabotropic glutamate receptors and epilepsy. *J Neurol Sci* 247:1–9
- Vissel B, Royle GA, Christie BR, Schiffer HH, Ghetti A, Tritto T, Perez-Otano I, Radcliffe RA, Seamans J, Sejnowski T, Wehner JM, Collins AC, O’Gorman S, Heinemann SF (2001) The role of RNA editing of kainate receptors in synaptic plasticity and seizures. *Neuron* 29:217–227
- Poolos NP (2005) The h-channel: a potential channelopathy in epilepsy? *Epilepsy Behav* 7:51–56
- Ma W, Berg J, Yellen G (2007) Ketogenic diet metabolites reduce firing in central neurons by opening  $K_{ATP}$  channels. *J Neurosci* 27:3618–3625
- Dzhala VI, Talos DM, Sdrulla DA, Brumback AC, Mathews GC, Benke TA, Delpire EJ, Jensen FE, Staley KJ (2005) NKCC1 transporter facilitates seizures in the developing brain. *Nat Med* 11:1205–1213
- Munoz A, Mendez P, DeFelipe J, Alvarez-Leefmans FJ (2007) Cation-chloride cotransporters and GABA-ergic innervation in the human epileptic hippocampus. *Epilepsia* 48:663–673

## Antidepressants

CYNTHIA L. DARLINGTON

Department of Pharmacology and Toxicology, School of Medical Sciences, University of Otago Medical School, Dunedin, New Zealand

### Definition

The symptoms of unipolar depression may vary widely between individuals and may include apathy, subdued mood, sadness or sorrow, loss of libido, sleep disturbances, weight loss or gain, and in children and adolescents, irritability. A defining symptom of depression is the loss of self-esteem, for which there may be no apparent explanation. Chronic depression is a debilitating disease that sometimes leads to suicide and is more prevalent in females than in males. In the USA it is the third leading cause of death among people aged 15–24 Years. It is an expensive disease in terms of lost working capacity, increased use of social services and impairment of family and social relationships. Antidepressants are drugs that are used in the treatment of unipolar depression, although they are often used in conjunction with some form of psychological therapy. In addition, some antidepressants are used for certain subtypes of anxiety disorders, such as obsessive compulsive disorder and phobias, as well as neuropathic pain.

### Characteristics

There is a genetic component to unipolar depression in many cases, with an increased incidence of the disease being reported in individuals with first degree relatives who also suffer from depression. In long-term depression, enlarged adrenal and pituitary glands have been observed, as have increased levels of cortisol in the blood, CSF and urine of patients. Elevated levels of corticotrophin releasing factor in the plasma of patients have also been observed. Taken together, these observations indicate constant elevated levels of stress and consistent with long term stress, in some patients, a reduced volume of the hippocampus has been observed.

Depression is attributed to a decreased availability of the biogenic amine neurotransmitters, noradrenaline, serotonin, and to a lesser extent, dopamine [1]. Current strategies in the treatment of depression aim to increase the available amount of these neurotransmitters. There are four main categories of antidepressant drugs: tricyclic antidepressants, selective serotonin reuptake inhibitors (SSRIs), monoamine oxidase inhibitors and an “atypical” category that includes dopamine modulating drugs.

Interestingly, the different categories of drugs all have a therapeutic lag of 2–3 weeks and a similar efficacy in treating depression. This therapeutic lag presents a problem in the initiation of antidepressant treatment, particularly in patients expressing suicidal ideations. The primary differences between the drugs are in the side effects and a patient’s acceptance of a particular drug is often side effect dependent.

### Tricyclic Antidepressants

The first successful antidepressants were the tricyclic antidepressants that became widely available in the 1960s [2]. Tricyclics such as imipramine, clomipramine and amitriptyline, inhibit the reuptake of noradrenaline from the synaptic cleft with moderate selectivity. Most of the drugs in this category have a relative long plasma half-life, and some have active metabolites, that further prolong the drug’s action. This prolonged action provides stable levels of the drug in the blood plasma and reduces the occurrence of fluctuating side effects that many patients find annoying. Although newer antidepressants are slowly replacing tricyclics in clinical practice, many prescribers prefer them because their long clinical use has provided evidence for their relative safety and efficacy.

The side effects associated with tricyclics include sedation, postural hypotension and anticholinergic effects including dry mouth, blurred vision and urinary retention. The occurrence of postural hypotension is a particular problem for elderly patients and has led to the preferential prescription of SSRIs in this patient population. There are also effects on the cardiovascular system that require consideration. In addition, these drugs can be fatal in overdose and may be contraindicated in patients expressing suicidal ideations. Tricyclic antidepressants generally have interactions with a number of other drugs including alcohol and these drugs are therefore contraindicated in alcoholic patients. Tricyclic antidepressants are included in Category D of the FDA classification of potentially teratogenic drugs. This category includes drugs for which there is evidence of risk in humans, however the benefit of the drug may outweigh the potential risk.

### Selective Serotonin Reuptake Inhibitors (SSRIs)

SSRIs have now overtaken tricyclic antidepressants as the most prescribed drugs for the treatment of unipolar depression [3]. Although they have similar efficacy to tricyclics, SSRIs demonstrate less acute toxicity and less risk of overdose, making them an overall safer choice for the severely depressed patient. SSRIs inhibit the reuptake of serotonin from the synaptic cleft with greater selectivity for serotonin than for noradrenaline. For most SSRIs, the selectivity for



serotonin is a factor of 10 greater than the selectivity of tricyclics for noradrenaline.

The side effects of SSRIs include nausea, insomnia, agitation and sexual dysfunction. For some patients, the experience of sexual dysfunction ultimately leads to dissatisfaction with the drug and a change to a different antidepressant. Although generally safer than tricyclics, there are two drug interactions with SSRIs that raise concern. In an effort to achieve better control of their depression, a number of patients have resorted to self-medication with the herbal remedy, St. John's Wort. St. John's Wort contains significant levels of serotonin and a life threatening "5-HT reaction" has been observed that includes muscular rigidity, hyperthermia and in the most severe cases, cardiovascular collapse. The other interaction is with cannabis, which can cause severe anxiety, panic, hypertension and muscle spasms.

### Monoamine Oxidase Inhibitors (MAOIs)

Monoamine oxidase is the enzyme in the presynaptic terminal that breaks down the aminergic neurotransmitters to allow recycling to their constituents. Inhibition of this breakdown increases the amounts of transmitter available for release into the synaptic cleft. MAOIs were discovered in the late 1950s and originally studied as drugs known to produce mania. These drugs have a number of other effects, including lowering blood pressure, and at one time were used as antihypertensives. Although MAOIs are effective treatments for depression, particularly when it is associated with anxiety and phobias, they are now used primarily when a patient has failed to respond to tricyclics and SSRIs.

There are two subtypes of monoamine oxidase, type A, that breaks down noradrenaline and serotonin, and type B, that breaks down dopamine. The early monoamine oxidase inhibitors were not specific for monoamine oxidase subtypes and, as a result, severe side effects were associated with their use. One of the most dangerous side effects associated with MAOIs was the hypertensive crisis resulting from interactions with tyramine containing foods or with other drugs. Interactions with tyramine containing foods pose the greatest problem for many patients, with banned foods including cheeses, beer, wine, yeast, chocolate and cream. Other common side effects include postural hypotension and sedation or excitation. There is also a severe interaction with tricyclic antidepressants, so that if a patient is changed from a tricyclic to an MAOI, a drug free washout period is necessary.

Newer MAOIs have been synthesized that are specific for monoamine oxidase subtypes. Moclobemide, for example, is selective for type A monoamine oxidase. Moclobemide and similar drugs have side effects similar

to tricyclics, although cautions for tyramine containing food still apply. In addition, seizures have been reported to be associated with acute overdose.

### Atypical Antidepressants

This is a mixed category of drugs that has been demonstrated to be effective for the treatment of depression in some cases, and includes trazodone, nefazodone and bupropion. The neuropharmacology of these drugs is less well understood, hence the name "atypicals." One of the major advantages of drugs in this category is that they tend to be safer and better tolerated by patients with fewer, if any, cardiovascular effects. It has been suggested that because of their relative safety, atypical antidepressants should be the first choice for the treatment of unipolar depression in geriatric patients.

Of particular interest in this category is bupropion, a reuptake inhibitor for noradrenaline, serotonin and dopamine. Bupropion is generally well tolerated and in addition to its antidepressant properties, it is also useful in withdrawal from nicotine [4]. Bupropion is not suitable for individuals with seizure disorders or a susceptibility to seizures. It has also been reported to produce mania in some depressed patients.

### Overview

While the immediate effect of antidepressants is to increase the availability of biogenic amines in the synaptic cleft, it is the longer term effects, developing over 2–3 weeks, that are thought to provide the antidepressant effects. The characteristic therapeutic lag associated with these drugs suggests that it is long term changes in receptors and transporters that provide the therapeutic effect. One consequence of this therapeutic lag is that antidepressants cannot be administered acutely "as required." Another consequence is that when the depression has been alleviated, the drug must be withdrawn slowly to allow the receptors or transporters to gradually adapt to a drug-free state.

In cases of severe recurrent depression, where antidepressants alone are not fully effective, administration of lithium has been reported to be an effective supplement to antidepressant treatment [5].

### Bipolar Disorder (Bipolar Depression)

Bipolar disorder is a mood disorder characterized by periods of depression followed by periods of mania or hypomania. Although depression is a significant part of the disorder, treatment with antidepressant drugs is not effective in the manic phase and may indeed exacerbate it. Instead, treatment is required that will stabilize the individual's mood, preventing both the episodes of depression and the episodes of mania [6].

In 1949 lithium was introduced for the treatment of mania but it was not until the 1970s that it became accepted world wide as an effective treatment for bipolar disorder. The effectiveness of lithium in bipolar disorder is interesting because a therapeutic dose has no discernable effect in a person without bipolar disorder. This distinguishes it from other drugs, such as tricyclics, that produce sleepiness when administered to non-depressed individuals. The actions of lithium are not well understood. It is speculated that it may produce its effect by acting upon sodium channels or possibly by inhibiting the release of dopamine and noradrenaline but not serotonin [6].

Although lithium is generally well absorbed after oral administration, absorption is somewhat erratic, with peak plasma levels exceeding the threshold for adverse events. Slow release lithium prevents the early erratic plasma peaks, but may result in later accumulation of the drug resulting in gastrointestinal side effects. Overall, lithium is a difficult drug to use. It has a very low therapeutic index, meaning that the therapeutic dose is in a very narrow margin between the ineffective dose and the toxic dose. Initiation of lithium treatment requires consistent monitoring until steady state plasma levels are achieved. Often the required dose, even for the slow release preparations, is given in divided doses throughout the day to minimize the fluctuating plasma levels. Acute toxic effects of lithium include gastrointestinal disturbances, tremor and sedation. More serious side effects include severe gastrointestinal side effects, coma and even death.

Because of the numerous problems associated with lithium administration, in recent Years there has been a move towards the use of antiepileptic drugs, particularly carbamazepine and valproic acid, for the treatment of bipolar disorder.

## References

1. Ruhe HG, Mason NS, Schene AH (2007) Mood is indirectly related to serotonin, norepinephrine and dopamine levels in humans: a meta-analysis of monoamine depletion studies. *Mol Psychiat* 12(4):331–359
2. Gillman PK (2007) Tricyclic antidepressant pharmacology and therapeutic drug interactions updated. *Br J Pharmacol* 151(6):737–748
3. Pae CU, Patkar AA (2007) Paroxetine: current status in psychiatry. *Expert Rev Neurother* 7(2):107–120
4. Grant KM, Kelley SS, Smith LM et al. (2007) Bupropion and nicotine patch as smoking cessation aids in alcoholics. *Alcohol* 41(5):381–391
5. Kok RM, Vink D, Heeren TJ et al. (2007) Lithium augmentation compared with phenelzine in treatment-resistant depression in the elderly: an open randomized controlled trial. *J Clin Psychiat* 68(8):1177–1185
6. Miklowitz DJ, Johnson SL (2006) The psychopathology and treatment of bipolar disorder. *Ann Rev Clin Psychol* 2:199–235

## Anti-DNA Antibodies against Microbial and Non-Nucleic Acid Self-Antigens

BETTY DIAMOND<sup>1</sup>, BRUCE T. VOLPE<sup>2</sup>

<sup>1</sup>Columbia University Medical Center,  
Department of Medicine, New York, NY, USA

<sup>2</sup>Weill Medical College of Cornell University,  
Department of Neurology & Neuroscience,  
The Burke Medical Research Institute, White Plains,  
NY, USA

### Synonyms

Autoimmune disease; Inflammatory response; Self-antigen; Systemic lupus erythematosus; Glutamate receptors

### Definition

Molecular ►mimicry refers to the similar structures shared by molecules from different genes or different proteins. In autoimmune or infectious disease, molecular mimicry also refers to shared cross reactive epitopes for B- and T-cells with the host. The concept of molecular mimicry evolved from monoclonal antibodies in which mutation analysis led to cross reactive B-cells and T-cells and now to its participation in human diseases.

### Characteristics

#### Activation of Cross-Reactive Lymphocytes

The innate immune system, which recognizes shared determinants on microbes, together with general tissue barriers function as an effective first line defense against the world of pathogens while an adaptive immune response with memory function develops. B- and T-cells form the central components of the adaptive immune response; each expresses one of an enormously diverse repertoire of antigen receptors and each is highly selective. The frequency of T- and B-cells expressing any given receptor can increase through clonal expansion or decrease through negative selection, the process of eliminating cells with specificity for self-antigens. B-cells or T-cells that cross-react with both foreign and self antigens may escape tolerance mechanisms because the self-antigen is present in too low a concentration to mediate negative selection, or because the affinity of the antigen for the antigen receptor is below the signaling threshold. If these B-cells and T-cells are initially activated by pathogens that resemble the self antigens, they may subsequently be able to respond to both foreign and self-antigens. In autoimmune-prone individuals, despite the disappearance of the foreign pathogen and the down regulation of the immune response, some degree of

immune activation may persist, sustained by the presence of cross-reacting antigen.

### Antibodies in Diseases without Antecedent Infection; Molecular Mimicry and SLE

Understanding the antigens involved in molecular mimicry also called antigenic ►cross-reactivity is of some therapeutic importance because knowledge of either the eliciting antigen or a cross-reactive target antigen may suggest interventions that prevent immune activation or organ damage. In this brief discourse, we will discuss only the diseases of the central (CNS) and peripheral (PNS) nervous systems in which one or the other antigen is known, and refer briefly to diseases in which the antigen is suspect. Our focus on cross-reactivity of anti-DNA antibodies in ►systemic lupus erythematosus (SLE) is derived from the observation that an antibody to phosphorylcholine (PC), the dominant epitope in the cell wall polysaccharide of *Streptococcus pneumoniae* (pneumococcus), could acquire a single amino acid substitution and gain reactivity to DNA [1]. This led to an analysis of antibodies produced by splenic B-cells from a patient with lupus who had just received a pneumococcal vaccination prior to splenectomy. Over half of the anti-pneumococcal antibodies cross-reacted with DNA. Similarly, over 40% of B-cells reactive with pneumococcus from mice immunized with PC coupled to a protein carrier cross-reacted with DNA. Normally these B-cells are regulated such that they do not secrete antibody and only B-cells specific for pneumococcus develop into antibody secreting plasma cells. Poor regulation of B-cells activated by microbial antigen may lead to autoantibody production. In fact, anti-DNA antibodies cross-react with many microbial and viral antigens [2]. In order to test whether protein antigens could elicit anti-DNA antibodies in SLE, we used a murine anti-DNA antibody to screen a phage peptide display library, and we found a consensus sequence, D/E W D/E Y S/G, that was bound by this antibody [3]. Immunization with a multimeric form of this consensus sequence induced an antibody response to both peptide and DNA. The peptide motif is present in pneumococcal choline kinase, and also on the extracellular ligand binding domain of the murine and human NR2A and NR2B subunits of the *N*-methyl *D*-aspartate receptor (NMDAR), a class of receptors activated by the amino acid glutamate.

### Glutamate Receptors

NMDARs are localized within the synapses of the forebrain (see Figs. 1 and 2) [4]. During excitatory synaptic transmission, glutamate is released from presynaptic terminals and binds to receptors on the postsynaptic membrane, resulting in rapid depolarization of the postsynaptic membrane. Growth- and

survival-promoting signals derive from synaptic NMDARs enriched with NR2A subunits, especially related to the regulatory role of mitogen-activated protein kinases, and distinct gene expression programs. Conversely, pro-death signals emerge from hypoactivity of synaptic NMDARs or extreme activity of extrasynaptic NMDARs. Pro-death signals are responsible for shutting-down cAMP response element binding protein function and triggering mitochondrial depolarization. The mechanism of cell death is believed to depend on the severity of the insult. Slow apoptotic cell death occurs after a mild (although ultimately toxic) episode of NMDAR activation. Rapid cell death occurs after acutely excessive NMDAR activation, and it is usually referred to as excitotoxicity. This condition is known to occur in several acute diseases (ischemia, trauma, and epileptic seizures).

Because lupus patients in growing numbers suffer from symptoms due to brain dysfunction – disorders of thinking and memory and mood, we tested whether a possible mechanism might depend on antibody-mediated NMDAR dysfunction. In fact, sera and cerebrospinal fluid (CSF) from SLE patients harbor antibodies to DNA that are cross-reactive with NMDARs, and these antibodies can cause apoptosis of neurons [5]. ►Anti-NMDAR antibodies are present in 30–50% of patients with SLE, and may present more frequently in those with cognitive complaints [6]. Furthermore, cross-reactive antibodies are found in the CSF of lupus patients where their presence correlates with symptoms of neuropsychiatric SLE. In one study, the symptoms of brain dysfunction in patients with SLE were improved commensurate with a decrease in the NMDAR antibody in CSF [6]. In mice immunized with multimeric peptide so that there is a high titer of NMDAR antibody that is also DNA reactive, there is no neurological damage unless the blood-brain barrier is breached [7]. Once the antibodies have access to brain, they mediate neuronal death leading to a cognitive or behavioral disturbance depending on the agent used to breach the blood-brain barrier and the site of the neuronal damage [7,8]. The presence in serum and CSF of autoantibody to a defined cell surface antigen that is known to function in neurocognitive processes which are disturbed in clinical disease strongly suggests that NMDAR antibodies may play a role in neuropsychiatric SLE. The development of an animal model in which anti-NMDAR antibodies actually mediate disease increases the potential validity of this mechanism.

As much as animal models can ever mimic human disease, these murine studies demonstrate histopathological and behavioral outcomes consistent with the cognitive and behavioral disorders that occur in SLE. Recently in human post mortem specimen, we were able to identify IgG localized to NMDARs on neurons in the hippocampus. Furthermore, IgG eluted from the

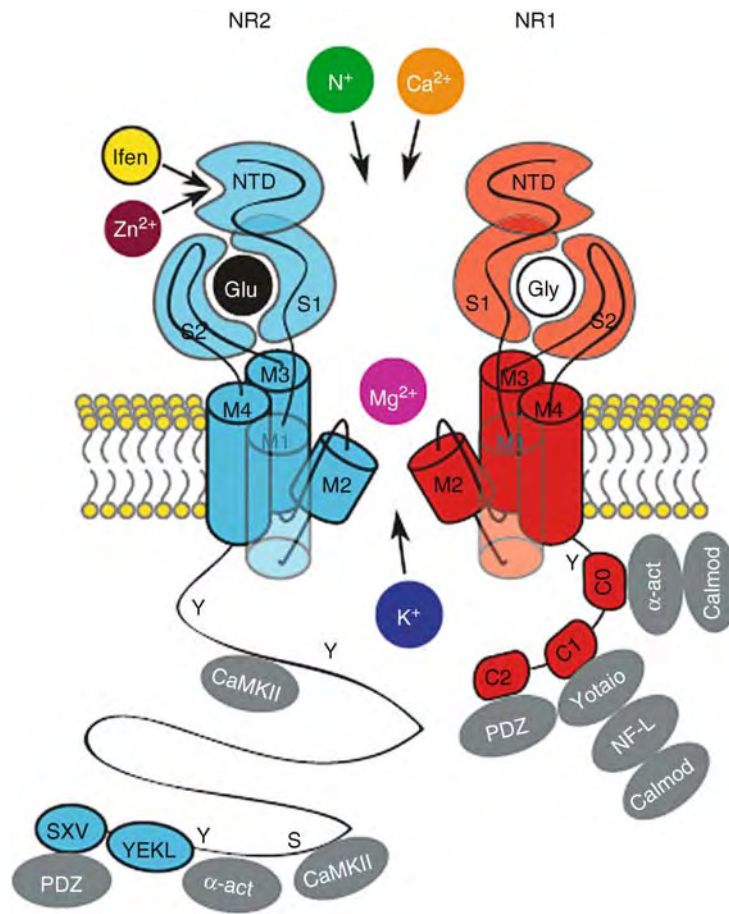

**Anti-DNA Antibodies against Microbial and Non-Nucleic Acid Self-Antigens. Figure 1** (from [4]) The NMDA receptor has conserved domains (S1 and S2) to form the binding site for glutamate (NR2) and for glycine (NR1). The extracellular region can contain modulatory sites that bind  $Zn^{2+}$  or ifenprodil. The channel lining region, M2, enters the membrane from the intracellular membrane. The ion channel is permeable to  $Na^+$ ,  $K^+$ ,  $Ca^{2+}$ . Extracellular  $Mg^{2+}$  binds deep in the pore and causes voltage-sensitive block. The C-terminal tail of each subunit binds to kinases and structural proteins.

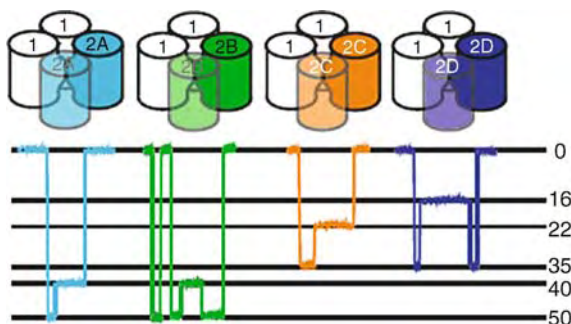

**Anti-DNA Antibodies against Microbial and Non-Nucleic Acid Self-Antigens. Figure 2** The NMDA receptor is formed as a tetramer of pairs of NR1 with NR2A, NR2B, NR2C, or NR2D. Each sub-type produces distinct receptor-channel properties. NMDA receptor with NR2A and NR2B subunits produce high conductance states, and those with NR2C and NR2D produce low conductance.

brain of a lupus patient demonstrated neuronal toxicity [9]. Finally, the mechanism of the observed neuron death in peptide immunized mice exposed to blood-brain barrier breaching agents suggests direct antibody toxicity. Preliminary electrophysiological analysis demonstrates that the antibody can act at the NMDAR as a partial agonist. It is noteworthy that there is precedent for antibodies to affect the electrophysiology of neurons without cytotoxicity. Patients with human T-lymphotropic virus type 1 (HTLV-1)-associated myelopathy (also called tropical spastic paraparesis) develop antibodies to heterogeneous nuclear ribonuclear protein-A1 that cross-reacts with HTLV-1-tax (a viral regulatory protein). These antibodies functionally inhibit the firing and amplitude of dopamine and pyramidal neurons in a dose dependent manner [10]. Whether differential binding characteristics of anti-NMDAR antibodies will lead to alternate behavioral and cognitive outcomes, and whether some are more

likely to moderate neuronal function and less likely to mediate toxicity remains to be investigated; nevertheless, this class of NMDAR antibodies may mediate aspects of brain dysfunction in patients with SLE.

### **Antibodies in Autoimmune Diseases Lacking Antecedent Infection; Molecular Mimicry and Neuromuscular Disease, Paraneoplastic Syndromes and Encephalitis**

The isolation and measurement of antibodies to acetylcholine receptor (AChR) from the serum of patients with myasthenia gravis (MG), led to the detailed description of anti-AChR antibodies, and the identification of antigenic epitopes on each of the two alpha subunits of the receptor and distinct from the acetylcholine binding site. The pathogenic activity of these antibodies has been demonstrated in studies in which adoptive transfer leads to weakness in recipient animals, and studies in which animals immunized with peptide fragments of the human extracellular domain of the alpha-AChR become weak. In MG there is no apparent antecedent infection and the auto-antibodies are currently thought to arise directly in response to the epitopes on the AChR. It is possible that antigen from a possible microbial source activates cross-reactive antibodies. It is even possible that the cross-reactive antibodies are not pathogenic, but that a process called epitope spreading in which a response to one determinant of an antigen (in this case the AChR) spreads to multiple determinants, and stimulates the generation of antibodies that cause the disease.

Other neurological diseases in which there is no antecedent infection or, at best, obscure or controversial prior inflammations include multiple sclerosis and the paraneoplastic disorders. In the paraneoplastic syndrome characterized by cerebellar dysfunction and associated with breast or ovarian cancer, the tumor expresses a protein termed cdr2 antigen that is routinely expressed in Purkinje neurons. The immune response generated against the tumor can also target brain, once the antibody or antigen-specific T- or B-cells traverse the blood-brain barrier to contact brain.

Small cell lung tumors express voltage gated calcium channels; if the immune system makes antibodies that down-regulate these calcium channels and reduce acetylcholine release, the patient develops severe muscle weakness. In yet another paraneoplastic syndrome, small cell lung and breast tumors stimulate the production of antibodies to amphiphysin, a synaptic vesicle associated protein, which result in aching, stiff axial muscles associated with painful spasms. A related antibody-mediated disease that also induces severe muscle stiffness occurs with ►[autoantibodies](#) to glutamic acid decarboxylase (GAD), the rate limiting enzyme in the synthesis of the neurotransmitter gamma amino butyric acid. While paraneoplastic syndromes may improve

when the tumor load is decreased, the anti-GAD antibody syndrome responds to immunomodulation.

Finally, Rasmussen's encephalitis that causes intractable epilepsy and is often preceded by febrile seizures, although a particular infection has not been identified, appears to be caused by auto-antibodies to the amino-3-hydroxy-5-methylisoxazole-4-propionic acid receptors (AMPA receptors) which mediate fast excitation, through the influx of sodium into the postsynaptic cell, resulting in rapid depolarization of the postsynaptic membrane. Immunosuppression was shown to be an effective therapy to avoid neurosurgical approaches to epilepsy control, supporting the pathogenic function of the autoantibodies. There is controversy whether the anti-AMPA antibodies are specific for this disease or are widely present in other forms of epilepsy.

### **Antibodies in Autoimmune Diseases With Antecedent Infection; Campylobacter and Autoimmune Polyneuropathy**

The Guillain-Barre syndrome is the prototypical post-infectious autoimmune inflammatory polyneuropathy, with or without axon sparing, caused by antibody and complement deposited on Schwann cells and myelin membranes. This disease depends on molecular mimicry between epitopes on bacteria and gangliosides on neurons. It is preceded by an often trivial infection, most commonly a Campylobacter infection, which can last for approximately a month and leaves variable neurological impairment that correlates with the location of antibody deposition and complement-mediated destruction. Prompted by earlier studies of specific T- and B-cell related responses to myelin (the so-called experimental allergic neuritis model), investigators have identified antigenic epitopes in axonal glycolipids specifically recognized by anti-ganglioside antibodies. Gangliosides are enriched in the synapses of neural tissues and bear structural similarities among these and the lipo-oligosaccharides of the Campylobacter jejuni and Hemophilus influenza. When antibody to ganglioside Q1b is abundant, the cranial nerves are involved in the demyelination process (the so-called Miller Fisher variant), thereby providing support for the hypothesis that toxic antibodies cross the blood brain barrier and produce destruction in the central nervous system, as well as the histopathologically verified damage to the peripheral nervous system.

### **Antibodies in Autoimmune Diseases With Antecedent Infection; Group A Streptococcus and Movement Disorders**

Another infectious agent that stimulates the immune system to generate cross-reactive antibodies is Group A Streptococcus-pyogenes. Antibodies to Streptococcus binding both the streptococcal M protein and cardiac myosin have been implicated in rheumatic heart disease. Cross-reactive antibodies now also appear responsible

for the neurological manifestations. The precipitating infection occurs a week to 6 months prior to the neurological sequela which include the classic movement disorder, chorea, but also include dystonias, tics, hemiballismus, and myoclonus. Recently, antibody derived from a human hybridoma generated from B-cells of a patient who developed chorea after a strep infection was demonstrated to cross-react with mammalian lysoganglioside and *N*-acetyl  $\beta$ -D-glucosamine (GlcNAc), which is the dominant epitope of the group A streptococcal carbohydrate. The monoclonal hybridoma derived antibody, as well as acute sera from patients with chorea, induced Ca/calmodulin-dependent protein (CaM) kinase II activation in a human neuroblastoma cell line, and recognized cell surface antigen in a neuroblastoma line and caudate-putamen *in vivo*. On further analysis, the chorea associated antibodies from sera and CSF were demonstrated to cross-react with lysoganglioside GM1 and GLcNAc. Similar to the molecular mimicry that occurs in SLE; antibody-mediated neuron signaling may underlie the pathophysiology of the post-streptococcal neurological disorders.

Molecular mimicry between epitopes on the basal ganglia and Group A *Streptococcus-pyogenes* carbohydrate has fueled interest in the pediatric clinical disorders in which children have tics or dystonias associated with psychiatric maladies like obsessive compulsive disorder, the so called pediatric autoimmune neuropsychiatric disorders associated with Streptococcal infections. The possibility that there is a pathogenic autoantibody was supported by the felicitous effect of plasma exchange in early studies, but larger trials have been disappointing.

Recently it has been suggested that Parkinsonism, and possibly encephalitis lethargica as well as a wide spectrum of neuropsychiatric syndromes can also be provoked by a prior strep infection. It is not determined whether any of these disorders are caused by antibodies.

### Conclusion

Molecular mimicry is a phenomenon in which antibodies or T-cells cross-react with identical or highly homologous epitopes that are present on both foreign and self-molecules. A “two-hit” model for disease, autoantibody plus breach in blood-brain barrier integrity suggest that to consider a mechanistic role for antibodies in disease requires: a cell surface antigen relevant to disease symptoms; antibodies in serum, and spinal fluid, and target nervous system tissue; the transmission of the disease to animals by human serum; successful treatment of the disease through immunomodulation.

### References

1. Diamond B, Scharff MD (1984) Somatic mutation of the T15 heavy chain gives rise to an antibody with autoantibody specificity. *Proc Natl Acad Sci USA* 81:5841–5844

2. McClain MT, Heinlen LD, Dennis GJ, Roebuck J, Harley JB, James JA (2005) Early events in lupus humoral autoimmunity suggest initiation through molecular mimicry. *Nat Med* 11:85–89
3. Gaynor B, Putterman C, Valadon P, Spatz L, Scharff MD, Diamond B (1997) Peptide inhibition of glomerular deposition of an anti-DNA antibody. *Proc Natl Acad Sci USA* 94:1955–1960
4. Cull-Candy SG, Leszkiewicz DN (2004) Role of distinct NMDA receptor subtypes at central synapses. *Sci STKE* 2004:re16
5. DeGiorgio LA, Konstantinov KN, Lee SC, Hardin JA, Volpe BT, Diamond B (2001) A subset of lupus anti-DNA antibodies cross-reacts with the NR2 glutamate receptor in systemic lupus erythematosus. *Nat Med* 7:1189–1193
6. Yoshio T, Onda K, Nara H, Minota S (2006) Association of IgG anti-NR2 glutamate receptor antibodies in cerebrospinal fluid with neuropsychiatric systemic lupus erythematosus. *Arthritis Rheum* 54:675–678
7. Kowal C, DeGiorgio LA, Nakaoka T, Hetherington H, Huerta PT, Diamond B, Volpe BT (2004) Cognition and immunity; antibody impairs memory. *Immunity* 21:179–188
8. Huerta PT, Kowal C, DeGiorgio LA, Volpe BT, Diamond B (2006) Immunity and behavior: antibodies alter emotion. *Proc Natl Acad Sci USA* 103:678–683
9. Kowal C, DeGiorgio LA, Lee JY, Edgar MA, Huerta PT, Volpe BT, Diamond B (2006) Human lupus autoantibodies against NMDA receptors mediate cognitive impairment. *Proc Natl Acad Sci USA* 103:19854–19859
10. Kalume F, Lee SM, Morcos Y, Callaway JC, Levin MC (2004) Molecular mimicry: cross-reactive antibodies from patients with immune-mediated neurologic disease inhibit neuronal firing. *J Neurosci Res* 77:82–89

---

## Antidromic

### Definition

Propagation of action potentials in the direction opposite to the naturally occurring direction.

#### ► Action Potential Propagation

---

## Antidromic Activation

### Definition

A method for identifying the axon projection target of a single neuron which can also be functionally studied.

An electrode passes a brief current directly activating an axon and resulting in an action potential that

travels “backward” to the cell body. There, it can be recorded using standard extracellular electrophysiological techniques.

The stimulating electrode can be moved to follow the path of the axon and a map of this pathway can be generated. Additional information about the response properties of the recorded neuron can be obtained by applying the appropriate stimuli to the receptive field.

- ▶ Extracellular Recording
- ▶ Receptive Field

## Anti-epileptic Medicine

- ▶ Anticonvulsants

## Antigen Presentation

### Definition

Antigen presentation is a process of antigen peptide fragments bound to MHC molecules on the surface of cells being specifically recognized by T cell surface receptors expressed by T lymphocytes. CD8<sup>+</sup> T lymphocytes recognize antigen peptides bound to MHC class I molecules on nucleated cells, while CD4<sup>+</sup> T lymphocytes recognize antigen peptides bound to MHC class II molecules on professional antigen presenting cells, such as dendritic cells, B lymphocytes, macrophages and microglia.

- ▶ Immune System and Pain

## Antigen-presenting Cell

### Definition

Antigen-presenting cells first take up antigen by pinocytosis or phagocytosis. The antigenic proteins are processed into antigenic peptides and presented on the major histocompatibility complex (MHC) to T cells.

T helper cells recognize antigens presented on MHC II and cytotoxic T cells recognize antigens presented on MHC I respectively.

## Anti-GQ1b Antibody

### Definition

IgG binding to GQ1b ganglioside characteristic for clinical syndromes manifested by brainstem and cranial nerve involvement.

## Anti-Motion Sickness Drugs

ARATA HORII

Department of Otolaryngology, Osaka University  
School of Medicine, Suita, Osaka, Japan

### Synonyms

Anti-sea sickness; Car sickness; Air sickness; Space motion sickness; Space adaptation syndrome drugs

### Definition

Motion sickness is a disorder characterized by nausea, vomiting, pallor, cold sweating, and increased salivation, which occur when exposed to certain types of real or apparent motion. It usually occurs during passive motion stimuli by vehicles, ships, airplanes, however, apparent motion by a simulator or virtual reality can cause the similar symptoms. Anti-motion sickness drugs are used for prevention of motion sickness. There are three types of drugs used for motion sickness: Anti-histaminergic drugs, anti-cholinergic drugs, and adrenergic drugs. Recently, other types of drugs such as anti-neurokinin1 (NK-1) receptor blockers, anti-arginine vasopressin 1 (AVP1) receptor blockers and serotonin (5-HT1A) receptor agonists have been tested for their effectiveness on motion sickness in animals.

### Characteristics

#### Neural Mechanisms of Motion Sickness

Neural mismatch theories for motion sickness are widely accepted [1,2]. According to this theory, ▶ **spatial orientation** is disturbed by a conflict between sensory inputs during ongoing motion and the expected pattern of sensory signals established by earlier

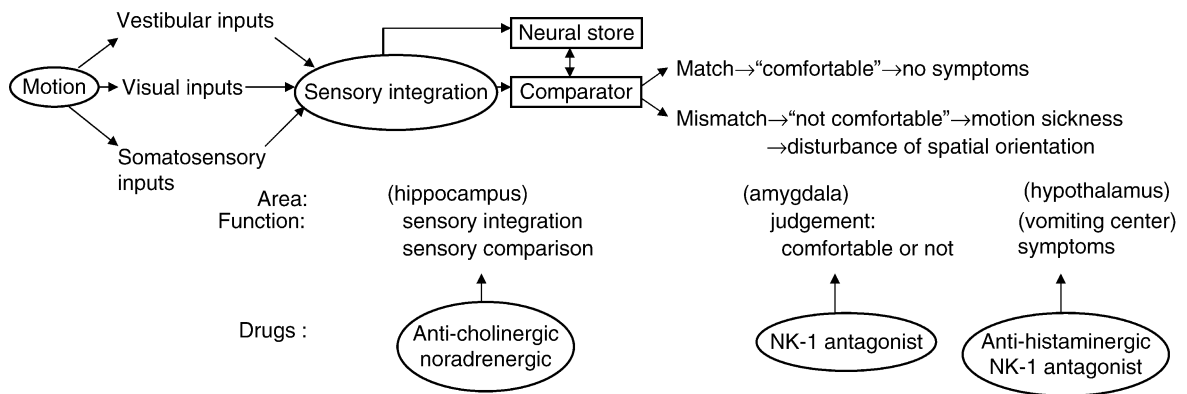

**Anti-Motion Sickness Drugs. Figure 1** Neural mechanisms of motion sickness and possible effective sites of anti-motion sickness drugs.

experience. Disturbance of spatial orientation finally causes motion sickness symptoms as a warning signal to withdraw the body from unfamiliar stimulus situations. Main sensory information involving sensory integration and maintenance of spatial orientation are the inputs from vestibular, visual, and somatosensory systems. It should be noted that deafened (and perhaps with no normal vestibular function) patients do but rarely experience motion sickness, probably because there arises fewer mismatch signals from fewer sensory modalities. Fig.1 shows the scheme of neural mechanisms of motion sickness and possible effective sites of anti-motion sickness drugs.

### Classification of Anti-Motion Sickness Drugs by Neural Mismatch Theories

According to the neural mismatch theories of motion sickness, there are three steps from motion perception to motion sickness symptoms: (i) perception of sensory information during motion stimuli, (ii) integration of new sensory information and comparison with stored sensory patterns, and (iii) final development of motion sickness symptoms. Takeda et al. postulated that anti-motion sickness drugs could be also divided into three classes [2]: Class A drug, reduces neural mismatch signals by a blockade of sensory inputs; Class B drug, facilitates the acquisition of habituation to a new pattern of sensory inputs; Class C drug, blocks the development of symptoms. Although each of these drugs could be effective in preventing motion sickness, their effects on habituation to motion stimuli would differ as follows: Class A drugs would retard the acquisition of habituation, because there are no longer new sensory inputs; Class B drugs would accelerate the habituation to motion stimuli; Class C drugs would not affect the habituation. Based on precise studies using a rat animal model of motion sickness, Takeda et al. demonstrated that cholinergic muscarinic receptor blockers and histamine H1 receptor blockers are the Class B and Class C

drugs, respectively [2]. Glutamate receptor blockers might be Class A drugs, however, it would be difficult to use Class A drugs in practice, because glutamate receptors are involved in most excitatory synaptic transmission in the brain.

### Central Activation and Inhibition by Peripheral Vestibular Stimulation and Its Relation to Motion Sickness

It has been reported that vestibular information is processed not only in the short brainstem and cerebellar circuits but also in higher center levels in the brain such as the hypothalamus, amygdala and hippocampus. Recent progress in this area could provide further information on neural substrates for motion sickness.

### Histaminergic Neurons

Histamine is well known as a chemical mediator of Type I allergy in the peripheral tissue, however, it also acts as a neurotransmitter in the central nervous system. Histaminergic neurons are known to have important roles in arousal, feeding, thermo regulations, circadian rhythms and other autonomic functions. In vivo release of hypothalamic histamine measured by a microdialysis technique was increased by electrical/caloric vestibular stimulation [3] or 2G-hyper gravity stimulation in rats. Histamine H1 blockers are clinically effective in the prevention of motion sickness and it is also demonstrated that H1 blockers prevented the final development of motion sickness symptoms without affecting the habituation process in the rat model of motion sickness (Class C drugs) [2]. The hypothalamus, which contains the histaminergic cell bodies, is the center of autonomic function and the histaminergic neurons project their nerve fibers to brainstem vomiting center. Therefore, it is postulated that the histaminergic neurons, which are activated by the vestibular inputs and provocative motion stimuli, would be involved in the final development of motion sickness symptoms.



### Cholinergic Neurons

Several lines of evidence suggest an important role of hippocampal cholinergic neurons in the central processing of vestibular information. For instance, spontaneous firings of neurons in the CA1 area of hippocampus are increased by the electrical stimulation of the vestibular nuclei and firing properties of place cells in the rat hippocampus, which fire only when an animal locates at a specific area in the space, was disturbed in rats that received bilateral vestibular deafferentation. The hippocampus is an area with many converging sensory inputs and therefore it would suit the hypothesis that the hippocampus acts as a neural store and a comparator in the neural mismatch model of motion sickness. Moreover, acetylcholine release from the hippocampus was increased by vestibular stimulation in rats [4] and anti-muscarinic drugs facilitated the habituation to motion in the rat animal model of motion sickness (Class B drugs) [2]. All these findings suggest that the integrated sensory signals would be compared with the stored patterns of sensory signals in the hippocampus and muscarinic blockers would facilitate the adaptation to the new sensory signals.

### Noradrenaline Neurons

Catecholamine releasers such as amphetamine and ephedrine are effective in preventing motion sickness, although addiction is a big problem for their clinical use. It is well known that a high degree of emotional or physical stress, which activates the noradrenergic neuron system, can prevent motion sickness. Therefore, these drugs would increase an arousal state and thus prevent motion sickness. In turn, it is reported that caloric vestibular stimulation decreases the spontaneous firing of Locus Coeruleus (LC) neurons, which is the largest nucleus of noradrenergic neurons. This might account for the drowsiness seen in motion sickness.

### Serotonergic Neurons

Serotonin 5-HT<sub>1A</sub> agonists are used clinically for anxiety disorders and have also been shown to prevent motion sickness in animals [5,6], although their effects have not been tested on humans. 5-HT<sub>1A</sub> receptors are located on both the pre-synaptic and post-synaptic sites. Pre-synaptic 5-HT<sub>1A</sub> receptors are the autoreceptors, whose activation decreases the release of serotonin from nerve terminals. Although the precise mechanisms of 5-HT<sub>1A</sub> agonists in preventing motion sickness are not clear, depletion of serotonin by the serotonin synthesis inhibitor parachlorophenylalanine was not effective against motion sickness, suggesting that active sites for 5-HT<sub>1A</sub> agonists for motion sickness may not be the pre-synaptic autoreceptors. A 5-HT<sub>1A</sub> agonist would affect any post-synaptic receptors among the neural circuit responsible for motion sickness. For

instance, the firing of vestibular nuclei neurons was negatively regulated by a 5-HT<sub>1A</sub> agonist [7]. Serotonin 5-HT<sub>3</sub> receptor blockers are used for emesis induced by anti-cancer drugs, however, they are not effective for emesis associated with motion sickness.

### Substance P Neurons

Substance P and its receptor neurokinin-1 (NK-1) function not only in peripheral tissue but also in the central nervous system. NK-1 receptor blockers were developed as anti-depressants and as anti-emetic drugs. Animal studies demonstrated their efficacy in the prevention of motion sickness [8]. Because these drugs are effective on emesis induced by both motion stimuli and emetic chemical agents, their effective site would be the brainstem vomiting center, which is the final common structure responsible for the emetic reflex. We reported that substance P mRNA was increased by 2G hypergravity stimulation in the amygdala and NK-1 receptor blockers were effective in preventing motion sickness in rats [9]. The Amygdala substance P neuron system is important for the judgment of whether the situation is “comfortable” or not. We hypothesized that neural mismatch signals from hippocampus might be sent to the amygdala and are then judged as to whether they are comfortable or not. If the signals are not “comfortable” for the body, they are sent to areas relating to the expression of motion sickness symptoms, working as warning signals. NK-1 receptor blockers may affect both the brainstem vomiting center and the amygdala.

### Vasopressin Neurons

Vasopressin is a pituitary hormone which has an anti-diuretic effect. Intra venous application of vasopressin induces emesis and arginine vasopressin 1 (AVP-1) blockers are effective in the prevention of motion sickness. Moreover, plasma vasopressin levels were increased by electrical/caloric vestibular stimulation in rats [10]. Therefore, AVP-1 blockers are expected to be effective on motion sickness and have been tested by several researchers. However, the effects of AVP-1 receptor blockers on motion sickness are different between species [6].

## References

- Reason JT (1978) Motion sickness adaptation: a neural mismatch model. *J Roy Soc Med* 71:819–829
- Takeda N, Morita M, Hasegawa S, Horii A, Kubo T, Matsunaga T (1993) Neuropharmacology of motion sickness and emesis. A review. *Acta Otolaryngol Suppl* 501:10–15
- Horii A, Takeda N, Matsunaga T, Yamatodani A, Mochizuki T, Okakura-Mochizuki K, Wada H (1993) Effect of unilateral vestibular stimulation on histamine release from the hypothalamus of rats in vivo. *J Neurophysiol* 70:1822–1826

4. Horii A, Takeda N, Mochizuki T, Okakura-Mochizuki K, Yamamoto Y, Yamatodani A (1994) Effects of vestibular stimulation on acetylcholine release from rat hippocampus: an in vivo microdialysis study. *J Neurophysiol* 72:605–611
5. Lucot JB, Crampton GH (1989) 8-OH-DPAT suppresses vomiting in the cat elicited by motion, cisplatin or xylazine. *Pharmacol Biochem Behav* 33:627–631
6. Yates BJ, Miller AD, Lucot JB (1999) Physiological basis and pharmacology of motion sickness: an update. *Brain Res Bull* 47:395–406
7. Johnston AR, Murnion B, McQueen DS, Dutia MB (1993) Excitation and inhibition of rat medial vestibular nucleus neurones by 5-hydroxytryptamine. *Exp Brain Res* 93:293–298
8. Rudd JA, Ngan MP, Wai MK (1999) Inhibition of emesis by tachykinin NK1 receptor antagonists in *Suncus murinus* (house musk shrew). *Eur J Pharmacol* 366:243–252
9. Uno A, Nakagawa A, Horii A, Mitani K, Takeda N, Kubo T (2004) Effect of an NK1 receptor antagonist on motion sickness in rats and its putative site of action. *J Vestib Res* 14:155
10. Horii A, Koike K, Uno A, Uno Y, Kubo T (2001) Vestibular modulation of plasma vasopressin levels in rats. *Brain Res* 914:179–184

---

## Anti-NMDAR Antibodies

### Definition

NMDA (N-methyl D-aspartate) receptor (NMDAR) antibodies. Antibodies to a protein molecule on the neuronal surface that bind to glutamate, a neurotransmitter that participates in excitatory neurotransmission.

Activation of NMDARs is important for learning and memory; overactivation of NMDARs injures the cell.

► NMDA Receptors

---

## Antinociception

► Analgesia

---

## Antinodes

### Definition

A point, line, or surface of a standing wave in which some characteristic of the wave field is maximal.

► Acoustics

---

## Antiporter

### Definition

► Chloride Channels and Transporters

► Ion Transport

---

## Antipsychotic Drugs

ROBERT MILLER, HONORARY FELLOW  
Department of Anatomy and Structural Biology,  
University of Otago, Dunedin, New Zealand

### Synonyms

Neuroleptic drug; Major tranquilizer; Ataractic drug

### Definition

Antipsychotic drugs are medications use to treat the state of mental turmoil called “►psychosis”.

### Characteristics

#### History

Antipsychotic drugs were discovered in 1952. A drug-development program by the French pharmaceutical company Rhône-Poulenc, primarily aimed at finding medications to alleviate post-operative shock, produced the agent chlorpromazine (“Largactil”). This was found to produce a remarkable calming effect on patients to whom it was given, and it was suggested that it be used to “tranquilize” disturbed patients in psychiatric hospitals. It was found to be effective in reducing symptoms of psychosis. However, right from its earliest use, it was found also to produce major motor side effects, reminiscent of symptoms of ►Parkinson’s disease. Further pharmaceutical research soon produced a variety of other medications with similar effects. The combination of their two effects (antipsychotic main effects and motor side effects) led to this group of drugs being called “►neuroleptic drugs”.

### *Antipsychotic Drugs and the Dopamine Hypothesis of Psychosis*

Research in the early 1960s led to the proposal by Carlsson that the common property of antipsychotic drugs was that they are antagonists of the forebrain neurotransmitter dopamine, a deficit of which had also recently been found to underlie many of the symptoms of Parkinson’s disease. This led to formulation of the so-called “►dopamine hypothesis of ►schizophrenia”.

However, this was always a misnomer: The phrase “dopamine hypothesis of psychosis” would have been more accurate, since the neuroleptic drugs do not alleviate many of the non-psychotic symptoms of schizophrenia. Even some of the distinctive apparently-psychotic symptoms of schizophrenia (auditory verbal ▶hallucinations, and the group of symptoms described by Kurt Schneider [see “▶passivity experience”]) can often persist despite otherwise effective antipsychotic drug treatment.

The birth of the “dopamine hypothesis” has led to many attempts to reveal directly an overactivity of dopamine in the forebrain of persons in active psychotic states. One line of enquiry has sought an excess of dopamine receptors associated with schizophrenia. Although much evidence for such an excess has been obtained, it has been difficult to show that this is really a feature of the illness, rather than a by-product of antipsychotic drug treatment, and there is no precedent for any illness caused by a primary excess of any receptor type. The other possibility is that there is excess release of the transmitter itself in these states. Starting with Reith et al [1], using a method based on ▶Positron Emission Tomography, several studies have now shown such an excess.

### Prediction of Antipsychotic Effects

Pharmaceutical research in the 1960s revealed a variety of behavioral effects of neuroleptic drugs in animal tests, which could be used to predict whether a new compound would have antipsychotic activity. Some of these tests were based on production of syndromes equivalent to the motor side effects seen in humans. However, the most reliable animal behavioral tests for determining the antipsychotic potency of new compounds were based on antagonism of simple ▶instrumental conditioning tasks (such as avoidance responding).

### Receptors Targeted by Antipsychotic Drugs

In the mid-1970s radio-ligands became available specific for the pharmacological receptors by which dopamine produces its effects. This provided independent verification of the thesis that the common property of neuroleptic drugs was their ability to block dopamine receptors. It was found that the affinity of a variety of antipsychotic drugs for the relevant ▶dopamine receptor varied in parallel with their clinical potency as antipsychotic agents. By the early 1980s, when ligands for different dopamine receptors became available, it was clear that the dopamine receptor type which showed this close relation to clinical effects was the so-called “▶dopamine D2” receptor. From this evidence, it became widely believed that the D2 receptor was the essential target of antipsychotic

drugs, and that this single receptor mediated both the therapeutic effects and the motor side effects of antipsychotic drugs.

More recently, several bodies of evidence have appeared which challenge this view. *First*, not all antipsychotic drugs are “neuroleptic”, in the sense of also producing motor side effects. This was known in the 1970s, when some the clinical properties of the antipsychotic drug clozapine were defined. More recently a wider range of medications has been developed with antipsychotic potency, but with a low tendency to produce motor side effects, at doses which are effective against psychosis. These are the “second generation” or “▶atypical” antipsychotic drugs. *Second*, the role of dopamine in instrumental conditioning depends on its actions as a psychological reinforcing signal in the brain, a role now generally believed to be independent of its role in motor performance [2]. Psychopharmacological experiments have generally shown the reinforcing role of dopamine to be based on its actions at the so-called “▶D1” dopamine receptor, and recent studies of the processes of synaptic plasticity in the striatum, upon which instrumental conditioning depends, support this [3]. Part of the mechanism underlying such dopamine-dependent synaptic plasticity is the increased production of the intracellular messenger ▶cyclic-Adenosine-Monophosphate (cAMP). As mentioned, blockade of instrumental conditioning is the best predictor of antipsychotic potency, and tests of this in animals recognize clozapine and similar drugs as antipsychotic agents when production of motor side effects in animals by these drugs does not [2]. This is paradoxical if it is assumed that the D2 dopamine receptor is the only essential target of antipsychotic drugs. *Thirdly*, in the 1990s methods became available to determine the percentage “occupancy” of dopamine receptors by antipsychotic drugs needed to produce therapeutic effects. For most antipsychotic drugs occupancy of 70–80% was needed. For clozapine, a substantially lower occupancy would suffice [4]. This suggests that receptors in addition to the dopamine D2 receptor are influential in antipsychotic drug therapy.

### Theory of Antipsychotic Drug Action

Starting in the mid-1970s, the author of this article has developed a theory to resolve these paradoxes [5]. A central fact in this work is that the full therapeutic effect of antipsychotic drugs is not achieved until long after the relevant receptors are blocked [2,6]. This applies particularly to ▶delusions (Symptom of Psychosis), which are the symptom which responds most slowly during antipsychotic drug therapy. The extended time course of antipsychotic drug therapy is still debated by some, but was clearly revealed in clinical trials in the 1960s, is mentioned explicitly in some “first-person” accounts of psychosis, and was

referred to in a recent symposium on antipsychotic drug treatment [6]. For patients whose psychotic state has remained untreated for a long period, it may take many months of drug treatment before resolution of symptoms is complete. This central fact was explained as follows: Active psychosis occurs when dopamine release is excessive, and this leads to an exaggeration of a process of dopaminergic reinforcement. In humans, this reinforcement is directed mainly at distinctively human cognitive information, whose representation in cerebral processes then becomes exaggerated and distorted. Many of the details of psychotic psychology can be explained on this basis (for instance the production of delusions, “incorrigible” by any amount of reasoning or contrary empirical evidence) (see reference [5], chapter 9). Administration of antipsychotic drugs halts the production of such exaggerated and distorted material, but does not immediately abolish that which has already been laid down in memory. However, by reducing the overall “pressure” on cognitive processes it becomes possible for a patient to gradually “work through” the conflicts of belief set up during the period of psychosis, and thus to work out which beliefs were symptoms of an illness, and which are more trustworthy. This process inevitably takes time.

The paradox about the dopamine receptor type involved in antipsychotic therapy is then accounted for by the proposal that D2-blocking neuroleptic drugs act indirectly, the ultimate target being either a reduction of activation at the dopamine D1 receptor (which mediates psychological reinforcement), or an attenuation of intracellular processes “downstream” to, and usually controlled by, this receptor type. At present, the most likely mechanism for this indirect action [5] is as follows: In the striatum, which has the highest concentration of dopamine, one class of neuron (about 2% of the total neuron count there) are the cholinergic interneurons. Dopamine, acting at D2 receptors inhibits the firing of these interneurons [7]. It is then expected that D2-blocking neuroleptic drugs would release these neurons from inhibition, leading to a sustained increase in acetylcholine release in the striatum. The principal neurons in the striatum bear cholinergic receptors of various types. Of importance are the so-called M4 receptors which reduce production of cyclic-AMP when the receptors are activated by acetyl choline [8]. Thus, D2 blockade would indirectly reduce cAMP production, an effect similar to that produced more directly by D1 blockade, and which would attenuate the dopaminergic reinforcement process.

#### **Adverse Effects of Long-Term Treatment**

Antipsychotic drugs have been controversial. In the past this has been because of the unpleasant nature of the motor side effects, a drawback which is less important

with the advent of the atypical antipsychotic drugs. An additional hazard of the traditional neuroleptic drugs, recognized as early as the late-1950s, was that they were a contributory cause of a more persistent motor abnormality, referred to as ► **tardive dyskinesia**. In this syndrome, abnormal involuntary movements occur, especially of tongue, mouth and face. The atypical antipsychotic drugs have a lesser tendency to cause this syndrome, but since tardive dyskinesia, once established, is often quite persistent and difficult to treat, there is still a legacy of disability due to past use of first-generation neuroleptic drugs, especially when they were used in large doses. The persistence of these abnormal movements suggests that they arise due to permanent cell loss in the brain. In 1993 [9] it was suggested that during neuroleptic treatment, the prolonged overactivity of the striatal cholinergic neurones might be so intense that it led to damage and destruction of these cells, this being the necessary cause of tardive dyskinesia. Animal experiments support the view that prolonged regimes of neuroleptic drugs can lead to loss of striatal cholinergic interneurons. Loss of such cells has also recently been documented in post-mortem brains of human schizophrenia patients treated with neuroleptic drugs (review in reference [5], chapter 10).

Psychotic states are not always alleviated by antipsychotic drugs. However, it is well established that clozapine is often an effective treatment when other antipsychotic medications have failed [10]. In addition, it has been suggested that prolonged treatment with traditional neuroleptic drugs, especially in high doses leads gradually to the re-emergence of psychotic symptoms despite drug treatment, and eventually to psychosis resistant to conventional treatment, though often still responsive to clozapine (“neuroleptic-induced supersensitivity psychosis”; review in reference [5], chapter 10). The parallel between this course of development, and the emergence of tardive dyskinesia during neuroleptic treatment, led to the suggestion that they are parallel pathologies, due in both cases to loss of striatal cholinergic interneurons, but in different parts of the striatum. The special effectiveness of clozapine then suggests that this drug acts more directly than typical neuroleptic drugs, by-passing the link through striatal cholinergic interneurons. Its direct action could be by either of two mechanisms, a direct blockade of D1 receptors (supported by the fact that clozapine has somewhat higher relative affinity for D1 versus D2 receptors than other antipsychotic drugs in clinical use), or by direct stimulation of M4 cholinergic receptors (for which clozapine may have an affinity, probably as an agonist). Either of these mechanisms would reduce cAMP formation, and attenuate the dopaminergic reinforcement process even when the normal mechanism for this, dependent on transmitter release from intact cholinergic interneurons, is no longer possible.

## References

1. Reith J, Benkelfat C, Sherwin A, et al. (1994) Elevated dopa decarboxylase activity in living brain of patients with psychosis. *Proc Natl Acad Sci USA* 91:11651–11654
2. Miller R (1987) The time course of neuroleptic action for psychosis: role of learning processes and implications for concepts of psychotic illness. *Psychopharmacology (Berl)* 92:405–415 (A review)
3. Farde L, Nordstrom AL (1992) PET analysis indicates atypical central dopamine receptor occupancy in clozapine-treated patients. *Br J Psychiatry Suppl* 17:30–33
4. Kerr JN, Wickens JR (2001) Dopamine D-1/D-5 receptor activation is required for long-term potentiation in the rat neostriatum in vitro. *J Neurophysiol* 85:117–124
5. Miller R (2007) A theory of the basal ganglia and their disorders (especially chapters 9 and 10). *Conceptual advances in brain research series*. CRC Press, Boca Raton
6. Marder SR, Essock SM, Miller AL, Buchanan RW et al. (2002) The Mount Sinai conference on the pharmacotherapy of schizophrenia. *Schizophrenia Bull* 28:5–16
7. Lehmann J, Lange SZ (1983) The striatal cholinergic interneuron: synaptic target of dopaminergic terminals? *Neuroscience* 4:1105–1120
8. Olanas MC, Adem A, Karlsson E, Onali P (1996) Rat striatal muscarinic receptors coupled to the inhibition of adenylyl cyclase activity: potent block by the selective M4 ligand muscarinic toxin 3 (MT3). *Br J Pharmacol* 118:283–288
9. Miller R, Chouinard G (1993) Loss of striatal cholinergic neurons as a basis for tardive and L-Dopa-induced dyskinesias, neuroleptic-induced supersensitivity psychosis and refractory schizophrenia. *Biol Psychiatry* 34:713–738
10. Kane JM, Honigfeld G, Singer J, Meltzer H (1988) Clozapine for the treatment-resistant schizophrenic: a double blind comparison with chlorpromazine. *Arch Gen Psychiatry* 45:789–796

## Antiretrovirals (ARVs)

### Definition

These are the agents active against retroviruses, and act at one or more sites. These inhibit reverse transcriptase, protease or integrase of the retroviruses or inhibit fusion of the virus with the host cells. Highly Active Anti-Retroviral Therapy (HAART) is a combination of the highly active anti-retrovirals with different mechanisms of action, and is used to prolong the life of a patient suffering from Acquired Immune Deficiency Syndrome (AIDS).

► Central Nervous System Disease – Natural Neuro-protective Agents as Therapeutics

## Anti-Saccade

### Definition

A saccade triggered by the appearance of an eccentric target but directed away from that target into the opposite, empty visual hemifield. Antisaccades are not a natural behavior but generally only obtained upon instruction. To generate an antisaccade, first the reflexive saccade toward the new target (often called prosaccade in this context) must be suppressed, a task requiring considerable attentional effort and imparting the antisaccade a long reaction time. The antisaccade task is of considerable practical interest as an elevated frequency of errors (inability to suppress prosaccades) is suggestive of frontal dysfunction.

- Oculomotor Control (Theory)
- Saccade, Saccadic Eye Movement

## Anti-Saccade Task

### Definition

At the beginning of a trial, a visual target is presented, and the subject (human or monkey) is required to fixate it. At the end of the fixation period, this target is extinguished at the same time that a second target comes on. The subject must then make a gaze shift to the location that is equal to the target in eccentricity, but opposite in direction.

- SC-Saccade Related Burst Neurons
- SC – Sensory Maps
- Superior Colliculus – Quasi-Visual Neurons
- Superior Colliculus – Role in Eye Movements

## Anti-schizophrenic Drugs

### Definition

Drugs that reduce schizophrenic and manic symptoms.

Their therapeutic efficacy correlates with their ability to block competitively dopamine-2 receptors in the limbic system.

- Antipsychotic Drugs
- Schizophrenia

## Anti-sea Sickness

- ▶ Anti-Motion Sickness Drugs

## Anti-seizure Medicine

- ▶ Anticonvulsants

## Antisense RNA

### Definition

Antisense RNA is a single-stranded RNA copy that is complementary to the sequence of nucleotides found in an mRNA. Antisense RNA can be introduced into a cell to block translation of mRNA.

## Anti-SSA (Anti-Ro)/Anti-SSB (Anti-La) Antibodies

### Definition

Antinuclear antibodies that typically occur in pSS.

Anti-SSB (Anti-La) antibodies are more specific to pSS, whereas anti-SSA (Anti-Ro) antibodies are also commonly associated with other autoimmune diseases, such as subtypes of systemic lupus erythematosus.

- ▶ Central Nervous System Disease in Primary Sjögren's Syndrome

## Anurans

### Definition

Anuran amphibians are one of three orders of living amphibians (order Anura). They are commonly referred to as frogs or toads. These are in many ways highly specialized vertebrates quite unlike ancestral amphibians.

Their visual systems are expanded and have specialized features related to visual prey capture. Their auditory systems are likewise enlarged with processing specializations reflecting the use of vocal signals in

reproductive social communication. The characteristic body shape of frogs and toads reflects the specialized mode of salutatory, or jumping, locomotion seen in many anuran species. There are no doubt motor system functional specializations related to this and to the vocal production common in this amphibian group. Anurans have by far been the subject of most neuroanatomical and neurophysiological studies of the amphibians.

- ▶ Evolution of the Brain: Amphibians

## Anxiety Disorder

### Definition

A blanket term covering several different forms of pathological anxiety, fear, phobias and nervous conditions that may impair or prevent the pursuit of normal daily routines.

- ▶ Learning and Extinction
- ▶ Neuroendocrinology of Psychiatric Disorders
- ▶ Hypothalamo-Pituitary-Adrenal Axis, Stress and Depression

## Anxiolytic Agents

### Definition

Anxiolytic agents such as benzodiazepines are capable of reducing anxiety. As a side-effect, they cause anterograde amnesia.

- ▶ Anterograde Amnesia
- ▶ Memory Improvement

## Anxiolytic and Hypnotic Drugs Acting on Ionotropic GABA Receptors

TINA HINTON, GRAHAM A. R. JOHNSTON  
Department of Pharmacology, The University of Sydney, NSW, Australia

### Definition

Anxiolytic and ▶hypnotic drugs are used in the treatment of anxiety disorders and sleep disturbances

to reduce anxiety and promote sleep. These drugs encompass a number of different classes of compounds, including the ►benzodiazepines. Most of the currently used anxiolytic and hypnotic drugs act on ►ionotropic receptors for ►GABA, the major inhibitory neurotransmitter in the brain. This reflects the importance of GABAergic systems for anxiety and sleep related behaviours [1].

The focus of this essay is on compounds acting at ionotropic GABA receptors and the development of new anxiolytic and hypnotic drugs. There is great diversity in these receptors and of particular interest are compounds that show selectivity for specific subtypes of ionotropic GABA receptors.

## Characteristics

### Ionotropic GABA Receptors

Ionotropic GABA receptors comprise the GABA<sub>A</sub> and ►GABA<sub>C</sub> receptors, whereas GABA<sub>B</sub> receptors are metabotropic [2]. Ionotropic GABA receptors are ►ligand-gated ion channels that are formed from five protein subunits surrounding a chloride channel, thus controlling the flow of chloride ions into nerve cells. To date, fifteen GABA<sub>A</sub> receptor subunits ( $\alpha$ 1-6,  $\beta$ 1-3,  $\gamma$ 1-3,  $\delta$ ,  $\epsilon$ ,  $\theta$ ) and three GABA<sub>C</sub> receptor subunits ( $\rho$ 1-3) have been cloned from the mammalian brain. ►GABA<sub>A</sub> receptors are heteromeric (►Heteromeric receptors), while GABA<sub>C</sub> receptors are known to be homomeric (►Homomeric receptors). The majority of GABA<sub>A</sub> receptors are assembled from two  $\alpha$ , two  $\beta$  and one  $\gamma$  subunit with the arrangement  $\alpha\beta\alpha\beta\gamma$ . The most commonly occurring GABA<sub>A</sub> receptors are  $\alpha$ 1 $\beta$ 2 $\gamma$ 2 receptors,  $\alpha$ 2,  $\beta$ 2/3,  $\gamma$ 2 and  $\alpha$ 3,  $\beta$ n,  $\gamma$ 2/3 heteromers. GABA<sub>A</sub> and GABA<sub>C</sub> receptors differ significantly in their molecular biology, pharmacology and physiology [2]. GABA<sub>A</sub> receptors are present on most, if not all, neurones in the brain, whereas GABA<sub>C</sub> receptors have a much more restricted distribution. GABA<sub>C</sub> receptors are considered to play an important role in vision, memory and sleep [3].

### Anxiolytic Drugs Acting on Ionotropic GABA Receptors

Benzodiazepines are the most well known class of ►anxiolytic drugs. Examples of widely used benzodiazepines include diazepam, oxazepam, nitrazepam, flunitrazepam and temazepam. Benzodiazepines act as allosteric ►modulators of many subtypes of GABA<sub>A</sub> receptors, enhancing the action of GABA at these receptors. In the presence of GABA, benzodiazepines increase the frequency of chloride channel opening without increasing the maximal response to GABA. Benzodiazepines are considered to be relatively safe and effective, however their main drawbacks are associated with dependence, ataxia and amnesia [4].

In addition to their anxiolytic effect, the classical benzodiazepines are also sedative (►sedative drugs),

►hypnotic (sleep inducers), anticonvulsant and myorelaxant. This is due to the fact that they act at all GABA<sub>A</sub> receptors containing  $\alpha$ 1,  $\alpha$ 2,  $\alpha$ 3 or  $\alpha$ 5 subunits, coupled with a  $\gamma$ 2 subunit. Benzodiazepines bind to the interface between  $\alpha$  and  $\gamma$ 2 subunits. The  $\gamma$ 2 subunit is essential for high affinity benzodiazepine binding, while the  $\alpha$  subunit predicts benzodiazepine ►efficacy.

Studies using knock-in point mutations at the  $\alpha$ 1,  $\alpha$ 2,  $\alpha$ 3 and  $\alpha$ 5 benzodiazepine binding site that render the subunit insensitive to benzodiazepines, show that the different  $\alpha$  subunits mediate different actions of benzodiazepines [5]. We now know that the  $\alpha$ 1 subunits mediate the sedative/hypnotic and anticonvulsant actions of benzodiazepines, the  $\alpha$ 2 subunits contribute to the anxiolytic action, and the  $\alpha$ 3 and  $\alpha$ 5 subunits partly mediate the myorelaxant effect. That  $\alpha$ 2 subunit-containing ►GABA<sub>A</sub> receptors contribute to the anxiolytic effects of benzodiazepines is consistent with localization of these subunits in the central nucleus of the amygdala, a key area in the brain for control of emotions and fear. There is also evidence that  $\alpha$ 3 subunit-containing GABA<sub>A</sub> receptors contribute to the anxiolytic effects of benzodiazepines.

### Anxiolytics Specific for Subtypes of GABA<sub>A</sub> Receptors

On the basis of this knowledge, subtype selective benzodiazepines have been developed. L-838,417 (Fig. 1) is one of a series of novel site ligands, selective for  $\alpha$ 2 and  $\alpha$ 3 subunits and which block  $\alpha$ 1 subunits, that have recently been described. Such agents produce anxiolysis and myorelaxation without associated sedation [4]. New benzodiazepine-site ligands with selectivity for  $\alpha$ 2 or  $\alpha$ 3 over  $\alpha$ 1 GABA<sub>A</sub> receptors are being developed but have yet to reach the clinic [2,4].

Patients taking fluoroquinolone antibiotics such as norfloxacin are known to show a low incidence of anxiety and convulsions. Chemical modification of norfloxacin has led to "compound 4" (Fig. 1) that shows  $\alpha$ 2 subunit selectivity as a GABA<sub>A</sub> receptor modulator. It is a non-sedating anxiolytic whose action is independent of classical benzodiazepine receptors [2].

### Hypnotics and Ionotropic GABA Receptors

GABA mechanisms play an important role in the sleep-wake cycle and it is well established that activation of GABA<sub>A</sub> receptors favours sleep [6]. This is the mechanistic basis of the action of three generations of hypnotics (Fig. 2) with increasing GABA<sub>A</sub> receptor subtype selectivity leading to more selective actions.

Barbiturates (such as pentobarbitone) enhance the activation of most, if not all, GABA<sub>A</sub> receptors by GABA. Benzodiazepines (such as diazepam) have a more specialised action, as noted above, acting only on subsets of GABA<sub>A</sub> receptors containing  $\alpha$ 1,  $\alpha$ 2,  $\alpha$ 3 or  $\alpha$ 5 subunits, coupled with a  $\gamma$ 2 subunit. The third

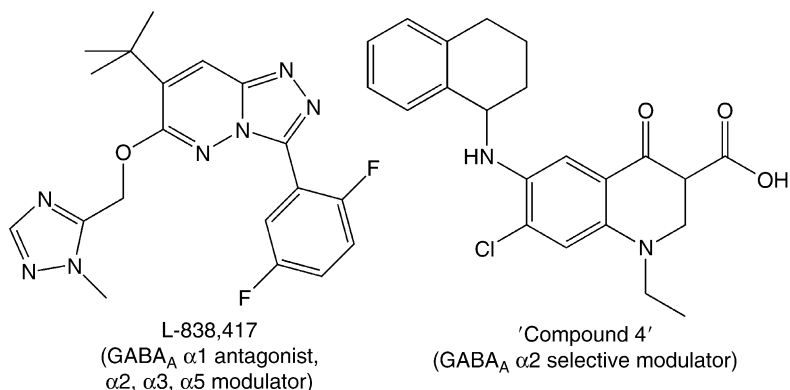

**Anxiolytic and Hypnotic Drugs Acting on Ionotropic GABA Receptors. Figure 1** Agents acting selectively on subtypes of GABA receptors.

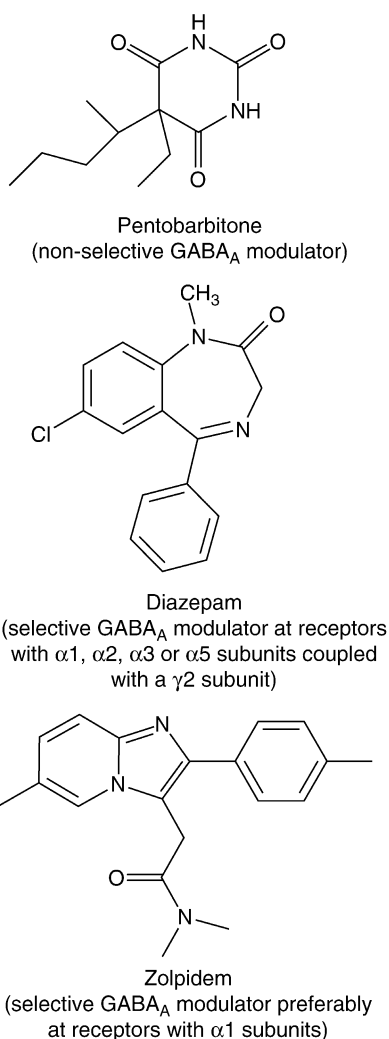

**Anxiolytic and Hypnotic Drugs Acting on Ionotropic GABA Receptors. Figure 2** Therapeutic agents acting on ionotropic GABA receptors.

generation of hypnotics (so-called “non-benzodiazepines” such as zolpidem, zolpiclone and indiplon) act on still more specialised subsets of GABA<sub>A</sub> receptors, acting preferentially on GABA<sub>A</sub> receptors that contain  $\alpha$ 1 subunits [7].

The development of new hypnotics is necessary due to significant problems associated with currently available agents. Barbiturates, in addition to their induction of liver enzymes and potential for lethal overdose, are far from ideal hypnotics as they massively extend the “intermediate stage” of sleep between slow-wave sleep and paradoxical sleep at the expense of the latter [6]. In the 1970s barbiturates were largely replaced as hypnotics by benzodiazepines; these were far safer drugs that enhanced slow-wave sleep. However, their use as hypnotics was associated with residual daytime sleepiness, anterograde amnesia and significant potential for dependence [7]. The third generation hypnotics showed significant improvement over the classical benzodiazepine hypnotics producing sedation without ataxia, but significant adverse effects have been reported with some of these agents. Indeed, zolpidem has been linked to bizarre compulsive activity including sleep walking and binge eating.

The sedative action of diazepam is abolished in mice in which the  $\alpha$ 1 GABA<sub>A</sub> receptor subunit has been made insensitive to diazepam by a point mutation [1]. This appears to be consistent with the hypnotic action of  $\alpha$ 1-preferring ligands such as zolpidem. However, changes in sleep patterns induced by diazepam are strongly attenuated in mice lacking a diazepam-sensitive  $\alpha$ 2 GABA<sub>A</sub> receptor subunit. This indicates that the sedative and hypnotic effects of diazepam are not equivalent and that more than one  $\alpha$ -subunit type contributes to the overall effects of diazepam on sleep. While the third generation hypnotics are classified as  $\alpha$ 1-preferring agents they do show some activity at  $\alpha$ 2 and  $\alpha$ 3-subunits. Thus the situation regarding the relative importance of specific  $\alpha$ -subunits to the hypnotic actions



of these agents is nowhere near as clear cut as originally thought. We need agents with significantly increased subunit selectivity to sort this out.

### Future Generations of Hypnotics Acting on Ionotropic GABA Receptors

It has been suggested that the development of newer GABAergic hypnotics might be targeted to producing changes in EEG patterns that correspond to those during physiological sleep [1]. A promising approach appears to be to move away from benzodiazepine-like modulation altogether and to target sites on **ionotropic** GABA receptors that are insensitive to the classical effects of benzodiazepines [3].

Oleamide (Fig. 3) is an endogenous cannabinoid that promotes sleep (see Chapter on Cannabinoids). It acts as a modulator at GABA<sub>A</sub> receptors that contain  $\beta 3$  subunits, being inactive in  $\beta 3$  knockout mice. Its action is flumazenil insensitive and thus independent of classical benzodiazepine sites. Interestingly, a patient with chronic insomnia is known to have a  $\beta 3$  GABA<sub>A</sub> receptor subunit mutation. Oleamide represents a lead

for the development of new hypnotics based on modulation of  $\beta 3$  containing GABA<sub>A</sub> receptors [2].

There is considerable interest in extrasynaptic  $\delta$  subunit-containing GABA<sub>A</sub> receptors on thalamocortical neurones as molecular targets for future generations of hypnotics [8]. Such receptors are more sensitive to GABA than most GABA<sub>A</sub> receptors and appear to be involved in tonic inhibition, regulating neuronal excitability. They are insensitive to benzodiazepines and are potently modulated by ethanol.

THIP (Gaboxadol, Fig. 3) is an important lead compound in the development of new types of hypnotics. THIP was originally developed as a novel GABA agonist of restricted conformation. It was found to be a potent analgesic, but unwanted sedative effects curtailed its clinical development. The sedative effects led to its investigation as a hypnotic [9]. THIP was found to produce high quality sleep characterised by increased non-rapid eye movement sleep and decreased awakenings. Studies with healthy elderly volunteers indicated that THIP reverses typical age-related changes in sleep by improving sleep efficiency and by boosting

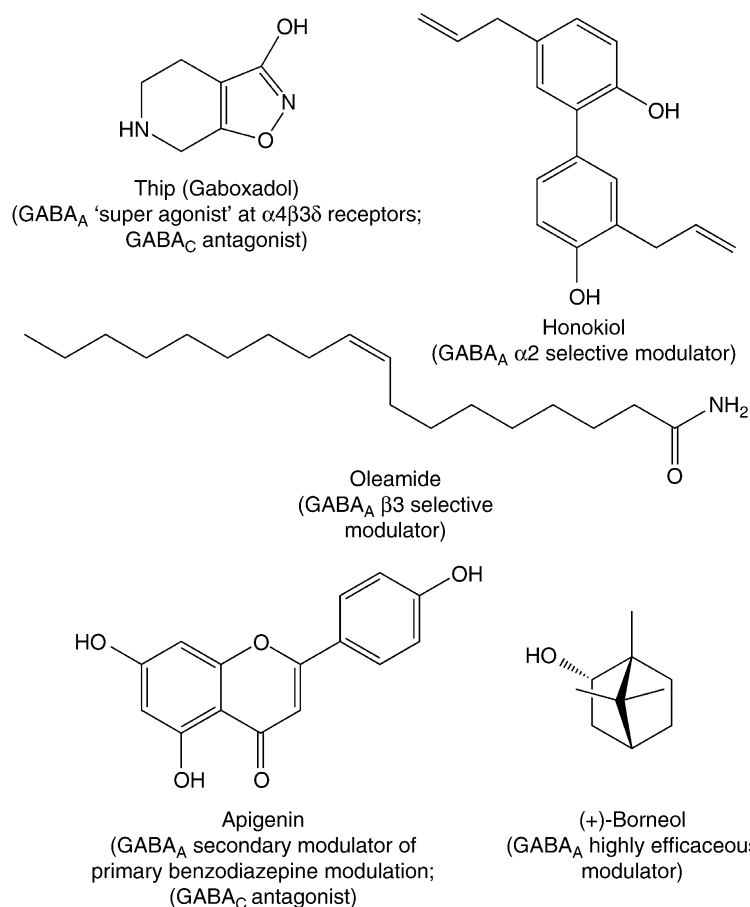

**Anxiolytic and Hypnotic Drugs Acting on Ionotropic GABA Receptors. Figure 3** Chemically diverse natural and synthetic agents acting on ionotropic GABA receptors.

slow wave sleep, which declines with age [7,9]. Studies in animals indicated that the hypnotic effects of THIP were not potentiated by benzodiazepines or ethanol. THIP is known to act as a “super agonist” at  $\alpha 4\beta 3\delta$  GABA<sub>A</sub> receptors, i.e. it produces a greater activation of these receptors than does GABA. The activation by THIP of these receptors in the thalamus is thought to produce a firing pattern that promotes restful, slow-wave sleep. THIP went into clinical trials in 2004, but it was withdrawn during stage three trials early in 2007 because the overall clinical profile for THIP in insomnia did not support further development.

THIP is almost as potent at GABA<sub>C</sub> receptors, where it acts as an antagonist, as it is as an agonist at  $\alpha 4\beta 3\delta$  GABA<sub>A</sub> receptors [3]. It is possible that an action on GABA<sub>C</sub> receptors may confound the hypnotic properties of THIP as other studies have shown that GABA<sub>C</sub> receptors that are insensitive to benzodiazepines and barbiturates are targets for the development of novel hypnotics [3,6]. Studies using TPMPA, a specific GABA<sub>C</sub> receptor antagonist that decreases slow wave sleep, show that these receptors are involved in sleep-waking regulation. GABA<sub>C</sub> receptor agonists and modulators, as distinct from antagonists, may be suitable for development as novel hypnotics [6].

### Herbal Preparations for Anxiety and Sleep Disorders

Many herbal preparations that have long been used for their anxiolytic and sleep promoting properties are now known to contain compounds that modulate ionotropic GABA receptors [10]. These preparations include valerian, chamomile and green tea, and their active constituents (Fig. 3) include flavonoids (e.g. apigenin), terpenoids (e.g. (+)-borneol) and polyphenolic compounds (e.g. honokiol). The rich chemical diversity of these GABA receptor modulating compounds and their effects on brain function provide a rational basis for the anxiolytic and hypnotic properties of the herbal preparations from which they are derived and may lead to the development of new therapeutic agents.

Plant flavonoids have long been known to interact with benzodiazepine binding sites on GABA<sub>A</sub> receptors and have served as lead compounds for the development of synthetic flavonoids that have anxiolytic and sedative properties. Two flavonoids, apigenin (from chamomile, Fig. 3) and epigallocatechin gallate (from green tea), have shown to have unique additional effects at GABA<sub>A</sub> receptors, enhancing the modulatory effects of benzodiazepines [10], and thus being the first known secondary modulators of GABA<sub>A</sub> receptors. In concentrations at which they have no direct effects on GABA<sub>A</sub> receptors they act as secondary modulators of primary modulation by benzodiazepines. This action is restricted to enhancing the modulation by benzodiazepines and is not seen with barbiturate or neurosteroid

modulation. These compounds are anxiolytic in animal models of anxiety suggesting that they are modulating an endogenous benzodiazepine-like modulation. Furthermore, the action of these flavonoids offers the opportunity of reducing the dose of benzodiazepine needed, possibly reducing side effects and dependence liability of benzodiazepines.

The terpenoid (+)-borneol (Fig. 3), an active constituent of valerian (*Valeriana officinalis*), acts with high efficacy at GABA<sub>A</sub> receptors, enhancing GABA action through a benzodiazepine-insensitive mechanism [10].

Honokiol, a polyphenolic compound from *Magnolia* species (Fig. 3), is an anxiolytic in animal models of anxiety without causing sedation, and this effect can be blocked by the benzodiazepine antagonist flumazenil [10]. It is thought that this compound acts preferentially at  $\alpha 2$  subunit-containing GABA<sub>A</sub> receptors, consistent with its non-sedating anxiolytic properties.

### Conclusion

Site-directed mutagenesis and the availability of increasingly subtype selective compounds acting at GABA<sub>A</sub> receptors has led to a greater understanding of the molecular basis of anxiolytic and hypnotic drug effects. This understanding, coupled with the availability of a diverse range of compounds from herbal preparations and lead development will result in new and better agents to treat anxiety and sleep disorders.

### References

- Möhler H (2006) GABA<sub>A</sub> receptors in central nervous system disease: anxiety, epilepsy, and insomnia. *J Recept Signal Transduct* 26:731–740
- Johnston GAR (2005) GABA<sub>A</sub> receptor channel pharmacology. *Current Pharm Des* 11:159–164
- Chebib M, Hanrahan JR, Mewett KN, Duke RK, Johnston GAR (2004) Ionotropic GABA receptors as therapeutic targets for memory and sleep disorders. *Annu Rep Med Chem* 39:13–23
- Rudolph U, Möhler H (2004) Analysis of GABA<sub>A</sub> receptor function and dissection of the pharmacology of benzodiazepines and general anaesthetics through mouse genetics. *Annu Rev Pharmacol Toxicol* 44:475–498
- Dawson GR, Collinson N, Atack JR (2007) Development of subtype selective GABA<sub>A</sub> modulators. *CNS Spect* 10:21–27
- Gottesmann C (2002) GABA mechanisms and sleep. *Neuroscience* 111:231–239
- Ebert B, Wafford KA, Deacon S (2006) Treating insomnia: current and investigational pharmacological approaches. *Pharmacol Ther* 112:612–629
- Belelli D, Peden DR, Rosahl TW, Wafford KA, Lambert JJ (2005) Extrasynaptic GABA<sub>A</sub> receptors of thalamocortical neurons: a molecular target for hypnotics. *J Neurosci* 25:11513–11520

9. Lancel M, Wetter TC, Steiger A, Mathias S (2001) Effect of the GABA<sub>A</sub> agonist gaboxadol on nocturnal sleep and hormone secretion in healthy elderly subjects. *Am J Physiol Endocrinol Metab* 281:E130–E137
10. Johnston GAR, Hanrahan JR, Chebib M, Duke RK, Mewett KN (2006) Modulation of ionotropic GABA receptors by natural products of plant origin. *Adv Pharmacol* 54:285–316

## AOS

### Definition

- ▶ Accessory Optic System
- ▶ Nerves

## AP2 $\alpha$

### Definition

AP2 $\alpha$  is a member of transcription factor AP-2 gene family that consists of three different genes. AP-2 is shown to have important functions in differentiation of neural crest-derived cell lineage. AP2 $\alpha$  is thought to be required for a number of morphogenetic events including aspects of craniofacial development and midline fusion.

- ▶ Neural Crest
- ▶ Neural Development

## APC (Adenomatosis Polyposis Coli)

### Definition

A protein involved in mobility of the growth cone through microtubule plus-end capping. GSK-3 $\beta$  phosphorylates.

APC, preventing microtubule plus-end capping, thereby reducing stability and decreasing motility. Neurotrophin binding (TrkA activation) allows microtubule plus-end capping by APC, through inhibition of glycogen synthase kinase 3 $\beta$  (GSK-3 $\beta$ ).

- ▶ Neurotrophic Factors in Nerve Regeneration

## Aperture Problem

### Definition

The aperture problem refers to the fact that the motion of a one-dimensional spatial structure, such as a bar or edge, cannot be determined unambiguously if it is viewed through a small aperture such that the ends of the stimulus are not visible. In the context of visual motion processing, the aperture problem is faced by individual neurons with receptive fields that sample only a spatially restricted region of the retinal image.

- ▶ Visual Motion Processing

## Aphasia

### Definition

Inability to produce and/or understand language that results from damage to portions of the brain that are responsible for language. Depending on which portion is affected, the language disability changes. Damage to the frontal lobe tends to cause a more expressive aphasia (the patient may understand what people say but cannot produce words), while damage to the temporal/parietal, i.e., auditory areas tends to cause more of a receptive aphasia: the patient speaks fluently but makes no sense nor understands other people talking. The damage is always on the dominant side of the brain which, in 95% of people, is the left.

- ▶ Ischemic Stroke
- ▶ Stroke

## Aplysia

### Definition

An invertebrate, a sea slug, which features in a number of important neurophysiological investigations of memory.

## Apnea

### Definition

Period of time during which breathing stops or is markedly reduced.

► Development of the Respiratory Network

differentiation which it involves a cascade of complex biochemical events leading to characteristic changes in cell morphology prior to death. The main feature of apoptosis is that events, including chromatin condensation and DNA fragmentation, are accomplished in such a way to dispose of cellular debris without inducing an inflammatory response.

► Development and Regeneration

## Apneusis

### Definition

Apneusis is characterized by a marked prolongation of inspiration and a plateau inspiratory discharge of respiration-related brainstem neurons regardless of length of expiration.

► Pontine Control of Respiration

► Respiratory Neurotransmitters and Neuromodulators

## Apparent Motion

### Definition

Apparent motion is an illusion of motion that can be produced by presentation of a sequence of discrete “snapshots” rather than a continuously changing image signal. For example, the motion in movies is apparent rather than real as it involves the rapid presentation of a series of static images.

► Visual Motion Processing

## Apodans

### Definition

► Evolution of the Brain: Amphibians

► Gymnophiones

## Appetite Regulation

► Neuropeptides in Energy Balance

## Aponeurosis

► Tendon

## Appetitive Behavior

### Definition

Explorative or goal-directed behavior.

## Apoptosis

### Definition

A type of programmed cell death in response to stress, oxidants and genetic aberrations. It may also be a controlled process during development and cell

## Appetitive Conditioning

### Definition

Conditioning with a rewarding unconditioned stimulus (US).

► Operant Conditioning

## Appetitive Response

### Definition

A class of conditioned Pavlovian responses that occurs to a stimulus predictive of the subsequent delivery of a reward (usually food or water). Increased salivation, licking, increased pupil dilation, and approach behavior can all be elicited in such appetitive situations.

► Value-based Learning

## APP/Secretase

### Definition

APP/secretase – an enzyme which cleaves inside the  $\beta$ /A4 portion of the amyloid precursor protein (APP); abnormal processing of APP occurs in AD brains.

► GAL4/UAS

## Apraxia

### Definition

Non-paralytic disorder of learned movements in the absence of sensory loss, weakness, incoordination, or the inability to understand commands. There are different forms of apraxia, related to different body parts and functions: buccofacial apraxia, truncal apraxia, limb apraxia, apraxia of eyelid opening, apraxia of speech. For example, in limb apraxia, patients may make simple movements but not perform complex motor acts with sequences of movements, such as combing their hair, shaving, toothbrushing. Ideomotor apraxia is characterized by disturbances of performing communicative gestures, e.g., waving the hand for goodbye, or imitative or requested tool-use gestures, such as using a hammer or other tool.

## Aprosodias

### Definition

Disturbances in recognizing or producing prosody (musical intonation) of language, which is an expression of affective components of speech. Aprosodia is

associated with lesions of the right hemisphere. Damage to anterior regions produces aprosodic, emotionless, flat tone of voice; damage to posterior regions entails incomprehension of affective components in other people's speech.

## Aquaporins

### Definition

A family of 7 members of molecules that form the water pores in the cell membrane.

► Drinking Disorders and Osmoregulation

## Aqueduct of Sylvius

### Definition

This is the cerebral aqueduct. It is a channel located in the midbrain that connects the third and fourth ventricles. It is filled with cerebrospinal fluid, and if constricted can cause hydrocephalus.

## 2-Arachidinoyl Glycerol (2-AG)

### Definition

2-Arachidonoylethanolamide (2-AG) is an endogenous cannabinoid neurotransmitter first isolated from canine gut. It is an ester formed from arachidonic acid and glycerol. Compared to anandamide, 2-AG is present at relatively high levels in the central nervous system.

► Cannabinoids  
► Hallucinogens

## Arboviral Infection

### Definition

Pertaining to arthropod-borne viruses causing infection of the central nervous system.

► Central Nervous System Infections: Humoral Immunity in Arboviral Infections

## Arbovirus

### Definition

Arbovirus denotes any virus in vertebrates biologically transmitted by infected hematophagous arthropods.

- ▶ Arboviral Infection
- ▶ Central Nervous System Infections: Humoral Immunity in Arboviral Infections

## Archaic Species

### Definition

Species of animals that are members of a presently extinct order of vertebrates.

- ▶ Evolution and Brain-Body Allometry

## Archosauria

### Definition

Diapsid reptile clade incorporating crocodiles, dinosaurs, pterosaurs and birds.

- ▶ The Phylogeny and Evolution of Amniotes

## Arcuate Fasciculus

### Synonyms

- ▶ Fasciculus longitudinalis sup.;
- ▶ Superior longitudinal fasciculus

### Definition

With its two branches (anterior brachium and posterior brachium), the superior longitudinal fasciculus establishes connections between virtually all cortical areas. The part of the fasciculus connecting the motor (Broca's) speech center with the sensory (Wernicke's) speech center is called the arcuate fasciculus.

- ▶ Telencephalon
- ▶ Broca's Aphasia
- ▶ Wernicke's Aphasia

## Arcuate Nucleus (Hypothalamus)

### Definition

This nucleus (also called the infundibular nucleus) is located in the floor of the hypothalamus adjacent to the ventralmost part of the third ventricle. Its axons project to the pituitary portal vessels at the median eminence of the hypothalamus. Its neuroendocrine cells contain various neuropeptides involved in the control of the anterior pituitary gland.

## Arcuate Nucleus (Medulla)

### Definition

The arcuate nucleus in the medulla is ventral to the pyramid that is continuous with the pontine gray. It projects to the contralateral cerebellum as mossy fibers via ventral external arcuate fibers.

## Are Humans Sensitive to Pheromones?

### Definition

Anatomically, there is clear evidence that the vomeronasal organ of human adult exists. However, there are serious doubts about its functionality. In the human genome, only five orthologs of the V1R genes are still functional, all the others are pseudogenes and, to date, no intact human V2R gene has been reported, suggesting that humans have a very limited number of functional vomeronasal receptors. In addition, the other members of the signal transduction cascade (PLC $\beta$ 2, TRPC2 channel) existing in vomeronasal cells of rodents, are pseudogenes. No ligand is known for any of the human vomeronasal receptors. There are various behavioral studies that implicate putative pheromones in regulating endocrine dependent behavior such as menstruation, but the detailed mechanisms of actions are unknown so far.

- ▶ Olfactory Sense
- ▶ Vomeronasal Organ (Jacobson's Organ)

## Area 4

### Definition

Primary motor cortex (MI, M1, F1).

- ▶ Visual Space Representation for Reaching

## Area 7b

- ▶ Visual Space Representation for Reaching

## Area Centralis

### Definition

The area centralis or central area is a small region, typically located in temporal retina, where neuron density peaks and neurons are smallest. It is the region of highest visual acuity and is used for the fixation of objects. Some animals (e.g. rabbit) have a horizontally elongated area centralis, which is termed a visual streak. The extent of the area centralis is somewhat arbitrarily defined by a ganglion cell density threshold or in some species by the presence of more than one tier of ganglion cell somata in the ganglion cell layer.

- ▶ Inherited Retinal Degenerations
- ▶ Retinal Ganglion Cells
- ▶ Visual Acuity, Hyperacuity

## Area F2

- ▶ Visual Space Representation for Reaching

## Area F3

- ▶ Visual Space Representation for Reaching

## Area F4

- ▶ Visual Space Representation for Reaching

## Area F5

- ▶ Visual Space Representation for Reaching

## Area F6

- ▶ Visual Space Representation for Reaching

## Area F7

- ▶ Visual Space Representation for Reaching

## Area 7m

- ▶ Visual Space Representation for Reaching

## Area MIP

- ▶ Visual Space Representation for Reaching

## Area PE

- ▶ Visual Space Representation for Reaching

## Area PEa

- ▶ Visual Space Representation for Reaching

## Area PEc

- ▶ Visual Space Representation for Reaching

## Area PFG

- ▶ Visual Space Representation for Reaching

## Area Postrema (AP)

### Definition

Belongs to circumventricular organs and is located dorsal to the nucleus tractus solitarii (NTS) on the dorsal surface of the medulla oblongata at the caudal end of the fourth ventricle, where it forms an about 1 mm long, but rather narrow elevation. The postremal area is strongly vascularized, during the second half of one's life degenerated, and rich in cells and fibers with different transmitters. Since blood vessels do not have a blood-brain-barrier here, substances with compulsory barriers reach the nervous tissue as well, which are analyzed here. The AP is the "vomiting center" of the brain, though it also plays an important part in vegetative processes, such as food intake, drinking and cardiovascular regulation. AP projects heavily to the adjacent NTS and dorsal motor nucleus of the vagus (DMV) using acetylcholine as the main neurotransmitter.

If intracranial pressure increases, the ensuing concomitant stimulation of the area postrema can elicit emesis.

To curtail elicitation of emesis, dopamine antagonists, *inter alia*, are used, to act upon the dopamine receptors of the AP, thus suppressing their activating effect.

- ▶ Autonomic Reflexes
- ▶ Myelencephalon
- ▶ Dorsal motor nucleus of the vagus (DMV)
- ▶ Nucleus Tractus Solitarii (NTS)

## Area SII

### Definition

In the lower portion of the postcentral gyrus is situated a cytoarchitectonically slightly modified zone which reaches as far as the lateral sulcus and features a complete representation of the contralateral body half. This area is called the secondary somatosensory cortex, abbreviated SII.

- ▶ Telencephalon

## Area V1

- ▶ Striate Cortex Functions

## Area V6

- ▶ Visual Space Representation for Reaching

## Area V6A

- ▶ Visual Space Representation for Reaching

## Areflexia

### Definition

Loss of tendon reflexes and may be genetic or due to a number of neurological diseases.

## Arginine Vasopressin

### Definition

A peptide hormone synthesized by neurons in the hypothalamus and released from the posterior pituitary.

- ▶ Motion Sickness



## Argument

RALF BUSSE

Institut für Philosophie, Universität Regensburg,  
Regensburg, Germany

### Synonyms

Reasoning; Inference

### Definition

An **argument** is a piece of text or speech that can be put forward in order to support a thesis. An argument in standard form is a finite sequence of meaningful sentences

$$\begin{array}{l} P_1 \\ \dots \\ P_n \\ \therefore C. \end{array}$$

$P_1, \dots, P_n$  are the **premises**,  $C$  is the **conclusion**, which is typically the thesis to be supported. Putting forward an argument normally involves three claims: firstly, that all premises are in fact **true**; secondly, that all premises are **justified** or warranted independently of justification or warrant for  $C$ ; thirdly, that the conclusion **follows from** the premises, or at least that the premises together strongly **support** the conclusion. An argument is **valid** just in case this third claim is true. An invalid argument is called a **fallacy**. An argument may also be presented with the third claim only, just to see where certain assumptions would lead. Or it may be presented together with the claim that the conclusion is already established as false so that it provides reason to give up at least one of the premises (**reductio ad absurdum**).

### Characteristics

#### Good, Valid and Sound Arguments

A large part of what may be called the theory of human rationality is concerned with criteria for distinguishing **good** arguments from bad ones. An argument as it is normally put forward is good just in case all three claims indicated above are true. The standard distinction is between valid and sound arguments: an argument is valid just in case the conclusion does indeed follow from or is strongly supported by the premises. It is **sound** just in case in addition to being valid it has only true premises. Consequently, there are two steps in checking an argument. The first step is to find out whether it is valid or not. If it is valid, the second step is to find out whether all premises are true or not. Establishing the truth of the premises is a matter of particular empirical or formal research.

Critical reflection on arguments as such primarily concerns their validity.

An argument in standard form is valid if and only if acceptance of all premises makes it rational also to accept the conclusion, or at least to attribute a high probability to the conclusion's being true. A special case of extraordinary importance is **deductive validity**. In a deductively valid argument the conclusion is a **consequence** of the set of premises, i.e. it follows from this set. So acceptance of the premises of a deductively valid argument makes it rational to accept the conclusion, because the truth of the premises **excludes** the falsity of the conclusion and so **guarantees** its truth: it is **impossible** that the conclusion is false while all premises are true.

This suggests an intuitive test for deductive validity: try to describe a consistent scenario that would render all premises true but the conclusion false. The scenario can be far-fetched and highly improbable. It can, for instance, involve science fiction elements such as beaming. The consistency of the scenario suffices to show that the argument is deductively invalid.

#### Deductive Logical Validity: Conditional Premises

The kind of deductive validity that has by far been studied best is validity according to deductive logic [1]. An argument is **logically valid** (in the sense of deductive logic) just in case the truth of its premises excludes the falsity of the conclusion for *logical* reasons rather than for reasons that concern the descriptive content of the sentences involved. This can be explained by means of an important kind of arguments that are subject to deductive logic, namely arguments with **conditional** premises. Suppose that prior medical examination has established the conditional premise "If test T is positive, the patient has illness I." Now the positive test result is submitted. The premise "Test T is positive" is added and the conclusion "The patient has illness I" is inferred. The whole argument is an instance of a certain logical schema:

Argument	Logical schema
If test T is positive, the patient has illness I	If A then B
Test T is positive	A

In the schema, only the connective "if – then" is retained, which may plausibly be dubbed a **logical expression**. The connected sentences are replaced by the place-holders "A" and "B." It is impossible to find an argument of the same logical schema all premises of which are true, while the conclusion is false (i.e. not true). The meaning of the logical expression "if – then"

excludes the falsity of the conclusion given that all premises are true. It is hence by logical reasons alone that it is excluded that all premises are true while the conclusion is false. The argument is logically valid.

This can be generalized. A ►logical schema only contains logical expressions and place-holders for descriptive expressions. Descriptive expressions can be sentences, but also sub-sentential expressions such as names like “Peter” or predicates like “is happy.” A particular argument is an ►instance of a logical schema just in case it can be obtained from the schema by replacing all occurrences of a certain place-holder by the same descriptive expression. An argument is a ►counter-instance to a logical schema just in case it is an instance of the schema and its conclusion is false, while all its premises are true. A ►logical schema is logically valid if and only if there is no possible counter-instance to it. A particular ►argument is logically valid if it is an instance of a logically valid schema. The general idea is that if an argument is an instance of a schema that has no counter-instance, the meanings of the logical expressions in the argument and the way they are connected to descriptive expressions alone guarantee the truth of the conclusion if all premises are true. It is by logical reasons alone that it is excluded that all premises are true but the conclusion is false. The argument is logically valid.

It is hard and perhaps impossible to systematically capture the exact logical behavior of ordinary conditional sentences. But in many cases asserting an indicative conditional can be understood as excluding the possibility (for whatever reason) that the antecedent *A* of the conditional is true but its consequent *B* false. Thus, when a person argues from a premise “If *A* then *B*” in the indicative we may often understand her as arguing from the premise “It is not the case that it is true that *A*, but false that *B*.” Let us abbreviate this latter sentence schema as “ $A \rightarrow B$ ,” which we will read for convenience as “If *A*, then *B*.” Its instances are called ►material or ►truth-functional conditionals.

The two most important logically valid logical schemata with conditional premises are (1) and (2). They can be contrasted with the two invalid schemata (1\*) and (2\*):

(1) Modus ponens	(2) Modus tollens	(1*) Invalid	(2*) Invalid
$A \rightarrow B$	$A \rightarrow B$	$A \rightarrow B$	$A \rightarrow B$
<i>A</i>	non- <i>B</i>	<i>B</i>	non- <i>A</i>

Here “non-...” is short for “It is not the case that ....” In both (1\*) and (2\*), substituting a false sentence for *A* and a true sentence for *B* yields the counter-instance.

Further important valid schemata are (3) and (4):

(3) Contraposition	(4) Conditional transitivity
$A \rightarrow B$	$A \rightarrow B$
$\therefore \text{non-}B \rightarrow \text{non-}A$	$B \rightarrow C$

A good part of the logical behavior of ordinary conditional sentences can be retained by standard translations by means of the material conditional “ $\rightarrow$ ”:

Ordinary sentence schema	Translation
If <i>A</i> , then <i>B</i>	$A \rightarrow B$
<i>A</i> is sufficient for <i>B</i>	$A \rightarrow B$
Only if <i>A</i> , <i>B</i>	$B \rightarrow A$
<i>A</i> is necessary for <i>B</i>	$B \rightarrow A$

**Deductive Logical Validity: General Premises**

So far we have been concerned with argument schemata with place-holders for complete sentences only. But there are important logically valid schemata with premises and conclusions of one of the so-called categorical forms:

	Affirmative	Negative
General	All <i>F</i> s are <i>G</i> s	No <i>F</i> is (a) <i>G</i>

“*F*,” “*G*” and “*H*” are place-holders for English predicates such as “is an animal” rather than for sentences. Here is an instance of a famous valid schema called ►modus Barbara:

Argument	Schema (modus Barbara)
All men are animals	All <i>F</i> s are <i>G</i> s
All animals are mortal	All <i>G</i> s are <i>H</i> s

A convenient way of looking for counter-instances to such schemata makes use of naïve set-theoretical predicates such as “is a member of the set {1, 2}.” A perspicuous counter-instance to an invalid schema can be formulated as follows:

Invalid schema	Counter-instance
All <i>F</i> s are <i>G</i> s	All members of {1, 2} are members of {1, 2, 3, 4}
Some <i>G</i> s are <i>H</i> s	Some members of {1, 2, 3, 4} are members of {3, 4}

Notice that if an argument is an instance of an invalid logical schema, it can still be valid because it is an instance of a more subtle schema that is valid.

Deductive arguments in scientific practice often involve sentences that contain relational predicates such as “is greater than” and iterations of means of quantification such as “all” and “some” or “there is.” An example from arithmetics is “For every natural number there is a greater number.” This should be construed as an instance of the schema “For every individual  $x$  there is an individual  $y$  such that  $y$  stands in relation  $R$  to  $x$ .” The inference from this to “There is an individual  $y$  such that every individual  $x$  is such that  $y$  stands in  $R$  to  $x$ ” is invalid. For every number there is a greater one, but there is no number that is greater than all numbers. If one fails to see through the fallacy from “For every – there is” to “There is – for every,” one can “prove” the existence of a necessary being:

$P_1$	Ex nihilo nihil fit
$P_2$	There exists something now
$C_1$	$\therefore$ There was no time at which nothing existed. (from $P_1$ and $P_2$ )
$C_2$	$\therefore$ But then there is something that has existed at all times. (from $C_1$ )
$P_3$	But no contingent being exists at all times

The invalid step is from ( $C_1$ ) to ( $C_2$ ).

### Non-logical Deductive Validity and Implicit Premises

The following argument appears to be valid, though the corresponding schema is invalid:

Argument	Schema
Peter is a bachelor	$a$ is $F$

The argument’s validity rests on the meanings of the descriptive expressions. Consequently we cannot apply the testing method of trying to find counter-instances to a logical argument schema. Often the intuitive test suffices: if a consistent scenario can be depicted that would render all premises true but the conclusion false the argument is deductively invalid. But in order to make one’s arguments perspicuous one should turn non-logically valid deductive arguments into logically valid inferences. In the example, just add as a premise the analytic truth “All bachelors are unmarried.” The relation between the meanings of the descriptive terms “bachelor” and “unmarried” on which the validity rests is thereby made explicit.

Arguments in science and philosophy are seldom in standard form, and very often they are incomplete [2,3]. Even when spelled out in an explicit sequence of sentences they rely on hidden premises that are not just uncontested explications of meanings. For example, nothing of scientific interest does directly follow from an experimental result formulated in a premise of the form “Activity in brain area  $B$  occurs whenever a subject performs cognitive task  $T$ .” A huge amount of substantial background assumptions is required for correctly deducing a conclusion to the effect that there is a typical process in area  $B$  that *is* or *realizes* the achievement of  $T$ . In many cases the background assumptions are scientific common ground. But the more general and substantial the conclusions become the more they draw on profound theoretical or even metaphysical assumptions that can reasonably be contested. A researcher is seldom explicitly aware of the way her scientific convictions or prejudices enter into her reasoning. So although scientists rarely spell out their scientific inferences in detail, knowledge of what a full-fledged deductively valid argument would look like can help them to keep a check on themselves and to deal reasonably with their disagreement.

### Reductio ad absurdum and Paradox

“From your hypothesis it follows that  $C$  is the case, which is absurd; so your hypothesis is false.” This popular mode of critique of another person’s hypothesis or theory is called reductio ad absurdum. However, usually the alleged absurdity  $C$  follows from a hypothesis  $H$  only if certain background assumptions  $P_1 \dots P_n$  are made. Moreover, the alleged refutation of  $H$  requires the assumption that  $C$  is false. A complete reductio ad absurdum is of the following form:

$P_1$	The critic’s background assumptions
...	
$P_n$	
$H$	Assumption of the hypothesis for the sake of argument
$\therefore C$	Conclusion inferred from $P_1 \dots P_n$ and $H$
non- $C$	Assumption of the negation of $C$ as the main premise

From  $P_1 \dots P_n$  and  $H$  the critic infers  $C$ , which contradicts her main premise non- $C$ . She thereby shows that at least one of the premises  $P_1 \dots P_n$ , non- $C$  and  $H$  must be false. Insisting on her own claims  $P_1 \dots P_n$  and non- $C$  she infers non- $H$ . In order to evade this rebuttal all the proponent of  $H$  has to do is to reject  $\blacktriangleright$ one among the critic’s premises  $P_1 \dots P_n$  and non- $C$ . Often this is easy to do, as the background assumptions tend to involve

fundamental but contested convictions of the critic's which the proponent need not share. Given the proponent's background theory even conclusion *C* may be acceptable.

There is a famous case in the history of science in which an attempted ▶*reductio* backfired [4]: Poisson showed that the wave theory of light implied that a bright spot had to occur at the center of the shadow of a disk (conclusion *C*). Making the common sense assumption that this is false (his main premise non-*C*) he took the wave theory to be refuted. But in careful experiments the spot was in fact observed. Unwillingly Poisson had contributed to an impressive confirmation of the wave theory.

▶*Paradoxes* are particularly fascinating philosophical arguments [5]. A paradox is a seemingly valid deduction of a seemingly unacceptable conclusion from seemingly inevitable premises. Skeptical arguments with conclusions such as “We do not know anything about the external world (or: the past, other minds, the laws of nature)” are paradoxes. Different reactions are possible: that the conclusion is in fact true and only *appears* to be false; that one of the premises is in fact false; or that the deduction rests on a logical or meaning explicating principle that should be rejected.

## References

1. Salmon W (1984) *Logic*, 3rd edn. Prentice Hall, Englewood Cliffs, NJ
2. Groarke L (2007) *Informal logic*, <http://plato.stanford.edu/entries/logic-informal/>
3. Irvine A, Walton D, Woods J (2004) *Argument: critical thinking, logic and the fallacies*, Prentice Hall, Toronto
4. Brittan G, Lambert K (1987) *An introduction to the philosophy of science*, 3rd edn. Ridgeview, Atascadero
5. Sainsbury M (1995) *Paradoxes*, 2nd edn. Cambridge University Press, Cambridge

---

## Argyll-Robertson Pupil

### Definition

A condition characterized by loss of light reflex but normal pupil constriction during accommodation. This is indicative of a lesion in brainstem neurons mediating the pupillary light reflex, and is characteristic of neurosyphilis.

- ▶ Neural Regulation of the Pupil
- ▶ Neurosyphilis
- ▶ Pupillary Light Reflexes

---

## Arm Trajectory Formation

TAMAR FLASH<sup>1</sup>, URI MAOZ<sup>2</sup>, FELIX POLYAKOV<sup>1</sup>  
<sup>1</sup>Department of Computer Science and Applied Mathematics, Weizmann Institute of Science, Rehovot, Israel  
<sup>2</sup>Interdisciplinary Center for Neural Computation, Hebrew University of Jerusalem, Jerusalem, Israel

### Definition

Arm ▶*trajectory* formation refers to the principles and laws that invariantly govern the selection, planning and generation processes of multi-joint movements, as well as to the factors that dictate their kinematics, namely geometrical and temporal features.

### Characteristics

The repertoire of human and animal goal-directed actions is broad and diverse, ranging from relatively simple single-joint movements to complex interactions among several limb segments or even among different limbs. These movements may follow various motion ▶*paths* with numerous ▶*speed profiles* along each ▶*path*, resulting in countless possible trajectories. Nonetheless, focusing here specifically on arm movements, there seem to be some stereotypical trajectories that the central nervous system (CNS) chooses for the arm to perform. Although many questions still remain open, some underlying principles behind the selection, planning and execution of these trajectories have emerged from the combination of behavioral and computational studies of trajectory formation.

### Computational Problems Associated with Trajectory Formation

The motor system transforms neural signals into contractile forces in muscles, which produce motion and enable us to act upon our environment. Some prominent research questions that have received great attention in recent years are as follows:

1. What are the geometric and temporal characteristics of simple and complex movements?
2. What coordinates or reference frames are used in movement representation and generation?
3. What are the interactions between CNS-based planning, body mechanics and physical laws and constraints in dictating the emerging movements? How do these aspects influence trajectory planning?
4. How does the nervous system resolve kinematic redundancies, especially those associated with the planning and execution of multi-joint arm movements?

5. To what extent are the produced behaviors constructed from a limited set of motion primitives, i.e., basic building blocks? What syntactic rules are used in constructing complex and/or sequential movements from such simpler elements?
6. Is the motor system hierarchically organized? Does trajectory formation and generation occur at different levels of representation?

Some attempts at answering these questions are presented below.

In robotics, the problem of trajectory formation is usually composed of two separate problems: trajectory planning and trajectory tracking. The first deals with the selection and planning phase. The second refers to the execution of the planned trajectory and to feedback control, guaranteeing minimal deviation from the desired trajectory. When investigating how disjoint these two problems might be in human movement generation, some analogy can be made with the question of whether there is a clear separation in the motor hierarchy between kinematics and dynamics in biological trajectory formation. Some recent load adaptation studies provided evidence that human arm trajectories tend to obey the same kinematic plan independently of the external force conditions [1]. These, among others, support the notion that the desired behavior is independent of movement dynamics. However, although there is some evidence that the kinematic and dynamic aspects of motion constitute two distinct levels of the motor hierarchy, this is neither sufficient nor conclusive enough to unequivocally decide the matter (this matter is also discussed in the “Internal models” article).

### Coordinate Frames for Trajectory Formation

When reaching for a cup of coffee, the hand can theoretically follow a wide variety of paths, each with numerous speed profiles. These hand trajectories could further result from different sets of joint rotations. Understanding how the motor system plans and executes motion under redundancy, or in the presence of an excess number of degrees of freedom (DOF), beyond those required to carry out a motor task, is paramount (the redundancy problem, or Bernstein problem, is also discussed in the articles “Equilibrium point control” and “Coordination”).

Numerous studies have demonstrated that during point-to-point movements in the horizontal plane the hand tends to follow rather straight hand paths (see Fig. 1a). This has prompted the suggestion that arm trajectories are planned in hand rather than in joint coordinates. By contrast, during unconstrained three-dimensional movements, or during movements in the vertical plane, the hand paths are likely to become considerably more curved [3] (see Fig. 2). This may be

due to the presence of gravity or the lack of a continuous visual tracking of the movements.

### Optimality and Trajectory Formation

Many studies have attempted to account for the observed characteristics of arm movements based on optimization theory [2]. Optimization theory is an important venue for discovering what organizing principles govern the generation of goal-directed motor behavior. It provides a convenient way to formulate a coarse-grained model of the underlying neural computation, without requiring specific details of the way those computations are carried out. Generally speaking, this approach consists of defining a quantitative objective function that defines the optimum (i.e., best) performance. Optimization tools are then applied in order to identify the specific behavior that achieves that optimum. Quantitative hypotheses regarding the goals of motor actions and their relation to observable behavior must therefore be explicitly stated.

Not all motor behaviors are necessarily optimal. Nevertheless, attempts to identify optimization principles can be useful for developing a taxonomy of motor behavior and for gaining insight into the neural processes that produce motor behavior. In particular, several different optimization principles were hypothesized in the context of reaching movements. These included smoothness maximization, expressed through the minimization of hand  $\triangleright$  jerk [2], the rate of change of joint torques [4], the minimization of movement variance [5] and optimal feedback control [6].

While in the minimum-jerk model the  $\triangleright$  cost function is kinematic in nature, some of the other models’  $\triangleright$  cost functions depend on dynamic variables such as torque change, muscle-tension or motor-command. A critical difference between the kinematics- and dynamics-based models is the separability of planning and execution. Kinematic models, which specify the hand trajectory in external or in joint coordinates, require separate movement execution processes to delineate the joint torques or muscle forces and eventually the motor commands that are needed in order to realize the desired trajectory. In contrast, the solutions to dynamic models are the joint torques, muscle forces and possibly also the motor commands (depending on the definition of the cost function) required to achieve the movement; and therefore planning and execution are no longer separated.

### Laws of Motion and Motor Invariants

A basic notion in current thinking about trajectory formation is that the motor memory does not store a huge collection of “motor tapes,” each encoding the neural commands specifying the generation of an individual movement. Rather, based on evidence from

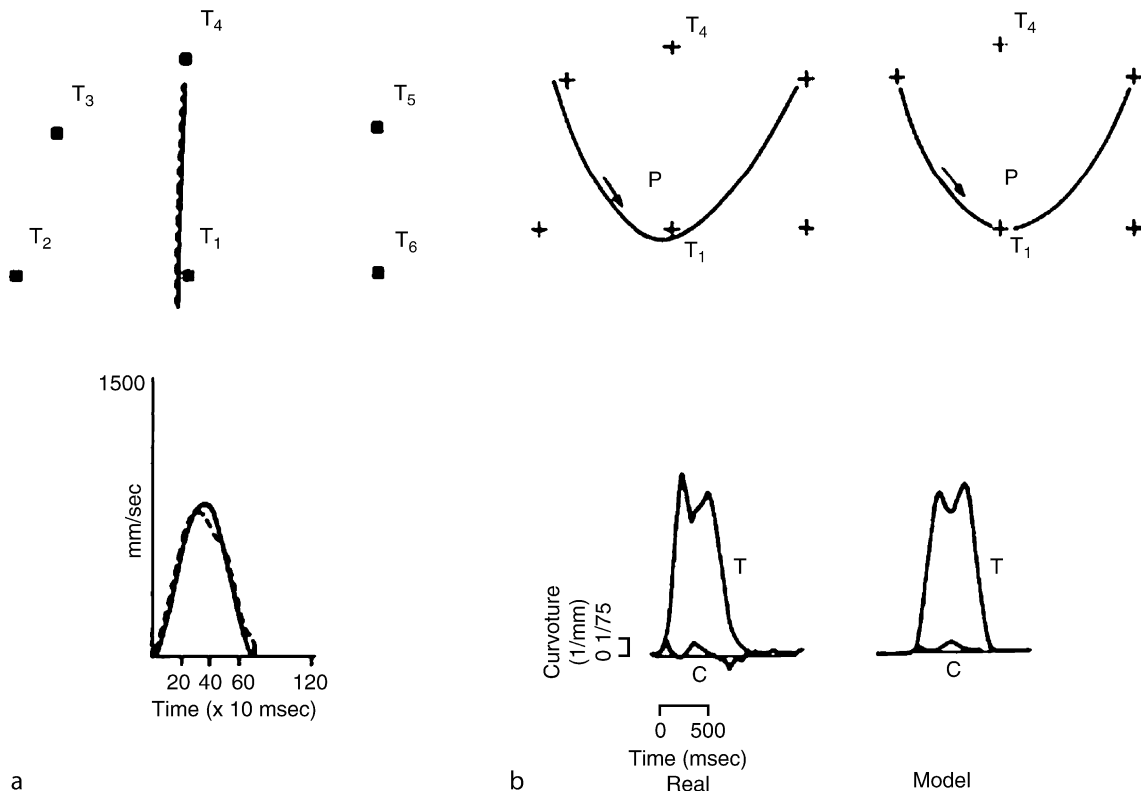

**Arm Trajectory Formation. Figure 1** An example of hand trajectories in the horizontal plane. (a) The experimental data are depicted by a *dashed line*, and the minimum-jerk model prediction is portrayed by a *solid line*. A point-to-point reaching movement is characterized by a *straight line* path (*top panel*), with a bell-shaped speed profile (*bottom panel*). (b) Reaching from one point to another through an intermediate via-point. The experimental data are given on the *top left* and the minimum-jerk prediction is on the *top right*. This time the path is curved and the speed profile shows a slowdown in the movement around the region of maximal curvature (*bottom panel*; T is movement speed and C movement curvature). As is apparent, there is good correspondence between the experimental data and the model predictions in both cases. Adapted from [2].

both behavioral observations and accurate kinematic analysis of movements, it is argued that motor memory stores more general plans, or programs. These dictate all the movements belonging to a particular class, which share similar geometric, kinematic and temporal characteristics.

A central problem in motor control research is therefore one of taxonomy, namely classifying and grouping all possible movements into different classes. This critically depends on our ability to define metrics that can be used to evaluate the similarity between different movements and motor behaviors. Another possibly more scrupulous method of classifying movements is by searching for differences among the principles that underlie the planning of different movements. Both schemes are based on the identification of ►motor invariants.

Several kinematic and temporal invariants have been observed in human arm movements. For example, point-to-point reaching movements in the horizontal

plane tend to follow straight paths with single-peaked bell-shaped speed profiles (see Fig. 1a). For more curved motions, as when reaching through a via-point, the movements slow down around the point of highest ►curvature (see Fig. 1b). Both behaviors are predicted by the minimum-jerk model [2], but also by the minimum torque-change and minimum variance models. In three-dimensional movements and movements in the vertical plane, the hand paths are more curved, though they still vary in a consistent manner across the workspace, while the speed remains more or less bell-shaped [3] (see Fig. 2). Studies that examined the symmetry of the speed profiles, found them to range from highly symmetrical profiles to ones which are more skewed or contain additional speed peaks. This may possibly indicate multiple corrections, as observed when subjects are instructed to be highly accurate.

One persistent temporal invariant is that of isochrony [7]. Global isochrony refers to the observation that

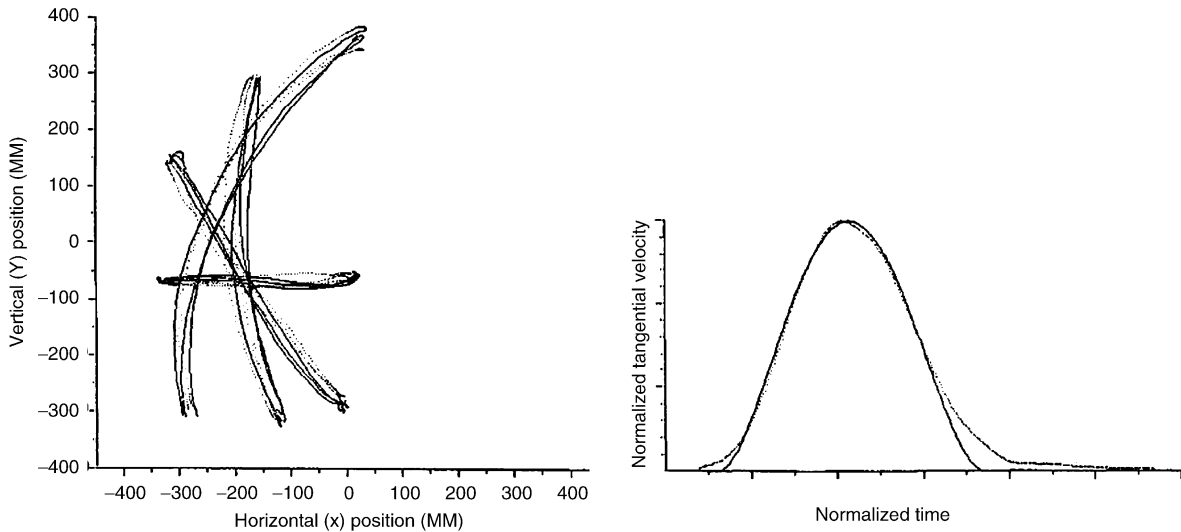

**Arm Trajectory Formation. Figure 2** Point-to-point reaching movements in the vertical plane. The left panel shows the superimposed paths of four different typical reaching movements. Upward movements (and leftwards movements, for the horizontal movement) are *dotted lines*, where downward (and rightwards movements, for the horizontal case) movements are *solid lines*. While the horizontal movement is rather straight, the other hand paths tend to be much more curved for both upward and downward movements. The right panel shows a typical experimental speed profile as the *dotted line*, with the minimum-jerk model prediction as the *solid line*. Adapted from [3].

the average speed of movements increases with the path length, thereby maintaining movement duration nearly constant. Local isochrony is the tendency to carry out motion subunits of unequal lengths in roughly equal times. For example, if subjects trace out a figure eight in which the two lobes are of unequal size, they are traversed with approximately equal durations. This second type of isochrony becomes an emergent property of the maximization of movement smoothness, i.e., the minimization of jerk [7] as well as other costs [4–6].

In addition to characterizing the path and **speed profile** separately, many studies have examined the dependency of the speed on the path geometry. Although there is no a priori reason for it, coupling between the geometrical form of the path and the hand speed have been repeatedly observed. When drawing simple forms like ellipses, this relationship takes the form of

$$V = K C^{-\beta}, \quad (1)$$

where  $V$  is the tangential speed,  $K$  is constant and  $C$  is the curvature. Expressing the same law in terms of angular speed, we get

$$A = K C^{1-\beta} \quad (2)$$

where  $A$  is now the angular speed. Originally the power  $\beta$  was found to be close to  $1/3$ , and the second formulation lent it the name “the two-thirds power law”

[8] (see Fig. 3). Nonetheless, in other non-elliptic paths the exponent was found to range between 0.2 and 0.4.

### The Notion of Motor Primitives

There is evidence that suggests that the brain may store a limited set of motor templates, and that it possesses mechanisms that generate our rich motor repertoire by applying some basic operations or transformations onto those elementary primitives, joining simple movements into more complicated behavior. This organization provides a parsimonious representation of our huge motor repertoire and eases learning of new behavior.

Some recent studies of the characteristics of hand trajectories that emerge following a period of extensive practice, suggest the emergence of purely geometric sub-movements from which the learned goal-directed movements are composed. Yet these sub-movements may not encompass the most elementary level in the plausible hierarchy of movement construction based on motor primitives. If we associate this hierarchy to that of an alphabet from which words are composed, which in turn are combined to yield complete sentences, the geometric primitives might correspond to words, not to letters. It remains to be seen, however, whether it is possible to identify a limited set of universal building blocks from which a wide variety of diverse movements are constructed. Nevertheless, the notion of the compositionality of complex movements via

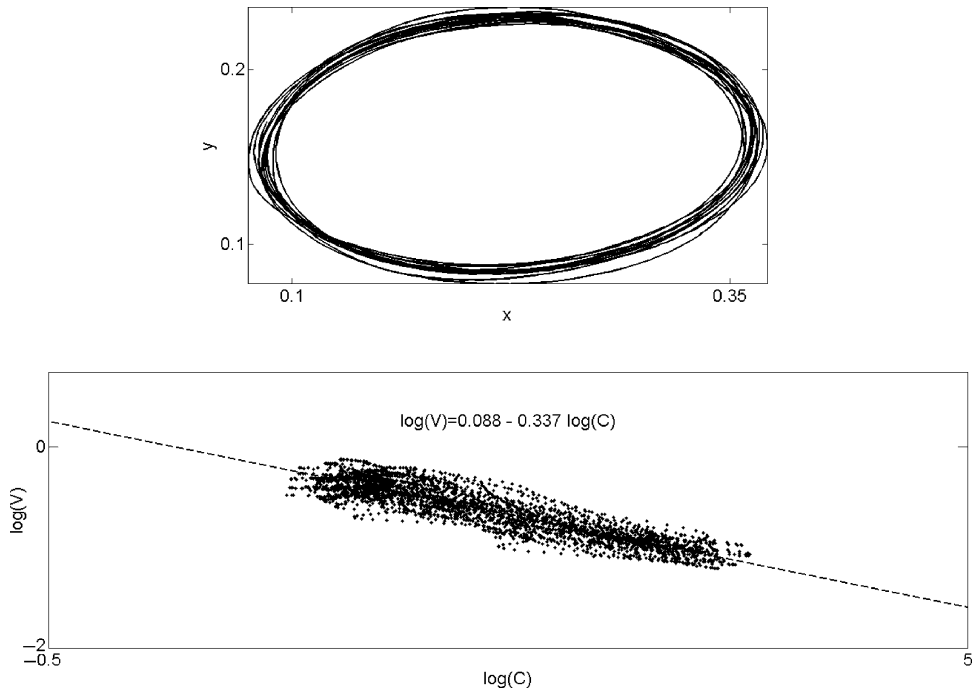

**Arm Trajectory Formation. Figure 3** A demonstration of the two-thirds power law. Top panel: an ellipse traced continuously and repetitively in the horizontal plane. Bottom panel: taking the logarithm of both sides of the power-law formulation, we get:  $\log(V) = \log(K) - \beta \log(C)$ . Therefore, plotting  $\log(V)$  versus  $\log(C)$  results in a roughly straight curve with a slope of about  $-1/3$ , in good agreement with the power law (1).

sequencing and superposition of sensory-motor primitives proved useful in robotic applications, such as robot humanoids learning from imitation.

### Three-Dimensional Trajectory Planning

The realm of three-dimensional (3D) arm movement was significantly less studied than that of planar arm movements. Movements that are restricted to the horizontal plane were, in turn, extensively studied. Moreover, the invariants of horizontal planar motion do not all scale up to 3D movement. The bell-shaped speed profiles of point-to-point reaching movements seem to be conserved. Yet the paths in 3D are much more curved, possibly suggesting motion planning in terms of joint coordinates. The two-thirds power-law describes 3D arm motion considerably less well than for horizontal planar movements. However, non-trivial mathematical considerations have led to a new power-law of 3D motion, which captures 3D drawing data quite well, namely:

$$V = K C^{-\beta} T^{-\gamma}, \quad (3)$$

where  $T$  designates the path's **torsion** (all other symbols are as above). Here  $\beta$  is about  $1/3$  and  $\gamma$  about  $1/6$ , although their exact values depend on path geometry, both global and local. We name this the “curvature-torsion power-law” [9].

The redundancy problem, mentioned above, is especially problematic for 3D arm movements. For horizontal plane motion, humans tend to utilize only two of their four DOF at the shoulder and elbow to produce the two DOF of the hand motion within the horizontal plane. Yet, in unconstrained 3D motion, all four DOF are utilized, while only three DOF are needed to specify hand position and movement in 3D space, resulting in the excess of one DOF. Transforming hand into joint coordinates, termed the inverse kinematics problem, does not have a unique solution and therefore it is ill-posed, making its solution far from being trivial.

Another reason for this complexity is that rotations are not commutative, meaning that an object's orientation after rotations along two non-co-linear axes depends on their order. This has severe implications for joints with three DOF (e.g. the shoulder). It implies that, if no constraints are imposed, a limb's orientation would depend on previous joint rotations. Some recent studies investigated the idea of intrinsic constraints, which restrict the number of DOF at the wrist, elbow and shoulder joints during hand-motion, thus resolving the kinematic redundancies [10]. These intrinsic constraints include kinematic ones such as Donders' and Listing's laws, which were originally developed in order to account for the observed 3D end-point eye orientation (Donders' law), and angular rotations



(Listing's law) during human saccadic eye movements. Examining whether these laws are also pertinent to 3D human arm movements, it was shown that while these constraints do account for certain aspects of the observed behavior, they cannot fully account for the entire spectrum of kinematic features of 3D arm reaching and pointing movements [10].

As is apparent from the material reviewed above, studies carried out in the last 20–30 years have made considerable contributions to our understanding of the principles underlying human arm trajectory formation. New models were conceived and old ones were refined and improved or discarded in view of new empirical observations. Yet there is still much work ahead, before we can claim to fully understand the complicated processes of arm trajectory formation during goal-directed motor behavior.

## References

1. Shadmehr R, Mussa-Ivaldi FA (1994) Adaptive representation of dynamics during learning of a motor task. *J Neurosci* 14:3208–3224
2. Flash T, Hogan N (1985) The coordination of arm movements: an experimentally confirmed mathematical model. *J Neurosci* 5:1688–1703
3. Atkeson CG, Hollerbach JM (1985) Kinematic features of unrestrained vertical arm movements. *J Neurosci* 5:2318–2330
4. Uno Y, Kawato M, Suzuki R (1989) Formation and control of optimal trajectory in human multi-joint arm movement. *Biol Cybern* 61:89–101
5. Harris CM, Wolpert DM (1998) Signal-dependent noise determines motor planning. *Nature* 394:780–784
6. Todorov E (2002) Optimal feedback control as a theory of motor coordination. *Nat Neurosci* 5:1226–1235
7. Viviani P, Flash T (1995) Minimum-jerk, two-thirds power law, and isochrony: converging approaches to movement planning. *J Exp Psychol Hum Percept Perform* 21:233–242
8. Lacquaniti F, Terzuolo C, Viviani P (1983) The law relating the kinematic and figural aspects of drawing movements. *Acta Psychol (Amst)* 54:115–130
9. Pollick F, Maoz U, Handzel A, Giblin P, Sapiro G and Flash T (2008) Three-dimensional arm movements at constant equi-affine speed. *Cortex* In Press
10. Soechting JF, Flanders M (1997) Flexibility and repeatability of finger movements during typing: analysis of multiple degrees of freedom. *J Comput Neurosci* 4:29–46

## Aroma

### Definition

“Aroma”, like “odor” refers to a mixture of chemical molecules that are perceived by the sense of smell.

While the term “odor” by itself is neutral in judgment, “aroma” refers frequently to odors of pleasant nature and is associated with the smell of consumables like food and coffee. Commercial interest in chemical aroma compounds derives from the food industry. Only 5% of the  $\approx 8,000$  odor molecules identified in food are present above detection thresholds that result in odor perception.

These so called key-food odorants determine the aroma of consumables. The aroma of roasted coffee for example is encoded by 27 key-food odorants out of 400 different compounds identified. Methyl-pyrazines are typical examples for key-food odorants that are formed during roasting of coffee, cocoa beans, and fried food.

► Odor

## Arousal

### Definition

Central nervous system stimulation driven by the ascending neuromodulatory projections, nervous system, and/or neuroendocrine systems resulting in heightened sensory sensitivity and readiness to respond. Arousal is involved in wakefulness, alertness, attention, cognition, awareness, motivation, sexual activity, emotion, and stress. The Yerkes-Dodson Law states that there is a U-shaped relationship between arousal and cognitive performance – either too little arousal (e.g., due to sleepiness from sleep deprivation) or too much arousal (e.g., from excessive caffeine consumption) has an adverse effect on performance.

Arousal can also be observed during sleep, where it may cause a transition to a lighter sleep stage or result in awakening.

► Alertness Level

## Arousal Threshold

### Definition

A measure of central nervous system response to external stimuli.

► Sleep States

## Arrhythmicity/Rhythmicity

CHRISTIAN BEAULÉ

Department of Biology, Washington University,  
St. Louis, MO, USA

### Synonyms

Aperiodicity/periodicity; Arrhythmic/rhythmic; Irregularity/regularity

### Definition

Refers to characteristics of cellular, physiological or behavioral variables that fail to display a rhythm or regularity (arrhythmicity) or that show such rhythm or regularity (rhythmicity).

### Types of Rhythms

Most biological variables display cyclic changes in their basal levels. These cyclical changes are called biological rhythms. Rhythmicity is expressed at the level of the whole organism (i.e., rhythms in behavior) all the way down to the molecular and genetic levels (i.e., rhythms in gene expression). The length of these cycles is extremely varied and can be classified based on the intrinsic period of the biological oscillation. Rhythms can be grossly classified into three non-overlapping categories.

### Circadian Rhythms

From the Latin *circa*: “around” and *dies*: “day.” Biological rhythms occurring with a frequency of one cycle per day (period of approximately 24 h in length). Examples of circadian rhythms include the ►rest-activity cycle, daily oscillations in core body temperature or blood pressure.

### Ultradian Rhythms

Biological rhythms occurring with a frequency of more than one cycle per day (period significantly shorter than circadian rhythms). Examples of ultradian rhythms include the 90 min Rapid-Eye Movement (REM) cycle during sleep, heart rate (72 beat/min, in humans), or the rhythm of human growth hormone secretion (3 h).

### Infradian Rhythms

Biological rhythms occurring with a frequency of less than one cycle per day (period significantly longer than circadian rhythms). Examples of infradian rhythms include the menstrual cycle (28–30 days in humans), seasonal migration cycles, and reproduction cycles. Infradian rhythms can be further sub-classified based on

their period length. For example, ►circannual (about 1 year), circatidal (about 12 h, associated with ocean’s tides), and circalunar (about 30 days, associated with cycles of the moon) can be used to further characterize ►infradian rhythms.

The present encyclopedic entry will focus on circadian rhythms.

### Characteristics

Circadian rhythms evolved as a need to adapt to the daily transitions between days and nights. This imposed day/night cycle shaped behavioral and physiological processes and led to the emergence of circadian clocks that generate biological oscillations with a period of approximately 24 h. This ensures that each organism is optimally tuned to its environmental niche (►nocturnal vs. diurnal), and capable of anticipating the transitions between days and nights. The ability to display circadian rhythms is endogenous and widely expressed across a very wide range of living organisms [1]. Naturally occurring, complete absence of rhythms in physiology and behavior (arrhythmicity), is uncommon.

The circadian fluctuations in a physiological variable can be plotted, in a simplistic manner, as a function with a period of approximately 24 h (Fig. 1 i). Note that the shape of circadian oscillations may vary greatly and will be determined by the physiological variable being measured. From this function, several measurements can be made. The phase of the circadian rhythm, (represented by the Greek letter  $\phi$ ,  $\varphi$ ) is a point of the function that can be reliably be measured over successive cycles. This phase marker is useful in determining other parameters of the circadian oscillation (or, in fact, any oscillation). The frequency of the circadian oscillation, or ►period of the rhythm (represented by the Greek letter  $\tau$ ,  $\tau$ ), can be measured between two or more consecutive stable phase markers on the curve. The amplitude (represented by the letter  $a$ ), is defined as the difference between the maximum (acrophase or peak) and minimum (bathypase or trough) values of the physiological variable measured. Of special interest to circadian ►oscillators is the fact that these parameters (phase, period, and amplitude) are endogenous, self sustaining, and relatively constant through time when the organism is kept in ►constant conditions. In contrast, during circadian arrhythmicity, none of the above parameters are constant (Fig. 1 ii). No reliable period can be extracted, the amplitude varies greatly through time, and a reliable phase marker is absent.

Figure 2 shows a representative behavioral ►actogram for a rhythmic (i) and an arrhythmic (ii) rat. In addition, Chi-square ( $X^2$ ) periodograms are also displayed for both animals (iii). Both will be described in detail below.

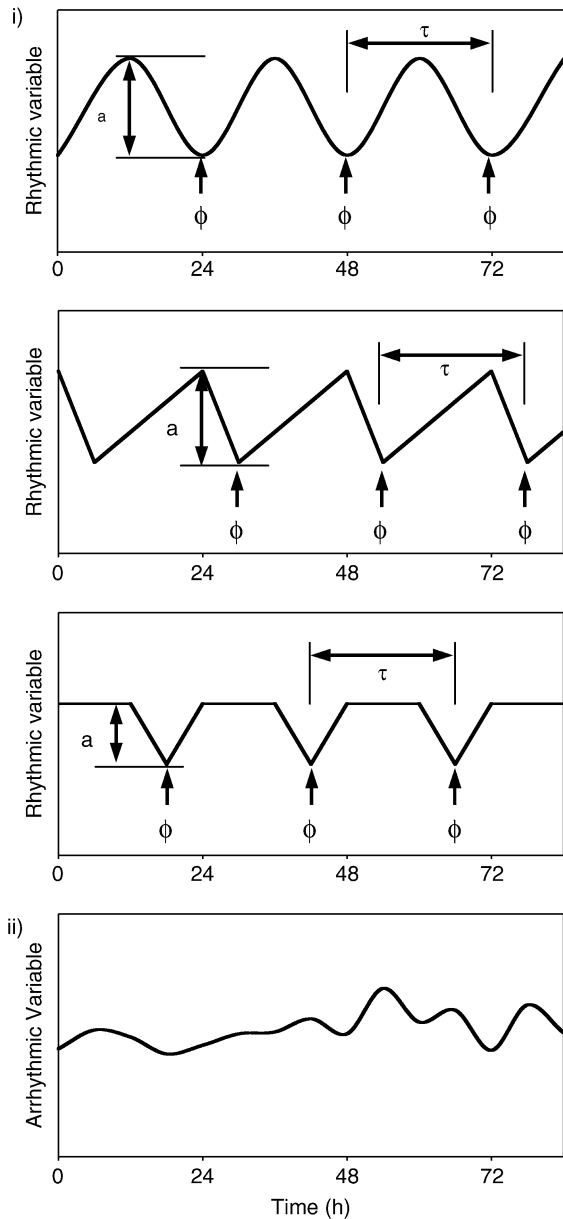

**Arrhythmicity/Rhythmicity. Figure 1** The circadian oscillation.

The preferred graphical representation for circadian rhythms is the actogram (Fig. 2 i, 2 ii). Actograms display time of day on the abscissa, and consecutive days on the ordinate. Activity counts are usually summed into 6 or 10 min intervals, or activity bins, and are represented as black ticks along the abscissa. Double-plotted actograms display 48 h of circadian activity on each line, facilitating the visualization of the rhythm. Although actograms were originally designed to graphically represent the locomotor activity rhythm of an organism, they can be used to plot

other physiological variables such as temperature, pupal eclosion, cell firing, or gene expression. The actogram on the left shows running wheel activity of a rat housed in complete darkness (Fig. 2 i). From this actogram, one can easily determine the phase of the rhythm: in this case (and by convention) locomotor activity onset; the period of the rhythm (the slope of the eye-fitted line of best fit that passes through successive activity onsets); and the amplitude of the rhythm (high activity at subjective nighttime (► subjective day/night), low activity at subjective daytime). In contrast, the actogram on the right shows arrhythmicity in a rat following a lesion of the central ► circadian pacemaker (Fig. 2 ii). Following the lesion (red dot on the actogram), no clear phase, period, or amplitude of the rhythms can be measured.

The Chi-square periodogram (Fig. 2 iii) is a statistical test that is commonly used to extract the presence, and compute the value, of circadian periods within a given time series data set. This procedure was first developed by Enright [2] and later refined by Sokolove & Bushnell [3]. Typically, a minimum of 10 consecutive days of activity data is required for the accurate computation of circadian periods using the Chi-square periodogram. Significant periods present in the sample are observed as peaks above the significance level of the Chi-square statistic. As can be seen in the periodogram in Fig. 2 iii, there is one significant and dominant period very close to 24 h in the rhythmic animal (Fig. 2 i) and a multitude of different periods in the arrhythmic animal (Fig. 2 ii). The Chi-square periodogram has the advantage of reducing experimenter bias in the computation of the period of circadian rhythms compared to the eye-fitted regression line used in the actogram. However, the precision of the Chi-square periodogram is affected by the size of the bins used to collect the activity data, and by very short data sets.

### Dependence on the Circadian Clock

Circadian rhythmicity in all organisms is driven by a small set of ► putative clock genes that are interlinked into one or more transcription-translation ► feedback loops [4]. These genes are expressed in various cell types, tissues, organs and organisms [1]. In animals with a central nervous system, a central pacemaker is responsible for the generation of circadian rhythms. For example, in mammals, the primary circadian pacemaker is localized within the hypothalamic ► suprachiasmatic nucleus (SCN). In *Drosophila melanogaster*, a small set of lateral neurons (LN) in the fly brain are responsible for circadian rhythmicity. Lesion of the mammalian SCN or the *Drosophila* LN will abolish rhythmicity. Mutations in the molecular mechanism driving the circadian oscillation will also lead to altered rhythmicity and/or arrhythmicity. For example, the ► tau

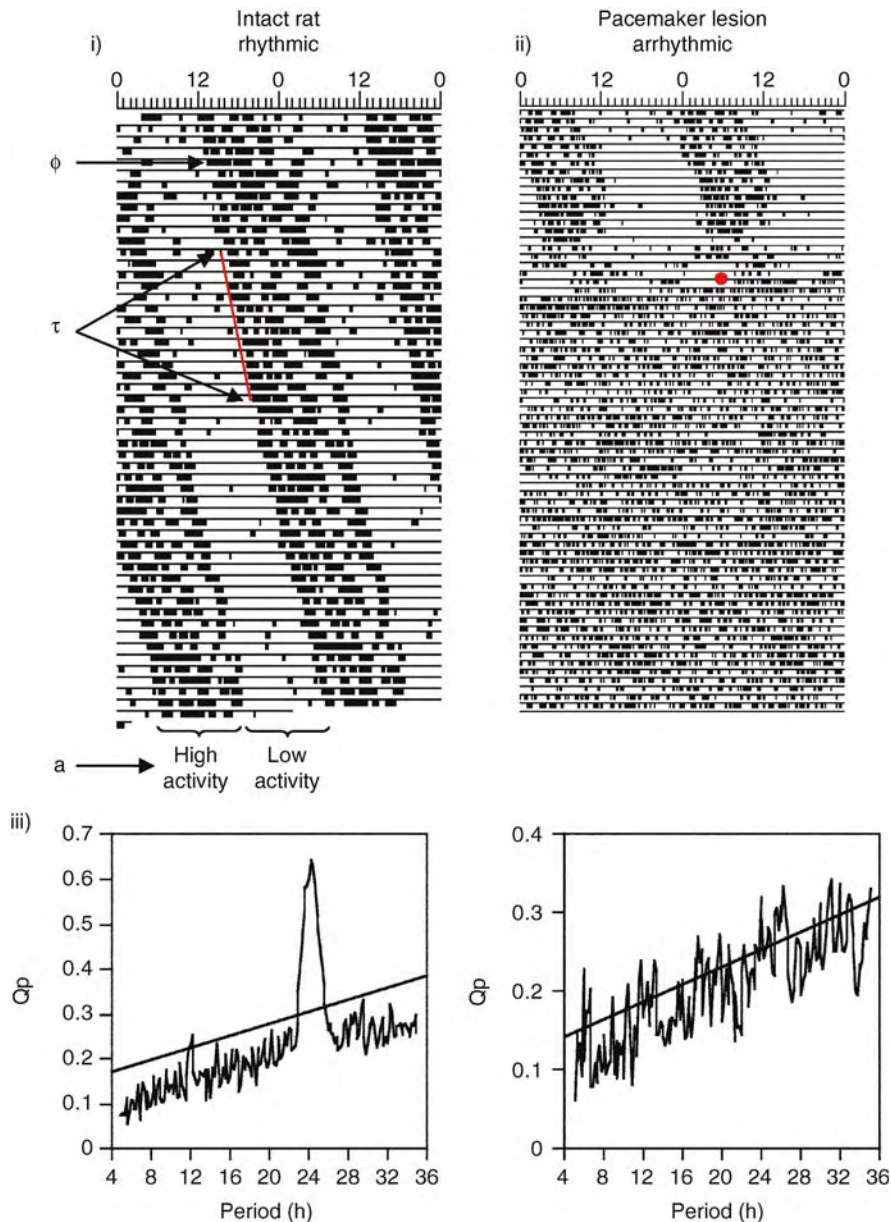

**Arrhythmicity/Rhythmicity. Figure 2** The actogram and periodogram as ways to analyze rhythmicity and arrhythmicity.

mutation in hamsters, which affects a key regulatory enzyme, leads to a circadian period of about 20 h [5]. The genes *cryptochrome*, *period*, and *bmal1* in mammals are considered essential components of the molecular clock and mutating or knocking-out these genes will lead to drastic changes in period and arrhythmicity [4]. In flies, the *timeless* gene is an essential component of the circadian machinery and its absence leads to arrhythmicity [6]. In *Neurospora*, the circadian oscillation relies on the expression of the *frequency* and *white-collar* genes [7].

### Environmental Causes for Arrhythmicity

Circadian arrhythmicity can occur through several ways. As described previously, destruction of the central pacemaker or mutations in key genetic elements will lead to immediate loss of circadian rhythmicity at the behavioral and physiological levels (see Fig. 2 ii). However, environmental signals can cause arrhythmicity as well. The best known exogenous stimulus that will severely affect circadian rhythmicity and often lead to arrhythmicity is light. Constant bright light exposure will initially affect the period of the circadian oscillation

(see ► **Aschoff's Rules**). Over time, constant light will lead to disruptions of circadian rhythms. ► **Splitting**, the fragmentation of the ► **activity phase** into two components 180° out of phase, occurs in mice and hamsters housed in constant bright light. Constant light can eventually lead to complete arrhythmicity, similar to what can be observed after destruction of the central pacemaker (Fig. 2 ii). Interestingly, the disruptive effects of constant light are slow to appear and typically necessitate weeks or months of constant exposure. The effects of constant light are also intensity-dependent. Constant light of low intensity is less disruptive than high intensity constant light. Importantly, the effects of constant light on rhythmicity cannot be attributed to a destruction of the pacemaker, because rhythmicity is restored upon transfer to complete darkness or a light/dark cycle.

## References

1. Dunlap JC (1999) Molecular bases for circadian clocks. *Cell* 96:271–290
2. Enright JT (1965) The search for rhythmicity in biological time-series. *J Theor Biol* 8:426–468
3. Sokolove PG, Bushell WN (1978) The chi square periodogram: its utility for analysis of circadian rhythms. *J Theor Biol* 72:131–160
4. Wager-Smith K, Kay SA (2000) Circadian rhythm genetics: from flies to mice to humans. *Nat Genet* 26:23–27
5. Ralph MR, Menaker M (1988) A mutation of the circadian system in golden hamsters. *Science* 241:1225–1227
6. Sehgal A, Price JL, Man B, Young MW (1994) Loss of circadian behavioral rhythms and per RNA oscillations in the *Drosophila* mutant timeless. *Science* 263:1603–1606
7. Dunlap JC, Loros JJ (2004) The neurospora circadian system. *J Biol Rhythms* 19:414–424

## Artemin

### Definition

A member of the glial cell line-derived neurotrophic factor (GDNF) family of neurotrophic factors that also includes neuroturin and persephin. GDNF family members use a receptor complex that consists of the common receptor tyrosine kinase signaling component.

Ret and one of the GPI-linked receptors (GFR $\alpha$ 1 to 4) that regulate ligand binding specificity. GFR $\alpha$ 3 is the preferred receptor for artemin.

- Glia Cell Line-derived Neurotrophic Factor (GDNF)
- Neurotrophic Factors in Nerve Regeneration
- Neuroturin
- Persephin

## Arterially Perfused Brainstem

- Central Integration of Cardiovascular and Respiratory Activity Studied In Situ

## Arthralgia

### Definition

Joint pain.

- Joints

## Arthritis

### Definition

Joint inflammation.

- Joints

## Arthropathy

### Definition

Painful, dysfunctional joint.

- Joints

## Arthroplasty

### Definition

Orthopedic surgery to rebuild or replace a joint.

- Joints

## Articular Cartilage

WALTER HERZOG

Professor, Faculty of Kinesiology, University of Calgary, Calgary, Canada

### Definition

Articular cartilage is a thin layer of fibrous connective tissue on the articular surfaces of bones in synovial joints (Fig. 1).

It consists of cells (2–15% in terms of volumetric fraction) and an intercellular ▶matrix (85–98%) that is made up of 65–80% water.

### Characteristics

#### Function

The major functions of articular cartilage are to transfer forces between articulating bones, to distribute forces in joints and to provide a nearly frictionless surface for joint movement.

#### Description of the Structure

Articular cartilage is heterogeneous and its material properties change as a function of depth. Although these changes are continuous, articular cartilage is typically divided into four zones (Fig. 2).

- Superficial zone
- Middle (or transitional) zone
- Deep (or radial) zone
- Calcified zone

The superficial zone is the thinnest, most superficial region that provides the gliding surface for joints. It

contains a superficial layer (▶*lamina splendens*) of about 2 μm thickness that is made up of randomly aligned ▶collagen fibrils and a deep layer of collagen fibrils aligned parallel to the cartilage surface following the so-called “split line” pattern [1], which follows the direction of normal joint movement.

The collagen fibrils of the superficial zone show a wave-like pattern referred to as ▶*crimp*. The deep layer of the superficial zone contains articular cartilage cells (▶*chondrocytes*) that are flat and metabolically relatively inactive [2], contains little proteoglycan, but has the highest water concentration of all zones (about 80%) [3].

The middle (or transitional) zone is typically thicker than the superficial zone. Collagen fibrils have a greater diameter in this zone than in the superficial zone and are oriented randomly. The proteoglycan content is greater and aggregate complexes are larger than in the superficial zone. The chondrocytes are nearly spherical and are thought to be metabolically more active than those in the superficial zone.

The deep (or radial) zone contains the largest diameter collagen fibrils. They are oriented perpendicularly to the subchondral bone and the cartilage surface. The chondrocytes tend to be aligned in radial columns and are thought to be metabolically highly active.

The calcified zone provides the mechanical transition that separates the relatively soft cartilage tissue from the stiff subchondral bone. It is characterized by hydroxyapatite, an inorganic constituent of the bone matrix. The calcified zone is separated from the deep (radial) zone by the ▶*tidemark*, an undulating line of a few micrometers thickness. Collagen fibers from the deep zone penetrate the tidemark and anchor the calcified zone, thereby adhering cartilage to bone. The calcified zone contains metabolically active

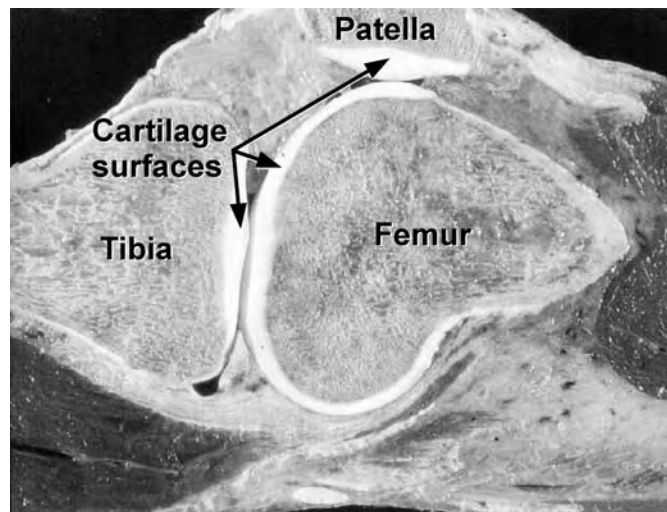

**Articular Cartilage. Figure 1** Sagittal plane section through a human knee showing the femur, tibia, and patella and associated articular cartilage.

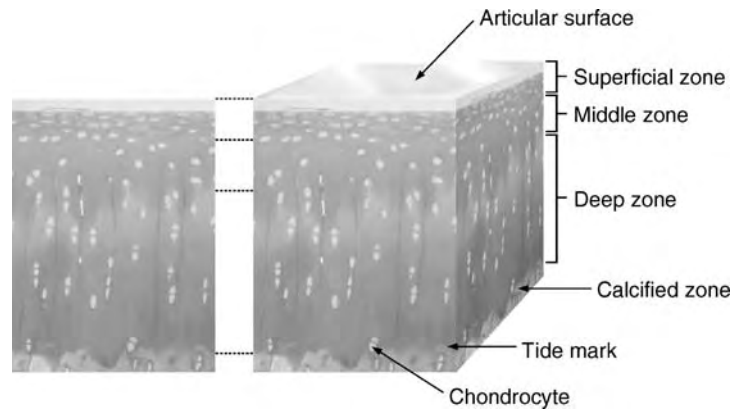

**Articular Cartilage. Figure 2** The four zones of articular cartilage. The superficial zone provides the sliding surface of joints with collagen fibrils aligned parallel to the surface and flat, relatively metabolically inactive cells. The middle (or transitional) zone contains collagen fibrils that are oriented randomly, and cells that are nearly spherical. The deep (or radial) zone contains collagen fibrils that are oriented perpendicular to the subchondral bone (and articular surface) and the cells are typically aligned in radial columns. The calcified zone provides a mechanical transition that separates the relatively soft cartilage tissue from the stiff subchondral bone.

chondrocytes, serves for structural integration and is considered important for nutrition and cartilage repair arising from the underlying bone [4].

### Composition

Articular cartilage consists mostly (85–98%) of *matrix* and a sparse population of cells (2–15%). It is avascular, aneural and alymphatic.

*Chondrocytes* are metabolically active cells in articular cartilage that are responsible for the synthesis and degradation of the matrix. They are isolated, lie in lacunae and receive nourishment through diffusion of substrates. The volumetric fraction, shape and metabolic activity of chondrocytes vary as a function of cartilage depth. Chondrocytes are soft compared to the surrounding matrix, but they are surrounded by a protective cover that consists of a pericellular matrix and capsule, called a **▶chondron**.

The *intercellular matrix* consists of structural macromolecules and fluid. Fluid comprises the greatest part of the extracellular matrix and its volume fraction decreases from the superficial (80%) to the deep zone (65%). Macromolecules, which are produced by the chondrocytes, comprise the remaining 20–35% of the matrix. Of the macromolecules, collagens are the most abundant (50%), while **▶proteoglycans** make up about 20–35%, and non-collagenous proteins/glycoproteins contribute 15–20% to the tissue dry weight [5].

There are at least 18 different types of *collagen*. However, in articular cartilage, type II collagen is by far the most abundant (about 80–85% of all collagens). Other types of collagen (V, VI, IX, X and XI) are also found in articular cartilage and have been associated

with specific functional roles [6, 7]. Collagen molecules are comprised of three  $\alpha$ -chains that are interwoven in a helical configuration. Each chain has a high hydroxylysine content and covalently bound carbohydrates that make it readily adhere to proteoglycans.

Collagens form a structural network that gives cartilage its tensile strength. Because of the characteristic orientation of the fibrillar network, collagens are associated with providing resistance to compressive loading through their coupling with fluid pressurization. Collagens are cross-linked for further strength [8] and are connected to proteoglycans via molecular chains arising from glycosaminoglycans and polysaccharides. Thus, collagens are intimately connected to other macromolecules and so make up a tough tissue that can withstand high repetitive loading effectively.

*Proteoglycans* are large molecules composed of a central core protein with glycosaminoglycan side chains covalently attached. The side chains contain sugars with a negative charge. When cartilage is loaded, proteoglycans are compressed and the repulsive forces from the negatively charged side chains are increased compared to the natural pre-tensed state.

Articular cartilage contains large aggregating proteoglycans (aggrecan and versican) and small interstitial proteoglycans (biglycan, decorin, fibromodulin and lumican). Aggrecan is the major proteoglycan. It consists of a core protein and up to 150 chondroitin and keratan sulfate chains (Fig. 3).

The core protein's N-terminal G1 domain interacts with link proteins and hyaluronan and these components form stable macromolecular complexes.

Changes in proteoglycan structure and decreased density often accompany articular cartilage degeneration

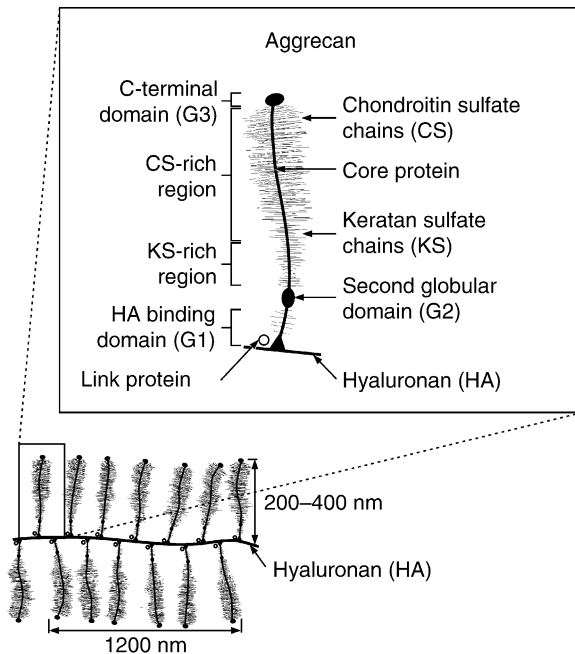

**Articular Cartilage. Figure 3** Macromolecular aggregate formed by aggrecan molecules (*inset-blown up*) binding to a chain of hyaluronan through a link protein. The aggrecan molecule consists of a core protein with several domains: hyaluronan binding G1 domain, G2 domain, keratin sulfate-rich region, chondroitin sulfate-rich region and C-terminal domain, G3.

and aging [9, 10]. These changes are associated with increases in water content, decreased stiffness and reduced resistance to withstand mechanical loading. They are often the first signs of ►osteoarthritis.

*Non-collagenous proteins* play a role in the assembly and integrity of the extracellular matrix. They form links between chondrocytes and matrix. Non-collagenous proteins include adhesive glycoproteins such as fibronectin, thrombospondin, chondroadherin and other matrix proteins such as the link protein, cartilage matrix oligomeric protein, cartilage matrix protein and proline/arginine-rich and leucine-rich repeat proteins.

Articular cartilage tissue *fluid* consists of water and dissolved gas, small proteins and metabolites. Loading of the articular cartilage produces fluid pressurization and movement. The tissue fluid is closely associated with the ►synovial fluid of the joint, which is essential for virtually frictionless movement of the articulating surfaces.

### Osteoarthritis

Osteoarthritis is a joint degenerative disease that affects about 50% of all people above the age of 60 in North

America. It is associated with a thinning and local loss of articular cartilage from the joint surfaces, osteophyte formation at the joint margins, swelling of the joint and pain. The causes for osteoarthritis are not well understood, although it is agreed that they are multi-factorial. Acknowledged risk factors include age, injury, weakness and obesity.

### References

1. Hultkrantz W (1898) Über die spalttrichtungen der gelenkknorpel. Verh Anat Ges 12:248–256
2. Wong M, Wuethrich P, Egli P, Hunziker E (1996) Zone-specific cell biosynthetic activity in mature bovine articular cartilage: a new method using confocal microscopic stereology and quantitative autoradiography. J Orthop Res 14(3):424–432
3. Maroudas A (1975) Biophysical chemistry of cartilaginous tissues with special reference to solute and fluid transport. Biorheology 12:233–248
4. Hunziker E (1992) Articular cartilage structure in humans and experimental animals. In: Peyron KE, Schleyerback JG, Hascall VC (eds) Articular cartilage and osteoarthritis. Raven, New York, pp 183–199
5. Buckwalter JA, Hunziker EB, Rosenberg LC, Coutts R, Adams M, Eyre D (1991) Articular cartilage: composition and structure. In: Woo SL-Y, Buckwalter JA (eds) Injury and repair of the musculoskeletal soft tissues. American Academy Orthopaedic Surgeons, Park Ridge, pp 405–425
6. Hasler EM, Herzog W, Wu JZ, Muller W, Wyss U (1999) Articular cartilage biomechanics: theoretical models, material properties, and biosynthetic response. Crit Rev Biomed Eng 27(6):415–488
7. Thomas JT, Ayad S, Grant ME (1994) Cartilage collagens: strategies for the study of their organisation and expression in the extracellular matrix. Ann Rheum Dis 53:488–496
8. Pins GD, Christiansen DL, Patel R, Silver FH (1997) Self-assembly of collagen fibers. Influence of fibrillar alignment and decorin on mechanical properties. Biophys J 73:2164–2172
9. Buckwalter JA, Kuettner KE, Thonar EJ (1985) Age-related changes in articular cartilage proteoglycans: electron microscopic studies. J Orthop Res 3:251–257
10. Lark MW, Bayne EK, Flanagan J, Harper CF, Hoerner LA, Hutchinson NI, Singer II, Donatelli SA, Weidner JR, Williams HR, Mumford RA, Lohmander LS (1997) Aggrecan degradation in human cartilage. Evidence for both matrix metalloproteinase and aggrecanase activity in normal, osteoarthritic, and rheumatoid joints. J Clin Invest 100:93–106

## Articular Pain

►Joint Pain



## Articulation

### Definition

The act or manner of producing a speech sound using the vocal tract (oral and nasal tracts).

► Speech Perception

## Artificial Intelligence

### Definition

The view that mental processes can be simulated or replicated in computers, at least in principle; that is, artificial systems can realize mental processes.

► Reductionism (Anti-Reductionism, Reductive Explanation)

## Artificial Life

### Definition

The study of life and life-like processes through simulation and synthesis.

► Emergence

## Artificial Neural Networks

BAGRAT AMIRIKIAN

Brain Sciences Center, Veterans Administration Medical Center, Minneapolis, MN, USA; Department of Neuroscience, University of Minnesota Medical School, Minneapolis, MN, USA

### Definition

Neural network modeling is a powerful research tool based on the combination of theoretical methods, including mathematical analyses and computer simulations, and is complementary to experimental techniques in neuroscience research. Neural networks are used to

understand how actual neuronal networks in a particular brain area represent and process information, and how they perform specific computations such as planning and execution of movements.

### Description of the Theory

#### General Frameworks

The relationship between theory and experiment plays an important role in neural network modeling and creates a wide spectrum of approaches [1–3]. Some models are heavily based on the anatomical and electrophysiological properties of the actual neuronal networks involved. Studies along this line usually proceed from the detailed description of single cells to the behavior of the network. This approach is most useful when accurate experimental data at the morphological and physiological levels are available, the function of the neuronal network is already known, and the network itself is relatively small. Such models can determine whether existing data are sufficient to explain observed network behavior, and intend to pinpoint drawbacks and missing components in the model. The alternative to this *data-driven/bottom-up* approach is a *theory-driven/top-down* approach. Here, the emphasis shifts to descriptions of higher-level functions such as a perceptual ability. Based on the theoretical analysis, an algorithm that performs the desired function is developed first and then embedded into a simplified network while imposing known biological constraints. This kind of approach tends to be more loosely bound to particular experimental data. However, by sacrificing specificity, the theory-driven approach attempts to address fundamental and puzzling questions, and can help in formulating and testing what kind of computational algorithms the brain is using in different tasks. In the long run, this approach is expected to suggest new experiments and research directions.

Whereas the data-driven and theory-driven approaches represent two opposite extremes, there are varieties of other approaches that combine different proportions of the “abstract” and “realistic” components of the modeling and fill in the gap between these two extremes. Anyhow, biologically plausible models must not contain all the known features of the target system; they need to include only those features that are necessary to accurately simulate a particular phenomenon under study.

In this essay, only basic concepts relevant to the modeling of large-scale neural networks are considered. For further readings on the theory-driven approaches, see the book by Hertz et al. [4] and the review by Ermentrout [5] that focus not so much on biological modeling as on general theoretical approaches and algorithms. In contrast, the monograph by Anderson [6] and the textbook by Dayan and Abbott [7] consider neural networks from a broad neuroscience perspective, with an emphasis on the biology behind the assumptions of

models, as well as on for what the models might be used. Finally, the link between the theoretical studies and experimental approaches is the main concern of the book by Koch and Segev [2]. It has an excellent collection of papers for those interested in biophysical mechanisms of computation in neurons and networks.

## Network Architecture and Operation

### Units and Connections

Depending on the complexity of a target neuronal system and the desired level of realism, each unit of the model network may simulate either a single neuron or a set of similar neurons with coherent functional properties. The communication of activity from one neuron to another is modeled by means of a connection between a corresponding pair of units. The entire set of units and the pattern of connections between them define the architecture of the network. The realistic design of architecture requires knowledge of the underlying neural structure from neuroanatomical studies. When such data are not available, which is often the case, an educated guess based on other indirect studies could be useful.

### Types of Units

Each unit can be classified as input, output, or hidden depending on the role that it plays in the operation of the network. ► **Input units** receive external signals that may represent sensory signals, signals from other networks, or some events in the external environment of an organism. The stimulation of input units may then change the activities of ► **hidden units** to which they are connected. This perturbation may further propagate across the whole network through connections to other hidden units and ultimately reach the ► **output units**.

The role of the latter is to provide an input to another network or simulate events at the behavioral level, for example, a motor action. Depending on the network architecture and its interpretation, the input, hidden, and output units may overlap partially or completely.

### Types of Architecture

There are two prevailing network architectures in neural networks. Fig. 1a shows an example of layered ► **feed-forward network**. The role of the input units is to feed external signals to the rest of the network.

All connections are feed-forward. There are no connections between units in the same layer. Units in the intermediate layers are considered as hidden units, whereas the last layer represents the output units.

Networks that are not strictly feed-forward but include feedback connections are called recurrent networks. An example of a fully ► **recurrent network** is presented in Fig. 1b. Unlike the feed-forward architecture, there is no explicit distinction between input, hidden and output units.

### Dynamical Rules

The specification of architecture is necessary but not sufficient for the complete definition of network operation. One also needs to define the dynamical rules that stipulate how and when the state of each neuron is updated. Once the network is fully specified its operation is to transform the input signals into output ones.

## Single Neuron Models and Synaptic Interactions

### Integrate-and-Fire Model

A simple single-neuron model that generates action potentials is known as ► **integrate-and-fire neuron**. The basic idea is to divide the operation of a neuron  $i$  into

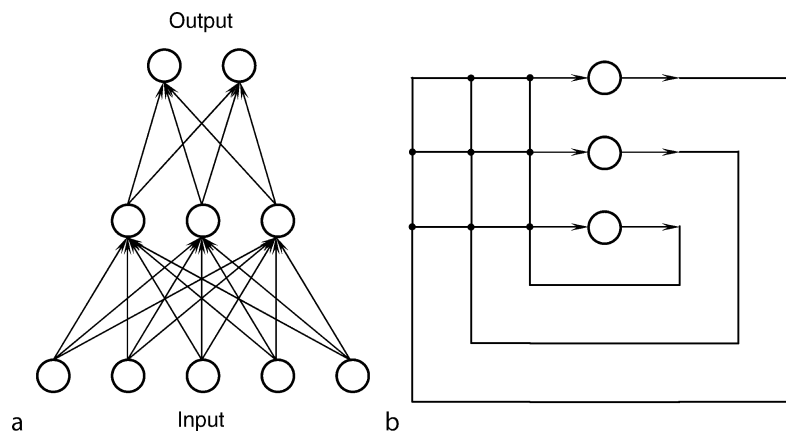

**Artificial Neural Networks. Figure 1** (a) Network architecture. Circles represent units, whereas lines show connections between them. Arrows indicate the directions of connections. (a) Feed-forward network with one hidden layer. (b) Fully recurrent network with three units.

two qualitatively different modes. In the first mode, the neuron builds up its membrane potential starting from a specific value  $u_i^{\text{rst}}$ , called the reset potential, by temporally integrating its inputs. During this mode, the membrane potential  $u_i(t)$  at an instant of time  $t$  obeys the dynamical rule given by a resistor-capacitor circuit charging equation:

$$\tau_i \frac{du_i}{dt} = -u_i(t) + R_i I_i(t). \quad (1)$$

Here, the time constant  $\tau_i = R_i C_i$  depends on the resistance,  $R_i$ , and capacitance,  $C_i$ , properties of the cell membrane; the term  $-u_i(t)$  is the trans-membrane leakage, whereas  $I_i(t)$  is the total synaptic current charging the spike emitting part of the cell, soma. Once the potential  $u_i(t)$  reaches a specific threshold value  $u_i^{\text{thr}}$ , the neuron enters into its second mode of operation by instantaneously firing a spike and resetting the potential to  $u_i^{\text{rst}}$ . After an absolute refractory period, during which the cell cannot emit spikes, the neuron restarts its operation in the first mode. Thus, the outcome of the model is the alteration of the prolonged period of integration and instantaneous firing.

In the framework of integrate-and-fire model, the effective synaptic current  $I_i(t)$  charging the soma can be modeled in several ways. The dynamics of  $I_i(t)$  depends on a set of synaptic time constants  $\{\tau_{ij}^{\text{syn}}\}$ . Each  $\tau_{ij}^{\text{syn}}$  characterizes the temporal variation of the synaptic conductance of neuron  $i$  invoked by arriving spikes fired by neuron  $j$ . In the approximation  $\tau_{ij}^{\text{syn}} \ll \tau_i$ , i.e. when the characteristic time of the synaptic current changes is much shorter than that of the charging of the soma, the effective total current  $I_i(t)$  is represented by a sum of elementary contributions made at the time of arrival of individual spikes [8]:

$$I_i(t) = \tau_i \sum_j w_{ij} \sum_k \delta(t - t_j^k - \Delta_{ij}), \quad (2)$$

where  $t_j^k$  is the time when neuron  $j$  emitted the  $k$ -th spike,  $\Delta_{ij}$  is the delay in the arriving time at synapse  $i$  of spikes fired by neuron  $j$ , and  $\delta(x)$  is the Dirac delta function. The synaptic efficacy,  $w_{ij}$ , is expressed in units of the current.

### Conductance-Based Models

A more realistic approach to representing the effective charging current  $I_i(t)$  utilizes a **conductance-based model** that accounts for a variety of transmembrane ionic currents. In this framework, (1) is usually given in the following form:

$$C_i \frac{du_i}{dt} + I_i^{\text{ion}}(t) = 0. \quad (3)$$

Here,  $I_i^{\text{ion}}(t)$  designates the net transmembrane ionic current, including the leakage. It is assumed that all ionic

current flow occurs through membrane channels, and the instantaneous voltage-current relationship obeys Ohm's law. The ionic current through channels of a particular type  $chn$  is then given by a linear expression:

$$I_i^{\text{chn}}(t) = g^{\text{chn}}(u_i(t) - E^{\text{chn}}), \quad (4)$$

whereas the net ionic current  $I_i^{\text{ion}}(t)$  is a simple sum of the currents through different types of channels:  $I_i^{\text{ion}}(t) = \sum_{\text{chn}} I_i^{\text{chn}}(t)$ . Here,  $g^{\text{chn}}$  is the conductance associated with the specific type of channel  $chn$ . The sign of the expression in (4), which indicates whether the current is outward or inward, depends on whether the membrane potential  $u_i(t)$  is above or below the channel reversal potential  $E^{\text{chn}}$ . It is usually assumed that  $E^{\text{chn}}$  does not explicitly depend on time or potential. The known ion channels can be divided into three distinct types: passive or leak, synaptic, and active. Depending on the type of the channel, the corresponding conductance  $g^{\text{chn}}$  may have a mathematical description that ranges from very simple to very complex. For example, the passive channels are represented by a constant (time- and voltage-independent) conductance. Other channels, such as those located at synapses, change their conductance to certain ions when the appropriate chemical agents (e.g. neurotransmitters or second messengers) bind to their receptors. As the release of chemical agents is triggered by a presynaptic action potential, the conductance of the synaptic channels is modeled as a time-dependent but voltage-independent function that has a sharp peak at the spike arrival time. The active channels have conductances that are both voltage- and time-dependent. The model neuron that incorporates these types of nonlinear channels may produce responses that mimic not only a subthreshold mode but also the generation of action potentials. Unlike the integrate-and-fire model, in which spikes are discontinuous in time, here the spike generation occurs in a continuous-time fashion. Therefore, the model neuron of this type, often referred to as Hodgkin and Huxley [9] or biophysical model, may produce action potentials that have a shape similar to those observed in experiments.

### Compartmental Approach and Realistic Modeling

The models considered so far are *single-point models* that disregard the underlying spatial structure of the neuron. The application of cable theory to nerve axons and dendrites, as well as the introduction of a **compartmental approach**, made it possible to develop increasingly realistic models of a single neuron. Advanced biophysical models of this kind, which are trying to incorporate as much morphological and physiological data as possible, represent a neuron as a set of electrically coupled isopotential compartments. The basic assumption is that the continuously distributed system can be divided into small segments,

called compartments. The geometry of compartments is modeled as an ellipsoid (soma) or cylinder (dendritic or axonal branch) of various sizes. Electrically, each compartment is modeled as a resistance-capacitance pair. Adjacent compartments are connected by series resistances. One must be aware, however, that detailed biophysical models incorporate a vast number of adjustable parameters. While these models are adequate for studying the behavior of a single neuron or a neuronal circuitry composed from a few cells, their application to large-scale networks may be inappropriate.

### Learning and Generalization

The performance of a neural network, which is the relationship between the input signals and the output units' activities produced by the network in response, depends on several factors such as the connectivity pattern, number of neurons, synaptic interactions, etc. Traditionally, the network performance is adjusted by varying only a set of parameters  $\mathbf{w}$  that, in the framework of the underlying model, effectively control the strengths of synaptic connections (e.g. synaptic efficacies in integrate-and-fire model, or synaptic conductances in conductance-based models). Such an approach is consonant to numerous experimental observations, indicating that during relatively short time periods the key mechanism, by which neuronal networks change their behavior, is the modification of the conductivity of pre-existing synapses (i.e. modification of the strength of connections) rather than the variation of the number of neurons or formation of new connections between them (i.e. modification of the network size and the connectivity pattern, respectively). For the sake of certainty, we shall refer to the parameters  $\mathbf{w}$  as the connection weights.

A fixed set of  $\mathbf{w}$  corresponds to a specific input-output transformation task implemented by the network. As the values of individual weights change, the same signals acting on the input units generate different activities of the output units. Therefore, by varying  $\mathbf{w}$ , one can force the network to implement different transformation tasks. This also means that the network memorizes the task that it implements in the set of connection weights  $\mathbf{w}$ . A key question in the theory of neural networks concerns the problem of *learning*: "How do we choose the connection weights so the network implements a specific task of interest?" The systematic adjustment of the connection weights, the goal of which is to find such a set  $\mathbf{w}$  that implements the desired task, is called training or learning and is described by a corresponding ►learning algorithm.

The common approach to network learning is formulated as follows. The known examples (i.e. input-output pairs) of a particular transformation task to be learned are divided into two subsets: the training set and the

testing set. The former is used to train the network to produce an appropriate output for each input in the set by applying a specific learning algorithm. It is expected that after training, the network will generate correct (or nearly correct) responses for all examples in the training set. Next, one would like to check whether the network indeed has learned the transformation task or whether it has simply memorized examples in the training set. For that purpose, examples from the testing set are presented to the network. If the responses to the novel examples of the same task are correct, then it is said that a *generalization* has taken place. If, however, the number of correct responses is at a chance level then there is no generalization.

### Types of Learning Paradigms

Two types of learning paradigms are generally distinguished: supervised and unsupervised. ►Supervised learning requires the knowledge of correct output responses for all examples in the training set. In this approach, which is also known as learning with a teacher, a direct comparison of the produced outputs against the correct responses provides a feedback to the network about its performance. The comparison is done in terms of the error function  $E(\mathbf{w})$  that is, as a rule, a simple quadratic form of differences between the produced and correct outputs. The learning algorithm is an iterative procedure that adjusts the connection weights based on the feedback error  $E(\mathbf{w})$ . Its ultimate goal is to find such a set of the connections  $\mathbf{w}$  that minimizes the error function. Thus, supervised learning, in essence, is an optimization problem. ►Back propagation and ►simulated annealing (see [4,6]) are two examples of supervised learning algorithms commonly used in neural networks.

Unlike supervised learning, in ►unsupervised learning there is no teacher and corresponding algorithms do not require any feedback about the performance. Therefore, unsupervised learning can be used when correct responses to the inputs in the examples are not known, or the learning goal at the neural level is not explicitly defined. In the course of unsupervised learning, the network is expected to detect features and regularities in the input signals by itself, and represent them in the output in some appropriate way. In the framework of this approach, during the presentation of an example in the training phase, the modification of an individual connection weight is influenced only by the states (activities) of the two units that it is linked to and by its own state (value). Thus, in unsupervised learning, changes in connection weights are affected only by local events whereas in supervised learning, due to the global character of the feedback error, those changes are affected by remote events (i.e. activities of the output units). In contrast to supervised learning, the unsupervised learning paradigm could

therefore provide a suitable framework for studying biological mechanisms of learning. A well-known example of unsupervised learning is ► **Hebbian learning** rule, which stipulates that concurrent firing in the pre- and post-synaptic neurons strengthens the synaptic connection.

## References

1. Abeles M (1991) *Corticonics: neural circuits of the cerebral cortex*. Cambridge University Press, Cambridge, New York
2. Koch C, Segev I (1998) *Methods in neuronal modeling: from ions to networks*. MIT Press, Cambridge, London
3. Marder E, Kopell N, Sigvardt K (1997) How computation aids in understanding biological networks. In: Stein PSG, Grillner S, Selverston AI, Stuart DG (eds) *Neurons, networks, and motor behavior*. MIT Press, Cambridge, London, pp 139–149
4. Hertz J, Krogh A, Palmer RG (1991) *Introduction to the theory of neural computation*. Addison-Wesley, Redwood City
5. Ermentrout GB (1998) Neural networks as spatio-temporal pattern-forming systems. *Rep Prog Phys* 61:353–430
6. Anderson JA (1995) *An introduction to neural networks*. MIT Press, Cambridge, London
7. Dayan P, Abbott LF (2001) *Theoretical neuroscience: computational and mathematical modeling of neural systems*. MIT Press, Cambridge, London
8. Amit DJ, Tsodyks MV (1991) Quantitative study of attractor neural network retrieving at low spike rates I: substrate – spikes, rates and neuronal gain. *Network Comput Neural Syst* 2:259–273
9. Hodgkin AL, Huxley AF (1952) A quantitative description of membrane current and its application to conduction and excitation in nerve. *J Physiol Lond* 117:500–544

## Artificial Neural Networks

► **Connectionism**

## Ascending Conjunctive Brachium

### Definition

► **Cerebellum**

► **Superior Cerebral Pedunculus**, ► **Ascending Branch**

## Ascending Neuromodulatory Projections

### Definition

This collective term is used to describe a number of varyingly loosely aggregated collections of neurons occupying the brainstem or basal forebrain that are characterized by long projections that ascend to innervate, usually diffusely, the cerebral cortex and certain of the deep telencephalic nuclei. Such projections are further characterized on the basis of their major neurotransmitters, among which are included epinephrine, norepinephrine, dopamine, serotonin, histamine, orexin and acetylcholine. Consistent with the typically neuromodulatory effects of such projection systems on telencephalic functions, they have also been referred to as “state-setting projections.”

## Ascending Nociceptive Pathways

STEVE DAVIDSON, GLENN J. GIESLER, JR  
Department of Neuroscience, University of Minnesota,  
Minneapolis, MN, USA

### Synonyms

Anterolateral pathway; Pain system; Ascending pain pathways

### Definition

Nociceptive neurons in the spinal cord and trigeminal nuclei send their axons to terminate within a large number of regions in the upper cervical spinal cord, brainstem and diencephalon. These neurons provide a link between peripheral nociceptors and pain perception in the brain. Precise roles for each ascending pathway in nociception have not yet been established with certainty and it is likely that their roles vary among species. This overview presents a summary of prominent findings on several of the most thoroughly examined ascending nociceptive projections.

### Characteristics

#### Spinothalamic Tract (STT)

Several early clinical cases in which injury to the spinal cord blocked the sense of pain suggested that axons carrying nociceptive information crossed within the spinal cord and then ascended within the anterior white matter [1]. These observations led to the first surgical

attempts to relieve chronic pain by ►cordotomy, i.e., cutting the anterolateral quadrant of the spinal cord, the area now known to carry an overwhelming majority of ►spinothalamic tract (STT) axons. Cordotomy can very effectively eliminate pain for patients, but the positive effects are short lived and pain frequently returns within several months. It is not known which tracts begin to carry the nociceptive information following a cordotomy.

Anatomical studies in a variety of species including primates demonstrated that lesions of the spinal cord caused degeneration of axons within the thalamus. Both ►anterograde and ►retrograde tracing studies have since determined the locations and numbers of the cells of origin of the STT, as well as the areas of termination of STT axons within the thalamus. ►Antidromic activation and extracellular recording techniques have been used to identify and functionally characterize the stimulus-response properties of STT neurons to mechanical, thermal, and chemical stimuli.

The cells of origin of the STT are found within the spinal gray matter at all levels of the cord. STT cell bodies and dendrites receive glutamatergic and several types of peptidergic inputs. It has been estimated that there are between 15 and 20 thousand STT neurons on one side of the spinal cord of primates [1,2]. The upper cervical segments have been shown to contain 1/3 of all cells of origin of the STT. Within the gray matter, STT neurons are concentrated in the marginal zone (lamina I) and within the deep dorsal horn (lamina V). STT neurons are also found within the intermediate gray zone and the ventral horn. Most axons of STT neurons decussate at a level near the cell body and then turn to ascend within the ►ventrolateral funiculus. STT axons originating from marginal zone neurons ascend in a position that is dorsal to STT axons originating from neurons within the deep dorsal horn. Within thoracic levels, STT axons of marginal zone neurons are generally located dorsal to the denticulate ligament in the dorsal lateral funiculus, whereas the axons of lamina V neurons are found within the ventral part of the lateral funiculus ([2], Fig. 1). There is a somatotopic organization of ascending STT axons such that axons from lumbosacral levels ascend on the periphery of the lateral funiculus, whereas STT axons from progressively rostral levels are located closer to the gray matter ([3], Fig. 2).

STT axons continue to ascend through the lateral and ventral brainstem. Collateral branches are frequently given off by these axons supplying nociceptive sensory information to a number of nuclei, particularly within the reticular formation.

STT axons terminate in three principle regions of the thalamus including the ventral posterior lateral (VPL), central lateral and adjacent parts of the medial dorsal nucleus, and posterior thalamic nuclei [1,4]. STT terminations within VPL are somatotopically organized.

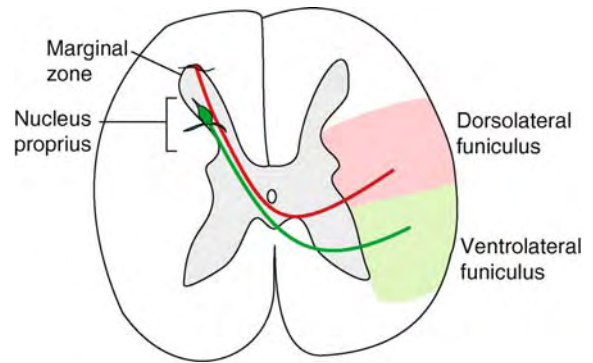

**Ascending Nociceptive Pathways. Figure 1** Axons of spinothalamic tract neuron cross to the contralateral side of the spinal cord and ascend the white matter within the antero- and dorsolateral funiculi.

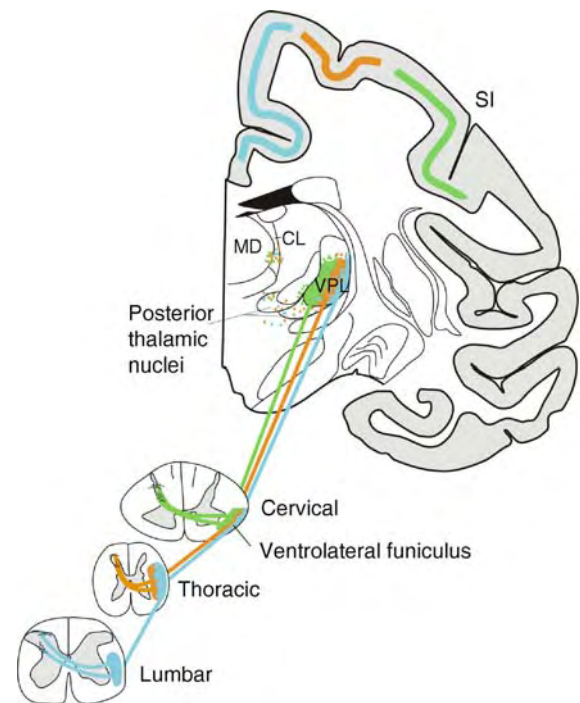

**Ascending Nociceptive Pathways. Figure 2** The spinothalamic tract is somatotopically organized. Axons from neurons in rostral segments of the spinal cord ascend medially relative to axons originating from caudal segments. The somatotopy is maintained within the major target nucleus of the thalamus, the ventroposterior lateral nucleus. Primary sensory cortex is somatotopically organized with lumbar segments (e.g. leg) represented medially within the post-central gyrus and cervical segments (e.g. arm) represented laterally.

Axons ascending from lumbosacral levels terminate within the lateral part of VPL; those from cervical levels end within the medial part of the nucleus. Within VPL of primates, STT terminals are concentrated within small

areas that are surrounded by large regions that are dominated by the endings of medial lemniscal axons. A high percentage of nociceptive neurons within the primate VPL can be antidromically activated from primary somatosensory cortex, indicating that nociceptive input to VPL neurons via STT axons is transmitted to the cortex (Fig. 2). A second area of termination of the STT is the central lateral nucleus and the adjacent lateral region of the medial dorsal nucleus. STT neurons projecting to this region are often located within the intermediate zone and ventral horn of the spinal cord. Many of the nociceptive neurons within this area of the thalamus have large, bilateral, even whole-body receptive fields. Thus it is unlikely that this region is involved in localization of nociceptive stimuli, and instead may be involved in the production of affective/emotional responses to nociceptive stimulation. STT axons that terminate in the posterior thalamic nuclei appear to arise predominantly from neurons of the marginal zone. A recently described area of primate thalamus, the posterior part of the ventral medial nucleus, is suggested to receive a large proportion of STT inputs

[4]. Nociceptive information originating from receptors on the face in the oral and nasal cavities is carried to the ventral posterior medial nucleus of thalamus by trigemino-thalamic tract projections.

Responses of STT neurons to a variety of somatic and visceral stimuli have been examined [1]. In primates, the vast majority of STT neurons have been classified as nociceptive, responding either preferentially (wide dynamic range, WDR) or specifically (high threshold, HT) to mechanical noxious stimuli (Fig. 3). In most studies, higher percentages of HT-STT neurons have been found in the marginal zone and more WDR neurons within the deep dorsal horn. Cutaneous receptive fields of neurons in the marginal zone tend to be smaller, sometimes being restricted to a single toe. The receptive fields of deeper neurons often cover much of the ipsilateral leg. Many STT cells are activated by noxious thermal stimulation of their receptive fields. Response thresholds to noxious heat stimuli are often between 45 and 55°C. Repeated applications of noxious heat stimuli lead to sensitization, including reduced response thresholds, increased response magnitude

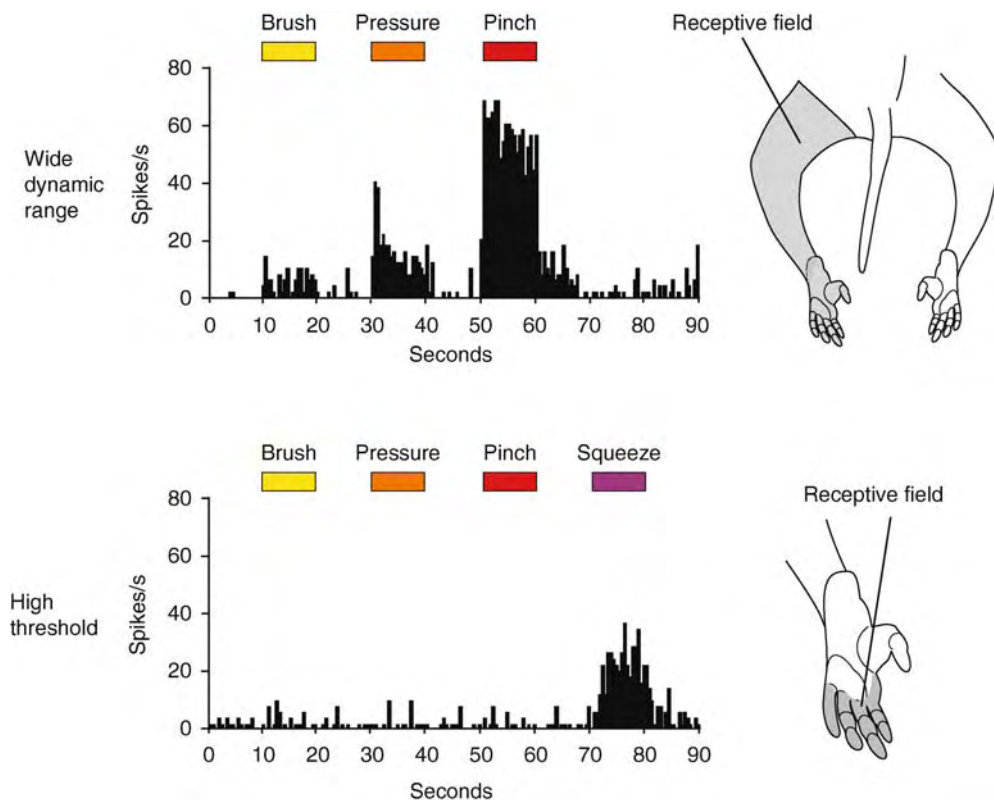

**Ascending Nociceptive Pathways. Figure 3** Spinothalamic tract neurons are typically classified as one of two types: Wide Dynamic Range or High Threshold. Wide Dynamic Range neurons are responsive to innocuous stimuli applied to their receptive fields as well as noxious stimuli. High Threshold neurons do not respond to innocuous mechanically stimuli. Both types may respond to thermal and/or chemical stimuli.

to identical noxious heat stimuli, and the production of ongoing activity. STT neurons also receive nociceptive input from muscles and joints, and they can be activated by stimulation using noxious chemicals such as Capsaicin, mustard oil and histamine.

STT neurons also can be activated by noxious stimulation of visceral tissues. In almost all cases, STT neurons that respond to stimulation of a visceral organ have somatic receptive fields as well. Frequently, somatic receptive fields are located in areas to which noxious stimulation of an organ would produce ►referred pain in human. STT axons are therefore capable of carrying nociceptive visceral information, and the convergence of somatic and visceral nociceptive input probably contributes to the phenomenon of referred pain.

### Spinohypothalamic Tract (SHT)

Burstein [5] noted that spinal cord neurons could be antidromically activated using small amplitude current pulses delivered through electrodes located within the hypothalamus of rats. In addition, injections of anterograde tracers into the spinal cord labeled axons within several areas of the hypothalamus, including the lateral, posterior, and ventromedial hypothalamus. Injections of retrograde tracers that were restricted to the hypothalamus labeled thousands of neurons within the spinal cords of rats. Spinohypothalamic tract (SHT) cell bodies were located in the marginal zone and the deep dorsal horn. SHT axons have been shown to ascend to the posterior thalamus, then turn ventrally to enter the supraoptic decussation. These axons continue to ascend in a position just dorsal to the optic tract and enter the hypothalamus (Fig. 4). Many SHT axons ascend to the level of the optic chiasm where they decussate a second time, turn posteriorly, and then descend within the supraoptic decussation on the side ipsilateral to the cell body form which they originated. SHT axons have been shown to terminate in the ipsilateral hypothalamus, posterior thalamus, and brainstem. Some have even been shown to descend as far as the level of the medulla. SHT neurons are frequently nociceptive. Some also receive an apparent input from innocuous thermoreceptors. It has been suggested that through their complex, bilateral projections and frequent branches, SHT axons could provide nociceptive input to a variety of areas of the brainstem and forebrain that are involved in nociceptive processing. SHT neurons have also been identified and characterized in monkeys. Large numbers of neurons within all divisions of the trigeminal complex and upper cervical segments similarly send axonal projections to the hypothalamus.

### Spinoreticular Tract (SRT)

The spinoreticular tract (SRT) is a direct projection from spinal cord neurons to the reticular formation of medulla, pons and midbrain ([1,6], Fig. 4). Regions that receive

these direct spinal afferent fibers include the nucleus gigantocellularis and nucleus dorsalis, both within the medulla, and the cuneiform nucleus of the midbrain. Because several of these regions in the reticular formation in turn send ascending nociceptive projections to the forebrain, it is believed that the SRT is part of a multisynaptic projection system to the thalamus and probably is involved in providing nociceptive information that is used in producing cortical arousal.

Studies in which antidromic methods have been used to demonstrate direct projection to the reticular formation have shown that many SRT neurons are nociceptive. These neurons have been frequently recorded deep within the spinal gray matter and have large complex receptive fields frequently including the face. Retrograde tracing studies indicate that SRT neurons are found within the marginal zone and deep dorsal horn, but a large percentage are located within the intermediate zone and ventral horn.

### Spinoparabrachial Tract

Somatic sensory and nociceptive information ascends directly from the spinal cord to several sub-nuclei of the parabrachial nucleus, which is located lateral to the superior cerebellar peduncle within the rostral pons and caudal midbrain ([7], Fig. 4). The locations of the cells of origin of the spinoparabrachial tract have been established using electrophysiological and anatomical techniques. Injections of retrograde tracers that are restricted to the parabrachial nucleus label a large number of spinal neurons at all levels of the spinal cord of rats and cats. Although spinoparabrachial tract neurons are found throughout much of the gray matter, the fact that they are highly concentrated within the marginal zone has generated a great deal of interest in this projection. Anterograde tracing studies indicate that neurons in the marginal zone send a large projection via the dorsal part of the lateral funiculus to the parabrachial nuclei on both sides. Studies in which antidromic activation has been used to identify spinoparabrachial tract neurons in cats indicate that the overwhelming majority is activated by noxious stimuli. The parabrachial nuclei are known to have large projections to several areas of the forebrain that are involved in nociception, including the hypothalamus and the amygdala. Therefore, this projection appears well suited for providing nociceptive information that is used for producing cognitive, emotional or affective responses to pain.

### Spinocervicothalamic Tract (SCT)

Spinocervical tract neurons are located throughout the length of the spinal cord. Many SCT neurons receive powerful afferent input from innocuous mechanoreceptors and as many as half of SCT neurons also receive nociceptive input [8]. These neurons send their ascending axons into the dorsal part of the ipsilateral lateral



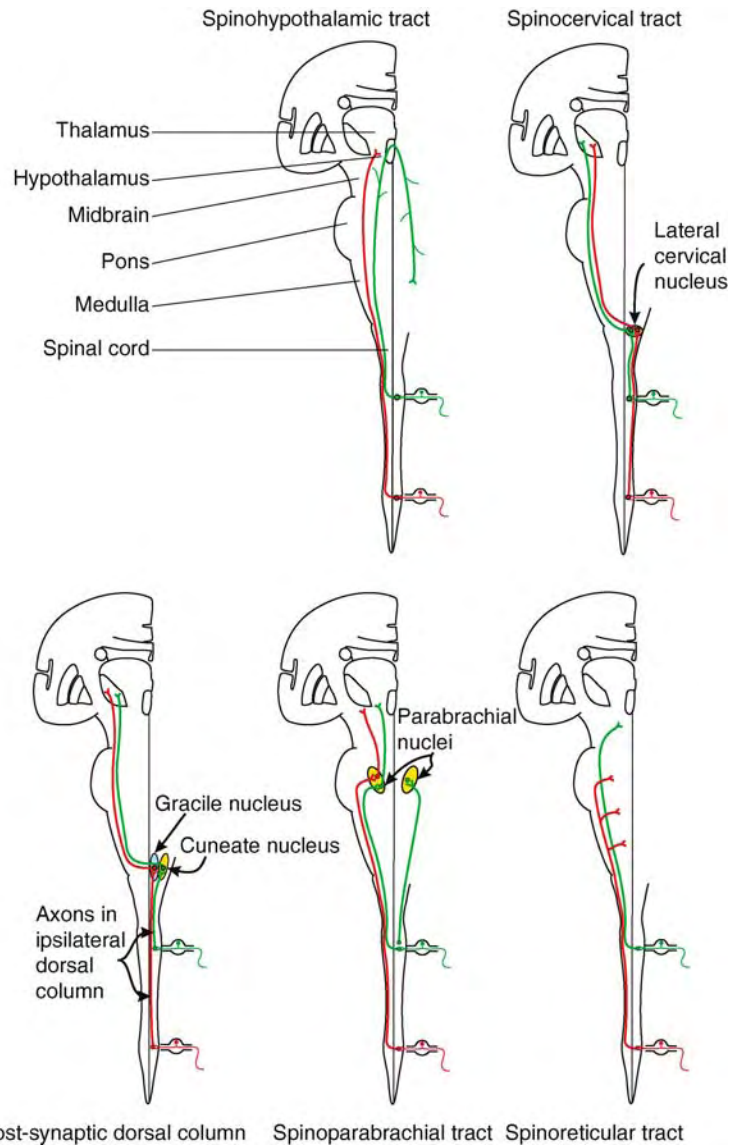

**Ascending Nociceptive Pathways. Figure 4** Illustrations of other ascending nociceptive pathways.

funiculus. SCT axons ascend to upper cervical segments where they terminate within the lateral cervical nucleus (LCN), an island of neurons extending from segment C3 through C1 that is located with the dorsal lateral funiculus (Fig. 4). The number of neurons that form the LCN varies greatly among species, but in carnivores may be as many as 10,000 neurons. The LCN is comparatively small in monkeys, although precise cell counts are not available. In humans the LCN has been reported to be highly variable. Some individuals appear to have a prominent LCN on one side and few if any LCN neurons on the other. Other individuals appear to have a clear LCN on both sides, and some have no LCN on either side. These findings suggest a lesser, variable role for the SCT in nociception in humans.

Roughly half of LCN neurons in carnivores are nociceptive and these have been shown to respond specifically or preferentially to noxious mechanical stimuli. Many of these neurons can also be activated by noxious heat stimuli. LCN neurons that receive mechano-receptive or nociceptive input are somatotopically organized; neurons in the lateral LCN receive input from lumbosacral segments, whereas neurons in the medial LCN receive input from cervical levels. A small number of neurons in the medial LCN have nociceptive whole-body receptive fields. Axons of LCN neurons decussate in upper cervical spinal cord and ascend to terminate in the contralateral VPL. As many as half of ascending axons of LCN neurons give off branches that terminate within the midbrain.

### Postsynaptic Dorsal Column Projection (PSDC)

Injections of retrograde tracers into the dorsal column nuclei of cats, rats and monkeys label large numbers of neurons throughout the length of the spinal cord [9]. Many of these are located in nucleus proprius (laminae III and IV). A smaller number are found near the central canal. Anterograde tracing studies indicate that most axons of this type ascend within the ipsilateral dorsal columns, but some appear to ascend within the dorsal lateral funiculus (Fig. 4). In cats, PSDC axons frequently terminate in the periphery of the dorsal column nuclei while primary afferent fibers often terminate in the cores of the two nuclei. In rats, the terminations of these projections appear to overlap more substantially. In cats, roughly half of PSDC neurons can be driven exclusively by innocuous mechanical stimulation and the remainder can be classified as WDR neurons, indicating that this projection is capable of conveying nociceptive information. PSDC cells have been shown to be powerfully activated by noxious mechanical and heat stimuli. Several lines of evidence indicate that nociceptive visceral information is carried by this projection in rats, monkeys and possibly humans. An elegant series of studies show that PSDC neurons convey nociceptive visceral information that reaches the thalamus [10]. These authors have also pointed out that surgical section of the medial area of the dorsal columns relieves chronic visceral pain in patients.

### References

- Willis WD Jr, Coggeshall RE (2004) Sensory mechanisms of the spinal cord, 3rd edn. Kluwer, New York
- Apkarian AV, Hodge CJ (1989) Primate spinothalamic pathways: I. a quantitative study of the cells of origin of the spinothalamic pathway. *J Comp Neurol* 288:447–473
- Applebaum AE, Beall JE, Foreman RD, Willis WD (1975) Organization and receptive fields of primate spinothalamic tract neurons. *J Neurophysiol* 38:572–586
- Craig AD (2004) Distribution of trigeminothalamic and spinothalamic lamina I terminations in the Macaque monkey. *J Comp Neurol* 477:119–148
- Burstein R, Cliffer KD, Giesler GJ Jr (1987) Direct somatosensory projections from the spinal cord to the hypothalamus and telecephalon. *J Neurosci* 7:4159–4161
- Yeziarski RP, Schwartz RH (1986) Response and receptive-field properties of spinomesencephalic tract cells in the cat. *J Neurophys* 55:76–95
- Bernard JF, Dalle R, Raboisson P, Villanueva L, Le Bars D (1995) Organization of the efferent projections from the spinal cervical enlargement to the parabrachial area and periaqueductal gray: A PHA-L study in the rat. *J Comp Neurol* 353:480–505
- Brown AG (1981) Organization in the spinal cord: the anatomy and physiology of identified neurones. Springer, Berlin Heidelberg New York, pp 17–72
- Giesler GJ Jr, Nahin RL, Madsen AM (1984) Postsynaptic dorsal column pathway of the rat. I. Anatomical studies. *J Neurophysiol* 51:260–275
- Al-Chaer ED, Feng Y, Willis WD (1998) A role for the dorsal column in nociceptive visceral input into the thalamus of primates. *J Neurophysiol* 79:3143–3150

## Ascending Pain Pathways

### ► Ascending Nociceptive Pathways

## Aschoff's Rules

CHRISTIAN BEAULÉ

Department of Biology, Washington University,  
St. Louis, MO, USA

### Definition

Aschoff's Rules are a set of three statements used to describe, and predict, the circadian behavior of animals housed under ►constant lighting conditions. These rules were attributed to the circadian biologist Jürgen Aschoff (1913–98), based on his observations of the spontaneous frequencies (free-running periods) of several animal species.

### Aschoff's First Rule

States that the endogenous free-running circadian period (*tau*,  $\tau$ ), observed in complete darkness (DD), will shorten for ►diurnal animals and lengthen for ►nocturnal animals when they are exposed to constant light (LL). The effects of LL are intensity dependent with brighter light enhancing these effects. Thus, Aschoff's First Rule predicts that  $\tau_{LL} < \tau_{DD}$  for diurnal animals and  $\tau_{LL} > \tau_{DD}$  for nocturnal animals.

### Aschoff's Second Rule

States that under constant bright light, ►activity time (*alpha*,  $\alpha$ ) increases compared to ►rest time (*rho*,  $\rho$ ) for diurnal animals and decreases for nocturnal animals. As a result, the duration of daily activity in constant conditions increases with increasing light intensity for diurnal animals and decreases with increasing light intensity for nocturnal animals. Thus Aschoff's Second Rule predicts that  $\alpha_{LL} > \rho_{LL}$  for diurnal animals and  $\alpha_{LL} < \rho_{LL}$  for nocturnal animals.

### Aschoff's Third Rule

States that the ►free-running period in DD is longer than 24 h for diurnal animals and shorter than 24 h for

nocturnal animals. Thus Aschoff's Third Rule predicts that:  $\tau_{DD} > 24$  h for diurnal animals:  $\tau_{DD} < 24$  h for nocturnal animals.

## Characteristics

### Historical Perspective

"Aschoff's Rule" is a term that was originally coined by Colin S. Pittendrigh (1918–96) in 1960 during the Cold Spring Harbor Symposia on Quantitative Biology (Vol XXV, Biological Clocks, 1960). During his symposium, Jürgen Aschoff presented a summary of the circadian behavior of diurnal and nocturnal animals housed under constant conditions (DD and various intensities of LL). Within the species reviewed, diurnal animals (finches, starlings, lizards) shortened their free-running period in LL and nocturnal animals (house mice and white-footed mice) lengthened their free-running period in LL compared to their period in DD. Pittendrigh, who was presenting after Aschoff, made several major empirical generalizations about circadian rhythms; one of these generalizations was "XII:  $\tau_{FR}$  is light intensity dependent. There is evidence of a fairly strong further generalization which I propose to call *Aschoff's Rule*. This can be summarized by  $\tau_{LL} > \tau_{DD}$  in nocturnal animals;  $\tau_{LL} < \tau_{DD}$  in diurnal animals" (where  $\tau_{FR}$  means free-running) [1]. Because of this, the first rule is often referred simply as Aschoff's Rule. The other two of Aschoff's rules were not as explicitly stated by Pittendrigh in this article, but nonetheless became part of the circadian nomenclature.

The effects of constant light on the circadian behavior of animals have long been recognized, but Aschoff was among the first to systematically analyze and describe them [2]. At that time, the circadian research field was still in its infancy and the exact conditions that would affect the circadian **▶oscillator**, or even the nature of such an oscillator, were unknown. A conceptual framework was needed in order to establish whether the circadian oscillator was endogenous or exogenous. For an endogenous oscillator to be revealed, one had to find conditions where extraneous entraining signals (see **▶Zeitgebers**) were kept constant. Light is the most important Zeitgeber affecting circadian rhythms. In order to prevent its entraining role, light level was held constant, from complete darkness (DD) to LL of different intensities. The free-running circadian behavior could then be studied in an unperturbed system.

### Behavioral Characteristics of Aschoff's Rules

In the absence of any light cues (DD), circadian rhythms persist with a spontaneous frequency of about one cycle per day, or a free-running period of approximately 24 h. This spontaneous frequency is species specific, with individuals within a given species showing some variability in their free-running periods. Free-running also occurs under constant illumination, suggesting that constant light does not provide any entraining cue

to the circadian clock. However, LL does affect the frequency of the circadian oscillation (period of circadian rhythms). Aschoff's observations showed that diurnal animals gradually increased the frequency of their circadian oscillation as the LL intensity increased (shortened free-running period), and that nocturnal animals decreased their spontaneous frequency (lengthened free-running period; Aschoff's First Rule). In addition to its effects on frequency, Aschoff observed that LL led to an increase in general locomotor activity for diurnal animals and to a suppression of locomotor behavior of nocturnal animals (Aschoff's Second Rule). Finally, based on a small initial sample of different animal species, Aschoff proposed that the free-running period in constant darkness is longer than 24 h for diurnal animals (finches, starlings, and lizards) and shorter than 24 h for nocturnal animals (house mice and white-footed mice (Aschoff's Third Rule).

### Violation of Aschoff's Rules

Like every good rule, or set of rules, Aschoff's Rules have their exceptions. The initial summary and description of the behavior of animals in constant conditions made by Aschoff in 1960 surveyed a small number of animal species (finches, starlings, lizards, and mice). In a follow-up article, Aschoff reviewed practically all the available data on the behavior of a wider range of animal species under DD and LL of various intensities [3]. This review article covered the behavior of close to 80 species of diurnal and nocturnal birds, mammals, reptiles, fishes, and arthropods [3]. Although, in general, most species seemed to follow Aschoff's Rules, there were a few exceptions. Some arthropods (e.g. some species of ground beetles) and some diurnal mammals (e.g. some species of squirrels) violate Aschoff's First Rule. The effects of increasing intensities of LL do not produce the predicted changes in their free-running rhythms. Arthropods also seem to violate Aschoff's Third Rule: both diurnal and nocturnal species have free-running periods shorter than 24 h. However, these observations and the generalizations derived from them are complicated by the fact that prior lighting history will change **▶pacemaker** properties of the circadian **▶oscillator**, and cause **▶after-effects** [4]. These history-dependent effects on the circadian period can last for a relatively long time and affect the observed compliance with Aschoff's Rules. It is unclear if all the species reviewed by Aschoff had the same lighting history.

### Mechanisms Underlying Aschoff's Rules

There has been surprisingly little research aimed specifically at determining the physiological, anatomical, or molecular mechanism (s) underlying Aschoff's Rules. There is, fortunately, some evidence from attempts that were made (directly or not) at explaining the

mechanism through which constant light will accelerate (diurnal) or decelerate (nocturnal) the circadian oscillator (Aschoff's First Rule). However, the evidence comes mostly from nocturnal rodents, species that tend to follow Aschoff's Rules. These are discussed below.

### Genetic Components of Aschoff's First Rule

When inbred strains of mice are compared for their expression of Aschoff's First Rule under ►[dim red light](#) versus LL, one can observe different magnitudes of the lengthening effect of LL on the spontaneous frequencies of the circadian oscillation. Because inbred mice are all species variants of the Genus *Mus*, this suggests that differences in genetic makeup, ability to perceive light, and/or circadian clock gene expression might account for these differences in the manifestation of Aschoff's First Rule in mice.

There is evidence that the ►[clock gene \*Period2\*](#) might be involved in the expression of Aschoff's First Rule. It has been shown that constant bright light, which increases the free-running period of mice, will also alter *Period2* protein levels. In rhythmic mice under LL, *Per2* mRNA is still rhythmic, but PER2 protein is elevated and non-rhythmic in the ►[suprachiasmatic nucleus](#) (SCN, the mammalian central circadian pacemaker) [5]. This is in contrast to mice kept in DD where both *Period2* mRNA and protein are rhythmic. In addition, mice bearing a mutation in the *Period2* gene violate Aschoff's First Rule. The free-running rhythm of *Period2* mutant mice is shorter in LL than it is in DD [6]. Thus, a differential regulation of putative clock genes (*Period2* or other) in mice appears to correlate with the differences in circadian behavior under LL.

### Anatomical Components of Aschoff's Rule

The pathway through which light reaches the circadian clock in mammals, the ►[retinohypothalamic tract \(RHT\)](#), has been very well studied. This monosynaptic projection from the retina to the SCN conveys the photic information necessary for the effects predicted by Aschoff's Rules. The transduction of the light signal starts in the ►[retina](#) where specialized ►[photoreceptor](#) cells convert light into a neuronal signal that is then transmitted through the optic nerve towards the SCN and other brain centers. The classical ►[photoreceptors \(rods and cones\)](#) are not required for the transmission of light signals to the SCN. Mice lacking rods and cones entrain normally to ►[light-dark cycles](#) and show normal lengthening of their free-running period under LL [7]. This suggests that there are other means of ►[phototransduction](#) in rodless-coneless mice. Indeed, the novel ►[photopigment melanopsin](#), exclusively expressed in ►[retinal ganglion cells](#) has been shown to be sufficient for the transmission of photic information to the circadian system. In melanopsin knockout

mice, the lengthening effect of LL on the free-running period is reduced [8]. This suggests that melanopsin-containing retinal ganglion cells that project to the circadian system participate in the expression of Aschoff's First Rule.

Besides the SCN, there is another structure that is part of the larger circadian system in mammals: the ►[intergeniculate leaflet \(IGL\)](#) of the thalamus. The IGL receives direct retinal inputs and sends information back to the SCN. Lesions of the IGL will reduce the lengthening effects of LL on the free-running period, but only in hamsters, not mice [9,10]. This suggests that, at least in hamsters, the IGL integrates part of the light information required for the increase in free-running period induced by LL.

Even after nearly 50 years, the observations made by Aschoff are still effective tools for the description of the effects of constant conditions on the spontaneous frequency of the circadian oscillator. Their real value for circadian biologists include: (i) they established that specific circadian behaviors are conserved across species and highly reproducible, (ii) that the circadian period is "plastic" and influenced by lighting history, and (iii) that, when combined with entrainment theory, they can be explained, at least in a qualitative way, to result from the effects of light on the ►[phase-response curve](#) of two coupled-circadian pacemakers (see ►[morning/evening oscillators](#)).

### References

1. Pittendrigh CS (1960) Circadian rhythms and the circadian organization of living systems. Cold Spring Harb Symp Quant Biol 25:159–184
2. Aschoff J (1960) Exogenous and endogenous components in circadian rhythms. Cold Spring Harb Symp Quant Biol 25:11–28
3. Aschoff J (1979) Circadian rhythms: influences of internal and external factors on the period measured in constant conditions. Z Tierpsychol 49:225–249
4. Pittendrigh CS, Daan S (1976) A functional analysis of circadian pacemakers in nocturnal rodents: I. The stability and lability of spontaneous frequency. J Comp Physiol A 106:223–252
5. Munoz M, Peirson SN, Hankins MW, Foster RG (2005) Long-term constant light induces constitutive elevated expression of mPER2 protein in the murine SCN: a molecular basis for Aschoff's rule? J Biol Rhythms 20:3–14
6. Steinlechner S, Jacobmeier B, Scherbarth F, Dernbach H, Kruse F, Albrecht U (2002) Robust circadian rhythmicity of *Per1* and *Per2* mutant mice in constant light, and dynamics of *Per1* and *Per2* gene expression under long and short photoperiods. J Biol Rhythms 17:202–209
7. Mrosovsky N (2003) Aschoff's rule in retinally degenerate mice. J Comp Physiol A Neuroethol Sens Neural Behav Physiol 189:75–78

8. Panda S, Sato TK, Castrucci AM, Rollag MD, DeGrip WJ, Hogenesch JB, Provencio I, Kay SA (2002) Melanopsin (Opn4) requirement for normal light-induced circadian phase shifting. *Science* 298:2213–2216
9. Morin LP, Pace L (2002) The intergeniculate leaflet, but not the visual midbrain, mediates hamster circadian rhythm response to constant light. *J Biol Rhythms* 17:217–226
10. Pickard GE (1994) Intergeniculate leaflet ablation alters circadian rhythms in the mouse. *Neuroreport* 5:2186–2188

## Aseptic Meningitis

### Definition

Aseptic meningitis is an illness mainly characterized by inflammation of the linings of the brain (meninges) and is not caused by bacteria.

## Aspinous Neuron/Cellular

### Definition

Neurons that do not have spines on their dendrites are classified as aspinous neurons.

## Association Cortex

### Definition

Refers to cerebral cortex other than the primary sensory and motor areas and, thus, most of the cortical mantle. The hallmark of association cortex is dominant cortico-cortical input-output relationships, thus suggesting the function of combining and recombining cortically processed information in the service of increasingly elaborate cortical representations of the internal and external environments in relation to memory, mood and motivation. Unimodal association areas flanking the primary sensory areas are concerned with the elaboration of modality specific sensory processing. Multimodal association areas merge information arising from

more than one sensory modality. Speech areas in the inferior frontal and parietotemporal regions comprise high-order multimodal association areas. High-order association areas involved in behavioral synthesis and sequencing and the emotional, motivational and mnemonic content of behavior, sometimes referred to as “limbic association cortex,” occupy parts of all of the cortical lobes, but culminate in the prefrontal, insular and medial temporal lobes.

## Association Tracts

### Definition

Commissures are fibers which exchange information between the hemispheres. Association pathways are fiber bundles within a hemisphere, while fibers between cerebral cortex and subcortical centers are called projection pathways.

► General CNS

## Associative Learning

### Definition

Associative learning is the learning of associations between events. In associative learning, a subject learns the relationship between two different stimuli or between the stimulus and the subject’s behavior.

Classical conditioning and operant (or instrumental) conditioning are typical examples of the associative learning.

- Associative Memory
- Classical Conditioning (Pavlovian Conditioning)
- Operant Conditioning (instrumental Learning)
- Learning

## Associative Long-lasting Potentiation

► Associative Long-Term Potentiation

## Associative Long-term Facilitation

### ► Associative Long-Term Potentiation

## Associative Long-Term Potentiation

TOSHIYA MANABE

Division of Neuronal Network, Department of Basic Medical Sciences, Institute of Medical Science, University of Tokyo, Tokyo, Japan

### Synonyms

Associative long-lasting potentiation; Associative long-term facilitation; LTP

### Definition

Long-lasting increase in the efficacy of synaptic transmission, induced in an input that is active when LTP-inducing high-frequency stimulation is applied to another independent strong input.

In a weak input, high-frequency stimulation (e.g. 100 Hz for 1s) often fails to induce LTP; however, when the weak input is stimulated simultaneously with high-frequency stimulation of another independent strong input, the weak input can also exhibit Long-term potentiation (LTP) (► [Long-term potentiation](#), ► [Gene expression](#)). This type of LTP is called “associative LTP.”

### Characteristics

#### Quantitative Description

LTP is usually induced in a relatively strong input, and is not induced in a weak pathway. This characteristic of LTP is referred to as “cooperativity,” and LTP induction requires activation of the sufficient number of afferent fibers that enables the postsynaptic cell to depolarize beyond a certain threshold level. However, a weak pathway can be potentiated when it is activated simultaneously with a strong pathway, because the strong pathway can provide sufficient depolarization of the postsynaptic cell. This characteristic of LTP is referred to as “associativity,” and is regarded as the most fundamental property for associative learning.

### Higher Level Structures

Associative LTP of excitatory synaptic transmission can be observed in the ► [hippocampus](#) and cerebral cortex.

### Lower Level Components

Associative LTP is a form of synaptic plasticity (► [Synaptic plasticity](#), ► [selectivity](#)) observed in certain kinds of excitatory central synapses.

### Higher Level Processes

Associative LTP is regarded as a cellular model for associative learning, which is observed in brain regions such as the hippocampus and cerebral cortex.

### Lower Level Processes

Associative LTP is usually observed at the synapse that exhibits NMDA receptor-dependent LTP (► [NMDA-LTP](#)). Standard tetanic stimulation at sufficiently strong stimulus strength causes depolarization in the postsynaptic cell, which is sufficient to relieve the  $Mg^{2+}$  block of NMDA receptor channels and to allow  $Ca^{2+}$  to flow into the postsynaptic cell. When one input is stimulated with a pattern that does not induce LTP by itself during the strong depolarization caused by tetanic stimulation of another independent input, the NMDA receptors of the former input become active and LTP is induced in both inputs. The LTP induced in this way in the former input is called “associative LTP” and the NMDA receptor plays an essential role in this process. In other words, the release of the neurotransmitter glutamate from the presynaptic terminal must occur simultaneously with the postsynaptic depolarization in order to induce LTP, and this is called a “► [Hebbian rule](#).”

### Process Regulation

The timing of synaptic activation and postsynaptic depolarization is extremely important for associative LTP. In order for associative LTP to occur, two independent pathways must be activated closely in time. A weak pathway must be active simultaneously with a strong pathway in order for the weak pathway to be potentiated. However, this process seems to be more complicated when we observe this phenomenon more carefully. As reviewed by Dan and Poo [1], associative LTP may be a type of spike-timing dependent plasticity: when the postsynaptic depolarization follows the synaptic activity, the synaptic response is potentiated. In contrast, when the synaptic activity follows the postsynaptic depolarization, the synaptic response is depressed. Thus, the sequence of the events, as well as the timing, may be a critical factor for associative LTP.

### Function

[Figure 1](#) demonstrates the three rules observed in synaptic plasticity in general [2]. In order to exhibit LTP, the strength of an input must be strong enough to depolarize the postsynaptic cell and activate NMDA receptors ([Fig 1a](#)). In other words, a relatively large

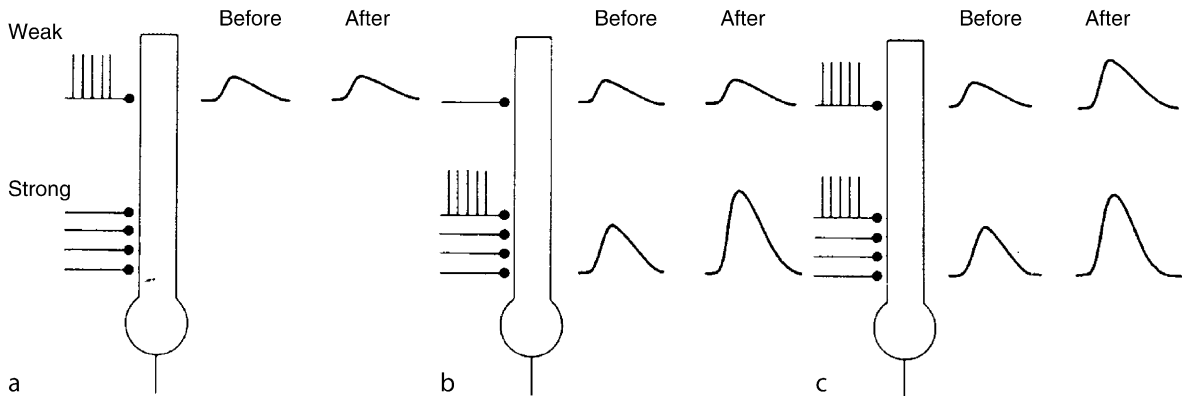

**Associative Long-Term Potentiation. Figure 1** (a) Cooperativity. A weak input fails to exhibit LTP even if it receives tetanic stimulation. (b) Specificity (selectivity). LTP is restricted to the input that receives tetanic stimulation. (c). Associativity. A weak input can be potentiated if it is concurrently active when LTP is induced in another strong input. (cited from Nicoll et al. 2).

number of afferent fibers must be stimulated to include LTP, and this property is called “cooperativity” (Fig 1b). Figure 1b also indicates that the input that does not receive tetanic stimulation fails to show LTP, even if the other input in the same cell exhibits LTP. This property is called “selectivity” or “specificity.” This type of LTP is referred to as “▶homosynaptic LTP” because LTP is restricted to the tetanized pathway. Another important property is “associativity,” which is shown in Figure 1c. In some sense, these properties are common to those of learning and memory, and associativity especially may be a cellular process underlying the formation of associative memory.

However, there are some exceptions. Strictly speaking, in some condition, synapse specificity of LTP breaks down locally at short distances [3,4]. Thus, ▶heterosynaptic facilitation and depression (▶heterosynaptic depression) can occur, and in some case, ▶heterosynaptic LTP can be observed in the hippocampus. Furthermore, LTP and ▶Long-term depression (LTD) can interact heterosynaptically [5]. These phenomena are regarded as “non-Hebbian.”

## References

1. Dan Y, Poo MM (2004) Spike timing-dependent plasticity of neural circuits. *Neuron* 44:23–30
2. Nicoll RA, Kauer JA, Malenka RC (1988) The current excitement in long-term potentiation. *Neuron* 1:97–103
3. Engert F, Bonhoeffer T (1997) Synapse specificity of long-term potentiation breaks down at short distances. *Nature* 388:279–284
4. Schuman EM, Madison DV (1994) Locally distributed synaptic potentiation in the hippocampus. *Science* 263:532–536
5. Muller D, Hefft S, Figueroa A (1995) Heterosynaptic interactions between LTP and LTD in CA1 hippocampal slices. *Neuron* 14:599–605

## Associative Memory

MAKOTO HIRAHARA

Faculty of Engineering, Hosei University, Tokyo, Japan

### Synonyms

Associatron; Content-addressable memory; Hopfield model

### Definition

Associative memory is one type of neural network model for human memory. The network stores input–output pattern pairs to recall a stored output pattern when a noisy or incomplete version of a stored input pattern paired with it is presented.

### Characteristics

#### Heteroassociative Memory

When looking at a banana, someone might recall a monkey. Human memory system probably represents the two different entities as two distinct firing patterns of neurons. So, it is possible that the associative recall is a transformation from the pattern “banana” to the different pattern “monkey.”

A neural network model that performs such a transformation from a pattern to a different pattern is referred to as ▶heteroassociative memory (Cross-associative memory). The most simplified model is a two-layer feedforward network as shown in Fig. 1. Let  $\{\xi_i^\mu\}$  ( $i = 1, \dots, N$ ) and  $\{\eta_i^\mu\}$  ( $i = 1, \dots, M$ ) be the  $\mu$ th ( $\mu = 1, \dots, Q$ ) of a  $N$ -dimensional input and a  $M$ -dimensional output pattern, respectively. It is often assumed that each component of the patterns takes a value of either +1 (firing) or –1 (not firing) independently with

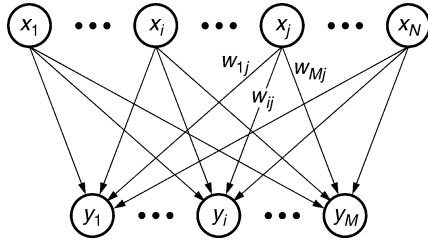

**Associative Memory. Figure 1** Two-layer feedforward network for heteroassociative memory. Input–output pattern pairs are stored in the weights,  $w_{ij}$ , which connect the input units  $\{x_j\}$  to the output units  $\{y_i\}$  ( $i = 1, \dots, M$ ;  $j = 1, \dots, N$ ).

equal probability. Then, the network stores (learns) the  $Q$  pattern pairs (associations) as follows

$$w_{ij} = \frac{1}{N} \sum_{\mu} \eta_i^{\mu} \xi_j^{\mu},$$

where  $w_{ij}$  ( $i = 1, \dots, M$ ;  $j = 1, \dots, N$ ) is the weight from the  $j$ th unit (neuron) in the input layer to the  $i$ th unit in the output layer (Fig. 1).

When an input pattern is presented, the state of the input layer,  $\{x_i\}$  ( $i = 1, \dots, N$ ), is set to that pattern and is fed through the weights to the output units  $\{y_i\}$  ( $i = 1, \dots, M$ )

$$y_i = \text{sgn}(h_i), h_i = \sum_j w_{ij} x_j,$$

where  $\text{sgn}(h)$  is  $+1$  for  $h > 0$  and  $-1$  otherwise.

If an input is one of the stored patterns, say,  $\{\xi_i^1\}$ , we hope that  $\{y_i\}$  would coincide with the target output pattern  $\{\eta_i^1\}$ . To see this possibility, we rewrite the activity  $h_i$  by putting  $\{x_i\} = \{\xi_i^1\}$  and have

$$\begin{aligned} h_i &= \sum_j \frac{1}{N} \sum_{\mu} \eta_i^{\mu} \xi_j^{\mu} \xi_j^1 = S_i + R_i, \\ S_i &= \frac{1}{N} \eta_i^1 \sum_j \xi_j^1 \xi_j^1 = \eta_i^1, \\ R_i &= \frac{1}{N} \sum_{\mu \neq 1} \eta_i^{\mu} \sum_j \xi_j^{\mu} \xi_j^1, \end{aligned} \quad (1)$$

where  $S_i$  is the signal to stabilize the target  $\eta_i^1$ , and  $R_i$  is known as cross-talk noise arising from the correlations of the stored patterns  $\{\xi_i^{\mu}\}$  ( $\mu \neq 1$ ) with the input  $\{\xi_i^1\}$ . The cross-talk noise often hinders the model from recalling the target,  $\{\eta_i^1\}$ : an error occurs at the  $i$ th output unit when  $R_i$  is of opposite sign to  $\eta_i^1$  and has an absolute value larger than 1 (i.e.,  $R_i \eta_i^1 < -1$ ). Since the quantity  $R_i \eta_i^1$  is the sum of many ( $= N(Q-1) \approx NQ$ ) independent random variables, each of which takes a value of  $+1/N$  or  $-1/N$  with equal probability, the

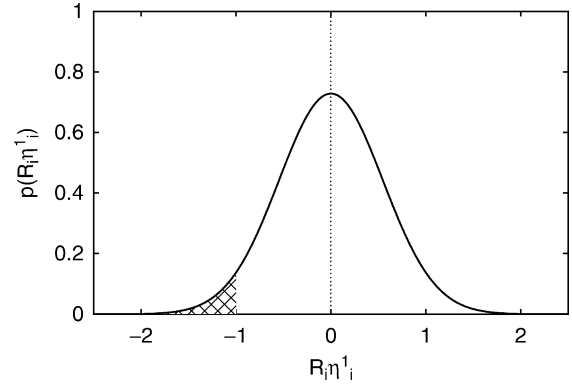

**Associative Memory. Figure 2** Distribution of cross-talk noise  $R_i$  times target  $\eta_i^1$ , when an original input pattern  $\{\xi_i^1\}$  paired with  $\{\eta_i^1\}$  is presented. The hatched area gives the error probability  $P(\alpha)$  for one output unit.

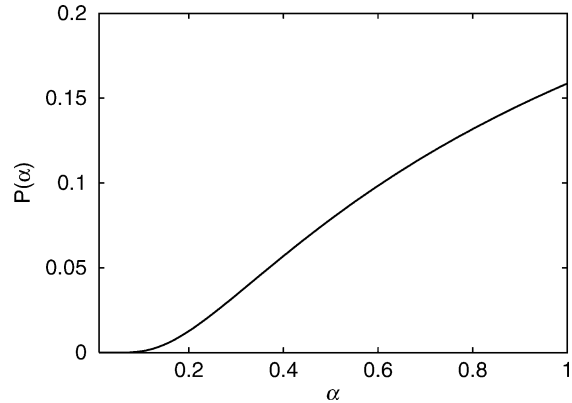

**Associative Memory. Figure 3** Error probability for one output unit as a function of load level  $\alpha$ . A higher  $\alpha$  causes a wider distribution of cross-talk noise, resulting in a higher error probability (see Fig. 2).

central limit theorem guarantees that it has a Gaussian distribution with mean zero and variance  $Q/N$ . The fraction  $Q/N$  is often referred to as load level (hereafter denoted as  $\alpha$ ). Figure 2 shows a Gaussian ( $\alpha = Q/N = 0.3$ ) where the hatched area (integral from  $-\infty$  to  $-1$  with respect to  $R_i \eta_i^1$ ) gives the error probability  $P(\alpha)$  for one output unit.

Rising load level  $\alpha$  widens the Gaussian, resulting in a higher error probability  $P(\alpha)$  as shown in Fig. 3.

Since the network has the  $N$  output units, the probability that the network recalls the target with no error is given by  $(1 - P(\alpha))^N$ . Perfect recalling is thus a severe condition, so we need to allow the network to make some errors. A different type of learning algorithm is needed to prevent the cross-talk noise [1,2], though we in this case have to present input–output pairs repeatedly during learning.



It is also important to see the ability to eliminate external noise. Let  $\{\rho_i\}$  ( $i = 1, \dots, N$ ) be a noise pattern, each component of which takes a value of either +1 with probability  $(1 + d)/2$  or -1 with probability  $(1 - d)/2$  ( $0 \leq d \leq 1$ ). Then, a noisy version of a stored input pattern  $\{\xi_i^1\}$  can be expressed as  $\{\xi_i^1 \rho_i\}$ . Since the sign of  $\xi_i^1$  is reversed when  $\rho_i = -1$ ,  $\{\rho_i\}$  acts as external noise embedded in  $\{\xi_i^1\}$ . The similarity between the original pattern and the noisy version (overlap at the input layer or initial overlap) can be evaluated as

$$m = \frac{1}{N} \sum_i \xi_i^1 \xi_i^1 \rho_i = \frac{1}{N} \sum_i \rho_i \approx d.$$

Thus,  $m$  is approximately equal to the parameter value  $d$  for generating external noise.

When such a noisy input is given, the network should eliminate the noise so that the overlap of the target output pattern  $\{\eta_i^1\}$  and the output state  $\{y_i\}$  (overlap at the output layer),  $m'$ , is larger than the initial overlap  $m$ . To evaluate this possibility, we present a noisy input  $\{\xi_i^1 \rho_i\}$  to the network and have

$$y_i = \text{sgn}(S_i + R_i),$$

$$S_i = \frac{1}{N} \eta_i^1 \sum_j \xi_j^1 \xi_j^1 \rho_j = m \eta_i^1,$$

$$R_i = \frac{1}{N} \sum_{\mu \neq 1} \eta_i^\mu \sum_j \xi_j^\mu \xi_j^1 \rho_j.$$

Then, the overlap at the output layer can be expressed as

$$\begin{aligned} m' &= \frac{1}{M} \sum_i \eta_i^1 y_i = \frac{1}{M} \sum_i \text{sgn}(S_i \eta_i^1 + R_i \eta_i^1) \\ &= \frac{1}{M} \sum_i \text{sgn}(U_i), \end{aligned}$$

$$U_i = m + R_i \eta_i^1.$$

The quantity  $R_i \eta_i^1$  has a Gaussian distribution with mean zero and variance  $\alpha$  ( $= Q/N$ ) for the same reason as above, and hence  $U_i$  is normally distributed with mean  $m$  and variance  $\alpha$  as shown in Fig. 4.

Since  $\text{sgn}(U_i)$  takes a value of either -1 with probability  $P(\alpha, m)$  (indicated by the hatched area) or +1 with the remaining probability, the overlap  $m'$ , given as the sum of a large number ( $= M$ ) of  $\text{sgn}(U_i)$  divided by  $M$ , should converge to the average

$$m' = (-1)P(\alpha, m) + (+1)(1 - P(\alpha, m)) = 1 - 2P(\alpha, m).$$

Figure 5 shows  $m'$  as a function of  $m$  for various values of load level  $\alpha$ .

The network has a good performance to eliminate external noise ( $m' > m$ ) if the initial overlap  $m$  does not

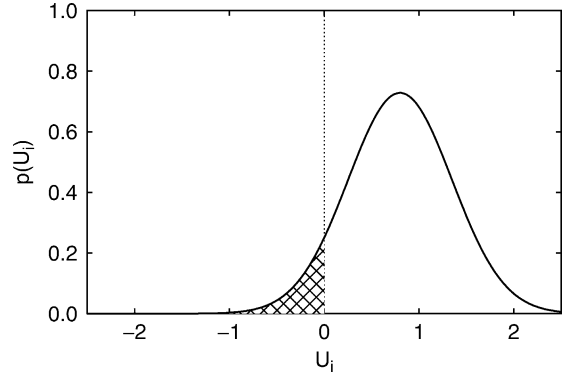

**Associative Memory. Figure 4** Distribution of  $U_i$  (see text). The hatched area gives the probability of  $\text{sgn}(U_i) = -1$ .

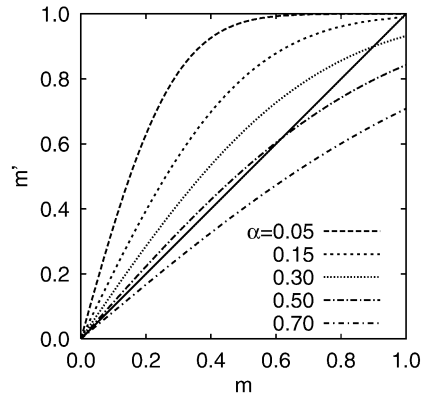

**Associative Memory. Figure 5** Noise reduction ability of heteroassociative memory for various values of load level  $\alpha$ . Overlap at the output layer,  $m'$ , is plotted as a function of overlap at the input layer,  $m$ .

exceed a critical value  $m_c(\alpha)$ , which is the intersection of each curve with the solid line ( $m' = m$ ). The critical value decreases with increasing  $\alpha$  (e.g.,  $m_c(0.05) \approx 1.0$ ,  $m_c(0.3) \approx 0.9$ ). Far more increase in  $\alpha$  results in the disappearance of the intersection (e.g.,  $m_c(0.7) \approx 0.0$ ).

### Autoassociative Memory

A neural network is referred to as **autoassociative memory**, when input and output patterns to be stored are the same. The network recalls the whole of a stored pattern when receiving a part (or a noisy version) of it as one might recall the whole concept of “apple” when smelling the scent of it. If we substitute  $\{\xi_i^\mu\}$  for  $\{\eta_i^\mu\}$  in the section of heteroassociative memory described earlier (and set  $w_{ii} = 0$  and  $M = N$ ), then we obtain a two-layer feedforward network for autoassociative memory storing  $\{\xi_i^\mu\}$ . This network has the same characteristics as the heteroassociative memory.

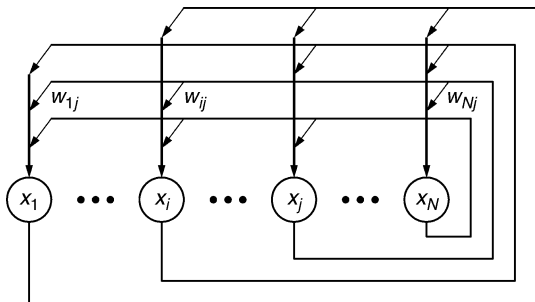

**Associative Memory. Figure 6** One-layer recurrent network for autoassociative memory. The  $N$  units are mutually connected through the weights  $W_{ij}$  ( $i \neq j$ ).

Here, we consider the case where the network has feedback connections to receive the current output as the next input (i.e.,  $\{x_i\} = \{y_i\}$ ). Then the network keeps updating its state (output), which may have more overlap with  $\{\xi_i^1\}$  than a previous state does. Such a recurrent neural network for autoassociative memory can be constructed with only one layer of units as shown in Fig. 6.

Let  $\{x_i(t)\}$  ( $i = 1, \dots, N$ ) be the state of the network at time  $t$ . The initial state  $\{x_i(0)\}$  is set to a given input pattern, after which  $\{x_i(t)\}$  develops at every discrete time step according to the following dynamics

$$x_i(t+1) = \text{sgn}(h_i), h_i = \sum_{j \neq i} w_{ij} x_j(t), \quad (2)$$

where  $w_{ij}$  ( $i, j = 1, \dots, N$ ) is the weight of the connection from the  $j$ th to the  $i$ th unit. If we again assume that each component of patterns to be stored,  $\xi_i^\mu$  ( $\mu = 1, \dots, Q; i = 1, \dots, N$ ), takes a value of either +1 or -1 independently with equal probability, the learning algorithm can be written in the form

$$w_{ij} = \frac{1}{N} \sum_{\mu} \xi_i^\mu \xi_j^\mu. \quad (3)$$

Now, the network keeps changing its state  $\{x_i(t)\}$ . The time evolution of  $\{x_i(t)\}$  could be captured in part by the overlap  $m(t)$  with a stored pattern, say,  $\{\xi_i^1\}$

$$m(t) = \frac{1}{N} \sum_i \xi_i^1 x_i(t).$$

Figure 7 shows simulation results for load level  $\alpha = 0.05$ , where the curves demonstrate the time courses of  $m(t)$  for various values of initial overlap  $m(0)$ .

When starting from 0.2 or more, the overlap  $m(t)$  converged to 1 after several steps. This means that the network was successfully attracted to a stable state (an attractor), which was just the target  $\{\xi_i^1\}$ . When  $m(0) = 0.1$ ,  $m(t)$  once went up, then went down, and finally converged to a small value (not shown). The increase in  $m(t)$  at time  $t = 1$  indicates that the network

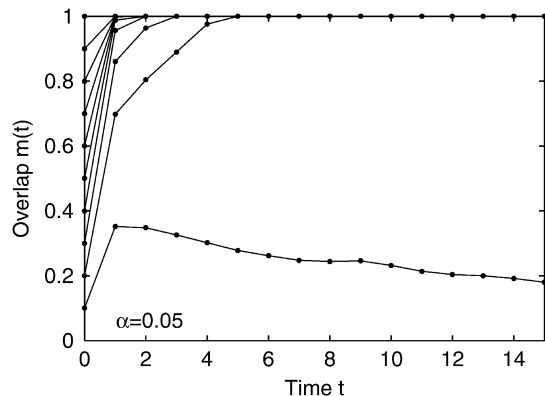

**Associative Memory. Figure 7** Time courses of overlap  $m(t)$  for various values of initial overlap  $m(0)$ , when  $\alpha = 0.05$ . If the network recalls a target pattern successfully,  $m(t)$  takes a value of 1.

once approached to the target  $\{\xi_i^1\}$ . This initial phenomenon could be understood from the curve for  $\alpha = 0.05$  shown in Fig. 5 where  $m' = m(1) \approx 0.35$  when  $m = m(0) = 0.1$ . After the initial increase, the network state gradually moved away from  $\{\xi_i^1\}$  and finally converged to an attractor that was different from  $\{\xi_i^1\}$  (see [3] for estimation of  $m(t)$  at time  $t \geq 2$ ). One may think that another stored pattern was recalled, but this was not the case. This attractor, not intended to be stored in the network, is called a spurious state (a spurious memory or a spurious attractor).

Thus, the network seems to converge to an attractor, regardless of whether the attractor is  $\{\xi_i^1\}$  or not. In fact, the convergence is guaranteed if the state of only one unit is updated at one time (although in the above simulation the states of all units were updated synchronously). This is because the network is governed by a lower bounded energy function,  $E(\{x_i\})$ , associated with its state  $\{x_i\}$ , and the dynamics given as Eq. 2 alters  $\{x_i\}$  so as to reduce the value of  $E(\{x_i\})$  [4]. The learning algorithm given as Eq. 3 is the process to make the intended patterns  $\{\xi_i^\mu\}$  be local minimum points (states with local minima of the energy function). In addition to this, the algorithm implicitly forces states closer to  $\{\xi_i^\mu\}$  to have lower energies and also creates additional local minima at unintended points (spurious states). The resulting landscape of the energy function is as shown in Figure 8. Since Eq. 2 always decreases the energy, the network starts starting with the initial state ① a noise version of  $\{\xi_i^1\}$  moves toward and stops at the target  $\{\xi_i^1\}$  (successful recall), whereas the state starting with ② a more noisy version of  $\{\xi_i^1\}$  moves away from  $\{\xi_i^1\}$  and reaches a spurious state ③. In the case of high load level  $\alpha$ , however the possibility of stopping at  $\{\xi_i^1\}$  becomes low: rising  $\alpha$  increases the number of spurious states and reduces the size of the basins of attraction (the width

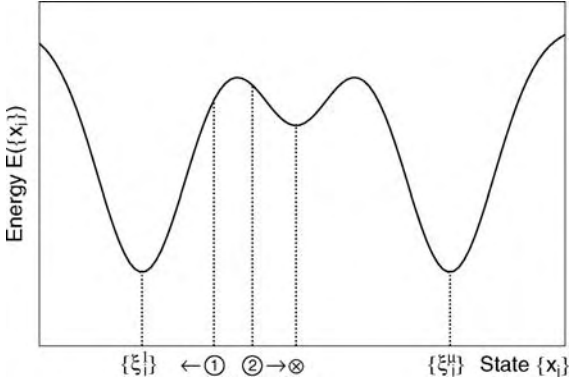

**Associative Memory. Figure 8** Landscape of energy function  $E(\{x_i\})$ . The network alters its state  $\{x_i\}$  so as to reduce the value of  $E(\{x_i\})$ . The network state starting with the initial state ① (a noise version of  $\{\xi_i^1\}$ ) moves toward and stops at the target  $\{\xi_i^1\}$  (successful recall), whereas the state starting with ② (a more noisy version of  $\{\xi_i^1\}$ ) reaches a spurious state  $\otimes$ .

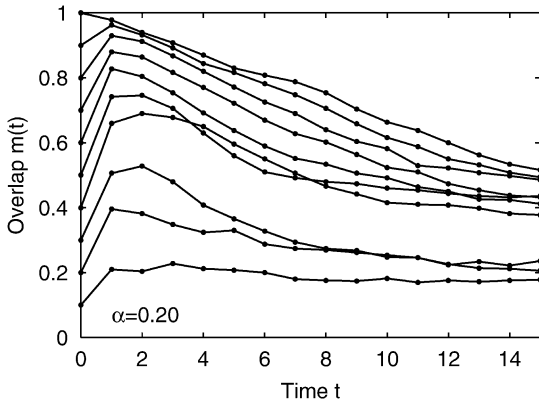

**Associative Memory. Figure 9** Time courses of overlap  $m(t)$ , when  $\alpha = 0.2$ .

of valleys) around the intended patterns. It is known that the stored patterns are no longer stable states (local minimum points) if  $\alpha$  is above about 0.15 [4,5]. The critical value of load level,  $\alpha_c$ , is often called **memory capacity** (storage capacity). Figure 9 shows the time courses of  $m(t)$  for load level  $\alpha = 0.2$ . Even if just a target  $\{\xi_i^1\}$  was presented ( $m(0) = 1$ ), the network state moved away from the target.

### Associative Memory for Storing Unbiased Patterns

Up to now, we assumed that each component of patterns to be stored took either +1 (firing) or -1 (not firing) independently with equal probability. Thus, the patterns are unbiased in the sense that the number of pattern components taking +1 is almost the same as that of components taking -1. This implies that single neurons respond to about one-half of stimuli.

However, this assumption would be physiologically implausible. Many physiologists have reported that neurons in the brain have selectivity for stimuli (e.g., face and object) or stimulus properties (e.g., orientation, shape, color, motion direction). It seems better to assume that, for a given stimulus, a small number of neurons are activated while the others are not.

The introduction of this alternative assumption allows an associative network to have a large memory capacity. Let  $\{\xi_i^\mu\}$  ( $\mu = 1, \dots, Q; i = 1, \dots, N$ ) be a biased pattern whose components take values of either +1 with probability  $(1+b)/2$  or -1 with the remaining, where  $-1 < b < 0$  (unbiased patterns if  $b = 0$ ). Patterns with  $b \approx -1$  are especially referred to as sparsely encoded patterns. The network stores the  $Q$  biased patterns according to the following covariance learning rule

$$w_{ij} = \frac{1}{N(1-b^2)} \sum_{\mu} (\xi_i^\mu - b)(\xi_j^\mu - b).$$

We also need to modify the dynamics as follows

$$x_i(t+1) = \text{sgn}(h_i), \quad h_i = \sum_j w_{ij}(x_j(t) - b) + b.$$

Note that, if  $b = 0$ , this network is reduced to the associative memory for storing unbiased patterns (Eqs. 2 and 3).

If we input a stored pattern  $\{\xi_i^1\}$  as did previously, we get

$$h_i = \sum_{j \neq i} \frac{1}{N(1-b^2)} \sum_{\mu} (\xi_i^\mu - b)(\xi_j^\mu - b)(\xi_j^1 - b) + b = S_i + R_i,$$

$$S_i = \frac{1}{N(1-b^2)} (\xi_i^1 - b) \sum_{j \neq i} (\xi_j^1 - b)(\xi_j^1 - b) + b \approx \xi_i^1,$$

$$R_i = \frac{1}{N(1-b^2)} \sum_{\mu \neq 1} (\xi_i^\mu - b) \sum_{j \neq i} (\xi_j^\mu - b)(\xi_j^1 - b).$$

The cross-talk noise  $R_i$  follows a Gaussian with mean zero and variance  $Q(1-b^2)/N$ , which decreases with increasing  $b$ . The network storing biased patterns thus has smaller cross-talk noise than the network storing unbiased patterns ( $Q/N$ ), while the two networks have almost the same signal  $S_i$ .

It is known that the memory capacity for biased patterns can be roughly estimated by

$$\alpha_c(b) = \frac{\alpha_c(0)}{1-b^2},$$

where ( $\alpha_c(0) \approx 0.15$ ) is the memory capacity for unbiased patterns [6]. Figure 10 shows  $\alpha_c(b)$  as a function of  $b$  ( $-1 < b < 0$ ). The capacity  $\alpha_c(b)$  increases with decreasing  $b$ . Figure 11 demonstrates the time courses of overlap  $m(t)$  when  $b = -0.9$  and  $\alpha = 0.4$ . Even if the network is at double the load level

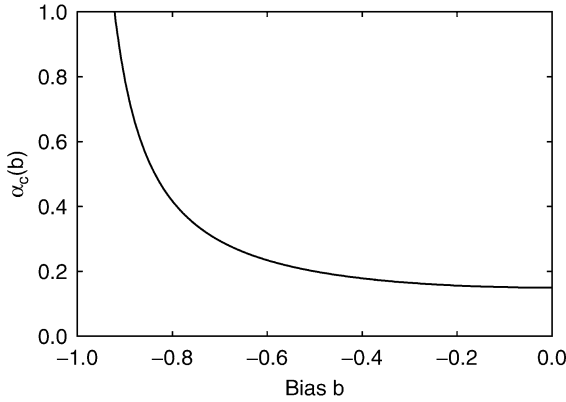

**Associative Memory. Figure 10** Memory capacity of autoassociative memory,  $\alpha_c(b)$ , as a function of bias  $b$  of stored patterns.

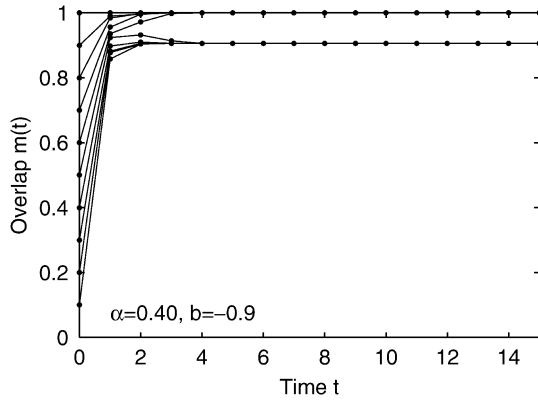

**Associative Memory. Figure 11** Time courses of overlap  $m(t)$  for autoassociative memory storing biased patterns ( $b = -0.9$ ,  $\alpha = 0.4$ ).

as the network storing unbiased patterns (Fig. 9), the target  $\{\xi_i^1\}$  was recalled after several steps ( $m(t) = 1$ ) if the initial overlap  $m(0)$  was 0.6 or above. When  $m(0)$  was small,  $m(t)$  converged to about 0.9. This means that all the units took  $x_i(t) = -1$  ( $m(t) = N^{-1} \sum \xi_i^1 x_i(t) \approx 0.9$ ).

### Associative Memory for Storing Hierarchically Correlated Patterns

The patterns treated above are independent of one another, which is a prerequisite for many conventional networks such as the earlier network to work properly. The independent patterns are distributed over the pattern space such that each pattern is located at almost the same distance from all the others. In other words, similarities between any two patterns are the same (i.e.,  $N^{-1} \sum \xi_i^\mu \xi_i^\nu \approx b^2$  for  $\mu \neq \nu$ ).

However, it seems better to suppose that similar things are encoded into similar patterns. Since a neuron,

in general, responds not only to an optimal stimulus but also to stimuli close to the optimal, presenting similar stimuli would yield similar firing patterns. Moreover, there are a plenty of (living and nonliving) things similar to one another, and we make use of their similarity in our daily life. For example, one would acquire a one's own concept "bird" (in part) by finding common (similar) properties among previously encountered instances (such as pigeons, sparrows, and crows), and the concept would, in turn, help us to recognize (categorize) a novel creature flying with wings as a member of that concept (the category represented by that concept). If the novel instance should be represented as an independent pattern, which is similar to neither patterns of the previous instances nor a pattern of the concept, we might be unable to identify it or may miscategorize it as a member of a different category such as "airplane," "ice cream," and "book." To begin with, we could not acquire concepts (similarities) from independent patterns of instances.

Hierarchically correlated patterns are often used to represent concepts and their instances (the second level concepts in a two-level hierarchy). Let  $\{\xi_i^\mu\}$  ( $\mu = 1, \dots, Q_1; i = 1, \dots, N$ ) be the  $\mu$ th concept pattern (representative of the  $\mu$ th category), which is not given to but acquired by the network (see later). For simplicity, each component of  $\{\xi_i^\mu\}$  is assumed to take either +1 or -1 independently with equal probability. Each category  $\{\xi_i^\mu\}$  has  $Q_2$  instances  $\{\xi_i^{\mu\nu}\}$  ( $\nu = 1, \dots, Q_2; i = 1, \dots, N$ ). Each component  $\xi_i^{\mu\nu}$  takes either the same value as  $\xi_i^\mu$  with probability  $(1+c)/2$  or the different value from  $\xi_i^\mu$  (i.e.,  $\xi_i^{\mu\nu} = -\xi_i^\mu$ ) with the remaining probability ( $0 < c < 1$ ). In this case, the similarity between an instance and its concept is given by  $N^{-1} \sum \xi_i^{\mu\nu} \xi_i^\mu = c$ . So the instances are distributed around their concepts with equal distance  $1-c$ . The similarity between any two instances of the same category is  $N^{-1} \sum \xi_i^{\mu\nu} \xi_i^{\mu\nu'} = c^2$  ( $\nu \neq \nu'$ ), so that, in each category, each instance is located at the same distance  $1-c^2$  from all the others. The similarity between any two instances of different categories is of zero.

Here, we consider the case where only the instances are given in learning phase. If we use the network given as Eqs. 2 and 3, we get

$$w_{ij} = \frac{1}{N} \sum_{\mu, \nu} \xi_i^{\mu\nu} \xi_j^{\mu\nu}.$$

When one of the instances, say,  $\{\xi_i^{11}\}$ , is input to the network, the activity of the  $i$ th unit is given by

$$h_i = \sum_{j \neq i} \frac{1}{N} \sum_{\mu, \nu} \xi_i^{\mu\nu} \xi_j^{\mu\nu} \xi_j^{11} = \xi_i^{11} + \frac{1}{N} \sum_{\nu \neq 1} \xi_i^{1\nu} \sum_{j \neq i} \xi_j^{1\nu} \xi_j^{11} + \frac{1}{N} \sum_{\mu \neq 1, \nu} \xi_i^{\mu\nu} \sum_{j \neq i} \xi_j^{\mu\nu} \xi_j^{11}.$$

The first term is the signal to stabilize the target  $\xi_i^{11}$ . The second and third terms are cross-talk noise arising from correlations of the input pattern  $\{\xi_i^{11}\}$  with the other instances of the same category  $\{\xi_i^1\}$  and of the different categories  $\{\xi_i^\mu\}$  ( $\mu \neq 1$ ), respectively. If we suppose that  $N$  and  $Q_2$  are large enough, the mean values of the second and third terms are estimated as about  $Q_2 c^3 \xi_i^1$  and zero, respectively. This suggests that when  $Q_2 c^3 > 1$ , the network comes to recall not the target instance  $\{\xi_i^{11}\}$  but the concept  $\{\xi_i^1\}$  to which the target belongs.

Thus, the network given as Eqs. 2 and 3 has the potential ability to acquire concepts by learning instances [2]. In return for this ability, however, the ability to recall instances is lost.

One way to overcome this problem is to introduce so-called nonmonotonic units to the network [7,8]. A usual monotonic unit emits an output value whose sign is always the same as that of an activity  $h_i$  (e.g., Eq. 2), whereas a nonmonotonic unit outputs a value opposite in sign to  $h_i$  if  $|h_i|$  is above a threshold  $T$  and outputs a value with the same sign as  $h_i$  otherwise. Thus, units whose activities are large in absolute value are destabilized so that their contributions to state transition would be reduced. Since the activities are, on average, larger in absolute value when a concept  $\{\xi_i^\mu\}$  is presented than when an instance  $\{\xi_i^{\mu\nu}\}$  is presented, setting  $T$  at high and low level leads the network to recall a concept and an instance, respectively [8]. It is also known that a network with nonmonotonic units is effective for storing unbiased patterns [7]: it has a large memory capacity [9], large basins of attraction around stored patterns, and a small number of spurious states.

Another way to recall instances is to use a cascade of two associative networks [10]. The first network acquires concepts by learning instances, just described above. The second network stores difference patterns defined by  $\{\eta_i^{\mu\nu}\} \equiv \{\xi_i^{\mu\nu} - \xi_i^\mu\}$ . Since  $\eta_i^{\mu\nu} = 1$  for  $\xi_i^{\mu\nu} = \xi_i^\mu$  and  $-1$  otherwise,  $\{\eta_i^{\mu\nu}\}$  contains information only on the difference of  $\{\xi_i^{\mu\nu}\}$  from  $\{\xi_i^\mu\}$ , thus interpreted as distinctive features of the instance  $\{\xi_i^{\mu\nu}\}$ . Because they are biased patterns ( $N^{-1} \sum \eta_j^{\mu\nu} = c$ ) independent of one another ( $N^{-1} \sum \eta_i^{\mu\nu} \eta_i^{\mu'\nu'} = c^2$ ), we can use the above network for storing biased patterns as the second network. Therefore, the second network has a large memory capacity (Fig. 10). Combining a concept  $\{\xi_i^\mu\}$  recalled by the first network and a difference pattern  $\{\eta_i^{\mu\nu}\}$  recalled by the second, the cascade network outputs (recalls) a target instance  $\{\xi_i^{\mu\nu}\}$  ( $= \{\xi_i^\mu + \eta_i^{\mu\nu}\}$ ). This cascade network is applicable, even if instances  $\{\xi_i^{\mu\nu}\}$  each have their own similarity  $c_{\mu\nu}$  ( $= N^{-1} \sum \xi_i^{\mu\nu} \xi_i^\mu$ ) to their concepts  $\{\xi_i^\mu\}$  (i.e.,  $c_{\mu\nu} \neq c_{\mu'\nu'}$  for  $\nu \neq \nu'$ ). In this case, a concept  $\{\xi_i^\mu\}$  is more similar to an instance  $\{\xi_i^{\mu\nu}\}$  than to another instance  $\{\xi_i^{\mu'\nu'}\}$  as a concept “bird” might be more similar to “pigeon” than to “owl.” In other words, instances of the

same category are ordered with respect to their similarity  $c_{\mu\nu}$ . It is known that, when being stored in the cascade network, the instance patterns are ordered with respect to stability: rising load level  $\alpha$  destroys (destabilizes) memories of the instances in ascending order of their similarity. Moreover, when a concept pattern (instead of an instance pattern) is presented as an input, the network recalls an instance having a higher similarity to the concept with a higher probability and in a shorter period of recall time, which seems to be consistent with human behavior (known as the typicality effect). When we are asked to recall an instance of “bird,” “pigeon” would be more probable and faster to be recalled than “owl.”

## References

1. Kohonen T (1974) An adaptive associative memory principle. *IEEE Trans Comput* C-23:444–445
2. Amari S (1977) Neural theory of association and concept-formation. *Biol Cybern* 26:175–185
3. Amari S, Maginu K (1988) Statistical neurodynamics of associative memory. *Neural Networks* 1:63–73
4. Hopfield JJ (1982) Neural networks and physical systems with emergent collective computational abilities. *Proc Natl Acad Sci USA* 79:2554–2558
5. Amit DJ, Gutfreund H, Sompolinsky H (1985) Storing infinite numbers of patterns in a spin-glass model of neural networks. *Phys Rev Lett* 55:1530–1533
6. Okada M (1996) Notions of associative memory and sparse coding. *Neural Networks* 9:1429–1458
7. Morita M (1993) Associative memory with nonmonotone dynamics. *Neural Networks* 6:115–126
8. Takeya H, Kindo T (1996) Hierarchical concept formation in associative memory composed of neuro-window elements. *Neural Networks* 9:1095–1098
9. Yoshizawa S, Morita M, Amari S (1993) Capacity of associative memory using a nonmonotonic neuron model. *Neural Networks* 6:167–176
10. Hirahara M, Oka N, Kindo T (2000) Cascade associative memory storing hierarchically correlated patterns with various correlations. *Neural Networks* 13:51–61

## Associative Priming

### Definition

A form of priming in which the prime and test are associated due to the experience of repeated pairing between the two concepts or stimuli. Although many associatively related words are semantically related, association measured as free association norms can be distinguished from a more direct form of semantic relation such as object category.

### ► Latent Learning

---

## Associatron

- ▶ Associative Memory

---

## Astereognosia

### Definition

Inability to recognize the form of an object by ▶touch (▶tactile sensation), resulting from lesions of the ▶parietal cortex.

- ▶ Active Touch
- ▶ Haptics

---

## Astrocyte

### Definition

Also known as astroglia, astrocytes are characteristic star-shaped glial cells in the brain. Astrocytes are irregularly shaped with many long processes. They are the largest and most numerous neuroglial cells in the brain and spinal cord. They regulate the extracellular ionic and chemical environment. “Reactive astrocytes” along with microglia respond to injury and amyloid plaques.

- ▶ Central Nervous System Disease – Natural Neuroprotective Agents as Therapeutics

---

## Astrocytoma

### Definition

The most common primary glial brain tumor. It can be found throughout the central nervous system (CNS). It is characterized by diffuse (infiltrating) or circumscribed growth. Astrocytomas can be classified by their histologic appearance and by their malignant potential.

The most commonly used grading system was developed by World Health Organization (WHO). It recognizes four different grades of astrocytoma; grade I describes low grade slow growing tumors while grade IV the most aggressive and deadly form (glioblastoma).

Grades II and III correspond to intermediate levels of malignancy.

- ▶ Gliomas

---

## Astrocytosis

- ▶ Glial Scar

---

## Asymmetry in Neurons

- ▶ Neuronal Polarity

---

## Asynergia

### Definition

Lack of coordination and poor harmony among various components of a complex motor task.

---

## Asynthesisia

### Definition

Failure to bind visual features together into the perception of an object. For example, a patient suffering from a stroke had lost color vision as well as the ability to recognize faces. His main problem was that he could perceive the local features of an object, but could not bind them together into a coherent object that consequently could not be recognized, although drawing it went quite well. He could also fluently describe objects he had known before his stroke.

---

## Ataractic Drug

- ▶ Antipsychotic Drugs

## Atasia-Abasia

### Definition

Inability to stand or walk.

## Ataxia

### Definition

Impaired motor coordination (= incoordination) usually related to disorders of the cerebellum or its connections with the brain and spinal cord. Ataxia [Greek, a (negative article) + taxi (order)] is characterized by slurred speech (ataxic dysarthria), nystagmus, dysmetria (undershooting or overshooting a target with trajectory limb movements), poor dexterity in performing rapid alternating movements (dysdiadochokinesis), and wide based gait (truncal ataxia). The term ataxia is also used to describe degenerative diseases of the cerebellum, most of them hereditary.

- ▶ Ischemic Stroke
- ▶ Posture Role of Cerebellum
- ▶ Proprioception: Effect of Neurological Disease
- ▶ Stroke

## Ataxic Respiration

### Definition

Uncoordinated respiratory movement characterized by complete irregularity of breathing, with irregular pauses and increasing periods of apnea.

- ▶ Development of the Respiratory Network

## Atelectasis

### Definition

The collapse of alveoli that are part of the lung.

## Athetosis

### Definition

Slow involuntary writhing movements, slower in character than chorea, but less sustained than dystonia.

Choreoathetosis is a mixture of fast and slow writhing movements.

- ▶ Chorea
- ▶ Dystonia

## Atomic Hypothesis

### Definition

A theory that postulates that all things are made of little particles, called atoms, which move around in perpetual motion.

- ▶ Brownian Motions

## Atomoxetine

### Definition

Atomoxetine is a selective noradrenaline transporter inhibitor drug that is used for the treatment of patients with attention deficit hyperactivity disorder (ADHD).

Unlike other ADHD medications (amphetamine, methylphenidate), atomoxetine appears to have little action on the brain dopamine neurotransmitter system in the dopamine-rich striatum. However, preliminary animal data suggest that the drug might increase extracellular levels of both dopamine and noradrenaline in the prefrontal cortex.

- ▶ Attentional Disorder
- ▶ Dopamine
- ▶ Noradrenaline
- ▶ Stimulants

## Atonia

### Definition

Absence of muscle tone (an extension of hypotonia, which is reduced muscle tone) seen in the acute phase of

spinal cord injury, or in disorders of the peripheral motor system, such as lower motor neuron disease, peripheral nerve disease, neuromuscular junction disorders, or myopathy. Atonia also occurs during ▶rapid eye movement (REM) sleep.

(paroxysmal atrial fibrillation). Raises the risk of ischemic stroke five times over.

- ▶ Stroke
- ▶ Ischemic Stroke

## Atonic Seizures

### Definition

Brief losses of consciousness and postural muscle tone without muscular contractions, such that the patient (usually a child) drops to the floor (“drop attack”); the ▶electroencephalogram (EEG) shows sequences of spikes and slow waves.

- ▶ Electroencephalography

## ATP

### Definition

Adenosine triphosphate: a high energy compound used by cells predominantly for metabolic purposes. ATP hydrolysis also provides the energy for muscular contraction.

- ▶ Sliding Filament Theory

## ATP-sensitive K<sup>+</sup> Channel(s)

### Definition

- ▶ Neuronal Potassium Channels

## Atrial Fibrillation

### Definition

Abnormal heart beat caused by an irregular and fast activity in the atria that is irregularly conducted to the ventricles. This may be consistent or episodic

## Attention

PETER KLAVER

Department of Psychology, University of Zurich, Zurich, Switzerland

### Definition

Attention represents a set of cognitive abilities that allow living beings to cope with the enormous amount of information flooding the sensory system, and to use this information in goal directed and adaptive behavior. More than one hundred years of research distinguished several major aspects of attention. One refers to selective attention, which is the ability to filter relevant from irrelevant information. The second refers to divided attention, which is the ability to cope with more than one task at the same time. The third refers to the ability to move attention and therefore select stimuli. The fourth refers to the ability to sustain attention to a task. This essay describes these aspects of attention and discusses the neural systems that support these attentional mechanisms and pathologies that impair them.

### Characteristics

#### Selective Attention

Selective attention refers to the ability to preferentially process relevant above irrelevant information. This is a fundamental cognitive process and can occur for example at the perceptual level when attention is directed to locations in space, objects or object features such as color or shape, auditory pitch or any other sensory information. Selection can also occur at higher levels of processing, for example when semantic categories such as natural and man-made objects need to be distinguished. Two crucial issues in selective attention studies will be discussed here. The first concerns the question how information is selected. What determines the relevance of information? Is selection determined by perceptual features such as salient object features (bottom-up processes) or by top-down processes such as task instructions, memory, or cues that initiate a selection process? The second issue concerns the question where and when information is selected. Particularly at the perceptual level many studies investigated whether selection takes place in the



low level sensory system (early selection), or after the processing of sensory information (late selection). This is called the “early-late selection debate.” For both the “how” and “when” question of selective attention one has to distinguish between spatial and non-spatial attention. Spatial attention is assumed to affect the sensory system and is guided by top-down processes, whereas non-spatial attention may not. When stimuli are spatially segregated it is presumed that spatial attention works as a spotlight or zoom focusing on a location. When attention is directed to a particular location, objects within the focus of attention are preferentially processed as compared with conditions in which attention is divided between locations or when attention is directed to another location. Human brain imaging and animal neurophysiological studies suggested that spatial attention directly operates at the sensory system, and increases the sensitivity of perception by means of competition between stimuli in relevant and irrelevant locations (sensory gating). Spatial selection may also be biased by top-down processes, even before a stimulus is presented on the attended location [1].

Mechanisms of spatial selective attention are thought to be a prerequisite of object perception. It is thought that all object features within the focus of attention are selected in parallel. This may be intuitive, since an object requires space but can contain different features within this space, such as luminance, color, texture, orientation, or motion direction. In order for selection to occur all information coming from feature specific processing areas needs to be integrated within this space, and conjoined with other features at different locations that build an object. The visual search paradigm is often used to study the selection of objects within space (Fig. 1).

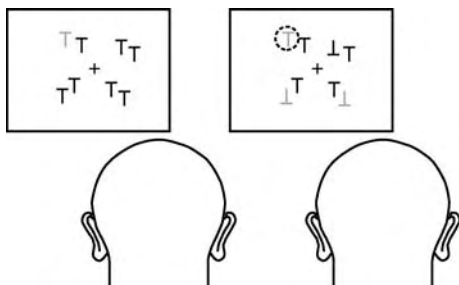

**Attention. Figure 1** An example of a spatial attention task including a virtual spotlight of attention. On the left a pop-out condition is displayed, in which a target object can be detected on the basis of a salient feature without much attention. On the right side a serial search condition is displayed in which detecting a target object requires reorienting of attention over the display. Here, the target distinguishes from distractors on the basis of a specific conjunction of object features (upright grey “T”).

The paradigm uses displays with arrays of objects with multiple features such as colors or shapes. Many studies using this paradigm suggested that much less attention is required when an object can be recognized on the basis of a salient feature. The object then seems to pop-out of the display and attention is automatically directed to the target object. When, however, objects need to be detected on the basis of a conjunction of features, the search process is time consuming and depends on the number of irrelevant objects [2]. It is then assumed that the spatial focus attention searches through the display. Findings that “illusory conjunctions” between features are made due to a lack of spatial attention suggested that spatial attention is needed to detect an object with multiple features. Such and other evidence supported the idea that object features are bound together within the focus of attention. Taken together, ample evidence showed that selective attention within the visual domain differs between spatial and non-spatial attention. Whereas selection of locations is determined by top-down processes that accompany the competition between relevant and irrelevant locations and the increase of perceptual sensitivity, the selection of objects relies upon both bottom-up and top-down processes. Salient object features may capture attention by a bottom-up process, whereas top-down processes guide spatial attention, perceptually integrate object features and bias locations or object features by task instructions in favor of behaviorally relevant objects.

### Characteristics: Divided Attention and Executive Control

The second aspect of attention deals with the cognitive resources that are available to allocate attention. The attentional resources are limited. For example, when two tasks are performed simultaneously performance may be impaired (driving a car in Cairo while using a mobile phone is virtually impossible). Subjects then have to deal with the coordination of goals. This is accompanied with a switch cost and can be attributed to limitations in [attention control system](#). A large amount of research investigated how attentional resources are organized, which processes require attention and which do not, how much time it takes to switch between tasks, and whether there is one central limited attentional resource or several resources in different sensory systems. An influential model of the executive control system assumes that most behavior is controlled by a contention scheduling system that coordinates goals and actions and is determined by previous experience and memories of responses to stimuli [3]. Executive control only then interferes and inhibits concurrent goals when the situation requires an alternative response. Such an alternative response is

required during decision making, planning, correcting errors, during coping with novel situations or responses, when overcoming habitual responses or when a situation is considered difficult or dangerous. This executive control has a limited capacity. A typical task demanding executive control is the Wisconsin card sorting task. In this task, the examiner places four cards with symbols that differ in number, shape or color in front of the subject, who is given a set of response cards with similar symbols on them. The subject is then asked to place an appropriate response card in front of the stimulus card based on a sorting rule established, but not stated, by the examiner (i.e. sort by color, number or shape). The examiner then indicates whether the response is “right” or “wrong.” After 10 consecutive correct responses, the examiner changes the sorting rule simply by saying “wrong.” The subject must then ascertain the new sorting rule and perform 10 correct trials. The sorting rule is then changed again, until six cycles have been completed. In this task, the change of situation demands a new response to a similar stimulus. Hence, the response that was previously tagged to a stimulus must be inhibited and changed to a new response. The Stroop task is also often used to test executive processes [4]. Here, a simpler process is required when solving a response conflict. For example, if the word “red” is printed in blue and subjects are required to pronounce the color of the printed word, there is a strong tendency to pronounce red instead of blue. In other words, the irrelevant information competes with the relevant information for a response. Attention is then required to suppress the tendency to respond to the irrelevant information. The mechanisms underlying selection of the relevant verbal response above the conflicting irrelevant response is thought to be similar to the perceptual selection process. Many studies showed that neurons in the prefrontal cortex have the possibility to perform such a selection process. These neurons show selective responses to either response information if the stimuli are presented separately, but if they are presented together the neural response to the irrelevant stimulus decreases [5]. Brain lesion studies and neuroimaging studies have shown that the brain areas responsible for executive control are located in the frontal lobe, the cingulate cortex and prefrontal cortex. Prefrontal neurons have been related to this ability. These neurons are decision sensitive rather than stimulus sensitive and are capable to adapt to new situations.

### **Characteristics: Orienting Attention**

Orienting of attention is particularly needed when searching in the environment for relevant information or during the tracing of stimuli through space. Searching in the environment is usually associated with the

foveation of a stimulus. This overt focusing with the eye can also be replaced by covert orienting of attention. As discussed under the term selective spatial attention that focusing attention improves detection of a stimulus. Moving a spotlight of attention from one stimulus location to another can also occur overtly and covertly by moving the eye or moving the “inner” eye. Several brain imaging and neurophysiological studies have shown that the neural mechanisms underlying overt and covert orienting of spatial attention has been associated with overlapping systems. Orienting attention has been associated with a network of at least three brain areas working strongly together, the posterior parietal lobe, the superior colliculus and the lateral pulvinar of the thalamus, representing the so called posterior attentional system [6]. These brain areas have been shown to contain representations of a spatial map that contain location sensitive neurons with relatively fixed relations among spatial locations and some more flexible spatial relationship to the body or the focus of attention. Neural activity in these neurons also suggests their capability to maintain and change the focus of attention. These three neural systems are thought to cope with subprocesses in orienting attention and in visual search. The movement of the attentional focus can be separated in at least three subprocesses; it requires the unlocking of attention to the old location (disengagement of attention), a shift of attention toward the new target location, and tagging to a new focus (engagement of attention). Lesions in the posterior parietal lobe have been associated with the disengagement of attention. Lesions in the superior colliculus have been associated with deficits in shifting the attention. These lesions not only result in slower shifts of attention and reduced capability to calculate the new target location, but patients with such lesions also return to a new location as easily as to a previously attended location. In healthy subjects, returning attention to a previously attended location is inhibited, in order to prevent searching at the same place again (inhibition of return). Finally, lesions in the lateral pulvinar of the thalamus have been associated with difficulties in engaging attention to a new location on the contralateral side of the lesion or to sustain attention to a location in particular when distracting stimuli are present in the ipsilateral visual hemifield. Indeed, this network of brain areas has been shown to be involved in visual search tasks. However, this network does not explain which stimulus locations are relevant and which stimuli draw and guide attention. Here, selective attention mechanisms are needed to distinguish relevant from irrelevant information. As discussed above, such selection mechanisms may be regulated in the occipital and temporal lobe. Thus, spatial orienting can be divided in several subprocesses and neural correlates, but this network does not operate without other

attentional processes and brain areas when coping with spatial attention demanding task.

### Characteristics: Arousal and Vigilance

Arousal represents the state of cortical activity or wakefulness. Cortical activity is accompanied with a desynchronization of slow rhythmic activity in the encephalogram. Arousal is regulated by different neurotransmitters in the brain stem, particularly nor-adrenaline, which innervate different patterns of cortical structures via the thalamus along ascending pathways. Yet, the relation between arousal and attentional functions, such as vigilance, remain under investigation. Vigilance or sustained attention represents the ability to detect and respond to small changes occurring at infrequent random time intervals in the environment. A typical vigilance test is the Continuous Performance Task, which is a 15 minute letter discrimination task. Performing this task requires at least durable (tonic) and momentary (phasic) attention and possibly arousal, that is vigilance requires maintaining a durable state without overt behavior while initiating sudden behavior once a target occurs. Vigilance can be measured by increased error rates and longer reaction times as a function of time (usually at least 5 min). The decrease in performance over time can be due to both a reduced tendency to judge a stimulus as a target and to a reduced sensitivity to discriminate between targets and distracters. Vigilance is thought to be controlled by the cholinergic system and noradrenergic system in the

nucleus locus coeruleus of the brain stem, the intralaminar thalamic nuclei and the right prefrontal cortex [7].

### Neural Networks of Attention

The brain areas that are involved in the attentional functions described above form a neural network that strongly interact and are coactive in many task situations (Fig. 2).

One of the most influential neural models of attention [6] consists of three subsystems. The posterior attention system (parietal cortex, superior colliculus, pulvinar) is concerned with spatial attention, the anterior attention system (anterior cingulate, basal ganglia and dorsolateral prefrontal cortex) with target detection and executive control, and the vigilance system (right prefrontal cortex, intralaminar thalamic nuclei and brainstem nuclei) with sustained attention.

### Pathology

Many patients with cognitive disorders also have attentional deficits. ▶ **Attention deficit disorder** is similar to the hyperactivity diagnosis in children and is referred to under the term ADHD (attention deficit/hyperactivity disorder). These diagnoses often have co-morbidity with disturbances in social behavior and the processing of emotions. Patients (children) are less persistent in performing a task, are overactive, impaired in short-term memory performance, and are often prone to make speeded errors and are less able to make decisions. These symptoms of ADHD can



**Attention. Figure 2** A neural network of attention according to Posner & Petrides (1994). This model highlights brain regions that are involved in the attentional control system (red), orienting of attention (green) and vigilance (blue).

be summarized under sustained attention, selective attention and executive control. These deficits correlate with impairments in neural networks of the right frontal (vigilance), posterior parietal (orienting/selective attention), and respectively anterior cingulate cortex (executive control) [8]. Other pathologies with attention deficits have often been associated with damage to the prefrontal cortex or with an imbalance in the neurotransmitter system. Patients with lesions in the prefrontal cortex can be impaired in sensory gating operations, in discriminating between old and new items and a disability to sustain attention. Deficits to discriminate between old and new stimuli or a lack of inhibition to previous responses may also lead to dysfunctions in executive control. Patients with schizophrenia have also been associated with attention deficits. Schizophrenia is often associated with sensory gating dysfunctions and the disability to inhibit interference of irrelevant information, inhibiting previously relevant but currently irrelevant responses or stimuli. Though the neural underpinnings of schizophrenia are largely unknown, a frontal dysfunction and neurotransmitter imbalance of dopamine and noradrenalin may play a role [9]. Patients with hemispatial neglect suffer from lesions in the right parietal or right prefrontal lobe. Some of the heterogeneous dysfunctions of these patients may be related to attention. The disorder of orienting that impairs awareness of stimuli located on the side of space opposite to the lesion in one cerebral hemisphere may be related to a disinhibited orienting to the ipsilesional field or deficits in disengaging attention to the contralesional field [10]. Thus, a variety of attentional deficits have been related to different pathologies. We now begin to understand how specific attentional functions are impaired in different pathologies. However, knowledge about the relation between pathology and specific attention functions is far from complete.

## References

1. Mangun GR, Hillyard SA (1995) Mechanisms and models of selective attention. In: Rugg MD, Coles MGH (eds) *Electrophysiology of mind: event-related brain potentials and cognition*, Oxford University Press, New York, NY, pp 86–131
2. Treisman AM, Gelade G (1980) A feature-integration theory of attention. *Cognit Psychol* 12:97–136
3. Norman DA, Shallice T (1986) Attention to action: willed and automatic control of behavior. In: Davidson RJ, Schwartz GE, Shapiro D (eds) *Consciousness and self-regulation*, Plenum Press, New York, NY, pp 1–18
4. Stroop JR (1935) Studies of interference in serial verbal reactions. *J Exp Psychol* 18:643–662
5. Desimone R, Duncan J (1995) Neural mechanisms of selective visual attention. *Annu Rev Neurosci* 18:193–222
6. Posner MI, Petersen SE (1990) The attention system of the human brain. *Annu Rev Neurosci* 13:25–42

7. Parasuraman R, Warm JS, See JE (1998) Brain systems of vigilance. In: Parasuraman R (eds) *The attentive brain*, MIT Press, Cambridge, MA, pp 221–256
8. Swanson J, Posner MI, Cantwell D, Wigal S, Crinella F, Filipek P, Emerson J, Tucker D, Nalcioglu O (1998) Attention-deficit/hyperactivity disorder: symptom domains, cognitive processes, and neural networks. In: Parasuraman R (eds) *The attentive brain*, MIT Press, Cambridge, MA, pp 445–460
9. Nestor PG, O'Donnell BF (1998) The mind adrift: attentional dysregulation in schizophrenia. In: Parasuraman R (eds) *The attentive brain*, MIT Press, Cambridge, MA, pp 527–546
10. Rafal RD (1998) Neglect. In: Parasuraman R (eds) *The attentive brain*, MIT Press, Cambridge, MA, pp 489–526

---

## Attention Deficit

### Definition

Many psychiatric and neurological diagnoses include deficits in attention. These diagnoses are, for example, neglect, attention deficit disorder, hyperactivity, schizophrenia, closed head injuries. Lesions in the prefrontal cortex, or deregulations of neurotransmitters may also accompany attention deficits. Patients with these diverse disorders suffer from a wide spectrum, yet specific patterns, of attention deficits. The spectrum may include impaired vigilance, concentration deficits, short-term memory, decision making, hyperactivity, perceptual, orienting deficits.

### ► Attention

---

## Attention Deficit Hyperactivity Disorder (ADHD)

### Definition

### ► Attentional Disorder

---

## Attention Demanding Process

### Definition

An attention demanding process is a process that involves cognitive resources, so another simultaneously performed task would suffer. For example, counting

backward is made increasingly demanding by counting backward in steps of two or three. Performing such a task impairs performance of the covert or overt rehearsal of numbers or words. Attention demanding tasks are suitable to demonstrate the limited capacity of attention.

► Attention

## Attention Shifts

### Definition

Attention can switch between tasks. If two tasks have to be performed simultaneously and processing resources are not able to perform the task in parallel, attention has to be divided and switched between the tasks. Task switches are accompanied with costs in processing in at least one of the tasks. It is assumed that the cost of processing is due to limitations in attentional resources.

Coping with task switches is thought to be part of the attentional control system.

► Attention

## Attentional Control System

### Definition

An influential model of the attentional control system consists of a set of brain regions that cope with the orienting of attention (posterior attentional control system, which includes the posterior parietal cortex, superior colliculus and lateral pulvinar of the thalamus), executive attention (anterior attentional control system, including the cingulate cortex and dorsolateral prefrontal cortex) and vigilance or alerting system (right prefrontal cortex). This model developed by Posner and Petersen (1990) covers about all attentional functions.

► Attention

## Attentional Disorder

### Definition

Many psychiatric disorders also include attentional deficits, while one percent of children suffer from

attention deficit disorder. Attention deficit disorder is not equivalent with hyperactivity, though attention deficit hyperactivity disorder (ADHD) is used as a common psychiatric diagnosis. The diagnosis includes impaired controlled processing of information, short-term memory, learning and decision making. The children are impaired in sustaining attention, are not able to focus long on a task, are disinhibited and overactive and reactions are less controlled. There is often a co-morbidity with social and emotional disorders.

► Attention

## Attentional Filtering

### Definition

Represents a particularly strong attentional effect, in which the context gates sensory input in an all-or-none fashion.

## Attractive Stimulus

### Definition

An attractive stimulus is a signal or a cue that is appealing and draws the receiver to the source of stimulation. The same stimulus can be attractive or aversive depending on physical features such as its intensity (for instance, concentration of an odor) or the behavioral context in which it is perceived.

- Aversive Stimulus
- Odor Coding

## A-type K<sup>+</sup> Current (IA)

### Definition

Voltage-dependent K<sup>+</sup> current, showing relatively rapid inactivation and contributing to action-potential repolarization in cortical neurons.

- Neuronal Potassium Channels
- Action Potential

## Atypical Depression

### Definition

This is a sub-type of dysthymia and major depression characterized by mood reactivity – being able to experience improved mood in response to positive events. It is also characterized by reversed vegetative symptoms, namely over-eating and over-sleeping. Leaden paralysis and sensitivity to personal rejection may also be observed.

► Major Depressive Disorder

## Atypical Neuroleptic Drugs

### Definition

Relatively newer neuroleptic drugs with less severe adverse effects on movements.

► Antipsychotic Drugs

## Audiogenic Seizures

### Definition

Seizures evoked by loud sound often beginning in the inferior colliculus.

► Inferior Colliculus

## Audiogram

### Definition

A chart showing the amount of hearing loss (in decibels) at each frequency.

► Hearing Aids

## Auditory Brainstem Response (ABR)

### Definition

An early latency sound-evoked event-related potential.

Typically elicited by clicks or tone bursts, and more recently by complex stimuli such as speech, the ABR has a distinctive pattern of neural waves arising within the first 10 ms after stimulation. Uses of the ABR include hearing assessment, tumor detection, intraoperative monitoring. Also known as Brainstem Auditory Evoked Response (BAER).

► Auditory Evoked Potentials

## Auditory Cortical Areas

CHRISTOPH E. SCHREINER<sup>1</sup>, JEFFERY A. WINER<sup>2</sup>  
<sup>1</sup>Coleman Memorial Laboratory, W.M. Keck Center for Integrative Neuroscience, Department of Otolaryngology-Head and Neck Surgery, School of Medicine, University of California at San Francisco, San Francisco, CA, USA

<sup>2</sup>Division of Neurobiology, Department of Molecular and Cell Biology, University of California at Berkeley, Berkeley, CA, USA

### Definition

Auditory cortical (AC) areas are structurally and functionally distinct regions in the temporal lobe that process acoustic information. Parcellation of these regions and the identity of areas are based on joint considerations of structural and functional properties, including cytoarchitecture, myeloarchitecture, neuro- and histochemistry, connectivity, electrophysiology and functional imaging. The number of AC areas is a matter of debate and may be species specific.

### Characteristics

#### Higher Level Structure

AC contains many areas as defined by tonotopic representations, i.e., an orderly progression of characteristic frequency (CF) or its absence; areas devoid of CF gradients are identified by their connectional affiliations or cytoarchitectonic attributes.

AC has a high degree of internal order, a stereotyped neuronal organization and intricate local microcircuitry. It is organized in all spatial axes. Thus, in cat AC, CF gradients are found in many (five of thirteen) areas, while other areas are polymodal (six) or limbic-related

(two) [1,2]. The CF gradient differs among areas, with local expansions or reductions of particular frequencies that may serve specific behavioral or ecological roles.

A further axis is laminar organization, which segregates afferent input systems to specific layers (e.g., thalamic projections preferentially end in layers III and IV, while corticocortical input targets layers II and III) and output (corticofugal projections to the midbrain arise exclusively from layer V, while those to the thalamus concentrate in layer VI). Even in areas without a CF representation, there is connective order on a laminar and topographic basis [1]. Thus, all areas have a topographic connective order, even if the physiological expression is area specific.

### Lower Level Components

Like all brain structures, AC has an intricate array of neuron types and connections that allow it to generate specific physiological responses by combining and recombining inputs in many ways. An elementary form of such order is in the membrane profile of cortical neurons, which is a consequence of genomic and ion channel-related features and endows cells with fundamental properties related to intrinsic excitability and filtering. A second basic level of this specialization is cell shape and chemical anatomy, which is diverse, ranging from glutamatergic pyramidal cells whose apical dendrites may be up to 2 mm long and which subserve vertical columnar organization within cortex, to tiny gamma-aminobutyric acid (GABA)-containing basket cells whose dendritic domain is confined completely to a cortical layer and whose range of synaptic action is a few hundred micrometers. Between these extremes a host of subtypes exist which endow AC with a multitude of processing regimes, including the ability to segregate and integrate streams of information entering it or exiting from it. Thus, even among pyramidal neurons there are subvarieties (giant versus small, classical versus inverted, single-spiking versus bursting, spinous versus smooth, corticothalamic versus corticotectal versus corticocortical) that confer diversity to intracortical intralaminar descending feedback and feedforward connections. Rather than serving as the final terminus for connections and processing, the cortex redistributes streams of information to the forebrain, thalamus, midbrain and medulla, enabling ongoing processing and filtering of ascending information and deconvolving an auditory stream into its constituent elements [1,2].

### Higher Level Processes

Segregation and integration are two fundamental aspects of cortical organization that must interact to enable functional processes. Cortical processes can be characterized as a combination of highly localized

and specific processes within areal subregions and global computational procedures and algorithms that reflect operations common to all areas. A basic operational principle is the systematic representation of behaviorally relevant attributes of proximity, similarity or dissimilarity within an organized parameter space. This requires detecting relevant features of the acoustic biotope, performing computed correlations and organizing perceptual space to implement behavior. Cognitive processes that occur in AC entail the analysis and interpretation of the environmental scene based on higher order correlations and in comparison with previously stored information regarding the behavioral relevance of objects, backgrounds and events.

In a mixed set of hierarchical and parallel processes, global groupings of auditory cortical fields can be distinguished [3]. These areas may be broadly subdivided into families that subserve and elaborate specific functional relations (Fig. 1).

Primary (first order or core [5]) areas represent intermediate stages in the synthesis of percepts after brain stem analysis and precede higher cortical tasks. The primary cortical regions represent auditory information topographically and with receptive field parameters tightly coupled to stimulus aspects [2]. Neurons typically respond to pure tones with a relatively short latency, prefer a restricted range of frequencies and have a global tonotopic organization preserving CF [6]. Other functional properties, such as spectral integration bandwidth, preferred sound intensity or binaural interactions are multiplexed on the tonotopic map and have systematic local organizations [2,6,7].

Secondary (second order, non-primary or belt) areas probably participate in discrimination, categorization and integration of information. Neurons in these areas show high local variability in frequency organization, response latencies and spatial and spectral integrative properties. Responses to pure tones are often reduced and complex sounds elicit stronger responses. Extreme examples are echolocation-specific maps in the AC of some bats [7]. Systematic representations of highly specific parameter-combinations of biosonar sounds and their echoes reflect distance or velocity information.

Multimodal (association, parabelt) areas include the parabelt regions and may process complex multimodal percepts and contribute to the foundation of concepts (for perceptual unity and consistency in decision-making and behavior). Their receptive field properties are poorly understood. A role in the analysis of communication and non-communication sound categories and in speech perception is plausible.

Supramodal areas are involved in the executive control of cognitive networks including language.

Limbic areas receive extralemnisal auditory input, show little regional specificity for particular stimulus aspects and convey auditory information to subcortical

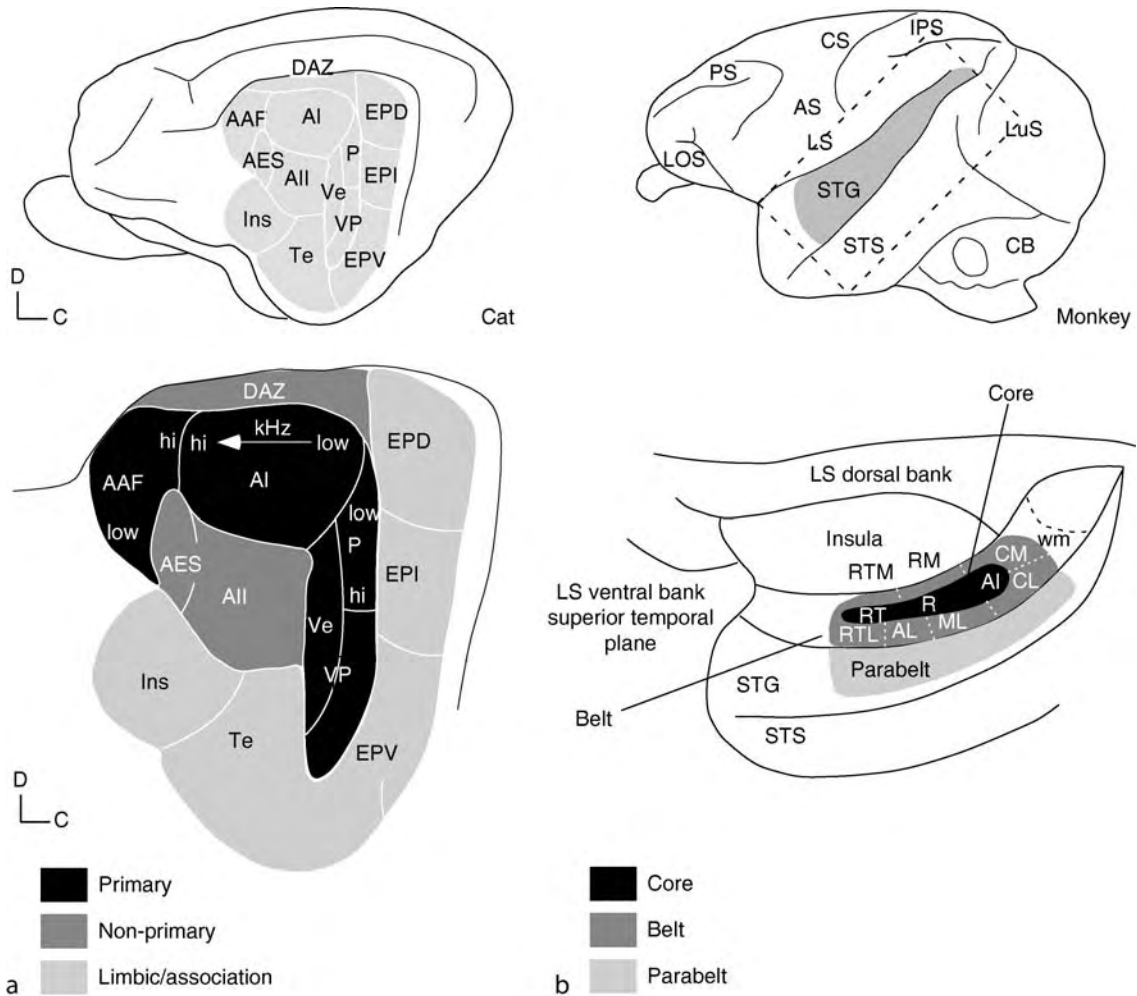

**Auditory Cortical Areas. Figure 1** Subdivisions of cat (a) and macaque (b) auditory cortex in a lateral view of the hemisphere (*upper panels*) and with the principal subdivisions indicated (*lower panels*). The macaque subdivisions are redrawn from [4]. For cat primary and macaque core areas, the local tonotopic gradient from low to high frequencies is indicated (*arrows*). A potential correspondence between cat primary, non-primary and limbic/association areas and macaque core, belt and parabelt areas remains to be established. Abbreviations: AAF anterior auditory area, AES anterior ectosylvian area, AI primary auditory cortex, All second auditory cortical area, AL anterolateral belt area, AS arcuate sulcus, CB cerebellum, CL caudolateral belt area, CM caudomedial belt area, CS central sulcus, D dorsal, DAZ dorsal auditory zone, EPD dorsal area of the posterior ectosylvian gyrus, EPI intermediate area of the posterior ectosylvian gyrus, EPV ventral area of the posterior ectosylvian gyrus, Ins insular area, IPS intraparietal sulcus, L lateral, LOS lateral orbitofrontal sulcus, LS lateral sulcus, LuS lunate sulcus, ML mediolateral belt area, P posterior auditory area, PS principal sulcus, R rostral core area, RT rostromedial core area, RTL lateral rostromedial, RTM medial rostromedial, STG superior temporal gyrus, STS superior temporal sulcus, Te temporal area, Ve ventral auditory area, VP ventral posterior area, wm white matter.

structures (amygdala and central gray) implicated in the control of smooth muscle.

### Lower Level Processes

A key feature of core areas is a gradual change in neurons' preferred frequency, creating a fundamental cochleotopic axis across AC. Within the continuous CF map are smaller pools of neurons with functional roles other than tonotopic organization, contributing

to specific representations of binaural differences, temporal patterns, stimulus intensity or sharpness of frequency tuning, which in turn are superimposed upon and integrated with CF maps [2]. Such representations could coordinate perceptual processes for binding and streaming, two prime functions for which AC is responsible, following processing in the brain stem. The functional organization of belt and parabelt regions is less well understood; however, they may have a local



order as demonstrated by the object-oriented maps in higher cortical areas of bats [2,7].

In the vertical axis, systematic functional distinctions between cortical laminae coexist with a columnar organization principle, i.e., with receptive field properties, such as CF, that are shared by neurons across the six layers. Lamina specific ensembles of cell types, modular microcircuits, thalamic and cortical inputs, as well as cortical and subcortical output targets, each suggest a fine-grained representation of functional properties within a column [1,6].

Neuromodulatory influences from many chemically specific subcortical sites, including cholinergic, serotonergic, noradrenergic and dopaminergic sources, converge onto AC areas and regulate cortical excitability, gate information processes, enhance signal-to-noise ratios and modulate receptive field synaptic plasticity [8]. These modulatory inputs can modify cortical function based on state, experience and behavioral context.

### Function

Communicative, predatory and reproductive behaviors rely critically upon AC to combine, transform and distribute acoustic information. AC interfaces hearing and higher order communication and cognitive networks, including human language areas. Transformations of auditory information in the thalamus and cortex support representations of the auditory environment for essential perceptual tasks. The neural algorithms for such transformations are common to all sensory systems but can also involve unique, modality-specific processes. Different AC subregions contribute to task-related computations and probably serve object specific analyses, suggesting the cortical emergence of processes that are either object related or embody processing stages and streams dedicated to specific features of the auditory environment [9]. Functional differences underlying these processes are created by thalamic and cortical circuits and by local diversity and specialization in synaptic and cellular mechanisms.

AC areas create distinct streams for cortical sound representation [6,9]. They may be less concerned with the representation of specific auditory attributes (a task which we suggest is largely completed in the brain stem) and more with the conjunction and coordination of acoustic, multisensory and limbic frames of reference, each contributing globally to auditory behavior and communication. The computed entities probably serve several central processing tasks, construction of a global representation of the acoustic world, determining object features such as form, texture and position, generating a reliable and stable feature representation, allowing subsequent multisensory integration, permitting the assignment of significance to particular environmental constellations and ultimately,

the emergence of unique perceptual attributes and concepts that trigger behavior.

Functional properties of neurons and neural networks of auditory cortical areas can be dynamically modified through experience. Critical behavioral decisions can reflect the contextual influences within the acoustic scene and their modification by experience. Thus, limbic circuits influence auditory processing, auditory stimuli can modulate behavioral arousal level and sound content and meaning can be assessed based on context and memory.

### Pathology

Dysfunction of AC results from many causes, including perinatal asphyxia, cerebrovascular disease (stroke), tumors, trauma, infection and developmental misadventures. In humans, consequences can range from minor auditory sensory disturbance, to auditory agnosia (impaired recognition of non-verbal sounds), to pure word deafness (impaired recognition of speech sounds), to cortical deafness (inability to recognize auditory stimuli). In human cases and infrahuman studies of AC lesions [10], perceptual deficits can involve discrimination of tone duration, auditory sequences and interaural order as well as impaired sound localization and reduced auditory speech perception. Often, tone detection and discrimination are unaffected. AC lesions also affect the construction of auditory objects, assessment of behavioral stimulus significance and decision-making in a learned stimulus/response contingency.

### References

1. Winer JA (1992) The functional architecture of the medial geniculate body and the primary auditory cortex. In: Webster DB, Popper AN, Fay RR (eds) Springer handbook of auditory research, vol 1. The mammalian auditory pathways: neuroanatomy. Springer, Berlin Heidelberg New York, pp 222–409
2. Winer JA, Lee CC, Miller LM, Schreiner CE (2005) Auditory thalamocortical transformation: structure and function. *Trends Neurosci* 28:255–263
3. Jacob B, Scheibel AB (2002) Regional dendritic variations in primate cortical pyramidal cells. In: Schuez A, Miller R (eds) Cortical areas: Unity and diversity. Taylor & Francis London, pp 111–132
4. Ghazanfar AA, Hauser MD (2001) The auditory behaviour of primates: a neuroethological perspective. *Curr Opin Neurobiol* 11:712–720
5. Hackett TA, Preuss TM, Kaas JH (2001) Architectonic identification of the core region in auditory cortex of macaques, chimpanzees, and humans. *J Comp Neurol* 441:197–222
6. de Ribaupierre F (1997) Acoustical information processing in the auditory thalamus and cerebral cortex. In: Ehret G, Romand R (eds) The central auditory system. Oxford University Press, New York, pp 317–398

7. Suga N (1988) Auditory neuroethology and speech processing: Complex-sound processing by combination-sensitive neurons. In: Edelman GM, Gall WE, Cowan WM (eds) Auditory function. Neurobiological bases of hearing. Wiley, New York, pp 679–720
8. Gu Q (2002) Neuromodulatory transmitter systems in the cortex and their role in cortical plasticity. *Neuroscience* 111:815–835
9. Rauschecker JP, Tian B, Pons T, Mishkin M (1997) Serial and parallel processing in rhesus monkey auditory cortex. *J Comp Neurol* 382:89–103
10. Heffner HE, Heffner RS (1990) Effect of bilateral auditory cortex lesions on sound localization in Japanese macaques. *J Neurophysiol* 64:915–931

## Auditory Division of the Statoacoustic Nerve

### ► Auditory Nerve

## Auditory Event-related Potentials

### ► Auditory Evoked Potentials

## Auditory Evoked Potentials

NINA KRAUS<sup>1</sup>, TRENT NICOL<sup>2</sup>

<sup>1</sup>Departments of Communication Sciences, Neurobiology and Physiology, Otolaryngology, Northwestern University, Evanston, IL, USA

<sup>2</sup>Department of Communication Sciences, Northwestern University, Evanston, IL, USA

### Synonyms

Auditory event-related potentials; ERP

### Definition

The firing of neurons results in small but measurable electrical potentials. The specific neural activity arising from acoustic stimulation, a pattern of voltage

fluctuations lasting about one half second, is an auditory evoked potential (AEP). With enough repetitions of an acoustic stimulus, signal averaging permits AEPs to emerge from the background spontaneous neural firing (and other non-neural interferences such as muscle activity and external electromagnetic generators), and they may be visualized in a time-voltage waveform. Depending upon the type and placement of the recording electrodes, the amount of amplification, the selected filters, and the post-stimulus timeframe, it is possible to detect neural activity arising from structures spanning the auditory nerve to the cortex.

### Characteristics

In general, as the time after stimulation (►latency) of a response increases, the neural generator becomes more central. In far field recordings from humans, the three typically used response classifications, based on response latency, are: early (the first 10 ms), middle (10–80 ms) and late (80 ms to 500+ ms). In terms of generators, these classes correspond roughly to brainstem, thalamus/cortex and cortex, respectively [1].

### Early Latency

Waves arising in the first ten ms after stimulation include both receptor potentials from the cochlea and neurogenic responses arising from the auditory nerve and low midbrain structures. With a near-field recording technique known as ►electrocochleography (►ECochG), two receptor potentials, originating in the cochlea's hair cells, can be recorded from the vicinity of the ear drum: the cochlear microphonic and the summing potential. They are AC and DC potentials, respectively, have an effective latency of zero, and last the duration of the stimulus. A millisecond and a half later, the dual-peaked neurogenic compound action potential of the distal auditory (eighth cranial) nerve can also be seen with ECochG. In contrast, using far-field electrodes, neurogenic responses known as the ►auditory brainstem response (ABR), can be recorded from the scalp (Fig. 1) [2].

These waves depend upon synchronous firing in the first relays of the afferent auditory pathway. For a given stimulus type (often an abrupt broadband click) and intensity level, the expected latency of ABR peaks falls within a very tight range (less than half a millisecond). Deviations from this range are useful in clinical diagnoses.

In particular, the ABR is a valuable objective measure of hearing. With decreasing stimulus intensity, wave latencies increase systematically until the hearing threshold is reached, below which the response is absent. Thus, an accurate measure of hearing threshold is possible in individuals who are unable to be tested behaviorally. Although there is a developmental time course (adult-like responses are attained by age two),

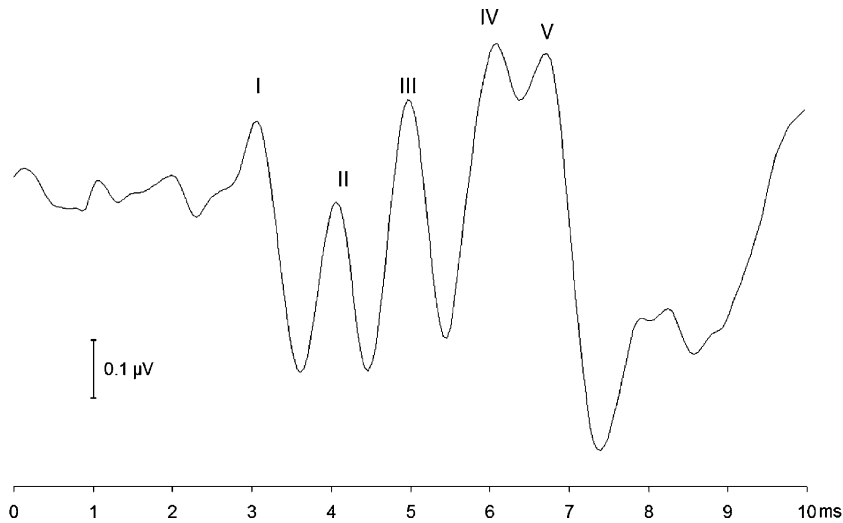

**Auditory Evoked Potentials. Figure 1** Early-latency auditory evoked potentials. The auditory brainstem response.

it is possible to test hearing in newborns with age-appropriate norms. Importantly, the ABR is unaffected by sleep or sedation, so obtaining hearing thresholds in babies or other uncooperative individuals is possible.

A second major clinical use of ABR is in the detection of lesions, tumors, demyelination, or conditions that cause increased intracerebral pressure (e.g., hydrocephalus, hematoma). ABR morphology, peak and interpeak latencies can have distinctive patterns that alert skilled clinicians to neural damage (e.g., eighth nerve tumors). Another major use of ABR is intraoperative monitoring. During neurosurgery, monitoring of ABR enables an immediate indication of whether any of the structures involved in the auditory pathway have been put at risk. Finally, the brainstem response provides a measure of neural synchrony necessary for normal perception of sound [3].

#### **Brainstem Responses to Complex and/or Long Stimuli**

Typical recordings employ short duration, relatively simple stimuli. However, complex sounds, some quite long in duration, are increasingly being used. Brainstem response to speech sounds can be used as a biological marker of deficient auditory processing associated with language and learning disorders [4]. A brainstem response whose nature depends on a long-duration stimulus is the ► **frequency-following response** (► **FFR**). The FFR, also known as auditory steady-state response, is an index of phase locking to a periodic stimulus. Examples of FFR-inducing stimuli are pure or modulated tones, tone complexes, modulated noise and speech [5]. Recorded from the scalp in humans, the FFR is a phase-locked response that, depending on electrode placement and stimulation and recording techniques, originates from as early in the auditory pathway as the auditory nerve or as late as the rostral brainstem. It is a measure of

both spectral and periodicity encoding, and because it is readily detectable in individuals, it has utility as a clinical measure of those processes as well as of hearing level. Brainstem responses are influenced by lifelong and short-term auditory experiences [6].

#### **Middle Latency**

The waves following the ABR, up to roughly 80 ms, are collectively known as the middle-latency response (MLR) (Fig. 2) [7].

Although responses in this time frame are less mappable to specific neural generators than the earlier ABR waves, the thalamus (P0, Na) and cortex (Pa, Nb, P1) are involved. (Note: Unlike ABR waves, the names of middle- and late-latency responses typically begin with P or N indicating positive or negative polarity.) As ABR requires a high degree of neural synchrony, individuals with certain neurological disorders may exhibit absent ABRs despite normal hearing. Thus, MLR can be useful in assessing hearing sensitivity. For this same reason, a lack of sufficient synchrony in response to low frequency signals often makes MLR superior to ABR in assessing low-frequency hearing. Two major caveats in MLR as a hearing measure is that it does not reach its mature morphology until adolescence, and in children, there is a strong influence of sleep state.

#### **Late Latency**

Late-latency (>80 ms) AEPs, historically the first discovered, are cortical in origin and are much larger and lower in frequency than early and middle-latency potentials. Highly dependent upon stimulus type, recording location, recording technique, patient age and state, the late-latency responses may differ dramatically in morphology and timing and may overlap one another. Thus, categorization of responses

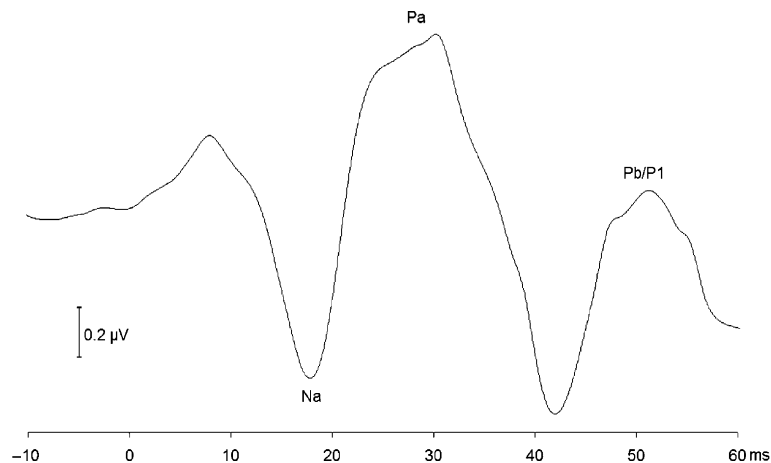

**Auditory Evoked Potentials. Figure 2** Middle-latency auditory evoked potentials.

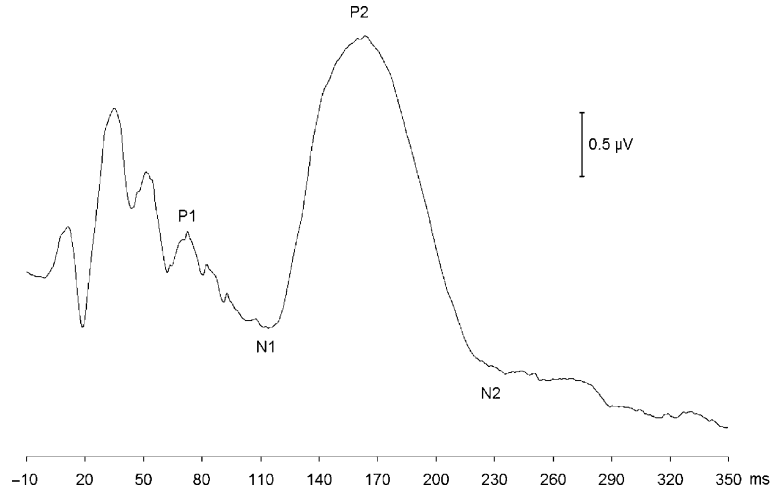

**Auditory Evoked Potentials. Figure 3** Late-latency auditory evoked potentials. Exogenous responses.

into two broad types, exogenous and endogenous, is useful in describing these late potentials. Exogenous responses, which also describe early and middle-latency potentials, are more-or-less obligatory responses to a sound. Endogenous responses typically require a stimulus manipulation or the performance of a task by the patient.

#### **Exogenous Responses**

The archetypal late-latency exogenous responses are illustrated in Fig. 3.

Beginning with P1 (which is sometimes classified as middle-latency) at about 80 ms through to N2 at about 250 ms, all are cortical in origin and maximal in amplitude at the central top of the scalp. The maturational time course of the various components varies. Late cortical responses do not reach maturity until post-adolescence. They have value in assessing

cortical auditory processing. In addition to the classic pattern of responses to stimulus onset, changes within an ongoing stimulus also evoke a response called the acoustic change complex (ACC) [9]. Tones or tone complexes changing in frequency, complexity or intensity and speech syllables are typical stimuli. The response can be evoked by an acoustic change that is very near threshold.

Bridging the exogenous and endogenous categories is the **mismatch negativity (MMN)**. MMN is an acoustic change detector. It is evoked by a sequence of identical sounds that is interrupted occasionally by a different sound. This stimulus presentation technique is termed “oddball paradigm.” The response to that infrequent stimulus differs from that to the main stimulus, and appears as a slow negative deflection in the 150–300 ms time frame. The types of stimulus manipulations that evoke MMN include intensity,

frequency and complexity, and the contrasting stimuli can be at (or even below) perceptual threshold.

### Endogenous Responses

Endogenous (literally “born within”) potentials are those that, while induced by external stimuli, originate not as an obligatory consequence of the inducing sound, but rather due to some level of cognitive processing. Examples of endogenous AEPs are the P300 and N400. Sequentially occurring later in time, the P300 and N400 represent successively higher levels of sound processing. Evoked using the oddball paradigm, the classic P300, unlike MMN, only occurs when the listener is consciously attending to the stimulus aberration. P300, which is also evoked by other sensory modalities, is considered an index of cognition because stimulus evaluation and classification must take place [10]. The response is further divided into P3a and P3b components. P3a either appears to a distracter stimulus which is presented along with the targets and non-targets within the oddball presentation, or, if stimulus differences are large enough, with no task at all. This component has more frontal lobe contribution than the classically elicited parietal-centered P3b. A higher level of cognition is required for the N400 response [11]. It requires a speech stimulus, and occurs in response to semantic incongruity and thus is an indication of language processing.

### Considerations

A number of considerations and caveats are involved in the recording of reliable auditory evoked potentials. No response is monolithic, either in its etiology or in interpretation. A thorough description of stimulus factors alone could fill a volume: the length, intensity, complexity and repetition rate of the stimulus all affect the responses. Some responses differ dramatically depending upon whether the stimulus is delivered to one or both ears or whether there is accompanying visual stimulation; others are relatively unaltered by these factors. Characteristics of the recording device, particularly filters, also have an effect on response recording. Successively later responses have increasing low-frequency content and high-pass filters must correspondingly be opened. However, with increasingly more energy being passed on the low end, recordings are more prone to contamination by non-stimulus related activity: artifacts. Artifacts fall under two categories, those internal to and external to the testee. Internal artifacts include eye blinks, movements, muscle contractions including the involuntary sound-evoked postauricular muscle (PAM) reflex, and brain activity that is unrelated to the sound stimulus. External artifacts are those arising from electrical sources such as AC power line and the electrical signal traveling

through the earphone or loudspeaker cables (stimulus artifact). The degree to which artifacts adversely affect response recordings depends upon how alike in frequency the artifact and the response are. For example, eye blinks are very low in frequency, and thus are more damaging to low-frequency late-latency responses. Most artifacts are random in time of occurrence. Two exceptions are stimulus artifact and PAM. Stimulus artifact lasts as long as the stimulus. Therefore, it is not a concern if the stimulus is a 100  $\mu$ s click and the response of interest is the middle-latency Pa. However, the stimulus artifact from a 5 ms tone burst may obliterate an early-latency brainstem response. PAM reflex occurs in response to the stimulus in the 15 ms timeframe and thus most affects middle latency responses.

Much information can be gleaned from AEPs for both clinical and theoretical purposes. As the power and speed of computers increases, multiple-channel recordings and advanced signal processing techniques are better able to inform us about the underlying neural processes that are signified by these minute perturbations in the electroencephalographic activity resulting from auditory stimulation. Together with advances in neural imaging, the exquisite timing resolution of AEPs can help us approach a better understanding of the biological bases of auditory function responsible for human communication such as speech and music.

### References

1. Kraus N, McGee T (1992) Electrophysiology of the human auditory system. In: Popper AN, Fay RR (eds) *The mammalian auditory pathway: neurophysiology*. Springer, New York, pp 335–403
2. Hood LJ (1998) *Clinical applications of the auditory brainstem response*. Singular, San Diego
3. Sininger Y, Starr A (eds) (2001) *Auditory neuropathy: a new perspective on hearing disorders*. Singular Thomson Learning, London
4. Banai K, Nicol T, Zecker S, Kraus N (2005) Brainstem timing: implications for cortical processing and literacy. *J Neurosci* 25:9850–9857
5. Galbraith GC, Threadgill MR, Hemsley J, Salour K, Songdej N, Ton J, Cheung L (2000) Putative measure of peripheral and brainstem frequency-following in humans. *Neurosci Lett* 292:123–127
6. Barai K, Kraus N (2008) The dynamic brainstem: implications for CAPD. In: McFarland D, Cacace A (eds) *Current Controversies in Central Auditory Processing Disorder*. Plural, San Diego
7. Kraus N, Kileny P, McGee T (1994) The MLR: clinical and theoretical principles. In: Katz J (ed) *Handbook of clinical audiology*. Williams and Wilkins, Baltimore, MD, pp 387–402
8. Burkard RF, Don M, Eggermont JJ (2007) *Auditory Evoked Potentials: Basic Principles and Clinical Applications*. Lippincott, Williams & Wilkins, Philadelphia

9. Martin BA, Boothroyd A (2000) Cortical, auditory, evoked potentials in response to changes of spectrum and amplitude. *J Acoust Soc Am* 107:2155–2161
10. Picton TW (ed) (1988) *Human event-related potentials: EEG handbook*. Elsevier, Amsterdam
11. Kutas M, Hillyard SA (1983) Event-related brain potentials to grammatical errors and semantic anomalies. *Mem Cognit* 11:539–550

---

## Auditory Maps

### ► Tonotopic Organization (Maps)

---

## Auditory-Motor Interactions

WALTER METZNER  
UCLA Department of Physiological Science,  
Los Angeles, CA, USA

### Definition

Interactions between hearing and various motor functions, such as protective reflexes and vocal behavior.

### Characteristics

Auditory signals guide a multitude of behavioral responses from simple reflex motor patterns for orientation to complex vocal communication behaviors in virtually all vertebrates and insects. Hence, auditory stimulation can elicit anything from simple motor patterns, such as head/neck turns or ear movements, to complicated, highly coordinated interactions of several motor patterns, such as calling, breathing, and postural changes that occur, for example, during birdsong. In turn, certain motor patterns, especially those associated with vocal behavior, can also affect how the brain processes auditory signals.

### Auditory Orientation Reflexes

Orienting movements of the head, neck and/or eyes in response to auditory signals are generally thought to be controlled by auditory input to the superior colliculus in mammals, or its homologue structure in birds, the optic tectum. Most of our knowledge about what controls head movements in response to external signals is based upon studies of visually guided orienting responses, where the topographic representation of the stimulus that ultimately guides the motor response is naturally

determined by the retinotopic organization of the visual system. Auditory input to the superior colliculus/optic tectum is topographically organized only in barn owls. In mammals, the representation of auditory space appears to be less developed, and is often even more complicated by movements of the external ears, or pinnae. Very little is therefore known about the neuronal basis of acoustically elicited orienting responses. It appears that output from the superior colliculus/optic tectum to small areas in the midbrain tegmentum mediate the sensory-motor transformation of stimulus location into a direction-specific pre-motor command. This in turn gives rise to a directed behavioral response through activation of the various pools of motor neurons in the brainstem and spinal cord that control head/neck turns, turns of the body axis, and/or eye movements.

### *Pinna Movements in Mammals*

The mammalian pinna plays an important role in sound localization, especially for sources in the midsagittal plane, which generate minimal interaural disparities. In species with mobile external ears, the pinnae can be oriented independently of the head's position, thus aiding in sound localization by allowing the animal to obtain multiple samples of an acoustic object. In such mammals, auditory targets elicit stereotyped pinna movements that typically consist of two parts: a short-latency component that is time-locked to the onset of the sound and a second long-latency component that is highly correlated with eye movements and is probably part of the animal's general orientation behavior. The second, slower response most likely involves the superior colliculus, and might be mediated by pathways linking the superior colliculus with the facial nucleus, either via the reticular formation (tectoreticular–facial pathway) or via the paralemniscal area (tectoparalemniscal–facial pathway). In particular, the paralemniscal area, situated in the lateral midbrain tegmentum, supplies an elaborate network of monosynaptic excitatory and inhibitory inputs to the medial portion of the facial nucleus, where the motoneurons that innervate the muscles of the pinna are located. It is not clear, however, if the superior colliculus is also involved in mediating the initial, faster response. This component of auditory-evoked pinna movements might be driven directly via the paralemniscal area, which receives multiple, binaural inputs from the ascending auditory pathway, notably from the dorsal nucleus of the lateral lemniscus.

### Acoustic Startle Response

The startle response is a fast reflexive response to intense, unexpected acoustic, tactile or vestibular stimuli and protects the animal from injury by blows or predatory attacks. The acoustic startle response (ASR) of mammals, including humans, consists of a quick eyelid-closure and a contraction of facial, neck

and skeletal muscles, an arrest of ongoing behaviors, and an increased heart rate. This results in a brief stiffening of the limbs, dorsal neck, and body wall before the animal can perform directed evasive or defensive actions [1]. The ASR can be modulated by various experimental manipulations, expressing habituation, sensitization, and fear conditioning. ASR has thus been used as a behavioral assay to examine the neuronal basis of behavioral plasticity, and to model neuropathological dysfunctions of sensorimotor information transfer.

The ASR is phylogenetically widespread and can also be found in fish and aquatic amphibians where it is expressed as “▶C-start escape” and is mediated by the ▶Mauthner cell system [2]. An ASR is even present in some insects [3]. Its neuronal implementation is therefore rather diverse, although it has been suggested that the most fundamental mechanisms for rapid motor control by the Mauthner system may even be shared between fish and mammals.

The behavioral latency of the ASR in mammals is very short (5–10 ms in rats), indicating that a simple circuit with very few synapses underlies this reflex response. The neuronal elements linking the cochlear nucleus to motoneurons controlling neck and limb muscles are found within the reticular formation. All current models proposed for the neuronal implementation of the ASR include an initial central relay in the cochlear nuclear complex leading to a central, integrating brainstem element within the reticular formation, which relays its output to motor neurons in brainstem and spinal cord. A small cluster of giant neurons in the caudal pontine reticular nucleus (PnC) represents the key component of this sensory-motor circuit, and is involved in sensory-motor integration and its modulation by other central-nervous inputs. Auditory information reaches the PnC via different nuclei of the central auditory pathway, such as the dorsal and ventral cochlear nucleus, the lateral superior olive and neurons of the cochlear root nucleus, a ganglion located within the auditory nerve.

### Middle Ear Muscle Reflex

The middle ear muscle reflex (MEMR) in mammals consists of contractions of two middle ear muscles, the ▶stapedius and ▶tensor tympani, respectively, in response to intense sound signals, thus protecting the inner ear from damage. Between the two muscles involved, the contraction of the stapedius contributes more to the overall MEMR. Measurements of the MEMR have become an important tool in audiologic examination and for detecting hearing loss in children and newborns [4].

In normal hearing humans, MEMR thresholds are approximately 95 dB SPL for tones and 75 dB SPL for wideband noise. As a result of the MEMR, hearing

thresholds increase between 15 and 20dB in all mammals tested, including humans. The short latencies for the MEMR of only 3–6 ms, with those for the tensor tympani reflex being slightly longer, suggest a simple underlying circuitry. However, the exact reflex pathways are still unknown. There is evidence for both, interneurons within or near the superior olivary complex (most likely in the medial superior olive) and direct projections from cochlear nucleus neurons to facial and trigeminal motor neurons, which ultimately innervate stapedius and ▶tensor tympani muscles, respectively.

A MEMR is also found in birds and involves a ▶stapedius muscle (also called “musculus columellae”), which is, like its mammalian counterpart, innervated by facial motor neurons. Further details of the underlying circuitry are not known. Reptiles and ▶anuran amphibians also possess a set of middle ear muscles that are attached to various structures in the middle ear, however, relatively little is known about their function(s) and the underlying neuronal control. It has recently been suggested that the middle ear muscle system in anuran amphibians (the so called “opercular system”), in addition to protecting the inner ear from sound shocks, might also play a protective role by reducing the large pressure changes that occur in the inner ear fluids during ambulatory or ventilatory movements.

## Auditory Feedback Control of Vocalizations

### Mammals

While the importance of auditory feedback for vocal learning in birds and mammals is well documented, its role in adulthood is much less understood [5–7]. Whereas auditory experience affects the overall structure of a species’ vocal repertoire on a large scale only in humans and songbirds, but not in non-human primates, more recent data indicate that subtle modifications of a fixed template indeed occur in a wide variety of call types in every major primate group. It appears, therefore, that vocal learning in non-human primates consists mostly of subtle spectro-temporal changes of an inherited basic call structure [8]. In certain songbirds, it has been demonstrated that auditory feedback also plays a major role in the maintenance of the bird’s acquired song throughout its life (see below). Although the evidence is patchy, among adult mammals, only humans, bats, and possibly cetaceans appear to require auditory feedback for the maintenance of basic parameters of species-specific vocalizations.

In humans, the detrimental effects of deafness on human language are well known, even when deafness was acquired postlingually. In addition, language dysfluencies and stuttering in hearing human subjects appear to be caused by a malfunction of the auditory feedback circuit that controls the production of

vocalizations. Apart from these complex effects on human language, basic vocal parameters, such as the fundamental frequency are also affected. Speaking deaf humans tend to speak in a voice that contains higher fundamental frequencies than in hearing human speakers. When adequate auditory feedback is provided, as with a cochlear implant, however, the fundamental frequency is one of the earliest acoustic features to approach normal values again. Numerous psychoacoustic experiments in adult humans also demonstrate that the fundamental frequency of their voice changes when artificially modified auditory feedback is presented, such as frequency-shifted formants.

Auditory feedback is also essential in echolocating bats [9]: the dynamic, temporal, and spectral pattern of their echolocation cries crucially depends on the information contained in the returning echo signal.

Reports on neural interactions between auditory processing and vocalization control are scarce, and few studies have addressed this issue at the level of single neurons. Auditory stimulation can affect neural activity in certain motor structures in various mammals, such as the paralemniscal area in bats, the parabrachial nucleus in cats, bats, and monkeys, the nucleus ambiguus, which controls laryngeal activity, and the laryngeal nerve in bats and rats. Neurons with dual vocal premotor and auditory function occur in the bat and monkey midbrain. So far, however, no coherent concept of what mechanism might underlie auditory feedback control of call production has emerged.

Conversely, vocalization has been shown to affect processing of auditory information in the superior olivary complex and adjacent areas (including the nucleus of the central acoustic tract), in the vicinity of the nuclei of the lateral lemniscus (within the paralemniscal area), adjacent to or within the inferior colliculus, in the medial geniculate body, and in the auditory cortex. This has been reported in several species of bats and in primates. In most cases, auditory responses were markedly suppressed during vocalization.

### Songbirds

Songbirds are one of the best-studied examples for the role of auditory feedback in vocal learning: young male songbirds learn to produce their species-typical song patterns by first forming a song memory or “song template” (normally resembling the father’s song), and then shaping their vocal output by comparing auditory feedback from their own vocalizations with this template. In addition, more recent work has shown that auditory feedback is not only needed to acquire song, but that in adults of some species, hearing their own song is also required for maintaining proper song patterns during adulthood well beyond the age at which song is learned. As many components of the brain

circuitry that mediates song learning have been identified, birdsong provides a powerful model system for studying the neural mechanisms of auditory-guided vocal learning [6], including various aspects of human speech [7].

Birdsong research focuses mainly on the neuronal sites and mechanisms that underlie song memory and auditory feedback. So called “song-specific neurons”, which respond selectively to playbacks of the bird’s own song, or in some cases the tutor’s song, but not to song produced by other males of the same species, appear to play a key role. Such song-specific responses are created within a forebrain nucleus (the “High Vocal Center”, HVC) and are then relayed to other nuclei throughout the song system; they were even found in the hypoglossal nerve that innervates the bird vocal organ, the syrinx. One particular pathway, the “anterior forebrain pathway”, which is strikingly similar to the mammalian cortical-basal ganglia circuit, may be a key player in the auditory feedback control of song during vocal learning, as well as during adulthood [6]. Various lesion experiments indicate that this pathway is essential to the vocal plasticity necessary for song learning.

Many neurons in the song system show both premotor and auditory function. Currently, however, we still have little knowledge of what song feedback information reaches the sensory-motor structures of the song control system, or how sensory and motor activity interact at the cellular level. For instance, how can these neurons distinguish self-generated sounds from those emitted by external sources? A neural mechanism involving a ▶corollary discharge (or ▶efference copy”) might play a role in solving this problem. Such a mechanism entails subtracting a motor copy of the vocal command signal from the sensory input, thus canceling out anticipated sensory feedback from the bird’s own song. The plasticity in the processing of auditory feedback also appears to depend upon other behavioral states, such as wakefulness or sleep.

### Fish

Sound communication is not unique to mammals or songbirds but rather is a trait shared with most vertebrates. ▶Teleost fishes include many species that hear and also produce sounds for communication purposes, such as midshipman, toadfish, and weakly electric mormyrid fish [10]. Playback of sounds produced by these fish evokes calling behavior and ▶phonotaxis. The vocal control system extends from forebrain to hindbrain levels and shares several organizational features with the vocal systems of birds and mammals. Various studies have also pinpointed sites where the auditory and vocal systems interface with



the ►[neuroendocrine axis](#) of the brain. Thus, the vocal and auditory feedback mechanisms identified in these simple systems are essential for producing vocal communication behaviors within the context of more complex social and reproductive behaviors.

### Cerebellar Learning

Cerebellar computation has recently been portrayed as a straightforward example of feed-forward processing of inputs in order to improve movement accuracy. In the context of auditory stimulation, the cerebellum plays a major role in temporally specific learning that occurs in rhythmic motor entrainment, for example, movements observed in musicians in response to auditory feedback from the instrument they are playing.

Similar to the fact that vocal motor patterns can also affect the processing of auditory signals, cerebellar processing also appears to be able to affect sensory information processing. This has been demonstrated, for example, for the perception of pitch in humans. Neuroimaging studies have shown that fine auditory discrimination depends critically upon non-motor sensory support functions of the cerebellum.

### References

1. Yeomans JS, Li L, Scott BW, Frankland PW (2002) Tactile, acoustic and vestibular systems sum to elicit the startle reflex. *Neurosci Biobehav Rev* 26:1–11
2. Eaton RC, Lee RK, Foreman MB (2001) The Mauthner cell and other identified neurons of the brainstem escape network of fish. *Prog Neurobiol* 63:467–485
3. Hoy RR (1989) Startle, categorical response, and attention in acoustic behavior of insects. *Annu Rev Neurosci* 12:355–375
4. Johnson KC (2002) Audiologic assessment of children with suspected hearing loss. *Otolaryngol Clin North Am* 35:711–732
5. Janik VM, Slater PJB (1997) Vocal learning in mammals. In: Slater PJB, Rosenblatt JS, Snowdon CT, Milinski M (eds) *Advances in the Study of Behavior*, vol. 26. Academic Press Inc., San Diego, California, USA; London, England, UK, 59–99
6. Zeigler HP, Marler P (eds) (2004) *Behavioral Neurobiology of Birdsong*. *Annals of the New York Academy of Sciences*, Vol. 1016. New York Academy of Sciences, New York, NY, 1–788
7. Doupe AJ, Kuhl PK (1999) Birdsong and human speech: Common themes and mechanisms. *Annu Rev Neurosci* 22:567–631
8. Egnor SE, Hauser MD (2004) A paradox in the evolution of primate vocal learning. *Trends Neurosci* 27:649–654
9. Moss CF, Sinha SR (2003) Neurobiology of echolocation in bats. *Curr Opin Neurobiol* 13:751–758
10. Bass AH, McKibben JR (2003) Neural mechanisms and behaviors for acoustic communication in teleost fish. *Prog Neurobiol* 69:1–26

## Auditory Nerve

JONATHAN SIEGEL

Department of Communication Sciences and Disorders, Northwestern University, Evanston, IL, USA

### Synonyms

Cochlear nerve; Auditory division of the statoacoustic nerve; Cochlear division of the vestibulocochlear nerve; Eighth cranial nerve

### Definition

The auditory nerve is the peripheral pathway comprised of the central processes of the sensory ►[spiral ganglion](#) neurons of the cochlea that project to the ipsilateral cochlear nucleus, as well as the axons of the neurons of the ►[olivocochlear efferent system](#) that originates in the superior olive.

### Characteristics

#### Quantitative Description

The number of spiral ganglion neurons in mammals ranges from about 10,000–50,000, 80–95% of which are classified as Type I, while the remainder are (Fig. 1) Type II. Type I neurons receive input from inner hair cells, while outer hair cells provide the input to Type II cells [1]. There are between about 475 and 2,500 olivocochlear efferent neurons in a range of mammals, approximately one-quarter to one-third of which belong to the medial olivocochlear system that contacts outer hair cells, while the remainder belong to the lateral olivocochlear system which projects primarily to the dendrites of the Type I spiral ganglion neurons within the organ of Corti [2].

#### Higher Level Structures

The auditory nerve is the beginning of the afferent auditory pathway that ascends through the brainstem and midbrain to reach the auditory cortex in the temporal lobe. The olivocochlear efferent system is the common final descending auditory pathway to the cochlea.

#### Lower Level Components

The auditory nerve is a subdivision of the ►[statoacoustic nerve](#), the eighth cranial nerve, the other being the vestibular division. The nerve carries both afferent and efferent axons between the cochlea and the medulla.

#### Afferent

The spiral ganglion, located in Rosenthal's canal, coiled around the modiolus of the cochlea, gives rise to the

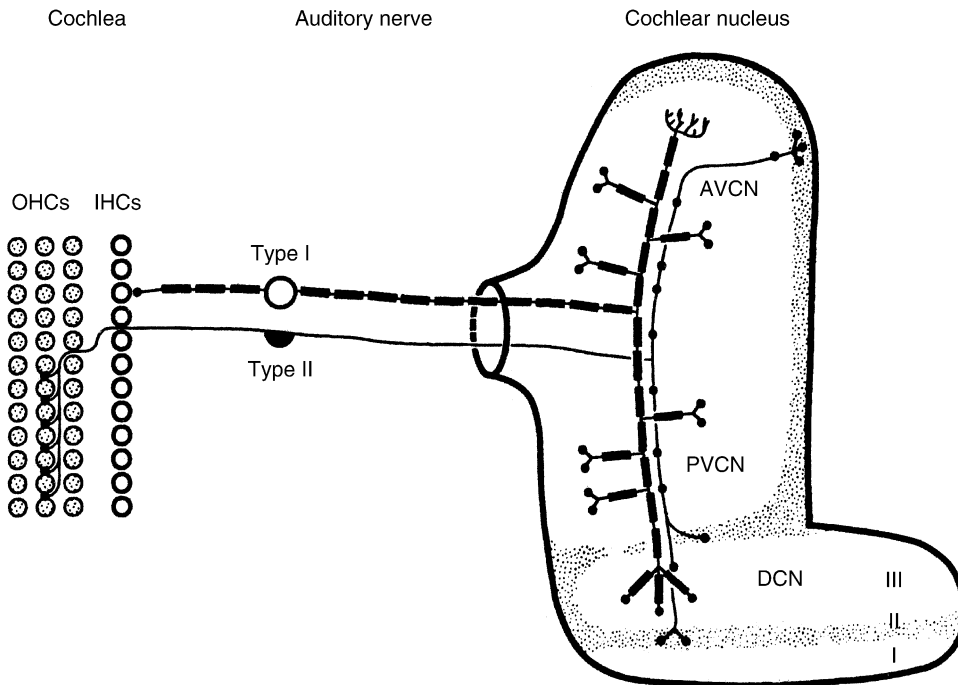

**Auditory Nerve. Figure 1** Diagram of the peripheral and central connection patterns of the spiral ganglion neurons. The type I neurons receive input exclusively from inner hair cells and bifurcate to terminate in ventral and dorsal regions of the cochlear nucleus that in turn project to other brainstem auditory nuclei. The type II neurons, which receive input exclusively from outer hair cells, follow the course of the type I neurons, but terminate in granule cell regions of the cochlear nucleus. (Reprinted from Fig. 2.19 of reference [1] with kind permission of Springer Science and Business Media).

afferent component of the auditory nerve. Two classes of bipolar ganglion cells provide separate sensory innervation for the inner and outer hair cells. The larger type I cells, which are 80–95% of the total, send mostly unbranched peripheral processes through the osseous spiral lamina to form small bouton endings on the inner hair cells. The remainder of spiral ganglion cells are generally smaller and their peripheral processes branch within the organ of Corti to form multiple small endings on outer hair cells.

Each inner hair cell typically contacts from about 10 (in the apical turn) to 25 (mid basal turn) different type I spiral ganglion cells. Each bouton ending is opposed by a specialized presynaptic complex in the hair cell typified by a presynaptic dense body that tethers synaptic vesicles via filamentous links. This synaptic organization, in which a single active zone provides the entire excitatory drive to a sensory neuron, is unique in the nervous system and undoubtedly exerts a strong influence on how auditory signals are encoded. On entering the cochlear nucleus the axons of the type I spiral ganglion cells bifurcate, with branches running rostral (ascending) and caudal (descending). The ascending type I axons terminate in the anteroventral cochlear nucleus (AVCN), forming large end-bulbs of Held on the somas and small bouton endings on

both the somas and dendrites of AVCN neurons. The descending branches form small to intermediate size endings on cells in both the posteroventral (PVCN) and dorsal (DCN) divisions of the cochlear nucleus.

The peripheral processes of the type II ganglion cells take a characteristic basal spiral course in the outer spiral bundles underneath the outer hair cells, before branching to form as many as 60 terminals on outer hair cells along their spiraling course. The type II cells and their processes are smaller than their type I counterparts and are far less heavily myelinated. While the central processes of type II ganglion cells follow the same course as the type I cells that originate in the same region of the cochlea, they terminate exclusively within the superficial granule cell regions of both the ventral and dorsal cochlear nucleus and thus do not appear to project to the same cochlear nucleus neurons that receive input from the type I spiral ganglion cells [1].

#### Efferent

The olivocochlear system provides the efferent component of the auditory nerve. Here too, there is specialization, with the medial division terminating on the basal somas of outer hair cells, while the lateral division terminating primarily on the peripheral processes of the type I spiral ganglion cells underneath the inner hair

cells. The cell bodies of the medial olivocochlear neurons are in the medial periolivary regions of the superior olivary complex. The majority of their large, myelinated axons cross the midline to project to the contralateral cochlea, but some project ipsilaterally. The relatively small somas of the more numerous lateral olivocochlear neurons are located in and near the lateral superior olivary nucleus and project primarily to the ipsilateral cochlea. Their axons are small in diameter and unmyelinated. Before leaving the brainstem, the axons of both medial and lateral olivocochlear neurons join to form the olivocochlear bundle, which leaves the brainstem in the vestibular division of the vestibulocochlear nerve, before crossing at the vestibulocochlear anastomosis into the cochlear division to enter the modiolus. Within the modiolus, the olivocochlear bundle forms the intraganglionic spiral bundle within Rosenthal's canal next to scala tympani of the cochlea. On entering the organ of Corti, the lateral olivocochlear neurons join the inner spiral bundle, running beneath the inner hair cells, where they terminate on the unmyelinated dendrites of the type I spiral ganglion cells. The medial olivocochlear neurons terminate in multiple large vesicular endings at the base of outer hair cells. The density of medial efferent terminations is greatest in the basal half of the cochlea, the region where the mechanical cochlear amplifier function of outer hair cells appears strongest [2].

### Process Regulation

The process of afferent auditory nerve signaling can be considered to be under regulation by the olivocochlear efferent system, as well as the acoustic reflex activity of the middle ear muscles. The physiology of the lateral olivocochlear efferent subsystem is largely unknown. The small size of the unmyelinated lateral olivocochlear neurons and their axons has made recordings impractical. Because of its innervation pattern, this system undoubtedly must regulate the transmission of afferent information to the brain via the type I spiral ganglion cells. The medial efferent neurons are generally tuned to the same frequencies as their type I afferent neighbors, suggesting a highly tonotopic central reflex arc. Because this system terminates directly on outer hair cells, it is likely to regulate their role in amplifying vibrations of the basilar membrane, referred to as the cochlear amplifier. There is evidence that this action may optimize performance in detecting signals in background noise and in selective attention to auditory stimuli in the presence of competing visual stimuli [3].

### Function

All sharp electrode recordings of responses to sound from single units in the auditory nerve reported thus far have been from the type I spiral ganglion cells which receive input exclusively from inner hair cells.

No recordings have been reported from the type II spiral ganglion neurons, likely because of their small size. Auditory nerve fiber single units discharge action potentials in the absence of stimulation, quantified as an average spontaneous rate (SR). There are two distinct classes of auditory nerve fibers, one with relatively low SR (less than 15 spikes/s) and with relatively high SR with a broad distribution centered around 60 spikes/s. The majority (85% or so) are high SR. These two classes of neurons exhibit different relations between stimulus sound pressure level (SPL) and the average rate during a tone burst stimulus. The minimal SPL that produces a detectable rate increase above the SR is defined as the threshold level. Thresholds are somewhat higher for low SR than for high SR neurons. High SR neurons tend to reach a saturating discharge rate of  $\sim 300$ /sec with increasing stimulus level within 30 dB of threshold. Low-SR neurons can exhibit much more shallow rate-versus-level relations and may not saturate until much higher stimulus levels are reached [4].

The neural **tuning curve** is constructed by measuring the thresholds for the entire range of tone frequencies to which the neuron responds (Fig. 2).

The frequency at which the lowest threshold SPL is measured is called the characteristic frequency (CF). The characteristic frequency is determined by the location along the cochlear spiral where the type I neuron receives its input from an inner hair cell. The rapid rise of threshold above CF is due to the steep decline in vibration of the traveling wave apical to the peak. The region of the tuning curve that dips

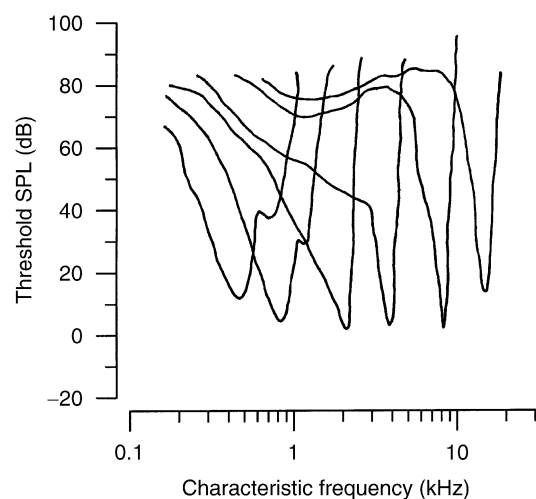

**Auditory Nerve. Figure 2** Schematic representation of **auditory nerve tuning curves** measured from type I spiral ganglion neurons that receive input from hair cells in different regions of the cochlea, as indicated by the characteristic frequency, the frequency of minimum threshold.

down to the CF is called the tip of the tuning curve, while the shallow low-frequency region is called the tail. The tuning curve resembles an inverted version of the low-level basilar membrane response because the amplitude of vibration of the hair bundle of the hair cells that contact the auditory neurons is determined fairly directly by the local vibration amplitude of the basilar membrane. In fact, the basilar membrane vibration threshold tuning curve closely resembles the tuning curves of both hair cells and the cochlear afferent neurons in the corresponding region of the cochlea. For stimulus level and frequency combinations above threshold the average rate of action potentials grows with increasing level and saturates as described above. So the neural threshold tuning curve allows us to know whether or not a particular neuron will respond to a stimulus with a given frequency and intensity, but nothing about how strongly it responds [4].

One of the most striking aspects of auditory nerve physiology is the ability of single neurons to encode the temporal waveform of acoustic stimuli, a phenomenon referred to as **phase locking**. This basic attribute is

illustrated in Fig. 3. Figure 3a, reproduced from a study by Don Johnson [5], shows histograms representing the relative probability that an action potential will be recorded at different phases of a single cycle of a sine wave stimulus tone.

The CF of the neuron was 2.5 kHz and the responses to tones ranging from 1.4 to 3.6 kHz all demonstrate a continuous modulation of discharge probability that corresponds to the temporal waveform of the stimulus. Note that the time axis (x-axis) for the 1.4 kHz tone represents 0.7 ms, while that of the 3.6 kHz tone is only 274 ms (the time of one period =  $1/\text{frequency}$ ), yet a modulation of probability within this short time is clearly seen. Phase-locked responses of auditory nerve units to tones have been used to demonstrate a neural version of the space-time pattern of basilar membrane vibration first described by von Békésy as a traveling wave (Fig. 3b) [6].

While fascination with temporal precision is understandable, Fig. 3a also demonstrates the equally significant feature that the encoded waveform remains remarkably undistorted, despite a change of stimulus

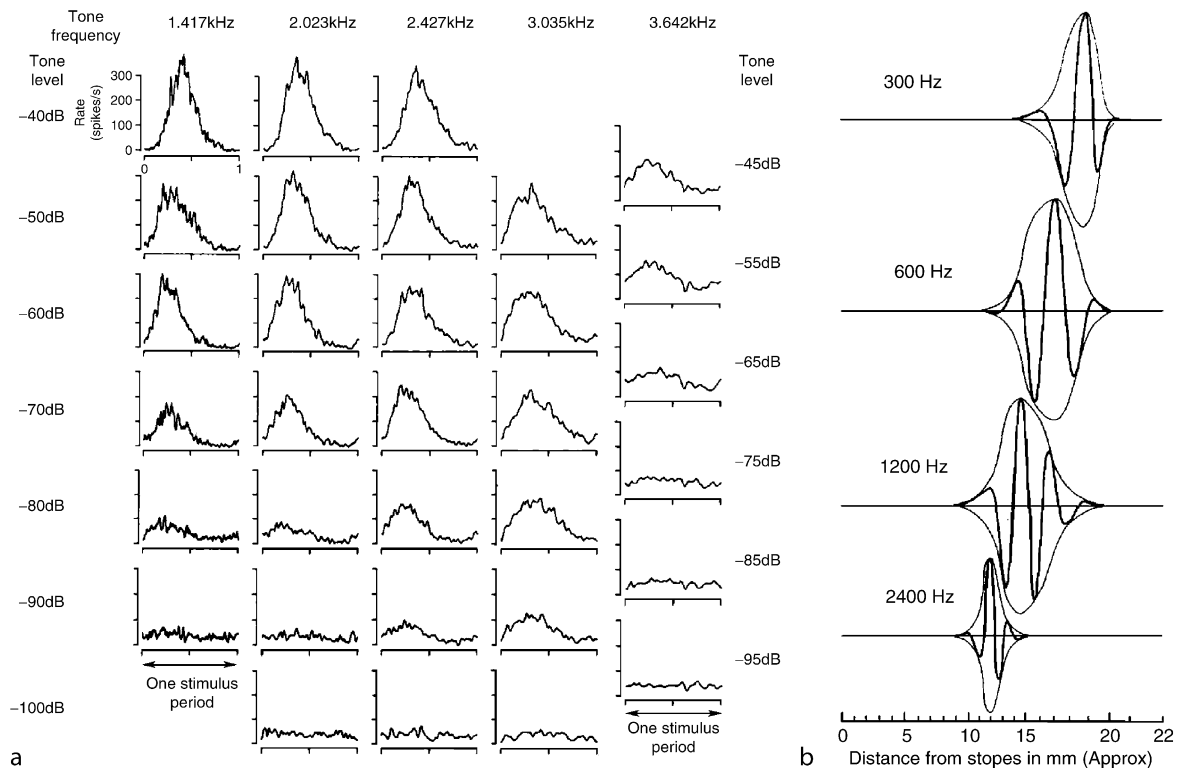

**Auditory Nerve. Figure 3** Phase-locked responses of auditory nerve units. (a) Period histograms measured from a neuron with characteristic frequency of 2.5 kHz for tones of different frequencies and intensities. Each histogram represents one period of the stimulus, which decreases from left to right. The waveform is preserved from stimulus amplitudes near threshold to several orders of magnitude larger (*bottom to top*). (Reproduced with permission from [5] Copyright 1978, Acoustical Society of America) (b) Neural representations of the basilar membrane traveling wave demonstrated in recordings from a population of auditory nerve fibers in a single animal. (Reproduced with permission from [6], Copyright 1975, Acoustical Society of America).

amplitude of three or more orders of magnitude. Much of this high-fidelity dynamic range is probably the result of the relatively mild compressive nonlinearity that originates in the cochlear amplifier. But it is still amazing that a signal passing through the essentially instantaneous and strongly saturating nonlinearity of the hair cell transducer, as well as what would be expected to be a highly nonlinear cascade of synaptic transmission and action potential generation, were this synapse typical of others in the nervous system. Such extreme timing precision and waveform preservation is undoubtedly essential to account for temporal auditory perceptual abilities including sound localization and the ability to extract speech from noisy backgrounds, or form mental images of auditory objects in three-dimensional acoustic space.

The cellular and molecular mechanisms that underlie this amazing performance of cochlear afferent neurons have been the focus of a spate of recent studies. Applying whole-cell patch-clamp recording techniques to hair cells has allowed presynaptic neurotransmitter release to be quantified as small cell capacitance changes caused by the fusion of synaptic vesicles with the hair cell membrane [7] at specialized active zones. The characteristic ▶presynaptic dense body appears to be a temporary storage site to rapidly replenish a limited number of release sites with readily-releasable synaptic vesicles (Fig. 4a).

The dark reaction product filling the synaptic cleft and numerous vesicles and other membranous compartments within the hair cell in Fig. 4a indicates that the synaptic vesicles are derived from the cell surface. These synapses appear share basic mechanisms with other excitatory glutamatergic synapses with some important exceptions.

First, these synapses are each capable of unlimited sustained release of around 500 vesicles per second, a rate that would be expected to produce pronounced synaptic depression in conventional chemical synapses. This means that one inner hair cell can release around 10,000 vesicles per second at its ~20 afferent synapses for an indefinite period of time. This profound specialization of the inner hair cell for synaptic transmission compliments the outer hair cell's specialization for its participation in the process of amplifying sound-induced vibrations of the basilar membrane.

Second, this synaptic organization appears essential for the temporal precision and waveform preservation discussed above. Elisabeth Glowatzki has recorded spontaneous and stimulated synaptic currents from mammalian type I nerve terminals on inner hair cells using patch-clamp [8]. Even though most of her recordings represented activity of a single hair cell active zone, individual synaptic events appeared to have far too much amplitude variation to be explained by a single population of unitary quanta with a normally

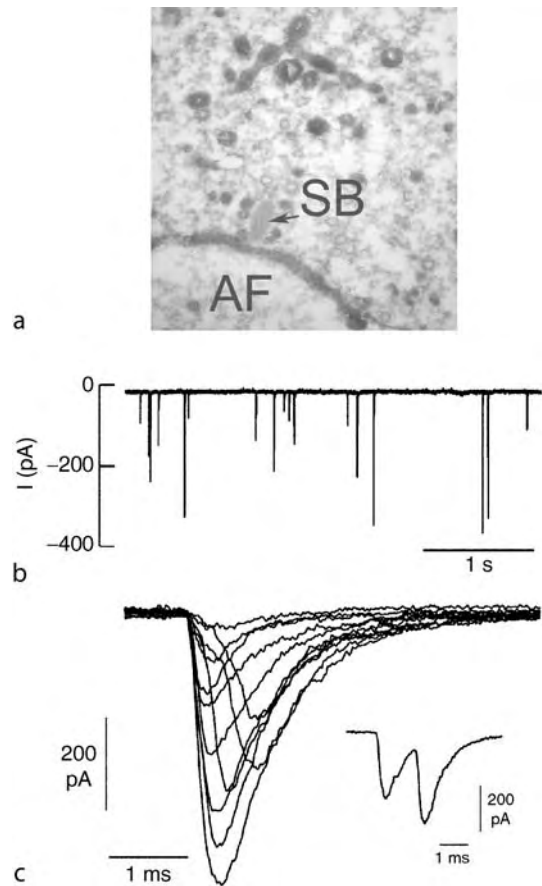

**Auditory Nerve. Figure 4** Ultrastructural and functional basis for auditory nerve stimulus encoding. (a) electron micrograph of an active zone at the synapse between an inner hair cell and a type I spiral ganglion neuron (AF). A characteristic presynaptic dense body (SB), with attached synaptic vesicles, is seen in the hair cell. (b) Excitatory postsynaptic currents recorded from an afferent terminal on an inner hair cell using patch-clamp show large amplitude variation. (c) Higher time resolution of postsynaptic currents reveals evidence for synchronized multiquantal release. (b and c Reprinted by permission from [5], Copyright 2002).

distributed amplitude distribution (Fig. 4b, c). Instead, synaptic events appeared to represent highly synchronized subunits that could sometimes be resolved when synchrony was not perfect (Fig. 4c). This finding confirmed preliminary measurements made by this author using sharp electrodes, but has provided the ability to address synaptic mechanisms with much greater power. This group has subsequently verified that the pronounced rate adaptation seen in the auditory nerve following the onset of a tone burst is due to synaptic depression caused by depletion of transmitter. Depolarizing voltage steps within the normal

physiological range for hair cell receptor potentials yielded a fairly linear relation between presynaptic calcium currents and the rate of synaptic transmission [9]. This near-linearity appears to arise from an interaction between the voltage-dependence of calcium channel activation, reduced driving force for calcium with depolarization and cooperativity of 3–4 calcium ions to activate exocytosis. Since the synchronized multiquantal postsynaptic potentials usually exceed the threshold for action potential initiation in the sensory neuron, there is a nearly 1:1 relation between the rate of postsynaptic action potentials and presynaptic release events. So the strong saturation of average rate observed in most auditory nerve units in the intact system is very likely due to saturation of the dc component of the hair cell receptor potential. The dc receptor potential saturates due to a combination of the compressive growth of the basilar membrane response for stimuli near CF, along with the saturating nature of the hair cell transducer function. By extension, the waveform preservation in phase-locked auditory nerve responses described above would be expected, as long as the probability of transmitter release is modulated by cycle-by-cycle variations in presynaptic calcium currents that are controlled by calcium channels with gating rate constants modulated extremely rapidly by changes in membrane voltage. Molecular mechanisms of hearing loss specifically related to synaptic transmission by the inner hair cells are beginning to be identified [10].

The implications are clear: extreme temporal precision is achieved in this system by generating excitatory postsynaptic potentials with extremely short rise-times which may reach action potential threshold in less than 50  $\mu$ s. At least for most synaptic events, this means that the statistics of action potential discharge of the postsynaptic neurons is determined by the statistics of presynaptic neurotransmitter release, which is largely determined by the statistics of presynaptic voltage-gated calcium channels at the active zones. Thus, the hair cell receptor potential temporal waveform appears to be encoded in individual type I spiral ganglion action potentials in a way very similar to that of an analog-to-digital converter with a pulse code modulation scheme. The presence of as many as 20–30 statistically independent synapses per hair cell assures a sufficient bit rate to encode the hair cell receptor potential waveform with reasonably good fidelity.

## References

1. Ryugo DK (1992) The auditory nerve: peripheral innervation, cell body morphology, and central projections. In: Webster DB, Popper AN, Fay RR (eds) *The mammalian auditory pathway: neuroanatomy*. New York, Berlin, Hiedelberg, Springer-Verlag, pp 23–65
2. Guinan JJ (2006) Olivocochlear efferents: anatomy, physiology, function, and the measurement of efferent effects in humans. *Ear Hear* 27:589–607
3. Delano PH, Elgueta D, Hamame CM, Robles L (2007) Selective attention to visual stimuli reduces cochlear sensitivity in chinchillas. *J Neurosci* 27:4146–4153
4. Ruggero MA (1992) Physiology and coding of sound in the auditory nerve. In: Popper AN, Fay, RR (eds) *The mammalian auditory pathway: neuroanatomy*. New York, Berlin, Hiedelberg, Springer-Verlag, pp 34–93
5. Johnson DH (1980) The relationship between spike rate and synchrony in responses of auditory-nerve fibers to single tones. *J Acoust Soc Am* 68:1115–1122
6. Pfeiffer RR, Kim DO (1975) Cochlear nerve fiber responses: distribution along the cochlear partition. *J Acoust Soc Am* 58:867–869
7. Nouvian R, Beutner D, Parsons TD, Moser T (2006) Structure and function of the hair cell ribbon synapse. *J Membr Biol* 209:153–165
8. Glowatzki E, Fuchs PA (2002) Transmitter release at the hair cell ribbon synapse. *Nat Neurosci* 5:147–154
9. Goutman JD, Glowatzki E (2007) Time course and calcium dependence of transmitter release at a single ribbon synapse. *Proc Natl Acad Sci USA* 104:16341–16346
10. Roux I, Safieddine S, Nouvian R, Grati M, Simmler MC, Bahloul A, Perfettini I, Le Gall M, Rostaing P, Hamard G, Triller A, Avan P, Moser T, Petit C (2006) Otoferlin, defective in a human deafness form, is essential for exocytosis at the auditory ribbon synapse. *Cell* 127:277–289

## Auditory Neuroscience – Introduction

ARMIN H. SEIDL, EDWIN W. RUBEL  
Virginia Merrill Bloedel Hearing Research Center,  
University of Washington, Seattle, WA, USA

### Definition

All animals, including man, must interact with their environment to survive. Such interaction is dependent on sensory information obtained from the environment, which is then processed by the brain and elicits specific motor and mental reactions. Amongst all types of sensory information, the perception of sound is one of the most important tasks the human brain has to accomplish. Sound allows us to communicate through speech (see essay on ► [Speech perception](#)), to detect prey or localize a predator. In higher and more complex life forms, sound can also be perceived as music. Sound enables us to process information about our environment in total darkness and over long distances, where visual and olfactory information might not be available.

Sound consists of pressure waves in the air or in any substrate that can transmit such waves (e.g. water). The

exact nature of sound is described by a branch of physics called acoustics (see essay on ►[Acoustics](#)).

The Auditory Neuroscience section consists of a series of essays describing how acoustic information reaches the brain, where it is processed in the brain and some fundamental properties on how we believe the information is coded. While the main focus of this section lies on the mammalian brain, it also makes references to hearing in birds as well as several invertebrates. Two chapters also touch on clinical applications, where scientifically acquired knowledge can be used to treat certain hearing-related disabilities (Fig. 1).

### Ears and Auditory Brain Areas

The external ear, called the auricle, directs sound waves towards the tympanic membrane and middle ear. Within the middle ear, a set of mechanical structures functions as a transformer to increase the force of the pressure waves such that more of their energy can be transmitted into an aqueous medium. This aqueous substrate is contained in a structure called the inner ear. The inner ear contains the organs of balance, the vestibular epithelia, and the organ of hearing, called the cochlea (see essay on ►[Cochlea](#)). Within the cochlea, a sensory epithelium translates pressure waves into electrical activity that is then passed on to higher auditory centers in the brain. The cochlea

is also the first place in the auditory system where incoming sound information is sorted according to spectral components or frequency bands (see essay on ►[Tonotopic organization](#)), a characteristic of the auditory system that is preserved throughout all levels in the brain as acoustic information is passed on to higher areas. From the cochlea, acoustic information is transferred to the brain via the auditory nerve (see essay on ►[Auditory nerve](#)). The auditory nerve also carries efferent information from the brain to the cochlea, presumably to fine-tune the cochlea for specific signals.

As in other parts of the brain, neurotransmitters are responsible in the auditory system for transmitting information from one neuron to another, or from sensory cells to neurons (e.g., hair cells to cells in the cochlear nucleus) (see essay on ►[Neurotransmitters in the auditory system](#)).

The first area within the brain to receive sound information from the auditory nerve is the cochlear nucleus, which serves as a relay station for ascending auditory information, but also executes a fair amount of information processing. The cochlear nucleus itself is divided into three subnuclei (see essay on ►[Cochlear nucleus](#)). These subnuclei have remarkably different characteristics in terms of the synaptology of auditory nerve afferents, cellular phenotypes, afferents from other locations and efferent projections.

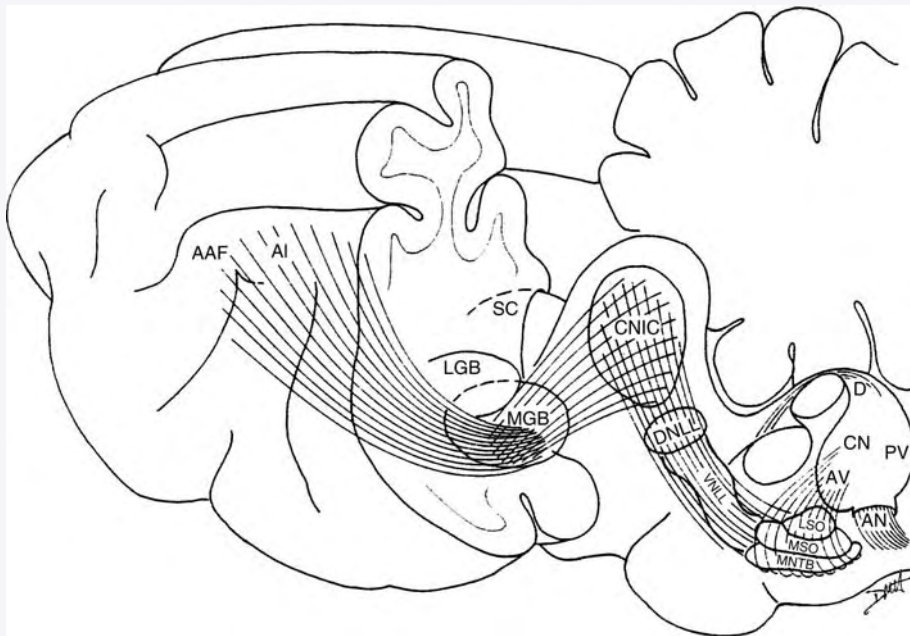

**Auditory Neuroscience – Introduction. Figure 1** Afferent auditory pathways in the cat brain. AN auditory nerve, CN cochlear nucleus (D dorsal, AV and PV anterior and posterior ventral), LSO lateral superior olive, MSO medial superior olive, MNTB medial nucleus of the trapezoid body, VNLL and DNLL ventral and dorsal nucleus of the lateral lemniscus, CNIC central nucleus of the inferior colliculus, MGB and LGB medial and lateral geniculate body, SC superior colliculus, A1 primary auditory cortex, AAF anterior auditory field (drawing by David M. Harris).

Coming from the cochlear nucleus, the information is distributed to nuclei located in the auditory brainstem (see essay on ►[Superior olivary complex](#), ►[Nuclei of the Lateral lemniscus](#)). The auditory brainstem is the first area within the brain where sound information from the two ears is compared, a phenomenon of critical importance for sound localization and hearing in noisy environments (see essay on ►[Binaural pathways and processing](#)). Neurons in both the cochlear nucleus and the auditory brainstem have specialized functional properties for the initial processing of sound signals (see essay on ►[Intrinsic properties of auditory neurons](#)).

From the brainstem, afferent information is conducted to the auditory midbrain (see essay on ►[Inferior colliculus](#)) and to the superior colliculus (see essay on ►[Superior colliculus and hearing](#)). The inferior colliculus, which comprises the auditory midbrain, acts as an integrative station as it receives input from virtually every auditory area in the brain. The superior colliculus is where acoustic information is integrated with other sensory information, such as visual and somesthetic cues.

The medial geniculate body, the principle thalamic target of neurons in the inferior colliculus is the source of auditory information to the neocortex, specifically the regions of the auditory cortex (see essay on ►[Medial geniculate body](#), ►[Auditory-motor interactions](#)).

Eventually sound information arrives in the auditory cortex, where the conscious perception of sound is thought to be created (see essay on ►[Auditory cortical areas](#)). The perception of sound can be described with psychoacoustical experiments (see essay on ►[Psycho-acoustics](#)).

As a whole, neuronal activity in the brain caused by an auditory stimulus can be detected by auditory evoked potentials. This method records patterns of voltage changes due to acoustic stimulation that can be detected with electrodes placed on the head (see essay on ►[Auditory evoked potentials](#)).

The brain areas described here are by no means static: Auditory brain centers can change their structural and functional properties in response to changing stimuli. These changes are an active process and are described as plasticity (see essay on ►[Plasticity in the central auditory system](#)).

### Hearing in Birds and Invertebrates

While structurally very similar, the auditory system of birds possesses several specializations in order to process the very complex bird songs (see essay on ►[Avian Auditory System](#)). Two properties are particularly interesting. First, in contrast to the mammalian auditory system, the sensory epithelium of the hearing system in birds can regenerate sensory cells after damage, leading to functional recovery. Second, the

forebrain areas related to the production of acoustic information are hypertrophied and show remarkable seasonal plasticity in some species of songbirds.

Insects are, apart from a few species of crustacea, the only invertebrates that have been shown to exhibit a sense of hearing. The hearing mechanism in insects can be very different from the mammalian hearing system, although the basic feature of pressure wave detection is preserved (see essay on ►[Invertebrate ears and hearing](#)). Characteristic for the hearing of insects is the widespread use of substrate sound.

### Clinical Applications

Two essays on clinical applications related to hearing loss are also included in this volume: [Hearing Aids and Cochlear Implants](#). [Hearing Aids](#) amplify sound to make it more accessible, e.g. in the case of presbycusis. [Cochlear Implants](#) on the other hand stimulate a functional auditory nerve directly. This can restore hearing when the sensory epithelium is not functional or irreparably damaged (see essays on ►[Hearing aids](#), ►[Cochlear implant](#)).

### Epilogue

To conclude, it is worthy of note that the hearing system, in contrast to the visual or the sensory system, cannot rely on a spatial representation of stimuli on its receptor surface. Frequency is extracted by the sensory epithelium via a matching of the physical properties of the sound waves to unique structural and functional properties of the sensory epithelium. It is solely because of an elaborate computational mechanism that a sound source can be understood and localized.

While often in the shadow of the literally more colorful visual system, the field of auditory neuroscience is a fascinating subject to study and unique in terms of its complexity.

### Acknowledgments

We thank David M. Harris for the sketch of the cat auditory system; Nicole C. Schmitt, Vincent Lin and Henry Ou for comments on the manuscript.

## Auditory Pathways

### Definition

Auditory pathways are neural connections between auditory centers of the brain along which mainly information originating from the ears is passed on.



## Auditory Processing

- ▶ Binaural Pathways and Processing

## Auditory Psychophysics

- ▶ Psychoacoustics

## Auditory Sensillum

- ▶ Invertebrate Ears and Hearing

## Auditory Space Map

- ▶ Superior Colliculus and Hearing

## Auditory System

### Definition

The network of auditory centers and auditory pathways of the brain involved in processing mainly information from the ears. The auditory system divides into two parts, the ascending part and the descending part. The ascending system starts in both ears and ends in the highest auditory representations, which are the auditory cortex where mammals including humans are concerned. The descending system starts with projections from the auditory cortex to lower centers and ends with nerve fiber terminals in the inner ear.

## Auditory System of Birds

- ▶ Avian Auditory System

## Auditory Thalamus

- ▶ Medial Geniculate Body

## Auditory Tuning

### Definition

Ability of the auditory system to discriminate between sounds of different frequencies.

- ▶ Hearing Aids

## Aura

### Definition

Focal, reversible neurologic dysfunction that precedes, accompanies or rarely follows a migraine headache. Most aura is visual, developing over several minutes and usually lasting less than 60 min. An aura may also precede some epilepsies, e.g., complex partial seizures (temporal-lobe or psychomotor seizures).

- ▶ Complex Partial Seizures (Temporal-lobe or Psychomotor Seizures)
- ▶ Headache

## Autapse

KAZUHIKO YAMAGUCHI

Laboratory for Memory and Learning, Brain Science Institute, Riken, Japan

### Synonyms

Self-synapse, recurrent synapse

### Definition

▶ *Autapse*: ▶ *Synapse* formed by the axon of a neuron on its own dendrites *in vivo* or *in vitro*. Autapses of solitary neuron grown on a micro-island of collagen or non-neural cells utilized widely as a simple, useful

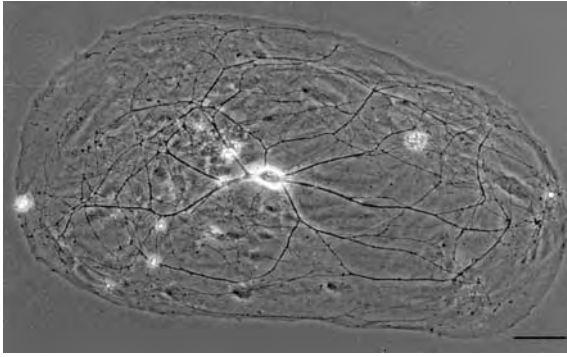

**Autapse. Figure 1** Solitary hippocampal neuron cultured on a glial micro-island that has many autapses, synapses formed by the axon of a neuron on its own dendrites. Bar, 50  $\mu\text{m}$ .

model of synaptic transmission (Fig. 1). Originally, autapse was defined in rabbit cortical neuron impregnated with Golgi methods [1].

### Characteristics

Functional autapse was found in solitary neuron cultured on a micro-island (diameter, 300–500  $\mu\text{m}$ ) of cardiac myocytes [2]. Acetylcholine (ACh) released from synaptic terminal onto itself, at autapses, evoked fast nicotinic excitatory postsynaptic potentials ( $\blacktriangleright$ EPSPs). Autapse provides an advantageous model to investigate factors affecting differentiation and development of a single neuron. In addition, autapse is adequate for image-analysis of single neurons using fluorescent dyes. Especially, autapse has a unique value to investigate the heterogeneity of presynaptic terminals belonging to one neuron.

### Purpose

Autapse provides the simplest model of epilepsy [3]. If a solitary hippocampal neuron grown in the micro-island culture has excitatory autaptic connections, it generates paroxysmal depolarizing shifts (PDSs) and sustained depolarizations, characteristic epileptiform activities. Thus, kynurenate, a non-specific blocker of glutamate receptors, is required to be added in culture medium. Washout of kynurenate elicits large depolarizing events or sustained depolarization with repetitive firings. Both NMDA- and AMPA-receptors are involved in the generation of these epileptiform activities. The generation mechanism for such epileptiform activities is attributable to self-regenerative excitatory pathway through autaptic connection. The autapse of excitatory neurons provides the opportunity to study in a very simple context the pharmacology of the initiation, continuation and termination of epileptiform activities [3]. A computational approach to examine conditions for long-lasting firing of autapse is also performed.

To widely utilize autapse as one of the standard models of the central synapse, basic characteristics of autaptic transmission should be proved normal. Electrophysiological characteristics of autaptic transmission of hippocampal neurons are analyzed by using the patch-clamp method [4]. Using this voltage-clamp method, epileptiform discharge is suppressed by controlling the membrane potential. For excitatory autapse, excitatory post-synaptic current ( $\blacktriangleright$ EPSC) amplitude is changed depending on the holding voltage of the cell body, and the estimated reversal potential is  $-4$  mV, which is almost the same as that for glutamate receptor channels in a usual synapse. This indicates that both autaptic and synaptic glutamate receptor channels have common ion-selectivity. Some excitatory autaptic transmission, like some excitatory synaptic transmission, is dual function: an early, rapid non-NMDA component and a prolonged NMDA-component, the latter is blocked by  $\text{Mg}^{2+}$  in a voltage-dependent manner. Some neurons make inhibitory autapse, which shows similar physiological and pharmacological properties to those of usual inhibitory synapse. Under a condition of low  $\blacktriangleright$ release probability, amplitude of autaptic EPSC shows probabilistic fluctuation. In the tail of stimulus-evoked large EPSC, spontaneous mini-EPSCs ( $\blacktriangleright$ asynchronous EPSCs) appear, which are attributable to the  $\blacktriangleright$ quantal release of glutamate. The probability of recording an autaptic current of a particular size is well described by the quantal theory of transmitter release, like physiological synapse. In general, autaptic transmission is considered the same as the normal synaptic transmission. Therefore, autapse provides a simple and reliable model for the synaptic transmission in mammalian CNS. Especially, autapse contributes to the analysis of synaptic properties of CNS neurons cultured from gene knocked-out animals.

Functional analysis of proteins relating to  $\blacktriangleright$ presynaptic exocytosis are difficult in the mammalian central synapse, because the size of the pre-synaptic terminal of the mammalian central synapse is very small (usually, less than 1  $\mu\text{m}$ ), and synaptic exocytosis is composed of several sub-steps and each step involves various types of proteins. A reconstruction system such as *Xenopus* oocyte for ion channel is not available for presynaptic exocytosis. Furthermore, presynaptic exocytosis is a very fast process. Time between spike arrival at the presynaptic terminal and transmitter release is less than half of a millisecond. Therefore, biochemical analysis of protein-protein interaction *in vitro* alone is not sufficient for the understanding of the molecular mechanism of the presynaptic exocytosis. To investigate the molecular mechanism in the presynaptic exocytosis, autapse of central neurons cultured from a gene knocked-out animal is widely utilized as one of the standard tools [5,6]. Presynaptic exocytosis consists

of several sub-steps such as docking, priming, membrane-fusion and endocytosis. Autapse has the advantage of estimating the total size of the ►readily releasable pool, a physiological counterpart of the docked vesicle pool, of each neuron. The total RRP size of autapses of one neuron is around several thousand quanta, estimated by hypertonic sucrose methods. Each action potential elicits release of a few hundred quanta from one neuron. Release probability, estimated from the released vesicle number divided by the readily releasable pool size, is several percent of the readily releasable pool [6]. Applying such a quantitative analysis to the autaptic transmission of a gene knocked-out animal, physiological function of a particular protein is assigned to some particular sub-steps of presynaptic exocytosis. For example, neurons lacking complexins, presynaptic proteins, show a remarkable reduction in release probability, while the readily releasable pool size is normal. Reduction in transmitter-release is attributable to decreased  $\text{Ca}^{2+}$  sensitivity of the membrane fusion process. Complexins are demonstrated to be acting at or following the  $\text{Ca}^{2+}$  triggering step of fast synchronous transmitter release by regulating the exocytosis  $\text{Ca}^{2+}$  sensor, its interaction with the core complex fusion machinery, or the efficiency of the fusion apparatus itself [5].

Autapse provides a model system for investigating the presynaptic type of synaptic plasticity. In the micro-island culture, one neuron has a few hundred presynaptic sites where synaptic vesicles are accumulated. These presynaptic sites, identified as synaptophysin- or synapsin I-immunoreactive sites, are not homogeneous in functional features. In autapses of cultured dentate gyrus neurons, about one third of the synaptophysin-positive sites are functional release sites that are visualized with styryl fluorescent FM dyes. FM dyes are up-taken by synaptic vesicle membranes through endocytosis following membrane-fusion at the functional autaptic terminals, but not at silent presynaptic sites. The presence of silent presynaptic sites is also demonstrated electrophysiologically. Some cortical neurons in the micro-island culture show spontaneous autaptic mini-EPSCs, but no evoked EPSC, which indicate silent presynaptic site [7]. In autapses of cultured dentate gyrus neurons, silent presynaptic sites are converted into functional ones by activation of the PKA cascade, which would be the underlying mechanism for the synaptic plasticity at the mossy fiber terminal in the hippocampus [8].

Autapse of central neuron cultured on a glial micro-island is utilized to address glial cell – neuron interaction in synaptic transmission. Evoked synchronous release of glutamate from an autaptic terminal activates rapid electrogenic glial glutamate-transporter currents, while clearance of released glutamate by glial cells may affect the decay time-course of autaptic EPSC [9].

Neuronal synaptogenesis is enhanced by the glial cell in the co-culture system; however, it is unclear whether diffusible or membrane-bound astrocyte-derived factors are responsible for the increase in synaptogenetic efficiency. To address this question, autapse provides an advantageous experimental system [10]. Under the condition of continual supplementation of astrocyte-diffusible factors from the rims of culture dishes, solely grown hippocampal neurons on a micro-island of collagen also forms autapses. After 8–9 days in culture, neurons may or may not be overlaid with astrocytes. Local contact with astrocytes enhances autaptic synaptogenesis robustly via integrin receptor elicited PKC activation [10]. Autapse is a useful model system for exploring both soluble and cellular factors affecting synaptogenesis.

### Principles

Though autaptic connection exists in normal cortical neurons *in vivo* [1], autapse in cultured neurons is formed under rather artificial conditions, the micro-island culture. A solitary neuron is grown on the micro-island and forms an autapse. However, neurons in the multi-cellular culture of the micro-island rarely form autapses.

To make the micro-island culture [3], the cover glass is coated with agarose and then attached to the bottom of a holed-plastic culture dish by Sylgard. Collagen solution is then sprayed from a glass micro-atomizer onto a dried film of agarose. The collagen is cross-linked by ammonium gas. The diameter of the micro-island distributes 50–500  $\mu\text{m}$ . The exposed agarose surface is resistant to cell attachment. Glial cells, plated 1–2 days before neural cell plating, grow to cover the micro-island. Hippocampal neurons of newborn rat, isolated by papain-treatment, are plated at a low density (2,000 cells per  $\text{cm}^2$ ). Soluble glial factors are supplied from glial cells grown on the outer rims of the plastic bottom. After 7–9 days in culture, neurons solely grown on the micro-island form an autaptic connection. A blocker for glutamate receptors (kynurate) or NMDA receptor (APV) is required to obtain healthy autaptic responses.

### Advantage and Disadvantage

#### Advantage

As a simple model of synaptic connection, autapse provides the following advantage; first, all autaptic terminals belonging to one cell share common basic properties, such as excitatory or inhibitory, though there are heterogeneity in detail. Cell types are selected by means of electrophysiology, pharmacology, immunocytochemistry and GFP-tag methods. Selective culture of the neurons from a specific brain region, such as “hippocampus CA3” or “dentate gyrus” is also available. Second, quantification of synaptic terminals per one neuron is possible in the autaptic system. Thus, autapse

provides a reliable assay system to examine synaptogenesis-ability of various chemicals or cells [10]. Third, unlike conventional approaches, in which pairs of neurons and electrodes are required (one presynaptic, the other postsynaptic), physiological experiments using autapse require only one electrode. Furthermore, we can inject chemicals into the cell through a whole-cell recording electrode. Fourth, since all presynaptic terminals contact on one neuron, it is possible to estimate the size of the total releasable pool belonging to one neuron [5,6]. Fifth, autapse provides a unique system to address heterogeneity among synaptic terminals from one neuron.

### Disadvantage

Though autaptic connection in cultured neurons provides a useful assay system to elucidate the roles of proteins and other chemicals in synaptic transmission, synaptogenesis and so on, it has a limitation. The age of the animal is restricted to be very young, since neurons should be cultured. Basic physiological properties of autapse and physiological synapse are proved the same [4], but this does not mean that all properties of autapse are necessarily the same as those in normal synapse. Even though autaptic connection exists in mammalian cortical circuits *in vivo*, most axon collaterals terminate to other neurons. In autapse, all axon terminals contact on one cell. Therefore, possible effects of a retrograde signal on a synaptic terminal could be different between autapse and normal synapse. In excitatory autapse, synaptic activities are restricted to some extent during culture. This restriction may affect autaptic synaptogenesis. Nevertheless disadvantage, autapse provides very useful and the simplest model of the neuronal circuit for investigation of synaptogenesis, synaptic transmission, plasticity and modulation.

### References

1. Van der Loos H, Glaser EM (1972) Autapse in neocortex cerebri: synapses between a pyramidal cell's axon and its own dendrites. *Brain Res* 48:355–360
2. Furshpan EJ, MacLeish PR, O'Lague PH, Potter DD (1976) Chemical transmission between rat sympathetic neuron and cardiac myocytes developing in microculture: Evidence for cholinergic, adrenergic and dual-function neurons. *Proc Natl Acad USA* 73:4225–4229
3. Segal MM (1991) Epileptiform activity in microcultures containing one excitatory hippocampal neuron. *J Neurosci* 65:761–770
4. Bekkers JM, Stevens CF (1991) Excitatory and inhibitory autaptic currents in isolated hippocampal neurons maintained in cell culture. *Proc Natl Acad Sci USA* 88:7834–7838
5. Reim K, Mansour M, Varoqueaux F, McMahon HT, Südhof TC, Brose N, Rosenmund C (2001) Complexins regulate a late step in  $Ca^{2+}$ -dependent neurotransmitter release. *Cell* 104:71–81
6. Yamaguchi K, Tanaka M, Mizoguchi A, Hirata Y, Ishizaki H, Kaneko K, Miyoshi J, Takai Y (2002) A GDP/GTP exchange protein for the Rab3 small G protein family up-regulates a postdocking step of synaptic exocytosis in central synapses. *Proc Natl Acad Sci USA* 99:14536–14541
7. Kimura F, Otsu Y, Tsumoto T (1997) Presynaptic silent synapses: Spontaneously active terminals without stimulus-evoked release demonstrated in cortical autapses. *J Neurophysiol* 77:2805–2815
8. Tong G, Malenka RC, Nicoll RA (1996) Long-term potentiation in cultures of single hippocampal granule cells: A presynaptic form of plasticity. *Neuron* 16:1147–1157
9. Mennerick S, Zorumski CF (1994) Glial contributions to excitatory neurotransmission in cultured hippocampal cells. *Nature* 368:59–62
10. Hama H, Hara C, Yamaguchi K, Miyawaki A (2004) PKC signaling mediates global enhancement of excitatory synaptogenesis in neurons triggered by local contact with astrocytes. *Neuron* 41:405–415

## Autism (Autistic Disorder, Childhood Autism)

### Definition

Autism is classified as a pervasive neurodevelopmental disorder including key characteristics such as abnormal communication skills and social interactions as well as repetitive and stereotyped patterns of behavior. Autism is thought to result from defective neuronal circuitry.

## Autoantibodies

### Definition

Serum immunoglobulins that react to self-antigens (own body).

## Auto-associative Memory

### Definition

A neural network that associates patterns with themselves to recall a stored pattern by receiving a noisy or incomplete version of that pattern.

► Associative Memory

## Auto-associative Network

### Definition

A neural circuit in which the outputs of a region feedback as input onto elements within that same region.

## Autobiographical Memory

### Definition

Remote memory is classified into autobiographical memory and public memory. Autobiographical memory is a recollection of the earlier events of one's own life.

It includes factual knowledge about oneself (e.g., addresses where lived, names of teachers/friends/colleagues) so-called personal semantics, and one's personal memory of events or episodes specifiable time and place so-called autobiographical incidents.

► Long-Term Memory

## Autocellular Septate Junctions

### Definition

Septate junctions are formed between the plasma membrane of the same glia cells.

► Alternative Splicing and Glial Maturation

## Auto-Covariance Function

### Definition

The cross-covariance is a linear measure of the relationship between two functions of time (variables), one taken at time  $t$  and the other at time  $t_i$ . The cross-covariance is computed as the average of the products of the deviations of each variable from their respective mean. The auto-covariance is the cross-covariance of a function at time  $t$  and itself at time  $t_i$ .

► Signals and Systems

## Autocrine Feedback Control

### Definition

A series of molecular events that originate on the same cell secreting neurotransmitters or hormones and possessing membrane receptors selective for these molecules (autoreceptors). The activated autoreceptors mediate a sequence of reactions, which usually compensate the original triggering event.

## Autogenetic Excitation and Inhibition of Motoneurons

### Definition

Excitation and inhibition of the motoneurons innervating the muscle from which the afferents eliciting the excitation and inhibition originate. Autogenetic inhibition was originally described as a disynaptic inhibition of motoneurons evoked by activation of Ib afferents from muscle tendons belonging to the muscle innervated by the motoneurons. The interneurons in the pathway (Ib inhibitory interneurons) receive input from a number of sensory modalities (including gr. Ia afferents and cutaneous afferents) in addition to descending motor tracts and the transmission in the pathway may therefore be greatly modulated in relation to movement. Subsequent experiments have demonstrated that the inhibition is depressed during functional tasks such as walking, whereas transmission in excitatory Ib pathways is facilitated. These excitatory pathways include at least a disynaptic autogenetic excitatory pathway in addition to a longer (polysynaptic) pathway.

► Integration of Spinal Reflexes

## Autografting

Synonym: autotransplantation

Transplantation of tissues or organ pieces between the different parts of the same individual or animal.

## Autoimmune Demyelinating Disorder (ADD)

Autoimmune Demyelinating Disorder (ADD) is an autoimmune disorder affecting nervous system, leading to neurodegeneration.

► Autoimmune Demyelinating Disorders: Stem Cell Therapy

## Autoimmune Demyelinating Disorders: Stem Cell Therapy

STEFANO PLUCHINO, LUCIA ZANOTTI,  
GIANVITO MARTINO  
Neuroimmunology Unit, DIBIT-San Raffaele  
Scientific Institute, Milano, Italy

### Synonyms

Autoimmune demyelinating disorder ADD; Multiple sclerosis; Experimental autoimmune encephalomyelitis; Neuroprotection; Remyelination; Neural stem cells; Cell transplantation

### Definitions

#### Stem Cell Transplantation

Medical procedure in the field of hematology, oncology or regenerative medicine that involves transplantation of ► stem cells (► stem cell transplantation) of different origin (e.g., ► neural stem cells, hematopoietic stem cells, mesenchymal stem cells, cord blood stem cells, etc.). It is most often performed on people with diseases of the blood or bone marrow, certain types of cancer or diseases of the central nervous system [e.g., ► multiple sclerosis (MS), Parkinson's disease (PD), Huntington's disease (HD), etc.]. Transplanted stem cells are usually administered either locally (e.g., intraparenchymally), intravenously or intrathecally (e.g., through the cerebrospinal fluid circulation). The main aims of the procedure are either: the repopulation of the host bone marrow and the production of new blood cells, the replacement of lost and/or injured neural cells or the induction of peripheral immune tolerance.

#### Stem Cells

Stem cells are primary cells common to all multi-cellular organisms that retain the ability to ► self-renew through asymmetric cell division and can differentiate – both in

vitro and in vivo – into a wide range of specialized (post-mitotic) daughter cells (► cellular potency). Two major categories of stem cells exist in mammals: ► embryonic stem (ES) cells, derived from blastocyst, and adult (somatic) stem cells, which are found in adult tissues.

#### Neuroprotection

Cellular and molecular mechanisms spontaneously taking place – or being fostered by a given therapy – within the central as well as peripheral nervous system by which neural cells are protected from apoptosis and/or degeneration (for example following a brain injury or as a result of chronic neurodegenerative diseases) (► neuroprotection).

#### Multiple Sclerosis

Chronic disease of the central nervous system (CNS) occurring as a consequence of an autoimmune attack against certain (*self*) myelin antigens. ► Multiple sclerosis (MS) primarily affects young adults, with an age of onset typically between 20 and 40 years, and is more common (2:1 ratio) in women than in men. Distinctive characteristics of MS is the presence of multifocal perivascular inflammatory infiltrates in the CNS white matter, mainly composed of cells of the immune system (e.g., macrophages and lymphocytes), that cause demyelination and secondary axonal degeneration. Symptoms of MS include changes in sensation, visual problems, muscle weakness, depression, difficulties with coordination and speech, severe fatigue, and pain. More severe MS cases can also be associated with impaired mobility and disability.

#### Experimental Autoimmune Encephalomyelitis (EAE)

Widely used animal model of the human demyelinating disease MS. ► Experimental autoimmune encephalomyelitis (EAE) is generally induced in rodents or primates by either immunization with myelin antigens [e.g., myelin oligodendrocyte glycoprotein (MOG), proteolipidic protein (PLP), myelin basic protein (MBP), etc.] in adjuvant (► active induction) or adoptive transfer of myelin-specific T cells (► passive induction). Induction of EAE typically results in ascending flaccid paralysis of limbs with inflammation and tissue damage primarily targeting the spinal cord.

#### Neural Stem Cells

Heterogeneous population of mitotically-active, self-renewing, multipotent cells of both the developing and the adult central nervous system (CNS). Neural stem cells (NSCs) have been successfully isolated from the entire embryonic as well as adult CNS. The ganglionic eminence(s), in the embryo, and both the subventricular zone (SVZ) of the lateral ventricles and the sub-granular zone (SGZ) of the hippocampus dentate gyrus (DG), in the adult, have been shown to consistently contain

stem-like cells capable of driving neuro- and gliogenesis. These regions are then defined as highly specialized ►CNS germinal niches. Protocols to obtain in vitro large-scale numbers of NSCs are available, thus supporting the concept that these cells might represent a renewable source of uncommitted ready-to-use cells for transplantation purposes.

### Characteristics

Multiple sclerosis (MS) is a chronic inflammatory demyelinating disease of the central nervous system (CNS) (►Autoimmune Demyelinating Disorder (ADD)), whose aetiology is still unknown. MS pathology is characterized by the presence within the CNS of perivascular lympho/mononuclear inflammatory infiltrates inducing patchy demyelination, axonal loss and reactive astroglial scarring.

Substantial proportion of demyelinated lesions within the CNS from MS patients are fully or partially remyelinated. Furthermore, in some MS cases the clinical course appears to be benign with no long-term accumulation of disability. Characteristic sclerotic plaques are identified in individuals without neurological disability, suggesting the existence of ►clinically silent” MS.

In this context, spontaneous remyelination may spontaneously occur and some axons may recover their capacity to conduct action potentials [1]. However, spontaneous repair is inefficient over time and, in the vast majority of MS cases, neurological disability progresses as irreversible axonal loss and neuronal damage accumulates [1].

### Remyelination Failure in MS

The most likely causes of remyelination failure in MS may be summarized as follows: (i) selective depletion of oligodendrocyte progenitor cells (OPCs) around demyelinating areas; (ii) failure of the recruitment of OPCs to the demyelinated areas; (iii) failure of recruited OPCs to differentiate into remyelinating oligodendrocytes; (iv) inhibition of remyelination as a net result of protective vs. detrimental effects of cytokines; (v) anatomical and molecular inhibition of remyelination associated with astroglial scarring; and (vi) acute and/or chronic axonal loss and/or dysfunction [1,2].

### Cell-Based Therapies for Myelin Repair in Autoimmune CNS Demyelination

The intrinsically complex nature of MS poses great challenges for cell-based remyelinating therapies. Two major requirements have to be satisfied: (i) an unlimited source of cells; and, (ii) the possibility of accessing several CNS damaged areas at the same time. Current studies are mostly aimed at addressing some preliminary issues that need to be solved before prospecting

any potential human application of cell-based therapies such as (i) the ideal stem cell source for transplantation; (ii) the route of cell administration; (iii) and, the differentiation and persistence of cells transplanted into the targeted tissue.

Several experimental transplantation procedures aimed at restoring the myelin architecture within CNS demyelinated areas have been developed so far. Different types of myelin-forming cells have been transplanted into rodent models of either genetic, chemical or autoimmune CNS demyelination. These approaches show serious limitations. In particular, lineage-restricted myelin-forming cells – either OPCs, Schwann cells or olfactory ensheathing cells – possess in vitro limited growth and expansion characteristics and, once transplanted, may drive remyelination only within restricted CNS areas close to the transplantation site [3].

The functional and morphological properties of stem cells might therefore represent a promising alternative for transplantation approaches in MS [4].

The therapeutic use of embryonic stem (ES) cells is still constrained by some key issues – such as feeder-independent growth (expansion) and in vivo teratocarcinoma formation – which need to be solved before proposing any ES cell-based therapy for human applications.

Adult stem cells represent a ready-to-use cell source for cell-based therapies, since they can be obtained by different tissues (e.g., bone marrow, brain, etc.) and have been widely used in experimental and clinical settings in vivo without causing tumor formation and overt toxic/side effects.

### Neural Stem Cells

Mammalian neural stem cells (NSCs) support neurogenesis and gliogenesis within restricted areas (germinal niches) of the CNS throughout adulthood, can undergo extensive in vitro expansion and possess the capacity to generate a progeny of daughter cells which can integrate into and repair the tissue of origin. These cells show: (i) growth factor (GF)-dependent proliferation and stable growth rate; (ii) capacity for ►self-renewal; (iii) multipotentiality; and, (iv) functional plasticity either over serial in vitro passaging or after several freezing-thawing cycles [4] (Fig. 1).

The route of cell administration represents a major constraint for NSC transplantation and appears to be dependent on the CNS lesion site(s). The anatomopathological features of certain focal CNS disorders, such as Parkinson’s disease (PD) or acute spinal cord injury (SCI), might suggest that direct local (*intralesional*) cell transplantation might facilitate tissue regeneration, while the multifocality of other CNS disorders – such as MS and epilepsy – would represent a major limitation for *intralesional* cell-transplantation approaches. In multifocal CNS disorders,

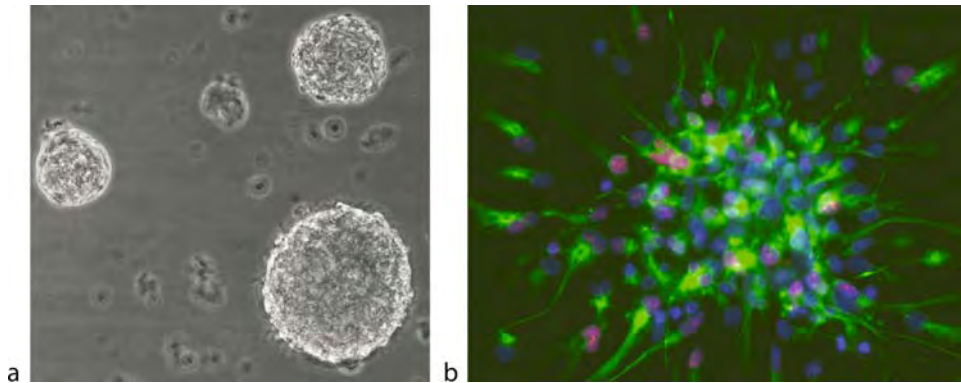

**Autoimmune Demyelinating Disorders: Stem Cell Therapy. Figure 1** In vitro characteristics of NSCs used for transplantation in CNS autoimmune demyelinating disorders. Upon continuous mitogen stimulation in serum-free growth media, NSCs appear in vitro as free-floating neurospheres (A, phase contrast). After plating on proteic substrates (e.g., poly-L-lysine, matrigel, etc.), display chain-like radial migration, still undergo cell cycle and express Ki67 (B, red) while maintaining immunoreactivity for nestin (B, green). Nuclei in B have been counterstained with dapi (blue). Magnification in A and B 40 X.

systemic (e.g., intravenous, intrathecal) transplantation of NSCs can be therapeutically efficacious owing to the ability of transplanted cells to follow, via the blood stream or cerebrospinal fluid circulation, a gradient of chemoattractants (e.g., pro-inflammatory cytokines and chemokines) occurring at the site of inflammatory lesions [4,5]. Specific homing of transplanted NSCs has been shown in SCI, epilepsy, and stroke. However, the exact molecular mechanism sustaining this phenomenon has been detailed, so far, only in experimental autoimmune encephalomyelitis (EAE). Tethering, rolling, and firm adhesion to inflamed endothelial cells and extravasation into inflamed CNS areas are sequentially mediated by the constitutive expression of functional cell adhesion molecules (CAM) (e.g., CD44), integrins (e.g.,  $\alpha 4$ ,  $\beta 1$ ), and chemokine receptors (e.g., CCR1, CCR2, CCR5, CXCR3, CXCR4) on NSC surface [4,5].

#### **Therapeutic Functions of Transplanted NSCs**

Irrespective of the characteristics of the experimental disease and type of inflammation, functional recovery obtained by NSC transplantation barely correlates with absolute numbers of transplant-derived newly generated terminally differentiated neuronal cells. Transplantation of NSCs into rodents with experimental PD or Huntington's disease (HD), very scarcely differentiate into tyrosine hydroxylase (TH)-immunoreactive neurons despite significant behavioral improvement. Mice with SCI, acute stroke and intracerebral hemorrhage do improve despite pathological evidence of preferential astroglial fate of transplanted NSCs. The large majority of NSCs injected into mice with experimental cerebral hemorrhage or with acute ischemic stroke, express markers of undifferentiation (e.g.,

nestin) when surrounding damaged CNS areas. In EAE, very low differentiation of transplanted NSCs into myelin forming oligodendrocytes is accompanied by striking neurophysiological evidence of axonal protection and remyelination. In the very same context, more than 20% of transplanted cells reaching inflammatory demyelinated areas do not express differentiation markers. This limited terminal differentiation and propensity for maintaining an undifferentiated phenotype within the host tissue, suggests that transplanted NSCs might also be therapeutic efficacious via a bystander mechanism(s) alternative to cell replacement. Indeed, transplanted NSCs reduce the scar formation and/or increase survival and function(s) of endogenous glial and neuronal progenitors surviving to the pathological insult. This neuroprotective effect is accompanied by increased in vivo bioavailability of major neurotrophins [e.g., nerve growth factor (NGF), brain-derived growth factor (BDNF), etc.]. Also, transplanted NSCs promote bystander immunomodulation as they release soluble molecules (e.g., cytokines and chemokines), express immune-relevant receptors (e.g., chemokine receptors, CAMs), capable of profoundly altering the inflammatory environment and up-regulate membrane expression of certain functional death receptor ligands (e.g., FasL, TRAIL, Apo3L) by which they induce programmed cell death (apoptosis) of inflammatory T lymphocytes [5]. Transplanted NSCs also significantly and specifically contribute to the down-regulation of effector functions of inflammatory T cells and macrophages within both the target tissue as well as within draining lymph nodes [6]. Major NSC transplantation studies in animal models of CNS disorders are summarized in Table 1 (reproduced from [4]).



**Autoimmune Demyelinating Disorders: Stem Cell Therapy. Table 1** Neural stem cell (NSC) transplantation studies in animal models of CNS disorders

Neural stem cell source	Route of cell administration	Disease model	Mechanism(s) of therapeutic efficacy		Outcome
			Cell replacement	Bystander effect	
<i>Demyelinating disorders</i>					
Adult brain SVZ NSCs (mouse)	Icv and iv single cell injection	Chronic EAE in mice	Oligodendroglial and neuronal differentiation	Rescue of endogenous OPCs and modulation of NGFs in vivo	Attenuation of clinical, neurophysiological and pathological parameters of EAE
Adult brain SVZ NSCs (mouse)	Iv single cell injection	Relapsing EAE in mice	Not tested	Induction of apoptosis of CNS-infiltrating T lymphocytes	Attenuation of clinical, and pathological parameters of EAE
Adult [19–64 years] brain NSCs (human)	Intralesional ( <i>epicentre</i> ) cell transplantation	EB-X focal demyelination of the thoracic (T10) spinal cord dorsal column in rats	Schwann cell-like driven remyelination (P0 immunoreactive cells)	Not tested	Functional restoration of peripheral nerve conduction
Adult brain striatal NSCs (rat)	Icv neurosphere injection	Acute EAE in rats	Not tested	Inhibition of MOG-specific lymphocyte proliferation	Attenuation of clinical and pathological parameters of EAE
<i>Traumatic brain injury</i>					
Neonatal cerebellum C17.2-CD NSCs (mouse)	Stx intraparenchymal ( <i>ipsi or contralateral</i> ) cell transplantation	Parieto-temporal CCI brain injury in mice	60% neuronal and 40% astroglial differentiation	Not tested	Improved coordination and vestibulomotor functions
Embryonic [E14.5] brain NSCs (mouse)	Stx ipsilateral intrastratial neurosphere transplantation	Fronto-parietal CCI brain injury in mice	No neuronal or astroglial differentiation, 85% of NG2 immunoreactivity	Not tested	Improvement of motor and learning performances No effects on necrotic cavity size or hippocampal degeneration
<i>Stroke</i>					
Neonatal cerebellar C17.2-CD NSCs (mouse)	Intralesional ( <i>infarction cavity</i> ) transplantation of PGA-NPC complex	Transient (3 hours) unilateral CCAO in mice	Neuronal, astro- and oligodendroglial differentiation	Decrease mononuclear cell infiltration and astrogliosis	Not tested
Embryonic [E14] hippocampal MHP36 NSCs (mouse)	Stx unilateral striatal cell graft	Transient (17 min.) bilateral CCAO in mice	50% neuronal differentiation	Rescue of endogenous neurons	Not tested
Foetal [15 weeks] brain immortalized [clone HB1. F3] NSCs (human)	Iv single cell injection	Stx intrastratial administration of bacterial collagenase in mice	10% neuronal and 75% astroglial differentiation	Increase of viable NGFs	Improvement of motor performances

**Autoimmune Demyelinating Disorders: Stem Cell Therapy. Table 1** Neural stem cell (NSC) transplantation studies in animal models of CNS disorders (Continued)

Neural stem cell source	Route of cell administration	Disease model	Mechanism(s) of therapeutic efficacy		Outcome
			Cell replacement	Bystander effect	
Foetal [15 weeks] brain immortalized [clone HB1. F3] NSCs (human)	Iv single cell injection	Transient (90 min.) MCAO in mice	20% neuronal and 60% astroglial differentiation 20% undifferentiation	Decreased atrophy Increase of viable NGFs	Lower sensory motor deficits
Fetal [16–20 weeks] brain NSCs (human)	Stx multiple cortical cell deposits	Transient (1 hour) distal MCAO in rats	50% neuronal and 15% astroglial differentiation	Less macrophage/microglial cell infiltration at lesion borders	Not tested
<i>Parkinson's disease</i>					
Neonatal cerebellar C17.2-CD NSCs (mouse)	Stx unilateral cell graft in the SN-VTA	MPTP-induced nigrostriatal degeneration in mice	10% neuronal differentiation	Rescue of endogenous TH <sup>+</sup> neurons Increase of viable GDNF	Decrease of amphetamine-induced turns
Foetal [10–12 weeks] brain NSCs (human)	Stx bilateral (CN) and unilateral (SN) cell graft	MPTP-induced nigrostriatal degeneration in monkeys	Low neuronal differentiation	Rescue of endogenous TH <sup>+</sup> neurons	Not tested
Foetal [12–20 weeks] brain NSCs (human)	Stx unilateral intrastriatal neurosphere graft	MPTP-induced nigrostriatal degeneration in mice	Infrequent TH <sup>+</sup> immunoreactivity	Not tested	Not tested
Foetal [P3] brain SVZ NSCs (mouse)	Stx unilateral intrastriatal graft of VM neurons/NPCs (1:1 and 1:8 ratios)	6-OHDA-induced nigrostriatal degeneration in rats	No evidence of neuronal differentiation. 12.5–31% increased neuronal survival, decrease of caspase-3 <sup>+</sup> /TH <sup>+</sup> neurons, less cell debris,	increase of viable Shh	Decrease of amphetamine-induced turns
Foetal [22 weeks] brain NSCs (human)	Stx unilateral intrastriatal neurosphere graft	6-OHDA-induced nigrostriatal degeneration in rats	Low neuronal differentiation, predominant astroglial differentiation	Not tested	Weak behavioral improvement
Embryonic [E14.5] brain NSCs (rat)	Stx unilateral cell graft into the MBF	6-OHDA-induced nigrostriatal degeneration in rats	13–16% doublecortin immunoreactivity, 20–25% GFAP immunoreactivity, infrequent TH <sup>+</sup> immunoreactivity	Not tested	Not tested
Embryonic [E12] brain NSCs (rat)	Stx unilateral cell graft into the SN	6-OHDA-induced nigrostriatal degeneration in rats	Poor integration, infrequent TH <sup>+</sup> immunoreactivity	Not tested	No behavioral differences

**Autoimmune Demyelinating Disorders: Stem Cell Therapy. Table 1** Neural stem cell (NSC) transplantation studies in animal models of CNS disorders (Continued)

Neural stem cell source	Route of cell administration	Disease model	Mechanism(s) of therapeutic efficacy		Outcome
			Cell replacement	Bystander effect	
Adult brain SVZ NSCs (rat)	Stx unilateral intrastriatal cell graft	6-OHDA-induced nigrostriatal degeneration in rats	No evidence of NeuN and Tuj1 immunoreactivity, nestin immunoreactivity, DAT immunoreactivity	Increase of viable neuroprotective and neuroregenerative factors	Decrease of amphetamine-induced turns
<i>Huntington's disease</i>					
Foetal [12 weeks] brain NSCs (human)	Stx unilateral intrastriatal cell graft	QA-induced striatal degeneration in rats	1% NeuN, 3.5% GFAP immunoreactivity, ki67 immunoreactivity (in vivo proliferation).	26% greater striatal volume Increase of viable CNTF, BDNF, GDNF	Improvement of motor function
Foetal [15 weeks] brain NSCs (human)	Stx unilateral intrastriatal cell graft	3-NP-induced striatal degeneration in rats	Predominant nestin immunoreactivity, low NeuN and GFAP immunoreactivity, certain calbindin and GAD immunoreactivity	Extensive survival of striatal neurons, increase of viable BDNF	Improvement of motor function
<i>Acute spinal cord injury</i>					
Neonatal cerebellar C17.2-CD NSCs (mouse)	Intralesional transplantation of PGA-NPC complex	Lateral thoracic (T9-T10) spinal cord hemisection in rats	Majority of cells immunoreactive for nestin	Major contribution of NPCs as trophic support	Improvement of motor function
Neonatal cerebellar C17.2-CD NSCs (mouse)	Intralesional ( <i>epicentre</i> ) cell transplantation	Dorsal cervical (C3) Kopf microwire knife-mediated spinal cord lesion in rats	No evidence of differentiation	In vivo secretion of NGF, BDNF, GDNF	Not tested
Foetal [15 weeks] brain NSCs (human)	Multiple (n = 4) intraspinal cell deposits	Dorsal thoracic (T9) spinal cord spinal cord weight drop injury in NOD- <i>scid</i> mice	2.9% astroglial, 26.3% neuronal, 64.1% oligodendroglial differentiation	Not tested	Improvement of coordinated forelimb-hind limb motor function
Embryonic [E15] hippocampal NSCs (rat)	Iv single cell injection	Dorsal thoracic (T7) spinal cord weight drop injury in rats	4.7% neuronal, 47% astroglial, 48% oligodendroglial differentiation	Cell accumulation within the injured spinal cord lesion,	Not tested
Adult spinal cord NSCs (rat)	Multiple (n = 4) intraspinal cell deposits	Dorsal thoracic (T8-T9) spinal cord weight drop injury in rats	74% astroglial, 17% oligodendroglial and 3% neuronal differentiation	Not tested	Improvement of motor function

**Autoimmune Demyelinating Disorders: Stem Cell Therapy. Table 1** Neural stem cell (NSC) transplantation studies in animal models of CNS disorders (Continued)

Neural stem cell source	Route of cell administration	Disease model	Mechanism(s) of therapeutic efficacy		Outcome
			Cell replacement	Bystander effect	
<i>Epilepsy</i>					
Foetal [15 weeks] brain NPCs (human)	iv single cell injection	Lithium chloride/pilocarpine seizures model in rats	Hippocampal distribution of transplanted cells, ~60% neuronal (26% GABA <sup>+</sup> , 31% PV <sup>+</sup> , 3% GluR <sup>+</sup> immunoreactivity), 21% astroglial differentiation, ~25% undifferentiation	Not tested	~85% decrease of generalized convulsive seizure frequency and severity, increase of GABAergic synaptic inhibition

\*Neural stem cells includes cells derived from embryonic, foetal, neonatal, and adult tissues. Abbreviations used: 3-NP, 3-nitropropionic acid; 6-OHDA, 6-hydroxydopamine; BDNF, brain-derived neurotrophic factor; CCAO, common carotid artery occlusion; CCI, controlled cortical impact; CN, caudate nucleus; CNS, central nervous system; CNTF, ciliary neurotrophic factor; DAT, dopamine transporter; EAE, experimental autoimmune encephalomyelitis; EB-X, -X irradiation and ethidium bromide-induced focal demyelination; GAD, glutamic acid decarboxylase; GDNF, glial-derived neurotrophic factor; GFAP, glial fibrillary acidic protein; icv, intracerebroventricular; iv, intravenous; MBF, medial basal forebrain; MCAO, middle cerebral artery occlusion; MOG, myelin-oligodendrocyte glycoprotein; MMP-2, matrix metalloproteinase-2; MPTP, 1-methyl-4-phenyl-1,2,3,6-tetrahydropyridine; NeuN, neuronal nuclear antigen; NGF, nerve growth factor; NGFs, neurotrophic growth factors; Ngn-2, neurogenin-2; NOD-scid, non-obese diabetic-severe combined immunodeficient mice; NPCs, neural stem/progenitor cells; OPCs, oligodendrocyte-progenitor cells; P0, peripheral nerve myelin protein P0; PGA, poly-glycolic acid; QA, quinolinic acid; SN, subthalamic nucleus; Shh, sonic hedgehog; Stx, stereotaxic; SVZ, subventricular zone; TH, tyrosine hydroxylase; VM, ventral midbrain; VTA, ventral tegmental area.

### Hematopoietic Stem Cells

The transplantation of hematopoietic stem cells (HSCs) from autologous or allogeneic bone marrow, umbilical cord or peripheral blood is a widely utilized form of therapy for patients with hematopoietic malignancies and solid tumors. Evidence suggests that HSCs may contribute to the generation of new neurons in the adult brain by means of (i) trans-differentiation; and/or (ii) cell fusion, thus suggesting that HSC transplantation might in principle be useful as a therapeutic tool for brain repair [7]. Other results indicate that in rats with a demyelinated lesion of the spinal cord, HSC transplantation – upon either intravenous or intraparenchymal cell injection – results in varying degrees of remyelination which appears proportional to the number of injected cells [7].

In addition to mechanism aiming at replacement of damaged CNS cells, HSC transplantation is successfully utilized to target the autoimmune response at the peripheral level in several autoimmune diseases including MS [8]. The efficacy of HSC transplantation (following intense chemotherapy) is likely to be based on the intense immune suppression, which ends up in the eradication of most autoimmune cells, followed by the successful engraftment of the transplanted stem cells leading to the reconstitution of the immune system representing a recapitulation of ontogenesis and thus

accompanied by the acquisition of self-tolerance [9]. Moreover, HSC transplantation induces immune tolerance in rodents with EAE, as sustained by increased numbers of circulating regulatory T cells, a shift in T cell epitope recognition and a strong reduction of autoantibodies [9].

### Mesenchymal Stem Cells

The adult bone marrow contains a non-haematopoietic cell lineage which is capable of differentiating into osteoblasts, adipocytes, and chondrocytes. Due to their preferential capacity of differentiating into cells of the mesodermal lineage, these cells are currently defined as “mesenchymal” stem cells (MSCs). MSCs constitute the stromal scaffold providing the appropriate microenvironment for maturation and differentiation of blood-derived progenitor cells possibly by means of the release of survival factors [10].

MSCs can also be induced to differentiate in vitro into cells with biochemical, anatomical, and electrophysiological characteristics of neuronal cells [10]. Upon intravenous injection, MSCs engraft into different tissues – including the brain – where they escape immune surveillance and differentiate expressing some microglial and astroglial markers [9]. Migration of intravenously-injected MSCs to the brain may well depend upon tissue injury, as demonstrated by their

minimal engraftment when transplanted into healthy non-human primates [9]. In contrast, in rodents with cerebral ischemia and traumatic brain injury, systemically-injected MSCs migrate to the injured CNS. These migratory properties are regulated by cell adhesion molecules and receptors for inflammatory chemokines, such as CXCL12, which plays a key role in the migration of CXCR4-positive mesenchymal stem cells to peripheral tissues [9].

MSCs can also significantly modulate many immune functions. MSCs inhibit T cell proliferation and induce T cell energy [9]. MSCs also affect dendritic cell maturation both in vitro and in vivo, thus resulting in the generation of tolerogenic antigen presenting cells (APCs) [9]. Interestingly, proof of MSC-dependent induction of CD4<sup>+</sup> T cell subsets with a regulatory phenotype has recently been provided in vitro. Human MSCs also affect B lymphocyte proliferation and maturation to antibody secreting cells [9].

In vivo, transplantation of syngenic MSCs ameliorates chronic EAE in mice. Moreover, systemically-injected MSCs also improve relapsing-remitting EAE and migrate to the CNS where they promote BDNF production and induce proliferation of endogenous oligodendrocyte progenitor cells [9].

All together these results consistently challenge the view that stem cells therapeutically work exclusively throughout cell replacement. Indeed, NSC transplantation may also promote CNS repair via intrinsic *neuroprotective* bystander capacities, mainly exerted by undifferentiated stem cells releasing, at the site of tissue damage, a milieu of *neuroprotective* molecules once temporally and spatially orchestrated by environmental needs. The intrinsic nature (*pleiotropism and redundancy*) of these molecules as well as their “►constitutive” characteristics, might represent a *stem cell signature* that also reconciles data showing that other sources of somatic stem cells (e.g., HSCs, MSCs), may efficiently promote CNS repair despite very low capabilities of neural (trans) differentiation.

The exact knowledge and the potential impact of *non-conventional* stem cell-mediated therapeutic mechanisms might result, in certain circumstances, in more efficacious curative alternatives.

## References

1. Franklin RJ (2002) Why does remyelination fail in multiple sclerosis? *Nat Rev Neurosci* 3:705–714
2. Waxman SG (2006) Axonal conduction and injury in multiple sclerosis: the role of sodium channels. *Nat Rev Neurosci* 7:932–941
3. Franklin RJ, Blakemore WF (1997) To what extent is oligodendrocyte progenitor migration a limiting factor in the remyelination of multiple sclerosis lesions? *Mult Scler* 3:84–87

4. Martino G, Pluchino S (2006) The therapeutic potential of neural stem cells. *Nat Rev Neurosci* 7:395–406
5. Pluchino S, Zanotti L, Rossi B, Brambilla E, Ottoboni L, Salani G, Martinello M, Cattalini A, Bergami A, Furlan R, Comi G, Constantin G, Martino G (2005) Neurosphere-derived multipotent precursors promote neuroprotection by an immunomodulatory mechanism. *Nature* 436:266–271
6. Einstein O, Fainstein N, Vaknin I, Mizrahi-Kol R, Reihartz E, Grigoriadis N, Lavon I, Baniyash M, Lassmann H, Ben-Hur T (2006) Neural precursors attenuate autoimmune encephalomyelitis by peripheral immunosuppression. *Ann Neurol* 2006 [Epub ahead of print]
7. Pluchino S, Furlan R, Martino G (2004) Cell-based remyelinating therapies in multiple sclerosis: evidence from experimental studies. *Curr Opin Neurol* 17:247–255
8. Gratwohl A, Passweg J, Bocelli-Tyndall C, Fassas A, van Laar JM, Farge D, Andolina M, Arnold R, Carreras E, Finke J, Kotter I, Kozak T, Lisukov I, Lowenberg B, Marmont A, Moore J, Saccardi R, Snowden JA, van den Hoogen F, Wulffraat NM, Zhao XW, Tyndall A (2005) Autologous hematopoietic stem cell transplantation for autoimmune diseases. *Bone Marrow Transplant* 35:869–879
9. Uccelli A, Zappia E, Benvenuto F, Frassoni F, Mancardi G (2006) Stem cells in inflammatory demyelinating disorders: a dual role for immunosuppression and neuroprotection. *Expert Opin Biol Ther* 6:17–22
10. Gregory CA, Prockop DJ, Spees JL (2005) Non-hematopoietic bone marrow stem cells: molecular control of expansion and differentiation. *Exp Cell Res* 306:330–335

## Autoimmune Disease

### Definition

Diseases caused by immune responses targeting a self component that leads to subsequent tissue/organ damage and dysfunction. Autoimmune diseases can be organ/tissue specific or systemic depending on the distribution of the self components attacked by the immune system. Both cell-mediated and humoral (antibody mediated) immune responses are involved in tissue damage. Susceptibility of autoimmune disease is controlled by both environmental and genetic factors.

►Anti-DNA Antibodies against Microbial and Non-Nucleic Acid Self-Antigens

## Autoimmune Neuroinflammation

### Definition

Inflammation caused by immune reactivity towards self antigens within the nervous system. Multiple sclerosis

and its animal model experimental autoimmune encephalomyelitis are prototype diseases for autoimmune neuroinflammation.

- ▶ Multiple Sclerosis
- ▶ Experimental Autoimmune Encephalomyelitis

## Autoimmune Response

### Definition

Humoral (antibody) or cellular (T cell) immune responses against self antigens (autoantigen). Autoimmune diseases are caused by autoimmune responses, and can be divided into organ specific and systemic autoimmune diseases. For example, among neurological diseases, myasthenia gravis is mediated by autoantibody against the acetylcholine receptor. Although multiple sclerosis has been suggested to be mediated by autoimmune responses against myelin and/or oligodendrocytes, no single myelin antigen has been identified as the autoantigen.

- ▶ Multiple Sclerosis
- ▶ Myasthenia Gravis

## Autoimmune T Cells

### Definition

T cells that recognize specific self-antigens. These T cell subpopulations mediate an autoimmune response (i.e. a response to self-antigens), which can be either protective (e.g. fighting off cancer cells or neurodegenerative conditions) or – if not properly regulated – destructive (causing an autoimmune disease).

- ▶ Autoimmune Response

## Autoimmunity

### Definition

A condition in which the body produces an immune response recognizing its own proteins. Autoimmune responses can be mediated by either T or B lymphocytes.

- ▶ Autoimmune Response

## Autologous Macrophage Therapy for Spinal Cord Injury

### Definition

A treatment for acute spinal cord injury, in which systemic monocytes withdrawn from the patient's own blood are activated *ex-vivo* and reintroduced into patient for the purpose of carrying out their innate therapeutic functions.

- ▶ Autologous Macrophages for Central Nervous System Repair

## Autologous Macrophages for Central Nervous System Repair

MICHAL SCHWARTZ<sup>1</sup>, ETI YOLES<sup>2</sup>

<sup>1</sup>The Weizmann Institute of Science, Rehovot, Israel

<sup>2</sup>Proneuron Biotechnologies, Beit-Gamliel, Israel

### Synonyms

Blood-borne monocytes for CNS repair

### Definition

Restoration of damaged neural (brain and spinal cord) tissues by the peripheral immune system; specifically, by blood derived monocytes injected following activation, into the margins of the lesion site, or by boosting of adaptive immunity as away of enhancing recruitment of blood-borne monocytes injected autologous activated macrophages or by endogenous innate immune cells recruited via T cell-based vaccination.

### Characteristics

Recovery from acute central nervous system (CNS) injuries requires recruitment of blood-borne monocytes whose numbers, activity, and localization are rigorously controlled. CNS-resident microglia also participate in the recovery process, but their ability to acquire the needed activity is limited. Spontaneous recruitment of blood-borne monocytes is also limited, but can be boosted either by vaccination (with T cell-specific antigens or dendritic cells loaded with such antigens) or by exogenous application of specifically activated autologous macrophages. The cells are harnessed for restoration of homeostasis by removing cell debris, balancing exogenous ionic and neurotransmitter concentrations, providing growth factors, attracting reparative cells, and supporting tissue recovery and renewal.

Based on the realization that peripheral monocytes are needed for CNS repair, a number of ►[immune-based approaches](#) have been developed. One such therapy for spinal cord injury makes use of specifically activated autologous macrophages [1–3]. Macrophages are prepared from the patient’s blood, activated on the patient’s skin to adopt a phenotype that promotes repair, and then reintroduced into the patient. The activated macrophages, unlike “classically” activated macrophages programmed to dispose of hostile invading organisms, express the cell-surface markers CD80, CD86, and CD54, as well as class II major histocompatibility complex molecules (MHC-II). All of these features are characteristic of antigen-presenting cells (APCs) reminiscent of ‘alternatively activated macrophages’ rather than classical pro-inflammatory macrophages [1]. In addition, they secrete the growth-promoting brain-derived neurotrophic factor but not the cytokine tumor necrosis factor- $\alpha$ . The abundant presence of the former coupled with the absence of the latter is suggestive of beneficial neuroprotection. The cellular features of these activated macrophages are reminiscent of those of microglia/macrophages recruited or activated by the adaptive immune system [4].

## Background

Up until about 10 years ago, activated macrophages were viewed simply as cells that secrete the inflammatory mediators needed to kill intracellular pathogens. Data accumulated over the last decade suggested, however, that monocytes are multi-talented cells that are capable of expressing different functional programs in response to distinct micro-environmental signals. The differentiation of monocytic phenotypes is profoundly affected by microbial products and cytokines. Microbial products are associated with the “classical” activation that turns monocytes into potent effector cells that kill microorganisms and tumor cells. At the other extreme are the “alternatively” activated macrophages, conditioned by APC-secreted cytokines to control local inflammation (shechter, London, unpublished observations), [5] promote angiogenesis, tissue remodeling, and repair [1].

Over the last decade, the activities of blood-borne macrophages and resident microglia in the CNS, which formerly were considered to be wholly detrimental, began to be viewed in a different light. It is now widely accepted that immune cells are essential players in CNS repair (See review). Experiments in rats with completely transected optic nerves or spinal cords demonstrated that local application of macrophages preincubated with fragments of sciatic nerve (a peripheral nerve, and thus capable of regeneration) promotes motor recovery [3]. Similar results were reported by Benowitz and his colleagues, who showed that macrophage-derived factors stimulate growth [6].

The early experiments in which autologous activated macrophages were locally injected into the injured optic nerve were repeated in a paradigm of rat spinal cord contusion in which blood-borne monocytes were activated by preincubation with autologous skin [1]. In these and subsequent experiments the macrophage phenotypes were characterized, and parameters such as the site of injection, dosage, regimen, and therapeutic window were established. Specifically, macrophages are needed at the margin of the lesion site, not at the hyperacute phase, and express factors needed for scar resolution and for controlling inflammation.

These and related studies made it clear that the reparative role of activated macrophages which exert beneficial effects on the injured spinal cord differs from that of the resident microglia. This raised an important question: are such macrophages spontaneously recruited after a CNS insult? Addressing this question became feasible with the introduction of chimeric mice in which a visible marker, green fluorescent protein, is expressed by bone marrow-derived monocytes [5,7] shechter et al., Rolls et al. unpublished observations. Studies showed that the majority of innate cells accumulating at the site of injury were the resident microglia, while hardly any blood-borne monocytes were seen to infiltrate the damaged CNS. Recruitment of blood-borne monocytes turned out to be a key factor in recovery from any CNS injury [8].

## Quantitative regulation

### When Are Macrophages Needed?

In studies aimed at establishing the optimal time for macrophage intervention after spinal cord injury it became clear that in the CNS, as in any other tissue, repair and restoration are dependent not only on context, but also on timing. The following time windows were examined in a rat model of spinal cord injury, each representing a different post-injury physiological stage: (i) 3–4 days after spinal cord injury, a period characterized by decline in primary infiltration of neutrophils participating in inflammation and a high incidence of apoptotic cells (ii) 7–10 days after injury, a period of maximal proliferation and/or accumulation of ED1-positive cells (activated microglia/macrophages), T cells, and progenitor glial cells (iii) 14 days after injury, when the numbers of ED1-positive cells and T cells are still very high, while cytokines and chemokines in the injured tissue are decreasing or disappearing; and (iv) 21 days after injury, by which time many of the injury-induced biochemical and cellular activities in the spinal cord have peaked and begun to return to normal. The best effect was observed when cells were implanted 7–9 days after the injury.

The outcome, assessed in terms of recovery of motor function, is also critically affected by the choice of injection site. Injection close to the caudal margin of a

contusive spinal injury was found to be beneficial. Injections one or three segments below that level yielded no significant improvement in recovery [9].

### Other immune-based therapies

Macrophages that beneficially affect recovery resemble APCs [1]. Studies of immune system participation in recovery from CNS insults disclosed that the peripheral immune system, traditionally viewed as being affected only in a passive way by CNS injury, in fact, plays an active role in CNS repair and is an integral part of it. That discovery led to a series of studies that culminated in formulation of the seminal concept of “▶protective autoimmunity” [10,11]. According to this concept, T cells that react with specific CNS autoantigens (“autoimmune” T cells), by locally controlling the activity of resident microglia, play a central role in the physiological processes of CNS protection and repair. Active vaccination (using specific T cells) and passive vaccination (using myelin-derived peptides or dendritic cells loaded with those peptides) yielded similar results, manifested by better locomotion and reduced scar tissue. Recovery was accompanied by changes in the behavior of microglia/macrophages at the margins of the lesion, such that they were found to express the phenotype reminiscent of that of the activated macrophages.

It was further discovered that a principal role of the T cells has to do with shaping microglial behavior and recruiting blood-borne monocytes [5,12]. The activated microglia can act as APCs, produce growth factors, and scavenge neurotoxins such as excessive quantities of glutamate. Thus, not only do they support neuronal survival but they also promote neurogenesis and oligodendrogenesis, as well as axonal sprouting from adult neural stem cells [4]. It also became clear that not only resident microglia but also bone marrow-derived blood-borne monocytes can be induced to undergo a switch in phenotype, so that the activity they express is similar to that of transplanted growth-promoting macrophages [7]. Blood-borne innate immune cells that are recruited as a result of a T cell-based vaccination reside mainly at the margins of the lesion site.

Recognition that adaptive immune cells confer local immunity capable of supporting cell renewal by supporting an ectopic stem-cell niche raised another important question: after CNS injury, can the ▶local immune response be controlled in a way that allows exogenously applied stem cells to be harnessed for promotion of recovery? Investigation of this possibility disclosed that a T cell-based vaccination given on the day of spinal cord contusion, if supplemented 1 week later by injection of neural stem cells into the CSF, results in significantly better recovery than that attained by vaccination alone. No effect was observed with the

stem-cell injection alone. Moreover, in the vaccinated injured mice (but not in mice that were not vaccinated after injury), stem cells that are injected into the CSF find their way to the lesion site, supporting the contention that the local immune response helps to create a niche which recruits not only stem cells but also additional immune cells for repair. The injected stem cells apparently do not undergo local differentiation into any of the neural lineages; rather, their functions appear to be related to immune activity and creation of a regulatory niche [13].

Taken together, the blood-borne monocytes, play a major role in CNS repair. They can be recruited in various ways, including bone-marrow transplantation, active or passive vaccination, and administration of autologous macrophages.

### References

1. Bomstein Y, Marder JB, Vitner K, Smirnov I, Lisaey G, Butovsky O, Fulga V, Yoles E (2003) Features of skin-coincubated macrophages that promote recovery from spinal cord injury. *J Neuroimmunol* 142:10–16
2. Knoller N, Auerbach G, Fulga V, Zelig G, Attias J, Bakimer R, Marder JB, Yoles E, Belkin M, Schwartz M, Hadani M (2005) Clinical experience using incubated autologous macrophages as a treatment for complete spinal cord injury: phase I study results. *J Neurosurg Spine* 3:173–181
3. Rapalino O, Lazarov-Spiegler O, Agranov E, Velan GJ, Yoles E, Fraidakis M, Solomon A, Gepstein R, Katz A, Belkin M, Hadani M, Schwartz M (1998) Implantation of stimulated homologous macrophages results in partial recovery of paraplegic rats. *Nat Med* 4:814–821
4. Butovsky O, Landa G, Kunis G, Ziv Y, Avidan H, Greenberg N, Schwartz A, Smirnov I, Pollack A, Jung S, Schwartz M (2006) Induction and blockage of oligodendrogenesis by differently activated microglia in an animal model of multiple sclerosis. *J Clin Invest* 116:905–915
5. Shechter R, London A, Varol C, Cusimano M, Raposo C, Rolls A, Pluchino S, Martino G, Jung S, and Schwartz M unpublished observations
6. Yin Y, Cui Q, Li Y, Irwin N, Fischer D, Harvey AR, Benowitz LI (2003) Macrophage-derived factors stimulate optic nerve regeneration. *J Neurosci* 23:2284–2293
7. Rolls A, Shechter R, London A, Segev Y, Jacob-Hirsch J, Amariglio N, Rechavi G and Schwartz M, unpublished observations
8. Simard AR, Soulet D, Gowing G, Julien JP, Rivest S (2006) Bone marrow-derived microglia play a critical role in restricting senile plaque formation in Alzheimer’s disease. *Neuron* 49:489–502
9. Schwartz M, Yoles E (2006) Immune-based therapy for spinal cord repair: autologous macrophages and beyond. *J Neurotrauma* 23:360–370
10. Hauben E, Agranov E, Gothilf A, Nevo U, Cohen A, Smirnov I, Steinman L, Schwartz M (2001) Posttraumatic therapeutic vaccination with modified myelin self-antigen prevents complete paralysis while avoiding autoimmune disease. *J Clin Invest* 108:591–599



11. Moalem G, Leibowitz-Amit R, Yoles E, Mor F, Cohen IR, Schwartz M (1999) Autoimmune T cells protect neurons from secondary degeneration after central nervous system axotomy. *Nat Med* 5:49–55
12. Butovsky O, Koronyo-Hamaoui M, Kunis G, Ophir E, Landa G, Cohen H, Schwartz M (2006) From the cover: Glatiramer acetate fights against Alzheimer's disease by inducing dendritic-like microglia expressing insulin-like growth factor 1. *Proc Natl Acad Sci USA* 103:11784–11789
13. Ziv Y, Avidan H, Pluchino S, Martino G, Schwartz M (2006) Synergy between immune cells and adult neural stem/progenitor cells promotes functional recovery from spinal cord injury. *Proc Natl Acad Sci USA* 103:13174–13179

## Automatic Postural Response

### Definition

The automatic postural response is a muscular response to a postural perturbation that is thought to be mediated by brainstem centers. The response can be modulated in amplitude by many factors, including habituation, anticipation, prior experience, etc. However, it is “automatic” because it cannot be completely suppressed and is therefore neither completely fixed nor completely voluntary.

► Postural Synergies

## Automatic Ventilation

► Central Integration of Cardiovascular and Respiratory Activity Studied In?Situ

## Automatism

► Epiphenomenalism

## Automaton Theory

► Epiphenomenalism

## Autonomic Control of Sensory Receptors

MAGDA PASSATORE, SILVESTRO ROATTA  
Department of Neuroscience – Physiology Division,  
University of Torino, Raffaello, Torino, Italy

### Definition

The autonomic nervous system consists of three divisions: sympathetic, parasympathetic and enteric nervous system, however, only the sympathetic system is considered relevant in the context of vegetative-sensory interaction. The sympathetic nervous system (SNS) is activated during states of arousal and, in general, by physical, psychological and psychosocial stress as part of a complex neuro-hormonal body adjustment. In particular SNS governs the so-called ► *defense reaction* that contributes at rapidly mobilizing body resources for a ► *fight or flight response*. In addition, or probably within the same adjustment procedures, SNS modulates the discharge of several ► *sensory receptors*. Among them are several types of cutaneous ► *mechanoreceptors*, ► *muscle spindle* receptors, pain receptors, some visceral ► *chemo-* and *mechanoreceptors*. As a consequence, also the reflex actions mediated by the affected receptors may be modified.

A list of the ► *receptors* affected by enhancement of sympathetic flow is presented in Table 1 [see also 1,2]. We will focus on muscle spindle receptors that have been studied more extensively, due to their relevance in control of skeletal muscle function. Pain receptors, which are affected by ► *catecholamines* only under particular circumstances, are given more extended treatment elsewhere, in chronic pain mechanisms.

### Characteristics

#### General Considerations

Claude Bernard in 1851 first suggested that sensory input can be modulated by the activation of the SNS, on the basis of the observation of changes in cutaneous sensitivity following the extirpation of the cervical ganglion in the cat. A large number of old and recent electrophysiological and pharmacological data show that the SNS modulates the discharge of numerous types of mechanical and chemical receptors, at least in a percentage of them. The electrical stimulation of the relevant sympathetic nerve and local administration of catecholamines affect the firing properties of these receptors, in terms of both resting discharge and excitability, as recorded from ► *primary afferents* in several animal species [1,2]. The majority of data available in the literature are in fact collected in *acute* experiments performed on animal models, or in *in vitro*

**Autonomic Control of Sensory Receptors. Table 1** Sympathetically induced modulation of receptors

Tactile, thermal receptors	+ (frog)	Loewenstein WR (1956) J Physiol 132:40; Chernetski KE (1964) J Neurophysiol 27:493
"Cutaneous mechanoreceptors " slowly adapting	- (frog) + (frog)	Spray DC (1974) J Physiol 237:15; Calof AL et al. (1981) J Physiol 310:481
Cutaneous hair follicles rec.	- (cat vibrissae)	Nilsson BY (1972) Acta Physiol Scand 85:390
Pacinian corpuscle rec.	+ (cat mesentery)	Loewenstein, Altamirano-Orrego (1956) Nature 178:1292; Schiff JD (1974) J Gen Physiol 63:601; Akoev GN et al. (1976) Progr Brain Res 43:187
	- or + (cat skin)	Freeman B, Rowe M (1981) Neurosci Lett 22:145
	+ or 0 (human skin)	Hallin RG, Wiesenfeld Z (1983) J Auton Nerv Syst 7:391
Type I slowly adapting	+ (humans)	Wiesenfeld-Hallin Z, Hallin RG (1984) Hum Neurobiol 3:41
"hairy skin"	+ (cat)	Roberts WJ et al. (1985) Somatosens Res 2:223
Type II slowly adapt. (Ruffini) Guard hair, rapidly adapting	+ or + - (cat) -, few + (cat, skin near joints)	Pierce JP, Roberts WJ (1981) J Physiol 314:411
High-T mechanoreceptors, myelinated	0 (rabbit)	Barasi S, Lynn B (1986) Brain Res 378:21
Hairy skin mechanoreceptors, C fibers	+ (cat)	Roberts WJ, Elardo SM (1985) Brain Res 339:123
	+ - or 0 (rabbit)	Barasi S, Lynn B (1986) Brain Res 378:21
Type I-II, fast -slowly adapting	- or 0 (humans, tactile receptors)	Elam M, Macefield VG (2004) Auton Neurosc 111:116
Periodontal mechanoreceptors	+ (rabbit)	Passatore M, Filippi GM (1983) Arch Ital Biol 121:55
	-/0 (cat)	Cash RM, Linden RWA (1982) J Physiol 329:451
Golgi tendon organs	0 (cat)	Hunt CC (1960) J Physiol 151:332
Muscle spindles	+ - <i>in vitro</i>	Calma I, Kidd GL Arch Ital Biol 100:381
	+ - (cat limb m.)	Eldred E et al. (1960) Exp Neurol 2:13
	+ -/0 (cat limb m.)	Hunt CC (1960) J Physiol 151:332
	+ - (cat)	Francini F et al. (1978) Boll Soc Ital Biol Sper 54:1353
	- (rabbit jaw m.)	Passatore M, Filippi GM (1981) Brain Res 219:162
	0/ - (cat limb m)	Hunt CC et al. (1982) Arch Ital Biol 120:371
	+ - (rabbit jaw m.)	Passatore M et al. (1996) J Auton Nerv Syst 57:163
	+ - (rabbit jaw reflexes)	Grassi C et al. (1993) Arch Ital Biol 131:213; Grassi C et al. (1993) J Physiol 469:601
	+ - (rabbit jaw m.)	Passatore M et al. (1996) J Auton Nerv Syst 57:163
	- SS (rat jaw m.)	Matsuo R et al. (1995) J Physiol 483:239
	+ - (rabbit jaw m.)	Roatta S et al. (2002) J Physiol 540:237
+ - (cat neck m.)	Hellström F et al. (2005) Exp Brain Res 165:328	
Gustatory receptors	+ (frog)	Chernetski KE (1964) J Neurophysiol 27:493
Olfactory receptors	+ (rabbit)	Tucker D, Beidler LM (1956) Am J Physiol 187:637
Intestinal receptors (perception)	+ (duodenum, humans)	Iovino P et al. (1995) Gastroenterology 108:680

**Autonomic Control of Sensory Receptors. Table 1** Sympathetically induced modulation of receptors (Continued)

Carotid sinus baroreceptors	+, or 0 at high carotid sinus pressures (opossum, dog)	Koizumi K, Sato A (1969) Am J Physiol 216:231; Bolter CP, Ledsome JR (1976) Am J Physiol 230:1026
Carotid glomus chemoreceptors	+ (dog)	Eyzaguirre C, Fidone SJ (1980) Am J Physiol 8:C135
	+ (cat)	Acker H, O'Regan RG (1981) J Physiol 315:99
Atrial and ventricular mechanoreceptors	+ (cat)	Nishi K et al. (1974) J Physiol 240:53
		Nishi K et al. (1977) Pflug Arch ger Physiol 372:53
Nociceptors		
Tooth pulp receptors	+ or + - (cat)	Edwall L, Scott DJ (1971) Acta Physiol Scand 82:555; Matthews B (1976) Adv Pain Res Ther 195
Cutaneous A $\delta$ fibers	0 (cat)	Roberts WJ, Elardo SM (1985) Somatosensory Res 3:33
	0 (rabbit)	Barasi S, Lynn B (1986) Brain Res 378:21
	0 (rat)	Lang PJ et al. (1990) Psychol Rev 97:377
	0 (humans)	Iovino P et al. (1995) Gastroenterology 108:680
Cutaneous C fibers	+ (rat: <i>in vitro</i> prep)	Kieschke J et al. (1991) Progr Brain Res 74:91
	+ (rat)	Mense S (1986) Prog Sens Physiol 6:139
	0 (rat)	Sanjue H, Jun Z, Pain 38:85; Sato A et al. (1993) Neurosci Lett 164:225
	+ - (rabbit)	Barasi S, Lynn B (1986) Brain Res 378:21
	- rabbit, single fibers, in sural nerve	Shyu BC et al. (1989) Acta Physiol Scand 137:85
	+ (cat)	Roberts WJ, Elardo SM (1985) Brain Res 339:123
	0 (humans)	Elam M et al. (1999) Brain 122:2237
	0 (monkey)	Selig DK et al. (1993) Soc Neurosci Abs 19:326
	0 (rabbit)	Shea VK, Perl ER (1985) J Neurophysiol 54:513; Sato J, Perl ER (1991) Science 251:1608; Bossut DF, Perl ER J Neurophysiol 73:1721
A $\delta$ and C fibers after "precipitating factors" occur, e.g., nerve lesion, inflammatory processes, previous sensitization	+ (cat)	Roberts WJ, Elardo SM (1985) Somatosensory Res 3:33
	+ (rabbit, C fibers)	Roberts WJ (1986) Pain 42:297; Shyu BC et al. (1990) Acta Physiol Scand 140:237; Sato J, Perl ER (1991) Science 251:1608
	+ humans (Sympathetically-Maintained Pain)	Walker AE, Nulsen F (1948) Arch Neurol Psych 59:559; Bonica JJ (1979) Adv Pain Res Ther 3:141; Levine JD et al. (1986) Nature 323:158; Bonica JJ 1990; Sanjue H, Jun Z (1989) Pain 38:85; Sato J, Perl ER (1991) Science 251:1608; Koltzenburg M et al. (1994) Brain 117:579; Drummond PD (1995) Pain 60:301; Torebjörk E et al. (1995) Pain 63:11; Drummond PD et al. (2001) Neurology 57:1296

Data obtained following sympathetic activation induced by either electrical stimulation of sympathetic supply (1–10 Hz) or application of catecholamines or through specific manoeuvres, in the species indicated. Effects reported are obtained by recording afferent discharges from primary neurons; symbols indicate the prevalent response: activation of the resting discharge and/or facilitation of the test response (+), inhibition and/or depression (–), diphasic response (+ – or – +), no effect (0).

preparations. Few studies are available on humans based on microneurography during sympathetic activation tests.

The mechanisms responsible for this action are still debated. For some of the reported actions, there is in fact some disagreement on whether they are due to the *direct* effect exerted by catecholamines on the sensory receptors or rather they are *indirect*, i.e., secondary to metabolic, mechanical or thermal changes induced in the receptor-bearing tissue by the concomitant sympathetically induced ▶**vasoconstriction**. For some cutaneous receptors, micromovements induced by contraction of adjacent ▶**piloerector muscles** has been also suggested. An action exerted directly on the sensory receptors, rather than secondary to vasoconstriction, is suggested by: (i) functional studies in which the sympathetic effect on the receptors was not mimicked by ischemia; (ii) morphological studies proving the existence of noradrenergic fibers in close contact with a number of receptors, such as Pacini corpuscles, muscle spindles and cutaneous hair receptors. Conclusive contribution to the debate should be provided by immunohistochemical investigations proving or disproving the presence of specific adrenoceptors on the various sensory receptor terminals. The studies listed in [Table 1](#) attribute the sympathetically induced effect to a direct action on the receptors, except for some of them, i.e., Freeman & Rowe (1981), Edwall & Scott (1971), Eldred et al. (1960), Eyzaguirre & Fidone (1980) and Elam & Macefield (2004).

It must be added that the sympathetically induced action on the same sensory receptors is likely to be different or more pronounced after “sensitization” processes develop in the affected area; this possibility has been particularly investigated for nociception (see below, under *Pain receptors*).

## Overview

Increase in sympathetic outflow and locally-applied noradrenaline is reported to elicit or enhance the resting discharge and/or to increase the sensitivity to the relevant stimuli, in various types of cutaneous mechanoreceptor. The effect was shown, in some case, to be mediated by increased amplitude and rate of rise of the generator potential, and possibly by an action at the level of the ▶**encoding site**. In general excitatory actions seem to predominate on slowly adapting mechanoreceptors while depressant actions are more commonly observed in rapidly adapting receptors. Besides characteristics of adaptation, sympathetic effects seem to depend on the ▶**afferent fiber type** (see [Table 1](#)).

Sympathetic stimulation enhances ▶**Pacini corpuscle** activity in experimental animal models, although some depressant effect is also reported. In some of these receptors, in humans, Hallin & Wiesenfeld [3] evidence a

clear relationship between extent of stress/sympathetic outflow and spontaneous discharge frequency of the receptor. A similar interaction is reported in their experiments for the discharge of slowly adapting type I receptors in response to light mechanical stimuli (see [Table 1](#)).

The two studies performed on periodontal mechanoreceptors show excitatory and depressant sympathetic actions on rabbit and cat models, respectively, while excitation occasionally followed by inhibition is reported for tooth pulp receptors, having nociceptive function.

An increase in visceral perception of intestinal distension is evidenced in humans during increase in sympathetic outflow ([Table 1](#)) while, in the same experimental condition, somatic sensitivity (cutaneous) appears scarcely affected. Sympathetic activation was elicited in this study by means of lower body negative pressure that produces venous pooling in lower extremities (which activates the sympathetic nervous system directly via cardiovascular reflexes).

## Muscle Spindles

Stimulation of peripheral sympathetic pathways has been shown to profoundly affect the resting discharge rate, as well as the stretch sensitivity of both Ia and II spindle afferents. However the results from different studies performed on various muscles and animal species are not uniform [1,2,4], the mechanisms of such modulator action are still disputed, and so is the functional relevance of the sympathetic action on spindles. In particular, the effects observed in hindlimb muscles of experimental animals were either considered secondary to vasoconstriction or exerted directly on spindles but having small magnitude, therefore scarce functional relevance [2]. By contrast, more recent studies performed on masticatory and neck muscles in several experimental models show that sympathetic activation exerts, in the large majority of muscle spindle afferents, a consistent depression of the response to muscle length changes, possibly preceded by a transient enhancement of variable magnitude. This response consists of a reduction in the ▶**static and dynamic sensitivity**, observed in both Ia and II units innervating bag and chain ▶**intrafusal muscle fibers**. This response was found to be mediated by  $\alpha_1$ -adrenoceptors and to be independent of sympathetically induced vasoconstriction [2,5]. To the action exerted by the sympathetic outflow on muscle spindle afferents is attributed the sympathetically-induced transient enhancement followed by remarkable decrease in the magnitude of both jaw ▶**jerk** and ▶**tonic vibration reflex** in jaw elevator muscles lasting throughout the stimulation and longer [6]. In fact these effects parallel, in relative magnitude and time course, the ones induced by the

sympathetic stimulation on spindle afferent discharge recorded from jaw elevator muscles. Thus the main action induced by the sympathetic stimulation consists of a considerable decrease in the quality of proprioceptive information. This should impair the ability of motor system both to correct perturbations, i.e., decrease the ►feedback control of muscle length, and to tune the motor program according to current constraints (►feed-forward control of movement).

Besides affecting muscle spindle afferents sensitivity to muscle length changes, sympathetic stimulation also affects their resting discharge, such effect ranging from enhancement to strong depression of firing. Even though the origin of this difference is not clarified, such action is of obvious importance since baseline activity is an important excitatory input that may affect ►muscle tone, through spindle support to ►motoneurons. The different time course exhibited by the effect on spontaneous discharge rate and sensitivity to stretch suggests that more than one mechanism is involved in the sympathetic action on spindles. Recent findings indicate that intrafusal muscle fibers are among the possible targets of sympathetic innervation. Bombardi et al. [7] report, in rabbit masseter muscle, the presence of sympathetic fibers, visualized by immunohistochemical fluorescent labeling of the noradrenaline-synthesizing enzymes tyrosine hydroxylase and dopamine beta-hydroxylase, along the entire length of the spindles, within the capsule wall, in periaxial fluid space and in close apposition to intrafusal fibers, confirming previous findings obtained, using traditional techniques, on limb muscles [8]. In addition  $\alpha_{1a}$ -adrenoreceptors are detected at the polar region of a large percentage of spindles, both bag and chain intrafusal fibres [7]. Recent work from the same group demonstrates the presence of  $\alpha_{1a}$ -adrenoreceptors, with the same localization, in spindles of several muscles i.e., trapezius, splenius, triceps (caput longum) and gastrocnemius muscles in rabbits (Bombardi, personal communication). Localization of the  $\alpha_{1a}$ -adrenoreceptors in the polar regions of the spindles suggests that the sympathetic mediator may modulate the spindle afferent discharge by altering the mechanics of both types of intrafusal fibers.

The functional implications of the sympathetic action on muscle spindle receptors are of considerable interest since this signal contributes to a number of body functions, such as control and coordination of ongoing movements, maintenance of postural control, perception of position and movement of our body (kinaesthesia), and learning of stereotyped movements and motor skills. Therefore, any system able to modulate the spindle receptors is liable to affect those functions. The action of sympathetic innervation on spindle receptors still needs to be confirmed in humans.

### Pain Receptors

The large majority of studies agree in showing that, under normal conditions, increase of sympathetic outflow does neither activate nociceptors nor affect their ongoing discharge (see Table 1). However, the sympathetic action may become powerful under pathological conditions, when some “precipitating factor” intervenes, such as peripheral nerve lesions resulting from injury or compression, trauma of soft tissues, inflammatory processes or previous sensitization of the relevant receptors. Under these conditions, in which pain problems are disproportional to the initial injury, some ►nociceptive receptors develop sensitivity to catecholamines, which may initiate or enhance the ongoing discharge [9] (see Table). The reasons suggesting that the SNS system plays a role in certain painful states are the following: (i) the control of the sympathetically innervated structures in the affected area is abnormal (sweating, temperature dysregulation, trophic changes); (ii) pain is exacerbated by emotionally arousing stimuli; (iii) pain is temporarily relieved by sympathetic blockade ( $\alpha$ -adrenoreceptors) and is rekindled by injecting small amounts of catecholamines or of  $\alpha$ -adrenergic agonists.

It has been hypothesized that this peripheral sympathetic-sensory coupling is one of the mechanisms involved in initiation and maintenance of a symptom defined ►sympathetically-maintained pain, that may be common to several diseases [4,9,10].

### Final Remarks

As reported above, the sympathetic nervous system exerts a widespread modulation of several receptors. It is well known that the central nervous system can control the inflow of sensory information at different spinal and supra-spinal levels, the aim being either to amplify or filter out specific signals, thus selecting the ones that are most relevant in a particular context. It is tempting to speculate that the SNS takes part to this aim/action acting directly at the receptor level, thereby constituting the peripheral branch of a general system controlling and processing afferent information.

### References

1. Akoev GN (1981) Catecholamines, acetylcholine and excitability of mechanoreceptors. *Prog Neurobiol* 15:269–294
2. Roatta S, Windhorst U, Ljubisavljevic M, Johansson H, Passatore M (2002) Sympathetic modulation of muscle spindle afferent sensitivity to stretch in rabbit jaw closing muscles. *J Physiol Lond* 540:237–248
3. Hallin RG, Wiesenfeld Z (1983) Does sympathetic activity modify afferent inflow at the receptor level in man? *J Auton nerv Syst* 7:391–397

4. Passatore M, Roatta S (2005) Influence of sympathetic nervous system on sensorimotor function: whiplash associated disorders (WAD) as a model. *Eur J Appl Physiol* 98:423–449
5. Hellstrom F, Roatta S, Thunberg J, Passatore M, Djupsjobacka M (2005) Responses of muscle spindles in feline dorsal neck muscles to electrical stimulation of the cervical sympathetic nerve. *Exp Brain Res* 165:328–342
6. Grassi C, Deriu F, Passatore M (1993) Effect of sympathetic nervous system activation on the tonic vibration reflex in rabbit jaw closing muscles. *J Physiol Lond* 469:601–613
7. Bombardi C, Grandis A, Chiochetti R, Bortolami R, Johansson H, Lucchi ML (2006) Immunohistochemical localization of alpha1a-adrenoceptors in muscle spindles of rabbit masseter muscle. *Tissue Cell* 38:121–125
8. Barker D, Saito M (1981) Autonomic innervation of receptors and muscle fibers in cat skeletal muscle. *Proc R Soc Lond B Sci* 212:317–332
9. Koltzenburg M (1997) The sympathetic nervous system and pain. In: Dickenson A, Besson JM (eds) *The pharmacology of pain*. Springer-Verlag, Berlin Heidelberg New York, pp 61–91
10. Bonica JJ (1990) Causalgia and other reflex sympathetic dystrophies. In: Bonica JJ (eds) *The management of pain*, 2nd edn. Lea & Febiger, Philadelphia, PA, pp 220–243

## Autonomic Dysfunction

### Definition

Autonomic dysfunction is an impairment of autonomic function which may be caused by disease or degeneration of the central or peripheral nervous system. The effects may be focal or widespread and tend to increase in prevalence with age, affecting the cardiovascular and thermoregulatory systems in particular.

#### ► Autonomic Insufficiency

## Autonomic Effects on Skeletal Muscle

SILVESTRO ROATTA, MAGDA PASSATORE

Department of Neuroscience – Section of Physiology,  
University of Torino, Torino, Italy

### Definition

The autonomic nervous system is generally considered to control “vegetative functions”. However, since the end of nineteenth century catecholamines (“adrenal extracts” at that time) were shown to increase the force

developed by skeletal ► **muscle twitches** in the dog. Besides this ► **inotropic** action, catecholamines have been shown to affect many other processes at the muscle fiber level that also impact on relevant aspects of muscle function, like fatigability, energy consumption and metabolism. Given that skeletal muscles receive no parasympathetic innervation (with possible exceptions, like the rat masseter muscle in which a vascular parasympathetic innervation is reported), the autonomic effects appear to be exclusively sympathetic in origin, mediated either by the neurally released noradrenaline or indirectly through circulating adrenaline released in the blood by the adrenal medulla. The issue was extensively reviewed by Bowman [1] and is here resumed and updated. The anatomical basis for autonomic effects on skeletal muscles is first introduced, then the different effects are dealt with separately, being grouped in the following categories:

1. Effects on contractility.
2. Effects on excitability.
3. Effects on glucose and protein metabolism.
4. Effects on neuromuscular transmission.

### Characteristics Anatomical Basis

Besides innervating blood vessels, post ganglionic unmyelinated sympathetic fibers have also been reported to lay interspersed and in neuroeffective association with skeletal muscle fibers [2]. However, most effects on the skeletal muscle appear to be mediated by the circulating adrenaline rather than by the noradrenaline released by sympathetic fibers. This results from experiments in which the effects observed by local or systemic injection of adrenaline were not reproduced by stimulation of the relevant sympathetic pathways and is explained by the following considerations: (i) among the increasing list of ► **adrenergic receptors** (ARs) ( $\alpha_1$ ,  $\alpha_2$ ,  $\beta_1$ ,  $\beta_2$ ,  $\beta_3$ , and relative subtypes),  $\beta_2$ -ARs mediate most adrenergic effects on skeletal muscle fibers; (ii) at difference from  $\alpha_1$ -ARs, the ubiquitous vascular receptors mediating vasoconstriction,  $\beta_2$ -ARs are not located in tight correspondence with sympathetic ► **varicosities** releasing noradrenaline; (iii)  $\beta_2$ -ARs are the preferential target of circulating adrenaline, which has for these receptors a much higher affinity than noradrenaline.

$\beta_2$  receptor density on the ► **sarcolemma** may depend on the ► **muscle fiber type** and has been reported to be higher in type-I, as compared to type-II. Conversely,  $\alpha_1$ - and  $\beta_1$ -ARs have been detected pre-junctionally in the motor endplate (see below) and are usually not found in skeletal muscle fibers. However, exceptions and differences may occur in different muscles and different animal species. For instance  $\alpha_1$  effects have

been reported in the rabbit masticatory muscles [3] and in rat muscles, where their expression in the sarcolemma was shown to increase in particular conditions like motor denervation, chronic ipokalemia and aging [1,4]. Finally, cotransmitters of adrenaline like NPY may also play a role [3].

### Effect on Contractility (Inotropic Effect)

Catecholamines affect the force developed by skeletal muscle fibers, the effects being different depending on the muscle fiber type. The effects on contractility are classically described through the modification exhibited by the muscle twitch: it generally results increased and longer lasting in fast contracting muscle fibres (type-II) while it is decreased and shorter lasting in slow-contracting fibres (type-I) [1]. The potentiating effect on type-I fibres, that in the masticatory muscles was shown to be partly mediated by the noradrenaline co-transmitter NPY [3], was also observed in limb muscles. However, the fact that in limb muscles such effect was observed at relatively high doses of injected adrenaline or at relatively high frequencies of splanchnic sympathetic nerve stimulation (which stimulates secretion of catecholamines from the adrenal medulla) has cast doubts on its actual physiological significance. On the contrary, the inhibitory effect on slow-twitch muscle fibres could be evoked with much lower doses of injected adrenaline, as well as by stimuli reflexly increasing the sympathetic outflow, and is therefore expected to have an impact in physiological conditions [1].

More recently, an increase in twitch amplitude was also described for type-I muscle fibres, in *in vitro* preparations exposed to  $\beta_2$  ARs agonists [5]. These experiments led to clarify that the contractility of the muscle fiber can be modulated by controlling the release/reuptake of calcium ions from/into the intracellular calcium store (the sarcoplasmic reticulum), through the following mechanisms: (i) increased  $\text{Ca}^{++}$  release from the sarcoplasmic reticulum mediates the increase in twitch amplitude in both fiber types; (ii) increased  $\text{Ca}^{++}$  re-uptake in the sarcoplasmic reticulum decreases the twitch duration (slow fibres only). These effects would be achieved by phosphorylation of both ryanodine receptors and the sarcoplasmic pump regulatory protein *phospholamban*, respectively, via the cAMP-PKA pathway [5]. The same pathway exists in cardiac muscle fibers and contributes to the increase in force and rate of relaxation produced by catecholamines via  $\beta_1$  ARs.

From the functional point of view, the potentiation of amplitude and/or duration of the twitch occurring in type-II muscle fibers would result in an increase in the force level developed by **▶subtetanic contractions**. Interest for these effects has recently emerged in sports physiology where the relevance of the positive inotropic effect and the *anti-fatigue* effect (see below) is

investigated to ascertain any possible improvement in muscle performance or endurance by administration of  $\beta_2$  agonists. However the most pronounced effect concerns type-I muscle fibers. It generally consists in a weakening of subtetanic contractions, due to the fact that the effect of twitch shortening overcomes the effect of amplitude increase. In response to  $\beta_2$ -agonists administration the developed force may decrease to less than 40% of the original value, the magnitude of such decrease depending on the experimental setup and on of stimulation frequency of the muscle fibers. The functional implication is not evident in this case. One possible interpretation is that, under the effect of adrenaline, the speed of contraction is privileged, rather than the force, so that slow-twitch (type-I) muscle fibers behave more similarly to the fast-twitch (type-II) fibers. This effect may improve the performance of fast movements in a **▶fight or flight response**.

### Effect on Excitability

Catecholamines, via  $\beta_2$  ARs, potentiate the activity of the **▶Na/K pump** located in the sarcolemma thus promoting a hyperpolarizing effect. This effect is not consistently observed in resting conditions but may become important in preserving muscle function (force) during exercise. During intense muscle activity a relevant outflow of potassium ions from muscle fibers to the interstitial fluid takes place. The ensuing decrease of concentration gradients across the sarcolemma (particularly at the level of T-tubules) leads to decreased excitability of muscle fibers and impaired force production, and constitutes a major peripheral mechanism of **▶muscle fatigue**.

An *anti-fatigue* effect of catecholamines has been demonstrated in several *in-vitro* and *in-vivo* preparations; these experiments show that the force level decreased by iperkalemia or fatigue could be partially restored by infusion of adrenaline or of  $\beta_2$ -agonists (e.g., salbutamol, terbutaline) [6], as well as by electrical stimulation of the lumbar sympathetic chain (Orbeli effect).

It may be worth considering the adrenergic stimulation of the Na/K pump in a systemic perspective. During exercise, the potassium loss from active fibers generally leads to a substantial increase in plasma potassium concentration that may rise from 4 mM to more than 8 mM, depending on exercise intensity and muscle mass involved. It is interesting to observe that, in steady-state exercising muscles, potassium efflux from active fibers is not affected by pharmacological blockade of  $\beta_2$ -ARs.

This suggests that the Na/K pump in active fibers cannot be further potentiated by the circulating adrenaline, being already stimulated by the locally altered ionic gradients. However, adrenaline may still effectively operate in all non-exercising muscles,

thereby stimulating a general potassium uptake. This attenuates the exercise-induced rise in plasma potassium concentration, thus preserving excitability of active fibers and delaying fatigue. An increased rise in plasma potassium concentration is in fact observed when this action is prevented by  $\beta$ -blockade.

Through the adrenergic modulation of the Na/K pump activity and the control on blood flow redistribution (via  $\alpha$ - and  $\beta$ -ARs) the sympato-adrenergic system operates a central control of plasma potassium concentration in exercise [7].

### Effect on Glucose and Protein Metabolism

Adrenaline, again through the  $\beta_2$ -ARs – cAMP – PKA pathway, modulates important metabolic functions in the skeletal muscle cells, that will be here briefly summarized.

Adrenaline and  $\beta_2$ -agonists were shown to reduce the release of amino acids (mainly alanine and glutamine) from isolated muscle preparations and to increase muscle mass when orally administered in different animal species. This anabolic effect is specific to striated muscle (smooth muscles are not affected); it appears within two days after  $\beta_2$ -agonists administration and is attenuated 14 days afterwards, possibly because of  $\beta$  receptors down-regulation. This *protein sparing* was recently shown to be mediated by inhibition of proteolysis (through a mechanisms involving PKA-activation of *calpastatin* which specifically inhibits the proteolytic enzyme *calpain*), although potentiation of protein synthesis may also occur [8].

Catecholamines promote glucose uptake and glycogenolysis in skeletal muscle, however some of the underlying mechanisms remain unclear.

As for glucose uptake, it is potentiated, particularly by noradrenaline, via unspecified  $\beta$ -ARs (it is debated whether  $\beta_3$  receptors are implicated). Adrenaline instead, via  $\beta_2$ -ARs, antagonizes the insulin-mediated glucose transport. Again, in antagonism with insuline adrenaline inhibits glycogen synthesis and promotes glycogenolysis, this latter process appears to be not particularly relevant in resting muscles, being conditioned to the simultaneous occurrence of muscle activity. These actions, however, result in increased lactate outflow from the muscle fibers; lactate diffuses out of the cells and may be then reconverted to glucose by the liver. These effects may contribute to the adrenaline-induced increase in  $\blacktriangleright$ glycemia [9].

The sympato-adrenal system plays an important role in the processes of storage and release of energy substrates by coherently modulating the activity of skeletal muscles, liver, pancreas and adipose tissue.

### Effects on Neuromuscular Transmission

In addition to the modulation of several intracellular processes, another action of catecholamines may be of interest in this context, i.e., the modulation of

acetylcholine release at the  $\blacktriangleright$ motor end plate, through an action exerted on the motor terminal. This pre-synaptic modulation appears to be (i) rather complex, being mediated by both  $\alpha$ - and  $\beta$ -ARs; (ii) difficult to study, given the concomitant postsynaptic effects on cell excitability (see above); and (iii) not particularly relevant in physiological condition, given the intrinsically high reliability and effectiveness of neuromuscular transmission. In fact, the effects of  $\blacktriangleright$ sympathomimetics were evidenced under partial curarization, i.e. an experimental model in which neuromuscular transmission is weakened in all motor end plates and blocked in some of them. In this condition both adrenaline and noradrenaline improve the efficacy of neuromuscular transmission, to the extent that neuromuscular blockade is overcome in some fibers (so called *anti-curare* effect) [1]. The hypothesized involvement of  $\beta$ -receptors has been confirmed in recent studies indicating that presynaptic  $\beta_1$ -ARs may potentiate the postsynaptic effect by increasing synchronization of vesicles exocytosis [10].

### Function

The autonomic nervous system affects several important functions of the skeletal muscle fiber primarily through the action of adrenaline via  $\beta_2$  ARs, although other ARs may be implicated in the modulation of neuromuscular transmission and in processes related to glucose uptake. Secretion of adrenaline increases during exercise and most of its actions on muscle fibers can be considered as part of a general strategy aimed at increasing muscle performance in terms of developed force, movement velocity, availability of energy substrates and protection from fatigue. However, it should be taken into account that adrenaline secretion also occurs in stressful conditions, possibly in the absence of relevant muscle activity; in this condition adrenergic effects on skeletal muscle may be inappropriate. A possibly similar situation occurs when  $\beta_2$ -agonists are systemically administered, e.g., for the treatment of asthma ( $\beta_2$ -ARs mediate broncho-dilation). No broncho-specific sympathomimetics have been devised, as yet, and a number of side-effects of these drugs, such as ipokalemia (see above), hyperglycemia (see above) and  $\blacktriangleright$ tremor, can partly be attributed to activation of  $\beta_2$ -ARs in skeletal muscles. Increased physiological tremor (in the range 8–12 Hz) due to administration of adrenaline was attributed to its negative inotropic effect on type-I muscle fibers: decreased fusion of subtetanic contractions (see above) implies increased oscillations in force/position in the limbs.

However, the involvement of muscle spindles in physiological tremor was also hypothesized, the oscillations having been attributed to instability of the  $\blacktriangleright$ feedback control of muscle length. Catecholamines might also affect this feedback control through their modulating action on muscle spindle receptor activity ( $\blacktriangleright$ Autonomic control of sensory receptors).



## References

1. Bowman WC (1980) Effects of arenergic activators and inhibitors on skeletal muscles. In: Szekeres (ed) *Handbook of experimental pharmacology, adrenergic activators and inhibitors*, vol 54/2. Springer-Verlag, Berlin NewYork Heidelberg, pp 47–128
2. Barker D, Saito M (1981) Autonomic innervation of receptors and muscle fibres in cat skeletal muscle. *Proc R Soc Lond B Biol Sci* 212:317–332
3. Grassi C, Deriu F, Roatta S, Santarelli R, Azzena GB, Passatore M (1996) Sympathetic control of skeletal muscle function: possible co-operation between noradrenaline and neuropeptide Y in rabbit jaw muscles. *Neurosci Lett* 212:204–208
4. Akaike N (1981) Sodium pump in skeletal muscle: central nervous system-induced suppression by  $\alpha$ -adrenoreceptors. *Science* 213:1252–1254
5. Ha TN, Posterino GS, Fryer MW (1999) Effects of terbutaline on force and intracellular calcium in slow-twitch skeletal muscle fibres of the rat. *Br J Pharmacol* 126:1717–1724
6. Clausen T, Andersen SL, Flatman JA (1993) Na(+)-K+ pump stimulation elicits recovery of contractility in K(+)-paralysed rat muscle. *J Physiol (Lond)* 472:521–536
7. Hallen J (1996) K+ balance in humans during exercise. *Acta Physiol Scand* 156:279–286
8. Navegantes LC, Migliorini RH, Do Carmo Kettelhut I (2002) Adrenergic control of protein metabolism in skeletal muscle. *Curr Opin Clin Nutr Metab Care* 5:281–286
9. Nonogaki K (2000) New insights into sympathetic regulation of glucose and fat metabolism. *Diabetologia* 43:533–549
10. Bukharaeva EA, Gainulov RKh, Nikol'skii EE (2002) The effects of noradrenaline on the amplitude-time characteristics of multiquantum endplate currents and the kinetics of induced secretion of transmitter quanta. *Neurosci Behav Physiol* 32:549–554

## Autonomic Failure

### ► Autonomic Insufficiency

## Autonomic Function and Exercise

M. J. JOYNER

Departments of Anesthesiology and Physiology, Mayo Clinic College of Medicine, Rochester, MN, USA

### Synonyms

Terms sometimes used to describe exercise and related phenomena include muscle contraction, muscular work, and physical activity

## Definition

Exercise can be defined as the voluntary activation of skeletal muscles for recreation, rehabilitation, or participation in sport. Since it is possible to evoke muscle contraction via electrical stimulation or segmental reflexes, this definition emphasizes the voluntary component of exercise and CNS involvement in the contractions. Terms like physical activity include exercise as defined above but also voluntary muscular contractions directed toward occupational and other activities of daily living.

Exercise has been categorized as “static,” “dynamic,” or “intermittent.” Static exercise refers to exercise associated with limited muscle shortening, and is the human analog to “isometric” contractions in isolated muscle preparations. Dynamic exercise describes rhythmic shortening and/or lengthening contractions and is exemplified by running or cycling. Intermittent exercise describes things like ball games where variable bursts of activity with varying muscle mass and forces are used. The basic mechanisms that govern the autonomic responses to static, dynamic and intermittent exercise are similar. In this chapter only “static” and “dynamic” exercise will be discussed further.

## Characteristics

### Quantitative Description

Exercise of all types is associated with several physiological responses governed by the autonomic nervous system:

- An increase in heart rate.
- An increase in blood pressure, especially systolic blood pressure.
- An increase in ventilation.
- Exercise lasting more than a few minutes also evokes autonomic responses directed at metabolism and thermoregulation.

The magnitude of these responses can be highly variable depending on the intensity and duration of the exercise along with subject specific variables. However, the direction of change across conditions is similar.

At the onset of exercise, heart rate (HR) rises instantaneously [1,2]. During heavy or maximal dynamic exercise in the young, values increase from around 60 beats/min at rest to about 200 beats/min. With a static handgrip, heart rate usually rises 10–20 beats per minute (depending on the fraction of maximal voluntary contraction), but with prolonged or fatiguing contractions larger increases occur. The rise in HR from rest to 100 beats/min is mainly due to withdrawal of vagal tone to the heart. As HR increases to values above 100 beats/min, the cardiac sympathetic nerves become increasingly engaged (Fig. 1).

At the onset of exercise there is also an instantaneous rise in arterial blood pressure [1,2]. During dynamic

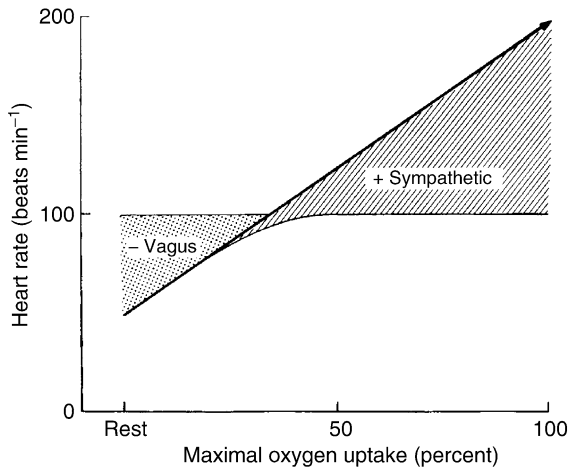

### Autonomic Function and Exercise.

**Figure 1** Schematic showing the contributions of vagal withdrawal and sympathetic activation to the rise in heart rate (HR) with exercise. At rest, vagal control of heart rate predominates. As exercise intensity increases to 30–40% of maximal, vagal tone is withdrawn and HR increases to about 100 beats per minute. At this exercise intensity, sympathetic traffic to the heart increases and is responsible for the further rise in HR as exercise intensity increases. (Figure from Rowell, LB: “Human Cardiovascular Control,” Oxford 1993.)

exercise, systolic pressure rises due to increases in stroke volume and heart rate that eject more blood into the aorta and large conducting vessels. The effects of dynamic exercise on diastolic pressure are more variable due to vasodilation in the active skeletal muscles. In young healthy subjects and trained athletes diastolic blood pressure does not change or falls. In older subjects and those with conditions like hypertension diastolic pressure can rise with exercise. The net effect of these changes is a modest to marked increase in mean arterial pressure.

During static exercise both systolic and diastolic pressure rise. The rise in systolic pressure is due to increased cardiac output (due primarily to an increased HR) and peripheral vasoconstriction caused by the sympathetic nervous system. Static muscle contractions also compress blood vessels in the active muscles [2,3]. With large muscle mass exercise this causes diastolic pressure to rise. In severe forms of large muscle mass static exercise or during very heavy weight lifting, systolic arterial pressure can rise to values above 300 mmHg.

Like heart rate and blood pressure, ventilation increases instantaneously at the onset of exercise. During heavy dynamic exercise values in excess of 100 L/min can be seen, and in some elite athletes values

in excess of 150–200 L/min are common. With static exercise, the rise in ventilation is usually much less.

The autonomic nervous system also maintains metabolic homeostasis during exercise (especially prolonged dynamic exercise), when the metabolic rate can increase by 10-fold or more. This is accomplished by mobilizing fuel from the liver and fat cells via the sympathetic nerves and release of epinephrine and other hormones [4]. During prolonged dynamic exercise core temperature can rise several degrees and engage autonomic thermoregulatory responses that evoke sweating and can cause skin blood flow to rise from very low levels to as much as 5–7 L/min [2].

The main structures that regulate the cardiovascular and respiratory responses are in or near the nucleus of the solitary tract, and for metabolic and thermoregulatory control they reside in the hypothalamus [1–3,5]. These structures receive descending commands from CNS centers (especially the sub-thalamic locomotor center) that are involved in the planning and execution of the contractions.

### Lower Level Components

The cardiovascular and respiratory centers receive continuous input from afferents located throughout the body. The primary afferent information affecting cardiovascular function during exercise comes from arterial baroreceptors and chemoreceptors located in the aortic arch and carotid sinus, and carotid body along with group 3 and 4 afferents in the active skeletal muscles [1–3,6,7]. There are also thermal sensors located throughout the body (but most notably in the hypothalamus), and sensory neurons in the hypothalamus also monitor blood glucose [2,4].

### Higher Level Processes

In general, a signal proportional to the central motor command provides “feed-forward” information to the brainstem cardiovascular and respiratory centers (and probably the centers that govern metabolism and thermoregulation). This “central command” evokes the instantaneous increase in heart rate, blood pressure and ventilation seen at the onset of exercise [1,2]. It permits substantial physiological adjustments to be made before there are vast increases in muscle metabolism that might overwhelm traditional feedback regulatory mechanisms. Central command clearly causes:

- Vagal withdrawal from the heart and a rapid increase in heart rate
- An increase in renal sympathetic nerve activity
- An increase in ventilation prior to any changes in arterial blood gases that might be sensed by chemoreceptors
- A resetting of arterial baroreflexes so that blood pressure and heart rate can rise with exercise [7]

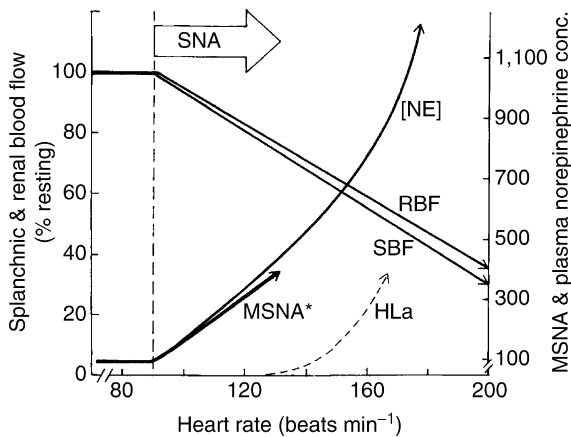

### Autonomic Function and Exercise.

**Figure 2** Schematic representation of how various indices of sympathetic outflow change with exercise intensity. Splanchnic and renal blood flow are 100% at rest and as exercise intensity increases vasoconstrictor outflow to these vascular beds can reduce blood flow to ~30% of resting values. The curvilinear line shows the rise in plasma norepinephrine, (NE) an index of whole body sympathetic activation. The rise NE does not start until exercise intensities become moderate. Muscle sympathetic nerve activity (MSNA) also rises during moderate and heavy exercise. Vasoconstriction in the visceral beds permits a higher fraction of the cardiac output to perfuse the contracting muscles. The rise in MSNA limits blood flow to inactive muscle and restrains metabolic vasodilation to maintain blood pressure. (Figure from [1].)

However, central command does not evoke “mass sympathetic” discharge to most organ systems, but provides discrete and targeted changes in autonomic outflow [Figure 2](#) [1–3,5].

### Lower Level Processes

Arterial baroreceptors respond to mechanical deformation in the aortic arch and carotid sinus. Increased deformation results in increased afferent firing and is related to changes in arterial pressure. Changes in arterial blood  $p\text{CO}_2$  and  $p\text{O}_2$  are sensed by the aortic and carotid chemoreceptors that are close to the baroreceptors. During mild and moderate dynamic exercise changes in any of the variables sensed by the arterial chemoreceptors are minimal, and it is unclear if these receptors are obligatory for the regulation of ventilation during exercise under most circumstances.

In skeletal muscle group III and IV afferents evoke cardiovascular and respiratory responses based on exercise-induced changes in the skeletal muscle, and thus provide the autonomic nervous system with information about the contracting skeletal muscle [1–3,5,6]. At rest the group III afferents are primarily mechanosensitive and the group IV afferents respond primarily to metabolic stimuli, especially acidosis. However, during exercise chemosensitive afferents can respond to mechanical stimuli and vice versa ([Fig. 3](#)).

As blood glucose declines, epinephrine is released from the adrenal medulla and (in conjunction with other hormonal adaptations) mobilizes glucose from liver glycogen and liberates free fatty acids from adipocytes

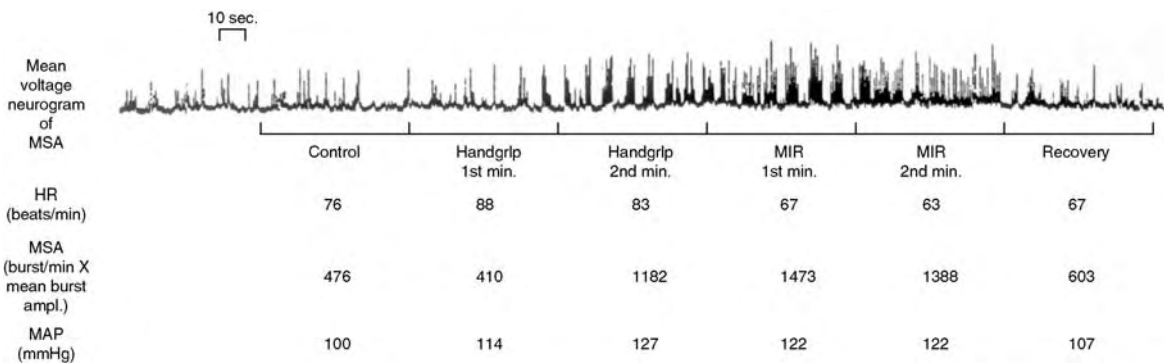

**Autonomic Function and Exercise. Figure 3** Change in Muscle Sympathetic Nerve Activity (MSNA) during a forceful handgrip lasting several minutes followed by muscle ischemia produced by inflation of an arm cuff to supersystolic levels. From rest to exercise there is a rapid rise in HR and blood pressure, however, MSNA does not rise for about a minute. Additionally, blood pressure and MSNA, but not heart rate, remains elevated during the muscle ischemic response (MIR). These data show that central command can cause HR and blood pressure to rise before MSNA is increased. During handgripping, the rise in MSNA is thought to occur when muscle acidosis acts locally to stimulate chemosensitive muscle afferents. This stimulation continues during the MIR when the acidotic metabolites are trapped in the previously active muscles. Experimental paradigms like this have been used to study the interplay between central command and feedback from muscle in regulating the autonomic responses to exercise. (Figure from [3].)

to support muscle metabolism during prolonged heavy dynamic exercise like marathon running.

Temperature sensitive neurons located in the preoptic/anterior hypothalamus monitor central temperature. This area also receives feedback from temperature sensitive afferents throughout the body. When core temperature falls there is an increase in vasoconstrictor activity to skin to conserve heat. When core temperature rises there is a withdrawal of vasoconstrictor activity, followed by activation of sympathetic cholinergic nerves to sweat glands and cutaneous blood vessels [2].

### Process Regulation

The current concept is that central command evokes changes in autonomic outflow that prepare the organism for exercise. However, the old idea of “mass sympathetic discharge” at the onset of exercise has been superseded. In this context, central command is thought to operate in two basic ways [1–3,6,7]. First, central command directly influences the cardiovascular and respiratory centers. Second, it is also thought to re-set feedback mechanisms so that the “operating point” and gain of the response facilitates the physiological

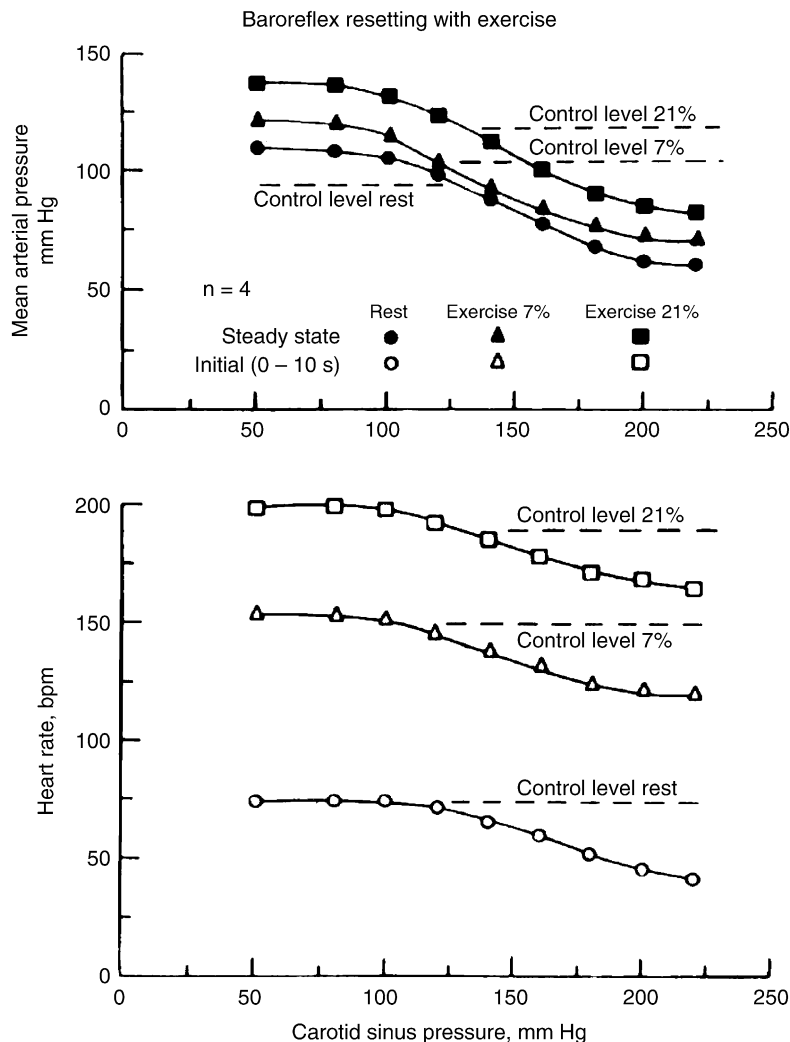

**Autonomic Function and Exercise. Figure 4** Effects of altering pressure in a surgically isolated carotid sinus preparation in a conscious dog during rest and several levels of exercise. This preparation permits manipulation of pressure in the carotid sinus and measurement of systemic responses. A rise in carotid sinus pressure will evoke a baroreflex mediated fall in systemic pressure and HR. By contrast, a fall in carotid sinus pressure will evoke a baroreflex mediated rise in systemic pressure and HR. During exercise, the ability of baroreflexes to regulate arterial pressure and heart rate are maintained, but their operating point is shifted upward so that a rise in BP and HR are permitted. Central command is thought to cause baroreceptor “resetting” in the brainstem cardiovascular centers. (Figure from [7].)

adjustments needed for exercise. For example, blood pressure and heart rate rise during exercise, but recent evidence suggests that baroreflexes operate normally but are re-set to defend a higher blood pressure during exercise [7] (Fig. 4).

The group III and IV afferents contribute to overall blood pressure and respiratory regulation by providing the brain with information about the metabolic and contractile state of the active muscles. When skeletal muscle becomes acidotic, Group IV afferents can evoke a robust pressor (and modest ventilatory) response and signal a “mismatch” between blood flow and

metabolism so that blood pressure rises to increase blood flow to the active skeletal muscles [1–3,5,6].

Normally, when core temperature increases by 0.5–1°C there is withdrawal of vasoconstrictor tone to the skin, and then activation of sudomotor (and vasodilator) nerves to the skin. The sudomotor nerves evoke sweating which increases evaporative heat loss and cools the skin. At about the same time there is marked neurally-mediated cutaneous vasodilation which transports heat from the core to the periphery. With exercise, the threshold for sweating and cutaneous dilation is shifted to a higher temperature [1].

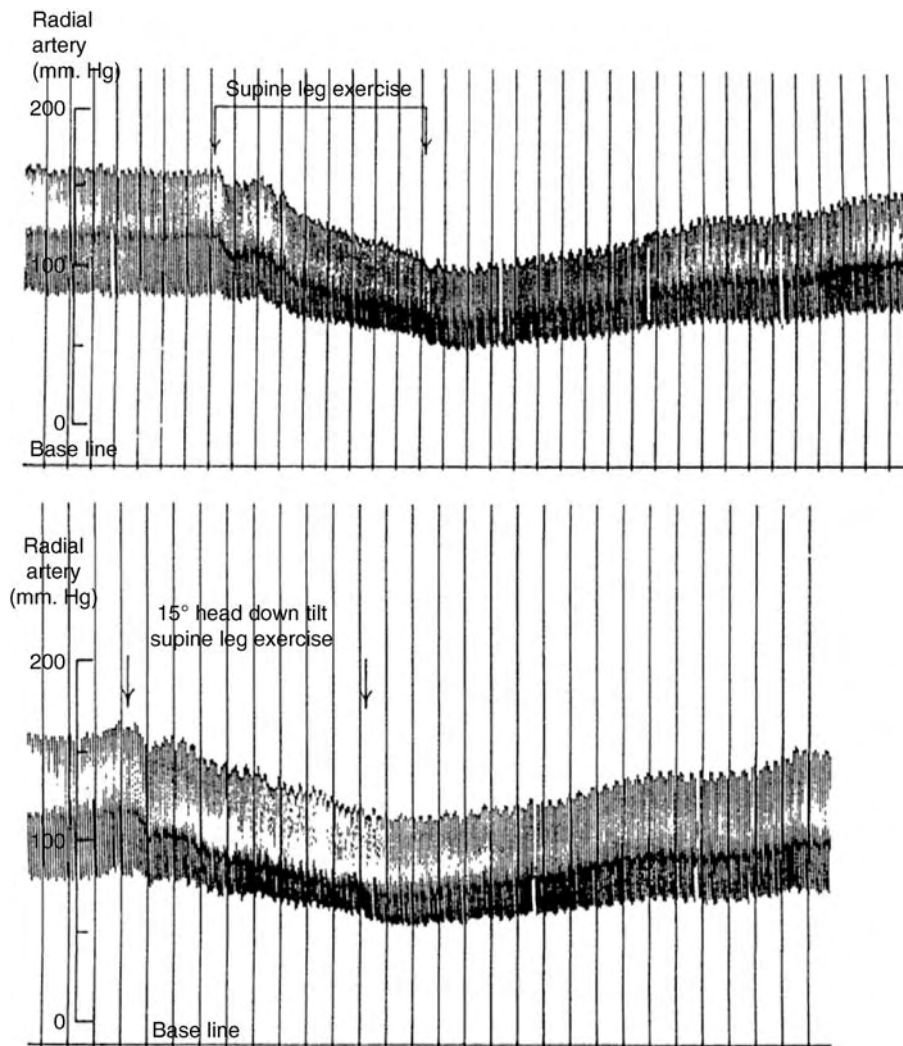

**Autonomic Function and Exercise. Figure 5** Total failure of arterial pressure regulation during exercise in a patient with autonomic failure. This patient had undergone extensive surgical sympathectomies for malignant hypertension before antihypertensive drugs were available. In the upper panel blood pressure falls as soon as supine exercise starts and continues to fall as it continues. A second trial of exercise was then attempted with a 15° head down tilt to augment venous return. However, blood pressure also fell during this trial. This demonstrates the essential role of the sympathetic nervous system in redistributing cardiac output and restraining vasodilation in the active muscles to regulate blood pressure during exercise. (Figure from [9].)

With the onset of exercise there is an increase in sympathetic outflow to visceral organs to mobilize glucose from the liver and suppress the release of insulin [4]. Additionally, with heavy, large-muscle-mass exercise, epinephrine is released from the adrenal medulla and also contributes to these and related responses. During prolonged, moderate exercise, these responses are more modest, and are important after one or two hours of exercise when glucose homeostasis is threatened by depletion of liver and intramuscular glycogen.

### Function

The overall function of the autonomic nervous system during exercise is to maintain whole body homeostasis in the face of potentially huge increases in skeletal muscle metabolism. With static exercise fuel for skeletal muscle and temperature regulation are not major problems, and the respiratory consequences are generally not limiting. The main problem is that high skeletal muscle forces compress blood vessels to the active muscles and contribute to skeletal muscle acidosis. A combination of relative or absolute skeletal muscle underperfusion and high levels of metabolic demand lead to autonomic responses designed to increase arterial blood pressure, and hence blood flow to the active muscles.

With large muscle mass dynamic exercise, skeletal muscle metabolic activity can increase to 10-fold in untrained healthy subjects and up to 20-fold in trained athletes. The first physiological “problem” is that there is a marked (up to 50- to 100-fold) vasodilation in the active skeletal muscles and without vasoconstriction of visceral organs, increases in heart rate, and some sympathetic restraint of metabolic vasodilation in the active skeletal muscles blood pressure will fall [1,2,8]. Additionally, if there is not a prompt and adequate increase in minute ventilation, potentially lethal changes in blood gases might occur. So, the increase in minute ventilation (probably evoked largely by central command) is essential to avoid exercise-induced asphyxia. A third main problem posed by dynamic exercise to homeostasis is thermoregulation.

However, when a large increase in skin blood flow is superimposed on the rise in skeletal muscle blood flow with exercise the vasodilation can threaten arterial pressure regulation [2].

### Pathology

There are many pathophysiological conditions associated with the autonomic nervous system that influence the physiological adjustments to exercise. Figure 5 shows the fall in blood pressure seen in patients with autonomic failure [9]. In these patients the sympathetic nerves do not restrain blood flow to the active muscles and visceral organs and exercise tolerance is severely limited. By contrast, in congestive heart failure, there

is augmented sympathetic outflow to muscle at rest and during exercise, contributing to skeletal muscle underperfusion and limiting exercise tolerance.

### Therapy

Endurance exercise is a common and effective therapy for a variety of “lifestyle” related diseases including: hypertension, diabetes, dyslipidemia, obesity, and rehabilitation from heart attack. Exercise is also a key anti-aging strategy. While there are many beneficial effects of regular exercise, at least some are likely to relate to improved autonomic control of heart rate and blood pressure.

### References

1. Rowell LB, O’Leary DS (1990) Reflex control of the circulation during exercise: chemoreflexes and mechanoreflexes. *J Appl Physiol* 69:407–418
2. Rowell LB, O’Leary DS, Kellogg DLJ (1996) Integration of cardiovascular control systems in dynamic exercise. In: Rowell LB, Shepherd JT (eds) *Handbook of physiology*, sect. 12, exercise: regulation and integration of multiple systems. Oxford University Press, New York, pp 772–783
3. Mark AL, Victor RG, Nerhed C, Wallin BG (1985) Microneurographic studies of the mechanisms of sympathetic nerve responses to static exercise in humans. *Circ Res* 57:461–469
4. Richter EA (1996) Glucose utilization. In: Rowell LB, Shepherd JT (eds) *Handbook of physiology*, sect. 12, exercise: regulation and integration of multiple systems. Oxford University Press, New York, pp 912–951
5. Mitchell JH, Victor RG (1996) Neural control of the cardiovascular system: insights from muscle sympathetic nerve recordings in humans. *Med Sci Sports Exerc* 28: S60–S69
6. McCloskey DI, Mitchell JH (1972) Reflex cardiovascular and respiratory responses originating in exercising muscle. *J Physiol* 224:173–186
7. Melcher A, Donald DE (1981) Maintained ability of carotid baroreflex to regulate arterial pressure during exercise. *Am J Physiol* 241:H838–H849
8. Joyner MJ, Proctor DN (1999) Muscle blood flow during exercise: the limits of reductionism. *Med Sci Sports Exerc* 31:1036–1040
9. Marshall RJ, Schirger A, Shepherd JT (1961) Blood pressure during supine exercise in idiopathic orthostatic hypotension. *Circulation* 24:76–81

---

## Autonomic Function in Space

TADAOKI MANO

Gifu University of Medical Science, Seki, Gifu, Japan

### Synonyms

Neurovegetative function in outer space; Sympathetic and parasympathetic nerve activity in microgravity

## Definition

Autonomic function, also called neurovegetative function, is essentially important to regulate vital functions in humans and animals. This function is mainly dependent on the autonomic nervous system being composed of the sympathetic and parasympathetic nervous system. The autonomic nervous system regulates different kinds of vital organs and organ systems in the living body, including heart, blood vessels, sweat glands, adrenal gland and other hormone secretory organs, gastrointestinal tract, genitourinary organs, etc., by automatically and involuntarily using complex central commands and reflex mechanisms. This system plays indispensable roles in maintaining the homeostasis of blood pressure, blood glucose level, body temperature, and body fluid volume. Some of the autonomic functions are important for the maintenance of homeostasis of blood pressure and body fluid volume against terrestrial gravity. Gravity-dependent autonomic function should be altered in **▶microgravity** in space to adapt to this unusual condition. Autonomic function in space has been studied in Skylab, Spacelab, and more recently in **▶Neurolab**, using the space shuttle Columbia launched by NASA in USA [1–3], as well as in the Russian space station Mir [4]. This function is going to be investigated in the International Space Station, and also in interplanetary flights, for example to Mars, in the future. The same function has also been studied using various ground-based simulations of microgravity including **▶parabolic flight** [5], lower body positive pressure [6], head-out water immersion [7], dry immersion [8] and head-down bed rest [9].

## Characteristics

### Quantitative Description

Autonomic function has been evaluated in the living body using several different methods. Indirect and direct methods have been used for the quantitative evaluation of autonomic function. One of the indirect methods is to determine the plasma level of noradrenaline that is secreted at **▶sympathetic nerve** terminals. The plasma level of noradrenaline has been used as a good index of overall sympathetic nerve activity. More recently, noradrenaline spillover measurement became available to assess sympathetic nerve function in the organ levels. Another method often used is power spectral analysis of heart rate and blood pressure variabilities. Heart rate and blood pressure are modulated depending on sympathetic and parasympathetic neural regulation. Power spectral analysis of the heart rate reveals low (around 0.1 Hz) and high frequency (around 0.25 Hz) peaks. High frequency peaks in the power spectrum of heart rate variations is dependent on respiration and is considered to represent cardiac parasympathetic (vagal) nerve activity. The value of

high frequency power divided by low frequency power is considered to represent cardiac sympathetic nerve activity; however, the assessment of this value is still under discussion. On the other hand, low frequency peaks in the power spectrum of blood pressure is related to so-called Mayer rhythm, and is considered to represent vasomotor sympathetic nerve activity. Based on these power spectral analyses of heart rate and blood pressure, quantitative analysis of autonomic functions has been possible in human subjects. In animals, direct recordings of sympathetic and **▶parasympathetic nerve** activity allows us a more precise and quantitative evaluation of autonomic function. Direct measurement of sympathetic nerve activity has also become possible in humans using a technique called **▶microneurography**. Microneurography has enabled us to record sympathetic nerve activity leading to muscle (**▶muscle sympathetic nerve activity**; MSNA) and skin (skin sympathetic nerve activity; SSNA) from human peripheral nerves. Unfortunately, direct evaluation of parasympathetic nerve activity is not yet possible in humans, Autonomic function in space has been analyzed in humans using these different methods including measurement of the plasma level of noradrenaline, noradrenaline spillover measurement, power spectral analysis of heart rate and blood pressure, as well as microneurography.

### Higher Level Structures

The autonomic nervous system is composed of higher and lower level structures. Higher level structures include cerebral cortex, hypothalamus and brainstem. Hypothalamus plays a particularly important role in central control of autonomic function. Functions of these higher structures have been studied on earth, but poorly in space. These problems are expected to be resolved by future research under microgravity conditions in space.

### Lower Level Components

Lower level components of the autonomic nervous system include spinal cord, peripheral nerve, **▶peripheral receptors** and target effector organs. The descending commands from upper structures descend through brainstem and spinal cord to control target effector organs through peripheral sympathetic nerve with adrenergic  $\alpha$  and  $\beta$  receptors, as well as parasympathetic nerves with cholinergic receptors. Peripheral **▶target organs**, also called effector organs, include pupils, heart, blood vessels, sweat glands, hormone secretory glands, gastrointestinal tracts, and genitourinary organs, etc., and react to efferent neural signals through peripheral receptors to maintain functional homeostasis against changes in environmental condition. Changes in efferent neural signals in peripheral sympathetic nerve leading to skeletal muscle (muscle sympathetic

nerve activity; MSNA) in humans have been studied using microneurography in ►simulated microgravity on the ground and also in space. MSNA was suppressed during exposure to short-term simulation of microgravity (parabolic flight [5], lower body positive pressure [6], and head-out water immersion [7]), but was enhanced after exposure to long-term simulation of microgravity (dry immersion [8], ►head-down bed rest [9]) and also after spaceflight of 17 days [1]. A lack of enhanced MSNA response after head-down bed rest of two weeks induced orthostatic hypotension.

### Structural Regulation

Structural regulation of the autonomic nervous system depends not only on descending commands from central structures, but also on different kinds of autonomic reflexes being composed of peripheral afferent (vagal and somatosensory) and efferent (sympathetic and parasympathetic) nerves, as well as reflex centers in spinal cord, brainstem and/or cerebral cortex. Autonomic reflexes play essential roles in maintaining homeostasis in the living body against changes in environmental conditions, including gravitational stress. For example, ►baroreflex is essentially important to maintain blood pressure homeostasis against terrestrial gravity. Changes in baroreflex and its components were studied in rats after exposure to spaceflight (Neurolab). The baroreflex sensitivity became lower with fewer unmyelinated nerve fibers, lower contraction ability and tension of the aorta, and a reduced number of smooth muscle cells in the aorta compared to preflight controls [3].

### Function

The function of the autonomic nervous system is highly complicated. Some of the autonomic functions are gravity-dependent. Gravity-dependent functions are more influenced by changes in gravitational loading and unloading. Some functional changes of the autonomic nervous system in space are comparable to age-related changes in autonomic function. For example, increases in basal MSNA after exposure to simulated (head-down bed rest) and real microgravity in space is similar to age-related changes in MSNA [10]. The MSNA increase induced by exposure to microgravity and aging may be related to similar compensatory mechanisms for changes in fluid volume, baroreflex, blood vessel and/or its receptors.

### Pathology

Different kinds of autonomic dysfunction occur in space. The autonomic disorder that appears at the early phase of spaceflight is ►space motion sickness. This disorder resembles motion sickness on earth, with symptoms such as nausea, vomiting, loss of appetite, vertiginous sensation, head heaviness, etc. Space motion sickness

is caused by abnormal vestibulo-autonomic reflex related to brainward fluid shift and/or mismatching among sensations of different modalities, i.e., visual, vestibular and somatosensory information. Another important autonomic disorder is cardiovascular deconditioning in space. This deconditioning is induced by many factors including ►headward fluid shift, loss of blood volume, changes in baroreflex, changes in blood vessels and its receptor, loss of muscle pumping due to leg muscle atrophy and so on. Cardiovascular deconditioning is a kind of adapted condition to microgravity. The problem occurs when astronauts return to the earth. They often experience ►orthostatic intolerance with hypotension when standing. Orthostatic hypotension is one of important post-spaceflight dysfunctions in the human body that maintains upright posture against terrestrial gravity. The cause of post-flight orthostatic intolerance has been discussed and several hypotheses have been proposed; (i) reduced circulatory plasma volume due to fluid shift, (ii) reduced vascular responsiveness to sympathetic stimulation, (iii) cardiac hypofunction, and (iv) altered baroreflex and cardiopulmonary reflex.

### Therapy

For the therapy of space motion sickness, drugs used for motion sickness on earth such as antihistamine can be administered. Biofeedback treatment is also applicable for this disorder. To prevent post-spaceflight orthostatic intolerance, in-flight exercise and lower body negative pressure loading have been recommended. Water and salt intake before landing is also effective to prevent orthostatic intolerance. Artificial gravity applying short radius centrifuge is being developed to prevent orthostatic intolerance after long-term spaceflight. As medical therapy, a selective  $\alpha$ -adrenoreceptor agonist midodrine hydrochloride and a peripheral noradrenaline competitor amezinium metilsulfate can be used for the treatment of orthostatic hypotension.

### References

1. Levine BD, Pawelczyk JA, Ertl AC, Cox JF, Zuckerman JH, Dietrich A, Biaggioni J, Ray CA, Smith MI, Iwase S, Saito M, Sugiyama Y, Mano T, Zhang R, Iwasaki K, Lane LD, Buckley JC, Cook WH, Baisch FJ, Robertson D, Eckberg DL, Blomqvist CG (2002) Muscle sympathetic neural and haemodynamic responses to tilt following spaceflight. *J Physiol* 538:331–340
2. Cox JF, Tahvanainen KUO, Kuusela TA, Levine BD, Cook WH, Mano T, Iwase S, Saito M, Sugiyama Y, Ertl AC, Biaggioni I, Dietrich A, Robertson MR, Zuckerman JH, Lane LD, Ray DA, White RJ, Pawelczyk JA, Buckley JC, Baisch FJ, Blomqvist CG, Robertson D, Eckberg DL (2002) Influence of microgravity on sympathetic and vagal responses to Valsalva's manoeuvre. *J Physiol* 538:309–320



3. Shimizu T, Yamasaki M, Waki H, Katsuda S, Oishi H, Katahira K, Nagayama T, Miyake M, Miyamoto Y (2002) Development of the aortic baroreflex in microgravity. In: Buckley JC, Homick JL (eds) *The Neurolab Spacelab mission: neuroscience research in space*. Lyndon B Johnson Space Center, Houston, TX, NASA SP-2003-535, pp 151–159
4. Cooke WH, Ames JEIV, Crossman AA, Cox JF, Kuusela TA, Tavanainen KUO, Moon LB, Drescher J, Baisch FI, Mano T, Levine BD, Blomqvist GC, Eckberg DL (2000) Nine months in space: effects on human autonomic cardiovascular regulation. *J Appl Physiol* 89:1039–1045
5. Iwase S, Mano T, Cui J, Kitazawa H, Kamiya A, Miyazaki S, Sugiyama Y, Mukai C, Nagaoka S (1999) Sympathetic outflow in humans during short period of microgravity produced by parabolic flight. *Am J Physiol* 46:R419–R426
6. Fu Q, Iwase S, Niimi Y, Kamiya A, Kawanokuchi J, Cui J, Mano T, Suzumura A (2001) Effects of lower body positive pressure on muscle sympathetic nerve activity response to head-up tilt. *Am J Physiol* 281: R1134–R1139
7. Miwa C, Mano T, Saito M, Iwase S, Matsukawa T, Sugiyama Y, Koga K (1996) Aging reduces sympatho-suppressive response to head-out water immersion in humans. *Acta Physiol Scand* 58:15–20
8. Iwase S, Sugiyama Y, Miwa C, Kamiya A, Mano T, Ohira Y, Shenkman B, Egorov A, Kozlovskaya IB (2000) Effects of three days of dry immersion on muscle sympathetic nerve activity and arterial blood pressure in humans. *J Auton Nerv Syst* 9:156–164
9. Kamiya A, Iwase S, Kitazawa H, Mano T, Vinogradova OL, Kharchenko IB (2000) Baroreflex control of muscle sympathetic nerve activity after 120 days of 6 head-down bed rest. *Am J Physiol* 278:R445–R452
10. Iwase S, Mano T, Watanabe T, Saito M, Kobayashi F (1991) Age-related changes of sympathetic outflow to muscles in humans. *J Gerontol Med Sci* 46:M1–M5

## Autonomic Ganglia

ELSPETH MCLACHLAN  
Prince of Wales Medical Research Institute and the  
University of New South Wales, Randwick, NSW,  
Australia

### Synonyms

Sympathetic ganglia; parasympathetic ganglia

### Definition

Signals from the CNS to all peripheral tissues except skeletal muscle are transmitted, and in some cases modulated, within autonomic ganglia. Autonomic ganglia are aggregations of neurones that lie along peripheral

nerve trunks where synapses are made by the axons of preganglionic neurones projecting from the brainstem and spinal cord.

## Characteristics

### General Description

The autonomic (Cross Ref) and somatomotor (Cross Ref) systems differ in that there is at least one autonomic synapse between the outflow from the central nervous system and the target organ. These synapses occur in swellings (“ganglia”) along peripheral nerve trunks where the cell bodies of autonomic neurones aggregate during development. The ganglia differ somewhat between the divisions of the autonomic nervous system. These divisions were defined by John Langley at the end of the nineteenth century, primarily on anatomical grounds. Sympathetic preganglionic neurones lie in the intermediate zone of the thoracic and upper lumbar spinal cord, whereas ►**parasympathetic** preganglionic neurones lie in the cranial nerve nuclei and in the intermediate zone of the sacral spinal cord. ►**Ganglia** of the ►**enteric nervous system** are located within nerve plexuses in the gastrointestinal tract (cross ref to Enteric NS): the effects of the central nervous system on the gut are mediated via axons of sympathetic and parasympathetic origin, i.e., the enteric nervous system is a target of the other divisions.

Sympathetic and parasympathetic ganglia are mainly located separately. Preganglionic neurones project their axons in a segmental ventral root or in a cranial nerve to reach their target ganglia. Neurones within the ganglia (“ganglion cells,” “postganglionic neurones”) have axons projecting to specific functional targets, largely without any somatotopic organization. In a few cases, as in the pelvic ganglion of the male rat [1], sympathetic and parasympathetic ganglion cells intermingle in a single ganglion. The postganglionic axons project to their target organs in the peripheral nerve trunks.

Autonomic and sensory ganglia have a common origin in the neural crest, and share dependence on nerve growth factor(s) for survival during development and for maintenance in the adult [2]. Axotomy without regeneration leads to significant loss of both sympathetic and small sensory neurones. (Cross Ref to Neurotrophins and Degeneration/regeneration) The capillaries of these ganglia lack a significant barrier from the blood so that circulating hormones and toxins have ready access to modify neurones and synaptic behavior.

### Quantitative Description

The innervation of all peripheral tissues except skeletal muscle fibers is provided by autonomic pathways. There are many hundreds of thousands of autonomic neurones located in peripheral ganglia, which amplify spatially the signals emanating from the central nervous

system and, in some cases, modify the signals via feedback from the target tissue. Many of the properties of ganglia have been summarized previously [3] and only newer information is referenced here.

### Higher Level Structures

Sympathetic paravertebral chain, sympathetic prevertebral ganglia, parasympathetic ganglia.

### Lower Level components

#### Functional Anatomy of Autonomic Pathways

Sympathetic ganglia are organized in two ways:

1. Bilateral paravertebral “chains” dorsal to the aorta extend to the base of the skull rostrally (to the superior cervical ganglion, SCG) and to the fused coccygeal ganglia (the ganglion impar) caudally. The segmental ganglia form beaded structures on either side that are more or less separate but often fuse at lumbar and sacral levels. Adjacent segmental ganglia may be fused (e.g., SCGs represent all cervical segments). Paravertebral ganglia are primarily involved with the innervation of blood vessels, sweat glands and erector pili in the trunk and limbs.

The neurones in each segmental ganglion project their axons to peripheral nerves via a grey ramus (reflecting the lack of myelination of postganglionic axons) or to the viscera via the splanchnic nerves. Each segmental ganglion between T1 and the most caudal sympathetic output for that species receives preganglionic axons via a white ramus (most preganglionic

axons are myelinated). The preganglionic axons branch rostrally and/or caudally along the chain at thoracolumbar levels, so that each preganglionic axon forms synapses in several adjacent chain ganglia (Fig. 1), whereas cervical and lumbar chain ganglia receive axons arising from the rostral and caudal ends of the spinal outflow, respectively.

2. The preganglionic axons to the abdominal viscera cross the paravertebral chain in the splanchnic nerves which project to the prevertebral ganglia (e.g., coeliac-superior mesenteric and hypogastric ganglia). Postganglionic axons from these large ganglia project along the visceral nerves to the gastrointestinal tract and other viscera.

Paravertebral ganglia contain only preganglionic terminals, postganglionic neurones and associated supporting glia, with occasional “paraganglion cells” (small intensely fluorescent (SIF) cells) which have no axon but may release catecholamines into the vasculature. In contrast, prevertebral ganglia also contain the terminals of axons from enteric afferent neurons. Together with collateral branches of peptidergic primary afferent axons, these inputs excite ganglion cells involved with the inhibition of motility and secretion (Fig. 2, [4]). Finally, the sympathetic innervation of the enteric nervous system involves presynaptic modulation of enteric synapses rather than direct synapses on enteric neurones.

The *parasympathetic* ganglia project largely to cranial and visceral organs (not the limbs) and are less

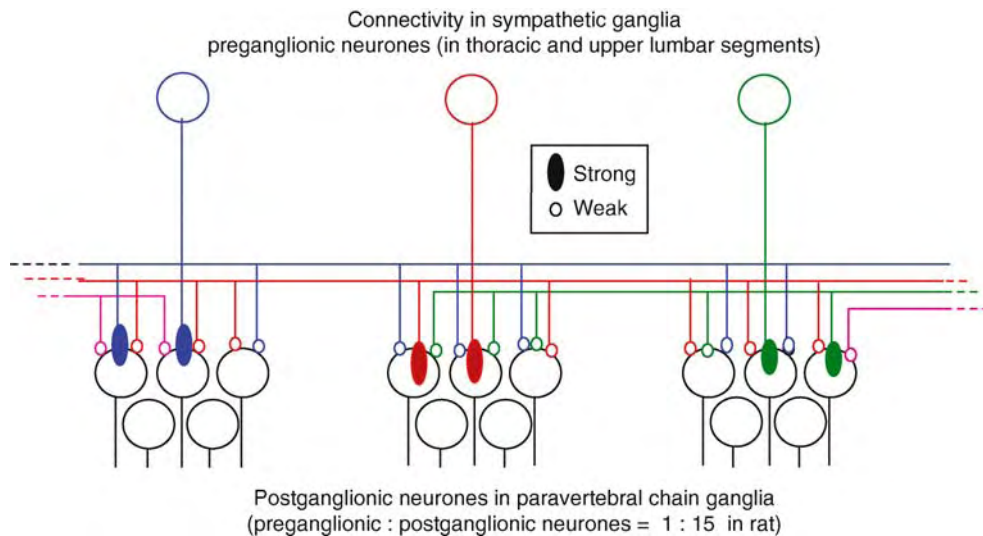

**Autonomic Ganglia. Figure 1** Connectivity in sympathetic ganglia of the thoracic paravertebral chain. Preganglionic axons arising in each spinal segment pass into the chain where they form synapses with postganglionic neurones. Synapses are either suprathreshold (“strong”) or subthreshold (“weak”). Preganglionic axons tend to form strong synapses in the corresponding segmental ganglion. They send collateral branches to adjacent segmental ganglia where they generally form weak synapses. The weak synapses hardly ever contribute to the postganglionic discharge, but they can grow and take over the connection if the strong axon disappears (after e.g., injury to the spinal cord).

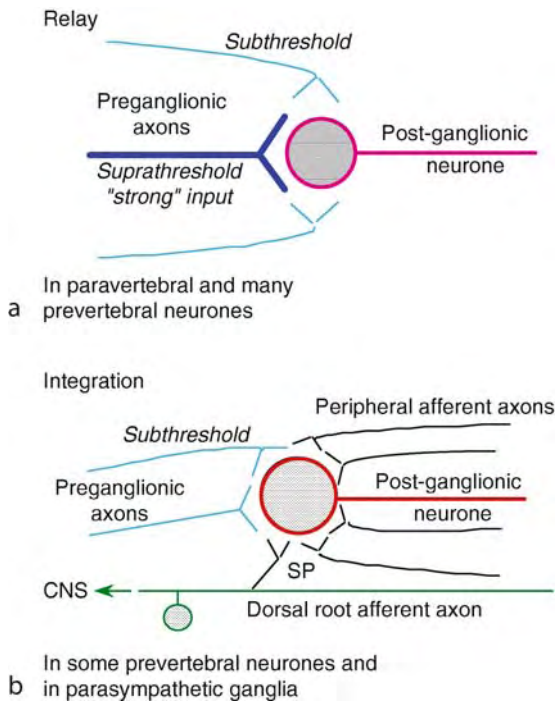

**Autonomic Ganglia. Figure 2** Function of synaptic transmission in ganglia. Transmission is by one of two mechanisms: (a) In most sympathetic ganglia, only one (occasionally two) of many preganglionic inputs activate the postganglionic cell, acting to relay precisely the CNS command via a suprathreshold cholinergic input. (b) In some prevertebral neurones and in parasympathetic ganglia, the postganglionic neurone integrates subthreshold information from many cholinergic inputs that arise both centrally and peripherally. Peptides such as Substance P (SP) released from collaterals of primary afferents act to potentiate the effects of the cholinergic inputs from other pathways by decreasing the conductance of the postganglionic cell.

organized. They resemble enteric ganglia in consisting of small clusters of neurones adhering to or lying within the walls of the viscera, e.g., salivary gland, heart, pancreas, bladder. Most of these ganglia contain sensory somata and interneurons as well as the postganglionic neurones that project to the target tissue. Thus, they have all the necessary components for reflex activity, although the precise function of the reflexes is largely unknown. The signals in parasympathetic pathways are more likely to be modified before they reach their targets than those in the sympathetic paravertebral chain (Fig. 2). Finally, parasympathetic neurones supplying the gastrointestinal tract directly innervate enteric neurones.

**Structure of Autonomic Ganglion Cells and their Synapses** Sympathetic neurones have large somata ( $\sim 20\text{--}50\ \mu\text{m}$  in diameter) and 0 to  $>20$  dendrites that are relatively

thin and sometimes varicose. The dendrites extend up to  $500\ \mu\text{m}$  from the soma (Fig. 3). The number of dendrites is proportional to the number of inputs that the neurone receives. Synaptic contacts ( $<1\ \mu\text{m}^2$ ) are made randomly by the varicosities of input neurones at a low density ( $<1/100\ \mu\text{m}^2$ ) over the soma, and dendrites and adjacent synapses can arise from distinct inputs [5]. About 50% of varicosities do not contact a ganglion cell, even with an intervening glial process. The number of synaptic contacts on a single guinea pig sympathetic paravertebral ganglion cell with  $\sim 10$  dendrites is  $\sim 100$ . In contrast, parasympathetic neurones are usually monopolar and tend to be small with synapses that arise from one preganglionic axon, sometimes together with other peripheral inputs.

### Higher Level Processes

#### Connectivity

In both autonomic divisions, each preganglionic axon innervates a number of ganglion cells (divergence), while most ganglion cells receive synaptic inputs from multiple preganglionic axons (convergence).

1. *Divergence* is probably more important, at least in paravertebral ganglia, as only one (rarely two) of the several inputs is involved in discharging the postganglionic neurone. This “strong” input has a large safety factor for transmission, like the skeletal neuromuscular junction. The remaining inputs rarely summate due to the low firing frequencies of individual preganglionic axon. Thus, activity in each sympathetic preganglionic neurone discharges many postganglionic neurones (up to  $>200$  or more in humans), amplifying the signal spatially and distributing it widely to the multiple innervated target tissues. Divergence is much less in parasympathetic ganglia ( $1: <10$ ).

2. *Convergence* is essential for ganglion cells that integrate information from sensory and interneurons with preganglionic signals within sympathetic prevertebral and parasympathetic ganglia. The synaptic events must summate before these neurones discharge.

### Lower Level Processes

#### Synaptic Transmission

Transmission in autonomic ganglia occurs via the ►quantal release of ►acetylcholine (ACh) from the preganglionic axons. These interact with nicotinic receptor channels (nAChR) composed of five subunits ( $\alpha 3, \alpha 5, \alpha 7, \beta 2, \beta 4$  in different combinations), as at the skeletal neuromuscular junction. The  $\alpha 3/\beta 4$  heteromultimer is the main ganglionic nAChR, and various specific drugs antagonize the synaptic channels by both competitive and open-channel block. Single quanta produce  $\sim 0.1\ \text{nA}$  peak inward postsynaptic current, whereas the strong input generates a synaptic current of 1 to  $>10\ \text{nA}$ , reflecting the action of between

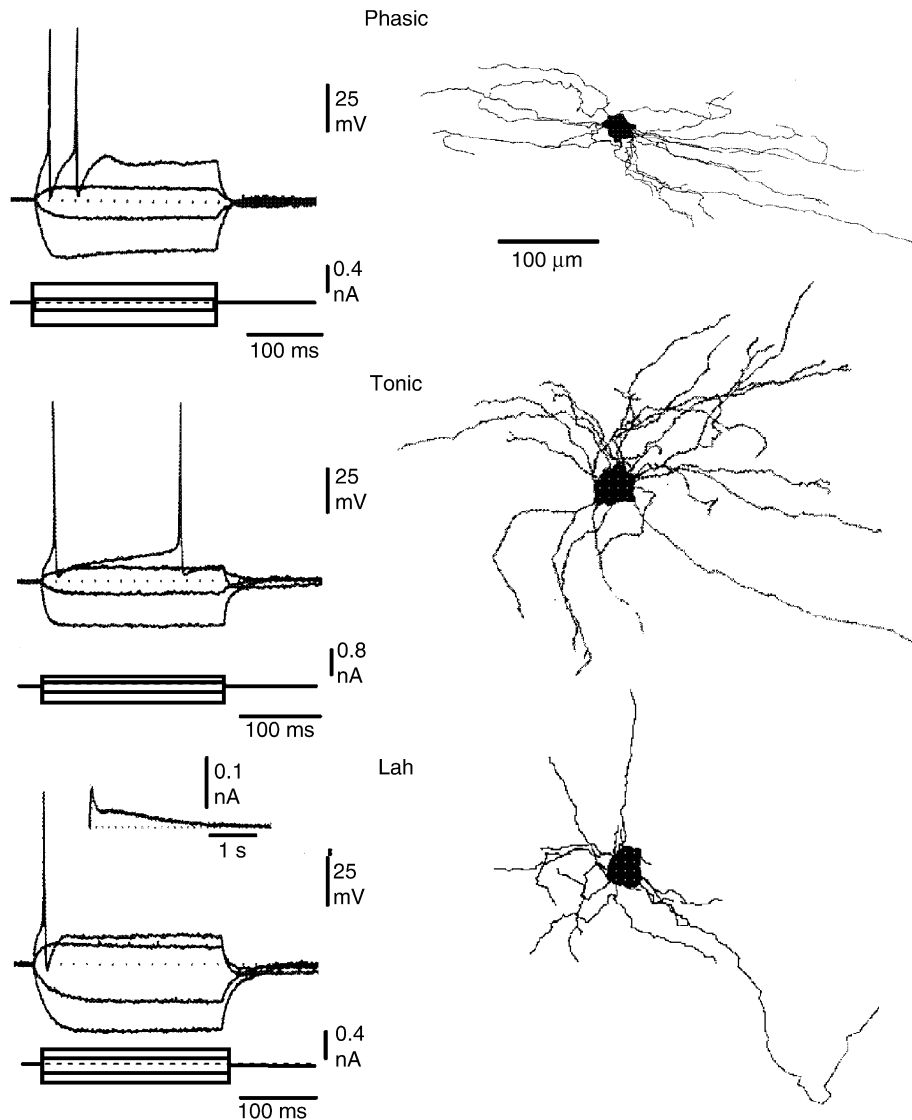

**Autonomic Ganglia. Figure 3** Three major classes of sympathetic ganglion cell can be distinguished in guinea pig ganglia by their discharge pattern when depolarized just above suprathreshold and by their distinctive morphology. The discharge depends primarily on the predominant expression and voltage-dependence of M-type K<sup>+</sup> channels (phasic neurones), A-type K<sup>+</sup> channels (tonic neurones) and a slow Ca-activated K<sup>+</sup> conductance (LAH or long-after hyperpolarizing neurones; the conductance takes the time course of the current shown in the inset). The neurones shown are examples close to the average morphologies in terms of soma size, numbers and length of dendrites. Modified from Boyd et al., *Journal of Comparative Neurology* 369:372–387 (1996).

10 and >100 quanta. As this is similar to the number of synaptic contacts, it is likely that each contact releases at most one quantum and that there is a high probability of release. Subthreshold “weak” inputs release only a few quanta, although these also arise with a relatively high probability (>0.5), presumably from a limited number of varicosities. The synaptic current decay reflects average channel lifetimes of ~5 ms and ~25 ms, arising from the average duration of bursts of openings of two groups of nAChR channels.

The subtypes of voltage-dependent Ca<sup>2+</sup> channel that are involved in ACh release from preganglionic terminals vary between species, but are usually multiple. They also vary between inputs to the same neurone. For example, in the guinea pig, ~40% of transmitters released from a strong preganglionic input results from Ca<sup>2+</sup> influx through N-type channels, while the rest involves another channel (R-type, resistant to blockade by known antagonists). However, weak inputs to the same cell utilize N-type (35%), R-type (25%) and P-type (40%) channels

[6]. Sympathetic and parasympathetic inputs impinge on some guinea-pig pelvic neurones, but only the parasympathetic pathway is sensitive to N-type antagonists [7]. Across all ganglia, a major part of ganglionic transmission is resistant to selective  $\text{Ca}^{2+}$  channel antagonists.

The postsynaptic nAChR channels permit the entry of both  $\text{Na}^+$  and  $\text{Ca}^{2+}$  ions, depolarizing the neurone to a threshold within a few ms. In the case of strong synapses, this leads to a postganglionic action potential. The weak post-synaptic potential lasts 30–100 ms because of the large input time constant of the ganglion cells (20–80 ms). Although this should assist the temporal summation of weak inputs, this rarely occurs as individual preganglionic axons discharge at <1.5 Hz. Even though axons in e.g., vasoconstrictor pathways fire with cardiac and respiratory rhythms, the low average frequency means that they rarely fire in consecutive cycles, so that the opportunity for summation is limited. Thus, the strong inputs dominate in firing the postganglionic cell, and the ganglia simply relay signals without modification in e.g., vasoconstrictor, pilomotor and sudomotor pathways but not in prevertebral ganglia (*see below*).

Evidence that synapses formed between cultured sympathetic neurones use adenosine 5'-triphosphate (ATP) has led to the idea that ATP contributes to synaptic transmission in normal autonomic ganglia. However, the evidence is against this at normal connections between preganglionic and postganglionic neurones [8], although it appears to be true for a subset of synapses in the enteric nervous system.

In addition to the preganglionic inputs, the synapses formed by peripheral afferent terminals in sympathetic prevertebral and parasympathetic ganglia are also ►cholinergic and utilize nAChRs, but these synapses release only a few quanta with a very low probability. Thus, individual axons release intermittently during repetitive stimulation, possibly due to a limited expression of synaptic proteins [9]. However, a barrage of weak synaptic potentials is generated during gut distension. At the same time, peptidergic primary afferents release Substance P within the ganglion. The activation of a variant NK-1 receptor on some ganglion cells decreases  $\text{K}^+$  conductance, depolarizing the membrane, enhancing the concurrent weak synaptic potentials and triggering action potentials. This integrative function of ganglia occurs only in the extrinsic control of visceral motility and secretion.

### Neuronal Excitability and the AHP

The postganglionic action potential is readily blocked by tetrodotoxin leaving a residual inward  $\text{Ca}^{2+}$  current.  $\text{Ca}^{2+}$  entry during the action potential produces an afterhyperpolarization (AHP) lasting several hundred ms, which may be enhanced by  $\text{Ca}^{2+}$  entry through nAChRs. The source of  $\text{Ca}^{2+}$  to activate the underlying

$\text{K}^+$  channels appears very localized.  $\text{Ca}^{2+}$  entry through L-type channels activates Ca-dependent ►BK channels to determine the early peak of the AHP, while  $\text{Ca}^{2+}$  entry through N-type channels activates ►SK channels that underlie the prolonged phase [10]. A small proportion of neurones also have a very slow Ca-dependent  $\text{K}^+$  conductance dependent on Ca-induced  $\text{Ca}^{2+}$  release. The long AHP limits the ability of the postganglionic neurone to fire at high frequency and may block inputs that are just suprathreshold at resting potential.

### Phenotypes of Autonomic Neurone

Sympathetic ganglion cells have been differentiated on the basis of their discharge pattern (phasic or tonic or with a long AHP), their expression of neuropeptides and of  $\text{K}^+$ ,  $\text{Na}^+$  and  $\text{Ca}^{2+}$  channels and their morphology (Fig. 3).

Different sympathetic phenotypes have distinct distributions between ganglia and targets and have been identified in several species. Similarly, postganglionic neurones in parasympathetic ganglia can be distinguished from their companion neurones. The full range of this diversity has yet to be described, but clearly reflects the expression of distinct functional autonomic phenotypes.

### Function

Autonomic ganglia contain cholinergic synapses that either relay the central (preganglionic) signal directly to the target organ or, in other pathways, integrate central and peripheral inputs to provide control of visceral targets. The characteristics of synaptic transmission have been well defined, showing species, strain and pathway diversity in the subtypes of  $\text{Ca}^{2+}$  channel and the subunit composition of nAChRs involved. Distinct neuronal phenotypes characterize different functional pathways.

### References

1. Keast JR (2000) Unusual autonomic ganglia: connections, chemistry, and plasticity of pelvic ganglia. *Int Rev Cytol* 193:1–69
2. Rush RA, Chie E, Liu D, Tafreshi A, Zettler C, Zhou XF (1997) Neurotrophic factors are required by mature sympathetic neurons for survival, transmission and connectivity. *Clin Exp Pharmacol Physiol* 24:549–555
3. McLachlan EM (1995) Autonomic ganglia. In: Burnstock G (ed) *The autonomic nervous system*, vol 6. Harwood Academic Publishers, Luxembourg, p 518
4. Szurszewski JH, Ermilov LG, Miller SM (2002) Prevertebral ganglia and intestinofugal afferent neurones. *Gut* 51 (Suppl 1):6–10
5. Gibbins IL, Jobling P, Messenger JP, Teo EH, Morris JL (2000) Neuronal morphology and the synaptic organisation of sympathetic ganglia. *J Auton Nerv Syst* 81:104–109
6. Ireland DR, Davies PJ, McLachlan EM (1999) Calcium channel subtypes differ at two types of cholinergic synapse in lumbar sympathetic neurones of guinea-pigs. *J Physiol* 514:59–69

7. Jobling P, Gibbins IL, Lewis RJ, Morris JL (2004) Differential expression of calcium channels in sympathetic and parasympathetic preganglionic inputs to neurons in paracervical ganglia of guinea-pigs. *Neuroscience* 127:455–466
8. Inokuchi H, McLachlan EM (1995) Lack of evidence for P2X-purinoceptor involvement in fast synaptic responses in intact sympathetic ganglia isolated from guinea-pigs. *Neuroscience* 69:651–659
9. Gibbins IL, Jobling P, Teo EH, Matthew SE, Morris JL (2003) Heterogeneous expression of SNAP-25 and synaptic vesicle proteins by central and peripheral inputs to sympathetic neurons. *J Comp Neurol* 459:25–43
10. Davies PJ, Ireland DR, McLachlan EM (1996) Sources of  $Ca^{2+}$  for different  $Ca^{2+}$ -activated  $K^{+}$  conductances in neurones of the rat superior cervical ganglion. *J Physiol* 495:353–366

## Autonomic Hyperactivity

### Definition

Autonomic hyperactivity may manifest as sympathetic hyperactivity, parasympathetic hyperactivity or both.

These most often occur in the context of acute brain injury resulting in loss of inhibition or irritation of excitatory foci within the central autonomic network.

Centrally mediated sympathetic hyperactivity is also seen in chronic spinal cord injury (Autonomic dysreflexia).

Sympathetic or parasympathetic hyperactivity are also occasional features of Guillain-Barré syndrome.

Patients may present with extraordinarily high blood pressure and heart rate – even a doubling of normal values – or conversely hypotension and bradycardia where vagal hyperactivity predominates.

These and other symptoms, such as salivary and bronchial hypersecretion, may place patients at immediate risk of cardiac or respiratory failure.

- ▶ Autonomic Insufficiency
- ▶ Guillain-Barré Syndrome

## Autonomic Insufficiency

BRIAN BUDGELL  
School of Health Sciences, Faculty of Medicine,  
Kyoto University, Kyoto, Japan

### Synonyms

Autonomic failure

### Definition

Autonomic insufficiency refers to autonomic output which is not adequate to meet homeostatic needs. In clinical practice, this most often refers to syndromes in which there is widespread failure of autonomic output due either to central or peripheral disease.

### Characteristics

Autonomic insufficiency occurs in a great many disorders and so the spectrum of dysfunction is broad and individual presentations are varied. Some diseases cause symptoms throughout the body, while others appear restricted to particular organs [1]. Autonomic insufficiency may appear as a congenital disorder, and a number of inherited syndromes have been identified [2]. These include the hereditary sensory and autonomic neuropathies (HSANs), such as familial dysautonomia (FD). While such disorders are relatively uncommon, in later life attenuation of autonomic output occurs with increasing prevalence, either as a component of senescence (▶ Ageing) or secondary to other disease processes. Most often, autonomic insufficiency presents clinically as orthostatic intolerance (▶ Orthostatic intolerance) associated with syncope or presyncope. Other common complaints are anhidrosis (▶ Sweating disorders), impaired thermoregulation, impaired gastrointestinal motility, urinary dysfunction and impotence.

### Quantitative Description

The impact of autonomic diseases cannot be quantified in broad statements. In part, this is due to the insidious nature of many of these disorders which makes diagnosis problematic. Additionally, autonomic insufficiency is most often secondary to other disorders whose own prevalences may be changing rapidly due to the evolution of preventative and management strategies. Nonetheless, a few examples will serve to illustrate the importance of autonomic insufficiency from a global perspective. Orthostatic hypotension (orthostatic intolerance), the most common clinical presentation in autonomic insufficiency is defined as a fall of at least 20 mmHg in systolic blood pressure or at least 10 mmHg in diastolic blood pressure within 3 min of assuming an upright posture. The prevalence of this complaint increases with age such that, depending upon the population surveyed, it may be so common as to be the norm. Furthermore, its occurrence correlates with multiple drug use [3], another phenomenon which is on the rise, especially in more developed nations with aging populations. Similarly, in diabetes mellitus, estimates of the prevalence of autonomic abnormalities range from a few percent to the overwhelming majority of patients tested [4]. While there is great variation in the prevalence of diabetes mellitus, worldwide it is increasing so that autonomic complications may be

expected to be quite common in many societies in the near future. This contrasts with Chagas disease, which is largely restricted to Central and South America and has historically been a very important cause of disability and death [5]. At the beginning of the 1990s, Chagas disease, caused by the parasite *Trypanosoma cruzi* and spread by a number of insects, effected millions of people in endemic areas, with new cases numbering in the hundreds of thousands each year, and deaths in the tens of thousands. In some areas with vigorous vector control the incidence has dropped in a logarithmic fashion in recent years. In other areas, however, Chagas disease remains a common cause of gastrointestinal and cardiac disease among adults in their working years. A final example to illustrate the spectrum of autonomic insufficiency will be provided by Portuguese-type amyloidosis, also called familial amyloid polyneuropathy type 1 (FAP-1). This inherited, autosomal dominant disorder is rare globally, but common in restricted areas [6], with a few percent of the population effected in some localities. Hence, in summary, autonomic insufficiency may be important both globally and locally as a cause of disability and death. Furthermore, the stage seems to be set for increased prevalence of some already common causes of this affliction.

### Higher Level Structures

Autonomic insufficiency may arise from disease of the central autonomic network (CAN), including stroke, trauma, infection and neoplasia (►[Central regulation of autonomic function](#)). However, since various components of the CAN also perform inhibitory functions, lesions to these areas may also result in disinhibition and consequent overactivity of the autonomic nervous system (►[Autonomic/enteric dysreflexia](#)). In many instances it is still not known which components of the CAN are involved or are most important in specific syndromes of autonomic insufficiency. Furthermore, as various diseases with autonomic involvement also result in impairment of cerebral circulation, it may be difficult to determine whether pathology in any given component of the CAN is primary or secondary. Notwithstanding these caveats, a few examples will serve to demonstrate the importance of particular higher level structures in representative disorders with autonomic involvement. A relatively common neurodegenerative disorder associated with autonomic insufficiency is Parkinson's disease [7], which is marked by degeneration of a number of nuclei including not only the substantia nigra but also the locus ceruleus (►[Periaqueductal gray matter](#)), the principle source of norepinephrine in the brain. Additionally, in both Parkinsonism and multiple system atrophy (MSA), loss of particular cell populations has been noted in the ventrolateral medulla [8]. With MSA, which normally develops insidiously late in life, there is also marked

degeneration in the intermediolateral (sympathetic preganglionic) cell columns of the spinal cord. Hence, in addition to motor and sensory symptoms, patients with CAN disorders may experience a range of localized or generalized autonomic deficits.

### Lower Level Structures

In truth, many disorders defy classification as strictly central versus peripheral, or preganglionic (►[Preganglionic neurons](#)) versus postganglionic (►[Postganglionic](#)). However, pure autonomic failure (PAF), which like MSA most often effects older adults, is representative of those disorders which are primarily postganglionic. Outwardly, the patients may appear very much like those suffering from MSA, often demonstrating orthostatic hypotension and disorders of urinary or gastrointestinal function. However, the CAN is largely unaffected in PAF, while there is loss of postganglionic sympathetic function [9]. In a number of clinically similar syndromes manifesting as postganglionic autonomic failure, patients have been shown to possess antibodies to postganglionic neurons, including antibodies to ganglionic neurotransmitter receptors. Autoimmune damage is, in fact, one of the mechanisms responsible for peripheral nerve damage in diabetic ►[autonomic neuropathy](#), the most common cause of postganglionic autonomic insufficiency in developed nations. There are, not surprisingly, many varieties of diabetic autonomic neuropathy, just as there are many varieties of diabetes mellitus. These autonomic neuropathies are most often accompanied by sensory and motor neuropathies which may demand more attention clinically. Nonetheless, the autonomic components of diabetic neuropathies are responsible for significant morbidity, and perhaps mortality. Signs and symptoms attributed to autonomic insufficiency include cold, discolored hands and feet due to loss of peripheral vascular tone. There is often asymmetrical loss of sweating, initially effecting the limbs. With loss of postganglionic vagal fibers, gastrointestinal motility is impaired and patients may experience complaints such as achalasia and constipation. Loss of autonomic, and particularly vagal, cardiac output may contribute to the increased risk of silent myocardial infarctions and sudden cardiac death in diabetic patients. Thus, diabetic autonomic neuropathies are commanding more attention, particularly as primary care increases the life expectancy of patients and allows autonomic dysfunction to manifest.

### Management

As autonomic insufficiency most often occurs as a secondary disorder, management commonly focuses on prevention or amelioration of the underlying disease. Additionally, autonomic insufficiency is sometimes successfully managed by supportive measures focusing

on strategies to minimize symptoms. These include modifying behaviors such as using supportive stockings, or altering eating and drinking patterns to control orthostatic hypotension. More recently, a number of neuroprotective drugs have appeared, and strategies such as stem cell transplantation show great promise in certain disorders. As the stage is set for an increase in autonomic insufficiency in more developed nations, it is most likely that there will be increasing research effort in these fields.

## References

1. Mathias C (2003) Autonomic diseases: clinical features and laboratory evaluation. *J Neurol Neurosurg Psychiatr* 74 (Suppl 3):iii31–iii41
2. Axelrod F, Chelimsky G, Weese-Mayer D (2006) Pediatric autonomic disorders. *Pediatrics* 118:309–321
3. Poon I, Braun U (2005) High prevalence of orthostatic hypotension and its correlation with potentially causative medications among elderly veterans. *J Clin Pharm Ther* 30:173–178
4. Hilsted J, Low P (1997) Diabetic autonomic neuropathy. In: Low P (ed) *Clinical autonomic disorders*, 2nd edn. Lippincott-Raven, Philadelphia, pp 487–507
5. Moncayo A (2003) Chagas disease: current epidemiological trends after the interruption of vectorial and transfusional transmission in the southern cone countries. *Mem Inst Oswaldo Cruz* 98(5):577–591
6. Labato L (2003) Portuguese-type amyloidosis (transthyretin amyloidosis, ATTR V30M). *J Nephrol* 16:438–442
7. Magerkurth C, Schnitzer R, Braune S (2004) Symptoms of autonomic failure in Parkinson's disease: prevalence and impact on daily life. *Clin Auton Res* 15:76–82
8. Benarroch E, Schmeichel A, Parisi J (2000) Involvement of the ventrolateral medulla in parkinsonism with autonomic failure. *Neurology* 54(4):965–968
9. Young T, Asahina M, Nicotra A, Mathias C (2006) Skin vasomotor reflex responses in two contrasting groups of autonomic failure; multiple system atrophy and pure autonomic failure. *J Neurol* 253:846–850

## Autonomic Interneurons

### Definition

Interneurons in the spinal cord or brain stem that form synapses with preganglionic neurons. These interneurons are segmental or intersegmental (propriospinal) interneurons in the spinal cord or equivalent in the brain stem (e.g., second-order neurons in the nucleus tractus solitarius receiving synaptic input from vagal visceral afferents).

► Autonomic Reflexes

## Autonomic Nervous System

### Definition

The autonomic nervous system is that part of the nervous system that regulates basic visceral processes, usually independently of voluntary control. The executing part of the autonomic nervous system is divided into a parasympathetic and a sympathetic branch. In many organs, these two branches have antagonistic effects, while in others (e.g. salivary glands), they act synergistically (even though not giving identical responses), and thereby enhance the effect of each system. In addition information about the functional condition of our organs is transmitted back to the brain via these two branches.

- Central Integration of Cardiovascular and Respiratory Activity Studied In Situ
- Neuroendocrine Regulation and the Autonomic Nervous System
- Sympathetic Nervous System
- Sympathetic Pathways
- Parasympathetic Nervous System
- Parasympathetic Pathways

## Autonomic Nervous System and Its Divisions: Sympathetic, Parasympathetic and Enteric

JOHN B. FURNESS

Department of Anatomy and Cell Biology and Centre for Neuroscience, University of Melbourne, Parkville, VIC, Australia

### Introduction

The autonomic nervous system (ANS) is that system of nerves that controls peripheral organs, other than striated muscle that is under voluntary control (Fig. 1). Thus it controls the visceral organs of the thoracic, abdominal and pelvic cavities, including the lungs, heart, digestive organs, kidneys, urinary bladder and internal generative organs. The autonomic nervous system also controls endocrine and exocrine glands throughout the body, the blood vessels that supply all organs, and, within the eye, ►neural regulation of the pupil. More recently, it has also become obvious that the autonomic nervous system can modulate the function of sensory receptors (see ►autonomic control



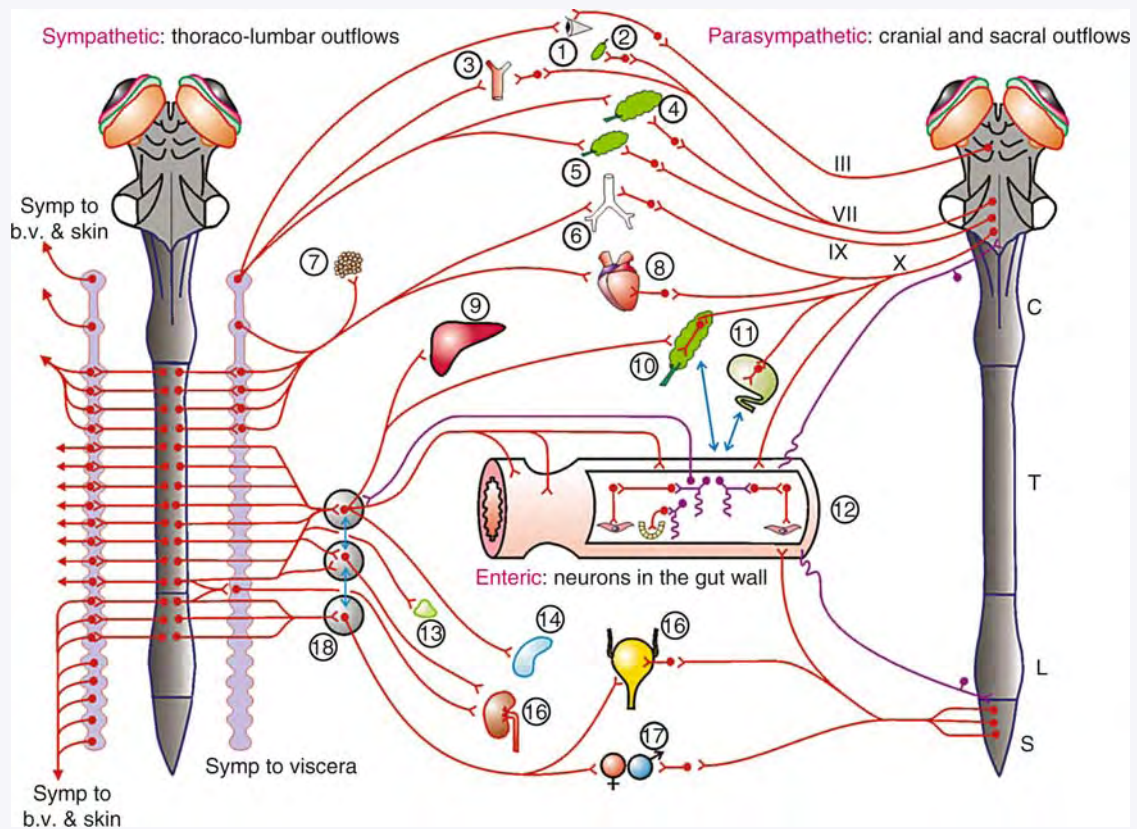

**Autonomic Nervous System and Its Divisions: Sympathetic, Parasympathetic and Enteric. Figure 1** Depiction of the organization of the peripheral pathways of the autonomic nervous system, showing its three parts, sympathetic, parasympathetic and enteric. The spinal cord and brainstem are pictured twice, at the left to show their sympathetic outflows and at the right to show parasympathetic outflows. Major organs that are supplied are numbered: 1 Eye; 2 Lacrimal gland; 3 Intracranial arteries; 4, 5 Salivary glands; 6 Respiratory tract; 7 Adipose tissue; 8 Heart; 9 Liver; 10 Pancreas; 11 Gallbladder and biliary tree; 12 Gastrointestinal tract; 13 Adrenal gland; 14 Spleen; 15 Urinary bladder; 16 Kidney; 17 Genital organs. 18 indicates prevertebral ganglia. Motor pathways are in red. The ANS also has associated afferent neurons. Some of these are shown in purple. Visceral afferents in fact supply all organs, but these are not shown, in order to simplify the diagram. Double-ended arrows indicate that there are neural connections between the pancreas and the gastrointestinal tract and between the biliary system and the gastrointestinal tract, as well as between pre-vertebral ganglia. Levels of the spinal cord are indicated, C, T, L and S.

of sensory receptors) and skeletal muscle (see ► [autonomic effects on skeletal muscle](#)).

### Autonomic Function

The functions of the autonomic nervous system are all related to ► [homeostasis](#) (Table 1), adjusting the activities of these organs so that the organs function at levels that are most favorable to the state of the body and to its environment (see [1]). This is achieved most often through reflex mechanisms which are largely involuntary. These ► [autonomic/enteric reflexes](#) particularly involve viscerovisceral reflexes. However, recently there has been a growing awareness that much autonomic function is also influenced by ► [somato-autonomic reflexes](#) [2] and entrained to circadian rhythms (see ► [circadian rhythms of autonomic function](#)). Thus, for

example, physiological parameters such as blood pressure show daily rhythms appropriate to the sleep-wake cycle [3]. Furthermore, it is apparent that humans may exert varying degrees of voluntary control over autonomic function (see ► [biofeedback of autonomic function](#)). Thus, while ► [tonic activity of autonomic nerves](#) is always present to some degree, there are substantial adjustments to homeostatic challenges, such as those presented by exertion (see ► [autonomic function and exercise](#)) [4]. Additionally, information from visceral autonomic afferents may, via ► [viscero-somatic reflexes](#), such as the ► [Hering-Breuer reflex](#), modulate musculoskeletal function. The autonomic nervous system is thus one of two systems, the other being the endocrine system, that control the functions of the internal and surface organs (the skin is included as an organ). The two systems

**Autonomic Nervous System and Its Divisions: Sympathetic, Parasympathetic and Enteric. Table 1** A summary of major autonomically controlled functions

Heart rate and force
Arterial diameter (all vascular beds)
Mesenteric venous capacity
Pupillary diameter, accommodation of lens
Exocrine gland secretion: lacrimal gland, salivary glands, gastric glands, exocrine pancreas, sweat glands
Secretion into organs: intestinal water and electrolyte secretion, pulmonary secretion, nasal secretion
Gastrointestinal wall movement
Gall bladder contraction, and biliary tract regulation
Regulation of the urinary bladder and control of micturition
Tracheal and bronchial diameter
Contraction of vas deferens
Penile erection, clitoral and labial engorgement
Fat mobilization
Secretion of adrenal medullary hormones
Piloerection

would be better thought of as one, because they act in synergy to control the organs (see ► [autonomic regulation of endocrine system](#)). However, largely due to the history and pattern of basic and clinical investigation, autonomic and endocrine control are often separated in text-books.

Autonomic control of organs is through reflexes and through cortical control centers [5]. To elicit a reflex, the relevant states of organs must be detected. This detection is through ► [visceral afferents](#) that are properly regarded as part of the autonomic nervous system. Many visceral afferent neurons also communicate other information, for example pain from the viscera, satiety from the digestive tract or temperature. Thus visceral afferent neurons, while part of the autonomic nervous system, carry signals to the central nervous system that serve other functions [6].

### Structural Organization of the Autonomic Nervous System

Since the nineteenth century or early twentieth century, it has been common to divide the autonomic nervous system into three divisions, the sympathetic, parasympathetic and enteric divisions (see ► [enteric nervous system](#)). There were pragmatic reasons for this separation of parts of what is essentially one control system. The efferent (motor) autonomic outflows from the central nervous system are not distributed uniformly in the peripheral nerves; rather there are gaps. More precisely, there are some cranial, cervical and lumbosacral nerves that do not carry autonomic motor pathways (Fig. 1). Autonomic fibers are absent from the first two cranial nerves – the olfactory and optic nerves, they are then present in cranial nerves III, VII, IX and X. Then a gap in outflow occurs, with no autonomic contribution

to cranial nerves XI and XII or the cervical nerves (there can rarely be a contribution from C7). The next group of nerve roots, T1 to L2 or 3 (the thoraco-lumbar outflows), all have autonomic components, and then there is a small gap where there are few autonomic fibers, which become prominent again in sacral roots 2–4. The outputs are thus considered as cranial, thoraco-lumbar and sacral.

Early studies of autonomic nervous system function particularly focused on ► [cardiovascular reflexes](#), including ► [blood volume regulation](#). It was noted that there are pathways that emerge from the cranial autonomics that slow the heart and dilate blood vessels, and that there are also dilator nerves in the sacral outflows. Thus, these were grouped together and called the cranio-sacral nerves. Conversely, there are cardio-accelerator and vasoconstrictor pathways in the thoraco-lumbar outflows. Furthermore, early investigations indicated that these opposite effects on cardiovascular function were elicited by two different ► [postganglionic neurotransmitters](#), acetylcholine and norepinephrine. Because of the opposite effects on the cardiovascular system, and the thoraco-lumbar effects being “sympathetic” (in sympathy with the body) the two anatomical divisions became known as sympathetic and parasympathetic (the latter being associated with slowing or lowering cardiovascular function).

The division of the ANS into sympathetic and parasympathetic systems has led to enormous misconceptions, the most serious being the concept that the two divisions are somehow in opposition to each other. Thus it may be envisioned that, for example, an increase in sympathetic outflow to a particular organ is necessarily linked to a decrease in parasympathetic outflow. This

is quite a wrong idea. Autonomic nerves, whatever their anatomical origin, act in concert to control visceral organs and the vasculature [7].

The third division of the ANS is the enteric division, which is the system of autonomic ganglia and nerve fibers that is contained within the walls of the digestive organs [8]. This is given the status of a separate division because it contains complete reflex circuits which can operate in the absence of connections with the central nervous system. In terms of numbers of neurons, the enteric is the largest autonomic division. In humans, it contains 200–600 million neurons.

The motor pathways of the ANS that arise in the central nervous system pass through ►autonomic ganglia and generally make synapses on the way to the organs that they innervate [9]. The adrenal glands are exceptional in that they are innervated by preganglionic neurons with cell bodies within the spinal cord. Synaptic transmission in autonomic ganglia is mediated primarily by acetylcholine (ACh) that acts on nicotinic receptors. The use of nicotine and other drugs that block these receptors has been important in analyzing the nerve pathways. Neurons with cell bodies in the central nervous system that make synapses in peripheral ganglia are known as autonomic (sympathetic or parasympathetic) pre-ganglionic neurons. The neurons with which they connect are called post-ganglionic neurons; most of those of the sympathetic nervous system producing the classical neurotransmitter norepinephrine and those of the parasympathetic nervous system producing acetylcholine. Both classes of post-ganglionic neurons also produce a range of other neuroactive substances which modulate the effects of their primary neurotransmitters (see [10]). Enteric neurons are innervated by both parasympathetic pre-ganglionic neurons and sympathetic post-ganglionic neurons.

►Central regulation of autonomic function involves higher integrating centers but depends most immediately on a series of nuclei in the brain-stem (including the Edinger-Westfall nucleus, the nucleus of the facial nerve, the salivatory nuclei, the dorsal motor nucleus of vagus and the nucleus ambiguus) which contain the cell bodies of preganglionic neurons [11]. Within the spinal cord, autonomic cell groups are arranged in columns in the lateral funiculus, intermediolateral nuclei, intermediomedial nuclei and central autonomic nuclei. The central autonomic motor nuclei of the brain stem and spinal cord receive inputs from autonomic integrative cell groups, including the nucleus of the tractus solitarius, the Bezhold-Jarisch complex, the autonomic cell groups of the rostral ventro-lateral medulla, the paraventricular nucleus and other cell groups. At higher levels, important autonomic control is exerted through the amygdala and the cingulate cortex. At these higher levels, it is no longer possible to distinguish the centers as simply autonomic. They are

also involved in endocrine control and affective behavior, both of which are closely related to autonomic function.

### Disorders of the Autonomic Nervous System

As homeostatic mechanisms normally manifest as subtle adjustments in physiology, the importance of the autonomic nervous system to human health is easily underestimated until we subject ourselves to extreme environments (see ►autonomic function in space) or encounter frank disease. In fact, disorders of the autonomic nervous system are numerous and diverse in their presentations (see [12]). ►Complex regional pain syndromes were recognized early in the evolution of our understanding of autonomic pathology. More recently, and especially with improvements in ►autonomic testing, it has been possible to differentiate disorders which, while similar in their presentations, actually have distinct etiologies and pathologies, and so warrant distinct treatment approaches [13]. Importantly, aging is associated with senescence of the autonomic nervous system [14] (see ►aging of autonomic/enteric function), although ►autonomic insufficiency is also a component of a range of disorders seen across the life cycle. Autonomic insufficiency is most apparent in its effects on cardiovascular function and frequently associated with orthostatic hypotension. However, insufficiency also has clinically important effects on digestive function (see ►salivary secretion control and ►bowel disorders), urogenital function (see ►micturition – neurogenic control and ►sexual reflexes) and sweating (see ►sweat gland control).

### Acknowledgement

This section of the Encyclopedia of Neuroscience is a tribute to the energy and foresight of the late Professor Akio Sato, whose scientific and personal contributions have substantially advanced understanding of the autonomic nervous system. His friendship and support are sadly missed.

### References

1. Jänig W (2006) The autonomic nervous system. Cambridge University Press, Cambridge
2. Sato A, Sato Y, Schmidt R (1997) The impact of somatosensory input on autonomic functions. *Rev Physiol Biochem Pharmacol* 130:1–328
3. Giles TD (2006) Circadian rhythm of blood pressure and the relation to cardiovascular events. *J Hypertens Suppl* 24:S11–S16
4. Joyner MJ, Coyle EF (2007) Endurance exercise performance: the physiology of champions. *J Physiol*: Epub ahead of print
5. Jordan B (1997) Central nervous control of autonomic function. CRC Press, Baton Rouge
6. Grundy D (2002) Neuroanatomy of visceral nociception: vagal and splanchnic afferent. *Gut* 51 Suppl 1:i2–i5

7. Malliani A (1997) The autonomic nervous system: a Sherringtonian revision of its integrated properties in the control of circulation. *J Auton Nerv Syst* 64:158–161
8. Furness JB (2006) *The enteric nervous system*. Blackwell, Oxford
9. McLachlan EM (2003) Transmission of signals through sympathetic ganglia – modulation, integration or simply distribution? *Acta Physiol Scand* 177:227–235
10. Burnstock G (2007) Physiology and pathophysiology of purinergic neurotransmission. *Physiol Rev* 87:659–797
11. Blessing WW (1997) *The lower brainstem and bodily homeostasis*. Oxford University Press, Oxford
12. Mathias CJ (2006) Multiple system atrophy and autonomic failure. *J Neural Transm Suppl* 70:343–347
13. Low PA (2003) Testing the autonomic nervous system. *Semin Neurol* 23:407–421
14. Schmidt RE (2002) Age-related sympathetic ganglionic neuropathology: human pathology and animal models. *Auton Neurosci* 96:63–72

autonomic interneurons associated with the preganglionic neurons and form synapses with these neurons are called autonomic (parasympathetic, sympathetic) premotor neurons.

#### ► Autonomic Reflexes

## Autonomic Reflexes

WILFRID JÄNIG

Department of Physiology, Christian-Albrechts-Universität zu Kiel, Kiel, Germany, Physiologisches Institut, Christian-Albrechts-Universität zu Kiel, Kiel, Germany

## Autonomic Neuropathy

### Definition

The autonomic neuropathies are disorders of peripheral autonomic function, and may manifest as autonomic hyperactivity, autonomic failure, or a mixture of both.

An exemplar of autonomic neuropathy is acute panautonomic neuropathy (pandysautonomia) in which there is often widespread and severe loss of sympathetic and parasympathetic function, but virtually no involvement of somatic fibers. At the other end of the spectrum is Guillain-Barré syndrome in which somatic nervous system dysfunction usually dominates, and there may be hypoactivity or hyperactivity of peripheral autonomic fibers.

- Autonomic Insufficiency
- Guillain-Barré Syndrome

## Autonomic Neurotransmitter

- Postganglionic Neurotransmitter

## Autonomic Premotor Neurons

### Definition

Neurons in brain stem, hypothalamus or even cerebral hemispheres that project to preganglionic neurons or

### Definition

Reflexes are functionally defined by an efferent (motor) output system leading to a distinct effector response when activated and by the population of afferent neurons stimulated. They are fragments of more complex somatomotor behaviors and are used in the laboratory as tools to study experimentally the central organization of neural regulation of movement. In this isolated context they are experimental artifacts or fictions [1]. The same applies to ►autonomic reflexes when seen in this restricted experimental context. Systematic experimental studies of autonomic reflexes using measurements of effector responses, recording from functionally identified autonomic neurons, pharmacological interventions, histological techniques, tracer methods etc. have given and will continue to give invaluable insight into the central and peripheral neural mechanisms underlying regulations in which the autonomic nervous system is involved. The functions of many individual autonomic reflexes mediated by the spinal cord, brain stem or hypothalamus or by the peripheral nervous system may not always be obvious at first sight. This does not mean that these reflexes have no function or are left-overs from development. As in the somatomotor system, the function of most autonomic reflexes cannot be considered in isolation but becomes obvious when looked at in the context of neural regulations in which these reflexes are integrated.

In the somatomotor system, reflexes are the basic building blocks of the initiation and maintenance of movements whether occurring automatically, e.g., during locomotion or in posture, or being initiated by the telencephalon [2,3]. In the autonomic nervous system reflexes are the basic building blocks of autonomic regulations. Coordinated responses generated by the somatomotor, autonomic and neuroendocrine

systems constitute behaviors of the organism. In this sense autonomic reflexes are also fragments of behavior (see the interesting discussion in [4] “What do *reflex* and *voluntary* mean? Modern views on an ancient debate.” For the autonomic nervous system this may be rephrased “What do *reflex* and autonomic *regulation* mean?”).

### Characteristics

Autonomic reflexes mediated by the spinal cord, brain stem or hypothalamus are functionally defined by their afferent input and efferent output. They are di- or polysynaptic, organized at the segmental or propriospinal (propriobulbar) level and form the building blocks of ►autonomic regulations. The interneurons of the autonomic reflex pathways are important for the integration and coordination of different autonomic systems as well as of autonomic and somatomotor systems. Command signals from higher centers act primarily via these interneurons rather than directly with the final autonomic pathways in autonomic regulations.

### Categories of Autonomic Reflexes

Autonomic reflexes can be divided into three categories:

1. Autonomic reflexes mediated by CNS structures: spinal cord, brain stem or hypothalamus. These reflex pathways are either segmental (spinal, bulbar), intersegmental (propriospinal, propriobulbar) or supraspinal reflex loops (spino-bulbo-spinal, spino-hypothalamospinal, bulbo-hypothalamo-bulbar etc.).
2. Autonomic reflexes mediated by autonomic (non-enteric) ganglia outside the spinal cord (i.e., “extracentral”). For example, reflexes involved in regulation of motility or secretion of the ►gastrointestinal tract (GIT) are mediated by sympathetic postganglionic neurons of prevertebral ganglia. These neurons are physiologically activated by intestino-fugal neurons during distension of or other processes in the GIT leading to inhibition of motility and/or secretion ([5]; Chaps. 5 and 6 in [6]). Other extracentral reflexes may be mediated by parasympathetic postganglionic neurons in cardiac ganglia, by sympathetic postganglionic neurons in the stellate ganglion innervating the heart or by postganglionic neurons in the inferior mesenteric ganglion projecting to pelvic organs. However, the nature of the peripheral afferent synaptic input to these postganglionic neurons as well as the function of these peripheral reflexes during autonomic regulation of the respective target organs are unclear. Sympathetic postganglionic neurons in the paravertebral ganglia innervating target cells in the somatic tissues (blood vessels, glands, non-vascular smooth muscle cells) do not mediate peripheral autonomic reflexes (Chap. 6 in [6]).

3. Autonomic reflexes mediated by the enteric nervous system (ENS) are related to regulation of motility and secretion of the GIT involving smooth (non-vascular, vascular) muscle cells, secretory epithelia and endocrine cells. Several enteric reflexes can be defined by their intrinsic primary afferent neurons and their enteric motor neurons (defined by the target cells). These reflexes are monosynaptic, disynaptic or polysynaptic. They are the building blocks of the autonomic regulation of the GIT by the ENS and of its control by the brain ([5]; Chap. 5 in [6]).

I will concentrate on the first category of autonomic reflexes and here in particular on segmental spinal and propriospinal as well as autonomic reflexes in the brain stem. Table 1 lists characteristics of several basic autonomic reflexes related to autonomic regulation of pelvic organs, the cardiovascular system, functions of skin, gastrointestinal tract, airways, eye and pineal gland.

### The Autonomic Reflex Pathway in Spinal Cord and Brain Stem

The peripheral parasympathetic and sympathetic systems consist of many functionally discrete pathways that transmit impulse activity generated in the CNS to autonomic effector cells. The pre- and postganglionic neurons of each pathway exhibit a distinct reflex pattern to physiological stimulation of somatic or visceral afferents that is dependent on the central circuits connected to this peripheral autonomic pathway ([7]; Chap. 4 in [6]). The centrally generated signals are faithfully transmitted from the preganglionic neurons through autonomic ganglia to the postganglionic neurons and from the postganglionic axons to the effector cells at the neuroeffector junctions ([7]; Chaps. 6 and 7 in [6]). Thus these pathways are anatomically and physiologically separate from each other and functionally distinct with respect to the effector cells (e.g., vasoconstrictor neurons, vasodilator neurons, secretomotor neurons etc.).

Each peripheral autonomic pathway is connected to several basic reflex pathways organized in spinal cord or brain stem (Table 1). The common theme of the structure of practically all of these reflex pathways is shown for ►spinal reflexes in Fig. 1. Primary afferent neurons, most of them innervating visceral organs, but some also somatic tissues (skin, deep somatic), form reflex circuits with the preganglionic neurons. These reflex circuits are di-, tri- or polysynaptic. Each reflex circuit is primarily characterized by the type of afferent input and by the response elicited in the neurons of the autonomic pathways and therefore by the effector response. This basic structure of the autonomic spinal reflex applies to most autonomic reflexes in spinal cord. The reflexes are either spinal

**Autonomic Reflexes. Table 1** Autonomic reflexes mediated by spinal cord and brain stem<sup>a</sup>

Organ, target cells	Reflex <sup>b</sup>	Afferents <sup>c</sup>	Efferent pathway	Central reflex pathway	Effector response to stim afferents	Integrated in regulation of ...
<b>Pelvic organs</b>						
Urinary bladder	Spinal segmental (micturition reflex)	Sacral urinary bladder	Sacral to detrusor Sacral to urethra	Sacral spinal cord Sacral spinal cord	Contraction Relaxation	Micturition, continence Micturition
	Spinal segmental	Sacral colon-rectum	Sacral to urinary bladder	Sacral spinal cord	Relaxation of urinary bladder	Continence of urinary bladder
Colon-rectum	Proprio-spinal	Sacral colon-rectum	Lumbar to pelvic organs	Sacro-lumbar spinal cord	Relax./contract. sphincters	Continence urinary bladder and colon-rectum
	Spinal segmental (defecation reflex)	Sacral colon-rectum	Sacral to colon-rectum	Sacral spinal cord	Contraction	Defecation, continence
Genital organs	Spinal segmental	Sacral urinary bladder	Sacral to colon-rectum	Sacral spinal cord	Relaxation of colon-rectum	Continence colon-rectum
	Proprio-spinal	Sacral urinary bladder	Lumbar to pelvic organs	Sacro-lumbar spinal cord	Relax./contract. sphincters	Continence Urinary Bladder and colon-rectum
Kidney	Spinal segmental (genito-genital reflex)	Somat sacral pudendal	Sacral to erect tissue	Sacral spinal cord	Vasodilation	Erection
	Proprio-spinal (genito-genital reflex)	Somat sacral pudendal	Lumbar to internal genital organs	Sacro-lumbar spinal cord	Contraction, secretion	Emission, ejaculation
Cardiovascular system	Spinal segmental (reno-renal reflex)	Thoracic kidney	Thoraco-lumbar to kidney	Thoraco-lumbar spinal cord	Vasoconstriction, renin release, tubular Na <sup>+</sup> reabsorption	Electrolyte and fluid balance
	Heart <sup>d</sup>	Thoracic heart	Thoracic cardiomotor	Thoracic spinal cord	Increase of heart rate and contractility	Cardiac output
Resistance vessels	Lower BS (baroreceptor reflex)	Arterial baroreceptor	Parasymp cardiomotor	NTS, ncl ambiguus	Decrease of heart rate and contractility of atria	Blood pressure, cardiac output
	Lower BS, bulbo-sp (baroreceptor reflex)	Arterial baroreceptor	Thoracic cardiomotor	NTS, CVLM, RVLM, thoracic spinal cord	Decrease of heart rate and contractility	Blood pressure, cardiac output
Cardiovascular System	Lower BS, bulbo-sp (part of diving reflex)	Trigem (face, nasopharyngeal), art.chemorec	Parasymp cardiomotor	NTS, trigeminal ncl, ncl ambiguus	Decrease of heart rate and contractility	Cardiovascular system during diving
	Resistance vessels	Noiceptive	MVC/VVC	Thoraco-lumbar sp c	Vasoconstriction	Body Protection

(Skeletal muscle, viscera)	Lower BS, bulbo-sp (baroreceptor reflex)	Arterial baroreceptor	MVC/VVC	NTS, CVLM, RVLM, thoraco lumbar sp	Vasodilation	Blood pressure, peripheral resistance
	Lower BS, bulbo-sp (chemoreceptor reflex)	Arterial chemoreceptor	MVC/VVC	NTS, ?, RVLM, thoraco lumbar sp c	Vasoconstriction	Blood pressure, peripheral resistance
	Lower BS, bulbo-sp (part of diving reflex)	Trigem (face, nasopharyngeal), art chemorec	MVC/VVC	NTS, trigem, ?, RVLM thoraco-lumbar sp c	Vasoconstriction	Cardiovascular system during diving
<b>Skin</b>						
Blood vessels skin	sp segm, proprio-sp (Lovén reflex)	Noceptive skin	CVC acral skin	Thoraco-lumbar sp c	Vasodilation, vasoconstriction	Body protection
	sp segm, proprio-sp	Mech skin (low threshold)	CVC acral skin?	Thoraco-lumbar sp c	Vasodilation	Body protection
	sp segm, proprio-sp	Warm spinal cord	CVC	Thoraco-lumbar sp c	Vasodilation	Thermoregulation
	Spinal segmental (viscero-cut reflex)	Thoraco-lumbar	CVC body trunk	Thoraco-lumbar sp c	Vasodilation, vasoconstriction	Referred zone, body protection?
Sweat glands	Lower BS, bulbo-sp (part of diving reflex)	Trigem (face, nasopharyngeal), art chemorec	CVC to arterio-venous anastomoses	NTS, trigem, ?, RVLM thoraco-lumb sp c	Vasodilation	Cardiovascular system during diving.
	sp segm, proprio-sp	Noceptive skin	SM	Thoraco-lumbar sp c	Sweating	Friction of skin (sensory discrim.)
Organ, target cells	sp segm, proprio-sp (vibration reflex)	Vibration receptor (paw/hand)	SM acral (paw/hand)	Thoraco-lumbar sp c	SWEATING	Friction of skin (sensory discrim.), territory marking (cat)?
	Spinal segmental (viscero-cut reflex)	Thoraco-lumbar	SM body trunk	Thoraco-lumbar sp c	Sweating	Referred zone, body protection?
	Reflex <sup>b</sup>	Afferents <sup>c</sup>	Efferent pathway	Central reflex pathway	Effector response to stim afferents	Integrated in regulation of ...
<b>Gastrointestinal tract<sup>d</sup></b>						
Stomach smooth m.	Lower BS	Vagal stomach	Gastromotor	NTS, DMNX	Contraction	Motility GIT
	Lower BS	Vagal duodenum	Gastromotor	NTS, DMNX	Inhibition	Motility GIT
	lower BS (receptive relaxation r)	Vagal esophagus	Gastromotor	NTS, DMNX	Inhibition	Motility GIT
Salivary glands	Lower BS	Oropharyngeal	Salivomotor	Trigeminal, ncl salivatorii	Salivation	Food intake

**Autonomic Reflexes. Table 1** Autonomic reflexes mediated by spinal cord and brain stem<sup>a</sup> (Continued)

Organ, target cells	Reflex <sup>b</sup>	Afferents <sup>c</sup>	Efferent pathway	Central reflex pathway	Effector response to stim afferents	Integrated in regulation of ...
Smooth m., glands	sp segm, proprio-sp	Thoraco-lumbar	MR, secretomotor	Thoraco-lumbar spinal cord	Inhibition	Protection of GIT
<b>Airways</b>						
Smooth muscle	Lower BS	Vagal mucosa airways	Bronchomotor	NTS, ncl ambiguus	Contraction	Airway resistance
Mucosal glands	Lower BS	Vagal mucosa airways	Secretomotor	NTS, ncl ambiguus?	Relaxation Secretion	Airway resistance Airway protection
<b>Eye</b>						
Iris	Mesencephalon (pupillary light reflex)	Retino-tectal tract (area pretectalis)	Pupilloconstrictor	Eddinger-Westphal nucleus, lateral	Constriction of pupil	Pupil diameter
	Hypothal, spinal	Retino-hypothalamic tract	Pupillodilator thoracic T1/T2	Hypothalamo-spinal	Dilation of pupil	Pupil diameter, defense
Pineal gland	Hypothal, spinal	Retino-hypothalamic tract	Thoracic T1/T2	SCN, PVN, spinal cord	Inhibition of melatonin synthesis	Circadian rhythms of hypothalamic functions

<sup>a</sup>(i) Only spinal segmental and propriospinal (and equivalent reflexes in the brain stem and hypothalamus [related to the iris or pineal gland and the retino-hypothalamic/tecal tract]) are listed. For references see [3]. (ii) No autonomic long-loop reflexes are listed (e.g., spino-bulbo-►spinal reflexes related to pelvic organs, resistance vessels, cutaneous blood vessels, sweat glands etc; long-loop reflexes related to peripheral autonomic [parasympathetic] pathways the brain stem). (iii) No autonomic reflexes are listed related to excitation or inhibition of hypothalamic neurons by osmotic stimuli (autonomic reflexes related to electrolyte-fluid balance), warm stimuli (thermoregulatory reflexes) or nutritive signals (glucose, lipids in the blood) and hormonal signals to neurons of the arcuate nucleus that are important in regulation of food intake and metabolism (leptin from adipocytes, insulin from B-cells of the endocrine pancreas, ghrelin from endocrine mucosa cells of the stomach, peptide YY from endocrine mucosa cells of ileum and colon-rectum).

<sup>b</sup>Some reflexes are listed by their genuine names as reported in the literature.

<sup>c</sup>Most afferent neurons are visceral (spinal or vagal); some afferent inputs are somatic (indicated) or central.

<sup>d</sup>Reflexes related to vagal afferents from atria and ventricles of the heart have not been listed.

<sup>e</sup>There must exist other reflexes mediated by the dorsal vagal complex (NTS, DMNX) that are related to regulation of secretion and transmural transport by the mucosa and to regulation of the endocrine cells of the mucosa (secreting e.g., cholecystokinin, gastrin, secretin, ghrelin, glucagon-like peptide, peptide YY or other hormones) or of the endocrine pancreas (secreting insulin, glucagon or pancreatic polypeptide). However, these reflex pathways have so far not been investigated (see [3] and Travagji RA, Hermann GE, Browning KN, Rogers RC (2006) Brainstem circuits regulating gastric function. *Annu Rev Physiol* 68:279–305).

List of Abbreviations *art*,arterial; *BS*brain stem; *CM*cardiomotor; *bulbo-spbulbo-spinal*; *CV*Cutaneous vasoconstrictor; *CVL*M; caudal ventrolateral medulla;*DMNX*; dorsal motor nucleus of the vagus *GIT* gastrointestinal tract *MVC* muscle vasoconstrictor *nclNTS*nucleus tractus solitarii;*pelv orgproprio-spproprio-spinalPV*paraventricular nucleus (hypothalamus)/*RVL*rostral ventrolateral medulla/*SCN*suprachiasmatic nucleus/*segmsegmentalsomaticSMS*sudomotor *sp* spinal cord/*trigeminalUB*urinary bladder/*V*visceral vasoconstrictor/*visc-cut*viscero-cutaneous.



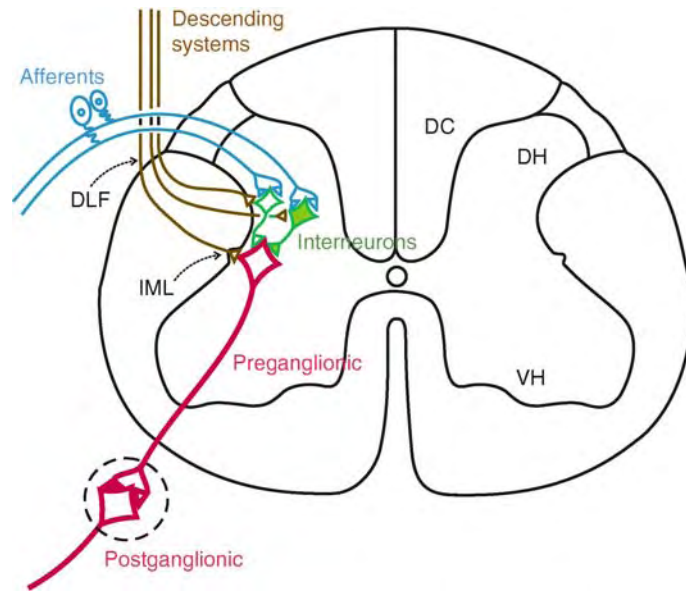

**Autonomic Reflexes. Figure 1** The spinal autonomic reflex pathway as building block between supraspinal centers and final autonomic pathways. There is usually at least one (excitatory or inhibitory [filled in]) interneuron (green) between (visceral or somatic) primary afferent neurons (blue) and preganglionic neurons (red). Supraspinal centers in brain stem and forebrain (hypothalamus and cerebral hemispheres) project mainly through the dorsolateral funiculus (DLF, brown) of the spinal cord and connect synaptically to the autonomic interneurons and the preganglionic neurons. DC, dorsal column. DH, dorsal horn. IML, intermediolateral nucleus. VH, ventral horn. Modified from [6].

segmental, in which afferent input and efferent output are located in the same spinal segment or neighboring spinal segments, or proprio-spinal in which afferent input and efferent output are located in different (separate) spinal segments (e.g., sacro-lumbar reflexes related to pelvic organs (see Fig. 4); muscle vasoconstrictor reflexes, cutaneous vasoconstrictor reflexes or sudomotor reflexes mediated by neurons innervating the hindlimb and elicited by stimulation of cutaneous afferents from the hindlimb).

The corresponding situation exists for autonomic reflexes mediated by the brain stem. Basic reflexes associated with the gastrointestinal tract (including salivary glands and mucosa of the oropharyngeal cavity), airways and eye mediated by the lower brain stem (nucleus tractus solitarius [NTS], trigeminal nuclei, nucleus ambiguus, dorsal motor nucleus of the vagus [DMNX], salivary nuclei) or the mesencephalon (nucleus Edinger-Westphal) correspond to segmental spinal reflexes, whereas other reflexes including the bulbo-spinal pathways (e.g., ►baroreceptor (see Fig. 2), chemoreceptor, diving reflexes) involving afferent inputs to the NTS [10] or trigeminal nuclei and sympathetic pathways to resistance blood vessels (in skeletal muscle and viscera, including kidney), to the heart, to cutaneous blood vessels (in particular arterio-venous anastomoses) or to other targets correspond to propriospinal reflexes.

### Function of Interneurons in Autonomic Reflex Pathways

It is generally assumed that reflexes are hard-wired components of the nervous system that can be inhibited or enhanced by higher centers. However, this ►concept may be misleading and too narrow. In analogy to the reflex pathways in the somato-motor system, the important components of the autonomic reflexes mediated by the spinal cord or the brain stem are the excitatory glutaminergic interneurons or GABA-ergic and/or glycinergic inhibitory interneurons interposed between afferent input and efferent output. These interneurons outnumber the preganglionic output neurons probably by an order of magnitude. With a few exceptions, notably baroreceptor reflexes (Fig. 2), reflexes represented in the dorsal vagal complex (Fig. 3) and reflexes related to the urinary bladder (Fig. 4), most autonomic interneurons have not been identified physiologically and anatomically. However, many functionally distinct types of interneurons are needed to explain the many distinct types of autonomic reflexes demonstrated in neurophysiological and other experimental investigations (Table 1). These pools of interneurons represent neural autonomic subroutines or “neural autonomic motor programs.” Command signals from higher autonomic centers may target the neural autonomic subroutines via the interneurons leading in this way to a spatially and temporally coordinated smooth regulation of autonomic target

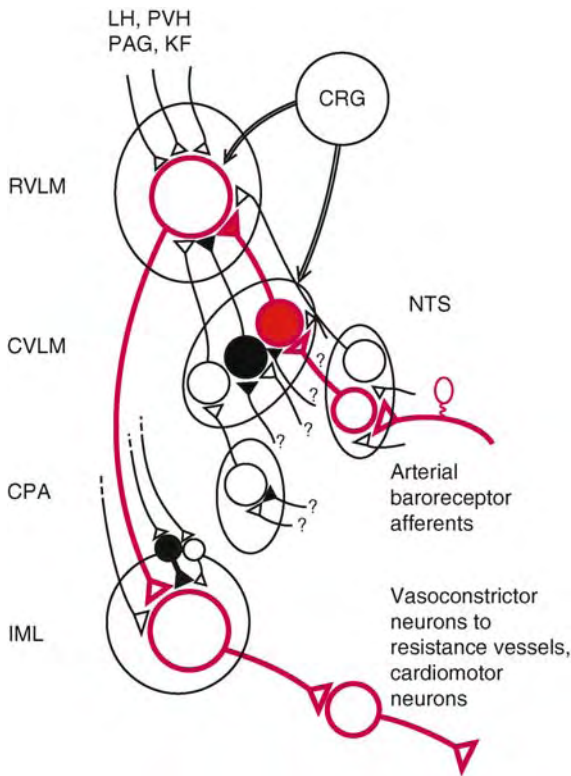

**Autonomic Reflexes. Figure 2** The baroreceptor reflex pathway to sympathetic cardiovascular neurons is modulated at all synapses in the brain stem and spinal cord. The neurons of the baroreceptor reflex pathway are outlined in red. Excitatory neurons/synapses, open symbols. Inhibitory neurons/synapses, closed symbols. CVLM, caudal ventrolateral medulla. CPA, caudal pressure area. CRG, central respiratory generator. IML, intermediolateral cell column. LH, lateral hypothalamus. KF, Kölliker-Fuse nucleus. NTS, nucleus tractus solitarii. PAG, periaqueductal gray. PVH, paraventricular nucleus of the hypothalamus. RVLM, rostral ventrolateral medulla. From [6].

organs. This principle of organization is probably responsible for the adaptability and flexibility of all autonomic regulations operating during behavioral changes of the organism. It applies to all levels of the central organization of the autonomic nervous system:

1. At the most basic level in spinal cord and lower brain stem the interneuron pools are responsible for the coordination and integration of different but functionally related autonomic systems (e.g., cutaneous vasoconstrictor and sudomotor systems; autonomic systems involved in regulation of pelvic organs) and of somatic and autonomic systems (e.g., sphincters and autonomic components of urinary tract (Fig. 4) or hindgut; cardiovascular and respiratory systems;

cardiovascular, thermoregulatory and somatomotor systems during muscular efforts; see Chap. 10 in [6]).

2. Sympathetic premotor neurons (e.g., in the rostral ventrolateral medulla, in the raphe nuclei of the medulla and in the hypothalamus) may not primarily target preganglionic sympathetic neurons but rather, spinal autonomic circuits via their interneurons. The same may apply to parasympathetic premotor neurons targeting the autonomic reflex circuits in the sacral and sacro-lumbar spinal cord, the dorsal vagal complex related to the GIT (Fig. 3) or the circuits in the nucleus ambiguus related to heart and airways.
3. Signals from the cerebral hemispheres (e.g., the anterior cingulate cortex and the medial and lateral prefrontal cortex) may equally target, for example by way of the hypothalamus or the periaqueductal grey, these autonomic reflex circuits via their interneurons. This would lead to a smooth adaptation of the body during exercise, defense, diving, digestion and food intake, thermoregulation, reproduction etc.; Chap. 11 in [6].

### Examples of Autonomic Reflexes and Their Integration in Autonomic Regulations

The concept of the functioning of autonomic reflexes during regulation of autonomic target organs as outlined above is exemplified by three examples.

#### Arterial Baroreceptor Reflexes Mediated by Sympathetic Cardiomotor Neurons

The main components of the baroreceptor reflex pathways mediated by sympathetic cardiovascular neurons and parasympathetic cardiomotor neurons have been worked out in the last 20 years (Fig. 2; [6]). Every relay of this reflex pathway (red in Fig. 2 for the sympathetic cardiovascular neurons) in the lower brain stem (NTS, CVLM, RVLM) and spinal cord (IML) is under multiple synaptic excitatory and inhibitory controls from other centers in spinal cord, brain stem and forebrain. This (together with the structure of the baroreceptor pathway to the parasympathetic cardiomotor neurons) is one basis for the acute and chronic adaptation and plastic changes of the regulation of cardiovascular targets (heart, resistance blood vessels) under various behavioral conditions.

#### Vago-vagal Reflexes of the Gastrointestinal Tract in the Dorsal Vagal Complex (DVC)

The functionally distinct reflex circuits formed in the DVC between the afferents from the GIT [10] and the preganglionic neurons to the GIT are the *basic building blocks* used by the brain to control GI functions (Fig. 3). Anatomical studies have shown that several nuclei in

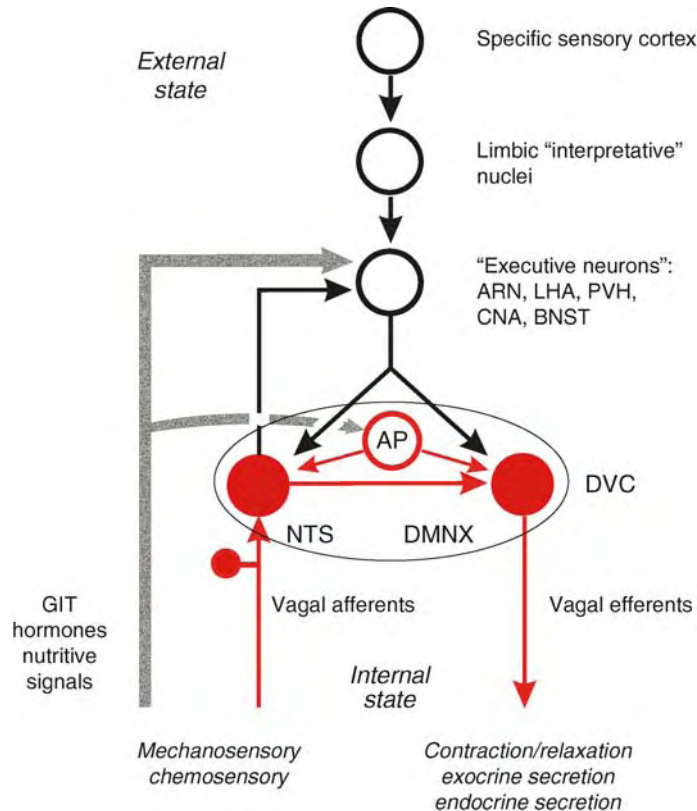

**Autonomic Reflexes. Figure 3** Gastrointestinal vago-vagal reflex pathways in the dorsal vagal complex (DVC) and their modulation by centers in the hypothalamus and cerebral hemispheres. Several functionally specific vago-vagal reflex pathways organized in the dorsal vagal complex (nucleus tractus solitarii [NTS], dorsal motor nucleus of the vagus [DMNX], area postrema [AP]) of the medulla oblongata are the *basic neuronal building blocks* of the control of the gastrointestinal tract (GIT) by the brain. Vagal afferents measure mechanical, chemical and other sensory events and project to the NTS [10]; vagal preganglionic neurons are located in the DMNX and are involved in regulation of motility, exocrine secretion and endocrine secretion of the GIT. Second-order neurons in the NTS project to the preganglionic neurons in the DMNX, the synaptic connection being either inhibitory (transmitter noradrenaline or gamma-amino-butyric acid) or excitatory (transmitter glutamate). Multiple hormonal afferent inputs from the GIT and nutritive inputs (glucose, lipids) occur to the DVC (via the area postrema [AP]) and to the hypothalamus (mostly via the arcuate nucleus [ARN]). Neurons of the “executive” centers (e.g., ARN, lateral hypothalamic and parafornical area [LHA], paraventricular nucleus of the hypothalamus [PVN], central nucleus of the amygdala [CNA], bed nucleus of the stria terminalis [BNST]) evaluate the state of the internal milieu (by way of inputs from visceral afferents, hormonal inputs and nutritive signals) as well as the current or anticipated behavioral state (via input from limbic nuclei that evaluate the significance of exteroceptive signals). These executive centers adapt the internal state (e.g., the functions of the GIT) to the behavioral state of the organism. Modified from Rogers RC and Hermann G (1992) Central regulation of brainstem gastric vago-vagal control circuits. In *Neuroanatomy and Physiology of Abdominal Vagal Afferents* (Ritter S, Ritter RC & Barnes CD eds), pp 99–134 and Travagli RA, Hermann GE, Browning KN, Rogers RC (2006) Brainstem circuits regulating gastric function. *Annu Rev Physiol* 68:279–305.

the brain stem, hypothalamus and telencephalon have *reciprocal connections* with the circuits of the DVC. The functions of most of these neural connections are poorly understood. Thus, the reflex pathways of the DVC are under modulatory control of neurons in the medulla oblongata and supramedullary brain centers, including the insula, the anterior cingulate cortex and medial prefrontal cortex (so-called “executive” neurons) which also receive detailed afferent information

from the GIT (via the NTS), from other visceral organs and from somatic body domains. Executive neurons and basic autonomic circuits in the DVC associated with the GIT represent the *internal state of the organism* as far as the GIT is concerned (Fig. 3).

An essential component of this internal state of the organism is the feedback by hormonal and nutritive signals from the GIT to the DVC via the area postrema and to the hypothalamus (mainly via the arcuate

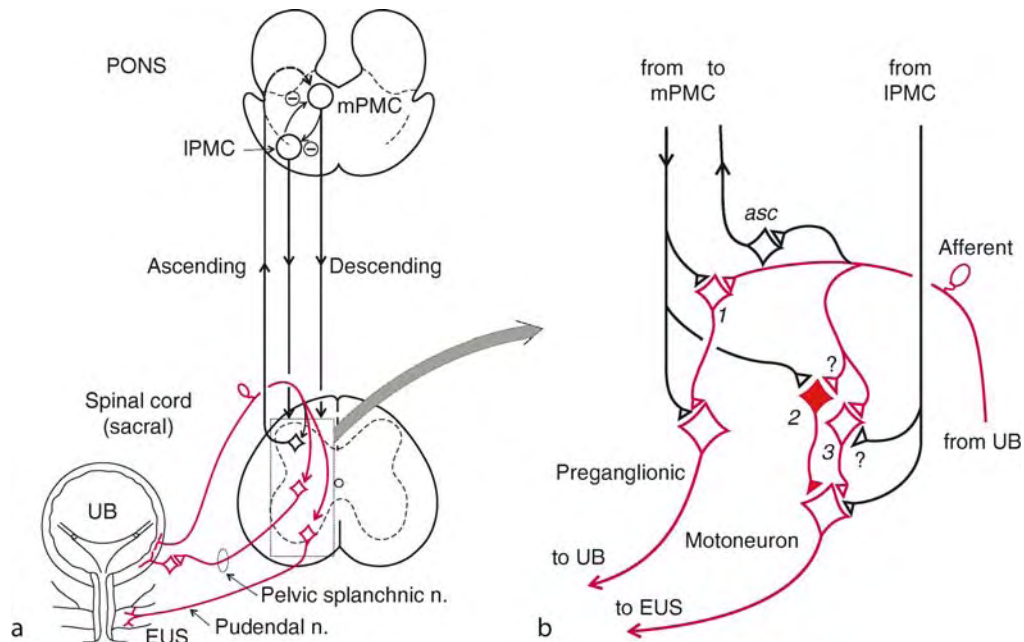

**Autonomic Reflexes. Figure 4** The spinal micturition reflexes and their supraspinal control. (a) Sacral visceral afferents from the urinary bladder (UB) project to interneurons involved in micturition and continence and to ascending tract neurons (ascending) which project (probably via the periaqueductal gray) to the pontine micturition center (PMC) consisting of the lateral PMC (IPMC) and the medial PMC (mPMC). Activation of mPMC Barringtons nucleus enhances/initiates micturition and activation of IPMC continence; both inhibit each other reciprocally. Neurons in the PMC project to the sacral spinal cord (descending). Sacral preganglionic neurons project to the bladder body inducing contraction of the urinary bladder. Other sacral preganglionic neurons project to urethra and bladder neck inducing relaxation (not shown). Motoneurons project to the external urethral sphincter (EUS) that is activated during continence and inhibited during micturition. (b) Afferents from the urinary bladder form reflex circuits to preganglionic neurons and motoneurons in the sacral spinal cord via interneurons 1, 2 and 3 (red). Neurons in the mPMC project to sacral preganglionic parasympathetic neurons and interneurons; they activate the preganglionic neurons to the UB (directly and via interneuron 1) and inhibit motoneurons to the EUS (via interneuron 2). Neurons in the lateral pontine micturition center (IPMC) activate motoneurons during continence (directly and possibly also via interneuron 3). It is a matter of debate whether the micturition center acts mainly at the interneurons or at the preganglionic neurons and somatomotor neurons in the adult. Modified from [6] (see [8,9]).

nucleus: ARN). This hormonal feedback consists of several components and is integrated into the homeostatic regulation of metabolism (nutrition), body temperature, electrolyte balance, reproduction and protection of the body by the brain involving lower brain stem and hypothalamus. These homeostatic regulations are adapted to the behavior of the organism by cortical and limbic system structures that monitor and represent the *external state of the organism* (Fig. 3), e.g., during strong exercise, large environmental temperature changes, food and fluid deprivation, invasion of toxic compounds or bacteria (sepsis, toxemia). This concept shows that there is a close integration between the homeostatic regulation of GIT functions and higher nervous system functions related to body perception, emotions and adaptation of behavior. The highly specific autonomic reflex pathways in the DVC are at the basis of this integration.

#### Micturition Reflexes in the Sacral Spinal Cord

In the adult under physiological conditions, the urinary bladder slowly fills and accommodates to the increasing intravesical volume. Depending on the degree of filling of the urinary bladder and the central (cortical) command signals, micturition is initiated. The detrusor muscle contracts and bladder neck, urethra and external urethral sphincter relax, resulting in the voiding of urine. These coordinated actions are initiated by activation of sacral afferents from the bladder dome and generated by (i) reflex activation of parasympathetic neurons to the detrusor muscle, (ii) reflex activation of inhibitory parasympathetic neurons to the urethra and bladder neck (leading to active relaxation of the outlet of the urinary bladder (not shown in Fig. 4) and (iii) inhibition of pudendal motoneurons.

Figure 4 outlines schematically the central reflex circuits involved in micturition:

1. Activity in sacral vesical afferents activates via an ascending pathway (*ascending* in Fig. 4b) neurons in the medial pontine micturition center (mPMC; Barrington's nucleus). The output neurons of Barrington's nucleus project to the sacral spinal cord and activate the preganglionic neurons mediating bladder contraction both directly and indirectly via interneurons (interneuron 1 Figure 4B) and at the same time, inhibit the motoneurons projecting to the external urethral sphincter via inhibitory interneurons (interneuron 2). The lateral pontine micturition center (IPMC) is inhibited by the mPMC.
2. It is a matter of debate whether the spinal circuits represented by the interneurons 1, 2 and 3 are important during normal micturition when the spinal cord is intact. De Groat and his coworkers believe that the spinobulbospinal reflex pathway involving the mPMC mediates micturition in the adult and that the spinal reflex pathways are unimportant during normal micturition [8]. Others favor the idea that these spinal reflex pathways are involved in the normal micturition reflexes [6,9]. It is suggested for example that the signals from the pontine micturition center are gated by spinal interneurons activated by afferents from the urinary bladder.
3. Motoneurons to the external urethral sphincter are activated by neurons in the lateral pontine micturition center (IPMC) projecting to the sacral spinal cord during continence. This activation occurs by direct synaptic activation of the motoneurons or by synaptic activation of excitatory interneurons antecedent to the motoneurons (interneuron 3 in Fig. 4b). The neurons in the IPMC are inhibited during micturition, probably from the mPMC.

### Acknowledgments

Supported by the Deutsche Forschungsgemeinschaft and the Bundesministerium für Bildung und Forschung (BMBF).

### References

1. Sherrington C (1906) The Integrative action of the nervous system. Yale University Press, New Haven
2. Baldissera F, Hultborn H, Illert M (1981) Integration in spinal neuronal systems. In: Brooks VB (ed) Motor control, Part I (Handbook of physiology, Section 1, The nervous system), Bethesda, Maryland: American Physiological Society, pp 509–595
3. Jankowska E (2001) Spinal interneuronal systems: identification, multifunctional character and reconfigurations in mammals. *J Physiol (Lond)* 533:31–40
4. Prochazka A, Clarac F, Loeb GE, Rothwell JC, Wolpaw JR (2000) What do reflex and voluntary mean? Modern views on an ancient debate. *Exp Brain Res* 130:417–432

5. Furness JB (2006) The enteric nervous system. Blackwell, Oxford
6. Jänig W (2006) The integrative action of the autonomic nervous system. Neurobiology of homeostasis. Cambridge University Press, Cambridge, New York
7. Jänig W, McLachlan EM (2002) Neurobiology of the autonomic nervous system. In: Mathias CJ, Bannister R (eds) Autonomic failure. Oxford University Press, New York, Oxford, pp 3–15
8. De Groat WC (2002) Neural control of the urinary bladder and sexual organs. In: Mathias CJ, Bannister R (eds) Autonomic failure. Oxford University Press, New York Oxford, pp 151–165
9. Shefchyk SJ (2001) Sacral spinal interneurons and the control of urinary bladder and urethral striated sphincter muscle function. *J Physiol (Lond)* 533:57–63
10. Udem B, Weinreich D (2005) Advances in Vagal Afferent Neurobiology. CRC Press, Boca Raton

## Autonomic Regulation

### Definition

Altering visceral processes including those associated with the cardiovascular system, digestion, respiration, metabolism and thermoregulation through the nervous system, mainly via innervation of smooth and cardiac muscle.

## Autonomic Regulation of the Endocrine System

### Definition

Both sympathetic and parasympathetic nerves regulate secretion of some hormones. Hormones secreted in response to stimulation by sympathetic nerves include catecholamines from the adrenal medulla, glucagon from the pancreas and renin from the kidney. Stimulation by sympathetic nerves inhibits insulin secretion from the pancreas. Hormones secreted in response to stimulation by parasympathetic nerves include gastrins from the stomach and insulin from the pancreas.

Secretion of these various hormones can be elicited by either direct stimulation of the central nervous system, or by visceral and somatic afferent stimulation whereby autonomic nerves serve as the efferent limbs of the respective reflex arcs.

## Autonomic Testing: The Clinical Laboratory

PHILLIP A. LOW, MAYO CLINIC  
Department of Neurology, Mayo Foundation,  
Rochester, MN, USA

### Advantages and Disadvantages

The autonomic nervous system (ANS) regulates such important functions as blood pressure (BP), heart rate (HR), respiration, and bowel, bladder, sexual, thermoregulatory and pupillary functions. Autonomic disorders affecting the brain, spinal cord, or peripheral nerves could cause damage to autonomic pathways and result in autonomic dysfunction. Testing can be done to evaluate the integrity of autonomic pathways and structures, and to detect deviations from normal. Such testing can be done as part of clinical laboratory evaluation or as research into ANS function and dysfunction. Autonomic tests can be divided into two broad categories, “Routine Tests” and “Research Studies.”

### Routine Laboratory Tests of Autonomic Function

The goal in clinical autonomic testing is to detect the presence of autonomic failure in patients with suspected autonomic disorders, using a panel of tests that meet certain criteria. Thus, since these tests are to be widely used on many patients, they need to be straightforward to perform, comprehensive, reliable, and based on sound autonomic physiology. One set of routine tests comprises a study of the integrity of autonomic nerves that regulate sudomotor, cardiovagal, and adrenergic function. The aims are to detect the presence of autonomic failure, to quantify the severity, to apportion the type (sudomotor, adrenergic, cardiovagal) and distribution of deficits, and to determine the site (preganglionic versus postganglionic) of the lesion [1].

Postganglionic sudomotor function is evaluated using the quantitative sudomotor axon reflex test (QSART). QSART utilizes an axon-reflex pathway and tests the integrity of the postganglionic sympathetic sudomotor axon [2]. The stimulus is iontophoresed acetylcholine and the evoked sweat response is recorded in a different site. Typically, recording sites are the forearm, proximal leg, distal leg, and foot. In normal subjects, sweat volumes for all sites are similar and women have volumes that are approximately one-half those of males. The distribution of abnormalities is particularly useful in monitoring a length-dependent neuropathy; sweat volumes undergo a progressive decrease from proximal to distal sites. The test is also useful in monitoring the course of a neurologic disorder

over time since the test is highly reproducible. Volumes from the same subjects on two different days correlate well ( $R = 0.9$ ) with a coefficient of variation of 14.7%. QSART can be supplemented by the thermoregulatory sweat test (TST). Sweating in TST, in response to raising core temperature using ambient heat, is detected by an indicator powder. This test provides information on the distribution of sweat loss. The percent of anterior body surface anhidrosis can be quantified [3]. Taken with QSART, the site of the lesion can be defined. For instance, if a patient were anhidrotic at a site but had normal QSART, the lesion would likely be preganglionic.

Cardiovascular function is relatively straightforward to evaluate. Both cardiac afferent and efferent nerve fibers that are activated by maneuvers such as deep breathing, standing up, or the Valsalva maneuver are carried in the vagus nerve. Hence, tests in the time domain, such as those measuring heart rate response to deep breathing or to the Valsalva maneuver, evaluate vagal pathways to the heart. An alternative approach is to evaluate cardiovascular function in the frequency domain. Tests of cardiovascular function, especially the response to deep breathing, are reliable and reproducible, provided that the end organ is healthy [4].

Adrenergic function controls blood pressure (and heart rate) by regulating tone to the microvessels (mainly arterioles) and cardiac contractility. The major reflex is the baroreflex, which responds instantaneously to changes in blood pressure and volume by an increase or decrease in sympathetic nerve traffic [5]. We evaluate adrenergic function by measuring beat-to-beat BP responses to maneuvers that change BP in a standardized way. Two useful maneuvers are the Valsalva maneuver and head-up tilt (HUT) [1]. The Valsalva maneuver is performed by maintaining expiratory pressure at 40 mm Hg for 15 seconds, and results in changes in venous return to the heart resulting in a transient reduction in stroke volume and BP. This, in turn, results in unloading of baroreflexes. The ensuing vasoconstriction and resultant pressor response provide an index of baroreflex function. The phases of the Valsalva maneuver are under adrenergic control [6]. In HUT, orthostatic stress results in volume shift to the dependent parts of the body, and whether BP is maintained or falls depends on the integrity of baroreflexes. An angle of tilt of 60 or 70° is recommended.

Plasma catecholamines measured with the patient supine and then upright provide a profile of the humoral (mainly noradrenergic) response to standing. In a normal subject standing values are approximately double those with the subject supine. The results of this test correlate well with muscle sympathetic nerve activity [7]. When widespread postganglionic adrenergic failure is present, as in pure autonomic failure,

supine norepinephrine is markedly reduced (70 pg/ml) and fails to increase on standing. With a preganglionic lesion, as in multiple system atrophy, supine values are normal but on standing norepinephrine fails to increase.

The effects of age and gender have significant effects on these autonomic responses, so that an autonomic laboratory must generate a large normative data set in order that percentiles and normal variations for age and gender can be determined.

Laboratory evaluation is useful in a number of circumstances. It is useful in detecting the severity and distribution of autonomic failure. It is valuable in monitoring the course of autonomic failure and evaluating the response to therapy. It is also helpful in differentiating benign disorders (such as syncope) from more serious disorders (such as neurogenic orthostatic hypotension).

### Autonomic Testing: Research Studies

There are numerous tests of autonomic function for use in the research laboratory. The selection of tests depends on the research question at hand. Below is a selection of some tests that are in relatively wide use. This description is by necessity selective. For instance, we will not describe the extensive molecular studies of a whole range of autonomic receptors.

#### Microneurography

Muscle sympathetic neural discharges from unmyelinated axons can be recorded in awake human subjects via tungsten microelectrodes inserted percutaneously into an accessible peripheral nerve [8]. This technique has provided important insights into normal autonomic physiology and aging. Recently, the technique is increasingly applied to gain insights into the pathophysiology of sympathetic dysfunction in the autonomic neuropathies, and pre- and post-ganglionic autonomic disorders.

#### Baroreflex Analysis

A fall in BP leads to unloading of baroreceptors located in the carotid sinus and aortic arch. This results in activation of sympathetic outflow and inhibition of cardiovagal neurons, and so an increase in heart rate. The converse occurs with a rise in BP. The most reliable method to estimate baroreflex sensitivity is to relate changes in heart period to changes in SBP induced first by intravenous sodium nitroprusside. This is followed by a bolus injection of phenylephrine hydrochloride, thus inducing first a fall and then a subsequent rise in arterial blood pressure – a modification of the Oxford method [9]. Noninvasive approaches that omit vasoactive drugs have been adapted using BP and heart

rate alterations that occur in response to autonomic maneuvers or even spontaneously. The sequence technique [10] is a time-domain method that relates spontaneous sequences of BP fluctuations to the associated heart rate fluctuations. The spectral technique is a frequency domain method, and the cross-spectral technique estimates the gain of the transfer function between changes in blood pressure and heart period [10]. Induced BP changes secondary to neck suction or the Valsalva maneuver can also be used.

#### Cerebral Vasoregulation

Cerebral autoregulation refers to the maintenance of constant cerebral blood flow in spite of changes in cerebral perfusion pressure [11]. Patients with autonomic baroreflex failure develop both orthostatic hypotension and supine hypertension. Cerebral autoregulation is especially important in these patients and indeed compensation is apparently sometimes augmented by an expansion of the range of autoregulation. The availability of transcranial Doppler methodology to measure blood flow velocity in the middle cerebral artery provides ready access to these measurements. Autoregulation can be studied by changing the steady-state BP (static method) or by rapidly altering BP (dynamic method). Both methods have yielded similar estimates of autoregulation in normal human subjects [12]. One concern with these methods is that the induced BP alterations cause rapid changes in critical closing pressure, rendering estimates of autoregulation inaccurate. Thus, a transfer function method has been proposed, and this is unaffected by changes in critical closing pressure. Cerebral autoregulation has been studied in orthostatic hypotension and intolerance [13].

#### Splanchnic-Mesenteric Vasoregulation

The splanchnic-mesenteric vascular bed is unique in that it is a baroreflex-responsive capacitance bed. It is of large volume containing up to 20–25% of blood volume. The blood volume increases by 200–300% after a meal. Not surprisingly orthostatic hypotension develops or is aggravated post-prandially. Recent advances in duplex ultrasound technology have allowed reliable noninvasive evaluation of the mesenteric circulation. Superior mesenteric artery (SMA) blood flow can be measured by a real-time Doppler ultrasound transducer [14]. The cross-sectional area of the SMA (SMA-area) and time-average velocity (SMA-TAV) are measured using dedicated software, and blood flow and vascular resistance are calculated. The post-prandial fall in BP is linearly related to the increase in SMA flow. It is possible to define the effects of tilt and vasoconstrictors.

### Cardiac Innervation

Cardiac postganglionic sympathetic adrenergic innervation can be studied using isotopes and SPECT, or positron-emission tomography (PET) scanning. Cardiac uptake of [<sup>123</sup>I]iodine-123 meta-iodobenzylguanidine, an analogue of norepinephrine which traces the functioning of postganglionic sympathetic adrenergic neurons [15], can be imaged using SPECT. PET scanning and 6-[<sup>18</sup>F]fluorodopamine provide better resolution [16]. This test has been useful in differentiating MSA (normal uptake) and Parkinson's disease (reduced uptake when autonomic failure is present [17]). Uptake is also reduced in diabetic autonomic neuropathy. Interestingly, PET scanning has been reported to show hyperinnervated adrenergic islands in rostral segments in these patients, raising the possibility that these might be conducive to arrhythmias.

### References

- Low PA (1993) Autonomic nervous system function. *J Clin Neurophysiol* 10:1427
- Low PA, Caskey PE, Tuck RR, Fealey RD, Dyck PJ (1983) Quantitative sudomotor axon reflex test in normal and neuropathic subjects. *Ann Neurol* 14:573–580
- Fealey RD, Low PA, Thomas JE (1989) Thermoregulatory sweating abnormalities in diabetes mellitus. *Mayo Clin Proc* 64:617–628
- Wieling W, van Brederode JF, de Rijk LG, Borst C, Dunning AI (1982) Reflex control of heart rate in normal subjects in relation to age: a data base for cardiac vagal neuropathy. *Diabetologia* 22:163–166
- deBoer RW, Karemaker JM, Strackee J (1987) Hemodynamic fluctuations and baroreflex sensitivity in humans: a beat-to-beat model. *Am J Physiol* 253: H680–H689
- Sandroni P, Benarroch EE, Low PA (1991) Pharmacological dissection of components of the Valsalva maneuver in adrenergic failure. *J Appl Physiol* 71:1563–1567
- Wall in BG, Sundlof G, Eriksson BM, Dominiak P, Grobecker H, Lindblad LE (1981) Plasma noradrenaline correlates to sympathetic muscle nerve activity in normotensive man. *Acta Physiol Scand* 111:69–73
- Wall in BG, Elam M (1997) Microneurography and autonomic dysfunction. In: Low PA (ed) *Clinical autonomic disorders: Evaluation and management*. Lippincott-Raven, Philadelphia, pp 233–243
- Smyth HS, Sleight P, Pickering GW (1969) Reflex regulation of arterial pressure during sleep in man. A quantitative method of assessing baroreflex sensitivity. *Circ Res* 24:109–121
- Eckberg DL, Sleight P (1992) *Human baroreflexes in health and disease*. Clarendon, Oxford
- Strandgaard S, Paulson OB (1984) Cerebral autoregulation. *Stroke* 15:413–416
- Tiecks FP, Lam AM, Aaslid R, Newell DW (1995) Comparison of static and dynamic cerebral autoregulation measurements. *Stroke* 26:1014–1019
- Novak V, Spies JM, Novak P, McPhee BR, Rummans TA, Low PA (1998) Hypocapnia and cerebral hypoperfusion in orthostatic intolerance. *Stroke* 29:1876–1881
- Fujimura J, Camilleri M, Low PA, Novak V, Novak P, Opfer-Gehrking TL (1997) Effect of perturbations and a meal on superior mesenteric artery flow in patients with orthostatic hypotension. *J Auton Nerv Syst* 67:15–23
- Braune S, Reinhardt M, Schnitzer R, Riedel A, Lucking CH (1999) Cardiac uptake of [<sup>123</sup>I]MIBG separates Parkinson's disease from multiple system atrophy. *Neurology* 53:1020–1025
- Goldstein DS, Holmes C, Eisenhofer G, Kopin H (1997) Sympathetic cardioneuropathy in dysautonomias. *N Engl J Med* 336:696–702
- Goldstein DS, Holmes C, Li ST, Bruce S, Metman LV, Cannon III RO (2000) Cardiac sympathetic denervation in Parkinson disease. *Ann Intern Med* 133:338–347

## Autonomic/Enteric Dysreflexia

### Definition

Autonomic dysreflexia is a clinical syndrome occurring in patients with severe cervical or upper thoracic spinal cord lesions. It normally appears several months following injury and manifests as exuberant reflex autonomic discharges in response to what might otherwise be relatively trivial stimuli. A classical presentation is paroxysmal hypertension, mediated via excessive splanchnic sympathetic output, triggered by bowel or bladder distension.

- ▶ Autonomic/Enteric Reflexes
- ▶ Autonomic Insufficiency

## Autonomic/Enteric Reflexes

JACKIE D. WOOD

Department of Physiology and Cell Biology and Internal Medicine, College of Medicine, The Ohio State University, Columbus, OH, USA

### Definition

Enteric reflexes are fundamental mechanisms in the autonomic neural control of motility up and down the digestive tract, starting with swallowing at the oral end and terminating with defecation at the anal end. With the exception of the control of the striated musculature in the pharynx during swallowing and control of the skeletal musculature of the pelvic floor during maintenance of fecal continence and defecation, most



enteric reflexes are mediated by the autonomic nervous system. The three divisions of the autonomic nervous system (i.e. the parasympathetic, sympathetic and enteric divisions) interact with each another in mediating involuntary control of motor behavior of the smooth musculature of the digestive tract, secretory behavior of the glands and gastrointestinal blood flow.

Reflex circuits were also called “reflex arcs” in earlier literature. A reflex circuit consists of a minimum of a sensory neuron that synapses with and excites a motor neuron, which in turn innervates an effector (e.g. muscle or gland). Reflex behavior evoked by a circuit consisting only of a sensory and motor neuron is a monosynaptic reflex. Reflex circuits in which interneurons are synaptically interposed between the sensory and motor neuronal components are polysynaptic reflex circuits. Enteric reflexes are generally polysynaptic with internuncial circuitry located in the brainstem, the spinal cord and within the **enteric nervous system** (ENS) positioned inside the walls of the digestive tract.

## Characteristics

### Brain-Stem Reflexes and ENS Reflexes

#### *Reflex Control of the Stomach*

Internuncial circuitry in both the brainstem and the gastric ENS is involved in reflex control of secretory and motor functions of the stomach. Motor functions in the stomach are more complex than in the intestines, and require the more sophisticated circuitry of the brainstem to achieve full moment-to-moment control during filling, grinding movements and emptying. Motor functions of the small and large intestines are less complex and are mainly organized by the ENS independent of the central nervous system (CNS).

Functionally, the stomach is divided into a proximal reservoir and distal antral pump on the basis of distinct differences in motility between the two regions. The differences in motility between the reservoir and antral pump reflect adaptations for different functions [8]. The muscles of the proximal stomach are adapted for maintaining continuous contractile tone (tonic contraction) and do not contract phasically. In contrast, the muscles of the antral pump contract phasically. The spread of strong phasic contractions in the region of the antral pump propels the gastric contents toward the gastroduodenal junction. Strong propulsive waves of this nature do not occur in the proximal stomach.

#### *Antral Pump*

Gastric action potentials determine the duration, strength and aboral direction of travel of the phasic contractions in the antral pump. Gastric action potentials are initiated by a dominant pacemaker located approximately in the mid-region of the stomach. After

starting at the pacemaker site, an action potential propagates rapidly around the gastric circumference and triggers a ring-like contraction. The action potential and associated ring-like contraction then travel more slowly until they reach the gastroduodenal junction where they stop [8]. **Electrical syncytial properties** of the myogenic gastric musculature (**myogenic musculature**) account for the propagation of the action potentials from muscle fiber to muscle fiber away from the pacemaker site toward the gastroduodenal junction. Gastric action potentials are generated at  $3 \text{ min}^{-1}$  in humans, have durations of about 5 s and have a rising depolarization phase, a plateau phase, and a repolarization falling phase (Fig. 1).

The action potentials trigger propulsive contractions when the plateau phase is above a threshold voltage and the strength of the contraction increases in direct relation to increases in the amplitude of the plateau potential beyond threshold.

The action potentials in the gastric reservoir are myogenic (i.e. an inherent property of the muscle) and occur in the absence of any neurotransmitters or other chemical messengers. The myogenic characteristics of the action potential are modulated by musculomotor neurons in the gastric ENS. Neurotransmitters released by enteric musculomotor neurons determine the amplitude of the plateau phase of the action potential, and thereby control the strength of the contractile event triggered by the plateau phase. Neurotransmitters (e.g. acetylcholine) released from excitatory motor neurons in the ENS increase the amplitude of the plateau phase and of the contraction initiated by the plateau (Fig. 1). Inhibitory neurotransmitters including norepinephrine, vasoactive intestinal peptide and nitric oxide decrease the amplitude of the plateau and the strength of the associated contraction. Postganglionic neurons projecting to the stomach from prevertebral ganglia of the sympathetic nervous system are the source of norepinephrine. The sources of vasoactive intestinal peptide and nitric oxide are inhibitory musculomotor neurons (**enteric inhibitory musculomotor neurons**) in the ENS. The magnitude of the excitatory or inhibitory actions of neurotransmitters is related directly to the concentration of the transmitter substance at receptors on the gastric musculature. Progressively higher frequencies of impulse discharge by **enteric excitatory musculomotor neurons** progressively release greater amounts of neurotransmitter. In this way, motor neurons determine, through the actions of their neurotransmitters on the plateau phase, whether or not a propagating contraction occurs in the antral pump. With sufficient release of transmitter, the plateau exceeds the threshold and a contraction occurs. Beyond threshold, the strength of contraction is determined by the amount of neurotransmitter released and present at excitatory receptors on the musculature.

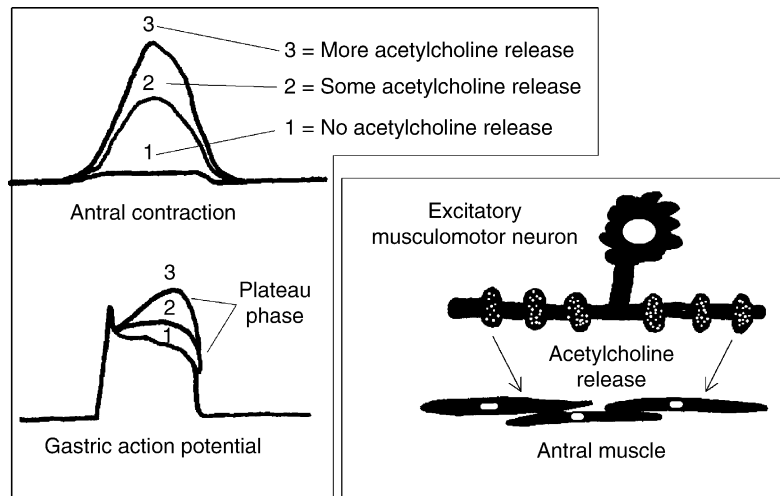

**Autonomic/Enteric Reflexes. Figure 1** Firing frequency and therefore the amount of acetylcholine released from excitatory musculomotor neurons in the myenteric plexus of the gastric antrum determine the amplitude of the plateau phase of the gastric action potential. The amplitude of the plateau phase determines the amplitude of antral contractions.

### Gastric Reservoir

The gastric reservoir functions in two ways. One is to accommodate the arrival of a meal without a significant increase in intragastric pressure and intramural tension. Failure of accommodation leads to the uncomfortable sensations of bloating, epigastric pain, and nausea in humans. The second function sustains a constant compressive force on the contents of the reservoir that “pushes” the contents into the 3-cycles  $\text{min}^{-1}$  motor activity of the antral pump. Drug-induced relaxation of the musculature of the gastric reservoir (e.g. by insulin or glucagon) neutralizes this function and suppresses gastric emptying.

The musculature of the gastric reservoir is innervated by enteric excitatory and inhibitory musculomotor neurons. Vagal efferent nerves and neural networks in the gastric ENS control the firing frequencies of the musculomotor neurons. Changes in the firing frequencies of the musculomotor neurons, and coordination of the activity in excitatory and inhibitory enteric musculomotor neuronal populations, function to adjust the volume and pressure of the reservoir to the amount of solid and/or liquid present, while maintaining constant compressive forces on the contents. Neural control mechanisms continuously readjust the volume and pressure within the reservoir as required during both ingestion and emptying of a meal.

Increased activity of excitatory musculomotor neurons coordinated with decreased activity of inhibitory musculomotor neurons, results in increased contractile tone in the reservoir, a decrease in its volume, and an increase in intraluminal pressure. Increased firing of inhibitory musculomotor neurons, coordinated with decreased activity of excitatory musculomotor neurons,

results in decreased contractile tone in the reservoir, expansion of its volume, and a decrease in intraluminal pressure.

Neurally mediated decreases in tonic contracture of the musculature are responsible for relaxation in the gastric reservoir (i.e. increased volume). Three kinds of relaxation are recognized: (i) Receptive relaxation is initiated by the act of swallowing. It is a reflex triggered by stimulation of mechanoreceptors in the oropharynx, followed by transmission over spinal and cranial afferents to the **dorsal vagal complex** in the medulla oblongata of the brainstem and activation of efferent vagal fibers to inhibitory musculomotor neurons in the gastric ENS. (ii) Adaptive relaxation is triggered by distension of the gastric reservoir. It is a **vago-vagal reflex** consisting of activation of stretch receptors in the gastric wall, transmission over vagal afferents to the brainstem, central processing of the afferent information and return transmission in efferent vagal fibers to stimulate inhibitory musculomotor neurons in the gastric ENS. (iii) Feedback relaxation is triggered by the presence of nutrients in the small intestine. This form of reservoir relaxation can involve both local reflex connections between receptors in the small intestine and the gastric ENS, or hormones (e.g. cholecystinin) that are released from endocrine cells in the small intestine and transported by the blood to signal the gastric ENS.

### Pathology

Adaptive relaxation is impaired in patients who have suffered injury to the vagus nerves during laparoscopic fundoplication surgery or have undergone gastric vagotomy for treatment of an acid-related disorder.

Following a vagotomy, increased tone in the musculature of the reservoir decreases the wall compliance, which in turn affects the responses of gastric stretch receptors to distension of the reservoir. The loss of adaptive relaxation following vagotomy is associated with a lowered threshold for sensations of fullness and pain during a meal and filling of the gastric reservoir. Increased sensitivity to gastric distension in these cases is explained by excessive stimulation of the gastric mechanoreceptors that sense distension of the gastric wall. These effects of vagotomy underscore the importance of sensory detection in the gastric wall and processing of the sensory information in the dorsal vagal complex (see next section), and help to understand disordered gastric sensations in diseases that have a component of vagal nerve pathology (e.g. autonomic neuropathy in diabetes mellitus).

### Vago-Vagal Reflexes

Sensory nerve fibers in the afferent arm of ► **vago-vagal reflexes** involved in control of gastric functions enter the brainstem and form synaptic connections with cell bodies of efferent vagal neurons that project efferent information back to the stomach. The cell bodies of efferent vagal neurons to the stomach are located in the dorsal motor nucleus of the vagus (DMNV). The vagal afferents also form synapses with second order neurons in the brainstem that distribute visceral information throughout the CNS. Fifty thousand vagal afferent fibers are estimated to supply the gastrointestinal tract. The number of vagal afferent fibers exceeds the number of efferent vagal fibers by about 10:1. Vagal afferent fibers are unmyelinated C-fibers that transmit different modalities of sensory information at low conduction velocity. Vagal afferents generally transmit physiological information on the nature and composition of the luminal contents, on shearing forces occurring at the mucosal surface and on contractile tension in the gastric musculature.

Some vagal afferents connect monosynaptically with vagal efferent neurons and thus become the sensory arm of monosynaptic vago-vagal reflex arcs. Nevertheless, the majority of gastrointestinal vagal afferents project to second order neurons in the nucleus tractus solitarius, and much of the afferent information from the upper gut is therefore processed in polysynaptic pathways through the brainstem. The nucleus tractus solitarius and DMNV combine to form the dorsal vagal complex. Various subnuclei form the nucleus tractus solitarius. Of these, the subnucleus gelatinosus and the medial and commissural nuclei are the principal targets for sensory information in gastric afferents. Gastric afferents also project to the area postrema in the medulla oblongata and transmit input that triggers nausea and emesis. Projections of neurons in the nucleus tractus solitarius to the DMVN complete the vago-vagal reflex

arcs involved in regulation of gastric function. Additional sensory pathways ascend through the mid-brain and reticular nuclei to innervate higher brain centers, and in particular to hypothalamic nuclei involved in mechanisms of satiety and regulation of food intake.

Vagal efferent neurons form the cephalic component of the parasympathetic division of the autonomic nervous system. The cell bodies of the vagal efferents are centered in the DMVN, which is a spindle-shaped nucleus running rostro-caudally through the medulla oblongata on either side of the central canal as it emerges into the fourth ventricle. The DMVN is organized anatomically into longitudinal columns of neurons that ultimately give rise to the branches of the vagal nerves that supply the various abdominal organs.

Vagal efferent nerve fibers transmit CNS input to the ENS. A relatively small number of efferent vagal fibers supply synaptic input to a much larger number of neurons in the ENS. Vagal efferent fibers branch extensively within the gastric ENS where they make synaptic contact with the excitatory and inhibitory musculomotor neurons that innervate the gastric musculature. Most of the vagal efferents release acetylcholine to stimulate nicotinic excitatory receptors on the post-synaptic neurons.

Experimental electrical stimulation of efferent fibers in the vagus nerves evokes a mixture of muscular contraction and relaxation as a consequence of activating parallel pathways to excitatory and inhibitory musculomotor neurons. Contractile responses to vagal stimulation are largely cholinergic and are suppressed by drugs that block nicotinic receptors on enteric neurons or muscarinic receptors on the musculature. Vagally-evoked relaxation is mediated by release of nitric oxide, ATP and vasoactive intestinal peptide from the inhibitory motor innervation of the musculature. Vagally-mediated excitatory or inhibitory gastric reflexes therefore arise from selective activation or suppression of populations of efferent vagal neurons in the DMNV, which project either to inhibitory or excitatory musculomotor neurons in the gastric ENS.

Spontaneously discharged impulses, which reflect ongoing generation of neural activity in the DVMN, can be detected by electrodes on vagal efferent fibers. The spontaneous activity may be generated by DVMN neurons themselves or result from activity in circuitry elsewhere in the brainstem or in higher brain centers that supply excitatory synaptic input to the DVMN neurons. A diverse array of neurotransmitters, including glutamate, serotonin and gamma aminobutyric acid, is expressed in the synaptic neuropil surrounding the DVMN neurons. Brain regions with a prominent input to the DVMN include the medullary raphe nuclei, the paraventricular nucleus of the hypothalamus and the central nucleus of the amygdala. These connections underlie emotional and behavioral influences on vagal

outflow to the gut, and in particular, the effects of physical and psychological stress on gastrointestinal function.

As vagal efferents connect to both excitatory and inhibitory motor neurons in the ENS, these pathways are suggested to be reciprocally controlled in the brainstem such that contraction of the gastric musculature arises from activation of cholinergic pathways and simultaneous inhibition of inhibitory pathways [4]. Accordingly, vagally-evoked relaxation of the musculature in the gastric reservoir would involve simultaneous activation of inhibitory pathways and suppression of excitatory pathways. The reflex circuits in the brainstem may therefore be “hardwired” for reciprocal control.

### Lower Level Components Reflexes Mediated by the ENS

The ENS division of the autonomic nervous system is embedded inside the walls of the digestive tract (Fig. 2).

It consists of ganglia, primary interganglionic fiber tracts and secondary and tertiary fiber projections to the musculature, glands and blood vessels. Two ganglionated plexuses are the most obvious gross morphological feature of the ENS. The ►myenteric plexus, also called Auerbach’s plexus, is located between the longitudinal and circular muscle layers of most of the digestive tract. The ►submucosal plexus consists of Meissner’s and Schabadasch’s plexuses and is situated in the submucosal region between the circular muscle and mucosa. The submucosal plexus is most prominent as a ganglionated network in the small and large intestine. It does not exist as a ganglionated plexus in the esophagus and is sparse in the submucosal space of the stomach. Neurons in submucosal ganglia project fibers to the myenteric plexus and also receive synaptic input from axons projecting from the myenteric plexus. The interconnections link the two networks into a functionally integrated nervous system.

The heuristic model for the ENS is the same as for the brain and spinal cord. Like the brain and spinal cord, the ENS develops with the neural elements and integrated circuitry necessary for independent processing of sensory information and programming of organized behavior of effector systems. The ENS controls the intestinal effector systems (i.e. musculature, secretory glands and blood vasculature) in the minute-to-minute regulation of the intraluminal environment of the gut. The population of neurons in the ENS, like the neurons in the brain and spinal cord, is divided into a subpopulation of sensory neurons, a subpopulation of interneurons and a subpopulation of motor neurons. The sensory neurons, interneurons and motor neurons are synaptically interconnected into integrated circuits that process sensory information, and program the variety of digestive functions found in the specialized compartments of the digestive tract during ever changing demands of the ingestive/digestive states of the functioning bowel.

Integrated circuits of the ENS determine the distinctive patterns of motility that characterize the digestive and interdigestive states of the small and large intestine. The ENS microcircuits include a polysynaptic peristaltic reflex circuit (Fig. 3) that underlies all forms of propulsive intestinal motility.

The programs for physiological ileus (i.e. absence of motility), digestive and interdigestive motor and secretory behavior and small intestinal retropulsion during emesis are all stored in the integrated circuits of the ENS.

Microcircuits in the myenteric division of the intestinal ENS contain the musculomotor neurons to the musculature (Fig. 3). Like in the stomach, one subpopulation of musculomotor neurons excites the intestinal musculature to contract; another subpopulation inhibits muscle contraction. Acetylcholine and substance P are primary neurotransmitters released by the subpopulation of excitatory musculomotor neurons.

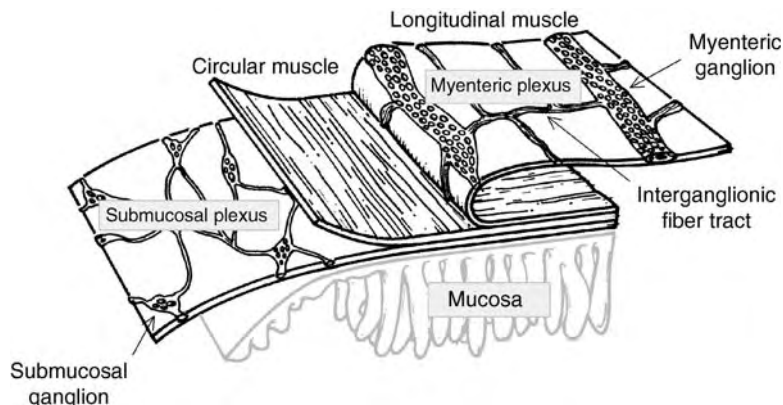

**Autonomic/Enteric Reflexes. Figure 2** Morphology of the enteric nervous system.

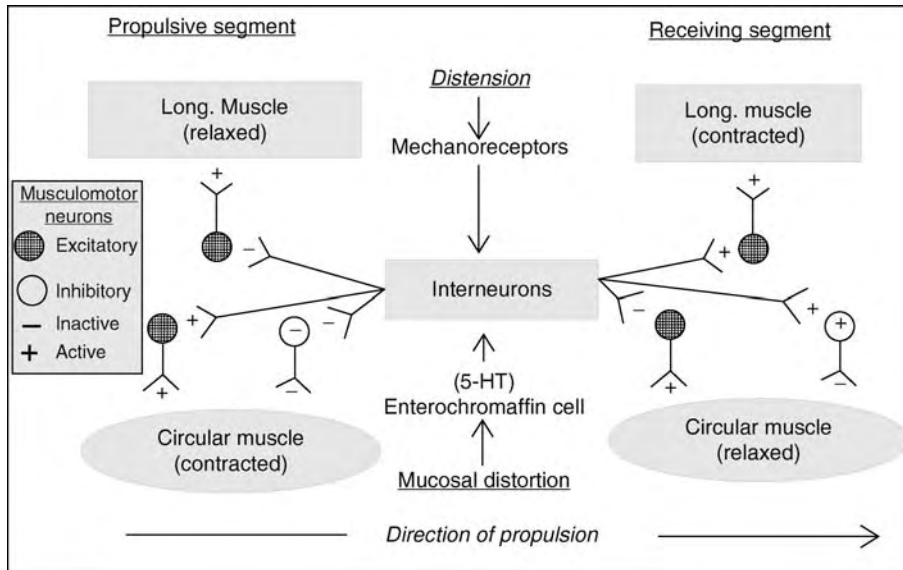

**Autonomic/Enteric Reflexes. Figure 3** A polysynaptic reflex circuit in the ENS evokes the peristaltic reflex. Two kinds of sensory input activate the reflex. One is distension of the intestinal wall and activation of stretch receptors that synapse with interneurons. Second is stimulation of release of 5-hydroxytryptamine from enterochromaffin cells by shearing forces on the mucosa. Output from the interneuronal reflex circuit activates excitatory musculomotor neurons to the longitudinal muscle and inhibitory musculomotor neurons to the circular muscle to form a receiving segment (see fig. 4) below the point of sensory stimulation. At the same time, the circuit inactivates excitatory musculomotor neurons to the longitudinal muscle, activates excitatory musculomotor neurons to the circular muscle, and inactivates inhibitory musculomotor neurons to the circular muscle in the propulsive segment above the point of stimulation (see fig. 4).

Nitric oxide, vasoactive intestinal peptide and ATP are implicated as inhibitory neurotransmitters.

Microcircuits in the submucosal division of the ENS contain ►**secretomotor neurons** that innervate the intestinal secretory glands (i.e. Brunner's glands and crypts of Lieberkühn). The secretomotor neurons are the efferent arm of secretory reflex arcs that release vasoactive intestinal peptide and/or acetylcholine at the neuroepithelial junctions to evoke secretion of H<sub>2</sub>O, electrolytes and mucus. Collaterals of secretomotor neurons innervate submucosal blood vessels and stimulate vasodilation to increase blood flow in concert with elevated glandular secretion.

Chemical synapses connect ENS interneurons into integrated microcircuits that determine the timing and strength of neural outflow in the motor neuronal pathways to the musculature, secretory glands and vasculature. In addition to control of each of these individual effector systems, interneuronal synaptic circuits coordinate the activity of each of the systems to achieve homeostatic behavior at the level of the integrated organ system.

The ENS is envisioned as a “mini-brain” placed close to the effector systems it controls and this led to coining of the term “brain-in-the-gut” [6]. The brain-in-the-gut contains as many neurons as the spinal cord. Rather

than packing the  $2 \times 10^8$  neurons required for control of gut functions into the skull as part of the brain, and relying on signal transmission over long-unreliable pathways to the gut, natural selection during biological evolution distributed the integrative neural networks in locations next to the effectors along the 7 m of human small intestine and 1.5 m of large intestine.

### The Peristaltic Reflex

Peristalsis is a stereotyped propulsive motor reflex that underlies all propulsive motility patterns found in the small and large intestine. The peristaltic reflex is the ENS analog of spinal motor reflexes (e.g. monosynaptic patellar and Achilles tendon reflexes and polysynaptic withdrawal reflexes). Monosynaptic spinal reflexes are investigator-evoked artifacts arising from connections of stretch receptors in the muscle to alpha spinal motor neurons that innervate the same muscle. They reflect the effects of abrupt activation of stretch receptors (i.e. muscle spindles) in the muscle and have little relevance for fully understanding the complexity of fine neural control of movement. Polysynaptic spinal withdrawal reflexes occur in stereotypic fashion in response to noxious stimulation, such as touching the hand to a hot object. The peristaltic reflex is much the same as spinal reflexes in that it is a fixed response

evoked by investigational stretching of the intestinal wall or stroking of the mucosa in isolated intestinal preparations. It is like a polysynaptic spinal reflex in that it is a motor response to sensory stimulation that is repeated the same way each time the “hardwired” reflex circuit is activated. The peristaltic reflex circuit is “wired” such that it evokes relaxation of the circumferentially oriented muscle layer, contraction of the longitudinal muscle below the point of stimulation and contraction of the circumferentially oriented muscle layer above the point of stimulation.

Like spinal reflexes, the peristaltic reflex is positioned at the lowest level of the hierarchical organization of neural control of intestinal motility, and undoubtedly underlies each of the various patterns of propulsive motility that impart functionality to the intestine during daily life. As with a spinal motor reflex, the sequencing of the pattern of behavior of the intestinal longitudinal and circular muscles is hardwired into the circuitry, while the strength of each motor component of the pattern, and the repetition rate of the pattern, are adjusted by sensory feedback or other commands to automatically compensate for local loads and higher functional demands on the intestine as a whole. Distance and direction in which propulsion occurs in the specific patterns of motility that characterize the various digestive states are additional factors requiring a higher order of neural control. Short distance propulsion in the postprandial digestive state, propulsion over intermediate distances during interdigestive

motility (i.e. the migrating motor complex) and long distance power propulsion, all in the orthograde direction, and retropulsion during emesis are neural control requirements that are met by the ENS. Better understanding of the neural basis for intestinal motility will require moving forward from the “over-worked” concept of the peristaltic reflex, on to investigation of microcircuits in positions at levels of organization beyond the reflex “hardwiring” that faithfully reproduces the muscle behavior each time the investigator stretches the intestinal wall or strokes the mucosa.

The muscle layers of the intestine contract and relax in a stereotyped pattern during peristaltic propulsion (Fig. 4).

This pattern is determined by the sequence in which the peristaltic polysynaptic reflex circuit activates excitatory and inhibitory musculomotor neurons to the longitudinal and circular muscle layers. During propulsion, the longitudinal muscle layer in the segment ahead of the advancing intraluminal contents contracts in response to activation of its excitatory motor innervation, while at the same time, the circular muscle layer relaxes in response to activation of its inhibitory motor innervation. The intestinal tube always behaves geometrically like a cylinder with constant surface area [10]. Shortening of the longitudinal axis of the cylinder during contraction of the longitudinal muscle is accompanied by a widening of the cross-sectional diameter. The simultaneous shortening of the longitudinal axis and relaxation of the circular muscle results

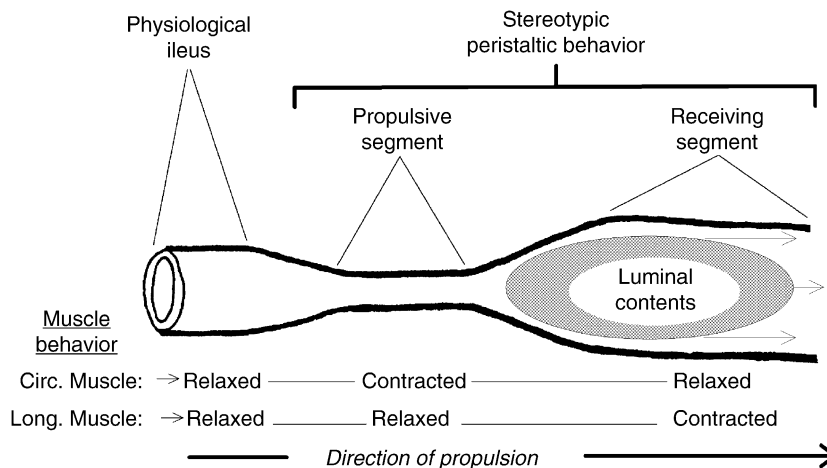

**Autonomic/Enteric Reflexes. Figure 4** The circular and longitudinal muscle layers of the intestine behave in a stereotypical pattern during peristaltic propulsion. A polysynaptic reflex circuit in the ENS determines the pattern of behavior of the two muscle layers. During peristaltic propulsion, the longitudinal muscle layer in the segment ahead of the advancing intraluminal contents contracts while the circular muscle layer relaxes. Simultaneous shortening of the longitudinal intestinal axis and relaxation in the circumferential axis in the same segment results in expansion of the lumen, which becomes a receiving segment for the forward-moving contents. The second component of the reflex is contraction of the circular muscle in the segment behind the advancing intraluminal contents. The longitudinal muscle layer in the same segment relaxes simultaneously with contraction of the circular muscle, which results in conversion of this region to a propulsive segment that propels the luminal contents ahead into the receiving segment.

in expansion of the lumen, which prepares a receiving segment for the forward-moving intraluminal contents during peristaltic propulsion.

Organization of a receiving segment constitutes one-half of propulsive peristaltic reflex behavior. The second-half is contraction of the circular muscle in the segment behind the advancing intraluminal contents. The longitudinal muscle layer in this segment relaxes at the same time that the circular muscle contracts, resulting in the conversion of this region to a propulsive segment that propels the luminal contents ahead, into the receiving segment. The propulsive segment is formed when neural connections in the reflex circuit inactivate both the excitatory innervation to the longitudinal muscle and the inhibitory innervation to the circular muscle. Omnipresent myogenic pacemakers, which are also called intestinal electrical slow waves, evoke contraction of the circular muscle in the propulsive segment while the inhibitory innervation to the segment is silenced [2,8].

The heuristic model for peristaltic propulsion has blocks of the basic polysynaptic reflex circuit connected “in series” along the length of small intestine and large intestine (Fig. 5). A block of the basic polysynaptic circuit

is formed by synaptic connections between sensory neurons, interneurons, and motor neurons (Fig. 3). Propulsion occurs over extended lengths of intestine, as blocks of the basic circuit are recruited to activity in consecutive segments. In this respect, the intestine is like the spinal cord where connections for polysynaptic reflexes remain irrespective of the destruction of adjacent regions of the spinal cord. Resection of an intestinal segment does not alter the reflex circuitry in the two segments remaining on either side of the resection. Consequently, organized propulsion is not impaired after surgical resection of various lengths of bowel.

Synaptic “gates” connect the blocks of basic circuitry in the heuristic model and contribute to a mechanism for controlling the distance over which the complex of propulsive and receiving segments travels (Fig. 5). When the gates are opened, neural signals pass between successive blocks of the basic circuit resulting in propagation of the peristaltic event over extended distances. Long-distance propulsion is prevented when all gates are closed.

Well understood presynaptic facilitatory and inhibitory mechanisms in the microcircuitry of the ENS [7,9]

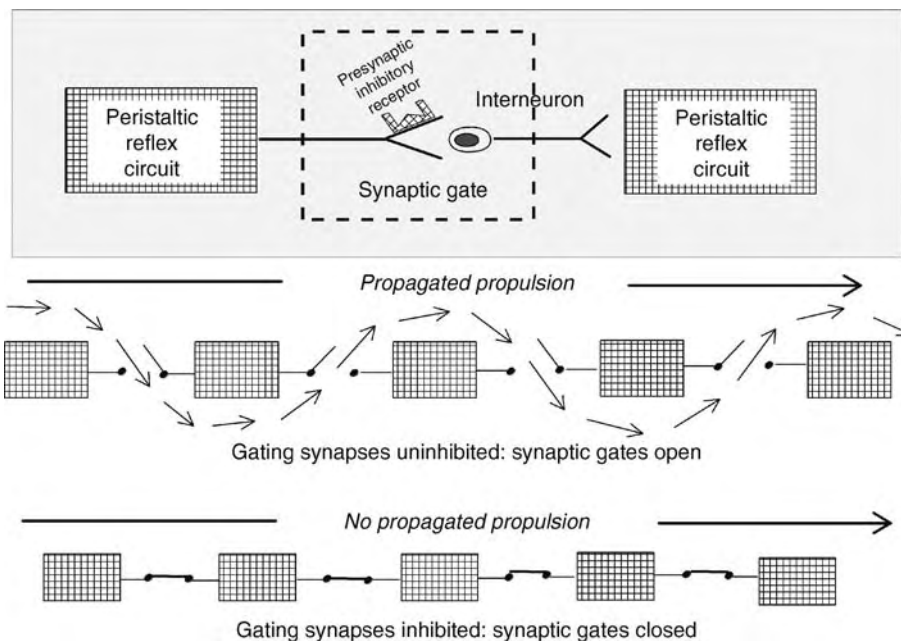

**Autonomic/Enteric Reflexes. Figure 5** Synaptic gates determine distance of propagation of intestinal propulsive motility. Presynaptic mechanisms gate the transfer of signals between sequentially positioned blocks of peristaltic reflex circuitry. Synapses between the neurons that carry excitatory signals to the next block of circuitry function as gating points for control of the distance over which peristaltic propulsion travels. Messenger substances that act presynaptically to inhibit the release of transmitter at the excitatory synapses close the gates for transfer of information, and thereby determine the distance of propagation. Drugs that facilitate the release of neurotransmitters at the excitatory synapses (e.g. cisapride and 5-HT<sub>4</sub> partial agonists) have therapeutic application by increasing the probability of information transfer at the synaptic gates, thereby enhancing propulsive motility.

are presumed to be involved in gating the transfer of signals between sequentially positioned blocks of reflex circuitry in the heuristic model. Synapses formed by the interneurons that transmit excitatory signals to the next downstream block of circuitry are gating points for controlling the distance over which peristaltic propulsion travels (Fig. 5).

Messenger substances that act presynaptically to inhibit the release of transmitter at the excitatory synapses stop transmission and close the entrance gates to the next downstream block of circuitry, thereby determining the distance of propagation. So-called “prokinetic drugs” that facilitate the release of neurotransmitters at the excitatory synapses (e.g. cisapride and tegaserod) [3,9] have therapeutic application by increasing the probability of information transfer at the synaptic gates, and thereby enhancing propulsive motility.

### Peristaltic Retropulsion

The enteric neural circuits can be programmed to control for peristaltic propulsion in either direction along the intestine. For example, if forward passage of the intraluminal contents is impeded in the large intestine of a mouse model for Hirschsprung’s disease, reverse peristalsis propels the bolus over a variable distance away from the obstructed segment. Retro-peristalsis then stops, and forward peristalsis propel the bolus again in the direction of the obstruction [1]. During the act of vomiting, reverse peristalsis occurs in the small intestine and rapidly transports the luminal contents toward the open gastro-intestinal junction [5]. In this case, as well as in the obstructed intestine, the coordinated muscle behavior required for effective propulsion is the same except that it is organized by the ENS to travel in the oral direction.

### References

1. Brann L, Wood JD (1976) Motility of the large intestine of piebald-lethal mice. *Am J Dig Dis* 21:633–640
2. Tamai T, Prosser CL (1966) Differentiation of slow potentials and spikes in longitudinal muscle of cat intestine. *Am J Physiol* 210:452–458
3. Tonini M, Galligan JJ, North RA (1989) Effects of cisapride on cholinergic neurotransmission and propulsive motility in the guinea pig ileum. *Gastroenterology* 96:1257–1264
4. Travagli RA, Hermann GE, Browning KN, Rogers RC (2003) Musings on the wanderer: what’s new in our understanding of vago-vagal reflexes? III. Activity-dependent plasticity in vago-vagal reflexes controlling the stomach. *Am J Physiol Gastrointest Liver Physiol* 284:G180–G187
5. Weisbrodt NW, Christensen J (1972) Electrical activity of the cat duodenum in fasting and vomiting. *Gastroenterology* 63:1004–1010

6. Wood JD (1981) Intrinsic neural control of intestinal motility. *Annu Rev Physiol* 43:33–51
7. Wood JD (2006) Cellular neurophysiology of enteric neurons. In: Johnson LR, Barrett KE, Ghishan FK, Merchant JL, Said HM, Wood JD (eds) *Physiology of the Gastrointestinal Tract* 4th edn. Elsevier, San Diego, CA pp 629–664
8. Wood JD (2009) Neurogastroenterology and digestive motility. In: Rhoades RA, Bell DR (eds) *Medical Physiology, Principles for Clinical Medicines* 3rd edn. Lippincott, Williams & Wilkins, Baltimore, MD pp 463–496
9. Grundy D, Al-Char ED, Aziz Q, Collins SM, Ke M, Taché E, Wood JD (2006) *Fundamentals of neurogastroenterology: basic science*. *Gastroenterology* 130:1391–1411
10. Wood JD, Perkins WE (1970) Mechanical interaction between longitudinal and circular axes of the small intestine. *Am J Physiol* 218:762–768

---

## Autonomous System

### Definition

In systems theory, the term indicates a dynamical system that does not have an external input, so that next state, or its rate of change, only depends on the actual state. In the context of robotics, the term refers to a robot that behaves without intervention of an external supervisor. These artefacts (also referred to as autonomous robots) are equipped with sensors and actuators. Their actions are determined by the available sensory information and by their internal logic.

► Computer-Neural Hybrids

---

## Autopsychic Neurosis

► Personality Disorder

---

## Auto-regressive Model

### Definition

A model of a system as a differential equation where the output at a given time instant is a linear combination of



the outputs at previous time instances and the current input, usually taken to be a white noise input.

► Signals and Systems

## Auto-regressive Moving Average Model [ARMA]

### Definition

A model of a system as a differential equation, where the output at a given time instant is a linear combination of the outputs at previous time instances and the inputs at previous time instances.

► Signals and Systems

## Auto-spectrum

### Definition

The estimation of the frequency content of a stochastic signal. While cross-spectrum is the linear relationship between two different variables, expressed in the frequency domain, the auto-spectrum is computed as the cross-spectrum of a signal and itself.

► Signals and Systems

## Aversion, Aversive Behavior

### Definition

A repugnance for something with a desire of avoidance; Scientifically aversion or aversive behavior means the avoidance of certain stimuli, environments or situations.

## Aversive Conditioning

► Aversive Learning

## Aversive Learning

YOAV LITVIN<sup>1</sup>, D. CAROLINE BLANCHARD<sup>2,3</sup>, HIROYUKI ARAKAWA<sup>3</sup>, ROBERT J. BLANCHARD<sup>1</sup>

<sup>1</sup>Department of Psychology, University of Hawaii at Manoa, Honolulu, HI, USA

<sup>2</sup>Department of Genetics and Molecular Biology, John A. Burns School of Medicine, University of Hawaii at Manoa, Honolulu, HI, USA

<sup>3</sup>Pacific Biomedical Research Center, University of Hawaii at Manoa, Honolulu, HI, USA

### Synonyms

Aversive conditioning

### Definition

In aversive learning an aversion is created toward a targeted behavior by pairing it with an unpleasant stimulus, such as a painful electric shock.

### Characteristics

Traditional analyses of learning posited two general classes of conditioning (i) classical or Pavlovian conditioning and (ii) operant or instrumental conditioning. In these analyses, the former involved stimulus–stimulus associations, whereas the latter reflected associations between responses and reinforcers. These paradigms were applied to both appetitive and aversive conditioning situations, and involved reinforcement or ►punishment, respectively.

In traditional models of aversive classical conditioning, the paradigm further emphasized that the unconditioned stimulus (US; usually some type of rapid onset pain such as footshock) elicits an unconditioned response, the UR. As associative conditioning develops, a conditioned response (CR) emerges in response to the conditioned stimulus (CS). The CR was regarded as basically the same response as the UR, with conditioning demonstrated by its elicitation by the formerly neutral CS.

Operant or instrumental learning involving aversive stimuli typically used the same types of US as in classical conditioning, but the learning component was evaluated by changes in responses that were either designed by the experimenter (e.g., bar pressing) or that enabled the animal to directly escape from a present US (►active avoidance learning) or to avoid the onset of a signaled US by inhibiting a previously punished response (►passive avoidance learning). In the ►learned helplessness model, animals undergo classic aversive conditioning to a shock US in an inescapable shock box, and are then tested in a two-way shuttle for ►active avoidance [1]. The effect depends on the degree of

controllability over the shock to which the animals are initially exposed.

These paradigms were less involved in analysis of responses to the US itself, except insofar as they might interfere with the operant response required to successfully escape from, avoid, or terminate the US. This interference could be substantial, particularly when elaborate operants such as bar pressing or wheel turning were required. In fact, higher levels of shock as a US often increased the time or trials required to learn an artificial, experimenter-imposed task, even though the higher shock should have produced an enhanced motivation to learn the response.

Although studies of classical and operant conditioning were about equally common several decades ago, with the rise of research on neural, neurochemical, and molecular mechanisms of learning, emphasis shifted from complex operant conditioning tasks (with the important exception of those analyzing behaviors related to addiction, most of which involve appetitive rather than aversive paradigms) to tasks providing simple, fast, and robust measures of conditioning. In terms of aversive learning, the shift has been dramatic, with the number of classical conditioning studies an order of magnitude higher than for operant conditioning, since the beginning of the millennium. This shift was associated with a number of developments in the analysis of aversive conditioning.

Two-factor theories of avoidance conditioning [1] long ago noted that the paradigm for classical conditioning is typically embedded in the operant paradigm: the CS that signals the opportunity to avoid necessarily has some temporal association with the US. In two-factor theory, the CS is regarded as eliciting an internal motivational state such as fear or anxiety that is reduced when the avoidance response was made. The operant behavior, avoidance, is reinforced by reduction of this aversive internal state, not by termination or omission of the US, *per se*. This formulation was useful in explaining difficulties in extinguishing avoidance learning with US omission.

Nonetheless, aversive conditioning studies were plagued by a number of poorly replicable or hard to explain results, many of which appeared to involve the intrusion of behaviors that did not reflect either the UR (in classical conditioning tasks) or to be related to the required CR in operant tasks. In analyzing these intrusive behaviors, R.C. Bolles coined the term “species-typical defensive responses” or “▶SSDRs” [2], later commenting that “I have often regarded defensive behaviors as a great nuisance in the study of learning” [3]. Bolles argued that stimuli associated with danger elicit innate defensive reactions at the expense of any other behaviors, whether extensively reinforced or not. If a prominent SSDR is similar to a designated avoidance response rats quickly learn to perform well in that

situation. For example, animals rapidly learn to jump onto a ledge of the apparatus or run to an adjacent compartment [1]. However, animals perform poorly when there is a conflict between an elicited SSDR and the designated measure; for example when required to shuttle back and forth between two compartments of a shuttle box [1] or to learn an extraneous behavior such as lever pressing.

### Freezing

Such SSDRs (more correctly called “species-typical defense reactions” or just “defensive behaviors” as they are highly conserved across mammalian species rather than specific to one group) have been extensively investigated in regards to both unconditioned threat and conditioning situations [3]. The first of these to be analyzed was an immobile “crouching” or “freezing” response following footshock. This behavior was strongly conditioned to the context in which shock occurred, sometimes after a single shock [4]. It was also elicited by exposure to nonpainful aversive stimuli such as noncontact encounters with predators or even partial predator stimulus such as odors [5]. Several features of this conditioning presented problems. Because the CR is quite different than the response to shock – generally limb twitching, running or jumping, depending on intensity – it is difficult to conceptualize freezing as a classical conditioned response, in terms of the classic model [6]. Similarly, a single aversive experience provides little scope for operant conditioning: The response to the shock is the only behavior that is consistently emitted just prior to shock termination, and thus positioned to be reinforced by termination of the aversive stimulus. As immobility, rather than the twitch/run/jump response, is the major behavior seen on replacement of animals into the shock situation, it is very difficult to view this as a conditioned operant response.

However, such immobility (for which the term “freezing” is most often employed) is so rapidly and robustly conditioned to contextual cues as to be virtually ubiquitous in a threat context, making it a particularly important modulator of other behaviors that might be used as measures in these tasks: The obvious solution has been to use freezing itself, rather than behaviors disrupted or facilitated by freezing, to evaluate classical aversive, or fear, conditioning. It has come to be one of the most common measures in aversive learning studies in a neuroscience context, with strong representation of both ▶contextual fear conditioning ([7] for review) and cue conditioning, e.g., auditory fear conditioning ([8] for review).

### The Startle Response

The other most common measure of classical aversive conditioning in a neuroscience context is the startle response. Startle is the response to a highly salient,

rapid-onset stimulus such as a loud noise or an air puff. In wild rats, which are generally more defensive than lab rats, rapid movement of a potential predator can elicit robust startle jumps. The intensity of the startle response can be enhanced by stimuli associated with shock or by a number of unconditioned factors that are aversive or associated with threat. Fear potentiated startle, in which a cue associated with shock potentiates startle to an auditory stimulus, has a long history in psychology [9]. Recent work with unconditioned potentiation of the startle response, for example by light or isolation has provided information on brain systems involved in such potentiation, enabling comparisons with those underlying fear potentiated startle and pointing out a number of differences between the two [9].

### Analyses of the Biology of These Models

The neuroanatomical, chemical and molecular mechanisms involved in these classical conditioning models have been extensively investigated. There is a general consensus that aversive cue conditioning is mediated by information about the CS and US from sensory inputs that generally include the thalamus and sometimes sensory cortices as well [8] to the lateral and basolateral nuclei of the amygdala, with output projections from the central amygdala to behavioral, autonomic, and endocrine response control systems located in the midbrain and brainstem regions [8]. Many of these same sites are involved in ►context conditioning, but the hippocampus is conceptualized as playing a particularly important role when contextual memories are an important component of a learning paradigm [7]. The amygdala also appears to be involved in operant conditioning situations, but this involvement is seen as more variable and less essential than that of the amygdala in classical aversive conditioning.

### Conditioning of Other Defensive Behaviors

Although freezing and startle are the most often utilized behaviors in classical aversive conditioning, a number of other defensive behaviors elicited by threat stimuli have been analyzed [3], and are coming to be used more extensively in classical conditioning situations. A single confrontation with a cat, or with the odor of a cat, is sufficient to produce conditioning to the exposure context or to specific cues associated with cat odor [10]. While freezing is often the focal measure in these studies, risk assessment, including orientation to the threat stimulus, and approach and investigation of it, is a particularly common defensive behavior to ambiguous or partial stimuli such as cat odor, and may be seen as a conditioned response to cues associated with threat.

A number of studies have mapped brain sites showing fos activation to cat-related stimuli [5]. Effects of lesions in many of these sites on unconditioned and

conditioned responses to cat or cat odor, and to foot-shock, suggest important differences in the brain systems serving shock-based versus predator-based unconditioned responses as well as conditioning to the two types of threat stimuli.

With regard to conditioning of defensive behaviors to partial predator stimuli, a current controversy may shed light on some possible evolutionary mechanisms involved in aversive conditioning. The odor of cat fur and skin supports one trial conditioning of responses such as freezing and risk assessment, whereas a number of additional predator-associated odors such as trimethylthiazoline (TMT), a component of fox feces, do not. However, given a number of trials, TMT does produce a conditioned aversive response in a two chamber “place preference” apparatus that enables avoidance of the situation where the odor was encountered. These data suggest two possibilities; First that TMT is effective in operant rather than classical conditioning tasks, or, second, that there is an important difference between conditioning based on aversive stimuli such as unpleasant odors, and those involving cues of potential danger, such as pain, confrontation with a predator, or the (rapidly dissipating and thus highly associated with cat presence) odor of cat fur/skin. According to the later view, rapid, i.e., 1-trial, learning of danger stimuli is particularly adaptive, whereas stimuli that are unpleasant or disgusting, but not dangerous can be conditioned in a more leisurely fashion. As responses to danger, rather than aversion of unpleasant stimuli, seem more likely to be involved in human emotional psychopathologies, this distinction may be an important one for understanding the role of aversive learning in emotional disorders.

### Aversive Conditioning and Human Emotional Psychopathology

The potential relationship between aversive conditioning and human psychopathology has served as the spur for a number of particular approaches to aversive learning. One such approach studies neurochemical and molecular processes that control the inhibition of fear signaled by previously conditioned stimuli (otherwise known as “fear extinction”). The fear extinction procedure involves reexposure to a CS in the absence of the aversive US, thereby successive extinction trials cause a decline in fearful reactions. Fear extinction is cue specific in that it shows negligible generalization across different sensory modalities. Extinction is not permanent, as shown in studies of reinstatement, renewal, and spontaneous recovery. Similar to fear acquisition processes, extinction has been shown to be dependant on NMDA receptors within the basolateral amygdala [9]. Extinction of aversive memories is of obvious relevance to disorders such as post traumatic stress disorder, that involve intrusive and debilitating

memories of trauma [9]. Extinction is procedurally comparable to several types of exposure-based psychotherapeutic treatments. Similar to fear extinction training, exposure therapy includes exposure to the feared cue or context in the absence of danger, with simultaneous psychotherapy aimed to reduce anxiety levels.

However, another traditional use of aversive conditioning tasks, to evaluate anxiety-like behaviors for preclinical psychopharmacology research, has (comparatively) declined in recent years, giving way to measures based on unconditioned responses in tasks such as the elevated plus maze (EPM) and the Open Field (OF). The exceptions are those tasks described above: Fear conditioning (to context or cue) or potentiated startle, which have increased in use over time; albeit not so rapidly as have the EPM and OF. In contrast, tests of anxiety-like behaviors evaluating punishment effects in operant tasks have all but dropped out of the anxiety researchers' armamentarium. While the need for "high throughput" tasks undoubtedly constitutes one reason for this change in use of classical versus operant conditioning models, it also reflects a view that the learning components of human emotional psychopathology more robustly reflect the former than the latter. However, a variety of aversive conditioning techniques and situations are currently being used in an attempt to identify brain areas and events associated with emotion-linked processes in people, and it is predictable that these processes will prove to involve both classical and operant conditioning, as well as individual differences in unconditioned responsiveness to evolutionarily significant danger stimuli and cues.

## References

- Mackintosh NJ (1983) Conditioning and associative learning. Clarendon, Oxford
- Bolles RC (1989) Acquired behaviors; aversive learning. In: Blanchard RJ et al. (eds) *Ethoexperimental approaches to the study of behavior*. Kluwer Academic, Boston, pp 167–179
- Blanchard DC (1997) Stimulus, environmental and pharmacological control of defensive behaviors. In: Bouton M, Fanselow MS (eds) *Learning, motivation and cognition. The functional behaviorism of Robert C. Bolles*. American Psychological Association, Washington DC, pp 283–305
- Blanchard RJ, Blanchard DC (1969) Crouching as an index of fear. *J Comp Physiol Psychol* 67(3):370–375
- Dielenberg RA, Hunt GE, McGregor IS (2001) "When a rat smells a cat": the distribution of Fos immunoreactivity in rat brain following exposure to a predatory odor. *Neuroscience* 104(4):1085–1097
- Fanselow MS (1997) Species-specific defense reactions: retrospect and prospect. In: Bouton M, Fanselow MS (eds) *Learning, motivation and cognition. The functional behaviorism of Robert C. Bolles*. American Psychological Association, Washington DC
- Anagnostaras SG, Gale GD, Fanselow MS (2001) Hippocampus and contextual fear conditioning: recent controversies and advances. *Hippocampus* 11(1):8–17
- LeDoux JE (2000) Emotion circuits in the brain. *Annu Rev Neurosci* 23:155–184
- Davis M (2006) Neural systems involved in fear and anxiety measured with fear-potentiated startle. *Am Psychol* 61(8):741–756
- Blanchard RJ et al. (2001) Cue and context conditioning of defensive behaviors to cat odor stimuli. *Neurosci Biobehav Rev* 25(7–8):587–595

---

## Aversive Stimulus

### Definition

An aversive stimulus is a signal or a cue that is repellent and leads the receiver away from the source of stimulation. The same stimulus can be attractive or aversive depending on physical features such as its intensity (for instance, concentration of an odor) or the behavioral context in which it is perceived.

- ▶ Attractive Stimulus
- ▶ Odor Coding

---

## Aversive Taste Memory

MILAGROS GALLO

Department of Experimental Psychology and Physiology of Behavior, Institute of Neurosciences, University of Granada, Granada, Spain

### Synonyms

Aversive taste memory; Bait shyness; Garcia's effect; Learned taste aversion; Learned toxiphobia; Taste aversion learning

### Definition

Conditioned taste aversion (CTA) is a robust type of learning relevant for predicting negative visceral consequences of oral intake. It relies on selective associations between taste and visceral cues. The association between a taste cue and a delayed visceral malaise can be readily formed in one trial. As a consequence the taste becomes disliked and it will be avoided in later presentations. This behavioral defensive mechanism, which favors survival by avoiding repeated poisoning, can be traced through the

phylogeny from invertebrates to humans and along the ontogenetic development from prenatal life to aging. Research on this type of learning has played a major role not only for modern learning theories but also for investigating the neurobiological basis of learning. It may also contribute to understand the learning mechanisms involved in human food selection, drug addiction, and cancer anorexia [1].

### Characteristics

CTA is widely considered as a form of classical conditioning since an associative link is formed between taste (conditioned stimulus) and visceral (unconditioned stimulus) cues. The learned response consists in a shift of the ►taste hedonic value, thus becoming unpalatable and being avoided in later encounters. Shifts of the taste hedonic value can be assessed in rats using the ►taste reactivity test. However, the acquisition of CTAs exhibits several peculiar features that can not be found together in other classical conditioning preparations [2]. First, CTA can readily be acquired in a single conditioning trial. Second, robust taste aversions are induced in spite of long delays, lasting conventionally 15–30 min, between the taste presentation and the outcome of visceral malaise. Moreover, the delay may be extended to several hours if visceral distress takes place under an unconscious state. Learning in unconscious states is also a fact not found in other types of classical conditioning. Third, the peculiar features of CTA rely on selective association between chemical sensory modalities. Robust one-trial and long-delay learning takes place only if gustatory cues, but not somatosensory, auditory, or visual cues, are followed by visceral malaise. However, similar aversions to olfactory cues may be formed provided that a flavor (odor and taste) was previously conditioned, a phenomenon termed ►taste-potentiated odor aversion [2]. The potential relationship between other food attributes such as color, texture, or temperature and CTA is not fully understood.

The adaptive role of CTA resides on its value for survival, since it is an efficient behavioral defensive mechanism to avoid repeated poisoning. Accordingly, it is extensively found from invertebrates to humans. Although it shows specializations throughout the phylogeny, such as resting on visual cues instead of taste cues in birds, it always enables to establish predictive associations among the sensory modality that identifies edibles and the aversive consequences of ingestion. Furthermore, CTA is one of the earliest types of learning demonstrated along the ontogenetic development. Even if it may not show all the characteristics of adult learning, prenatal chemosensory learning has been demonstrated from insects to mammals, including amphibians, fish, and birds. Prenatal CTA in mammals depends on the composition of the amniotic fluid that the foetus swallows. While the potential protective role in utero of prenatal learned aversions requires further

research, these aversions can be retained after birth and they can be expressed during the postnatal life. Thereafter, the early development of the chemical senses allows mammals to learn in advance about the chemical environment to be encountered after birth, thus favoring survival. Moreover, CTA seems to be very resistant to aging. Far from being impaired, the acquisition of learned taste aversions is even enhanced in old rats as longer delays can be introduced between the taste cue and visceral malaise. This CTA facilitation by aging, which can not be attributed to an enhanced gustatory or visceral sensitivity, may represent an advantage for survival since to recover from poisoning may represent a stronger challenge during aging because physical deterioration [1].

### Related Phenomena

The acquisition of learned taste aversions is influenced by several phenomena, which depend on the way that taste cues are presented and on the previous experience with the conditioned taste [3]. Taste novelty is a potent modulator of CTA. A novel taste induces an unconditioned neophobic response, leading to a reduced intake. Subsequent taste presentations lead to habituation of the neophobic response as the taste becomes familiar. Thus, ►taste neophobia may be evident either by a reduced intake compared with the baseline intake or by a reduced intake during the first presentation compared with a later presentation. In fact, the habituation of neophobia (►Habituation of taste neophobia) may take place in the absence of a reduced intake during the first presentation as it is the case of highly palatable tastes. Taste neophobia facilitates CTA. Robust learned aversions are developed to novel tastes. On the contrary, the repeated exposure to the taste without consequences before the conditioning session retards CTA acquisition, a phenomenon called latent inhibition. However, under other training circumstances taste preexposure may facilitate learning. When using complex compound tastes or discrimination tasks, the preexposure to the taste may reduce generalization and facilitate learning, as perceptual learning takes place.

The novelty of the visceral malaise experience is also an important modulator of CTA acquisition. CTA acquisition is retarded if the visceral malaise has been experienced before conditioning, a phenomenon called the effect of the US preexposure. Moreover, random preexposures of both taste and visceral malaise induce a greater impairment of later conditioning than preexposing either taste or visceral malaise separately. This phenomenon is called learned irrelevance. In addition to the preexposure effects mentioned, CTA shows a variety of complex learning phenomena, similar to those appearing in other learning tasks [3]. A schematic account of the behavioral procedures used to study complex learning phenomena is presented in Table 1.

**Aversive Taste Memory. Table 1** Schematic account of the conditioned taste aversion procedures showing complex learning effects

	Phase I	Phase II	Test	Outcome
First-order CTA		A+	A	Aversion
Preexposure effects				
Attenuation of neophobia		A	A	Increased intake
Latent inhibition	A	A+	A	Reduced aversion
Effect of the US exposure	+	A+	A	Reduced aversion
Learned irrelevance	A/+	A+	A	Reduced aversion
Perceptual learning	A, B	A+, B	A, B	Increased discrimination
Cue-competition tasks				
Blocking	A+	AB+	B	Reduced aversion
Overshadowing		Ax+	X	Reduced aversion
Simultaneous compound tasks				
Negative patterning	A+, B+	AB	A, B, AB	A,B aversion AB no aversion
Positive patterning	A, B	AB+	A, B, AB	A,B no aversion AB aversion
Serial compound tasks				
Occasion setting	A...B+	B	B	Aversion only if A present
Sensory preconditioning	A...B	B+	A	Aversion
Second-order conditioning	B+	A...B	A	Aversion
Effects of context				
Context dependency of LI	A(Y)	A(X)+	A(X)	Increased aversion
Context dependency of CTA		A(X)+	A(Y)	Reduced aversion

Most of them require two behavioral phases before testing. Note that control groups are not included. A and B represent tastes, (X) and (Y) indicate contexts and + means the aversive agent, such as LiCl. A/B refers to unrelated stimuli; AB refers to compound; “,” separates different trials and “...” indicates that the first taste precedes the second in the same conditioning trial.

## Neural Circuit

In spite of being considered a primitive form of learning, the acquisition of CTA depends on a widely distributed neural circuit that engages multiple taste–visceral integration brain regions located at different levels from the brainstem to the forebrain [2,4–6]. Fig. 1 shows the rodent basic neural circuit involved in CTA acquisition.

On the one hand, facial, glossopharyngeal and vagus nerves convey taste afferents to the ►nucleus of the tractus solitarius (NTS), which in turn projects to the ►parabrachial area (PBN) in rodents and to the gustatory nucleus of thalamus directly in monkeys. Taste information reaches the gustatory area in the insular cortex (IC) either through thalamic or direct PBN projections. On the other hand, visceral information conveyed by the vagus nerve and the ►area postrema (AP) project to these brain regions in parallel with the gustatory projections and also reaches the amygdala (AM). Thus, the gustatory and visceral afferent pathways converge in the same brainstem areas from the first relay nucleus in the brainstem. Electrophysiological and immunohistochemical studies have

shown that CTA modifies the neural response to the conditioned taste in brainstem areas, such as the nucleus of the solitary tract and the parabrachial area. CTA induces a shift in the response of gustatory neurons processing the hedonic value but not the quality of the taste. Additional data provided by permanent and reversible lesion studies in rodents have pointed out to the PBN, second relay station both for taste and visceral sensory pathways, as a crucial site for the taste–visceral integration involved in CTA acquisition [7]. The proposal of a brainstem integration site relevant for CTA acquisition is consistent with the primitive nature of this type of learning. However, the acquisition of CTA requires also the taste and visceral information to reach forebrain areas, because chronic decerebrate rats do not show CTA. The location of the forebrain integration site or sites remains elusive, although both IC and AM seem to play relevant roles related with higher taste and visceral processing and integration [2,4,5,8]. It has been proposed that interactions among multiple brain regions may be required for CTA acquisition. A critical role of the gustatory insular cortex in long-term maintenance of CTA memories in

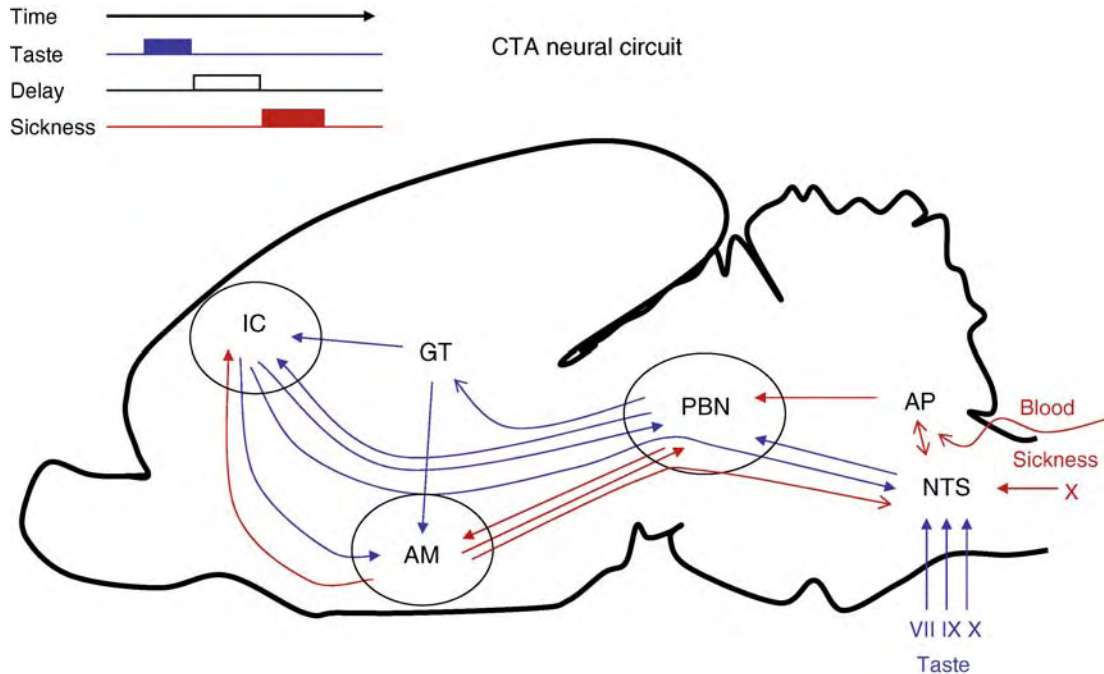

**Aversive Taste Memory. Figure 1** Schematic drawing of the known rodent brain regions involved in conditioned taste aversion acquisition. AM, amygdala (central and basolateral nuclei); AP, area postrema; GT, gustatory thalamus (parvocellular part of the ventralis posteromedial thalamic nucleus); IC, insular cortex; NTS, nucleus of the tractus solitarius; PBN, parabrachial nuclei; VII, facial nerve; IX, glossopharyngeal nerve; X, vagus nerve.

rodents has been proposed [11]. The contribution of other brain regions associated with memory and central feeding control systems, such as the bed nucleus of stria terminalis, hypothalamus, the accumbens nucleus, the ventral tegmental area and prefrontal cortex to the acquisition, retention, and expression of CTA is not fully understood. As in other types of learning tasks, the hippocampal system may modulate CTA acquisition when complex learning phenomena are involved.

### Predictivity

The high reliability, robustness, and easiness to obtain CTA in the laboratory using a variety of strain and species, in addition to the fact that it allows to study a wide range of learning phenomena, have made CTA a sensitive tool for the behavioral and neurobiological study of learning. In addition, CTA has proven to be a useful tool for the determination of taste psychophysics and characterization of drug toxicity. However, the results strongly depend on the behavioral procedure applied.

CTA was first studied in the laboratory by John Garcia and coworkers. Since their pioneering study published in 1955 [9], the rat has become the choice animal model in CTA research. Taste solutions are typically used to induce CTA in the laboratory, because they are easily handled and they allow a precise assessment of the amount

ingested. The procedure requires subjecting the animals to a water deprivation procedure. The standard behavioral procedure usually applies palatable taste solutions that will be avoided as a consequence of learning. After stabilizing the water consumption during the daily drinking sessions along several days, during the conditioning trial a novel taste solution is presented either for spontaneous drinking or intra oral administration. Several agents, such as radiation, body rotation, and a variety of drugs, being lithium chloride (LiCl) the most widely used, may induce CTA. All of them have in common the induction of behavioral and autonomic indexes of gastrointestinal illness, including emetic responses and also vomiting in those species with emetic ability. Testing consists either in a one-bottle session, with only the conditioned taste solution available or in a choice test in which the animals can choose between the conditioned taste solution and other (two-bottle test) or others (multiple-bottle test) nonconditioned taste solutions. One-bottle tests allow within-subjects comparison between the amount of taste solution drunk during the conditioning and testing sessions, and also between-groups comparisons with nonconditioned groups receiving a sham saline injection. The results of the choice tests are usually shown as a preference rate, which can be compared with that of the control nonconditioned groups. Choice tests are very sensitive for detecting weak

aversions, but they may not differentiate between groups showing different strength aversions. On the contrary, when using one-bottle tests weak aversions may be unnoticed, since the thirsty animal has no other choice to drink, but they are very sensitive for distinguishing among different strength aversions.

In addition, taste reactivity tests for recording orofacial and somatic responses may be required to assess the change of the hedonic response induced by CTA. CTA acquisition induces a change of the taste reactivity behavioral pattern from appetitive to aversive. Besides fluid rejection, the aversive pattern of responses to the conditioned taste include gaping, chin rubbing, forelimb flailing, increased locomotion, and aversive posturing.

Thereafter, when using basic CTA procedures, critical issues should be considered, such as unlearned palatability and novelty of the taste solution applied, form of taste solution presentation (spontaneous drinking versus intra oral administration) and testing protocol. If complex CTA learning procedures are applied, careful behavioral control groups for identifying potential alternative phenomena explaining the outcome should be designed.

### Relevance to Humans

Learned aversions play an important role in the human everyday life food selection. It reduces not only the repeated intake of potentially noxious substances but it also may lead to the avoidance of nutritious foods [4]. Understanding the mechanisms of CTA is crucial for studying and treating daily likes and dislikes, which contribute to diet-induced diseases. However, this issue remains relatively unexplored due to the difficulty of assessing food aversions by conscious verbal reports, a commonly used procedure [4,10]. Studies applying taste reactivity tests in humans may help to understand and modify naturally occurring learned food aversions, such as those involved in the rejection of certain foods by children and the elderly.

CTAs have also important clinical applications related with cancer anorexia and drug abuse. Besides food aversions induced by certain kinds of cancer associated with abdominal discomfort, nausea, and vomiting, controlled clinical studies have indicated that learned food aversions develop in patients receiving chemotherapy and radiation, being gastrointestinal toxicity and nausea the inducing agents. Of interest for the later situation, a behavioral intervention method to reduce the likelihood of forming aversions to the familiar foods consists in providing a novel tasting food before the treatment. The novel taste has proven to act as a scapegoat and to prevent the decrease in familiar food consumption and preference, both in children and adults. A similar treatment using a novel flavor may be also applied to prevent or reduce the anticipatory nausea

described in cancer patients associated to the chemotherapy context [4].

Since the 1930s, chemical aversion induction by paired ethanol ingestion with emetically induced nausea was applied as a component of multimodal treatments for certain alcoholic populations [10]. At present, CTA have clinical applications to the aetiology and control of alcohol use and abuse, the receptor characterization of the motivational effects of drugs, the occurrence of drug interactions, and the characterization of drug withdrawal [1].

### References

1. Riley AL, Freeman K (2007) Conditioned taste aversion: an annotated bibliography. Available at <http://www.ctalarning.com>
2. Bures J, Bermudez-Rattoni F, Yamamoto T (1998) Conditioned taste aversion: memory of a special kind. Oxford University Press
3. Gallo M, Ballesteros MA, Molero A, Moron I (1999) Taste aversion learning as a tool for the study of hippocampal and non-hippocampal brain memory circuits regulating diet selection. *Nutr Neurosci* 2:277–302
4. Bernstein IL (1999) Taste aversion learning: a contemporary perspective. *Nutrition* 15:229–234
5. Bermudez-Rattoni F (2004) Molecular mechanisms of taste-recognition memory. *Nat Rev Neurosci* 5:209–217
6. Yamamoto T, Shimura T, Sako N, Yashoshima Y, Sakai N (1994) Neural substrates for conditioned taste aversion in the rat. *Brain Res* 65:123–137
7. Reilly S (1999) The parabrachial nucleus and conditioned taste aversion. *Brain Res Bull* 48:239–254
8. Reilly S, Bornovalova MA (2005) Conditioned taste aversion and amygdala lesions in the rat: a critical review. *Neurosci Biobehav Rev* 29(7):1067–1088
9. Garcia J, Kimeldorf DJ, Koelling RA (1955) Conditioned aversion to saccharin resulting from exposure to gamma radiation. *Science* 122:157–158
10. Scalera G (2002) Effects of conditioned food aversions on nutritional behavior in humans. *Nutr Neurosci* 5:159–88
11. Shema R, Sacktor TC, Dubai Y (2007) Rapid erasure of long-term memory associations in the cortex by an inhibitor of PKMzeta. *Science* 317(5840):951–953

---

## Avian Auditory System

FRÉDÉRIC E. THEUNISSEN  
UC Berkeley, Department of Psychology and  
Neurosciences Institute, Berkeley, CA, USA

### Synonyms

Auditory System of Birds; Hearing in Birds



## Definition

The avian auditory system is composed of multiple brain regions whose principal function is to process acoustical signals and to mediate sound source detection, localization and recognition.

## Characteristics

### Quantitative Description

The avian auditory system begins at the bird's ears and ends in what is referred to as higher or secondary auditory areas in the forebrain. These two end points are connected by a series of auditory processing stages that follow a gross anatomical plan very similar to the mammalian auditory system (see higher level structures). Birds rely heavily on the auditory sense (see function) and therefore have a well developed auditory system. Among the large number of avian species (~9,000), some auditory specialists have emerged. Barn owls hunt in total darkness and excel at localizing the sounds made by their prey. Songbirds use complex acoustic signals, including song and other calls, for social communication and use auditory feedback of their own vocalizations to guide vocal learning. In contrast with the mammalian system, the auditory hair cells, the sensory epithelium of the hearing system, in the bird's inner ear can regenerate after damage. For all the above reasons, the avian auditory system has become a powerful model system to study the neural basis of sound localization, as well as to investigate how the brain memorizes and processes vocalizations in order to mediate behavioral discrimination and recognition. The avian model has also been used to study neural plasticity in the auditory system and its potential in treating deafness.

### Higher-Level Structures

The auditory system of vertebrates is an evolutionarily conserved structure. Therefore the avian system shares gross features across all avian groups and resembles other vertebrates, including mammals (► [The Evolution of the Avian Auditory System](#)). The most noticeable similarity rests in the number of auditory nuclei (or neural processing stages) and the pattern of feed-forward connections from the cochlear nucleus to the auditory forebrain. As shown in [Fig. 1](#), afferents from the hair cells in the ear project to two cochlear nuclei in the medulla, called nucleus magnocellularis (NM) and nucleus angularis (NA), which are analogous to the anterior ventral and dorsal subdivisions, respectively, of the mammalian cochlear nucleus. As in mammals, the connections between the cochlear nuclei and the auditory midbrain have both a direct and an indirect route. In birds, the indirect route is via the nucleus laminaris (NL) and the nuclei in the lateral lemniscus. These pathways converge in the midbrain, in the dorsal

lateral nucleus of the mesencephalon (MLd), which is analogous to the inferior colliculus (IC) in mammals [1]. Both MLd and IC are used in the avian literature. The auditory midbrain projects to a relay nucleus in the thalamus, Ovoidalis (Ov), just as the IC projects to the medial geniculate body (MGB) in mammals. Ov, in turn, sends projections to the primary auditory area in the pallium, field L. Field L has been further divided into subregions (L1, L2a, L2b/L, and L3) based on differences in cyto-architecture and connectivity [2,3]. Input from the auditory thalamus goes to subregions L2a and L2b, which in turn project to L1 and L3. Subregions L1 and L3 make bi-directional connections with two secondary auditory areas in the pallium: the nidopallium caudal medial (NCM) and the caudal mesopallium (CM).

Noticeable differences between the mammalian and the avian auditory system are observed in the feedback and inter-hemispheric connectivity patterns. In mammals, the primary auditory cortex shows strong feedback projections to the thalamus and more limited ones to the midbrain (► [Mammalian Auditory Cortex](#)). In birds this feedback circuitry exists, but it involves two additional processing stages in the forebrain, in the shell regions of song system structures HVC and the robust nucleus of the arcopallium (RA). Feedback circuitry in songbirds, is illustrated in the figure, and it lies in similar anatomical locations in non-songbirds. The direct inter-hemispheric connectivity between primary auditory cortex present in mammals is absent in birds.

### Lower-Level Components

The micro-circuitry of the lower auditory nuclei is relatively well known, particularly those involved in sound localization (► [sound localization](#)). In the medulla, excitatory neurons from NM converge bilaterally in NL providing temporal information for detecting interaural time differences (► [ITD](#)), whereas GABA-ergic neurons originating in the superior Olive provide a mechanism for gain control. Further morphological adaptations are observed on this pathway to enhance or to preserve temporal information. In the pathway involved in the computation of interaural level differences (► [ILD](#)), neurons in the lateral lemniscus receive excitatory input from the contralateral NA, and inhibitory input from the contralateral lateral lemniscus. At the next level of auditory processing, in MLd/IC, ILD and ITD information is combined by multiplication. This multiplication is performed by the local network and cellular mechanisms. The local network combines focused excitatory input from the concurrence of desired ILD and ITD responses with more diffuse inhibitory input from non-desired ILD and ITDs. The cellular properties provide a non-linear thresholding operation. This structure leads to neurons that are tuned for particular ILD and ITDs and correspondingly to a single location of a sound source [1].

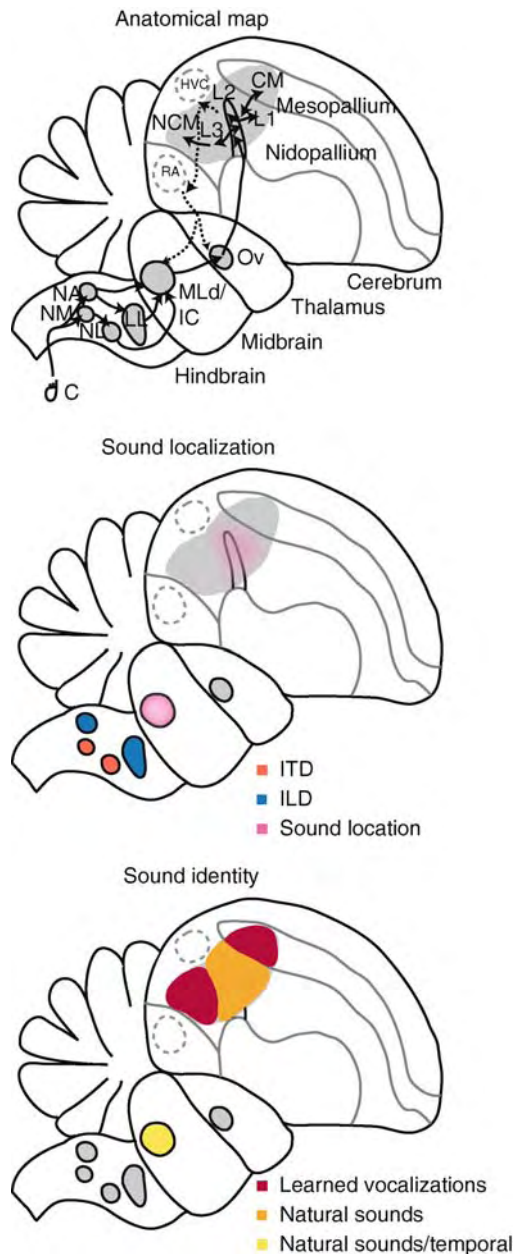

**Avian Auditory System. Figure 1** Anatomical and functional cartoons of the avian auditory system shown in sagittal section. *Top row: Anatomical map.* The figure shows the auditory nuclei and regions in gray as well as two of the song system nuclei that would be found in songbirds (HVC and RA). The feed-forward pathways are shown in solid and the feedback pathway is shown with a *dotted line*. Note that not all the pathways are shown; for example, the reciprocal pathway between NCM and CM has been omitted for clarity. The diagram is also only approximately anatomically correct: NCM would be found in a more medial region than the one drawn here. See text for the name of the areas. *Middle row: functional map for sound localization.* The figure shows the auditory areas specialized for extracting

The micro-circuitry of the higher auditory areas, the morphology of neuron types and their cellular properties have not been examined in detail. Golgi stains suggest the presence of at least four types of neurons in the auditory forebrain [4]. The auditory telencephalon is also densely packed with inhibitory ►GABA-ergic neurons, most of which are very small and presumed to be ►interneurons.

### Structural Regulation

The development of the auditory system occurs either in the egg or soon after hatching. As in other sensory systems, both maturational and experience-dependant factors affect the neural structure. This interaction has been studied best in the sound localization system of the barn owl [5].

### Higher Level Process

As described above, a significant fraction of neural computations underlying sound localization are performed in the auditory medulla and midbrain, leading in the MLd/IC to an anatomically mapped representation of space based on sound source location. The relative contribution of these two areas for auditory scene analysis is currently being investigated [1].

The avian auditory system has also been used extensively to examine how complex acoustical communication signals – bird song and social calls – are processed by the nervous system for detection, recognition and memorization. Neurophysiologists have recorded responses to vocalizations and other complex sounds throughout most of the auditory system and have found a hierarchical processing that leads to specialized

interaural time differences (ITD), interaural level differences (ILD) and the brain regions where neurons coding sound source location are found. The sound source location neurons in MLd/IC are found in the shell of the nucleus and make a topographical map of space. The sound source location neurons in the forebrain are found diffusively and are not organized in a mapped fashion. *Bottom row: functional map for sound identity.* The figure illustrates the hierarchical processing of complex sounds. MLd/IC is tuned for low-level statistics of natural sounds and its population response efficiently represents the temporal changes in the amplitude envelope of the sound. The primary auditory forebrain also efficiently represents sounds with natural statistics and, in addition, its neurons code complex temporal and temporal acoustical features. The secondary areas are sensitive to higher order acoustic features found in vocalizations. The neural response in these areas is also affected by the sounds that the animal learned and remembered. In both functional maps, the areas in gray indicate that the function of these nuclei has not been well characterized.

selectivity for complex natural sounds, and ►conspecific vocalizations in particular [6].

Auditory neurons in MLd respond robustly to pure tones, complex tones, and songs, but show higher information rates for stimuli that contain the spectrotemporal features of natural sounds. The population neural response is able to track the temporal changes found in birdsong very accurately.

Neurons in the primary auditory forebrain area, field L, show an additional degree of selectivity in the sense that many of them respond poorly to simple synthetic sounds. Selectivity for conspecific sounds is present in field L but restricted to selection for the relatively low-level statistics of the spectrotemporal acoustical structure found in vocalizations and in other natural sounds. Neurons in MLd and field L can also be classified according to their joint spectrotemporal tuning. This classification shows specialization for detecting distinct acoustical features. Different groups of neurons specialize for detecting fast temporal changes in the sound envelope, the entire sound envelope, slow precise harmonic features or a coarse spectral shape. The efficient representation of these distinct acoustical features might underlie basic acoustical percepts such as rhythm, pitch, and timbre and constitute the building blocks for more selective representations in the secondary auditory regions [7].

Neurophysiological recordings with complex stimuli showed a higher number of selective units in CM than field L. Neurons in CM were also more sensitive than field L neurons to the natural phase of the temporal and spectral modulations found in song. Lesion experiments further support the role in CM for song discrimination.

Experiments using the degree of expression of the immediate early gene (►IEG), *zenk*, in NCM show selectivity for conspecific song as opposed to ►heterospecific song, and show a lack of response to tone bursts. Neurophysiological studies in NCM also suggest selectivity for complex sounds, which might be absent in subarea L2a of field L. The degree of selectivity for vocalizations in the two secondary auditory areas NCM and CM, and their respective roles in processing and memorizing song in songbirds, is an active area of research.

Songbirds have evolved another specialized set of interconnected brain areas known as the song system, whose function is to produce, and to learn motor control of, ►song. The song system receives input from the auditory system from potentially multiple pathways, the most established one being via auditory area CM. The song system must receive information about what to sing (the tutor's song), about what the bird is actually singing (the bird's own song), and from acoustical signals that trigger singing (e.g., songs of other conspecific males and female calls). The pathway between the avian auditory system and the song system, and

the nature of the acoustical information entering the song system, are other active areas of research.

### Lower Level Process

The cellular physiology of the auditory system has been investigated most in the lower-level auditory areas, as described above. There is a lack of neurophysiological research at the cellular level in the higher levels of the auditory system. On the other hand, studies using histochemical techniques in the auditory telencephalon of songbirds have assessed the expression of receptors for particular neurotransmitters and neuromodulators, as well as ►sexual hormones. More recently, gene-array technology in combination with *in situ* hybridization has been used to make maps of gene expression in the auditory system [8].

### Process Regulation

Short-term and long-term plasticity have been well studied in the responses of neurons tuned to the spatial location of sound, in the external nucleus of the IC/MLd. These neurons change their tuning if there is a mismatch between the location specified by the auditory information and that obtained from visual feedback information. The plasticity is observed both in young barn owls and to a lesser extent in adult owls. In adults, greater neural plasticity is observed for owls that have had experience with mismatched feedback as juveniles [5].

Short-term plasticity has also been measured in adult birds during the processing of complex sounds, in the tuning of neurons in the secondary auditory forebrain areas NCM and CM.

NCM exhibits stimulus specific adaptation (SSA). SSA manifests itself as a reduced neural response to repeated stimulation. However, unlike the ubiquitous neural adaptation which is a function of the output of the neuron, SSA is specific to the input of the neuron in the sense that the presentation of a novel (or unfamiliar) stimulus during SSA yields a normal response. SSA can last days and can therefore be considered a form of memory. SSA has been measured in NCM using both IEG studies and neurophysiological recordings. Recent neurophysiological experiments showed that the tutor song memorized by a young bird will later elicit an adapted response in the adult bird, even if that tutor song was not heard for an extended period of time. IEG and behavioral studies involving lesions similarly point to NCM as a potential auditory region where a memory trace for the tutor song resides [9].

Shorter-term plasticity has been measured in neurophysiological recordings in CM. After training birds to recognize individual conspecific songs either in a two-alternative forced choice (AFC) or a go/no-go paradigm, neurons in CM became selective as a population

for the songs. Interestingly, in the AFC experiment the two songs elicited similarly enhanced responses, whereas in the go/no-go experiment, the response to the go song was enhanced relative to the response to the no-go song. Therefore the learned selectivity cannot simply be explained by familiarity but must also involve top-down processing [10].

The avian auditory system also has great potential as a model to study the effect of sensory experience (beyond tutor song) on neural development. This line of research has just recently been initiated. The first study on this subject observed significant changes in the response of field L neurons of birds that were deprived of normal acoustical experience during early development; both the selectivity and the organization of frequency tuning properties were altered [6].

### Function

The acoustical sense is important in birds for detecting predators (of all species), for finding prey (e.g., in the barn owl), for echolocation (e.g., in the cave swiftlet) and, perhaps more remarkably, for complex communication. Listening to others allows birds to classify them as conspecific or heterospecific, neighbor or stranger, male or female, mate or non-mate, parent or non-parent, kin or non-kin. Birds are known to be particularly adept at recognizing individual conspecifics based solely on their vocalizations, often in unfavorable acoustical environments. How the auditory system performs such a difficult auditory scene analysis remains unknown. Furthermore, the communication signals are not just a signature of the sender but carry specific messages. Birds produce calls to maintain contact (contact call), to restore contact (separation call), to obtain food (begging call) or to advertise danger (alarm call). The complex song produced by birds of the suborder oscine (the songbirds) is used by males for territorial defense and mate attraction, and by male–female pairs for pair-bonding and cooperation. In songbirds, audition serves another important function: juvenile songbirds need to listen to adult conspecific song as well as their own vocalizations in order to learn to sing.

### Pathology and Therapy

The avian auditory system is also an experimental model system to study the effects of deafness, sensory deprivation or noise exposure, and hair cell regeneration on the central auditory circuitry.

### References

1. Konishi M (2003) Coding of auditory space. *Annu Rev Neurosci* 26:31–55
2. Fortune ES, Margoliash D (1992) Cytoarchitectonic organization and morphology of cells of the field L complex in male zebra finches (*Taenopygia guttata*). *J Comp Neurol* 325(3):388–404
3. Vates GE et al. (1996) Auditory pathways of caudal telencephalon and their relation to the song system of adult male zebra finches (*Taenopygia guttata*). *J Comp Neurol* 366:613–642
4. Saini KD, Leppelsack HJ (1981) Cell types of the auditory caudomedial neostriatum of the starling. *J Comp Neurol* 198:209–230
5. Knudsen EI (2002) Instructed learning in the auditory localization pathway of the barn owl. *Nature* 417(6886):322–328
6. Theunissen FE, Shaevitz SS (2006) Auditory processing of vocal sounds in birds. *Curr Opin Neurobiol* 16(4):400–407. Epub 2006 Jul 13
7. Theunissen FE et al. (2004) Song selectivity in the song system and in the auditory forebrain. *Ann NY Acad Sci* 1016:222–245
8. Clayton DF (2004) Songbird genomics: methods, mechanisms, opportunities, and pitfalls. *Ann NY Acad Sci* 1016:45–60
9. Bolhuis JJ, Gahr M (2006) Neural mechanisms of birdsong memory. *Nat Rev Neurosci* 7(5):347–357
10. Gentner TQ, Margoliash D (2003) Neuronal populations and single cells representing learned auditory objects. *Nature* 424(6949):669–674

## Avian Pineal Gland as “Third Eye”

### Definition

The pineal gland of birds is capable of photoreception and, therefore, light can directly regulate melatonin synthesis and release. The light perceived by the pineal gland can be used by the birds to entrain the entire circadian system. At least two functional photopigments.

Pinopsin and Melanopsin, are present in the pineal gland. One of these photopigments may mediate the acute suppression of melatonin synthesis while the other may mediate the entrainment of the circadian pacemaker that drives melatonin synthesis.

## Avoidance Behavior

### Definition

A response to elude negatively valenced events such as painful stimulation. One of the primary organizers of avoidance behaviors is the mid-cingulate cortex where predictions are generated about the outcomes of particular events and motor system responses are determined to minimize or avoid physical harm.

► Cingulate Gyrus

## Avoidance Learning

### Definition

Form of learning that leads to the recognition of dangerous or harmful situations and results in avoidance of such stimuli.

varying diameters depending on their function. They may be myelinated or non-myelinated.

- ▶ Action Potential
- ▶ Action Potential Propagation

## AVOR (Angular VOR)

- ▶ Vestibulo-Ocular Reflex

## Awakening Agents

- ▶ Stimulants

## Axo-axonal Synapse

### Definition

Synapse formed between two axons.

- ▶ Synaptic Transmission: Model Systems

## Axogenesis

- ▶ Axon Outgrowth

## Axon

### Definition

A tubular process extending from a nerve cell body towards target cells and carrying action potentials from the cell body to the nerve terminal. Axons may have

## Axon Degeneration and Regeneration of Peripheral Neurons

D. W. ZOCHODNE

Department of Clinical Neurosciences, University of Calgary, Calgary, AB, Canada

### Definition

Axon degeneration and regeneration of ▶ peripheral neurons refers to a series of sequential events that occur following a peripheral nerve injury. Axon degeneration involves the breakdown of axons and myelin distal to an injury site, a requisite for subsequent regeneration, or regrowth of axons.

### Characteristics Introduction

Long term disability from neurological disease depends as much on loss of axons, or connections, as it does on loss of parent neurons. Sundered axons cannot simply reattach to restore function. Instead, axons must regrow, navigating their way to target tissues once again, as they did during development. Unfortunately this task is incomparably more difficult during adulthood. Cues once present and growth factors once plentiful may no longer exist.

This brief review will address some newer and older concepts concerning ▶ axonal regeneration of peripheral neurons. Contrary to assumptions otherwise, while peripheral axons regrow, they do so slowly and incompletely. They are also much more frequently injured by trauma or disease than axons of the spinal cord. In a patient with a brachial plexus lesion that disrupts axons supplying the upper limb, it is unlikely that regeneration of motor and sensory axons as far as the hand will occur. Hand movement and sensation are unlikely to be restored. The further axons must grow the less likely they are to find the correct target. Moreover, the pathway they follow becomes far less hospitable. Nerve trunks distal to an injury that have not been reinnervated for several months become much less supportive of regrowth [1]. The Schwann cell (SC), the essential partner of regrowing axons, changes its

phenotype, becomes atrophic and is unlikely to elaborate growth factors to support new axons.

The challenges of peripheral axon regeneration however, start immediately after the injury. These barriers require unique consideration of how axons interact with their microenvironment during the events of regeneration. Before axons re-enter a distal nerve following injury, it is essential that previous material from degenerating axons and myelin are cleared and that basement membrane pathways, or Bands of Bungner, are prepared for them. Injured axons must reseal, sprout, navigate the injury site they encounter, then move en masse towards their targets. Each step of this process can have a major bearing on the success of regeneration and I will briefly cover some aspects of each here (Fig. 1).

#### Sequential nerve regeneration

INJURY : Neurapraxia, axonotmesis, neurotmesis

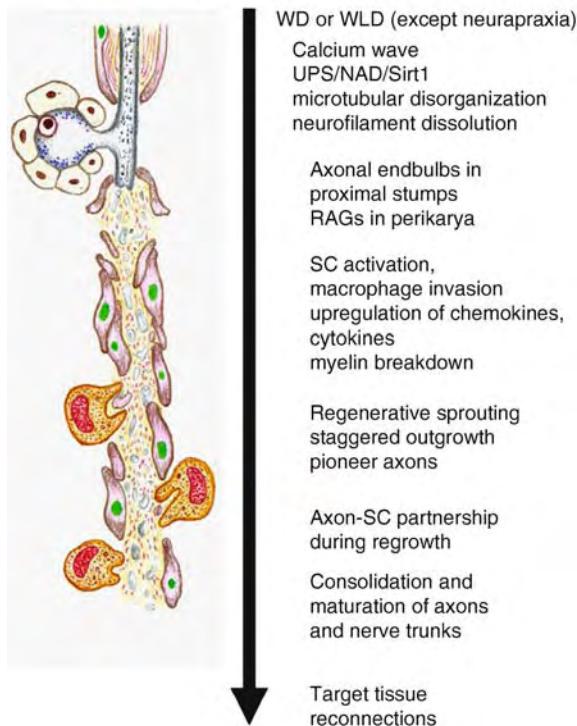

**Axon Degeneration and Regeneration of Peripheral Neurons. Figure 1** A simplified schema listing major sequential events involved in regrowth of peripheral nerves after injury. Wallerian degeneration and axon regrowth are involved in injuries that damage axons (axonotmesis and neurotmesis). Neurapraxic lesions are milder injuries involving segmental demyelination without axon interruption or ► axonal degeneration. The image on the left illustrates SC proliferation and macrophage entry into a zone of Wallerian degeneration distal to an injury site (illustration by Scott Rogers).

#### Wallerian and Wallerian-Like Degeneration

In 1850 Augustus Waller described a series of morphological changes that developed in peripheral nerve axons following a transection injury. This series of events has subsequently been described as “► Wallerian degeneration” [2]. Strictly speaking, Wallerian degeneration (WD) refers to events that follow a nerve transection, also known as a neurotmesis or a Sunderland Type V injury of a nerve trunk. In this injury, the proximal and distal stumps of the nerve trunk are completely separated. “Wallerian-like degeneration” describes similar events and shared mechanisms that occur after many types of traumatic nerve injury where the injury may not be as catastrophic e.g. crush or blunt injuries. It also occurs in diseases of nerves known as neuropathies. In the central nervous system, Wallerian-like degeneration (WLD) is also an essential prelude to axon regrowth but it operates at a much slower and less complete pace, a factor linked to very poor regrowth. Finally, axonal “pruning” in development or regeneration, a process that scales back supernumerary axons, shares in the machinery and mechanisms of WD.

WD involves the breakdown of axons and myelin distal to the injury site. Until recently, WD was thought to be a passive distal degeneration because of loss of protein axoplasmic transport from the cell body of the neuron. It is now recognized that WD is an active process with a unique set of signals triggered by an initial calcium transient [3]. The subsequent signals involve the ubiquitin-proteasome system (UPS) and inhibitors of the UPS can delay WD. Additional machinery involved in WD was identified through investigations of a spontaneous mouse mutant known as *Wld<sup>S</sup>*. This mouse has axons that survive and persist for long periods after they have been transected: they appear to resist degeneration. The *Wld<sup>S</sup>* mutation is a triplication that forms a fusion protein involving UFD2/E4 (a protein involved in protein ubiquitination), and nicotinamide mononucleotide adenylyltransferase (*Nmnat*, an enzyme involved in nicotinamide metabolism). As a result of this mutation and overexpression of the fusion protein, rises in *Nmnat* activity increase levels of nicotinamide adenine dinucleotide (NAD), an axonal protectant. NAD, in turn, operates through a protein deacetylase known as SIRT1 (a member of the Sir family of protein deacetylases). Discovery of these new mechanisms of WD offer opportunities to interrupt axon damage in some circumstances, such as axonal damage from peripheral neuropathies.

The next steps of WD involve axon microtubule dissolution, breakdown of the neurofilament axon lattice and, in the case of myelinated axons, a change in the phenotype of SCs associated with these fibers. “Activated” SCs upregulate a series of protein markers including GFAP (glial fibrillary acidic protein), N-CAM,

A5E3, Ran-2 and p75 [4], dissolve their own myelin and behave as phagocytes. To effectively break down axons and clear myelin debris, an inflammatory cascade is next required. This results from invasion of blood borne macrophages within the first 3–5 days after injury. In concert with inflammatory cell invasion, nerves undergoing WD express a series of cytokines and chemokines including IL-1 $\beta$ , IL-6, IFN- $\gamma$ , TNF- $\alpha$ , MCP-1 (monocyte chemoattractant protein-1) and MIP-1 $\alpha$  (macrophage inflammatory protein 1 $\alpha$ ). These molecules help coordinate inflammatory cell trafficking, axon and myelin digestion, or may operate as trophic factors for new axons. Interruption of their expression delays WD and subsequent regeneration.

Nitric oxide (NO) is an important participant in WD and it is generated by iNOS (inducible nitric oxide synthase) expressed in SCs and macrophages. Local NO dilates local blood vessels to promote clearance and to deliver trophic factors to the injured peripheral nerve trunk. Through lipid peroxidation, NO also promotes myelin breakdown, a task that removes inhibitory myelin products from areas of new axon ingrowth. Mice lacking iNOS have slowed WD and subsequent regeneration. Overexpression of iNOS and excess generation of NO however, may be detrimental to regeneration. NO released during intense inflammation or local infection can paradoxically shut down regeneration and collapse growth cones [5].

Thus, overall evolving concepts concerning WD emphasize its role as an active molecular cascade that later involves a directed inflammatory response. WD is an essential prelude to successful later regrowth.

### Early Regenerative Events

Once severed, axons quickly reseal then change the configuration of their microtubules, an alteration that may alter axoplasmic transport turnaround. Turnaround refers to the change in axoplasmic transport from anterograde to retrograde movement. Axonal endbulbs or boutons, originally described by Cajal as “sterile clubs” or necrotic profiles, next form at the proximal ends of transected axons. These structures, distinguished from growth cones, accumulate axoplasmic material that can include depolymerised neurofilaments, peptides, ion channels, enzymes and other molecules. As bulbs degenerate, some of their constituents can egress into the injury microenvironment and influence local glial cells, other axons or local microvessels. The neuropeptide CGRP (calcitonin gene-related peptide) released from endbulbs can dilate local microvessels and helps to render hyperemia, or rises in nerve blood flow, at injury sites. Endbulbs can also accumulate functional opioid receptors, sodium channels and nitric oxide synthases that generate NO within the injury milieu. These

contents of axonal endbulbs may thereby influence the development of ectopic axon electrical discharges associated with neuropathic pain.

Axon sprouting develops at the ends of injured axons, or at nodes of Ranvier proximal to the injury zone in myelinated fibers. Sprouting is a local phenomenon that does not require a connection to the cell body and may normally be suppressed by nodal molecules. For an early sprout to form thereafter into a mature and growing new axon however, does require a connection to the perikaryon. In fact, an injury to an axon is associated with a cascade of changes in the parent cell body that shift its phenotype from a “stable” transmitting neuron to a robust regenerating one [6]. The genes that change in association with injury and regeneration are known as **RAGs (regeneration associated genes)**. While the list of these changes is now extensive, key alterations include downregulation of neurofilament subunits, upregulation of tubulin that forms microtubules, upregulation of GAP43/B50 (growth associated protein 43) an actin assembly molecule, upregulation of nNOS (neuronal nitric oxide synthase) and upregulation of HSP27 (heat shock protein 27), a chaperone protein that helps refolding. Some RAGs develop from impaired retrograde transport of trophic factors and can be reversed with their replacement. Alternatively, in the CNS an attenuated RAG response may contribute to poor regeneration.

The overall progress of axon outgrowth and the behavior of growth cones therefore depends on coordinated activity between the cell body and local axons. For example, Perlson and colleagues have described a complex retrograde kinase signaling mechanism involving interactions between importins, dynein, depolymerized vimentin and pErk. Vimentin, an intermediate filament protein, and  $\beta$  importin, upregulated in sciatic axons after injury, complex with dynein and recruit phosphorylated activated Erk. Delivery of pErk to the cell body then allows it to influence nuclear gene transcription [7]. It is likely that more anterograde and retrograde signalling cascades like this will be identified. The interaction does illustrate how a nominal structural intermediate filament, vimentin, is upregulated in axons but subsumes a completely new role when depolymerised. Multiple tasking and interactions of neuronal molecules underlie regenerative events.

### Ras Superfamily GTPases

The list of molecular players influencing growth cones is also rapidly expanding. Their roles *in vivo* however, are less well defined during peripheral neuron regeneration. The Ras family GTPases (**Ras GTPases**), specifically RHO GTPases, are molecular switches important in defining cell polarity and directed growth. In neurons, they appear critical to growth cone advance

or collapse. One member, RHOA, has emerged as a critical brake on regenerative activity within the injured spinal cord. Additional RHO GTPase members are CDC42 and RAC1 that promote filopodia and lamellipodial extension and facilitate growth cone advance. RAC1 influences actin filament behavior, stabilizes adherent contacts, and activates the kinase PAK (p21-activated kinase) to then activate NF $\kappa$ B and MAPK.

RHOA localizes to the leading edges of migrating cells, or growth cones in neurons where it can promote its actions [8]. It interacts with p75, formerly known as the “low affinity” nerve growth factor receptor, and other molecules that include LINGO-1, TAJ/TROY, and the epidermal growth factor receptor (EGFR). RHOA, operating through a kinase known as ROK (RHO kinase) and other pathways, collapses growth cones through increases in actin “arc” formation and central actin bundle contractility and stability. To accomplish this task, ROK enhances myosin II phosphorylation and subsequent actin mediated growth cone retraction. It may also accomplish retraction by inhibiting of myosin phosphatase and by activating LIM kinase. This latter pathway in turn phosphorylates and deactivates *cofilin* (also known as actin depolymerizing factor [ADF]) interrupting growth cone advance. There is a long list of additional players that influence actin dynamics and the fate of peripheral nerve regeneration. They include the Arp 2/3 complex, N-WASP, cortactin, Scar/WAVE, Ena/Mena/VASP proteins, Cap Z, actin monomer binding proteins, and profilin to name a few. Further protein cascades and interactions, not discussed here, but including RHO GTPases, are involved in microtubular plasticity, a second major determinant of growth cone behavior.

RHOA has garnered particular attention because its inhibition facilitates axon outgrowth. This has been demonstrated in several ways using central neurons or peripheral neurons growing on inhibitory central substrates such as myelin or myelin-associated glycoprotein (MAG). RHOA is activated by a number of molecules that include Nogo-66, MAG, semaphorins, ephrins, oligodendrocyte myelin glycoprotein and chondroitin sulphate proteoglycans. Wu and colleagues [9] have demonstrated that RHOA GTPase is actually synthesized in growth cones where it facilitates collapse in response to inhibitory cues. In peripheral neurons, an important role for RhoA in inhibiting *in vivo* regeneration across transection injuries also exists. Blocking ROK improves regeneration.

The role of RHOA in suppressing axon outgrowth is contrasted with that of PI3K-Akt (phosphatidylinositol 3-kinase-Akt; Akt is also called protein kinase B [PKB]), a growth factor activated pathway that promotes growth and differentiation. One of its actions is to phosphorylate and inactivate glycogen synthase kinase 3 $\beta$  (GSK3 $\beta$ ), a multifunctional serine/threonine

kinase at the leading edges of growth cones that suppresses growth cone extension and axon formation. When it is phosphorylated through the PI3K-Akt signaling pathway, GSK3 $\beta$  activity is shut down, allowing growth to occur.

Overall, while the impact of many of these proteins has been examined *in vitro* or in the CNS, their role specifically on peripheral nerve regeneration is less well known. Some are synthesized by the perikaryon and transported to growth cones to effect their actions. Some however, are also locally synthesized by axons, a novel mechanism for responding to regeneration cues including those from SCs [10]. The other important caveat is that optimal early growth cone behavior in complex injured nerve trunks does not necessarily translate into optimal functional reconnections. Each step of the regenerative process can enhance or inhibit the final outcome.

### Schwann Cell Plasticity

► **Schwann cells** (SCs) are essential partners for axon maintenance and outgrowth in the peripheral nervous system. Activated SCs lead axons, in part with long laminin trails, through three dimensional trajectories during regeneration. Long and delicate SC processes closely accompany outgrowing axons and participate in a bidirectional exchange of molecules. SCs lay down adhesive substrates of the extracellular matrix such as laminin and fibronectin, but they also provide gradients of growth factors. Axons, in turn, offer substantial signals of their own to SCs that lead, for example, to a change in the “stable” phenotype associated with an intact myelinated axon to a “reactive” SC. Reactive SCs recapitulate development in that they re-express markers such as GFAP and others listed above. Interestingly, many of these markers have ongoing expression in SCs of Remak bundles, the structures that ensheath unmyelinated axons in peripheral nerve trunks. Neuregulins (NRGs), a critical signal to SCs, are products of alternative-splicing of the *NRG1* gene and belong to a family of growth and differentiation factors. NRGs are released from axons to act on SC receptors *erbB2* and *erbB3* in order to activate an intracellular second messenger cascade. NRGs thus support new axon outgrowth but may also operate also during WD and myelination. SCs can coax NRG release from axons by offering a menu of growth factors to them first.

Overall, we have labelled these essential bidirectional exchanges the “axon-Schwann cell dance.” The importance of this relationship is illustrated by experiments in which SC proliferation is deliberately inhibited by radiation or a mitosis inhibitor. Regeneration is severely limited. Alternatively, deliberately seeding gaps between proximal and distal nerve stumps after transection with SC precursors, substantially facilitates regeneration. Only rare axons advance “naked” for any



significant distances during regrowth. To support regeneration therefore, SCs must dedifferentiate, proliferate and migrate. In some injuries, such as nerve trunk crush, activated proliferating SCs form Bands of Bungner, guidance pathways for regrowth of axons into the distal denervated stump.

### Staggered and Preferential Regeneration

One of the interesting conundrums facing peripheral neurobiology revolves around why outgrowth of axons, for example from proximal nerve stumps, is not synchronized. Classical depictions of axon outgrowth envision simultaneous advance of growth cones and axons from all of their parents in the proximal nerve

stump. This view, however, is incorrect and we now recognize that outgrowth is “staggered” such that some axons grow out early, and others lag far behind. After transection nerve injuries, for example, only a small proportion of axons from the proximal nerve stump may cross into the regenerative zone even within the first week. In regenerative bridges, instead of a uniform pattern of new axons of similar maturity, new axons exhibit a wide variation in their level of maturity (Fig. 2). “Staggered” axon regeneration has only recently been highlighted by Gordon and colleagues during regrowth of motor axons [1]. This interesting phenomenon was also linked to another, known as preferential motor reinnervation (PMR) described by Brushart [1]. PMR

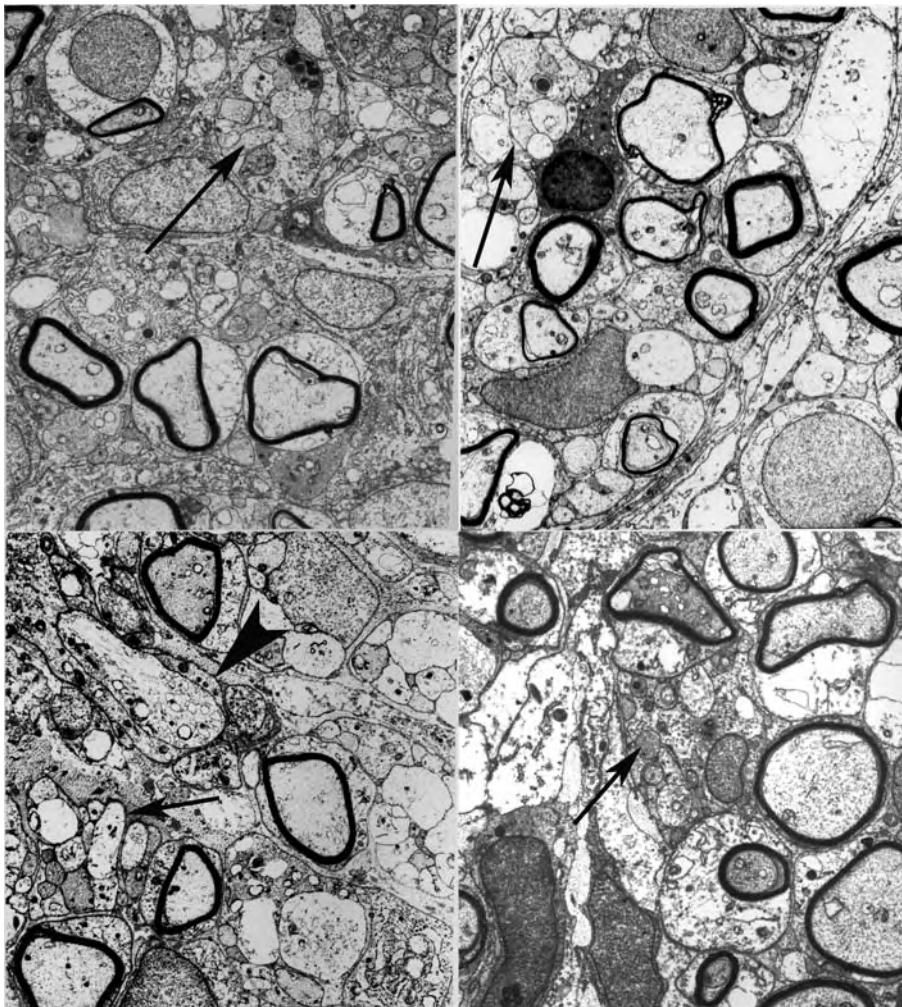

**Axon Degeneration and Regeneration of Peripheral Neurons. Figure 2** An electron composite micrograph from a regenerative bridge connecting a transected peripheral nerve trunk forming a few days after injury. The bridge consists of regenerative clusters and axons of varying levels of maturity and myelination. The *arrows* point to small clusters of regenerating axons. The *arrowhead* shows a longitudinally directed axon process, probably a growth cone, accompanied by fine SC processes on either side of it. Although the nerve trunk underwent a single injury, the bridge illustrates “staggered” regeneration in which more mature elongated axons are closely associated with later appearing smaller and less mature axons (image taken by David McDonald, Zochodne lab).

refers to the tendency of motor axons to prefer to regrow along “motor” pathways when offered a choice.

Both “staggered” and preferential regeneration illustrate the less explored concept that local cues for guidance and outgrowth have major impacts on the success of peripheral nerve regeneration. PMR may be accounted for by specific basement membrane molecules expressed by “motor” SCs, but not others that prefer to interact with sensory axons. Axons may have staggered growth because they need these kinds of cues to begin their advance. “Pioneer” axons, following leading migrating SCs, may start the process, and they facilitate axons to follow by offering cues.

### Other Features of the Regenerative Cascade

We provide here only a brief overview of some selected topics and players in the early regenerative cascade of a peripheral neuron. There are many other parts to this story. These include the role of nerve microvessels, or vasa nervorum, during the support of nerve trunk regrowth. A major topic for consideration is the problem of target tissue innervation. Targets include the neuromuscular junction with its specialized complement of terminal SCs and the skin where both dermal and epidermal fiber innervation are required. Regrowing axons must reform the proper architecture of a nerve trunk, re-establish disrupted blood-nerve barriers and in many cases, acquire a stable mature myelin sheath. I have also not discussed the burgeoning topic of neuron growth factors and their downstream intracellular signals. The list has extended well beyond the classical neurotrophin family of nerve growth factor, first discovered by Levi-Montalcini almost 50 years ago. New neuron growth factors, sometimes originally described in other tissues, have emerged such as erythropoietin, GDNF family members and bone morphogenic proteins (BMPs), and vascular endothelial growth factors (VEGFs). Finally, the roles of adhesive molecules interacting with axon and SC integrin receptors are critical to the regenerative process. Not only do these interactions provide outgrowth and guidance cues, but they can generate intracellular signals of their own, interacting for example with growth factors.

### Summary

Peripheral nerve regeneration is a complex, coordinated cascade of events that involves multiple cellular players and an intensive series of molecular interactions. Central among these are the axon-SC partnership and their bidirectional exchange. There is a beauty to the sequential unfolding of all of these relationships, yet they remain largely unexploited for therapeutic purposes. While nerves regenerate, they have major barriers to do so and frequently fail to accomplish their tasks. The upsurge of interest and work on these barriers does promise to overcome them.

### Acknowledgements

Brenda Boake provided expert editing assistance for the manuscript. Work in the Zochodne lab is funded by the Canadian Institutes of Health Research, the Canadian Diabetes Association and Alberta Heritage Foundation for Medical Research. DWZ is a Scientist of AHFMR.

### References

1. Fu SY, Gordon T (1997) The cellular and molecular basis of peripheral nerve regeneration. *Mol Neurobiol* 14:67–116
2. Stoll G, Jander S, Myers RR (2002) Degeneration and regeneration of the peripheral nervous system: from Augustus Waller’s observations to neuroinflammation. *J Peripher Nerv Syst* 7:13–27
3. Luo L, O’Leary DD (2005) Axon retraction and degeneration in development and disease. *Annu Rev Neurosci* 28:127–156
4. Jessen KR, Morgan L, Stewart HJ, Mirsky R (1990) Three markers of adult non-myelin-forming Schwann cells, 217c(Ran-1), A5E3 and GFAP: development and regulation by neuron–Schwann cell interactions. *Development* 109:91–103
5. Hess DT, Patterson SI, Smith DS, Skene JH (1993) Neuronal growth cone collapse and inhibition of protein fatty acylation by nitric oxide. *Nature* 366:562–565
6. Verge VM, Gratto KA, Karchewski LA, Richardson PM (1996) Neurotrophins and nerve injury in the adult. *Philos Trans R Soc Lond B Biol Sci* 351:423–430
7. Perlson E, Hanz S, Ben-Yaakov, K et al. (2005) Vimentin-dependent spatial translocation of an activated MAP kinase in injured nerve. *Neuron* 45:715–726
8. Luo L, Jan LY, Jan YN (1997) Rho family GTP-binding proteins in growth cone signalling. *Curr Opin Neurobiol* 7:81–86
9. Wu KY, Hengst U, Cox LJ et al. (2005) Local translation of RhoA regulates growth cone collapse. *Nature* 436:1020–1024
10. Willis DE, Twiss JL (2006) The evolving roles of axonally synthesized proteins in regeneration. *Curr Opin Neurobiol* 16:111–118

---

## Axon Elongation

### ► Axon Outgrowth

---

## Axon Guidance

### ► Axon Pathfinding

## Axon Outgrowth

TATSUMI HIRATA

Division of Brain Function, National Institute of Genetics, Graduate University for Advanced Studies (Sokendai), Mishima, Japan

### Synonyms

Axon elongation; Axogenesis; Neurite extension

### Definition

The **axon** is the crucial output machinery of neurons. Along this cable, electrical signals, called **action potentials**, are propagated and transmitted to other cells via a **synapse**. Axon outgrowth is an important developmental process, in which the axon is projected from the cell body (**soma**) toward specific target cells. Both intrinsic and extrinsic factors precisely control this process to make sure that the nervous system builds up the correct wiring pattern of axons, because the neural network is fundamental to the complex functioning of the nervous system. The **growth cone** at the distal tip of axons plays a primary role in axon outgrowth, sensing extrinsic factors and determining the direction of the growth. Neurite is a special term referring to a fiber that has outgrown in culture, where the distinction between axons and **dendrites** is not necessarily clear.

### Characteristics

#### Quantitative Description

The lengths of axons vary enormously according to the type of neuron. For example, motor neurons in human have axons that sometimes reach one meter in length, while **interneurons** tend to have much shorter axons, such as tens of microns. The speed of axon outgrowth also depends on neuronal type. The typical speed of axonal outgrowth in culture is in the range of tens to hundreds of micrometers per hour [1]. It is difficult to measure the speed of axon outgrowth *in vivo*, but the speed has been estimated to be in this range in living animals such as *Xenopus* and *C. elegans* in which axon outgrowth is accessible [2]. The speed of **axon regeneration** in peripheral nerves is usually assumed to be 2–3 mm per day.

#### Lower-Level Structures

The distal tip of the axon is called the growth cone and comprises finger-like protrusions, the **filopodia** and ruffling membrane called the **lamellipodia** (Fig. 1).

The **actin** cytoskeleton is the major structural component of the growth cone and the driving force for its movement. Bundled **actin filaments** control the extension and retraction of the filopodia and branched

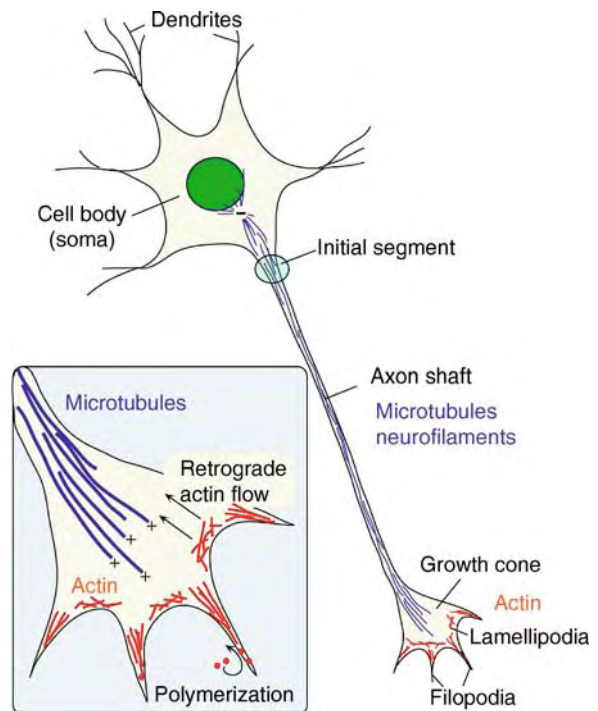

**Axon Outgrowth. Figure 1** Structure of a neuron developing neurons can be divided into several parts such as the dendrite, cell body, axon shaft, initial segment and growth cone, each of which has a specific cytoskeletal composition. The *inset* is a close-up of the growth cone showing active cytoskeletal dynamics.

actin meshwork controls the ruffling movement of the lamellipodia. **Microtubules**, another major cytoskeletal component, are the backbone of the axon shaft and also partially populate the central part of the growth cone. **Neurofilaments**, which belong to a class of intermediate filaments, are also abundant in the axon shaft and seem to add stability to the axon cytoskeleton. The axon initial segment or the **axon hillock**, which is positioned at the boundary between the axon and the cell body (soma), usually develops a specialized structure in which various membrane scaffold proteins and ion channels are concentrated and serves as the ignition site for action potentials.

#### Higher-Level Structure

The ultimate goal of axon outgrowth is making synapses onto specific targets. During the process, axon terminals turn into **pre-synaptic** structures, in which synaptic vesicles and the releasing machinery are properly installed. The pre-synaptic structure is usually perfectly matched with the **post-synaptic** structure on the target cell. This structural matching is achieved by accurate distribution of a variety of molecules such as cell-adhesion, cytoskeletal and scaffold proteins and ion

channels, through bi-directional signaling between the pre- and post-synaptic elements.

The ►**myelin** sheath is another important feature of the high level structure of axons. This intricate membrane is synthesized by ►**oligodendrocytes** and ►**Schwann cells** in the central and peripheral nervous systems respectively, wraps around many long axons in vertebrates and insulates electrical activity along the axons from leaking, so that the axons can propagate action potentials rapidly.

### Structural Regulation

The actin cytoskeleton and microtubules are dynamically controlled in axons [3]. Actin filaments are continuously transported in the proximal direction within the growth cone (retrograde actin flow in Fig. 1). To cope with this flow, actin filaments are polymerized by incorporating actin monomers at the distal end facing the leading edge of the growth cone. For axons to outgrow, the speed of actin polymerization has at least to keep up with that of the retrograde flow. If not, actin filaments will be withdrawn from the growth cone, stripping off the filopodia and lamellipodia altogether, leading to the reaction called growth cone collapse. Most repulsive ►**guidance molecules** induce growth cone collapse by affecting actin dynamics and inhibiting axon outgrowth. Microtubules also have a polarized structure and position the fast-polymerized plus-end to the distal direction of axons. When axons grow, microtubules selectively invade the distal part of the growth cone along actin filaments, converting the growth cone into the shaft and actually lengthening the axons. These cytoskeletal dynamics are regulated by a number of tubulin- and ►**actin-binding proteins**.

### Upstream Process

Generally, neuronal differentiation and migration precede axon outgrowth, although some types of neurons begin to grow axons while their cell bodies are still migrating. In culture, many neurons initially extend multiple immature processes that have the characteristics of neither axons nor dendrites. Subsequently, one of the processes, usually the longest one, is chosen and differentiates into the axon, whereas the others are committed to be dendrites [4]. Although we cannot see the exactly same phenomenon in vivo, a similar competitive interaction among initial processes is believed to take place in the establishment of the highly polarized structure of neurons that have a single axon and multiple dendrites.

### Downstream Process

The axon is not always a simple single line structure but sometimes bifurcates and makes branches, which enable it to connect to multiple target cells and broaden

the terminal field. There is also a naturally occurring degenerative process for axons, in which axons that have once projected are later eliminated. This ►**axon pruning** is widely used for the refinement of early rough neural networks and the establishment of more functional circuits during a later stage of development.

### Process Regulation

The route of axon outgrowth is stereotyped and barely differs among individuals, suggesting that it is mainly determined genetically. Indeed, the direction of axon outgrowth is controlled by a variety of extrinsic signals called guidance molecules, which are synthesized at a fixed time and place according to the developmental genetic program. The guidance molecules, which are basically proteins, can be categorized into several groups (Fig. 2).

One group is that of attractive molecules that pull the growth cone by changing the cytoskeletal status locally within the growth cone. ►**Netrin** is a famous example of this category. Another group is that of ►**repulsive molecules**, which repel the growth cone and create a domain inaccessible to axons. The repulsive molecules

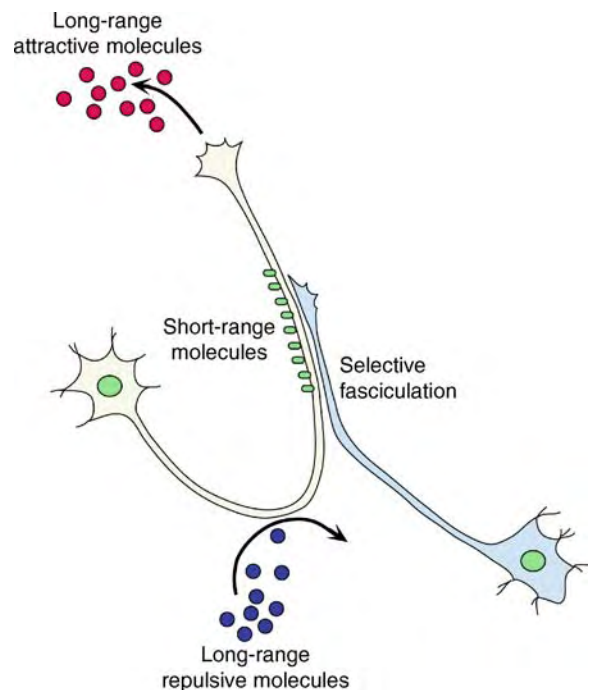

**Axon Outgrowth. Figure 2** Guidance of axon outgrowth. Axon outgrowth is guided by attractive or repulsive guidance molecules. Either attractive or repulsive guidance molecules can act in the short- or long-range. In a later developmental stage, selective fasciculation can be a strong guidance force for the following axons.

destroy the actin cytoskeleton in the growth cone and induce collapse, thereby inhibiting axon outgrowth. Recent studies have identified many molecules that belong to this category including ►semaphorin, ►eprhrin and ►slit. Another type of classification from a different standpoint is that of long-range versus short-range guidance molecules. The long-range molecules diffuse from their source and form a concentration gradient, which determines the pattern of axon outgrowth. The short-range molecules are somewhat immobilized in the place where they were synthesized and act only locally on axons. ►Extracellular matrix proteins and ►cell-adhesion molecules are often categorized in this group. Theoretically, either attractive or repulsive guidance molecules can have short- or long-range actions.

During outgrowth, axons are not always individual navigators but often travel together, bundling with each other in the same route. This is especially marked in later projecting axons, some of which simply follow earlier axons by adhering to them (Fig. 2). This selective ►fasciculation apparently eases the pathfinding task of followers; only the first ►pioneer neurons are assigned to the challenging job of pioneering the pathway.

### Function

Axon outgrowth is an important process that enables neurons to connect with distant targets. Therefore, this process underlies all the functions of the nervous system such as sense, movement, perception, memory, emotion and behavior.

### Pathology

Genetic engineering technology has generated many animals that have mutations in various types of genes involved in axon outgrowth and guidance. These animals show specific phenotypes and pathologies in the nervous system according to properties of the genes and could serve as animal models for various human diseases.

### Therapy

In mammals, axon outgrowth is only marked during development and the axons lose the capacity to grow with maturation of the central nervous system. Clinically, it remains extremely difficult to induce re-growth of central axons, although this field has been investigated extensively. Differences in the growing capabilities of developmental and adult axons can be partly attributed to the growth-inhibitory environment of the adult central nervous system. Especially, myelin in the adult central nervous system is assumed to be a component of the materials that prohibit axon regeneration.

## References

1. Yamamoto N, Higashi S, Toyama K (1997) Stop and branch behaviors of geniculocortical axons: a time-lapse study in organotypic cocultures. *J Neurosci* 17:3653–3663
2. Chien CB, Rosenthal DE, Harris WA, Holt CE (1993) Navigational errors made by growth cones without filopodia in the embryonic *Xenopus* brain. *Neuron* 11:237–251
3. Dent EW, Gertler FB (2003) Cytoskeletal dynamics and transport in growth cone motility and axon guidance. *Neuron* 40:209–227
4. Dotti CG, Banker GA (1987) Experimentally induced alteration in the polarity of developing neurons. *Nature* 330:254–256

## Axon Pathfinding

NOBUHIKO YAMAMOTO

Dept Cellular and Molecular Neurobiology, Graduate School of Frontier Biosciences, Osaka University, Osaka, Japan

### Synonyms

Axon guidance; Axonal targeting

### Definition

During development, axons grow to appropriate directions and reach their target cells to form synaptic connections. In this developmental event, axons are guided by various molecular cues. Fundamentally, there are two types of axon guidance molecules, attractive and repulsive molecules. These molecules are further categorized into diffusible and contact-mediated cues, based on their chemical properties and/or actions.

### Characteristics

#### Quantitative Description

The volume of adult human brain is 1300–1500 cm<sup>3</sup> and composed of approximately 100 billion neurons. During development, neurons are produced by proliferation from neuronal stem cells, at a speed of 250,000 per min. After mitosis, a neuron extends an axon, a fine process with a small diameter (less than one micron in most cases). Axons grow at a speed of several ten microns per hour (~1mm/day). An axonal tip is called a growth cone, which is a swelling structure with various detectors to sense surrounding molecules. The size of a growth cone is varied among nervous systems and species, ranging from several to several ►tens of microns. One axon extends from a neuronal cell body, but forms branches and synaptic connections with numerous target cells.

### Higher Level Structures

The fundamental patterns of neural connections are surprisingly stereotyped. For instance, in the visual system (Fig. 1a), a million of the retinal axons originating from one eye run towards the midline of the brain.

Half of them further project to the opposite (contralateral) side of the brain to form connections with ►contralateral visual thalamus (lateral geniculate nucleus, LGN). The remaining half alters the direction at the midline (optic chiasm) and project to the LGN in the same (ipsilateral) side. Axons from the LGN, in turn, send axons to the ipsilateral visual cortex. In a microscopic view, LGN axons project to a particular layer of the visual cortex, which is composed of six cell layers. These connection patterns are completely the same among individuals and even common in higher mammals. Such stereotyped connections are found ►in many other systems. Thus, axons run in specific pathways and form connections with their target cells.

### Lower Level Components

Axons grow towards the location where diffusible attractive factors are concentrated, whereas axons turn away from the source of diffusible repulsive factors. The former and latter phenomena are called chemoattraction and chemorepulsion, respectively. Netrins and ►semaphorins (secreted type) are well-known protein families that have chemoattractive and chemorepulsive activities.

Cell surface and ►extracellular matrix (►ECM) molecules can also act as guidance molecules. Immunoglobulin domain-containing proteins and cadherins (calcium-dependent cell adhesion proteins) are typical

cell surface molecules which influence axon growth. Ephrins, ligands for a receptor tyrosine kinase family (Eph family), are also cell surface molecules, and are known to act as ►repulsive guidance molecules for axonal growth. Laminin and fibronectin are large glycoproteins in ECM, and promote axon growth of peripheral and central neurons. Proteoglycans, proteins with abundant sugar residues, are also ECM molecules and known to affect axon growth. The proteoglycans are categorized into several types such as heparan-sulfate proteoglycans and chondroitine sulfate proteoglycans based on kinds of sugar residues.

On the other hand, growth cones have various receptors that sense the above guidance molecules. Unc5 families and DCC (deleted in colorectal carcinoma) are receptor proteins for netrin family members; neuropilin and plexin are receptors for semaphorin family; Ephs are ephrin receptors; Integrin families are receptors for laminin and fibronectin. These receptors are membrane proteins with specific cytoplasmic domains, which influence cytoskeleton components *via* second messenger systems and/or gene expression.

### Higher Level Processes

#### Chemotactic Behavior and Contact-Mediated Behavior

The growth cone exhibits ►chemotaxis in *in vitro* experiments. When attractive factors are applied to a growth cone through a glass micropipette, it begins to extend towards the pipette [1]. When a repellent factor is applied, growth cones turn away from the source. Such turning behavior is thought to reflect a guidance property of chemoattractive and chemorepulsive factors *in vivo*: If target or intermediate target cells release attractive factors, growth cones could be directed

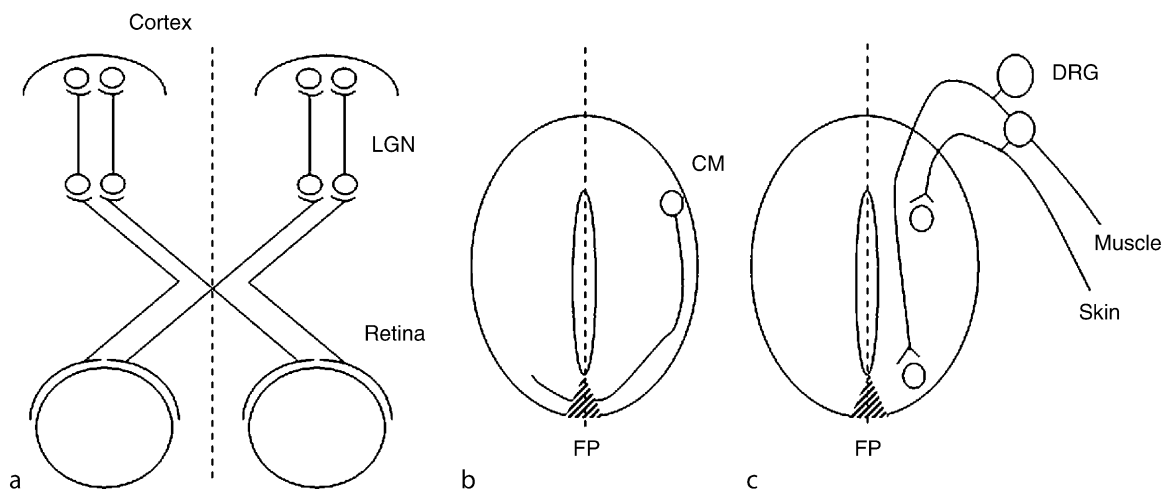

**Axon Pathfinding. Figure 1** Stereotyped neural connection patterns in the central and peripheral nervous systems. (a) Neural connections from the retina to the visual cortex. (b) Trajectory of commissural axons in the spinal cord. (c) Projection patterns of distinct sensory neurons. Dashed lines represent the midline. LGN lateral geniculate nucleus; CM commissural neurons; FP floor plate; DRG dorsal root ganglion.

toward them. Conversely, axons could avoid entering the brain region where chemorepulsive factors are released.

Growth cones exhibit not only chemotactic but also contact-mediated responses. When growth cones of retinal axons encounter (make a contact) axons from peripheral neurons *in vitro*, retinal growth cones are repelled by the peripheral axons [2]. By contrast, retinal growth cones do not exhibit retraction when meeting other retinal axons. Such contact-mediated cues also contribute to axon guidance.

### Pathway Choice and Target Selection by Attraction and Repulsion

Pathway choice and [▶target selection](#) are required for the formation of appropriate neural connections in the brain. In the spinal cord, commissural neurons, which interconnect both sides, are located in the dorsal part. During development, axons from these neurons extend ventrally, pass through the ventral midline and reach the contralateral side (Fig. 1b). *In vitro* experiments have shown that commissural axons from the dorsal spinal cord explant grow towards the cocultured floor plate (midline structure of the spinal cord), but do not grow towards explants dissected from the other parts of the spinal cord [3]. Commissural axons from the hindbrain also exhibit similar behavior [4]. These findings indicate that some factor released from floor plate cells, the intermediate target, acts as an attractive factor for commissural axons.

The dorsal root ganglion (DRG) neurons that are involved in pain or heat sensation (nociceptive DRG neurons) send axons to the interneurons that are located in the dorsal part of spinal cord, but do not project to motor neurons in the ventral part of spinal cord

(Fig. 1c). In a culture experiment, the developing ventral spinal cord has been shown to secrete the factor that inhibits the growth of these sensory axons [5]. The DRG neurons that sense muscular extension (proprioceptive DRG neurons) are not affected by the factor. Correspondingly, these sensory axons enter the ventral spinal cord to form synaptic connections with motor neurons. Thus, each type of DRG neurons can select their target cells ([▶target selection](#)).

### Fasciculation and Axonal Branching

Axons often make a bundle in their pathways. The axon that first extends towards the target cells during development is called a pioneer fiber. The axons originating from the same origin follow the pioneer fiber, and form a bundle (fasciculation). Once these axons reach the target zone, they separate each other (defasciculation). Individual axons further grow to more specific locations and form branching to connect with a certain number of target neurons. In the retinogeniculate system, retinal axons form a bundle (optic tract), but defasciculate in the LGN and form arbors to make synaptic contacts with several LGN neurons. Moreover, LGN axons grow towards the visual cortex with fasciculation (optic radiation). Once arriving at the visual cortex, LGN axons defasciculate to innervate a lot of cortical neurons. Individual axons further form branching in their target layer (target selection) to form synaptic connections (Fig. 2) [6].

### Lower Level Processes

#### Molecular Mechanisms of Attraction and Repulsion

Ligand-receptor interactions are critical for axon guidance. In the commissural axon guidance, netrin family members are released from the floor plate and

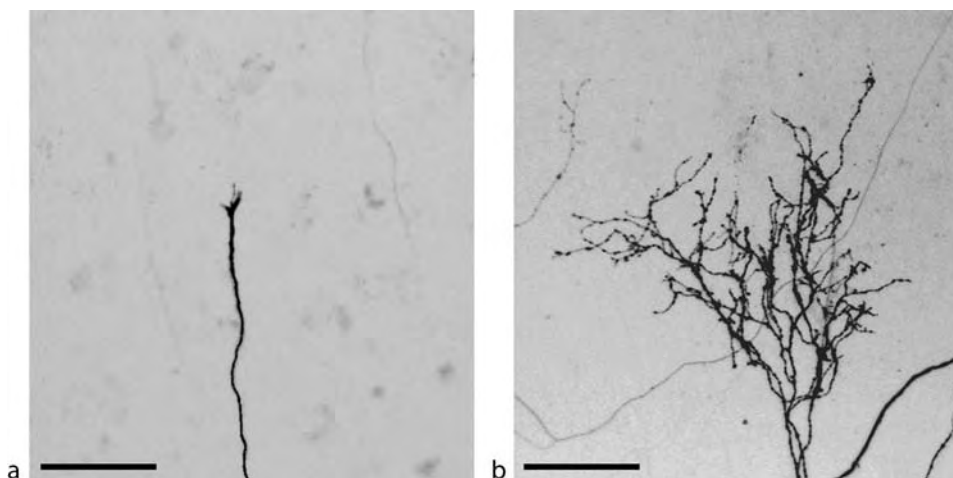

**Axon Pathfinding. Figure 2** Axon growth and branching. (a) Growth cone of a thalamocortical axon extends in the cortex *in vitro*. (b) Thalamocortical axon forms arbors in later developmental stages (*in vitro*). Scale bars in a and b represent 0.05 and 0.1 mm, respectively.

act as attractive factors for the commissural axons that express netrin receptors (Fig. 1b) [7].

Interactions between a member of the semaphorin family and its receptor, neuropilin are necessary for repulsive axon guidance of nociceptive DRG neurons. In this system, the semaphorin is expressed in the ventral half of the spinal cord and act as a repulsive guidance molecule for nociceptive DRG axons [5]. As a result, these axons do not enter the ventral spinal cord. By contrast, proprioceptive DRG axons can enter the ventral spinal cord as they do not express the receptor. However, these ligands do not necessarily produce the same effects in terms of attraction and repulsion. Netrins act as attractive factors in the commissural axon growth, but produce a repulsive action for axon guidance of a particular type of motor neurons. This is true for action of semaphorins.

Another molecular species also contribute to attractive and repulsive guidance mechanisms. Ephrin-Eph interaction produces growth-inhibitory action. Axons expressing Eph receptors are repelled by the brain region where ephrin ligands are expressed [8]. Moreover, chondroitin sulfate proteoglycans, an ECM molecule, also act as repulsive guidance molecules. On the other hand, laminin and fibronectin, ECM molecules, can promote axonal extension in a contact-mediated manner from most central and peripheral neurons that express integrin receptors.

#### **Molecular Mechanisms for Fasciculation and Branching**

Adhesion molecules are involved in axonal fasciculation primarily through their homophilic binding properties. If two axons express the same adhesion molecule, these two axons could run side by side, as high affinity is present between their extracellular domains. Immunoglobulin-superfamily proteins such as the neural cell adhesion molecule (NCAM) is crucial to form axon bundle. Axonal defasciculation is also ►regulated by adhesion molecules. In motor nerve projections, axons from motor neurons form a bundle on the way, but defasciculate around target muscle cells. A certain amount of sugar residues binding to NCAM promote the defasciculation by weakening homophilic binding of L1, the other adhesion molecule [9].

Axonal branching is also regulated by adhesion molecules, ECM and cell-surface molecules. In the cortex, thalamocortical axon branching is inhibited by the sugar residues, whereas it is promoted by ECM or cell surface molecules in the target layer [6]. Axonal branching is further regulated by neurotrophic factors secreted from target cells.

#### **Process Regulation**

Expressions of guidance molecules and their receptors are regulated primarily by transcriptional factors. For instance, ephrin (ligand of receptor tyrosine kinase)

expression is graded rostrocaudally in the visual center of amphibians as well as mammals. This expression pattern matches that for En (►Engrailed), which is a homeodomain-containing transcriptional factor. Similarly, the receptor expression in the retina is also regulated transcriptionally.

#### **Function**

Brain functions are mostly attributable to its neural networks, that is, axon pathfinding mechanisms produce elaborate neural circuitries that enable us to sense everything and behave appropriately.

#### **References**

1. Gundersen RW, Barrett JN (1979) Neuronal chemotaxis: chick dorsal-root axons turn toward high concentrations of nerve growth factor. *Science* 206:1079–1080
2. Kapfhammer JP, Grunewald BE, Raper JA (1986) The selective inhibition of growth cone extension by specific neurites in culture. *J Neurosci* 6:2527–2534
3. Tessier-Lavigne M, Placzek M, Lumsden AG, Dodd J, Jessell TM (1988) Chemotropic guidance of developing axons in the mammalian central nervous system. *Nature* 336:775–778
4. Shirasaki R, Tamada A, Katsumata R, Murakami F (1995) Guidance of cerebellofugal axons in the rat embryo: directed growth toward the floor plate and subsequent elongation along the longitudinal axis. *Neuron* 14:961–972
5. Messersmith EK, Leonardo ED, Shatz CJ, Tessier-Lavigne M, Goodman CS, Kolodkin AL (1995) Semaphorin III can function as a selective chemorepellent to pattern sensory projections in the spinal cord. *Neuron* 14:949–959
6. Yamamoto N, Inui K, Matsuyama Y, Harada A, Hanamura K, Murakami F, Ruthazer ES, Rutishauser U, Seki T (2000) Inhibitory mechanism by polysialic acid for lamina-specific branch formation of thalamocortical axons. *J Neurosci* 20:9145–9151
7. Kennedy TE, Serafini V, de la Torre JR, Tessier-Lavigne M (1994) Netrins are diffusible chemotropic factors for commissural axons in the embryonic spinal cord. *Cell* 78:425–435
8. Nakamoto M, Cheng HJ, Friedman GC, McLaughlin T, Hansen MJ, Yoon CH, O'Leary DD, Flanagan JG (1996) Topographically specific effects of ELF-1 on retinal axon guidance *in vitro* and retinal axon mapping *in vivo*. *Cell* 86:755–766
9. Rutishauser U, Landmesser L (1996) Polysialic acid in the vertebrate nervous system: a promoter of plasticity in cell-cell interactions. *Trends Neurosci* 19:422–427

## **Axon Reaction**

►Chromatolysis

►Neuronal Changes in Axonal Degeneration and Regeneration



## Axon Reflex

### Definition

Generally, the term *axon reflex* denotes a neurally mediated effector response that is brought about by the passage of nerve impulses along axons without traversing a synapse, except that between the nerve ending and the effector tissue. Specifically, an axon reflex is elicited by a stimulus that excites afferent neurons which without transmission to efferent neurons modify the activity of effector tissues. The best known example is the cutaneous *flare* response of Thomas Lewis' triple response to irritation or injury. The reddening (flare due to vasodilatation) that spreads beyond a pin-point injury of the skin is explained as the result of axon reflexes between the arborizing collaterals of sensory nerve fibers. When some axon branches are activated by an irritant stimulus, nerve impulses travel centrally to the branching points where they pass antidromically to the other branches and thus back to the skin. Here, periarteriolar branches of sensory neurons can release vasoactive transmitters (e.g., calcitonin gene-related peptide and substance P) and thereby cause arteriolar dilatation.

- ▶ Calcitonin Gene Related Peptide (CGRP)
- ▶ Nociceptors and characteristics
- ▶ Substance P

## Axonal Conduction

### Definition

- ▶ Action Potential Propagation

## Axonal Degeneration

### Definition

There are two types: (i) Wallerian degeneration occurs distal to a lesion and effectively removes the damaged axon; (ii) dying back neuropathy occurs proximal to the lesion and ultimately causes apoptosis of the neuron.

- ▶ Axon Degeneration and Regeneration of Peripheral

- ▶ Neuronal Cell Death and Axonal Degeneration: Neurofilaments as Biomarkers
- ▶ Neurons
- ▶ Wallerian-Like Degeneration

## Axonal Neuropathies

### Definition

Subgroup of ▶ peripheral neuropathies in which the ▶ myelin sheaths remain intact.

## Axonal Pathfinding and Network Assembly

GAYNOR E. SPENCER, NATHAN R. FARRAR,  
ROBERT CARLONE

Department of Biological Sciences, Brock University,  
St. Catharines, ON, Canada

### Synonyms

Growth cone guidance

### Definition

For correct functioning of the mature nervous system, precise synapse formation and network assembly during development is required. The neurons, which are the signaling units of the nervous system, possess specialized neurite processes known as dendrites and axons, which are responsible for receiving and sending signals. These neuritic processes, which grow out from the cell body of the neuron during development, must make accurate connections with appropriate targets. The axon in particular, may need to traverse great distances before reaching such targets and the process by which the axon navigates to its eventual destination is known as axonal pathfinding. The structure responsible for this pathfinding task is known as the neuronal ▶ growth cone [1].

### Characteristics

#### Early Development of the Nervous System – A Prelude to Axon Pathfinding and Network Assembly

The construction of an organ as complex as the human nervous system requires an integrated series of precise developmental steps that precede the formation of connections between maturing nerve cells. These

connections ultimately lead to the ability of these networks to process information and mediate complex behaviors. Uncommitted ectodermal cells in the future dorsal side of the embryo require factors provided by neighboring mesodermal and endodermal cells to become a columnar neuroepithelium, the neural plate, in a process called neural induction. Cellular shape changes and mitotic activity in this layer of cells leads to the folding up of this plate and formation of a dorsal ►neural tube. The neural tube contains an inner layer of cells called the germinative or ependymal layer consisting of the mitotically active progenitor cells for both neurons and glia of the brain and spinal cord. As these progenitor cells cease dividing, their fates as specific neuronal cell types or glial cells (►Radial glia) are determined by both intrinsic and extrinsic factors in the local environment of the early neural tube. Extrinsic factors include many diffusible molecules, cell surface glycoproteins and extracellular matrix factors (►Collagens). These factors influence the array of gene products produced in these now committed progenitors which influence neuronal shape, axonal pathway selection, connectivity and chemistry. Once determined, cells migrate away from the ependymal layer through the ever thickening neural tube, toward their final destinations. At the same time, within the dorsal outermost layer of the tube, a population of cells unique to vertebrates, the ►neural crest cells, are beginning to migrate along specific paths toward their ultimate destination in the periphery of the developing embryo. Once there, depending upon a mix of intrinsic factors and target-derived signals, they will differentiate into a wide variety of cell types, including autonomic and sensory ganglia as well as peripheral glia (Schwann cells).

### Structure of the Growth Cone

The growth cone is a small motile expansion of the cytoplasm at the ends of growing axons and dendrites and was first characterized in the late 1800s by the famous neuroanatomist Santiago Ramon y Cajal. The basic morphology of the growth cone is often described as resembling a hand, though growth cone appearance may vary depending upon its surrounding environment. *In vivo*, growth cones tend to acquire a compact shape, whereas *in vitro*, there is a tendency for the growth cone to splay out and enlarge, sometimes reaching diameters as great as 50  $\mu\text{m}$  for large invertebrate neurons. Structurally, the growth cone is divided into two major domains, the central or C-domain and the peripheral, P-domain. Two characteristic features of the growth cone, the filopodia and lamellipodia, emanate from the P-domain. Filopodia are long, slender protrusions that extend from the growth cone and are important for sensing the external environment, whereas the lamellipodia are flattened veils between the adjacent filopodia. The thicker central (C)

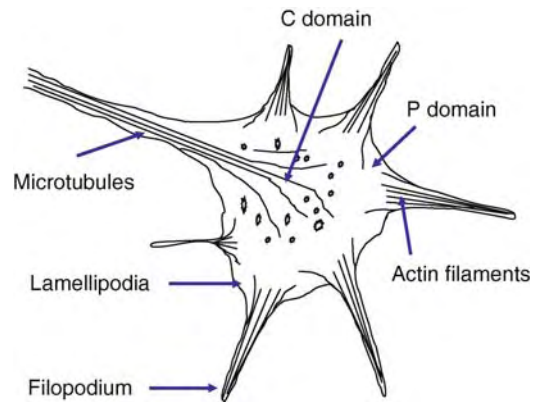

**Axonal Pathfinding and Network Assembly.**  
Figure 1 Schematic of a neuronal growth cone.

domain of the growth cone, unlike the filopodia and lamellipodia, contains organelles, vesicles and ►microtubules extending into the C-domain from the axonal shaft (Fig. 1).

### The Cytoskeleton

The growth cone is a highly motile structure, a feature which is dependent on the fact that the cytoskeleton of the growth cone is dynamic in nature [2]. Within the P-domain, extending filopodia contain bundled microfilaments made up of F-actin, the continuing polymerization of which pushes the ►filopodium outwards. The sheet-like lamellipodia contain a meshwork of short actin filaments, as well as longer, bundled filaments. Microtubules, which are long polymers of  $\alpha$ - and  $\beta$ -►tubulin, extend down the axon shaft and enter the growth cone, radiating out distally in the C-domain, sometimes forming kinks and loop structures. Microtubules have also been seen entering the P-domain in such a way that they are aligned with a filopodium, even entering the most proximal portion of it. ►Microtubule growth has a polarity such that polymerization occurs at the “plus-end,” which is directed into the growth cone. Microtubules are the key players in neurite extension, while the actin filaments are more important for filopodia and lamellipodia extension.

The ability of the growth cone to collapse the cytoskeleton in some regions, while constructing new cytoskeletal domains, underlies the motility of the growth cone. Due to the dynamic nature of the cytoskeleton, a host of specialized proteins are needed both to help stabilize, but also remodel the cytoskeleton. Microtubule-associated proteins (MAPs) known to be present in the growth cone include Tau and MAP1B (microtubule stabilizers), MAP2 (a microtubule bundling protein), SCG10 (a microtubule destabilizer) and Ezrin (a linking protein used to join microtubules and actin filaments). A different set of proteins contribute

to actin filament dynamics. These include ADF/cofilin (actin filament depolymerization),  $\alpha$ -actinin and fascin (actin filament bundling), and GAP-43 (actin filament length control), among many others [1]. Ultimately, an environmental signal that affects elongation of the axon or growth cone behavior, will somehow regulate the actin and microtubule assemblies described above.

### Responses to Environmental Cues

A large number of guidance cues that direct the motile growth cone have now been identified [3,4]. These include cell surface molecules which generally act as short-range signals, or secreted and diffusible molecules that may act as long-range signals. These signals act in either a repulsive or attractive manner. Repulsive signals may cause a growth cone to turn away from the source, whereas attractive signals induce growth cone turning toward the source. An alternative behavior is growth cone collapse, which often results in the growth cone “shriveling up” (and sometimes retracting) in response to a contact-mediated or diffusible inhibitory signal.

The most well-known cell surface molecules that mediate attraction are the ►cell adhesion molecules (CAMs); for example, the cadherins and neural cell adhesion molecule (NCAM). EphrinAs are examples of repulsive cell surface signals that play an important role in retinotectal mapping [5]. Another repulsive surface signal is myelin associated glycoprotein, MAG, which is a component of myelin and can induce growth cone collapse *in vitro*. MAG may be one molecule that prevents neuroregeneration in some animals, (though it is necessary for both forming and maintaining the myelin sheath). Secreted or diffusible guidance signals are numerous and include the well studied netrins, slits, and semaphorins (class 3), but also include ►growth factors such as nerve growth factor (NGF) and brain-derived growth factor (BDNF), classical morphogens such as Wnts and bone morphogenetic proteins (BMPs), neurotransmitters, and extracellular matrix proteins such as the ►substrate adhesion molecules (SAMs), ►laminin and ►fibronectin.

### Transduction of Signals

A neuronal growth cone possesses a remarkable sensitivity to chemical gradients of guidance cues and has the capacity to detect a concentration difference of as little as one molecule across its surface [6]. The binding of a guidance cue (or ligand) to a surface receptor on the growth cone generates a signal that is ultimately transduced to the cytoskeleton, but exactly how this occurs is not clear. A number of second messengers have been identified as playing important roles in this process including calcium [7] and the cyclic nucleotides cAMP and cGMP [8]. The role of calcium has been known for many decades and it is generally proposed that global increases in growth cone calcium

regulate the growth of the neurite (►Neurite out-growth), whereas local asymmetric increases in the growth cone determine the turning response. Studies on the role of cyclic nucleotides have shown that the ratio of these messengers may be one determining factor for the growth cone’s response. For example, studies in *Xenopus* spinal neurons have shown that the direction of growth cone turning in response to the cue netrin-1 is determined by the ratio of cAMP to cGMP, such that a high ratio supports chemo-attraction and a lower ratio, chemo-repulsion. Signaling involving cAMP generally involves the cAMP-dependent protein kinase (PKA) while cGMP involves cGMP-dependent protein kinase (PKG). Both of these kinases are able to affect changes in the cytoskeleton, which is important for the motility of growth cones.

Though most well known guidance factors act by binding to receptors on the surface of the growth cone there are others that may act at the cytoplasmic level and these include nitric oxide, retinoic acid and even a transcription factor, Engrailed-2 (which is internalized by the growth cone). Furthermore, the ability of electric fields to influence growth cone behavior, though not a recent observation, is gaining new attention [9]. Recent research suggests that electric fields may bring about changes in growth cone behavior *via* small GTPases which alter the cytoskeleton. In addition, electric fields may interact with trophic factors such as BDNF and the neurotrophins NT-3 and NT-4, thereby modulating growth cone responses. Table 1 provides some representative examples of guidance factors and their actions on specific cell types.

### Switching Responses

Growth cone responses to a particular guidance cue are not rigid or absolute, but can vary, depending on a number of conditions. The response to a guidance cue may be cell-type specific and even then, a single neuron may produce a differing response depending on the types of receptors present, the ratio of second messengers activated, the source of calcium, as well as the age of the cell. It is also very likely that most guidance signals do not act in isolation, but rather that the growth cone integrates many signals at any given moment in time. A growth cone’s response will thus depend greatly on the context in which a specific guidance cue is encountered. A well-known example involves the retinal ganglion cell axons exiting the retina at the optic nerve head, to which netrin-1 serves as an attractive cue. If laminin is ectopically added at the optic nerve head however, netrin-1 is converted to a repulsive cue and the retinal ganglion cell axons fail to exit the eye. When the retinal ganglion cell axons travel from the retina to their targets in the brain, the repulsive guidance cue slit helps to define their pathway by constraining where these axons can grow. However, the

**Axonal Pathfinding and Network Assembly. Table 1** Representative examples of chemotropic molecules and their effects on growth cone behavior

Chemotropic molecule	Response	Cell type
<i>Neurotransmitters</i>		
GABA	Attractive	Rat spinal cord neurons
Acetylcholine	Attractive	<i>Xenopus</i> spinal neurons
Dopamine	Repulsion	<i>Lymnaea</i> PeA neurons
Nitric oxide (high concentration)	Repulsion	<i>Helisoma</i> B5 neurons
<i>Classical guidance molecules</i>		
Netrin-1	Attractive	Chick commissural neurons
Netrin-1	Repulsive	Rat trochlear motor neurons
Semaphorin3A	Repulsive	Rat DRG neurons
Semaphorin3F	Attractive	Rat cerebellar neurons
Slit-2	Repulsive	<i>Xenopus</i> retinal neurons
<i>Neurotrophins</i>		
Nerve growth factor (NGF)	Attractive	Chick DRG neurons
Brain-derived neurotrophic factor (BDNF)	Attractive	<i>Xenopus</i> spinal neurons
<i>Transcription factors</i>		
Engrailed-2	Attractive	<i>Xenopus</i> nasal retinal neurons
Engrailed-2	Repulsive	<i>Xenopus</i> temporal retinal neurons
<i>Morphogens</i>		
BMP-7	Attractive	<i>Xenopus</i> spinal neurons
BMP-7	Repulsive	<i>Xenopus</i> spinal neurons
Retinoic acid	Attractive	<i>Lymnaea</i> visceral F neurons
Wnt-1	Repulsive	Mouse motor cortical neurons
Wnt-4	Attractive	Rat commissural neurons
FGF-2	Repulsive	<i>Xenopus</i> retinal ganglion neurons
FGF-8	Attractive	Rat trochlear neurons
Sonic hedgehog	Attractive	Rat spinal cord neurons
Sonic hedgehog	Repulsive	Chick commissural neurons
<i>Other</i>		
SDF-1 (a chemokine)	Repulsive	Rat cerebellar neurons
Endocannabinoids	Repulsive	Rat cortical interneurons

chemokine CXCL12 (SDF-1) is able to attenuate the repulsive effect of slit, thereby modulating the response of the growth cone. There may also be changes within a growth cone which lead to altered responses to a particular guidance cue. In *Xenopus* spinal neurons, BMP7 is initially attractive but later becomes repulsive. This change is mediated by the insertion of a calcium channel leading to the influx of calcium.

### Growth Cone Autonomy

It has become increasingly clear that growth cones are capable of local protein synthesis and that this is likely to contribute to rapid growth cone responses to environmental guidance cues [10]. One example is the requirement for local synthesis of the small GTPase Rho A in the collapsing response of *Xenopus* growth

cones to the inhibitory factor Sema 3A. mRNAs that have been identified in developing axons include  $\beta$ -actin,  $\beta$ -tubulin, RhoA and cofilin, which likely play an important role in local regulation of the cytoskeleton. However, there is also evidence that membrane receptors may be synthesized locally at key developmental stages, such as the insertion of the ephrin receptor EphA2 following mid-line crossing in chick embryos. With local protein synthesis, comes the need for local control over mRNA expression. Localization signals may include “zip-code” sequences present on the mRNA, and control over local translation may involve microRNAs, short polynucleotide sequences that are incorporated into the RNA-induced silencing complex (RISC) and mediate repression of mRNA translation. In addition to local protein synthesis, local

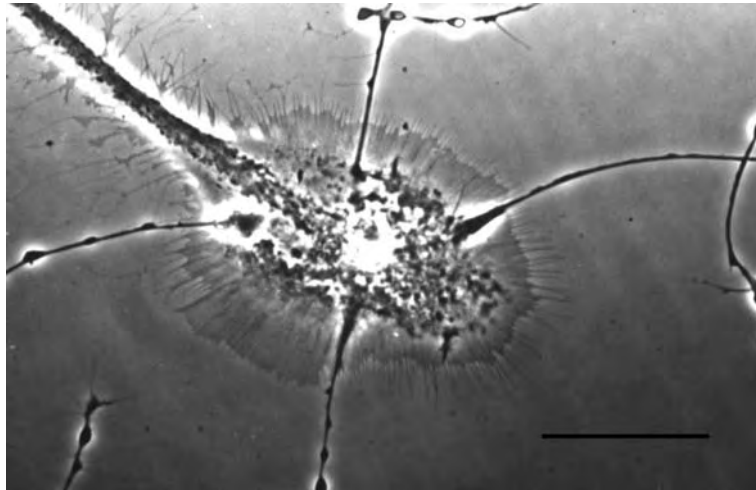

**Axonal Pathfinding and Network Assembly. Figure 2** A *Lymnaea* growth cone in cell culture. Photomicrograph of regenerated neuritic processes from individually identifiable cultured neurons taken from the central nervous system of the pond snail, *Lymnaea stagnalis*. The large central growth cone is being contacted by 4 different target cell growth cones. Scale bar = 25  $\mu\text{m}$  (Spencer and Syed, unpublished).

protein degradation plays an important role in producing some growth cone behaviors.

### Experimental Systems Used for Studying Axonal Pathfinding

Axonal pathfinding and growth cone behavior have been studied in many systems including vertebrate models such as chicks and frogs (*Xenopus laevis*) as well as invertebrate models such as worms (*C. elegans*), flies (*Drosophila*) and molluscs (*Aplysia californica* and *Lymnaea stagnalis* (Fig. 2)).

Perhaps some of the most well-studied systems to date include the role of netrins and their receptors (DCC/UNC5) at the midline in the vertebrate spinal cord, the role of slit and the roundabout (robo) receptor in crossing the midline, and the role of ephrinAs and ephrinBs and their receptors (EphAs and EphBs) in the establishment of topographic projections from the retina to the brain [3].

### Target Recognition Precedes Synapse Formation and Network Assembly

At the end of its journey, the neuronal growth cone is required to identify its appropriate target cells or synaptic partners, which include other neurons, glands or muscle cells. In order for correct formation of synapses and network assembly, this target cell selection must be an accurate process. It involves a number of processes that might include branching of the axon, growth cone stalling, increased morphological

complexity of the growth cone, and eventual molecular recognition of the appropriate synaptic target, at which point, the axonal growth cone will eventually form the presynaptic terminal.

### Acknowledgements

NSERC (Canada) for funding to G.E.S, N.R.F and R.C.

### References

1. Gordon-Weeks P (2000) Neuronal growth cones. Cambridge University Press, Cambridge, UK
2. Kalil K, Dent E (2005) Touch and go: guidance cues to the growth cone cytoskeleton. *Curr Opin Neurobiol* 15:521–526
3. Chilton J (2006) Molecular mechanisms of axon guidance. *Dev Biol* 292:13–24
4. Huber A, Kolodkin A, Ginty D, Cloutier J (2003) Signaling at the growth cone: ligand-receptor complexes and the control of axon growth and guidance. *Annu Rev Neurosci* 26:509–563
5. Erskine L, Herrera E (2007) The retinal ganglion cell axon's journey: insights into molecular mechanisms of axon guidance. *Dev Biol* 308:1–14
6. Rosoff W, Urbach J, Esrick M, McAllister R, Richards L, Goodhill G (2004) A new chemotaxis assay shows the extreme sensitivity of axons to molecular gradients. *Nat Neurosci* 7:678–682
7. Henley J, Poo MM (2004) Guiding neuronal growth cones using  $\text{Ca}^{2+}$  signals. *Trends Cell Biol* 14:320–330
8. Piper M, van Horck F, Holt C (2007) The role of cyclic nucleotides in axon guidance. *Adv Exp Med Biol* 621:134–143

9. McCaig C, Rajnicsek A, Song B, Zhao M (2005) Controlling cell behavior electrically: current views and future potential. *Physiol Rev* 85:943–978
10. Hengst U, Jaffrey S (2007) Function and translational regulation of mRNA in developing axons. *Semin Cell Dev Biol* 18:209–215

---

## Axonal Regeneration

### Definition

The unique series of steps involved in the reconnection of damaged axons to their targets.

- ▶ Axon Regrowth
- ▶ Axon Degeneration and Regeneration of Peripheral Neurons
- ▶ Peripheral Nerve Regeneration and Nerve Repair

---

## Axonal RNA Translation

- ▶ mRNA Targeting: Growth Cone Guidance

---

## Axonal-soma Synapse

### Definition

Synapse formed between an axon (presynaptic) and a cell body (postsynaptic).

- ▶ Synaptic Transmission: Model Systems

---

## Axonal Sprouting

### Definition

The process where fine nerve processes – sprouts - grow out from the intact axons or nerves to make contacts with target cells that have lost their nerve fibers.

- ▶ Axonal Sprouting in Health and Disease

---

## Axonal Sprouting in Health and Disease

SIU LIN TAM, TESSA GORDON

Centre of Neuroscience, Division of Physical Medicine and Rehabilitation, Faculty of Medicine and Dentistry, University of Alberta, Edmonton, AB, Canada

### Definition

▶ **Axonal sprouting** is a process where fine nerve processes – sprouts – grow out from the intact axons to reinnervate denervated muscle fibers. Thereby the sprouting sustains the nerve supply to muscles and, in turn, the ability to move.

### Characteristics

Axon sprouting from intact ▶ **motor units** (a ▶ **motoneuron** and the muscle fibers that it supplies) commonly compensates for motoneuron loss in aging and/or in diseases such as poliomyelitis and amyotrophic lateral sclerosis, and/or partial nerve injuries due to the loss of axonal contact and/or death of many of the motoneurons [1]. The Schwann cells at the neuromuscular junction, the ▶ **perisynaptic Schwann cells**, play an essential role in leading the axon sprouts from intact axons to the denervated muscle fibers to reinnervate them at the neuromuscular junction. Excessive neuromuscular activity interferes with the normal role of the perisynaptic Schwann cells and thereby the enlargement of motor units (the inclusion of more muscle fibers) by sprouting. In ageing and in post-polio syndrome the number of functional motor units declines progressively. High levels of neuromuscular activity may be counter-indicated due to the inhibitory effects of the neuromuscular activity on the perisynaptic Schwann cells and in turn, on the enlargement of the surviving motor units.

### Axonal Sprouting and Motor Unit Enlargement

Axonal sprouting is a process where fine nerve processes – sprouts – grow out from the intact axons including ultraterminal (Fig. 1a), preterminal (Fig. 1b), and nodal sprouts to reinnervate denervated muscle fibers (Fig. 1c). More complicated sprouting can occur (Fig. 1d, e).

Each motoneuron normally innervates as few as 10 muscle fibers and as many as thousands, the motoneuron and its muscle fibers being referred to as a motor unit (MU) [1] (Fig. 2). The muscle fibers that lose some of their nerve supply after nerve injuries and/or pathology, or motoneuron diseases, may be reinnervated by axonal sprouts such that the number of muscle

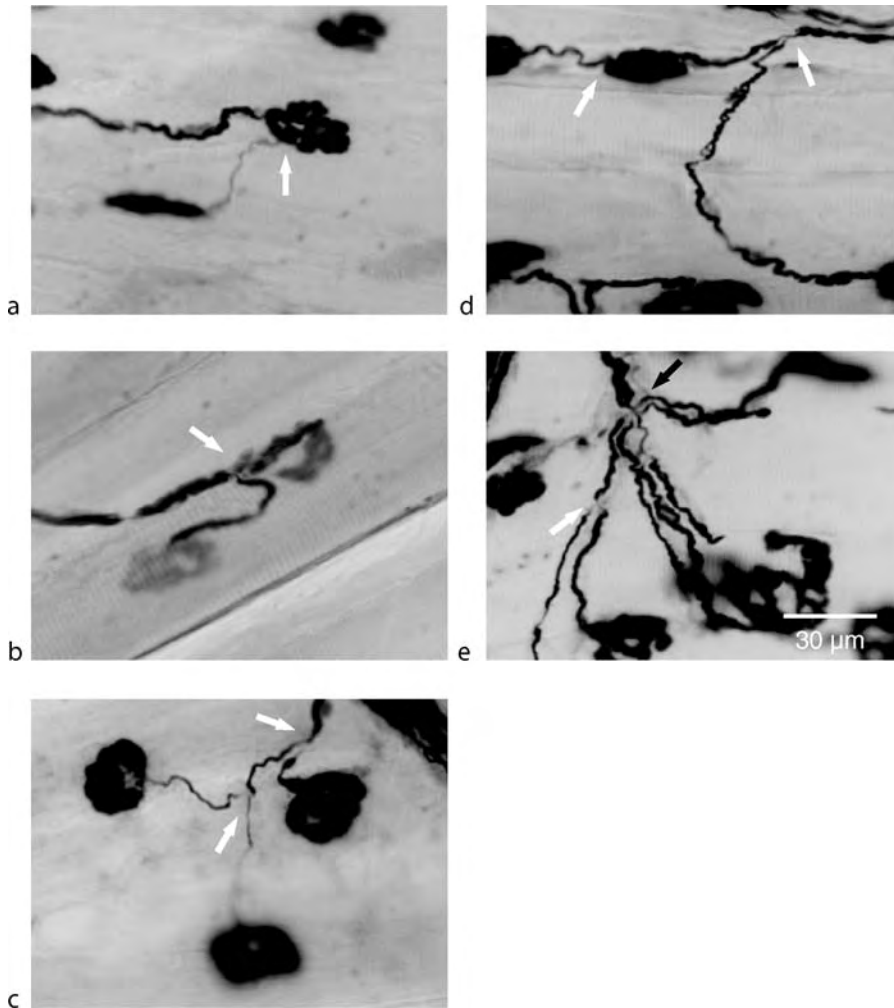

**Axonal Sprouting in Health and Disease. Figure 1** Types of axonal sprouts visualized with silver staining. Ultraterminal (a), preterminal (b) and nodal (c) sprouts. When more extensive sprouting is demanded a single axon can give rise to more than 1 sprout type (Fig. 1d: an ultraterminal and a nodal sprouts) or numerous sprouts of the same type (Fig. 1e: nodal sprouts). (Reproduced from Tam et al. 2001 with permission).

fibers innervated by each motoneuron increases up to a maximum of 8-fold [2]. Hence sprouting is able to compensate for loss of as many as 85% of the normal number of MUs. When less than 20% of functional MUs remain, the maximal capacity of axonal sprouting is exceeded, reinnervation of all denervated muscle fibers fails, and muscle weakness becomes evident [2].

Axonal sprouting is commonly seen to compensate for motoneuron loss at least in part, in aging and/or in diseases such as poliomyelitis and amyotrophic lateral sclerosis (ALS), and/or partial nerve injuries due to the loss of axonal contact and/or death of many of the motoneurons [1]. Although the etiology of these neurodegenerative diseases is not well understood, it has been suggested that the severe debilitation suffered

by the patients with these diseases, is a direct consequence of over-exhaustion and subsequent loss of the chronically enlarged MUs.

### The Role(s) of Perisynaptic Schwann Cells in Axonal Sprouting

► **Perisynaptic Schwann cells (PSCs)**, which cover the intramuscular nerve terminals, play a critical role in supporting axonal sprouting in partially denervated muscles [3] (Fig. 3). PSCs at both innervated and denervated endplates form cellular processes which bridge between both types of endplates to the maximum level within about 1 week (Fig. 3a). These bridges behave like “tunnels” to guide the growing axonal sprouts to the denervated endplates (Figs. 3a, b). Muscarinic ► **acetylcholine** receptors on the PSCs at the endplate

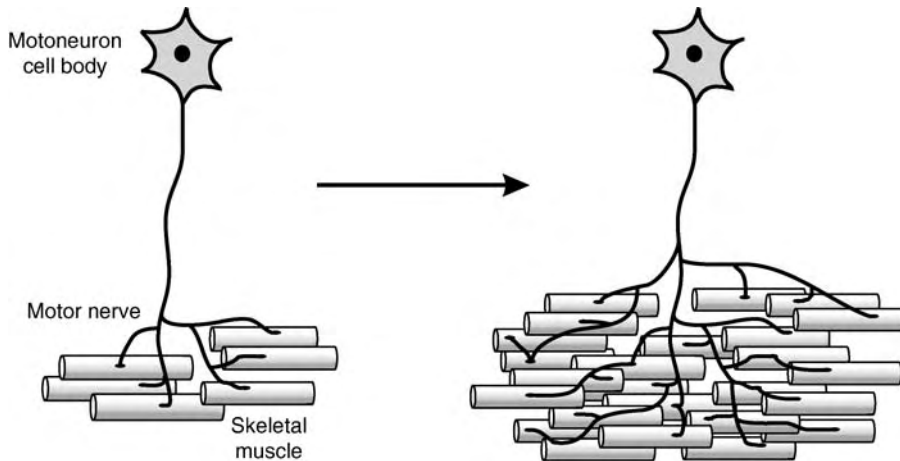

**Axonal Sprouting in Health and Disease. Figure 2** The motor unit and its enlargement by sprouting. Each motoneuron innervates many muscle fibers. When some muscle fibers are denervated by nerve injury or motoneuron disease, axonal sprouts from intact motor units can expand the size of the motor unit (the number of muscle fibers per motoneuron) to a maximum of 3–8 times.

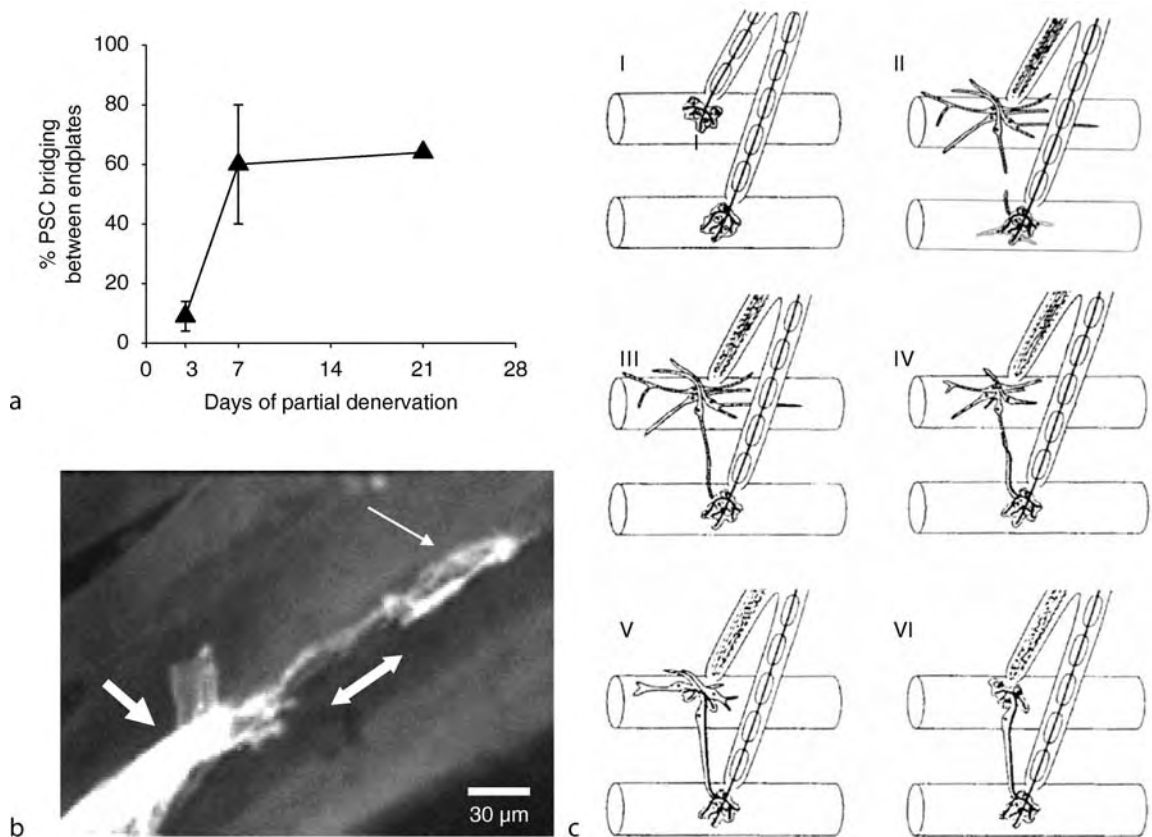

**Axonal Sprouting in Health and Disease. Figure 3** Guidance of axonal sprouting by the bridging of perisynaptic Schwann cells (PSCs) between ►muscle endplates. This bridging reaches a maximum within 1 week of partial muscle denervation (a). PSC processes formed at both innervated and denervated endplates form bridges to direct sprouts to reinnervate denervated endplates (b). Once a sprout reaches its target, the PSC processes withdraw (c). (Reproduced from Tam et al. 2001 with permission).



region of the neuromuscular junction normally respond to acetylcholine released from nerve terminals. The acetylcholine causes an influx of calcium which maintains low levels of glial fibrillar acidic protein (GFAP), in association with the absence of PSC processes (Fig. 3cI) [4]. Upon partial muscle denervation, the PSCs at the denervated endplates, which are no longer exposed to acetylcholine, upregulate GFAP and extend processes (Fig. 3cII). It has been postulated that the short-range diffusible, sprout-inducing stimuli generated from the denervated or inactive muscle fibers, have sufficient influence on the PSCs at the innervated endplates in the partially denervated muscles to trigger these PSCs to produce processes (Fig. 3cII) [1]. The PSC processes that form at both the innervated and the denervated endplates navigate out and bridge to support axonal sprouting (Fig. 3cIII). Once the sprouts make functional neuromuscular contact, the PSCs

withdraw their processes in response to release of nerve acetylcholine (Fig. 3cIV–VI).

### Effects of Neuromuscular Activity on Axonal Sprouting

The effect of increased neuromuscular activity on axonal sprouting and MU enlargement was unclear and controversial for many years [3]. In attempt to clarify the controversy, we undertook a thorough evaluation to re-examine this issue. We analyzed MU enlargement in several functionally different rat hindlimb muscles whose extent of partial denervation was determined. This study clearly demonstrated that high daily neuromuscular activity imposed either by functional electrical stimulation (FES) or daily exercise constrained axonal sprouting and MU enlargement [5], by inhibiting PSC bridging (Fig. 4) [3]. The effect of neuromuscular inactivity on axonal sprouting was not inconsequential:

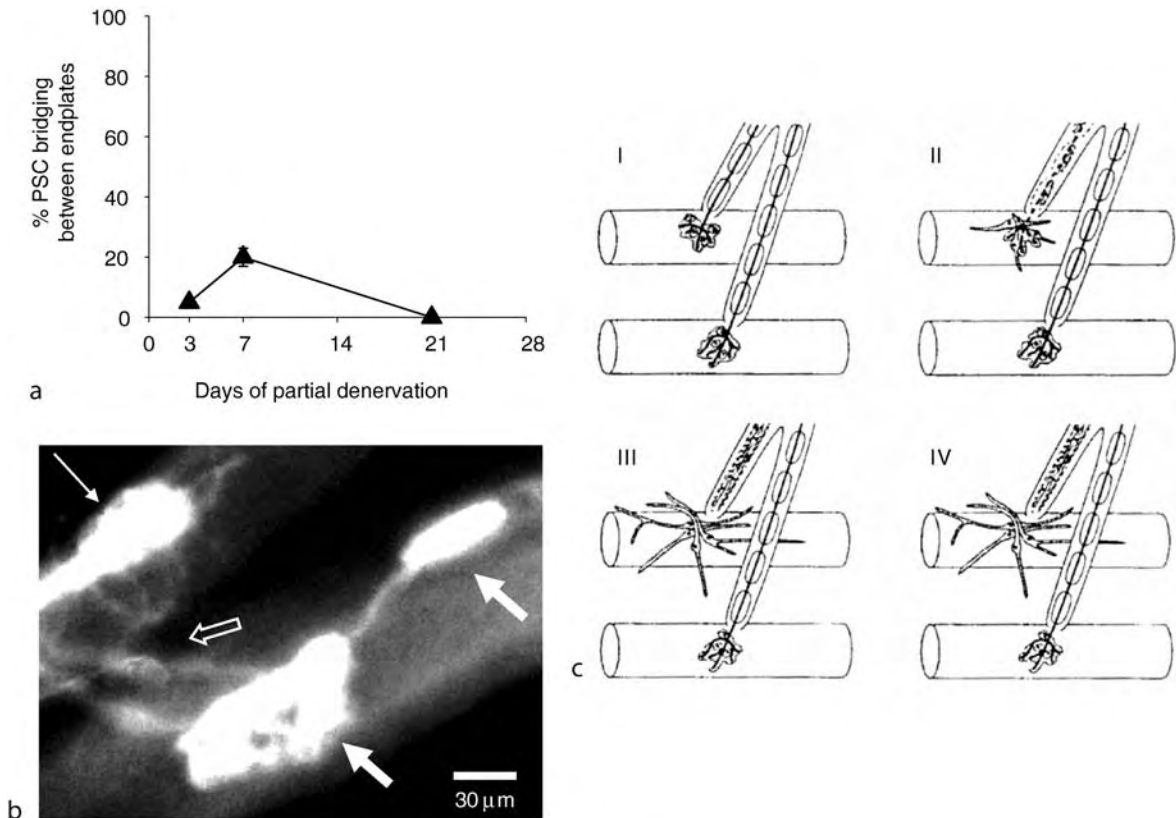

**Axonal Sprouting in Health and Disease. Figure 4** Increased neuromuscular activity inhibits bridging of perisynaptic Schwann cells. Daily exercise abolishes the PSC bridging right from the early stage (a). Immunofluorescent labeling with S-100 shows that high neuromuscular activity inhibits formation of PSC processes at innervated endplates (thick arrows) (b). Despite the formation of cellular processes of the PSCs at denervated endplates (thin arrow), the cellular processes entangle around the endplate regions and do not navigate out and in turn, do not bridge (open arrow) with the innervated endplates. A schematic representation details that daily exercise does not impair the formation of perisynaptic Schwann cell processes (CI,II) but effectively prevents the bridging of the processes from innervated to denervated endplates and thereby, prevents sprouting of axons from innervated to denervated muscle endplates (C III-IV) (Adapted from Tam et al., 2003).

blockade of neuromuscular activity using either or ►tetrodotoxin or ► $\alpha$ -bungarotoxin, significantly reduced axonal sprouting and MU enlargement in partially denervated muscles [6,7].

### Normal Aging: Progressive Loss of Functional MUs in the Context of Progressive Increase in Oxidative Stress and Neuromuscular Activity

With aging, there is a slow progressive decline in numbers of motoneurons and loss of ventral root axons that becomes more obvious from the sixth decade of life [8]. Oxidative stress progressively rises in the aging motoneurons, oxidative stress being generally defined as a condition where production of reactive oxygen species produced during normal aerobic metabolism overwhelms the endogenous antioxidant defence systems [1]. Ultimately the anti-oxidative enzymes, including copper/zinc superoxide dismutase (SOD1) in the cytoplasm and manganese superoxide dismutase (MnSOD) in the mitochondria, can no longer eliminate reactive oxygen species (superoxide and hydroxyl radicals) effectively. The oxidative stress progressively reduces neuromuscular efficacy. This is followed by loss of functional MUs,

decline in axon transport rates, and transmitter storage and release that eventually reduces the capacity of MUs to sustain stable nerve-muscle connections, the endplate region undergoing progressive expansion and finally axonal die-back [1] (Fig. 5).

As the number of functional MUs declines with age, neuromuscular activity may be counter-indicated due to inhibitory effects of very high neuromuscular activity of progressively fewer intact MUs on the bridging of PSCs between denervated and innervated endplates [5]. Hence the sprouting and enlargement of the intact MUs becomes progressively compromised with age [9].

### ALS: Progressive Loss of MUs in Relation to Progressive Increase in Levels of Neuromuscular Activity and/or Oxidative Stress

ALS, unlike acute poliomyelitis, is strictly an adult onset disease, which usually presents in the fifth or sixth decade of life with a survival time of 3–5 years. Approximately 10% of all ALS cases are familial in origin, and of these 20% are linked to mutations in the SOD1 gene. The identified mutations to SOD1

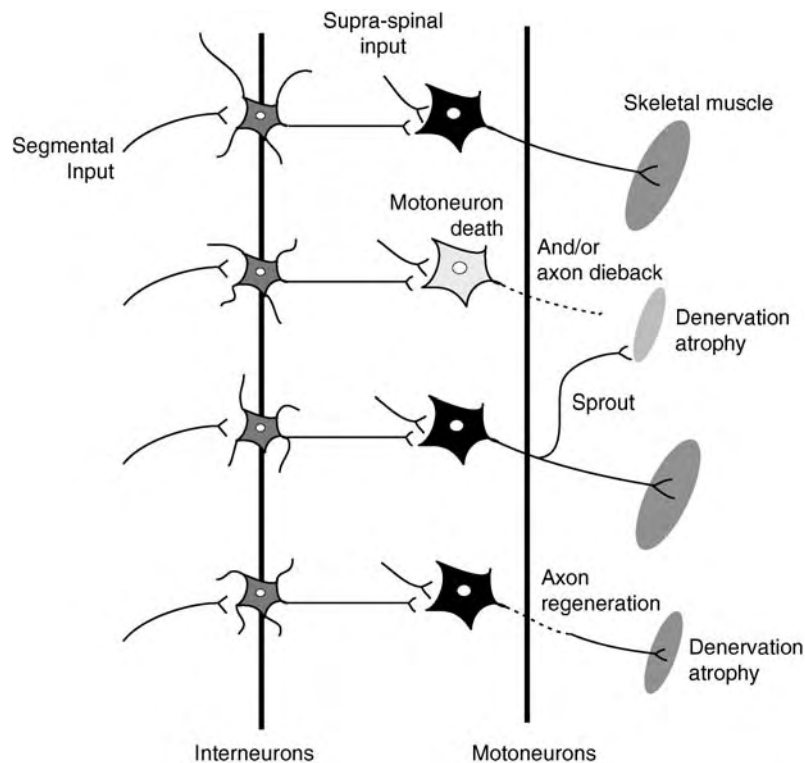

**Axonal Sprouting in Health and Disease. Figure 5** Loss of motor units as a result of aging and motoneuron diseases. At the initial stage of ageing and motoneuron disease, motor axons die back and the infected or susceptible motoneurons in the case of poliomyelitis or early stage of ALS, respectively, succumb to cell death. The remaining intact motoneurons enlarge their sizes by axonal sprouting to reinnervate the denervated muscle fibers which have lost their nerve terminals from axonal die-back and undergone denervation atrophy. The axons, which have died back and lost connections with affected muscles may regenerate their axons to reinnervate the denervated muscle.

confer a gain of cytotoxic function that increases the susceptibility of motoneurons to cell death, most likely linked to a direct involvement of misfolded SOD1 in the disease process, and through elevations in oxidative stress that can cause cellular damage, ► **glutamate excitotoxicity**, disruption of calcium homeostasis, motoneuron die-back and their subsequent neuronal death (Fig. 5).

Higher than normal levels of oxidative stress in association with genetic and/or environmental factors in familial and sporadic ALS, may be compounded by age-related accumulations of oxidative stress-induced cellular damage possibly contributing to a rapid decline in the safety factor of neuromuscular transmission and, in turn, the axonal die-back that initiates denervation of motor endplates [1]. The largest motoneurons with the lowest ► **oxidative potential** [8,10] are likely to be the most vulnerable to oxidative stress. Indeed, these motoneurons are the first ones whose axons die back and whose intact axons progressively fail to sprout effectively. It is only the motoneurons with higher

oxidative capacity that supply the more oxidative muscle fibers that sustain their sprouting capacity [10]. In most muscles that contain relatively few oxidative muscle fibers, there is a rapid attrition of the motoneurons with progressive muscle weakness and paralysis [1].

### PPS: Progressive Loss of Enlarged MUs in Relation to Progressive Increase in Levels of Neuromuscular Activity and/or Oxidative Stress

Infection by the polio enterovirus results in extensive axonal die-back and death of many of the affected motoneurons [8] (Figs. 2, 3), while the surviving axotomized motoneurons may regenerate their axons, the remaining intact MUs undergo adaptive sprouting. Both the surviving intact and regenerating MUs enlarge their normal size to a maximum of 5–8-fold to reinnervate those muscle fibers that were denervated by death of their parent motoneurons [1]. The enlarged MUs are able to sustain muscle function for periods of time as long as 25 years or more until the chronically enlarged MUs progressively deteriorate in association

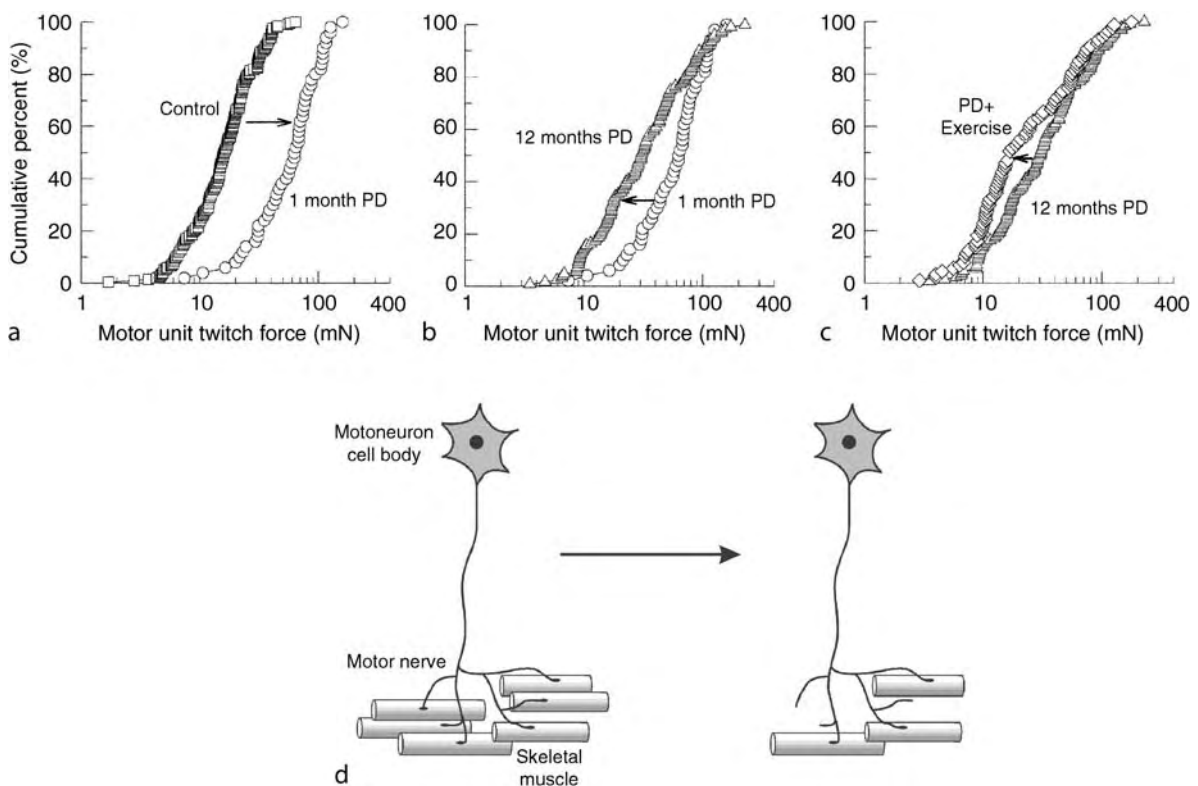

**Axonal Sprouting in Health and Disease. Figure 6** Regression in the size of motor units (MUs) in post-polio syndrome (PPS). In a rat PPS model, the maximum enlargement of MU force that is observed a month after partial (a) has receded after 12 months of partial denervation (b). There is a preferential decline of the size of the enlarged MUs at the lower end of the force spectrum, indicating that the least active motoneurons sustain more stable neuromuscular connections. High daily exercise imposed on chronically denervated nerve-muscle connections reduces the size of the enlarged MUs (c) by further destabilizing functional MUs. The destabilization and withdrawal of synaptic contacts by motoneurons in PPS is illustrated figuratively (D).

with the age-related loss of functional MUs. Because the reduced number of functional MUs are unable to enlarge beyond the normal limit of 5–8 fold, muscles become progressively denervated with the onset of muscle fatigue and weakness—post-polio syndrome (PPS) [8] (Fig. 2).

In PPS, the reduced numbers of enlarged MUs that survive the acute phase of the disease become progressively vulnerable to destabilization of nerve terminals and axon die-back, possibly concomitant with an increasing state of oxidative stress in the remaining motoneurons that had sprouted and sustained long-term innervation of large numbers of muscle fibers [1]. As the number of MUs declines, the high levels of neuromuscular activity will compromise the capacity of the surviving motoneurons to undergo sprouting to reinnervate denervated muscle fibers and, in turn, to compensate for the axonal die-back. This was shown in a study using an animal model of PPS in which rat muscles were partially denervated during adulthood and the remaining intact MUs enlarged maximally to compensate for the loss of motoneurons (Fig. 2). The MUs, showed a time-dependent regression of nerve terminals and a reduction in their size 1 year after partial denervation (Fig. 6a, b) [8]. The preferential decline of in the size of the enlarged MUs at the lower end of the force spectrum indicated that the most active MUs progressively failed to reform stable connections and hence the process of axonal sprouting became maladaptive. When these fewer MUs were subjected to high daily neuromuscular activity, significant reductions in MU size were detected (Fig. 6c).

In summary, motor axons can sprout to reinnervate denervated muscle fibers to enlarge MUs up to 8-fold. This compensatory mechanism is compromised by high levels of neuromuscular activity. The effects of this compromise are evident physiologically during the process of aging and, pathologically, in motoneuron diseases where sprouting may become maladaptive with instability and withdrawal of the axon sprouts.

## References

1. Gordon T, Hegedus J, Tam SL (2004) Adaptive and maladaptive motor axonal sprouting in aging and motoneuron disease. *Neurol Res* 26:174–185
2. Rafuse VF, Gordon T (1996) Self-reinnervated cat medial gastrocnemius muscles. I. Comparisons of the capacity of regenerating nerves to form enlarged motor units after extensive peripheral nerve injuries. *J Neurophysiol* 75:268–281
3. Tam SL, Gordon T (2003) Neuromuscular activity impairs axonal sprouting in partially denervated muscles by inhibiting bridge formation of perisynaptic Schwann cells. *J Neurobiol* 57:221–234
4. Georgiou J, Robitaille R, Charlton MP (1999) Muscarinic control of cytoskeleton in perisynaptic glia. *J Neurosci* 19:3836–3846

5. Tam SL, Archibald V, Jassar B, Tyreman N, Gordon T (2001) Increased neuromuscular activity reduces sprouting in partially denervated muscles. *J Neurosci* 21:654–667
6. Tam SL, Archibald V, Tyreman N, Gordon T (2002) Tetrodotoxin prevents motor unit enlargement after partial denervation. *J Physiol* 543:655–663
7. Connold AL, Vrbova G (1991) Temporary loss of activity prevents the increase of motor unit size in partially denervated rat soleus muscles. *J Physiol* 434:107–119
8. McComas AJ (2001) *Skeletal muscle*. Human Kinetics, Champaign, IL
9. Tam SL, Archibald V, Tyreman N, Gordon T (2002) Effect of exercise on stability of chronically enlarged motor units. *Muscle Nerve* 25: 359–369
10. Frey D, Schneider C, Xu L, Borg J, Spooren W, Caroni P (2000) Early and selective loss of neuromuscular synapse subtypes with low sprouting competence in motoneuron diseases. *J Neurosci* 20:2534–2542

---

## Axonal Targeting

- ▶ Axon Pathfinding

---

## Axonal Tip

- ▶ Growth Cones

---

## Axonal Transport

### Definition

Axonal transport is the transport of molecular cargo and organelles bidirectionally within the axon. Anterograde axonal transport carries cargo from the cell body to the periphery, whereas retrograde transport carries materials from the periphery towards the cell body. Neurons need to provide a constant supply of new material to the growth cone and mature synapse. The majority of proteins and all mRNA and membrane are synthesized in the cell body of a neuron, and need to be transported in an anterograde direction down the length of the axon.

Microtubules, oriented in axons with their plus ends distal to the cell body, are known to provide the support on which rapid axonal transport occurs. There are specific microtubule-based molecular motors called

dyneins and kinesins that move cargo towards the minus and plus ends of microtubules, respectively.

- ▶ Dynein
- ▶ Growth Cones
- ▶ Kinesin
- ▶ Microtubule

## Axonal Wrapping

### Definition

Wrapping of axons by glial cells to insulate them from the hemolymph, and to form the Blood-Brain Barrier.

- ▶ Blood-Brain Barrier

## Axontemesis

### Definition

A nerve injury in which axons are interrupted, but with little disruption of the internal connective tissue elements within the peripheral nerve. With this injury severity type, nerve regeneration tends to be excellent.

- ▶ Peripheral Nerve Regeneration and Nerve Repair

## Axoplasma

### Definition

Fluid within an axon.

- ▶ Membrane Potential: Basics

## Axospinous Synapses

### Definition

A synapse that is formed between an axon terminal and a dendritic spine.

- ▶ Synaptic Transmission: Model Systems

## Axotomy

### Definition

Transection or severing of an axon. This type of denervation is often used in experimental studies on neuronal physiology and neuronal death or survival, towards an understanding of nervous system disease.

## Ayurveda

### Definition

It is a traditional system of Indian Medicine dating back many centuries, and is still popular in India. The Charak Samhita and Sushruta Samhita form the basis of most of the Ayurvedic practices. Surgical procedures are believed to have their origin in Ayurveda, and Sushruta is said to be the Father of Surgery. Charaka has described many herbs for treating various ailments including disorders of the brain. Many modern and standardized herbal products manufactured in India are based on the Ayurvedic principles mentioned in the Charak Samhita.

- ▶ Central Nervous System Disease – Natural Neuro-protective Agents as Therapeutics

## B1-B9 Cell Groups (Serotonergic Cell Groups)

### Definition

B1-B9 is the original designation of nine serotonin-containing cell groups visualized in the brainstem by the use of fluorescent histochemical methods. Some of these serotonergic groups project caudally to the spinal cord and others rostrally to different parts of the forebrain.

## Babinski Reflex (Babinski Response, Babinski Sign)

### Definition

Reflex response elicited preferably by a blunt rodlike instrument stroked along the lateral footsole from heel to toes. In neurologically normal adult persons, the stimulus elicits a flexor of foot and toes. In infants and adult patients with lesions of the ►pyramidal tract, the toes are spread apart, the big toe slowly extends and the other toes flex. Lesions limited to the pyramidal tract produce a Babinski sign and paresis (i.e., negative symptoms such as temporary weakness and loss of dexterity), but neither spastic ►dystonia nor permanent weakness.

►Pyramidal Tract

## Back Pain

### Definition

Pin perceived anywhere in a region bounded superiorly by an imaginary transverse line between the 12th

thoracic and 1st lumbar vertebrae, inferiorly by an imaginary transverse line through the 4th sacral segment, and laterally by a line tangential to the lateral border of the erector spinae and a line between the posterior superior iliac spine and the inferolateral corner of the sacrum.

Etiology

Causes

►Low Back/Spine Pain

## Backache

►Low Back/Spine Pain

## Back-Propagation in Neurons

### Definition

►Action Potential Propagation

## Back-Propagation Learning in Neural Networks

### Definition

The backpropagation algorithm is one of the most popular procedures for training multi-layer artificial neural networks. Neurons in all layers change their synaptic weights based on the gradient descent of the sum of squared differences between the network output and the target vector, where this sum is propagated backwards through the net to adjust weights deep within

the network. This algorithm is capable of solving many practical problems that are nonlinearly separable.

- ▶ Connectionism
- ▶ Neural Networks

## Bacterial Artificial Chromosome (BAC)

### Definition

Bacterial artificial chromosome (BAC) is a DNA vector whose basis is a fertility plasmid (F-plasmid), which contains sites necessary for DNA to be handled and replicated as a bacterial chromosome. BACs are used for cloning in *E. coli*, and because their insert sizes can be large (100–300 kb), have proven useful in the identification of gene regulatory sequences that can involve huge pieces of DNA upstream of a gene. Human and yeast artificial chromosomes are also available.

## Bait Shyness

- ▶ Aversive Taste Memory

## Balance Laws

MARCELO EPSTEIN

Schulich School of Engineering, University of Calgary, Calgary, AB, Canada

### Definition

The statement of the causes of change of content of an extensive physical quantity (such as mass, energy, momentum, entropy and so on) over a certain domain. The quantitative aspects of balance laws are expressed in terms of balance equations.

### Description of the Theory

A *balance equation* in continuum physics is a rigorous accounting of the causes for the change in content, over

a certain domain, of an extensive physical quantity. In continuum mechanics, in particular, physical content is attributed only to a material body or a part thereof (as opposed to a field theory such as electromagnetism, where a vacuum can be a carrier of fields). The time rate of change of the content of a physical quantity  $\Psi$  in the body is postulated to be entirely due to only two causes, a *production*  $\Pi$  within the body and a *flux*  $\Phi$  through its boundary:

$$\frac{D\Psi}{Dt} = \Pi + \Phi. \quad (1)$$

To convert this general statement of balance into a more specific form can be done in either the referential (“Lagrangian”) or spatial (“Eulerian”) setting. The total content can be represented in terms of the referential volume element  $d\Omega$  or its spatial counterpart  $d\omega$  as follows:

$$\Psi = \int_{\Omega} \Psi_0 d\Omega = \int_{\omega} \Psi d\omega, \quad (2)$$

where  $\Psi_0$  and  $\Psi$  represent the content density per unit referential and spatial volume, respectively. These two densities are related by:

$$\Psi_0 = J\Psi, \quad (3)$$

where  $J$  is the determinant of the deformation gradient  $\mathbf{F}$ , as defined in the kinematics of deformation (q.v.). Similarly, the production is assumed to be expressible as:

$$\Pi = \int_{\Omega} \pi_0 d\Omega = \int_{\omega} \pi d\omega, \quad (4)$$

with

$$\pi_0 = J\pi. \quad (5)$$

A flux is assumed to be defined not only through the external boundary of the body, but also through any internal boundary between sub-bodies. Moreover, the flux is assumed to be given by an integral (over the area of interest) of some density. But, unlike the case of the volume integrals, now it is not allowed to simply claim that this density is a mere function of position on the surface. A simple example will clarify this situation. If sun-tanning on the beach, it makes a difference whether one is lying horizontally or standing up. The heat energy flows at a maximum rate when the exposed surface is perpendicular to the rays. This is as true for the outer boundary as for an internal point. When considering an interior point of the endodermis, the flux at that point will vary depending on the orientation of the imagined surface element considered at the point. In other words, the flux density must depend not only on position but

also on some other characteristic of the boundary. The simplest assumption is that the flux depends on the boundary only through its (local) normal, namely through its orientation alone (as opposed to its curvature, for example). Having made these assumptions:

$$\Phi = \int_{\partial\Omega} \phi_0(\mathbf{X}, \mathbf{N}, t) dA = \int_{\partial\omega} \phi(\mathbf{x}, \mathbf{n}, t) da, \quad (6)$$

where  $\partial$  stands for “boundary of” and where the notation of kinematics of deformation (q.v.) is used. To obtain the relation between the referential and spatial flux densities ( $\phi_0$  and  $\phi$ , respectively), (4) of kinematics of deformation (q.v.) might be invoked. However, in this equation the dependence on the normal is explicitly linear, whereas the assumed dependence of the flux densities on the normal is so far arbitrary. It would appear that the only way out of the impasse would be to *assume* such linearity (a logical thing to do, particularly considering the example of the sun rays, whose effect on the skin is governed by a simple projection on the normal). It is a rather remarkable fact, however, that such an assumption is superfluous, since it can be *derived* from the general statement of the balance law. This result is called *Cauchy’s theorem*, since it was Cauchy who, in a series of papers published in the 1820’s, first established its validity in the context of his theory of stress. The proof is based in the so-called *tetrahedron argument*. Assuming that the general balance law, (1), is valid, with the same densities for any sub-body (thereby essentially ruling out scale effects such as surface tension) and applying it to a tetrahedron with three faces aligned with the coordinate system and the fourth face with its vertices lying on the surface of interest, the mean value theorem is applied to each term of (1) and the far vertex of the tetrahedron is allowed to approach the surface. Observing that the two volume integrals approach zero with the cube of a typical line dimension of the tetrahedron, while the surface integral does so with the square, thereby being the only “survivor” in the limit, the theorem follows. Therefore:

$$\Phi = \int_{\partial\Omega} \mathbf{H}(\mathbf{X}, t) \cdot \mathbf{N} dA = \int_{\partial\omega} \mathbf{h}(\mathbf{x}, t) \cdot \mathbf{n} da, \quad (7)$$

where  $\mathbf{H}$  and  $\mathbf{h}$  are the Lagrangian and Eulerian *flux vectors*, respectively. If the quantity to be balanced is vectorial in nature, these become *flux tensors*. Invoking now (4) of kinematics of deformation (q.v.), the following relation between the Lagrangian and Eulerian flux densities is obtained:

$$\mathbf{H} = J \mathbf{F}^{-1} \mathbf{h}. \quad (8)$$

The integral statement of the generic law of balance in Lagrangian form is finally:

$$\frac{D}{Dt} \int_{\Omega} \Psi_0 d\Omega = \int_{\Omega} \pi_0 d\Omega + \int_{\partial\Omega} \mathbf{H} \cdot \mathbf{N} dA, \quad (9)$$

and in Eulerian form:

$$\frac{D}{Dt} \int_{\omega} \Psi d\Omega = \int_{\omega} \pi d\Omega + \int_{\partial\omega} \mathbf{h} \cdot \mathbf{n} da. \quad (10)$$

Although these statements may suffice for computational applications (such as the “finite-volume” method), under suitable assumptions of smoothness their local (differential) forms can be obtained by using the divergence theorem to convert the flux integral into a volume integral and invoking the fact that the resulting three integrals must be identically equal regardless of the domain of integration within the body. The results are, therefore,

$$\frac{\partial \Psi_0}{\partial t} = \pi_0 + \text{Div } \mathbf{H}, \quad (11)$$

and

$$\frac{D\Psi}{Dt} + \Psi \text{div } \mathbf{v} = \pi + \text{div } \mathbf{h}, \quad (12)$$

where the last equation necessitated the application of Reynolds’ transport theorem. The operators *Div* and *div* stand for the referential and spatial divergence, respectively. Applying the general prescription just obtained to the five fundamental quantities to be balanced in a traditional continuum mechanics treatment gives the following.

### Conservation of Mass

A balance law is said to be a *conservation law* if the production and the flux vanish identically. This is the case for the mass of a classical continuum. (In modern theories of biological growth, however, or in theories of chemically reacting mixtures (when looking at each component of the mixture), conservation of mass does not hold, and specific mass production and/or flux terms are to be included). Denoting by  $\rho_0$  and  $\rho$  the referential and spatial mass densities, respectively, the Lagrangian and Eulerian differential balances are obtained as:

$$\frac{\partial \rho_0}{\partial t} = 0, \quad (13)$$

and

$$\frac{D\rho}{Dt} + \rho \text{div } \mathbf{v} = 0. \quad (14)$$

The latter (Eulerian) version is known in hydrodynamics as the *continuity equation*.

### Balance of Linear Momentum

This balance is a statement of Newton’s second law as applied to a deformable continuum. It is, therefore,



important to recall that the frame of reference (which has been identified with a Cartesian coordinate system) must be assumed to be actually inertial. The quantity to be balanced is the (vectorial) linear momentum, whose Lagrangian and Eulerian densities are, respectively,  $\rho_0 \mathbf{v}$  and  $\rho \mathbf{v}$ . Note that in both cases there is a *spatial* vector to balance, whether the statement of the law is referential or spatial. The production term is given by the (distributed) forces per unit volume, or *body forces*, with densities  $\mathbf{B}$  and  $\mathbf{b}$  respectively in the Lagrangian and Eulerian formulations. The flux terms are given by the *surface tractions* (namely forces  $\mathbf{S}$  and  $\mathbf{s}$  per unit referential or spatial area). It must be emphasized that these forces, even when measured per unit referential area, are *spatial* vectors. By Cauchy's theorem, it is known that these surface tractions are governed by a (tensorial) flux, which can be denoted by  $\mathbf{T}$  and  $\mathbf{t}$ , respectively for the Lagrangian and Eulerian settings:  $\mathbf{S} = \mathbf{T}\mathbf{N}$  and  $\mathbf{s} = \mathbf{t}\mathbf{n}$ . To avoid any possible confusion, the final equations are expressed in components. Plugging the various terms into the corresponding forms of the generic law of balance, and invoking the already obtained conservation of mass, the following Lagrangian and Eulerian forms of the balance of linear momentum are obtained:

$$T_{,I}^{iI} + B^i = \rho_0 \frac{Dv^i}{Dt}, \quad (15)$$

and

$$t_{,j}^{ij} + b^i = \rho \frac{Dv^i}{Dt}. \quad (16)$$

The fluxes  $\mathbf{T}$  and  $\mathbf{t}$  are called, respectively, the *first Piola-Kirchhoff* and the *Cauchy* stress tensors. Note that, whereas the Cauchy stress is a purely spatial tensor, the first Piola-Kirchhoff stress is a mixed tensor. What these tensors do is to produce linearly out of vectors with components  $N_I$  and  $n_i$  respectively, the spatial forces acting on elements of area to which they are normal. The relation between these tensors follows directly from (8) as:

$$T^{iI} = J (F^{-1})^I_j t^{ij}. \quad (17)$$

Note that in the Lagrangian version (15), the material time-derivative of the velocity (appearing on the right hand side of the equation) boils down to a partial derivative. In the Eulerian version (16) on the other hand, the material time derivative includes a non-linear convective term.

### Balance of Angular Momentum

In the Newtonian mechanics (q.v.) of systems of particles, the law of balance of angular momentum follows from Newton's second law under the assumption that the particles of the system interact by means of

forces abiding by Newton's third law ("action and reaction"). In the case of a continuum, the analog of such internal forces is the stress tensor, but this analogy is not easy to pursue rigorously. In fact, in continuum mechanics the postulation of a law of balance of momentum leads to a new result, without a clear analog in discrete systems. The balance of angular momentum states that the rate of change of the total angular momentum with respect to a fixed point (the origin, say) of an inertial frame is equal to the moment of all the external forces with respect to the same point. Using the general prescription of the Eulerian balance law, and invoking conservation of mass and balance of linear momentum, the somewhat surprising final result is

$$t^{ij} = t^{ji}, \quad (18)$$

namely, the Cauchy stress is symmetric. At this point it is appropriate to go back to the discrete analogy. There, it is assumed that the internal forces between the particles of the system abide by the principle of action and reaction. In the continuum case, what has been implicitly assumed is that the surface interactions are merely forces (stresses) and that there are no extra contributions of surface couples. A similar assumption was made regarding the external body forces. In other words, the only contribution to the moment equation is that arising from the moments of forces (no couple interactions). This assumption may have to be abandoned when dealing with electrically or magnetically polarizable materials. In those cases, the antisymmetric part of the stress may not vanish, but will be balanced by the external body-couple.

### Balance of Energy (the First Law of Thermodynamics)

In the case of a single particle or a rigid body, a direct application of Newton's laws yields the result that the rate of change in kinetic energy  $K$  is exactly balanced by the mechanical power  $W_{ext}$  of the external forces acting on the system. In other words, the application of an external force over time along a trajectory produces (or extracts) work, and this work is entirely expended in increasing (or decreasing) the kinetic energy of the system. In the case of a continuum, the kinetic energy is given by:

$$K = \int_{\Omega} \frac{1}{2} \rho_0 \mathbf{v} \cdot \mathbf{v} d\Omega = \int_{\omega} \frac{1}{2} \rho \mathbf{v} \cdot \mathbf{v} d\omega, \quad (19)$$

and the power of the external forces is:

$$\begin{aligned} W_{ext} &= \int_{\Omega} \mathbf{B} \cdot \mathbf{v} d\Omega + \int_{\partial\Omega} (\mathbf{T}\mathbf{N}) \cdot \mathbf{v} dA \\ &= \int_{\omega} \mathbf{b} \cdot \mathbf{v} d\omega + \int_{\partial\omega} (\mathbf{t}\mathbf{n}) \cdot \mathbf{v} da. \end{aligned} \quad (20)$$

It is a matter of daily experience that continuous media deform under applied heat and conversely deformation

may lead to the emission of heat (bending a metal paperclip repeatedly until it breaks is a good experiment to reveal this common effect, but more relevant examples abound in muscle mechanics). There are other occurrences of “non-mechanical” energy sources (chemical reactions, electromagnetic fields, etcetera). The non-mechanical power input (“heating”) is lumped as might be expected into two terms, one corresponding to distributed volumetric sources (“radiation”) and the other to an input across the boundaries (“conduction”):

$$\begin{aligned} W_{heat} &= \int_{\Omega} R \, d\Omega + \int_{\partial\Omega} Q \, dA \\ &= \int_{\omega} r \, d\omega + \int_{\partial\omega} q \, da. \end{aligned} \quad (21)$$

The law of balance of energy (first law of thermodynamics) asserts that, in addition to the kinetic energy  $K$ , there exists another kind of energy content  $U$ , called *internal energy*, such that the rate of change of the total energy content  $K + U$  exactly balances the combined external mechanical and heating powers, namely:

$$\frac{D(K + U)}{Dt} = W_{ext} + W_{heat}. \quad (22)$$

To obtain the local versions of this balance law, the internal energy is assumed to be given by an integral of a density  $u$ , which is usually assumed to be given per unit mass (rather than unit volume). Using the tetrahedron argument, it can be shown that the flux terms in the heating input in (21) are given by referential and spatial flux vectors as:  $Q = -\mathbf{Q} \cdot \mathbf{N}$  and  $q = -\mathbf{q} \cdot \mathbf{n}$ , the minus signs being chosen so that the flux vectors point in the direction of the flux (if the normals are the external normals to the boundary of the domain of interest). The standard procedure now yields the following Lagrangian and Eulerian forms of the local equations of energy balance:

$$\rho_0 \dot{u} = R - Q^I_{,I} + T^I v_{i,I} \quad (23)$$

and

$$\begin{aligned} \rho \dot{u} &= r - q^i_{,i} + t^i v_{i,j} = r - \operatorname{div} \mathbf{q} \\ &+ \operatorname{trace}(\mathbf{tD}). \end{aligned} \quad (24)$$

Naturally, in this last (Eulerian) version, the material time-derivative of  $u$  must include the convective term.

### Entropy Inequality (the Second Law of Thermodynamics)

An important conceptual element in continuum mechanics is the presence of an arrow of time, that is the natural irrevocable direction of phenomena prescribed by the second law of thermodynamics. There are different ways to deal with this delicate issue, but here

only the formulation based on the Clausius-Duhem inequality is presented. There are two new ingredients that need to be added to the picture. The first one is a new extensive quantity, the *entropy*  $S$ , whose content will be measured in terms of the integral of a density  $s$  per unit mass. The second element to be introduced is a new field,  $\theta$ , called the *absolute temperature*. It is assumed that  $\theta$  is strictly positive and measurable instantaneously and locally by appropriate instruments (such as thermo-couples). This temperature scale is consistent with the temperature appearing naturally in the theory of ideal gases. It is moreover assumed that there are two universal sources of entropy production, one volumetric and the other through the boundary. These sources are obtained, respectively, by dividing the corresponding (volume or surface) heating source by the local value of the absolute temperature. The Clausius-Duhem inequality asserts that the rate of entropy production is never less than what can be accounted by these universal sources, namely:

$$\frac{D}{Dt} \int_{\Omega} \rho_0 s \, d\Omega \geq \int_{\Omega} \frac{R}{\theta} \, d\Omega - \int_{\partial\Omega} \frac{\mathbf{Q} \cdot \mathbf{N}}{\theta} \, dA \quad (25)$$

or, in the Eulerian version,

$$\frac{D}{Dt} \int_{\omega} \rho s \, d\omega \geq \int_{\omega} \frac{r}{\theta} \, d\omega + \int_{\partial\omega} \frac{\mathbf{q} \cdot \mathbf{n}}{\theta} \, da. \quad (26)$$

The equality corresponds to *reversibility* of a physical process, while all other processes (for which the strict inequality holds) are *irreversible*. The local forms of the inequality are obtained by the standard procedure as:

$$\rho_0 \dot{s} \geq \frac{R}{\theta} - \operatorname{Div} \frac{\mathbf{Q}}{\theta}, \quad (27)$$

and

$$\rho \dot{s} \geq \frac{r}{\theta} - \operatorname{div} \frac{\mathbf{q}}{\theta}. \quad (28)$$

It is often convenient to replace the Clausius-Duhem inequality by a linear combination with the balance of energy. In particular, subtracting from the (Lagrangian) equation of energy balance, (23), the (Lagrangian) entropy inequality, (27), multiplied by the absolute temperature, and defining the (Helmholtz) free energy density per unit mass as:

$$\psi = u - \theta s, \quad (29)$$

Equation (27) can be written in the form:

$$\rho_0 \dot{\psi} + \rho_0 \dot{\theta} s - T^I v_{i,I} + \frac{1}{\theta} Q^I \theta_{,I} \leq 0, \quad (30)$$

with a similar expression for the Eulerian version.

In closing, it must be emphasized that the laws of balance presented in this article are limited by the

assumptions made in their derivation. In particular, it should be mentioned that in theories of continuous growth and remodeling (q.v.) important modifications take place. Essential modifications of the laws of balance and of the kinematics of deformation (q.v.) are also to be considered for theories of mixtures, particularly when the components of the mixture may react with each other chemically. Particular cases of mixture theories are routinely used in biomechanics (for example, the bi-phasic theory of cartilage). These topics are beyond the scope of the present article.

## References

1. Truesdell C, Toupin R (1960) The classical field theories. In: Flügge S (ed) *Handbuch der Physik*, vol III/1. Springer-Verlag, Heidelberg
2. Truesdell C, Noll W (1965) The non-linear field theories of mechanics. In: Flügge S (ed) *Handbuch der Physik*, vol III/3. Springer-Verlag, Heidelberg
3. Eringen AC (ed) (1971) *Continuum physics*, vols I–IV. Academic, New York
4. Fung YC (1981) *Biomechanics*. Springer-Verlag, Heidelberg
5. Gurtin M (1982) *An Introduction to continuum mechanics*. Academic, New York
6. Chadwick P (1999) *Continuum mechanics: concise theory and problems*, 2nd edn. Dover, New York
7. Epstein M, Maugin GA (2000) Thermomechanics of volumetric growth in uniform bodies. *Int J Plasticity* 16:951–978

---

## Balance-recovery Reactions

- ▶ Postural Strategies

---

## Balint's Syndrome

### Definition

- ▶ Visual Neuropsychology

---

## Ballism

### Definition

Involuntary violent flailing movements of the arm, mostly unilaterally.

---

## Ballistic Movements

### Definition

Movements that are believed to be executed in an open-loop fashion without the benefit of online feedback corrections.

- ▶ Movement Sequences
- ▶ Eye-Hand Coordination

---

## Balo's Concentric Sclerosis

### Definition

An aggressive form of multiple sclerosis (MS), Balo's concentric sclerosis is usually characterized by an abrupt clinical onset with steady progression to major disability and death within months. Symptoms can include altered mental status, aphasia, headache and seizures. Demyelinating lesions are typically large, characterized by alternating layers of myelinated and demyelinated tissue. These alternating layers of myelin loss are seen as hypointense and hyperintense rings on T2-weighted MRI.

- ▶ Multiple Sclerosis

---

## Band of Gennari

### Synonyms

- ▶ Stria occipitalis (Gennari); ▶ Occipital stripe (Gennari)

### Definition

Typical white stripe visible with the naked eye which is the characteristic feature of the area 17 (striate cortex) of the primary visual cortex.

- ▶ Telencephalon

---

## Band-pass

### Definition

A filter, which passes only those frequency components in the central band of the spectrum (i.e. it stops

frequency components in the low and high ends of the spectrum)

► Signals and Systems

## Bands of Bungner

### Definition

Proliferating Schwann cell columns within the basal lamina in the distal nerve, that are awaiting regrowing axons from the proximal nerve.

► Peripheral Nerve Regeneration and Nerve Repair

## Bandwidth

### Definition

The effective range of frequencies in a signal, i.e. the difference between the frequency of the highest frequency component and frequency of the lowest frequency component of a signal.

► Signals and Systems

## Baroreceptor

### Definition

A receptor located on sensory nerve endings in the wall of arteries, which responds to an increase in arterial blood pressure. The actual stimulus to the receptor is stretch of the wall of the artery, which results from an increase in blood pressure. The baroreceptor nerve endings are located mainly in the outer layer (adventitia) of arteries, predominantly in the carotid sinus and aortic arch, but also in other arterial regions including the brachiocephalic artery and pulmonary artery. The baroreceptor sensory nerves in the carotid sinus are part of the glossopharyngeal nerve (IX cranial nerve), while the other baroreceptor sensory nerves are all part of the vagus nerve (X cranial nerve). The carotid sinus and aortic arch baroreceptors are tonically active at normal

levels of arterial pressure, and increase (or decrease) their rate of firing in response to an increase (or decrease) of both the mean level as well as the pulsatile component of arterial pressure.

► Blood Volume Regulation

► Homeostasis

## Baroreceptor Reflex

### Definition

The baroreceptor reflex (baroreflex) is a cardiovascular reflex devoted to the control of blood pressure. An increase in baroreceptor activity resulting from an increase in arterial blood pressure normally results in a reflex inhibition of the activity of sympathetic nerves innervating blood vessels (especially arterioles) and the heart, and a reflex excitation of vagal nerves innervating the heart. The effects of these reflex changes in sympathetic and vagal activity are to dilate blood vessels and reduce the rate and contractility of the heart, thus reducing the arterial blood pressure. Similarly, a decrease in baroreceptor activity leads to a reflex increase in sympathetic activity and a reflex decrease in cardiac vagal activity that tend to increase arterial pressure. Thus, the main effect of the baroreceptor reflex is to minimize changes in arterial blood pressure that would normally result from disturbances, e.g. a change in posture.

► Baroreceptor

► Blood Volume Regulation

► Homeostasis

► Sympathetic Pathways

► Vagus Nerve

## Barrel Cortex

FORD EBNER, MARIA POPESCU

Department of Psychology, Vanderbilt University, Nashville, TN, USA

### Synonyms

Barrel field cortex; Posteromedial barrel subfield; PMBSF

## Definition

The entire layer IV of mouse and rat S-I cortex is parsed into zones that, when viewed in sections cut parallel to the cortical surface and stained with the cytochrome oxidase (CO) stain, appear as oval dense zones: one for each of the digits and pads on the feet, and one for each of the large and many of the small whiskers on the face around the nose and mouth. The largest barrels are representations of the large facial whiskers (a.k.a. mystacial vibrissae or facial sinus hairs), and these barrels were given the specific name of the posteromedial barrel subfield or PMBSF [9].

## Characteristics

### Whisker Somatosensory Pathway

Different species have evolved different sensory capabilities to survive in their particular ecological niche. Rodents, in particular mice and rats, have specialized the whiskers on their face into exquisitely sensitive tactile organs with which they explore their environment, especially under low light conditions, by moving the whiskers back and forth (whisking). Each whisker in these species is a complex sensorimotor organ that can move the whiskers precisely to gather the most salient information. In mice and rats, but not all rodents, the facial muscles have been specialized such that they form a sling around the whisker follicle, and when the muscle contracts the whisker is levered (protracted) so far forward that they extend well in front of the nose.

Each whisker follicle is innervated by over 200 sensory fibers that render it extremely sensitive to the direction, magnitude, duration, frequency and velocity of any stimulus that can perturb the whiskers. The motor fibers that innervate these intrinsic, individual, facial muscles travel in the seventh cranial nerve and arise in the brainstem from motor neurons in the facial nerve nucleus. The sensory fibers that innervate the follicle travel with the fifth cranial or trigeminal nerve and terminate in the brainstem trigeminal nuclei.

In the rat's vibrissa (whisker) system, neurons representing whiskers at each level in the pathway are topographically organized into functional "whisker maps." These maps correlate well with the anatomically discrete cell aggregates at each level: "barrelettes" in the brainstem [Ma PM 1991], "barreloids" in thalamus [Van der Loos 1976] and "barrels" in layer IV of the primary somatosensory cortex (SI) [9]. Each map replicates the spatial arrangement of whiskers on the contralateral face (Fig. 1).

The mechanosensory axons bifurcate as they enter the brainstem: some collaterals end in the Principal Trigeminal Nucleus (PrV) and others end in a descending cascade of axon terminals along the length of the the Spinal Trigeminal Nucleus (SpV). SpV is subdivided into three sub-nuclei, oralis, interpolaris, and caudalis, with the interpolaris division (SPV)

providing the main projection to the thalamus. The receptive field of PrV cells includes one, sometimes two, whiskers, while the receptive field of SpVi cells is much larger and includes 6–8 whiskers on average. Since nearly all of the primary mechanosensory axons bifurcate on entry, this difference in receptive field size can be accounted for by the degree of axon divergence and convergence in the two nuclei. PrV is the beginning of the lemniscal sensory pathway to thalamus and then to barrel cortex, and SpV is the beginning of the paralemniscal pathway. As each of these pathways ascends to the thalamus they decussate to the opposite side of the brain. This crossing is what causes the whiskers on the right side of the face to be represented in the left cortex, and vice versa.

In the thalamus, the PrV fibers terminate primarily in the ventral posterior nucleus of the thalamus (VPM), while the SpV fibers terminate primarily in an adjacent thalamic nucleus, the medial division of the posterior nucleus (POm). New findings in the last few years have identified two subdivisions of the VPM nucleus into a dorsal lateral portion (VPMdl) that receives mainly lemniscal inputs, and a ventral medial portion (VPMvm) that receives mainly paralemniscal inputs [7]. This has led to the notion that there are in fact three parallel pathways to cortex: lemniscal (PrV to VPMdl), paralemniscal (SpV to POm), and what has been called extralemniscal (SpV to VPMvm) pathway [10]. Physiological evidence supports the idea that the lemniscal pathways convey information mainly about object perception, the paralemniscal pathway mainly about whisker position, and the extralemniscal pathway mainly about a combination of the two. The lemniscal VPMdl nucleus projects to primary somatosensory cortex (S-I) after giving off collaterals just outside the thalamus to cells in an inhibitory thalamic feedback nucleus called the thalamic reticular nucleus (RTN). In cortex the VPMdl fibers give rise to a substantial number of axon collaterals that spread out and end in the deep layers, between layer V and VI, and then proceed to terminate profusely in one of the discrete cell aggregates of layer IV (a barrel): these layer IV cell clusters are the basis for calling this "barrel cortex."

In layer IV of the rat barrel cortex there is a clear distinction between cell dense barrels that receive a VPMdl input, and the region around the barrels called the septa that receive input from another nucleus in the thalamus, the POm nucleus. The barrel/septum feature of barrel cortex is very species specific, and hence, has caused considerable confusion in the literature. Clear evidence suggests that the septa are well developed in rat cortex, but almost non-existent in mouse cortex (<20  $\mu$ m wide). In the rat POm fibers terminate in layer Va, IV<sup>septa</sup>, and layer III. The extralemniscal projections from the VPMvm cells in the rat go mainly to the second somatosensory cortex (S-II), with a smaller contingent

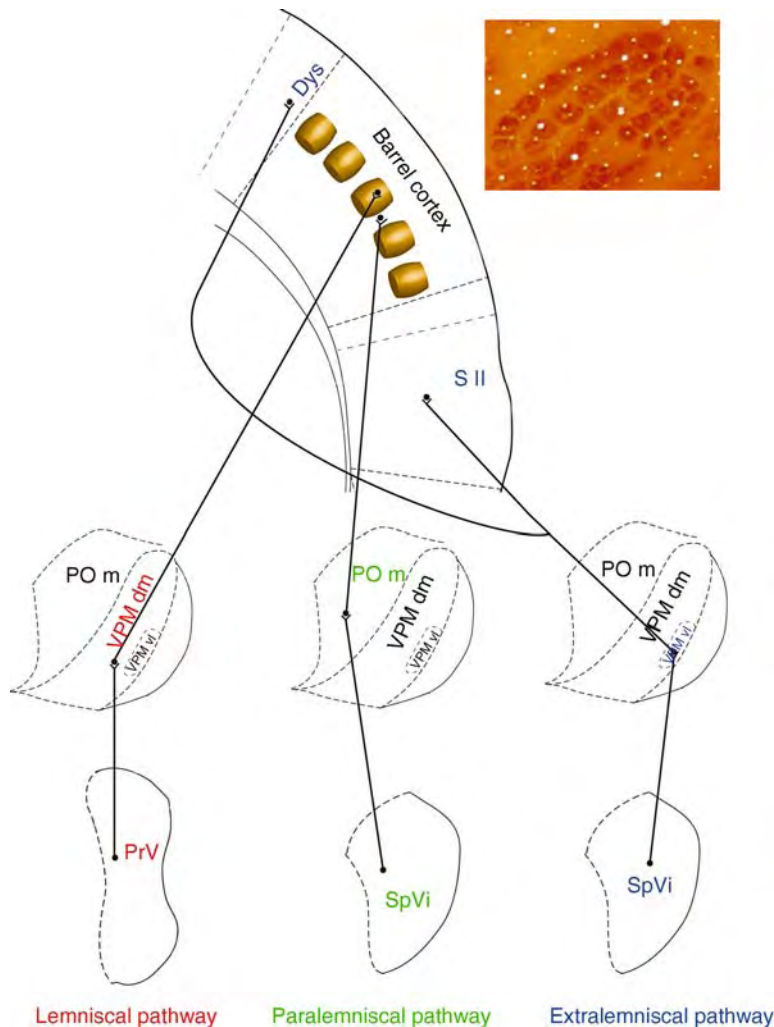

**Barrel Cortex. Figure 1** Three ascending pathways relaying touch-related information from the whiskers to the barrel field cortex and neighboring cortical areas (PrV: principal trigeminal nucleus, SpVi: interpolaris division of the spinal trigeminal nucleus, VPM dm: dorso-medial division of the ventral posterior nucleus of the thalamus, VPM vl: ventro-lateral division of the ventral posterior nucleus of the thalamus, POm: medial division of the posterior nucleus, Dys: dysgranular cortex, S II: secondary somatosensory cortex) Inset: Layer IV barrels in barrel field cortex replicate the spatial arrangement of whiskers on the face (cytochrome oxidase staining). Only the major projections are indicated.

that terminates in the septal zones of S-I cortex similar to the POm terminal field (Fig. 1). Neurons in layer IV project mostly to layer III: barrels project to above the barrels and septa project to above the septa.

### Cortical Organization

The general organization of barrel cortex is similar to other mammalian sensory cortices. Granular layer IV where the barrels are located is the primary input layer, the supragranular layers II, III project to other areas of cortex both ipsilateral and contralateral, and the infragranular layers V and VI project widely to cortex and to subcortical structures, such as striatum, thalamus, midbrain, medulla and spinal cord. A major feature of

barrel cortex that is now receiving deserved attention is the massive layer V and VI projections back to the thalamus and trigeminal nuclei in the sensory pathway that project to cortex. These massive projections allow cortex to influence the directional preference and enhance the contrast of multiwhisker responses in the subcortical relay nuclei. Layer V gives rise to a driving input to POm, while layer VIa provides a precise modulatory input to the RTN and VPM, and layer VIb projects more diffusely to VPM.

Two cortical domains have been anatomically and physiologically described in the barrel cortex: the barrel columns and the septal columns. They are considered to be involved in distinct intrinsic and corticocortical

circuitries and to relay information about different sensorimotor processes. The intrinsic projections of barrel column neurons are generally short-ranged and terminate for the most part within the most immediate neighboring barrel columns. In contrast, the septal cells send projections as far as three barrel diameters along the same whisker row, preferring the septal columns. Moreover, the corticocortical projections of the barrel columns reach the second somatosensory cortex, S II, in a loosely topographic manner. The septal columns preferentially connect to dysgranular cortex anterior to the E-row, S II, and to the posteromedial parietal cortex [6]. Recent physiological data also points to the barrel columns as conveying information related to whisking-touch signals as part of the lemniscal pathway, while the septal columns are implicated in processing and transmitting information related to the rat's whisking behavior [10].

### Physiology

The receptive fields of barrel field cortical neurons are organized into center and surround subdivisions of the whiskers that activate a given cortical cell. The whisker generating the maximum response at the shortest latency forms the center receptive field, and is called the principal or best whisker. The principal whisker is almost always the whisker that is anatomically connected to a single barrel. The whiskers constituting the excitatory surround receptive field are classically defined as all other surround whiskers that elicit suprathreshold responses. However intracellular recordings have shown that all whiskers on the contralateral side of the face can generate postsynaptic potentials in any barrel field neurons.

Principal whisker angular tuning or directional preference maps have also been described. Thus, each barrel can be divided in minicolumns of cells exhibiting the same preferred stimulus direction.

The transmission of principal whisker responses through its respective barrel column is relayed from layer IV and then to layers III and II. Barrels and septa transmit separately until the activity is integrated in layer III [8]. Layer V receptive fields are then usually quite large and integrate inputs over a larger area [3].

Guic-Robles et al. showed that rat whiskers can be used to perform a texture discrimination task, and this is dependent upon a functional barrel cortex. Newer studies by [1] showed that barrel cortex neurons use stimulus frequency and amplitude to represent texture at the cortical level.

### Plasticity

While each barrel column is the primary representation of a distinct whisker, much of the barrel cortex research has focused on uncovering cortical plasticity mechanisms. Thus, peripheral activity has been manipulated mostly by trimming or plucking whiskers, but also by using

different patterns of stimulation to certain vibrissae, resulting in both firing pattern and anatomical changes.

Barrel cortex remains modifiable by selective activation of sensory inputs throughout life [2], even though there is a critical period just after birth, when cortical plasticity can be elicited by sensory experience in ways that are diminished later in life [5]. If sensory inputs are abnormally reduced in barrel cortex during an early postnatal period of roughly 1 month, then synaptic modification is impoverished in ways that persist throughout life. The behavioral effect of sensory deprivation is to decrease the ability of the rats to make tactual discriminations. The physiological correlate of similar deprivation is to reduce the magnitude of sensory response and to significantly slow the rate of plasticity that is usually induced by trimming all but two whiskers (called "whisker pairing plasticity"). A major current thrust of research on barrel cortex is to understand the coding of tactual information by ensembles of whiskers and cortical neurons that leads to perception and higher order processes [1].

Corticothalamic projections have also been shown to be important for cortical and thalamic plasticity. Corticothalamic projections are highly reciprocal, and studies in auditory, somatosensory and visual systems in bats, cats, rats and monkeys have demonstrated that corticofugal projections are responsible for altering the transmission mode and the receptive field properties of thalamic relay neurons as well as firing synchrony during the animal's sleep/wake cycle. Such studies make it clear that barrel cortex influences the thalamus through top-down processes which may modulate the sensory information processing. Recent results have shown that the cortex modulates the responsiveness of thalamic relay neurons by sharpening the tuning properties of thalamic neurons recorded and modifying their directional preference.

### References

1. Arabzadeh E, Petersen RS, Diamond ME (2003) Encoding of whisker vibration by rat barrel cortex neurons: implications for texture discrimination. *J Neurosci.* 23(27):9146–54
2. Armstrong-James M, Diamond ME, Ebner FF (1994) An innocuous bias in whisker use in adult rats modifies receptive fields of barrel cortex neurons. *J Neurosci.* 14 (11pt 2):6978–91
3. Armstrong-James M, Fox K, Das-Gupta A (1992) Flow of excitation within rat barrel cortex on striking a single vibrissa. *J Neurophysiol* 68(4):1345–1358
4. Delacour J, Houcine O, Talbi B (1987) "Learned" changes in the responses of the rat barrel field neurons. *Neuroscience* 23(1):63–71
5. Feldman DE, Brecht M (2005) Map plasticity in somatosensory cortex. *Science* 310(5749):810–815
6. Kim U, Ebner FF (1999) Barrels and septa: separate circuits in rat barrels field cortex. *J Comp Neurol* 408(4):489–505

7. Pierret T, Lavallée P, Deschênes M (2000) Parallel streams for the relay of vibrissal information through thalamic barreloids. *J Neurosci* 20(19):7455–62
8. Shepherd GM, Pologruto TA, Svoboda K (2003) Circuit analysis of experience-dependent plasticity in the developing rat barrel cortex. *Neuron*. 38(2):277–89
9. Woolsey TA, Van der Loos H (1970) the structural organization of layer IV in the somatosensory region (SI) of mouse cerebral cortex. The description of a cortical field composed of discrete cytoarchitectonic units. *Brain Res.* 17(2):205–42
10. Yu C, Derdikman D, Haidarliu S, Ahissar E (2006) Parallel thalamic pathways for whisking and touch signals in the rat. *PLoS Biol* 4(5):e124

## Basal Forebrain

### Definition

The term basal forebrain refers to a heterogeneous set of telencephalic and diencephalic structures that are located on the ventral aspect of the brain underneath or at the level of the anterior commissure. Despite the lack of a precise definition, the main brain regions included are the preoptic-anterior hypothalamic continuum, septal nuclei, bed nucleus of the stria terminalis, diagonal band nuclei, substantia innominata including the basal nucleus of Meynert, nucleus accumbens, olfactory tubercle, olfactory cortex, and the amygdaloid nuclei.

A more common definition refers to the cholinergic neurons related to these systems that occupy the sublenticular areas of the brain (i.e. the areas below the lenticular nuclei which are comprised of the “lens shaped” putamen and globus pallidus).

- ▶ Amygdala
- ▶ Basal Ganglia
- ▶ Extended Amygdala
- ▶ Hypothalamus
- ▶ Olfactory Cortex
- ▶ Olfactory Tubercle

## Basal Ganglia

SUZANNE N. HABER

Department of Pharmacology and Physiology,  
University of Rochester School of Medicine, Rochester,  
NY, USA

### Definition

The basal ganglia (BG), a collection of interconnected subcortical structures, have captured the interest of

scientists and clinicians for well over a century due to the remarkable range of dysfunctions associated with BG disorders. Historically, the BG have been associated with the control of movement. Motor control problems are prominent in several BG disorders including the tremor and rigidity in Parkinson’s disease (PD), graceful writhing movements, in Huntington’s chorea (HD), and motor tics in Gilles de la Tourette’s syndrome. However, in addition to motor deficits, these BG diseases also impair the intellect and emotions, and dementia and depression are prominent in both HD and PD. Recent advances in understanding the connections and physiology of these structures as well as a more thorough understanding of clinical manifestations associated with their dysfunction have expanded our appreciation of the functions of the BG to include a critical role in cognitive, emotional and motivational functions as well as motor control. Indeed, parts of each BG structure are linked to cognition, emotion and motivation. It is now well accepted that pathology in these structures, plays an important role in drug addiction and psychiatric disease, including schizophrenia and obsessive-compulsive disorder.

Despite the continued interest and clinical relevance of the BG, this collection of subcortical nuclei remains among the least understood of all brain structures. Still, neurobiologists and clinicians have advanced the field extensively in the past decade and continue to move it forward with new imaging tools and molecular biology techniques. For example, using a combination of PET and MRI imaging techniques, we know which specific regions of the BG are affected by drugs of abuse such as cocaine and amphetamine and involved in cognitive dysfunction and impulse control.

### Characteristics

#### Components and Anatomy of the BG

Key to understanding the anatomy and function of the BG is that these structures are intimately associated with the cerebral cortex, which provides the main input to the BG. There are two main outputs of the BG. One descends to brainstem motor effector systems in the mesopontine tegmentum. The other is directed toward the thalamus, which in turn projects back to cortex. Thus the basic cortical BG loop is: cortex-BG-thalamus-cortex. The BG do not have direct input or output connections with the spinal cord. The BG are composed of four nuclei: the striatum (the caudate nucleus, putamen, and nucleus accumbens), globus pallidus (comprising internal segment and external segments, and the ventral pallidum), substantia nigra, (pars compacta and pars reticulata), and subthalamic nucleus. The putamen and globus pallidus are referred to as the lenticular nucleus. For a review of the anatomy and connections of the BG, see reference [1].



### Striatum

The striatum is the main afferent component of the BG, receiving input from the entire cerebral cortex. Three nuclei, which are similar with respect to their cells types, general projections, transmitters and receptors, comprise the striatum: the caudate nucleus, putamen and nucleus accumbens (Fig. 1a–c).

The internal capsule divides the caudate nucleus and the putamen. Although the caudate nucleus is one structure, it has three parts: the head, body, and tail. The nucleus accumbens is located in the ventral region of the rostral striatum. At this rostral level, the caudate nucleus, the putamen, and the nucleus accumbens are joined. Recently the nucleus accumbens has been incorporated into the concept of the ventral striatum, a term used to refer to the part of the striatal complex associated with reward and motivation.

The striatum is the receiving end of the BG. Inputs are derived from the cortex, thalamus, and the brain stem. These project to the striatum in a generally topographic manner. Areas associated with reward and motivation (orbital prefrontal cortex and cingulate cortex) along with the amygdala and temporal pole of the cortex, project to the ventral striatum. Cortical areas associated with cognition (the dorsolateral prefrontal cortex) project to the dorsal and medial caudate nucleus. Finally, cortical regions involved in motor control, including motor cortex and premotor areas, project to the dorsolateral striatum. Thalamic inputs associated with these various functions project onto the same striatal region as does the comparable functional area of cortex. The midbrain dopamine cells project in an inverse dorsal/ventral

manner, such that the dorsal midbrain projects to the ventral striatum and the ventrally placed cells project dorsally.

There are two general neuronal cell types in the striatum: (i) projection neurons and (ii) interneurons. The projection neurons make up 95% of the striatal neurons. They are called medium spiny neurons because they are medium sized neurons and have many spines on their dendrites. These cells receive an excitatory glutamatergic input from the cortex and thalamus and a dopaminergic input from the SNc. They also receive input from the striatal interneurons. Medium spiny neurons are GABAergic and thus are inhibitory and project to the globus pallidus and substantia nigra. They also contain one of two pharmacologically distinct types of dopamine receptors, the D1 and D2 receptors. Thus, there are two types of medium spiny neurons: (i) Cells in which GABA is colocalized with the neuropeptide, enkephalin. These enkephalin-positive cells also contain D2 receptors, which inhibit cAMP. The dopamine signal to these cells is therefore inhibitory. These cells project primarily to the external segment of the globus pallidus (GPe); and (ii) Cells in which GABA is colocalized with the neuropeptide, substance P. These substance P-positive cells also contain D1 receptors, which stimulate cAMP, such that the dopamine signal to these cells is excitatory. The substance P-positive cells project primarily to internal segment of the globus pallidus (GPi) and to the substantia nigra, pars reticulata (SNr). There are four types of striatal interneurons, each of which has different physiological and chemical characteristics. Three are aspiny-type I interneurons, each of which co-contains

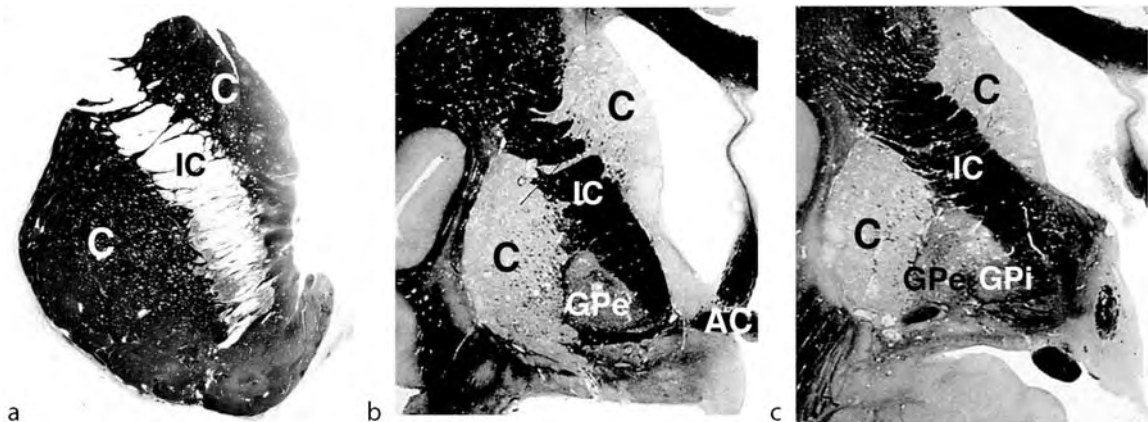

**Basal Ganglia. Figure 1** Photomicrographs at coronal levels to illustrate specific BG structures: (a) the rostral striatum (stained for acetylcholinesterase); (b) at the level of the anterior commissure (stained for Nissl); (c) at the level of both the internal and external segments of the globus pallidus (stained for Nissl). AC anterior commissure; C caudate nucleus; GPe globus pallidus external segment; GPi globus pallidus internal segment; IC internal capsule; P putamen.

GABA as a transmitter and either calretinin, parvalbumin, or somatostatin and neuropeptide Y. The other main interneuron type is the large cholinergic cell. These cells fire spontaneously and are referred to as “tonically active neurons” or TANS.

The striatum projects primarily to the pallidal complex, (GPe, GPi and ventral pallidum), substantia nigra (both the SNr and SNc) and ventral tegmental area in a generally topographic manner. Projections to the pallidal complex are arranged in a dorsal/ventral, medial/lateral topography. However, those to the midbrain are organized in an inverse dorsal/ventral manner, such that the ventral striatum projects dorsally, and the dorsal striatum projects ventrally. We will return to the striatal-midbrain-striatal projection system and its functional significance below.

### The pallidum

Pallidal cells are large, with long dendrites that extend throughout a broad medial/lateral region. They use GABA as a transmitter and are inhibitory. Unlike the components of the striatum, the GPi, GPe and ventral pallidum do differ with respect to projections. The GPi receives a GABAergic (colocalized primarily with substance P) input from the striatum and a glutamatergic input from the subthalamic nucleus. It projects primarily to the ventral lateral and ventral anterior nuclei of the thalamus, which, in turn, project to specific regions of frontal cortex, completing the basic cortico-BG-thalamocortical loop (see Fig. 2).

The GPe receives a GABAergic (colocalized primarily with enkephalin) input from the striatum and a glutamatergic input from the subthalamic nucleus. However, unlike the GPi, the GPe projects to the subthalamic nucleus and to the SNr, but not directly to the thalamus.

The ventral pallidum receives input from the ventral striatum. It contains intermixed elements of both the internal and external segments. That is, both enkephalin and substance P containing GABA striatal neurons project here. The ventral pallidal output is to both the thalamus (primarily to the medial dorsal nucleus and lateral habenular nucleus) and to the subthalamic nucleus. It also projects to the VTA in the midbrain.

### The Subthalamic Nucleus

The subthalamic nucleus is located at junction of diencephalon and mesencephalon and receives an excitatory glutamatergic input from cortex, an inhibitory GABAergic input from the GPe and also input from the SNc. It contains glutamate and is therefore excitatory. As mentioned above, the subthalamic nucleus projects to both the internal and external

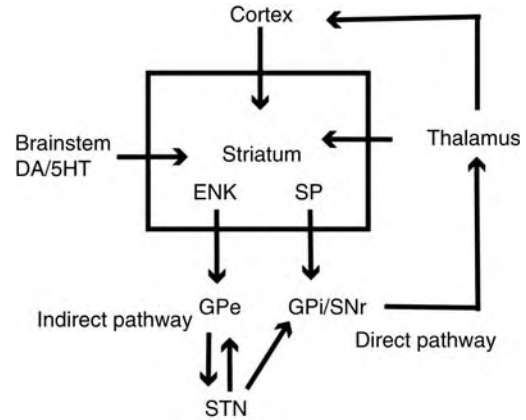

**Basal Ganglia. Figure 2** Diagram demonstrating the connections of the BG, including the direct and indirect pathways. 5HT serotonin; DA dopamine; ENK enkephalin; GPe globus pallidus external segment; GPi globus pallidus internal segment; SNr substantia nigra, pars reticulata; SP substance P; STN subthalamic nucleus.

segments of the globus pallidus, to the ventral pallidum, and to the SNr. The subthalamic nucleus receives a fast glutamatergic input directly from cortex. This input triggers activity in the subthalamic nucleus that, in turn, activates the pallidal segments. Because this cortical input reaches the subthalamic nucleus before the pallidal input, it is referred to as the “hyper direct” pathway.

### The Substantia Nigra

The SNc receives inhibitory input from the striatum and GPe, and excitatory input from brainstem nuclei. It is made up of dopamine containing cells and can be either excitatory or inhibitory, depending on the postsynaptic receptor subtype. Dopaminergic SNc neurons project primarily to the striatum, but also to the globus pallidus, subthalamic nucleus and cortex, and are the cells that degenerate in PD. The SNr also receives input a GABAergic from the striatum, a glutamatergic input from the subthalamic n and other brainstem inputs including, e.g. from the dorsal raphe nucleus (serotonergic). SNr neurons are similar to pallidal cells and are GABAergic and inhibitory. They project to the ventral anterior nucleus of the thalamus and superior colliculus. The ventral tegmental area is located medial to the substantia nigra and contains components of both the SNc, in that there are dopamine cells that project to the striatum (the nucleus accumbens, or the ventral striatum), and SNr, in that they receive input from the ventral striatum. The VTA is associated with reward functions of the BG.

### Overview of the Circuits

There are two cortico-BG-thalamocortical circuits: (i) The direct pathway; and (ii) The indirect pathway (Fig. 2).

The circuit through the direct pathway is: cortex-striatum-GPi/SNr-thalamus-cortex. Information carried through this pathway has a net effect of excitation. The cortex sends an excitatory input to the striatum. This increases firing in the striato-GPi/SNr pathway. Remember, this pathway is inhibitory. Thus, cortical excitation inhibits the GPi/SNr. Since these nuclei are also inhibitory, this striatal inhibition removes the inhibitory influence of the GPi/SNr on the thalamus. The thalamus is excitatory, and the removal of the GPi/SNr inhibition to the thalamus increases the thalamocortical firing. Thus, the direct pathway has a positive feedback effect on cortex.

The indirect pathway involves the intrinsic nuclei, i.e. the GPe and the subthalamic nucleus. This circuit is: cortex-striatum-GPe-subthalamic nucleus-GPi/SNr-thalamus-cortex. Note, the indirect pathway involves a side loop through the GPi and subthalamic nucleus before projecting to the output nuclei. Information carried through this pathway has a net effect of inhibition. The cortex sends an excitatory input to the striatum. This increases firing in the striato GPe pathway. Remember, this pathway is inhibitory. Thus cortical excitation inhibits the GPe. Since this nucleus is also inhibitory, the striatal inhibition removes the inhibitory influence of the GPe on the subthalamic nucleus. The subthalamic nucleus is excitatory, and the removal of the GPe inhibition to the subthalamus increases the subthalamo-GPi firing. The increase in excitation of GPi results in an increase of the inhibitory GPi projection to the thalamus. Inhibition of the thalamic firing results in decreased cortical activity.

Thus, the direct and indirect pathways affect the cortex (via the thalamic neurons) in opposite ways. This model of circuits has been used extensively to model how the BG may function in motor behavior. There are at least such two functional models: (i) Signals associated with a particular voluntary movement are directed over both pathways to the same population of neurons in the GPi. Inputs from the direct pathway facilitate the movement while inputs from the indirect pathway simultaneously brake or smooth the movement. (ii) Signals associated with a particular voluntary movement are directed to different sets of neurons in the GPi. The selected pattern of voluntary movement is reinforced by the direct pathway and conflicting patterns are suppressed via the indirect pathway, thus focusing on the desired movement. Insofar as loss of striatal dopamine inhibits the facilitatory direct pathway and disinhibits the inhibitory indirect pathway, with both effects theoretically

depressing BG-thalamocortical activity, these models have been used to explain the pathophysiology underlying Parkinson's disease.

### Functional Cortico-BG-Thalamocortical Pathways

The striatum receives input from all of cortex and projects, via the thalamus, primarily back to frontal cortex. Cortico-BG-thalamocortical projections are topographically organized. This topography renders a remarkable functional specificity within each structure. The frontal cortex can be divided into general functional regions: motor (involved in sensorimotor processing), including motor and premotor cortex; association (involved in cognition, working memory, strategic planning), including the dorsolateral prefrontal cortex; and limbic (involved in reward processing and motivation), including the anterior cingulate cortex and orbital cortex. Each of these cortical regions projects to specific parts of the striatum. In general, the motor regions project to a large area of the putamen, caudal to the anterior commissure; the association areas project to a large part of the caudate nucleus and putamen rostral to the anterior commissure; and the limbic regions project to the ventral striatum including the nucleus accumbens. Each of these parts of the striatum project to specific parts of the pallidum and SNr, which, in turn project to specific parts of the thalamus. These thalamic regions extend the functional specificity in their projections back to the cortex of origin. This organization has been referred to as parallel processing of information via separate and segregated circuits.

The topography of cortico-BG projections has led to a model of BG function based on parallel and segregated pathways operating through discrete functional channels (limbic, associative, and sensorimotor), which are represented in specific regions in each BG structure. However, mechanisms by which information flows through functional circuits are now being explored. At least two networks have been identified, one through the striato-dopamine-striatal pathway, and one through the cortico-thalamic cortical pathway. Within each of these sets of connected structures, there exist both reciprocal connections linking up regions associated with similar functions and, in addition, non-reciprocal connections linking up regions that are associated with different cortical BG circuits. For example, the midbrain dopamine neurons play a unique role in BG and cortical circuits modulating a broad range of behaviors from learning and "working memory" to motor control. This is achieved by the interface between the efferent and afferent projections of the striatum to the dopamine cells. Projections from the limbic regions of the striatum terminate in the region of dopamine neurons that project not only back to the

limbic striatal domain, but also to the cognitive portions of the striatum. Striatal cells in the cognitive domain project, not only to midbrain regions that have a reciprocal connection, but also terminate in motor control areas. In this way information from the ventral striatum reaches more dorsal striatal parts to influence cognitive and motor control striatal areas. Of particular interest is the fact that dopamine neurons do not respond to movement, but rather signal unpredicted reward, thus focusing attention on significant and rewarding stimuli, a requirement for the acquisition of new learned behaviors [2]. The dopamine pathways that signal salience, are in a position, through their input from the striatum and projections back to the striatum, to provide an interface between cognitive, motor, and limbic functional domains of the forebrain, through complex forebrain neuronal networks [3]. The BG are a key element in the development of goal-directed behaviors and the action plans that they carry out. Goal-directed behaviors require processing a complex chain of events beginning with motivation, proceeding through cognitive processing that shapes final motor outcomes. This sequence is reflected in the feedforward organization of both the striato-nigral connections and the thalamo-cortical connections. Information is channeled from limbic, to cognitive, to motor circuits. Decision-making processes are thus influenced by motivation and cognitive inputs, allowing the animal to respond appropriate to environmental cues.

### The BG in Neurological and Psychiatric Disorders

The substantia nigra was first identified in eighteenth century, but it wasn't until the twentieth century that it was linked to the motor system, primarily due to the connection of nigral cell loss in Parkinson's disease. The involvement midbrain dopamine in the pathogenesis of major psychoses evolved in the 1950's when it was discovered that the phenothiazines were an effective treatment for psychosis. Since that time the midbrain dopamine system has been linked to psychosis and behavioral disorders including, Gilles de la Tourette's disease, and drug abuse. Because of the early distinction between limbic and motor components of the BG circuitry, including anatomical and behavioral studies, the dopamine cells have been divided into a motor group (the SNc), and a limbic group (the ventral tegmental area). However, our concept of BG function has dramatically changed in the last 30 years, to a recognition that this division is too simplistic and the realization through new imaging techniques, among other new methodologies, that the BG mediate the full range of goal-directed behaviors, including, the elements that drive actions, emotions, motivation, and cognition. As indicated above, regions within each of the BG nuclei have been identified as serving not only a sensory-motor function, but also

different aspects of reward processing and cognitive planning. Ventral regions of the BG play a key role in reward and reinforcement [4] and are important in the development of addictive behaviors and habit formation [5]. More central BG areas are involved in cognitive functions such as procedural learning and working memory tasks [6]. Diseases affecting mental health, including schizophrenia, drug addiction, and obsessive-compulsive disorder, are linked to pathology in both the dorsal and ventral striatum [7,8]. This is in contrast to diseases that interfere with motor control and primarily affect the dorsal BG. Thus, the role of the BG in cognitive and emotional behaviors is now as well accepted as is the role in motor control. Although several new theories of general function have emerged from the enormous progress in understanding the anatomy, physiology, and behaviors associated with the BG [9], the actual role of the BG in executing goal-directed behaviors remains elusive. What is clear from the recent progress is that this set of subcortical nuclei work in tandem with cortex (particularly frontal cortex) via a complex cortico-BG network to develop and carry out complex behaviors.

In summary, the concept of what the function of the BG do is changing from sole involvement in motor control to mediation of learning and the development of goal directed behaviors. Cortico-BG networks work together, allowing coordinated behaviors to be maintained and focused, but also to be modified and changed according the appropriate external and internal stimuli. Indeed, loss of both the ability to execute specific behaviors and to adapt appropriately to external and internal cues, are key deficits in BG diseases which thus affect motor control, cognition and motivation.

### References

1. Haber SN, Gdowski MJ (2004) The basal ganglia. In: Paxinos G, Mai JK (eds) *The human nervous system*, 2nd edn. Elsevier, Academic Press, New York, NY, pp 676–738
2. Schultz W, Dayan P, Montague PR (1997) A neural substrate of prediction and reward. [Rev] [37 refs]. *Science* 275:1593–1599
3. Haber SN, Fudge JL, McFarland NR (2000) Striatoni-grostriatal pathways in primates form an ascending spiral from the shell to the dorsolateral striatum. *J Neurosci* 20(6):2369–2382
4. Everitt BJ, Robbins TW (2005) Neural systems of reinforcement for drug addiction: from actions to habits to compulsion. *Nat Neurosci* 8(11):1481–1489
5. Koob (1999) Drug reward and addiction. In: Michael J Zigmond, Floyd E Bloom, Story C Landis, James L Roberts, Larry R Squire. *Fundamental neuroscience*. Academic Press, New York, pp 1261–1279
6. Levy R, Friedman HR, Davachi L, Goldman-Rakic PS (1997) Differential activation of the caudate nucleus in primates performing spatial and nonspatial working memory tasks. *J Neurosci* 17:3870–3882

7. Volkow ND, Wang GJ, Telang F et al. (2006) Cocaine cues and dopamine in dorsal striatum: mechanism of craving in cocaine addiction. *J Neurosci* 26(24):6583–6588
8. Pantelis C, Barnes TR, Nelson HE et al. (1997) Frontal-striatal cognitive deficits in patients with chronic schizophrenia. *Brain* 120(Pt 10):1823–1843
9. Wise SP, Murray EA, Gerfen CR (1996) The frontal cortex-basal ganglia system in primates. *Crit Rev Neurobiol* 10:317–356

## Basal Ganglia Disorders

### Definition

#### ► Basal Ganglia

## Basal Ganglia: Motor Functions of

WAYNE HENING<sup>1</sup>, DEBORAH L. HARRINGTON<sup>2</sup>,  
HOWARD POIZNER<sup>3</sup>

<sup>1</sup>Department of Neurology, University of Medicine and Dentistry of New Jersey, New Brunswick, NJ, USA

<sup>2</sup>Department of Radiology, University of California, San Diego and V.A. San Diego Healthcare Center, San Diego, CA, USA

<sup>3</sup>Institute for Neural Computation, University of California, San Diego, CA, USA

### Definition

The basal ganglia consist of four prominent nuclei, which are interposed between the cerebral cortex and the lower centers of the brain stem and spinal cord. These nuclei include the:

1. Striatum (caudate, putamen, ventral striatum including nucleus accumbens)
2. Globus pallidus internal (GPi) and external (GPe) segments
3. Substantia nigra pars compacta (SNpc) and pars reticulata (SNpr)
4. Subthalamic nucleus (STN)

Most of the inputs and outputs of the basal ganglia arise from or go to the cortex either directly or indirectly through the thalamus. Thus, the basal ganglia form something of a side loop or detour in the relation of the brain to behavior. As a result, determining the function

of the basal ganglia has been more difficult than for brain areas that more directly respond to impinging sensory stimuli (See ► [Sensory Cortex](#)) or elicit distinct motor outputs (See ► [Motor Cortex](#)).

While the basal ganglia mediate many nonmotor functions including cognition, emotion, and sensory processing, they have long been regarded as primarily involved with movement. Lesions of the basal ganglia cause motor deficits. The disorders most associated with the basal ganglia – such as Parkinson’s disease (PD), dystonia, and Huntington’s disease (HD) – are considered movement disorders, even though other functions can be disrupted in these patients (e.g. sleep in PD, mood in HD, cognition in both PD and HD).

Within the basal ganglia, the putamen is most directly associated with movement and receives abundant cortical input. From the putamen, impulses flow through the GPi/GPe, STN, and SNpr to the thalamus. The SNpc sends a large dopaminergic projection to the striatum (See ► [Dopamine](#)). The SNpc is the nucleus most degenerated in PD.

### Characteristics

1. The basal ganglia is a source of motor disorders
  - The close connection between the basal ganglia and movement goes back to classical clinical neurological findings showing basal ganglia damage in many patients with movement difficulties. Indeed, the whole field of *movement disorders* has focused primarily on conditions that involve the basal ganglia. More recent explorations using cellular recordings and neuroimaging (see below) have confirmed this finding by establishing abnormal activities within these nuclei in motor disorders [1].
2. Methods of elucidating the motor functions of the basal ganglia

Several different techniques have contributed to our understanding of the organization and function of the basal ganglia. These techniques include neuroanatomical studies of animals and human autopsy tissue, cellular recordings from animals and humans undergoing invasive brain surgery, radiotracer and functional imaging studies (► [functional neuroimaging methods](#)), and behavioral studies of patients with motor disorders, particularly PD.

#### a. Anatomical organization

Earlier studies confirmed the general scheme of input and output relations of the basal ganglia. More recent studies have identified several more distinctive and specialized pathways. The following discussion is a simplified view of these results and omits much of the emerging complexity of the basal ganglia pathways.

- i. The direct and indirect pathways

These two pathways are thought to work as a push-pull system that can finely control the level of basal ganglia output. A correct balance is necessary for normal motor function. All basal ganglia output is thought to be inhibitory and to suppress thalamic activity, which in turn reduces stimulation of interconnecting cortical regions. The direct pathway runs from the striatum to the GPi and suppresses GPi output, thus releasing the thalamus to provide excitation to the cortex. The indirect pathway from the striatum to the GPe and STN, excites the GPi, thereby suppressing the thalamus and withdrawing excitation from the cortex. Selective activation of different elements of these pathways can create a “center-surround” input to the cortex that selects specific motor activities for expression while inhibiting others [2]. In PD, a hypokinetic disorder, relative hyperactivity of the indirect pathway leads to excessive inhibitory GPi output and poverty of movement; this may be due to thalamic inhibition, but it could also be due to a breakdown in the specificity and segregation of GPi output [3]. In dystonia, a hyperkinetic disorder, relative hyperactivity of the direct pathway leads to reduced GPi output and excessive, involuntary motor activity.

More recent studies indicate that a third, “hyper-direct” pathway exists, with cortical input going directly to the STN. This pathway would also tend to increase GPi inhibitory output and reduce cortical excitation.

#### ii. The nigrostriatal pathway

This dopamine projection is the most degenerated in PD and has abundant projections to the striatum, whereas other dopaminergic systems project widely from the cortex to the spinal cord. Its basic effect is to increase basal ganglia output by acting on ►D1 dopamine receptors in striatal neurons that stimulate the direct pathway and on ►D2 dopamine receptors that stimulate the indirect pathway. Much of SNpc activity tends to be tonic or sustained rather than phasic or transient, which has led to some difficulty in establishing the pathway’s explicit contribution to motor control (►motor control Hierarchy).

#### iii. Basal ganglia loops

A major advance in understanding the circuitry of the basal ganglia was the recognition that its neurons were organized within a series of parallel loops. Each loop began in the cortex with excitation of the striatum followed by input to the GPi, which then variably inhibited the thalamus whose projections sent excitation back onto the original cortical source. Although this architecture continues to be studied, more than five separate loops and several divergent connections have been identified. The “motor loop” has been most studied and is best understood [1]. This form of organization is especially suited for

feedback or feed-forward effects, while cross-talk between loops may be crucial for correlated activities in different cortical regions.

#### b. Single cell and local potential recording

Single cell recording was pioneered in animal models where implanted electrodes could be used to monitor cellular activity during a variety of behaviors. Such studies include normal primate models and disease models such as the MPTP monkey, which has been rendered Parkinsonian by the targeted administration of MPTP, a selective neurotoxin for dopaminergic cells. More recently, cellular studies have been extended to patients, especially those with PD, who have been recorded during ablative procedures or the installation of stimulators in the GPi, thalamus, or STN.

These studies have shown that like thalamic and cortical somatotopy, some degree of somatotopy exists throughout the nuclei of the basal ganglia, with activity in the skeletomotor loop segregated between arm, leg, and orofacial movements. While the general background activity of cells is one of frequent discharge, it can be modulated by the behavioral context both during preparatory periods prior to the onset of a goal-directed movement and during movement. Because most cells directly related to movement fire during, rather than before, a movement, basal ganglia activity does not appear to directly produce movement. Altogether, these observations are consistent with a role for the basal ganglia in planning movements and in motor learning [4]. The physiological changes in firing rate observed in normal animals have led to the suggestion that altered rate might underlie basal-ganglia dysfunction in PD. Indeed, GPi firing is excessive in PD, consistent with an overall inhibitory effect of this output on movement. However, this hypothesis is inconsistent with a similar increase of GPi firing in HD, a hyperkinetic disorder. Moreover, changes in firing frequency are modest. As a result, more attention has focused in recent years on the patterning of GPi output, especially the modulation of firing in an oscillatory manner within different frequency bands. It has been suggested that low frequency oscillatory activity – in the theta to beta range (4–30 Hz) – may be associated with inhibition of motor activity and bradykinesia, while higher frequency activity in the gamma range (>40 Hz) may facilitate movement. In both the MPTP monkey and humans with PD, slower oscillations are more prominent [5]. Treatment of PD with dopaminergic agents or deep brain stimulation (DBS) can enhance higher frequency oscillatory power.

#### c. Neuroimaging

►Radiotracer imaging, which measures nigrostriatal neuronal loss during a “resting state,” has been

widely used in PD to study disease progression and the effects of pharmacotherapy. In contrast, functional neuroimaging techniques, such as positron emission tomography (PET) and functional magnetic resonance imaging (fMRI), typically measure brain activity while a person actively performs a task to assess how neural systems function in different behavioral contexts. One standard method to study normal brain functioning is to compare brain activity at rest with activity during movement or motor learning in neurologically intact individuals. In general, basal ganglia and cortical activity are increased for self-generated movements. Similar to cellular recordings in animals, basal ganglia activity during task-activated fMRI is modulated by the behavioral context such that it increases with the complexity of movement in planning stages, but not during motor execution [6]. During motor learning, however, both increases and decreases in basal-ganglia and cortical activity have been reported, depending in large part on the degree of uncertainty about what movements are required and the amount of practice given [4]. Another approach has been to compare patients with normal individuals to identify abnormal patterns of brain activity in the patients. Some PET studies of resting-state brain activity have revealed a disease-related pattern of activity in PD characterized by elevated pallidal, thalamus, pontine and cerebellar activation and reduced premotor and parietal-occipital activity relative to normal individuals [7]. Even more interesting are PET and fMRI studies that have investigated brain functioning during movement and motor learning. In PD, dysfunction of the basal ganglia and interconnecting cortical regions can be studied by temporarily stopping pharmacotherapy so that dopamine levels are reduced to a practical “off state” or by turning off DBS devices. In areas specifically related to planning movements, such as the supplementary motor area, PD “off” patients typically show decreased activity. In other areas, such as the premotor, prefrontal and parietal cortices, PD patients can show hyperactivity together with a failure to show normal reductions in activation as motor behaviors become learned or “automatized” [8]. This abnormal functional pattern can be reduced by reinstatement of dopaminergic or DBS treatment.

### 3. Presumed functions of the basal ganglia

Progress has been made in understanding how the basal ganglia modulate different aspects of movements. In this section, we discuss the contribution of the basal ganglia to regulating intensive aspects of movement, motor planning, motor coordination, and motor learning. Although these facets of movement are not entirely independent,

their relative importance can be emphasized by certain task conditions. Emerging research suggests that some treatments for PD can better remediate certain aspects of motor function, while having little or no effect on others, which lends support to their distinctiveness.

#### a. Intensive dimensions of movement

Peak force, velocity, and scaling are all aspects of movement that show a single major dimension of intensity. Clinically, PD patients are hypokinetic, so that they are slower, take longer to complete certain tasks, and generate less force. PD patients are also hypometric (e.g., ▶*micrographia*) and tend to fall short of a target when reaching for it. With farther targets their output increases, but continues to be hypometric, even when it far exceeds the output needed to reach a closer target. Yet when permitted feedback of their position, PD patients can acquire targets as accurately as normal individuals. This may indicate a reliance on compensatory pathways that are relatively intact. Treatments of PD rather effectively remediate deficits in the intensity aspect of movements; with medication or surgical treatments, PD patients become faster and reach further. This suggests that the basal ganglia play a more trophic role with regard to movement intensity, which is mediated by the balance between direct and indirect pathways that inhibit undesired movements while facilitating chosen ones [2].

#### b. Feed-forward versus feedback control

In general, the basal ganglia are more important for self-generated movements that require feed-forward control than for sensory-guided movements under feedback control, suggesting that they play a key role in prediction or planning. This agrees with cellular and fMRI studies reporting that the basal ganglia exhibit dynamic modulation largely during response preparation [6]. These findings contrast with reports that PD patients can be faster than normal individuals in making saccadic eye movements to targets. This is likely due to relatively intact pathways involving the cerebellum, parietal cortex, and frontal eye fields, which process and modulate responses to external stimuli. Without adequate ability to prepare responses, feedback dominates predictive control.

#### c. Sensorimotor processing and integration

PD patients are also impaired in processing and utilizing proprioceptive information, a task analog of the postural deficit that is among the key clinical features of the disorder. As a general rule, PD patients have difficulty with integrating different forms of sensory input with sensorimotor (▶*sensorimotor integration*) transforms that guide behavior, and with the integration of different

components of targeted movements (e.g. integration of reach and grasp components when moving to a target object) [9]. Such coordinative aspects of basal ganglia function are less readily normalized by pharmacological or DBS treatment of PD. This suggests that current treatment approaches may restore more trophic or intensive functions of the basal ganglia, but may not restore the more precise, highly localized integrative functions related to specific brain regions or behaviors. Like most basal ganglia functions, we cannot indicate with great specificity how this occurs. One possible function is the ability of the BG to facilitate the binding of different cortical regions as they act in a coordinated fashion to shape motor behavior. Different sensory and motor coordinates resident in separate brain regions are required to effectively shape motor output, and the evidence from PD indicates that the basal ganglia are needed to facilitate their coordination.

Coordinative abilities are also important for sequencing motor behaviors and for dual task performance, both of which are impaired in PD. The basal ganglia may be most critically important in the preparation of motor sequences [6], which involves assembling a series of movements into a coordinated action. When preparation fails, actions may be decomposed into a series of movement segments rather than a smoothly structured sequence. Similarly, performance of even well-learned behavioral sequences may break down when a dual task is imposed [8].

#### d. Role in motor learning

The basal ganglia are important for learning new motor acts, which partially depend on preparative processes. A recent fMRI study reported that basal ganglia plasticity during both motor-sequence learning and when switching to new motor sequences correlated with reaction time, a measure of preparation [4]. No other structures, except the thalamus, showed this relationship, which agrees with its key role in preparation. This finding is consistent with slowed and incomplete visuomotor learning in PD, especially when there is a need to change from one behavioral context to another, a deficit in set shifting [10]. The distinction between preparation and learning may be one of degree; even well-learned behaviors need to be calibrated and prepared when called upon. Thus preparation and learning form a continuum in which overlapping abilities are needed to predict and model behavior.

## Conclusions

New conceptualizations are emerging about corticostriatal circuitry, cellular properties of basal ganglia

nuclei, and brain-behavior-treatment (e.g., pharmacotherapy, surgical) relationships, which have considerably advanced our knowledge about facets of motor function and their physiological underpinnings. One dominant theme is the central role of the basal ganglia in modulating intensive aspects of movement and feed-forward control, the latter of which may support to some extent other functions including integrative processing and learning. Especially fruitful have been studies demonstrating that these aspects of movement are differentially responsive to pharmacotherapy in PD. Exciting developments are also now taking place in neuroimaging studies of PD, which are beginning to delineate abnormal neural patterns associated with motor dysfunction, and assess their response to therapeutic interventions. Continued progress in these areas holds promise for further illuminating the workings of the basal ganglia nuclei and their modulation of motor, but also nonmotor functions represented more directly by the cerebral cortex.

## Acknowledgments

This work was supported in part by NIH grant # NS36449 and NSF Center grant, The Temporal Dynamics of Learning Center, to UCSD.

## References

1. Delong MR, Wichmann T (2007) Circuits and circuit disorders of the Basal Ganglia. *Arch Neurol* 64:20–24
2. Mink JW (1996) The basal ganglia: focused selection and inhibition of competing motor programs. *Prog Neurobiol* 50:381–425
3. Pessiglione M, Guehl D, Rolland AS et al. (2005) Thalamic neuronal activity in dopamine-depleted primates: evidence for a loss of functional segregation within basal ganglia circuits. *J Neurosci* 25:1523–1531
4. Parsons MW, Harrington DL, Rao SM (2005) Distinct neural systems underlying learning of visuomotor and spatial representations of motor skills. *Human Brain Mapp* 24:229–247
5. Rivlin-Etzion M, Marmor O, Heimer G, Raz A, Nini A, Bergman H (2006) Basal ganglia oscillations and pathophysiology of movement disorders. *Curr Opin Neurobiol* 16:629–637
6. Elsinger CL, Harrington DL, Rao SM (2006) From preparation to online control: reappraisal of neural circuitry mediating internally generated and externally guided actions. *Neuroimage* 31:1177–1187
7. Trost M, Su S, Su P et al. (2006) Network modulation by the subthalamic nucleus in the treatment of Parkinson's disease. *Neuroimage* 31:301–307
8. Wu T, Hallett M (2005) A functional MRI study of automatic movements in patients with Parkinson's disease. *Brain* 128:2250–2259



9. Schettino LF, Adamovich SV, Hening W, Tunik E, Sage J, Poizner H (2006) Hand preshaping in Parkinson's disease: effects of visual feedback and medication state. *Exp Brain Res* 168:186–202
10. Messier J, Adamovich S, Jack D, Hening W, Sage J, Poizner H Visuomotor learning in immersive 3D virtual reality in Parkinson's disease and in aging. *Exp Brain Res* 2007; 179:457–474

## Basal Ganglia: Role in Eye Movements

OKIHIDE HIKOSAKA

Laboratory of Sensorimotor Research, National Eye Institute, National Institute of Health, Bethesda, MD, USA

### Definition

A major function of the basal ganglia is the control of body movements. This is illustrated by a variety of movement disorders caused by dysfunction of the basal ganglia, such as Parkinson's disease and Huntington's disease. Symptoms include the inability to initiate a movement and the inability to suppress involuntary movements. Eye movement is not an exception [1]. A fixed, vacant facial expression of patients with Parkinson's disease, which is often called the "Parkinson's mask," is due to the paucity of movements in the face, including the paucity of eye movements. Most affected among various kinds of eye movements are smooth pursuit and saccade, which require more voluntary control. Parkinsonian patients are often impaired in smoothly pursuing a moving object (deficit in smooth pursuit). They are also often impaired in shifting their gaze from one position in space to another (deficit in saccade).

### Characteristics

#### Higher Level Processes

The impairment in ►saccadic eye movement in patients with basal ganglia disorders has been repeatedly demonstrated using more rigorous tests with accurate measurement of eye position [1]. Typically, the subjects are required to fixate their gaze on a spot of light (target) on the screen and, if the target steps, follow it by quickly shifting their gaze. This is called a "visually guided saccade task." Compared with age-matched control subjects, saccades (►Spontaneous Saccades) of parkinsonian patients tend to be small in amplitude (i.e., hypometric), slow, and delayed (i.e., long latency). Curiously, the deficit in saccade is often more severe if there is no visible object and the saccade must rely on memory. In a "memory-guided saccade task" a target

appears briefly while the subject is fixating at the central spot and the subject has to make a saccade after a delay to the position where the target was presented. Parkinsonian patients are more impaired or selectively impaired in ►memory-guided saccades than in ►visually guided saccades. This phenomenon may illustrate the context-dependent movement deficits in Parkinson's disease, which are widely recognized among neurologists. Selective deficits in memory-guided saccades are observed in other basal ganglia disorders, including Huntington's disease. The similarity between Parkinson's and Huntington's diseases is noteworthy because they are caused by different mechanisms, the former by a loss of neurons in the substantia nigra (SN) and the latter by a loss of neurons in the caudate nucleus (CD). This suggests that the SN and the CD work together for the control of saccadic eye movement (see the sections ►caudate – role in eye movements and ►substantia nigra – role in eye movements).

How the basal ganglia might control eye movements has been studied by single unit studies using trained animals [1]. The animals were trained on the visually guided and ►saccade – memory-guided tasks. Electrical activity of single neurons was recorded with microelectrodes and was correlated with saccadic eye movements. Saccade-related activity has been found in various nuclei in the basal ganglia, including the substantia nigra, CD, ►subthalamic nucleus (STN), and ►globus pallidus (GP) [1]. Such saccade-related neurons are clustered in a sub-region of each nucleus: dorsolateral part of the pars reticulata of the substantia nigra (SNr), central-ventral part of the CD, ventral part of the STN, and dorsal part of the external segment of the globus pallidus (GPe). Anatomical studies have shown that these saccade-related parts are connected within the basal ganglia and with saccade-related regions outside the basal ganglia. For example, the saccade-related part of the CD receives inputs from the ►frontal eye field and the ►supplementary eye field in the frontal cerebral cortex [2], while the saccade-related part of the SNr projects their axons to the ►superior colliculus (SC) [3]. Note that neurons related to skeletal movements are found in different sub-regions in the basal ganglia, such as the putamen (equivalent to the CD) and the internal segment of the globus pallidus (GPi) (equivalent to the SNr). These facts are consistent with the idea that there are functional sub-divisions within the basal ganglia as well as in larger networks including the cerebral cortex and the cerebellum, each of which may form a closed-loop functional unit [4]. Recent studies, however, indicate that such functional segregation is not perfect.

#### Lower Level Processes

An interesting feature of the basal ganglia circuits is that they use inhibitory connections as a primary means

to convey signals [5] (Fig. 1). Each area contains projection neurons and interneurons. While cortical inputs to the CD are excitatory and use glutamate as a transmitter, projection neurons in all areas in the basal ganglia, except the STN, are thought to be GABAergic and inhibitory. This means that the polarity of a signal is reversed each time it passes through projection neurons in one area. There are at least three parallel pathways in which saccade-related signals can be processed in the basal ganglia [6]: (i) direct pathway from the CD to the SNr; (ii) indirect pathway from the

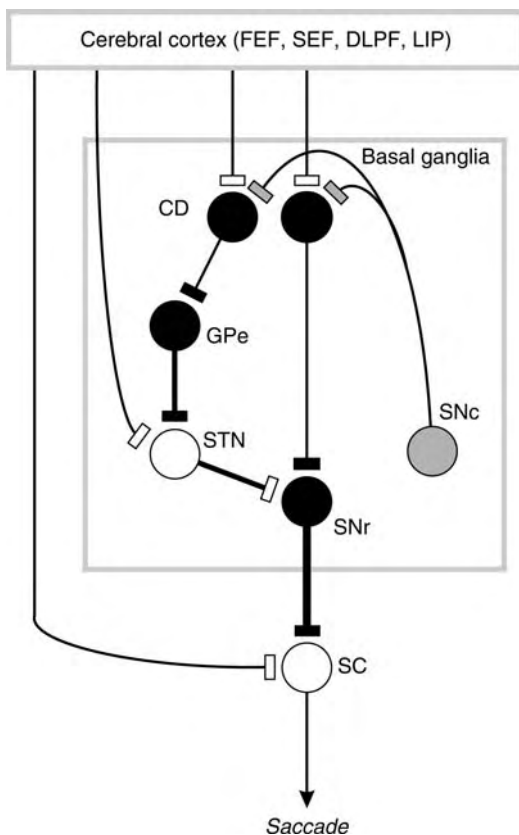

### Basal Ganglia: Role in Eye Movements.

**Figure 1** Basal ganglia neural network involved in the control of saccadic eye movement. *CD*, caudate nucleus; *SNr*, substantia nigra pars reticulata; *SC*, superior colliculus; *SNc*, substantia nigra pars compacta; *GPe*, globus pallidus external segment; *STN*, subthalamic nucleus; *FEF*, frontal eye field; *SEF*, supplementary eye field; *DLPF*, dorsolateral prefrontal cortex; *LIP*, area LIP in parietal cortex. Excitatory and inhibitory neurons and synapses are indicated by open and filled symbols, respectively. Gray symbol indicates dopaminergic neuron which exerts modulatory effects on CD neurons. The thickness of the line (axon) roughly indicates the level of spontaneous activity. The direct excitation of SC neurons by inputs from the cerebral cortex is gated by the inhibitory input from the SNr.

CD to the SNr through the GPe and/or the STN; (iii) hyper-direct pathway from the STN to the SNr. Since the direct pathway consists of a series of two inhibitory connections (CD and SNr), the net effect is facilitatory. Since the indirect pathway and the hyper-direct pathways consist of three and one inhibitory connection, respectively, the net effect is inhibitory. The basal ganglia thus could facilitate or inhibit motor processes by selectively using these pathways. Another determinant of the basal ganglia mechanisms is background activity of neurons: very high in the output areas (i.e., SNr and GPi) and very low in the input areas (i.e., CD and putamen). Neurons in the target areas of the basal ganglia are thus inhibited most of the time (due to the rapid firing of SNr or GPi neurons), but are released from the inhibition (if the direct pathway is deployed) or are further inhibited (if the indirect or hyper-direct pathway is deployed). The target area for saccadic eye movement is the SC.

### Process Regulation

The throughput of these GABAergic and glutamatergic pathways is thought to be modified by various groups of neurons [7]. Probably the most important among them is a group of dopaminergic neurons located in the substantia nigra pars compacta (SNc) and surrounding regions. They modulate saccadic and other motor signals in the CD or putamen by projecting their axons to these nuclei. The power of the dopaminergic modulatory action is evident by the deficits in saccadic eye movement and other movements in patients with Parkinson's disease. The role of cholinergic interneurons in saccades is less clear.

With respect to saccadic motor control in general, the basal ganglia system is situated as a side path that has been added to the direct effect of the cerebral cortex on the SC (Fig. 1). Probably the most important question is: How unique is the function of the basal ganglia, compared with the direct cortico-SC effect? The answer to this question should be found in two other sections: "caudate – role in eye movements" and "substantia nigra – role in eye movements".

### References

1. Hikosaka O, Takikawa Y, Kawagoe R (2000) Role of the basal ganglia in the control of purposive saccadic eye movements. *Physiol Rev* 80:953–978
2. Parthasarathy HB, Schall JD, Graybiel AM (1992) Distributed but convergent ordering of corticostriatal projections: analysis of the frontal eye field and the supplementary eye field in the macaque monkey. *J Neurosci* 12:4468–4488
3. Hikosaka O, Wurtz RH (1983) Visual and oculomotor functions of monkey substantia nigra pars reticulata. IV. Relation of substantia nigra to superior colliculus. *J Neurophysiol* 49:1285–1301

4. Alexander GE, Crutcher MD (1990) Functional architecture of basal ganglia circuits: neural substrates of parallel processing. *Trends Neurosci* 13:266–271
5. Kita K (1993) GABAergic circuits of the striatum, In: Arbuthnott GW, Emson PC (eds) *Chemical signalling in the basal ganglia*. Elsevier, Amsterdam, pp 51–72
6. Nambu A, Tokuno H, Takada M (2002) Functional significance of the cortico-subthalamo-pallidal ‘hyper-direct’ pathway. *Neurosci Res* 43:111–117
7. Graybiel AM (1990) Neurotransmitters and neuromodulators in the basal ganglia. *Trends Neurosci* 13:244–254

## Basal Ganglia-thalamocortical Circuit

### ► Cortico-Subcortical Re-Entrant Circuit

## Basal Lamina in Nerve Regeneration

CHIZUKA IDE<sup>1,2</sup>

<sup>1</sup>Department of Anatomy and Neurobiology, Kyoto University Graduate School of Medicine, Yoshidakonoe-cho, Sakyo-ku, Kyoto, Japan

<sup>2</sup>Department of Occupational Therapy, Aino University Faculty of Nursing and Rehabilitation, Shigashiohta, Ibaragi City, Osaka, Japan

### Synonyms

Basement membrane

### Definition

The ► **basal lamina** is a thin layer of extracellular matrix covering the connective tissue surface of Schwann cells, muscle fibers and epithelial cells in general. The main structural component of basal lamina is type IV collagen, with which heparan sulfate proteoglycans and laminin, a major adhesion molecule, are associated. Regenerating axons grow through basal lamina tubes derived from Schwann cells, skeletal muscle fibers and other tissues. This means that extracellular matrices such as basal laminae can serve as an effective scaffold for the growth of regenerating axons.

### Characteristics

#### Axonal Growth Through the Nerve Segments of Wallerian Degeneration

The peripheral nerve fiber consists of axons and Schwann cells. Schwann cells cover axons along their

entire length except at the ► **node of Ranvier**, where a gap is formed between the neighboring Schwann cells. In addition, Schwann cells are covered on their outer surfaces by basal laminae that are continuous, even at the node of Ranvier. Therefore, the peripheral nerve fiber resides within a basal lamina tube.

Following Wallerian degeneration, degraded myelin sheaths are removed by macrophages that have invaded the basal lamina tube. These macrophages are derived from blood monocytes. Schwann cells that lose their myelin sheaths during Wallerian degeneration form cell strands called Schwann cell columns. Regenerating axons extend along such Schwann cell columns to the target.

#### Nerve Regeneration Through the Extracellular Matrix

If a nerve fiber is freeze-treated, the Schwann cells die, and the myelin sheaths disintegrate. Macrophages invade the basal lamina tubes and phagocytose the degraded myelin sheaths. However, the basal laminae remain intact in the form of the original tube. If a freeze-treated nerve segment is grafted to the proximal stump of the transected nerve, regenerating axons extend through the basal lamina tube [1,2] (Fig. 1). Growing axons are always in contact with the inner surface of the basal laminae. Laminin is the main adhesion molecule in the basal lamina. In mice in which the  $\gamma 1$  laminin chain was disrupted, nerve regeneration was impaired [3]. On the other hand, integrin  $\alpha 7 \beta 1$ , a receptor for laminin, is essential for the neurite outgrowth of sensory neurons, as demonstrated in the  $\alpha 7$ -integrin null mice [4] and an *in vitro* experiment [5]. In addition,  $\alpha 4$  integrin is also an important receptor of fibronectin in neurite outgrowth [6].

In regeneration, de-differentiated Schwann cells migrate from the proximal stump along regenerating axons. At first, these immature Schwann cells surround all axons as a bundle within a basal lamina tube, and then gradually separate thick-diameter axons into individual ones, with Schwann cells vs. axons at a ratio of 1:1. Finally, myelin sheaths are formed on axons. Thus, complete nerve regeneration occurs in basal lamina tubes in the absence of living Schwann cells. This indicates that the basal lamina tube provides an appropriate scaffold for axonal regeneration in the peripheral nervous system [7].

The fact that the extracellular matrix, like the basal laminae, can efficiently support the growth of regenerating axons is the theoretical basis for the artificial nerve in the peripheral nervous system. Basal laminae form a three-dimensional matrix of all tissues including nerve fibers. Therefore, the three-dimensional architecture of the basal laminae provides an essential scaffold for the repair of tissues and organs in general.

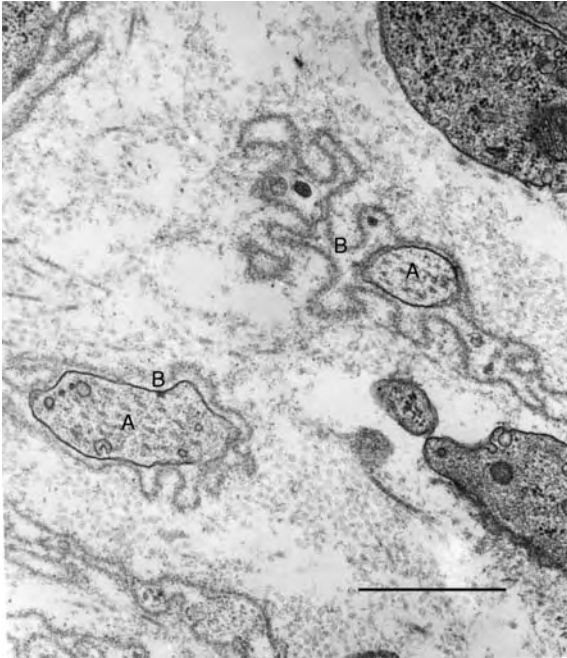

### Basal Lamina in Nerve Regeneration.

**Figure 1** A nerve segment excised from the sciatic nerve of mice was freeze-treated to kill Schwann cells, and sutured again to the original site, allowing the growth of regenerating axons from the proximal stump into the segment. Within several days, degraded myelin sheaths had been removed by macrophages, and the original basal laminae of Schwann cells remained in the form of a tube. Regenerating axons (A) extend through such basal lamina tubes (B) of Schwann cells. Scale bar: 1  $\mu\text{m}$ .

Basal laminae derived from non-neural tissues are also effective conduits for regenerating axons. By freezing- or detergent-treatment, skeletal muscle fibers die and the basal laminae remain in the form of original tubes, as in the case of freeze-treated Schwann cells. When such basal lamina preparations are grafted onto the proximal stump of the transected peripheral nerve, regenerating axons enter and extend through the basal lamina tube [8], indicating that the basal laminae of non-neural tissues can also serve as a scaffold for regenerating axons.

It has been proposed that basal lamina tubes can be used for clinical application as a substitute for fresh nerve grafting. At present, **autografting** is generally used for clinical treatment. On the other hand, **allografting** has a limited application for clinical use. Our study shows that allogeneic basal laminae cause almost no immunological rejection, indicating that the allografting of Schwann cell basal laminae might be of clinical use. In fact, the grafting of a long segment of freeze-treated peripheral nerve facilitates good nerve regeneration in dogs [9].

### Sprouting and Growth

Regenerating sprouts usually emanate from the node of Ranvier at the proximal stump near the site of injury. Sprouts from the node extend without exception through the space between the basal laminae and myelin sheath, i.e., the Schwann cell plasma membrane [10]. Sprouts contain many vesicles at an early stage, and extend along the inner surface of the basal laminae of Wallerian-degraded nerve fibers as growth cones containing many mitochondria and vesicles. Regenerating sprouts never extend through the space surrounded by old myelin sheaths, in which the original axon resided. All myelin sheaths of nerve fibers disintegrate, and are removed by phagocytosis carried out by macrophages in Wallerian degeneration. Axons that were regenerated or merely demyelinated remain for a long time with thin and irregular-lamellated myelin sheaths in the spinal cord.

### References

1. Ide C, Tohyama K, Yokota R, Nitatori T, Onodera S (1983) Schwann cell basal lamina and nerve regeneration. *Brain Res* 288:61–75
2. Fujimoto E, Mizoguchi A, Hanada K, Yajima M, Ide C (1997) Basic fibroblast growth factor promotes extension of regenerating axons of peripheral nerve. In vivo experiments using a Schwann cell basal lamina tube model. *J Neurocytol* 26:511–528
3. Chen ZL, Strickland S (2003) Laminin gamma1 is critical for Schwann cell differentiation, axon myelination, and regeneration in the peripheral nerve. *J Cell Biol* 163:889899
4. Gardiner NJ, Fernyhough P, Tomlinson DR, Mayer U, von der Mark H, Streuli CH (2003) Alpha7 integrin mediates neurite outgrowth of distinct populations of adult sensory neurons. *Mol Cell Neurosci* 28:229–240
5. Ekstrom PA, Mayer U, Panjwani A, Pountney D, Pizzy J, Tonge DA Involvement of  $\alpha 7 \beta 1$  integrin in the conditioning-lesion effects on sensory axons regeneration. *Mol Cell Neurosci* 22:383–395
6. Voegelzang MG, Liu Z, Relvas JB, Raivich G, Scherer SS, French-Constant C (2001) Alpha4 integrin is expressed during peripheral nerve regeneration and enhances neurite outgrowth. *J Neurosci* 21:6732–6744
7. Dubovy P (2004) Schwann cells and endoneurial extracellular matrix molecules as potential cues for sorting of regenerated axons: a review. *Anat Sci Int* 79:198–208
8. Ide C (1984) Nerve regeneration through the basal lamina scaffold of the skeletal muscle. *Neurosci Res* 1:379–391
9. Ide C, Tohyama K, Tajima K, Mizoguchi A (1998) Long acellular nerve transplants for allogeneic grafting and the effects of basic fibroblast growth factor on the growth of regenerating axons in dogs. *Exp Neurol* 154:99–112
10. Ide C, Kato S (1990) Peripheral nerve regeneration. *Neurosci Res (Suppl 13):S157–S164*

## Basal Nucleus of Meynert (Ch.4)

### Synonyms

- ▶ Basal nucleus of basal substance

### Definition

In the basal forebrain, between the septum verum and amygdaloid body directly in the middle of the substantia innominata, are situated four groups (Ch.1–Ch.4) comprised of large cholinergic cells, of which Ch.4 are the most pronounced in humans. Afferents come primarily from the limbic system, the projections pass, on to all parts of the cerebral cortex. The nuclear region plays a role in the coupling of complex behavioral modes to basic emotional state (motivation).

In the presence of presenile or senile demence, especially in the case of Alzheimer's disease, there is marked degeneration of the cells of the basal nucleus Meynert (Ch.4), with concomitant impairment of memory, disorientation, motor unrest and impaired speech.

- ▶ Telencephalon

## Basal Optic Neuropil (BON)

### Definition

A small number of retinal axons separates forming quickly a distinct fascicle, the basal optic tract. It consists of a lateral and a medial fascicle, which innervate different parts of the teminal field of the BON.

Afferents originate mainly from the entire contralateral retina. Neurons are sensitive to temporo-nasal direction of stimulus movement; cells that respond preferentially to vertical movement are also present. Together with the pretectum, the BON is involved in the guidance of compensatory optomotor movements.

- ▶ Evolution of the Visual System: Amphibians

## Basal Plate

### Definition

The ventral half of the neural tube. In the spinal cord and rhombencephalon, it contains most of the motor neurons.

- ▶ Evolution of the Posterior Tuberculum and Preglomerular Nuclear Complex

## Base of Support (BOS)

### Definition

The area of the body that contacts the environment and thereby allows generation of supporting “environment reaction” forces (i.e. ground reaction forces at the feet, and analogous forces occurring at the hand if it is in contact with a stable object or surface). In the absence of hand support, the horizontal location of the center of mass of the body must remain within the limits of the base of support defined by the feet (i.e. the area circumscribed by the outer margins of the feet) in order to maintain a state of static postural equilibrium.

- ▶ Postural Strategies

## Basement Membrane

- ▶ Basal Lamina in Nerve Regeneration

## Basic Law of Psychophysics

### Definition

- ▶ Psychophysics
- ▶ Sensory Systems

## Basic-Helix-Loop-Helix-PAS Protein MOP1

- ▶ HIF-1 and Neuroinflammation

## Basilar Membrane

### Definition

The acellular membrane of the cochlea upon which rests the organ of Corti. Due to its graded stiffness, it

sustains traveling waves that propagate from the cochlear base toward its apex. Traveling waves peak at cochlear sites with tonotopically-arranged characteristic frequencies, so that sites near the base and apex, respectively, vibrate maximally when stimulated by high- and low-frequency stimuli.

► Cochlea

---

## Basis Pedunculi

### Definition

The basis pedunculi (L. foot or stalk) is a large collection of descending fibers located at the base of the midbrain. All arise from cell bodies in the cerebral cortex. They end in the pons, medulla and spinal cord. This bundle is more commonly called the cerebral peduncle or crus cerebri.

---

## Basolateral Amygdala

### Definition

Brain region in the medial temporal lobe involved in regulating emotional arousal influences on memory.

► Emotional Learning/Memory

---

## Bat

### Definition

Mammalian family (Chiroptera). Two subfamilies are distinguished (Macro- and Microchiropterans). While Macrochiropterans (fruit eating bats) are herbivores and do not possess a biosonar system, Microchiropterans hunt prey by using biosonar. The echolocation behavior and the neural basis of this behavior have been a neuroethological model system (see essay on “Neuroethology of biosonar in bats”).

---

## Bauplan

### Definition

The anatomical organization of a body or structure that is characteristic of a taxonomic group. In essence, the “bauplan” defines the basic organizational plan that typifies a particular group of organisms and sets them apart from other groups. For the vertebrate nervous system, the bauplan would include the fundamental embryological divisions of the brain as well as basic features of the connections defining sensory and motor systems.

- Evolution of the Brain: Amphibians
- Evolution of the Brain: In Fishes
- Evolution of the Telencephalon: In Anamniotes

---

## Bayesian Filter

### Definition

A state estimator which optimally combines the previous state estimation with sensory information and knowledge on the plant dynamics and effector activations.

► Neural Networks for Control

---

## Bayesian Statistics (with Particular Focus on the Motor System)

KONRAD KÖRDING  
Institute of Neurology, London, UK

### Synonyms

Probabilistic inference; Statistical inference; Bayesian inference; Antonym: Frequentist statistics

### Definition

As our sensors are not perfect and do not provide information about all the properties of the world, we are faced with sensory *uncertainty*. Moreover, our muscles also produce noisy outputs and so we are also faced with motor uncertainty. *Bayesian statistics* is the

systematic way of dealing with uncertainty by expressing its many forms in terms of probability.

### Description of the Theory

Bayesian statistics can be used to infer the states of variables that are not directly measured, a process called *Bayesian inference*. “For example, when we see a tennis ball (observed variable) and we know from experience how they usually fly (prior knowledge) then Bayesian statistics allows us to calculate how likely the ball will land at any given position on the field (unobserved variable).” The way inference is done is the following:

(i) The *prior knowledge* about the system is specified. The structure of the problem is defined, specifying which variables depend on which other variables in which way. (ii) Bayesian methods are used to infer how probable each state of the unobserved variables is given the values of the observed variables. There are numerous methods available towards this goal. Some methods deliver an approximate answer efficiently while some other methods deliver exact solutions to simpler problems.

Numerous articles summarize the mathematical [1] and philosophical [2] ideas that are behind Bayesian statistics and how to use them. The main focus of this article is on the concepts behind Bayesian methods that are used to understand the human behavior.

### Notation

Upper case letters denote random variables (e.g., the position of my hand); lower case letters denote a particular value that a random variable can take (e.g. 10 cm).

$p(A = a)$  is the probability that a random variable  $A$  takes on a specific value  $a$ , given that there is no additional knowledge about other related variables.

$p(A = a|B = b)$  is the probability of observing  $A = a$  given that the statistician has the knowledge that the variable  $B$  has the value of  $b$  (*conditional probability*).

$p(A = a, B = b)$  is the probability that  $A = a$  and  $B = b$ . It can be rewritten to be:

$$p(A = a, B = b) = p(A = a)p(B = b|A = a)$$

### Conditional Independence and Graphical Bayesian Models

Statistical problems become a lot easier once we understand their structure. If we have three variables,  $A$ ,  $B$  and  $C$  we could, for example, know that  $A$  causes  $B$  and  $C$  and that  $B$  and  $C$  do not interact. As an example,  $A$  could be the size of an object,  $B$  is the size as reported by our sense of touch alone and  $C$  is the size reported by our visual system alone.  $B$  and  $C$  thus show *conditional independence* on  $A$ . As many problems have such a structure, graphs are often drawn to depict how variables depend on one another. There is a range of variants of such graphs, but for the problems considered here *graphical Bayesian networks* (directed acyclic graphs) are used. If no direct link exists between two variables  $B$  and  $C$  then they are independent, conditional on the other variables that are “in-between”:

$$p(B = b|C = c, \text{Others} = o) = p(B = b|\text{Others} = o).$$

### Using Bayes Rule: Ball Positions in Tennis

If we are playing tennis we want to estimate where the ball will hit the ground (see Fig. 1a). As vision does not provide perfect information about the ball’s speed, there is uncertainty about where the ball will land. If we, however, have played a lot of tennis before, we can have knowledge about where our partner is likely to play to. We want to combine this knowledge with what we see to obtain an optimal estimate of where the ball will hit the ground.

This example can be abstracted the following way (Fig. 1b): The physical properties of the ball define the

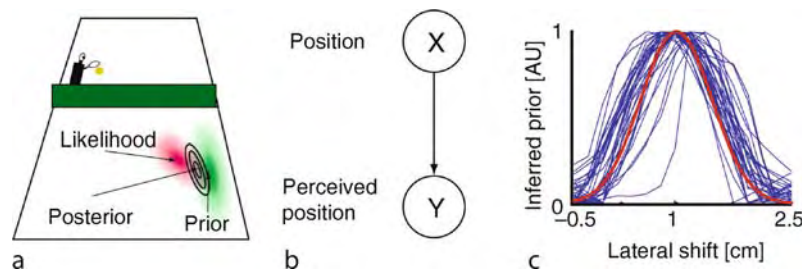

**Bayesian Statistics (with Particular Focus on the Motor System).** Figure 1 a) Example: The other player is hitting the ball. Seeing the ball we can estimate that it will land in the red region (with a likelihood proportional to the saturation). We have prior knowledge that the ball is likely to land in the green region (with a probability proportional to the saturation). The black ellipses denote the posterior, the region where the Bayesian estimate would predict the ball to land. b) Structure: The position influences the perceived position. c) Human subjects had to estimate a position. From these measurements their priors were inferred (blue lines). The real distribution is shown in red. Data replotted from citation 3.

position  $X = x$  where the ball will hit the ground. The visual system, however, does not perceive where the ball will really hit the ground but rather some noisy version thereof,  $Y = y$ . Knowing the uncertainties in the visual system we know how likely it is to perceive the ball being at  $Y = y$  if it is really at  $X = x'$ . This is called *likelihood* ( $p(Y = y|X = x')$ ) and is sketched in red in Fig. 1a. Just based on this knowledge we could ignore any other knowledge we might have and our best estimate would be in the middle of the red cloud, at  $y$ . This procedure, however, ignores that we could have prior knowledge about the way our partner plays. In particular, over the course of many matches the positions where the ball hits the ground will not be uniformly distributed but highly concentrated within the confounds of the court, and if our enemy is a good player highly peaked near the boundary lines where it is most difficult to intercept them. This distribution of positions where the ball hits the ground,  $p(X = x)$ , is what is called a *prior* and which could be learnt using methods of *Bayesian learning*. We can apply *Bayes Rule* to compute the *posterior* ( $p(X = x|Y = y)$ ), the probability of the ball landing taking into account the prior and the new evidence:

$$p(X = x|Y = y) = p(Y = y|X = x) \frac{p(X = x)}{p(Y = y)}.$$

Our uncertainty about its position is thus set in terms of probability. We know where we can expect the ball to land with which probability, given everything we know about it.

If we can assume that the prior distribution is a symmetric two-dimensional Gaussian with variance  $\sigma_p^2$  and mean  $\hat{\mu}$ , and the likelihood  $p(Y = y|X = x)$  is also a symmetric two-dimensional Gaussian with variance  $\sigma_v^2$  and mean  $y$ , it is possible to compute the optimal estimate  $\hat{x}$ , as:

$\hat{x} = \alpha y + (1 - \alpha)\hat{\mu}$  where  $\alpha = \frac{\sigma_p^2}{\sigma_p^2 + \sigma_v^2}$ . It is thus possible to define the optimal estimate given, seen and prior knowledge. Not only is it possible to calculate what the optimal strategy is, it is also possible to calculate how much better the estimate is compared to a strategy ignoring prior knowledge: The variance of the estimate if only the visual feedback is used is  $\sigma_v^2$  if, however, the prior is used to the variance is  $\frac{\sigma_p^2}{\sigma_p^2 + \sigma_v^2} \sigma_v^2$  which is always less than the variance of the non-Bayesian estimate. If the prior has the same variance as the likelihood then the variance of the Bayesian estimate is half the variance of the non-Bayesian estimate.

In a recent experiment [3] it was tested if such a Bayesian strategy was used by human volunteers. Subjects had to estimate the value of a one-dimensional variable, the displacement of a cursor relative to the hand, in close analogy of estimating the position where the ball will land. This variable was drawn randomly in each trial out of a Gaussian distribution defining a *prior* distribution, and subjects received extensive training so

that they would know the *prior*. In addition, they saw the position, thus receiving the *likelihood*. The experiment allowed the measurement of the subject's estimate of the displacement. Out of this data, it is possible to infer the prior that human volunteers are using. If they ignore the prior information the prior should be flat. The data shown in Fig. 1c (blue) shows that human volunteers used a prior that was very close to the optimal one (shown in red). This experiment thus showed that human volunteers can use Bayes rule to estimate the state of an important variable.

It is possible to use the same method used here for combining prior knowledge with new evidence to combine information obtained from two different sensors. A large number of cue combination experiments have since been modeled successfully using these techniques. A recent experiment also showed that human volunteers use Bayesian methods to combine visual and haptic information [4] [5].

### Kalman Controllers: Hand Position in the Dark

If we move our hand in the dark we have uncertainty about its exact position or velocity because our proprioceptive sensors are not perfect (Fig. 2a). We are thus faced with the problem of estimating the state  $\mathbf{X}$  of the hand, which is characterized by the position and velocity. From experience, people know how the state of the hand changes over time. In particular they know that the position changes proportional to its velocity and that the velocity changes proportional to the force applied, although there might be noise in this process. The subjects thus have *prior* knowledge that they can combine with the *likelihood* provided by their sensors. In this case, however, they constantly have to update their estimate, thus effectively using Bayes rule at every time-step.

The model for the hand is shown in Fig. 2b. Assuming that the real state  $\mathbf{X}$  of our hand is  $\mathbf{X} = \mathbf{x}$ , then the perceived state  $\mathbf{Y}$  will be some noisy version thereof and  $\mathbf{U} = \mathbf{u}$  is the motor command we are sending to our muscles. We know something about the structure of the problem: The state of the hand at time  $t$  only depends on the state of the hand at time  $t-1$  and the applied force, this is the *Markov property*. The state of the hand does not explicitly depend on the state of the hand at any but the preceding time. Using Bayes rule twice it is possible to obtain:

$$\begin{aligned} p(X_t = x_t | X_{t-1} = x_{t-1}, Y_t = y_t, U_t = u_t) \\ \approx p(X_t = x_t | X_{t-1} = x_{t-1}, U_t = u_t) p(Y_t = y_t | X = x_t) \end{aligned}$$

Where  $p(X_t = x_t | X_{t-1} = x_{t-1}, M = m_t)$  is the probability of finding oneself in state  $x_t$  at time  $t$  after having been in state  $x_{t-1}$  at  $t-1$ . People can be expected to have a model for their hand in terms of these variables (called *forward model*) that they acquired from past experience.



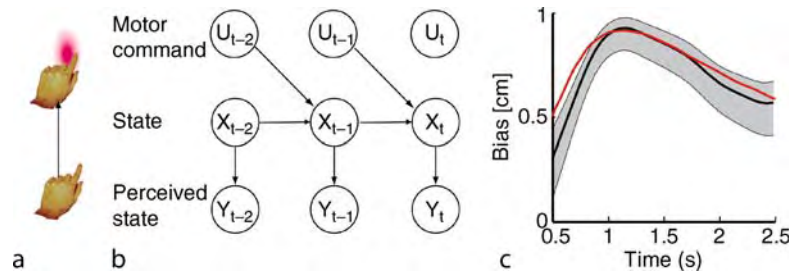

**Bayesian Statistics (with Particular Focus on the Motor System). Figure 2** a) Example: The hand is moving in the dark, we want to estimate where it is. The uncertainty about the state of the hand is sketched in red. b) Structure: The state at time  $t$  is influenced only by the previous state and the motor command. The perceived state is the state with added noise. c) The error of the human estimates of travelled distance is shown as a function of the duration of the movement. The optimal (assuming overestimated force) Kalman controller predicts the red curve. Data replotted from citation 5.

Figure 2b shows the graph with the relations between the variables.

Assuming that random variables have  $n$ -dimensional Gaussian distributions, the equations obtained describe the optimal *Kalman controller* and it is possible to derive the optimal strategy [5] for predicting the state of the hand:

$$\hat{\dot{x}}(t) = \hat{A}\hat{x}(t) + \hat{B}u(t) + K(t)[y(t) - \hat{x}(t)]$$

where  $\hat{x}$  is the current optimal estimate,  $\hat{\dot{x}}$  is the change of the optimal estimate,  $\hat{A}$  is a matrix that characterizes how the hand moves without perturbation,  $\hat{B}$  a matrix that characterizes how forces change the state of the hand, and  $K(t)$  is the *Kalman gain* that is a function of the other matrices. The Kalman controller is a generalization of the *Kalman filter* [7] that does not allow a motor signal.

In an experiment, human volunteer subjects [6] moved their hands in the dark. After each movement they had to estimate where their hand was. Movements of varying temporal duration were done between 500 ms and 2500 ms. Subjects systematically estimated that their hand had moved further than it actually had moved (Fig. 2c gray). An optimal Kalman controller (Fig. 2c, red) produced very similar results if it was assumed that people systematically overestimate their forces. For small times, the overestimation of distance increased with time. This was due to the overestimated forces. As times increased, however, the likelihood became more important compared to the prior. That is why the controller becomes better if the movement lasts a long period of time. The optimal controller thus shows very similar errors to those made by human subjects. It seems, therefore, that people are able to continuously update their estimates based on information coming in from the sensors.

### Dealing with Rewards

In many situations there are not only probabilities involved but also costs or rewards. Consider for example

throwing darts. While the 20 gives us a large number of points the neighbours only give a low number of points (1 and 5). The 19 however has neighbours that give more points (3 and 7). An expert thrower will therefore usually try to hit the triple 20 as she is unlikely to miss it. An intermediate player will try and go for the triple 19 while a novice is best off targeting the middle of the board. Such problems thus ask for a combination between statistical theory and information about rewards, called *Bayesian Decision Theory*.

Figure 3a shows a simple abstraction of such a task. People have to move their hand very fast towards a target, just like in darts, so that uncertainty cannot be avoided. There are two circles that people can touch. Touching one leads to a monetary gain, touching the other leads to a monetary loss. Depending on the motor command  $U$  there will be a probability distribution of hitting each target  $p(A = a|U = u)$ . Fig. 3b shows the structure of the problem. Optimal behaviour for such tasks can be derived calculating the expected value of the reward:

Expected Reward =  $\int p(A = a|\text{knowledge})\text{Reward}(a) da$  where  $\text{Reward}(a)$  is the number of points scored that way. The optimal behaviour is then defined as the one that leads to a maximal expected gain. Bayesian decision theory thus emerges naturally as probabilities are combined with rewards.

A recent experiment tested if human subjects are able to use Bayesian decision theory to move optimally [8]. Subjects had to touch a touchscreen monitor very fast that displayed two spheres, one defining a monetary loss, the other one a monetary gain. They then measured where on average subjects touched the screen. Fig. 3c shows the position where the screen was touched against the optimal position according to the theory. Subjects are very close to the optimal solution. This deconstructs that people can move in a fashion that is close to the optimal predictions of Bayesian decision theory.

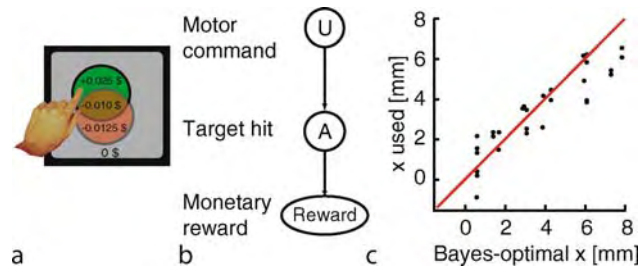

**Bayesian Statistics (with Particular Focus on the Motor System). Figure 3** a) Example: People rapidly move their hand to a computer screen to touch circles and gain rewards. The circles are quite small and they have to move so fast that they cannot be certain about their final finger position. b) Structure. Depending on the motor commands there is a probability distribution about which circles are hit. Depending on which circles are hit there are monetary rewards. c) The positions towards which people moved are shown against the positions they should have pointed to assuming the use of Bayesian decision theory. Data replotted from citation 7.

## Outlook

Bayesian statistics is a large field [9]. Some researchers develop novel algorithms for Bayesian inference. They developed fast algorithms that lead to exact solutions. There are a large number of novel uses of this algorithm for complicated problems where the graph has loops called loopy belief propagation, which often results in good approximations. As an example, the technologically important issue of efficient data transmission through noisy information channels is best solved using this method [9]. Bayesian methods are a systematic way of thinking about function approximations and thus supersede the neural networks literature. Bayesian methods are also the best known methods for speech recognition using *hidden Markov models*, which are a discrete version of the Kalman filter.

“Bayesian methods as they are applied to the study of the movement system are a special case of normative models [5]. Normative models assume, that the nervous system needs to solve a specific problem. They also assume that the nervous system is likely to solve these problems in a fashion that is close to optimal. Many of the problems, that the nervous system needs to solve involve uncertainty. Whenever we want to derive how the nervous system could optimally solve a problem that involves uncertainty, we will need to use Bayesian statistics. Recent work has allowed those techniques to move well beyond simple Gaussian problems [10]. The main challenge for the field at the moment is extending the methods that work so well for simple problems, such as the combination of two cues in a dark room to more realistic problems encountered in the real world.”

## References

1. Cox RT (1946) Probability, frequency and reasonable expectation. *Am J Phys* 17:1–13
2. Freedman DA (1995) Some issues in the foundation of statistics. *Found Sci* 1:19–83
3. Körding KP, Wolpert DM (2004) Bayesian integration in sensorimotor learning. *Nature* 427:244–247
4. Ernst MO, Bulthoff HH (2004) Merging the senses into a robust percept. *Trends Cogn Sci* 8:162–169
5. Körding K (2007) Decision theory: what “should” the nervous system do? *Science* 318:606–610
6. Wolpert DM, Ghahramani Z, Jordan MI (1995) An internal model for sensorimotor integration. *Science* 269:1880–1882
7. Kalman RE (1960) A new approach to linear filtering and prediction problems. *J Basic Eng (ASME)* 82D:35–45
8. Trommershauser J, Maloney LT, Landy MS (2003) Statistical decision theory and the selection of rapid, goal-directed movements. *J Opt Soc Am A Opt Image Sci Vis* 20:1419–1433
9. MacKay DJC (2003) *Information Theory, Inference, and Learning Algorithms*. Cambridge University press, Cambridge, UK [also available online at <http://www.inference.phy.cam.ac.uk/mackay/itila/book.html>]
10. Körding KP, Beierholm U, Ma WJ, Quartz S, Tenenbaum JB, Shams L (2007) Causal inference in multisensory perception. *PLoS ONE* 2:e943

## BBB Score

### Definition

This score was proposed by Basso, DM, Beattie, MS, and Bresnahan, JC in 1995 (*J. Neurotrauma* 12:1–21).

This indicates the open field locomotor scale to assess recovery after contusion injuries to the spinal cord in the rat. The score has a range from 0 to 21, showing a totally paralyzed condition at 0, and the normal state at 21.

Score 9 is critical, because this score means that the rat can walk with the weight support on the hind limbs.

► **Transplantation of Bone Marrow Stromal Cells for Spinal Cord Regeneration**

## BDNF

### Definition

Brain derived neurotrophic factor.

- ▶ Neurotrophic Factors

## BDNs

- ▶ Burster-Driving Neurons

## Beaconing

### Definition

Beaconing is the use of a single distal cue as a goal.

There are numerous forms of beaconing, from simple to sophisticated. Taxis, and its subform chemotaxis, is the process of moving up or down an environmental gradient to reach a goal. Chemotaxis is a common form of navigation in one-celled organisms. In the visual system the offset of the beacon image from the foveaserves as a signal to turn the head towards the beacon and move forward. In sound localization (mammals), echolocation (bats), electrolocation (fish) and infrared detection (snakes) the receptors are paired; comparison of the two inputs serves as an orienting cue. Bees follow chemical trails by bees flying in a zigzag pattern along the edge of an odor plume. In dogs odor tracking is accomplished by a similar zig-zag sampling of the trail on the substrate. Snakes follow prey-odor trails in a manner similar to dogs, but rely on their vomeronasal organs rather than the main olfactory apparatus. Finally, a variety of insects use “snap shot memory” to reach a goal. This is accomplished by comparing current visual input with goal memory and moving to decrease the difference.

- ▶ Chemotactic Attractant
- ▶ Echolocation
- ▶ Odor Tracking (Localization)
- ▶ Spatial Learning/Memory
- ▶ Taxis
- ▶ Vomeronasal organ (Jacobson’s Organ)

## Becker Muscular Dystrophy

### Definition

Milder form of ▶ Duchenne muscular dystrophy, such that dystrophin is present, but at lower amounts or with reduced length.

- ▶ Duchenne Muscular Dystrophy

## Bed Nucleus of the Stria Terminalis

### Definition

Group of neurons near the tip of the lateral ventricle that is connected to the amygdala and involved in sexual behavior, anxiety, the stress response and autonomic regulation.

- ▶ Neuroendocrinology of Psychiatric Disorders

## Bedwetting

### Definition

The voiding of urine while asleep. Bedwetting is common in childhood. Most children stop wetting the bed at five years of age, but in some cases bedwetting may still occur in adolescence and adulthood. If bedwetting continues past the age of five, it may be referred to as nocturnal enuresis. There is a strong genetic component to bedwetting and bedwetting is two to three times more common in males than in females.

Various mechanisms that may contribute to bedwetting include a small bladder, inability to react to a full bladder, inadequate release of the hormone vasopressin, developmental delays, urinary tract infections, urinary tract abnormalities, stress, sleep apnea or other primary sleep disorders, seizures, type-I diabetes, spinal cord trauma, and drug and medication use. Behavioral and pharmacological treatments for bedwetting are available.

- ▶ Sleep – Motor Changes
- ▶ Sleep – Sensory Changes

## Behavior

HERMANN WAGNER

Institute for Biology II, RWTH Aachen, Germany

### Synonyms

Ethology; Neuroethology; Behavioral neurobiology

### Definition

The biological discipline to study behavior is ethology. The biology of behavior may be discussed in relation to 3 key issues: evolution, ontogeny and mechanism. Behavior has been shaped by evolution. The main function of evolution lies in optimizing fitness. Innate behavioral programs may be modified during ontogeny by learning. The mechanisms underlying behavior are based on physiology. However, behavior is more than physiology: for example, some animals have physiological mechanisms to control body temperature. If an animal such as a lizard is sunbathing, a behavioral component is included in addition to the physiological control mechanism. This synopsis deals mainly with the proximate, physiological mechanisms of behavior and not the ultimate, socio-biological causes underlying a certain behavior. Thus, the term behavior as it is used here refers to the actions or reactions of animals and man to internal and external stimuli. Since neural activity plays such an important role in behavior, the discipline of neuroethology developed. Neuroethology integrates behavioral studies with neurobiology. This synopsis shall mainly deal with neuroethological approaches to behavior.

- ▶ Behavioral models of memory and learning
- ▶ Behavioral Neuropharmacology
- ▶ Cognitive elements in animal behavior
- ▶ Communication in electric fish
- ▶ Neural correlates of imprinting
- ▶ Neuroethology of biosonar in bats
- ▶ Neuroethology of the behavior in caenorhabditis
- ▶ Neuroethology of visual orientation in flies
- ▶ Song learning in songbirds
- ▶ Sound localization in the barn owl

### Characteristics

#### History

People have long been interested in animal behavior (review in [1]). Explanations of the underlying causes and mechanisms have changed through the centuries. The vitalists of the 19th century claimed internal, subjective causes as the source of behavior: for example, that the cause underlying singing in the ▶ **songbird** was the joy the birds experienced or that curiosity would drive moths to approach a light source. Such claims could not be validated on a scientific basis. As a reaction,

the behaviorists developed a theory strongly opposing every internal cause of behavior. Behavior was regarded as occurring in reaction to external stimuli. In a similar way, Sherrington's reflex theory did not require internal sources for generating behavior. It was realized by the ethologists that both the reflex theory as well as the concepts of the behaviorist fell short of explaining all observations on behavior. The ethologists filled the gap by recognizing that internal causes indeed played important roles in behavior – but in a different way as envisioned by the vitalists.

The precise observations and field experiments of ethologists such as von Frisch, Lorenz and Tinbergen built a solid fundament for the study of behavior [2,3]. Lorenz, for example, working with jackdaws and goslings observed that behavioral patterns had a stereotyped part that he called ▶ **fixed action pattern**. He also saw that there were flexible components that he called ▶ **taxis**. Animals would display a behavior if certain ▶ **key or sign stimuli** were there, acting like a trigger by having a so-called ▶ **releasing value**. However, action might also occur without any external stimuli (▶ **vacuum activity**), pointing towards internal causes of behavior.

Working with newly hatched gulls, Tinbergen observed that some stimuli had higher ▶ **releasing values** than the natural stimulus. Such stimuli were called ▶ **supernormal stimuli**. Also, some behavioral patterns were innate (▶ **innate (instinctive)** behavior), and some were learned (learned behavior). In some cases, ▶ **learning** was life long, in others there were ▶ **sensitive** and ▶ **critical periods** during which a learned pattern was imprinted and could not be changed afterwards. The neural basis of ▶ **imprinting** is investigated in ▶ **animal models** these days. ([4]; Essay on “Neural correlates of imprinting.”) All behaviors of an animal were summarized in an ▶ **ethogram**.

From their observations the ethologist drew general conclusions about the organization of behavior. Some of the claims, especially of Lorenz, as, for example, that ▶ **aggression** is an innate behavior of man, have received much criticism, and can no longer be held up. Scientifically, a much bigger problem was that most of the elements in the models of behavior could not be (easily) found in neurophysiological studies and could not be implemented in computer models of behavior (▶ **computational approach**). Therefore, in most modern work on behavior the terminology developed by the ethologists plays only a marginal role.

### Levels of Analysis

According to [5], function may be studied at three different levels: the phenomenological level, the theoretical level and the level of implementation. In the most general sense, ethology refers to the phenomenological description of behavior. However, the development of models of behavior has always played a key

role in the study of behavior. The level of implementation in brain and motor circuits is investigated by ►neuroethology. This level may be split into several sublevels: the molecular, the cellular and the systems levels. Each of these levels has its own methods of description and explanation. One may even add another level: the level of application. At this level modeling and implementation are combined in building neurons, neural circuits, or robots that mimic certain neural action, sometimes even behavior (►neuromimes). Seen on a broad perspective, behavioral studies encompass all levels of function.

Physiologist, often being close to physics, have favored ►bottom-up approaches, using simple, well-described stimuli. Such work has been very useful, but often, peripheral mechanisms turned out to be so difficult that physiological research has neglected central processes for a long time. In addition, in a bottom-up approach, it was often not clear what had to be explained. A typical example is auditory physiology. Neuroethologists, on the other hand, have used ►top-down approaches. This allowed to define the behaviorally relevant situation, derive the behaviorally relevant stimuli and find neural structures where a given behavior was implemented. The integration of both approaches turned out to be very fruitful as in the study of sound ►localization in the barn ►owl (Essay on Sound localization in the barn owl) and of biosonar in ►bats (Essay on Neuroethology of biosonar in bats).

Scientific analysis of behavior may take place in the field, in a more restricted environment such as a zoo or in the laboratory. To study behavior, one always has to consider the range of action needed by an animal to display a certain behavior. This range has at least to be available to obtain meaningful data. Ethology is a science that developed mainly from field studies. The strength of field studies lies in the possibility to investigate behavior in natural settings. On the other hand, laboratory studies in general allow for a better stimulus as well as (re-) active control. They allow for a controlled manipulation of behavior to dissect the often complex whole into simpler sequences. Modern research has mainly turned towards laboratory studies, but it remains a challenge to study brain function in the field, because this is where the brain and the behaviors it controls evolved.

### What has to be Explained?

Take a singing robin. The male is singing. He shows that he is present, that he is a robin, that he has a territory and is willing to mate and produce offspring. But through singing the male also exposes itself to predators. The female has to detect the song, discriminate it from songs of other species, decide which singing male to approach, then approach the male

thereby localize its position, start to fly, land, and show willingness to mate by herself...

The questions underlying this example may be sorted into 3 categories:

- Ultimate questions: Why did this behavior evolve? What is its survival value?
- Developmental questions: How does the behavior mature? Is it innate or learned? What kind of learning is involved?
- Proximate issues: How does the bird generate the song? How does the syrinx work? How does the female recognize the male and how does it approach it? In other words, we have to deal with issues of ►detection, ►recognition, ►discrimination, ►localization, decision making, motor control, ►orientation, ►cognition, and ►attention.

How can these questions be put into basic terms? In the most general sense, behavior needs effectors, sensors and nervous activity (Fig. 1). Effectors, muscles, etc., translate the neural programs into movement (motor control). The motor system is organized in a hierarchical way (►hierarchy), including a level that makes a decision about the purpose of the movement, a level that is concerned with the formation of a motor plan, a level that coordinates spatial-temporal details and a level that executes the movements. The motoneurons often act as a ►final common pathway by integrating different aspects into one command to a muscle or set of muscles. Sensors measure the behavioral consequences of effector action. There is also subdivision of work: reflexes are stereotyped reactions as are rhythmic movements, while voluntary movements are goal-directed. The sensory pathways are also organized in a parallel and hierarchical way and often have feedback loops. The activity of nerve cells and brain circuits governs behavior and may initiate behavior even without external stimuli. Internal, self-generated action may, in turn, be influenced by ►endocrinal or (spontaneous, i.e. unexplained) neural activity. Internal factors often

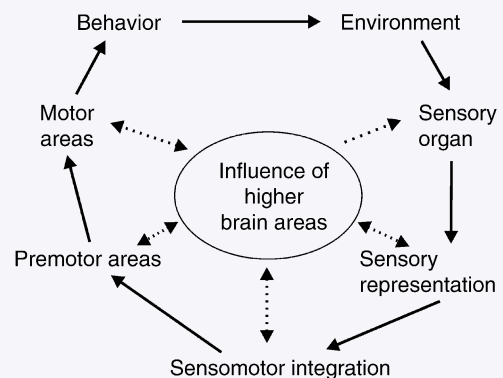

**Behavior. Figure 1** Thye Sensory-motor 100P.

influence ►motivation or ►emotion. Hormonal action may be influenced by a ►biological clock and then induce a circadian, circalunar or circannual ►rhythm.

Behavior is not a one-way process from the brain to muscular action; it is also not only a reflex-like reaction to external stimuli. Instead, behavior influences the environment, and thus the sensory input. Thus, behavior may be seen to be embedded in a closed-loop situation (►closed-loop behavior). Of course, in the lab the loop may be opened (►open-loop behavior) thus separating the actions from their consequences on the sensory input. The brain has evolved mechanisms to deal with the consequences of actions, and signals are sent out to cope with expected as well as unexpected sensory input (►corollary discharge, ►efference copy, saccadic suppression).

### Function of Behavior

Behavior certainly has an adaptive value. It helps the animal in the “struggle for life”. Behavior improves ►fitness. Thus, in an ultimate sense, behavior helps the “selfish” genes of its carrier to spread. The selfishness leaves limited space for ►altruistic behavior. Indeed, most claims of ►altruistic behavior have in many cases been explained by fitness models or game-theory models.

As was already indicated in the example of the singing robin, behavior may help an animal to find a conspecific, to orient, to navigate, to mate, to reproduce, but also to find a resting place, to find food, and so on.

Many behaviors require ►communication. In a communication situation, a ►sender emits an en ►coded signal that is transmitted through a ►transmission channel to a ►receiver. The receiver decodes the signal and reacts accordingly. Signals may be directed to a conspecific, as in courtship behavior, or to a predator, as in mimicry, or to both, as in ►defensive, escape, ►aversive or avoidance behavior. On the other hand internal ►drives may initiate behaviors to serve an animal’s own needs, like in ►appetitive behavior (drinking, feeding) and sleep.

To achieve these functions, genetic determinants constitute an important basis, but ontogenetic and sometimes life-long shaping by learning is required in addition to fine tune behavior. There has been a long debate about “nature and nurture” in the behavioral community. However, it is clear now that both play a role. In some behaviors such as the courtship behavior of crickets, involving ►phonotaxis, innate mechanisms are more important, while in others such as hunting in wolves acquired factors play a dominant role. The function of learning may be seen as a means to increase behavioral variability as well as a means to adapt to unpredictable situations. Learning occurs as a reaction to evolutionary pressure and is observed in both invertebrates and vertebrates. Paradigms of ►associative

learning such as ►classical and ►operant conditioning have become very important instruments to study behavior. Studies on learning also encompass simpler forms of learning (habituation, sensitization) as well as more complex forms of learning (►context learning, ►spatial learning, ►avoidance learning). Where learning occurs, memory is necessary. Indeed many concepts of memory observed in humans underlie animal behavior as well (►working memory, ►spatial memory, ►eidetic and ►photographic memory). In the last decade it has been realized that ►cognitive functions (►attention, ►recognition) are part of animal behavior as well, sometimes even in invertebrates. For example, bees have developed a language to direct conspecifics to a food source.

The recent advances in genetic techniques allow for studying behavioral mutants. In fact, many *Drosophila* mutants were detected by behavioral screens. Such screens have been used in fish as well as in tadpoles to study phenomena like ►optomotor responses [6]. While careful analysis of heredity has already revealed the genetic basis of some complex human behaviors and diseases, the near future will certainly bring more refinement of techniques to allow for a better dissection and study of complex behaviors in both animals and humans. In the animal kingdom it has, for example been found that the mongoose that is preying on the poisonous cobra, has as a protection from the venom in form of a mutation in the acetylcholine receptor [7].

### Neural Basis of Behavior

Most behavior is controlled by brain circuits [8]. These may be simple, automate like in optomotor behavior or more complex as in face recognition. Real simple behaviors don’t exist. Even the behavior of a seemingly simple animal like the nematode ►*Caenorhabditis* has turned out to contain complex elements [9]; Essay on Neuroethology of the behavior in *Caenorhabditis*). Similar arguments hold for the model system for animal learning, the snail ►*Aplysia*. The gill ►withdrawal reflex of this animal has proven to be complex enough to study many phenomena of learning, from the behavioral via the neural to the molecular level [10]. Studies in ►honey bees have detected a neuron that represents the conditioned stimulus [11]. The stomatogastric ganglion and the ►gastric mill of ►lobsters has served to understand the control of a simple behavior by networks made up of a small number of neurons [12].

In their attempt to understand behavior, neuroethologists have typically taken a top-down approach. Based on the belief that evolution has shaped brains to meet specific behavioral needs, bee behavior and bee brains have been used to study orientation and learning. Electric fishes have served as a model system for

dealing with a communication situation [13], Essay on communication in electric fish). Studies on barn owls have contributed much to understand the neural basis of sound localization [14], Essay on sound localization in the barn owl). The biosonar in bats has served to understand the specific adaptations underlying the occupation of specific ecological niches in the different species, the parallel and hierarchical processing of the different stimulus attributes and has been compared with speech-processing in humans [15,16], Essay on Neuroethology of biosonar in bats). Studies on song-learning in songbirds have also strongly influenced our thinking about motor learning [17], Essay on song learning in songbirds). The finding of ►place cells in hippocampus has changed our view on how this structure is involved in orientation [18].

One important issue in studying behavior has been the question of whether neural action reflects perception and whether we can influence behavior by ►electrical stimulation. Indeed early experiments by [19] indicated that this was possible. Recent experiments with awake, behaving monkey on binocular rivalry demonstrated that in certain brain areas the activity changes of a reasonable number of cells corresponded to changes in perception reported by the monkey [20]. Furthermore, in motion-detection and stereo-vision tasks, it was demonstrated that electrical stimulation changed the monkeys behavior in specific, predictable ways [21]. This paved the ground for the possible use of neural responses to control the movement of external robot arms [22], which in turn gave hope for the use of neural prostheses in paralyzed patients. Neural stimulators are already successfully used in Parkinson patients to help them initiate movements [23]. We do not know yet how our perception is changed by stimulation. An answer could only be obtained by experiments with humans. Such experiments are ethically questionable and have not been done.

### Models of Behavior

Models of behavior attempt explanation at different levels. First, there is the general communication model as outlined above that underlies the description of many behaviors. Second there are the phenomenological models developed by the ethologists. A good example is the so-called psychohydraulic model of Lorenz [24]. In this model, a large reservoir of water provided an internal force to drive behavior. This reservoir was connected to a valve. The valve might be opened to initiate behavior by a releasing stimulus or, if this was missing, by the build-up of action-specific energy (internal ►drive), symbolized by a continuous influx through an open water-tap.

The most detailed models describe a behavior in terms of its processing stages, sometimes symbolized by black boxes containing equations, but sometimes also realized

through exact neural circuits. Models at this last level include concepts developed in control theory and have the goal to reveal the neural basis of behavior in general and specific mechanisms underlying neural ►coding (e.g. [25]). As indicated in Fig. 1, one basic insight was that behavior may best be described as a loop, thus requiring feedback control. It has long been recognized that sensory circuits, ►sensorimotor transformation, and motor loops are organized in a parallel and hierarchical way. Neurons functions as filters (►neural filters), thus, selecting specific stimulus attributes. However, there has been a long debate on how specific these filters are. Theoretical arguments speak against the representation of one attribute by one neuron as was implied by the ►grandmother-neuron concept and favor distributed processing (►ensemble code) [26]. On the other hand, the observation of specific neurons, such as face neurons have made it clear, that the brain uses both distributed processing and specific processing to represent stimuli. As this became clear, the terms ►detector neurons, ►decision neurons, ►deviation-detecting neurons, ►command neurons, and ►central pattern generators that were popular in the 70ies and 80ies lost attraction. Neural ►network theory, suggested that most of the detection and decision processes are part of the underlying networks, leading to ►ensemble coding, and not of single neurons. Nevertheless, in some examples, such as the escape response of cockroaches, it seems that the fast, stereotyped response is driven by a command-like neural signal. However, even there parallel pathways exists, and the slower pathway is plastic, while the faster pathway is not. In a similar sense, the ideas of ►gating, developed amongst others to explain locomotor activity in ►locusts [27]. A similar situation occurs in ►fly orientation in which widefield optomotor stimuli interact in specific ways with smallfield, object-defining stimuli [28], Essay on Neuroethology of visual orientation in flies).

Thus, behavior is an integral part of neuroscience. It should be the ultimate goal to explain behavior from molecular action. We just appear to come close of having all the experimental tools to achieve this task.

### ►Action, Action-Theory

### References

1. Camhi JM (1984) Neuroethology. Sinauer, Sunderland, MA
2. Kruuk H (2003) Niko's Nature. Oxford University Press, Oxford
3. Immelmann K (1982) Wörterbuch der Verhaltensforschung. Parey, Berlin und Hamburg
4. Gruss M, Bock J, Braun K (2003) Haloperidol impairs auditory filial imprinting and modulates monoaminergic neurotransmission in an imprinting-relevant forebrain area of the domestic chick. J Neurochemistry 87:686–696
5. Marr D (1982) Vision. WH Freeman and Co, San Francisco

6. Huang YY, Neuhaus SC (2008) The optokinetic response in zebrafish and its applications. *Front Biosci* 13:1899–1916
7. Asher O, Lupu-Meir M, Jensen BS, Paperna T, Oron Y, Fuchs S (1998) How does the mongoose cope with alpha-bungarotoxin? Analysis of the mongoose muscle AChR alpha-subunit. *Ann NY Acad Sci* 841:97–100
8. Carew (2000) Behavioral neurobiology: the cellular organization of natural behavior. Sinauer
9. Giles AC, Rose JK, Rankin CH (2006) Investigations of learning and memory in *Caenorhabditis elegans*. *Int Rev Neurobiol* 69:37–71
10. Kandel ER (2001) The molecular biology of memory storage: a dialogue between genes and synapses. *Science* 294:1030–1038
11. Hammer M (1993) An identified neuron mediates the unconditioned stimulus in associative olfactory learning in honeybees. *Nature* 366:59–63
12. Nussbaum MP, Beenhakker MP (2002) A small-systems approach to motor pattern generation. *Nature* 417:343–350
13. Fortune ES (2006) The decoding of electrosensory systems. *Curr Opin Neurobiol* 16:474–480
14. Konishi M (2006) Behavioral guides for sensory neurophysiology. *J Comp Physiol A* 192:671–676
15. Siemers BM, Schnitzler HU (2004) Echolocation signals reflect niche differentiation in five sympatric congeneric bat species. *Nature* 429:657–661
16. Suga N, Ma X (2003) Multiparametric corticofugal modulation and plasticity in the auditory system. *Nat Rev Neurosci* 4:783–794
17. Suthers RA, Margoliash D (2002) Motor control of birdsong. *Curr Opin Neurobiol* 12:684–690
18. McNaughton BL, Battagila FP, Jenson O, Moser EI, Moser MB (2006) Path integration and the neural basis of the ‘cognitive map’. *Nat Rev Neurosci* 7:663–678
19. Holst EV, Saint Paul UV (1960) Vom Wirkungsgefüge der Triebe. *Naturwissenschaften* 47:409–422
20. Leopold DA, Logothetis NK (1996) Activity changes in early visual cortex reflect monkeys’ percepts during binocular rivalry. *Nature* 379:549–553
21. DeAngelis GC, Newsome WT (2004) Perceptual “read-out” of conjoined direction and disparity maps in extrastriate area MT. *PLoS Biol* 2:E77
22. Lebedev MA, Nicolelis MA (2006) Brain-machine interfaces: past, present and future. *Trends Neurosci* 29:536–546
23. Anderson KE, Mullins J (2003) Behavioral changes associated with deep brain stimulation surgery for Parkinson’s disease. *Curr Neurol Neurosci Rep* 3:306–313
24. Lorenz K (1965) Über tierisches und menschliches Verhalten. Deutsche Buchgemeinschaft, Berlin, Darmstadt, Wien
25. Pouget A, Deneve S, Duhamel JR (2002) A computational perspective on the neural basis of multisensory spatial representations. *Nat Rev Neurosci* 3:741–747
26. Haberly LB (2001) Parallel-distributed processing in olfactory cortex: new insights from morphological and physiological analysis of neuronal circuitry. *Chem Senses* 26:551–576
27. Ritzmann RE, Buschges A (2007) Adaptive motor behavior in insects. *Curr Opin Neurobiol* 17:629–636
28. Egelhaaf M (2008) Fly Vision: neural mechanisms of motion computation. *Curr Biol* 18:R339–341

## Behavior, Innate

### Definition

A behavior is supposed to be innate, if an animal can display it without learning from conspecifics. Usually behaviors shown by animals reared in isolation are thought to be innate. There is some debate on how much experience changes “innate” behaviors.

## Behavior, Simple, Complex

### Definition

In general actions or reactions of animals to internal and external stimuli. There is not a well defined distinction between simple and complex behavior, but a graded transition.

## Behavioral Dimension

### Definition

The way an individual behaves or acts in response to a particular setting, process, characteristic, attitude, or sensation. A full description of a particular item would usually include the behavioral dimension of the item, along with its cognitive and affective dimensions (plus sometimes the sensory dimension).

## Behavioral Methods in Olfactory Research

GILLES GHEUSI

Pasteur Institut, Laboratory of Perception and Memory, Paris, France

### Synonyms

Experimental approaches to the study of olfactory control of behavior; Behavioral measurement of olfactory processing; Olfactory-guided behavior studies



## Definition

A variety of behavioral paradigms have been developed to assess the ability of a subject to process olfactory information. Here, I will examine how the behavioral methods in olfactory research, mostly coming from research on laboratory animals and especially the rodent, aim to give insight and generate hypotheses in the way animals detect, discriminate and memorize olfactory information. These methods range from simple recording of spontaneous olfactory investigation of odorant stimuli to psychophysical measures providing detailed sensory analyses. These extremes reflect two main approaches: one which relies on ethologically relevant procedures that take advantage of some species' tendency to use the sense of smell for gathering information of their world and one which relies on classical and ▶**operant conditioning (instrumental learning)** procedures used to train animals to perform tasks designed to probe their olfactory capabilities. The formers generally involve paradigms, which are based on the spontaneous responses of subjects to odorants whereas the latter used differential ▶**reinforcement** of odorants. These different behavioral methods used in olfactory research differ widely in their experimental settings, in the control of generating and delivery of odor stimuli, and in the control of quantifying sensory and performance variables. Behavioral paradigms in olfactory research can be classified in three main sections: those, which are based on measurements of spontaneous responses to odors, classical conditioning (▶**classical conditioning (Pavlovian conditioning)**) and operant conditioning (operant conditioning (instrumental learning)). However, all represent a critical tool to examine the predictions based on coding mechanisms such as spatial map and temporal patterns of neural ensembles, which emerge during olfactory processes.

## Characteristics

In light of the significant advances in the field of molecular and neurobiology of olfaction during the past years, understanding how chemosensory information is encoded and processed into the brain is a central goal of olfactory research and behavioral methods constitute a critical step to complete our knowledge of the functional organization of the sense of smell. Unlike vision and hearing, olfaction's stimulus space is highly multi-dimensional and it still remains difficult to specify which aspects of an odorant space are connected with which aspect of our perceptual experience. Many experimental animals, like rodents and insects, exhibit a very keen sense of smell and the ability to detect, discriminate and memorize odor stimuli. Furthermore, there exist very striking similarities between the synaptic organization of the antennal lobe and the olfactory bulb, respectively in insects and mammals [1] suggesting that several mechanisms for olfactory processing

may be very well conserved. Behavioral experiments represent a unique opportunity to provide information about the functional aspects between neural processes sustaining olfactory perception, discrimination and memory and behavioral outcomes of these neural processes. The importance of considering behavioral approaches in studying neuronal dynamics in the olfactory system is definitively supported by the evidence that the activity in the olfactory bulb greatly differs between anesthetized and awake animals [2]. A variety of behavioral methods have been developed to assess olfaction in animals [3]. They differ in many aspects such as the control over the purity, concentration, timing and delivery of odor vapors. Whatever the limits associated with the use of each method, they all represent a unique tool to understand how the brain generates representations of odors, achieves precise odor identification, defines broad odor categories, extract invariant features and stores the representations for efficient memorization and recognition. I will now concentrate my analysis on the main behavioral methods used in olfactory research with laboratory animals, especially the rodent, to assess the functional properties of the olfactory system.

## Spontaneous Responses to Odors

Measurements of spontaneous responses of subjects to odors represent a simple way to investigate olfactory performance in animals. It consists in presenting odor stimuli and measuring their ability to detect, discriminate, prefer or avoid odorants. The *food localization test* has been first introduced by Alberts and Galef [4] to explore olfactory sensitivity in the rat. Hungry animals are introduced in a random location into a clean cage with a 3–5 cm thick layer of bedding underneath, which a food pellet was buried. Subjects are run for one to several trials with one scented pellet available per trial. The latency to locate the food pellet is defined as the time required for the animal to dig up and grasp the pellet following introduction into the cage. As expected, olfactory bullectomy induces a failure to find the target pellet in rats. This procedure has been used to assess impaired olfactory sensitivity in animals with damage to the olfactory system as well as in transgenic mice deficient in the expression of proteins involved in olfactory transduction processes. The procedure is simple and requires no special apparatus. However, it provides no control of odor delivery. Furthermore, according to the technique used to induce olfactory deficits, some manipulations may produce secondary effects, which alter the motivation, the physiology and the behavior of the animal studied, thus increasing their latency to find the food pellet.

Recording the sniffing duration, as the measure of behavioral responses to odors, represents also a very simple way to examine and compare the spontaneous

degree of interest of subjects for different odorants. Sniffing attraction tasks consist of recording the time spent by an animal investigating a single odorant whereas preference tasks involve the simultaneous exposure of the subjects to two or more odorants. Tests are generally carried out in the home cage of the subjects or in neutral arenas (open field, maze), although testing in neutral arenas has been reported to provide more sensitive measures [5]. In forced-choice preference tasks, which always test the relative attractiveness of each odor, the interpretation may be problematic since it may not be clear whether the subject is attracted to one stimulus or repelled by others. Preference tests are also used to assess the acquired properties of odors that had previously been paired with reinforcement. Acquisition of a conditioned odor preference (or aversion) has been widely studied in young rat and mouse pups using a variety of ►**reinforcers**. These include intraoral milk infusion, tactile stimulation, warmth, shock, tail-pinch.

Across many mammalian and non-mammalian species, recognition of a stimulus can be easily assessed by a decline in spontaneous investigation measured in repeated encounters of this same stimulus. Indeed, the successive presentations of the same odorant lead to a decreased interest to that odor, a form of learning known as ►**habituation**. Habituation and habituation-derived paradigms have become useful tools with which to investigate odor memory and odor discrimination processes in animals. Habituation tests are categorized into two types: *habituation-dishabituation* tests and *habituation-discrimination* tests, each type involving a two-phase process. During the first phase, habituation is conducted over repeated presentations of the same odorant separated by inter-trial intervals of varying lengths. The use of various lengths between two brief exposures of a same odor stimulus can provide information about the duration of memory for that odor. Habituation–dishabituation tests involve a second phase (post-habituation phase) in which individuals encounter a novel odor. The presentation of a novel odor during this phase triggers an increase in sniffing showing that the subject is able to discriminate between the first and second odor. The renewed responsiveness to a novel odor argues against sensory or effector fatigue during the first phase. The habituation-discrimination tests represent a variation of the habituation-dishabituation tests. Here, following repeated exposures to a first odor, the subjects are given a choice between the previously encountered odor and a novel odorant. Comparing the difference in the time spent investigating the familiar and unfamiliar odor stimuli assesses discrimination between the two odors. Using habituation tests, amnesic and memory-enhancing properties of different drug treatments can be examined in tests scheduled at various time intervals

after administration. The appeal of the habituation tests rests in their simplicity. Here again, the odor response occurs spontaneously without any prior training. One of the principal advantages of these tests is that they can be implemented rapidly with minimal instrumentation. One shortcoming of this type of test, however, is that it provides information about memory for familiar versus unfamiliar odor, but not about memory for a specific odor among equally known odors. Another shortcoming is that, using this type of paradigm, only short-lived memories for odors can be studied. Furthermore, a main drawback to habituation-dishabituation and habituation-discrimination tests is that a lack of differentiated responses in subjects towards familiar and novel stimuli does not necessarily imply that no discrimination occurred.

### Classical Conditioning

Classical conditioning has become a predominant paradigm in studying mammals and insect olfactory processes. Classical conditioning basically involves two stimuli: a neutral ►**conditioned stimulus (CS)** paired with a biologically significant ►**unconditioned stimulus (UCS)**. The UCS reflexively elicits strong responding. As a result of CS-UCS pairings, the CS becomes associated with the UCS so that the previously neutral CS elicits the same reflexive response as the UCS. In conditioned aversion (or preference) learning, odorants are presented to animals and subsequently followed by a noxious (or pleasant) event. Such approach has provided compelling evidence for the formation of olfactory memory traces due to classical conditioning in the olfactory bulb of mammals as well as in the antennal lobe of insects. Measuring the rate of responding to the conditioned odor stimulus can easily assess learned odor preference/aversion. Conditioned odor aversion is a learned association that involves the avoidance of a tasteless solution (CS), which precedes illness (UCS). However, it has been reported that in contrast to the well-known conditioned taste aversion paradigm, conditioned odor aversion is obtained if the delay separating the presentation of the odor from the malaise is short. Despite mixed results, conditioned odor aversion has been shown to be a robust and long-lasting learned association and may be useful for assessing generalization among similar odors. Furthermore, the combined presentation of both an odor and a taste paired with visceral malaise leads to a strong aversion to the odor [6]. In this case, the taste might enhance the odor processing and subsequently might facilitate its association with illness. It has been proposed that the taste cue could gate the olfactory information and make it associated with the visceral illness. Such phenomenon has been referred as ►**taste-potentiated odor aversion**. Due to its particular features, such as rapid acquisition, possibility of long intervals between the CS and the UCS and its robustness, taste-potentiated odor aversion is a powerful model to study the neuronal and

behavioral mechanisms that subserve the acquisition, consolidation and retrieval of olfactory information in subjects.

### Operant Conditioning

Psychophysical studies of olfactory processes widely use operant conditioning to probe the subject's ability to detect, discriminate and memorize odors. Briefly, animals are first trained to discriminate between two odors. During training, they received trials in which one odor (CS<sup>+</sup>) is paired with a reward and another odor is paired with no reward. The go/no-go olfactory discrimination training paradigm illustrates this approach. Operant olfactory conditioning may be carried out using computer-controlled systems, such as olfactometers, which generate and deliver odors. Water-deprived animals are trained to introduce their snout into a combined odor/reward port. A nose poke triggers the opening of one of several odor valves and a stimulus odor is presented. During the presentation of the S<sup>+</sup> odor, the animal is required to keep its nose into the sampling port for a specific length of time and lick the water tube. This is followed by the delivery of a reward. If the S<sup>-</sup> odor stimulus is presented, no reward is given whatever the duration of the nose poke and the response on the water tube made by the animal. Subjects therefore learn to maintain nose pokes and lick the tube during the presentation of the S<sup>+</sup> odor stimulus and to withdraw rapidly from the odor/reward port during the presentation of the S<sup>-</sup> odor stimulus. Because animals are required to act (lick) and are rewarded only upon presentation of the S<sup>+</sup> odor, the go/no-go task is asymmetrical. Training animals to perform two-alternative choice odor discrimination can achieve symmetrical reinforcement. In this case, subjects initiate trials by a nose poke into an odor sampling port, which triggers the delivery of an odor for a specific length of time. After leaving the odor sampling port, the animal is rewarded for making a nose poke at the water port designated as correct between two spatially separated water choice ports.

Operant olfactory conditioning has also been developed by exploiting rodents' natural foraging strategies that employ olfactory cues [7]. Animals are trained with stimuli that consist of distinctive odors added to a mixture of ground rat chow and sand through which they dig to obtain buried cereal rewards. Training consists of presenting two stimulus cups, one scented with an odor stimulus (S<sup>+</sup>) paired with the reward and the other scented with another odor stimulus (S<sup>-</sup>) presented alone. A choice response is scored when the animal touches the sand in one of the stimulus cups with its paw. A correct response is recorded when the first dig occurs in the baited cup. Problems associated with the olfactory digging task are the weak control over odor dispersion from the cups and the difficulty to prevent mixing of the odors.

Mazes and runways represent also conventional systems to study associative olfactory learning processes. These designs have been used to demonstrate that mice are able to discriminate between various types of odors, although they vary among studies [8,9]. Basically, animals are trained in the maze to enter one arm scented with an odor stimulus in order to receive a reward. Another arm is scented with a different odor but contains no reward. The odors are randomly assigned to either arm after each trial. In some cases, fans are used to direct odor flows at the choice point and an exhaust fan is mounted above this choice point to pull the odors down the arms and out of the testing maze. However, the levels of odor control remain approximate compared to those offered by the computer-controlled olfactometers mentioned above.

In addition to the sensitive measures provided by combining operant conditioning with computer-controlled systems, a considerable body of literature from several laboratories demonstrates that rat olfactory learning has unique properties. Behavioral studies have revealed that odors provide particularly salient cues for rodents. Rats are able to show errorless learning of detection and discrimination tasks, ►reversal learning, rapid interproblem transfer and acquisition of a learning set, learn matching and non-matching to sample tasks (►delayed matching-to-sample task – delayed nonmatching-to-sample task) and demonstrate excellent memory for odors [10]. Thus the development of psychophysical methods has not only made olfaction amenable to specialists interested in the field of olfactory sensory processing but also to cognitive neuroscientists.

Undoubtedly, future works combining the accuracy of psychophysical approaches with the functional interest of ethologically relevant methods constitute a critical challenge in behavioral olfactory research.

### References

1. Hildebrand JG, Shepherd GM (1997) Mechanisms of olfactory discrimination: converging evidence for common principles across phyla. *Annu Rev Neurosci* 20:595–631
2. Rinberg D, Koulakov A, Gelperin A (2006) Sparse odor coding in awake behaving mice. *J Neurosci* 26:8857–8865
3. Slotnick B, Schellinck H (2002) Behavioral methods in olfactory research with rodents. In: Simon SA, Nicolelis MAL (eds) *Methods & new frontiers in neuroscience. Methods in chemosensory research*. CRC Press LLC, Boca Raton, FL, pp 21–61
4. Alberts JR, Galef BG (1971) Acute anosmia in the rat: a behavioral test of a peripherally-induced olfactory deficit. *Physiol Behav* 6:619–621
5. Johnston RE (1981) Attraction to odors in hamsters: an evaluation of methods. *J Comp Physiol Psychol* 95:951–960

6. Rusiniak KW, Hankins WG, Garcia J, Brett LP (1979) Flavor-illness aversions: potentiation of odor by taste in rats. *Behav Neural Biol* 25:1–17
7. Bunsey M, Eichenbaum H (1996) Conservation of hippocampal memory function in rats and humans. *Nature* 16:159–182
8. Yamazaki K, Yamaguchi M, Baranoski L, Bard J, Boyse EA, Thomas L (1979) Recognition among mice: evidence from the use of a Y-maze differentially scented by congenic mice of different histocompatibility types. *J Exp Med* 150:755–760
9. Staubli U, Fraser D, Faraday, Lynch G (1987) Olfaction and the data memory system in rats. *Behav Neurosci* 101:757–765
10. Slotnick B (2001) Animal cognition and the rat olfactory system. *TICS* 5:216–222

## Behavioral Neurobiology

### ► Behavior

## Behavioral Neuropharmacology

THOMAS M. TZSCHENTKE  
Grünenthal GmbH, Research and Development,  
Department of Pharmacology, Aachen, Germany

### Synonyms

Behavioral pharmacology; Psychopharmacology; Neuropsychopharmacology

### Definition

Behavioral neuropharmacology is concerned with understanding the neural and pharmacological mechanisms of complex behavior, as well as the behavioral abnormalities that accompany neuropsychiatric disorders, using animal models. The use of these animal models can follow two approaches: first, behavior is used to answer questions where the primary interest is in pharmacology, and a behavioral measure is studied to evaluate drug effects in much the same way as in any other experimental preparation. Second, the study of behavior itself is the primary interest, and drugs are used to dissect and elucidate the underlying mechanisms of certain behavioral phenomena. The goal for both approaches is to observe and quantify behavior in animals (or humans) and to relate this behavior to specific brain processes. In order to do this, one can either study spontaneous behavior and correlate it with brain activity (measured

in vivo by means of intracranial ►microdialysis, voltammetry, electrophysiological recording, brain imaging techniques, or measured ex vivo by means of histological, morphological or gene expression analysis), or one can manipulate the central nervous system by means of drugs, lesions, or electrical stimulation, and study how this affects behavior. As such, behavioral neuropharmacology stands at the threshold of a profound scientific challenge: to understand the neuroanatomical, neurochemical, cellular and molecular basis for the enormously complex and varied human behavior and the functions of the human brain. In this regard, the concept of “animal models” of human neuropsychiatric diseases rests on the assumption that one can appropriately infer, from observations of behavior or physiology, that the states experienced by animals are equivalent to the emotional states experienced by humans, expressing the same types of behavioral or physiological changes.

Note that because of space constraints, this essay will focus on behavioral neuropharmacology as it relates to animal (i.e., predominantly rodent and primate) models of human neuropsychiatric disorders. It should be noted, however, that there are other fields within this discipline that examine the neuropharmacological underpinnings of behavior, e.g., in insects or lower vertebrates – a line of research that is not related to issues mentioned above and that will therefore not be elaborated further.

### Characteristics

#### Principles of Behavior

When studying behavior for neuropharmacological purposes, it is important to be aware of some basic principles of behavior and of different categories of behavior, which in turn influence the way a particular behavior is analyzed. Over time, the various forms of behavior have been categorized differentially. Below, only one of these categorizations, which is particularly pertinent to the present topic, has been outlined. One basic type of behavior is ►reflexive (or respondent) ►behavior. It is elicited by specific stimuli and usually involves no specific training or conditioning; rather, the responses are typically part of the natural behavioral repertoire of the species and are expressed under suitable environmental conditions. In some cases, the behavior is elicited by the administration of a drug, and then the particular behavior is used to define or assess pharmacological activity of that drug. Examples of this type of behavior include the startle reflex and the phenomenon of ►prepulse inhibition (an animal model for testing antipsychotic drugs, or for studying mechanisms of schizophrenia), the avoidance of the open arms of an ►elevated plus maze or the production of ultrasonic vocalizations of pups upon maternal separation (animal models for testing anxiolytic drugs, or for studying mechanisms of anxiety), or the various

nocifensive responses to nociceptive stimuli, e.g., tail-withdrawal, paw-withdrawal, vocalizations, increase in blood pressure (animal models for testing analgesic drugs, or for studying mechanisms of pain) [1–3].

In contrast to ►**reflexive behavior**, ►**operant behavior** is controlled by its consequences, i.e., by positive ►**reinforcement** or negative reinforcement (=punishment) that is the consequence of a particular behavior and that shapes the future expression of that behavior. Examples of this type of behavior include: various forms of navigation in mazes (►**water maze**, T-maze, eight-arm maze) (animal models for testing cognition-disrupting or – enhancing drug effects, or for studying mechanisms of learning and memory); various forms of responding in ►**operant chambers** (►**Skinner boxes**) (animal models for assessing the abuse potential or the ►**discriminative stimulus** effects of drugs, or for studying mechanisms of drug addiction, regulation of food intake, etc.); or conditioned avoidance reactions to electric shocks (e.g., conflict procedures such as the ►**Vogel conflict test**) (animal models for testing anxiolytic drugs, or for studying mechanisms of anxiety) [1–3].

### Principles of Animal Models and the Issue of Validity

In the present context, a model is defined as an experimental preparation intended for studying a condition in a different species. Typically, models are animal preparations that attempt to mimic a human condition and that allow the study of that condition. Different animal models can have different intended purposes. At the one extreme, an animal model can attempt to reproduce a whole psychiatric disorder in a laboratory animal. Such an approach is fraught with difficulties, in part because it often relies on arguments of apparent similarities that are not well defined and can be subjective (see the issue of validity, below), and in part because often the human psychiatric disorder itself that is intended to be modeled is not well characterized in every aspect. The defining symptoms and the diagnostic categories for many psychiatric disorders have sometimes changed repeatedly over the decades.

At the other extreme, a more limited purpose for an animal model is to provide a way to systematically study the effects of potential new therapeutic drugs. In this case, the aim is not to model a disease but to find a preparation in which the therapeutic utility against a certain disease can be tested. Although this approach is usually less burdened with the conceptual problems mentioned above, there are other problems. Such models are usually developed and validated by reference to the effects of known therapeutic drugs. This can limit the ability of the model to identify drugs with new mechanisms of action, and it can fail to detect drugs that would be active against symptoms that are refractory to the known drugs [3,4].

The primary purpose of an animal model is to enhance understanding of a human condition or to predict the action of a drug in humans. Therefore, from a practical point of view, the single most important feature of a model is the model's ability to lead to accurate predictions, i.e., its ►**predictive validity**. There are a number of other categories of validity that can have great heuristic value from a scientific or theoretical point of view, such as ►**construct validity** (the accuracy of a model with which the model measures what it is intended to measure), ►**etiological validity** (the phenomenon in the model has the same etiology as the phenomenon in the human condition) or ►**face validity** (the phenomenological similarity between a behavior exhibited in an animal model and in the human condition) [3,5].

A problem related to the issue of validity is that some ethologically-based models work with healthy animals that are exposed to an artificial situation, and the effects of a drug are evaluated in that situation. There have been attempts to create better models by inducing particular “pathological” states in experimental animals against which a drug can then be tested. These states can be produced by molecular, pharmacological, neurodevelopmental or behavioral manipulations and are aimed at enhancing the construct or etiological validity of the models.

These issues can be exemplified with the available animal models of Parkinson's disease and anxiety. The symptomatology and pathology of Parkinson's disease is well described (progressive degeneration of dopaminergic neurons within the midbrain substantia nigra pars compacta, leading to progressive disturbance of motor functions), however, the etiology of the underlying pathophysiological mechanisms is not known yet. In other words, it is known what is happening in Parkinson's disease, but very little is known about why this is happening. The human syndrome is mainly characterized by the typical symptoms, akinesia, rigor, and tremor. In a very simple animal model, “neuroleptic-induced ►**catalepsy**”, akinesia and rigor is induced by a dopamine antagonist, e.g., haloperidol. This drug mimics the hypo-dopaminergic state of Parkinsonism insofar as it blocks dopamine receptors. However, this pharmacologic manipulation does not produce tremor in rodents or primates. This catalepsy is alleviated by known anti-Parkinson drugs. Thus, this model has reasonable predictive validity (because it can show therapeutic effects of drugs), but only partial face validity (because it only mimics akinesia and rigor, but not tremor), and it does not have etiological validity (because the symptoms are produced by a manipulation that is completely unrelated to the underlying pathophysiology, i.e., dopamine receptor blockade versus degeneration of dopaminergic neurons).

Therefore, more elaborate animal models attempt to mimic the underlying pathophysiology more closely

by lesioning (i.e., destroying by means of a neurotoxin) the dopaminergic cells. Although this more closely mimics the real pathophysiology, it is still an artificial situation inasmuch as the neurotoxin produces an acute degeneration of the dopaminergic neurons within a few days, whereas in humans the degeneration is a very slow and chronic process. The model that is currently thought to best mimic the etiology and progression of Parkinson's disease is the "rotenone model" [6]. Rotenone is a mitochondrial complex I inhibitor which, when administered over many weeks, causes a slowly progressing degeneration of dopaminergic neurons that may even involve some of the pathophysiological mechanisms that are also active in the human situation.

Although these models of Parkinson's disease may lack etiological and face validity, they do have a good degree of predictive validity. This situation is rather different regarding animal models of anxiety. There are a number of models with a varying degree of face and etiological validity; the major problem, however, is that the models have little or unknown predictive validity. The most widely used model is the elevated plus maze. Rodents have an innate tendency to avoid wide, open space and to prefer enclosed areas; thus, naïve animals show a clear preference on the plus maze for the closed arms versus the open arms. Standard anxiolytic drugs such as benzodiazepines increase the time spent on the open arms, the interpretation being that the drug makes the animals less "afraid" of the open arms. The model is well suited to detect anxiolytic-like effects of drugs with a benzodiazepine-like mechanism of action. However, in modern psychiatry first line treatment for anxiety disorders has changed from benzodiazepines to antidepressant drugs with a serotonergic mechanism of action (selective serotonin reuptake inhibitors, SSRIs). Despite being clinically effective, these drugs do *not* increase the time spent on the open arms of an elevated plus maze; if anything, they even show an anxiogenic-like effect and decrease the time on the open arms. Thus, the elevated plus maze is well suited to detect the effects of one class of drugs, but entirely unsuited to detect the effects of another class of drugs that has demonstrated clinical efficacy. Thus, the model does not have general predictive validity, and it is not known whether drugs with new mechanisms of action would show anxiolytic-like effects in this model. This is a big dilemma for pharmaceutical drug development searching for compounds with new mechanisms of action, especially since other animal models of anxiety have the same principle problem.

### Methods for Monitoring Brain Mechanisms

As mentioned above, the aim of behavioral neuropharmacology is not only the pharmacological manipulation and analysis of behavior, but also to relate behavior to brain mechanisms. Methods for measuring

and analysing brain function were developed concurrent with the methods for systematic manipulation and analysis of behavior. The earliest method for direct assessment of activity in the nervous system was electrophysiology. This method allows region- or even cell-specific measurement of the activity of nerve cells. In the 1980s, the method of intracranial microdialysis was developed. At the tip of a probe implanted into the brain, molecules diffuse across a semi-permeable membrane along a concentration gradient. This very valuable method allows the measurement of transmitter release in response to pharmacological or environmental manipulations. For example, with this method it has been shown convincingly that drugs of abuse, but also naturally rewarding stimuli such as sex or food, lead to an increase of dopamine release in the nucleus accumbens. This observation has become one of the central building blocks of the dopamine hypothesis of reward [7].

With the fast development of molecular methods, new tools for analysing brain function and activity have become available. The analysis of expression profiles of genes, RNA or proteins is now a valuable tool for assessing the effects of pharmacological or environmental manipulations. The newest addition to the methods available for the study of the interrelationship between brain function and behavior are neuro-imaging techniques such as functional magnetic resonance imaging (fMRI). Although first only available for use in humans, technology has now reached a stage where it can also be applied to experimental animals [8].

### Outlook

Molecular techniques like the creation of transgenic animals (e.g., knock-out or knock-in mice) are regarded by some as a panacea for a range of human diseases, and the advent of molecular biology was already considered by some as the end of behavioral neuropharmacology. However, it is becoming increasingly clear that the important genotypes that are created by molecular techniques can only be fully exploited for the benefit of human therapeutics when their phenotype, and in particular, their behavioral phenotype is thoroughly characterized [9]. On the other hand, behavioral neuropharmacology can profit from the generation of transgenic animals, in particular in cases where highly specific pharmacological tools for certain receptors are lacking. Deleting or overexpressing a particular receptor can offer valuable insights into the relevance of this receptor for a certain disease, and can facilitate the establishment of new animal models [4]. Furthermore, the discovery of new receptor subtypes or subunits provides an opportunity for improved pharmacological selectivity of drug tools. Thus, despite (or because of) the advances in molecular neurobiology, it is to be expected that behavioral neuropharmacology will remain an indispensable discipline of the neurosciences.

## References

1. Buccafusco JJ (ed) (2001) *Methods of behavior analysis in neuroscience*. CRC, Boca Raton, USA
2. Sahgal A (ed) (1993) *Behavioural neuroscience – a practical approach*, vols. I and II. IRL/Oxford University Press, Oxford, UK
3. Willner P (ed) (1991) *Behavioural models in psychopharmacology*. Cambridge University Press, Cambridge, UK
4. Tecott LJ, Nestler EJ (2004) Neurobehavioral assessment in the information age. *Nat Neurosci* 7:462–466
5. Hogg S (1996) A review of the validity and variability of the elevated plus-maze as an animal model of anxiety. *Pharmacol Biochem Behav* 54:21–30
6. Bashkatova V, Alam M, Vanin A, Schmidt WJ (2004) Chronic administration of rotenone increases levels of nitric oxide and lipid peroxidation products in rat brain. *Exp Neurol* 186:235–241
7. Di Chiara G, Tanda G, Carboni E (1996) Estimation of in-vivo neurotransmitter release by brain microdialysis: the issue of validity. *Behav Pharmacol* 7:640–657
8. Cherry SR (2001) Fundamentals of positron emission tomography and applications in preclinical drug development. *J Clin Pharmacol* 41:482–491
9. Crawley JN (2000) *What's wrong with my mouse? Behavioral phenotyping of transgenic and knockout mice*. Wiley-Liss, New York, USA

## Behavioral Pharmacology

► Behavioral Neuropharmacology

## Behavioral Plasticity

### Definition

Changes in a behavior or behaviors as a result of some experience the organism undergoes. Included under the heading of behavioral plasticity are adaptation, learning, memory and changes in adult behavior as a result of experience during development.

## Behavioral State Control

### Definition

Vertebrates exist in three different behavioral states – waking, slow wave sleep and rapid eye movement

sleep. Behavioral state control refers to the mechanisms that enable transition between these.

► Mesopontine Tegmentum

## Behaviorism, Logical

MICHAEL SCHÜTTE

Otto-von Guericke Universität Magdeburg, Institut für Philosophie, Universität Magdeburg, Magdeburg, Germany

### Synonyms

Analytical behaviorism; Semantical behaviorism

### Definition

Logical Behaviorism is the view that every statement about mental phenomena can be translated without loss of meaning into a statement about behavioral dispositions [1]. Thereby it could be conceived as a version of ► Semantical physicalism which is the view that every statement containing mental terms can be translated without loss of meaning into a statement containing only non-mental (broadly physical) terms [2,3]. There also is a definition of Logical Behaviorism available in the material mode. Logical Behaviorism, then, is the view that beliefs, desires, thoughts, feelings and all other mental phenomena are basically behavioral dispositions. Logical Behaviorism is accurately called “behaviorism” because, according to it, mental phenomena are reducible to mere dispositions to behave. And it is correctly called “logical” because, according to it, this reduction is not an empirical matter, but results from the meanings (the “logic”) of mental expressions alone.

### Description of the Theory

Behaviorism comes in many varieties, the most important of which are Methodological (or Psychological) Behaviorism, Eliminative Behaviorism, and Logical Behaviorism. In psychology, behaviorism became increasingly dominant in the 1930s by the influence of Watson [4] and Skinner [5]. Their approach, aptly called Methodological Behaviorism, can be characterized by two main claims. The first is the claim that psychology is at its core a discipline about the explanation, prediction and control of behavior. The second is the claim that the only scientifically acceptable data in psychology are behavioral data, i.e. data which concern patterns of observable responses to physical stimuli. Watson and Skinner, though, were less clear about the ► ontological status of mental

phenomena. Despite their view that inner states are not objects adequate for psychological explanations, they were not clear about whether inner mental states do exist but are irrelevant to psychology or simply do not exist at all. The latter thesis is known as Eliminative Behaviorism, a forerunner of Eliminative Materialism [6].

In philosophy, behaviorism became popular as Logical Behaviorism. This view is one of the classical materialist positions towards the mind-body problem and, as such, is an account of how mental phenomena fit into the natural order. Often it is said that Ryle [1] and Wittgenstein [7] are proponents of Logical Behaviorism. This may not be exactly true, but there can be no doubt that Ryle's and Wittgenstein's analyses of many mental concepts inspired philosophers to go forward in trying to understand mental phenomena as behavioral dispositions. Logical Behaviorism does not entail either Eliminative Behaviorism, nor Methodological Behaviorism: It does not eliminate mental phenomena, but says that they are nothing but certain behavioral dispositions; and it is a claim about the nature of mentality which is not tied to any particular scientific methodology.

The Semantical Physicalists (Carnap [2], Hempel [3]) were mainly concerned with the question of how psychology as a special science relates to physics. As part of their unity-of-science agenda, they aimed to show that "psychology is an integral part of physics" (Hempel [3]:18). And they tried to demonstrate this by trying to show that every bit of mentalistic discourse can be translated into synonymous bits of physicalistic discourse. If this were true, it would be obvious how every psychological explanation also would be a kind of physicalistic explanation. In their argument for this rather strong view, the so called ►[Verification theory of meaning](#) played an essential role. This theory of meaning, popular in the Vienna Circle, is basically the view that the meaning of every non-analytic statement "is established by the conditions of its verification" (Hempel [3]:17). Two empirical statements have the same meaning, according to this view, if and only if they can be verified under exactly the same conditions. The Semantical Physicalists used this theory in order to make plausible their reductive view on mentalistic statements. Hempel's example is the mentalistic sentence "Paul has a toothache." He claims that all circumstances which verify this sentence are expressed by a very long list of physical test sentences which includes "Paul weeps and makes gestures of such and such kinds"; "At the question "What is the matter?", Paul utters the words "I have a toothache"; but also "Such and such processes occur in Paul's central nervous system" (Hempel [3]:17). Therefore, Hempel argues, given the Verification theory of meaning, this mentalistic sentence is synonymous with the conjunction of all the relevant physical test sentences.

### Motives for Logical Behaviorism

Logical Behaviorism could be seen as a special version of Semantical physicalism, because it implies that every mental sentence is translatable into a synonymous sentence which does not include mental expressions. But it is important to note that the Logical Behaviorists neither shared the motives of Carnap and Hempel, nor are committed to their ideas of the ►[unity of science thesis](#) and the Verification theory of meaning in particular. Instead, one important motive behind Logical Behaviorism was to avoid Cartesian Dualism with its "dogma of the Ghost in the Machine" (Ryle [1]: 17). According to the view which Ryle attacks, an action is, e.g. intelligent (or clever, prudent, wise etc.) if and only if it is caused by a piece of intelligent reasoning, and an action is voluntary if and only if it is the effect of a volition or act of the will. What makes an action intelligent or voluntary, therefore, are certain "ghostly" inner processes which cannot be observed by people other than the actor itself. Ryle thinks that this picture of the mind is due to a deep misunderstanding of our mental concepts. These concepts, he argues, do not refer to private inner processes in the mind, but are correctly analyzed as dispositional concepts. Expressions like "intelligent," "critical," "logical," "witty" are, as Ryle tries to show, semantically closer to "fragile," "water-soluble, or "inflammable" than to expressions which denote objects or processes. (Although, unlike "water-soluble," mental concepts are what Ryle calls "determinable concepts," i.e. refer to ►[multi-track dispositions](#) whose manifestations can widely vary.)

Another important motive is the Logical Behaviorist's elegant dissolution of the problem of mind-body interaction. How do mental and physical events interact? How can we understand that events in the physical world like Mary's walk to the office are the effects of mental events like Mary's thought that going to the office would be the best thing to do? According to the Logical Behaviorists, the assumption that there are such causal relations between the mental and the physical is just a misunderstanding. They think that mental concepts denote behavioral dispositions and these dispositions are not the causes of behavior, but rather a piece of behavior is a manifestation of a disposition.

But perhaps the most important motive behind Logical Behaviorism is its solution to an epistemological worry: How can we know what other people think, believe, desire, hope, intend, etc.? If these are essentially events in other people's minds, and we can not literally look into these minds, it seems that we are precluded in principle from knowing what other people think and feel or even whether they think and feel at all. Maybe they are like robots without an inner mental life. According to Logical Behaviorism, this is not a real problem because mental states are no mysterious



inner episodes in people's minds, but are behavioral dispositions whose manifestations are as observable as any other public manifestations are.

### Objections to Logical Behaviorism

Logical Behaviorism faces several strong objections. The first is that it raises a worry concerning ►**first-person authority**. Logical Behaviorism explains our knowledge of other people's mental states by viewing these as behavioral dispositions. But this third-person account of knowledge of minds leads to a related difficulty: How do we know our own mental states? If these were really behavioral dispositions, then we should know our own minds primarily by observing our own behavior. But this seems to be plainly false. Instead, there seems to be a kind of privileged access to our own mental states.

There is a second objection saying that Logical Behaviorism ignores the essential ►**phenomenal character** of many mental phenomena. Is it credible that mental phenomena like pains or sensations of warmth are mere dispositions to behave? Most laymen and many philosophers do not think so. Instead, there is a nagging intuition that there is definitely more to a pain than just being disposed to whine and groan, say that one is in pain, go to the doctor, and take some pills, etc. This objection naturally leads to a view (e.g. the Identity Theory as defended in [8]) that understands sensations as manifest inner states which cause things like my whining and groaning.

A third objection is perhaps the strongest one. It emphasizes the conceptual interdependence of many intentional expressions as a fundamental obstacle to analyzing mental states solely in terms of behavioral dispositions. Take beliefs. To believe that there is a bottle of Bordeaux in the basement, according to Logical Behaviorism, just means to be disposed to go down the stairs when certain circumstances occur. But, as Chisholm [9] demonstrated, a substantial reference to a desire is hidden here behind the phrase "when certain circumstances occur": Believing that there is a bottle of Bordeaux in the basement, I will go down the stairs for the bottle only if I desire to drink it. Unless I indeed have such a desire, the bottle will remain in the basement. The upshot is that you cannot understand what it is to believe something, unless you know what it is to desire something. And the converse is also true: You cannot understand what it is to desire something, unless you have the concept of belief. Desiring to drink a bottle of Bordeaux, I will go down the stairs for the bottle only if I believe that there is a bottle of Bordeaux in the basement. Unless I do believe this, the bottle, again, will remain in the basement. Such conceptual relations make it clear that belief sentences and desire sentences cannot be translated without loss of meaning into sentences about mere behavioral dispositions.

And this kind of reasoning generalizes to many other ascriptions of mental states.

This last objection naturally leads to ►**Analytical functionalism** which is another classical materialist position concerning the mind-body problem. What seems to have gone wrong in analyzing mental phenomena as mere behavioral dispositions is the Logical Behaviorist's ignorance of conceptual relations between mental concepts themselves. They overlook that relations between individual mental states and actual or possible behavior are not the only ones relevant to our mental concepts. This is fixed in the Analytical Functionalist's picture (see [10]). Analytical functionalism is the theory that, by conceptual necessity, every mental state of an organism can be characterized by its causal relations to perceptual input, other internal states, and the behavioral output of the organism. Because according to Analytical functionalism, mental states are explicitly defined by reference to input and other internal states of the organism, they are not mere behavioral dispositions. But nevertheless mental states are conceptually tied to behavior, because they are defined by reference to behavioral output as well. Analytical functionalism therefore can preserve one important feature of Logical Behaviorism without being vulnerable to the objection that it ignores certain essential conceptual relations.

These objections are rather strong. As a reductive account of the mental Logical Behaviorism is an almost philosophically dead position. That does not mean that it is wrong about every mental phenomenon. Textbook wisdom nowadays has it that there are two features of the mind which are basic, namely intentionality and phenomenal content, and that every mental state has either one of these basic features or both in some combination. And although as it seems to many that Functionalism is a quite good account of the former, and the Identity Theory a quite good account of the latter basic feature, there are some non-basic kinds of mental states that Logical Behaviorism seems to be a quite good account of, e.g. talents or traits of character and personality like honesty, ambitiousness, and short-temperedness.

### References

1. Ryle G (1949) *The Concept of Mind*. Hutchinson, London
2. Carnap R (1932) *Psychologie in physikalischer Sprache*. Erkenntnis 3:107–142
3. Hempel CG (1935) The logical analysis of psychology. In: Block N (ed) *Readings in the philosophy of psychology*, vol 2. Harvard University Press, Cambridge, MA, pp 14–23
4. Watson JB (1930) *Behaviorism*. University of Chicago Press, Chicago
5. Skinner B et al. (1984) Skinner: canonical papers. *Behav Brain Sci* 7:473–701

6. Churchland P (1981) Eliminative materialism and the propositional attitudes. *J Philos* 78:67–90
7. Wittgenstein L (1953) *Philosophical investigations*. Blackwell, Oxford
8. Smart JJC (1959) *Sensations and brain processes*. *Philos Rev* 58:141–156
9. Chisholm R (1957) *Perceiving*. Cornell University Press, Ithaca, NY
10. Braddon-Mitchell D, Jackson F (1996) *The philosophy of mind and cognition*. Blackwell, Oxford

## Belief

### Definition

A belief is either a person's state of believing something or a propositional content that is believed. Belief states are long-term mental attitudes rather than mental events like thoughts.

They play a typical causal role : they are changed by perceptual input and influence our behavior. Beliefs come in different degrees. It is a controversial matter whether beliefs are representational states.

- ▶ Argument
- ▶ Logic

## Bell's Palsy

### Definition

Bell's palsy results from injury of the VIIth cranial nerve, commonly after viral infections, e.g. a herpes zoster infection of the ▶ [geniculate ganglion](#), leading to blisters in the external ear canal, loss of ▶ [taste](#) sensation, distortion of the face (pull to the contralateral side because of ipsilateral weakness of facial muscles). Aberrant subsequent nerve regeneration may lead to ▶ [synkinesias](#), such as jaw winking, in which movements of the lower face coincide with, e.g., eye closure.

## Bell-shaped Speed Profile

### Definition

The velocity profile for a movement between two points in space with velocity zero at the begin and end, as

predicted by the minimum-jerk model, is symmetric in time relative to peak velocity. This profile is bell-shaped.

- ▶ [Motor Control Models](#)

## Benedikt Syndrome

### Definition

The Benedikt syndrome results from lesion (infarction) of the ▶ [midbrain](#) peduncle and ▶ [tegmentum](#) and characterized by oculomotor paresis, weakness and ataxia.

## Benign Essential Tremor

- ▶ [Essential Tremor](#)

## Benign Familial Tremor

- ▶ [Essential Tremor](#)

## Benign Paroxysmal Positional Vertigo (BPPV)

### Definition

Disorder of the labyrinth that occurs when otoconial crystals become dislodged from the otoconial membrane and pass into one or more semicircular canals.

The posterior semicircular canal is most commonly affected because it is in the most dependent position of the labyrinth. Head movements in the plane of the affected canal result in motion of the crystals, which leads to abnormal deflection of the cupula. Vertigo and nystagmus then follow. Repositioning maneuvers can be very effective in the treatment of BPPV.

- ▶ [Disorders of the Vestibular Periphery](#)

## Bergmann Glia

### Definition

Bergmann glia are specialized astrocyte glia cells in the cerebellar cortex. Their cell bodies are in the Purkinje cell layer and their processes extend upward through the molecular layer to the pial surface of the cerebellum.

## Bernstein Problem

### Definition

The problem of elimination of redundant degrees-of-freedom during natural movements.

- ▶ Coordination

## Best Disease

### Definition

- ▶ Chloride Channels and Transporters

## Bestrophin

### Definition

A  $\text{Ca}^{2+}$ -activated  $\text{Cl}^-$  channel predominantly expressed in the basolateral membrane of the retinal pigment epithelium. Mutations in Bestrophin result in Best disease, an inherited form of macular degeneration.

- ▶ Best Disease
- ▶ Chloride Channels and Transporters

## Beta Rhythm

### Definition

A neocortical pattern of 13–35 Hz EEG activity characteristic of alert wakefulness in humans.

- ▶ Brain Rhythms

## Beta Sheet

### Definition

A secondary protein structure in which two or more extended strands of the polypeptide chain lie side by side (running either parallel or antiparallel), held together by a regular array of hydrogen bonds between backbone NH and C = O groups, to form a ridged planar surface.

- ▶ Alpha-Synuclein: From Neurological Disorders to Molecular Pathways

## Beta-motoneuron

### Definition

A motoneuron that innervates both extra- and intrafusal muscle fibers.

- ▶ Motor Units

## Betz Cells

### Definition

Betz cells, discovered by and named for a nineteenth century Russian anatomist, are large pyramidal-shaped neurons found in primary motor cortex. Some Betz cells have cell bodies of over 100  $\mu\text{m}$  across.

## Bezold-Jarisch Reflex

### Definition

The Bezold-Jarisch reflex is a cardiovascular response consisting of a decrease in heart rate and arterial blood pressure automatically evoked as a direct consequence of chemical or pharmacological stimulation of receptors in the heart or lungs. The decrease in blood pressure is due both to the slowing of the heart and a vasodilation caused by inhibition of sympathetic vasomotor activity.

This reflex was first described by von Bezold and Hirt in 1867, who observed that intravenous injection of veratrum alkaloids caused a profound fall in blood pressure and heart rate. Other chemical agents, such as phenylbiguanide, also trigger the response. The receptors for the reflex are located on the terminals of sensory unmyelinated fibers in the vagus nerve (CN X). The functional significance of the Bezold-Jarisch reflex in circulatory regulation is not understood, although it has been suggested that the reflex may contribute to the severe hypotension associated with vasovagal syncope.

## B-FABP

### Definition

B-FABP is a member of the fatty acid binding protein family. It is highly related to the peripheral myelin protein P2. B-FABP is expressed by radial glial cells in the developing CNS, and also expressed by satellite cells in DRGs in embryonic and adult mice and by glial cells in embryonic nerve trunks but not by adult.

Schwann cells. B-FABP is not expressed by migrating crest cells or by developing neurons. Therefore, it likely labels cells that are common precursors of Schwann cells and satellite cells.

- ▶ Schwann Cell
- ▶ Schwann Cell Precursor
- ▶ Schwann Cells in Nerve Regeneration

## Biased Competition Theory of Attention

### Definition

Biased competition theory was originally proposed by John Duncan and colleagues in order to explain two basic phenomena that occur while processing a crowded visual scene. First, not all objects in a scene can be processed at the same time, that is, there is limited processing capacity. Second, while processing a particular object, one is able to filter out the unwanted information in the scene, that is, there is selectivity.

Biased competition theory rests on three general principles that conceptualize these basic observations further. First, of the many brain systems that represent

visual information (sensory and motor, cortical and subcortical), most are competitive. Within each system, a gain of representation for a visual object will be at the expense of other objects' representations. Competitive interactions among multiple objects (such as the faces in a crowd) occur automatically and operate in parallel across the visual field. Second, the competition between systems is integrated. As a visual object gains dominance in representation within one system (e.g. visual cortex), it will tend to gain similar dominance in other systems (e.g. higher-order frontal and parietal areas). And third, competition is controlled within and across brain systems. If one looks for a particular object (e.g. a friend's face), units matching the internal "template" of that object will be pre-activated and therefore gain an advantage by receiving an increased processing weight. Thus, such top-down attention mechanisms introduce bias signals that help resolve the ongoing competition. The competition among multiple objects can also be biased by bottom-up mechanisms that separate figures, or constitute objects, from their background by principles of perceptual organization (see Visual attention).

- ▶ Visual Attention

## Bickerstaff's Brainstem Encephalitis

TOMASZ BERKOWICZ, KRZYSZTOF SELMAJ  
Department of Neurology, Medical University of Lodz,  
Lodz, Poland

### Synonyms

Bickerstaff's encephalitis; Bickerstaff's syndrome

### Definition

▶ **Bickerstaff's brainstem encephalitis (BBE)** is an uncommon central nervous system (CNS) disease characterized by acute external ophthalmoplegia, cerebellar ataxia with disturbances of consciousness and pyramidal signs. Its etiology remains unknown but it is postulated that BBE has an autoimmune origin because of an antecedent illness and frequently the presence of anti-GQ1b antibodies. BBE is usually a monophasic disease with a generally good outcome.

### Characteristics

#### Clinical Presentation

The first cases of descending brainstem syndrome were described in 1951 by Bickerstaff and Cloake under the title "Mesencephalitis and rhombencephalitis" [1].

In 1957 Bickerstaff defined the disease as “brainstem encephalitis” [2]. The condition has been called Bickerstaff’s brainstem encephalitis since 1978 when Bickerstaff wrote a review for the Handbook of Clinical Neurology under the title “Brain stem encephalitis (Bickerstaff’s encephalitis)” [3]. The largest cohorts of BBE patients were published by Al-Din et al. (18 cases) in 1982 [4] and Odaka et al. (62 cases) in 2003 [5]. Most of the BBE patients described in the literature had signs of infection before the onset of neurological disease. They usually had upper respiratory infection symptoms, fever, headache or diarrhoea. In the antecedent infections many pathogenic microorganisms were identified. They include *Campylobacter jejuni*, herpes simplex virus, cytomegalovirus, Epstein-Barr virus, varicella zoster virus, *Salmonella typhi* and *Mycoplasma pneumoniae* [6]. Cases of BBE were also reported during pregnancy, after generalized trauma, head trauma and after otological operation (mastoidectomy for a cholesteatoma).

The most common initial symptoms are diplopia, gait disturbances and drowsiness. During the course of the illness almost all the patients develop external ophthalmoplegia, ataxia and most of them have disturbances of consciousness (drowsiness, stupor, semicoma or coma). Ophthalmoplegia has characteristic features, progressing frequently from symmetrical impairment of conjugate upward and lateral gaze to complete ophthalmoplegia. Disturbances of consciousness tend to be a reflection of involvement of the rostral part of the reticular formation. Extensor plantar response (Babinski’s sign), papillary abnormalities, nystagmus, facial weakness and bulbar palsy are also frequently found. The progression of cranial palsies is usually rostral-caudal. If ataxia is the primary demonstration of BBE, it involves gait instability, upper and lower extremities dysmetria, dysidiadochokinesis, past-pointing and truncal instability. Development of neurological symptoms of BBE is relatively fast, within 1–2 days. Deep tendon reflexes are usually brisk, but can be normal or decreased. There are cases of BBE with symmetric flaccid limb weakness and with dysesthesias occurring as typical initial symptoms. These cases are classified as BBE with overlapping/coexisting ► **Guillain-Barré syndrome** (GBS), an acute demyelinating neuropathy. Two atypical cases of BBE with severe muscle rigidity were observed. One of them was misdiagnosed in the beginning as tetanus. Some of the BBE patients develop respiratory failure in the period of maximal disability. They need intubation followed by mechanical ventilation in a critical care unit. When prolonged mechanical ventilation is necessary sometimes a tracheostomy is performed. BBE progresses from 1 to 8 weeks in a steady and unremitting way. The period of most severe neurological symptoms is variable, from 5 days to 4 weeks. The main signs typically improve within 2–3 weeks but full recovery can take as long as 3–18 months. BBE usually has a monophasic

course but there are also reports of remitting cases. We observed two remitting cases, one of them with overlapping GBS. The final outcome is generally good but occasionally the disease can be fatal. From the largest group of 62 patients only three died. Some patients have residual symptoms: dysesthesias, limb weakness, diplopia, gait disturbances, dementia, dysphagia and psychotic changes (emotional lability, violent behavior). Bickerstaff also described a case of BBE with development of typical Parkinsonism during the recovery phase. For a diagnosis of BBE, it is necessary to exclude the following conditions: vascular lesions of the brainstem, Wernicke’s encephalopathy, central pontine myelinolysis botulism, myasthenia gravis, neoplasm of the brainstem (glioma, lymphoma), pituitary apoplexy, acute disseminated encephalomyelitis, multiple sclerosis, neuro-Behcet disease, Lyme disease, neurosarcoidosis, Whipple’s disease and toxic effects of alcohol and drugs, especially anticonvulsant drugs. In this regard it is worth remembering that sometimes cerebral tumors, for example brainstem glioma, may relapse and remit.

### Laboratory Findings

In BBE no abnormalities are usually discovered in routine blood investigations and urinary tests.

The cerebrospinal fluid (CSF) pressure is usually normal. CSF examination shows mild lymphocytic pleocytosis (usually not more than 100 cells/ $\mu$ l) with or without a moderate rise of protein. Albuminocytological dissociation (protein  $\geq$ 45 mg/l, cellularity  $\leq$ 5cells/ $\mu$ l) can also be observed.

About two-thirds of BBE patients have high titers of immunoglobulin G (IgG) antibodies against ganglioside NeuAca2–8NeuAca2–3Gal $\beta$ 1–3GalNac $\beta$ 1–4(NeuAca2–8NeuAca2–3) Gal $\beta$ 1–4Glc $\beta$ 1–1’Cer (GQ1b). ► **Anti-GQ1b antibody** titres decrease with clinical improvement of the disease. The potential role of this antibody in the pathogenesis of BBE supports the fact that the third, fourth and sixth cranial nerves contain GQ1b ganglioside. The paranodal regions of the extramedullary portion of human oculomotor, trochlear and abducens nerve can be strongly stained using mouse anti-GQ1b monoclonal antibody. It is also probable that anti-GQ1b antibody is closely associated with impairment of these cranial nerves involved in ocular movement. This antibody also weakly stains deep cerebellar nuclei, the gray matter in the brainstem, spinal cord, some cells of large dorsal root ganglion and muscle spindles. Anti-GQ1b antibodies cross react with lipopolysaccharide present in the bacterial coat of *Campylobacter jejuni* and in fact serological evidence of recent *Campylobacter jejuni* infection was found in many of the BBE patients. Additionally, an absorption done with anti-GQ1b antibody showed that human fibroblasts express the

GQ1b epitope after herpes simplex virus (HSV) infection was also detected in patients with BBE. In some patients, therefore, anti-GQ1b antibodies may be induced after *Campylobacter jejuni* or HSV infection. Antibody to GQ1b ganglioside can also be detected in the sera of patients with ► **Miller Fisher's syndrome** (MFS), GBS with ophthalmoplegia and acute ophthalmoparesis positive for anti-GQ1b antibodies. Due to the possibility of common autoimmune mechanisms of these four illnesses and the fact that they are similar clinically a term "Anti-GQ1b antibody syndrome" was created [7]. Anti-GM1b and anti-Ga1Nac-GD1a IgM antibodies were also detected in the sera of BBE patients. These antibodies are much less frequent than the antiGQ1b antibody, but they may, however, also

be useful serological markers for identifying BBE patients.

Electroencephalography (EEG) in BBE shows widespread diffuse slow-wave activity in the theta and delta range. Features of sleep with K complexes and vertex sharp waves are also seen. Pathological activity is normalized with clinical improvement.

Electrophysiological examination shows that even in the BBE patients without overlapping GBS almost half of the patients have abnormal nerve conduction study findings. Predominantly BBE patients have features of axonal degeneration with reduced amplitudes of CMAPs and relatively normal motor conduction velocities in peripheral nerves. Findings characteristic for frank demyelination are much more frequent.

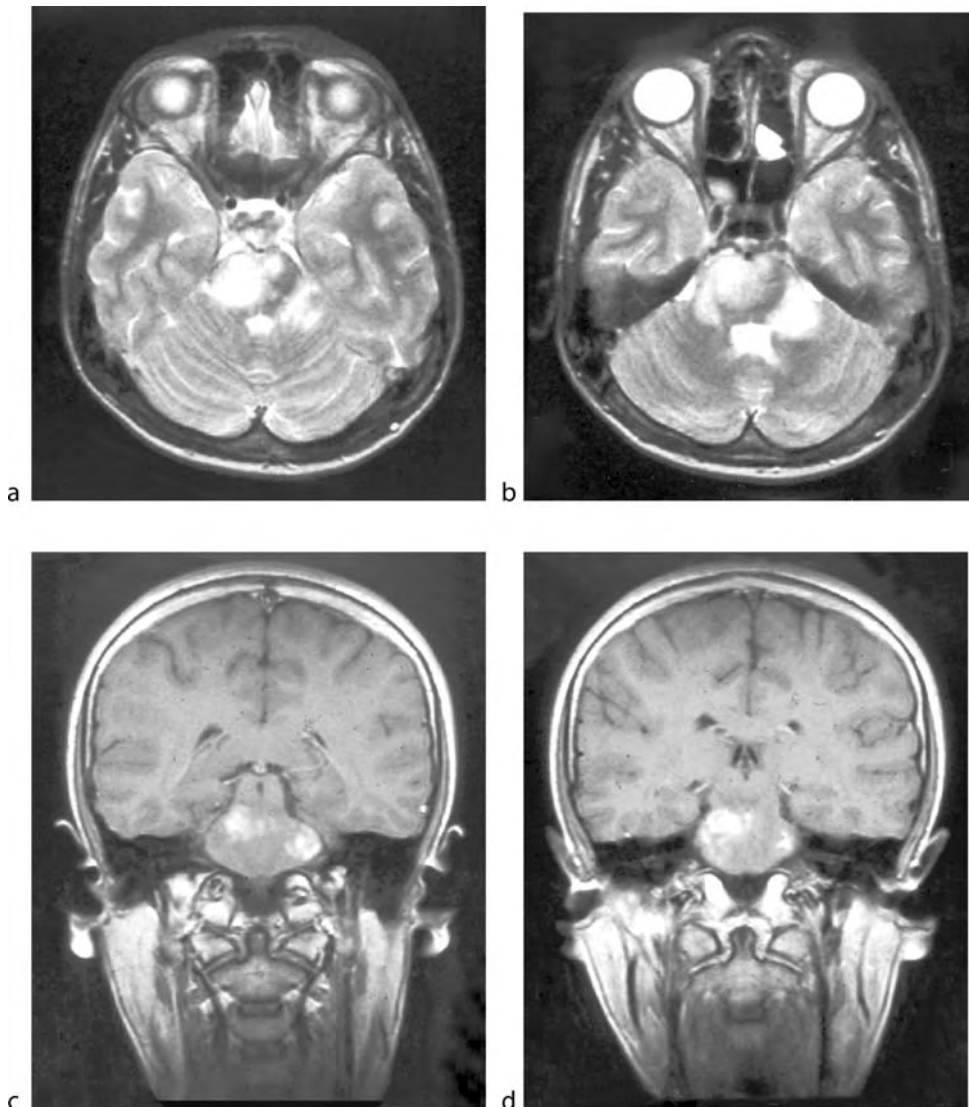

**Bickerstaff's Brainstem Encephalitis. Figure 1** MRI of the patient during the course of BBE – T2-weighted images (a, b), T1-weighted images enhanced with gadolinium (c, d).

### Imaging

Computed tomography (CT) was used for the imaging of brains of patients suspected of suffering with BBE before the magnetic resonance imaging (►MRI) era. CT scans showed no abnormalities or low density areas with various degrees of enhancement localized in brainstem, particularly in the pons and sometimes in the thalamus.

MRI is the most helpful tool in establishing diagnosis of BBE. In the majority of BBE cases MRI shows typical changes localized within brainstem [8]. On T1-weighted images, brainstem swelling is usually seen as well as widespread hypointense lesions within the pons, medulla oblongata and sometimes in the upper midbrain. These hypointense lesions showed various degree of gadolinium enhancement (Fig. 1) on most occasions. The enhancement lasts for several days. On T2-weighted sequences large lesions of hyperintensity can be easily spotted in the brainstem and sometimes

outside it, within cerebellum, thalamus or even in white matter of the cerebrum. Frequently these lesions were nearly symmetrical and combined large portions of brainstem. These changes can migrate or regress with the clinical course of the disease. Caudal migration of these changes was described during the course of the disease. BBE lesions usually vanish after several months (Fig. 2). Occasionally MRI can be normal in BBE despite of typical clinical presentation. In the absence of any abnormality on brain MRI, involvement of brainstem and cerebellum can be visualized with (18) F-FDG positron emission tomography (PET).

### Pathology

Due to the good prognosis of BBE, neuropathological findings in this disease are relatively scarce but consistent with clinical signs. On the section of the brainstem numerous focal lesions with large areas of central necrosis were described. Perivascular lymphocytic infiltrations

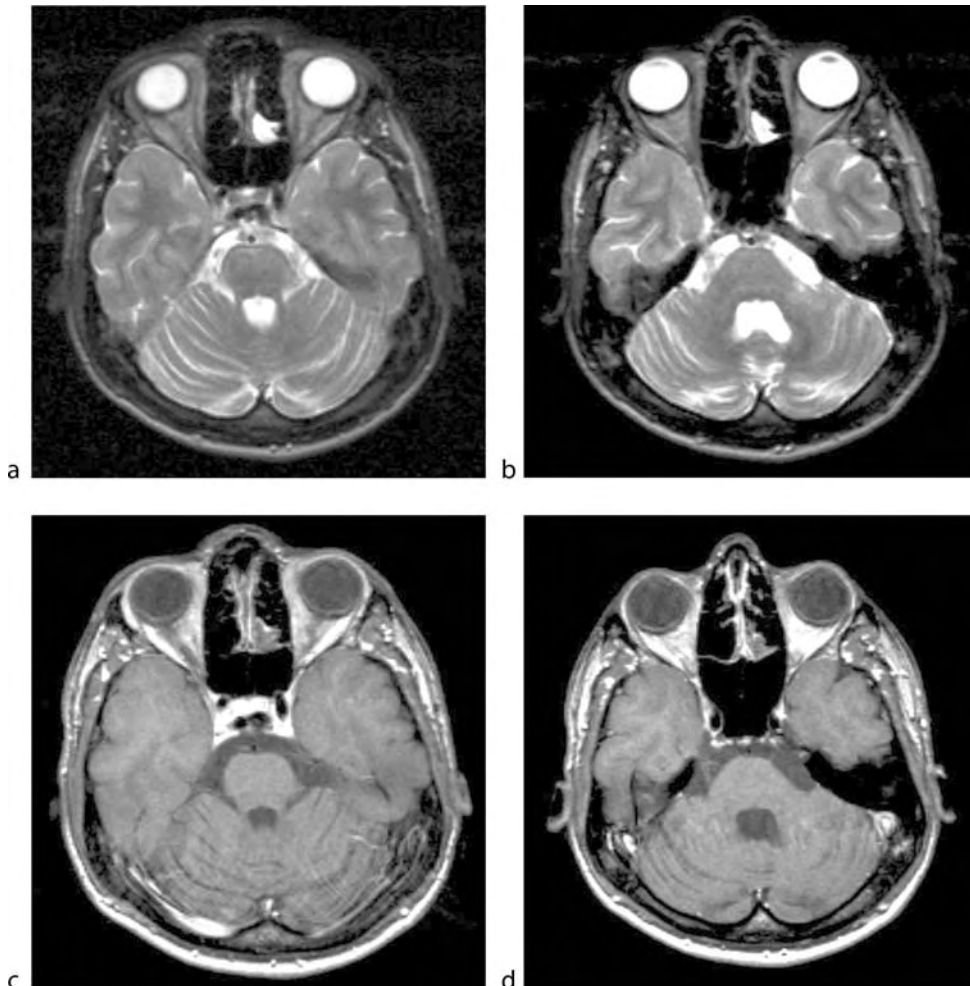

**Bickerstaff's Brainstem Encephalitis. Figure 2** Control MRI of the same BBE patient after 4 years – T2-weighted images (a, b), T1-weighted images enhanced with gadolinium (c, d).

with perivascular oedema were also found, and sometimes with very large numbers of macrophages. There was astrocytic proliferation present, sometimes forming “glial stars”. In the cerebellum, loss of Purkinje cells and degenerative changes in the dentate nucleus were found. Lymphocytic infiltration was also seen in the dorsal root ganglia. Chromatolytic changes of neuronal cytoplasm were described in the trigeminal motor nucleus and in the spinal anterior horn. Outside the central nervous system lymphocytic infiltrations were also described in bronchial mucosa of the lungs and peri-portal areas in the liver, which might indicate the appearance of systemic infective processes.

### Diagnosis

Early diagnosis of BBE could be difficult based on clinical findings, because characteristic symptoms do not always come together during the early phase of the disease. In our opinion the diagnosis of BBE should not only be based on symptomatology. Odaka et al. proposed very strict, purely clinical criteria. Based on them, “Progressive, relatively symmetric external ophthalmoplegia and ataxia by 4 weeks” and “disturbance of consciousness or hyperreflexia” are required for the diagnosis. We think that if clinical criteria are not complete, typical MRI pictures with a high signal lesion on T-2 weighted images localized in the brainstem confirms the diagnosis of BBE. The high titers of anti-GQ1b antibody may contribute to diagnosis of BBE. A good recovery from clinical symptoms helps to diagnose BBE.

### Therapy

There is no established therapy for BBE. Most patients are given immunotherapy such as steroids, plasmapheresis and intravenous immunoglobulins (IVIg). There are various types of plasmapheresis used, such as plasma exchange, double filtration plasmapheresis (DFPP) or immunoadsorption with a tryptophan-conjugated column, which highly absorbs anti-GQ1b IgG antibody [9]. In some BBE patients treatment with IVIg leads to rapid clinical recovery. IVIg may be an alternative treatment in BBE if plasma exchange is not available or contra-indicated. Also, combination of these therapies was very often used, for example, steroids followed by plasmapheresis, steroids and plasmapheresis followed by IVIg etc. Some patients are treated additionally with antibiotics and antiviral drugs. We also observed BBE cases misdiagnosed as pontine glioma. Brainstem lesions were irradiated with good outcome, although this could not of course be considered as a potential therapy for BBE.

### References

1. Bickerstaff ER, Cloake PCP (1951) Mesencephalitis and rhombencephalitis. *Br Med J* 2:77–81
2. Bickerstaff ER (1957) Brain-stem encephalitis: further observations on a grave syndrome with benign prognosis. *Br Med J* 1:1384–1387
3. Bickerstaff ER (1978) Brain stem encephalitis (Bickerstaff’s encephalitis). In: Vinken PJ, Bruyn GW (eds) *Handbook of clinical neurology*, vol 34. North-Holland, Amsterdam, pp 605–609
4. Al-Din AN, Anderson M, Bickerstaff ER, Harvey I (1982) Brainstem encephalitis and the syndrome of Miller Fisher. A clinical study. *Brain* 105:481–495
5. Odaka M, Yuki N, Yamada M, Koga M, Takemi T, Hirata K, Kubawara S (2003) Bickerstaff’s brainstem encephalitis: clinical features of 62 cases and subgroup associated with Guillain-Barré syndrome. *Brain* 126:2279–2290
6. Yuki N, Odaka M, Hirata K (2000) Bickerstaff’s brainstem encephalitis subsequent to *Campylobacter jejuni* enteritis. *J Neurol Neurosurg Psychiatry* 68:680–681
7. Odaka M, Yuki N, Hirata K (2001) Anti-GQ1b antibody syndrome: clinical and immunological range. *J Neurol Neurosurg Psychiatry* 70:50–55
8. Berkowicz T, Siger-Zajdel M, Zaleski K, Sokołowska D, Wendorff J, Selmaj K (2006) Bickerstaff’s brainstem encephalitis – an analysis of clinical and MRI findings. *Neurol Neurochir Pol* 40:1–6
9. Yuki N (1996) Tryptofan-immobilized column adsorbs immunoglobulin G anti-GQ1b antibody from Fisher’s syndrome: a new approach to treatment. *Neurology* 40:1644–1651

## Bickerstaff’s Encephalitis

- ▶ Bickerstaff’s Brainstem Encephalitis

## Bickerstaff’s Syndrome

- ▶ Bickerstaff’s Brainstem Encephalitis

## Bilateral Labyrinthectomy

### Definition

The surgical or chemical ablation of the sensory receptors of both inner ears.

- ▶ Vestibular Compensation and Plasticity



## Bilaterian Animals (Bilateria)

### Definition

The animals that have bilateral symmetry and whose bodies develop from three germ layers, the ectoderm, mesoderm and mesoderm. Comprises all groups of multicellular animals except sponges, cnidarians (jellyfishes, sea pens, hydras, etc.) and ctenophores (comb jellies). Consists of the deuterostomes (chordates, hemichordates, echinoderms, and xenoturbellid worms) and the protostomes (arthropods, nematodes, flatworms, annelid worms, brachiopods, molluscs, etc.).

► Evolution and Phylogeny: Chordates

## Bilirubin

### Definition

A byproduct of hemoglobin degradation, which is involved with neuronal and glial activation in neurotoxicity.

► Glial and Neuronal Reactivity to Unconjugated Bilirubin

## Binaural

### Definition

Having, or relating to, two ears. Sensitivity to binaural localization cues, including differences in the time of arrival or intensity of the sound at the ears, enable humans and other animals to determine the direction of a sound source.

## Binaural Beats

### Definition

A stimulus paradigm in which tones of slightly differing frequencies are presented to each ear. At the

site where the timing of sounds from the left and right ears are compared, such as the nucleus laminaris in birds or the medial superior olivary nucleus in mammals, the slight difference in frequency causes a slight difference in phase between the left and right ears inputs. This interaural phase difference varies as a function of time, leading to a sensation of motion.

► Neuroethology of Sound Localization in Barn Owls

## Binaural Cross-Correlation

### Definition

A process that approximates the computation of the delay between the signals in the two ears. In ordinary cross-correlation, a signal is multiplied by a delayed version of another signal in a point-by-point fashion, and the products are summed. The delay, called the “argument,” is changed and the multiplication and addition are repeated. The sum of the products is plotted as a function of argument. The cross correlation  $r(J)$  is computed thus:

$$r(\vartheta) = \int l(t)r(t+\vartheta)$$

where  $l(t)$  and  $r(t)$  are the two signals and  $J$  is the argument. The argument  $J$  is equivalent to the interaural time difference. Mathematically, the result is a graph of the sum of products as a function of  $J$ , with a major peak at the  $J$  that equals the delay between  $l(t)$  and  $r(t)$ . In the brain, typically in the nucleus laminaris of birds or the medial superior olive of mammals, a neuron tuned to a particular ITD ( $J$ ) is maximally activated.

► Neuroethology of Sound Localization in Barn Owls

## Binaural Interactions

### Definition

The neural process of combining the input from the two ears in some way.

## Binaural Pathways and Processing

DAVID McALPINE

UCL Ear Institute and Department of Physiology,  
University College London, London, UK

### Synonyms

Auditory processing; Sound localisation pathways

### Definition

Binaural hearing refers to the ability to extract information about the acoustic environment using two ears, which would not be possible using one ear only. Most commonly, binaural hearing is considered in terms of sound localisation cues, interaural time and interaural intensity differences. Specialized brainstem pathways exist that converge input from each ear onto individual neurons, rendering them sensitive to one or other of the binaural cues. The means by which binaural information is processed in the brain has been of considerable interest for some time, in large part due to the exquisite temporal capabilities of neurons that process interaural time differences.

### Characteristics

#### Spatial and Binaural Hearing

In the visual system a relatively complete understanding of spatial processing has been achieved, at least with respect to the two-dimensional representation of visual space projected on the back of the retina. In contrast, the study of neural coding of auditory space constitutes an altogether more complex problem – the primary representation of the ►cochlea, the sensory end organ in hearing, is sound frequency, rather than the location of the source. Nevertheless, the percept of a sound as originating from a distinct source is a fundamental property of normal hearing. Most ecologically-relevant sounds have a distinct quality that renders them spatially extant, and this attribute is provided for by a combination of the acoustic spatial cues, namely sensitivity to binaural cues for sounds in the horizontal plane, and sensitivity to spectral changes that occur as a sound source shifts in the vertical dimension.

According to Rayleigh's ►duplex theory [1], human ►binaural hearing is subserved by two mechanisms: at low frequencies (<1,500 Hz), sources of sounds are localized using ►interaural time differences (ITDs), whereas at high frequencies ►interaural intensity differences (IIDs, also called interaural level differences, ILDs) mediate localization. The dichotomy suggested by the duplex theory is, to a first approximation, reflected in the anatomy and physiology underlying sensitivity to ITDs and IIDs in the mammal brainstem. The medial superior

olive (MSO) of the brainstem shows a relative overrepresentation of neurons tuned to low ►characteristic-frequencies (CFs) and, in many mammals, appears to be specialized for the processing of ITD information, whilst the lateral superior olive (LSO), with a relative overrepresentation of high (>2 kHz) CF neurons, processes IID information. The tonotopic (sound frequency) organization at subsequent centers in the auditory pathway maintains this separation.

### Functional Anatomy of Pathways Sub-serving Binaural Hearing

Brainstem pathways underpinning binaural hearing (Fig. 1) mainly those contributing to ITD sensitivity, are highly specialized, comprising the most temporally-precise neural elements in the brain. An absolute requirement for ITD sensitivity is the ability to generate and retain information concerning the fine-structure waveform of the sound arriving at each ear independently, at least until the primary stage of binaural integration in the brainstem. Primary ►auditory nerve fibers (ANFs) synapsing at the base of the inner hair cells (IHCs) of the cochlea respond to the cycle-by-cycle changes in the IHC membrane potential (itself reflecting the back-and-forth deflections of the stereocilia) with action potentials that are “phase-locked” to the stimulus waveform (see Fig. 1).

The ability of ANFs to phase-lock their action potentials degrades with increasing frequency, such that for frequencies above approximately 4-kHz, ►phase-locking is absent in mammals, providing an upper limit for which temporal information is accessible. This upper limit is reduced at each synaptic stage, so that by the level of binaural integration the upper limit lies around 2 kHz. Certainly most mammals are insensitive to ITDs in the fine-structure of a sound above this frequency. However, although the upper limit of phase-locking is reduced in the ascending auditory pathway, both the synchronization (quality of phase-locking) and entrainment (whether or not an action potential is generated during each stimulus cycle) improves between the ANFs and the first synaptic stage in the ►cochlear nucleus (CN). ANFs entering the CN bifurcate, innervating both the ventral and dorsal aspects of the CN (VCN and DCN, respectively). Neurons of the VCN, particular the ►spherical bushy cells (SBCs) of the anterior division (AVCN) and the ►globular bushy cells (GBCs), appear specialized for temporal processing, with large synaptic contacts and fast membrane kinetics. Recordings made from the axons of SBCs indicate improved synchrony entrainment of phase-locking relative to ANFs, particularly for frequencies up to 1 kHz. As well as projecting ipsilaterally to the MSO, SBCs innervate the MSO on the opposite side via the fibers of the trapezoid body. The MSO in most mammals with well-developed low-frequency hearing is a laminar structure several cells thick located medially to the more prominent LSO.

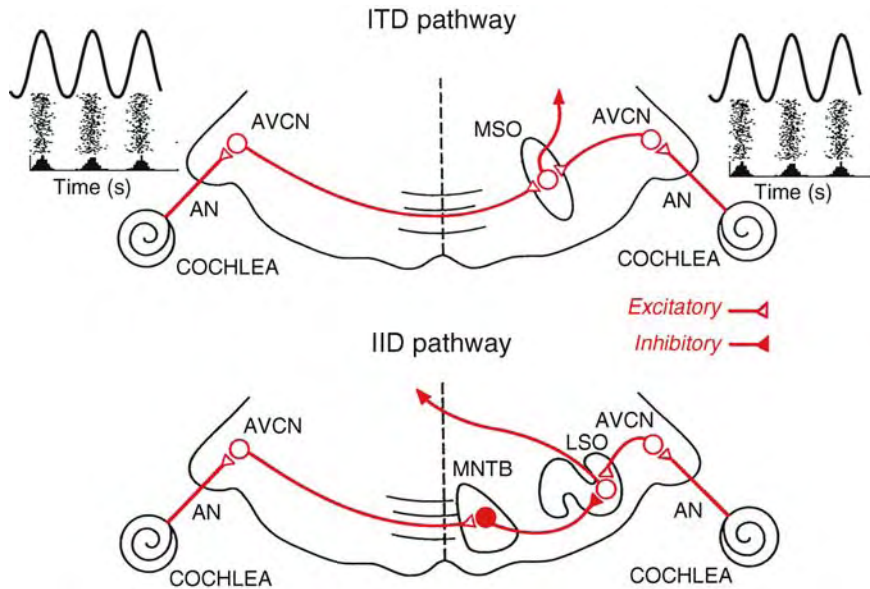

**Binaural Pathways and Processing. Figure 1** Traditional dichotomy of binaural brainstem pathways:- *Top*: Presumed pathway involved in processing ITDs. Phase-locked action potentials are transmitted from the auditory nerve fibers to the spherical bushy cells of each AVCN. Outputs of these neurons converge onto individual MSO neurons. *Bottom*: Projections from the cochlear nucleus innervate the principal cells of the MNTB on the opposite side. LSO neurons receive excitatory inputs from ipsilateral AVCN, and a glycinergic inhibitory projection from the MNTB. This pathway underpins sensitivity to IIDs. It is now known that the MNTB also provides the MSO with inhibitory input, and that this input is also important in the processing of ITDs (see text).

It is organized such that CFs are highest towards the ventrolateral pole of the nucleus, and lowest towards the dorso-medial. Individual MSO neurons typically show bipolar morphology, with two major dendrites emerging from the soma 180° to each other extending orthogonally with respect to the dorsoventral axis of the nucleus. Spherical bushy cells from the CN on each side of the brain converge onto single MSO neurons, with ipsilateral inputs synapsing on the lateral dendrites and contralateral inputs on the medial dendrites. MSO neurons also receive bilateral inhibitory inputs via some of the largest and most reliable synapses in brain, including the ▶calyx of Held in the ▶medial nucleus of the trapezoid body (MNTB). Recent studies indicate that for mammals such as gerbils with well-developed low-frequency hearing, these inhibitory inputs are largely restricted to the soma of MSO neurons following a period of developmental refinement [2]. Species in which low-frequency ITD processing is absent do not show this refinement. The major output of the MSO is primarily to the ipsilateral ▶inferior colliculus (the major auditory nucleus of the midbrain).

LSO neurons receive their major inputs from the SBCs of the ipsilateral AVCN and the principal neurons of the ipsilateral MNTB. In turn, the principal neurons of the MNTB receive their main input from the GBCs of the contralateral AVCN via the fibers of the

▶trapezoid body. It is interesting to note that although the LSO is associated primarily with the processing of interaural intensity, rather than temporal, cues, its neurons are innervated by neurons possessing exquisite temporal capabilities. Several reasons can be posited for this. First, as in the MSO neurons, low-CF neurons in the lateral limb of the LSO show sensitivity to fine-structure ITDs. Second, sensitivity to ITDs in the envelope structure of high-frequency modulated sounds is widely-reported to exist in the LSO [3]. Third, the fast-temporal capabilities of SBCs and neurons of the MNTB likely also support extraction of temporal cues other than binaural temporal cues, albeit cues requiring lower temporal fidelity. The largest excitatory projection from the LSO is to the contralateral IC, although the low-frequency lateral limb projects largely ipsilaterally. This ipsilateral projection contains both excitatory and inhibitory (glycinergic) neurons.

### Binaural Coincidence Detection

It is well established that neural sensitivity to ITDs arises first in the MSO, although the reported difficulties in recording from the MSO mean that relatively few successful recordings of ITD-sensitive MSO neurons have been made compared with other auditory centers. From those studies that have been successful, the consensus is that MSO neurons act as ▶binaural

coincidence detectors [4], responding maximally to sounds at favorable ITDs; i.e. when phase-locked input from each ear arrives in temporal coincidence, and sub-maximally at other ITDs (Fig. 2).

Neural discharge rates are highest (and modulation of those rates generally greatest) for tones near the CF. Other frequencies elicit fewer spikes and lower depths of response modulation. Consistent with the Jeffress model of coincidence detection [4], neurons show a characteristic delay (CD) an ITD for which the relative discharge rate

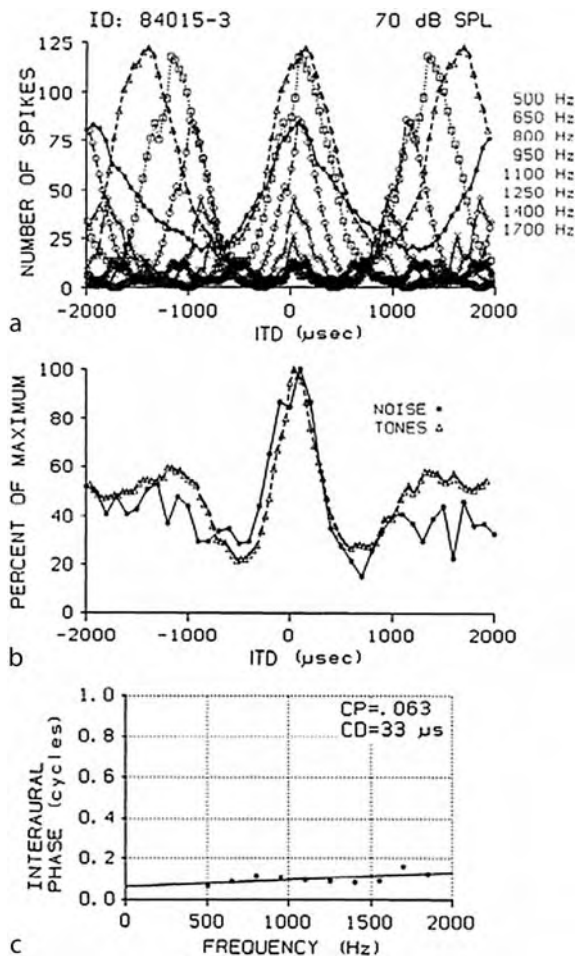

**Binaural Pathways and Processing. Figure 2** [Fig. 10 from: Yin TC, Chan JC. (1990) Interaural time sensitivity in medial superior olive of cat. *J Neurophysiol.* 64 (2):465–488] Response of MSO neuron to interaurally-delayed sounds. (a) Response to tones of different frequencies. (b) Summed responses to tones compared with response to interaurally-delayed broadband noise. (c) Function plotting best interaural phase difference (IPD) as a function of stimulus frequency, to derive the characteristic delay (CD). The characteristic phase (CP), which is close to zero, indicates that the CD occurs close to the peak of the response function.

is identical for different stimulus frequencies. When a range of static ITDs is imposed on the stimulus waveform, a cyclic pattern of responses is evoked; response maxima occur at intervals separated by the period of the stimulus waveform (See Fig. 2a). This reflects the underlying binaural coincidence detection, presumably at the level of the MSO. Theoretically, for neurons with a fixed axonal conduction delay from one or either ear, the CD corresponds to the ITD at which response peaks are aligned for all stimulus frequencies to which the neuron is sensitive. The CD is often evident in responses to different tonal frequencies (or by presenting interaurally-delayed broad-band noise as a stimulus – Fig. 2b), and can be quantified by plotting the response phase (with respect to the period of a pure tone) as a function of the stimulating frequency (Fig. 2c). However, although MSO neurons satisfy the basic requirement of coincidence detectors, evidence for any systematic arrangement of preferred ITDs that would indicate an ordered arrangement of delay lines in mammals is, at best, equivocal (in contrast to the well-established anatomical arrangements reported for birds). Further, recent evidence indicates that the preference of individual MSO neurons to respond maximally to a particular ITD is mediated by the inhibitory neurotransmitter ►glycine, most likely derived from MNTB and/or LNTB inputs. Blocking glycinergic inhibition *in vivo* shifts a neuron's preferred tuning for ITD towards zero [5], suggesting axonal conduction delays between the ears are essentially matched.

Despite the MSO being the site of primary binaural integration, the majority of studies examining ITD sensitivity in mammals have been investigated in the IC. Chief amongst these is the series of reports throughout the 1980s by Yin and Kuwada [6], documenting responses of IC neurons to a range of binaural stimuli containing ITDs, including interaurally-delayed tones, ►binaural beats noise and clicks. To a first approximation, IC neurons were reported to respond to ITD cues in a similar manner to (the relatively few) MSO neurons previously recorded at that time, an observation confirmed by later, more extensive MSO recordings in several laboratories.

### The Neural Code for Interaural Time Difference

A common assumption of most models of ITD processing is that individual neurons signal the location of a sound source by virtue of their peak firing rate; neurons are selectively tuned to a specific ITD, and therefore to a unique spatial location in the horizontal plane. One consequence of such behavior would be the requirement that at some level of the brain, neurons be sufficiently sharply tuned for ITD to account for the observed behavioral sensitivity (a few tens in human listeners). Skottun and colleagues [7], argued that, as in many other neural systems, the slopes of ITD

functions are likely to be the most sensitive region in terms of neural discrimination of ITDs. Such an eventuality answers a long-standing puzzle concerning the distribution of preferred ITDs across populations of neurons, many of which lie outside the range of natural ITDs, defined by the head-size of most small mammals. Related to this is recent evidence indicating that the arrangement of preferred ITDs in the IC runs parallel with, rather than orthogonal to, the main frequency gradient [8]; Figure 3a plots the distribution of peak ITDs as a function of neuronal CF. Surprisingly, given that sound frequency is the primary feature represented in the cochlea, and that this mapping is maintained at least to the level of primary cortex in the form of tonotopically-organized auditory centers, the relationship between neural CF and preferred ITD has been overlooked. The demonstration that peak ITD tuning is CF dependent marked the beginning of a significant departure from the view that ITD is represented in the brain in form of a “local code.” The outstanding question as to whether this relationship represents specific processing in the IC or reflects processing at the level of the MSO appears to have been answered by reports of a similar relationship in MSO of the gerbil [5]. The functional importance of this relationship appears indeed to be related to the need to position the slopes of ITD functions through the range of ecologically-relevant ITDs. In response to interaurally-delayed noise, neurons with the lowest CFs, and consequently the broadest ITD functions, show peak responses at relatively long ITDs – beyond the ecologically-relevant range – placing the sensitive slope of the function where

greatest ITD discrimination is required. As CF increases, peak ITDs shift closer to zero, maintaining the position of a function’s slope through the range of ecologically-relevant ITDs (Fig. 3b).

### Neural Sensitivity to Interaural Intensity Differences

In contrast to ITDs, the magnitude of IIDs depends on sound frequency as well as head-size (higher frequencies, with their shorter wavelengths, evoke a larger ▶head-shadow). One way of overcoming the limitations in localisation performance this would bring is by exploiting ITDs at low-frequencies (e.g. gerbils, kangaroo rats), or by extending the hearing to the ultra-sound range (e.g. bats, mice). Species in which the latter strategy has been adopted have contributed to a significant number of studies of IID sensitivity, particularly echo-locating bats, in which spatial hearing extends beyond the assessment of interaural differences. Significantly more reports of LSO recordings exist than is the case for the MSO, and many LSO neurons, particularly those in the high-frequency limb, are excited by the ipsilateral ear and inhibited by the contralateral in a manner dependent on the relative intensity of the sound at each ear (see Fig. 4).

Nevertheless, despite the relative ease with which LSO responses can be recorded compared with the MSO, it is equally the case that the IC provides a substantial number of reported studies of IID sensitivity. As with ITD cues, the largest single factor determining the sensitivity of IC neurons to IIDs is presumed to be the synaptic input they receive from binaural brainstem neurons, almost certainly the LSO.

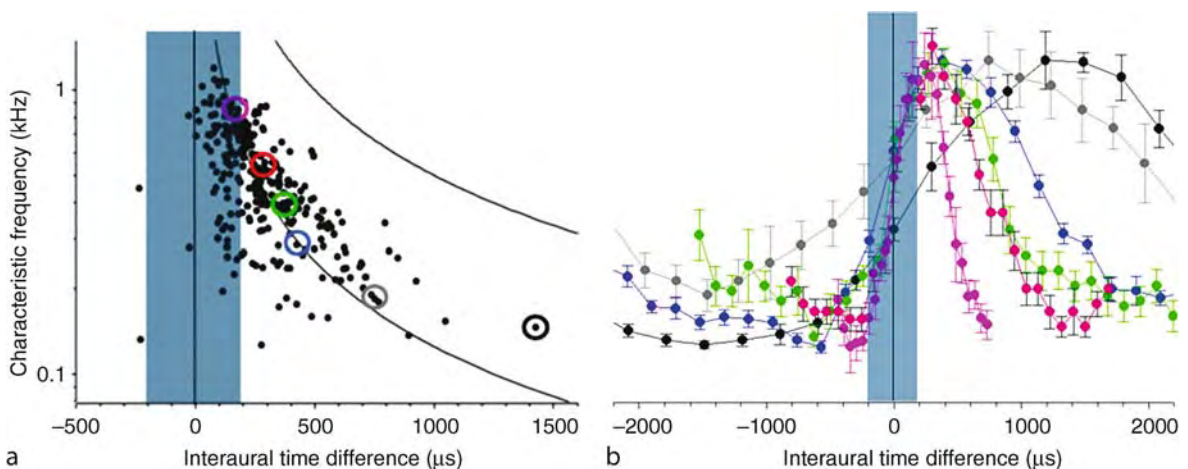

**Binaural Pathways and Processing. Figure 3** (a) Distribution of peak ITDs for inferior colliculus neurons as a function of neuronal CF. The shaded area indicates the ecologically-relevant range of ITDs for the guinea pig ( $\pm 180 \mu\text{s}$ ). Note the CF dependence of the distribution and that many neurons are tuned to ITDs beyond the ecologically-relevant range. (b) Representative ITD functions for six neurons (color-coded from part a). As CF increases, the peak ITD shifts closer to zero, maintaining the steep slope of the function through the ecologically-relevant range (*shaded area*).

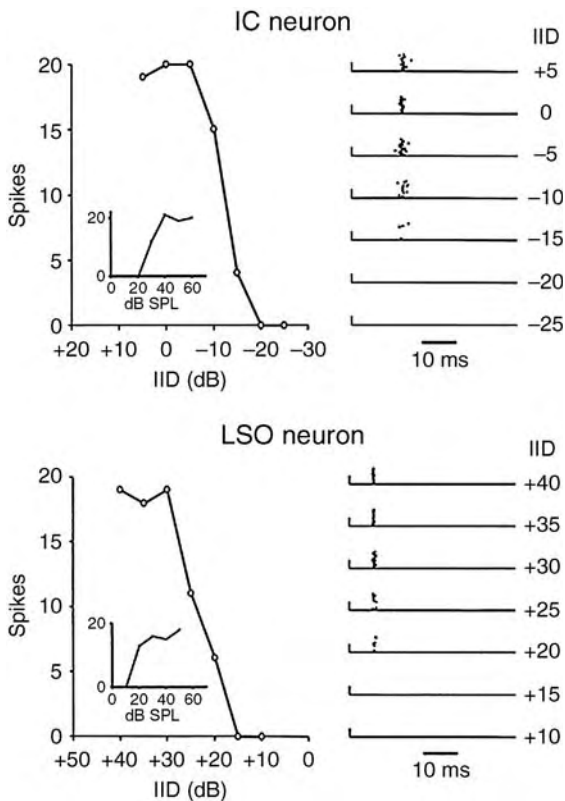

### Binaural Pathways and Processing.

**Figure 4** [Fig. 1 of [9]] Plots of discharge rate as a function of IID for a typical IID-sensitive neuron in the inferior colliculus (IC; top) and a typical IID-sensitive neuron in the lateral superior olive (LSO; bottom). Raster plots are shown to the right of each function. Positive IIDs indicate a greater intensity at the excitatory ear (opposite ears for IID sensitive neurons in the LSO and IC). *Inset*: rate-level functions for each neuron.

The decussating projection pattern of the LSO renders IC neurons excited by contralateral, and inhibited by ipsilateral, stimulation. However, this sign reversal aside, a major difference between neural coding for ITDs and IIDs exists in the possibility that neural sensitivity to IIDs can be created *de novo* at multiple stages in the auditory pathway. Unlike the requirements of exquisite temporal sensitivity in ITD processing, which is supported by specialized anatomical structures in the auditory nuclei of the lower brainstem and imposes limitations on the ability of neurons higher in the auditory pathway to retain and/or extract timing information, IID sensitivity does not require the same degree of specialization. As such, there is no reason *a priori* why neurons in the IC, for example, or indeed any neurons in the auditory pathway at which inputs from the two ears could conceivably converge, should not constitute a site at which neural sensitivity to IIDs is generated. Consistent with this notion, several studies

have demonstrated, by means of blocking the action of inhibitory neurotransmitters locally in the IC, the modification, or even complete abolition, of IID sensitivity in IC neurons [10]. A likely source of **GABA-ergic inhibition** to the IC is the cross projection from the **dorsal nucleus of the lateral lemniscus (DNLL)** and removing this connection, either by sectioning its projecting axons or by pharmacological inactivation of the DNLL itself, results in a release from binaural inhibition in IC neurons. Nevertheless, given the sufficiency of the LSO in producing neural sensitivity to IIDs, it seems likely that IID sensitivity in the majority of IC neurons reflects LSO input, with modifications provided by mechanisms local to the IC. Indeed, several studies have reported a transformation in the coding of IID cues between the LSO and the IC. In particular, Park [9] reported that IID sensitivity (in Mexican free-tail bats) was relatively more biased toward the inhibitory ear in the IC than in the LSO, with neurons requiring a more intense signal at the inhibitory ear to achieve the same degree of suppression. Further, a greater proportion of IC than LSO neurons show IID functions that are stable with absolute sound intensity. Whereas IID sensitivity in LSO neurons was characterized by IID functions that shifted in a systematic manner with increasing intensity to the excitatory ear, those in IC were less affected by absolute intensity, suggesting that at one function of hierarchical processing of IIDs is to provide for a stable representation of IIDs across a wide range of absolute sound intensities.

### References

1. Lord Rayleigh (1907) On our perception of sound direction. *Philos Mag* 13: 214
2. Kapfer C, Seidl AH, Schweizer H, Grothe B (2002) Experience-dependent refinement of inhibitory inputs to auditory coincidence-detector neurons. *Nat Neurosci* 5(3):247–253
3. Joris PX, Yin TC (1995) Envelope coding in the lateral superior olive. I. Sensitivity to interaural time differences. *J Neurophysiol* 73(3):1043–1062
4. Jeffress LA (1948) A place theory of sound localisation. *J Comp Physiol Psychol* 41:35
5. Brand A et al. (2002) Precise inhibition is essential for microsecond interaural time difference coding. *Nature* 417:543–547
6. Yin TC, Kuwada S (1983) Binaural interaction in low-frequency neurons in inferior colliculus of the cat. III. Effects of changing frequency. *J Neurophysiol* 50(4):1020–1042
7. Skottun BC, Shackleton TM, Arnott RH, Palmer AR (2001) The ability of inferior colliculus neurons to signal differences in interaural delay. *Proc Natl Acad Sci USA* 98 (24):14050–14054
8. McAlpine D, Jiang D, Palmer AR (2001) A neural code for low-frequency sound localization in mammals. *Nat Neurosci* 4(4):396–401

9. Park TJ (1998) IID sensitivity differs between two principal centers in the interaural intensity difference pathway: the LSO and the IC. *J Neurophysiol* 79 (5):2416–2431
10. Kelly JB, Li L (1997) Two sources of inhibition affecting binaural evoked responses in the rat's inferior colliculus: the dorsal nucleus of the lateral lemniscus and the superior olivary complex. *Hear Res* 104(1–2):112

## Binding Problem

MICHAEL HERZOG

Laboratory of Psychophysics, Brain Mind Institute,  
Ecole Polytechnique Fédérale de Lausanne, Lausanne,  
Switzerland

### Definition

Information processing in the human brain is highly parallel. This means that different features of an object are processed in different parts of the brain. For example, the color and the shape of a red square are coded by different neurons in the visual system (►visual field). However, we do not perceive “red” and “square shaped” separately but a “red square.” The binding problem deals with the question of how features that are processed in parallel are bound to the one unique percept.

The term “binding problem” usually refers to the binding of features such as color and shape in contrast to, for example, binding the visual experience of one square to general concepts about squares such as equiangularity. Feature binding is often implicitly thought to occur in an epoch of 50–200 ms.

### Characteristics

#### Information Processing

A picture is presented. Recognizing an object in this picture cannot simply be accomplished by comparing this object with some mental “images” stored in memory. Such a strategy would require an abundantly huge memory capacity. Think about a square. Even a slight rotation or translation of the square changes its projection on the retina dramatically. Moreover, views of an object from different perspectives would not be recognized as the same object if neural representations of these different views were not be related to each other.

For this and other reasons, information processing is thought to be parallel in higher animals. The brain contains many areas that analyze certain features of a visual picture separately. For example, there are

different brain areas dedicated to different tasks such as analyzing motion, faces, or simple visual features. Moreover, different regions within one brain area analyze different features, e.g., the orientation of a line is coded by different neurons than its color in the ►primary visual cortex of macaque monkeys.

If a red square is presented, different neurons are active than if a green disc is displayed. In the first case, some neurons fire for vertical and horizontal contours while others for red, analogously for the green disc. A problem arises when the red square and the green disc are presented simultaneously (Fig. 1). How does the brain know that the square was red and not green? This problem was called the superposition catastrophe [1].

There are three major approaches to solve the binding problem.

### Convergent Hierarchical Coding

It is assumed that information processing proceeds from the analysis of low level to high-level feature detectors in a feedforward manner (►Feedforward processing). For example, a visual image is first analyzed in terms of the orientations of the single elements in the image. In a second step, this information is combined. On further stages, more and more complex features are added (Fig. 1a). In convergent coding, recognition of an object occurs if one metaphorical “grandmother” neuron or a designated “sparse” population of neurons is activated by neurons converging to this neuron or the population of neurons (e.g., [2]). The activity of this population is thought to be sufficient for perception, i.e., no other aspects such as the temporal firing pattern of neurons are of interest.

Converging coding models may quickly run into abundant memory problems, since not only for each object but also for each view of an object neurons are required. Current architectures avoid this problem by assuming that, for example, not every color has to be coded but only a few basic ones [3]. Other colors can be represented by a combination of neuronal activities. For example, “red” and “green” may be coded by the full activity of one dedicated neuron, respectively, whereas half activity of these two neurons may represent “yellow” (Fig. 1a).

### Evidence

In physiological experiments, it was shown that, indeed, some neurons were vigorously activated for a certain view of an object whereas other views seemed to be presented by combinations of such neurons. Moreover, neurons responding to highly specialized feature combinations were found (e.g., [4]). In accordance with feedforward object recognition, it was shown that animals in a visual scene could be ultrarapidly detected.

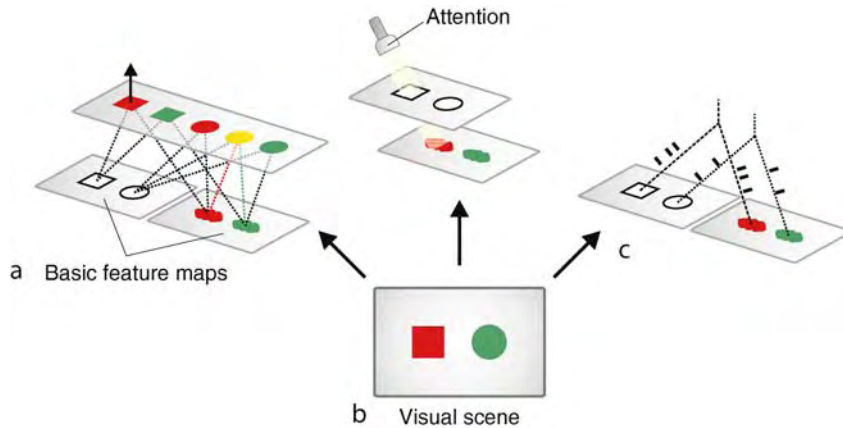

**Binding Problem. Figure 1** Three approaches to solve the binding problem. In all theories, basic feature detectors analyze a scene of the outer world, indicated by the red square and the green disc. In each basic feature map, there are detectors for all basic features at one retinotopic position. In the above figure, only the most active detectors are shown. (a) In *convergent coding*, basic feature detectors, makes neural connections to specialized feature indicating the presence or absence of combined features. On a higher stage, the activation of a “red square” neuron occurs when both the basic “red” and “square” neurons are active. Not all objects have to be coded by one neuron. A “yellow disc” neuron may be activated by the “disc” neuron and both the “red” and “green” coding neurons. (b) In *feature integration theory*, attention binds the information of basic-feature maps into a master map. (c) In *temporal coding*, the presence of combined features is indicated, for example, by a synchronous firing of basic feature detectors. In the figure, temporal patterns are indicated by the black strokes. In temporal coding, there is no explicit need for combined feature detectors.

### Discussion

One question is whether convergent coding can account for the recognition of entire visual scenes. It is unlikely that for each novel object and scene a prewired representation exists. For this reason, learning plays an important role in recent approaches of convergent coding. However, many novel objects and scenes can be recognized without prior experience. Just think about a red square with bird wings. It remains to be shown whether convergent coding and learning are sufficient to account for novel real-world scene recognition.

### Feature Integration Theory

It is assumed that there are distinct maps coding for basic features such as the different colors and shapes (Fig. 1b). A red square elicits responses in the “color” and the “shape” map in a retinotopic manner (►Retinotopic organization), i.e., for each spatial location of the visual field, there is a bundle of basic feature detectors in each map. For example, at each spatial position, there are neurons coding for each basic color. A retinotopic *master* map determines to which location attention is paid. At this attended location, the various features in the different maps are integrated. The superposition catastrophe is avoided since attention focuses only on the features at one spatial position at one point of time. No memory capacity problem occurs since only basic, single features are coded and not conjunctions of features such as a “red square.”

### Evidence

Feature integration theory implies that binding errors occur if attention is not deployed to a certain location. Exactly this was found in illusory conjunctions [5]. For example, a red square might be perceived as green when also a green disc is in the display but less likely as a yellow square if no yellow element is in the display. Hence, illusory conjunctions do not result from “hallucinations.” Patients with deficits in certain brain regions, related to attention, show such illusory conjunctions also if attention is not distracted. Moreover, it was shown that attention could change the responses of neurons and possibly the shape of their ►receptive fields. A narrowing of receptive fields may contribute to avoiding illusory conjunctions.

### Discussion

Although there is strong evidence for the involvement of attention in many object recognition processes, it is an open question whether attention is necessary for the binding of features. For example, it may be that illusory conjunctions do not result from a faulty “perceptual” feature binding but are caused by a faulty combination of features during the recall when giving the response. Moreover, fast object recognition can also occur if attention is deployed in dual-task paradigms.



### Temporal Coding

To gain a higher flexibility of coding, it was proposed to add the timing of neuronal responses as an independent dimension to information processing (Fig. 1c). In this theory, basic feature detectors analyze the visual scene as described before [6,7]. The existence of a combination of features is indicated with a unique temporal pattern. For example, if a red square is presented “square neurons” fire in *synchrony* with “red neurons.” If in addition, a green disc is contained in the scene, “disc” and “green” neurons fire synchronously with each other but in asynchrony with the “square” and “red” neurons. If a red disc and a green square are presented in the next scene, the same neurons will fire, only the synchrony of firing changes. Hence, no superposition catastrophe occurs. Temporal coding is very flexible without a need for combined feature detectors. If, for example,  $m$  types, such as shape and color, have to be coded of which each comprises  $n$  features, such as the particular colors, then,  $m \times n$  neurons are required for temporal coding. If each conjunction of features has to be coded explicitly,  $n^m$  neurons are required.

### Evidence

It could, indeed, be shown that two neurons fire in synchrony if they code for features belonging to the same object, but neural firing is out of synchrony if the features belong to different objects. In psychophysical experiments, if elements are flickered with the same frequency but with different phase, these elements appear as distinct objects even though the flicker itself is barely visible. Hence, it may be that presenting visual elements with different phases induces asynchronous firing rates. Amplitudes in the electroencephalogram (EEG) (►[Electroencephalogram \(EEG\)](#)) arise when many neurons fire synchronously.

Changes in the recognition of objects usually change the EEG.

### Discussion

Although there are no doubts about the existence of temporal patterns in neural firing, it remains unclear whether these patterns are causal for object recognition and are not epiphenomenal. For technical reasons, there are, up to date, almost no studies that investigated whether changing the temporal pattern of neural responses induces a change of binding states. Moreover, the biological plausibility of synchrony coding was doubted (e.g., [8]). Another question is how the synchronous firing is detected in the brain. Are special neurons needed that detect whether primary neurons fire in synchrony to indicate the binding of certain features?

### General Discussion

The binding problem is at the very heart of neuroscience because it addresses questions about how neurons code the stimuli of the external world, how these stimuli are represented in the brain, and how neurons communicate in general with each other. The binding problem touches also the problem of consciousness since it is about how distributed neural activity (a physiological concept) gives rise to the unity of conscious experience (a psychological concept).

A solution of the binding problem is, moreover, of primary interest for the experimentation itself. For example, if binding is mediated by temporal mechanisms data obtained by an averaging of neural responses in a certain time window may overlook some important aspects of neural coding and must be considered inadequate.

An important distinction has to be made between the mechanisms of binding and the representation of combined features (see also [4,8]). In Fig. 2, single



**Binding Problem. Figure 2** Perceptual grouping. (a, b) Dependent on the spatial layout of elements and following so-called Gestalt rules, elements are bound into different entities. Changes in the spatial layout of the elements can change perceptual grouping. For example, rotating the second and fourth row from the top by 45° yields a clear grouping of all elements into lines (b). (c) The picture contains the image of a Dalmatian dog. To perceive the dog, some of the black dots have to be bound to the background whereas others to the Dalmatian dog.

elements are displayed. Depending on their spatial arrangement and so-called Gestalt laws, these elements are grouped differently together. This perceptual grouping can be regarded as evidence of binding of features within the spatial domain. It is not different from binding, for example, one color to one shape since in both cases different neurons at different positions in the brain are responding. In displays analogous to Fig. 2, it was shown that neurons fire synchronously when elements are grouped. Hence, a temporal pattern of neural firing may represent whether or not two features belong together. However, the temporal coding hypothesis does not specify *explicitly* when two dots in Fig. 2b belong to the Dalmatian dog and when not. However, this seems to be the first important step to solve the binding problem.

### Acknowledgements

I would like to thank Andreas Kreiter, Joseph Krummenacher, Thomas Otto, and Maximilian Riesenhuber for helpful comments.

### References

1. von der Malsburg C (1981) The correlation theory of brain functioning. In: Schulten K, von Hemmen J (eds) Models of neural networks. Springer, Berlin
2. Barlow HB (1972) Single units and sensation: a neuron doctrine for perceptual psychology? *Perception* 1:371–394
3. Riesenhuber M, Poggio T (1999) Are cortical models really bound by the “binding problem”? *Neuron* 24:87–93
4. Ghose GM, Maunsell J (1999) Specialized representations in visual cortex: a role for binding? *Neuron* 24:79–85
5. Treisman A, Schmidt H (1982) Illusory conjunctions in the perception of objects. *Cogn Psychol* 14:107–141
6. Eckhorn R, Bauer R, Jordan W, Brosch M, Kruse W, Munk M, Reitboeck HJ (1988) Coherent oscillations: a mechanism of feature linking in the visual cortex? *Biol Cybern* 60:121–130
7. Gray CM, Singer W (1989) Stimulus-specific neuronal oscillations in orientation columns of cat visual cortex. *Proc Natl Acad Sci USA* 86:1698–1702
8. Shadlen MN, Movshon JA (1999) Synchrony unbound: a critical evaluation of the temporal binding hypothesis. *Neuron* 24:67–77

## Binocular Correspondence

### Definition

A condition in which images from left and right eyes occupy identical positions on the two retinæ.

► Binocular Vision

## Binocular Deprivation

### Definition

A condition in which normal visual experience is prevented for varying periods by a natural or artificial condition.

► Binocular Vision

## Binocular Disparity

### Definition

Each eye sees an object in space from a slightly different view. The difference in images constitutes binocular disparity, which is the necessary and sufficient condition for stereopsis.

► Binocular Vision

## Binocular Fusion

### Definition

Images from left and right eyes are physically and perceptually fused so as to constitute a single percept.

► Binocular Vision

## Binocular Rivalry

ALEXANDER MAIER, DAVID A. LEOPOLD  
Unit on Cognitive Neurophysiology and Imaging, NIH,  
Bethesda, MD, USA

### Synonyms

Interocular Rivalry; Dichoptic Rivalry

### Definition

In normal vision, the two eyes receive largely matching views of the world from slightly different perspectives,

and perception is stable. Yet under certain circumstances, which are typically exploited in the laboratory by showing different images to each eye, the eyes may face irresolvable conflict.

The term binocular rivalry (BR) is commonly used to describe the perceptual phenomenon that occurs under these conditions. During BR, the brain proves incapable of arriving at a single, stable visual percept for an extended period of time. The percept is not a transparent superposition of the dissimilar images as one might expect. An observer rather experiences an unstable and wavering series of perceptual snapshots, with one eye's view dominating for a few seconds before being replaced by its rival from the other eye. With continued viewing of such binocular conflict, one inevitably experiences a sequence of subjective perceptual reversals, separated by

random time intervals, that proceeds as long as the sensory conflict is present.

The study of the geometry of binocular vision dates back to the classical world and it is very likely that BR was already known to the ancient Greeks. From the nineteenth century on, when Charles Wheatstone introduced an apparatus to show different images to each eye (the mirror stereoscope; see Fig. 1), to the present day, the very essence of BR has been a topic of debate, with modern neuroscientific theories of rivalry ranging from concrete hypothetical neuronal models to more abstract cognitive models.

### Characteristics

While the experience during BR is often described as a simple alternation process between the right- and left

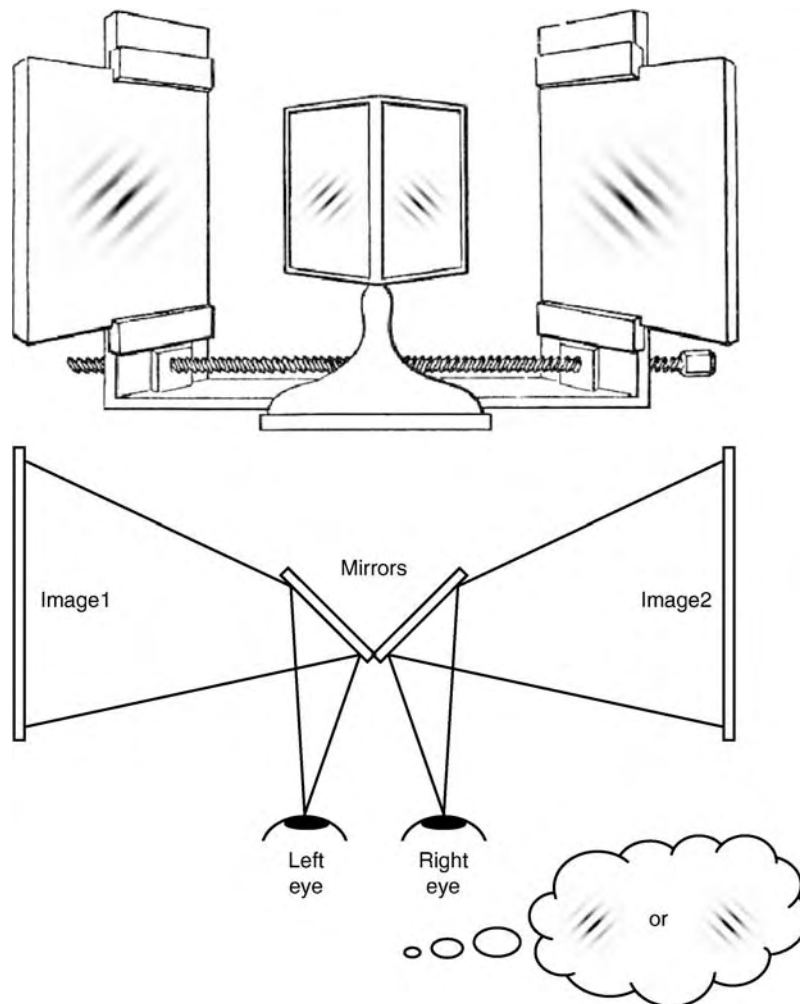

**Binocular Rivalry. Figure 1** Depiction of a common way how binocular rivalry is brought about in the laboratory. The upper panel depicts a drawing by Sir Charles Wheatstone of his invention, the mirror stereoscope, accompanied by a set of stimuli with the potential to instigate binocular rivalry. The lower panel schematically demonstrates the optical geometry that allows to separately stimulate the two eyes. Note that a person using this setup would be unaware of either the leftward or the rightward titled stimulus at any point in time.

eye's views (not unlike opening and closing each eye successively), this is a considerable oversimplification of what subjects observe under most rivalry conditions. Particularly with larger stimuli, perception during BR can proceed as a much more complex sequence of ever-changing mosaics (so-called piecemeal percepts), each consisting of an interleaved patchwork of the two eyes' views. Several other features of rivalry further speak against the assumption of a simple alternation process between each eye's view. First, the perceived structure of this patchwork is influenced and sometimes even determined by ►Gestalt- or even semantically driven grouping principles (such as to complete geometric patterns or photographs that appear to be split between the two eyes). Second, perceptual switches often entail wave-like transitions between the left- and right- eye's view that may reflect the spatial spread of neuronal activity in the ►visual cortex. Third, competing rivalry patterns which are very low in their ►visual contrast and poor in detail can sometimes be seen in superposition. Finally, very short presentations of conflicting binocular stimuli are frequently perceived as stably fused, suggesting that the conflict must be present for several hundred milliseconds for the brain to lapse into a bistable perceptual state.

Nonetheless, for a circumscribed conflict of a few visual degrees or less, rivalry suppression is generally "complete," with the non-dominant pattern rendered wholly invisible. At the same time, and somewhat paradoxically, perceptual suppression is very superficial when measured psychophysically. The threshold for detecting test probes presented in the perceptually non-dominant eye is only minimally elevated during this period of time. In other words, even minimal changes to the suppressed stimulus will instantly return this eye to perceptual dominance. As information presented to the perceptually suppressed eye is not completely lost, neither is information about the unperceived stimulus, which continues to impact the brain. In fact, careful measurements show that the temporal dynamics of BR alternation processes is largely determined by the suppressed, rather than the dominant, stimulus. This counterintuitive finding is in agreement with neurophysiological studies demonstrating that most neurons in the ►primary visual cortex (V1) continue to respond to a suppressed stimulus during BR. Perceptual suppression, it appears, does not significantly affect the responses of most neurons in this major area of the visual cortex. As discussed below, however, neuroimaging results in humans have reached a nearly opposite conclusion, and this puzzle is presently a topic of active research.

Interocular rivalry can be considered, more generally, a form of *bistable perception*, owing to the temporal alternation between two mutually exclusive perceptual solutions. While BR may seem unrelated to ambiguous geometric patterns that give rise to two competing

perceptual interpretations (e.g., the famous ►Necker cube and the ►Rubin's Face vs. Vase, *Visual Illusions*), the shared temporal dynamics of their reversals are nearly identical. In fact, virtually all bistable visual phenomena share the same temporal dynamics, often characterized as a memory-less process that results in a long-tailed probability distribution of reversal times. In other words, the perceptual alternations during BR are for the most part completely unpredictable and spontaneous (although some limited voluntary control can be achieved with training).

Interestingly, it has been shown that the temporal dynamics of BR and other bistable visual phenomena are linked to several cognitive variables that seem to be unrelated at first sight. Switching frequency can vary by an order of magnitude between observers while remaining consistent within an observer over multiple testing sessions that are separated by weeks or even months (the perceptual reversal rate does seem to decline slowly with age). A large number of studies have attempted to link IQ and personality type to alternation rate with bistable figures and binocular rivalry, albeit with limited success. Although observers can improve their ability to control perceptual reversals with practice, it seems impossible for normal observers to inhibit reversals altogether. Neurostimulants, mood disorders, and certain meditative states can all impact the rate of reversal. Brain damage to the right frontal cortex has been shown to slow the reversal rate down, and in some cases even abolish perceptual switching. The connection between the diverse variables affecting the temporal dynamics, and processing of sensory stimuli, is by no means clear, but the general influence of these variables may hint at the possibility that perceptual alternation is initiated outside the sensory domain. This hypothesis is strongly supported by neuroimaging data showing activation in the frontal and parietal cortex associated with spontaneous perceptual reversals.

The vanishing of salient patterns in BR is closely related to that in phenomena that do not require local conflict between the two eyes, such as the inappropriately termed *monocular rivalry* and other illusions (i.e., "Motion induced Blindness," "Generalized Flash Suppression" and "Induced Perceptual Fading"). All of these similarly involve complete perceptual suppression of an otherwise easily visible stimulus that is shown to both eyes or against a blank background in the other eye. While not yet fully understood, these illusions seem to rely on other, more global types of visual conflict and are generally limited to a very specific set of stimuli.

It is the fact that BR is the only paradigm that permits the suppression of virtually any visual pattern that has made it the centerpiece for the study of perceptual suppression. It is possible that this unique quality is related to its relevance in natural vision, as binocular

vision in a cluttered 3-D environment involves zones of interocular discrepancy, including a vast zone outside of so-called ►**Panum's fusional area** where there is no interocular correspondence at all. Under these conditions, the brain is often forced to choose one eye's view while completely suppressing the other's. However, remarkably little is known about the role of BR in natural vision, and this real-world account of the origins of binocular rivalry remains speculative.

The neural mechanism underlying both the alternation and maintenance of a perceptually dominant rivalry state have been explored using functional imaging and electroencephalography techniques in humans, as well as single neuron and local field potential recordings in laboratory animals and epileptic patients. The importance of these studies lies in the fact that understanding BR has direct implications for our understanding of how a percept gets established and supported in the brain. The only factor that is changing over time during rivalry is the perceptual experience itself. Thus, any neuronal mechanisms that co-fluctuates with the changing visual impressions are likely to be linked to the perceptual level rather than to sensory processing. It follows that by gaining insight into the neuronal mechanisms of BR, we will also learn about the brain processes underlying visual perception in general. All studies unanimously agree upon the fact that there are widespread activity changes throughout the brain at the moment of a spontaneous perceptual reversal. Disagreement exists, however, between imaging and single-unit data on the role of the earliest stages of cortical processing. In particular, it has been shown that single neurons in the first stages of visual processing such as the ►**lateral geniculate nucleus (LGN)** in the thalamus or the primary visual cortex (V1) show none or minimal correspondence with the perceptual state. This is at odds with several human neuroimaging studies that have reported hemodynamic responses in the LGN and V1, which are closely coupled to the visibility of a pattern during rivalry. Recent data hints at a resolution of this apparent conflict by demonstrating electrical signal changes in V1 that are likely to be caused by recurrent activity from other brain areas rather than being generated by a local population of neurons. This finding unifies theories about a limited role of V1 for binocular rivalry with other studies that suggested its involvement. Yet, much remains to be learned about the distributed networks that give rise to the alternating perceptions during binocular rivalry and vision in general.

The phenomenon of BR has always attracted students of diverse disciplines. It has been used as a tool to study the human unconscious, to assess cognitive abnormalities, and to learn more about binocular vision and perception in general. Its complex temporal dynamics have invited comparisons with earthquakes, stock prices and mammalian sleep patterns. It has served as an unlikely but

important common ground for philosophers, biologists, psychologists and physicists, who all seem captivated by the implications for subjective experience. While a great deal is known about BR, it is, perhaps surprisingly, the big picture questions that are the most contentious. With technical advances in neurophysiology and imaging, passive-correlational approaches are slowly being complemented by causal manipulations (such as electrical or pharmacological brain stimulation). Binocular rivalry has been and continues to be a vital and fascinating paradigm for the study of sensory processing and visual awareness in the brain.

### Acknowledgments

We thank K.M. Mueller and Drs. M. Schmid, M. Wilke and S. Guderian for comments on the manuscript.

### References

1. David Alais, Randolph Blake (2005) Binocular rivalry. MIT Press. For an extensive bibliography, see also: [http://psy.otago.ac.nz/r\\_oshea/BR\\_bibliography/br\\_bibliography.html](http://psy.otago.ac.nz/r_oshea/BR_bibliography/br_bibliography.html)

---

## Binocular Vision

**RALPH D. FREEMAN**

Vision Science, School of Optometry, Helen Wills Neuroscience Institute, University of California, Berkeley, CA, USA

### Synonyms

Coordinated visual processing through both eyes, coordinated dichoptic processing, neurophysiological mechanisms, binocular correspondence, far and near cells, position and phase disparity

### Definition

Binocular vision is a process by which signals from left and right eyes are combined to produce a fused image of visual space. This is a necessary condition for stereoscopic depth discrimination.

### Characteristics

#### Overview

Evolution has created a variety of species with multiple eyes. But two eye species predominate. In order to achieve binocular vision, the visual fields of the two eyes must overlap extensively. There is a wide range of degrees of overlap. In general, animals such as rabbits have widely spaced eyes with minimum overlap

of left and right images. But their visual field range is very wide permitting early detection of a predator. The fusion of overlapping visual fields for animals with frontally positioned eyes provides a basis for ►stereopsis as illustrated in Fig. 1.

A subject views three vertical bars, two of which are in adjacent positions at the same distance from the observer. The third bar (red) is closer to the observer, as illustrated. A top view of the object to image condition shows the different image patterns on the ►retina of each eye. Since each eye has a slightly different view of the three vertical bars, the image patterns on left and right eyes are dissimilar. Specifically, the angle between the closer bar (red) and the central distant one (blue) is larger for the right compared to the left eye. This is depicted by the images on the lower right in which linear distances are represented by angular subtense. In this case,  $\alpha_R$  and  $\alpha_L$ , are the angular distances between right and left eye images of two of the three bars. This difference is called retinal or ►binocular disparity [1]. It is the necessary and sufficient condition for stereoscopic vision, which has been studied in a wide range of theoretical, behavioral, and physiological investigations.

### Theoretical

The required condition for stereopsis, binocular disparity, is problematic because the process of fusion of left and right eye images is not straight-forward. The reason for this is that the visual system must eliminate false targets in order to obtain the correct depth plane for fusion. This problem is illustrated in Fig. 2.

There are six objects in visual space, depicted as squares numbered 1–6 in Fig. 2, which may be fused in different combinations that represent the depth planes illustrated by the dashed lines in the figure. However, only one depth plane, the solid line, is correct. This plane is defined when objects 1 and 4 (yellow) are fused by the visual system. Other combinations, 2 and 5, and 3 and 6, will also define the correct plane. But all other combinations will produce false target planes. A theoretical consideration of this problem was put forward to account for how this process may occur. It involves a trade-off between disparity range and resolution. The theoretical solution to the correct fusion problem is a four-step process. First there is a match in image coarseness for left and right eyes. Second, the coarse channels activate ►vergence eye movements, which guide fine channels to correspondent positions. Third, correspondence between left and right eye images is then fixed. Fourth, a depth map is then embedded in ►memory, which assists the fusion process. The entire process means that accurate stereopsis is a coarse-to-fine process [2]. Recent neurophysiological experiments provide data that are consistent with this hypothesis [3].

### Behavior

Stereoscopic vision is one of the finest facilities that the eye or any sense organ exhibits. The resolution of ►stereoscopic acuity is extraordinarily high. An example of this precise function is illustrated in Fig. 3, which shows the dimensions involved in the simple act of threading a needle.

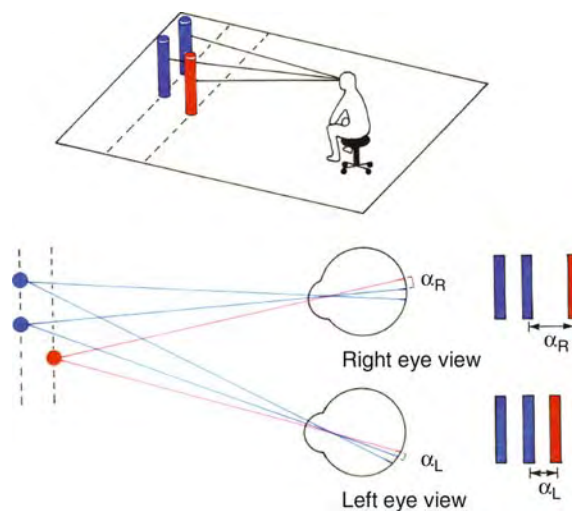

**Binocular Vision. Figure 1** Viewing condition for binocular disparity. A person views three vertical posts, two of which (*blue*) are in a single distance plane and the third (*red*) is closer to the viewer. Geometrical relationships from a top view are illustrated which shows the angular subtense for left and right eyes ( $\alpha_R$  and  $\alpha_L$ ) of the differences in images for the three vertical posts. The same angular distance differences are shown in vertical depictions of the images of the posts.

That process is depicted on the left of the figure. On the right side, the approximate dimensions are given. A working distance from the head of the needle to the eye is around 50 cm. The opening in the needle into which the thread fits may be as small as 0.2 mm. A standard distance between the two eyes is 6.5 cm. For these dimensions, the angular subtense of the opening of the needle head is 10 s of arc. This is an exceedingly small space but the standard human visual system is able to detect it successfully to enable threading of a needle.

### Neural System

A great deal of data have been collected on various behavioral aspects of binocular visual performance [4].

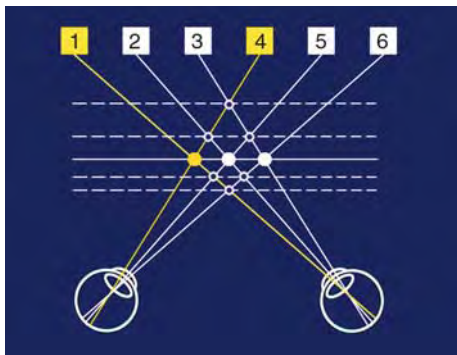

**Binocular Vision. Figure 2** Illustration of the **binocular correspondence** problem. Five depth planes are illustrated for binocular viewing. The correct plane is represented by a solid line and the dashed lines depict incorrect depth planes. The numbered squares (1–6), are points in object space for which different combinations yield different depth planes. In this case, the correct combination is squares 1 and 4.

The neural basis of that performance has also been investigated. The original study was conducted in the cat's visual cortex where it was determined that there were neurons apparently tuned specifically to different distances in visual space [5]. Later, awake behaving monkeys were trained to respond to specific distances. Simultaneously, neurons were studied in the **primary visual cortex** (striate cortex, area V1) in order to ascertain their response properties while monkeys viewed different distance planes [6]. The experimental arrangement is illustrated in Fig. 4.

A fixation point is viewed via a beam splitter such that it is superimposed on a stimulus display. The position of the receptive field (**Visual cortical receptive fields**) for the cell under study, that is the territory within which a neuron is responsive to visual stimuli, is also shown on the display. The resulting populations of neurons studied provided categories of response properties as shown in Fig. 5.

Four categories are shown. On the left side of the figure are two types of responses, tuned excitatory and tuned inhibitory. These cell types are excited or inhibited by a narrow range of stimuli at the fixation plane. The other two types, on the right, are excited by visual stimuli further or closer, respectively, than the fixation plane. For the opposite distance, these cells are suppressed. These are termed “far” and “near” cells, which correspond to uncrossed and crossed disparities, respectively. In the original study, these cell types were considered to be comprehensive [6]. In subsequent work, additional categories were added [7]. These are based on the notion of a discrete set of cell types rather than a continuum, which may be more appropriate. In any case, the original categorization was based on the idea that binocular disparity is encoded by relative position differences between right and left eye receptive fields.

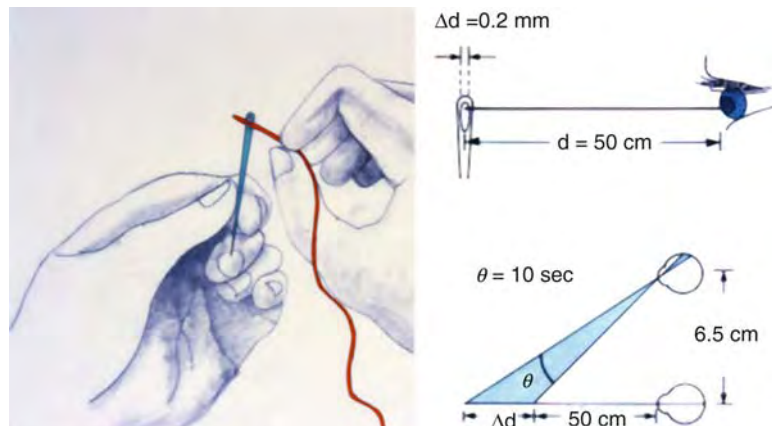

**Binocular Vision. Figure 3** Dimensions involved in the threading of a needle. A typical viewing distance of 50 cm is used to illustrate this fine sensory task. A needle opening of 0.2 mm for an interocular distance of 65 mm corresponds to an angular distance of 10 arc s. This is much finer than a standard visual resolution task.

An alternative idea is that receptive field position between the two eyes is constant but the shape of one receptive field is different than that of the other [8]. The difference in these two schemes is depicted in Figs. 6 and 7.

In Fig. 6, both eyes observe a target at the center of the plane of fixation. The images are represented by

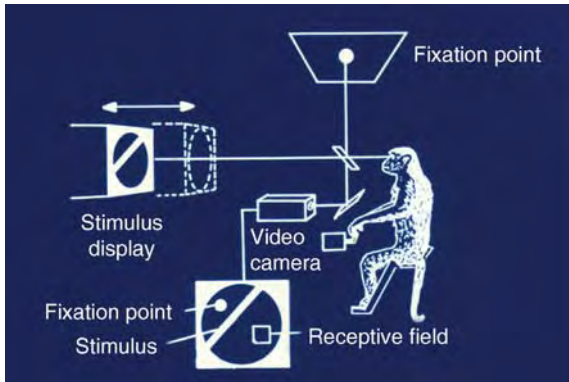

**Binocular Vision. Figure 4** A behaving monkey responds to targets at different depth planes. The monkey fixates a target and visual stimuli are presented at different depths. As the monkey performs behaviorally, neurons in visual cortex are recorded.

Gabor functions, white and yellow for left and right eyes, respectively. Planes closer and further than the fixation distance have conjugate images represented by blue and red Gabor functions, respectively. In this case all images are depicted by identical Gabor functions. Differences in binocular disparity occur via shifts in positions of these functions. The alternative idea is represented in Fig. 7.

As in the previous case, distance planes are depicted which represent near, far, and fixation plane conditions. However, in this case, the positions of the receptive fields are superimposed for the three conditions. The internal shapes of the receptive fields, however, change which can be specified as a relative difference of phase in the Gabor functions. In this manner, the near and far distance planes may be encoded, as illustrated in the figure, not by position but by internal receptive field structural differences between the two eyes.

There are thus two basic mechanisms for encoding binocular disparity to enable depth processing. To determine the relative roles of these two mechanisms, it is necessary to study them both in a single investigation. This has been done by mapping left and right eye receptive fields in the primary visual cortex in order to estimate disparities by both position and phase encoding. The general finding is that position disparities are limited to small values so that large disparities are not

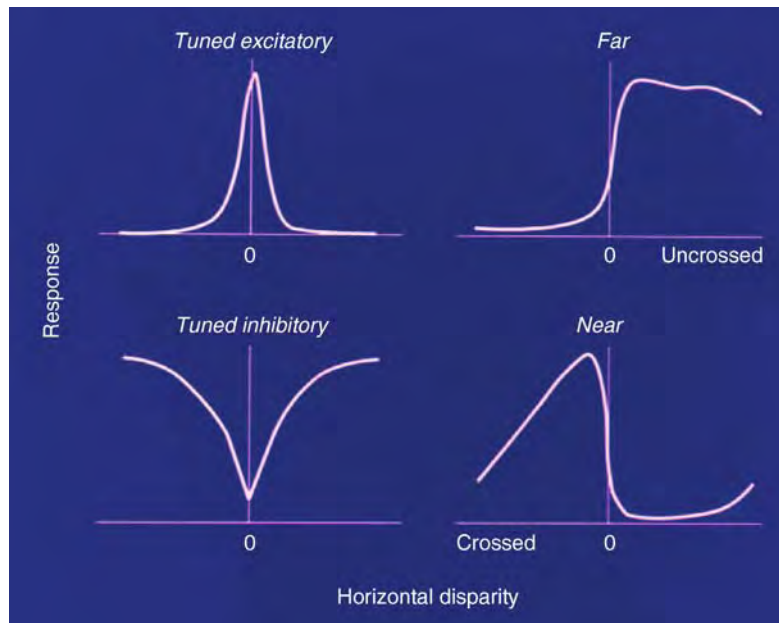

**Binocular Vision. Figure 5** Categories of tuning curves are depicted for neurons in the primary visual cortex. The two examples on the left are for cells that respond only when the visual target is at the plane of fixation. The cells are excited (*upper*) or suppressed (*lower*). Examples on the right respond to visual targets further away or closer than the fixation plane (*upper* and *lower* examples, respectively). These conditions represent uncrossed and crossed binocular disparities in upper and lower panels, respectively.



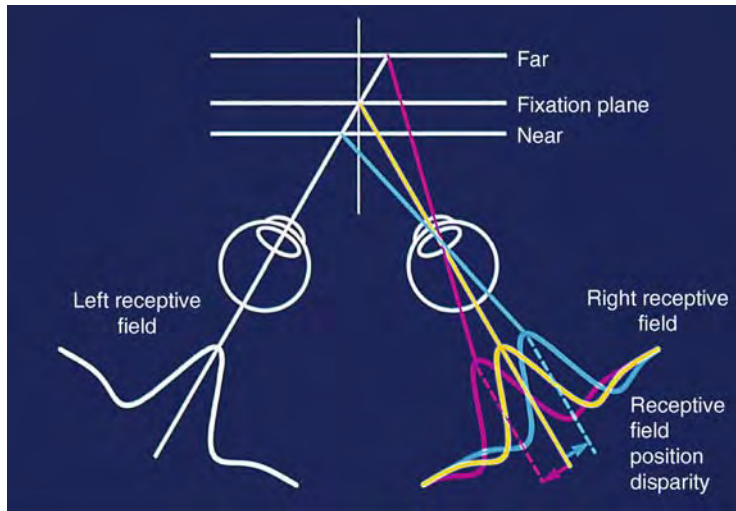

**Binocular Vision. Figure 6** Position binocular disparity. For this situation, receptive fields are represented by Gabor functions. Differences in far and near positions relative to the fixation plane are depicted by changes in the positions of the Gabor functions relative to that for the fixation plane. So, far (*red*) and near (*blue*) are shifted to the left and right, respectively.

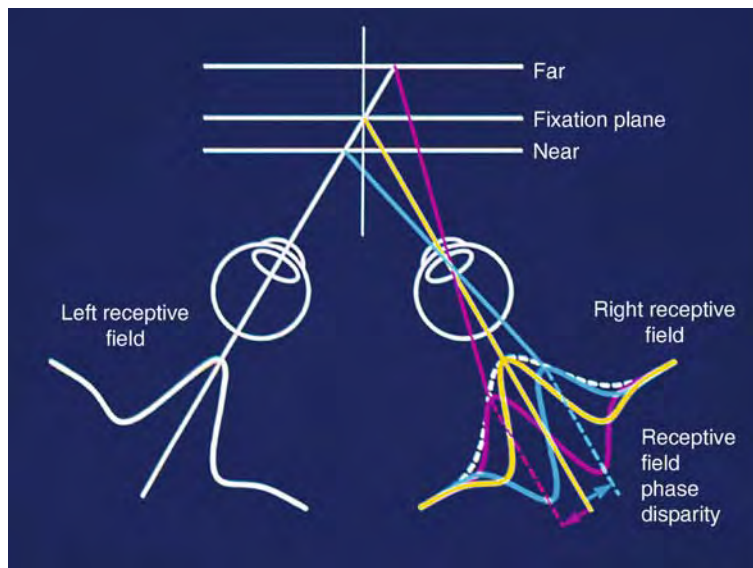

**Binocular Vision. Figure 7** Phase binocular disparity. This is the same situation as that of Fig. 6 only the Gabor functions have different phase values. The one for the fixation plane remains as before with a phase angle of  $0^\circ$  (*yellow*). Far and near functions have phase angles near  $90^\circ$  (*red*) and  $270^\circ$  (*blue*). The Gaussian envelope for these conditions is centered at  $0^\circ$  (*dashed curve*).

encoded. On the other hand, phase disparities cover a wide range of disparities. In addition, phase disparities depend on orientation and spatial frequency of visual stimuli in ways that are consistent with a binocular encoding mechanism [8]. This work shows that binocular disparity is encoded mainly via a phase disparity mechanism. But position disparity may be important for

neurons with high spatial frequency selectivity. These cells are constrained to small phase disparities.

The evidence that phase encoding plays a prominent role in the binocular apparatus forms the basis of a disparity processing system. In this model, stereoscopic depth information is encoded and transmitted according to a hierarchical series of transformations whereby

information from both eyes is combined in the visual cortex. In this process, the first stage of transmission from early visual pathways is to a specific neuron type, the *simple cell*. Depth information at this stage is encoded by a process based on differences in internal receptive field structure between the two eyes as noted above. The next stage involves transmission to second-order neurons, *complex cells*, which determine depth information independent of variations in the positions of visual objects (Visual cortical receptive fields). The ideas associated with this process are considered in previous reviews [9,10].

## References

1. Pettigrew JD (1972) The neurophysiology of binocular vision. *Sci Am* 227:84–95
2. Marr D, Poggio T (1979) A computational theory of human stereo vision. *Proc R Soc Lond B Biol Sci* 204:301–328
3. Menz MD, Freeman RD (2003) Stereoscopic depth processing in the visual cortex: a coarse-to-fine mechanism. *Nat Neurosci* 6:59–65
4. Howard IP, Rogers BJ (1995) Binocular vision and stereopsis. Oxford University Press, Oxford
5. Barlow HB, Blakemore C, Pettigrew JD (1967) The neural mechanism of binocular depth discrimination. *J Physiol* 193:327–342
6. Poggio GF, Fischer B (1977) Binocular interaction and depth sensitivity in striate and prestriate cortex of behaving rhesus monkey. *J Neurophysiol* 40:1392–1405
7. Poggio GF, Gonzalez F, Krause F (1988a) Stereoscopic mechanisms in monkey visual cortex: binocular correlation and disparity selectivity. *J Neurosci* 8:4531–4550
8. Anzai A, Ohzawa I, Freeman RD (1997) Neural mechanisms underlying binocular fusion and stereopsis: position vs. phase. *Proc Natl Acad Sci USA* 94:5438–5443
9. Ohzawa I, DeAngelis GC, Freeman RD (1997a) The neural coding of stereoscopic depth. *Neuroreport* 8:iii–xii
10. Freeman RD, Ohzawa I (1990) On the neurophysiological organization of binocular vision. *Vision Res* 30:1661–1676

## Binocular Visual Field

### Definition

The region of visible space seen by both eyes.

► Binocular Vision

## Biochronometry

### Definition

Biochronometry is the scientific study of time measurement in living organisms. Biochronometry was the title of a textbook edited by Michael Menaker (1971), indicating the discipline which is now established under the name of “chronobiology” and which studies temporal organization, characterized by biological rhythms and clock systems.

► Circannual Rhythms

## Biofeedback of Autonomic Function

BERNARD T. ENGEL

Schulich School of Engineering, University of Calgary, Calgary, AB, Canada

### Definition

Biofeedback refers to both scientific and clinical procedures. In the former context, biofeedback is synonymous with ► [operant conditioning](#). When used in a clinical context, biofeedback is often used broadly to describe a wide range of psychological and physiological methodologies and interventions. In this essay the term will be limited to its scientific usage.

### Characteristics

#### Historical Background

There has been almost 2000 years of research, theory and speculation about the organization and regulation of the autonomic nervous system. Of particular relevance to this essay are the notions about the extent to which individuals are conscious of their autonomically mediated responses, and the extent to which those responses are subject to voluntary control. The nature of the sympathetic ganglia intrigued investigators for hundreds of years. At one time it was believed that the ganglia were independent of the central nervous system; however, as it became clearer that the ganglia were connected to the spinal cord, ideas about its functional role changed [1]. For example, in the seventeenth century, Willis introduced the concepts of voluntary and involuntary movement, and proposed that visceral sensations were typically unconscious; however, they could become conscious if they were strong enough. In the eighteenth century, Johnstone proposed that the ganglia intercepted and prevented determinations of the will from reaching various organs. And in the nineteenth century Bichat introduced

the notions of organic and animal life, concepts, which exist today in the distinctions between visceral and somatic functions, respectively. By the end of the nineteenth and beginning of the twentieth centuries, autonomic function became linked to emotional behaviors through the theories of James, Lange and Cannon. Pavlov and his colleagues introduced the question of behavioral control of autonomic function and showed unequivocal evidence that autonomically mediated responses could be elicited as part of a learned pattern of behavior. In addition, it should also be noted here that among various Eastern religious traditions, (for example, Transcendental Meditation) it has been reported that many practitioners are able to demonstrate considerable skill at controlling visceromotor behaviors. None of these studies directly address the question of whether visceral responses can be emitted voluntarily, or whether these responses are concomitants of somato-motor behavior. That question is at the heart of biofeedback of autonomic responses and will be addressed in the next section.

### Basic Research

The most robust studies of autonomic biofeedback have used animal models. In the natural environment, many mammalian species have been observed to mark their territories with their urine: a behavior pattern that certainly meets the criterion of learned, emitted behavior. In formal, laboratory studies non-human primates have been trained to emit blood pressure or cardiac responses to avoid electric shock [1]. Monkeys have been trained to decrease and increase their heart rates reliably, and to maintain this control over 15 min or more. In these experiments, the contingencies were signaled by different colored lights; however, the feedback and ►reinforcement was identical in both conditions.

Several studies have been carried out to show that animals that were trained to modify their heart rates could do so, even in the face of a stimulus that would elicit an opposite cardiac response. In one such study, animals that were trained to lower and raise their heart rates to avoid tail shock were challenged by infusions of nitroglycerin or phenylephrine, which elicited conflicting, baroreceptor-induced changes in heart rate. These trained animals consistently attenuated the elicited baroreflex (that is, the slope of the line measuring the change in heart rate per unit change in systolic pressure) [2]. In another study, it was shown that animals that were operantly conditioned to slow their heart rates could inhibit the tachycardia elicited by electrical stimulation in the hypothalamus [3].

It has also been shown that the cardiac response to exercise can be emitted independently of any reflexes. It has been shown that dogs, which are classically conditioned (►Classical conditioning) to exercise by walking on a treadmill, will increase leg blood flow in

response to the conditional stimulus – that is, prior to the onset of the exercise, itself. Furthermore, if the animals are trained to discriminate between two conditional signals, one indicating a higher level of exercise than the other does, the animal will emit a greater blood flow response during the foreperiod of the higher-level cue [4]. This study showed that the anticipatory responses to exercise (both somato-motor and cardiovascular) could be conditioned. Biofeedback studies have extended that finding to show that operant training can modulate the regulation of the cardiovascular responses to exercise. Monkeys were operantly conditioned to exercise (lift weights) to avoid a tail shock. They were then operantly conditioned to slow their heart rate to avoid the identical shock. The two behavioral contingencies were signaled by different sets of cues. When the animals were performing the two behaviors reliably, they were taught to perform both tasks at the same time. Thus, the animals had to lift weights to avoid tail shock, and they had to attenuate the tachycardia of exercise to avoid tail shock. All performed highly reliably. In fact, some of the animals were able to attenuate the tachycardia of exercise, even while lifting the weights, more often than during control sessions when they were required to lift weights without the cardiac contingency [5]. In order to identify the autonomic mechanisms underlying this skill, these studies were repeated with three of the animals at times when they were receiving any of three autonomically active drugs: (i) atenolol, which is a cardiac-specific  $\beta$ -blocker; (ii) atenolol and prazosin, the latter being an  $\alpha$ -adrenergic blocker; or (iii) methyl-atropine, which is a vagal blocker that does not cross the blood-brain barrier. Thus, these drugs completely blocked one or another efferent limb of the autonomic nervous system. None of the drugs interfered with performance. No matter which drug the animals received, they were able to attenuate the tachycardia of exercise consistently and reliably [6]. These exercise studies also address a poorly defined concept that has existed in the exercise physiology literature for many years: the notion that some aspects of exercise behavior are under “central command.” In an experiment combining the exercise training procedure just described, animals were trained to exercise while their brains were electrically stimulated. A detailed analysis of the brain stimulation studies identified some areas that probably mediated central command [7].

Much of the work in biofeedback has been directed at clinical endpoints. Thus, it should not be surprising that many of the studies have been carried out with normal human subjects or patients. This review will be limited to clinical studies in which biofeedback met the operant conditioning criterion; a more complete review can be found in [1].

Bleecker and Engel [8] studied a group of patients with atrial fibrillation. In these patients the normal

cardiac rate control mechanism – modulation of the depolarization of the atrial pacemaker – is absent. Thus, the ability of these patients to regulate their ventricular rates must have been expressed either at the level of the atrio-ventricular node, or at the ventricle itself. They also reported success in training a patient with Wolff-Parkinson-White syndrome, a cardiac dysfunction characterized by accessory conduction pathways that bypass the atrio-ventricular node and often by uncontrollable tachyarrhythmia. The patient learned to produce normally and aberrantly conducted heart beats both in the laboratory, and subsequently in the clinic [9]. Burgio, Whitehead and Engel [10] trained patients with so-called, uninhibited urinary bladder contractions, to inhibit these contractions. Since the urinary bladder has only autonomic innervation, the ability to emit these responses could only occur through direct autonomic action.

### Commentary

From a scientific perspective, the findings from these studies of autonomic biofeedback are important because they underscore the integrative function of the nervous system. The autonomic nervous system certainly has unique features; however, it is not isolated from the overall regulatory conditions explicit in neural control systems. The fact that autonomously mediated responses can be brought under voluntary control through appropriate training conditions, is a strong testament to the role of the nervous system in enabling organisms to adapt to their environment. The clinical significance of such control – for example, in the control of the urinary bladder – is a demonstration of such adaptability. The findings also highlight an important distinction between anatomic and functional properties of the nervous system. While classification based on structure is rational, one must be careful not to equate structure with function.

### References

1. Engel BT (2001) Visceral learning. In: Baum A, Revenson TA, Singer JE (eds) Handbook of health psychology. Lawrence Erlbaum, Mahwah, pp 85–94
2. Engel BT, Joseph JA (1982) Attenuation of baroreflexes during operant cardiac conditioning. *Psychophysiology* 19:609–614
3. Joseph JA, Engel BT (1981) Instrumental control of cardioacceleration induced by central electrical stimulation. *Science* 214:341–343
4. Bolme P, Novotny J (1969) Conditional reflex activation of the sympathetic cholinergic vasodilator nerves in the dog. *Acta Physiol Scand* 77:58–67
5. Engel BT, Talan MI (1991) Hemodynamic and respiratory concomitants of learned heart control during exercise. *Psychophysiology* 28:225–230
6. Engel BT, Talan MI (1991) Autonomic blockade does not prevent learned heart rate attenuation during exercise. *Physiol Behav* 49:373–382

7. Chefer SI, Talan M, Engel BT (1997) Central neural correlates of learned heart rate control during exercise: central command demystified. *J Appl Physiol* 83:1448–1453
8. Bleecker ER, Engel BT (1973) Learned control of ventricular rate in patients with atrial fibrillation. *Psychosom Med* 35:161–175
9. Bleecker Engel BT (1973) Learned control of cardiac rate and cardiac conduction in the Wolff-Parkinson-White syndrome. *New Engl J Med* 288:560–562
10. Burgio KL, Whitehead WE, Engel BT (1985) Urinary incontinence in the elderly: bladder-sphincter biofeedback and toileting skills training. *Ann Int Med* 103:507–515

## Bioinformatics

DR. FIONA MANSERGH<sup>1</sup>, DR. MICHAEL WRIDE<sup>2</sup>

<sup>1</sup>Ocular Genetic Unit, Smurfit Institute of Genetics, Trinity College Dublin, Dublin 2, Ireland

<sup>2</sup>Department of Zoology, Trinity College Dublin, Dublin 2, Ireland

### Synonyms

Computational biology; Systems biology; Biological databasing; *in silico* biological analysis; Biological information processing

### Definition

Bioinformatics refers to the computational analysis of complex biological datasets. Bioinformatics is a broad term, covering the analysis of DNA, RNA (cDNA) and protein sequences, the management of data from microarray (►microarrays) and proteomics experiments, structural biology, imaging techniques, protein binding studies and large scale mutagenesis screens, to name but a few. Given the vast amounts of biological data now stored in databases worldwide, the computational analysis of new data is now just as important as its generation at the bench.

### Characteristics

Bioinformatics is an essential part of the biological revolution of the last few decades. The development of high throughput methods for DNA and protein sequencing, followed by the completion of various genome projects, and, latterly, functional genomics and proteomics, has meant that we have been literally swamped with information. Development of sophisticated bioinformatic tools has allowed us to manage these data [1,2].

## Sequence Analysis

DNA sequencing was first developed using chemical methods by Maxam and Gilbert in 1973. However, the use of dideoxynucleotide chain terminators by Fred Sanger and colleagues allowed faster and simpler generation of sequence data; this is the method largely used, with modifications, today. Initial generation of DNA sequence proceeded slowly, but technological improvements in both the core method and in protocols for template preparation (cloning segments of foreign DNA into microorganisms and the development of the polymerase chain reaction (PCR) in particular) meant that DNA sequence data soon started to accumulate at a logarithmic rate. For example, GenBank, the repository for sequence data, started life in 1962 with 606 sequences (680,338bp). The same database contained over 52 million sequences, representing over 56 billion base pairs of DNA, by the end of 2005 (<http://www.ncbi.nlm.nih.gov/Genbank/genbankstats.html>). Numerous genome sequences have been compiled in the last few years; most notably, with respect to study of the nervous system, the eukaryotic genomes of the yeast (*Saccharomyces cerevisiae*), the worm (*Caenorhabditis elegans*), the fruit fly (*Drosophila melanogaster*), the mouse (*Mus musculus*), the rat (*Rattus norvegicus*), the chicken (*Gallus gallus*) and humans (*Homo sapiens*) are now complete. In addition to genomic sequence data, protein sequences, both determined directly and inferred from nucleic acid sequence, and RNA derived cDNA sequences are also stored in various databases such as GenBank, EMBL DDBJ, SWISSPROT and RefSeq ([2], Table 1).

Collation of genome sequence with sequence from ►ESTs, genes, sequence repeats and other features has allowed the annotation of genomes, which can be examined using genome browsers such as Ensembl or UCSC. Sequence analysis tools (e.g. ►BLAST), can be used for identifying similarities between different DNA and protein sequences. Evolutionary sequence comparisons can be carried out using ClustalW, Phylip, MultAlign and others, which identify highly conserved regions or domains within a gene or protein family, and can be used to build evolutionary trees, which assess the relationships between groups of species (see Table 1 for further bioinformatic resources). Such studies can help when forming hypotheses with regard to the function of unknown proteins.

## Gene Expression and Function

Curating, compiling, annotating and comparing sequence data is a challenge that is being met, thanks to improvements in computing power, the growth of the Internet and the development of genome databases and browsers ([1,2], see Table 1). However, we are left with the difficulty of interpreting function; even years after the completion of the first human draft genome sequence,

many of the genes are still completely functionally uncharacterized. Expressed regions can be identified via comparisons between ESTs and the genome sequence. In this regard, large scale EST sequencing projects have been invaluable, as, owing to the presence of introns, the identification of coding sequences in eukaryotes is no simple matter [3–5]. Alignment of ESTs with the genome sequence has allowed us to identify the intron–exon structure and expression profiles of many previously uncharacterized genes; this information is available using the genome browsers. Furthermore, many large EST libraries derived from most tissue and organs have been sequenced and databased in recent years (UniGene, Riken, NIA, Table 1), allowing not only the annotation of expressed regions of the genome, but also the compiling of estimated full length gene sequence via so-called contigs built from contiguous ESTs. UniGene can be used to provide estimates of gene expression patterns, based on the tissue(s) of origin of ESTs from the same gene.

Non-coding regions can be important as well, however, as they contain regions which control gene expression, such as imprinting control centers, enhancers and promoters. Various computational tools, such as GRAIL and FGENES, are available that can be used to query sequences for likely exons, splice sites, promoters, polyA sites, CpG islands and other sequences of interest (Table 1); again, comparisons between conserved, homologous sequences derived from closely related species can be extremely useful.

## Microarrays, Large Scale Expression Studies

The development of microarray technology has allowed the large scale generation of expression data on an unprecedented scale. Microarrays were initially developed using chips upon which EST derived cDNA fragments were printed; however, the oligonucleotide arrays developed by Affymetrix (Santa Clara, CA, USA) have been just as widely used. Both can bind to labeled cDNA derived from cells or tissues of interest; the expression profiles of the genes on the array can thus be determined. The analysis of array data, however, is computationally intensive. Images scanned from array experiments are first processed using an image analysis programme that converts spot intensities into numerical values and calculates background (e.g., Spot, ImaGene). These raw data are then statistically analyzed; at this stage, differentially regulated genes can be identified. Finally, clustering analysis can be used to identify genes with similar expression profiles. Numerous packages are available for this purpose; lists are given on sites such as MicroArray World or Statsci.org (see Table 1). Since the introduction of MIAME standards (MGED site [6]), which aim to provide the minimum information about a microarray experiment in order to reproduce it fully, published data are also usually databased and publicly accessible. Results from large expression studies are

**Bioinformatics. Table 1** Online Bioinformatics Resources

Name	Website	Purpose
<i>Sequence analysis tools and databases</i>		
UCSC Genome Browser	<a href="http://genome.ucsc.edu/">http://genome.ucsc.edu/</a>	Genome browser
Ensembl	<a href="http://www.ensembl.org/">http://www.ensembl.org/</a>	Genome browser
NCBI	<a href="http://www.ncbi.nlm.nih.gov/">http://www.ncbi.nlm.nih.gov/</a>	Comprehensive collection of interlinked databases and bioinformatic tools, including the scientific literature database PubMed
EBI	<a href="http://www.ebi.ac.uk/">http://www.ebi.ac.uk/</a>	European Bioinformatics Institute
GenBank	<a href="http://www.ncbi.nlm.nih.gov/entrez/query.fcgi?db=nucleotide&amp;cmd=search&amp;term=">http://www.ncbi.nlm.nih.gov/entrez/query.fcgi?db=nucleotide&amp;cmd=search&amp;term=</a>	Archive of publicly available nucleotide and amino acid sequences, compiled from GenBank, DDBJ (DNA databank of Japan) and EMBL (European molecular biology laboratory)
BLAST	<a href="http://www.ncbi.nlm.nih.gov/BLAST/">http://www.ncbi.nlm.nih.gov/BLAST/</a>	Online tool for aligning nucleotide or amino acid sequences
Molbiol-tools	<a href="http://molbiol-tools.ca/">http://molbiol-tools.ca/</a>	Collection of useful online bioinformatic tools, including programs such as ClustalW for sequence alignment
Clc Bio	<a href="http://www.clcbio.com/index.php?id=502">http://www.clcbio.com/index.php?id=502</a>	Collection of online bioinformatic tools
Just Bio	<a href="http://www.justbio.com/tools.php">http://www.justbio.com/tools.php</a>	Collection of online bioinformatic tools
SoftBerry	<a href="http://www.softberry.com/berry.phtml">http://www.softberry.com/berry.phtml</a>	Collection of online bioinformatic tools
Scientific resources at the NIH	<a href="http://www.nih.gov/science/">http://www.nih.gov/science/</a>	Databases, training opportunities and bioinformatics tools available through the NIH
NIA EST search	<a href="http://lgsun.grc.nia.nih.gov/cgi-bin/pro1">http://lgsun.grc.nia.nih.gov/cgi-bin/pro1</a>	Search tool for NIA ESTs
UniGene	<a href="http://www.ncbi.nlm.nih.gov/entrez/query.fcgi?db=unigene">http://www.ncbi.nlm.nih.gov/entrez/query.fcgi?db=unigene</a>	ESTs compiled with regard to the identity of the gene to which they map
GrailEXP	<a href="http://compbio.ornl.gov/grailexp/">http://compbio.ornl.gov/grailexp/</a>	Predicts exons, genes, promoters, polyas, CpG islands, EST similarities, and repetitive elements within DNA sequence
GenScan	<a href="http://genes.mit.edu/GENSCAN.html">http://genes.mit.edu/GENSCAN.html</a>	Predicts coding sequence within up to 1MB of sequence
EST resources	<a href="http://genome.gsc.riken.go.jp/">http://genome.gsc.riken.go.jp/</a>	The Riken institute has been a key player in large scale EST sequencing projects, especially in generating full length clones
COG	<a href="http://www.ncbi.nlm.nih.gov/COG/">http://www.ncbi.nlm.nih.gov/COG/</a>	orthologous genes
<i>Microarray and SAGE resources</i>		
Microarray World	<a href="http://www.microarrayworld.com/">http://www.microarrayworld.com/</a>	A collection of array resources
Omics World	<a href="http://www.omicsworld.com/">http://www.omicsworld.com/</a>	High throughput expression analysis tools
ArrayExpress	<a href="http://www.ebi.ac.uk/Databases/microarray.html">http://www.ebi.ac.uk/Databases/microarray.html</a>	MIAME compliant public array data repository
GEO	<a href="http://www.ncbi.nlm.nih.gov/geo/">http://www.ncbi.nlm.nih.gov/geo/</a>	Gene expression omnibus, searchable MIAME compliant repository for microarray data, includes SAGE libraries
MGED	<a href="http://www.mged.org/">http://www.mged.org/</a>	Microarray gene expression data society, emphasis on standards and data sharing
Bibliography on microarray data analysis	<a href="http://www.nslj-genetics.org/microarray/">http://www.nslj-genetics.org/microarray/</a>	Collated microarray literature
Statsci.org	<a href="http://www.statsci.org/micrarra/">http://www.statsci.org/micrarra/</a>	Array analysis resources
Affymetrix	<a href="http://www.affymetrix.com/index.affx">http://www.affymetrix.com/index.affx</a>	A-Z of Affymetrix arrays
Stanford Microarray database	<a href="http://genome-www5.stanford.edu/">genome-www5.stanford.edu/</a>	Array database
SAGE	<a href="http://www.sagenet.org/">http://www.sagenet.org/</a>	Sage resources

**Bioinformatics. Table 1** Online Bioinformatics Resources (Continued)

Name	Website	Purpose
DAVID	<a href="http://david.abcc.ncifcrf.gov/">http://david.abcc.ncifcrf.gov/</a>	Web resource for the annotation of microarray genes
GO	<a href="http://www.geneontology.org">http://www.geneontology.org</a>	Gene ontology database
<i>Protein analysis tools</i>		
SMART	<a href="http://smart.embl-heidelberg.de">http://smart.embl-heidelberg.de</a>	Protein function
Cath	<a href="http://www.biochem.ucl.ac.uk/bsm/cath_new/">http://www.biochem.ucl.ac.uk/bsm/cath_new/</a>	Protein 3D folding
Scop	<a href="http://scop.mrc-lmb.cam.ac.uk/scop/">http://scop.mrc-lmb.cam.ac.uk/scop/</a>	Protein 3D folding
BLOCKS	<a href="http://www.blocks.fhcrc.org/">http://www.blocks.fhcrc.org/</a>	Protein function
PRINTS	<a href="http://www.bioinf.man.ac.uk/dbbrowser/PRINTS/">http://www.bioinf.man.ac.uk/dbbrowser/PRINTS/</a>	Protein function
TIGRFAMs	<a href="http://www.tigr.org/TIGRFAMs">http://www.tigr.org/TIGRFAMs</a>	Protein function
Pfam	<a href="http://pfam.wustl.edu">http://pfam.wustl.edu</a>	Protein function
PredictProtein	<a href="http://www.predictprotein.org/">http://www.predictprotein.org/</a>	Protein structure prediction
Psipred	<a href="http://bioinf.cs.ucl.ac.uk/psipred/">http://bioinf.cs.ucl.ac.uk/psipred/</a>	Protein structure prediction
Expasy	<a href="http://expasy.org/tools/">http://expasy.org/tools/</a>	Proteomics tools
TMHMM	<a href="http://www.cbs.dtu.dk/services/TMHMM-2.0">http://www.cbs.dtu.dk/services/TMHMM-2.0</a>	Predicts transmembrane helices
Multalin	<a href="http://bioinfo.genopole-toulouse.prd.fr/multalin/multalin.html">http://bioinfo.genopole-toulouse.prd.fr/multalin/multalin.html</a>	Protein alignments
PDB	<a href="http://www.rcsb.org/pdb/home/home.do">http://www.rcsb.org/pdb/home/home.do</a>	Protein tools
Owl	<a href="http://www.bioinf.manchester.ac.uk/dbbrowser/OWL/">http://www.bioinf.manchester.ac.uk/dbbrowser/OWL/</a>	Composite protein sequence database
BIMAS	<a href="http://www.bimas.cit.nih.gov/molbio/hla_bind/">http://www.bimas.cit.nih.gov/molbio/hla_bind/</a>	Protein binding predictions
NetOGlyc	<a href="http://www.cbs.dtu.dk/services/NetOGlyc/">http://www.cbs.dtu.dk/services/NetOGlyc/</a>	Glycosylation predictor
NetPhos	<a href="http://www.cbs.dtu.dk/services/NetPhos/">http://www.cbs.dtu.dk/services/NetPhos/</a>	Phosphorylation predictor
Human proteome organization	<a href="http://www.hupo.org/resources/related/tools.asp">http://www.hupo.org/resources/related/tools.asp</a>	Collection of protein analysis tools
<i>Human and animal model mapping and mutation resources</i>		
OMIM: Online Mendelian Inheritance in Man	<a href="http://www.ncbi.nlm.nih.gov/entrez/query.fcgi?CMD=search&amp;DB=omim">http://www.ncbi.nlm.nih.gov/entrez/query.fcgi?CMD=search&amp;DB=omim</a>	Database of human inherited disorders, map locations of disorders (where known), causative genes (where known)
Jackson laboratories	<a href="http://www.jax.org/">http://www.jax.org/</a>	Comprehensive mouse resources, mouse suppliers
Charles River	<a href="http://www.criver.com/">http://www.criver.com/</a>	Laboratory animal supplies
OMIA: Online Mendelian Inheritance in Animals	<a href="http://www.ncbi.nlm.nih.gov/entrez/query.fcgi?db=omia&amp;cmd=search&amp;term=">http://www.ncbi.nlm.nih.gov/entrez/query.fcgi?db=omia&amp;cmd=search&amp;term=</a>	Database of animal mutants and phenotypes, in animals other than human and mouse
SGD	<a href="http://www.yeastgenome.org">http://www.yeastgenome.org</a>	Saccharomyces genome database
WormBase	<a href="http://www.wormbase.org">http://www.wormbase.org</a>	C. elegans genome database
FlyBase	<a href="http://flybase.bio.indiana.edu">http://flybase.bio.indiana.edu</a>	Drosophila genome database
Genome Web, human mutation databases	<a href="http://www.cbi.pku.edu.cn/mirror/GenomeWeb/human-gen-db-mutation.html">http://www.cbi.pku.edu.cn/mirror/GenomeWeb/human-gen-db-mutation.html</a>	List of disease causing mutation databases (some disease or organ specific)
Entrez SNP	<a href="http://www.ncbi.nlm.nih.gov/entrez/query.fcgi?CMD=search&amp;DB=snp">http://www.ncbi.nlm.nih.gov/entrez/query.fcgi?CMD=search&amp;DB=snp</a>	Single nucleotide polymorphism database
MGI: Mouse genome informatics	<a href="http://www.informatics.jax.org/">http://www.informatics.jax.org/</a>	Provides information on mouse mutants and genetics, genomics and biology of the laboratory mouse

**Bioinformatics. Table 1** Online Bioinformatics Resources (Continued)

Name	Website	Purpose
HGMD	<a href="http://www.hgmd.cf.ac.uk/ac/index.php">http://www.hgmd.cf.ac.uk/ac/index.php</a>	Human gene mutation database
CEPH	<a href="http://www.cephb.fr/">http://www.cephb.fr/</a>	Human genotype and mapping data
STS based human genome map	<a href="http://www.broad.mit.edu/cgi-bin/contig/phys_map/">http://www.broad.mit.edu/cgi-bin/contig/phys_map/</a>	Searchable microsatellite map of the human genome
MapView	<a href="http://www.ncbi.nlm.nih.gov/mapview/">http://www.ncbi.nlm.nih.gov/mapview/</a>	Maps of various genomes
Neuromice	<a href="http://www.neuromice.org">http://www.neuromice.org</a>	Developing mouse mutants for neuroscience research
RGD	<a href="http://rgd.mcg.edu/">http://rgd.mcg.edu/</a>	Rat genome database
Mouse mutagenesis for developmental defects	<a href="http://www.mouse-genome.bcm.tmc.edu/ENU/ENUhome.asp">http://www.mouse-genome.bcm.tmc.edu/ENU/ENUhome.asp</a>	Developing mouse mutants for developmental research
Center for modeling human disease	<a href="http://www.cmhd.ca/">http://www.cmhd.ca/</a>	Models created by gene trapping and ENU mutagenesis
MRC-Harwell mutagenesis database	<a href="http://www.mgu.har.mrc.ac.uk/facilities/mutagenesis/mutabase/">http://www.mgu.har.mrc.ac.uk/facilities/mutagenesis/mutabase/</a>	MRC ENU mutagenesis webpage
Munich ENU mutagenesis project	<a href="http://www.gsf.de/ieg/groups/genome/enu.html">http://www.gsf.de/ieg/groups/genome/enu.html</a>	Munich ENU mutagenesis website
Cre-X mice	<a href="http://nagy.mshri.on.ca/cre/">http://nagy.mshri.on.ca/cre/</a>	Database of Cre transgenic mice
IGTC	<a href="http://www.genetrap.org/">http://www.genetrap.org/</a>	International gene trap consortium: access to gene-trap ES cell lines
SIGTR	<a href="http://www.sanger.ac.uk/PostGenomics/genetrap/">http://www.sanger.ac.uk/PostGenomics/genetrap/</a>	Sanger institute gene trap resource
MICER	<a href="http://www.sanger.ac.uk/PostGenomics/mousegenomics/">http://www.sanger.ac.uk/PostGenomics/mousegenomics/</a>	Publicly available targeting vectors for ES cell mutagenesis
German gene trap consortium	<a href="http://tikus.gsf.de/">http://tikus.gsf.de/</a>	German gene trap resource
Soriano lab	<a href="http://www.fhcr.org/science/labs/soriano/trap.html">http://www.fhcr.org/science/labs/soriano/trap.html</a>	Gene trap resource
PhenoGo	<a href="http://phenos.bsd.uchicago.edu/mphenogo/query.jsp">http://phenos.bsd.uchicago.edu/mphenogo/query.jsp</a>	Provides a multi-organism phenotype searchable database that relates to GO gene ontology classifications
Tennessee mouse genome consortium	<a href="http://www.tnmouse.org/">http://www.tnmouse.org/</a>	Mouse genome resource
NIH neurogenomics	<a href="http://www.genome.northwestern.edu/neuro/">http://www.genome.northwestern.edu/neuro/</a>	Northwestern university neurogenomics initiative
NIFTI	<a href="http://www.bic.mni.mcgill.ca/nifti/">http://www.bic.mni.mcgill.ca/nifti/</a>	Neuroimaging informatics technology initiative: brain imaging
LONI	<a href="http://www.loni.ucla.edu/ICBM/">http://www.loni.ucla.edu/ICBM/</a>	International consortium for brain mapping
BIRN	<a href="http://www.nbirn.net/downloads/human_imaging_gui/index.shtml">http://www.nbirn.net/downloads/human_imaging_gui/index.shtml</a>	Biomedical informatics research network: imaging informatics tools
BrainInfo	<a href="http://braininfo.rprc.washington.edu/">http://braininfo.rprc.washington.edu/</a>	Identification of brain structures
BrainWeb	<a href="http://www.bic.mni.mcgill.ca/brainweb/">http://www.bic.mni.mcgill.ca/brainweb/</a>	Simulated brain database
<i>Interaction databases</i>		
BIND	<a href="http://bond.unleashedinformatics.com/Action?">http://bond.unleashedinformatics.com/Action?</a>	Protein binding and interactions
DIP	<a href="http://dip.doe-mbi.ucla.edu/">http://dip.doe-mbi.ucla.edu/</a>	Database of interacting proteins
KEGG	<a href="http://www.genome.ad.jp/kegg/">http://www.genome.ad.jp/kegg/</a>	Molecular interactions, reactions and relations
BioCyc	<a href="http://www.biocyc.org/">http://www.biocyc.org/</a>	Genome and pathway databases



**Bioinformatics. Table 1** Online Bioinformatics Resources (Continued)

Name	Website	Purpose
The binding database	<a href="http://www.bindingdb.org/bind/index.jsp">http://www.bindingdb.org/bind/index.jsp</a>	Affinities for biomolecules
Dpinteract	<a href="http://arep.med.harvard.edu/dpinteract/">http://arep.med.harvard.edu/dpinteract/</a>	Protein-DNA binding
PPID	<a href="http://www.anc.ed.ac.uk/mcscs/PPID/">http://www.anc.ed.ac.uk/mcscs/PPID/</a>	Protein-protein interaction database
MIPS	<a href="http://mips.gsf.de/proj/ppi/">http://mips.gsf.de/proj/ppi/</a>	Mammalian protein-protein interaction database
HPID	<a href="http://wilab.inha.ac.kr/hpid/">http://wilab.inha.ac.kr/hpid/</a>	Human protein interaction database

often made available online in a searchable manner (GEO and ArrayExpress, Table 1). Further methods used to assess gene expression profiles include large scale cDNA sequencing (see above) and serial analysis of gene expression (SAGE), which combines DNA based molecular tagging, cloning and sequencing to assess gene expression profiles (SageNet [7], Table 1).

### Protein Expression and Structure

RNA expression patterns, while easier to assay, do not always tally with final protein expression levels; for example, the control of gene expression, in many cases, is at the level of translation. Therefore, it is often useful to be able to assay large scale changes in protein expression levels, as well as those for RNA. Therefore, advances have been made, in both antibody based protein arrays and in imaging and analyzing 2D gels. Furthermore, the determination of protein crystal structures has become more high-throughput; as more structures become available, the structures of related proteins can be estimated computationally. Comparisons of protein secondary and tertiary structure can give valuable information with regard to likely subcellular localizations and possible functions. A large number of online tools are now available for the study of protein structure and prediction of possible function (Table 1).

### Mutant and Phenotype Databases

However, expression levels, while interesting, are often entirely uninformative with regard to gene function. The most useful indicators of gene function have undoubtedly been genetic mutants. Naturally occurring, often disease causing mutations have been documented for generations; however, the technology with which to map them on a large scale became widely available in the 1980s, initially using polymorphic markers, ►RFLPs, assayed by Southern blot. These were replaced by more informative ►microsatellite markers, assayed by PCR, in the early 1990s. Linkage analysis was then used to correlate the transmission of the mutant allele with mapped polymorphic markers. Inheritance of the mutant phenotype with a mapped polymorphic allele could be given a statistical score, or

LOD score. A LOD of greater than 3 is considered statistically significant evidence of linkage. Multiple microsatellite markers in a given region can be assessed, and haplotypes generated, in order to more accurately pinpoint the location of the disease gene. Generation of a dense “marker map” of the human genome, the Genethon Map (CEPH site, Table 1) preceded the actual genome sequence and allowed the mapping and subsequent identification of thousands of genes that, when mutated, cause disease in humans. The Online Mendelian Inheritance in Man (OMIM) database maintains records of human phenotypes, and, where known, the location and/or identity of disease genes. Similar databases are maintained for animal models (OMIA, MGI, SGD, FlyBase, WormBase). Searchable linkage marker maps for the more widely used model organisms are also available (Table 1).

The functional study of human mutations can be taken further in animal models. The development of ►gene targeting has been invaluable in often confirming that mutation of a given gene results in the expected phenotype, and in modeling the mechanisms by which a mutation causes disease. The development of ►conditional mutagenesis has refined this process further, allowing genes to be turned on or off in specific tissues or at specific times in development. ►ENU mutagenesis is a method of introducing point mutations into the genome in a high throughput manner and has been used widely [8]. Plans to mutate every gene in the mouse genome, both by targeting and ENU, are underway and are being databased accordingly (Table 1). Similarly, phenotype databases, catalogues of available mutant mice, mutated ES cells, targeting vectors and phenotypes are now available online (Table 1, [9]). Single nucleotide ►polymorphisms (►SNPs) are being catalogued in order to determine the relationships between common genetic variants, predispositions to common disorders and differing responses to therapeutic pharmaceuticals. Advances in imaging have also taken place. An increasing number of databases and bioinformatic resources are becoming available with regard to virtual maps of the brain and nervous system. However, compiling these data in a searchable format is still an enormous challenge ([10], Table 1).

## The Interactome and Systems Biology

The wealth of pre-existing data with respect to protein-protein and protein-nucleic acid interactions and other functional data are being collated to unravel metabolic pathways. Databases such as BIND and DIP are collating information from previously published work and building searchable databases that catalogue how a given gene fits into previously established metabolic or signaling pathways ([2], 2003, Table 1). Data from individual gene studies and from large scale studies such as those involving yeast 2 hybrid screens are collated with a view to building models of the interactomes of various cell types. ► **Systems biology** approaches can then be used to collate the data from individual functional experiments, genomics, proteomics, phenomics etc. and build mathematical models that can mimic the behavior of cellular biochemical networks. Integration of information and training of models should allow predictions of treatment outcome and drug associated toxicity, which would be of great value to medicine [7].

### Overview

Advances in biology have led us, in 50 years, from the discovery of the structure of our genetic material, to the complete decoding of our genome and beyond. The major challenge is to interpret the structures and functions of the genes encoded in the genome. Fortunately, developments in information technology have led to rapid advances in bioinformatics, allowing the amateur bioinformatician easy access to a wide variety of research tools online (Table 1). Bioinformatic and systems biology approaches to analysis of currently available data will be essential to further progress, given the increasing complexity of the knowledge base.

### References

1. Akalin PK (2006) Introduction to bioinformatics. *Mol Nutr Food Res* 50:610–619
2. Kanehisa M, Bork P (2003) Bioinformatics in the post sequence era. *Nat Genet* 33 (suppl):305–310
3. Ko MS, Threat TA, Wang X, Horton JH, Cui Y, Pryor E, Paris J, Wells-Smith J et al. (1998) Genome wide mapping of unselected transcripts from extraembryonic tissue of 7.5 day mouse embryos reveals enrichment in the t-complex and under-representation on the X chromosome. *Hum Mol Genet* 7:1967–1978
4. Carninci P, Waki K, Shiraki T, Konno H, Shibata K, Itoh M, Aizawa K, Arakawa T, Ishii Y, Sasaki D, Bono H, Kondo S, Sugahara Y, Saito R, Osato N, Fukuda S, Sato K, Watahiki A, Hirozane-Kishikawa T, Nakamura I, Shibata Y, Yasunishi A, Kikuchi N, Yoshiki A, Kusakabe M, Gustincich S, Beisel K, Pavan W, Aidinis V, Nakagawara A, Held WA, Iwata H, Kono T, Nakauchi H, Lyons P, Wells C, Hume DA, Fagiolini M, Hensch TK, Brinkmeier M, Camper S, Hirota J, Mombaerts P, Muramatsu M, Okazaki Y, Kawai J, Hayashizaki Y (2003) Targeting a complex transcriptome: the construction of the mouse full-length cDNA encyclopedia. *Genome Res* 13:1273–1289

5. Marra M, Hillier L, Kucaba T, Allen M, Barstead R, Beck C, Blistain A, Bonaldo M, Bowers Y, Bowles L, Cardenas M, Chamberlain A, Chappell J, Clifton S, Favello A, Geisel S, Gibbons M, Harvey N, Hill F, Jackson Y, Kohn S, Lennon G, Mardis E, Martin J, Mila L, McCann R, Morales R, Pape D, Person B, Prange C, Ritter E, Soares M, Schurk R, Shin T, Steptoe M, Swaller T, Theising B, Underwood K, Wylie T, Yount T, Wilson R, Waterston R (1999) An encyclopedia of mouse genes. *Nat Genet* 21:191–194
6. Brazma A, Hingamp P, Quackenbush J, Sherlock G, Spellman P, Stoeckert C, Aach J, Ansorge W, Ball CA, Causton HC, Gaasterland T, Glenisson P, Holstege FC, Kim IF, Markowitz V, Matese JC, Parkinson H, Robinson A, Sarkans U, Schulze-Kremer S, Stewart J, Taylor R, Vilo J, Vingron M (2001) Minimum information about a microarray experiment (MIAME)-toward standards for microarray data. *Nat Genet* 29:365–371
7. Baranzini SE (2004) Gene expression profiling in neurological disorders. *Neuromol Med* 6:31–51
8. Goldowitz D, Frankel WN, Takahashi JS, Holtz-Vitaterna M, Bult C, Kibbe WA, Snoddy J, Li Y, Pretel S, Yates J, Swanson DJ (2004) Large-scale mutagenesis of the mouse to understand the genetic bases of nervous system structure and function. *Mol Brain Res* 132:105–115
9. Lussier YA, Liu Y (2007) Computational approaches to phenotyping. *Proc Am Thorac Soc* 4:18–25
10. Vercelli A (2006) Brain maps and connectivity representation *Neuroinformatics* 4:319–320

## Biological Clocks

### Definition

Basis for periodic behavior under stationary environmental conditions. A genetic basis of biological clocks was discovered in the first half of the twentieth century. Currently the molecular bases are studied. The most important clocks have periods of about a day (circadian), a lunar cycle (circalunar) or a year (circannual).

## Biological Databasing

► Bioinformatics

## Biological Information Processing

► Bioinformatics

## Biological Motion Processing

### Definition

This term is used in the literature in two distinct ways. (i) “Biological” refers to the stimulus, specifically to patterns of motion characteristic of biological systems such as a walking human figure. There is evidence that in the human brain a region of the superior temporal sulcus is specialized to process such biological motion. (ii) “Biological” refers to the processing, so as to draw a distinction between the way in which visual motion is processed in animal brains and schemes for processing image motion in artificial computational or robotic systems.

► Visual Motion Processing

## Biological Psychiatry

► Forensic Neuropsychiatry

## Biological Rhythms and Sleep

MARTHA U. GILLETTE

Departments of Cell and Developmental Biology, Molecular and Integrative Physiology, and Neuroscience Program, University of Illinois at Urbana-Champaign, Urbana, IL, USA

### Introduction

The processes of life are dynamic, varying in response to both internal and external conditions. These dynamic variations may be arrhythmic, without regular occurrence, or rhythmic, marked by regular, cyclic changes (see ► *arrhythmicity/rhythmicity*). Rhythmic changes vary over a range of natural environmental ► *cycles*. Regular, predictable changes in day and night, the tides, the moon and the annual cycle of seasons over the course of evolution have shaped the temporal organization of life on Earth. ► *Chronobiology*, the study of these biological rhythms, has revealed that the timing of the rhythms of life is woven into the genetic fabric. Time-keeping is endogenous, marked by internal biological ► *clocks*, whose cycles are shaped, but not driven, by

environmental signals. The regular, repeated nature of biological rhythms provides a time base upon which other internal processes become entrained. This enables organisms to anticipate predictable environmental features with which to align appropriately their physiology and behavior.

The most thoroughly studied biological rhythm is the ► *circadian cycle* (from the Latin *circa*, around + *diem*, a day), which is about 24 h in length. Circadian cycles that repeat with daily regularity are characteristic of all eukaryotic organisms, and some prokaryotes (e.g., *Cyanobacteria*, a blue-green algae that is a major component of Pacific Ocean plankton). In the absence of environmental cues, circadian rhythms repeat over a ► *period* that is about, but not exactly, 24 h. This small, but significant, mismatch between the internal circadian and external solar cycles is evidence that circadian rhythms are endogenous, and not driven by periodic external cues. Circadian rhythms characterize virtually every biological process: changes in the transcription of digestive enzymes in the liver, the release of growth hormone from the pituitary, the strength in large muscles of the forearm, and in global brain state and behavior that characterize the ► *sleep-wake cycle*.

This synopsis first will review circadian rhythms: basic timekeeping processes, ► *cellular clocks* and ► *clock genes*, temporal orchestration of the body clocks, regulatory signals, circadian systems in seasonal adaptation to the changing world, and ► *circadian sleep phase syndromes*. Next, it will consider sleep and wakefulness: sleep-wake states, sleep regulation, mechanisms that generate sleep and waking states in the brain, and the effects of sleep-wake states on body systems. Lastly, future directions and opportunities of these highly active research areas will be highlighted.

### Circadian Rhythms Circadian Fundamentals

We know from casual observation of the natural world that organisms perform different behaviors at different times in the day–night cycle. The wolf hunts for prey in daytime, searching for food while the owl sleeps. When night comes, their behaviors reverse: the wolf is sleeping while the owl hunts. These ► *nocturnal/diurnal* differences in the timing of behaviors enable animals to compete effectively in different niches for the basic necessities of life, e.g., acquisition of nutrients, mates and shelter, and to partition restorative processes and growth to the alternate phase of the cycle. When these behaviors are quantified over time, they are observed to recur each day in a rhythmic pattern, with peak and trough occurring over the day–night cycle at roughly the same time every 24 h. For crepuscular, twilight-active animals, two activity peaks, proposed to be driven by ► *morning (M) and evening (E) oscillators*, are evident [1].

Chronobiology has identified a core set of fundamental characteristics that are hallmarks of circadian rhythms. (i) Despite the tendency to think that daily rhythmic patterns are governed by the environmental cycle of light and darkness, these rhythms persist with regularity under constant conditions, or ▶**free-run**, in the absence of timing cues from the environment. (ii) The period of the ▶**free-running** rhythms, ▶**tau** (▶ $\tau$ ), is significantly different from the solar cycle, which is invariantly 24.0 h. This period length is endogenous and bears a predictable relationship to diurnality or nocturnality. These relationships follow ▶**Aschoff's Rules** under various constant lighting conditions [2]. For example, the free-running period in constant darkness is generally >24 h for diurnal animals and <24 h for nocturnal species. (iii) Circadian rhythms are precise in period and robust in amplitude. (iv) Circadian clocks show independency in the speed of circadian clock processes (compensation) for environmental variations, such as nutrients or temperature (see ▶**Circadian pacemakers – temperature compensation**). Although the mechanism is unknown, contemporary models predict that temperature compensation emerges from two opposing and counterbalancing effects on the periodicity of the clock system [3]. (v) Circadian rhythms can be synchronized by appropriate extrinsic and intrinsic signals through a process termed ▶**entrainment**.

### Cellular Clocks and Clock Genes

Circadian rhythms are expressed at the molecular, cellular, tissue, organ, organ systems and behavioral levels of organization. What is the basic autonomous timekeeping unit? Isolated single cells possess the intrinsic cellular mechanisms to generate regular, repeating circadian oscillations [4]. All cells within the body possess circadian clocks that tune the functions of the various differentiated types of cell to organismic state over the day–night cycle. However, tissue-level phenomena and communication among cellular clocks within and between tissues are necessary for organismic physiology and behavior to function in integrative, time-of-day appropriate ways [5].

Within the cell, timekeeping is governed by clock genes, whose action is necessary to generate the circadian cycle. Clock genes are any of a number of genes that interact with each other to form dynamic, auto-regulatory ▶**feedback loops** with a circadian period [6]. Both transcriptional activation and repression of clock genes cycle over a period of about a day. The first clock genes were identified by mutagenesis screens of *Drosophila* for flies with altered behavioral rhythms [7]. They were named **Period**, ▶**Timeless** and **Cycle**, reflecting their effect on circadian behavioral rhythms. Homologous genes (*Period*, *Timeless* and *CLOCK*) were found in mammals, some of which could

substitute functionally for fly homologs. Clock genes discovered initially encode transcription factors, a class of proteins that can either positively or negatively alter transcription of other clock genes. In addition, clock gene transcription factors can alter expression of ▶**clock-controlled genes**, such that their transcription varies in a time-of-day-dependent manner. Clock genes have been identified that encode other types of proteins, as well. A major class of proteins encoded by clock genes cause critical post-translational modifications (PTMs), such as phosphorylation or ubiquitination, of the clock gene transcription factors and other substrate proteins [8]. Remarkably, a cyanobacterial protein, Kai, a tripartite protein kinase complex, oscillates with a period in the circadian range when provided with exogenous ATP in a cell-free system [9]. This finding suggests that, indeed, timekeeping may be invested in post-translational modifications of a few clock proteins. Very recently, small molecules, such as cADP ribose, which can regulate intracellular  $Ca^{2+}$ , also have been found to be key clock regulators [10]. Genes encoding proteins that regulate cADP ribose levels also would likely fulfill the criteria for clock genes. No doubt the classes of proteins encoded by clock genes will continue to increase as understanding of timekeeping mechanisms continues to expand.

### Orchestration of Body Clocks

In organisms with complex behaviors, circadian rhythms are orchestrated by discrete areas in the nervous system. With increased cephalization, regulation of circadian clocks throughout the body became centralized in the brain. In higher vertebrates and mammals, the ▶**suprachiasmatic nucleus (SCN)** is key to circadian regulation. The SCN orchestrates the symphony of ▶**peripheral oscillators**, the body clocks of mammals. Positioned at the base of the hypothalamus and directly above the optic chiasm, the SCN is central to other hypothalamic regions involved in regulating systems-level circadian rhythms in the sleep-wake cycle, feeding, drinking, body temperature, sexual functions and multiple hormones systems. The SCN comprises roughly 10,000 neurons that are among the smallest cells in the body (8–12  $\mu\text{m}$  in diameter) and 3,000 glial cells [11]. The SCN is characterized by many intrinsic connections, but the functions of only a few are known. The SCN is highly peptidergic. Some SCN peptides contribute to synchronization among the SCN neurons (e.g., ▶**VIP**), some are output signals to nearby hypothalamic regions (e.g., ▶**VP**) and some contribute to ▶**gating** responsiveness to input signals (e.g., ▶**GRP**) [12]. Lesion and transplantation studies demonstrate that the SCN is necessary and sufficient to impart coordinated rhythms both to the brain and to circadian clocks of other cells and organs throughout the body. With the insight that the circadian rhythms of behavior,

physiology and metabolism are governed as ►**multi-oscillator systems** [13] that rely on the SCN for global synchronization, the search is on for ►**clock-coupling factors**. When discovered, these clock-coupling factors may have therapeutic potential for alleviating the adverse effects of ►**internal desynchronization**, the loss of synchrony between two or more circadian rhythms, which is caused by ►**jet lag** and ►**shift work**.

### Regulation of the Circadian System by Zeitgebers

A consequence of the circadian period being significantly different from 24 h is that, under constant environmental conditions, circadian rhythms drift away from the 24-h solar cycle over the course of days and weeks. This condition is called “free-running,” and is found in some blind individuals, who pass in- and out-of-phase with day and night. Virtually all organisms ►**entrain** to the cyclic environmental conditions in the natural world. The circadian system relies on ►**zeitgebers**, time-giving cues, for adjustment to the solar cycle and other significant variables.

The most salient zeitgeber is environmental light. Special ►**photoreceptor** systems inform the circadian system of the presence of light in the environment. In organisms with translucent bodies, like *Drosophila*, light can be sensed directly by all cells with photoreceptive molecules. One such photosensor is ►**cryptochrome**, a molecular clock element. In higher vertebrates with large brains, a specialized ►**photopigment**, ►**melanopsin**, is localized in intrinsically photoreceptive ►**retinal ganglion cells** of the eye [14]. These photoreceptors are photon-counters, sensing the presence and intensity of light. Axons of the melanopsin-bearing retinal ganglion cells project directly to the SCN, forming the ►**retinohypothalamic tract (RHT)** [11]. This is the primary pathway by which light information reaches the SCN. The presence of light during the night is perceived by the melanopsin retinal ganglion cells and communicated to the SCN by neurochemical signals, glutamate and the peptide PACAP [15]. The input from these retinal ganglion cells changes the phase of the SCN, correcting for deviations of internal time with respect to day and night. The relation between the timing of the light signal and its effect on SCN phase is described by a ►**phase response curve (PRC)**. This relationship is stereotypic: for all organisms, whether diurnal or nocturnal, it is characterized by a delay of clock phase when light is experienced in early night (correcting for a failure to reckon day as long enough) and an advance of clock phase in late night (correcting for an early dawn). ►**Type 1 and Type 0 resetting** describe the dependency of the response on *when* during the cycle the stimulus is received and the effect of *stimulus strength* on the rate of the phase-change in the circadian system.

Whereas light is the primary determinant of the phasing of circadian rhythms, including the timing of the

sleep-wake cycle, many stimuli can entrain or modulate circadian rhythms. Beyond light, regularly occurring extrinsic stimuli can act as zeitgebers. Temperature cycles are effective entrainment signals for poikilothermic invertebrates. Social stimulation can entrain, especially when light is absent as in some blind subjects. Nutrient availability is a strong entraining stimulus when food is limited, either during the dry season of equatorial birds or experimentally induced in mammals (►**food entrainment**). Because the SCN drives circadian rhythms of feeding, the fact that under restricted conditions food can entrain indicates that feedback loops communicate the timing of food availability to the SCN. Some retinal melanopsin cells also project to the ►**intergeniculate leaflet (IGL)** of the thalamus, which in turn projects back to the SCN via the ►**geniculohypothalamic tract (GHT)** [16]. The IGL integrates information from >100 brain regions and transmits information regarding non-photic zeitgebers to the SCN via the GHT. A novel running wheel or the drug triazolam, a short-acting benzodiazepine derivative used as a sedative to treat ►**insomnia**, act on the SCN via this GHT projection. The IGL communicates with the SCN via ►**neuropeptide Y (NPY)** and enkephalins.

Intrinsic signals also can alter phasing of the circadian system. Emerging evidence indicates that the sleep-wake state is communicated to the SCN. ►**Cholinergic brainstem** signals from the sleep-wake system and the pineal hormone, ►**melatonin**, can feed back on the SCN to alter its phasing when sleep patterns are disturbed [17]. Eating more fat can shift the circadian rhythms, as well [18]. Furthermore, clock-controlled variables such as effects on locomotor activity by light and on core body temperature by posture and sleep, can enhance or attenuate a clock-controlled variable, phenomena termed ►**masking** (►**positive, negative**). Overall, the circadian system is finely tuned to align circadian rhythms appropriately with external and internal states.

### Circadian Regulation in a Changing World

In addition to night-to-day variations, the Earth undergoes long-term cyclic changes over the course of the year. Regardless of the latitude, seasonal changes in ambient temperature and/or rainfall restrict the availability of food. Animals anticipate the annual waning and waxing of nutrient poor or rich conditions by remodeling hormonal, physiological and behavioral systems. ►**Seasonality** occurs in systems that control energy balance and reproduction, as well as behavioral aggression and immune function. ►**Hibernation**, adaptive behaviors that allow animals to survive winter by minimizing exposure to the harsh conditions, is widespread in the animal kingdom [19]. Seasonal changes include ►**circannual rhythms**, which cycle over the course of the year and have a component that allows

animals to initiate preparative changes in body state in anticipation of the forthcoming fall and spring [20].

The progressive change in ►**photoperiod**, the relative length of day vs. night, is the most reliable predictor of seasonal change. This dynamic signal cues a range of seasonal changes in physiology and behavior and may modulate circannual rhythms driven by an endogenous clock with a stable period of about a year [21]. Photoperiod is encoded in the duration of the nightly signal of the pineal hormone, melatonin. Melatonin is the internal signal of darkness in the environment. It is synthesized and secreted at night in a circadian rhythm under the control a neural pathway from the SCN to the ►**pineal gland**, and nocturnal light rapidly and acutely suppresses melatonin. The melatonin signal is transduced by ►**melatonin receptors**, which have restricted distribution in brain and peripheral tissues. Where and how the melatonin signal of changing photoperiod is interpreted to induce the range of seasonal changes in multiple systems is under study.

### Circadian Sleep Phase Syndromes

Certain classes of sleep disorders are embedded in the circadian system (►**Process C**). These include ►**Advanced Sleep Phase Syndrome (ASPS)**, ►**Delayed Sleep Phase Syndrome (DSPS)** and free-running circadian rhythms [22]. Advanced sleep phase syndrome (ASPS) has been reported in human families with an altered form of *Period 2*, in which a post-translational site is missing. This inherited disorder results in a life-long, fast-running circadian clock. ASPS is also seen in the elderly, where the melatonin profile is advanced. Sleep maintenance insomnia may be related. Circadian sleep phase syndromes can be assessed using sleep times and the ►**dim light melatonin onset (►DLMO)**, which are early in ASPS and late in DSPS. They can be treated by exposure to bright light (2,000–10,000 lux) at appropriate light-sensitive points in the phase response curve (PRC) and low-dose melatonin upon night-time awakening. The phase angle difference between DLMO and mid-sleep reports the degree of circadian misalignment. Circadian misalignment of the melatonin profile is high in ►**seasonal affective disorder (►SAD**, seasonal depression), and may contribute to other circadian sleep phase and psychiatric disorders.

### Sleep and Wakefulness

#### Sleep-Wake States

The primary behavioral states of organisms alternate rhythmically over the circadian cycle between wakefulness and sleep. Active behaviors necessary for sustaining life, such as acquisition of nutritional resources and reproduction, are accomplished during the waking state and require a net expenditure of energy. Sleep, which also is necessary for life, suppresses active behaviors

while facilitating anabolic activities that restore energy levels and process experiences of the waking state [23]. Sleep behavior is marked by distinct species-specific postures, reduced sensitivity to external stimuli and rebound after deprivation. These traits define sleep in diverse species from flies to man. Sleep in birds and mammals can be subdivided into two distinct ►**sleep states**: ►**non-rapid-eye movement (NREM)** and ►**rapid-eye movement (REM) sleep**. ►**Electroencephalography (EEG) in sleep states** reveals distinct ►**brain rhythms**. EEG patterns during NREM sleep can be divided into four stages, with increasing amounts of ►**slow wave activity (SWA)**. During REM or ►**paradoxical sleep**, EEG patterns resemble those of quiet wakefulness, but are associated with ►**rapid eye movements (REM)** and lack of tone in skeletal muscles. These changes in EEGs during sleep states are thought to report changes in synchronized cortical activity, although subcortical actions can modify these cortical activity states. In wakefulness, EEGs reveal distinct patterns of massed neuronal activity associated with the specific behaviors and the fully activated brain.

Why do we sleep? The answer to this most fundamental question remains elusive [24]. Studies of ►**sleep phylogeny** in mammals indicate that sleep stages are conserved, but show wide variations in sleep duration that correlate with body size and the energetics of food intake. Body mass is inversely related to mass-specific metabolic rate, such that metabolic rate is high in small animals and low in large. Carnivores and omnivores sleep more than predicted based on relative body weight. The strong correlation between high metabolic rate and longer sleep time suggests that “sleep need” may be based in metabolism. If this were the case, sleep could serve to reverse oxidative stress. Additionally, brain protein synthesis and neurogenesis increase during sleep. ►**Dreaming**, an altered state of awareness familiar to us all, is characterized by accurate simulation of experiential flow and contents and occurs during ►**REM sleep**. Possible functions that would increase adaptive fitness have been tied to this simulation process. During certain brain rhythms exhibited in ►**slow wave sleep (SWS)**, neuronal patterns appear to repeat those observed during specific training sessions in the previous period of wakefulness. These observations together with ►**microarray** studies of gene expression suggest cellular and molecular associations between sleep and processes underlying memory formation [25].

### Sleep Regulation

Regulation of the complex set of state changes underlying sleep can be distilled into two fundamentals that your mother first told you: sleep when you are tired and nighttime is for sleeping. In other words, sleep regulation has a homeostatic restorative component and

a time of day component. These fundamentals were formalized in Borbély's ►two-process model of sleep regulation [23]. One process, ►sleep homeostasis (►Process S), is based on the observation that the need for sleep accumulates during wakefulness and requires sleep to be alleviated. The greater the sleep need, beyond a threshold, the greater the cognitive deficit and negative health consequences, and the more sleep it takes to restore the waking state. The circadian process (Process C) defines the thresholds between which Process S oscillates, and thus determines what times within the circadian cycle are permissive for sleep and waking. Superimposed upon these processes is the alternation between the two main sub-states of sleep, NREM and REM sleep, both of which show homeostatic and circadian features. These processes work in concert to maintain the temporal occurrence and duration of sleep and wakefulness within a range that enhances health and evolutionary fitness.

### Mechanisms of Wake and Sleep States

►Sleep-wake mechanisms are complex, emerging from actions and interactions of the many neural and neurotransmitter systems that generate wake, NREM (slow wave sleep, SWS) and rapid eye movement (REM), or paradoxical sleep states [26]. The waking state is defined by ►alertness level [27]. The ability to direct and sustain attention is enabled by cortical activation. Alertness levels vary over the course of the waking period and are affected negatively by ►sleep deprivation. Individuals exhibiting reduced alertness experience sleepiness and fatigue, negative effects on mood, cognitive impairment and decreased attention, which may reflect sleep processes intruding into wakefulness. Many brain ►arousal systems contribute to the waking state: monoaminergic neurons of the rostral pons, midbrain and posterior hypothalamus, neurons of the cholinergic brainstem and basal forebrain, dopaminergic neurons in the ventral tegmentum, and ►hypocretin/orexin neurons of the lateral hypothalamus. Neuronal activity in these arousal systems is characterized by low-voltage, fast-frequency cortical EEG patterns, providing a tonic level of brain activation that is manifest as behavioral alertness.

►Sleep generating mechanisms cause coordinated inhibition of these arousal systems, so that their level of activity decreases rapidly with the onset of sleep. This is accomplished through the action of three interrelated systems: (i) activation of neurons in the ►preoptic area (►POA) of the hypothalamus – sleep-active neurons of the ►ventrolateral preoptic nucleus (VLPO) and median preoptic nucleus (MnPN) that impose GABA- and ►galanin-mediated inhibition of arousal systems; (ii) modulatory effects of endogenous sleep-promoting factors, such as ►adenosine, cytokines, prostaglandins and growth hormone-releasing hormone; and (iii) SCN

efferent signals, which may be both neural and hormonal, that control the timing of sleep generation via circadian changes in excitatory modulation of hypothalamic arousal systems and inhibition of the VLPO [28]. Activity in the monoaminergic arousal system during waking inhibits neurons of the VLPO, thereby preventing inappropriate activation of the sleep-generating neurons during the active period. Mutually inhibitory interactions between monoaminergic arousal systems and sleep-generating neurons of the VLPO act coordinately as a “flip-flop switch,” facilitating rapid, stable sleep-wake transitions [29]. Deficits in one element of the arousal system, hypocretin/orexin signaling, result in ►narcolepsy, a hereditary neurological disorder marked by excessive daytime sleepiness.

### Effects of Sleep-Wake State on Brain and Body Systems

So profound are the changes in brain state between waking and sleep, that the transition into sleep is marked by significant shifts in activation state of the major neural systems. ►Sleep-sensory changes diminish sensitivity in all sensory systems via alterations in the ascending arousal systems and activation of sleep-generating systems [30]. ►Sleep-motor changes affect motoneuron pools that innervate skeletal and respiratory muscle fibers. Motoneurons are hyperpolarized during NREM sleep relative to waking, and even more so during REM states. This accounts for muscle atonia during REM. Sleep movement disorders, including ►periodic limb movements of sleep (PLMS), sleep bruxisms (e.g., tooth grinding, jaw clenching), REM sleep behavior disorder, sleep waking, sleep-related eating disorder and obstructive sleep apnea, may arise from neurological defects in accomplishing sleep-appropriate motor changes. ►Sleep-Wake Autonomic Regulation support the shift from catabolic activities during waking to anabolic physiology during SWS [31]. Somatic inactivity and parasympathetic activity cause respiration, heart rate, blood pressure, core body temperature and basal metabolism to be low, commensurate with rest. Mobilization of amino acid uptake and protein synthesis enables repair, growth and replenishment of energy stores throughout the body. During excursions into REM sleep, antigravity skeletal muscles remain anabolic, but brain activity is catabolic. Surges in sympathetic outflow during REM sleep raise respiration, heart rate, and blood pressure, which may reflect dreaming activity.

►Sleep-endocrine changes are significant. Many hormones are rhythmically released over a circadian period, with specific phase-relationships to day and night (e.g., melatonin), or with a shorter ultradian period but strongly influenced by the sleep-wake cycle (e.g., thyroid stimulating hormone), or with a longer than 24-h infradian period, but possibly still gated within the sleep-wake cycle, as for reproductive

hormones [32]. High glucose levels and insulin secretion are characteristic of the anabolic processes that dominate during sleep. Sleep deprivation or curtailment impacts the profiles of many hormones, including growth hormone, cortisol and thyroid-stimulating hormone. Sleep debt-induced hormonal imbalances also occur in rhythms in ghrelin, the appetite-stimulating hormone, with concomitant decrease in leptin, the counter-balancing satiety-stimulating hormone. This may account for the observation that lifestyles that are short in sleep ( $\leq 6$  h) correlate strongly with extreme weight gain and metabolic syndrome [33].

► **Sleep–developmental changes** start shortly after birth, as all parents know, and span the life cycle. These changes affect total sleep time, the proportion and timing of sleep states, and electrophysiological features of sleep. ► **EEGs in sleep states** emerge by the third prenatal trimester. Neonates sleep  $>16/24$  h, largely in daytime. This shifts to nighttime as the ► **circadian pacemaker** matures. Early in life, NREM and REM sleep oscillate over 60 min, whereas in adults this cycle is  $\sim 90$  min. REM occupies  $\sim 50\%$  of sleep at birth, then declines to 15–20% at the end of puberty when slow wave activity (SWA) during NREM sleep also declines. Thus, sleep patterns reflect maturational changes in brain structure and function, and sleep doubtlessly contributes importantly to normal development of the nervous system [24]. It follows that abnormal sleep patterns in early life may have profound cognitive and emotional consequences.

## Conclusions and Future Directions

Biological rhythms and sleep are fundamental organizers of behavior, physiology and metabolic state. Over the course of evolution, they have been shaped by daily oscillations of day/night, food availability, temperature, predation and the need for counter-balanced catabolic/anabolic states within brain and body that enhance adaptive fitness. Thus, not surprisingly, they are based in evolutionarily conserved mechanisms and processes and shaped by the needs of adaptation to specialized niches. Recognition of the fundamental nature of biological rhythms and sleep and their underlying general mechanisms poises them for remarkable discovery that is both broad and deep. Important advances will be forthcoming in basic science as well as in applications to health and disease. Significant opportunities are highlighted here.

Advances in understanding biological rhythms will yield basic discoveries regarding novel timekeeping elements, how clocks impinge on the range of life functions of eukaryotic organisms, clock-to-clock coupling and SCN organization.

- Circadian clock elements have been thought to be transcriptional regulators, but the types of cellular

elements necessary to timekeeping is growing and extends well beyond nuclear processes. Small molecule and metabolic regulators have emerged as potential timing elements. Studying roles of these novel forms of potential clock elements surely will generate new insights as to biological-clock gears.

- Discovery that circadian clocks orchestrate all cellular states over a near 24-h timebase demands that we re-evaluate the myriad processes in the range of cell and tissue types in the context of dynamic circadian regulation. New insights on *rheostasis*, the range of fluctuating homeostatic states, will emerge [34].
- Although each and every cell in multicellular organisms appears to function as a circadian clock, all cells rely on the SCN for global synchronization. We know little about how the SCN conducts the cellular orchestra to play in synchrony. Opportunities abound for identifying and understanding clock-coupling factors that function within the SCN, communicate to brain, transmit entraining signals to peripheral clocks and coordinate clocks within each tissue [35].
- Complex brains have a specialized clock tissue that is required to orchestrate the cellular rhythms. How do SCN cells and tissue process light information? What are the special SCN coupling properties? What is the range of zeitgebers, and how and when do they interact? How are seasonal signals transduced into changes in multiple tissue and organ systems?

Knowledge that sleep is an active and necessary state together with new methods of analysis positions this field for remarkable discoveries. Advances in understanding will be possible regarding the most fundamental nature of sleep and its processes, and their molecular, cellular and systems substrates.

- Why do we sleep? Why is sleep necessary? Understanding the “why” of sleep from molecular to systems levels and in brain and periphery will be possible. The relation of brain states reported by EEG and brain imaging to the functions of sleep and the molecular, cellular and brain circuits will emerge.
- What is the array of conserved molecular and cellular substrates of sleep, and how and why are they necessary to sleep processes in various brain regions?
- If fundamental features and molecules of sleep are conserved, why do sleep states differ so markedly in phylogenetically different organisms?
- How do Process S and Process C intersect in waking and sleep?
- How and why does sleep deprivation negatively impact the brain and body?
- Why do we dream? How does the process of dreaming access circuits encoding prior experience?
- What is the relationship between sleep and learning and memory?



Both biological rhythms and sleep are subject to dysregulation by lifestyle pressures and by acquired or inherited disorders. Determining the mechanisms of the real-life consequences for these systems in the “24-7” global business enterprise are major challenges before us. Understanding how these fundamental processes function in health and disease is a primary goal that will yield tremendous practical benefit.

## References

- Pittendrigh C, Daan S (1976) A functional analysis of circadian pacemakers in nocturnal rodents. I. The stability and lability of spontaneous frequency. *J Comp Physiol* 106:223–252
- Aschoff J (1960) Exogenous and endogenous components in circadian rhythms. *Cold Spring Harb Symp Quant Biol* 25:11–28
- Gould PD, Locke JC, Larue C, Southern MM, Davis SJ, Hanano S, Moyle R, Milich R, Putterill J, Millar AJ, Hall A (2006) The molecular basis of temperature compensation in the Arabidopsis circadian clock. *Plant Cell* 18:1177–1187
- Welsh DK, Logothetis DE, Meister M, Reppert SM (1995) Individual neurons dissociated from rat suprachiasmatic nucleus express independently phased circadian firing rhythms. *Neuron* 14:697–706
- Gillette MU, Sejnowski TJ (2005) Physiology. Biological clocks coordinately keep life on time. *Science* 309:1196–1198
- Young MW, Kay SA (2001) Time zones: a comparative genetics of circadian clocks. *Nat Rev Genet* 2:702–715
- Konopka RJ, Benzer S (1971) Clock mutants of *Drosophila melanogaster*. *Proc Natl Acad Sci USA* 68:2112–2116
- Gallego M, Virshup DM (2007) Post-translational modifications regulate the ticking of the circadian clock. *Nat Rev Mol Cell Biol* 8:139–148
- Nakajima M, Imai K, Ito H, Nishiwaki T, Murayama Y, Iwasaki H, Oyama T, Kondo T (2005) Reconstitution of circadian oscillation of cyanobacterial KaiC phosphorylation in vitro. *Science* 308:414–415
- Dodd AN, Gardner MJ, Hotta CT, Hubbard KE, Dalchau N, Love J, Assie JM, Robertson FC, Jakobsen MK, Goncalves J, Sanders D, Webb AA (2007) The Arabidopsis circadian clock incorporates a cADPR-based feedback loop. *Science* 318:1789–1792
- Moore R, Leak R (2001) Suprachiasmatic nucleus. In: *Circadian clocks: handbook of behavioral neurobiology*. Kluwer/Plenum, New York
- Silver R, Schwartz WJ (2005) The suprachiasmatic nucleus is a functionally heterogeneous timekeeping organ. *Methods Enzymol* 393:451–465
- Pittendrigh C (1981) Circadian organization and the photoperiodic phenomena. In: *Biological clocks in seasonal reproductive cycles*. Scientechica, Bristol 32: 1–35
- Berson DM (2007) Phototransduction in ganglion-cell photoreceptors. *Pflugers Arch* 454:849–855
- Gillette MU, Mitchell JW (2002) Signaling in the suprachiasmatic nucleus: selectively responsive and integrative. *Cell Tissue Res* 309:99–107
- Morin LP, Allen CN (2006) The circadian visual system, 2005. *Brain Res Rev* 51:1–60
- Arendt J, Skene DJ (2005) Melatonin as a chronobiotic. *Sleep Med Rev* 9:25–39
- Kohsaka A, Laposky AD, Ramsey KM, Estrada C, Joshu C, Kobayashi Y, Turek FW, Bass J (2007) High-fat diet disrupts behavioral and molecular circadian rhythms in mice. *Cell Metab* 6:414–421
- Lyman C, Willis J, Malan A, Wang L (1982) Hibernation and torpor in mammals and birds. Academic, New York
- Lincoln GA, Andersson H, Loudon A (2003) Clock genes in calendar cells as the basis of annual timekeeping in mammals – a unifying hypothesis. *J Endocrinol* 179:1–13
- Gwinner E (2003) Circannual rhythms in birds. *Curr Opin Neurobiol* 13:770–778
- Sack RL, Auckley D, Auger RR, Carskadon MA, Wright KP Jr., Vitiello MV, Zhdanova IV, American Academy of Sleep M (2007) Circadian rhythm sleep disorders: part II, advanced sleep phase disorder, delayed sleep phase disorder, free-running disorder, and irregular sleep-wake rhythm. An American Academy of Sleep Medicine review. *Sleep* 30:1484–1501
- Dijk D-J, Franken P (2005) Interaction of sleep homeostasis and circadian rhythmicity: dependent or independent systems. In: *Principles and practice of sleep medicine*. Elsevier Saunders, Philadelphia
- Siegel JM (2005) Clues to the functions of mammalian sleep. *Nature* 437:1264–1271
- Frank M (2007) Hippocampal dreams, cortical wishes: a closer look at neuronal replay and the hippocampal-neocortical dialogue during sleep. *Cell Sci Rev* 3:161–171
- Jones B (2005) Basic mechanisms of sleep-wake states. In: *Principles and practice of sleep medicine*. Elsevier Saunders, Philadelphia
- Van Dongen H, Dinges D (2005) Circadian rhythms in sleepiness, alertness, and performance. In: *Principles and Practice of Sleep Medicine*. Elsevier Saunders, Philadelphia
- Szymusiak R, Gvilia I, McGinty D (2007) Hypothalamic control of sleep. *Sleep Med* 8:291–301
- Saper CB (2006) Staying awake for dinner: hypothalamic integration of sleep, feeding, and circadian rhythms. *Prog Brain Res* 153:243–252
- Wright K Jr. (2005) Environmental influences on sleep and sleep deprivation. In: *Sleep deprivation: basic science, physiology, and behavior*. Marcel Dekker, New York
- Parmeggiani P (2005) Physiological regulation in sleep. In: *Principles and practice of sleep medicine*. Elsevier Saunders, Philadelphia
- Czeisler CA, Klerman EB (1999) Circadian and sleep-dependent regulation of hormone release in humans. *Recent Prog Horm Res* 54:97–130; discussion 130–132
- Van Cauter E, Holmback U, Knutson K, Leproult R, Miller A, Nedeltcheva A, Pannain S, Penev P, Tasali E, Spiegel K (2007) Impact of sleep and sleep loss on neuroendocrine and metabolic function. *Horm Res* 67 Suppl 1:2–9
- Mrosovsky N (1990) Rheostasis: the physiology of change. Oxford University Press, New York
- Gillette M, Beaulé C (2008) Coupling of circadian clocks in brain and body. *Prog Neurobiol* (In press)

## Biomarker

### Definition

A characteristic that is objectively measured and evaluated as an indicator of normal biologic processes, pathogenic processes, or pharmacological responses to therapeutic intervention.

## Biomechanics

WALTER HERZOG

Faculties of Kuriology, Engineering and Medicine,  
University of Calgary, Calgary, AB, Canada

### Introduction

*Biomechanics* is the science that deals with explaining the ►mechanics of living things and life itself [1]. Living involves movement, growing, aging, adaptation, degeneration, reproduction. Living requires metabolic ►energy (►energy/energetics), and energy requirements change with movement demands. Living processes occur on the molecular, cellular, organ, system, and organism level and all these processes must obey the laws of mechanics.

Biomechanics is a composite term containing the words biology and mechanics ►Classical Mechanics, ►Continuum Mechanics, ►Constitutive Theory, ►Continuous growth and Remodeling, ►Principle of Virtual Work, ►Statics. It is defined as the science that deals with the mechanics of biological systems. Mechanics can be divided into ►kinematics of Deformation and kinetics, and may deal with rigid and deformable bodies. The most frequently considered system in biomechanics research is the human body, however animal and plant biomechanics are firmly established disciplines. Biomechanics is an umbrella term for many associated sub-disciplines such as *biophysics* which deals primarily with biological systems at the cell level and smaller, or *biomedical engineering* which is primarily concerned with advances in human health through mechanical approaches.

### Historical Background

Biomechanics is a relatively new science that emerged in an organized manner in the 1960s, although its origins may be seen in the dynamic drawings of athletes and working people in the ancient Greek culture, and the rendering of anatomically correct surface anatomies in antiquity. The Italian Renaissance also saw a revival

of the ancient Greek philosophy and its associated interest in human movement and the workings of the body. Leonardo da Vinci (1452–1519) contributed substantially to the understanding of biomechanical problems such as the flight of birds, and made careful analyses of human movements by considering the actions of muscles around ►joints. Giovanni Borelli (1608–1679) is often considered the father of biomechanics. Borelli, like many of his contemporaries, was a “multi-disciplinary” scientist: a mathematician, physicist, and physiologist, who wrote treatises on the Jupiter moons, on fever and blood, but made his impact on the world of biomechanics with his book “*De Motu Animalium*” published after his death.

Modern biomechanics was first introduced in the early twentieth century in Faculties of Physical Education and was aimed at improving the efficiency of sports movements and performance. The first International seminar on biomechanics was organized by E. Jokl and J. Wartenweiler and was held in Zurich, Switzerland in late August of 1967. This seminar series proceeded with an international gathering of scientists every 2 years, and in 1973, at the meeting held at Penn State University, the *International Society of Biomechanics* (ISB – (<http://isbweb.org/>)) was founded and J. Wartenweiler became its first president. The Congress of the International Society of Biomechanics has continued in a 2 year cycle and presently attracts approximately 1,000 scientists from all continents. Other “international societies of biomechanics” have emerged successfully: for example the *World Council of Biomechanics* organizes a scientific conference every 4 years that attracted almost 3,000 scientists at its latest gathering in Munich, Germany in 2006 (<http://www.wcb2006.org/worldcouncil.htm>). Sub-groups, such as the International Society of Biomechanics in Sports (ISBS – (<http://www.twu.edu/biom/isbs/>)) also make important contributions to furthering the field in specialized areas. Many countries in Europe, North America, and Austral-Asia have a national biomechanics organization, and efforts of establishing national biomechanics chapters in South America and Africa have been initiated, some of them with great success.

Biomechanics was defined above generically as the science that deals with the mechanics of living, biological systems. More specifically, it is the science that deals with the ►forces acting on and within biological systems and the effects that are produced by these forces [2]. These effects include movements of biological systems, be it locomotion in humans and animals, the bending of trees and plants exposed to air, fluid flow in ►cardiovascular mechanics, or the random displacements of molecular motor proteins exposed to ►Brownian motion. Movement is one of the primary outcomes of biomechanical analyses, and has provided many problems and spurred numerous scientific investigations.

## Kinematics

The part of biomechanics that deals with *movement* is called kinematics. ▶*Kinematics of Deformation* is formally defined as that part of mechanics that deals with the geometric description of motion and deformation. Movement involves locomotion of humans and animals; locomotion may occur in the air, in water or on land and the specific environment places different mechanical demands on the system. Locomotion may occur on the molecular (▶*molecular and cellular biomechanics*) level, for example the “walking” of processive myosin proteins on actin tracks, a situation where gravitational forces have little significance, viscosity dominates the mechanics, and thermal noise provides randomness.

Human and animal movements are under voluntary control. Muscle coordination patterns that produce smooth movements for such actions as writing or playing the piano, are finely tuned and precisely executed. Muscle forces producing these movements are controlled by voluntary commands from the brain, by spinal feedback loops from a variety of proprioceptive organs in skin, joints, muscles and other tissues, and by pattern generators intrinsic to the spinal cord. Musculoskeletal systems are typically redundant with respect to the number of muscles available to produce movements and those strictly required from a mechanical point of view [3]. Therefore, movements, such as walking could be produced theoretically with an infinite number of muscle coordination strategies, but they are not. Repeat steps are associated with similar, albeit not identical coordination patterns, and coordination patterns across individuals are similar as well, although anatomical and structural variations in the neuro-musculoskeletal system are thought to account for individual differences. This redundancy has the advantage that loss of isolated muscle function can typically be compensated for with little functional reduction in performance [4].

Movement is associated with energy consumption. The generic metabolic fuel for muscle contraction is adenosinetriphosphate (ATP) which becomes hydrolyzed (ADP + P) and so provides the energy for movement, breathing, beating of the heart and many other vital functions in living systems. Typically, more vigorous movement or exercise is associated with a greater rate of energy demand. When a person changes from walking to running to sprinting, the rate of breathing increases and so does the pumping of blood, all aimed at providing more oxygen to the working muscles and thereby increasing the rate of energy supply. Exceptions seem to exist in the animal world. For example, it has been observed that increasing the hopping speed of kangaroos is not necessarily associated with an increase in metabolic energy demand as one would expect, presumably because of the extraordinary

ability of these animals to store (and release) elastic energy in their hind limb musculature and ▶*tendons* [5].

The precise measurement of movements of biological systems has produced great developments in commercially available ▶*motion analysis* systems. Movements have been depicted in the drawings of the ancient Greeks and the paintings and sculptures of Renaissance artists. However, sophisticated motion capture devices became available with the invention of photography. E. J. Marey (1838–1904) is associated with transforming the study of locomotion from an observational, qualitative science to an objective, quantitative description of movement (▶*Measurement Techniques, Optical Techniques*). With support from the federal government, Marey established a scientific facility devoted to biomechanical analysis of human and animal movement. His studies of locomotion remain exceptional to this day. A contemporary of Marey’s, E. Muybridge (1830–1904) was an avid photographer with interest in human and animal locomotion. He introduced sequential photography as the primary tool for movement analyses, and is probably best known for his discovery that there was a brief phase in a horse’s trot where all four hooves were off the ground.

With the advent of modern biomechanics in the early 1970s, sequential photography and single exposure photography, such as chronophotography or stroboscopy were replaced by high-speed cinematography [6]. Pin registered high-speed cameras could produce up to 500 frames/s while rotating prism cameras provided sampling frequencies of up to 10 kHz. However, the costs associated with “conventional” cinematography, the delay from filming to viewing (associated with processing film), and the problems associated with filming in low or changing light conditions favored the development and use of high-speed video for biomechanical analysis. Today, video motion analysis systems with sophisticated software for three-dimensional analysis of movements are commercially available, and motion analysis tasks that took days to complete just three decades ago, can now be accomplished virtually instantaneously, thereby providing unique opportunities for instantaneous movement feedback as required in the training of athletes or rehabilitation of patients.

## Kinetics

The part of biomechanics that deals with the effects of forces (▶*Measurement Techniques (forces)*) on systems is called *kinetics*. Forces in biomechanical investigations have been obtained principally in two ways: by theory or direct experimental measurement. Although foundations for force measurements had been made in the nineteenth century, commercial “force measuring devices” for biomechanical applications started to emerge in the 1970s. One of these devices, the force platform, is used to measure the ground reaction

forces exerted by humans (or animals) during locomotion. From its humble beginnings as an instrument built for specific applications by individual investigators, force platforms can now be obtained from various manufacturers, and they have become a standard tool in biomechanical analysis, not only in scientific laboratories, but also in hospitals, rehabilitation centers, and sport shoe stores where they are used to characterize gait abnormalities in patient populations, assess rehabilitation programs, and identify individual foot **▶pressure** patterns for fitting optimal recreational shoe ware.

Specialized force measurement devices have also been invented to determine the forces inside the human or animal body. One such example is the tendon force transducer aimed at measuring muscle forces continuously in a freely moving subject. Conceptually, two devices have been used for this purpose: one that is attached to the outside of the tendon (Fig. 1); another that is implanted within the tendon. The action principle is the same in both. The transducers are shaped such that they deform when a muscle produces force and stretches the corresponding tendon. This deformation is sensed by a set of strain **▶Measurement Techniques (strain)** gauges which emit a voltage signal in proportion to the deformation, and this signal can then be translated into tendon (muscle) force by appropriate calibration [7]. Measurements of this kind in several muscles crossing a given joint have provided novel insight into the control of muscle coordination during voluntary movements and have served to estimate forces acting on musculoskeletal structures, such as diarthrodial joints, **▶ligaments**, tendons, and **▶bones**.

Force measurements in biomechanics are made across all structural levels of a system, and the two devices mentioned above suffice to measure relatively large forces with technology that is generally available and can be built in any scientific laboratory. Recent advances in technology have opened the doors to measure pico-Newton ( $10^{-12}$  N) forces which are forces that occur at the interactions of single proteins of molecular motors. Jim Spudich and collaborators [8]

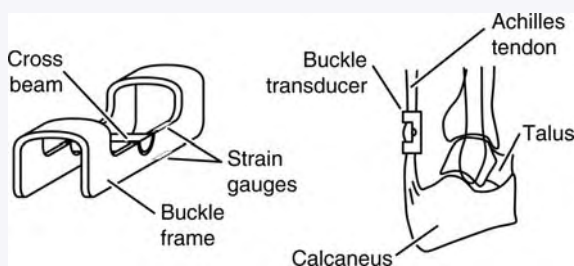

**Biomechanics. Figure 1** Schematic illustration of a buckle tendon force transducer (left) and a possible arrangement on an Achilles tendon (right) (from Salmons, 1969, with permission).

were the first to measure the forces of a single cross-bridge of a skeletal muscle attaching to an isolated actin protein. Thus, the elementary force of skeletal muscle contraction could be quantified. The forces were measured using a so-called laser trap (Fig. 2). Measurements of cross-bridge forces were achieved by attaching micron-sized beads to either end of the actin protein, capturing the beads with two independent laser beams, and focusing the beams in such a manner that the beads were held in the focal plane like in a potential energy well. Upon attachment of the cross-bridge to actin and force production, the actin protein is pulled away from the center of the laser beam and knowing the displacement of the bead and the stiffness of the laser trap, the force exerted by the cross-bridge on actin could be determined. This system was copied quickly, and commercial laser trap systems are now available.

There are many situations in biomechanical research when forces cannot be readily measured. For example, in vivo human muscle forces cannot be determined directly, and although tendon force transducers (as discussed above) have been used in humans (e.g. [9]), proper calibration is difficult in these situations because tendons cannot be detached for independent and known force application required in the calibration process. Similarly, forces and stresses in biological tissues typically cannot be measured but are thought to be of great importance. For example, **▶articular cartilage** degeneration, leading to osteoarthritis in joints is thought to be mechanically mediated. However, the pathways linking **▶pressure (▶measurement techniques (pressure))** on articular cartilage surfaces, to the corresponding stress within the tissue and cartilage cells, is not known for in vivo dynamic situations, and the corresponding effects of these stresses on adaptive and degenerative processes within the tissue remain a mystery. In order to address these types of problems, theoretical approaches are used, as illustrated with examples below.

One of the basic questions that have eluded satisfactory explanation in biomechanics research is the so-called **▶distribution problem**. The distribution problem deals with the determination of the forces across joints. A human diarthrodial joint is typically crossed by many muscles (tendons), ligaments and contains bony contact areas. For example, the knee has four major extensor muscles, three major flexor muscles, four ligaments and at least three distinct and separate bony contact areas. Thus, a complete understanding of knee mechanics requires that all these forces (seven muscle + four ligamentous + three bony contact forces) are known at each instant in time. However, only the resultant joint forces and moments can be readily obtained through the so-called inverse dynamics approach [10]. These resultants, by definition, are equivalent to the sum of all forces across the joint; that is:

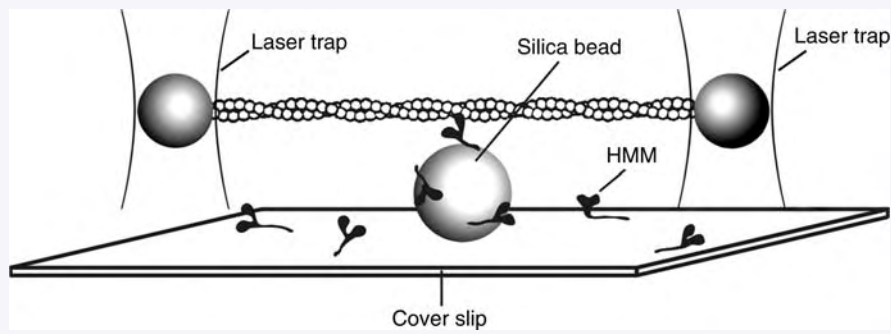

**Biomechanics. Figure 2** Schematic illustration of single Heavy Meromyosin (HMM) cross-bridge interaction with an actin filament. The silica bead on the cover slip is coated with skeletal muscle heavy meromyosin cross-bridges. Coated polystyrene beads are attached to the ends of actin. The actin filament with its two beads is caught and suspended in laser traps. The suspended actin filament is lowered to the silica bead, and single HMM interactions with the actin filament are now possible (reprinted by permission from *Nature*, Finer et al., 1994. Copyright 1994 Macmillan Magazines Ltd.).

$$F = \sum_{i=1}^N (F_i^m) + \sum_{j=1}^P (F_j^l) + \sum_{k=1}^Q (F_k^c) \quad (1)$$

$$M_o = \sum_{i=1}^N (r_{i/o} \times F_i^m) + \sum_{j=1}^P (r_{j/o} \times F_j^l) + \sum_{k=1}^Q (r_{k/o} \times F_k^c) \quad (2)$$

where

$F$  = variable resultant external joint force  
 $M_o$  = variable resultant external joint moment  
 $F^m$  = internal muscular forces  
 $F^l$  = internal ligamentous forces  
 $F^c$  = internal bony contact forces  
 $r_{i/o}$  = location vector for muscular force  $i$   
 $r_{j/o}$  = location vector for ligamentous force  $j$   
 $r_{k/o}$  = location vector for bony contact force  $k$   
 $N$  = integer indicating the number of muscular forces  
 $P$  = integer indicating the number of ligamentous forces  
 $Q$  = integer indicating the number of bony contact forces

Equations (1) and (2) are two vector (or equivalently six scalar) equations, and therefore can be solved for a maximum of two vector or six scalar unknowns. However, for the example of the human knee, there are at least 14 vector unknowns, and although the direction of the muscle and ligamentous forces may be assumed to coincide with the long axis of the tendons and ligaments, respectively, this would still leave 11 force magnitudes (muscles and ligament forces) and three force vectors (bony contacts) to be determined. Most diarthrodial joints have this redundancy; that is less

system equations than unknowns. In order to obtain the internal forces of interest, biomechanics researchers have adopted various strategies. The most frequently used approach to solve the [distribution problem in biomechanics](#) is optimization theory. In this situation, muscles are assumed to be recruited during normal movement in such a way as to minimize, maximize or optimize a specific physiologic criterion, for example, the minimization of metabolic energy [3]. With such a criterion, muscle forces can be determined in a unique way, but the accuracy of such predictions are the topic of intense scientific debate, and the distribution problem remains one of the foremost challenges in biomechanics research. Experimental approaches, such as electromyographical, [EMG \(Wavelet analysis of Electromy grains\)](#), [measurements of muscle excitation](#) and relating these to muscle forces, are fraught with problems.

When determining forces and stresses inside a tissue, such as skeletal muscle, theoretical models describing these tissues are required. Representing biological tissues can take two basic forms: either phenomenological or structural [11]. Phenomenological models of muscle contraction typically treat muscle as an assembly of rheological components ([Rheological Models](#)) that provide the appropriate force output for given contractile conditions. Such models are collectively referred to as "Hill-type" models in reference to AV Hill, a Nobel Prize winner in 1922 for his work on oxygen consumption in muscle. Hill models of muscle function have the advantage that they are simple to describe, require little mathematical knowledge for implementation and provide force output as a function of the contractile conditions. However, they provide little insight into the molecular mechanisms underlying contraction.

Structural models of muscles either have focused on the molecular mechanisms of contraction or the description of anatomically accurate muscles. Muscle contraction, as we know it today, is based on the sliding filament and the cross-bridge theory [12–14]. The ►sliding filament theory suggests that muscle contraction is achieved through the relative sliding of two sets of filaments, the actin or thin, and the myosin or thick filament. The cross-bridge theory proposes that the relative movement of these two filaments, and its associated muscle shortening and force production, are produced by cross-bridges arising from the myosin filament that attach and detach cyclically at specific binding sites on the actin filament, and when attached pull actin past myosin through a configurational change of the cross-bridge (Fig. 3). Each cross-bridge cycle is associated with the hydrolysis of one ATP. Alternative theories of muscle contraction, such as molecular ►ratchet theories, (►brownian ratchet), myosin shortening, and electrostatic considerations [15] have received limited attention, but are driven by observations, such as

►force depression/enhancement in skeletal muscles, that cannot be explained within the framework of the classic cross-bridge theory.

Structural models of non-contractile biological tissues, such as articular cartilage, bone or tendon, are aimed at simulating the mechanical and biological (adaptive) behavior of these tissues by appropriate representation of the important structural features. In articular cartilage, for example, collagen fibrils, the proteoglycan matrix and the fluid phase are thought to play important roles in the transmission of forces across the tissue, and the regulation of cell volume and the associated stresses and strains experienced by the cells. These structural components can be captured using ►continuum mechanics approaches in which the various phases of the tissue (e.g. matrix and fluid phase) can be represented, and structural components that are essential for the understanding of the tissue biomechanics can be added [16,17].

### Applications

The initial applications in modern biomechanics were focused on human movement and human performance. This bias reflected the background and interests of the founders of modern biomechanics. However, animal and plant biomechanics and areas other than human performance have become increasingly strong in the past three decades.

Biomechanical applications in the field of orthopedics, medical imaging and blood flow resulted in a strong emergence of the field of biomedical engineering. This evolution was helped by private foundation sponsors, such as the Whitaker Foundation in North America (<http://www.whitaker.org/home.html>) which provided financial support between 1975 and 2006 for the development of biomedical engineering scholars and research centers in Canada and the USA. From an unknown discipline in the mid 1970s, biomedical engineering has evolved into a driving research force at many academic institutions.

From its humble beginnings in the 1960s, biomechanics has become a scientific discipline with specialized journals, organizations and conferences. The field has grown exponentially and the future looks bright with nano-biomechanics applications in the health and wellness field, and an ever growing population that wants to be active and mobile into old age. As in the renaissance, when science was a single person venture and required multi-disciplinary talents to address the problems of the time, biomechanists of the twenty-first century need to be multi-disciplinary, equally conversant in the laws of physics and evolutionary or molecular biology. Only such people, organized in cross-disciplinary teams, will be able to successfully address the problems facing biomechanics research today and in the future.

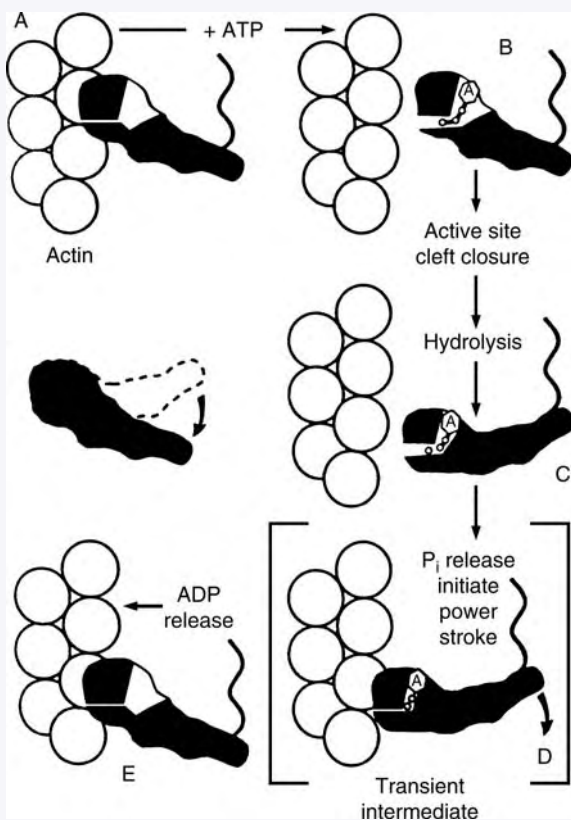

**Biomechanics. Figure 3** Diagram illustrating a cross-bridge attachment-detachment cycle based on x-ray crystallography (reprinted with permission from Rayment et al., 1993, Copyright 1993 American Association for the Advancement of Science).

## References

1. Fung YC (1990) Biomechanics, motion, flow, stress, and growth. Springer, Berlin Heidelberg New York, Germany
2. Hay JG (1993) The biomechanics of sports techniques. Prentice-Hall, Englewood Cliffs, NJ
3. Crowninshield RD, Brand RA (1981) The prediction of forces in joint structures: distribution of intersegmental resultants. *Exerc Sport Sci Rev* 9:159–181
4. Herzog W (1996) Force-sharing among synergistic muscles: theoretical considerations and experimental approaches. In: Holloszy JO (ed) Exercise and sport sciences reviews. Williams & Wilkins, Baltimore, pp 173–202
5. Taylor CR, Heglund NC (1982) Energetics and mechanics of terrestrial locomotion. *Annu Rev Physiol* 44:97–107
6. Nigg BM, Cole GK, Wright IC (2007) Optical Methods. In: Nigg BM, Herzog W (eds) Biomechanics of the musculo-skeletal system. Wiley, Chichester, England, pp 362–391
7. Walmsley B, Hodgson JA, Burke RE (1978) Forces produced by medial gastrocnemius and soleus muscles during locomotion in freely moving cats. *J Neurophysiol* 41:1203–1215
8. Finer JT, Simmons RM, Spudich JA (1994) Single myosin molecule mechanics: piconewton forces and nanometre steps. *Nature* 368:113–119
9. Komi PV, Salonen M, Järvinen M, Kokko O (1987) In vivo registration of Achilles tendon forces in man. I. Methodological development. *Int J Sports Med* 8 Supplement:3–8
10. Andrews JG (1974) Biomechanical analysis of human motion. *Kinesiol* 4:32–42
11. Epstein M, Herzog W (1998) Theoretical models of skeletal muscle: biological and mathematical considerations. Wiley, New York
12. Huxley AF (1957) Muscle structure and theories of contraction. *Prog Biophys Biophys Chem* 7:255–318
13. Huxley AF, Niedergerke R (1954) Structural changes in muscle during contraction. Interference microscopy of living muscle fibres. *Nature* 173:971–973
14. Huxley HE, Hanson J (1954) Changes in cross-striations of muscle during contraction and stretch and their structural implications. *Nature* 173:973–976
15. Pollack GH (1990) Muscles and molecules – uncovering the principles of biological motion. Ebner & Sons, Seattle, WA
16. Herzog W, Federico S (2007) Articular cartilage. In: Nigg BM, Herzog W (eds) Biomechanics of the musculo-skeletal system. Wiley, Chichester, England, pp 95–109
17. Mow VC, Kuei SC, Lai WM, Armstrong CG (1980) Biphasic creep and stress relaxation of articular cartilage in compression: theory and experiments. *J Biomech Eng* 102:73–84

## Biotinylation (Biotinylated)

### Definition

Biotinylation involves covalent linking of biotin to another molecule. Biotin binds with an extremely high

dissociation constant ( $K_d = 10^{-15}$ ) to the avidin protein and is one of the strongest known noncovalent interactions. Therefore when linking of two macromolecules is desired without the use of conditions to create covalent linkages, one macro-molecule is first linked to biotin while the other is linked to avidin. When the two macromolecules are mixed in solution they form a very stable complex.

► [Serial Analysis of Gene Expression](#)

## Bipartite GAL4/UAS Expression system

► [GAL4/UAS Expression System](#)

## Bipedalism

► [Evolution of the Vestibular System](#)

## Bipolar Affective Disorder

HEINZ BOEKER

University Hospital of Psychiatry Zurich, Hospital for Affective Disorders and General Psychiatry Zurich East, Zurich, Switzerland

### Synonyms

Bipolar disorder; Manic-depressive illness (MDI); Bipolar depression; Mania

### Definition

Bipolar affective disorder is one of the most common, severe and persistent mental illnesses. Bipolar disorder is characterized by periods of deep, prolonged and profound depression, alternating with periods of excessively elevated and/or irritable mood (mania).

The symptoms of mania include a need for less sleep, pressured speech, increased libido, reckless behavior with no regard for the consequences, grandiosity and severe thought disturbances, which may or may not

include psychosis. Between depressive and manic episodes, patients usually experience periods of greater functionality and are able to lead a productive life. Bipolar disorder is a lifelong challenge.

## Characteristics

### History/Background

Bipolar affective disorder or manic depressive illness has been recognized since at least the time of Hippocrates who described such persons as “amic” and “melancholic.” In 1899 the German psychiatrist Emil Kraepelin defined manic-depressive illness and noted that sufferers lacked deterioration and dementia, normally associated with schizophrenia.

Both modern classification systems (ICD and DSM) contain categories for both single episodes and recurrent episodes of mood disorder, and repeatedly alternating high and low mood is described as cyclothymia. ► **Hypomania** is distinguished from mania because of the difference in the degree of severity of symptoms and social incapacity.

### Diagnostic Considerations

Bipolar affective disorder is a recurrent and disabling mental illness, typically beginning early in life. It constitutes one pole of a spectrum of mood disorders including bipolar I (BP I), bipolar II (BP II), cyclothymia (oscillating high and low mood) and major depression [1]. BP I is also referred to as classic manic depression and is characterized by distinct episodes of major depression contrasting vividly with episodes of mania which lead to a severe impairment in function. In comparison, BP II is a milder disorder consisting of depression alternating with periods of hypomania [2].

Although bipolar affective disorder is defined by manic and hypomanic episodes, in most cases the depressive episodes constitute the more virulent aspect of the illness. The depressive episodes are usually more frequent, of longer duration, and are more difficult to treat than the manic episodes. Moreover, depression is the principle cause of the illness’s high suicide rate [3,4].

### Epidemiology

Findings from recent studies generally report an overall lifetime prevalence of bipolar I disorder of around 1–1.5%. This percentage range hardly varies from country to country. In the United States, Europe, Scandinavia, the South Pacific, South America and the United Kingdom the lifetime prevalence of bipolar I disorder ranges from 0.2% (Iceland) to 2.0% (The Netherlands and Hungary). Exceptionally low prevalence rates can be found in Iceland (0.2%) and three Asian countries (0.015–0.3%). The reasons for the particularly low rates in Asian countries are unclear (e.g. genetic, cultural or diagnostic factors) [5].

The two types of disorder differ in adult populations, BP I occurring in approximately 0.8% and BP II in approximately 0.5%. Studies involving a broad bipolar spectrum produce much higher lifetime prevalence rates of 3.0–8.3%. The validity of such studies, however, may be questionable in view of the fact that it is difficult to distinguish between normal mood and mild hypomania.

Most studies have not shown large differences in bipolar disorder rates with regard to gender. The illness is more prevalent in divorced or separated than in married persons. Differences concerning social class and ethnic group are less well documented. Pregnancy and the menopause represent periods of greater vulnerability for the development of manic episodes in females. A family history of bipolar disorder in a first-degree relative remains the strongest predictor.

The WHO has ranked bipolar disorder among the top ten disabling disorders in both developed and developing countries.

### Course and Outcome

The age of onset of bipolar disorders varies greatly. It ranges for both BP I and BP II from childhood to 50 years, with a mean age of approximately 21 years. Most cases commence at the age of 15–19 years, the second most frequent age range is 20–24 years. Some patients diagnosed with recurrent major depression may indeed have bipolar disorder and develop their first manic episode after the age of 50 [6]. They may have a family history of bipolar disorder. However, if manic episodes develop after the age of 50, it is advisable to examine the patient for medical or neurological disorders such as cerebro-vascular disease. Almost all bipolar patients experience relapse, given adequate observation time. Cycle length does not change predictably over time, although it may shorten progressively in the initial stages of the illness in a sub-group of individuals.

A significant proportion of bipolar patients develop ► **rapid cycling** [7]. Manic episodes are briefer than depressive or ► **mixed episodes**. The average episode duration remains stable throughout the illness.

About 1–2% of unipolar depressive patients per year experience a first manic or hypomanic episode, suggesting that over a long follow-up period a significant minority of patients previously diagnosed with unipolar depression will subsequently have their diagnosis changed to bipolar disorder. Initial episodes of depression are commonly misdiagnosed and this not only often delays starting appropriate therapy but also increases the likelihood of the illness being treated with antidepressants alone. Unfortunately, the correct diagnosis is often only arrived at after a treatment-emergent affective switch has occurred [4].



Psychosocial and physical stress situations still appear to be strong predictors for relapse, although such severe life events most likely interact with the patients' underlying vulnerability in a complex manner. Life events appear to be more strongly associated with relapse in earlier than in later phases of bipolar illness.

Long-term data suggest that up to one third of bipolar patients achieve complete remission, and a similar number achieve complete functional recovery. Although syndromal recovery is at least twice as frequent, fewer patients ultimately recover pre-morbid levels of functioning. Chronic persistence of symptoms can be expected in about 20% of cases, and social incapacity in about 30% [5].

Early age of onset, depression, mixed episodes, psychosis, substance abuse, medication non-compliance and probably the long-term use of antidepressants are all associated with poor outcome. Mortality and suicide rates are higher in bipolar illness, but can be substantially reduced by adequate lithium treatment.

### Pathophysiology

Up to now, no objective biological markers have been found that correspond definitively with the illness state. However, twin, family and adoption studies all indicate strongly that bipolar disorder has a genetic component. In fact, first-degree relatives of bipolar patients are approximately seven times more likely to develop the disorder than the rest of the population.

Findings from gene expression studies of post-mortem brain tissue from bipolar disorder patients have stressed that levels of expression of oligodendrocyte-myelin-related genes appear to be decreased in brain tissue from bipolar disorder patients [8]. Oligodendrocytes produce myelin membranes that wrap themselves around axons, insulating them and permitting the efficient conduction of nerve impulses in the brain. Therefore, loss of myelin is thought to disrupt communication between neurons, leading to some of the thought disturbances observed in bipolar disorder and related illnesses.

Brain imaging studies in patients with bipolar disorder also show abnormal myelination in several brain regions associated with the illness [9]. Interestingly, gene expression and neuroimaging studies in persons with schizophrenia and major depression also demonstrate similar findings, indicating that mood disorders and schizophrenia may share some biological underpinning.

Another approach to investigating the pathophysiology of bipolar disorder involves studying changes in gene expression induced in rodent brains after administration of pharmacological agents used to treat bipolar disorder. For example, two chemically unrelated drugs

used to treat bipolar disorder, lithium and valproate, both up-regulate the expression of the cytoprotective protein Bcl-2 in the frontal cortex and the hippocampus of rat brains. Neuroimaging studies of individuals with bipolar disorder or other mood disorders also suggest evidence of cell loss or atrophy in these same brain regions. Thus, another suggested cause of bipolar disorder is damage to cells in the critical brain circuit that regulates emotion. According to this hypothesis, mood stabilizers and antidepressants are thought to alter mood by stimulating cell survival pathways and increasing levels of neurotrophic factors to improve cellular resiliency.

Post and Weiss [10] proposed a mechanism involving electrophysiological ►**kindling** and behavioral sensitization processes, a method also seen in previous hypotheses based on neuronal injury. Post asserts that an individual susceptible to bipolar disorder experiences an increasing number of minor neurological assaults, perhaps caused by drug-abuse, and excessive glucocorticoid stimulation, resulting from acute or chronic stress or other factors, which eventually results in mania. Subsequently, sufficient brain damage might persist causing mania to recur even with no or only minor environmental or behavioral stress (see Fig. 1). This type of formulation helps explain the effective role of anticonvulsant medications, e.g. carbamazepine and valproate, in the prevention of highs or lows in bipolar disorder. It also suggests that the more episodes a person experiences, the more he or she will have in the future, underlining the need for long-term treatment.

### Psychopharmacotherapy

There are no specifically approved treatments for bipolar disorder in youth and, among antidepressants, only the selective serotonin-reuptake inhibitor fluoxetine has received approval.

When bipolarity is suspected, treatment with mood stabilizers, both conventional (lithium) and the anticonvulsant medications (valproate and carbamazepine) and those more recently classified (lamotrigine), and atypical antipsychotics should be prioritized. When antidepressants are indicated in combination with mood stabilizers, first-choice options include bupropion and the selective serotonin-reuptake inhibitors.

The manic patient presents multiple clinical challenges beyond the choice of medication, such as dealing with law enforcement and deciding when to hospitalize the patient against his/her will, how best to involve the family and how to enhance adherence to the treatment regimen. For those patients whose manic episodes are heralded by a hypomanic period, the clinician may have the opportunity to prevent escalation by prescribing drugs to restore normal sleep. An on-going relationship

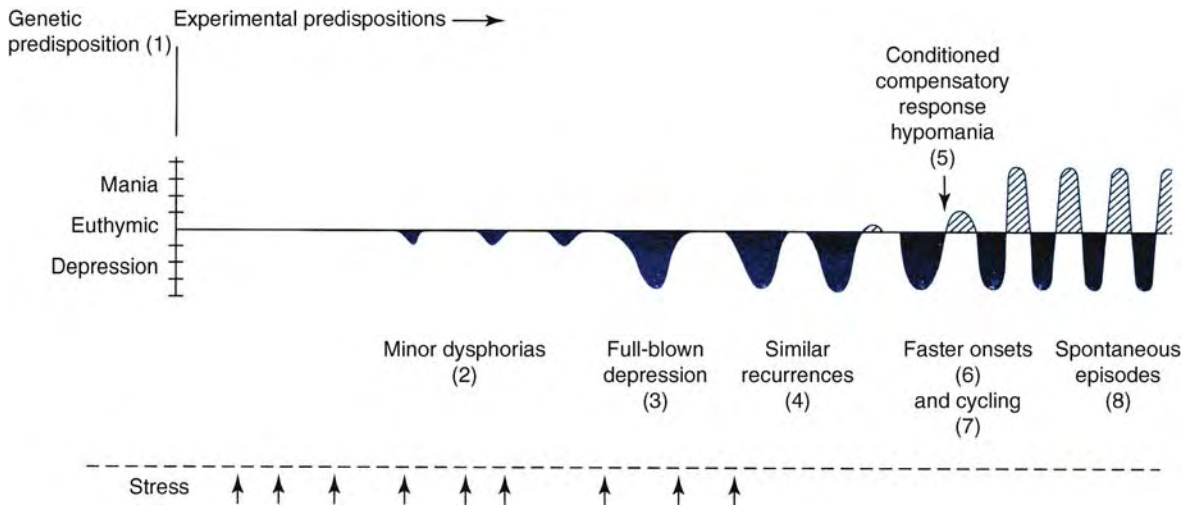

**Bipolar Affective Disorder. Figure 1** Behavioral sensitization paradigm of progressive course of illness leading to rapid cycles [10].

with the family and the patient is the best way of assuring that the clinician is alerted in time.

### Psychotherapy and Psychosocial Interventions

While in most cases drug treatment is effective in eliminating the severe disruptions of manic and depressive episodes, the best treatment results for bipolar affective illness are achieved by combining mood stabilizers or other medications with psychotherapy. Psychotherapy can help the patient come to terms with the repercussions of past episodes and to comprehend the practical and existential implications of the illness.

Educating patients and their families is essential as it helps them recognize the symptoms of emerging episodes. The charting of moods appears to be useful to provide an objective record of mood patterns and treatment response and to give the patient a sense of control and collaboration.

Various forms of psychosocial intervention have been found effective as adjunctive treatments for bipolar disorder. These include family-focused therapy, interpersonal and social rhythm therapy, cognitive-behavioral therapy and individual or group psycho-education. When used in conjunction with pharmacotherapy, these interventions may prolong the time up to relapse, reduce symptom severity and increase medication adherence.

Family-focused therapy aims at reducing the high levels of stress and conflict in the families of bipolar patients, thereby improving the course of the illness. Interpersonal and social rhythm therapy focuses on stabilizing the patient's day and night routines and resolving key interpersonal problems. Cognitive-behavioral therapy helps patients to modify dysfunctional

cognition and behavior that may aggravate the course of the disorder. Group psycho-education provides a supportive, interactive setting in which patients learn about their illness and how to cope with it. Participation in a self-help group can also supplement, or in some cases, replace formal psychotherapy.

### References

1. Angst J (1998) The emerging epidemiology of hypomania and bipolar II disorder. *J Affect Disord* 50:143–151
2. Akiskal HS, Pinto O (1999) The evolving bipolar spectrum: prototype I, II, III, IV. *Psychiatr Clin North Am* 22:517–534
3. Post RM (2005) The impact of bipolar depression. *J Clin Psychiatry* 66(suppl 5):5–10
4. Thase ME (2006) Bipolar depression: diagnostic and treatment considerations. *Dev Psychopathol* 18(4):1213–1230
5. Goodwin FK, Jameson KR (2007) Manic-depressive illness: bipolar disorders and recurrent depression. Oxford University Press, Oxford, New York
6. Leboyer M, Henry C, Paillere-Martinot ML, Bellivier F (2005) Age at onset in bipolar affective disorders: a review. *Bipolar Disord* 7(2):111–118
7. Coryell W, Andicott J, Keller M (1992) Rapid cycling affective disorder: demographics, diagnosis, family history and course. *Arch Gen Psychiatry* 49:126–131
8. Quiroz JA, Singh J, Gould TD, Denicoff KD, Zarate CA, Manji HK (2004) Emerging experimental therapeutics for bipolar disorder: clues from the molecular pathophysiology. *Mol Psychiatry* 9(8):756–776
9. Haldane M, Frangou S (2004) New insights help define the pathophysiology of bipolar affective disorder: neuroimaging and neuropathology findings. *Prog Neuropsychopharmacol Biol Psychiatry* 28(6):943–960
10. Post RM, Weiss SR (1989) Sensitization, kindling, and anticonvulsants in mania. *J Clin Psychiatry* 50 (suppl):23–30; Discussion 45

## Bipolar Cells

### Definition

Interneurons in the retina that transfer visual information from photoreceptors to amacrine and ganglion cells.

- ▶ Photoreceptors
- ▶ Retinal Bipolar Cells
- ▶ Retinal Ganglion Cells

---

## Bipolar Depression

- ▶ Bipolar Affective Disorder

---

## Bipolar Disorder

- ▶ Bipolar Affective Disorder

---

## Bipolar Neuron

### Definition

A nerve cell that has anatomical processes located on opposite sides of the cell body (perikaryon): dendrite(s) carrying information toward the soma, and a single axon carrying information toward other targets.

---

## Bipolar Recording

### Definition

Recording of an electrical potential difference between two active regions of an excitable tissue (e.g., nerve or muscle).

- ▶ Extracellular Recording

---

## Birdsong

### Definition

Partly learned, partly innate singing behavior of Passerine birds. For more information see essay on “Song learning in songbirds.”

---

## Birds-Own-Song

### Definition

The song produced by an individual.

- ▶ Song Learning of Songbirds

---

## Bistability (Neuron)

### Definition

The ability of a neuron, in isolation, to have two stable states of activity at different voltages. Typically one is below threshold and is silent, while the other is above threshold and the neuron fires tonically. Brief synaptic excitation or inhibition can switch the neuron between the two states.

---

## Bistable Neuronal Network

### Definition

A neuronal network that can switch between two distinct states, e.g. silent and active. The switch can either be caused by an external trigger, e.g. one stimulus switches the network from its silent state to an active state, whilst a second stimulus switches the network from its active to a silent state. Alternatively, intrinsic network properties can cause rhythmic alternations between the two network states resulting in a two phasic activity pattern.

- ▶ Central Pattern Generator

## Bitemporal Hemianopsia

### Definition

- ▶ Hemianopsia

## Bithermal Tests of Inner Ear

- ▶ Vestibular Tests Caloric Test

## Bitter Taste

### Definition

- ▶ Taste - Bitter

## Biventer Lobule

### Synonyms

- ▶ Lobulus biventer; ▶ Biventral lobule

### Definition

The biventer lobule belongs to the posterior lobe and is part of the cerebellar hemispheres. Apart from the areas in proximity to the vermis (intermediate part), the hemispheres belong to the phylogenetically young neocerebellum and receive their afferents via the mossy fibers of the pontocerebellar tract from the pontine nuclei. All hemisphere segments are hence also assigned to the pontocerebellum.

- ▶ Cerebellum

## BK

### Definition

BK refers to large conductance Ca-activated  $K^+$  channels present in autonomic neurones and sometimes involved in repolarization of the action potential.

## BK Channels

### Definition

Large-conductance  $Ca^{2+}$ -activated  $K^+$  channels.

- ▶ Neuronal Potassium Channels
- ▶ Action Potential

## BKCa Channel

### Definition

A BK  $K^+$  channels with a large conductance, controlled by the membrane potential and the submembrane  $Ca^{2+}$  concentration.

## Bladder

- ▶ Visceral Afferents

## Bladder Control (Neural)

### Definition

The nervous system regulates the storage and release of urine by coordinating the activity of the urinary bladder and the urethral outlet. In infants and young children the elimination of urine (also known as voiding, urination or micturition) is purely involuntary and is mediated by reflexes triggered by bladder afferent nerves in response to bladder distension. In adults, micturition is voluntary and is dependent upon neural circuitry located in the brain, spinal cord and peripheral nervous system that regulates autonomic and somatic nerve inputs to the lower urinary tract. Micturition is one of the few visceral functions under voluntary control.

- ▶ Micturition, Neurogenic Control

## BLAST

### Definition

Basic Local Alignment Search Tool. BLAST is used to align high scoring, short stretches of sequence identity at speed. BLAST replaced FASTA, a previous method of analysing sequence similarities. Various different types of BLAST can be used, depending on requirements.

Discontinuous megablast, blastn, or megablast can be used to assess the similarity of nucleotide sequences. Protein sequences can be tested from DNA sequence using tblastx (which uses a translated database to match a translated query) or blastx, (which uses a protein sequence database to match a translated query). Peptide or protein sequences can be matched using standard protein BLAST (blastp), or more sophisticated analysis of domains within a protein query can be carried out using PSI-BLAST, PHI-BLAST or RPS-BLAST. Protein sequences can also be used to query translated nucleotide databases (tblastn).

► [Bioinformatics](#)

## Blepharospasm

### Definition

Dystonia of eyelid closing and frowning muscles (orbicularis oculi, corrugator, and procerus muscles) characterized by usually symmetric forceful eyelid closure for a few seconds at a time. Meige syndrome is a combination of blepharospasm and dystonia of lower facial, oromandibular, or cervical muscles.

► [Dystonia](#)

## Blind Spot

### Definition

A light-insensitive area in the visual field for each eye corresponding to the photoreceptor-free region in the eyeball called the optic disc where the ganglion cell axons go out and the central retinal artery comes in. An oval-shaped area of approximately 5 degrees wide in

the human eye, located at approximately 15 degrees nasally from the fovea of the retina, or temporally in the visual field.

► [Retinal Ganglion Cells](#)  
 ► [Visual Field](#)

## Blindness

### Definition

Blindness is, of course, loss of the ability to see and may be caused by damage to the eye, the retina of the eye, areas of the brain involved in processing visual stimuli or the nerve tracts connecting these. Blindness can be subtotal in that vision is only lost in particular regions of the visual field either in one or both eyes. Blindness affecting one entire side of vision (e.g. everything to the left of the direction of gaze) is known as hemianopia.

► [Hemianopia](#)

## Blindsight

ROBERT W. KENTRIDGE

Psychology Department, University of Durham,  
Durham, UK

### Synonyms

Residual vision following loss of striate cortex.

### Definition

“Blindsight” is a term coined by Weiskrantz ([ref?](#)) to describe a condition found in patients who have suffered brain damage to the rearmost area of the cortex of the brain or to the nerve fibers leading immediately to it. This area, known as ► [primary visual cortex](#), is, as its name suggests, involved in the initial stages of processing visual information in the cerebral cortex. It has been known for over a century that damage to this area can render patients blind (or blind within a specific portion of the ► [visual field](#) if the damage does not destroy the primary visual cortex in its entirety). In 1973 Pöppel et al. (see [1] for an account) discovered that although patients with damage to this area reported that they were blind, they could nevertheless perform well in simple visual tasks such as indicating the location of a

spot of light. The patients denied that they saw the spots of light and thought that they were just guessing at the spots' locations. Their "guesses" were, however, consistently related to the positions of the spots. Subsequent studies have revealed that visual abilities other than location of simple targets are also spared in blindsight. Blindsight can therefore be defined as residual visual abilities remaining despite lack of acknowledged awareness of visual stimuli following damage to primary visual cortex or its immediate afferents.

### Characteristics

Most visual information reaches the brain through a pathway in which neurons in the ►retina of the eye send their signals to the ►lateral geniculate nucleus (LGN) (a part of the ►thalamus), the LGN, in turn, projects to primary visual cortex which then sends signals to other parts of the cortex. Spared visual function in blindsight is likely to depend upon other pathways which also convey information from the eyes to the brain but do not pass through primary visual cortex. The nature of the information that can be carried over these alternative visual pathways determines the extent of visual functions spared in blindsight. It has, however, also been suggested that the brain damage in patients with blindsight might have left sufficient primary visual cortex functioning to mediate their residual visual abilities. If this suggestion is correct then blindsight becomes less interesting as an example of an anatomical dissociation between conscious and unconscious processes. In order to characterize blindsight we therefore need to consider its anatomical basis, the extent of the functions that are spared and the strength of evidence for and against sparing of primary visual cortex as an explanation for blindsight.

### Anatomy

Information from the eyes is used for many things other than vision – the control of ►eye-movements, coordination of head and eyes, setting ►circadian rhythms, to name but a few. These functions are controlled by a range of subcortical structures which receive signals from the retina. Some of these structures also send signals to areas of the cortex beyond primary visual cortex. In particular the ►superior colliculus, which is involved in eye-movement control, receives substantial input from the retina in which the relative spatial positions of signals are retained. These projections could therefore, in principle, mediate ►spatial vision (information about the structure of the visual scene as opposed to unstructured information like overall light levels). The superior colliculus sends dense projections to the ►pulvinar (a major division of the thalamus, rather larger than the LGN). The pulvinar sends and receives connections from many

areas of cortex and is implicated in a range of visual functions. For example, it contains cells that are sensitive to visual motion (►Visual motion processing) and even cells whose activity is modulated by visual attention (►Visual attention). It is conceivable that information conveyed through retino-collicular inputs to the pulvinar (together with a smaller number of direct retinal inputs) could be forwarded to the cortex and mediate some aspects of blindsight (this depends, however, on the specific relationship between the destinations of collicular projections within the pulvinar and the origins of pulvinar projections to the cortex which are not fully understood). In addition to projecting to cortex the pulvinar also sends signals to the ►amygdala, a forebrain structure centrally involved in the control of emotion. It has been suggested that these connections mediate responses to unseen emotionally significant stimuli in blindsight. Again, the plausibility of this suggestion relies upon there being a correspondence between cells receiving visual signals in the pulvinar and those projecting to the amygdala. Finally, the LGN itself does not send all of its projections to primary visual cortex, it is also known to project directly to a number of ►extra-striate cortical areas (i.e. areas other than primary visual cortex, which is also often referred to a striate cortex or, in the monkey, area V1), including ►areas V2, ►V4 and ►MT. The projections to area MT in particular may mediate residual discrimination of visual motion (Visual motion processing) in blindsight. There are, therefore, a range of pathways via which visual abilities might be retained in the absence of primary visual cortex.

### Visual Abilities in Blindsight

Blindsight has been studied in a relatively small number of patients, although estimates of its frequency vary, it may occur undetected in many patients who have suffered damage to primary visual cortex. The patients in which it has been studied have almost all had damage which did not destroy all of primary visual cortex. These patients lost conscious vision in the part of their visual field subserved by the damaged visual cortex. So, for example, if primary visual cortex is lost only in the left cerebral hemisphere then conscious vision will be lost in the right visual field (the patient will have ►homonymous hemianopia). Such patients may exhibit blindsight in their ►scotomata (regions of visual loss). In these regions the patients deny experiencing visual stimuli yet may still respond systematically to stimuli they do not see. This type of subtotal loss must not be confused with the notion that tissue *within* an area of damage might be spared. This possibility will be considered when criticisms of blindsight are discussed later.

The earliest studies of blindsight revealed patients' ability to localize spots of light presented within their

scotomata using either eye-movements or pointing as a behavioral measure. It is conceivable that this ability might be mediated entirely by the collicular eye-movement system. Even pointing responses might be guided by patients monitoring incipient eye-movements whose final execution is suppressed. It was, however, soon shown that blindsight patients could also make a range of simple visual discriminations including discriminating straight from curved lines, discriminating stimuli differing in color, discriminating the orientation of lines or gratings (patterns of bright and dark bars) and the spatial frequency of gratings (the fineness of these patterns) [1]. These abilities could not plausibly be explained in terms of eye-movement monitoring. It is, however, also important to stress that spatial vision in blindsight is very limited compared to normal vision. Although blindsight patients can discriminate properties of the components from which objects are constructed they do not appear to be able to integrate this information into representations of objects. For example, blindsight patients cannot discriminate between an equilateral triangle with its apex oriented upwards and one with its apex pointing down. Both triangles are constructed of the same three line segments, it is the spatial relationship between these components that defines their difference and, apparently, residual visual function in blindsight does not extend to extraction of such relationships. Blindsight patients can, however, determine whether a pair of targets presented in their scotomata match or differ in terms of the simple properties just discussed. There is one probable exception to the rule that complex shape discrimination is absent in blindsight. There is recent evidence that blindsight patients can discriminate the emotional expression of faces [2]. It has been suggested that this ability is mediated by projections to the amygdala. As the amygdala has a specialized role in processing social signals and emotion this might explain why discrimination of facial expressions, but not other complex shapes, is spared in blindsight.

When blindsight patients are asked to grasp objects in their blind fields they do not, in general, shape their hands to match the size and shape of the objects. There is, however, an exception. If part of the object is visible (i.e. falls in the undamaged part of the visual field) then the unseen part can influence grasp [3]. It is possible that there are weak residual inputs to the visual control of action (►Visual space representation of action) which are normally insufficient to guide action in blindsight but which can be brought into play when actions are at least partially shaped by conscious vision.

It has been known since the early twentieth century that motion perception survives damage to primary visual cortex. Residual vision of motion can be (but is not always) conscious. Conscious perception of motion

by cortically blind patients is known as the ►Riddoch phenomenon. Blindsight patients also often report conscious experience of rapidly moving stimuli or ones which change brightness very quickly. Again, it would be a mistake to assume that residual motion perception in blindsight, be it conscious or otherwise, resembles normal perception of motion. Blindsight patients can detect the onset of motion and can discriminate the direction and velocity of motion of isolated individual targets. They cannot, however, discriminate the direction of motion when that motion is made up of the average trend of many small movements (in what is known as a random dot kinematogram) despite the fact that such tasks are trivial for a normal person [4].

Finally, it has been shown that blindsight patients can orient spatial attention (Visual attention) within their blind fields – that is, if they are cued to the likely location of a stimulus within their blind field patients are quicker and more accurate at discriminating its properties than if the stimulus is presented at an unattended location [5]. It is noteworthy that stimuli which can be shown to be attended by virtue of advantages in the speed or accuracy of their discrimination nevertheless still remain unseen. This demonstrates dissociation between visual attention and ►visual consciousness (often thought to be closely related).

We have noted that some stimuli can elicit conscious experience in blindsight patients. The nature of that experience is the subject of considerable controversy. It has been argued that it is in some sense a non-visual experience, for example a “feeling of knowing” that a stimulus has been presented rather than an experience of seeing the stimulus. Attempts to establish the quality of such experiences are fraught with difficulty. It is, however, clear that there are differences in the pattern of activity in the brain elicited by stimuli which do or do not give rise to experience in blindsight patients [6].

### Objections

As the phenomenon of blindsight has such great implications beyond neuropsychology for our understanding of consciousness it is not surprising that it has been the focus of intense scrutiny [7]. The first class of objection revolves around anatomy. It is common in brain damage caused by ►stroke, for example, for some tissue to survive within an area of damage. It has been argued that blindsight is, in fact, mediated by spared primary visual cortex rather than the non-striate routes described earlier. Patients can indeed be found who retain small patches (or “islands”) of viable tissue within a larger area of damaged primary visual cortex. These patients can detect stimuli presented in the tiny regions of their visual fields corresponding to these islands of sparing [8]. Moreover, they deny awareness of such stimuli. It is, however, unlikely that islands of

sparing can account for all cases of blindsight. Experiments in which stimuli in many locations are tested using equipment which tracks eye-position and hence prevents eye-movements from allowing the stimuli to activate anything but a very small region of the retina (and hence cortex) suggest that blindsight is too spatially extensive to be accounted for by undetected islands of sparing. High-resolution neuroimaging has also failed to detect islands of activity within the primary visual cortex of blindsight patients even when it is sufficiently powerful to detect activity elicited in extrastriate areas.

As nearly all blindsight patients retain undamaged regions of vision it is also possible that what appear to be residual abilities are in fact based on response to light that has scattered so as to fall within these regions of normal vision. Although scatter in the environment can be controlled for it is much harder to ensure that light is not scattered within the eye itself. Elegant experiments suggest, however, that intraocular scatter cannot account for residual vision in blindsight. In the normal retina we all have a region called the ► **blind-spot** where the ► **optic nerve** leaves the eye and hence where there are no ► **photoreceptors**. Although we do not notice it, we are all completely blind within this region. A stimulus presented in the ► **blindspot** of a blindsight patient cannot directly elicit any neural signals, it should, however, scatter just as well as a stimulus presented outside the blindspot. If blindsight is mediated by light scatter then stimuli should be detected just as well whether they fall in or out of the blindspot. Blindsight subjects fail to detect targets presented at their blindspots although they do detect adjacent stimuli outside the blindspot – good evidence that blindsight cannot depend upon light scatter [9].

If blindsight is somehow mediated by an impoverished signal to the primary visual cortex (although this seems unlikely) then it should resemble weak normal vision. It has been suggested that blindsight patients' denial of visual experience is due to a bias against reporting stimuli in what they know to be an abnormal area of vision. Experiments using techniques based on signal detection theory permit such biases to be distinguished from patients' discriminative abilities [10]. These experiments suggest that bias in conjunction with poor normal vision cannot explain blindsight.

All of the objections raised against blindsight can be addressed, so the phenomenon itself seems genuine. It is, however, important to note that findings from individual patients or specific experiments might nevertheless still be accounted for in terms of one or more of these objections. Careful control of stimuli and detailed anatomical data are essential in conducting and assessing experiments on blindsight.

## References

1. Weiskrantz L (1986) *Blindsight*. Oxford University Press, Oxford
2. de Gelder B, Vroomen J, Pourtois G, Weiskrantz L (1999) Non-conscious recognition of affect in the absence of striate cortex. *Neuroreport* 10:3759–3763
3. Jackson SR (1999) Pathological perceptual completion in hemianopia extends to the control of reach-to-grasp movements. *Neuroreport*. 10:2461–2466
4. Azzopardi P, Cowey A (2001) Motion discrimination in cortically blind patients. *Brain* 124:30–46
5. Kentridge RW, Heywood CA, Weiskrantz L (1999) Attention without awareness in blindsight. *Proceedings of the Royal Society, London B* 266:1805–1911
6. Sahraie A, Weiskrantz L, Barbur JL, Simmons A, Williams SCR, Brammer MJ (1997) Pattern of neuronal activity associated with conscious and unconscious processing of visual signals. *Proceedings of the National Academy of Science USA* 94:9406–9411
7. Champion J, Latto R, Smith YM (1983) Is blindsight an effect of scattered light, spared cortex, and near threshold vision? *The Behavioral and Brain Sciences* 6:423–486
8. Kentridge RW, Heywood CA, Weiskrantz L (1997) Residual Vision in Multiple Retinal Locations within a Scotoma: Implications for Blindsight. *Journal of Cognitive Neuroscience* 9:191–202
9. Stoerig P, Cowey A (1991) Increment threshold spectral sensitivity in blindsight: Evidence for colour opponency. *Brain* 114:1487–1512
10. Azzopardi P, Cowey A (1997) Is blindsight like normal, near-threshold vision? *Proceedings of the National Academy of Science USA* 94:14190–14194

## Block Diagram

### Definition

A diagram of a system as blocks connected by wires.

Each block performs a function and passes the results to all the blocks connected to it.

### ► Signals and Systems

## Blocking

A well-established CS presented on later conditioning trials in compound with a new stimulus blocks the new stimulus from associating with the US.

### ► Conditioned Taste Aversion



## Blocking in Classical Conditioning

### Definition

The failure of a conditioned stimulus (CS) to elicit a conditioned response when its pairings with the unconditioned stimulus (US) take place in the presence of a previously established signal for that unconditioned stimulus. Assessment of the magnitude of blocking is made through comparison with an overshadowing control group that receives identical pairings of the CS and US but in the presence of a neutral stimulus.

This is one of several examples of cue competition or stimulus selection effects that prompted development of predictive-driven learning models.

### ► Theory on Classical Conditioning

## Blood Brain Barrier

### Definition

The blood brain barrier (BBB) acts to protect the brain extracellular fluid from fluctuations in blood composition. Because of the BBB, not all blood constituents can pass freely into the brain extracellular space.

## Blood Volume Homeostasis

### Definition

The human body's total blood volume (V) of approximately 5L is not uniformly distributed along branchings of the cardiovascular system, from left heart to right heart, and back to left. The blood volume can be divided as follows: (i) the systemic circulation (where  $\approx 85\%$  of blood is contained), the pulmonary circulation ( $\approx 10\%$ ), and the heart chambers ( $\sim 5\%$ ); (ii) the high-pressure system ( $\approx 15\%$ ), the low-pressure system ( $\approx 80\%$ ), and the heart chambers ( $\approx 5\%$ ); (iii) the systemic venous system versus the remainder of the circulation; and (iv) the central blood volume (volumes of the right heart + pulmonary circulation) versus the rest of the circulation. Changes in blood volume are mostly determined by the degree of fullness of various regions of the cardiovascular system, which includes neural mechanoreceptors

and non-neural mechanoreceptors, and by physical factors.

### ► Blood Volume Regulation

## Blood Volume Regulation

HIROSHI KANNAN

Department of Physiology, Faculty of Medicine, University of Miyazaki, Miyazaki, Japan

### Synonyms

Physiology of body fluid balance; Control of extracellular fluid (ECF) and blood volume

### Definition

Body water is the fluid environment of the cells, and all life depends upon the stability of this "internal sea." The homeostasis of body fluids is primarily maintained by the balance between those mechanisms controlling the intake of water and electrolytes, and those regulating water and electrolyte loss in the kidneys.

### Characteristics

#### Quantitative Description

Water, the largest constituent of the body, makes up 55–65% of the body weight in animals and humans. Total body water is distributed between intracellular fluid (ICF) and extracellular fluid (ECF) compartments, with 55–65% in the former and 35–45% in the latter. The ECF can be further subdivided into the interstitial fluid (ISF) surrounding the cells and the plasma volume within blood vessels. The intravascular fluid averages 7–8% of total body water or, approximately, one fifth of the ECF. The body's total blood volume (V) of approximately 5 L is not uniformly distributed in the body: the high-pressure arterial circuit contains 13% of the blood volume, the capillary bed 7%, and the low-pressure venous bed 64%. The pulmonary circulation contains 9% of the blood volume, and the heart 7%.

Total body fluid compartments differ not only in their volumes but also in the solutes that are dissolved in them. Specifically, membrane-bound  $\text{Na}^+/\text{K}^+$  pumps maintain  $\text{Na}^+$  primarily outside the cells, whereas  $\text{K}^+$  is largely found inside them. However, the osmotic pressure, which reflects the concentrations of all solutes in a fluid compartment, is always equivalent in the ECF and ICF because most biological membranes are freely permeable to water. Thus, water flows across the membranes by osmosis from a relatively dilute compartment into one

with a higher solute concentration until a steady state is reached in which the osmotic pressure is equalized on both sides of the cell membrane.

## Higher Level Structures

### Relevant Sensing Structures

#### Low-Pressure Volume Sensors

A loss of blood is detected by stretch receptors in the great veins entering the right atria/ventricle of the heart and in the pulmonary artery (low-pressure volume receptors), and provides an afferent vagal signal to the ►**nucleus tractus solitarius (NTS)** in the brain stem (Fig. 1). These receptors are located at the end of afferent axons – either A or B fibers – that join the vagus nerve (X). The A fibers fire in synchrony with the atrial systole and therefore monitor the heart rate. The B fibers fire in a burst during the ventricle systole and gradually increase their firing rate as the atria fill. Thus, the B fibers monitor the rising atrial volume. As the central venous pressure (CVP) – the pressure inside large systemic veins leading to the right heart – is the main determinant of right atrial filling, the B fibers also detect changes in the CVP. Therefore, the B-type low-pressure stretch receptors primarily monitor the effective circulating volume and venous return. The afferent pathways for the low-pressure receptors are similar to those for high-pressure ►**baroreceptors** along the vagus nerve and project to the NTS and other nuclei of the medullary cardiovascular center. To some extent, the efferent pathways and effector organs (i.e., heart and blood vessels) are also similar. However, whereas an increased stretch of the high-pressure baroreceptor decreases generalized sympathetic outflow, an increased stretch of the atrial B-type receptors decreases sympathetic vasoconstrictor output only to the kidney. The net effect of an increased atrial stretch (i.e., tachycardia and renal vasodilatation) is an increase in renal blood flow and an increase in urine output. A decreased atrial stretch has little effect on the heart rate but increases sympathetic output to the kidney. Therefore, as far as their direct cardiovascular effects are concerned, the high-pressure baroreceptors respond to a stretch (i.e., increased blood pressure) by attempting to decrease blood pressure. The low-pressure volume receptors respond to a stretch (i.e., increased fullness) by attempting to eliminate fluid.

#### High-Pressure Baroreceptors

Even larger decreases in blood volume may also lower arterial blood pressure, which reduces the stretch of receptors in the walls of distensible arterioles in the carotid sinus and aortic arch (high-pressure baroreceptors). That information is similarly communicated to the NTS and integrated there with neural messages from the low-pressure, venous side of the circulation. The activity of these sensors modulates both sympathetic

nerve outflow and vasopressin (ADH) secretion. For example, a decrease in the filling of the pulmonary vessels and cardiac atria increases sympathetic nerve activity and stimulates vasopressin secretion. Conversely, distention of these structures decreases sympathetic nerve activity. In general, 5–10% changes in the blood volume and pressure are necessary to evoke the response.

#### Cardiac Sensors

The cardiac atria possess an additional mechanism related to the control of blood volume. The myocytes of the atria synthesize and store a peptide hormone, termed atrial natriuretic peptide (ANP), which is released when the atria are distended.

#### Renal Sensors

The kidney also contains volume/pressure sensors, the juxtaglomerular apparatus (JGA), which respond directly to changes in pressure. If perfusion pressure of the afferent arterioles is reduced, renin is released from the myocytes. Renin determines the blood levels of angiotensin II and aldosterone, both of which play an important role in regulating renal  $\text{Na}^+$  and water excretion.

#### Hepatic Sensors

The liver contains sensors to changes in pressure and  $\text{Na}^+$  concentration that, although not as important as the vascular sensors in monitoring the effective circulating volume, can modulate renal  $\text{NaCl}$  excretion. Afferent signals from both types of sensors are carried to the central nervous system (CNS) in the hepatic vagal nerves. Increased pressure within the hepatic vasculature, or an increase in portal vein  $[\text{Na}^+]$ , results in a decrease in renal sympathetic nerve activity [1].

#### Osmolality/ $\text{Na}^+$ Sensors in the CNS

The whole-body  $\text{Na}^+$  content determines the ECF volume, whereas the whole-body water content determines the ►**osmolality**. As the body generally stabilizes the osmolality, an increase in extracellular  $\text{Na}^+$  content will increase the ECF volume.

The osmoreceptors/ $\text{Na}$  receptors appear to be located in two areas: the organum vasculosum lamina terminalis (OVLT) and the subfornical organ (SFO), two of the circumventricular organs (OVLTs). Neurons in these regions are thus able to sense changes in plasma osmolality/ $\text{Na}$  concentration. They apparently behave as osmometers, responding to elevated osmolality/ $\text{Na}$  concentration by increasing the activity of mechanosensitive ►**(stretch-inactivated) cation (SIC) channels** located in their cell membranes, resulting in significant membrane depolarization that increases the frequency of action potentials [2]. In addition, vasopressin and oxytocin secretory neurons themselves in

the ►paraventricular (PVN) and supraoptic (SON) nuclei have osmo- /Na-sensitivity.

### Higher Level Processes

#### Efferent Systems

The kidneys (output) and drinking behavior (input) play important roles in body water fluid balance. Both neural and hormonal regulating signals are involved (Fig. 1).

#### Renal Sympathetic Nerve Activity

Renal sympathetic nerves innervate the afferent and efferent arterioles of the glomerulus as well as the ►nephron cell. With negative Na<sup>+</sup> balance (i.e., volume depletion), the Na<sup>+</sup> sensors (especially the low- and high-pressure vascular baroreceptors) stimulate renal sympathetic nerve activity. Increased renal sympathetic nerve activities produce the following: (i) decreased hydrostatic pressure within the glomerular capillary

lumen and, thereby, a decreased ►glomerular filtration rate (GFR); (ii) renin secretion via activation of beta-adrenergic receptors; (iii) enhanced NaCl reabsorption along the nephron via activation of alpha-adrenergic receptors [3,4]. The combined effects of these actions contribute to overall decreases in NaCl and water excretion, an adaptive response that works to restore the euvolemia.

#### Renin-Angiotensin-Aldosteron System

Three factors play an important role in stimulating renin secretion: (i) reduced perfusion pressure to the kidney results in renin secretion; (ii) activation of the renal sympathetic nerve results in an increase in renin secretion; (iii) decreased NaCl delivery to the macula densa results in an increase in GFR and an increase in renin secretion. Renin alone does not have a physiological function; it functions solely as a proteolytic enzyme. Its substrate is a circulating protein, angiotensinogen,

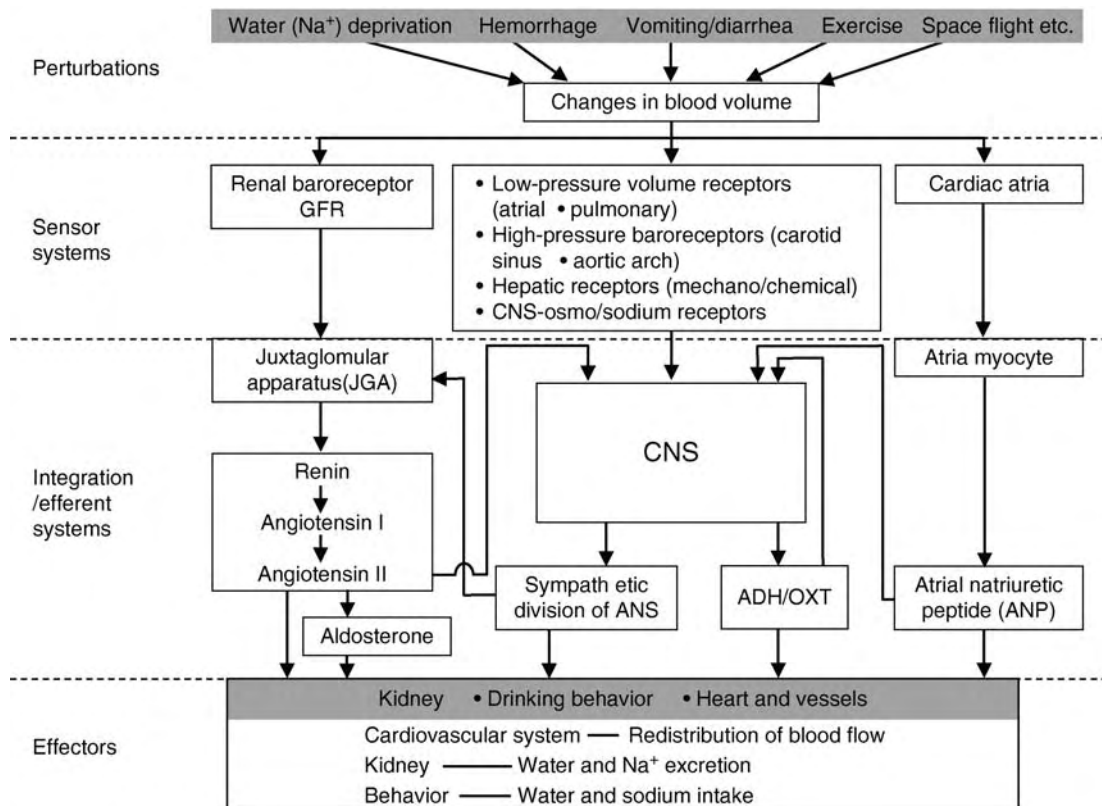

**Blood Volume Regulation. Figure 1** Basic mechanisms involved in blood volume regulation. The most important organs involved in the regulation of blood volume are shown (for explanations, see text). In these organs, a variety of different cell types and molecular events are related to blood volume regulation. Adaptive responses are initiated by the detection of changes in volume/pressure and osmolality/Na concentration, then the following four parallel effector pathways that act on cardiovascular function, kidney and drinking behavior, are triggered: (a) sympathetic nerve activity; (b) renin-angiotensin-aldosterone system; (c) natriuretic peptide; (d) vasopressin (ADH)/oxytocin (OXT). Additional events linked to blood volume regulation involve the need to drink water and sodium appetite. GFR, glomerular filtration rate.

which is produced by the liver. Angiotensinogen is cleaved by renin to yield a 10-amino acid peptide, angiotensin I. Angiotensin I has no known physiological function and is cleaved to an 8-amino acid peptide, angiotensin II, by a converting enzyme (angiotensin-converting enzyme [ACE] found on the surface vascular endothelial cells (pulmonary endothelial cells are important sites for the conversion of angiotensin I to angiotensin II). Angiotensin II has several important physiological functions: (i) stimulation of aldosterone secretion; (ii) arteriolar vasoconstriction; (iii) stimulation of vasopressin secretion; (iv) enhancement of NaCl reabsorption; and (v) drinking behavior.

### **Atria Natriuretic Peptide (ANP)**

ANP is released with an atrial stretch, as would occur with positive Na<sup>+</sup> balance and blood volume expansion. The circulating form of ANP is 28 amino acids in length. In general, ANP actions, as they relate to renal NaCl and water excretion, antagonize those of the renin-angiotensin-aldosterone system. ANP, as its name implies, promotes natriuresis (i.e., Na<sup>+</sup> excretion). ANP plays a role in the diuretic response to the redistribution of ECF and plasma volume into the thorax that occurs during water immersion and space flight. ANP inhibits renin secretion, aldosterone secretion, NaCl reabsorption, ADH secretion, and drinking behavior [5].

### **Vasopressin (ADH)**

The posterior pituitary releases vasopressin primarily in response to increases in extracellular osmolality. Indeed, ADH mainly increases distal-nephron water permeability, thus promoting water retention. However, the posterior pituitary also releases ADH in response to large reductions in circulating blood volume (hemorrhage). Vasopressin is a nonapeptide with a molecular weight of 1,084. It is synthesized in the cell bodies of magnocellular neurons in the paraventricular (PVN) and supraoptic (SON) nuclei of the hypothalamus, where it is packaged along with neurophysin into neurosecretory vesicles. These vesicles are transported along the axons of these neurons to the posterior lobe of the pituitary, where they are stored. Stimuli for vasopressin release, acting via neural inputs to the PVN and SON, result in the depolarization of these neurons and the release of vasopressin and its accompanying neurophysin into the circulation via the process of exocytosis. The primary physiological stimuli for the release of vasopressin are an increase in the osmotic pressure of the plasma and reductions in blood pressure/volume. Other stimuli, such as nausea and “stress” may also affect vasopressin release. Vasopressin can increase reabsorption of water in the kidney by activating V<sub>2</sub> receptors on the distal nephron. Vasopressin is also a potent vasoconstrictor as a result of activation of V<sub>1a</sub> receptors on vascular smooth muscles.

### **Oxytocin (OXT)**

The neurohypophysial hormone oxytocin has traditionally been considered to be associated with the female reproductive functions of lactation and parturition. However, more recent evidence suggests oxytocin may also play a role in body ►fluid homeostasis. Oxytocin is a natriuretic factor that may be involved in the volume expansion response. Blood volume expansion increases circulating oxytocin, and oxytocin has been shown to facilitate the release of the atrial natriuretic peptide (ANP) from isolated atria. Thus, during volume expansion, vasopressin is inhibited to decrease water retention and increase vasoconstriction, while oxytocin is secreted to increase natriuresis directly at the level of the kidney and indirectly via the release of ANP [6].

### **Process Regulation**

#### **Integrative Sites in the CNS Relevant to Blood Volume Regulation**

Changes in blood volume affect a number of regions in the CNS, including the area postrema, NTS, caudal ventrolateral medulla (CVLM), locus coeruleus (LC), diagonal band of Broca (DBB), PVN, and SON (Fig. 2). In regard to vasopressin release to a decrease in blood volume/pressure, two afferent pathways are proposed: one, NTS→A1 noradrenergic neurons in the CVLM→AVP-secreting neurons in the PVN/SON; another, the NTS→LC→DBB→perinuclear zone in the PVN/SON→AVP-secreting neurons in the PVN/SON [7]. In regard to the activation of renal sympathetic nerve activation to a decrease in blood volume, central pathways mediating the baroreceptor reflex may be involved and, in some part, overlapped. In addition, the parvocellular neurons in the PVN are involved in mediating volume-related signals directly projecting to the intermediolateral cell column (IML) of the spinal cord or indirectly via the ►rostral ventrolateral medulla (RVLM) [8,9].

Circumventricular organs (CVOs) are sites for mediating humoral signals relevant to ►blood volume homeostasis to the CNS.

The small restricted areas that lack a ►blood-brain barrier (BBB) are called the circumventricular organs (CVOs) because they surround the ventricle system; these areas include the area postrema (AP), posterior pituitary, SFO, median eminence, pineal gland, sub-commisural organ, and organum vasculosum lamina terminalis (OVLT). Neurons in the CVOs are directly exposed to blood solutes and macromolecules; this arrangement is believed to be part of a signal transmission system for detecting endogenous systemic peptides. Peptide hormones, such as vasopressin, angiotensin II (AII) and ANP, are believed to exert their central effects primarily through actions at the CVOs. The CVOs maintain numerous reciprocal connections with brain regions that are intimately

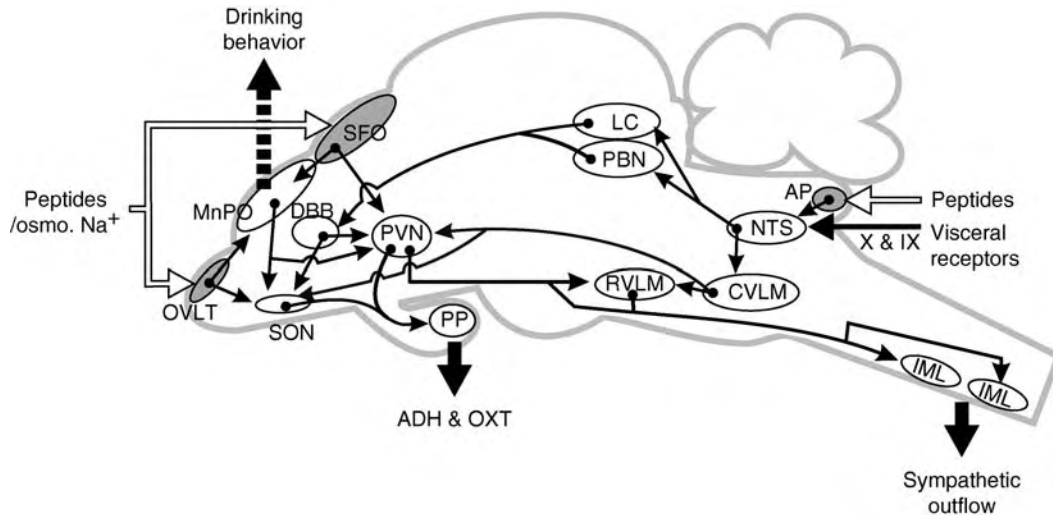

**Blood Volume Regulation. Figure 2** Drawing showing how afferent (neural and humoral) information from the internal environment relevant to body fluid balance is transmitted in the central autonomic and endocrine network of the brain, and selected neural pathways subserving blood volume regulation in the CNS. Abbreviation: AP, area postrema; CVLM, caudal ventrolateral medulla; DBB, diagonal band of Broca; IML, intermediolateral cell column; LC, locus ceruleus; MnPO, median preoptic nucleus; NTS, nucleus tractus solitarius; OVLT, organum vasculosum lamina terminalis; PBN, parabrachial nucleus; PP, posterior pituitary; PVN, paraventricular nucleus; SFO, subfornical organ; SON, supraoptic nucleus.

involved in the regulation of blood volume/pressure and osmolality/Na homeostasis.

### Function

#### Homeostasis of Blood Volume

Hemorrhage, water (sodium) loss, or localized sequestration of ECF (edema) decreases the blood and interstitial fluid (ISF) volume. The immediate response to hypovolemia is the activation of the components of the autonomic nervous and endocrine systems in a manner that mitigates the consequences of reduced cardiac output and falling blood pressure. The activation of the sympathetic nervous systems contributes to increased vascular tone, venous return, heart rate and contractility, and renal sodium and water reabsorption. Elevated vasopressin (ADH) and renin-angiotensin-aldosterone act directly or indirectly to retain sodium and water or to redistribute blood and interstitial fluids in an attempt to maintain critical regional blood flows. In addition, drinking behavior participates in adaptive responses. The blood volume that is necessary to achieve adequate perfusion of key organs is sometimes referred to as the effective circulating volume.

### Pathology

Disorders of body fluid homeostasis can result either from disturbances in the physiological mechanisms that control the conservation, distribution, and excretion of water and solutes or from disturbances in the

behavioral mechanisms that control the intake of water and solutes.

Generally speaking, water balance is more finely regulated by changes in osmolality, whereas sodium balance is regulated to a greater degree by changes in effective ECF volume. Therefore, disorders of osmotic homeostasis are mainly caused by abnormalities of water balance, and disorders of volume homeostasis largely result from abnormalities of sodium balance.

Representative disorders relevant to ECF/blood volume homeostasis: ► **Adrenal insufficiency (Addison's disease)**; Hypovolemia (hemorrhage, diarrhea, excessive sweating); ► **Hyperaldosteronism**.

Representative disorders relevant to body osmolality homeostasis: ► **Diabetes insipidus**; ► **Syndrome of inappropriate ADH secretion**; Osmoreceptor dysfunction; Primary polydipsia.

### References

1. Morita H, Matsuda T, Tanaka K, Hosomi H (1995) Role of hepatic receptors in controlling body fluid homeostasis. *Jpn J Physiol* 45:355–368
2. Voisin DL, Bourque CW (2002) Integration of sodium and osmosensory signals in vasopressin neurons. *Trends Neurosci* 25:199–205
3. Kannan H (1996) Changes in renal sympathetic nerve activities in the regulation of body fluid balance with special reference to central neuropeptides in conscious rats. *Jpn J Physiol* 46:111–122

4. DiBona (1982) The functions of the renal nerves. *Rev Physiol Biochem Pharmacol* 94:75–181
5. Antunes-Rodrigues J, de Castro M, Elias LL, Valenca MM (2004) Neuroendocrine control of body fluid metabolism. *Physiol Rev* 84:169–208
6. McCann SM, Antunes-Rodrigues J, Jankowski M, Gutkowska J (2002) Oxytocin, vasopressin and atrial natriuretic peptide control body fluid homeostasis by action on their receptors in brain, cardiovascular system and kidney. *Prog Brain Res* 139:309–328
7. Dampney RAL (1994) Functional organization of central pathways regulating the cardiovascular system. *Physiol Rev* 74:323–364
8. Badoer E (1996) Cardiovascular role of parvocellular neurons in the paraventricular nucleus of the hypothalamus. *News Physiol Sci* 11:43–47
9. Pyner S, Deering J, Coote JH (2002) Right atrial stretch induces renal nerve inhibition and c-fos expression in parvocellular neurons of the paraventricular nucleus in rats. *Exp Physiol* 87:25–32

## Blood-Brain Barrier

JAMES M. STADDON, TOSHAL PATEL,  
TERENCE SMITH  
Eisai London Research Laboratories, University  
College London, London, UK

### Definition

The blood-brain barrier (BBB) serves to protect the brain from the potentially adverse effects of fluctuations in molecular and macromolecular components of the blood. Such fluctuations may be due to diet, metabolism and disease. The anatomical basis of the BBB is attributable to the endothelium of the brain capillaries. Here, the endothelial cells differ from those in the periphery by being sealed to their neighbors by extremely well developed ►**tight junctions**, limiting paracellular flux of blood-borne substances. Additionally, the cells (which are only about 0.2–0.3  $\mu\text{m}$  thick) lack channels and fenestrations, restricting transcellular traffic of agents. Transporters ensure that nutrients and other essential substances cross the BBB to support the metabolically active but environmentally sensitive cells of the CNS.

### Historical Development

In 1885 the German microbiologist Paul Ehrlich reported that when vital dye was injected intravenously in animals, peripheral organs became stained as dye leaked from the blood into the tissue; in contrast, the brain did not. Ehrlich's interpretation was that the brain had a low affinity for the dye. His student Edwin Goldmann subsequently showed that the brain was

capable of being stained and concluded that it didn't stain in his mentor's experiment because the dye could not cross the walls of brain capillaries. This was an early realization that the brain is somehow separated from blood, leading to the concept of the BBB. Now, the physical and cellular basis of the BBB is fairly well understood. Its most important role is to carefully maintain and protect the brain parenchymal environment to ensure optimal neuronal and glial functioning. Excessive glutamate, for example, is toxic for neurons and oligodendrocytes. Nutrients and factors that the brain needs for efficient activity are allowed in; toxins and undesirable agents are excluded and, indeed, can be actively ejected. It is believed that there are approximately 400 miles of capillaries perfusing the human brain with a surface area of endothelium of about 20  $\text{m}^2$ . The BBB is the major interface between blood and brain.

### Ultrastructure and Cellular Basis

It was not clear if the structural basis for the BBB was at the level of the endothelium, the basement membrane (to which the endothelial cells are attached) or the glia or pericytes ensheathing the endothelial cells. In the late 1960's, Ehrlich's experiment was repeated by Reese, Karnovsky and Brightman [1,2] but with analysis at the ultrastructural level using the, then new, electron microscope. Rather than using dyes, they exploited horseradish peroxidase as a relatively small protein tracer. This could be chemically fixed in place and sensitively detected by allowing enzymatic reaction with a suitable substrate to generate an electron-opaque product. The electron microscope images showed that the tracer was prevented from entering the brain by tight junctions between the endothelial cells. Similar findings were made using lanthanum ions as an even smaller tracer. In peripheral organs such as heart, the tracers could be seen passing across the capillary endothelium, apparently through the looser interendothelial cell junctions. Tight junctions had been identified previously by Farquhar and Palade as a structure of the junctional complex in epithelium, known to possess well-developed barrier properties. From the ultrastructural studies, it was also realized that brain endothelial cells, unlike those in the periphery, have very few endocytic vesicles that are usually involved in internalization and transcellular movement of substances in the bulk-phase.

### Permeability Properties

A picture of the anatomical basis of the BBB thus emerges. Endothelial cells lining brain capillaries are connected to each other by a seamless organization of epithelial cell-like tight junctions. The plasma membrane of the endothelial cell, as in any cell, is continuous and hydrophobic and therefore restricts transcellular movement of charged or large molecules from blood to

brain. The low rate of endocytosis and vesicular transcytosis additionally limits transcellular movement of substances via the bulk phase. Well-developed tight junctions inhibit the paracellular movement of substances from blood to brain. Therefore, the barrier functions because substances in general are limited from getting across (transcellular route) or around (paracellular route) the endothelial cells lining brain capillaries. Later on it was realized that the tight junctions of brain endothelial cells are so well developed that they even limit the passage of small ions. Indeed, transendothelial electrical resistance is often used to measure the permeability of brain endothelial tight junctions, which *in vivo* is believed to be of the order of a few thousand  $\Omega \cdot \text{cm}^2$  (Fig. 1).

### Transport across the BBB

The term, BBB is, however, somewhat misleading. Literally, it implies that there is an impenetrable seal between blood and brain. For certain types of blood-borne substances, this is true to a large extent. However, the brain is highly active metabolically, so, clearly, it cannot be completely sealed off from the nutrients and cofactors that blood carries. If a toxic or undesirable substance in blood is hydrophilic it cannot cross the BBB by either the paracellular or transcellular routes. Nutrients such as glucose and amino acids would likewise be excluded from the brain. These, however, are enabled to cross the BBB due to appropriate expression of ►transporter proteins in the endothelial cells. Transport can be either active or facilitative. The tight junction is also important in this respect because it separates the plasma membrane, and therefore polarizes membrane proteins, into apical and basolateral compartments. Other important molecules such as ►transferrin are selectively transcytosed across the endothelial

cells. Therefore, the BBB is a barrier but it is selective rather than being completely exclusive. Clinically, transport across the BBB can be exploited for therapeutic purposes. For treatment of Parkinson's disease, peripherally administered L-DOPA is transported into the brain via the ►large neutral amino acid transporter type 1 (LAT1). Once in the brain it is enzymatically decarboxylated, giving rise to dopamine.

### Ejection Out of the CNS: The Role of P-Glycoprotein

Unfortunately, some noxious substances do manage to get across the BBB. These tend to have hydrophobic character, meaning that they can cross via the transcellular route by simple partitioning. However, the BBB is sophisticated further in that it has additional mechanisms to deal with this problem. This realization derived from the mechanism of resistance of tumor cells to many chemotherapeutic drugs. These cells express drug-transporting ►P-glycoprotein (P-GP), a large plasma membrane protein that actively extrudes a large variety of cytotoxic drugs from the cell. From mice in which P-GP had been genetically removed, it emerged that P-GP is expressed in brain endothelial cells and is very actively involved in removal of certain substances that had managed to enter the CNS. Drugs that have CNS side effects can be improved by making them better substrates for P-GP. Conversely, CNS acting drugs have to escape ejection by P-GP [3]. Many drug-metabolizing enzymes are also expressed in the endothelial cells of the BBB, acting as another level of defense against xenobiotics.

### The Role of the Microenvironment

Brain endothelial cells have become much more specialized than those in peripheral tissues. How this has developed and evolved is not clearly understood. However, the microenvironment seems to have an important

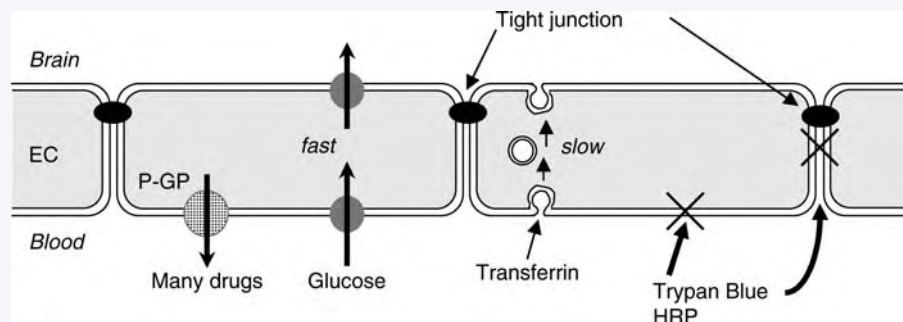

**Blood-Brain Barrier. Figure 1** Essential features of the blood-brain barrier. Endothelial cells (ECs) lining brain capillaries are connected to each other by extremely well developed tight junctions, limiting paracellular flux of ionic, membrane-impermeant substances. Rates of transcytosis are low but receptor-mediated mechanisms exist to ensure transport of essential macromolecules such as Fe-transferrin. Carriers and transporters (active or facilitative) mediate rapid entry of nutrients such as glucose and amino acids into the CNS. P-glycoprotein (P-GP) is a non-selective transporter that removes many hydrophobic and amphipathic molecules (drugs, metabolites etc.) from the CNS environment.

influence. In 1981, Stewart and Wiley performed tissue transplantation studies between quail and chick embryos [4]. When gut tissue was transplanted into brain, the transplant was vascularized by brain endothelial cells that became leaky. Conversely, brain tissue transplanted to gut became vascularized by gut endothelial cells that became brain-like in terms of their barrier properties. The specialized phenotype of brain endothelial cells is perhaps due to contact or interaction with other cells of the CNS, the glial and neuronal cells. Astrocyte endfeet (the terminal regions of astrocytic processes) are known to cover much of the basal surface of brain capillaries, and there has been speculation and some evidence that these may provide inductive factors.

### Proteins at Tight Junctions

Understanding of the molecular basis of the specialized cell-cell adhesion that is necessary for the blood-brain barrier has also advanced [5]. Tight junctions were identified as anatomical entities in the early 1960's. There seems to be a lot of similarity in terms of the molecular composition of tight junctions in both epithelial cells and the endothelial cells of the BBB. Peripheral proteins such as ►zonula occludens-1 (ZO-1) are localized to tight junctions on the cytoplasmic side of the cell. ►Occludin is an integral membrane protein with four transmembrane domains that localizes to tight junctions and seems to form a complex with cytoplasmic protein components. The extracellular loops of occludin may have some intercellular adhesive function. Occludin expression is very high in brain endothelial cells but much lower in those of peripheral organs, suggesting that it may contribute to the paracellular properties of brain endothelial cells. Another group of transmembrane proteins localizing to tight junctions are the ►claudins, a multigene family consisting of greater than 20 members. Like occludin, claudin bears four transmembrane domains and is also believed to be involved in intercellular adhesion at the tight junction. In particular, claudin-5 may be responsible for the limited paracellular permeability of brain endothelial cells [6].

### Proteins at Adherens Junctions

The intercellular adhesion of brain endothelial cells is also crucially dependent on ►adherens junctions. Tight junctions provide the barrier properties of brain endothelial cells but the adherens junction generates mechanical strength between the cells. Adherens junctions are based on ►cadherins, the  $\text{Ca}^{2+}$ -dependent adhesion molecules [7]. Cadherins also form a multigene family; VE-cadherin (vascular endothelial cadherin) being important for interendothelial cell adhesion. Cadherins span the plasma membrane once (a type I membrane protein) and, in a homophilic and  $\text{Ca}^{2+}$ -dependent manner, interact with and bind to cadherins on neighboring cells. The

cytoplasmic domain of cadherin is fairly well conserved between classical members of the family. This links cadherin to the actin-based cytoskeleton through a group of proteins termed ►catenins that physically associate with the cytoplasmic tail.  $\beta$ -catenin binds directly to cadherin and, via  $\alpha$ -catenin, links to the actin cytoskeleton. ►p120 is another catenin that may play a signaling and regulatory role (Fig. 2).

### Cell Culture Models

In order to study the BBB, cell culture models have also been employed. These mainly involve the isolation of brain capillaries by homogenization and filtration of the tissue. Incubation with a nutrient medium encourages the endothelial cells to migrate out of the capillaries and proliferate. After some days in culture, many cells are generated. These can then be trypsinized off the culture dish and transferred to special filters for culture where the apical chamber is separated from the basolateral, thus mimicking the separation of brain and blood environments. Once a confluent monolayer of cells has been generated, the development of tight junctions can easily be measured by determining transcellular electrical resistance. A variety of experiments can then be performed.

### The Blood-brain Barrier in Disease Multiple Sclerosis

The BBB also plays a role in pathology, especially as relates to CNS inflammation [8]. ►Multiple sclerosis (MS) is a devastating neurological disease of the CNS, which develops when the body's immune system apparently attacks the myelin sheath which wraps axons of neurons in the brain and spinal cord (autoimmune hypothesis). Demyelination results in decreased efficiency of saltatory conductance of nerve impulses to and from the CNS. This in turn manifests itself in a variety of symptoms from blurred vision to complete paralysis of one or more limbs. The pathological hallmark of MS, the MS plaque, is a clearly defined region of demyelinated axons interspersed with a network of astrocyte scar tissue, giving the lesion a shiny or "sclerotic" appearance at post mortem. Historically, the CNS was considered an immune privileged organ, but now it is realized that a degree of immune surveillance does occur in the normal brain without causing inflammation. In this process, lymphocytes have to bind to brain endothelial cells and cross the BBB to migrate in to the CNS. Adhesion molecules on lymphocytes and endothelium enable a passing T-cell to bind, initially loosely, and roll along the endothelium. Firmer adhesion results in the T-cell finally stopping close to the endothelial tight junction. Engagement of lymphocyte and endothelium activates a series of signaling events, which culminates in transmigration of the leukocyte. In MS, the T-cell becomes activated and



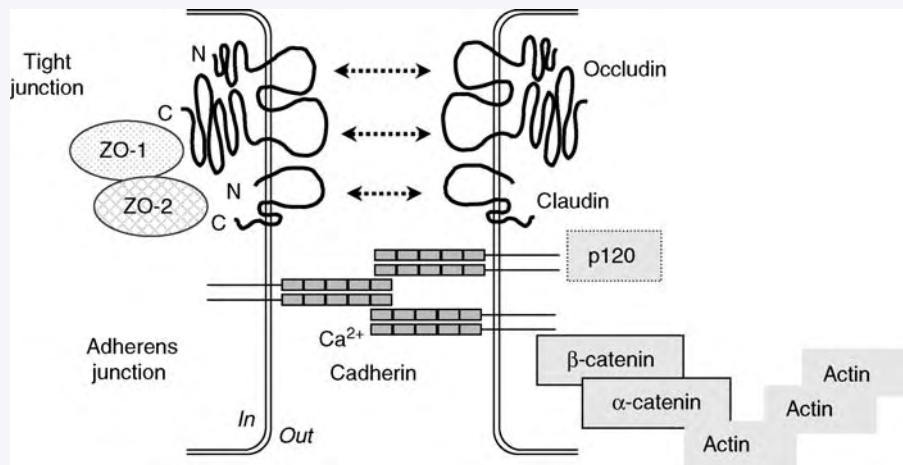

**Blood-Brain Barrier. Figure 2** Overview of some of the proteins involved in tight junction formation in the blood-brain barrier. Occludin and claudin are localized to tight junctions. These integral membrane proteins span the plasma membrane four times, and their cytoplasmic domains interact with peripheral tight junction proteins such as ZO-1 (zonula occludens-1) and ZO-2). The extracellular loops are believed to mediate adhesive interaction with protein on the neighboring cell. The claudin family has many members. Cadherins are responsible for calcium-dependent adhesion between adjacent endothelial cells and are localized to adherens junctions. These transmembrane proteins are made up of repeats that create calcium binding sites in the protein. The binding of calcium alters the conformation of the protein, rendering it adhesion-competent with neighboring molecules. The cytoplasmic tail of cadherin is linked to the actin-based cytoskeleton via  $\beta$ - and  $\alpha$ -catenins. p120, another catenin, may play a regulatory role.

a variety of inflammatory cytokines are released which further up-regulate the expression of additional adhesion molecules in the brain endothelial cells. The BBB becomes more adhesive for blood borne T-cells and macrophages, which are further enticed into the CNS by a gradient of chemokines and cytokines. Trafficking and activation of lymphocytes compromises the BBB further, allowing the ingress of plasma from blood to brain, causing edema, which also interferes with nerve impulse conduction. Dysregulation of the BBB is the earliest detectable event in the evolution of inflammatory demyelinating lesions that characterize MS. Clinically, extravasation of the MRI imaging agent gadolinium from the cerebro-spinal vasculature, is used as a paraclinical marker to diagnose and monitor disease progress and to assess efficacy of therapeutic agents in MS. Thus, in early relapsing-remitting and secondary progressive multiple sclerosis, where around ten new or enhancing lesions are detected for each clinical relapse, interferon- $\beta$  has been reported to block BBB leakage and gadolinium enhancement within 2 weeks. The BBB itself is a potential therapeutic target in MS in that humanized anti-adhesion molecule antibodies have shown promise in clinical trials of MS.

### Stroke and Head Trauma

Strokes can be either infarct or hemorrhagic in origin. Strokes due to infarct involve the blockage of the large cerebral arteries and starvation of brain tissue of oxygen and glucose. Hemorrhagic strokes are the result of

ruptures of the blood vessels and the leakage of blood into brain tissue. Inflammatory mediators are believed to cause the increases in BBB permeability that develop as the pathology of stroke develops. These include matrix metalloproteases, free radicals and **vascular endothelial growth factor (VEGF)**. The current definitions of brain edema are based upon Klatzo's classifications into cytotoxic or vasogenic. An increase in brain water content, known as vasogenic edema, is due to influx of protein from the vasculature. Normally, the interstitial protein content of brain is about 100 times less than that of plasma. Cytotoxic edema is also a problem in stroke. This involves a failure of ion pumps in neurons and glia and cell swelling can ensue. Understanding and managing edema in stroke and head trauma is a major cause of clinical concern [9,10].

### Brain Tumor

In brain tumors, e.g. gliomas and neuroblastomas, the usual features of the BBB are lost and the endothelium lining the capillaries supplying the tumor adopts a more peripheral phenotype [9]. The capillaries become leaky due to poorly developed tight junctions and increased fenestration. The basis of these differences is not clear but probably relates to the more hypoxic environment and VEGF. Also, the normal astrocytic influence may be lost or subverted. In both stroke and brain tumor, the edema can displace normal brain tissue resulting in pressure on areas of the brain that regulate vital functions. As a result, it is important to treat the causes of brain

edema. Corticosteroids are the mainstay treatment of tumor but side effects have to be carefully monitored. Osmotherapy (administration of hyperosmotic agents via the carotid artery) and surgery may be used in emergency situations. Novel and safer therapies continue to be sought and evaluated.

### Other Pathologies

Neurological disorders such as Alzheimer's disease or HIV-induced dementia alter the integrity of the BBB. Inflammatory stimuli, free radicals or toxic proteins (e.g. TNF- $\alpha$ , superoxide anions,  $\beta$ -amyloid) produced during the course of the disease can cause the loss of tight junction proteins and BBB breakdown [9].

### References

1. Reese TS, Karnovsky MJ (1967) Fine structural localization of a blood-brain barrier to exogenous peroxidase. *J Cell Biol* 34:207–217
2. Brightman MW, Reese TS (1969) Junctions between intimately apposed cell membranes in the vertebrate brain. *J Cell Biol* 40:648–677
3. Lin JH (2004) How significant is the role of P-glycoprotein in drug absorption and brain uptake? *Drugs Today* 40:5–22
4. Stewart PA, Wiley MJ (1981) Developing nervous tissue induces formation of blood-brain barrier characteristics in invading endothelial cells: a study using quail – chick transplantation chimeras. *Dev Biol* 84:183–192
5. Rubin LL, Staddon JM (1999) The cell biology of the blood-brain barrier. *Annu Rev Neurosci* 22:11–28
6. Nitta T, Hata M, Gotoh S, Seo Y, Sasaki H, Hashimoto N, Furuse M, Tsukita S (2003) Size-selective loosening of the blood-brain barrier in claudin-5-deficient mice. *J Cell Biol* 161:653–660
7. Yap AS, Bricher WM, Gumbiner BM (1997) Molecular and functional analysis of cadherin-based adherens junctions. *Annu Rev Cell Dev Biol* 13:119–146
8. Minagar A, Alexander JS (2003) Blood-brain barrier disruption in multiple sclerosis. *Mult Scler* 9:540–549
9. Ballabh P, Braun A, Nedergaard M (2004) The blood-brain barrier: an overview: structure, regulation, and clinical implications. *Neurobiol Dis* 16:1–13
10. Rosenberg GA (1999) Ischemic brain edema. *Prog Cardiovasc Dis* 42:209–216

## Blunt-ends (DNA)

### Definition

A blunt-end DNA double helix terminates in a base pair.

► Serial Analysis of Gene Expression

## Bmal

### Definition

Brain Muscle ARNT-Like is a protein that forms an essential component of the molecular circadian clock machinery. A member of the PAS-domain family, this protein is stimulated by retinoic acid-related orphan nuclear receptor  $\alpha$  (ROR $\alpha$ ) and repressed by REVERB $\alpha$  to resulting in a circadian periodicity in its expression. Together with CLOCK, it forms the positive arm of the primary feedback loop that regulates molecular circadian rhythmicity in mammals. It forms heterodimers with CLOCK that bind to E-boxes in to drive transcription from the Period, Cryptochrome and Timeless loci. It is the mammalian ortholog of the *Drosophila* Cycle gene.

► Circadian Rhythm

► Clock

## BMP Signaling and Synaptic Development

PEJMUH HAGHIGHI

Department of Physiology, McGill University, Montreal, QC, Canada

### Synonyms

SMAD Signaling; TGF- $\beta$ ; Signaling

### Definition

Bone morphogenic proteins (BMPs) are members of the transforming growth factor beta (TGF- $\beta$ ) superfamily of secreted polypeptide growth factors. These proteins regulate a wide variety of developmental processes including cell proliferation, differentiation, cell fate specification, tissue patterning and apoptosis [1,2]. Multiple functions and molecular components of BMP signaling are evolutionarily conserved across many species from fly to human. Canonical BMP signaling begins by binding of secreted BMP ►ligands to cell surface receptors followed by activation of intracellular ►SMAD transcription factors and culminates in transcriptional regulation of target genes. Recently, genetic and functional experiments have uncovered a key role for BMP signaling in the regulation of synaptic growth and plasticity.

## Characteristics

### SMAD-Dependent BMP/TGF- $\beta$ Signaling

BMPs/TGF- $\beta$  ligands signal through two transmembrane serine/threonine **▶kinases** known as the type I and type II receptors (Fig. 1). Upon ligand binding, type I and type II receptors form a heterotetrameric complex allowing for phosphorylation of the type I receptor by the type II receptor (Fig. 1).

The Phosphorylated type I receptor, now activated, interacts with and phosphorylates intracellular proteins known as receptor-regulated SMADs (R-SMADs). Phosphorylation of R-SMADs is followed by their co-assembly with the common partner known as the Co-SMAD and the subsequent translocation of the phospho-R-SMAD/Co-SMAD complex to the nucleus. The presence of phosphorylated R-SMADs in the nucleus is commonly used as an index for the activation of BMP/TGF- $\beta$  signaling. Once in the nucleus, this complex, together with other cofactors, can either activate or repress gene transcription depending on the cellular context. The human genome encodes eight SMAD proteins, 42 BMP/TGF- $\beta$  ligands and 12 receptors [1]. This diversity of signaling molecules portrays the complexity and specificity of this signal transduction pathway.

### Function of BMP Signaling in Synaptic Growth and Plasticity

Emerging data suggest that **▶retrograde signaling** from postsynaptic target cells to the presynaptic neurons plays a crucial role in the regulation of appropriate synaptic growth and **▶plasticity**. While many lines of evidence have suggested the presence of retrograde signaling at synapses, the identity of such signals has been elusive. Recent experimental data have demonstrated that BMPs can act as retrograde signals at the synapse [3–5]. This discovery has relied largely on powerful genetic approaches in the fruit fly *Drosophila melanogaster*. In particular, the *Drosophila* neuromuscular junction (NMJ) synapses have provided an ideal model synapse for studying retrograde BMP signaling. During *Drosophila* larval development NMJ synapses sprout new branches and add new **▶synaptic boutons** as the muscles grow; in the few days following the emergence of the larva to its final maturation, the number of synaptic boutons increases several fold to keep up with the rapidly growing postsynaptic muscles. This **▶homeostatic** synaptic growth is tightly regulated and highly stereotypical, suggesting that a signal from the growing muscle back to the presynaptic neuron is most likely involved in coordinating synaptic growth. The first step in validating this model was achieved through a large-scale **▶forward genetic** screen for genes involved in synaptic growth. This screen identified mutations in the type II BMP receptor Wishful thinking (Wit) that led to a drastic reduction in synaptic span and

in the number of synaptic boutons [3]. These results suggested that BMP signaling is likely involved in the regulation of synaptic development. A series of subsequent experiments demonstrated that BMP signaling indeed regulates synaptic development, and that the signaling cascade is initiated in the postsynaptic muscles with the release of BMP ligands, followed by their interaction with BMP receptors present on presynaptic nerve terminals [3,4].

### Retrograde BMP Cascade

The key finding in support of the involvement of BMP signaling in the retrograde control of synaptic growth came with the discovery that the BMP ligand glass bottom boat (Gbb), secreted by postsynaptic muscles, can interact with the type II receptor Wit on presynaptic motor neurons [4]. In addition to Gbb and Wit, several other members of the BMP signaling pathway were also identified to function in presynaptic neurons at the fly NMJ. These include the type I receptors Thickveins (Tkv) and Saxophone (Sax), the R-SMAD, Mad, and the Co-SMAD, Medea (Fig. 1). Mutations in all these signaling molecules result in abnormally reduced numbers of synaptic boutons with defective ultrastructure and reduced neurotransmitter release [3–5]. The synaptic defects associated with mutant receptors and transcription factors are restored by providing them in presynaptic neurons, while synaptic structural defects in *gbb* mutants are restored by providing Gbb exclusively in postsynaptic muscles [4]. In addition, phosphorylated Mad (p-Mad), used as an indicator of active BMP signaling, disappears from the nuclei of motor neurons when retrograde axonal transport is inhibited, further indicating that the BMP signaling acts in a retrograde fashion [4]. These results provide conclusive genetic and functional evidence that retrograde BMP signaling is required for normal synaptic growth. Furthermore, these results suggest that the regulation of gene transcription may play an important role in ensuring normal synaptic growth.

### Negative Regulation of BMP Signaling

BMP signaling can be negatively regulated at different stages of the signaling pathway [1,2]. BMP antagonists such as noggin and chordin act at the level of ligand/receptor. These antagonists inhibit BMP signaling by binding to BMP ligands and preventing them from interacting with their receptors. Secondly, BMP signaling can be modulated at the level of SMAD/receptor interaction via inhibitory SMADs. Among other mechanisms, inhibitory SMADs attenuate the signal by competing with R-SMADs for binding with the receptor. While inhibitory SMADs have been shown to negatively regulate BMP signaling in several tissues, their role in controlling synaptic growth and plasticity remain unclear. Thirdly, BMP signaling can be negatively regulated by

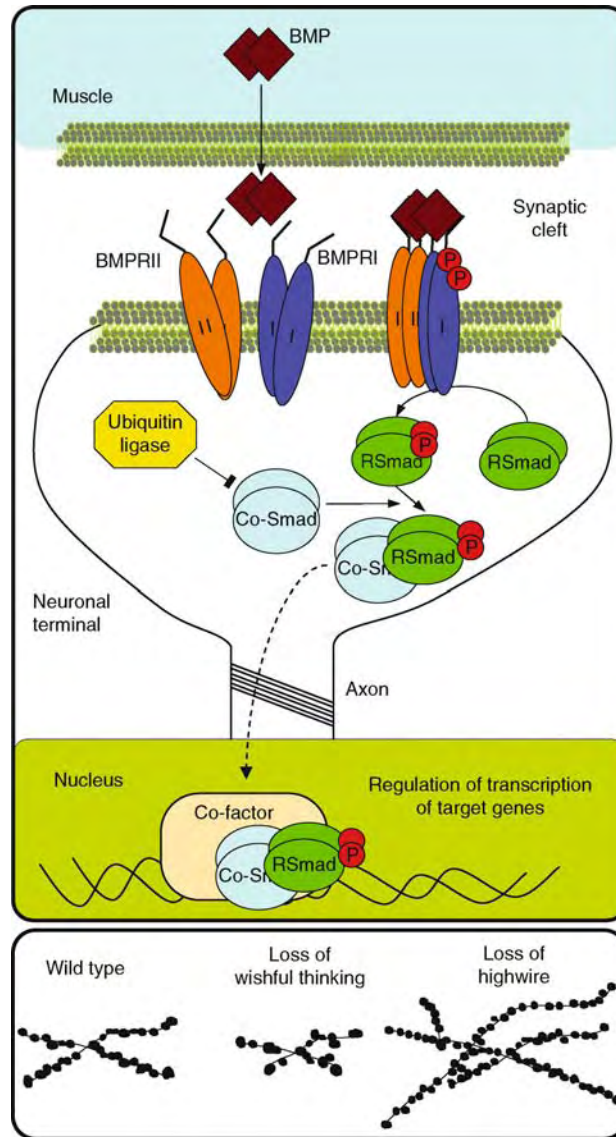

**BMP Signaling and Synaptic Development. Figure 1** A model for retrograde BMP signaling pathway at *Drosophila* neuromuscular junction synapses. *Upper Box:* The BMP ligand is released from the muscle and binds its receptors on the presynaptic terminal of the motor neuron. Upon binding to the ligand the BMP receptors type I (BMPRI) and type II (BMPRII) come together and this allows the phosphorylation of BMPRI by BMPRII. Once BMPRI is phosphorylated it becomes an active kinase; it can then interact with and phosphorylate intracellular receptor-regulated Smad proteins (R-Smad). The phosphorylated R-Smad forms a complex with its partner Co-Smad and translocates to the nucleus of the motor neuron via retrograde axonal transport (*broken arrow*). Once in the nucleus, this complex can interact with other co-factors and regulate gene transcription. The ubiquitin ligase Highwire negatively regulates this signaling pathway via its interaction with the Co-Smad. The following members of the signaling pathway have been identified to function in this cascade: Ligand: Glass bottom boat; BMPRI: Saxophone and Thickveins; BMPRII: Wishful thinking; R-Smad: Mad; Co-Smad: Medea. This model is based on references 3–5. See text for more detail. *Lower Box:* A graphic representation of neuromuscular junction synapses in *Drosophila* larvae from wild type, BMPRII *wishful* mutants and E3 ubiquitin ligase *highwire* mutants. Normal synaptic growth is achieved when the growth promoting effect of BMP signaling is balanced by the negative regulatory action of Highwire. In mutants of *wishful* thinking, synapses do not grow to wild type levels; both synaptic span and the number of synaptic boutons are reduced. In contrast, when the inhibitory action of Highwire is removed, synapses show a drastic overgrowth. Synaptic span, numbers of synaptic branches as well as numbers of synaptic boutons are greatly increased in Highwire mutants.

►ubiquitination of SMADs and their subsequent degradation by the proteasome [1]. Experimental findings suggest that the latter is a likely mechanism for controlling BMP signaling at synapses [5].

As discussed above, loss of BMP signaling at the synapse leads to underdevelopment of synapses, suggesting that over activation of BMP signaling at the synapse should cause an increase in synaptic growth. Surprisingly, however, increase in BMP signaling does not cause any additional growth of the NMJ synapses. The explanation for this apparent dichotomy came from studies on another synaptic gene, *hiwire* (*hiw*). In contrast to BMP mutants, *hiw* mutants develop expanded synaptic structures with more boutons, higher ordered branches and a greater synaptic span compared to wild type larvae, indicating that *Hiw* is a negative regulator of synaptic growth [6]. *Hiw* is a large intracellular protein containing among other motifs a C-terminal RING-H2 zinc finger domain, shared by a large family of E3 ubiquitin ligases. Interestingly, a protein–protein interaction screen identified a specific interaction between *Hiw* and the Co-SMAD *Medea* [5]. This presented an exciting possibility for a functional link between *Hiw* and BMP signaling at the NMJ. Based on the physical interaction data and the opposite phenotypes of BMP signaling pathway mutants and *hiw* mutants, a simple model emerges where BMP signaling is normally under the control of *Hiw*, and thus in the absence of *Hiw*, excess BMP signaling leads to synaptic overgrowth (Fig. 1). If this model is correct, then disrupting BMP signaling should suppress the synaptic overgrowth in *hiw* mutants. Genetic interaction experiments supported this model: genetic removal of BMP signaling members completely suppressed the synaptic overgrowth in *hiw* mutants. This model was further supported experimentally with the demonstration that in the absence of *Hiw*, activation of BMP signaling was able to increase the synaptic span and the number of boutons [5]. These results support a model in which *Hiw* controls the level of BMP signaling at the synapse to regulate the extent of synaptic growth, revealing a balance between positive growth promoting BMP signaling and negative regulation by *Hiw* (Fig. 1).

### Retrograde BMP Signaling Beyond Synaptic Growth at the NMJ

Considering the complexity and versatility of BMP/TGF- $\beta$  signaling molecules, it isn't surprising that retrograde BMP/TGF- $\beta$  signaling plays other roles in nervous system development beyond the retrograde control of ►synaptic plasticity at the NMJ. One such example is the action of retrograde BMP signaling at *Drosophila* central synapses between motoneurons and cholinergic interneurons. Here again, the ligand *Gbb* is responsible for the initiation of a retrograde signaling cascade that is required for the regulation of

neurotransmitter release at these synapses [7]. Another example for the involvement of retrograde BMP signaling has been described in *Drosophila* peptidergic neurons [8,9]. The neuropeptide *FMRFamide* is normally expressed by a subset of peptidergic neurons known as *Tv* neurons. *Tv* neurons express *FMRFamide* only after they have innervated their target glands, suggesting that a target driven factor may be involved in initiating the expression of *FMRFamide* in these neurons. Interestingly, the BMP ligand *Gbb*, released by the target glands, was identified to be the retrograde agent that turns on a retrograde BMP cascade in *Tv* neurons. Unlike what is observed at the NMJ, loss of *Gbb* in *Tv* neurons does not affect the morphology of the presynaptic terminals; however, it leads to a loss of *FMRFamide* expression in these neurons. Additional experiments have demonstrated that in order for *Tv* neurons to produce *FMRFamide*, activated SMADs require two additional transcription factors to be present [9]. Furthermore, expression of this ►combinatorial transcription factor code together with activation of SMADs is sufficient to cause expression of *FMRFamide* in additional peptidergic neurons where it is not expressed normally. These results reveal another level of complexity whereby BMP signaling can specifically modulate target gene expression depending on the presence of other co-factors and the cellular context.

### BMP Signaling and Higher Brain Functions

The role of BMP signaling during embryonic nervous system development in vertebrates is well documented [2]. BMP signaling is involved at different stages of neuronal development and different regions of the central nervous system regulating a range of processes including neuronal specialization, proliferation and patterning [2]. Characterization of the role of BMP/SMAD signaling in synaptic growth and plasticity in vertebrate systems has been more complicated partly due to the versatility of BMP signaling molecules and partly because of the practical difficulties in performing complex genetic analyses in experimental animals such as mice. Nevertheless, accumulating evidence suggests that BMP/TGF- $\beta$  signaling may play a role in the regulation of synaptic plasticity in the vertebrate central nervous system. The most recent evidence for involvement of BMP signaling in higher brain functions is based on the characterization of *chordin* mutant mice [10]. Loss of *chordin* leads to defects in neurotransmitter release and abnormalities in the establishment of short-term and long-term synaptic plasticity in hippocampal preparations. In addition, these mice show altered cognitive functions including changes in their learning skills. Interestingly, in hippocampal preparations from wild type mice application of a specific BMP ligand is capable of mimicking the abnormalities seen in hippocampal preparations from *chordin* mutant

mice, suggesting that BMP signaling can regulate synaptic plasticity and influence higher brain functions.

## References

1. Massagué J, Seoane J, Wotton D (2005) Smad transcription factors. *Genes Dev* 19:2783–2810
2. Liu A, Niswander LA (2005) Bone morphogenetic protein signaling and vertebrate nervous system development. *Nature Neurosci Rev* 6:945–954
3. Aberle H, Haghighi AP, Fetter RD, McCabe BD, Magalhães TR, Goodman CS (2002) Wishful thinking encodes a BMP type II receptor that regulates synaptic growth in *Drosophila*. Marqués G, Bao H, Haerry TE, Shimell MJ, Duchek P, Zhang B, O'Connor MB (2002) The *Drosophila* BMP type II receptor wishful thinking regulates neuromuscular synapse morphology and function. *Neuron* 33:529–543; 33:545–558
4. McCabe BD, Marqués G, Haghighi AP, Fetter RD, Crotty ML, Haerry TE, Goodman CS, O'Connor MB (2003) The BMP homologue Gbb provides a retrograde signal that regulates synaptic growth at the *Drosophila* neuromuscular junction. *Neuron* 39:241–254
5. McCabe BD, Hom S, Aberle H, Fetter RD, Marqués G, Haerry TE, Wan H, O'Connor MB, Goodman CS, Haghighi AP (2004) Highwire regulates presynaptic BMP signaling essential for synaptic growth. *Neuron* 41:891–905
6. Wan HI, DiAntonio A, Fetter RD, Bergstrom K, Strauss R, Goodman CS (2000) Highwire regulates synaptic growth in *Drosophila*. *Neuron* 26:313–329
7. Baines R (2004) Synaptic strengthening mediated by bone morphogenetic protein-dependent retrograde signaling in the *Drosophila* CNS. *J Neurosci* 24:6904–6911
8. Marqués G, Haerry TE, Crotty ML, Xue M, Zhang B, O'Connor MB (2003) Retrograde Gbb signaling through the BMP type II receptor wishful thinking regulates systemic FMRFa expression in *Drosophila*. *Development* 130:5457–5470
9. Allan D, St. Pierre S, Miguel-Aliage I, Thor S (2003) Specification of neuropeptide cell identity by the integration of retrograde BMP signaling and a combinatorial transcription factor code. *Cell* 113:73–86
10. Sun M, Thomas MJ, Herder R, Bofenkamp ML, Selleck SB, O'Connor MB (In Press) Presynaptic contribution of chordin to hippocampal plasticity and spatial learning. *J Neurosci*

## Bodily Self

### Definition

The non-conceptual processing and body-related representation that underlies self-consciousness.

► Action Representation

## Body-centered Coordinates

### Definition

► Visual Space Representation for Reaching  
Also Visual space representation for reaching.

## Body Fluid Loss

### Definition

Body fluid becomes reduced to compensate for headward fluid shift depending on neurohumoral fluid regulation under conditions of microgravity in space and also under simulated microgravity, as with head-down bed rest.

## Body Force

### Definition

External force per unit volume.

► Mechanics

## Body Mass Index (BMI)

### Definition

A measure of the weight of a person scaled according to height, i.e. body weight/(body height)<sup>2</sup>.

► Neuroendocrinology of Psychiatric Disorders

## Body Plan

MICHIO YOSHIDA, KENJI SHIMAMURA  
Division of Morphogenesis, Institute of Molecular Embryology and Genetics, Kumamoto University, Kumamoto, Japan

### Definition

The body plan describes the overall organization of an organism, for example the position of head and tail and

the plane of bilateral symmetry, where it exists [1]. The plan is mainly composed of the definition of body axes and the allocation of each organ into the body. Each organ of most animals is organized around two main axes, the anterior–posterior (A/P) axis and the dorsal–ventral (D/V) axis. The A/P axis is the line extending from head to tail. The D/V axis is the line extending from back (dorsum) to belly (ventrum). These two axes are almost always at right angles to one another. The A/P and D/V axes also define the left and right sides of the animal. The line running between left and right which always crosses at right angles to the other axes, is defined as the left–right (L/R) axis. These axes make up a coordinate system for the allocation of each organ.

Most animals have three germ layers, distinct regions of the embryo that give rise to the specific organs. The ectoderm constitutes the outer layer of the embryo and produces the epidermis, brain and nervous system. The endoderm becomes the innermost layer of the embryo and gives rise to the epithelia of the digestive tube and its associated organs. The mesoderm is located between the ectoderm and endoderm and generates the blood, heart, kidney, gonads, bone, muscles and connective tissues.

## Characteristics

### Higher Level Structures

#### *The Body Plan of the Vertebrate*

The vertebrates share a common body plan. The basic plan is that the head is at the anterior end of the A/P axis, followed by the trunk and terminating in a post-anal tail. Along the D/V axis, the nervous system takes the most dorsal position above the notochord, flanked by bilateral somites and the alimentary structure including the gut takes the most ventral location.

The vertebrate body is bilaterally symmetrical outwardly, but deposition of the internal organs in the body cavities is organized asymmetrically with respect to the longitudinal axis. The lung has three lobes on the right side and two lobes on the left, the apex of heart points to the left side, the liver is formed on the right side and stomach and spleen are on the left side in the thoracic cavity. The gut coils counterclockwise in the abdominal cavity. This asymmetric deposition along the L/R axis, called *situs solitus*, is a distinctive feature of the vertebrate body plan.

### Higher Level Processes

#### *The Establishment of the Vertebrate Body Plan*

The basic body plan is established through the processes of gastrulation. Before gastrulation, the A/P, D/V and L/R axes are set up in the embryo by various strategies, which differ among the vertebrates probably in part depending on the amount of yolk in the egg. At the same time, three germ layers are specified in particular regions of the embryo with respect to these

axes. These initial processes define the position of the organizer.

The organizer is a signaling center that emits a variety of signaling molecules to direct the pattern formation of the prespecified mesoderm and ectoderm along the A/P and D/V axes. The organizer is initially found in the dorsal blastopore lip of amphibians. This region, the so-called Spemann's organizer, has the activity to induce an entire secondary embryo when transplanted into the ventral side of another embryo. Similar developmental and molecular properties have also been identified in the shield in the fish, Hensen's node in the chick and the node in the mouse.

The organizer also has the ability to initiate the movement of gastrulation. A primary role of gastrulation is germ layer rearrangement. The mesoderm and endoderm are initially specified and patterned on the surface layer of the blastula embryo. Gastrulation leads to internalization of these layers in the embryo. In the frog and fish, the sheet of future endoderm and mesoderm involutes sequentially into the interior of the embryo through the dorsal blastopore lip. In the mouse, the epiblast moves toward the primitive streak where it undergoes epithelial–mesenchymal transition and give rise to the mesoderm and endoderm. Subsequently they ingress between the epiblast and primitive endoderm; the endoderm displaces the primitive endoderm and the mesoderm forms a layer between the ectoderm and endoderm. Gastrulation further involves the convergence and extension of all three germ layers along the A/P axis, while the ectoderm also spreads to cover whole embryo by a process known as epiboly. Consequently, the precursor cells for each organ become located in their proper positions in relation to the overall body plan of the animal.

The fate for each organ is established through the processes of gastrulation. Tissue transplantation experiments using amphibian embryos have indicated that at the neurula stage the regions of the embryo that will form limbs, eyes, heart and other organs have become determined. During the morphogenetic movement in gastrulation, cells of each organ primordium encounter a new environment, where new cell–cell interactions probably lead to determination of the cell fates according to the body plan. Cells in each germ layer express a specific set of transcription factors, Hox factors in particular, depending on positional information along the A/P axis. The combinatorial expression of homeodomain transcription factors confers the positional identities along the A/P axis and activates the specific program for region-specific differentiation and morphogenesis.

#### *Determination of Left–Right Asymmetry*

Although the asymmetric features become obvious macroscopically from the mid or late gestation stage, it

is considered that the process generating left–right asymmetry has already started in the early embryo. The process for establishment of left–right asymmetry can be subdivided into three steps. The first step is the breaking of symmetry. Conceptually, to achieve consistent L/R asymmetric features along the body plan, the L/R axis must be oriented with respect to the A/P and D/V axes. Although the timing of the first step of L/R asymmetry is still being debated, the general expression pattern of asymmetric genes suggests that the node is the most likely site for the initial symmetry-breaking event responsible for specifying the orientation of the L/R axis. At the end of this process, the asymmetric pattern of gene expressions or protein distributions has been established in the small region around the organizer. This initial information of local asymmetries is transmitted onto much broader regions of the embryo in the next step. The process is carried out by inductive and repressive interactions between asymmetrically expressed genes; however the patterns of gene expression involved in this mechanism appear to differ somewhat among species. In the final step, side-specific information transmitted onto the lateral plate mesoderm (LPM) activates the programs that regulate differential cell proliferation, adhesion and/or cell migration in the LPM and its derivatives, leading to asymmetric organ morphogenesis.

### Process Regulation

#### *Establishment of the Vertebrate Body Plan*

##### **Specification of the Body Axes**

The strategies for specifying the A/P and D/V axes are varied among the vertebrates. For example, in the frog, differential distributions of maternally provided mRNA specify the animal–vegetal axis in the unfertilized egg and this axis relates to the A/P axis of the tadpole. The D/V axis and the plane of bilateral symmetry are determined by the site of sperm entry at fertilization. In the frog, specification of the organizer sets the initial D/V polarity. After fertilization, the plasma membrane and cortex rotate about 30° toward the site of sperm entry. This cortical rotation leads to interaction between the shifted cortex and the cytoplasm around the equator on the opposite side to the sperm entry site, which subsequently induces the activity of Spemann’s organizer in this region [2].

The mouse blastocyst is a hollow sphere of epithelium containing the inner cell mass (ICM) attached at one side. The outer epithelia give rise to the extraembryonic structures and the embryo proper develops only from the cells of the ICM. Thus, the placement of the ICM defines the embryonic–abembryonic axis. In a geometrical sense, this axis in the blastocyst corresponds to the D/V axis of the embryo proper. A recent cell-tracing study has proposed that the point of sperm entry appears to be related to this axis [3]. The point of sperm entry

predicts the plane of the first cleavage and the first cleavage plane defines the border between the embryonic and abembryonic halves of the future blastocyst.

The A/P axis in the mouse is specified by anterior migration of the visceral endoderm [4]. The embryo at the pre-streak stage is organized along the proximal–distal axis; the epiblast originated from the ICM becomes a cup shape. The extraembryonic ectoderm positions proximal to the epiblast and the visceral endoderm covers the distal surface of the epiblast. Before gastrulation, the distal tip of the visceral endoderm is specified as the anterior visceral endoderm (AVE), which subsequently moves towards one side of the epiblast. AVE migration defines the underlying proximal epiblast as the anterior ectoderm. In addition, the AVE prevents the anterior ectoderm from induction of the primitive streak. The primitive streak is induced at the other side of the proximal epiblast, opposite to the anterior ectoderm, thereby defining the posterior end of A/P axis.

##### **Specification of the Germ Layers**

In the frog, the yolky vegetal region gives rise to most of the endoderm and the animal hemisphere becomes the ectoderm. Specification of these germ layers is regulated by the maternal factors that distribute differentially along the animal–vegetal axis. In contrast, the mesoderm is induced around the equator between the ectoderm and endoderm by diffusible signals produced from the vegetal region. These signals convert a band of adjacent animal cells from ectodermal to mesodermal fate.

In the mouse, the epiblast forms all germ layers. At the beginning of gastrulation, the posterior end of the epiblast forms the primitive streak, which gives rise to the mesoderm and endoderm while the rest of the epiblast becomes the ectoderm. The endoderm starts to ingress at the early primitive streak stage; mechanisms of its induction are largely unknown. The induction of mesoderm is regulated by both positive and negative signals emanating from surrounding extraembryonic tissues [5]. The initial signal for mesodermal induction appears to originate from the extraembryonic ectoderm, however the molecular nature of this signal is still unknown. The expression of *Nodal* is induced by this signal in the proximal epiblast initially and subsequently expands throughout the epiblast and the visceral endoderm. Once the Nodal signal is transmitted to the visceral endoderm, AVE is established at the distal tip of the visceral endoderm. The AVE secretes Nodal inhibitors, Cerberus-like (*Cerl*) and *Lefty1* and thus restricts the actions of Nodal as well as its expression to the proximal epiblast. The anterior movement of the AVE further keeps this expression restricted to the posterior epiblast. In the posterior epiblast, the Nodal signal induces formation of the primitive streak,



subsequently producing the mesoderm in cooperation with Wnt3 and bone morphogenetic proteins (BMPs). The AVE also secretes the antagonists against Wnts and BMPs. Therefore, the AVE functions in restricting mesoderm induction to the posterior side of the epiblast.

### **Functions of the Organizer in Pattern Formation**

The organizer governs the initial pattern formation along the A/P and D/V axes by secreting several inhibitory molecules against Wnt, BMP and Nodal signals. The mesoderm is divided into a number of subregions along the D/V axis. This patterning is regulated by different concentrations of BMP [2]. In the frog, Nodal-related factors from the vegetal cells initially induce the ventral-type mesoderm and progressively more dorsal mesoderm is induced by lowering the levels of BMP signaling. BMP is expressed in the ventral mesoderm and a high dose of BMP induces the most ventral fate (the blood-forming tissue). The dorsal mesoderm (the organizer) secretes BMP antagonists (Chordin, Noggin, Follistatin), which create a dorsal-high–ventral-low gradient of BMP activities. The intermediate level of BMP signaling induces the mesoderm with intermediate fates (the somite and intermediate mesoderm) between ventral mesoderm and dorsal mesoderm.

The A/P patterning of the ectoderm is thought to be regulated by the regionally specific induction of the organizer derivatives [6]. The organizer is not a homogenous tissue; cells originated from the organizer acquire different fates and inductive properties while they migrate during gastrulation. In the frog, the prechordal mesoderm cells are among the first to gastrulate, being fated to the foregut and head mesenchyme and have head inducing activity. The chordamesodermal cells are next to involute, giving rise to the notochord and have trunk-inducing activity. In the case of the mouse, the node is not capable of inducing anterior structures in a secondary embryo when transplanted ectopically. The AVE seems to be necessary for induction of the anterior structures in the addition to the node [4]. Although the AVE itself does not have any inductive activity as the organizer, an AVE graft together with the node is able to induce expression of the anterior neuroectoderm markers.

In molecular terms, inhibitions of Wnt and BMP signals are required for the formation of regionally divergent structures. In the frog, inhibition of BMP, Wnt and also Nodal signaling is necessary to complete the anterior head structures. The prechordal mesoderm expresses secreted BMP antagonists (Noggin and Follistatin), the Wnt antagonist (Dkk1) and the multifunctional antagonist Cerberus. BMP inhibition alone induces only the trunk structure. Indeed the chordamesoderm expresses only BMP antagonists (Noggin, Chordin, and Follistatin). The requirement of Wnt and

BMP inhibitions for induction of the anterior structures has been confirmed by genetic evidence in mice; mice deficient in *Dkk1* or lacking *Noggin* and *Chordin* activities fail to form the anterior head structures. BMPs expressed in the ventral ectoderm are required for the epidermal fate and *Wnts* expressed by the caudal tissue are necessary to transform the anterior neuroectoderm into that with more posterior characters. The anterior head structures are therefore induced by preventing the ectoderm from becoming the epidermis by the BMP signal and from being posteriorized by the Wnt signal.

### **Determination of Left–Right Asymmetry**

#### **Breaking Symmetry**

Although several molecular or cellular mechanisms for breaking symmetry have been proposed in different model animals, there is little empirical evidence about the symmetry-breaking event. Moreover, many questions as to which mechanism is first to operate, whether these mechanisms are conserved among the vertebrates and whether each mechanism is mutually exclusive remain unanswered [7].

In the mouse, experimental and genetic evidence has indicated that leftward liquid flow on the ventral surface of the node, called the nodal flow, functions as the initial event in the formation of the L/R axis [8]. The ventral node of the mouse is a small triangular pit, composed of motile monociliated cells. The cilia on the nodal pit cells rotate clockwise with the axis tilted posteriorly. This vortical rotation movement of the cilia generates leftward flow of the extraembryonic fluid in the nodal pit and results in accumulation of the extracellular signals (Sonic hedgehog (Shh) and retinoic acid) to the left side and in initiation of expression of the left side genes such as *Nodal* and *Lefty1*. However, it is still unclear how the directional fluid flow triggers the cascade of gene expression on the left side. In an alternative hypothesis (two-cilia hypothesis) [9], the node contains two distinct classes of primary cilia; the nodal flow generated by motile cilia produces differential fluid pressures at the left and right sides of the node, leading to asymmetric stimulation of the immotile mechanosensory cilia. These mechanosensory cilia initiate a calcium-mediated signal transduction event that leads to specification of the left characteristics. While the nodal cilia exist in several vertebrate species, whether this mechanism is conserved and is a truly initial mechanism for symmetry breaking remains to be elucidated.

#### **Transmission of L/R Positional Information from the Organizer Region to the LPM**

In this process, Nodal is a key player for transmitting information to the LPM. *Nodal* expression is detected in the perinodal region on the left side of the embryo and is subsequently propagated in the LPM on the left side

of the embryo. This left-sided expression of *Nodal* is highly conserved among all the vertebrates examined to date and misexpression of *Nodal* on the right side of the embryo is sufficient to randomize the L/R asymmetry in multiple organs. In chick embryos, *Nodal* expression is induced by Shh expressed on the left side of the node, but this induction is likely to be indirect. Expression of *Nodal* is usually repressed by BMPs bilaterally. Shh relieves the repressive effect of BMP by activating expression of *Caronte*, an antagonist of BMP, on the left side of the perinodal region and the LPM, leading to *Nodal* expression in the left LPM. On the other hand, there are some mechanisms to prevent the left-sided pathway from becoming inappropriately activated on the right side. For examples, the right-sided expression of fibroblast growth factors *Fgf4* and *Fgf8* in the chick Hensen's node blocks *Nodal* expression on the right side. In addition, the midline structures (floor plate and notochord) act as a physical and biochemical barrier inhibiting contralateral diffusion of the asymmetric signals.

### Specific Programs for Asymmetric Morphogenesis

Several molecular clues that are expressed in either side of the LPM and in fact play roles in asymmetric development have been identified, although how asymmetric organ development is controlled at the cellular level remains largely unsolved. Among them, the *bicoid*-type homeodomain transcription factor *Pitx2* is considered to be a conserved factor in the left-specific program among the vertebrates. *Pitx2* acts downstream of the Nodal signal and is expressed in the left LPM. Later, even when the sided expression of *Nodal* is no longer detectable, *Pitx2* continues to be expressed in the left side of several organ primordia including the heart, gut and stomach. Misexpression of *Pitx2* on the right is capable of inducing laterality defects in a variety of vertebrates and *Pitx2*-deficient mice show laterality defects in the lung, suggesting involvement of other factors in the entire left-specific morphogenesis.

### References

1. Gilbert SF (2003) Developmental biology, 7th edn. Sinauer, Sunderland, pp 305–388
2. De Robertis EM, Larrain J, Oelgeschläger M, Wessely O (2000) The establishment of Spemann's organizer and patterning of the vertebrate embryo. *Nat Rev Genet* 1:171–181
3. Piotrowska K, Zernicka-Goetz M (2001) Role for sperm in spatial patterning of the early mouse embryo. *Nature* 409:517–521
4. Beddington RSP, Robertson EJ (1999) Axis development and early asymmetry in mammals. *Cell* 96:195–209
5. Brennan J, Lu CC, Norris DP, Rodriguez TA, Beddington RSP, Robertson EJ (2001) Nodal signaling in the epiblast patterns the early mouse embryo. *Nature* 411:965–969

6. Niehrs C (2004) Regionally specific induction by the Spemann–Mangold organizer. *Nat Rev Genet* 5:425–434
7. Levin M (2005) Left–right asymmetry in embryonic development: a comprehensive review. *Mech Dev* 122:3–25
8. Nonaka S, Tanaka Y, Okada Y, Takeda S, Harada A, Kanai Y, Kido M, Hirokawa N (1998) Randomization of left–right asymmetry due to loss of nodal cilia generating leftward flow of extraembryonic fluid in mice lacking KIF3B motor protein. *Cell* 95:829–837
9. Tabin CJ, Vogan KJ (2003) A two-cilia model for vertebrate left–right axis specification. *Genes Dev* 17:1–6
10. Wolpert L, Beddington R, Jessell T, Lawrence P, Meyerowitz E, Smith J (2002) Principles of development, 2nd edn. Oxford University Press, New York, pp 65–142

## Body Schema

### Definition

► Sensory Systems

## BOLD, Blood Oxygenation Level Dependent

### Definition

The BOLD effect is the endogenous contrast mechanism employed in functional MRI experiments to monitor changes in the absolute concentration of deoxygenated hemoglobin that is related to changes in neuronal activity in the brain. The BOLD contrast mechanism rests upon the fact that deoxy-hemoglobin is paramagnetic, and thus gives rise to local microscopic inhomogeneities in the magnetic field, which can be detected with pertinent MR acquisition schemes.

► Magnetic Resonance Imaging

## Boltzmann Statistics

### Definition

A statistical theory developed by Ludwig Boltzmann, which describes the way molecules behave in gas or fluids.

► Brownian Motions

## Bone

TED S. GROSS, SARAH E. WARNER  
Department of Orthopaedics and Sports Medicine,  
University of Washington, Seattle, WA, USA

### Definition

Bone is a cellular, vascularized, innervated, fluid filled, mineralized, regenerative connective tissue that serves as the primary mineral reservoir, ion reservoir, and load-bearing structure of the body.

### Characteristics

#### Quantitative Description

In the healthy adult, bone is approximately 2/3 mineral and 1/3 organic matrix.

#### Higher Level Structure

At the tissue level, the adult mammalian skeleton's organic and non-organic constituents are organized into either cortical or trabecular bone (Fig. 1).

Cortical bone is dense and compact and predominates in the appendicular skeleton, particularly in the diaphyses of long bones. When viewed in cross-section, cortical bone is organized into cylindrical lamellar sheets that yield the appearance of tree rings. Lamellar bone predominates near the endocortical (internal) and periosteal (exterior) surfaces of long bones. Within the cortex, lamellar bone is organized in smaller cylindrical sheaths surrounding small blood vessels termed Haversian canals. Trabecular (or cancellous) bone comprises of approximately 20% of the total skeleton, and is predominately located within vertebrae and beneath joint surfaces. In these locations, the trabeculae demonstrate a morphology reminiscent of a sponge and are surrounded by a thin cortical shell. Haversian systems are rare within trabeculae. In conditions in which bone must be generated with great speed (e.g. rapid growth or fracture repair), the collagen orientation appears random yielding the term "woven bone."

#### Lower Level Structure

Bone's inorganic mineral consists primarily of calcium and phosphate salts in combination with a number of additional ions (including potassium, chloride, magnesium, and sodium). Nearly all of body calcium (99%) is located in the skeleton [1]. The primary component of bone's organic matrix is Type 1 collagen (85–90%). A variety of collagenous (e.g. Type III collagen) and non-collagenous proteins (e.g. alkaline phosphatase, osteonectin, osteopontin, and osteocalcin) constitute the remainder of the protein content of bone. The organic components of bone are deposited extracellularly and

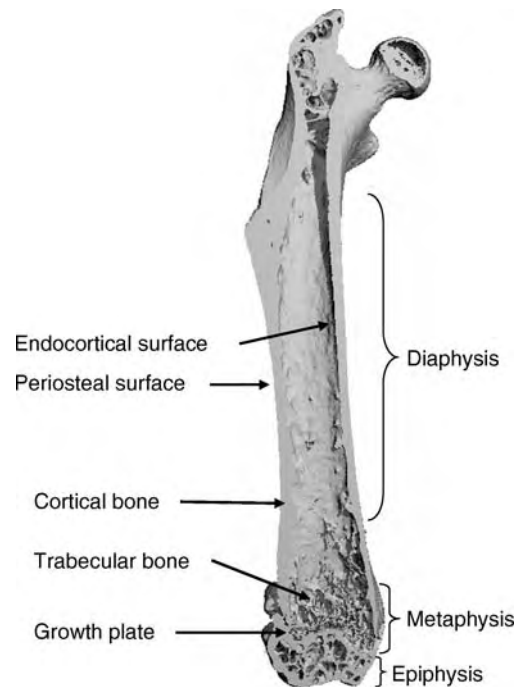

**Bone. Figure 1** A micro-CT image of a mouse femur. Half of the bone is removed to illustrate the endocortical and periosteal surfaces of the diaphysis, to distinguish solid cortical bone from spongy trabecular bone, and to note the metaphysis and epiphysis bracketing the growth plate.

are integral to the process of calcification (i.e. hardening). Specifically, the collagenous matrix provides a framework for the initial deposition of bone mineral in the form of small apatite crystals. During maturation of the matrix, apatite crystals increase in dimension via interaction with extracellular fluids within bone [2].

#### Structural Regulation

The balance between the rigidity of mineral apatite, the flexibility of collagen, and the impurities found within the mineralized matrix define bone's behavior as a composite material. As a structure, bone's primary objective is to avoid failure. To achieve this objective, bone must be able to withstand a wide range of loading challenges, ranging from millions of cycles of loads induced by locomotion (fatigue resistance) to occasional extreme overload conditions such as might occur during an unexpected fall (ultimate strength). Material deformation is expressed by the dimensionless parameter termed strain. While loading induced by locomotion generates strains of 0.2–0.35% (or 2,000–3,500 micro-strain), failure, depending on the type of loading, begins to occur at strains approaching 6,000–8,000 microstrain. The ratio between these measures, or safety factor, is quite consistent across species that

demonstrate well over two orders of magnitude range in body mass [3,4]. The strength of bone is influenced by two factors: material properties and morphology. As a material, the Young's modulus of bone is approximately three times greater than wood and 30% that of aluminum. The stiffness of bone is mediated in large part by its mineral content. Although the mineral content of bone varies substantially across different animals (e.g. deer antler vs. tympanic bulla from a whale), variation within a given individual is more subtle. In contrast, bone morphology varies dramatically within a skeleton. For example, the hollow circular cross-section of long bones provides maximal resistance to bending with minimal material, while the trabeculae between two cortical surfaces in the cranium effectively disperses energy from blunt trauma [5].

### Higher Level Processes

Following embryologic limb patterning, which is mediated via both spatial and temporal expression of a variety of genes, long bone development occurs through a process termed endochondral ossification. Initially, a peanut shaped concentration of mesenchymal cells transitions into cartilage. Subsequent ►osteoclastic erosion and vascular invasion enables the formation of primary (center of the long bone diaphysis) and secondary (growth plate) centers of ossification [6]. The continual transition from cartilage to bone fuels longitudinal and circumferential expansion of long bones through puberty. Continual resorption and formation on interior and exterior bone surfaces serve to sculpt the final morphology of long bones. The development of flat bones occurs through intramembranous ossification. In this pathway, an initial grouping of mesenchymal stem cells is stimulated to transition directly into bone forming cells and bypasses the cartilaginous phase integral to endochondral ossification.

### Lower Level Processes

The three primary bone cells are the ►osteoblast, the osteoclast, and the ►osteocyte. Osteoblasts differentiate from fibroblast precursors when stimulated by a series of growth factors. Osteoblasts are located on both interior and exterior bone surfaces and are responsible for secretion of osteod which, when mineralized, becomes bone matrix. Following cessation of skeletal growth, osteoblasts residing upon bone surfaces transition into quiescent lining cells (i.e. attached to bone surface but not secreting osteod). Activation of lining cells into mature osteoblasts is induced by a variety of stimuli including alterations in circulating and local hormones, steroids, growth factors, and mechanical loading of the skeleton. The osteoclast is a giant multi-nucleated cell of macrophage lineage that is derived from marrow precursors when stimulated by necessary factors. ►Bone resorption occurs when the osteoclast attaches to the

matrix and locally acidifies an extracellular space that precipitates digestion of both the mineral and non-mineral components of bone. The osteocyte is the most populous bone cell, comprising nearly 90% of all bone cells. When osteoblasts are driven to secrete osteod a small percentage (10–15%) become trapped within the mineralizing matrix. During this process, the cells undergo a terminal differentiation and become osteocytes. Osteocytes reside within lacunae and are characterized by dendritic processes extending in all directions within canaliculae. Via canaliculae, cell processes of a given osteocyte form contacts with adjacent osteocytes and bone lining cells that include gap junctions [7]. These junctions serve to enable nutrients and small signaling molecules to pass through the bone. A viable osteocyte population is essential for maintaining healthy bone tissue, as osteocyte death is associated with bone degradation. Although still under investigation, osteocytes are thought to play an essential role in mediating bone ►mechanotransduction and the tissue's adaptive response to altered mechanical loading.

Bone also contains a variety of other cell types. Endothelial and smooth muscle cells populate blood vessels within bone. Bone is highly innervated, particularly the periosteal surface, and neural cells have been identified within bone. Finally, within bone marrow resides an extremely heterogeneous population of stromal cells that serve to enable hematopoiesis. Also, marrow contains stem cells that possess the ability to differentiate into a variety of diverse cell types such as connective tissue cells (muscle, cartilage, bone, and tendon), adipocytes, and vascular cells.

### Function

Integral to bone's ability to succeed as a tissue, is its unique ability to self-renew via a process of coupled resorption and formation termed remodeling. Remodeling is thought to be required for the constant (albeit slow) renewal of osteocytes and bone matrix. During remodeling, osteoclasts are activated, migrate to bone surfaces and remove a volume of bone, which is subsequently replaced by osteoblasts [8]. In healthy young adults, bone resorption and ►bone formation are balanced with little change in overall bone mass.

Bone also possesses a substantial ability to alter both its mass and morphology in response to functional loading of the skeleton. Just as muscle mass is increased by exercise, bone mass is locally augmented by habitual activity [9]. While the mechanotransduction pathway(s) within bone remain elusive, bone is highly responsive to increased physical stimuli such as running and jumping and rapidly diminishes its mass when deprived of these stimuli. Ultimately, homeostasis of the skeleton reflects a dynamic balance between biochemical (growth factors, cytokines, hormones, diet) and mechanical (daily activity) influences upon the skeleton.

## Pathology

Alterations in skeletal morphology are maximal during early puberty. Men tend to achieve greater bone mass than women due to longer periods of skeletal growth. Once peak bone mass is attained in humans during the third decade, both cortical and trabecular bone mass begin to diminish. ► **Osteoporosis** is a clinical condition in which bone mass and morphology have been sufficiently degraded to the point of fracture. As one ages, the normally balanced remodeling process becomes imbalanced with resorption exceeding formation. Age induced bone loss begins near age 40, and has been estimated at 0.3–0.5% per year. Post-menopausal bone loss occurs within the decade following menopause, is directly related to diminished levels of estrogen, and superimposes an additional 2–3% annual bone loss upon normal age related declines in bone mass [10]. Based on these rates of loss, a 70-year-old woman can be expected to have only 55–75% of the bone mass she possessed at 30 years of age. Given the magnitude of this bone loss and the resulting structural degradation, it is easy to understand why the same fall is much more likely to induce a fracture in the elderly than in a young adult. While age induced bone loss affects both trabecular and cortical bone, post-menopausal bone loss is primarily manifested in trabecular bone.

## Therapy

Current strategies to counteract bone loss are focused upon either inhibiting resorption or augmenting formation. With respect to inhibiting resorption, pharmaceutical bisphosphonates have proven to be highly effective. Anabolic stimulation of bone formation is currently being pursued using both pharmaceutical (e.g. Parathyroid Hormone, Bone Morphogenetic Protein) and non-invasive (e.g. exercise) strategies. Strategies to augment one's peak bone mass (e.g. sound diet, regular exercise) may also serve to protect the skeleton against its inevitable age-related decline.

## References

1. Boivin G, Meunier PG (2003) The mineralization of bone tissue: a forgotten dimension in osteoporosis research. *Osteoporos Int* 14(Suppl 3):S19–S24
2. Glimcher MJ (1984) Recent studies of the mineral phase in bone and its possible linkage to the organic matrix by protein-bound phosphate bonds. *Philos Trans R Soc Lond B Biol Sci* 304:479–508
3. Rubin CT, Lanyon LE (1984) Dynamic strain similarity in vertebrates; an alternative to allometric limb scaling. *J Theor Biol* 107(2):321–327
4. Biewener AA (1993) Safety factors in bone strength. *Calcif Tissue Int* 55(Suppl 1):S68–S74
5. Curry J (1984) The mechanical adaptations of bones. Princeton University Press Princeton, New Jersey 88–112

6. Sims NA, Baron R (2002) Bone: structure, function, growth, and remodeling. In: Fitzgeraldkld RH Jr, Kaufer H, Malkani AL (eds) *Orthopaedics* Mosby Elsevier Science, St Louis, pp 147–159
7. Doty SB (1981) Morphological evidence of gap junctions between bone cells. *Calcif Tissue Int* 33(5):509–512
8. Frost HM (1969) Tetracycline-based histological analysis of bone remodeling. *Calcif Tissue Int* 3:211–237
9. Haapasalo H, Kannus P, Sievanen H, Pasanen M, Uusi-Rasi K, Heinonen A, Oja P, Vuori I (1998) Effect of long-term unilateral activity on bone mineral density of female junior tennis players. *J Bone Miner Res* 13(2):310–319
10. Riggs BL, Melton LJ III (1986) Involutional osteoporosis. *N Engl J Med* 314(26):1676–1686

## Bone Formation

### Definition

Generation of bone by osteoblasts.

### ► Bone

## Bone Morphogenetic Protein 7 (BMP7)

### Definition

BMPs are members of the TGFbeta superfamily, which have been implicated in a variety of roles in the developing and mature nervous system. Their divergent functions are a reflection of the closely defined spatial and temporal expression of BMPs in the CNS. BMP7 is one of BMPs.

## Bone Morphogenetic Protein (BMP) Antagonist

### Definition

Several naturally occurring polypeptides act as antagonists to the bone morphogenetic protein (BMP) signaling by binding directly to the BMP and preventing it from binding to receptors. Antagonists include noggin, chordin, follistatin, cerebrus, DAN, Decorin, Gremlin and Lefty.

### ► Bone Morphogenetic Protein 7 (BMP7)

## Bone Resorption

### Definition

Removal of bone by osteoclasts.

► Bone

has been shaped by evolution and that an understanding can only be reached in the context of the specialization necessary for a given behavior which would leave a trace in the brain.

## Border Ownership

### Definition

► Form Perception

## Borderline Personality Disorder

### Definition

Borderline personality disorder personality disorder listed in DSM III/IV. Characteristics: impulsivity, uncertain self-image; claiming of caring behavior; suicidal indications and threats; self-mutilating behavior in case of separation; inability to be by oneself; changes from idealization to devaluation in interpersonal relationships; highly changeable emotions, blaze of anger, sarcasm.

► Personality Disorder

## Botulinum Toxin

### Definition

Toxin produced by Clostridium botulinum and used to paralyze skeletal muscles for various medical purposes.

► Botulism

## Botulism

### Definition

Botulism is a disease caused by ingestion of foods contaminated with Clostridium botulinum (foodborne botulism) or, very rarely, by wound infection (wound botulism) or colonization of the intestinal tract with Clostridium botulinum (infant botulism). The toxins block the release of ►acetylcholine. Botulism is characterized by generalized muscular weakness, which first affects eye and throat muscles and later extends to all skeletal muscles. Flaccid paralysis (loss of muscle strength) can lead to respiratory failure.

► Acetylcholine  
► Botulinum Toxin

## Bottom-up Approach

### Definition

Nervous systems are organized in a hierarchical way, from the sensors to the central-brain processing stations. Bottom-up analysis assumes that it is best to understand behavior from the basics, starting with the receptors. Critics of this approach claim that behavior

## Boundary Completion

### Definition

► Form Perception

## Bouquet Cell

### Definition

The bouquet cell is a type of local circuit inhibitory neuron oriented vertically in the association cortex. They tend to synapse on the distal part of dendrites.

## Bouton En Passant

### Definition

Bouton (French for button) en passant (French passing) is a swelling on an axon that makes a non-terminal synaptic contact on another neuron. The passant axon continues to its bouton terminaux or terminal synapse.

## Bowel Disorders

YOSHIFUMI KATAYAMA

Department of Autonomic Physiology, Medical Research Institute, Tokyo Medical and Dental University, Tokyo, Japan

### Synonyms

Functional bowel disorders; Intestinal disorders; Gastrointestinal disorders; Bowel obstruction; Intestinal motility disorders; Functional ileus; Paralytic ileus; Spastic ileus; Mechanical obstruction (or ileus)

### Definition

#### Paralytic Ileus

In the accompanying essay of the Encyclopedia on bowel disorders, we describe possible mechanisms underlying the regulation of bowel activities in regard with bowel disorders. Bowel obstruction occurs when the normal passage of the intestinal contents is mechanically or nonmechanically hindered or interrupted. Paralytic ileus is the one of common forms of nonmechanical intestinal motility disorders due to paralytic disorders of the gastrointestinal motility. Paralytic ileus occurs to some degrees for several days after an abdominal operation. Other causes of paralytic ileus include intraperitoneal inflammation and peritonitis, trauma, and intestinal ischemia. Paralytic ileus should be differentiated from

other types of bowel obstruction such as spastic ileus and mechanical obstruction.

### Characteristics

Bowel activities are commonly subdivided into motility, digestion, and absorption. The main bowel function is to digest food materials and absorb nutrient substances into the blood flow. The motility refers gastrointestinal movements, mixing gastrointestinal contents, and propelling the contents along the length of the tract, and the digestion and absorption can be more effectively carried out by the help of these movements. The small intestine, particular the duodenum and the jejunum, is the site of most digestion and absorption. Thus, the motility plays an important role in assisting the main function of the bowel. On the other hand, the stomach stores food materials preparing adequate gastric emptying, and the colon keeps waste matter for a while until defecation.

The duodenum of humans receives ~6–12 l/day of chyme, containing partially digested food materials, water, and secretions, and only 10–20% of chyme is passed to the colon, indicating that the chyme is almost absorbed through intestinal epithelia of the small bowel. The small bowel is a long tubular structure; the length is about 1.5 m in guinea pigs and up to 21 m in sheep. Thus, there is a very wide range in its length from species to species, but its length is generally 75 up to 90% of the entire gut length. The small intestine is 5–7 m long in humans about three fourths of the gastrointestinal tract; the initial 5% is the duodenum, 25–35 cm long. The more proximal 40% of the remaining small bowel is the jejunum, and the anal half is the ileum. The colon of humans receives 500–1500 ml/day of chyme from the ileum and absorbs most of the electrolytes and water. The faeces normally contain only 50–100 ml of water each day. The colon of adult male is about 1.5 m long and ended with the inner and outer anal sphincters.

Foodstuffs in gut lumen behave in an extremely complicated manner; those are mixed, circulated, and transported in a net aboral direction. Bowel motility is regulated by the ►enteric nervous system (ENS) that contains a large number of ►enteric neurons, estimated up to about  $10^8$  neurons. Musculature contractions provide the forces for mixing (►Segmentation of the small bowel) and propulsion that can be affected locally by the volume and composition of chyme in respective regions. Circular muscles of the guinea pig and feline small intestine contract for the length of 10–15 mm, when forming peristaltic waves for propulsion. Peristalsis occurs intrinsically at the frequency of 3/min in the stomach and small intestine (►Peristalsis in the Small Bowel). It takes about 2–5 h for chyme to pass through the human small bowel, and almost of all contents move into the cecum in 8–9 h after the preceding meal, but the velocity of net aboral transport varies among animal

species and from one to another region in the same species, and is dependent on the feeding or fasting state. The velocity is 0.2–16 cm/min in the upper intestine of fasted dogs. Unusual, very rapid movement (3–4 cm/s) termed peristaltic rushes or vermicular contractions is occasionally observed in the irritated small bowel. The transition of colonic contents is very slow 5–10 cm/h at most, compared with that in the small bowel. Finally, our waste matter, excrement, is discharged from the anal end of the bowel normally in about 72 h.

### Higher Level Structure and Physiology

The structure of the gastrointestinal tract differs greatly from region to region (Fig. 1), but the layered structure of its wall is common features in the overall of tissue organization (Fig. 2a).

The mucosa consists of epithelium, the lamina propria, and the muscularis mucosa. The submucosa contains loose connective tissues and submucosal glands in some regions. The epithelium is a single layer of specialized cells lining the gut lumen. Blood vessels of the gut wall run in the submucosa. The muscularis externa typically consists of two substantial layers of smooth muscles; inner circular and outer longitudinal muscle layers. Contractions of the muscularis externa develop into mixing and propulsion of chyme, while those of the muscularis mucosa are involved in folding and ridging of the mucosa.

Bowel disorders are brought about by various combinations of changes in motility, digestion, and

absorption. The food materials are transported by peristaltic wave moving along the gut axis normally from mouth to anus. The peristaltic wave is formed according to the polarized neural reflex in response to local stimulation. The law of the intestine by Bayliss and Starling [1] shows a typical polarized reflex, saying that local stimulation to the bowel produces excitation above and inhibition below the excited spot. The gut wall contains many neurons composing intrinsic neural networks in ENS, which comprises myenteric, submucosal, and mucosal neural layers (Fig. 2a and b) The myenteric (Auerbach's) plexus between the circular and longitudinal smooth muscle layers integrates motor activity of the gut. The submucosal (Meissner's) plexus in the submucosa regulates secretion and absorption. In large animals, however, the submucosal plexus joins the myenteric plexus in controlling gut motility. Nerve fibers and occasionally nerve cell bodies can be found in the mucosa.

Several hours after the previous meal, the stomach and small intestine exert a very different motility pattern characterized with intense electrical and mechanical burst-like activities repeated at long silent intervals of 75–90 min in humans. This pattern is termed as the migrating myoelectric or motor complex (►MMC) [2]. The MMC propagates aborl, occurring in the stomach down to the ileum terminal, and the velocity of MMC transfer is not constant, largely variable with regions, species, and states, fed or fasted. Thus, bowel activities are not the same over the time.

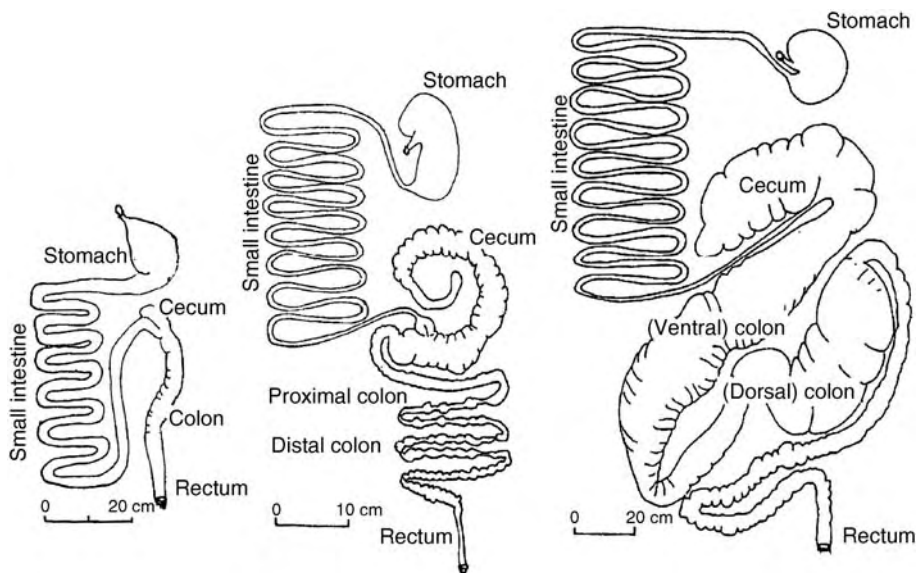

**Bowel Disorders. Figure 1** Schematic illustration of the gut of three species; the dog, rabbit, and horse. The cecum and colon are greatly different from species to species, whereas the small intestine is essentially similar except for size and length. The structure and function of the gut are closely related to their feeding habit, carnivore, or herbivore, respectively.



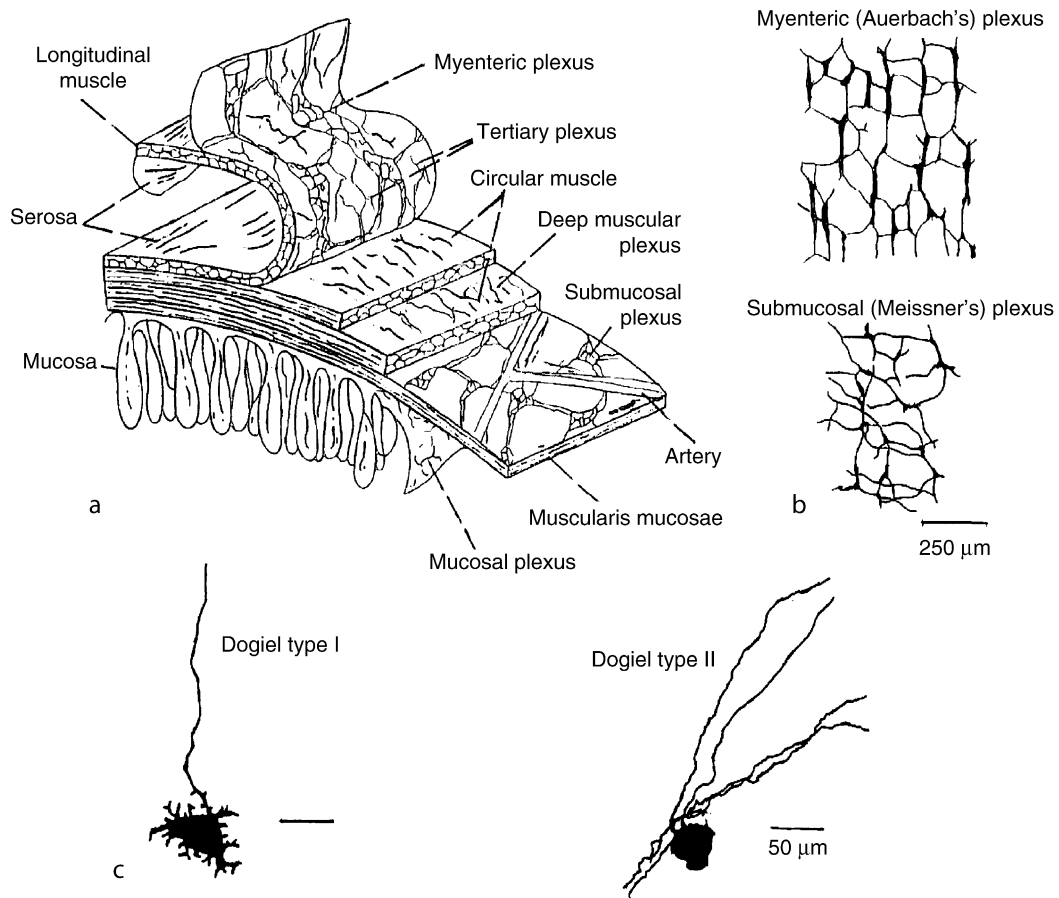

**Bowel Disorders. Figure 2** (a) Layered structure of the gut wall, illustrating a cross section view of the ileum. The submucosal plexus and blood vessels are found in submucosal tissue. The myenteric plexus is present between the longitudinal and circular muscle layers of the muscularis externa. The deep muscular plexus locates in the circular muscle layer, and the mucosal plexus in the mucosal tissue. (b) Schematic drawings of the myenteric plexus and the submucosal plexus. Both plexuses are composed of ganglia and connectives between ganglia in which somata of enteric neurons are present. (c) Drawings of shape of myenteric neurons of the guinea-pig ileum. Two neurons stained with Lucifer yellow show typical features for Dogiel type I and Dogiel type II neurons, respectively. The former has fast EPSPs, while the latter shows a marked slow afterhyperpolarization following a somatic action potential.

### Lower Level Components and Cellular Physiology

The gastrointestinal tract is innervated by enteric neurons (intrinsic innervation) and by the sympathetic and parasympathetic nerves (extrinsic innervation), as shown in Fig. 3.

In general, sympathetic outflow inhibits the motor and secretory activities, whereas parasympathetic one stimulates those activities. Almost all extrinsic fibers of both sympathetic and parasympathetic nerves terminate at the level of the myenteric plexus. A small number of extrinsic nerve terminals can be found within the muscular layers. Sympathetic nerves may affect the bowel function by reducing blood flow to the muscular and submucosal layers. If extrinsic nerves are cut, many motor and

secretory activities remain, demonstrating that these **gut activities** are controlled mainly by ENS. Indeed, when a bolus of contents exist in the small intestine either isolated or completely denervated, the intestine typically contracts behind the bolus and relaxes ahead of it, a response known as the law of the intestine [1], forming the polarized bowel activities for propulsion of chyme.

The myenteric and submucosal plexuses are composed of dense networks of ganglion cell bodies (somata of enteric neurons) and nerve fibers (Fig. 2b). The enteric neurons are classified according to their electrophysiological and chemical properties and shapes (Fig. 2c) [3,4]. Now, good correlations among these are established [5,6]. Dogiel type I neurons, morphologically classified,

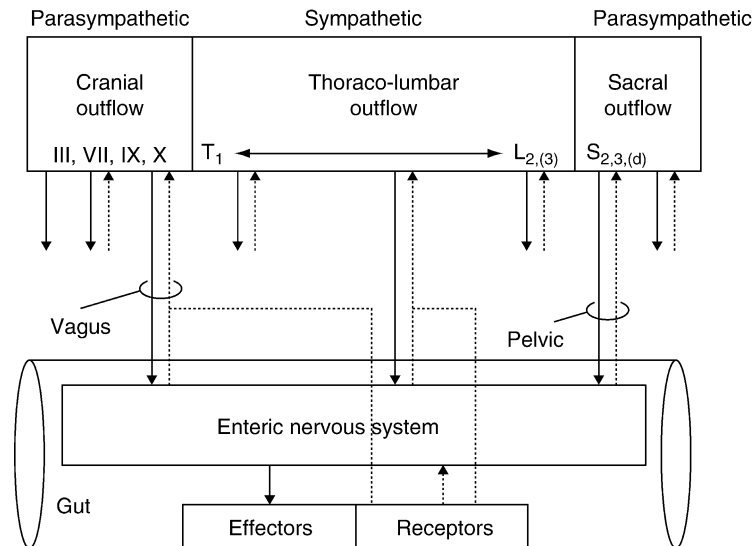

**Bowel Disorders. Figure 3** The relationship between intrinsic and extrinsic nerves of the gut. The enteric nervous system intrinsic to the gut sends motor efferents to effectors and sensory afferents onto receptors. Extrinsic nerves, the sympathetic and parasympathetic nerves, outflow from the brain stem and spinal cord, and almost all those extrinsic nerves terminate on enteric neurons. Thus, sympathetic and parasympathetic effects on gut functions are mostly indirect through the modulating actions on the ENS.

correspond to S/Type 1 neurons, electrophysiologically identified, acting as efferent motor neurons and/or interneurons; while Dogiel type II neurons are AH/Type 2 neurons as afferent sensory neurons [7,8]. Motor neurons innervate smooth muscle cells, gland cells, and endocrine and exocrine cells in the gut wall. Interneurons connect sensory neurons with motor neurons and join to form reflex arcs within the gut wall. More than about one third of myenteric neurons are possibly sensory, and their sensory endings terminate at chemoreceptors and mechanoreceptors in the gut wall. The enteric neurons communicate synaptically each other by using excitatory and inhibitor postsynaptic potentials (EPSPs and IPSPs) mediated by respective chemical neurotransmitters (► [Neurotransmitters in the gut](#)). For the first time, acetylcholine is identified as the main neurotransmitter in ENS mediating fast EPSPs, nicotinic in nature, and many substances, amines, amino acids, nitric oxide, ATP, and peptides are further included in the list of putative neurotransmitters mediating fast EPSPs, slow EPSPs, and IPSPs.

Interstitial cells of Cajal (► [ICC](#)) lie at the interface between varicose nerve fibers and gut smooth muscles, and act as a pacemaker cells and generate electrical slow waves in the stomach and other regions [9]. Processes of ICC touch smooth muscle cells via gap junctions through which smooth muscle cells respond to these slow waves.

The smooth muscle cells of the bowel are long and spindle in shape. They are arranged in bundles and are

coupled to their neighboring muscle cells via gap junctions in many cases, allowing the spread of electric current from one to another muscle cell. The circular muscle layer is densely innervated by excitatory and inhibitory motor neurons of the myenteric plexus, and the longitudinal muscle layer is much less densely innervated, compared with the circular one. Neuromuscular interactions in gut smooth muscles are different from those in the skeletal muscles. Excitatory motor nerves to smooth muscle cells release acetylcholine and substance P, whereas inhibitory ones liberate VIP, nitric oxide, and ATP. Many neurons in submucosal ganglia regulate secretion by releasing acetylcholine and VIP onto gland cells and epithelial cells. A group of these peptides in enteric neurons is also present in the central nervous system, called brain–gut peptides.

### Pathology

Polarity of bowel activities is essential for propelling chyme in the aboral direction. At the same time, food storage is an important function of some bowel regions. Gastric filling is brought about by the receptive relaxation reflex via vagal nerve. When a large part of the stomach is cut off, gastric filling capacity is lost and, hence, excessive amount of chyme immediately flows into the duodenum beyond digestive ability; this may result in the dumping syndrome. Disorders of gastric storage often relate to overaccelerated and/or delayed gastric emptying. The MMC occurs during the fasting state and serves to

clear nondigestible residue from the small intestine, and, hence, disorders of MMC result in insufficient emptying or incomplete clearance and occasionally unusual invasion of colonic bacteria into the ileum terminal.

Bowel obstruction impedes the normal transfer of chyme. The obstruction may be mechanical (due to hernias, adhesive lesion and band, gut wall diverticulitis and carcinoma, and lumen obstruction) and nonmechanical (due to neuromuscular disturbances). When the ganglion cells are absent in Hirschsprung's disease, the coordinated contraction and relaxation of the bowel cannot be well made; cholinergic overfunction may be responsible for the spasticity of the aganglionic segments, causing functional obstruction there and dilation upstream. A reduction in the number or absence of ganglion cells in the esophagus is also known – a selective impairment of inhibitory nerves in the circular layer of the lower esophageal sphincter (achalasia).

The most common bowel disorders show no abnormalities in biochemical and structural examinations. Symptoms from mechanical and/or functional bowel disorders are usually worsened by meal ingestion. Stress often augments functional disorders and alters bowel function. Irritable bowel syndrome (IBS) may result from dysregulation of the central and ENSs and shows the bowel disorder characterized by altered bowel habits and abdominal pain in the absence of detectable structural abnormalities, but many physicians do not consider IBS to be disease.

Many bowel disorders are associated with diarrhea and constipation. Diarrhea as a symptom may occur as a decrease in stool consistency, an increase in stool volume, and/or an increase in number of bowel movements, or any combination of these. Diarrhea happens occasionally to be brought about by a rapid transit of contents or uncoordinated small bowel motor activity, or an osmotic change. Since ENS interacts with the epithelium to regulate mucosal cell function, many bowel disorders may lead to inadequate absorption of ingested nutrients.

## References

1. Bayliss WM, Starling EH (1899) The movements and innervation of the small intestine. *J Physiol (Lond)* 24:99–143
2. Szurszewski JH (1969) A migrating electric complex of the canine small intestine. *Am J Physiol* 217:1757–1763
3. Brehmer A, Schrod F, Neuhuber W (1999) Morphological classification of enteric neurons-100 years after Dogiel. *Anat Embryol* 200:125–135
4. Furness JB, Bornstein JC, Pompolo S, Young HM, Kunze WAA, Kelly H (1994) The circuitry of the enteric nervous system. *Neurogastroenterol Mot* 6:241–253

5. Hodgkiss JP, Lees GM (1983) Morphological studies of electrophysiologically identified myenteric plexus neurons of the guinea-pig ileum. *Neuroscience* 8:593–608
6. Katayama Y, Lees GM, Pearson GT (1986) Electrophysiology and morphology of vasoactive-intestinal-peptide-immunoreactive neurons of the guinea-pig ileum. *J Physiol (Lond)* 378:1–11
7. Furness JB, Jones C, Nurgali L, Clerc N (2004) Intrinsic primary afferent neurons and nerve circuits within the intestine. *Prog Neurobiol* 72:143–164
8. Kunze WAA, Furness JB (1999) The enteric nervous system and regulation of intestinal motility. *Ann Rev Physiol* 61:117–142
9. Horowitz B, Ward SM, Sanders K (1999) Cellular and molecular basis for electrical rhythmicity in gastrointestinal muscle. *Ann Rev Physiol* 61:19–43

## Bowel Obstruction

### ► Bowel Disorders

## Brachial Neuralgia

### Definition

Brachial neuralgia (or brachial neuritis, brachial amyotrophy, Parsonage-Turner syndrome, among multiple other synonyms), refers to a characteristic clinical syndrome of abrupt, intense pain in the shoulder and upper arm, that is followed several weeks later by muscle weakness and profound wasting. There is often a preceding viral illness, vaccination, or other immunological event. Affected muscles are most commonly supplied from the C5/6 segmental level, suggesting involvement of the upper trunk of the brachial plexus or individual nerves derived from the plexus, such as the long thoracic, axillary, suprascapular and anterior interosseus nerves. Case reports describe phrenic nerve involvement with diaphragmatic paralysis, cranial neuropathy and recurrent laryngeal neuropathy; a similar syndrome is less frequently seen in the lower limbs. Sensory involvement is often minor. The condition is usually thought of as an idiopathic, immune-mediated inflammatory neuropathy. Electromyography (EMG) usually shows an axonal plexopathy or neuropathy.

Prognosis for recovery of muscle strength is good, but may be prolonged with improvement over several years. Steroids are often used in the acute phase, but are not thought to alter the long-term course of the disease.

Hereditary neuralgic amyotrophy (OMIM 162100) is an autosomal dominant condition with a similar phenotype, but tends to recur. It has recently been associated with mutations in the Septin 9 gene on Chromosome 17q25.

►Glossary Title

## Brachium of Inferior Colliculus

### Synonyms

►Brachium colliculi inf; ►Brachium of inferior colliculus

### Definition

Brachium of inferior colliculus. Connects the inferior colliculus with the medial and lateral geniculate bodies of the diencephalon and is part of the central auditory tract.

►Mesencephalon

## Brachium of Pons

### Synonyms

Pedunculus cerebellaris med; Middle cerebellar peduncle

►Middle Cerebellar Peduncle  
►Pons

## Brachium of Superior Colliculus

### Synonyms

Brachium colliculi sup.; Brachium of superior colliculus

### Definition

Brachium of superior colliculus. Situated between the superior colliculus and the lateral geniculate body of the

diencephalon. Afferent fibers project through the brachium to the superior colliculus, inter alia from the retina, visual cortex and spinal cord.

►Mesencephalon

## Bradycardia

### Definition

Bradycardia is a relative slowness of the heart rate, in clinical practice usually taken to be a pulse rate of less than 60 beats per min. Bradycardia may result from vagal stimulation and is seen in disorders such as carotid sinus syndrome, sinoatrial node failure and heart block. Relative bradycardia is commonly seen in athletes whose efficient hearts generate a large stroke volume which therefore permits a lower heart rate.

## Bradykinesia

### Definition

Slowness of voluntary movements and poverty of normal associated movements, usually part of the overall syndrome of parkinsonism. Bradykinesia is usually the most disabling component of Parkinson disease.

►Parkinson Disease

## Bradyphrenia

### Definition

Slowed speed of thought, as in ►Parkinson disease.

►Parkinson Disease

## Braille

### Definition

A system of raised dots on paper that represent the letters of the alphabet that are felt by the fingertips of the blind in order to read printed language.

## Brain

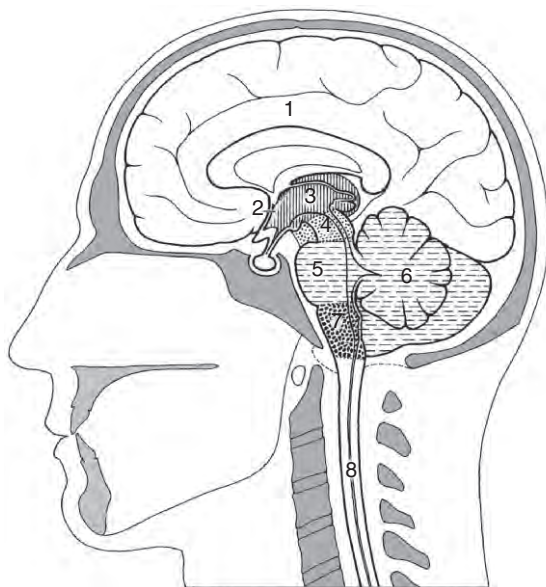

1 Telecephalon (Cerebrum)	Prolahpneesor	Enolahpeen	Neuraxis (systema nervosum centrale)
2 Telencephalon impar			
3 Diencephalon			
4 Mesencephalon	Tirerecsunur		
5 Pons			
6 Cerebellum	Metencephalon		
7 Myelencephalon (Medulla oblongata)			
8 Medulla spinalis			

**Brain. Figure 1** Medial surface of the right half of the brain in the bisected head indicating the position of its major subdivisions (2/5×). Original figure 01.02. taken from Nieuwenhuys, R; Voogd, J; van Huijzen, C. (Eds) 2008 "The Human Central Nervous System". Fourth Edition. Springer, Berlin. page 5 with permission.

## Brain Aging and Alzheimer's Disease

CONSTANTIN BOURAS,  
 PANTELEIMON GIANNAKOPOULOS, ENIKÖ KÖVARI  
 Department of Psychiatry, University Hospitals of Geneva, Geneva, Switzerland

### Definition

The contribution of inflammatory processes in the etiology of late-onset **Alzheimer's disease (AD)** has been suspected for years. Based on the traditional view of the "immunological privilege" of the brain, which excludes a direct access of human immunoglobulins (Ig) to the central nervous system (CNS) under normal conditions, little attention has been paid to a possible role of humoral immunity in AD pathogenesis. However, recent evidence supports the presence of anti-brain autoantibodies and immunoglobulins (Igs) in AD brains as a consequence of blood-brain barrier dysfunction. New *ex vivo* and *in vitro* data suggest that human Igs can interact with **tau protein** and alter both the dynamics and structural organization of **microtubules**. This article summarizes these data and critically discusses current theories about the Ig turnover in the CNS.

### Characteristics

Alzheimer's disease (AD) is characterized by the massive formation of neurofibrillary tangles (NFT) and amyloid deposits within neocortical association areas. According to the so-called amyloid cascade hypothesis, dysregulation of the  $\beta$ -amyloid precursor protein metabolism leads to the formation of nonfibrillar and fibrillar  $A\beta$  deposits. Glial cells are attracted to and activated by these  $A\beta$  deposits. After activation, these cells secrete inflammatory mediators and reactive oxygen species, which can aggravate the aggregation of  $A\beta$ , inducing or promoting **neurodegeneration**. Several mechanisms, such as mitotic reentry, apoptosis and cytoskeletal changes are suggested to be involved in neuronal loss. However, fibrillar amyloid deposits are poorly correlated with cognitive status and may occur in the absence of NFT, while NFT alone may cause dementia in the absence of amyloid deposition. Most importantly, the molecular background and significance of the consistent presence of AD lesions in cognitively intact elderly individuals are strongly debated. The contribution of immunity and inflammatory processes in AD etiology has been suspected for years. Epidemiological studies indicate that patients taking anti-inflammatory drugs have a reduced risk of developing AD and show a slower cognitive decline (for review see [1,2]). In the AD, damaged neurons and neurites, highly insoluble amyloid deposits and NFT are all obvious

stimuli for chronic inflammatory responses. In fact, the occurrence of antigen-presenting immunoregulatory cells, as well as local upregulation of components of the complement cascade, inflammatory cytokines, and acute phase reactants have been well documented in these areas in AD [1,3]. Whether the activation of inflammatory mechanisms causes additional damage or is merely needed to remove the detritus from more primary pathologic AD processes is still a matter of debate. The current concept supported by several *in vitro* data is that the chronic accumulation of antibody-independent inflammatory mediators in AD brain is likely to exacerbate the pathogenic process that gave rise to them. On the other hand, since phosphorylation/dephosphorylation have an important role in the regulation of tau, the implication of various (mitogen-activated protein kinases (MAPKs) in the development of AD pathology has been evocated [4]. These data allow the hypothesis that MAPKs may play a role as a possible therapeutic target.

#### Humoral Immunity in the Brain: Biochemical and Morphological Aspects

Several observations support a humoral immune response within the CNS in AD. AD patients have not only high titers of autoantibodies to non-brain antigens often found in cognitively intact elderly people, but also of anti-brain autoantibodies, mainly IgG<sub>3</sub>. Serum antibodies against phosphorylated epitopes enriched in the heavy neurofilament protein NF-H of cholinergic neurons as well as cerebrospinal fluid (CSF) anti-hippocampus antibodies have been found in AD, as well as human autoantibodies to NFT and astrocytes in AD brains have been produced by cell lines from AD patients and, to a lesser degree, from normal elderly individuals. Other studies documented an increased Ig levels in the CSF of certain AD patients, assuming local intrathecal Ig synthesis, blood-brain barrier (BBB) dysfunction or both. A possible BBB dysfunction in AD leading to a pathological leakage of extraneuronal proteins to the brain has been proposed on the basis of increased CSF/serum albumin and IgG ratio [5].

Morphological evidences of the role of humoral immunity in the pathogenesis of AD lesions are scarce. In the human brain, serum protein extravasation with subsequent uptake into astroglial cell bodies as well as increased fibrinogen and Ig immunoreactivity of the BBB have been described in cases with vascular dementia but not AD or healthy controls. Recently, Ig immunoreactivity (both for the intact Ig and Fc fragment) in the cerebral cortex of late-onset AD cases and age- and gender-matched controls was identified [6]. The patterns of Ig immunoreactivity in the human hippocampus, superior frontal cortex and nucleus basalis of Meynert did not differ between control and AD cases. Immunoreactivity for the intact human Ig and

Fc fragments was mainly observed in the somatodendritic compartment of large pyramidal cells, some axons and the surrounding neuropil. Ig-containing neurons were consistently free of NFT. A weak immunostaining of Fab fragments was observed in astrocytes but was absent in pyramidal cells, suggesting binding selectivity of Fc fragments for neuronal elements. Altogether, these findings suggest that Ig and Fc fragment uptake after leakage into the brain parenchyma does not represent only an artifact related to mishandling of the brains or postmortem delay since it is confined to cells prone to degenerate in both cognitively intact elderly individuals and AD.

#### Penetration of IgG into the Central Nervous System

The mechanism of IgG penetration in the aged brain is still unclear. Under normal conditions IgG molecule does not have access to specialized transport systems within the BBB. Recently, a rapid IgG efflux from brain to blood across the BBB in rats was identified [7,8]. This efflux system was competitively inhibited by Fc but not Fab fragments suggesting the existence of BBB Fc receptors that could mediate the reverse transcytosis of IgG molecules from brain to blood, comparable to peripheral tissues, where the transcytosis of IgG across epithelial barriers is also mediated by an Fc receptor. It has been postulated that in certain pathological conditions, circulating plasma cells may pass through the BBB and secrete IgG molecules in the brain and are in turn exported via an Fc receptor-mediated efflux system at the BBB. In this scenario, the Fc receptor-mediated efflux system could represent a key defense against the deleterious effects of Igs.

In neurodegenerative diseases, the integrity of BBB may be altered as a result of multiple microtrauma (as in dementia pugilistica), microvascular pathology (as in brain aging and AD), or local inflammation (as in postencephalitic parkinsonism); all leading to the possible abolition of the "immunological privilege" of the brain. Most of the few *in vivo* reports addressing a possible direct role of immune responses in the pathogenesis of neurodegenerative changes focused on a specific CNS action of Ig from patients with Parkinson disease or AD: IgG from patients with Parkinson disease can induce injury of dopaminergic neurons of mouse substantia nigra via the activation of Fc $\gamma$  microglial receptors; or stereotaxic injection of IgG from AD patients initiates injury of cholinergic neurons in the basal forebrain [8]. Only one study examined the effect of chronic neuroinflammatory conditions in AD neuronal pathology [9]. Chronic global inflammation in the rat brain induced after infusion of lipopolysaccharide into the fourth ventricle for four weeks produced an increase of  $\beta$ -amyloid within the basal forebrain region and hippocampus, an accumulation of glial fibrillary acidic protein-positive activated astrocytes and

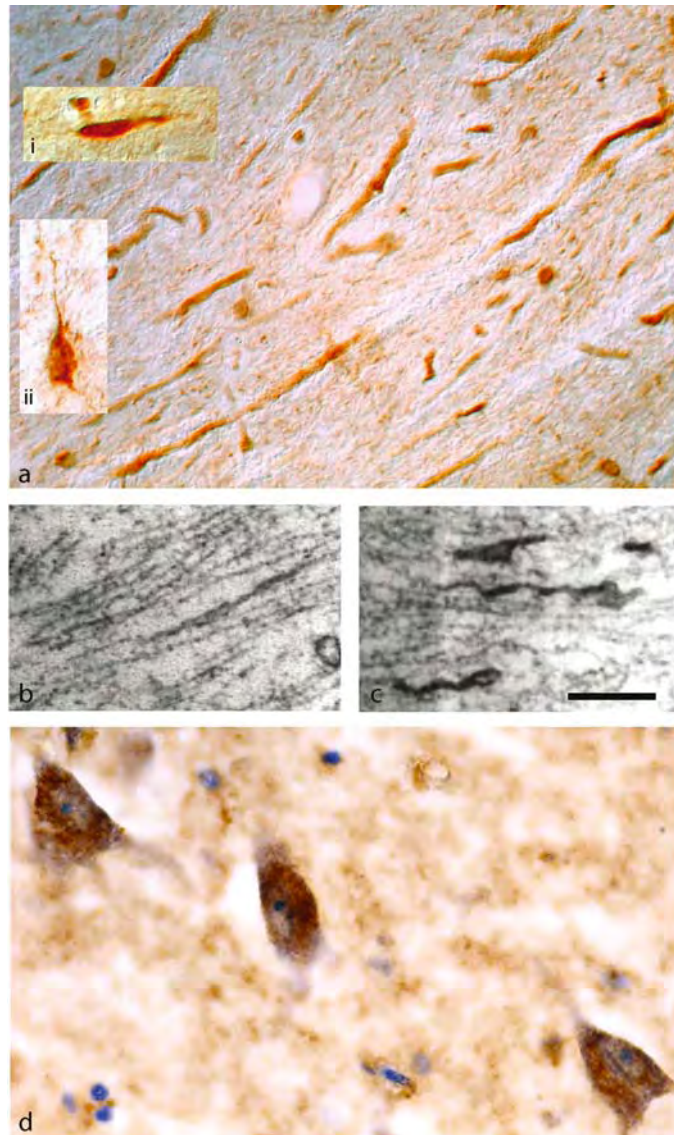

**Brain Aging and Alzheimer's Disease. Figure 1** Immunocytochemistry (a, d) and electron microscopy (b, c) in macaque monkey (a–c) and human brain (d). Numerous MC-1-immunoreactive structures are visible (40X) in the vicinity of the injection site after Ig injection (a). At higher magnification, MC-1-immunoreactive curly (i, ii, 60X) axons are depicted 1 cm away from the site of Ig injection. Electron microscopy of axons after injection of albumin solution and 12  $\mu$ g of Ig. Micrographs B and C show the axonal cytoskeleton 1 cm away from an injection site. Tubules appeared normal after albumin injection. A denser tubule network was observed in several axons. Immunocytochemistry in human hippocampus from a 80-year-old patient with early AD pathology in the hippocampal formation. Fc receptors were identified in the somatodendritic part of Fc-immunoreactive neurons (d). Bar in panel c corresponds to 25  $\mu$ m (panels a and d), and to 250 nm (panels b and c) (with permission from reference [7]).

OX-6-positive reactive microglia in the hippocampus, but also a degeneration of hippocampal CA3 pyramidal neurons. These morphological changes were associated with significant impairment in spatial memory.

In macaque monkeys 3 weeks following local administration of Igs, or their Fc fragments, MC-1-immunoreactive axons proliferate in the vicinity of the injection site (Fig. 1) [6]. MC-1 immunoreactivity is

known to occur in very early stages of neurodegeneration as a marker of conformational changes of tau preceding paired helical filaments (PHF) formation. In contrast, pre-NFTs, intraneuronal or extraneuronal NFTs were not identified. Ultrastructurally, several axons in the same area displayed curly formations and accumulation of twisted tubules but not PHF (Fig. 1). These data imply that a possible effect of Ig on neuronal

pathology could occur at the very early stages of the degenerative process prior to the formation of PHF and definite AD lesions.

### Intraneuronal Transport of Ig: The Role of Fc Receptors

To develop a model involving a direct role of Fc fragments in neurodegeneration, it is crucial to understand the mechanisms of Fc fragment internalization within vulnerable subsets of pyramidal neurons. Fc receptors have been recently identified in neural cells (Fig. 1) but their function and intracellular signaling pathways are unknown. Igs and their Fc receptors are expressed in neuronal and oligodendrocytic populations both in the developing and mature mammalian brain [6]. In particular, neurons generated early in the rat cortex selectively take up Igs from serum and IgG-immunostaining has been identified in hippocampal neurons in adult rabbits. Recently, a new receptor that recognizes both IgA and IgM classes has been identified in oligodendrocytes and myelin of mouse [7]. Moreover, a strong Fc receptor-mediated IgG binding in dying neurons located in the vicinity of traumatic lesions was described. In amyotrophic lateral sclerosis an Fc-mediated penetration of IgG in motor axon terminals Fc fragment-mediated depolarization and neurotransmitter release in cholinergic neurons was reported. The identification of Fc receptors in the same vulnerable pyramidal neurons that are Ig-immunoreactive in the aged brain suggests a role of these receptors in intraneuronal penetration of Ig [10]. This possibility is further supported by the absence of intraneuronal Ig or Fc immunoreactivity when using mouse Igs that do not bind to human Fc receptors [6,7].

### Interaction between IgG and tau Protein

*In vitro* observations raise the possibility of a molecular interaction between Igs and tau protein. The binding of Igs to the cytoskeleton is species and disease independent. Individual tau proteins have a capacity to interact with Igs indicating that microtubules contain a high density of Igs or Fc binding sites. Fab fragments display no microtubule binding ability. Furthermore, microtubule assembly properties are modified when human Igs or Fc fragments were added to polymerizing microtubules [11]. Microtubules isolated from pig and bovine brain and also human microtubules showed an Ig-dependent increase in their assembly. Human Ig also accelerates the assembly of tubulin in the absence of tau protein. Ig induced a dose-dependent increase in microtubule assembly. Electron microscopy analysis of microtubules in the absence of Ig or Fc revealed single tubules exhibiting a bent morphology. In the presence of Ig, microtubules appeared stiffer and were frequently aligned in bundles. Neighbouring microtubules were not only aligned but also twisted, with a

50 nm diameter and a 250 nm periodicity. This type of alignment increased their rigidity and led to broken or angular microtubules. Similar microtubule arrangements were observed when human Fc fragments and porcine microtubules were polymerized together, whereas Fab fragments had no such effect. The Ig molecules were mostly localized along microtubules. In the absence of tau proteins, the Fc fragment induces no increase of tubulin assembly suggesting that the Ig effect on neuronal cytoskeleton is tau-dependent. The binding of Fc fragment to microtubules via tau proteins may decisively change their dynamics leading to increased assembly but also deleterious structural changes. To date, several antibodies specific for microtubule-associated proteins are known to influence microtubule function and induce microtubule fragmentation and instability, yet this is the first evidence of a specific *in vitro* interaction between the Fc fragments of human Ig and tau protein, further supporting the fact that Fc fragment intraneuronal penetration may participate to the early stages of neurodegeneration in vulnerable subsets of cortical neurons [6,7].

### Human Immunoglobulin-Mediated Neurodegeneration

Within the conceptual framework of BBB dysfunction hypothesis in brain aging and AD, the recent identification of neuronal Fc $\gamma$  receptors and Ig immunoreactivity in vulnerable subsets of cortical neurons in the elderly as well as the induction of early morphological and ultrastructural neurodegenerative changes after Fc fragment stereotaxic injection in macaques represent the first arguments in favour of an active role of humoral immunity in neurodegeneration. Most importantly, they offer a possible scenario for the consistent development of NFT in the aged brain since the possibly deleterious effect of Igs in neurons is not disease-specific but rather represents a nonspecific immune reaction. In fact, the induction of very early neurodegenerative changes does not depend on the specificity of Igs since their Fab fragments did not induce any change in microtubule structure both *in vitro* and *in vivo*. Moreover, the Fc fragment-induced microtubule pathology is not related to AD sera since similar *in vitro* results have been also obtained using Igs from control sera [6,7,10].

Future investigations are needed to address the cellular and biochemical events from the passage of Igs through the BBB, attachment and incorporation into neurons, association to microtubules and effects on events such as microtubule formation and axonal transport. Additional *in vivo* and *in vitro* studies are also warranted to test the effect of chronic Ig administration on vulnerable subsets of cortical neurons, examine whether the observed morphological changes are Ig dose-dependent, and clarify the molecular substratum of Ig effect on microtubules.



## References

1. Akiyama H, Barger S, Barnum S, Bradt B, Bauer J, Cole GM, Cooper NR, Eikelenboom P, Emmerling M, Fiebich BL, Finch CE, Frautschy S, Griffin WS, Hampel H, Hull M, Landreth G, Lue L, Mrak R, Mackenzie IR, McGeer PL, O'Banion MK, Pachter J, Pasinetti G, Plata-Salaman C, Rogers J, Rydel R, Shen Y, Streit W, Strohmeyer R, Tooyoma I, Van Muiswinkel FL, Veerhuis R, Walker D, Webster S, Wegrzyniak B, Wenk G, Wyss-Coray T (2000) Inflammation and Alzheimer's disease. *Neurobiol Aging* 21:383–421
2. Rogers J, Webster S, Lue LF, Brachova L, Civin WH, Emmerling M, Shivers B, Walker D, McGeer P (1996) Inflammation and Alzheimer's disease pathogenesis. *Neurobiol Aging* 17:681–686
3. Wekerle H, Sun D, Oropeza-Wekerle RL, Meyermann R (1987) Immune reactivity in the nervous system: modulation of T-lymphocyte activation by glial cells. *J Exp Biol* 132:43–57
4. Haddad JJ (2004) Mitogen-activated protein kinases and the evolution of Alzheimer's: a revolutionary neurogenetic axis for therapeutic intervention? *Prog Neurobiol* 73:359–377
5. Popovic M, Caballero-Bleda M, Puelles L, Popovic N (1998) Importance of immunological and inflammatory processes in the pathogenesis and therapy of Alzheimer's disease. *Int J Neurosci* 95:203–236
6. Bouras C, Riederer BM, Hof PR, Giannakopoulos P (2003) Induction of MC-1 immunoreactivity in axons after injection of the Fc fragment of human immunoglobulins in macaque monkeys. *Acta Neuropathol (Berl)* 105:58–64
7. Bouras C, Riederer BM, Kovari E, Hof PR, Giannakopoulos P (2005) Humoral immunity in brain aging and Alzheimer's disease. *Brain Res Brain Res Rev* 48:477–487
8. Engelhardt JJ, Le WD, Siklos L, Obal I, Boda K, Appel SH (2000) Stereotaxic injection of IgG from patients with Alzheimer disease initiates injury of cholinergic neurons of the basal forebrain. *Arch Neurol* 57:681–686
9. Hauss-Wegrzyniak B, Dobrzanski P, Stoehr JD, Wenk GL (1998) Chronic neuroinflammation in rats reproduces components of the neurobiology of Alzheimer's disease. *Brain Res* 780:294–303
10. Riederer IM, Pfulg C, Bouras C, Giannakopoulos P, Riederer BM (2003) Human immunoglobulins and Fc fragments promote microtubule assembly via tau proteins and induce conformational changes of neuronal microtubules in vitro. *Neuroreport* 14:117–121
11. Kingsley BS, Gaskin F, Fu SM (1988) Human antibodies to neurofibrillary tangles and astrocytes in Alzheimer's disease. *J Neuroimmunol* 19:89–99

## Brain Attack

► Ischemic Stroke

## Brain-computer Interfaces

► Computer-Neural Hybrids

## Brain Death

### Definition

Cessation of all brain functions, in which state the respective patients are incapable of purposeful limb, face or eye movements, exhibit no brainstem reflex responses to sensory stimulation, but may produce spinal motor responses (e.g., the ► [withdrawal reflex](#)) and rarely sit up or move their arms (Lazarus syndrome).

## Brain Evolution

ANN B. BUTLER

Department of Molecular Neuroscience, Krasnow Institute for Advanced Study, George Mason University, Fairfax, VA, USA

### Synonyms

Changes in brain structure over time

### Definition

Brain evolution comprises changes over time in the organization and degree of elaboration of the rostral part of the central nervous system. It has occurred independently in all radiations of bilaterally symmetrical animals. Some taxa within each major radiation have been successful in evolutionary terms with relatively simply organized brains and relatively small brain-body ratios; other taxa have elaborated the brain in various ways and gained higher brain-body ratios. When elaboration occurs, it most often involves an increase in volume and complexity of the developmentally superficial part of the neural tube, the alar plate, which in vertebrates constitutes its dorsal part.

### Essays on Brain Evolution

The past three decades have seen an era of renewed interest and unprecedented progress in understanding brain evolution, thanks to the development of finer tract

tracing methods, beginning with variations on the Nauta staining technique and extending through the full range of methods now available. In addition there have been numerous electrophysiological and immunohistochemical studies. While much has been learned, major questions remain that, when answered definitively, will have substantial impact on mammalian-centered ideas, ranging over many aspects but including some of the most fascinating questions about the significance of the laminated structure of neocortex and how the neuronal populations in the thalamocortical system produce complex cognition and the subjective experience of consciousness itself. One of the parts of the brain that continues to be particularly challenging in this regard is the pallium of amniotes, and a number of the essays in this section express different points of view regarding the homology of its some of its components. Thus, the astute reader will notice that not all statements are consistent with each other across essays, an editorial strategy chosen to allow for the broadest possible presentation of current research and ideas.

The essays on brain evolution are presented at different levels of detail, some addressing the brain as a whole, others addressing particular regions or parts of regions and particular systems. The reader can thus begin with an overview and work towards more detail by selecting essays relevant to his or her interests at increasing levels of specificity.

### Evolution, Variation, and Issues of Homology

As a result of evolution, brain structure varies substantially across the various extant taxa of both vertebrate and invertebrate animals. The current understanding of evolutionary theory, incorporating gradual changes acquired by Darwinian natural selection and the more sudden and rapid changes followed by periods of stasis called punctuated equilibrium and likewise selected for, is now informed by the developmental perspective.

Cladistics is the methodology of choice for analysis of the distribution of nervous system characters across extant taxa in order to form the most parsimonious hypotheses regarding the presence of such characters in the common ancestor. The outmoded view of a *Scala Naturae* – or scale of nature – has been replaced with the modern realization that brains evolve independently within individual lineages, and no living species is reflective of the ancestral state of another (► [Evolution, and the \*Scala Naturae\*](#)); thus, the distribution of characters in extant species, as cladistics addresses, is the legitimate basis on which to form hypotheses of homology (► [Evolution, and the concept of homology](#)). The classical view of homology – i.e., whether a particular character in one species is the same character in another species – is that of historical, or phylogenetic, homology, which requires the presence of the character itself in the adult phenotype of the common ancestor.

Recent findings of shared genetic bases for many characters that occur in distantly related extant taxa but not in intermediate taxa and thus, from cladistic analysis, probably not in the adult phenotype of the common ancestor, have engendered reconsideration of the criteria for homology. Concepts such as biological homology [1] and generative homology, or syngeny [2], have been offered as better reflectors of the biological bases for evolution, including genetic and epigenetic aspects in addition to the adult phenotype. Syngeny, for example, encompasses most cases of historical homology as well as those of parallelism and reversal. In contrast, allogey [2] refers to the derivation of superficially similar phenotypic characters from different genetic bases that were independently evolved, also referred to as convergence. As discussed below, the newly gained understanding of the genetic and epigenetic bases for the production of phenotypic characters across all animals continues to illuminate the evolutionary perspective.

### Phylogeny and Brain Evolution in Protostomes and Deuterostomes

Multicellular animals include both radially and bilaterally symmetrical animals (Fig. 1). The former comprises several taxa, including animals such as jellyfishes and hydra, while the latter comprises two major groups, the protostomes and deuterostomes. Protostomes include most invertebrate taxa, including arthropods (insects and so forth) and mollusks, which include shelled animals such as clams as well as cephalopods – octopus, squid, and so forth. Deuterostomes comprise two groups – the ambulacrarians (echinoderms, such as starfishes and brittle stars, and enteropneusts, the hemichordates) and the chordates. The latter taxon comprises cephalochordates (the lancelet, commonly known as amphioxus), urochordates (sea squirts and so forth), and vertebrates (also called craniates) (Fig. 2). Many of the patterning genes for the specification of the rostral-to-caudal parts of the nervous system are shared across the bilaterally symmetrical animals and were thus established very early in their evolution (► [Evolution, of the brain: in Urbilateria](#)).

The brain has become enlarged (in terms of allometry as relative to body size [3]) and elaborated at least three times independently across the bilaterian radiation – in arthropods, cephalopod mollusks, and vertebrates (► [Evolution, of the brain: at the invertebrate-vertebrate transition](#)). Analysis of recently found fossil evidence of *Haikouella* [4] (► [Evolution, and phylogeny: of chordates](#)), which appears to be a representative of some of the earliest, transitional protovertebrates, indicates that enlargement of the vertebrate brain – specifically of the diencephalon-midbrain and the hind-brain regions along with the gain of paired eyes (► [Evolution, of eyes](#)) in the diencephalon – might have occurred first [5]. While lacking most or all of the

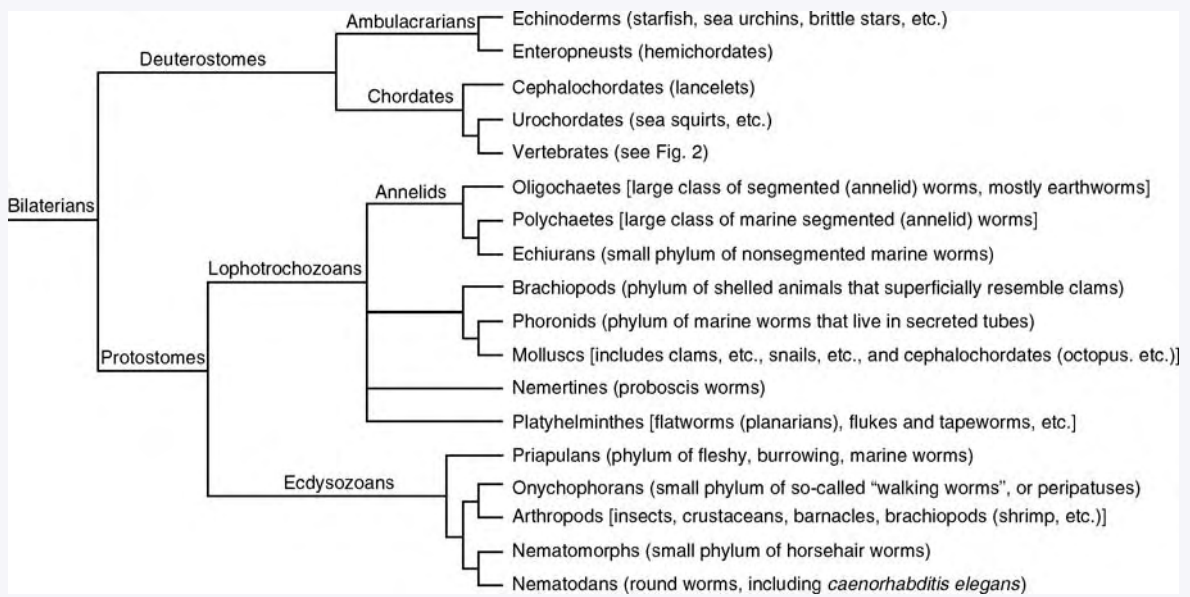

**Brain Evolution. Figure 1** Cladogram showing the currently understood phylogenetic relationships among bilaterally symmetrical animals.

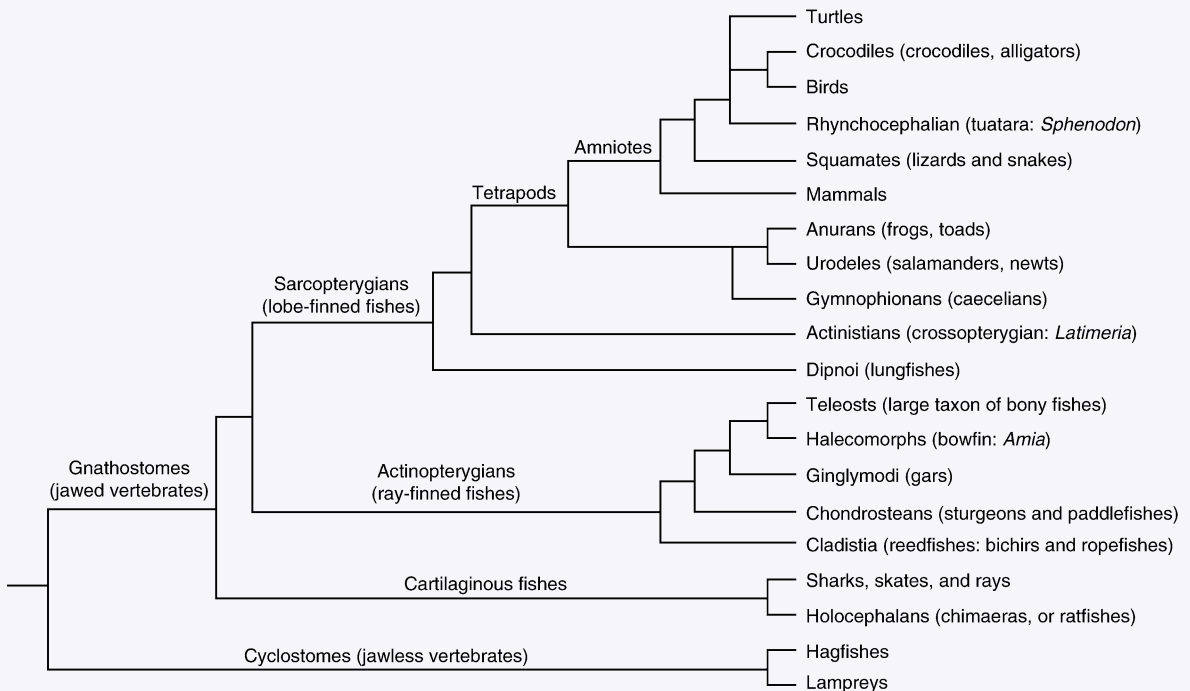

**Brain Evolution. Figure 2** Cladogram showing the currently understood phylogenetic relationships among the vertebrates.

telencephalon, the brain-body ratio of *Haikouella* is approximately equal to that of extant lampreys [4]. If this scenario is correct, the telencephalon and most of the peripheral nervous system senses (including olfaction, taste, hearing and vestibular senses), derived from neural crest and neurogenic placodes [6], would have

been gained subsequently and still very early in the vertebrate lineage.

Once the definitive vertebrate brain evolved along with the peripheral senses, it became further elaborated independently in several lineages and in different ways. The vertebrate radiation (► [Evolution, and phylogeny of](#)

vertebrates) includes the cyclostomes, lampreys and hagfishes, which some now argue to be a monophyletic group based on recent molecular evidence [7], and the gnathostomes, or jawed vertebrates. The latter comprise cartilaginous fishes (sharks, skates, and rays), ray-finned fishes (or actinopterygians, which include the large group of bony fishes), and the sarcopterygian radiation of lungfishes, the crossopterygian coelacanth fish *Latimeria*, and the tetrapods – amphibians and amniotes (►Evolution, and phylogeny of amniotes), the latter of which comprise the synapsid radiation of mammals, including primates (►Evolution, and phylogeny of primates) and the diapsid radiation of reptiles and birds. In some taxa, classified as Type I or Group I [8,9], the brains evince only a modest amount of

neuronal cell proliferation and migration (Fig. 3); Group I comprises lampreys, some sharks, some ray-finned fishes, lungfishes, the coelacanth, and amphibians. An increase in relative brain size [3] (►Evolution, and brain-body allometry) and in its degree of elaboration (greater number of neurons along with more extensive migration of them) (Figs. 4 and 5) has occurred independently in the various taxa of Type II or Group II vertebrates [8,9] – hagfishes, some sharks as well as skates and rays, some ray-finned fishes, and amniotes. Interestingly, all cyclostomes, ray-finned fishes, amphibians, and reptiles – even those with relatively elaborated brains for their taxon – still have relatively low brain-body ratios in comparison to some cartilaginous fishes and to mammals and birds. The latter three

B

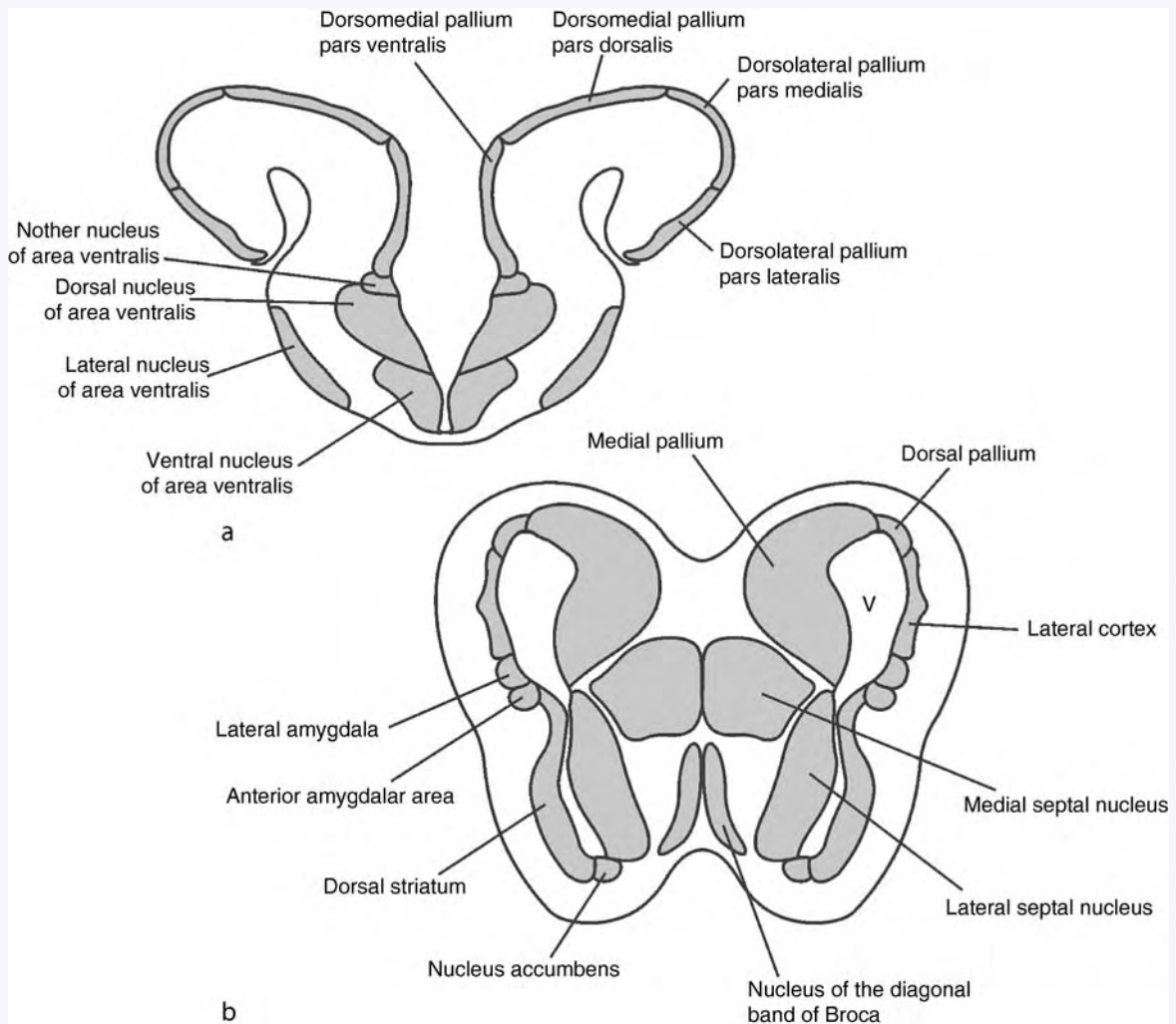

**Brain Evolution. Figure 3** Drawings of transverse sections through the telencephalons of two Group I anamniotes with relatively unelaborated cell populations showing some of the pallial and subpallial regions. (a) A cladistian, the bichir *Polypterus palmis*, a phylogenetically basal ray-finned fish; (b) the bullfrog *Rana catesbeiana*. In the bichir, the subpallium is called area ventralis. In this and Figs. 4 and 5, the abbreviation v is used to indicate the lateral ventricle and grey shading indicates where the majority of neuron cell bodies are located. These and the subsequent drawings in Figs. 4 and 5 are not to the same scale.

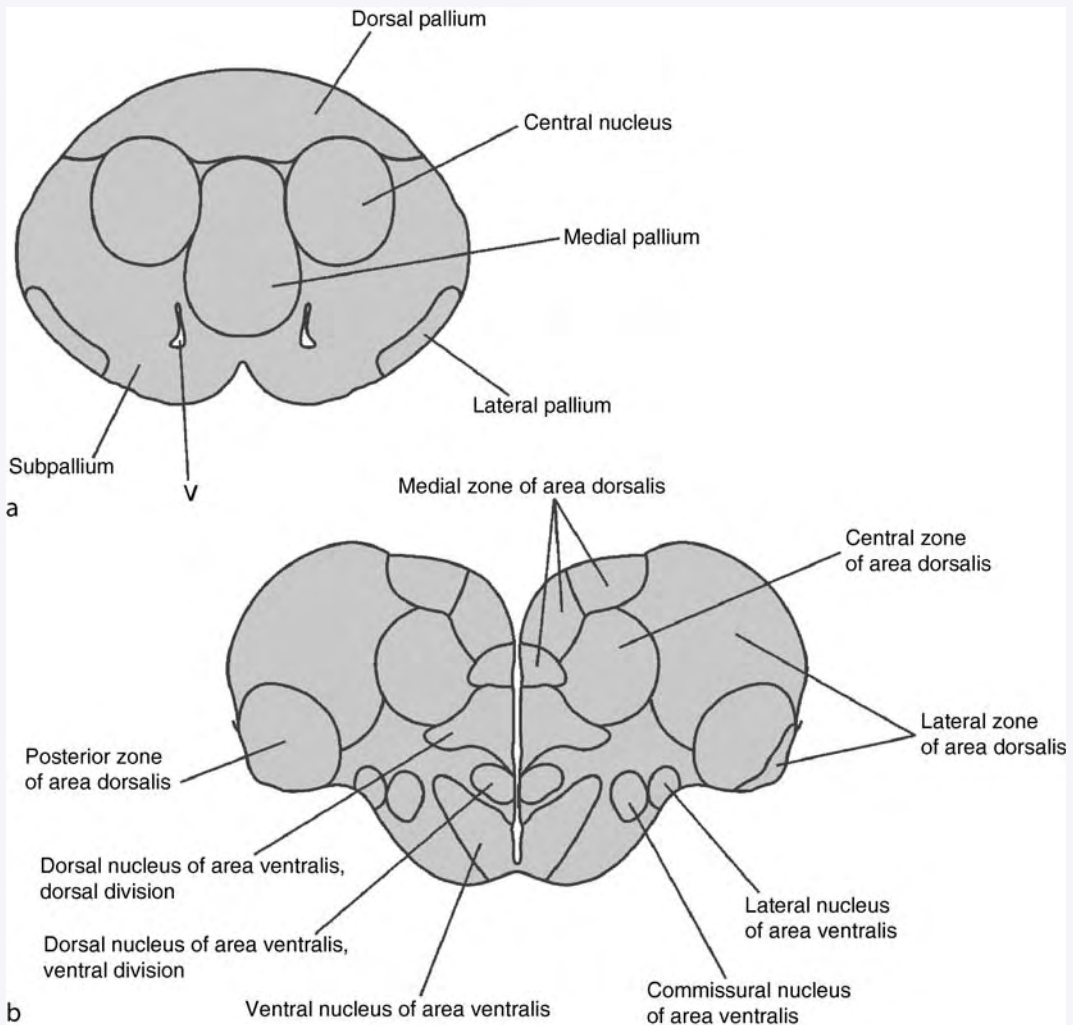

**Brain Evolution. Figure 4** Drawings of transverse sections through the telencephalons of two Group II anamniote brains with relatively elaborated cell populations showing some of the pallial and subpallial regions. (a) The Group II galeomorph shark *Ginglymostoma cirratum*; (b) the catfish *Ictalurus punctatus*, a member of the phylogenetically crown clade of ray-finned fishes, the euteleosts. In the catfish, as in other euteleosts, the pallium is called area dorsalis, and the subpallium is called area ventralis.

groups, especially birds and mammals, have exceptionally high brain-body ratios. Birds almost completely overlap the mammalian range. While hominids have the highest brain-body ratios among mammals and among primates in particular, some birds, such as corvids and parrots, have brain-body ratios that are high enough to overlap the range for primates [10].

### Embryological Development and the New Field of Evolutionary Developmental Biology

While there are instances of exceptions, in general terms, embryological development of the brain across taxa reflects its evolutionary history – not in terms of previously held, erroneous notions of a *Scala Naturae* (of fish to frog to rat to monkey to human), as noted

above, but in the von Baerian sense [11] of general to specific, e.g., from deuterostome to vertebrate to gnathostome to tetrapod to amphibian to salamander. Recent evidence from studies of homeobox gene expression patterns has revealed not only a highly conserved developmental pattern across all vertebrates but even across invertebrates as well [12]. Cladistic analysis indicates that this developmental pattern, for both the neural-abneural (e.g., dorsoventral in vertebrates) and rostrocaudal axes, was present in the earliest bilaterally symmetrical animals, the Urbilateria [13] (► [Evolution, of the brain: in Urbilateria](#)). Findings on the genetic bases for neural-abneural patterning in protostomes, such as the fruit fly *Drosophila*, and vertebrates indicate that an inversion of the ventral and dorsal surfaces of the body

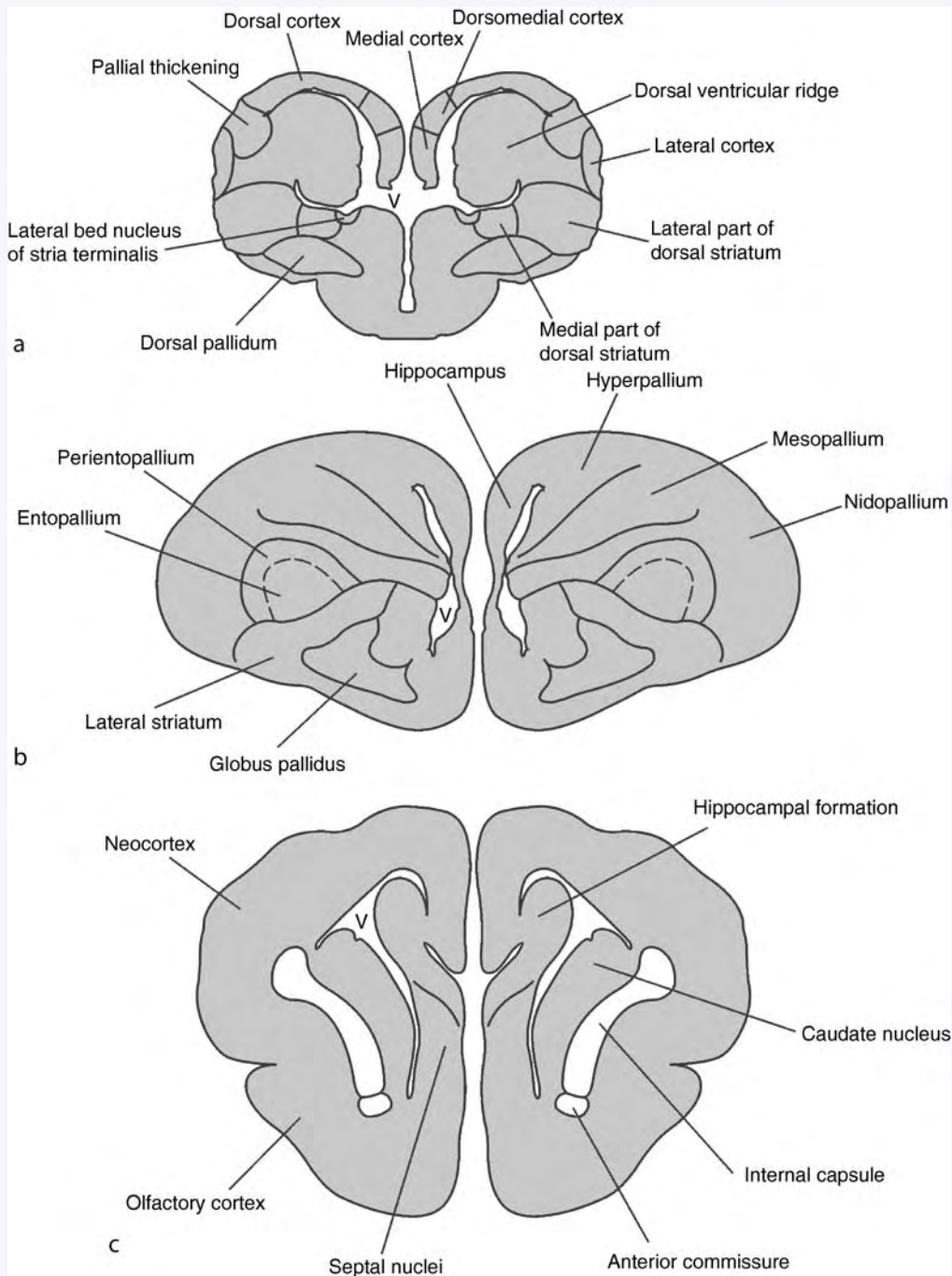

**Brain Evolution. Figure 5** Drawings of transverse sections through the telencephalons of three amniotes, all members of Group II with relatively elaborated cell populations, showing some of the pallial and subpallial regions. (a) A turtle, *pseudemys scripta*; (b) a pigeon, *Columba livia*; (c) a marsupial, *Hypsiprymnus rufescens*.

occurred at some point within the deuterostome radiation, such that the dorsal, or neural, surface in vertebrates corresponds to the ventral, also neural, surface in protostomes [14]. Nonetheless, the developmental patterning for the dorsoventral specification of the nervous system has been conserved. Likewise, rostrocaudal

patterning genes, including those for the initiation of eye development [15], have been highly conserved across all the Bilateria.

Across vertebrates, variation in the amount of cell proliferation and of the subsequent radial or tangential migration of neuron cell bodies at various rostrocaudal

locations along the neural tube accounts for much of the variation in brain structure. Such variation is particularly marked in the telencephalic pallium (the upper part of the telencephalon) in mammals (► [Evolution, and embryological development of cortex: in amniotes](#)) as compared to reptiles and birds (► [Evolution, and embryological development: of forebrain](#)). The evolutionary relationships (homologies) of various pallial regions, including some neocortical regions in mammals, are currently the subject of controversy [9] but clearly involve several crucial differences in proliferation and migration patterns during embryogenesis.

### Evolution of Regions and Systems across Vertebrate Brains

As a general rule, the evolution of caudal regions of the brain across vertebrates tends to be more conservative than that of more rostral regions, and much more variation in proliferation and migration patterns occurs in the sensory-related dorsal portion of the nervous system, the alar plate, than in the motor-related, ventral half, the basal plate [9]. While the alar plate is classified as sensory-related, this is in a broad sense, since the alar plate gives rise to a number of structures that are involved in motor-feedback relays and in regulation of movement initiation – the cerebellum and its related nuclei (such as the deep cerebellar and red nuclei) and the basal ganglia and their related nuclei (such as the substantia nigra). Brain evolution exhibits both conserved features and extensive diversity across the different, independent radiations of vertebrates – the jawless, cartilaginous, and ray-finned fishes (► [Evolution, of the brain: in fishes](#)); amphibians (► [Evolution, of the brain: in amphibians](#)); mammals (► [Evolution, of the brain: in mammals](#)); and the sauropsids, reptiles (► [Evolution, of the brain: in reptiles](#)) and birds (► [Evolution, of the brain: in birds](#)).

The spinal cord (► [Evolution, of the spinal cord](#)) exhibits specializations related to adaptations to particular niches across various taxa. Exceptionally large motor neurons involved in escape behaviors characterize the spinal cords of many fishes and of amphibians. The spinal cord in most tetrapods has enlarged segments related to the innervation of the limbs. The hindbrain (► [Evolution, of the hindbrain](#)) and midbrain (► [Evolution, of the optic tectum: in anamniotes](#); ► [Evolution, of the optic tectum: in amniotes](#); ► [Evolution, of nucleus Isthmi](#)) vary in the degree of development of the reticular formation (► [Evolution, of the reticular formation](#)) and of cranial nerve nuclei. Major variations in the cranial nerves (including those of the forebrain) include the presence of the lateral line series (► [Evolution, of mechanosensory and electro-sensory lateral line systems](#)) of cranial nerves in aquatic anamniotes [16], exceptional development of the gustatory system in some ray-finned fishes [17], dramatic variation of the trigeminal nerve sensory modality (including electrosensory and mechanosensory in mono-

tremes [18] (► [Evolution, of the trigeminal sensory system and its specializations](#)), magnetic in some fishes, amphibians, and birds [19], and infrared in snakes [20]. Additionally, some variation also exists across the more common modalities of touch, position sense, pain, and temperature, and vestibular sense (► [Evolution, of the vestibular system](#)), and, on the motor side, the oculomotor nerves (► [Evolution, of the oculomotor system](#)), and the presence of a distinct hypoglossal nucleus in tetrapods [21]. Likewise, variations occur across the telencephalic cranial nerves for the vomeronasal [22] and olfactory systems (► [Evolution, of the olfactory and vomeronasal systems](#)), and the terminal nerve (► [Evolution, of the terminal nerve](#)).

The reticular formation (► [Evolution, of the reticular formation](#)) is relatively conservative in its columnar organization across vertebrates, and ascending serotonin, norepinephrine, and dopamine systems are present in all the major taxa. Across mammals, variation in the number of subdivisions of these systems occurs in comparing one order to another, but these reticular formation systems and other areas of the brain as well appear to have a similar number of components in all species of a given order, indicating that the subdivisions were established at the time of ordinal evolution and have maintained themselves subsequently [23].

Substantial variation occurs across cerebellar evolution (► [Evolution, of the cerebellum](#)). Cyclostomes either have a very small cerebellum (lampreys) or lack it entirely (hagfishes). Across gnathostomes, the cerebellum exhibits a relatively high degree of conservation in its neural constituents and their organization [9], although variation occurs in the structure of the granule cell conglomerations, such as the presence of long, cylindrical granular eminences in cartilaginous fishes. In some ray-finned fishes, such as mormyrids, the cerebellum is markedly enlarged and elaborated in conjunction with its complex functional role in electroreception and conspecific communication. Also in ray-finned fishes, cerebellar efferent neurons called eurydendroid cells are present but are located within the cerebellar cortex rather than grouped in deep nuclei.

The roof of the midbrain – called the tectum in nonmammals and the colliculi in mammals – is conserved in its cortical cytoarchitecture and the basic organization of its afferent and efferent connections [9] (► [Evolution, of the optic tectum: in anamniotes](#); ► [Evolution, of the optic tectum: in amniotes](#)). The neurons in the more superficial layers of the optic tectum, or superior colliculus, receive visual system input, while the neurons within the deeper layers receive multisensory (somatosensory and/or auditory system) inputs and also give rise to efferent projections. The torus semicircularis, or inferior colliculus, receives auditory inputs, as well as other inputs such as those from lateral line nuclei in anamniotes. One rarely noted observation is that the

periaqueductal, or so-called central, gray of mammals is exceptionally well developed in comparison to all other vertebrate taxa.

Rather substantial variation occurs in the diencephalon [9] (►Evolution, of the diencephalon). Its four major divisions – epithalamus, dorsal thalamus (►Evolution, of the dorsal thalamus), ventral thalamus, and hypothalamus (►Evolution, of the hypothalamus: in anamniotes; ►Evolution, of the hypothalamus: in amniotes) – are universally present across vertebrates, but their degree of elaboration varies considerably. The dorsal thalamus is very modestly developed in anamniotes in comparison to amniotes but is involved in some of the ascending system pathways (►Evolution, of the visual system: in fishes; ►Evolution, of the visual system: in amphibians; ►Evolution, of the auditory system: in anamniotes). Likewise, the degree of elaboration of two more posterior diencephalic components – the pretectum and posterior tuberculum (►Evolution, of the posterior tuberculum and preglomerular nuclear complex) – generally shows an inverse relationship to that of the dorsal thalamus. In anamniotes, the dorsal thalamus generally consists of three nuclei, the two caudal of which comprise the collothalamus since they receive their predominant inputs from the midbrain roof, and the rostral of which comprises the lemnothalamus, since it receives its predominant inputs more directly either from the retina or other nontectal sources [9,24]. In many anamniotes, the more caudal parts of the diencephalon are more complexly elaborated. In many ray-finned fishes, for example, the pretectum has three superficial-to-deep divisions, each with multiple nuclei, and the posterior tuberculum has both dopamine-containing cells (homologous to the pars compacta of the substantia nigra and related cell groups of amniotes) and migrated nuclei of the preglomerular nuclear complex that receive ascending sensory input from the midbrain roof and relay it to the telencephalon (►Evolution, of mechanosensory and electrosensory lateral line systems).

In amniotes, the posterior tuberculum is represented by dopamine-containing cell groups but has no migrated sensory-relay nuclei, and the pretectum is reduced in comparison with some anamniotes. The dorsal thalamus, in contrast, contains numerous nuclei and/or nuclear groups that separately relay multiple modalities of sensory information to the telencephalon. Some of these nuclei are collothamic, receiving most of their inputs from the midbrain roof, and others are lemnothamic, receiving their predominant inputs from more direct, nontectal sources. Both sauropsids (birds and reptiles) and mammals have a number of homologous intralaminar, somatosensory-relay (►Evolution, of the somatosensory system: in nonmammalian vertebrates; ►Evolution, of the somatosensory system: in mammals), visual-relay (►Evolution, of the visual system: in

mammals – comparative evolutionary aspects across orders; ►Evolution, of the visual system: in mammals – color vision and the function of parallel visual pathways in primates; ►Evolution, of the visual system: in reptiles and birds), auditory-relay (►Evolution, of the auditory system: in mammals; ►Evolution, of the auditory system: in reptiles and birds), and limbic-related dorsal thalamic nuclei, although the currently understood parcellation of these nuclei is greater in birds and mammals than in reptiles. All amniotes have generally similar epithalamic, hypothalamic and ventral thalamic nuclei, although the relative development of the latter is more elaborate in mammals than in sauropsids. A thalamic reticular nucleus has also been identified in all amniotes.

The telencephalon is highly variable across vertebrates. Telencephalic evolution across anamniotes (Figs. 3 and 4) is surveyed in one essay specifically (►Evolution, of the telencephalon: in anamniotes) as well as in additional essays on particular brain regions and systems, while that in amniotes is covered in numerous regional and systems essays. In most major groups, its dorsal, or pallial, portion develops embryologically by a process of evagination, or out-pouching, of the hemispheres. In ray-finned fishes, however, it develops by a process called eversion (►Evolution, of the brain: in fishes; ►Evolution of the pallium: in fishes), in which the midline roof portion thins to only an ependymal tissue layer and the originally medial-most part of each hemisphere turns outward, coming to lie in the lateral-most position with regard to other pallial regions, and the originally lateral-most portion likewise is reversed in its topology, coming to lie in the medial-most position. Nonetheless, the specification of the originally medial pallium as the hippocampal formation and the originally lateral pallium as like the amygdala in nature is apparently established before the eversion process commences and thus retained in the adult phenotype [25].

The degree of pallial development and elaboration corresponds in most taxa with the brain-body ratio, and thus some cartilaginous fishes, some ray-finned fishes, and, among amniotes, birds and mammals, exhibit the relatively largest pallial regions and elaboration of them in terms of cell proliferation and migration. Amphibians (►Evolution, of the pallium: in amphibians), in contrast, are among the taxa with a lesser degree of pallial elaboration. As noted above, differences in both these developmental factors account for substantial anatomical differences between the pallia of sauropsids and mammals (Fig. 5). In mammals, the neocortex occupies the largest portion of the pallium, with areas for primary and associated sensory system inputs, as discussed for those systems individually, and higher-order association areas (►Evolution, of association pallial areas: parietal association areas in mammals). Across the different orders of mammals, including



eulipotyphlans (previously called insectivores), carnivores, bats, rodents, and primates, some of the association areas for multiple sensory representations have been independently gained [26,27]. As in other vertebrates, the hippocampus occupies the medial part of the pallium (►Evolution, of the hippocampus). The olfactory cortex (►Evolution, of the olfactory and vomeronasal systems) and the pallial components of the amygdala (►Evolution, of the amygdala: in tetrapods; ►Evolution, of the pallium: in fishes) occupy its lateral part. Pallial areas are relatively modest in reptiles (►Evolution, of the pallium: in reptiles and birds; ►Evolution, of association pallial areas: in reptiles), but birds exhibit a substantially enlarged pallium, including regions, such as the Wulst (►Evolution, of the Wulst), entopallium, and area L (for the newly revised avian terminology, see [28]), that receive ascending sensory inputs from dorsal thalamic nuclei, as well as multiple, higher-order association areas [29] (►Evolution, of the pallium: in birds and reptiles; ►Evolution, of association pallial areas: in birds). Hominids have few if any neocortical or other neural characters that distinguish them from the rest of primates and/or other mammals [30], but recent insights into hominid evolution have been gained from comparative studies (►Evolution, of the brain: in humans – paleoneurology; ►Evolution, of the brain: in humans – specializations in the comparative perspective).

At least part of the subpallium receives ascending dopaminergic input across all vertebrates (►Evolution, of the telencephalon: in anamniotes), but the basal ganglia (striatopallidal complexes) are most robustly developed in amniotes (►Evolution, and embryological development: of forebrain). The same relative development also characterizes the septal nuclei (►Evolution, of the septal nuclei) and the basal forebrain cholinergic cell groups (►Evolution, of the subpallial cholinergic cell groups). Likewise, descending motor pathways show differential development (►Evolution of motor systems: corticospinal, reticulospinal, rubrospinal, and vestibulospinal systems). Nonmammalian tetrapods are characterized by a prominent pathway from the basal ganglia to the tectum via the pretectum [31], while in mammals other descending motor pathways predominate. Birds have elaborate forebrain nuclei and pathways involved in the production of song [32] (►Evolution, of motor systems: vocal and song systems of birds). Some fishes have uniquely evolved motor pathways for the production of acoustic or electromotor system signaling [33].

### Evolutionary Transitions

As noted above, currently available evidence indicates that the evolutionary transition from invertebrate chordate to definitive vertebrate (►Evolution, of the brain: at the invertebrate-vertebrate transition) entailed

at least two major steps – first, the enlargement and elaboration of the diencephalon with paired eyes and the hindbrain along with the gain of visceral arches and, second, the further enlargement of the brain with the gain of a definitive telencephalon, the elaboration of the neural crest and all or most neurogenic placode-derived sensory systems, and the substantial further elaboration of other neural crest derivatives. Among the major vertebrate taxa, the Group II grade of organization, with enlargement and elaboration of brain regions, in most cases involving the pallium, has occurred multiple times independently – in hagfishes, some cartilaginous fishes, some ray-finned fishes (Fig. 4), and, within the sarcopterygian radiation, in amniotes (Fig. 5). In contrast, the Group I grade of organization, with relatively little cell proliferation and migration, characterizes the brains of lampreys, some cartilaginous and ray-finned fishes, and amphibians [9] (Fig. 3).

The transition to ray-finned fishes involved a novel mode of telencephalic development, as discussed above – eversion of the pallium that results in a reversal of the medial-to-lateral topology (►Evolution, of the brain: in fishes; ►Evolution, of the pallium: in fishes). The crossopterygian fish *Latimeria*, a sarcopterygian, also has partial eversion of the pallium, a condition that may have been independently derived. At the anamniote-amniote transition, several major changes occurred in forebrain organization. Two shifts in the predominant projection target occurred for medially and laterally projecting ascending sensory pathways – from the medial, hippocampal pallium to the newly expanded lemnopallial areas (in receipt of lemnthalamic projections) and from the laterally lying and subpallial striatum to the newly expanded collopallial areas (in receipt of collothamic projections). The lemnopallium in reptiles and birds includes cortical-like areas such as the Wulst in birds and part of the mesopallium, while the collopallium comprises the dorsal ventricular ridge (which includes part of the mesopallium and all of the nidopallium in birds). In contrast, in the line to mammals, these same shifts in projections occurred, but in mammals, the lemnopallium includes the primary sensory areas for the visual and somatosensory system, while the collopallium includes all of the auditory cortical areas, multiple association cortical areas for other sensory systems, and the lateral amygdala [34]. Since the dorsal ventricular ridge is unique to sauropsids and the neocortex unique to mammals, these structures may have become enlarged and elaborated separately in the two lineages after their evolutionary divergence [34,35].

Subsequently, at the reptile-bird transition (►Evolution, of the brain: at the reptile-bird transition) a further and substantial expansion of telencephalic pallial regions occurred. In the earliest sauropsids, predominant expansion of collothamic nuclei and their telencephalic projections characterized the dorsal

thalamus, in contrast to predominant expansion of lemnthalamic nuclei and their telencephalic projections in the earliest mammals. In multiple orders of mammals, subsequent elaboration of the collothalamus and collopallium then occurred [34]. In contrast, within sauropsids, in birds a subsequent elaboration of the lemnthalamus and lemnopallium occurred [34]. Thus, in both mammals and birds, both lemnthalamic and collothalamus systems are robustly developed.

### Brain Evolution across Vertebrates

The substantial amount of variation in brain structure across vertebrates depends, at its most fundamental level, on variations in cell proliferation and migration, orchestrated by patterning gene expression in the rostrocaudal, mediolateral (radial), and dorsoventral axes, with most of the variation occurring in alar plate-derived (dorsal) structures. While some animals have utilized strategies of having enlarged brains relative to their body weight (Group II), others have retained or secondarily acquired relatively laminar, less elaborated brains (Group I). Either strategy can be successful evolutionarily as evinced by the range of taxa that currently are extant.

Some of the most marked variations occur in the arrangement of neurons within particular areas, one of the most dramatic examples being that of the largely nuclear sauropsid pallium versus the largely cortical mammalian pallium. Despite the marked differences in cytoarchitecture, many of the ascending sensory and motor-feedback pathways and descending motor output pathways exhibit extensive similarities, and both of these pallial architectures are capable of high-level cognitive functions, particular for birds among the sauropsids in comparison to mammals.

The field of comparative neurobiology has substantial potential to contribute insights to how neural circuits perform certain functions, from the most basic sensory analyses to very high-level cognitive processes. The comparative method allows one to test hypotheses based on mammalian brain architecture and address the most fundamental mechanisms of neural computations and their resultant mental and behavioral manifestations.

► Evolution of the Brain: Amphibians

► Evolution of the Brain: Urbilateria

### References

1. Wagner GP (1989) The biological homology concept. *Annu Rev Ecol Syst* 20:51–69
2. Butler AB, Sidel WM (2000) Defining sameness: historical, biological, and generative homology. *Bioessays* 22:846–853
3. Jerison HJ (1973) *The evolution of the brain and intelligence*. Academic Press, New York
4. Mallatt J, Chen J-Y (2003) Fossil sister group of craniates: predicted and found. *J Morphol* 258:1–31
5. Butler AB (2000) Chordate evolution and the origin of craniates: an old brain in a new head. *Anat Rec New Anat* 261:111–125
6. Northcutt RG, Gans C (1983) The genesis of neural crest and epidermal placodes: a reinterpretation of vertebrate origins. *Quart Rev Biol* 58:1–28
7. Furlong RF, Holland PWH (2002) Bayesian phylogenetic analysis supports monophyly of Ambulacraria and of cyclostomes. *Zool Sci* 19:593–599
8. Northcutt RG (1981) Evolution of the telencephalon in nonmammals. *Annu Rev Neurosci* 4:301–350
9. Butler AB, Hodos W (2005) *Comparative vertebrate neuroanatomy: evolution and adaptation*, 2nd edn. Wiley-Liss, Hoboken NJ
10. Jerison HJ (2001) The study of primate brain evolution: where do we go from here? In: Falk D, Gibson KR (eds) *Evolutionary anatomy of the primate cerebral cortex*. Cambridge University Press, Cambridge UK, pp 305–333
11. Northcutt RG (1990) Ontogeny and phylogeny: a re-evaluation of conceptual relationships and some applications. *Brain Behav Evol* 36:116–140
12. Holland PWH, Takahashi T (2005) The evolution of homeobox genes: implications for the study of brain development. *Brain Res Bull* 66:484–490
13. Reichert H, Simeone A (2001) Developmental genetic evidence for a monophyletic origin of the bilaterian brain. *Philos Trans R Soc Lond B* 356:1533–1544
14. De Robertis EM, Sasai Y (1996) A common plan for dorsoventral patterning in Bilateria. *Nature* 380:37–40
15. Halder G, Callaerts P, Gehring WJ (1995) New perspectives on eye evolution. *Curr Opin Genet Dev* 5:602–609
16. Atema J, Fay RR, Popper AN, Tavolga WN (eds) (1988) *Sensory biology of aquatic animals*. Springer, Berlin Heidelberg New York
17. Finger TE (1991) Gustatory nuclei and pathways in the central nervous system. In: Finger TE, Silver WL (eds) *Neurobiology of taste and smell*. Krieger, Malabar, FL, pp 331–353
18. Proske U, Gregory JE, Iggo A (1998) Sensory receptors in monotremes. *Philos Trans R Soc Lond B* 353:1187–1198
19. Wiltschko R, Wiltschko W (1995) *Magnetic orientation in animals*. Springer, Berlin Heidelberg New York
20. Hartline P (1974) Thermoreception in snakes. In: Fessard A (ed) *Electroreceptors and other specialized receptors, handbook of sensory physiology*, vol. III/3. Springer, Berlin Heidelberg New York, pp 297–312
21. Schmidt A, Wake DB, Wake MH (1996) Motor nuclei of nerves innervating the tongue and hypoglossal musculature in a caecilian (Amphibia: Gymnophiona), as revealed by HRP transport. *J Comp Neurol* 370:342–349
22. Eisthen HL (1997) Evolution of vertebrate olfactory systems. *Brain Behav Evol* 50:222–233
23. Manger PR (2005) Establishing order at the systems level in mammalian brain evolution. *Brain Res Bull* 66:282–289
24. Butler AB (1994) The evolution of the dorsal thalamus of jawed vertebrates, including mammals: cladistic analysis and a new hypothesis. *Brain Res Rev* 19:29–65

25. Broglio C, Gómez A, Durán E, Ocaña FM, Jiménez-Moya F, Rodríguez F, Salas C (2005) Hallmarks of a common forebrain vertebrate plan: specialized pallial areas for spatial, temporal, and emotional memory in the actinopterygian fish. *Brain Res Bull* 66:277–281
26. Kaas JH (1995) The evolution of isocortex. *Brain Behav Evol* 46:187–196
27. Krubitzer L, Huffman KJ (2000) Arealization of the neocortex in mammals: genetic and epigenetic contributions to the phenotype. *Brain Behav Evol* 55: 322–335
28. Reiner A, Perkel DJ, Bruce LL, Butler AB, Csillag A, Kuenzel W, Medina L, Paxinos G, Shimizu T, Striedter G, Wild M, Ball GF, Durand S, Güntürkün O, Lee DW, Mello CV, Powers A, White SA, Hough G, Kubikova L, Smulders TV, Wada K, Dugas-Ford J, Husband S, Yamamoto K, Yu J, Siang C, Jarvis ED (2004) Revised nomenclature for avian telencephalon and some related brainstem nuclei. *J Comp Neurol* 473: 377–414
29. Avian brains Nomenclature consortium: Jarvis ED, Güntürkün O, Bruce L, Csillag A, Karten H, Kuenzel W, Medina L, Paxinos G, Perkel DJ, Shimizu T, Striedter G, Wild JM, Ball GF, Dugas-Ford J, Durand SE, Hough GE, Husband S, Kubikova L, Lee DW, Mello CV, Powers A, Siang C, Smulders TV, Wada K, White SA, Yamamoto K, Yu J, Reiner A, Butler AB (2005) Avian brains and a new understanding of vertebrate brain evolution. *Nat Rev Neurosci* 6:151–159
30. Preuss TM (1995) The argument from animals to humans in cognitive neuroscience. In: Gazzaniga MS (ed) *The cognitive neurosciences*. MIT, Cambridge, MA, pp 1227–1241
31. Reiner A, Medina L, Veenman CL (1998) Structural and functional evolution of the basal ganglia in vertebrates. *Brain Res Rev* 28:235–285
32. Hall WS, Brauth SE (eds) (1994) Avian auditory-vocal interfaces. Fifth Annual Karger Workshop. *Brain Behav Evol* 44:187–286
33. Meek J, Grant K (1994) The role of motor command feedback in electrosensory processing. *Eur J Morphol* 32:225–234
34. Butler AB (1994) The evolution of the dorsal pallium in the telencephalon of amniotes: cladistic analysis and a new hypothesis. *Brain Res Rev* 19:65–101
35. Reiner A (2000) A hypothesis as to the organization of cerebral cortex in the common amniote ancestor of modern reptiles and mammals. In: Bock GR, Cardew G (eds) *Evolutionary developmental biology of the cerebral cortex*, Novartis Foundation Symposium 228. Wiley, Chichester, UK, pp 83–102

cytokines and involves activation of microglia as a key feature; it can result in brain lesions and/or altered brain structure.

#### ► Prenatal Brain Injury by Chronic Endotoxin Exposure

## Brain Inflammation: Biomedical Imaging

HAIDER ALI KHAN<sup>1</sup>, NASSER S. BALLANI<sup>2</sup>  
<sup>1</sup>Nuclear Medicine Department, Kuwait Center for Specialized Surgery, Kuwait  
<sup>2</sup>Biomedical Sciences, Lebanese International University, Beirut, Lebanon

### Definition

Brain imaging confirms early diagnosis which is important as delay in treatment of an infection-dependent brain disease reduces the chance of cure. Different modalities and methods that are used in the brain inflammatory/infection imaging will be reported and briefly discussed here.

Brain inflammatory diseases determine the imaging modality and the specific methods that have to be implemented. For instance, whereas Computed Tomography (CT) technique is sufficient to detect anatomical changes associated with most infectious processes in the brain, Single Photon Computerized Tomography (SPECT) or Positron Emission Tomography (PET) techniques would differentiate lymphoma from toxoplasmosis based on principles of functional imaging [1]. Magnetic Resonance Imaging (MRI) is a superior imaging modality and meets the demands for more complicated extended infectious disease process detection. MRI is a sensitive tool in detection of the inflammatory brain diseases and the specificity can be further increased by using new advanced MRI techniques; parenchymal complications are resolved by diffusion weighted imaging (DWI) and complications like subdural and epidural empyema can be resolved using fluid attenuated inversion recovery (FLAIR) sequences [2].

Although the brain is well protected by the cranial vault, the covering meninges, and the blood brain barrier (BBB) which acts a mechanical shock absorber, anatomical barrier and physiological filter, yet once an infective agent gets into the brain it can cause a severe inflammatory response due to the absence of lymphatic channels in the brain, lack of capillaries in the subarachnoid space and the existence of a good culture and dissemination medium like the circulating CSF [2].

## Brain Inflammation

### Definition

Inflammation occurs in response to hypoxemia/ischemia and infection. It is mediated by pro-inflammatory

The immune system plays an important role in the development of CNS involvement in viral infections and in patients with Acquired immunodeficiency syndrome (AIDS).

Cerebral Infections may be conveniently compartmentalized [2] to different parts of the brain e.g. Brain abscess is characterized by a focal infectious process, while Encephalitis results in a more diffuse involvement of the brain parenchyma. Infection of the pia-arachnoid (Leptomeninges) and intervening cerebrospinal fluid is termed as meningitis and involvement of dura-matter result in subdural or epidural empyema.

## Characteristics

### Brain Abscess

Early diagnosis of bacterial brain sepsis is essential in order to avoid morbidity. Brain abscesses are about two to three times more frequent in males than in females. The most common cause is extension from adjacent sinuses, penetrating trauma or surgery and hematogenous spread in the case of structural integrity of the skull. Hematogenous abscess typically results in septic emboli being deposited in the distribution of the middle cerebral arteries. In approximately 20–30% of brain abscesses, the source of origin is inapparent.

Diseases of the brain, including brain abscess, result in a breakdown of the blood brain barrier (BBB), which allows localization of conventional brain imaging agents in these lesions. Conventional brain scintigraphy agents include Tc99m-Pertechnetate, Tc99m-Glucoheptonate, or Tc99m-DTPA. Although not extensively used currently, imaging with these agents show invariably increased blood flow to inflammatory lesions on initial dynamic acquisition. Abscesses revealed increased activity on delayed images, with a “doughnut” appearance [3]. These findings were, however, not specific and could also be seen with neoplasms and infarction, albeit rarely. Others have found leucocyte scintigraphy [4] as a valuable aid in the differential diagnosis between abscess and neoplasm with a reported sensitivity, specificity and diagnostic accuracy for leucocyte scintigraphy of 100, 97.8 and 98.4%, respectively. They also claim that the results of leucocyte scintigraphy is not effected by corticosteroid therapy and that the necessity to wait for 24 h in order to obtain the most reliable information does not seem to be an unacceptable delay in the daily clinical routine. However a false-positive result cannot be avoided if there is an intense inflammatory process infiltrating the tumor.

Anatomical localization of brain abscess by CT and MRI depends on its stage of development. The initial stage is a focal cerebritis, which soon develops central necrosis and is surrounded by edema. With time, the lesion forms a capsule and “ripens” into an established brain abscess. During the cerebritis phase, CT scans show low-density abnormalities with mass effect, in close proximity to sinuses with evidence of inflammatory changes. In a

mature abscess, the CT scan show characteristic ring-enhancing lesion with smooth margins. Attempts have been made to identify distinctive radiologic characteristics of ring-enhancing lesions. In general, abscesses are said to possess a thin, uniform ring, which is thinner on the medial border, and a smoother outer margin; satellite lesions are often present. By contrast, neoplasms have thicker, more irregular rims. Ring-enhancing lesions seen in demyelinating disease tend not to be perfect rings, but rather incomplete rings, hence the “open-ring sign” [2]. However, despite these attempts to correlate imaging features with specific underlying lesions, such lesions cannot be distinguished purely on the basis of radiological findings. The differential diagnosis of ring-enhancing lesions largely depends on the immune status of the patient. In the immunocompetent host, tumors – both primary and metastatic – and pyogenic abscesses remain the most likely diagnostic criteria; abscesses caused by atypical organisms and demyelinating disease must also be considered. In the immunocompromised host, the leading diagnoses are toxoplasmosis and primary CNS lymphoma. Furthermore, these patients are at risk for abscesses, from both pyogenic and atypical organisms, and tumors. Tuberculous brain abscess should be considered in endemic regions in both immunocompetent and immunocompromised hosts.

MRI can detect contrast enhancement with higher sensitivity. It is especially useful for detecting or excluding accompanying meningeal and ependymal reactions. It is also better than CT for detection of complicating dural sinus thrombosis. In cerebritis MRI, the characteristic findings are areas of low density on T1-weighted images and, on proton-density or T2-weighted images, high-intensity areas surrounded by areas of patchy enhancement with gadolinium. In a mature abscess, on T1-weighted images, the encapsulated abscess appears as a round, low-intensity lesion with mass effect and a surrounding area of low density, signifying edema. On proton-density and T2-weighted images, the abscess has a high-intensity signal in the center and in the surrounding parenchyma as a consequence of the adjacent cerebral swelling. Ring enhancement occurs with gadolinium [2].

Advanced ►neuroimaging techniques, such as single-voxel MRI spectroscopy (MRS) and diffusion-weighted imaging (DWI), have markedly improved the specificity of MRI for distinguishing bacterial abscess from other infections and from cystic and necrotic tumors. MRS reveals metabolites of bacterial origin, including acetate, lactate, succinate, cytosolic acid, and amino acids (alanine, valine, leucine). The spectral pattern of cystic or necrotic brain tumors is quite different and normally contains elevated choline (indicating cellular proliferation) and decreased *N*-acetyl-aspartate (NAA) (denoting loss of neurons), with variable amounts of lactate and lipids. In fact, a succinate peak on MR spectroscopy, although not seen in all brain abscesses, is fairly specific

for the diagnosis of intracranial infection rather than neoplasm because it was not seen in any brain tumors investigated. Acetate and pyruvate were only seen in conjunction with infection and not with tumors, as well [5], however, MR spectroscopy does not appear helpful in distinguishing parasitic or fungal infections from tumors.

Stationary water, unlike freely moving water, is depicted as high signal intensity on DWI, with a decreased signal on the corresponding apparent diffusion coefficient (ADC) maps. DWI shows restricted diffusion and high signal intensity in bacterial abscesses. The presence of pus within the abscess cavity, which consists of numerous leukocytes and proteinaceous fluid with high viscosity, accounts for the restricted diffusion and high signal intensity on DWI and low ADC values. In contrast, the cystic or necrotic portions of brain tumors typically are less cellular and have less viscous fluid consistency. As a result, tumors show low signal intensity on DWI and higher ADC values [2].

Because of the known uncertainties in the differential diagnosis of an intracerebral ring-enhancing lesion on CT and MRI, preoperative metabolic imaging with PET is under investigation as a novel tool for the noninvasive identification of benign or malignant ring-enhancing lesions. Positron emission tomography (PET) can provide dynamic information regarding the metabolism of a lesion, which may be useful for differentiating tumors from abscesses, with specificity and sensitivity above 90%. Most commonly used agents are 18F-FDG, [methyl-11C]-L-methionine (11C-MET) and *O*-(2-18F-fluoroethyl)-L-tyrosine (18F-FET). Tumors typically show increased metabolic activity in the center of the lesion, whereas abscesses do not. However, in high-grade neoplasms that often hold a necrotic center, the reduced metabolic activity in the center of the tumor can make it difficult to differentiate from the pattern found in abscesses [6].

### Leptomeningeal Diseases

The differential diagnosis includes meningitis (fungal, TB, bacterial and neurosyphilis), sarcoidosis and cysticercosis. Imaging studies are done to confirm the diagnosis and to detect complications like vascular thrombosis, brain infarctions, abscess, ventriculitis, hydrocephalus, empyemas of epidural or subdural spaces and subdural effusions.

**Acute bacterial meningitis:** Acute Meningitis is either bacterial or viral in origin. Viral meningitis is usually self limiting and seldom requires treatment while bacterial meningitis can cause irreversible brain damage if not treated promptly.

MRI without contrast enhancement is usually unremarkable in acute meningitis, however after gadolinium administration there is intense diffuse leptomeningeal enhancement which is over the cerebrum,

inter-hemispheric fissure and the sylvan fissure. Meningeal enhancement is non-specific as it also occurs after ventriculo-peritoneal shunts, craniotomy and subarachnoid hemorrhage. Moreover absence of contrast enhancement does not rule out meningitis as it may be missing in some cases. Fluid attenuation inversion recovery (FLAIR) show increased CSF signal intensity due to increased CSF protein concentration and combined with leptomeningeal gadolinium enhancement further increase the sensitivity of MRI findings for the diagnosis of meningitis [2].

### Tuberculosis

Diffuse Tuberculosis [2] leptomeningitis is the most common presentation of intracranial TB. On unenhanced CT scans, parasellar, perimesencephalic, and sylvian cisterns appear obliterated by abnormal isodense enhancing soft tissue. Communicating hydrocephalus and basal infarctions may develop. Granulomas show solid or ring enhancement. Tuberculomas may be indistinguishable from malignant gliomas; lesion is hypodense and has an irregular contour. It shows either nodular or ring enhancement.

### Neurocysticercosis

Neurocysticercosis, [2] a CNS infection by the larval stage of pork tapeworm, *Taenia solium*, can involve brain parenchyma, ventricles, or its meninges and is characterized by homogeneously enhancing multifocal lesions, which later develop into fluid-filled cysts without surrounding edema and enhancement. In due course, calcification (70%), and hydrocephalus develops in 70% of these patients.

### Sarcoidosis

CNS involvement is rare in Sarcoidosis, seen as enhancing tissue in the basal cisterns, optic chiasm, and pituitary stalk on contrast enhanced CT scans. MRI is more accurate for the sagittal and coronal localization of lesions. Low-grade primary brain tumors may also cause obstruction of the basal CSF spaces, in which case coronal MRI using fluid-attenuated inversion recovery (FLAIR) sequences – can define the mass as originating in the brain parenchyma [2].

### Encephalitis

Encephalitis is characterized by diffuse brain parenchymal inflammation and is most commonly viral in origin. Common viruses are herpes simplex virus type I and II (HSV 1 & 2), herpes zoster, arboviruses and enteroviruses. In immune compromised host human immunodeficiency virus (HIV), cytomegalovirus (CMV) papovavirus (progressive multifocal leukoencephalopathy) and a variety of other organism are involved and discussed separately under AIDS-related Infections.

### **Herpes Encephalitis (Type I)**

Herpes Encephalitis (Type I) is characterized by fulminant, necrotizing, hemorrhagic meningoencephalitis; 70% of cases are adult, with a mortality of about 70%. CT is normal until 4 days. Later areas of hypodensity without enhancement appear [7] usually in the medial temporal lobe and inferior frontal lobes, 20–50% are bilateral. Hemorrhages occur in 50%. Late gyral enhancement may be seen. MRI as areas of ill defined low signal intensity on T1W images and high signal intensity on T2W and FLAIR images, beginning on one side and becoming bilateral. Variable gyral enhancement and mass effect may be present. Hemorrhagic foci appearing as high signal intensity on both T1 and T2W images may occasionally be seen. Herpes encephalitis is curable with early antiviral therapy but if left untreated there is high incidence of sequelae with high mortality rate.

SPECT agents such as Tc-HMPAO and Tc-ECD reflect cerebral perfusion and brain SPECT scintigraphy help provide complementary functional information to anatomical imaging. Activated neurons have increased glucose consumption, but lack the ability to store glucose. Therefore, increased cerebral blood flow (CBF) is needed to deliver the glucose required for an increased metabolic demand. Thus, CBF is coupled to neuronal activity and the delivery of nutrients like oxygen and glucose to each cerebral region is according to its metabolic need. CBF and metabolism remain coupled under most physiologic conditions, with some exceptions, e.g. subacute stroke and some brain tumors. This relation between CBF, metabolism, and neuronal activity forms the basis of brain perfusion SPECT imaging for detecting cerebral dysfunction [1]. Studies have shown that Tc-ECD is a perfusion marker of viable brain tissue, while Tc-HMPAO fixation is not metabolically linked and therefore demonstrates luxury perfusion, which can result in an inability to properly identify areas of nonviable brain [1].

### **Viral Encephalitis**

Viral Encephalitis during the acute phase show typically an area of increased Tc99m-HMPAO uptake at the site of infection due to cerebral hyperemia (i.e. a “hot spot”) in up to 94% of cases. During the subacute phase (15 days after presentation), a follow-up scan may demonstrate either normal or decreased tracer uptake at the same site. Patients with a normal perfusion pattern in the subacute phase have very good clinical prognosis, while those with decreased perfusion pattern are associated with decreased intelligence or learning disabilities [8]. Discordant increased Tc-HMPAO activity, but decreased activity on Tc-ECD exam, has been reported [1].

### **Lyme Disease**

Lyme disease (borreliosis) is Tick-borne multisystem inflammatory disease caused by the spirochete *Borrelia burgdorferi*. The Central nervous system (CNS) involvement [2] occurs in 10–15% of cases. Produce a variety of neurologic and psychiatric disturbances like short-term memory loss, severe depression (seen in up to 70% of patients), and personality changes marked by irritability and mood swings may be produced. CNS involvement may take the form of neuritis, meningitis, encephalitis, and myelitis. CT scan may reveal bilateral focal low-attenuation enhancing lesions due to demyelination and perivascular inflammation in the deep cerebral white matter. Most commonly seen in the frontal lobes. The diagnosis is made serologically (titers). Erythema migrans is often present.

Lyme encephalopathy most commonly produces multiple focal areas of hypoperfusion on brain perfusion SPECT affecting both the cortex and deep brain structures. Significant perfusion abnormalities can be identified in up to 50% of affected patients. Diffusely reduced cerebral cortical flow has also been described. SPECT imaging can also be used to monitor response to therapy as areas of abnormal perfusion can reverse with treatment [8]. MRI [2] is more sensitive. CNS involvement by Lyme disease can resemble multiple sclerosis in both its clinical and imaging features. Unlike multiple sclerosis, however, the focal white-matter hypodensities on CT scans tend to be peripheral rather than periventricular. Contrast enhancement may or may not occur and is seen more clearly on magnetic resonance images. If meningitis is present, meningeal enhancement will be seen if the findings are sufficiently pronounced. The focus in follow-up is on assessing the treatment response. MRI is generally preferred for this purpose.

### **Listeriosis**

Listeriosis [7] is caused by the bacterium *Listeria monocytogenes*. The CNS, particularly the brain stem (rhombencephalitis), is most commonly involved which leads swiftly to respiratory failure. CT shows decreased density and slightly increased volume in the affected brain areas. Faint contrast enhancement may be evident. MRI is considerably more sensitive than CT in most respects, and it has become the preferred modality for evaluating listeriosis. However neither MRI nor CT can confirm listeriosis as the cause of meningitis or encephalitis. The diagnosis is established by serologic methods.

### **Immune-Mediated Encephalomyelitis or Acute Disseminated Encephalomyelitis (ADEM)**

Immune-mediated encephalomyelitis or Acute disseminated encephalomyelitis (ADEM) is probably an autoimmune reaction in response to a preceding infection or vaccination. Mortality range from 10 to

25%, survivors may recover completely. CT may be normal. Bilateral confluent low-attenuation changes in subcortical white matter may occur [7]. MR demonstrates lesions in the white matter of the cerebrum, cerebellum and brainstem, often while CT is normal or non-diagnostic. The lesions may be patchy and involve the deep and subcortical white matter. Involvement of the deep gray matter has also been reported.

### **Subdural and Epidural Empyemas**

Subdural and epidural empyemas result from spread of infection from sinusitis, mastoiditis or sites of trauma and craniotomy. In children it most commonly results as a complication of bacterial meningitis. Even small subdural empyemas, may cause severe sequelae such as vein thrombosis, infarcts and parenchymal abscesses if left untreated. In most cases anti-microbial therapy is not sufficient and surgical drainage is required for satisfactory recovery and brain decompression. Small peripheral crescent shaped empyemas near the cranial vault are not well visualized on CT scans. MRI is the imaging modality of choice [2]. On T1W and FLAIR images they appear as areas of high signal intensity in comparison to the CSF because of their high protein content and inflammatory debris and on T2WI signal intensity is equal to that of CSF. Similar to brain abscess they show high signal intensity on DWI with low ADC values. Mass effect on adjacent CSF and associated parenchymal abnormalities like brain edema, abscesses, cortical and dural vein thrombosis can all be evaluated on more reliable on MRI. In contrast epidural empyemas have an insidious course and are characterized by a lentiform extra-dural collection associated with marked enhancement of the often thickened inflamed dura with no involvement of the adjacent brain parenchyma.

### **Acquired Immunodeficiency Syndrome (AIDS) and AIDS-Related CNS Infections**

CNS involvement is the cause of initial complaint in about 10% of AIDS patients. However, in due course of the disease neurological complications develop in more than one-third of patients. Most infections are opportunistic and bacterial infections are rare. A distinct feature of CNS infection in AIDS is the lack of inflammatory response of the surrounding neural tissue and the neuroimaging features are characterized by cerebral atrophy, mass lesions, white matter changes and chronic meningitis [2].

The most common brain involvement in AIDS is Progressive diffuse leukoencephalopathy (PDL) (subacute encephalomyelitis or AIDS dementia complex) resulting from direct invasion by Human immunodeficiency virus. Impairment of cellular immunity causes reactivation of cytomegalovirus and papovavirus infections in AIDS patients resulting in necrotizing encephalitis and progressive multifocal leukoencephalopathy (PML).

Intracranial mass lesions account for as many as one-half the neurologic disorders associated with HIV infection. Toxoplasmosis is the most common cause of intracerebral mass lesion occurring in adults in association with HIV infection, followed by fungal meningo-encephalitis caused by *Cryptococcus neoformans* (Cryptococcosis). Other nonpyogenic organisms causing brain abscess in AIDS patients include mycobacterium tuberculosis and fungi like *Aspergillus*, *Mucormycosis* and *Candida*. The most common brain neoplasm observed in association with HIV infection is primary CNS lymphoma (PCNSL). Other neoplasms that have been reported in association with HIV infection include gliomas, Kaposi's sarcoma, and metastatic tumor [2].

### **Progressive Diffuse Leukoencephalopathy**

The HIV virus cause direct damage of the brain causing sub acute encephalitis in about two thirds of the patients. The onset is gradual but the course is progressive with impairment of cognition, memory, and loss of concentration. Although extensive changes are seen in brain parenchyma on biopsy specimen however the findings on CT and MRI are not so remarkable. Not infrequently there is only diffuse nonspecific brain atrophy with a central predominance, inconsistent with the patient's age. MRS can demonstrate significant drop in NAA and an elevation of choline and myoinositol (glial marker), reflecting early neuronal damage long before the above structural abnormalities become evident on conventional MRI [2].

### **Cytomegalovirus Encephalitis**

Reactivation of CMV causes necrotizing encephalitis involving mainly the grey matter and ependymitis, sparing the white matter to a large extent. This is in contrast to HIV encephalitis and PML which mainly affect the white matter. FLAIR and T2WI show increased intensity signals of nodular pattern in the periventricular region often involving the splenium and genu of the corpus callosum with patchy subependymal enhancement [7].

### **Progressive Multifocal Leukoencephalopathy**

PML is caused by JC papovavirus infection and is a late finding with an average survival time of 3 months. It mainly affects the myelin forming oligodendrocytes causing subcortical and deep white matter demyelination resulting in a rapidly deteriorating neurological syndrome with altered mental status, motor weakness and visual field defects and ataxia. Dementia is not a feature of PML. CT shows asymmetric focal decrease of attenuation in the parieto-occipital area [7]. On MRI, affected regions appear hyperintense on T2 and FLAIR sequences, and hypointense on T1. Gadolinium enhancement occurs in less than 10% of active lesions [7]. Hyperintensity on diffusion-weighted imaging has also been reported [7].

### Intracranial Mass Lesion

Intracranial mass lesion in an HIV-infected person is generally heralded by headache, seizures, altered level of consciousness, impaired cognitive function, or focal neurologic signs and symptoms. High-resolution CT after double dose iodinated contrast is a very sensitive technique for detecting these lesions. However, its limitations, particularly with respect to the visualization of lesions in the posterior fossa, are well recognized. The most sensitive diagnostic study for the demonstration of an intracranial mass lesion is cranial MRI performed with and without a contrast agent, such as gadolinium. Although imaging studies are sensitive for detecting focal brain lesions, they have low specificity for establishing a specific pathologic diagnosis and brain biopsy remains the gold standard. However brain biopsy is an invasive procedure and although associated with an overall yield of 90% it has an alarmingly high reported morbidity/mortality rate of 7% [9].

It is interesting to note that CNS lymphoma is hyperperfused, while CNS infections like Toxoplasmic or Lyme disease lesions, when detectable by SPECT, are hypoperfused. Reduced rCBF was also seen in brain regions not affected directly, but functionally associated with altered areas [1].

### Thallium 201 SPECT in CNS Lymphoma Versus Toxoplasmosis

Thallium 201 SPECT imaging can be used to aid in discriminating CNS lymphoma (30% incidence) from toxoplasmosis (60% incidence) in HIV patients. Lymphoma would avidly accumulate thallium, while toxoplasmosis infection would typically demonstrate only mild thallium uptake. The lesion to non-lesion uptake ratio is generally greater than 2.5:1 in cases of CNS lymphoma [10]. Sequential thallium-gallium scanning may help to improve the exams sensitivity and specificity. Lymphomas would generally be thallium and gallium positive, while toxoplasmosis infection is thallium negative, but gallium positive [10]. There have been case reports of thallium accumulation in cerebral infections including CMV encephalitis (with a semiquantitative uptake ratio suggesting a malignant lesion), candidiasis, bacterial abscess, CNS abscesses, inflammatory demyelinating diseases, tuberculomas and toxoplasmosis [9]. Thallium imaging should be delayed (3–4 h after injection) as early accumulation within inflammatory lesions washes out, while activity remains within neoplasms [10]. Moreover, Th-SPECT may still be useful in this differentiation when results of other tests are taken into account, such as toxoplasmosis serology or CSF Epstein-Barr virus polymerase chain reaction (PCR) [9]. PCNSL is associated with latent Epstein-Barr virus (EBV) infection; detection of EBV DNA in cerebrospinal fluid (CSF) has been promoted as a useful diagnostic test. A patient with contrast-enhancing mass lesions who has failed to respond to empiric

antitoxoplasmosis therapy for 10 days and who has positive CSF EBV DNA PCR results and positive uptake on a thallium SPECT scan is highly likely to have PCNSL [9].

### References

1. Catafau AM (2001) Brain SPECT in clinical practice. I. Perfusion. *J Nucl Med* 42(2):259–271
2. Anslow P (2004) Cranial bacterial infection. *Eur Radiol* 14:E145–E154
3. Fogelman I, Maisy MN, Clarke SEM (eds) (1994) Brain, chapter five: In an atlas of clinical nuclear medicine, 2nd edn. Deutscher Arzte-Verlag, pp 313–396
4. Spinelli F, Sara R, Milella M, Ruffini L, Sterzi R, Causarano IR, Sberna M (2000) Technetium-99m hexamethylpropylene amine oxime leucocyte scintigraphy in the differential diagnosis of cerebral abscesses. *Eur J Nucl Med* 27:46–49
5. Burtcher IM, Holtas S (1999) In vivo proton MR spectroscopy of untreated and treated brain abscesses. *AJNR Am J Neuroradiol* 20:1049–1053
6. Floeth FW, Pauleit D, Sabel M, Reifenberger G, Stoffels G, Stummer W, Rommel F, Hamacher K, Langen KJ (2006) 18F-FET PET differentiation of ring-enhancing brain lesions. *J Nucl Med* 47(5):776–782
7. Cosma A (2004) Cranial viral infections in the Adult. *Eur Radiol* 14:E132–E144
8. Logigian EL, Johnson KA, Kijewski MF, Kaplan RF, Becker JA, Jones KJ, Garada BM, Holman BL, Steere AC (1997) Reversible cerebral hypoperfusion in Lyme encephalopathy. *Neurology* 49(6):1661–1670
9. Olatinwo TF, Herbowy MT, Hewitt RG (2001) Toxoplasmic Encephalitis and primary Lymphoma of the Brain – The shift in epidemiology: a case series and review of the literature. *AIDS Read* 11(9):444–449
10. Lee VW, Antonacci V, Tilak S, Fuller JD, Cooley TP (1999) Intracranial mass lesions: sequential thallium and gallium scintigraphy in patients with AIDS. *Radiology* 211(2):507–512

## Brain Inflammation: Tumor Necrosis Factor Receptors in Mouse Brain Inflammatory Responses

AMALIA MOLINERO<sup>1</sup>, ALBERT QUINTANA<sup>1</sup>,  
MILENA PENKOWA<sup>2</sup>, JUAN HIDALGO<sup>1</sup>

<sup>1</sup>Institute of Neurosciences and Department of Cellular Biology, Physiology and Immunology, Animal Physiology Unit, Faculty of Sciences, Autonomous University of Barcelona, Bellaterra, Barcelona, Spain  
<sup>2</sup>Department of Medical Anatomy, The Panum Institute, University of Copenhagen, Copenhagen, Denmark

### Synonyms

TNFR1: Tumor necrosis factor receptor 1, PPF, p55, TNF-R, TNFAR, TNFRI, Tnfr1; p55-R; CD120a;



TNF-R1; TNFR60; Tnfr-2; TNF-R-I; TNF-R55; TNFRp55; TNFR2:Tumor necrosis factor receptor 2; Tumor necrosis factor; Beta receptor; tnfr; p75; TNF-R75; TBPII; TNFR2; CD120b; TNF-R-II; TNFR80

## Definition

► **TNF- $\alpha$**  exerts its biological functions via interaction with two receptors, the 55 kDa type-1 receptor (TNFR1) and the 75 kDa type 2 receptor (TNFR2). Both TNFR1 and TNFR2 possess sequences capable of binding to intracellular adaptor proteins that trigger cell signaling. The TNF receptor superfamily is defined by the presence of repeating units of cysteine clusters. TNFR-1 and TNFR-2 are both N-glycosylated but only TNFR-2 is O-glycosylated.

## Characteristics

### Higher Level Structure (General and Common)

The extracellular domains of TNFR1 and TNFR2 are highly conserved. The cytoplasmic domains of TNFRs are modest in length and function as docking sites for signalling molecules.

Most cell types express both receptors, with few exceptions such as erythrocytes and unstimulated T lymphocytes. Receptor density ranges from 200–10,000 per cell but usually the expression of one of them predominates. Based on similarities in their cysteine-rich extracellular domains, TNFR-1 and TNFR-2 belong to a TNFR superfamily, which besides a number of death inducing receptors, includes CD40 and the low-affinity nerve growth factor receptor.

TNF- $\alpha$  receptors present diverging mechanisms of action both in normal and altered brain in mice and blockade of any of them in the early stages after an injury seem to improve final outcome after a brain injury. Signaling occurs through two principal classes of cytoplasmic adaptor proteins: TRAFs (TNF receptor-associated factors) and “death domain” (DD) molecules. Signaling is very rapid and highly specific, for the subset of receptors that have DDs ligand engagement typically causes the association of adaptors such as Fas-associated DD protein (FADD) and TNFR-associated DD protein (TRADD) that finally cause caspase activation and cell death. In this way the response of a cell to TNF- $\alpha$  is profoundly correlated with the type of TNFR predominantly expressed, both constitutively and in response to cytokines (for review see [1]). Several works support an independent functioning for the two receptors in several diseases [2], but contradictory results are found when TNFR null mice have been used. TNFR1 is activated equally well by soluble and membrane-bound TNF $\alpha$  (mTNF). TNF $\alpha$  ligand acts primarily in the immune system whereby it would activate TNFRs through cell–cell interactions. As such, most of the TNF $\alpha$  effects *in vivo* may be mediated

by mTNF (TNFR1=TNFR2 activation) rather than soluble TNF (TNFR1>TNFR2 activation) and the physiological role of TNFR2 may be underestimated by most of the TNF $\alpha$  research conducted in the laboratory which uses soluble TNF $\alpha$  as the stimuli. Soluble TNF $\alpha$  acts somewhat like a partial agonist on TNFR2 since it binds to the receptor, but is not highly potent and efficient in its activation.

Altogether, these studies reveal neuronal responses to TNF $\alpha$ . Subsequent neuronal death or survival may ultimately depend on a particular subtype of TNF receptor that is predominately expressed in neurons of the brain both during neural development and in neurological diseases. In this way, a ► **neuro-immunomodulation** could explain different brain responses to injury

### Lower Level Structure (Specific)

#### TNFR1

##### Structure

Tumor necrosis factor receptor 1, also known as the p55 TNF receptor, binds to two ligands: TNF $\alpha$  and Lymphotoxin- $\alpha$  (LT $\alpha$ , previously termed TNF $\beta$ ).

The TNF $\alpha$  trimer binds three receptor molecules, one at each of three TNF monomer-monomer interfaces. The extracellular domain of the receptor is an elongated molecule composed of 3 disulphide-containing 40 residues motifs, essential for its activity. Only three or four extracellular modules of TNFR-1 are visualized.

##### Function

A central question about TNFR-1 is how a single receptor can trigger many different responses using a limited repertoire of signalling molecules.

The dominant signalling pathway for TNFR-1 promotes inflammation by up-regulating inflammatory cytokines, ► **chemokines** and adhesion molecules and also suppresses apoptosis by the induction of IAPs (inhibitors of apoptosis) through nuclear factor- $\kappa$ B (NF- $\kappa$ B)-dependent pathways. The TNFR-NF- $\kappa$ B signal transduction pathway is important for maintaining cell viability. NF- $\kappa$ B exerts anti-apoptotic effects via an endogenous caspase inhibitory system mediated by cellular inhibitor of apoptosis protein 2 (c-IAP2). NF- $\kappa$ B transactivates c-IAP2 to inhibit caspase-3 activation.

TNFR-1 can also mediate cell death by activation of caspases 3 and 7 via pro-caspase 8, but also by the caspase independent c-jun-N-terminal (JNK) death pathway, that activates the transcription factor activator protein 1 (AP-1), inducing transcription of a number of proinflammatory, immunomodulatory and pro-apoptotic genes such as the tumor suppressor protein p53 and the FAS ligand [1]. Astrocytes have been shown to express TNFR-1 and inflammatory mediators such as chemotactic factors and adhesion molecules. Several works reported astrocyte production of CCL2 in response to

RANTES, and also that astrocyte expression of VCAM-1 is TNF-dependent.

## TNFR2

### Structure

TNFR2 was fully cloned after TNFR1 and its structural and functional properties are less understood than TNFR1. Part of the reason for the relative lack of signalling information about TNFR2 is that, generally, it is not efficiently activated in the laboratory. Within the intracellular domain of TNFR2, a C-terminal region of 78 amino acids binds TRAF2, a protein containing a C-terminal TRAF domain and an N-terminal RING finger motif.

### Function

TNFR2, although not possessing a DD sequence, can lead to apoptosis via adaptor proteins (for review [3]). It has been involved in cell proliferation and has been suggested to play a role in TNF-mediated elimination of autoreactive effector cells in a EAE paradigm [4]. In addition, TNFR2 is the principal mediator of the effects of TNF $\alpha$  on cellular immunity, and it may cooperate with TNFR1 in the killing of nonlymphoid cells.

Deletion of TNFR2 in transgenic mice has uncovered that this receptor subtype is important in low dose TNF-induced lethality. Besides its involvement in thymocyte proliferation, TNFR2 plays an important role in models of cerebral malaria and microvascular endothelial cell damage.

## Description of the Process and Conditions

### Mouse Brain Inflammatory Responses

►Brain injury initiates a complex sequence of pathophysiological responses named ►Inflammation at the lesion site. Inflammation is a protective mechanism that isolates the injured area, destroys affected cells and repairs the extra-cellular matrix. However, chronic presence of inflammatory mediators may be followed by increased oxidative stress and cell death (for review: [5–7]). Inflammatory response is orchestrated, among others, by relevant proinflammatory cytokines such as interleukin-1 (IL-1), interleukin-6 (IL-6) and tumor necrosis factor- $\alpha$  (TNF $\alpha$ ), which may be produced and/or act on lymphocytes, endothelial cells and microglia among other cell types, producing secondary damaging effects that in turn lead to lymphocyte recruitment and activation and may cause neuronal cell death.

### TNF $\alpha$ Increase as a Signal in Brain Inflammation

The existence of a protein termed tumor necrosis factor (TNF $\alpha$ ) that was released into the blood circulation of animals after ►reticuloendothelial system stimulation was demonstrated in 1975. Now it is known that TNF $\alpha$  (185 amino acid glycoprotein peptide hormone) is a ►pleiotropic cytokine produced by activated macrophages, neutrophils, astrocytes and other cell types. Its action is not restricted to the periphery but extends to important physiological and pathophysiological roles in the CNS. In the intact CNS, TNF- $\alpha$  expression is low but is dramatically increased following pathological stimuli such as in injury, ►ischaemia or infection and

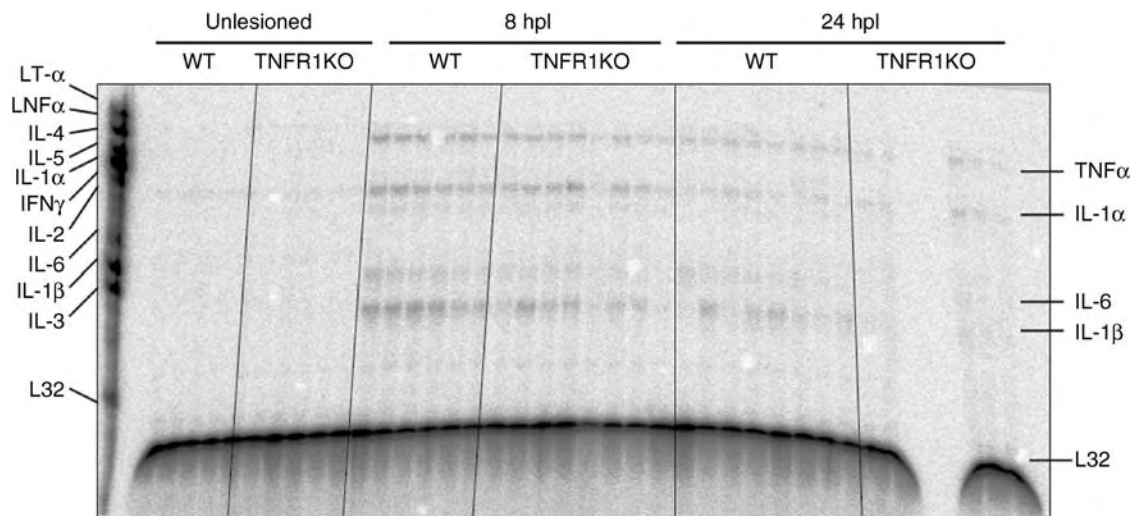

## Brain Inflammation: Tumor Necrosis Factor Receptors in Mouse Brain Inflammatory Responses.

**Figure 1** Analysis of cytokine gene expression by ►Rnase protection assay (RPA). Wild type (C57Bl/6) and TNFR1 knockout (TNFR1 KO) mice were subjected to a cryolesion of the left cortex and killed 8 or 24 h after the lesion (8 and 24 hpl, respectively). Unlesioned mice from both strains were also killed (0 hpl). TNF $\alpha$ , IL-1 $\alpha$ , IL-6 and IL-1 $\beta$  were significantly increased by the injury, a response decreased by TNFR1 deficiency. (Published in (2005) J Neurosci Res 82:701–716).

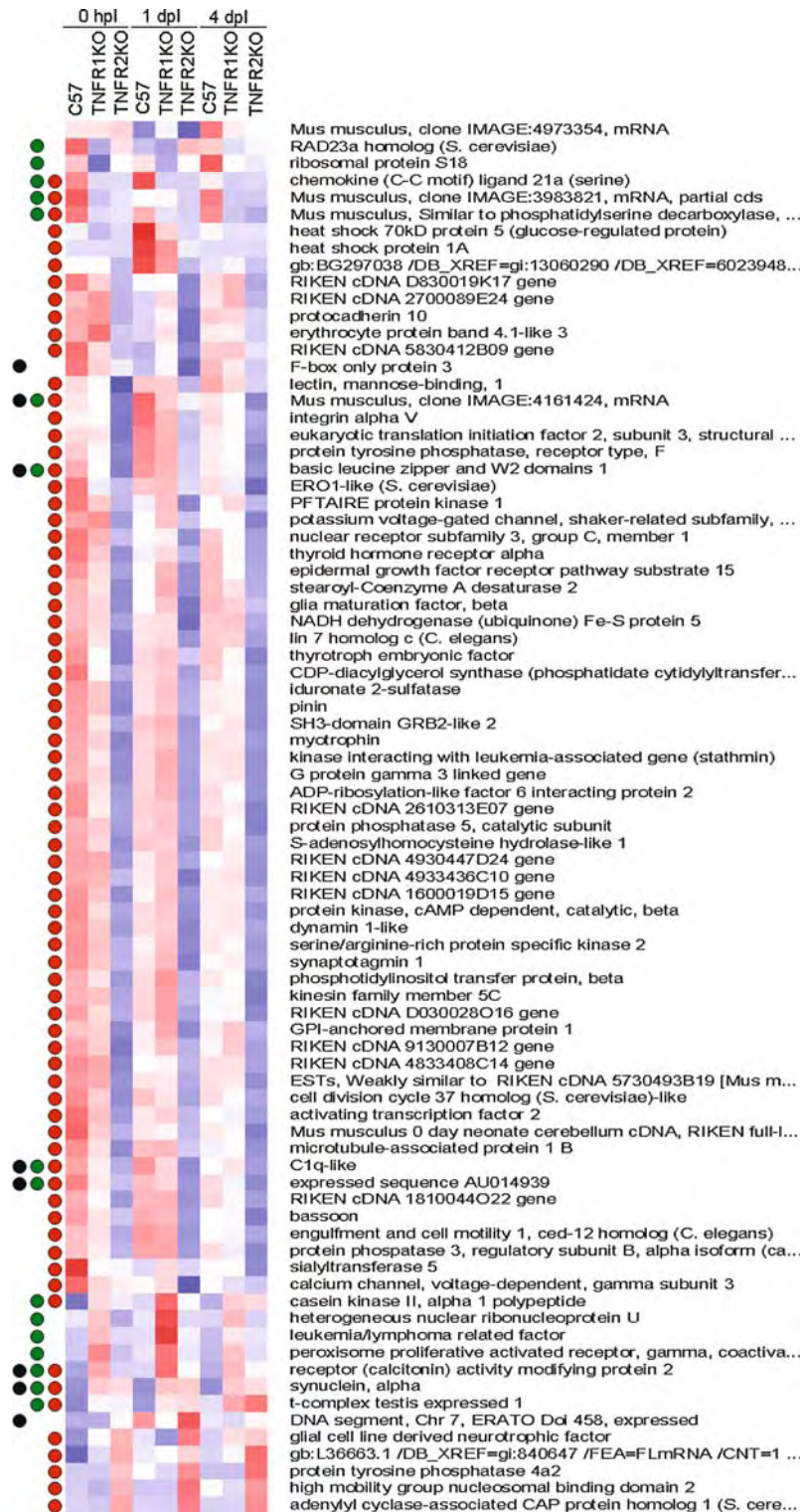

### Brain Inflammation: Tumor Necrosis Factor Receptors in Mouse Brain Inflammatory Responses.

**Figure 2** Hierarchical clustering of the subset of genes (including genes of unknown function) identified to be significantly ( $P < 0.05$ ) affected by TNFR deficiencies. *Green dots*: TNFR1 KO vs. WT. *Red dots*: TNFR2 KO vs. WT. *Black dots*: TNFR1KO vs. TNFR2KO.

has been implicated in the pathogenesis of many neurological conditions including MS, AIDS dementia and Alzheimer disease among others. TNF $\alpha$  is one of the mediators that leads to the activation, proliferation and hypertrophy of mononuclear, ►phagocytic cells and gliosis. In turn astrocytes, endothelial cells, and/or microglia in the CNS respond to TNF $\alpha$  by recruiting monocytes and polymorphonuclear leukocytes to the CNS. These recruited cells may be a source of ►metalloproteinases, additional chemokines, TNF $\alpha$  or other mediators of acute pathogenesis.

### Dual Role of TNF $\alpha$

A neuroprotective role of TNF $\alpha$  in the CNS has been described in mice lacking both TNF receptors in ischemia and kainic acid administration. Opposing roles have also been described for both receptors, having TNFR1 a detrimental effect while TNFR2 is the beneficial counterpart in a multiple sclerosis animal paradigm ([4], being these opposite roles confirmed by some in vitro studies). However, no effect on damage following deletion of either TNFR1 or TNFR2, alone, is observed in the axotomized facial motor nucleus model [8], and even a detrimental role of TNFR2 but not of TNFR1 has been also described [9]. Even an almost complete prevention of cell death is seen when both TNFR are not present, thus suggesting a detrimental role of TNF $\alpha$  [8]. Nevertheless, it has to be considered that a different role for TNF $\alpha$  has been described depending on the moment of its action, suggesting a beneficial role at later time points. TNFR1 is involved in the early establishment of the inflammatory response and its deficiency causes a decreased inflammatory response and tissue damage following brain injury [10] (Fig. 1). Therefore, preliminary evidences suggest that TNFR2 pathway is involved in many different areas of cell maintenance, and in this regard recent results from a ►microarray study (Fig. 2) should be used as a starting point to clarify the role of this receptor both in physiological and pathological conditions (Quintana et al. 2007, J Neurosci Res 85(12):2668–85). However, the validity of direct comparisons between TNFR-null transgenic mice and normal cells and tissues, which ubiquitously express TNFRs at altering TNFR1:TNFR2 ratios, always has to be considered when interpreting the physiological role of TNFRs.

### References

1. Debatin KM (2004) Apoptosis pathways in cancer and cancer therapy. *Cancer Immunol Immunother* 53 (3):153–159
2. MacEwan DJ (2002) TNF receptor subtype signalling: differences and cellular consequences. *Cell Signal* 14 (6):477–92
3. Rothwell NJ, Hopkins SJ (1995) Cytokines and the nervous system II: actions and mechanisms of action. *Trends Neurosci* 18(3):130–136

4. Suvannavejh GC et al. (2000) Divergent roles for p55 and p75 tumor necrosis factor receptors in the pathogenesis of MOG(35–55)-induced experimental autoimmune encephalomyelitis. *Cell Immunol* 205(1):24–33
5. Munoz-Fernandez MA, Fresno M (1998) The role of tumour necrosis factor, interleukin 6, interferon-gamma and inducible nitric oxide synthase in the development and pathology of the nervous system. *Prog Neurobiol* 56 (3):307–340
6. Rothwell N (2003) Interleukin-1 and neuronal injury: mechanisms, modification, and therapeutic potential. *Brain Behav Immun* 17(3):152–157
7. Shohami E, Ginis I, Hallenbeck JM (1999) Dual role of tumor necrosis factor alpha in brain injury. *Cytokine Growth Factor Rev* 10(2):119–130
8. Raivich G, Liu ZQ, Kloss CU, Labow M, Bluethmann H, Bohatschek M (2002) Cytotoxic potential of proinflammatory cytokines: combined deletion of TNF receptors TNFR1 and TNFR2 prevents motoneuron cell death after facial axotomy in adult mouse. *Exp Neurol* 178 (2):186–193
9. Akassoglou K et al. (2003) Exclusive tumor necrosis factor (TNF) signaling by the p75TNF receptor triggers inflammatory ischemia in the CNS of transgenic mice. *Proc Natl Acad Sci USA* 100(2):709–714
10. Quintana A, Giralto M, Rojas S, Penkowa M, Campbell IL, Hidalgo J, Molinero A (2005) Differential role of tumor necrosis factor receptors in mouse brain inflammatory responses in cryolesion brain injury. *J Neurosci Res* 82(5):701–716

## Brain-machine Interfaces

- Computer-Neural Hybrids

## Brain Plasticity

### Definition

Brain's ability to change its structure and function during maturation, in response to environmental challenges or during pathological processes.

## Brain Repair

### Definition

Defines an area of investigation studying the means to repair damaged brain. Until recently, the brain was

considered as a surgically unreachable structure according to the complexity of neuronal circuits.

Accordingly, it was considered only reachable by pharmacological means. Plethora of molecules targeting the brain were developed in order to treat, among others, depression, schizophrenia, epilepsy as well as Parkinson's disease. With the emergence of stem cell research, new promising strategies to heal the brain are envisaged as stem cells provide an endless source of new neurons or glial cells that can be used to replace dead cells.

#### ► Regeneration

## Brain Reward System

### Definition

Brain reward system areas (mainly the lateral hypothalamus and midbrain ventral tegmental area) which are identified as a very effective locus for brain stimulation reward (positive reinforcement).

## Brain Rhythms

MARCOS G. FRANK

Department of Neuroscience, University of Pennsylvania, Philadelphia, PA, USA

### Synonyms

EEG waves; Synchronized, Desynchronized brain activity

### Definition

Brain rhythms refer to distinct patterns of massed neuronal activity associated with specific behaviors, arousal level and sleep states. They are typically measured by the electroencephalogram (EEG) and/or neuronal population field recordings. Brain rhythms have been best studied in the hippocampus, the thalamus and the neocortex [1,2].

### Characteristics

EEG rhythms can be broadly divided into those associated with an awake or activated brain and those associated with different stages of sleep [1]. Wakefulness is accompanied by fast, low-amplitude brain rhythms that are further segregated into "alpha"

(► **alpha rhythm**) (8–13 Hz), "beta" (13–35 Hz) and "gamma" waves (35 Hz and higher) [2]. Beta (► **beta rhythm**) and gamma (► **gamma rhythm**) waves are typically observed in alert wakefulness and during ► **REM sleep** while alpha waves are associated with quiet arousal – commonly with the eyes closed. The onset of sleep is associated with a progressive slowing and increasing amplitude of EEG waves along with stereotyped bursts of synchronized activity. These include "K-complexes" and "spindles" which are characteristic of the lighter stages of ► **non-REM sleep**. As non-REM sleep progresses into deeper stages, the EEG becomes dominated by "delta" waves (1–4 Hz). A slower neocortical rhythm (<1 Hz) groups and organizes these sleep rhythms by coordinating depolarization and hyperpolarization in intra-cortical and thalamocortical networks: a phenomenon also referred to as "up" and "down" states [1,3]. The hippocampus also exhibits state-dependent changes in neuronal activity. Alert wakefulness and REM sleep in non-human animals are often accompanied by gamma and "theta" rhythms (► **theta rhythm**) (5–9 Hz), while non-REM sleep and quiet wakefulness are associated with bursts of 200 Hz activity known as "ripples" [4–7].

### The Cellular Basis of Brain Rhythms

Interactions between three basic mechanisms underlie neocortical brain rhythms [1]. These include intrinsic membrane properties of different classes of neurons, intracortical and thalamocortical network interactions and modulation by alerting/arousal circuits. Many neurons within the thalamus and the cortex can switch between two basic modes of activity: tonic firing and intrinsically bursting. This change in activity is due to several ionic membrane currents that are differentially activated, inactivated and de-inactivated by changes in neuronal hyperpolarization [1]. During transitions from wakefulness to sleep, the thalamus becomes increasingly hyperpolarized, thereby switching thalamocortical relay neurons from a tonic firing mode to intrinsically bursting. This process is mediated by the reticular thalamic nuclei which innervate relay thalamocortical neurons. Relay nuclei then transmit oscillatory bursts to the neocortex as spindles. The neocortex also becomes hyperpolarized during the descent into sleep and via cortical-thalamic projections "groups" spindles into an envelope of cortical slow, oscillatory activity. As sleep progresses into deeper stages of non-REM sleep, additional membrane currents are activated leading to the appearance of delta waves (► **delta waves/rhythms**) in the thalamus and neocortex. These slow oscillations are rapidly reversed by the onset of wakefulness due to increased release of excitatory neurotransmitters (monoamines, acetylcholine and ► **glutamate**) onto the thalamus and cortex. The resulting depolarization switches neurons back into a tonic

firing mode and produces brain rhythms typical of wakefulness [1]. Similar mechanisms operate in other brain regions that exhibit state-specific brain activity, although the precise contribution of intrinsic membrane properties, network events and neuromodulators are different [1,7].

### The Regulation and Function of Brain Rhythms

The precise function of different brain rhythms remains mysterious. Gamma waves in the neocortex have been suggested to play a role in synchronizing different cortical modules in cognitive tasks and in consciousness [1]. Hippocampal theta and gamma rhythms may also be important for encoding information and memory formation [8]. The function of sleep rhythms, however, is more enigmatic. Sleep deprivation produces an increase in non-REM sleep delta wave activity, which declines as sleep progresses. This suggests that delta waves are part of the homeostatic mechanism that, in addition to the circadian pacemaker, regulates sleep expression [9]. In addition, spindles produce short-lasting forms of thalamocortical plasticity and the synchronous firing of neurons during delta waves might provide a mechanism for spike-timing dependent plasticity [9]. Neocortical “up-states” and hippocampal ripples during sleep are also associated with a “replay” of waking patterns of neuronal activity. These findings are consistent with the hypothesis that sleep promotes memory formation. Definitive tests of these putative functions, however, have not been performed [6,9].

### References

1. Steriade M (2005) Brain electrical activity and sensory processing during waking and sleep states. In: Kryger MH, Roth T, Dement WC (eds) Principles and practice of sleep medicine, vol 4. Saunders, Philadelphia, pp 101–119
2. Miller R (2007) Theory of the normal waking EEG: from single neurones to waveforms in the alpha, beta and gamma frequency ranges. *Int J Psychophysiol* 64:18–23
3. Destexhe A, Hughes SW, Rudolph M, Crunelli V (2007) Are corticothalamic “up” states fragments of wakefulness? *Trends Neurosci* 30(7):334–342
4. Siegel JM (2005) REM sleep. In: Kryger MH, Roth T, Dement WC (eds) Principles and practice of sleep medicine, vol 4. Saunders, Philadelphia, pp 120–135
5. Leung SL (1998) Generation of theta and gamma rhythms in the hippocampus. *Neurosci Biobehav Rev* 22:275–290
6. Frank MG (2007) Hippocampal dreams, cortical wishes: a closer look at neuronal replay and the hippocampal-neocortical dialogue during sleep. *Cell Sci Rev* 3:161–171
7. Dickson CT, Clayton T, Magistretti J, Shalinsky M, Hamam B, Alonso A (2000) Oscillatory activity in entorhinal neurons and circuits: mechanisms and function. *Ann NY Acad Sci* 911:127–150
8. Axmacher N, Mormann F, Fernandez G, Elger CE, Fell J (2006) Memory formation by neuronal synchronization. *Brain Res Rev* 52:170–182
9. Benington JH, Frank MG (2003) Cellular and molecular connections between sleep and synaptic plasticity. *Prog Neurobiol* 69:77–101

## Brain Slices

KLAUS BALLANYI, ARAYA RUANGKITTISAKUL  
Department of Physiology, Faculty of Medicine & Dentistry, University of Alberta, Edmonton, AB, Canada

### Synonyms

*in vitro* brain preparations; *en bloc* preparations; isolated nervous tissues

### Definition

Brain slices are *ex vivo* preparations obtained by serial sectioning of brain tissue, typically from rats or mice. Acute brain slices are kept vital *in vitro* for time periods between four and, sometimes, more than twenty-four hours and contain a functional brain cell micro-circuitry *in situ*. The *in vivo* function of most brain slices is reduced as their thickness is often < 0.5 mm to permit mammals diffusional supply with energy substrates. Several millimeter thick *en bloc* preparations from perinatal mammals or otherwise anoxia-tolerant animals are vital due to a low metabolic rate and/or increased anaerobic metabolism. Interactions between distinct brain regions are studied in brain slices extending laterally by upto several centimeters. ► **Organotypic cultures** from acute brain slices retain their basic structural and functional identity although their thickness is reduced to few cell layers.

### Purpose

About 50 years ago, Henry McIlwain established *in vitro* methods to acutely isolate brain slices and keep them vital for several hours for electrophysiological analysis of specific nervous functions [1]. Since this pioneering work, brain slices have been used more often than *in vivo* approaches because (i) Biophysical membrane properties of identified brain cells can be analyzed with stable ► **intracellular (microelectrode) recording** or ► **patch-clamp** recording; (ii) A quantitative analysis of drug effects is often more feasible while, in contrast to systemic application *in vivo*, specific agents can exert their effects directly on the targeted brain tissue; (iii) (Multiphoton) ► **brain cell imaging** of intracellular  $[Ca^{2+}]$  or other cellular messengers or factors is possible in slices from brain regions located too deep to be imaged in the intact brain; (iv) Neuronal and glial micro-circuits remain basically functional; (v) *In vivo* recordings cannot

be performed in a major number of genetically modified (“knock-out”) animal models that are not vital at birth; (vi) Brain slices can be virally transfected (▶[viral transfection](#)) for manipulation of neuronal functions; (vii) Cellular properties of human brain structures can only be studied in brain slices obtained from patients that underwent surgery.

## Principles

The following procedures for preparation and storage of acute brain slices represent a condensed version of corresponding sections of reference [2]. The present text also refers to information provided by references [1,3–9]. ▶[Organotypic cultures](#) of brain slices are described elsewhere [10].

## Artificial Cerebro-spinal Fluid

Under appropriate *in vitro* conditions, brain slices remain functional for time periods of between four and sometimes more than twenty-four hours. One important factor determining their viability is the composition of the superfusate which is used for their preparation, storage and recording in the experimental chamber. The ionic composition of superfusate is often close to (in mM): 118 NaCl, 3 KCl, 1.5 CaCl<sub>2</sub>, 1 MgCl<sub>2</sub>, 1 NaH<sub>2</sub>PO<sub>4</sub>, 26 NaHCO<sub>3</sub>. This solution is typically gassed with carbogen, i.e., 5% CO<sub>2</sub> in O<sub>2</sub>. The CO<sub>2</sub>/HCO<sub>3</sub><sup>−</sup> system constitutes the predominant pH buffer of the interstitial fluid mimicked by the superfusate. In particular in slices thicker than 300 μm (Figs. 1 and 2), ongoing metabolic activity produces a tissue concentration gradient for CO<sub>2</sub>, HCO<sub>3</sub><sup>−</sup> and H<sup>+</sup>, and thus pH.

Thick slices or *en bloc* preparations from mammals containing neurons with pronounced metabolic activity, require an elevated superfusate concentration of dextrose, i.e., D-glucose. Glucose concentrations of 10–30 mM have to be used in such preparations, in particular when the experiments are done at physiological temperature. Such glucose levels can evoke hyperglycemic brain cell damage *in vivo*, but seem to be tolerated quite well *in vitro*. This tolerance may be related to the assumption that steady metabolic activity within the slices produces a concentration gradient of interstitial glucose. Thus, glucose levels in deeper layers of brain slices may be close to the physiological range of 2–7 mM in arterial blood depending on the mammalian species. Similar to the tissue gradients for pH and glucose, the inner core of brain slices contains a different concentration of O<sub>2</sub> than superficial layers. Superficial tissue layers are often hyperoxic, while core regions in brain slices can be hypoxic. The extent of tissue gradients for O<sub>2</sub>, CO<sub>2</sub>, HCO<sub>3</sub><sup>−</sup>, depends on various factors such as temperature, slice thickness, flow rate of the superfusate or metabolic rate, which is often correlated with the maturational state of the brain structure under study.

The tissue ion and gas gradients can affect membrane properties of brain cells such as ATP-sensitive or other types of K<sup>+</sup> channels.

In isolated brain structures from mature mammals, a notable increase in interstitial levels of excitatory ▶[neurotransmitters](#) or ▶[neuromodulators](#) may occur during anoxia-ischemia associated with circulatory arrest upon killing the animal. Accordingly, brain tissue is often isolated and sliced in ice-cold solution with reduced [Ca<sup>2+</sup>], e.g. 0.5 mM, to reduce excitotoxic (▶[Excitotoxicity](#)) effects of ▶[glutamate receptor](#)-related Ca<sup>2+</sup> influx. In contrast, [Mg<sup>2+</sup>] in the superfusate is sometime elevated by several mM, while ketamine or other antagonists of glutamate receptors can be added to depress neuronal activity. It may also be beneficial to substitute NaCl with an equimolar concentration of sucrose in the solution used for preparation of slices. However, a lack of extracellular Na<sup>+</sup> ions can perturb neuronal functions, e.g., due to a Na<sup>+</sup> dependence of several pH regulatory mechanisms. Potential cell swelling can be avoided by adding to the solution a high molecular weight dextran, while redox active agents such as ascorbic acid can be used to depress cytotoxic free-radical formation. Superfusate [K<sup>+</sup>] is often raised by several mM above the physiological level of 3 mM to increase neuronal excitability *in vitro*.

## Preparation and Storage of Brain Slices

Anesthetics modulate brain cell properties. Thus, the appropriate agent should be chosen for anesthesia according to the function to be studied. Anesthesia with volatile agents such as ether or isoflurane may produce minor, if any, interference since these anesthetics are likely rapidly washed out from brain slices. Alternatively, animals are anesthetized and subsequently killed by cooling, exposure to CO<sub>2</sub> (in adult mammals) or decapitation. Also the surgical procedures for isolation of a particular brain region may modify the function of brain slices. For example, anoxia-ischemia upon killing the animal may not only lead to release of excitotoxic neurotransmitters, but also induce post-mortem synthesis of ▶[prostaglandins](#) from released ▶[arachidonic acid](#). Consequently, it is sometimes difficult to estimate basal levels of neurotransmitters or other neuroactive substances in the interstitial space of acute slices, at least within the initial period after their preparation. To minimize anoxia-ischemia-related release of endogenous substances or ▶[immediate early gene](#) expression, the dissection should be done fast, ideally within 1–3 min. As soon as the skull is opened, and also later during the dissection, the exposed brain should be rinsed with ice-cold superfusate. This may be particularly important if animals older than one week are used. After isolation, the block of brain tissue should be kept at 4°C in carbogenated solution to reduce cell damage and also improve the texture for slicing. Under these conditions,

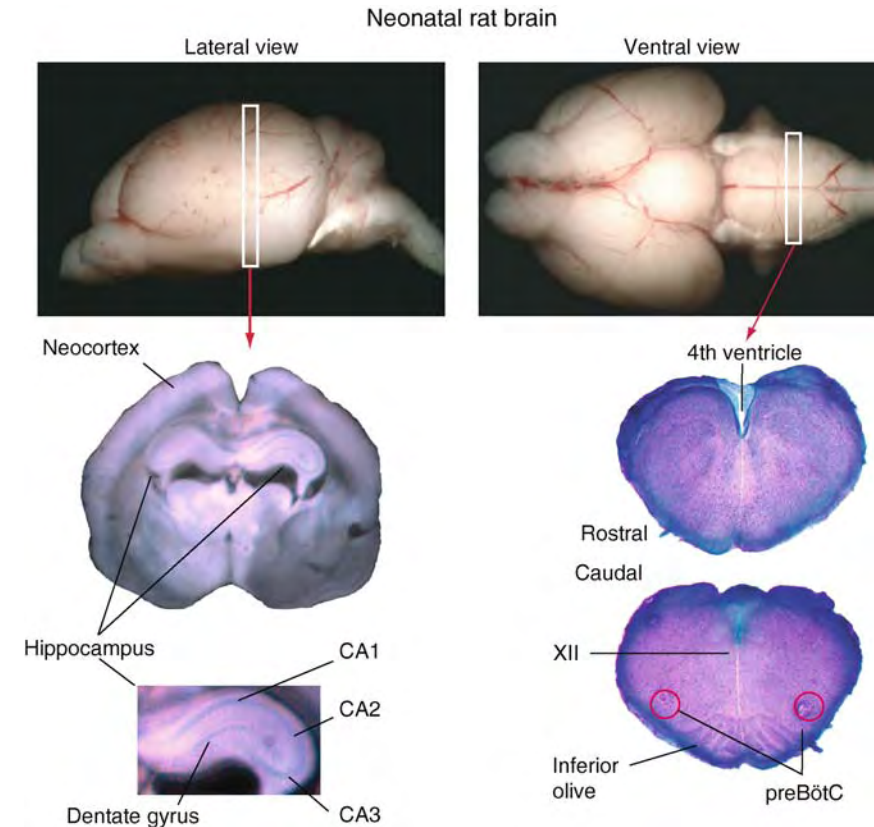

**Brain Slices. Figure 1** Newborn rat hippocampal and medullary brain slices. The upper left panel shows a lateral view of a freshly prepared forebrain, cerebellum, lower brainstem and rostral cervical spinal cord from a 7-days-old rat pup. The image below illustrates a coronal (transverse) 300  $\mu\text{m}$  thick brain slice, cut at the level indicated by the white box in the upper left image. This living brain slice contains, besides various other structures, the neocortex and the hippocampus, the latter being shown at a magnified view in the lower left panel. The ►dentate gyrus and ►CA1–3 areas are the major somata layers of principal hippocampal neurons. The upper right panel shows a ventral view of the forebrain, midbrain and lower brainstem (medulla oblongata). The middle and lower right images illustrate the rostral and the caudal side, respectively, of a 700  $\mu\text{m}$  thick medullary slice containing the respiratory center, the pre-Bötzing Complex (preBötC). After electrophysiological recording of respiratory activity, this slice had been fixed in paraformaldehyde and stained for 2 min with thionin to reveal structural features. In contrast to neocortical or hippocampal slices, only one respiratory-active slice can be obtained from an individual animal. As a further difference, the rostral and caudal boundaries of respiratory slices are not almost symmetrical. In this example, the caudal surface contains, e.g., the inspiratory-active hypoglossal (XII) motor nucleus and the laterally most extended portion of the ►inferior olive, while the rostral surface is devoid of major histological landmarks. The ►facial (VII) motonucleus (►Facial (VII) motor nucleus) would be located slightly more rostral to the rostral end of this slice, while the rostral end of the inferior olive would be more caudal. All images from A. Ruangkittisakul and K. Ballanyi, unpublished.

blocks of most nervous tissues can be stored for at least 60 min, thus allowing for consecutive slicing of various brain regions.

For studies, in which visualization of the recorded cells is not required, a series of brain slices with a typical thickness of 150–600  $\mu\text{m}$  can be produced within only few minutes using “McIlwain”-type tissue choppers. Vibrating microtomes (“vibratome”) may be advantageous, if recording is going to be performed under microscopic control from superficial neurons or

glia (Figs. 2 and 3). A clear-cut slice surface can be obtained with low-cost vibratomes such as the vibroslice HA752 (Campden Instruments, UK). However, it may take notably more time to cut a series of brain slices using a vibratome, as slicing is usually done at a low speed of forward movement of the blade to reduce mechanical damage of superficial cell layers. If a vibratome is used, the slicing chamber should be filled with ice-cold superfusate with reduced  $[\text{Ca}^{2+}]$ . For some types of brain tissues, e.g., ►brainstem slices



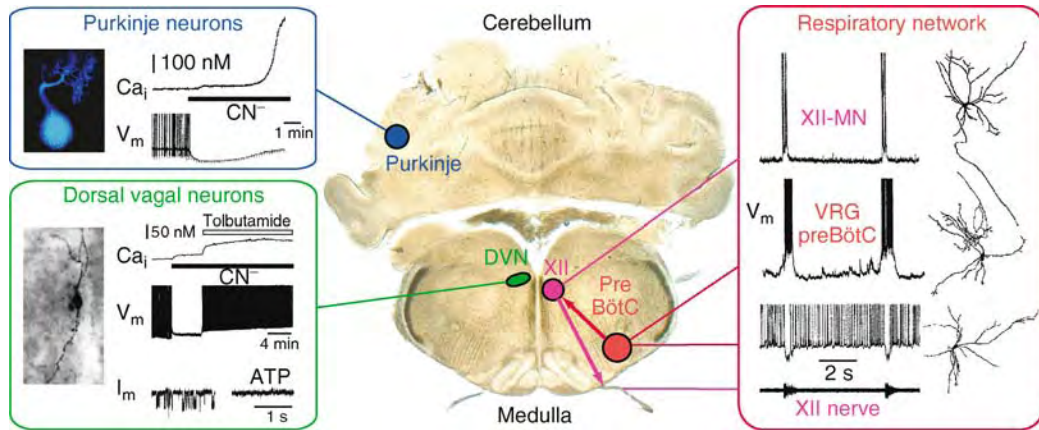

**Brain Slices. Figure 2** Properties of neurons in brain slices. The paraformaldehyde-fixed histological section shows a 200  $\mu\text{m}$  thick transverse, slice of the lower brainstem (medulla oblongata) plus cerebellum from a 4-days-old rat (K. Ballanyi and A. Ruangkittisakul, unpublished). Traces in upper left box show that chemical anoxia due to 1 mM cyanide ( $\text{CN}^-$ ) both-application evoked a transient, ATP-sensitive  $\text{K}^+$  ( $\text{K}_{\text{ATP}}$ ) channel-mediated hyperpolarization in a juvenile rat Purkinje neuron patch-clamped under visual control (Fig. 3). This membrane potential ( $V_m$ ) response was accompanied by an initial  $<50$  nM rise of cytosolic  $[\text{Ca}^{2+}]_i$ , which, after a delay of about 5 min, turned into a progressive  $[\text{Ca}^{2+}]_i$  rise to  $>0.5$   $\mu\text{M}$ .  $[\text{Ca}^{2+}]_i$  was measured using a digital videocamera system as the fluorescence decrease of a  $\text{Ca}^{2+}$ -sensitive dye, Fura-2, administered intracellularly via the patch electrode. The lower box shows that neurons within the dorsal vagal nucleus (DVN) of mature rats are tolerant to anoxia.  $\text{CN}^-$  induced a  $\text{K}_{\text{ATP}}$  channel-mediated hyperpolarization and a very minor ( $<30$  nM) rise of cytosolic  $[\text{Ca}^{2+}]_i$ . Both the hyperpolarization and  $[\text{Ca}^{2+}]_i$  rise were stable for  $>20$  min. In this experiment, the anoxic hyperpolarization was blocked by the  $\text{K}_{\text{ATP}}$ -channel blocker tolbutamide. This recovered spontaneous action potential discharge leading to a rise of  $[\text{Ca}^{2+}]_i$  that was much smaller than the progressive  $[\text{Ca}^{2+}]_i$  increase in the Purkinje neurons. Lower traces show block of single  $\text{K}_{\text{ATP}}$ -channel-mediated membrane currents ( $I_m$ ) in inside-out excised patches by 20  $\mu\text{M}$  ATP. (Note that the dorsal vagal nucleus as indicated by the green symbol is most prominent in a more caudal plane than that of the slice in the schematic.) The right side graph illustrates  $V_m$  fluctuations of respiratory neurons in transverse brainstem slices from newborn rats. An inspiratory hypoglossal motoneuron (XII-MN) as well as an inspiratory plus an expiratory neuron of the ventral respiratory group (VRG) including the preBötC were labeled via the patch electrode with biocytin, as was the dorsal vagal neuron. All non-respiratory neuron recordings from K. Ballanyi, unpublished or Ballanyi (2004) *J Exp Biol* 207, 3201. Respiratory neuron recording and staining from K. Ballanyi and S. W. Schwarzacher, in preparation.

exhibiting respiratory activity (Figs. 1 and 2), ice-cold solution is not mandatory, and slicing at room temperature can even result in preparations with improved cellular or network responses. Immediately after cutting, the brain slices are transferred to either a storage beaker or the experimental chamber, e.g., by using a fine brush or the reversed end of a Pasteur pipette. For storage, slices are positioned on a plastic Petri dish, whose bottom has been replaced by a fine cotton mesh (Fig. 3). For humidification of the gas phase above the slices, the top of the Petri dish is attached to the opening of the beaker, in which the solution is gassed from the bottom via a hypodermic needle (Fig. 3).

### Recording Chambers

Chambers for recording from brain slices must allow for: (i) Adequate supply of the studied structure with superfusate of the desired temperature, pH and  $\text{O}_2$  content; (ii) Mechanical stability of the slices, in particular when the superfusate is exchanged; (iii) Easy

access to the target tissue of recording and/or stimulating  $\blacktriangleright$ electrodes as well as of high magnification objectives for visualization of brain cells. In either “interface”- or “submersion”-type chambers (Fig. 3), solution is administered by gravity or a roller pump and removed by suction with a needle or dripping over the rim. The superfusate is sometimes re-circulated, in particular when expensive drugs are added. During transport of the superfusate to the experimental chamber, the pH and gas content are kept stable by using tubings with a low permeability to  $\text{O}_2$  and  $\text{CO}_2$ , e.g. Tygon<sup>®</sup>.

In interface chambers, slices are positioned on a (nylon) mesh, sometimes covered with a piece of lens or filter paper (Fig. 3). The fluid level is adjusted to the upper surface of the slice, thus stabilizing the tissue by surface tension. Drying-out is prevented by establishing a humid  $\text{O}_2/\text{CO}_2$  atmosphere above the slices. Advantages of interface chambers are the large amplitude of  $\blacktriangleright$ field potentials due to reduced electrical shunt

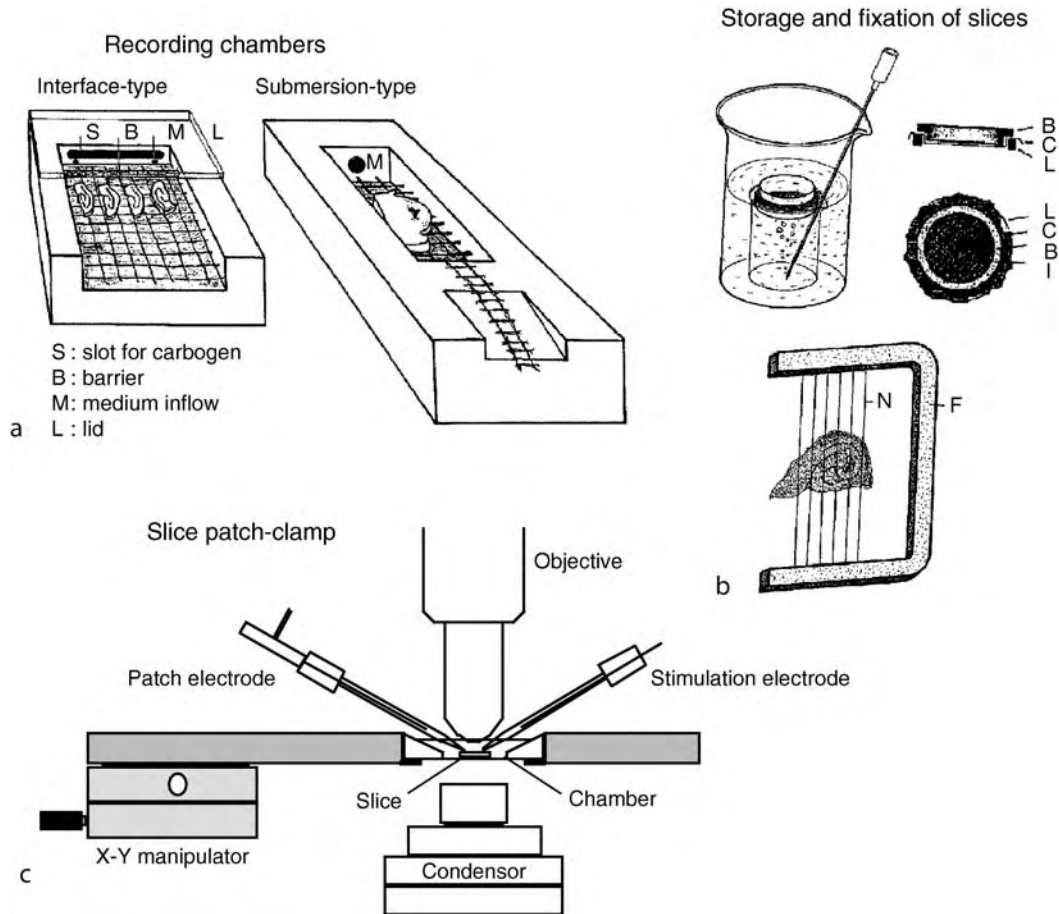

**Brain Slices. Figure 3** Accessories for maintenance, mechanical fixation and recording of brain slices. a, in an “interface”-type recording chamber (*left*), slices rest on a net with the fluid level high enough to keep the surface moist and low enough to avoid mechanical disturbance. Warmed and moistened carbogen is blown over the slices from a slot (S) and directed to their surface by a lid (L; wet paper weighted by a glass slide). The superfusate also enters in the back (M) and crosses a barrier (B). Another barrier may be used at the front end; the fluid level is adjusted by the amount of draining material at the front end, from which the fluid drips. In “submersion”-type chambers (*right*), slices are either stabilized with a grid (see b) or weights. They can also be fixed with insect needles pinned into a Silgard<sup>®</sup> bottom layer of the chamber. (Reproduced with permission from [7]). B, a slice-holding chamber is placed on top of a 50 ml beaker inserted into a 250 ml beaker. These beakers are filled with superfusate to the level of the top of the holding chamber. A hypodermic needle inserted through the spout of the inner beaker serves to oxygenate the slices. The whole assembly is placed in a water bath (at 25–37°C, depending on the slice type) and covered to prevent evaporation. A suitable holding chamber is made by breaking the top (L) and bottom (B) out of a small (10 x 35 mm) plastic Petri dish, forming two rings. When inverted, the ring formed by L fits tightly onto the lip of B. A piece of fine cotton mesh (C) is stretched over B and can be clamped in place by L. Grids for fixation of slices consist of nylon threads (N), glued to a platinum frame (F). (Reproduced with permission from [5]). c schematic diagram of the experimental set-up for patch-clamping visually identified neurons in slices. The slice is fixed on the glass at the bottom of the chamber, which is mounted on the moveable stage of an upright microscope, equipped with a long-distance, water immersion objective. (Reproduced with permission from Konnerth, 1990; Trends Neurosci 13, 321.

and superior visibility of nervous structures such as axon tracts, neuronal somata layers or brain cell nuclei (Fig. 1). Major drawbacks of interface chambers are the lack of visualization of (sub)cellular structures and the slow kinetics of responses to drugs applied via the superfusate. The latter can be improved by focal drug injection via

►pressure ejection or ►micro-iontophoresis. In submersion-type chambers, slices are mechanically stabilized with a grid (Fig. 3) or small weights. Submerged slices, preferentially positioned on a mesh to allow for subfusion of solution, can also be fixed with insect needles, pinned into a Silgard<sup>®</sup> layer at the bottom of the chamber (Fig. 3).

Dissection microscopes are helpful for positioning of recording and stimulating electrodes in complex experimental arrangements, but do usually not permit visualization of mammalian neurons with a 5–50  $\mu\text{m}$  diameter of their soma. Superficial neurons and glial cells in submerged brain slices are visualized using (upright) microscopes with  $>x20$  magnification water immersion objectives (Figs. 2 and 3). Infrared and **▶multi-photon microscopy** techniques allow for visualization not only of superficial cells, but of cellular structures located at depths of up to 100  $\mu\text{m}$  and  $>500 \mu\text{m}$ , respectively, below the surface of the slices. **▶Multiphoton**, **▶confocal** or CCD videocamera imaging applied to brain slices enables online monitoring of changes of cellular ions like  $\text{Ca}^{2+}$  or  $\text{H}^+$  or of cellular properties such as mitochondrial membrane potential combined with simultaneous (patch-clamp) analysis of biophysical plasmalemma membrane properties (Fig. 2) (see **▶Neuron-Glia-Imaging**).

### Advantages and Disadvantages

Major advantages of brain slices have already been described in the “Purpose” section. Below, examples are given for properties of brain slices from two basically different brain regions. This outlines some aspects that need to be considered before deciding to use brain slices for analyzing a specific brain function. (For details and citations in this section, see [2]).

A majority of electrophysiological studies on acutely isolated brain tissue is done on brain slices of the **▶hippocampus** or **▶neocortex** (Fig. 1). The hippocampal slice model is particularly attractive because the hippocampal formation is highly organized, thus allowing for stimulation of and recording from identified neuronal elements (Fig. 1). Because the thickness of most brain slices is restricted due to limited diffusional substrate supply (see above), axons and dendrites of neurons are more or less cut in brain slices. Besides, afferent axonal projections to the isolated brain regions are incomplete resulting in an attenuated or removed physiological synaptic input. This can be partially compensated by electrical stimulation of distal afferent fiber tracts in the slices with patterns mimicking those *in vivo*. Despite such limitations, relevant neurophysiological phenomena can be studied in brain slices, such as cellular and molecular mechanisms of **▶long-term potentiation (LTP)** or **▶long-term depression (LTD)**.

Differences in the *in vitro* conditions of brain slices can lead to conflicting results. For example, the extent or specific quality of LTP depends on various *in vitro* factors, including use of submerged versus interface slices and superfusate temperature. Besides, the *in vitro* temperature notably influences basic biophysical neuronal properties such as propagation speed and duration

of **▶action potentials**. A reduced temperature of 20–30° C is often chosen as most brain slices are viable for longer time periods due to reduced aerobic metabolism that may induce an hypoxic-anoxic core at physiological temperature (see above). A relatively high flow rate of the superfusate is preferable as it results in better oxygenation of deeper cell layers while reducing tissue gradients for  $\text{K}^+$ , pH or neuromodulators released into the interstitial space. But, superficial cell layers would become hyperoxic, which may damage cells at the surface of the slices. It should be considered that a high flow rate is not effective when an experimental chamber with a large ( $>5 \text{ ml}$ ) fluid volume is used. As an example for the influence of flow rate on neuronal properties, the antidromic action potential after-discharge is attenuated in hippocampal slices in response to flow rates  $<2 \text{ ml/min}$ . This phenomenon is reversed by theophylline, indicating an inhibitory effect of metabolically produced **▶adenosine**, which accumulates within the slices at low flow rates.

Most experiments on brain slices are currently done on juvenile rodents, typically rats and mice, for several reasons. *In vivo* studies are not feasible on knockout mice when the animals die during or shortly after birth. **▶Intracellular recording**, mostly performed in the “whole-cell” patch-clamp configuration, and frequently combined with digital imaging, mostly of cytosolic  $[\text{Ca}^{2+}]$ , is often done in superficial cells under visual control (Figs. 2 and 3). In many brain regions, this is only possible in newborn or juvenile animals due to the lack of myelination of glial structures that develop considerably only after that period. However, within the first two weeks after birth, most neuronal structures are not mature. Therefore, results cannot always be compared directly with *in vivo* findings on adult animals. For example, the inhibitory neurotransmitter **▶ $\gamma$ -aminobutyric acid (GABA)** has a depolarizing, and often excitatory, action on many brain structures during the first two postnatal weeks.

As a further example for the potency of brain slices, a neuronal network with defined function can be isolated from the medulla within the lower brainstem of newborn and juvenile rodents. This transverse **▶medulla oblongata** slice model contains, within the **▶pre-Bötzinger Complex (preBötC)**, a kernel of interneurons, which ultimately initiate and control muscles mediating inspiratory breathing movement (Figs. 1 and 2). The preBötC has a three-dimensional extension of approximately 200  $\mu\text{m}$  [2] [see essay on **▶isolated respiratory centers**] and provides within the slice an inspiratory drive to **▶hypoglossal** motoneurons whose axons exit the preparation in the same transversal plane (Figs. 1 and 2). In medullary slices with a rostrocaudal diameter of 500–700  $\mu\text{m}$ , a regular **▶respiratory rhythm** can be recorded from inspiratory active hypoglossal nerve rootlets for several hours at physiological superfusate

[K<sup>+</sup>], i.e. 3 mM. Such nerve recording (►neurogram) can be combined routinely with whole-cell patch-clamp measurement of biophysical membrane properties of rhythmogenic interneurons or hypoglossal motoneurons for analysis of cellular mechanisms of generation or modulation of the respiratory rhythm (Fig. 2). Furthermore, these electrophysiological techniques can be combined with multiphoton or confocal ►Ca<sup>2+</sup> imaging for recording inspiratory-related cytosolic [Ca<sup>2+</sup>] oscillations in preBötC interneurons or hypoglossal motoneurons, located within 30–90 µm below the surface of the slices (see ►Neuron-Glia-Imaging).

When the thickness of these medullary slices is reduced to <600 µm, respiratory activity in 3 mM [K<sup>+</sup>] solution disappears after several hours, possibly due to “washout” of an excitatory neurostimulator. Thus, [K<sup>+</sup>] is typically elevated from 3 to a total of typically 7–9 mM to provide a stable rhythmic inspiratory-related hypoglossal nerve signal. This indicates that the activity of rhythmogenic preBötC Complex neurons requires a steady tonic excitatory influence from a critical number of cells within the reticular formation. This kernel of the ►respiratory network is devoid of afferent influences from sensory systems mediating, e.g., peripheral chemosensitivity or the lung-stretch reflex. Nonetheless, the reduced *in vitro* preparation contains the neuronal elements mediating central chemosensitivity. This means that the activity of the respiratory slices is modulated by a change in superfusate pH or O<sub>2</sub>, although not to the same extent as *in vivo*. The medullary slices are thought to require superfusate glucose concentrations of about 10–30 mM for long-term maintenance of the respiratory rhythm, while the *in vitro* temperature is usually set to for 26–26 for same reason. Under these conditions, respiratory active slices respond to a large variety of neuromodulators in a fashion very similar to that in more intact *en bloc* or *in vivo* preparations from newborn rodents, and even in (preterm) infant humans. This indicates that these brainstem slices are a potent model to study the nervous control of breathing. Respiratory-active brainstem slices cannot be obtained from adult rodents. Possibly, thicker slices would be needed to fully include a possibly larger preBötC plus a critical number of stimulatory tonic ►reticular formation neurons. Due to an increased metabolic activity and thus substrate demand, these slices would contain a more or less extended hypoxic-anoxic core, which may depress respiratory network activity as does severe systemic hypoxia in mature mammals *in vivo*.

The composed graph in Fig. 2 does not only exemplify the organization and some electrophysiological plus morphological features of the medullary respiratory network. It also shows some properties of non-respiratory neurons within the ►cerebellum and the dorsal aspect of the lower brainstem. In the upper left part of Fig. 2, it is shown that superficial ►Purkinje cells of cerebellar slices

from juvenile rodents can be loaded via the recording whole-cell patch electrode with ►Ca<sup>2+</sup>-sensitive dye for Ca<sup>2+</sup> imaging. In this example, fura-2 was used to monitor a rise of cytosolic [Ca<sup>2+</sup>] in a Purkinje neuron in response to block of aerobic metabolism with cyanide. Such chemical anoxia evoked an early hyperpolarization due to activation of ►ATP-sensitive K<sup>+</sup> channels (Fig. 2). Within few minutes, the hyperpolarization was reversed and an irreversible micromolar increase of cytosolic [Ca<sup>2+</sup>] occurred. This shows that the clinically well-known extreme vulnerability of Purkinje neurons to anoxia-ischemia is retained in cells of brain slices recorded with combined whole-cell patch-clamp and Ca<sup>2+</sup> imaging techniques. That the vulnerability to anoxia is not a general or artificial feature of neurons in brain slices is demonstrated by recordings under identical conditions from neurons of the ►dorsal vagal nucleus, which is adjacent to the dorsal aspect of the hypoglossal nucleus (Fig. 2). In these medullary neurons, anoxia induces a hyperpolarization due to activation of ATP-sensitive K<sup>+</sup> channels (Fig. 2). In contrast to Purkinje neurons, this hyperpolarization persists for time periods >20 min, and cytosolic [Ca<sup>2+</sup>] is increased by only <100 nM. These examples show that specific features of neurons from diverse brain regions are preserved in brain slices and could principally be recorded simultaneously in acute brain slices containing these structures.

### Acknowledgments

The study was supported by AHFMR, CIHR and CFI-ASRIP.

### References

- Collingridge GL (1995) The brain slice preparation: a tribute to the pioneer Henry McIlwain. *J Neurosci Methods* 59:5–9
- Ballanyi K (1999) *In vitro* preparations. In: Windhorst U, Johansson H (eds) *Modern techniques in neuroscience research*. Springer, Berlin, New York, Heidelberg, pp 307–326
- Aitken PG, Breese GR, Dudek FF, Edwards F, Espanol MT, Larkman PM, Lipton P, Newman GC, Nowak TS, Jr, Panizzon KL, Raley-Susman KM, Reid KH, Rice ME, Sarvey JM, Schoepp DD, Segal M, Taylor CP, Teyler TJ, Voullas PJ (1995) Preparative methods for brain slices: a discussion. *J Neurosci Methods* 59:139–149
- Dingledine R, Dodd J, Kelly JS (1980) The *in vitro* brain slice as a useful neurophysiological preparation for intracellular recording. *J Neurosci Methods* 2:323–362
- Edwards FA, Konnerth A, Sakmann B, Takahashi T (1989) A thin slice preparation for patch clamp recordings from neurones of the mammalian central nervous system. *Eur J Physiol* 414:600–612
- Eilers J, Schleggenburger R, Konnerth A (1995) Patch clamp and calcium imaging in brain slices. In: Sakmann B, Neher E (eds) *Single channel recording*. Plenum Press, New York, NY, pp 213–229

7. Haas HL, Büsselberg D (1992) Recording chambers-slices. In: Kettenmann H, Grantyn R (eds) *Practical electrophysiological methods*. Wiley-Liss, New York pp 16–19
8. Lipton P, Aitken PG, Dudek FE, Eskessen K, Espanol MT, Ferchmin PA, Kelly JB, Kreisman NR, Landfield PW, Larkman PM, Leybaert L, Newman GC, Panizzon KL, Payne RS, Phillips P, Raley-Susman KM, Rice ME, Santamaria R, Sarvey JM, Schuur A, Segal M, Sejer V, Taylor CP, Teyler TJ, Vasilenko VY, Veregge S, Wu SH, Wallis R (1995) Making the best of brain slices: comparing preparative methods. *J Neurosci Methods* 59:151–156
9. Reid KH, Edmonds HL Jr, Schuur A, Tseng MT, West CA (1988) Pitfalls in the use of brain slices. *Progr Neurobiol* 31:1–18
10. Gähwiler BH, Knöpfel T (1990) Cultures of brain slices. In: Jahnsen H (ed) *Preparations of vertebrate central nervous system in vitro*. Wiley amp; Sons, Chichester, pp 77–100

---

## Brain States and Olfaction

ALAN GELPERIN  
Monell Chemical Senses Center, Philadelphia,  
PA, USA

### Definition

Global brain states, both intrinsically and extrinsically generated, have dramatic effects on the processing of olfactory information, by alterations of attention and effects of anesthetics on local inhibitory interneurons and on excitability levels of relay neurons.

### Characteristics

Global brain states have direct and dramatic affects on the processing of olfactory information. There are two general categories of brain states, intrinsically generated and exogenously imposed. Intrinsically generated brain states occupy the continuum from alert focused attention to deep sleep. Exogenously imposed brain states arise from administration of anesthetics that produce various depths of anesthesia by a variety of pharmacological mechanisms. To understand the mechanisms of olfactory information processing we must understand how both intrinsically and exogenously generated changes in brain state affect the processing of olfactory sensory input.

A large body of work has examined various stages of the processing of olfactory sensory input in anesthetized preparations. A much smaller body of work has analyzed the processing of olfactory sensory input in awake behaving animals [1]. Mitral cells represent the first stage of synaptic processing of olfactory

information as mitral cells and tufted cells receive direct input from olfactory sensory neurons [2]. Recent studies of single mitral cell responses in awake behaving rodents performing odor-guided tasks show dramatic differences between observed mitral cell responses and those predicted from studies in anesthetized animals [3]. In one recent study the odor responsiveness of a single mitral cell was compared in the awake and anesthetized states. This study revealed that a mitral cell giving clear responses to an odorant in the anesthetized state was often not responsive to the same odorant in the awake state [4]. These observations suggest that an analysis of how changes in brain states, whether endogenously or exogenously generated, influence sensory processing can clarify how inputs from olfactory neurons are normally influenced by the action of global neuromodulators (e.g. acetylcholine, noradrenalin, serotonin, dopamine) and local inhibitory circuits (e.g. periglomerular cells, granule cells) to determine what olfactory information finally reaches higher cortical centers that ultimately generate the olfactory percept [5].

An important source of variation in global brain state is attention, which is conceptualized as the shifting allocation of computational resources among different aspects of the current array of sensory inputs. Variations in attentional state have dramatic effects on information processing in all sensory systems, including olfaction. For example, subjects alerted to expect an odor stimulus showed different patterns of brain activation and faster odor identification than subjects given the same odor stimulus with no warning. Attention can modify the processing of stimuli that do not rise to the level of consciousness. Some of the variability in responses to repetitive olfactory stimuli is undoubtedly due to spontaneous fluctuations in global brain state as measured using functional magnetic resonance imaging.

### Context and Expectation

Olfactory processing, even at early stages in the olfactory bulb, is responsive to the context in which olfactory stimuli are experienced [3] and expectations about the nature and timing of olfactory stimuli based on experience in a particular context. This is shown with particular clarity in the anticipatory responses of rodent mitral cells. These cells increase their rate of action potential production prior to receipt of an olfactory stimulus when the mouse has placed its nose in an odor port and anticipates receiving an odor stimulus based on prior experience with the delivery of odor stimuli with a delay after a nose-poke into the odor port [4]. Similar mitral cell anticipatory responses were recorded in trained rats [3]. These anticipatory responses of mitral cells are not seen when mice are trained to hold their nose in an odor port under conditions where odor exposure is not expected and when odor exposure, when it occurs, is not a cue for any contingent event.

## Endogenous Brain States and Olfaction

Very clear evidence for the influence of global brain state on olfaction is seen in measurements of the processing of olfactory stimuli during sleep. Sleep has been shown to affect the ability of olfactory stimuli to arouse human subjects. Even repeated presentations of 8 ppm hydrogen sulfide, a strong but selective olfactory stimulus, did not arouse sleeping subjects as judged by concurrent overnight ► [polysomnography](#). A stimulus such as carbon dioxide, that activates receptors belonging to the trigeminal system, did produce arousal of sleeping subjects. Olfactory ► [event related potentials](#) (ERPs) could be recorded during sleep suggesting that chemosensory stimuli are processed on a cortical level during sleep. In another study exploring how sleep modulates olfactory processing, peppermint and pyridine at four concentrations were presented through previously implanted nasal cannulas, to sleeping subjects during stages 1, 2, 4 and REM sleep. ► [Electroencephalogram](#), ► [electro-oculogram](#), ► [electromyogram](#), ► [electrocardiogram](#), and respiration rate were recorded during automated application of olfactory stimuli using an air-dilution ► [olfactometer](#). Subjects responded to olfactory stimuli on 92% of trials during stage 1 sleep, but did not respond to peppermint, a pure olfactory stimulus at the concentrations used in this study, during sleep stages 2, 4, and REM sleep. Pyridine produced responses on 45% of sleep stage 2 trials, none in sleep stage 4, and one third of REM sleep trials.

Sleep stages have also been shown to directly gate odorant-evoked responses in single unit recordings from olfactory cortex, even though inputs to olfactory cortex are not subject to direct thalamic control [6]. In the urethane-anesthetized rat, the cortical EEG alternates between two states, a fast wave state and a slow wave state, which normally are associated with awake and sleep states. Single neurons in olfactory cortex showed strong responses to odors during fast wave sleep but not during slow wave sleep. The intracellular recordings indicated that during the fast wave state of the cortical EEG, the cortical neurons were in a relatively depolarized state and therefore more responsive to odorant-elicited excitatory synaptic inputs. Sleep cycles are regulated by activity in ► [orexin](#) (► [hypocretin](#)) neurons so it will be very interesting to test the effects of directly activating orexin neurons on mitral and tufted cell processing of inputs from olfactory sensory neurons.

## Olfactory Thalamus

Behavioral and brain state-dependent gating of the access of sensory information to cortex in vision and audition is controlled by sensory-specific nuclei in the thalamus. Thalamic control of sensory access to cortex is exerted both by control of the gain of synapses from the sensory pathway onto thalamic relay neurons and

by control of the mode of firing, tonic or bursting, of thalamic relay neurons. The mode of action potential production by thalamic neurons has dramatic effects on their postsynaptic effects in cortex and the temporal synchrony among co-active thalamic neurons. Mediodorsal thalamus does receive a small projection from olfactory cortex but the major projection from olfactory cortex to prefrontal cortex is direct. How does olfactory perception work without a thalamus?

Kay and Sherman [7] have recently drawn attention to functional properties of circuits in the olfactory bulb analogous to those of visual and auditory thalamus and suggested that the olfactory bulb may perform the role of cortical gatekeeper in olfaction. Two main types of feedback are found in both thalamus and olfactory bulb: feedbacks from other sensory-specific cortical sites and feedback from more general ► [neuromodulatory](#) centers, primarily in brainstem nuclei. The feedback from sensory-specific cortical sites may serve to guide selective attention while feedback from modulatory centers in brainstem is involved in more global state changes such as sleep. The olfactory bulb fits this scheme as feedback to the olfactory bulb from other olfaction-specific cortical sites, such as anterior and posterior piriform cortex, is very strong. Similarly, inputs to the olfactory bulb from global neuromodulatory sites in brainstem supplying cholinergic, noradrenergic, serotonergic and dopaminergic inputs, among others, are known to have clear effects on mitral cell odor responsiveness. Some combination of cortical-bulbar interaction and global neuromodulation is likely to determine how a mitral cell getting strong input from receptors activated by odor A, as judged by responses of the mitral cell to odor A in the anesthetized state, can show no response to odor A in the awake state [4]. Sparse coding in the olfactory system may result from the action of feed-forward inhibition.

## Arousal, Sniffing and Olfactory Filtering

Another way that brain state is manifest in the control of olfactory processing is by the control of active odor sampling, or sniffing. Access of odorant molecules to the olfactory receptor epithelium is controlled by the act of respiration, and the increased rate of respiration known as sniffing. For some behavioral tasks a mouse or rat will take a single sniff and make an odorant-based decision based on the input obtained during the single sniff, even if the accuracy of odorant identification is less than optimal. If mice are forced to take longer odor samples, their accuracy of odorant identification and discrimination increases [8]. Perhaps if the task was designed to both reward accuracy of performance and punish mistakes, animals would spontaneously take more time for odor sampling as the task demands were made more difficult.

The role of sniffing in shaping the central representation of olfactory information in the olfactory bulb has been clarified in studies using optical imaging of input patterns from olfactory sensory neurons in an awake head-restrained rat sampling odors in order to perform a lick/no lick odor discrimination task [9]. At sniff frequencies below 3 Hz, each sniff produced a brief burst of glomerular activation with an odor-specific glomerular pattern. However, during investigative sniffing at 4–6 Hz olfactory receptor input signals to activated glomeruli appeared as tonic, decremting signals so that the integrity of sniff-specific inputs was lost. The implications of this result require a complete rethinking of the role of active sampling in olfaction [10].

### Attention

The current concept of attention equates it to the shifting allocation of computational resources. The focus of attention on an olfactory task over multiple testing sessions can in fact cause a dramatic increase in sensitivity to a monomolecular odorant by human subjects. An increased sensitivity averaging five orders of magnitude for several common monomolecular odorants was observed over test sessions, but only for female subjects of reproductive age. Induction of odorant sensitivity was previously demonstrated for the volatile steroid androstenone (5- $\alpha$ -androst-16-en-3-one), a volatile steroid.

Normal attentional focus not only increases the computational resources available to identify and discriminate olfactory stimuli, but also protects the processing of the sensory stream from distracting stimuli extraneous to the olfactory task at hand. This effect has recently been demonstrated in mice. Targeted single gene mutations in mice show the importance of normal attentional focus in the following way. In a mouse model of **fragile X syndrome**, exhibiting an attendant attentional dysfunction, the unpredicted presentation of a potent olfactory distracter stimulus produced a generalized disruption in performance, which was not found in mice of the same strain free of the induced mutation.

### Summary

As in all other sensory systems, changes in brain state caused by sleep, attentional fixation or anesthesia produce very clear and dramatic changes in the processing of olfactory information, both at the level of the olfactory bulb as well as at the level of olfactory cortex and the olfactory components of prefrontal cortex. The role of active sensory sampling in olfaction, called sniffing, has recently been shown in studies of awake behaving rats to have consequences for the representation of olfactory information in the olfactory bulb not predicted by studies of the same phenomenon in anesthetized animals. Similarly, by following the responses of single mitral cells from the awake state to the anesthetized state and

back to the awake state, it was shown that a mitral cell giving strong responses to an odor in the anesthetized state could show no response to the same odor in the awake state. These findings and related studies begin to show how changes in global brain state can influence odor information processing in the mammalian olfactory system and highlight the need for more studies of cellular mechanisms of odor information processing in the awake behaving animal.

### References

1. Rinberg D, Gelperin A (2006) Olfactory neuronal dynamics in behaving animals. *Sem Cell Dev Biol* 17:454–461
2. Wilson RI, Mainen ZF (2006) Early events in olfactory processing. *Annu Rev Neurosci* 29:163–201
3. Kay LM, Laurent G (1999) Odor- and context-dependent modulation of mitral cell activity in behaving rats. *Nat Neurosci* 2:1003–1009
4. Rinberg D, Koulakov A, Gelperin A (2006) Sparse odor coding in the behaving mouse. *J Neurosci* 26:8857–8865
5. Wilson DA, Kadohisa M, Fletcher ML (2006) Cortical contributions to olfaction: plasticity and perception. *Semin Cell Dev Biol* 17:462–470
6. Murakami M, Kashiwadani H, Kirino Y, Mori K (2005) State-dependent sensory gating in olfactory cortex. *Neuron* 46:285–296
7. Kay LM, Sherman SM (2007) An argument for an olfactory thalamus. *Trends Neurosci* 30:47–53
8. Rinberg D, Koulakov A, Gelperin A (2006) Speed-accuracy tradeoff in olfaction. *Neuron* 51:351–358
9. Verhagen JV, Wesson DW, Netoff TI, White JA, Wachowiak M (2007) Sniffing controls an adaptive filter of sensory input to the olfactory bulb. *Nat Neurosci* 10:631–639
10. Kepecs A, Uchida N, Mainen ZF (2007) Rapid and precise control of sniffing during olfactory discrimination in rats. *J Neurophysiol* 98:205–213

---

## Brainstem

### Definition

The brainstem is the part of the central nervous system (CNS) located between the spinal cord and the forebrain. It is divided into three parts. The medulla is the area immediately rostral to spinal cord. More rostral to the medulla is the pons and further rostrally is the mesencephalon also referred to as midbrain. Sensory and motor pathways pass through as they relay information between brain and spinal cord. The brainstem contains many nuclei associated with cranial nerves and involved in sensory and motor functions, as well as autonomic regulatory centers that control cardiovascular and respiratory functions.

- 1 Lateral ventricle
- 2 Third ventricle
- 3 Pineal body
- 4 Brachium of the superior colliculus
- 5 Superior colliculus
- 6 Brachium of the inferior colliculus
- 7 Inferior colliculus
- 8 Cerebral peduncle

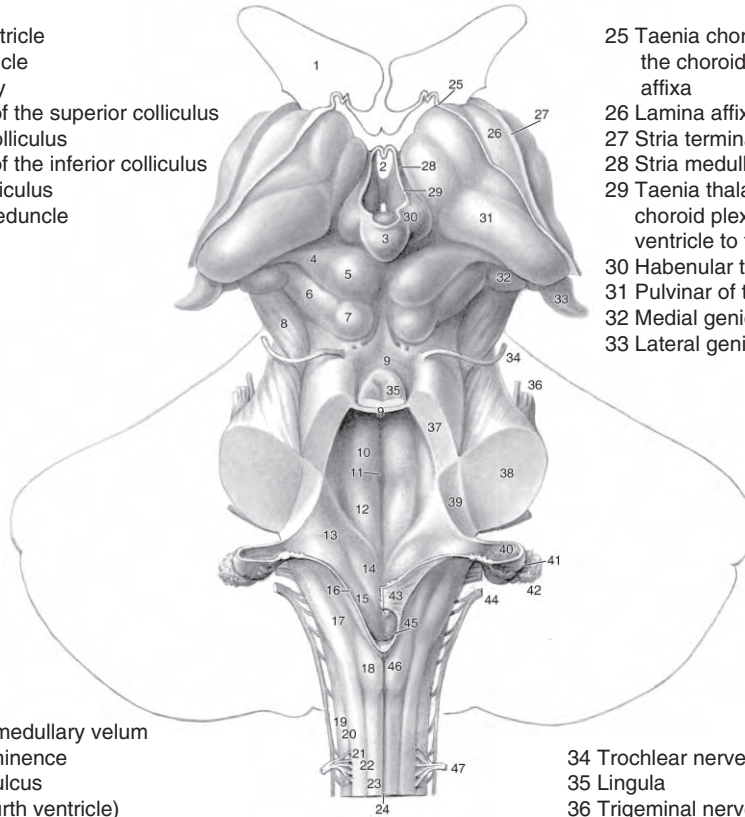

- 25 Taenia choroidea: attachment of the choroid plexus to the lamina affixa
- 26 Lamina affixa
- 27 Stria terminalis
- 28 Stria medullaris of the thalamus
- 29 Taenia thalami: attachment of the choroid plexus of the third ventricle to the thalamus
- 30 Habenular triangle
- 31 Pulvinar of the thalamus
- 32 Medial geniculate body
- 33 Lateral geniculate body

- 9 Superior medullary velum
- 10 Medial eminence
- 11 Median sulcus (of the fourth ventricle)
- 12 Facial collicle
- 13 Vestibular area
- 14 Hypoglossal triangle
- 15 Vagal triangle
- 16 Attachment of the roof of the fourth ventricle
- 17 Cuneate tubercle
- 18 Gracile tubercle
- 19 Lateral funiculus
- 20 Lateral posterior sulcus
- 21 Cuneate fascicle
- 22 Posterior intermediate sulcus
- 23 Gracile fascicle
- 24 Posterior median sulcus

- 34 Trochlear nerve
- 35 Lingula
- 36 Trigeminal nerve
- 37 Superior cerebellar peduncle (brachium conjunctivum)
- 38 Middle cerebellar peduncle (brachium pontis)
- 39 Inferior cerebellar peduncle (restiform body)
- 40 Lateral recess of the fourth ventricle
- 41 Lateral aperture of the fourth ventricle
- 42 Bochdalek's flowerbasket [3]
- 43 Ependymal roof of the fourth ventricle
- 44 Accessory nerve
- 45 Median aperture of the fourth ventricle
- 46 Obex
- 47 Dorsal root

**Brainstem. Figure 1** Dorsal view of the brain stem and the diencephalon after removal of the structures surrounding the thalamus. The contour of the cerebellum is indicated ( $3/2\times$ ). Original figure 3.10. taken from Nieuwenhuys, R; Voogd, J; van Huijzen, C. (Eds) 2008 "The Human Central Nervous System". Fourth Edition. Springer, Berlin. page 82 with permission.

## Brainstem Burst Generator

CHARLES SCUDDER  
Portland, OR, USA

### Synonyms

Saccadic burst generator; Burst generator

### Definition

The saccadic burst generator is a set of interconnected neuronal populations that collectively generate a burst

of activity that provides powerful excitation to agonist extraocular motoneurons and inhibition to antagonist motoneurons for the production of saccades. A "horizontal burst generator" for the control of horizontal saccades is located in the ►[paramedian pontine reticular formation \(PPRF\)](#), and a "vertical burst generator" for the control of vertical saccades is located in the mesencephalic reticular formation. The two are coordinated during oblique saccades by virtue of sharing the same set of omnipause neurons and by sharing synchronized excitatory inputs from higher centers including the ►[superior colliculus](#). The bursting is thought to be generated by the network and its



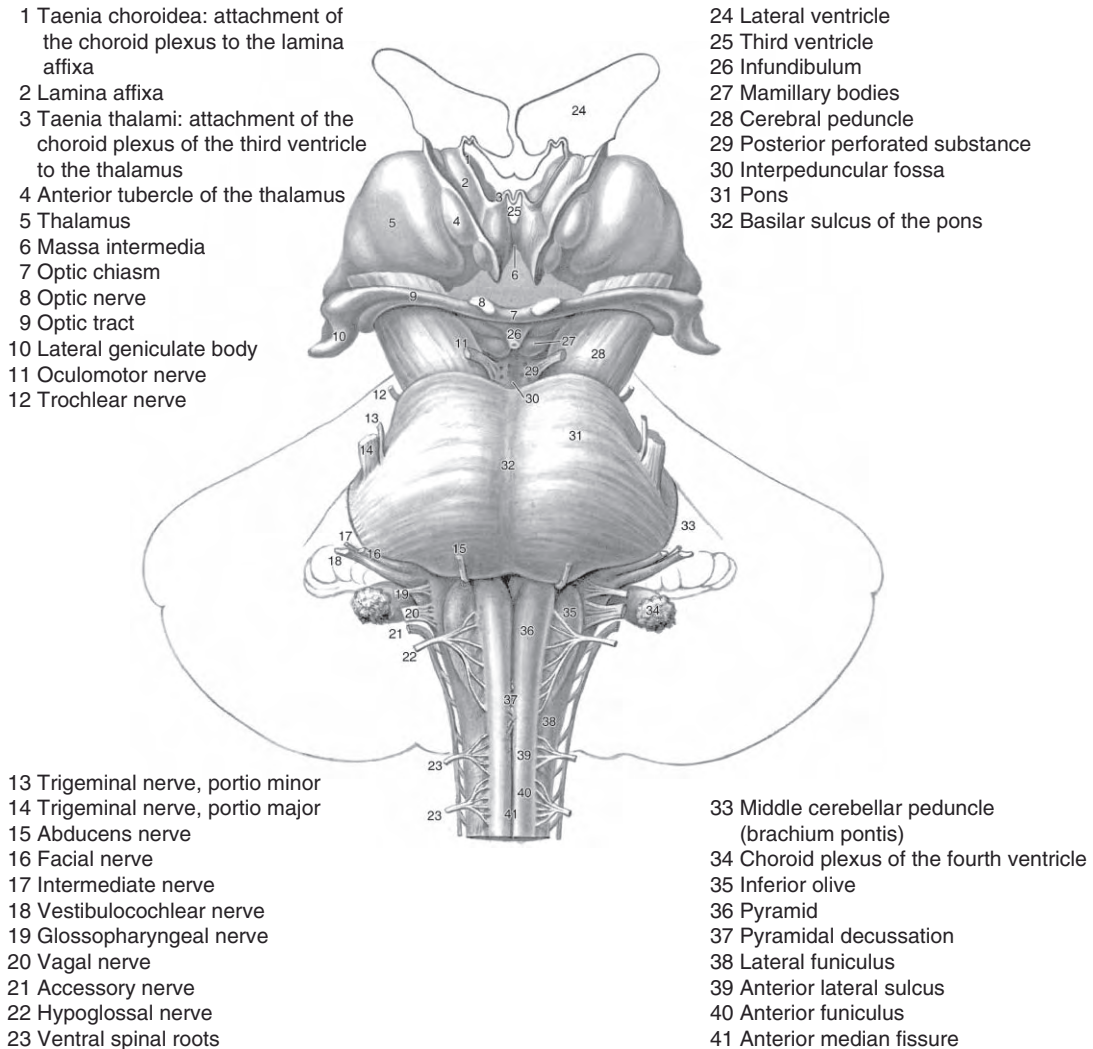

**Brainstem. Figure 2** Ventral view of the brain stem and the diencephalon. The structures surrounding the thalamus have been removed (3/2×). Original figure 3.12. taken from Nieuwenhuys, R; Voogd, J; van Huijzen, C. (Eds) 2008 "The Human Central Nervous System". Fourth Edition. Springer, Berlin. page 84 with permission.

excitatory inputs rather than intrinsic bursting properties of the constituent neurons.

## Characteristics

### Parts of the Burst Generator

The neuronal population central to the burst generator consists of ►**excitatory burst neurons (EBNs)**. These are ►**medium-lead burst neurons (MLBNs)** that project to motoneurons and make excitatory synapses (Fig. 1) [reviewed in 1,2]. The horizontal EBNs are in the PPRF rostral to the abducens nuclei and project to ipsilateral abducens neurons as well as other ipsilateral reticular targets. They discharge during all ►**ipsiversive** saccades to produce the burst component of the burst-►**tonic discharge** characteristic of all abducens neurons (►**burst cells/tonic cells (BTNs)**). EBNs are silent

or fire weakly during ►**contraversive** saccades. The populations of excitatory burst neurons that generate vertical saccades are located in the ►**rostral interstitial nucleus of the MLF (riMLF)**. Neurons that discharge exclusively during upward and those that discharge during downward saccades are intermixed. Each population projects to different subdivisions of the nearby oculomotor (III) nucleus [reviewed in 2].

A second population of MLBNs in the burst generator are the ►**inhibitory burst neurons (IBNs)**. Horizontal IBNs discharge for ipsiversive saccades and are silent or fire weakly during contraversive saccades. They are located immediately caudal to the abducens nuclei. Their axons cross the midline and connect with contralateral abducens neurons where they make inhibitory synapses (Fig. 1) [reviewed in 1,2]. IBNs are responsible for the

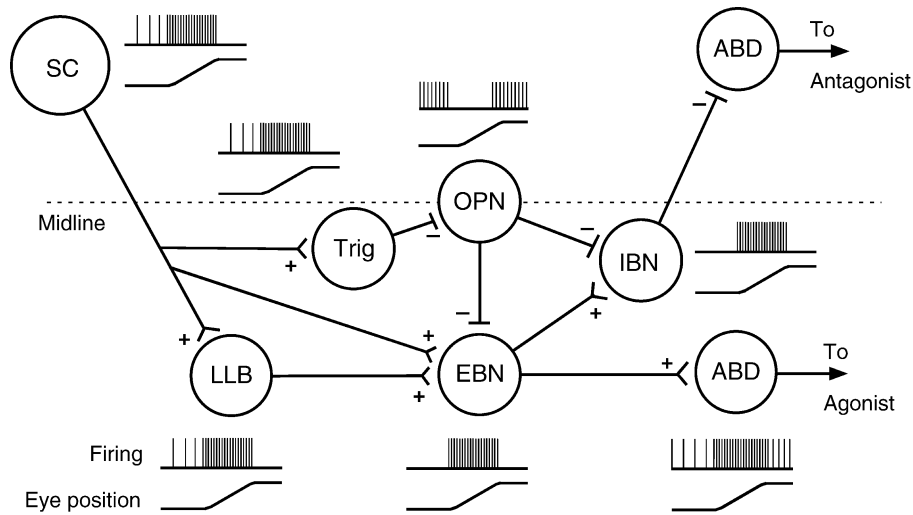

**Brainstem Burst Generator. Figure 1** Simplified diagram showing the essential elements of the horizontal saccadic burst generator. Each circle represents a pool of neurons; *SC*, superior colliculus; *LLB*, long-lead burst neuron; *Trig*, trigger neuron; *EBN*, excitatory burst neuron; *OPN*, omnipause neuron; *IBN*, inhibitory burst neuron; *ABD*, abducens motoneuron. Firing rates and associated saccadic eye movement are illustrated adjacent to each neuronal pool. Connections with arrow-tails and + are excitatory; connections with flat ends and – are inhibitory. Only the active neurons are shown, while their counterparts on the opposite side are mostly omitted. Latch neurons, tonic neurons, and the connection from the SC to OPNs were omitted from the figure for clarity.

reduction or cessation of firing in abducens neurons when saccades are contraversive to the innervated abducens nucleus. Vertical IBNs are intermixed with vertical EBNs in the riMLF. Those discharging during upward and those discharging during downward saccades are also intermixed and project to separate subdivisions of the oculomotor nucleus (Cerebellum – oculomotor vermis) (reviewed in [2]).

The third important population of neurons in the burst generator is the ► **omnipause neurons (OPNs)**. These neurons are located in the midline raphe interpositus and connect with inhibitory synapses to the ipsilateral EBNs and IBNs of both the horizontal and vertical burst generators (Fig. 1) (reviewed in [1,2]). Omnipause neurons in Rhesus monkeys have steady firing rates of 50–200 spikes/s during fixations or smooth eye movements, but completely cease discharging (pause) during saccades in any direction. The sudden pause in firing precedes the onset of the burst in EBNs and IBNs, hence it is believed that pause onset releases the MLBNs from total inhibition and allows them to respond to their already active excitatory inputs with a sudden burst of activity. The strong inhibitory control of EBNS and IBNs by omnipause neurons has been confirmed by the truncation of ongoing saccades induced by microstimulation in the raphe interpositus [3].

In addition to these established neuronal pools and connections, two other pools are thought to participate in the generation of saccadic bursts. These populations have not been physiologically identified, but rather have been predicted based on theoretical grounds. The first

of these are the ► **trigger neurons**, which are putative inhibitory neurons interposed between the superior colliculus efferents, frontal eye field efferents and the omnipause neurons (Fig. 1). The necessity of a trigger to produce the initial inhibition of OPN firing is dictated by findings that the OPNs receive excitatory projections from caudally located superior-colliculus neurons, whose discharge during saccades would otherwise keep the OPNs firing (see below). The second population of inhibitory interneurons, the ► **latch neurons**, has been hypothesized to maintain the inhibition of OPNs until the saccade reaches its intended target. As originally envisioned, latch neurons received excitatory input from the EBNs, and so inhibited the OPNs as long as the EBNs fired at a sufficient rate [4]. However, with the discovery that the superior colliculus and cerebellum may participate in the control of saccade duration [2,5–7], the role of the latch neuron may need to be broadened to accommodate input from these structures.

### Higher Level Structures

The principal excitatory inputs to EBNs, IBNs, and OPNs are derived directly or indirectly from the intermediate and deep layers of the contralateral superior colliculus and from the contralateral cerebellum. Inputs to the superior colliculus arise in turn from the ► **frontal eye fields**, the ► **supplementary eye fields**, the ► **lateral intraparietal area (LIP)**, the ► **substantia nigra**, and the superficial (sensory) layers of the superior colliculus. After relays in the brainstem, some of the same structures provide saccade-related input to the cerebellum

(see ►Cerebellum – role in eye movements, and ►Precerebellar LLBNs).

In many species, efferents of the superior colliculus have been shown to terminate in the regions where EBN and IBN somata are located [8]. Monosynaptic connections from the superior colliculus to the EBNs and IBNs have been demonstrated electrophysiologically in the cat, but attempts to demonstrate direct connections in primates have failed [9]. Rather, superior-colliculus efferents project to long-lead burst neurons (►Burst cells – long lead (LLBNs)), and it is hypothesized that LLBNs connect with EBNs and IBNs. Some LLBNs do indeed project to the loci of EBN and IBN somata (see ►Pontopontine LLBNs), but a direct connection remains to be proven. The frontal eye fields also have projections to the PPRF and the mesencephalic MLBNs, but their contribution to the firing of EBNs and IBNs is thought to be weak [reviewed in 2]. EBNs and IBNs also receive excitatory inputs from the caudal part of the most medial of the deep cerebellar nuclei, which is also called the ►fastigial oculomotor region [Cerebellum – fastigial oculomotor region (FOR)] (see ►Cerebellum – role in eye movements).

The very rostral part of the superior colliculus, which contains the so called “►fixation neurons,” also projects to the PPRF where it makes excitatory connections with OPNs.

## Function of the Burst Generator

### Initiation of a Saccade

From the perspective of the burst generator, the generation of a saccade begins with the onset of activity in a circumscribed region of the superior colliculus on one side. Firing begins in the ►buildup neurons and increases as additional neurons are recruited, including the later-onset ►saccade-related burst neurons (see ►Superior colliculus). Summed activity is passed on to the inhibitory trigger neurons. Commensurate with this buildup, fixation neurons in the rostral pole of the colliculus rapidly decrease firing. This causes a disfacilitation of the OPNs, which when combined with the building inhibition from the trigger neurons, ultimately suppresses the firing of the OPNs. Frontal eye field neurons and efferents of the fastigial oculomotor region may participate in this process [reviewed in 2]. The release of inhibition by the OPNs allows the MLBNs (EBNs and IBNs) to begin firing and achieve a rapid peak. Activity in the superior colliculus, the fastigial oculomotor region, the EBNs, IBNs, and presumably the trigger and latch neurons slowly declines until it is inadequate to maintain silence in the OPNs. At this point, the OPNs rapidly resume firing and the EBNs and IBN discharges are inhibited. The exact time of MLBN burst offset is thought to be under tight control, as discussed later.

### Downstream Effects of the Burst Generator

The burst in the EBNs produces a burst of activity in agonist motoneurons and a pulse of force in the agonist muscles. Simultaneously, the burst in the IBNs produces a pause in the antagonist motoneuron discharge and a relaxation of the antagonist muscle. The burst neurons (►Burst cells) have an additional effect by virtue of their projections to the prepositus nucleus in the horizontal system or the interstitial nucleus of Cajal in the vertical system. These nuclei have neurons exhibiting tonic and burst-tonic discharges, and evidence has accumulated that these nuclei internally generate the tonic component by a mathematical integration of the burst-neuron input (see ►Neural integrator). This tonic signal is conveyed to the horizontal and vertical motoneurons where it is used to maintain force in the agonist muscle. This force counteracts the elastic restoring force of the globe, and thereby holds the eye in a stable position during the fixation following a saccade.

### Control of Saccade Size and Direction

As the saccade size is determined by the number of spikes in the bursts of the premotor MLBNs, control of saccade size is achieved by modulation of both MLBN burst-rate and burst-duration. It now appears that burst rate is determined by the density of synaptic terminals from active superior colliculus efferents. Specifically, more caudal sites in the superior colliculus give rise to a greater synaptic density in the PPRF [10], which presumably produces the higher firing rates observed in MLBNs during larger saccades. The ratio of horizontal to vertical MLBN activation determines saccade direction, which in turn is also presumably determined by the ratio of synaptic densities to the two burst generators. Saccade duration appears to be under feedback control [2–4]. That is, the saccade is terminated when feedback says that gaze is directed at the intended saccade target. The feedback must be “local” (►Local feedback) (internal to the saccadic system) because delays in the periphery, especially in the visual system, are too long to produce accurate targeting. In the simplest scheme, the local-feedback signal is obtained by mathematically integrating the MLBN burst to continuously generate a neural estimate of physical eye position, and the saccade is terminated when this estimate is equal to the desired position of the eye (i.e. target position, [4]). The exact nature of the feedback signal, its location, and the parts of the burst generator that receive the feedback are the subject of ongoing investigation. Feedback from the MLBNs, from the cerebellum, to the burst generator itself, and to the superior colliculus are all partly supported by data [reviewed in 2].

## Pathology

The neural circuitry that generates saccades is widespread throughout the brain, so central pathologies frequently affect some aspect of saccade generation. Pathology of the burst generator *per se* usually produces slow saccades, sometime accompanied by undershooting. Slowing of saccades in all directions may be due to damage to the OPNs. Slowing, undershooting, or an inability to produce vertical saccades is typically due to damage to the midbrain; slowing, undershooting, or an inability to produce horizontal saccades is typically due to damage to the PPRF. Undershooting and especially overshooting of saccades having normal amplitude-velocity relationships is most likely due to damage to the cerebellum.

## References

1. Fuchs AF, Kaneko CRS, Scudder CA (1985) Brainstem control of saccadic eye movements. *Annu Rev Neurosci* 8:307–337
2. Scudder CA, Kaneko CRS, Fuchs AF (2002) The brainstem burst generator for saccadic eye movements: a modern synthesis. *Exp Brain Res* 142:439–462
3. Keller EL, Gandhi NJ, Shieh JM (1996) Endpoint accuracy in saccades interrupted by stimulation in the omnipause region in monkey. *Vis Neurosci* 13:1059–1067
4. van Gisbergen JAM, Robinson DA, Gielen S (1981) A quantitative analysis of generation of saccadic eye movements by burst neurons. *J Neurophysiol* 45:417–442
5. Soetedjo R, Kaneko CRS, Fuchs AF (2002) Evidence that the superior colliculus participates in the feedback control of saccadic eye movements. *J Neurophysiol* 87:679–695
6. Thier P, Dicke PW, Haas R, Barash S (2000) Encoding of movement time by populations of cerebellar Purkinje cells. *Nature* 405:72–76
7. Waitzman DM, Ma TP, Optican LM, Wurtz RH (1991) Superior colliculus neurons mediate the dynamic characteristics of saccades. *J Neurophysiol* 66:1716–1737
8. Scudder CA, Moschovakis AK, Karabelas AB, Highstein SM (1996) Anatomy and physiology of saccadic long-lead burst neurons recorded in the alert squirrel monkey. I. Descending projections from the mesencephalon. *J Neurophysiol* 76:332–352
9. Keller EL, McPeck RM, Salz T (2000) Evidence against direct connections to PPRF EBNs from SC in the monkey. *J Neurophysiol* 84:1303–1313
10. Moschovakis AK, Kitama T, Dalezios Y, Petit J, Brandt AM, Grantyn AA (1998) An anatomical substrate for the spatiotemporal transformation. *J Neurosci* 18:10219–10229

## Brainstem Saccade Generators

### Definition

Areas that contain neurons that generate signals necessary for saccadic eye movements and send them to motoneurons of the extra-ocular muscles. The

horizontal and vertical saccade generators are located in the ponto-medullary reticular formation and the midbrain reticular formation, respectively.

► Saccade, Saccadic Eye Movement

## Brainstem–cerebellar Vestibular Disorders

► Central Vestibular Disorders

## Brain-stimulation Reward

### Definition

Electrical stimulation via chronically implanted electrodes aimed initially at the medial forebrain bundle within the lateral hypothalamus was shown by Olds and Milner (1954) to provide positive reinforcement in both instrumental (operant) and Pavlovian conditioning procedures. This phenomenon was subsequently called intracranial self-stimulation (ICSS) and was used to locate neural systems involved in motivation and reward processes. Subsequent experiments showed that the neurotransmitter dopamine is essential for brain stimulation reward in many (but not all) regions of the brain. Facilitation of ICSS by psychostimulant and opiate drugs, also known for their abuse liability, supported the hypothesis that drug-reward is also involves activation of brain dopamine neurons.

► Learning and Motivation

## Breathing Cycle

► Nasal Passageways

## Bregma

### Definition

Bregma is a horizontal plane reference point. It is the meeting point of the sagittal and coronal sutures located on the dorsal surface of the skull.

## Breuer-Hering Reflexes

► Respiratory Reflexes

## Bridge Laws

### Definition

The connecting laws between higher level sciences and lower level sciences. So, for example, genes are identified (in eukaryots) with DNA sequences.

► Reductionism (Anti-Reductionism, Reductive Explanation)

## Broad-Band Noise

### Definition

Broad-band noise is noise of neural origin made up of a wide range of frequencies (e.g., 0.1–1,000 Hz) and giving the appearance of a completely random signal while it may, in fact, be fractal rather than random.

## Broca's Aphasia

### Definition

Broca's aphasia is characterized by retained language comprehension, but impaired speech production, resulting from lesions of ► Broca's area (posterior regions of the left third frontal gyrus: ► Brodmann's areas 44 and 45) and, in severe cases, of areas 6, 8, 9, 10 and 46. Symptoms range from muteness to slowed deliberate speech using only key words without coordinated grammatical structure, and include difficulty reading

aloud and writing. Moreover, these patients often exhibit right ► hemiparesis and ► homonymous hemianopsia.

## Broca's Speech Area

### Definition

The inferior frontal gyrus comprises the following:

- Inferior frontal gyrus, orbital part
- Inferior frontal gyrus, triangular part
- Inferior frontal gyrus, opercular part

In the areas of the frontal gyrus close to the precentral gyrus is situated the premotor cortex, which plays an important role in planning effector voluntary movements and has close interaction with the cerebellum, thalamic nuclei and basal ganglia.

In the inferior frontal gyrus, opercular part, lies the motor speech center (Broca). Here speech is planned but not executed.

► Telencephalon

## Brodmann's Areas (by Douglas Bowden)

### Definition

Brodmann's areas are regions of the cerebral cortex distinguished from one another by differences in cellular organization (cytoarchitecture) and white matter patterns (myeloarchitecture). Brodmann (a German neurologist in the late nineteenth and early twentieth centuries) laid these areas out on comprehensive map of the medial and lateral surfaces of the cerebral hemispheres. Brodmann's diagrams are by far the best known of the cerebral cortex subdivided on the basis of internal structure.

Students of cerebral architecture are blessed with half a dozen classical maps that vary in terms of underlying methodology, complexity, nomenclature and accessibility to English-bound readers. Brodmann's maps, published in German between 1908 and 1914, were the earliest comprehensive product of the Vogt Institute in Berlin. Brodmann established a basic nomenclature and numbering system that was elaborated in maps developed by the Vogts themselves into the 1920s.

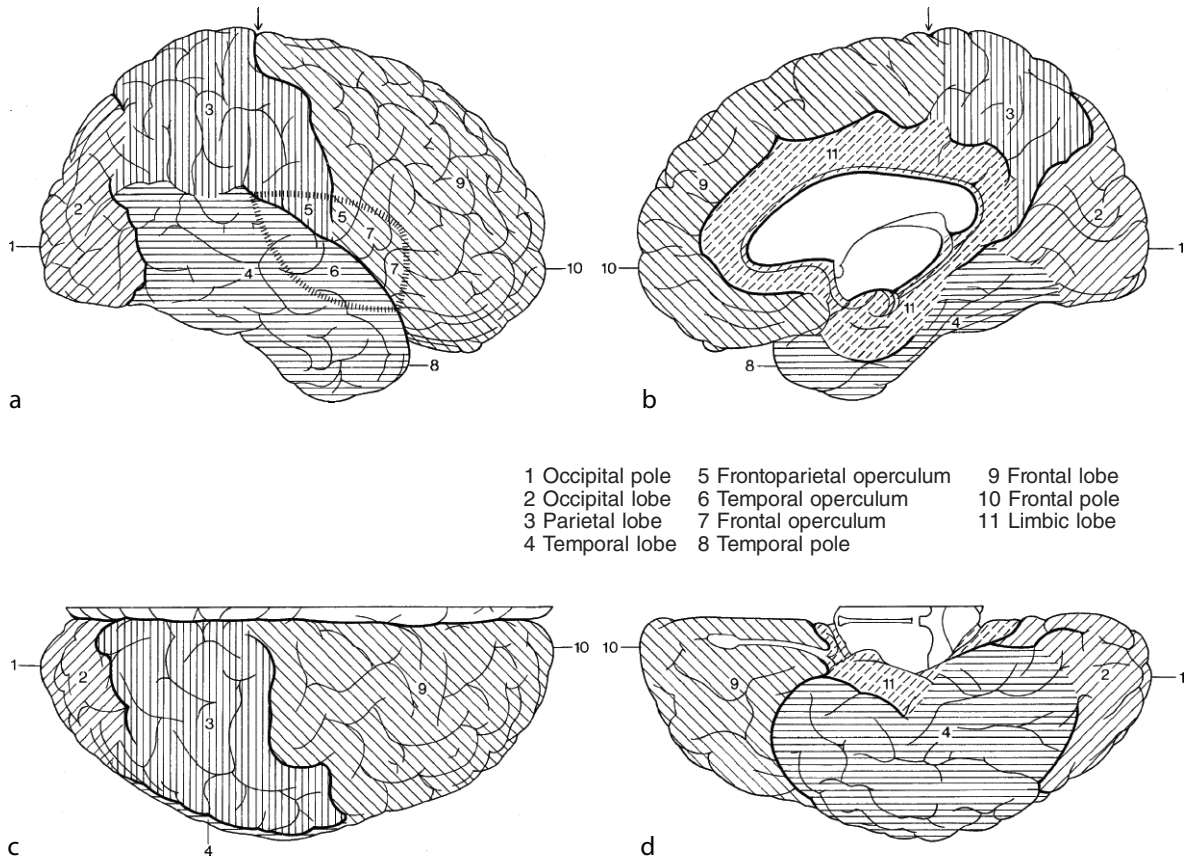

**Brodman's Areas (by Douglas Bowden). Figure 1** a–d Subdivisions of the right cerebral hemisphere into lobes. a Lateral view; b medial view; c superior view; d inferior view (1/2 $\times$ ).

Their maps were further refined and documented with high resolution photomicrographs in the maps of Sarkisov and Filimonov, which were published in Russian in 1955. A second classical series began in 1927 with the highly detailed maps and extensive photomicroscopic documentation published in German by Economo and Koskinas. They developed a somewhat different nomenclature and very different lettering system, which were adopted by Bonin and Bailey for maps published in 1951. Few if any comprehensive maps of human cortex have been published since the mid-1950s.

In subsequent decades neuroanatomists have tended to focus on more detailed investigation of particular cortical areas using stains for cellular features other than the classical Nissl and myelin stains. Perhaps more importantly, surface views show only about a third of the total area of cerebral cortex. Development of computerized image processing has made it possible to generate flat maps, inflated models, and spherical models that allow one to view relations among all cortical areas, including those ordinarily hidden in the walls and floors of sulci.

## Brownian Motion

RACHID AIT-HADDOU, WALTER HERZOG  
University of Calgary, Human Performance Laboratory,  
Calgary, AB, Canada

### Synonyms

Stochastic Processes

### Definition

Any entity that is constantly undergoing small, random fluctuations.

### Characteristics

In 1827, the botanist Robert Brown [1] investigated, under his microscope, the irregular and jittery motion of pollen particles floating in water. He believed that he had found the “primitive molecule” of living matter. A quantitative and physical explanation of this movement had to await the 1905 work of Albert Einstein [2].

Postulating the **atomic hypothesis** of matter (still controversial at that time) and Boltzmann’s statistical physics, Einstein was able to derive the fluctuation-dissipation theorem, relating the observed diffusion of the Brownian particles to the viscosity and temperature of the medium. In simple terms, a suspended particle is constantly and randomly bombarded from all sides by molecules of the fluid. If the particle is very small, the hits it takes from one side may be stronger than hits from the other side, causing it to jump. These small random jumps are what make up **Brownian motion** (Fig. 1).

Experiments performed by Jean Baptiste Perrin [3] confirmed the quantitative results of Einstein and the victory of the atomic hypothesis. Perrin was awarded the 1926 Nobel Prize for his work.

Einstein considered the motion of a free particle in which the only forces acting on the particle are those of the molecules in the surrounding medium. Consider the projection of the motion of the free particle in the x-axis, and denote by  $X(t)$  the position of the particle at time  $t$ . Since the collisions of the particles in the medium with the target particle are chaotic, the position of the particle cannot be precisely determined, and the function  $X(t)$  is a random process. However, we can calculate the probability,  $p(x_0/X(t) = x_1)$ , of finding the particle at point  $x_1$  at time  $t$ , when starting at point  $x_0$  at time  $t = 0$ . To do so, Einstein made a few general assumptions about the physical phenomena. The medium was assumed homogeneous; therefore, the velocity of the colliding molecules is independent of the position and the velocity of the molecules in the medium. Therefore, if it is assumed that the mass of the target particle is negligible, the displacement of the particle from an arbitrary position and within a time interval,  $\Delta t$ , is

independent of the particle or its previous motion. Assuming that the state of the medium does not change over time, the process  $X(t)$  is continuous and homogeneous in time. Since the direction of collision of the molecules in the medium is independent of the position of the particle, the mean displacement of the particle vanishes at every instant. Therefore, the process  $X(t)$  is a Gaussian process with a mean of zero and a variance,  $Dt$ , proportional to the time,  $t$ ; that is, the probability of finding the particle between  $x_1$  and  $x_2$  at time  $t$ , when starting at  $x_0$  at time  $t = 0$  is

$$p(x_0/x_1 \leq X(t) \leq x_2) = \frac{1}{\sqrt{4\pi Dt}} \int_{x_1}^{x_2} e^{-(x-x_0)^2/4Dt} \quad (1)$$

where  $D$  is the so-called diffusion coefficient. The density probability of (1) satisfies the **diffusion equation**

$$\frac{\partial p(x, t)}{\partial t} = D \frac{\partial^2 p(x, t)}{\partial x^2} \quad (2)$$

A different way of arriving at the same result consists of discretizing the motion of the particle in space and time. Assume that the particle moves along the x-axis by a single discrete step of length  $\Delta$  to the right or to the left, and that the duration of the step is  $\tau$ . Furthermore, let us assume that we are dealing with a free particle, and that the probability of moving to the left or right is the same (i.e.  $1/2$ ). Now, denote by  $p(n\Delta/m\Delta; s\tau)$  the probability that the particle is at  $m\Delta$  at time  $s\tau$ , if it starts at  $n\Delta$ . This probability is equal to

$$p(n\Delta/m\Delta; s\tau) = \begin{cases} \frac{1}{2^s} \frac{s!}{(s+|m-n|/2)!(s-|m-n|/2)!} & \text{if } |m-n| \leq s \text{ and } |m-n| + s \text{ even} \\ 0 & \text{otherwise} \end{cases}$$

Letting  $\Delta$  and  $\tau$  approach 0 in such a way that

$$\frac{\Delta^2}{2\tau} = D, \quad n\Delta \rightarrow x_0, \quad s\tau = t$$

it follows from the classical Laplace-Moivre theorem that

$$\lim_{x_1 < m\Delta < x_2} \sum p(n\Delta/m\Delta; s\tau) = \frac{1}{\sqrt{4\pi Dt}} \int_{x_1}^{x_2} e^{-(x-x_0)^2/4Dt}$$

Which gives the same fundamental result as found by Einstein.

### Fluctuation-Dissipation Relationship

Smolowski extended Einstein’s theory to take into account outside forces. In particular, he showed that for a constant force  $F(x) = -a$  and a friction constant  $\eta$ , equation (2) must be modified to

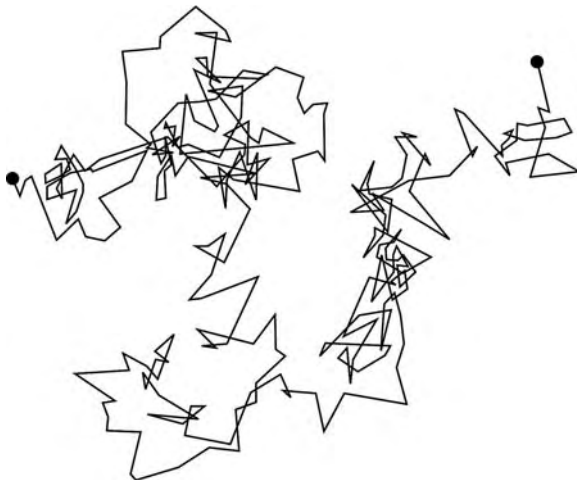

**Brownian Motion. Figure 1** Random Brownian motion of a microscopic particle that is suspended in fluid.

$$\frac{\partial p(x, t)}{\partial t} = -\frac{\partial}{\partial x} \left( \frac{-a}{\eta} p(x, t) \right) + D \frac{\partial^2 p(x, t)}{\partial x^2} \quad (3)$$

Assume now that a large number of Brownian particles are in a cup of fluid under the action of gravity and with a reflecting barrier at the bottom. Therefore, the flow of the particle at the bottom vanishes and equation (3) has the stationary solution

$$p(x) = \text{Const} e^{-\frac{g}{D}x} \quad (4)$$

where *Const* is the normalization constant and *g* is the gravitation constant.

Postulating the atomic hypothesis of matter and Boltzmann's statistical physics, such a physical system has a stationary solution of the shape

$$p(x) = \text{Const} e^{-\frac{mg}{k_B T}x} \quad (5)$$

where *T* is the temperature of the medium,  $k_B$  is the Boltzmann constant and *m* the mass of the Brownian particle.

Equating (4) and (5), we arrive at the famous Einstein fluctuation-dissipation theorem, relating the observed diffusion of Brownian particles to the viscosity and temperature of the medium.

$$D = \frac{k_B T}{m\eta}$$

## References

1. Brown R (1928) A Brief account of microscopical observations made in the months of June, July, and August, 1827, on the particles contained in the pollen of plants; and on the general existence of active molecules in organic and inorganic bodies. *Phil Mag* 4:161–173
2. Einstein A (1956) *Investigations on the theory of Brownian Movement*. Dover, New York
3. Perrin JB (1913) *Les Atomes*, Lib Felix Alan, 3rd edn. p.188

## Brownian Ratchet

RACHID AIT-HADDOU, WALTER HERZOG  
University of Calgary, Human Performance Laboratory,  
Calgary, AB, Canada

### Synonyms

Noise-induced transport

### Definition

► **Brownian ratchet** theory refers to the phenomenon that non-equilibrium fluctuations in an isothermal

medium and anisotropic system can induce mechanical force and motion. This concept of ► **noise-induced transport** has motivated an abundance of theoretical and applied research. One of the exciting applications of the ratchet theory lies in the possible explanation of the operating mode of biological molecular motors, such as the myosin II motor involved in muscle contraction or the F-motor involved in ATP synthesis.

### Description of the Theory

In his lectures [1], Feynman designed a theoretical model, the so-called ► **Feynman ratchet and pawl**, to demonstrate the subtleties of the second law of thermodynamics. The model consists of (Fig. 1) a ratchet that is wheel-shaped, like a circular saw with asymmetric teeth, i.e. one face of the teeth is oriented orthogonal to the circumference of the wheel, while the other face is at an angle of inclination smaller than  $\pi/2$ .

A spring is attached to a pawl that prevents free rotation of the ratchet. The ratchet is connected to a vane by means of a rod. A load is attached to the vane. We assume that all elements of the machine are perfect isolators and that the vane and spring are in two separated, isolated boxes filled with a gas of temperature  $T_1$  and  $T_2$ , respectively. We further assume that the device is of microscopic size. Therefore, fluctuations of the thermal bath become important in the operation of the device. Denote by  $\varepsilon = kh^2$  the energy needed to lift the pawl above the tooth and against the spring attached to the pawl. *k* is the stiffness of the spring and *h* the height of the teeth. Due to the heat bath, Brownian particles hit against the vane. They provide enough energy to move the ratchet to the next tooth at a rate equal to  $e^{-(\varepsilon+\alpha L)/k_B T_1}$ , where *L* is the torque acting on the wheel (produced by a load attached to the vane),  $\alpha$  is the angle between two teeth of the ratchet,  $\tau$  is the entropic barrier and  $k_B$  the Boltzmann constant. The fluctuations of the spring that is attached to the pawl allow for backward rotation of the wheel at a rate equal to  $\tau e^{-\varepsilon/k_B T_2}$ . Therefore, the net counter-clockwise velocity of the ratchet is given by

$$V = V_0 (e^{-(\varepsilon+\alpha L)/k_B T_1} - e^{-\varepsilon/k_B T_2}), \quad (1)$$

where  $V_0$  is the maximal speed of rotation, corresponding, heuristically, to the case in which  $T_1 \rightarrow \infty$  and  $T_2 \rightarrow 0$ . In the absence of a load, no directed movement of the ratchet can be induced if the vane and spring are embedded in thermal baths of equal temperature, despite the asymmetry of the system. However, from (1), we can deduce that if the spring is embedded in a thermal bath with a temperature  $T_2$  that is lower than  $T_1$ , the ratchet will move counter-clockwise. Conversely, if temperature  $T_2$  is greater than  $T_1$ , the ratchet will move clockwise. Therefore, thermal gradients can drive the ratchet in a directed motion



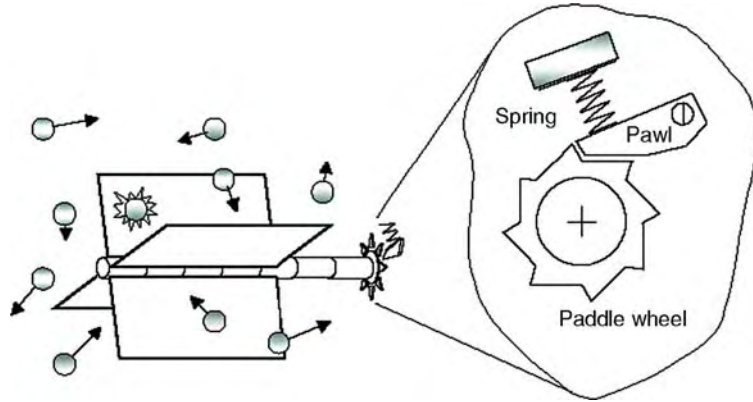

**Brownian Ratchet. Figure 1** Ratchet and pawl introduced by Feynman to illustrate the subtleties of the second law of thermodynamics (adapted from [2]).

or they can perform work against a load. Denoted by  $\Delta T = (T_1 - T_2)/2$  and  $T = (T_1 + T_2)/2$ . If we assume that  $\Delta T \ll T$  (low thermal gradient), then by Taylor expansion of (1), it can be shown that the velocity of the ratchet is given by

$$V \approx V_0 \frac{\varepsilon \Delta T}{2k_B T^2} e^{-\varepsilon/k_B T}$$

**Flashing Ratchet**

Consider an overdamped particle  $E$ , moving along a one dimensional, periodic, asymmetric sawtooth potential of period  $L$  (Fig. 2).

Neglecting inertial effects, the motion of the particle follows the Langevin equation

$$\eta \frac{dx}{dt} = -V'_1(x) + \zeta(t),$$

where  $\eta$  is the coefficient of viscous friction of the medium,  $\zeta(t)$  represents the Gaussian white noise with zero average and autocorrelation function

$$\langle \zeta(t)\zeta(s) \rangle = 2\eta k_B T \delta(t - s),$$

Where  $\delta$  is the Dirac function and  $T$  the temperature of the medium.

The diffusion equation, describing the probability distribution of the position of the particle, is given by the **Fokker-Planck equation**

$$\frac{\partial p(x, t)}{\partial t} = \frac{\partial}{\partial x} \left( \frac{V'_1(x)}{\eta} p(x, t) \right) + D \frac{\partial^2 p(x, t)}{\partial x^2}, \quad (2)$$

where we denote by  $p(x, t)$  the probability of finding particle  $E$  at position  $x$  at time  $t$ , and by  $D$  the diffusion coefficient that is related to the friction coefficient and temperature by the Einstein fluctuation-dissipation theorem:  $D = k_B T / \eta$  (we normalize the mass of the particle to unity). The mean position of the particle is given by

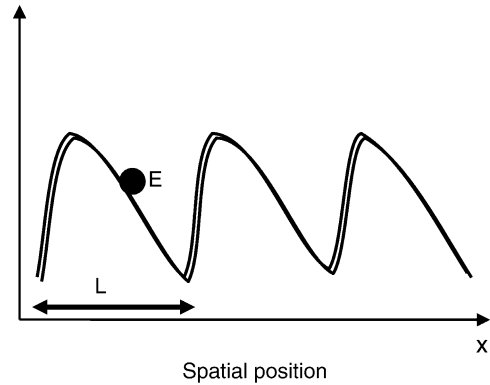

**Brownian Ratchet. Figure 2** Schematic illustration of a particle ( $E$ ) moving along a one-dimensional, periodic, asymmetric sawtooth potential ( $V_1$ ) of period  $L$ .

$$\langle x \rangle (t) = \int_{-\infty}^{+\infty} xp(x, t)dx,$$

while the velocity of the particle is related to the flux probability

$$J(x, t) = -\frac{k_B}{\eta} T \partial_x p(x, t) - \frac{V'_1(x)}{\eta} p(x, t)$$

by

$$\frac{d \langle x \rangle (t)}{dt} = \int_{-\infty}^{\infty} J(x, t) dx.$$

When the motion of the particle becomes steady, and if we are only interested in the mean velocity of the particle, we only need to consider the steady-state solution over a period, with periodic boundary conditions. In other words, we sit at the end point of a period, and every time the particle reaches the end point, we return it to the origin of the period. In this case, the steady-state velocity

of the particle is  $v = LJ$ . Since the energy potential profile satisfies  $V_1(0) = V_1(L)$ , the stationary solution of (2) gives no net flux. In other words, because of the thermal fluctuations of the medium, the charged particle takes energy from the bath to overcome the energy barrier to the left or to the right. The probability for going to the left or to the right is the same despite the asymmetry of the potential.

Now, assume that the motion of the particle depends on two potentials that can be switched on and off at a rate  $k$ . Once the potential is switched off, that is, we have a flat potential,  $V_2(x)$ , the particle  $E$  undergoes a free Brownian motion. In the first potential,  $V_1(x)$ , particle  $E$  is near a local minimum, while in the second potential,  $V_2(x)$ , the particle diffuses freely. Clearly, if the potential  $V_1(x)$  is symmetric, the average displacement of the particle exposed alternatively to both potentials must be zero. However, if  $V_1(x)$  is asymmetric, as shown in Fig. 3, the particle will, on average, move to the right [3,4].

In order to understand this phenomenon, let us assume the conditions shown in Fig. 3, where one slope of the potential,  $V_1(x)$ , is taken infinitely steep and the rate constants satisfy:

$$\frac{k_B T L}{F D} \ll \frac{1}{k}; \quad \frac{1}{k} \ll \frac{L^2}{D} \quad \text{and} \quad k_B T \ll F L, \quad (3)$$

where  $F = -V_1'(x)$  is the finite slope of the potential  $V_1(x)$ . The first inequality of (3) ensures that the particle, once in potential  $V_1(x)$ , has reached a local minimum of the potential before the potential is switched off. The second inequality indicates that when the particle diffuses freely, it can rarely travel the distance  $L$  before the potential is switched back on. The third inequality states

that the deviation of the particle from a local minimum, when subjected to potential  $V_1(x)$  can be neglected.

The motion of the particle thus follows the following path: The particle in  $V_1(x)$  is located near a local minimum. Once  $V_2(x)$  is activated, the particle diffuses freely but typically no farther than the period  $L$ . Therefore, once  $V_1(x)$  is switched back on, the particle moves to the same local minimum or to the next local minimum to the right with equal probability. Another way of looking at the mechanism of transport is as follows: In  $V_2(x)$ , the probability distribution of the position of the particle follows a Gaussian function with the mean located near a local minimum of the potential  $V_1(x)$ . Once  $V_1(x)$  is switched on, half of the area of the Gaussian function is located on the slope leading to the right-neighboring local minimum, and the other half on the slope leading to the same local minimum at which the particle was located in the previous step. Therefore, the movement of the particle is biased towards the right (Fig. 3). The average velocity of the particle is

$$v = \frac{Lk}{4}.$$

Switching between diffusion, which spreads the particles uniformly through the medium, and transport, which concentrates the particles at specific sites, creates a non-equilibrium situation in which particles undergo directed motion.

### Application to Muscle Contraction

In the following, we present a simple two state model for a possible mechanism of muscle contraction (Fig. 4), emphasizing the role of thermal noise and the **flashing ratchet** behavior [5].

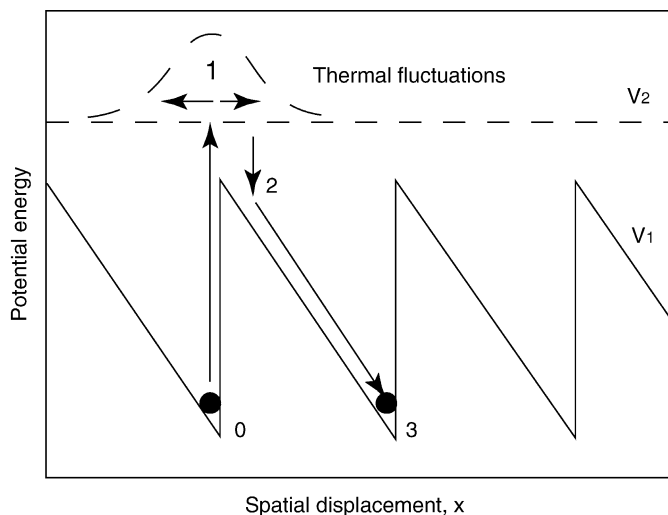

**Brownian Ratchet. Figure 3** Schematic illustration of particle moving along in a flashing ratchet. The flashing ratchet shown has a periodic, asymmetric potential ( $V_1$ ) of period  $L$ , and a flat potential ( $V_2$ ) in which the particle undergoes free Brownian motion. Switching between the two potentials occurs at a characteristic rate  $K$ .

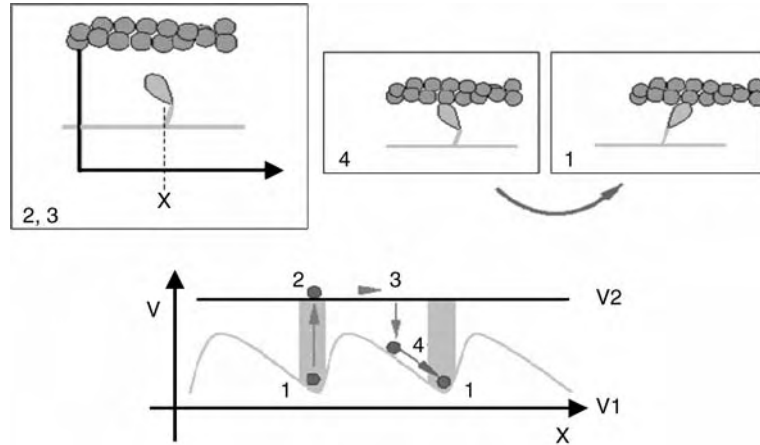

**Brownian Ratchet. Figure 4** Flashing ratchet model for muscle contraction using two potentials (from [5]).  $V_1$  represents an asymmetric, periodic potential, while  $V_2$  represents a flat potential. In state 1, the myosin cross-bridge head is attached to the actin filament in the post-power stroke configuration; states 2 and 3 represent the detached cross-bridge head; while state 4 represents initial attachment of the cross-bridge head to actin in the pre-power stroke configuration.

Denote by  $x$  the position of the center of mass of the myosin head. Assume that the chemical variable takes two discrete states: A (attached state) and D (detached state) from the following scheme:

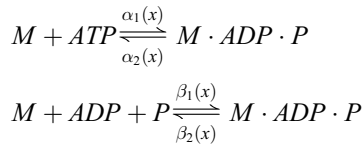

where  $M$  refers to the myosin motor. The state  $M \cdot ADP \cdot P$  corresponds to the detached state  $D$  in which the myosin head is detached from the thin filament. In this state, and because the myosin head is assumed to move freely and far away from the actin filament, the free energy potential of the mechanical variable  $x$  can be chosen to be constant,  $V_2(x) = \text{const}$ , reflecting that the different conformations of the myosin head possess the same free energy and are independent of the position of the myosin head relative to the actin filament. The two other states,  $M + ATP$  and  $M + ADP + P$ , refer to the attached state (A), in which the myosin head is attached to the thin filament, and therefore, its motion depends on the myosin-actin filament interaction. Due to the geometric periodicity of the actin filament, and the asymmetry of its monomers, we can assume that the free energy potential in this state is periodic and asymmetric over a period. Assuming a detailed balance for each chemical reaction, we have

$$\frac{\alpha_1(x)}{\alpha_2(x)} = \exp\left(\frac{V_1(x) - V_2(x) + \Delta\mu}{k_B T}\right) \quad \text{and} \quad \frac{\beta_1(x)}{\beta_2(x)} = \exp\left(\frac{V_1(x) - V_2(x)}{k_B T}\right)$$

where  $\Delta\mu = \mu_{ATP} - \mu_{ADP} - \mu_P$  is the difference in the chemical potential.

The functioning of the myosin motor can now be understood as follows: In the detached state, the myosin head is at a position  $x$  and is subjected to free Brownian motion. The probability distribution of the position of the myosin head follows a Gaussian function that spreads out over time. Once the chemical reaction has advanced the myosin head to the attached state, and because of the asymmetry of the potential in this state, the myosin head is more likely to be located in the region of the potential with negative slope than the region with positive slope (Fig. 4). Therefore, the myosin head is more likely to be in a position to exert positive force (which would tend to shorten the sarcomere) than negative force.

## References

1. Feynman RP, Leighton RB, Sand M (1966) The Feynman lectures on physics. Addison-Wesley, Reading, MA
2. Astumian RD (2001) Making molecules into motors. *Sci Am* 285:57–64
3. Astumian RD (1997) Thermodynamics and kinetics of a Brownian motor. *Science* 276:917–922
4. Mogilner AH, Wang T, Elston T, Oster G (2001) Molecular motors: theory and experiments. In: Fall C, Marland E, Wagner J, Tyson J (eds) *Joel Keizer's mathematical biology*. Springer, Berlin Heidelberg, New York
5. Julicher F (1999) Force and motion generation in molecular motors: A generic description. In: Muller SC, Parisi J, Zimmermann W (eds) *Transport and structure in biophysical and chemical phenomena*. Lecture notes in physics, Springer, Berlin Heidelberg, New York

## Brown-Séquard Syndrome

### Definition

This syndrome provides a very clear demonstration of differential sensory (and motor) loss, which can be easily derived from the spinal tract anatomy. For example, if the left side of the ► **spinal cord** is severed, a number of functions fail ipsi- and contralaterally. Since descending tracts to ► **motoneurons** and ► **preganglionic sympathetic neurons** are cut, the ipsilateral side becomes ► **hemiparetic** and vegetative functions such as vasomotor tone and sweat production are reduced, leading to an initial overwarming, reddening and dryness of the skin. Due to interruption of the ► **dorsal columns**, deep kinaesthetic and vibration sensitivity is gone ipsilaterally. On the contralateral side, pain and temperature sensation are abolished and touch sensitivity is slightly reduced, leading to a dissociated sensibility disturbance.

## Bruce Effect

### Definition

Egg implantation failure resulting from exposure of a recently mated female mouse to the urine of a male genetically different from the inseminating male, coupling a pheromone effect with the detection of “individuality cues.”

► Accessory Olfactory System

## Buccal Mucosa

### Definition

Epithelium that lines the cheeks intraorally.

► Tactile Sensation in Oral Region

## Bulbar Respiratory Neurons

### Definition

Six types of respiratory neurons are classified according to the pattern of membrane potential fluctuation

and action potential discharge. The respiratory neurons interact with each other using chemical neurotransmission.

The respiratory neurons are excitatory or inhibitory.

► Anatomy and Function in the Respiratory Network  
► Respiratory Neurotransmitters and Neuromodulators

## Bulbospinal Fibers

### Synonyms

► Tractus bulboreticulospinalis; ► Bulboreticulospinal tract

### Definition

Fibers coming from the brainstem (often called the bulb) to the spinal cord. These fibers constitute the bulbospinal tract, come from the medial reticular formation (e.g. gigantocellular reticular nucleus) and pass on to the ventromedial area of the spinal intermediate zones accommodating the interneurons, which generate an influence on the motoneurons of the axial and proximal muscles of the extremities.

► Myelencephalon

## Bulimia Nervosa

### Definition

Attacks of binge eating, often followed by self-induced vomiting. Neurobiological risk factors are becoming apparent.

► Neuroendocrinology of Eating Disorders

## $\alpha$ -bungarotoxin

### Definition

$\alpha$ -bungarotoxin is a neurotoxin from snakes that irreversibly binds to nicotinic acetylcholine receptors and thereby prevents depolarization of muscle

membrane in response to acetylcholine that is released from the active nerve terminals at the endplate region on muscle fiber. The toxin is therefore a paralytic agent.

► Neuromuscular Junction

---

## Burrowing Lizards and Snakes

### Definition

Living in the soil, or in termite mounds (Typhlopidae and Leptotyphlopidae snakes, Amphisbaenidae lizards).

► Evolution of the Brain: At the Reptile-Bird Transition

---

## Burst Cells in Eye Movement

### Definition

When unqualified, refers to saccadic burst neurons, a varied class of neurons that discharge a high frequency burst of spikes at the time of saccades, and are silent or nearly silent, during fixations or smooth eye movements (smooth pursuit or the vestibulo-ocular reflex (VOR)). The bursts of medium-lead burst neurons and long-lead burst neurons precede saccade onset and are often involved in the generation of saccades. The bursts of “following burst neurons” follow saccade onset. Burst neurons also have a variety of spatial properties, e.g., firing only for ipsiversive saccades, contraversive saccades, upward, downward, or saccades to a circumscribed region of visual space.

More recent discoveries have shown that some burst neurons encode the metrics of gaze movements and not just the eye component of the gaze-saccade. The term can be qualified to refer to “head burst neurons”, which discharge in relation to the head component of gaze saccades.

Burst neurons are found in the brainstem reticular formations, the cerebellum, the deeper layers of the superior colliculus, the caudate nuclei, particular thalamic nuclei, and in circumscribed regions of the cerebral cortex.

- Brainstem Burst Generator
- Saccade, Saccadic Eye Movement
- Smooth Pursuit Eye Movements
- Vestibulo-ocular Reflexes

---

## Burst Cells – Long Lead (LLBNs) in Eye Movement

### Definition

Like other burst neurons, these neurons discharge a high-frequency burst of spikes at the time of saccades, and are silent or nearly silent, during fixations or smooth eye movements. Long-lead burst neurons (LLBNs) are distinguished from medium-lead burst neurons primarily on the basis of the onset of their discharge relative to the onset of saccades. The dividing line is somewhat arbitrary, but in macaques, neurons having bursts that lead saccade onset by more than 15 ms are considered to be long-lead. Leads can be as long as 300 ms. A frequent discharge pattern is a gradual buildup in firing rate to a peak near saccade onset, while another has a low-frequency prelude leading to a sudden high-frequency burst that precedes saccade onset. Spatial properties range from discharging for all saccades with a component in a given direction, e.g., ipsiversive, contraversive, upward, downward (called directional LLBNs), or discharging only for saccades to a narrowly circumscribed region of visual space (called vectorial LLBNs). Populations of LLBNs are found in large parts of the brainstem reticular formation, the superior colliculus, the caudate nuclei, the thalamus, and cerebral cortex, and the axonal projections of each population are equally varied (e.g., ponto-pontine, precerebellar, or reticulospinal LLBNs).

Each population has a characteristic spatial and temporal discharge pattern.

- Brainstem Burst Generator
- Ponto-Pontine Long-Lead Burst Neurons
- Precerebellar Long-Lead Burst Neurons
- Reticulospinal Long-Lead Burst Neurons
- Saccade, Saccadic Eye Movement

---

## Burst Cells – Medium Lead – Horizontal

CHRIS R. S. KANEKO

Department of Physiology and Biophysics, Washington National Primate Research Center, University of Washington, Seattle, WA, USA

### Synonyms

Medium lead burst neurons, mlbns; Short lead burst neurons, slbns; Excitatory burst neurons, ebns; Inhibitory burst neurons, ibns; HMBLs

## Definition

Horizontal medium lead burst neurons (HMLBs) are the neurons that produce laterally-directed saccadic eye movements. These neurons are located in the medial pons and medulla, and are normally silent but discharge an intense burst of action potentials (up to 1,200 ▶spikes/s in ▶rhesus monkey) in association with ipsilateral saccades (Fig. 1). Their discharge begins just before (~10 ms) the onset of the movement and the metrics of the discharge are linearly related to the metrics of the ipsilateral movement (Fig. 2). That is, the number of action potentials in the burst is correlated well with the size of the movement (Fig. 2a), the peak firing frequency with the peak eye velocity (Fig. 2b), and the duration of the burst with the duration of the movement (Fig. 2c). Thus, their discharge can account for the ▶kinematics of the eye movement. Anatomical investigations have shown that HMLBs are the immediately pre-motor neurons that drive the saccadic burst in abducens neurons (i.e. *both* motoneurons and ▶internuclear neurons). Since abducens motoneurons innervate the lateral rectus muscle and abducens internuclear neurons innervate the ▶contralateral medial rectus motoneurons that, in turn, drive the medial rectus muscle, and since all abducens neurons receive identical inputs, burst neuron discharge

accounts for nearly all of the drive necessary to evoke horizontal conjugate saccades. Finally, inactivation of HMLBs, either transiently or permanently, leads to a loss of horizontal saccades. Taken together, the available evidence demonstrates that HMLBs are necessary and sufficient to produce horizontal saccades.

The evidence that has led to this conclusion has accumulated over the last 30 years and has been extensively reviewed (for recent discussions, see [1,2]). Much of the functional role has been inferred from studies in alert monkeys and cats, while the connections mediating those functions have been demonstrated mostly in studies on cats. In summary, pioneering lesion studies [3] of the medial pons, which Cohen and colleagues named the paramedian pontine ▶reticular formation (pprf), showed that the pprf was essential for horizontal eye movements. More recent studies using progressively more punctate, chemical inactivation of the pprf, and specifically of ebns, has shown that the region is essential for the generation of normal horizontal saccades. HMLBs were first identified by Eric Luschei and Albert Fuchs [4] and Bernard Cohen and Volker Henn [5] during recordings in the pontine and medullary reticular formation of alert monkeys. Luschei and Fuchs named them medium lead burst

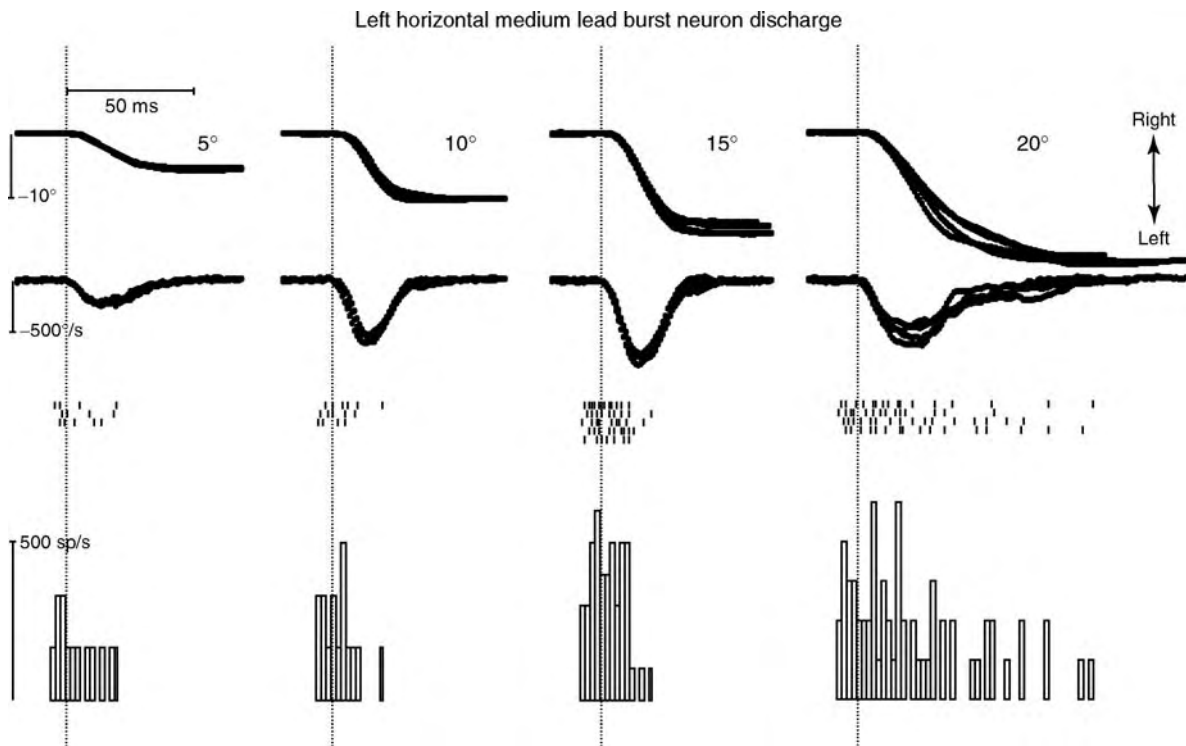

**Burst Cells – Medium Lead – Horizontal. Figure 1** HMLBs Discharge. Discharge of a horizontal medium lead burst neuron recorded from the left pprf of an alert, trained monkey. Examples of 5°, 10°, 15° and 20° leftward saccades (columns). Traces are (top to bottom) eye position, eye velocity, raster of neuronal discharge, and histogram of 3–5 saccades of each size). Note the saturating peak velocity and peak discharge.

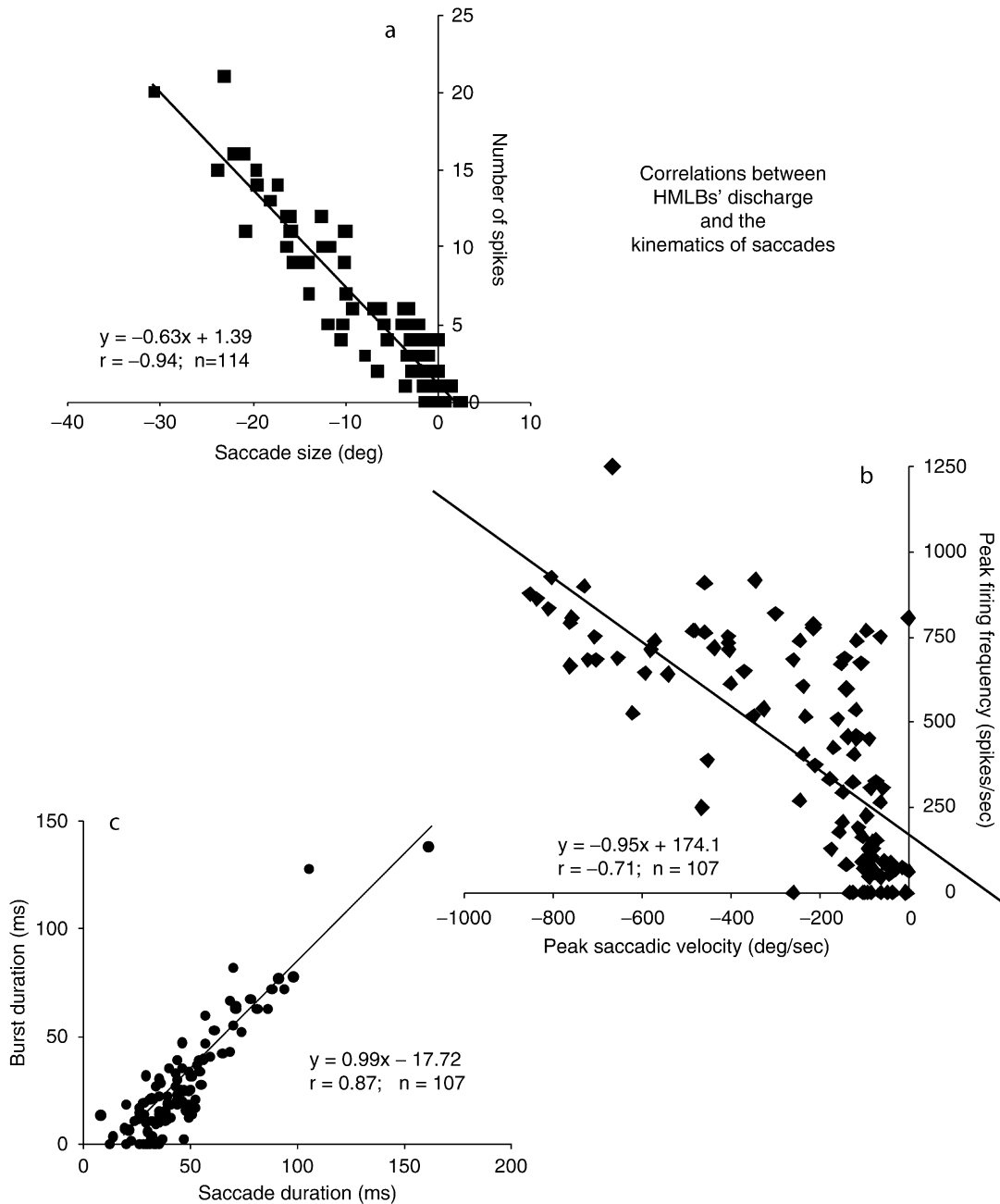

**Burst Cells – Medium Lead – Horizontal. Figure 2** Correlation of HMBL Discharge and Saccade metrics. Scatter plots of Number of action potentials within the burst against saccade size in the leftward (on-) direction (a); peak firing frequency vs. peak saccade velocity (b); and burst duration vs. saccade duration (c). Each scatterplot has been fitted with a linear regression (black lines) whose equation is inset. Same neuron as in Fig. 1.

neurons (mlbns), to distinguish them from abducens neurons that also discharged a burst of action potentials at an even shorter ( $\sim 8$  ms) lead before and during saccades. At a meeting in Reisenberg Germany [6], it was decided to rename them short lead burst neurons (slbns) to further distinguish them from long-lead burst neurons (LLBs; see ►PPLLBs (ponto-pontine LLBs), ►PCbLLBs (precerebellar LLBs), and ►RSLLBs

(reticulospinal LLBs)) that had also been identified and were beginning to accrue a potentially distinct role in saccade generation (see ►Burst generator). After their initial identification, Ed Keller [7] offered the first quantitative analysis of their discharge. Since then several labs have agreed that the discharge in a number of different species can be characterized by a burst duration that is equal to the saccade duration, with a slope of

the linear regression for burst duration and saccade duration that is equal to one and has a correlation coefficient of about 0.8, on average (Fig. 2c). In addition, the number of action potentials within each burst is linearly related to horizontal amplitude of the associated saccade (Fig. 2a). The linear regression of these two metrics is a line with a slope (gain) that ranges from less than 1 (Fig. 2a) to more nearly 3 spikes/deg, and averages around 2 spikes/deg across animals and studies. The correlation coefficients are the highest of the correlations between burst and saccade metrics and range between 0.8 and 0.9 in different studies. Finally, although both the peak velocity of saccades and the peak firing rate of HMLBs saturate for larger saccades (Fig. 2c), the peak velocity and peak firing are linearly correlated with an average slope of about 0.8 spikes/s/deg/s and a correlation coefficient slightly lower than that for the number of spikes and size of about 0.8 (0.6–0.9 in different studies, Fig. 2b). The slopes are somewhat lower for cats and higher in squirrel monkeys than in rhesus monkeys, and the correlation coefficients are somewhat lower in squirrel monkeys than in macaques.

Intracellular labeling with horseradish peroxidase (e.g. [8]; see below) proved that functionally identified HMLBs in alert squirrel monkeys project to the abducens nucleus (Fig. 3). These studies substantiated many previous investigations that had used anatomical tracers, including orthograde, retrograde and, most recently, transynaptic labeling techniques, to show connections between the two regions (e.g. [9]). Parallel and continuing electrical activation studies from several labs (see below) have elucidated the detailed connections of HMLBs. Older studies showed that stimulation, specifically at the site of these sbns, produced depolarizing ►post-synaptic potentials (psps) in identified abducens motoneurons and internuclear neurons so they are excitatory burst neurons (ebns). The parallel work of Hikosaka et al. (e.g. [10]) distinguished a second group of HMLBs, the inhibitory burst neurons (ibns), which also discharged for ipsilateral saccades but were located in the medullary reticular formation just caudo-medial to the abducens nuclei and inhibited contralateral abducens neurons [10]. Analogous, alert animal investigations of ibns showed that their discharge is actually more tightly correlated (i.e. modestly higher correlations coefficients) with saccade metrics than ebns, and that they provide monosynaptic inhibition of contralateral abducens motoneurons and internuclear neurons. Thus, ibns provide symmetrical, conjugate inhibition of contralateral medial and lateral rectus motoneurons. More recent investigations have elegantly confirmed these details and added the likelihood of interconnections between ebns and ibns as first indicated from intracellular staining studies (see below).

## Characteristics

### Higher Order Structures

HMLBs receive input from the contralateral Superior colliculus that is relayed, at least in part, by LLBs. In cat, inputs are both direct and indirect but they may be entirely indirect in monkeys. There are also inputs from the Frontal Eye Fields that are relayed via the superior colliculus as well as those projecting directly to the pons, and these latter may also be relayed by LLBs. There may also be inputs from the ►supplementary eye fields. Finally, HMLBs receive direct input from the caudal fastigial nucleus of the cerebellum. The fastigial input may play a role in adaptive plasticity of saccade amplitude and/or saccadic error correction during on-going saccades.

### Parts of this Structure

The somata of HMLBs (Fig. 3a and d) are located in the medial portions of the nucleus reticularis pontis oralis and caudalis (ebns; Fig. 3e) and the supragigantocellular medullary reticular formation (ibns; Fig. 3b). They are small-to-medium (~25 µm diameter), multipolar neurons (Fig. 3a and d); ibns being slightly larger. They have 4–9 primary dendrites that arborize relatively sparsely (Fig. 3b and e). Ebn axons (Fig. 3e, arrow) project only ipsilaterally to the ibn region and medial vestibular nucleus (mvn), as well as the aforementioned abducens and nucleus prepositus hypoglossi (Fig. 3f). Ibn axons (Fig. 3c, arrow) project solely contralaterally to the ebn region and the lateral and superior vestibular nuclei, in addition to the same places as ebns (Fig. 3c). Both axons are about 3 µm in diameter, but ibns have slightly larger boutons (1.5 µm diameter cf. 1.1 µm; Fig. 3c cf. Fig. 3f) that are the largest in the contralateral abducens nucleus. The reciprocal connections between HMLBs may explain clinically observed ocular oscillations.

### Function of This Structure

HMLBs provide the immediate pre-abducens input that conveys the saccadic drive. Thus, they provide the symmetric push-pull (i.e., excitation and inhibition) as well as the conjugate drive for saccades. Therefore, they mediate ►Hering's Law of equal innervation for saccades. In addition, they synapse on neurons in the nph. The nph integrates (mathematically) their burst discharge (pulse) into a tonic holding input (step) to the abducens to maintain eye position following the saccade (see burst generator).

### Higher Order Function

HMLBs are low-level premotor neurons with no higher order (e.g., cognitive) functions yet indicated. The function of the direct, cortical inputs is not yet clear, but all of the HMLB inputs seem to share at least a portion



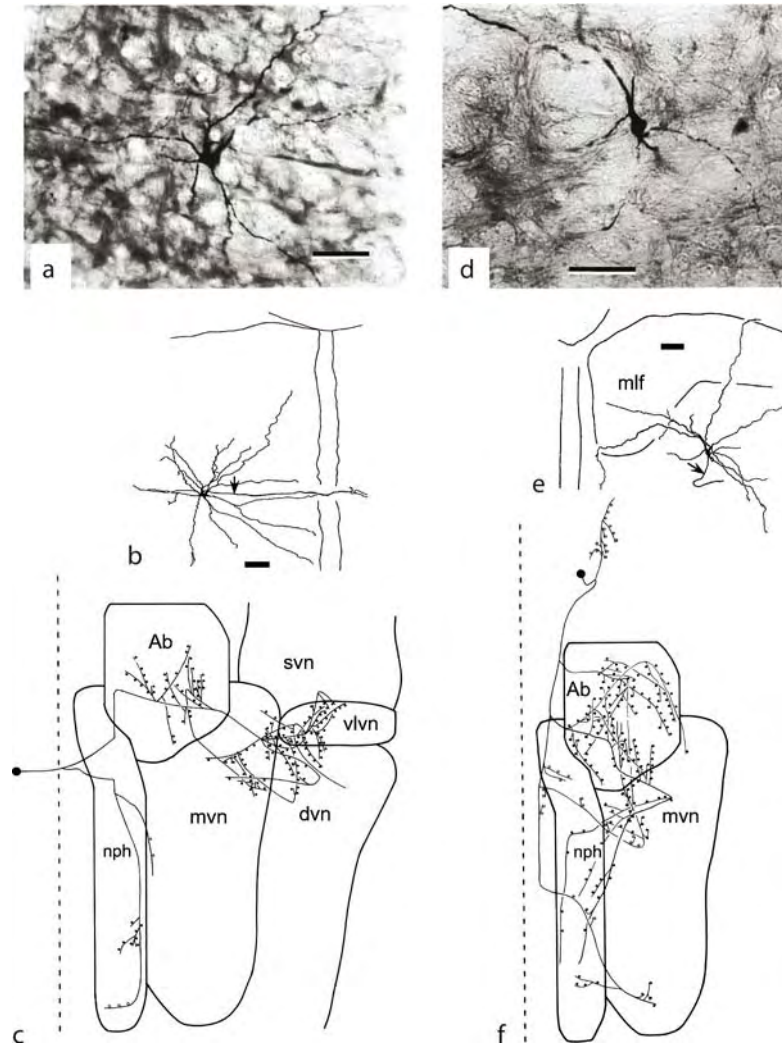

**Burst Cells – Medium Lead – Horizontal. Figure 3** HMLBs. Top row – photomicrographs showing horseradish peroxidase, intracellularly-stained soma and initial dendrites from a left ibn (a) and right ebn (d). Middle row – camera lucida, drawings of coronal sections of the ibn (b) and ebn (e) pictured in top row showing the reconstructed soma-dendritic structure and initial axon (arrows). Calibration for top row is 50  $\mu\text{m}$  and middle row is 100  $\mu\text{m}$  for bottom. Bottom row-horizontal section showing the reconstructed trajectory of a representative ibn (c) and ebn (f). Dots on branches represent buttons indicating synaptic terminations, soma indicated in black, dashed line is midline. Abbreviations: *Ab*, abducens nucleus; *dvn*, descending vestibular nucleus; *mlf*, medial longitudinal fasciculus; *mvn*, medial vestibular nucleus; *nph*, nucleus prepositus hypoglossi; *svn*, superior vestibular nucleus; *vlvn*, ventrolateral vestibular nucleus. After: Strassman A, Highstein SM, McCrea RA (1986) Anatomy and physiology of saccadic burst neurons in the alert squirrel monkey. I. Excitatory burst neurons. *J Comp Neurol* 249:337–357 and [8] (Reprinted by permission of Wiley-Liss, a subsidiary of Wiley).

of the responsibility for commanding, coding, triggering, and modifying saccades to varying degrees. Although still somewhat controversial, there don't appear to be any HMLBs that are specialized either for head or coordinated eye and head movements, even though some LLBs are so specialized. In contrast, HMLBs are responsible for a number of higher order motor functions in the saccadic system. As mentioned, their connectivity imparts conjugacy of saccades

(Hering's Law of equal innervation), and the push-pull organization of ebns and ibns results in relaxation of antagonist during agonist activation (► [Sherrington's law of reciprocal innervation](#)). It should be noted that there are a number of outstanding issues in oculomotor physiology. Two prominent current questions center on the dynamics of oculomotor motor units and the coordinate transformations from spatially coded (i.e., two-dimensional) visual commands for movements into

temporally coded motoneuron discharge that remain to be understood. Whether HMBLs play a role in either of these functions remains to be determined. Finally, recent evidence indicates that some HMBLs discharge in relation to the movements of only one eye, and that that eye can be the contralateral one, suggesting a role for some HMBLs in coordinated ►vergence and versional (►Version) eye movements during saccades. This coordination is necessary to focus the eyes on objects at different depths in space.

### Quantitative Measure for This Structure

The number of HMLBs is not clear because of technical limitations in marking all of them so that they may be counted. Perhaps transneuronal retrograde labeling techniques will allow an estimate in the near future. About 60% of ibns evoke unitary inhibitory psp (ipsps) in contralateral abducens motoneurons, with an average latency of 0.7 ms and a range of amplitudes between 18 and 220  $\mu$ V [10]. Comparable data are not available for unitary excitatory psp (epsps) evoked by ebns in abducens neurons, but stimulation in the ebn region evokes summated epsps of a few millivolts amplitude at similar, monosynaptic latencies to the ipsps from ibns. Membrane biophysical measurements are still completely lacking, but specialized currents have been hypothesized to explain a number of phenomena including saccadic oscillations and slowed saccades following inactivation of omnipause neurons (see burst generator).

### References

1. Moschovakis AK, Scudder CA, Highstein SM (1996) The microscopic anatomy and physiology of the mammalian saccadic system. *Prog Neurobiol* 50:133–254
2. Scudder CA, Kaneko CRS, Fuchs AF (2002) The brainstem burst generator for saccadic eye movements: a modern synthesis. *Exp Brain Res* 142:439–462
3. Cohen B, Komatsuzaki A, Bender MB (1968) Electro-oculographic syndrome in monkeys after pontine reticular formation lesions. *Arch Neurol* 18:78–92
4. Luschei ES, Fuchs AF (1972) Activity of brain stem neurons during eye movements of alert monkeys. *J Neurophysiol* 35:445–461
5. Cohen B, Henn V (1972) Unit activity in the pontine reticular formation associated with eye movements. *Brain Res* 46:403–410
6. Fuchs AF, Becker W (1981) Progress in oculomotor research. In: Fuchs AF, Becker W (eds) *Developments in neuroscience*, vol 12. Elsevier, New York, pp 63–70
7. Keller EL (1974) Participation of medial pontine reticular formation in eye movement generation in monkey. *J Neurophysiol* 37:316–332
8. Strassman A, Highstein SM, McCrea RA (1986) Anatomy and physiology of saccadic burst neurons in the alert squirrel monkey. II. Inhibitory burst neurons. *J Comp Neurol* 249:358–380

9. Büttner-Ennever JA (ed) (1989) *Neuroanatomy of the oculomotor system. Reviews of oculomotor research*, vol 3. Elsevier, New York, pp 1–489
10. Hikosaka O, Igusa Y, Nakao S, Shimazu H (1978) Direct inhibitory synaptic linkage of pontomedullary reticular burst neurons with abducens motoneurons in the cat. *Exp Brain Res* 33:337–352

## Burst Cells – Medium Lead – Vertical

ADONIS MOSCHOVAKIS

Institute of Applied and Computational Mathematics, and Department of Basic Sciences, University of Crete, Heraklion, Crete, Greece

### Synonyms

VMLBs

### Definition

Neurons discharging a compact burst of discharge before and during upward or downward saccades with latencies intermediate between those of extraocular motoneurons (OMNs) and long-lead burst (LLB) neurons.

### Characteristics

#### Higher Order Structure

VMLBs are crucial components of the burst generators of the vertical saccadic system.

### Parts of this Structure

The morphological features of VMLBs were elucidated when their axons were injected with HRP and the behavioral relevance of their discharge was recorded intraaxonally in alert monkeys [1,2]. Fig. 1. illustrates two typical premotoneuronal VMLBs, one preferring upward (UMLB, in blue) and one preferring downward (DMLB, in red) saccades. UMLB somata are quite small in size and are located in the rostral interstitial nucleus of the medial longitudinal fasciculus (►riMLF) intermingled with the somewhat bigger somata of DMLBs. The relatively thin axons of premotoneuronal VMLBs (1.7–5.2  $\mu$ m in diameter) course caudally through the ipsilateral riMLF, the interstitial nucleus of Cajal (NIC) and the medial longitudinal fasciculus (►MLF). As shown in Fig. 1, they emit several collaterals that ramify extensively within the NIC, the adjacent mesencephalic reticular formation and the oculomotor complex, mainly bilaterally (UMLBs) or ipsilaterally (DMLBs). The former are consistent with the signals that the vertical burst generators are expected to send to the vertical “velocity to position integrators” and the fact that the latter are housed in

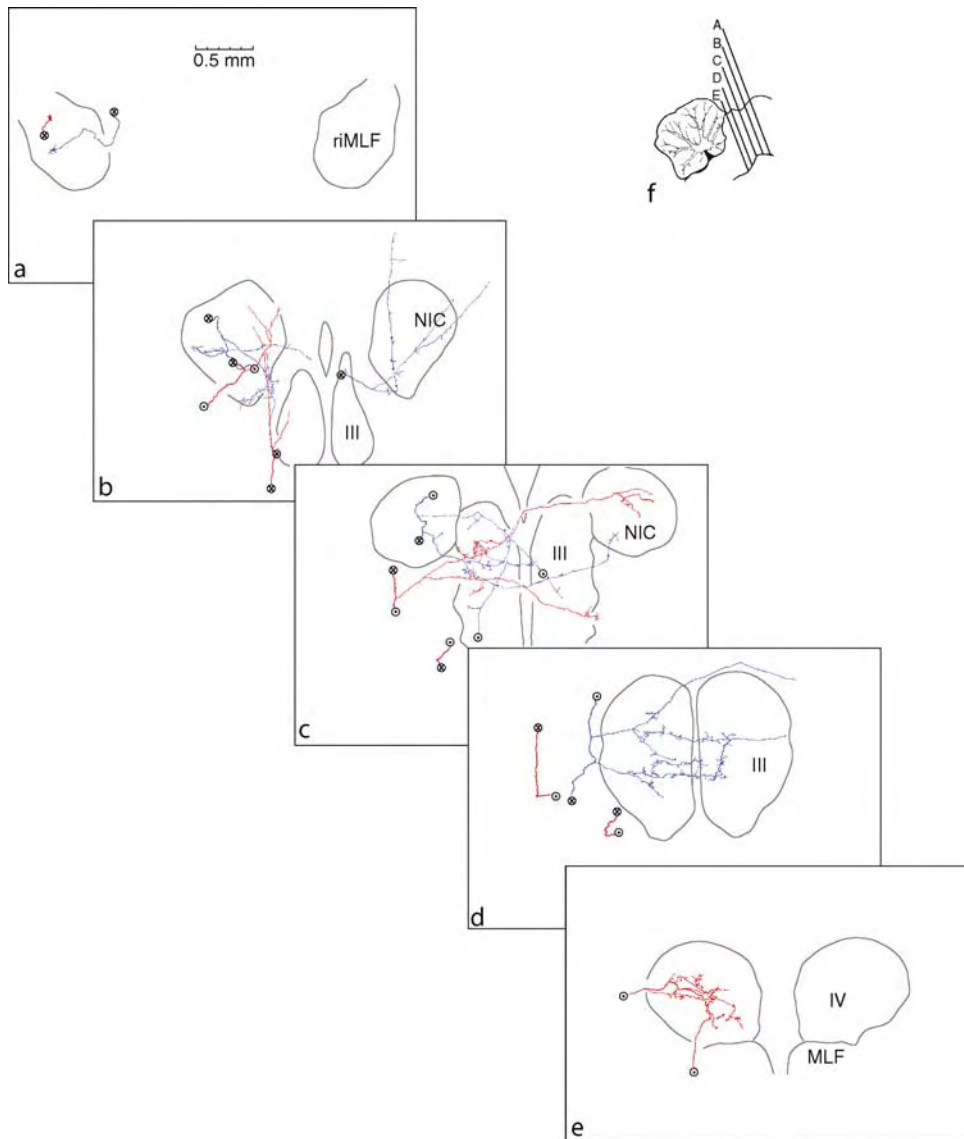

**Burst Cells – Medium Lead – Vertical. Figure 1** Salient morphological features of VMLBs. (a–e) Reconstruction of the axonal system of an intraaxonally HRP injected UMLB (blue; modified from [1], with permission) and DMLB (red; modified from [2], with permission). Relative location of sections is indicated in (f). Encircled symbols indicate fibers that can be followed in an adjacent section either rostrally (solid circle) or caudally (x). Abbreviations: *III*, oculomotor nucleus; *IV*, trochlear nucleus; *MLF*, medial longitudinal fasciculus; *NIC*, interstitial nucleus of Cajal; *riMLF*, rostral interstitial nucleus of the MLF.

the NIC. The connections that VMLBs establish with vertical OMNs are also important as they account for the presaccadic pulse of activity that motoneurons display during saccades in their on-direction. The existence of excitatory connections between VMLBs and vertical MNs is suggested by the disclosure of monosynaptic EPSPs in superior rectus (SR), and superior oblique (SO) MNs in response to the electrical stimulation of the mesodiencephalic junction in the cat (e.g. [3]). Excitatory vertical MLBs of the cat utilize glutamate and aspartate as neurotransmitters [4].

As does the horizontal system (IBNs), the vertical saccadic system contains inhibitory premotoneuronal VMLBs [1]. Like excitatory neurons, inhibitory VMLBs deploy terminal fields within the NIC, but in contrast to excitatory neurons, their axonal system contains recurrent collaterals ramifying in the riMLF and deploys terminal fields in territories occupied by extraocular motoneurons with the opposite on-direction. In the cat, the existence of inhibitory premotoneuronal VMLBs is supported by the disclosure of monosynaptic IPSPs in SR and SO MNs in response to the electrical stimulation of the

mesodiencephalic junction [3]. Inhibitory vertical MLBs of the cat utilize GABA as a neurotransmitter [4].

Not all neurons emitting similar bursts of discharge for vertical saccades (in terms of latency, intensity, time course and relationship to the metrics and dynamics of eye movements, described in the next paragraph) are last order premotoneurons nor are they all located in the riMLF [1,2]. Fig. 2. illustrates two such examples. The one preferring downward saccades (in red) was encountered in the NIC while the one preferring upward saccades (in blue) was found in the nucleus of posterior commissure (nPC). Neither projected to extraocular motoneurons. Instead, their axons ramified within the NIC and the riMLF, ipsilaterally (the downward neuron of the NIC) or contralaterally (the upward neuron of the nPC), and then continued rostrally towards the thalamus. The existence of neurons with such dissimilar connections despite virtually identical firing patterns emphasizes the need to be cautious when interpreting a neuron's role on the basis of knowledge about its discharge pattern alone.

### Functions of the Structure

During periods of drowsiness, VMLBs show an irregular low-frequency activity. When the subjects are fully alert, their VMLBs emit high frequency bursts for saccades whose onset does not differ much from those of extraocular MNs with vertical on directions; they precede saccade onset by 5.6 ms, on average (S.D. = 4.7; range: -4.0–12.8 ms) for UMLBs and 4.6 ms (S.D. = 4.0; range: -3.9–15.8 ms) for DMLBs. Depending on the on-direction of the neuron (upward or downward), VMLB bursts precede saccades with an upward (Fig. 3a) or downward (Fig. 3b) component. Finding the on-direction of a VMLB, involves the statistical analysis of the relationship between its neuronal discharge and the vector projection of saccades onto a test direction ( $\phi$ ). To see how this is done, suppose that their discharge has been sampled for saccades of horizontal component  $h$ , and vertical component  $v$ . From these values the amplitude  $\Delta E (= (h^2 + v^2)^{1/2})$  and direction  $\theta (= \tan^{-1}v/h)$  of each saccade is computed. Then the amplitude of their

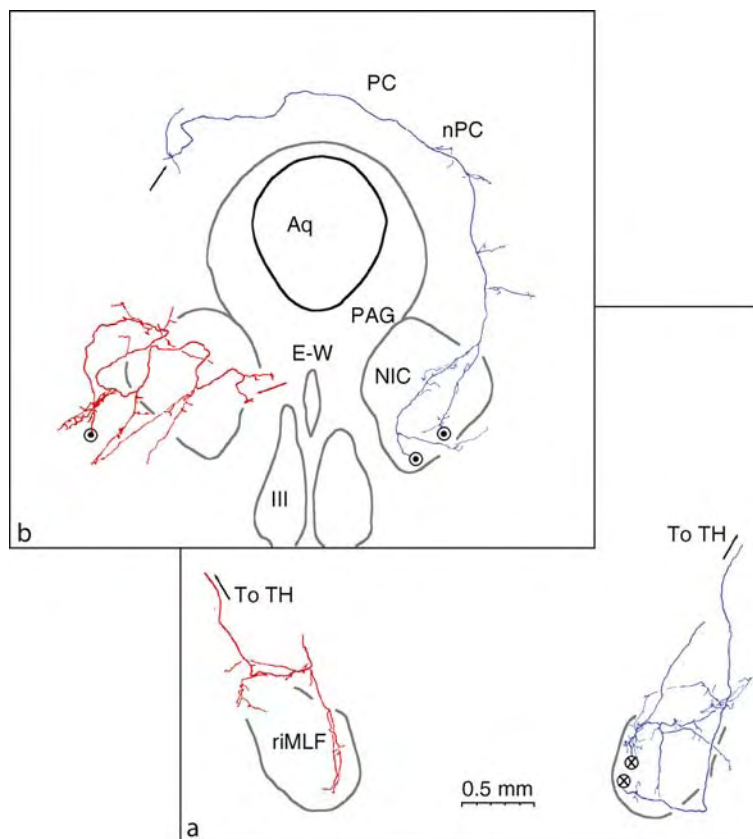

**Burst Cells – Medium Lead – Vertical. Figure 2** Examples of non-premotoneuronal VMLBs. (a, b) Reconstruction of the axonal system of an intraaxonally HRP injected nPC UMLB (blue; modified from [1], with permission) and an NIC DMLB (red; modified from [2], with permission). Abbreviations: *Aq*, aqueduct of Sylvius; *E-W*, nucleus Edinger-Westphal; *nPC*, nucleus of posterior commissure; *PAG*, periaqueductal gray; *PC*, posterior commissure; *TH*, thalamus. Other symbols and abbreviations as in Fig. 1.

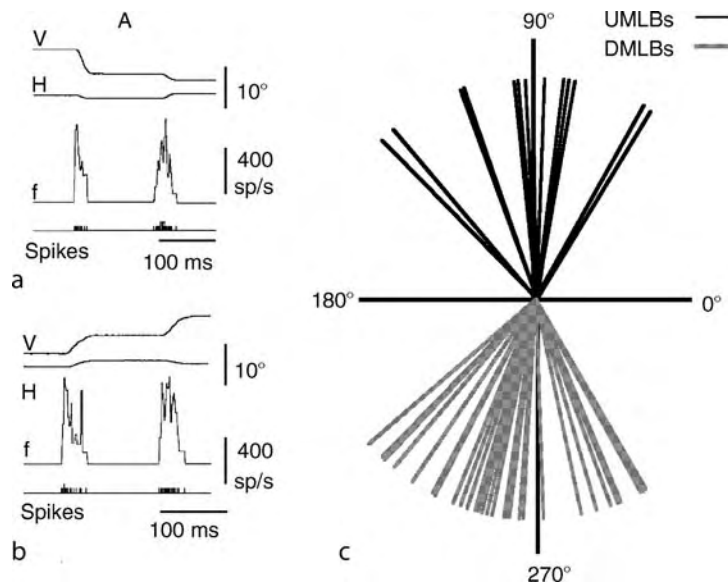

**Burst Cells – Medium Lead – Vertical. Figure 3** Saccade related discharge pattern of VMLBs. (a) DMLB discharge. (b) UMLB discharge. Upward deflections of the spike train trace (spikes) correspond to one or more spikes. Abbreviations: *H*, instantaneous horizontal eye position; *V*, instantaneous vertical eye position; *f*, instantaneous firing rate. (c) Distribution of UMLB and DMLB on-directions.

component  $\Delta E \cos(\theta - \varphi)$  on the test direction ( $\varphi$ ) is computed for all saccades within  $90^\circ$  of  $\varphi$ , and linear regression analyses are performed between the number of spikes in the burst ( $N_b$ ) and  $\Delta E \cos(\theta - \varphi)$ , while  $\varphi$  is rotated systematically between  $0^\circ$  and  $360^\circ$  at  $1^\circ$  or  $5^\circ$  intervals. The on-direction of the cell is defined as the one that maximizes the goodness of fit of these linear regressions. When defined in this manner, the on-directions of UMLBs vary between  $46^\circ$  and  $121^\circ$  (Fig. 3c) but, on average, they do not differ significantly from vertical up. Similarly, the on-directions of DMLBs vary between  $221^\circ$  and  $300^\circ$  (Fig. 3c), but the average on-direction for the population ( $264^\circ$ ) does not differ significantly from purely down.

Knowledge of the relationship between parameters of VMLB discharges and parameters of vertical saccades can help elucidate the neural mechanisms responsible for the neural control of movement variables. Quantitative descriptions of the relationship between neuron discharge and saccade metrics was first described for riMLF VMLBs in the riMLF with the help of the extracellular recording technique [5]. The strongest correlation between a parameter of VMLB discharge and a movement metric is the one between the number of spikes in the burst ( $N_b$ ) and the amplitude of the upward (for UMLBs) or downward (for DMLBs) component of saccades. An example of such a relationship is illustrated in Fig. 4a for one DMLB. Also, the duration of DMLB bursts ( $B_d$ ) is well correlated to the duration of saccades ( $S_d$ ) as illustrated in Fig. 4b. The constants of proportionality of these

relationships vary for different neurons, as does the reliability with which  $N_b$  and  $B_d$  encode the amplitude of the downward components and the duration of saccades, respectively. Similar relationships apply to UMLBs.

The pattern of termination of single identified vertical MLBs inside the oculomotor complex indicates that *they do not influence one muscle but at least two different ones, simultaneously*, in a manner that respects the first corollary of Hering's "law of equal innervation" [6]. To see how this could be realized in the brain, at least for vertical saccades, consider that there are four pairs of synergistic muscles acting in the vertical plane: (i) left SR-right inferior oblique (IO), (ii) left SO-right inferior rectus (IR), (iii) left IO-right SR, and (iv) left IR-right SO (pairs 1 and 2 are innervated by MNs in the right oculomotor complex, while pairs 3 and 4 are innervated by MNs in the left oculomotor complex). To implement Hering's law, the axonal branches of single excitatory VMLBs would need to contact both of the MN pools that supply the two muscles of each pair. The pattern of DMLB axonal terminations indicates that this is indeed the case [7]. DMLBs of the left riMLF contact MNs supplying pair 4 (the IR muscle of the left eye and the SO muscle of the right eye), while DMLBs of the right riMLF contact MNs supplying pair 2 (the IR muscle of the right eye and the SO muscle of the left eye). Since the iso-frequency curves of all upward MNs are indistinguishable, each UMLB could contact all four upward MN pools. This is indeed the case as shown by the pattern of axonal terminations of single VMLBs visualized with the help of the intraaxonal HRP injection technique [7].

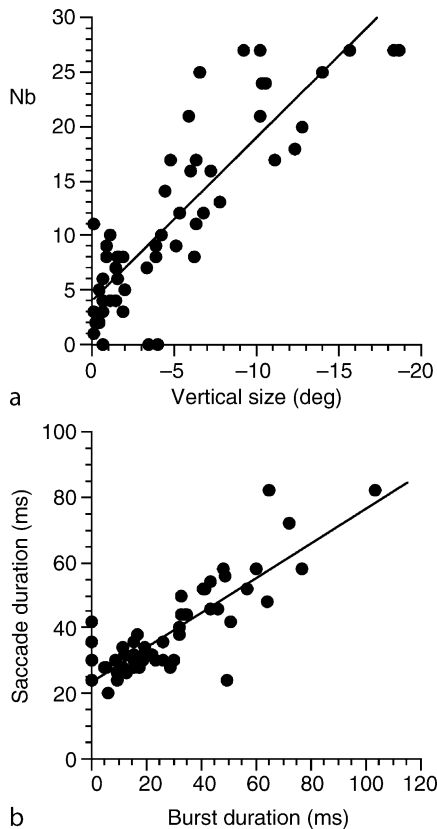

#### Burst Cells – Medium Lead – Vertical.

**Figure 4** Relationship between parameters of DMLB discharge and saccade metrics. (a) Plot of the number of spikes in the burst ( $N_b$ , ordinate) versus amplitude of downward saccades ( $\Delta V$ , abscissa). The solid line is the linear regression line for downward saccades (*solid circles*) and obeys the expression  $N_b = -1.5\Delta V + 4$  ( $r = 0.86$ ). (b) Plot of saccade duration ( $S_d$ , ordinate) versus burst duration ( $B_d$ , abscissa). The solid line is the linear regression line for downward saccades (*solid circles*) and is described by equation  $S_d = 0.53B_d + 23.8$  ( $r = 0.84$ ).

The pattern of terminations of premotoneuronal VMLBs contrasts with the case in the horizontal system where one additional cell, the abducens internuclear one, must convey to medial rectus MNs a copy of the inputs received by lateral rectus MNs.

The NIC is also known to contain VMLBs. As in squirrel monkeys, only downward neurons have been found in the cat [8], while both upward and downward neurons have been found in macaques [9]. The saccade related discharge pattern of non-premotoneuronal DMLBs of the NIC does not differ in any obvious manner from that of riMLF premotoneuronal DMLBs. Parameters of their discharge ( $N_b$ ,  $B_d$ ) are as well correlated with saccade metrics (vertical component size,  $\Delta V$ , and saccade duration,  $S_d$ ) as that of

premotoneuronal VMLBs. For example, they are related through the expressions  $N_b = 0.93\Delta V + 8.7$  ( $r = 0.7$ ) and  $B_d = 1.2S_d - 7.1$  ( $r = 0.6$ ) in the case of the NIC cell illustrated in Fig. 2, and through the expressions  $N_b = 0.94\Delta V + 5.6$  ( $r = 0.63$ ) and  $B_d = 1.33S_d - 22$  ( $r = 0.94$ ) in the case of the nPC cell. The role played by non-premotoneuronal VMLBs remains speculative. Due to their discharge pattern and their projections to a nucleus containing UMLBs (the riMLF), non-premotoneuronal UMLBs of the nPC are good candidates for playing the role of Resettable Integrator Neurons (RINs), as postulated in a model of the upward burst generator [10]. Similarly, because of their discharge pattern (similar to that of DMLBs), their location in a nucleus targeted by riMLF DMLBs (the NIC) and their projections to a nucleus containing DMLBs (the riMLF), DMLBs of the NIC are the only candidates known to date that could play the role of Inhibitory Feedback Neurons (IFNs), the existence of which was predicted for the horizontal burst generator by Scudder [11]. On the other hand, the average firing rate of about 50% of all NIC DMLBs of the cat is well correlated with the average downward smooth pursuit velocity of the eyes [8], and thus such neurons could underlie the confluence of saccade and smooth pursuit commands.

#### Higher Order Function

The discharge patterns, synaptic relationships and pattern of distribution of boutons of the inhibitory and excitatory premotoneuronal VMLBs is such as to provide the appropriate combination of synergist motoneurons (as prescribed by macroscopic laws such as Hering's law) with the input signals they need to generate discharges with the appropriate frequency content while inhibiting the appropriate combination of antagonistic motoneurons. On the other hand, the discharge patterns, synaptic relationships and pattern of distribution of boutons of non-premotoneuronal VMLBs is that required of neurons embodying the feedback paths of the relevant control loops. The more general importance of VMLBs in oculomotor control is indicated by the fact that their destruction leads to vertical gaze palsy, a syndrome also known as Parinaud's [12]. Consistent with the presence of UMLBs in the nPC and the course of their axons in the PC, lesions of this nucleus and of the posterior commissure in humans (usually due to pinealomas or thalamic gliomas) cause paralysis of upward gaze [12]. Also, consistent with the fact that it contains both DMLBs and UMLBs, damage of the riMLF-NIC region often results in paralysis of downward gaze, either alone [13] or together with upward gaze paralysis [14], in both the diseased human and the animal preparation.

### Quantitative Measure for this Structure

Besides detailed quantitative descriptions of the pattern of their discharge, as illustrated in the examples provided above, there is a wealth of quantitative information regarding morphological features of VMLBs in several species. For example, the size and spatial distribution of the riMLF neurons projecting to the motoneuron pools of single extraocular muscles, and the proportion of the total riMLF population each of them comprises (22%), has been described in rhesus monkeys [15] as has the distribution and relative frequency of riMLF neurons projecting to different oculomotoneuron pools of the cat [16]. Also, the 3D spatial distribution of the terminals deployed in the oculomotor complex by single functionally identified VMLBs has been described in squirrel monkeys [7].

### References

- Moschovakis AK, Scudder CA, Highstein SM (1991) Structure of the primate burst generator. I. Medium-lead burst neurons with upward on-directions. *J Neurophysiol* 65:203
- Moschovakis AK, Scudder CA, Highstein SM, Warren JD (1991) Structure of the primate burst generator. II. Medium-lead burst neurons with downward on-directions. *J Neurophysiol* 65:218
- Nakao S, Shiraiishi Y (1985) Direct excitatory and inhibitory synaptic inputs from the medial mesodiencephalic junction to motoneurons innervating extraocular oblique muscles in the cat. *Exp Brain Res* 61:62
- Spencer RF, Wang S-F (1996) Immunohistochemical localization of neurotransmitters utilized by neurons in the rostral interstitial nucleus of the medial longitudinal fasciculus (riMLF) that project to the oculomotor and trochlear nuclei in the cat. *J Comp Neurol* 366:134
- Büttner U, Büttner-Ennever JA, Henn V (1977) Vertical eye movement related activity in the rostral mesencephalic reticular formation of the alert monkey. *Brain Res* 130:239
- Hering E (1868) *The theory of binocular vision*. Plenum Press, New York
- Moschovakis AK, Scudder CA, Highstein SM (1990) A morphological basis for Hering's law: projections to extraocular motoneurons. *Science* 248:1118
- Missal M, de Brouwer S, Lefèvre P, Olivier E (2000) Activity of mesencephalic vertical burst neurons during saccades and smooth pursuit. *J Neurophysiol* 83:2080
- Helmchen C, Rambold H, Büttner U (1996) Saccade-related burst neurons with torsional and vertical on-directions in the interstitial nucleus of Cajal of the alert monkey. *Exp Brain Res* 112:63
- Moschovakis AK (1994) Neural network simulations of the primate oculomotor system. I. The vertical saccadic burst generator. *Biol Cybern* 70:291
- Scudder CA (1988) A new local feedback model of the saccadic burst generator. *J Neurophysiol* 59:1455
- Christoff N (1974) A clinicopathologic study of vertical eye movements. *Arch Neurol* 31:1
- Bender MB (1980) Brain control of conjugate horizontal and vertical eye movements. A survey of the structural and functional correlates. *Brain* 103:23
- Büttner-Ennever JA, Büttner U, Cohen B, Baumgartner G (1982) Vertical gaze paralysis and the rostral interstitial nucleus of the medial longitudinal fasciculus. *Brain* 105:125
- Horn AKE, Büttner-Ennever JA (1998) Premotor neurons for vertical eye movements in the rostral mesencephalon of monkey and human: histologic identification by parvalbumin immunostaining. *J Comp Neurol* 392:413
- Wang S-F, Spencer RF (1996) Spatial organization of premotor neurons related to vertical upward and downward saccadic eye movements in the rostral interstitial nucleus of the medial longitudinal fasciculus (riMLF) in the cat. *J Comp Neurol* 366:163

## Burst Cells – Short Lead in Eye Movement

### Definition

The term is usually synonymous with medium-lead burst neurons, but was originally set aside to refer to ocular motoneurons. When it became clear that no motoneurons exhibit burst-only discharges, but rather all exhibit burst-tonic discharges when adequately tested, there was a brief effort to replace the term “medium-lead” with “short-lead” when referring to burst neurons. They include excitatory and inhibitory burst neurons.

- ▶ Brainstem Burst Generator
- ▶ Burst Cells – Medium Lead – Horizontal
- ▶ Burst Cells – Medium Lead – Vertical
- ▶ Saccade, Saccadic Eye Movement

## Burst Generator in Eye Movement

### Definition

The group of neurons that creates the intense discharge of action potentials (burst) in motoneurons that, in turn, results in a saccadic eye movement.

- ▶ Brainstem Burst Generator
- ▶ Saccade, Saccadic Eye Movement

## Burst Stimulation

### Definition

Burst stimulation is electrical stimulation imitating the irregular firing pattern of nerve fibers such as those involved in salivary gland autonomic innervation. Applying high frequencies in bursts may result in increased release of VIP with augmented secretory and vasodilator responses compared to the responses obtained with continuous stimulation at a low frequency delivering the same total number of shocks.

## Burster-Driving Neurons

TOSHIHIRO KITAMA

Center for Life Science Research, University of Yamanashi, Yamanashi, Japan

### Synonyms

BDNs

### Definition

Burster-driving neurons (BDNs) are located within and immediately below the nucleus prepositus hypoglossi (NPH), in the cat. BDNs receive a short latency excitation from the vestibular nerve and show ▶**type II response** during natural vestibular stimulation by head rotation. BDN axons cross the midline to project to the region where the premotor burst neurons are located, and make monosynaptic excitatory connections with the ▶**excitatory burst neurons (EBNs)** and ▶**inhibitory burst neurons (IBNs)** [1]. BDNs show irregular tonic discharges during fixation and exhibit a burst of spikes associated with quick phases of nystagmus and saccades in the contralateral direction [1,2] (the terms “contralateral” and “ipsilateral” are here defined with respect to the side of the cell soma). The burst discharge of BDNs resembles that of long-lead burst neurons and contains information required to control the metrics of rapid eye movements. BDNs also receive excitatory input from the ipsilateral ▶**superior colliculus (SC)** [2].

### Characteristics

#### Firing Characteristics of BDNs

BDNs were first described as neurons that mediate an excitatory input from the ▶**labyrinth (▶vestibular labyrinth)** to burst neurons [1]. They are activated with short latencies (1.4–2.7 ms) after electrical stimulation

of the contralateral vestibular nerve, indicating that the shortest pathway from the contralateral labyrinth to BDNs is disynaptic (Fig. 2a and b). The axons of BDNs have been shown to cross the midline to terminate in the contralateral EBN and IBN areas and to make monosynaptic excitatory connections with the premotor burst neurons, EBNs and IBNs [1]. BDNs are located in the NPH and the underlying medullary reticular formation in the cat (their spikes can usually be recorded in the region approximately 1.0–2.5 mm caudal to the abducens nucleus, 1.0–1.5 mm from the midline, and 0.5–1.5 mm below the surface of the fourth ventricle). BDNs are spontaneously active in the light and in the dark, and display irregular tonic firing during fixation periods. The firing rate of BDNs during periods of fixation is not significantly correlated with horizontal or vertical eye position. In response to natural vestibular stimulation by head rotation in horizontal plane, they exhibit type II responses of Duensing and Schaefer [3] (Fig. 1a). When ▶**vestibular nystagmus** is induced by head rotation, BDNs exhibit a high-frequency burst of spikes associated with contralateral quick phases, and are slightly suppressed during ipsilateral quick phases of large amplitude (Fig. 1b and c). A similar response pattern is found during ▶**optokinetic nystagmus**. BDNs increase their tonic discharges with surround motion directed to the ipsilateral side and exhibit a burst in association with contralateral quick phases. The tonic firing rate decreases when the direction of surround motion is reversed. BDNs also emit a burst of discharges for contraversive spontaneous saccades both in the light and in the dark (Fig. 1d). BDNs are therefore characterized by burst activity for all rapid eye movements having a contraversive component, regardless of how these eye movements are induced.

During bursts, the firing rate of BDNs begins to increase steeply 20–40 ms before the onset of saccades (Fig. 1e) [2]. In many cells, the intense portion of the bursts is preceded by a slow rise of firing rate that begins 100–150 ms before the onset of saccades. The number of spikes in the intense bursts has been shown to linearly increase with the amplitude of the contralateral horizontal component of rapid eye movement (Fig. 1f). Similar slopes of regression lines are observed for saccades and quick phases of nystagmus, suggesting that the functional role of BDNs is similar for both kinds of rapid eye movements. The average slope of the regression line pooled for both kinds of rapid eye movements is 1.14 spikes/deg, which is similar to that previously reported for cat EBNs and IBNs (0.74 and 1.47 spikes/deg, respectively [4]). Significant correlation is also found between the mean firing rate in the burst and the mean contralateral component velocity (average slope of the regression line is 0.82 (spikes/s)/(deg/s)).



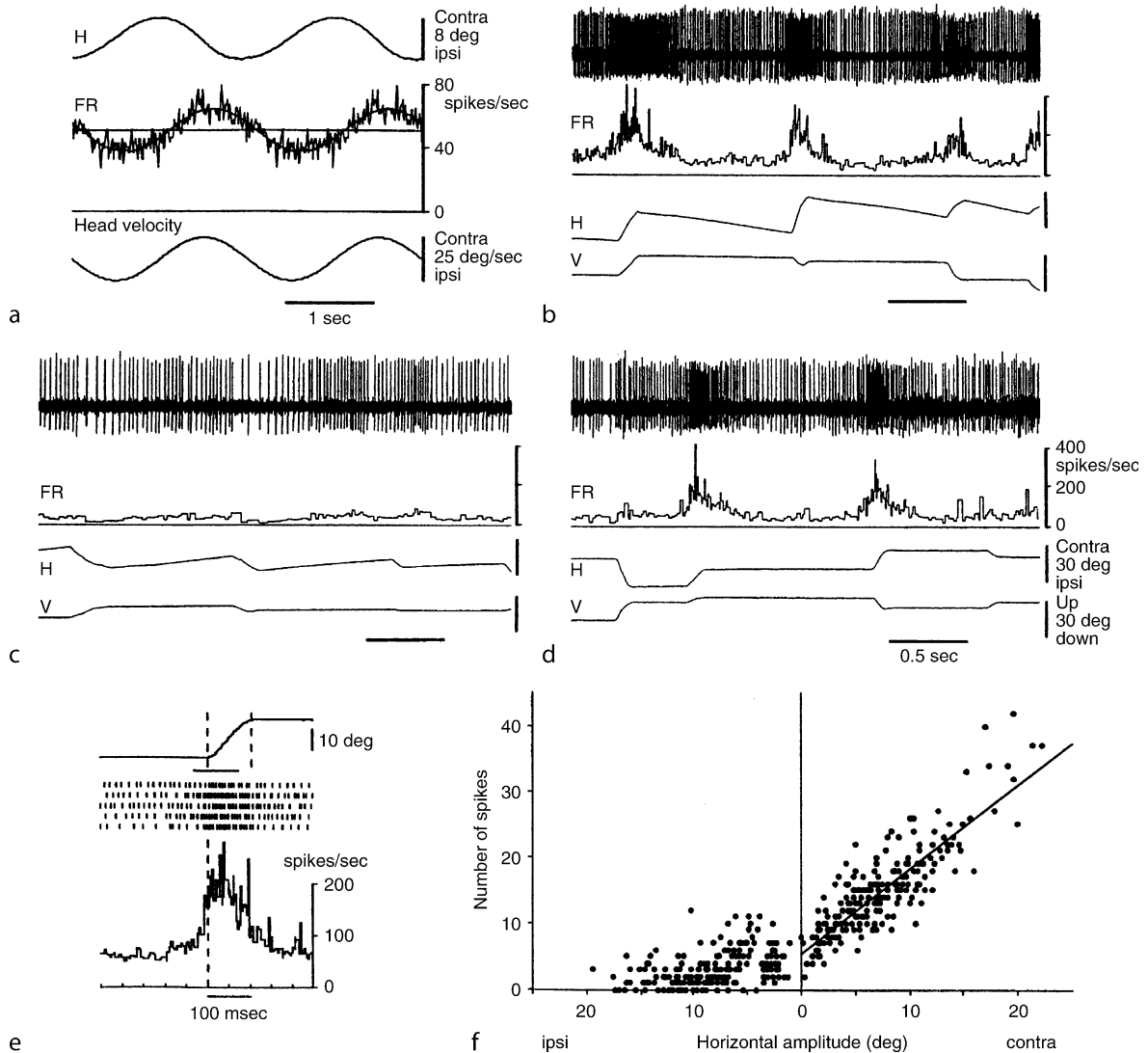

**Burster-Driving Neurons. Figure 1** Firing pattern of BDNs (a–d) and characteristics of BDN burst (e–f). (a) type II response of a BDN to sinusoidal horizontal rotation in light at 0.5 Hz. Horizontal eye position (H) and firing rate (FR) are averaged over eight stimulus cycles. Superimposed sine wave indicates best-fitting response fundamental calculated by the least-squares method. The firing rate is modulated approximately sinusoidally in phase with contralateral head angular velocity. (b–d) sample records from a BDN showing activity during nystagmus and spontaneous saccades. Traces indicate, from top to bottom, spike activity, its instantaneous firing rate (FR), and horizontal (H) and vertical (V) eye position. Nystagmus is induced by contralateral (b) and ipsilateral (c) head rotation in light. A difference in background firing rate between (b) and (c) shows type II response to head rotation. (e) burst activity of a BDN associated with saccades. Traces indicate averaged horizontal eye position (top), raster of spike activity (middle), and averaged instantaneous firing rate (bottom) for five saccades with similar amplitudes (15°–20°) aligned on the onset of saccades. Vertical broken lines indicate the onset and the end of saccades. Horizontal bar below eye position trace indicates the period over which the number of spikes was counted. (f) relationship between the number of spikes in the burst and the amplitude of horizontal component of rapid eye movement for a BDN. The correlation for contralateral component is highly significant ( $r = 0.86$ ,  $p < 0.001$ ). The slope of regression line: 1.28 spikes/deg (from Ref. [2]).

The similar burst firing properties of BDNs and **medium-lead burst neurons (MLBNs)** suggest that BDNs provide burst neurons with appropriate information for the direction, amplitude, and velocity of rapid

eye movements. The ON direction of MLBNs is ipsilateral, which is consistent with a crossed projection of BDNs to burst neurons. In contrast, during fixation periods or slow phases of nystagmus, EBNs and IBNs

show no spontaneous discharges, whereas BDNs are spontaneously active and display irregular tonic firing. This difference may be caused by tonic inhibition from omnipause neurons (OPNs) acting on MLBNs, but probably not on BDNs.

In addition to the vestibular modulation of their tonic firing, BDNs sometimes show a burst of spikes even during fixation periods. Visual stimulation, such as the abrupt presentation of an object in the contralateral visual field, induces a brief burst of spikes even in the absence of any eye movement [2]. The latency of such bursts is  $\sim 30\text{--}40$  ms after the onset of visual stimulation. When a saccade is induced in response to a visual stimulus, BDNs exhibit a burst consisting of early visual and later saccade-related components, although the transition from the early to later responses is not always distinct. Similar neuronal responses have been observed in the deeper layers of the SC [5]. It may be suggested that collicular efferent signals impinging on BDNs arise from visually responsive deep layer

neurons, which also discharge before saccades. Indeed, BDNs receive excitatory input from the SC (see below).

### Afferent Organization of BDNs

Moreover, there are several reasons to think that BDNs could be a site of interaction between saccadic signals and vestibular signals. As described above, BDNs display vestibular type II responses during head rotation and are activated disynaptically from the contralateral vestibular nerve [1,2], suggesting that BDNs receive excitatory input from **▶type I secondary vestibular neurons** on the contralateral side (Fig. 2e). Among various functional types of vestibular nucleus neurons, those which modulate their firing approximately in phase with head angular velocity and have no significant correlation to eye position during fixation would be candidates for supplying the BDNs. BDNs also receive input from the ipsilateral SC [2]. BDNs are excited di- or trisynaptically after single-pulse stimulation of the ipsilateral SC (the latency of the induced

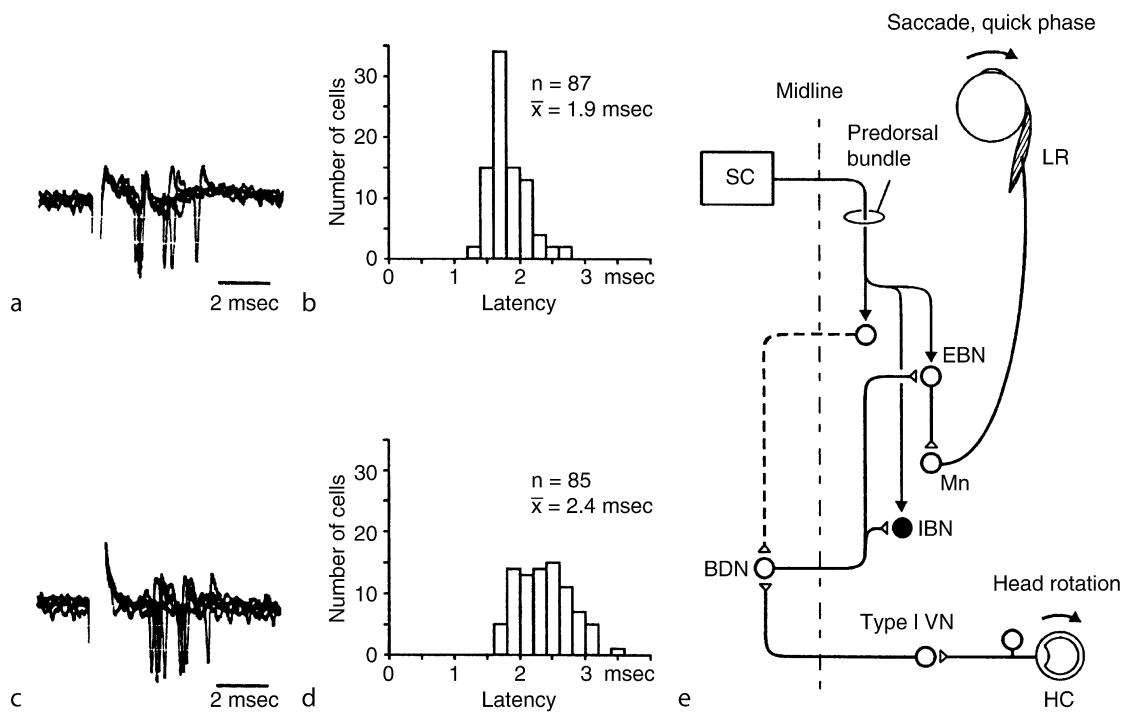

**Burster-Driving Neurons. Figure 2** Response of BDNs to stimulation of the vestibular nerve and the SC (a–d), and input-output connections of BDN (e). (a) response of a BDN to stimulation of the contralateral vestibular nerve (five superimposed traces). (b) latency histogram of excitation induced from the contralateral vestibular nerve for 87 BDNs. (c) response to stimulation of the ipsilateral SC (five superimposed traces). Same cell as in (a). (d) latency histogram of excitation induced from the ipsilateral SC for 85 BDNs. (e) only excitatory connections relating to rightward (contralateral to BDN) rapid eye movement are shown. *Mn*, abducens motoneuron; *EBN*, excitatory burst neuron; *IBN*, inhibitory burst neuron; *BDN*, burster-driving neuron; *HC*, horizontal semicircular canal; *SC*, superior colliculus; *Type I VN*, type I secondary vestibular neurons. Intercalated neuron(s) along the pathway from SC to BDN (dotted lines) have not been identified (From Ref. [2]). Monosynaptic connections of SC efferent neuron to EBN and IBN have been suggested in the cat.

spikes ranges from 1.7 to 3.5 ms) (Fig. 2c and d). The crossed descending pathway through the predorsal bundle is likely to mediate the collicular excitation of BDNs (Fig. 2e), because electrical stimulation of the contralateral predorsal bundle can activate BDNs with a slightly shorter latency (shortest latency: 1.5 ms) than that following collicular activation [2]. No short-latency excitation is induced from the contralateral SC. Neurons that transmit collicular effects to BDNs have not been identified, but may be located in the pontomedullary reticular formation or the NPH on the contralateral side where collateral axons of ►**tecto-reticulo-spinal neurons** terminate. ►**Long-lead burst neurons (LLBNs)**, which show a prelude of activity similar to that of BDNs, are known to receive monosynaptic excitation from the contralateral SC in the monkey [6], and might provide a relay station. However, the pathway from LLBNs to BDNs has not been verified.

The response of BDNs to ipsilateral SC stimulation is greatly affected by head rotation [2]. Collicular activation of BDNs is facilitated during contralateral head rotation and suppressed during ipsilateral rotation as compared with their response in the absence of rotation. The latency of the response becomes shorter during contralateral rotation than during ipsilateral rotation. Convergence of afferent inputs from the contralateral horizontal ►**semicircular canal** and the ipsilateral SC makes sense in terms of the generation of spike bursts in BDNs, since activation of both afferents leads to the induction of rapid eye movements to the contralateral side. In view of the convergence and interaction of vestibular and collicular inputs to BDNs, it seems likely that their saccade related burst discharges are also affected by inputs from the horizontal semicircular canal, resulting in modulation of the amplitude of saccades induced by SC stimulation. It has been shown that the amplitude of the horizontal component of saccades evoked in response to stimulation of the SC in the cat is larger during contralateral and smaller during ipsilateral head rotation than in the absence of rotation [7]. Similar effects of rotation on SC-induced saccades have also been reported in the monkey [8]. As the interaction between saccade signals and the vestibular signals takes place at the level of BDNs, changes in the excitability of BDNs would modify the mode of interaction between eye and head movements.

The firing characteristics and connections of BDNs described above are based on experiments concerning the horizontal system controlling rapid eye movements. In the vertical system, putative BDNs with a downward ON direction have been reported in the region of the interstitial nucleus of Cajal in the cat [9]. However, similar populations of BDNs have not been found in either the horizontal or the vertical system of the monkey despite extensive searches [10]. The fact that

different results were obtained in these two species might be due to the different strategies they employ during eye-head coordination.

## References

1. Ohki Y, Shimazu H, Suzuki I (1988) Excitatory input to burst neurons from the labyrinth and its mediating pathway in the cat: location and functional characteristics of burster-driving neurons. *Exp Brain Res* 72:457–472
2. Kitama T, Ohki Y, Shimazu H, Tanaka M, Yoshida K (1995) The site of interaction between saccade signals and vestibular signals induced by head rotation in the alert cat: functional properties and organization of burster-driving neurons. *J Neurophysiol* 74:273–287
3. Duensing F, Schaefer KP (1958) Die Aktivität einzelner Neurone im Bereich der Vestibulariskerne bei Horizontalbeschleunigungen unter besonderer Berücksichtigung des vestibulären Nystagmus. *Arch Psychiat Nervenkr* 198:225–252
4. Kaneko CRS, Fuchs AF (1981) Inhibitory burst neurons in alert trained cats: comparison with excitatory burst neurons and functional implications. In: Fuchs AF, Becker W (eds) *Progress in oculomotor research. Developments in neuroscience*, vol.12. Elsevier, New York, pp 63–70
5. Sparks DL, Hartwich-Young R (1989) The deep layers of the superior colliculus. *Rev Oculomot Res* 3:213–255
6. Raybourn MS, Keller EL (1977) Colliculoreticular organization in primate oculomotor system. *J Neurophysiol* 40:861–878
7. Kitama T, Shimazu H, Tanaka M, Yoshida K (1992) Vestibular and visual interaction in generation of rapid eye movements. *Ann N Y Acad Sci* 656:396–407
8. Van Beuzekom AD, Van Gisbergen JAM (2002) Collicular microstimulation during passive rotation does not generate fixed gaze shifts. *J Neurophysiol* 87:2946–2963
9. Fukushima K, Fukushima J, Ohashi T, Kase M (1991) Possible downward burster-driving neurons related to the anterior semicircular canal in the region of the interstitial nucleus of Cajal in alert cats. *Neurosci Res* 12:536–544
10. Kaneko CRS, Fukushima K (1998) Discharge characteristics of vestibular saccade neurons in alert monkeys. *J Neurophysiol* 79:835–847

## Bursting

### Definition

The endogenous ability of a neuron to oscillate in membrane potential and to fire rhythmic bursts of action potentials. This is a voltage-dependent mechanism, based on the set of active voltage-dependent currents expressed by the neurons. Some neurons can only burst in the presence of specific neuromodulators: these are conditional bursting neurons.

### ► Action Potential

## Bursting Pacemakers

JAN-MARINO RAMIREZ

Department of Organismal Biology and Anatomy  
Committees on Neurobiology, Computational  
Neuroscience and Molecular Medicine, The University  
of Chicago, Chicago, IL, USA

### Synonyms

Bursting neurons; Pacemaker neurons

### Definition

A pacemaker neuron is a neuron with the intrinsic ability to generate rhythmic bursts that emerge through voltage- and time-dependent ion fluxes. These ion fluxes give rise to rhythmic membrane fluctuations that are defined as “drive potentials” or “▶pacemaker potentials.” The ion fluxes leading to drive potentials are carried by sodium, calcium, and/or non-specific cations, but there are also other ionic conductances contributing to the shape and frequency of these potentials. The drive potentials can, but do not always, give rise to a series of action potentials. A drive potential that gives rise to action potentials is called a “burst.” The ability to generate pacemaker activity is a universal property of many cell types and is not restricted to neurons. Pancreatic beta cells, gut cells, oocytes and cardiac myocytes are well-known cells with pacemaker properties.

### Characteristics

#### Quantitative Description

The identity of a pacemaker neuron is not necessarily genetically determined, as many non-pacemaker neurons can be turned into pacemaker neurons by just modulating the strength of their ion channels. Conversely, pacemaker neurons can also become non-pacemakers. Such transformations may be more common in the nervous system than generally appreciated. For example, the discharge patterns of neocortical and thalamic neurons change dramatically during the transition from wake to sleep [1,2], and there are numerous other examples in which neurons can lose or attain pacemaker properties. Mechanistically, this is not surprising as the ion channels that give rise to pacemaker properties are continuously modulated by ▶neuromodulators, such as amines and peptides. A neuron that generates pacemaker activity only in the presence of a neuromodulator is called a “▶conditional pacemaker.” However, the term “conditional pacemaker” is not always used in a very strict manner. Neurons are sometimes referred to as “conditional pacemaker” if they generate pacemaker activity only at certain de- or hyperpolarizing membrane potentials. For

example, relay neurons in the thalamus are tonically active at depolarized membrane potentials, and intrinsically bursting when hyperpolarized [1]. To use the term “▶conditional pacemaker neuron” in this context is justified, as not only current injections, but also different neuromodulators can change the mode of these neurons [1]. The more we learn about pacemaker neurons, the more we realize how flexible their properties are. In fact, it may well be that all pacemaker neurons are conditional in one way or the other.

The major challenge in demonstrating that a neuron is a pacemaker is to show that the rhythmicity recorded in a neuron is generated intrinsically, and is not the result of rhythmic synaptic input that emerges through network interactions. This can be achieved in several different ways, but most methods have certain caveats. For this reason, different mechanical, electrophysiological and pharmacological approaches are usually combined. One approach is the acute mechanical dissociation of portions of the CNS that yields isolated neuronal cell bodies. These cell bodies may or may not contain the ion channels required for the expression of pacemaker properties, which are often located in the dendrites. Long-term culture of isolated neurons will lead to the recovery of dendritic arborizations. However, these dendrites may have different ion channels from those of the original neuron, which will potentially alter the activity patterns of these neurons. A very elegant method to isolate pacemaker neurons without damaging dendritic processes is the ▶photo-inactivation technique [3]. Fluorescent dyes are injected into all cells that provide synaptic input to a putative pacemaker neuron. Upon illumination by a laser beam or ultraviolet light source, injected neurons die leaving the putative pacemaker neuron intact and isolated. This technique has been successfully used in the stomatogastric ganglion of crustaceans. However, this approach is not very useful for investigating pacemaker neurons in the much larger mammalian neuronal networks. Thus, most studies in the mammalian nervous system employ pharmacological approaches to isolate pacemaker neurons [1,4,5]. By exogenously applying neurotransmitter antagonists, it is possible to block inhibitory and excitatory neurotransmission, thereby blocking possible rhythmic synaptic inputs. The pharmacological approaches are usually combined with electrophysiological approaches that take advantage of the voltage-dependency of ion channels [5]. Brief de- or hyperpolarizing current injections can reset ongoing pacemaker activity by advancing or delaying the generation of a pacemaker burst. Long-lasting de- or hyperpolarizing current injections can accelerate or slow the frequency of pacemaker activity. Brief depolarizing current pulses can prematurely trigger, while hyperpolarizing current pulses can prematurely terminate ongoing pacemaker bursts.

### Higher Level Structures

Pacemaker neurons are found throughout the nervous system [6]. In fact, the majority of neuronal networks generate rhythmic activity, including the networks within the spinal cord, medulla, neocortex, basal ganglia, thalamus, locus coeruleus, ventral tegmentum area (VTA), hippocampus and amygdala. Neuronal structures that generate rhythmic activity are associated with sleep, wakefulness, arousal, motivation, addiction, memory consolidation, cognition and fear. However, in many cases it is unclear how the rhythmicity in general and how pacemakers in particular contribute to these higher brain functions. While it is easy to imagine how strengthening synaptic interactions could engrave memory, it is less easy to understand how rhythmicity contributes to memory, arousal, motivation, or addiction [6].

### Lower Level Components

The ionic mechanisms that give rise to pacemaker activity are very heterogeneous, and typically involve a complex interaction between voltage-dependent and voltage-independent components of ion channels within their intra- and extracellular environment [7]. In general, a neuron depolarizes and ultimately bursts either in response to the activation of inward currents that are carried by sodium and/or calcium ions, or in response to the cessation of outward currents that are carried by potassium ions. The inward currents include the hyperpolarization-activated current (I<sub>h</sub> current), the persistent sodium current, various low- and high-voltage activated calcium currents and the ►calcium-activated non-specific cation (CAN) current [7]. The ongoing burst is commonly terminated by either of two principal ionic mechanisms. (i) The channels responsible for the inward current inactivate. An example is the inactivation of the T-type calcium channel, which leads to burst termination of thalamic relay neurons [1]. (ii) The calcium or sodium influx during the ongoing burst can activate calcium- or sodium-dependent potassium currents that hyperpolarize the membrane and thereby terminate the burst. The hyperpolarization caused by these outward currents can subsequently activate the I<sub>h</sub> inward current, which will slowly depolarize the pacemaker neuron to initiate the onset of the next burst. However, the onset of the next burst can also be caused by other ionic mechanisms. Possible mechanisms include voltage-independent intracellular signals, and slow activation or inactivation properties of inward or outward currents.

### Structural Regulation

There is no characteristic anatomical structure that defines a pacemaker neuron. Similarly, there are many different discharge patterns that characterize a pacemaker neuron, and pacemaker neurons with different

shapes and discharge patterns are found throughout the CNS. “Irregular-” and “regular-bursting” neurons are differentiated by the regularity of the burst periodicity. A “one-spike bursting neuron” generates a single action potential per drive potential. Such a neuron is sometimes called “beater neuron.” Given that rhythmic drive potentials can arise through a variety of ionic mechanisms, it is not surprising that the same anatomical region may contain different types of pacemaker neurons. In the neocortex, “fast rapid bursting” (FRB) neurons or “chattering neurons” generate fast-rhythmic drive potentials that give rise to one or two action potentials per drive potential [2]. The “intrinsic bursting neurons” of the neocortex on the other hand generate bursts that consist of many action potentials. The fact that the same anatomical region contains more than one type of pacemaker neuron is not the exception, but presumably the rule [4,7,8]. It is assumed that different types of pacemaker neurons play different roles in the generation of network activity, an issue of much ongoing research [2,4,9]. This complexity is not unique to the nervous system: cardiac pacemakers for example are also very diverse.

### Higher Level Processes

Pacemaker neurons are embedded in complex neuronal networks. Hence, there are many synaptic and modulatory processes that govern the activity of a pacemaker neuron. Many principle insights into the interactions between pacemaker neurons, synaptic transmission and neuromodulators were gained from studying small neuronal networks of invertebrates. These networks exhibit the full complexity of larger networks, yet due to the relatively small number of neurons are amenable to rigorous cellular and systems level analysis. In invertebrates, it is possible to study the contribution of well-defined pacemaker activity to the overall network output in intact behaving animals, and also in completely isolated portions of the nervous system, such as the stomatogastric ganglion of crustaceans [3,7,8]. By manipulating the activity of a single pacemaker neuron, it is often possible to reset the activity of an entire neuronal network. Although, this is also possible in the mammalian whisker system, most mammalian neuronal networks will not respond to changes in the activity of a single neuron. Nevertheless, major advances into the functional role of pacemaker neurons are also increasingly being gained in the mammalian nervous system. Various mammalian preparations are now available that are amenable to a rigorous cellular and systems level analysis. Intracellular studies are routinely performed in intact behaving animals [2,10] as well as brain slices [1,4,5,9] in which rhythm generating networks are functionally isolated. These isolated neuronal networks continue to generate spontaneously rhythmic activity, which is consistent with the definition of a ►central

**pattern generator** (►CPG). ►CPGs are neuronal networks that are capable of generating a specific rhythmic activity that is characteristic of a specific behavior even in the absence of rhythmic afferent feedback. For the mammalian respiratory network, it has been demonstrated that following isolation an area called the ►pre-Bötzinger complex is still capable of generating three specific rhythmic activities that have many characteristics of normal respiratory activity (eupnea), gasping and sighing [4]. Pacemaker neurons within the respiratory network differentially contribute to the generation of these activity patterns [4]. These studies further confirmed the notion that neuronal networks are not hard-wired, but that they undergo considerable ►reconfiguration as the behavioral, environmental and metabolic conditions change [4].

### Lower Level Processes

Neuromodulators play a critical role in modulating the cellular events that govern the discharge pattern of a pacemaker neuron. Endogenously released neuromodulators can phosphorylate voltage-dependent ion channels, or alter second messenger pathways and intracellular calcium thereby changing ion channel properties. This complex interplay between neuromodulators, the intracellular milieu and voltage-dependent ion fluxes will significantly alter pacemaker activity. In doing so, neuromodulators can determine the burst frequency, amplitude and shape of the drive potential [7,8]. Neuromodulators are also responsible for the fact that the pacemaker property itself is not a fixed property.

### Function

Various functions have been ascribed to pacemaker neurons. Pacemaker neurons can have a variety of inhibitory or excitatory effects on other neurons, and/or on non-neuronal cells such as muscle cells [7,8]. In doing so, pacemaker neurons can release fast neurotransmitters, neuromodulators as well as neurohormones. Pacemaker bursts may entrain the activity of neuronal ensembles, thereby giving rise to rhythmic network activity. In this scenario, an individual pacemaker neuron or a group of pacemaker neurons will theoretically act as the rhythmic driver of a given neuronal network. However, pacemakers are typically embedded in neuronal networks, and therefore pacemaker activity itself will be influenced by synaptic inputs. Thus, in general, pacemaker activity will not only drive network activity, but will in turn be driven by synaptic inputs. Thus, assigning a specific function to a pacemaker neuron becomes difficult if not impossible. Many different scenarios are realized in invertebrate and vertebrate neuronal networks. Tonic excitatory or inhibitory synaptic inputs can determine the frequency of pacemaker activity. Excitatory synaptic input can prematurely trigger pacemaker activity, which means

that synaptic inputs can determine the timing of pacemaker activity. A pacemaker burst can act as a non-linear amplifier of synaptic excitatory inputs, while synaptic inhibitory inputs can act as leak currents that will greatly suppress pacemaker activity.

### Process Regulation

The number, the types of pacemakers, and the degree of their bursting properties in a functional neuronal network will be continuously regulated by neuromodulators and synaptic interactions. Consequently, the contribution of pacemaker properties to the overall network output will not be fixed [4]. By altering, for example, the number of active pacemaker neurons, a network can assume different configurations that can lead to different network outputs. These complex modulatory interactions imbue neuronal networks with a high degree of plasticity. This is an essential prerequisite for generating a rhythmic behavior that has to continuously adapt to changes in behavioral, environmental and metabolic conditions.

### Pathology

It has been hypothesized that the induction of pacemaker properties may play an important role in epileptogenesis. Indeed, the number of intrinsic bursting neurons is significantly increased in seizing tissue [2]. Conversely, the suppression of pacemaker properties may lead to the failure of gasping, and possibly ►Sudden Infant Death Syndrome [4].

### Therapy

Consistent with the hypothesis that induction of pacemaker properties may contribute to the generation of seizure activity, is the fact that many anti-epileptic drugs act on sodium and calcium currents that contribute to the generation of pacemaker activity. Consequently, a better understanding of the ionic basis of pacemaker activity and their modulation may be an important step towards developing rational therapies for various neurological disorders including epilepsy.

### References

1. Pape HC, McCormick DA (1989) Noradrenaline and serotonin selectively modulate thalamic burst firing by enhancing a hyperpolarization-activated cation current. *Nature* 340:715–8
2. Steriade M (2004) Neocortical cell classes are flexible entities. *Nat Rev Neurosci* 5:121–134
3. Miller JP, Selverston A (1979) Rapid killing of single neurons by irradiation of intracellularly injected dye. *Science* 206:702–704
4. Peña F, Parkis MA, Tryba AK, Ramirez JM (2004) Differential contribution of pacemaker properties to the generation of respiratory rhythms during Normoxia and Hypoxia. *Neuron* 43:105–117

5. Thoby-Brisson M, Ramirez JM (2001) Two types of inspiratory pacemaker neurons in the isolated respiratory network of mice. *J Neurophysiol* 86:104–112
6. Arshavsky YI (2003) Cellular and network properties in the functioning of the nervous system: from central pattern generators to cognition. *Brain Res Brain Res Rev* 41:229–67
7. Harris-Warrick RM (2002) Voltage-sensitive ion channels in rhythmic motor systems. *Curr Opin Neurobiol* 12:646–51
8. Marder E, Calabrese RL (1996) Principles of rhythmic motor pattern generation. *Physiol Rev* 76:687–717
9. Cunningham MO, Whittington MA, Bibbig A, Roopun A, LeBeau FE, Vogt A, Monyer H, Buhl EH, Traub RD (2004) A role for fast rhythmic bursting neurons in cortical gamma oscillations in vitro. *Proc Natl Acad Sci USA* 101:7152–7157
10. Buzsaki G, Draguhn A (2004) Neuronal oscillations in cortical networks. *Science* 304:1926–1929

and tonic components each have a preferred direction, which are typically the same, e.g., bursting only for leftward saccades and increasing tonic discharge for increasing leftward eye position. Prototypical burst/tonic neurons include motoneurons that innervate the extraocular muscles. These neurons exhibit a decline in firing for saccades opposite to the preferred direction, but this is not an essential part of the burst-tonic discharge. Burst-tonic neurons are found in several other parts of the brain in addition to the ocular-motor (III, IV, VI) nuclei.

- ▶ Brainstem Burst Generator
- ▶ Saccade, Saccadic Eye Movement
- ▶ Smooth Pursuit Eye Movements

---

## Burst/Tonic Cells (BTNs)

### Definition

Combine the firing properties of burst neurons and tonic neurons, i.e., they discharge a burst of activity at the time of saccadic eye movements and have a “tonic” discharge during fixations or smooth eye movements that covaries with eye angular position. Both the burst

---

## Bushy Cells

### Definition

Neurons in the ventral cochlear nucleus that receive calyces of Held from auditory nerve fibers and project to the superior olive.

- ▶ Calyx of Held Synapse
- ▶ Cochlear Nucleus
- ▶ Superior Olive

## C. elegans Neuroethology

JUSTIN R. DAVIS, ANDREW C. GILES,  
CATHARINE H. RANKIN  
Brain Research Centre, University of British Columbia,  
Vancouver, BC, Canada

### Synonyms

Nematode; Worm; Genetic control of behavior

### Definition

In 1974, Sidney Brenner first introduced the nematode *Caenorhabditis elegans* as a model for studies of the genetic control of nervous systems and behavior [1]. Since then, a great deal of research has been focused on this 1 mm long roundworm. With its small nervous system, and fully sequenced genome, *C. elegans* is an excellent system in which to investigate the cellular mechanisms of behaviors such as foraging, feeding, defecation, movement, egg-laying, male mating behavior, sensory responses to touch, smell, taste and temperature, as well as simple forms of learning. It has a small and tractable nervous system, which consists of 302 neurons and approximately 5,000 chemical synapses [2]. Every neuron has been identified, its cell lineage traced and its connectivity patterns mapped [2]. Many of the *C. elegans* genes involved in coding its neural machinery are ►homologous to those in other organisms [3], including neurotransmitters, ►second messengers, ►growth factors and many metabolic pathways. Many different strategies are used to study neuroethology in *C. elegans*, including detailed behavioral analyses, laser ablation of identified neurons and mutants with alterations in genes expressed in specific neurons to determine the neural circuits underlying the behavior, genetic screens to determine genes involved in the behavior, modern genetic techniques to determine gene expression patterns and patterns of gene interaction. In this review, we will highlight several sensory behaviors, behavior plasticity and a foraging behavior as examples of how *C. elegans* can be used for studies of neural and genetic analyses of behavior.

## Characteristics

### Higher Level Processes: Modes of Sensory Input

Studies of the behavior and anatomy of *C. elegans* have determined that *C. elegans* has three major types of sensory receptors: chemoreceptors, thermoreceptors and mechanosensory receptors [3]. *C. elegans* behavior and its ability to adapt to environmental cues are mediated by these three modes of sensory input, and allows for interesting investigations into the neural circuitry and genetic pathways that underlie these systems.

### Lower Level Process: Chemotaxis

Studies investigating chemotactic behavior have used behavioral analysis, genetic manipulation and laser ablation (killing) of specific neurons to lead to the identification of the 22 specific chemosensory neurons necessary for *C. elegans* to detect and respond to different chemical cues [4]. The 11 pairs of chemosensory neurons located in the anterior amphid sensillum (nose; see Fig. 1) have been divided into two separate classes responsible for either the sensation of taste or smell.

Taste is defined as the detection of soluble compounds and is mediated by eight pairs of neurons (ADF, ADL, ASE, ASG, ASH, ASI, ASJ, ASK), while smell is defined as the detection of volatile compounds and is mediated by a separate set of three pairs of neurons (AWA, AWB, AWC) [4]. Despite its seemingly simple neural circuitry, *C. elegans* has the ability to discriminate between and respond to different chemical stimuli based on its previous experiences [5]. In essence, *C. elegans* can learn and form memories from chemosensory data.

Through the use of chemotaxis assays, hundreds of aqueous and volatile chemicals have been identified as either attractants or repellants to *C. elegans*. This ability to discriminate between attractants and repellents is essential in order for *C. elegans* to successfully navigate its soil habitat in terms of both feeding behavior and spatial orientation [6]. Further genetic investigations into the behavior of *C. elegans* have led to the discovery of a group of 14 ►G-Protein Coupled Receptor subunits that are specifically involved in mediating chemotactic behavior [5,6]. Future comparisons of the physical structure and biochemical action



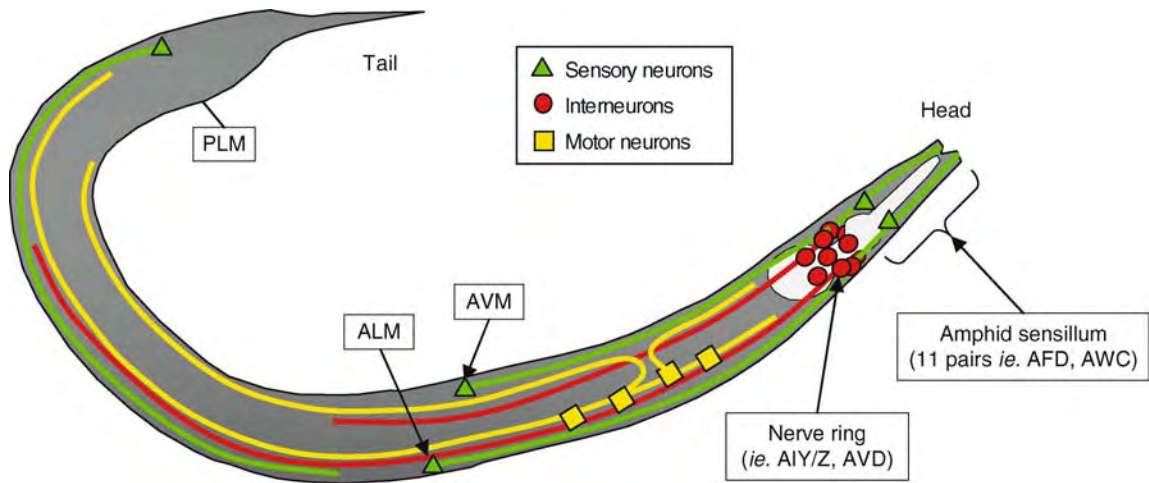

**C. elegans Neuroethology. Figure 1** Drawing of *C. elegans* showing some of the elements of the neural circuitry involved in chemotactic, thermotactic, and mechanosensory behaviors; sensory neurons represented by triangles; interneurons represented by circles; motor neurons represented by squares. The neurons shown are representative of the neurons used for these behaviors, not all neurons in the circuits described in the text are drawn.

of these G-protein subunits and other signaling components will help to provide an even more detailed description of the chemosensory system and chemotactic behaviors of *C. elegans*.

A worm that is exposed to a taste or an odor for a long period of time decreases its response to the compound; this reversible decrease in response is called ▶adaptation [5,6]. In *C. elegans*, olfactory adaptation to different volatile compounds is mediated by either AWA or AWC sensory neurons. When a worm is adapted to a particular odorant, the responses to other odors detected by the same sensory neuron are not affected indicating that adaptation is not a cell wide phenomenon, but rather is odorant specific. Mutations in two genes, *adp-1* and *osm-9* expressed in the AWC sensory neurons, show normal initial responses to specific odors, however they fail to adapt to these odors [5,6]. This suggests that detection of odors and adaptation to the odors are separate processes. The expression of adaptation differs depending on whether worms are in the presence of food or not. Thus, olfactory adaptation is another complex form of ▶behavioral plasticity that can be studied in this simple system.

#### Lower Level Process: Thermotaxis

As early as 1975, *C. elegans* was observed to show a behavioral response to thermal gradients [7]. When *C. elegans* are cultivated in a well-fed state at a given temperature and then transferred to an environment containing a thermal gradient they will migrate to ▶isotherms equivalent to the temperature in which they were raised (Fig. 2).

In contrast, worms experiencing starvation at a given temperature will avoid that temperature. This behavior appears to be the result of associative learning, where the worm learns to associate a specific temperature with the presence or absence of food.

In order for *C. elegans* to perform thermotaxis, they must be able to sense temperature. Laser ablation of any of the AFD, AIY, AIZ, and RIA neurons leads to animals with disrupted thermotactic behavior [5]. It is believed that the actual sensation of temperature is accomplished by AFD sensory neurons, whose specialized ▶microvillus-like nerve endings are embedded just within the cuticle of the amphid sensillum in the nose of the worm [5]. The axon projects from the amphid towards the AIY, AIZ, and RIA interneurons in the nerve ring in the neck area of the worm [2]. Ablation of AIY or AIZ causes different abnormal behaviors, with *C. elegans* becoming either ▶cryophilic or ▶thermophilic, respectively, while killing RIA leaves worms unable to track temperatures (athermotactic). Mori and colleagues [5] have suggested that AIY and AIZ are interneurons integrated via direct synapses with the downstream interneuron RIA in order to produce the observed thermotactic response. When AFD neurons are destroyed using laser ablation, most but not all thermotactic behavior is arrested, indicating that there may be other neurons that have the ability to sense temperature; however, it is believed that most thermal information is collected by AFD [5].

Studies of mutants showing abnormal thermotactic behavior lead to the discovery of components that may be involved in the cellular mechanisms of thermotaxis. *tax-2* and *tax-4* are two genes that encode

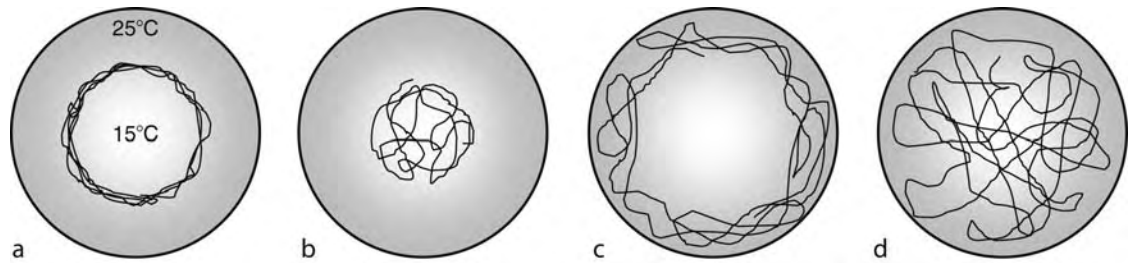

**C. elegans Neuroethology. Figure 2** Path of a *C. elegans* on an agar filled Petri dish with a radial thermal gradient of 15–25°C after being well fed at 20°C. Wild-type (N2) strain shows thermotactic behavior (a) Mutant strains, or laser-ablated wild-types can be abnormal showing cryophilic (b) thermophilic (c) or athermotactic behavior (d).

subunits of a ►cyclic nucleotide-gated cation channel. Mutants with disruptions of either *tax-2* or *tax-4* are athermotactic, completely ignoring thermal gradients [5]. When the gene products of *tax-2* and *tax-4* are tagged with ►green fluorescent protein, they are found localized to the membranes of the microvillus-like projections of AFD, suggesting an early role in the thermosensation mechanism [5]. Interestingly, the hypothesized TAX-2/TAX-4 channel is most similar to the cGMP-gated channels found in rod photoreceptors of the human retina that are important for visual sensation [5].

Thermotactic behavior in *C. elegans* has become model of learning and memory because worms are able to learn and remember a specific temperature and pair this memory with the appropriate feeding-state [5]. This memory can be modified simply by further cultivation for 2–4 h at a new temperature [7]. Recently, mutants have been discovered that can memorize a cultivation temperature but cannot couple it to a feeding state [5], suggesting that these processes are two distinct mechanisms.

#### Lower Level Process: Mechanosensory Behavior

*C. elegans* responds to mechanosensory stimuli, in response to a touch to the head worms will swim backwards, in response to a touch to the tail worms will swim forwards. In addition, worms will swim backwards in response to a mechanical tap to their surroundings, such as within a laboratory Petri dish [8]. This tap-withdrawal response is a perfect example of how a seemingly simple behavior has more complexity than it originally appears; this response is plastic and shows short-term ►habituation and dishabituation, ►context conditioning and long-term memory for habituation [8]. Short-term habituation occurs with a series of taps separated by an inter-stimulus interval (ISI). Short ISIs lead to fast decreases in the withdrawal response, but this response is recovered quickly. Worms exposed to long ISIs, on the other hand, take longer to fully habituate, but have a much longer recovery period [8]. The tap-withdrawal response can also show

long-term memory of habituation lasting at least 24 h [8]. The neural circuit for the tap response consists of the mechanosensory neurons ALM, AVM and PLM and the interneurons AVA, AVB, AVD and PVC [8]. Behavioral experiments led to the hypothesis that plasticity was occurring at the synapse between the sensory neurons and interneurons [8]. This synapse uses glutamate as its neurotransmitter, thus mutations that affect glutamate transmission affect both short-term and long-term memory. Mutations in the gene *eat-4*, which is responsible for expressing a pre-synaptic vesicular glutamate transporter, causes more rapid and complete short-term habituation of the tap-withdrawal response and no dishabituation [8]. When *C. elegans* have mutations in the gene, (*glr-1*) a post-synaptic glutamate receptor, no long-term memory of habituation is observed [9]. This indicates that glutamate transmission between mechanosensory neurons and interneurons is necessary for short-term and long-term memory for habituation of the tap-withdrawal response in *C. elegans*. This is of special interest because glutamate transmission has been implicated in long-term memory in many different animals [9], and may be part of a primitive, highly conserved mechanism of memory.

#### Higher Level Process: Natural Variation in Feeding Behavior

Natural variations in feeding behavior have been identified within *C. elegans* populations [10]. Wild type (N2) strains feed in a solitary fashion, they slow down when they contact food, and disperse randomly as they feed. *C. elegans* variants such as the RC301 strain and *npr-1* mutants show a feeding pattern whereby they forage for food in groups, they speed up when they contact food and they congregate at the edges of food patches where levels of oxygen are low [10]. The differences between the solitary and social strains are the result of a single amino acid substitution in the gene *npr-1* (a predicted G protein-coupled receptor of the neuropeptide Y receptor family). The *npr-1* gene is expressed in several neurons (AQR, PQR and URX) that are exposed to *C. elegans* body fluid, and are involved in

monitoring oxygen levels [10]. This research demonstrates how a “social” behavior can be dissected genetically, allowing a deeper understanding of the ways that neurons can produce and regulate behavior.

### Summary

Detailed behavioral studies of the worm have shown that this tiny creature has a rich and complex behavioral repertoire, making it an ideal system in which to unravel the mysteries of the cellular control of behavior. Findings such as those described here contribute to the ever-growing database of knowledge within the *C. elegans* community. This database of knowledge (much of it available via the internet), coupled with the development of new investigative techniques, allows for research to be conducted at the behavioral, neuronal and genetic level making *C. elegans* an ideal model for the study of how genes regulate behavior.

Each of the examples that we have described show some of the ways that having all of the neurons in the nervous system identified and knowing their connectivity, as well as having a fully mapped and sequenced genome, has greatly aided the investigations of the roles of identified genes in behavior and extended our understanding of the neuroethology of *C. elegans*.

### References

1. Brenner S (1974) The genetics of *Caenorhabditis elegans*. *Genetics* 77:71–94
2. White JG, Southgate E, Thompson JN, Brenner S (1986) The structure of the nervous system of the nematode *Caenorhabditis elegans*. *Phil Trans R Soc Lond B* 314:1–340
3. Bargmann CI (1998) Neurobiology of the *Caenorhabditis elegans* genome. *Science* 282:2028–2033
4. Bargmann CL, Mori I (1997) Chemotaxis and thermotaxis. In: Riddle DL, Blumenthal T, Meyer BJ, Preiss JR (eds) *C. elegans* II. Cold Spring Harbor Laboratory Press, Cold Spring Harbor, pp 717–737
5. Mori I (1999) Genetics of chemotaxis and thermotaxis in the nematode *Caenorhabditis elegans*. *Annu Rev Genet* 33:399–422
6. Colbert HA, Bargmann CI (1995) Odorant-specific adaptation pathways generate olfactory plasticity in *C. elegans*. *Neuron* 14:803–812
7. Hedgecock EM, Russell RL (1975) Normal and mutant Thermotaxis in the nematode *Caenorhabditis elegans*. *Proc Natl Acad Sci USA* 72:4061–4065
8. Rose JK, Rankin CH (2001) Analyses of habituation in *C. elegans*. *Learn Mem* 8:63–69
9. Rose JK, Kaun KR, Chen SH, Rankin CH (2003) GLR-1, non-NMDA receptor homolog, is critical for long-term memory in *Caenorhabditis elegans*. *J Neurosci* 23:9595–9599
10. Cheung BHH, Cohen M, Rogers C, Albayram O, de Bono M (2005) Experience-dependent Modulation of *C. elegans* behavior by ambient oxygen. *Current Biology* 15:905–917

## C Fiber

### Definition

The C fiber is an unmyelinated axon (less than 1  $\mu\text{m}$  in diameter) found in a peripheral nerve trunk. It conducts pain and temperature senses.

► Development of Nociception

## C1 - C2 Cell Groups (Adrenergic Cell Groups)

### Definition

The C1-C2 (and C3) cell groups are adrenergic cells groups located in the medulla. They contain the enzyme that converts norepinephrine to epinephrine. Projections to several regions have been found: paraventricular nucleus of the hypothalamus; locus coeruleus; solitary nucleus; dorsal motor nucleus of the vagus; and intermediolateral cell column of the spinal cord.

## Ca<sup>2+</sup>

### Definition

The divalent calcium ion. Calcium is a light metal with atomic number 20, atomic mass 40.08, ionic radius 94 pm, and hydrated Ionic radius 410 pm.

## Ca<sup>2+</sup> Channels

### Definition

► Calcium Channels – an Overview

## Ca<sup>2+</sup>-activated Cl<sup>-</sup> Channels

### Definition

► Chloride Channels and Transporters

## Ca<sup>2+</sup>-dependent K<sup>+</sup> Channels (KCa)

### Definition

A type of voltage-gated ion channel specific for K<sup>+</sup> ions, which requires the binding of Ca<sup>2+</sup> ions to its internal surface to be gated open. Ca<sup>2+</sup> is an important intracellular signaling molecule in neurons.

► Neuronal Potassium Channels

## Ca<sup>2+</sup> Microdomain

### Definition

A localized increase in the cytosolic free Ca<sup>2+</sup> concentration in the vicinity of open Ca<sup>2+</sup> channels at the plasma membrane (e.g. the active zone; more likely to be on the scale of tens of nanometers) or intracellular Ca<sup>2+</sup> stores (e.g. store-operated Ca<sup>2+</sup> channels; generally referred to as Ca<sup>2+</sup>-induced Ca<sup>2+</sup> release). These microdomains generally serve triggering/signaling roles.

► Synaptic Proteins and Regulated Exocytosis

## CA1

### Definition

A part of brain regions in the hippocampus, which receives synaptic inputs mainly from the hippocampal CA3 region through Schaffer collaterals. The output from CA1 pyramidal cells is sent to the cerebral cortex.

► Associative Long-Term Potentiation (LTP)  
 ► Long-Term Potentiation (LTP)  
 ► Memory, Molecular Mechanisms

## CA3

### Definition

A part of brain regions in the hippocampus, which receives synaptic inputs from the dentate gyrus and the CA3 pyramidal cells of the ipsilateral and contralateral

hippocampi. The output from CA3 pyramidal cells is sent to the CA1 region via Schaffer collaterals and to the CA3 region via associational/commissural fibers.

► Associative Long-Term Potentiation (LTP)  
 ► Long-Term Potentiation (LTP)  
 ► Memory, Molecular Mechanisms

## Cable Theory

JONATHAN BELL

University of Maryland, Baltimore, MD, USA

### Definition

Voltage signals in neurons travel down thin, long, cable-like dendritic and axonal processes. The theoretical modeling and mathematical/computational analysis of signal propagation within these processes is called cable theory. Due to the initial important work of Rall (see [1] and references therein), much of the focus has been concerned with the effects of ►synaptic inputs propagating to the cell's soma, how these inputs interact with each other, and how inputs to various dendritic tree locations affect the neuron's output signal.

### Characteristics

Modeling various observed neural properties, where variations of voltage with location are important, leads to a partial differential equation description of the evolution of electrical potential in the neuron. For understanding information processing in neural networks, the contributions of individual neurons and their dendritic trees takes on central importance.

In the ►core conductor model of a neural process, cable theory classically has assumed a cylindrical membrane with an electrically conducting core. The core cross-section is sufficiently small compared to the length of the fiber that the core can be considered as cross-sectionally isopotential. Thus, the cable model only depends on voltage differences in the axial direction. The cell membrane is surrounded by extracellular space that is assumed isopotential. These considerations conveniently allow visualization of a circuit model for the membrane (see Fig. 1) from which the mathematical model is derived via ►Kirchhoff's conservation laws.

One can also start from the more fundamental ►Maxwell's equations. Some other assumptions behind the model include the neuron's electrical membrane properties being uniform (constant), and the intracellular and extracellular spaces having homogeneous electrical properties. Also, magnetic field effects

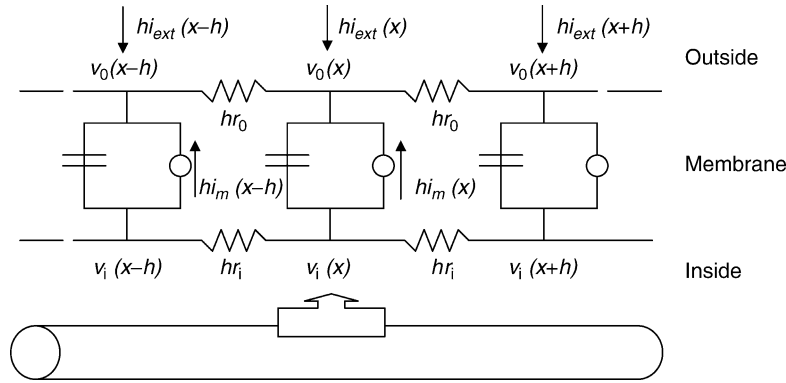

**Cable Theory. Figure 1** A representation of a segment of dendritic cylinder cable and a discrete electrical circuit model of a dendritic membrane segment. Intracellular and extracellular longitudinal currents and resistances per unit length of cable are, respectively,  $i_i(x), i_o(x), r_i, r_o$ ;  $v_i(x), v_o(x)$  are the intracellular and extracellular potentials, at  $x$ . Also indicated is the external current per unit length of cable,  $i_{ext}(x)$ , and  $i_m(x)$  is the sum of ionic currents and current through the membrane ►capacitance, per unit length of cable, at  $x$ . For convenience the time dependence of the potentials and currents has been notationally suppressed.

are negligible and the membrane can be modeled by a ►capacitor in parallel with a ►conductance. The steps to deriving the cable equation from the circuit model in Fig. 1 involve writing current conservation equations for each node, using ►Ohm's law between nodes, and taking appropriate limits as the spacing between nodes goes to zero in order to arrive at the differential equation model. With the definition that the trans ►membrane potential is the difference between the intracellular and the extracellular longitudinal potentials, that is  $v = v_i - v_o$ , (notation from Fig. 1), then after some algebra the cable equation becomes

$$c_m \frac{\partial v}{\partial t} + i_{ion} = \frac{1}{r_o + r_i} \frac{\partial^2 v}{\partial x^2} + i_{ext} \quad (1)$$

This is really just a statement that the total membrane current (right side of equation), including external source current  $i_{ext}$ , is just the sum of ►capacitance and resistive (ionic) currents. Details of the derivation can be found in various references; see, e.g. [2]. The source current  $i_{ext}$  can be a sum of point synaptic currents, or an externally applied current stimulus. The extracellular and intracellular longitudinal resistances per unit length of cable are  $r_o, r_i$ , respectively, and  $r_o$  is usually so much smaller than  $r_i$  that it is ignored ( $r_o = 0$ ). Representative values of some of the parameters are given in Table 1.

### Some Special Problems for Passive Cables

If the membrane is passive (no active ion channels), the membrane element represented by the circles in Fig. 1 become resistor-battery elements. Using  $E$  as a constant ►rest(ing) potential for the cell, and  $g_m = 1/r_m$  as a constant membrane conductance, then  $i_{ion} = g_m \times (v - E)$ . Also, a scaling more compatible with measurements, and using  $a$  = cylinder's (uniform) radius,

define  $R_i = r_i \pi a^2$ ,  $R_m = r_m / 2\pi a$ , and  $C_m = c_m / 2\pi a$ . Ignoring external current sources ( $i_{ext} = 0$ ), and substituting these into (1), one arrives at the linear cable theory model

$$C_m \frac{\partial v}{\partial t} + \frac{v - E}{R_m} = \frac{a}{2R_i} \frac{\partial^2 v}{\partial x^2}. \quad (2)$$

The cable's ►space constant is given by  $\lambda = \sqrt{r_m/r_i} = \sqrt{aR_m/2R_i}$ . To illustrate the nature of  $\lambda$ , consider the time independent problem (that is, drop the  $t$ -derivative in (2)) of a very long cable that for all intents one can take as semi-infinite (defined for  $x > 0$ ). Impose at  $x = 0$  a constant current step stimulus,  $I_0$  (see Fig. 2a).

The appropriate boundary condition is given by  $\frac{dv}{dx}(0, t) = -I_0/G_\infty$ . Here  $G_\infty$  is the input conductance, and is given by  $G_\infty = 1/\lambda r_i = 1/\sqrt{r_m r_i} = \sqrt{2\pi^2/R_i R_m a^3}/2$ . If we let  $\tilde{v}(x)$  be the deviation of potential away from the fiber's rest potential, that is,  $\tilde{v}(x) = v(x) - E$ , where  $v(x)$  is the bounded, time independent solution to (2) for all  $x > 0$ , with this boundary condition at  $x = 0$ , then  $\tilde{v}(x) = \tilde{v}(0)e^{-x/\lambda} = (\lambda I_0/G_\infty)e^{-x/\lambda}$ . Thus, the ►depolarization decays exponentially, and  $x = \lambda$  is the value where  $\tilde{v}$  has dropped to  $1/e$  times the initial value  $\tilde{v}(0)$ . Hence, the smaller  $\lambda$  is, the faster the decay, and the less the stimulus is felt down the fiber. Injection of a known constant current at the terminal, then measuring the steady-state voltage response will determine  $\lambda$  from the decay of potential. Since the cell's rest potential is measurable, knowledge of  $v(0) - E = \lambda I_0/G_\infty$  gives  $G_\infty$ , hence  $r_i$ . Since  $\lambda = \sqrt{r_m/r_i}$ ,  $r_m$  can be determined. A couple of typical values of  $\lambda$  are given in Table 1. With the parameters determined the time dependent problem can be solved exactly and various questions can be explored (see [5]).

**Cable Theory. Table 1** Representative parameter values (adapted from [3])

Symbol	Units	Squid giant axon	Cat spinal motoneuron
$R_m$	$\Omega - cm^2$	1000	2500
$C_m$	$\mu F/cm^2$	1	2
$R_i$	$\Omega - cm$	30	60
$r_i$	$\Omega/cm$	$15 \times 10^3$	$8.9 \times 10^7$
$a$	$\mu m$	250	10 (primary dendrite)
$\tau$	$ms$	1	5
$\lambda$	$\mu m$	6500	1000

A simple case to consider is Rall's **▶motoneuron** ([4]; see Fig. 2b). If the cable has physical length  $L$  (electrotonic length  $L/\lambda$ ), then a reasonable boundary condition at  $x = L$  is to have zero axial current. This is commonly the boundary condition used for the terminus of dendritic branches. With longitudinal current being proportional to the spatial derivative of potential, this ("sealed-end") boundary condition just states that this spatial derivative of  $v$  equals zero at  $x = L$ , for all time  $t > 0$ . In Rall's model the soma is a (passive) point soma representation with capacitance  $C_s$  and conductance  $G_s$ . Then the left-end (somatic) boundary condition is a linear combination of potential and its space and time rates of change at  $x = 0$ . This addition to the cable model became the basis for improvements in various parameter estimation formulas that could be correlated with experimental findings. See [1,4] for details.

### Passive Dendritic Trees and Rall's Equivalent Cylinder Theorem

In the motoneuron model above the dendritic structure is represented by a single cylinder. Under certain constraints a branching structure can be reduced to a single **▶electrically equivalent cylinder model** [2,3]. This approach has proved quite useful in interpreting various experimental observations [1]. The structure Rall set up is flexible enough to handle arbitrary branching geometries where the branches may have nonuniform membrane properties.

To give some idea of the assumptions needed (consult [2] for details) consider first a simple tree with a "trunk" segment connected to a soma (at  $x = 0$ ), and at each branch point of the tree there is a parent branch (with radius  $a_{parent}$  in the direction of the soma, and some number of sibling branches emanating from it. Some assumptions imposed on the tree are: the initial depolarization is the same at all points equal distance from the soma (for instance, the whole tree is at its rest potential), and each dendritic tip has the same terminal boundary condition (e.g., the sealed-end condition). Also, at each branching point a three-halves law is assumed to hold:  $(a_{parent})^{3/2} = \sum_i a_i^{3/2}$ , the sum taken

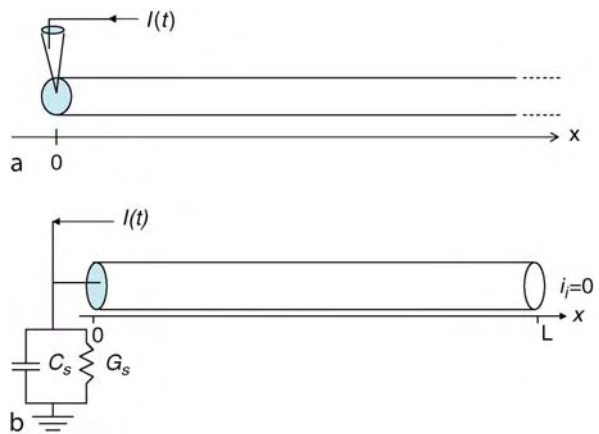

**Cable Theory. Figure 2** (a) A representation of a semi-infinite cylinder cable with a step applied current imposed at the left end ( $x = 0$ ). (b) A representative drawing of Rall's motoneuron model [4], indicating his point-soma circuit with capacitance  $C_s$  and conductance  $G_s$ . Also indicated is an applied current injected at the soma. The cable is of finite length, with a sealed-end condition (no longitudinal current flow) at the right end.

over all sibling branches  $i$  associated with the specific parent branch. This can be considered an **▶impedance matching condition**, and it is a reasonable physiological approximation in many cases [3]. Rall had the assumption that with distances measured in space constants  $\lambda$ , the dendritic terminal points were assumed to be at the same electrotonic distance from the soma. This is generally not satisfied; dendritic tips can vary considerably across branches. This may have the effect that an **▶equivalent cylinder** actually tapers gradually to zero moving from the soma to its terminus. However, the assumption has been weakened in later generalizations of the theory. With these conditions the depolarization at any point in the tree can be determined from the solution to the cable equation at the same distance from the soma.

There are relatively few problems of interest that can be solved analytically and so one must resort to

numerical methods. Because of morphological complexity of dendritic trees and the need to investigate the effects of distributed synaptic inputs, there are now excellent modeling simulation tools available that take the philosophy that cables and trees can be segmented into numerous compartments.

### Nonlinear Cable Theory

If the **▶membrane potential** is not relatively close to the neuron's rest potential, and the cable has active ion channels, then the **▶current-voltage relation**  $i_{ion}$  in (1) has nonlinear dependence on voltage. The most important and most studied example of this is the **▶Hodgkin–Huxley model** [6]. The Hodgkin-Huxley model for **▶squid giant axon** could reproduce and explain a large range of data, including shape and **▶conduction velocity** of a propagating action potential (impulse), its sharp threshold, **▶refractory period**, anode-break excitation, **▶accommodation**, and subthreshold oscillations. The conductance-based modeling framework formulated by the Hodgkin-Huxley model has remained remarkably flexible for modeling other neural processes, including some human neuronal processes.

Much of the analysis of the cable model of Hodgkin and Huxley (including later modifications, generalizations, and simplifications) has concerned the initiation and behavior of single impulses and pulse trains under various circumstances. Examples include dependence of conduction speed on temperature, density of **▶sodium channels**, conductance properties, initiation and sustained firing patterns, etc. (see, e.g. [5]).

Dendrites (and axons) are very non-uniform, particularly in geometry and distribution of ionic channels. Generalizations of classical cable theory have tried to assess a functional role for these non-uniformities, taking into consideration the cell type, but results are rather scattered. The effect on conduction when there are present significant changes in dendritic cable diameter has had a long history. The main issues here concern conditions for conduction block (stopping spike propagation), and reflecting “echo” waves that back propagate [7]. This behavior may have functional consequences regarding synaptic activity. Also, the distribution of **▶dendritic spines** on a cable can determine whether signal propagation will be successful. Simulations show that sometimes clumping of spines is needed for successful conduction [8]. As an example of another study, model simulations of a cable show amplification of **▶excitatory post-synaptic potentials** even when there are only persistent sodium channels that are sparsely distributed in isolated clumps [9].

### Myelinated Cable Modeling

The most extreme non-uniform case is that of myelinated (myelination) axons. Because sodium channels are

concentrated at **▶nodes of Ranvier**, and various ion channels are in relatively low density in the **▶internodes**, theoretical models have concentrated on saltatory aspects of conduction (saltatory conduction), and have incorporated spatially discrete dynamics. These models assumed the internodes were perfect insulators. Cable theory based models have considered the internodes as passive cable segments, separated by active nodes (see, e.g. [2]). Simulations have indicated that internodal structure and parameters have far more control on velocity than does the node, though the nodal characteristics are important for getting the correct threshold level. Analysis and simulation studies have most often been concerned with the dependence of conduction velocity on parameters such as diameter ratio between node and internode, internodal length, temperature, ratio of capacitances, etc. For example, if the internodal length and internodal diameter (with **▶myelin sheath**) is, respectively,  $L$  and  $D$ , and  $d$  is the axon diameter, then conduction velocity tends to be insensitive to  $d/D$  and  $L/D$  over a range of values, and tending to increase linearly with  $d$ , other parameters being fixed. Where investigated, conduction will proceed through one unexcitable node, but if there are two adjacent unexcitable nodes conduction block will generally occur. Some studies have looked at the effects of **▶demyelination** and partial remyelination on conduction characteristics. For example, Waxman and Brill [10] studied conduction near demyelinated regions. The reduction in length of two internodes closest to the demyelinated regions to approximately one third of their normal length or less will still facilitate conduction.

### References

1. Segev I, Rinzel J, Shepherd GM (eds) (1995) The theoretical foundations of dendritic function, selected papers of Wilfrid Rall, with commentaries, MIT Press, Cambridge, MA
2. Tuckwell HC (1988) Introduction to theoretical neurobiology, vols 1 & 2, Cambridge University Press, New York
3. Rall W (1977) Core conductor theory and cable properties of neurons. In: Kandel ER, Brookhart JM, Montcastle VB (eds) The handbook of physiology, nervous system, vol 1: Cellular biology of neurons. American Physiological Society, Bethesda, MD
4. Rall W (1969) Time constants and electrotonic length of membrane cylinders and neurons. *Biophys J* 9:1483–1508
5. Koch C (1999) Biophysics of computation: information processing in single neurons, Oxford University Press
6. Hodgkin AL, Huxley AF (1952) A quantitative description of membrane current and its application to conduction and excitation in nerve. *J Physiol* 117:500–544
7. Ermentrout GB, Rinzel J (1994) Reflected waves in an inhomogeneous excitable medium. *SIAM J Appl Math* 56:1107–1128

8. Baer S, Rinzel J (1991) Propagation of dendritic spikes mediated by excitable spines: a continuum theory. *J Neurophysiol* 65:874–890
9. Poznanski RR, Bell J (2000) Theoretical analysis of the amplification of synaptic potentials by small clusters of persistent sodium channels in dendrites. *Math Biosci* 166:123–147
10. Waxman SG, Brill MH (1978) Conduction through demyelinated plaques in multiple sclerosis: computer simulations of facilitation by short internodes. *J Neurol Neurosurg Psychiatr* 41:408–416

## CaCC

### Definition

►  $\text{Ca}^{2+}$ -activated  $\text{Cl}^-$  Channels

► Chloride Channels and Transporters

## Caecilians

### Definition

A group of long bodied, limbless living amphibians.

► The Phylogeny and Evolution of Amniotes

## Caenorhabditis

### Definition

Worm of the phylum Nematelminthes, class Nematodes. Nematodes are special, because they have constant cell numbers. *Caenorhabditis* has served as model system for genetics and development, but also for many different aspects of behavior (see essay on “Neuroethology of behavior in *caenorhabditis*”).

## Calcarine Sulcus

### Synonyms

Sulcus calcarinus; Calcarine sulcus

### Definition

Typical groove running on the median side of the occipital lobe, often entering the parietooccipital sulcus. Area 17, the striate cortex, stretches along this sulcus.

► Telencephalon

## CADASIL

### Definition

Cerebral autosomal dominant arteriopathy with subcortical infarcts and leukoencephalopathy. Hereditary stroke disorder that is caused by mutations of the Notch 3 gene on chromosome 19.

► Ischemic Stroke  
► Stroke

## Cadherins

HIROSHI KIMURA, TADASHI UEMURA  
Graduate School of Biostudies, Kyoto University,  
Kyoto, Japan

### Synonyms

Cadherin superfamily

### Definition

Founding members of the cadherin superfamily were identified by their ability to mediate calcium-dependent cell-to-cell adhesion. They were designated as cadherins (*calcium + adhere + protein*) and are now classified as classical cadherins. Classical cadherins are type I transmembrane proteins and defined by two additional structural features (Fig. 1). One is the extracellular cadherin repeat or cadherin domain of roughly 110 amino acids, which mediates calcium-dependent homotypic interaction between cells. This domain is typically organized in tandem repeats. Another is the intracellular domain with which a group of cytoplasmic molecules, i.e., ► *catenins*, interact. In addition to classical cadherins, the cadherin superfamily includes many subfamilies of non-classical cadherins [1,2]. Although non-classical molecules also have cadherin repeats in their ectodomains, they lack the catenin-binding motif and are characterized by a variety of transmembrane domains and intracellular sequences. Non-classical



cadherins include desmosomal cadherins, protocadherins and seven-pass transmembrane cadherins. “Cadherin” is used as a synonym for classical cadherin hereafter.

## Characteristics

### Quantitative Description

In a single vertebrate species such as humans, over 20 different subtypes of classical cadherins have been found so far, whereas the total number of non-classical cadherins is 80 at a moderate estimate.

### Description of the Structures

Each vertebrate classical cadherin has five cadherin repeats, whereas the number of repeats and the presence or absence of other extracellular motifs are variable among invertebrate cadherins [1,2], even in a single species such as *Drosophila* (Fig. 1).

Compared to other cell-surface molecules, such as calcium-independent cell adhesion molecules, cadherins are unique in their ability to induce tight cell aggregates in which cells adhere to neighbors with maximum areas of contact. This ability appears to be dependent on the interaction of the cadherin–catenin multiprotein complex with the actin cytoskeleton. The classification of non-classical cadherins is based on sequence similarities of their intracellular regions and

the overall structure of all domains. It is reasonable to assume that distinct subfamilies of non-classical cadherins are responsible for different functions and that they are coupled to different signaling pathways that have been under investigation.

## Higher Level Structures and Their Regulation

### 3D Structure of Ectodomains

In the presence of calcium, cells expressing a certain subtype of classical cadherins only form stable contacts with cells expressing the same type, with some exceptions. This homotypic adhesion between cells arises from homophilic interactions between ectodomains of the same subtype and consequently differential expression of cadherins underlies various roles in vivo (as explained later). Many different structural approaches have been used to unravel the molecular basis for cadherin-mediate adhesion. Although several different models of the cadherin homophilic bond have been proposed, all essentially agree that the specificity lies in the most N-terminal part of the ectodomains and that molecular interaction occurs not only between adjacent cells (in trans), but also on the surface of the same cell (in cis) [3]. A study using a two-repeat fragment of E-cadherin showed that calcium-binding in between consecutive repeats stabilizes otherwise flexible linker regions.

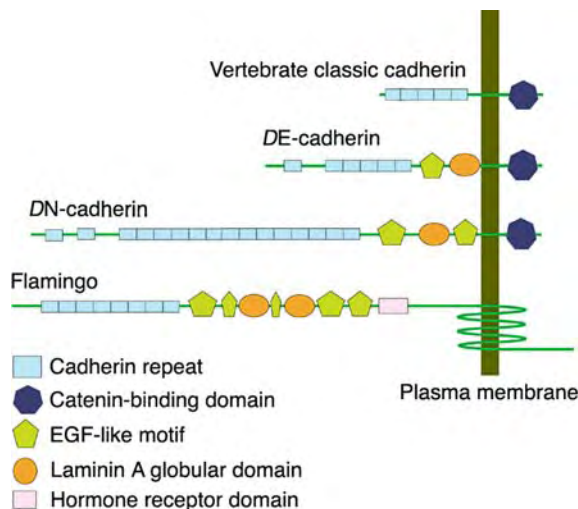

**Cadherins. Figure 1** Structural diversity of the cadherin superfamily. Overall structures of four selected members of the cadherin superfamily: a vertebrate classical cadherin (about 750 amino acids in length), two *Drosophila* classic cadherins (DE and DN are 1,507 and 3,108 respectively) and the *Drosophila* seven-pass transmembrane cadherin, Flamingo (3,575). Both vertebrate and *Drosophila* classical cadherins have catenin-binding domains, although the number of repeats and the presence or absence of other extracellular motifs are variable.

### Distinct Protein Complexes at Two Intercellular Junctions

Classical cadherins, one subfamily of non-classical cadherins (desmosomal cadherins) and their associated proteins are structural components of intercellular junctions that were previously documented at the electron microscopic level. In polarized epithelial cells, the adherens junction (AJ) is formed near the apical surface and E-cadherin is typically localized there [2,4]. Catenins assemble on the intracellular domain of E-cadherin and this complex is linked to the cortical actin. An AJ is not necessarily a stable structure. Epithelial cells regulate their contacts with neighboring cells during development and in disease states such as tumor metastasis. Underlying mechanisms include endocytic recycling of cadherin and loss of one of the catenins by mutations respectively [5]. A synapse contains cadherins and catenins and is structurally similar to an AJ (see below).

A desmosome is another type of intercellular junction that is abundant in tissues that experience mechanical stress, where two subtypes of desmosomal cadherins, desmocolins and desmogleins, are localized. Heterodimers of desmocolin and desmoglein are linked to the keratin intermediate filament cytoskeleton via interactions with one of the catenins, plakoglobin, and other components of the desmosome.

## Function

### **Cell Sorting, Cell Rearrangement and Epithelial to Mesenchymal Transitions**

Maintenance of solid tissues is just one of the multiple missions of classical cadherins. Differential expression of cadherin subtypes and spatiotemporal control of cadherin–catenin activity play pivotal roles in dynamic morphogenetic events that take place numerous times during development [1,6,7]. Such tissue morphogenesis can be classified at least into three categories. First there are numerous examples demonstrating that cell populations expressing different cadherins sort out in vivo and boundaries are generated between them. For example, expression of N-cadherin in the presumptive neural epithelium allows it to separate from the E-cadherin-expressing ectoderm. Other examples are the roles of cadherins in the establishment/maintenance of early embryonic brain divisions. Second, dynamic breaking and reforming of cadherin adhesive cell–cell binding is required for cells to change neighbors and this cell rearrangement controls the reshaping of tissues. Third, epithelial cells are often converted to motile, fibroblast-like cells and a hallmark of this epithelial to mesenchymal transition is decreased expression of E-cadherin. Down-regulation or dysfunction of E-cadherin also plays a part in tumor cell invasion and metastasis.

### **Axonal and Dendritic Outgrowth, Fasciculation, Pathfinding and Target Recognition**

A number of classical cadherins are distributed in axons during the period of active elongation and the expression of most vertebrate cadherins studied to date is restricted to subsets of growing fiber tracts. It therefore has been assumed that cadherins are used by growth cones to navigate along pre-existing pathways expressing the same type of cadherin. A number of in vitro experiments indicate that N-cadherin is an excellent substrate for axonal outgrowth from N-cadherin-positive neurons and is also required for axonal fasciculation. Furthermore in vivo analyses have strengthened or demonstrated roles of cadherins in various aspects of neuronal network formation including axonal and dendritic outgrowth, fasciculation, pathfinding and target recognition [2,7,8].

In the *Xenopus* visual system, expression of a dominant negative form or injection of antibodies against N-cadherin cause loss or reduction of neurite growth or pathfinding errors. Genetic studies in *Drosophila* and *C. elegans* have shown that loss of N-cadherin function causes defective axonal fasciculation and pathfinding errors in mutant animals. In the fly visual system, N-cadherin appears to mediate a homophilic, attractive interaction between photoreceptor growth cones and their targets that precedes synaptic partner choice. An important role of cadherin

in dendrodendritic interaction is shown in the fly olfactory system. N-cadherin confines dendritic terminals of projection neurons (counterparts of vertebrate mitral cells) to a particular glomerulus following an initial overgrowth into adjacent glomeruli.

Non-classical cadherins also regulate neuronal wiring; for example a series of recent studies have revealed that seven-pass transmembrane cadherins are involved in regulation of dendritic growth. The *Drosophila* seven-pass transmembrane cadherin Flamingo (Fmi; also known as Starry night) is required for sensory neurons and central mushroom-body neurons to restrict dendritic growth. In contrast to the overextension phenotypes in the fly nervous system, knock-down of one of the mammalian Fmi homologs, Celsr2, by a RNA interference (RNAi) approach in pyramidal and Purkinje neurons reduced branch number and length, leading to simplification of dendritic arbors. What the downstream signal transduction pathways are and why loss of Fmi function and knocking down of Celsr2 produce superficially opposite phenotypes are under investigation. Another vertebrate homolog, Celsr3, is required for formation of major axonal fascicles in the mouse brain.

### **Synaptogenesis and Synaptic Plasticity**

After axons traverse long distances and reach correct target regions, these axons and the dendritic filopodia of their target cells recognize each other and subsequently form a synapse. Neurons utilize the characteristics of classical cadherins to “zip synapses up.” Classical cadherins are detected at the earliest points of axon-filopodial contact and persist in mature synapses where cadherins and catenins are localized in the close vicinity of the transmitter-release zone, although this varies according to the type of synapse. Roles of cadherins and catenins in synapse formation have been examined in cultured mammalian neurons and in the visual system of *Drosophila* mutants. These studies have indicated that the cadherin–catenin system is required for stabilizing contacts between incoming axons and targets, morphological maturation of synapse and the maintenance of stable synaptic contacts through regulating spine motility [2,7,8,9]. A sub-class of protocadherins, protocadherin  $\gamma$ , is also found in synaptic junctions.

Multiple subtypes of classical cadherins are expressed in the brain and their expression profiles often correlate with neuronal connectivity. This finding, together with the homophilic binding specificity of individual subtypes, led to the proposal that the differential binding among the subtypes may connect pre- and post-synaptic membranes and lock them together, thus forming selective neuronal connections. Many protocadherins are also expressed in the nervous system. Thus it is intriguing to envisage whether the molecular diversity of classic cadherins and protocadherins play a role

in specifying synaptic connectivity and if so, how the roles of these two different subfamilies came to be differentiated.

Cadherins are also important physiologically. Application of anti-N-cadherin antibodies to hippocampal slices indicated that N-cadherin is needed to hold nascent synaptic contacts and establish L-LTP. The functions of cadherins and catenins have been studied at the behavioral level as well. For example, LTP is elevated in hippocampal neurons in cadherin-11-knockout mice. This observation has been explained by assuming that reducing the activity of cadherin might enhance the deformability of spines, so rendering them more sensitive to LTP-inducing stimuli.

### Planar Cell Polarity

In many organs, epithelial cells are polarized not only along the apicobasal axis, but also along a second axis within a plane. Acquisition of the latter polarity, known as planar cell polarity (PCP) or tissue polarity, is crucial for specialized cellular functions. A typical example of PCP is seen in the sensory epithelium of the inner ear, where stereocilia that protrude from the apical surfaces of hair cells are uniformly oriented. This coordinated alignment maximizes the ear's sensitivity to sound and acceleration. Genetic programming of PCP has been thoroughly studied in *Drosophila*. Such studies highlight the pivotal roles of three non-classic cadherins, the seven-pass transmembrane cadherin Flamingo (Fmi) and the single-pass transmembrane proteins Dachsous (Ds) and Fat (Ft) [1,2,10]. It was previously postulated that polarity information is passed from one end of a tissue to another, possibly via a secreted factor; nowadays it is speculated that direct cell-cell interaction, mediated by Ds-Ft heterophilic interaction, transmits polarity locally within the tissue and that subsequently Fmi is involved in polarization of individual cells. All of the three *Drosophila* molecules are conserved in vertebrates and at least one of the Flamingo homologs has been shown to be required for acquisition of PCP in the mouse inner ear.

### References

1. Tepass U, Truong K, Godt D, Ikura M, Peifer M (2000) Cadherins in embryonic and neural morphogenesis. *Nat Rev Mol Cell Biol* 1:91–100
2. Hirano S, Suzuki ST, Radies C (2003) The cadherin superfamily in neural development: diversity, function and interaction with other molecules. *Front Biosci* 1:306–355
3. Koch AW, Manzur KL, Shan W (2004) Structure-based models of cadherin-mediated cell adhesion: the evolution continues. *Cell Mol Life Sci* 61:1884–1895
4. Wheelock MJ, Johnson KR (2003) Cadherins as modulators of cellular phenotype. *Annu Rev Cell Dev Biol* 19:207–235

5. D'Souza-Schorey C (2005) Disassembling adherens junctions: breaking up is hard to do. *Trends Cell Biol* 15:19–26
6. Gumbiner BM (2005) Regulation of cadherin-mediated adhesion in morphogenesis. *Nat Rev Mol Cell Biol* 6:622–634
7. Radies C, Treubert-Zimmermann U, Luo J (2003) Cadherins as regulators for the emergence of neural nets from embryonic divisions. *J Physiol Paris* 97:5–15
8. Ye B, Jan YN (2005) The cadherin superfamily and dendrite development. *Trends Cell Biol* 15:64–67
9. Takeichi M, Abe K (2005) Synaptic contact dynamics controlled by cadherin and catenins. *Trends Cell Biol* 15:216–221
10. Strutt H, Strutt D (2005) Long-range coordination of planar polarity in *Drosophila*. *Bioessays* 27:1218–1227

---

## Cadmium-insensitive Pacemakers

### Definition

Pacemaker neurons that are dependent on persistent sodium ( $\text{Na}^+$ ) current and burst in the presence of cadmium.

- ▶ Persistent  $\text{Na}^+$  Currents
- ▶ Respiratory Pacemakers

---

## Cadmium-sensitive Pacemakers

### Definition

Pacemaker neurons that depend on calcium-activated non-specific cation (CAN) current and are blocked by cadmium.

- ▶ Calcium-activated Non-specific Cation (CAN) Current
- ▶ Respiratory Pacemakers

---

## Calcitonin Gene Related Peptide (CGRP)

### Definition

CGRP is one of the numerous peptides found in neurons and acting as co-transmitters. It is derived from the gene

encoding calcitonin by alternative splicing of mRNA and by proteolytic processing of a precursor peptide. It is mainly found in sensory neurons of the central nervous system. Its prime target is the CGRP receptor, a member of the family of G protein-coupled receptors. In contrast to calcitonin, which is involved in calcium homeostasis and bone remodelling, CGRP causes vasodilatation and vascular leakage. It is expressed in group C sensory nerve fibers. It works as a stimulatory (pro-nociceptive) neurotransmitter when it is released centrally, and as a pro-inflammatory mediator when released peripherally. The central role of CGRP in primary headaches has led to a search for suitable antagonists of CGRP receptors.

## Calcium-activated Non-specific Cation (CAN) Current

### Definition

An inward current that is generated by ion channels that open in response to an increased intracellular calcium concentration. The opening of these ion channels leads to an inward current that is carried by non-specific cations including calcium and sodium ions. The CAN current has been implicated in generating pacemaker activity in various pacemaker neuron types.

### ► Bursting Pacemakers

## Calcium Binding Proteins

YOSHI KIDOKORO

Institute for Molecular and Cellular Regulation, Gunma University, Gunma, Japan

### Synonyms

Syt; 65-kDa synaptic vesicle protein; CaMKII; Type II Ca/Calmodulin-dependent kinase

### Definition

Syt: A putative major ►Ca<sup>2+</sup> sensor for synaptic transmission, which resides in the synaptic vesicle membrane. Syt has two Ca<sup>2+</sup> binding domains (►Calcium domain) and binds multiple Ca<sup>2+</sup> ions.

CaMKII: A major constituent of ►postsynaptic density in excitatory synapses in the mammalian brain.

### Characteristics

Ca<sup>2+</sup> is a ubiquitous messenger and participates in a variety of cell functions in physiological and pathological conditions. The specificity of signal transmission is maintained by spatial and temporal localization of Ca<sup>2+</sup> signals and Ca<sup>2+</sup> binding proteins. At the synapse, Ca<sup>2+</sup> plays crucial roles both in pre- and post-synaptic events. In each event, specialized Ca<sup>2+</sup> binding proteins are involved. Among Ca<sup>2+</sup> binding proteins at the synapse two proteins have been extensively studied. The role of a Ca<sup>2+</sup> binding protein in the presynaptic terminal (►Presynaptic active zone), Synaptotagmin (Syt), is generally believed to be in detection of Ca<sup>2+</sup> influx for synchronized fusion of ►synaptic vesicles (for review, [1,2]). Another Ca<sup>2+</sup> binding protein, Ca<sup>2+</sup>/Calmodulin-dependent protein kinase II (CaMKII) is abundant in the postsynaptic membrane and essential for plastic regulation of glutamate receptor channels (for review, [3]). There are many other Ca<sup>2+</sup> binding proteins in neurons. Calbindin-D28K, calretinin and parvalbumin are distributed in specific neurons in the brain and considered to play a role as Ca<sup>2+</sup> buffers. Calmodulin modifies channel functions and neuronal excitability, whereas Protein kinase C is involved in modulation of glutamate receptor channel functions and synaptic plasticity in the brain. ►Annexins are a family of Ca<sup>2+</sup>- and phospholipid-binding proteins and bind to various presynaptic proteins such as rabphilin and synapsin. ►CAPS, Ca<sup>2+</sup>-dependent activator protein for secretion, is an essential cytosolic component of the protein machinery involved in large dense-core vesicle exocytosis and in secretion of a subset of neurotransmitters.

In this essay, concentration will be on Syt in the presynaptic nerve terminal and CaMKII in the postsynaptic cell.

### Synaptotagmin (Syt)

Electrical signals conveyed along an axon are converted into chemical signals at the synapse. The basic mechanism for synaptic transmission was established at the frog neuromuscular junction, about 50 years ago, by Katz and his collaborators [4]. Ca<sup>2+</sup> plays the central role in this story. The electrical signal at the presynaptic terminal results in a transient influx of Ca<sup>2+</sup> through voltage-gated Ca<sup>2+</sup> channels, which is detected by a specialized Ca<sup>2+</sup> sensor. Through a series of molecular interactions, this signal causes rapid fusion of synaptic vesicles and transmitter release. Among Ca<sup>2+</sup>-binding proteins in the presynaptic terminal, Syt is the most promising candidate for the Ca<sup>2+</sup> sensor.

### Ca/Calmodulin-Dependent Protein Kinase II (CaMKII)

Synaptic transmission is malleable and plastic, which is believed to be the basis for memory and learning. Ca<sup>2+</sup> again plays an important role in this process. CaMKII is

the major player among  $\text{Ca}^{2+}$  binding proteins in the postsynaptic side of the synapse. This kinase has been studied extensively in the mammalian central nervous system as it constitutes the postsynaptic density, and is intimately involved in ►long-term potentiation (LTP) of synaptic transmission in the brain.

### Quantitative Description

#### Molecular Weight

Syt: ~65 kDa, probably works as an oligomer.

CaMKII, CaMKII $\alpha$ , ~50 kDa and CaMKII $\beta$ , ~60 kDa: Carboxy-terminal holoenzymes consisting of a stacked pair of hexameric subunit rings [5].

### Higher Level Structures

Syt; Neurons, Endocrine and Exocrine cells, Presynaptic terminals, Synaptic vesicles, CaMKII; Mammalian brain, Hippocampus, Neurons, Synapses.

### Lower Level Components

Syt: A major protein in the membrane of synaptic vesicles and ►dense core vesicles, which has an amino (N)-terminal transmembrane region followed by two  $\text{C}_2$  domains (C2A and C2B). The  $\text{C}_2$  domains are in the cytoplasm and uniquely situated to sense  $\text{Ca}^{2+}$  influx at the transmitter release site.

CaMKII: A major component in the postsynaptic density in the glutamatergic synapse.

### Homologs

Syt: Syt includes 13 isoforms in humans, and by the database search, an additional six potential isoforms have been suggested. Although most Syt's are localized on transport vesicles, some (Syt III, VI, and VII) are present at the plasma membrane.

CaMKII, CaMKII $\alpha$ , and CaMKII $\beta$  are major isoforms in the brain.

### Higher Level Processes

Syt: Inter-neuronal communication, regulation of hormone secretion.

CaMKII: Postsynaptic modulation of synaptic transmission, synaptic plasticity, memory and learning.

### Lower Level Processes

Syt: ►Vesicle fusion, transmitter release.

CaMKII: Regulation of channel permeability and insertion of AMPA-type glutamate receptors in the postsynaptic density.

### Process Regulation

CaMKII: Extensive synaptic activities translocate CaMKII from cytosol in the postsynaptic ►spines of dendrites to the postsynaptic density.

## Function

### Syt

#### Characteristics of the $\text{Ca}^{2+}$ Sensor for Fast Synaptic Transmission

The  $\text{Ca}^{2+}$  sensor for ►fast synaptic transmission has the following characteristics: Synaptic potentials are steeply dependent on the  $\text{Ca}^{2+}$  concentration, indicating that multiple  $\text{Ca}^{2+}$  ions have to bind to the  $\text{Ca}^{2+}$  sensor for fast synaptic transmission. Furthermore,  $\text{Ca}^{2+}$  sensor for synaptic transmission is considered to have a low  $\text{Ca}^{2+}$  affinity. In a microdomain, the Ca concentration is considered to increase rapidly to high levels, since slow binding EGTA does not affect synaptic transmission but fast BAPTA does (but see review by Augustine et al. [6]). Since the  $\text{Ca}^{2+}$  sensor detects transient changes (sub-msec) of  $\text{Ca}^{2+}$  concentrations in the micro- or nanodomain, accurate determination of the  $\text{Ca}^{2+}$  concentration has been difficult. Two methods are suitable to estimate local  $\text{Ca}^{2+}$  concentrations. Caged  $\text{Ca}^{2+}$  can be released instantaneously by photolysis. Since caged  $\text{Ca}^{2+}$  compound can be equilibrated before photolysis, uncaged  $\text{Ca}^{2+}$  will distribute homogeneously in the presynaptic nerve terminal, and the  $\text{Ca}^{2+}$  concentration can be determined with a  $\text{Ca}^{2+}$  dye injected together with the caged  $\text{Ca}^{2+}$  compound. At the rat auditory synapse, calyx of Held, estimated values for release of transmitter are around 10  $\mu\text{M}$ . Whereas, by using  $\text{Ca}^{2+}$ -sensitive  $\text{K}^+$  channels localized close to presynaptic Ca channels as a probe for local changes of  $\text{Ca}^{2+}$  concentration, the peak concentration was estimated to be 175  $\mu\text{M}$  (for review, [6]). Thus, the  $\text{Ca}^{2+}$  sensor for fast synaptic transmission has a relatively low affinity for  $\text{Ca}^{2+}$ . Syt is localized close to the release site and has multiple binding sites with low  $\text{Ca}^{2+}$  affinities. Thus, Syt is a good candidate for the  $\text{Ca}^{2+}$  sensor.

#### Functional Sites in Syt

Syt has multiple binding sites. Two  $\text{Ca}^{2+}$  binding domains, C2A and C2B, altogether have five putative  $\text{Ca}^{2+}$  binding sites. Among these binding sites, recent evidence indicates that C2B is the  $\text{Ca}^{2+}$  sensing domain for fast synaptic transmission (Fig. 1; [7]).

#### Oligomerization

Syt oligomerizes  $\text{Ca}^{2+}$ -dependently. Whether this oligomerization is essential for vesicle fusion is a current issue.  $\text{Ca}^{2+}$ -dependent oligomerization occurs at C2B, and is conserved in all members of the Syt family.

#### Phospholipid Binding

Syt binds phospholipids  $\text{Ca}^{2+}$  dependently, and this interaction is proposed to be a trigger for vesicle fusion.

#### Interaction with SNARE Complex

Syt also binds syntaxin 1, SNAP-25,  $\text{Ca}^{2+}$  channels, and AP-2. AP-2 is an adaptor protein for clathrin that is

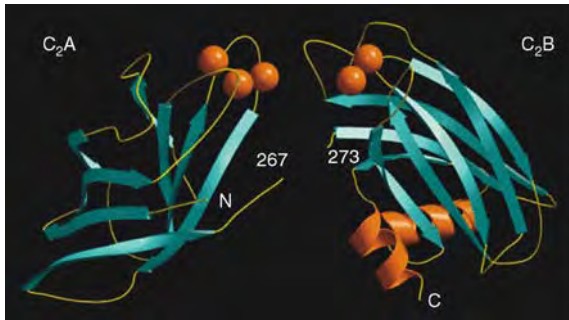

**Calcium Binding Proteins. Figure 1** Structure of Synaptotagmin I. C2A and C2B domains are oriented with their  $\text{Ca}^{2+}$  binding sites in a close proximity (reproduced from Fernandez et al. [7] with permission).

essential for endocytosis (for review [2]). Syt seems to be a multifunctional protein.

#### Phenotypes of Syt I-Null Mutations

Animals that lack Syt were generated in *Drosophila*, *C. elegans*, and mouse. Synaptic transmission in *Drosophila syt I*-null embryos, and in synapses formed in culture from neurons derived from *syt I*-null mouse embryos, have been studied. Nerve-evoked synchronous synaptic transmission is severely impaired, supporting the hypothesis that Syt I is a major  $\text{Ca}^{2+}$  sensor for fast synaptic transmission [2].

#### CaMKII (CaMKII $\alpha$ and CaMKII $\beta$ )

##### Localization

The postsynaptic density (PSD), an electron-dense structure directly apposed to the cytoplasmic face of the postsynaptic membrane, is prominent at excitatory glutamatergic synapses in the mammalian brain. CaMKII is a major protein in the PSD, and is specifically localized to the cytoplasmic face of PSD in a single layer, and in a highly ordered array of tower-like structures (Fig. 2; [8]).

This location of CaMKII is highly suited for detection of  $\text{Ca}^{2+}$  entering through NMDA-type glutamate receptor channels. CaMKII may be connected directly to ▶NMDA receptor channels.

##### Phosphorylation

CaMKII $\alpha$  and CaMKII $\beta$  are contained in relatively high concentrations in brain tissue and phosphorylate non-specifically Ser and Thr residues in numerous proteins. CaMKII binding to NMDA receptors exposes CaMKII to high  $\text{Ca}^{2+}$  concentrations entering through the channels and induces autophosphorylation, which is necessary for induction of long-term potentiation (LTP). Once phosphorylated, CaMKII binds more tightly to the NMDA receptor channel and is persistently active, even after a fall in the  $\text{Ca}^{2+}$  level.

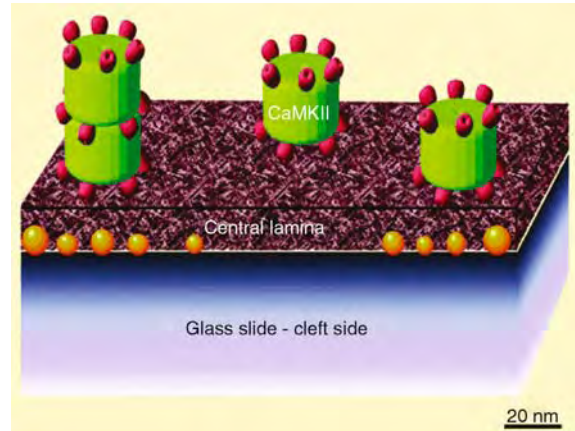

**Calcium Binding Proteins. Figure 2** Diagram showing the structural relation between CaMKII and postsynaptic density (reproduced from Petersen et al. [8] with permission).

This persistent activity then promotes enzymatic and structural processes that increase the number of AMPA-type glutamate receptor channels in the postsynaptic membrane.

##### Translocation During Synaptic Activities

Upon strong activation of NMDA receptor channels, CaMKII translocates to the PSD, where it can optimally detect  $\text{Ca}^{2+}$  entry through NMDA receptor channels and become phosphorylated. Under this condition, more ▶AMPA receptor channels are recruited into the PSD [9]. By interaction with CaMKII, AMPA receptor channels also increase the single channel conductance. Both of these effects lead to potentiation of AMPA-mediated synaptic transmission.

##### Memory Impairments in CaMKII Knock-Out Mice

As described above, the involvement of CaMKII in LTP is convincing, however, it is yet to be established whether LTP is essential in memory acquisition in the animal. This was studied in CaMKII $\alpha$  knock-out mice. In these mice, the hippocampus was deficient in LTP, although synaptic transmission was normal. These mice exhibit spatial learning impairments [10]. Thus, CaMKII plays an important role in the higher brain functions.

#### References

1. Koh T-W, Bellen HJ (2003) Synaptotagmin I, a  $\text{Ca}^{2+}$  sensor for neurotransmitter release. *TINS* 26:413–422
2. Kidokoro Y (2003) Roles of SNARE proteins and synaptotagmin I in synaptic transmission: studies at the *Drosophila* neuromuscular synapse. *Neurosignals* 12:13–30

3. Colbran RJ, Brown AM (2004) Calcium/calmodulin-dependent protein kinase II and synaptic plasticity. *Curr Opin Neurobiol* 14:318–327
4. Katz B (1969) The release of neural transmitter substances. The Sherrington Lectures X. Charles C. Thomas, Springfield, IL
5. Kolodziej SJ, Hudmon A, Waxman MN, Stoops JK (2000) Three-dimensional reconstructions of calcium/calmodulin-dependent (CaM) kinase II $\alpha$  and truncated CaM kinase II $\alpha$  reveal a unique organization for its structural core and functional domains. *J Biol Chem* 275:14356–14359
6. Augustine GJ, Santamaria R, Tanaka K (2003) Local calcium signaling in neurons. *Neuron* 40:331–346
7. Fernandez I, Araç D, Ubach J, Gerber SH, Shin O-H, Gao Y, Anderson RGW, Südhof TC, Rizo J (2001) Three-dimensional structure of the synaptotagmin 1 C<sub>2</sub>B-domain: synaptotagmin 1 as a phospholipid binding machine. *Neuron* 32:1057–1069
8. Petersen JD, Chen X, Vinade L, Dosemeci A, Lisman JE, Reese TS (2003) Distribution of postsynaptic density (PSD)-95 and Ca<sup>2+</sup>/calmodulin-dependent protein kinase II at the PSD. *J Neurosci* 23:11270–11278
9. Hayashi Y, Shi S-H, Esteban JA, Piccini A, Poncer J-C, Malinow R (2000) Driving AMPA receptors into synapses by LTP and CaMKII: requirement for GluR1 and PDZ domain interaction. *Science* 287:2262–2267
10. Silva AJ, Paylor R, Wehner JM, Tonegawa S (1992) Impaired spatial learning in  $\alpha$ -calcium-calmodulin kinase II mutant mice. *Science* 257:206–211

## Calcium/Calmodulin-dependent Protein Kinase II in Neurons

MADO LEMIEUX, PAUL DE KONINCK  
 Department of Biochemistry and Microbiology, Laval University, Centre de recherche Université Laval  
 Robert-Giffard, Quebec, QC, Canada

### Synonyms

CaM kinase II; CaMKII

### Definition

Calcium(Ca<sup>2+</sup>)/calmodulin-dependent protein kinase II, or CaMKII, is a multifunctional serine-threonine kinase highly abundant in the brain (1–2% of all proteins). The enzyme is activated by the binding of the complex Ca<sup>2+</sup>-calmodulin (CaM). The hallmarks of CaMKII are its unique structural and regulatory properties, which endow the enzyme with the ability to decode the spatial and temporal patterns of Ca<sup>2+</sup> signals. As such, the enzyme is well equipped to control multiple functions in nerve cells via the ubiquitous Ca<sup>2+</sup> signaling systems. CaMKII is particularly abundant in the post-synaptic density (PSD), accounting for its

important role in synaptic plasticity and some forms of learning and memory. This essay is an overview of the structure and regulation of CaMKII followed by some examples of how the unique features of the enzyme support its ability to serve as a major decoder of neuronal activity. Finally, a particular focus is made on the important role of CaMKII in regulating glutamatergic synapses of the hippocampus, because, synaptic plasticity and the implication of CaMKII have been extensively studied in this brain region.

### Characteristics

#### Structure and Regulation of CaMKII

The CaMKII family is encoded by four different genes  $\alpha$ ,  $\beta$ ,  $\delta$  and  $\gamma$ , from which at least 28 isoforms can be derived. The gene encodes for three principal domains in the protein: catalytic, autoinhibitory and association domains. In the brain, the  $\alpha$  and  $\beta$  genes are predominantly expressed. In the cell, the enzyme is not expressed as a single protein, but rather as a homo- or heteromeric complex (holoenzyme) of 12 subunits. The 12 catalytic and regulatory domains form 2 hexameric rings on each side of a central core comprising 12 association domains (Fig. 1).

The catalytic domain is not only responsible for substrate phosphorylation, it also supports the binding of the enzyme to various proteins. Under basal conditions, the autoinhibitory domain keeps its counterpart catalytic domain inactive [1–3]. The structure of both the catalytic and regulatory domains of CaMKII, in its autoinhibited conformation, has been recently determined by crystallography, revealing that the regulatory segments of two subunits form a dimeric structure that blocks ATP and substrate binding to the catalytic domain [3]. Following a rise in intracellular Ca<sup>2+</sup>, Ca<sup>2+</sup>-bound CaM (Ca<sup>2+</sup>/CaM) molecules bind to the autoinhibitory domain of individual kinase subunits thereby activating them by relieving their inhibition.

#### CaMKII as a Molecular Memory

CaMKII activity is regulated by Ca<sup>2+</sup>/CaM binding, but also by phosphorylation. Binding of Ca<sup>2+</sup>/CaM not only activates each kinase subunit, but also exposes an important amino acid for their regulation: Thr286 (for  $\alpha$  isoforms, Thr287 for  $\beta$  isoforms). This amino acid on one subunit can be phosphorylated by a neighboring catalytic domain from another subunit in the holoenzyme, a process termed autophosphorylation. Autophosphorylation at Thr286, residing in the autoinhibitory domain, switches the kinase subunit to an autonomous, Ca<sup>2+</sup>-independent state. Thus, once Ca<sup>2+</sup> levels in the cell have returned to baseline, the phosphorylated subunits remain active despite the eventual dissociation of Ca<sup>2+</sup>/CaM, which itself is also slowed down 10,000 fold. As such, Thr286 phosphorylation is considered a biochemical memory of a previous rise in Ca<sup>2+</sup>.

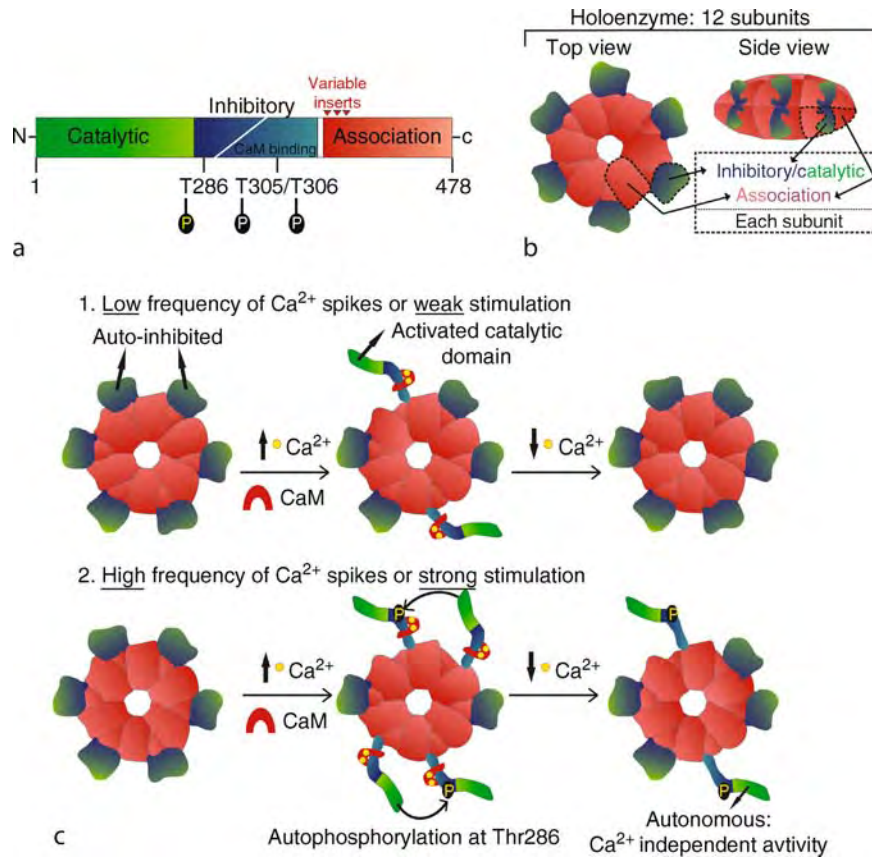

### Calcium/Calmodulin-Dependent Protein Kinase II in Neurons. Figure 1 Structure of CaMKII.

(a) Primary structure of CaMKII domains. (b) Model structure of CaMKII dodecamer. (c) Model of CaMKII activation by  $\text{Ca}^{2+}$  spikes [1,3].

Following Thr286 phosphorylation and  $\text{Ca}^{2+}$ /CaM dissociation, a second autophosphorylation can occur at Thr305/306, located in the  $\text{Ca}^{2+}$ /CaM binding domain. But in opposition to Thr286, this phosphorylation blocks subsequent  $\text{Ca}^{2+}$ /CaM binding, preventing those subunits from being activated [1,2]. Thus, phosphorylation allows for a bi-directional control of CaMKII activity.

In addition to activating CaMKII,  $\text{Ca}^{2+}$ /CaM binding and phosphorylation at Thr286 expose binding sites on the enzyme for interactions with other proteins. One example of such activity-dependent interactions at synapses is with the N-Methyl-D-Aspartate (NMDA) receptor, particularly the NR2B subunit. The binding of NR2B to activated CaMKII also leads to a similar form of biochemical memory because it prevents the autoinhibitory domain from flipping back on the catalytic region, thereby leading to autonomous activity of CaMKII [4]. The interesting distinction for this form of CaMKII autonomy, in comparison to the classical autophosphorylation-dependent autonomy, is that it cannot be reversed by phosphatase activity.

Furthermore, this binding interaction between CaMKII and NR2B can switch to a persistent mode after a strong  $\text{Ca}^{2+}$ /CaM activation [4,5], providing a long-lasting form of molecular memory that is ideally suited to sustain ongoing changes in synaptic biochemistry.

#### CaMKII as a Decoder of Calcium Oscillations

The rules governing Thr286 phosphorylation of individual subunits within CaMKII dodecamers make the enzyme capable of decoding the number and frequency of  $\text{Ca}^{2+}$  spikes. The Thr286 phosphorylation reaction can occur only between two neighboring subunits that have been coincidentally activated by  $\text{Ca}^{2+}$ /CaM binding (Fig. 1c). If exposed to brief  $\text{Ca}^{2+}$  spikes, as seen at excitatory synapses, the dual binding of  $\text{Ca}^{2+}$ /CaM to neighboring subunits has a low probability. Upon repetitive spikes, the probability of coincident binding of  $\text{Ca}^{2+}$ /CaM increases, but only if the spike intervals are sufficiently brief to favor accumulation of bound  $\text{Ca}^{2+}$ /CaM on the holoenzyme. Thus, above a steep threshold frequency of  $\text{Ca}^{2+}$



oscillations, the number of phosphorylated subunits per holoenzyme increases over time. The differential accumulation of phosphorylated – or autonomous – subunits in a CaMKII dodecamer encodes the number and frequency of  $\text{Ca}^{2+}$  oscillations. The initial fraction of autophosphorylated subunits in CaMKII, the amplitude and duration of individual  $\text{Ca}^{2+}$  spikes and the affinity of different CaMKII subtypes for CaM have all been shown to modulate the frequency response of the enzyme [6]. These remarkable features should allow the enzyme to decode the temporal patterns of neuronal activity.

### Spatiotemporal Regulation of CaMKII

Specificity in signaling is also achieved by controlling the subcellular location of molecules. The subcellular localization of CaMKII is highly regulated by  $\text{Ca}^{2+}$ .

Thus, in response to synaptic or electrical activities, the enzyme translocates rapidly to various neuronal compartments, where it can act on diverse functions. (Fig. 2).

Different subunits, such as  $\alpha$  and  $\beta$ , bind to common as well as different targets. These subunits can co-assemble in various ratios within dodecamers, allowing the enzyme to be recruited to an increased number of sites in the cell [1,7]. Among the multiple sites that CaMKII can probably translocate to, only a few have been characterized, as described below.

*Nucleus:* Because of its large multimeric structure, CaMKII cannot enter the nucleus by passive diffusion. However, the kinase has been detected by immunocytochemistry in the nucleus of a variety of cell types. The enzyme thus needs a nuclear localization signal (NLS) or a binding partner that contains one to enter the nucleus. In the brain, only the splice variant  $\alpha_B$ -CaMKII

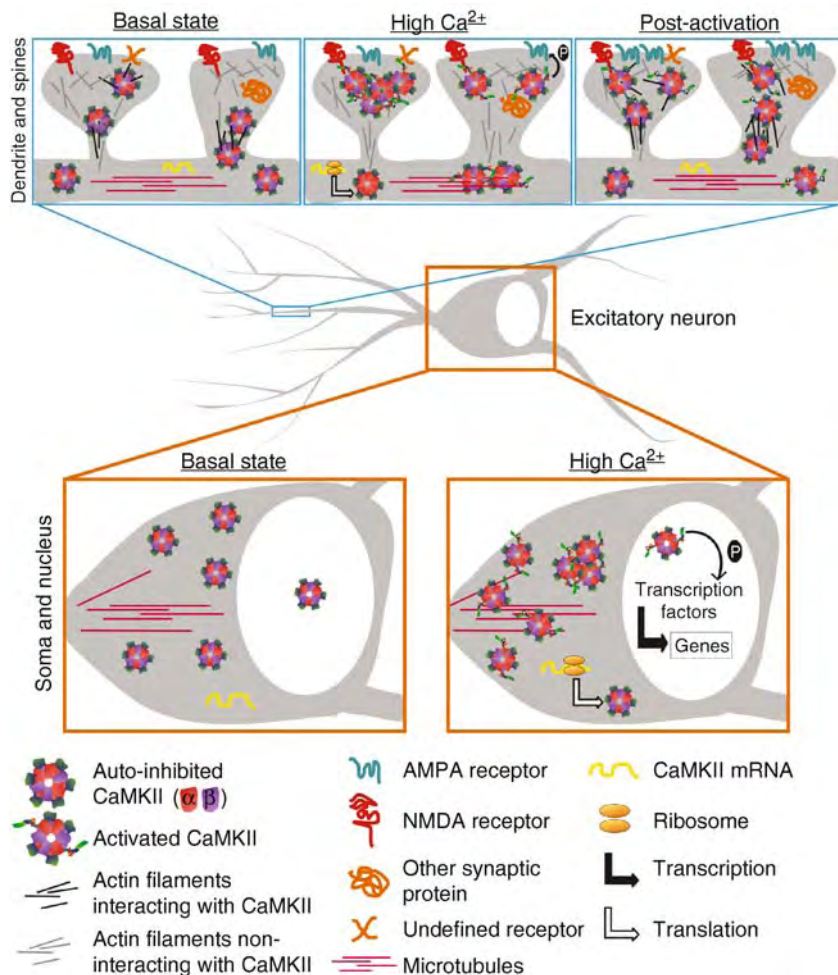

**Calcium/Calmodulin-Dependent Protein Kinase II in Neurons. Figure 2** Multiple sites of CaMKII targeting and activity-dependent translocation in neurons.

contains a functional NLS. But  $\alpha$ KAP, a CaMKII anchoring protein that is derived from the  $\alpha$  gene, also contains an NLS.  $\alpha$ KAP lacks the catalytic and regulatory domains but contains the association domain. It can thus form holoenzymes with other CaMKII isoforms and can target them to the nucleus. Indeed, only 1 or 2 subunits per holoenzyme are necessary for nuclear translocation of the dodecamer. Functionality of the NLS is also regulated by phosphorylation. For example, autophosphorylation at Thr286 affects its nuclear translocation [1,7].

**Membranes:**  $\alpha$ KAP contains an N-terminal hydrophobic sequence instead of the standard N-terminal kinase domain. This can support the recruitment of the enzyme to intracellular membranes, like to the sarcoplasmic reticulum in skeletal muscle [7].

**Cytoskeleton:** In their non-activated state,  $\beta$ -CaMKII binds to  $\blacktriangleright$ F-actin whereas  $\alpha$ -CaMKII is predominantly cytosolic. Following activation,  $\beta$ -CaMKII unbinds actin and both subunits can bind to other cytoskeletal components, like  $\blacktriangleright$ microtubules. Microtubule-associated proteins, such as Tau, MAP2 and MAP6 are major substrates for CaMKII [1,2].

**Synapses:** CaMKII can translocate to postsynaptic sites during neuronal activity, where the kinase can also bind to several synaptic proteins. Its multivalent structure should in fact allow CaMKII to simultaneously bind several partners (Fig. 2). This is particularly relevant in the PSD, where proteins are tightly packed (hence the electron-dense nature) and where CaMKII is particularly abundant. One major activity-dependent binding target of CaMKII at synapses is the NMDA receptor, as described above. This interaction is of particular interest because it can be made persistent above a certain activation threshold, and may lock the enzyme at stimulated synapses [5].

In addition, the  $\blacktriangleright$ messenger RNA (mRNA) of  $\alpha$ -, but not  $\beta$ -CaMKII, is transported in dendrites in an activity-dependent manner, where local translation can occur. This enables a rapid and localized delivery of CaMKII proteins to synapses [8]. At presynaptic sites, CaMKII is associated with synaptic vesicles and can bind and phosphorylate  $\blacktriangleright$ synapsin I [2].

**Intracellular clustering:** During ischemia, or during strong stimulation at synapses, CaMKII holoenzymes bind to each other. This process called self-association forms supramolecular aggregates of holoenzymes. Those inter-holoenzyme interactions, which are formed via catalytic and autoinhibitory domains, need activation of the kinase by  $\text{Ca}^{2+}$ /CaM and are regulated by intracellular pH, ATP concentration and autophosphorylation. Aggregates of CaMKII have been observed in vitro as well as in intact cells, both at synaptic and extrasynaptic sites [1,9]. This process could favor additional recruitment of CaMKII at

strongly stimulated synapses and might support the formation of post-synaptic scaffolds embedded with multiple CaMKII and binding partners.

### CaMKII and Neuronal Function

CaMKII is implicated in various cellular functions, including the regulation of carbohydrate metabolism, membrane current,  $\blacktriangleright$ neurotransmitter synthesis and release, cytoskeletal organization, intracellular  $\text{Ca}^{2+}$  homeostasis,  $\blacktriangleright$ transcription, synaptic plasticity and some forms of memory [1]. Here, we will focus on CaMKII implications in gene regulation and synaptic plasticity.

### CaMKII and Gene Regulation

During neuronal activity,  $\text{Ca}^{2+}$  levels increase in the cytosol, but also in the nucleus. The ability of some isoforms of CaMKII to target the nucleus suggests that the enzyme is involved in regulating gene expression. CaMKII can phosphorylate  $\blacktriangleright$ transcription factors, like CREB, ATF-1 and NeuroD, and is known to regulate the transcription of the immediate-early gene *c-fos*. To date however, most evidence showing that CaMKII regulates gene expression comes from studies in non-neuronal systems. For example, the first experimental evidence that nuclear localization of CaMKII was required for transcriptional regulation was shown for the gene coding for atrial natriuretic factor in heart tissue [1,7,8].

### CaMKII and Synaptic Plasticity; Learning and Memory

CaMKII has attracted the attention of neuroscientists in particular because of its role in synaptic plasticity, learning and memory. Studies have been done mostly in the hippocampus, but results from other regions also support the role of CaMKII in synaptic plasticity. Long-term potentiation (LTP) of synaptic transmission is a type of synaptic plasticity that is thought to underlie some forms of learning and memory. Several results indicate that CaMKII, activated by the rise in  $\text{Ca}^{2+}$  that accompanies the high-frequency stimulation required to induce LTP, initiates a biochemical cascade that potentiates synaptic transmission. Indeed, after the induction of LTP, autonomous activity of CaMKII increases. Peptide inhibitors blocking both  $\text{Ca}^{2+}$ -dependent and -independent activity of CaMKII prevented LTP induction by different protocols. But because of the possible lack of specificity of these inhibitors, the essential role of CaMKII in LTP was only confirmed after the observation of an impaired synaptic potentiation in  $\alpha$ CaMKII knockout mice and in mice that express a mutant CaMKII that cannot autophosphorylate at Thr286. Those mice also show deficits in both learning and memory. For instance, preventing CaMKII autophosphorylation was shown to interfere with experience-dependent plasticity, such as spatial

learning. Local translation of  $\alpha$ CaMKII in dendrites is also important for synaptic plasticity because disrupting the transport of its mRNA impairs LTP and some types of memory. Conversely, instead of inhibiting or removing CaMKII, introducing activated CaMKII in neurons of hippocampal slices can induce LTP [8,10].

How does CaMKII regulate synaptic transmission? Many mechanisms have been examined, but one good example is its effects on **AMPA receptors**. CaMKII phosphorylates these synaptic receptors, thereby enhancing their conductance, and also leads to the addition of new AMPA receptors into synapses. Both effects contribute to strengthening the synapse [8,10]. But in addition to its signaling effects, CaMKII seems to play a structural role in synaptic plasticity. A recent study demonstrated that  $\beta$ -CaMKII, but not  $\alpha$ , was capable of bundling F-actin, independently of its kinase activity. This bundling stabilizes the architecture of dendritic spines and might support dendritic spine remodeling that accompany synaptic plasticity.

### Summary

CaMKII is a multifunctional kinase highly abundant in the brain and critically involved in the regulation of several functions in neurons. Its unusual structural and regulatory properties support its multiple functions by enabling the enzyme to decode specific patterns of  $\text{Ca}^{2+}$  signals in time and in space, for brief and long-lasting effects. Since the discovery of CaMKII by Howard Schulman and colleagues three decades ago, many studies have unraveled some of its functions and mechanisms of action, but many aspects are still unresolved. Nevertheless, what we have learned so far about this enzyme has contributed to a better understanding of how signaling in cells can be achieved with specificity, multiplicity, efficiency, and persistence.

### References

- Hudmon A, Schulman H (2002) Neuronal  $\text{Ca}^{2+}$ /calmodulin-dependent protein kinase II: the role of structure and autoregulation in cellular function. *Annu Rev Biochem* 71:473–510
- Hanson PI, Schulman H (1992) Neuronal  $\text{Ca}^{2+}$ /calmodulin-dependent protein kinases. *Annu Rev Biochem* 61:559–601
- Rosenberg OS, Deindl S, Sung RJ, Nairn AC, Kuriyan J (2005) Structure of the autoinhibited kinase domain of CaMKII and SAXS analysis of the holoenzyme. *Cell* 123:849–860
- Bayer KU, De Koninck P, Leonard AS, Hell JW, Schulman H (2001) Interaction with the NMDA receptor locks CaMKII in an active conformation. *Nature* 411:801–805
- Bayer KU, LeBel E, McDonald GL, O’Leary H, Schulman H, De Koninck P (2006) Transition from reversible to persistent binding of CaMKII to postsynaptic sites and NR2B. *J Neurosci* 26:1164–1174
- De Koninck P, Schulman H (1998) Sensitivity of CaM kinase II to the frequency of  $\text{Ca}^{2+}$  oscillations. *Science* 279:227–230
- Bayer KU, Schulman H (2001) Regulation of signal transduction by protein targeting: the case for CaMKII. *Biochem Biophys Res Commun* 289:917–923
- Colbran RJ, Brown AM (2004) Calcium/calmodulin-dependent protein kinase II and synaptic plasticity. *Curr Opin Neurobiol* 14:318–327
- Hudmon A, Lebel E, Roy H, Sik A, Schulman H, Waxham MN, De Koninck P (2005) A mechanism for  $\text{Ca}^{2+}$ /calmodulin-dependent protein kinase II clustering at synaptic and nonsynaptic sites based on self-association. *J Neurosci* 25:6971–6983
- Lisman J, Schulman H, Cline H (2002) The molecular basis of CaMKII function in synaptic and behavioural memory. *Nat Rev Neurosci* 3:175–190

---

## Calcium Channel Blocker

### Definition

A family of clinically used compounds that block the L-type Cav1.2 calcium channel and relaxes smooth muscle.

---

## Calcium Channelopathies

### Definition

One type of ion **channelopathies** leading to neurological disorders in vertebrates including humans. Since rises in intracellular  $\text{Ca}^{2+}$  concentration  $[\text{Ca}^{2+}]_i$  regulate or initiate a plethora of intracellular events including metabolic processes, secretion of **neurotransmitters** and hormones, muscle contraction, cell differentiation and gene expression, and since these  $[\text{Ca}^{2+}]_i$  rises are largely generated by influx into the intracellular medium via **voltage-gated L-type  $\text{Ca}^{2+}$  channels**, genetic dysfunctions of these channels cause multifarious neurological diseases, including **hypokalemic periodic paralysis** (loss of muscle strength), failures in muscle **excitation-contraction coupling**, **migraine**, **ataxia**, congenital stationary night blindness, or malignant hyperthermic sensitivity.

- ▶ Ataxia
- ▶ Hypokalemic Periodic Paralysis
- ▶ Migraine

## Calcium Channels – An Overview

EMILIO CARBONE

Department of Neuroscience, NIS Center of Excellence, CNISM Research Unit, Torino, Italy

### Definition

▶ Voltage-gated  $\text{Ca}^{2+}$  channels are integral membrane proteins forming aqueous pores which open in response to cell depolarization.  $\text{Ca}^{2+}$  channels play a key role in controlling vital functions: they shape the ▶ action potential and membrane electrical oscillations and act as gate-controller of  $\text{Ca}^{2+}$ , the most ubiquitous ▶ second messenger [1]. As such,  $\text{Ca}^{2+}$  channels are implicated in cardiac, skeletal and smooth ▶ muscle contraction (▶ excitation-contraction coupling), ▶ hormone and neurotransmitter release (▶ excitation-secretion coupling) and  $\text{Ca}^{2+}$ -dependent processes that modulate short- and long-term cell activity and gene expression (▶ excitation-transcription coupling) [2–5].

### Characteristics

$\text{Ca}^{2+}$  channels have been grouped into two main classes, based on their threshold of activation: the ▶ high voltage-activated (HVA) channels and the ▶ low voltage-activated (LVA) channels [4]; although this classification could not be strictly applied since some of the HVA channels activate at significantly low voltages [2]. LVA channels activate “▶ transiently” during small depolarizations near ▶ resting membrane potentials (→ ▶ Membrane potential – basics) and are therefore commonly indicated as T-type channels. T-type channels are responsible for ▶ low-threshold spikes, oscillatory cell activity, muscle contraction, hormone release, cell growth, differentiation and proliferation [5]. The HVA channels require larger membrane depolarizations to open and are further subdivided into four types (▶ L-, N-, P/Q- and R-type  $\text{Ca}^{2+}$  channels) based on their structural, pharmacological and biophysical characteristics [2,3]. They are responsible for the sustained depolarizing phase of action potentials, muscle contraction, hormone and neurotransmitter release, gene expression and cell differentiation.

### Molecular Structure

The principal pore-forming subunit of both LVA and HVA channels is the  $\alpha_1$ -subunit, a high-molecular weight protein (190–250 kDa), which is structurally similar to the ▶  $\text{Na}^+$  channel  $\alpha$ -subunit [1]. It is formed by four domains (I–IV) linked together in a single polypeptide chain and each domain contains six putative transmembrane segments (S1–S6), plus a loop (P) that dips partially into the pore to form the pore-lining region (Fig. 1). The cytoplasmic loops

linking the four domains are structurally important for their interactions with  $\beta$ -subunits, second messengers, membrane binding proteins and channel ▶ gating.

Molecular cloning of  $\text{Ca}^{2+}$  channels has provided evidence for the existence of ten different pore-forming  $\alpha_1$  subunits with pharmacological and biophysical profiles similar to the endogenous  $\text{Ca}^{2+}$  channels expressed in most tissues. Alignment of their amino acid sequences suggests strong homologies and divergences between the various  $\text{Ca}^{2+}$  channel types (Fig. 2). Strong homologies exist between the four L-types (Cav1), the N-, P/Q- and R-type ( $\text{Ca}_v2$ ), and the three T-type ( $\text{Ca}_v3$ ) channels, while large divergences exist between the HVA and LVA subfamilies. Figure 2 reports the  $\text{Ca}^{2+}$  channel classifications most used in the literature [2,3].

At variance with the T-type channels, whose  $\alpha_1$ -subunit is sufficient to warrant ▶ activation and ▶ inactivation gating, channel expression and membrane incorporation, the HVA channels are heteromultimeric protein complexes which comprise the  $\alpha_1$ -subunit in association with auxiliary  $\beta$ ,  $\alpha_2\text{-}\delta$  and  $\gamma$ -subunits (Fig. 3). Coexpression of  $\alpha_2\text{-}\delta$  with the  $\alpha_1$ -subunit ensures proper  $\text{Ca}^{2+}$  current kinetics and current densities. The same occurs with the co-expression of  $\beta$  and  $\alpha_1$ -subunits. Still vague is the role of  $\gamma$ -subunits ( $\gamma_1$  to  $\gamma_8$ ) which consist of four transmembrane domains and whose site of interaction with the  $\alpha_1$ -subunit is still unknown. The  $\alpha_2\text{-}\delta$ -subunit is formed by a membrane-spanning  $\delta$ -peptide (27 kDa) and an extracellular  $\alpha_2$ -peptide (143 kDa) bound together by a disulfide bridge (Fig. 1). Presently, four genes encoding for different  $\alpha_2\text{-}\delta$ -subunits ( $\alpha_2\text{-}\delta_1$  to  $\alpha_2\text{-}\delta_4$ ) have been identified with several additional splice variants. The up-regulation of the  $\alpha_2\text{-}\delta$  gene appears to correlate with the onset of ▶ allodynia (non-noxious stimuli eliciting pain) and ligands that target the  $\alpha_2\text{-}\delta$ -subunit, the gabapentins, are used for treatment of neuropathic pain. The four  $\beta$ -subunits ( $\beta_1$  to  $\beta_4$ ) and their splice variants so far identified are almost exclusively cytosolic. They possess a hydrophobic region containing SH3 and guanylate kinase domains, indicating that they belong to the membrane-associated guanylate kinase (MAGUK) family and as such may integrate multiple signaling pathways near the channel. The  $\beta$ -subunit has high-affinity for a conserved region within the domain I-II region of N- and PQ-type channels, termed the *alpha interaction domain* (AID).

### Activation-Inactivation Gating

As for other voltage-gated ion channels, the probability of  $\text{Ca}^{2+}$  channels opening is strictly voltage-dependent, i.e., the switch from a closed (non-conductive) to an open (conductive) configuration is strictly dependent on voltage, usually requiring 4–8 mV to change e-fold the probability of channel opening [6]. Structure-function

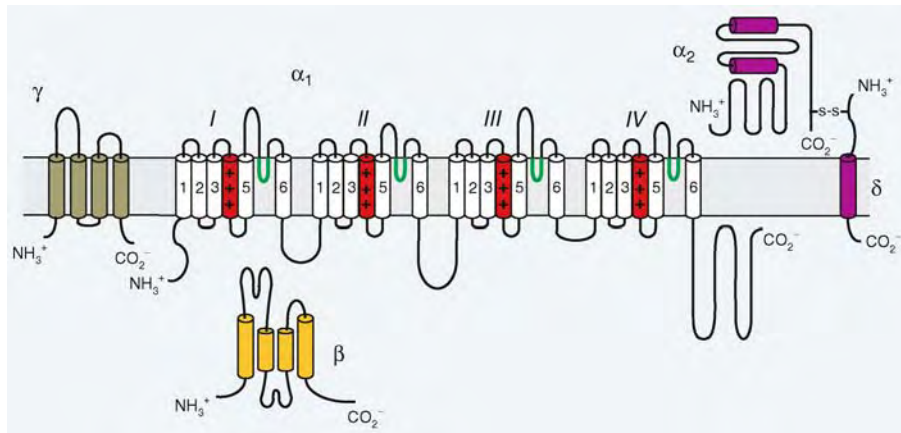

**Calcium Channels – An Overview. Figure 1** Subunit structure of voltage-gated  $\text{Ca}^{2+}$  channels: transmembrane topology of the  $\alpha_1$  and associated auxiliary subunits ( $\beta$ ,  $\alpha_2$ - $\delta$ ,  $\gamma$ ). Predicted  $\alpha$ -helices are depicted as cylinders. For the  $\alpha_1$ -subunit the transmembrane spanning  $\alpha$ -helices (1 to 6) are repeated in the four domains (I to IV). Red cylinders indicate the positively charged S4 segments (voltage sensors), and the thick green lines denote the pore loops (P) that line the permeation pathway for  $\text{Ca}^{2+}$ . The lengths of lines are not intended to represent the exact lengths of the polypeptide segments indicated. The same is for the size of various subunits. Adapted and redrawn from ref [2].

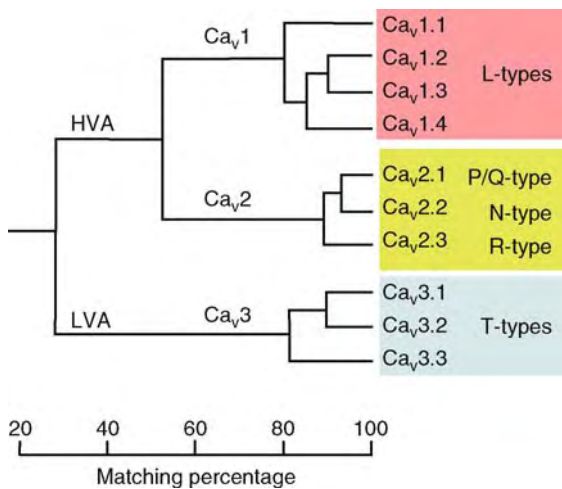

### Calcium Channels – An Overview.

**Figure 2** Phylogenetic tree of voltage-gated  $\text{Ca}^{2+}$  channels, showing the percentage of identity between the different cloned  $\text{Ca}^{2+}$  channels [5]. The first bifurcation occurs between HVA and LVA channels. The HVA family includes four genes encoding the L-type channels ( $\text{Ca}_v1.1$ – $\text{Ca}_v1.4$ ) and three genes encoding the P/Q ( $\text{Ca}_v2.1$ ), N- ( $\text{Ca}_v2.2$ ) and R-type ( $\text{Ca}_v2.3$ ) channels. The LVA family includes three genes encoding the  $\text{Ca}_v3.1$ – $\text{Ca}_v3.3$  channels. Adapted and redrawn from ref [5].

studies have associated this property to the presence of positively charged lysine and arginine residues distributed in the S4 transmembrane segment of each domain, which form the “▶voltage sensor” (Fig. 1). However, the exact location of the activation gates that

regulate the open and closed states of the pore remains unknown.

During maintained depolarization,  $\text{Ca}^{2+}$  channels tend to inactivate, but the speed and extent of channel inactivation may vary dramatically. In general,  $\text{Ca}^{2+}$  channels inactivate by either  $\text{Ca}^{2+}$ - or voltage-dependent mechanisms.  $\text{Ca}^{2+}$ -dependent inactivation is dominant for the cardiac  $\text{Ca}_v1.2$  L-type channel, but may also occur for other HVA channels. ▶ $\text{Ca}^{2+}$ -dependent inactivation is a ▶calmodulin-dependent process, involving sites on the C-terminal domain of the  $\alpha_1$ -subunit. Voltage-dependent inactivation is a general term for inactivation that does not clearly depend on  $\text{Ca}^{2+}$ . ▶T-type  $\text{Ca}^{2+}$  channels tend to inactivate rapidly and almost completely, while inactivation of HVA channels is usually slow and incomplete. Spontaneous switch between inactivating and non-inactivating modes have been observed in single N-type channels, perhaps reflecting modulation by some intracellular signaling process. However, how  $\text{Ca}^{2+}$ -binding or membrane voltage affect the inactivation gate is still widely unknown [6].

### Channel Permeability

The present view of  $\text{Ca}^{2+}$  channel permeability is based on the existence of an intrapore binding site controlling both ion selectivity and channel block: the ▶selectivity filter. This highly specialized region of  $\text{Ca}^{2+}$  channels consists of a ring of four negative charged groups inside the pore. In HVA channels, each of the four P loops contains a glutamate forming the EEEE locus, in T-type channels two glutamates are substituted by two aspartates in the corresponding position (EEDD locus). The spatial arrangement of the four negative charges

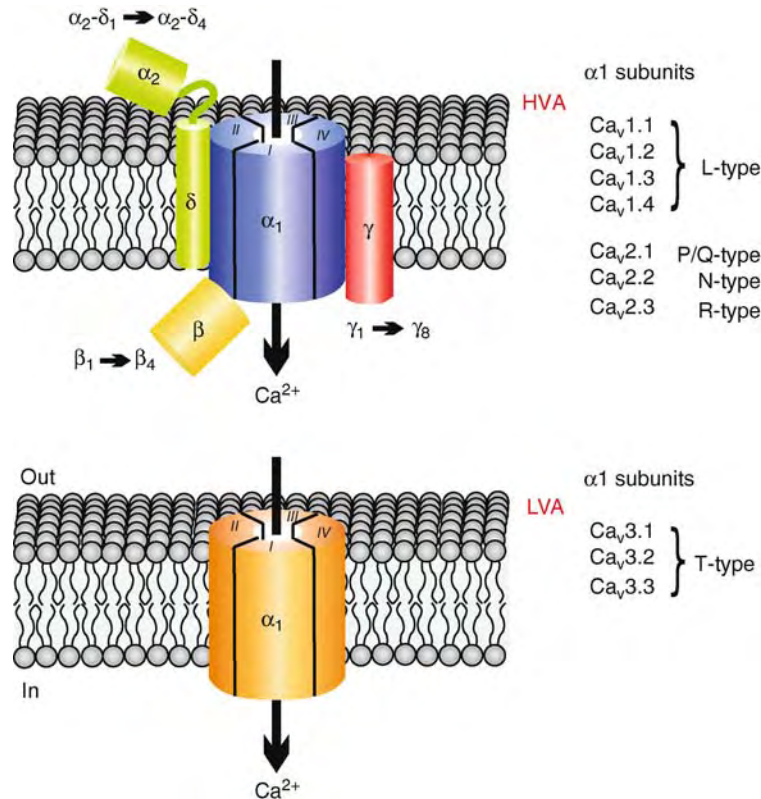

**Calcium Channels – An Overview. Figure 3** Schematic representation of the voltage-gated  $\text{Ca}^{2+}$  channel complex. On top is represented the heteromeric structure of the HVA  $\text{Ca}^{2+}$  channel, consisting of the pore forming  $\alpha_1$ -subunit (with the four domains I to IV) plus the  $\beta$ ,  $\gamma$  and  $\alpha_2\text{-}\delta$  auxiliary/regulatory subunits. To the bottom is represented the LVA  $\text{Ca}^{2+}$  channel consisting only of the pore forming  $\alpha_1$ -subunit. To the right are listed the different  $\alpha_1$ -subunits that correspond to different  $\text{Ca}^{2+}$  channel isoforms. Adapted and redrawn from ref [3].

in the P loops is postulated to closely coordinate two  $\text{Ca}^{2+}$  ions whose sequential entrance and subsequent interaction induce high  $\text{Ca}^{2+}$  fluxes while preserving high affinity for the pore-site [7]. Although this simple ion-ion interaction would explain the dual nature of  $\text{Ca}^{2+}$  as permeant ions at millimolar concentrations and as blockers of  $\text{Na}^+$  currents at micromolar concentrations, the complete understanding of  $\text{Ca}^{2+}$  channel permeability is likely to require a further hypothesis of ion-pore structure interactions. The recent availability of T-type channel clones [5] has allowed closer comparisons between LVA and HVA channel permeability properties, highlighting the role that the EEEE or EEDD locus play in the regulation of ion selectivity in the two channel groups.  $\text{Ca}_v3.1$  T-type channels have apparently a narrower pore size (5.1 Å diameter) compared to the  $\text{Ca}_v1.2$  L-type pore size (6.2 Å diameter) [7]. This structural difference may explain the different  $\text{Ca}^{2+}/\text{Ba}^{2+}$  selectivity and blocking action of  $\text{Cd}^{2+}$  and  $\text{Ni}^{2+}$  of the two channel families (LVA and HVA): the L-, N- and P/Q-type channels being more permeable to  $\text{Ba}^{2+}$  than  $\text{Ca}^{2+}$  and more sensitive to the block by  $\text{Cd}^{2+}$  and the T-type

channels being equally permeable to  $\text{Ca}^{2+}$  and  $\text{Ba}^{2+}$  and more sensitive to the block by  $\text{Ni}^{2+}$  (Table 1).

### Physiology, Pharmacology and Channelopathies

In the following paragraphs are described the tissue and cellular location, physiological role, pharmacology and related **channelopathies** associated to each  $\text{Ca}^{2+}$  channel type as summarized in Table 1.

L-type channels ( $\text{Ca}_v1$ ). L-type channels are widely expressed in many tissues and control a number of  $\text{Ca}^{2+}$ -dependent responses in excitable cells. In central neurons they are preferentially located on proximal dendrites and cell bodies and are involved in postsynaptic integration, neuronal plasticity, gene transcription and mood behavior. In sensory neurons (**cochlear hair cells and photoreceptors**), they directly control neurotransmitter release and sensory perception. The L-type family includes four  $\alpha_1$ -subunits ( $\text{Ca}_v1.1$  to  $\text{Ca}_v1.4$ ) with different structure-function characteristics but common blockers: **1,4-dihydropyridines (DHPs)**, **phenylalkylamines** and **benzothiazepines**. With the exception of  $\text{Ca}_v1.3$  and  $\text{Ca}_v1.4$ , which activate at

**Calcium Channels – An Overview. Table 1** Selective and often used blockers, distribution and established channelopathies [10] of the various voltage-gated  $\text{Ca}^{2+}$  channels

Channel	Blockers		Distribution	Channelopathies		
	Selective	Unselective (often used)		Gene	Diseases	
L	Ca <sub>v</sub> 1.1	Dihydropyridines, phenylalkylamines, benzothiazepines	Cd <sup>2+</sup>	Skeletal muscles, transverse tubule	CACNA1S	Hypokalemic periodic paralysis & malignant hyperthermia in humans, muscular dysgenesis in mice
	Ca <sub>v</sub> 1.2	Dihydropyridines, phenylalkylamines, benzothiazepines	Cd <sup>2+</sup>	Cardiac & smooth muscle myocytes; endocrine cells, neuronal cell bodies & dendrites	CACNA1C	Timothy syndrome
	Ca <sub>v</sub> 1.3	Dihydropyridines, phenylalkylamines, benzothiazepines	Cd <sup>2+</sup>	Endocrine cells; neuronal cell bodies & dendrites, atrial myocytes & pacemaker cells, cochlear hair cells	CACNA1D	Deafness, sinoatrial & atrioventricular node dysfunction
	Ca <sub>v</sub> 1.4	Dihydropyridines, phenylalkylamines, benzothiazepines	Cd <sup>2+</sup>	Retinal rod & bipolar cells, spinal cord, adrenal gland, mast cells	CACNA1F	Congenital stationary night blindness type 2, X-linked cone-rod dystrophy type 3
P/Q	Ca <sub>v</sub> 2.1	ω-agatoxin IVA	Cd <sup>2+</sup>	Nerve terminals & dendrites, neuroendocrine cells	CACNA1A	Episodic ataxia type-2, spinocerebellar ataxia type-6, familial hemiplegic migraine
N	Ca <sub>v</sub> 2.2	ω-conotoxin VIA, SNX 111 (ziconotide)	Cd <sup>2+</sup>	Nerve terminals & dendrites, neuroendocrine cells	CACNA1B	
R	Ca <sub>v</sub> 2.3	SNX 482	Cd <sup>2+</sup> , Ni <sup>2+</sup>	Nerve terminals & dendrites, neuroendocrine cells, cardiac myocytes	CACNA1E	
T	Ca <sub>v</sub> 3.1	none	Ni <sup>2+</sup> , mibefradil	Neuronal cell bodies & dendrites, cardiac & smooth muscle myocytes	CACNA1G	
	Ca <sub>v</sub> 3.2	none	Ni <sup>2+</sup> , mibefradil	Neuronal cell bodies & dendrites, cardiac & smooth muscle myocytes, neuroendocrine cells	CACNA1H	Childhood absence epilepsy
	Ca <sub>v</sub> 3.3	none	Ni <sup>2+</sup> , mibefradil	Neuronal cell bodies & dendrites	CACNA1I	

relatively low voltages, the other Ca<sub>v</sub>1 channels activate at voltages much more positive than resting potential. Activation is fast and sharply voltage-dependent while inactivation is relatively slow in the presence of Ba<sup>2+</sup> but speeds-up in the presence of Ca<sup>2+</sup> (▶Ca<sup>2+</sup>-dependent inactivation). Deactivation (giving rise to ▶tail currents) is also fast, ensuring rapid closing of the channels on membrane repolarization to resting levels. L-type channels are distinguished from the other Ca<sub>v</sub> channels by their high sensitivity to DHPs. DHP antagonists (nifedipine, nitrendipine) reversibly block the channels and help quantifying the amount of L-type

channels expressed in a cell, while DHP agonists (Bay K 8644) prolong the open state of the channel, producing slow tail currents near resting potential. As such, DHP agonists allow measuring the ▶single channel activity of high conductance L-type channels in membrane patches, otherwise hardly detectable [8]. L-type channels can be often distinguished from the other Ca<sup>2+</sup> channels for their ▶cAMP/PKA-mediated up-regulation which causes increased mean open times and probability of openings at the single channel level and increased Ca<sup>2+</sup> current amplitude in whole-cell recordings [9]. Neuronal and neuroendocrine L-type

channels can be also inhibited by a fast **▶G-protein coupled receptor (GPCR)** mechanism activated by neurotransmitters which could be at the basis of an **▶autocrine feedback control** of hormone release.

P/Q-type channels (Ca<sub>v</sub>2.1). The Ca<sub>v</sub>2.1 family includes two Ca<sup>2+</sup> channels which are nearly indistinguishable except for their different affinity to a common blocker: the spider venom  $\omega$ -agatoxin IVA. P-type channels are more sensitive to  $\omega$ -agatoxin IVA (K<sub>d</sub> 1–3 nM) than Q-type channels (K<sub>d</sub> 100–200 nM). Ca<sub>v</sub>2.1 channels are widely expressed in neurons but are also available in pancreatic, pituitary and chromaffin cells. Their main physiological function is to control neurotransmitter release in central neurons and mammalian **▶neuromuscular junctions** where they are highly expressed at the presynaptic sites. P/Q-type channels control also the excitation-secretion coupling in pancreatic and chromaffin cells. Ca<sub>v</sub>2.1 channels play a key role in neurotransmitter release due to their high-density of expression at the release sites of central synapses and share most of the modulatory properties of N-type channels described below. Similarly to the N-type channels they bind tightly to the **▶SNARE complex** proteins at the **▶synprint motif** of the II-III linker of the channel. P/Q-type channels are also effectively inhibited by the neurotransmitter activated GPCRs mechanism described below. Missense mutations of P/Q-type channels cause **▶familial hemiplegic migraine (FHM)** associated to an apparent gain of function as a result of an increased probability of channel openings and alteration of synaptic transmission (Table 1).

N-type channels (Ca<sub>v</sub>2.2). Ca<sub>v</sub>2.2 channels are widely expressed in the central and peripheral nervous system and chromaffin cells. They are highly expressed at the nerve terminals, where they control neurotransmitter release, and to a minor degree at the dendritic sites, where they are involved in Ca<sup>2+</sup> signaling. Ca<sub>v</sub>2.2 channels control also hormone release in neuroendocrine cells. The channels activate at relatively high voltages. Maximal activation at positive potentials and deactivation on return to resting levels are both fast. Inactivation is variable but significantly faster than L-type channels and slower than T-type channels. Ca<sub>v</sub>2.2 channels are insensitive to DHPs but are selectively blocked by  $\omega$ -conotoxin GVIA and related cone snail toxins (Table 1).

N-type channels play a key role in neurotransmitter release due to their high-density of expression at the release sites and their tight binding to the SNARE complex of the vesicle release machinery (syntaxin 1A, SNAP-25, VAMP2/synaptobrevin and synaptotagmin). These proteins bind at the synprint motif of the II-III linker of the channel and the tight interaction affects the availability and gating of the channel. The SNARE complex in fact either steadily inactivates the channel or inhibits its activation through a G<sub>βγ</sub> subunit.

Interestingly, N-type channels are effectively modulated by GPCRs activated by neurotransmitters and the mechanism is thought to be at the basis of **▶presynaptic inhibition**. Briefly, an activated G<sub>βγ</sub> subunit binds directly to the pore-forming  $\alpha_1$ -subunit of the N-type channel and shifts the gating mode from “willing” (from which the channel readily opens) to “reluctant” (from which the channel opens less frequently). The **▶modulatory mechanism** is **▶membrane-delimited**, voltage-dependent and causes an increased delay of the channel opening which produces an overall slow activation of the “reluctant” channel. Strong depolarizations opening the channels reduce the affinity of G<sub>βγ</sub> for the  $\alpha_1$ -subunit and the channel recovers its normal gating mode.

R-type channels (Ca<sub>v</sub>2.3). Ca<sub>v</sub>2.3 channels are widely expressed in the central nervous system at the cell bodies, dendrites and presynaptic terminals. They are also expressed in **▶motoneurons**, heart, pituitary and chromaffin cells. The Ca<sub>v</sub>2.3 channel has been originally reported to encode a Ca<sup>2+</sup> channel type with biophysical properties between LVA and HVA channels, or usually as an HVA channel resistant to DHPs,  $\omega$ -toxins and thus called R-type (for “residual”). Ca<sub>v</sub>3 channels are likely to form a family of several channels with fast activation but variable inactivation that could be fast and comparable to the Ca<sub>v</sub>3 types or slow like the Ca<sub>v</sub>1 channels. They are involved in neurotransmitter and hormone release, repetitive firing (→ **▶Action potential**) and **▶long-term potentiation**. The tarantula toxin SNX-482 blocks exogenously expressed Ca<sub>v</sub>2.3 currents but is only partially or not effective on native R-type currents, suggesting that Ca<sub>v</sub>2.3 does not always conduct a significant portion of the R-type current which remains after blocking all the other **▶voltage-gated Ca<sup>2+</sup> channels**. Ca<sub>v</sub>2.3 channels are also sensitive to small doses of Ni<sup>2+</sup>. In some case the Ni<sup>2+</sup> block has K<sub>d</sub> comparable to that of the Ca<sub>v</sub>3.2 T-type channel described below.

T-type channels (Ca<sub>v</sub>3). Ca<sub>v</sub>3 channels (Ca<sub>v</sub>3.1 to Ca<sub>v</sub>3.3) are ubiquitously expressed and sustain key physiological functions which derive from their unique properties [4,5]: (i) they activate and inactivate at unusually negative voltages and are responsible for a window-current near resting potentials, (ii) they exhibit fast and complete inactivation during sustained depolarization and deactivate slowly on repolarization, (iii) they are equally or slightly more permeable to Ca<sup>2+</sup> than Ba<sup>2+</sup> and have small single channel conductance, (iv) they outlast **▶membrane-patch excision** and (v) they are preferentially blocked by low doses of mibefradil and Ni<sup>2+</sup> (particularly the Ca<sub>v</sub>3.2) (Table 1). At present, Ca<sub>v</sub>3 channels are recognized to play a critical role in many physiological functions in which a low-threshold Ca<sup>2+</sup> entry is required to trigger, or sustain, specific cell activities. This is particularly true for the generation of low-threshold spikes, pacemaking activity, hormone



secretion, cell growth and differentiation. T-type channels play also a critical role in several pathologies in which either their recruitment, overexpression, or altered gating cause cardiac hypertrophy, hypertension, heart failure, ►absence epilepsy, ►neurogenic pain, and ►Parkinson's disease. Most recently, T-type channels are shown to control the vesicular release of neurotransmitters in neurons, and very recent data indicate that they are involved in fast ►catecholamine release in adrenal chromaffin cells.

## References

1. Hille B (2001) Ion channels of excitable membranes, 3rd edn. Sinauer, Sunderland, MA
2. Catterall WA, Perez-Reyez E, Snutch TP, Striessnig J (2005) International union of pharmacology. XLVIII. Nomenclature and structure-function relationships of voltage-gated calcium channels. *Pharmacol Rev* 57:411–425
3. Dolphin AC (2006) A short history of voltage-gated calcium channels. *Br J Pharmacol* 147:S56–S62
4. Carbone E, Lux HD (1984) A low voltage-activated, fully inactivating Ca channel in vertebrate sensory neurones. *Nature* 310:501–502
5. Perez-Reyes E (2003) Molecular physiology of low-voltage-activated T-type calcium channels. *Physiol Rev* 83:117–161
6. Jones SW (2003) Calcium channels: unanswered questions. *J Bioenerg Biomembr* 35:461–475
7. Talavera K, Staes M, Janssens A, Klugbauer N, Droogmans G, Hofmann F, Nilius B (2001) Aspartate residues of the Glu-Glu-Asp-Asp (EEDD) pore locus control selectivity and permeation of the T-type  $\text{Ca}^{2+}$  channel  $\alpha_{1G}$ . *J Biol Chem* 276:45628–45635
8. Hess P, Lansman JB, Tsien RW (1984) Different modes of Ca channel gating behaviour favoured by dihydropyridine Ca agonists and antagonists. *Nature* 311:538–544
9. Bean BP, Nowycky MC, Tsien RW (1984)  $\beta$ -adrenergic modulation of calcium channels in frog ventricular heart cells. *Nature* 307:371–375
10. Lorenzon NM, Beam K (2005) Calcium channelopathies. In: Zamponi G (ed) *Voltage-Gated Calcium Channels*. Kluwer Academic, London, UK, pp 240–261

## Calcium Channels: Regulation of Gene Transcription

ADRIANO SENATORE, J. DAVID SPAFFORD  
B1–173, Department of Biology, University  
of Waterloo, Waterloo, ON, Canada

### Synonyms

Excitation-transcription coupling; Voltage-gated calcium channels/ligand-gated calcium channels and control of gene expression; Calcium-regulated nuclear signaling

### Definition

Nerve activity induces  $\text{Ca}^{2+}$  influx through voltage-gated calcium channels (►VGCCs), and activates vital functions such as ►neurotransmitter release (NT) and gene transcription. The latter function is often coupled to permanent changes to the structure of synapses (e.g., ►synaptic plasticity) and the survivability of neurons. Recent research indicate that the specificity of local nuclear signaling pathways depends upon the association of specific channel types to cytosolic  $\text{Ca}^{2+}$ -sensitive factors and not just  $\text{Ca}^{2+}$  influx *per se*. Indeed, it is only the L-type ( $\text{Ca}_v1.2$ ) channels which are critical for the transcriptional regulation of many genes and these contribute only to a fraction of the total  $\text{Ca}^{2+}$  influx during neural activity.  $\text{Ca}^{2+}$  influx by other means, such as the ►N-methyl-D-aspartate receptors (NMDA), also contribute to calcium-dependent gene expression changes and share many but not all of the same nuclear signaling pathways.

### Characteristics

#### Calcium as a Signaling Molecule

The nervous system relies on charged molecules to relay information. Whereas the relatively inert  $\text{Na}^+$  and  $\text{K}^+$  ions serve mostly to establish membrane potential and carry action potentials along excitable membranes,  $\text{Ca}^{2+}$  has properties that allow it to accomplish additional functions. First, it has a unique affinity for binding ligands containing oxygen-donating groups such as carboxyls, carbonyls, ethers, and alcohols. Second,  $\text{Ca}^{2+}$  is kept at low levels within the cytosol since it precipitates organic anions and is toxic to cells at high concentrations. These features likely lead to the exploitation of the calcium ion not only as a charge carrier but also as a signaling molecule.

#### Calcium-regulated Genes

Nerve activity promotes subcellular calcium “hotspots” or microdomains around individual channels, and collectively these active channels contribute to global cellular processes including synaptic plasticity and neuronal survival. An example is long-term memory which involves synaptic connectivity changes activated via ►long term-potential (LTP). Strengthening of synapses induced by LTP requires gene transcription mediated by calcium-sensitive signaling pathways [1]. Furthermore, activity-dependent neuronal survival, which is important during cognitive development, also requires calcium-dependent gene transcription [2].

“First responder” genes are termed ►immediate early genes (IEGs), whose transcription is upregulated without a requirement for newly synthesized proteins. The expression of IEGs is tightly regulated in space and time in active neurons by the summation of nerve inputs and local  $\text{Ca}^{2+}$  flux. ►Brain-Derived Neurotrophic Factor (BDNF) is a classical calcium-activated IEG

that mediates activity-dependent neuronal survival and is required for establishment of LTP (reviewed in [3]). BDNF is a neurotrophin that activates downstream signaling pathways through binding to ▶receptor tyrosine kinase TrkB and low affinity receptor p75 (▶p75 Neurotrophin Receptor) to exert immediate and long term effects on synaptic activity. Not surprisingly, mutations in the BDNF gene have been correlated with neuronal dysfunction including impaired episodic memory [3]. Numerous other genes encoding transcription factors, growth factors, cytoskeletal proteins, and proteins involved in signaling and metabolism have also been classified as IEGs including *c-fos*, *fos B*, *c-jun*, *jun B*, *zif268*, *Egr-3*, *Cox-2*, *Rheb*, *Arc*, *Narp*, *β-actin*, *Homer*, and *nur77*; many have been implicated in aspects of neuronal development and survival, and synaptic plasticity changes [2,4].

### Calcium-mediated Cell Signaling

Calcium signaling depends on a cascade of electrochemical and biochemical events. These include stimulus sensation and opening of a channel or receptor and influx of  $\text{Ca}^{2+}$  into the cytosol, binding of  $\text{Ca}^{2+}$  ions to intracellular ligands, and signaling to terminal effectors.  $\text{Ca}^{2+}$  influx occurs along steep electrochemical gradients across the plasma membrane, through highly-selective channels or receptors including VGCCs and NMDA receptors, or from intracellular stores through

▶ryanodine and ▶inositol 1, 4, 5-triphosphate receptors ( $\text{IP}_3$ ). Cytosolic  $\text{Ca}^{2+}$  is quickly buffered and limited to transient microdomains (▶Calcium Microdomains) surrounding the pores of open channels (Fig. 1c).

Consequently, calcium-sensing signaling molecules must be in close proximity or directly coupled to channels. Voltage-gated L-type channels, which are important for coupling excitation with transcriptional changes in the nucleus, are localized in the proximal dendrites and cell soma where they are positioned to both sense incoming waves of depolarization originating in the dendrites and to signal to the nucleus.

### Calcium-sensitive, Nuclear Signaling Pathways

Calcium/cAMP Response Element Binding protein (▶CREB) is a transcription factor whose activity is implicated in calcium-related signaling events and is activated through phosphorylation of a serine residue (Ser-133). Cytosolic  $\text{Ca}^{2+}$  microdomains trigger CREB phosphorylation via several pathways with distinct temporal kinetics, the most significant of which are the ▶Ras/MAPK pathway and the ▶calcium/calmodulin-dependent kinase pathway (▶CaMK) (reviewed in [3], Fig. 1c). Whereas the CaMK pathway is involved in early phosphorylation of CREB, the Ras/MAPK pathway is required for sustained CREB phosphorylation [5]. Both pathways are critical since a sustained CREB phosphorylation is required for

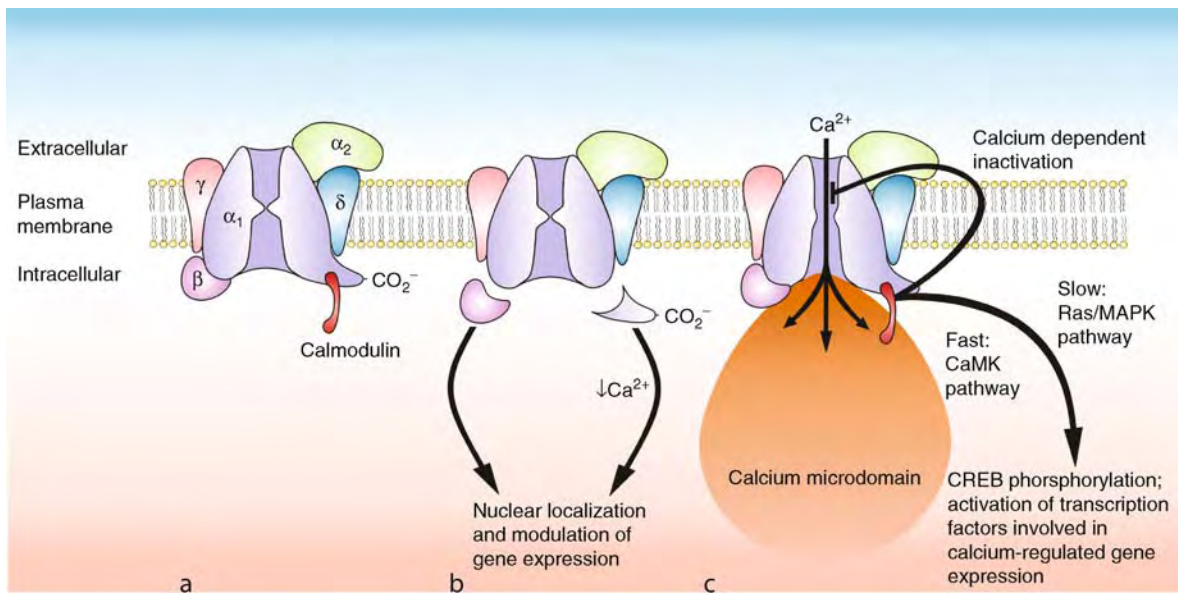

**Calcium Channels: Regulation of Gene Transcription. Figure 1** (a) Illustration of the subunit complex of high voltage-activated calcium channels. Calmodulin or CaM (shown in red) containing EF-hand motifs, bind the C-terminus of the  $\alpha_1$  subunits of calcium channels. (b) Cleaved C-termini of  $\text{Ca}_v1.2$  channels translocate to the nucleus to activate gene transcription. A  $\beta_4$  subunit isoform also translocates to the nucleus and interacts with nuclear factors involved in gene expression. (c) L-type channels mediate  $\text{Ca}^{2+}$  signaling via CaM bound to their C-termini. CaM is activated by  $\text{Ca}^{2+}$  entry through L-type ( $\text{Ca}_v1.2$ ) channels and mediates both calcium-dependent inactivation and gene transcription.

transcriptional activation [5]. Phosphorylated CREB promotes transcription of a variety of IEGs including BDNF and mediates both activity-dependent neuronal survival and synaptic plasticity [3].

Besides CREB, additional calcium-dependent transcription factors have been identified. Like CREB, these are typically regulated by CaM or downstream members of the CaM signaling pathway, and translocate to the nucleus upon activation. These include:

1. **►Nuclear Factor of Activated T cells:** NF-AT has been implicated in synaptic plasticity [reviewed in 6]. NF-AT translocates to the nucleus upon dephosphorylation by calcineurin, a protein phosphatase controlled by the CaMK pathway.
2. **►Myocyte Enhancer Factor 2:** MEF2 is involved in neuronal survival and apoptosis. Phosphorylation of MEF2 via the Ras/MAPK pathway leads to transcription of MEF2-regulated genes that promote survival of cerebellar granule neurons. During T-cell receptor mediated apoptosis, MEF2 activation via the calcium/CaM pathway leads to the expression of the pro-apoptotic IEG Nur77 [2]. MEF2 can also be cleaved by calcium-activated caspase enzymes, generating pro-apoptotic, dominant-interfering forms that bind DNA to inhibit MEF2 transcription.
3. **►Nuclear factor  $\kappa$ B:** NF- $\kappa$ B promotes neuronal survival by transcribing genes that inhibit apoptosis such as **►manganese superoxide dismutase (MnSOD)**, **►Inhibitors of Apoptosis (IAPs)**, and the **►Bcl-2 homologue Bfl-1/A1** [7]. Calcium/CaM mediated dissociation of an inhibitory subunit from the NF- $\kappa$ B hetero-trimeric complex leads to nuclear localization of a transcriptionally active heterodimer [7]. NF- $\kappa$ B has also been implicated in synaptic plasticity changes and spatial learning [7].
4. **Downstream Regulatory Element-Antagonist Modulator:** **►DREAM** contains four EF-hand motifs for binding  $\text{Ca}^{2+}$ , and acts as a nuclear transcriptional repressor that binds to regulatory DRE motifs of target genes in conditions of low calcium. Genes regulated by DREAM include the IEG *c-fos* and **►Prodynorphin**, a transcription factor involved in memory acquisition and pain [8]. Interestingly, in the absence of nuclear  $\text{Ca}^{2+}$ , DREAM binds CREB and prevents it from recruiting **►CREB Binding Protein (CBP)**, a factor critical for CREB-mediated transcriptional activation.

#### **L-type calcium channels and control of gene expression**

Of the known VGCCs in the nervous system (i.e.,  $\text{Ca}_v1$  (L-type),  $\text{Ca}_v2$  (N-, P/Q-, R-types), and  $\text{Ca}_v3$  (T-type)), L-types are the only channel type established to couple excitation with transcription. Selectively blocking L-type channels with **►dihydropyridines** inhibits the expression of many IEGs. Intracellular

microdomains of  $\text{Ca}^{2+}$  generated by L-type channels lead to both nuclear signaling and negative feedback regulation of channel gating itself by means of calcium-dependent inactivation. It has been reported that both processes are dependent on the tethering of calcium-sensitive molecules to the channel where they can sense the local increase in calcium concentration. CaM, a cytosolic protein able to directly bind calcium via its EF-hand motifs, remains tethered to L-type ( $\text{Ca}_v1.2$ ) channels via an isoleucine-glutamine (IQ) motif in the channel's C-terminus. Disrupting either the ability of CaM to interact with L-type channels or CaM's ability to bind  $\text{Ca}^{2+}$  leads to loss of calcium-dependent inactivation [9] (Fig. 1c). Subsequent research from Dolmetsch and colleagues illustrates that CaM also mediates nuclear signaling by L-type channels [5] (Fig. 1c). This research group assayed the phosphorylation of CREB and activation of the Ras/MAPK signaling pathway in neurons where endogenous L-type channels had been blocked by dihydropyridines. By transfecting functional drug-resistant L-type channels into cultured primary neurons, Dolmetsch et al. showed that mutating the CaM-binding IQ motif or co-expressing calcium-insensitive CaM abrogated calcium-dependent activation of the Ras/MAPK pathway, CREB phosphorylation, and activation of MEF2. As illustrated in Fig. 1c, this research establishes CaM as a pivotal regulatory center for L-type channels, in channel self-regulation and the feed-forward control of gene expression.

Some intriguing twists in the story of how L-type channels modulate gene transcription are now emerging. The C-terminus of  $\text{Ca}_v1.2$  translocates to the nucleus as a ~75 kDa peptide (termed CCAT) after proteolytic cleavage at the cell membrane. In the nucleus, CCAT peptide binds transcriptional regulator **►p54(nrb)/NonO**, associates with endogenous promoters, and promotes a significant up-regulation of 16 genes (e.g., axon guidance factor **►Netrin4** and gap junction protein Cx31.1) and down-regulation of 31 genes (e.g., **►NMDA receptor subunit Grin2d** and the **►Na<sup>+</sup>/Ca<sup>2+</sup> exchanger Scl8A1**) [10] (Fig. 1b). Nuclear translocation of CCAT is observed in several central neuron types, especially in adults and heterologous expression of CCAT promotes increased neurite outgrowth in cultured primary neurons. Interestingly, CCAT translocation requires low cytosolic  $\text{Ca}^{2+}$  levels suggesting a mode of transcriptional regulation unlike the CaM dependent pathway which requires  $\text{Ca}^{2+}$  and neuronal activity. It has been suggested that a CCAT-like cleavage mechanism may be widely applicable since the C-terminus of the P/Q-type channel ( $\text{Ca}_v2.1$ ) is also cleaved and translocates to the nucleus; yet, it remains to be determined whether truncated  $\text{Ca}_v2.1$  peptides affect gene expression.

With the exception of T-type channels, the pore-forming  $\alpha_1$  subunits of VGCCs associate with accessory

subunits (termed  $\alpha_2$ ,  $\delta$ ,  $\beta$ , and  $\gamma$ ) which significantly modulate the electrophysiological properties and surface expression of the  $\alpha_1$  subunits (Fig. 1a). Recent evidence suggests that a short  $\beta_4$  isoform translocates to the nucleus and interacts with heterochromatin protein 1 $\gamma$  to promote gene silencing, however the underlying mechanisms and significance remains to be elucidated (Fig. 1b).

### Control of Gene Expression by NMDA, Ryanodine, and IP<sub>3</sub> Receptors

Calcium flux through post-synaptic NMDA receptors shares many of the downstream targets as L-type calcium channels to promote gene expression and neuronal survival. The similarities with L-type channels include activating CREB by phosphorylation, promoting the expression of some IEGs [8], and nuclear signaling via the CaMK and the Ras/MAPK signaling pathways. It has been reported that different calcium sources may be required for different phases of gene transcriptional activation. In particular, the NMDA receptors mediate an earlier phase of CREB phosphorylation (i.e., 10 min after depolarization), while the L-type channels are required in later stages. NMDA receptors also operate through downstream effectors associated with LTP induction, that do not overlap with L-type calcium channels. For example, **EphB receptor tyrosine kinases** localize at excitatory synapses and enhance the expression of NMDA receptor-mediated genes, but not those mediated by L-type channels. Interestingly, variations in the composition or location of the NMDA receptors create highly divergent signaling. Whereas synaptic NMDA receptors mediate neuronal survival, calcium entry via extra-synaptic receptors inhibits CREB phosphorylation and promotes cell death. Furthermore, changes in the composition of NMDA receptor subunit alters MAPK pathway signaling leading to either LTP or LTD (**Long Term Potentiation and Long Term Depression**).

Internal calcium sources may also participate in regulating gene transcription, but there is not much evidence for this mechanism occurring in neurons. IP<sub>3</sub> receptor activity can mediate the phosphorylation of CREB and activate NF-AT and NF- $\kappa$ B transcription factors in both muscle and neuronal cells (reviewed in [6]). **Ryanodine receptor-mediated Ca<sup>2+</sup> influx** has been linked to activation of the transcription factor NF-AT and expression of the slow myosin heavy chain I gene in muscle (reviewed in [6]).

### Conclusion

Gene transcriptional changes are the capacity of neurons to adapt to changing conditions, such as to modify their structure, their survivability and enhancement of connectivity. Regulation of gene expression is necessary in neural development, for the process of learning and memory, and for apoptosis. Importantly, regulatory

mechanisms may be harnessed for possible treatment of neurodegenerative disease.

Specificity in gene regulation is governed by nerve activity and calcium flux. Different calcium sources mediated through L-type calcium channels as well as NMDA receptors and intracellular sources converge through multiple, and often overlapping, signaling pathways (e.g., CREB, CaMK, Ras/MAPK and cAMP dependent protein kinase A (reviewed in [3,6])). These likely contribute collectively to global cellular changes in nuclear Ca<sup>2+</sup> to enhance the transcription of IEGs. At a local level, calcium is sensed by tethered CaM at the C-terminus of L-type calcium channels. CaM serves as a regulatory control point for tuning up or down calcium channel activity and its downstream regulators of gene transcription. Interestingly, low calcium also appears to be a signal for gene expression, as both the transcriptional modulator DREAM as well as the C-terminal cleavage product CCAT of L-type channels, require low nuclear and cytosolic Ca<sup>2+</sup> levels respectively for activation [8,10]. Future experimentation will further clarify how the varied signaling mechanisms activated by calcium, coming through calcium channels or other sources (eg. NMDA receptors), contribute to the regulation of gene transcription.

### References

1. Nguyen PV, Abel T, Kandel ER (1994) Requirement of a critical period of transcription for induction of a late phase of LTP. *Science* 265:1104–1107
2. Youn HD, Sun L, Prywes R, Liu JO (1999) Apoptosis of T cells mediated by Ca<sup>2+</sup>-induced release of the transcription factor MEF2. *Science* 286:790–793
3. West AE, Chen WG, Dalva MB, Dolmetsch RE, Kornhauser JM, Shaywitz AJ, Takasu MA, Tao X, Greenberg ME (2001) Calcium regulation of neuronal gene expression. *PNAS* 98:11024–11031
4. Bading H, Segal MM, Sucher NJ, Dudeck H, Lipton SA, Greenberg ME (1995) *n*-methyl-d-aspartate receptors are critical for mediating the effects of glutamate on intracellular calcium concentration and immediate early gene expression in cultured hippocampal neurons. *Neuroscience* 64:653–664
5. Dolmetsch RE, Pajvani U, Fife K, Spotts JM, Greenberg ME (2001) Signaling to the Nucleus by an L-type Calcium Channel-Calmodulin Complex Through the MAP Kinase Pathway. *Science* 294:333–339
6. Carrasco MA, Hidalgo C (2006) Calcium microdomains and gene expression in neurons and skeletal muscle cells. *Cell Calcium* 40:575–583
7. Mattson MP, Culmsee C, Yu ZF, Camandola S (2000) Roles of Nuclear Factor  $\kappa$ B in Neuronal Survival and Plasticity. *J Neurochem* 74:443–456
8. Carrion AM, Link WA, Ledo F, Mellström B, Naranjo JR (1999) DREAM is a Ca<sup>2+</sup>-regulated transcriptional repressor. *Nature* 398:80–84
9. Zühlke RD, Pitt GS, Deisseroth K, Tsien RW, Reuter H (1999) Calmodulin supports both inactivation and

facilitation of L-type calcium channels. *Nature* 399:159–162

10. Gomez-Ospina N, Tsuruta F, Barreto-Chang O, Hu L, Dolmetsch R (2006) The C Terminus of the L-Type Voltage-Gated Calcium Channel  $Ca_v1.2$  Encodes a Transcription Factor. *Cell* 127:591–606

---

## Calcium Chelator

### Definition

Calcium ions have a double positive charge. Calcium chelators are molecules that bind calcium and cover the ion in a way that it is no longer available for cellular metabolism. It was the invention of calcium chelators that allowed understanding the role of calcium in biological cells, because calcium concentrations in cells are so low that it is impossible to create artificial solutions with lower calcium concentrations unless calcium is removed using chelators. The event of calcium chelators, that can be titrated to create known calcium concentrations, made this ion accessible to direct experimental analysis.

---

## Calcium-regulated Nuclear Signaling

- ▶ Calcium Channels: Regulation of Gene Transcription

---

## Calibration

### Definition

A routine undertaken to correlate the readings of an instrument with known physical quantities. This is often carried out by applying a series of carefully controlled physical quantities, recording the instrument readings and plotting a graph of the instrument readings as a function of the physical quantity.

- ▶ Measurement Techniques (Pressure)

---

## Calmodulin

### Definition

Calmodulin (CaM) is a ubiquitous, calcium-binding protein that can bind to and regulate a multitude of

different protein targets, thereby affecting many different cellular functions. For example, it binds to RyRI, the sarcoplasmic reticulum  $Ca^{2+}$  release channel in skeletal muscle, and partially activates the channel at low  $Ca^{2+}$  concentrations but acts as an inhibitor of  $Ca^{2+}$  release at high  $Ca^{2+}$  concentrations.

- ▶ Excitation-Contraction Coupling

---

## Caloric Stimulation

### Definition

Caloric stimulation of the labyrinths is a procedure for stimulating the vestibular labyrinths without moving the head, and is most often used in a clinical evaluation of the vestibular system. The principal advantage of caloric stimulation is that one labyrinth can be tested at a time, whereas natural or artificial head movements stimulate both labyrinths and sometimes the otolithic organs too. This stimulation induces nystagmus via vestibulo-ocular reflex (VOR) pathways, which in a healthy person, builds up slowly, reaches slow-phase angular velocities up to  $80^\circ/s$  (ice water irrigation), and then decays slowly.

Actual stimulation is produced by circulating warm (up to  $40^\circ C$ ) or cool (down to  $0^\circ C$ ) water in the outer ear canal either directly or by use of a small balloon that fits snugly in the canal. The effects of this stimulation are produced mainly by temperature gradients in the horizontal (lateral) semicircular canal, which is closest to the outer ear canal, although minor direct effects on firing rates of primary vestibular afferents and stimulation of other semicircular canals may also occur.

- ▶ Brainstem Burst Generator
- ▶ Nystagmus
- ▶ Peripheral Vestibular Apparatus
- ▶ Vestibular Tests: Caloric Test
- ▶ Vestibulo-ocular Reflexes (VOR)

---

## Calsequestrin (CSQ)

### Definition

The major luminal sarcoplasmic reticulum  $Ca^{2+}$  binding protein located in the junctional terminal cisternae that binds  $Ca^{2+}$  with high capacity but low affinity which enables it to bind and release large quantities of  $Ca^{2+}$  rapidly.

- ▶ Excitation-Contraction Coupling

## Calyx of Held Synapse

### Definition

A large glutamatergic synapse in the mammalian auditory brainstem between a projection of globular bushy cells (presynaptic) in the anterior ventral cochlear nucleus and the cell soma of a principal neuron (postsynaptic) in the medial nucleus of the trapezoid body (MNTB).

- ▶ Bushy Cells
- ▶ Cochlear Nucleus
- ▶ Synaptic Transmission: Model Systems
- ▶ Trapezoid Body

## Camera Calibration

### Definition

A procedure by which parameters defining camera positions, orientations, and lens distortions are determined in image-based motion analysis.

- ▶ Motion Analysis

## CaMKII (CaM Kinase II)

- ▶ Calcium Binding Proteins
- ▶ Calcium/Calmodulin-Dependent Protein Kinase II in Neurons

## cAMP

### Definition

- ▶ Cyclic AMP

## cAMP-dependent Protein Kinase (Protein Kinase A)

### Definition

A family of protein kinases whose activity are dependent on the level of cAMP in the cell.

## cAMP/PKA-mediated Up-regulation

### Definition

Sequence of events that originate from a Gs protein-mediated activation of adenylate cyclase (AC). The activated AC raises the intracellular cAMP levels and promotes the activation of protein kinase A, which phosphorylates specific intracellular  $\text{Ca}^{2+}$  channel sites (phosphorylation sites). In the case of the cardiac Cav1.2 channel, the phosphorylated channel increases the probability of opening and causes increased  $\text{Ca}^{2+}$  flux into the cell.

- ▶ Calcium Channels – an Overview

## cAMP Response Element (CRE)

### Definition

cAMP response element is a leucine zipper domain in DNA which is bound by CREB transcription factors, resulting in the modulation of gene transcription.

## CAN

### Definition

$\text{Ca}^{2+}$ -activated nonspecific cation channel.

- ▶ Respiratory Pacemakers

## Canal Neuromast

### Definition

Neuromasts found within canals, primarily in phylogenetically conservative locations on the head and trunk. Typically acceleration sensitive.

- ▶ Evolution of Mechanosensory and Electrosensory Lateral Line Systems

## Canal Plugging

### Definition

Occlusion of the semicircular canals to block sensitivity to angular motion stimuli to study the influence of individual canal afferent inputs to the vestibular reflex system. Spontaneous discharge of primary afferent inputs to the brainstem and residual angular motion sensitivity persist even after complete surgical occlusion of the canal. The magnitude of the plugged canal response increases with angular acceleration and is largest for rapid or high frequency head movements.

- ▶ Semicircular Canals
- ▶ Vestibulo-spinal Reflexes

## Canalo-ocular Test at Medium Frequency

- ▶ Vestibular Tests Head-Shaking Test

## Cancer

### Definition

Class of diseases or disorders characterized by uncontrolled division of cells and the ability of these cells to invade other tissues, either by direct growth into adjacent tissue through invasion or by implantation into distant sites by metastasis.

## Cancer-associated Retinopathy

### Definition

- ▶ Inherited Retinal Degenerations

## Candelabrum Cell

### Definition

Candelabrum cells are inhibitory interneurons in the cerebellar cortex. Their cell bodies are in the Purkinje

cell layer and their dendrites reach into the molecular layer. Candelabrum cell axons also reach into the molecular layer.

## Cannabinoids

MEGAN J. DOWIE\*, NATASHA L. GRIMSEY\*

MICHELLE GLASS

Department of Pharmacology and Clinical Pharmacology, University of Auckland, Auckland, New Zealand

### Definition

▶ **Cannabinoids** are chemicals that bind to ▶ **cannabinoid receptors**. These lipophilic compounds are commonly classified by their source: herbal (derived from the plant *Cannabis sativa*), endogenous (produced in animal cells) or synthetic, and by their chemical structures (e.g., classical, non-classical, aminoalkylindole).

### Characteristics

*Cannabis sativa*, also known as marijuana, has been used for over 4,000 years as a recreational and therapeutic drug. Cannabis use produces a range of physiological and psychoactive effects such as CNS depression, appetite stimulation, memory deficits and analgesia. Activity of the ▶ **endocannabinoid system** is broadly involved in motor coordination, ▶ **memory**, ▶ **learning** and ▶ **cognition**, ▶ **nociception**, appetite and emesis, ▶ **reward**, psychological effects of ▶ **anxiety** reduction, sensory perception, ▶ **mood** enhancement and mild sedation, anti-▶ **inflammation**, anti-▶ **excitotoxicity**, ▶ **neuroprotection** and ▶ **neurogenesis**.

The isolation of the ▶ **psychoactive** constituent of cannabis – ▶ **delta-9-tetrahydrocannabinol** (THC), generation of synthetic cannabinoid compounds, discovery of ▶ **endocannabinoids** and cloning of cannabinoid receptors have facilitated great progress in understanding the mechanisms by which cannabinoids elicit their effects. Such advances have revealed that dysfunction of the endocannabinoid system is involved in the pathogenesis of a variety of diseases and reinforced that cannabinoid compounds may be of therapeutic benefit in these and other disorders.

### Cannabinoid Receptors

The majority of the biological effects of cannabinoids are mediated through two class A (▶ **rhodopsin-like**) ▶ **G-protein coupled receptors** (GPCRs) termed cannabinoid receptor 1 (CB1) and 2 (CB2). Although THC and

\*These authors contributed equally.

a number of other cannabinoids have similar affinities for these receptors, their amino acid sequences share only 44% identity and their distributions in the body and ►**brain** are very different. Not surprisingly therefore, the receptors are responsible for different functions.

CB1 is expressed in peripheral tissues including the lungs, liver, kidneys and reproductive organs, and is extremely abundant in the mammalian ►**CNS**. Distribution is widespread with particularly high levels present in the ►**basal ganglia**, ►**hippocampus**, ►**cerebellum** and ►**cortex** (Fig. 1); areas which correlate well with the effects of cannabinoids on memory, perception and movement control. Consistent with the lack of lethality of cannabis administration, CB1 is essentially absent from regions of the brainstem controlling cardiovascular and respiratory functions [1]. Splice variants of CB1 have been reported, however their physiological relevance is not yet established.

As is the case for all GPCRs, CB1 receptor activation is transduced into intracellular signals via interaction with a ►**G-protein** complex consisting of alpha, beta and gamma subunits. Association of CB1 with the inhibitory G-alpha i/o family is most commonly observed, although affinity for Gs has also been demonstrated under particular conditions. Activation of Gi/o inhibits ►**adenylate cyclase** and the accumulation of ►**cyclic AMP** (cAMP), with downstream effects including the activation of ►**inward rectifying K<sup>+</sup> channels** and the regulation of cAMP-dependent enzymes. Other consequences of CB1 activation, likely mediated by the G-protein beta-gamma subunits, include the inhibition of calcium channels and the induction of ►**immediate early gene expression**. In the brain, CB1 signaling is associated with the modulation of neuronal excitability. Depolarization-induced release of endocannabinoids into synaptic terminals and subsequent activation of pre-synaptic CB1 receptors tends to inhibit the release of other ►**neurotransmitters**, including ►**glutamate**

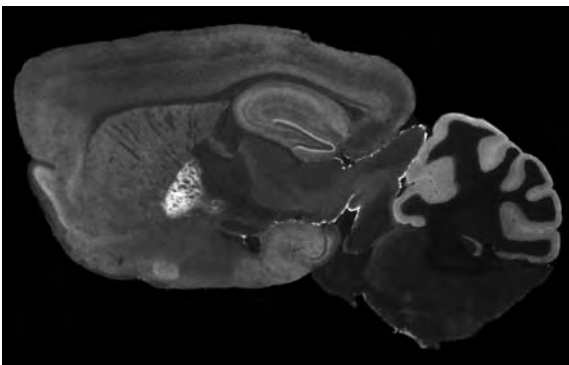

**Cannabinoids. Figure 1** Immunohistochemical localisation of the CB1 receptor in the mouse brain.

and ►**acetylcholine**. This activity, combined with CB1's wide distribution, contributes to explaining how cannabinoids influence such a wide variety of brain functions that are primarily controlled by different neurotransmitter-receptor classes. Further, dimerization of CB1 with other receptors, such as ►**dopamine D2** and ►**orexin** receptors, has been demonstrated and the resultant alteration of receptor activity represents a further level of complexity in this system.

CB2 receptor expression was until recently considered to be limited exclusively to the periphery, with the highest levels observed in immune and haematopoietic cells. However it is now established that CB2 is expressed in ►**microglia**, an immune cell found in the brain, and in selected ►**neurons** of the ►**brainstem**. During neurodegeneration and following brain injury, microglia tend to proliferate and become active, upregulating CB2 expression and often producing inflammatory damage additional to the primary insult. CB2 stimulation tends to reduce microglial reactivity, therefore this system may represent an attractive therapeutic target. CB2 signaling is primarily mediated by interaction with Gi/o, but differs from CB1 in that activation does not appear to affect calcium and potassium ion channels.

Although CB1 and CB2 receptors are considered to be the primary mediators of cannabinoid effects, pharmacological evidence suggests that still unidentified cannabinoid receptors might exist, for example in the hippocampus, modulating the release of ►**glutamate**, and on ►**endothelial cells**. Signaling in response to some cannabinoids is observed in the brains of CB1/CB2 knockout mice which is suggestive of additional sites of action. Initial characterization of a cannabinoid receptor candidate known as GPR55 demonstrated its sensitivity to some cannabinoids, its presence in several CNS cell types and that its activation increased intracellular calcium. Interestingly, some cannabinoids are able to bind to and activate the transient receptor potential vanilloid type 1 (►**TRPV1**) receptor, an interaction which may be involved in nociception. Cannabinoids have also been noted to possess anti-oxidative and neuroprotective properties which do not appear to be receptor mediated, however high cannabinoid concentrations are required and it is thus unclear as to whether this effect is physiologically relevant or holds therapeutic potential. Further research to characterize and classify these potential interactions is warranted [2].

### Endogenous Cannabinoids

Several ►**endogenous cannabinoid** ligands (endocannabinoids) have been isolated and demonstrated to bind to cannabinoid receptors. These compounds are all derived from ►**arachidonic acid**. To date the most studied of these are ►**anandamide** and ►**2-arachidonoyl glycerol** (Fig. 2). 2-arachidonoyl glycerol exhibits higher selectivity and



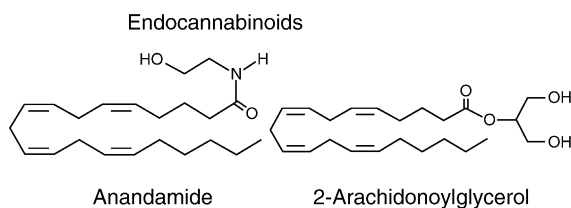

**Cannabinoids. Figure 2** Structures of the endocannabinoids.

efficacy for CB1 and CB2 receptors than anandamide, which also interacts with non-cannabinoid receptor targets (e.g., ▶TRPV1). The endocannabinoids are synthesized “on demand” in response to increased intracellular calcium, and released from cells immediately following their production. Recent studies have identified synthesizing and degradative enzymes for both of these compounds, and these enzymes provide new drug targets for the manipulation of endocannabinoid levels in vivo [3].

### Cannabinoid Based Drug Therapies: Now and in the Future

Cannabinoids have been implicated in many neurological diseases and conditions that originate in or are mediated by the CNS. Those where aberrations in the endocannabinoid system have been linked to disease mechanisms and pathology include neuropsychiatric diseases such as Tourette’s syndrome, ▶bipolar affective disorder and ▶schizophrenia, and neurodegenerative diseases such as amyotrophic lateral sclerosis (ALS; ▶Lou Gehrig’s disease), ▶multiple sclerosis (MS) and ▶Alzheimer’s, ▶Parkinson’s, and ▶Huntington’s diseases. Additionally, cannabinoids are postulated as symptomatic therapeutics for conditions including ▶stroke, ▶epilepsy, glaucoma, obesity and ▶addiction.

Few cannabinoid compounds are currently approved for pharmaceutical use (Fig. 3). Synthetic THC is available for prescription in capsule form as dronabinol (marketed as Marinol<sup>®</sup>) and an analog nabilone (marketed as Cesamet<sup>®</sup>). These products were originally approved for the suppression of nausea in cancer sufferers and were later approved as appetite stimulants for use by patients with HIV and cancer, who commonly experience a wasting syndrome. Subsequent approval has been granted for treatment of MS ▶neuropathic pain. An aerosol form of dronabinol is under investigation for migraine treatment in addition to the existing indications (<http://www.marinol.com>, <http://www.cesamet.net>).

Sativex<sup>®</sup> is a prescription drug administered as an oromucosal spray produced primarily from the *Cannabis* plant extracts THC and cannabidiol. Sativex<sup>®</sup> was

approved in 2005 in Canada for the symptomatic relief of neuropathic pain in MS with many current clinical studies investigating its potential use for the control of spasticity and in several other pain conditions (<http://www.gwpharm.com>). The most recently approved pharmaceutical cannabinoid compound is the CB1 inverse agonist Rimonabant (Acomplia<sup>®</sup>). Available since 2006 in some European countries for prescription as an anorectic anti-obesity drug, it is indicated for use in conjunction with diet and exercise in obese patients. Rimonabant has also been proposed to assist with smoking cessation and to aid in the prevention of weight gain in former smokers; however approval is yet to be granted for these indications (<http://en.sanofi-aventis.com>).

Early clinical trials have been undertaken to assess a THC metabolite-like synthetic cannabinoid, IP 751 (Ajulemic Acid/CT-3), as an anti-inflammatory/▶analgesic medication (<http://www.indevus.com>). Further clinical trials of cannabinoid drugs are expected in the near future including: inhibitors of endocannabinoid enzymatic breakdown (▶fatty acid amide hydrolase inhibitors) such as URB597 (also known as KDS-4103) for the treatment of anxiety, depression and pain; compounds such as oleylethanolamide (KDS-5000) that activate endocannabinoid related pathways through mechanisms other than CB1 or CB2 for the control of appetite, obesity and liver disease; compounds that activate central and/or peripheral cannabinoid receptors for neuropathic pain (topical anandamide to target receptors in peripheral sensory nerves, KDS-2000 <http://www.kadmuspharma.com>) and nociceptive pain management (CB2 selective agonists, Cannabinor <http://www.pharmoscorp.com>). Recent research has demonstrated that the cannabinoid quinone HU-331 is a highly specific inhibitor of topoisomerase II and therefore shows potential as an anticancer drug [4].

Molecular and preclinical studies have demonstrated that cannabinoid drugs could also be useful in other specific conditions. For example, in models of the heritable neurodegenerative illness Huntington’s disease, various cannabinoid compounds have decreased toxin-induced striatal degeneration in rats and protected cells expressing the pathogenic protein from cell death. CB1 receptors are lost early in the disease and preferentially to colocalized receptors, suggesting involvement of the cannabinoid system in disease mechanisms [5]. Several cannabinoid-related treatments decrease motor deficits in animal models of the degenerative movement disorder Parkinson’s disease, potentially providing protection against neuronal injury and influencing local pathological inflammatory events [6].

Hyperactivity of the endocannabinoid system is postulated to be involved in schizophrenia pathology or the mechanisms of negative disease symptoms.

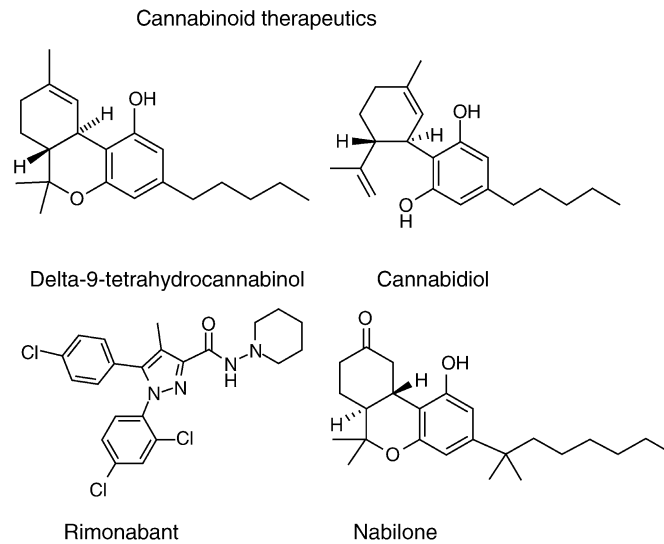

**Cannabinoids. Figure 3** Cannabinoid compounds currently approved for therapeutic use.

Alterations in the central endocannabinoid system in people with schizophrenia include increased density of CB1 in subregions of the ►prefrontal cortex and increased anandamide in the ►cerebrospinal fluid. There is also some suggestion that cannabis consumption may induce ►psychosis and schizophrenia in susceptible people [7].

Pathogenic mechanisms underlying ►motorneuron degeneration in ALS are unclear. However, endocannabinoids are involved in the modulation of several proposed mechanisms including excitotoxicity, oxidative stress, neuroinflammation and microglial activation, which may explain the neuroprotective effects of increasing endocannabinoid levels in models of ALS. Disease progression in mouse models has also been delayed with CB1 and CB2 receptor agonists [5].

While the endocannabinoid system does not appear to contribute to the cause of stroke, neuroprotective endocannabinoid signaling in response to brain injury has been observed. In animal models both CB1 and CB2 receptor expression in the brain is increased, anandamide levels are elevated and CB1 blockade is protective [8]. Finally, the endocannabinoid system has been implicated in seizure activity and epilepsy due to its ability to modulate the release of other neurotransmitters and reduce excitotoxicity; properties which may help to explain cannabinoid anticonvulsant properties. As endocannabinoids are synthesized “on demand” seizure activity can directly stimulate increased production. However, cannabinoids have also been suggested to have proconvulsant activity in certain circumstances, therefore further investigation will be necessary before cannabinoids can be pursued in a therapeutic capacity [9].

There is a wealth of research currently being carried out in the cannabinoid field. This will no doubt lead to the emergence of many novel drug targets for neurological disease over the coming years.

## References

- Glass M, Dragunow M, Faull RL (1997) Cannabinoid receptors in the human brain: a detailed anatomical and quantitative autoradiographic study in the fetal, neonatal and adult human brain. *Neuroscience* 77:299–318
- Pertwee RG (2006) The pharmacology of cannabinoid receptors and their ligands: an overview. *Int J Obes (Lond)* 30(Suppl 1):S13–S18
- Di Marzo V, Petrosino S (2007) Endocannabinoids and the regulation of their levels in health and disease. *Curr Opin Lipidol* 18:129–140
- Kogan NM, Schlesinger M, Priel E, Rabinowitz R, Berenshtein E, Chevion M, Mechoulam R (2007) HU-331, a novel cannabinoid-based anticancer topoisomerase II inhibitor. *Mol Cancer Ther* 6:173–183
- Maccarrone M, Battista N, Centonze D (2007) The endocannabinoid pathway in Huntington’s disease: a comparison with other neurodegenerative diseases. *Prog Neurobiol* 81:349–379
- Lastres-Becker I, Fernandez-Ruiz J (2006) An overview of Parkinson’s disease and the cannabinoid system and possible benefits of cannabinoid-based treatments. *Curr Med Chem* 13:3705–3718
- Ujike H, Morita Y (2004) New perspectives in the studies on endocannabinoid and cannabis: cannabinoid receptors and schizophrenia. *J Pharmacol Sci* 96:376–381
- Galve-Roperh I, Aguado T, Palazuelos J, Guzman M (2007) The endocannabinoid system and neurogenesis in health and disease. *Neuroscientist* 13:109–114
- Alger BE (2004) Endocannabinoids and their implications for epilepsy. *Epilepsy Curr* 4:169–173

## Capacitance (Electrical)

### Definition

Ability of a capacitor to separate and store electrical charges, measured in farads (F).

- ▶ Action Potential
- ▶ Action Potential Propagation
- ▶ Cable Theory
- ▶ Membrane Potential: Basics

## Capacitance Measurement

KEVIN D. GILLIS

Department of Biological Engineering,  
Department of Medical Pharmacology and Physiology,  
Dalton Cardiovascular Research Center, University of  
Missouri – Columbia, Columbia, MO, USA

### Definition

The process of measuring the time course of changes in membrane capacitance. In this essay, we restrict our attention to patch-clamp capacitance measurements used to quantify changes in membrane surface area that accompany ▶exocytosis and ▶endocytosis.

### Characteristics

#### Purpose

Molecules that mediate cell-to-cell communication, such as hormones and neurotransmitters, are packaged and stored within cells in membrane-delimited vesicles. In neurons and other excitable cells, the trigger for release of these signaling molecules is influx of  $\text{Ca}^{2+}$  through voltage-gated  $\text{Ca}^{2+}$  channels upon membrane depolarization. The consequent elevation of the intracellular  $\text{Ca}^{2+}$  concentration ( $[\text{Ca}^{2+}]_i$ ) triggers the fusion of vesicles with the cell plasma membrane, and release of the vesicle contents to the extracellular space by the process of exocytosis. The vesicle membrane is taken up again into the cell by the process of endocytosis. Application of membrane capacitance measurements, in conjunction with other techniques, has greatly increased our understanding how  $\text{Ca}^{2+}$  triggers exocytosis and how specific proteins and second-messenger cascades regulate exocytosis and endocytosis.

The capacitance of the cell membrane is proportional to its area, thus the insertion of vesicle membrane during exocytosis results in an increase in capacitance, whereas endocytosis decreases membrane capacitance. Just as patch-clamp techniques can resolve the currents

due to the opening and closing of individual ion channel molecules, capacitance measurements from small membrane patches can resolve the fusion (exocytosis) and fission (endocytosis) of individual synaptic vesicles with millisecond time resolution [1].

The modern era of membrane capacitance measurements dates to the early days of the patch-clamp recordings. In a seminal report in 1982, Neher and Marty described changes in membrane capacitance associated with exocytosis in chromaffin cells [2]. Unlike single-channel recording, however, capacitance measurement was slow to catch on as a mainstream approach and only a handful of laboratories used the technique in the 1980s. Capacitance measurements blossomed in the 1990s, partly due to the emergence of powerful software that greatly simplified application of the method. The capacitance technique continues to make a large contribution towards a mechanistic understanding of exocytosis and endocytosis.

### Advantages and Disadvantages

#### Chief Strengths of the Capacitance Technique

1. Under appropriate conditions, the time course of fusion of individual vesicles, including the formation of the ▶fusion pore, can be resolved. The fusion reaction has been shown to be reversible, in that a step increase in capacitance is followed by a decrease in capacitance of the same size (e.g. [3]). This allows one to follow the duration of time that vesicles remain fused with the plasma membrane. A particularly powerful approach for correlating single-vesicle fusion kinetics with the discharge of vesicle contents is ▶patch-amperometry [3].
2. The process of membrane fusion can be monitored independently from the discharge of vesicle contents. ▶Carbon-fiber amperometry (reviewed in [4]) and styryl dye (e.g. FM143) fluorescent measurements are powerful techniques for measuring the efflux of material from vesicles during exocytosis. However, capacitance measurements uniquely identify the distinct kinetics of vesicle membrane fusion and fission. Understanding the kinetics of membrane fusion is essential to develop quantitative models relating  $[\text{Ca}^{2+}]_i$  to exocytosis.
3. Patch clamp capacitance measurements allow a high level of control over parameters that trigger and modulate exocytosis:
  - Patch-clamp capacitance measurements occur under voltage-clamp control. This allows the experimenter to depolarize the cell in a controlled manner, and measure the relationship between  $\text{Ca}^{2+}$  influx through voltage-gated  $\text{Ca}^{2+}$  channels and exocytosis assayed with the capacitance technique. It is thus possible to determine which steps in the stimulus-secretion cascade, (membrane depolarization leading to  $\text{Ca}^{2+}$

influx leading to  $\text{Ca}^{2+}$ -triggered exocytosis) are affected by an experimental maneuver such as application of a drug.

- Substances such as fluorescent indicators, drugs, peptides and soluble second messengers can easily be loaded into a cell by diffusion from the pipette solution during whole-cell recording. For example,  $\text{Ca}^{2+}$  bound to a high-affinity photo-labile chelator (“cage”) can be introduced into the cell. Photolysis of the cage with ultraviolet light can be used to elevate  $[\text{Ca}^{2+}]_i$  uniformly throughout the cell, while the time course of exocytosis is measured using the capacitance technique (e.g. [5]). This approach is the most direct way currently employed to measure the relationship between  $[\text{Ca}^{2+}]_i$  and exocytosis.

### Chief Weaknesses of the Technique

1. The greatest weakness of the capacitance technique is that it only reports the difference between the rates of exocytosis (addition of surface membrane) and endocytosis (removal of surface membrane). This is not a large issue in recordings from membrane patches, where step changes in capacitance due to fusion or fission of single vesicle can be resolved. In contrast, in whole-cell or perforated-patch recordings, unitary events cannot be resolved and increases in capacitance may underestimate the rate of exocytosis if endocytosis is occurring at the same time. In the whole-cell recording condition, application of a mild stimulus often results in a rapid increase in capacitance followed with a much slower “compensatory” decrease towards the baseline value. Under this experimental condition, the separation of exocytosis and endocytosis is relatively clear because exocytosis is much faster than endocytosis, and the initial capacitance increase is interpreted as reflecting exocytosis. On the other hand, endocytosis is more rapid when the stimulus elevates  $[\text{Ca}^{2+}]_i$  to many 10s of  $\mu\text{M}$ , or when the cellular contents are better preserved such as during perforated-patch recording [6]. Under these conditions, great caution must be applied in quantitatively relating capacitance changes to exocytosis and endocytosis. Carbon-fiber amperometry can be used to confirm the relationship between capacitance increases and exocytosis.
2. Capacitance changes may result from phenomenon other than changes in membrane surface area. The capacitance of a biological membrane is usually assumed to be  $\sim 10 \text{ fF}/\mu\text{m}^2$ , but this value will change slightly depending on the mobility of charges in integral membrane proteins such as voltage-gated ion channels. For example, Horrigan and Bookman [7] have described a transient change in capacitance following depolarizing steps that is unrelated to exocytosis or endocytosis, but instead reflects recovery of  $\text{Na}^+$  channels from inactivation.

This non-exocytosis-related capacitance change is reproducible and transient, and thus can be eliminated from the capacitance trace by subtraction. In addition, large changes in membrane resistance can cause erroneous changes in estimated capacitance unless great care is taken.

3. The usual application of the capacitance technique is based on a simple, 3-component equivalent circuit representation depicted in, and thus can only be applied to preparations with a single **▶membrane compartment**. The technique has been most widely applied to endocrine cells because these spheroidal cells are well described by the equivalent circuit of Fig. 1. Special neural cells such as cochlear hair cells and retinal bipolar nerve terminals [8] are also amenable to the technique. Capacitance measurements have recently been made in presynaptic terminals at the calyx of Held [9] and in hippocampal mossy fiber terminals [10]. These preparations are not always well described by a single **▶membrane compartment** model, however, simulations indicate that the estimated capacitance change faithfully follows changes in the terminal capacitance [9,10]. The extension of the capacitance technique to explicitly account for more complex equivalent

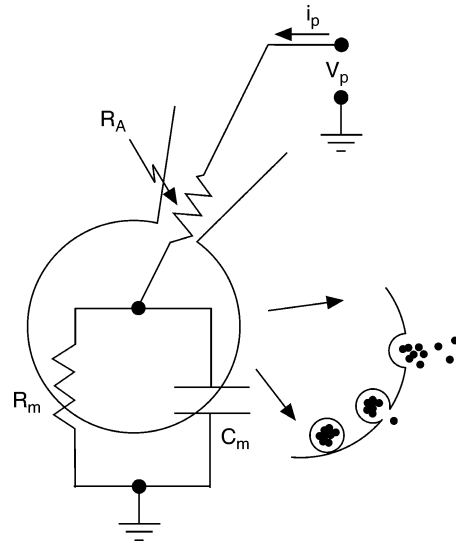

**Capacitance Measurement. Figure 1** The equivalent circuit commonly used as a basis for capacitance measurements during patch-clamp recordings. The whole-cell patch clamp configuration is illustrated, but the same equivalent circuit, with different parameter values, applies to on-cell recordings from membrane patches. The inset depicts the increase in membrane surface area, and thus  $C_m$ , that occurs during exocytosis.  $R_A$  is the “access” resistance through the patch-clamp pipette, whereas  $R_m$  and  $C_m$  are the membrane resistance and capacitance, respectively.

circuits than represented in Fig. 1, is likely to be an important future direction for increasing the applicability of this powerful technology.

### Principles

Present here is only a very brief survey of techniques for estimating changes in membrane capacitance related to exocytosis and endocytosis, see [11] for a detailed treatment. Most capacitance techniques are based on the three component equivalent circuit of the recording configuration depicted in Fig. 1. In this circuit, we neglect the pipette capacitance because the current passing through this pathway is electronically subtracted upon proper adjustment of the pipette capacitance compensation circuitry of the patch-clamp amplifier. During whole-cell recording of a neuroendocrine cell, typical parameters are  $C_m \sim 6$  pF,  $R_A \sim 8$  M $\Omega$ , and  $R_m > 2$  G $\Omega$ . For on-cell recording,  $R_A$  is somewhat smaller and  $C_m$  is a fraction of a pF.

The most common approach to estimating capacitance changes is to apply a sinusoidal voltage stimulus and analyze the resulting sinusoidal current. The amplitude of the stimulus sinusoid is usually less than 50 mV, whereas the frequency ranges from  $\sim 1$  kHz for whole-cell recordings to 50 kHz or higher for on-cell measurements. A significant limitation is that a single sinusoid only provides two pieces of information (magnitude and phase), whereas there are three unknown components of the equivalent circuit. Next are described two approaches used to obtain the additional information needed.

In the **“sine + dc”** approach, the dc (average) current is measured and used, together with an estimate of the extrapolated zero-current potential, to estimate the dc conductance ( $R_A + R_m$ ) [12]. This approach is incorporated in “Pulse” and “PatchMaster” (HEKA Inc., Lambrecht, Germany) software, and is probably the most widely used approach currently for capacitance measurements in the whole-cell configuration. The simplest version of the sine + dc approach assumes the reversal potential does not change during the recording. The sensitivity of capacitance estimates to errors in the value of the assumed reversal potential is small if  $R_m$  is high (G $\Omega$  range). More complicated multi-sinusoid or square-wave approaches are necessary if the  $R_m$  is both small and changing.

The **piecewise-linear approach** is the original implementation of the patch-clamp capacitance technique by Neher and Marty [2]. A single-frequency sinusoid voltage stimulus is applied and a phase-sensitive detector (lock-in amplifier) is connected to the patch-clamp amplifier, to extract the component of the sinusoidal current that is proportional to changes in membrane capacitance. Thus, the output signal of the lock-in amplifier, when set to an appropriate phase,

is directly proportional to changes in membrane capacitance but has little sensitivity to changes in  $R_A$  or  $R_m$ . Dithering of the membrane capacitance compensation knob of the patch-clamp amplifier is used both to find the appropriate phase setting of the lock-in amplifier and to calibrate the capacitance signal. A subsequent variant of the technique (“phase tracking”) uses computer-controlled dithering of series resistance introduced between the bath and ground to find the appropriate phase setting [13]. The piecewise-linear approach was initially quite popular because it can be implemented entirely in hardware (e.g. in the Cairn Optopatch patch-clamp amplifier), however, it has largely been replaced by more powerful (and less *ad hoc*) computational approaches for whole-cell capacitance measurements.

A number of **multi-sinusoid approaches** are also used. In the case of two sinusoids there are 4 pieces of information to determine the values of the three unknown parameters. Optimal use of the information to “fit,” i.e. estimate the parameters with the minimal variance “noise,” is a complex problem that is thoroughly addressed in an elegant study by Barnett and Mislser [14]. A number of sub-optimal, but computationally simpler, *ad hoc* approaches to estimate the equivalent circuit parameters from dual sinusoid excitation have also been implemented. A challenging problem with all multi-sinusoid approaches is optimizing the choice of amplitudes and frequencies of the stimuli, and therefore these approaches tend to give noisier estimates of membrane capacitance than single-sinusoid techniques. In addition, the non-ideal frequency dependence of  $C_m$  results in an underestimation of  $R_m$  (unpublished observations).

Approaches using **square-wave** stimuli are also used. In response to a square step in pipette potential, the equivalent circuit depicted in Fig. 1 will respond with a transient current that decays with an exponential time course.

Fit of the current transient to an exponential function can be used to produce estimates of the three circuit parameters. An excellent implementation of this approach is described in [15]. This approach can be quite robust in that estimates of  $C_m$  can be generated that are quite insensitive to changes in  $R_A$  and  $R_m$ , and  $C_m$  estimates can be produced with nearly as low a noise as sinusoidal techniques [15]. This method requires a high bandwidth setting of the patch-clamp amplifier, a high sampling rate and is computationally intense. Nevertheless, an efficient algorithm running on a modern computer can generate estimates at  $\sim 100$  Hz [15].

### Conclusion

Any of the above techniques, when carefully applied, can produce valid estimates of changes in membrane

capacitance related to exocytosis and endocytosis, so the choice of technique often depends on finding an attractive software package. In general, for capacitance techniques to be truly useful, they must be embedded within a powerful, flexible software package that is capable of executing complex stimulus protocols while recording and displaying multiple data streams in real time.

## References

1. Neher E, Marty A (1982) Discrete changes of cell membrane capacitance observed under conditions of enhanced secretion in bovine adrenal chromaffin cells. *Proc Natl Acad Sci USA*. 79(21):6712–6716
2. Smith C, Neher E (1997) Multiple forms of endocytosis in bovine adrenal chromaffin cells. *J Cell Biol* 139(4):885–894
3. Horrigan F, Bookman R (1994) Releasable pools and the kinetics of exocytosis in adrenal chromaffin cells. *Neuron* 13:1119–1129
4. Sun JY et al. (2004) Capacitance measurements at the calyx of Held in the medial nucleus of the trapezoid body. *J Neurosci Methods* 134(2):121–131
5. Hallermann S et al. (2003) A large pool of releasable vesicles in a cortical glutamatergic synapse. *Proc Natl Acad Sci USA* 100(15):8975–8980
6. Gillis KD (1995) Techniques for membrane capacitance measurements. In: Sakmann B, Neher E (eds) *Single channel recording*. Plenum Press, New York and London, pp 155–197
7. Pusch M, Neher E (1988) Rates of diffusional exchange between small cells and a measuring patch pipette. *Pflugers Arch* 411(2):204–211
8. Fidler N, Fernandez JM (1989) Phase tracking: an improved phase detection technique for cell membrane capacitance measurements. *Biophys J* 56(6):1153–1162
9. Barnett DW, Misler S (1997) An optimized approach to membrane capacitance estimation using dual-frequency excitation. *Biophys J* 72(4):1641–1658
10. Thompson RE, Lindau M, Webb WW (2001) Robust, high-resolution, whole cell patch-clamp capacitance measurements using square wave stimulation. *Biophys J* 81(2):937–948

## Capacitative $\text{Ca}^{2+}$ Entry

### Definition

The phenomenon of capacitative  $\text{Ca}^{2+}$  entry has been identified upon the receptor-mediated or pharmacologically induced depletion of intracellular endoplasmic  $\text{Ca}^{2+}$  stores. In response to depletion of the intracellular  $\text{Ca}^{2+}$  stores, stimulation of a plasma membrane  $\text{Ca}^{2+}$

entry mechanism can be measured, being interpreted as a refilling mechanism in order to restore the  $\text{Ca}^{2+}$  loading of the endoplasmic reticulum. In this context, a distinct  $\text{Ca}^{2+}$  release-activated  $\text{Ca}^{2+}$  current has been identified and described as *I<sub>crac</sub>*.

## Capacitative Current

### Definition

- ▶ Action Potential
- ▶ Action Potential Propagation
- ▶ Cable Theory
- ▶ Membrane Potential: Basics

## Car Sickness

- ▶ Anti-Motion Sickness Drugs

## Carbon Monoxide Poisoning

### Definition

Carbon monoxide poisoning is due to the extremely high affinity of carbon monoxide to hemoglobin and ▶ *myoglobin*, where it replaces oxygen depending on its concentration, resulting in hypoxia, anaerobic metabolism and lactic acidosis. Clinical symptoms include shortness of breath, headache, confusion, emotional lability, nausea, vomiting, diarrhea, clumsiness, ▶ *syncope* and, in severe cases, cerebral and pulmonary edema, respiratory depression and ▶ *coma*.

## Cardiac Arrhythmias

### Definition

An abnormal heart rhythm that may be too slow (bradycardia), too rapid (tachycardia), irregular, or too early.

## Cardiac Ganglia

### Definition

Cardiac ganglia are autonomic ganglia that lie close to the surface of the heart, around the origins of the great vessels.

- ▶ Autonomic Ganglia

## Cardiac Output

### Definition

Cardiac output refers to the volume of blood ejected by the left ventricle, and is usually expressed in milliliters per minute. Cardiac output is therefore the mathematical product of heart rate (contractions per minute) and stroke volume (ml of blood ejected per contraction). In a resting human adult, this may amount to approximately 5,000 ml/min but can range from as little as 2,000–3,000 ml per minute up to 25,000 ml per minute depending upon factors such as level of activity. As the heart normally pumps all of the blood received from the veins without permitting blood to dam in the venous system, cardiac output remains reasonably constant over a wide range of arterial pressure.

## Cardiac Shunt

### Definition

Direct connection between the two sides of the heart: In a left-right shunt the blood goes from the left side of the heart directly to the right side without passing through the body. In the more common right-left shunt, blood goes from right (the venous system) to left (arterial system) without passing through the lungs. The most common right to left shunt is a patent foramen ovale (PFO); a small residual connection between the right and left atria of the heart (uniformly present during fetal development).

- ▶ Ischemic Stroke
- ▶ Stroke

## Cardioembolic/Cardiac Embolism

### Definition

Sudden blocking of an artery by a clot or foreign material (embolus), which traveled through the blood stream and originated in the heart.

- ▶ Ischemic Stroke
- ▶ Stroke

## Cardiovascular Mechanics

PETER HUNTER

Auckland Bioengineering Institute, University of Auckland, Auckland, New Zealand

### Definition

▶ **Cardiovascular mechanics** deals with soft tissue mechanics, blood flow mechanics and the coupling between these two.

### Description of the Theory

The equations governing the mechanics of both solid and fluid components are derived from the physical principles of conservation of mass and conservation of both linear and angular momentum. These equations are formulated in terms of stress tensors and either strain tensors for solid mechanics or strain-rate tensors for fluid mechanics. For the solid soft tissue component the displacements and strains are large (unlike those occurring in bone and in fact most engineering materials) and therefore the theoretical framework requires the use of large deformation elasticity theory. The relationship between stress and strain (or strain rate) is determined by the material properties of the tissue and has the following characteristics:

1. ▶ **Stress-strain relations** are highly nonlinear and typically exhibit “strain hardening” or stiffening with increased strain. This is illustrated in Fig. 1 where components of axial stress are plotted against the corresponding axial strain in experiments on a small block of myocardial tissue [1]. As the strain increases the material becomes stiffer (the slope of the stress-strain curve increases).
2. Materials are highly anisotropic, meaning that the stress-strain relationship is quite different in three orthogonal material directions [2]. This is a consequence of the material growing to support the

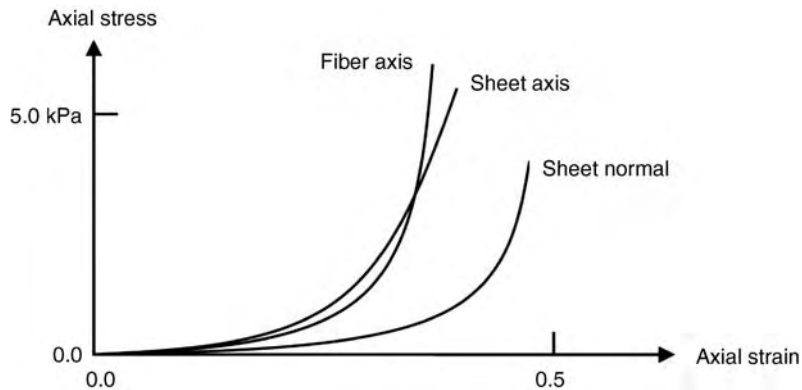

**Cardiovascular Mechanics. Figure 1** Components of axial stress plotted against the corresponding components of axial strain for myocardial tissue [3]. The different curves correspond to the different orientations of the axial test with respect to tissue structure (see Fig. 2 and discussion below). The curve labeled “*fiber axis*” shows the change in axial stress when the tissue is stretched along the muscle fiber direction. The curve labeled “*sheet axis*” is the corresponding stress-strain relationship when the tissue is stretched in a direction orthogonal to the fibers in the plane of the sheets (see below). The curve labeled “*sheet norma*” is the stress-strain relation for stretch in a direction normal to the sheets. The fact that these curves are different for the different material directions indicates that the material is anisotropic. The J-shaped non-linear shape of these curves is a reflection of the “**►strain-hardening**” nature of soft tissues.

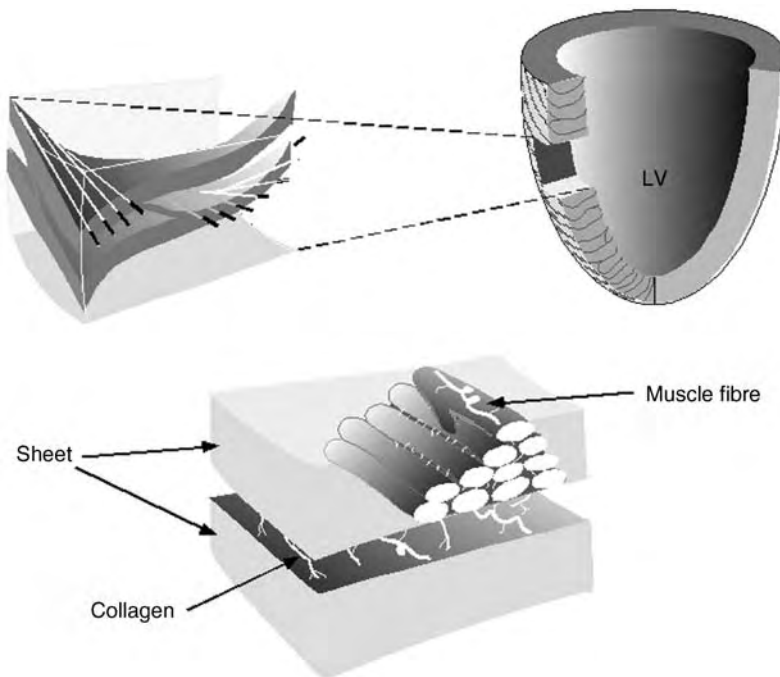

**Cardiovascular Mechanics. Figure 2** Schematic illustration showing (*top*) the variation in muscle fiber direction across the wall in a segment removed from the left ventricle, and (*bottom*) the branching lamellar structure of myocardium in which the sheets are composed of myocytes bound in layers 3–4 cells thick by endomysial collagen and surrounded by perimysial collagen, which also links to the adjacent sheet. This “fibrous-sheet” architecture allows for shearing to occur between the layers and aids the process of wall thickening at end-systole [4].



loads it is subjected to. For example, the axial stress in an artery wall, associated with tethering forces that hold the artery in position, is quite different from the circumferential stress required to support the blood pressure. The ►**anisotropy** of cardiac tissue can be seen in Fig. 1 where the stress-strain relations are significantly different in the three orthogonal tissue material directions [3]. The anisotropy of myocardial tissue derives from the underlying fibrous sheet structure, as illustrated in Fig. 2. Myocytes (the contractile cells in the heart) are oriented in a “fiber” direction, shown by the straight lines at the top left of Fig. 2. These cells are bound into sheets of tissue that are three to four cells thick (see lower part of Fig. 2). The sheets can shear relative to one another fairly easily (lowest curve in Fig. 1) – i.e. a given ►**shear strain** in this orientation produces a lower stress than a shear strain in the plane of the sheets [2].

3. The tissue properties are inhomogeneous (i.e. vary spatially), reflecting the different functional requirements of different regions. For example, the arterial walls contain three layers: (i) the innermost “intima” that contains a monolayer of endothelial cells on a basement membrane and regulates transport between the tissue and blood, (ii) the thick “media,” containing smooth muscle for active contraction and bundles of collagen and elastin, which give wall the ability to store elastic energy as the wall is distended at high blood pressure and then to return this energy as the blood pressure drops, in order to maintain flow and (iii) the outer “adventia” which contains collagen, nerves and the small blood vessels that supply nutrients to the arterial wall. Similarly, the fibrous sheet structure of myocardial tissue shows ►**inhomogeneity** both in the orientation of the material axes across the wall of the heart (see Fig. 2 top left) and in the density of the collagen surrounding the sheets.

Both soft tissues and blood are usually considered to be incompressible (a consequence of the high water content) and for most soft tissues viscous behavior plays a small but important damping role. For the muscular components of the cardiovascular system (e.g. heart muscle and arterial smooth muscle) the mechanical function is also greatly influenced by the myofilament-generated forces that produce active muscle contraction.

Computational analysis of large deformation soft tissue mechanics is usually performed with finite element techniques, which divide the material into small coupled blocks or “elements” (see Fig. 3) and then apply integral stress balance equations to these elements. Continuous fields representing the geometric and material properties of the tissue are defined via

nodal parameters, which are defined on the element boundaries and shared between adjacent elements in order to ensure continuity of the fields both within and across the elements. The equations governing blood flow are usually solved with finite element techniques, finite volume techniques or finite difference techniques. In this last case a Taylor series approximation of the governing Navier-Stokes partial differential equations produces a system of discrete equations for computation. Computational analysis of coupled solid-fluid structures is difficult and usually requires the two sets of equations to be solved simultaneously to achieve a converged solution.

A finite element mesh for the ventricular ►**myocardium** is shown in Fig. 3. This mesh, based on tricubic-Hermite elements is used for solving the large deformation equations of nonlinear elasticity theory. In this example the governing equations (representing conservation of mass and momentum) can be solved subject to ventricular pressure boundary conditions acting directly on the inside walls of the heart, but if these wall mechanics equations are coupled to equations governing fluid flow in the

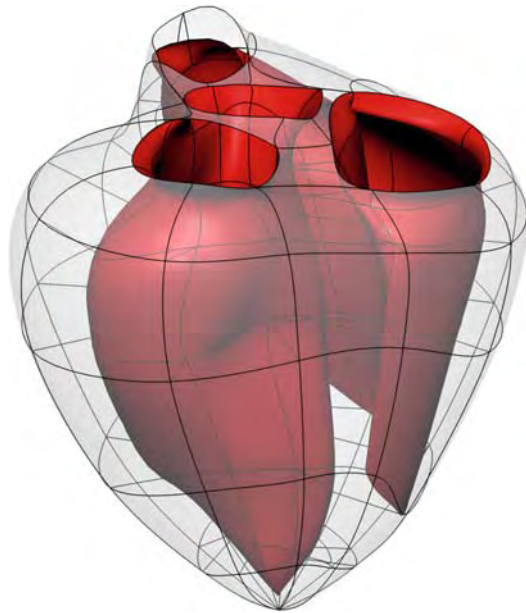

**Cardiovascular Mechanics. Figure 3** A finite element mesh used for solving the large deformation mechanics of the left and right ventricles. The surfaces shaded *red* are the internal surfaces – endocardium – surrounding the left and right ventricles, and the outer translucent surface is the epicardium. The holes at the top are the orifices regulated by the four cardiac valves – the mitral and tricuspid valves link to the left and right atria respectively and the aortic and pulmonary valves link the ventricles to the aorta and pulmonary artery, respectively.

ventricles, the boundary conditions become flow or pressure conditions specified at the flow inlets and outlets.

In some applications the finite element mesh used for solving ventricular mechanics is also used for solving reaction diffusion equations governing the spread of electrical activation through the myocardium. The equations of cardiac cell electrophysiology are based on models of the ionic currents that underlie the cardiac action potential. The cellular models can also be extended to include other aspects of cellular function, such as metabolism, pH control, signal transduction and gene regulation [7].

## References

1. Schmid H, Nash MP, Young AA, Hunter PJ (2006) Myocardial material parameter estimation – a comparative study for simple shear. *J Biomech Eng* 128(5):742–750
2. Nash MP, Hunter PJ (2001) Computational mechanics of the heart. *J Elasticity* 61(1–3):113–141
3. Hunter PJ, Pullan AJ, Smaill BH (2003) Modelling total heart function. *Annu Rev Biomed Eng* 5:147–177
4. LeGrice IJ, Smaill BH, Chai LZ, Edgar SG, Gavin JB, Hunter PJ (1995) Laminar structure of the heart: ventricular myocyte arrangement and connective tissue architecture in the dog. *Am J Physiol* 269:H571–H582
5. Hunter PJ, Nielsen PMF (2005) A strategy for integrative computational physiology. *Physiology* 20:316–325
6. Holzapfel GA, Ogden RW (eds) (2006) *Mechanics of biological tissue*. Springer, Berlin Heidelberg New York
7. Humphrey JD, Delange SL (2004) *An introduction to biomechanics*. Springer, New York

## Cardiovascular Reflexes

BRIAN BUDGELL

School of Health Sciences, Faculty of Medicine,  
Kyoto University, Kyoto, Japan

### Synonyms

Somato-cardiovascular reflexes; Viscero-cardiovascular reflexes

### Definition

#### Cardiovascular Reflexes

The cardiovascular reflexes are those reflexes which impact cardiovascular structures (and so, functions) either through direct innervation or secondarily, for example by influencing the release of substances such as ADH.

### Characteristics

There is, of course, a wealth of reflexes contributing to cardiovascular function, and a number of these reflexes

are dealt with specifically in separate essays or as glossary entries in this text. The large number and the intricacy of some cardiovascular reflexes make this area of physiology challenging to understand. Sometimes this apparent complexity is augmented by the natural human tendency of students and researchers to focus so much on the fine details of specific reflex mechanisms that we fail to “see the forest for the trees.” In this essay, we wish to particularly consider the principles revealed by those cardiovascular reflexes which manifest their effects via autonomic efferent neurons. We shall begin by looking at representative reflexes which are dependent upon afferent input from the cardiovascular system itself, and then expand our perspective to consider the influence of input from other organ systems.

The baroreceptor reflex, described in detail by Professor Dampney (►[Baroreceptor reflex](#)), is a well-studied reflex which demonstrates a number of important principles governing cardiovascular reflexes [1]. This reflex occurs in response to the stimulation of various subtypes of receptors located in a number of different locations in the cardiovascular system (most notably, the carotid sinus). Hence, there is a degree of *redundancy* which tends to dampen the effects of dysfunction in any one component of the afferent arm of the reflex. The reflex is *adaptive* in that it functions to maintain a fairly constant flow of blood to the brain despite alterations in blood pressure. In regard to *adaptivity*, this reflex also probably functions to optimize the efficiency of gas exchange in the lungs by increasing perfusion during inhalation. The reflex is highly *sensitive*, responding to very small changes in central blood pressure. However, it is also *adaptable* in that it permits blood pressure and ►[heart rate](#) to increase in tandem during physical exertion (►[Autonomic function and exercise](#)). The baroreceptor reflex also demonstrates another principle of autonomically-mediated cardiovascular reflexes: *reciprocal modulation* of sympathetic and parasympathetic tone. In fact, it may demonstrate this principle too well, for as we shall see, and notwithstanding popular perception, *co-activation* of sympathetic and parasympathetic output may be as common a strategy, or even a more common strategy [2].

Other cardiovascular reflexes initiated by input from within the cardiovascular system include the Bainbridge reflex, in which acute volume loading of the atria leads to sympathetically-mediated ►[tachycardia](#), and the ►[Bezold-Jarisch reflex](#) in which excitation of ventricular receptors, especially left ventricular vagal afferents, leads to vagally-mediated ►[bradycardia](#) and vasodilation. The Bainbridge reflex may provide a mechanism of *adaptation* to increased blood volume, and is accompanied by hypothalamically-mediated strategies to reduce blood volume. The Bainbridge reflex also provides a degree of *redundancy* to the baroreceptor reflex by facilitating tachycardia during

inspiration. The Bezold-Jarisch reflex, which may contribute to dysrhythmia following, for example, ischemic damage to the ventricles, may also have an *adaptive* role in dampening the sympathetic response to orthostatic hypotension.

In addition to contributions by mechanoreceptors within the heart and great vessels, chemoreceptors in the central nervous system and in blood vessels provide important information on blood gases and pH leading to reflex modulation of circulatory function (and, of course, respiratory function as well).

Non-cardiovascular **▶visceral afferents**, such as those in the respiratory and digestive systems, also have the capability of influencing cardiovascular function. The integration of afferent input from different visceral organs occurs most notably in the nucleus of the solitary tract (NTS) [3]. Hence, stimuli signaling metabolic demand in particular viscera will result in reflex alterations in sympathetic outflow to the corresponding vascular beds in order to facilitate appropriate perfusion. Conversely, noxious stimulation of afferents within the airways of the respiratory system often results in bradycardia and systemic (as well as pulmonary) hypertension – a reflex which, in conjunction with changes in ventilatory behavior, likely inhibits the uptake of noxious chemicals into the blood stream.

Bradycardia with hypertension suggests *co-activation* of sympathetic and parasympathetic efferents, a pattern characteristic of the trigeminocardiac reflexes [2]. These are a family of cardiovascular reflexes involving afferent stimulation within the distribution of the trigeminal nerve, and the most familiar example is the so-called “diving reflex.” This phenomenon, triggered by immersion of the face in cold water (or even cold air blowing on the face), manifests as apnea, bradycardia and hypertension – a highly *adaptive* strategy when submerged! Interestingly, the oculo-cardiac reflex, initiated by stimulation within the distribution of the ophthalmic branch of the trigeminal nerve, is characterized by hypotension – a response which is more common when confronted with noxious visceral stimulation, particularly deep pain.

Cardiovascular reflex responses to noxious stimulation, especially noxious somatic stimulation, have been well-characterized [4] and are discussed elsewhere in this text by Dr. Uchida (**▶Somato-autonomic reflex**). Normally, noxious stimulation of somatic tissues leads to tachycardia and systemic hypertension – the “fight or flight response” – leading to increased **▶cardiac output** with obvious *adaptive* significance. In detail, however, the responses of different vascular beds are specific rather than stereotypical, and may be influenced by coincident innocuous stimulation. In simpler terms, pain does not necessarily lead to wholesale sympathetic activation, but rather a tailored response. Innocuous

somatic stimulation, conversely, is often, but not invariably, associated with reduction in heart rate and blood pressure attributed to increased vagal tone (**▶Vagus nerve**) and decreased sympathetic tone. However, the precise response is *adaptable* and will be influenced, for example, by the site, modality and psychosocial context of the stimulation.

Cardiovascular reflexes may also be initiated or modulated by information concerning body position and movement, especially information from the vestibular system [5]. A role has also been postulated for postural information from paraspinal muscles, and in humans, this would particularly include the muscles of the neck [6].

### Higher Level Structures

In humans, reflex sympathetic output to the cardiovascular system originates most immediately in the rostral ventrolateral medulla (VLM), and incorporates input from the hypothalamus and brain stem nuclei [1,3] (**▶Central regulation of autonomic function**). Specifically, parvocellular neurons of the paraventricular nucleus of the hypothalamus project both to the rostroventrolateral medulla and directly to spinal sympathetic preganglionic neurons (SPNs). Neurons of the rostral ventrolateral medulla are arranged in clusters which project in a topographic, and therefore viscerotropic, fashion to sympathetic preganglionic neurons. Hence, stimulation of more cephalad cell clusters may result in constriction of the renal vascular bed, whereas stimulation of more caudal cells results in constriction of mesenteric and hind limb muscle vascular beds. The VLM neurons project primarily to the intermediolateral cells columns of the thoracic cord, and release catecholamines and L-glutamate to excite spinal SPNs [7]. Within the spinal cord, the activity of some SPNs is inhibited by nitric oxide and glycine, although the effects of nitric oxide are complex and involve multiple pathways in the spinal cord.

Parasympathetic innervation to the heart originates in the dorsal vagal motor nucleus and the nucleus ambiguus. Neurons in the dorsal vagal motor nucleus, stimulated directly by the nucleus of the solitary tract (NTS), are probably of less importance to cardiac function than neurons of the nucleus ambiguus, which are indirectly stimulated by the NTS via the caudal VLM. Increased input to the NTS from baroreceptors brings about reflex attenuation of heart rate via vagal stimulation. The dorsal vagal motor nucleus and nucleus ambiguus are also the source of relatively sparse parasympathetic innervation to vascular beds in a variety of organs.

### Lower Level Components

As somatic and visceral afferents are dealt with in depth elsewhere in this text, below we will particularly consider

the lower level efferent components of cardiovascular reflexes, dealing first with sympathetic motor neurons and then parasympathetic motor neurons.

Spinal sympathetic preganglionic neurons are located principally within the intermediolateral and, to a lesser extent, intermediomedial columns of the thoracic and upper lumbar spinal cord [7]. In humans, some SPNs are also located within the central autonomic nuclei and the lateral funiculus. The cells of the spinal sympathetic nuclei are not uniformly distributed, but rather are arranged in nests along the length of the thoracic and upper lumbar cord. Axons from each cluster of SPNs exit the spinal cord mainly through the immediately adjacent nerve roots and so project to particular peripheral targets. Upper thoracic SPNs, the overwhelming majority arising from the first to fifth thoracic levels, project to the heart, particularly the ventricles, via the cervical sympathetic ganglia (►Autonomic ganglion). Additionally, SPNs along the length of the thoracolumbar spinal cord also project in a segmentally-organized fashion to adjacent vascular beds.

The cell bodies of postganglionic neurons within the cervical sympathetic ganglion are arranged in a topographical fashion and form morphologically distinct clusters [7]. Hence, by way of example, stellate ganglion cells projecting to the heart may be distinguished from SPNs to, for example, the vascular bed of the sternocleidomastoid muscle.

Cardiac sympathetic nerves arising from the left and right cervical sympathetic chains and ganglia cross (and sometimes cross back again) from left to right on their journey to the heart [8]. Furthermore, it is apparent, and consistent with their anatomical targets, that left and right autonomic nerves serving the heart are functionally distinct. In particular, sympathetic fibers arising from the left stellate ganglion appear to have a greater influence on heart rate and heart rate variability, such that excessive activity of fibers from the left stellate ganglion or loss of modulating influences from the right stellate ganglion favor arrhythmogenesis.

The cardiac vagus nerve consists of parasympathetic preganglionic fibers which project through mixed sympathetic and parasympathetic plexi to parasympathetic ganglia close to or in contact with the heart. From these ganglia, postganglionic fibers course to the electrical conduction system of the heart and, to a lesser extent, to the myocardium [9]. In histological sections of human heart, the greatest concentration of acetylcholinesterase-positive cells is seen in the region of the sinoatrial node, with concentrations diminishing through the atrioventricular node, the atrioventricular bundle and into the bundle branches. In general, parasympathetic innervation of the sinoatrial node is predominantly from the right vagus nerve, while innervation of the atrioventricular node is predominantly from the left vagus nerve.

### Higher Level Processes

Autonomic output to the cardiovascular system originates from the interaction of a number of components of the central nervous system (►Central regulation of autonomic function). In particular, the nucleus tractus solitarius (NTS) integrates sensory input from the viscera with information from higher brain centers in order to synthesize output to other brainstem and spinal reflex centers [1]. A portion of visceral afferent input to the NTS projects in a viscerotropic fashion such that information from particular organs projects to specific nuclei within the NTS. The anatomical basis therefore exists for reflex responses which are influenced by the current afferent input from particular visceral organs.

Baroreceptor afferents (►Baroreceptor reflex), which provide beat to beat information on cardiovascular function, project particularly to the intermediate (general visceral) region of the NTS. From the NTS afferent information of different types is relayed to various centers including the insular cortex (the primary viscerosensory cortex), the periaqueductal gray (PAG) of the midbrain, the parabrachial region of the pons, and the ventrolateral medulla. Baroreceptor information is especially relayed to the caudal then rostral ventrolateral medulla and cardiovagal neurons. Receptors similar to those of the carotid sinus, but perhaps less studied, have also been identified in the aortic arch and the myocardium, and pulmonary and thoracic stretch receptors also have a small role in modulating the rhythmicity of central autonomic neurons. There may also be a very short feedback loop by which intrinsic cardiac neurons increase their activity in response to local mechanical stimulation. Some vascular and pulmonary baroreceptors convey afferent information via the vagus nerve giving this nerve an afferent and efferent role in the reflex regulation of the cardiac cycle. Visceral pain and perhaps some baroreceptor information may also ascend via the spinothalamic, spinoreticular and spinomesencephalic pathways to influence baroreceptor reflex behavior. Noxious input, and so activation of the PAG, tends to dampen baroreflexes by augmenting the activity of cardiac sympathetic efferents. Conversely, baroreceptor excitation also depresses somato-cardiac sympathetic reflex responses to A- and C-fiber excitation [4].

Sensory input from the viscera may also be influenced at the level of the primary afferent by convergence with information from somatic tissues, including convergence of thoracic somatic and cardiac afferents onto single spinal neurons. Histological and physiological data also indicate projections of somatic afferents to visceromotor centers. The implied interaction is self-evident in, for example, cardiovascular responses to pain, and involves, at least in part, projections via the periaqueductal gray to the rostral ventrolateral medulla.

In preparation for increased demand on the cardiovascular system, anticipatory “central command” may increase heart rate and blood pressure prior to signaling of work from receptors within the muscle (► [Autonomic function and exercise](#)). Additionally, chemoreceptors and mechanoreceptors within muscle signal ongoing exercise. However, input from large diameter group Ia and Ib afferents generally has little influence on cardiovascular function. Central projections and effects of afferent input from neck muscles may represent a special case. Some low-threshold somatic afferents from the neck region project directly to the vestibular nuclei and thereby modulate vestibular influences on cardiovascular function. There is also physiological evidence of more direct connections between cervical muscle afferents and autonomic motor neurons; specifically, projection of muscle afferents directly to spinal sympathetic preganglionic neurons. These results suggest a special role for afferent input from axial muscles, especially those of the neck [6]. The adaptive rationale for these interconnections would include maintenance of appropriate blood pressure and blood volume distribution during postural changes.

### Lower Level Processes

Within the heart, the sympathetic efferents innervate many targets. Human heart contains subtypes of  $\alpha_1$ ,  $\alpha_2$ ,  $\beta_1$  and  $\beta_2$ -adrenergic receptors.  $\beta$ -adrenergic receptor subtypes are the more abundant and their stimulation generally results in increased heart rate and increased force of contraction. Although these receptors are fairly evenly distributed throughout the atria and ventricles, the sinoatrial node is especially richly invested [10]. Both of  $\alpha$  and  $\beta$ -adrenergic receptors are also found on vascular smooth muscle. Stimulation of  $\alpha$ -adrenergic receptors leads to vasoconstriction, whereas the stimulation of  $\beta$ -adrenergic receptors on skeletal muscle and liver vasculature leads to vasodilation.

The effects of vagal stimulation on the heart have been attributed primarily to the release of acetylcholine and somatostatin. A number of subtypes of muscarinic acetylcholine receptors are found in the mammalian heart. The M2 subtype is the most abundant muscarinic receptor in human myocardium, and is more abundant in atrial than ventricular tissue.

While parasympathetic innervation of blood vessels is sparse when compared with sympathetic innervation, M3 muscarinic receptors are found in vascular endothelium. Activation of endothelial muscarinic receptors leads to the production of NO which diffuses into adjacent smooth cells initiating vasodilation.

### Process Regulation

It has been argued that as a result of integration of information from diverse receptors, cardiovascular reflexes are fundamentally adaptive and adaptable to

the unique circumstances in which they arise in each individual. Interestingly, however, at the level of the spinal nuclei, virtually all stimuli result in what could be regarded as excitatory reflexes. Hence, both noxious and innocuous stimulation at any given site will initiate responses characteristic of “fight or flight.” It is the influence of descending excitatory and inhibitory pathways which then modulates (facilitates or depresses) the spinal reflexes in order to produce the final response most appropriate to the subject’s current circumstances [4]. The coordinated regulation of cardiovascular reflexes is most easily appreciated when the harmonious interaction of supraspinal and spinal components is disrupted by spinal injury, as described briefly below.

### Function

Collectively, the cardiovascular reflexes are designed to partition a limited blood supply among tissues with changing and often competing demands. Furthermore, this task must be accomplished in a dynamic creature whose movements may impose sudden gravitational challenges on the partitioning of the blood (not to mention other fluids and tissues of the body). The remarkable success of reflex regulation of cardiovascular function owes much to the effectiveness of the central nervous system in integrating afferent input from many sources: the cardiovascular system itself, other viscera, the somatic tissues of the musculoskeletal system and skin, and of course input from higher centers of the nervous system itself (► [Homeostasis](#)).

### Pathology

Cardiovascular reflexes come to clinical attention most often when pathology prevents their appropriate expression, for example when autonomic failure leads to phenomena such as orthostatic hypotension. However, the reflexes may themselves become pathological when dysfunction occurs in the afferent or efferent arms of the reflex pathway, or when there is an error in central processing. This occurs most dramatically in autonomic dysreflexia (► [Autonomic/enteric dysreflexia](#)) following high spinal cord injury. Often following high spinal cord injury, more caudal spinal autonomic reflex centers are liberated from descending inhibition. Additionally, new and inappropriate synapses may form following injury and this may facilitate over-exuberant cardiovascular responses to somatic or visceral stimulation. Clinically, this may manifest as paroxysmal hypertension, which is an important source of morbidity and mortality in spinal patients.

### Therapy

Cardiovascular reflexes see little application in conventional western medicine. Clinicians, and patients themselves, may occasionally take advantage of the

oculo-cardiac reflex or the baroreceptor reflex (by applying pressure to the eyes or the carotid bifurcation) to transiently attenuate hypertension or palpitations. In various forms of traditional medicine, however, innocuous or noxious stimulation may be applied to the skin (for example, via acupuncture) or muscles (for example, via mobilization or manipulation) with the intent of effecting long-term changes in cardiac function, systemic blood pressure or perfusion of particular vascular beds. The clinical effectiveness of these approaches is largely untested.

## References

1. Dampney R, Coleman M, Fontes M, Hirooka Y, Horiuchi J, Li Y et al. (2002) Central mechanisms underlying short- and long-term regulation of the cardiovascular system. *Clin Exp Pharmacol Physiol* 9:261–268
2. Paton J, Boscan P, Pickering A, Nalivaiko E (2005) The yin and yang of cardiac autonomic control: vago-sympathetic interactions revisited. *Brain Res Rev* 49:555–565
3. Loewy A (1990) Anatomy of the autonomic nervous system: an overview. In: Loewy A, Spyer K (eds) *Central regulation of autonomic functions*. Oxford University Press, New York, pp 3–16
4. Sato A, Sato Y, Schmidt R (1997) The impact of somatosensory input on autonomic functions. *Rev Physiol Biochem Pharmacol* 130:1–328
5. Ray C, Carter J (2003) Vestibular activation of sympathetic nerve activity. *Acta Physiol Scand* 177:313–319
6. Bolton P, Ray C (2000) Neck afferent involvement in cardiovascular control during movement. *Brain Res Bull* 53:45–49
7. Cabot J (1990) Sympathetic preganglionic neurons: cytoarchitecture, ultrastructure, and biophysical properties. In: Loewy A, Spyer K (eds) *Central regulation of autonomic functions*. Oxford University Press, New York, pp 44–67
8. Pather N, Partab P, Singh B, Satyapal K (2003) The sympathetic contributions to the cardiac plexus. *Surg Radiol Anat* 25:210–215
9. Quan K, Lee H, Van Hare G, Biblo L, Mackall J, Carlson M (2002) Identification and characterization of atrioventricular parasympathetic innervation in humans. *J Cardiovasc Electrophysiol* 13:735–739
10. Brodde O, Bruck H, Leineweber K, Seyfarth T (2001) Presence, distribution and physiological function of adrenergic and muscarinic receptor subtypes in the human heart. *Basic Res Cardiol* 96:528–538

## Carotid Angioplasty and Stenting

### Definition

This is a possible alternative to carotid endarterectomy to treat narrowing in the carotid artery: A carotid stent

is a small metal mesh tube that is inserted into the carotid artery via a catheter inserted through the femoral artery.

The stent is advanced up to the carotid artery and expanded, thus the narrowed carotid artery is widened (sometimes with the assist of a small balloon inflation, i.e., angioplasty).

- ▶ Ischemic Stroke
- ▶ Stroke

## Carotid Body Chemoreceptors and Respiratory Drive

ARIJIT ROY, RICHARD J. A. WILSON  
Hotchkiss Brain Institute, Department of Medical Physiology and Biophysics, University of Calgary, Calgary, AB, Canada

### Synonyms

Peripheral chemoreceptors; Respiratory rhythmogenesis

### Definition

The carotid bodies (CBs) are peripheral chemoreceptors that detect changes in arterial blood O<sub>2</sub>, CO<sub>2</sub>, pH, glucose and temperature and provide a key source of stimulation to brainstem respiratory centers.

### Characteristics

#### Introduction

Carotid bodies (CBs) are peripheral arterial **▶ chemoreceptors** located in the neck that detect changes in PO<sub>2</sub>, PCO<sub>2</sub>, pH, temperature and glucose in arterial blood. The importance of the CB to the control of breathing was first revealed by the Belgium physiologist, Corneille Jean Francois Heymans. Heymans discovered that cutting the neuronal connections between the carotid body and brainstem caused breathing to slow (hypoventilation) in the resting state and eliminated fast breathing (hyperventilation) caused by creating a local hypoxia-like situation by injecting cyanide into the CB circulation. These experiments demonstrated an essential role for the CBs in maintaining normal arterial carbon dioxide levels and initiating the primary respiratory and cardiovascular physiological responses to hypoxia. In 1938, Heymans was awarded the Nobel Prize for his discovery, arguably one of the most significant in respiratory research to date.

## Overview of the Carotid Body

### Anatomy, Morphology, Innervations and Blood Supply

Oxygen is sensed by almost all mammalian cells (excitable and non-excitable), but the principle sensors, those with the greatest sensitivity and capability of initiating systemic responses, are the carotid bodies (CBs). While the CBs are the principle oxygen sensors, they also participate in the regulation of carbon dioxide, pH, temperature and glucose. The CBs are paired organs located bilaterally at each of the common carotid bifurcations in the neck (see Fig 1). This is a strategic location, between the heart and brain, two of the most oxygen-dependent organs.

The CBs vary in size and weight depending upon species. In humans, a normal CB measures 3–5 mm in diameter but the CBs are often larger in people living at higher altitudes. The histological appearance of the CB includes two types of cells: glomus cells (also known as type I cells) and sustentacular cells (also called type II). Glomus cells are the primary oxygen sensors. There are ~9,000 and ~60,000 glomus cells in the rat and cat, respectively. Glomus cells are embryologically derived from the ►neural crest, are electrically excitable and have globular cell bodies usually 8–15 µm in diameter. Ultrastructural studies have shown that the glomus cell cytoplasm contains dense as well as clear cored vesicles that actively synthesize and package neurotransmitters, e.g., catecholamine, acetylcholine. They also have an abundance of mitochondria which explains the comparatively high oxygen consumption measured for CB tissue. Groups of 5–10 glomus cells are typically arranged into clusters surrounded by 2–3 sustentacular cells and separated from other clusters by blood vessels. Recent evidence suggest that glomus cells are electrically coupled, and that coupling is modulated by hypoxia.

The principal sensory innervation of glomus cells is via the carotid sinus nerve (CSN), a branch from the glossopharyngeal nerve (GPN; IXth ►cranial nerve) which carries ►afferent signals to the brainstem respiratory center. The afferent nerve endings on glomus cells are part of neurons whose cell bodies are located in the petrosal ganglion (Fig. 1).

Such nerve endings comprise more than 95% of the nerve endings on glomus cells. The CB also receives sensory innervation from the jugular and nodose ganglia. Recent investigations have shown that CBs receive efferent innervation from nNOS (neuronal nitric oxide synthase)-containing neurons located in the GPN and CSN. In addition, carotid afferent neural discharge is also regulated by ►efferent fibers from the ►sympathetic supply of the superior cervical ganglion (SCG), through the ganglioglomerular nerve. These efferent pathways are generally considered to be inhibitory to the CB.

Blood vessels comprise nearly 20% of the total volume of the CB, consistent with the organ's enormous

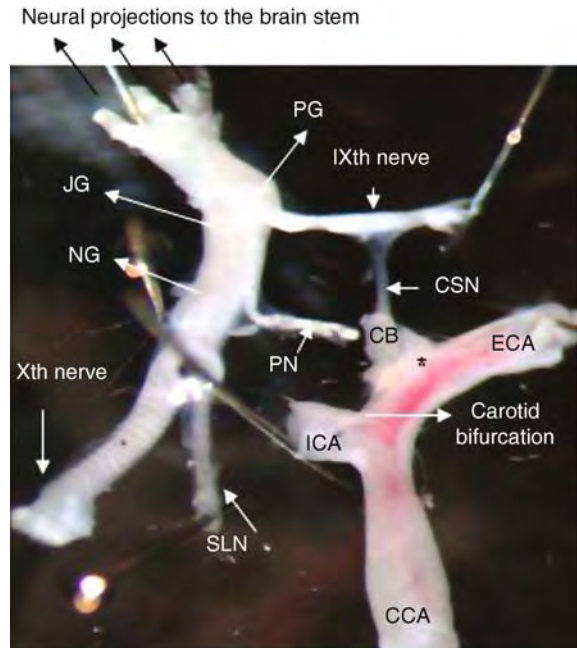

**Carotid Body Chemoreceptors and Respiratory Drive. Figure 1** Photograph of an *in vitro* CB with other surrounding structures from a neonatal rat. PG, petrosal ganglion; NG, nodose ganglion; JG, jugular ganglion, CB, carotid body; ECA, external carotid artery; ICA, internal carotid artery; CCA, common carotid artery; PN, pharyngeal nerve; SLN, superior laryngeal nerve; CSN, carotid sinus nerve. IXth nerve, glossopharyngeal; Xth nerve, vagus. \*The occipital artery was severed to make the CB visible.

blood flow (about 40 µl/min per cat CB or more than 2 l/min/100g). In most species the CB's blood flow comes from the external artery or its branches. In the rat a single CB artery usually arises directly from the external carotid artery near the bifurcation of the common carotid artery or from the occipital artery, but in the cat the source of the vessel is quite variable. Arterio-venous (A-V) ►anastomoses play an important role in regulating blood flow within the CB during hypoxia. A rise in sympathetic nerve activity during hypoxia causes a redistribution of blood flow in the CB, with a-v anastomoses diverting arterial blood from regions of glomus cells with a high metabolic rate to regions of low metabolism.

## Carotid Body Responses to Hypoxia

### Acute Versus Chronic. Mechanisms of Oxygen Sensing in the CB. Integration of the Hypoxia Signaling Pathway Within the CB from Sensors to Couplers (Signaling Molecules) to Effectors

Oxygen deprivation/low ►partial pressure of oxygen, or ►hypoxia, can arise from many physiological as well as pathological situations. It is widely accepted that

glomus cells of the CB are the primary site for oxygen sensing and that hypoxia causes their depolarization, triggering neurotransmitter release. However, the precise details need to be worked out. As reviewed in the following sections, CB responses to hypoxia can be acute (time scale of seconds to minutes) or chronic (time scale of hours to days). Further, there are various proposed mechanisms for oxygen sensing and multiple signaling pathways that may be involved in mediating the CB responses to hypoxia.

### Acute Responses

During normoxia (100 Torr PO<sub>2</sub>) CSN shows mild levels of activity. Activity is almost abolished at higher levels of PO<sub>2</sub> (>200 Torr) but increases exponentially as the level of PO<sub>2</sub> is decreased. Studies using isolated CB preparations suggest that the response to a bout of hypoxia can be multiphasic. Accordingly, activity reaching a maximum within the first few minutes of hypoxia, and then declines slightly but remains elevated for the remainder of the bout (*sensory hypoxic decline*). Following termination of the bout, CSN activity falls below that preceding the bout (*sensory post-hypoxic decline*). Augmentation occurs when multiple bouts occur in succession (sensory augmentation) and under some stimulus paradigms it's possible to induce long lasting increases in baseline activity (*sensory long term facilitation*). Whether these responses contribute to similar time-dependent ventilatory responses remains to be determined.

The richness of the acute response of the carotid body to hypoxia, may reflect the complexity of the organ which is endowed with a plethora of neurotransmitter and neuromodulator systems and involves the possible interaction of multiple oxygen sensing mechanisms, as summarized below:

### Metabolic or Mitochondrial Pathway

The metabolic hypothesis was originally proposed by [1] and eventually developed by [2] The hypothesis states that due to less oxygen (during hypoxia) electron transport from the substrate to oxygen through the ►mitochondrial respiratory chain is retarded, as a result the electron carriers (i.e., different complexes) operate in more reduced states. This inhibits ►oxidative phosphorylation, increases ►NADH concentration and decreases ►ATP production leading to an increase in mitochondrial matrix H<sup>+</sup> concentration. Eventually, the mitochondria depolarize, triggering calcium release from the endoplasmic reticulum-mitochondrial stores that eventually results in plasma membrane depolarization and neurotransmitter release. In support of the mitochondrial hypothesis, high concentrations of carbon monoxide [CO; a complex IV inhibitor; partial pressure of CO (Pco) > 300 Torr] during normoxia augment CB sensory discharge in the dark and mimic

hypoxia. Consistent with the hypothesis, the CO-induced increase is reversible by white light, with the photochemical action spectrum of the light effect on sensory activity matching the absorbance spectrum of the ►cytochrome aa<sub>3</sub> – CO complex. Further, mitochondrial inhibitors, like rotenone (complex I inhibitor), antimycin (complex III inhibitor), cyanide (complex IV inhibitor), and oligomycin (ATP - synthase inhibitor) transiently increase CB chemosensory activity and abolish the hypoxic response. According to this hypothesis, the terminal oxidase of the mitochondrial respiratory chain within glomus cells, cytochrome aa<sub>3</sub> (a heme protein), is different from that in other tissues, having an unusually low affinity for oxygen. This low affinity makes the CB cytochrome aa<sub>3</sub> more sensitive to slight falls in oxygen, and hence a likely candidate for an oxygen sensor.

### Membrane or Ion Channel Pathway

[3] from Spain were the first to enunciate this hypothesis. According to this hypothesis, the immediate O<sub>2</sub> sensor is coupled directly to K<sup>+</sup> channels situated within the plasma membrane of glomus cells, the seminal biophysical change during hypoxia being a reduction in the conductance of these channels, leading to cell depolarization. Various types of K<sup>+</sup> channels have been identified in CB glomus cells that demonstrate a reduction in conductance in the presence of hypoxia, but their relative importance in oxygen sensing is likely to be species dependent. These include: (i) ►Ca<sup>2+</sup> insensitive, voltage-dependent transient K<sup>+</sup> channels (IK<sub>v</sub>); (ii) ►Ca<sup>2+</sup> sensitive, voltage-dependent K<sup>+</sup> channels (IK<sub>Ca</sub>) - similar to large conductance BK-type channels; (iii) Voltage insensitive TASK-like ►leak K<sup>+</sup> channels - active around the resting membrane potential of glomus cells; and (iv) ►HERG-like K<sup>+</sup> channels.

It is worth mentioning that the mitochondrial and ion channel hypotheses are not mutually exclusive and may act synergistically to regulate CB neural discharge (see Fig. 2).

### ROS Hypothesis

[4] postulated that NADPH oxidase, a heme-containing enzyme present in the CB glomus cells, produces reactive oxygen species (ROS) such as H<sub>2</sub>O<sub>2</sub> during normoxia. Hypoxia reduces the activity of the enzyme, leading to a decrease in H<sub>2</sub>O<sub>2</sub> production. According to the ROS hypothesis, a decrease in H<sub>2</sub>O<sub>2</sub> production results in an increased ratio of reduced to oxidized glutathione (GSH/GSSG), which in turn reduces the opening probability of the K<sup>+</sup> channels in the plasma membrane, leading to depolarization of the glomus cells. In support of this hypothesis, diphenyliodonium (DPI), an inhibitor of NADPH oxidase, augments CB basal activity and blocks further augmentation by



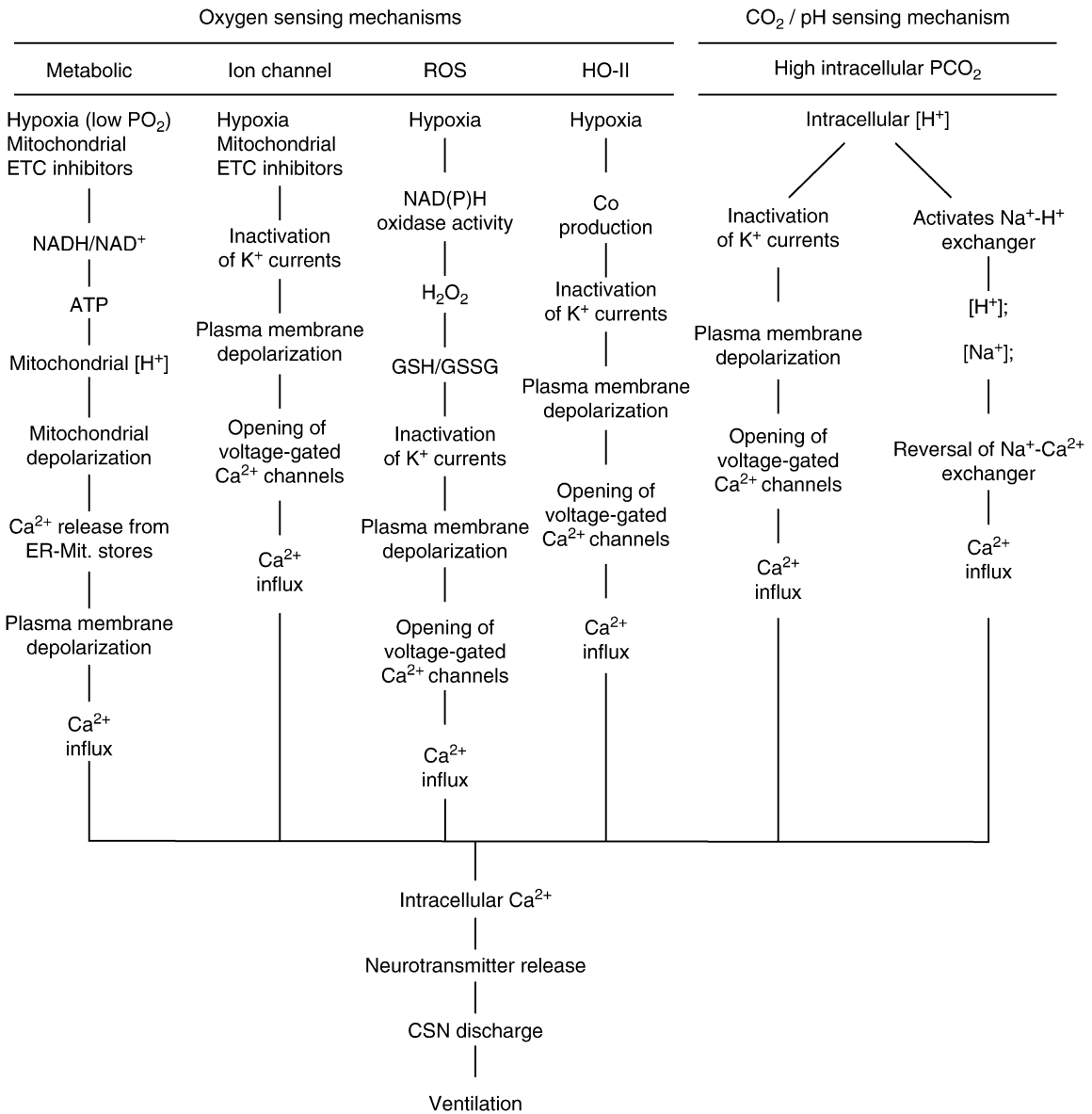

**Carotid Body Chemoreceptors and Respiratory Drive. Figure 2** Proposed models of O<sub>2</sub> and CO<sub>2</sub>/pH sensing in the CB. Arrows upward and downward indicate increase and decrease respectively. ROS, reactive oxygen species; HO-II, heme oxygenase-II; ETC, electron transport chain.

hypoxia. Thus, NAD(P)H oxidase may serve as an oxygen sensor.

### Heme Oxygenase-2

Membrane bound heme oxygenase -II (HO-II) immunoreactivity has been reported in glomus cells. In normoxia, HO-II likely breaks down heme oxidatively to iron, biliverdin and CO. This endogenous CO has the capability of exerting an excitatory influence on large conductance K<sup>+</sup> channels (BK channels) reducing the excitability of the glomus cell. Thus, according to the hypothesis, oxygen becomes rate limiting for the

HO-II during hypoxia and CO production is reduced which, in turn, reduces the conductance of the BK channels leading to depolarization of glomus cells. In support of this hypothesis, HO-II inhibition by Zn-protoporphyrin-IX blocks endogenous CO and augmented the CB chemosensory activity [5]. This is consistent with the inhibition of chemosensory activity during hypoxia in the presence of low levels of CO. Hence, HO-II has now been claimed as an oxygen sensor.

The final consequence of hypoxic-modulation of the glomus cell function is neurotransmitter release.

The conventional neurotransmitters involved include catecholamines, ATP and acetylcholine.

### ATP

Increasing evidence suggests that the purines, ATP and adenosine, make key contributions in CB hypoxic signaling. Glomus cells release ATP in response to hypoxia which can stimulate P2X receptors on afferent terminals, elevating intracellular  $\text{Ca}^{2+}$  and producing excitatory responses. The ATP released from the glomus cells can also be dephosphorylated to adenosine by a series of extracellular enzymes, which in turn can stimulate  $A_1$ ,  $A_{2A}$  and  $A_{2B}$  adenosine receptors. When stimulated, these receptors increase ventilation rate. Prolonged hypoxic challenge can alter the expression of purinergic receptors, suggesting a role in hypoxic adaptation.

### Acetylcholine (ACh)

Glomus cells express the enzymes necessary for the generation and inactivation of ACh. Hypoxia results in release of ACh in cat CBs, however in rat and rabbit CBs hypoxia inhibits the basal release of ACh. ACh has both excitatory and inhibitory effects within the carotid body, mediated by nicotinic and muscarinic ACh receptors, respectively. The relative abundance of the nACh and mACh in the CBs varies among species leading to different species-dependent effects of ACh on CSN discharge.

### Catecholamines

Glomus cells from cat, rabbit and rat CBs express tyrosine hydroxylase (TH) and dopamine  $\beta$  hydroxylase, (DBH) the enzymes responsible for the synthesis of dopamine (DA) and norepinephrine (NE), respectively. Both DA and NE are released from glomus cells in response to hypoxia in a  $\text{Ca}^{2+}$  dependent manner, though DA would appear to be released preferentially. Both catecholamines are considered to be inhibitory to CB. Blockade of dopaminergic receptors for example usually potentiates the response to hypoxia.

### Chronic Responses

Long lasting changes in the CB morphology and functioning are evident in chronic sustained and chronic intermittent hypoxia. One of the many physiological adaptive responses to **chronic sustained hypoxia** is **ventilatory acclimatization to hypoxia (VAH)**. VAH occurs most frequently in mountaineers that ascend to high altitudes (low environmental  $\text{P}_{\text{O}_2}$ ) or in patients suffering from severe obstructive pulmonary diseases (resulting in hypoxemia). VAH is manifested as a hyperventilation over and above the acute response to the same level of hypoxia. Plasticity within the CB likely plays an important role in VAH. A number of morphological and biochemical alterations in the CB are associated with chronic hypoxic exposure including

hyperplasia of the glomus cells, increased vascularization, hypertrophy of the CB and increased catecholamine levels. Recent evidences suggest that some of these effects may involve hypoxia inducible factor-1 (HIF-1) [6]. The net result is a long-lasting, but reversible increase in the CB response to hypoxia. Interestingly, individuals born and raised in hypoxic environments show blunted hypoxic ventilatory responses. **Chronic intermittent hypoxia (IH)** occurs during periodic breathing experienced by sojourners sleeping at high altitude and humans suffering from obstructive and central apneas. While longterm effects of intermittent hypoxia on the ventilation of animals have been well documented, only recently have the longterm effects of intermittent hypoxia on ventilation in humans been reported. While most animal data points to a direct effect of IH on structures within the brainstem, increasing evidence suggesting that IH may also causes an increase in CB sensory activity that persists in normoxia, resembling long term facilitation (LTF) of breathing [7].

### $\text{CO}_2/\text{pH}$ Sensing in the CB

As demonstrated by Heymans, the CB is also a principal  $\text{pH}/\text{Pco}_2$  chemoreceptor involved in ventilation. They compliment additional sets of  $\text{CO}_2/\text{pH}$ -sensitive cells located in the brainstem, cerebellum and hypothalamus, known as the central respiratory chemoreceptors. However, the relative contribution of the CBs and central respiratory chemoreceptors remains hotly debated [8]. A simple view is that the CBs provide the rapid response, but the central chemoreceptors provide most of the steady-state response. However, as Heymans demonstrated, transecting the CSN leads to hypoventilation, an increase in arterial  $\text{PCO}_2$  and a resulting respiratory acidosis. Thus, while the CB's are vital for maintaining normal  $\text{PCO}_2$  the central chemoreceptors alone are insufficient.

There are two opposing hypothesis as to how hypercapnia (increase in partial pressure of  $\text{CO}_2$ )/fall in intracellular pH might elevate intracellular calcium and trigger CSN activity (Fig. 2): (i) Intracellular acidosis or hypercapnia inhibits membrane  $\text{K}^+$  channels, causing cell membrane depolarization and leading to  $\text{Ca}^{2+}$  entry through voltage-gated channels. (ii) Intracellular acidosis activates the  $\text{Na}^+ - \text{H}^+$  exchanger system, extruding  $\text{H}^+$  and increasing  $\text{Na}^+$  influx. This results in a rise in intracellular  $\text{Na}^+$  and subsequent  $\text{Ca}^{2+}$  influx through the reversal of the  $\text{Na}^+ - \text{Ca}^{2+}$  exchanger.

### Importance of the CB in Health and Disease

#### Oxford Fan

Hypoxic blood is often accompanied by alteration of  $\text{Pco}_2$ . At the organ/cellular level, low  $\text{O}_2$  and high  $\text{CO}_2$  interact synergistically to stimulate glomus cells ( $\text{O}_2 - \text{CO}_2$  stimulus interaction); the effects of hypoxia and hypercapnia applied simultaneously are greater

than the sum of these two stimuli when applied separately to the CB. As the  $P_{O_2}$  levels decline, the relationship between the sensory afferent nerve activity and  $P_{CO_2}$  becomes increasingly steeper, leading to enhanced ventilatory reflexes.

#### **Living Without Carotid Body/Carotid Body Denervation**

Carotid body denervation (CBD) in neonates results in significant mortality owing to hypoventilation, irregular breathing and long apneas. These effects seem to be age dependent. In adults, loss of CBs in otherwise healthy individuals is not acutely life threatening despite the resulting hypoventilation and loss of hypoxic response. In fact in, CBD survivors there is enough redundancy and plasticity in the control of breathing to eventually compensate for most of the consequence of CBD. One site of plasticity is the oxygen chemoreceptors of the aortic arch which change from having a weak to significant effect on ventilation.

#### **Chronic Mountain Sickness**

Humans living at altitudes are exposed to chronic hypobaric hypoxia and some suffer from chronic mountain sickness. The morphological alterations of the carotid bodies in people living at high altitudes are well known (see Section 3, Chronic response above). These may be adaptive, increasing the responsiveness of the carotid body to sustained hypoxia and therefore incomplete CB adaptation may exacerbate the likelihood of mountain sickness.

#### **Sleep Apnea**

A substantial population of humans experience chronic intermittent hypoxia as a consequence of recurrent **▶ apneas** during sleep. People with recurrent apneas are prone to hypertension, myocardial infarctions, metabolic syndrome and even stroke. The chemoreceptor gain of the carotid body in these patients is elevated, which may contribute to the cause of periodic breathing and the excitation of the carotid body during apnea is a primary cause of hypertension.

#### **Acute Respiratory Distress Syndrome (ARDS) and Chronic Obstructive Pulmonary Disease (COPD)**

Patients suffering from ARDS and COPD have profound morphological alterations in the carotid body. In some rare diseases, such as the **▶ congenital hypoventilation syndrome** and the **▶ sudden infant death syndrome**, anatomical and biochemical abnormalities of the carotid body have been shown.

#### **Unanswered Questions and Broad Range of Research Opportunities in CB Chemoreceptor Physiology**

1. Relative contribution of different  $O_2$ -sensing molecules to glomus cell excitability.

2. Understanding interaction between oxygen and carbon dioxide sensing within the CB.
3. Understanding sustentacular-glomus cell interactions.
4. Modulation of the CB function by **▶ efferents**.
5. Characterization of the signaling pathway from CB to the brainstem respiratory controller.
6. Understanding system-level interactions between peripheral and central chemosensors.

#### **References**

1. Anichkov SV Belehkii ML (1963) Pharmacology of the Carotid Body Chemoreceptors, Pergamon Press, UK Oxford
2. Lahiri S, Roy A, Baby SM, Hoshi T, Semenza GL, Prabhakar NR (2006) Oxygen sensing in the body. *Prog Biophys & Mol Biol* 91:249–286
3. Lopez-Barneo J, Pardal R, Ortega-Saenz P (2001) Cellular mechanisms of oxygen sensing. *Ann Rev Physiol* 63:259–287
4. Acker H (2005) The oxygen sensing signaling cascade under the influence of reactive oxygen species. *Phil Trans R Soc B*. 360:2201–2210
5. Prabhakar NR (2001) Oxygen sensing during intermittent hypoxia: cellular and molecular mechanisms. *J Appl Physiol* 90:1986–1994
6. Roy A, Baby SM, Wilson DF, Lahiri S (2007) Rat carotid body chemosensory discharge and glomus cell HIF-1 $\alpha$  expression in vitro: regulation by a common oxygen sensor. *Am J Physiol* 293:R829–836
7. Cummings KJ, Wilson RJ (2005) Time-dependent modulation of carotid body afferent activity during and after intermittent hypoxia. *Am J Physiol Regul Integr Comp Physiol* 288(6):R1571–1580
8. Lahiri S, Forster RE 2nd (2003)  $CO_2/H^+$  sensing: peripheral and central chemoreception. *Int J Biochem Cell Biol* 35:1413–1435

---

## **Carotid Chemoreflex**

- ▶ Respiratory Reflexes**

---

## **Carotid Endarterectomy**

#### **Definition**

Is the surgical procedure whereby the carotid artery is opened and the atherosclerotic plaque inside removed.

Indicated after a stroke if the carotid artery is narrowed >70%.

- ▶ Ischemic Stroke**
- ▶ Stroke**

## Carpal Tunnel Syndrome

### Definition

Characterized by numbness and paresthesias in the palm and pain up the forearm due to nerve entrapment of the median nerve in the carpal tunnel at the wrist.

## Cartesian Dualism

### Definition

The view, deriving from René Descartes in the seventeenth century, that mind and body are fundamentally different sorts of things, distinct from one another and independent.

► Reductionism (Anti-Reductionism, Reductive Explanation)

## Cartilage

### Definition

The thin avascular tissue that lines the ends of bones in synovial joints.

► Joints

## CASK

### Definition

Calcium/Calmodulin-associated serine/threonine kinase. A multi-functional adaptor protein that appears to serve a scaffolding function in the synapse and to recruit/organize other signaling molecules. At the synapse, key binding partners include Mint and Velis, as well as neurexins.

► Synaptic Proteins and Regulated Exocytosis

## Caspase

### Definition

Caspase is an acronym that stands for cysteine-aspartate protease. Caspases are proteolytic enzymes that contain a cysteine residue in the catalytic site and cleave their substrates at a consensus motif, Asp-Glu-Val-Asp. It plays a pivotal role in apoptosis by cleaving key substrates.

## Cataplexy

### Definition

Sudden loss of muscular tonus. Occurs in narcolepsy.

► Neuroendocrinology of Eating Disorders

## Catastrophic Inference

### Definition

One of the problems that arise during the training process of an artificial neural network is catastrophic inference, in which a task being learned overwrites previous learning. As network weights are adjusted to improve performance on the new task, performance on a previous task that relied on the old set of weights decreases, often catastrophically. This has presented a challenge to the application of connectionist simulations as models of biological or psychological data.

► Connectionism

## Catatonia

### Definition

Usually defined as a subtype of schizophrenia characterized by dominance of psychomotor symptoms such as lack of movements (stupor) or speech (mutism) frequently associated with extreme anxiety. Similar symptoms can also be encountered in patients with severe depression and in patients with organic brain lesions.

► Schizophrenia

## Catch-Up Saccade

### Definition

A saccade elicited when smooth pursuit eye movements (SPEM) lag behind a moving target because of limitations of SPEM velocity, acceleration, or frequency response. As long as such conditions apply, catch-up saccades repeatedly eliminate the resulting lag (in the rare case of too fast SPEM, the resulting lead is reduced by back-up saccades). Their amplitude is determined by the position and velocity errors of the eye with respect to the target sampled about 120 ms prior to saccade occurrence, with the velocity-related component predicting the increase in position error by the time of saccade occurrence. SPEM is being continued during catch-up saccades and its velocity adds to theirs.

- ▶ Oculomotor Control
- ▶ Saccade, Saccadic Eye Movement
- ▶ Smooth Pursuit Eye Movements

## Catecholamines

### Definition

Catecholamines are dihydroxylated biologic amine compounds derived from the amino acid L-tyrosine. The most important biogenic catecholamines are adrenaline (epinephrine), noradrenaline (norepinephrine), dopamine and L-DOPA.

- ▶ Adrenaline
- ▶ Dopamine
- ▶ Noradrenaline

## Catechol-O-methyl Transferase (COMT)

### Definition

An enzyme that breaks down levodopa. Inhibitors of COMT prolong the duration of action of levodopa, thus alleviating end-of-dose wearing off.

## Categorization

### Definition

The recognition of different entities as members of the same group (category) based on some internal representation.

- ▶ Cognitive Elements in Animal Behavior
- ▶ Sensory Plasticity and Perceptual Learning

## Category Learning/Memory

### Definition

Category learning (or categorization) refers to the process of assigning an object to a concept. A concept is the set of properties that we associate with a particular class. To categorize an object appropriately, we need to have the prototype of the concept, which is one set of properties that describe the best examples of the concept. The prototype of the concept can also be established by learning.

- ▶ Learning

## Category-specific Naming Deficits

### Definition

Naming difficulty for words in specific semantic categories. Cases with herpes simplex virus encephalitis (HSVE or HSE) and degenerative diseases like Alzheimer's disease often reveal semantic memory loss for specific semantic categories. In HSVE, for instance, semantic memory loss for animates (mainly animals) is more striking than that for inanimate objects (e.g. hammer, scissors). Since picture or object naming is a serial process including activation of semantics and then retrieval of word phonology in the mental lexicon, naming reflects characteristics of this particular semantic memory loss, i.e. category-specific naming deficits.

- ▶ Alzheimer's Disease
- ▶ Verbal Memory

## Cathodic Stimulation

### Definition

Electrical stimulation of a structure performed by placing the negative pole of the stimulator over the structure itself.

## Cauchy Stress

### Definition

The flux tensor corresponding to the flux of linear momentum (i.e. the surface traction) in the Eulerian formulation.

► Mechanics

## Cauchy's Theorem

### Definition

If the flux of a physical quantity governed by a standard form of the balance law is assumed to depend on the boundary only through its local normal vector, then this dependence is actually linear. As a consequence of this important theorem, all fluxes are governed by linear operators (vectors and tensors).

► Mechanics

## Cauda Equina (Filia Radicularia)

### Synonyms

Cauda equina (filia radicularia)

### Definition

The spinal cord extends from the brain down through the spinal canal inside the vertebral column. The spinal cord ends near the first lumbar vertebra in the lower back, forming the conus medullaris. The fibrous extension of the spinal cord is the filum terminale. The ventral and dorsal spinal nerves of the lumbar and sacral cord course in the shape of a horse's tail,

parallel to the filum terminale, through the lumbar and sacral portion of the spinal canal to their respective exit points.

► Medulla Spinalis

## Caudal

### Definition

Towards the cauda (tail).

## Caudal Ventrolateral Medulla (CVLM)

### Definition

The CVLM is part of the ventrolateral medulla and located caudal to the rostral ventrolateral medulla. It contains inhibitory interneurons (e.g., involved in the baroreceptor reflexes to sympathetic cardiovascular neurons) and excitatory interneurons that mediate reflexes involving the rostroventrolateral medulla and peripheral sympathetic cardiovascular pathways.

► Autonomic Reflexes

## Caudate Nucleus

### Synonyms

Nucl. Caudatus; Caudate nucleus

### Definition

The caudate nucleus and putamen together form the corpus striatum. Both are derived ontogenetically from the same anlagen, but are separated by incoming fibers from the internal capsule.

The corpus striatum is an important inhibitory component of motor movement programs and has manifold connections with the globus pallidus, substantia nigra and the motor cortex.

► Telencephalon

## Caudate: Role in Eye Movements

OKIHIDE HIKOSAKA

Laboratory of Sensorimotor Research, National Eye Institute, National Institute of Health, Bethesda, MD, USA

### Definition

The caudate nucleus (CD) is a large structure in the basal ganglia and, together with the putamen, is called the striatum or the dorsal striatum. Its contribution to eye movements is mentioned in the section ►Basal ganglia – Role in eye movements.

### Characteristics

#### Higher Level Structures

A majority of inputs to the basal ganglia is destined to the striatum (CD and putamen); the striatum acts as the input station of the basal ganglia. After being processed in the striatum, signals are sent to other nuclei in the basal ganglia, substantia nigra (SN) and ►globus pallidus (GP). The final outputs of the basal ganglia are issued from part of the SN, which is pars reticulata (SNr), and part of the GP, which is the internal segment. The neural circuit in the basal ganglia related to eye movements originates in the CD and converges on the SNr, which then projects to the ►superior colliculus (SC) [1] (Fig. 1).

#### Lower Level Components

The saccade-related region in the CD roughly corresponds to the area that receives inputs from the ►frontal eye field (FEF) and ►supplementary eye field (SEF) [2]. It is therefore likely that the CD receives saccade-related signals from these cortical eye fields. However, inputs to the CD are only loosely segregated. That is, the saccade-related region in the CD receives inputs from other cortical areas including the ►dorsolateral prefrontal cortex. In addition to these converging inputs, the entire CD (together with the putamen and the ventral striatum) receives diffuse inputs from dopaminergic neurons in the substantia nigra pars compacta (SNc) and its surrounding regions [3]. It is likely that particular combinations of these inputs create signals unique to CD neurons.

A majority of neurons comprising the CD are called medium-spiny neurons: neurons with medium-sized cell bodies and many dendrites thickly covered with spines. They are the projection neurons: neurons that project axons to the outside of the CD. They are GABAergic and inhibitory. The projection neurons are highly hyperpolarized in the resting state and emit action potentials only occasionally. A minority of neurons (less than 5%) in the CD consist of several types of interneurons. One conspicuous type is the cholinergic interneuron, which is characterized

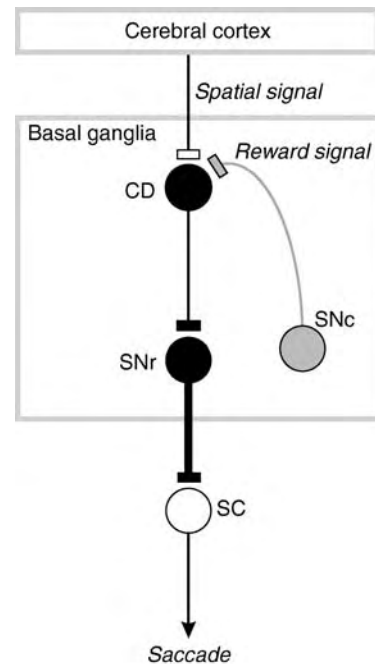

### Caudate: Role in Eye Movements.

**Figure 1** Information processing in the caudate nucleus (CD) for the control of saccadic eye movement. CD, caudate nucleus; SNr, substantia nigra pars reticulata; SC, superior colliculus; SNc, substantia nigra pars compacta. Excitatory and inhibitory neurons and synapses are indicated by open and filled symbols, respectively. Gray symbol indicates a dopaminergic neuron which exerts modulatory effects on CD neurons. The thickness of the line (axon) roughly indicates the level of spontaneous activity. CD neurons receive spatial signals from the saccade-related areas in the cerebral cortex and reward-related signals from dopaminergic neurons in the SNc.

anatomically as a large-spiny neuron. They fire tonically and irregularly and are often called “tonically active neurons” or “TANs” [4].

### Higher Level Processes

Single unit studies using monkeys trained on saccade tasks have revealed that many CD projection neurons are clearly related to ►saccadic eye movements. Some of them respond to visual stimuli that potentially induce saccades to them. Other neurons become active before saccades. These visual-saccadic neurons have response fields which are usually centered in the contralateral field. The responses are often highly dependent on the context. Visual responses may be enhanced if the animal attends to or memorizes the stimulus. Saccadic activity may be present only when the saccade is guided by memory, or only when it is guided by visual stimuli. The neurons usually do not fire in relation to ►spontaneous saccades. Intermingled with such visual-saccadic neurons are

found more complex neurons, such as those related to expectation of task-specific events or ►reward. Such a complex nature of CD projection neurons appears to reflect the convergent inputs from the cortical eye fields (FEF and SEF) and from the dorsolateral prefrontal cortex.

### Lower Level Processes

Studies suggest that these saccade-related neurons in the CD neurons control saccadic motor outputs by modifying neuronal activity in the SNr and the SC (Fig. 1) (see the section ►Substantia nigra – Role in eye movements). Electrical stimulation in the CD saccade-related region may elicit saccadic movements of the eye and the head to contralateral directions. If the electrical stimulation is short and weak, no movements are evoked, but it induces inhibitions and sometimes facilitations in SNr neurons. The former is likely to be mediated by the direct CD-SNr inhibitory connection, while the latter is likely to be mediated by the indirect pathway through the GP. Unlike CD projection neurons, SNr neurons are very active spontaneously, usually firing at more than 50 Hz. During the saccade tasks, many SNr neurons exhibit visual, saccadic, and memory-related activities, similarly to CD projection neurons. However, these activities usually show up as decreases in firing rates, unlike CD projection neurons. Since SNr neurons, especially those exhibiting saccade-related activity, have inhibitory connections to neurons in the SC, the decrease in SNr neuronal firing should lead to a disinhibition of SC neurons which control saccades to contralateral directions. In short, saccade-related activities in CD projection neurons would usually lead to facilitation of saccades to the contralateral directions. Note, however, the role of the CD on saccades may sometimes be suppressive, since some SNr neurons increase firing rates in relation to saccades presumably through the indirect pathways.

Recent studies have revealed another striking feature of CD neurons: Relation to reward-oriented behavior. Here, the amount of reward is biased depending on the direction of saccade: for example, rightward saccades are followed by a big reward and leftward saccades are followed by a small reward. This task has a strong behavioral impact: the saccade to the position associated with big reward is faster and earlier than that associated with small reward. The visual response of CD projection neurons is greatly enhanced and diminished if the saccade to the visual stimulus is expected to be followed by a bigger and smaller reward, respectively [5]. A minority of neurons exhibit the opposite reward modulation. The modulation is very common among visually responsive CD neurons (about 80%), and is often very strong such that the original directional tuning can be completely reversed. Similar reward-dependent modulation occurs for saccadic activity.

The relation of the CD to reward-oriented behavior is highlighted by a conspicuous group of CD projection neurons which cannot be classified as simply related to visual-saccadic processes [6]. They exhibit growing activity while the animal is waiting for the go-signal for a saccade. It appears to be related to saccade preparation. However, the activity occurs before instruction is given to which position the saccade should be made. The activity is nonetheless spatially selective in that it is present only when saccades to a contralateral, rather than ipsilateral, position are followed by a big reward. If there is no positional bias in reward, the anticipatory activity is much weaker.

Further studies suggest that the reward-position-sensitive anticipatory activity is transmitted to the SC through the SNr. Suppose a bigger reward is associated with saccades to a right target than a left target, CD neurons on the left side would exhibit stronger anticipatory activity than those on the right side (according to the findings described above). Since a major effect of CD neurons on SNr neurons is inhibitory, SNr neurons on the left side would exhibit a stronger decrease in firing rates than those on the right side. This is actually observed experimentally [7]. Since SNr neurons in turn inhibit SC neurons, the excitability of SC neurons on the left side would be elevated compared with those on the right side. This has also been confirmed experimentally [8]. There is now a clear imbalance in excitability between the two sides of the SC: Neurons in the left SC are more excitable than neurons in the right SC. This occurs before any instruction is given and far before a saccade is executed. This is an internal process based on the knowledge of the positional difference in reward amount. Under such a biased condition, a target that appears on the right side (i.e., associated with a big reward), which activates neurons on the left SC, would trigger a saccade more easily and more quickly than a target on the left side. In other words, the animal would make saccades more quickly to a more highly rewarded position. Such a behavioral bias is consistently observed experimentally. These results suggest that the CD is a critical brain area for reward-oriented motivational behavior.

### Process Regulation

Such strong reward-dependent modulation of CD neurons may be caused by dopaminergic inputs (Fig. 1). As mentioned above, CD projection neurons have dendrites with many spines on which both axons from cortical neurons and axons from midbrain dopaminergic neurons make synapses. A majority of cortical axons originate from the cortical eye fields and are therefore likely to carry spatial signals. In contrast, midbrain dopaminergic neurons are known to carry reward-related signals, but not spatial signals [9]. They respond to reward which is given unexpectedly or, if



reward is expected, to a sensory stimulus that predicts the reward. In the reward-biased saccade task, dopaminergic neurons respond by excitation and inhibition to sensory stimuli that predict a reward that is larger and smaller than what is expected, respectively.

How could dopamine influence activity of CD projection neurons? Dopamine does not exert fast excitatory or inhibitory actions, but is thought to modulate other synaptic inputs, especially glutamatergic inputs from the cerebral cortex. These findings led to the following hypothesis: the spatial signals from the cortical eye field are enhanced if dopaminergic inputs are increased (i.e., a bigger reward is expected) and depressed if dopaminergic inputs are decreased (i.e., a smaller reward is expected). The interaction may occur within individual ►[dendritic spines](#). This interaction may be due to the interactions among different ionic conductances. Or, it may be due to ►[long-term potentiation \(LTP\)](#) or depression (LTD). Recent studies have indicated that LTP indeed occurs if cortical inputs come in simultaneously with dopaminergic inputs and if the CD neuron fires [10]. In support of this hypothesis, the reward-dependent bias in saccades is reduced if dopaminergic transmission in the CD is blocked by injecting ►[dopamine D1 antagonist](#) [11].

The role of interneuronal processing in the CD is less clear. TANs, which are thought to be cholinergic, respond to reward or reward predictor, similarly to dopaminergic neurons, but also respond to a sensory stimulus that predicts the absence of reward or punishment. It has been suggested that cholinergic interneurons indicate that the reward is not equal among actions to choose, but do not indicate which action is the best or the worst. The latter function would be carried out by dopaminergic neurons. Cholinergic interneurons might detect the condition in which rewards are unequal and guide dopaminergic neurons to fully operate. However, this hypothesis needs to be examined in future experiments.

### Pathology

The role of the CD in eye movements is usually not emphasized in clinical literature. However, patients with degenerative diseases involving the CD, such as Parkinson's disease and Huntington's disease, may exhibit severe difficulty in making eye movements [1]. The deficits may be more evident when the patients are asked to make eye movements voluntarily or based on memory; the deficits are less clear or absent when eye movements are made to visible targets. Local deprivation of dopaminergic innervation in the CD in monkeys leads to the severe paucity of spontaneous saccades and deficits in ►[memory-guided saccades](#) to the side contralateral to the denervation. However, eye movement deficit after a lesion in the CD is not a universal finding. This may partly be due to the anatomical configuration of the eye movement-related region in

the CD. In monkeys trained on saccade tasks, many saccade-related neurons are found distributed in an anterior-posteriorly elongated zone in the CD excluding the most anterior part. A small lesion in the CD may not seriously disrupt information processing for saccadic eye movement.

### References

1. Hikosaka O, Takikawa Y, Kawagoe R (2000) Role of the basal ganglia in the control of purposive saccadic eye movements. *Physiol Rev* 80:953–978
2. Parthasarathy HB, Schall JD, Graybiel AM (1992) Distributed but convergent ordering of corticostriatal projections: analysis of the frontal eye field and the supplementary eye field in the macaque monkey. *J Neurosci* 12:4468–4488
3. Ungerstedt U (1971) Stereotaxic mapping of the monoamine pathways in the rat brain. *Acta physiologica scandinavica Supplementum* 367:1–48
4. Aosaki T, Tsubokawa H, Ishida A, Watanabe K, Graybiel AM, Kimura M (1994) Responses of tonically active neurons in the primate's striatum undergo systematic changes during behavioral sensorimotor conditioning. *Journal of Neuroscience* 14:3969–3984
5. Kawagoe R, Takikawa Y, Hikosaka O (1998) Expectation of reward modulates cognitive signals in the basal ganglia. *Nat Neurosci* 1:411–416
6. Lauwereyns J, Watanabe K, Coe B, Hikosaka O (2002) A neural correlate of response bias in monkey caudate nucleus. *Nature* 418:413–417
7. Sato M, Hikosaka O (2002) Role of primate substantia nigra pars reticulata in reward-oriented saccadic eye movement. *J Neurosci* 22:2363–2373
8. Ikeda T, Hikosaka O (2003) Reward-dependent gain and bias of visual responses in primate superior colliculus. *Neuron* 39:693–700
9. Schultz W (1998) Predictive reward signal of dopamine neurons. *Journal of Neurophysiology* 80:1–27
10. Mahon S, Deniau JM, Charpier S (2004) Corticostriatal plasticity: life after the depression. *Trends Neurosci* 27:460–467
11. Nakamura K, Hikosaka O (2006) Role of dopamine in the primate caudal nucleus in reward modulation of saccades. *J Neurosci* 26:5360–5369

## Causal Closure of the Physical

### Definition

That the physical is causally closed means that every physical occurrence (which has a sufficient cause at all) has a sufficient totally physical cause. Usually, the causal closure of the physical is understood to allow that physical events have non-physical causes, too, and to deny only that non-physical causes are necessary.

Hence, if one traces the causal ancestry of a physical event, one never needs to leave the physical domain. If the physical is causally closed, there must be some true physical theory capable of exhaustively explaining why physical processes unfold in precisely the way they do (modulo, perhaps, quantum indeterminacies).

- ▶ Emergence
- ▶ Epiphenomenalism

## Causal Theories of Knowledge

### Definition

According to these theories, the true belief that  $p$  has to have an appropriate causal connection to the fact that  $p$  in order to count as knowledge.

- ▶ Knowledge

## Causalgia

### Definition

Causalgia is also called ▶ **Complex Regional Pain Syndrome Type II (CRPS II)** and develops after major peripheral nerve injury.

- ▶ **Complex Regional Pain Syndromes – Pathophysiological Mechanisms**

## Causality

MICHAEL ESFELD<sup>1</sup>, JENS HARBECKE<sup>2</sup>

<sup>1</sup>Department of Philosophy, University of Lausanne, Switzerland

<sup>2</sup>Department of Philosophy, University of Witten-Herdecke, Germany

### Definitions

For the purpose of this essay, ▶ **causality** can be regarded as a relation between individual events, one event  $e_1$  causing another event  $e_2$ . If one conceives causality in that way, one is well advised to adopt a fine-grained conception of events: an event is the instantiation (i.e. the occurrence) of a property by an object at a time.

Neuroscientific research seeks to provide us with some insight into the way in which the mind works. The problem of causality is the question how to account for causal relations that involve mental events (▶ **Causality, mental**), in particular mental events that cause physical events. In this context, “physical events” is to be understood in a broad sense, including chemical, biological, and neurophysiological events. There are causal chains that involve both physical and mental events. For instance, Mary’s headache at noon today is a mental event. That mental event causes a chain of physical events that includes her lifting her right arm, her grasping an aspirin and her swallowing the aspirin. That latter event, in turn, causes her headache to vanish.

But how is it possible that mental events have physical effects? Consider the following four principles:

1. *Non-identity*: Mental events are not identical with physical events. Mental events are instantiations of properties that involve consciousness (what it is like to, e.g., have a headache) or intentionality (that is, they represent something, being about something). These traits seem to draw a line of distinction between mental and physical events.
2. *Mental ▶ causation*: Mental events cause physical events. It is an essential part of our self-conception as human beings that our beliefs and desires cause a good deal of our behavior. It is a common and successful practice to explain the behavior of a person by referring to her beliefs and desires. Behavior – such as raising one’s arm – includes changes on the microphysical level.
3. *Completeness*: For any physical event  $p$ , insofar as  $p$  has a cause, it has a complete physical cause. The search for an explanation of any physical event never takes us outside the physical domain (▶ **Completeness of the physical domain**). The laws of physics do not contain any gaps that would allow mental variables to make a causal contribution to physical events that is not made by physical variables. If we go down to fundamental physics, all events on the microphysical level have their probabilities completely determined by other microphysical events and microphysical laws.
4. *No systematic overdetermination*: If mental events cause physical events, there is no systematic overdetermination of the physical events in question by complete physical causes and additional mental causes.

From (1) to (4) follows what is known as the exclusion problem of mental causality: physical events seem to exclude – or at least to pre-empt – any causal efficiency of mental events. The problem is that each of the principles (1) to (4) is plausible if taken on its own. Any three of these principles are consistent, but the

conjunction of the four is not. In order to solve the problem of mental causality, one has to abandon – or at least to modify – one or more of these principles.

## Description of the Theory

### *Theories of Causality*

The main line of division in the metaphysics of causality is the one between Humean and anti-Humean theories. According to the Humean theories, causality is not a fundamental feature of the world. The causal relations that obtain between events in the world supervene on the distribution of the basic fundamental physical properties in space-time as a whole. These properties are not causal properties: they are purely qualitative, categorical properties. What they are (their essence) does not include any dispositions or causal powers. In short, the properties are not causal in themselves. Causality consists in relations of regular co-occurrence or counterfactual dependence between events that obtain against the background of the whole distribution of the fundamental, non-causal properties in space-time. Consequently, since that distribution is contingent, the relations of causality – and the laws that obtain in the world – are contingent, too [1].

The transference theory of causation [2] goes beyond Humeanism in conceiving causation as a physical process, namely as the transfer or exchange of a conserved physical quantity such as energy. This theory contradicts Humeanism in conceiving causality as a relation between two events that depends only on the space-time region in which these events are localized instead of supervening on the distribution of the physical properties as a whole. However, it remains neutral on the central issue as to whether the physical properties are causal in themselves or categorical. Consequently, it leaves open whether the causal link between two events is a contingent or a necessary one. As regards mental causality, in tying causality to physical processes, this theory can admit mental causality only on the assumption that mental events are identical with physical events, that is, only by rejecting principle (i).

According to anti-Humean theories, causality cannot be reduced to relations of regular co-occurrence or counterfactual dependence among events against the background of the whole distribution of the fundamental physical properties. There is causality in the production sense, that is, in the sense of one event bringing other events into existence in virtue of its properties. Consequently, the properties are themselves causal instead of being purely qualitative, categorical [3]: insofar as properties are certain qualities, they are powers to produce certain specific effects. Take charge as an illustrative example: insofar as charge is a qualitative property, distinct from e.g. mass, it is the power to build up an electromagnetic field, resulting in

the attraction of opposite-charged and the repulsion of like-charged objects. Consequently, the causal relations that obtain between events in the world amount to necessary connections among those events, resulting from the powers that are the essence of the properties that the events that are causes instantiate. By the same token, the laws of nature are metaphysically necessary, being determined by the powers that are the essence of the properties instantiated in the world. For instance, in any possible world in which charge is instantiated, the occurrences of charge build up an electromagnetic field, resulting in the attraction of opposite-charged and the repulsion of like-charged objects.

The exclusion problem of mental causality is largely independent of the stance that one takes in the metaphysics of causality: even if one favors a Humean theory of causality, causality is tied to laws (laws of regular co-occurrence of events of the same types, or laws that are central to fixing the truth-values of the counterfactuals expressing causal relations). The physical laws prevail in any case, since the laws of the special sciences including psychology are always *ceteris paribus* laws, whereas the physical laws are strict laws (or at least stricter laws than the ones of the special sciences). Nonetheless, the metaphysics of causality has a bearing on mental causality: arguably only an anti-Humean theory of causation that recognizes causal properties (causal powers) can do justice to our experience of agency, that is, our experience of acting beings in the physical world [4].

### *Interactionistic Dualism*

Since the conjunction of the four above-mentioned principles is not consistent, there are exactly four types of solution to the exclusion problem of mental causality, consisting in abandoning or modifying one of the four principles. If one maintains that mental events are not physical events (i) and if mental events cause physical events (ii), whilst physical events are not systematically causally overdetermined (iv), then one is committed to rejecting principle (iii), the causal completeness of the physical domain. The result is a dualistic metaphysics according to which mental and physical events constitute two different realms of being that causally interact with one another.

However, abandoning principle (iii) runs into a dilemma. The one horn of the dilemma is the conclusion that the laws of physics are false, because they do not indicate the correct probabilities for the occurrence of certain physical events in the brain. Even if we go down to the level of quantum physics and admit that the laws of quantum physics are irreducibly probabilistic, a problem occurs. If mental events are to count among the causes of some (quantum) physical events, they are thereby considered as raising the probabilities for the

occurrence of certain (quantum) physical events in the brain. Whenever a person has the intention to lift her left arm, the intention, being a mental cause, makes the occurrence of certain (quantum) physical events in her brain that are necessary for her arm going up much more probable than in the case where the person does not have that intention. Consequently, the laws of (quantum) physics must be taken to be false, for they do not yield the correct probabilities for the occurrence of certain (quantum) physical events in the brain, due to the presence of a further, mental variable. If one wishes to avoid this conclusion, one runs into the other horn of the dilemma, having to maintain that the laws of physics are not applicable to certain physical events: the brain has to be considered as not being a closed physical system, because it interacts with a mental system. Therefore, instead of the laws of physics, specific psycho-physical laws are necessary for neuroscientific research.

The general idea of interactionistic dualism implies that certain physical causal chains occurring in the brain contain gaps, and these gaps are filled by mental causes. However, neuroscientific research has not discovered any discontinuities within the causal chains that tie brain activities to bodily movements. For these reasons, interactionistic dualism is maintained only by a small minority of philosophers and scientists. The most detailed contemporary version of interactionistic dualism is due to the late neuroscientist John Eccles [5].

### Epiphenomenalism

The fact that there are no gaps in the chains of physical causes that admit additional mental causes may be taken to cast doubt on the second principle (ii), claiming a causal efficacy of mental events. If mental events are distinct from physical events (i) and if there is a complete causal history of each physical event that contains only other physical events (iii) whilst systematic overdetermination is not admitted (iv), then the principle of mental causality has to go. The resulting position is ►epiphenomenalism: physical events determine mental events, whereas mental events, being distinct from physical events, do not determine anything. Hence, they neither cause other mental events nor physical events. However, epiphenomenalism simply abandons the view of ourselves as acting beings in the world. It is therefore not pursued as a serious option in the literature.

### Physicalism

A less radical position is the one that recognizes the causal efficacy of mental events, but seeks to accommodate mental causality within the scientific worldview, rejecting the principle of non-identity of mental and physical events (i). Mental events cause physical events, being identical with physical events.

Consequently, the principle of mental causation does not clash with the principles of completeness (iii) and no systematic overdetermination (iv). More precisely, if events are conceived in a fine-grained manner as an object instantiating a property at a time and if all mental events are identical with physical events, then some physical events are mental events: insofar as they are instantiations of a mental property  $M$ , they are instantiations of a physical property  $P$ , so that what they cause qua being  $P$ , they cause qua being  $M$ .

One way to spell out physicalism is the type-type identity theory according to which every mental type is identical with a physical type. For instance, every pain event is identical with a neuronal event of the type  $N$ . It is the task of neuroscientific and psychological research to establish biconditional correlations between mental and physical types that license the inference to identity. The discovery of correlations is an empirical matter. The conclusion to identity between mental and physical types is a matter of philosophical argument. If mental types are identical with physical types, then the description of any mental type can be reduced to a physical description, although the meaning of the mental concepts can remain different from the meaning of the corresponding physical concepts. In the same way, if water is  $H_2O$ , then the description of water can be reduced to the chemistry of  $H_2O$ , although the meaning of the concept “water” is different from the meaning of the concept “ $H_2O$ .” Therefore, the type-type identity theory is a reductive ►physicalism.

The classical objection against the type-type identity theory is based on the notion of the ►multiple realization of mental types. This objection claims that one and the same mental type can be realized in different physical ways so that the mental type is not identical with any single physical type. For instance, pain may be identical with neural events of the type  $N$  in humans, but in octopuses, it is identical with brain events of another type. Furthermore, it seems in principle possible that even robots or extraterrestrial beings (“Martians”) are in pain, although in that case pain would be realized in an entirely different physical way. Over and above this kind of multiple realizability limited to species, it has been claimed that not even within a species, or even within a single individual, a given mental type is always realized by tokens of the same physical type. Mental events of the type “desiring an ice-cream” may be realized in different ways in a single individual throughout time.

However, type-identity is not necessary to solve the problem of mental causality within the framework of physicalism. Token identity is sufficient: for mental events to be causally efficacious given completeness (iii) and no systematic overdetermination (iv), it is sufficient that for each single event insofar as it is  $M$ , it is identical with a  $P$ , but no identity of the property

types *M* and *P* is necessary. In that vein, retreating to token identity is the common reply to the argument from multiple realizability, and ►functionalism is the most common way to spell out token identity in the mentioned fine-grained sense. According to functionalism, a type of mental events *M* is defined by the characteristic causes and effects that events of the type *M* have. Each event of the type *M* is realized in a physical way – that is, by a configuration of physical events that satisfies the functional definition of *M* –, but there is no unique physical way in which every event of the type *M* is realized. In that sense, mainstream functionalism considers itself as a non-reductive physicalism [6].

Nonetheless, functionalism faces a problem as has become clear since the nineties: insofar as mental types are not identical with physical types, they cannot be but epiphenomenal given completeness (iii) and no systematic overdetermination (iv). One may seek to avoid that problem by conceiving types not as anything ontological, but as concepts that we employ to classify the events in the world: property tokens that come under one and the same abstract mental concept “*M*” may come under different, more precise physical concepts “*P*<sub>1</sub>,” “*P*<sub>2</sub>,” “*P*<sub>3</sub>,” etc. However, the problem remains: if one maintains that the descriptions (theories, laws) in “*M*”-terms cannot be reduced to descriptions (theories, laws) in “*P*”-terms due to multiple realizability, it is unclear how non-reducible mental concepts, laws or theories can possess a scientific quality: as a consequence of (iii), there is a complete physical description of every event possible that fully explains the event in question.

Due to the mentioned problems, a reductive physicalism within the framework of a functional conception of mental events has become one of the central topics of the current discussion [7]: if one accepts completeness (iii) and no systematic overdetermination (iv), then it seems that in order to vindicate the causal efficacy of mental events, one is committed to token identity in the mentioned fine-grained sense; and in order to vindicate the scientific quality of the descriptions, laws and theories that use mental concepts, one is committed to the possibility of reducing the mental descriptions (laws, theories) to physical descriptions (laws, theories). Against that background, it seems furthermore that multiple realizability does not necessarily imply non-reductionism: one can avoid the anti-reductionist consequences of multiple realizability by conceiving more fine-grained mental sub-types that are finally coextensive with the physical realizer-types [8].

In any case, even if these issues are cleared, the main question remains whether the characteristic features of mental events (consciousness, intentionality) can be understood within the conceptual framework of physicalism and functionalism: as regards consciousness, the

question is whether the phenomenal character of experience (what it is like to be ...) can be conceived in a functional manner. As regards intentionality, the question is whether conceptual content can be conceived in terms of causal roles that are internal to the person or her brain or whether there is a constitutive dependence of conceptual content on external factors such as the social environment. In the latter case, two persons can be indistinguishable as regards the physical properties of their brains, but distinct as regards the conceptual content that their mental events instantiate.

### Overdeterminationism

Finally, one can call into question the rejection of systematic overdetermination (iv), making use of the possibility to postulate some sort of overdetermination in order to retain mental causality together with the principles of completeness (iii) and non-identity (i). By formulating a test for overdetermination based on certain counterfactual conditionals, it can be shown that the way mental events overdetermine physical effects is disanalogous to that found in paradigm cases of overdetermination, such as the victim being killed by two fatal shots in the heart at the same time [9]. This disanalogy ultimately results from the fact that mental causes, even if non-identical to physical causes, are still taken to stand to these causes in a metaphysical determination relation, namely strong supervenience, and from the fact that they are spatiotemporally coincident with the physical causes. At least under the counterfactual criteria for causality, many mental events can then be shown to satisfy all conditions that are necessary and sufficient for causality without being identical to physical events ([10], Chap. 4).

However, by tying the mental causes to physical causes through strong supervenience in order to avoid the stock objections against the idea of systematic overdetermination, this solution implies that for one event to supervene strongly on another event with which it is not identical is a sufficient condition for the supervenient event systematically overdetermining the effects that the subvenient event causes. Furthermore, one can object that it is possible to show that in the typical situations, the physical cause satisfies still stronger counterfactual criteria with respect to the effect than does the mental cause. It seems therefore possible that, in the end, this asymmetry will imply an epiphenomenality of mental events after all.

Nonetheless, the overdetermination solution has long been neglected in the literature, but today, it stands together with the renewed interest in reductive physicalism at the centre of the discussion: if one is not prepared to endorse token identity of mental and physical events in the mentioned fine-grained sense, trying to make a case for some sort of systematic overdetermination seems to be the only other reasonable option.

## References

1. Lewis D (1973) Causation. *J Philos* 70:556–567
2. Dowe P (2000) *Physical causation*. Cambridge University Press, Cambridge
3. Shoemaker S (1980) Causality and properties. In: van Inwagen P (ed) *Time and cause*. Reidel, Dordrecht, pp 109–135
4. Esfeld M (2007) Mental causation and the metaphysics of causation. *Erkenntnis* 67:207–220
5. Eccles JC (1994) *How the self controls its brain*. Springer, Heidelberg
6. Putnam H (1975) The nature of mental states. In: Putnam H (ed) *Mind, language and reality*. Philosophical papers, vol. 2. Cambridge University Press, Cambridge, pp 429–440
7. Kim J (2005) *Physicalism, or something near enough*. Princeton University Press, Princeton
8. Esfeld M, Sachse C (2007) Theory reduction by means of functional sub-types. *Int Stud Philos of Sci* 21:1–17
9. Bennett K (2003) Why the exclusion problem seems intractable, and how, just maybe, to tract it. *Noûs* 37:471–497
10. Harbecke J (2008) *Mental causation. Investigating the mind's powers in a natural world*. Ontos-Verlag, Frankfurt (Main)

## Causality, Mental

### Definition

Mental events are causally efficacious: they bring about other mental events as well as physical events.

► Causality

## Causation

### Definition

► Causality

## (CBAxC57BL/6)F1

### Definition

The hybrids of one generation of mice of lines CBA and C57Bl/6.

## CCK

### Definition

► Cholecystokinin

## CD8

### Definition

T cells express either CD4 or CD8 molecules on their cell surface. While CD4 is expressed on helper T cells, CD8 molecules are expressed on cytotoxic T cells, and interacts with major histocompatibility complex (MHC) I molecules. CD8 belongs to the immunoglobulin superfamily.

## CD14

### Definition

Cell surface molecule that functions as a receptor for lipopolysaccharide.

## CD120

► Brain Inflammation: Tumor Necrosis Factor Receptors in Mouse Brain Inflammatory Responses

## Cdc42

### Definition

A member of the Rho-family of GTPases that regulates several aspects of cell function by definition controlling cytoskeletal changes. The activities of Rho-family GTPases are highly regulated and their cytoskeletal changes are one of the basic mechanisms involved in controlling cellular size, shape, and motility.

## Cell Adhesion Molecules

### Definition

A diverse family of cell surface molecules, such as neural cell adhesion molecules (N-CAM), which allow cell–cell and cell–extracellular matrix adhesion, recognition, activation, and migration.

## Cell Autonomy

### Definition

Description of the source of a signal with respect to the cell the signal acts upon. Cell autonomous means a cell produces its own signal, whereas a signal-independent of the receiving cell functions in a cell non-autonomous fashion.

## Cell Cycle

TAKAYUKI MITSUHASHI, TAKAO TAKAHASHI  
Department of Pediatrics, School of Medicine,  
Keio University, Tokyo, Japan

### Synonyms

Cell cycling

### Definition

The “cell cycle” is defined as the process by which a single cell divides into two daughter cells. This essay will discuss somatic cell division or somatic mitosis, i.e. the process during which a single diploid cell divides into two diploid cells, in the context of the ontogeny of the central nervous system in mammals. The focus will be on the regulatory mechanisms of cell cycles of neural progenitor cells that generate the projection neurons of the neocortex. The emphasis is on the G1 phase regulation of neural progenitor cells and the regulatory mechanisms embedded in the G1 phase that ultimately determine the number of projection neurons and their distribution through the six-layered structure of the neocortex.

### Characteristics

#### Phases of the Cell Cycle

A single cell division cycle has two major phases, namely the DNA synthesis (S) phase and the cell

division or mitosis (M) phase. Between these two phases, there are two “gap” or “inter-” phases called gap 1 (G1) and gap 2 (G2) phases. There is another cell cycle state called the G0 phase, when cells remain resting but capable of reentering into a proliferative cell cycle. It is believed that in the developing brain most, if not all, newly developed neurons are not in the G0 state but in the terminally differentiated state. The G1 phase is initiated as M phase is completed and completed as S phase begins; the G2 phase is initiated as S phase is completed and completed as M phase begins. Dividing cells proceed through these four phases repeatedly. Thus, this continuing process is called the cell “cycle.”

Among the four phases of the cell cycle, the G1 phase is considered to be a critical period when proliferative cells receive extracellular “cues” that may lead these cells to either proceed to S phase or to exit from the cycle. These extracellular cues include extrinsic molecules such as neurotrophic factors and mitogens/anti-mitogens of various kinds and environmental substances such as drugs and pollutants.

### Length of the Cell Cycle

Generally, the total cell cycle length of undifferentiated progenitor cells varies greatly, not only among different types of tissues/organs to which these cells give rise but also among different time points during ontogeny of the tissue/organ. For example, while neural progenitor cells in the pseudostratified ventricular epithelium (PVE, Fig. 1a) lining the surface of the lateral ventricles of the mouse embryonic forebrain take ~8 h to complete a single cell cycle on embryonic day 11 (E11), those on E16 take as long as 18 h (Fig. 2) [1].

In this respect, the observation that the major contributor to such cell cycle length alteration is the prolongation of G1 phase but of no other phases of the cell cycle is of critical biological significance; the length of the G1 phase increases systematically from 3.2 h to 12.4 h as neocortical histogenesis proceeds, whereas the lengths of G2, M and S phases remain unchanged or change only unsystematically (Fig. 2) [1].

### Probability of Cell Cycle Exit

It is of note that G1 phase is the phase of the cell cycle when a given proliferative progenitor cell chooses whether to proceed to S phase and remain in the proliferative cell cycle or to leave the cycle and become terminally differentiated (Fig. 1a). In other words, for a single G1 phase progenitor, there are only two fates to follow (all-or-none kind of decision making) either to stay in or to exit the cycle [2]. Obviously, the population of neuronal progenitor cells is composed of numerous proliferative cells, which makes the population probability of cell cycle exit anywhere between 0% and

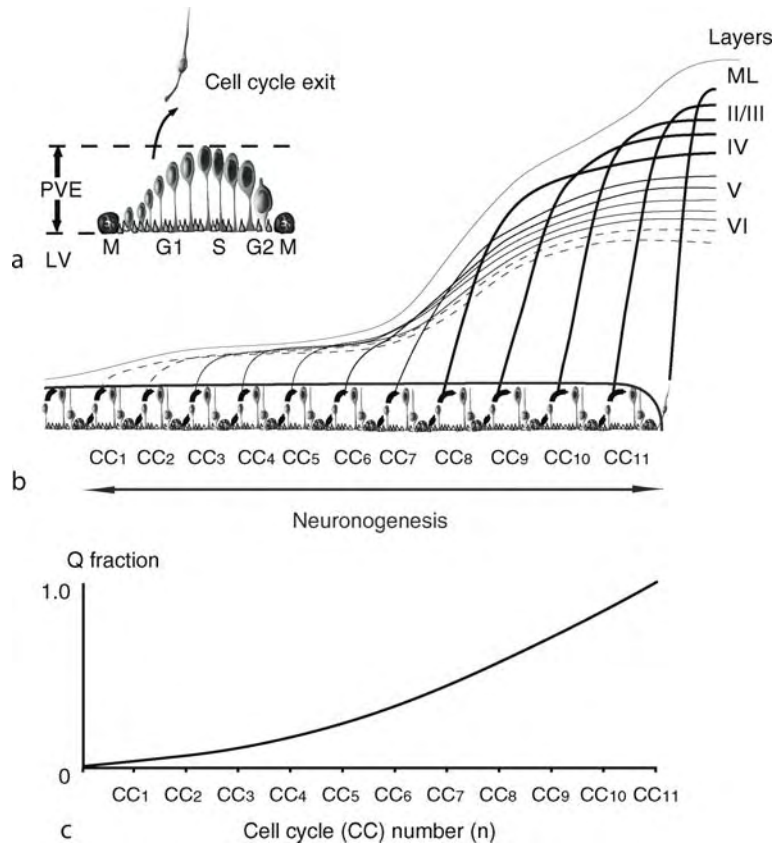

**Cell Cycle. Figure 1** Overview of Critical Events of Neocortical Neuronogenesis. (a) Schematic representation of interkinetic nuclear migration. The position of cell nuclei of neuronal progenitor cells changes systematically as they proceed through cell cycle phases (M, G1, S, G2 *along the abscissa*). A fraction of cells exits the cycle during G1 phase (*upward arrow*). PVE pseudostratified ventricular neuroepithelium; LV lateral ventricle. (b) The founder population of neural progenitors and their progenies execute 11 cell cycles (CC<sub>1</sub>-CC<sub>11</sub>) over the neuronogenetic interval. The early-formed neurons are destined for the deepest cortical layers (*dotted curved lines* connecting the PVE and layers VI), whereas the later formed neurons are destined for the more superficial layers (*solid curved lines* connecting the PVE and layers IV and II/III). (c) The fraction of daughter cells that exits the cell cycle (Q fraction) increases slowly during the initial phase of neuronogenesis and then accelerates to reach the final value of 1.0 at the completion of neuronogenesis when 100% of progenitor cells leave the cycle.

100%. In the course of neocortical histogenesis, the probability of cell cycle exit or **quiescent (Q) fraction** increases from 0 (i.e. 0%) at the outset to reach 1.0 (i.e. 100%) at the completion of the interval of neuron generation (i.e. neuronogenesis, Fig. 1c) [2].

### Structural Regulation

#### Interkinetic Nuclear Migration

The position of the cell nuclei of neural progenitor cells changes systematically as they proceed through cell cycle phases. This phenomenon is called interkinetic nuclear migration (Fig. 1a). The nuclei of S phase cells are located within the outer half of the proliferative epithelium. This area is called the S phase zone. Nuclei of cells in S phase are readily recognized by S phase

tracers such as BrdU. Those nuclei then in the course of G2 phase move “downward” to the lateral ventricle to execute mitotic process (M phase) at the surface of the lateral ventricle. Nuclei of neural progenitor cells in G1 phase move “upward” towards the S phase zone.

#### Cell Cycle Sequence and Layer Composition

It has long been known that the early-formed neurons are distributed in the deeper layers of the neocortex, while the later formed neurons are distributed in the superficial layers (inside-out pattern neuronogenesis). Investigations in mice revealed that the cell cycle of origin is the strong determinant of the layer distribution of projection neurons arising from that cell cycle (Fig. 1b) [3].



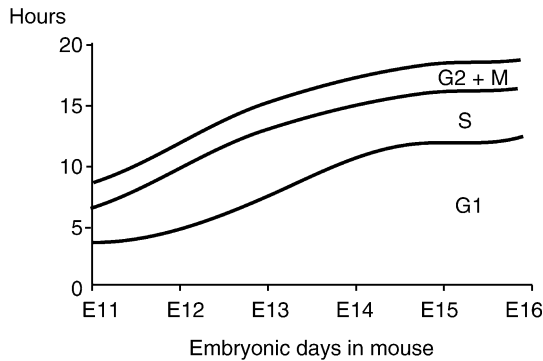

**Cell Cycle. Figure 2** Lengths of cell cycle phases. The major contributor to cell cycle lengthening during neurogenesis is the prolongation of the G1 phase but of no other phases of the cell cycle.

## Process Regulation

### Molecules that Control Cell Cycle Progression

#### Cyclins and Cyclin Dependent Kinases

Progression through cell cycle phases is strongly governed and precisely regulated by a set of proteins called ►cyclins and cyclin dependent kinases (►CDKs). Cyclins and CDKs act as accelerators of the progression of cell cycles i.e. CDKs phosphorylate substrates in the presence of cyclins, phosphorylation of key molecules is critical to trigger entry into the next phase of the cell cycle. Cyclin molecules have been named after their expression pattern during a single cell cycle; expression increases and then decreases in a cell cycle-phase specific manner. For example, cyclin D1 expression level increases in the course of G1 phase and decreases before initiation of S phase. The kinase activity of CDKs is also known to be augmented by cyclin activating kinases (CAK) [4].

There are eight cyclins and nine CDKs reported to date. These cyclins and their specific partner CDKs working together serve to promote cell cycle progression, particularly at the passage through the corresponding ►restriction point (see “Function” for details).

There are many target substrates of cyclin/CDK complexes. In G1 phase progression, cyclin Ds/CDK4/6 and cyclin E/CDK2 are the critical sets of molecules to hyperphosphorylate retinoblastoma protein (Rb). Hyperphosphorylation of Rb releases transcription factor E2F from Rb, which leads to E2F dependent transcription of target genes including cyclin E, which in turn is necessary for S phase progression [4].

#### CDK Inhibitors

There is a group of ►CDK inhibitors (CDKIs), which serve as negative regulators of cell cycle progression. CDKIs are divided into two groups, inhibitors of CDK4 (INK4) and CDK interacting (Cip) or kinase inhibitor

proteins (Kip). INK4s include four proteins, p16INK4a, p15INK4b, p18INK4c and p19INK4d. Cip/Kip includes p21Cip1, p27Kip1 and p57Kip2 [4].

As is the case with cyclins/CDKs, each of the CDKIs has specific inhibitory activity and functions as a decelerator of cell cycle progression only upon specific pairs of cyclins/CDKs. INK4s in general bind to CDK4 and inhibit kinase activity; p27Kip1 specifically inhibits cyclin E/CDK2 kinase activity, which leads to inhibition of entry into S phase.

Given that anti-mitogenic factors serving as differentiation inducers induce some of the CDKIs including INK4s and Cip/Kip, it is thought that CDKIs promote cell cycle exit and hence cellular differentiation.

## Function

### The Restriction Point as a Critical Regulatory Checkpoint

There are some kinds of checkpoints called “restriction points” during cell cycles [5]. These “points” are actually short “intervals” embedded within each of G1, S, G2 and M phases, during which a sequence of critical events for proper cell cycle progression occurs [4]. They were first discovered by analysis of the cell cycles of yeast. For example, once a cell passes through the G1 restriction point, the cell is committed to enter S phase and duplicate DNA. Probably more precisely, unless the cascade of molecular events for G1 phase progression and for S phase re-entry has been duly completed, no cell is allowed to pass through the G1 restriction point [5] hence the word “restriction.”

### Critical Parameters for Neuron Production

Two parameters govern the proliferative behavior of the progenitor populations and thus determine the total number of neurons produced. These parameters are (i) the total number of cell cycles executed during the interval of neurogenesis and (ii) the probability of cell cycle exit (►quiescent or Q fraction) i.e. the proportion of daughter cells that becomes permanently quiescent after cell division (Fig. 1c). The incidence of apoptotic cell death within the proliferative progenitor population is very small and is unlikely to be a major factor in determining the total number of neurons produced.

The number of cell cycles that constitute the neurogenetic interval has been estimated to be 11 in mice. The values of Q fraction have been directly measured by using two S phase tracers, BrdU and tritiated thymidine [6]. The Q fraction determined thus increased very slowly during the initial phase of neurogenesis and then accelerated rapidly to reach the final value of 1.0 at the completion of neurogenesis when 100% of progenitor cells have left the cycle (Fig. 1c).

Experimental over-expression of p27Kip1 protein, one of the CDKIs, has been shown to result in a premature increase in Q fraction, leading to a decreased number of projection neurons in the neocortex [7,8]. On the contrary, experimental deprivation of p27Kip1 resulted in abnormally low values of Q fraction in the early/middle phases followed by a “catch-up” increase in the late phase of neurogenesis [9]. Such an altered pattern of Q fraction progression resulted in an increased number of projection neurons in the neocortex.

It has been inferred that both G1 phase length and Q fraction are coordinately regulated during G1 phase by common mechanisms that involve such molecules as cyclin/CDKs and CDKIs. Given that the cell cycle of origin (time of production) and the layer distribution of those neurons arising from that cell cycle are closely correlated, it may be concluded that such mechanisms governing G1 phase progression and cell cycle exit are also intimately involved in phenotype determination once out of the cell cycle.

## References

1. Takahashi T, Nowakowski RS, Caviness VS Jr (1997) The cell cycle of the pseudostratified ventricular epithelium of the embryonic murine cerebral wall. *J Neurosci* 15:6046–6057
2. Takahashi T, Nowakowski RS, Caviness VS Jr (1996) The leaving or Q fraction of the murine cerebral proliferative epithelium: a general model of neocortical neurogenesis. *J Neurosci* 16:6183–6196
3. Takahashi T, Goto T, Miyama S, Nowakowski RS, Caviness VS Jr (1999) Sequence of neuron origin and neocortical laminar fate: relation to cell cycle of origin in the developing murine cerebral wall. *J Neurosci* 19:10357–10371
4. Harper JV, Brooks G (2005) The mammalian cell cycle. In: Humphrey T, Brooks G (eds) *Cell cycle control*. Humana, Totowa, pp 113–153
5. Caviness VS Jr, Takahashi T, Nowakowski RS (1999) The G1 restriction point as critical regulator of neocortical neurogenesis. *Neurochem Res* 24:497–506
6. Takahashi T, Nowakowski RS, Caviness VS Jr (1994) Mode of cell proliferation in the developing mouse neocortex. *Proc Natl Acad Sci USA* 91:375–379
7. Mitsuhashi T, Aoki Y, Eksioğlu YZ, Takahashi T, Bhide PG, Reeves SA, Caviness VS Jr (2001) Overexpression of p27Kip1 lengthens the G1 phase in a mouse model that targets inducible gene expression to central nervous system progenitor cells. *Proc Natl Acad Sci USA* 98:6435–6440
8. Tarui T, Takahashi T, Nowakowski RS, Hayes NL, Bhide PG, Caviness VS (2005) Overexpression of p27Kip1, probability of cell cycle exit, and laminar destination of neocortical neurons. *Cereb Cortex* 15:1343–1355
9. Goto T, Mitsuhashi T, Takahashi T (2004) Altered patterns of neuron production in the p27 knockout mouse. *Dev Neurosci* 26:208–217

## Cell Differentiation

RYOICHIRO KAGEYAMA, RYOSUKE OHSAWA, TOSHIYUKI OHTSUKA

Institute for Virus Research, Kyoto University, Kyoto, Japan

### Definition

Differentiation is the process by which cells become more specialized and mature. In this process, neural stem cells become mature neurons or glial cells.

### Characteristics

#### Description of the Process

In the developing central nervous system, multipotent neural stem cells progressively become mature neurons or glial cells. This process involves three steps, (i) fate determination, (ii) subtype selection and (iii) maturation. In the fate determination step, the ►cell fate is determined; cells acquire a neuronal or glial ►cell identity. During or subsequent to the fate determination step, neuronal and glial subtypes are selected. In the case of neurons, a subtype selection is made from many options, such as motor versus sensory subtypes and excitatory (glutamatergic) versus inhibitory (GABAergic) subtypes. For glial cells, selection for oligodendrocytes versus astrocytes is made. In most cases, the fate determination and subtype selection steps proceed at the same time. Each subtype of cells then becomes morphologically and functionally mature.

#### Higher Level Processes

The developing central nervous system initially consists of neuroepithelial cells, which have epithelial cell characteristics such as tight junctions and adherens junctions at the apical side and a basal lamina on the basal side (Fig. 1) [1,2].

Neuroepithelial cells are the first form of neural stem cells. These cells undergo self-renewal by symmetrical cell divisions but do not usually give rise to neurons. As development proceeds, neuroepithelial cells gradually change into radial glial cells, which have radial processes (radial fibers) reaching the ventricular (apical) and pial (basal) surfaces (Fig. 1) [1,2]. Radial glial cells were named thus because they were long thought of as specialized glia with radial fibers that guide neuronal migration. However, it was later found that they are the second form of neural stem cells. Radial glial cells undergo asymmetrical cell divisions in which one radial glial cell produces one radial glial cell and one neuron (or one neuroblast). Radial glial cells also undergo symmetrical cell divisions in which one radial glial cell

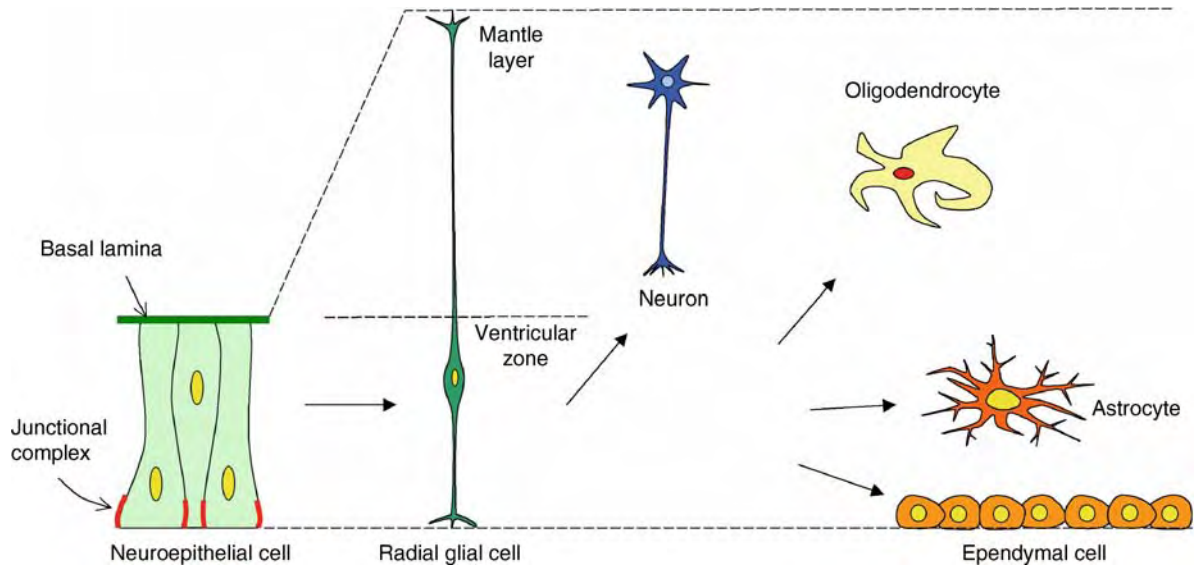

**Cell Differentiation. Figure 1** The cell fate determination step. Neuroepithelial cells, the first form of neural stem cells, have epithelial cell characteristics such as the junctional complex at the apical side and the basal lamina on the basal side. These cells undergo symmetrical cell divisions and do not usually give rise to neurons. Neuroepithelial cells gradually change into the second type of neural stem cells, called radial glial cells. These cells undergo asymmetrical cell divisions and give rise first to neurons. After the production of neurons, radial glial cells give rise to oligodendrocytes, astrocytes and ependymal cells. Radial glial cells disappear after birth, but some astrocytes or astrocyte-like cells function as neural stem cells in the adult brain.

produces two neurons (or two neuroblasts). While the cell bodies of radial glial cells remain in the ventricular zone, neurons (or neuroblasts) migrate along the radial fibers to the outer layers. During migration, neuroblasts proliferate further to produce more post-mitotic neurons. These cells settle in the outer layer (mantle layer, cortical plate) and become mature neurons.

During or after neuronal fate determination, neuronal subtype selection is made. In the telencephalon, excitatory (glutamatergic) neurons are developed in the dorsal region, while inhibitory (GABAergic) neurons are developed in the ventral region (Fig. 2).

Excitatory neurons migrate radially inside the dorsal telencephalon while inhibitory neurons migrate tangentially from the ventral to the dorsal telencephalon. Thus, excitatory and inhibitory neurons in the dorsal telencephalon have different origins, indicating that subtype selection is controlled by spatial cues. In the dorsal telencephalon, early developed neurons form deep cortical layers while later developed neurons migrate through the early developed neurons towards the outer surface and form more superficial cortical layers (inside-out) (Fig. 3).

Different layers contain different subtypes of neurons. Early developed neurons in the deep layers (mainly, layer V) have projection efferents (projecting to the subcortical regions, brainstem and spinal cord), while late developed neurons in the superficial layers (layers II and III) have association efferents (projecting to the ipsilateral or

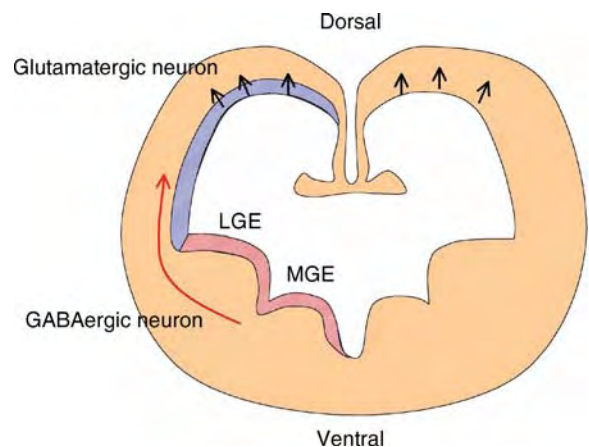

**Cell Differentiation. Figure 2** Spatial control of the subtype selection step. In the telencephalon, excitatory (glutamatergic) neurons are developed in the dorsal region while inhibitory (GABAergic) neurons are developed in the ventral region. Excitatory neurons migrate radially inside the dorsal telencephalon while inhibitory neurons migrate tangentially from the ventral to the dorsal telencephalon. Thus, subtype selection is controlled spatially.

contralateral cortex), indicating that cells with different times of development acquire different neuronal subtypes. Thus, neuronal subtype selection is controlled by temporal cues as well as by spatial cues. Neurons then

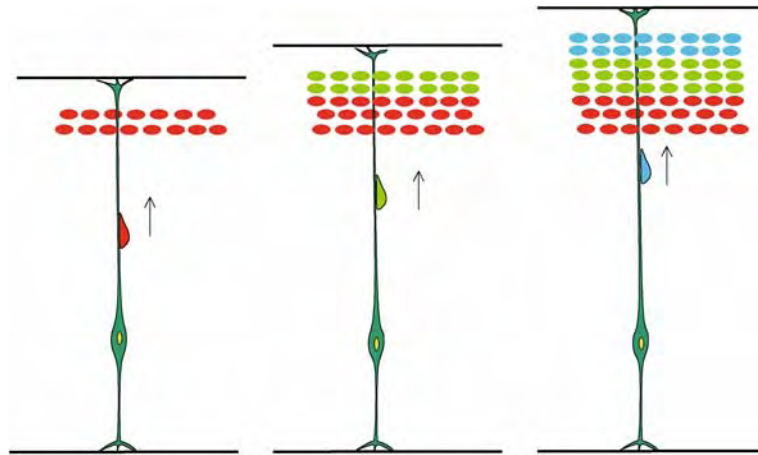

**Cell Differentiation. Figure 3** Temporal control of the subtype selection step. Early developed neurons (*red*) form the deep cortical layers while later developed neurons (*green and blue*) migrate through the early developed neurons towards the outer surface and form the more superficial cortical layers (inside-out). Neurons in different layers acquire different properties. Thus, the subtype selection is controlled temporally.

become mature by extending axons and dendrites and forming synapses.

After production of neurons, radial glial cells give rise to glial cells (oligodendrocytes and astrocytes) (Fig. 1). Oligodendrocytes are developed in some restricted regions from early to late stages of neural development, while astrocytes are developed widely in the nervous system at the last stage. Radial glial cells also give rise to ependymal cells, the epithelial lining of the ventricles (Fig. 1). After birth, radial glial cells disappear, but neural stem cells remain in the adult brain and are morphologically similar to astrocytes at this stage. Active neurogenesis from such astrocyte-like adult neural stem cells occurs in the subventricular zone of the lateral ventricles and in the subgranular zone of the dentate gyrus.

## Regulation of the Process

### Regulation by Two Types of bHLH Genes

Cell differentiation involves fate determination, subtype selection and maturation steps, as described above. These steps are regulated by basic helix-loop-helix (bHLH) genes, which are classified into two types, activators and repressors [3–5]. Both types of bHLH factors form a dimer through the HLH domain and bind to DNA via the basic region. The activator-type bHLH factors such as *Mash1*, *Math1* and *Neurogenin* form heterodimers with the ubiquitously expressed bHLH factor E47 and activate gene expression by binding to the E box (CANNTG) (Fig. 4a).

The repressor-type bHLH factors such as *Hes1*, *Hes3* and *Hes5* form homodimers and repress gene expression by binding to the N box (CACNAG) or the class C site (CACGCG) (Fig. 4b). The target genes for *Hes* factors include the activator-type bHLH genes such as

*Mash1*. *Hes1* also forms heterodimers with activator-type bHLH factors, but these heterodimers cannot bind to DNA (Fig. 4c). Thus, *Hes1* inhibits both the expression and activities of the activator-type bHLH factors. Other factors, *Id1*, *Id2* and *Id3*, which have an HLH domain but lack a basic region, cannot bind to DNA. *Ids* inhibit activator-type bHLH factors by forming non-DNA-binding heterodimers through the HLH domains (Fig. 4d).

### Fate Determination by bHLH Genes

Maintenance of neural stem cells is regulated by repressor-type bHLH genes (Fig. 5). Misexpression of *Hes1*, *Hes3* or *Hes5* inhibits neuronal fate determination by repressing activator-type bHLH genes and maintains neural stem cells. Conversely, in the absence of *Hes* genes, neural stem cells prematurely differentiate into early-developing neurons at the expense of later developing cell types.

Neuronal fate determination is regulated by the activator-type bHLH genes such as *Mash1*, *Math* and *Neurogenin* (Fig. 5). Misexpression of *Mash1*, *Math* or *Neurogenin* induces neuronal fate determination, while in the absence of these genes glial fate determination is promoted [3–5]. The activator-type bHLH genes not only induce neuronal-specific gene expression, but also, inhibit glial-specific gene expression and suppress the neural stem cell state by inducing *Hes6*, an inhibitor for *Hes1*.

Glial fate determination is regulated by repressor-type bHLH genes. Oligodendrocyte formation is regulated by the repressor-type bHLH genes *Olig1* and *Olig2* and astrocyte formation is regulated by *Hes1* and *Hes5* (Fig. 5). It was recently shown that fate determination of subsets of astrocytes is also regulated

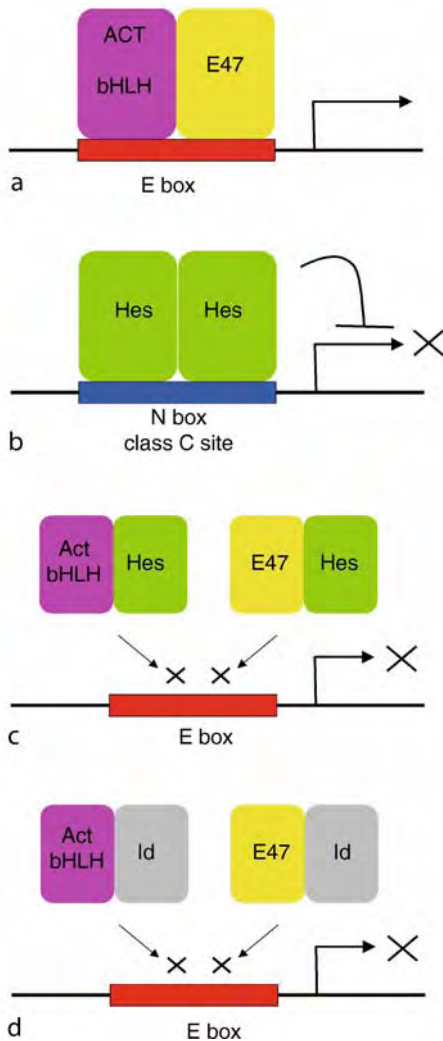

**Cell Differentiation. Figure 4** Two types of bHLH factors. (a) The activator-type bHLH factors form heterodimers with the ubiquitously expressed bHLH factor E47 and activate gene expression by binding to the E box. (b) The repressor-type bHLH factors such as Hes1 form homodimers and repress gene expression by binding to the N box (CACNAG) or the class C site. (c, d) Both Hes and Id factors inhibit activator-type bHLH factors by forming non-DNA-binding heterodimers through the HLH domains.

by the activator-type bHLH gene *Scf* [6] (Fig. 5). Thus, in glial development, both fate determination and subtype selection seem to be controlled at the same time.

#### Cross-Regulation of bHLH Genes and Notch Signaling

*Hes1* and *Hes5* expression is regulated by Notch signaling [5]. Notch, a transmembrane protein, is activated by its ligands such as Delta. Upon activation by Delta, the intracellular domain of Notch (ICN) is

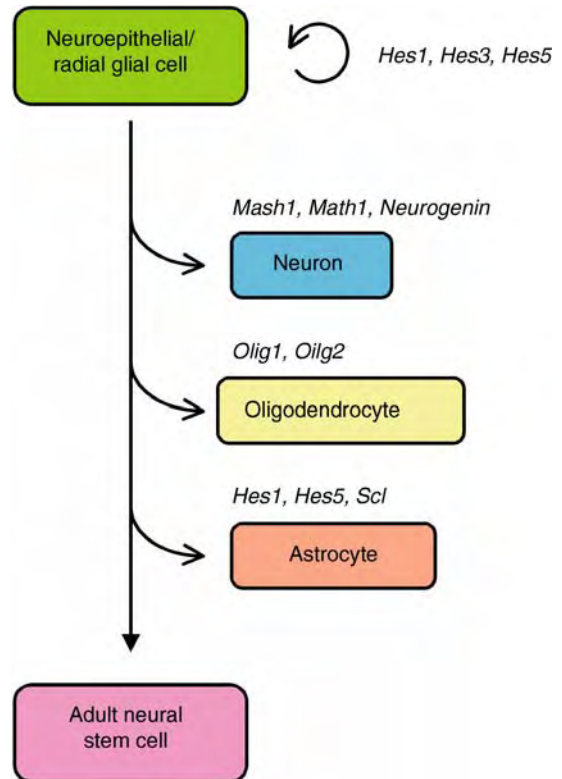

**Cell Differentiation. Figure 5** Regulation of cell fate determination by bHLH genes. Maintenance of neural stem cells is regulated by the repressor-type bHLH genes *Hes1*, *Hes3* and *Hes5*. Neuronal fate determination is regulated by the activator-type bHLH genes such as *Mash1*, *Math1* and *Neurogenin*. Oligodendrocyte formation is regulated by the repressor-type bHLH genes *Olig1* and *Olig2*, while astrocyte formation is regulated by *Hes1*, *Hes5* and *Scf*.

cleaved and transported into the nucleus to form a complex with RBP-J (Fig. 6).

RBP-J alone represses *Hes1* and *Hes5* expression, but the ICN-RBP-J complex activates *Hes1* and *Hes5* expression. Thus, Notch activation leads to induction of *Hes1* and *Hes5*, which maintain neural stem cells by repressing the activator-type bHLH gene expression (Fig. 6). When neural stem cells undergo asymmetric cell division, Numb is asymmetrically distributed, yielding  $\text{Numb}^+$  and  $\text{Numb}^-$  cells (Fig. 7) [7,8].

Numb is known to inhibit Notch activity by interacting with its intracellular domain. Thus, in the  $\text{Numb}^+$  cell, Notch signaling is suppressed, resulting in down-regulation of *Hes1* (Fig. 7) and *Hes5* and induction of activator-type bHLH genes (Fig. 6). The activator-type bHLH factors suppress residual *Hes1/5* activities by inducing *Hes6* and up-regulate expression of Delta, which activates Notch signaling of the neighboring cells (which are  $\text{Numb}^-$  cells). As a result,

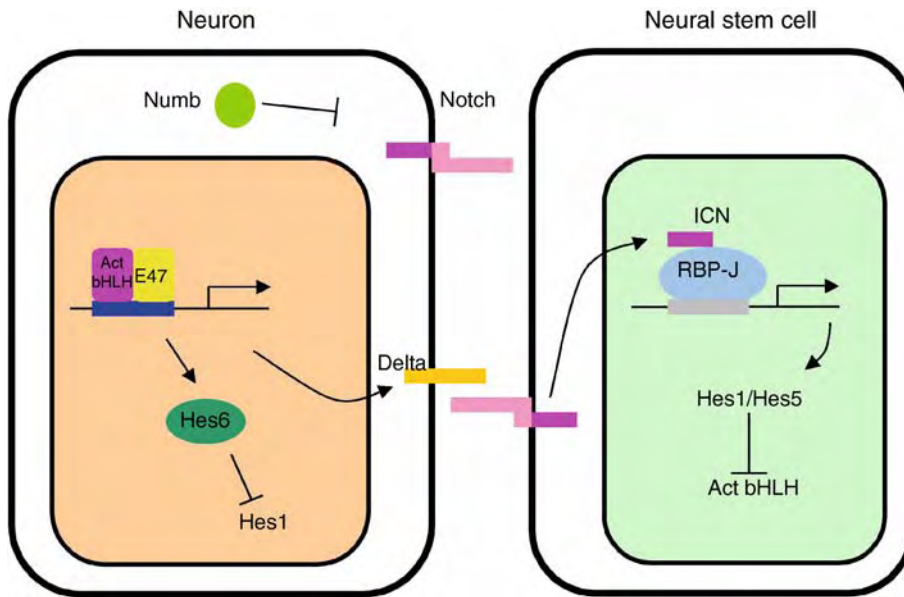

**Cell Differentiation. Figure 6** Cross-regulation of bHLH genes and Notch signaling. During asymmetric cell divisions, Numb is asymmetrically distributed, resulting in Numb<sup>+</sup> and Numb<sup>-</sup> cells. In Numb<sup>+</sup> cells, Notch signaling is inactivated, resulting in down-regulation of *Hes1* and *Hes5* and induction of activator-type bHLH genes. The activator-type bHLH factors suppress residual *Hes1/5* activities by inducing *Hes6* and up-regulate expression of *Delta*, which activates Notch signaling of the neighboring Numb<sup>-</sup> cells. In Numb<sup>-</sup> cells, Notch is activated by *Delta* and the intracellular domain of Notch (ICN) is cleaved and transported into the nucleus to form a complex with RBP-J. The ICN-RBP-J complex induces expression of *Hes1* and *Hes5*, which inhibit activator-type bHLH factors. As a result, Numb<sup>+</sup> cells become neurons while Numb<sup>-</sup> cells remain as neural stem cells.

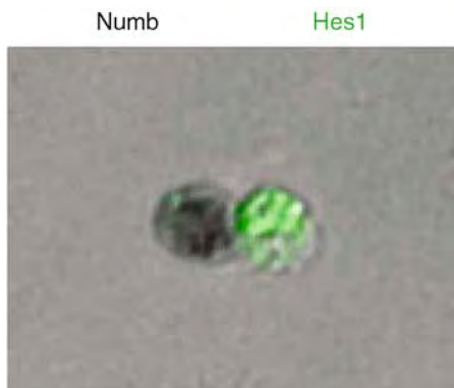

**Cell Differentiation. Figure 7** Asymmetric distribution of Numb. is distributed into one cell, which becomes negative for *Hes1* expression. In contrast, the other cell, which does not receive Numb, expresses *Hes1*. Modified from [8].

the Numb<sup>-</sup> cells are maintained as neural stem cells. In the absence of *Hes1* and *Hes5* however, activator-type bHLH genes cannot be repressed and both daughter cells become neurons. Thus, cross-regulation between the activator-type and repressor-type bHLH genes through Notch signaling is essential to allow some

cells to differentiate into neurons while keeping others as neural stem cells until later stages.

#### Regulation of Subtype Selection and Maturation

The subtype selection step is also regulated by bHLH genes. For example, excitatory neurons developed in the dorsal telencephalon are specified by *Neurogenin*, while inhibitory neurons developed in the ventral telencephalon are specified by *Mash1* [3,4]. Similarly, glial subtype selection, oligodendrocyte versus astrocyte, is regulated by the bHLH genes *Olig1/2*, *Hes1/5* and *Scl*. Thus, bHLH genes regulate not only the fate determination step but also the subtype selection step, indicating that these two steps proceed together. However, bHLH genes alone are not sufficient; other types of regulators such as homeodomain genes are required for subtype selection of many neurons. For example, in the dorsal spinal cord, the homeodomain gene *Lbx1* selects the GABAergic cell type, while the other homeodomain genes *Tlx1* and *Tlx3* select the glutamatergic cell type [9]. In the absence of *Lbx1*, the GABAergic neurons are transformed into glutamatergic neurons. Similarly, in the retina, combinations of bHLH and homeodomain genes are important for specification of neuronal subtypes. Different subtypes of retinal neurons are aligned in different layers, and this layer specificity is regulated by

homeodomain genes. Homeodomain genes alone cannot make neurons, but co-expression of bHLH and homeodomain genes can efficiently produce neurons with subtype specificity [10].

The maturation step of neurons is regulated by bHLH genes such as *NeuroD* and *Math2*, which belong to the family of activator-type bHLH genes. These bHLH genes seem to promote neurite extension and survival of immature neurons.

## References

1. Fishell G, Kriegstein AR (2003) Neurons from radial glia: the consequences of asymmetric inheritance. *Curr Opin Neurobiol* 13:34–41
2. Götz M, Huttner WB (2005) The cell biology of neurogenesis. *Nat Rev Mol Cell Biol* 6:777–788
3. Bertrand N, Castro DS, Guillemot F (2002) Proneural genes and the specification of neural cell types. *Nat Rev Neurosci* 3:517–530
4. Ross SE, Greenberg ME, Stiles CD (2003) Basic helix-loop-helix factors in cortical development. *Neuron* 39:13–25
5. Kageyama R, Nakanishi S (1997) Helix-loop-helix factors in growth and differentiation of the vertebrate nervous system. *Curr Opin Genet Dev* 7:659–665
6. Muroyama Y, Fujiwara Y, Orkin SH, Rowitch DH (2005) Specification of astrocytes by bHLH protein SCL in a restricted region of the neural tube. *Nature* 438:360–363
7. Zhong W, Feder JN, Jiang MM, Jan LY, Jan YN (1996) Asymmetric localization of a mammalian Numb homolog during mouse cortical neurogenesis. *Neuron* 17:43–53
8. Ohtsuka T, Imayoshi I, Shimojo H, Nishi E, Kageyama R, McConnell SK (2006) Visualization of embryonic neural stem cells using Hes promoters in transgenic mice. *Mol Cell Neurosci* 31:109–122
9. Cheng L, Samad OA, Xu Y, Mizuguchi R, Luo P, Shirasawa S, Goulding M, Ma Q (2005) Lbx1 and Tlx3 are opposing switches in determining GABAergic versus glutamatergic transmitter phenotypes. *Nat Neurosci* 8:1510–1515
10. Hatakeyama J, Kageyama R (2004) Retinal cell fate determination and bHLH factors. *Sem Cell Dev Biol* 15:83–89

## Cell Membrane Components and Functions

PETER M. LALLEY

Department of Physiology, Medical Sciences Center, University of Wisconsin School of Medicine and Public Health, Madison, WI, USA

### Synonyms

Plasma membrane – structure and functions;  
Plasmolemma – structure and functions

### Definition

The ►[nerve cell membrane](#) is a microscopically thin membrane that separates the cell cytoplasm and intracellular organelles from the extracellular milieu. Its chemical composition and structural features allow free passage of most lipids, and selective passage of ions, sugars and amino acids. The membrane, in addition, contains the molecular machinery for cell-to-cell chemical and electrical communication and immune responsiveness.

### Characteristics

#### Membrane Structure: Complex and Organized for Multi-tasking

Until relatively recently the nerve cell membrane appeared to be a somewhat simple structure with a few simple, internal stereotyped tasks, whereas the accomplishment of complex neuronal tasks was thought to be the exclusive domain of networks of neurons. What we knew about membrane structure through the 1960's was comparatively modest. The membrane was unmistakably very thin, on the order of 50 nm. It was made up largely of proteins and lipids, the latter organized into a bilayer. It was electrically charged (polarized) at rest (►[Membrane potential – basics](#)). It had aqueous channels through which various ions passed that allowed the cells to be excitable, i.e., to generate ►[action potentials](#) for communication among cells. It was endowed with ►[receptors](#), defined mainly by pharmacological testing, that enabled cells to communicate chemically through release and receptor binding of ►[neurotransmitters](#). The membrane was also thought to somehow facilitate growth and development of ►[neurites](#) (dendrites and axons) for local and distant cell-cell communication.

The introduction of new methodologies beginning in the 1970's, including x-ray diffraction, freeze fracture electron microscopy, advances in crystallography, computerized methods for analysis and modeling, and an avalanche of molecular biological methodologies and discoveries, brought a new appreciation of cell membrane structural complexity; and with it, the discovery of heretofore unknown, built-in mechanisms of ►[synaptic control](#) and ►[neuroplasticity](#).

This article provides a contemporary survey of membrane structural components, how they are assembled and how they contribute to nerve cell function.

### Anatomy and Chemical Makeup of the Nerve Cell Membrane

The unit membrane of the nerve cell is depicted in [Fig. 1](#). It is, on average, about 50 nm thick and comprised of various types of ►[phospholipids](#), proteins and carbohydrates. Proteins, being the largest molecules, make up the greatest membrane mass but the smaller phospholipids are the largest in number and carbohydrate molecules are

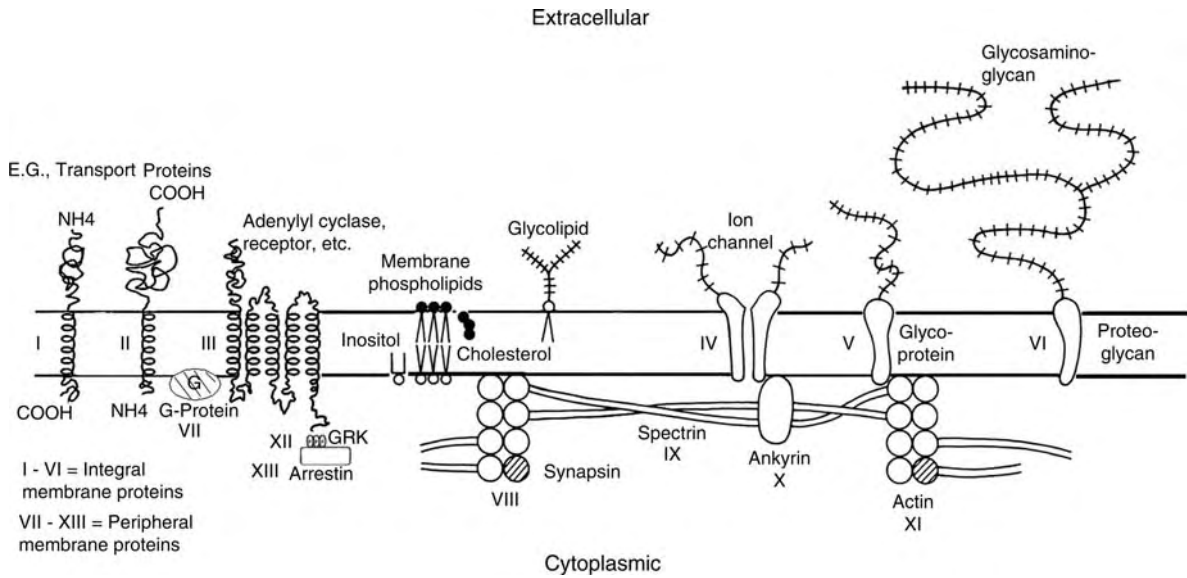

**Cell Membrane Components and Functions. Figure 1** Diagram of the nerve cell membrane. Shown are phospholipids, cholesterol, and various proteins (I–XIII) that make up membrane structure. See text for a description of their chemical properties and functions. Revised composite assembled from [4–6,10].

the fewest. The molecules making up the membrane proper, or attached to it, are mobile, interactive and in many cases functionally interdependent. They are replaced by intracellular biosynthesis, and turned over by a process called [▶membrane trafficking](#).

### Composition and Organization of Membrane Phospholipids

Membrane lipids are esters of glycerol phosphate attached to two long-chain fatty acids, each generally 14–20 carbon atoms long, and arranged in a bilayer with the glycerol phosphates facing the extracellular and intracellular fluids, and the fatty acid chains arranged in rows side by side in the membrane.

The phospholipid molecules are synthesized in the endoplasmic reticulum (ER), mainly in the cytoplasmic monolayer. Four different phospholipids are the major constituents of the bilayer: [▶sphingomyelin](#), phosphatidylcholine, phosphatidylethanolamine and phosphatidylserine. Smaller amounts of other phospholipids such as inositol phosphates are also found in the membrane. Phospholipids are differentially distributed in the cell membrane. More sphingomyelin and phosphatidylcholine are found in the outer leaflet of the bilayer, while more phosphatidylethanolamine and phosphatidylserine are found in the inner leaflet.

Phospholipid molecules have a high degree of lateral mobility in the bilayer, which facilitates movement of small nonpolar molecules across the cell membrane. Fluidity of cell membrane phospholipids also facilitates [▶transport](#) processes and enzyme activities. In fact, some membrane proteins require the presence of

phospholipids for proper function. Less frequently, phospholipid molecules will “flip-flop,” i.e., migrate from a monolayer on one side to that on the other.

### Functions of Membrane Phospholipids

1. *Insulation and barrier properties.* The lipid bilayer acts as a barrier to passage of polar substances including water and electrolytes, although gases such as oxygen and carbon dioxide pass through it, along with various lipid-soluble substances including alcohol and local anesthetics. The barrier property protects the cell from loss of vital polar cytoplasmic constituents and entry of many potentially harmful extracellular substances.
2. *Intracellular signaling.* The phospholipid inositol 1,2,3-trisphosphate (IP<sub>3</sub>), formed by G-protein-mediated activation of phospholipase C on the cytoplasmic side of the cell membrane, is a [▶second messenger](#) that mobilizes release of Ca<sup>2+</sup> and thus activation of Ca<sup>2+</sup>-dependent intracellular processes.
3. *Electrical properties.* The phospholipid bilayer, along with open ion [▶\(leak\) channels](#) of the cell membrane, acts as a [▶resistance-capacitance \(RC\) circuit](#) (Fig. 2a) as well as a low-pass filter and integrator of electrical input signals.

The extremely thin, expansive lipid bilayer of the nerve cell membrane has a [▶membrane capacitance](#) on the order of 1 μF/cm<sup>2</sup> that produces a charge of about 8 × 10<sup>-9</sup> coulombs/cm<sup>2</sup> at a [▶resting membrane potential](#) (membrane potential – basics) of –80 mV, or approximately 5 × 10<sup>11</sup> monovalent ions/cm<sup>2</sup>. Even



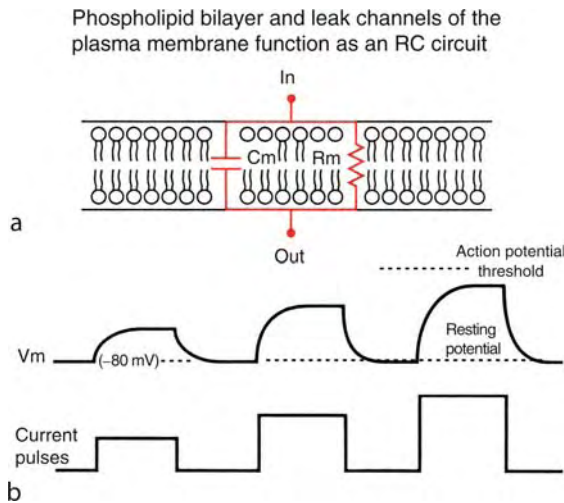

### Cell Membrane Components and Functions.

**Figure 2** Membrane capacitance and resistance, and effect on membrane current. (a) The membrane phospholipid bilayer acts as a capacitor, and membrane proteins assembled as ion channels provide a pathway with resistance for current flow. (b) The transmembrane voltage response ( $V_m$ ) to current pulses of different intensity. Revised from [7].

under steady state, or resting conditions, membrane channels, including some  $K^+$  and  $Na^+$  channels, stay open and generate a “▶leak conductance” [1]. In effect, what results is a leaky RC circuit, with a specific membrane resistance of about  $1,000 \Omega cm^2$  [2].

The RC circuit properties have functional consequences (Fig. 2b). In the resting state, the net movement of  $K^+$  ions down its concentration gradient through leak channels will leave behind impermeant cytoplasmic organic anions that accumulate on the inner side of the cell membrane and an accumulation of cations on the extracellular side [3], which accounts for the potential difference ( $V_m$ ) of about  $-80$  mV across the cell membrane (membrane potential – basics).

Figure 2b also shows subthreshold membrane potential responses to square wave pulses of current applied through a microelectrode inserted through the cell membrane (also membrane potential – basics). Each depolarizing current pulse will first mainly charge the membrane capacitor, and then the voltage difference will promote ion movement through the leak channels. The consequence is that the voltage transients caused by the applied current steps from the microelectrode develop more gradually than the current changes. Synaptically evoked ▶postsynaptic potentials (PSPs) will also build up more slowly than their corresponding synaptic currents. The RC properties of the membrane act as a low-pass filter, and an integrator of PSPs if frequency of occurrence leads to temporal summation. They can also affect the time required for an action

potential to reach threshold, and consequently the interspike interval during a burst of action potentials.

### Cholesterol

The nerve cell membrane contains large amounts of ▶cholesterol, which is synthesized mainly in the endoplasmic reticulum (ER). Cholesterol enhances the permeability-barrier property of the lipid bilayer. The hydroxyl groups of cholesterol are in proximity to the polar heads of the phospholipid molecules (Fig. 1) and partially immobilize the hydrocarbons close to the polar heads. This renders the lipid bilayer less permeable to small water-soluble molecules.

### Glycolipids

These lipids contain carbohydrate groups, usually galactose but also glucose, inositol or others, and are found only on the extracellular side of the cell membrane. ▶Glycolipids associate into micro-aggregates and are believed to be involved in cell-cell interactions. Five to ten percent of the total lipid mass consists of a particular type of glycolipid called a ▶ganglioside.

Gangliosides are thought to alter the electrical field across the cell membrane, as well as the concentration of  $Ca^{2+}$  ions along the external surface of the cell membrane. They may also be involved in cell-cell recognition at the extracellular matrix that promotes cell aggregation.

### Membrane Proteins

Figure 1 illustrates only 13 of a much larger group of currently identified and characterized membrane proteins. Proteins are subdivided according to position into integral (types I–V in Fig. 1) and peripheral (VI–XIII). ▶Integral proteins completely traverse the cell membrane, whereas ▶peripheral proteins are anchored to either the cytoplasmic or extracellular side. Singer [4] subdivided integral proteins into four general types, I–IV. Types I and II have just one transmembrane segment, and terminal amino and carboxyl groups on opposite sides of the cell membrane. Some transport proteins are part of this group. Members of the Type III group, which include the  $\beta$ -▶adrenergic receptor and adenylyl cyclase, an intracellular signaling component, have polypeptide chains that traverse the cell membrane several times. Members of type IV, which includes ▶ion channels, have several domains that are arranged around an aqueous pore that serves as the channel. Hydrophobic parts of integral proteins are positioned within the cell wall, in parallel with the lipid bilayer. Hydrophilic parts of integral proteins face the cytoplasm and extracellular fluid. The proteins have some degree of lateral mobility, less so than phospholipids.

Membrane proteins exhibit function-dependent polarity. For example, transporting enzymes have ATP-binding sites on the cytoplasmic side and glycoproteins have sugar residues on the outer surfaces.

Synthesis of cell membrane proteins takes place largely in the soma endoplasmic reticulum (ER), under the direction of nuclear DNA in ribosomal RNA-protein complexes. Selective axonal and dendritic transport processes deliver proteins to all regions of the neuron. Rough ER bears the ribosomes during protein synthesis. Newly synthesized protein is stored in cisternae, transported in vesicles through the Golgi apparatus and inserted into the cell membrane.

Cell membrane proteins are also synthesized on polyribosomes and stored in membranous cisterns in dendrites and axons, where they play important roles in ►synaptic plasticity and ►axon growth.

### Functions of Membrane Proteins

The locations of different types of proteins in the cell membrane serve as general predictors of how they function in the nerve cell.

Integral membrane proteins serve as:

1. ►Ion pumps, moving ions against a concentration gradient, using energy derived from ATP
2. Ion channels, allowing flow of ions and water across the cell membrane down an electrochemical gradient

3. Transporters of sugars and amino acids
4. Cell-cell recognition sites

Glycoproteins have three main subgroups, each involved one way or another with cell-cell recognition: the immunoglobulin super-family, the cadherin family and the integrins. The immunoglobulin family imparts Immunoreactivity, homophilic cell-cell interactions and outgrowth of neurites and fiber bundling during development. The cadherin family promotes  $\text{Ca}^{2+}$ -dependent neurite growth and axon bundling. The integrins promote cellular interactions with the extracellular matrix and also promote neurite growth and extension of axons to their targets.

►Proteoglycans, another group of integral proteins thought to be involved in cell-cell recognition, have long sugar chains that form a structure around the cell called the ►glycocalyx that is important for structural support.

Peripheral proteins function as:

1. Receptors for neurotransmitters, ►neuromodulators, ►hormones and other chemical messengers that trigger membrane ion permeability changes.

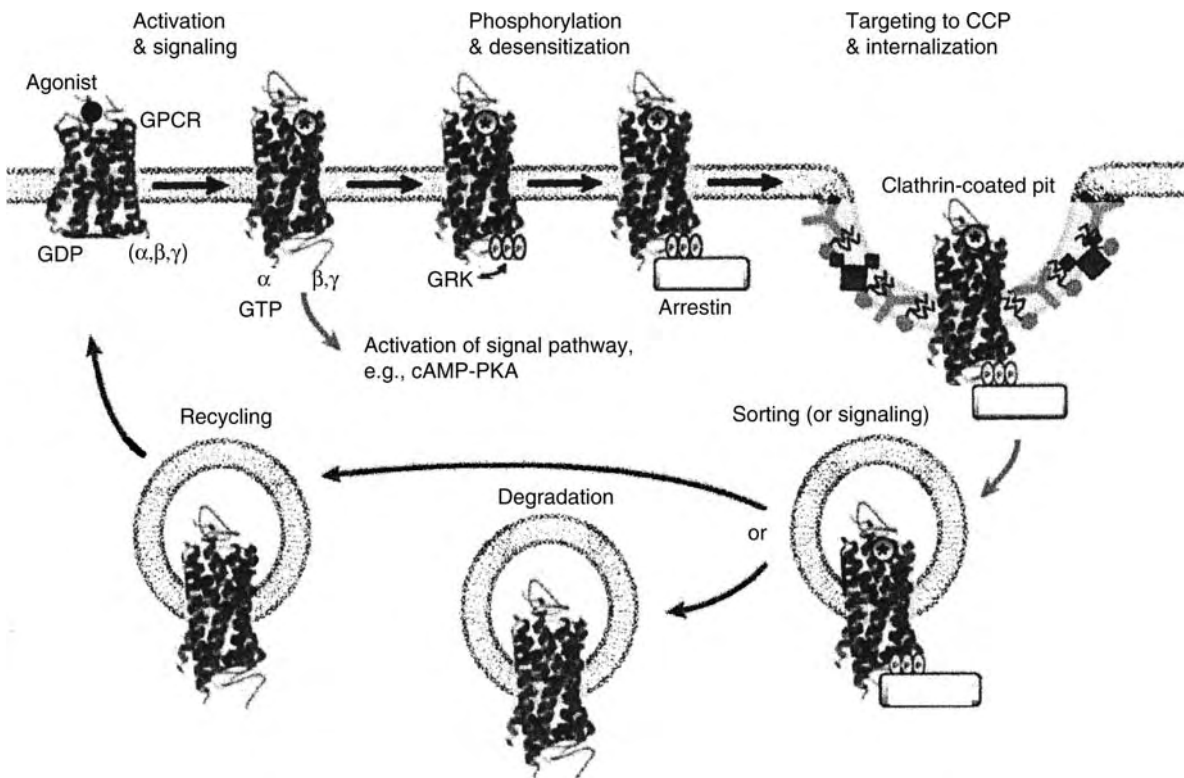

**Cell Membrane Components and Functions. Figure 3** Trafficking (cycling) of a G protein-coupled receptor (GPCR) under the influence of GPCR kinase (GRK) and Arrestin. After agonist binding and G-protein-mediated activation (or suppression) of a signal pathway, GRKs phosphorylate GPCR and Arrestin forms a complex that terminates signaling and translocates the complex to a clathrin-coated pit, followed by internalization and either degradation or recycling. Adapted from [6].

2. Enzymes that catalyze intracellular signal cascades.
3. Immunoreactive elements.
4. Membrane structural support proteins, such as ►actin, ankyrin, fodrin, and spectrin.
5. Mediators of neurite outgrowth and axon bundling
6. Intermediaries in membrane trafficking, a term that applies to recycling of agonist-activated receptors and ►synaptic vesicles. These processes are central to the development of desensitization to neurotransmitters and drugs and cell-cell communication.

### Receptor Recycling and the Development of Desensitization

The fidelity of chemically mediated ►synaptic transmission is affected by the affinity of an agonist for a

receptor and by the number of available receptors. Each of the two factors plays a key role in neural network responsiveness to endogenous ►neurohumoral agents as well as drugs such as ►opiates.

Desensitization of response to a ►receptor agonist most often occurs after prolonged or repeated receptor binding, particularly if the agonist has a high affinity for the receptor.

As shown in Fig. 3, binding of the agonist to its receptor triggers activation of several cytoplasmic membrane proteins, including G-Protein-coupled receptor kinases and a family of proteins known as ►arrestins. The consequence is internalization of the receptor, which is either degraded or reincorporated into the cell membrane.

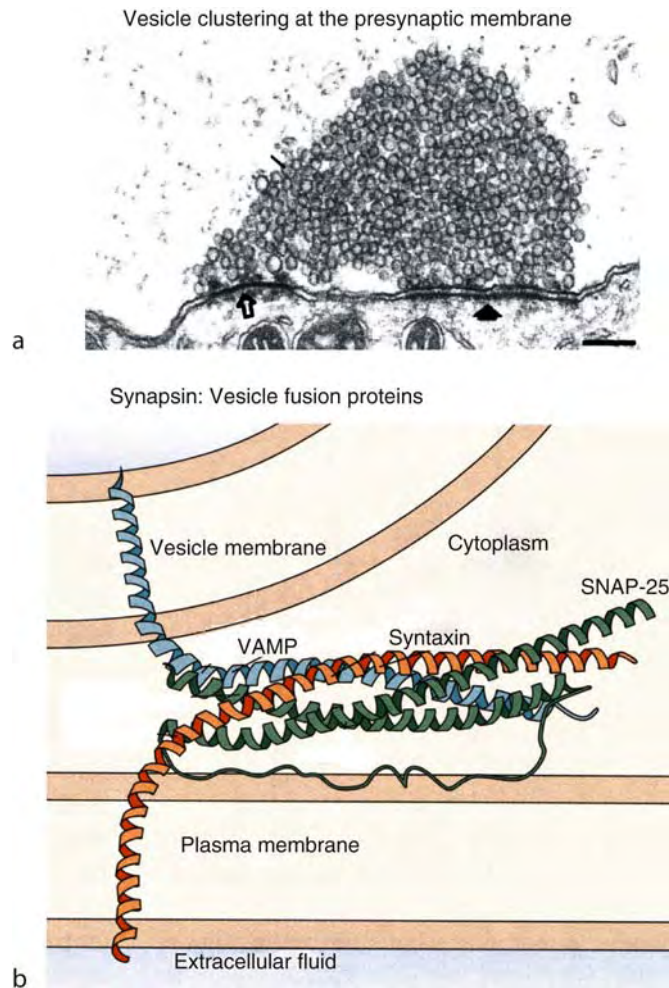

**Cell Membrane Components and Functions. Figure 4** Vesicle exocytosis and synaptic membrane proteins. (a) Electron micrograph of a lamprey reticulospinal, axodendritic synapse. A cluster of synaptic vesicles containing neurotransmitter is seen next to the presynaptic membrane. Active zones on the membrane where exocytosis occurs are distinguished by the dark bands and filled arrow (*open arrow* points to a gap junction). (b) Synapsins (proteins that bind vesicles to the presynaptic membrane) are shown, such as VAMP (synaptobrevin), SNAP-25 and Syntaxin. Adapted from (a): [8]; (b): [9].

### Vesicle Recycling and Neurotransmitter Release

Release of neurotransmitter into the ▶synaptic cleft is contingent on binding and incorporation of vesicles containing the secretory substance to the presynaptic membrane, at specialized release sites called ▶active zones. Figure 4 illustrates an electron micrograph of a synaptic cleft, with vesicles positioned for release at the active sites (Fig. 4a), and a cartoon of the different proteins that affect binding of the vesicle to a release site (Fig. 4b).

### Summary

The nerve cell membrane consists of a functionally efficient organization of phospholipids, proteins and carbohydrates that orchestrate static functions such as insulation and membrane electrical charge, and dynamic functions related to cell excitability, cell-cell communication and cell responsiveness to receptor agonists.

### References

1. Snutch TP, Monteil A (2007) The sodium “leak” has finally been plugged. *Neuron* 54:505–507
2. Aidley DJ (1998) The physiology of excitable membranes 4th edn., Chap. 3. Cambridge University Press, UK
3. Woodbury JW (1965) In: Ruch TR, Paton HD, Woodbury JW, Towe AL *Neurophysiology*, 2nd edn, Chap. 1. W.B. Saunders Co., Philadelphia
4. Singer SJ (1990) The structure and function of membranes – a personal memoir. *J membr Biol* 129:3–12
5. Alberts B, Bray D, Lewis J, Raff M, Roberts K, Watson JD (1994) *Molecular Biology of the Cell*, 3rd edn., Chap. 13. Garland Publishing, Inc., New York
6. Moore CAC, Milano SK, Benovic JK (2006) Regulation of receptor trafficking by GRKs and Arrestins. *Annu Rev Physiol* 69:451–482
7. Levitan IB, Kaczmarek LK (1997) The neuron, cell and molecular biology, 2nd edn., Chap. 3. Oxford University Press, New York
8. Brodin L, Shupliakov O (2006) Giant reticulospinal synapse in lamprey: molecular links between active and periaxonal zones. *Cell Tissue Res* 326:301–310
9. Koester J, Siegelbaum SA (2000) Local signaling: passive electrical properties of the neuron. In: Kandel ER, Schwartz JH, Jessel TM (eds) *Principles of neural science*, 4th edn., McGraw-Hill, New York
10. Shepherd GM (1994) *Neurobiology*, 3rd edn., Chap. 3. Oxford University Press, New York

## Cell Signaling

▶New Developments in G Protein-Coupled Receptor Theory

## Cell Soma

### Definition

The cell soma is the body of a neuron as apposed to its dendritic and axonic processes.

## Cell Transplantation

▶Autoimmune Demyelinating Disorders: Stem Cell Therapy

## Cellular and Humoral Immunity

### Definition

Cellular immunity utilizes phagocytes (such as macrophages, neutrophils, and eosinophils), which engulf antigens, and T-lymphocytes, which are thymus-derived, antigen-specific immune cells containing receptors specific for a special antigen. Cellular immunity is particularly important in defending the body against tumors and infections. Macrophages phagocytize antigens and secrete proteins (cytokines) that regulate cells involved in immune responses. One cytokine is interleukin-2, which stimulates an increase in the number of T-lymphocytes. The T-lymphocytes then develop surface receptors for specific antigens.

Because T-lymphocytes survive for months or years, cellular immunity toward the antigen remains with the individual for a long time. If re-exposed to the same antigen, the sensitized T-lymphocytes recognize the antigen and secrete their own proteins (lymphokines), which stimulate phagocytes to destroy the antigen. If an antigen is located on foreign or tumor cells, certain T-lymphocytes are transformed into cytotoxic T-lymphocytes, which destroy the target cells.

Humoral immunity utilizes antibodies, also known as immunoglobulins (Ig), produced by B-lymphocytes. B-lymphocytes are lymphocytes derived from the spleen, tonsils, and other lymphoid tissues. They become plasma cells, which make antibodies. There are five classes of antibodies: IgG, IgM, IgA, IgD, and IgE. IgG, IgM, and IgA are involved in humoral immunity, the function of IgD is not known, and IgE takes part in immediate hypersensitivity. Humoral

immunity involves the inactivation, removal, or destruction of antigens. Antibodies can inactivate viruses by binding to them. With two antigen binding sites per protein unit, an antibody can also precipitate the antigen by crosslinking in a network formed with other antibodies. After the antigen is precipitated, it can be removed by phagocytes. In addition, antigen binding by IgG or IgM activates a serum protein, called a complement, which can then initiate antigen precipitation, amplifying the inflammatory response. If the antigen is on the surface of certain cells, activated complement can also facilitate the lysis of these cells. IgG or IgM can also link the antigen to phagocytes or to killer cells, resulting in lysis of the cell by an unknown mechanism.

## Cellular Clock

MICHAEL N. NITABACH

Department of Cellular and Molecular Physiology, Yale School of Medicine, New Haven, CT, USA

### Synonyms

Cellular oscillator

### Definition

Cellular clock refers to the intrinsic physiological mechanisms by which cells function as autonomous circadian oscillators. There are similarities and differences between the cellular clock mechanisms of plants, fungi, animals, and prokaryotes.

### Characteristics

#### Cellular Clocks Can Function Autonomously

One of the key features of many cellular clocks is that they can function autonomously, i.e., they do not require intercellular communication. A seminal experiment demonstrating this revealed that mammalian **▶circadian pacemaker neurons** cultured under conditions where synaptic communication is abolished continue to exhibit circadian rhythms of action potential firing rate [1]. This leads to the conclusion that circadian oscillation is an intrinsic property of the cell itself, and is not solely a tissue-level phenomenon. This constrains the search for underlying mechanisms of circadian oscillation to processes that occur at the cellular level. Nevertheless, intercellular communication at the tissue level and communication between different tissues at the organismic level play important roles in the integrative physiology of circadian timekeeping.

#### Cellular Clocks Involve Negative Transcriptional Feedback

A key common feature of the cellular clock in fungi, plants, and animals is negative transcriptional feedback, a mechanism in which a gene product negatively regulates the gene that encodes it [for review, see 2]. Many “clock proteins” are transcription factors that, upon nuclear entry from the cytoplasm where they are synthesized, inhibit transcription of the “**▶clock genes**” that encode them. This mechanism ensures that when clock protein levels increase, there is a decrease in clock gene transcription, and consequent decrease in clock protein synthesis. In conjunction with clock protein degradation, this leads to a decrease in clock protein levels. This results in release from inhibition of clock gene transcription, and a consequent increase in clock protein levels, thus completing one cycle of an oscillation in the abundance of both clock gene transcripts and, with a delay, clock proteins.

#### Cellular Clocks Involve Post-Translational Covalent Modification of Clock Proteins

While this simple model of the cellular clock explains how negative transcriptional feedback can underlie a **▶self-sustaining oscillation** of clock gene transcript and clock protein abundance, it does not account for the fact that circadian **▶oscillators** cycle with a **▶period** very close to 24 h. The period of oscillation is determined by the time occupied by each of the steps of the cycle outlined above: transcription of clock gene, translation of clock gene transcript into clock protein, nuclear import of clock protein, degradation of clock protein. The most important mechanisms for setting the period of oscillation of the cellular clock appear to be regulation of the rates of nuclear import and degradation of clock proteins, implemented via post-translational modification of clock proteins [for review, see 3]. The two main post-translational modifications of clock proteins are protein phosphorylation – the covalent attachment of phosphate groups – and ubiquitination – the covalent attachment of the small polypeptide ubiquitin. Phosphorylation of clock proteins catalyzed by protein kinase enzymes regulates both nuclear import and ubiquitination. Ubiquitination of clock proteins catalyzed by ubiquitin ligase enzymes regulates degradation. Clock proteins can also be dephosphorylated and/or deubiquitinated by protein phosphatases and ubiquitin-specific proteases, respectively. Thus, the balances of phosphorylation and dephosphorylation, and of ubiquitination and deubiquitination, ultimately determine the period of oscillation of the cellular clock, with an appropriate balance resulting in a period of oscillation close to 24 h. Point mutations either in clock-protein transcription factors or the kinases that phosphorylate them that affect phosphorylation lead to aberrant periods substantially shorter or longer than 24 h. Some of these

point mutations have been implicated in human disorders of circadian regulation of the ►sleep-wake cycle [for review, see 4].

### Cellular Clocks do not Always Require Negative Transcriptional Feedback

While most cellular clocks appear to require negative transcriptional feedback, circadian oscillation in cyanobacteria – photosynthetic prokaryotes – can occur under some circumstances in the complete absence of transcription altogether. When a completely purified cyanobacterial clock protein that has protein kinase activity is incubated in a test tube with ATP, the clock protein itself exhibits a circadian rhythm in its level of phosphorylation [5]. Since this rhythm occurs in a reconstituted cell-free system without any gene transcription or protein translation, it establishes the existence of cellular clock mechanisms that do not rely on negative transcriptional feedback.

### Cellular Clocks Can Require Membrane Depolarization

In addition to negative transcriptional feedback and post-translational modifications, some circadian pacemaker neurons require membrane depolarization for continued oscillation (for review, see [6]). When the plasma membrane of fruit fly or mammalian pacemaker neurons is chronically hyperpolarized, cellular oscillation is severely impaired. Interference with intracellular calcium signaling also severely impairs cellular oscillation. These kinds of studies have led to a model of cellular oscillation in which circadian rhythms of membrane potential and/or intracellular calcium also participate – along with negative transcriptional feedback – in circadian timekeeping.

### Cellular Clocks are Temperature Compensated

One of the most fascinating features of cellular clocks is that they are ►temperature compensated, meaning that they run with the same period at a relatively wide range of temperatures. Since cellular clocks are based on a complicated set of interlocking biochemical reactions, and since the rates of biochemical reactions have a temperature dependence determined by principles of thermodynamics, then the simplest prediction would be that the period of cellular oscillation would also be temperature dependent. The fact that cellular clocks are temperature compensated thus implies the existence of specific compensatory mechanisms that counteract the effect of temperature on the biochemical reactions that underlie cellular timekeeping. While the nature of these compensatory mechanisms remains obscure, it is noteworthy that the reconstituted cell-free cyanobacterial oscillator is temperature compensated [5].

## References

1. Welsh DK, Logothetis DE, Meister M, Reppert SM (1995) Individual neurons dissociated from rat suprachiasmatic nucleus express independently phased circadian firing rhythms. *Neuron* 14(4):697–706
2. Young MW, Kay SA (2001) Time zones: a comparative genetics of circadian clocks. *Nat Rev Genet* 2(9):702–715
3. Gallego M, Virshup DM (2007) Post-translational modifications regulate the ticking of the circadian clock. *Nat Rev Mol Cell Biol* 8(2):139–148
4. Raizen DM, Mason TB, Pack AI (2006) Genetic basis for sleep regulation and sleep disorders. *Semin Neurol* 26(5):467–483
5. Nakajima M, Imai K, Ito H, Nishiwaki T, Murayama Y, Iwasaki H, Oyama T, Kondo T (2005) Reconstitution of circadian oscillation of cyanobacterial KaiC phosphorylation in vitro. *Science* 308(5720):414–415
6. Nitabach MN, Holmes TC, Blau J (2005) Membranes, ions, and clocks: testing the njus-sulzman-hastings model of the circadian oscillator. *Methods Enzymol* 393:682–693

## Cellular Oscillator

### ► Cellular Clock

## Cellular Potency

### Definition

Potential of a given (primary) cell to differentiate into a number of daughter cell fates. In cell biology, cellular potency varies from pluri- to uni-potency. Pluripotency has come to refer to a stem cell that has the potential to differentiate into any of the three germ layers: endoderm (e.g., interior stomach lining, gastrointestinal tract, the lungs), mesoderm (e.g., muscle, bone, blood, urogenital), or ectoderm (e.g., epidermal tissues and nervous system). Pluripotent stem cells can eventually specialize in any bodily tissue, but they cannot themselves develop into a human being because they cannot develop into extraembryonic tissue, such as the placenta. In contrast, many progenitor cells (e.g., adult stem/progenitor cells) are multipotent (e.g., capable of generating a limited number of cell fates).

Totipotent stem cells are produced from the fusion of an egg and sperm cell. Cells produced by the first few divisions of the fertilized egg are also totipotent. These cells can differentiate into embryonic and extraembryonic cell types.

Pluripotent stem cells are the descendants of totipotent cells and can differentiate into cells derived

from the three germ layers. Multipotent stem cells can produce only cells of a closely related family of cells (e.g., neural stem cells differentiate into neurons, oligodendrocytes, astrocytes).

Unipotent cells can produce only one cell type, but have the property of self-renewal which distinguishes them from non-stem cells.

---

## Center of Mass (CoM)

### Definition

The center of mass is the point in or near the body where total body mass is concentrated and about which the body would balance without a tendency to rotate. Center of mass of the body is a function only of the locations and masses of individual body segments. As a result, it varies with body build, posture, gender, and age. For an average individual standing erect with arms at the side the center of mass location is just anterior to the lower lumbar/upper sacral vertebrae. Also known as the center of gravity, because the vertical gravitational force due to the weight of the body can be considered to act through this point. Based on Newton's second law of motion, the net actions of external forces and torques acting on the body, computed with respect to the center of mass, determine the net acceleration of the body.

- ▶ Postural Strategies
- ▶ Postural Synergies

---

## Center of Pressure

### Definition

The centroid of the pressure distribution exerted by the body on the ground. It is the point in the support surface where the resultant of the vertical force components acts, causing a force, but no moments.

- ▶ Motion Analysis
- ▶ Stabilometry

---

## Center-surround Antagonism

### Definition

Retinal ganglion cells and lateral geniculate nucleus relay cells have receptive fields made of two concentrically

arranged subregions, a disk shaped "center" and an annular "surround." The boundaries between subregions are defined by different preferences for stimulus contrast (bright or dark) or sometimes by preferences for stimulus wavelength (color). Within On subregions, bright stimuli excite and dark inhibit, with the reverse profile for Off subregions. Because of this push-pull relationship between stimuli of opposite contrast, neighboring subregions have an antagonist effect on each other when both are filled with a spatially uniform stimulus.

- ▶ Lateral Geniculate Nucleus
- ▶ Retinal Ganglion Cells
- ▶ Visual Cortical and Subcortical Receptive Fields

---

## Center-surround Receptive Fields

- ▶ Visual Cortical and Subcortical Receptive Fields

---

## Central Amygdaloid Nucleus

### Synonyms

Nucl. amygdalae centralis; Central amygdaloid nucleus

- ▶ Amygdaloid Body
- ▶ Telencephalon

---

## Central Cerebellar Nuclei

### Synonyms

Nuclei cerebelli; Cerebellar nuclei

### Definition

The central cerebellar nuclei are located partly in the vermis cerebelli (fastigial nucleus, emboliform nucleus, globose nucleus) and partly in the medulla of the hemispheres (dentate nucleus). Their afferents have their origin in the Purkinje cells of the cerebellar cortex. The cells of the cerebellar hemisphere, lateral part project to the dentate nucleus, the cerebellar hemisphere, intermediate part to the emboliform nucleus and globose nucleus and the vermis cerebelli to the fastigial nucleus.

- ▶ Cerebellum

## Central Chemoreception

### Definition

Central chemosensitive neurons, which are sensitive to pH alteration in the cerebrospinal fluid, are tonically active and continuously activate the respiratory neurons. This tonic excitation may be synaptically transmitted to each respiratory neuron during the active phase and be gated during the inactive phase by periodic waves of inhibitory postsynaptic potentials (IPSPs).

- ▶ Central Nervous Chemoreceptors and Respiratory Drive
- ▶ Cerebrospinal Fluid (CSF)

## Central Chemoreceptor

### Definition

A chemoreceptor which exists within the central nervous system.

- ▶ Central Nervous Chemoreceptors and Respiratory Drive
- ▶ Respiratory Reflexes

## Central Cholinesterase Inhibitors

### Definition

Drugs that inhibit the enzyme acetylcholine esterase in the central nervous system, thus increasing the levels of acetylcholine in the brain.

## Central Core Disease (CCD)

### Definition

A rare, nonprogressive myopathy often present at infancy, which is characterized by hypotonia and proximal muscle weakness. In most cases, CCD has been linked to mutations in the *RyR1* gene encoding the  $Ca^{2+}$  release channel of the sarcoplasmic reticulum. Diagnosis is made on the basis of the lack of mitochondria and oxidative enzyme activity in central

regions of skeletal muscle cells, observed upon histological examination of muscle biopsies.

- ▶ Excitation-Contraction Coupling

## Central Gray Matter

### Synonyms

Substantia grisea centralis; Periaqueductal gray substance

### Definition

The central gray matter, also called periaqueductal gray matter, surrounds the mesencephalic aqueduct in the Mesencephalon, passing far into the metencephalon. Hence a distinction is made between:

- Central gray matter of Mesencephalon
- Central gray matter of metencephalon

The centrally located band of cells is an autonomic integration center, akin to the reticular formation. It receives afferents from virtually all parts of the brain and regulates e.g. coordination of the cranial nerve nuclei (e.g. swallowing). By virtue of the close interaction with the limbic system, the central gray matter is also involved in affective fear and flight reactions as well as in pain suppression.

- ▶ General CNS

## Central Integration of Cardiovascular and Respiratory Activity Studied In Situ

JULIAN F. R. PATON

Department of Physiology, Bristol Heart Institute, School of Medical Sciences, University of Bristol, Bristol, UK

### Synonyms

Arterially perfused brainstem; Autonomic nervous system; Sympathetic; Parasympathetic; Automatic ventilation; Coupling between cardiovascular and respiratory control systems; Respiratory sinus arrhythmia

### Definition

Within the brainstem there are neural circuits that control visceral functions; these are independent of



conscious control. One such network regulates the cardiovascular system by controlling ►autonomic (►nervous system) motor outflow (i.e., sympathetic and parasympathetic) to target organs such as the heart, arterioles and adrenal glands, for example. The activity within this network is, in part, generated from within the central nervous system itself. Part of this originates from the brainstem respiratory rhythm generator which is coupled synaptically to neurons controlling autonomic cardiovascular activity. Another source of excitation comes from sensory peripheral afferents that provide feedback signals. Both the latter as well as centrally generated inputs are computed (i.e., integrated) by neurons regulating arterial pressure and/or respiration. In this sense, the control of the cardiovascular and respiratory systems are coupled together allowing a matching of cardiac output with minute ventilation, which is crucial for optimizing physiological function. This system can be studied ►in situ, which is neither in vitro nor in vivo. In situ is the study of either an organ or organs (and their interactions) maintained viable within their own body space. Here, an in situ preparation containing much of the cardiovascular system and brainstem will be reviewed in terms of recent advances regarding our understanding of central neural integration of cardiovascular and respiratory function.

## Characteristics

### The In Vitro Approach

An enormous amount of information has been gained from in vitro mammalian brain preparations. Examples range from the discovery of long term potentiation to mechanisms of synaptic transmission and oscillatory neuronal behavior, as well as imaging of somatic and dendritic integration. The in vitro brain slice preparations evolved from the need to circumnavigate the technical obstacles and limitations encountered when working on the brain in vivo. Indeed, in vitro brain slice preparations are advantaged by the ability to control precisely multiple physiological variables (e.g., temperature; osmolarity) as well as the extracellular milieu thereby enabling the administration of pharmacological agents that include those that would be toxic if administered in vivo. Of major benefit is the mechanically stable environment of in vitro brain slice preparations. For example, maintaining intracellular recordings in vivo is plagued by the constant movement of the brain caused by the cardiac pulse and/or breathing cycle. With the significant advances in live imaging at the cellular level, brain slices, particularly those from neonates (which are more transparent as myelination is incomplete), allow visualization of cells (neurons, glia or vessels) and measurement of intracellular events such as calcium fluxes and translocation of fluorescently tagged proteins. Importantly, the brain

slice is ►insentient and data are not compounded by the unphysiological effects of anesthesia.

### The Drive to Go In Situ

The viability of the brain slice is determined by its thickness. Thus, the neuronal circuitry and connectivity is restricted. Without a circulation oxygen delivery is dependent on diffusion. This is limited as demand for oxygen by brain tissue is relatively high. To assist in delivery, high concentrations of oxygen are used (95% with 5% carbon dioxide, or carbogen) to elevate the diffusion gradient. Measurements in slices indicate that the tissue oxygen levels at the surface of the slice are hyperoxic (►hyperoxia) but levels decline rapidly such that anoxia occurs by 150–175 µm below the surface [1]. En-bloc brainstem and brainstem-spinal cord preparations of neonatal rats have been used in cardiovascular and respiratory research but these are known to have an anoxic core and viability is limited to the early neonatal period only. To improve the viability of thicker in vitro brain preparations and to allow studies to be performed on adult tissues, researchers developed arterially perfused in vitro preparations which, for example, included those of the brainstem [2] and cerebellum.

### The In Situ Approach

Despite these technological advances, there was a requirement to study the brain in situ. In situ means studying the brain within the body of the animal. This had the distinct advantage over isolated in vitro brain preparations (slice, en bloc, arterially perfused) of not only preserving both significant regions of the brain but also maintaining the peripheral afferent pathways and their peripheral receptors intact. It was apparent that the motor pathways were also preserved allowing ►kinesiological (►Kinesiology) studies as target organs were functional. Motor outflows (autonomic and somatic) could be shown to respond appropriately to stimulation of classical reflex pathways such as those mediating nociception, baroreceptor and peripheral chemoreceptor information. With such integrity of the in situ preparation, the question of how it was different to in vivo preparations and what added benefits there were arose. The in situ approach is distinct to in vivo in that anesthesia could be avoided by decortication or decerebration, the pulse pressure that caused mechanical instability in vivo was either minimized or abolished meaning the brainstem was more receptive to intracellular recording and imaging (see below). If forebrain structures were required then anesthetic agent could always be added to the perfusate. Finally, there was good pharmacological access as drugs could be applied topically or to the perfusate. A number of in situ preparations from multiple researchers using a variety of species have been utilized previously (e.g., [3]) and

all demonstrated superior mechanical stability of the brainstem relative to in vivo rats and the ability to antagonize receptors with drugs given systemically.

### The In Situ Working Heart-Brainstem Preparation

Since 1995 three new in situ preparations have been developed (i) the working heart-brainstem preparation (WHBP; [4]); (ii) the perfused hind limb and trunk preparation and, (iii) the decerebrate arterially perfused whole rat preparation [5]. In all cases, the preparations were perfused arterially with a cell-free perfusate consisting of a Ringer's solution containing an oncotic agent (to prevent edema) with an osmolarity of 290 mosm.kg<sup>-1</sup>.H<sub>2</sub>O and gassed with carbogen (pH 7.35) at 31–33°C. All these variables can be “clamped” or manipulated as the experiment demands. No oxygen carriers were required. This was a major benefit as they are both expensive and difficult to dissolve in aqueous solution. Adequate oxygenation is achieved because the perfusate is less viscous than blood allowing higher flow rates to be used for a given arterial pressure. Additions of vasopressin to the perfusate were

effective in increasing vascular tone allowing long term manipulation of perfusion pressure to within physiological or hypertensive levels (Fig.1).

The lower temperature than normal 31–33°C reduces metabolic rate so reducing oxygen usage. As a result, the oxygen supply satisfies demand. Indeed, measurements of PO<sub>2</sub> throughout the brainstem of the WHBP demonstrated that even at its core there is plenty of oxygen; in fact, the preparation is somewhat hyperoxic [6] such that 70–75% oxygen would maintain PO<sub>2</sub> at a physiological level. Thus, both the lower temperature and hyperoxic nature are potential drawbacks of this approach. At all depths within the brainstem pH was constant and reflected that of the perfusate (e.g., 7.35; [6]). An additional benefit of these preparations is the speed at which they can be set-up. The in situ preparation typically takes 20 min. A comparable in vivo animal may take several hours to establish. Moreover, the preparations can be made from most small mammals of up to 150 g of either adult or neonatal age and have included: mouse, rat, shrew and guinea pig. Because neonatal rats can be used (from day zero) developmental studies can be made in the

C

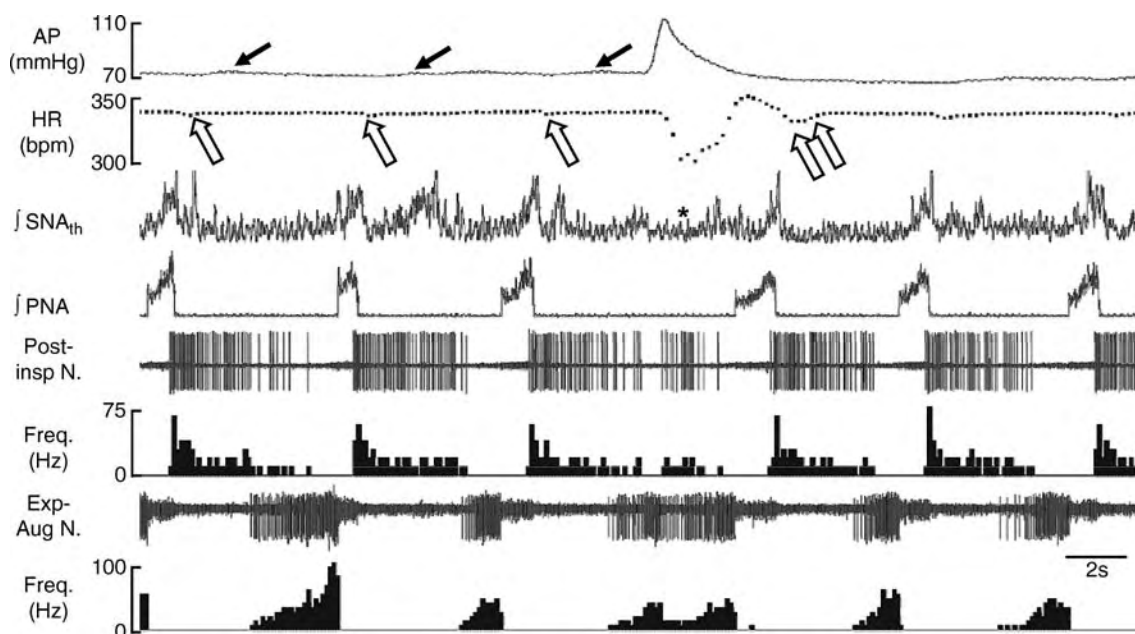

**Central Integration of Cardiovascular and Respiratory Activity Studied In Situ.** Figure 1 Integrating across systems in situ. Simultaneous recording of arterial pressure (AP), heart rate (HR; beats per minute, bpm), integrated thoracic sympathetic activity (SNA<sub>th</sub>), integrated phrenic nerve activity (IPNA) and two expiratory neurons from the Bötzing complex. Note the Hering-Traub waves in the arterial pressure trace (solid arrow) and the sinus arrhythmia (open arrow); the former reflect the respiratory-related increase in sympathetic discharge whereas the latter indicate heightened excitability of cardiac vagal motoneurons in early expiration. Stimulation of the baroreceptor reflex by raising systemic pressure (achieved by increasing perfusion pump rate transiently) reduces both heart rate and SNA(\*) but prolongs expiratory time which is coincident with an activation of the post-inspiratory neuron (Post-Insp) and an inhibition of the expiratory augmenting (Exp-Aug) neuron. Note the prolonged post-inspiratory neuron firing and enhanced sinus arrhythmia (two open arrows) after the baroreceptor stimulus. Unpublished (D. Baekey, T. E. Dick & J. F. R. Paton).

same preparation, which is advantageous and essential for direct comparisons with age. The preparation is free from anesthesia as the brain is decerebrated pre-collicularly, which removes the compounding problems relating to anesthesia but also means that forebrain structures are absent.

The WHBP consists of the thorax, neck and head with lower body (below the diaphragm) removed. It is perfused retrogradely via the descending aorta and within minutes respiratory movements of the chest and diaphragm resume and phrenic nerve discharges with an augmenting pattern characteristic of **eupnea** (Fig. 1). The eupneic-like respiratory pattern generated spontaneously for many hours by the in situ preparation is analogous to that generated by in an in vivo unanesthetized decerebrate rat. It was this “normal” pattern of inspiratory neural discharge that was essential for establishing the viability of the preparation. However, the respiratory frequency of the WHBP is considerably slower than that reported in vivo and in this regard the breathing is not eupneic. However, the slow respiratory rate was found to be a product of the lower running temperature (31–33°C) and absence of pulmonary vagal afferent feedback resulting from lung inflation [7]. Lung inflation is not required as the perfusate is aerated with carbogen but if the lungs are inflated mechanically and if perfusate temperature is raised to 37°C then breathing rates are close to those observed in decerebrate rats in vivo.

### The Integrative Aspect of the Working Heart-Brainstem Preparation

The integrative nature of the WHBP is portrayed by the central nervous coupling between multiple systems. Fig. 1 shows that the preparation exhibits respiratory sinus arrhythmia that occurs naturally to assist the matching of cardiac output with minute ventilation. This has a central nervous correlate with the firing of neurons located in the ventrolateral medulla. These are expiratory neurons exhibiting a decrementing discharge that fire maximally coincident with the onset of the sinus arrhythmia bradycardia (Fig. 1). The firing of these neurons occurs at an identical time as well as exhibiting a similar pattern to the decrementing expiratory motor activity recorded from the central vagus nerve. This decrementing (post-inspiratory) motor activity targets cardiac vagal post-ganglionic neurons but also laryngeal adductor muscle. Interestingly, it is possible to measure the respiratory phase-dependent changes in laryngeal resistance in the preparation, which is a good example of how the preparation offers a **kinesiological** approach. Respiratory modulation of the airway acts to facilitate inhalation (upper airway **abduction**) as well as stalling exhalation (laryngeal **adduction**) to prolong time for gas exchange at the level of the alveoli. In addition, sympathetic nerve activity is also respiratory phase modulated peaking at the transition

between the end of inspiration and start of expiration (Fig. 1). Again, expiratory neurons (Bötzinger augmenting type) show a similar firing pattern and temporal relationship with sympathetic nerve activity (Fig. 1).

The WHBP has contributed to the understanding of central integration of cardiovascular and respiratory reflexes. These include reflexes originating from nociceptors (somatic and visceral), peripheral chemoreceptors, cardiac, pulmonary, nasal, pharyngeal and oesophageal receptors. Additionally, the baroreceptor reflex is functional evoking the classical response of bradycardia, sympathoinhibition and prolongation of expiratory time (Fig. 1). Incidentally, the gain of the cardiac baroreceptor reflex is comparable to that measured in the conscious unrestrained rat (i.e., ~1.8 bts/min/mmHg). With the ability to precisely control arterial pressure, including its resting level, we were able to demonstrate a difference in the pressure threshold for baroreceptor reflex evoked vagal bradycardia versus sympathoinhibition. This led to the new idea of separate reflex sympathetic and parasympathetic arcs existing at the level of the nucleus tractus solitarius, the site of termination of baroreceptor afferents [8]. In addition, for the first time baroresponsive cells were recorded intracellularly from the nucleus tractus solitarius using **whole cell patch recording**, while stimulating the baroreceptors using the physiological stimulus of pressure. This has allowed novel insight into their sub-threshold activity, intrinsic membrane properties and morphology, for example. The WHBP has also played an important role in the introduction of viral gene transfer as a method to unravel central mechanisms involved in regulating the sensitivity of the baroreceptor reflex at the level of the nucleus tractus solitarius [9]. In the absence of a pharmacological antagonist for endothelial nitric oxide synthase (eNOS), adenoviral gene delivery of an eNOS dominant negative was used to demonstrate that the well established depressant effect of angiotensin II acting at the level of the nucleus tractus solitarius on baroreceptor reflex gain was via production of nitric oxide generated by stimulation of eNOS. This led to the novel idea of *vascular-neuronal signaling* in which paracrine signaling by chemical messengers released from the endothelium, such as nitric oxide, cross the blood brain barrier to affect neural processing of baroreceptor reflex circuitry. Subsequently, it was functionally shown that this process plays an essential role in the homeostatic reflex regulation of arterial pressure in both health and disease.

### Imaging Central Respiratory Activity In Situ

With the robust and eupneic respiratory motor pattern generated by the WHBP, the preparation has been adopted by multiple laboratories to understand neural mechanisms governing respiratory rhythm and pattern generation. In a recent study, a voltage sensitive dye was

used to image spontaneous respiratory activity from the pre-Bötzinger complex (Fig. 2) in the WHBP [10]. This was the first time that the adult mammalian central respiratory rhythm generator had been visualized during eupneic-like activity. The study unearthed the temporal and spatial organization of neural circuitry employed during eupneic- and ▶gasp- like respiration which led to

the conclusion that there was a significant difference in the spatial organization of the gasp relative to the region exhibiting eupnea.

### A Perspective for In Situ

For the future, a new direction for the WHBP will be to image single functionally identified cardiorespiratory

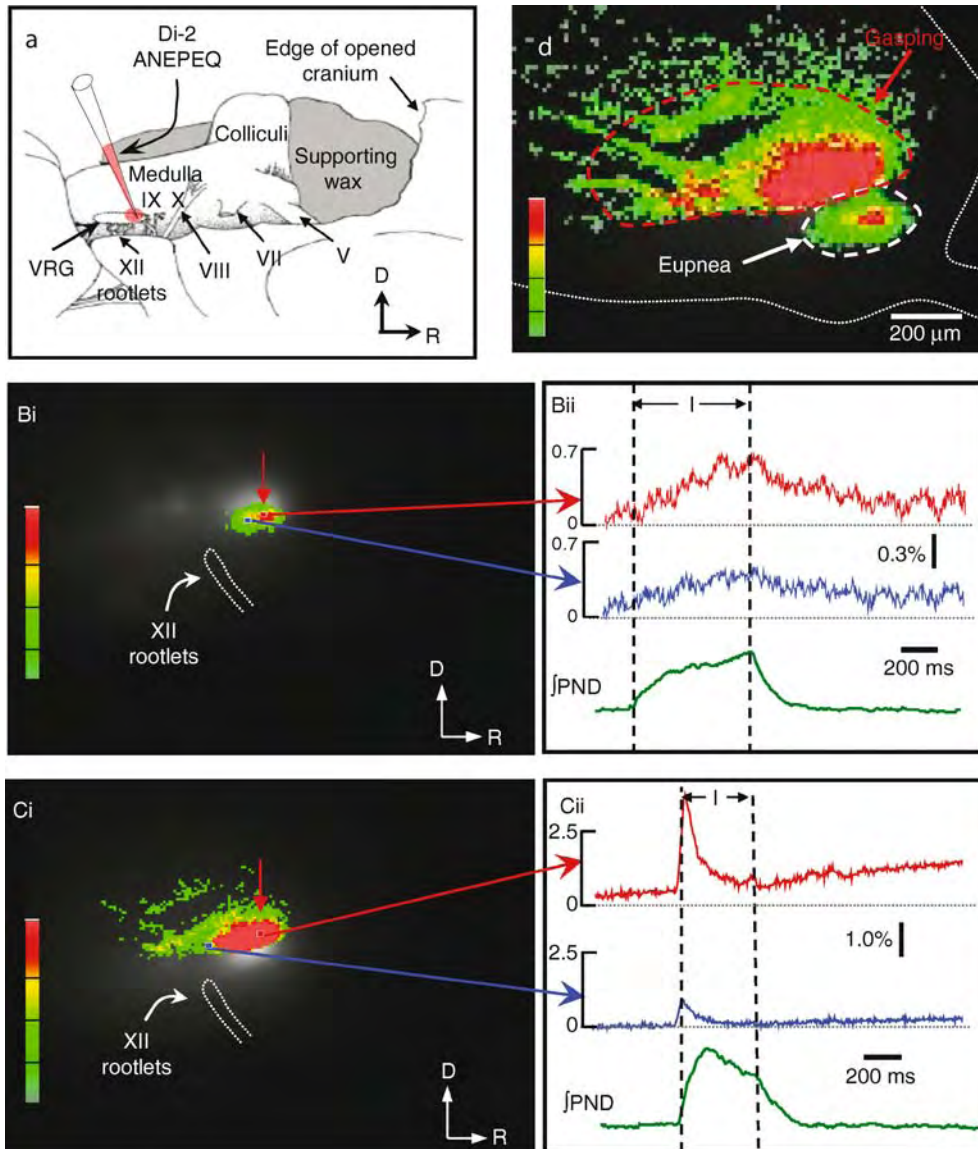

**Central Integration of Cardiovascular and Respiratory Activity Studied In Situ. Figure 2** Imaging brainstem respiratory network activity during eupnea and gasping in situ. Using the WHBP, we exposed the lateral edge of the medulla oblongata and injected a voltage-sensitive dye (Di-2 ANEPEQ) into the Pre-Bötzinger complex (a). Using a fast CCD camera, we performed phrenic nerve discharge (PND) triggered imaging of respiratory activity during eupnea (b) and hypoxic-induced gasping (c). Temporal and spatial patterns of activity were compared (d) and indicated distinct sites for the genesis of eupneic- and gasp- like respiratory patterns. The vertical colored scale indicates degree of depolarization with red being greatest. Abbreviations: *D*, dorsal; *R*, rostra; *VRG*, ventral respiratory group; *V*, *VII*, *VIII*, *IX*, *X* and *XII* are all cranial roots;  $\int$ , integrated. From [10], with permission.

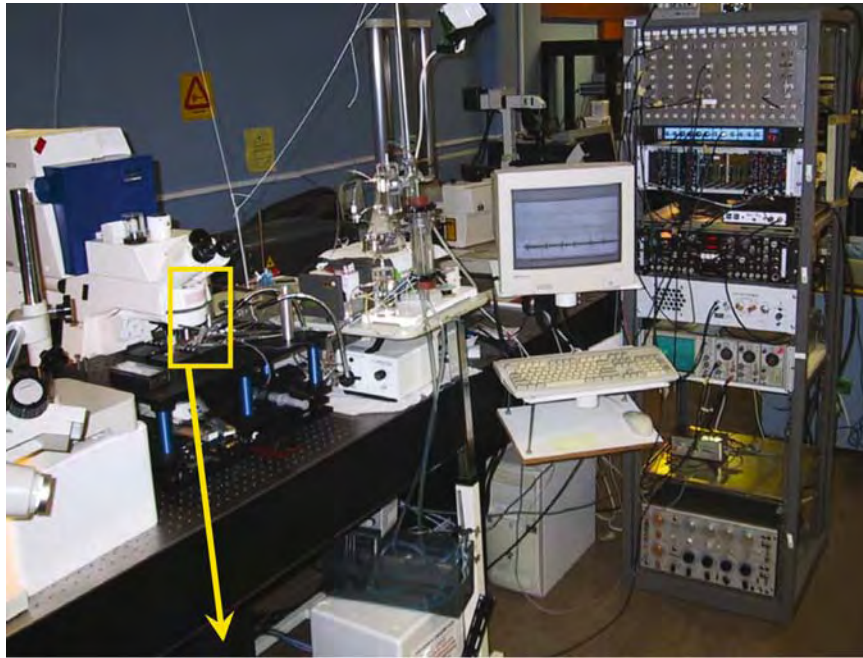

**Central Integration of Cardiovascular and Respiratory Activity Studied In Situ. Figure 3** The future in situ.

A future challenge would be to image neurons within an intact functional brainstem using multi-photon microscopy. Such a system equipped with a physiological recording rig and perfusion circuit for a WHBP is shown in (a). Using a custom designed stage it is possible to mount a WHBP beneath the objective turret of a two-photon microscope giving the potential to image brainstem cardiovascular and respiratory neurons (b).

neurons using two-photon imaging (Fig. 3). This may be possible because the brainstem is mechanically stable and overlying superficial structures of the brainstem can be trimmed off to expose underlying cardiovascular and respiratory brainstem regions. Such an approach would

allow unprecedented analysis of somatic and dendritic intracellular calcium fluxes and synaptic integration under different physiological and pathophysiological conditions (i.e., hypoxic (►hypoxia) driven gasping) on physiologically characterized neurons.

## Acknowledgements

I would like to thank all colleagues who have worked with me on the in situ preparations for their interest, enthusiasm and great fun. My thanks to Professor David Williams and Dr Andrew Allen at the Department of Physiology, University of Melbourne, Australia for assisting with a two photon study. I am in debt to the British Heart Foundation for their generous financial support. I also acknowledge the Royal Society from whom a Royal Society Wolfson Research Merit Award was gleaned.

## References

1. Paton JFR, Ramirez J-M, Richter DW (1994) Functionally intact in vitro preparation generating respiratory activity in neonatal and mature mammals. *Pflugers Arch* 428:250–260
2. Llinas R, Muhlethaler M (1988) An electrophysiological study of the in vitro, perfused brain stem-cerebellum of adult guinea-pig. *J Physiol* 404:215–240
3. Richerson GB, Getting PA (1987) Maintenance of complex neural function during perfusion of the mammalian brain. *Brain Res* 409:128–132
4. Paton JFR (1996) A working heart-brainstem preparation of the mouse. *J Neurosci Meth* 65:63–68
5. Pickering AE, Paton JFR (2006) A decerebrate, artificially-perfused in situ preparation of rat: utility for the study of autonomic and nociceptive processing. *J Neurosci Meth* 155:260–272
6. Wilson RJ, Remmers JE, Paton JF (2001) Brain stem PO<sub>2</sub> and pH of the working heart-brain stem preparation during vascular perfusion with aqueous medium. *Am J Physiol* 281:R528–R538
7. Paton JFR (1996) The respiratory network in the ventrolateral medulla of the mature mouse studied in a working heart-brainstem preparation. *J Physiol* 493 (3):819–831
8. Simms AE, Paton JF, Pickering AE (2007) Hierarchical recruitment of the sympathetic and parasympathetic limbs of the baroreflex in normotensive and spontaneously hypertensive rats. *J Physiol* 579:473–486
9. Paton JFR, Deuchars J, Ahmad Z, Wong L-F, Murphy D, Kasparov S (2001) Adeno viral vector demonstrates that angiotensin II induced depression of the cardiac baroreflex is mediated by endothelial nitric oxide synthase in the nucleus tractus solitarii. *J Physiol* 531(2):445–458
10. Potts JT, Paton JFR (2006) Optical imaging of medullary ventral respiratory network during eupnea and gasping in situ. *Eur J Neurosci* 23:3025–3033

## Central Lobule

### Synonyms

Lobulus centralis; Central lobule

## Definition

The central lobule forms the ventral, upper segment of the vermis cerebelli and rests on the lingula of cerebellum and hence on the fourth ventricle.

Like the entire vermis cerebelli, the central lobule receives its afferents primarily from the spinal cord. It is part of the spinocerebellum – palaeocerebellum.

► Cerebellum

## Central Medulla Oblongata Nucleus

### Synonyms

Nucl. reticularis centralis; Central reticular nucleus

### Definition

Belongs to the lateral reticular formation, i.e. to the parvocellular longitudinal zone of the RF, extending across the entire myelencephalon. Afferents come from the spinal cord, solitary tract, vestibular nuclei and the spinal nucleus of the trigeminal nerve. Efferents go to the gigantocellular reticular formation, the mesencephalic reticular formation as well as the bulbospinal tract in the intermediate substance of the spinal cord.

► Myelencephalon

## Central Mesencephalic Reticular Formation – Role in Eye Movements

DAVID M. WAITZMAN

University of Connecticut Health Center, Department of Neurology, Farmington, CT, USA

### Definition

This article is focused on the role of the long lead burst neurons in the ► Mesencephalic reticular formation (MRF) in the control of gaze (i.e. combined head and eye movements). Anatomically, the MRF is located just ventral to the superior colliculus (SC) (see also ► Superior colliculus – role in eye movements), situated between the oculomotor nuclei medially and the lateral lemniscus laterally (Fig. 1).

The brachium conjunctivum (i.e. crossing of the superior cerebellar peduncle) forms the caudal border, and the MRF extends rostrally through the core of the brain stem ending to the caudal portion of the thalamic

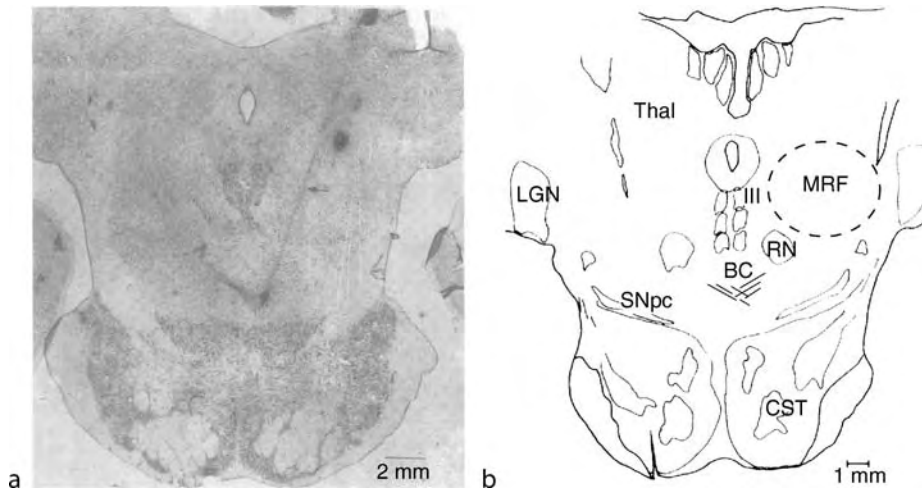

**Central Mesencephalic Reticular Formation – Role in Eye Movements. Figure 1** Coronal sections through the midbrain and pons of a non-human primate (*Macaca mulatta*) showing the location of the MRF at caudal A3.5 (a) and rostral (A5.0) levels (b). A. Photomicrograph showing the location of an open movement field cMRF neuron (arrow). Dark region at bottom of the track is an electrolytic identifying lesion. B. Diagram at approximately A5.0 identifying the various structures surrounding the MRF in a monkey (dashed line surrounds the approximate area from which 12 MRF neurons were recorded). Abbreviations: *III*, oculomotor nuclei; *BC*, brachium conjunctivum; *CST*, cortico-spinal tracts; *LGN*, lateral geniculate nucleus; *MRF*, Mesencephalic Reticular Formation; *RN*, red nucleus; *SN<sub>pc</sub>*, substantia nigra pars compacta; *Thal*, reticular nucleus of the thalamus.

reticular nucleus. Neurons in the cMRF not only receive collicular input, but form reciprocal connections that topographically target regions of the SC [1]. The cMRF also has strong, reciprocal projections to the omnipause region that gate saccades, the adjacent paramedian pontine reticular formation (PPRF) (see also ►Paramedian pontine reticular formation) [2] as well as descending direct and indirect projections (via the nucleus reticularis gigantocellularis, the putative premotor head movement region) to the cervical spinal cord. Ascending afferents to the cMRF arise from the fastigial nuclei of the cerebellum, the cervical spinal cord, and the PPRF itself [2]. These anatomic connections support the idea that cMRF neurons could assist in parceling the tectal outflow into separate eye and head channels (via PPRF and NRG) as well as mediating feedback to the SC about the current progress of gaze movements.

## Characteristics

### Lower Level Components

Three electrophysiological techniques have provided a better understanding of the organization of the cMRF and its role in gaze control: (i) electrical microstimulation; (ii) single unit recording; and (iii) reversible inactivation of the MRF in awake, behaving monkeys (*Macaca mulatta*). (For details of preparation and localization see [3]. All experiments have been carried out with the approval of the Animal Care and Use Committee of the University of Connecticut Health Center.

### Electrical Micro-Stimulation of the MRF

Electrical microstimulation in the MRF of head-restrained monkeys has demonstrated that saccades with fixed amplitude and direction could be elicited from dorsal portions of the MRF, and saccades with variable amplitudes and directions – dependent upon initial eye position – could be elicited from the ventral MRF. Recent work has systematically examined the effects of initial eye position on the size and direction of the elicited saccade [4]. Stimulation in the dorsal portion of the cMRF of monkeys whose heads were both restrained and unrestrained confirmed and extended the earlier results. These experiments evoked saccades whose amplitude and direction remained constant and were thus initial eye position independent (i.e. “fixed vector”). However, stimulation in the more ventral portion of the cMRF elicited two types of variable amplitude saccades. One set of ventral sites evoked saccades in which the amplitude of the vertical and horizontal components varied with changes in initial eye position such that the eyes converged toward a goal in space. At many of these stimulation sites the choice of an initial eye position beyond the “goal” reversed saccade direction. Again this finding was confirmed with the head both restrained and unrestrained. This phenomenon became more pronounced with stimulation of the most caudal and ventral portions of the cMRF. At these locations, electrical stimulation generated “centering saccades” that brought the eyes from an eccentric location towards primary position.

Such centering movements have never been elicited from stimulation of the superior colliculus. In sum, electrical stimulation has suggested that the cMRF harbors a dorsal to ventral organization with respect to saccade amplitude and initial eye position.

### Single Neuron Recording in the MRF

Single neuron recording has demonstrated two further subdivisions of the MRF. The neurons in the central portion of the MRF (the cMRF), located caudal to the posterior commissure discharge in association with horizontal eye movements [3], while MRF neurons located rostral to the posterior commissure are related to oblique saccades with larger vertical components [5]. Two major types of neurons have been identified in the cMRF. Neurons whose discharge started before saccades were called pre-saccadic, while neurons whose discharge began after saccade onset were called post-saccadic. The discharge of the pre-saccadic cMRF neurons began as an irregular, low rate of firing 100–125 ms before saccade onset. This prelude activity was then interrupted by a strong burst of activity that began 30 ms before saccade onset, qualifying these cells as long-lead burst neurons. The pre-saccadic group of cMRF neurons could be further subdivided into neurons with and without a high spontaneous level of activity upon which saccade associated changes in activity were superimposed. The high spontaneous level of activity of cMRF neurons was often inhibited before ipsilateral saccades. Similar to neurons in the superior colliculus, the cMRF pre-saccadic neurons discharge before a select group of contraversive saccades and thus had movement fields. However, the movement fields of cMRF pre-saccadic neurons were of three not the two types described in the SC. Like the SC, one sub-set of cMRF neurons had “closed movement fields” with a distinct distal border and they did not discharge for saccade amplitudes larger than the distal amplitude. A second group of cMRF neurons, again like those in the SC, had non-monotonic open movement fields and were very similar to the build-up neurons recorded in the superior colliculus (see also ►superior colliculus – role in eye movements). Thus, their discharge increased for saccade amplitudes up to an optimal beyond which larger amplitude movements were associated with equal or lower activity. Recent work in head unrestrained monkeys have shown that the cMRF harbors yet a third group of pre-saccadic neurons. Distinct from open-movement field neurons in the SC, the discharge of these monotonically open movement field, cMRF neurons continued to increase for movements up to the limit of measurement (approximately 70°), and were similar to the directional long-lead burst neurons found in the PPRF [6].

About 50% of the pre-saccadic cMRF discharged following the appearance of a visual stimulus, and thus

had visual characteristics [3]. Like the movement associated discharge, the “visual” discharge was elicited for a select group of stimuli within the contralateral visual field. This visual receptive field was either the same or larger in size than the corresponding movement field. The visual response was typically phasic and was not maintained for the duration of the stimulus. When monkeys performed saccades to a previously flashed target the visual discharge would disappear and a second, movement associated burst would occur before a saccade to the remembered location of the target (a REM saccade). Evidence of this phasic discharge for REM saccades suggested that pre-saccadic cMRF neurons carried signals related to the execution of the upcoming saccade.

The idea that cMRF neurons participate in the generation of a *motor* signal used for saccade generation was supported by evidence that a phasic discharge occurred just before spontaneous or REM saccades made in total darkness. As a result, the discharge of cMRF neurons was not solely mediated by vision. At the same time, the peak discharge of cMRF neurons during visually guided (VG) saccades often exceeded by an order of magnitude the discharge during similarly sized spontaneous saccades made in darkness. Since visually guided saccades are often faster than spontaneous saccades generated in the dark, the increased response of cMRF neurons could have been the result of either a fusion of their visual and motor responses or a reflection of the velocity of the upcoming saccade [3]. However, in this earlier study, saccades of the same amplitude, but different velocities, were not directly compared.

One way to decide if cMRF neurons carried an independent temporal signal related to eye velocity was to directly compare their discharge during VG and REM saccades. If the REM and VG movements are closely matched for amplitude and direction, REM saccades are slower than their VG counterparts and thus a cell related to eye velocity should display a lower discharge. The neuron shown in Fig. 2 had a movement field with its highest discharge for saccades up and to the right (Red region of Fig. 2a).

If the spike number in the burst associated with all of the movements across a swath of the movement field within  $\pm 7.5^\circ$  of a line extending from fixation to the optimal discharge was plotted against amplitude there was a monotonic increase in the discharge up to  $40^\circ$  (the limit of measurement) (Fig. 2b). Furthermore, the majority of open-movement field (both monotonic and non-monotonic) cMRF neurons had a close correlation between burst and saccade duration (Fig. 2c,  $r = 0.79$ ), as well as a tight correlation of peak discharge of the cell and peak eye velocity (Fig. 2d,  $r = 0.59$ ). Based on these static measures, we hypothesized that the open movement field pre-saccadic cMRF neurons temporally encode eye velocity. To decide if this hypothesis was



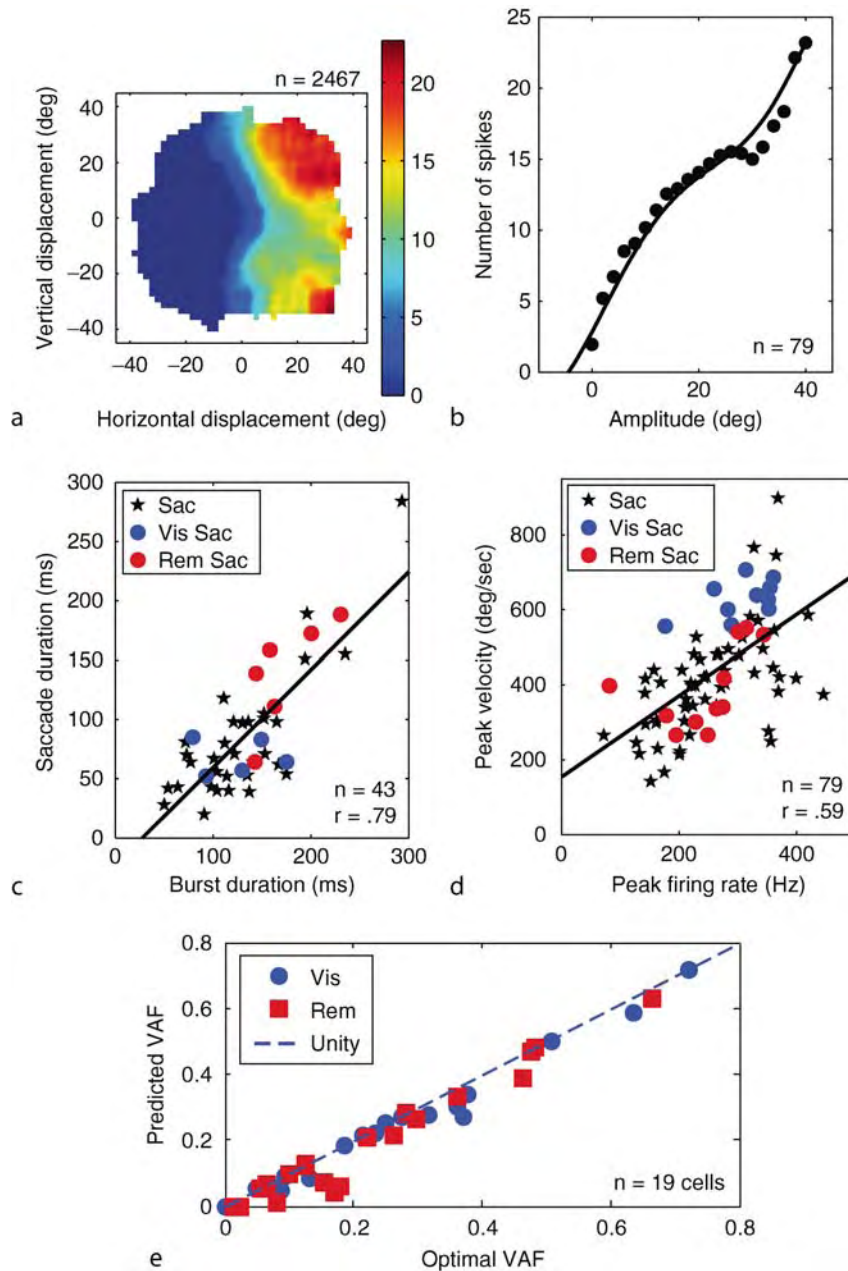

**Central Mesencephalic Reticular Formation – Role in Eye Movements. Figure 2** Analysis of a monotonically open movement field pre-saccadic cMRF neuron. (a) Movement field showing the spikes in the burst starting 30 ms before the saccade and ending with saccade offset. (b) Relationship of spike number to saccade amplitude across the movement field from primary position (straight ahead gaze) to the optimal discharge point for VG (Blue dot), (Red dots) and spontaneous saccades (Black stars). (c) Relationship of duration of the neuronal burst to the duration of the saccade for both VG (blue) and REM (red) saccades. (d) Relationship between the peak discharge of the neuron in the above analysis interval to the peak velocity of the saccade (VG data is blue, REM data is red) (e) Relationship between optimal VAF (Variance accounted for) and the predicted VAF. The optimal fit was determined by using either VG or REM data and relating firing rate, FR, to a scaled version of eye velocity. For example, for the VG data, the eye velocity model ( $FR = a + b \times E_{VG}$ ) was used. The predicted FR for REM saccades was generated by using the same parameters (a and b) obtained from the VG fit and applying them to the velocity of the amplitude matched remembered saccades (i.e.  $FR = a + b \times REM$ ). The ratio of the VAF (predicted)/VAF (optimal) would be 1 if the prediction was precisely the same, and lower than one if the estimate using the VG saccades was weaker (blue dots). This process was also repeated using the REM saccades to predict the firing rate during VG saccades (red squares).

correct, we calculated the variance accounted for (VAF) using an eye velocity model using all saccades in the optimal direction. The accuracy of our prediction was assessed by taking the ratio of the VAF generated using the VG parameters, applied to the REM velocity, divided by the optimal VAF generated using just the REM saccades alone. The results for 22 cMRF neurons with monotonically open movement fields are shown in Fig. 2e. Note that when the VAF was 0.12 or higher, there was an excellent correlation between the predicted and optimal VAF. These findings strongly suggest that the increased discharge observed during visually guided saccades was the result of the increased velocity of the movements and NOT the combination of visual and motor responses.

A second major group of cMRF neurons, the post-saccadic neurons, has been discovered in monkeys free to move their heads. The discharge of these “post-saccadic” neurons began after the onset of gaze, would continue as long as the head was moving, but often ended just before the head stopped moving. No similar group of cMRF neurons has been identified when the head was restrained [3,5]. Like the pre-saccadic cMRF neurons, the post-saccadic neurons had movement fields, but spike number correlated most closely with increases in the amplitude of the head and not the gaze movement. A multiple regression analysis of the bursts of these neurons showed that the peak discharge of the majority of post-saccadic cMRF neurons was most closely associated with peak head velocity, with a small minority related to the end of the head movement. Similar to pre-saccadic neurons, the post-saccadic neurons discharged before gaze movements directed to the contralateral side. However, a significant minority discharged for head movements in both directions. A few of the post-saccadic neurons were also associated with vertical head movements. Analysis of the dynamics of the post-saccadic neuron discharge showed that a majority could not be modeled by scaled versions of head velocity. Moreover, the duration of their discharge was poorly correlated with the duration of either the accelerating or decelerating phase of the head movement. Additional experiments will be needed to further understand the role of these neurons in gaze control.

### Higher Level Structures

Much of the human brain is devoted to acquiring visual information and then reorienting gaze (i.e. the combined movements of the head and eyes) to view targets of interest. The visual regions (e.g. V1, lateral geniculate nucleus, etc.) are organized topographically, such that neurons in a particular portion of the brain are only activated when a particular portion of the contralateral visual field is illuminated (see also Visual Cortex, connectivity and Visual Field Defects). This constitutes a spatial map: each individual neuron has a

“visual receptive field”. Once a target of interest activates such a receptive field, a series of steps ensue that they activate excitatory burst neurons in the paramedian pontine reticular formation (the PPRF) of the brain stem whose temporal pattern of discharge is closely associated with the force and speed of contraction required to move the muscles of the eyes (a temporal code) [6]. A similar area for control of head movement is thought to reside in the nucleus reticularis gigantocellularis (NRG) located at the ponto-medullary junction. The neuronal mechanisms necessary to convert topographically organized sensory information into the temporal pattern of activity required to carry out motor actions has been termed a spatial to temporal transformation (► [spatial temporal transformation STT](#)).

One locus in the brainstem where this STT may begin is in the superior colliculus (SC) of the mid-brain (see also ► [Superior colliculus – role in eye movements](#)). In the primate SC, neurons in the intermediate and deep layers are topographically organized and are activated before a specific sub-set of contraversive head and eye movements (i.e. gaze) called a “movement field” (see also ► [Superior colliculus – role in eye movements](#)). As a result, the discharge of neurons in the intermediate and deep layers of the SC encodes the ► [gaze displacement signal](#) in retinotopic coordinates required to shift the fovea using a combination of head and eye movement to fixate the new visual target. Critical to understanding the current discussion is the observation that the temporal discharge pattern of an individual SC neuron is poorly correlated with the velocity of the upcoming saccade, and the duration of discharge is only moderately related to gaze duration [7]. The movement fields of SC neurons are either “closed” (i.e. activity abates for gaze shifts larger than an optimal amplitude) or “open” (i.e. spike number increases to a maximum and then begins to decline, but does not disappear for movements beyond the optimal amplitude) (see also ► [Superior colliculus – role in eye movements](#)). In other words, these open movement fields are “non-monotonic” with respect to amplitude. Thus, while neurons in the SC, especially those in the caudal portion of the SC, discharge for a wide range of gaze movements, their activity could not encode the temporal pattern required to precisely activate the muscles moving the eyes or head. This suggests that the tectal output must undergo further processing before being incorporated into the activity of the short-lead, excitatory burst neurons of the PPRF whose discharge profile is closely correlated with both saccade duration and velocity.

### Function

A variety of techniques including electrical microstimulation, single neuron recording, and reversible inactivation, have demonstrated that neurons in the central Mesencephalic Reticular Formation (cMRF) participate

in the control of saccadic eye movements. Four neuronal sub-types have been identified. Evidence that the burst duration and peak discharge of pre-saccadic, monotonically increasing open movement field cMRF neurons were closely associated with saccade duration and peak velocity, respectively, suggested that these neurons were similar to the directional long-lead burst neurons found in the PPRF [6]. Since cMRF neurons have direct projections to the PPRF, they could be a critical component of an indirect tecto-reticular-pontine pathway that parallels the direct tecto-pontine pathways [6]. The close association of the directional long-lead burst neurons of the pons, and the monotonically increasing long-lead burst neurons of the MRF with saccade dynamics, supports a role for these neurons in the conversion of ►gaze signals coded spatially in the SC (i.e. movement fields organized topographically) into the temporal pattern of activity (i.e. rate of discharge) found in the excitatory burst neurons of the pons [8].

The precise role of the other neuronal sub-types in the cMRF remains unclear. For example, the physiological characteristics of cMRF neurons with non-monotonically open movement fields and neurons with closed movement fields were most similar to neurons located in the superior colliculus. The evidence of hypermetric saccades following the reversible inactivation of the caudal portion of the cMRF suggested that these two neuronal sub-types could participate in a feedback pathway that provided the SC with a signal of the current change in horizontal eye position [9]. However, a distinct feature of the non-monotonic open movement field neurons was the close association of their burst duration with saccade duration, particularly the horizontal component. This suggests an alternative idea that these neurons could feedback a saccade duration signal from the omnipause neurons to the SC [7]. By extension, MRF neurons located rostral to the posterior commissure could provide a feedback signal corresponding with either the current change or duration of the vertical component of eye movement to the SC. Finally, the physiological properties of the post-saccadic neurons are unique and may reflect aspects of either a feed-forward or feedback mechanism for controlling movements of the head. Future work will be directed to better understanding the different roles played by these other neurons in the control of gaze movements.

### Pathology

#### **Reversible Inactivation of the Neurons in the MRF**

One question raised by the electrical stimulation and single neuron recording in the MRF was: What role do cMRF neurons play in the control of eye movement? Previous experiments had shown that electrolytic destruction of the MRF produced an ipsilateral gaze

preference and a reduction in the speed of the slow phases of contralateral optokinetic nystagmus (OKN) [10]. The primary drawback of electrolytic lesions placed in the reticular formation was that they destroyed both cMRF neurons and fibers in passage, and may have encroached upon the ►nucleus of the optic tract associated with smooth pursuit eye movements (see also ►Smooth pursuit eye movements), which is located just above the cMRF. As a result, we injected the GABA-A agonist muscimol within the cMRF [4]. This agent selectively blocked neuronal activity leaving axons in passage unaffected. Three findings were evident following microinjections (0.5–1.5 µg) of muscimol placed at the location of previously recorded neurons in four monkeys. Injections caudal to the posterior commissure produced hypermetric, contralateral saccades and an instability in fixation (macro-saccadic square-wave jerks) [4]. There were two intriguing aspects to the injections in the MRF caudal to the posterior commissure (i.e. the cMRF). First, most of these injections generated a contralateral head tilt. Second, the hypermetria was most evident in oblique and vertical saccades. The horizontal component of oblique saccades was actually mildly hypometric while the vertical component was hypermetric. On the other hand, injections in the MRF rostral to the posterior commissure generated severe hypometria of the vertical component (both up and down) of oblique or vertical saccades. The horizontal component of oblique saccades was essentially unaffected by injections rostral to the posterior commissure. Taken in conjunction with single neuron recording [3,5] the results of inactivation support the view that the cMRF can be divided into two zones. The region caudal to the posterior commissure was most closely associated with the horizontal component of gaze shifts, and the portion rostral to the posterior commissure was most closely associated with the vertical component of saccades.

### References

1. Chen B, May PJ (2000) The feedback circuit connecting the superior colliculus and central mesencephalic reticular formation: a direct morphological demonstration. *Exp Brain Res* 131:10–21
2. Buttner-Ennever JA (1988) *Neuroanatomy of the oculomotor system*. Elsevier, New York, NY
3. Cromer JA, Waitzman DM (2006) Neurons associated with saccade metrics in the monkey central mesencephalic reticular formation. *J Physiol* 570:507–523
4. Waitzman DM, Pathmanathan J, Presnell R, Ayers A, DePalma S (2002) Contribution of the superior colliculus and the mesencephalic reticular formation to gaze control. *Ann NY Acad Sci* 956:111–129
5. Handel A, Glimcher PW (1997) Response properties of saccade-related burst neurons in the central mesencephalic reticular formation. *J Neurophysiol* 78:2164–2175

6. Hepp K, Henn V (1983) Spatio-temporal recoding of rapid eye movement signals in the monkey paramedian pontine reticular formation (PPRF). *Exp Brain Res* 52:105–120
7. Soetedjo R, Kaneko CR, Fuchs AF (2002) Evidence that the superior colliculus participates in the feedback control of saccadic eye movements. *J Neurophysiol* 87:679–695
8. Moschovakis AK, Kitama T, Dalezios Y, Petit J, Brandt AM, Grantyn AA (1998) An anatomical substrate for the spatiotemporal transformation. *J Neurosci* 18:10219–10229
9. Waitzman DM, Silakov VL, DePalma-Bowles S, Ayers AS (2000) Effects of reversible inactivation of the primate mesencephalic reticular formation. I. Hypermetric goal-directed saccades. *J Neurophysiol* 83:2260–2284
10. Komatsuzaki A, Alpert J, Harris HE, Cohen B (1972) Effects of mesencephalic reticular formation lesions on optokinetic nystagmus. *Exp Neurol* 34:522–534

## Central Motor Conduction Time (CMCT)

### Definition

The time needed for the evoked signals to pass from the motor cortex to spinal motoneurons along the corticospinal tract. Used as an indication of pathological processes affecting descending motor pathways and as a measure of their progress.

- ▶ Corticospinal Tract
- ▶ Motor Cortex – Output Properties and Organization
- ▶ Transcranial Magnetic Stimulation

## Central Nervous Chemoreceptors and Respiratory Drive

EUGENE NATTIE, AIHUA LI  
Department of Physiology, Dartmouth Medical School,  
Lebanon, NH, USA

### Synonyms

Central chemoreception

### Definition

Central nervous chemoreception refers to the process by which changes in ▶PCO<sub>2</sub> and pH within the central nervous system are detected and stimulate or inhibit ▶respiration. Respiratory drive here refers to the endogenous stimulation of normal respiration that arises, in part, from central chemoreceptors.

## Characteristics

### Respiration

Respiration serves to exchange O<sub>2</sub> and CO<sub>2</sub> between body and atmosphere. The initiation and maintenance of respiration occurs in the brainstem and involves a network of ▶respiratory neurons (see Respiratory Network Analysis). The amount of respiration depends on the response of this neuronal network to inhibitory and excitatory afferent input from peripheral and central sensors (see Respiratory Reflexes; Carotid Body Chemoreception and Respiratory Drive). Here we discuss central chemoreception.

### Central Chemoreceptors: Locations and Cell Types

Central chemoreception was initially identified by the presence of respiratory responses to the perfusion of acidic fluids within the brain ventricles [1]. It was then localized to cells of unknown type at or beneath the ventral surface of the medulla oblongata by the direct application of acidic fluids [2]. But studies in vitro showed that neurons from many other locations within the hindbrain were responsive to pH changes see [3].

More recent experiments in vivo have provided support for the hypothesis that central chemoreception is a distributed property, i.e., that central chemoreceptor sites are widespread within the hindbrain [3–7]. In conscious animals, respiration is stimulated by the focal application of an acidic stimulus (increased CO<sub>2</sub>) by reverse microdialysis at the (i) ▶retrotrapezoid nucleus [3], (ii) caudal aspect of the nucleus of the tractus solitarius [3], (iii) medullary raphe [3] (see Medullary Raphe Nuclei and Respiratory Control), and (iv) the fastigial nucleus of the cerebellum [4]. Similar studies in anesthetized animals also showed chemosensitivity at the locus ceruleus and the ▶ventral respiratory group see [3]. Others have indicated the presence of chemoreception near the surface of the caudal ventral medulla as well [5].

In the retrotrapezoid nucleus, the chemosensitive neurons are glutamatergic and are identified by the presence of the vesicular glutamate transporter 2 (VGLUT2) see [3,7]. Their location is ventral to the caudal aspect of the facial nucleus just below one ventral medullary surface site at which earlier studies identified central chemoreception by application of acidic fluids [2]. The retrotrapezoid nucleus chemosensitive neurons express Phox2b, a gene associated with the development of the autonomic nervous system, and they also receive information arising in the peripheral chemoreceptors, the carotid bodies, via the nucleus of the tractus solitarius [7]. Inhibition or lesion of retrotrapezoid nucleus neurons diminishes the respiratory response to exogenously elevated CO<sub>2</sub> [3].

In the medullary raphe, the chemosensitive neurons are serotonergic [6]. They are located in the ventral medulla

with some being quite close to the ventral medullary surface. The blood supply to the medulla originates at the ventral surface and many chemosensitive serotonergic neurons are anatomically situated close to penetrating arteries. Inhibition or lesions of medullary raphe serotonergic neurons diminishes the respiratory response to exogenously elevated  $\text{CO}_2$  [3]. (see Medullary Raphe Nuclei and Respiratory Control).

The chemosensitive neurons of the caudal part of the nucleus of the tractus solitarius, the fastigial nucleus of the cerebellum and the caudal ventral medulla have yet to be identified in terms of their cell type.

The chemosensitive neurons of the locus ceruleus are catecholaminergic see [3]. Their location is in the dorsal pons and they too are situated close to blood vessels. Lesions of locus ceruleus and other catecholaminergic neurons diminish the respiratory response to exogenously elevated  $\text{CO}_2$ .

ATP release from cells of unknown type at the ventral medulla has also been postulated as involved in central chemoreception see [3].

Central chemoreception is a widely distributed property with many types of neurons involved. Each of the central chemoreceptor locations has known neuronal projections to the major groups of brainstem respiratory neurons.

### Central Chemoreceptors: Function

The control of respiration, designed to maintain normal levels of arterial  $\text{PO}_2$  and  $\text{PCO}_2$ , depends on constant feed-back from peripheral and central chemoreceptors. The peripheral chemoreceptors in the carotid body located at the bifurcation of the carotid artery detect and produce rapid respiratory responses to small changes in arterial  $\text{PCO}_2$ . They also respond to lowered arterial  $\text{PO}_2$  levels but the magnitude of the response is small until arterial  $\text{PO}_2$  is about 70 mm Hg (normal arterial  $\text{PO}_2 = 90$  mm Hg). The central chemoreceptors are not directly affected by changes in  $\text{PO}_2$ . Their response to changes in  $\text{PCO}_2$  is robust (~60% of the steady-state response to elevated  $\text{CO}_2$  levels) but occurs more slowly than that of the carotid bodies [8,9]. These differences between central and peripheral chemoreceptors in response magnitude and dynamics indicate the presence of complex chemical-feedback system for  $\text{CO}_2$  that governs respiration [8]. In order to maintain normal respiration, input from both receptors is necessary as lesions of either result in decreased respiration (and elevated arterial  $\text{PCO}_2$  levels). Thus both contribute a drive to normal respiration. In contrast, sudden decreases in arterial  $\text{PCO}_2$  can result in the cessation of breathing (apnea) if they occur in non-waking conditions. This hypocapnic apnea arises in the more rapidly responding peripheral chemoreceptors and is likely tempered by the slower central chemoreceptor response [8,9].

Central chemoreceptors are located within the parenchyma of the hindbrain. While some are situated quite close to arteries and vessels, in terms of overall function they are able to detect the pH of brain interstitial fluid [1]. In body fluids,  $\text{CO}_2$  is in rapid equilibrium with water forming  $\text{H}_2\text{CO}_3$  and then  $\text{H}^+$  and  $\text{HCO}_3^-$  ions. Thus a pH sensing mechanism can be responsive to both primary changes in  $\text{PCO}_2$  and in pH. Brain interstitial fluid pH is determined by three interacting processes: (i) the level of **alveolar ventilation**, which determines the arterial  $\text{PCO}_2$ , (ii) cerebral metabolic rate, which determines the rate of  $\text{CO}_2$  production, and (iii) cerebral blood flow. For example, brain interstitial fluid can become more acidic and respiration stimulated if the alveolar ventilation is decreased, if metabolic  $\text{CO}_2$  production is increased, or if cerebral blood flow is decreased, which would slow the clearance of tissue  $\text{CO}_2$ . Central chemoreceptors can be viewed as detecting a product, pH, of these three vital processes. Further, dysfunction of alveolar ventilation or cerebral blood flow such as to impair  $\text{O}_2$  delivery to the brain would be detected as a change in interstitial fluid pH thus allowing central chemoreceptors to act as indirect sensors of cerebral oxygen delivery.

Central chemoreceptors, activated by brain interstitial fluid pH, provide a drive to breathe. They may also act as a “buffer” to modulate rapid responses that might arise from the peripheral chemoreceptors. There are many locations and cell types that are chemosensitive and the specific functions of each within the overall system design are not well understood. For example, different chemoreceptor sites can interact dramatically. Simultaneous inhibition of the retrotrapezoid nucleus and the medullary raphe produces a much greater inhibitory effect on the respiratory response to exogenously elevated  $\text{CO}_2$  than does inhibition of either site alone [10].

### References

1. Fencel V, Miller TB, Pappenheimer JR (1966) Studies on the respiratory response to disturbances of acid-base balance, with deductions concerning the ionic composition of cerebral interstitial fluid. *Am J Physiol* 210:459–472
2. Mitchell RA, Loeschcke HH, Massion WH, Severinghaus JW (1963) Respiratory responses mediated through superficial chemosensitive areas on the medulla. *J Appl Physiol* 18:523–533
3. Nattie E, Li A (2006) Central chemoreception 2005: a brief review. *Auton Neurosci: Basic Clin* 126–127:332–338
4. Martino PF, Davis S, Opansky C, Krause K, Bonis JM, Pan LG, Qian B, Forster HV (2007) The cerebellar fastigial nucleus contributes to  $\text{CO}_2$ - $\text{H}^+$  ventilatory sensitivity in awake goats. *Respir Physiol Neurobiol* 157:242–251
5. Ribas-Salgueiro JL, Gaytán SP, Crego R, Pásaro R, Ribas J (2003) Highly  $\text{H}^+$ -sensitive neurons in the caudal ventrolateral medulla of the rat. *J Physiol* 549 (1):181–194

6. Richerson GB, Wang W, Hodges MR, Dohle CI, Diez-Sampedro A (2005) Homing in on the specific phenotype(s) of central respiratory chemoreceptors. *Exp Physiol* 90:259–266; discussion 266–269
7. Takakura AC, Moreira TS, Colombari E, West GH, Stormetta RL, Guyenet PG (2006) Peripheral chemoreceptor inputs to retrotrapezoid nucleus (RTN) CO<sub>2</sub>-sensitive neurons in rats. *J Physiol* 572:503–523
8. Nattie E (2006) Why do we have both peripheral and central chemoreceptors? invited editorial. *J Appl Physiol* 100:9–10
9. Smith CA, Chenuel BJ, Henderson KS, Dempsey JA (2007) The apneic threshold during non-REM sleep in dogs: sensitivity of carotid body vs central chemoreceptors. *J Appl Physiol* 103:578–586
10. Li A, Zhou S, Nattie E (2006) Simultaneous inhibition of caudal medullary raphe and retrotrapezoid nucleus decreases breathing and the CO<sub>2</sub> response in conscious rats. *J Physiol* 577:307–318

## Central Nervous System (CNS)

### Definition

The central nervous system (CNS) is a portion of the vertebrate nervous system consisting of the brain and spinal cord.

## Central Nervous System Degeneration Caused by Autoimmune Cytotoxic CD8<sup>+</sup> T Cell Clones and Hybridomas

IKUO TSUNODA, MIKAKO KOBAYASHI-WARREN, JANE E. LIBBEY, ROBERT S. FUJINAMI  
Department of Pathology, University of Utah School of Medicine, Salt Lake City, Utah, USA

### Definition

►Theiler's murine encephalomyelitis virus (TMEV) infection of mice causes a demyelinating disease, which has similarities to ►multiple sclerosis (MS). Spleen cells from TMEV-infected SJL/J mice stimulated with antigen presenting cells (APCs) infected with TMEV resulted in a population of ►autoimmune CD8<sup>+</sup> cytotoxic ►T lymphocytes (CTLs) that killed not only TMEV infected but also uninfected syngeneic cells. We established CD8<sup>+</sup> CTL ►clones that kill both TMEV-infected and uninfected targets. Intracerebral injection of the clones into naïve mice induced central nervous system (CNS) degeneration. Using BWα-β-cells that

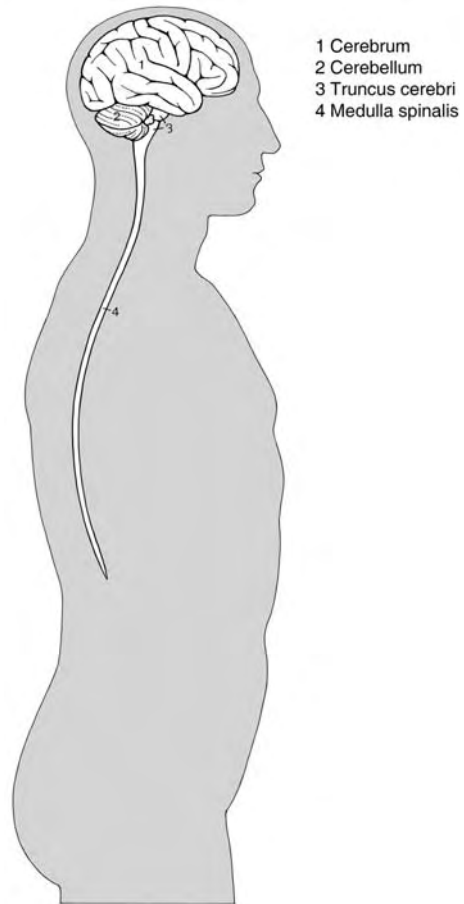

**Central nervous system (CNS).** Figure 1 The central nervous system in situ (1/6×). Original figure 01.01; taken from Nieuwenhuys, R; Voogd, J; van Huijzen, C. (Eds) 2008 "The Human Central Nervous System". Fourth Edition. Springer, Berlin. page 4 with permission.

lack T cell receptors (TCRs) as a fusion partner, we generated CD8<sup>+</sup> T cell hybridomas from the T cell clones. The T cell hybridomas produced interferon-γ (IFN-γ) when incubated with either infected or uninfected syngeneic target cells, which was blocked by CD8 or major histocompatibility complex (MHC) class I antibody. Our results indicate that CD8<sup>+</sup> T cells can recognize both a self antigen and a different viral protein. The T cell clones and hybridomas can be powerful tools to analyze TCR usage as well as CTL epitopes of viral and self antigens.

### Characteristics

#### Historical and Technical Perspective on CD8<sup>+</sup> T Cell Versus antibody and CD4<sup>+</sup> T Cell Research

Although we do not know the exact mechanism by which the central nervous system (CNS) is damaged in

multiple sclerosis (MS), an example of a ►CNS demyelinating disease, ►viral CNS infection and immune responses have been suggested to play important roles in its pathogenesis. Historically, among the various effector mechanisms of the immune system, the antibody was first suggested as an effector molecule; this has been supported by findings, such as oligoclonal immunoglobulin G (IgG) bands in the cerebrospinal fluid (CSF) and demyelinating antibodies in organotypic cultures. Later, T cells were regarded as another candidate effector. The delay was partly because analyses of cellular immune responses were established after analyses of humoral immune responses [1]. Currently, many in the field consider MS to be a major histocompatibility complex (MHC) class II-restricted CD4<sup>+</sup> T helper 1 (Th1)-mediated disease, despite the observation that CD8<sup>+</sup> T cells have been found more frequently than CD4<sup>+</sup> T cells in demyelinating lesions of MS patients. This could reflect the technical feasibility of analyzing MHC class II-restricted CD4<sup>+</sup> Th cells *in vitro*, compared with that of MHC class I-restricted CD8<sup>+</sup> cytotoxic T lymphocytes (CTLs).

Endogenous antigens (usually made within the cells) are presented by MHC class I molecules, while exogenous antigens are presented by MHC class II molecules with a few exceptions [1]. Thus, if investigators add a protein of interest into cultures *in vitro* or inject protein into animals *in vivo*, protein in the extracellular space will be taken up by antigen presenting cells (APCs) and presented with MHC class II molecules, which enable detection of sensitized or stimulated CD4<sup>+</sup> T cells specific for the protein of interest. On the other hand, to stimulate CD8<sup>+</sup> T cells, a protein of interest needs to be expressed in the cytoplasm (in general) of APCs or target cells [1]. For this purpose, researchers usually either transfect APCs and target cells with cDNA encoding the particular protein or infect APCs and target cells with virus encoding the protein. In addition to the above technical difficulty stimulating CD8<sup>+</sup> T cells, there are storage and handling problems in CD8<sup>+</sup> T cell analyses. For instance, standard CTL assays have low throughput and require handling of chromium-51 (<sup>51</sup>Cr) that decays by electron capture and gamma (γ) emission with a short half-life of 27.7 days, while standard helper T cell assays, to detect lymphoproliferative responses, have high throughput using 96-well microtiter plates and require tritiated (<sup>3</sup>H)-thymidine that emits a weak beta (β) ray with a half life of 12.3 years. The <sup>51</sup>Cr release assay is still a standard assay to detect CD8<sup>+</sup> CTL responses, although several alternative detection methods have been introduced to detect CD8<sup>+</sup> T cell responses [1], such as flow cytometry with intracellular cytokine staining and lactate dehydrogenase (LDH) release assays.

### Theiler's Murine Encephalomyelitis Virus Infection

Various viruses have been found to induced demyelination in laboratory animals. One of the most studied experimental models is infection of mice with Theiler's murine encephalomyelitis virus (TMEV) [2]. TMEV belongs to the family ►Picornaviridae. Although the precise mechanism of demyelination is not known, several effector mechanisms have been demonstrated to play important roles, including direct oligodendrocyte infection, TMEV-specific antibody (reviewed in [2]), TMEV-specific CD4<sup>+</sup> Th1 cells, macrophages, apoptosis of oligodendrocytes and axonal damage [3].

We have demonstrated the generation of autoimmune CD8<sup>+</sup> CTLs that cross-react with both virus and autoantigen in TMEV infection. Here, we will describe the history and direction of our investigations into the autoimmune CTLs generated in TMEV infection: (i) discovery and characterization of autoimmune T cells in bulk lymphocyte culture derived from mice infected with TMEV; (ii) establishment and characterization of T cell clones; (iii) generation of T cell hybridomas; and (iv) T cell receptor (TCR) and CTL epitope analyses, which will provide useful information to elucidate its pathogenesis and to develop tailor-made immunotherapies such as DNA immunization and tolerance induction (Fig. 1).

### Autoimmune CD8<sup>+</sup> T Cell in Bulk Lymphocyte Culture

CD8<sup>+</sup> CTLs have been suggested to play an important role in not only eradication of virus but also demyelination in TMEV infection. To explore the role of CTLs, we monitored CTL activity using a 5h <sup>51</sup>Cr release assay [4]. We utilized splenic mononuclear cells (MNCs) from SJL/J mice (*H-2<sup>s</sup>*) infected with the Daniels (DA) strain of TMEV as effector cells and a syngeneic fibroblast cell line, PSJLSV (PSJL, *H-2<sup>s</sup>*), as target cells. We stimulated the MNCs with TMEV-infected APCs for 1 week *in vitro*, and used these stimulated cells as effector cells in CTL assays. To our surprise, the MNCs killed not only TMEV-infected PSJL, but also uninfected PSJL (syngeneic or autoimmune killing). The autoimmune CTLs showed the highest killing against syngeneic target cells, intermediate killing against F1 target cells (*H-2<sup>b/s</sup>*), and low killing against allogeneic target cells (*H-2<sup>b</sup>*). The phenotype of the CTLs was CD3<sup>+</sup>/CD4<sup>-</sup>/CD8<sup>+</sup>. The autoimmune killing required cell-to-cell contact and was mediated by the Fas-FasL pathway, not by the perforin pathway. Killing was associated with interferon (IFN)-γ production in enzyme linked immunospot (ELISPOT) assays [5]. The CTLs were efficiently induced by vaccinia virus (VV) encoding the DA virus capsid proteins, but not by APCs infected with GDVII virus, a non-demyelinating strain of TMEV. Injection of the CTLs into the brain of naïve mice caused meningitis and perivascular cuffing, not only in the brain parenchyma, but also in the spinal cord distant from the injection site.

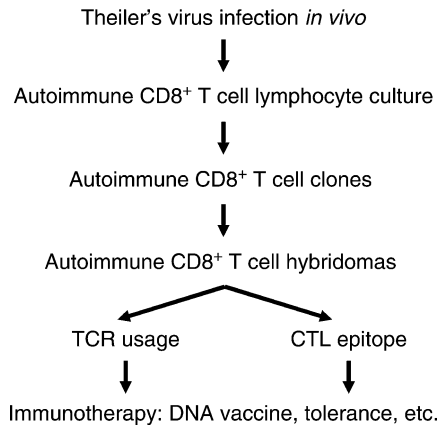

**Central Nervous System Degeneration Caused by Autoimmune Cytotoxic CD8<sup>+</sup> T Cell Clones and Hybridomas.** **Figure 1** From mice infected with TMEV, we detected autoimmune CD8<sup>+</sup> T cells that kill both uninfected and TMEV-infected syngeneic target cells. To characterize the autoimmune CTLs induced following TMEV infection, it was necessary to establish long-term T cell lines and clones. To maintain cytotoxicity, supplementation with interleukin (IL)-2 was necessary except during the first week of *in vitro* stimulation with TMEV-infected APCs. From the T cell clones, we established autoimmune CD8<sup>+</sup> T cell hybridomas. Unlike the T cell clones, the T cell hybridomas can be grown and expanded without the addition of APCs or exogenous IL-2. We found that CD8<sup>+</sup> T cell clones and hybridomas can recognize both a self antigen and a viral protein. Determination of TCR V $\beta$  and CDR3 spectratyping of TMEV-specific T cell hybridomas, clones and uncloned bulk autoimmune T cell cultures will allow us to attempt modulation of TMEV infection by treating mice with V $\beta$  antibodies or by vaccination with cDNA encoding TCR V $\beta$ . Our novel experimental findings and approach can be applicable to elucidation of involvement of CD8<sup>+</sup> CTLs in immune-mediated diseases, including MS, where CD8<sup>+</sup> T cells have been demonstrated in demyelinating lesions. Analyses of TCR usage and CTL epitopes of viral and self antigen will provide useful information to elucidate its pathogenesis and to develop tailor-made immunotherapy such as DNA immunization and tolerance induction. This will extend the studies of several other groups where autoreactive CD4<sup>+</sup> T cells have been described as containing degenerate TCRs that can recognize both autoantigen and microbial peptides. Since CD4<sup>+</sup> T cells have been reported to recognize both self and microbial antigens from MS patients, similar autoreactive CD8<sup>+</sup> CTLs could also contribute to the pathogenesis in MS and other virus infections.

### Autoimmune CD8<sup>+</sup> T Cell Clone

By limiting dilution, we established CD3<sup>+</sup>/CD4<sup>-</sup>/CD8<sup>+</sup> CTL clones [6]. The CTL clones showed MHC class I-restricted killing of both TMEV-infected and uninfected syngeneic target cells, although infected target cells were killed more efficiently. Intracerebral (i.c.) injection of

the clones into naïve mice induced large CNS degenerative lesions with loss of myelin and oligodendrocyte apoptosis. In contrast, we did not see degenerative lesions in mice injected with control CD8<sup>+</sup> T cells activated with concanavalin A (ConA) or CD8<sup>+</sup> enriched lymphokine-activated killer (LAK) cells.

### Autoimmune CD8<sup>+</sup> T Cell Hybridoma

In most CTL assays, T cells mediate killing through direct lysis. For example, in Fas-mediated killing, APCs present antigen to and thereby activate CTLs. This leads to up-regulation of FasL on CTLs, enabling the CTLs to kill the APCs positive for Fas. But in rare instances, CTLs have been shown to mediate killing through bystander lysis, where the APCs present antigen to and activate CTLs, inducing expression of FasL, but the target is a third Fas-positive cell that lacks the appropriate MHC restriction or antigen presentation. Here, the FasL-positive CTLs recognize the antigen presented by MHC molecules on the APCs, and the CTLs kill Fas-positive target cells without the trimolecular interaction of TCR with antigen and MHC molecules on the target cells.

In our system, uncloned splenic populations and T cell clones contain APCs [6]. After the 1 week *in vitro* culture of bulk T cells with TMEV-infected APCs, live cell populations were separated by a density gradient and used as effector cells in CTL assays. Here, the effector cells consisted mainly of TMEV-specific T cells, since the majority of other cell types were not able to survive after 1 week in culture. However, we cannot rule out the possibility of the existence of small numbers of live TMEV-infected APCs mixed in among the effector cell populations. Thus, this raised the question that the killing by splenic bulk culture or CTL clones might be due to bystander killing of the target, not by direct lysis of the target. To rule out this possibility, we developed T cell hybridomas having similar specificities and properties to those of the T cell clones.

All T cell hybridomas were CD4<sup>-</sup> (Fig. 2). The majority of clones were also TCR<sup>+</sup>, although three hybridomas were TCR<sup>-</sup>. Some hybridomas express low levels of  $\blacktriangleright$ CD8 antigen, while others were CD8<sup>-</sup>. Hybridomas produced IFN- $\gamma$  when incubated with infected or uninfected PSJL cells and TMEV-infected astrocytes but not uninfected astrocytes (Fig. 3a). The IFN- $\gamma$  production was inhibited by the addition of CD8 and MHC class I antibodies to the cultures, but not by addition of CD4 antibody (Fig. 3b). I.c. injection of some hybridomas resulted in CNS pathology characterized by parenchymal and perivascular cell infiltration and gliosis (Fig. 4).

### Characterization of TCR

One of the characteristics of organ-specific  $\blacktriangleright$ autoimmune disease is that the development of the disease is



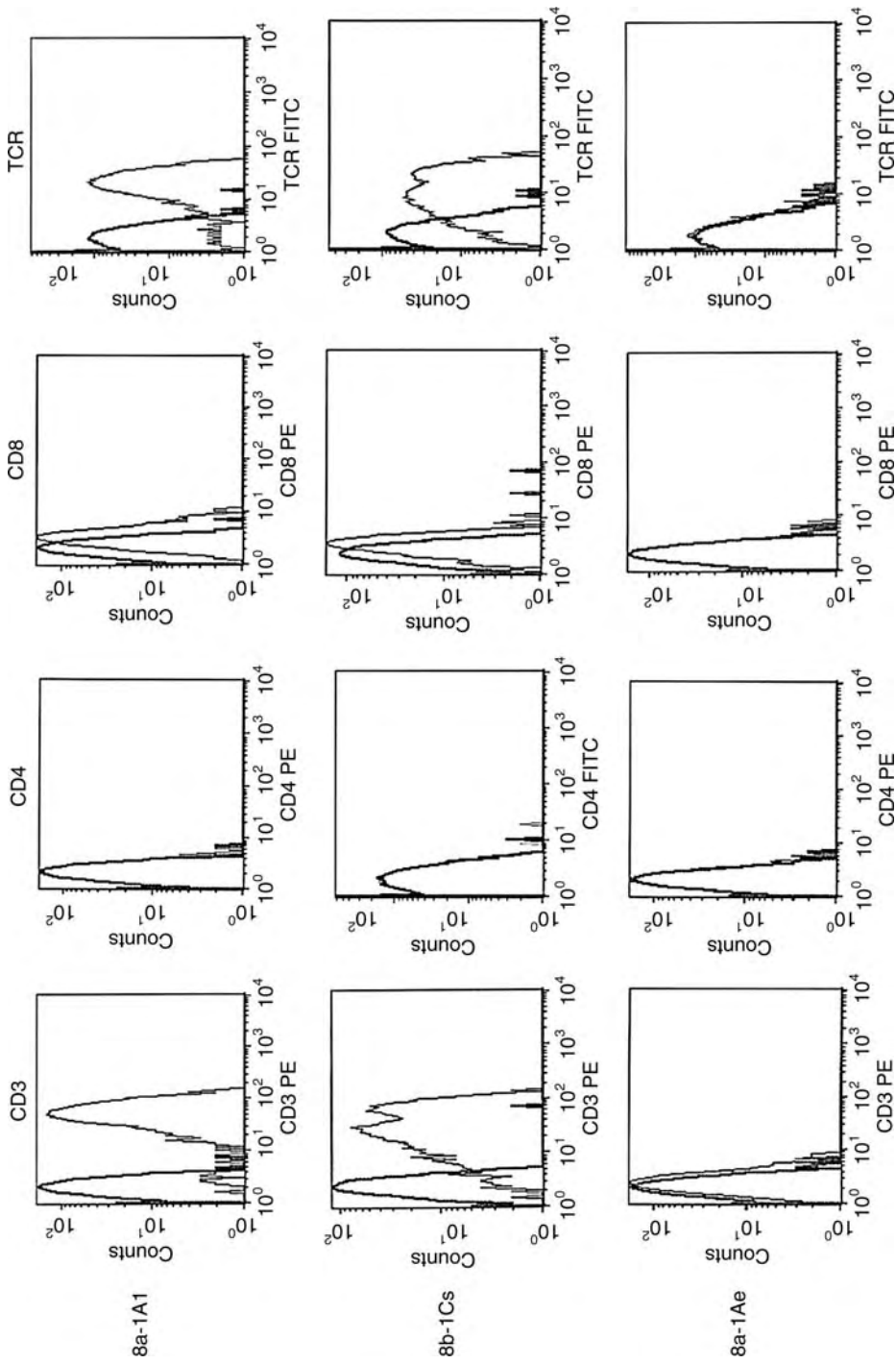

**Central Nervous System Degeneration Caused by Autoimmune Cytotoxic CD8<sup>+</sup> T Cell Clones and Hybridomas. Figure 2** We generated the autoimmune T cell hybridomas, using TMEV autoimmune CD8<sup>+</sup> CTL clone cells, 8a-1A or 8b-1C, with the BW6-β- (BW-1100, 129,237) cell line that lacks the α and β chains of the TCR. Using flow cytometry, we characterized the T cell hybridomas according to surface antigens. T cell hybridomas were tested for surface markers by using monoclonal antibodies directed against CD4, CD8 and TCR. The surface phenotype of TMEV-induced autoimmune T cell hybridomas was CD3<sup>+</sup> CD4<sup>-</sup> CD8<sup>dim</sup> TCR<sup>+</sup> (8a-1A1, top and 8b-1Cs, middle) or CD3<sup>dim</sup> CD4<sup>-</sup> CD8<sup>-</sup> TCR<sup>-</sup> (8a-1Ae, bottom). CD8 may be preferentially down-regulated during prolonged *in vitro* culture or fusion, because the parent T cell clones were originally highly positive for CD8. FITC, fluorescein isothiocyanate. PE, phycoerythrin.

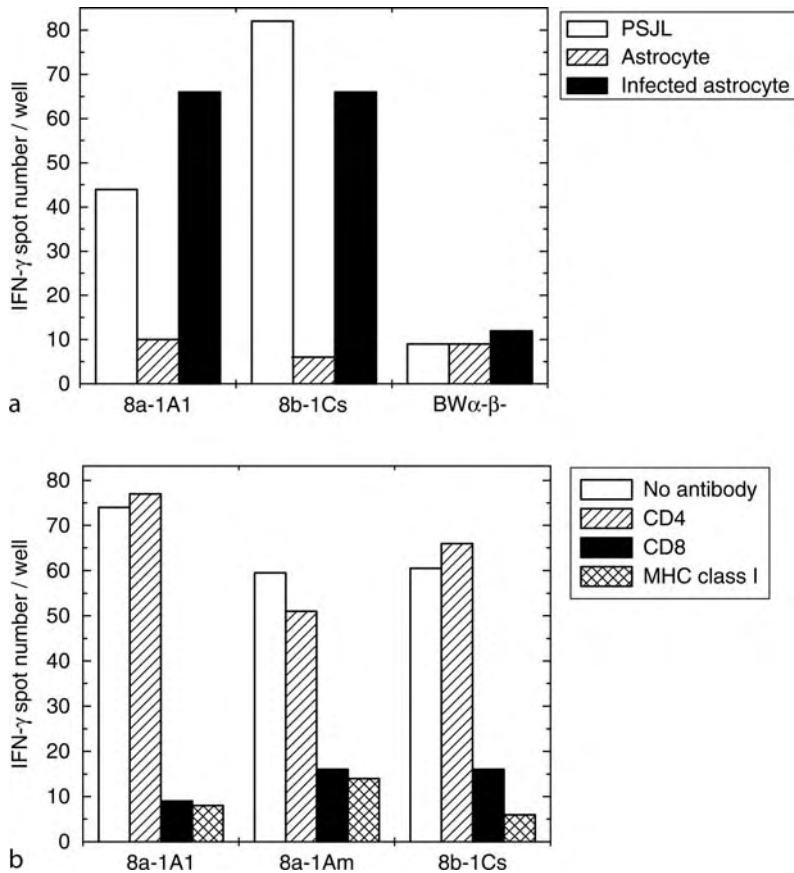

**Central Nervous System Degeneration Caused by Autoimmune Cytotoxic CD8<sup>+</sup> T Cell Clones and Hybridomas. Figure 3** TMEV-induced T cell hybridomas were tested for IFN- $\gamma$  production, using an ELISPOT assay. Hybridomas (8a-1A1, 8a-1Am, 8b-1C, or the fusion partner (BW $\alpha$ - $\beta$ -) were used as effector cells. Uninfected PSJL, astrocytes, or infected astrocytes (multiplicity of infection = 20) were used as target cells. A concentration of  $1 \times 10^5$  cells/well of effector cells were incubated overnight with target cells at an effector/target (E/T) ratio of 1:1. (a) TMEV-induced hybridomas, 8a-1A1 and 8b-1Cs, produced IFN- $\gamma$  when cultured with uninfected PSJL (PSJL, *open*) and infected astrocytes (*closed*), but not with uninfected astrocytes (Astrocyte, *hatched*). BW $\alpha$ - $\beta$ - cells did not produce IFN- $\gamma$ . (b) TMEV-induced CD8<sup>+</sup> T cell hybridomas were incubated with uninfected PSJL in the absence (No antibody, *open*), or presence of antibody against CD4 (*hatched*), CD8 (*closed*), or MHC class I (*cross hatched*). CD8 and MHC class I, but not CD4, antibodies blocked the IFN- $\gamma$  production.

closely associated with, or induced by, a particular type of T cell reactive to organ-specific antigens [7]. Thus, it has been postulated that autoantigen-reactive T cells bearing particular types of TCRs are expanded clonally during the course of the disease. Based on limited usage of the TCR repertoire in some types of experimental autoimmune encephalomyelitis, a particular single TCR has been suggested to be involved in encephalitogenicity (V-region disease hypothesis). More recently, to identify TCRs expressed on clonally expanded T cells, there are at least three types of analysis: complementarity determining region (CDR) 3 spectratyping, single-stranded conformational polymorphism (SSCP) and heteroduplex analysis [7]. CDR3 is encoded by the V (D)J junctional sequences and may directly contact the MHC-bound peptide, thus conferring T cell specificity for a particular peptide-MHC complex (CDR1 and 2 are

encoded by germline and allow the TCR to interact with the  $\alpha$  helices of the MHC molecule). In SSCP and heteroduplex analyses, each band on the gel represents expansion of a particular single TCR clone. In contrast, each band demonstrated in CDR3 spectratyping simply represents those TCRs with a CDR3 region of the same size. Therefore, the nucleotide sequence of the CDR3 region of the TCR clones derived from expanded bands should be determined to confirm the presence of clonal expansion in the bands [8].

TCR usages and CDR3 spectratyping are the methods that show TCRs of oligoclonally expanded T cells, compared with control samples. The methods do not require knowledge of putative autoantigens that are not known in most autoimmune diseases, including MS. Nucleotide and amino acid sequences of the CDR3 region of the TCR clones derived from the spectratypes

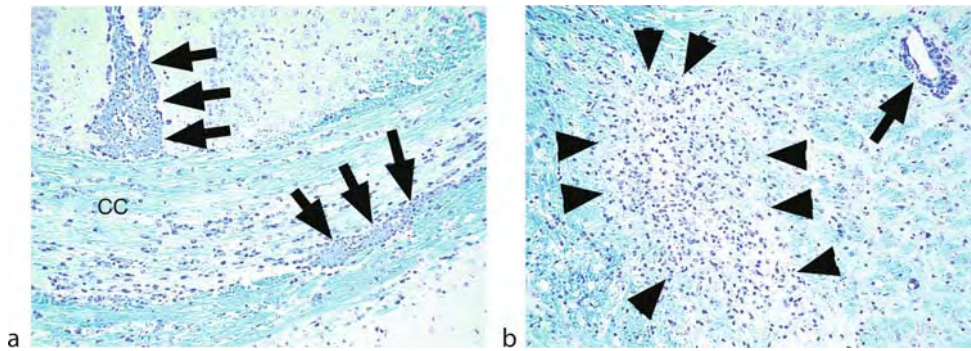

### Central Nervous System Degeneration Caused by Autoimmune Cytotoxic CD8<sup>+</sup> T Cell Clones and Hybridomas. Figure 4

We investigated whether T cell hybridomas could induce CNS pathology. We inoculated  $1 \times 10^6$  T hybridoma cells, 8a-1Ae (a) and 8b-1C5 (b) into the right cerebral hemisphere of naïve SJL/J mice. CNS histology was examined 1 week after inoculation. Mice receiving T cell hybridomas developed different pathology depending on the T cell hybridoma lines. Some hybridoma lines stayed only in the meningeal spaces, while others infiltrated into the parenchyma, including the corpus callosum (CC) (Fig. 4a, arrow) and the internal capsule, and spinal cord nerve roots, which were distant from the injection site. (b) Gliosis (arrowhead) and perivascular cell infiltration (arrow) were seen in the internal capsule. However, we did not see large white matter degenerative lesions, comparable to those observed in mice injected with TMEV-induced autoimmune CD8<sup>+</sup> T cell clones. Mice receiving BW $\alpha$ - $\beta$ - cells (fusion partner) had only meningeal cell infiltrates. Luxol fast blue stain. Magnification,  $\times 84$ .

of interest can be used to determine whether there is a clonal expansion and whether specific CDR3 motifs are used or not. For example, Matsumoto and colleagues [9] found that the V $\beta$ 5.2 spectratype is expanded more frequently than other V $\beta$ s in MS patients, suggesting that the finding provides useful information for designing TCR-based immunotherapy in MS. Thus, information on the identified pathogenic TCRs can be used in the prognosis of the disease or future treatment using antibodies and DNA vaccination against TCRs.

It is controversial whether specific TCR V $\beta$  or CDR3 motifs are used in TMEV infection; some reports support specific TCR usage and others do not. We attempted to determine TCR usage by TMEV-induced CD8<sup>+</sup> T cell hybridomas, using flow cytometry with a mouse V $\beta$  TCR screening panel, containing monoclonal antibodies against V $\beta$  2, 3, 4, 5.1, 5.2, 6, 7, 8.1, 8.2, 8.3, 9, 10<sup>b</sup>, 11, 12, 13, 14, and 17<sup>a</sup> TCR. We found that hybridoma, 8a-1A1, was positive for TCR V $\beta$ 3 and 8b-1C5 was negative for all antibodies included in the panel. TCR V $\beta$  region gene sequence analyses also showed the presence of V $\beta$ 3 in 8a-1A1 (Table 1).

### Defining the Viral Epitope and Self Antigen

There are several methods currently employed for identifying antigens recognized by CTLs: (i) molecular biology approaches using cDNA libraries from a microbe or tissue of interest [10]; (ii) direct acid elution and amino acid sequence analysis of MHC-associated peptides; (iii) epitope mapping conducted with a series of overlapping peptides in cases where the antigenic protein is known; (iv) the use of algorithms that employ known MHC binding motifs for epitope predictions within a protein of interest; and (v) synthetic

combinatorial libraries that do not require knowledge about T cell specificity or MHC restriction. Of these methods, expression cloning of cDNA libraries and peptide elution have been the preferred methods to identify antigens recognized by T cells for which no molecular information is available. ELISPOT assays have improved the sensitivity and efficiency of T cell antigen cloning from cDNA expression libraries [10].

We have developed T cell hybridomas that are easy to grow and produce IFN- $\gamma$  in ELISPOT assays in response to TMEV-infected or uninfected PSJL, or infected astrocytes but not uninfected astrocytes. These T cell hybridomas can be used to define the viral epitope as well as the self epitope that is recognized by the cross-reactive TCR. We are using astrocytes transfected with a pCMV vector encoding each of the viral capsid proteins, VP1, 2, 3, and 4 [2] as well as the P2 or P3 regions of the TMEV genome encoding nonstructural proteins [2]. We will use a similar approach to identify what cellular antigen(s) is recognized by the TMEV-induced autoimmune CTL by transfecting astrocytes with an expression library constructed from the CNS of SJL/J mice. Once the protein is identified, either deletion mapping or overlapping peptides can be used to identify the self epitope. If it is a cell-specific protein found only in oligodendrocytes, then one could predict that direct killing of the oligodendrocyte would be a plausible mechanism for the demyelination. *In vivo* roles of TMEV-induced autoimmune CTLs can be clarified by sensitization of TMEV-infected or uninfected mice with (i) the CTL epitope peptide (or its altered ligand) of TMEV and autoantigen, emulsified in complete Freund's adjuvant (disease induction and exacerbation) or in incomplete Freund's adjuvant

**Central Nervous System Degeneration Caused by Autoimmune Cytotoxic CD8<sup>+</sup> T Cell Clones and Hybridomas.****Table 1** TCR V $\beta$  chain gene segment usage in TMEV specific hybridomas<sup>a</sup>

	CDR3 <sup>b</sup>		
	V $\beta$ 3	D $\beta$ 1/N <sup>c</sup>	J $\beta$ 2.1
8a-1A1	GCAGTC	AGGG/ACAG	AACTAT
8b-1Cs	ND <sup>d</sup>	ND <sup>d</sup>	ND
BW $\alpha$ - $\beta$ -	ND	ND <sup>d</sup>	ND

<sup>a</sup>We tested 8a-1A1 and 8b-1Cs for the presence of V $\beta$ 3 in their TCR $\beta$  chain by means of reverse transcription (RT)-PCR and sequencing. BW $\alpha$ - $\beta$ - cells were tested as a negative control. Primers used to amplify the TCR V $\beta$  region gene sequences were as follows: V $\beta$ 3, 5' GGCTACAAGGCTCCTCTGTAC 3', which is specific for the V $\beta$ 3 gene and C $\beta$ , 5' GACAGGTTTGGGTGAGCCCTCTGG 3', which is specific for the constant region and was used for RT and PCR. Appropriately sized bands were isolated from agarose gels, and the band-isolated PCR products were sequenced. TCR V $\beta$  region gene sequences were compared with those in the GenBank database using the BLAST sequence alignment program.

<sup>b</sup>CDR3; complementarity determining region 3.

<sup>c</sup>N, non-templated nucleotide insertions.

<sup>d</sup>ND, not detected.

(treatment or tolerance induction); (ii) recombinant VV; or (iii) cDNA encoding the epitope. Induction of the CTLs that recognize both virus and autoantigen can result in viral clearance in the CNS of mice infected with TMEV, while the CTL induction in uninfected mice can lead to CNS degeneration.

**Acknowledgments**

We thank Sarah E. Doyle BS, Faris Hasanovic, Nikki J. Kirkman BS, Li-Qing Kuang MD, Benjamin J. Marble, J. Wes Peterson, Daniel G. Smith, Emily Jane Terry and Steven R. Wheelwright for excellent technical assistance. We are grateful to Ms. Kathleen Borick for her excellent preparation of the manuscript. This work was supported by NIH grant NS34497.

**References**

1. Germain RN (1999) Antigen processing and presentation. In: Paul WE (ed) *Fundamental immunology*, 4th edn. Lippincott-Raven, Philadelphia, PA, pp 287–340
2. Tsunoda I, Fujinami RS (1999) Theiler's murine encephalomyelitis virus. In: Ahmed R, Chen IS (eds) *Persistent viral infections*. Wiley, Chichester, West Sussex, England, pp 517–536
3. Tsunoda I, Fujinami RS (2002) Inside-Out versus Outside-In models for virus induced demyelination: axonal damage trigger demyelination. *Springer Semin Immunopathol* 24:105–125
4. Tsunoda I, Kuang L-Q, Fujinami RS (2002) Induction of autoreactive CD8<sup>+</sup> cytotoxic T cells during Theiler's murine encephalomyelitis virus infection: Implications for autoimmunity. *J Virol* 76:12834–12844
5. Tsunoda I, Libbey JE, Kobayashi-Warren M, Fujinami RS (2006) IFN- $\gamma$  production and astrocyte recognition by autoreactive T cells induced by Theiler's virus infection: Role of viral strains and capsid proteins. *J Neuroimmunol* 172:85–93
6. Tsunoda I, Kuang L-Q, Kobayashi-Warren M, Fujinami RS (2005) Central nervous system pathology caused by autoreactive CD8<sup>+</sup> T-cell clones following virus infection. *J Virol* 79:14640–14646
7. Matsumoto Y (2005) New approach to immunotherapy against organ-specific autoimmune diseases with T cell receptor and chemokine receptor DNA vaccines. *Curr Drug Targets Immune Endocr Metabol Disord* 5:73–77
8. Libbey JE, Tsunoda I, Fujinami RS (2006) Autologous hematopoietic stem cell transplantation: a cure for multiple sclerosis? *Future Neurol* 1:403–408
9. Matsumoto Y, Yoon WK, Jee Y, Fujihara K, Misu T, Sato S, Nakashima I, Itoyama Y (2003) Complementarity-determining region 3 spectratyping analysis of the TCR repertoire in multiple sclerosis. *J Immunol* 170: 4846–4853
10. Uenaka A, Hata H, Win S, Ono T, Wada H, Nakayama E (2001) ELISPOT cloning of tumor antigens recognized by cytotoxic T-lymphocytes from a cDNA expression library. *Cancer Immunol* 1:8–17

## Central Nervous System Disease – Natural Neuroprotective Agents as Therapeutics

AMOD P. KULKARNI<sup>1,2</sup>, LAURIE A. KELLAWAY<sup>2</sup>,  
GIRISH J. KOTWAL<sup>3</sup>

<sup>1</sup>Division of Medical Virology, Department of Clinical Laboratory Sciences, Institute of Infectious Disease and Molecular Medicine

<sup>2</sup>Division of Neuroscience, Department of Human Biology, Faculty of Health Sciences, University of Cape Town, Cape Town, South Africa

<sup>3</sup>Inflamed, Louisville, KY, USA

**Synonyms**

Neuroinflammatory brain disorders; Pro-inflammatory mediators; Herbal neuroprotectives

## Definition

Pro-inflammatory mediators in disorders of the central nervous system and potential neuroprotective agents of natural origin.

## Characteristics

### Pathology

Disorders of the central nervous system (CNS) cover a wide range of diseases from depression, Alzheimer's disease (AD), multiple sclerosis (MS), Parkinson's disease (PD), ►HIV-associated dementia (HAD) and viral encephalopathies. However, ►non-steroidal anti-inflammatory drugs (NSAIDs) currently available on the market are not as effective as originally anticipated. Furthermore, side effects associated with long term use of these medicines discourage their use in chronic CNS pathologies. In order to develop effective treatment strategies, insight into the molecular basis of these disorders is essential. The complexity of the brain architecture, its components and neurocircuitry has made this task immensely challenging. The advent of rapidly evolving technology has enabled us to understand the common hallmarks of the pathophysiology of

most of these disorders. The root cause in each one of them may differ from the other, but all of them show the involvement of inflammatory responses initiated by cells of the immune system in the brain. In the current essay, the primary factors involved in the etiologies of AD and HAD are described, and both primary and secondary factors contributing towards ►neuroinflammation (Autoimmune, Chronic) in major CNS disorders are summarized in Fig. 1.

### AD

AD is characterized by the presence of ►amyloid plaques, ►amyloid  $\beta$  protein, and neurofibrillary tangles (NFT). The role of these proteins in the pathogenesis of AD is described in detail in many reviews, consequently it is briefly summarized in this essay. The reader is referred to a descriptive review by J Haddad [1] where the role of pathogenic proteins involved in the etiology of AD such as ►amyloid protein, tau, and the importance of mitogen-activated protein kinases (MAP kinases) in their processing is discussed. As mentioned in this review, the amyloid plaques develop due to altered metabolism of

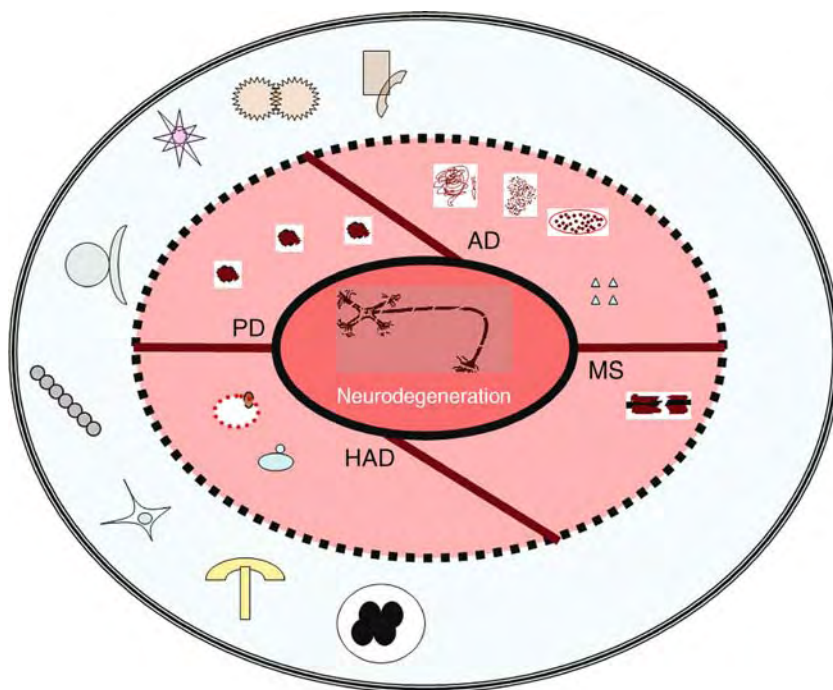

**Central Nervous System Disease – Natural Neuroprotective Agents as Therapeutics. Figure 1** The primary and secondary factors involved in the etiology of major neurodegenerative disorders of the brain (AD, PD, HAD and MS) are outlined in this figure. The primary factors (● Lewy body, ● A $\beta$  peptide, ● diffuse plaques, ● well defined amyloid plaques, ● neurofibrillary tangles, ● demyelinated neurons, ● HIV with gp41, and ● Nef are shown in the inner dotted eclipse. The secondary pro-inflammatory mediators, ● the complement system, ● activated microglia, ● T cells, ● macrophages, ● COX enzymes, ● astrocytes, ● free radicals, and ● NF- $\kappa$ B are shown in the outer eclipse. The neurodegeneration due to these factors is symbolised by a cartoon of damaged neuron in the centre.

▶ **amyloid precursor protein (APP)**. Mutations in APP, Presenilin (PSEN1 and PSEN2) genes lead to the formation of A $\beta$  peptides and plaques, and phosphorylation is an important mechanism for the formation of plaques. In AD, there is also hyperphosphorylation of tau protein. MAP kinases play an important role in the phosphorylation of these proteins. All these factors contribute towards the primary pathogenesis of AD.

#### HAD

Both viral and host factors contribute to the neuro-pathophysiology of HAD. The HIV envelope protein gp120 plays an important role in the pathophysiology of the virus. This protein undergoes structural arrangement before binding CD4, and therefore escapes the antibody response. In a recent study by T Zhou et al., the structural analysis of gp120 stabilized in CD4 binding site and bound to a broadly neutralizing antibody b12 revealed that the antigenic epitopes are conserved in gp120 [2]. This is an important therapeutic target for the development of neutralizing antibodies against the HIV envelope to reduce the viral load and thereby reducing the neurological symptoms associated with AIDS. The other HIV proteins which play an important role in the HIV mediated neurodegeneration are ▶ **Nef** and ▶ **gp41**. These proteins induce activation

of ▶ **the complement system** through their direct actions on the promoter of the C3 component of the complement system. This results in the up-regulation of the complement system ultimately leading to neuroinflammation [3]. The recent evidence suggests that there is deposition of amyloid protein in the brain of HIV positive patients [4]. The pathogenesis in HAD with the focus on complement up-regulation is shown in Fig. 2.

#### Common Pro-Inflammatory Mediators

Although, the primary etiologies of CNS disorders affecting a large sector of populations worldwide differ from each other, most of them show an activation of the immune system and the involvement of common pro-inflammatory mediators (▶ **pro-inflammatory cytokines**). The activation of cells of the immune system and ▶ **residual brain cells**, although beneficial initially, results in the release and/or activation of several pro-inflammatory mediators, which are responsible for damage to the brain tissue. Activation of ▶ **astrocytes** and ▶ **microglia** can be found in most of the brain disorders. The common pro-inflammatory mediators found in most of the neurodegenerative disorders such as AD, PD and HAD are free radicals, ▶ **NF- $\kappa$ B**, cyclooxygenases (COX-2), and most importantly, the complement system. Several studies have shown

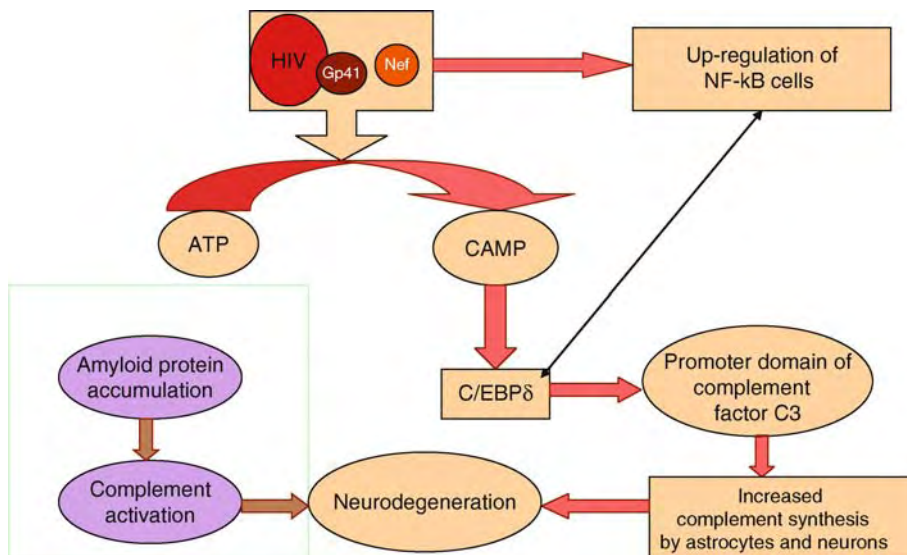

**Central Nervous System Disease – Natural Neuroprotective Agents as Therapeutics. Figure 2** Activation of the complement system by HIV, and its pathogenic proteins. The speculations from Cornelia Bruder et al., [3] and the finding that circulating monocytes and macrophages in the brain of HIV infected patient express APP as well as diffuse plaques [4] are combined in this figure. As shown in the figure, HIV and its pathogenic proteins Nef and gp41 activate the transcription factor C/EBP $\delta$ . The activated transcription factor can simultaneously bind to NF- $\kappa$ B and C3 promoter. Activation of NF- $\kappa$ B increases viral replication, and simultaneous binding to C3 promoter lead to increased expression of C3 complement component and subsequent neuroinflammation. Also, the diffuse amyloid plaques and increased APP expression by circulating monocytes and brain macrophages of HIV infected patient may lead to the activation of the complement system, a major pro-inflammatory mediator responsible for neurodegeneration.

the involvement of COX-2 in HAD. Many theories have been suggested for the induction of COX-2 in HIV mediated neuroinflammation. According to one theory, HIV-1-infected monocyte derived macrophages interact with the brain endothelium and this leads to the induction of COX-2 in the brain. Induction of COX-2 in the brain of HIV infected patients could be one of the major neuroinflammatory event mediated by HIV [5]. The common pro-inflammatory mediators and the role of the complement system in disorders of the CNS have been reviewed by many including Kulkarni et al., 2004 [6].

The two major disorders of concern with no effective treatment are AD and HAD. Although, their root causes differ from each other, both of them show altered APP metabolism leading to amyloid formation. It is well established that the amyloid plaques are responsible for the activation of pro-inflammatory mediators including the complement system in AD. Thus, amyloid deposition found in HIV positive patients might also be responsible for the activation of the complement system. Recently, it was found that both HIV and its pathogenic proteins are responsible for up-regulation of the complement system [3]. Here, activation of microglia and other cells of the immune system is also evident. The other disorders with similar up-regulation of the complement system and aforementioned pro-inflammatory mediators affecting the majority of the World's population are MS, scrapie and PD. Thus, pro-inflammatory mediators including complement components could be regarded as common therapeutic targets in the treatment and prevention of these disorders. However, targeting the root causes of these disorders will be a more effective approach. In disorders such as AD and MS, attempts are being made to treat the root causes discussed earlier. In HAD, the Highly Active Anti-Retroviral Therapy (HAART) has shown definite beneficial effects, but still better agents need to be developed. Although the anti-inflammatory agents could be neuroprotective, their roles are still limited. The novel therapies such as gene therapy are still at the stage of infancy. The bottom line is that the specific pharmacological treatment of the primary cause of most of the neuroinflammatory disorders is currently not available and general anti-inflammatory agents available on the market have limited scope. Development of suitable neuroprotective agents, therefore, needs urgent attention.

## Therapy

### Neuroprotective Agents

The synthesis of newer drug molecules employing principles of medicinal chemistry and drug designing is a rational approach for the development of novel drug molecules with neuroprotective abilities. However, natural sources should never be underestimated

as they provide an important source for the development of new drugs. As an example, the ►**Mediterranean diet** largely consists of vegetables and fruits, and this could probably be the key to the healthy life of the aged population in that region. ►**Ayurveda**, the traditional Indian medicinal system still popular in India, is based on herbal medicines for the treatment of many disorders, including CNS disorders. Many modern medicines have their roots in nature.

Several naturally occurring molecules are being studied for their neuroprotective abilities. These could be divided into two groups, the first group targeting the root cause of the disease (specific in action), and the second group targeting the common pro-inflammatory mediators (Non-specific in action). The agents targeting the primary cause of the disease may also have direct actions against one or more of the pro-inflammatory mediators.

### Group I Neuroprotective Agents of Natural Origin Targeting Primary Pro-Inflammatory Mediators

Attempts are being made to treat the primary causes of the brain disorders. The success rate is still low, and only a few agents are being targeted specifically to treat the root cause of the disease. Three of these agents with significant potential for the treatment of amyloidopathies and/or HIV associated neurological complications are discussed below.

The first example is curcumin, a polyhydroxy phenolic compound found abundantly in turmeric, the later being widely used in Indian curries as spice and in Ayurveda as a medicine. It has been shown to inhibit the formation of A $\beta$ 40 in an *in vitro* assay at an IC<sub>50</sub> value at a concentration of 0.8  $\mu$ M. It disaggregated A $\beta$ 40 at 1  $\mu$ M concentration. The A $\beta$ 40 inhibition activity was more pronounced than that of ibuprofen and naproxen, the most commonly used NSAIDs for the treatment of inflammatory disorders. Unlike ibuprofen and naproxen, inhibition of A $\beta$  formation by curcumin was dose dependent. The effect of curcumin on amyloid fibrils was dependent on fibril-related conformation, and not on A $\beta$  sequence. Curcumin showed preferential staining of amyloid plaques in the brain, but weakly labeled NFTs. In an *in vivo* study, peripherally administered curcumin crossed the blood brain barrier (BBB), and reduced A $\beta$  burden and plaque formation in transgenic mice. It suppressed A $\beta$  formation in 17 month old transgenic mice (Tg2576). It also blocked A $\beta$  mediated toxicity in SH-SY5Y neuroblastoma cells [7]. Based on this discussion, as well as the safety profile of curcumin demonstrated in other studies, it can be regarded as a potential candidate for the clinical trials.

Berberine is an isoquinoline alkaloid from *Coptidis rhizoama*. It was studied for its effect on APP production in APP<sub>NL</sub>-H4 cells. It had neither cytotoxic effect on these cells, nor did it alter their morphology or

lactate dehydrogenase (LDH) release by these cells. Berberine did not show any change in the A $\beta$ 42/A $\beta$ 40 ratio, but reduced A $\beta$ 42 and A $\beta$ 40 levels in the cultured APP<sub>NL</sub>-H4 cells. It did not alter APP expression levels or APP processing, but shifted the amyloidogenic processing of APP to a non-amyloidogenic pathway by increasing  $\alpha$ -Secretase activity, and reducing  $\beta$ -Secretase activity [8]. Thus, berberine could possibly be used effectively for the treatment of AD or other amyloidopathies.

Propolis is a resinous substance collected by honey bees from plants. It protects against the entry of microorganisms and other creatures in the hive. It is a mixture of many compounds, relatively safe for human consumption, and is traditionally known for its medicinal properties. In a recent study, it was tested for its anti-viral properties in CD4<sup>+</sup> lymphocytes and microglial cells. When activated CD4<sup>+</sup> lymphocytes infected with HIV-1<sub>AT</sub> and microglial cells infected with HIV-1SF<sub>162</sub> were treated with propolis, it inhibited the expression of HIV-1 in these cells in a dose dependent manner. Propolis from various geographic regions showed similar inhibitory activity. It was shown to inhibit the viral entry in CD4<sup>+</sup> lymphocytes, and also showed an additive effect on inhibition of HIV by AZT [9]. Thus, it offers significant potential in the treatment of toxic effects of HIV on brain microglial cells, and could possibly be safely combined with ►antiretrovirals (ARVs) for the treatment of HIV-associated complications.

### **Group II Neuroprotective Agents of Natural Origin Targeting Secondary Proinflammatory Mediators**

As discussed earlier, neuroinflammation, immune activation and antioxidants play an important role in the etiology of AD, PD and HAD. Flavonoids that form an important part of the diet and other nutritional food supplements could be used in the prophylaxis and possible treatment of neuroinflammation associated with these disorders. A vast number of scientific data is available on the anti-inflammatory roles, neuroprotective abilities and therapeutic potential of flavonoids. They cover a broad range of compounds from simple polyphenolic compounds to phytoestrogens found in medicinal plants, fruits and vegetables. Naturally occurring polyphenols are active against free radicals, and are known to attenuate oxidative stress. Some of the flavonoids alter hormonal levels, whereas others show pharmacological manipulation of receptors in the brain and are able to modulate the neuronal activity. These compounds, with significant therapeutic potential to control damage due to pro-inflammatory mediators, are discussed in many reviews, and thus are not included in the current essay.

A strategy to evaluate the neuroefficacy and bio-efficacy of dietary components and medicinal plants

is described by Aruoma A, et al., 2003 [10]. Many flavonoids with anti-HIV abilities and reduction of gp120 from HIV infected C8166 (human T-lymphoblastoid) cells are also discussed in the aforementioned article. (–)Epicatechin-3-O-gallate, (–)Epicatechin, 3,3',4',5',7-penta-hydroxyflavan and Myricetin, 3,3',4',5',7-hexahydroxy-flavone were found to be potent amongst them. As discussed in the aforementioned article, the reduced glutathione level found in many disorders of the brain including HIV associated brain disorders, PD and AD could be corrected by using flavonoids, which increase the glutathione level, and thereby increase the chances of survival.

There are also many complement regulatory molecules of herbal origin available for the treatment of inflammation. These are summarized, classified and their potential for the treatment of neuroinflammatory disorders discussed in a recent review by Kulkarni et al., [11]. Most of them have not been studied for their ability to offer ►neuroprotection, but theoretically may offer neuroprotection. Vaccinia virus complement regulatory protein (VCP) is a complement regulatory molecule of viral origin with neuroprotective potential and can serve as a role model for the development of complement based neurotherapeutics. Other potential complement regulatory molecules discussed in the aforementioned review [11] that can be used as neuroprotective agents are glycyrrhizin, rosmarinic acid, Kaemferol, polysaccharides, curacycline-A, apigenin and other flavonoids from olive oil. As discussed in the aforementioned review, the complement system is the final activation point of many pro-inflammatory mediators and complicates the brain environment by activating the immune cells to release other pro-inflammatory mediators. Thus, regulation of the complement system by using the complement regulatory molecules of herbal origin could be one of the rational approaches for the treatment and prevention of neuroinflammatory disorders.

### **Cautions While Using Herbal Medicines**

While dealing with the herbal medicines, one should be aware of the potential side effects or drug interactions of these medicines. Interested readers should refer to a review article by W. Abebe [12], which mentions the interaction of ingredients of herbal origin with NSAIDs. As pointed out in this article, care should be taken while administering curcumin, ginseng or coumarin with NSAIDs. Aspirin is known to interact with ginkgo, garlic, ginger, bilberry, dong quai, feverfew, ginseng, turmeric, meadowsweet and willow which are known to have antiplatelet activity. Interaction of NSAIDs with these drugs may lead to internal bleeding. Acetaminophen may interact with ginkgo to increase the chances of bleeding. The analgesic effect of opioids may be decreased by ginseng. The



compounds of herbal origin form a part of many non-prescription medications. Thus, there is a need for thorough study, and knowledge of the adverse drug reactions, drug interactions and potential side effects of these drugs when combined with herbal treatments. While marketing herbal products, information regarding drug interaction and possible adverse reactions should be included in the label. In addition, proper optimization of the dose and bioavailability studies with a focus on appropriate route of administration is necessary for getting optimal benefit from these natural neuroprotective agents. All the ingredients to be used in neuroinflammatory disorders should either cross the blood brain barrier, or should be able to be delivered to the brain by alternative route of administration, such as via an intranasal route.

### Conclusion

Neurodegenerative disorders are marked by the complexity of their pathogenesis. The primary etiologies of most of these disorders differ from each other, but most of them show some common pathological hallmarks. Ingredients of natural origin offer significant potential for the development of effective treatment strategies, by their specific actions on the root cause or by targeting common pro-inflammatory mediators. However, proper study of route of administration, bioavailability, side effects, adverse interactions and standardization of dose is necessary for the development of efficient neuroprotective agents.

### Acknowledgements

APK is the recipient of the UCT research associateship award (2005 and 2006), poliomyelitis research foundation bursary, UCT International Students' Fellowship and the Senior Entrance Merit Fellowship at UCT, and acknowledges UCT for providing funding for the study.

### References

- Haddad JJ (2004) Mitogen-activated protein kinases and the evolution of Alzheimer's: a revolutionary neurogenetic axis for therapeutic intervention? *Prog Neurobiol* 73:359–377
- Zhou T, Xu L, Dey B, Hessel AJ, Van Ryk D, Xiang SH, Yang X, Zhang MY, Zwick MB, Arthos J, Burton DR, Dimitrov DS, Sodroski J, Wyatt R, Nabel GJ, Kwong PD (2007) Structural definition of a conserved neutralization epitope on HIV-1 gp120. *Nature* 445:732–737
- Bruder C, Hagleitner M, Darlington G, Mohsenipour I, Wurznner R, Hollmuller I, Stoiber H, Lass-Flörl C, Dierich MP, Speth C (2004) HIV-1 induces complement factor C3 synthesis in astrocytes and neurons by modulation of promoter activity. *Mol Immunol* 40:949–961
- Green DA, Masliah E, Vinters HV, Beizai P, Moore DJ, Achim CL (2005) Brain deposition of beta-amyloid is a common pathologic feature in HIV positive patients. *AIDS* 19:407–411
- Pereira CF, Boven LA, Middel J, Verhoef J, Nottet HS (2000) Induction of cyclooxygenase-2 expression during HIV-1-infected monocyte-derived macrophage and human brain microvascular endothelial cell interactions. *J Leukoc Biol* 68:423–428
- Kulkarni AP, Kellaway LA, Lahiri DK, Kotwal GJ (2004) Neuroprotection from complement-mediated inflammatory damage. *Ann NY Acad Sci* 1035:147–164
- Yang F, Lim GP, Begum AN, Ubada OJ, Simmons MR, Ambegaokar SS, Chen PP, Kayed R, Glabe CG, Frautschy SA, Cole GM (2005) Curcumin inhibits formation of amyloid beta oligomers and fibrils, binds plaques, and reduces amyloid *in vivo*. *J Biol Chem* 280:5892–5901
- Asai M, Iwata N, Yoshikawa A, Aizaki Y, Ishiura S, Saido TC, Maruyama K (2007) Berberine alters the processing of Alzheimer's amyloid precursor protein to decrease A $\beta$  secretion. *Biochem Biophys Res Commun* 352:498–502
- Gekker G, Hu S, Spivak M, Lokensgard JR, Peterson PK (2005) Anti-HIV-1 activity of propolis in CD4 (+) lymphocyte and microglial cell cultures. *J Ethnopharmacol* 102:158–163
- Aruoma OI, Bahorun T, Jen LS (2003) Neuroprotection by bioactive components in medicinal and food plant extracts. *Mutat Res* 544:203–215
- Kulkarni AP, Kellaway LA, Kotwal GJ (2005) Herbal complement inhibitors in the treatment of neuroinflammation: future strategy for neuroprotection. *Ann NY Acad Sci* 1056:413–429
- Abebe W (2002) Herbal medication: potential for adverse interactions with analgesic drugs. *J Clin Pharm Ther* 27:391–401

## Central Nervous System Disease in Primary Sjögren's Syndrome

KATRIN E. MORGEN

Department of Neurology, Giessen University, Giessen, Germany

### Definitions

► **Primary Sjögren's syndrome (pSS)** is a chronic, multisystem autoimmune disorder characterized by dryness of eyes (keratokconjunctivitis sicca), mouth and other mucous membranes. Extraglandular manifestations are arthralgias, Raynaud's syndrome, pulmonary involvement, renal tubular acidosis, peripheral and central nervous system (CNS) disease. According to the revised international (American European Consensus Group) classification criteria [1], 4 out of 6 criteria (I. ocular symptoms, II. oral symptoms, III. objective ocular signs, IV. focal lymphocytic sialoadenitis, defined as at least one lymphocytic focus per 4 mm<sup>2</sup> of glandular tissue, i.e., a focus score  $\geq 1$  in a minor

salivary gland biopsy, V. objective evidence of salivary gland involvement obtained by the measurement of unstimulated salivary flow or by sialography and VI. presence of anti-SSA or anti-SSB antibodies) are required for the diagnosis of ▶**Sjögren's syndrome** (SS), as long as either histopathological evidence (IV) or serologic evidence (VI) is present. Alternatively, three out of four objective criteria (III-VI) must be positive. The diagnosis of pSS implies the absence of an associated autoimmune rheumatic disease (secondary SS). The revised international classification criteria [1] were introduced as a standardized set of criteria intended to replace earlier classification systems [2,3].

CNS involvement in pSS includes cognitive impairment, psychiatric abnormalities and migraine as well as focal deficits resulting from meningoencephalitis, transverse myelitis and subarachnoid hemorrhage. The definition of CNS symptoms is limited to physical disability in some studies, but includes nonfocal symptoms such as subtle cognitive dysfunction in others [4].

## Characteristics

### Clinical Presentation

Primary Sjögren's syndrome is generally diagnosed between the ages of 30 and 60 years and affects women nine times as often as men. The main features are dry eyes and mouth, often involving caries, but the disease can become systemic and affect other organs, leading to symptoms such as muscle and joint pain, itchy skin, vaginal dryness, gastroesophageal reflux and dry cough. Among neurological findings, peripheral neuropathy is most common, affecting between 10 and 20% of patients. It may cause progressive and initially distal tingling/numbness and weakness of the upper and lower extremities (polyneuropathy), asymmetrical sensory and/or motor deficits (e.g., radiculopathy, multiple mononeuropathy) or cranial nerve dysfunction.

The symptoms and course of CNS involvement are also heterogeneous. Patients may experience a sudden onset of focal deficits, such as hemiparesis or speech disturbance, suggesting stroke. They may also develop symptoms subacutely (e.g., transverse myelitis, optic neuritis) or over months and years (e.g., chronic myelopathy), and the course of disease can be progressive or relapsing-remitting. Rarely, CNS disease in pSS may manifest as seizures. Symptoms are sometimes discrete and not easily detected in routine neurological exams. This applies especially to mild cognitive disturbances, which may reflect brain damage, but can also be associated with fatigue and/or depression, other common symptoms in pSS.

It is important to note that CNS disease may occur before typical sicca symptoms (▶**sicca syndrome**) [5].

The prevalence of reported CNS disease is controversial and ranges from 0 to 62%. Reasons for the

differences in prevalence in previous studies are (a) the use of diverging diagnostic criteria [1–3], (b) varying definitions of CNS involvement and (c) the selection of patients from varying populations [4]. To standardize the diagnostic criteria, the revised international (American European Consensus Group) classification criteria [1] were formulated in 2002. Definitions of CNS involvement differ regarding the inclusion or exclusion of nonfocal symptoms, specifically cognitive and neuropsychiatric disturbances. Studies disregarding patients with cognitive and neuropsychiatric impairment tend to underestimate the prevalence of pSS-related CNS symptoms. Moreover, a selection bias towards more severe CNS disease is likely to occur in tertiary referral centers, which may help explain the high prevalences reported in some hospital-based studies [6]. Another reason for discrepancies in the reported prevalence of CNS-involvement has recently been suggested: CNS disease may be more rarely associated with immunological markers of pSS than, for example, PNS involvement [5].

### Pathology

Sjögren's syndrome is an autoimmune disorder in which immune cells destroy the exocrine glands that produce tears and saliva. At the beginning of the disease process, plasma cells and lymphocytes infiltrate the periductal salivary tissue. The original glandular structure is replaced by dense infiltrates of lymphocytes. Sjögren's syndrome may result from T-cell abnormalities or may be caused by a deficiency of T-lymphocytes and subsequent hyperactivity of B-lymphocytes and the production of autoantibodies. Both environmental and genetic factors are likely to contribute to the immunological dysregulation that occurs in pSS [7].

The mechanisms of neurological disease in pSS are still unclear. Regarding peripheral nervous system involvement, different mechanisms seem to be associated with specific clinical features. Thus, sensory ataxic, painful and trigeminal neuropathy may be related to more immediate neuropathic processes than multiple mononeuropathy and multiple cranial neuropathy, which appear to result from vasculitis [8].

Evidence on the pathology of CNS damage is diverse. Some studies have suggested ischemic mechanisms. Other possible mechanisms are mononuclear cell infiltration in CNS tissue, immunologically mediated CNS vascular damage and the action of antibodies (antineuronal and/or anti-Ro/SSA antibodies [5]). The types of tissue damage observed in pSS-associated CNS disease vary greatly, in accord with the heterogeneous mechanisms mentioned above. Thus patients may develop severe conditions resulting from vascular damage or obstruction, such as subarachnoid hemorrhage and ischemia; other types of tissue injury, such as meningoencephalitis and transverse myelitis

indicate demyelination, and may be hard to distinguish from multiple sclerosis (MS).

## Disease Markers

### Immunological Markers

pSS is typically associated with anti-SSA/Ro and anti-SSB/La antibodies ▶(Anti-SSA (Anti-Ro)/Anti-SSB (Anti-La) antibodies), of which anti-SSB/La is more specific to pSS, as well as with other anti-nuclear antibodies, antiphospholipid-antibodies, rheumatoid factor and cryoglobulins, which are elevated in numerous autoimmune diseases. Whether the presence of any of these immunological markers ▶(disease markers) predicts the presence or severity of CNS involvement remains contradictory.

### CNS-Imaging Markers

▶CNS imaging, specifically ▶magnetic resonance imaging (MRI), permits the detection of lesions as well as tissue atrophy in pSS. Large lesions, indicative of ischemia or hemorrhage have been identified. On T1-weighted MRI, which attributes tissue with high water content a low signal and tissue containing macromolecules (such as myelin) a relatively high signal, lesions involving severe damage of the tissue matrix appear hypointense. In contrast, T2-weighted MRI also reveals more subtle white matter damage, which occurs more commonly in pSS patients. FLAIR images, which are strongly T2-weighted and involve a nulling of cerebrospinal fluid, are especially sensitive to white matter lesions (Fig. 1). Because T2-weighted MRI is sensitive to increases in the concentration of free protons, it may indicate reversible edema as well as gliosis, demyelination and axonal loss. Conventional MRI is thus not sensitive to the type of white matter tissue damage. Furthermore, small white matter lesions are common in elderly individuals and are associated with cerebrovascular risk factors. Thus, it is not possible to use MRI as a

simple marker of white matter damage in pSS, though recent studies have indicated an elevated number of white matter lesions in groups of pSS patients [4].

Brain atrophy has been reported in pSS patients, but not analyzed in a controlled study [4].

Previous MRI studies in pSS have largely been limited to conventional T2-weighted analyses of lesions. However, newer imaging techniques, which can provide more sensitive and/or specific information on tissue injury and have been successfully applied in other inflammatory CNS diseases, such as multiple sclerosis and systemic lupus erythematosus, are likely to become established in pSS research. ▶Magnetization transfer imaging (MTI), for example, can help indicate the degree of tissue damage in selected regions as well as globally [9]. The principle underlying MTI is the selective saturation of protons bound to macromolecules such as myelin. In damaged tissue, the increased concentration of protons in free water leads to a quantifiable reduction of MT saturation effects. MT effects tend to be extensive in demyelinated tissue, less pronounced in vasculitic damage and discrete in edematous tissue. Moreover, MT effects can be detected in tissue that appears normal on conventional MRI. The high sensitivity of MTI makes it a potentially valuable marker of CNS tissue injury in pSS studies.

▶MR-spectroscopy (magnetic resonance spectroscopy (MRS)) is another imaging technique likely to gain importance in the investigation of pSS-associated CNS pathology. By producing spectra that reflect levels of brain metabolites, MR spectroscopy conveys information on the type of potential tissue injury. For example, an elevated level of choline normalized to creatine (Cho/Cr) points to active demyelination or gliosis, whereas a decreased N-acetyl aspartate creatine (NAA/Cr) ratio is associated with neuronal dysfunction or loss [4]. This technique could, for example, help attribute

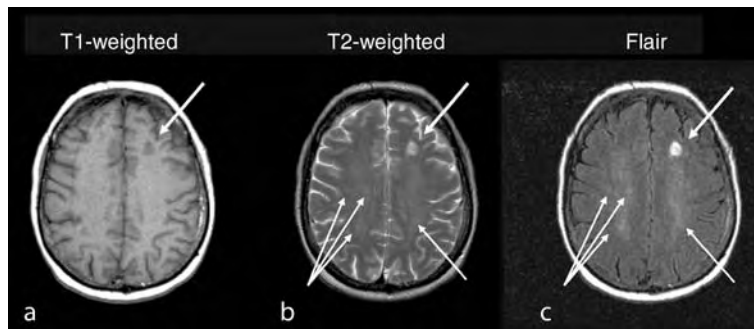

**Central Nervous System Disease in Primary Sjögren's Syndrome. Figure 1** White matter damage in a patient with primary Sjögren's syndrome. T1-weighted MRI only indicates one relatively large lesion (a, *wide arrow*). T2-weighted MRI and FLAIR (b, c) are more sensitive to more subtle white matter abnormalities; on FLAIR images (c), the strong tissue contrast helps reveal small lesions more clearly than conventional T2-weighted MRI (b, *thin arrows*).

pSS-associated tissue damage to demyelination or to vasculitis.

In pSS patients with mild cognitive impairment or neuropsychiatric symptoms, functional imaging has revealed metabolic abnormalities in specific brain regions. ► **Single photon emission computed tomography (SPECT)**, a nuclear medicine tomographic imaging technique based on gamma rays, has been used in pSS patients to assess regional brain metabolism. A tracer, such as  $^{99m}\text{Tc}$ -HMPAO or  $^{99m}\text{Tc}$ -ECD, is absorbed by brain tissue proportional to blood flow. By emitting gamma rays, the tracer permits the measurement of blood flow, which, in turn, is coupled to local brain metabolism. In pSS patients with neuropsychological disturbances, hypoperfusion has been identified in various brain regions including the frontal, temporal and parietal cortex as well as the striatum [4,10].

## References

- Vitali C, Bombardieri S, Jonsson R, Moutsopoulos HM, Alexander EL, Carsons SE, Daniels TE, Fox PC, Fox RI, Kassan SS, Pillemer SR, Talal N, Weisman MH, the European Study Group on Classification Criteria for Sjögren's Syndrome (2002) Classification criteria for Sjögren's syndrome: a revised version of the European criteria proposed by the American-European Consensus Group. *Ann Rheum Dis* 61:554–558
- Vitali C, Bombardieri S, Moutsopoulos HM, Balestrieri G, Bencivelli W, Bernstein RM et al. (1993) Preliminary criteria for the classification of Sjögren's syndrome. Results of a prospective concerted action supported by the European Community. *Arthritis Rheum* 36:340–347
- Fox RI, Robinson CA, Curd JG, Kozin F, Howell FV (1986) Sjögren's syndrome. Proposed criteria for classification. *Arthritis Rheum* 29:577–585
- Morgen K, McFarland HF, Pillemer SR (2004) Central nervous system disease in primary Sjögren's syndrome: the role of magnetic resonance imaging. *Semin Arthritis Rheum* 34:623–630
- Delalande S, de Seze J, Fauchais AL, Hachulla E, Stojkovic T, Ferriby D, Dubucquoi S, Pruvo JP, Vermersch P, Hatron PY (2004) Neurologic manifestations in primary Sjögren syndrome: a study of 82 patients. *Medicine (Baltimore)* 83:280–291
- Alexander EL (1993) Neurological disease in Sjögren's syndrome: mononuclear inflammatory vasculopathy affecting central/peripheral nervous system and muscle. *Rheum Dis Clin North Am* 19:869–908
- Garcia-Carrasco M, Ramos-Casals M, Rosas J, Pallares L, Calvo-Alen J, Cervera R, Font J, Ingelmo M (2002) Primary Sjögren syndrome: clinical and immunologic disease patterns in a cohort of 400 patients. *Medicine (Baltimore)* 81:270–280
- Mori K, Tijima M, Koike H, Hattori N, Tanaka F, Watanabe H, Katsumo M, Fujita A, Aiba I, Ogata A, Saito T, Asakura K, Yoshida M, Hirayama M, Sobue G (2005) The wide spectrum of clinical manifestations in Sjögren's syndrome-associated neuropathy. *Brain* 128:2518–2534
- Van Buchem MA, McGowan JC, Grossman RI (1999) Magnetization transfer histogram methodology: its clinical and neuropsychological correlates. *Neurology* 53: S23–S28
- Chang CP, Shiau YC, Wang JJ, Ho ST, Kao A (2002) Abnormal regional cerebral blood flow on  $^{99m}\text{Tc}$  ECD brain SPECT in patients with primary Sjögren's syndrome and normal findings on brain magnetic resonance imaging. *Ann Rheum Dis* 61:774–778

## Central Nervous System Infections: Humoral Immunity in Arboviral Infections

MARIA GRAZIA CIUFOLINI, LOREDANA NICOLETTI  
Department of Infectious, Parasitic and Immune-Mediated Diseases, Istituto Superiore di Sanità, Viale Regina Elena, Rome, Italy

### Definition

This essay describes the humoral immune response during neurological infection caused by Arthropod-Borne Viruses.

### Characteristics

Virus infections of the central nervous system (CNS) are relatively uncommon, but potentially devastating. The longevity of many cells in the CNS and the relative inaccessibility of this tissue to components of the immune system make the brain and spinal cord particularly susceptible to persistent virus infection. Clearance of virus from nonneural tissues often involves cytolytic elimination of the infected cells. Because of the potential for neurological damage by inflammatory mediators and cytotoxic cells, the brain has intrinsic mechanisms for controlling immune responses that are different from other organs. Nevertheless, immune responses to virus infection of the CNS can clear the virus from the tissue or sustain prolonged inhibition of virus replication without damage to the structure or function of the nervous system. The degree to which clearance is successful differs with the type of virus that causes the infection and with the target cells that the virus infects.

Of the ► **viral infections** of the CNS, ► **meningoencephalitis** and/or **encephalomyelitis** caused by ► **arboviruses** (Arthropod-Borne viruses) are among the most serious (► **arboviral infection**).

Arboviruses cause significant human illness ranging from mild, asymptomatic infection to fatal ► **encephalitis** or hemorrhagic fever. The most significant arboviruses causing human neurological illness

belong to genera in three viral families, Togaviridae, Flaviviridae, and Bunyaviridae. These viruses have a marked neurotropism, which leads to the characteristic pathological disease state. They may cause meningoencephalitis and/or encephalomyelitis often leading to a fatal outcome or permanent neurological sequelae such as neuropsychiatric symptoms in adults or mental retardation in children or paralysis of the extremities. The arboviruses most frequently involved in CNS infections in humans are listed in [Table 1](#).

Here we report clinical symptoms and the humoral immune response in humans to the diseases caused by the principal virus transmitted by arthropods.

### Description of the Process

Among animal viruses, arboviruses are unique in that they are transmitted by blood-sucking arthropods (vectors) to vertebrates, a mode of transmission commonly known as biological transmission involving the three essential components: virus, vector and vertebrate. Arboviruses generally require horizontal transmission by arthropod vectors among vertebrate hosts for their natural maintenance. On the basis of their arthropod vector, arboviruses that cause neurological infections can be classified as mosquito borne, tick borne, and viruses transmitted by different species of sandflies and by other vectors.

### Togaviridae

Among mosquito-borne viruses some members of Alphavirus genus in the family Togaviridae represent an important group of neurological disease agents. Alphaviruses of neurological interest include Western Equine Encephalitis virus and Eastern Equine Encephalitis virus and Venezuelan equine encephalitis virus, which can cause severe disease in horses and encephalitis in humans. Human outbreaks of all three of these viral diseases occur shortly after outbreaks are observed in horses.

Alphavirus encephalitis results in either localized or diffuse signs of cerebral dysfunction. Signs of meningeal irritation (meningoencephalitis) are nearly always present but may not be evident in the very young, the very old or the comatose patients. Inflammation of the leptomeninges may occur in some patients without evidence of brain dysfunction (▶aseptic meningitis). Onset of neurological disease is preceded by a period in which the patient has an influenza-like illness. Encephalitis may follow quite soon after the onset or may follow days or weeks later [1].

While in the New World the arboviruses of neurological importance belong to the Togaviridae family (with the exception of West Nile virus), in the Old World (Europe, Asia and Africa) the viruses involved belong to the Flaviviridae family and are transmitted by mosquitoes and by ticks, as illustrated in [Table 1](#).

### Flaviviridae

Flaviviruses that cause neurological disease can be classified on the basis of their mode of transmission as tick-borne or mosquito-borne viruses. In Europe the most important agent of human disease is the Tick-borne encephalitis virus (TBE), transmitted by ticks; in Southern and eastern Asia the Japanese encephalitis virus (JEV) is the most important pathogen transmitted by mosquitoes. Recently the Flavivirus West Nile spread from the Old World to America and since 1999 it represents an important cause of neurological disease in the United States.

### Tick-Borne Viruses

#### Tick-Borne Encephalitis Virus (TBE)

The TBE virus species includes three sub-types, namely Far Eastern (previously RSSE), Siberian (previously west-Siberian) and Western European (previously Central European Encephalitis, CEE) virus.

The incubation period of the disease is usually 7–14 days, but it may vary from 2–28 days. The main clinical neurological syndromes associated with TBE are febrile headache, aseptic meningitis, meningoencephalitis, ▶meningoencephalomyelitis, and post-encephalitic syndrome.

Encephalitis produced by European subtype viruses is biphasic with fever during the first phase and neurological disorders of differing severity, during the second phase, which occurs in 20–30% of patients. In contrast with severe Far Eastern subtype virus infections, those following infection by European strains are usually milder, mostly without sequels; case fatality rates are often as low as 1–2% and the disease in children is less severe than in adults.

Aseptic meningitis is the most common form of clinical TBE disease. It usually presents with high fever, headache, vomiting, and vertigo. Signs of meningeal irritation usually occur but may not be pronounced; however, all patients exhibit cerebrospinal fluid (CSF) pleocytosis.

Presentation of meningoencephalitis is variable. Meningeal signs are usually present, and patients are somnolent or unconscious. Severe tremors of extremities and fasciculations of the tongue, profuse sweating, asymmetrical paresis of cranial nerves, and nystagmus are common symptoms. In some patients, delirium and psychosis may develop rapidly (within hours).

Meningoencephalomyelitis is the most severe form of the disease. It is characterized by paresis that usually develops 5–10 days after the remission of fever. Severe pain in the arms, back, and legs occasionally precedes development of paresis. Involvement of cranial nerve nuclei and motor neurons of the spinal cord produces flaccid paralysis of the neck and upper-extremity muscles. Death may occur within 5–7 days of the onset of the neurological signs [2].

**Central Nervous System Infections: Humoral Immunity in Arboviral Infections. Table 1** Major arboviruses that cause neurologic disease

Family (genus)/virus	Arthropod vector	Geographic distribution	Human disease	Occurrence
Togaviridae (Alphavirus)				
Eastern equine encephalitis	<i>Culiseta</i> , <i>Culex</i> mosquitoes and other species	North and South America	Febrile illness	Epidemic
			Encephalitis	
Venezuelan equine encephalitis	<i>Aedes</i> , <i>Culex</i> mosquitoes and other species	Central and South America, southern Florida	Febrile illness	Epidemic
			Encephalitis	
Western equine encephalitis	<i>Culex</i> mosquitoes	North and South America	Febrile illness	Epidemic
			Encephalitis	
Flaviviridae (Flavivirus)				
Japanese encephalitis	<i>Culex</i> mosquitoes	Asia, India, far-eastern former Soviet Union	Encephalitis	Epidemic
Murray Valley encephalitis	<i>Culex</i> mosquitoes	Australia, New Guinea	Encephalitis	Epidemic
Rocio	<i>Culex</i> mosquitoes	Brazil	Encephalitis	Epidemic
St. Louis encephalitis	<i>Culex</i> mosquitoes	North and South America	Encephalitis	Epidemic
West Nile	<i>Culex</i> mosquitoes and other species	Eurasia, Africa, North America	Encephalitis	Epidemic
			Encephalomyelitis	
Tick-borne encephalitis	<i>Ixodes</i> , <i>Dermacentor</i> , <i>Haemaphysalis</i> ticks	Europe, Russia, former Soviet Union	Encephalitis	Epidemic
				Endemic
Louping ill	<i>Ixodes ricinus</i> tick	Great Britain	Encephalitis	Rare - sporadic
Powassan	<i>Ixodes</i> , <i>Dermacentor</i> , <i>Haemaphysalis</i> ticks	Russia, North America	Encephalitis	Rare - sporadic
Bunyaviridae (Bunyavirus)				
California encephalitis	<i>Ochlerotatus</i> and <i>Aedes</i> mosquitoes	Western North America	Febrile illness	Rare - sporadic
			Encephalitis	
Jamestown Canyon	<i>Culiseta</i> and <i>Ochlerotatus</i> mosquitoes	North America	Febrile illness	Rare - sporadic
			Encephalitis	
La Crosse encephalitis	<i>Ochlerotatus</i> mosquitoes	North America	Febrile illness	Epidemic
			Encephalitis	
Snowshoe hare	<i>Ochlerotatus</i> and <i>Culiseta</i> mosquitoes	North America	Febrile illness	Rare – sporadic
			Encephalitis	
Bunyaviridae (Phlebovirus)				
Toscana	<i>Phlebotomus perniciosus</i> , <i>P. perfiliewi</i> sandflies	Europe, Mediterranean basin	Febrile illness	Epidemic
			Meningitis	Endemic
			Meningoencephalitis	
			Encephalitis	

## Mosquito -Borne Viruses

### Japanese Encephalitis Virus

The Japanese encephalitis virus (JEV) serocomplex includes other human pathogens such as West Nile virus, Murray Valley encephalitis, St. Louis encephalitis, and Kunjin viruses. JEV is a leading cause of childhood viral encephalitis in southern and eastern Asia and has also been a problem among military personnel and travelers to these regions.

Disease symptoms vary from a mild febrile illness to acute meningoencephalomyelitis. After an asymptomatic incubation period of 1–2 weeks, patients exhibit signs of fever, headache, stupor, and generalized motor seizures, especially in children. The virus invades and destroys the cortical neurons and causes encephalitis. This neuronal damage is similar to the destruction of anterior horn cells seen in poliomyelitis. The fatality rate ranges from 10–50% and most survivors have neurological and psychiatric sequelae [3].

### West Nile Virus

The West Nile virus (WNV) causes encephalitis in humans and horses. In humans, incubation ranges from 2–15 days. About 80% of WNV infections are asymptomatic, but some patients have symptoms ranging from mild febrile illness (>95% of patients) to meningitis or encephalitis (<1% of patients). People infected with WNV could experience fever, headache, and other non-specific symptoms that typically last for several days. Patients can also have a variety of other signs and symptoms including nausea, vomiting, macular-papular rash, chills, abdominal pain, muscle weakness, photophobia, conjunctivitis, movement disorders, parkinsonism, confusion, and slurred speech. For some patients, a febrile prodrome is immediately followed by encephalitis. More severe neurologic manifestations, such as a syndrome resembling poliomyelitis and acute flaccid paralysis, have been seen. The most severe complications are commonly seen in the elderly, with reported case fatality rates from 4–11% [3].

## Bunyaviridae

The Bunyaviridae are a large group of viruses that infect a diversity of arthropod vectors and animal hosts. They have a worldwide distribution and can be the cause of human illness. The most important viruses in the family Bunyaviridae that produce neurological disease in humans belong to genus *Bunyavirus*, transmitted by mosquitoes and *Phlebovirus*, transmitted by different species of sandflies.

### Genus *Bunyavirus*

The viruses that cause neurological disease are classified into the California serogroup: California encephalitis virus (CEV), La Crosse virus (LACV), Jamestown Canyon virus (JCV), and snowshoe hare

virus. Symptoms range from unapparent or mild febrile disease to encephalitis and death. After a 3–7-day incubation period, sudden onset of fever, followed by stiff neck, lethargy, headache, nausea, and vomiting may be observed in infected individuals. Seizures have been seen in approximately half of the infected patients, and about 65% of the adult patients exhibit signs of meningitis. Seizures are the most important sequelae in children and have been observed in approximately 10–15% of children 1–8 years after infection [4].

### Genus *Phlebovirus*

Viruses causing neurological disease are Toscana (TOS) virus and Rift Valley fever virus [5]. Although TOS virus infection in most cases consists of a mild disease with a favorable outcome, a small number of severe cases have been reported in the literature [6]. After an incubation period ranging from a few days to 2 weeks, disease onset is intense (70%) with headache (100%, 18 h – 5 days), fever (76%–97%), nausea and vomiting (67%–88%), and myalgias (18%). Physical examination may show neck rigidity (53%–95%), Kernig signs (87%), poor levels of consciousness (12%), tremors (2.6%), paresis (1.7%), and nystagmus (5.2%). In most cases reported so far, CSF contained >5–10 cells with normoglycorachia and normoproteinorachia. Blood samples may show leukocytosis (29%) or leukopenia (6%). The mean duration of the disease is 7 days, and the outcome is usually favorable.

## Regulation of the Process

### Alphaviruses

Studies on the structure and function of the various structural and non-structural proteins have been extensively conducted to understand the ►humoral immunity response to Alphaviruses infection.

Virus-specific IgM antibodies are detectable very early in human disease and often provides a means for rapid diagnosis of infection. Virus-specific immunoglobulin A (IgA) also appears early in infection, but declines rapidly. IgG antibodies appear in serum after 7–14 days and are maintained at relatively high levels for years. Rapidity of host antibodies synthesis is predictive of outcome from encephalitis because patients without evidence of antibodies at the time of illness are most likely to die. Accumulating data support the hypothesis that recovery from alphavirus infection is dependent primarily on the antibody response. Antibodies can neutralize virus infectivity and promote virus clearance by reticuloendothelial system (RES) in conjunction with complements. As described in Fig. 1 the infection is characterized by a biphasic course, viremia occurs during the febrile phase and ends when neurological symptoms appear. Appearance of antibodies correlates with cessation of viremia [7]. This specific characteristic is common to all neurological

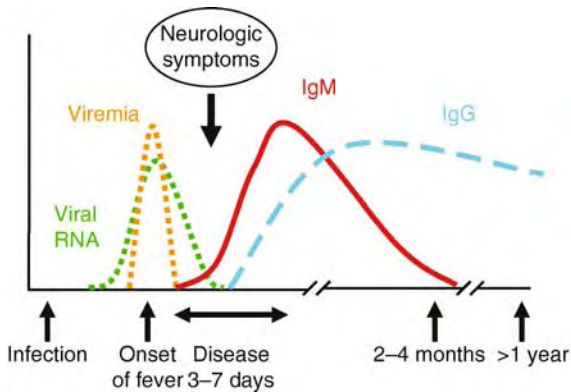

**Central Nervous System Infections: Humoral Immunity in Arboviral Infections. Figure 1** General course of symptoms of arboviral neurological diseases. The infection is characterized by a biphasic course. Viremia occurs during the febrile phase and ends when neurological symptoms appear. Appearance of antibodies correlates with cessation of viremia.

diseases caused by arboviruses, independently of their arthropod vector.

### Flaviviruses

Susceptibility to flavivirus encephalitis implies a failure at some stage of the immune response that theoretically may be defined in either qualitative or quantitative terms. There is substantial clinical and experimental evidence for a correlation between protection against encephalitic disease and the presence of virus-specific antibodies, but the molecular and cellular basis for the development of this response has not been defined thoroughly. In studies that have shown protection by antibodies, the roles of other immune system components in the process have not often been assessed. Furthermore, there is increasing evidence that flaviviruses have evolved mechanisms to manipulate the effector functions of both innate and adaptive immune responses. The magnitude and importance of these responses probably vary from one experimental model to another and account for differences observed in studies that have examined the immune system in the context of either a primary or a memory response [8].

Extensive studies have been conducted in JEV patients. In humans infected with JEV a rapid and potent antibody response has been observed. Serum IgM to the virus can be detected in many patients when symptoms first appear, by the seventh day of disease, and can be detected in most survivors. On the other hand, there are patients who succumb so rapidly to Japanese encephalitis that antibody levels remain undetectable (diagnoses being made by isolation of the virus from brain). Antibodies are directed in part against the envelope (E) glycoprotein and therefore have virus-neutralizing (▶neutralizing antibody) and

▶hemagglutination-inhibiting activity, and in part against virus non-structural proteins NS1, NS3 and NS5.

Antibody synthesis undergoes class switching so that IgGs to JEV can be detected in most patients within 30 days of disease onset. In patients previously infected with another flavivirus (e.g. dengue virus), there is an anamnestic response to flavivirus-group common antigens so that IgGs to JEV are present sooner and in greater quantities.

Antibody levels are lower in instances of subclinical infection compared to disease. A correlate of that phenomenon is the longer persistence of IgM to JEV observed in clinically severe versus mild infections; serum IgM to the virus can be measured in some patients 1–2 years after convalescence. Thus, in some patients, antibody responses reflect the severity of disease, possibly correlating with the duration and extent of virus replication.

Anti-viral IgM and IgG are present in CSF of patients with overt Japanese encephalitis but not in those infected subclinically. B cells and differentiated plasma cells are present in the perivascular cuffs of brain tissue from fatal encephalitis, as well as in CSF during acute disease. CSF leukocytes collected during acute Japanese encephalitis spontaneously produce IgM and IgG to JEV; moreover, antibody levels in CSF are greater than those in serum. These data provide a pathophysiologic basis for regarding CSF IgM to JEV as a marker of virus localization within the CNS [9].

While Flavivirus diseases have been extensively studied, only few information are available for neurological diseases caused by Phleboviruses.

### Phleboviruses

The principal studies have been conducted on Toscana virus that has been considered as one of the emerging disease in Europe.

In Toscana virus patients, IgM antibodies, usually present at the onset of symptoms, can reveal elevated titers by enzyme-linked immunosorbent assay (ELISA). IgM antibodies are detected in serum of patients 4–5 days after the onset of symptoms, reaching their highest titer 1–4 weeks after, and can persist for at least 1 year. IgG antibodies can be absent at the onset of symptoms: titers rise in convalescent sera and persist for many years. High titers of neutralizing antibodies are present in convalescent sera (range from 1:40–1:2,560). However, there appeared to be no correlation between the severity of illness and the subsequent titer of neutralizing antibodies.

At least five proteins have been identified in Toscana virus-infected cells: nucleoprotein N, glycoproteins G1 and G2, a large protein (L) assumed to be a component of the polymerase, and two nonstructural proteins, NSm and NSs. Immunoblotting and semiquantitative radioimmunoprecipitation assay (RIPA) allow



identification of nucleoprotein N as the major antigen responsible for both IgM and IgG responses. Antibodies to glycoproteins are detected in about one-third of patients, and their presence always predicts neutralizing activity. Antibodies to non-structural proteins NSm and NSs are also identified. These results raise some questions about antigenic variability and relevant ►neutralization epitopes of Toscana virus [10].

## References

- Weaver SC, Barrett AD (2004) Transmission cycles, host range, evolution and emergence of arboviral disease. *Nat Rev Microbiol* 10:789–801
- Gritsun TS, Lashkevich VA, Gould EA (2003) Tick-borne encephalitis. *Antiviral Res* 57:129–146
- Mackenzie JS, Gubler DJ, Petersen LR (2004) Emerging flaviviruses: the spread and resurgence of Japanese encephalitis, West Nile and dengue viruses. *Nat Med* 12 (Suppl):S98–S109
- Gonzalez-Scarano F, Jacoby D, Griot C, Nathanson N (1992) Genetics, infectivity and virulence of California serogroup viruses. *Virus Res* 2:123–135
- Nicoletti L, Verani P, Cacioli S, Ciufolini MG, Renzi A, Bartolozzi D et al. (1991) Central nervous system involvement during infection by the phlebovirus Toscana of residents in natural foci in central Italy (1977–1988). *Am J Trop Med Hyg* 45:429–434
- Baldelli F, Ciufolini MG, Francisci D, Marchi A, Venturi G, Fiorentini C et al. (2004) Unusual presentation of life-threatening TOSV meningoencephalitis. *Clin Infect Dis* 38:515–520
- Griffin DE, Ubol S, Despres P, Kimura T, Byrnes A (2001) Role of antibodies in controlling alphavirus infection of neurons. *Curr Top Microbiol Immunol* 260:191–200
- Aberle JH, Aberle SW, Kofler RM, Mandl CW (2005) Humoral and cellular immune response to RNA immunization with flavivirus replicons derived from tick-borne encephalitis virus. *J Virol* 79:15107–15113
- Halstead SB, Jacobson J (2003) Japanese encephalitis. *Adv Virus Res* 61:103–138
- Magurano F, Nicoletti L (1999) Humoral response in Toscana virus acute neurologic disease investigated by viral-protein-specific immunoassays. *Clin Diagn Lab Immunol* 6:55–60

## Central Nervous System Inflammation: Astroglia and Ethanol

RANDALL L. DAVIS

Neuroinflammation Research Laboratory, Department of Pharmacology/Physiology, Oklahoma State University Center for Health Sciences, Tulsa, OK, USA

### Synonyms

Alcohol; Astrocytes; Neuroinflammation

## Definition

Long-term chronic and acute, binge-type alcohol (ethanol) consumption disrupts cognitive function and causes structural brain damage. The adverse effects of ethanol are typically realized when blood ethanol levels reach 20–50 mM; however, blood ethanol concentrations have been reported to exceed 200 mM. Among the cells profoundly affected by ethanol are the astroglia. Astroglia are the most prevalent cell type in the human central nervous system (CNS) and perform important roles both in normal tissue homeostasis and response to injury and infection. Physiological functions of astroglia include neurotrophic factor production, regulation of neuronal development and function, neurotransmitter metabolism and extracellular regulation of pH and K<sup>+</sup> concentration and they comprise a critical component of the ►blood-brain barrier (BBB). Important astroglial derived inflammatory mediators include cytokines, ►chemokines, inducible nitric-oxide synthase (iNOS), and cyclooxygenase type-2 (COX-2). These inflammatory molecules are involved in the highly orchestrated sequence of events whereby peripheral immune cells and resident glia are activated and recruited to the affected brain region. Activated immune cells and glia are instrumental in the clearance of infectious and foreign agents, promotion of neuronal survival and tissue repair. With prolonged inflammation, these protective and repair activities are lost and neurotoxicity ensues. Increasing evidence suggests that ethanol-induced brain damage may be, in part, related to modulation of neuroinflammation. Similarly, excessive ethanol intake appears to compromise CNS immunocompetence.

## Characteristics

### Description of the Process

It is well known that alcohol abuse results in structural and functional damage to the brain. Damage to the CNS is clearly evidenced in alcoholic individuals by a significant reduction in both brain weight and brain volume compared to control subjects. Interestingly, the neuropathology caused by alcohol appears to be region and cell type specific. For instance, the cerebral cortex, hypothalamus and cerebellum are quite vulnerable to the adverse effects of alcohol. Additionally, while both neurons and astroglia are affected by alcohol, astroglia are particularly susceptible to the detrimental effects of alcohol. Ethanol alters astroglial cell function and proliferation and the reduction in brain size is likely due in part to the cytotoxic effects of ethanol on astroglia. These ethanol-mediated effects on astroglia are potentially very important given that astroglia are essential for neuronal survival and function and are instrumental in response to infectious and traumatic insults to the CNS. The mechanism responsible for ethanol-induced brain damage is not fully understood but a major contributor appears to be inflammation. That is, ethanol

induces inflammation in the brain and alters inflammatory pathways in the brain. These changes in inflammatory pathways likely contribute to brain damage but may also alter CNS immunocompetence and response to injury. For instance, risk and fatality of bacterial meningitis is greater in patients with alcoholic liver cirrhosis than in patients with non-alcoholic cirrhosis [1]. The poor outcome of alcoholic individuals with bacterial meningitis is likely a consequence of altered BBB function and CNS immunocompetence, given the involvement of BBB breakdown, leukocyte infiltration and neuronal injury in the pathogenesis of bacterial meningitis. Another instance in which alcohol abuse may be particularly detrimental to infection related neuropathogenesis is ►**human immunodeficiency virus (HIV)** infection. More specifically, neuroimaging analysis indicates common loci of neuropathology in the human brain between HIV infected and alcoholic individuals suggesting that co-occurrence of these diseases may compound neuropathology [2]. Experimental findings suggest that ethanol and the HIV protein, ►**Tat protein**, synergistically increase oxidative stress and proinflammatory gene expression in the brain [3]. These clinical insights, as well as other key experimental findings have led researchers in the field to target several inflammatory molecules as likely molecules involved in ethanol modulation of CNS immunocompetence and response to injury. The remainder of this essay will discuss key insights regarding ethanol effects on these inflammatory molecules.

## Regulation of the Process

### Nuclear Factor (NF)- $\kappa$ B

The transcription factor, ►**nuclear factor kappa B (NF- $\kappa$ B)** plays a pivotal role in inflammatory and immune related responses in astroglia. *In vitro* studies indicate that ethanol effects on NF- $\kappa$ B activation in astroglia vary, depending on the origin of the astroglial cells (i.e., species or among different cell lines within a species), and the stimulus used to activate NF- $\kappa$ B. In human astroglial cells, ethanol enhances cytokine-induced NF- $\kappa$ B activity as indicated by increases in nuclear levels of the RelA (p65) subunit of NF- $\kappa$ B. Furthermore, in A172 astroglia, ethanol enhances cytokine stimulated NF- $\kappa$ B-DNA binding [4]. However, it is unclear whether this ethanol-mediated increase in p65 protein is a consequence of enhanced entry into the nucleus or reduced degradation or export. Seemingly in contrast, in a separate human astroglial cell line, ethanol inhibits carbachol-stimulated NF- $\kappa$ B activity [5]. Together these findings suggest that the mechanism by which ethanol modulates NF- $\kappa$ B activation differs with activation pathway and cell type. It is also important to note that other NF- $\kappa$ B proteins (i.e., p50, p52, c-Rel and Rel-B), as well as associated regulatory proteins such as inhibitor of NF- $\kappa$ B (I $\kappa$ B) and I $\kappa$ B kinase (IKK) may also be affected in astroglia by ethanol. Further investigation

is necessary to identify the specific molecular sites of ethanol action.

### Inducible Nitric-Oxide Synthase

The inducible isoform of nitric-oxide synthase (iNOS) is not usually present in the healthy CNS. However, following traumatic or pathologic insult, iNOS is transcriptionally induced via an NF- $\kappa$ B-dependent mechanism, particularly in the affected astroglia. iNOS subsequently catalyzes the generation of nitric oxide (NO) in the region of the activated astroglia. Induction of astroglial iNOS, which is instrumental in response to injury and immunocompetence within the CNS, is modulated by ethanol exposure [6]. For instance, proinflammatory-induced iNOS expression in rat astroglial cells is inhibited by ethanol. In contrast, cytokine-induced iNOS expression in human astroglial cells is biphasically modulated by ethanol such that lower concentrations enhance iNOS expression and higher levels are inhibitory. In some astroglial cell models, ethanol exposure alone is sufficient to induce iNOS expression [6]. Hence, ethanol effects on astroglial iNOS expression are stimulus and cell-type dependent. The mechanism by which ethanol modulates iNOS expression in astroglia is not completely understood. Increasing evidence suggests that ethanol modulates inflammatory-induced iNOS expression by altering the transcription of iNOS. Given the integral role of NF- $\kappa$ B in iNOS activation and sensitivity of this transcription factor to ethanol it may be speculated that ethanol disrupts iNOS expression in part via an NF- $\kappa$ B-dependent mechanism [4].

### Cyclooxygenase-2

The inducible isoform of cyclooxygenase, ►**cyclooxygenase-2 (COX-2)** is instrumental in the production of prostaglandin E<sub>2</sub> (PGE<sub>2</sub>) from arachidonic acid. Increased expression of COX-2 and prostaglandin production following traumatic or pathologic insult in the CNS is involved in inflammatory-mediated neuropathogenesis. Enhanced expression and activity of COX-2 in astroglia may be involved in ethanol-induced brain damage given that ethanol-induced overexpression of COX-2 occurs predominantly in astroglia not neurons. Similar to what has been observed for astroglial iNOS, ethanol up-regulates astroglial COX-2 through an NF- $\kappa$ B-dependent mechanism. Furthermore, ethanol-induced neurotoxicity can be blocked through inhibition of NF- $\kappa$ B or specific inhibition of COX-2 [7]. The mechanism by which ethanol alters NF- $\kappa$ B signaling to attenuate COX-2 activation remains to be elucidated.

### Toll-Like Receptor-4 and Type I Interleukin-1 Receptors

Bacterial lipopolysaccharide (LPS; endotoxin) and interleukin-1 $\beta$  (IL-1 $\beta$ ) stimulate astroglial expression of inflammatory mediators through activation of the ►**Toll-like receptor (TLR)-4** and IL-1RI receptors,

respectively. Ethanol-induced inflammation is attenuated when TLR-4 and IL-1RI activation is blocked [8]. More specifically, antagonism of these receptors prevents ethanol induced activation of NF- $\kappa$ B and subsequent induction of iNOS and COX-2. The activity and function of TLRs other than TLR-4 may also be modulated by ethanol. It is yet unclear, however, whether ethanol directly or indirectly alters the activation or function of these receptors. Additionally, TLR's other than TLR-4 may also be ethanol-sensitive and therefore, may be important in ethanol effects on inflammatory signaling in astroglia.

### Intercellular Adhesion Molecule-1

The glycoprotein, intercellular adhesion molecule (ICAM)-1 is constitutively expressed on the surface of multiple cell types including astroglia. As a ligand for integrin receptors on leukocyte cell surface membranes, this molecule is instrumental in leukocyte migration.

While the importance of ICAM-1 on astroglia has not been fully elucidated, this adhesion molecule seems to be instrumental in neuroinflammation. Involvement of ICAM-1 in neuroinflammation is evidenced by increased expression of ICAM-1 on astroglia following exposure to inflammatory stimuli. Also, recruitment of leukocytes into the CNS involves ICAM-1 and activation of astroglial ICAM-1 results in the expression of an array of inflammatory cytokines. These astroglial events are likely involved in sustaining the inflammatory response within the CNS. The enhanced cell surface expression of ICAM-1 on astroglia following proinflammatory stimulation is prevented by ethanol exposure [9]. The ethanol mediated reduction in ICAM-1 protein expression results in part from reduced ICAM-1 mRNA expression [9]. In addition to the effects of ethanol on ICAM-1 transcription, ethanol may also modulate posttranscriptional or posttranslational events that influence cell surface expression; however, the mechanistic

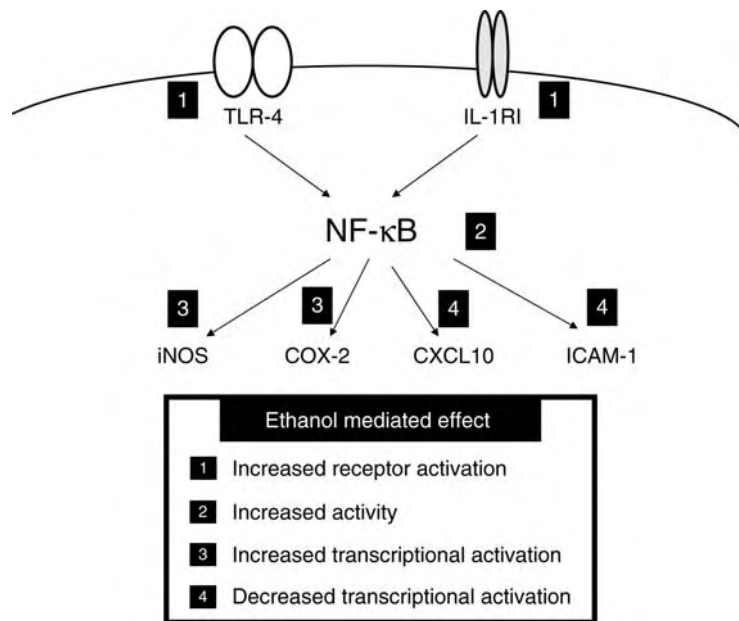

**Central Nervous System Inflammation: Astroglia and Ethanol. Figure 1** Schematic representation of the ethanol-sensitive sites which may influence inflammatory signaling in astrocytes. The exact mechanism by which ethanol modulates inflammatory signaling in astrocytes remains unclear. However, as gleaned from several *in vitro* models of neuroinflammation, there are multiple ethanol-sensitive sites in astrocytes that may impact CNS immunocompetence and response to brain injury in alcohol abuse. Ethanol alters signaling through two cell surface receptors, toll-like receptor (TLR)-4 and type 1 interleukin (IL)-1 receptors, which are activated by bacterial lipopolysaccharide (LPS) and IL-1 $\beta$ , respectively. Following activation of the receptors, signal transduction cascades are activated, many of which activate the transcription factor nuclear factor (NF)- $\kappa$ B, which is central to inflammatory signaling in astrocytes and consistently implicated in ethanol mediated effects on neuroinflammation. NF- $\kappa$ B transactivation is instrumental in the induction of numerous genes which encode for inflammatory proteins including inducible nitric-oxide synthase (iNOS), cyclooxygenase type 2, chemokines (i.e., interferon- $\gamma$  inducible protein or CXCL10) and intracellular adhesion molecule-1. Additional studies are warranted in order to identify the molecular mechanisms through which ethanol alters the expression and/or activity of these inflammatory molecules. Subsequent studies are also needed to determine the interactive effects of ethanol on multiple target molecules in a given astrocyte or astrocyte population.

details remain to be elucidated. Similarly, the consequences of ethanol-induced changes in astroglial ICAM-1 expression are uncertain.

### CXC Chemokine Ligand 10

Important functions of chemokines within the CNS include recruitment, activation and proliferation of leukocytes, microglia, and astrocytes. One chemokine that has emerged as instrumental in both physiological and pathological events in the CNS is interferon- $\gamma$  inducible protein or CXCL10. Indeed, infection within the CNS and injury to the brain is often associated with enhanced astroglial CXCL10 expression in the affected region. Thus, it appears that astroglial CXCL10 has an integral role in CNS immunocompetence and response to injury. Ethanol-induced changes in astroglial CXCL10 expression could potentially compromise CNS immunocompetence or be involved in ethanol-induced CNS pathologies. In fact, ethanol has been found to modulate CXCL10 expression *in vitro* and *in vivo*. It has been demonstrated *in vitro* that LPS + IL-1 $\beta$  stimulates CXCL10 production in human astroglial cells [10]. However, chronic exposure to ethanol attenuates proinflammatory induced CXCL10 expression in astroglia [10]. The functional importance of ethanol effects on astrocytes has been demonstrated using astroglial-mediated leukocyte chemotaxis. That is, exposure of astroglial cells to LPS + IL-1 $\beta$  increases release of chemotactic factors that induce leukocyte chemotaxis. Involvement of CXCL10 in this model of astrocyte-mediated leukocyte chemotaxis is evidenced by the fact that anti-CXCL10 neutralizing antibody reduces astroglial-mediated leukocyte chemotaxis. Importantly, chronic exposure of astroglia to ethanol inhibits astroglial-mediated leukocyte chemotaxis, presumably in part, through a reduction in astroglial CXCL10 production. The mechanism by which ethanol modulates chemokine production in astroglia is still unclear. Ethanol likely alters CXCL10 expression by altering transcription of CXCL10 mRNA, but it is also possible that ethanol modulates specific upstream signal transduction events that are instrumental in chemokine expression [10].

There is much work to be done in order to fully appreciate the cellular and molecular mechanisms by which ethanol alters inflammatory pathways in astroglia. Furthermore, the differential effects of acute and chronic ethanol exposure on astroglial inflammatory pathways also need to be determined. While several ethanol-sensitive targets likely exist, NF- $\kappa$ B is central to neuroinflammation and consistently implicated in the ethanol-mediated effects on astroglial inflammatory mediators (Fig. 1). Further analysis of this transcription factor and its numerous associated proteins may provide important insights into the mechanism by which ethanol alters neuroinflammation. These insights

may foster novel therapeutic strategies to treat and prevent alcohol-mediated neuropathogenesis.

### References

1. Molle I, Thulstrup AM, Svendsen N, Schonheyder HC, Sorensen HT (2000) Risk and case fatality rate of meningitis in patients with liver cirrhosis. *Scand J Infect Dis* 32:407–410
2. Pfefferbaum A, Rosenbloom M, Sullivan EV (2002) Alcoholism and AIDS: magnetic resonance imaging approaches for detecting interactive neuropathology. *Alcohol Clin Exp Res* 26:1031–1046
3. Flora G, Pu H, Lee YW, Ravikumar R, Nath A, Hennig B, Toborek M (2005) Proinflammatory synergism of ethanol and HIV-1 Tat protein in brain tissue. *Exp Neurol* 191:2–12
4. Davis RL, Syapin PJ (2004) Ethanol increases nuclear factor- $\kappa$ B activity in human astroglial cells. *Neurosci Lett* 371:128–132
5. Guizzetti M, Bordi F, Dieguez-Acuna FJ, Vitalone A, Madia F, Woods JS, Costa LG (2003) Nuclear factor  $\kappa$ B activation by muscarinic receptors in astroglial cells: effect of ethanol. *Neuroscience* 120:941–950
6. Davis RL, Syapin PJ (2005) Interactions of alcohol and nitric-oxide synthase in the brain. *Brain Res Rev* 49:494–504
7. Luo J, Lindstrom CL, Donahue A, Miller MW (2001) Differential effects of ethanol on the expression of cyclooxygenase in cultured cortical astrocytes and neurons. *J Neurochem* 76:1354–1363
8. Blanco AM, Valles SL, Pascual M, Guerri C (2005) Involvement of TLR4/type I IL-1 receptor signaling in the induction of inflammatory mediators and cell death induced by ethanol in cultured astrocytes. *J Immunol* 175:6893–6899
9. DeVito WJ, Stone S, Mori K, Shamgochian M (2000) Ethanol inhibits prolactin- and tumor necrosis factor- $\alpha$ -, but not  $\gamma$  interferon-induced expression of intercellular adhesion molecule-1 in human astrocytoma cells. *J Cell Biochem* 77:455–464
10. Davis RL, Syapin PJ (2004) Chronic ethanol inhibits CXC chemokine ligand 10 production in human A172 astroglia and astroglial-mediated leukocyte chemotaxis. *Neurosci Lett* 362:220–225

## Central Nervous System Inflammation: Cytokines and JAK/STAT/SOCS Signal Transduction

MARKUS J. HOFER, IAIN L. CAMPBELL  
School of Molecular and Microbial Biosciences, The University of Sydney, Sydney, NSW, Australia

### Definition

►Cytokines are key effectors of cellular communication in many pathophysiological states that affect the

central nervous system (CNS). Cytokine communication depends upon a molecular circuitry consisting of cell surface receptors and multiple receptor-coupled intracellular signaling pathways that determine the timing, nature and strength of the cellular response to an external cytokine stimulus. Pivotal in the action of a great many cytokines are the receptor-associated Janus tyrosine kinases (JAKs) and their substrates, latent cytoplasmic transcription factors termed signal transducers and activators of transcription (STATs) (for review see: [1]). The duration and intensity of cytokine-activated JAK/STAT signaling is subject to control by physiological feedback inhibitory proteins known as the suppressors of cytokine signaling (SOCS).

## Characteristics

### Quantitative Description

There are four members of the JAK family (JAK1, JAK2, JAK3 and TYK2) and seven members of the STAT family (STAT 1, 2, 3, 4, 5A, 5B and 6). JAKs have a molecular weight of 120–140 kDa and contain seven JAK homology (JH) domains. The C-terminal JH1 domain has tyrosine kinase activity while JH2 has a pseudokinase structure but no catalytic function and regulates JAK activity. Regions JH3 to JH7 are required for interaction with the receptor. The molecular weight of the seven STATs ranges from 80 to 115 kDa. They also show a related structure with an N-terminal dimerisation domain and a central SH2-domain that are required for STAT dimerisation. The SH2 domain also contains a conserved tyrosine residue that serves as a substrate for the JAKs. Phosphorylation of this tyrosine is essential for STAT activity. Adjacent to the dimerisation domain are a coiled-coil domain that is involved in protein-protein interactions and the DNA binding domain. The transcriptional activation domain (TAD) is close to the C-terminus.

The SOCS family currently contains eight members, SOCS1–SOCS7 and CIS that range in molecular weight from 22 to 63 kDa. Members of this family share two common motifs – a central SH2 domain interacts with phosphorylated tyrosine residues and the C-terminal SOCS-box mediates ubiquitination and degradation of the SOCS protein.

## Description of the Process

### JAK and STAT Activation

Many cytokines and hormones that use type I or type II cytokine receptors mediate their biological effects via JAK/STAT signaling pathways including the colony stimulating factors, ►interferons, many interleukins (e.g., IL-2, 3, 4, 5, ►interleukin 6, 10 and ►interleukin 12), leukemia inhibitory factor (LIF), ciliary neurotrophic factor, growth hormone, prolactin, erythropoietin and leptin (Fig. 1) [1]. Binding of a cytokine to its cognate receptor triggers tyrosine phosphorylation and

activation of specific JAKs (Fig. 2). These kinases phosphorylate tyrosine residues on multiple target proteins, including each other as well as cytoplasmic domains of the receptor. The receptor chain phosphotyrosine sites then interact with SH2 domains on STAT molecules. After recruitment to the receptor, STATs also become phosphorylated on specific tyrosine residues by the JAKs, before dissociating from the receptor. These activated STAT monomers form dimers that translocate to the nucleus and bind to specific DNA target sequences located in the promoter regions of genes thereby modulating transcriptional activity. Importantly, individual cytokines activate specific STATs thus conferring the specificity of the cellular response. For example, IL-6 signals via activated STAT3 homodimers while IFN- $\gamma$  uses activated STAT1 homodimers.

Abbreviations: CIS, cytokine-inducible SH2 protein; CNTF, ciliary neurotrophic factor; CSF, colony stimulating factor; CT, cardiotrophin; Epo, erythropoietin; G-CSF, granulocyte colony stimulating factor; GM-CSF, granulocyte macrophage colony stimulating factor; GPCR, G-protein coupled receptor; IFN, interferon; IL, interleukin; JAK, Janus kinase; MCP-1, monocyte chemotactic protein-1; MIP-1 $\alpha$ , macrophage inflammatory protein-1 alpha; RANTES, regulated on activation, normal T-cell expressed and secreted; SDF1- $\alpha$ , stromal derived factor 1 alpha; STAT, signal transducer and activator of transcription; SOCS, suppressors of cytokine signaling; Tyk2, tyrosine kinase 2.

### Regulation of JAK/STAT Signaling Through SOCS

Mechanisms exist to downregulate the JAK/STAT signaling cascade and thereby avert potentially damaging consequences of unrestrained cytokine signaling. SOCS constitute an important physiological feedback mechanism for self-limiting the cellular cytokine response. There are multiple targets through which the SOCS molecules inhibit cytokine-activated JAK/STAT signaling (Fig. 2). For example, SOCS1 can directly associate with high affinity, with all four JAK molecules, directly inhibiting their catalytic activity while SOCS3 functions in part, by interacting with activated cytokine receptors resulting either in the inhibition of JAK activity or blocking STAT binding.

## Regulation of the Process

### STATs and SOCS in Neuroinflammatory Disorders

Our current understanding of cytokine signaling and its regulation in the CNS during neuroimmune diseases comes mostly from studies in animal models [2,3]. ►Experimental autoimmune encephalomyelitis (EAE) is an animal model for the human disease multiple sclerosis (MS). In EAE, autoreactive T- and B-cells infiltrate the CNS leading to demyelination, loss of oligodendrocytes and some axonal injury. Prominent cytokine production occurs in the CNS of mice with

Receptor family	Interferons			gp130		$\beta c$	$\gamma c$		Homodimeric		GPCRs							
	IFN- $\alpha/\beta$	IFN- $\gamma$	IL-10	IL-6, IL-11, CNTF, CT-1, G-CSF, LIF, OSM	IL-12	Leptin	IL-3, IL-5, GM-CSF	IL-2, IL-7, IL-9, IL-15	IL-4	IL-13	Growth hormones	Epo, Prolactin	Thrombopoietin	Angiotensin	Serotonin	MCP-1, MIP-1 $\alpha$	SDF-1 $\alpha$ , RANTES, MCP-1, MIP-1 $\alpha$	
JAKs	Jak1																	
	Jak2																	
	Jak3																	
	Tyk2																	
STATs	STAT1																	
	STAT2																	
	STAT3																	
	STAT4																	
	STAT5a/b																	
	STAT6																	
SOCS	SOCS1																	
	SOCS2																	
	SOCS3																	
	SOCS5																	
	CIS																	

**Central Nervous System Inflammation: Cytokines and JAK/STAT/SOCS Signal Transduction.**

**Figure 1** Utilization of JAKs, STATs and SOCS for signal transduction by some selected cytokines, hormones and growth factors. The JAK/STAT signal transduction pathway is central to the action of the majority of cytokines. On the whole the specific biological responses of cells to individual cytokines is the culmination of the activation of different STAT molecules. Here, ligands are grouped and combined according to receptor family. Reported activation of a specific JAK (green), STAT (dark blue) or SOCS (orange). In addition, light blue indicates reported alternative activation of STATs. Note, unstained cells do not necessarily mean absence of activation but rather no scientific reports are known to the authors.

EAE and includes elevated levels of IFN- $\gamma$ , IL-1, IL-6 and TNF. In addition, transgenic mice developed by us with CNS-restricted, astrocyte production of the key host defense cytokines IL-12 or IFN- $\alpha$  develop a cell-mediated immune response with T-cell activation and the production of IFN- $\gamma$  causing demyelination and neurodegeneration or inflammatory encephalopathy with neurodegeneration. Analysis of these different neuroinflammation models revealed stimulus- and cell-specific upregulation of various STAT and SOCS mRNAs and or proteins. In all three neuroimmune models, elevated STAT1 protein is found in a number of neural cells including neurons, microglia, astrocytes and oligodendrocytes where it exhibits nuclear localization consistent with activation (Fig. 3). Both IFN- $\alpha$  and IFN- $\gamma$  activate STAT1 as a key mechanism in the signal transduction process mediated by these cytokines. The levels of STAT3 and STAT4 proteins also increase in the CNS of mice with EAE and transgene-encoded IL-12 while STAT3 is activated in the CNS of mice with transgene encoded IFN- $\alpha$  [4].

However, in contrast with STAT1, the localization of the STAT4 and STAT3 proteins is restricted to infiltrating T-lymphocytes (STAT4) and macrophage/microglia (STAT4 and STAT3). Since IL-12 is known to signal predominantly through STAT4 it is clear that T-cells and possibly other immune cells (e.g., NK cells), recruited to the CNS are the principal cellular targets of locally produced IL-12 and respond with increased production of IFN- $\gamma$ . The absence of STAT4 in resident CNS cells indicates that these cells are non-responsive to IL-12 but, conversely, via STAT1 are highly responsive to the IFNs, IFN- $\alpha$  and IFN- $\gamma$ . Interestingly, and similar to STAT4, SOCS1 and SOCS3 RNA are also increased in the CNS of the IL-12 transgenic mice and mice with EAE, and are found largely in infiltrating mononuclear cells.

In summary we can say that cells intrinsic to the CNS such as neurons and oligodendrocytes respond vigorously to cytokines such as IFNs with strong positive feed forward regulation of the JAK/STAT signal transduction pathway leading to significant increases in



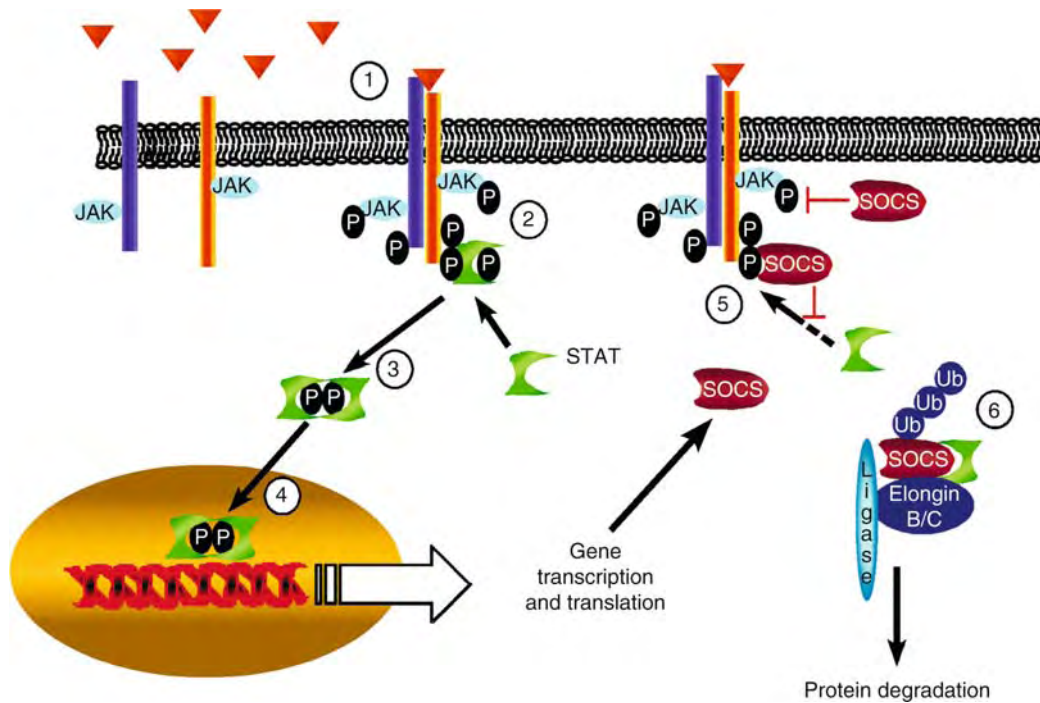

### Central Nervous System Inflammation: Cytokines and JAK/STAT/SOCS Signal Transduction.

**Figure 2** A generic JAK/STAT signaling pathway and its feedback inhibition by SOCS. (i) Binding of a cytokine to its receptor causes receptor subunit association. (ii) Receptor-associated JAKs are brought into close proximity resulting in JAK tyrosine phosphorylation/activation and JAK-mediated receptor chain tyrosine phosphorylation followed by STAT recruitment and JAK-mediated tyrosine phosphorylation of the STAT. (iii) Phosphorylated STAT molecules dissociate from the receptor chain and form dimers. (iv) Nuclear translocation of STAT-dimer and binding to specific DNA recognition sites modulates the transcriptional activity of target genes such as SOCS genes that are induced. (v) SOCS bind to JAKs thus inhibiting their catalytic activity or prevent STAT-binding to the receptor. (vi) SOCS-mediated complex formation with elongin B and C and a putative E3 ubiquitin ligase involved in the proteosomal degradation of the SOCS molecule and the bound STAT.

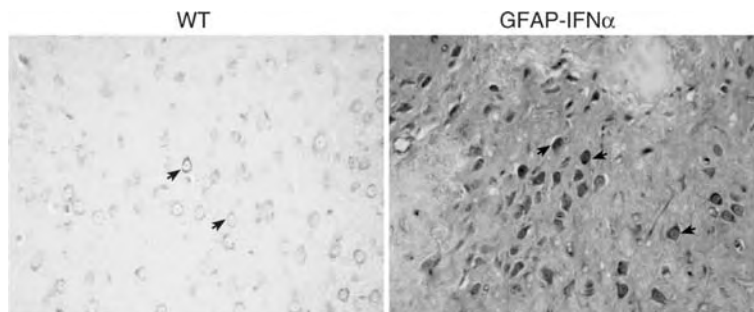

**Central Nervous System Inflammation: Cytokines and JAK/STAT/SOCS Signal Transduction. Figure 3** STAT1 is elevated in the brain of mice with chronic production of IFN- $\alpha$ . Sections of brain from a wild type (WT) or a transgenic mouse (termed GFAP-IFN $\alpha$ ) with astrocyte-targeted production of the type I IFN, IFN- $\alpha$ . Sections were stained by immunohistochemistry using a polyclonal antibody against murine STAT1. The STAT1 molecule forms part of the canonical IFNAR-coupled JAK-STAT signal transduction pathway that mediates the actions of type I IFNs such as IFN- $\alpha$ . Neurons in healthy WT mice show only low expression of STAT1 protein that is located predominantly in the cytoplasm (arrows). By contrast, levels of STAT1 are much higher in neurons of GFAP-IFN $\alpha$  mice and STAT1 is also found in the nucleus (arrows). This is indicative of activation of STAT1 and coincides with STAT1-dependent gene transcription.

these cells in the expression of a number of target genes. However, under these conditions *in vivo*, these cells also exhibit a relative deficiency in SOCS1 and SOCS3 which may compromise their ability to negatively regulate JAK/STAT signaling activated by these cytokines. As discussed in more detail below, one consequence of this may be to predispose these cells to cytokine-mediated injury during immunoinflammatory states.

### **Consequences of Dysregulated JAK/STAT/SOCS Signaling in Cytokine-Mediated CNS Responses**

As we have seen the cerebral expression of various STATs, their activation, as well as that of the major physiological inhibitors of this pathway, SOCS1 and SOCS3, is highly regulated in a stimulus- and cell-specific fashion. Recent work has begun to focus on the relationship between the JAK/STAT/SOCS activity and biological responses to cytokines in the CNS.

### **Deficiency of STAT1 or STAT2 Alters IFN- $\alpha$ Induced Disease in the CNS**

Transgenic mice (termed GIFN) with astrocyte-targeted production of IFN- $\alpha$  while resistant to CNS viral infection, develop progressive neurodegenerative disease with inflammation and calcification associated with increased expression of IFN-regulated genes and activation of the IFN-signaling molecules STAT1 and STAT2. The role of STAT1 or STAT2 in mediating the actions of IFN- $\alpha$  has been explored by generating GIFN mice null for these STAT genes [5,6]. Surprisingly, and despite the loss of signaling activity and downstream target gene modulation associated with these STAT molecules, these animals develop either more severe and accelerated neurodegeneration with calcification and inflammation (GIFN/STAT1 null) or severe inflammation and medulloblastoma (GIFN/STAT2 null). In GIFN/STAT2 null mice the formation of medulloblastoma was linked to chronic autocrine stimulation of granule neuron proliferation caused by IFN- $\gamma$  stimulated STAT1-dependent activation of the sonic hedgehog (Shh) signaling pathway. Shh plays a crucial role in the development of the granule layer of the cerebellum and stimulates the proliferation of granule neuron progenitor cells. While GIFN mice lacking STAT1 do not develop tumors, increased levels of proinflammatory cytokines and an influx of neutrophils point to an increased innate inflammatory response that likely underlies the severe neurodegenerative phenotype of these animals.

These studies indicate that IFN-receptor signaling is clearly complex, involving the coexistence of multiple JAK/STAT as well as alternative pathways. The balance in the activity of these pathways dictates the repertoire of CNS responses regulated by IFN- $\alpha$ . Signaling via the primary pathway involving STAT1 and STAT2

stimulates the induction of genes such as 2'5'oligoadenylate synthetase that may play a beneficial role in the CNS, for example in anti-viral defence. Moreover, the activation of this primary pathway suppresses or inhibits through unknown mechanisms, signaling via alternative type I IFN receptor-coupled signaling pathways. A reduction or loss of signaling by the primary pathway results in increased activity of the alternative signaling pathways. As the strength of the cytokine-receptor coupled signaling shifts to these alternative pathways the level and nature of the cellular response also changes which, in the case of IFN- $\alpha$  leads to pathogenetic responses in the CNS and thus exacerbation of disease.

### **Altered Expression of SOCS Influences Demyelinating Diseases in Mice**

While STATs are positive regulators of cytokine signaling, SOCS act as negative regulators. The cytokine IFN- $\gamma$  is produced in the CNS in the course of demyelinating diseases such as MS or EAE and has been shown to inhibit remyelination and injure oligodendrocytes. As we noted above, in EAE and cell-mediated immune responses in the GFAP-IL12 transgenic mice, there is an apparent deficit of SOCS1 or SOCS3 gene expression by oligodendrocytes. This in turn may result in increased and more prolonged cytokine activated JAK/STAT signaling predisposing these cells to adverse effects by cytokines such as IFN- $\gamma$ . In support of this idea, the forced expression of SOCS1 in oligodendrocytes diminishes the responsiveness of these cells to IFN- $\gamma$  and protects against damage mediated by this cytokine [7].

In contrast to IFN- $\gamma$ , the cytokine leukemia inhibitory factor (LIF) ameliorates demyelination, increases the viability of oligodendrocytes and increases SOCS3 gene expression. In the cuprizone-induced demyelination model, LIF activates STAT3 signaling in oligodendrocytes resulting in increased SOCS3 expression by these cells [8]. Note that this situation contrasts with the immune-mediated models of demyelination where oligodendrocytes appear deficient for SOCS3 expression. Ultimately, by reducing LIF-activated STAT3 signaling, SOCS3 compromises the protective actions of this cytokine against oligodendrocytes. Conversely, the selective ablation of SOCS3 in oligodendrocytes significantly increases the protective actions of LIF in the cuprizone model, resulting in increased oligodendrocyte regeneration and more efficient recovery.

In all, these studies illustrate that depending on the type of cytokine and the context of the pathophysiologic state, SOCS expression can be variably regulated in neural cells such as oligodendrocytes and may have either beneficial or detrimental functions in the evolution of CNS injury and recovery from inflammatory insult.



### ***JAK/STAT/SOCS During Inflammatory-CNS Diseases in Humans***

To date little is known concerning the role of cytokines and the JAK/STAT/SOCS signaling pathways in human neuroinflammatory diseases with most information available for the autoimmune disease MS. Expression of several cytokines including IL-12, IL-6 and IFN- $\gamma$  is upregulated in microglia and astrocytes of patients with active MS as compared with control patients [9]. Importantly, expression of the corresponding receptors was found on microglia but also on oligodendrocytes that form the myelin sheath and are a main target of the immune response in MS. In addition, microglia (JAK1, STAT1, STAT4), astrocytes (JAK1, STAT3, STAT4) and oligodendrocytes (JAK1, STAT4, STAT6) express JAK1 and/or STAT molecules indicating that in addition to microglia and astrocytes, oligodendrocytes can react to the inflammatory stimuli present in active MS lesions. Furthermore, in contrast to EAE, STAT3 and STAT4 were expressed by resident CNS cells in humans during MS. While this needs further clarification it could point to fundamental differences in the transcription factor content and therefore responsiveness of CNS resident cells towards cytokines in humans as compared with mice.

### ***Therapeutic Approaches***

If we assume a similar role for JAKs and STATs in human neuroinflammatory diseases as compared with experimental animal models, then drugs that affect the activity of the JAK/STAT pathway might prove to be effective therapeutics. In support of this possibility, experimental studies suggest pharmacological modulation of the JAK/STAT pathway can have a beneficial impact on the course of neuroimmune diseases such as EAE.

While several tyrosine kinase inhibitors have been developed that target specifically JAK kinase activity, effects of most of these compounds on CNS diseases has not yet been thoroughly investigated. However, from the limited data available it is clear that targeting the activity of the JAK kinases is an effective approach to suppressing EAE in rodents.

Targeting the SOCS might be another strategy to modulate the activity of signal transduction pathway activity and target cell sensitivity in CNS disease. A SOCS mimetic has been developed that mimics the effects of SOCS1 [10]. This mimetic binds to the autophosphorylation site of JAK2 and thus inhibits the activation of JAK2 and the subsequent phosphorylation of its substrates such as STAT1 (IFN- $\gamma$ , TNF- $\alpha$ ) or STAT3 (IL-6). Treatment of mice with this SOCS mimetic can reduce the incidence of EAE significantly but also is effective in ameliorating symptoms when given after onset of clinical symptoms.

### ***Final Discussion***

Similar to peripheral organs, inflammatory stimuli affecting the CNS induce the local production of a variety of cytokines that orchestrate the host response. For many cytokines binding to their cell surface receptor is coupled to the activation of the JAK/STAT/SOCS signaling cascade as well as other signal transduction pathways. Further complexity is introduced due to the cell-specific localization of specific molecular components of these pathways. Achieving coherent, balanced and specific cytokine signaling is the culmination of multiple levels of control with cross-talk between individual pathways as well as direct regulatory inputs that further modulate the duration of signaling. Disruption in this balance can produce undesirable consequences as bias towards an individual signal pathway can lead to inappropriate cellular responses and cause damage or retard repair and regeneration within the CNS. Therefore, altered cytokine signal transduction may contribute to the pathogenesis of certain neurological diseases. In this regard, it is significant that there are environmental agents such as viruses as well as genetic determinants that are known to interact directly with the signal transduction networks for many cytokines altering signaling thresholds that in turn can lead to an inappropriate cellular response. Achieving a thorough understanding of the dynamics and consequences of the signaling mechanisms in the CNS for individual cytokines is therefore an important goal that could lead to more effective therapeutic strategies for the treatment of adverse neuroinflammatory diseases.

### ***References***

1. Murray PJ (2007) The JAK-STAT signalling pathway: input and output integration. *J Immunol* 178:2623–2629
2. Wang J, Campbell IL (2002) Cytokine signalling in the brain: putting a SOCS in it? *J Neurosci Res* 67:423–427
3. Wang J, Asensio VC, Campbell IL (2002) Cytokines and chemokines as mediators of protection and injury in the central nervous system assessed in transgenic mice. *Curr Topics Microbiol Immunol* 265:23–48
4. Maier J, Kincaid C, Pagenstecher A, Campbell IL (2002) Regulation of signal transducer and activator of transcription and suppressor of cytokine-signalling gene expression in the brain of mice with astrocyte-targeted production of interleukin-12 or experimental autoimmune encephalomyelitis. *Am J Pathol* 160:271–288
5. Wang J, Schreiber RD, Campbell IL (2002) STAT1 deficiency unexpectedly and markedly exacerbates the pathophysiological actions of IFN- $\alpha$  in the central nervous system. *Proceed Natl Acad Sci USA* 99:16209–16214
6. Wang J, Pham-Mitchell N, Schindler C, Campbell IL (2003) Dysregulated Sonic hedgehog signalling and medulloblastoma consequent to IFN- $\alpha$ -stimulated

STAT2-independent production of IFN-gamma in the brain. *J Clin Invest* 112:535–543

7. Balabanov R, Strand K, Kemper A, Lee JY, Popko B (2006) Suppressor of cytokine signalling 1 expression protects oligodendrocytes from the deleterious effects of interferon-gamma. *J Neurosci* 26:5143–5152
8. Emery B, Cate HS, Marriott M, Merson T, Binder MD, Snell C, Soo PY, Murray S, Croker B, Zhang JG, Alexander WS, Cooper H, Butzkueven H, Kilpatrick TJ (2006) Suppressor of cytokine signalling 3 limits protection of leukemia inhibitory factor receptor signaling against central demyelination. *Proceed Natl Acad Sci USA* 103:7859–7864
9. Cannella B, Raine CS (2004) Multiple sclerosis: cytokine receptors on oligodendrocytes predict innate regulation. *Ann Neurol* 55:46–57
10. Mujtaba MG, Flowers LO, Patel CB, Patel RA, Haider MI, Johnson HM (2005) Treatment of mice with the suppressor of cytokine signalling-1 mimetic peptide, tyrosine kinase inhibitor peptide, prevents development of the acute form of experimental allergic encephalomyelitis and induces stable remission in the chronic relapsing/remitting form. *J Immunol* 175:5077–5086

## Central Neuropathic Pain

### ► Central Pain

## Central Nucleus

### Definition

The main subdivision of the inferior colliculus that receives most inputs ascending from the lower auditory system in the brainstem. It projects to the ventral division of the medial geniculate body.

### ► Inferior Colliculus

## Central Pain

TROELS S. JENSEN, NANNA B. FINNERUP  
Department of Neurology and Danish Pain Research Center, Aarhus University Hospital, Aarhus, Denmark

### Synonyms

Thalamic pain; Deafferentation pain; Central neuropathic pain

### Definition

The International Association for the Study of Pain (IASP) defines neuropathic pain as “Pain initiated or caused by a primary lesion or dysfunction of the peripheral or central nervous system.” A new classification is being introduced by a working group on Neuropathic pain. According to this working group, it is suggested that neuropathic pains are pains arising as a direct consequence of a lesion or disease affecting the somatosensory system. This revised definition fits into the nosology of neurological disorders and also distinguishes neuropathic pain from normal physiological plasticity seen when the somatosensory system is activated following noxious stimulation.

Central Pain (CP) occurs following lesions of the sensory pathways in the spinal cord or brain. The essential pathological feature is a lesion in the CNS resulting in partial or complete loss of sensory input in the nervous system with corresponding negative sensory phenomena, such as partial or complete anesthesia in the area subserved by the structure with the lesion [1]. In parallel with loss of input, ectopic activity, regeneration and disinhibition may take place resulting, in some cases, and with variable risk among different etiologies, in secondary development of hypersensitivity. A key issue in diagnosing CP is a detailed pain history and thorough neurological examination that should include a careful sensory examination, evaluating decreased or increased responses to touch, vibration, pinprick, and thermal stimuli as well as a mapping of the distribution of the sensory dysfunction (see also ►Neuropathic Pain).

### Characteristics

#### Etiology

A variety of diseases may give rise to CP (Table 1). The most common and well described central pains are central post-stroke pain and CP in spinal cord injury and ►multiple sclerosis, but any lesion along the sensory neuraxis from the dorsal horn to the brainstem, thalamus, subcortical white matter and probably

**Central Pain. Table 1** Etiology of central neuropathic pain

Infarction or hemorrhage of brain or spinal cord
Multiple sclerosis
Syringomyelia or syringobulbia
Neoplasm of brain or spinal tissue
Spinal cord injury
Parkinson's disease
Epilepsy
Inflammation of brain or spinal cord tissue

cortical areas may cause CP [1]. Patients with ▶**Parkinson's disease**, which is dominated by rigidity, bradykinesia and tremor, may also experience pain and sensory disturbances, but some of these pains may be related to dystonia and fluctuations in anti-parkinsonian medication [1]. Patients with ▶**epilepsy** may have pain as part of a seizure or aura [1].

### Symptoms and Signs in CP

Central pains are characterized by a specific lesion or disease of the CNS and

- Pain located in a neuroanatomical area with partial or complete sensory loss.
- Spontaneous ongoing or paroxysmal pain (stimulus independent).
- Stimulus evoked pain (stimulus dependent), including for example touch-evoked or cold ▶**allodynia**, ▶**hyperalgesia**, abnormal summation of pain and after-sensations.

These symptoms/signs may occur in various combinations, but do not necessarily have to be present altogether. The underlying disease itself may also influence the pain and sensory pattern and contribute to heterogeneity of the core phenomena of CP.

*Stimulus-independent pains* are spontaneous pains and can be either continuous or paroxysmal. The character differs, but shooting, shock-like, aching, cramping, crushing, burning types of pain are descriptors that have been used. The pain may be described as superficial or deep or both. Other sensations such as ▶**paraesthesia** and ▶**dysaesthesia** may be present spontaneously or evoked (e.g., ongoing tight or tingling

sensations evoked by touching the area). The onset of CP varies, but in most cases patients develop CP within three to six months after their central nervous system lesion. Any delayed onset of neuropathic pain should prompt an examination for other causes (e.g., syringomyelia in cases of spinal cord injury). After a ▶**stroke**, CP may be distributed in a hemi body fashion or it may affect a smaller part of one side with sensory disturbance (e.g., part of a limb). In lateral medullary ▶**infarction**, the symptoms may be crossed with pain in one side of the face and the other side of the rest of the body (Fig. 1).

In spinal cord injury, pain may be located at the level of injury as a band around the thorax, or below the level of injury, either diffusely or in patches (Fig. 1), while in syringomyelia, pain is often distributed in a segmental pattern. In multiple sclerosis, both hemi body pain and bilateral pain may occur (Fig. 1). Many patients report that the pain is increased by changes in weather, cold, psychological factors like stress or changes in mood.

*Stimulus-dependent pains* are classified according to the stimulus modality that provokes them (i.e., mechanical, thermal or chemical). Evoked pain is a common feature of CP patients [1–7]. Evoked pain is often present within the area of spontaneous pain, but may extend beyond this area or be present in patients without spontaneous pain. In spinal cord injury, patients may experience evoked pain below the level of injury in cases of incomplete spinal cord injury or in the border zone at the level of injury. There seems to be a correlation between evoked pain felt at the level of injury and spontaneous pain below the level of injury [4].

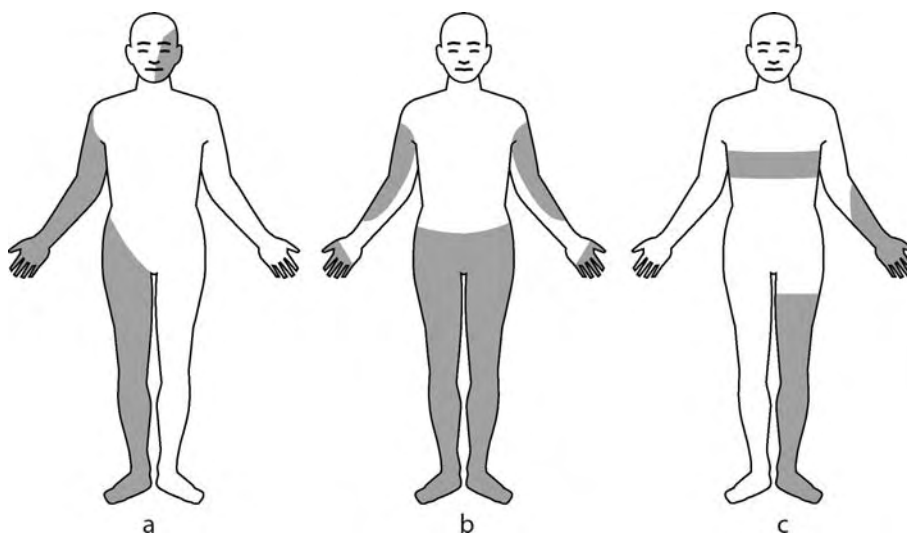

**Central Pain. Figure 1** Examples of distribution of central pain in a patient with central post-stroke pain following a lateral medullary infarction (a), a patient with at- and below level neuropathic pain in spinal cord injury (b), and a patient with central pain following multiple sclerosis (c).

The most common and important forms of stimulus-dependent pains include allodynia, which implies that stimuli which normally do not provoke pain now do so. Allodynia may coexist with hyperalgesia. Non-noxious brush, touch or thermal stimuli are examples of stimuli that can give rise to allodynia. Allodynia may be present with little impact on the patient's daily life; in other cases, it is the dominating clinical feature and very disabling. The touch from cloth or taking a shower may cause intense pain, and a gentle touch may be felt as a burning sensation. While allodynia usually is considered to be a cutaneous phenomenon, recent observations suggest the presence of a deep tissue allodynia. For example, in post-stroke pain, movement-induced pain has been described and deep pain may be associated with a lowering of pain threshold to mechanical pressure. Allodynia to touch is best assessed using cotton wool or a small brush and is assessed by brushing the skin lightly. This may elicit a burning pain sensation in patients with dynamic mechanical allodynia but also non-painful dysaesthesia. Allodynia to cold and warm stimuli may be assessed using thermo-rollers. In cases of pinprick hyperalgesia, the patient will report increased pain compared to the mirror site when pricked on the skin with a pin. After-sensations with continued pain long after the stimulation has ceased may be observed [see also Neuropathic Pain].

### Sensory Deficits and CP

An essential part of neuropathic pain is loss of sensory function. In some cases, sensory changes are subtle and a thorough sensory examination is needed, including perhaps the use of quantitative methods. Abnormal temperature and pain sensibility is the most consistent abnormality in post-stroke pain and it is suggested that a spino-thalamo-cortical sensory deficit is a necessary, albeit not a sufficient condition for the occurrence of CP [2–4]. The sensory deficit may be dissociated from a decrease in thermal and pinprick sensations and a relative preservation of vibration and other somatosensory functions. In addition to the sensory deficits, some patients may have a paradoxical sensitivity to cold and heat such that cold is perceived as hot and vice versa.

### Epidemiology of CP

There is limited information on the frequency of CP. In a prospective study that included 207 consecutive stroke patients, 8% developed CP within the first year after their stroke [2]. Lesions of the thalamus and lateral medullary infarction are associated with higher risks of developing CP. Multiple sclerosis pain is likewise frequent [6], and Österberg et al. reported that 28% of patients with multiple sclerosis have CP [7]. In spinal cord injury, CP occurs in about 30–45% [8]. Pain at the level of injury seems to have an early onset, while CP below the level of injury may develop later after the spinal injury. Both types

of pain tend to persist despite attempts at management [8]. Although some studies have indicated a higher incidence of CP in patients with incomplete lesions, other studies suggest that there is no relationship between the extent or site of spinal lesion and the presence of pain. Older age at time of injury has been found to be related to spinal core injury neuropathic pain.

### Mechanisms of CP

The mechanisms responsible for CP are still unclear, but various theories have been advanced to explain these pains. The frequent incidence of evoked pain and decreases in mechanical thresholds in painful areas suggest the presence of hyperexcitability, and clinical and experimental studies indicate the presence of sensitization of 2nd or 3rd order neurons in the CNS that have lost their normal patterned input [3]. After a central nervous system lesion, several changes, including release of glutamate, up-regulation of sodium channels, activation of glia and loss of inhibition, are thought to increase the excitability of central neurons from which abnormal input may arise. In addition, the thalamus is thought to play a key role in CP [3] and bursting activity and reorganization has been demonstrated in the thalamus following central lesions. Disinhibition due to partial lesions and imbalance between pathways has also been suggested to contribute to the development of CP. Among the more interesting recent theories, Craig has suggested that CP is due to loss of a normal inhibitory effect exerted by cool-signaling pathways from lamina I projecting to the thalamus and insula [9]. According to this hypothesis, a lesion of the lateral cool projection system disinhibits the medial system of heat-pinch-cold neurons passing from Lamina I to the medial part of the thalamus. This disinhibition results in a release of cold allodynia, burning and ongoing pain [9]. Disruption of thermo-sensory integrations leads to a disinhibition of thalamocortical neurons that respond to noxious inputs and a sensation of burning pain [9].

### Treatment of CP

Like other chronic pain conditions, CP is a complex psychological experience which may have consequences for daily activities, sleep, cognition, emotion, behavioral and social relations and a broad approach to the treatment is essential. There is limited data on the pharmacological treatment of CP. Gabapentin, pregabalin, tricyclic antidepressants, lamotrigine and cannabinoids are treatments that have been shown to relieve CP, but other drugs like serotonin-noradrenaline reuptake inhibitors and opioids have not yet been studied in CP conditions [10]. Gabapentinoids and antidepressants are often considered first drugs of choice, but as in other neuropathic pain conditions these drugs, even when given in effective and tolerable doses, only reduce pain to a variable extent and

other drugs or drug combinations may be considered. Patients with CP often have concurrent medical problems and impairment, are treated with multiple drugs with unwanted side-effects, and they may be elderly, which should be considered when treating CP.

## References

1. Boivie J (2006) Central pain. In: McMahon SB, Koltzenberg M (eds) Textbook of pain. Churchill Livingstone, Edinburgh, pp 1057–1074
2. Andersen G, Vestergaard K, Ingeman-Nielsen M, Jensen TS (1995) Incidence of central post-stroke pain. *Pain* 61:187–193
3. Jensen TS, Lenz FA (1995) Central post-stroke pain: a challenge for the scientist and the clinician. *Pain* 61:161–164
4. Finnerup NB, Jensen TS (2004) Spinal cord injury pain - mechanisms and treatment. *Eur J Neurol* 2004:73–82
5. Ducreux D, Attal N, Willer JC, Bouhassira D (2006) Mechanisms of central neuropathic pain: a combined psychophysical and fMRI study in syringomyelia. *Brain* 129:963–976
6. Svendsen KB, Jensen TS, Overvad K, Hansen HJ, Koch-Henriksen N, Bach FW (2003) Pain in patients with multiple sclerosis: a population-based study
7. Österberg A, Boivie J, Thuomas KA (2005) Central pain in multiple sclerosis—prevalence and clinical characteristics. *Eur J Pain* 9:531–542
8. Siddall PJ, McClelland JM, Rutkowski SB, Cousins MJ (2003) A longitudinal study of the prevalence and characteristics of pain in the first 5 years following spinal cord injury. *Pain* 103:249–257
9. Craig AD (1998) A new version of the thalamic disinhibition hypothesis of central pain. *Pain Forum* 7:1–14
10. Finnerup NB, Otto M, McQuay HJ, Jensen TS, Sindrup SH (2005) Algorithm for neuropathic pain treatment: an evidence based proposal. *Pain* 118:289–305

---

## Central Pattern Generator

VOLKO A. STRAUB

Department of Cell Physiology & Pharmacology,  
University of Leicester, Leicester, UK

### Synonyms

Neural pattern generator; Neural oscillator

### Definition

A central pattern generator (CPG) is an assembly of neurons that possesses the ability to produce a rhythmic activity pattern without phasic sensory feedback information. The rhythm generating ability can be due

to either endogenous bursting properties within individual neurons (Pacemaker-driven CPGs) or synaptic interactions between neurons (►[Network Oscillators](#)).

## Characteristics

### Peripheral Versus Central Control Debate

The concept of central pattern generation was introduced in the early part of the twentieth century to account for experiments which demonstrated that deafferented hind limbs in anaesthetized cats were still able to produce rhythmic movements/muscle contractions [1]. This observation suggested that the rhythmic pattern of alternating contractions of flexor and extensor muscles underlying limb movements during locomotion are generated centrally within the spinal cord without the requirement of sensory feedback from the contracting muscles.

This “central control hypothesis” contradicted the “peripheral control hypothesis” of locomotion that was prevalent at the time. The “peripheral control hypothesis” considered the reflex as the basic functional unit in the nervous system and proposed that rhythmic movements (e.g. walking, swimming) are caused by the activation of alternating reflexes, i.e. contraction of a flexor muscle causes the activation of a reflex that triggers contraction of the antagonistic extensor muscle, which in turn activates the reflex that causes contraction of the flexor muscle leading to rhythmic movements. Furthermore, it was thought that the sequential activation of individual reflexes, where the action of one reflex causes a sensory response that triggers a second reflex and so on (►[Reflex Chain](#)), also underlies the control of complex behavioral sequences.

Based on a wide range of studies in both invertebrates and vertebrates this debate has been settled in favor of the central control hypothesis and the CPG has emerged as a general principle of neuronal organization. However, it has also been recognized that phasic sensory feedback has an important role to play in shaping CPG output.

It should be noted that CPGs do not only generate rhythmic activity that directly controls motor behaviors, but that they also play a role in CNS activity patterns that are believed to be important for cognitive functions (e.g. hippocampal gamma and theta rhythms [2]). However, this essay concentrates on motor pattern generation as it has proved particularly useful to study the organization and function of CPGs.

### Mechanisms of Central Pattern Generation

Mechanisms for the generation of rhythmic activity in CPGs have frequently been divided into two broad categories – pacemaker-driven CPGs and ►[neuronal network oscillators](#). Pacemaker-driven CPGs rely on neurons with intrinsic bursting properties (►[Intrinsic properties](#)), so called ►[endogenous bursters](#), for their

rhythm generating ability (Fig. 1a). The inherent ability of endogenous bursters (pacemaker) to generate rhythmic membrane potential oscillations that drive bursts of activity is due to the specific interplay between various ion channels. Most commonly, the sustained depolarization of the membrane potential during a burst, a so called ►plateau potential, is caused by voltage-activated persistent  $\text{Na}^+$  currents, voltage-activated  $\text{Ca}^{++}$  currents or the activation of NMDA receptors. Calcium-dependent  $\text{K}^+$  currents or slow  $\text{I}_A$  currents are the most common channels responsible for the termination of the plateau potential and the repolarization of the membrane potential. The activation of a hyperpolarization-activated slow depolarizing current  $\text{I}_h$  by the repolarization at the end of the burst is frequently responsible for the initiation of the next burst. In some pacemaker neurons, so called ►conditional bursters, the bursting property is dependent on the action of modulatory neurotransmitters (e.g. serotonin, dopamine).

In contrast to pacemaker-driven CPGs, the rhythm generating property of network oscillators is an emergent network property based on the synaptic connections between neurons that form a CPG. The ►half-centre oscillator, first proposed by Graham Brown [1], is arguably the most successful model of a ►network oscillator (Fig. 1b). This neuronal network owes its rhythm generating ability to reciprocal inhibitory synaptic connections between two antagonistic neurons or populations of neurons; the “►half-centers.” In addition, the neuronal network requires restorative mechanisms that will limit the reciprocal inhibitory effects to enable rhythmic switching of activity in the two half-centers. This can be spike frequency adaptation, activity-dependent synaptic depression, or some other mechanism that results in an activity-dependent reduction of the inhibitory effect. Tonic excitation of the CPG triggers activity in one half-centre, which consequently suppresses activity in the second half-centre. The restorative mechanisms will enable the suppressed half-centre to escape from the inhibition, which will inhibit the first half-centre causing the switch of activity between the two half-centers. Thus, the two half-centers produce an alternating two phase rhythm. If the two half-centers possess ►post-inhibitory rebound properties, they can sustain prolonged bursting activity in the absence of a tonic command signal. Here rebound from the inhibition caused by activity in the antagonistic half-centre can be sufficient to initiate a new burst of activity. A neuronal network consisting of three neurons/neuron populations with recurrent inhibitory connections (Fig. 1c) can be seen as an extension of the half-centre oscillator that produces a three phase activity pattern. This type of CPG does not require any specific restorative mechanism as one neuron is always in the recovery phase; e.g. whilst neuron A is active, neuron C is inhibited allowing neuron B to recover; when neuron B

starts to fire it will inhibit neuron A allowing neuron C to recover, and so on.

Both *in vitro* experiments and theoretical modeling studies have shown that ►neuronal networks connected solely by excitatory connections can also produce rhythmic activity patterns without the need for pacemaker neurons [2]. In these ►bistable networks, fast excitatory interactions synchronize the activity within a group of neurons causing a population burst of activity, whilst the inter-burst interval is determined by the inter-spike interval in the individual neurons (Fig. 1d). These models can account for the observed rhythm generating properties in isolated spinal cord preparations after complete block of inhibitory synaptic connections.

Studies in a wide variety of vertebrate and invertebrate preparations have shown that most CPGs do not rely on a single mechanism for rhythm generation, but use a combination of mechanisms and should be considered as hybrid CPGs. For example, the leech heart CPG was considered a half-centre oscillator, but it has now been recognized that leech heart interneurons also possess intrinsic pacemaker properties [3]. Endogenous bursting neurons are important for the rhythm generating properties in one of the best understood CPGs, the pacemaker-driven pyloric network located in the crustacean stomatogastric ganglion. However, synaptic network interactions also contribute significantly to the pyloric rhythm [4]. Similarly, the mammalian respiratory CPG located in the Preboetzing complex appears to rely on a combination of interneurons with pacemaker properties and excitatory connections that form an excitatory network oscillator for its rhythm generating ability [5]. Excitatory network oscillators have also been proposed to underlie rhythm generating abilities within the mammalian spinal hemicord when inhibitory connections are blocked [2]. However, left-right coordination in the mammalian spinal cord is organized by a half-centre oscillator. Modeling studies have clearly shown that the combination of multiple pattern generating mechanisms helps to stabilize and enhance the robustness of the rhythm generating ability of a CPG. It can also increase the dynamic range of a CPG and introduces a degree of redundancy to the neuronal network.

### The Role of Sensory Feedback in Motor Pattern Generation

Most insights into the rhythm generating mechanisms of CPGs have been derived from *in vitro* experiments using isolated nervous system preparations that were completely deprived of sensory information. Whilst these experiments have proved extremely useful to demonstrate that the basic rhythm generating properties do not require sensory information, they ignore the role of sensory feedback in rhythm generation. However, in

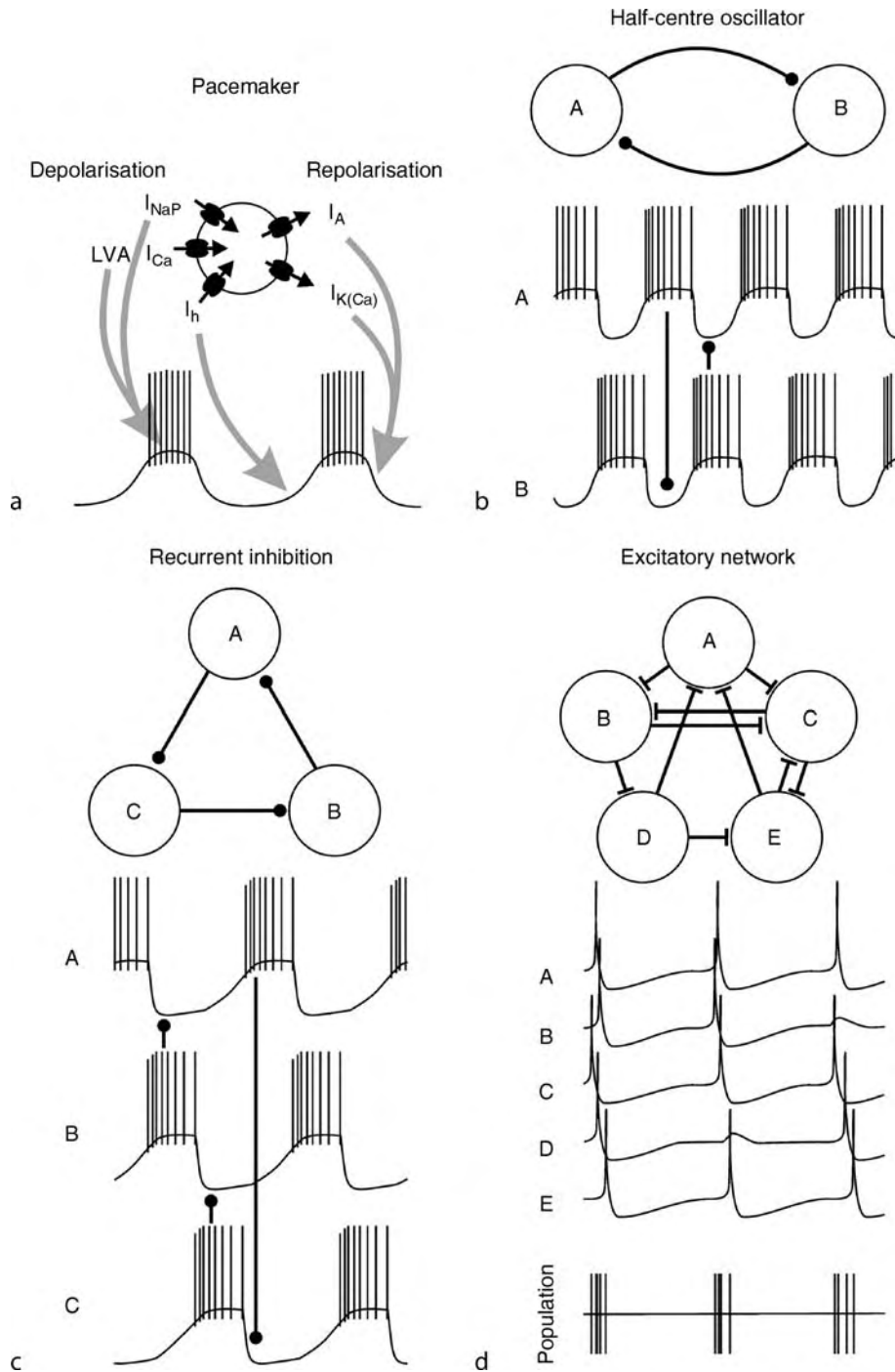

**Central Pattern Generator. Figure 1** Diagrams of various CPG rhythm generating mechanisms. (a) Pacemaker CPG. The upper diagram shows various ion channels that commonly underlie the endogenous bursting property in pacemaker neurons ( $I_{NaP}$ : persistent  $Na^+$  current, LVA  $I_{Ca}$ : low-voltage activated  $Ca^{++}$  current,  $I_{K(Ca)}$ :  $Ca^{++}$ -dependent  $K^+$  currents,  $I_A$ : slow activating  $K^+$  currents,  $I_h$ : hyperpolarisation-activated inward currents). The lower trace shows a schematic representation of the electrical activity pattern in a pacemaker neuron. The grey arrows indicate which ion channels are responsible for the different phases of the bursting pattern. (b-d) Schematic representations of the network configurations and activity patterns of three types of network oscillators. The diagrams at the top of each panel show the connectivity between the network elements. Circles denote inhibitory synapses, whilst bars denote excitatory synapses. The traces below the diagrams show the activity pattern in the correspondingly labelled network elements. See text for more details.

the intact animal CPGs do not operate in isolation but receive constant inputs from peripheral sense organs and proprioceptors (Fig. 2). The influence of sensory feedback on pattern generation is obvious in locusts where removal of phasic sensory feedback from wing proprioceptors significantly reduces wingbeat frequency. The natural burst frequency of the flight CPG can be restored by electrical stimulation of afferent sensory fibers in phase with the CPG activity pattern [6]. Similarly, sensory feedback significantly influences the rhythmic activity in the lamprey swim CPG as can be demonstrated by alternate bending of the caudal segments to simulate natural swimming movements. This activates stretch receptors along the spinal cord that can entrain the internal locomotor rhythm generated by the swim CPG to the frequency of the external movements [7]. Extensive evidence also exists for an important role of sensory feedback in mammalian locomotion. Overall sensory feedback appears to fulfill three main functions. Firstly, it can provide a corrective signal to adapt CPG activity to changes in an unpredictable environment as is necessary for the accurate step placement in a rough terrain or the

adjustment of a wingbeat in a turbulent air stream. Secondly, sensory feedback can provide timing cues about ongoing activity resulting in the stabilization of the pattern. For example, stepping movements in cats become more variable in the absence of sensory feedback [7]. Similarly, mechanosensory feedback from the lips reduces the variability of bite intervals in the pond snail *Lymnaea* [8]. Thirdly, sensory feedback provides information about the position of the body or a limb within space which is important for adapting and planning further movements. Thus, in most systems central pattern generating mechanisms and sensory feedback mechanisms are closely integrated and interact to produce a robust rhythmic activity pattern that can be rapidly adjusted to cope with unpredictable environmental disturbances.

### Command Systems, Modulation and Behavioral Choice

CPG driven activity patterns can be active continuously throughout the life of an organism (e.g. mammalian respiration) or can be short episodic events triggered by a specific stimulus (e.g. fish escape response). The study of command systems that drive CPG activity has concentrated particularly on well-defined, robust episodic behaviors in relatively simple preparations that are reliably triggered by a specific stimulus. These preparations promised the possibility of identifying specific neurons, so called **command neurons** that can trigger a specific CPG activity/behavior. The definition of what actually constitutes a **command neuron** has been intensely debated and it has been proposed that only neurons that are both sufficient and necessary for the initiation of a specific behavior should be considered command neurons [9]. However, very few neurons actually fulfill these stringent criteria. Whilst there are a range of neurons, in particular in invertebrates, that fulfill the sufficiency criteria (e.g. slow oscillator and some cerebral buccal interneurons for activating the feeding CPG in molluscs such as *Lymnaea* and *Aplysia*, the Mauthner cell for the escape behavior in fish, etc.), very few also fulfill the necessity criteria (e.g. the dorsal ramp interneuron for activating escape swimming in the marine mollusc *Tritonia*).

This observation is consistent with the recognition that CPG activity can be driven by different stimuli and that there are usually parallel pathways that all contribute to the activation of a CPG. Thus, it is not surprising that most neurons that can drive a CPG do not appear to be absolutely necessary to trigger activity in a specific CPG. Furthermore, CPGs are flexible and can generate different activity patterns depending on the precise nature of the stimulus and an organism's requirements. Whilst the different patterns utilize the same muscle groups, motoneurons and CPG interneurons, the sequence and phase relationship of activation of these elements can differ. For example, the

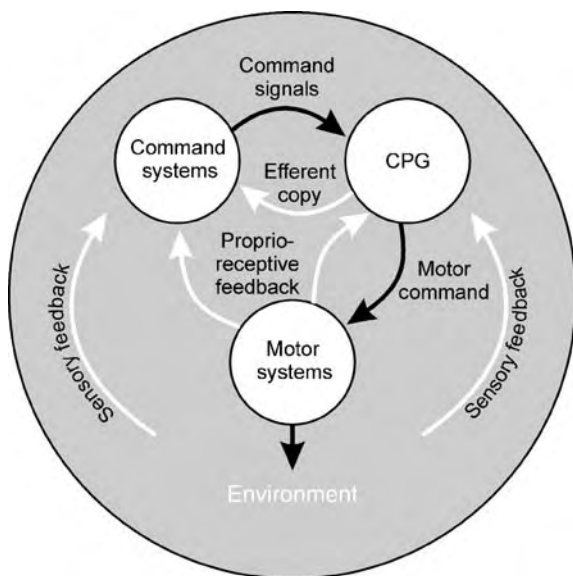

**Central Pattern Generator. Figure 2** Diagram of interactions between command systems, CPGs, motor systems and the environment. CPGs need to be considered in the context of the entire organism and its interaction with the environment to fully understand their function. Whilst CPGs can generate a basic motor pattern, this pattern is influenced by command and modulatory signals from higher order command systems as well as feedback from the motor system and the environment. Black arrows: command signals, white arrows: feedback signals.



*Aplysia* feeding CPG can produce ingestive and egestive motor patterns. These different patterns can both be driven by activity in the cerebral-buccal interneuron 2 (CBI-2). However, if CBI-2 is activated on its own the elicited feeding pattern is more ingestive-like, whilst co-activation of CBI-2 together with CBI-3, a second cerebral-buccal interneuron produces a more egestive-like activity pattern [10]. There are now many examples of modulatory interneurons that can affect the pattern of CPG activity. Some of the most striking and best characterized examples of network reconfigurations by the action of neuromodulators and higher order interneurons have been provided by studies of the pyloric and gastric mill CPGs in the crustacean stomatogastric nervous system. Here, it has been analyzed in great detail how different neuromodulators can alter CPG activity, how individual CPG interneurons can switch between different CPGs, and how higher-order interneurons can cause the complete reconfiguration of CPG networks to produce different activity patterns [4]. Thus, CPGs are not hard-wired, but dynamic ►**polymorphic networks** that can be reconfigured by the action of higher order interneurons, which are part of a general command system. This is clearly considerably more efficient than individual hard-wired CPGs for different behaviors (e.g. walking, running and jumping in mammals). Furthermore, the inherent flexibility in the CPGs and command systems that drive CPG activity provides the basis for behavioral choice as it enables motor patterns to be chosen for and adapted to specific requirements.

## References

- Graham Brown T (1911) The intrinsic factors in the act of progression in the mammal. *Proc R Soc Lond Ser B* 84:308–319
- Grillner S (2006) Biological pattern generation: the cellular and computational logic of networks in motion. *Neuron* 52:751–766
- Cymbalyuk GS, Gaudry Q, Masino MA, Calabrese RL (2002) Bursting in leech heart interneurons: cell-autonomous and network-based mechanisms. *J Neurosci* 22:10580–10592
- Marder E, Bucher D (2007) Understanding circuit dynamics using the stomatogastric nervous system of lobsters and crabs. *Annu Rev Physiol* 69:291–316
- Feldman JL, Del Negro CA (2006) Looking for inspiration: new perspectives on respiratory rhythm. *Nat Rev Neurosci* 7:232–242
- Wolf H, Pearson KG (1988) Proprioceptive input patterns elevator activity in the locust flight system. *J Neurophysiol* 59:1831–1853
- Grillner S (2003) The motor infrastructure: from ion channels to neuronal networks. *Nat Rev Neurosci* 4:573–586
- Staras K, Kemenes G, Benjamin PR (1999) Electrophysiological and behavioral analysis of lip touch as a component of the food stimulus in the snail *Lymnaea*. *J Neurophysiol* 81:1261–1273
- Kupfermann I, Weiss KR (1978) Command Neuron Concept. *Behavioral and Brain Science* 1:3–10
- Cropper EC, Evans CG, Hurwitz I, Jing J, Proekt A, Romero A, Rosen SC (2004) Feeding neural networks in the mollusc *Aplysia*. *Neurosignals* 13:70–86

## Central Regulation of Autonomic Function

EDUARDO E. BENARROCH

Department of Neurology, Mayo Clinic, Rochester, MN, USA

### Definition

The central regulation of autonomic function depends on structures distributed throughout the neuraxis. They include the ►**insular cortex**, ►**anterior cingulate cortex**, ►**amygdala**, ►**hypothalamus**, ►**periaqueductal gray matter (PAG)** of the midbrain, ►**parabrachial nucleus** in the dorsolateral pontine tegmentum, and several areas of the medulla, including the ►**nucleus of the solitary tract (NTS)**, reticular formation of the ventrolateral medulla (VLM) (►**Ventrolateral medullary reticular formation**) and medullary raphe nuclei [1–3]. These areas are reciprocally interconnected, receive converging visceral and somatosensory information, and their activity is modulated according to the behavioral state of the individual, including the sleep-wake cycle. These areas control, directly or indirectly, the activity of preganglionic sympathetic or parasympathetic neurons, and generate stimulus-specific patterns of autonomic output critical for homeostatic reflexes and integrated responses to emotion, stress, or other stimuli [2].

### Characteristics Description

The insular cortex is the site of cortical representation of visceral, pain, and temperature sensation [2]. Nuclei in the ventromedial portion of the thalamus relay these sensory modalities to the insula. This cortical area is connected to the amygdala, lateral hypothalamus and brainstem autonomic nuclei, and is also interconnected with the anterior cingulate and ventromedial prefrontal cortices. The anterior cingulate cortex has a major role in regulation of affective behavior, and modulation of bodily arousal via the autonomic nervous system [4]. It has extensive connections with the prefrontal cortex, amygdala, hypothalamus, and brain stem and receives thalamic inputs involved in arousal and relay of nociceptive information.

The amygdala nuclear complex attaches emotional significance to sensory stimuli, including pain, and initiates the autonomic responses associated with emotion, including fear [5]. The amygdala receives inputs from all sensory modalities via projections from the brainstem, thalamus, and association areas of the cerebral cortex. The central nucleus of the amygdala is the effector structure of the amygdala complex and projects to the hypothalamus and brain stem areas involved in autonomic, endocrine, and motor expression of emotional responses [5].

The hypothalamus has a central role in the integration of autonomic and endocrine responses required for homeostasis and adaptation to internal or external stimuli. It is subdivided functionally into a periventricular zone, involved in circadian and neuroendocrine control, a medial zone involved in control of foraging behavior, and a lateral zone controlling arousal and motivated behavior. Several hypothalamic nuclei innervate brain stem and spinal targets controlling sympathetic and parasympathetic neurons. These include the ►paraventricular nucleus (PVN), the dorsomedial nucleus, the arcuate (infundibular) nucleus, and the posterior lateral hypothalamus (perifornical region) [1–2]. These hypothalamic regions contain separate populations of neurons that project to different subsets of preganglionic neurons to generate distinct patterns of autonomic response according to specific stimuli.

The PAG consists of different longitudinal columns that receive specific inputs from sensory pathways, hypothalamus, and cerebral cortex and initiate stimulus-specific autonomic, somatic, and antinociceptive responses to external stressors [6]. The parabrachial nucleus, located in the dorsolateral pontine tegmentum, is a major relay center for converging visceral, nociceptive, and thermoreceptive information to the forebrain and contains separate subnuclei involved in taste, salivation, gastrointestinal activity, cardiovascular activity, and respiration [2,3]. The NTS is the first relay station for taste and general visceral afferents in the brainstem and conveys this information to all central autonomic regions, both directly and via the parabrachial nucleus. The NTS is also critically involved in all medullary reflexes controlling cardiovascular, respiratory, and gastrointestinal functions [3,7,8].

The VLM contains neurons that control sympathetic vasomotor tone, cardiac function, respiration, and endocrine function [3,7,8]. The rostral VLM contains glutamatergic neurons that provide the major tonic excitatory input to the sympathetic preganglionic vasomotor neurons and mediate most descending and reflex influences controlling arterial pressure. Epinephrine synthesizing C1 neurons of the rostral VLM contribute to this glutamatergic input and are required for sympathoexcitatory reflexes. The caudal VLM contains GABAergic neurons that, via their projections

to the rostral VLM, mediate the baroreflexes and other sympathoinhibitory reflexes. Norepinephrine synthesizing A1 neurons of the caudal VLM project to the hypothalamus and participate in control of endocrine function, including secretion of arginine vasopressin. The medullary raphe contains serotonergic neurons that project to the spinal cord and control nociceptive, sympathetic, and respiratory functions. Medullary raphe-spinal pathways are involved in thermoregulatory responses, including skin vasoconstriction [2,3].

### Higher Level Structures

The insular and anterior cingulate cortices, amygdala, hypothalamus, and PAG form a functional unit that has a critical role in integrated responses to stress, emotional responses, and motivated behavior [1,4,5,6]. These areas receive and integrate inputs from several sources. Inputs from visceral receptors, nociceptors, and thermoreceptors reach these areas via both the dorsal horn and the NTS. The dorsal horn receives inputs from the dorsal root ganglia and projects via spinothalamic and spinobulbar pathways [2]. The NTS relays inputs from taste receptors, baroreceptors, chemoreceptors, pulmonary, and gastrointestinal receptors, carried via the facial, glossopharyngeal, and particularly the vagus nerves [2,3]. Both the dorsal horn and the NTS project to the parabrachial nucleus, hypothalamus, and amygdala, as well as to the thalamus, which then relays visceral inputs to the insular and anterior cingulate cortices [2]. At all these levels, there is integration of visceral with pain and temperature sensations. Humoral information, including levels of circulating peptides such as angiotensin II or cytokines, reaches the central autonomic structures in part via the circumventricular organs, which lack a blood brain barrier. These include the area postrema at the level of the fourth ventricle, and the subfornical organ and vascular organ of the lamina terminalis at the level of the anterior wall of the third ventricle [1]. The central autonomic structures, either directly or via the hypothalamus, receive influences from the suprachiasmatic nucleus (circadian pacemaker), the limbic cortical areas, and the cholinergic and monoaminergic cell groups involved in behavioral arousal and regulation of the sleep-wake cycle.

The NTS, VLM, and medullary raphe are involved in autonomic reflexes and mediate the effects of rostral areas, including the amygdala, hypothalamus, and PAG, on sympathetic and parasympathetic outflow [3,7,8]. The medullary cardiovascular and respiratory reflexes have several features in common. Baroreceptor, cardiac receptor, chemoreceptor and pulmonary mechanoreceptor afferents provide an excitatory input to the NTS that via direct and indirect propriobulbar connections, activate or inhibit the sympathoexcitatory neurons of the rostral VLM, vagal neurons of the

nucleus ambiguus or dorsal vagal nucleus, and the neurons of the ventral respiratory group [3,7,8].

### Lower Level Components

The preganglionic sympathetic or parasympathetic neurons are the final central effectors of the forebrain and brainstem structures controlling autonomic output [2]. The sympathetic preganglionic neurons are located primarily in the intermediolateral cell column at T1–L2 levels of the spinal cord and are organized into different functional units that specific targets via the paravertebral ganglia, prevertebral ganglia, or adrenal medulla. The sympathetic outflow is critical for responses to stress, such as hypoglycemia or hemorrhage, control of arterial blood pressure, and thermoregulation. Descending pathways from the hypothalamus and brain stem exert a differential influence on the different populations of sympathetic preganglionic neurons so that there is patterned activation of preganglionic outflow according to the physiological needs. For example, the rostral VLM activates muscle and splanchnic vasoconstrictor preganglionic neurons for maintenance of arterial pressure, whereas the medullary raphe controls skin vasomotor preganglionic neurons related to thermoregulation [2,3].

The vagus nerve provides the most widespread cranial parasympathetic output. Vagal preganglionic neurons are located in the dorsal motor nucleus, which controls respiratory and abdominal viscera, and in the ventrolateral region of the nucleus ambiguus, which innervates the heart. The vagus has a critical role in beat-to-beat control of the heart rate and regulation of gastrointestinal motility and secretion [3]. The sacral parasympathetic outflow arises from the sacral parasympathetic nucleus, located at the S2–S4 segments of the spinal cord, and is critical for micturition, defecation, and penile erection.

### Function

The anterior cingulate cortex and the amygdala control autonomic responses associated with motivated behavior and emotion. The human anterior cingulate cortex is activated during goal-directed behaviors associated with sympathetic activation [4]. Stimulation of the anterior cingulate cortex elicits increases or decreases in blood pressure, heart rate or respiration; mydriasis; piloerection and facial flushing; salivation; nausea or vomiting; and bowel or bladder evacuation. The amygdala receives inputs from all sensory modalities, both directly via the thalamus or parabrachial nucleus, and indirectly after cortical processing in association areas, particularly the insula and anterior temporal cortex [5]. In humans, the amygdala is activated by exposure to emotionally arousing stimuli, passive viewing of facial expressions (particularly fear), and conditioned aversive stimuli. Together with the orbitomedial prefrontal cortex, the amygdala is critical

for emotional and decision making on the basis of previously experienced sensations. The central nucleus of the amygdala is the effector structure for emotional responses. Both directly or via the bed nucleus of the stria terminalis, it innervates the hypothalamus, PAG, NTS and VLM, which initiate sympathoexcitation, release of stress hormones, and motor responses, including startle and vocalization [5].

The hypothalamus is critical for integration of autonomic with endocrine and behavioral responses required for homeostasis and adaptation [1,2,9,10]. The hypothalamic autonomic nuclei receive direct input from the anterior cingulate cortex, insula, and hippocampal formation, amygdala, and basal forebrain, as well as ascending inputs from the NTS, parabrachial nucleus, and A1/C1 catecholaminergic neurons of the VLM. The PVN provides the most widespread autonomic output of the hypothalamus and is crucial for coordinated endocrine and autonomic responses to stress [9]. Different neuronal subpopulations of the PVN, including the magnocellular neurons that secrete AVP to the general circulation, the parvocellular neurons that synthesize corticotrophin releasing hormone and activate the pituitary-adrenocortical axis, and the neurons projecting to autonomic nuclei of the brain stem and spinal cord, are activated, in a stimulus-specific fashion, by hypoglycemia, hypovolemia, cytokines, pain, and environmental stressors [2,9]. An important group of neurons in the posterior lateral hypothalamus synthesize hypocretin (also called orexin) and provide widespread projections to the hypothalamus, brain stem, and spinal cord. Via these projections, the hypocretin/orexin neurons prevent abrupt transitions between wakefulness and sleep, promote food intake and regulate sympathetic function [10].

The PAG is a critical component of the circuits involved in emotion and stress responses, including those triggered by pain [6]. The different columns of the PAG receive specific inputs and generate stimulus-specific responses. The lateral column of the PAG, which receives well-localized cutaneous nociceptive inputs, initiates flight-or-flight responses characterized by sympathetic activation with hypertension and tachycardia and blood flow redistribution to the face (fight) or lower limbs (flight) responses; these responses are associated with opioid-independent analgesia. In contrast, the ventrolateral PAG, which receives poorly localized somatic, visceral, and muscle inputs, elicits hypotension, bradycardia, immobility, and hyporeactivity to the environment; this is associated with opioid-dependent analgesia. The lateral and ventrolateral columns of the PAG provide descending inputs to different targets in the VLM and ventromedial medulla, which mediate both the cardiovascular and pain-modulatory responses [6].

The rostral VLM has a critical role in tonic maintenance of arterial blood pressure [7]. Medullary reflexes are critical for control of the blood pressure,

heart rate, respiration, and gastrointestinal function [3,7,8]. A typical example is the baroreceptor reflex (baroreflex), which provides a powerful moment-to-moment negative feedback regulation of arterial pressure that minimizes the fluctuations of arterial pressure during standing, exercise, emotion, and other conditions. An increase in arterial pressure activates mechanosensitive baroreceptor terminals in the carotid sinus and aortic arch. Baroreceptor afferents excite neurons in the NTS that (i) directly activate the cardiovagal neurons in the nucleus ambiguus (leading to a decrease in the heart rate; (ii) via GABAergic neurons in the caudal VLM, inhibit the sympathoexcitatory neurons of the rostral VLM controlling vasomotor tone in muscle and visceral blood vessels (resulting in a decrease in total peripheral resistance); and (iii) via polysynaptic pathways, inhibit AVP release from the hypothalamus. Unloading of the baroreceptors, as occurs during standing, elicits opposite responses vasoconstriction and tachycardia [3,8]. Vasoconstriction of muscle and splanchnic blood vessels is critical to prevent orthostatic hypotension.

### Pathology

The central control of autonomic functions can be affected by focal or degenerative disorders. Ischemic stroke involving the insular cortex can produce cardiac arrhythmias, which are a potential cause of sudden death. Limbic seizures arising from the amygdala or anterior cingulate cortex may produce cardiac arrhythmias, cutaneous vasomotor and sudomotor changes, mydriasis, vomiting, or respiratory manifestations. Hypothalamic disorders are commonly associated with disturbances in thermoregulation, which may be paroxysmal or chronic and are commonly associated with disturbances in the sleep-wake cycle and food intake. Neurologic catastrophes, such as head trauma and subarachnoid hemorrhage, may manifest with paroxysmal sympathetic hyperactivity (hypertension, tachycardia, pallor, excessive sweating, hypothermia or hyperthermia) due to activation or disinhibition of hypothalamic and medullary sympathoexcitatory regions, including the PVN and rostral VLM. Medullary lesions, such as tumors, strokes, or syringobulbia, may manifest with paroxysmal hypertension, orthostatic hypotension, cardiovagal failure, or sleep apnea. High spinal cord lesions interrupting descending inputs to the preganglionic neurons may manifest with orthostatic hypotension and thermoregulatory failure as well as with paroxysmal unpatterned reflex sympathetic activity triggered by bladder distension and other stimuli (autonomic dysreflexia). Neurodegenerative disorders, such as multiple system atrophy, produce sympathetic and parasympathetic failure due to loss of preganglionic sympathetic and parasympathetic neurons, as well as neuronal loss in the VLM, medullary raphe, and other central autonomic nuclei.

### References

1. Benarroch EE (1993) The central autonomic network: functional organization, dysfunction, and perspective. *Mayo Clin Proc* 68:988–1001 (Review)
2. Saper CB (2002) The central autonomic nervous system: conscious visceral perception and autonomic pattern generation. *Annu Rev Neurosci* 25:433–469
3. Blessing WW (1997) Lower brain stem regulation of visceral, cardiovascular, and respiratory function. In: Paxinos G, Mai JK (eds) *The human nervous system*, 2nd edn. Elsevier, San Diego, CA, pp 465–477
4. Critchley HD, Mathias CJ, Josephs O, O’Doherty J, Zanini S, Dewan BK, Cipolotti L, Shallice T, Polan RJ (2003) Human cingulate cortex and autonomic control: converging neuroimaging and clinical evidence. *Brain* 126:2139–2152
5. Misslin R (2003) The defense system of fear: behavior and neurocircuitry. *Neurophysiol Clin* 2:55–66
6. Keay KA, Bandler R (2001) Parallel circuits mediating distinct emotional coping reactions to different types of stress. *Neurosci Biobehav Rev* 25 669–678
7. Dampney RA, Horiuchi J, Tagawa T, Fontes MA, Potts PD, Polson JW (2003) Medullary and supramedullary mechanisms regulating sympathetic vasomotor tone. *Acta Physiologica Scandinavica* 177:209–218
8. Spyer KM (1994) Annual review prize lecture: central nervous mechanisms contributing to cardiovascular control. *J Physiol* 474:1–19
9. Benarroch EE (2005) Paraventricular nucleus, stress response, and cardiovascular disease. *Clin Auton Res* 15:254–263
10. Kukkonen JP, Holmqvist T, Ammoun S, Akerman KE (2002) Functions of the orexinergic/hypocretinergic system. *Am J Physiol Cell Physiol* 6:C1576–C1591

## Central Sensitization

### Definition

Increased sensitivity of central neurons processing sensory information.

- ▶ Hyperalgesia and Allodynia
- ▶ Pain

## Central Set

### Definition

The cognitive and emotional state of the individual, as it pertains to modulating effects on sensorimotor systems.

Central set is largely determined by prior experience and current expectations and is influenced by factors

such as affect (e.g. fear, anxiety, depression), arousal and attention.

► Anticipatory Postural Responses

---

## Central Sulcus

### Definition

The central sulcus (or fissure) separates the primary motor (precentral gyrus) and primary somatosensory (postcentral gyrus) areas of the cerebral cortex. It marks the boundary between the frontal and parietal lobes.

---

## Central Tegmental Tract

### Synonyms

Tractus tegmentalis centralis; Central tegmental tract

### Definition

The central tegmental tract also known as the large longitudinal catecholaminergic bundles, is the most important terminal segment of the extrapyramidal-motor system. Uniting here are efferents from the corpus striatum, globus pallidus, red nucleus, reticular formation, central gray matter of ► **Mesencephalon**, pons and myelencephalon. The fibers chiefly terminate in the nucleus of the inferior olive from which a powerful tract passes to the cerebellum (olivocerebellar tract). In this manner, a motor feedback system is created, governing coordination of motor control.

► Pathways

---

## Central Vestibular Disorders

ADOLFO M. BRONSTEIN

Division of Neuroscience, Imperial College London, Charing Cross Hospital and the National Hospital for Neurology and Neurosurgery, London, UK

### Synonyms

CNS vestibular disorders; Brainstem–cerebellar vestibular disorders; Non-peripheral vestibular disorders

### Definition

Dysfunction of the vestibular system due lesions in the central nervous system (CNS).

### Characteristics

#### Background

The vestibular system is divided into a peripheral portion, housed in the labyrinth of the inner ear, the vestibular portion of the ► **VIII** (= acoustic-vestibular) cranial nerve, and the central connections of the vestibular nerve. Clinically, disorders of the vestibular system are divided into peripheral (labyrinth) and central (CNS) [1]. Ear specialists (usually ear, nose and throat surgeons) may consider disorders of the VIII nerve as central but ► **neurologists** regard them either as peripheral or extra-axial (outside the neural axis).

Central vestibular disorders can be classified in different ways, according to (i) the underlying pathological process (e.g., inflammatory, demyelinating, tumoural, vascular, ► **degenerative**, traumatic), (ii) topography (e.g., medullary, cerebellar, cortical) and (iii) system involved (e.g., vestibulo-spinal, vestibulo-autonomic, vestibulo-ocular, vestibulo-cortical). Whenever possible, a physician would apply all these classifications simultaneously to his/her patient; for instance a patient can have a *degenerative* disorder of the *cerebellum*, predominantly involving the *vestibulo-ocular system*, as in the down-beat nystagmus syndrome (see below).

#### Vestibular Symptoms

In clinical practice it is customary to divide patients' problems into *symptoms*, what the patient reports (e.g., dizziness) and *signs*, what the examining doctor finds (e.g., nystagmus). The main symptoms in patients with vestibular disorders are vertigo, dizziness, oscillopsia and unsteadiness.

*Vertigo* is an illusion of body movement. The more common form is rotational or "true" vertigo in which patients feel that they are spinning round. Patients can also report that they see the world spin around them. Rotational vertigo is a useful symptom for diagnosis as it indicates involvement of the semicircular canals or their central projections. Apart from the canals and will nerve (as in peripheral vestibular disorders) the more frequent lesion site inducing vertigo is the area of the vestibular nuclei in the floor of the IV ventricle in the pontomedullary junction. More rarely patients describe sensations of linear bodily motion, called linear vertigo and thought to reflect involvement of the otolith organs or their central pathways.

*Dizziness* is more difficult to define. Patients with central vestibular disorders often use terms such as light-headedness, giddiness, dizziness or rocking sensations to describe their symptoms. Although common, these symptoms are less specific than vertigo for

indicating vestibular system disease as many general medical conditions (anemia, hypoglycaemia, arterial hypotension, psychological disorders) also provoke dizziness [1].

*Oscillopsia* is the illusion of movement or oscillation of the visual world. It is due to loss of stability of the visual image on the retina. Oscillopsia results from basically two situations, either the vestibulo-ocular reflex (VOR) is significantly reduced and as a result ocular stability during head movements is lost or the eye has involuntary movements such as nystagmus [2]. Bilateral peripheral disorders are usually responsible for the former whereas central disorders are usually the cause in the latter.

*Unsteadiness.* This is the result of direct disturbance in the vestibulo-spinal projection or functionally related structures, such as the vestibulo-cerebellum (the flocculo-nodular lobe). If the lesion is unilateral and acute, patients tend to fall to one side (lateropulsion), usually ipsilesionally as in lateral medullary stroke involving the vestibular nuclei (Wallenberg syndrome). If the lesion is bilateral or diffuse, as in progressive cerebellar degenerative disease, the patient is globally unsteady. It is important to realize that most central vestibular disorders are not confined to vestibular pathways and thus the unsteadiness observed in any individual patient is likely to result from involvement of other balance mechanisms, e.g., motor, cerebellar and proprioceptive pathways.

### Vestibular Signs

The clinical findings that allow a distinction between a peripheral and a central vestibular disorder to be made are emphasized here. Apart from the presence of abnormal findings on the general neurological examination, such as limb weakness, anesthesia or ataxia, most signs indicative of a central vestibular disorder concern eye movement abnormalities. These include various forms of nystagmus, briefly mentioned below, as well as abnormalities in smooth pursuit, vestibulo-ocular reflex suppression and saccades, not discussed here.

### Central Nystagmus

Nystagmus is an involuntary, repetitive back and forth movement of the eyes. During head or whole body rotation there is a normal physiological nystagmus, which consists of a slow velocity component stabilizing the eyes on earth-stationary objects and a fast phase that resets the eyes approximately to the middle of the orbit. Pathological peripheral vestibular nystagmus arises when a labyrinth on one side is hypoactive (or less frequently hyperactive). The slow phase is toward the damaged (hypoactive) side and the fast phase beats away from the lesion. Physiological and pathological nystagmus is labeled on the basis of the beat direction of the fast phase, e.g., destruction of the left labyrinth induces right-beating nystagmus.

The term central nystagmus indicates that the lesion is in the CNS. However, some forms of central nystagmus relate to non-vestibular ocular stabilization mechanisms (e.g., ► *gaze paretic nystagmus*, ► *pendular nystagmus*). In contrast, central vestibular nystagmus is specifically due to asymmetry in vestibular mechanisms controlling ocular stability; some examples are downbeat nystagmus (due to cerebellar floccular damage), spontaneous torsional nystagmus (due to unilateral vestibular nuclei lesions) and upbeat nystagmus (due to lesions interfering with the central vestibulo-ocular integrator in the ponto-medullary and ponto-mesencephalic tegmentum).

### Main Central Vestibular Syndromes

#### *The Downbeat Nystagmus Syndrome (DBNS)* (or *Vestibulo-Cerebellar Syndrome*)

The main causes of the DBNS syndrome are (i) ► *congenital malformation* of the cranio-cervical junction (the Arnold–Chiari malformation), in which the cerebellar tonsils descend (herniate) into the spinal canal (hence the alternative name of “cerebellar ectopia”); (ii) cerebellar degenerations, sporadic or inherited; (iii) cerebellar disorders of various etiology, such as stroke, ► *multiple sclerosis*, neuro-toxicity and (iv) unknown, i.e., ► *idiopathic*. The lesion site frequently responsible for DBNS is the flocculo-nodular lobe of the cerebellum, also known as the vestibular cerebellum or archi (“ancient”)-cerebellum, whose main afferent input comprises vestibular nuclear neurons. Patients with this syndrome complain of two main symptoms, unsteadiness of gait and vertical oscillopsia. The exact mechanism of the unsteadiness is not known but lesions of the flocculo-nodular lobe disrupt cerebellar processing of the vestibular input and, hence, gait ataxia develops.

Vertical opsillopsia is a reflection of the cardinal sign, downbeat nystagmus. The DBN is due to the fact that the pathways conveying the head-up vestibulo-ocular reflex traverse through the flocculus, hence lesions here create an imbalance in favor of the head-down VOR.

The flocculo-nodular lobe of the cerebellum also plays an important role in other ocular-motor functions, such as eccentric gaze holding, smooth pursuit and VOR suppression control. Accordingly, many patients also display abnormal gaze holding, in the form of gaze paretic nystagmus and abnormal pursuit and VOR suppression on clinical or laboratory examination of the eye movements.

#### *Central Positional Nystagmus*

An important step in the examination of the patient with balance or vestibular symptoms is the positional maneuver. The Hallpike or Dix–Hallpike maneuver is the most frequently used. The patient is rapidly moved by the examiner from the sitting position to a supine, ear-down position. The most frequent abnormality

found is due to a peripheral vestibular disorder called benign paroxysmal position vertigo (BPPV; see under peripheral vestibular disorders). In most disorders of the brainstem and the cerebellum involving central vestibular connections, a positional nystagmus is also induced. Since the physician does not normally know a priori whether the patient has a peripheral or a central vestibular lesion, careful examination of the positionally induced nystagmus is vital to establish a topographic diagnosis. Usually, peripheral positional nystagmus as in BPPV is accompanied by intense rotational vertigo (“positional vertigo”) and discomfort, but these symptoms are less common and intense in central lesions. The more important distinctive features however, relate to the characteristics of the positionally induced nystagmus. In peripheral positional nystagmus there is usually a latency of several seconds to nystagmus onset after reaching the ear down position. The nystagmus subsides and disappears after 10–20 s (“adaptation”) and diminishes on repeated positional maneuvers (“fatigability”). All these features, which are due to the underlying mechanism of canal lithiasis (canalolithiasis, see under peripheral vestibular disorders), are absent in central positional nystagmus. There is no latency so the nystagmus appears immediately on arrival in the ear down position and the nystagmus can persist for as long as the offending head position is maintained and reoccurs on each new positional maneuver (lack of adaptation and fatigability). Of utmost importance, the beat direction of the nystagmus in BPPV can be traced to a specific semicircular canal (usually the posterior canal) whereas this is usually not the case in central positional nystagmus. In particular, positional downbeat or upbeat nystagmus should raise a “red flag” for an underlying neurological condition.

### **Vascular Central Vestibular Syndromes**

*Vascular diseases* of the CNS are divided into *ischemic* (loss of blood supply, usually due to atherosclerosis and thrombo-embolic phenomena) and *hemorrhagic* (bleeds). Bleeds into the subarachnoid space (subarachnoid hemorrhage) are usually secondary to ruptured aneurisms or arterio-venous malformations. Bleeds within the brain parenchyma are often secondary to hypertensive/atherosclerotic disease and less frequently due to aneurisms or arterio-venous malformations. In the acute stage, the clinical picture of a posterior fossa bleed is usually dominated by severe headache and potentially fatal alterations of consciousness, respiratory and autonomic function and neurological brainstem signs. The latter often include central ocular-motor and vestibular disorders, which if the patient survives can cause troublesome dizziness, unsteadiness, diplopia and oscillopsia secondary to a central vestibular syndrome.

The two main ischemic syndromes with central vestibular implications are infarctions in the territory of the posterior inferior cerebellar artery (PICA) and the anterior inferior cerebellar artery (AICA). The *PICA syndrome* gives rise to the lateral medullary or Wallenberg syndrome. In addition to infarction to the vestibular nuclei, various cranial nerve, sensory, motor and cerebellar pathways are involved (not reviewed here). Infarction of the vestibular nucleus produces a mostly torsional nystagmus (i.e., the eyes rotate around the line of sight, sometimes called “rotatory nystagmus”) with the fast phase beating to the opposite direction of the lesion. An “ocular tilt reaction” can also be observed, in which the ipsilesional eye is lowered and the contralesional eye elevated, causing vertical diplopia (double vision) and an apparent tilt of visual scenes. These ocular vertico-torsional disorders are secondary to interruption of otolithic and vertical semicircular canal pathways to the eye muscles. The head can also be ipsilesionally tilted, due to lesion of the vestibulo-spinal (vestibulo-colic) projection.

Since the AICA irrigates not only brainstem and cerebellar structures but also the labyrinth itself, *infarctions of the AICA* cause a clinical picture combining central and labyrinthine features, including severe ipsilesional deafness.

### **Migraine**

Although the most notorious symptom in migraine is headache, visual, auditory, somatosensory and vestibular features are also prominent. Although migraine is an inherited disorder, its symptoms are mostly episodic. Triggers for the episodes can often be identified and include sleep deprivation, certain foods (e.g., red wine, chocolate) and intense sensory stimulation such as bright lights. The underlying biochemical disorder responsible for migraines is not fully understood, but vascular mechanisms, channelopathies (dysfunctional neuronal membrane ion channels) and peptide-mediated irritation of V nerve terminals may all play a part.

Migraneous headaches are pulsating or “throbbing,” accompanied by nausea and intolerance to loud sounds (phonophobia), bright lights (photophobia) or smells (osmophobia). In recent years, the role of migraine as one of the main causes of episodic vertigo has been recognized. In parallel it has been observed that vestibular stimulation and motion sickness can trigger migraine in susceptible subjects. Observations of migraine patients in the middle of their vertiginous attacks indicate that peripheral (labyrinthine) and central vestibular syndromes or both can occur [3]. The treatment of vestibular migraine is not standardized as there are no good randomized control trials published, but most clinicians believe that preventive (prophylactic) treatment with beta-blockers such as

propranolol is moderately effective. The International Headache Society (IHS) periodically reviews the classification of migraine and headaches, although vestibular issues do not feature prominently in their discussions.

### Disorders of the Vestibular Nerve

The most frequent disorder of the vestibular nerve is a slowly growing benign tumor called *vestibular schwannoma* or *acoustic neuroma*. The most prominent symptom caused by this tumor is due to compression of the acoustic rather than the vestibular portion of the VIII cranial nerve, since patients report slowly progressive unilateral deafness and tinnitus. Although the vestibular nerve is equally damaged by the neuroma, its slow progression rarely leads to noticeable unsteadiness or vertigo. As the tumor grows it eventually leads to compression of other structures in the cerebello-pontine angle, including the V, VI and VII cranial nerves and the cerebellar flocculus. This level of growth is exceptional these days, as the diagnosis is established earlier with neuro-radiological procedures, in particular MRI scans.

*Neurofibromatosis 2 (NF2)* is an autosomal dominant disease characterized by the development of nervous system tumors, ocular abnormalities and skin tumors. Vestibular schwannomas (usually bilateral) occur in about 95% of adult NF2 patients and presenting symptoms are audio-vestibular. In contrast, children with NF2 often present with non-VIII nerve tumors and non audio-vestibular symptoms [4]. Other forms of neurofibromatosis are not dealt with here.

### Diagnostic Procedures in Central Vestibular Disorders

A reliable clinical history provides vital clues as to whether symptoms of vertigo, dizziness, oscillopsia or unsteadiness are caused by peripheral or central vestibular disease. In favor of a central topography are symptoms attributable to brainstem and cerebellar structures, such as numbness (V) or weakness (VII) of the face, speech disturbance (cerebellar ►*dysarthria*), swallowing difficulties (IX, X) or to long tracts, such as unilateral body weakness or numbness. Although unilateral hearing symptoms can occasionally be due to central disease (e.g., see AICA syndrome above) they are more common in peripheral (e.g., Meniere's disease) or VIII nerve (e.g., vestibular schwannoma) disease.

In the clinical examination, the physician seeks to establish if there are abnormalities attributable to CNS disease, e.g., abnormalities of the motor-sensory systems such as hemiparesis, hemianesthesia or ataxia. The presence of signs of cranial nerve dysfunction (e.g., facial weakness or anesthesia), central nystagmus (torsional, pendular, gaze parietic, central positional

nystagmus) and other abnormalities of eye movements, such as slow or ►*dysmetric saccades* and broken up pursuit or VOR suppression, are particularly important.

*Electro-oculography, EOG, (or electro-nystagmography, ENG) and video-oculography, VOG* are eye movement recording techniques which allow laboratory examination of vestibular and eye movement functions in a standardized and quantitative manner. Visuo-motor function is assessed with illuminated visual targets for gaze holding, smooth pursuit and saccades. Vestibular stimulation is delivered either with physiological stimuli, such as rotational techniques or with the caloric test. These tests are normally carried out in darkness to avoid confounding visuo-motor effects. The caloric test consists of individual irrigation of the external auditory canals with water or air that is cooler (30°C) or warmer (44°C) than body temperature. This creates a transient asymmetry in vestibular function, mostly in the horizontal semicircular canal system, in turn inducing nystagmus that can be recorded and quantified.

In unilateral or bilateral peripheral vestibular disease the main abnormality is a reduction in rotational or caloric responsiveness, uni- or bi-laterally respectively. In contrast, in central vestibular disorders the main indicator of CNS disease is the presence of abnormal pursuit, VOR suppression or saccades, even if vestibular symmetry to caloric or rotational stimulation is preserved. Examination of the waveform of a spontaneous or gaze evoked nystagmus can also help to distinguish between peripheral and central vestibular disease and between acquired and congenital nystagmus.

*Neuro-imaging* constitutes the major step in identifying (or ruling out) the presence of a structural intracranial abnormality. Current imaging techniques do not have sufficient resolution to detect abnormalities in the in vivo labyrinth in the vast majority of peripheral disorders (except some congenital abnormalities or in the superior semicircular canal dehiscence syndrome). In contrast, the majority of diseases giving rise to central vestibular syndromes can be visualized, e.g., degenerative (atrophic) cerebellar-brainstem disorders, demyelination including multiple sclerosis, spontaneous or traumatic hemorrhage as well as ischemia, tumors and cranio-cervical disorders. In general, MRI is superior to CT scan for disorders of the cerebellum, brainstem and the VIII and other cranial nerves.

General *blood tests* are of only limited function in the evaluation of a patient with central vestibular symptoms. They are however useful to rule out that patients' symptoms are not provoked by a general medical condition such as anaemia or inflammatory/infectious disorders. *Neurogenetic testing* can be useful particularly



in cases where a positive family history of neurological disorder is present, as in inherited cerebellar disease [5] and NF2. The list of familial disorders identified genetically is growing fast and neurogenetic testing is widespread nowadays; hence neurogenetic testing is often carried out in patients despite the absence of a known family history.

### **Physiological (Non-Structural) Vestibular Disorders (Mismatch; Motion Sickness; Visual Vertigo)** ***Motion Sickness (“Car Sickness”; “Sea Sickness”)***

Motion sickness is a common experience at some point in our lives. Symptoms of nausea, pallor, cold sweatiness and vomiting can be induced by land, air or sea travel in most normal subjects. However, susceptibility varies greatly within the population and within an individual, with children and women being more susceptible than adult males. A possible hormonal influence underlying this trend is suspected. Apart from its impact in the general population, motion sickness is intensively studied because of its impact in civilian and military air and sea crews [6].

#### ***Mechanisms***

The vestibular system plays a prominent role in motion sickness as indicated by the fact that subjects lacking vestibular function cannot be made sick by motion. Also, the autonomic symptoms induced by caloric and rotational stimulation of the labyrinth or by vestibular disease are almost identical to those of motion sickness. Motion dynamic characteristics are important; low frequencies particularly centered at 0.10–0.30 Hz (e.g., one cycle every five seconds) as experienced on ships are more provocative than faster frequencies as experienced in a small sports car.

Visual field motion (= optokinetic stimuli) can also induce similar but less intense sickness. This is explained by the fact that optokinetic stimuli activate central vestibular neurons and induce sensations of self-motion (=vection). An example of avection illusion is that induced by departure of a train on the track next to the train on which one is seated.

There is no ecological explanation as to why animals and humans should develop motion sickness. Neural projections between the vestibular system and the autonomic centers (including vomiting centers) in the floor of the IV ventricle underlie the gastric and circulatory physiological phenomena. A possible role of the vestibular system in detecting circulating toxins, where vomiting would have a beneficial role in precluding further intestinal absorption, has been discussed; alcohol intoxication is an example. Also, the fact that motion sickness is more readily induced in situations of sensory conflict (= disorientation mismatch; see below) suggest that the unpleasant sensations induced may serve the purpose of raising

awareness that conditions in the environment are unusual and potentially threatening for the organism. For instance, the motion sickness symptoms experienced when locked up in a moving enclosure, as inside a ship with no windows, are partly due to the visuo-vestibular conflict in which vestibular cues inform the CNS that there is body motion but visual cues do not confirm it. If the person finds the way to the deck and looks at the moving horizon, the sensory conflict is resolved and motion sickness improves to some extent.

#### ***Treatment***

Prevention is the best tactic against motion sickness. Drugs used to prevent motion sickness belong to two main groups, anti-muscarinic (scopolamine = hyoscine) and antihistaminic (cinnarizine; cyclizine), which are used for their central (CNS) effects on vestibular and vomiting centers. Scopolamine is considered to be the most effective drug. Non-pharmacological treatment is effective and consists of de-sensitizing the subject to the provoking stimuli, namely body and visual motion. The motion devices required for this treatment are relatively complex and the treatment is usually reserved for professional air and sea crews.

#### ***Mismatch Disorientation (Visuo-Vestibular Conflict)***

This is the name given to the spatial disorientation, dizziness and motion sickness that arise when a subject is exposed to conflicting sensory information.

Orientation in space is provided by various sensory channels, of which the more important are the visual, vestibular and proprioceptive systems. In normal circumstances the information provided by these various inputs is coherent and congruent. For instance, when we turn our heads the motion provided by these systems agrees with each other. Two common examples in which sensory conflict arise are (i) being inside a ship or reading while riding a bus, where vestibular input signals head motion but visual input does not (because the visual scene remains head-fixed and the eye sees no change with respect to the visual surroundings) and (ii) when viewing tilted or moving large visual scenes. In the latter case the visual input is centrally interpreted as due to self-motion, but this is not confirmed by the vestibular or proprioceptive systems.

As with motion sickness, the susceptibility to becoming disoriented or dizzy due to conflicting visuo-vestibular input varies greatly within the population. One of the factors involved in this variability relates to how much “weight” an individual places on his/her visual input for spatial orientation. This is so because vision, as a non-inertial sensory system, is more likely to provide the “wrong” information when sensory conflict arises. Hence, subjects who place more weight on vision (“visually dependent”) are more likely to

experience disorientation than those who rely more on inertial cues for spatial orientation.

### **Visual Vertigo (= Space and Motion Discomfort; Visuo-vestibular Mismatch)**

This is a syndrome that develops in some patients with peripheral vestibular disorders, although it is based on central physiological mechanisms akin to “mismatch disorientation” (see previous paragraph).

In the majority of patients with acute peripheral vestibular disorders the central process of vestibular compensation suppresses the symptoms (e.g., dizziness) and signs (e.g., nystagmus; postural imbalance) within weeks or a few months. In some patients, symptoms continue ►chronically, particularly when visuo-vestibular conflict arises, such as viewing moving visual scenes as in traffic or in complex urban scenarios such as supermarkets. Research has shown that increased visual dependence (see previous paragraph) underlies the syndrome of visual vertigo [7]. Desensitization techniques such as those used for motion sickness, with special emphasis on visual motion stimuli are helpful aids in the rehabilitation of these patients [8].

### **References**

1. Bronstein AM, Lempert T (2007) Dizziness: a practical approach to diagnosis and management. Cambridge University Press, Cambridge
2. Bronstein AM (2004) Vision and vertigo: some visual aspects of vestibular disorders. *J Neurol* 251(4):381–387
3. Von Brevern M, Zeise D, Neuhauser H, Clarke AH, Lempert T (2005) Acute migrainous vertigo: clinical and oculographic findings. *Brain* 128(Pt 2):365–374
4. Baser ME, Evans DG, Gutmann DH (2003) Neurofibromatosis 2. *Curr Opin Neurol* 16(1):27–33
5. Kerber KA, Jen JC, Perlman S, Baloh RW (2005) Late-onset pure cerebellar ataxia: differentiating those with and without identifiable mutations. *J Neurol Sci* 238(1–2):41–45
6. Golding JF, Gresty MA (2005) Motion sickness. *Curr Opin Neurol* 18(1):29–34
7. Guerraz M, Yardley L, Bertholon P, Pollak L, Rudge P, Gresty MA, Bronstein AM (2001) Visual vertigo: symptom assessment, spatial orientation and postural control. *Brain* 124(Pt 8):1646–1656
8. Pavlou M, Lingeswaran A, Davies RA, Gresty MA, Bronstein AM (2004) Simulator based rehabilitation in refractory dizziness. *J Neurol* 251(8):983–995

## **Central Vestibular Lesions**

### **Definition**

►Central Vestibular Disorders

## **Centrifugal Fibers in Olfactory System**

ANTOINE NISSANT

Laboratory for Perception and Memory, Pasteur Institute, Paris Cedex 15, France

C

### **Synonyms**

Central projections; Centrifugal inputs

### **Definition**

The olfactory system is at the interface of the environment and the central nervous system. It is responsible for coding sensory information from thousands of odorous stimuli. To accomplish this, odor information must be processed through various levels. A modified representation of the odor stimulus is generated at each level. In mammals, an olfactory stimulus activates an ensemble of olfactory receptor neurons in the olfactory epithelium, each of which expresses an odorant receptor. These sensory neurons project to the first central relay of the olfactory system, called the main olfactory bulb, where the olfactory nerve contacts the bulbar output neurons, the mitral and tufted cells. These neurons project directly to the olfactory cortex. The olfactory bulb is the first major site of integration for olfactory information.

The olfactory bulb does more than processing sensory information; it also integrates information communicated via centrifugal projections (fibers) from many central structures [1]. Olfactory perception is strongly influenced by experience. Thus, these centrifugal fibers may modulate the function of olfactory microcircuits at various sites in a concerted fashion to tune olfactory bulb processing. This centrifugal modulation may influence the meanings associated with particular odorant perceptions, depending on the internal state or experience of the animal. It may also play an important role in attentional processes, as is the case for other sensory systems.

### **Characteristics**

There are many types of centrifugal fibers projecting to the olfactory bulb from various brain areas [1]. We can mainly distinguish glutamatergic feedback projections from the olfactory cortex and fibers coming from modulatory structures, e.g., the raphe, the locus coeruleus, and the basal telencephalon.

### **Feedback Projections from Olfactory Cortical Structures**

Glutamatergic afferences are coming from many brain areas including several cortical regions and some hippocampal structures. The feedback projections coming from olfactory cortex are the main centrifugal fibers

innervating the olfactory bulb (Fig. 1). They project mainly onto somata or basal dendrites of granule cells, the main GABAergic interneurons of the olfactory bulb [1].

It has been shown earlier that stimulation of primary olfactory cortical structures or anterior commissure, which is the major route for centrifugal fibers, produces a negative ▶local field potential (LFP) in the granule cell layer (GCL) consistent with an activation of granule cells. More recently, ▶patch clamp recording has confirmed that stimulating the piriform cortex produces excitatory postsynaptic currents (EPSCs) (▶Postsynaptic currents (EPSCs and IPSCs) or potentials (EPSPs and IPSPs)) in granule cells [2].

The main role of granular GABAergic interneurons is to deliver inhibitors onto mitral cell dendrites via reciprocal dendrodendritic synapses. These synapses allow recurrent release of inhibitors onto activated mitral cells and lateral inhibition between two neighboring mitral cells. These phenomena are thought to be the basis of mitral cell synchronization, ▶network oscillations, and contrasted responses to various odors. Modulating granule cell responsiveness to mitral cell stimulation may be a very efficient way to modulate olfactory bulb activity in response to odorant activation.

Many studies demonstrate that dendrodendritic inhibition of mitral cells depends on activation of granule cell spines via AMPA and NMDA ionotropic glutamate receptors. However, NMDA channels are tonically blocked by extracellular  $Mg^{2+}$ . Repetitive stimulation of terminals arriving in the GCL or tetanic stimulation in the piriform cortex produces a large depolarization of granule cells sufficient to remove the  $Mg^{2+}$  blockade of NMDA receptors in the granule cell spines [2]. This

mechanism allows efficient triggering of GABA release by activation of the reciprocal synapse.

The ability of granule cells to inhibit mitral cells is highly dependant on their excitation by centrifugal inputs. Thus, any changes in the characteristics of these excitatory inputs may have large consequences on the properties of the entire network. Controlling granule cell inhibition of mitral cells is a powerful way for the cortex to modulate olfactory bulb activity.

For example, it is known that beta frequency oscillations of the olfactory bulb network are essential for olfactory function and can be modified by olfactory experience. They are enhanced during olfactory learning tasks and repetitive presentation of an odorant. Disruption of cortical centrifugal fibers eliminates odor-evoked ▶beta oscillations and their experience-dependant enhancement. The integrity of these cortical projections is also essential for the formation of odor-reward olfactory associations [3].

### Neuromodulatory Projections

In addition to the massive innervation by glutamatergic terminals, the olfactory bulb receives inputs from neuromodulatory regions (Fig. 2). Cholinergic, noradrenergic, and serotonergic fibers reach the olfactory bulb circuit to modulate the network activity at several synaptic and extrasynaptic levels.

Cholinergic fibers extend from the horizontal limb of the diagonal band of broca (HDB) to every bulbar layer, but their principal target is the dendrodendritic synapse between the granule cells and the mitral cells in the external plexiform layers [1].

Acetylcholine has various effects, depending on cell type. This ▶neuromodulator increases the excitability

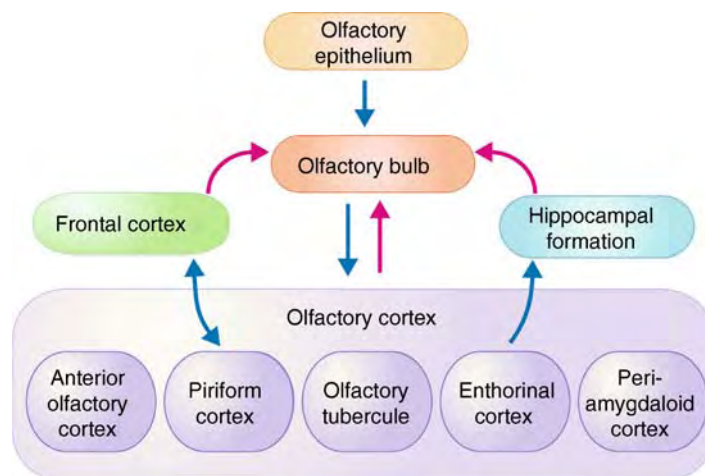

**Centrifugal Fibers in Olfactory System. Figure 1** Main glutamatergic projections onto olfactory bulb. The olfactory bulb receives feedback projections from every part of the olfactory cortex. It also receives glutamatergic projections from other cortical areas (including frontal cortex) and from hippocampal structures.

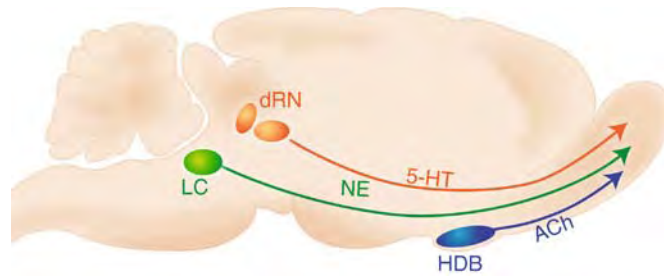

**Centrifugal Fibers in Olfactory System. Figure 2** Neuromodulatory projections onto olfactory bulb. Neurons from the horizontal limb of the diagonal band of Broca (HDB) are releasing acetylcholine (ACh). Neurons from the dorsal raphe nucleus (DRN) are releasing serotonin (5-HT). Neurons from the locus coeruleus (LC) are releasing norepinephrine (NE).

of periglomerular interneurons and mitral cells via the synaptic and extrasynaptic nicotinic receptor [4]. Conversely, acetylcholine acts on the soma of granule cells via the muscarinic receptor to decrease their excitability and acts on their dendrites to increase the release of GABA.

These cholinergic fibers are beginning to be recognized as being heavily involved in olfactory function. Spontaneous olfactory discrimination is impaired when these fibers are damaged and is more accurate with increased efficiency of these fibers. If the nicotinic receptor is blocked in the olfactory bulb, the animal cannot discriminate between two closely related odors [5].

Noradrenergic fibers extend from the locus coeruleus. *In vivo* studies of behaving animals have shown that olfactory cues increase the activity of locus coeruleus noradrenergic neurons and lead to an increase in norepinephrine concentration in the olfactory bulb. The spatial distribution of these fibers is highly specific. They innervate mainly the inner plexiform layer (IPL) and the GCL. Only a few fibers penetrate the external plexiform layer (EPL); however, the main targets of these **neuromodulators** are the dendrodendritic synapses between mitral cells and granule cells. Norepinephrine impairs the release of GABA from granule cell dendrites. It also decreases spontaneous synaptic activity in mitral cells and granule cells.

The influence of norepinephrine on olfactory performance depends on the age of the animals. In neonates, within the first postnatal week, the locus coeruleus is essential for formation and stabilization of conditioned olfactory learning [6]. In adults, norepinephrine is involved in the consolidation of olfactory memory.

Serotonergic fibers extend from the dorsal raphe nuclei and innervate the glomeruli. In neonate rats, serotonergic activity is important for conditioned learning [6]. Intrabulbar infusion of serotonergic antagonists prevents formation of olfactory preference. In adult rats, the injection of a serotonergic neurotoxin impairs olfactory discrimination [7].

### Centrifugal Inputs and Network Plasticity

Centrifugal projections extending from olfactory and neuromodulatory structures act together to regulate activity of the main olfactory bulb. This concerted modulation of olfactory information processing illustrates the intensive crosstalk between these areas of the brain.

The large variety of centrifugal projections and cell types innervated by these fibers give this system a high level and various sources of plasticity. There are many situations in which the olfactory bulb needs to be highly plastic. Behavioral studies clearly demonstrate the major role of centrifugal projections in enhancement of spontaneous odor discrimination, olfactory learning, and recall of specific olfactory memories. Furthermore, computational modeling has suggested that these inputs may increase in contrast in mitral cell responses to various odors.

Physiological studies have shown the possibilities of long-lasting changes in the strength of centrifugal inputs and the excitability of olfactory bulb neurons. Centrifugal fiber's stimulation in fish can induce long-term potentiation (LTP) at the mitral cell to granule cell synapse [8]. Additionally, *in vivo* recordings in anesthetized rats have shown that high-frequency stimulation in the GCL can induce LTP of centrifugal inputs to granule cells [9].

Another major source of plasticity in the olfactory bulb network is continuous neurogenesis in the adult, consisting of production of granular and periglomerular interneurons throughout the life of the animal. As interneurons are the main targets of centrifugal projections and as adult neurogenesis is regulated by olfactory experience and sensory activity [10], this extreme form of network plasticity may be controlled by the concerted action of neuromodulators and feedback excitatory projections.

### Centrifugal Inputs and Attention

Feedback projections from cortical structures play a major role in attentional processes in other sensory

pathways, including the visual system. The existence of attentional mechanisms in the olfactory system is under debate; presence of the classic type of attentional processes, as in other sensory systems, is excluded by the fact that the olfactory centrifugal projections do not pass through the thalamus. However, some of the defects in olfactory performances reported in behavioral studies of animals with altered centrifugal innervation may be interpreted as an impairment of olfactory attention.

## References

1. Shepherd GM, Chen WR, Greer CA (2004) Olfactory bulb. In: Shepherd GM (ed) *The synaptic organisation of the brain*, 5th edn. Oxford University Press, New York, pp 165–216
2. Balu R, Pressler RT, Strowbridge BW (2007) Multiple modes of synaptic excitation of olfactory bulb granule cells. *J Neurosci* 27(21):5621–5632
3. Martin C, Gervais R, Chabaud P, Messaoudi B, Ravel N (2004) Learning-induced modulation of oscillatory activities in the mammalian olfactory system: the role of the centrifugal fibres. *J Physiol Paris* 98(4–6):467–478
4. Castillo PE, Carleton A, Vincent JD, Lledo PM (1999) Multiple and opposing roles of cholinergic transmission in the main olfactory bulb. *J Neurosci* 19(21):9180–9191
5. Mandairon N, Ferretti CJ, Stack CM, Rubin DB, Cleland TA, Linster C (2006) Cholinergic modulation in the olfactory bulb influences spontaneous olfactory discrimination in adult rats. *Eur J Neurosci* 24(11):3234–3244
6. McLean JH, Harley CW (2004) Olfactory learning in the rat pup: a model that may permit visualization of a mammalian memory trace. *Neuroreport* 15(11):1691–1697 (Review)
7. Moriizumi T, Tsukatani T, Sakashita H, Miwa T (1994) Olfactory disturbance induced by deafferentation of serotonergic fibers in the olfactory bulb. *Neuroscience* 61(4):733–738
8. Satou M, Hoshikawa R, Sato Y, Okawa K (2006) An in vitro study of long-term potentiation in the carp (*Cyprinus carpio* L.) olfactory bulb. *J Comp Physiol A Neuroethol Sens Neural Behav Physiol* 192(2):135–150
9. Patneau DK, Stripling JS (1992) Functional correlates of selective long-term potentiation in the olfactory cortex and olfactory bulb. *Brain Res* 585(1/2):219–228
10. Alonso M, Viollet C, Gabellec MM, Meas-Yedid V, Olivo-Marin JC, Lledo PM (2006) Olfactory discrimination learning increases the survival of adult-born neurons in the olfactory bulb. *J Neurosci* 26(41):10508–10513

## Centromedian Nucleus

### Synonyms

Nucl. Centromedianus; Centromedian nucleus

### Definition

The centromedian nucleus belongs to the Intralaminar thalamic nuclei and receives its afferents from motor and parietal cortex as well as from the globus pallidus. It projects to the putamen, which in turn projects to the globus pallidus. This functional loop conveys poly-sensory information to the corpus striatum, which is important for execution of correctly oriented motor responses.

- ▶ Diencephalon
- ▶ Headache

## Cephalgia

- ▶ Headache

## Cerebellar Commissure

### Synonyms

Commissura cerebelli; Cerebellar commissure

### Definition

The two cerebellar hemispheres communicate via long commissural fibers. The associated bundle of fibers crossed the vermis cerebelli close to the fastigial nucleus. The preceding part is called the anterior cerebellar commissure and the succeeding part is known as the posterior cerebellar commissure (Stilling).

- ▶ Cerebellum

## Cerebellar Cortex

### Synonyms

Cortex cerebelli; Cerebellar cortex

### Definition

Just like the cerebrum, the cerebellum also evidences a pronounced cortical structure. The gray nuclear cortex is greatly folded and interspersed with white, fiber-containing matter. The cerebellar cortex has a typical cyto-architecture whose chief components are Purkinje cells, granular cells, basket cells and Golgi cells.

The cerebellar cortex compares motor program with motor action and optimizes the motor program.

► Cerebellum

## Cerebellar Corticonuclear Projection

### Definition

The topographical projection of Purkinje cells located within the sagittal zones of the cerebellar cortex to specific locations in the cerebellar nuclei.

- Cerebellar Functions
- Purkinje Cell, Neuron

## Cerebellar Functions

JAMES R. BLOEDEL, VLASTISLAV BRACHA  
Department of Biomedical Sciences, Iowa State  
University, Ames, IA, USA

### Definition

Defining the function of the cerebellum has been an elusive target of investigators for at least a century. Most initial inferences resulted from ablation experiments in animals and clinical studies of cerebellar patients. In general, disturbances in balance, posture, eye movements, and control of volitional, goal-directed movements were observed. Fundamentally, these disturbances were primarily related to the fine control of various movements, not an inability to initiate or execute the task. Based on these observations, the cerebellum was considered to play a major role in regulating a wide variety of motor behaviors with little involvement in nonmotor functions. This restrictive view changed dramatically in the early 1980s with the discovery that lesions of the cerebellum in otherwise intact animals made it impossible to acquire and recall the classically conditioned eyeblink reflex. More recent imaging studies showed correlates of neuronal activity in the cerebellum during a variety of cognitive tasks. Consequently, it is now well accepted that the cerebellum is engaged in motor as well as nonmotor functions.

### Characteristics

#### Functional Organization of Cerebellar Systems

Structurally, the cerebellum consists of a foliated cortex and the deep cerebellar nuclei. The output neurons of

the cerebellar cortex, the Purkinje cells, project to the cerebellar nuclei as the corticonuclear projection (► [cerebellar corticonuclear projection](#)), and the output neurons of the deep nuclei convey the information processed in the cerebellum to the brainstem and thalamus. The cortex and corresponding regions of the cerebellar nuclei are organized into ► [sagittal zones](#). Traditionally, the cerebellum is divided into three primary sagittal zones: the midline (vermal), the intermediate (paravermal), and the lateral (hemispheric) zones. However, detailed neuroanatomical studies indicate that there are at least eight such zones in higher vertebrates, depending on the species and the region of the cerebellum. In general, these more restrictive zones specify the location of Purkinje cells within the cerebellar cortex projecting to a specific medio-lateral location in the deep cerebellar nuclei. In addition these zones define the topographic distribution of the climbing fiber projection (the olivocerebellar projection) originating from specific locations in the inferior olive. The relation of these zones to the olivocerebellar system will be discussed below. These relationships are characterized in Fig. 1.

The output of the cerebellum originates largely from the cerebellar nuclei, with the exception of some Purkinje cells that project from the vermal region to components of the vestibular system. These output pathways affect neuronal interactions in the spinal cord, numerous brainstem nuclei, as well as the hypothalamus, thalamus and cortex. The vermal, intermediate, and lateral cerebellar regions, the larger sagittal zones described above, are each related to a specific set of afferent and efferent projections. The midline or vermal zone, of which the fastigial nucleus is a part, interacts extensively with the vestibular system, components of the eye movement system, and descending projections to the spinal cord originating primarily from the medulla. These descending projections play an important role in the regulation of posture and locomotion. The intermediate zone and the associated interposed nuclei are unique in having extensive interconnections with the spinal cord as well as the pontine nuclei, the thalamus, and the cerebral cortex. This zone is involved in the coordination of ongoing volitional movements, and it also is involved in the regulation of spinal reflexes, including the ► [cutaneomuscular reflexes](#). The lateral region, associated with the dentate nucleus, interacts primarily with the corticopontine and the thalamocortical projections, particularly those related to portions of the cortex involved in motor planning and other higher cortical functions. In addition to playing an important role in the performance of complex, goal-directed limb movements, it is primarily involved in regulating movements requiring the integration of motor behavior with higher cortical functions. Components of the hemispheres may also play a role in the control of eye

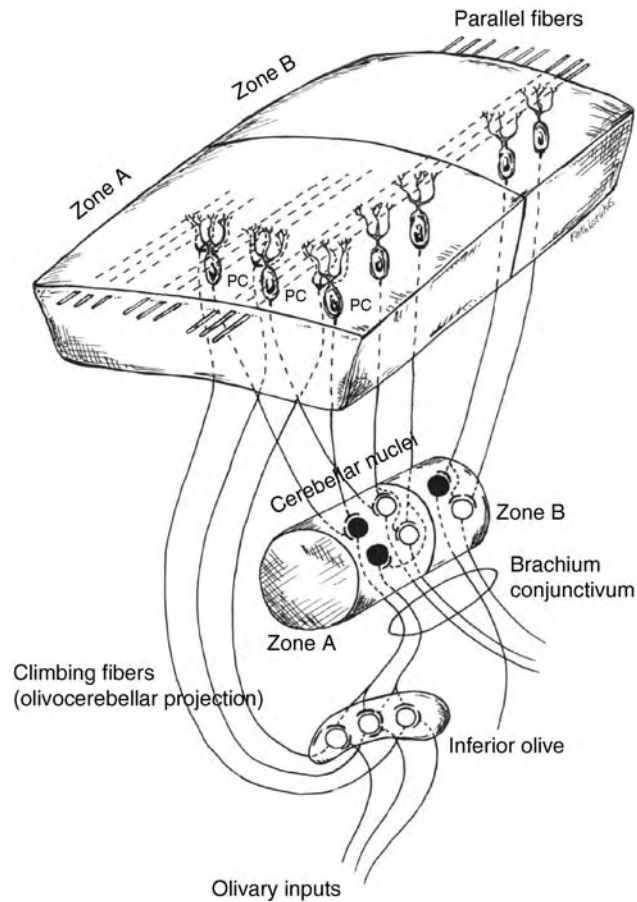

**Cerebellar Functions. Figure 1** Diagrammatic illustration of the cerebellar-olivary loop, a set of interconnections relating the nuclear projection of Purkinje cells (PC) to the projection of climbing fibers from the inferior olive to the cerebellar cortex. Note the corresponding projections from Zones A and B to the related regions of the deep nuclei. Inhibitory nuclear neurons project in turn to olivary neurons which ultimately terminate on Purkinje cell dendrites in the same sagittal zones. Brachium conjunctivum: ascending output projection from the cerebellar nuclei. In the cerebellar nuclei and inferior olive, clear cells are excitatory and filled cells are inhibitory.

movements. (See [1] for additional information regarding the movements regulated by each zone.)

Across all of the zones, there are two primary types of afferent projections to the cerebellum, the mossy fibers and the climbing fibers. In general, each afferent pathway projects to both the cerebellar cortex and the nuclei, although the majority of projections are received by the cerebellar cortex. Mossy fiber projections originate from multiple sites within the brain and spinal cord receiving inputs from the same sagittal zone to which these afferents project. These include inputs from virtually all sensory modalities that are important for the control of movement, inputs from the collaterals of output neurons in the cerebellar nuclei, and from the cerebral cortex. Mossy fibers inputs projecting from different regions of the body terminate in a pattern within the cerebellar cortex called a “patchy mosaic.” The representation of different body regions are

intermixed in a mosaic-like distribution across the folia of specific cerebellar cortical regions. The inputs to the cerebellar cortex from mossy fibers are conveyed by a cerebellar cortical neuron, the granule cell, which in turn projects to the Purkinje cells via parallel fibers. These fibers are shown in Fig. 1 without their relation to their cells of origin, the granule cells. Mossy fiber projections are responsible for providing the graded modulation of Purkinje cells and nuclear cells that reflect the magnitude of relevant sensory inputs as well as the activity in descending motor pathways important for initiating and controlling movement.

Each of the approximately eight sagittal zones also receives a specific projection from a unique afferent system, the climbing fiber system. As shown diagrammatically in Fig. 1, the climbing fibers projecting to a specific sagittal zone originate from a region of the inferior olive receiving an inhibitory input from neurons

located in a corresponding zone of the cerebellar nuclei. The dendritic tree of a single Purkinje cell receives an input from only one climbing fiber, although each climbing fiber can branch and contact other Purkinje cells in the same zone. The contribution of these loops to the function of the cerebellum is in the early stages of investigation.

This unique afferent projection is activated under specific functional conditions and produces a very large depolarization of the Purkinje cell dendritic tree. These afferents are known to generate these responses following unexpected sensory stimuli as well as during certain features of a voluntary movement. In addition, they respond to vestibular inputs and moving visual stimuli (stimuli moving across the retina). See [2] for a brief review. The functional significance of the unique responses they evoke is still being discussed. Proposals include the induction of plastic changes in the responses of Purkinje cells, the generation of synchronous responses of cerebellar nuclear neurons, and the signaling of specific features of a sensory stimulus.

It is beyond the scope of this review to describe these systems further except to emphasize that they provide a substrate for integrating multiple sensory inputs with information characterizing the activity in descending projections involved in generating movements. The importance of the cerebellum in integrating a variety of sensory information with the control of ongoing movement is emphasized by the fact that this structure receives inputs activated by virtually all types of sensory stimuli. These inputs provide updated information about the movement and position of the extremities, balance, and multiple characteristics of the environment. Very importantly, cerebellar systems are designed to modify motor behavior as a consequence of integrating information from sensory pathways with information from the pathways more directly responsible for generating movements. The cerebellum's efferent projections are among the most diverse of the nervous system, making it feasible for the cerebellum to influence all aspects of motor behavior as well as autonomic and cognitive functions of the nervous system.

### Regulation of Motor Behaviors

One of the primary functions of the cerebellum is the real-time control and coordination of a wide variety of movements. Characteristically, the more precise and complex the movement and the greater the integration required for its execution, the more the cerebellum is involved in its control. In general, the cerebellum is particularly important for the coordination of discrete, goal-directed smooth pursuit movements of the eyes (►smooth pursuit eye movements), control of ►gaze, and the regulation of multijoint movements of the extremities, particularly those requiring the integration

of postural changes with phasic limb movements. This structure is also important for the coordination of combined eye and hand movements.

Cerebellar circuits utilize both feedforward and feedback control mechanisms in regulating these movements. However, much of the literature emphasizes the importance of the cerebellum in predictive or feedforward control mechanisms (See [3] for Review). In general, feedforward mechanisms are utilized to generate preparatory modifications in motor output that enhance the performance of previously rehearsed or experienced movements. Feedforward control involving ►motor set and scaling of responses when novel tasks require modification of movements to attain a target accurately.

An example of this is shown in Fig. 2. In these experiments [4], cerebellar patients and normal controls were asked to move a manipulandum from a start position to a specific target through a force field, a velocity-dependent directional load imposed on the movement.

This force field deflected the movement down and to the right as the manipulandum moved from the start position to the target. It was necessary for a subject to properly predict the change in muscle activation required to compensate for the force field in order to move to the target in a straight line. Normal subjects (Control, top row) can acquire this capability after adequate practice. However, cerebellar patients who had spinocerebellar ataxia (SCA), even those that were not so ataxic (patient shown in B, E, and H) were incapable of compensating for the imposed force field. It is important to note that this type of cerebellar deficit appears task- and/or condition dependent. For example, animals with the critical components of the cerebellar efferent systems inactivated are still capable of acquiring and retaining compensation for a different type of elastic load applied every trial in a reaching task (see [5] for review of task dependency).

Likely related to the use of feedforward mechanisms is the capacity to establish ►internal representations critical to the performance of the task. These representations may relate to properties and location of the target, dimensions defining extrapersonal space, features of the musculoskeletal system and/or body image, and elements of the motor sequence. Experiments of the type illustrated in Fig. 2 suggest that cerebellar patients cannot form the appropriate internal representation of the force field. Other experiments indicate that this deficit is not limited to properties of the work space. For example, cerebellar patients also have deficits representing object shapes, particularly when the characteristics of the shapes must be acquired using kinesthetic cues.

In addition, the cerebellum also participates in feedback regulation by playing a role in modifying motor responses on the basis of updated information



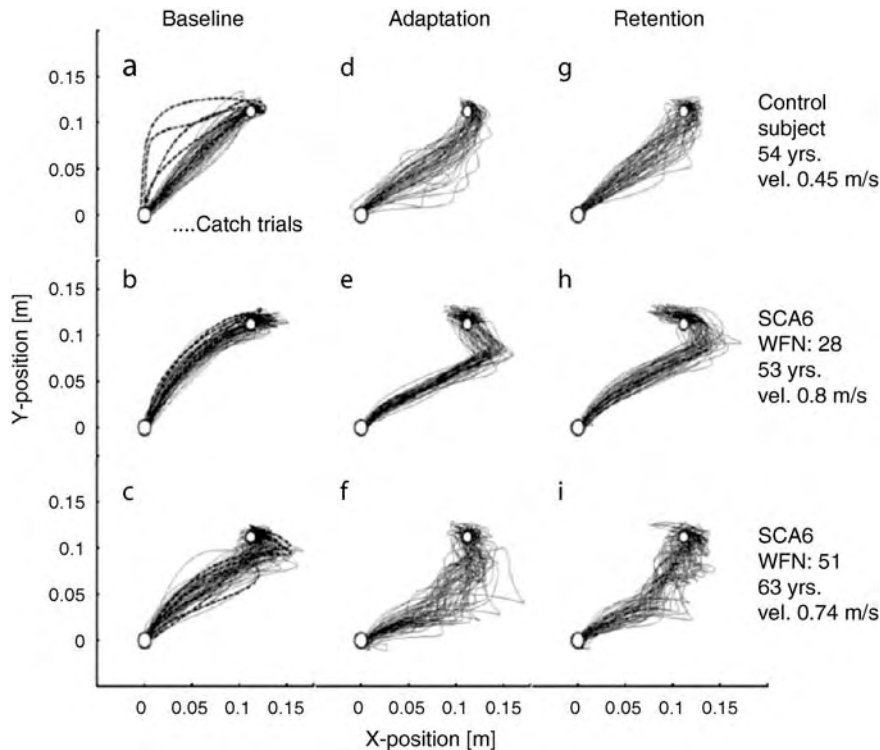

**Cerebellar Functions. Figure 2** Trajectories of a control subject and two cerebellar patients (WFN: 28 and WFN: 51) from a start position (circle, lower left) to a target (circle, upper right). A–C: control trials. Catch trials, trials in which no force field was applied during the trials in D–I, are shown as dashed lines. D–F: trials during adaptation. G–I: trials during the test for retention. Note that the force field consistently displaced the trajectory of the cerebellar patients. However, the control subject effectively compensated and also retained the task. Catch trials illustrate that the control subject had learned a new strategy to compensate for the load, since in the absence of the load, the movements demonstrated an after effect, a movement approximately opposite to the one learned in order to compensate for the load. SCA, spinocerebellar ataxia. Figure is from [4].

about the progress and accuracy of an ongoing movement. Consequently, this structure is very important in generating coordinated responses to perturbations encountered during the execution of a variety of tasks.

As introduced above, certain eye movements are among the movements most dependent upon the cerebellum for their normal performance. Without the required cerebellar circuitry, eye movements necessary for following slowly moving objects in the visual field, designated smooth pursuit movements, cannot be performed. In addition, very rapid or saccadic movements of the eyes are very dysmetric in the absence of cerebellar control. Finally, portions of the midline cerebellar region are critical for the full adaptation of the ►vestibular ocular reflex, a process required for recalibrating the movement of the eyes relative to the movement of the head.

### Motor Learning and Higher Cortical Functions

Considerable evidence has implicated the cerebellum in the learning of a wide variety of motor behaviors.

These range from classically conditioned reflexes to complex, operantly conditioned tasks. The specific contributions of the cerebellum to this function are reviewed in other entries in the Encyclopedia. Consequently, this overview will focus on the cerebellum's involvement in higher functions other than motor learning.

Studies implicating the cerebellum in other nonmotor functions have utilized imaging techniques such as fMRI and PET to illustrate changes in the activity of cerebellar regions during the execution of certain complex tasks, or they have examined the deficits manifested by cerebellar patients in related behaviors. Acknowledging that studies of this type provide strong inferences that the cerebellum is involved in these behaviors, they do not implicate this structure *causally* nor do they indicate *how* the cerebellum might be involved. That said, there is substantial evidence for the involvement of the cerebellum in the following higher order functions: solving tasks requiring the manipulation and perception of objects during the

solving of puzzles such as the Tower of Hanoi, certain word association and word selection tasks, perception of tone duration, the characteristics of imagined movements, and the perception of object shapes during ongoing movement. In addition, the occurrence of autism and schizophrenia has been associated with structural abnormalities in the cerebellum (See [6] for review).

### Summary: Overview of Cerebellar Function

The above sections emphasize that the cerebellum receives information from virtually every sensory system as well as from projections originating from structures important in motor control. In addition, the cerebellum plays at least some role in most if not all aspects of motor behavior. This heterogeneity of involvement has made it very difficult to assign a single function to this interesting structure. In attempting to integrate this information, general hypotheses have been proposed suggesting that the cerebellum acts as a “mediator” or “metasystem” for integrating information from multiple sensory systems on-line with information characterizing the task and the state of the organism in order to generate an optimized, well-coordinated movement ([7–9], see also the “context linkage” proposal of Thach [6]). The sensory systems convey information about the external environment or the influence of the environment on the body, each with its own unique reference frame (See [10] for overview of reference frames). These data must be effectively integrated with data represented in internal reference frames reflecting features of the intended movement and body scheme as well as with reference frames describing muscle space and execution space. Although the cerebellum and its afferent and efferent projections appear to be appropriately organized to contribute to this complex function, little is known regarding precisely how this integration is performed.

In addition to its role in regulating on-line motor behavior, the cerebellum also contributes to functions related to motor learning as well as other complex behaviors which are not movement related. The specific role the cerebellum plays in these higher order functions is still a matter of discussion. Similar to its role in regulating movements, its role in higher order functions may also be task- and condition-dependent. Consequently, its specific contribution to storing motor engrams and in regulating the storage-related processes at other sites remains uncertain and may be dependent on the type of behavior being learned and the conditions under which the task is being performed. Its role in other non-motor functions has been inferred largely from testing cerebellar patients and from imaging studies. The current evidence clearly shows that activity in certain cerebellar regions is modulated during the

performance of certain higher order tasks, and that some complex higher order functions are impaired in cerebellar patients [6].

Many questions remain regarding the precise mechanisms by which the cerebellar cortex and nuclei contribute to the multiple types of neuronal and system interactions required for the execution of the wide variety of behaviors in which this structure is involved. Attaining the answers to these questions is confounded not only by the complexity of the integration required but also by the fact that the extent of the cerebellum’s involvement in both the on-line control of movement and higher functions associated with motor control appear to be task- and/or condition-dependent. Thus, the extent and the nature of the cerebellum’s involvement in any given movement is likely dependent on factors such as: the type or class of movement (reflexive, volitional, postural, etc.), the characteristics of the motor sequence, the novelty of the movement, the extent to which learning is required, the association of posture and movement, the occurrence of a perturbation during execution, and the requirement of feedforward and/or feedback control.

### References

1. Thach WT, Goodkin HP, Keating JG (1992) The cerebellum and the adaptive coordination of movement. *Ann Rev Neurosci* 15:403–442
2. Bloedel JR, Bracha V (1998) Current concepts of climbing fiber function. *Anat Rec* 253:118–126
3. Bastian AJ (2006) Learning to predict the future: the cerebellum adapts feedforward movement control. *Curr Opin Neurobiol* 16:645–649
4. Maschke M, Gomez CM, Ebner TJ, Konczak J (2004) Hereditary cerebellar ataxia progressively impairs force adaptation during goal-directed arm movements. *J Neurophysiol* 91:230–238
5. Bloedel JR (2003) Task-dependent role of the cerebellum in motor learning. *Brain*. In: Mori S, Stuart DG, Wiesendanger M (eds) Mechanisms for the integration of posture and movement. *Prog Brain Res* 143:313–323
6. Thach WT (1996) On the specific role of the cerebellum in motor learning and cognition: clues from PET activation and lesion studies in man. *Behav Brain Sci* 19:411–431
7. Bloedel JR (1992) Functional heterogeneity with structural homogeneity: how does the cerebellum operate? *Behav Brain Sci* 15:666–678
8. MacKay WA, Murphy JT (1979) Cerebellar modulation of reflex gain. *Prog Neurobiol* 13:361–417
9. Pellionisz A (1985) Tensorial brain theory in cerebellar modeling. In: Bloedel JR, Dichgans J, Precht W (eds) *Cerebellar functions*. Springer-Verlag, New York, pp 201–229
10. Soechting JF, Flanders M (1992) Moving in three dimensional space: reference frames, vectors, and coordinate systems. *Ann Rev Neurosci* 15:167–191

## Cerebellar Hemisphere

### Synonyms

Hemispherium cerebelli; Hemisphere of cerebellum

### Definition

The cerebellum can be divided into three parts:

- Hemispheres (cerebellar hemisphere)
- Vermis cerebelli
- Peduncles (cerebellar peduncles)

The hemispheres have a pronounced cortical structure (cerebellar cortex) rising like a tree from the central matter (medullary body of cerebellum) and is called arbor vitae, the tree of life.

► Cerebellum

## Cerebellar Hemisphere, Intermediate Part

### Definition

The regions of the cerebellar hemisphere that are close to the vermis are called the cerebellar hemisphere, intermediate part. This runs around 1 cm to the right and left of the vermis, and like the latter it receives its afferents primarily from the spinal cord (spinocerebellum). As opposed to the vermis, the Purkinje cells of the intermediate part project to the interpositus nucleus and not, as in the case of the vermis, to the fastigial nucleus.

► Cerebellum

## Cerebellar Hemisphere, Lateral Part

### Definition

The cerebellar hemisphere is subdivided into the intermediate part close to the vermis and the remaining lateral part. This has resulted from important functional observation, indicating that the Purkinje cells located in this lateral part have a common projection area, i.e. the dentate nucleus, while conversely the Purkinje fibers of the of the cerebellar hemisphere, intermediate part, project to the interpositus nucleus.

► Cerebellum

## Cerebellar Hemorrhage

### Definition

Cerebellar hemorrhage often occurs around the ► dentate nucleus and causes ► ataxia-abasia and ipsilateral limb ► ataxia. Sometimes there is ipsilateral facial weakness and gaze palsy. With increasing swelling, ► coma, ► miosis, ► ophthalmoplegia and disturbances of respiration may occur and end in demise.

## Cerebellar Long-Term Depression

### Definition

Long-term depression is a type of synaptic plasticity accompanied with the long-lasting decrease in efficacy of synaptic transmission. In the cerebellar cortex, repetitive coupled activation of parallel fibers and a climbing fiber induces the long-lasting decrease of transmission efficacy at the parallel fibers and Purkinje neuron synapses. This cerebellar long-term depression has been considered as a cellular basis of motor learning.

► Sensory Motor Learning/Memory and Cerebellum

## Cerebellar Nuclei

### Definition

A set of three discrete nuclei within the cerebellum consisting of medial, intermediate and lateral nuclear groups. These nuclei receive inputs from extrinsic sources and from cerebellar Purkinje cells from different regions of the cerebellum. The axons of cerebellar nuclear neurons project to the brainstem and thalamus.

- Cerebellar Functions
- Purkinje Cell, Neuron

## Cerebellar Nuclei

### Synonyms

Nuclei cerebelli; Cerebellar nuclei

**Definition**

Subsumed under this collective term are four central cerebellar nuclei:

- Dentate nucleus
- Fastigial nucleus
- Emboliform nucleus
- Globose nucleus

► Cerebellum

---

## Cerebellar Sagittal Zone

**Definition**

An anterior-posterior strip of the cerebellar cortex containing Purkinje cells projecting to a specific mediolateral region in the cerebellar nuclei. Each zone also receives projections from a specific region of the inferior olive. There are also chemical markers that demarcate these zones.

- Cerebellar Functions
- Purkinje Cell, Neuron

---

## Cerebellum

**Definition**

Cerebellum is composed of a centrally situated vermis (“worm”) and the two hemispheres. It is responsible above all for planning motor programs and for preserving equilibrium.

---

## Cerebellum – Flocculus Target Neurons

STEPHEN M. HIGHSTEIN

Department of Otolaryngology and Department of Anatomy and Neurobiology, Washington University Medical School, St. Louis, MO, USA

**Synonyms**

FTNs

**Definition**

Neurons in the cerebellar roof nuclei or brainstem that receive the terminals of cerebellar cortical Purkinje cells.

**Characteristics****Quantitative Description**

FTNs are usually only one or two synapses distant from the motor output. Thus, while Purkinje cells receive mixed sensory and motor signals, FTNs tend to be more related to the motor system. FTNs receive the terminals of cerebellar cortical Purkinje neurons, usually upon their somata and proximal dendrites. This results in powerful mono-synaptic inhibition that is also tonic, as the average firing rate of a Purkinje cell, at least in the cerebellar ► **flocculus**, is about 100 impulses/s. FTNs, in turn usually fire at high rates, ca. 120 impulses/s because they are bombarded by excitatory inputs (► **Flocculus hypothesis**). This balance between FTN afferent excitation and Purkinje cell inhibition determines the moment-to-moment firing rate of FTNs.

**Higher Level Structures**

The head can be envisioned as a sphere mounted on a ball joint, the neck, and is thus free to rotate in pitch, roll, and yaw. The head and body can also translate linearly. (An example of linear translation is walking.) The brain needs to be kept informed of the linear motion and position of the head and body and of the angular motion of the head. Relevant information is carried by the primary vestibular afferents that originate within the vestibular labyrinth. The labyrinth, located within the inner ear, is composed of linear accelerometers that sense the impulsive and gravitational components of linear acceleration and angular accelerometers that sense angular head motion. The angular sensors, the semicircular canals, are three in number bilaterally, and anatomically situated in the pitch, roll, and yaw axes of head rotation. Primary vestibular afferents terminate within the vestibular nuclei in the brainstem, while a subset projects directly to the cerebellum. **Fig. 1** illustrates these neural connections.

The brainstem terminal sites of primary vestibular afferents define the territory of the vestibular nuclei. Some vestibular nuclear neurons send their (axons) nerve fibers to the cerebellum. These are called flocculus projecting neurons or FPNs (**Fig. 1**), and relay information about head motion and position that originates within the labyrinth. The vestibular nuclei are often viewed as a subset of the cerebellar roof nuclei (fastigial, interpositus, and dentate nuclei) because of the volume of vestibulo-cerebello-vestibular impulse traffic.

The sole output of the cerebellar cortex is the axons of the Purkinje cell, and while the terminal sites of these axons are localized to certain nuclear sites, they can also be diffuse in other regions. Thus, there is no specific,

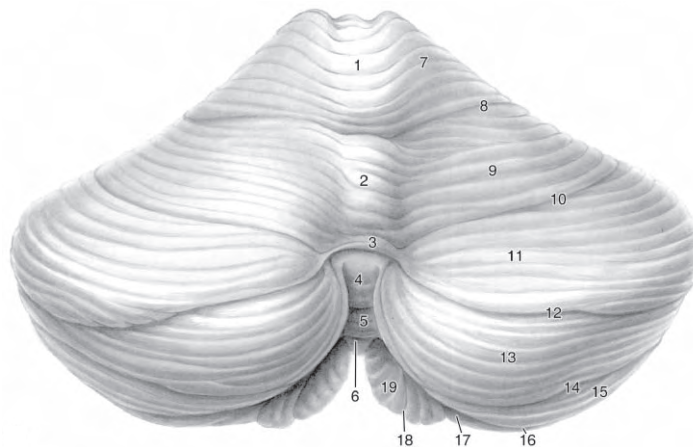

- |                       |                                     |                         |
|-----------------------|-------------------------------------|-------------------------|
| 1 Culmen              | 8 Primary fissure                   | 15 Gracile lobule       |
| 2 Declive             | 9 Lobulus simplex                   | 16 Prebiventral fissure |
| 3 Folium vermis       | 10 Posterior superior fissure       | 17 Biventral lobule     |
| 4 Tuber vermis        | 11 Superior semilunar lobule        | 18 Secondary fissure    |
| 5 Pyramis             | 12 Horizontal fissure               | 19 Tonsil               |
| 6 Uvula               | 13 Inferior semilunar lobule        |                         |
| 7 Quadrangular lobule | 14 Pregracile fissure<br>(variable) |                         |

**Cerebellum. Figure 1a** Dorsal view of the cerebellum (6/5×). Original figure 3.11a and b; taken from Nieuwenhuys, R; Voogd, J; van Huijzen, C. (Eds) 2008 "The Human Central Nervous System". Fourth Edition. Springer, Berlin. page 83 with permission.

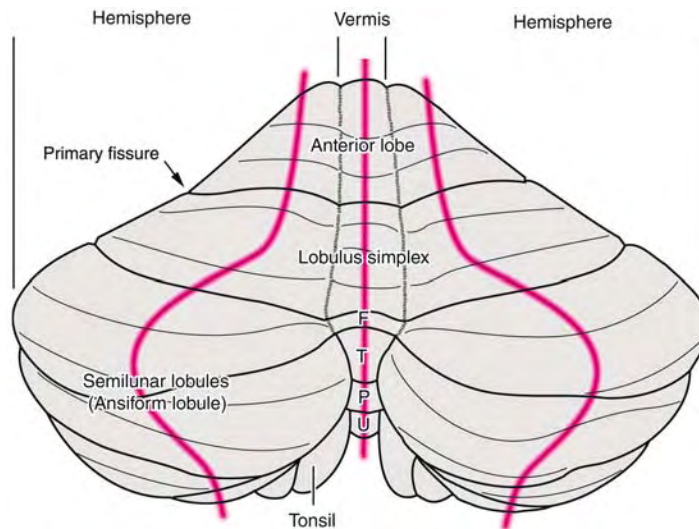

**Cerebellum. Figure 1b** Diagram of a dorsal view of the cerebellum. The direction of the folial chains of vermis and hemispheres is indicated by red lines. Note folial loop of the semilunar lobules. (The ansiform lobule of the comparative anatomical nomenclature, see also Fig. 20.2) F, folium; P, pyramis; T, tuber; U, uvula; taken from Nieuwenhuys, R; Voogd, J; van Huijzen, C. (Eds) 2008 "The Human Central Nervous System". Fourth Edition. Springer, Berlin. Page 83 with permission.

anatomical vestibulo-cerebellar territory. The vestibulo ocular reflex or VOR can serve as an example system to illustrate some principles of vestibular, cerebellar interactions.

VOR circuitry, although touted as a simple system because of the three-neuron arc, from vestibular nerve input to oculomotor neuron output, is actually decidedly more complex. This arc is imbedded into a structure

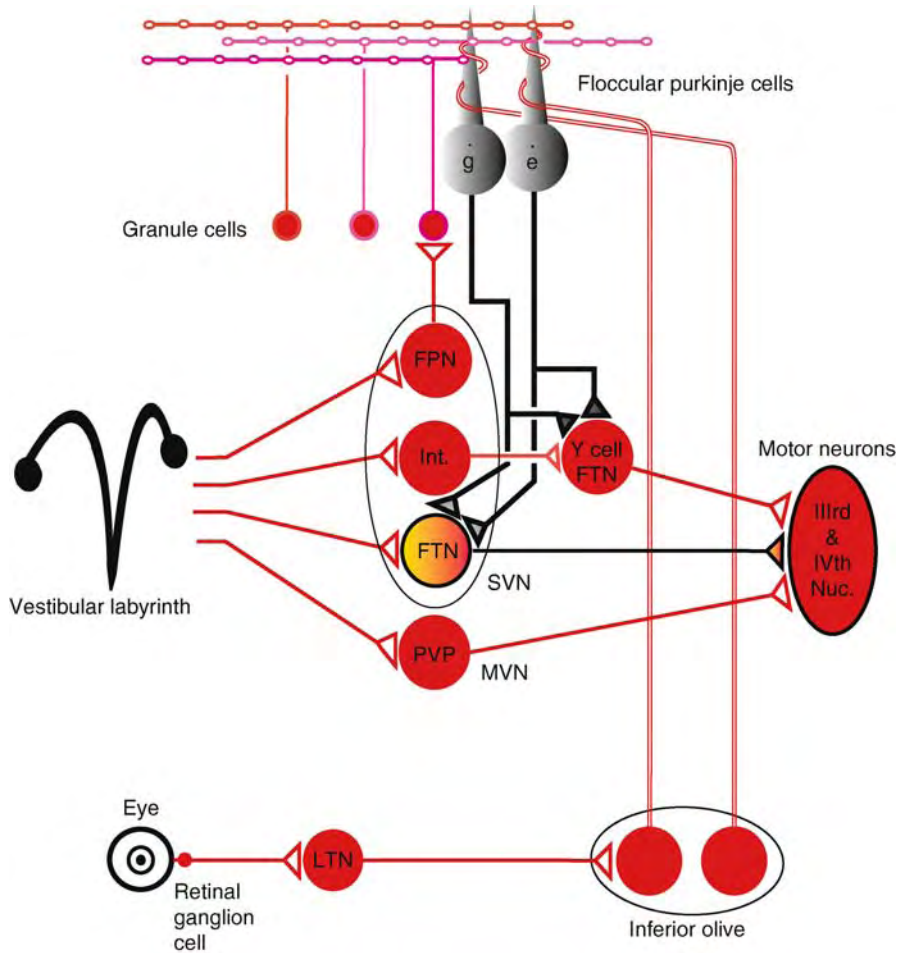

**Cerebellum – Flocculus Target Neurons. Figure 1** A schematic of the connections between the flocculus of the cerebellum and brainstem that control the VOR. FTN is a flocculus target neuron, FPN is a flocculus projecting neuron, PVP is a position-vestibular-pause neuron, Y Cell is a cell in the Y group of the vestibular nuclei, Int. is an interneuron, SVN is a superior vestibular nucleus, MVN is a medial vestibular nucleus, IIIrd and IVth nuc. are the oculomotor and trochlear nuclei, respectively.

containing highly recursive and interconnected loops between the brainstem and cerebellum. Inputs to the cerebellum via FPNs of the vestibular nuclei transmit head velocity and eye movement parameters to the cerebellar cortex carried by mossy fibers. This information is processed within the cortical circuitry and the output of the computation is returned to the vestibular nuclei by Purkinje axons that terminate on a subset of nuclear neurons, the FTNs (Fig. 1). VOR-FTNs generally project directly to extraocular motor neurons, the output of the three-neuron arc. Due to this anatomy, Ito, [1] more than 30 years ago, envisioned the flocculus as a side loop of the main VOR circuitry. While VOR-FTNs are the most intensely studied, it should be realized that the cerebellar cortex also projects to many other nuclei such as Deiters' nucleus, the dorsal, and the lateral vestibular nucleus. Giant Deiters' neurons receive some primary afferent vestibular input, are the recipient

of anterior lobe Purkinje axons, and give rise to the lateral vestibulo-spinal tract that terminates upon spinal extensor motor neurons. Fastigial nucleus neurons are also the targets of cortical Purkinje cell axons and are involved in the formation of saccadic and smooth pursuit eye movements. There is also major cerebellar projecting and recipient traffic within the descending and medial vestibular nuclei that has not yet been the object of much study, but is likely involved in velocity storage and oculomotor integration.

#### Lower Level Components

The somatodendritic morphology of vestibular neurons is correlated with their axonal projection targets. Vestibular VOR neurons project rostrally to the oculomotor nuclei and to the cerebellum. Many superior vestibular nucleus (SVN)-VOR neurons are FTNs. Mitsacos et al. [2,3] injected SVNs neurons with horseradish peroxidase for

morphological study. Cells were identified as projecting to the oculomotor nuclear complex (VOR-SVN) or to the cerebellum. VOR-SVN neurons vary in shape from pyramidal or multipolar to ovoidal or elongated. Most neurons exhibited their longest dendritic extent along the rostro-caudal axis while their shortest extent was in the coronal plane. Most of the dendrites remained within the cellular boundaries of the nucleus. The branching pattern of VOR neurons is isodendritic [4] i.e. most dendrites follow a straight course and branch in such a manner that the primary dendritic segments are shorter than the secondary ones and these, in turn, are shorter than the tertiary ones. Fig. 2 illustrates examples of FPN and VOR neurons. Note the differences in dendritic trees.

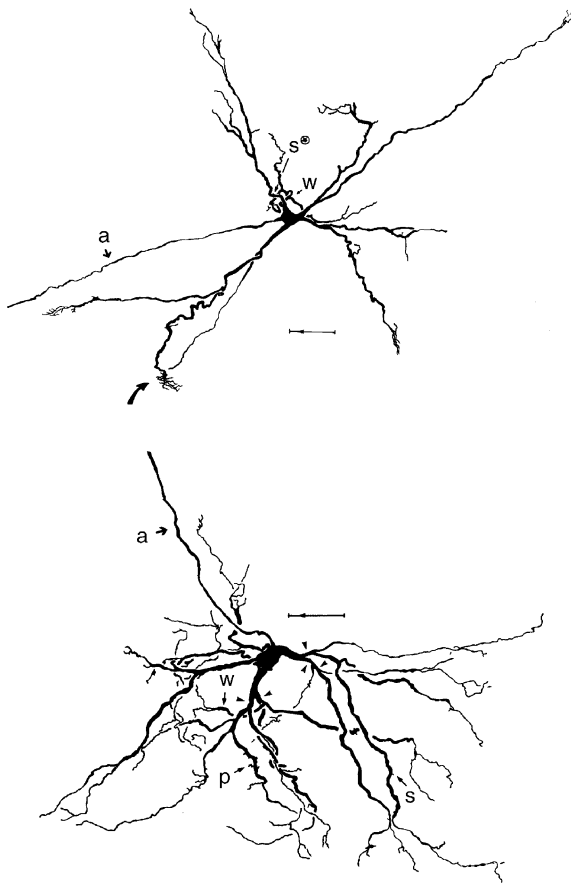

### Cerebellum – Flocculus Target Neurons.

**Figure 2** Reconstructions of two superior vestibular nucleus neurons. The upper neuron is the soma and dendrites of an SVN-VOR neuron. The curved arrow points to a terminal dendritic formation, s is a dendritic spine, w is a wavy dendrite and a is the axon. The bottom neuron is an SVN-cerebellar projecting neuron. Arrowheads point to dendritic segments displaying an allodendritic branching pattern, p is a dendritic process, and w is a wavy dendrite. Calibration is 100  $\mu$ m; arrow in the calibration bar points to the midline.

Cerebellar-projecting neurons had dendrites also confined to the SVN cellular boundaries and demonstrated the same rostro-caudal orientation as VOR neurons. While on average only 16% of VOR neuronal dendrites exhibited an allodendritic branching pattern (daughter branches shorter than parents, resulting in a dendritic arborization that is denser towards the periphery of the dendritic tree), neurons projecting to the cerebellum exhibit a particularly high degree of allodendritic branching. In the Squirrel monkey, SVN-VOR and cerebellar projecting neurons are morphologically similar to those described in the cat [5].

The cerebellar-brainstem loop has long been implicated in VOR plasticity, smooth pursuit eye movement generation, and the oculomotor integrator. Removal of the cerebellum completely abolishes the ability to change VOR gain, severely compromises smooth pursuit eye movements and affects the ability to hold gaze at eccentric positions.

### References

1. Ito M (1972) Neural design of the cerebellar motor control system. *Brain Res* 40:81–84
2. Mitsacos A, Reisine H, Highstein SM (1983a) The superior vestibular nucleus: an intracellular HRP study in the cat. I. Vestibulo-ocular neurons. *J Comp Neurol* 215:78–91
3. Mitsacos A, Reisine H, Highstein SM (1983b) The superior vestibular nucleus: an intracellular HRP study in the cat. II. Non-vestibulo-ocular neurons. *J Comp Neurol* 215:92–107
4. Ramon-Moliner E, Nauta WJ (1966) The isodendritic core of the brain stem. *J Comp Neurol* 126:311–335
5. Highstein SM, Goldberg JM, Moschovakis AK, Fernandez C (1987) Inputs from regularly and irregularly discharging vestibular nerve afferents to secondary neurons in the vestibular nuclei of the squirrel monkey. II. Correlation with output pathways of secondary neurons. *J Neurophysiol* 58:719–738

## Cerebellum – Oculomotor Vermis

### Definition

The circumscribed portion of the cerebellar vermis (lobules VIc and VII) that appears to be integral to the control of saccadic and smooth-pursuit eye movements.

- ▶ Cerebellum – Role in Eye Movements
- ▶ Oculomotor Vermis
- ▶ Saccade, Saccadic Eye Movement
- ▶ Smooth Pursuit Eye Movements

## Cerebellum – Role in Eye Movements

CHARLES A. SCUDDER  
Portland, OR, USA

### Synonyms

Oculomotor cerebellum; Vestibulocerebellum

### Definition

As with other motor systems, circumscribed parts of the cerebellar cortex and deep cerebellar nuclei participate in the generation and control of eye movements. These eye movements include ►saccades, smooth pursuit (►smooth pursuit eye movements), the ►vestibulo-ocular reflex (VOR), and ►vergence [1]. Visual and vestibular signals and oculomotor command signals arise from relay nuclei in the brainstem, are processed in the cerebellum, and project back to the brainstem where they are ultimately conveyed to the ocular motor nuclei. Such trans-cerebellar pathways that mediate the generation of saccades and the VOR each parallel a more direct pathway confined to the brainstem, as is typical of other motor systems. However, trans-cerebellar pathways that mediate the generation of smooth pursuit do not appear to have a direct counterpart in the brainstem.

### Characteristics

#### Parts of the Cerebellum

The ►oculomotor vermis (►cerebellum – oculomotor vermis) consists of lobules VIc and VII of the midline cerebellar cortex. It was first defined in the monkey as the region where low amplitude (<10  $\mu$ A) electrical microstimulation elicits saccadic eye movements, but slower, smooth-pursuit like eye movements are also elicited. Prominent saccade, smooth-pursuit, and head-movement related signals are present in the discharges of neurons in this region [2]. Nearby regions that are not in the circumscribed oculomotor vermis (e.g. vermal lobules VIa,b and VIII) may nonetheless participate somewhat in the control of eye movements, since eye movements can be elicited in this area by microstimulation at moderate current strengths, and eye- and head-movement neuronal discharges can also be recorded.

The ►fastigial oculomotor region (FOR) (►cerebellum – fastigial oculomotor region (FOR)) is a circumscribed region in the caudal fastigial nucleus, the most medial of the deep cerebellar nuclei, where saccades are elicited by microstimulation and where neurons exhibiting saccade-related and smooth-pursuit related discharges are found. This region corresponds closely with the part of the fastigial nucleus that receives Purkinje-cell input from the oculomotor vermis.

The ►flocculus and ventral paraflocculus are contiguous structures adjacent to the cerebellar

hemispheres and overlying the eighth cranial nerve. Due to past inconsistencies in the naming of the ventral paraflocculus and to similarities of its connections and neuronal discharges with those of the flocculus (see below), the two areas are sometimes lumped together as the ►floccular lobe. Collectively, they participate in the generation of smooth pursuit and the regulation of the VOR. The flocculus receives direct input from the vestibular portion of the eighth nerve, and so is one part of the vestibulocerebellum.

The nodulus and uvula are vermal regions on the underside of the cerebellum that corresponds to midline lobules X and IX, respectively. The nodulus and rostral uvula also receive direct input from the vestibular nerve and have heavy reciprocal connections with the vestibular nuclei. It is the second component of the vestibulocerebellum. The nodulus/uvula is integral to the velocity storage mechanism, and so, participates in controlling the time course and direction of prolonged vestibularly and optokinetically induced eye movements (see ►velocity storage).

The ventral portion of the monkey posterior interpositus nucleus and adjacent portions of the caudal dentate nucleus have been implicated in the control of saccades. Inputs to this area derive from saccadic and/or smooth-pursuit regions of parietal cortex by way of the dorsal and dorsolateral pontine nuclei. The same inputs innervate the dorsal and ventral paraflocculus, which project back to the interpositus/dentate. This region also projects directly to the superior colliculus and interstitial nucleus of Cajal, and indirectly to the frontal eye fields; all structures known to participate in the generation of saccades. In addition, the interpositus contains neurons that exhibit saccade-related discharges, and its transient inactivation using the GABA agonist, muscimol, results in an upward bias in the endpoints of saccades (dysmetria). This data is suggestive but preliminary, and a better understanding of the role of the ventral posterior interpositus and dentate area will require additional data.

A second more rostral oculomotor part of the dentate nucleus, which may overlap the part of the first area, is an extension of the y-group of the vestibular complex. This region contains neurons that are excited during upward eye velocity during smooth pursuit and during upward head rotation with the VOR suppressed. In macaques, these eye and head signals are roughly equal, and approximately cancel during VOR in the dark (i.e. they encode ►gaze velocity). Some neurons have eye position sensitivity and most have saccadic eye-movement sensitivity. As the dentate/y-group area receives inputs from the paraflocculus and projects to the oculomotor nucleus, this region is thought to participate in generating vertical smooth pursuit.

Finally, evolution in humans produced a huge expansion of the lateral cerebellum along with its target



nucleus, the dentate. There are strong indications that this expanded region participates in human cognitive functions. Accordingly, a portion of the lateral cerebellum has increased activity in functional-MRI studies of humans generating memory-guided saccades (►memory-guided saccade task) and ►antisaccades.

### Higher Level Structures

Oculomotor portions of the cerebellum receive direct input from the eighth nerve, the vestibular nuclei, the pontine reticular formation (paramedian pontine reticular formation (PPRF)), raphe nuclei in the pons and medulla, and indirectly from the superior colliculus and specific regions of the cerebral cortex. The latter are relayed through the ►nucleus reticularis tegmenti pontis (NRTP) and the pontine nuclei (see below). The cortical inputs to these relay nuclei include the ►frontal eye fields (FEF), the ►supplementary eye fields (SEF), parietal areas middle temporal (MT), medial superior temporal (MST), and ►lateral intraparietal area (LIP). (Each of these areas is discussed more fully elsewhere in this Encyclopedia). A previous concept that each cortical region served one particular type of eye movement, (e.g. the FEF subserved saccades and area MST subserved smooth pursuit) has been replaced after the demonstration that the FEF, SEF, and LIP each have adjoining or partially overlapping saccade-related, smooth-pursuit related, and sometimes vergence-related areas, and that visual motion processing areas MT and MST have connections with the saccade-related as well as pursuit-related cortical and subcortical structures. Accordingly, both saccade-related, smooth-pursuit related and vergence-related signals have been recorded from neurons in NRTP and the dorsolateral pontine nuclei.

The inferior olive provides climbing fiber inputs to all portions of the contralateral cerebellum, but these inputs are not thought to be important in short-term signal processing and will not be considered further.

### Lower Level Processes

There are several targets of the cerebellar output that are best examined in the context of the pathways mediating each type of eye-movement. For the saccadic system, cerebellar efferents arise from the FOR and project to the saccadic burst generators in the contralateral pontine and midbrain reticular formations, the contralateral superior colliculus, and thalamus. The burst generators excite agonist and inhibit antagonist motoneurons to generate the saccade (see ►brainstem burst generator). For the smooth-pursuit system, different fastigial-nucleus efferents project to the vestibular nuclei and the pontine and midbrain reticular formations near the burst generators. An additional smooth pursuit pathway traverses the floccular lobe, which in turn, also projects to the vestibular nuclear complex. Specific output targets, which are better

known for the floccular pathway, include the superior vestibular nucleus, the medial vestibular nucleus, the ventrolateral vestibular nucleus, and the y group. Signals are then conveyed to the ocular motoneurons to produce smooth-pursuit eye movements. There is also a projection of the floccular lobe to the basal interstitial nucleus of the cerebellum, whose function is not known. Details regarding these pathways are elaborated for each eye-movement system below.

## Functions of the Cerebellum

### Generation and Control of Saccades

Preliminary commands for the generation of saccades originate in cortical areas that include the FEF, SEF, LIP, and the ►substantia nigra. These signals converge on the deep and intermediate layers of the ►superior colliculus, which issues the final command to generate a saccade (Fig. 1). Crossed collicular efferents convey this command directly to the ►brainstem burst generator and indirectly to the cerebellum via medial parts of NRTP. In addition, the FEF and SEF have direct ipsilateral projections to medial and dorsal NRTP and to the medial and dorsolateral pontine nuclei, while LIP has direct projections to the dorsolateral pontine nuclei. These areas of NRTP and the pontine nuclei in turn send projections to the fastigial oculomotor region (FOR) and to the oculomotor vermis bilaterally. Purkinje cells in the oculomotor vermis project to the FOR, which in turn projects to the saccadic burst generator. Thus, the burst generator receives a direct saccadic command from the superior colliculus and an indirect one via the cerebellar loop. Present thinking is that the former is a course command that is refined by the output of the cerebellum to achieve more precise control of saccade size and direction. Moreover, it is thought that this refined signal is the product of adaptive motor learning regulated by the cerebellum (see ►saccadic adaptation).

Purkinje cells in the oculomotor vermis have a spontaneous discharge, and the majority exhibit saccade-related responses [3]. Of these, the great majority (71–97%, depending on the study) exhibit a burst of spikes during or preceding saccades in at least one direction, while the remainder cease or reduce their firing during or preceding the saccade. Of the neurons that burst, most have a burst that precede saccades in one direction and have a later burst in the opposite direction. Others have no directional preference, while others burst in one direction and pause in the opposite direction. Directional preferences can be either ►ipsiversive or ►contraversive, with a slight contraversive preference. The duration of the Purkinje cell burst is, on average, correlated with the duration of the saccade, and may serve to control saccade duration [4].

Purkinje cells in the oculomotor vermis make inhibitory connections with neurons in the ipsilateral FOR. However, the saccade-related discharges of FOR

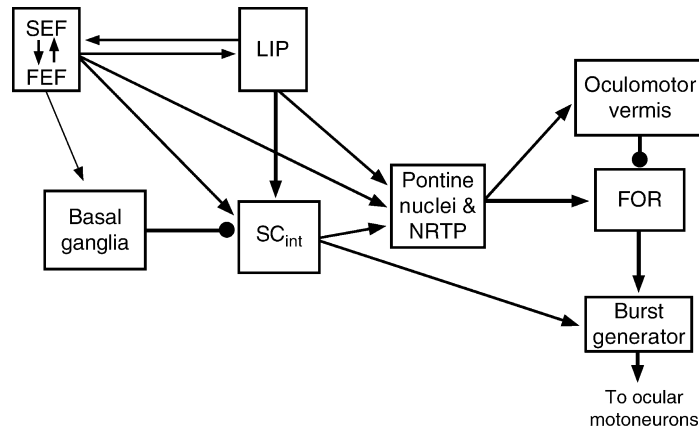

**Cerebellum – Role in Eye Movements. Figure 1** Block diagram of the saccadic system showing cortical input converging on the intermediate and deep layers of the superior colliculus ( $SC_{int}$ ) and on to precerebellar relay nuclei in the ventral pons (NRTP and Pontine Nuclei). These relay nuclei also receive a copy of the saccadic command from the  $SC_{int}$ , and all signals are sent to the oculomotor vermis and the fastigial oculomotor region (FOR). The major feed-forward pathways are shown; feedback pathways from the cerebellum to NRTP, from cerebellum to the thalamus, and from thalamus to cortex, have been omitted. Thinner lines represent pathways not discussed in the text. Lines ending in arrow-heads represent excitatory connections; lines ending in circular bulbs represent inhibitory connections. FEF, frontal eye fields; SEF, supplementary eye fields; LIP, lateral intraparietal area; NRTP, nucleus reticularis tegmenti pontis.

neurons resemble those of the vermis more than their inverse (see below). Evidently, FOR neurons are strongly influenced by the collaterals of the same mossy-fiber afferents that provide input to the vermis. FOR neurons typically have a spontaneous firing rate and a burst of spikes for all saccades, but the timing is characteristically dependent on saccade direction. Bursts for contraversive saccades typically lead saccade onset by an average 4–19 ms [5], and end about the same time as the saccade. The burst onset for ipsiversive saccades typically lag saccade onset but lead saccade termination, and the burst typically outlasts the saccade. The loose correlation between ipsiversive burst onset and saccade termination has led to the idea that this burst may bring about saccade end. The bursts are frequently preceded by decreases in firing or frank pauses, especially for ipsiversive saccades, and sometimes are followed by pauses. These pauses are possibly the work of inhibition from the vermis, and may reflect a process of sculpting the leading and trailing edges of the FOR bursts. Presumably, the vermis also affects the peak burst frequency of FOR neurons.

A minority of FOR-neurons have a qualitatively similar discharge pattern that is rotated into a predominantly vertical direction.

Efferents of the FOR target the horizontal and vertical burst generators, and physiological data show that efferents make excitatory connections with horizontal burst neurons (see ▶brainstem burst generator). Based on these connections, the discharges of FOR neurons,

and the effect of unilateral lesions (see below), the FOR appears to augment the discharge frequency of the premotor excitatory burst neurons (EBNs) during contraversive saccades, and may assist in terminating the discharge of excitatory burst neurons during ipsiversive saccades. By having such control of the burst duration and amplitude of the agonist and antagonist premotor neurons, the FOR is well suited to exert powerful control over saccade size and direction.

#### Generation of Smooth Pursuit

Smooth pursuit is initiated by the decision to track a moving target or the perception of motion without frank motion. Little is known about the neural substrate of the decision or the perception, but the encoding of target motion by striate and extrastriate visual cortex is well understood. In particular, cortical areas MT and MST are thought to be the source of the target motion signal used by the smooth-pursuit system. Medial parietal area 7m may also participate, but there is currently insufficient data to be positive. These regions project to the dorsolateral pontine nuclei, the frontal eye fields, and the supplementary eye fields, which each contain regions dedicated to smooth pursuit (see ▶frontal pursuit area). The FEF and SEF, in turn, project principally to the medial, dorsal, and dorsolateral pontine nuclei and to medial and dorsal NRTP. These pontine precerebellar nuclei convey the highly processed visual information to two different cerebellar circuits which are both important for the generation of smooth pursuit [6].

### Medial Cerebellar Circuit

The first circuit includes the oculomotor vermis and caudal fastigial nucleus in a pathway very reminiscent of the saccade-related circuit above (Fig. 2). FEF- and SEF-recipient regions of medial and dorsal NRTP and dorso-medial pontine nuclei, and parietal-recipient regions of the dorsolateral pontine nuclei project to the oculomotor vermis and to the caudal fastigial nucleus via collaterals. Electrophysiological studies of Purkinje cells in the oculomotor vermis have yielded highly variable results, so the following description will not be quantitative. The majority of cells are excited during movement of the eye in a characteristic preferred direction that varies from cell to cell. Substantial numbers of these Purkinje cells also respond to image motion across the stationary retina and/or to vestibular stimulation in the absence of eye movements (subjects suppress their VOR during whole-body oscillation by fixating a target that moves in conjunction with their head). Eye-movement and vestibular responses are in phase with eye and head velocity, respectively. Many Purkinje cells have eye- and head-velocity sensitivities that are quantitatively similar and are in the same direction (“gaze-velocity neurons”). These gaze-velocity signals are likely a combination of processed visual signals being shaped into a smooth-pursuit command, eye-velocity signals, and head velocity signals that are input by way of projections from the brainstem. A smaller number of Purkinje cells have eye- and head-velocity sensitivities

that are substantially unequal or in different directions. According to some studies, many eye- and head-velocity signals can also be recorded from vermal areas of lobules VIa,b and VIII, which are immediately adjacent to the oculomotor vermis.

Purkinje cells in the oculomotor and surrounding vermis project to the caudal fastigial nucleus. Additionally, the fastigial nucleus receives input from NRTP, the dorsolateral and dorsomedial pontine nuclei, as noted above. Smooth-pursuit neurons in the fastigial nucleus exhibit discharges reminiscent of those in the vermis, with almost all exhibiting head-velocity and eye-velocity sensitivity [7]. However, the head-velocity and eye-velocity sensitivities were usually different in phase and magnitude, so that the neurons did not exhibit gaze-velocity discharges. There was also a large preponderance of neurons preferring contraversive and downward eye movement. During sudden-onset smooth pursuit, the latency of the response sufficiently preceded eye acceleration to support the hypothesis that the caudal fastigial participates in the initiation of smooth pursuit. The bias in preferred directions together with the effect of transient inhibition of caudal fastigial neurons by injection of muscimol has led to the idea that caudal fastigial neurons appear to assist in promoting contraversive eye acceleration and ipsiversive eye deceleration [1]. The smooth-pursuit related neurons in the caudal fastigial constitute a substantially separate population from the saccade-related neurons, since only 29% of the neurons discharged during saccades.

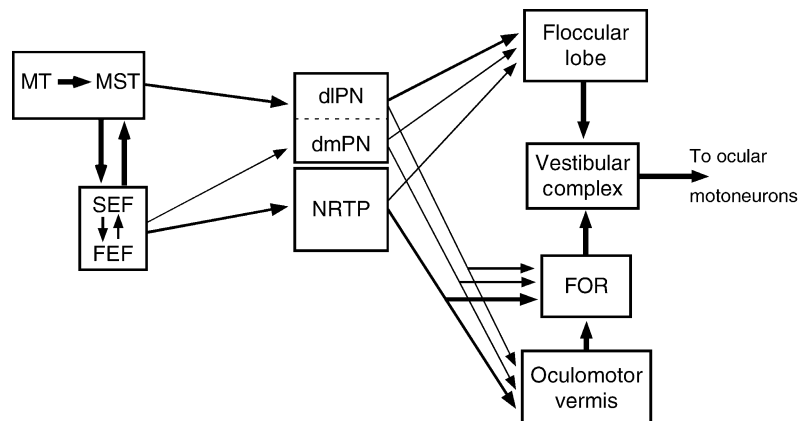

**Cerebellum – Role in Eye Movements. Figure 2** Block diagram of the smooth pursuit system showing the flow of target-motion information from cortical areas MT and MST to cortical areas FEF and SEF, from the cortex to relays in the ventral pons (dIPN, dmPN, NRTP), and then to the cerebellum via two routes (Floccular lobe and Oculomotor vermis). Signals converge on the vestibular nuclei, which drive the ocular motoneurons. Thinner lines represent weaker pathways. *MT*, middle temporal; *MST*, medial superior temporal; *FEF*, frontal eye fields; *SEF*, supplementary eye fields; *dIPN*, dorsolateral pontine nuclei; *dmPN*, dorsomedial pontine nuclei; *NRTP*, nucleus reticularis tegmenti pontis; *FOR*, fastigial oculomotor region. The vestibular complex includes the medial, superior, and ventrolateral vestibular nuclei and the y group. Only major feed-forward pathways are shown; feedback pathways from the cerebellum to NRTP and the thalamus have been omitted.

The exact pathway by which fastigial smooth-pursuit signals reach ocular motoneurons has not been adequately explored. Efferents of the caudal fastigial nucleus target the vestibular nuclei in addition to the ►[paramedian pontine reticular formation](#). Parts of the vestibular nuclei contain neurons that encode eye position and/or velocity during smooth pursuit and that project to the abducens nucleus. There are also neurons in the reticular formation that encode eye position and/or velocity, but their projections are unknown.

### **Floccular Smooth-Pursuit Pathway**

The floccular lobe receives information from some of the same areas as does the oculomotor vermis. Processed visual information originating in parietal cortex is conveyed to the floccular lobe via the dorsolateral and dorsal pontine nuclei. Smooth-pursuit signals originating in the FEF and SEF are conveyed via medial NRTP and medial pontine nuclei (Fig. 2). In addition, the floccular lobe receives eye- and head-movement signals from the vestibular nuclei, and eye-movement signals from raphe and paramedian structures in the pontine reticular formation.

The ventral paraflocculus receives the bulk of the projections from the pontine nuclei, while the flocculus *per se* receives a heavier projection from the vestibular nuclei. This has led to the hypothesis that the ventral paraflocculus is more specialized for generating smooth-pursuit commands, while the flocculus is more specialized for controlling the VOR [8]. Nonetheless, the signals recorded from neurons in both regions differ only in minor ways. The flocculus is further subdivided into three parasagittal “zones”. A middle zone exhibits neural signals related to horizontal eye- and head-movements and is most strongly connected to the medial vestibular nucleus, which preferentially mediates horizontal eye movements. Two surrounding zones exhibit signals related to vertical eye- and head-movements and are most strongly connected to the superior vestibular nucleus and y group, which preferentially mediate vertical eye movements.

Eye- and head-movement signals recorded from Purkinje cells in the floccular lobe resemble those recorded from the oculomotor vermis. The predominant group of neurons exhibit horizontal or vertical gaze-velocity discharges [9]. As described earlier, the gaze-velocity discharge could be a smooth-pursuit command first constructed in higher centers, but the prevalence of eye-position, eye-velocity, and head-velocity input signals conveyed on ►[mossy fibers](#) [9] from the pontine reticular formation and the vestibular nuclei makes it likely that these latter signals also contribute to the firing of gaze-velocity neurons. In fact, an eye-movement corollary discharge fed back to the flocculus forms the basis of one hypothesis about the generation of predictive smooth-pursuit. In squirrel

monkeys, the “gaze-velocity” neurons have a sensitivity to eye velocity that is twice the sensitivity to head velocity. Moreover, all monkey species have another large group of Purkinje cells encode eye position and eye velocity. Altogether, there is a surfeit of eye-velocity information that makes it difficult to explain how the floccular lobe both produces smooth pursuit and suppresses the VOR.

The floccular lobe conveys the smooth pursuit command to the motoneurons via the vestibular nuclei. Horizontal Purkinje-cell (►[Horizontal-gaze-velocity purkinje cells](#)) efferents impinge upon known “flocculus target neurons” in the medial vestibular nucleus and more weakly upon secondary vestibular neurons in the ventrolateral vestibular nucleus. Some flocculus target neurons make direct connections with abducens motoneurons while others make indirect connections. Vertical Purkinje-cell efferents synapse in the superior vestibular nucleus and in the y group, both of which project to motoneuron pools in the oculomotor nucleus that subserve vertical eye movements.

### **VOR**

As stated earlier, the floccular lobe receives a major input from the vestibular nuclei and the flocculus *per se* receives direct input from the vestibular nerve. This vestibular information presumably contributes to the construction of gaze-velocity signals on floccular Purkinje cells. This heavy input, together with the projections back to portions of the vestibular complex that influence ocular motoneurons, puts the floccular lobe in a good position to affect the ►[gain](#) of the VOR. Probable uses of this capability include increasing VOR gain with increasing convergence of the eye (see ►[VOR](#)), and adaptive long-term modulation of VOR gain by plastic mechanisms (see ►[VOR adaptation](#)).

### **Vergence**

Neurons responding to pure vergence and/or combinations of version and conjugate eye movements have been found in the oculomotor vermis, the fastigial nucleus, the interpositus nucleus, and in the floccular lobe. The origin of these signals is likely from vergence areas in the superior colliculus and near the frontal eye fields, conveyed by way of NRTP. Thus, it is likely that these structures play a role in producing vergence eye movements, but much research is needed to be more precise.

### **Pathology**

Experimental lesions of the midline cerebellum (oculomotor vermis and caudal fastigial nucleus) produce substantial deficits in saccade generation and in smooth pursuit. Saccade deficits are more pronounced with lesions or chemical inactivation of one side. Inactivation of the caudal fastigial nucleus causes

ipsiversive saccades to overshoot the target by up to a factor of two, and contraversive saccades to undershoot the target by as much as half. Unilateral lesions or inactivation of the oculomotor vermis cause reversed effects. Vertical saccades are misdirected for both types of lesions. Bilateral lesions cause smaller and more balanced ►**saccadic dysmetria** [1]. Smooth pursuit is similarly affected. Unilateral fastigial inactivation increases ipsiversive eye acceleration for ramp targets up to two times normal, and decreases contraversive acceleration as much as 30%. Bilateral inactivation of the FOR or lesions of the vermis decreased smooth-pursuit gains by 30–50% when subjects track periodic stimuli [1]. The residual smooth pursuit reflects the fact that the FOR/oculomotor vermis is only one of at least two smooth-pursuit pathways, and that pursuit is a closed-loop system.

Experimental lesions of the flocculus and ventral paraflocculus together produce a 50–60% deficit in smooth pursuit and in suppression of the VOR. The gain of the VOR in the dark is affected very little. The ability to hold eccentric gaze is severely affected, as the eye returns towards a neutral point with a ►**time constant** around 2 s. This has been interpreted as disruption of the velocity-to-position integrator (see ►**Neural Integrator**) by loss of a high-gain feedback loop through the flocculus.

Localized cerebellar lesions in humans caused by infarcts, tumors, surgery, head trauma, or degenerative disease produce the same symptoms. However, such lesions are rarely as well confined as experimental lesions, so humans exhibit additional eye-movement disorders. These include several different forms of gaze deviations or inability to hold eccentric gaze and nystagmus [10].

## References

1. Robinson FR, Fuchs AF (2001) The role of the cerebellum in voluntary eye movements. *Annu Rev Neurosci* 24:981–1004
2. Suzuki DA, Keller EL (1988) The role of the posterior vermis of the monkey cerebellum in smooth pursuit movement control. II. Target velocity-related Purkinje cell activity. *J Neurophysiol* 59:19–40
3. Helmchen C, Buttner U (1995) Saccade-related Purkinje cell activity in the oculomotor vermis during spontaneous eye movements in light and darkness. *Exp Brain Res* 103:198–208
4. Thier P, Dicke PW, Haas R, Barash S (2000) Encoding of movement time by populations of cerebellar Purkinje cells. *Nature* 405:72–76
5. Fuchs AF, Robinson FR, Straube A (1993) Role of the caudal fastigial nucleus in saccade generation. I. Neuronal discharge patterns. *J Neurophysiol* 70:1723–1740
6. Fukushima K (2003) Roles of the cerebellum in pursuit-vestibular interactions. *Cerebellum* 2:223–232

7. Fuchs AF, Robinson FR, Straube A (1994) Participation of caudal fastigial nucleus in smooth pursuit eye movements. I. Neuronal discharge patterns. *J Neurophysiol* 72:2714–2728
8. Nagao S, Kitamura T, Nakamura N, Hiramatsu T, Yamada J (1997) Differences of the primate flocculus and ventral paraflocculus in the mossy and climbing fiber input organization. *J Comp Neurol* 382:480–498
9. Miles FA, Fuller JH, Braitman DJ, Dow BM (1980) Long-term adaptive changes in primate vestibuloocular reflex. III. Electrophysiological observations in flocculus of normal monkeys. *J Neurophysiol* 43:1437–1476
10. Dichgans J, Jung R (1975) Oculomotor abnormalities due to cerebellar lesions. In: Lennerstrand G, Bach-y-Rita P (eds) *Basic mechanisms of ocular motility and their clinical implications*. Pergamon Press, New York, pp 281–302

## Cerebellum, Zonal Arrangement

### Definition

Although the cerebellum features horizontal organization by virtue of its fissures, it is divided functionally into three vertical zones: the central part corresponds to the vermis cerebelli and projects to the fastigial nucleus. The intermediate part is a strip of hemisphere that is less than 1 cm wide to the left and right of the vermis. It projects to the interpositus nucleus. The lateral part, the remaining hemisphere region, projects to the dentate nucleus.

### ► Cerebellum

## Cerebral Cortex

### Synonyms

Cortex cerebri

### Definition

The cerebral cortex is often referred to simply as cortex. Strictly speaking, this is not correct since the cerebellum also has a cortex.

The cerebral cortex is the thin outer sheet of the forebrain, and contains several layers of nerve cells. Because of its gray color, it is termed “gray matter” as opposed to the “white matter” beneath it, which is made up of fibers (axons) connecting nerve cells in different areas of the brain. The human cortex is 3 mm (0.1 in) thick. According to cytoarchitecture you differentiate Isocortex and allocortex. A more detailed analysis

reveals nearly 50 different cortical areas, the so called Brodmann Areas. The cerebral cortex is divided into five lobes: frontal, parietal, temporal, occipital and limbic lobe. The cerebral cortex is essential for cognition, memory, consciousness, speech and voluntary movement.

▶ Telencephalon

## Cerebral Cortex Development

▶ Cortical Development

## Cerebral Hypoxia

### Definition

Transient exposure of brain cells to hypoxia (low oxygen levels), resulting in severe damage, inflammation and degeneration.

## Cerebral Meningitis

### Definition

Inflammation of the meninges of the brain.

## Cerebral Pachymeningitis

### Definition

Inflammation of the dura mater of the brain.

## Cerebral Palsy

### Definition

Cerebral palsy comprises several motor dysfunctions usually resulting from ischemic and/or hypoxic brain

injury in the perinatal period. Disorders vary widely depending on the severity of lesions. Mild forms may show ▶ **hyperreflexia** and ▶ **Babinski sign**, severe forms bilateral ▶ **hemiparesis** with spastic posture and gait. An accompanying ▶ **athetosis** is frequent.

▶ Babinski Reflex

▶ Spasticity

## Cerebral Peduncle

### Synonyms

Pedunculus cerebri; Cerebral peduncle

### Definition

Above the pons are two large, v-shaped parallel fiber bundles, containing efferents descending from the cerebral cortex in the direction of the brainstem and spinal cord. These two strands are called cerebral peduncles.

▶ Mesencephalon

## Cerebral Trunk

### Definition

Brainstem. Is composed of the three segments myelencephalon, metencephalon (cerebellum + pons) and Mesencephalon.

▶ General CNS

## Cerebro-cortical Area V1

### Definition

The primary visual cortex (also called Brodmann's area 17 and striate cortex), which receives the predominant (but not only) input from the retinas. It was long thought to be the only part of the cortex devoted to vision.

▶ Striate Cortex Functions

▶ Geniculo-striate Pathway

▶ Visual Perception

## Cerebro-cortical Area V4

### Definition

One of the many cortical visual areas lying outside area V1, and with which it is reciprocally connected, both directly and indirectly. It is specialized for generating color and damage to it leads to the syndrome of cerebral achromatopsia. Together with area V5, it has provided some of the most robust evidence in favor of functional specialization in the visual brain.

- ▶ Color Processing
- ▶ Extrastriate Visual Cortex
- ▶ Visual Neuropsychology
- ▶ Visual Perception

## Cerebro-cortical Area V5

### Definition

One of the many cortical visual areas lying outside area V1, with which it is reciprocally connected. A majority of its cells are responsive to motion and usually in a given direction only. It is thus specialized for visual motion and damage to it leads to the syndrome of cerebral akinetopsia.

- ▶ Extrastriate Visual Cortex
- ▶ Visual Motion Processing
- ▶ Visual Neuropsychology
- ▶ Visual Perception

## Cerebrospinal Fluid (CSF)

### Definition

The fluid surrounding the brain and spinal cord. The CSF is mainly secreted from the epithelial (ependymal) cells of the choroid plexuses in the ventricle, and moves into the subarachnoidal spaces through the medial and lateral apertures of the fourth ventricle. The rate of human CSF formation is estimated to be 600–700 ml per day. The total volume of CSF in the subarachnoid spaces and ventricles is about 1,400 ml. Ventricular volume is only about 25 ml. The arachnoid villi are the site through which the CSF is passively transported into the venous flow of dural sinuses. The CSF consists

to 99% of water and has a much lower protein concentration (approximately  $350 \text{ mg L}^{-1}$ ) than the serum ( $70,000 \text{ g L}^{-1}$ ). Of these proteins only about 10% originate from the extracellular fluid (ECF) drained from the central nervous system (CNS) parenchyma. These may be called “brain specific proteins” and are of particular interest for biomarker research.

## Cerebrovascular Accident (CVA)

- ▶ Ischemic Stroke

## Cerebrovascular Disease

- ▶ Ischemic Stroke
- ▶ Stroke

## Cerebrum (Outer Surface)

### Synonyms

Cerebrum (external features)

### Definition

At a deep level, is composed of the basal ganglia and peripherally of the greatly folded cerebral cortex, which is subdivided into two hemispheres.

Here all “higher” brain functions such as voluntary motor control, motor and sensory speech, cognition, visual and auditory system, superficial and deep sensibility are processed.

- ▶ Telencephalon

## Certainty Equivalence

### Definition

Certainty Equivalence is a term used in the adaptive control area to indicate that a controller is designed

using current estimated system parameters, as if they were the “true” system parameters.

► Adaptive Control

## Cervical Enlargement

### Synonyms

Intumescencia cervicalis; Cervical enlargement

### Definition

The spinal cord evidences two enlargements: the cervical enlargement in the cervical region and the lumbosacral enlargement in the lumbar region. The fibers of the upper and lower extremities synapse in the enlargements.

## Cervico-collic Reflex

### Definition

Activation of neck muscles induced by stimulation of neck (cervical) sensory receptors. They induce the contraction of the muscles stretched by a rotation of the head with respect to the body and are aimed at stabilizing the position of the head with respect to the body.

► Vestibulo-spinal Reflexes

## Cervico-spinal Reflexes

### Definition

Activation of body muscles induced by stimulation of neck sensory receptors, that are particularly represented by muscle spindle afferents in deep, intervertebral muscles. Cervicospinal reflexes acting on the limbs muscles modify the position of the trunk according to the relative position of the head with respect to the body.

They stabilize the position of trunk in space, working together with VS reflexes. Cervicospinal reflexes acting

on the neck (cervicocollic) reflexes stabilize the position of the head with respect to the trunk.

- Muscle Spindles
- Proprioception: Role of Muscle Receptors
- Vestibulo-spinal Reflexes

## C-fiber Afferent Nerve Fibers

### Definition

C-fiber afferent nerve fibers are unmyelinated afferent nerves that conduct action potentials at low velocities (less than 2.5 m/s) and that are often involved in detecting tissue injury or nociceptive stimuli. Activation of these afferents usually triggers painful sensations, neurogenic inflammation and hyperactivity of visceral organs.

► Nociceptors and Characteristics

## c-Fos

### Definition

c-Fos is a proto-oncogene that belongs to the immediate early gene family of transcription factors. c-Fos is often used as a marker of neural activity.

## CFUs-8

### Definition

The number of 8-day colony-forming units in spleen of mice, i.e. the parameters of the hemopoiesis.

► Nervous Immune and Hemopoietic Systems: Functional Asymmetry

## cGMP

### Definition

► Cyclic GMP



## cGMP-dependent Protein Kinase (Protein Kinase G)

### Definition

A family of serine/threonine protein kinases whose activity are dependent on the level of cGMP in the cell.

### Ch1

► Evolution of Subpallial Cholinergic Cell Groups

### Ch2

► Evolution of Subpallial Cholinergic Cell Groups

### Ch3

► Evolution of Subpallial Cholinergic Cell Groups

### Ch4

► Evolution of Subpallial Cholinergic Cell Groups

## Chandelier Cell

### Definition

The chandelier cell is a distinct morphological type of cerebral cortical interneuron that uses GABA as an inhibitory transmitter. Its axon terminals form a series of boutons linked together by thin connecting pieces, giving the cell a chandelier-like appearance. These terminals

end on the initial segments of pyramidal cell axons. The chandelier neuron is also called an axo-axonic cell.

## Change in Support Strategy

### Definition

A reaction to postural perturbation in which the limbs are moved so as to alter the base of support, i.e. stepping or reaching to grasp or touch an object for support.

► Postural Strategies

## Channel Expression

► Intrinsic Properties of Auditory Neurons

## Channel Myotonia

### Definition

► Myotonia

## Channels of Smell

### Definition

In the frame of information (or communication) theory, “channel” refers to a link between a source and a receptor allowing data transmission. In olfaction, two channels or sets of channels can be distinguished: the main olfactory system and the accessory olfactory system.

► Chemical Senses

## Chaos

### Definition

In the field of science and technology, the word chaos usually means deterministic chaos. Nonlinear dynamics

with non-periodicity and sensitive dependence on initial conditions generated not by stochastic process but by deterministic process is called deterministic chaos or simply chaos.

► Neural Networks

## Chaotic Neural Networks

### Definition

Neuron models with chaotic dynamics are called chaotic neurons. A discrete time chaotic neuron model consists of the terms of the internal states of the external inputs, the feedback inputs, and the relative refractoriness.

Neural network models that are composed of chaotic neurons are called chaotic neural networks. The model of the chaotic neural networks is applied to associative memory networks and combinatorial optimization networks with chaotic dynamics beyond convergent dynamics.

► Neural Networks

## Chaperone

### Definition

Chaperones are proteins that assist the non-covalent folding/unfolding and the assembly/disassembly of other macromolecular structures, but do not occur in these structures when the latter are performing their normal biological functions.

## Chaperones: Protein Trafficking

TORAH M. KACHUR, DAVE B. PILGRIM  
Department of Biological Sciences, University  
of Alberta, Edmonton, AB, Canada

### Definition

► Chaperones are proteins or protein complexes throughout the cell that aid in the proper folding of nascent polypeptides, promote correct folding of misfolded proteins and target terminally misfolded proteins for degradation. Chaperones are ubiquitous in all tissues and

are of specific interest in the nervous system for their role in preventing diseases of neural protein aggregation in conditions such as ► Alzheimer's disease and ► Parkinson's disease.

### Characteristics

#### Chaperones in the Nervous System

The folding of nascent peptides into a specific three-dimensional mature conformation is essential to allow proper function of all proteins. Chaperones are a large family of factors that promote this process, preventing aggregation of misfolded intermediates and by targeting terminally misfolded proteins for degradation. Chaperone mediated ► protein folding is required in all cells and is particularly important in the nervous system, as aberrant protein aggregation of misfolded proteins is a hallmark of many of the major neurodegenerative diseases. Although the majority of proteins fold properly and are quite stable in their functional conformation, different environmental stresses that are placed on the cell can result in unfolding or misfolding of proteins. The neuronal synapse is a particularly challenging area in maintaining proper protein folding conformations due to a dense protein filled cytosol and rapidly changing ion and pH levels. Proteins with abnormal conformations can accumulate over time due to exposure to extrinsic or naturally produced oxidizing agents or environmental stresses and this can result in the protein quality control system being taxed beyond its ability to deal with these misfolded proteins. Therefore, chaperones are thought to play an integral role in the manifestation of neurodegenerative diseases whose common pathological feature is protein aggregates and neuronal cell death.

The neuron has long cellular extensions that require transport from the cell body where proteins are made to the dendritic and axonal termini. Synaptic proteins are translated at the cell body and must be transported to the site of action via vesicles that move along the cytoskeleton. A loss in efficiency of vesicle and cellular traffic increases the stress on the protein quality control network at synapses, thus increasing the chance that a toxic aggregation is undetected by the chaperone system. Components of the protein degradation pathway are common at the synapse and associate with endocytic vesicles, suggesting a link between cellular traffic and cytosolic chaperones. Although aggregates are the universal indicator of many neurodegenerative diseases the underlying cellular cause of neuronal loss has many different effectors, one of which includes the role of protein trafficking in maintaining protein quality.

#### Molecular Role of Chaperones

The functional specificity of a protein is dictated by its conformation and folding is driven by the interaction between the aqueous cytosol and hydrophobic amino acids incorporated into the protein. Normally, the

hydrophobic amino acids are driven into the centre of the protein to avoid the association with water and this drives the folding of the hydrophilic domains around them. A form of protein secondary structure called the  $\beta$ -pleated sheet is prone to aggregation due to exposed hydrophobic domains. Self-propagating aggregation is a fundamental property of  $\blacktriangleright$ amyloids, or aggregates of peptides that polymerize into a cross beta structure. Chaperones can prevent aggregate formation by recognizing stretches of hydrophobic amino acids that are exposed upon translation or misfolding and can initiate one of three pathways: promoting proper folding by an ATP dependent mechanism, preventing aggregation by shielding the hydrophobic domains that would normally aggregate with hydrophobic domains of other proteins or targeting misfolded proteins for degradation by recruiting ubiquitinating enzymes and subsequent degradation by the 26S proteasome (Fig. 1).

The proteasome is a major component of the protein quality control system that recognizes ubiquitinated proteins that have been targeted for degradation by chaperones.

Common eukaryotic chaperones include the  $\blacktriangleright$ heat shock family of proteins that were originally identified as proteins upregulated in response to thermal stress but are now understood as essential components of the chaperone network in all cells. Two members of the heat shock family have particular importance in the nervous system: Hsp70 and Hsp90 [1]. Hsp70 is a chaperone that acts in a large multisubunit complex responsible for interacting with hydrophobic stretches of amino acids in nascent polypeptides to prevent the aggregation of peptides that have not completed translation, and is also required for folding the new protein [2]. Chaperones typically assist in folding by associating with exposed hydrophobic surfaces using several rounds of ATP

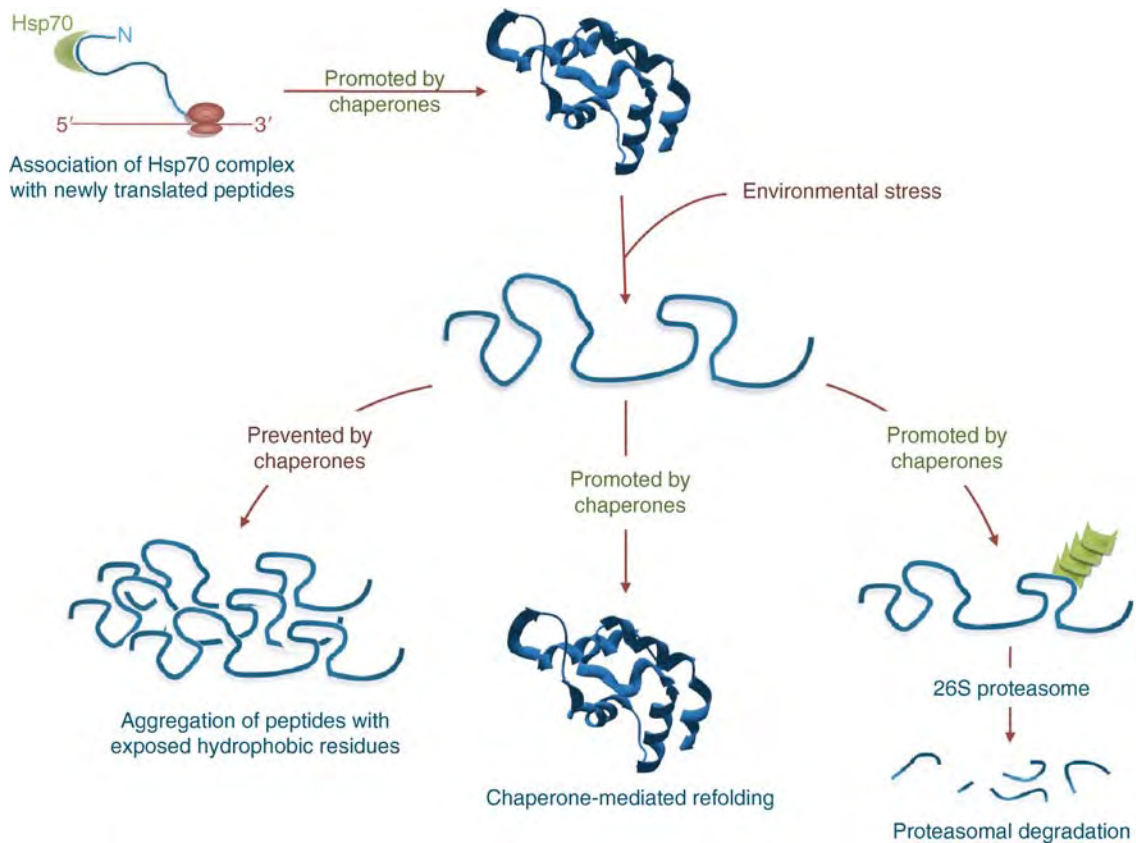

**Chaperones: Protein Trafficking. Figure 1** Generalized chaperone function. Chaperones, particularly the Hsp70 complex, associate with hydrophobic domains of newly translated proteins off the ribosome. The Hsp70 complex can aid in the proper folding of the protein into its functional conformation. Environmental stress and exposure to toxic agents can cause denaturation of the folded protein. Depending upon the degree of damage, and the type of chaperone associated with the misfolded peptide, chaperones can prevent aggregation of misfolded intermediates, promote refolding, or target the peptide for degradation by ubiquitination and subsequent degradation by the proteasome.

dependent substrate binding and release. When the degree of unfolding is terminal, the Hsp70 complex can interact with CHIP (carboxyl-terminus of Hsp70 interacting protein) and BCL-2 associated athanogene-1 (BAG-1) that ubiquitinate the peptide to target it for degradation by the ►ubiquitin proteasome pathway (UPP) [3]. It has been found that the UPP components in particular are abundant in cytoplasm at synapse suggesting that protein degradation is a common mechanism at the neuron termini.

Hsp90 has been shown to have chaperone activity on a wide variety of client proteins and is thought to act later in the folding cascade than Hsp70. Additionally, Hsp70 and Hsp90 are often found together as a large chaperone complex that service a wide range of misfolded intermediates and act with an equally diverse array of substrate-specific co-chaperones to promote folding or refolding. Both the Hsp70 and Hsp90 complexes have been associated with neurodegenerative diseases of protein accumulation including Alzheimer's, Parkinson's and ►Huntington's diseases, suggesting that a failure of protein folding may be a primary cellular factor in determining onset of these diseases.

Because the common feature of many neurological diseases are large cellular inclusions it was thought that the aberrant aggregation caused cell death, however, the dogma is shifting to advocate that a pre-aggregated form of the affected protein oligomerizes into ►protofibrils and it is the protofibril that causes disease. How, or if, these protofibrils cause disease is unclear but it has been suggested that the cause of neuron death may be due to an effect on multiple different cellular processes including cell cycle regulation and protein quality control pathways. Aggregates not only contain the major disease specific protein but also often contain chaperones, components of the proteasomal pathway and cell cycle machinery suggesting that multiple

mechanisms attempt to rectify the aggregation of toxic proteins but in turn are sequestered into the inclusion [4]. Sequestering toxic proteins may be a strategy used by the neuron to neutralize the toxic protofibrils, where cellular machinery such as the microtubule organizing centre (MTOC) are actively involved in inclusion formation. Protofibril formation may not be the sole cause of all the various neurodegenerative diseases but is likely a critical step in disease progression.

### Neurodegenerative Diseases of Protein Quality

Protein aggregates are a unifying feature of a large number of neurodegenerative diseases that affect the human population (Table 1).

Alzheimer's disease (AD) is the most prevalent neurodegenerative disease where 10% of individuals over the age of 65 will eventually develop AD and 1–2% of the same demographic will develop Parkinson's disease (PD). The diseases show diverse clinical manifestations as a result of cell death occurring in different neural subtypes in the brain where specific toxic peptides cause eventual death of those neurons and the formation of brain lesions. Alzheimer's disease, Parkinson's disease and the polyglutamine diseases represent a major class of neurodegenerative disorders that result from defects in protein folding and aberrant aggregation.

Alzheimer's Disease: AD is characterized by the formation of both intra- and extracellular protein aggregates. The extracellular plaques are composed mainly of  $\beta$ -amyloid whereas the intracellular neurofibrillary tangles (NFT) are composed mainly of a microtubule associate protein, tau. It has been known for some time that amyloid precursor protein (APP) is associated with AD; APP is a single pass membrane protein that is normally trafficked through the endocytic and secretory pathways (Fig. 2). Cleavage of APP

**Chaperones: Protein Trafficking. Table 1** Types of aggregates in common neurodegenerative diseases

Disease	Inclusion	Abnormal Protein	Co-aggregates
Alzheimer's disease	Cytosolic neurofibrillary tangles	Tau	Ubiquitin, Hsp70, CHIP
	Extracellular amyloid plaques	$\beta$ -Amyloid peptide	Hsp20,27,72 and Hsp90
Polyglutamine diseases	Nuclear and cytosolic inclusions	Huntingtin, ataxin and more	Hsp70, Hsp40, ubiquitin
Amyotrophic lateral sclerosis	Skein and Bunina bodies	Superoxide dismutase	Ubiquitin
Parkinson's disease	Lewy body	$\alpha$ -synuclein	Ubiquitin, proteasome, Hsp70, Hsp40
Prion disease	Extra and intracellular aggregates	PrP	Hsc70, ubiquitin

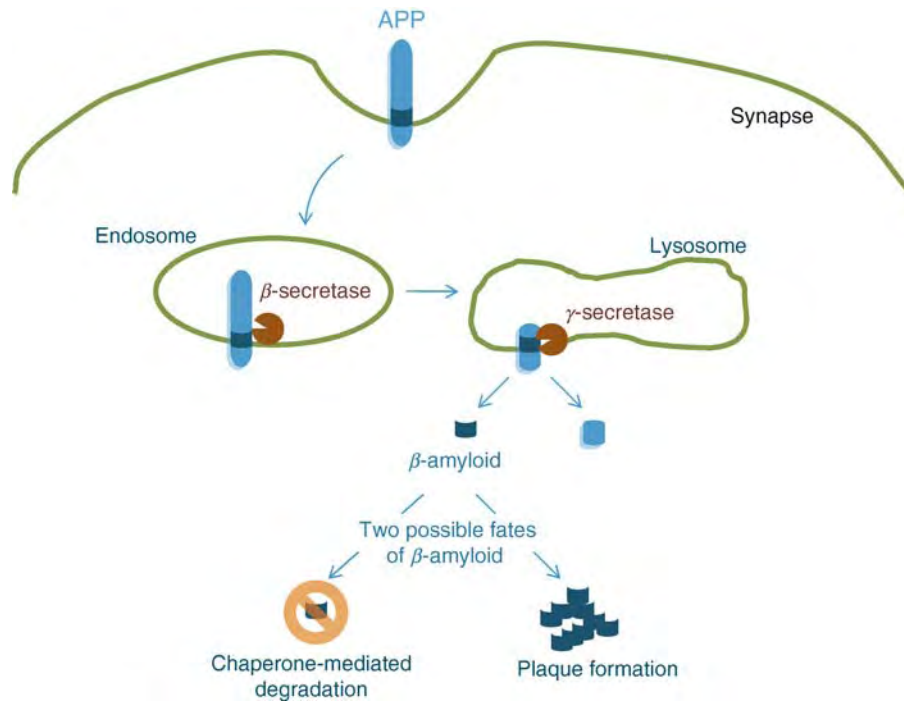

**Chaperones: Protein Trafficking. Figure 2** Production of  $\beta$ -amyloid in the neuron. Amyloid precursor protein (APP) is a single pass transmembrane protein that is recycled via the endocytic pathway. Once in the endosome an enzyme called  $\beta$ -secretase can cleave APP at amino acid 671 leaving a membrane bound fragment. As the endosome enters the lysosome another secretase ( $\gamma$ -secretase) can cleave the sAPP $\beta$  fragment into  $\beta$ -amyloid.  $\beta$ -amyloid can be degraded by the proteasome through chaperone-mediated degradation or, if the UPS system is overloaded, may aggregate into disease causing protofibrils.

produces the disease causing peptide ( $\beta$ -amyloid) and this cleavage occurs during normal cell protein turnover by enzymes located in the endosomes releasing the extracellular domain. It is the location of the cleavage site that causes the formation of neutral or toxic  $\beta$ -amyloid.  $\beta$ -amyloid can be produced intracellularly during receptor recycling of cellular vesicles, and it can also occur in the ER/Golgi network prior to APP secretion, suggesting that the formation of the toxic peptide is a result of normal cell protein turnover. The reduced efficiency of vesicle movement with age or due to mutation may result in a traffic jam of cellular components in the axon; this decreased movement of vesicles may increase the susceptibility of cleaving APP into  $\beta$ -amyloid.

The normal production of  $\beta$ -amyloid suggests that chaperones, specifically the Hsp70/90 complex could be involved in preventing oligomerization and targeting  $\beta$ -amyloid for degradation. There is substantial evidence that induction of **heat shock proteins** provides protection from AD in mouse and cell culture models suggesting that chaperones play a role in the pathogenesis of the disease. Additionally, Hsp70 is a common

component of both neurofibrillary tangles and amyloid plaques suggesting that chaperones attempt to process the toxic peptides prior to accumulating in the aggregates.

Research suggests that intracellular  $\beta$ -amyloid is an early event in neuronal dysfunction and there is mounting evidence that  $\beta$ -amyloid is the causative agent of neuronal cell death [5]. Therefore, the findings in Alzheimer's disease cellular progression represent a new way of thinking about protein folding disorders where it is the soluble form of an oligomeric peptide that causes disease and the aggregates in fact represent the cells strategy to cope with the accumulation of toxic soluble proteins.

► **Huntington's and other Polyglutamine Diseases:** Polyglutamine (polyQ) diseases are inherited disorders that result from an increased number of the glutamine codon (CAG) tandemly repeating in specific genes. Chaperones co-aggregate with polyQ peptides in the intranuclear inclusions suggesting that molecular chaperones are required for processing the aberrant peptides. Evidence for the role of chaperones in polyQ diseases is that overexpression of multiple different chaperones

(Hsc70, Hsp70, Hsp40 and Hsp27) all suppress the disease phenotype, but have varying effects on the formation of inclusions, suggesting a central role for chaperones in the pathogenesis of these diseases [6]. Additionally, components of the ubiquitination pathway are found in the inclusions and it has been shown that the proteasome can only hydrolyze shorter segments of polyglutamine tracts [1]. Therefore, the cause of polyglutamine diseases may be that the polyQ tracts exceed the capacity of the proteasome to degrade the toxic protein.

► **Parkinson's:** Parkinson's disease (PD) is diagnosed by  $\alpha$ -synuclein aggregates that form in dopaminergic neurons of the substantia nigra in the brain causing resting tremor, muscle rigidity and reduced strength in patients. Similar to the other neurodegenerative disorders, the aggregates or Lewy bodies are not thought to be the toxic agent;  $\alpha$ -synuclein has been found to selectively block transport between the ER and Golgi resulting in a traffic jam and accumulation of partially folded proteins in the ER. Protein accumulation results in ER stress and activation of the ERAD (► **ER associated degradation**) cascade to translocate proteins back into the cytosol and degrade proteins via the proteasome. The intracellular accumulation of  $\alpha$ -synuclein protofibrils has been shown to affect multiple cell processes including induction of the ► **apoptosis (or Programmed Cell Death)** cascade possibly resulting from increased ER stress.

Familial Parkinson's disease (PD) can be caused by more than five different genetic loci with many of the linked genes being related to the protein quality control mechanism, including UCH-L1, Parkin and  $\alpha$ -synuclein [7]. PD is the only neurodegenerative disease thus far that is caused by mutations in the UPP directly forming a link of protein quality control and neurodegeneration. Hsp70 and Hsp40, along with ubiquitin and components of the proteasome are found in Lewy bodies suggesting that chaperones and the UPP are essential in attempting to deal with the increased  $\alpha$ -synuclein accumulation and get sequestered into aggregates without degrading or refolding the toxic species.

### Future Directions and Therapeutics

Protofibril formation and protein misfolding are likely occurring throughout a lifetime and it may be that the loss of chaperone activity with age contributes to the late age of onset for the majority of non-inherited neurodegenerative diseases. Many unknowns still exist regarding the initial toxic agent in different neurodegenerative diseases but all potential therapeutic interventions must address the initial cause of disease progression. Chaperones provide a potential therapeutic target for dealing with the early stages of neurodegeneration because upregulation

of chaperones has been shown in multiple different disease models to suppress the progression of the disease. How chaperones suppress disease progression is unknown but may act at multiple different stages including protofibril formation, prevention of fibrillar structures, promotion of protofibril refolding or degradation or promotion of amorphous aggregates. The complexity of the cellular effects of aggregation diseases indicates that simply interfering with one of the downstream effects may not prevent disease progression and neurodegeneration.

### References

1. Sherman M, Goldberg A (2001) Cellular defenses against unfolded proteins: A cell biologist thinks about neurodegenerative diseases. *Neuron* 29:15–32
2. Young J, Agashe V, Siegers K, Hartl FU (2004) Pathways of chaperone-mediated protein folding in the cytosol. *Nat Rev Cell Bio* 5:781–791
3. Dickey C, Patterson C, Dickson D, Petrucelli L (2006) Brain CHIP: removing the culprits in neurodegenerative diseases. *Trends Mol Med* 13:32–38
4. Kopito R (2000) Aggresomes, inclusion bodies and protein aggregation. *Trends Cell Biol* 10:524–530
5. Hardy J, Selkoe D (2002) The amyloid hypothesis of Alzheimer's disease: progress and problems on the road to therapeutics. *Science* 297:353–356
6. Muchowski P (2002) Protein misfolding, amyloid formation, and neurodegeneration: A critical role for molecular chaperones? *Neuron* 35:9–12
7. Outiero T, Tetzlaff J (2007) Mechanisms of Disease II: Cellular protein quality control. *Semin Pediatr Neurol* 14:15–25

## Character Neurosis

- **Personality Disorder**

## Characteristic Frequency

### Definition

The frequency of a sound at which the response threshold of a given auditory neuron is the lowest, i.e. at which the neuronal sensitivity is highest.

- **Cochlea**  
 ► **Tonotopic Organization (Maps)**

## Characterogenic Neurosis

► Personality Disorder

## Charcot-Marie-Tooth (CMT) Disease

### Definition

Inherited, slowly progressing ► peripheral neuropathy appearing in early childhood and characterized by muscle weakness and wasting, reflex reductions or loss, and reduced sensation in the limbs according to a glove-and-stocking pattern. Type 1 of CMT shows ► demyelination of peripheral nerves (with reduced nerve conduction velocities) with some (at times excessive) childhood remyelination, while Type 2 does not. Both types are autosomal recessive. A severe childhood form (CMT3) is also called Severine-Sottas disease. The three different forms may be due to differences in “gene dosage” resulting from alterations of the number of alleles remaining intact after mutations. For instance, CMT1 may come about by doubling of one allele on one chromosome yielding dosage three; in CMT2, one allele on one chromosome may be dysfunctional yielding dosage one; and in CMT3, both alleles may be dysfunctional yielding dosage zero and giving rise to the severe childhood form.

► Peripheral Neuropathies

## Chemesthetic Substances

### Definition

Chemical compounds which activate receptors located in the oral and nasal area and mediating sensations such as pain, touch thermal, irritation (burning, cooling, stinging, tingling) through the trigeminal nerve (cranial nerve V).

Chemesthetic sensations can arise from anywhere on the body’s surface since these receptors are present in skin and mucosal surfaces.

## Chemical Communication

► Muscle and Tendon Energy Storage

## Chemical Energy

### Definition

The energy associated with the chemical state of the matter in the system.

► Energy/Energetics

## Chemical Gradient

### Definition

A concentration gradient reflecting gradual changes in molecule density. A chemical gradient can be generated by diffusion of soluble or volatile molecules, or by graded expression of surface-bound signals and their receptors.

## Chemical Senses

HOLLEY ANDRÉ

Centre Européen des Sciences du Goût (CESG),  
CNRS-INRA-Université, de Bourgogne, Dijon, France

### Definition

Chemical senses (► chemical sensors) are sensory organs and neural systems dedicated to the molecular detection and neural processing of environmental or biological signals.

### Characteristics

Cells are “irritable”: they react when exposed to chemicals. Chemical sensitivity is a property of the simplest forms of life that are endowed with chemical sensors and is also manifest in the most evolved organisms. To detect chemical signals, evolution has provided animals with specific receptor proteins distributed in the membrane of specialized sensory cells. These receptor cells are distributed in distinct chemosensory organs and systems, namely the main and accessory olfactory systems (i.e., the two ► channels of smell), the taste system and the chemoreceptive component of the trigeminal nerve. Here, the focus will be placed on major features of these chemical senses.

## Chemical Signals

Chemical stimuli are molecules and ions and chemical senses are molecular senses. Molecules are transported to the contact of chemosensory cells either by air or by water. Yet, knowing the nature of the diffusion medium does not offer a sufficient criterion to classify sense organs. Even though the olfactory system detects airborne stimuli at low concentration in mammals and insects while the gustatory system detects waterborne, sapid molecules with a lower sensitivity, this is not the case for fish and aquatic crustaceans that have a true olfactory system detecting waterborne odorants with a high sensitivity [1].

Another system bringing ►chemosensory information is represented by the taste system specialized in the detection of chemical properties of potential foods and evaluation of their nutritional value. In contrast, the olfactory system has a much wider involvement in the detection of environmental and social odors. Yet, odors are also strongly involved in food intake and cooperate with taste as essential components of flavors.

Odorants emitted and sensed by individuals of the same species, for example sex attractants, are called pheromones. There are several categories of pheromones. Reproductive pheromones trigger sex recognition, courtship displays and sexual activity; in addition to these behavior-oriented functions, they also initiate long-term physiological – mainly hormonal – changes in the recipient animal. Maternal pheromones guide newborn towards mother nipples; recognition pheromones are involved in labeling the identity and social status of individuals; aggregation and dispersion pheromones maintain individual spacing. Odorants and pheromones (at least sex pheromones) were thought to be detected by two distinct sensory organs, the olfactory epithelium (OE) and the vomeronasal organ (VNO), respectively. In fact, the OE can also detect pheromones, whereas the VNO can also detect ordinary odorants.

## Receptors

All animals detect odorants using seven-transmembrane domain receptors that activate G protein-based signalling cascades. In 1991, Buck and Axel [2] discovered a wide family of these G protein-coupled receptors (GPCRs) expressed in the rat OE and proposed that they were ►chemosensory receptors called odorant receptors (ORs). Subsequent molecular and bioinformatic studies confirmed the pioneer discovery and indicated that mammals, birds, fish, and amphibians have large numbers of genes for olfactory GPCRs expressed in olfactory organs. The OR repertoire contains around 1,000 genes in mouse and rat, 500–750 genes in human, and 100 genes in zebrafish and catfish. Independently expanded families of chemosensory GPCRs have a chemosensory function in invertebrate species [1].

The VNO of the accessory olfactory system expresses two families of GPCRs called V1R and V2R [3]. Some empirical evidence suggests that V1Rs bind to small airborne chemicals whereas V2Rs recognize water-soluble molecules.

In the gustatory system, two GPCR families, T1R and T2R, are involved in the detection of sapid molecules inducing sweet, bitter and umami sensations [4]. Identified proteins, T1R2 and T1R3, might compose a heterodimeric receptor to sweet tasting molecules whereas the T2R family contains around 30 different bitter receptors. Another family of GPCRs, the heterodimere T1R1/T1R3 that responds to many aminoacids in mice is especially sensible to L-glutamate and L-aspartate in humans. This receptor is therefore a good but non exclusive candidate to the role of umami taste detection.

Gustation use channel-receptors differing from GPCRs to sense salt and sour tastes [5]. For example, one of the most studied Na<sup>+</sup> taste receptor is a Na<sup>+</sup> highly selective channel known as ENaC, the amiloride sensitive epithelial sodium channel. This receptor is an oligomeric complex comprising three homologous subunits. Receptors to sour taste can be ordered in two groups: one group includes a channel-like ENaC that conducts an inward proton current when protons are available in the oral cavity. The second group comprises several H<sup>+</sup>-gated channels.

Knowledge of trigeminal chemoreception that operates in both oral and nasal cavity has benefited from recent studies on primary somatosensory neurons [6]. Studies led to discovering receptors to irritant substances like capsaicin, the active principle of chilli pepper and isothiocyanates found in mustard oil and horseradish. These receptors are members of the TRP ion channel family. Interestingly, capsaicin-sensitive nerve fibers are also activated by noxious heat. TRPV1 (also known as vanilloid receptor 1 or VR1), can be activated by both capsaicin and high temperature. Alternatively, low temperature activates a cold receptor called TRPM8 that is also sensible to menthol, a chemical eliciting a sensation of cold.

## Receptor Evolution

The size of the OR gene superfamily varies considerably among species. Duplications have greatly increased the number of genes but deletions and inactivating mutations resulting in a large number of *pseudogenes* contributed to reduce the size of the functional repertoire [7]. The proportion of intact OR genes and pseudogenes is also quite variable. For example, the human genome contains less than 400 functional OR genes and over 400 OR pseudogenes. This decline of the OR gene repertoire is already visible, even though less marked, in apes and Old World monkeys, coinciding with the acquisition of a full trichromatic vision, which may indicate that



improving visual abilities made olfaction redundant in some its adaptive functions.

Considerable variations in gene repertoire are also observed for VNO receptors, V1R and V2R. The differences in number of V1R and V2R functional genes among vertebrates seem to point to an asymmetric evolution followed by the two gene families [8]. Only very few intact VR1 genes are found in fishes whereas the mouse and rat have over 100 genes. In contrast, the V2R repertoire is virtually lost or severely reduced in many terrestrial vertebrates (in the cow, dog and primates, including humans), but not in the opossum and rodents that have a wide V2R gene repertoire. The existence of a functional vomeronasal organ in adult humans is highly questionable.

### Transduction Pathways

Olfactory neurons use two main intracellular signalling pathways utilizing cyclic nucleotides and phosphoinositide-derived signals. Cyclic nucleotide signalling is common in vertebrates and is thought to operate in nematodes (*Caenorhabditis elegans*) and arthropods [1]. Cyclic nucleotides target the olfactory cyclic nucleotide-gated ion channel through which calcium enters the cell and secondarily activates a chloride current. When activated, ion channels generate a graded voltage response that triggers action potentials. In crustaceans, olfactory receptors seem to use phosphoinositide signalling, whose target is a presumptive homolog of the TRP family of ion channels. Phosphoinositide signalling has been implicated in some way in olfactory transduction in other, phylogenetically diverse species, including nematodes, insects, fish and mammals.

Taste transduction is complex [5]. Bitter taste detection involves the taste-specific signalling G protein, gustducin. Two transduction pathways are simultaneously activated by receptors of the T2R family: receptor activation triggers a transient decrease in cAMP and cGMP, along with a transient increase in IP<sub>3</sub>. Like bitter-taste transduction, sweet-taste transduction has cyclic nucleotides and IP<sub>3</sub> as intracellular messengers. Sugars and artificial sweeteners are supposed to use distinct pathways.

### Sensory Organs and Pathways

The peripheral organization of sensory pathways differs notably between the main and accessory olfactory systems, on the one hand, and the taste system, on the other hand. Several common features can be observed in olfactory systems of vertebrates and arthropods. In most animals, the primary olfactory afferents that are axons of receptor neurons, project to the CNS without intermediate synapsing. The first synaptic relay, that is the olfactory bulb in mammals, antennal lobe in insects and olfactory lobe in crustaceans, is similarly organized in arthropods and mammals. The olfactory afferents

converge into the dense neuropile of glomeruli where they terminate on both projection neurons and local interneurons. In mammals, this projection is narrowly selective: all receptor neurons expressing the same type of OR converge onto one or two glomeruli. In turn, each projection neuron connects one or a few glomeruli to the primary olfactory cortex in mammals and the lateral protocerebrum and corpora pedunculata in arthropods.

A similar organization pattern is shown by the accessory olfactory system. VNO receptor cells that are neurons project to glomeruli in the accessory olfactory bulb (AOB) located in the caudal part of the main OB. In those mammals that have both V1R- and V2R-expressing sensory neurons (rodents, opossum), the two populations separately project their axons to segregated (anterior and posterior) regions of the AOB. In all other examined mammals that have VNO, the projection system is uniform. Then, relay neurons directly project to the hypothalamus.

Gustatory receptor cells are grouped in taste buds inside three types of taste papillae. The spatial distribution of the different taste receptors in the tongue and the mouth is not homogenous but expression zones of different receptors overlap to some extent. Differing from olfactory sensory cells, taste cells have an epithelial origin, they are not neurons. The apical portion of a taste cell possesses fine expansions, called microvilli, equipped with taste receptors. Receptor activation by sapid molecules triggers ionic currents generating action potentials that are synaptically transmitted to fibers of the gustatory nerves (cranial nerves VII, IX, X). A single afferent fiber makes synapses with several taste cells. Taste afferents project to the rostral part of the Nucleus Tractus Solitarius (NTS) in the brain stem.

### Neural Coding

Chemical senses have the function of allowing animals to identify substances, objects, places or living beings on the basis of their molecular properties that induce sensations endowed with specific qualities. Understanding how the molecular identity of an odor or a taste is coded in corresponding sensory organs and pathways is a fundamental question. Some common principles and notable differences can be found between olfaction and taste. In the olfactory system it is generally agreed that each cell expresses a single type of OR, individual receptor cells can be activated by different odorants and individual odorants activate multiple receptor cells [9]. These properties give support to the concept of combinatorial coding [9] that is valid in both vertebrates and insects: an odor is represented as a specific combination of excited neurons that reproduces the specific combination of activated ORs. The other possible coding strategy consisting in dedicating neurons to the detection of a particular odorant ("labeled lines" coding), seems to be exceptional (lobster). Recent

studies suggest that the discriminative capacity of the static combinatorial coding could be improved in projection neurons by including a temporal dimension.

There is less agreement regarding the coding of taste qualities [10]. Like in the olfactory system, in the taste system individual afferent fibers respond to multiple stimuli and even to stimuli representing different “basic” qualities: i.e., NaCl, HCl, sucrose, quinine. This can be explained because individual afferent fibers innervate several taste cells and taste cells individually display multiple chemical sensitivities. A combinatorial coding, originally called “across-fiber pattern” [10] coding could therefore operate in the taste system. However, the taste system differs from the olfactory system in that a limited number of taste qualities can be recognized in the former, whereas qualities cannot be consensually classified in the latter. A solution was proposed once to conciliate apparently opposite views: among several stimuli inducing responses from a taste afferent, one would be more efficient than every other; afferents could thus be grouped according to their “best” stimuli. This proposal failed to close the debate. Whether neural activity data support the view that taste qualities form a continuum or are more in favor of the traditional “four basic taste” theory is still a matter of individual belief. Falsification of either model seems to be difficult or impossible. Hopefully, unrevealing mechanisms of taste reception does not require previous solving of the conceptual puzzle.

## References

1. Ache BW, Young JM (2005) Olfaction: diverse species, conserved principles. *Neuron* 48:417–430
2. Buck L, Axel R (1991) A novel multigene family may encode odorant receptors: a molecular basis for odor recognition. *Cell* 65:175–187
3. Dulac C, Axel R (1995) A novel family of genes encoding putative pheromone receptors in mammals. *Cell* 83:195–206
4. Montmayeur JP, Matsunami H (2002) Receptors for bitter and sweet taste. *Curr Opin Neurobiol* 12:366–371
5. Lindemann B (2001) Receptors and transduction in taste. *Nature* 413:219–225
6. McKemy DM, Neuhauser WM, Julius D (2002) Identification of a cold receptor reveals a general role for TRP channels in thermosensation. *Nature* 416:52–58
7. Young JM, Friedman C, Williams EM, Ross JA, Tonnes-Priddy L, Trask BJ (2002) Different evolutionary processes shaped the mouse and human olfactory receptor gene families. *Hum Mol Genet* 11:535–546
8. Young JM, Trask BJ (2007) V2R gene families degenerated in primates, dog and cow, but expanded in opossum. *Trends Genet* 23:212–215
9. Malnic B, Hirono J, Sato T, Buck LB (1999) Combinatorial receptor codes for odors. *Cell* 96:713–723
10. Erickson RP (2000) The evolution of neural coding ideas in the chemical senses. *Physiol Behav* 69:3–13

## Chemical Sensor

### Definition

A type of detector that is sensible and reacts to molecular properties of chemical compounds.

► [Chemical Senses](#)

## Chemical Synapse

### Definition

Specific junction of contact between nerve cells and their targets allowing transmission of chemical signals from the nerve cell to target cells.

► [Synaptic Transmission: Model Systems](#)

## Chemical Transmitter

► [Neurotransmitter](#)

## Chemokines

### Definition

Chemokines are families of cytokines that induce directed chemotaxis in nearby responsive cells, hence the name chemotactic cytokines. Chemokines are small secreted proteins, produced by many different cell types, which function in both physiological and pathological conditions. These proteins signal effector cells through cell surface binding to seven transmembrane domain G-protein coupled receptors. At least 50 different chemokines have been identified. Chemokines are best characterized as chemoattractants for immune cells and glia. However, certain chemokines also have antimicrobial activity, angiostatic activity, can stimulate cell proliferation and are neurotrophic.

► [Chemotaxis](#)  
 ► [Cytokines](#)

## Chemoreceptor

### Definition

Chemoreceptors are receptors which are sensitive to changes in chemical substances or gas tension. The peripheral chemoreceptors are in the carotid artery bifurcation (carotid bodies) and arch of the aorta (aortic bodies). They are sensitive to changes in oxygen and carbon dioxide tension and hydrogen ion concentration in the blood. Central chemoreceptors located in the brain are sensitive to hydrogen ion concentration of the cerebrospinal fluid. The chemical to which a chemoreceptor is sensitive may bind receptors on the cell surface or affect cellular processes such that the ionic currents across the cell membrane are differentially affected, thereby affecting membrane potential and altering the spiking activity of the cells. The ambient abundance of the chemical substance to which the chemoreceptor is sensitive can therefore be encoded by the amount of spiking activity of the cells comprising the chemoreceptor.

- ▶ Central Chemoreception
- ▶ Central Nervous Chemoreceptors and Respiratory Drive
- ▶ Homeostasis

## Chemosensation

### Definition

Identification of chemical compounds encountered by the organisms. Mediated by cells specialized for detection and transformation of information into electrical signal.

- ▶ Olfactory Sense

## Chemosensory Information

### Definition

Information generated by biological chemical sensors and transmitted in sensory pathways; the olfactory system and the taste system transmit and process chemosensory information.

- ▶ Chemical Senses
- ▶ Gustation
- ▶ Olfactory Sense

## Chemosensory Receptor

### Definition

A type of chemical sensor or detector of biological origin that equips a chemosensory system; a G protein-coupled receptor (GPCR) is a chemoreceptor.

- ▶ Chemical Senses

## Chemotactic Attractant

### Definition

Chemotactic attractants are chemical molecules that induce motile behavior towards the source of the attractant (positive chemotaxis). This behavior occurs at all levels of biological organisation, from single-cell organisms such as bacteria to eukaryotic cells, organs and entire multicellular organisms. In contrast, chemotactic repellents induce the adverse migratory effect (negative chemotaxis). Chemotaxis is a receptor-mediated process and dependent on concentration gradients of chemical cues.

Classical examples for chemotactic behavior are bacteria detecting glucose as food source; the aquatic protozoan tetrahymena shows chemo-attraction for the amino acids glycine, proline, and glutamine, while tyrosine and phenylalanine act repulsive; the eukaryotic amoeba dictyostelium discoideum expresses cyclic AMP receptors; semaphorins represent negative axon guidance molecules; together with the olfactory and taste receptors, most receptors underlying chemotaxis of eukaryotic cells belong to the superfamily of G protein-coupled receptors (GPCRs).

Recently, an odor receptor that functions in chemotaxis of human sperm has been identified and may represent a critical component of oocyte fertilization. Stimulation of sperm with the aldehyde burgeonal, which is perceived as "lily of the valley" by the human nose, increases chemotaxis behavior of sperm, while the aldehyde undecanal appears to act as competitive antagonist on sperm navigation.

- ▶ Cyclic AMP
- ▶ G Protein-Coupled Receptor (Metabotropic Receptor)
- ▶ G-Protein Coupled Receptors (GPCRs) in Sensory Neuron Function and Pain
- ▶ G-protein Coupled Receptors (GPCRs): Key Players in the Detection of Sensory and Cell-Cell Communication Messages
- ▶ Olfactory Receptor
- ▶ Semaphorin
- ▶ Taste

## Chemotaxis

### Definition

Cell movement in response to a concentration gradient of a specific chemical.

► Chemotactic Attractant

## Chemotopic Representation

### Definition

A chemotopic representation indicates an orderly spatial arrangement of olfactory glomeruli (or other neural elements in a chemosensory system) that is related to the chemical attributes of the effective sensory stimuli. In the rodent olfactory bulb, chemotopic organization involves the spatial clustering of glomeruli responding to odorant chemicals with similar functional groups, hydrocarbon structures, or overall molecular properties such as water solubility. A further chemotopic organization is present in some glomerular modules of the rat bulb, wherein glomeruli responding to aliphatic odorants of increasing length are located in progressively ventral glomeruli.

► Glomerular Map  
 ► Olfactory Bulb  
 ► Olfactory Sense

## Chewing

► Mastication

## Cheyne-Stokes Breathing

### Definition

Disturbed pattern of breathing in ► coma patients with diffuse forebrain damage but without brainstem injury, characterized by increasing and decreasing depth of respiration and interposed apneas.

► Coma

## Chinese Room Argument

### Definition

This thought experiment, conceived of by John Searle, is intended to show that computers are not capable of understanding, or in other words, that implementing a computer program defined in terms of the manipulation of formal symbols, or syntax, is not sufficient for semantics. Searle, a non-Chinese speaker, imagines himself inside a room performing counterparts to all of the relevant operations that a computer running a program designed to respond in Chinese to Chinese questions would perform. For example, when a card comes in through a slot in the box with a question, (the input), he consults a rule book (the program), which tells him which cards with Chinese symbols he should slide out of the slot (the output). Searle argues that though his output could be mistaken for that of a native Chinese speaker, the process of performing these operations according to the rule book provides him with no understanding of Chinese. Since, he argues, there is no significant difference between what he does inside of the room and what a computer does, he concludes that the computer does not understand Chinese either.

► Physicalism

## ChIP

► Chromatin Immunoprecipitation and the Study of Gene Regulation in the Nervous System

## Chitosan

### Definition

Chitosan is the de-acetylated derivative of chitin, a polysaccharide extracted from crustacean exoskeletons or generated via fungal fermentation processes. Chitosan is a beta-1,4-linked polymer of 2-amino-2-deoxyd-glucose. It carries a positive charge from amine groups.

► Transplantation of Artificial Materials for Nerve Regeneration

## CHL1

### Definition

One type of L1, immunoglobulin superfamily.

► [Regeneration of Optic Nerve](#)

## Chloride Channels (ClC)

### Definition

Chloride (ClC) channels are ion channels which bear a high selectivity for inorganic anions, principally, chloride ions. Chloride channel gates open in response to depolarization, but their voltage-sensing capabilities are weaker than the voltage-gated ion channels such as potassium, sodium or calcium channels. Chloride channels contribute to the negative resting membrane potential in skeletal muscle, and have critical physiological roles in regulation of cell volume and pH.

► [Chloride Channels and Transporters](#)

## Chloride Channels and Transporters

JOSEPH A. MINDELL<sup>1</sup>, MERRITT MADUKE<sup>2</sup>

<sup>1</sup>Membrane Transport Biophysics Unit, Porter Neuroscience Research Center, National Institute of Neurological Disorders and Stroke, National Institutes of Health, Bethesda, MD

<sup>2</sup>Department of Molecular and Cellular Physiology, Stanford University School of Medicine, Stanford, CA

### Definition

Chloride (Cl<sup>-</sup>) channels and transporters are ► [integral membrane proteins](#) that function to allow Cl<sup>-</sup> and other inorganic anions to cross the ► [cell membrane](#) (► [Cell membrane – components and functions](#)). Chloride channels act by forming a continuous aqueous pore across the membrane that allows Cl<sup>-</sup> ion to move passively down its electrochemical gradient. Chloride transporters, on the other hand, link Cl<sup>-</sup> movement across the membrane to that of another ion thereby allowing, in some situations, Cl<sup>-</sup> to diffuse *against* its electrochemical gradient (► [Ion transport](#)).

## Characteristics

### Introduction

Chloride is a unique ion in the cellular physiology of the nervous system. Whereas the electrically important inorganic cations (Na<sup>+</sup>, K<sup>+</sup>, Ca<sup>2+</sup>) are maintained with strong, predictable gradients across neuronal membranes (► [Membrane potential – basics](#)), Cl<sup>-</sup> anion gradients are variable, tailored to the physiological role of this anion in a given cell type at a given developmental stage. In some cells, Cl<sup>-</sup> is passively distributed, adjusting its gradient according to the ► [resting membrane potential](#) of the cell. Activation of Cl<sup>-</sup> conductances in those cells cannot therefore change the membrane potential; it can, however, attenuate ► [electrical excitability](#) by reducing the ► [membrane resistance](#). In other neurons, Cl<sup>-</sup> concentrations are more tightly controlled, being either actively extruded or accumulated. The resulting shift in the Cl<sup>-</sup> ► [equilibrium potential](#), by controlling whether activation of Cl<sup>-</sup> channels is inhibitory or excitatory, has a major effect on excitability in the central nervous system (CNS). This effect can be dynamic, as in the ► [suprachiasmatic nucleus](#), where there is a daily oscillation in the neuronal response to ► [GABA<sub>A</sub> receptor](#) activation, or it can be developmentally regulated, as in ► [synapses](#) containing GABA<sub>A</sub> receptor Cl<sup>-</sup> channels which switch during development from excitatory to inhibitory [1]. (For further information see essays on ► [Chloride homeostasis and development](#) and ► [Ion transport](#)).

Chloride conductances serve a wide range of physiological roles in the nervous system. These functions result not only from channel activity but also from the working of a series of transporters that move Cl<sup>-</sup>, both passively and actively. Perhaps the most thoroughly studied neuronal Cl<sup>-</sup> channel is the ► [GABA<sub>A</sub> receptor](#), a member of the cys-loop family of ► [neurotransmitter-activated](#) (► [ligand-gated](#)) channels. As this protein is covered thoroughly in other articles, we will focus here on other Cl<sup>-</sup>-transport mechanisms. These other pathways fall into two broad categories: some have been identified at a molecular level, offering the possibility of genetic (and other) manipulations; others have been described only in terms of their functional behavior, observed in ► [patch clamp](#) recordings of neuronal cells but not yet cloned.

## Molecularly Identified Cl Conductances

### CLCs

The CLC “Cl<sup>-</sup> channel” family is a broad molecular family with diverse neurological functions. The family is unique in that it contains both types of Cl<sup>-</sup>-transport proteins, channels and transporters. The family members that are channels reside on the ► [plasma membranes](#) of cells, while the transporters reside on intracellular membranes.

The high-resolution structure of a prokaryotic CLC family member, a transporter from *E. coli*, has been solved [2]. The protein is a two-subunit homodimer, with separate and independent Cl<sup>-</sup> permeation pathways housed within each subunit. The proton permeation pathway is less well defined, but is thought to be coincident with the Cl<sup>-</sup>-permeation pathway at the extracellular entrance to the protein, and to diverge at the intracellular end. Both CLC channels and CLC ▶**antiporters** are thought to share this same basic architecture.

### CLC Channels [3]

#### CIC-1

CIC-1 is a ▶**depolarization-activated** Cl<sup>-</sup> channel that resides in the plasma membrane of ▶**skeletal muscle** cells and is crucial for the rapid recovery of the ▶**membrane potential** between ▶**action potentials**. Skeletal muscle cells receive input from ▶**motor neurons**, which leads to the opening of ▶**voltage-gated Na<sup>+</sup> channels** and results in membrane depolarization. Subsequent movement of Cl<sup>-</sup> through the depolarization-activated CIC-1 channels facilitates ▶**repolarization** of the membrane to allow continued electrical excitability. In addition to being activated by depolarization, CIC-1 ▶**open probability** is also activated by intracellular pH and by extracellular Cl<sup>-</sup>. Defects in CIC-1 lead to ▶**myotonia congenita**, a disease in which the skeletal muscle repolarization is delayed, thus causing trouble with movement. Over 60 different mutations that cause this disease are known.

#### CIC-2

CIC-2, like CIC-1, is voltage-, Cl<sup>-</sup>- and pH-dependent; however, it is activated by ▶**hyperpolarization** rather than by depolarization of the membrane. CIC-2 is expressed broadly in the nervous system. It may play a role in controlling neuronal excitability by determining whether GABA responses are excitatory or inhibitory, as discussed above. CIC-2 is also broadly important for Cl<sup>-</sup> ion ▶**homeostasis** in the CNS. A CIC-2 knockout mouse has ▶**retinal degeneration** and ▶**leukoencephalopathy**. In humans, mutations in CIC-2 have been reported to cause some forms of ▶**absence epilepsy**.

#### CIC-K

The two CIC-K channels (Ka and Kb) lack significant voltage dependence. This is consistent with their role in transepithelial transport (▶**Ion transport**). They are also regulated by extracellular Ca<sup>2+</sup> and H<sup>+</sup>, though the pH dependence is the opposite to that found in CIC-1 and CIC-2. Although the CLCKs are predominantly expressed in the kidney, they are also found in the ▶**cochlea** (▶**organ of Corti**, ▶**spiral ligament**, and ▶**stria vascularis**), where they contribute to the ion homeostasis essential for cochlear function. Unlike

CIC-1, which appears to act independently, the CIC-K proteins require an accessory subunit, Barttin. (It is not yet known whether CIC-2 has any accessory subunits.) Mutations in Barttin cause deafness in humans.

### CLC antiporters [4]

Two of the three subfamilies of mammalian CLC proteins are comprised of Cl<sup>-</sup>/H<sup>+</sup> antiporters (CIC-3/4/5 and CIC-6/7). These proteins are primarily targeted to intracellular organelles where they seem to play roles in organellar acidification. Knocking out the genes for these proteins leads to a range of defects, with several having important repercussions for the CNS.

#### CIC-3

CIC-3 is a protein with a controversial history. At one time CIC-3 was proposed to be a volume-regulated Cl<sup>-</sup> channel, but this is no longer considered likely, as CIC-3 knockout mice display normal volume-regulated Cl<sup>-</sup> currents. Knocking out CIC-3 has profound results in the CNS; CIC-3 knockout mice show severe CNS degeneration with specific loss of the ▶**hippocampus** by 3 months postnatal (Fig. 1). CIC-3 was suggested to play a role in neurotransmitter transport vesicles as it is primarily localized to these compartments. A recent publication proposed a competing view of CIC-3 in the CNS, with it functioning as a ▶**CAMKII-regulated Cl<sup>-</sup> channel** that can modulate the efficacy of ▶**synaptic transmission**.

#### CIC-4/CIC-5

CIC-4 and CIC-5 are generally agreed to localize to intracellular compartments; both were recently demonstrated to act as Cl<sup>-</sup>/H<sup>+</sup> antiporters. Though disease phenotypes resulting from CIC-5 primarily manifest in the kidney, this protein is also highly expressed in the brain. CIC-4 which has high (>75%) sequence identity with CIC-5 (and with CIC-3) is expressed at high levels in brain and several other organs. Though neither of these has been studied in the CNS, in other tissues they have been shown to be important for the acidification of endosomes early in the endocytic pathway and they probably subserve similar roles in the brain.

#### CIC-6/CIC-7

The third CIC subfamily, consisting of CIC-6 and CIC-7, are localized to late endosomes (CIC-6) and lysosomes (CIC-7) where, similarly to CIC-5, they may be important for allowing the acidification by shunting the voltage generated by the ▶**vacuolar H<sup>+</sup>-ATPase**. Both proteins are prominently expressed in brain as well as other organs, and for both proteins knockout experiments indicate roles in CNS physiology. For CIC-6 the major phenotype in the knockout is impaired ▶**nociception** and mild behavioral abnormalities; these apparently result from a ▶**lysosomal storage disease**

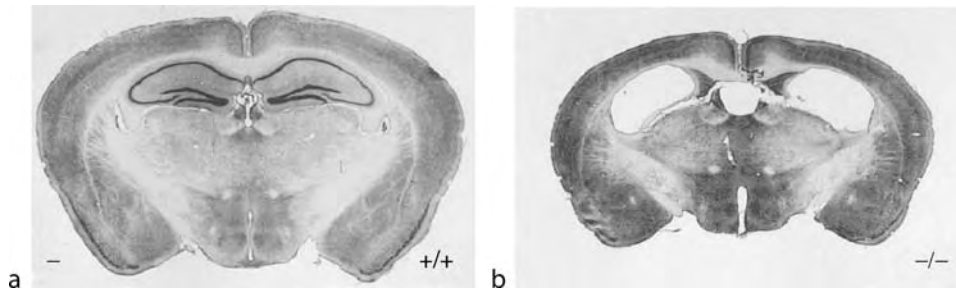

**Chloride Channels and Transporters. Figure 1** CNS effects of knocking out the CIC-3  $\text{Cl}^-$  transporter. Frontal sections of brains from wildtype (left) and CIC-3 knockout (right) mice (7 months old) are shown, revealing the prominent absence of the hippocampus in the knockout mouse. The hippocampus is present at birth in the knockout mice, but gradually degenerates starting at about 3 months of age and is replaced by a large cavity communicating with the ventricular system. These mice also suffer from retinal degeneration. Reprinted from *Neuron*, 29, S. M. Stobrawa et al. Disruption of CIC-3, a  $\text{Cl}^-$  channel expressed on synaptic vesicles, leads to a loss of the hippocampus, pp 185–196 (2001), with permission from Elsevier.

that resembles human neuronal ceroid lipofuscinosis. The phenotypes of CIC-7 knockouts are consistent with its broader expression: in both affected humans and knockout mice, loss of CIC-7 leads most prominently to osteopetrosis, the hypercalcification of the bone matrix. Additionally, these individuals also suffer from retinal degeneration as well as a severe lysosomal storage disease, which again resembles neuronal ceroid lipofuscinosis. Targeting of CIC-7 to lysosomes requires the presence of a recently-reported  $\beta$ -subunit, Ostml, whose knockout causes a similar disease spectrum to that of disrupting CIC-7 itself.

#### Bestrophin [5]

►Best disease is an inherited form of ►macular degeneration wherein accumulation of retinal metabolites leads to retinal cell death and blindness. Features of the electroretinogram in Best disease patients suggest involvement of a  $\text{Cl}^-$  conductance in the basolateral membrane in the ►retinal pigment epithelium. Furthermore, ►Bestrophin, the protein affected in Best disease, has been shown to function as a ► $\text{Ca}^{2+}$ -activated  $\text{Cl}^-$  channel (below) when expressed in heterologous systems. It remains unclear whether Bestrophin is responsible for  $\text{Ca}^{2+}$ -activated  $\text{Cl}^-$  conductances in other tissues.

#### Neurotransmitter Transporter Anion Conductances [6]

In addition to those proteins whose primary purpose is to transport  $\text{Cl}^-$ , a variety of neurotransmitter transporters carry associated  $\text{Cl}^-$  conductances. Both the ►dopamine and ►glutamate transporters, responsible for clearing synapses of these neurotransmitters, show such conductances. Different glutamate transporters have different relative capacities for  $\text{Cl}^-$  flux versus glutamate transport, with some showing significantly higher  $\text{Cl}^-$  currents than transport-associated currents. These  $\text{Cl}^-$  currents recently have been shown to contribute to the communication between rod bipolar

cells in the retina. Similarly, anion currents through dopamine transporters have been shown to modulate excitability in ►midbrain dopaminergic neurons.

#### Chloride Conductances Not Yet Molecularly Identified Volume-sensing Channels [7]

Changes in osmolarity, either in the extracellular fluid or in a cell's own cytoplasm, lead to osmotically-induced movements of water which can, in turn, cause cell swelling or shrinkage. Such changes can result pathologically from changes in serum osmolarity (as a result from congestive heart failure or diabetes, for example) or from changes in cellular osmolarity (as a result from ►hypoxia or metabolic disturbances). To respond to these changes and return to normal cell volume, neurons and other cells activate a class of anion channels termed ►VRAC (for ►Volume-Regulated Anion Conductance; many other terms have been used, see [8]). These channels open in response to cellular volume changes and are instrumental in returning to normal cell volume. Though these currents have been described in a wide range of cell types, a particularly well-examined group is expressed in ►gliomas, a type of CNS cancer. These glioma  $\text{Cl}^-$  channels have been proposed to play roles in the changes in cell volume required for tumor cells to invade the densely-packed surrounding tissue.

#### $\text{Ca}^{2+}$ Activated $\text{Cl}^-$ Channels [8,9]

Although ► $\text{Ca}^{2+}$ -activated  $\text{Cl}^-$  channels (►CaCCs) are physiologically widespread, the molecular identity of these channels remains controversial and the precise function of these channels is not fully understood. The best described function of the  $\text{Ca}^{2+}$ -activated  $\text{Cl}^-$  channels is in ►olfactory receptor neurons. Binding of ►odorants to these neurons results in membrane depolarization and elevation of intracellular  $\text{Ca}^{2+}$ . This rise in  $\text{Ca}^{2+}$  activates the CaCCs, which causes an efflux

of  $\text{Cl}^-$  and further membrane depolarization. This depolarization provides a critical amplification of the signal and thus enhances sensitivity to odorants. In **taste receptor** cells, activation of CaCCs occurs similarly; however, in this case the activation produces a hyperpolarization of the cells (because the reversal potential of  $\text{Cl}^-$  in these cells is quite negative). The hyperpolarization may play a role in taste adaptation.

CaCCs are additionally expressed in many types of neurons, where they may modulate excitability by facilitating action-potential repolarization, generating after-polarizations, and inducing membrane oscillatory behavior.

## References

1. Fiumelli H, Woodin MA (2007) Role of activity-dependent regulation of neuronal chloride homeostasis in development. *Curr Opin Neurobiol* 17(1):81–86
2. Dutzler R (2006) The CIC family of chloride channels and transporters. *Curr Opin Struct Biol* 16(4):439–446
3. Jentsch TJ et al. (2005) Physiological functions of CLC  $\text{Cl}^-$  channels gleaned from human genetic disease and mouse models. *Annu Rev Physiol* 67:779–807
4. Jentsch TJ (2007) Chloride and the endosomal-lysosomal pathway: emerging roles of CLC chloride transporters. *J Physiol* 578(pt 3):633–640
5. Hartzell C et al. (2005) Looking chloride channels straight in the eye: bestrophins, lipofuscinosis, and retinal degeneration. *Physiology (Bethesda)*, 20:292–302
6. Torres GE, Amara SG (2007) Glutamate and monoamine transporters: new visions of form and function. *Curr Opin Neurobiol* 17(3):304–312
7. Nilius B et al. (1996) Volume-activated  $\text{Cl}^-$  channels. *Gen Pharmacol* 27(7):1131–1140
8. Hartzell C, Putzier I, Arreola J (2005) Calcium-activated chloride channels. *Annu Rev Physiol* 67:719–758
9. Frings S, Reuter D, Kleene SJ (2000) Neuronal  $\text{Ca}^{2+}$ -activated  $\text{Cl}^-$  channels – homing in on an elusive channel species. *Prog Neurobiol* 60(3):247–289

## Chloride Homeostasis and Development

JOHN ORMOND, MELANIE A. WOODIN  
Department of Cell & Systems Biology, University of Toronto, Toronto, ON, Canada

### Synonyms

GABA switch; Chloride switch; Excitatory GABA

### Definition

The regulation of intracellular chloride ( $[\text{Cl}^-]_i$ ) during nervous system development determines the polarity

of GABAergic and glycinergic synaptic transmission. In embryonic development, the  $\text{Na}^+ - \text{K}^+ - 2\text{Cl}^-$  (**NKCC1**) cotransporter maintains a high concentration of neuronal  $[\text{Cl}^-]_i$ , rendering GABAergic and glycinergic synaptic transmission excitatory. At this stage, excitatory GABA and glycine act as trophic regulators of progenitor proliferation, neuronal migration, neurite growth, and synapse formation. During postnatal development there is an extrusion of  $[\text{Cl}^-]_i$  by the neuron specific  $\text{K}^+ - \text{Cl}^-$  (**KCC2**) cotransporter, which renders GABA and glycinergic synaptic transmission inhibitory. In the mature CNS, the strength of inhibitory GABAergic and glycinergic synaptic transmission can be altered by both physiological levels of neuronal activity and by pathological events, through a KCC2-mediated regulation of  $\text{Cl}^-$ -homeostasis.

## Characteristics

### Neurons Regulate Chloride Homeostasis

Chloride ( $\text{Cl}^-$ ) is the most abundant permeant anion in cells. In many non-neuronal cells, active transport does not maintain a  $\text{Cl}^-$  gradient across the neuronal membrane. The resulting passive distribution of this ion establishes an equilibrium potential for  $\text{Cl}^-$  ( $E_{\text{Cl}}$ ) which is equal to the resting membrane potential ( $V_r$ ).  $E_{\text{Cl}}$  is the membrane voltage at which there is no net flow of  $\text{Cl}^-$  across the membrane. Unlike non-neuronal cells, neurons express **cation-chloride cotransporters** (CCC) which precisely regulate  $\text{Cl}^-$  homeostasis throughout development and in the mature CNS [1–3]. Electroneutral cotransport of  $\text{Cl}^-$  and  $\text{K}^+$  and/or  $\text{Na}^+$  is mediated by members of the CCC gene family SLC12 (solute carrier family 12) [4]. The CCCs are all secondarily active cotransporters that utilize energy from extrusion of ion(s) down their electrochemical gradient(s) in order to fuel the transport of other ions against their electrochemical gradient(s).

### Neuronal $\text{Cl}^-$ Homeostasis is Maintained by NKCC1 and KCC2

The  $\text{Na}^+ - \text{K}^+ - 2\text{Cl}^-$  (NKCC1) is a ~1,280 amino acid protein SLC12 gene family member, which is widely expressed in both epithelial and nonepithelial cells, including neurons and glia [4]. Early in development there is a high neuronal expression of NKCC1, which produces an influx of  $\text{Na}^+$ ,  $\text{K}^+$ , and  $\text{Cl}^-$  (Fig. 1).

NKCC1 derives energy from the inward  $\text{Na}^+$  electrochemical gradient to uptake  $\text{Cl}^-$ ; the  $\text{Na}^+$  gradient is generated and maintained by the  $\text{Na}^+ - \text{K}^+ - \text{ATPase}$ . Neuronal NKCC1 expression is maximal in the embryonic period, with a significant decrease in expression during early postnatal development. While NKCC1 mutations do not result in any known disease states, knockout mice develop deficiencies in inner ear function, endolymph secretion, sensory perception, and fertility.



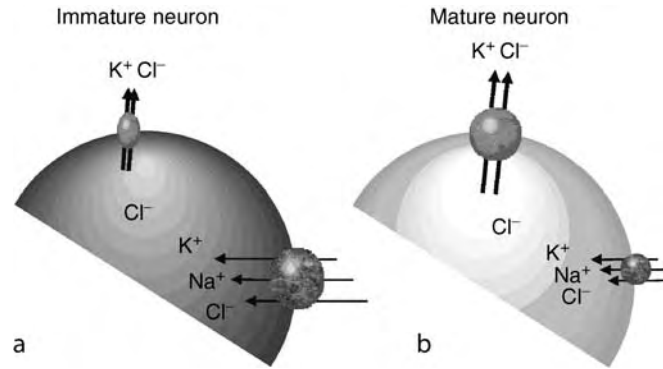

**Chloride Homeostasis and Development. Figure 1** The balance of CCCs determines  $[Cl^-]_i$  during development. (a) NKCC1 is the dominantly expressed CCC in immature neurons. This inward transport of  $Cl^-$  results in a relatively high  $[Cl^-]_i$ . (b) In mature neurons, the developmental up-regulation of KCC2, coupled with decreased NKCC1 expression, produces a net  $Cl^-$  extrusion which maintains a low  $[Cl^-]_i$ .

During postnatal life, when NKCC1 expression is decreasing, there is a gradual up-regulation of the ~140 kDa  $K^+ -Cl^-$  cotransporter KCC2 [1,4,5] (Fig. 1). There are four  $K^+ -Cl^-$  cotransporters in the SLC12 gene family: KCC1, KCC2, KCC3, and KCC4; of these only KCC2 is neuron-specific. KCC2 is widely expressed throughout the CNS, with high expression in hippocampal pyramidal neurons, granule cells and Purkinje neurons of the cerebellum, and retinal neurons. KCC2 utilizes energy from the  $K^+$  gradient, which is established by the  $Na^+ -K^+ -ATPase$ , to transport  $Cl^-$  against its electrochemical gradient. For every  $K^+$  ion that leaves the neuron, one  $Cl^-$  ion enters. KCC2 is unique among the KCCs because it operates under isotonic conditions, while the other KCCs are strongly activated by cell swelling. KCC2 also has a higher cation affinity than the other KCCs, making it suited to serve as a buffer for external  $K^+$   $[K^+]_o$ . When  $[K^+]_o$  is increased to 10–12 mM, which may result from increased neuronal activity, KCC2 cotransport can be reversed.

Together, decreased NKCC1 and increased KCC2 expression lead to a shift in the  $Cl^-$  electrochemical gradient during early postnatal life, resulting in a low neuronal  $[Cl^-]_i$ . While there is variation in the time line of this shift, both among brain structures within a species, and across species, it has been observed in nearly all brain structures and organisms examined [2].

### Chloride Homeostasis Determines the Polarity and Magnitude of GABAergic and Glycinergic Synaptic Transmission

The neurotransmitters GABA and glycine both bind to ionotropic receptors (GABAARs and glycineRs, respectively) which are permeable to  $Cl^-$ . Early in development the dominant expression of NKCC1 maintains a high  $[Cl^-]_i$  which maintains  $E_{Cl}$  more depolarized than the action potential threshold. Under

these circumstances GABAergic and glycinergic synaptic transmission can produce action potential firing, and thus their actions are excitatory [2] (Fig. 2).

When KCC2 expression dominates in the mature nervous system, neuronal  $[Cl^-]_i$  is low, which maintains  $E_{Cl}$  more hyperpolarized than the action potential threshold, rendering GABAergic and glycinergic synaptic transmission inhibitory [1,5].

What regulates the  $Cl^-$ -mediated switch from excitation to inhibition is an open question [3]. *In vitro*, when GABAergic transmission was blocked during development, there was a decreased up-regulation of KCC2 expression. Similarly, *in vivo*, blocking the GABAergic transmission during development prevented the developmental up-regulation of KCC2. These results are in direct contrast with two other studies which demonstrated that chronically antagonizing GABAARs had no effect on the normal developmental time course of KCC2 up-regulation.

### Trophic Roles of Excitatory GABA & Glycine

GABA is present and functional prior to the development of synaptic, where it has been shown *in vivo* to exert trophic functions during neuronal development. Premature lowering of  $[Cl^-]_i$  in a subpopulation of ventricular neural progenitors, by *in utero* electroporation of KCC2, eliminated the tonic excitatory actions of GABA [3]. This resulted in a severe impairment of the morphological maturation of those newly born neurons. In addition to the role of excitatory GABA on neurite morphology, excitatory GABA also plays a critical role in the establishment of excitatory and inhibitory inputs within neuronal circuits. When KCC2 was prematurely expressed in immature tectal cells of the *Xenopus* tadpole tectum, there was increased GABAergic synaptic input to tectal neurons, while the normal developmental increase in AMPA receptor-mediated transmission was blocked [6].

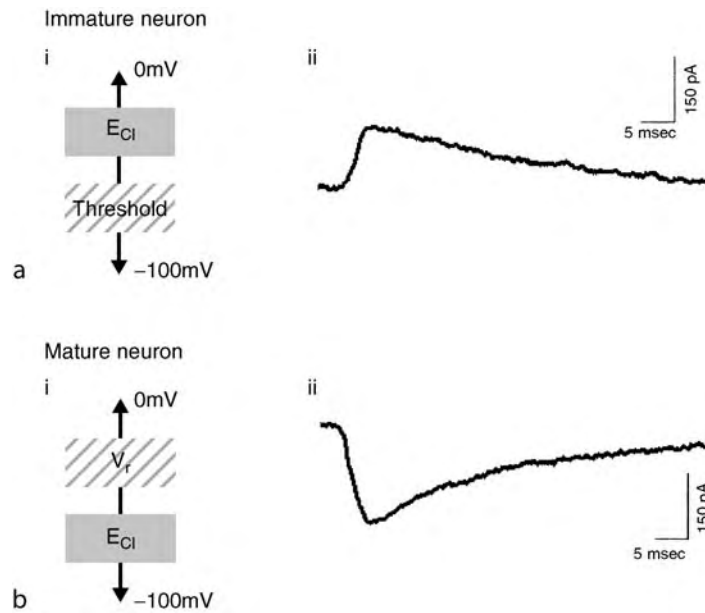

**Chloride Homeostasis and Development. Figure 2**  $E_{Cl}$  Determines the polarity of GABAergic and glycinergic synaptic transmission. (ai) In immature neurons  $E_{Cl}$  is more depolarized than the action potential threshold rendering GABAergic and glycinergic synaptic transmission excitatory. (aii) Under such conditions inward GABAergic currents are recorded electrophysiologically. (bi) In mature neurons, when  $E_{Cl}$  is more hyperpolarized than  $V_r$ , GABAergic and glycinergic synaptic transmission is inhibitory, producing outward currents (bii).

Early excitatory glycinergic signaling also exerts trophic functions which are required for proper nervous system development. Early excitatory glycinergic signaling was perturbed in the **►zebrafish** using **►morpholino oligonucleotides** (morpholinos) [7]. The resulting knockdown of the glycine receptor  $\alpha_2$ -subunit produced **►morphants** with disrupted interneuron differentiation. This decrease in excitatory glycinergic signaling resulted in a reduction in the frequency of spontaneous glycinergic and glutamatergic synaptic transmission.

The excitatory trophic actions of GABAergic and glycinergic signaling are not restricted to development. In the dentate gyrus of the hippocampus, where neurogenesis continues into adulthood, excitatory GABA regulates neurogenesis, morphological maturation, and synapse formation. In particular, when NKCC1 expression is reduced and GABA's actions are converted from excitatory to inhibitory, the dendritic development of newly generated granule cells is impaired [8].

Many of the excitatory actions of GABA and glycine are likely mediated by receptor-induced membrane depolarization, which regulates  $Ca^{2+}$  influx through both voltage-gated channels and neurotransmitter receptors. Membrane depolarization which triggers action potentials, will in turn activate voltage-gated calcium channels (VGCCs) allowing significant  $Ca^{2+}$  influx. In addition, membrane depolarization may be sufficient to remove the  $Mg^{2+}$  block from the  $Ca^{2+}$ -permeable NMDA receptor.

The VGCC- and/or NMDA-dependent rise in  $[Ca^{2+}]_i$  may then trigger  $Ca^{2+}$ -dependent signaling cascades responsible for developmental processes such as progenitor proliferation, neuronal migration, neurite growth, and synapse formation.

### Regulation of $Cl^-$ Homeostasis by Pain & Epileptic Activity

Peripheral nerve injury can lead to neuropathic pain, which results from hyperexcitability of dorsal horn neurons in the spinal cord. Nerve injury leads to an increased synthesis and activation of the ATP receptor on microglia. Recently, it was shown that ATP stimulates brain-derived neurotrophic factor (BDNF) release from microglia, which acts via the TrkB receptor to depolarize  $E_{Cl}$  in spinal lamina I neurons [9]. The depolarization of  $E_{Cl}$  was significant enough to convert GABAergic and glycinergic synaptic transmission from inhibitory to excitatory. A link between neurotrophic factors and  $Cl^-$  homeostasis has also been demonstrated in the hippocampus. Following epileptic seizure activity there is a BDNF-induced decrease in KCC2 expression [10].

### Activity-Dependent Regulation of $Cl^-$ Homeostasis

In the mature CNS, when GABAergic synaptic transmission is inhibitory, physiological patterns of neuronal activity can regulate the strength of inhibition [3]. When hippocampal GABAergic synapses are

repetitively stimulated with spike-timing induction protocols or when the postsynaptic neuron is stimulated alone, there is a  $\text{Ca}^{2+}$ -dependent decrease in KCC2 function. This activity-induced regulation of KCC2 leads to an increase in neuronal  $[\text{Cl}^-]_i$  which depolarizes  $E_{\text{Cl}}$ . Because  $E_{\text{Cl}}$  determines the strength of inhibition, the activity-dependent increase in  $[\text{Cl}^-]_i$  decreases the effectiveness of inhibition. Inhibitors of  $\text{Ca}^{2+}$ -dependent protein kinase C (PKC) abolished the postsynaptic spiking induced  $E_{\text{Cl}}$  shift, whereas activation of protein tyrosine kinases or phosphatases were not required, suggesting that  $\text{Ca}^{2+}$  may act via a PKC-dependent pathway to regulate KCC2. The postsynaptic spiking-induced and spike-timing induced down-regulation of KCC2 activity occurred within minutes, suggesting an alteration in membrane trafficking, and/or posttranslational modification of KCC2, as opposed to changes in gene transcription or protein synthesis.

### Conclusions

NKCC1- and KCC2-mediated  $\text{Cl}^-$  homeostasis determine the polarity and strength of GABAergic and glycinergic synaptic. Early in development when  $[\text{Cl}^-]_i$  is high, excitatory GABAergic and glycinergic synaptic transmission play important roles in progenitor proliferation, neuronal migration, neurite growth, and synapse formation. In the mature neuronal systems when  $[\text{Cl}^-]_i$  is low, both physiologically- and pathologically-induced neuronal activity can alter  $\text{Cl}^-$  homeostasis via a regulation of KCC2, which effectively weakens the strength of inhibition.

### References

- Rivera C, Voipio J, Kaila K (2005) Two developmental switches in GABAergic signaling: the  $\text{K}^+$ - $\text{Cl}^-$  cotransporter KCC2 and carbonic anhydrase CAVII. *J Physiol* 562:27–36
- Ben-Ari Y (2002) Excitatory actions of gaba during development: the nature of the nurture. *Nat Rev Neurosci* 3:728–739
- Fiumelli H, Woodin MA (2007) Role of activity-dependent regulation of neuronal chloride homeostasis in development. *Curr Opin Neurobiol* 17:81–86
- Mercado A, Mount DB, Gamba G (2004) Electroneutral cation-chloride cotransporters in the central nervous system. *Neurochem Res* 29:17–25
- Rivera C et al. (1999) The  $\text{K}^+$ / $\text{Cl}^-$  co-transporter KCC2 renders GABA hyperpolarizing during neuronal maturation. *Nature* 397:251–255
- Akerman CJ, Cline HT (2006) Depolarizing GABAergic conductances regulate the balance of excitation to inhibition in the developing retinotectal circuit *in vivo*. *J Neurosci* 26:5117–5130
- Brustein E, Drapeau P (2005) Serotonergic modulation of chloride homeostasis during maturation of the locomotor network in zebrafish. *J Neurosci* 25:10607–10616
- Ge S et al. (2006) GABA regulates synaptic integration of newly generated neurons in the adult brain. *Nature* 439:589–593
- Coull JA et al. (2005) BDNF from microglia causes the shift in neuronal anion gradient underlying neuropathic pain. *Nature* 438:1017–1021
- Rivera C et al. (2002) BDNF-induced TrkB activation down-regulates the  $\text{K}^+$ - $\text{Cl}^-$  cotransporter KCC2 and impairs neuronal  $\text{Cl}^-$  extrusion. *J Cell Biol* 159:747–752

## Chloride Switch

### ► Chloride Homeostasis and Development

## Cholecystokinin

### Definition

Cholecystokinin (CCK) is a peptide intestinal hormone that is released in response to food entering the intestine, and causes contractions of the gall bladder and secretion of enzymes from the pancreas. It is also found in neurons and may appear to act within the central nervous system (CNS) as a neuromodulator.

### ► Visceral Afferents

## Cholesterol

### Definition

A lipid molecule with a four-ringed steroid structure found in the cell membrane that affects membrane rigidity and water permeability.

### ► Membrane Components

## Choline Acetyltransferase

### Definition

Enzyme required to synthesize acetylcholine.

### ► Evolution of Subpallial Cholinergic Cell Groups

## Cholinergic

### Definition

Cholinergic refers to acetylcholine and neurons that secrete acetylcholine as a neurotransmitter.

#### ► Acetylcholine

## Cholinergic Brainstem

SUBIMAL DATTA

Sleep and Cognitive Neuroscience Laboratory,  
Department of Psychiatry, Boston University School  
of Medicine, Boston, MA, USA

### Synonyms

Cholinergic neurons in the brainstem; Sources of acetylcholine in the brainstem

### Definition

Cholinergic brainstem refers to neurons (neuronal cells) in the brainstem that synthesize and release acetylcholine as their neurotransmitter.

### Characteristics

#### Identification of Cholinergic Neurotransmitter and Neurons in the Brainstem

In 1936, the English physiologist Sir Henry Dale and the German-Austrian-American pharmacologist Otto Loewy shared the Nobel Prize in physiology and medicine for their discoveries of ►acetylcholine (►ACh) as a neurotransmitter. In fact, ACh was the first chemical transmitter to be recognized as a neurotransmitter. In cholinergic neurons, the enzymes choline acetyltransferase (ChAT) and acetylcholinesterase (AChE) are synthesized at the cell body and then move to the nerve terminals [1]. Terminals of the cholinergic neurons contain acetyl coenzyme A (acetyl-CoA), produced by an intermediary metabolic step, and choline, taken up from the synaptic cleft and other parts of the extracellular space by an active, sodium dependent, high-affinity transport system. In the nerve terminals, acetyl-CoA and choline are combined by the enzymatic activity of ChAT to synthesize ACh molecules [1]. These ACh molecules are stored within synaptic vesicles and are released in response to action potentials. Released ACh activates postsynaptic as well as presynaptic receptors. Since cholinergic neurons synthesize both ACh synthesizing enzyme, ChAT, and a degradation enzyme, AChE, the 1960s studies first

aimed at the identification of brainstem cholinergic neurons attempted to do so by localizing cells containing the enzyme AChE. Later it was discovered that AChE is also synthesized by non-cholinergic neurons containing cholinergic receptors. It turns out that the presence of the ACh synthesizing enzyme ChAT is a more specific marker for the identification of cholinergic neurons. In the 1980s, for the first time, the cholinergic neurons in the brainstem were identified definitively with immunohistochemical staining of ChAT [2].

#### Anatomical Characteristics of Brainstem Cholinergic Cells

There are two categories of cholinergic neurons in the ►brainstem. Neurons in the first category have their cell bodies in the brainstem whereas their axons terminate in the periphery. This category of cholinergic cells is located in the hypoglossal nucleus, the nucleus ambiguus, the dorsal motor nucleus of the vagus nerve, the facial nucleus, the salivatory and lacrimatory complexes, the motor nucleus of the trigeminal nerve, the trochlear nucleus, the oculomotor complex, and the Edinger-Westphal nucleus. Another category of brainstem cholinergic neurons is completely contained within the central nervous system. This category of brainstem cholinergic cells is mainly located in the pontomesencephalic junction in two aggregates [2]. One aggregate of these cholinergic neurons is located in the pedunculo-pontine tegmentum (PPT, also called Ch5 sector) and another aggregate of neurons is located in the laterodorsal tegmentum (LDT, also called Ch6 sector). Cholinergic neurons within the PPT and LDT are medium to large in size (diameter ranging from 15 to 25  $\mu\text{m}$ ) [3]. These cholinergic neurons are variously shaped but are mainly fusiform, polygonal, and oval. Cholinergic neurons in the PPT are slightly more irregularly shaped than those in the LDT. The cytoplasm of these cholinergic neurons is highly developed and remarkably rich in organelles, including free ribosomes, rough and smooth endoplasmic reticulum, Golgi apparatus, and mitochondria [3]. The nucleus of these neurons typically contains large, dense, eccentric nucleoli with invaginated nuclear membranes.

#### Physiological Characteristics of Brainstem Cholinergic Cells

Physiological characteristics of brainstem cholinergic cells have been studied by recording extracellular-single-cell-unit (single-unit) activity of PPT and LDT neurons [4]. Single-unit activity recording is a technique that records extracellularly the occurrence and duration of action potentials of a neuron. The frequency of extracellularly recorded action potentials (number of action potentials per second) is expressed as firing rate (also called discharge rate). Increased firing rate of a neuron means increased physiological activity of that neuron and similarly decreased firing rate of a

neuron means decreased physiological activity. Based on the patterns of sleep-wake-state-dependent single-unit activity rates, five different types of cholinergic neurons have been identified in the PPT and LDT of cats and rats [4,5]. The firing rate of the first type of neurons, called ►REM-on cells, increases as the animal transitions from wakefulness to non-REM (NREM) sleep (►Non-REM Sleep) and then to ►Rapid eye movement (REM) sleep. The firing rate of the second group of neurons, called ►Wake-REM-on cells, increases during both wakefulness and REM sleep. The third group of neurons, ►Wake-on cells, begins to discharge seconds before sleep is terminated and then maintains a high discharge rate until the end of the waking period. This type of cell remains silent throughout the sleep period. The fourth group of neurons, called ►REM-off cells (also called PS-off cells), stops firing during REM sleep. The firing rates of the neurons in the fifth group, called state-independent cells, do not change as a function of sleep-wake behavioral states. The majority of the PPT and LDT cells are of REM-on and Wake-REM-on types. The durations of action potentials of these cholinergic cells are between 0.8 and 2.0 ms [5]. Another important physiological characteristic of a neuron is the mode of firing. Normally, a neuron fires in two different modes: tonic and bursting. In the tonic mode the neuron discharges as a single spike and in bursting mode the neuron discharges as a cluster of three to five action potentials within a very short period of time. In behaving rats, PPT and LDT cholinergic cells fire only in a tonic mode. In the cat, PPT and LDT cholinergic cells fire mostly in a tonic mode, but occasionally during REM sleep, about 5% of those cells also fire in a bursting mode.

### Brainstem Cholinergic Cells as Source of Acetylcholine in the Brain

There are three different ways to identify cerebral sites that receive ACh from the brainstem cholinergic cells: (i) anatomically, by localizing the sites that receive axonal terminals of brainstem cholinergic cells, (ii) neurochemically, by measuring brainstem cholinergic cell activation-induced ACh release in different parts of the brain, and (iii) by combining electrophysiological and pharmacological techniques to identify brainstem cholinergic cell activation-induced postsynaptic cholinergic effects [6]. Brain areas that receive axonal terminals of the brainstem cholinergic cells have been identified by visualizing the movements of different tracers from the PPT and LDT cholinergic cells to other parts of the brain and vice versa. A limited number of studies have also measured brainstem cholinergic cell activation-induced ACh release in some areas of the brainstem and forebrain [6]. There are some studies that have used a combination of electrophysiological recordings and pharmacological

techniques to identify the postsynaptic targets of brainstem cholinergic cells and the postsynaptic effects of ACh released from those brainstem cholinergic cells [7]. Collectively, those anatomical pathway tracing, ACh release, and electrophysiological-pharmacological studies have provided evidences that the PPT and LDT cholinergic cells are the main supplier of ACh for the entire brainstem and also the thalamus [6]. Those studies also provided evidence that the PPT and LDT cholinergic cells are part of the Ach source for several nuclei in the hypothalamus, basal forebrain, and limbic areas. Although the targets for Ach released from the cholinergic cells of the PPT and LDT are mostly common, some parts of the brain receive ACh from only the PPT or the LDT. For example, in the medial prefrontal cortex, the brainstem source of ACh is the LDT and in the suprachiasmatic nucleus the source of brainstem ACh is the PPT. Interestingly, the PPT and LDT cholinergic cells are not the direct source of ACh for the cerebral cortex. In summary, the brainstem cholinergic cells act as a source of ACh for many different parts of the brain but the brain areas and proportion of total ACh are area specific.

### Functions of Brainstem Cholinergic Cells

There is some conclusive evidence to suggest that the cholinergic cells in the PPT and LDT are directly involved in the regulation of REM sleep [6]. REM sleep is characterized by a constellation of events including the following: (i) activated cortical EEG; (ii) marked atonia of the postural muscles; (iii) rapid eye movements; (iv) a theta rhythm within the hippocampus; (v) spiky field potentials in the pons [►pontine wave (P-wave)], lateral geniculate nucleus, and occipital cortex (also called ►ponto-geniculo-occipital (PGO) spikes); (vi) myoclonic twitches, most apparent in the facial and distal limb musculature; and (vii) pronounced cardio-respiratory and core body temperature fluctuations. Distinct cell groups located in the brainstem generate individual events of REM sleep. They are discrete components of a widely distributed network rather than a single REM sleep “center” [6]. For example, muscle atonia is executed by the activation of neurons in the ►locus coeruleus alpha, rapid eye movements result from the activation of neurons in the peri-abducens reticular formation, PGO waves emerge by the activation of neurons in the caudo-lateral peribrachial area of predator mammals and in the dorsal part of the nucleus subcoeruleus of prey mammals, hippocampal theta rhythm is produced via the activation of neurons in the pontis oralis, muscle twitches appear with the activation of neurons in the nucleus gigantocellularis (especially the caudal part), and increased brain temperature and cardio-respiratory fluctuations occur via the activation of neurons in the parabrachial nucleus.

The desynchronized cortical EEG signature of REM sleep, however, is executed jointly by the activation of neurons in the mesencephalic reticular formation and rostrally projecting bulbar reticular formation [6]. Each of these particular cell groups is simply a set of executive neurons for an individual sign. For the final expression of an individual sign, the relevant executive neurons employ a specific neuronal circuit unique to that REM sleep sign. In essence, each of these REM sleep signs has a separate, specialized network. Thus, each of these REM sleep signs could be modulated with multiple neurotransmitters at multiple sites within their circuits. Turn-on or turn-off conditions of REM sleep generating executive neurons are regulated by the ratios of available aminergic and cholinergic neurotransmitters within those cell groups [6]. The source of aminergic neurotransmitters is the locus coeruleus (LC) and raphe nuclei (RN), while cholinergic neurotransmitters, as stated above, originate from the LDT and PPT [6]. The activity of both aminergic and cholinergic cells is approximately equal during wakefulness and the onset of NREM sleep results in an equal reduction in activity. Therefore, during wakefulness and NREM sleep the ratio of aminergic to cholinergic neurotransmitters in REM sleep generators is proportionate. During REM sleep, however, aminergic cell activities are markedly reduced or absent and cholinergic cell activities are comparatively high. Thus, when a hypothetical ratio of aminergic and cholinergic neurotransmitters is low (1:1 ratio), the REM sleep sign-generators remain in the turned-off condition; however, when this ratio is high (0:0.65 ratio), the generators are turned-on to express REM sleep signs [5]. This is how the activity of PPT and LDT cholinergic cells regulate REM sleep. To initiate and maintain the activation of REM sleep sign generators, brainstem cholinergic cells in the PPT are activated by the stimulation of kainate-type glutamate receptors [6]. Activation of GABA-B receptors inhibits PPT cholinergic cell activity to terminate REM sleep [6].

Single-cell recordings, chemical stimulation, and anatomical pathway tracing studies also suggest that the activation of PPT cholinergic cells could promote wakefulness [6]. Single-cell recording studies examining sleep-wake state-dependent firing patterns in the PPT and LDT of behaving cats and rats identified the five aforementioned major groups of cholinergic cells: (i) REM-on, (ii) Wake-REM-on, (iii) Wake-on, (iv) REM-off, and (v) sleep-wake state-unrelated. Of those five categories of cells, Wake-REM-on cells are active during both wakefulness and REM sleep [5,6]. In contrast, the Wake-on cells were found to be active only during wakefulness. The presence of Wake-REM-on and Wake-on types of cells suggests that the PPT and LDT are involved in promoting wakefulness. A recent single cell recording study in freely moving rats has

shown that the Wake-REM-on cell population within the cholinergic cell compartment of the PPT increases neuronal activity as a prelude to wakefulness and remains very active until 5–8 s before the end of wakefulness [5]. Consistent with this analysis, Ach release in the thalamus is highest during waking, slightly less during REM sleep, and at a minimum during SWS. The causal evidence that the PPT is involved in generating wakefulness came from local chemical stimulation studies [6]. Chemical stimulation studies have demonstrated that the activation of NMDA-type glutamate receptors within the PPT cholinergic cell compartment induces wakefulness. PPT and LDT cholinergic cells project directly to multiple wake-promoting areas of the forebrain via thalamo-cortical, hypothalamo-cortical, basalo-cortical pathways [6]. Activation of the PPT NMDA receptors promotes wakefulness by activating multiple wake-promoting areas of the forebrain. On the contrary, inhibition of PPT cholinergic cells reduces the total amount of wakefulness [6].

The projections from the PPT and LDT to the thalamic nuclei constitute a major component of the ascending reticular activating system [4,7]. Increased activity of these cholinergic cells increases the levels of ACh release in the thalamus. ACh is an excitatory neurotransmitter for the thalamo-cortical cells. Since those PPT and LDT cells are active during both wakefulness and REM sleep, ACh release from these brainstem cholinergic cells may play an important role in cortical activation during both waking and REM sleep. Indeed, the NMDA receptor-mediated activation of PPT cholinergic cells increases cortical activation [4,6]. Cortical activation is a prerequisite for cognitive functions, and thus, the activation of PPT cholinergic cells may contribute positively to cognitive processing. In summary, the normal functioning of the brainstem cholinergic cells in the PPT and LDT is involved in the regulation of REM sleep, wakefulness, and cortical activation processes.

### Brainstem Cholinergic Cells and Disease

Although there is no known direct causal relationship between the patho-physiology of brainstem cholinergic cells and any disease condition, a number of degenerative neurological diseases involve brainstem cholinergic cells [8,9]. For example, both amyotrophic lateral sclerosis and Mobius syndrome involve degeneration of brainstem motoneurons. Parkinson's disease (PD) and progressive supranuclear palsy (PSP), which are both characterized pathologically by the loss of PPT neurons, share varying degrees of insomnia and motor dysfunction as clinical manifestations. More recently, using a transgenic animal model, it has been shown that cholinergic cell loss in the PPT may be a causal factor for a number of symptoms in Alzheimer's disease,

especially the disturbances in REM sleep [6]. It is also suspected that developmental abnormalities of PPT cholinergic cells during prenatal and early postnatal periods could be a significant contributing factor for the development of endogenous depression and schizophrenia in adolescence and adulthood [10].

## References

1. Blusztajn JK, Wurtman RJ (1983) Choline and cholinergic neurons. *Science* 221:614–620
2. Mesulam M-M, Mufson EJ, Wainer BH, Levey AI (1983) Central cholinergic pathways in the rat: an overview based on an alternative nomenclature (Ch1-Ch6). *Neurosci* 10:1185–1201
3. Steininger TL, Wainer BH, Rye DB (1997) Ultrastructural study of cholinergic and noncholinergic neurons in the pars compacta of the rat pedunculopontine tegmental nucleus. *J Comp Neurol* 382:285–301
4. Datta S (1995) Neuronal activity in the peribrachial area: relationship to behavioral state control. *Neurosci Biobehav Rev* 19:67–84
5. Datta S, Siwek DF (2002) Single cell activity patterns of pedunculopontine tegmentum neurons across the sleep-wake cycle in the freely moving rats. *J Neurosci Res* 70:611–621
6. Datta S, MacLean RR (2007) Neurobiological mechanisms for the regulation of mammalian sleep-wake behavior: Reinterpretation of historical evidence and inclusion of contemporary cellular and molecular evidence. *Neurosci Biobehav Rev* 31:775–824
7. Garcia-Rill E (1991) The pedunculopontine nucleus. *Prog. Neurobiol.* 36:363–389
8. Hirsch EC, Graybiel AM, Duyckaerts C, Javoy-Agrid F (1987) Neuronal loss in the pedunculopontine tegmental nucleus in Parkinson disease and in progressive supranuclear palsy. *Proc Natl Acad Sci USA* 84:5976–5980
9. Rye DB (1997) Contributions of the pedunculopontine tegmental region to normal and altered REM sleep. *Sleep* 20:757–788
10. Garcia-Rill E, Kobayashi T, Good C (2003) The developmental decrease in REM sleep. *Thal Rel Syst* 2:115–131

## Cholinergic Fiber

### Definition

A cholinergic fiber is the axon of an autonomic neuron that synthesizes acetylcholine. These include axons of some postganglionic sympathetic neurons, most postganglionic parasympathetic neurons, some enteric neurons and probably all preganglionic autonomic neurons. Many cholinergic fibers contain co-transmitters such as neuropeptides or nitric oxide, and acetylcholine may not necessarily be the primary neurotransmitter.

► Acetylcholine

## Cholinergic Neurons in the Brainstem

► Cholinergic Brainstem

## Chondrichthyans

### Definition

Outgroup of remaining gnathostomes: include all cartilaginous fishes, i.e., elasmobranchs (sharks, skates and rays) and holocephalans (chimaeras).

► Evolution of the Brain: In Fishes

► Evolution of the Telencephalon: In Anamniotes

## Chondrocytes

### Definition

The metabolically active cells of articular cartilage that maintain the intercellular matrix.

► Articular Cartilage

## Chondroitin and Keratan Sulfate Proteoglycans

### Definition

Proteoglycans are a set of ubiquitous proteins found on cell surfaces, within intracellular vesicles, and incorporated into extracellular matrix. Both chondroitin and keratan sulfate proteoglycans are included in the proteoglycans family.

► Regeneration

## Chondroitin Sulfate Proteoglycans (CSPGs)

### Definition

CSPG are part of a larger family of proteoglycans that consist of a protein core and long sulfated

sugar residues (glycosaminoglycans, GAGs). Other family members are heparan sulfate proteoglycans, keratan sulfate proteoglycans and dermatan sulfate proteoglycans. The difference between the family members is due to the different sulfated GAG chains. CSPGs are expressed on the surface of most cells and in the extracellular matrix of most tissues. In the CNS, CSPGs such as brevican, versican, aggrecan, phosphacan, neurocan, NG2 and neuroglycan are expressed mainly by astrocytes and oligodendrocyte precursors. They play a role in cell migration, brain development, neurite outgrowth and axon path finding. After CNS injury, astrocytes that form the glial scar express increased amounts of CSPGs at the site of injury. CSPGs inhibit axonal regeneration, mostly due to the presence of the GAG chain, and contribute to the inhibitory effects of glial scar. Removal of the GAG chains by the enzyme chondroitinase ABC reduces its inhibitory effect and promotes axon regeneration in the injured CNS.

► [Inhibitory Molecules in Regeneration](#)

## Chondroitinase

### Definition

Several bacteria have evolved enzymes which have the ability to digest chondroitin sulfate proteoglycans (putative components of the extracellular matrix that inhibits axonal regeneration). These are collectively called chondroitinase, followed by the capital letters A, B, C, indicating the sulfation forms of the chondroitin sulfate that they are able to digest.

► [Regeneration](#)  
 ► [Regeneration of Optic Nerve](#)

## Chondron

### Definition

A chondron consists of a chondrocyte and its protective pericellular matrix and capsule.

► [Articular Cartilage](#)

## Chorda Tympani (CT)

### Definition

The chorda tympani (CT) is a branch of the inter-mediofacial nerve complex. It carries efferent parasympathetic axons to the submandibular ganglion to supply two major salivary glands (sublingual and submandibular glands). The CT also contains afferent gustatory axons supplying the fungiform taste buds of the anterior part of the tongue. Their nuclei are situated in the ganglion geniculi, but the first relay lies in the rostral part of the nucleus of the solitary tract.

► [Neural Coding of Taste](#)

## Chordates

### Definition

The taxon that is characterized by the presence of a notochord. The extant members of this taxon comprise the cephalochordates (amphioxus), urochordates (sea squirts), and vertebrates.

► [Evolution of Brain: at Invertebrate–vertebrate Transition](#)

## Chordotonal Organ

### Definition

A type of proprioceptive stretch receptor in crustaceans and insects consisting of thin, elastic strands of connective tissue stretched between adjacent body regions and comprised of individual mechanosensory units called scolopidia.

► [Invertebrate Ears and Hearing](#)

## Chorea

### Definition

Literally meaning “dance” in Greek, chorea resembles exaggerated fidgetiness with fast writhing movements.



The movements are usually generalized and purposeless, although in mild cases, chorea may be blended into natural movements and appear purposeful. Choreoathetosis is the term used when the movements have a slower writhing component. Chorea is seen in Huntington's disease, can be caused by chronic use of levodopa in Parkinson disease, and occurs in the rare condition known as Sydenham chorea (also known as St. Vitus' dance).

- ▶ Huntington's Disease
- ▶ Parkinson Disease
- ▶ Sydenham Chorea

## Chorea Chronica Progressiva

### Definition

- ▶ Huntington's Disease

## Chorea Hereditaria

### Definition

- ▶ Huntington's Disease

## Chorea Minor (Chorea Infectiosa, Chorea Rheumatica)

### Definition

- ▶ Sydenham Chorea

## Chromaffin Cells

### Definition

Cells in the adrenal medullary tissue that are derived from the neural crest ectoderm.

## Chromatic Processing

- ▶ Color Processing

## Chromatic Vision

- ▶ Color Processing

## Chromatin Immunoprecipitation and the Study of Gene Regulation in the Nervous System

DAVID D. EISENSTAT

Manitoba Institute of Cell Biology, Departments of Pediatrics and Child Health, Human Anatomy and Cell Science, Ophthalmology, and Biochemistry and Medical Genetics, Faculty of Medicine, University of Manitoba, Winnipeg, MB, Canada

### Synonyms

Chromatin immunoaffinity precipitation; ChIP; Chromatin immunopurification

### Definition

Chromatin immunoprecipitation (ChIP) is a biochemical technique wherein antibodies, usually directed to [▶transcription factors](#), are used to immunoprecipitate proteins (the specific transcription factor of interest or proteins bound to that transcription factor in a protein complex) bound to chromatin, usually genomic DNA (gDNA) sequences *in vitro* or *in situ*. The isolated gDNA fragments are likely to encode transcriptional regulatory units (promoters, enhancers, repressors) and can be used to identify direct transcription factor targets *in vivo*. Various methods are available to [▶cross-link](#) proteins to DNA. The ChIP procedure enables immuno-enrichment of putative target DNA sequences bound to the transcription factor *in vivo*. Subsequently, the identified sequences must be characterized to validate specific protein-DNA interactions *in vitro*, using electrophoretic mobility shift assays (EMSA), and their functional significance by implementation of gain and loss-of-function strategies both *in vitro* using reporter gene assays, and *in vivo* using transgenic animals or [▶interfering RNA](#) approaches.

Increasingly, the ChIP procedure has been quantified ([▶qChIP](#)) or coupled to various sequencing (ChIPSeq) or array technologies, including cDNA or oligonucleotide microarrays used for expression profiling, [▶promoter](#) arrays, [▶CpG island](#) arrays, and [▶tiling](#) arrays, in order to identify the target sequences as well as [▶consensus binding motifs](#) in a high-throughput

manner. These technologies are often grouped together under the term ►ChIP-chip assays. ChIP methodologies have enabled investigators interested in nervous system development and function to study gene regulation under physiologic conditions, thereby permitting the identification of gene networks directly regulated by the transcription factor of interest. To date, transcription factors under study have included: ►homeobox proteins, ►helix-loop-helix (HLH) proteins, ►p53, ►E2F, and ►NF- $\kappa$ B.

►ChIP-chip technologies

- ChIP – cDNA or oligonucleotide microarrays
- ChIP – promoter microarrays
- ChIP – CpG island microarrays
- ChIP – tiling microarrays

## Characteristics

### Description of the Process

A major advance towards the identification of target genes of specific transcription factors was the development of ChIP [1]. ChIP involves a biochemical rather than genetic approach to the identification of direct target genes. Unlike cDNA microarray analysis, ChIP isolates direct targets from relevant tissues under physiologic conditions [2]. Gould et al. [1] used an antibody to the *Ubx* homeobox gene product to immunopurify *Ubx* bound to DNA sequences from soluble chromatin. After immunoprecipitation (IP), the

complexes were disrupted and the released genomic DNA (gDNA) fragments were cloned. The DNA fragments isolated by ChIP were enriched for sequences matching defined ►homeodomain binding sites and used to screen genomic DNA libraries for transcription units. Modifications of the ChIP protocol include stabilization of DNA-protein adducts in intact nuclei by cross-linking using ultraviolet (UV) light, formaldehyde (cross-links protein to DNA and protein to protein) and cisplatin, a chemotherapy agent that cross-links protein to DNA [3]. Utilizing these methods, homeodomain targets have been isolated and these targets include: homeobox genes, other transcription factors, growth factors, adhesion molecules, and secreted proteins. Until recently, the search for homeobox targets in vertebrates has not been as productive as in *Drosophila melanogaster*. Although several candidate genes have been identified using *in vitro* and tissue culture methods, the significance of these interactions *in vivo* remains to be confirmed. Takahashi's group also modified the ChIP approach to identify *mgl-1*, a ►tumor suppressor gene and putative adhesion molecule, as a downstream target of HOX-C8 from mouse spinal cord [4], showing that it is possible to isolate other direct vertebrate homeobox gene targets.

The most widely applied ChIP method is adapted [4,5] and modified by our group [6] (refer to Fig. 1).

►Optimizing the ChIP procedure

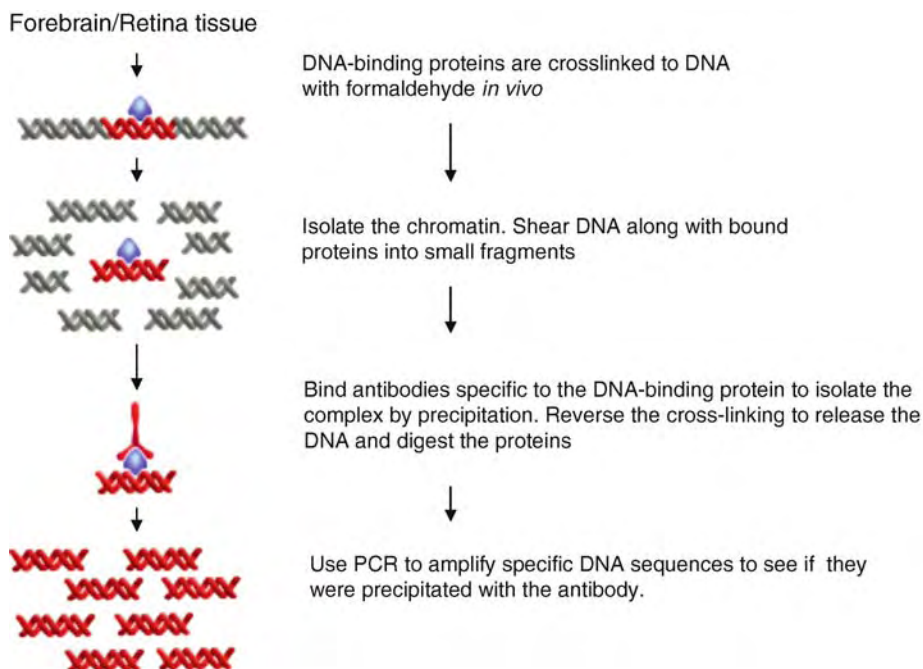

## Chromatin Immunoprecipitation and the Study of Gene Regulation in the Nervous System.

**Figure 1** Schematic outline of the chromatin immunoprecipitation (ChIP) procedure.

- Use sensitive and highly specific antibodies to the transcription factor
- Use antibodies with high binding affinities
- Use antibodies that work under varying conditions of tissue fixation and/or cross-linking
- Vary time of exposure to determine optimal duration of cross-linking protein to DNA
- Vary concentrations of the cross-linking reagent to favor protein-DNA complex formation
- Use cells obtained from embryonic tissues or the adult nervous system where peak temporal and spatial expression of the transcription factor occurs

We have optimized cross-linking by reducing paraformaldehyde concentration from 4% to 1% and decreasing the duration of cross-linking from overnight to 2 h to promote protein-DNA interactions [6]. Paraformaldehyde is used to cross-link protein to DNA. As input material, tissue that expresses the transcription factor of interest (such as embryonic day 13.5 (E13.5) ► *ganglionic eminences* that highly express members of the ► *Dlx* homeobox gene family) is isolated and freely dissected using a stereomicroscope. Ideally,  $1-2 \times 10^7$  cells are required, but the amount of input material depends upon the relative abundance of the transcription factor. Tissues are incubated, cross-linked at 4°C with 1% paraformaldehyde, then homogenized, sonicated to yield solubilized nucleoprotein complexes, and centrifuged. Shorter incubation times with the cross-linking reagent may yield increased quantities of DNA bound to protein and it is recommended that the investigator perform time course experiments [6]. The supernatant is incubated with protein A±G sepharose bound to antibodies specific to the transcription factor under study. The bound complexes are eluted following reversal of cross-linking by heating at 65°C, dialyzed, then incubated with RNase and proteinase K. Proteinase K treatment removes the antigen-antibody complexes, leaving only genomic DNA fragments that are directly bound to transcription factor proteins *in vivo*. Following purification, gDNA fragments can be subcloned to generate a ChIP library, directly sequenced or used as input material for ChIP-chip assays. Controls may include immunoprecipitation of tissue that does not express the transcription factor at all (such as embryonic hindbrain for *Dlx* genes or embryonic heart for *Pax6*). Other investigators have used tissues derived from mutants for the specific transcription factor as a negative control. Control immunoprecipitations without primary antibody and with an unrelated polyclonal antibody are also recommended. The average size of the cloned gDNA fragments is approximately 300 base pairs [4].

## Higher Level Processes

### ChIP Libraries and ChIP-Sequencing

The ► ChIP library approach has been used as a means of high-throughput screening to identify the targets of

homeobox genes. A ChIP library was constructed for the *Drosophila* homeoprotein Engrailed using a UV-cross-linking method in which 203 Engrailed binding sites within intergenic regions or introns were identified [7]. The observation of transcription factors frequently binding within introns is consistent with previous reports. Many identified potential target genes are involved in key developmental pathways, including axonal guidance [7]. Sets of replica library filters from gDNA target libraries developed following cross-linking can be hybridized with randomly selected clones. Clones that hybridize to multiple plaques may be screened by genomic Southern hybridization to determine the presence of repetitive DNA sequences (multiple bands or a smear of hybridization in the lane). Unique sequences give a single band and are likely to contain candidate regulatory sequences that can be further characterized [4].

Another means to rapidly analyze all gDNA fragments immunoprecipitated through the ChIP procedure is to identify DNA fragments bound to protein by direct DNA sequencing, using a method called ► ChIPSeq [8]. Johnson et al used a monoclonal antibody to neuron-restrictive silencing factor (► NRSF), also known as repressor element-1 silencing transcription factor (REST), to identify 6,718 single NRSF binding sites in the genome using criteria of at least 13 independent sequence reads and a fivefold enrichment relative to control DNA samples derived from chromatin not treated with the NRSF antibody. Since NRSF/REST silences neuronal gene expression in neural progenitors as well as non-neuronal cell types, this high-throughput sequencing approach shows promise as a means to identify the direct targets of other transcription factors important to mammalian nervous system development and function [8].

### ChIP-Chip Assays

Unbiased mammalian ► promoter microarrays are not readily available due to insufficient annotation of regulatory sequence information. Nevertheless, attempts have been made to construct partial proximal promoter arrays of human cells. One group constructed a human proximal promoter array representing 13,000 genes [9]. The 13,000 proximal promoters were selected based on annotated transcription start sites. Despite these initial successes, the mammalian promoter array is still in its infancy due to the bias of how the promoter is defined and isolated in these arrays. Many regulatory elements, such as enhancers and silencers are located distal to transcription start sites, upstream or downstream of the coding region, or in intronic regions.

► CpG island arrays have also been generated to approximate promoters in the human genome [2,10]. CpG-rich sequences or CpG islands are associated with transcriptional activities. Weinmann et al. [2] have

successfully applied ChIP to isolate targets of the transcription factor E2F, including coupling of ChIP to CpG island microarray analysis. In this CpG array based ChIP-chip experiment, E2F binding targets were studied in HeLa cells [2]. Interestingly, within the 68 unique targets identified from the ChIP-on-chip screening, many targets were associated with DNA repair and recombination rather than cell cycle control, suggesting that the use of specific “chips” after ChIP may yield different yet overlapping classes of transcriptional target sequences. CpG island arrays are currently hampered by noise due to antibody specificity and the bias of the constructed array which only contains a representation of all CpG islands selected based upon the hypermethylation status of the sequence [2].

► **Tiling microarrays** provide an opportunity to examine transcription factor binding sites in a truly unbiased fashion. However, dozens of arrays are required to adequately represent the mouse and human genome and the costs of such experiments may be prohibitive.

Following ChIP, Linker-Mediated PCR is used to amplify the isolated DNA fragments. The PCR products are then labelled with either Cy3 or Cy5, using indirect labelling with aminoallyl dUTP and random priming of the template. These labelled PCR products can be hybridized to mouse or human CpG island spotted arrays. Slides are then scanned using a microarray scanner and associated software. Spots for which the ratio of the Ab(+):Ab(-) control is greater than 1.5 (having a signal more than twice background) may be considered significant. CpG island and tiling arrays, scanners and software are available in the public and private sectors. Additional control experiments, such as performing ChIP (with and without antibody) on a negative tissue control prior to hybridization on the CpG island arrays, should also be performed. Of interest, ChIP-gDNA library and the ChIP-CpG island array technologies applied to embryonic mouse tissues may yield different yet overlapping lists of target genes (Cheng, Pind and Eisenstat, unpublished observations), similar to findings reported using human cells.

### Regulation of the Process

Cisplatin or *cis-diamminedichloroplatinum (II)* will not cross-link protein to protein and may be a more selective cross-linking reagent than formaldehyde compounds [6]. The cell lysate is added to hydroxylapatite resin. RNA and proteins not cross-linked to DNA are washed away. The cross-linking is reversed by incubating in thiourea, releasing proteins from the hydroxylapatite, while the DNA will remain bound. ChIP using cisplatin cross-linking of protein to DNA may isolate different gene targets than by paraformaldehyde cross-linking, such as those associated with the ► **nuclear matrix**. It is reported that transcriptionally active genes are nuclear matrix associated.

### Function

The utilization of biochemical approaches such as ChIP provides several ► **advantages**. Identified target genes are directly downstream and are derived from physiological transcription factor-DNA complexes obtained *in vivo*. The isolated gDNA fragments may be from transcriptional regulatory elements of previously identified or novel genes. ChIP may be applied to diverse species, including *Drosophila melanogaster* and vertebrates. The advantage of cross-linking is preservation of a naturally existing (*in situ*) protein-DNA interaction. Identification of a transcription factor consensus binding sequence using ChIP-chip arrays may be more efficient than by screening random oligonucleotide pools.

Chromatin immunoprecipitation does have several ► **limitations**. The choice of the cross-linking reagent may influence whether targets are indirectly or directly downstream. IP screens require specific antibodies and require the construction of separate DNA libraries for each protein for which targets are sought and these libraries may be hampered by low cloning efficiency. It might be difficult to identify targets that interact with the regulatory protein in only a few cells or during brief developmental periods. It may be necessary to perform ChIP at several developmental time points to obtain different functional classes of transcription factor targets. Another problem may be that there is promiscuous binding. One way to reduce the non-specific DNA obtained from the ChIP procedure is to subtract the ChIP-DNA with input DNA before sub-cloning. In addition, binding may be significantly distant from the coding region as well, since most homeodomain proteins, for example, bind to a consensus TAAT core motif, many of the immunopurified fragments may not be specifically regulated by the homeobox gene itself. Finally, multiple factors may be required for the regulated expression of the target gene.

### References

1. Gould AP, Brookman JJ, Strutt DI, White RAH (1990) Targets of homeotic gene control in *Drosophila*. *Nature* 348:308–312
2. Weinmann AS, Yan PS, Oberley MJ, Huang TH, Farnham PJ (2002) Isolating human transcription factor targets by coupling chromatin immunoprecipitation and CpG island microarray analysis. *Genes Dev* 16: 235–244
3. Breiling A, Turner BM, Bianchi ME, Orlando V (2001) General transcription factors bind promoters repressed by Polycomb group proteins. *Nature* 412:651–655
4. Tomotsune D, Shoji H, Wakamatsu Y, Kondoh H, Takahashi N (1993) A mouse homologue of the *Drosophila* tumour suppressor gene *l(2)gl* controlled by Hox-C8 *in vivo*. *Nature* 365:69–72

5. Kuo MH, Allis CD (1999) In vivo cross-linking and immunoprecipitation for studying dynamic protein: DNA associations in a chromatin environment. *Methods* 19: 425–433
6. Zhou QP, Le T, Qiu X, Plews M, de Melo J, Du G, Fonseca M, Spencer V, Sun JM, Davie J, Eisenstat DD (2004) Identification of *Dlx* homeodomain targets in the developing forebrain and retina by optimization of chromatin immunoprecipitation of embryonic mouse tissues. *Nucleic Acids Res* 32: 884–892
7. Solano PJ, Mugat B, Martin D, Girard F, Huibant JM, Ferraz C, Jacq B, Demaille J, Maschat F (2003) Genome-wide identification of in vivo *Drosophila* Engrailed-binding DNA fragments and related target genes. *Development* 130:1243–1254
8. Johnson DS, Mortazavi A, Myers RM, Wold B (2007) Genome-wide mapping of in vivo protein-DNA interactions. *Science* 316:1497–1502
9. Odom DT, Zizlsperger N, Gordon DB, Bell GW, Rinaldi NJ, Murray HL, Volkert TL, Schreiber J, Rolfe PA, Gifford DK, Fraenkel E, Bell GI, Young RA (2004) Control of pancreas and liver gene expression by HNF transcription factors. *Science* 303:1378–1381
10. Oberley MJ, Farnham PJ (2003) Probing chromatin immunoprecipitates with CpG-island microarrays to identify genomic sites occupied by DNA-binding proteins. *Methods Enzymol* 371:577–596

## Chromatin Immunopurification

► Chromatin Immunoprecipitation and the Study of Gene Regulation in the Nervous System

## Chromatolysis

KAARE SEVERINSEN, JOHANNES JAKOBSEN  
Department of Neurology, Aarhus University Hospital,  
Aarhus, Denmark

### Synonyms

Axon reaction; Retrograde degeneration

### Definition

The term chromatolysis (chroma: color; lysis: disintegration) refers to the disintegration or dispersal of the basophilic nissl bodies (► nissl body). The reaction takes place in the neuronal cytoplasm following ► axotomy or other traumatic or metabolic nerve injuries. Dispersal of the basophilic Nissl bodies due

to disintegration of the stacked rough endoplasmatic reticulum is only one of many changes of the neuronal cell body following axotomy [1]. In this text we have chosen to embrace all the morphological changes taking place following axotomy [2].

### Characteristics

#### Quantitative Description

The morphological reaction of chromatolysis has been extensively studied for more than a century in experimental animal models. It was Nissl in 1894 and Marinesco in 1898 who first described the reaction using light microscopy. The classical chromatolytic appearance of the neuronal cell body can easily be recognized using light microscopy and cresyl violet or toluidin stained tissues. It includes disintegration of the basophilic Nissl bodies to a dust like appearance, peripheral condensation of basophilic substances, eccentricity of the nucleus, a basophilic nuclear cap and crenation (folding) of the nucleolemma. Often the cell body is surrounded by activated small basophilic satellite glial cells (sattelitosis). Swelling of the cell body is frequently reported as part of the chromatolytic reaction in early neurocytological studies. In a series of studies from our own laboratory using modern stereological methods we have shown an initial cellular shrinkage amounting to approximately 30% following nerve crush and nerve transection [3,4]. In surviving cell bodies shrinkage was followed by a return to normal cellular dimensions after 3–5 months [4]. The initial morphological changes appear during the first 2–5 days following nerve damage [2] and progress during the following weeks followed by a gradual recovery with return to normal cell morphology among surviving cells. Four days after axotomy no significant cell loss can be detected. After 15 days the cell loss amounts to 31% without further progression during the following weeks.

### Morphology

Chromatolysis is observed in neuronal cells in the peripheral and central nervous system. Furthermore, the reaction is not confined to the neurons but also involves the surrounding glial cells. Some authors refer to this as an activation of the satellitic glial cells and in the light microscope it is recognizable as satellitosis, the neuron being surrounded by basophilic glial cells. The role of the activated glial cells is controversial, but it is hypothesized that they play a key role in supplying the neuron with neurotrophic growth factors which it is denied because of damage to the peripheral axon.

Sattelitosis should not be mistaken as an inflammatory response. There is no immune reaction surrounding the neurons and when cell death occurs it is by apoptosis and not by necrosis.

### Ultrastructure

Chromatolysis leads to intracellular reorganisation of the cytoplasm and its organelles. Electron microscopic studies have only provided sparse information as to the actual changes of the organelles, and the details are beyond the scope of this essay. The nissl bodies, smooth endoplasmic reticulum, lysosomes, cytoskeleton, nucleus and nucleolus are all influenced by the shift to a state of regeneration with increased synthesis of ►household proteins. The characteristically morphological changes occurring in the cell (eccentricity of the nucleus and peripheral displacement of basophilic substances) has traditionally been hypothesised to be caused by osmotic swelling. Later studies, however, revealed an abundance of nissl body-free cytoskeletal components stockpiled in the cytoplasm of axotomised neuronal cells [5] believed to cause the displacement of the organelles, including that of the nucleus.

### Structural Regulation

Chromatolysis is a temporary condition of regeneration in response to a harmful stimulus rather than a step in a chain of inevitable events leading to cell death. Axotomy, traumatic, pathological as well as toxicologic conditions can result in a condition leading to chromatolysis. With regard to axotomy, which by definition leads to loss of the axon terminal, the chromatolytic regenerative state is supposed to be caused by massive intracellular reorganization caused by the need to initiate a growth program for the formation of the axonal growth cone to replace the amputated axonal terminal [5,6]. Dependent on the harmful stimulus a fraction of the cells will die, by apoptosis, and another fraction will regenerate and resume normal morphology and function when possible. Neurons in the central nervous system seem very vulnerable to traumatic damage whereas neurons in the peripheral nervous system seem rather resilient to traumatic damage and in most cases regenerate dependent of the severity of the trauma. In a series of experiments performed in our laboratory, permanent central nerve damage of spinal nerves in rats lead to a reduction of L5 dorsal root ganglion (DRG) neuronal cells of 26% after 3 months whereas 46% of the cells were chromatolytic. In diabetic rats there was no increase in cell loss and 46% of the remaining neurons were also chromatolytic [7]. This indicates that in spite of a severe trauma of the spinal nerve, 1 cm distal to the DRG only one fourth of the neurons succumb to apoptosis, and roughly half of the remaining cells are in a state of chromatolysis with the potential to survive.

The amount of loss of neuronal DRG cells is dependent on the distance to the DRG. In sciatic nerve axotomy in rats the DRG cell loss is smaller than after spinal nerve axotomy and occurs later [8].

### Neurotropic Factors

Structural damage as well as other pathological conditions can cause a neuron to enter a state of chromatolysis. The signal for this transformation has not yet been identified but strong evidence points toward loss or reduction of neurotrophic factors derived from the periphery [1]. ►NGF has been suggested to play a role because experiments have shown that axotomy-induced chromatolysis of sympathetic ganglia cell bodies in vitro is blocked by application of NGF and that application of NGF antisera leads to axotomy like changes [1]. Other neurotrophic factors might play a role and up and down regulation of neurotrophic receptors in pathological conditions might well be involved.

### Process Regulation

The signal leading to chromatolysis has been debated for decades, and in comprehensive reviews during the 70's [2,9] not less than ten possible candidates were presented. Strong evidence, however, suggests an important role of axonally retrogradely transported signaling proteins. In reviews, [1,6] the lack of retrogradely transported peripheral trophic factors important for the continuous upheaval of the cell body integrity as well as the presence of peripheral electrical stimuli via calcium influx en masse and retrogradely transported chromatolysis inducing proteins are discussed. It seems likely, however, that the signal for chromatolysis is in part the lack of retrogradely transported peripheral trophic factors usually achieved from the axon terminal as well as traumatic initiated electrical or biochemical stimuli of the cell body. In contrast to the traditionally held belief that all neuronal proteins are produced centrally and anterogradely transported to the axon and the axon terminal, new research indicates that protein synthesis capacity is present in the axon [6,9], and that damage to the axon might trigger translation of mRNAs. Peripherally produced peptides possibly play an important role in initiating the chromatolytic reaction in response to axonal damage by retrogradely transporting to the cell body, including the formation of a growth cone for regeneration of the axon terminal [6,10], the latter only being an ability characteristic of the peripheral nervous (Fig. 1).

### Function

Chromatolysis is considered to be a state of regeneration in damaged neuronal cells characterized by increased synthesis of cytoskeletal and other housekeeping proteins with down regulation of neurotransmitter-related enzymes and receptors. The state is a shift from external functioning to internal build up and the surface of the cell is covered by glial profiles from activated satellite glial cells leading to a temporary loss of most presynaptic dendritic terminals.

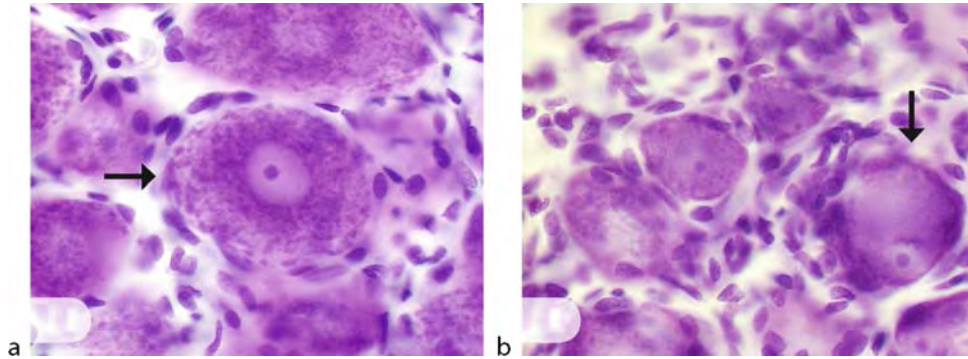

**Chromatolysis. Figure 1** Non-chromatolytic dorsal root ganglion cells with preserved nissl substance and a centrally placed nucleus (a). Chromatolytic dorsal root ganglion cells showing disintegration of nissl substance, displacement of nucleus and satellitosis of glial cells around the neuronal cell body (b).

### Pathology

The bulk of experimental work regarding chromatolysis has been performed in animal models inflicting physical (axotomy or crush [3,4]), thermal or chemical (acrylamide intoxication) damage to the peripheral (DRG or sympathetic ganglia) or central nervous system (visual cortex and retinal ganglia or olfactory bulb). Chromatolysis is, however, observed in part of many disease processes including multiple sclerosis, porphyria, pellagra, amyotrophic lateral sclerosis and poliomyelitis.

### Therapy

Chromatolysis is a regenerative cytologic response to harmful physical or metabolic exposure. In accordance with this statement there is no information about conditions in which chromatolysis is the primary pathology. In traumatic injury it seems attractive to support regrowth of damaged axonal or dendritic processes by supplying patients with neurotrophic growth factors, or by manipulation of axonal protein synthesis, growth cone formation and propagation. The knowledge of this field is still limited and on a strictly experimental basis. In the future, however, stimulation and manipulation of chromatolysis and regeneration of neuronal cells might prove to be a new approach in posttraumatic neurology.

### ► Neuronal Changes in Axonal Degeneration and Regeneration

### References

1. Hanz S, Fainzilber M (2006) Retrograde signaling in injured nerve – the axon reaction revisited. *J Neurochem* 99:13–19
2. Lieberman AR (1971) The axon reaction: a review of the principal features of perikaryal responses to axon injury. *Int Rev Neurobiol* 14:49–124
3. Vestergaard S, Tandrup T, Jakobsen J (1997) Effect of permanent axotomy on number and volume of dorsal root ganglion cell bodies. *J Comp Neurol* 388:307–312

4. Degn J, Tandrup T, Jakobsen J (1999) Effect of nerve crush on perikaryal number and volume of neurons in adult rat dorsal root ganglion. *J Comp Neurol* 412:186–192
5. McIlwain DL, Hoke VB (2005) The role of the cytoskeleton in cell body enlargement, increased nuclear eccentricity and chromatolysis in axotomized spinal motor neurons. *BMC Neurosci* 6:19
6. Willis DE, Twiss JL (2006) The evolving roles of axonally synthesized proteins in regeneration. *Curr Opin Neurobiol* 16:111–118
7. Severinsen K, Jakobsen J (2007) Diabetes does not accelerate neuronal loss following nerve injury. *J Peripher Nerv Syst* 12:262–268
8. Tandrup T, Woolf CJ, Coggeshall RE (2000) Delayed loss of small dorsal root ganglion cells after transection of the rat sciatic nerve. *J Comp Neurol* 422:172–180
9. Cragg BG (1970) What is the signal for chromatolysis? *Brain Res* 23:1–21
10. Verma P, Chierzi S, Codd AM, Campbell DS, Meyer RL, Holt CE, Fawcett JW (2005) Axonal protein synthesis and degradation are necessary for efficient growth cone regeneration. *J Neurosci* 25:331–342

## Chromophore

### Definition

In biological molecules that serve to capture or detect light energy, the chromophore is the moiety that causes a conformational change of the visual pigment. Linked with an opsin protein, the chromophore is based on either the vitamin A1 aldehyde, 11-cis-retinal (rhopsin) or the vitamin A2 aldehyde, 11-cis-3, 4-dehydroretinal (porphyropsin).

### ► Photopigments

## Chromosome

### Definition

A chromosome is a single large linear DNA macromolecule in a cell's nucleus, which contains genes, regulatory elements and other nucleotide sequences.

## Chronaxy

### Definition

Duration that a rectangular direct current (DC) current of double rheobase strength must flow in order to elicit an action potential.

- ▶ Action Potential
- ▶ Rheobase

## Chronic Daily Headache (CDH)

### Definition

Headaches which occur more than 4 h/day, more than 15 days/month. Most CDH is medication overuse headache, though chronic tension-type headache, new daily persistent headache or hemicrania continua may occur.

- ▶ Headache

## Chronic Endotoxin Exposure

### Definition

Prolonged exposure to lipopolysaccharide, the major component of the outer membrane of gram negative bacteria, to mimic a chronic infection; exposure via chronic systemic infusion or repeated bolus doses.

- ▶ Prenatal Brain Injury by Chronic Endotoxin Exposure

## Chronic Insufficient Sleep Syndrome

### Definition

Insufficient nocturnal sleep, which can be behaviorally or environmentally induced, and results in sleep deprivation and reduced waking alertness.

- ▶ Alertness Level

## Chronic Nerve Denervation

### Definition

The condition of the nerve distal to injury which is still devoid of axons. Schwann cells in the chronically denervated nerve undergo progressive deconditioning, atrophy and even loss. They thus become increasingly incapable of supporting axonal regeneration.

- ▶ Peripheral Nerve Regeneration and Nerve Repair
- ▶ Schwann Cell
- ▶ Schwann Cells in Nerve Regeneration

## Chronic Pain

### Definition

- ▶ Pain

- ▶ Development of Nociception

## Chronic Peripheral Neuropathies

### Definition

Chronic peripheral neuropathies manifest themselves in various forms, and their severity may range from mild to fatal. There are many etiologies, including genetic causes such as ▶Charcot-Marie-Tooth disease and acute intermittent porphyria, metabolic diseases such as vitamin B12 deficiency and diabetes, nutritional disorders such as ▶thiamine deficiency and alcoholism, immunological diseases such as amyloidosis and



plasma cell diseases, intoxication e.g. by lead, and carcinomas e.g. of the lung.

- ▶ Charcot-Marie-Tooth Disease
- ▶ Diabetes mellitus
- ▶ Thiamine (Vitamin B1) Deficiency
- ▶ Vitamin B12 Deficiency

## Chronobiology

MARTHA MERROW<sup>1</sup>, TILL ROENNEBERG<sup>2</sup>

<sup>1</sup>The University of Groningen, Haren, The Netherlands

<sup>2</sup>The University of Munich, Munich, Germany

### Definition

Chronobiology is the study of biological processes with respect to time, specifically concerning the four environmental rhythms, namely tide, day, moon and season. It is not concerned with linear time-dependent processes such as aging.

### Characteristics

Chronobiology refers to temporal aspects of life which have been shaped by regular, predictable and repeating structures in the environment. On earth, four geophysical time structures cycle in a predictable way: the annual cycle with its seasonally changing ▶photoperiods (day length) and temperature; the lunar cycle with its changing nocturnal light levels and weak gravitational forces (that are probably irrelevant for non-tidal organisms); the daily cycle with its changing light and temperature levels; and the tidal cycle with concurrent gravitational forces leading to alternating exposure of coastal terrain to water and air. These four temporal structures have shaped biological rhythms (or biological clocks) through evolution. When shielded from their corresponding environmental cycles, all four biological rhythms are capable of oscillating with their own period which is always close to that of the environmental cycle (365.25 days, 28.5 days, 24 h and 12.5 h, respectively). Because of their moderately deviating endogenous periods, they are called circa-rhythms (circ-annual, circa-lunar, circa-dian, and circa-tidal). The environmental signals that synchronize biological clocks to the exact period of their respective environmental counterpart are called ▶zeitgebers. The complex, active biological mechanism enabling this synchronization is called ▶entrainment.

The biological mechanisms underlying the endogenous circannual, circa-lunar, circadian or circa-tidal clocks are the subject of intensive experimental (chronobiological) research. Most chronobiological research concerns daily and annual rhythms.

### Daily Rhythms

By far the most studied biological rhythm is the ▶circadian rhythm (Latin: *circa* – about – and *dies* – a day). It is an excellent example of how circa-rhythms affect living systems at all levels of biology – from gene expression, hormone secretion and physiology to complex behavior. The circadian clock represents internal time-of-day and ensures that the appropriate biological functions in cells, tissues and organs occur at the right time in relationship to other endogenous processes and to the external environment.

The signature of circadian rhythms is their persistence in constant conditions, (shielded from all zeitgebers) revealing their ▶free-running period. Examples of circadian rhythms are the sleep-wake behavior in humans and other animals, leaf movement in plants, fungal spore formation, and virtually all of gene expression in cyanobacteria, to name only a few. Circadian rhythms are ubiquitous, i.e., they have been identified in organisms of all phyla, and, in each organism, they modulate all aspects of biology [1].

In spite of being built by different cellular and molecular components in different organisms (see below), circadian rhythms share basic properties. They are (i) rhythmic and (ii) self-sustained (i.e., non-dampened), (iii) with a circa 24-h period in constant conditions; (iv) circadian rhythms are both robust in their amplitude (sufficient to drive output rhythms) and precise in their period (though not exact, circadian rhythms have been shown to continue for years with deviations of only minutes [2]); (v) their period is compensated against spurious environmental changes (e.g., of temperature or nutrients); (vi) circadian rhythms can be synchronized by appropriate environmental signals (zeitgebers). This synchronization is a complex, active process called entrainment. Under natural conditions, circadian clocks are perfectly entrained to the 24-h rotation of the Earth by using the environmental changes that have shaped circadian clocks through evolution (predominantly light, but poikilotherms also use temperature) as zeitgeber signals.

### Annual or Seasonal Rhythms

Similar to the day, the year also shows distinct characteristics in its temporal structure. With growing distance from the equator towards the poles, seasonal changes in day length become increasingly obvious (even at the equator, seasonal progression is apparent, for example, by different amounts of rain). Two different chronobiological strategies allow organisms to adapt their physiology and behavior to the progression of seasons: the circannual clock and photoperiodism.

Similar to the circadian clock, a circannual clock represents internal time-of-year and ensures that the appropriate biological functions in cells, tissues and organs occur at the right time in relationship to both other

endogenous functions and to external time-of-year. Similar to the case of the circadian clock, alterations in light and dark are the predominant zeitgeber that entrain ►circannual rhythms – in this case, alterations in changing photoperiod. Circannual clocks can run free when photoperiod is kept constant, slightly deviating from 365.25 days (some circannual clocks only show a free-run in a specific constant photoperiod of, for example, 10 h light and 14 h darkness, LD10:14 [3]).

While the entrained circannual program ensures continuous adjustment of immunological, metabolic and behavioral processes to seasonal environmental changes, photoperiodism opens a once-a-year window, which is called the critical photoperiod, triggering a (photoperiodic) response. In most plants and animals, this response is related to reproduction. The mechanisms that detect this critical photoperiod involve the circadian system as an internal reference (abnormal photoperiodic timing is typical for ►circadian clock mutants [4]). The sensitivity to certain critical photoperiods requires a previous sensitization by, for example, short days. Hamsters provide an impressive example for a photoperiodic response, as they rapidly enlarge testes and become reproductive following exposure to days with photoperiods over 12 h [5].

Compared to the circadian program, we know far less about the anatomical structures, genes and molecular mechanisms which form the basis of both circannual rhythmicity and photoperiodism.

### Molecular Chronobiological Mechanisms

Genetics has been broadly applied to describe the circadian clock mechanism, an approach pioneered in the lab of Seymour Benzer. Mutant screens have revealed a complex network of so-called ►clock genes – genes that, when mutated or deleted, change at least one of the six fundamental properties of circadian rhythms (see above). Clock genes, involved in generating the circadian rhythmicity at the cellular level, form a transcriptional-translational negative feedback loop. Activators control the production of gene transcripts leading to proteins which undergo a progressive modification (mainly phosphorylation) and eventually feed back to inhibit their own transcription. In the cyanobacterial system, circadian oscillations have been definitively shown to depend on rhythmic phosphorylation and dephosphorylation of a set of proteins, a process which even persists in a test tube [6]. It is not clear how this may relate to eukaryotic molecular clocks.

Clock genes have been identified in model genetic organisms from all phyla. Interestingly, animals, plants, fungi and bacteria all feature distinct gene sets, which nonetheless function similarly on the molecular level. This suggests that these are species-specific adaptations to their environment, rather than evidence of a primordial, common clock.

### Human Chronobiology

One of the easiest ways to understand chronobiology is to recall common human daily behaviors. For example, the human ►sleep-wake cycle occurs once per 24 h when entrained but runs free (with a circa 24-h period) when shielded from zeitgebers. There is, however, a tremendous difference in *when* sleep occurs in different individuals. The temporal differences in these so-called chronotypes are not restricted to sleep, but extend to other clock-controlled processes, such as melatonin or cortisol production. Within a population, the frequencies of different chronotypes show an almost normal distribution, reflecting that chronotype is a multi-genic, highly complex trait. Chronotypes result from individual differences in entrainment characteristics due to a variety of reasons: within the population there are polymorphisms or mutations in clock genes [7]; the late-to-bed, late-to-wake teenager is well known to all of us, and it reflects a systematic effect of development on the circadian clock [8]. From childhood to adolescence, the clock entrains progressively later, a trend that reverses – at the population level – at around the age of 20; there are gender differences in chronotype also, at least until the age of menopause, with females typically being earlier chronotypes than males; exposure to strong or weak zeitgebers also determines when the clock is entrained within the daily cycle. People who work outside in broad daylight are generally earlier chronotypes than office workers [8]. Thus, genes, environment, age and gender all contribute to chronotype.

The implications of chronotype are manifold. If chronotype, for example, is not incorporated into medical practice, results of tests or the efficacy of treatments may differ merely due to the patient's chronotype. Chronotype is also a quality of life issue. The more discrepancy between internal and external time (e.g., between an individual's circadian timing and his or her work hours), the more sleep debt accumulates during the work-week, culminating in a chronic "social jetlag." The larger this social jetlag, the more likely an individual is to be a smoker, indicating that a chronic jetlag acts as a stressor [8].

### Chronobiology Concerns all of Biology

Because chronobiology has an impact on broad aspects of an organism's biology, it represents a scientific specialty similar in scope to development or reproduction. Circadian rhythms are a fundamental property of all organisms (with few exceptions). The concept of selective advantage due to increased fitness is inherent to evolutionary theory. The adaptive advantage of biological clocks lies in the benefit of being able to anticipate environmental changes. The activity of animals is frequently restricted to certain times of day, and straying outside of these domains can increase the risk of predation, for instance [9]. Sessile organisms

such as plants and fungi also benefit from prediction of temperature, nutrient, or humidity changes. The fitness concept was recently substantiated in vitro using cyanobacteria, showing that a circadian oscillation with a period similar to the environmental one is more successful [10]. Similar adaptive advantages hold for all circadian clocks, whereby organisms prepare for seasons, tides or nocturnal light levels.

## References

1. Roenneberg T, Merrow M (2005) Circadian clocks – the fall and rise of physiology. *Nat Rev Mol Cell Biol* 6:965–971
2. Richter CP (1968) Inherent 24-hour and lunar clocks of a primate – the squirrel monkey. *Comp Behav Biol* 1:305–332
3. Gwinner E (1986) Circannual rhythms. In: Farner DS (ed) *Zoophysiology*, vol. 18. Springer Verlag, Berlin, p 154
4. Nunes MV, Saunders DS (1999) Photoperiodic time measurement in insects: a review of clock models. *J Biol Rhythms* 14(2):84–104
5. Elliott JA, Bartness TJ, Goldman BD (1989) Effects of melatonin infusion duration and frequency of gonad, lipid, and body mass in pinealectomized male siberian hamsters. *J Biol Rhythms* 4:439–455
6. Nakajima M, Imai K, Ito H, Nishiwaki T, Murayama Y, Iwasaki H, Oyama T, Kondo T (2005) Reconstitution of circadian oscillation of cyanobacterial KaiC phosphorylation in vitro. *Science* 308:414–415
7. Toh KL, Jones CR, He Y, Eide EJ, Hinze WA, Virshup DM, Ptacek LJ, Fu YH (2001) An hPer2 phosphorylation site mutation in familial advanced sleep phase syndrome. *Science* 291(5506):1040–1043
8. Roenneberg T, Kuehnle T, Juda M, Kantermann T, Allebrandt K, Gordijn M, Merrow M (2007) Epidemiology of the human circadian clock. *Sleep Med Rev* 11(6):429–438
9. DeCoursey PJ, Krulas JR (1998) Behavior of SCN-lesioned chipmunks in natural habitat: a pilot study. *J Biol Rhythms* 13:229–244
10. Yan OY, Andersson CR, Kondo T, Golden SS, Johnson CH, Ishiura M (1998) Resonating circadian clocks enhance fitness in cyanobacteria. *PNAS* 95(15):8660–8664

## Chronobiotics

### Definition

A biological compound that can alter parameters (phase, period or amplitude) of circadian oscillators, or their responsiveness to other inputs, thereby changing the phase relationship between circadian rhythms and local time, or the rate at which circadian rhythms are

resynchronized following a shift of local time (e.g., transmeridian jet travel).

- ▶ Circadian Rhythm
- ▶ Human Circadian Timing System

## Ciliar Body

### Synonyms

Corpus ciliare; Ciliary body

### Definition

Ciliary body of the eye. Contraction of the circular ciliary muscle results in relaxation of the lens ligament (zonal fibers), so that the lens can follow its inner elasticity and thicken. This increases its refractive power, needed for focusing on close objects. If conversely, the ciliary muscle is relaxed, the eye is distant accommodated.

- ▶ Eye

## Ciliary Ganglion

### Synonyms

▶ Ganglion ciliare; ▶ Ciliary ganglion

### Definition

Parasympathetic ganglion, some 2 cm behind the eyeball. The postganglionic fibers innervate, inter alia, two intraocular muscles:

- Ciliary muscle (accommodation)
- Sphincter of pupil muscle (adaptation)

- ▶ Nerves

## Ciliary Neurotrophic Factor (CNTF)

### Definition

▶ Neurotrophic Factors

## Ciliary Neurotrophic Factor Receptor (CNTFR)

### Definition

Following ciliary neurotrophic factor (CNTF) binding, the CNTF receptor forms a complex with gp130, a highly promiscuous cytokine signaling co-receptor essential for various mammalian cell growth and homeostasis pathways. Ligand binding results in signaling through the JAK/STAT and MAPK pathways.

### ► Neurotrophic Factors in Nerve Regeneration

## Cingulate Cortex – Role in Eye Movements

JEFFREY D. SCHALL

Department of Psychology, Center for Integrative and Cognitive Neuroscience, Vanderbilt Vision Research Center, Vanderbilt University, Nashville, TN, USA

### Definition

Cingulate cortex, occupying the gyrus and surrounding cortex encompassing the corpus callosum includes a variety of areas with diverse functions.

### Characteristics

#### Higher Level Structures and Lower Level Components

Traditionally regarded as part of the limbic system, the cingulate cortex is a large and heterogeneous part of the cerebral cortex that can be partitioned based on architecture, connectivity and functional properties [1,2]. First, cingulate cortex is divided into a posterior part (Brodmann's area 23) and an anterior part. The anterior cingulate cortex can be divided into a ventral zone (occupying the surface of the cingulate gyrus, containing Brodmann's areas 24a, 24b and the subcallosal area 25) and a dorsal zone (mainly in the cingulate sulcus, containing Brodmann's areas 24c and 32). In humans, this functional area often extends into the surrounding paracingulate gyrus.

A putative cingulate eye field has been described in the caudal portion of anterior cingulate cortex (Fig. 1), and visual and saccade-related activity has been described in a portion of posterior cingulate cortex (not shown). Anterior cingulate cortex can contribute indirectly to ocular motor function through dense, reciprocal connectivity with the supplementary eye field and a weaker

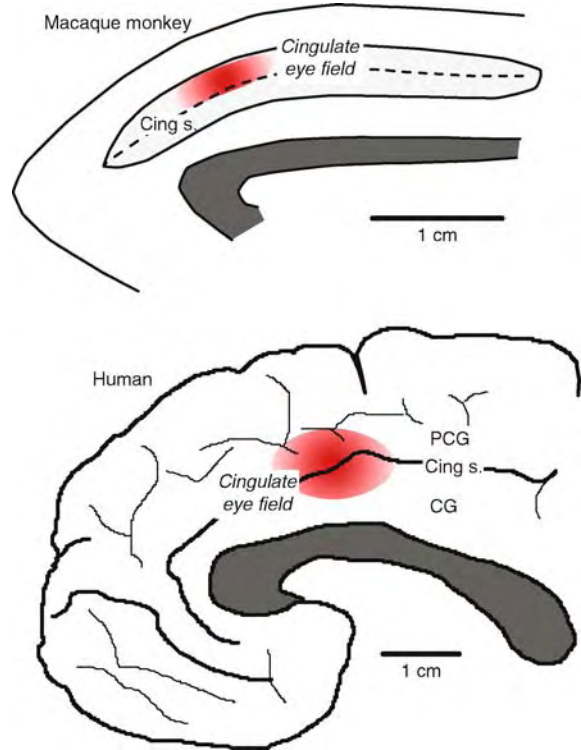

### Cingulate Cortex – Role in Eye Movements.

**Figure 1** Medial view of macaque monkey (*top*) and human (*bottom*) brains showing estimated location of zone in cingulate cortex related to movements of the eyes. Abbreviations: CG, cingulate gyrus; *cing s.*, cingulate sulcus; PCG, paracingulate gyrus.

linkage with the frontal eye field, superior colliculus and ocular motor thalamic nuclei [3].

#### Higher Level Processes and Lower Level Processes

Neurons in posterior cingulate cortex of macaque monkeys discharge in response to visual stimuli and following saccadic eye movements [4], and functional imaging in humans has described activation in posterior cingulate cortex associated with visually guided saccades [5]. However, more evidence indicates a role in gaze control for a caudal zone in anterior cingulate cortex. Saccadic eye movements can be evoked by electrical microstimulation of a region in the upper bank of the cingulate sulcus directly ventral to the SEF, in area 24c [6]. Functional brain imaging studies have reported activation in anterior cingulate cortex during production of self-generated saccades guided by arbitrary cues [7].

In macaque monkeys performing a task that requires inhibition of a partially prepared movement in response to an imperative stop signal, neurons in anterior cingulate cortex were modulated following errors or when reinforcement was earned but not delivered (Fig. 2) [8].

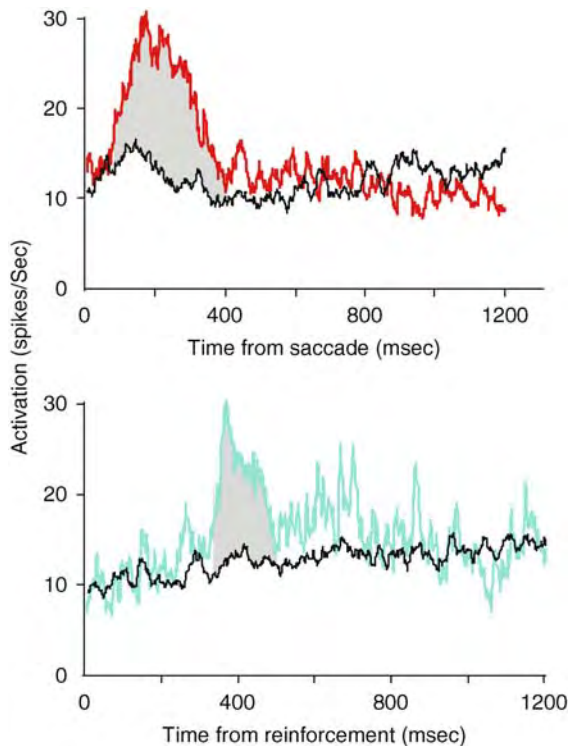

### Cingulate Cortex – Role in Eye Movements.

**Figure 2** Monitoring signals in anterior cingulate cortex. Activity of a single neuron is shown aligned on the time of a saccade (*top*) or time of reinforcement (*bottom*) on trials when the saccade was correct and earned reinforcement (black), when the saccade was an error and received no reinforcement (red), and when the saccade was correct but reinforcement was not delivered (blue). This representative neuron signaled the unexpected absence of reinforcement.

This signal from single neurons corresponds to a scalp potential referred to as the error-related negativity, which may originate from a single dipole in anterior cingulate cortex. In addition, a diversity of neurons in anterior cingulate cortex signal when reinforcement is earned and received, earned and not received, or delivered but not earned. The activation of these neurons can guide adjustments of performance, probably derived from signals arriving from brainstem dopamine neurons, the ventral striatum or orbital frontal cortex. These results are consistent with a body of research indicating that anterior cingulate cortex monitors performance for executive control.

### Function

Three general perspectives have framed hypotheses about the function of cingulate cortex: motor control, performance monitoring and motivation. Cingulate cortex seems to contribute indirectly to gaze control through mediating the influence of motivation derived from the consequences of previous actions.

### Pathology

Damage to cingulate cortex in humans results in diverse disorders. Lesions focused in a limited part of anterior cingulate cortex result in impairments in producing memory-guided saccades and antisaccades [9]. These deficits involved impaired suppression of reflexive saccades as well as increased latency of visually guided saccades.

### References

1. Paus T (2001) Primate anterior cingulate cortex: where motor control, drive and cognition interface. *Nat Rev Neurosci* 2:417–424
2. Dum RP, Strick PL (2002) Motor areas in the frontal lobe of the primate. *Physiol Behav* 77:677–682
3. Luppino G, Rozzi S, Calzavara R, Matelli M (2003) Prefrontal and agranular cingulate projections to the dorsal premotor areas F2 and F7 in the macaque monkey. *Eur J Neurosci* 17:559–578
4. Olson CR, Musil SY, Goldberg ME (1996) Single neurons in posterior cingulate cortex of behaving macaque: eye movement signals. *J Neurophysiol* 76:3285–3300
5. Mort DJ, Perry RJ, Mannan SK, Hodgson TL, Anderson E, Quest R, McRobbie D, McBride A, Husain M, Kennard C (2003) Differential cortical activation during voluntary and reflexive saccades in man. *NeuroImage* 18:231–246
6. Mitz AR, Godschalk M (1989) Eye-movement representation in the frontal lobe of rhesus monkeys. *Neurosci Lett* 106:157–162
7. Paus T, Petrides M, Evans AC, Meyer E (1993) Role of the human anterior cingulate cortex in the control of oculomotor, manual, and speech responses: a positron emission tomography study. *J Neurophysiol* 70:453–469
8. Ito S, Stuphorn V, Brown JW, Schall JD (2003) Performance monitoring by the anterior cingulate cortex during saccade countermanding. *Science* 302:120–122
9. Gaymard B, Rivaud S, Cassarini JF, Dubard T, Rancurel G, Agid Y, Pierrot-Deseilligny C (1998) Effects of anterior cingulate cortex lesions on ocular saccades in humans. *Exp Brain Res* 120:173–183

## Cingulate Gyrus

BRENT A. VOGT<sup>1</sup>, ROBERT J. MORECRAFT<sup>2</sup>  
<sup>1</sup>Department of Neuroscience and Physiology, State University of New York, Upstate Medical University, Syracuse, NY, USA  
<sup>2</sup>Division of Basic Biomedical Sciences, University of South Dakota School of Medicine, Vermillion, SD, USA

### Definition

The cingulate gyrus is a prominent part of the cerebral cortex on the medial edge of each cerebral hemisphere (Fig. 1).

It is dorsal to the body of the corpus callosum and wraps around the genu of the corpus callosum rostrally and the splenium caudally. The cingulate gyrus is an integrative premotor structure that participates in remembering and predicting outcomes and, where necessary, generating behaviors to integrate autonomic

and ►**skeletomotor** outputs for specific environmental contexts. Structural and functional observations show this cortex is organized into four regions [1], an anterior cingulate cortex (ACC), a midcingulate cortex (MCC), a posterior cingulate cortex (PCC) and a retrosplenial cortex (RSC) (Fig. 2).

C

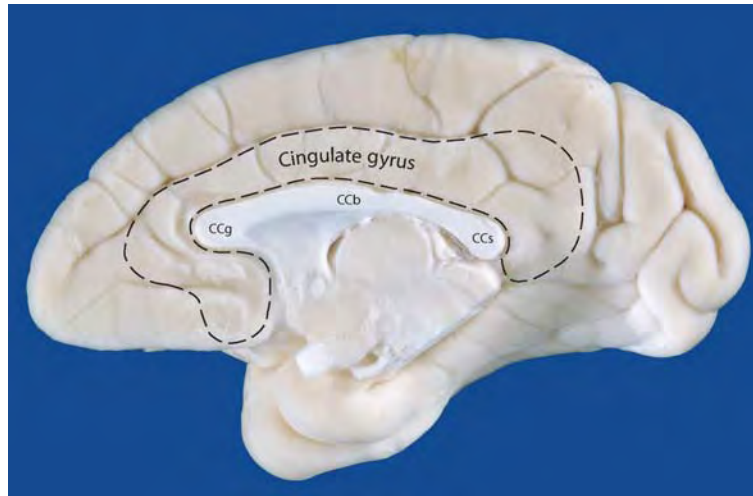

**Cingulate Gyrus. Figure 1** Medial surface of the monkey (*Macaca mulatta*) cerebral hemisphere showing the cingulate gyrus (outlined by the dashed line). Abbreviations: CCb, CCg, CCs, body, genu and splenium of the corpus callosum, respectively.

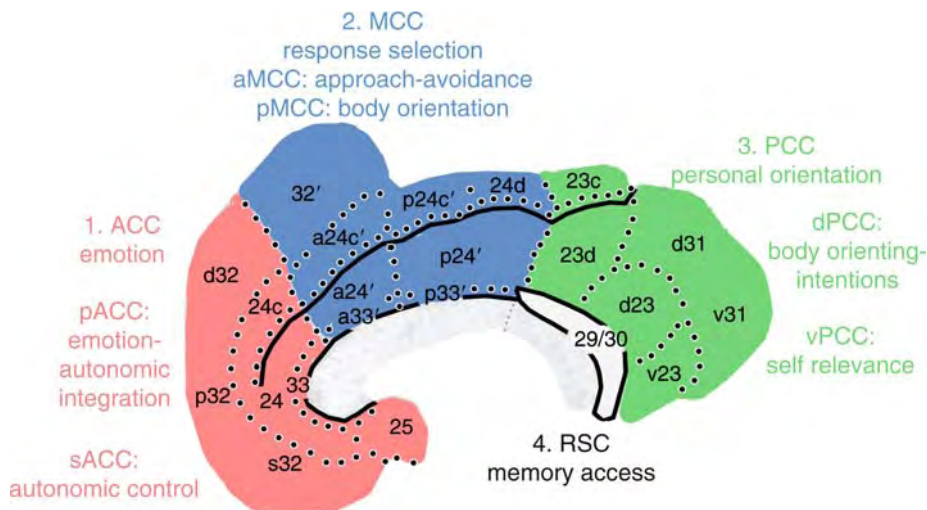

**Cingulate Gyrus. Figure 2** The four region neurobiological model of cingulate cortex is based on interdisciplinary observations in cytology, connections, functions and disease vulnerabilities. This overview of the four regions is plotted onto a flat map of human cingulate cortex such that areas in the cingulate and callosal sulci can be shown. The *thick black lines* are the dorsal and ventral apices of the cingulate gyrus and the retrosplenial cortex (RSC) is in the depths of the callosal sulcus. The *dotted lines* separate each cytoarchitectural area. In consonance with the regional designations, some areas are subdivided further; ACC into subgenual *s* and pregenual *p*; MCC into anterior *a* and posterior *p*; PCC into dorsal *d* and ventral *v*. The rationale for each region and subregion is detailed in Chapter 1 of *Cingulate Neurobiology and Disease* [11].

These four regions serve as the basis for evaluating cingulate functions and vulnerability to particular diseases.

## Characteristics

### Regional Structure and Functions

The ACC is involved in assessment of valenced information and the long-term storage of emotional objects and events and contributes to tonic mood states (Fig. 2). It appears to separately store happy events rostrally in area 32 and sad events caudally in areas 24 and 25. The ACC receives a massive input from the amygdala and a link between emotion and ▶autonomic regulation occurs in area 25 in the subgenual ACC which projects to autonomic regulatory sites including the hypothalamus, periaqueductal gray and parabrachial nucleus. The highest concentration of cingulate glutamate receptors is in the ACC. There are proportionately fewer  $\gamma$ -aminobutyric acid (GABA) receptors, which are higher in the PCC [2].

The MCC coordinates decision-making about behavioral outcomes in a number of ways, i.e., anticipation of outcomes, comparing actual with expected outcomes and modifying behaviors as rewards are reduced [3]. In view of its prominent role in both rewarded and aversive (i.e., painful) outcomes, it is not surprising that an important feature of this region is the two cingulate premotor areas located along the cingulate sulcus that regulate skeletomotor outputs (Fig. 2). Both cingulate motor areas have extensive motor system projections that include the frontal cortical motor areas and subcortical structures. Important subcortical projection targets include the putamen, red nucleus, pontine nuclei, facial motor nucleus and spinal cord [4].

The anterior and midcingulate regions have high densities of dopaminergic inputs and D1 receptors. The anterior MCC appears to have the highest such innervation in the cingulate gyrus and, in view of the interactions with reward centers such as the nucleus accumbens, it is likely that the MCC in particular is involved in selecting among rewarded outcomes.

The PCC and RSC are adjacent to one another on the posterior cingulate gyrus, but they differ considerably in their structural organization including cytology and circuitry and contribute to memory and visuospatial functions (Fig. 2). The ventral subdivisions of these two regions are involved in assessing self-relevant sensory information, storing self-relevant memories and in making this information available for ▶premotor processing and decision making in the ACC and MCC. Acetylcholine is a modulatory neurotransmitter in high concentrations in the PCC. GABA receptors, which regulate a chloride conductance and are the chief inhibitory neurotransmitter in the central nervous system, are in highest concentration in the PCC [2].

## Sensory Integration Function

### Medial Pain System

The MCC is one of the most frequently activated cortices during noxious ▶cutaneous stimulation that generates the conscious perception of pain and is a critical component of limbic structures that form the medial pain system [5]. This system is involved in the emotional and motivational (premotor) aspects of pain processing and anticipation of pain. In contrast, the primary role of the lateral pain system is in the localization and intensity coding of ▶noxious stimuli. The nociceptive signal to the medial pain system/cingulate cortex arises from the midline, mediodorsal, and intralaminar thalamic nuclei and results in large receptive field organization. This region in turn, projects to the midbrain periaqueductal gray, which regulates many emotional expressions as well as the descending noxious inhibitory system. Functional imaging studies show that the ACC and MCC respond to both ▶visceral and cutaneous ▶noxious stimuli. While the visceral responses predominate in the ACC, cutaneous related, nociceptive responses predominate in the MCC. The ACC is thought to mediate the affective component of pain. Neurons in the ACC respond to multiple forms of noxious ▶cutaneous stimuli irrespective of somatotopic origin [6] and the site of nociceptive visceral activation in this region overlaps with the site generated during the anticipation of noxious visceral stimulation. Innocuous distension in contrast has no such effect. The MCC is involved in pain ▶avoidance behaviors and both the ACC and MCC are active when anticipating pain and may code for the relative intensity of noxious stimulation even though this is not their primary role in pain. Finally, the highest density of mu-opioid receptors in the brain is in ACC and the opiate placebo is associated with activation in this region.

### Visual and Spatial Integration

The PCC receives extensive sensory inputs from parietal, temporal and occipital cortices as well as from the thalamus, including the pulvinar nucleus. Such information is employed in orientation of the head and body to sensory stimulation, orientation in larger (allocentric) spaces and in processing large scale/whole visual field information (Fig. 2). The dorsal PCC is involved in body orientation in space and its structural and functional relationships with the caudal cingulate motor area of the MCC may contribute to movement associated with visuospatial stimuli. The ventral PCC monitors self-relevant information and engages in self-reflection and context dependent sensory processing. Such information from sensory afferents enters the cingulate gyrus for processing via connections with the ACC that determine which information is particularly relevant to current needs and will be used

to guide premotor processing in other parts of the cingulate gyrus [7].

### Regional Disease Vulnerabilities

Impaired neuronal processing in the cingulate gyrus has been implicated in the symptoms of many neuronal diseases. To some extent each region is vulnerable to different types of disease insults. Clinically, the ACC is vulnerable to major depression during which volumetric reductions have been noted along with reductions in glucose metabolism. Intracranial electrical stimulation of this structure in drug resistant depressed patients significantly reduces symptom expression [8]. Additionally, structural changes have been associated with alterations in the serotonin transporter gene and one of the primary sites of clinical efficacy for selective serotonin reuptake inhibitors (SSRIs) is in the ACC. In the light of the relatively high concentrations of serotonin 1A receptors in the ACC, there is yet another reason for considering this to be the site of symptom resolution over the course of SSRI treatment.

Many movement disorders are related to disruption of processing in the MCC. Obsessive-compulsive disorder is associated with various forms of repetitive behaviors including hoarding and cleaning and with high levels of activity in the MCC. The role of the MCC in this disorder is emphasized by the fact that neurosurgical midcingulate ablations can abolish such behaviors. Attention deficit/hyperactivity disorder is another movement disorder and it has been shown that the anterior MCC is reduced in volume in this disorder and that cognitive processing is altered in this region as well. Finally, since there is a high level of nociceptive activation of the anterior MCC and hypnosis modulates activity in this region, hypnosis can be used to induce sedation for surgical procedures that employ only local anesthetics [10].

A number of disorders have a reciprocal influence on activity in the ACC and the MCC. Thus, irritable bowel syndrome is associated with reduced activation in the ACC (where visceral nociceptive information is normally processed) accompanied by enhanced processing in the anterior MCC. This heightened activity could result from anticipatory processing associated with bowel symptoms and premotor activity required to resolve intrusive bowel habits. It is an interesting fact that the anterior MCC is also active during micturition in healthy subjects and urinary incontinence accompanies anterior cingulate trauma. Thus, decision-making about the appropriate context for bowel habits may be guided by the MCC.

It is well known that the PCC is involved in Alzheimer's disease, in many instances quite early in symptom expression. Some cases of mild cognitive impairment have been shown to progress to Alzheimer's disease and the first site of damage in

some cases is in the dorsal PCC and RSC [9]. Thus, early signs of memory and visuospatial impairment may be mainly due to damage in the posterior cingulate gyrus rather than solely a product of medial temporal lobe damage as is often assumed.

A current and general reference on the structure, circuits, functions and diseases of the cingulate cortex will be available in 2008 titled *Cingulate Neurobiology and Disease* (Oxford University Press). The four regions of cingulate cortex are very important to the clinical diagnosis of many psychiatric diseases and the selective vulnerabilities of cingulate regions validate the four region neurobiological model. In the future, treatments for many neurological and psychiatric diseases will employ pharmaceutical and behavioral strategies to target the cingulate gyrus.

### References

1. Vogt BA, Hof PR, Vogt LJ (2004) Cingulate Gyrus. In: Paxinos G, Mai JK (eds) The human nervous system, 2nd edn. Academic, New York, pp 915–949
2. Palomero-Gallagher N, Zilles K (2008) Transmitter receptor systems in cingulate regions and areas. In: Vogt BA (ed) Cingulate neurobiology and disease. Oxford University Press, Oxford, Chapter 2 (in press)
3. Bush G, Vogt BA, Holmes J, Dale AM, Greve D, Jenike MA, Rosen BR (2002) Dorsal anterior cingulate cortex: a role in reward-based decision-making. *Proc Natl Acad Sci* 99:523–528
4. Morecraft RJ, Van Hoesen GW (2003) Functional neuroanatomy of limbic structures and some relationships with prefrontal cortex. In: Fogel BS, Schiffer RD, Rao EM (eds) Neuropsychiatry, 2nd edn. Lippincott Williams and Wilkins, Philadelphia, pp 294–327
5. Vogt BA (2005) Pain and emotion interactions in subregions of the cingulate gyrus. *Nat Rev Neurosci* 6:533–544
6. Sikes RW, Vogt BA (1992) Nociceptive neurons in area 24 of rabbit cingulate cortex. *J Neurophysiol* 68:1720–1731
7. Vogt BA, Vogt L, Laureys S (2006) Cytology and functionally correlated circuits of posterior cingulate areas. *NeuroImage* 29:452–466
8. Holtzheimer P, Mayberg HS (2008) The role of the cingulate gyrus in depression: review and synthesis of imaging data. In: Vogt BA (ed) Cingulate neurobiology and disease. Oxford University Press, Oxford, Chapter 2 (in press)
9. Johnson JK, Vogt BA, Kim R, Cotman CW, Head E (2004) Isolated executive impairment and associated frontal neuropathology: a case report. *Dement Geriatr Cogn Disord* 17:360–367
10. Vogt BA, Porro CA, Faymonville M-E (2006) Pain processing and modulation in the cingulate gyrus. In: Fluor H, Kalso E, Dostrovsky JO (eds) Proceedings of the international association for the study of pain, IASP, Seattle, pp 415–430
11. Vogt BA (2008) Regions and subregions of cingulate cortex. In: Vogt BA (ed) Cingulate neurobiology and disease. Oxford University Press, Oxford, Chapter 1 (in press)



## Cingulate Motor Areas

### Definition

Secondary motor areas located in the cingulate gyrus of the frontal lobe in the medial wall of the cerebral hemisphere. Three cingulate motor areas have been identified and all contain corticospinal neurons.

- ▶ Corticospinal Neurons
- ▶ Motor Cortex: Output Properties and Organization

## Cingulate Sulcus

### Synonyms

Sulcus cinguli; Cingulate sulcus

### Definition

A sulcus visible in median section, which surrounds the cingulate gyrus and thus encloses the limbic lobe. In the transitional region between occipital lobe and parietal lobe it joins the marginal part and ascends to the margin of the hemisphere.

- ▶ Telencephalon

## Cingulum

### Definition

The cingulum is a strong bundle of association pathways of varying length that connects different cortical centers of a hemisphere. It is situated on the lower margin of the cingulate gyrus.

- ▶ Telencephalon

## Circadian Activity

### Definition

Activities with an endogenous period of about 24 h, of about a day. Such rhythms are seen in all living organisms, including plants, animals, fungi and cyanobacteria. These rhythms are not driven by or dependent

upon stimuli in the external world, but instead, they persist in constant conditions. Circadian activities have the same period over a range of temperatures (i.e., they are temperature compensated), and are largely resistant to metabolic changes that might influence rhythmic activity that might result from high or low temperatures.

External stimuli can however, reset the phase (or start time) of a circadian rhythm.

- ▶ Circadian Rhythm

## Circadian Clock Genes

- ▶ Clock Genes

## Circadian Cycle

SHELLEY TISCHKAU

Southern Illinois University School of Medicine,  
Department of Pharmacology, Springfield, IL, USA

### Definition

The sequence of molecular, biochemical, physiological and behavioral changes that occur over the course of a single near-24 h period within an organism.

### Characteristics

A circadian cycle defines the sequence of molecular, biochemical, physiological and behavioral changes that occur over the course of a single near-24 h period within an organism. Presumably, these characteristic near-24 h temporal programs represent an adaptation to existence on a planet where the repetitive cycle of light and darkness may well be the most ancient and most persistent event under which all life has evolved. The fundamental nature of these 24-h rhythms is evident from their wide range of expression; they are present in organisms across all phyla. Circadian [▶oscillations](#) in organismic physiology and behavior allow anticipation of daily environmental change. The capacity to anticipate, and subsequently, to prepare for change promotes reproductive fitness, thereby enhancing survival of the species.

Importantly, this periodicity is present under unchanging, or constant, environmental conditions, which demonstrates that the oscillation represents a program that is endogenously generated. Circadian cycles can be

slightly longer or shorter than 24 h, depending on the organism. For example, most strains of mice exhibit a ▶rest/activity cycle that is slightly shorter than 24 h, whereas hamsters display a rhythm that is slightly longer than 24 h. Although rest/activity cycles are a commonly studied expression of the circadian cycle in animals, similar oscillations can be observed in hundreds of other biological events, ranging from the level of whole organism behavior to gene expression. The fungus, *Neurospora crassa*, rhythmically produces asexual spores with a period of 22 h under ▶constant conditions, including constant darkness (DD) [1]. Leaf movements in plants were among the first circadian oscillations to be recorded. Photosynthesis, opening of stoma and growth are all circadian controlled phenomena in plants. The prokaryotic cyanobacterium, *Synechococcus*, uses the 24-h cycle to separate the process of nitrogen fixation from photosynthesis. At the molecular level, the cycle is defined by a single revolution of the interlocking feedback loops that comprise the core molecular clock machinery [2]. A primary function of the cycle is to allow synchronization between the organism and the recurrent environmental sequence of light and darkness. Thus, the cycle is typically divided into subjective day and subjective night. ▶Subjective day may be defined as the sequence of events that occur during the lighted portion of a typical 24-h period. Likewise, ▶subjective night may be defined as the sequence of events that occurs during the dark portion of a typical 24-h period.

### Characteristics of the Circadian Cycle

Across all phyla, circadian cycles are characterized by several common features. The self-sustained oscillation is always close to, but not necessarily exactly, 24 h in duration, and can be adjusted in response to environmental changes. These oscillations persist when the organism is placed into constant environmental conditions, which expose the endogenous nature of the rhythm. Although historically these rhythms were first investigated at the level of the whole organism, rhythms are expressed in organs, tissues and even in cells cultured *in vitro*. Perhaps the most studied example of this is the firing rate rhythm of the mammalian ▶suprachiasmatic nucleus (▶SCN). Hypothalamic brain slices containing the SCN, the home of the primary clock in mammals, exhibit ▶self-sustained circadian oscillations in the neuronal ensemble firing rate, metabolic glucose uptake and clock gene levels [3]. More recently, persistent rhythms in other mammalian tissues, as well as in dissociated body parts in *Drosophila melanogaster*, and finally, in dissociated cells, including rat fibroblasts.

Perhaps the most important attribute of the circadian cycle is its ability to adjust in response to environmental change. Although periodicity is determined

by placing the organism in constant conditions, life transpires under conditions of cyclic environmental change. Although the circadian cycle is temperature compensated, meaning that it runs with a constant periodicity through a wide range of temperatures, temperature cycles of 24-h duration can be used to set the phase of the cycle. Many other cyclic environmental conditions, such as food availability, presence of predators, and, most importantly, light, can also act as ▶zeitgebers for circadian cycles. Zeitgebers mimic the cycle formed by the earth's rotation, and can entrain the circadian cycle such that physiological and behavioral activities are synchronized with the environmental cycle of light and darkness. This active adjustment of the circadian cycle by zeitgebers is termed ▶entrainment.

### Biochemical Time Zones

The internal circadian cycle is a series of programmed biochemical events that occur in a defined sequence. The cycle is sensitive to external stimuli, which can act to adjust the internal workings of the clock to synchronize with the environment. The cycle is, however, differentially sensitive to stimuli. Certain stimuli only affect the cycle during the clock's subjective night, whereas others are restricted to access the clock during the day. Generally, if a particular stimulus might be perceived as an error signal at a given position within the cycle, it is that time that the cycle is sensitive to change in the presence of that signal. Light, for example, will only act to adjust phase during the portion of the cycle where light would not be expected to be present. Thus, the clock itself, temporally defines, or gates, the information that can access the timekeeping mechanism. The clock itself opens and closes gates as the circadian cycle progresses. Although the filter changes fluidly over the course of the cycle, sets of specific time domains, or phases have been identified.

In the SCN, each time domain is characterized by the activation of specific signal transduction pathways. Generally, ▶gating of the SCN circadian cycle is divided into four domains, day, night, dusk and dawn [3]. Dusk and dawn, which are the periods that encompass the transition periods between the day and night time domains, are similar. These periods are characterized by sensitivity to phase ▶resetting in response to ▶melatonin, a hormone used to measure day length, via essential activation of protein kinase C-dependent signal transduction pathways. The daytime domain is sensitive to phase adjustment by stimuli that act through cAMP and cAMP-dependent protein kinase. Generally, ▶serotonin and ▶pituitary adenyl cyclase activating peptide (▶PACAP) are neurochemicals known to act through cAMP-dependent mechanisms to alter clock function during the daytime domain.

The nighttime domain is perhaps the most complex. The gates for adjustment in response to cAMP dependent pathways are closed. Opened are two distinct gates. A pathway that responds to cholinergic stimulation, which may be involved in circadian regulation of sleep and wakefulness, can access the timekeeping mechanism through elevation of cGMP and activation of cGMP-dependent protein kinase. In addition, at night the clock is sensitive to pathways activated by environmental light, acting through glutamatergic neurotransmission. Influx of calcium and nitric oxide production are characteristic of light-signaling.

Temporal restriction of sensitivity to exogenous signals is fundamental to maintaining synchrony of the circadian cycles with the environment. Internal gating within the clock itself allows the clock to anticipate environmental change. This ensures that the individual can maintain synchrony with a constantly changing external environment.

### Molecular Building Blocks

Although organismic rhythm generation is likely an emergent property of a complex system, the source of the circadian cycle lies within individual cells. The search for a genetic basis for the circadian cycle began early in the last century with the selection of bean plants for breeding based upon expression of long or short periods under constant conditions. The first “clock” gene, (►*Period*, *Per*) was discovered in *Drosophila melanogaster* using mutagenesis screens [4]. Shortly thereafter, a similar approach led to discovery of the Frequency (*Frq*) gene in *Neurospora crassa* [5]. The 1990s were witness to a ►clock gene “explosion,” distinguished by the discovery of numerous core components of the machinery that drive circadian cycles, in many model organisms, including mice, humans, frogs, plants, fungi and cyanobacteria.

Sequence analysis has determined that there is little similarity among proteins that form clock components across the major phyla. However, the genetic basis for generation of a circadian cycle in all organisms studied to date is a functional transcriptional/translational feedback loop(s) (Fig. 1). In its simplest form, the cycle is generated by transcription of a gene, translation of the transcript into a protein product, followed by negative feedback, whereby the protein product or one of its downstream targets, returns to inhibit further transcription of the gene. Release of the negative feedback requires degradation of the protein product, which allows the cycle to begin again. Thus, many of the core “clock” genes are circadian-controlled transcription factors. Rhythmic transcription leads to rhythmic production of proteins. The *Per* genes of *Drosophila* and mammals are examples of transcriptionally regulated clock components. Rhythmic control of transcription is not, however, the only source of rhythmic protein formation. Evidence

suggests that regulation of translation initiation may be important for the *Neurospora* clock gene, *Frq*.

More recent studies suggest that rhythmic transcription is not required for generation of a circadian cycle. Circadian oscillations can be generated in a test tube containing just three cyanobacterial proteins and ATP [6]. The observed oscillation, which was rhythmic phosphorylation of the *Synechococcus* protein KaiC, was robust and temperature compensated. These studies suggest that a metabolic oscillator, independent of the transcriptional/translational feedback loop, generates the circadian cycle. Whether this is a unique feature of the cyanobacterial clock, or a general principle that pertains to construction of circadian clocks, remains to be determined. It is possible that the circadian cycle results from complex interactions between two oscillators, one formed by the genetic component expressed as the transcriptional/translational feedback loop, and a second derived from a metabolic oscillator.

Although the mechanism for forming a cycle can be relatively simple, making the cycle repeat with 24-h periodicity is the source of complexity. A simple feedback loop can be completed in as little as 3 h. Multiple interlocking feedback loops and posttranslational modification of protein products (similar to that described above for cyanobacteria) are important for generation of the circadian cycle in multicellular organisms. Despite more than a decade of research in this area, the molecular details of generating a clock that measures time on a 24 h scale are still relatively unclear.

In mammals, the protein products of the ►clock (*Clk*) and ►Brain muscle ARNT-like1 (►*Bmal1*) genes heterodimerize through interactions of PAS domains to form a complex that binds to e-boxes in the promoters of target genes. The *period* (*Per*) and ►*cryptochrome* (*cry*) gene promoters are clock-relevant targets of CLK:BMAL1-driven transcription. As PER and CRY proteins accumulate, they form multimeric complexes that enter the nucleus and inhibit CLK:BMAL1-mediated activity, effectively blocking their own transcription. A key element of the PER/CRY feedback component is a delay in the accumulation of PER proteins by about 6-h, relative to the mRNA levels. This is likely that posttranslational modification, such as phosphorylation of PER plays an important role in regulating the accumulation, activity and/or subcellular localization of the protein. Similar events regulate the FRQ protein in *Neurospora*. At the end of the circadian cycle, PER proteins are targeted for degradation, which releases the repression of transcription, thereby allowing the initiation of a new biological day. This primary loop is stabilized by activities of orphan nuclear receptors ►*Rora* and Rev-Erba, which activate and repress *Bmal1* expression, respectively. CLOCK:BMAL heterodimers activate ►*Rev-Erba* by binding to ►E-box

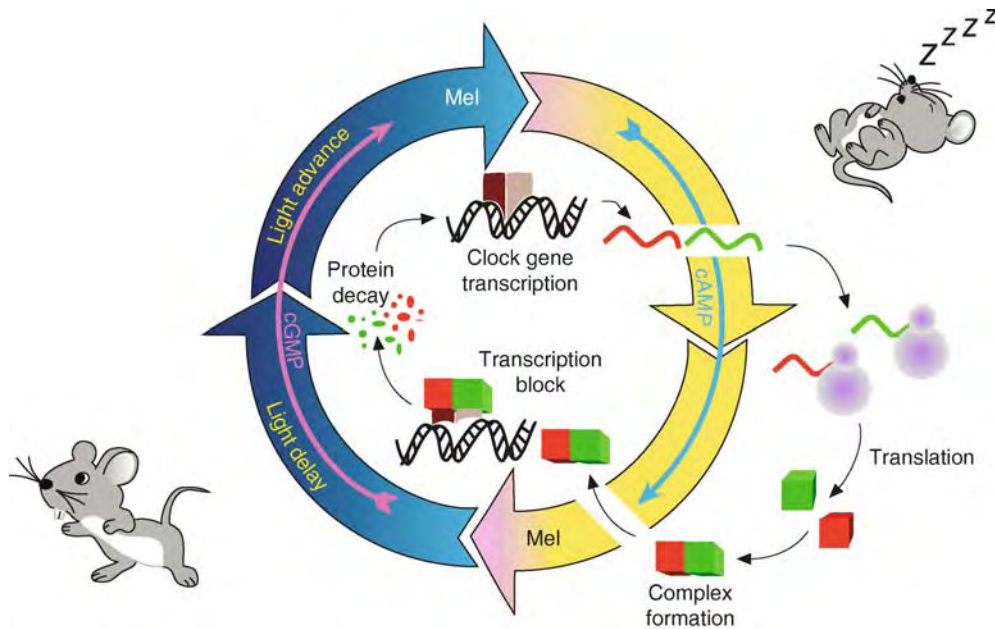

**Circadian Cycle. Figure 1** The circadian cycle is a sequence of molecular, biochemical, physiological and behavioral changes that occur over the course of a single near-24 h period within an organism. The left side of the diagram depicts events that occur during the night, whereas the right side depicts events occurring during the day. The nocturnal mouse spends more time sleeping and resting during the day, and shows increased activity levels during the night. Transcription of negative elements of the clock's feedback loop is initiated in the nucleus (represented by the inner part of the circle) during the late night and proceeds into the first half of day. Transcripts are transported into the cytoplasm where translation occurs at ribosomes. Proteins accumulate during the late part of the day and into the early night. Protein complexes form and re-enter the nucleus, where they act to inhibit their own transcription. Mid to late night is marked by degradation of the proteins, which releases transcriptional repression and allows the cycle to repeat. Also depicted on the diagram are times when the clock mechanism is subject to resetting by specific signaling molecules. During the day, clock resetting occurs primarily through signals that activate cAMP. In contrast, night is dominated by resetting in response to cGMP. Light can reset the clock throughout the night, causing phase delays during early night and phase advances during late night. The clock is also sensitive to resetting in response to melatonin (Mel), with windows of sensitivity occurring at dusk (day-to-night transition) and dawn (night-to-day transition).

elements in its promoter, and Rev-Erba subsequently feeds back to attenuate *Bmal1* transcription. Rora is necessary for normal expression of *Bmal1* and consolidation of locomotor activity [7].

### Circadian Cycle in Disease

Studies of animals bearing mutations in their circadian cycle are revealing new information regarding the importance of circadian clocks in health and well-being. In humans, mutations of the *Per* genes lead to abnormal sleep patterns, such as seen in Advanced phase sleep disorder. *Per1* and *Per2* mutant mice have increased risk of multi-site carcinogenesis [8]. Clock mutant mice develop obesity [9]. Although the relationship between the circadian cycle defects and development of pathologies remain unclear, it is certain that clock defects can lead to health problems. The importance of the circadian cycle to health is only beginning to be appreciated.

### References

1. Kramer C (2007) Rhythmic condition in *neurospora crassa*. *Methods Mol Biol* 362:49–65
2. Young MW, Kay SA (2001) Time zones: a comparative genetics of circadian clocks. *Nat Rev Genet* 2:702–715
3. Gillette MU, Mitchell JW (2002) Signaling in the suprachiasmatic nucleus: selectively responsive and integrative. *Cell Tissue Res* 309:99–107
4. Konopka RJ, Benzer S (1971) Clock mutants of *drosophila melanogaster*. *Proc Natl Acad Sci USA* 68:2112–2116
5. Feldman JF, Hoyle MN (1973) Isolation of circadian clock mutants of *neurospora crassa*. *Genetics* 75:605–613
6. Nakajima M, Imai K, Ito H, Nishiwaki T, Murayama Y, Iwasaki H, Oyama T, Kondo T (2005) Reconstitution of circadian oscillation of cyanobacterial *kaic* phosphorylation in vitro. *Science* 308:414–415
7. Emery P, Reppert SM (2004) A rhythmic *ror*. *Neuron* 43:443–446

8. Lee CC (2005) The circadian clock and tumor suppression by mammalian period genes. *Meth Enzymol* 393:852–861
9. Turek FW, Joshu C, Kohsaka A, Lin E, Ivanova G, McDearmon E, Laposky A, Losee-Olson S, Easton A, Jensen DR, Eckel RH, Takahashi JS, Bass J (2005) Obesity and metabolic syndrome in circadian clock mutant mice. *Science* 308:1043–1045

---

## Circadian Desynchronization/ Circadian Desynchrony

- ▶ Circadian Sleep Phase Syndromes

---

## Circadian Food Anticipatory Activity (FAA)

- ▶ Food Entrainment

---

## Circadian Output Genes

- ▶ Clock-Controlled Genes

---

## Circadian Pacemaker – Temperature Compensation

MENNO P. GERKEMA

Department of Chronobiology, Faculty of Mathematics and Natural Sciences, University of Groningen, Groningen, The Netherlands

### Definition

One of the defining characteristics of circadian pacemakers and indicates the independence of the speed of circadian clock processes of environmental temperature. Mechanisms involved, so far not elucidated in full detail, entail at least two processes that are similarly

affected by temperature changes, but with an opposing and counterbalancing effect on the periodicity of the clock system. As a result of temperature compensation, the increase in reaction velocity for every 10° rise in temperature (▶ $Q_{10}$ ) of processes governed by ▶**circadian pacemakers** reaches values of about 1.

### Characteristics The Phenomenon

The first study on temperature independence in circadian timing was published in 1932 [1], showing the precision in time memory of foraging bees in spite of changes in environmental temperature. The early notion that the velocity of circadian processes does not vary with environmental temperature (within certain ranges) has been based on experimental evidence from a wide variety of sources. Evidence for temperature compensation of circadian rhythms has been collected for luminescence rhythms in unicellular algae, daily leaf movements in plants, and locomotor activity in cockroaches and lizards (as compiled in [2]). Comparisons of ▶**period** length, expressed as  $Q_{10}$ , the quotient of reaction rates per 10°C, revealed  $Q_{10}$ s in the range of 0.9–1.2 [3]. This is in sharp contrast to the usually temperature-dependent kinetics of biochemical processes resulting in  $Q_{10}$  values of roughly 2–3 [4]. These findings, together with the insight that a functional clock subject to temperature dependence would be prone to inaccuracy in the natural environment, caused Pittendrigh to list temperature compensation as item XI on his famous list of 16 empirical generalizations about circadian rhythms [3]. Since then, a vast literature on circadian  $Q_{10}$  values has accumulated, confirming early observations. Recently, temperature compensation has been demonstrated in ▶**clock gene** expression rhythms in mammalian fibroblast cultures [5]. Also the phosphorylation rhythms of the Cyanobacterial protein KaiC *in vitro*, in the presence of two other proteins but in absence of transcription and translation, shows temperature compensation, in the range of 25–35°C [6].

### Mechanism

A simple model for temperature compensation has been based on two chemical reactions, both of which are temperature-dependent. The rate of the first reaction may control period length, whereas the product of the second reaction would inhibit the first reaction. With such a model,  $Q_{10}$  values slightly smaller than 1 also can be explained [7]. Temperature compensation also is an important aspect of neuromodulation (e.g., motor networks), and here again the intrinsic temperature dependences of the processes that contribute to the system output can simply balance each other because reaction rates have been “chosen properly” [8].

Alternatively, the structure of the network itself can stabilize its output, as also has been suggested for networks in clock systems, emphasizing pathway phenomena rather than results of single enzyme properties [9]. The hunt for molecular key players in the process of temperature compensation has nevertheless started, as illustrated in a study on the role of specific core clock proteins in *Arabidopsis* [10].

## References

1. Wahl O (1932) Neue Untersuchungen über das Zeitgedächtnis der Bienen. *Z vergl Physiologie* 16:529–589
2. Bünning E (1958) *Die physiologische Uhr*. Springer, Berlin
3. Pittendrigh CS (1960) Circadian rhythms and the circadian organisation of living systems. In: Cold spring harbor symposia on quantitative biology XXV, Long Island, New York, pp 159–184
4. Hoff JH van 't (1884) *Études de dynamique chimique*. Muller, Amsterdam
5. Tsuchiya Y, Akashi M, Nishida, E (2003) Temperature compensation and temperature resetting of circadian rhythms in mammalian cultured fibroblasts. *Genes Cells* 8:713–720
6. Nakajima M, Imai K, Ito H, Nishiwaki T, Murayama Y, Iwasaki H, Oyama T, Kondo T (2005) Reconstitution of circadian oscillation of cyanobacterial KaiC phosphorylation in vitro. *Science* 308:414–415
7. Hastings JW, Sweeney B (1957) On the mechanism of temperature independence in a biological clock. *Proc Natl Acad Sci USA* 43:804–811
8. Zhurov Y, Brezina V (2005) Temperature compensation of neuromuscular modulation in *Aplysia*. *J Neurophysiol* 94:3259–3277
9. Ruoff P, Zakhartsev M, Westerhoff HV (2007) Temperature compensation through systems biology. *FEBS J* 274:940–950
10. Gould PD, Locke JCW, Larue C, Southern MM, Davis SJ, Hanano S, Moyle R, Milich R, Putterill J, Millar AJ, Hall A (2006) The molecular basis of temperature compensation in the *Arabidopsis* circadian clock. *The Plant Cell* 18:1177–1187

## Circadian Pacemaker Neuron

### Definition

Circadian rhythms of animal behavior and physiology are coordinated by a master clock in the central nervous system of each individual. This master clock comprises a collection of multiple circadian pacemaker neurons.

Each pacemaker neuron has the capacity for autonomous circadian oscillation of cellular parameters such as gene transcription and action potential firing rate. Pacemaker neurons communicate circadian phase information to one another – for the purpose of

synchronizing or otherwise coordinating their autonomous rhythms – and to downstream neural targets – for the purpose of driving overt behavioral and physiological rhythms. This communication of phase information occurs via both classical synaptic neurotransmission and the release of peptide neuromodulators.

- ▶ Cellular Clock
- ▶ Circadian Rhythm
- ▶ Human Circadian Timing System
- ▶ Morning/Evening Oscillators

## Circadian Rhythm

### Definition

A circadian rhythm is a biological oscillation that has a frequency of about once per 24 h when conditions are constant (e.g., when removed from regular, 24 h daily cycles of the environment, such as light and dark or warm and cold). The word “circadian” is derived from *circa dies*, Latin for “about a day.” Circadian rhythms are synchronized to exactly 24 h under natural conditions by zeitgebers, with light acting as the major synchronizing agent.

- ▶ Chronobiology
- ▶ Entrainment
- ▶ Human Circadian Timing System

## Circadian Rhythm Sleep Disorders

- ▶ Circadian Sleep Phase Syndromes

## Circadian Rhythms of Autonomic Functions

RUUD M. BUIJS

Instituto de Investigaciones Biomedicas, Department Fisiologia, Universidad Nacional Autonoma de Mexico, Mexico City, Mexico

### Synonyms

Circadian rhythms are all biological rhythms that express themselves with a rhythm of  $\sim 24$  h.

Autonomic functions are all processes that are not voluntarily controlled and are executed by the brain via nerve fibers of “the autonomic nervous system” that target our organs.

### Definition

Autonomic nervous system is that part of the central nervous system that operates outside our voluntary control. The executing branches of the autonomic nervous system form a parasympathetic or a sympathetic branch. These two branches, in general, target structures and organs in the body and have an antagonistic function whereby it is assumed that the parasympathetic branch is involved in anabolic functions and the sympathetic branch in catabolic functions.

### Characteristics

#### Origin of Circadian Rhythms

The suprachiasmatic nucleus (SCN) is a small brain structure of ~60,000 neurons located on the top of the optic chiasm. Light input reaches the SCN via retinal fibers that terminate in the ventral part. Many individual neurons of the SCN have their own rhythmicity of electrical activity whereby electrical activity and relative inactivity occur with a frequency of about 24 h. The SCN has been shown to be responsible for generating all rhythmicity in mammals; without SCN, no endogenous rhythmicity can sustain. The output of the biological clock transmits its endogenous rhythmicity to the brain and the rest of the body via its projections to hypothalamic target structures. In addition, transfer of its information, especially to generate behavioral activity, may occur by diffusible substances [1]. However, the presence of precise anatomical connections and the presence of locally acting (amino acid) neurotransmitters in SCN projections make it likely that large part of SCN information will be transmitted via precise anatomical connections.

Anatomical studies showed that the SCN uses at least four different types of neuronal targets in the hypothalamus to pass on its circadian signal: (i) endocrine neurons, (ii) autonomic neurons located in the paraventricular nucleus of the hypothalamus (PVN), (iii) hypothalamic structures that may dissipate the circadian signal to brain regions within and outside the hypothalamus, (iv) areas outside the hypothalamus (Fig. 1). The connection from the SCN to the ventrolateral preoptic nucleus is important for the induction of sleep. It is not clear at present how and where the SCN may synchronize other behaviors such as food intake and locomotor activity.

Here, special attention will be given how the SCN targets the body via the autonomic nervous system. It is unmistakable, however, that this action on the autonomic nervous system cannot be viewed independently from the way the SCN affects the hormonal systems of the body. For many hormones, it holds that they are

released with a circadian pattern; responsible for this is the SCN that influences neuroendocrine neurons or the endocrine organs or both.

SCN-mediated control of the melatonin surge indicates that control of hormone secretion via the autonomic nervous system is an important aspect of SCN function. In addition, a pronounced circadian change in the sensitivity of the adrenal cortex to ACTH has been demonstrated since long. Transneuronal tracing and physiological experiments provided proof that, apart from the classical neuroendocrine control of the adrenal cortex by the PVN-CRH-ACTH-cascade, an important neuronal SCN-PVN-sympathetic-adrenal cortex link also determines the final corticosterone secretion from the adrenal. Thus, the SCN utilizes a dual mechanism to organize an optimum secretion of corticosterone not only via direct control of the hypothalamic neuroendocrine (CRH) neurons but also via control of autonomic motor neurons. We propose this as a general principle that holds not only for endocrine glands but also for other organs [2]. For example, recent evidence indicates that just before onset of activity, the SCN not only increases insulin sensitivity, resulting in a physiological meaningful increased uptake of glucose in muscle tissue but also causes increased hepatic glucose production at the same moment.

This evidence warrants a closer look at the possibility that the SCN controls the organs of our body.

#### SCN Prepares the Body for Changes in Activity

The influence of the SCN on hormonal secretion seems to be one of the important routes by which the SCN may affect the body. This conjecture is enforced by the fact that the secretion of several hormones is influenced or even completely regulated (melatonin) by the SCN. A number of anatomical and physiological studies clarified that the SCN affects melatonin secretion by inhibiting its secretion by GABA and stimulating its secretion with glutamate at the level of the preautonomic neurons of the PVN. However, it does not seem very likely that other organs are affected via the same sympathetic branch. In humans, for example, the moment of melatonin secretion is also the moment for sleep, not the best moment to activate indiscriminately the whole sympathetic system because just before sleep, e.g., the heart rate needs to slow down instead of going up. In fact, the autonomic output to our organs is even further differentiated: anatomical evidence has shown that not only separate sets of neurons in PVN and SCN control parasympathetic and sympathetic motor neurons in brain stem and spinal cord, respectively, but also separate neurons affect different organs. This provides the anatomical basis to allow the SCN to influence both autonomic branches at the same time in an opposite manner. This is illustrated by the fact that while the sympathetic input to the pineal is increased for melatonin secretion, the sympathetic input to the heart

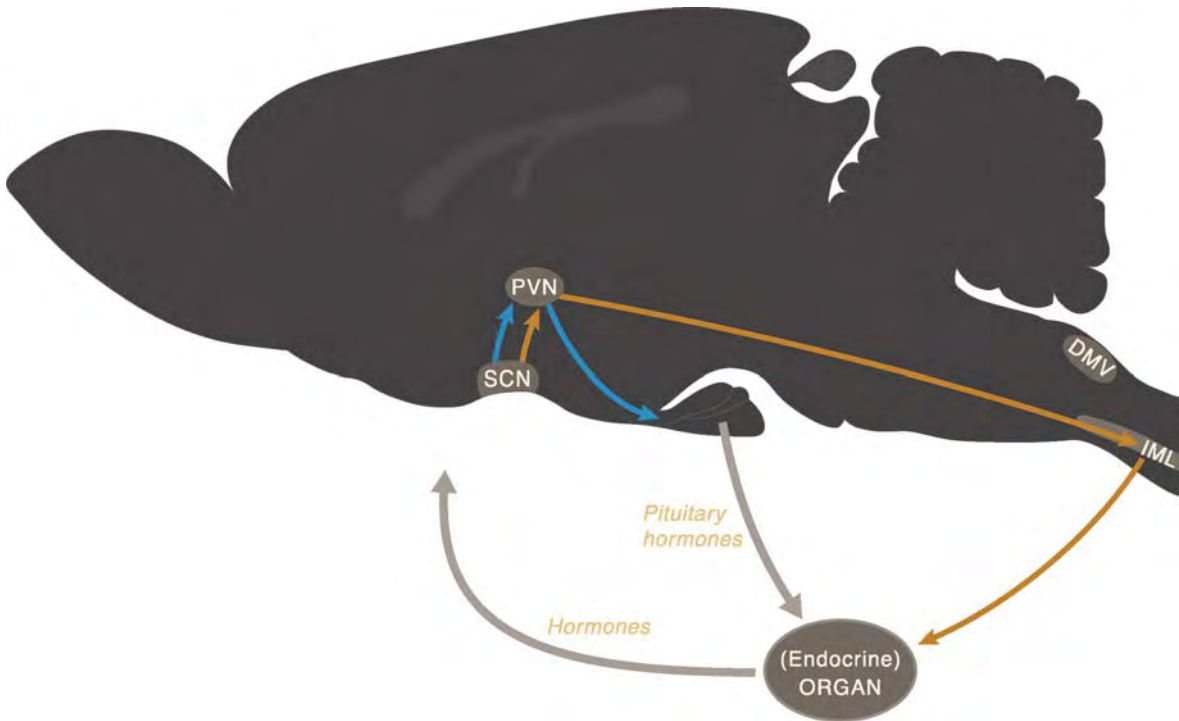

**Circadian Rhythms of Autonomic Functions. Figure 1** The main pathways by which information from the SCN is transmitted to the body, mainly by the PVN via hormonal and autonomic signals. These signals, hormonal, parasympathetic, and sympathetic, reach peripheral organs ranging from adrenal gland and liver to fat tissue and gonads. From these organs, both visceral sensory and hormonal information will reach the hypothalamus. These connections provide the hypothalamus with unique information that allows the organism to adjust and balance both peripheral light/dark information and the metabolic information from the peripheral organs.

is lowered to allow the heart to beat slower. Other studies indicate that already before an animal becomes active its physiology is changed such that the animal is optimally prepared for activity. These changes are largely mediated by the autonomic nervous system.

Furthermore, the rhythmic secretion of corticosterone (cortisol in humans) is primarily driven by the SCN; lesioning the SCN removes the daily corticosterone increase, just before the active period, completely. Clearly, other stimuli also affect corticosterone secretion, e.g., disturbing events (stress) that take place in the environment of the animal still increase corticosterone in SCN-lesioned animals; in fact, the animal even responds with much higher corticosterone secretion to stress after SCN-lesioning, indicating that the SCN plays an important role in inhibiting corticosterone secretion. These observations stimulate the concept that for a normal function of our physiology it is essential that a large number of organ functions are perfectly synchronized and that circadian time, signaled by the SCN, is integrated with all other events that influence behavior or physiological processes. For example, even after fasting for an extended period, the SCN will stimulate an individual to conserve energy during the

rest period. It accomplishes that, e.g., by decreasing the set point for body temperature, decreasing glucagon levels, and promoting sleep. Even then, prior to the onset of the activity period, the SCN will initiate the processes to prepare for activity (e.g., increasing core body temperature and plasma glucose) so that the animal is ready to hunt for food at the end of the sleep.

Another example of how the SCN prepares our body for the upcoming activity by the autonomic nervous system is that it sensitizes our organs for hormones of which the secretion is also influenced by the SCN. An example is the adrenal that just before the onset of the activity period is more sensitive for adreno corticotropin releasing hormone (ACTH). The result of the action of the SCN on the adrenal is that with the same amount of ACTH the adrenal cortex releases more corticosterone at the end of the sleep period than in the beginning of the sleep period. The mechanism for this increased sensitivity is the sympathetic innervation of the adrenal, which is essential for the circadian variation in corticosterone secretion. Signals from the SCN may reach the adrenal via multisynaptic pathways including the PVN and the sympathetic motor neurons located in the intermediolateral column of the spinal cord (IML). This



affects the adrenal such that changes in corticosterone secretion are obtained without any discernable change in ACTH secretion.

Since light is used as a stimulus for the SCN resulting at night in phase shifts and inhibition of melatonin secretion, this stimulus was used to examine the influence of the SCN on the autonomic output of the brain. In (day-active) humans, light exposure resulted in opposite reactions of the autonomic nervous system as compared to the nocturnal rat. Light increased heart rate in humans, as compared to a decrease in heart rate in the rat. Also, these observations fit into the idea that the SCN prepares the individual for the coming activity period and for the coming sleep period and that light, as the signal of the daytime, promotes activity in man and promotes inactivity in rodents.

Similarly we suggest that the SCN – probably by the autonomic nervous system – prepares the muscles for the activity period by increasing their sensitivity to insulin and thus to have a higher glucose uptake. These series of observations have drawn the attention to the capacity of the SCN to change the functionality of our organs not only by the message of hormones but also by affecting the functionality of the organs by the autonomic nervous system.

These examples illustrate one of the main functions of the SCN: preparing the body for the coming activity period. We propose that without this synchronization in physiology, we may have a higher chance to develop diabetes and cardiovascular disease. Consequently, we would like to propose that to live out of synchrony with our SCN would result in the feeling of continuous jet lag or possibly depression. The observation that in depressed persons also a diminished activity of the VP cells in the SCN is observed supports this idea and suggests a possible dysfunction of the SCN in depression.

### Autonomic Control of Our Organs

Early studies by Nijima and Nagai [3] showed that autonomic nerve activity is changed after exposure to light while this effect is gone after lesioning the SCN, indicating that light affects the autonomic nervous system by the SCN. Next, PRV tracing techniques showed the SCN to be connected with a large variation of organs, e.g., white and brown adipose tissue, the adrenal, the heart, the liver, ovary, the kidney, and the pancreas. In the hypothalamus and SCN, both parasympathetic and sympathetic preautonomic neurons are differentially connected with these organs of the body. This anatomical framework allows the hypothalamus to affect selectively parasympathetic and sympathetic autonomic output [4].

Consequently, a network is revealed that allows the SCN to communicate its time signal to the body by means of at least three different routes:

(i) parasympathetic outflow to the organs, (ii) sympathetic outflow to the organs, and (iii) the secretion of hormones into the circulation (Fig. 1).

### An Unbalanced Autonomic Output; Leading to Disease?

Until recently, a number of organs were thought to be excluded from parasympathetic input such as white adipose tissue. However, we obtained evidence for parasympathetic input to white adipose tissue, not only as visceral organ but also as subcutaneous tissue. Parasympathetic input has the function to build up the fat depot while sympathetic input serves to burn fat. This evidence fits quite well with the observations that exercise enhances sympathetic output to the visceral compartment and results in the diminishment of fat stores there. The opposite, a sedentary life style, may result in the accumulation of fat due to a higher parasympathetic and a lesser sympathetic outflow, especially to the visceral fat. Vagal motor neurons in the brain stem that provide input to the subcutaneous fat are completely separated from those that project to visceral fat. At the other hand, the organs in the visceral compartment, such as the liver, pancreas, and abdominal fat, share the same neurons. These observations indicate why an enhanced parasympathetic output to the pancreas after a meal in order to release insulin should also result in an enhanced parasympathetic output to the liver and visceral adipose tissue. In the liver, enhanced levels of insulin from the pancreas will not only stimulate glucose uptake but also the increased parasympathetic input will result in higher glucose uptake and higher storage of glycogen. In the visceral adipose tissue, this combination of enhanced parasympathetic input and elevated insulin levels will result in increased glucose uptake and an accumulation of fat. We propose a hypothesis of autonomic imbalance as one of the possible causes for the metabolic syndrome. A (disturbed) high parasympathetic output to the visceral compartment is the main cause for visceral obesity, hyperinsulinemia, and high levels of FFA. In addition, a simultaneous higher sympathetic output to the muscle and heart compartment would lead to vasoconstriction and hence to insulin insensitivity and hypertension (Fig. 2).

The fact that also the PVN and SCN show this division in projections fits well in our hypothesis that food abundance and the major change in lifestyle in the western world resulting in inactivity during the active period, and enhanced food intake and activity in the rest period (shortened sleep period) may not only affect our daily activity and food pattern but may also lead to a disturbed balance in the hypothalamus. Thus, the biological clock is getting the wrong type of signals across the 24-h period, resulting in general in a flattened rhythm output. One of the major effective treatments of the metabolic syndrome, that is, enhanced activity during daytime together with a moderation in food and

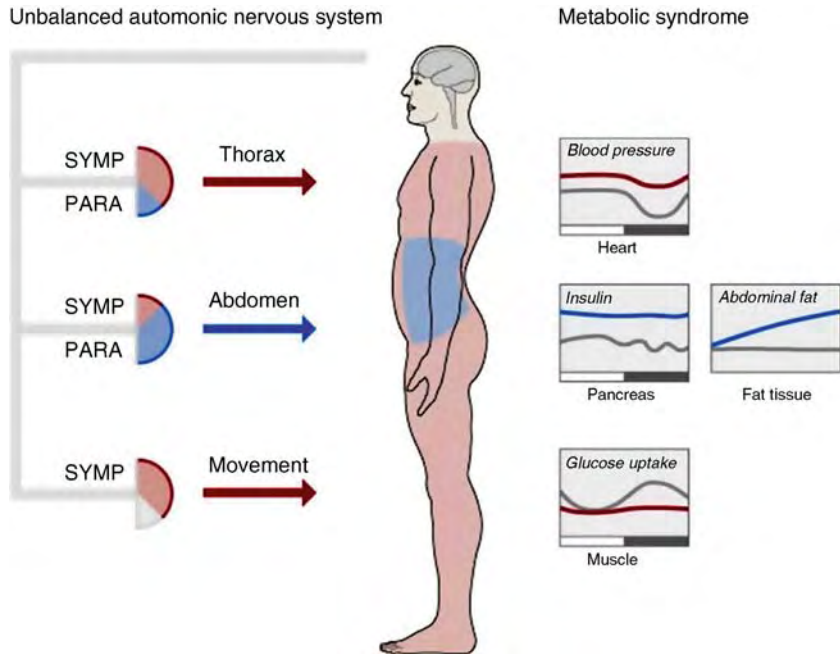

**Circadian Rhythms of Autonomic Functions. Figure 2** Model of the metabolic syndrome caused by a central nervous deregulation. The disturbed output of the biological clock effects the selective balance of the autonomic nervous system in different parts of the body. In the intra-abdominal compartment, the ANS is shifted in favor of the parasympathetic branch, resulting in high insulin secretion, growth of intra-abdominal fat tissue and fatty liver. Contrarily, in the thorax and movement compartment the sympathetic branch prevails, leading to high blood pressure and impaired glucose uptake by the muscle. In this model, the symptoms of the metabolic syndrome are the result and not cause of the disease.

carbohydrate intake, results in an increased sympathetic tone to the abdominal compartment and will amplify the daily rhythm in the activity/sleep cycle.

Several studies indicate that the SCN has a major role in diminishing the effect of stressful events. An analysis of the hypothalamus in people/individuals who died of a cardiovascular incident or brain infarct after a long history of hypertension revealed a diminishment of the size of the SCN in hypertensive patients as compared to controls in which the SCN contained at least two times more VP neurons than the hypertensive SCN. Moreover coinciding with the diminished SCN activity, the activity of the CRH neurons in the PVN was increased, indicating that similar as in the rat also in the human brain the biological clock may serve to inhibit the activity of the HPA axis [5]. The main question that needs to be resolved is whether these observed hypothalamic changes are the cause or consequence of hypertension. An indication that a diminishment of SCN activity may occur already before the onset of hypertension is the observation that people who sleep irregular and less than 5 h per night have a three times higher chance to develop hypertension [6]. This fits in our hypothesis that hypertension might be caused by a defective biological clock that is less well able to maintain a longer rest period and to prepare the

individual for the upcoming activity period and hence results in cardiovascular problems. Several studies show that in humans especially in the early morning a high incidence of cardiovascular incidents occur. This not only suggests that the organization of the daily transition from the inactivity period to the activity period is sensitive to failure but it may also support our idea that this transition should be prepared by our biological clock. Furthermore, if the biological clock is less active or shows less strong amplitude in its output it might prepare us less well for activity. This may in the long-term lead to disease.

The SCN is not only involved in the organization of the physiology of the body in association with the light–dark cycle but the body also communicates back to the SCN. Hereto, the SCN also receives information from the circulation. The observation that in diseases such as diabetes and hypertension a flattened rhythm is observed in autonomic parameters together with a decrease in activity of the SCN suggests that the biological clock may play an important role in the etiology of these diseases. We can see the interaction of the SCN with the body as a closed circle in which changes in any part of this circuit will result in changes in functions either of the body or the biological clock.

## References

1. Kraves S, Weitz CJ (2006) A role for cardiotrophin-like cytokine in the circadian control of mammalian locomotor activity. *Nat Neurosci* 9(2):212–219
2. Buijs RM, Kalsbeek A (2001) Hypothalamic integration of central and peripheral clocks. *Nat Rev Neurosci* 2:521–526
3. Nijjima A, Nagai K, Nagai N, Nakagawa H (1992) Light enhances sympathetic and suppresses vagal outflows and lesions including the suprachiasmatic nucleus eliminate these changes in rats. *J Auton Nerv Syst* 40:155–160
4. Buijs RM, La Fleur SE, Wortel J, Van Heyningen C, Zuiddam L, Mettenleiter TC, Kalsbeek A, Nagai K, Nijjima A (2003) The suprachiasmatic nucleus balances sympathetic and parasympathetic output to peripheral organs through separate preautonomic neurons. *J Comp Neurol* 464(1):36–48
5. Goncharuk VD, Van Heerikhuizen J, Swaab DF, Buijs RM (2002) Paraventricular nucleus of the human hypothalamus in primary hypertension: activation of corticotropin-releasing hormone neurons. *J Comp Neurol* 443(4):321–331
6. Gangwisch JE, Boden-Albala B, Buijs RM, Kreier F, Pickering TG, Rundle AG, Zammit GK, Malaspina D (2006) Short sleep duration as risk factor for hypertension: analysis of the NHANES. I. *Hypertension* 47:833–839

## Circadian Sleep Phase Syndromes

ALFRED J. LEWY

Department of Psychiatry, Oregon Health & Science University, Portland, OR, USA

### Synonyms

Circadian rhythm sleep disorders; Circadian desynchronization/circadian desynchrony

### Definition

Broadly defined, a ►circadian sleep phase syndrome is when ►sleep occurs at an abnormal or undesirable clock time or occurs out of phase with other endogenous ►circadian rhythms.

### Characteristics

#### Assessing Circadian Disorders with the Dim Light Melatonin Onset (DLMO)

►Circadian rhythm disorders are best characterized by measuring the timing of sleep and the time of the ►dim light melatonin onset (DLMO) in sighted people [or the melatonin onset (MO) in blind people]. In normally phased sighted people entrained to the ►light/dark cycle, ►melatonin is produced by the ►pineal gland

only during the hours of nighttime darkness. The plasma DLMO<sub>10</sub> (10 pg melatonin/ml plasma) occurs on average about 14 h after waketime; therefore, its ►circadian time (CT) is CT 14 [1]. In individuals who are low melatonin producers, a lower threshold is used, 2 pg/ml: the plasma DLMO<sub>2</sub> is on average about an hour earlier than the DLMO<sub>10</sub> and indicates CT 13. Around the time of the ►DLMO, salivary melatonin levels are about one-third those of plasma. Hence, the saliva DLMO<sub>3</sub> or DLMO<sub>0.7</sub> is used to mark CT 14 or CT 13, respectively. Whether at home or in the lab, light exposure should not exceed 10–30 lux after about 5 p.m. (the use of amber-tinted goggles may permit brighter light exposure). The DLMO as defined above almost always occurs before usual sleep onset (when the DLMO is not followed by a subscript, the subscript of 10 for plasma levels or 3 for saliva levels is assumed). Therefore, these collections do not interfere with sleep and can even be done in the sleep lab before polysomnographic studies.

#### Delayed Sleep Phase Syndrome (DSPS)

The most common circadian phase sleep disorder is ►delayed sleep phase syndrome (DSPS). It is characterized by a tendency to go to sleep late and to wake up late – even after a night of sleep deprivation, it is difficult for these people to go to sleep earlier. The clock time of the DLMO is also delayed in these individuals. DSPS is most common in adolescents. One of the first treatments for it was “chronotherapy [2],” which was based on a theoretical model that postulated two endogenous circadian pacemakers, one that regulates the ►sleep/wake cycle [located in the ►suprachiasmatic nucleus (►SCN) of the hypothalamus] and another that regulates the temperature circadian rhythm (thought by some to be located elsewhere [3]). The scheduling of sleep was thought to have a direct entraining effect on the latter, independent of imposing structure on the light/dark cycle. According to this model, treatment of DSPS consisted of delaying sleep times 3 h per day for 6–7 days, so that the patient would eventually be able to go to sleep earlier.

Beginning with studies in which the sleep/wake cycle was held constant, consensus was eventually achieved on the following points: there is only one ►endogenous circadian pacemaker, it is located in the SCN and it is relatively insensitive to direct phase-resetting effects of sleep compared to those of bright light and melatonin, the two most commonly used phase-shifting agents for treating DSPS, as well as other circadian disorders [4]. Scheduling sleep times remain important, however, particularly because sleep imposes structured darkness upon the perceived light/dark cycle and the latter will have profound phase-resetting effects on the endogenous circadian pacemaker.

### Advanced Sleep Phase Syndrome (ASPS)

A less common circadian rhythm sleep disorder is ►advanced sleep phase syndrome (ASPS). However, it is thought to be the most typical phase disturbance of the elderly [5,6]. These individuals awaken early in the morning and have difficulty staying up in the evening. The clock time of the DLMO also is advanced in these individuals. Sleep maintenance insomnia often is related to ASPS.

### Treating DSPS and ASPS Based on the Light Melatonin Phase Response Curves (PRCs)

Treatment of these disorders is based on the human ►phase response curves (PRCs) to bright light exposure and low-dose melatonin administration [4]. These PRCs are about 12 h out of phase with each other, because melatonin is a chemical signal for nighttime darkness (Fig. 1). According to the light PRC, bright light exposure causes phase advances when it is scheduled between CT 18 and CT 6 and causes phase delays when it is scheduled between CT 6 and CT 18 (on average, about noon and midnight, respectively, for individuals who usually awaken at 6 a.m.). According to the melatonin PRC, melatonin causes phase delays when it is administered between CT 18 and CT 6 and

causes phase advances when it is administered between CT 6 and CT 18.

For treatment of DSPS, bright light (including sunlight) should be scheduled immediately upon awakening. Low-dose ( $\leq 0.3$ – $0.5$  mg) melatonin should be taken about 8 h later. Because about one in three people experience sleepiness as a side effect of melatonin, particularly at higher doses, an additional 3–10 mg can be taken before bedtime. Waketime and bedtime should be gradually shifted to the desired time. The treatment(s) may need to be continued indefinitely.

For treatment of ASPS, bright light (2,000–10,000 lux) should be scheduled 7 and 9 p.m., ending no later than 1 h before desired sleep time. Melatonin should be taken at each awakening during the night, but only after 1 a.m. The most important melatonin dose is the one taken at final awakening in the morning, which may need to be reduced, so as to minimize soporific side effects that might interfere with early morning activities.

### Free-Running Circadian Rhythms

A third type of circadian phase sleep disorder is one in which the individual “free-runs.” A ►free-running sleep/wake cycle is very uncommon, however, even

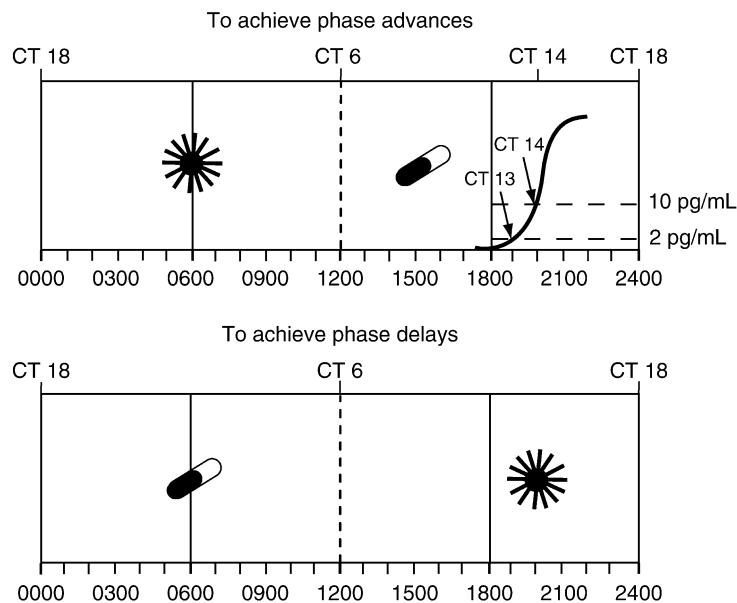

**Circadian Sleep Phase Syndromes. Figure 1** The optimal times to schedule bright light exposure and low-dose melatonin administration to cause circadian phase shifts are based on their respective phase response curves (PRCs) which are about 12 h out of phase with each other [4]. The plasma DLMO<sub>10</sub> (saliva DLMO<sub>3</sub>), marking circadian time (CT) 14, can be used to indicate when advance and delay responses occur, in order to maximize phase shifts. The crossover times are 8 h before (CT 6), and 4 h after (CT 18), the DLMO<sub>10</sub>. Also indicated are clock times typical for individuals who awaken at 6 a.m. (0600). Optimally, exogenous melatonin should overlap with either the onset or the offset of the endogenous melatonin profile. High doses (greater than about 5 mg) may be less effective than lower doses, because of spillover onto the wrong zone of the melatonin PRC. Adapted from Lewy [1], with permission. DLMO, dim light melatonin onset.

in blind people (in fact, particularly in blind people). A small number of sighted people have free-running disorders, which is often referred to as non-24-h sleep/wake syndrome. It can be treated by daily bright light exposure and low-dose melatonin administration.

Free-running rhythms, best characterized by the circadian rhythm of melatonin production, occur in most totally blind people who have no light perception. Nevertheless, these blind free-runners (BFRs) try to sleep at conventional times. However, when the MO is out of phase with the sleep/wake cycle, sleep quality is poor and daytime sleepiness occurs. The consequential recurrent sleep and mood disorder is a great burden for many BFRs, second only to lack of vision [7]. The pattern of recurrence is related to the ►circadian period ( $\tau$ ). A BFR with a  $\tau$  of 25 h will go through a complete circadian beat cycle every 24 days: about once a month, sleep quality will be poor for a few days. A BFR with a  $\tau$  of 24.1 h will go through a complete circadian beat cycle every 240 days: about once every 8 months, sleep quality will be poor for several weeks.

Most BFRs can be treated by taking low-dose melatonin around 6 p.m. A few BFRs should take melatonin at waketime (if they have a  $\tau < 24$  h). Also, all BFRs studied to date appear to be more or less sensitive to as-yet-unknown weak ►zeitgebers (that are probably related to social cues) [8]. About 25% of totally blind women and apparently few if any totally blind men are sufficiently sensitive to these zeitgebers so as to be naturally entrained by them. Even bilaterally enucleated BFRs drift faster than average as their MO occurs between about 8 a.m. and 8 p.m. and drift slower than average as the MO occurs between about 8 p.m. and 8 a.m. This pattern appears to be the same in all BFRs. However, some BFRs (usually women) show greater relative coordination to them than other BFRs (usually men). Identification of these weak zeitgebers, which are probably related to social cues, may lead to a third type of treatment modality for circadian rhythm disorders. To a small extent, these weak zeitgebers probably affect the phase angle of ►entrainment of sighted people. Sometimes the weak zeitgebers are referred to as ►non-photic zeitgebers.

### The Phase Angle Difference (PAD) Between the DLMO and Mid-Sleep

In ASPS and DSPS, abnormal sleep times have traditionally sufficed for diagnosis and management. However, sleep times alone do not take into account the recent finding that internal circadian misalignment may be an important component in some sleep and psychiatric disorders. First tested in winter depression (►seasonal affective disorder (SAD)), the phase angle difference (PAD) between the DLMO and mid-sleep may be a significant component of this disorder. In healthy, sighted people, PAD = 6 h, on average (Fig. 2). When

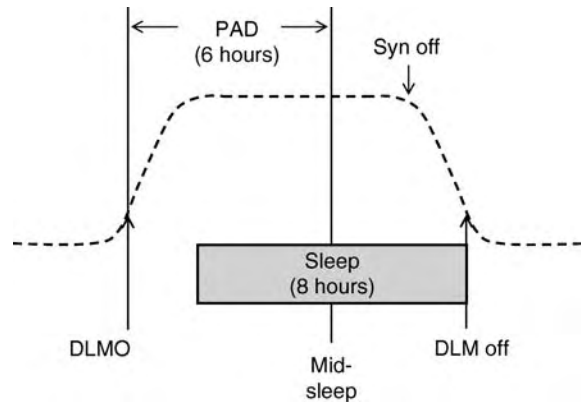

**Circadian Sleep Phase Syndromes. Figure 2** The phase angle difference (PAD) between the plasma DLMO<sub>10</sub> (saliva DLMO<sub>3</sub>) and the time of mid-sleep is on average about 6 h in healthy controls. PAD 6 can be used to phase type individuals and to assess internal circadian misalignment. A person with a PAD > 6 is a phase-advanced type, whereas a person with a PAD ≤ 6 is a phase-delayed type. PAD 6 represents optimal circadian alignment (the “sweet spot” for the DLMO). Deviations from 6 in either direction indicate circadian misalignment, which correlates with increasing depression ratings in seasonal affective disorder (SAD, or winter depression); this finding has helped establish the phase shift hypothesis (PSH) for SAD [9]. Testing the PSH in other psychiatric (and sleep) disorders may also reveal a circadian misalignment component. From Lewy [1], with permission. *SynOff*, melatonin synthesis offset; *DLMOOff*, dim light melatonin offset.

PAD = 6, SAD patients are least symptomatic, before and after treatment with a phase-resetting agent. In this study [9], the phase-resetting agent was low-dose melatonin. Appropriately timed melatonin was significantly antidepressant. Future studies of patients with ASPS and DSPS will need to take into account PAD, so as to assure optimal sleep quality. In fact, treating these disorders with too much of a phase-resetting agent can result in causing internal circadian misalignment that might cause depression in vulnerable individuals.

Previously, phase typing was done by assessing sleep times, which could only reliably distinguish between the most extreme cases. The use of PAD 6 offers a way to phase type people who are slightly different from each other. PAD ≤ 6 indicates a DLMO that is delayed with respect to the sleep/wake cycle. PAD > 6 indicates a DLMO that is advanced with respect to the sleep/wake cycle. However, there may be some inter-individual variability. Alternative ways to assess PAD using the DLMO and sleep times are the waketime-to-DLMO interval [DLMO ►zeitgeber time (ZT)] and the DLMO-to-sleep onset interval (melatonin sleep interval, or MSI).

### Winter Depression (SAD)

The ►phase shift hypothesis (PSH) for SAD posits that most patients become depressed in the winter at least in part because of the later dawn. This causes a ►phase delay in the circadian rhythms tightly coupled to the endogenous circadian pacemaker (marked by the DLMO) relative to the sleep/wake cycle [9]. A corollary of the PSH is that a smaller subgroup of SAD patients become advance in the winter. The prototypical phase-delayed SAD patient should be treated with bright light exposure in the morning and/or low-dose melatonin in the afternoon/evening, so as to provide a corrective ►phase advance. The atypical phase-advanced SAD patient should be treated with bright light exposure in the evening and/or low-dose melatonin in the morning so as to provide a corrective phase delay.

Although delayed sleep times correspond to a delayed DLMO clock time, they do not necessarily correspond to a delayed PAD – and the same applies to the advance direction. This is because if a DLMO is delayed with respect to mid-sleep, then sleep time will be advanced with respect to the DLMO. Therefore, assessment of circadian rhythm disorders will require knowledge of the person's DLMO and sleep times.

### Jet Lag

Phase typing is not necessary in designing treatment strategies for the circadian misalignment component of ►jet lag. This is because a reasonably accurate estimate of DLMO time at destination can be made by adjusting for the number of time zones crossed. Before traveling east, low-dose melatonin should be taken in the afternoon/evening followed by a higher dose at bedtime. Before traveling west, low-dose melatonin should be taken in the morning. The times for low-dose melatonin at destination should then be adjusted according to the direction and number of time zones crossed. For travel across six or fewer time zones, sunlight exposure at destination should occur in the morning after going east and towards the end of the day after going west. For travel across more than six time zones, sunlight exposure should be avoided at these times for the first day or two after arrival, in order to prevent stimulating the “wrong” zone of the light PRC. During these days exposure should occur either in the late morning (going east) or in the afternoon (going west). If these instructions are followed, a phase shift of 3 h per day should occur and the above exposure and administration times should be adjusted accordingly over the course of the next few days.

### The Phase Shift Hypothesis (PSH) in Other Disorders

In SAD, circadian misalignment is substantial and necessary, but alone, not a sufficient cause of the disorder. In BFRs, circadian misalignment is necessary

and sufficient to be causal. Investigations into the circadian misalignment component of other sleep and psychiatric disorders should lead to increased use of adjunctive phase-resetting agents in appropriately phase-typed individuals. The PSH is expected to be tested in non-seasonal major depression, insomnia and attention deficit hyperactivity disorder (ADHD), among other disorders.

### Shift Work Maladaptation and Irregular Sleep Wake Rhythm

Some circadian sleep disorders are schedule-induced. This certainly is the case with ►shift work maladaptation. Few night shift workers reverse their endogenous circadian rhythms, even after a week of sleeping during the day. This is probably due in part to sunlight exposure encountered in the morning on the way home that is stimulating the advance zone of the light PRC, thus preventing the appropriate phase delay to achieve a reversal in circadian phase. Appropriately scheduled bright light and melatonin can be effectively used to do provide the desired phase delay, as well as to provide the desired phase advance for adjusting back to sleeping at night during days off work; however, treatment must be individualized to each person's particular circumstances.

Irregular sleep wake rhythm is characterized by an absence of a clearly defined sleep bout and a clearly defined activity bout whose sum is about 24 h. Sleeping out of phase with the endogenous circadian rhythm of sleep propensity can result in this disorder. However, there are many other possible causes of fragmented sleep.

### Circadian Phase Typing and Chronotypes

It is important to distinguish between circadian phase typing and chronotypes. The latter is based on questionnaires to identify evening types and morning types. Logically, these chronotypes, also referred to as “night owls” and “morning larks,” respectively, might be thought to correspond to phase-delayed types and phase-advanced types. However, preferred sleep times are not always indicative of phase types. Furthermore, as mentioned above, although a DLMO that is delayed with respect to the sleep/wake cycle (i.e., mid-sleep) indicates a phase-delayed type, the sleep/wake cycle in this individual is by definition advanced with respect to the DLMO. While it is technically correct to describe this phase relationship as sleeping at an abnormally early circadian phase, delaying sleep would not necessarily be helpful, because it would delay the perceived light/dark cycle, resulting in a concomitant delay of the DLMO. The treatment of choice for this person would be morning bright light exposure and afternoon/evening low-dose melatonin administration that would provide a corrective phase advance.

### Speculating on the Function of Endogenous Melatonin Production

The research done on BFRs during the past few decades can now be applied to sighted perinates. This is because melatonin can entrain BFRs according to a physiological dose-response curve [10]. This curve was constructed by determining the lowest entraining dose for each of ten BFRs. Depending on their tau (actually, tau at entrainment phase, or TEP), the amount of phase advance per day could be calculated necessary for entrainment. When  $TEP - 24\text{ h}$  is plotted on the ordinate and the lowest entraining dose is plotted on the abscissa, the log-linear regression line is statistically significant (Fig. 3). BFRs can be entrained to very low doses of melatonin ( $10\text{ }\mu\text{g}$  [1]), three orders of magnitude less than those used formerly ( $10\text{ mg}$  [7]). Efficacy of low, physiological exogenous doses suggests that

endogenous melatonin production may have a circadian function. This function may be to augment entrainment to the light/dark cycle.

However, this function may be redundant, except for sighted perinates. Another future application of this work may be in perinates, to help them sleep at night (when their mothers prefer to sleep). Although vision is possible shortly after birth, entrainment to the light/dark cycle occurs a few months later. Before this time, the infant may require another signal in order to maintain entrainment to the 24-h day of their parents. Entrainment to the mother's sleep/wake cycle may help the mother sleep better and deliver better maternal care, even if it makes no other difference to the perinate. This means that the amount of melatonin in breast milk may be sufficient to entrain the suckling infant, provided the mother is not exposed to too much bright light

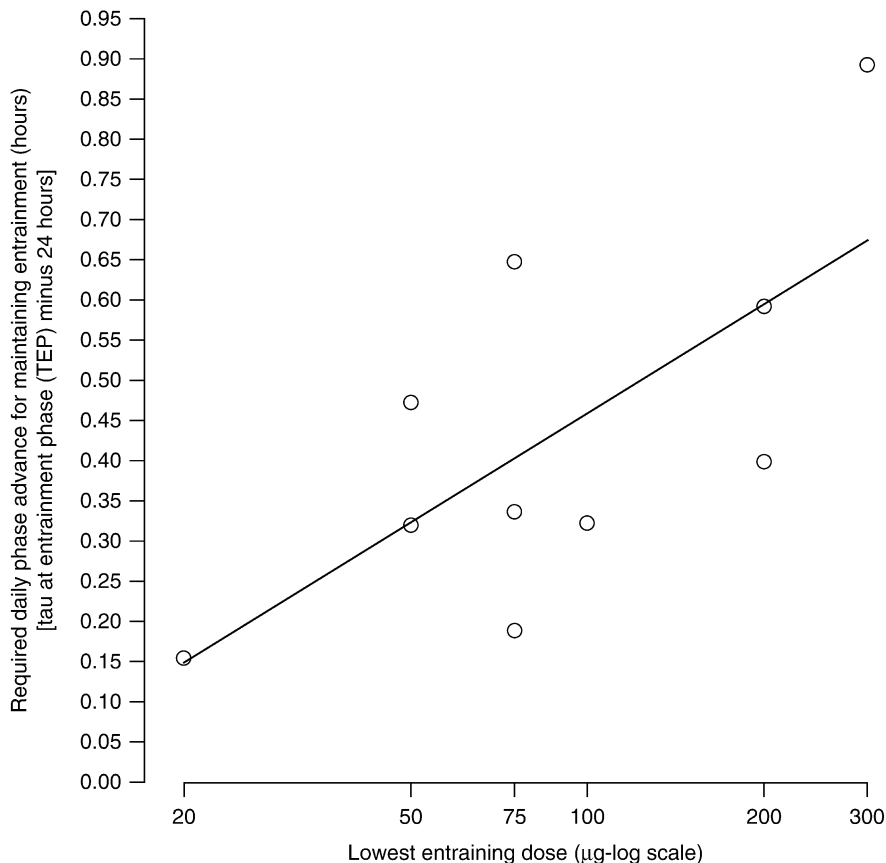

**Circadian Sleep Phase Syndromes. Figure 3** Physiological dose-response curve for melatonin in humans. The lowest dose found to entrain each of ten blind free-runners (BFRs) is plotted on the abscissa. The daily phase advance required for entrainment is plotted on the ordinate and is calculated for each BFR by subtracting 24 h from tau at entrainment phase (TEP). TEP is the BFR's tau when the MO (melatonin onset) was previously free-running across the clock time at which it has now been entrained to a daily dose of melatonin taken in the early evening (see text and Emens et al. [8]). Doses even lower than  $20\text{ }\mu\text{g}$  are effective if tau is close to 24 h [1], which suggest that endogenous melatonin production may have a circadian function in humans. The regression line ( $r = 0.69$ ) is statistically significant ( $p = 0.026$ ). From Lewy et al. [10], with permission.

during the night. During the third trimester, melatonin produced by the mother crosses the placenta and is available to stimulate ► [melatonin receptors](#) in the SCN.

### Conclusion

In conclusion, circadian phase sleep disorders are best assessed using sleep times and the DLMO. These occur late in phase-delayed types and early in phase-advanced types. In a sense, they are redundant, obvious and exoteric. More esoteric, but no less important, is the time interval between the DLMO and mid-sleep: this PAD represents the degree of internal circadian misalignment, which is important in SAD and may be an important component in other circadian phase sleep and psychiatric disorders. As basic investigations progress in this area of neuroscience, it is expected that the salivary DLMO and PAD will move beyond being just research tools and will become standard clinical tests as well. The PSH for SAD is expected to undergo further testing in other patient populations.

There are at least three ways in which the DLMO is useful. One, it is the basis for phase typing, particularly in combination with sleep times and its timing relative to the sleep/wake cycle (PAD). Two, it indicates the phase of the light and melatonin PRCs, so that treatment using these phase-resetting agents can be optimized. Three, it provides a way of monitoring the induced phase shift.

### References

- Lewy A (2007) Melatonin and human chronobiology. Cold Spring Harbor Symp Quant Biol Vol. 2. Posted online 24 January 2008
- Czeisler CA, Richardson GS, Coleman RM, Zimmerman JC, Moore-Ede MC, Dement WC, Weitzman ED (1981) Chronotherapy: resetting the circadian clocks of patients with delayed sleep phase insomnia. *Sleep* 4(1):1–21
- Kronauer RE, Czeisler CA, Pilato SF, Moore-Ede MC, Weitzman ED (1982) Mathematical model of the human circadian system with two interacting oscillators. *Am J Physiol* 242:R3–R17
- Lewy AJ, Bauer VK, Ahmed S, Thomas KH, Cutler NL, Singer CM, Moffitt MT, Sack RL (1998) The human phase response curve (PRC) to melatonin is about 12 hours out of phase with the PRC to light. *Chronobiol Int* 15(1):71–83
- Sack RL, Auckley D, Auger RR, Carskadon MA, Wright KP, Vitiello MV, Zhdanova I (2007) Circadian rhythm sleep disorders: part I, basic principles, shift work and jet lag disorders. *Sleep* 30(11):1460–1483
- Sack RL, Auckley D, Auger RR, Carskadon MA, Wright KP, Vitiello MV, Zhdanova I (2007) Circadian rhythm sleep disorders: part II, advanced sleep phase disorder, delayed sleep phase disorder, free-running disorder, and irregular sleep-wake rhythm. *Sleep* 30(11):1484–1501
- Sack RL, Brandes RW, Kendall A, Lewy AJ (2000) Entrainment of free-running circadian rhythms by melatonin in blind people. *N Engl J Med* 343:1070–1077
- Emens JS, Lewy AJ, Lefler BJ, Sack RL (2005) Relative coordination to unknown “weak zeitgebers” in free-running blind individuals. *J Biol Rhythms* 20(2):159–167
- Lewy AJ, Lefler BJ, Emens JS, Bauer VK (2006). The circadian basis of winter depression. *Proc Natl Acad Sci USA* 103:7414–7419
- Lewy AJ, Emens JS, Lefler, BJ, Yuhas K, Jackman AR (2005) Melatonin entrains free-running blind people according to a physiological dose-response curve. *Chronobiol Int* 22(6):1093–1106

## Circadian Time

### Definition

A standard marker of time that is based upon the free-running period of an oscillation or rhythm. By convention, circadian time 0 (CT 0) is defined as the initiation of activity in a diurnal organism. Likewise, CT 12 is defined as the initiation of activity in a nocturnal organism.

- [Circadian Cycle](#)
- [Clock](#)
- [Human Circadian Timing System](#)

## Circannual Rhythms

DAVID HAZLERIGG

Jackwat Consulting Services Springview, NSW, Australia

### Definition

Endogenously generated biological rhythm with a period length approximating to 1 year.

### Characteristics

The term circannual rhythm is a derivative of the term circadian. ► [Circadian rhythms](#) are endogenously generated biological rhythms with a period length of approximately one day (from the Latin *circa diem*). Correspondingly then, a circannual rhythm may be defined as annual. There are many different examples of circannual rhythms including the pupation rhythm in carpet beetles [1], the urge to migrate in birds [2], hibernation cycles in ground squirrels [3], and cycles of reproductive activity and moulting in ungulates [4].



In species living outside of the equatorial zones, the seasonal change in the daily pattern of light/dark exposure, (that is, the ►photoperiod), is the major synchronising signal for circannual rhythms. Responsiveness to photoperiodic changes ensures that appropriate physiological or behavioral responses occur at the different phases of the sidereal year. Thus, to explore the endogenous component of circannual rhythms, it is necessary to hold organisms on constant photoperiods for long durations (years), this being analogous to holding animals on constant light or constant darkness to explore circadian rhythms. Consequently, research into circannual rhythms is very long-range, which has no doubt been partly responsible for the relatively low level of research activity on this subject.

It is interesting to consider the possible selective benefit that maintaining an endogenous long term timing mechanism might confer. For animals living above ground, such benefit may be very subtle, being limited to those phases of the year during which changes in the environmental photoperiod occur slowly, near to the summer and winter solstices. Here, it may be envisaged that the endogenous “circannual” component allows animals to initiate preparative changes in physiology in readiness for the forthcoming autumn/spring. This anticipation argument has been widely used also to account for circadian ►rhythmicity, but direct experimental evidence for or against this adaptive conjecture is lacking.

The preparative argument is probably strongest for those animals undergoing torpor or ►hibernation during the winter season, as a consequence of which they do not monitor the prevailing photoperiod for several months. In many species, this does not prevent precise timing of the end of the hibernation phase, such that individuals emerge each year in a remarkably consistent time-window. Strong ecological arguments based upon resource availability or competition can be made to support the benefit of achieving such tight long term timing of emergence.

A comparison of the basic features of circannual rhythms, suggests that generally have a period length of less than 1 year – approximately 40 weeks in most instances [1–4]. There have been limited efforts to examine the phase-dependent ►resetting of circannual rhythms by changes in day length, but published work argues for “►Type 0” resetting of the circannual rhythm in beetles and sheep [1,4]. Here, the new phase is independent of the phase at which the resetting stimulus is applied (giving a slope of 0 when new phase is plotted against old phase). In the circadian context, this type of resetting response has been suggested to be indicative of a weak underlying ►oscillator [5], and this may be linked to the fact that circannual rhythms often show considerable instability and dampening under constant photoperiodic conditions.

Compared to circadian rhythms, much less is known about the underlying physiological mechanisms driving circannual rhythms, and their relationships to the machinery governing photoperiodic response mechanisms. In terms of formal mechanism, three distinct possibilities can be envisaged: (i) circannual rhythms are an emergent property of circadian rhythms, through a process known as frequency demultiplication; (ii) they emerge as consequence of transitions through a sequence of stages each of fixed duration; and (iii) a true circannual oscillator exists analogous to a circadian oscillator. Of these, the first is not favoured since experiments in which animals are entrained to daily photoperiod cycles with periods unequal to 24 h do not lead to proportionate changes in circannual rhythm duration. It is very difficult to distinguish between the latter two possibilities partly because data on the neuroanatomical basis of circannual rhythm generation are absent.

Recent studies in the Soay sheep may lead to progress on this front. In common with other seasonal mammals, the photoperiodic response mechanism in this animal can be traced to the pineal neurohormone ►melatonin, and its target sites within the neuroendocrine system. Recent work suggests that circannual rhythm of prolactin secretion in Soay sheep depends on processes within one melatonin target tissue, the *pars tuberalis* region of the anterior pituitary, and that a maintained nightly pattern of melatonin exposure is crucial for expression of the circannual prolactin rhythm [6]. It remains unclear whether this anatomical implication of the *pars tuberalis* in circannual rhythm expression reflects its role as a circannual ►pacemaker, or as part of a network of tissues serving this function.

## References

1. Miyazaki Y, Nisimura T, Numata H (2005) A phase response curve for circannual rhythm in the varied carpet beetle *Anthrenus verbasci*. *J Comp Physiol A Neuroethol Sens Neural Behav Physiol* 191(10):883–887
2. Gwinner E (2003) Circannual rhythms in birds. *Curr Opin Neurobiol* 13(6):770–778
3. Kondo N, Sekijima T, Kondo J, Takamatsu N, Tohya K, Ohtsu T (2006) Circannual control of hibernation by HP complex in the brain. *Cell* 125(1):161–172
4. Lincoln GA, Andersson H, Loudon A (2003) Clock genes in calendar cells as the basis of annual timekeeping in mammals – a unifying hypothesis. *J Endocrinol* 179(1):1–13
5. Daan S, Pittendrigh CS (1976) A functional analysis of circadian pacemakers in nocturnal rodents II. The variability of phase response curves. *J Comp Physiol* 106:253–266
6. Lincoln GA, Clarke IJ, Hut RA, Hazlerigg DG (2006) Characterizing a mammalian circannual pacemaker. *Science* 314(5807):1941–1944

## Circumvallate Papillae

### Definition

(Papilla: small protuberance, Circum: around, Vallum: rampart). These structures are distributed along a chevron shaped line on the dorsal-posterior surface of the human tongue in front of the sulcus terminalis. Each circumvallate papilla has the appearance of a dome surrounded by a horseshoe-shaped invagination opening a trench under the surface of the tongue. The walls of the trench are covered with up to 800 taste buds opening into it and the base of the moat is irrigated by the ducts of the von Ebner gland. Their total number varies between 3 and 13 per individual. They all contain taste buds.

► Taste

## Circumventricular Organ

### Definition

A small, highly vascular neural region within the brain that protrudes into the third or fourth ventricle and lacks a functional blood-brain barrier (BBB). By this strict Definition, the organum vasculosum of the lamina terminalis, subfornical organ, median eminence, and area postrema are all circumventricular organs. Classically, however, some authors have included other sites, such as the subcommissural organ (which does not lack a BBB), choroid plexus (does not contain any neural elements), posterior lobe of the pituitary gland (located outside the brain), and pineal gland (located outside the brain). The neurons and glia within most circumventricular organs monitor the concentrations of ions and hormones in the blood plasma, and adjust various autonomic and behavioral functions via axonal connections to nuclei in the hypothalamus, brainstem, and other subcortical regions. Other sites, particularly the median eminence, represent a site of axonal transmission of transmitter molecules directly into a portal capillary network.

## Cis-regulatory Element

### Definition

A discrete region of DNA that affects transcription of a gene.

## c-Jun

### Definition

A member of the Jun family of proteins that form a component of the AP-1 transcription factor. c-Jun dimerizes with other molecules including other Jun or Fos family members to form transcriptionally active complexes. The expression of c-Jun and the activation of the AP-1 transcription factor complex are increased in response to neurotrophic molecules as well as axonal injury.

► Neurotrophic Factors in Nerve Regeneration

## c-Jun N-terminal Kinases (JNKs)

### Definition

The c-Jun N-terminal kinases (JNKs) comprise one of the subfamilies of the mitogen-activated protein kinases (MAPK). JNK-mediated phosphorylation activates c-Jun, a component of the AP-1 transcription factor, in response to neurotrophin signaling. JNK activation regulates AP-1-dependent target genes involved in cell proliferation, cell death, inflammation, and DNA repair.

## Cladistic Relationships

### Definition

Those relationships between species that are based on evolutionary history.

► Evolution of the Brain: in Birds

## Cladogram

### Definition

Branching diagram of taxa exclusively based on shared derived characters (synapomorphies).

► Evolution of the Brain: In Fishes

► Evolution of the Cerebellum

► Evolution of the Telencephalon: In Anamniotes

## Clasp-knife Reflex

### Definition

Sudden yield to passive slow stretch of muscles with increased resistance in spastic patients, this yield depending on muscle length and joint angle; differential sign to distinguish increased muscle resistance in ▶spasticity from ▶rigidity as appearing, e.g., in ▶Parkinson disease.

- ▶ Parkinson Disease
- ▶ Spasticity

## Classical Architecture

### Definition

A cognitive system has a classical architecture if its cognitive processes rely on structure-sensitive manipulations of symbols.

- ▶ Representation (Mental)

## Classical Conditioning (Pavlovian Conditioning)

TAKASHI YAMAMOTO

Department of Oral Physiology, Graduate School of Dentistry, Osaka University, Osaka, Japan

### Synonyms

Responding Conditioning

### Definition

A type of associative learning between the successively applied two stimuli resulting in prediction of the second stimulus by the first stimulus.

Classical conditioning, which was formalized by Pavlov in 1906, is a type of associative learning in which the neutral ▶conditioned stimulus (CS) comes to evoke a ▶conditioned response (CR) that is similar to the ▶unconditioned response (UR) induced by the ▶unconditioned stimulus (US) after repetitive pairings of the CS with the US. In order to elucidate the brain mechanisms of such an associative learning, ▶conditioned taste aversion (CTA) that is defined as a learned association of taste (CS)

with malaise (US) is extensively studied because CTA is firmly acquired by single association of the CS and the US even with a long CS–US interval.

### Characteristics

#### Basic Nature of Classical Conditioning

There are two forms of conditioning: one is classical conditioning and the other is operant conditioning. Classical conditioning is also referred to as respondent conditioning or Pavlovian conditioning. Apart from operant conditioning, the subject learns relations between stimuli, i.e., classical conditioning is a type of associative learning formed by pairing of unconditioned stimulus (US) with the conditioned stimulus (CS). In the case of salivation conditioning experiments in dogs by Pavlov [1], repetitive pairings of a neutral stimulus such as a metronome sound with the following exposure to a small amount of meat powder were conducted. Salivary secretion was evoked by the meat powder presentation, but not by the metronome sound per se at the beginning of pairings; salivary secretion, however, was gradually evoked by the metronome sound with the repetition of pairings. The neutral metronome sound to which conditioning was acquired is the CS, and the salivation induced by the CS is referred to as the conditioned response (CR). The meat powder is the US and the innate reflex salivary secretion to the US is the unconditioned response (UR). In classical conditioning, the USs are chosen so that they elicit reflex responses as URs, such as salivary secretion, changes of skin resistance, vasomotor responses, and visceral responses, as the autonomic reactions, and flexion reflex, patellar tendon reflex, and eyelid reflex as the muscle movements.

For the successful establishment of conditioning, the timing and the order of the presentation of the CS and US are important. The CS should be presented before the US onset and should terminate during the US presentation or at the US onset. When the onset time of the CS coincides with that of the US, conditioning is effective provided that the CS terminates before the US. If the CS starts and ends before the US starts (or the CS and US are not overlapping) and the interstimulus interval (the time period between the end of the CS and the start of the US) is short (usually within the second range), conditioning is attained. If the US onset precedes the CS onset and the US terminates before the CS, this protocol (backward conditioning) is usually ineffective.

The strength of the acquired conditioning can be influenced depending on the properties and relationships of the CS and US. The followings are examples:

1. *Conditioned Inhibition.* A CS– that is conditioned to the absence of the US inhibits the development of the CR to a mixed stimulus of CS– and CS+ compared with the CR to the CS+ that is solely conditioned to the presence of the US [1].

**Classical Conditioning (Pavlovian Conditioning). Table 1** Characteristics of classical conditioning (CC) and taste aversion conditioning (TAC)

	CC	TAC
Association learning between CS and US	o	o
CS should precede US	o	o
CS should be novel	o	o
CR is generalized to similar CSs	o	o
CR can be extinguished	o	o
Necessary pairing of CS and US	Repetitive	One
Interval between CS and US	Short (within seconds)	Long (up to several hours)

CS, conditioned stimulus; US, unconditioned stimulus; CR, conditioned response; o, yes.

2. *Latent Inhibition.* A CS that has been repeatedly presented in the absence of the US requires more pairings with the US to elicit the CR [2]. Such lowered conditioning performance, called latent inhibition, may be derived from the diminution of novelty of the CS and the development of safe learning leading to a failure to new association to such stimuli or a failure of retrieval even if the association of the preexposed CS to the US proceeds normally.
3. *Overshadowing.* When two CSs with markedly different salience (CS+ vs. CS+++ ) are presented as a compound CS, CS+ forms a much weaker CR than it would in the presence of only the CS+, whereas the CR to the CS+++ remains undiminished [3]. The stronger CS may overshadow the weaker CS.
4. *Blocking.* A well-established CS presented on later conditioning trials in compound with a new stimulus blocks the new stimulus from associating with the US [4].
5. *Second-Order Conditioning.* Animals presented with a novel CS followed by presentation of the well-established CS without presentation of the US acquire the CR to the novel CS [5].

Psychologists have introduced a number of sophisticated theories of associations [6]. However, There is no accepted unified theory covering all manifestations and properties of classical conditioning [7].

### Conditioned Taste Aversion

CTA, or taste aversion conditioning is widely accepted as a kind of Pavlovian learning in which animals acquire an aversion to a tastant (CS) that has been associated with visceral distress or malaise (US) [8]. Following a CTA, reexposure to the CS elicits aversive behaviors that are similar to those shown to innately aversive tastants such as quinine. When saccharin is used as the CS and an intraperitoneal injection of 0.15 M LiCl (2% of body weight) as the malaise-inducing CS, the sweet and palatable taste is treated as an aversive taste after CTA

acquisition. The quality itself may not change, whereas the perceived intensity may be enhanced to facilitate detection of the harmful substance, and a hedonic shift from positive to negative occurs. As shown in Table 1, besides the similarities to classical conditioning, CTA has the following characteristics that are distinguished from classical conditioning: (i) Strong CTAs to novel taste stimuli can be established in a single learning procedure, i.e. after one pairing of CS and US. (ii) Successful CTAs can develop to the CS after delays of as long as 4–12 h between exposure to the CS and delivery of the US. (iii) The association between the CS and the US can proceed under deep pentobarbital anesthesia. (iv) The aversive behavior to the CS is not the CR because an intraperitoneal injection of LiCl does not elicit aversive taste reactivity as the UR. One of the URs induced by LiCl injection is lowered temperature, and it is shown that after acquisition of CTA, gustatory stimulation with the CS elicits lowered body temperature, indicating that CTA is really a Pavlovian conditioning. Consequently, CTA has two aspects: one is classical conditioning and the other is fear conditioning (or fear learning where a stimulus becomes associated with fear).

The single learning procedure with the long CS–US interval enables CTA to be a good model to elucidate the neural substrate, neuroactive substances involved and cellular and molecular processes [9,10] in the relevant areas of the brain concerning the acquisition, consolidation, and retention of the associative learning.

### References

1. Pavlov IP (1927) *Conditioned reflexes: an investigation of the physiological activity of the cerebral cortex.* Oxford University Press, London
2. Lubow RE, Moore AU (1959) Latent inhibition: the effect of nonreinforced pre-exposure to the conditional stimulus. *J Comp Physiol Psychol* 52:415–419
3. Lindsay GP, Best PJ (1973) Overshadowing of the least salient of two novel fluids in a taste aversion paradigm. *Physiol Psychol* 1:13–15

4. Kamin LJ (1969) Predictability, surprise, attention and conditioning. In: Campbell BA, Church RM (eds) Punishment and aversive behavior. Appleton-Century-Crofts, New York, pp 279–296
5. Bond NW, DiGiusto EL (1976) One trial higher-order conditioning of a taste aversion. *Aust J Psychol* 28:53–55
6. Rescorla RA (1988) Behavioral studies of Pavlovian conditioning. *Annu Rev Neurosci* 11:329–352
7. Pearce JM, Bouton ME (2001) Theories of associative learning in animals. *Annu Rev Psychol* 52:111–139
8. Garcia J, Kimmeldorf DJ, Koelling RA (1995) Conditioned aversion to saccharin resulting from exposure to gamma radiation. *Science* 122:157–158
9. Bermudez-Rattoni F (2004) Molecular mechanisms of taste-recognition memory. *Nat Rev Neurosci* 5:209–217
10. Yasoshima Y, Sako N, Senba E, Yamamoto T (2006) Acute suppression, but not chronic genetic deficiency, of *c-fos* gene expression impairs long-term memory in aversive taste learning. *Proc Natl Acad Sci USA* 103:7106–7111

---

## Classical Mechanics

MARCELO EPSTEIN

Schulich School of Engineering, University of Calgary, Calgary, AB, Canada

### Definition

The term classical mechanics refers to the study of the motion of particles, systems of particles and rigid bodies as understood before the advent of relativity and quantum mechanics, that is, roughly until the dawn of the twentieth century. It is important to bear in mind that the new physics inaugurated by these two disciplines did not invalidate the results of classical mechanics, a discipline that still remains at the foundation of most of engineering and biomechanics. Classical mechanics can be divided into two major sub-disciplines, ►Newtonian mechanics and ►analytical mechanics.

### Description of Theory

The basic geometric idea of ►analytical mechanics is that of ►configuration space of a mechanical system. If the system is considered as a whole, rather than as an assembly of interconnected material points, the configuration space is a geometrical representation of all the possible configurations that the system can attain. Mathematically speaking, the configuration space is assumed to be a ►differentiable manifold. As a non-trivial example of the conceptual difference between the ►Newtonian mechanics approach and that of ►analytical mechanics, consider a plane double pendulum,

namely, a material particle linked by a massless rigid bar to a fixed point of suspension and to another material particle by means of a similar link. (This example is kinematically similar to the two-bone system discussed in the article ►Statics. The particles are assumed to move in a vertical plane. From the point of view of ►Newtonian mechanics, to obtain the equations of motion of the system each of the two particles would have to be isolated and its equations of motion written, taking into account the fact that the rigid links provide unknown reactive forces (each acting, in this case, in the direction of one of the bars). Taking advantage of the extra information provided by the geometric constraints (in this case, the constant distance between the first particle and the point of suspension, and the constant distance between the two particles), two extra (algebraic) equations can be obtained which, when coupled with the equations of motion, allow for the solution of the motion and of the forces of constraint. This method has at least two drawbacks. The first is that for systems with multiple geometric constraints the formulation can become very cumbersome. The second drawback is that the resulting system of equations is a mixture of algebraic and differential equations, with the ensuing numerical problems. Although it may be said that with today's computing power these are not major drawbacks, there are deeper physical and mathematical reasons to look at the system in a global manner that may be able to factor out the geometrical constraints. In the case of the double pendulum, it is just necessary to observe that the first particle can only move in a circle around the fixed point, while the second particle can only occupy positions that lie on a circle around the instantaneous position of the first particle. A moment's reflection reveals that the collection of all possible configurations of the system describes, therefore, the surface of a torus (a doughnut), which becomes the configuration space of the system in this particular case. The configuration space does not carry any special system of coordinates, but such a system can be chosen (at least locally). For example, the angular deviations of the links from the vertical direction, or the horizontal distances from the vertical line through the point of suspension, will do as *generalized coordinates*. At any rate, the number of coordinates (the *dimension* of the configuration space) in the example is just two. In general, the dimension of the configuration space is equal to the number of true degrees of freedom the system possesses. Unlike in Newtonian mechanics, the geometrical constraints are already incorporated in the definition of the space itself and, as a result, the forces of constraint may be eliminated altogether from the analysis.

A useful way to understand the transition from classical to analytical mechanics is provided by the ►principle of virtual work.

## Newtonian Mechanics

At the outset, classical mechanics postulates the existence of *material points* or *particles* endowed with an invariant strictly positive scalar property called *mass*. Another primitive concept of classical mechanics is *classical space-time*. The precise definition of this entity is beyond the scope of this article, but an intuitive way to visualize it is to imagine that to each point of a real line (the time line) is attached a Euclidean space (a space of points where the theorem of Pythagoras is valid globally). An *event* is a point in space-time. Given two events, it can be established whether or not they correspond to the same time (*absolute simultaneity*). Given two non-simultaneous events, on the other hand, it is impossible to determine in an absolute way whether or not they correspond to the same location. Thus, in classical mechanics, time is absolute, but space is not. Only for simultaneous events can their relative locations be unequivocally ascertained. The gap is filled by the notion of (classical) *observer*. An observer (or frame) is defined by choosing smoothly, for every instant of time, an origin (an event) and three mutually perpendicular directions. Thus, any event can be assigned a *position vector*  $\mathbf{x}$  relative to a given observer. A *motion* of a particle is a smooth assignment of an event to each instant of time. For an observer, therefore, the motion of a particle consists of a time-dependent position vector  $\mathbf{x}(t)$ . The same motion, as seen by a different observer, will be denoted by, say,  $\mathbf{x}^*(t)$ . For simplicity, it is assumed that both observers have synchronized their clocks. The relation between  $\mathbf{x}^*(t)$  and  $\mathbf{x}(t)$  cannot be completely arbitrary, since both observers must agree on the measurement of distances between simultaneous events. As discussed under ►kinematics of deformation, the most general relation between the position vectors is:

$$\mathbf{x}^*(t) = \mathbf{c}(t) + \mathbf{Q}(t) \mathbf{x}(t), \quad (1)$$

where  $\mathbf{c}(t)$  is a time-dependent vector and  $\mathbf{Q}(t)$  is a time dependent rotation (represented in a coordinate system by a proper orthogonal matrix). The ►velocity  $\mathbf{v}(t)$  and ►acceleration  $\mathbf{a}(t)$  of a particle relative to an observer are, respectively, given by the first and second time-derivatives of the position vector, namely:  $\mathbf{v}(t) = \dot{\mathbf{x}}(t)$  and  $\mathbf{a}(t) = \ddot{\mathbf{x}}(t)$ . By differentiating (1), the following relations between the observed velocities and accelerations of the same motion as seen by two observers are obtained:

$$\mathbf{v}^*(t) = \dot{\mathbf{c}}(t) + \dot{\mathbf{Q}}(t) \mathbf{x}(t) + \mathbf{Q}(t) \mathbf{v}(t), \quad (2)$$

$$\begin{aligned} \mathbf{a}^*(t) = & \ddot{\mathbf{c}}(t) + \ddot{\mathbf{Q}}(t) \mathbf{x}(t) \\ & + 2\dot{\mathbf{Q}}(t) \mathbf{v}(t) + \mathbf{Q}(t) \mathbf{a}(t). \end{aligned} \quad (3)$$

Two observers are *inertially related* if  $\ddot{\mathbf{c}}(t) = \dot{\mathbf{Q}}(t) \equiv 0$  (they recede at a constant velocity without rotating).

Thus, all observers can be partitioned into equivalence classes of inertiality. It follows from (3) that all inertially related observers agree on the value of the acceleration vector of a particle (although they in general disagree on the position and velocity vectors). By “agreement” it is meant that their measurements differ only by the (constant) rotational correction, but are not otherwise affected by the relative state of motion of the observers. Newton’s *first law of motion* postulates that among all these inertial classes there exists a privileged one for which the laws of mechanics appear particularly simple. A frame belonging to the privileged class is called an *inertial frame*. To recognize an inertial frame, it is necessary to accept another primitive concept, that of *force*. In the absence of forces, Newton’s first law asserts that the motion of a particle as seen from an inertial frame has a constant velocity (equivalently, zero acceleration). Thus, forces are not the causes of motion, but rather the causes of change of motion relative to an inertial frame. Newton’s *second law of motion* quantifies this idea by asserting that the force  $\mathbf{f}$  impressed upon a particle is directly proportional to its acceleration in an inertial frame, and that the constant of proportionality is the mass of the particle. This is the famous equation:

$$\mathbf{f} = m\mathbf{a}. \quad (4)$$

An equivalent way to state this law, more in the spirit of Newton’s original verbal formulation, can be obtained by defining the *momentum* of a particle (relative to an observer) as the vector  $\mathbf{p} = m\mathbf{v}$ , where  $m$  is the mass of the particle. In terms of the momentum, (4) reads:

$$\mathbf{f} = \dot{\mathbf{p}}, \quad (5)$$

thus evidencing the cause-effect relationship between forces and changes of momentum. To solve a particular problem in Newtonian particle mechanics, all that needs to be known is the force applied as a function of time and/or position and/or velocity, and the *initial conditions*, namely, the position and velocity for a specific (initial) time. The theory of ordinary differential equations then ensures the existence of a solution of (4), at least for some interval of time.

Consider now a *system of  $N$  particles* of masses  $m_i$  ( $i = 1, \dots, N$ ). It is now possible to distinguish between forces exerted upon each particle by the external world and forces exerted by the particles upon each other. The first kind may be called *external forces* and the second kind *internal forces*. (Naturally, the choice of the “system” is in the hands of the analyst. For example, considering a subsystem with less particles, say  $N' < N$ , the effect of the remaining  $N - N'$  particles on this subsystem must now be considered as part of the external forces). Let  $\mathbf{f}_i^{\text{ext}}$  denote the external force acting on the  $i$ -th particle and let  $\mathbf{f}_{ij}$  represent the (internal) force exerted by particle  $j$  upon particle  $i$ . Newton’s

*third law* assumes that the internal forces abide by the *principle of action and reaction*. According to this principle,  $\mathbf{f}_{ji} = -\mathbf{f}_{ij}$ . In words the force exerted by particle  $i$  on particle  $j$  is a vector belonging to the line joining both particles and is equal in magnitude, but opposite in sense, to the force exerted by particle  $j$  on particle  $i$ . An immediate consequence of this principle is that a particle does not exert a force on itself (i.e.  $\mathbf{f}_{ii} = \mathbf{0}$ ). This principle does not stand on the same footing as the first two laws, since the possibility of forces not abiding by it is not excluded. It is more than anything else a statement of the assumptions made to obtain specific results that are applicable in many cases of interest (Newton, of course, had in mind mainly the forces of gravitational attraction). Be that as it may, the total force acting on particle  $i$  is  $\mathbf{f}_i^{total} = \mathbf{f}_i^{ext} + \sum_{j=1}^N \mathbf{f}_{ij} = \dot{\mathbf{p}}_i$ , using (5). Adding these

expressions over  $i$ , it can easily be seen that the internal forces cancel out, and we obtain the important equation:

$$\mathbf{F}^{ext} = \dot{\mathbf{P}}, \quad (6)$$

where the  $\mathbf{F}^{ext} = \sum_{i=1}^N \mathbf{f}_i^{ext}$  is the total external force, and  $\mathbf{P} = \sum_{i=1}^N \mathbf{p}_i$  is the total momentum of the system.

Defining the *center of mass* of the system as the point whose position vector is given by the average:  $\bar{\mathbf{x}} = \frac{1}{M} \sum_{i=1}^N m_i \mathbf{x}_i$ , where  $M = \sum_{i=1}^N m_i$  is the total mass, it is easy to show that the total momentum is equal to the momentum of a fictitious particle of mass  $M$  moving with the center of mass of the system. The *theorem of the center of mass* is thus produced: the center of mass of a system of particles interacting according to Newton's third law moves as if it were a particle whose mass is the total mass of the system subjected to the vector sum of all the external forces acting on the system.

The  $\blacktriangleright$  *angular momentum* of the particles is next considered. By definition, the angular momentum with respect to a point  $O$  (which, for convenience, is identified with the origin of the inertial frame) is equal to the cross product  $\mathbf{h}_i^O = \mathbf{x}_i \times \mathbf{p}_i$ . A reasoning similar to the one just exposed leads to the following result:

$$\mathbf{M}_O^{ext} = \dot{\mathbf{H}}_O, \quad (7)$$

where  $\mathbf{M}_O^{ext} = \sum_{i=1}^N \mathbf{x}_i \times \mathbf{f}_i^{ext}$  is the total moment of the

external forces and where  $\mathbf{H}_O = \sum_{i=1}^N \mathbf{h}_i^O$  is the total angular momentum of the system. Equations (6) and (7) are both indicative of average quantities of the motion of the system; much in the same way as the mean and

the standard deviation of a statistical distribution give a good indication of the nature of the distribution. But, just as in the statistical analogy, these two quantities are not sufficient to completely characterize the distribution, so too in the case of a system of particles the knowledge of the total momentum and total angular momentum is not sufficient to determine the detailed motion of each particle of the system. There is, however, one instance for which these quantities are sufficient; this is the case of a *rigid system*. (Without pursuing the analogy any further, this case is the counterpart of the normal Gaussian distribution).

A (discrete or continuous) system of particles is said to be *rigid* if the distances between particles are pairwise constant in time. Under these conditions, it can be shown that the most general motion of a rigid system can be described by the motion of any one of its points (the center of mass, say) and a time-dependent rotation. In other words, although the physical meaning is different, the most general form of a *rigid-body motion* is given by (1), which can be rewritten as:

$$\mathbf{x}(t) = \bar{\mathbf{x}}(t) + \mathbf{R}(t) \mathbf{x}', \quad (8)$$

and interpreted as follows. Let primes denote quantities measured in a frame whose origin is at the center of mass and which is "frozen" within the system (in other words, the three perpendicular axes defining the frame are made up of material particles). Thus,  $\mathbf{x}'$  denotes the position vector of a particle relative to this *material frame*. It is precisely for this reason that the dependence on time has been dropped; in a material frame (moving as it does in unison with the rigid body) the particles appear not to move at all. The orthogonal operator  $\mathbf{R}(t)$  and the vector  $\bar{\mathbf{x}}(t)$  represent the rotational and translational components of the change of frame, from an inertial frame of reference to the material frame. It follows from (2) and (3) that the velocity and acceleration vectors, with respect to the outer inertial frame, of an arbitrary particle of the rigid system are given respectively by:

$$\mathbf{v}(t) = \dot{\bar{\mathbf{x}}}(t) + \dot{\mathbf{R}}(t) \mathbf{x}', \quad (9)$$

$$\mathbf{a}(t) = \ddot{\bar{\mathbf{x}}}(t) + \ddot{\mathbf{R}}(t) \mathbf{x}'. \quad (10)$$

The nine entries of an orthogonal matrix can at most depend on three independent parameters, since they have to abide by the six constraints of orthonormality. It can be concluded that the most general motion of a rigid body is completely describable by means of six quantities (or *degrees of freedom*), namely, the three coordinates of its center of mass and the three independent parameters of the rotation matrix. Equations (6) and (7) constitute a system of six ordinary differential equations and it turns out that they are

independent and that their solution allows in principle (with appropriate initial conditions) the obtaining of the time evolution of the six degrees of freedom just described. This is the content of *Euler's theorem*, which, by a judicious choice of variables, provides a more explicit form of the equations of motion. To sketch this important result, the total angular momentum of a rigid system (assumed to be discrete and finite, for simplicity) is evaluated. By definition:

$$\mathbf{H}_0 = \sum_{i=1}^N \mathbf{x}_i \times \mathbf{p}_i = \sum m_i (\bar{\mathbf{x}} + \mathbf{R} \mathbf{x}'_i) \times (\dot{\bar{\mathbf{x}}} + \dot{\mathbf{R}} \mathbf{x}'_i) = \bar{\mathbf{x}} \times \mathbf{P} + \mathbf{J}\omega, \quad (11)$$

where use is made of (8) and (9) and the fact that  $\bar{\mathbf{x}}$  is the position of the center of mass. The symbol  $\mathbf{J}$  stands for the symmetric positive-definite *tensor of inertia*, which can be calculated in the inertial frame as:

$$\mathbf{J} = \sum_{i=1}^N m_i (\text{trace}(\mathbf{R}\mathbf{x}_i \otimes \mathbf{R}\mathbf{x}_i) \mathbf{I} - (\mathbf{R}\mathbf{x}_i \otimes \mathbf{R}\mathbf{x}_i)), \quad (12)$$

where  $\mathbf{I}$  is the identity tensor and  $\otimes$  stands for the tensor product. The vector  $\omega$  appearing in (11) is the *angular velocity vector*. It is defined as the vector equivalent (through the cross product) to the skew-symmetric tensor  $\Omega = -\dot{\mathbf{R}}\mathbf{R}^T$ . The tensor of inertia  $\mathbf{J}_M$  in a material frame is independent of time and can be calculated once and for all (using  $\mathbf{x}_i$  instead of  $\mathbf{R}\mathbf{x}_i$  in (12)), with the result that:

$$\mathbf{J} = \mathbf{R}\mathbf{J}_M\mathbf{R}^T. \quad (13)$$

To obtain **►Euler's equations**, the *principal axes of inertia* are chosen as a material frame (so that  $\mathbf{J}_M$  attains a diagonal form), the time-derivative of (11) is taken and finally the result is transferred back to the moving material frame. From the practical point of view, this classical reduced form of the equations of motion is hardly necessary. It should be clear from (11) and (12) that (6) and (7) provide a system of six ordinary differential equations for the six degrees of freedom of a rigid body.

## References

- Whittaker ET (1947) A treatise on the analytical dynamics of particles and rigid bodies, 4th edn. Cambridge University Press, Cambridge
- Goldstein H (1950) Classical mechanics. Addison-Wesley, Reading, MA
- Neimark JI, Fufaev NA (1972) Dynamics of nonholonomic systems. In: Translations of mathematical monographs, vol 33. American Mathematical Society, Providence, RI
- Lanczos C (1970) The variational principles of mechanics, 4th edn. Toronto University Press, Toronto

- Abraham RA, Marsden JE (1982) Foundations of mechanics, 2nd edn. Addison-Wesley, Reading, MA
- Arnold VI (1989) Mathematical methods of classical mechanics. In: Graduate texts in mathematics, 2nd edn, vol 60. Springer-Verlag, Heidelberg
- Newton I (1687) Philosophiae Naturalis Principia Mathematica. London. English translation: Motte A (1952) Mathematical principles of natural philosophy. In: Encyclopaedia Britannica Great Books 34. Benton
- Syngé JL (1960) Classical dynamics. In: Flügge S (ed) Handbuch der Physik, vol III/1. Springer-Verlag, Heidelberg

## Classical Neurotransmitters

### Definition

The classical neurotransmitters are a collection of small molecular weight molecules that meet specific criteria for chemical neurotransmission. They are generally divided into three main classes: cholinergic, biogenic amine or monoamines, and amino acid transmitters.

►Acetylcholine

►Monoamines

## Clathrin-mediated Endocytosis (CME)

### Definition

Is a prominent cellular mechanism by which membrane proteins internalize from the plasma membrane via the formation of clathrin coated endocytic vesicles. The process involves three distinct steps. In step 1 an adaptor protein recognizes and recruits a membrane protein into a segment of the plasma membrane that will become the endocytic vesicle. A common adaptor of CME is the tetrameric adaptor protein complex-2 (AP-2). The interaction is mediated via a sequence specific motif within the intracellular domain of the membrane proteins and a subunit of the AP-2 complex. In addition to a direct interaction with AP-2, AP-2 accessory proteins can also be involved in the recognition of membrane protein, such as the recruitment of mono-ubiquitinated membrane proteins by the AP-2 accessory protein the epidermal growth factor substrate 15 (EPS15). In step 2 (which probably occurs coincident with step 1) the AP-2 complex recruits clathrin and certain accessory proteins, such as the neuron-specific AP180 or its ubiquitously expressed homolog the



clathrin assembly lymphoid myeloid leukemia protein (CALM), to this membrane segment. These accessory proteins promote the localized polymerization of clathrin into a polyhedral lattice. AP-2 as well as several of these accessory proteins encode binding sites for phosphatidylinositol (4,5)-bisphosphate (PIP<sub>2</sub>), a prominent lipid found in the plasma membrane and this helps to anchor and localize coat formation at the plasma membrane. Other accessory proteins such as Epsin encode a highly conserved Epsin N-terminal homology (ENTH) domain, that can induce membrane curvature via insertion of an  $\alpha$ -helix into the outer leaflet of the membrane. This function promotes the membrane invagination of the forming coated pit, while the clathrin lattice stabilizes the curvature. AP-2 therefore plays a central role in clustering and linking the membrane protein to a complex of proteins that promotes formation of the growing clathrin coated pit (CCP) and the subsequent clathrin-coated vesicle (CCV). In step 3 the membrane connecting the CCV to the plasma membrane is severed. This involves the action of two proteins, Amphiphysin and Dynamin. Amphiphysin encodes two domains involved in this process, a BAR domain through which it dimerizes and binds the neck of the CCV and an SH3 domain used to recruit the GTPase enzyme dynamin. This binding activates Dynamin polymerization into a collar at the neck of the CCV and the specific localization of the GTPase action of dynamin leads to the membrane cleavage.

Following vesicle scission the endocytic vesicle quickly loses its clathrin coat, via the action of Hsp70 and the accessory protein auxilin. Clathrin may then be recycled for further use in a next round of endocytosis. The action of another accessory protein the lipid phosphatase, Synaptojanin, then converts PIP<sub>2</sub> to Phosphatidylinositol, which further contributes to the uncoating of the vesicle of AP-2 and other bound accessory proteins. The endocytic vesicle then fuses with early endosomes to enable the internal sorting of its cargo, which will decide whether they are to be recycled or targeted for degradation. The membrane of the endocytic vesicle will ultimately be recycled back to the plasma membrane.

► Receptor Trafficking

characterized by oculomotor ► paresis and contralateral ► ataxia and ► tremor.

► Ataxia  
► Tremor

---

## Clausius-Duhem Inequality

### Definition

A commonly accepted version of the second law of thermodynamics for continuous systems.

► Mechanics

---

## Clastrum

### Definition

The claustrum (Latin for fence or barrier) is a thin band of neurons positioned between the insula and the putamen (lateral part of the lentiform nucleus). Its principal connections are with the cerebral cortex; it has discrete inputs from somesthetic, auditory and visual cortices.

---

## CLC Cl<sup>-</sup> Channel/Transporter

### Definition

A member of a related molecular family of Cl<sup>-</sup> channels and transporters. This family is unique in that some members are bona-fide ion channels, transporting Cl<sup>-</sup> down its electrochemical gradient through a continuous aqueous pore while others are Cl<sup>-</sup>/H<sup>+</sup> antiporters, able to utilize the energy stored in the gradient of one of these ions to drive the other uphill, against its electrochemical gradient.

► Chloride Channels and Transporters  
► Ion Transport

---

## Claude Syndrome

### Definition

Claude syndrome results from unilateral ► tegmental lesion (infarction) of the ► midbrain and is

---

## Clinical Gait Analysis

### Definition

Procedure during which joint rotations, moments, and powers are collected along with electromyographic data

for purposes of clinical assessment and treatment decisions in patients with movement disorders.

### ►Motion Analysis

## Clock

SHELLEY TISCHKAU

Department of Pharmacology, Southern Illinois University School of Medicine, Springfield, IL, USA

### Definition

CLOCK, an acronym for circadian locomotor output cycles kaput, is a basic helix-loop-helix, PAS domain-containing transcription factor considered a core element of both mammalian and *Drosophila* circadian clocks. CLOCK is one of two positive elements in the central ►feedback loop that defines the molecular clockwork. Protein products of the *Clock* (*Clk*) and *Brain muscle ARNT-like1* (►*Bmal1*) genes heterodimerize through interactions of PAS domains to form a complex that drives transcription of negative elements.

### Characteristics

#### Discovery

Prior to the discovery of *Clock*, successful genetic approaches had been limited to identification of core circadian clock elements in *Drosophila* (►*Period* and ►*Timeless*) and *Neurospora* (*Frequency*). Attempts at cloning analogous genes in mammals were unsuccessful; the mammalian clockwork was truly a “black box.” Although a genetic basis for mammalian circadian rhythmicity was indicated by the spontaneously occurring, semi-dominant mutation, *Bmal1* ►*Tau* mutation [1], the lack of knowledge regarding the hamster genome hampered efforts toward dissection of the molecular clock in this species. Positive identification of the first mammalian circadian ►clock gene, *Clock*, was finally accomplished using a forward genetic approach involving (i) isolation of circadian rhythm mutants following phenotypic analysis of *N*-ethyl-*N*-nitrosourea (ENU) mutagenesis screens [2]; (ii) identification of affected genes using positional cloning and candidate gene methods [3]; and (iii) elucidation of gene function to understand their role in generation of circadian rhythmicity [4,5].

The initial ENU mutagenesis screen of 304 animals resulted in a single animal with phenotypic alteration of circadian period. This animal, the founder of the *Clock* mutant line, displayed an abnormally long circadian period under ►constant conditions. Further genetic analysis revealed a heritable, semidominant mutation

involving alteration at a single locus. Heterozygous, *Clock*<sup>+</sup> mice, exhibit lengthened circadian periodicity under constant conditions. Mice homozygous for the ►*Clock* mutation, the *Clock* mutant mice (*Clock*/*Clock*), demonstrate an extreme lengthening of their endogenous period, and eventually these mice become arrhythmic. The single gene mutation in these mice has been mapped, by linkage analysis, to murine chromosome 5 [2]. The *Clock* mutant allele is an A → T nucleotide transversion that occurs at the third base position of the 5' splice donor site of exon 19. The mutation causes production of an mRNA transcript that is missing exon 19. Although there is no change in reading frame, the mutant protein lacks 51 amino acids in the glutamine rich C-terminus domain [3]. The resulting protein is an antimorph, which acts in a dominant-negative fashion. The *Clock* mutant mice have provided a valuable tool for dissection of the molecular mechanisms of circadian rhythmicity in mammals.

### Role of Clock in Regulation of Molecular Rhythmicity

*Clock* encodes a beta helix-loop-helix transcription factor that contains two PAS heterodimerization domains. CLOCK also has significant histone acetyltransferase activity [6]. It is a core component of the molecular mechanism that drives circadian rhythmicity in vertebrates, as well as in *Drosophila*. In mammals, *Clock* transcript and protein are constitutively expressed. Oscillations of its heterodimerization partner, ►*BMAL1*, confer circadian rhythmicity in transcriptional activity. In the *Drosophila* clock, however, CLOCK oscillates while *CYCLE* (*Drosophila* analog of *BMAL1*) remains constant. Binding *BMAL1* enhances CLOCK's histone acetyl transferase activity, allowing chromatin remodeling to promote CLOCK: *BMAL1* DNA binding [6]. CLOCK: *BMAL1* heterodimers bind to E-box enhancer elements in the promoters of target genes to act as positive elements driving the molecular clock. CLOCK: *BMAL1* activity is enhanced during late subjective night. Targets for CLOCK: *BMAL1* include several clock genes, three-*Period* genes, two ►*Cryptochrome* genes and *Timeless*. As transcripts for these targets accumulate, they are translated, form heterodimeric complexes (primarily PER:CRY in mammals and PER:TIM in flies) and re-enter the nucleus where they act as negative elements to inhibit further transcription by CLOCK: *BMAL1*. Turnover of the negative elements allows CLOCK: *BMAL1* activity to initiate a new cycle of transcription.

### Physiological Relevance of CLOCK

The *Clock* mutant mice have been an invaluable tool for revealing the genetic underpinnings of circadian rhythmicity. Behavioral studies have demonstrated the importance of *Clock* in regulation of endogenous rhythms driven by the central oscillator in the

suprachiasmatic nucleus. *Clock* is important for regulating period length and for establishing stable persistence of behavioral rhythms.

More recent studies have focused on the role of the circadian clock in health and disease. A specific allele of *Clock* (3111C/C) is associated with evening preference in humans [7]. ►**Delayed sleep phase syndrome**, a circadian sleep-phase syndrome, in which individuals fail to adapt their sleep-wake cycle to environmental time cues, may be an extreme form of evening preference. *Clock* mutant mice also show rest/activity patterns consistent with delayed sleep phase syndrome, suggesting a role for *Clock* in regulation of the timing of sleep and wakefulness [8].

Polymorphisms in the 3' flanking region of human *Clock* are associated with mania, insomnia and decreased need for sleep. *Clock* mutant mice, like bipolar patients in the manic state, are hyperactive and show increased responsiveness to the rewarding effects of psychostimulants. Treatment with the mood stabilizer, lithium, restores wild-type behavior. Thus, *Clock* may be an important regulator of brain neurochemistry associated with mood [9].

The circadian clock is central in control of energy balance. Disruption of the clock gene network, as occurs in the *Clock* mutant mice, leads to obesity and metabolic syndrome. Mutant mice have a severely disrupted diurnal feeding rhythm, which manifests as hyperphagia. Animals develop hyperlipidemia, hyperglycemia, hyperleptinemia and attenuated expression of several hypothalamic peptides associated with energy balance [10]. The fact that obesity does not result from a simple disruption of the circadian feeding pattern, or from mutation of other circadian clock genes, such as *Bmal1*, *Per1* or *Per2*, suggests that the *Clock* mutation may cause obesity in mice. Clearly, the circadian clock gene network in general, and the gene *Clock* in particular, are central to maintenance of health.

## References

1. Ralph MR, Menaker M (1988) A mutation of the circadian system in golden hamsters. *Science* 241:1225–1227
2. Vitaterna MH, King DP, Chang AM, Kornhauser JM, Lowrey PL, McDonald JD, Dove WF, Pinto LH, Turek FW, Takahashi JS (1994) Mutagenesis and mapping of a mouse gene, *clock*, essential for circadian behavior. *Science* 264:719–725
3. King DP, Zhao Y, Sangoram AM, Wilsbacher LD, Tanaka M, Antoch MP, Steeves TD, Vitaterna MH, Kornhauser JM, Lowrey PL, Turek FW, Takahashi JS (1997) Positional cloning of the mouse circadian clock gene. *Cell* 89:641–653
4. Antoch MP, Song EJ, Chang AM, Vitaterna MH, Zhao Y, Wilsbacher LD, Sangoram AM, King DP, Pinto LH, Takahashi JS (1997) Functional identification of the

mouse circadian clock gene by transgenic bac rescue. *Cell* 89:655–667

5. King DP, Vitaterna MH, Chang AM, Dove WF, Pinto LH, Turek FW, Takahashi JS (1997) The mouse clock mutation behaves as an antimorph and maps within the w19h deletion, distal of kit. *Genetics* 146:1049–1060
6. Doi M, Hirayama J, Sassone-Corsi P (2006) Circadian regulator *clock* is a histone acetyltransferase. *Cell* 125:497–508
7. Mishima K, Tozawa T, Satoh K, Saitoh H, Mishima Y (2005) The 3111t/c polymorphism of *hclock* is associated with evening preference and delayed sleep timing in a Japanese population sample. *Am J Med Genet* 133:101–104
8. Wakatsuki Y, Kudo T, Shibata S (2007) Constant light housing during nursing causes human dsps (delayed sleep phase syndrome) behavior in *clock*. -mutant mice. *Eur J Neurosci* 25:2413–2424
9. Roybal K, Theobald D, Graham A, Dinieri J, Russo S, Krishnan V, Chakravarty S, Peevey J, Oehrlein N, Birnbaum S, Vitaterna MH, Orsulak P, Takahashi JS, Nestler E, Carlezon W, McClung C (2007) Mania-like behavior induced by disruption of *clock*. *Proc Natl Acad Sci USA* 104:6406–6411
10. Turek FW, Joshu C, Kohsaka A, Lin E, Ivanova G, McDearmon E, Laposky A, Losee-Olson S, Easton A, Jensen DR, Eckel RH, Takahashi JS, Bass J (2005) Obesity and metabolic syndrome in circadian clock mutant mice. *Science* 308:1043–1045

## Clock Cells

### Definition

Cells that express endogenous circadian oscillations that regulate cellular functions and outputs.

- Cellular Clock
- Circadian Rhythm

## Clock-Controlled Genes

JÜRGEN A. RIPPERGER, URS ALBRECHT  
Department of Medicine, Division of Biochemistry,  
University of Fribourg, Fribourg, Switzerland

### Synonyms

Circadian output genes

### Definition

Genes whose time-of-day specific expression is dependent on the circadian oscillator.

## Characteristics

The mammalian circadian oscillator is based on interconnected transcriptional and post-translational feedback loops. In the negative limb, transcriptional repressors of the ►**Cryptochrome** (Cry) and ►**Period** (Per) family periodically modulate the activation potential of the transcription factors Clock (or Npas2) and Bmal1 (see ►**clock genes**). By contrast, in the positive limb the orphan nuclear hormone receptors of the Rev-erb family repress transcription in the opposite phase of the negative limb. Both limbs together interact and govern oscillations of gene expression with a ►**free-running period** length of about a day. Due to the make-up of the circadian ►**oscillator** as transcriptional feedback loops, it is not surprising that most of the direct output is hardwired to the clock mechanism (Fig. 1).

A recent *in vitro* study combined with a systems biological approach came to the conclusion that the

phase of circadian expression resulted from the utilization of three different types of response elements: ►**E-box** motifs as binding sites for Clock (or Npas2) and Bmal1, RORE motifs as binding sites for Ror and Rev-erb family members, and D-elements as binding sites for PAR bZip factors [1].

To address the question of how many *clock-controlled genes* exist, DNA microarray experiments have been conducted using the site of the central oscillator, the ►**Suprachiasmatic nucleus** (►**SCN**) in the brain as tissue source [2]. The obtained data were filtered afterwards to identify periodically expressed genes. Surprisingly, about 5% of the steady-state mRNA was rhythmically expressed with robust but sometimes low amplitude. This is still a rough estimate since the analysis of steady-state mRNA does not account for mRNA stability and many low-level cycling genes maybe eliminated artificially by the filters employed for data mining. The rhythmic genes

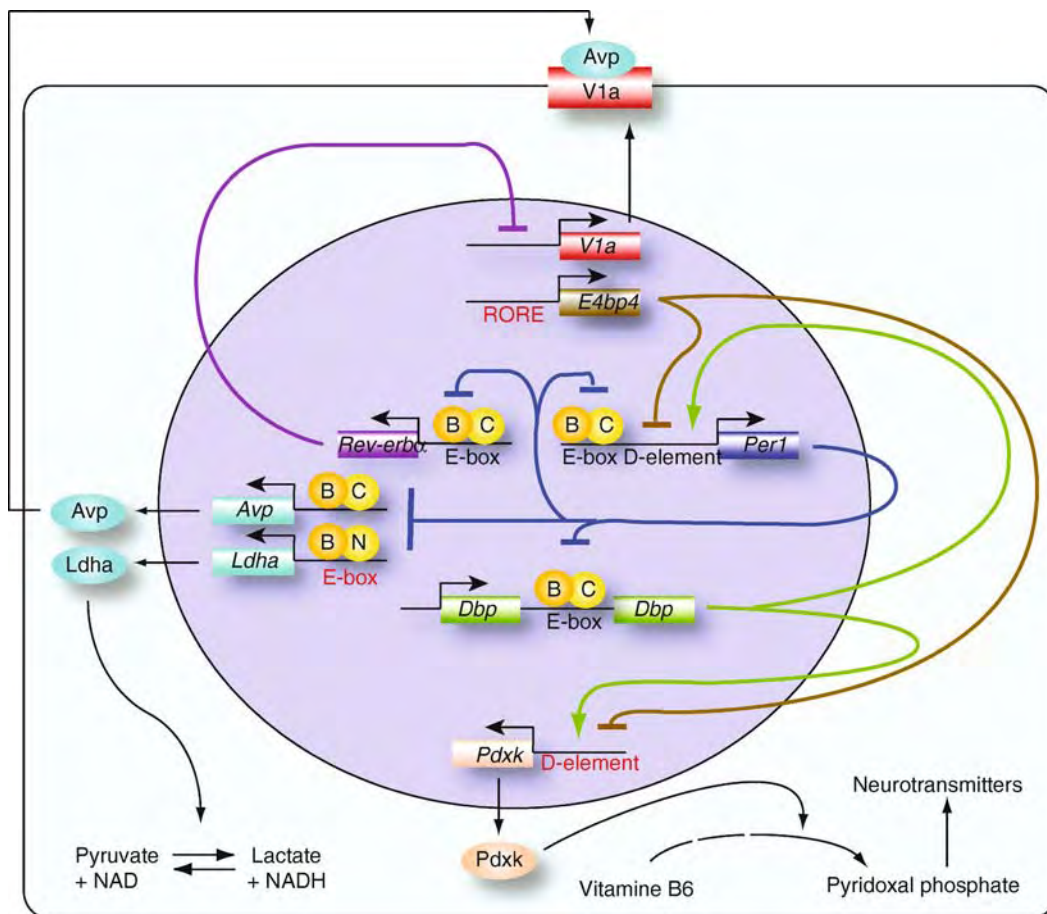

**Clock-Controlled Genes. Figure 1** Clock-controlled genes are linked to the circadian oscillator. Circadian output genes are linked to the oscillator by E boxes, RORE, and/or D-elements. *Per1* inhibits the activity of the Clock (C) or Npas2 (N) and Bmal1 (B) heterodimers. Lactate dehydrogenase A (*Ldha*) can affect the redox state of a cell, pyridoxal kinase (*Pdxk*) generates pyridoxal phosphate, a coenzyme involved in neurotransmitter synthesis, and arginine vasopressin (*Avp*) can bind rhythmically to its receptor *V1a* on SCN neurons. For details, see text.

identified included those for prohormone/neuropeptide synthesis, processing, and degradation, thought to be one of the main outputs of the SCN to govern the circadian rhythmicity of mammals. Some of these hormones, like ►**pituitary adenylate cyclase-activating ►polypeptide 1** (►**PACAP**) and *arginine vasopressin (AVP)* had been known before as rhythmically expressed genes in the SCN. Another important set of coordinately expressed genes contained enzymes important for carbon source utilization and oxidative phosphorylation in the mitochondria. The detailed analysis of this pathway suggested a circadian rhythm in the energy metabolism and redox state of SCN neurons.

A major surprise was the relatively small overlap of rhythmic transcripts between different tissues examined. In the study by Panda et al. [2], about 330 rhythmic transcripts specific for either the SCN region in the brain, or the liver were found and there were only 28 overlapping transcripts, which included most core oscillator components. Therefore, the output genes are not only subject to circadian control of gene expression, but also to tissue-specific control. At the moment, we have much better insight into the circadian control than the tissue-specific control of circadian output genes. However, it appears that both components together are necessary to orchestrate the expression of genes in a manner optimal for a specialized tissue such as the SCN. In the context of this essay we will focus on known *clock-controlled genes* in the brain.

The first gene to be analyzed in great detail and linked to the molecular oscillator was the *arginine vasopressin* gene ([3], Fig. 1). This hormone is synthesized mainly in the vasopressinergic neurons of the paraventricular nuclei (PVN) and the *Supraoptical nuclei* (SON). It is released into the bloodstream from the posterior pituitary to regulate the salt and water balance. However, this hormone acts also as a neuropeptide in the *central nervous system* (CNS). For instance, it is rhythmically produced by the neurons of the SCN and modulates the firing rate of SCN neurons in a very local fashion. The expression of this gene was nearly abolished in the SCN but not in the SON of *Clock $\Delta$ 19/Clock $\Delta$ 19* homozygous mutant mice, which carry a dominant-negative version of the Clock protein. Subsequent analysis revealed the importance of the E-box motif in the promoter region of this gene as a binding site for Clock and Bmal1. Altogether, the data suggested that the *arginine vasopressin* gene was directly hardwired to the molecular oscillator via its E-box motif and the transcriptional activators Clock and Bmal1. Interestingly, in the SON region there were barely detectable levels of Bmal1, and this may impair an effect of the Clock $\Delta$ 19 mutation on the transcription of this gene. However, it is still an unresolved issue, why the expression of this gene is so highly specific for the CNS.

The transcription factor *D-site binding protein* (Dbp) was originally thought to manifest a liver-specific regulator of the *albumin* gene. However, it was identified as a ubiquitous output gene expressed with very high circadian amplitude. Mice deficient of this gene display a 30 min shorter free-running period length indicating a feedback of this protein to the circadian oscillator. As a rhythmically expressed transcription factor, Dbp can amplify the action of the circadian oscillator on many D-element bearing target genes (Fig. 1). In triple knock out mice with an inactivation of the *Dbp* gene and the two other members of the PAR bZip transcription factors, sporadic and audiogenic epileptic seizures occurred [4]. This phenotype was linked to a slight deregulation of the gene for pyridoxal kinase (*Pdxk*), involved in the pathway for the conversion of vitamin B6 derivatives into pyridoxal phosphate. Pyridoxal phosphate is a coenzyme of many enzymes involved in the metabolism of various neurotransmitters. This is an example of a very drastic phenotype provoked by a subtle deregulation of an enzymatic activity. Thus, subtle circadian changes in enzymatic activities can have a drastic influence on physiology and metabolism.

The circadian regulation of the *Dbp* gene was analyzed in great detail in the liver but the mechanism is probably very similar for the SCN ([5], Fig. 2).

The transcription cycle of *Dbp* is initiated by binding of Clock and Bmal1 to three defined E-box containing regions within the gene. The binding of these factors provokes a change in the local chromatin structure as evidenced by the acetylation of lysine 9 of histone H3, the trimethylation of lysine 4 of histone H3, and a reduction of the histone density overall. Under these conditions transcription of the gene commences. After a certain time, Clock and Bmal1 fall off their target sites within *Dbp*, the transcription ceases, and the chromatin closes in to form a heterochromatin-like, inactive state. Upon re-binding of Clock and Bmal1 the next day, another circadian cycle can start. While *Dbp* is expressed in the liver and the SCN neurons with very high circadian amplitude, its amplitude of cycling in the other parts of the brain is much lower, indicating some additional tissue-specific component.

Npas2 is an analog of Clock expressed mainly in the forebrain. To address the regulatory potential of this transcription factor, an inducible neuroblastoma cell line for Npas2 and Bmal1 was engineered. One surprising target gene upregulated after the induction of these transcriptional regulators was the *A isoform of lactate dehydrogenase (Ldha)* ([6], Fig. 1). This enzyme reversibly catalyses the dehydrogenation of pyruvate to lactate. Therefore, it has a direct impact on the redox state within a cell by influencing the ratio of reduced nicotinamide adenine dinucleotide (NADH) to its oxidized form, NAD. Astonishingly,

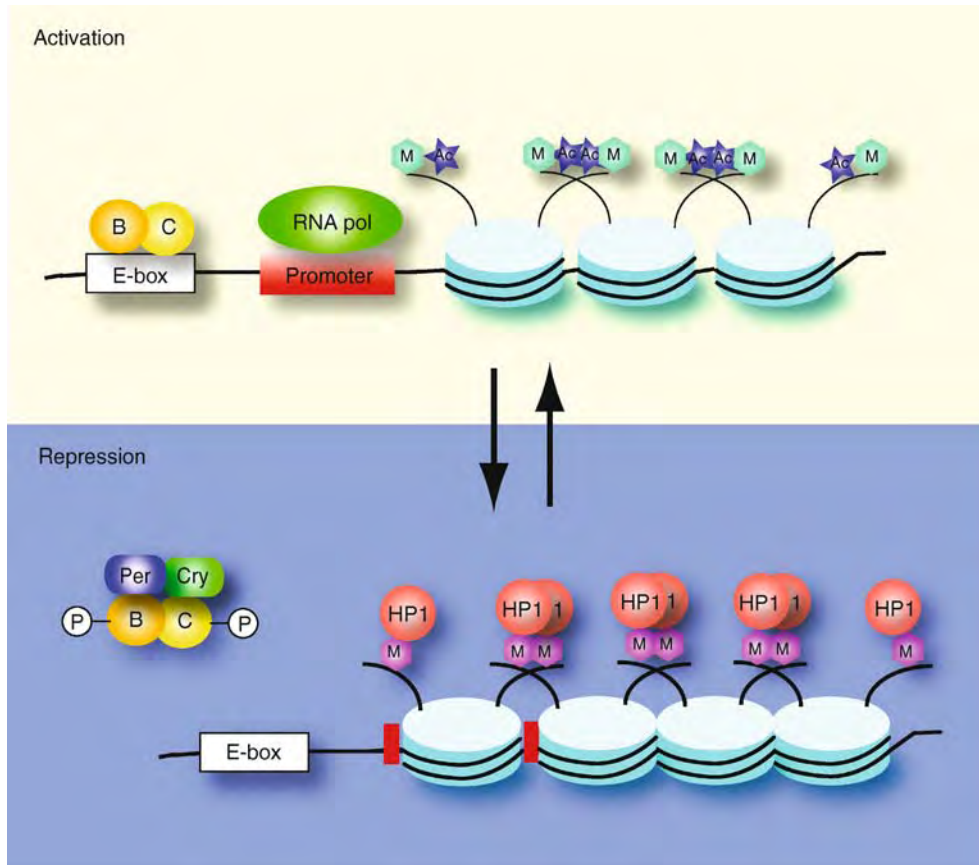

**Clock-Controlled Genes. Figure 2** Rhythmic binding of Clock (*yellow*) and Bmal1 (*orange*) to DNA governs circadian *Dbp* transcription and chromatin transitions. During active transcription there are less histones (*light blue discs*) around the promoter (*red rectangle*), and they are marked by acetylation of lysine 9 (*blue stars*) of histone H3 and trimethylation of lysine 4 (*teal hexagons*) of histone H3. During repression, the heterochromatin closes as a consequence of change in methylation (*pink hexagons*), binding of heterochromatin binding protein 1 (HP1, *rose circles*) and loss of acetylation of histones. The promoter (*red*) is packed by histones (*blue disc*) and the transcription shuts off. The chromatin transitions and the transcription are dependent on rhythmic Clock and Bmal1 binding. Light yellow background represents activation during the day, whereas blue shows repression during the night.

the heterodimer formation between Npas2 and Bmal1, and the binding activity of this heterodimer to DNA were both dependent on the ratio of NADH to NAD: the reduced form repressed heterodimer formation and concomitantly DNA binding of the heterodimer. This led to an interesting but still preliminary model of entrainment of neurons by changes in the redox state of neurons: in a first step, astrocytes take up extra-cellular glutamate from the synaptic clefts secreted during neuronal activity. This stimulates glycolysis in these cells and subsequently the secretion of lactate. The lactate is taken up by the neurons again and provokes circadian fluctuations of the redox state that govern the activity of the NPAS2 and BMAL1 heterodimers. This may in turn rhythmically affect the neuronal activity and therefore the periodic secretion of glutamate.

After these examples of *clock-controlled genes* that are direct targets of activation by Clock (or Npas2) and Bmal1, we now turn towards genes that contain binding sites for the transcriptional repressors of the Rev-erb family (Fig. 1). The function of ROREs within the circadian clock was found by two independent approaches: (i) the circadian amplitude of the expression of *Bmal1* in the SCN and liver of  $\blacktriangleright$ *Rev-Erba* homozygous knock out mice was severely dampened [7]; (ii) in a DNA microarray study the circadian transcripts of SCN and liver were grouped according to their phases of expression, then the transcription start sites were identified, and the promoter regions subsequently analyzed for common binding motifs for transcriptional regulators [8]. The target genes identified in this fashion included *Bmal1*, *E4bp4*, and the *arginine vasopressin receptor 1A (V1a)*. Interestingly,

E4bp4 is a repressor of transcription with the same DNA binding specificity as the PAR bZip transcription factors that become expressed in the opposite phase. It is tempting to speculate that a particular target gene can alternatively bind PAR bZip transcription factors or the repressor E4bp4, allowing precise transcriptional regulation. Circadian expression of the V1a receptor was also an interesting finding since its ligand arginine vasopressin is expressed in a different phase in the SCN neurons (see above).

A completely different kind of circadian regulation is found in the pineal gland regarding the translation of the rate-limiting enzyme in melatonin synthesis, the arylalkylamine N-acetyltransferase (AANAT) ([9], Fig. 3).

In rodents, the peaks of mRNA and protein accumulation are separated by four to six hours. This delay is due to a co-translational regulatory mechanism. The 5'-untranslated region of the mRNA contained an *internal ribosome entry site* (IRES), which allowed 5'-Cap independent translation. However, this particular IRES permitted the translation of the mRNA only in the presence of sufficient amounts of *Heterogeneous nuclear ribonucleoprotein Q* (hnRNP Q). This protein bound specifically to the IRES sequence of AANAT and recruited the ribosome complex to initiate the translation. HnRNP Q accumulated in the nuclei of pinealocytes in a circadian fashion, gating the

translation of the AANAT mRNA to a specific time-window. It is tempting to speculate that this complicated mechanism of co-translational regulation is a rather widespread phenomenon within the mammalian circadian oscillator.

Taken together, *clock-controlled genes* within the CNS and other tissues are controlled by different mechanisms. The simplest fashion is a direct coupling of the target genes to the core oscillator via Clock (or Npas2) and Bmal1, or the Rev-erb family. A more indirect way exploits various transcriptional regulators, e.g., Dbp and E4bp4, as intermediaries. Maybe this could account also for the differences observed in the circadian clocks of different tissues. One should keep also in mind that changes in the transcriptional status of a gene not necessarily reflect drastic changes in the protein levels, and vice versa (see the co-translational mechanism).

Where does the research go? Many mental syndromes like depression, mania, and bipolar disorder are somehow linked to the circadian clock. Therefore, it is an important task to identify potential target genes whose unbalanced circadian expression interferes with the normal health status. However, this task is by far not an easy one, since even subtle changes in the level of neurotransmitters might have drastic effects as seen, for example, for the pyridoxal kinase. Another example concerns the influence of the clock gene *Per2* on

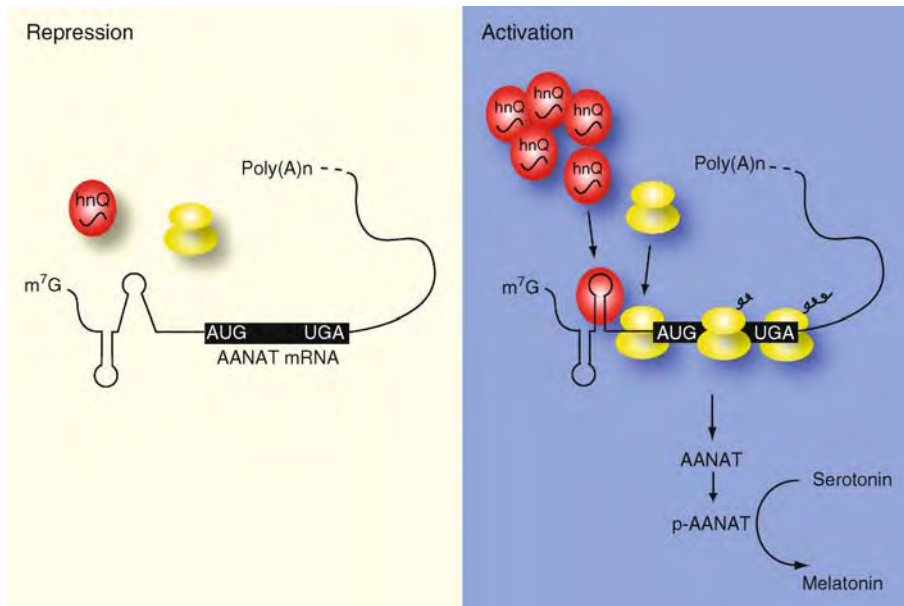

**Clock-Controlled Genes. Figure 3** Co-translational regulation of the arylalkylamine N-acetyltransferase (AANAT) gene in the pineal gland important for melatonin production. High amounts of HnRNP Q protein are necessary to bind to an IRES sequence within the 5'-untranslated region of the AANAT mRNA to allow for the formation of active translation complexes to initiate the production of AANAT protein. Upon phosphorylation (p-AANAT) serotonin is converted to melatonin. Light yellow background represents repression during the day, whereas blue shows activation during the night.

alcohol consumption [10]. In *Per2<sup>Brdm1</sup>* homozygous mutant mice, the expression of an astrocyte-specific glutamate transporter is slightly down regulated, provoking a hyper-glutamatergic state within the CNS. As a consequence, the animals consume more and are more resistant to alcohol. The effect of the *Per2* mutation can be reverted by the application of acamprostate, a drug that is thought to act by dampening a hyper-glutamatergic state. As an estimate, 10% of alcoholic patients respond well to this drug. In the future, with a more detailed knowledge of the circadian oscillator of the CNS and its target genes, it will be possible to understand and to develop new therapies that will help to treat mental disorders.

## References

1. Ueda HR, Hayashi S, Chen W, Sano M, Machida M, Shigeyoshi Y, Iino M, Hashimoto S (2005) System-level identification of transcriptional circuits underlying mammalian circadian clocks. *Nat Genet* 37:187–192
2. Panda S, Antoch MP, Miller BH, Su AI, Schook AB, Straume M, Schultz PG, Kay SA, Takahashi JS, Hogenesch JB (2002) Coordinated transcription of key pathways in the mouse by the circadian clock. *Cell* 109:307–320
3. Jin K, Shearman LP, Weaver DR, Zylka MJ, De Vries GJ, Reppert SM (1999) A molecular mechanism regulating rhythmic output from the suprachiasmatic circadian clock. *Cell* 96:57–68
4. Gachon F, Fonjallaz P, Damiola F, Gos P, Kodama T, Zakany J, Duboule D, Petit B, Tafti M, Schibler U (2004) The loss of circadian PAR bZip transcription factors results in epilepsy. *Genes Dev* 18:1397–1412
5. Ripperger JA, Schibler U (2006) Rhythmic Clock-Bmal1 binding to multiple E-box motifs drives circadian *Dbp* transcription and chromatin transitions. *Nat Genet* 38:369–374
6. Rutter J, Reick M, Wu LC, McKnight SL (2001) Regulation of Clock and Npas2 DNA binding by the redox state of NAD cofactors. *Science* 293:510–514
7. Preitner N, Damiola F, Lopez-Molina L, Zakany J, Duboule D, Albrecht U, Schibler U (2002) The orphan nuclear receptor *Rev-erb* controls circadian transcription within the positive limb of the mammalian oscillator. *Cell* 110:251–260
8. Ueda HR, Chen W, Adachi A, Wakamatsu H, Hayashi S, Takasugi T, Nagano M, Nakahama K, Suzuki Y, Sugano S, Iino M, Shigeyoshi Y, Hashimoto S (2002) A transcription factor response element for gene expression during circadian night. *Nature* 418:534–539
9. Kim TD, Woo KC, Cho S, Ha DC, Jang SK, Kim KT (2007) Rhythmic control of AANAT translation by hnRNP Q in circadian melatonin production. *Genes Dev* 21:797–810
10. Spanagel R, Pendyala G, Abarca C, Zghoul T, Sanchis-Segura C, Magnone MC, Lascorz J, Depner M, Holzberg D, Soyka M, Schreiber S, Matsuda F, Lathrop M, Schumann D, Albrecht U (2004) The clock gene *Per2* influences the glutamatergic system and modulates alcohol consumption. *Nat Med* 11:35–42

## Clock Coupling Factors

ACHIM KRAMER

Laboratory of Chronobiology, Charité  
Universitätsmedizin Berlin, Berlin, Germany

C

### Definition

In this essay, the term “clock coupling factors” is understood in two ways: (i) factors by which the circadian pacemaker in the suprachiasmatic nucleus (SCN) of mammals controls circadian behavioral rhythms and (ii) factors that synchronize the cellular clocks within the SCN to enable a coherent rhythmicity of the SCN tissue.

### Characteristics

#### Candidate Factors That Couple the Clock to Locomotor Activity Rhythms

The mammalian circadian clock residing in the ▶suprachiasmatic nucleus (▶SCN) is thought to drive circadian rhythms of locomotor behavior by secreting diffusible factors that act locally within the hypothalamus. This concept is primarily based on SCN transplant experiments: when fetal SCN tissue is transplanted into animals made arrhythmic by lesion of the SCN, circadian rhythms of locomotor activity are restored with the period of the donor tissue [1]. This occurs even when the graft is encapsulated to prevent extension of axons but allow diffusion of secreted factors [2]. These results demonstrate that in the transplanted animal the SCN secretes “locomotor factors” that reach their targets by diffusion in a paracrine fashion. Hamsters with functional SCN tissue of both wild type and short-period mutant (▶tau-mutation) genotypes (“temporal chimeras”) displayed locomotor activity rhythms influenced by the oscillators of both genotypes. While there was no evidence of coupling between the two underlying oscillators, locomotor activity was suppressed at times when the ▶rest phase (▶rho) of one influence intersected with the ▶activity phase (▶alpha) of the other, indicating that the SCN inhibits locomotor activity at one phase and probably promotes it at another, with inhibition dominating when the two influences coincided [3]. Three factors have been identified that strongly inhibit locomotor activity when injected or infused into the third ventricle of the hypothalamus, i.e. ▶transforming growth factor alpha (▶TGF-α) [4], ▶prokineticin 2 (PK-2) [5] and cardiotrophin-like cytokine (CLC) [6]. So far, no SCN factor promoting activity has been proposed.

TGF-α is expressed in the SCN in a circadian fashion, and, when infused into the third ventricle, reversibly inhibits locomotor activity and disrupts circadian



sleep-wake cycles. These actions are likely mediated by epidermal growth factor (EGF) receptors on neurons in the hypothalamic ►subparaventricular zone, a major relay station for SCN efferents. Mice with a hypomorphic EGF receptor mutation exhibit excessive daytime locomotor activity and fail to efficiently suppress activity when exposed to light (so-called “►masking”) [4].

PK2’s rhythmic expression in the SCN is directly mediated by ►CLOCK-►BMAL1 activity acting on E-box enhancer elements in the promoter of the PK2 gene (see ►Clock-controlled genes). Receptors for PK2 are abundantly expressed in major target nuclei of the ►SCN output pathway. Intracerebroventricular infusion of PK2 at night, when endogenous PK2 mRNA levels are low, markedly reduces the nocturnal increase in locomotion. Mice with a disruption of the PK2 gene display significantly reduced rhythmicity for a variety of circadian physiological and behavioral parameters including sleep-wake cycle, locomotor activity, body temperature, and circulating glucocorticoid as well as glucose levels [5].

CLC is rhythmically expressed in a small subpopulation of vasopressin containing SCN neurons with a peak in the ►subjective day. CLC receptors flank the third hypothalamic ventricle and acute infusion of CLC into the third ventricle results in a reversible inhibition of locomotor activity without affecting the circadian clock. Infusion of CLC receptor neutralizing antibodies produces access locomotor activity at a time when CLC is maximally expressed [6].

Together, these results suggest that the aforementioned SCN signals may provide a crucial link between the circadian clock and outputs by shaping daily rhythms of behavior.

### Candidate Factors That Synchronize the Cellular Oscillators Within the SCN

SCN neurons generate endogenous circadian rhythms endogenously and adjust them according to the ►light-dark cycles of the environment (►entrainment). SCN neurons dispersed in cell culture display cell-autonomous oscillations with periods ranging from 20 to 28 h. Despite of this broad distribution of ►free-running periods of isolated neurons, the oscillation of the 20,000 ►SCN neurons *in vivo* (see also ►Multi-oscillator system) is coherent and ►self-sustained (►oscillation) with an average period of about 24 h indicating that a coupling mechanism is operating between the SCN neurons. Without such an intercellular communication – e.g. when action potentials are blocked with tetrodotoxin (TTX) – synchrony between rhythmic SCN neurons is lost. In addition, at least some neurons lose rhythmicity on the cellular level suggesting that synchrony among neurons is a prerequisite for self-sustained ►rhythmicity in some cases. Criteria for being a

candidate synchronizing factor are: (i) expression in SCN ►pacemaker neurons, (ii) circadian activity, and (iii) expression of the respective receptor in the SCN (for a review see [7]).

Up to now, the strongest putative candidate synchronization factor is the neuropeptide vasoactive intestinal polypeptide (VIP), because it meets many of the above mentioned criteria. VIP is synthesized in the ventrolateral part of the SCN, VIPergic neurons project densely within the SCN, VIP is rhythmically released from rat SCN *in vitro*, its receptor VPAC2 is expressed in about 60% of all SCN neurons, and VIP pulses phase-shift the circadian clock of the SCN. Targeted disruption of the genes coding for VIP or its receptor results not only in a loss of synchrony between SCN neurons but also in the arrhythmicity of most of the SCN neurons [8,9]. These results suggest that VIPergic signaling serves two functions in the SCN: promoting rhythmicity in a subset of non-pacemaking SCN neurons, and synchronizing pacemaking neurons.

Among other synchronizing factor candidates (for a review see [7]) are the neurotransmitters gastrin-releasing peptide (GRP) and prokineticin 2, whose expression patterns, as well as that of their receptors, are compatible with a putative role in synchronization. Furthermore the neurotransmitter GABA has been suggested as a putative synchronizing factor. GABA, as well as the GABA<sub>A</sub> and GABA<sub>B</sub> receptors, are expressed abundantly throughout the SCN and there is evidence for a circadian release of GABA. Moreover, it has been reported that GABA application can ►phase-shift the electrical activity of SCN neurons *in vitro*. In addition, signals using the G-protein subunits Gi/o [10] as well as gap junctions have been implicated in the intra-SCN synchronization mechanism. However, with the exception of VIP, the aforementioned candidates are far from being established as synchronizing factors within the SCN, and more work needs to be done to evaluate their individual contribution to SCN synchrony.

### References

1. Ralph MR, Foster RG, Davis FC, Menaker M (1990) Transplanted suprachiasmatic nucleus determines circadian period. *Science* 247:975–978
2. Silver R, LeSauter J, Tresco PA, Lehman MN (1996) A diffusible coupling signal from the transplanted suprachiasmatic nucleus controlling circadian locomotor rhythms. *Nature* 382:810–813
3. Vogelbaum MA, Menaker M (1992) Temporal chimeras produced by hypothalamic transplants. *J Neurosci* 12:3619–3627
4. Kramer A, Yang FC, Snodgrass P, Li X, Scammell TE, Davis FC, Weitz CJ (2001) Regulation of daily locomotor activity and sleep by hypothalamic EGF receptor signaling. *Science* 294:2511–2515
5. Cheng MY, Bullock CM, Li C, Lee AG, Bermak JC, Belluzzi J, Weaver DR, Leslie FM, Zhou QY (2002)

- Prokineticin 2 transmits the behavioural circadian rhythm of the suprachiasmatic nucleus. *Nature* 417:405–410
6. Kraves S, Weitz CJ (2006) A role for cardiotrophin-like cytokine in the circadian control of mammalian locomotor activity. *Nat Neurosci* 9:212–219
  7. Aton SJ, Herzog ED (2005) Come together, right...now: synchronization of rhythms in a mammalian circadian clock. *Neuron* 48:531–534
  8. Aton SJ, Colwell CS, Hattar AJ, Waschek J, Herzog ED (2005) Vasoactive intestinal polypeptide mediates circadian rhythmicity and synchrony in mammalian clock neurons. *Nat Neurosci* 8:476–483
  9. Maywood ES, Reddy AB, Wong GK, O'Neill JS, O'Brien JA, McMahon DG, Hattar AJ, Okamura H, Hastings MH (2006) Synchronization and maintenance of timekeeping in suprachiasmatic circadian clock cells by neuropeptidergic signalling. *Curr Biol* 16:599–605
  10. Aton SJ, Huettner JE, Straume M, Herzog ED (2006) GABA and Gi/o differentially control circadian rhythms and synchrony in clock neurons. *Proc Natl Acad Sci USA* 103:19188–19193

## Clock Genes

URS ALBRECHT, JÜRGEN A. RIPPERGER  
Department of Medicine, Division of Biochemistry,  
University of Fribourg, Fribourg, Switzerland

### Synonyms

Circadian clock genes

### Definition

Any of a number of genes that interact with each other to make up an auto-regulatory feedback loop, in which its activation and repression cycle takes about one day.

### Characteristics

Clock genes are components of the circadian clock comparable to the cogwheels of a mechanical watch. They interact with each other in an intricate manner generating oscillations of gene expression. The underlying principle of circadian clocks is successive gene activation in the form of a cycle: the initial activation of a gene is regulated by the last one in the sequence, making up an auto-regulatory feedback loop for which one cycle takes about 24 h. This principle is illustrated in Fig. 1.

Positive elements activate the expression of negative elements, which in turn stop the activity of the positive elements. This system moves away from equilibrium before returning and hence, perpetual cycling is the consequence. Although the genes involved in this mechanism can differ in various organisms, the principle illustrated in Fig. 1 is common to all of them (reviewed in [1]).

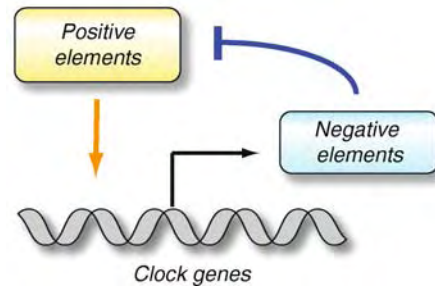

**Clock Genes. Figure 1** General principle of the transcriptional autoregulatory feedback-loop. This principle underlies the clock mechanism in organisms that have a circadian clock.

In mammals the circadian clock mechanism is made up of two interlocking, regulatory feedback loops (Fig. 2, orange and blue lines).

In the first loop (blue lines), two transcriptional activators ►*Bmal1* (brain and muscle ARNT-like protein 1) and ►*Clock* (or *Npas2* in neuronal tissue) form heterodimers in the cytoplasm and enter the nucleus where they bind to ►*E-box* sequences in the promoters of ►*Period* (*Per1,2*) and ►*Cryptochrome* (*Cry1,2*) genes contributing to the activation of their expression. In the cytoplasm various combinations of *Per* and *Cry* proteins interact with each other, enter the nucleus and inhibit the activity of *Bmal1/Clock* or *Bmal1/Npas2* complexes. Without these complexes activating transcription of the *Per* and *Cry* genes, levels of *Per* and *Cry* transcripts and their respective protein products decline, hence *Per* and *Cry* genes shut off their own transcription (reviewed in [2]).

A second loop regulates the expression of the *Bmal1* gene (orange lines, Fig. 2). In the nucleus *Bmal1/Clock* or *Bmal1/Npas2* heterodimers bind to *E-boxes* present in the promoters of genes that encode the retinoic acid-related orphan nuclear receptors ►*Rev-erba* and ►*Rora*, which compete for the ROR element (RORE) in the *Bmal1* promoter. *Rora* activates *Bmal1* expression, while *Rev-erba* represses it. As a consequence oscillations of *Bmal1* and *Rora/Rev-erba* are out of phase. If activation wins over expression *Bmal1* protein is produced and it forms heterodimers in the cytoplasm with *Clock* or *Npas2* depending on the tissue [3]. These heterodimers enter the nucleus and initiate the next cycle of gene activation of both loops. The regulation of *Clock* and *Npas2* is at present not understood.

How do *Bmal1* and *Clock* contribute to the activation of transcription of other clock genes? It appears that transcriptional activation is facilitated by the histone acetyl transferase (HAT) activity of the *Clock* protein [4]. Histone acetylation promotes transcription through the modification of histones (Ac, Fig. 3) and allows

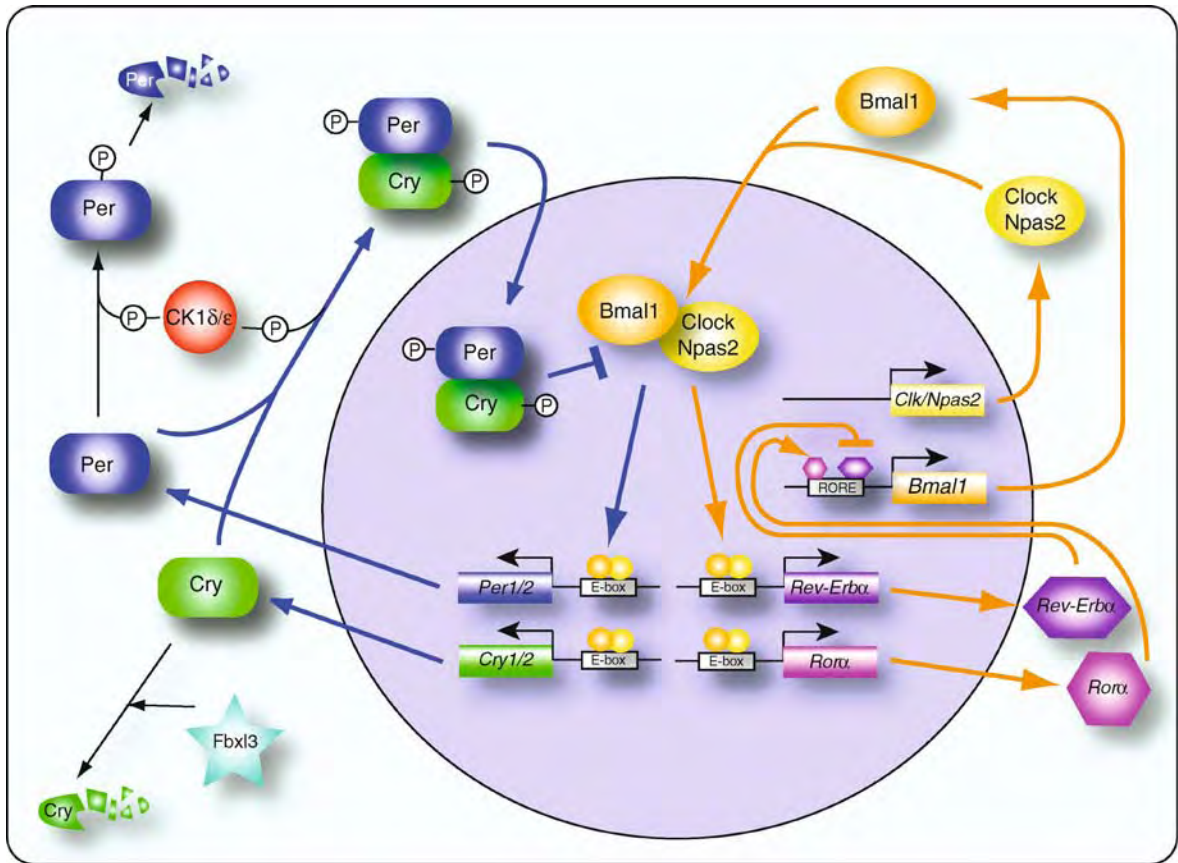

**Clock Genes. Figure 2** Hypothetical clock mechanism in mammals. Note the two loops (*blue lines and orange lines*) converging on the transcriptional activators Bmal1 and Clock/Npas2. Besides transcription, nuclear import of clock factors and posttranslational modification of these factors (such as phosphorylation, circled P in diagram) seem to play an important role in the regulation of the feedback-loop. For details see text.

opening of the condensed chromatin. This provides access to the transcriptional machinery (Fig. 3, RNA Polymerase II and general transcription factors).

The HAT activity of Clock is necessary for the transcriptional activation of the clock genes *Per* and *Cry* and therefore seems to be essential for the generation and maintenance of endogenous circadian rhythms in mammals. Transcriptional repression is mediated by several events. Per and Cry bind to the Bmal1/Clock complex. This results in loss of HAT activity of Clock by promoting Clock phosphorylation (P) and/or inducing a conformational change of Bmal1/Clock. Whether these changes induced by Per and Cry leave Bmal1/Clock bound to the E-box or cause dissociation from it is not known. In either case, loss of Clock HAT activity promotes histone deacetylation. This prevents the general transcription machinery from binding to DNA and hence transcription is repressed. Upon degradation of Per and Cry, Clock is either dephosphorylated or degraded and resynthesized. It

then interacts again with Bmal1 and acetylates histones to activate a new transcription cycle.

Clock gene expression regulated exclusively by transcriptional processes would run into equilibrium and no oscillation of gene expression would be observed. Transport of clock proteins from the cytoplasm into the nucleus as well as posttranscriptional processes are additional levels of regulation of the clock mechanism for generating oscillations of approximately 24 h. Per and Cry proteins interact with each other which prevents rapid degradation of these proteins and enables them to enter the nucleus. Mutation of interaction sites in either Per or Cry protein disturbs the nuclear and cytoplasmic localization with consequences on the clock oscillator (reviewed in [2]).

Phosphorylation and dephosphorylation of proteins is a widely used mechanism to regulate protein stability, activity, and structure in many biological processes such as signal transduction. In the generation of mammalian circadian rhythms phosphorylation and

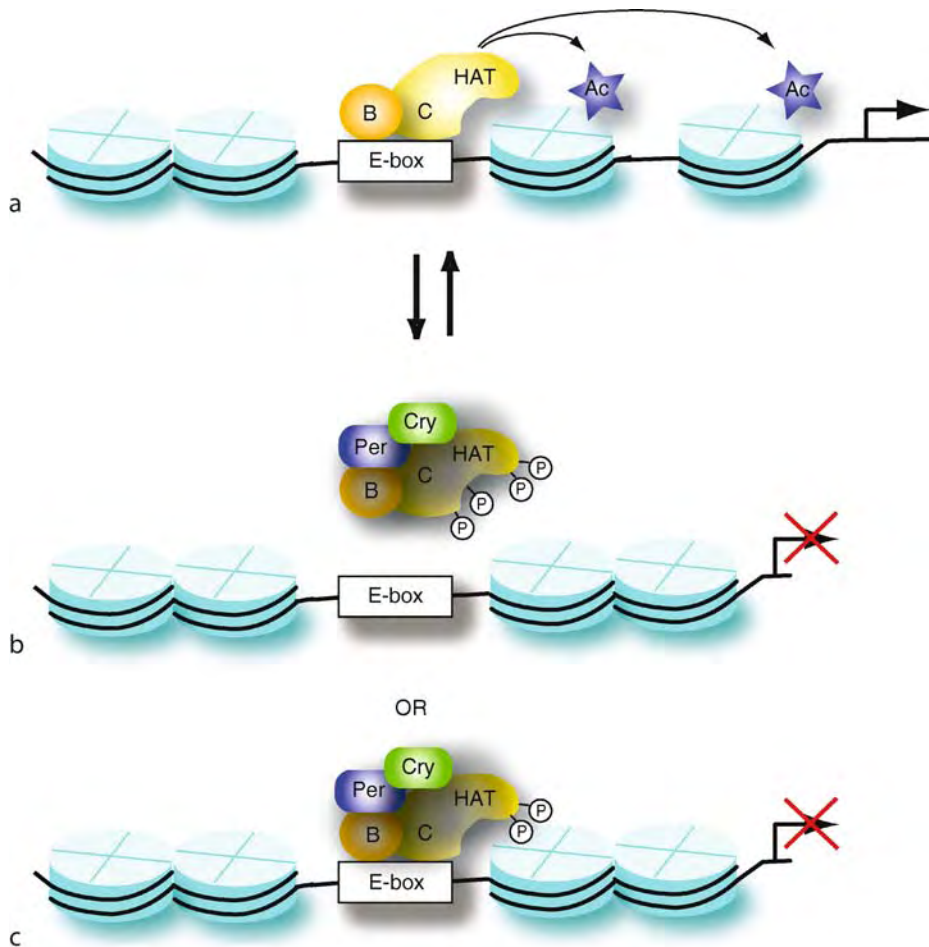

**Clock Genes. Figure 3** Diagram depicting the histone acetyltransferase (HAT) activity of Clock (yellow). (a) Acetylation (Ac, blue stars) of histones (light blue discs) near the promoter region of target genes greatly facilitates transcription by RNA polymerase II. Upon binding of Per/Cry, Clock is phosphorylated which either leads to detachment of the complex from the E-box (b) or simply inactivates HAT activity (c) leading to inactivation of transcription (red crosses).

dephosphorylation of Per proteins plays a critical role in determination of period length. For example, casein kinase 1  $\epsilon$  or  $\delta$  (CK1 $\epsilon/\delta$ , Fig. 2) phosphorylates Per2 protein at different sites. If predominantly amino-terminal sites are phosphorylated, Per2 protein will be degraded. However, if sites in the second part of the Per2 protein sequence are phosphorylated, Per2 is stabilized and can interact with Cry proteins to enter the nucleus and interfere with the Bmal1/Clock or Bmal1/Npas2 complexes (Fig. 2) (reviewed in [5]). Interestingly, mutations in the CK1 $\epsilon$  as well as in sites of Per2 that are important for CK1 $\epsilon$  binding and phosphorylation cause alterations in period length. Patients with a specific form of familial advanced sleep phase syndrome have the mutation S662G in their PER2 protein, leading to a loss of binding of casein kinase 1 $\epsilon/\delta$  (CK1 $\epsilon/\delta$ ) and hypo-phosphorylation of PER2 [6]. This leads to a shortened period length of the circadian

clock and hence these patients have an accelerated clock. As a consequence they display a 4-h advance of the daily sleep-wake rhythm. *In vitro* studies and mouse genetics revealed that alteration of the serine at position 662 in mouse Per2 recapitulates the finding in humans. Furthermore a change from S to D, mimicking by its constitutive phosphorylation and allowing constitutive binding of CK1 $\delta$ , increased phosphorylation of Per2 leading to a longer period length (reviewed in [5]). This indicates the importance of regulation of clock proteins to specify period length. Therefore it is not unexpected that Cry also is regulated by CK1 $\epsilon/\delta$ . Furthermore, Cry abundance is regulated by its interaction with Fbx13, a subunit of one of more than 70 mammalian ubiquitin ligase complexes that recognizes targets for degradation by the proteasome, a multisubunit molecular protein shredding machine (reviewed in [7]). Upon binding of Cry to Fbx13 it becomes ubiquitinated and is degraded

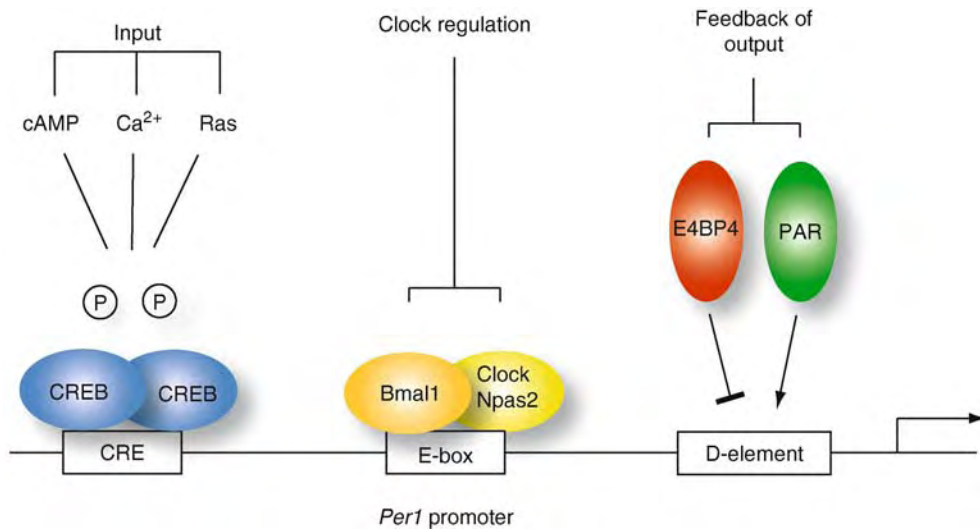

**Clock Genes. Figure 4** Regulatory elements in the promoter of the clock gene *Per1*. Besides regulation by clock factors through E-boxes, activation of the input pathway for example by light leads to changes in various signaling pathways converging on the CRE-element. Also clock-controlled genes can feed back and influence clock gene expression by binding to D-elements either activating (PAR leucine zipper transcription factors such as Dbp) or inhibiting (E4BP4) transcription.

by the proteasome. It appears that circadian oscillations are tuned by a delicate ratio of Per and Cry proteins, whose levels are regulated by phosphorylation and ubiquitination. If their relative abundance is changed, alterations in the clock oscillator are the consequence [8].

The circadian clock is not only a timekeeper. To serve as a predictor of recurring events in nature it needs to have the potential to adapt to changes in lighting and feeding conditions. Therefore clock genes not only respond to regulators of the clock mechanism described in Fig. 2, but also to signaling pathways that connect the organisms biochemical organization with timed events in the environment (reviewed in [9]). Signals such as light stimulate cellular changes in calcium and cAMP levels which lead to phosphorylation of the cAMP responsive element binding protein (CREB) that homodimerizes and binds to the cAMP responsive element (CRE) in the promoter of some clock genes such as *Per1* (Fig. 4).

This causes fast induction of transcription of this gene leading to an adjustment of the circadian clock. Transcription factors, such as E4BP4 and Dbp (PAR leucine zipper transcription factor) are regulated by nutritional cues and the clock (see ►clock-controlled genes). Through binding to the D-element in the promoter of clock genes such as *Per1* they either stimulate (Dbp) or repress (E4BP4) transcription [10]. In this way, the metabolic state of an organism is reported back to the clock (Fig. 4, feedback of output). Hence, clock genes are not only generating a circadian

rhythm but also integrate the metabolic state of the organism and information from the environment.

## References

1. Young MW, Kay S (2001) Time zones: a comparative genetics of circadian clocks. *Nat Rev Genet* 2:702–715
2. Ko CH, Takahashi JS (2006) Molecular components of the mammalian circadian clock. *Hum Mol Genet* 15(2): R271–R277
3. DeBruyne JP, Weaver DR, Reppert SM (2007) CLOCK and NPAS2 have overlapping roles in the suprachiasmatic circadian clock. *Nat Neurosci* 10:543–545
4. Doi M, Hirayama J, Sassone-Corsi P (2006) Circadian regulator CLOCK is a histone acetyltransferase. *Cell* 125:497–508
5. Albrecht U (2007) Per2 has time on its side. *Nat Chem Biol* 3:139–140
6. Toh KL, Jones CR, He Y, Eide EJ, Hinze WA, Virshup DM, Ptacek LJ, Fu Y (2001) An hPer2 phosphorylation site mutation in familial advanced sleep phase syndrome. *Science* 291:1040–1043
7. Gatfield D, Schibler U (2007) Proteasomes keep the circadian clock ticking. *Science* 316:1135–1136
8. Oster H, Baeriswyl S, van der Horst GTJ, Albrecht U (2003) Loss of circadian rhythmicity in aging *mPer1*<sup>-/-</sup> *mCry2*<sup>-/-</sup> mutant mice. *Genes Dev* 17:1366–1379
9. Hirota T, Fukada Y (2004) Resetting mechanism of central and peripheral circadian clocks in mammals. *Zool Sci* 21:359–368
10. Mitsui S, Yamaguchi S, Matsuo T, Ishida Y, Okamura H (2001) Antagonistic role of E4BP4 and PAR proteins in the circadian oscillatory mechanism. *Genes Dev* 15:995–1006

## Clock Mutation

### Definition

An alteration of the circadian clock gene identified as circadian clock output cycles kaput. The Clock mutation, discovered through an N-ethyl-N-nitrosourea mutagenesis screen, was the first circadian clock gene to be identified in mammals. The mutant allele is a 5' splice donor mutation that skips exon 19, thereby producing a form of CLOCK protein that is missing 51 amino acids from the C-terminal activation domain.

The resulting protein is an antimorph, which acts in a dominant-negative fashion. The mutated CLOCK protein retains the ability to form PAS-domain dependent heterodimers with BMAL1. Although heterodimers formed between BMAL1 and mutated CLOCK also retain their DNA-binding capabilities, transcriptional activation is deficient. Animals bearing a mutation of the Clock allele display lengthened periodicity, and ultimately, failure in expression of behavioral circadian rhythms.

- ▶ Cellular Clock
- ▶ Circadian Rhythm
- ▶ Clock-controlled Genes
- ▶ Clock Genes

## Clonus

### Definition

Oscillatory muscle contraction at about 4-6 Hz. It is considered to result from increased stretch-reflex excitability, caused by sufficient muscle stretch and increased spinal cord excitability, in particular in ▶spasticity.

- ▶ Spasticity

## Closed-loop Behavior

### Definition

Behavior in which the consequences of the actions have an influence on the sensory input. Under normal conditions behavior is closed loop. The loop may be opened by an experimenter. There are also natural situations that resemble an open loop: when the

stimulus is over before the reaction starts (see also open-loop behavior).

## Cluster Headache

### Definition

An excruciating, primary headache lasting 15 min to 3 h. It is unilateral, orbital, supraorbital, or temple pain accompanied by autonomic features.

- ▶ Headache

## CNG channels

- ▶ Cyclic Nucleotide-Regulated Cation Channels

## CNS Demyelinating Disease

### Definition

Demyelination is myelin loss with relative preservation of axons. The central nervous system (CNS) is composed of the brain and the spinal cord. The most common CNS demyelinating disease in humans is multiple sclerosis. Demyelinating diseases do not include genetic disorders of myelin formation (dysmyelination) or diseases causing myelin destruction secondary to neuronal death and Wallerian degeneration, such as amyotrophic lateral sclerosis and spinal cord injury.

- ▶ Amyotrophic Lateral Sclerosis (ALS)
- ▶ Multiple Sclerosis
- ▶ Wallerian Degeneration

## CNS Germinal Niche

### Definition

Specialized central nervous system (CNS) microenvironment in which neural stem cells reside and support self-renewal and differentiation (neuro- and gliogenesis). Environmental cues and intrinsic genetic

programs are required to maintain stem cell properties within CNS germinal niches. The subventricular zone (SVZ) of the lateral ventricle wall and the subgranular zone (SGZ) of the dentate gyrus (DG) of the hippocampus are two major brain germinal niches in the adult mammalian life. Cells with structural and molecular characteristics of astrocytes [immunoreactive for glial fibrillary acidic protein (GFAP)] are the true stem cells (or type B cells) in the SVZ and SGZ. GFAP+ astrocytes are in intimate contact with all other SVZ cell types, including type C cells (rapidly dividing transit amplifying cells) and the type A cells (lineage-committed post-mitotic migratory neuroblasts). Type B cells in the SVZ are in close contact (e.g., interdigitated) with both the BL and the blood vessels. The cell lineage differentiation pathway goes from type B, through type C to type A cells, with type B cells believed to be the self-renewing primary precursors.

GFAP+ astrocytes also function as stem cells (type B cells) in the SGZ, undergo self-renewal, proliferation and differentiation into transit amplifying cells (type D cells) and then into lineage-committed migratory granule neurons (type G cells). In the SGZ, bursts of endothelial cell division are spatially and temporally related to clusters of neurogenesis. Stem cell maintenance within CNS germinal niches appears to be dependent on stem cell physical contact to the basal lamina (BL) which acts as a scaffold concentrating and/or modulating cytokines/growth factors derived from local cells (e.g., fibroblasts, macrophages, pericytes, etc.).

- ▶ Autoimmune Demyelinating Disorders: Stem Cell Therapy
- ▶ Stem Cell

---

## CNTF

### Definition

- ▶ Ciliary Neurotrophic Factor

---

## Co-activation

### Definition

Simultaneous activation of skeletomotor and fusimotor neurones.

- ▶ Proprioception Roles of Muscle Receptors

---

## Co-activation, Co-activation Zone

### Definition

A range of positions of a joint or body segments within which opposing groups of muscles are co-active; threshold control is responsible for the extent and localization of the zone(s).

- ▶ Equilibrium Point Control

---

## Coarticulation

### Definition

Phenomenon in speech whereby attributes of successive speech units overlap in articulatory or acoustic patterns.

- ▶ Speech Perception

---

## Cocaine

### Definition

Cocaine is a stimulant drug that increases brain extracellular levels of the neurotransmitters dopamine, serotonin, and noradrenaline by inhibiting the monoamine neurotransmitter transporters.

- ▶ Stimulants

---

## Coccus

### Definition

A (roughly) spherical bacterium, with two bundles of short flagella near one pole of the cell.

- ▶ Magnetic Bacteria

## Cochlea

MARIO A. RUGGERO

The Hugh Knowles Center and Institute for Neuroscience, Northwestern University, Evanston, Illinois, USA

### Synonyms

Acoustic Labyrinth

### Definition

The **cochlea** is the hearing organ of mammals, located in the inner ear. It contains the **organ of Corti**, where **hair cells** convert **sound-stimulated vibrations** into electrical signals.

### Characteristics

#### Anatomy of the Mammalian Ear

All vertebrate animals possess hearing organs which convert sounds (see **Acoustics**) into neural signals for transmission to the auditory centers of the **brain**.

The cochlea is the hearing organ of humans and other mammals (Figs. 1 and 2). (The hearing organs of non-mammalian vertebrates differ substantially from the cochlea; see **Avian Auditory System**). Sounds stimulate the cochlea via vibrations of the tympanic membrane (eardrum) and the three middle-ear ossicles (malleus, incus and stapes) (Fig. 1).

Enclosed within the bony shell of the cochlea are three stacked fluid-filled membranous tubes, the organ of Corti (the organ of hearing proper), the spiral ganglion (containing the somata of **auditory-nerve afferents**) and various accessory structures, which jointly coil around a central axis (Figs. 1 and 2). The outer tubes, scala vestibuli and scala tympani, contain perilymph, which resembles other extracellular fluids, such as **cerebrospinal fluid**, in that they contain a relatively a high concentration of sodium ions and a low concentration of potassium ions. Scala vestibuli and scala tympani communicate with each other via the helicotrema at the apex of the cochlea (Figs. 1 and 2a). The inner tube, scala media, contains **endolymph**, with ionic composition (high potassium concentration and low sodium concentration) unusual for an extracellular fluid, which sustains a

C

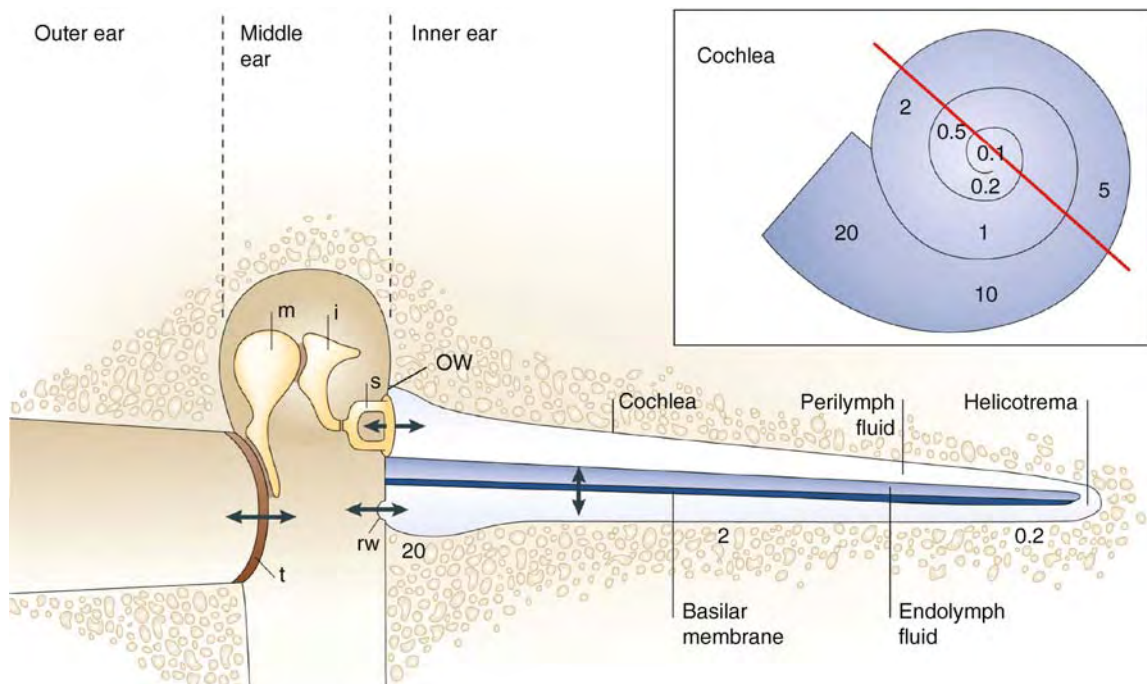

**Cochlea. Figure 1** A cartoon of the mammalian ear. *Inset.* The cochlea coils around a central axis and resembles a land snail (hence its name). *Red line* indicates the plane of section for Fig. 2a. *Main.* the cochlea is shown uncoiled, in longitudinal section. m: malleus; i: incus; s: stapes; t: tympanic membrane; ow: oval window; rw: round window. The basilar membrane performs a spatial frequency analysis, with high-frequency sounds (e.g., 20 **kHz** or **kHz**: “20”) causing largest vibrations at the cochlear base, near the round window, and low-frequency sounds (e.g., 0.2 **kHz**: “0.2”) eliciting peak vibrations at the apex, near the helicotrema. Modified after Fig. 1 of [1], by permission of Macmillan Publishers Ltd.: Nature Reviews Neuroscience, copyright 2006.



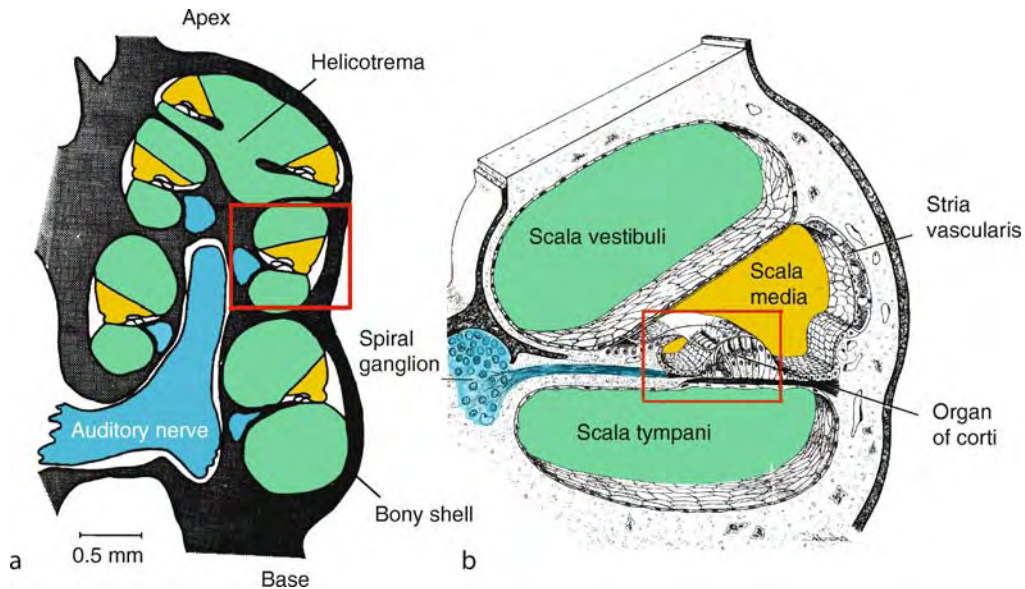

**Cochlea. Figure 2** *The cochlea.* (a) Cross section along its central axis (see red line in inset of Fig. 1). Green: perilymph fluid in scala vestibuli and scala tympani. Yellow: endolymph in scala media. Blue: auditory nerve and spiral ganglion. Red rectangle encloses an area comparable to Fig. 2b. (b) Cross section through a single turn of cochlear spiral. Red rectangle encloses an area comparable to Fig. 3a. Figure 2a modified after Fig. 13a of [2], by permission of Wiley-VCH, copyright 1991. Figure 2b modified after Fig. 35–10 of [3], by permission of Chapman & Hall, copyright 1994.

large electrical potential (+80 mV relative to perilymph). The lateral or peripheral wall of the scala media contains the stria vascularis (Fig. 2b), a richly vascularized tissue responsible for the ionic composition and electrical potential of endolymph.

The organ of Corti, which is attached to the ▶basilar membrane, contains hair cells, the transducers that convert vibrations into electrical signals, and the peripheral terminals of the afferent and efferent ▶neurons (Figs. 2b and 3a). Arranged longitudinally along the cochlea there are a single row of ▶inner hair cells and three rows of ▶outer hair cells. Bundles of “hairs” (rigid microvilli or ▶stereocilia) protrude from the apical poles of the hair cells into scala media, where they are bathed by endolymph. Overlying the organ of Corti is the tectorial membrane, which contacts the stereocilia of the outer (but not inner) hair cells.

The innervations of inner and outer hair cells differ greatly. The afferent innervation consists of neurons with somata located in the spiral ganglion which send their ▶axons via the ▶auditory nerve (Fig. 2) to the ▶cochlear nucleus. The auditory nerve consists largely of the axons of Type I afferent neurons, which amount to 95% of all afferent neurons and innervate inner hair cells exclusively. Thus, it is the inner hair cells that funnel most of cochlear signals into the brain. The efferents innervating the cochlea (Fig. 3) originate in neurons surrounding the superior olivary nuclei (see ▶Efferent System and ▶Superior Olivary Complex)

and ▶synapse with the outer hair cells and the Type-I afferent terminals.

### The Basilar-Membrane Traveling Wave

The stapes transmits vibrations to scala vestibuli via the oval window at the base of the cochlea and the adjacent elastic round window, located over scala tympani, provides pressure relief (Fig. 1). The vibrations generate acoustic waves that propagate rapidly (within a few microseconds) throughout the cochlea. Those (“fast”) acoustic waves, in turn, induce transverse vibrations of the basilar membrane and the organ of Corti which arise first near the stapes at the base of the cochlea and then travel relatively slowly (within a few milliseconds) toward the cochlear apex. As they propagate longitudinally along the cochlea, the “slow” ▶basilar-membrane traveling waves grow larger, reach a peak and then they die out. At behavioral or neural ▶thresholds (▶sound pressure level of 0–20 ▶dB), the peak of the basilar-membrane vibration is literally of atomic dimensions, about 1 nm [4]. The speed of the “slow” traveling waves vary as a function of distance: propagation is relatively fast at the basal end so that ▶wavelengths are long; as waves proceed toward the apex, they slow down and wavelengths shorten. Because of travel time, basilar-membrane vibration phases increasingly lag stapes vibration as a function of distance from the stapes and, at any given site, as a function of stimulus frequency. Where traveling waves reach their peak

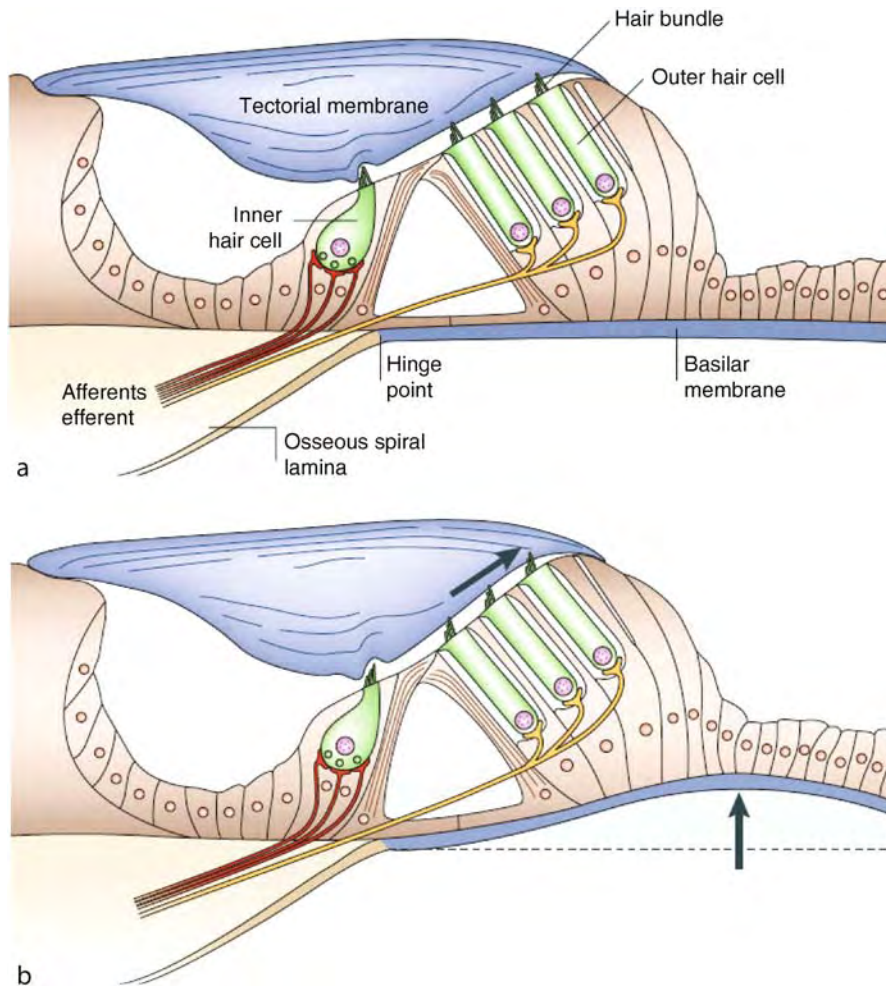

**Cochlea. Figure 3** A cross section of the organ of Corti and the ►basilar and tectorial ►membranes. (a) Only the Type-I afferents, which innervate inner hair cells, and the efferents to the outer hair cells are illustrated. (b) When the basilar-membrane and the organ of Corti are displaced (*upward arrow*) toward the tectorial membrane, the stereocilia of outer hair cells are deflected radially, away from the inner hair cells. Reprinted by permission from Macmillan Publishers Ltd.: Nature Reviews Neuroscience, Fig. 2 of [1], copyright 2006.

depends on frequency: high-frequency waves peak near the stapes whereas very-low frequency waves travel all the way to the cochlear apex. In other words, the cochlea performs a mechanical Fourier analysis, mapping frequency into space so that each basilar-membrane site has a ►characteristic frequency.

### Vulnerability and Nonlinearity of Basilar-Membrane Vibrations in the Living Cochlea

Basilar-membrane traveling waves can be demonstrated post-mortem in experimental animals, as well as human cadavers. This indicates that spatial frequency analysis in the cochlea is inherent in the physical (►passive) properties of the basilar membrane, which is narrow and stiff at the base of the cochlea and wide and relatively floppy at the cochlear apex. However, basilar membrane vibrations are crucially dependent on biological

(“active”) processes, so that they are much more sensitive and much more sharply frequency-tuned in living cochleae than post-mortem.

At the basal half of normal cochleae, basilar-membrane vibrations stimulated by tones with frequencies close to the characteristic frequency grow with stimulus intensity at compressive rates (i.e., <1 dB of vibration magnitude per ►decibel of stimulus magnitude), while response growth is linear at other frequencies. Hence, because the compressive ►nonlinearity is confined to frequencies near the characteristic frequency, ►frequency tuning varies with stimulus level: basilar-membrane responses are more sharply tuned, and exhibit more gain (vibration amplitude divided by stimulus level), for low-level than for high-level stimuli. Basilar-membrane vibrations in normal cochleae also exhibit other nonlinear phenomena, including two-tone suppression and harmonic and

intermodulation ► **distortion**, all of which are prominently reflected in the responses to sound of inner hair cells and auditory-nerve fibers, and in auditory perception (see ► **Psychoacoustics**). Following cochlear damage or death, basilar-membrane responses to tones with frequency far from the characteristic frequency remain unchanged while responses to tones with frequency near the characteristic frequency are drastically affected: they become linear, poorly frequency tuned, and less sensitive, their magnitude being reduced by as much as 60 dB.

In the basal half of the cochlea, the frequency selectivity and other properties of the responses of inner hair cells and auditory-nerve fibers derive more or less directly from the corresponding properties of basilar-membrane vibrations. The dominance of basilar-membrane vibrations in determining inner hair cell and neural responses is less clear for the apical half of the cochlea, where technical difficulties have made it difficult to measure vibrations in healthy cochleae. The few available data indicate that basilar-membrane frequency tuning is substantially less sharp at apical sites than at basal sites, in agreement with corresponding differences in frequency tuning in auditory-nerve fibers. The compressive nonlinearity is less salient at apical sites and, in contrast with basal cochlear sites, it is not confined to frequencies near the characteristic frequency, so that frequency tuning does not change as a function of stimulus level and is only minimally affected by cochlear trauma or death.

### Hair Cell Receptor Potentials

When the basilar membrane and the organ of Corti vibrate, the stereocilia of outer hair cells, which are embedded in the tectorial membrane, are deflected radially (Fig. 3b). Organ of Corti displacements toward (or away from) scala vestibuli deflect the stereociliar bundle toward (or away from) the tallest stereocilia. How inner hair cell stereocilia are deflected is less clear. Since their stereocilia do not touch the tectorial membrane, it is presumed that they are deflected by streaming endolymph. When the stereocilia are in their normally erect position, a small ionic current flows from the scala media into the inner and outer hair cells. This current is modulated by changes in conductance associated with deflection of the stereociliar bundle: deflections toward and away from the tallest stereocilia cause conductance increases and decreases, respectively. The changes in conductance result from the ► **gating** of mechanically sensitive ion channels, non-specifically selective for cations, located near the tips of the stereocilia [5]. Gating is very fast, via direct mechanical interactions between the ► **transduction** channel and elastic filaments (“tip-links”) which link adjacent stereocilia along the axis of maximum sensitivity. Upon bundle deflection, the tips of adjacent stereocilia are separated and the tip

links pull open the transduction channels. When the transduction channels are opened, the electrical potential difference between endolymph and the cytoplasm of hair cells [ $+80 \text{ mV} - (-60 \text{ mV}) = 140 \text{ mV}$ ] pushes scala-media cations, principally potassium but also calcium (►  $\text{Ca}^{2+}$ ), into the hair cells.

The modulation of the transduction current generates ► **receptor potentials** across the basolateral membrane of the hair cells; depolarization and hyperpolarization correspond, respectively, to increased and decreased current. Hair cell receptor potentials follow the deflections of their stereocilia monotonically and hence have frequency tuning roughly similar to that of basilar-membrane vibrations. However, hair cell transduction is nonlinear and currents and voltages are sigmoidal functions of stereocilia deflection. Furthermore, opposite but equal displacements of the hair bundle from the resting position generate unequal conductance changes, resulting in depolarization that is larger than hyperpolarization. As a consequence of this asymmetry, depolarizing DC (“direct current”) responses are generated in addition to AC (“alternating current”) responses. For high stimulus frequencies, the AC responses become smaller due to the shunting of the current by the parallel ► **resistance** and ► **capacitance** of the basolateral membrane of the hair cell, which jointly act as a ► **low-pass filter**. Nevertheless, inner hair cells can still signal the presence of high-frequency stimulation by means of their DC depolarization response, which grows bigger as the stimulus grows larger. Depolarization, in turn, causes release of excitatory ► **neurotransmitter** (► **glutamate-like?**) into the ► **synaptic cleft** of Type I afferent terminals (see Auditory Nerve). Since Type I neurons constitute the overwhelming majority of ► **cochlear afferents** and innervate solely inner hair cells, inner hair cells are viewed as the true transducers that funnel acoustic information toward the cochlear nucleus.

### The Role of Outer Hair Cells in Cochlear Function

The outer hair cells probably play a negligible direct role in transmitting acoustic information to the brain but participate crucially in enhancing cochlear vibrations, increasing their sensitivity and frequency tuning. When moved by the basilar membrane, outer hair cells reciprocate by actively moving the basilar membrane. This positive feedback loop, which serves as a mechanical amplifier, was demonstrated by monitoring basilar-membrane responses to sound after systemic injection of furosemide, a diuretic which reversibly abolishes the endocochlear potential by shutting down metabolically driven ion pumps in the stria vascularis (Fig. 2b) and reduces hair cell transduction currents. The sensitivity, nonlinearity and frequency tuning of basilar-membrane responses to sound were drastically but reversibly reduced, an indication that cells of the

organ of Corti normally provide mechanical feedback to the basilar membrane [6]. The specific role of the outer hair cells was demonstrated by showing that stimulation of the medial efferent system, which innervates those cells, cause selective loss of sensitivity of basilar-membrane vibrations at the characteristic frequency [7].

The nature of the mechanical feedback from the outer hair cells is not certain. One candidate is somatic electromotility, the ability of outer hair cells to change length when subjected to fluctuating transmembrane voltages. In vitro, outer hair cells shorten when depolarized and lengthen when hyperpolarized. Somatic electromotility is not based on a muscle-like mechanism, since it does not directly require metabolic energy or calcium ( $\text{Ca}^{2+}$ ). Rather, it reflects the collective deformations of millions of voltage-sensitive intramembranous prestin molecules. Prestin apparently plays a crucial role in cochlear function, since “knockout” mice lacking prestin have elevated hearing thresholds [8]. However, since the receptor potentials of outer hair cells are very small at high frequencies, it is difficult to envision how they can cause outer hair cell vibrations sufficiently large to influence basilar-membrane motion significantly.

Amplification mechanisms also exist in the hearing organs of non-mammalian tetrapod vertebrates, which broadcast ► **otoacoustic emissions** (sounds emitted by the ear) much as mammals do [9] but which have neither prestin nor outer hair cells. In non-mammals, the very same stereocilia that mediate mechanical-to-electrical transduction also act as amplifiers of mechanical motion: for example, when mechanically stimulated, the stereocilia of frog sacculus hair cells generate more power than is present in the stimulus [5]. A similar mechanism may also exist in the outer hair cells of mammals, which in vitro react to mechanical stimulation with active and nonlinear stereociliar motion [1].

## References

1. Fettiplace R, Hackney CM (2006) The sensory and motor roles of auditory hair cells. *Nature Rev Neurosci* 7:19–29
2. Ruggero MA, Semple MN (1991) Acoustics, physiological. In: Trigg GL (ed) *Encyclopedia of applied physics*. VCH Publishers, Weinheim, Germany, pp 213–259
3. Fawcett DW (1994) Bloom and Fawcett – A textbook of histology. Chapman & Hall, New York
4. Robles L, Ruggero MA (2001) Mechanics of the mammalian cochlea. *Physiol. Rev.* 81:1305–1352
5. Hudspeth A (2005) How the ear’s works work: mechano-electrical transduction and amplification by hair cells. *Comptes Rendus Biol* 328:155–162
6. Ruggero MA, Rich NC (1991) Furosemide alters organ of Corti mechanics: evidence for feedback of outer hair cells upon the basilar membrane. *J Neurosci* 11:1057–1067
7. Murugasu E, Russell IJ (1996) The effect of efferent stimulation on basilar membrane displacement in the basal turn of the guinea pig cochlea. *J Neurosci* 16:325–332
8. Dallos P, Zheng J, Cheatham MA (2006) Prestin and the cochlear amplifier. *J Physiol* 576:37–42
9. Manley GA (2001) Evidence for an active process and a cochlear amplifier in nonmammals. *J Neurophysiol* 86:541–549

## Cochlear Implants

ROBERT V. SHANNON

House Ear Institute, Los Angeles, CA, USA

### Definition

A cochlear implant (CI) is a prosthesis that electrically activates the auditory nerve in deaf patients to restore hearing sensations. CIs were originally developed in the 1960s and the early single-electrode devices restored only minimal hearing, with little or no ability to understand speech sounds. Modern, multichannel CIs restore hearing at a level that allows telephone conversation in most patients.

### Characteristics

#### Quantitative Description

The CI (Fig. 1) consists of an internally implanted receiver/stimulator and an external signal processor.

Modern multichannel CIs have between 16 and 22 electrodes in an array that is inserted through the round window into the scala tympani of the cochlea. Sound is received through a microphone and the acoustic signal is transformed to be appropriate for electrical stimulation. Typically, sound is split into 16–22 frequency bands and the energy in each band is compressed and applied to a different electrode implanted within the cochlea. Each electrode is stimulated with biphasic electrical pulses at rates between 250 and 5,000 pulses/s. Some CI devices allow presentation of analog electrical waveforms on each electrode.

### Higher Level Structures

Although the CI activates neurons in the cochlea, the electrically driven neural activity then is processed by the auditory brainstem nuclei and auditory cortex. Areas of the cortex specialized for speech (e.g. Wernike’s area, Broca’s area) receive the abnormal pattern of neural activity. Pattern recognition processes and linguistic processes decode the distorted neural input into recognizable sounds and words.

### Lower Level Components

The cochlea or inner ear is a fluid filled coiled structure that converts mechanical vibration of sound into nerve impulses to the brain. Most types of deafness result

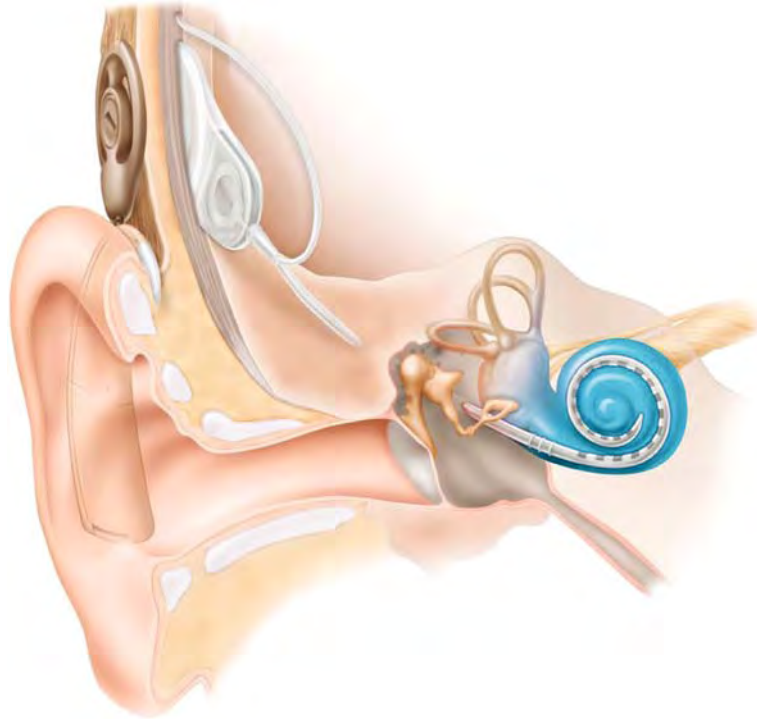

**Cochlear Implants.** **Figure 1** Schematic representation of a cochlear implant. The external portion of the device resembles a behind-the-ear hearing aid and consists of a microphone, sound processor and transmitter coil. Auditory signals are received by the microphone, processed and transmitted across the skin to the implanted portion of the device. The implanted portion contains a hermetically sealed receiver/stimulator package, which receives and decodes the transmitted signal and the electrode array that is inserted into the scala tympani of the cochlea.

from the loss of sensory hair cells, which transduce the mechanical vibrations of sound into nerve impulses. The CI electrode array is placed in the scala tympani of the cochlea and is designed to activate the remaining neurons in a deaf cochlea. Modern CI devices contain 16–22 electrode contacts spaced along a silicone carrier. Electrode arrays are designed to be inserted 25–30 mm into the cochlea (normal cochlear length is 35 mm). Electrical signals are delivered to individual electrodes as either analog electrical waveforms or short biphasic current pulses. Auditory neurons are activated either on their peripheral processes (if they have survived the deafening pathology) or at the cell bodies of the spiral ganglion.

### Structural Regulation

The normal cochlea is organized tonotopically; neurons near the base represent high-frequency information and neurons located at the apical end represent low-frequency information. The CI stimulating electrodes are arranged longitudinally along the silicone carrier to take advantage of this tonotopic organization. Electrodes at the base of the cochlea are stimulated to indicate high-frequency sounds and electrodes at the tip of the array (closer to the apex of the cochlea) are stimulated to

indicate low frequency sounds. Temporal patterns of sound are represented as modulation in the amplitude of the stimulating electrical pulses.

### Higher Level Processes

Since the pattern of neural activity has different temporal and spectral characteristics from that in a normally hearing ear, it is unclear how this abnormal pattern of neural information will be processed by specialized central processing mechanisms. Some complex auditory percepts, like musical pitch, require specific fine temporal information that is not represented by the CI [1]. These higher-level processes do not receive the peripheral information required for their function. Extracting signals in noisy listening environments also requires temporal and spectral fine structure that is not provided by the implant [2]. However, speech recognition and recognition of familiar environmental sounds relies on higher-order pattern recognition processing that is relatively insensitive to temporal and spectral fine structure [3]. Thus, most CI listeners can recognize speech at a level that allows conversational use of the telephone. When this level of auditory information is combined with visual cues from lip-reading, CI listeners can converse face-to-face at

near normal speaking rates. This pattern recognition is only obtained in adults who have been deafened after a period of normal hearing, whose central processing system has been trained by normal acoustic processing. Adults who are congenitally deafened are generally not able to recognize speech because their central brain mechanisms have not been trained by years of exposure to normal acoustic sound. Children who are implanted below the age of 2 years are able to recognize speech with the CI because their central processing mechanisms are still in a stage of biological plasticity and are able to effectively utilize the pattern of neural activity provided by the CI.

### Lower Level Processes

Electrical stimulation of the auditory nerve produces abnormal patterns of nerve activation in terms of both the spectral and temporal dimensions. Temporally, electrical stimulation produces abnormally high phase locking, in which the nerve responds at precisely the same time within each stimulus cycle and all activated nerves fire synchronously [4]. In contrast, normal acoustic stimulation produces stochastic responses in proportion to the amplitude of the activating waveform, and each neuron is stochastically independent. Spatially (along the tonotopic dimension of the cochlea) the neurons are activated by the spreading electrical current field rather than by the mechanical traveling wave of the cochlea. Auditory nerve fibers are activated when there is a specific difference in the current at adjacent nodes of Ranvier. The current in the cochlea falls off as the inverse of the square of the distance between the electrode and neurons, modified by the geometry of the cochlea and cochlear fluids and the differences in impedance between fluid, soft tissue and bone. Measurement of the spread of activation from electrical stimulation [5] shows that the selectivity is poorer than with acoustic stimulation and that the selectivity depends on the electric field orientation and on the distance between the stimulating electrodes and neurons.

Perceptually, there is evidence [6] that speech recognition is correlated with the ability to detect amplitude modulation. CI listeners who do well on speech recognition tests can also detect 1–3% modulation, while listeners who are poor at speech recognition require more than 10% modulation for detection. CI speech recognition, while excellent under quiet listening conditions, is considerably poorer than normal hearing in the presence of competing talkers or competing wideband noise [2]. This reduction in performance appears to be due to the limited spectral resolution and to the limited access to temporal fine structure in CIs. Thus, it appears that the complex perceptual abilities of CI users are dependent on low-level peripheral processing. Signal processing methods that can improve the quality of

the peripheral representation might result in improved speech recognition [7].

### Process Regulation

Electric signals are processed in the CI to replicate as closely as possible the temporal and spatial pattern of neural activity in a normal acoustically driven cochlea. The CI can reproduce global aspects of the normal pattern of neural activation but cannot reproduce the fine temporal or spectral patterns present in a normal cochlea. The CI signal processor attempts to present electrical signals that will produce the most normal patterns of nerve activity.

### Function

Modern multi-electrode implants were introduced in the 1970s and the level of performance has improved steadily so that in 2006 most deaf patients can recognize more than 95% of the words in simple sentences [8]. CIs are routinely implanted in deaf children under 1 year of age. Results show that children implanted under the age of 2 years are developing language at age-appropriate levels and rates [9,10]. Most implanted children are able to attend mainstream educational facilities with minimal special services.

### Pathology

CIs are useful for any auditory pathology in which deafness results from the loss of hair cells. Most deafness is caused by the loss of hair cells and leaves the primary auditory neurons largely intact. Pathologies that cause the loss of primary auditory neurons are not suitable for a cochlear implant.

### Therapy

Cochlear implants are a proven prosthetic therapy for most types of deafness. CIs allow post-lingually deafened adults and congenitally deaf children to recognize speech at a level that allows fluent conversation, even over the phone.

### References

1. Smith ZM, Delgutte B, Oxenham AJ (2002) Chimaeric sounds reveal dichotomies in auditory perception. *Nature* 416:87–90
2. Fu Q-J, Nogaki G (2005) Noise susceptibility of cochlear implant users: the role of spectral resolution and smearing. *J Assoc Res Otolaryngol* 6(1):19–27
3. Shannon RV, Zeng F-G, Kamath V, Wygonski J, Ekelid M, (1995) Speech recognition with primarily temporal cues. *Science* 270:303–304
4. Van den Honert C, Stypulkowski PH (1987b) Temporal response patterns of single auditory nerve fibers elicited by periodic electrical stimuli. *Hear Res* 29:207–222
5. Van den Honert C, Stypulkowski PH (1987a) Single fiber mapping of spatial excitation patterns in the electrically stimulated auditory nerve. *Hear Res* 29:195–206

6. Fu Q-J (2002) Temporal processing and speech recognition in cochlear implant users. *NeuroReport* 13:1635–1639
7. Wilson BS, Finley CC, Lawson D, Zerbi M (1997) Temporal representations with cochlear implants. *Am J Otol* 18(6 Suppl):S30–S34
8. Spahr AJ, Dorman MF (2006) Performance of subjects fit with the Advanced Bionics CII and Nucleus 3G cochlear implant devices. *Arch Otolaryngol Head Neck Surg* 130:624–628
9. Robbins KM, Koch DB, Osberger MJ, Zimmerman-Phillips S, Kishon-Rabin L (2004) The effect of age at cochlear implantation on auditory skill development in infants and toddlers. *Arch Otolaryngol Head Neck Surg* 130:570–574
10. Svirsky MA, Robbins AM, Kirk KI, Pisoni DB, Miyamoto RT (2000) Language development in profoundly deaf children with cochlear implants. *Psychol Sci* 11(2):153–158

## Cochlear Nerve

### Synonyms

N. cochlearis; Cochlear nerve

### Definition

First section of the auditory tract. Is part of vestibulocochlear nerve (VIII) and goes from the spiral ganglion (first neuron of the auditory tract) to the cochlear nuclei. The fibers are organized in strict tonotopic fashion (ace. to tone frequencies).

- ▶ Auditory Nerve
- ▶ Nerves

## Cochlear Nucleus

MANUEL S. MALMIERCA<sup>1</sup>, PHILIP H. SMITH<sup>2</sup>  
<sup>1</sup>Auditory Neurophysiology Unit, Laboratory for the Neurobiology of Hearing, Faculty of Medicine and Insitute for Neuroscience of Castilla y León, Salamanca, Spain  
<sup>2</sup>Department of Anatomy, University of Wisconsin, Medical School – Madison, Madison, WI, USA

### Synonyms

Cochlear nuclear complex

### Definition

The cochlear nuclear complex (CNC) is the first relay center in the auditory brain. From here the signals of

the cochlear nerve diverges into a number of parallel ascending tracts, each with its own particular course and destination, as well as conduction velocities, properties and relays.

## Characteristics

### Introduction

The cochlear nucleus (CN) is the site of termination of all auditory nerve (AN) fibers and is thus the first relay center of the ascending auditory pathway [1]. The axons of CN projection neurons use three primary pathways to reach higher auditory structures, the dorsal, intermediate and ventral ▶acoustic striae (DAS, IAS, and VAS respectively; the VAS is also referred to as the trapezoid body). The CN receives descending projections from the auditory brainstem, midbrain and cortex as well as other non-auditory brain structures [1]. There are some interspecies variations in the location and spatial orientation of the CN, most probably due to differences in the shape of the brainstem [2], but across species the CN consists of a ▶ventral cochlear nucleus (VCN),. and a ▶dorsal cochlear nucleus (DCN) The former is subdivided by the cochlear nerve root into an ▶anteroventral (AVCN) and a ▶posteroventral (PVCN) nucleus. As it enters the CN, the typical AN fiber bifurcates into an ascending branch, which supplies the AVCN, and a descending branch, which supplies the PVCN and DCN [3]. Fibers from the apical, low frequency part of the cochlea divide ventrally and terminate within laminar fields in the ventrolateral part of each division of the CN, while those from more basal, high frequency parts of the cochlea divide progressively more dorsally and medially and supply laminar fields in the dorsal parts of the CN subdivisions [2] The anatomical distribution of the primary fibers forms the basis for the physiologically demonstrated ▶tonotopic organization of the three subnuclei [2].

### Primary Afferents

There are two types of AN fibers: Myelinated type I axons carrying auditory information from cochlear inner ▶hair cells and unmyelinated type II axons carrying unknown information from outer hair cells (Figs. 1 and 2).

All recordings from AN fibers have been from type I axons which can show high, medium or low spontaneous activity, a physiological feature that is correlated with the location of the synapse of the fiber on the inner hair cell. In response to pure tones at their characteristic frequency (CF, the sound frequency at which a cell responds with the lowest threshold) high CF type I axons display a primary-like (onset response followed by a gradual reduction in driven rate) ▶peristimulus time histogram (PSTH) whose threshold is dependent on the

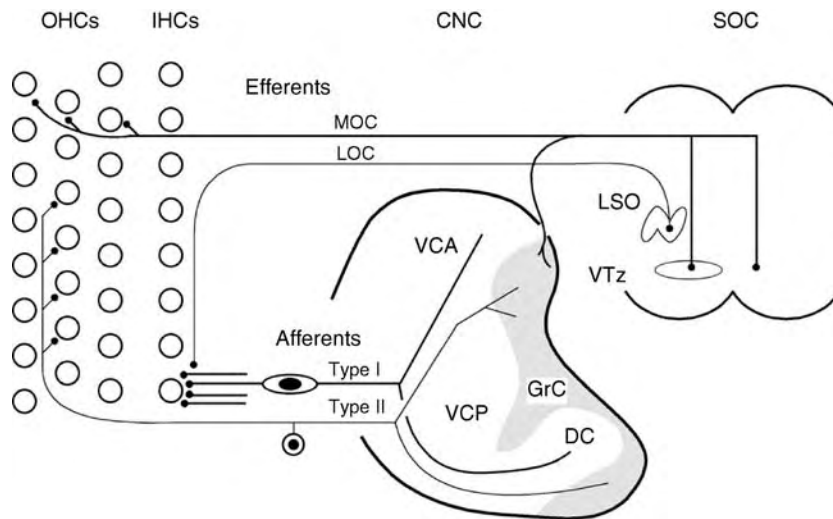

**Cochlear Nucleus. Figure 1** Diagrammatic representation (modified from Brown et al. 1988, [4]) of the efferent and afferent innervation of the cochlea illustrating the hair cells of the cochlea (*left*), the cochlear nucleus complex (*middle*) and the superior olivary complex (*right*). The three rows of outer hair cells receive medial olivocochlear efferent inputs from axons of neurons in the medial aspect of the superior olivary complex. The outer hair cell output to the cochlear nucleus is via thin unmyelinated type II auditory nerve fibers that branch and innervate the granule cell region. The single row of inner hair cells receives lateral olivocochlear efferent inputs from axons of neurons in the lateral aspect of the superior olivary complex. The inner hair cell output to the cochlear nucleus is via thick myelinated type I auditory nerve fibers that branch and innervate the core region. See text for details. Abbreviations: CNC, cochlear nucleus complex; DC, dorsal cochlear nucleus; GrC, granule cell area; IHCs, inner hair cells; LOC, lateral olivocochlear fibers; LSO, lateral superior olive; MOC, medial olivocochlear fibers; OHCs, outer hair cells; SOC, superior olivary complex; VCA, anteroventral cochlear nucleus; VCP, posteroventral cochlear nucleus; VTz, ventral nucleus of the trapezoid body.

AN spontaneous rate. Low CF fibers show phase locking (spiking at a specific phase of each stimulus cycle). Both fiber types possess similar bifurcation patterns as they enter the CN, but the mode and total terminal area of termination differ. Type I fibers supply all parts of the CN except the periphery and granule cell areas (Fig. 1) [3] and produce large, axosomatic endings called “bulbs of Held” as well as small boutons (Fig. 3) [2,3].

These bulbs of Held arise mainly from the ascending branches, while the small boutons arise from loosely ramifying collaterals of both ascending and descending branches [2,3]. The type II fibers do not form bulb of Held endings and innervate areas rich in granule cells and appear to supply the marginal shell of the VCN as well [2,3].

### Ventral Cochlear Nucleus

The VCN contains five main cell types (Fig. 2): spherical bushy, globular bushy, ▶octopus, multipolar and small cells [3], that may be collected into two groups according to their dendritic architecture, targets and distribution within the CN: (i) spherical, globular and octopus and (ii) multipolar and small. The spherical ▶bushy cells are found rostrally in the AVCN, the globular bushy cells lie centrally on both sides of the

nerve root in the caudal AVCN and the rostral PVCN, while the ▶octopus cells are found caudally in the PVCN. Multipolar and small cells are present throughout the VCN. The small cells are most abundant around the peripheral margins of the nucleus deep to the superficial granule cell layer. A distinct collection of small cells located dorsolaterally in a superficial location forms the small cell cap of the VCN (Fig. 2) [3]. Each cell type defined anatomically has several features which allow them to convert their auditory nerve input into a unique response characteristic of that cell type. These features include (i) the location, size and timing of activation of these AN synapses on the cell, (ii) the relationship of these AN synapses to other inputs from other sources and (iii) the unique features of the postsynaptic receptors and their currents and what ion channels these receptor currents activate. A discussion of the unique features of each CN cell type is beyond the scope of this chapter but several reviews are available (e.g. [6]).

Each bushy (globular or spherical) cell receives a small number of bulbs of Held, has non-tapering dendrites ending in numerous small branches and an axon that projects into the trapezoid body (Fig. 3). Spherical- and globular bushy cells differ with regard



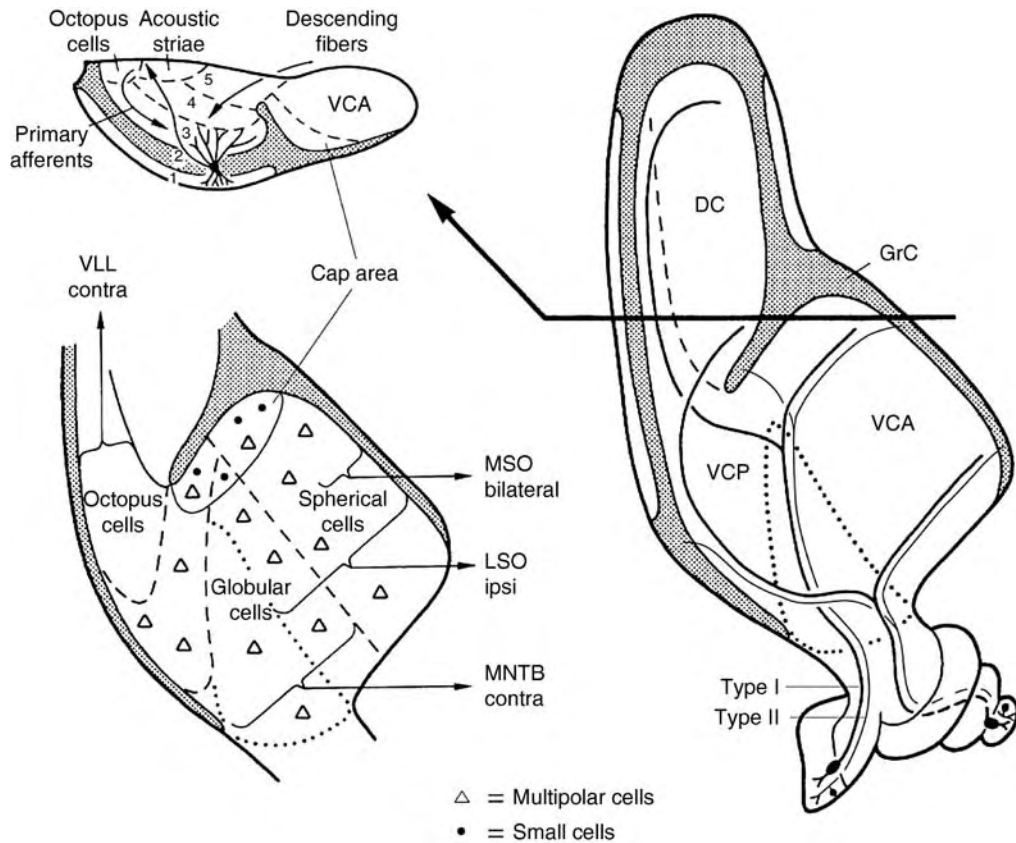

**Cochlear Nucleus. Figure 2** Diagrammatic representation (modified from Osen, 1988, see [4]) of the major cell types in the cochlear nucleus. **Right:** Sagittal view of the major subdivisions of the cochlear nucleus and its innervation pattern by auditory nerve fibers. Both type I and II fibers from the high frequency base and low frequency apex of the cochlea are represented illustrating how the tonotopic map is formed in the cochlear nucleus by the type I fibers. Type II fibers project to the granule cell area in a non tonotopic fashion. **Lower left:** Bottom portion of the same illustration showing the location of the major cell types in the ventral cochlear nucleus and the major termination sites of their axons (arrows). **Upper left:** Section through the dorsal cochlear nucleus, ventral cochlear nucleus and cap area (see arrow and line through figure on right for location) illustrating the layers of the dorsal cochlear nucleus (1–5), how the auditory nerve fibers enter (curved line with arrow) and a fusiform cell in the fusiform cell layer whose axon is entering the acoustic stria. See text for details. Abbreviations: DC, dorsal cochlear nucleus; GrC, granule cell area; VCA, posteroventral cochlear nucleus; VCP, posteroventral cochlear nucleus.

to the number and relative length of the stem dendrites, the morphology of the terminal bush and their axonal projections to the superior olive. Spherical bushy cells with CFs below 10 kHz send their primary axonal projection bilaterally to the medial superior olive and to the ipsilateral lateral superior olive (Fig. 3) but there may be a set of spherical bushy cells with higher CFs that only project to the ipsilateral LSO. The primary axonal projection of the globular bushy cell is to the contralateral medial nucleus of the trapezoid body (Fig. 3). Spherical bushy cells which have high CFs possess primary-like PSTH responses to pure tone stimulation (Fig. 3), similar to those of the AN fibers [7]. Globular bushy cells with high CFs usually respond with a primarylike-with-notch (abrupt onset peak

followed by a brief pause and then a resumption of sustained activity) PSTH while low CF units show phase locking that is better than their AN input. Many of the unique properties of the bushy cell membrane and its AN input make this cell capable of transmitting precise temporal information necessary for both high and low frequency sound localization [7].

The octopus cells receive small boutons from collaterals of a number of AN fibers on their dendrites (Fig. 3). Their main axonal projection is via the IAS to the superior paraolivary nucleus on both sides and to the contralateral ventral complex of the lateral lemniscus where some fibers terminate in large calyx-like synaptic endings (Fig. 3). They respond at CF with a single onset spike to a tone burst [7] (Fig. 3) and can respond to

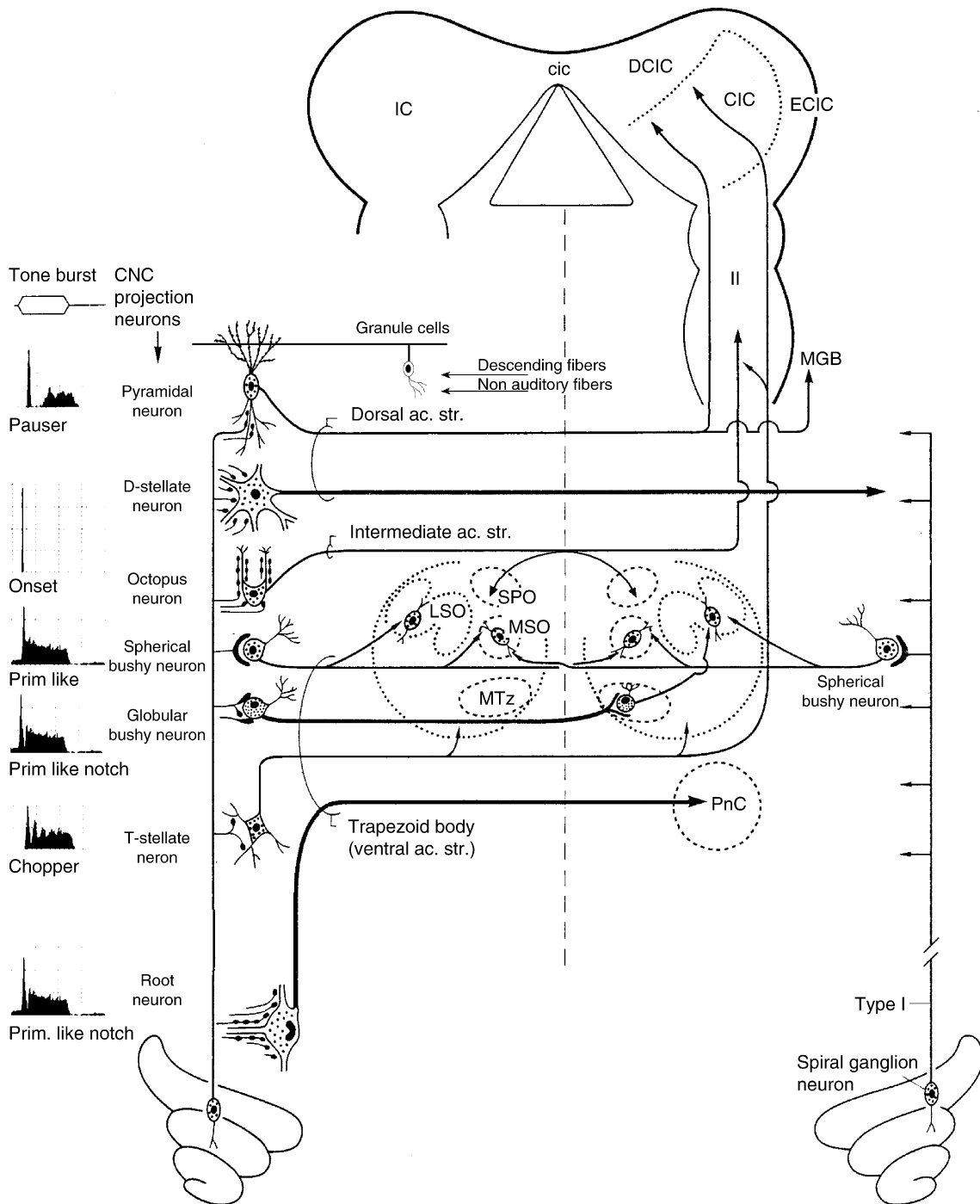

**Cochlear Nucleus. Figure 3** Diagrammatic representation (modified from Moore and Osen, 1979, see [4]) of the major projection neurons in the cochlear nucleus (CN), their innervation pattern by type I auditory nerve fibers, their responses to tones and the major termination sites of their axons outside the cochlear nucleus. Peristimulus time histograms (PSTs) on the left represent the typical responses of the named cell type to short tone bursts. Cell drawings show representative auditory nerve fiber input size and location on the major CN projection cells. Axonal projections of these cells illustrate their pathway out of the CN and their major termination sites in nuclei outside the CN. Only the spherical bushy cell is represented on the right side to illustrate one of the known convergent circuits from the two cochlear nuclei. See text for details. Abbreviations: *cic*, commisure of the inferior colliculus; *CIC*, central nucleus of the inferior colliculus; *DCIC*, dorsal cortex of the inferior colliculus; *ECIC*, external cortex of the inferior colliculus; *LSO*, lateral superior olive; *II*, lateral lemniscus; *MSO*, medial superior olive; *MTz*, medial nucleus of the trapezoid body; *PnC*, pontine reticular nucleus.

click stimuli at rates up to 800/s with remarkable precision. The unique membrane properties of these cells, the distribution of their AN inputs and their unusual response features has led to suggestions that they encode the pitch period in their temporal firing patterns [8].

The multipolar cells receive ▶primary afferents from many AN fibers by means of small boutons located mostly on their dendrites (Fig. 3). Two types of multipolar cells (type I and II) have been defined (e.g. [2]) but it is not yet clear how many subtypes may be represented within these two major classes. Corresponding cell types, given other names, have also been described in the mouse and rat. The type I correspond to the T-▶stellate cells described in mice and planar neurons in rat [4]. They send what is presumed to be an excitatory projection via the trapezoid body to the periolivary region of the superior olive, the nuclei of the lateral lemniscus and the central nucleus of the IC [2] (Fig. 3). Some may also supply motoneurons of the middle ear muscles or send frequency specific collaterals to the DCN. In response to tone bursts, they show “chopper” responses (regular train of action potentials not related to stimulus frequency) and they are narrowly tuned in their frequency response. Choppers may be specialized for conveying frequency specific excitatory information about complex acoustic stimuli including speech. The type II multipolar cells correspond to the large D-stellate cells of the mouse [4] and radiate cells in rat [4]. Their axons exit the CN via the ▶acoustic stria and project to the contralateral CN. For this reason they are referred to as commissural neurons [2] (Fig. 3). These multipolar type IIs are glycinergic [4] and function to provide wide band inhibition to several principal cell types in the CN bilaterally. Thus, they are the only known inhibitory projection neurons of the CN complex. They respond to pure tone stimulation with an “on-chop” pattern (2–3 onset peaks followed by little or no sustained activity) [5] and often respond over a very large frequency range (Fig. 3) A few published examples of type II multipolars with a slightly different form of PSTH ( $O_L$ , single onset peak followed by a pause and then a low level of sustained activity) have been reported but it is not yet clear where these cells project and whether they constitute a separate subpopulation. Nor is it clear what features of these various forms of stellate cells causes them to display different PSTH patterns (chopper, on-chop or  $O_L$ ).

Very little information is available yet on the response features or the intrinsic membrane and synaptic features of those cells in the VCN classified as “small”.

The CN of some rodents contains a population of large cells scattered in the cochlear nerve root (Fig. 3), between the main body of the VCN and the glial Schwann-cell border of the AN. These cochlear ▶root

neurons have dendrites oriented orthogonal to the AN fibers and receive small boutons from axon collaterals of AN fibers (Fig. 3). The cochlear root neurons possess an exceptionally thick axon (5–7  $\mu\text{m}$ ) that projects mainly to the contralateral reticular pontine nucleus. These cells respond with a short latency and, like globular bushy cells, show primary-like with notch PSTHs to tones (Fig. 3) [4]. It has been suggested that these root neurons participate in the acoustic startle reflex [4].

### Dorsal Cochlear Nucleus

The ▶DCN shows large interspecies variations and is virtually absent in some cetaceans. It varies from being markedly laminated in rodents and carnivores (Figs. 2, top left, and 4), where it resembles the cerebellar cortex, to being non-laminated in humans and some bat species (see e.g. [4,5]).

The three superficial layers of the DCN are related to the morphology of the principal ▶fusiform cells (pyramidal). The spiny apical dendritic arbor of pyramidal cells occupies layer 1 together with granule cell axons and several other types of ▶interneurons (see below). Pyramidal cell bodies define layer 2, and their spinous basal dendritic arbors comprise layer 3. The pyramidal cells are the main ▶projection neurons of the DCN, supplying fibers to the contralateral IC via the DAS (Fig. 3). In addition, some have a direct projection to the medial division of the medial geniculate body [4]. Pyramidal cell dendritic arbors are flattened across the long, frequency gradient axis of the DCN (see, e.g. [2,4]). The highest degree of flatness and mutually parallel orientation is found in the basal arbor, which is supplied by primary afferents in a strictly tonotopic manner. The deepest layer of the DCN contains two size categories of cells, the giant cells which project to the contralateral IC through the DAS and smaller glycinergic tuberuloventral interneurons. As in the ▶VCN, each DCN cell type possesses unique anatomical, synaptic and intrinsic membrane features that allow it to convert auditory nerve input into a response pattern characteristic of that cell type.

Interneurons of the DCN may be divided into two systems, the ▶granule cell system, related to the apical dendritic arbors and cell bodies of pyramidal cells and the tuberuloventral system, related to the basal dendritic arbors of the pyramidal cells (Fig. 4).

The granule cell system includes the excitatory granule cells and unipolar brush cells as well as three types of inhibitory cells: the GABAergic Golgi and stellate cells and the glycinergic cartwheel cells [5]. The granule cells receive direct excitatory input from many sources including the somatosensory system [1,2]. Inhibitory input from these same sources also reaches the granule cells indirectly via the Golgi cells. The granule cells contribute parallel fibers to layer 1 where

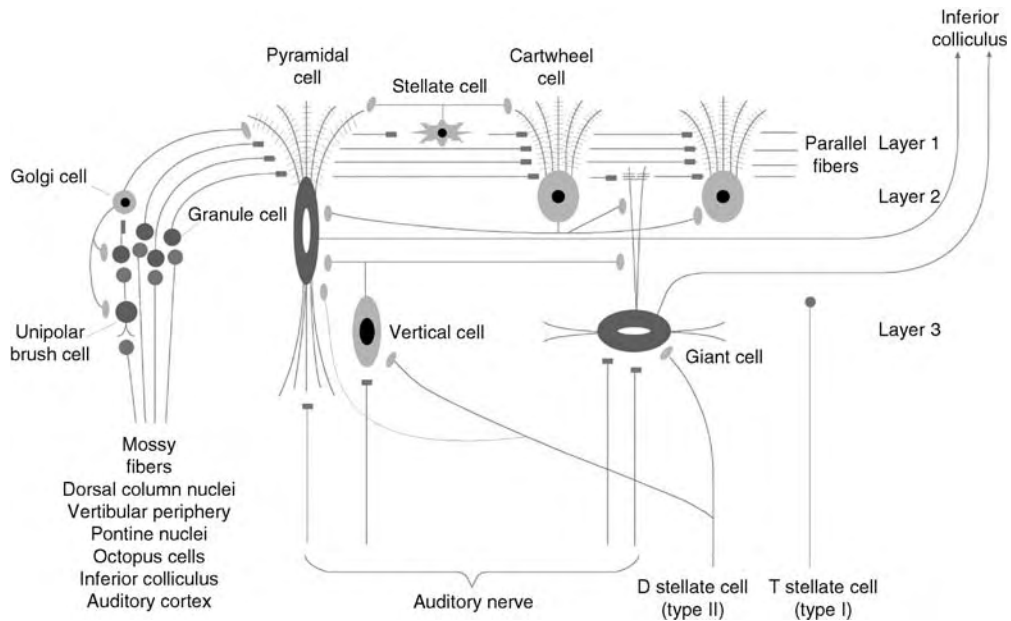

**Cochlear Nucleus. Figure 4** Diagrammatic representation (modified from Oertel and Young, 2004, see [5]) of the cell types and their connections in the superficial layers of the dorsal cochlear nucleus. See text for details.

they form asymmetric contacts en passant with the dendritic spines of both pyramidal cells and cartwheel cells and the smooth dendrites of the stellate cells. Such terminals show synaptic plasticity. The unipolar brush cells may represent a device for feedforward, excitation to links along the mossy fiber pathways. The stellate cells and cartwheel cells provide feed-forward inhibition to the pyramidal cells. Very little is known about the responses of cells in the granular cell system to auditory stimuli. Cartwheel cells show complex spikes (two or three action potentials riding on a depolarization) and weak responses to auditory stimuli that are difficult to classify.

The **tuberculoventral system** reciprocally interconnects the DCN and VCN. It contains both frequency specific and diffuse projections [1,2]. The frequency specific projection from the DCN to the VCN originates from small interneurons, a subset of the glycinergic “vertical cells” (Fig. 4).

A separate set of vertical cells with only local collaterals contain both GABA and glycine, the relative amounts of which vary among species. They are located amongst the basal pyramidal cell dendrites in layer 3. The dendritic arbors of the vertical cells that project to the VCN are flattened and parallel to the pyramidal cell basal dendrites in the isofrequency planes. They receive primary afferents and project to the VCN via the tuberculoventral tract after giving off recurrent collaterals to the DCN, which terminate on pyramidal cells [2,3]. Thus, the vertical cells of the DCN provide

tonotopically organized inhibition in both the DCN and VCN. Responses of positively identified vertical cells that do not project to the VCN (type II) are characterized by little or no spontaneous spiking, non-monotonic rate level functions, little or no response to noise and a tone-evoked PSTH that consists of an onset response followed by a gradual decrease in activity. The tonotopic, presumably excitatory projection from the VCN to the DCN is made up of the collaterals of type I multipolar or planar cells described above (see [4]). The inhibitory projection from the VCN to DCN is composed of axons of the glycinergic commissural radiate or D-stellate cells described above. It has been speculated that off-CF or wideband inhibition from these cells might allow these cells to function as “spectral contrast detectors” [9]. Some small cells of the marginal shell surrounding the AVCN also project to the DCN. They receive ascending inputs from type II auditory nerve fibers and descending cholinergic inputs [4]. Thus, these cells emerge as very interesting players in the integration of neural activity in ascending and descending systems. Finally, yet another type of neuron referred to as adendric has been found to participate in the VCN to DCN projection (see [4]).

Pyramidal and giant cell excitatory responses are more strongly influenced by their inhibitory inputs than are those of other projection neurons in the CN, and have been classified as type III and IV [10]. Much of the inhibition is thought to arise from two cell types, the DCN vertical cells and the glycinergic type II stellate

cells in the VCN described above. The vertical cells provide inhibition over a narrow frequency range while the on-chop, type II stellate cells generate inhibition over a wide frequency range. This inhibition also presumably accounts for the response patterns of these cells to pure tones, which have been classified as “pauser” (Onset response followed by a pause then a resumption of firing, see Fig. 3) and “build-up” (a slow buildup of spike activity rather than an abrupt increase in firing). Behavioral studies in cats following surgical lesions of the dorsal and intermediate acoustic striae suggest that the DCN plays some role in directing attention to sound. The type IV units have been found to be sensitive to spectral notches created by the pinna, that may be important cues for localizing sounds. DCN projection neurons receive and respond not only to auditory information but to somatosensory inputs from muscle proprioceptors in and around the pinna as well [4]. Such evidence has led to speculation that the DCN output may be involved in coordinating pinna orientation with localization cues found in the different spectra of sounds located at different points in space (see [10]). In fact, bilateral lesions of the DAS in cats result in reduced accuracy in head orientation responses to broad-band sounds, particularly in elevation.

## References

1. Cant NB, Benson CG (2003) Parallel auditory pathways: projection patterns of the different neuronal populations in the dorsal and ventral cochlear nuclei. *Brain Res Bull* 60:457–474
2. Osen KK (1988) Anatomy of the mammalian cochlear nuclei, a review. In: Syka J, Masterton RB (eds) *Auditory pathway, structure and function*. Plenum Press, New York, pp 65–75
3. Osen KK (1969) Cytoarchitecture of the cochlear nuclei in the cat. *J Comp Neurol* 136:453–484
4. Malmierca MS (2003) The structure and physiology of the rat auditory system: an overview. In: Bradley RJ, Harris RA, Jenner P (eds) *Int Rev Neurobiol* 58:147–211. Academic Press, San Diego
5. Oertel D, Young ED (2004) What’s a cerebellar circuit doing in the auditory system? *Trends Neurosci* 27:104–110
6. Trussel LO (2002) Cellular mechanisms for information coding in auditory brainstem nuclei. In: Oertel D, Fay RR, Popper AN (eds) Chapter 3 in *Springer handbook of auditory research*, vol 15: Springer, Berlin Heidelberg New York, pp 72–98
7. Young ED, Shofner WP, White JA, Robert JM, Voigt HF (1988) Response properties of cochlear nucleus neurons in relationship to physiological mechanisms. In: Edelman GM, Gall WE, Cowan WM (eds) *Auditory function: neurobiological bases of hearing*. Wiley, New York, pp 277–312
8. Oertel D (1999) The role of timing in the brain stem auditory nuclei of vertebrates. *Ann Rev Physiol* 61:497–519
9. Doucet JR, Ross AT, Gillespie MB, Ryugo DK (1999) Glycine immunoreactivity of multipolar neurons in the ventral cochlear nucleus which project to the dorsal cochlear nucleus. *J Comp Neurol* 408:515–531
10. Young ED, Davis KA (2002) Circuitry and function of the dorsal cochlear nucleus. In: Oertel D, Fay RR, Popper AN (eds) Chapter 5 in *Springer handbook of auditory research*, vol 15: Springer, Berlin Heidelberg New York, pp 160–206

---

## Cocontraction

### Definition

Simultaneous activation of muscles with opposite mechanical action on a joint (antagonists). Since the net torque acting on a joint is the algebraic sum of the torques generated by the individual muscles, torques with opposite signs cancel each other and the net torque may be zero. However, for a given net torque, the joint stiffness (the torque resisting an externally imposed joint displacement) increases with the level of cocontraction.

### ► Reaching Movements

---

## Code, Coding

### Definition

When information is stored, it has to be encoded. The nervous system stores information. Therefore, neurons must code information (see also ensemble code, grandmother neuron).

---

## Coelacanth

### Definition

Group of sarcopterygian fish once thought to be extinct but then found unexpectedly in an African fish market in 1938. Modern coelacanths are deep sea fin only rarely caught by fisherman and unable to survive in shallow waters.

### ► The Phylogeny and Evolution of Amniotes

## Coenzyme Q10

### Definition

A cofactor (a vitamin-like substance) upon which at least three mitochondrial enzymes (complexes I, II and III) depend for their function. The mitochondrial enzymes are essential for the production of energy in the cell.

## Coeruleospinal Tract

### Synonyms

Tractus caeruleospinalis

### Definition

In the dorsal noradrenergic bundle of the locus coeruleus, fibers run in the direction of the spinal cord where they run in the lateral column and pass to all segments of the spinal cord, terminating in the posterior horn, in the anterior horn and in the intermediate substance. This portion of the coerulean efferents are globally called the coeruleospinal tract.

► Mesencephalon

## Cognition

### Definition

Mental processes that includes – according to Neisser (Cognitive Psychology, Englewood Cliffs, NJ: Prentice-Hall 1967) – transformation, reduction, elaboration, storage, recovery and usage of sensory information.

## Cognition Enhancement

► Memory Improvement

## Cognitive Aging

► Cognitive Impairment

## Cognitive Behavior Therapy

### Definition

A form of psychological intervention that focuses on changing maladaptive thoughts, beliefs and behaviors.

► Pain in Older Adults (Including Older Adults with Dementia)

## Cognitive Decline

► Cognitive Impairment

## Cognitive Development

BEATE SODIAN

Department of Psychology, Ludwig-Maximilians-Universität München, München, Germany

### Synonyms

Intellectual development; Mental development; Development of thinking

### Definition

Cognitive development refers to changes with age in human ontogeny in mental processes and abilities, that is, the development of higher mental processes such as problem solving, reasoning, conceptualizing, classifying, and planning, as well as more basic processes such as perception and language. Although modern developmental psychology studies psychological change over the entire lifespan, the field of childhood cognitive development is distinct from cognitive development in adulthood, in terms of theoretical issues and research paradigms. Only childhood cognitive development will be covered in this article.

### Characteristics

Accounts of cognitive development in childhood address three major issues: (i) The initial (newborn) state, (ii) The description of “what” develops in children’s thinking, and (iii) Accounts of how developmental change occurs. The field of childhood cognitive development was shaped by Jean Piaget (1896–1980) who viewed children’s thinking as a source of insight into fundamental

epistemological issues (see [1], for an overview). Current theories of cognitive development generally subscribe to a view of human cognition as an information processing system and ask for similarities and differences between children's and adults' information processing. Most modern approaches can also be seen as alternatives to Piaget's theory, in the sense that they address major weaknesses of Piaget's theory and propose alternative solutions.

### Piaget's Theory

In Piaget's view, infants begin life equipped with reflexes, perceptual abilities and basic learning mechanisms that allow them to actively construct their own knowledge. This constructive process starts at birth and is driven by the interplay of two complementary adaptive mechanisms, assimilation (the construal of external objects or events in terms of the child's present mental structures) and accommodation (the adaptation of existing mental structures in response to environmental pressure). Piaget viewed development as progression through an ordered sequence of stages which involves qualitative reorganization of the cognitive system. In the sensorimotor period (birth to 2 years) intelligence is bound to immediate perceptions and actions. Infants form sensorimotor representations of motor behaviors and construct fundamental concepts through their interactions with the environment. Piaget inferred cognitive immaturity from immature motor behaviors. For instance, he concluded from infants' immature search behaviors that they lack the concept of a "permanent" object that continues to exist independently of the infant's object directed actions. Towards the end of the sensorimotor period, with the onset of language, children acquire symbolic-representational thought. In the preoperational stage (age 2–7) children have the cognitive capability to represent past and future events, and to engage in symbolic activities. However, their cognition is limited by the inability to perform operations (reversible mental activities). Thus, they often focus on a single, perceptually salient aspect of an event, and fail to solve tasks in a logically consistent way. For instance, preschoolers are often misled by changes in appearance, such as the height of the level of liquid after pouring it from a wider into a taller, narrower glass. Their failure to mentally reverse the pouring operation results in a failure to "conserve" liquid quantity. Preschoolers' pre-logical thinking is also pre-causal and egocentric since preoperational children are limited in their ability to construct fundamental concepts that underlie our understanding of reality. In the concrete operational stage (age 7–11) children overcome these limitations and reason logically about concrete objects and events, based on fundamental concepts such as time, space, and causality. In the formal operational stage (age 11–15) young adolescents go beyond the limits

of concrete operational reasoning in thinking hypothetically or theoretically about problem domains. They systematically test hypotheses and draw appropriate conclusions from their experiments according to the standards of scientific rationality.

Critical evaluations of Piaget's theory have focused on three major weaknesses [1]: (i) Empirical findings indicate that children's thinking at any given point in development is much less consistent than the stage model predicts. Thus, Piaget's elegant description of developmental change as a series of major cross-domain "structural" changes is not well supported by empirical evidence. (ii) Piaget greatly underestimated infants' and young children's cognitive capabilities. (iii) Piaget's theory is vague with respect to the mechanisms underlying developmental change. Since the 1970s the critical evaluation of Piaget's claims about young children's cognitive limitations has led developmentalists to adopt an "early competence" view of cognition in children: To mention just a few examples: Young preschoolers' causal reasoning is quite similar to adults' when task demands are kept simple, even toddlers master simple forms of visual perspective taking, rather than being fundamentally egocentric, and five-year-olds can integrate dimensional information, rather than focusing on just one dimension. Even more impressively, infants have been shown to be cognitively competent when tested with looking-time methods [2]. With the violation-of-expectation method it was shown that 3.5-month-olds are surprised when seeing a physically impossible event (a screen apparently passing through the space where a box was), thus indicating object permanence. Numerous studies have shown physical, numerical and social reasoning abilities in young infants which are inconsistent with Piaget's view of sensorimotor intelligence. Thus, Post-Piagetian research has led developmentalists to recognize similarities, rather than fundamental differences between children's and adults' thinking, and to emphasize continuity rather than discontinuity in cognitive development. Two major theoretical approaches have emerged as alternatives to Piaget's theory: Information-processing theories which focus on the development of domain-general capacities, such as processing speed and strategies, and theories of conceptual development which focus on the development of knowledge in foundational domains.

### The Information-Processing Approach

Since the 1970s, information-processing accounts of cognitive development have productively used the metaphor of the child as a computational system. Like computers, humans suffer from limited information processing resources. Limitations may be due to hardware and/or software features, that is, the speed and efficiency with which basic processes are executed on

the one hand, and strategies and knowledge on the other hand. Information processing theorists attempt to specify in computational terms the cognitive processes underlying children's task performance, and the sources of developmental growth. This approach has led to a reinterpretation of some of the cognitive limitations described by Piaget. For instance, in Piaget's view, preschoolers' failure to draw correct transitive inferences ("Peter is taller than Max," "Max is taller than John." "Who is taller? Peter or John?") is due to the "structural" limitations of preoperational (pre-logical) thought. Training experiments showed, however, that preschool children can reliably draw transitive inferences when they are taught to memorize the premise information. Thus, developmental progress appears to arise from children's increasing ability to surmount processing limitations, rather than from a stage-like, qualitative change in logical reasoning abilities. The information processing approach has focused on problem solving and memory development [3]. Important determinants of memory development are speed of information processing, which increases greatly over childhood due to both biological maturation and experience, strategy development, the development of content knowledge and metamemory (memory-related knowledge and monitoring abilities). These cognitive processes interact in enhancing cognitive performance. While Neo-Piagetian information processing theories have retained the stage-model, describing children's thinking at each stage in information processing terms, and specifying developmental mechanisms, alternative theories focus on cognitive variability at each given point in development. Siegler [4] proposes an "overlapping-waves" model of strategy development, claiming that children possess more than one strategy for solving a given type of problem, and that strategic variability has an adaptive function throughout development. Other alternative information processing theories are ►**connectionist** theories, emphasizing parallel distributed information processing. Connectionist modeling has demonstrated that apparently discontinuous developmental changes may reflect gradual, incremental progress. While most information processing models have focused on a single aspect of cognitive functioning, ►**dynamic systems theory** [5] addresses the interrelations among perception, motor behavior, attention, language, and conceptual understanding. This approach has contributed to a revision of the interpretation of classical developmental phenomena, such as infant search errors which were attributed to a lack of conceptual understanding. The dynamic systems approach emphasizes the interplay between motor activities and attention in influencing success on such tasks, and has improved our understanding of how development progresses on a microgenetic level of analysis.

## Conceptual Development

Both Piagetian and information processing approaches view development as a domain-general process of acquisition and refinement of cognitive abilities. Both approaches make minimal assumptions about the cognitive capabilities the infant is equipped with at birth (i.e. perceptual abilities, general learning mechanisms). In contrast, Post-Piagetian research on conceptual development emphasizes the domain-specificity of cognitive development, and makes assumptions about innate domain-specific knowledge and domain-specific learning mechanisms [6]. One reason to assume that domain-specific conceptual understanding underlies developmental change is that many claims about domain-general, across the board changes have been proven wrong. For example, Piaget attributed childhood animism (young children's tendency to attribute properties of living things to inanimate objects) to pre-causal thinking (a failure to understand mechanical causality, resulting in a tendency to explain all phenomena in terms of intentional causality). This interpretation cannot be correct, since more recent research found no deficits in preschoolers causal reasoning when tasks were chosen from domains that preschoolers were able to understand. An alternative explanation for childhood animism is a lack of conceptual understanding of biological phenomena (properties and functions shared by all living things) resulting in an overattribution of life to non-living things [7]. Knowledge acquisition in foundational domains (biology, physics, psychology) cannot be analyzed in terms of domain-general causal or logical reasoning, since each domain is characterized by specific core concepts and explanations. Thus, we explain psychological phenomena in terms of beliefs and desires, and physical phenomena in terms of gravity and inertia. Recent research on infant cognition indicates that young infants possess core knowledge in foundational domains: They expect physical objects to be solid and to move on continuous paths, they distinguish between living and non-living things, and they understand human action as goal-directed. Such findings support "core-knowledge" theories [8] which postulate innate domain specific systems of knowledge characterized by a set of core principles that define the entities covered by the domain and support reasoning about these entities. Such innate specialized learning abilities allow the infant to quickly acquire domain-specific knowledge of evolutionary importance. If core-knowledge is innate, what develops? There is evidence for both continuity and discontinuity in conceptual development [9]. Continuity can be seen as an enrichment of core principles. Discontinuity involves conceptual change. One model of conceptual change is theory change in the history of science [7].

An example of conceptual development in a domain of evolutionary importance is ►**theory of mind development**, that is, the ability to attribute mental states to



oneself and others (see [10], for an overview). Core concepts of our common-sense mentalistic explanations of human action are beliefs and desires. Children acquire a concept of belief (i.e. the ability to differentiate beliefs from reality) relatively late, around the age of four years. Desire-reasoning (in 2- and 3-year-olds) developmentally precedes belief reasoning, and reasoning about action goals can be demonstrated even in the second half of the first year of life. Children with autism suffer from a severe and specific delay in theory of mind development. Domain-specific theories of theory of mind development have recently received support from brain-imaging studies, indicating a specialized mindreading system in the human brain.

### Conclusions

Cognitive development in childhood can be viewed as an interplay between domain-general changes in speed and efficiency of information processing, strategies, and metacognition, and domain-specific acquisition of conceptual knowledge. Research on infant cognition indicates that humans possess core knowledge in important domains early in life, possibly innately. Both enrichment of core principles and conceptual change contribute to cognitive development.

### References

1. Miller PH (2002) Theories of developmental psychology, 4th edn. Worth, New York, NY
2. Baillargeon R, Kotovsky L, Needham A (1995) The acquisition of physical knowledge in infancy. In: Sperber D, Premack D, Premack A (eds) Causal cognition: A multidisciplinary debate. Oxford University Press, New York, pp 79–116
3. Schneider W, Bjorklund DF (1998) Memory. In: Kuhn D, Siegler RS (eds) Cognition, perception and language development, vol 2. In W. Damon (Hrsg.) Handbook of child psychology. Wiley, New York
4. Siegler RS (1994) Cognitive variability: a key to understanding cognitive development. *Curr Dir Psychol Sci* 3:1–5
5. Thelen E, Smith LB (1998) Dynamic systems theory. In: Damon W, Lerner RM (eds) Handbook of child psychology, vol 1: Theoretical models of human development, 5th edn. Wiley, New York, pp 563–634
6. Wellman HM, Gelman SA (1998) Knowledge acquisition in foundational domains. In: Kuhn D, Siegler RS (eds) Handbook of child psychology, vol 2, 5th edn. Wiley, New York, pp 523–573
7. Carey S (1985) Conceptual change in childhood. MIT Press, Cambridge, MA
8. Carey S, Spelke ES (1994) Domain-specific knowledge and conceptual change. In: Hirschfeld LS, Gelman SA (eds) Mapping the mind: Domain specificity in cognition and culture. Cambridge University Press, Cambridge, England, pp 169–220
9. Carey S (1995) Continuity and discontinuity in cognitive development. In: Smith EE, Osherson DN (eds) Thinking: An invitation to cognitive science, vol 3, 2nd edn. MIT-Press, Cambridge, MA, pp 101–129
10. Sodian B (2005) Theory of mind. The case for conceptual development. In: Schneider W, Schumann-Hengsteler R, Sodian B (eds) Interrelationships among working memory, theory of mind, and executive functions. Erlbaum, Hillsdale, NJ, pp 95–130

## Cognitive Dimension

### Definition

The way an individual thinks about or processes information in response to a particular setting, process, characteristic, attitude, or sensation. A full description of a particular item would usually include the cognitive dimension of the item, along with its affective and behavioral dimensions (plus sometimes the sensory dimension).

## Cognitive Elements in Animal Behavior

ANDREAS NIEDER

Primate NeuroCognition Laboratory, Department of Cognitive Neurology, Hertie-Institute for Clinical Brain Research, University of Tuebingen, Tuebingen, Germany

### Synonyms

Cognitive ethology; Complex behavior; Intelligent behavior; Flexible behavior; Adaptive behavior

### Definition

Cognition can be seen as a “behavioral survival device” to solve problems in the individual’s complex environment. According to Tomasello & Call’s [1] ecological approach, cognitive processes “(i) are organized *flexibly*, with the individual organism making decisions among possible courses of action based on an assessment of the current situation in relation to its current goal, and (ii) involve some kind of mental *representation* that ‘goes beyond the information’ given to direct perception.” Rather than simply coding outside information that is directly routed to motor output (e.g., as in reflexes), cognition involves all sorts of adaptable behaviors that evaluate information in the light of external and internal states to allow an individual to perform informed choices.

Over the last decades, it became evident that many complex behaviors cannot be understood without attributing mental, cognitive states to animals.

“Cognitive ethology” emerged as a new behavioral science to analyze high-level aspects of behavior, which, in turn, tremendously inspired brain research. Examples of cognitive phenomena that will be addressed in this essay are: (i) Categories & Concepts, (ii) Referential communication, (iii) Intentionality & Theory of Mind, and (iv) Conscious perception.

## Characteristics

### Higher Level Processes

#### Categories & Concepts

Perceptual ►**categorization** refers to the recognition of different entities as members of the same group based on some internal representation. Strategies to achieve perceptual categorization are the memorization of individual stimuli, feature analysis, and the formation of prototypes. Categories provide useful grouping criteria across stimulus dimensions. For adaptive behavior, an individual must thus learn and memorize which objects can be regarded as being the “same,” belonging to the same category, or being “different,” belonging to another category. This involves the learning of abstract relations (e.g., more/less, same/different) to form categories, a process termed “►**conceptualization**” (or conceptual categorization, respectively).

Insects have long been viewed as simple reflex automata, not capable of complex behavioral flexibility. However, experiments in honeybees showed that at least some insects are endowed with complex visual learning and memory capacities, such as contextual learning, categorization and conceptualization. The classical behavioral protocol to test learning of relationships is the ►“**delayed matching-to-sample**” task. In such a task, animals are presented with a sample stimulus and temporally delayed with a set of test (or comparison) stimuli. One of the test stimuli matches the sample stimulus (in some feature dimension), and the animal’s task is to always choose this correct match, despite the fact that the matching test stimulus is being changed regularly. Giurfa and co-workers [2] trained bees on a delayed matching-to-sample task in which they were presented with a changing sample stimulus (one of two different color disks, or one of two different black-and-white gratings) at the entrance of a maze (Fig. 1).

Once they entered the maze, the bees’ task was to approach the test stimulus that was identical to the sample to receive a sucrose solution reward. For example, bees confronted with a yellow disk as sample stimulus were required to choose the yellow disk inside the maze and avoid the blue disk. Most importantly, bees that learned such a concept of “sameness” were able to apply it successfully in so-called ►“**transfer tests**,” in transfer tests, subjects are confronted with novel stimuli they have never experienced before. In addition, to prevent subjects from learning a “correct” answer, choice behavior is not reinforced (i.e., the

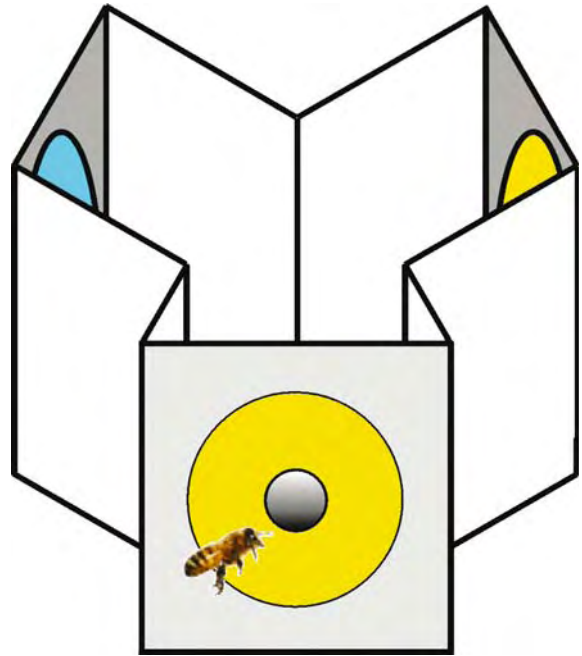

#### Cognitive Elements in Animal Behavior.

**Figure 1** Delayed matching-to-sample test demonstrating categorization and conceptualization in bees. A graphical sketch of the experimental setup (y-maze) to test bees is shown. The sample is presented at the entrance of the maze (here: *yellow disk*). The bees should pass through the sample disk and choose the matching color (*yellow*) at the rear of the maze to receive sucrose solution. Adapted from [2].

animals are randomly rewarded independent of their performance). The huge advantage of transfer trials is that they allow the investigation of how an animal applies rules learned in one situation to another, novel situation without having been conditioned by reward contingencies. Importantly, bees examined in transfer tests were able to apply the concept of “sameness” to new situations. For example, bees trained with texture stimuli and tested with color stimuli in transfer tests also solved the problem and chose the novel color corresponding to that of the colored disk at the maze entrance. Even more, transfer was not constrained to the visual domain (color versus pattern), but could also operate between different sensory domains, such as vision and olfaction. Bees that were trained to match odors (lemon and mango) were spontaneously able to match color in transfer tests.

Deriving the quantity of items is another, most abstract form of categorization. The ability to judge the number of items is highly adaptive; social animals such as primates make decisions to fight or flee by judging the relative number of friends versus foes. In foraging, choosing a larger alternative can contribute to survival. Not surprisingly, therefore, numerical competence

has been described in many species, most notably birds (corvids, parrots, pigeons) and mammals (rats, monkeys, apes). These animals show an approximate capacity to derive numerosity, they have a rudimentary understanding of *cardinal number* (estimating set size). Recently, a neural correlate for numerosity discrimination was described in the prefrontal cortex of monkeys performing a delayed matching-to-sample task based on the number of displayed items [3]. Single neurons were found to be tuned to different preferred numerosities (Fig. 2), thus forming a bank of overlapping quantity filters that can explain fundamental effects in numerical discrimination.

Beyond mere numerosity discrimination, an elegant study by Brannon & Terrace [4] demonstrated that rhesus macaques were even able to understand the ordinal relationship among numerosities; in other words, the monkeys understood that four was larger than three, but smaller than five. Numerical competence in animals is of special interest because it is thought

to form an evolutionary precursor for verbal counting abilities in human adults.

### Referential Communication

Classification of stimuli can be based on sensory features. In social animals, however, such a simple classification scheme may fall short if there is a need to communicate information from one group member to another. Human speech is an impressive example of a communication system that is not primarily based on acoustic features, but rather on the meaning of a sound. Even though the words “enemy” and “foe” sound completely different in terms of their acoustic features, we know immediately that we are dealing with an opponent who may do us harm. Thus, humans categorize speech sound based on “referential” similarities, similarities in meaning (or semantics, respectively).

Vervet monkeys produce acoustically distinct alarm calls in response to potential predators (Fig. 3). The call types are specific for the type of predator (e.g., an

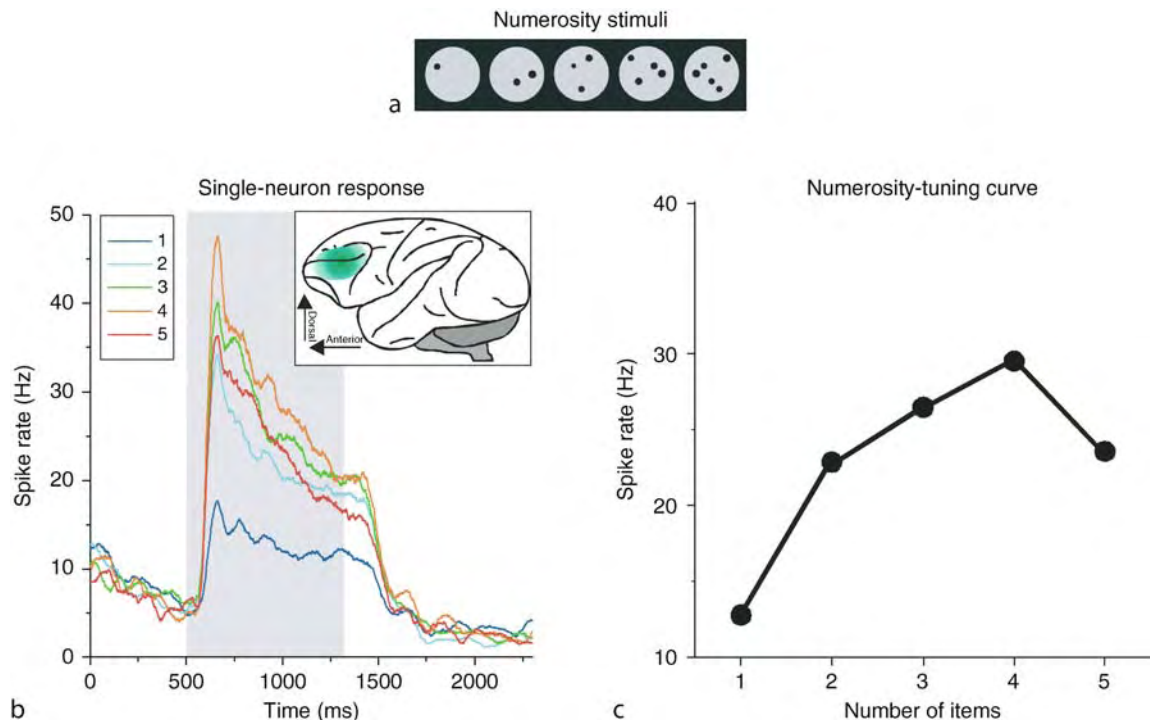

**Cognitive Elements in Animal Behavior. Figure 2** Neural basis of numerical competence. (a) Rhesus monkeys were trained to discriminate the number of dots. While the monkeys performed the numerosity discrimination task, discharges from single neurons were recorded from the prefrontal cortex (see inset in B, showing a lateral view of a rhesus macaque brain with the prefrontal cortex shaded in green). (b) Spike density histogram illustrating the average response of a single neuron to numerosities one to five (see color code for line graphs). After 500 ms, the numerosity was displayed for 800 ms (time interval shaded in grey), which elicited vigorous discharges. The neurons, however, responded with different strengths to different numerosities. In (c), the same neuron’s responses are averaged and plotted against the number of shown items. This very neuron formed a tuning curve and discharged maximally to numerosity “four”, its preferred numerosity. Different neurons had different preferred numerosities. The neurons encoded abstract numerical information rather than visual parameters that may co-vary with an increase in the number of items (data not shown). Data modified from [3].

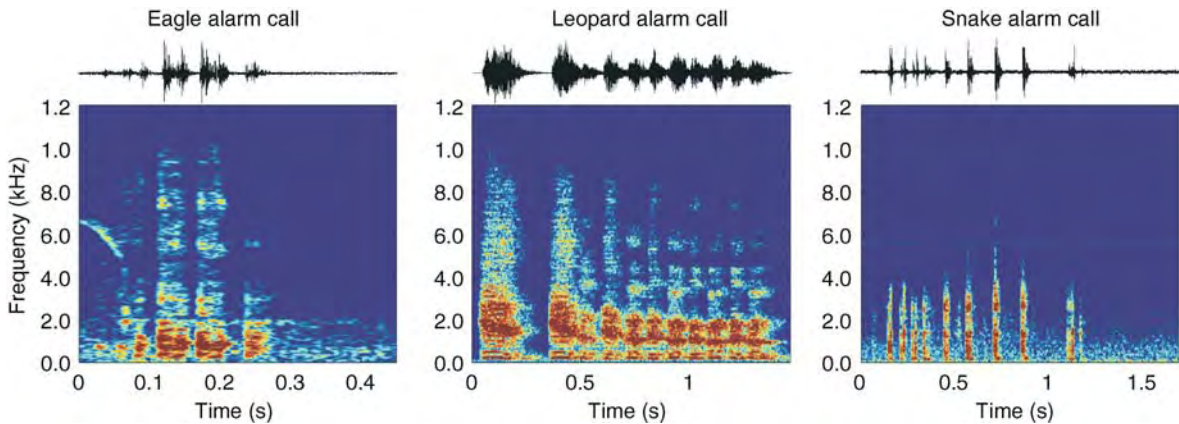

**Cognitive Elements in Animal Behavior. Figure 3** Vervet monkey alarm calls. Vervet monkeys have three major call types to warn of predators (from left to right): “eagle alarm call”, “leopard alarm call”, and “snake alarm call”. The calls are visualized as oscillograms (top panels, sound amplitude plotted against time) and spectrograms (bottom panels, sound frequency plotted against time, yellow to reddish color indicates high sound intensity). Note the different time scales.

“eagle alarm call” is only used when seeing flying birds of prey) and elicit specific and reasonable reactions (e.g., the monkeys climb up a tree when the “leopard alarm call” is heard). Experiments with playbacks (recorded alarm calls played through a speaker) demonstrated that recipients respond to the calls as they do to the actual predator in sight, which indicates that these calls may convey meaning [5]. Referential communication is also suggested through studies using the habituation-dishabituation protocol (animals habituate and stop responding to frequently repeated stimuli, but they dishabituate and become responsive again as soon as a novel stimulus is presented). It could be shown that habituation is not due to acoustic similarity of the alarm calls, but depends on the semantic context of the calls. For example, monkeys habituate if they hear an eagle alarm call followed by an original eagle call, but they do not habituate if they hear a leopard alarm call followed by an original eagle call. Therefore, these non-human primates appear to process alarm calls on a conceptual-semantic (i.e., referential) rather than a perceptual-acoustic level [6]. Referential signaling in monkeys, however, remains a controversial issue; it has been argued that vocalizations may simply elicit emotional (affective) responses in the recipient, which may then alter the recipient’s behavior. Thus, alarm calls are often said to be *functionally* referential.

#### Intentionality and “Theory of Mind”

Do monkeys purposely warn their conspecifics of a potential prey, in other words, do animals intend to inform their group mates? Intentional states are characterized as being *about* things, like beliefs and desires, plans and wishes. From a philosophical point

of view, different orders of intentionality are distinguished [7]: Organisms are said to have zero-order intentionality if they lack beliefs, desires or other intentional states at all, i.e., they show behavior as mere response to stimuli. First-order intentionality encompasses an agent having beliefs and desires about the world (e.g., a vervet monkey *wants* to warn a fellow monkey). Second-order intentionality would be evident if a sender *wanted* a receiver to *believe* something (in our example, a monkey giving a leopard warning call wants another monkey to believe that a leopard is approaching).

Neuroscientists studying the neural basis of expectation, planning, self-monitoring and the like would attribute desires, wishes and plans, and thus, first-order intentionality to “higher” animals. Whether animals have second-order intentionality, meaning that an animal is capable of having beliefs regarding another’s beliefs, is a much more difficult question. Second-order intentionality, however, is a defining characteristic of what is called “theory of mind” (TOM). An animal has a TOM when it can form a representation of the beliefs, desires and capabilities of other animals, and so predict other animals’ behavior and the probable consequences of their actions in an internal model. TOM may be a defining characteristic of adult human mental states that develops over the first years of childhood. Therefore, research on TOM has been done almost exclusively with non-human primates, particularly apes.

The strongest support for TOM in apes comes from recent experiments in which a dominant and a subordinate chimpanzee compete over food [8]. Normally, the dominant chimpanzee takes all the food in a competitive situation, and the subordinate misses out. However, when a subordinate can see a piece of

food that the dominant cannot see due to a physical barrier, the subordinate takes advantage of this situation by avoiding the food the dominant can see and instead pursuing the food the dominant cannot see. A subordinate also seems to know whether a dominant has just witnessed a human hiding food; the subordinate avoids the food the dominant has seen being hidden and instead pursues the food the dominant had not seen being hidden. These experiments indicate that chimpanzees can understand some psychological states in others.

### Conscious Perception

Consciousness can be divided into different aspects. Conscious perception, defined here as access to and evaluation of sensory representations to draw informed choices, has become the most rewarding line of neuroscience research to tackle the problem of consciousness. Bistable visual illusion phenomena offer a fascinating window into conscious processing. Bistable percepts result from the brain having to decide whether an image should be perceived in one or the other way, thus perception regularly switches between two different interpretations of a sensory input (Fig. 4).

Bistable percepts are also present in binocular rivalry phenomena, when two different images are projected onto the left and right eyes, respectively, but only one of them can be perceived in alternation. Logothetis and co-workers [9] exploited binocular rivalry by training monkeys to report whether they saw the left eye picture or the right eye picture at a given moment. While the monkeys reliably reported the perceptual

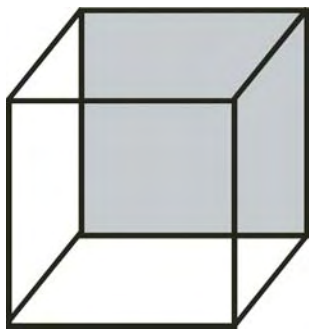

### Cognitive Elements in Animal Behavior.

**Figure 4** Necker cube. The drawing is perceived as a three-dimensional cube, but the perspective changes every few seconds: Note that the grey surface of the cube is sometimes seen as the rear panel, next time as the front panel. The Necker cube is a nice example of a bi-stable percept, showing that conscious perception inevitably switches in certain ambiguous situations. Switching of conscious percepts is reflected in the responses of neurons in the primate visual cortex (see text).

switching between the two images, the researchers recorded the activity of single nerve cells in the visual brain of the behaving monkeys. Only neurons at advanced stages of the visual hierarchy, i.e., cells in inferior temporal cortex that are known to encode very complex visual stimuli (such as faces), responded vigorously when the monkey indicated to consciously perceive an image. These neurons remained silent without conscious experience by the monkey.

Another fascinating way to see consciousness at work is to study the ability to shift **▶attention**, thus being aware of features we attend to, while filtering out not attended aspects that do not reach conscious experience. Many animals are able to shift attention. For example, attention improves the ability of barn owls to localize a sound source; barn owls moved their head faster towards the direction of a sound source if they attended to this location. Electrophysiological recordings in behaving monkeys showed that neuronal responses to attended locations or stimulus features are enhanced, whereas those from unattended locations or features are suppressed. This influence of attention increases as one ascends the hierarchy of visual areas in primate cortex. At the highest processing levels, the neural representation of the visual world is dominated by the behavioral relevance of the information, rather than mirroring an accurate and complete description of it [10].

Conscious perception is an empirically addressable issue; other aspects of consciousness, however, may scarcely be accessible to objective investigations. The “hard problem” of consciousness relates to the question of how elemental personal feelings and impressions arise from neuronal discharges. These only-subjective experiences (“**▶qualia**”), such as the taste of wine or the aching of a tooth, are only accessible via introspection. Whether other animals have “qualia”, or even how this question may be addressed in an objective, scientific way, remains a fundamental philosophical question.

### References

1. Tomasello M, Call J (1997) Primate cognition. Oxford University Press, New York
2. Giurfa M, Zhang S, Jenett A, Menzel R, Srinivasan MV (2001) The concepts of ‘sameness’ and ‘difference’ in an insect. *Nature* 410:930–933
3. Nieder A, Freedman DJ, Miller EK (2002) Representation of the quantity of visual items in the primate prefrontal cortex. *Science* 297:1708–1711.
4. Brannon EM, Terrace HS (1998) Ordering of the numerosities 1 to 9 by monkeys. *Science* 282:746–749
5. Cheney DL, Seyfarth RM (1990) How monkeys see the world: inside the mind of another species. Chicago University Press, Chicago
6. Zuberbühler K (2003) Referential signalling in non-human primates: cognitive precursors and limitations for the evolution of language. *Adv Stud Behav* 33:265–307

7. Dennett DC (1983) Intentional systems in cognitive ethology: the “Panglossian paradigm” defended. *Behav Brain Sci* 6:343–390
8. Tomasello M, Call J, Hare B (2003) Chimpanzees understand psychological states - the question is which ones and to what extent. *Trends Cogn Sci* 7:153–156
9. Logothetis NK (1999) Vision: a window on consciousness. *Sci Am* 281:69–75
10. Treue S (2001) Neural correlates of attention in primate visual cortex. *Trends Neurosci* 24:295–300

## Cognitive Enhancers

### Definition

Drugs that are proposed to enhance cognitive functions such as attention, learning and memory without affecting other physiologic functions in humans with cognitive deficits as well as in healthy subjects.

#### ► Memory Improvement

## Cognitive-enhancing Drugs

#### ► Nootropic Drugs

## Cognitive Ethology

#### ► Cognitive Elements in Animal Behavior

## Cognitive Functions

FRED W. MAST  
Department of Psychology, University of Lausanne,  
Bâtiment Anthropole, Lausanne, Switzerland

### Definition

Cognitive functions are concerned with mental processes and activities used in perceiving, remembering, problem solving and thinking. Cognitive functions are studied experimentally.

## Introduction

This synopsis focuses on cognitive functions and how they are related to brain processes. Particular emphasis is given to knowledge based on behavioral research in cognitive psychology, which has established an inventory of well-defined tasks and sound experimental designs necessary for a thorough assessment of cognitive functions. However, the results based on behavioral research were not always conclusive regarding the underlying mechanisms. Either of two otherwise totally different psychological theories could sometimes equally well account for exactly the same pattern of behavioral results. Consequently, there was a need for an independent data source allowing for discrimination between competing theories. Only with the advent of new technologies do we now have such an independent database at hand. In particular, the study of neuronal activation enabled us to better understand the nature of the mechanisms that underlie a cognitive task. The combination of behavioral data paired with brain activation patterns can provide a strong support for a cognitive theory. Bridging the gap between cognitive performance and brain function is precisely the core idea of cognitive neuroscience. With the rise of this discipline a plurality of different methods has deeply enriched the study of cognitive functions. This synopsis will provide an overview of the main fields of research on cognitive functions, which is a rapidly growing field with many new insights yet to come.

The word cognition has its origin in the Latin word “cognoscere,” which means “to become acquainted with, to get to know.” Interestingly, the term cognition was not used until the nineteenth century and only then has it gotten more influential when it came to counter the claims raised by behaviorist psychology. Cognitive psychology acknowledged the existence of mental states and rejected introspection as a valid method of investigation. It has soon gotten evident that verbal reports would never suffice to tap into the underlying mechanisms. Moreover, unlike observable behavior cognitive operations are hidden and not directly accessible. Therefore, psychologists have begun to develop experimental methods, which help to tease apart the underlying mechanisms. The results from decades of behavioral research have provided an impressive wealth of knowledge. Nowadays, however, still many questions remain open for further investigation. What are the conditions for cognition to arise? When are brain processes associated with cognitive processes and when are they not? Are all brain processes involved in cognition? Or only some, and if so, which are the ones that qualify?

## Sensory Processing and Perception

To date, a wealth of knowledge is known about ►visual perception (►vision), which is the most studied sensory

function. The essay on ►[perception](#) written by Dirk Kerzel will explain in detail how visual (and other sensory) processes operate. A distinction has often been made that characterizes early and late processes. Early processes involve elementary processes associated with the initial encoding of sensory information whereas late processes come into play when sensory information has been processed already and needs to be interpreted or categorized. Several cognitive scientists conceived an architecture of information processing steps, which is organized in different modules. Early processes involved in perception are separate from late processes, which involve more abstract and language-based thought processes. According to a strictly modular view early processes involved in the processing of perceptual information are completed before cognition comes into play; they are not cognitively penetrable [1]. Even though early processes appear more tied to the uptake of sensory input there is now growing evidence showing that activity in relatively early brain areas can be modulated by input from higher brain areas. Back projections from higher brain areas to early visual areas – the anatomical pre-requisite of ►[top-down processes](#) – have been demonstrated already, but empirical evidence that these projections are involved in cognitive functions is still relatively recent. For example, functional neuroimaging (e.g., ►[fMRI](#)) has revealed that activation in ►[primary visual cortex](#) is modulated by ►[attention](#) (►[Visual attention](#)). A study by Ress et al. [2] used a psychophysical target detection task (low contrast target on a uniform background) and demonstrated that the response in primary visual cortex was modified by the subject's attention, even when there was no sensory information present. The authors could also show that the activity in visual cortex was highly correlated with task performance. The greater the response the more likely the subjects were able to correctly detect the presence or absence of a pattern. Moreover, this research confirms earlier evidence based on recordings from single neurons showing that firing rates in monkey visual cortex are elevated by attention [3].

### Attention and its Capacity

The study of basic sensory processes is important because cognitive operations can act on those data, thus providing us with a means to explore the nature of cognitive functions such as attention. The mechanisms of attention are elaborated more in detail in the essay written by Peter Klaver. Several aspects make this topic interesting in the context of cognitive functions, one of which is the selection of information. If a target object is defined by the presence of one salient feature it can be easily identified (e.g., a red ball on the lawn). In this case attention is automatically directed toward the object (this phenomenon is also known as *pop-out*). However, targets can differ by the conjunction of two

features from the many irrelevant items present in a display. The search process is then time consuming and depends on the number of irrelevant items. Hence, visual attention can be guided via top-down processes to integrate object features or allocate spatial attention and it can be captured automatically via ►[bottom-up processes](#). In fact, attention is not based on a single mechanism but is rather a composite of a plurality of numerous and partly distinct mechanisms. This is strongly supported by studies on the neuronal implementation of networks of attention. For example, disengaging visual attention from its previous location is associated with the ►[posterior parietal lobe](#) whereas the ►[superior colliculus](#) in the brain stem is involved in shifting attention to a new location.

Another important aspect of attention concerns its resources. The limits of attentional resources become evident when two tasks need to be coordinated at the same time. Compelling demonstrations have been given by studies on *inattentional blindness* [4], in which participants are engaged in a demanding task (e.g., counting events) while at the same time they fail to notice relatively obvious perceptual events (e.g., the appearance of a gorilla walking through a crowd of people [4]). In this context, it is noteworthy that research on attention is not only concerned with basic science. In fact, there are several applied implications such as the frequent use of video games and its impact on children's cognitive abilities. For example, there is evidence that video-game experts can have an enhanced capacity to process visual information [5]. Yet another topic covered by the essay written by Peter Klaver concerns the role attentional deficits play in cognitive disorders such as the ►[ADHD – attention deficit/hyperactivity disorder](#).

How does the brain create a coherent and unique perception? When we search for an object the information processing in the brain is highly parallel. This means that different features of the same object are processed in different parts of the brain (for example, if the target is a green square). Nevertheless, we are able to combine different features such as color or shape to a coherent and unique conscious experience. This discussion is known as ►[binding problem](#) and Michael Herzog has written an overview about it. For example, it was suggested that the timing of different neural responses is in synchrony if they code for features of the same object. There are still open questions about the temporal patterns but future studies will probably clarify many issues of the binding problem and its relation to consciousness.

### Memory and Mental Imagery

Only a few remarks will here be made about learning and memory, which are treated extensively in other contributions. The functions of memory are revealed

best by clinical cases from neuropsychology showing how some functions of memory can still be preserved while others are no longer available. For example, ►**anterograde amnesia** prevents the ability to consolidate new information in memory whereas previously stored information can still be retrieved. Interestingly, however, the ability to learn implicit tasks such as new motor skills remains intact. Memorizing implicit and explicit information draws on at least partly different neuronal mechanisms. Yet other dissociations concern the distinction between short-term and long-term memory or the distinction between episodic and semantic memory. Memory does not only serve the purpose to represent what happened in the past and, in fact, its nature is rather constructive and can lead to illusions or misattributions. For example, people can fail to correctly indicate the true source of their memories despite the fact that they strongly believe that what they remember did happen exactly the way they think. Yet another and often understudied type of memory is ►**spatial memory**, which is addressed in a separate essay written by Catherine Brandner.

Information stored in memory is also crucial when it comes to other cognitive functions such as mental imagery. Only the information provided by the senses can be stored in memory so that we can later retrieve it and use this information when we remember an event or imagine an object or a person. ►**Visual memories** are stored in temporal brain areas and research on mental imagery has in fact shown activation in those areas when people visualize objects or faces [6]. Some types of imagery require a high-resolution representation and neuroimaging studies revealed activation in early visual areas when subjects are engaged in such tasks. Specifically, this is the case when the task requires vivid and richly detailed images allowing for fine visual discriminations. Klein et al. [7] have shown that mental imagery of a bowtie-shaped figure with a checkerboard pattern activates voxels (volume elements) in primary visual cortex that overlapped widely with those voxels when people viewed the same stimulus. Depending on the orientation of the imagined stimulus the activation changed according to the corresponding perceptual condition. Moreover, converging evidence from studies based on other methods such as repetitive ►**transcranial magnetic stimulation** provided further evidence that early visual areas are in fact functionally involved in the process of visual mental imagery [8].

What is the functional relevance of early visual activation during visual mental imagery or attention? One interpretation suggests that mental imagery is in the service of perceptual anticipation [9]. Imagery has been described as “getting ready to see” and therefore (pre) activates those brain areas that are normally engaged in the processing of sensory input. This anticipatory function could facilitate the process of perception and

finally lead to a faster or more reliable detection of a visual object.

It remains an open question as to what extent early visual activation during attention and mental imagery overlaps. Mental imagery and visual attention are still experienced differently and future research will better determine the differences between cognitive functions such as mental imagery, visual attention, and visual perception. However, this example shows to what extent different cognitive functions are nested and intertwined.

## Reasoning

Yet another cognitive function is ►**reasoning**. Our brain enables us to reason and thus to go beyond what is actually given. Mental reasoning is the ability to infer conclusions based on previously established premises. Even though it is conceivable that reasoning as computational problem can be implemented in any type of hardware this assumption turned out to be wrong. Neuroimaging studies helped to constrain the wide range of possible mechanisms. For example, when people reason in the absence of any semantic context they use the visuospatial system in the right hemisphere involving parietal areas, ►**precuneus**, and the extrastriate (and sometimes striate) visual cortex (►**Extrastriate visual cortex**). Left temporal areas, however, come into play as soon as the reasoning task has a semantic content. Neuropsychological studies with patients have provided some knowledge already but it remained widely inconclusive as to what components of the reasoning process are in fact altered by the lesion. The essay on reasoning written by Markus Knauff is focusing specifically on reasoning and how different brain areas are drawn upon when people solve reasoning tasks.

## Cognition and Motor Behavior

The involvement of the motor system (►**Motor control**) in understanding cognitive functions has long been underestimated and still today modern textbooks often miss a chapter on motor functions. The representation of an action is of particular interest because it links thoughts with observable actions. It is noteworthy that an action not only includes the planning and execution of a movement but also its recognition. Rizzolatti et al. [10] have discovered visuo-motor neurons in monkey’s ►**premotor cortex**. These neurons respond to the execution of a particular movement and to the observation of the same movement. The discovery of the mirror neurons had far-reaching consequences on the understanding of the motor system and current research includes their involvement in the detection of others’ intentions and how we interpret observed actions. The essay written by Laura Bamert and Fred Mast deals with yet other topics of ►**action representation** such



as motor imagery. Imagined actions share several commonalities with executed actions and there is growing evidence as to how execution can benefit from motor imagery training.

### Cognitive Development

A promising area is the study of human brain development and how it is mapped to ►cognitive development. There is an increasing amount of evidence demonstrating that the gap between developmental psychology and neuroscience has in fact narrowed, and there are still more research interactions to be established between developmental psychologists and cognitive neuroscientists. Recent research in cognitive development has elucidated preschool children's abilities. Their competences are far more developed than previously assumed and include perspective taking, knowledge about emotions, and causal thinking. Beate Sodjan has written an essay on cognitive development.

In the context of cognitive development, the role of brain plasticity has received considerable attention, for example the modification of synaptic strength that underlies changes in cognitive function. Moreover, there is an increasing amount of research showing how ►chronic stress can suppress neurogenesis and the remodeling of dendrites. This again elucidates the links between cognitive functions and brain processes. The recent years have strengthened the importance of cognitive factors that in combination with the environment regulate genes, ►hormones and ►transmitters.

Not only is it relevant to study cognitive processes at work but also the changes of performance over the entire span of life. Why and in particular how does cognitive performance decline? Future research in cognitive neuroscience will provide us with more profound knowledge about the aging brain, and how we can slow down the debilitating effects of aging. Ben Godde has written an essay on ►cognitive impairment, in which different theories on cognitive aging are discussed. The essay also addresses the neuronal mechanisms that underlie the aging processes and demonstrates that there is plenty of evidence showing reduced induction and maintenance of ►long-term potentiation (LTP) and reduced neurogenesis in ►hippocampus. Using neuroimaging, the aging brain can be studied in humans and the results revealed under- and overactivations. The latter is particularly interesting since it suggests a compensatory role for processing deficits in the sensory domain. Changes in the brain during aging are partly due to degenerative mechanisms but they can be influenced by the individual lifestyle. It has been found that cognitive performance and prefrontal and parietal activity is increased after a cardiovascular fitness program. Besides neuronal survival several other mechanisms are currently discussed and yet discovered

that are responsible for the relation between cognitive functions and cardiovascular fitness.

### Spatial Processing and Cognitive Functions

Spatial processing is involved in almost any cognitive function and knowing more about it helps to understand how basic cognitive functions operate such as attention, mental imagery, action control or perception [11]. When we open our eyes we are confronted with the visual perceptual world. The perceptual world is spatially organized, the figures are segregated from the ground, the objects are clearly defined by their contours and they appear to us in a defined spatial location (Vision). This is possible because the perceptual system establishes a spatial ►frame of reference allowing for correct evaluations of directions and coordinated actions. It has to be distinguished between an egocentric frame of reference, which is bound to an axis fixed to the observer's body, and an allocentric frame of reference, which is defined with respect to a spatial reference outside the observer's body such as visual landmarks in the environment. It is noteworthy that the allocentric frame of reference includes the gravitational force, which acts "invisibly" and is independent of the body. The two types of spatial coding differ also in terms of their neuronal underpinnings even though there is also substantial overlap of the brain areas involved [12]. The reference frame is explained thoroughly in the chapter on spatial memory written by Catherine Brandner.

►Spatial cognition is yet another topic related to spatial functions. This growing field is outlined in the essay written by Sarah Creem-Regehr. Depending on the actual task, the perceptual space has been classified as personal space (the space within reach), action space (the space in which we act and locomote), and vista space (the visual space we see beyond 30 m). Not only is the involvement of the spatial frame of reference absolutely evident in perception and orientation tasks but it also plays an important role in higher cognitive tasks such as mental imagery when there is no sensory information to be processed [13]. For example, we are able to mentally transform the egocentric frame of reference in order to make a spatial judgment from some other viewpoint outside of our own body. This other viewpoint could be fixed to another person. "Watch out, on your left side!" This is what we hear parents shout out aloud when they attend a soccer game and see their own child just going to be tackled by a defender from the other team. In this example, the parents need to take on the child's perspective and use it as reference for their spatial judgment. Spatial updating tasks have shown that mental transformations of one's own perspective are highly efficient and a performance advantage has been shown when compared to an

object-based strategy, in which they rotate mentally the visual representation of the surrounding environment.

### Social Cognition

Even though it goes beyond the scope of this synopsis it should be noted that the study of cognitive functions is not independent of socially relevant information. Social psychology has been studying how people process social information and social cognition has gotten one of its most rapidly growing fields. For example, the mental ability to take on someone else's viewpoint has been discussed as a prerequisite of empathy. In fact, several other social phenomena involve cognitive processing such as attraction, competition, cooperation, and altruism. We are often not aware of how the underlying cognitive processes operate but they are powerful and can influence decision taking and behavior (e.g., in the case of stereotyping). In fact, several experimental tasks have been developed which require the participants to respond without having to verbalize their thoughts about other people or situations. Social cognitive neuroscience is one of the most recent advances in the field. This implies the study of social situations and relate those to brain activation.

### Acknowledgments

We thank the support of the Swiss National Science Foundation, grants PDFM1-114406 and 611-066052.

### References

1. Pylyshyn ZW (2002) Mental imagery: in search of a theory. *Behav Brain Sci* 25:157–182
2. Ress D, Backus BT, Heeger DJ (2000) Activity in primary visual cortex predicts performance in a visual detection task. *Nat Neurosci* 3:940–945
3. Luck SJ, Chelazzi S, Hillyard A, Desimone R (1997) Neural mechanisms of spatial selective attention in areas V1, V2, and V4 of macaque visual cortex. *J Neurophysiol* 77:24–42
4. Simons DJ, Chabris CF (1999) Gorillas in our midst: sustained inattention blindness for dynamic events. *Perception* 28:1059–1074
5. Green CS, Bavelier D (2003) Action video game modifies visual selective attention. *Nature* 423:534–537
6. Ishai A, Haxby JV, Ungerleider LG (2002) Visual imagery of famous faces: effects of memory and attention revealed by fMRI. *NeuroImage* 17:1729–1741
7. Klein I, Dubois J, Magnin JF, Kherif F, Flandin G, Poline JB, Denis M, Kosslyn SM, Le Bihan D (2004) Retinotopic organization of visual mental images as revealed by functional magnetic resonance imaging. *Cogn Brain Res* 22:26–31
8. Sparing R, Mottaghy FM, Ganis G, Thompson WL, Töpper R, Kosslyn SM, Pascual-Leone A (2002) Visual cortex excitability increases during visual mental imagery – a TMS study in healthy human subjects. *Brain Res* 938:92–97
9. Kosslyn SM, Thompson WL (2003) When is early visual cortex activated during visual mental imagery? *Psychol Bull* 129:723–746
10. Rizzolatti G, Fogassi L, Gallese V (2001) Neurophysiological mechanisms underlying the understanding and imitation of action. *Nat Rev Neurosci* 2:661–670
11. Mast FW, Jäncke L (2007) Spatial processing in navigation, imagery and perception. Springer Science and Business Media, New York
12. Zachle T, Jordan K, Wüstenberg T, Baudewig J, Dechent P, Mast FW (2007) The neural basis of the egocentric and allocentric spatial frame of reference. *Brain Res* 1137:92–103
13. Mast FW, Kosslyn SM (2002) Visual images can be ambiguous: insights from individual differences in spatial transformation abilities. *Cognition* 86:57–70

## Cognitive Impairment

BEN GODDE

Jacobs Center on Lifelong Learning and Institutional Development, Jacobs University Bremen, Bremen, Germany

### Synonyms

Cognitive aging; Cognitive decline

### Definition

Cognitive impairment describes the decline in cognitive functions like memory, ►selective attention, ►executive control, or conscious perception. This decline may be the consequence of lesions of the brain, or diseases like ►Alzheimer's disease (AD) or other forms of ►dementia, but often also accompanies normal aging. As compared to subjects suffering from dementia, people with so-called ►mild cognitive impairment (MCI) show only moderate loss of cognitive functioning, e.g., poor performance in memory tasks, but mostly no problems with activities of daily living. However, patients with MCI have increased risk of developing AD in their later life. Thus MCI can be regarded as intermediate stage between normal, non-pathological aging and dementia. During normal aging at least three different patterns of development can be distinguished. Whereas some cognitive functions decline continuously from very early in life, others remain stable or even improve. This essay will be restricted to processes of cognitive impairment during normal healthy aging.

### Characteristics

#### Behavioral Changes

Cognitive impairment during aging is characterized by a high variability of developmental trajectories – between

individuals as well as within individuals for different cognitive functions. Whereas some cognitive functions decline continuously from very early in life (from 25–30 years of age), others remain stable or even improve. Cognitive functions that show increasing impairment with age are perception and processing accuracy, speed of processing and ►reaction times, the ►encoding of new memories into episodic memory and the ability to learn new things, the recall of information from long-term memory, the capacity of the ►working memory, executive control, selective attention, and inhibition of distracting information. These functions are attributed to the domain of so-called ►fluid intelligence or ►cognitive mechanics and are mostly biologically and genetically determined. According to the two-component theory of intelligence [1] they can be distinguished from functions belonging to the ►cognitive pragmatics or ►crystalline intelligence, e.g., verbal knowledge and comprehension, autobiographical memory, emotional processes, strategies of processing and learning, and learned skills like reading, writing, or occupational skills. These knowledge and wisdom based abilities remain not only stable but may be improved even at old age and are often able to compensate for decline in the cognitive pragmatics. As a consequence of these compensatory mechanisms, in normal aging cognitive impairment has only little impact for activities of daily living. Nevertheless, particularly under laboratory settings in which subjects have to perform two or more tasks simultaneously, differences in performance levels between young and old subjects increase with task complexity.

### Theories of Cognitive Aging

There exist different theories about the causes of cognitive impairment during aging and the debate is still going on. General factors or *common cause* theories favor single biological factors to cause decline in most cognitive abilities. White matter integrity deficits or decreased signal-to-noise ratios might be responsible for a general slowing of cortical processing as indicated by increased reaction times for various cognitive tasks (*General slowing hypothesis*, [2]). Support for the common cause hypothesis comes from a close correlation between age-related changes in cognitive, sensory, and motor functions. Other explanations for this correlation might be that cognitive deficits cause sensory decline or that sensory deficits cause cognitive decline. However, no causal relationships in either direction between sensory and cognitive decline could be revealed. Thus *cross domain resource competition* together with decreasing resources available are a more likely alternative explanation.

The *frontal lobe hypothesis* states that neuronal decline in the frontal lobe, particularly the ►prefrontal cortex (PFC), has major impact for cognitive

impairment since functions controlled by the PFC like executive control, selective attention, response inhibition, and working memory seem to be more affected by aging than functions that rely on activity in other cortical or even subcortical regions. One of the most recent theories argues that deficient dopaminergic ►neuromodulation due to a decline in the frontostriatal network is a promising correlate of cognitive impairment during aging [3]. It is argued that reduced signal-to-noise ratios due to a loss of ►dopamine support of the PFC may explain age effects in working memory, selective attention, inhibitory control, and other cognitive functions.

Recent evidence further revealed that common causes cannot easily explain all facets of cognitive impairment during aging and that age-effects vary considerably across tasks. These task-dependent age-effects indicate that one factor is not sufficient to explain cognitive impairment during normal aging but that both common and specific factors have to be regarded.

### Evidence from Functional Neuroimaging

Functional neuroimaging reveals patterns of over- and underactivation in the aging cortex. As compared to young adults, older adults with difficulties in working memory and executive control often show reduced activity in the PFC [4]. Less activity in the ►hippocampal formation of the mediotemporal lobe (MTL) is related to impaired ►recognition memory and attentional orienting and novelty detection processes [5]. Underactivation has also been shown for sensory cortical networks like the occipitotemporal (ventral) visual pathway [5] and may be conceived as equivalent of reduced integrity of cortical areas and neuronal circuitries. Based on these findings, behaviorally derived theories suggest a failure in self-initiated control of activating task-specific brain regions [6]. This is in accordance with various findings that changed processing strategies in well-performing older adults may lead to normalized activation patterns.

On the other hand cognitive aging is also paralleled by overactivation of certain brain regions which is particularly the case for executive functions, motor control, and episodic, autobiographical and working memory [6]. It has been suggested that increased activity in PFC, as shown for a variety of tasks like face matching, lexical decision, word-pair encoding and retrieval, temporal-order memory, and verbal working memory, compensates for processing deficits in the sensory domain. The cost of such compensatory overactivation might be a reduction of cognitive resources available for task performance as formulated by the *resource competition hypothesis* or CRUNCH (*compensation-related utilization of neural circuits hypothesis*, [6]).

More task-specific age-effects include a decreased ►lateralization of the PFC. Whereas in young adults the left PFC is activated primarily in working memory tasks and the right PFC in visual attention tasks, in older subjects increased activity in the contralateral homologous regions of the PFC can be found. This *hemispheric asymmetry reduction in older adults* (“HAROLD”, [5]) might be the consequence of compensation processes to enable normal cognitive functioning by recruiting contralateral resources. This view is supported by findings that asymmetry reduction mostly occurs in high-performing versus low-performing older adults or in successful versus unsuccessful trials.

On the other hand, decreased lateralization can be conceived as decreased specialization of brain processes reflecting difficulties in recruiting specialized neuronal processes (*De-differentiation hypothesis*, [7]). Thus overactivation might mirror decreased inhibition and inefficient processing. Supporting evidence comes from human imaging studies which show increased activations in perceptual areas and the anterior cingulate in tasks with conflicting conditions and from animal experiments revealing reduced tuning strength of neurons in the ►visual cortex and ►somatosensory cortex.

### Morphological Changes of the Brain

During aging the average brain volume decreases from 1,300 grams at the age of 20 to 1,150 grams at the age of 80. This finding suggested that the number of cortical neurons declines with age and that this process is related to cognitive impairment. However, recent studies revealed that during normal aging there is – if at all – only a modest reduction in cell number of about 10% and it is now common sense that this decline is not significant for functional loss. This is in contrast to patients suffering from AD which in fact show cell loss rates between 30% and 50%. Even though white matter volume is reduced with age, possibly resulting in slowing of neuronal processing and deficits in its integrity, there is also no general reduction of axonal extent and dendritic branching as well as synaptic density. Thus, not the total number of neurons and their connections but the specificity of neurons and connections affected seem to be crucial for cognitive functioning.

PFC and MTL structures, for example, show more decline in brain volume and white matter integrity than other regions like sensory or ►motor cortices [4] and these changes are well correlated to deficits in executive control and memory processes. Animal studies reveal decreased dendritic branching of ►pyramidal neurons in the PFC and anterior cingulate but not the ►hippocampus ([8]). Specific effects also include the frontostriatal system resulting in decreased levels of neurotransmitters ►dopamine, norepinephrine and ►serotonin which in turn negatively influence

the functional integrity of the PFC as supposed by the *dopamine theory of aging* (see [3]).

Other age-related changes of the brain include alterations in the brain hemodynamics and microvasculature. With aging, there can be found a general reduction of both the general cerebral blood flow (CBF) and the increase of local CBF accompanying neural activity. The resulting reduced hemodynamic response strength may be one cause for the cortical underactivation as measured with functional brain imaging. Interestingly, morphological changes do not inevitably correlate with alterations in neuronal activity. As outlined above, there is if at all only a modest decline in grey and white matter in the occipital cortex which, however, is characterized by decreased activation areas and response strength during visual processing tasks.

### Neuronal Mechanisms of Cognitive Impairment

Aging rats are a well established model to study in vivo and in vitro cognitive processes at the neuronal level. Particularly, ►long-term potentiation (LTP) within the hippocampus plays a key role in spatial cognition and memory formation. LTP induction and maintenance is impaired in the hippocampus of aged rats. Possible explanations include reduced gene expression and protein synthesis, known to be crucial for LTP maintenance as well as changes in the  $Ca^{2+}$ -regulation, directly influencing ►NMDA-dependent plastic processes (for review, see [8]). Since the ►postsynaptic  $Ca^{2+}$ -concentration crucially affects the probability of the induction of either LTP or ►LTD (long-term depression), deficits in Calcium homeostasis may be the reason for an observed increased susceptibility of aged rats to LTD.

Also reduced ►neurogenesis in the hippocampus is associated with deficits in ►spatial cognition and memory formation. Interestingly, facilitation of neurogenesis in the hippocampus by, e.g., housing in enriched environments or regular physical activity (running in a treadmill) correlates with improved cognitive performance. Furthermore, spatial memory seems to be particularly sensitive to a loss of ►axodendritic synapses in the ►dentate gyrus. As a consequence of this decline in synapse number, field ►excitatory postsynaptic potentials are reduced in aged rats, thus increasing the threshold for induction of LTP [8].

Studies on the neuronal level outside the hippocampus are rare. Dinse and colleagues in detail investigated the functional properties of neurons and neuronal population in the somatosensory cortex of aged rats. Comparing young and old animals as well as different functional areas within aged individuals they were able to separate general age-dependent processes from those related to changed behavior during aging, the latter being reversible or at least subject to deceleration by normalization of behavior [9]. General age-dependent changes were reduced response strengths and prolonged latencies.

Resulting in impaired perception according to the hypothesis of cross domain resource competition these changes might lead also to cognitive impairment. On the other hand, decline of neuronal selectivity and topographic order, as well as reduced size of cortical activation areas correlated with changed behavior or disuse of body parts, resulting in reduced sensory experience with these body parts [9]. Taken together these studies reveal that not all changes in the brain during aging are due to general degenerative mechanisms but may be influenced by behavior.

### The Role of Lifestyle for Preservation of Cognitive Performance During Aging

The high inter- and intraindividual variability of cognitive impairment during aging indicates that besides genetic predisposition individual lifestyle is a crucial factor. Cognitive training programs and active social involvement may stimulate functional plasticity and therefore compensation for cortical atrophy, white matter damage, and neurotransmitter dysfunction [6]. Even caloric restriction and cardiovascular fitness training have positive effects on cognitive functioning. Using functional MRI, Colcombe et al. could show that older subjects after a six months cardiovascular fitness program (walking) performed better in both simple and complex cognitive tasks with particular improvement in executive functioning. These behavioral effects were paralleled by significantly increased activity in PFC and parietal cortex and reduced activity in the anterior cingulate cortex which indicates a more efficient inhibition of task-irrelevant information [10]. Mechanisms of the relationship between cardiovascular fitness and cognitive functioning are not yet fully understood and still under discussion for different micro- and macroscopic levels of the brain. Besides neuronal survival and increased neurogenesis, possible mechanisms as revealed by animal experiments are increased angiogenesis in the capillary systems and thus improved blood supply, increased synthesis of synapses and neurotransmitters, and facilitation of gene expression and thus production of growth factors like ►BDNF and ►IGF-1. Not at last, physical fitness might prevent diseases like heart disease, hypertension, or diabetes which also have been related to cognitive decline. Taken together all these different processes further the brain metabolism and therefore improve cognitive performance.

### References

1. Baltes PB, Lindenberger U, Staudinger U (2006) Life-span theory in developmental psychology. In: Damon W, Lerner RM (eds) Handbook of child psychology. Wiley, New York, pp 569–664
2. Salthouse TA (1996) The processing-speed theory of adult age differences in cognition. *Psychol Rev* 103:403–428

3. Backman L, Ginovart N, Dixon RA, Robins-Wahlin T-B, Wahlin A, Halldin C, Farde L (2000) Age-related cognitive deficits mediated by changes in the striatal dopamine system. *Am J Psychiatry* 157:635–637
4. Hedden T, Gabrieli JDE (2004) Insights into the aging mind: a view from cognitive neuroscience. *Nat Rev Neurosci* 5:87–96
5. Cabeza R, Daselaar SM, Dolcos F, Prince SE, Budde M, Nyberg L (2004) Task-independent and Task-specific age effects on brain activity during working memory, visual attention and episodic retrieval. *Cereb Cortex* 14:364–375
6. Reuter-Lorenz PA, Lustig C (2005) Brain aging: reorganizing discoveries about the aging mind. *Curr Opin Neurobiol* 15:245–251
7. Baltes PB, Cornelius SW, Spiro A, Nesselroade JR, Willis SL (1980) Integration versus differentiation of fluid/crystallized intelligence in old age. *Dev Psychol* 16(6):625–635
8. Burke SN, Barnes CA (2006) Neural plasticity in the ageing brain. *Nat Rev Neurosci* 7:30–40
9. Godde B, Berkefeld T, David J, Dinse HR (2002) Age-related changes in primary somatosensory cortex of rats: evidence for parallel degenerative and plastic-adaptive processes. *Neurosci Biobehav Rev* 26:743–752
10. Colcombe SJ, Kramer AF, Erickson KI, Scalf P, McAuley E, Cohen NJ, Webb A, Jerome GJ, Marquez DX, Elavsky S (2004) Cardiovascular fitness, cortical plasticity, and aging. *Proc Natl Acad Sci* 101:3316–3321

---

## Cognitive Map

### Definition

A mental map of space represented in an allocentric framework. The hippocampus is one brain region which has been defined as integral to spatial memory and a cognitive map theory in animals. Human cognitive mapping defined from cognitive psychology and geography involves extracting information from large-scale environments to store in a mental representation of space.

- Spatial Cognition
- Spatial Memory

---

## Cognitive Map Theory

### Definition

The concept of a cognitive map derives from Kant's epistemology. Kant believed that humans and animals have innate perceptual schemes for processing sensory

information and that a geometrical-spatial framework is one of them. Tolman, an early twentieth century psychologist, pursued this notion and proposed that rats and other animals had cognitive maps that permitted flexible and efficient navigation. O'Keefe and Nadel, in the landmark book *The Hippocampus as a Cognitive Map* (1978), proposed the hippocampus as the neural substrate for the mapping system. Although hotly debated, the relationship of the hippocampus to the cognitive map remains a focus of current research.

► Spatial Learning/Memory

## Cognitive Science

### Definition

Scientific discipline, which developed in the second half of the twentieth century and integrates insights from psychology, linguistics, artificial intelligence, neuroscience, philosophy, and other disciplines to understand human cognition.

► Emergence  
 ► Reductionism (Anti-Reductionism, Reductive Explanation)

## Coherence

### Definition

A function that shows the normalized relationship between two signals in the frequency domain. This function is similar to the cross-spectrum after normalization.

► Cross-spectrum  
 ► Signals and Systems

## Coherence Function

### Definition

Coherence function refers to a normalized version of the cross-spectrum defining the linear relationship between two signals in the frequency domain.

## Cold Pressor Test

### Definition

The cold pressor test is a psychophysical protocol used to measure pain tolerance. The subject places a distal extremity in a circulating water bath maintained near 0° C. The duration of time that the person can keep his extremity in the water bath is the measure of pain tolerance.

► Pain Psychophysics

## Collagens

### Definition

Collagens are a family of glycoproteins that are the main proteins of connective tissue (cartilage, ligaments, tendons, bone and teeth) in animals and the most abundant proteins in mammals, making up about 25% of the total protein content. Known for their tensile strength, collagens are made of three polypeptide chains, known as  $\alpha$ -chains, which wind together forming a triple helix.

The different types of collagen arise from the fact that the  $\alpha$ -chains differ in amino acid sequence and length (over 40 types of  $\alpha$ -chains), allowing collagen molecules to be either homotrimeric or heterotrimeric.

► Articular Cartilage

## Color Agnosia

### Definition

Color agnosia is a difficulty in associating colors and shapes, e.g. to assign the color red to a black-and-white drawing of a strawberry. In order to associate a color with an object, these patients have to take deviant routes through other memorized associations.

## Color Blindness

### Definition

Group of inherited or acquired defects in ► color vision. Congenital defects include: anomalous protanomaly

with abnormal red-▶**cone** pigment; anomalous deuteranomaly with abnormal green-cone pigment; anomalous tritanomaly with abnormal blue-cone pigment; dichromatopsia (with only two cones present) includes protanopia with missing red-cone, deuteranopia with missing green-cone, tritanopia with missing blue-cone; monochromatopsia (achromatic) in a typical form (all cones missing) and an atypical form (two cones missing). Acquired defects include tritanopia (▶**retinal** outer-layer disease), protan-deutan defects (retinal inner-layer disease), and normal with all three cones present.

## Color Processing

THORSTEN HANSEN, KARL R. GEGENFURTNER  
Abteilung Allgemeine Psychologie,  
Justus-Liebig-Universität, Giessen,  
Germany

### Synonyms

Color vision; Chromatic vision; Chromatic processing

### Definition

Color is a sensation caused by the activation of *cone photoreceptors* (▶**Photoreceptors**) in the ▶**retina** and the subsequent processing of this activation pattern in the ▶**cerebral cortex**. The physical property most closely related to color is the reflectance spectrum of a surface. Color as an estimate of the reflectance spectrum is an invariant object property and more than an aesthetic component of visual experience: Color facilitates object recognition (▶**Visual object representation**) and plays an important role in scene segmentation and ▶**visual memory**.

### Characteristics

Color is a sensation, not a property of the physical world. It is often stated that color is closely related to the wavelength of light, but it has to be kept in mind that most illuminants and surfaces have broad spectra that contain many wavelengths. Furthermore, the perception of color (▶**color perception**) depends to a large degree on other colors in the whole scene. By taking all colors into account, the visual system can discount changes in illumination (see below and ▶**Color constancy**) and compute the object color that is closely related to the reflectance spectrum of a surface. Various stages of visual processing interact to extract a robust estimate of the reflectance spectrum that gives rise to the sensation of color.

At the first stage in the retina, light is measured by three types of cone photoreceptors having different peak wavelength sensitivities. The cone responses are processed and recombined in the retina to form three channels, one purely achromatic channel and two chromatic channels. The visual input from the retina is transmitted in these three channels via the ▶**lateral geniculate nucleus** (▶**LGN**) to the cortex. In the retina and the LGN, neurons have a broad, linear wavelength tuning with peak sensitivities that cluster around two chromatic axes, L–M and S–(L+M), which are called “cardinal directions.” Neurons with linear broad tuning curves are found at all stages, but the proportion of nonlinear neurons, narrowly tuned for color, increases along the visual pathway. Also, the peak sensitivities of cortical neurons no longer cluster. Instead, neurons sensitive to different chromatic directions exist, giving rise to multiple chromatic mechanisms. The multiple mechanisms are grouped at a higher stage, maybe in the ▶**inferior temporal cortex** (IT), to form color categories. A specialized ▶**cerebro-cortical area** devoted only to the processing of chromatic information has not been identified conclusively. Instead, color is processed at many stages and in many areas, involving – at different degrees – all visual cerebro-cortical areas.

### Retinal Processing and Lateral Geniculate Nucleus

The retina is the first and best understood stage in color processing. Important constraints and transformations are of retinal nature [1].

At the first stage of color processing, electromagnetic radiation between 400 and 700 nm is absorbed by three different types of cone photoreceptors in the retina, with peak sensitivities at short (S, 430 nm), medium (M, 530 nm) and long (L, 560 nm) wavelengths [2]. The absorption spectra of the three types of cones are shown in Figure 1. The fact that humans have three types of cone photoreceptors is called ▶**trichromacy**. Trichromacy is the reason why colors in any color space can be described by no more than three numbers.

The cones have overlapping sensitivity curves. The S cone photoreceptor absorbs light from 400 to 600 nm. The L and M cones have very similar absorption spectra that are broad and cover almost the entire visible spectrum. Already in the retina, the three classes of cones are recombined in three anatomically and physiologically distinct paths. One path pools activity from L and M (and maybe also S) cones and signals achromatic luminance. The two other paths are cone-opponent and form the basis of color vision. The two cone-opponent paths are sometimes referred to as L–M and S–(L+M) and define together with the luminance pathway the cardinal directions of the DKL color space [3]. The cone-opponent channels are sometimes referred to as “red-green” and “blue-yellow.” These labels are misnomers for two

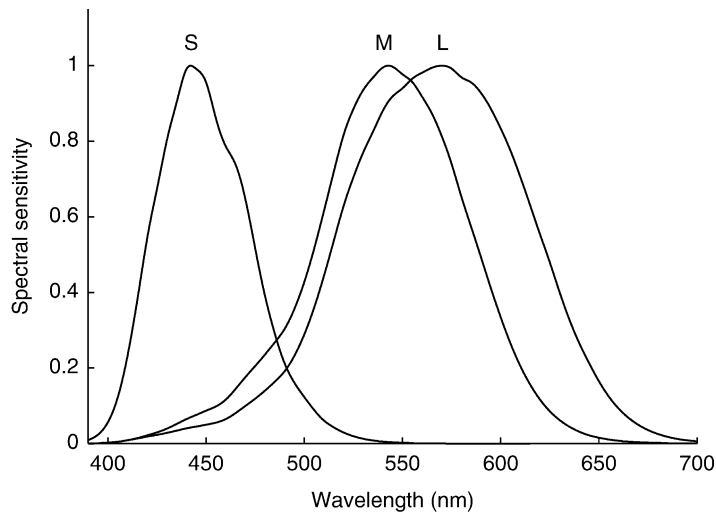

**Color Processing. Figure 1** Cone absorption spectra.

reasons: First, neurons in the L–M path respond both to color and luminance [4]. For example, a L–M single opponent cell responds best to a white spot on a black background and to a uniform red region. Second, the unique hues (red, green, yellow and blue) do not emerge in the retina: Colors along the L–M channel vary between a pinkish-red and a bluish-green, and colors along the S– (L + M) channel vary between a yellowish green and purple.

The cardinal directions correspond to anatomically and physiologically distinct pathways. The L + M or ►magnocellular (visual) pathway carries only achromatic information, is fast and transient (M-cells, Y cells in the cat). The L–M ►parvocellular (visual) pathway (P-cells, X cells in the cat) transmits L and M cone-opponent signals. Due to the ►antagonistic center-surround arrangement of the ►receptive fields (►Visual cortical and subcortical receptive fields), neurons in the parvocellular pathway transmit both chromatic and achromatic signals. Chromatic signals are transmitted with a low-pass characteristic and achromatic luminance signals with a band-pass characteristic. Input from the S cones is processed by bistratified ganglion cells and feeds the ►koniocellular (visual) pathway (►Retinal ganglion cells; ►Geniculo-striate pathway).

### Cortical Processing and Higher-Order Mechanisms

The properties of the neurons in the retina and the LGN have been studied in great detail and are well understood. The properties of cortical neurons at subsequent “higher-order” stages of cortical processing are less clear and a subject of intense research [5].

Chromatic mechanisms are typically characterized by their number, tuning peak direction, and tuning width. Subcortical neurons in the retina and the LGN

have peak sensitivities that cluster along the cardinal directions (Fig. 2, left). Tuning curves of neurons in the retina and the LGN are broad, consistent with a linear transformation of cone inputs.

How do these properties of neurons change during further processing? First, peak sensitivities of cortical neurons do not cluster, but have a continuous distribution (Fig. 2, right). Second, neurons with narrow tuning curves are found. Broad tuning curves still occur at all levels of processing, but the proportion of neurons with a narrow tuning width increases as the processing proceeds along the hierarchy of visual areas. Narrow tuning widths indicate a nonlinear transformation of cone inputs. Third, ►double-opponent cells are found. A double-opponent cell can signal the color contrast independent of the illumination and presumably plays an important role in color constancy.

### Segregation and Integration

One of the most fundamental questions of cortical processing is whether visual attributes such as form, color and luminance are processed in segregated visual processing streams or together (►Visual processing streams in primates; ►Extrastriate visual cortex). At the level of the retina and the LGN, chromatic and luminance signals are processed together by cells of the parvocellular pathway. A P-cell responds both to an achromatic luminance contrast (band-pass) and to a homogeneous color (low-pass).

Early hypotheses about the further cortical processing have often favored the wrong idea of a neatly segregated processing of color and luminance. For example, the coloring book theory assumes that first a sketch of achromatic edges of the scene is extracted, that is subsequently colored by chromatic surface information.



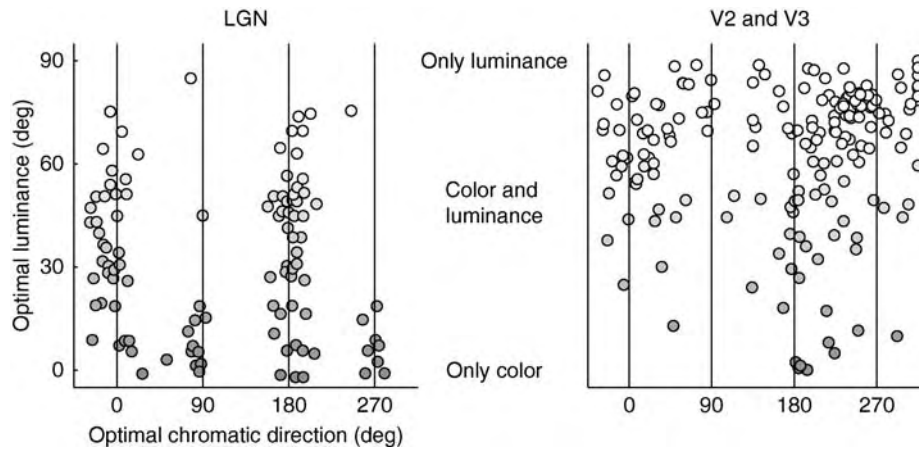

**Color Processing. Figure 2** Color and luminance preferences of neurons in the LGN and in the cortex (► areas V2 and V3). The x-axis denotes the optimal chromatic direction as azimuth in the isoluminant plane of the DKL color space, the y-axis denotes the preferred luminance as elevation above the isoluminant plane. Neurons in the LGN cluster around the cardinal directions, neurons in the cortex do not. Most neurons in the LGN and the cortex respond to both luminance and color.

Recent physiological findings have consistently drawn a different picture. Most neurons in ► area V1 (primary visual cortex, striate cortex, Brodmann’s area 17) are color-luminance cells that respond best to an oriented contrast (► Visual cortical and subcortical receptive fields; ► Geniculostriate pathway), defined by a combination of color and luminance.

Likewise, the idea that color-preferring cells are localized preferentially in the ► blobs has not been confirmed by recent findings. The wrongly presumed separation in area V1 has been hypothesized to occur also in ► area V2. However, a meta-analysis of six studies investigating color and orientation preference in different compartments of macaque monkey area V2 reveals a combined processing of color and orientation. Further it has been shown that the vast majority of color-selective neurons in areas V1 and V2 are also selective for orientation. Recent physiological findings consistently show that at the early cortical stages color, luminance and orientation are processed together by the same neurons [5].

### Color Appearance

The appearance of a color can be described along three perceptual dimensions, namely hue, saturation, and brightness. Hue is the dimension commonly referred to as color, changing along a color circle from, e.g. red through orange, yellow, green, blue, purple back to red. Saturation is the perceptual difference from an achromatic color (black, gray, white). Brightness is the perceived achromatic intensity.

There are 7–11 basic color terms, which agree remarkably across many cultures. The English names for these basic color terms are black, white, red, yellow,

green, blue, brown and orange, pink, purple and gray. Some languages deviate from this scheme, such as Russian having not a single name for blue but two for light and dark blue, while other languages merge blue and green into a single “grue” category.

Color appearance and processing is influenced by higher-level factors such as ► memory and language. The color appearance of a familiar object with a distinct object color is biased towards the object color. For example, fruit images appear neutral gray only when tinted with the color that is opponent to the object color [6]. The involvement of language in color processing results in faster discrimination across color categories [7]. Modulating feedback-connections could provide the neural substrate of these higher-level influences on color processing.

### Color Constancy

Color constancy is the ability to assign a constant color to objects independent of changes in illumination. If we look at a blue object under daylight, the object reflects mainly short wavelengths. The same object when illuminated by a light bulb reflects more light of longer wavelengths. Despite such gross reflection changes the object consistently appears blue. The remarkable feat of the visual system is to somehow “discount the illuminant” and to estimate the surface reflectance as an invariant object property. How can this ability of the visual system be achieved? The light reflected from an object depends both on the spectral reflectance properties of the surface and on the spectral distribution of the illumination. To disentangle the effects of illumination and surface reflectance the visual system needs more

than one source of information. Many potential cues can be used such as local edge contrast between different surfaces, global average of a scene, knowledge about the three-dimensional arrangement of a scene, or knowledge about the typical color of an object [8].

One possible neural substrate in the cortex involved in color constancy are double-opponent cells. Unlike single-opponent cells in the LGN, double-opponent cells signal the color contrast of the center relative to the surround. Double-opponent cells have been found in area V1 [9]. Another cortical area presumably involved in color constancy is ►area V4. Neurons in area V4 shift their color-tuning profile with a change in background illumination, as required for color constancy [10].

►Retinal Color Vision in Primates

## References

1. Wässle H (2004) Parallel processing in the mammalian retina. *Nat Rev Neurosci* 5:1–11
2. Stockman A, Sharpe LT (1999) Cone spectral sensitivities and color matching. In: Gegenfurtner KR, Sharpe LT (eds) *Color vision – From genes to perception*. Cambridge University Press, New York, pp 3–51
3. Derrington AM, Krauskopf J, Lennie P (1984) Chromatic mechanisms in lateral geniculate nucleus of macaque. *J Physiol* 357:241–265
4. De Valois RL, De Valois KK (1988) *Spatial vision*. Oxford University Press, New York
5. Gegenfurtner KR (2003) Cortical mechanisms of colour vision. *Nat Rev Neurosci* 4:563–572
6. Hansen T, Olkkonen M, Walter S, Gegenfurtner KR (2006) Memory modulates color appearance. *Nat Neurosci* 9:1367–1368
7. Winawer J, Witthoft N, Frank MC, Wu L, Wade AR, Borodowsky L (2007) Russian blues reveal effects of language on color discrimination. *Proc Natl Acad Sci USA* 104:7780–7785
8. Smithson HE (2005) Sensory, computational and cognitive components of human colour constancy. *Philos Trans R Soc Lond B* 360:1329–1346
9. Conway BR, Livingstone MS (2006) Spatial and temporal properties of cone signals in alert macaque primary visual cortex. *J Neurosci* 26:10826–10846
10. Kusunoki M, Moutoussis K, Zeki S (2006) Effect of background colors on the tuning of color-selective cells in monkey area V4. *J Neurophysiol* 95:3047–3059

## Color Vision

- Color Processing  
►Retinal Color Vision in Primates

## Colubridae

### Definition

A family of snakes; beside many harmless snakes, as grass snake, Aesculapian snake, it comprises, according to some taxonomy, cobras and coral snakes as well.

►Evolution of the Brain: At the Reptile-Bird Transition

## Columella

### Definition

Single middle ear ossicle of sauropsids, homologue of the mammalian stapes (stirrup).

►Evolution of the Auditory System in Mammals

## Columnar Structures

### Definition

Hypothetical structures that are perpendicular to the cortical surface and are assumed to be a functional unit of the neocortex.

►Somatosensory Cortex I

## Coma

### Definition

Coma denotes a patient's state, from which he/she cannot be aroused even by strong stimuli and makes no attempt at avoiding them. It may be caused by destruction of certain areas in ►brainstem and ►cerebral cortex (anatomical coma) or by disturbances of metabolic processes (metabolic coma). The latter may come about by ischemia, hypoxia or hypoglycemia, or by drug/alcohol intoxication, toxic endogenous metabolites (associated with hyponatremia, hyperosmolarity, hypercapnia; metabolic encephalopathies of hepatic and renal failure, hypercalcemia, hypothyroidism, vitamin B12 deficiency, hypothermia), or ►epilepsy.

## Combinatorial Coding

PHILIPPE FAURE

Department of Neurobiology, Pasteur Institute and CNRS, Paris, France

### Synonyms

Spatial coding; Binding; Sparse coding

### Definition

One of the fundamental concerns of neuroscience is the data structure or the code by which the brain represents information about the outside world. Evidence has accumulated that such information is encoded in the pattern of neuron electrical activity. A number of coding schemes have been proposed to explain how neurons represent, store, recall and manipulate “information” about outside world, and most of them share a common principle: they correlate various temporal and spatial aspects of the neuronal representation with the features of the stimuli.

The basic tenet of perception is that the different aspects of “natural objects” (color, shape, odor, etc.) are processed separately in specialized sets of neurons and then combined to form a unified perceptual experience. The question is then how the nervous system can cope efficiently with the complexity of the combinatorial environment: complex objects and situations are constructed by combining simpler elements, the diversity of such combining being virtually unlimited [1]. Understanding how neuronal networks perform such a task remains a challenge, but many agree that combinatorial codes that use the “power of combinatorial arrangement” to counterbalance the combinatorial complexity of the environment is, among others, a strategy that could be used by the brain. Consider that a given “feature” of an object is coded by units that are, for the sake of simplicity, either “active” or “passive”; combining  $N$  such units leads to  $c = 2^N$  possible combinations ( $c = 1024$  if  $n = 10$ ). This number grows exponentially with increasing  $N$  ( $c > 1^{301}$  for  $n = 1000$ ). A combinatorial coding is then based on the activation of specific combinations of identified units. Depending on the stimulus, the number of active units could vary from 1 to  $N$ . This is different from local coding where only one unit is activated and sparse coding where the amount of active units is small compared to their total number [2].

### Characteristics

#### Description of the Process: The Olfactory System Case

Humans can distinguish a huge number of volatile chemicals, typically small organic molecules that vary in a number of parameters (size, shape, charge) and

chemical structure (alcohols, aldehydes, esters, aromatics, alicyclics, etc.). Odors are detected initially at the level of odorant receptors located on the cilia of olfactory sensory neurons in the olfactory epithelium of the nasal cavity. In mammals, the total number of genes coding for odorant receptors varies across species, with, for example, around 1,000 functional genes identified in mice, whereas around 400 have been identified in humans. The question then is – how can many thousands of volatile chemicals be perceived and discriminated with so few odorant receptors?

It has been proposed that the sense of smell in mammals is based on combinatorial coding. That is, instead of dedicating an individual OR to a specific odor, the olfactory system uses combinations of receptor types to greatly reduce the number of receptors required to convey a broad range of odors. That is:

1. A single receptor can recognize multiple odorants, indicating that the system is not based on a strict specificity “one odorant = one receptor.”
2. A single odorant is typically recognized by multiple receptors.
3. In contrast to the genetic code where several “words” have the same meaning (different codons can specify the same amino acid), coding of odorants does not seem to be degenerated, that is different odorants are recognized by unique combinations of activated receptors.

These results illustrate how the specific detection of an odorant can be achieved using a device of low specificity (a single odorant receptor recognizes multiple odorants). The functional overlap among receptors and their low specificity is exploited to expand the coding capacity of the system by allowing for combinatorial coding. Specificity is achieved through the combination of responses of several receptors.

In mammals, information carried by odorant receptors are summarized within a spatial organization and specific **▶ oscillations**. Axon terminals from olfactory sensory neurons that express the same olfactory receptor converge in the olfactory bulb on spherical structures known as glomeruli. The olfactory sensory neurons synapse with the dendrite of mitral cells, which in turn output to the olfactory cortex. Then mitral cells in a given glomerulus form their responses to a given odor from very large numbers of converging sensory inputs, ensuring the reliability of the transmission of the information [3,4]. Signals from different types of olfactory sensory neurons are sorted into different glomeruli and a given odorant object is coded by a specific combination of activated glomeruli. In such a way, combinatorial activation of glomeruli defines a two-dimensional map in the olfactory bulb which “shows” which of the olfactory receptors have been activated within the sensory epithelium. Discrimination

of odor then results from the spatial coordinates of the activated glomeruli.

The combinatorial problem is not only due to the large number of chemical components, but also to the huge number of possible mixtures of these components. To cope with the problem of mixtures, any combinatorial system needs mechanisms that allow the neural instantiations of the different elements to be related temporarily in such a way that the relations between the constituents are preserved.

### Intensity and Mixture Recognition With Combinatorial Coding

Information about odor composition or intensity is of great significance for behavior. For example, the ability to discriminate intensity is essential for successful navigation toward odor source or for detection of a predator's odor from the ambient one. In terms of perception, combinations of many individual compounds can be perceived either as new odorants or as a sum of odorants. Furthermore, the same odorant can be perceived similarly or differently depending on its intensity: thiols, for instance, have a strong, repulsive smell that is obnoxious at high concentrations, but is perceived as a sweet citrus aroma when diluted. However, most odors maintain the same quality over orders of magnitude of concentration. If the quality of an odor is reflected in the combination of responses of several receptors, then this raises the problem of superposition. Distributed representation of information by coactive neurons leads to the classical "superposition catastrophe". Consider an assembly of coactive neurons activated by stimulus X and another one by stimulus Y. If both stimuli come together, it would be impossible to distinguish the two assemblies, as information on their membership in the original sets is lost [1]. To avoid such problems, the co-activation induced by compound elements should be different from the sum activation induced by individual elements. In such a way, downstream circuits can benefit by interpreting patterns of activation as distinct coding symbols, that is, each combination can be handled as a unit having an explicit structure allowing comparison, classification, and decomposition.

Experimentally, it has been found that the number of glomeruli that are activated by a single odorant depends on its concentration, suggesting that this number would allow a precise assessment of an odorant's concentration. At a relatively high concentration, simple chemical compounds activate specific but large subsets of receptor types [5]. A simple additive reasoning would suggest that natural odorants, which are each composed of hundreds of simple chemicals, would therefore lead to the recruitment of large and overlapping fractions of glomeruli, a condition that would entail a combinatorial code to avoid "superposition catastrophe". However, a

recent experiment with complex odorants at their natural concentrations shows that only a small fraction of the glomeruli are activated, suggesting a "sparse coding" in natural conditions [6]. This is possible because a mixture seems to be identified by specific and strong responses to only a small number of its constituent chemicals. The response induced by a mixture is then the sum of the responses to specific individual constituents. Sparse coding prevents overlapping and reduces the risk of superposition catastrophe, however it also reduces the coding capacity of the system, raising the question of the capacity of the system to code for the large number of volatile odorants. Furthermore, sparse coding is linear while combinatorial is not, and as indicated above, the perception of complex odorants can be different from the simple superposition of components. It could be the consequence of processing that occurs in a higher brain area, but other mechanisms that take place at the level of the olfactory bulb can also be invoked.

### Combinatorial Coding and Dynamics

Depending on its composition, a given odor will activate a specific combination of glomeruli. A reasonable question would then be whether a code based on an "all or none" activation of combinations of glomeruli is sufficient to represent all the olfactory information that an animal processes in its lifetime. Furthermore, the assumption that specific combinations are available when and where required could be problematic. Finally, the "spatial" view of the coding is rather static and all notion of learning, for example, is removed. Recent studies indicate that the spatial pattern of bulbar activity is not only distributed, but also extremely dynamic. Dynamics provide a set of mechanisms by which the glomeruli repertoire of activation can extend the "coding capacity" of the olfactory system. Such coding encompasses various aspects that are all related to combinatorial coding.

First, it should be noted that the sampling of the "olfactory world" is not a continuous process. In mammals, the sense of smell relies on sniffing, and as a consequence, the world of odors is conveyed in discrete samples, i.e. olfactory "snapshots" [7]. This active sampling of the environment also exists in fishes, crustaceans and insects. In rats, experimental evidence has shown that a correct discrimination of two subtly different odors activating largely overlapping glomerular representations can be achieved within one sniff that is in less than 200 ms. These place a necessary temporal constraint on the overall processing time that is available to interpret the spatial code of activity. Even if it is clear that discrimination might benefit from larger integration times, a trade-off between accuracy and detection of a new odorant or gradient of odorant has

to be found. Overall, it appears that olfactory discrimination is fast and probably occurs within a sniff (Fig. 1).

Combinatorial coding is based on a differential activation of glomeruli (or of receptors) and a simple scheme would be that mitral cells or their equivalent in non-mammal systems respond to an odorant either by no change in activity or by an increased firing rate. A number of laboratories have recorded the electrophysiological activity of such cells and a simple rate coding (increase or decrease of number of action potential per window of time) does not seem to be the rule. In addition to the spatial aspect of odor representation, it has been suggested that glomerular activation maps also contain reliable stimulus-specific sequences of action potential patterns [8] or sequences of onset times [9]. In the drosophila antenna, it has been suggested that receptors confer not only the odor but also the response mode and the response dynamics upon the olfactory sensory neurons that express them, as well as the level of spontaneous activity. Coding is then expanded by the multiplication of response characteristics exhibited by each receptor.

Finally, it has been proposed that the nervous system uses spatiotemporal patterns of neuronal activation to create a large coding space. In such a view, the odor

is encoded not in the topography, but in the temporal dynamics of the action potentials elicited by different odors [10].

## Conclusions

At first sight, the olfactory system uses a relatively straightforward strategy based on combinatorial coding for perceiving and discriminating odorant molecules. Combinatorial coding seems appropriate when the purpose of the system to be modeled is feature detection, but seems more problematic when it is a general purpose device. Indeed, to be exploited in other contexts, any experience gained in a particular circumstance should be affixed to the most general description of the situation [1]. Most of the neurophysiological evidence deals with sensory detection of odors that is the association of a given odorant with a sole pattern of activity in the olfactory system ending into the orbitofrontal cortex (►cortex orbitofrontal), leaving aside the interpretation of odors and how this directs behaviors. Such a role is supposed to be attributed to the brain cortex, but opinions differ on the extent to which it could begin in the olfactory bulbs themselves.

Finally, it should be stressed that all odors in our environment are certainly not processed using the same coding strategy. During an animal's life some odors have to be learned, others not. Combinatorial codes can be envisioned for odors that are characteristic of a given species. Indeed, most animals have innate behaviors that are associated with given odors and it has been demonstrated that a single type, but also a few types, of receptor acting combinatorially mediate robust behaviors in drosophila. Overall, much remains to be understood about the detailed mechanisms of odor perception, but these mechanisms are certainly shaped by the specificity of olfaction. If light or sounds are constant physical stimuli, the world of smell varies with evolutionary time [3].

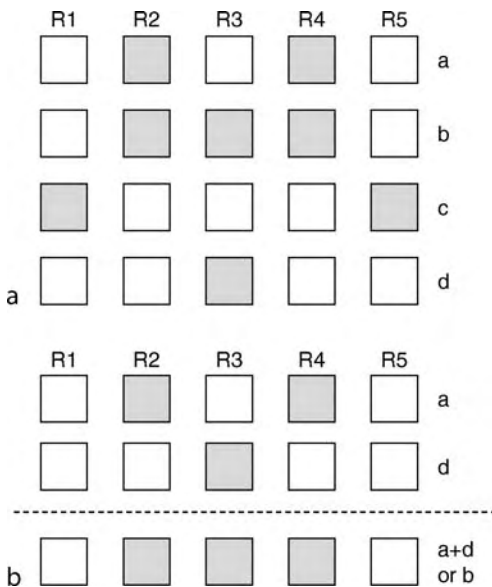

**Combinatorial Coding. Figure 1** (a) Pattern of activation of receptors or glomeruli (represented by a square): A particular odor compound (labeled a, b, c or d) is coded according to which receptors are activated, as indicated by color (white represents no activation). Four odor compounds are depicted with the specific array of receptors each would activate. (b) If two sets of active neurons (a and d) are simultaneously activated (panel above dashed line), information on their membership in the original sets is automatically lost.

## References

1. von der Malsburg C (2000) The what and why of binding: the modeler's perspective. *Neuron* 24(1): 95–104, 111–125
2. Olshausen B, Field D (2004) Sparse coding of sensory inputs. *Curr Opin Neurobiol* 14(4):481–487
3. Bargmann C (2006) Comparative chemosensation from receptors to ecology. *Nature* 444(7117):295–301
4. Lledo P, Gheusi G, Vincent J (2004) Information processing in the mammalian olfactory system. *Physiol Rev* 85(1):281–317
5. Malnic B, Hirono J, Sato T, Buck L (1999) Combinatorial receptor codes for odors. *Cell* 96(5):713–723
6. Lin DY, Shea S, Katz L (2006) Representation of natural stimuli in the rodent main olfactory bulb. *Neuron* 50(6):937–949
7. Kepecs A, Uchida N, Mainen Z (2006) The sniff as a unit of olfactory processing. *Chem Senses* 31(2):167–179

8. Hallem E, Carlson J (2006) Coding of odors by a receptor repertoire. *Cell* 125(1):143–160
9. Schaefer A, Margrie T (2007) Spatiotemporal representations in the olfactory system. *Trends Neurosci* 30(3):92–100
10. Laurent G (2002) Olfactory network dynamics and the coding of multidimensional signals. *Nat Rev Neurosci* 3(11):884–895

## Combinatorial Transcription Factor Codes and Neuron Specification

DOUGLAS W. ALLAN

Department of Cellular and Physiological Sciences,  
University of British Columbia, Vancouver, BC,  
Canada

### Synonyms

Transcription factor codes; Combinatorial action of transcription factors; Neuronal determination; Neuronal differentiation

### Definition

A “combinatorial code” of **transcription factors** is commonly used to refer to two related phenomena in the specification of neurons:

1. Cellular definition. i) A combination of transcription factors that is required together to activate or repress a certain gene in a certain cell. ii) A combination of transcription factors that is required together to execute a neuron’s distinct differentiation program.
2. Developmental definition. i) The difference in the combination of transcription factors, between neurons, that accounts for their distinct gene expression profiles. ii) A spatial or temporal transition in transcription factor expression that confers a distinct program of neuronal differentiation or gene expression.

### Characteristics

The nervous system contains many different types of neurons, whose differences ultimately reside in their distinct gene expression profiles. This essay outlines how the deployment of specific combinations of transcription factors in neuronal progenitors and **post-mitotic neurons** direct the execution of distinct programs of neuronal differentiation. Discussed here are the functions of these transcription factors from the perspective of their acting in “combinatorial codes” that diversify neuronal gene expression profiles.

### Combinatorial Codes and *cis*-Regulatory Modules

Transcription factors are proteins that bind DNA at specific sequences (termed transcription factor binding sites - TFBS) in a gene’s **regulatory region**, from where they modulate (activate or repress) activity of the gene’s **promoter**. TFBS are clustered into *cis*-regulatory modules that bind specific combinations of 2–10 transcription factors. By clustering TFBS for different transcription factors, *cis*-regulatory modules are a critical platform for decoding cell-specific combinations of transcription factors into cell-specific patterns of gene expression [1].

Efforts to unravel the organization of *cis*-regulatory modules in *C.elegans* neurons have proven illuminating [2] (Fig. 1). Most of the genes expressed in AIY neurons (sensory processing neurons) are activated by the combinatorial action of the LIM-**homeodomain** transcription factor TTX-3 and the Paired-homeodomain transcription factor CEH-10. These factors bind cooperatively to a 16bp *cis*-regulatory module in the regulatory

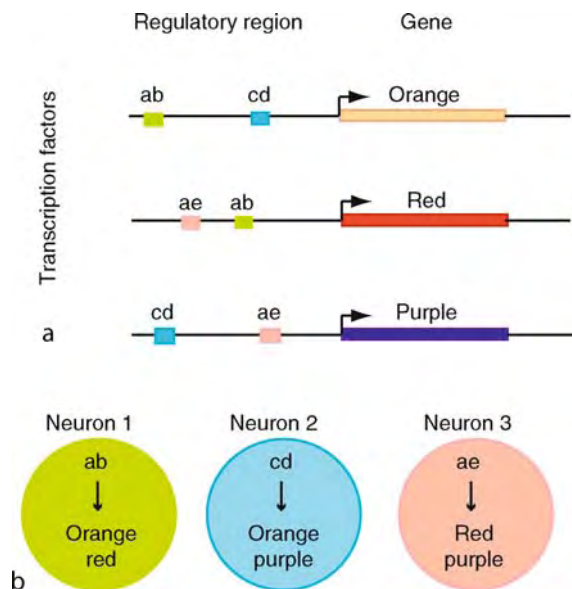

### Combinatorial Transcription Factor Codes and Neuron Specification. Figure 1

*Cis*-regulatory modules respond to different combinations of transcription factors to assign gene expression to specific neurons (a) Three genes – orange, red and purple – that have an array of *cis*-regulatory modules (coloured boxes) in their regulatory region. *cis*-regulatory modules bind to a certain combination of transcription factors (a + b, or c + d, or a + e). Arrow denotes the gene’s promoter. (b) Neuron 1 expresses transcription factors a + b. This combination activates the orange and red genes because those genes contain a *cis*-regulatory module that binds the a + b combination of transcription factors (in a). A similar rationale controls gene activation in neurons 2 and 3.

region of most AIY-expressed genes, and that is necessary and sufficient for gene expression in AIY neurons. This work also found a simple mechanism for gene expression in different neurons. Each gene has an array of *cis*-regulatory modules. Each module assigns expression of the gene to a different neuron - by binding the combination of transcription factors in that neuron [2] (Fig. 1).

This elegant organization has been elaborated upon by evolution. First, *cis*-regulatory modules can be more complex. The expression of a single gene in a single cell can require the binding of eight or more transcription factors to TFBS, which are not all clustered into one module [1,3]. Second, the genes expressed in a single cell are often not all controlled by the same combination of transcription factors. For example, the two subunits of luteinizing hormone are controlled by different combinations of transcription factors in the same cells - pituitary gonadotrophs [3]. More examples are outlined below; “Transcriptional sub-programs in neurons.”

In the era of genomic sequencing, researchers are taking advantage of TFBS clustering and the sequence-specificity of transcription factor binding to develop methods for identifying and studying gene regulatory

elements of genes [4]. These efforts are providing a wealth of new data and highlight how little we currently understand.

### Combinatorial Codes in Neuronal Differentiation

Neuronal differentiation starts in ►progenitor cells that translate extrinsic “positional” cues, related to the body plan, into the regionalized expression of different combinations of transcription factors [5] (Fig. 2).

These factors initiate hierarchical transcriptional cascades that diversify those progenitor populations, culminating in the generation of post-mitotic neurons endowed with different combinations of transcription factors [5]. Each cell-specific combination of transcription factors then activates a ►cell-specific battery of terminal differentiation genes, which shapes the neuron’s distinct form and function [1,2,5].

### Spatial combinatorial codes translating axial cues into progenitor domains

The chick and mammal neural tube emerges as a field of ►multipotent neuroepithelial cells. In the early spinal cord, these cells are regionalized along the

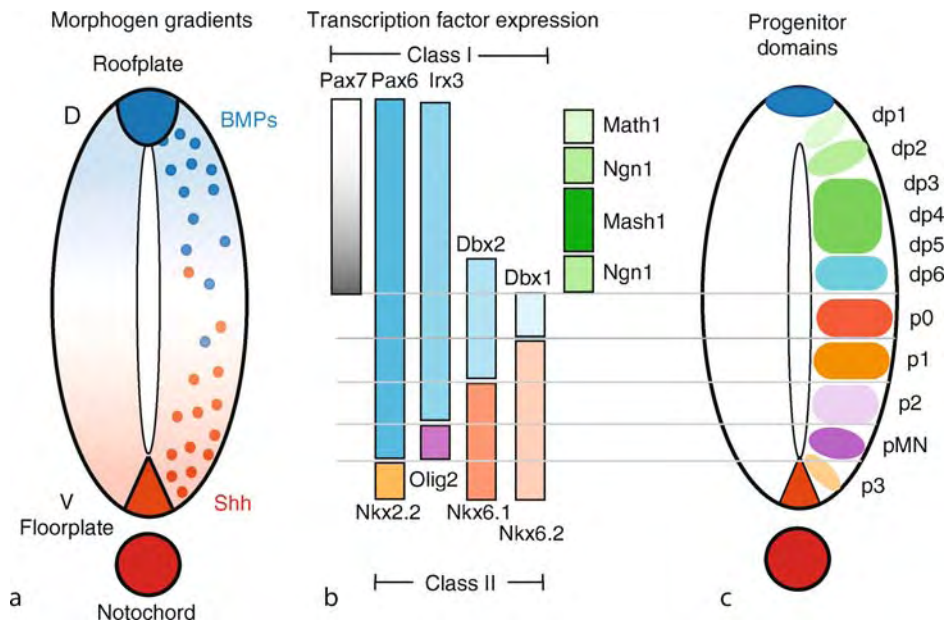

**Combinatorial Transcription Factor Codes and Neuron Specification. Figure 2** Generation of a spatial combinatorial code of transcription factors in the developing spinal cord from apposed gradients of two morphogens. Cartoons representing a transverse section through the developing spinal cord. (*D* dorsal; *V* ventral) and the expression domains of transcription factors in progenitor cells. (a) The developing spinal cord is patterned along the dorsoventral axis by apposed gradients of bone morphogenetic proteins (BMPs), secreted from the roof plate, and Sonic hedgehog, secreted from the notochord and floorplate. (b) In response to the local level of Shh and BMPs, a set of homeodomain and bHLH transcription factors become expressed in specific domains. Transcription factors apposed vertically are mutually repressive. A set of BMP-activated bHLH transcription factors are shown in green boxes. (c) The combinatorial expression of these transcription factors define domains of progenitor cells (their names are on the right) that will give rise to distinct types of neurons. Additional transcription factors contribute to this spatial code, but are omitted here for clarity.

dorso-ventral (D-V) axis by apposed gradients of secreted Sonic hedgehog (Shh) and bone morphogenetic proteins (BMP). Progenitors transduce their position along this gradient into the expression of different homeodomain and basic helix-loop-helix factors [5] (Fig. 2). Coordinately, the antero-posterior (A-P) axis is set up by gradients of secreted retinoic acid, fibroblast growth factors and Wnts. Progenitors transduce their position along this axis into expression of different homeodomain Hox factors.

Patterning of the ventral-half spinal cord by Shh is well-studied [5]. Shh, secreted from the ►notochord and ►floorplate, establishes a D-V gradient that is translated into five expression domains of mainly homeodomain transcription factors by the following mechanisms: i) Shh represses Class I transcription factors (Pax6, Irx3, Dbx2, Dbx1 and Pax3/7), and activates Class II transcription factors (Nkx2.2, Olig2, Nkx6.1 and Nkx6.2). ii) Each of these factors responds at a different threshold (step) of the Shh gradient. At each step, a single Class I factor is repressed (limiting further ventral expansion), and a single Class II factor reaches its threshold for activation (limiting further dorsal expansion). iii) Class I and II factors, whose limits of expression coincide at a single step, mutually antagonize one another's expression. This sharply delineates the borders of each factor's expression domain. This spatial combinatorial code of transcription factors commits progenitor cells to distinct neuronal differentiation programs [5]. For example, loss of Nkx6.1 expression allows ventral expansion of its repressive partner, Dbx2. This re-specifies progenitor cells that normally express Nkx6.1 (that would differentiate into ►motoneurons or V2 interneurons) into progenitor cells that now express Dbx2 (and that now differentiate into V1 interneurons). These early transcriptional codes act via primarily repressive mechanisms, suggesting that neuronal fate assignment in progenitors is largely determined by the progressive restriction of alternate fates [5,6].

From invertebrates to vertebrates, equivalent mechanisms exist throughout the nervous system to regionalize the differentiation of specific types of neurons. Remarkably, the involvement of many of the secreted axial cues and transcription factors are conserved [6].

### Combinatorial codes that diversify neuronal subtypes

The emergence of distinct neuronal subtypes from progenitor cells entails hierarchical, combinatorial cascades of transcription factors [5,6,7,8]. Vertebrate motoneuron differentiation from pMN progenitors in the spinal cord is well studied [5,6]. The Shh gradient establishes Pax6 and Nkx6.1 expression in pMN progenitors. These act combinatorially to activate Olig2 expression only in pMN progenitors. The combined

action of Olig2 and Nkx6.1 then promotes expression of the ►bHLH transcription factor, Ngn2. In the context of Ngn2 expression, Olig2 then promotes expression of the homeodomain factors Lhx3, Isl1 and HB9 (and MNR2 in chick) and the bHLH factor NeuroM, around the time of motoneuron birth. This combination of transcription factors is then critical for executing a motoneuron-specific program of differentiation. The combinatorial nature of Olig2 function is underscored by events that occur after motoneuron birth. Remaining pMN progenitors switch from Olig2/Ngn2 co-expression to Olig2/Nkx2.2 co-expression. This re-commits pMN progenitors from motoneuron differentiation to an oligodendrocyte differentiation program. This type of hierarchical transcription factor cascade is a common theme for neuronal differentiation from progenitor populations in the nervous system of all organisms [2,5,6].

Expression of HB9, Islet1 (Isl1), Lhx3 and NeuroM (and MNR2 in chick) around the time of cell-cycle exit is critical for motoneuron differentiation. Islet1, Lhx3 and NeuroM combinatorially activate and ensure maintained expression of HB9. In turn, HB9 (and chick MNR2) promotes Isl1 and Lhx3 expression. This type of positive feedback mechanism that consolidates the robust expression of a cell-specific transcription factor code has been observed in neurons of all organisms [2,5,6].

After motoneuron birth, the LIM-homeodomain transcription factor family (Isl1/2, Lhx3/4, Lhx1) subsequently acts to diversify motoneurons into distinct subtypes with different axon pathfinding trajectories [4]. Vertebrate spinal motoneurons maintain HB9 and Isl1 expression, however, the other LIM-homeodomain transcription factors (Islet2, Lhx1, Lhx3 and Lhx4) become differentially expressed in the different motoneuron subtypes. Experimental manipulation has demonstrated the functional relevance of this so-called LIM-code. For example, Isl1/Lhx3-expressing motoneurons pathfind within the dorsal ramus to axial muscles whereas Isl1-only motoneurons pathfind within the ventral ramus. Lhx3 overexpression forces Isl1-only motoneurons to pathfind into the dorsal ramus. Similarly, Lhx1 acts combinatorially with Isl1 to control innervation of the dorsal vs. ventral half of the limb bud. The function of the HB9/LIM-homeodomain combinatorial code for motoneuron differentiation is remarkably well conserved from *Drosophila* to mammals [5,6]. However, in spite of some progress in defining the genes downstream of these combinatorial codes, this persists as an important challenge.

Some progress has been made in elucidating the biochemical nature of these combinatorial codes. The functional significance of the Isl1/Lhx3 code has been tested for V2 interneuron versus motoneuron differentiation [5]. V2 neurons arise from p2 progenitors, which reside in the domain adjacent to pMN progenitors



(those that generate motoneurons) (Fig. 2). Around the time that p2 and pMN progenitor cells undergo their final round of cell division, Lhx3 is expressed in p2 progenitors, whereas Islet1 and Lhx3 are co-expressed in pMN progenitors. In p2 cells, a complex comprising two Lhx3 proteins - bridged by the self-dimerizing NLI cofactor (Lhx3-NLI:NLI-Lhx3) - is formed. In pMN cells, a complex of Islet1 - bridged by the NLI dimer - is formed. Lhx3 then binds to the apposed Islet1 proteins to form a pMN-specific complex comprising Lhx3: Islet1-NLI:NLI-Islet1:Lhx3 [5]. Experimental manipulation of these complexes have proven their functional potency in promoting p2 to V2 differentiation versus pMN to motoneuron differentiation. The Pfaff Lab subsequently demonstrated that motoneuron-specific activation of HB9 depends upon the binding of the Lhx3:Islet1-NLI:NLI-Islet1:Lhx3 complex to a *cis*-regulatory module in the regulatory region of the HB9 gene. The activity of different transcription factor complexes at discriminatory *cis*-regulatory modules is proving to be a common mechanism for exerting unique transcriptional readouts from subtly different combinations of transcription factors.

In contrast to earlier-acting transcription factors that act largely as repressors, many factors acting in post-mitotic neurons are activators of gene expression [2,5,8]. Interestingly, when misexpressed, certain post-mitotic transcription factor codes can trespass upon earlier-acting codes to dominantly impose their own late program of terminal differentiation [8]. Does this indicate that early-acting codes merely act to establish late-acting codes, which then execute the program of terminal differentiation? It is unlikely this simple. Examples from all model organisms show that certain early-acting factors persist to play critical roles in later-acting combinatorial codes, a concept termed “combinatorial feedforward coding” [8]. Further research will likely illuminate the temporal function of individual factors acting within the transcriptional cascades that shape neuronal differentiation.

### Temporal Combinatorial Codes that Transition Progenitors between Competence States

A common mechanism for generating neuronal diversity is to progressively alter the competence of progenitor pools, or neuroblasts, to produce different types of neurons at specific timepoints [9]. Within a single lineage, certain transcription factors become expressed at different steps of lineage progression, that alter the program of neuronal differentiation (Fig. 3).

*Drosophila* neuroblasts undergo an invariant series of cell divisions, each time generating a neuroblast and a ganglion mother cell (GMC). The GMC subsequently divides once to produce two post-mitotic cells. The first neuroblast expresses Hunchback. When this neuroblast divides, it produces a daughter GMC and a daughter

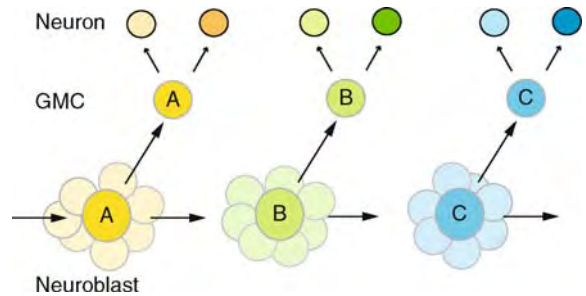

### Combinatorial Transcription Factor Codes and Neuron Specification.

**Figure 3** A temporal code of transcription factors that generates distinct neurons from the same neuroblast or progenitor pool. Neuroblast A represents a neuroblast or progenitor pool (lighter cells) within a specific lineage that expresses the temporally-encoded transcription factor A. Upon a round of cell division, neuroblast A produces a daughter ganglion mother cell (GMC), with the same transcription factor A, and a daughter neuroblast, which expresses transcription factor B, instead of A. For progenitor pools, transitions in transcription factor expression can be regulated by feedback from the neurons produced at each timepoint. The result is a diverse set of neurons that were produced from the same lineage.

neuroblast. The GMC expresses Hunchback. However, the daughter neuroblast expresses Kruppel, rather than Hunchback. Upon division of this new neuroblast, the daughter GMC expresses Kruppel but the daughter neuroblast expresses Pdm. Subsequent division results in the GMC and Castor expression in the daughter neuroblast. Studies on Hunchback and Kruppel have shown that these transcription factors function to change the program of differentiation of each GMC, resulting in the production of different neurons. Although there can be some variability between lineages, many different neuroblast lineages utilize this same code. Thus, the temporal code acts in the context of distinct lineage-restricted transcription factors to diversify the neurons produced by each lineage [9]. Similar events occur in the vertebrate retina where a common progenitor pool produces all neuronal types of the retina by undergoing temporally-encoded changes in transcription factor expression, each of which results in the generation of a particular type of neuron [9].

There is less information regarding how successive transitions in temporal cues are controlled. Work in the vertebrate retina has provided evidence for feedback from recently born cells that instruct progenitors to transition. Implicated signaling pathways include cytokines, BMP-type signals and Sonic hedgehog [9]. One clear example has been described in the developing spinal cord. Vertebrate lateral motor column (LMC) motoneurons are born in two waves. The first

differentiates into medial LMC neurons that express *Isl1* and *RALDH-2* (which synthesizes retinoids). Retinoid secretion from those neurons activates expression of *Lhx1* in the second wave of LMC neurons, which results in a distinct differentiative outcome [5].

### Transcriptional Sub-Programs in Neurons

Neurons often fall into common types, such as motoneurons, neuropeptidergic neurons, ciliated neurons etc. Certain transcription factors independently control the expression of genes that are generic to neurons of a particular type, often in parallel and sometimes in concert with subtype-specific transcription factor codes. In *C.elegans*, *DAF-19* is expressed in all ciliated neurons, activating expression of the structural components of ciliary structures independently of subtype-specifying mechanisms. ▶ **Proneural transcription factors** are well known to promote cell-cycle exit of progenitors into newborn neurons and activate generic neuronal genes [7]. However, in many cases, these factors are also required to activate cell-specific properties, usually in a context-dependent manner. In the vertebrate spinal cord, *Mash1* is essential for the emergence of a subset of dorsal interneurons and *Ngn2* for motoneurons. Although both have been shown to act as proneural factors that activate generic neuronal properties in both sets of neurons, they cannot compensate for one another in the subtype-specification of their respective neuronal populations [7]. These data indicate that these factors play at least two distinct roles in the differentiation of their respective neurons, one generic and the other subtype-specific. Work in *Drosophila* has provided direct evidence to demonstrate this duality in function [10]. The bHLH factor *dimmed* is expressed in neuropeptidergic neurons, activating generic genes independently of other transcription factors, but acting combinatorially with local subtype-specific combinations of transcription factors to activate subtype-specific genes appropriate to the neuropeptidergic cell-type, eg specific neuropeptides [10].

Not only can individual transcription factors act in parallel to cell-specific combinatorial codes to specify generic sets of genes, but certain combinations of transcription factors can operate in this manner as a sub-code in otherwise distinct neurons. These function to turn on the same genes in different neurons [7]. A transcription factor code of *Mash1* and *Phox2a/b* specifies the expression of noradrenalin-synthesizing enzymes in different types of vertebrate neurons. This pro-adrenergic code appears to exist as a sub-code within an otherwise distinct transcription factor milieu to specify this particular aspect of neuronal differentiation [7].

### Summary

Our understanding of how combinatorial codes of transcription factors drive diverse programs of neuronal

differentiation has progressed dramatically, facilitated by the remarkable conservation of transcription factor function between ▶ **metazoans**. The future promises a highly detailed description of the gene regulatory networks that guide the differentiation and maturation of the many types of neurons in the nervous system. This information will be of paramount importance to the development of novel therapeutic approaches aimed at tackling the devastating effects of nervous system disorders and trauma.

### References

- Davidson EH (2001) Genomic regulatory systems. Academic Press, San Diego, CA
- Wenik AS, Hobert O (2004) Genomic cis-regulatory architecture and trans-acting regulators of a single interneuron-specific gene battery in *C. elegans*. *Dev Cell* 6:757–770
- Jorgensen JS, Quirk CC, Nilson JH (2004) Multiple and overlapping combinatorial codes orchestrate hormonal responsiveness and dictate cell-specific expression of the genes encoding luteinizing hormone. *Endocr Rev* 25:521–542
- Wasserman WW, Sandelin A (2004) Applied bioinformatics for the identification of regulatory elements. *Nat Rev Genet* 5:276–287
- Lee S-K, Pfaff SL (2001) Transcriptional networks regulating neuronal identity in the developing spinal cord. *Nat Neurosci Suppl* 4:1183–1191
- Arendt D, Nubler-Jung K (1999) Comparison of early nerve cord development in insects and vertebrates. *Review Article. Development* 126:2309–2325
- Bertrand N, Castro DS, Guillemot F (2002) Proneural genes and the specification of neural cell types. *Nat Rev Neuro* 517–530
- Baumgardt M, Miguel-Aliaga I, Karlsson D, Ekman H, Thor S (2007). Specification of neuronal identities by feedforward combinatorial coding. *PLoS Biol* 5(2):e37, 0295–0308
- Pearson BJ, Doe CQ (2004) Specification of temporal identity in the developing nervous system. *Annu Rev Cell Dev Biol* 20:619–647
- Allan DW, Park D, St. Pierre SE, Taghert PH, Thor S (2005) Regulators acting independently and in combinatorial codes to specify different aspects of neuronal identity. *Neuron* 45:689–700

## Combined Dexamethasone-CRH (Dex-CRH) Suppression Test

### Definition

After oral administration of dexamethasone (Dex) the previous night, patients are injected with corticotrophin releasing hormone (CRH) to examine the efficacy of the

feed back loop of the hypothalamic-pituitary-adrenal (HPA) axis. A strong response to CRH after Dex pre-treatment in rodents has been shown to reflect impaired negative feedback at the pituitary level.

► Neuroendocrinology of Multiple Sclerosis

---

## Command Neuron

### Definition

A neuron that can activate a specific behavior or behavioral sequence. There has been a considerable debate concerning the criteria that define a command neuron. The most stringent definition is a neuron, which is both sufficient and necessary for the initiation of a specific behavior. However, whilst many neurons fulfil the sufficiency criterion, i.e. their activity can activate a specific behavior, only very few neurons also fulfil the necessity criterion, i.e. the specific behavior will only be elicited when this neuron is active. This is consistent with the recognition that most behaviors are activated by multiple parallel pathways.

► Central Pattern Generator

---

## Command Nucleus

### Definition

A group of neurons that together is both necessary and sufficient for generating a behavior. In the case of mormyrid electric fish, the nucleus is responsible for generating each electric organ discharge (EOD).

► Rafferent Control in Electric Communication

---

## Commissure

### Definition

A commissure (Latin joining together) is a bundle of axons that crosses the midline, usually connecting homotypical (the same) cell groups on the left and right sides of the neuraxis, e.g., the corpus callosum, and anterior and posterior commissures. On the other hand, the anterior commissure of the spinal cord is composed

of axons from the dorsal horn simply crossing the midline en route to the opposite anterolateral quadrant of the spinal cord white matter.

---

## Common Crus

### Definition

Common “leg” (Latin), a portion of the semicircular canal system shared by two canals.

► Evolution of the Vestibular System

---

## Common Marmoset (*Callithrix Jacchus*)

### Definition

Common marmoset are small monkeys (300–500 g at maturity) of Brazilian origin, with a chromosome number of  $2n = 46$  and a life span of 12–15 years. They are easier to manipulate than Macaque monkeys, and their high breeding efficiency allows an adequate number of common marmosets to be obtained for use in research experiments. Thus, they are often used in a variety of fields of research for preclinical trials, e.g., the experimental autoimmune encephalomyelitis (EAE) model for multiple sclerosis, cerebrovascular disease, Alzheimer’s disease, delayed dyskinesia, Parkinsonism, and Huntington’s disease.

- Alzheimer’s Disease
- Experimental Autoimmune Encephalomyelitis (EAE)
- Huntington’s Disease
- Multiple Sclerosis
- Parkinson Disease

---

## Common Sense Functionalism (Folk Functionalism)

### Definition

The claim that mental states like beliefs, desires and intentions are understood solely in terms of their causal

relations to other states, to input from the environment and to observable behavior.

► Theory Theory (Simulation Theory, Theory of Mind)

## Comparator in Motor Control

### Definition

In an engineering model of a feedback system the element that serves as a junction for the input signal and the feedback signal is called a comparator. Since the feedback signal is usually negative and the input signal positive, the comparator computes the difference between the two signals. In neural models, a comparator is hypothesized to compute remaining motor error, the difference between the signal representing the goal of the movement and a feedback signal representing how far the movement has moved toward the goal at the present instant.

## Compartmental Approach

### Definition

An advanced biophysical model of a single neuron, in which the neuron is represented as a set of electrically coupled isopotential compartments.

► Neural Networks

## Compartmentalized Protein Synthesis

► mRNA Targeting: Growth Cone Guidance

## Compatibilism

### Definition

The thesis that acting freely is compatible with the truth of determinism

► Freedom of Will

## Compensatory Linear Vestibulo-Ocular Reflex (IVOR)

### Definition

The reflex that responds to high frequency linear accelerations of the head in space to produce eye movements that tend to maintain a gaze point fixed relative to the head. This reflex has been also referred to as the translational VOR (TVOR).

► Velocity Storage  
► VOR-translational

## Compensatory Plasticity

### Definition

Neuronal plasticity to compensate for impaired functionality after injury or experimentally induced lesion (e.g., denervation) (to be distinguished from learning-induced and developmental plasticity).

► Neuroethological Aspects of Learning

## Competitive Antagonist

### Definition

A competitive antagonist is a receptor antagonist that binds to a receptor but fails to activate it. If an agonist competes with a competitive antagonist for the same binding site on the same receptor, the agonist molecules can be displaced from the binding site.

## Competitive Learning

### Definition

A learning mechanism of neural networks in which neurons are competing with each other to output maximum value to input signals. As a result of the competition, the input signal space is divided and each neuron becomes to output maximum value for input signals in a certain divided area of signal space.

► Competitive Learning Theory

## Competitive Learning Theory

HIDEKI ASOH

Information Technology Research Institute, National Institute of Advanced Industrial Science and Technology, Tsukuba, Ibaraki, Japan

### Definition

▶ **Competitive learning** theory refers to mathematical and computational theories on learning of neurons which compete with each other to generate maximum output. Various self-organizing phenomena in the central nervous system such as formation of the feature extraction neurons in the visual cortex are explained by these theories. The theories also explain self-organizing phenomena in cognitive level such as categorization of input stimuli and feature extraction for pattern recognition.

### Description of the Theory

#### Self-Organization of Neural Circuit

Various organized structures are observed in the central nervous system. For example, as Hubel and Wiesel discovered, simple cells which respond selectively to specific visual stimuli such as oriented light bar form aligned columns in the visual cortex, and neurons in neighboring columns respond to similar orientation. Such organized structures composed of neurons which selectively respond to certain stimulus are observed quite often in the nervous system. It is a natural and interesting question how they are constructed. The competitive learning theory is one of major theories to explain the self-organization process of the structures.

#### Competitive Learning

Consider a set of  $M$  neurons. As shown in Fig. 1, all neurons receive the same  $N$  input signals  $x_1, \dots, x_N$  from other neurons. Let the synaptic weight of the  $i$ th neuron at time  $t$  be  $\mathbf{w}_i(t) = (w_{i1}(t), \dots, w_{iN}(t))$ ,  $i = 1, \dots, M$ . Each discrete time step, input signals  $\mathbf{x}(t) = (x_1(t), \dots, x_N(t))$  is fed into the neurons. The output of the  $i$ th neuron is assumed to be the weighted sum of inputs, that is, inner product of the vector  $\mathbf{w}_i(t)$  and  $\mathbf{x}(t)$ ,

$$y_i(t) = \sum_{j=1}^N w_{ij}(t)x_j(t) = \mathbf{w}_i(t) \cdot \mathbf{x}(t).$$

The neuron which outputs the maximum value is called “winner,” and we assume that the synaptic weights of the winner neuron are modified according to the following learning rule:

$$\mathbf{w}_i(t+1) = \mathbf{w}_i(t) + \eta(t)(\mathbf{x}(t) - \mathbf{w}_i(t)).$$

Here  $\eta(t)$  is a small positive value called learning rate and decreases as time  $t$  passed. This rule is the most typical one, and various learning rules are proposed and investigated by many researchers.

This learning rule causes the weight vector of the winner to become closer to the input signal vector. If the several input signals form a cluster, then the weight vector comes closer to the center of the cluster. Figure 2 illustrates the result of the competitive learning. Here  $M = 9$  and  $N = 2$ , and nine neurons are arranged on a  $3 \times 3$  two dimensional grid. Input signals and weight vectors are shown by small and large dots respectively. The weight vectors of neighboring neurons are connected by a line. Input signals are distributed forming nine clusters. At the initial state shown in Fig. 2a, nine weight vectors  $\mathbf{w}_i$  are distributed randomly. Hence, a weight vector is closest to a certain cluster. For the input signal in the closest cluster, the neuron which has the weight vector will become the winner and the weight vector comes closer to the cluster center. In the end, each weight vector goes to the center of a cluster as is shown in Fig. 2b.

In this way, competitive learning neurons can find clusters in the input signal space, and each neuron becomes to output maximum response to signals in a cluster. This means that the neuron becomes a detector of the cluster. Imagine that each input signal is a light bar stimuli in some orientation, then the competitive learning can produce the orientation selective neurons.

Choosing the winner neuron and applying the learning rule only to it may seem an artificial trick. However, various biologically plausible neural network architectures, which can realize the equivalent process, have been proposed. Most of them are composed of Hebbian learning neurons and mutual inhibition between neurons.

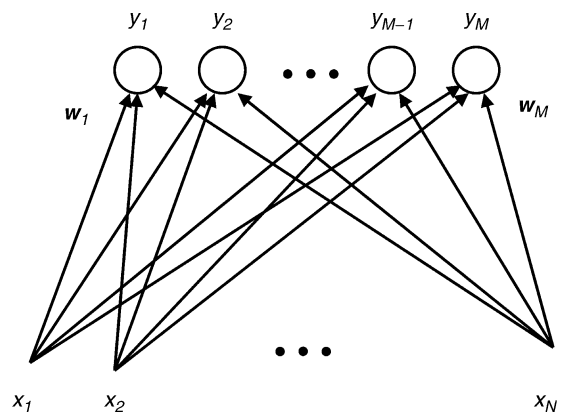

**Competitive Learning Theory. Figure 1** A competitive learning network.

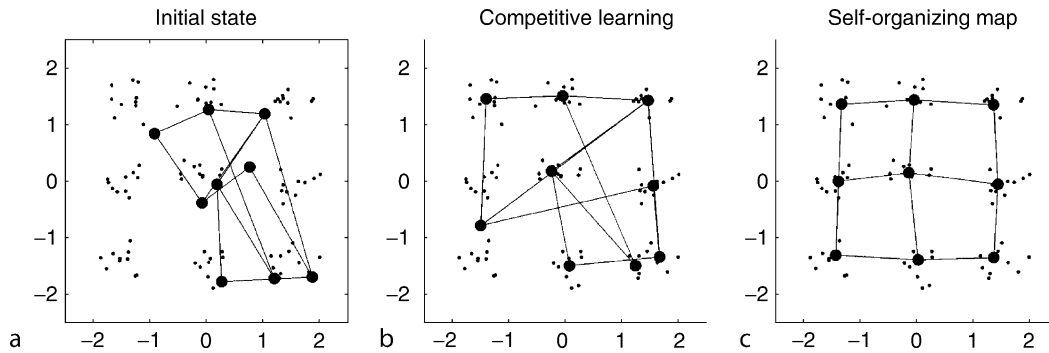

**Competitive Learning Theory. Figure 2** Competitive learning and self-organizing map.

An important factor for the success of the competitive learning is the number of learning neurons. If the number is smaller than the number of clusters, the result of learning will not be stable. However, it is impossible to know the number of clusters beforehand. Taking the dynamic nature of learning environments into consideration, the problem becomes more serious. Even though the number of output cells is enough at a certain time, there is a possibility that new clusters will emerge according to the change of the environment. In order to cope with the problem, Grossberg first proposed an idea to add output units one by one during the learning process and called it adaptive resonance theory [1]. This idea of adding or removing output units during learning was further investigated by many researchers and various heuristic rules for addition or deletion were proposed.

From a computational or engineering point of view, the competitive learning solves the problem called clustering, categorization, or vector quantization. The procedure of the competitive learning is closely related to clustering algorithms such as the k-means algorithm and the [expectation maximization](#) learning of Gaussian mixture distribution. The idea of the competitive learning was extended to competition between modular neural circuits. Jacobs et al. proposed a learning model named “mixture of experts,” where multiple modular networks are competing and each network becomes an expert for a certain subtask [2]. Haruno et al. also proposed a model of self-organization of functional modules and named it “Mosaic.” They applied the model to the problem of complex motor learning [3].

### Formation of Cortical Maps

The competitive learning explains formation of neurons which respond to specific input signals selectively. In cortical maps, it is known that such feature detecting neurons are arranged as the neighboring neurons tend to respond to similar inputs. The self-organizing maps

(SOM) proposed by Kohonen is one of the most popular mathematical models of the formation of the cortical maps [4]. Kohonen proposed to apply the learning procedure not only to the winner neuron but also the neurons close to the winner. A typical learning rule can be written as

$$\mathbf{w}(t+1) = \mathbf{w}(t) + \eta(t) D(i, i^*, t)(\mathbf{x}(t) - \mathbf{w}(t)).$$

Here,  $D(i, i^*, t)$  is called neighborhood function and takes 1 for neuron  $i$  close to the winner neuron  $i^*$ . The learning rate  $\eta(t)$  and the neighboring area where  $D(i, i^*, t) = 1$  are controlled to become smaller as the learning proceeds. Various modifications of the learning rule have been proposed and investigated by many researchers.

Figure 2c shows the result of the self-organizing process. The initial state and the input signals are the same as the competitive learning. Note that the lines connecting neighboring neurons are resolved and neighboring neurons begin to respond to neighboring clusters.

In order to realize the neighborhood function in a biologically plausible way, various network architectures have been proposed. Most of them are composed of excitatory connections between neighboring neurons and inhibitory connections between far away neurons. Due to the connections, neighboring neurons begin to behave similarly and separated neurons begin to behave competitively.

### Models of the Development of the Visual Cortex

We have introduced two elements of self-organization mechanism. The first one is the competition between neurons for generating selectively responding neurons. The second one is the positive interaction within the neighborhood for generating a topology preserving arrangement of neurons. A mathematical model of the self-organization process of orientation sensitive cells in the visual cortex, which has the above two elements, was first proposed by von der Malsburg [5]. The model

is composed of two layers of excitatory neurons and inhibitory neurons connecting each other. Using the set of orientating light bar as stimuli, the model succeeded to produce the orientation sensitive cells through the learning. The neighboring cells had the tendency to react to similar stimuli as discovered by Hubel and Wiesel.

Inspired by the work, many researchers proposed and studied various versions of models. Amari performed deep mathematical analysis of the model, and theoretically proved important natures of the model such as the formation of discrete column structures and the stability of the organized structure [6]. Linsker proposed a multi-layer network of Hebbian learning neurons [7]. Instead of competition between neurons in a layer, localization of connections between layers was introduced, that is, each neuron receives inputs only from a neighborhood in the previous layer. It was demonstrated by computer simulation that featured extraction cells such as on-center off-surround type cells, and orientation sensitive cells that emerged in the higher level layers. The most interesting point of this model is that the input signal is just a white noise without any structure. Hence, this model can explain the fact that even in the visual cortex of very young animals which have no visual stimulus, some orientation specific cells are found. Miller et al. improved Linsker's model to be more biologically realistic [8]. Tanaka proposed more sophisticated mathematical models using the formalism of the statistical mechanics and succeeded in reproducing a very natural pattern of ocular dominance columns and orientation columns [9]. Olshausen et al. incorporated the maximum information preservation principle and sparse coding principle, and have shown simple-cell like receptive fields by using natural images as input stimulus [10].

## References

- Grossberg S (1987) Competitive learning: from interactive activation to adaptive resonance. *Cognit Sci* 11:23–63
- Jacobs RA, Jordan MI, Nowlan SJ, Hinton GE (1991) Adaptive mixture of local experts. *Neural Computation* 3:79–87
- Haruno M, Wolpert DM, Kawato M (2001) Mosaic model for sensorimotor learning and control. *Neural Computation* 13:2201–2220
- Kohonen T (2000) *Self-organizing maps*, 3rd edn. Springer-Verlag, Berlin
- von der Malsburg C (1973) Self-organization of orientation sensitive cells in the striate cortex. *Kybernetik* 14:85–100
- Amari S (1990) Mathematical foundations of neurocomputing. *Proc IEEE* 78:1443–1463
- Linsker R (1988) Self-organization in a perceptual network. *Computer* 22:105–117
- Miller KD, Keller JB, Stryker MP (1989) Ocular dominance column development: analysis and simulation. *Science* 245:605–615
- Tanaka S (1990) Theory of self-organization of cortical maps: mathematical framework. *Neural Networks* 3:625–640
- Olshausen DA, Field DJ (1996) Emergence of simple-cell receptive field properties by learning a sparse code for natural images. *Nature* 381:607–609

---

## Complement

### Definition

An important innate immune system composed of almost 30 proteins expressed by phagocytes, glial cells, neurons and most other cell types. C3 is the canonical complement protein with the capacity to bind to pathogens and promoting clearance by phagocytes expressing C3 receptors. Small fragments of C3 called C3a and C5a anaphylatoxins have stimulatory activities through signaling to G-protein-coupled seven transmembrane receptors.

---

## Complement System

### Definition

It is a cascade of more than 30 proteins in the plasma, and forms an important part of the host immune system and normal inflammatory response. Under normal circumstances, the activation of the complement components is controlled by complement regulatory proteins. However, the system is up-regulated in many disorders of the brain. The major pathways of complement activation are the classical pathway (CP), the alternative pathway (AP) and the Lectin pathway. Although, controlled activation of the complement system is beneficial and neuroprotective, the uncontrolled activation leads to neurodegeneration.

► [Central Nervous System Disease – Natural Neuroprotective Agents as Therapeutics](#)

---

## Complementary DNA (cDNA)

### Definition

A complementary DNA copy of an mRNA synthesized by reverse transcriptase.

## Complete Homonymous Hemianopsia

### Definition

- ▶ Hemianopsia

## Completeness of the Physical Domain

### Definition

For any physical event *p*, insofar as *p* has a cause, it has a complete physical cause.

- ▶ Causality

## Complex, Basal, of the Amygdala

### Definition

The basal (also called basolateral, including rostromedial magnocellular and caudolateral parvocellular divisions), accessory basal (also called basomedial) and lateral nuclei of the amygdala. These nuclei are composed of neurons that much resemble those in the cortex, including a variety of calcium binding protein-immunoreactive interneurons and pyramidal neurons that are reciprocally connected with other parts of the cortex. In view of these characteristics, the nuclei of the basal complex have been regarded as cortical-like, despite lacking a laminar organization.

- ▶ Ventral Striatopallidum

## Complex Behavior

- ▶ Cognitive Elements in Animal Behavior

## Complex Cells in Visual Cortex

### Definition

Complex cells are one of two main physiological types of cells in the primary visual cortex. They differ from the other class (simple cells) in that their receptive fields

lack segregated On and Off subregions. Complex cells are usually tuned for stimulus orientation and excited by bright or dark contours placed anywhere inside the receptive field.

Unlike simple cells, which are similar to one another in many ways, complex cells have heterogeneous response properties that vary according to cortical layer of origin.

- ▶ Form Perception
- ▶ Striate Cortex Functions
- ▶ Visual Cortical and Subcortical Receptive Fields

## Complex Partial Seizures (Temporal-lobe or Psychomotor Seizures)

### Definition

These seizures may start with an aura that arises in the ▶autonomic, ▶visceral and ▶olfactory regions of the ▶temporal lobe and ▶limbic system. The aura is characterized by ▶auditory, ▶gustatory, olfactory or visual ▶hallucinations; by changes in cognition such as déjà vu, jamais vu or recurrent memories; by illusions of spatial distortions, shrinkage or angulation; and by affective alterations (anxiety, fear, seldom rage). The aura may terminate the attack or transcend into movements or behaviors (swallowing, smacking the lips, undressing, ▶dysphasic speech), which the patient is ▶amnesic of after the attack.

## Complex Receptive Fields

### Definition

- ▶ Visual Cortical and Subcortical Receptive Fields

## Complex Regional Pain Syndromes: Pathophysiological Mechanisms

WILFRID JÄNIG

Department of Physiology, Christian-Albrechts-Universität zu Kiel, Kiel, Germany

### Definition

▶Complex regional pain syndrome (CRPS) type I (previously termed ▶reflex sympathetic dystrophy) is



characterized by pain (spontaneous pain, hyperalgesia, and allodynia), active and passive movement disorders, abnormal regulation of blood flow and sweating, edema and trophic changes. It typically develops after trauma with a small or no obvious nerve lesion at an extremity (e.g., bone fracture, sprains, bruises or skin lesions, surgeries); occasionally it may develop after remote trauma in the visceral domain (e.g., myocardial ischemia) or even after a central nervous system (CNS) lesion (e.g., stroke). An important feature of CRPS I, which cannot be overemphasized, is that *the severity of symptoms is disproportionate to the severity of trauma* with a tendency to spread in the affected distal limb. The symptoms are not confined to the innervation zone of an individual nerve. Thus, all symptoms of CRPS I in their typical pattern may occur *irrespective of the type of the preceding lesion*. CRPS Type II (previously termed causalgia) is similar in its symptoms to that of CRPS I, the only exception being that a partial nerve lesion of a peripheral nerve is mandatory for its diagnosis [1–5].

This paper will discuss the underlying mechanisms of CRPS, in particular type I, and focus on the ►**sympathetic nervous system**. An explanatory ►**hypothesis** will be presented showing that the syndrome is mainly a systemic disease involving the central nervous system and the peripheral nervous system.

## Characteristics

### Observations in Human Patients and their Underlying Mechanisms

#### Somatic Sensory Abnormalities and Pain

Until recently, experimental investigations have mainly concentrated on ►**pain**, sympathetically maintained pain (SMP) and abnormalities of the skin. This has led to a rather limited view, with a tendency to put the nociceptive system and its peripheral coupling to the sympathetic nervous system into the foreground. Yet clinical observations demonstrate that in CRPS I, pain is commonly projected into the deep somatic tissues, that many patients with CRPS I do not have SMP (as judged by clinical criteria, i.e., the patients have no significant decrease in pain following sympathetic blocks), and that some 5% of the patients with CRPS I do not have spontaneous pain (and rather discrete evoked pathological pains).

#### Pain and Other Somatic Sensations

Patients with CRPS I generally report a burning spontaneous pain felt mostly deep in the distal part of the affected extremity. Characteristically, the pain is disproportionate in intensity to the inciting event. Stimulus-evoked pains include mechanical, cold and heat allodynia and/or hyperalgesia. These sensory abnormalities often appear early, are most pronounced

distally, and have no consistent spatial relationship to individual nerve territories or to the site of the inciting trauma. Typically, pain can be elicited by movements and pressure at the joints (deep somatic allodynia), even if these are not directly affected by the inciting lesion, indicating that the deep somatic tissues are involved [1]. Based on experimental findings in animals, spontaneous pain and various forms of allodynia/hyperalgesia at the distal extremity are thought to be generated by processes of peripheral and central sensitization.

Fifty per cent of patients with chronic CRPS I develop hypoesthesia and hypoalgesia on the affected half of the body, or in the upper quadrant ipsilateral to the affected extremity. Quantitative sensory testing has shown that these patients have increased thresholds to mechanical, cold, warmth and noxious heat stimuli in the affected part of the body compared with the responses generated from the corresponding contralateral healthy body side (Fig. 1). Patients with these extended sensory deficits have longer illness duration, greater pain intensity, a higher frequency of mechanical allodynia, and a higher tendency to develop changes in the somatomotor system than do patients with spatially restricted sensory deficits [1,2,6]. The anatomical distribution of these changes suggests that they are due to CNS changes, which may cause widespread alterations in the perception of painful as well as non-painful sensations.

These findings have considerable implications:

- The central representation of somatosensory sensations is changed, probably in the thalamus and cortex. This implication is supported by studies on CRPS patients using positron emission tomography (PET) or magnetoencephalography (MEG) [1,2].
- If generalized sensory deficits in patients with chronic CRPS I are permanent and irreversible, it would be the *first* documented case of such irreversible changes in the brain that is triggered by trauma with minor or *no* nerve lesion.
- Most CRPS I patients have deep somatic spontaneous pain and mechanical hyperalgesia/allodynia. Are the non-painful sensations elicited from muscle and joints changed as well?
- Do the generalized sensory changes depend on a continuous nociceptive input from the affected extremity and disappear after successful treatment of the pain? After all, the continuous nociceptive afferent input could be subthreshold for the conscious perception of pain, but high enough to maintain the central changes.
- Are the somatosensory changes (including pain) independent of a continuous nociceptive afferent input, but fully dependent on dynamic changes in the central ►**somatosensory system**?

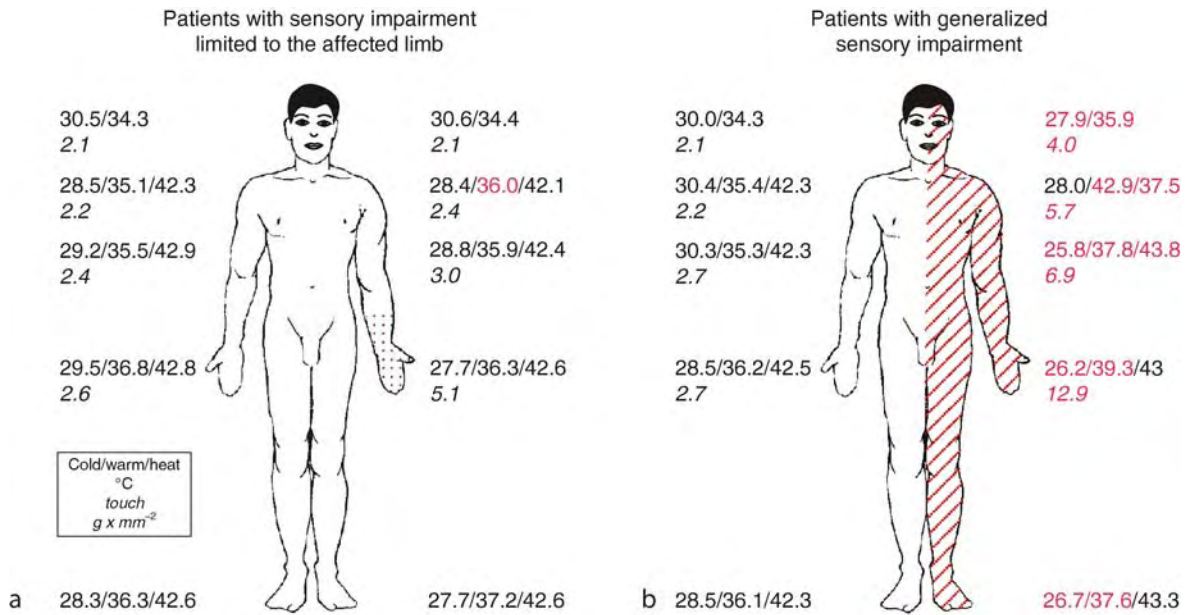

**Complex Regional Pain Syndromes: Pathophysiological Mechanisms. Figure 1** Detection thresholds to cold, warm and heat stimuli (*upper rows*) and to von Frey filament stimulation (*lower rows* in *italic*) in CRPS I patients with sensory impairment spatially restricted to the affected side (a) and in CRPS I patients with generalized sensory impairment (b). The thermal stimuli were applied utilizing the Peltier effect. Cool and warm stimuli were applied at a rate of  $0.7^{\circ}\text{C}\cdot\text{s}^{-1}$  on a skin surface of  $5.8\text{ cm}^2$ , starting from a reference temperature of  $32^{\circ}\text{C} \pm 0.5^{\circ}\text{C}$ . Heat stimuli were applied at the same rate and surface, but starting from a reference temperature of  $40^{\circ}\text{C}$ . Detection threshold to von Frey filament stimulation in  $\text{g}\cdot\text{mm}^{-2}$ . Cooling and warm stimuli applied to face, chest, upper arm, hand and foot ( $N = 14$  patients). Heat stimuli applied to chest, upper arm, hand and foot ( $N = 14$  patients). Mechanical stimuli with von Frey filaments applied to face, chest, upper arm/thigh and hand/foot ( $N = 24$  to 25 patients with limited sensory impairment;  $N = 15$  patients with generalized sensory impairment). Generalized sensory changes occur preferentially in chronic CRPS I patients, and are correlated with a higher incidence of mechanical allodynia and motor deficits than in CRPS I with spatially restricted sensory changes. Numbers show mean values. Significant differences between left and right are indicated in red (two-tailed paired  $t$ -test,  $p < 0.05$ ). Modified from Rommel O, Malin JP, Zenz M, Jänig W (2001) *Pain* 93:279–293.

### Sympathetically Maintained Pain (SMP)

#### Influence of Sympathetic Activity and Catecholamine on Primary Afferents in Patients with CRPS

Clinical studies in humans support the idea that cutaneous nociceptors may develop catecholamine sensitivity after partial nerve lesions (CRPS II). Intracutaneous application of noradrenaline into a symptomatic skin area may rekindle spontaneous pain and dynamic mechanical hyperalgesia/allodynia that had been relieved by sympathetic blockade [6–8]. Intracutaneous injection of noradrenaline in control subjects does not elicit pain.

In CRPS I patients with SMP, selective activation of the cutaneous sympathetic vasoconstrictor outflow to the painful extremity by whole body cooling increases the intensity of spontaneous pain and mechanical hyperalgesia/allodynia (dynamic/punctate), and the area of dynamic mechanical hyperalgesia/allodynia, but not in CRPS I patients without SMP (Fig. 2). In

these CRPS patients with SMP, the relief of spontaneous and evoked pain after sympathetic blockade is significantly more pronounced than the changes in spontaneous and evoked pain induced experimentally by sympathetic activation, which is generated experimentally by change of the activity in cutaneous vasoconstrictor neurons from the thermoregulatory hot state (cutaneous vasoconstrictor activity absent or low) to the thermoregulatory cold state (cutaneous vasoconstrictor activity high) ( $44.0\% \pm 9.1\%$  vs.  $16.0\% \pm 4.0\%$ ,  $p < 0.05$  [1,2]). This difference in reduction of pain is explained by the fact that a complete sympathetic block affects *all* sympathetic outflow channels projecting to the affected extremity. Thus, sympathetic-afferent coupling may particularly occur in the deep somatic domain such as bone, muscle or joint, and less so in the skin. That the deep somatic structures are especially extremely painful in some cases with CRPS supports this view [1,2].

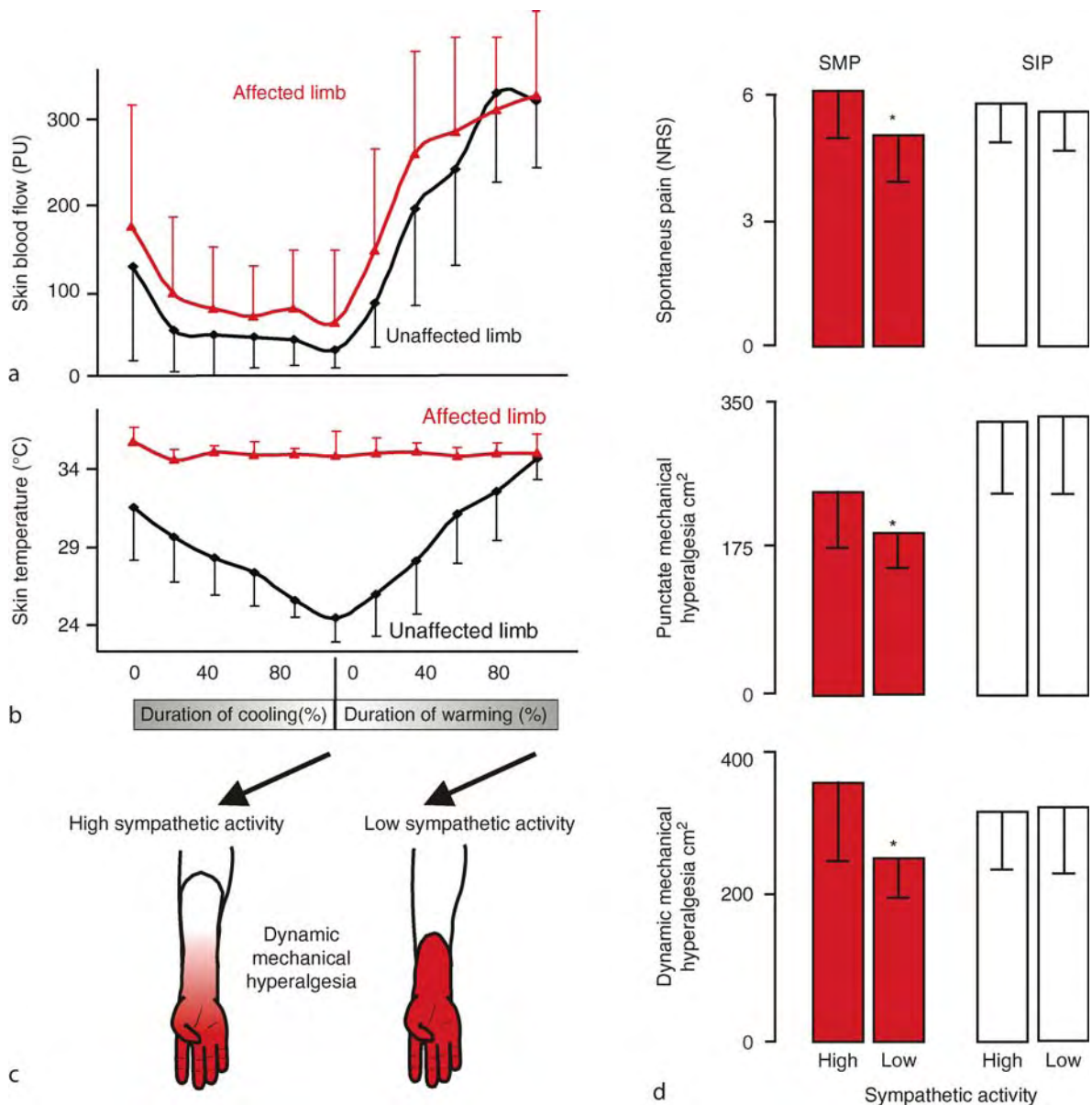

**Complex Regional Pain Syndromes: Pathophysiological Mechanisms. Figure 2** Experimental modulation of cutaneous sympathetic vasoconstrictor neurons by physiological thermoregulatory reflex stimuli in 13 CRPS patients. With the help of a thermal suit, whole-body cooling and warming was performed to alter sympathetic skin nerve activity. The subjects were lying in a suit supplied by tubes, in which running water of 12°C and 50°C, respectively (inflow temperature) was used to cool or warm the whole body. By these means sympathetic activity can be switched on and off. (a) High sympathetic vasoconstrictor activity during cooling induces considerable drop in skin blood flow on the affected and unaffected extremity (laser Doppler flowmetry). Measurements were taken at 5 min intervals (mean + SD). (b) On the unaffected side, a secondary decrease of skin temperature was documented. On the affected side, the forearm temperature was clamped at 35°C by a feed-back-controlled heat lamp to exclude temperature effects on the sensory receptor level. Measurements were taken at 5 min intervals (mean + SD). (c) Effect of cutaneous sympathetic vasoconstrictor activity on dynamic mechanical hyperalgesia in one CRPS patient with sympathetically maintained pain (SMP). Activation of sympathetic neurons (during cooling) leads to an increase of the area of dynamic mechanical hyperalgesia. (d) Spontaneous pain (*upper*; NRS, numerical rating scale), area of punctate mechanical hyperalgesia (*middle*; in cm<sup>2</sup>) and area of dynamic mechanical hyperalgesia (*lower*; in cm<sup>2</sup>) during high sympathetic activity to the skin (whole body cooling) or low sympathetic activity to skin (whole body warming) in CRPS I patients with sympathetically maintained pain (SMP, N = 7) and CRPS I patients without SMP (sympathetically independent pain [SIP], N = 6). Mean + 1 SD. \*,  $p < 0.05$  (Wilcoxon's paired test). Modified from Baron R, Schattschneider J, Binder A, Siebrecht D, Wasner G (2002) *Lancet* 359:1655–1660.

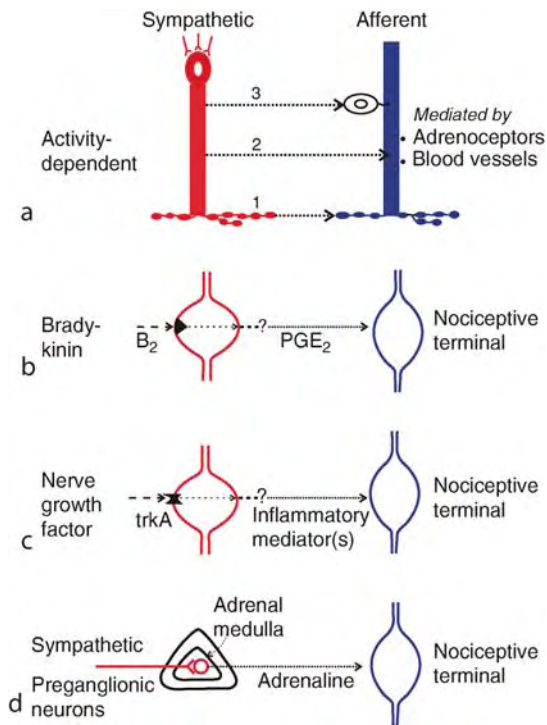

### Complex Regional Pain Syndromes: Pathophysiological Mechanisms.

**Figure 3** (a) Possible ways of coupling between sympathetic neurons and primary afferent neurons following peripheral nerve lesion. These types of coupling depend on the activity in the sympathetic neurons and on the expression of functional adrenoceptors by the afferent neurons or are mediated indirectly via the blood vessels (blood flow). It can occur in the periphery (1), in the dorsal root ganglion (3) or possibly also in the lesioned nerve (2). (b–d) Ways of coupling between sympathetic neurons and nociceptive afferent neurons which are possibly not dependent on activity in the sympathetic neurons (b, c') or involve the sympatho-adrenal system (d). (b) The inflammatory mediator bradykinin (BK) reacts with B<sub>2</sub> receptors in the membrane of the sympathetic varicosities, inducing release of prostaglandin E<sub>2</sub> (PGE<sub>2</sub>) and sensitization of nociceptors. (c') Nerve growth factor (NGF) released during an experimental inflammation reacts with the high-affinity receptor trkA and/or the low-affinity pannerotrophin receptor p75 for NGF in the membrane of the sympathetic varicosities, inducing release of an inflammatory mediator or inflammatory mediators and sensitization of nociceptors. (d) Activation of the adrenal medulla by sympathetic preganglionic neurons leads to release of a hormone (possibly adrenaline) which generates sensitization of nociceptors. For details and literature see text and [8,10]. Modified from Jänig W, Häbler HJ (2000) *Prog Brain Res* 129:451–468.

### Mechanisms involved in SMP

Quantitative measurements in patients with CRPS I with SMP clearly demonstrate: (i) that the underlying mechanism of SMP must be a coupling between

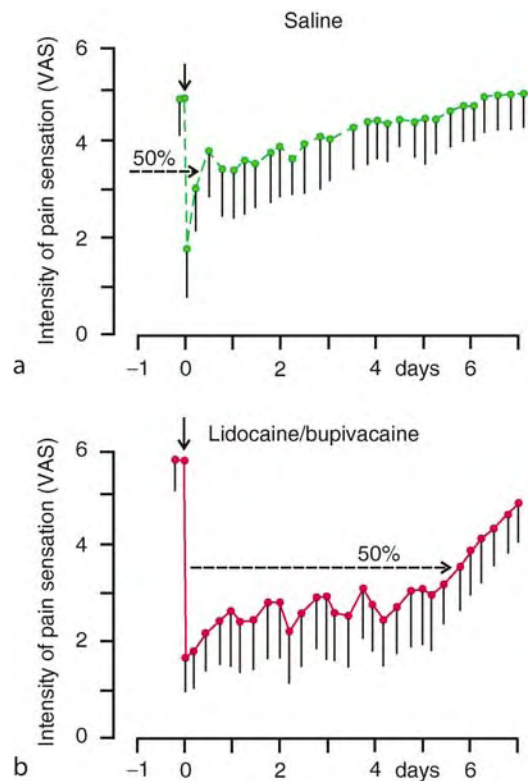

### Complex Regional Pain Syndromes: Pathophysiological Mechanisms.

**Figure 4** Affect of sympathetic blocks with a local anesthetic (lidocaine/bupivacaine) or of injection of saline close to the corresponding paravertebral sympathetic ganglia on pain in seven patients with CRPS I. Double-blind crossover study. Effect on pain following both interventions at the sympathetic supply was measured in the *same* group of CRPS I patients. Pain was systematically measured repeatedly using the visual analogue scale (VAS) on the day of the injection and on seven days after the injection. Both interventions produced pain relief (see 50% value of pain relief). However, the mean relief of pain to injection of the local anesthetic lasted for 6 days, and was significantly longer than the mean pain relief following local injection of saline, which lasted for 6 h (placebo block). The initial maximal peaks of analgesia were not statistically different. Means + SEM. Modified from Price DD, Long S, Wilsey B, Rafii A (1998) *Clin J Pain* 14:216–226.

sympathetic noradrenergic neurons and primary afferent neurons in the periphery of the body, and (ii) that the mechanism of this coupling is different in CRPS II compared to that in CRPS I.

Animal models support the peripheral mechanisms of SMP occurring in CRPS II (Fig. 3a; for review [7, 8]). Coupling of sympathetic neurons not only to nociceptive afferent neurons but also to non-nociceptive mechanosensitive or cold-sensitive neurons may turn out to be important. Sympathetic activation of these afferent

neurons may excite sensitized or hyperexcitable central neurons of the somatosensory system (e.g., in the dorsal horn) and contribute to mechanical or cold allodynia in CRPS II patients.

It is unlikely that mechanisms of SMP occurring in CRPS II (i.e., after trauma with nerve lesion) can explain SMP in CRPS I. In CRPS I patients with SMP, only a minor component of the coupling occurs in the skin (see above). It is suggested that an important sympathetic-afferent coupling occurs in the deep somatic tissues [9], and that the mechanism of this coupling is indirect, involving the vascular bed and possibly other non-neural components. This mode of coupling, although repeatedly postulated, has never been explored experimentally using animal models.

Other potential ways of coupling between sympathetic neurons and afferent nociceptive neurons have been developed from animal experiments, but have not been explored in patients (Fig. 3b). These modes of coupling do not involve activity in the sympathetic nerve fibers, but the sympathetic fibers may mediate the effects of inflammatory mediators (e.g., bradykinin) or other compounds (e.g., nerve growth factor) to nociceptive fibers in the peripheral tissue. This sympathetic-afferent coupling may turn out to be important in inflammatory pain and in CRPS I [7,8,10].

Finally, the sympathetic nervous system may be involved in coupling to nociceptive neurons via the adrenal medulla (Fig. 3b). Behavioral experiments have shown this mechanism to exist in rats, implying that adrenaline released by the adrenal medulla (during its activation by preganglionic neurons) leads to sensitization of nociceptors for mechanical stimulation. The process of sensitization has a slow time course, taking up to 2 weeks to fully develop [7,8,10].

#### **The Pain-Relieving Effect of Sympathetic Blocks**

In CRPS patients with SMP, pain relief outlasts the conduction block of sympathetic neurons by at least one order of magnitude. Sometimes only a few temporary sympathetic blocks (and in the extreme only a single block) are necessary to produce permanent pain relief (Fig. 4). The long-lasting pain-relieving effects of sympathetic blocks clearly argue that activity in sympathetic neurons, which is of central origin, maintains a positive feedback circuit via the primary afferent neurons. Animal models for positive feedback circuits are lacking. It is postulated that activity in sympathetic neurons maintains a central state of hyperexcitability (e.g., of neurons in the spinal dorsal horn), via excitation of afferent neurons initiated by an intense noxious event. The persistent afferent activity necessary to maintain such a central state of hyperexcitability is probably low. This central state of hyperexcitability is switched off during a temporary block of conduction in the sympathetic chain lasting only a few hours. It cannot be switched

back on when the block wears off and the sympathetic activity returns, along with the sympathetically-induced activity in afferent neurons. Sympathetic systems and afferent systems innervating deep somatic tissues may be more important than those innervating the skin in this hypothetical positive feedback circuit, and they need to be investigated experimentally [1,2].

#### **Sympathetic Systems and Regulation of Target Organs in Skin and Deep Somatic Tissues**

In CRPS, abnormalities related to the sympathetic nervous system include changes of sweating and skin blood flow [1,2]. In the acute stages of CRPS I, the affected limb is more often warmer than the contralateral limb. Sweating abnormalities, either hypohidrosis or, frequently in acute stages, hyperhidrosis, are present in almost all CRPS I patients [1].

Sympathetic denervation and mechanisms of denervation hypersensitivity cannot account for vasomotor and sudomotor abnormalities in CRPS I patients, since there is no overt nerve lesion [1,2]. In fact, there is direct evidence for a reorganization of central autonomic control in these syndromes. Resting sweat output is increased in many CRPS I patients, as is thermoregulatory and axon reflex sweating. Increased sweat production cannot be explained by a peripheral mechanism since, unlike blood vessels, sweat glands do not develop denervation supersensitivity.

Studies of central reflexes in the cutaneous vasoconstrictor innervation induced by thermoregulatory (whole-body warming or cooling) and respiratory stimuli (by measuring skin temperature and skin blood flow bilaterally at the extremities using infrared thermometry and laser Doppler flowmetry) demonstrate changed vascular regulation patterns in CRPS I patients [1,2]: (i) In the acute stage (<6 months) the affected limb is warmer and skin perfusion values are higher than contralaterally. Body cooling or respiratory stimuli (deep inspiration and expiration) fail to activate cutaneous vasoconstrictor neurons. Noradrenaline levels from the venous effluent from the area of pain are reduced in the affected extremity. (ii) In the chronic stage, temperature and perfusion are lower, and noradrenaline levels are still decreased on the affected side.

The changes in thermoregulatory and respiration-related sympathetic reflex activity in *acute CRPS I*, as reflected by changes of cutaneous blood flow and temperature, can only be attributed to central changes of the cutaneous vasoconstrictor system. These central changes are fully reversible after successful treatment of CRPS. Secondary changes of neurovascular transmission, which are reflected in supersensitivity of the vascular smooth muscle as a consequence of chronically decreased activity in the vasoconstrictor neurons, may account for the severe vasoconstriction and cold skin in *chronic CRPS I* [1,2]. Thus, the decreased levels

of noradrenaline are fully consistent with the cutaneous vasoconstriction observed.

Based on the observation that the changes in patients are restricted to the affected side and are not present on the contralateral extremity, it is postulated that these changes occur in the spinal autonomic circuits. Thus, descending systems, which normally mediate signals to these spinal autonomic circuits from supraspinal centers being involved in thermoregulation (e.g., in hypothalamus and brain stem), may no longer have access to these spinal autonomic circuits, which are linked to peripheral cutaneous vasoconstrictor pathways. By the same token, this may explain the dysregulation of sweat glands. In support of this idea, animal experiments have demonstrated that experimental nerve lesions lead to chronic changes, sometimes persisting for several years, in chemoreceptor, baroreceptor, and nociceptor reflexes in cutaneous vasoconstrictor neurons, but not in muscle vasoconstrictor neurons. The differentiation in reflex pattern between muscle and cutaneous vasoconstrictor neurons disappears, and cutaneous vasoconstrictor neurons tend to exhibit reflexes that are identical to those of muscle vasoconstrictor neurons [4,6]. However, there is no animal model simulating the changed reflex pattern in cutaneous sympathetic neurons in CRPS I.

### Somatomotor System

About 50% of CRPS patients show a weakness of all muscles of the affected distal extremity and a decrease of active range of motion. Small precise movements are characteristically impaired. About half of the patients have a postural or action tremor that represents an increased amplitude of physiological tremor. In about 10% of cases, dystonia of the affected hand or foot develops, especially in chronic cases. Furthermore, a neglect-like syndrome is clinically described to be responsible for the disuse of the extremity.

The motor changes are unlikely to be related to a peripheral process (e.g., influence of sympathetic nervous system on neuromuscular transmission or on the contractility of skeletal muscle). Since these changes are lateralized, they may be related to changes in spinal reflex circuits linked to the motoneurons, i.e., they have a central origin. They may be induced by the continuous nociceptive input. However, it is entirely unclear why these motor changes may disappear after sympathetic blocks in CRPS patients with SMP. Animal models to study these motor changes systematically do not exist and have to be developed.

A pathological sensorimotor integration located in the parietal cortex may induce an abnormal central programming and processing of motor tasks. A recent controlled study also supports the view of a mismatch between central motor output and sensory input as an underlying mechanism in CRPS. Using the method of mirror visual

feedback, it was shown that the visual input from a moving unaffected limb to the brain is able to re-establish the pain-free relationship between sensory feedback and motor execution. After six weeks of therapy, pain and function were improved as compared with the control group [1–3].

### Inflammation and Edema: Role of the Sympathetic Nervous System

Controversial issues are the mechanisms underlying swelling (edema) and inflammation in CRPS (in particular CRPS I). *Swelling* is a very common symptom in acute CRPS patients, and mostly extends far beyond the territory of the trauma. It depends very critically on aggravating stimuli and may decrease following sympathetic blocks, indicating that activity in sympathetic neurons is important in maintaining it (Fig. 5). However,

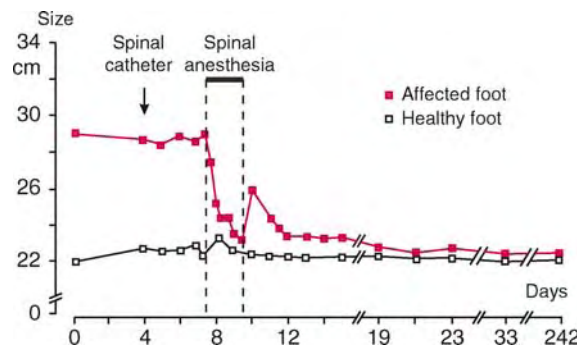

**Complex Regional Pain Syndromes: Pathophysiological Mechanisms. Figure 5** Spinal anesthesia reduced severe edema in a patient with CRPS I. Female patient, 15 years, 3 months after trauma on foot. No spontaneous pain, cutaneous hyperalgesia or allodynia, but deep hyperalgesia. Implantation of spinal catheter at thoracic level T10 on day 4. Spinal anesthesia for 43 h starting on day 7 with 1.4 ml 0.5% bupivacaine per hour. Increase in skin temperature of foot to 36°C (indicating complete decrease of activity in cutaneous vasoconstrictor neurons). Significant decrease of edema in 1 day and its complete disappearance with time after termination of the spinal anesthesia together with the other symptoms of CRPS I. The decrease of the edema was considered to be due to decrease of activity in sympathetic neurons. However, the following possibility cannot entirely be excluded: Peptidergic primary afferent neurons with unmyelinated fibers may conduct impulses antidromically to the periphery and generate the swelling. These antidromic impulses are produced by continuous strong primary afferent depolarization of the central terminals of these afferent neurons (Willis WD (1999) *Exp Brain Res* 124:395–421). Spinal anesthesia interrupts the primary afferent depolarization. Modified from Blumberg H, Hoffmann U, Mohadjer M, Scheremet R (1994) In: Gebhart GF et al. (1994) *Prog in Pain Res and Management*, vol 22, IASP, Seattle.

the underlying mechanism is entirely unknown. It is important to emphasize that one block or a few blocks of sympathetic activity may lead to a long-lasting (sometimes permanent) decrease of edema, this being reminiscent of the long-lasting decrease of pain following sympathetic blocks in CRPS patients with SMP (Fig. 4).

- It has been proposed that the capillary filtration pressure is high due to an imbalance of the activity or pattern of activity between vasoconstrictor neurons innervating precapillary blood vessels and those innervating postcapillary blood vessels (e.g., veins). Accordingly, venous congestion plethysmography shows that the hydrostatic pressure to achieve net capillary filtration is elevated on the affected side in patients with CRPS [1,2]. However, venules and small deep veins are not, or only sparsely, innervated by sympathetic noradrenergic fibers, if at all. Thus, the sympathetic fibers do not form close contacts with the smooth muscle cells of the venules as they do with the precapillary resistance vessels (Fig. 6a).
- Sympathetic fibers may be coupled to peptidergic unmyelinated fibers leading to release of peptides with subsequent precapillary vasodilation and postcapillary (venular) plasma extravasation (neurogenic inflammation) (Fig. 6a). However, animal models supporting this idea are lacking.

The idea that CRPS I patients undergo *inflammatory processes* in the affected extremity, in particular in the deep somatic tissues including bones, goes back to Sudeck who believed that this syndrome is an inflammatory bone atrophy [6]. Accordingly, bone scintigraphy has demonstrated periarticular tracer up-take in acute CRPS and synovia biopsies, and scintigraphic investigations with radiolabeled immunoglobulins have shown protein extravasation, hypervascularity and neutrophil infiltration. Microdialysis through the skin revealed that evoked neurogenic inflammation produced by activation of peptidergic unmyelinated afferents is enhanced, and that lactate is increased in the skin, suggesting enhanced anaerobic glycolysis due to tissue hypoxia. In the fluid of artificially produced skin blisters of the involved extremity, significantly higher levels of interleukin 6 (IL-6) and tumor necrosis factor  $\alpha$  (TNF  $\alpha$ ) are present. Furthermore, based on animal experiments, it is proposed that oxygen-derived free radicals are involved, leading to an increase in vascular permeability, soft tissue damage and pain (for references [1,6]).

Although there is some evidence that inflammatory processes are involved in the pathogenesis of early CRPS, the exact mechanisms of initiation and maintenance of these reactions are still unclear. Animal studies demonstrate that the sympathetic nervous system can influence the intensity of an inflammatory process [7,8], and clinical studies indicate that sympatholytic procedures

can ameliorate both inflammation and edema in humans. However, this concept has yet to be proven in patients with CRPS.

### A General Explanatory Model

Results obtained in experiments on human CRPS patients and quantitative clinical data clearly set the stage for the formulation of hypotheses that can be tested experimentally using various *in vivo* or *in vitro* animal models (which include by definition human models). Research on mechanisms should focus on quantifiable symptoms which can be observed in the patients (e.g., mechanical allodynia, spontaneous pain, tremor, changes of blood flow, swelling, etc.). Each symptom may be generated by more than one mechanism, depending on the type of CRPS patient. Experimental models to study the underlying mechanisms of CRPS cannot represent CRPS I or II as such. For this purpose the human patient is the best model. A general explanatory model must fulfill the following main criteria (Fig. 7):

1. CRPS is a neurological disease of the CNS involving sympathetic, afferent (sensory) and **motor systems** [6]. It is hypothesized that the CNS orchestrates the sensory, motor, autonomic, inflammatory and trophic changes, which are then reflected in the typical clinical phenomenology.
2. Important characteristics of CRPS I are signs of inflammation with edema and vasodilation in skin (increased cutaneous temperature); therefore an inflammatory process in the periphery is discussed. *Cutaneous vasodilatation* is particularly prominent at the beginning of CRPS I in the first 2–4 months, but later may reverse into vasoconstriction when CRPS I is becoming chronic [1,2]. By the same token, the inflammatory changes also appear to be particularly prominent in the early stages of CRPS.
3. Both central and peripheral mechanisms interact with each other. This interaction may occur by way of various channels. The CNS receives information from the periphery via the hard-wired afferent nociceptive and non-nociceptive neurons and possibly chemical signals (e.g., cytokines from inflamed tissues). The CNS sends its information to the periphery through sympathetic channels, possibly neuroendocrine systems (e.g., the sympatho-adrenal system) or perhaps even by antidromic activity in peptidergic primary afferent neurons. The central neural programs regulating sympathetic, somatomotor and afferent systems may be changed due to a mismatch between the sensory representations and the motor and autonomic representations in the forebrain (which is clinically reflected in the changes related to the motor, sensory and autonomic systems).

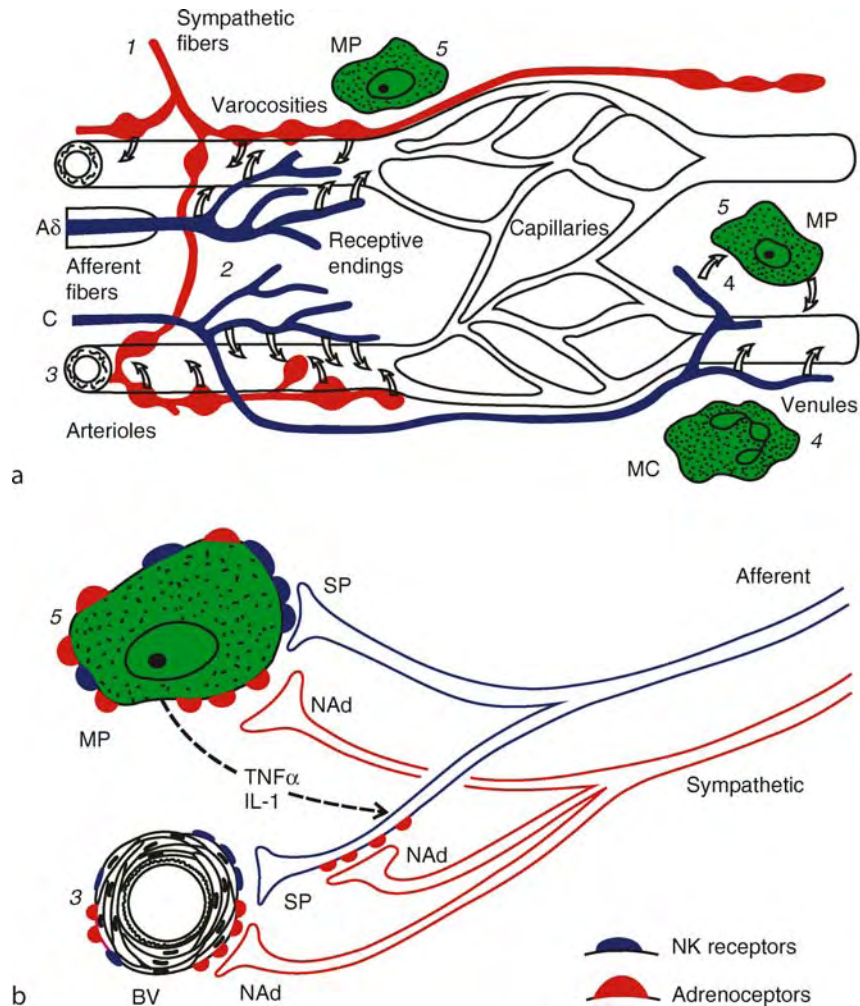

**Complex Regional Pain Syndromes: Pathophysiological Mechanisms. Figure 6** a The microenvironment of nociceptors. The microenvironment of primary afferents is thought to affect the properties of the receptive endings of myelinated (A) and unmyelinated (C) afferent fibers. This has been particularly documented for inflammatory processes, but one may speculate that pathological changes in the direct surroundings of primary afferents may contribute to other pain states as well. The vascular bed consists of arterioles (directly innervated by sympathetic and afferent fibers), capillaries (not innervated and not influenced by nerve fibers) and venules (not directly innervated but influenced by nerve fibers). The microenvironment depends on several interacting components: Neural activity in postganglionic noradrenergic fibers (1) supplying blood vessels (3, BV) causes release of noradrenaline (NA) and possibly other substances and vasoconstriction. Excitation of primary afferents (A $\delta$ - and C-fibers) (2) causes vasodilation in precapillary arterioles (mainly release of calcitonin gene-related peptide, CGRP) and plasma extravasation in postcapillary venules (C-fibers only) by the release of substance P (SP) and other vasoactive compounds (e.g., CGRP). Some of these effects may be mediated by non-neuronal cells such as mast cells (MC, 4) and macrophages (MP, 5). Other factors that affect the control of the microcirculation are the myogenic properties of arterioles (3) and more global environmental influences such as a change of the temperature and the metabolic state of the tissue. Modified from [20]. (b) Hypothetical relation between sympathetic noradrenergic nerve fibers (1), peptidergic afferent nerve fibers (2), blood vessels (3) and macrophages (4). The activated and sensitized afferent nerve fibers activate macrophages (via substance P release). The immune cells start to release cytokines, such as tumor necrosis factor  $\alpha$  (TNF- $\alpha$ ) and interleukin 1 (IL1), which further activate afferent fibers by enhancing sodium influx into the cells. Substance P (and CGRP) released from the afferent nerve fibers reacts with neurokinin 1 (NK1) receptors (CGRP receptors) in the blood vessels (arteriolar vasodilation, venular plasma extravasation; neurogenic inflammation). The sympathetic nerve fibers interact with this system on three levels: (i) via adrenoceptors (mainly alpha) on the blood vessels (vasoconstriction); (ii) via adrenoceptors (mainly beta) on macrophages (further release of cytokines), and (iii) via adrenoceptors (mainly alpha) on afferents (further sensitization of these fibers). Modified from [6].



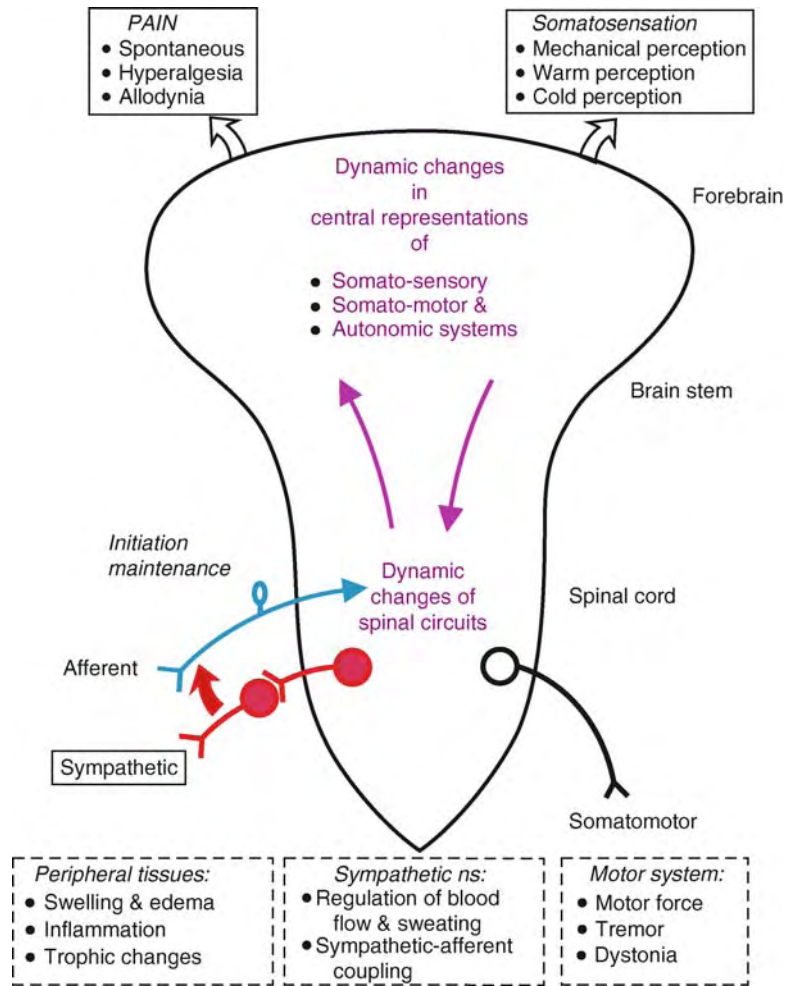

**Complex Regional Pain Syndromes: Pathophysiological Mechanisms. Figure 7** Schematic diagram summarizing the sensory, autonomic and somatomotor changes in complex regional pain syndromes I (CRPS I) patients. The figure symbolizes the CNS (forebrain, brain stem and spinal cord). Changes occur in the central representations of the somatosensory, the motor and the sympathetic nervous system (which include the spinal circuits) and are reflected in the changes of the sensory painful and non-painful perceptions, of cutaneous blood flow and sweating, and of motor performances. They are triggered and possibly maintained by the nociceptive afferent input from the somatic and visceral body domains. It is unclear whether these central changes are reversible in chronic CRPS I patients. These central changes possible also affect the endogenous control system of nociceptive impulse transmission. Coupling between the sympathetic neurons and the afferent neurons in the periphery (see bold closed arrow) is one component of the pain in CRPS I patients with sympathetically-maintained pain (SMP). However, it seems to be unimportant in CRPS I patients without SMP. Modified from [6].

According to the central hypothesis, the acute vasodilation might be due to inhibition of activity in cutaneous vasoconstrictor neurons, and the vasoconstriction might depend on decentralization supersensitivity of cutaneous blood vessels to impulses in cutaneous vasoconstrictor neurons. According to the peripheral inflammatory hypothesis, vasodilation might potentially be linked to the peptidergic primary afferent neurons with C-fibers, and therefore to the neurogenic inflammatory component. Activation of (probably a subset

of) peptidergic primary afferent neurons leads to precapillary vasodilation mediated by release of calcitonin gene-related peptide (CGRP) and substance P and postcapillary plasma extravasation by release of substance P [6]. Furthermore, there is enough evidence from investigations of patients with CRPS I to show that blockade of the sympathetic supply to the affected extremity may be followed by a decrease of the edema (Fig. 5). Thus, how do we bring together the centrally generated components related to the afferent

(sensory), motor and sympathetic systems and the peripheral components related to inflammation and sympathetic-afferent coupling? Do these mechanisms in CRPS I patients operate independently or are they functionally linked, and if so, how can this link be explained? How does the brain generate and modulate the peripheral inflammatory processes?

Research based on these thoughts will radically change our approach to this pain syndrome in diagnostic classification and therapy. This is already visible in some investigations published recently, and clearly demonstrates how successful approaches based on basic research concepts can be [1,2].

### Future Research Directions

CRPS patients exhibit changes that occur in systems processing noxious, tactile, and thermal information; in sympathetic systems controlling blood vessels, sweat glands, and possibly other targets; and in the somatomotor system. This constellation of signs indicates that the central representations of these systems are changed. The way these central changes are triggered by the peripheral trauma, which is often minor compared to the dramatic expression of the clinical phenomena, remains an enigma. However, based on the work of McCabe and Moseley [see 1,2], it can be hypothesized that the sensory feedback from the body tissues is no longer precisely, temporarily and spatially welded to the central somatic and autonomic motor programs represented in spinal cord, brain stem, hypothalamus and cerebral hemispheres. This “sensory-motor mismatch” results in the somatic motor, autonomic motor and sensory abnormalities (including pain). Furthermore, how these central changes relate to the peripheral inflammatory/immune changes is entirely unclear. However, these questions can now be investigated using the human patient and animals as models.

Finally, we cannot explain why pain and the other changes associated with the sympathetic nervous system (including swelling), the motor system and the somatosensory system may disappear, not only in CRPS patients with SMP but also in those without, after sympathetic blockade. Based on the clinical changes that can be measured quantitatively, hypotheses about the underlying mechanisms have to be formulated. These hypotheses should be tested by using a multidisciplinary approach, which includes clinical experimentation, human models and various types of animal models (*in vivo*, *in vitro*). This type of integrative research is a necessity if we are to unravel the mechanisms that operate in CRPS, and if we are to find out the organizing pathophysiological principles that orchestrate the different changes. It is essential that basic research in animal models, human beings and clinical studies of CRPS should be closely aligned.

### Conclusions

The subject *sympathetic nervous system and pain* is a developing field in the clinics as well as in research. Research on CRPS with the aim to improve diagnostic criteria, classification and therapy has increased considerably. In future, this research will be better anchored in basic research on the systems affected (sympathetic nervous system, somatic and visceral ►sensory systems, motor system, ►central nervous system, immune system, etc.). Furthermore, research on the mechanisms of CRPS will be better integrated with the clinic. The directions to be taken in basic and clinical research should have the following priorities:

1. Basic research focusing on the brain in order to find out in which way the brain orchestrates the changes seen in the somatosensory, sympathetic and somatomotor systems.
2. Basic research focusing on the peripheral inflammatory and other peripheral processes, and on how these peripheral changes are linked to the central changes.
3. Studies to validate existing models and to develop new models of CRPS or its components.
4. Studies on research mechanisms giving rise to CRPS in susceptible individuals.
5. Research on CRPS serves as a model for exploration of the pathophysiological mechanisms in related clinically important fields, such as neural regulation of rheumatoid diseases, fibromyalgia, irritable bowel syndrome, inflammatory bowel disease or of the immune system, etc., [5,10].

### Acknowledgement

Supported by the Deutsche Forschungsgemeinschaft and the Bundesministerium für Bildung und Forschung (BMBF).

### References

1. Baron R (2006) Complex regional pain syndromes. In: McMahon SB, Koltzenburg M (eds) Wall and Melzack's textbook of pain, 5th edn. Elsevier Churchill Livingstone, Edinburgh, pp 1011–1027
2. Baron R (2008) Complex regional pain syndrome. In: Bushnell C, Basbaum AL (eds) The senses: a comprehensive reference, vol 3: pain. Elsevier, San Diego
3. Harden RN, Baron R, Jänig W (eds) (2001) Complex regional pain syndrome. Progress in pain research and management, vol 22. IASP, Seattle
4. Stanton-Hicks M, Jänig W, Hassenbusch S, Haddox JD, Boas R, Wilson P (1995) Reflex sympathetic dystrophy: changing concepts and taxonomy. Pain 63:127–133
5. Wilson P, Stanton-Hicks M, Harden RN (eds) (2005) CRPS: current diagnosis and therapy. Progress in pain research and management, vol. 32. IASP, Seattle
6. Jänig W, Baron R (2003) Complex regional pain syndrome: mystery explained? Lancet Neurol 2:687–697

7. Jänig W (2008) The autonomic nervous system and pain: neurobiological mechanisms. In: Mathias CJ, Bannister R (eds) *Autonomic failure*, 5th edn. Oxford University Press, Oxford
8. Jänig W (2008) Autonomic nervous system and pain. In: Bushnell C, Basbaum AL (eds) *The senses: a comprehensive reference*, vol 3: pain. Elsevier, San Diego
9. Jänig W (2006) The integrative action of the autonomic nervous system. *Neurobiology of homeostasis*. Cambridge University Press, Cambridge, New York
10. Jänig W, Levine JD (2006) Autonomic-neuroendocrine-immune responses in acute and chronic pain. In: McMahon SB, Koltzenburg M (eds) *Wall and Melzack's textbook of pain*, 5th edn. Elsevier Churchill Livingstone, Edinburgh, pp 205–218

---

## Complex Sound

### Definition

A sound with more than one frequency component.

► Acoustics

---

## Complex Trait

### Definition

Complex trait is a trait or characteristic that is inherited in a fashion that does not follow strict Mendelian inheritance, because it may involve interactions between two or more genes.

---

## Computational Approach

### Definition

Part of neuroscience that includes mathematical modeling and simulations to understand the functioning of the nervous system.

---

## Computational Biology

► Bioinformatics

---

## Computational Model

### Definition

A computer model is a computer program that attempts to simulate an conceptual model of a particular system with the aim of gaining insight into how the system operates.

---

## Computational Modeling of the Respiratory Network

ILYA A. RYBAK<sup>1</sup>, JEFFREY C. SMITH<sup>2</sup>

<sup>1</sup>Department of Neurobiology and Anatomy, Drexel University College of Medicine, Philadelphia, PA, USA

<sup>2</sup>Cellular and Systems Neurobiology Section, National Institute of Neurological Disorders and Stroke, National Institutes of Health, Bethesda, MD, USA

### Synonyms

Respiratory network; respiratory central pattern generator; respiratory CPG

### Definition

► **Respiratory network** is a neural circuitry in the mammalian ► **brainstem** that generates the ► **respiratory rhythm** and complex pattern of neuronal activity controlling movement of respiratory muscles that provide ► **lung ventilation** and perform the vitally important function of ► **breathing**. Computational modeling of the respiratory network is a powerful tool for theoretical investigations aimed at increasing our understanding of the complex neural mechanisms involved in generation and control of the respiratory rhythm and motor pattern.

### Characteristics

#### Generation of the Respiratory Rhythm: Concepts, Mechanisms and Computational Models

#### *Respiratory Network: Location, Types of Neurons, and the Respiratory Pattern*

The motor pattern observed during normal breathing (► **eupnea**) consists of three phases: ► **inspiration** (I), ► **postinspiration** (pI or E1), and late ► **expiration** (E2), which can be recognized in the integrated activity of the ► **phrenic nerve** and ► **cranial nerves**. This pattern originates within a bilateral column of neurons, called the ► **ventral respiratory column (VRC)**, located in the ► **ventrolateral medulla**, and is controlled by inputs from other medullary and pontine regions. The VRC includes

several compartments arranged in the rostral-caudal direction: ► **Bötzinger Complex (BötC)**, ► **pre-Bötzinger Complex (pre-BötC)**, and rostral (rVRG) and caudal (cVRG) subregions of the ► **ventral respiratory group (VRG)**. Respiratory neurons in these compartments are classified based on their temporal firing pattern (e.g., decrementing, augmenting) and the phase of activity relative to the breathing cycle, such as: early-inspiratory (early-I or I-DEC), i.e., ► **inspiratory neurons** with a decrementing discharge pattern; ramp-inspiratory (ramp-I or I-AUG), i.e., inspiratory neurons with an augmenting firing pattern; ► **post-inspiratory neurons** (post-I or E-DEC), i.e., neurons with a decrementing pattern during expiration; augmenting or stage II expiratory (aug-E or E-AUG or E-2), i.e., ► **expiratory neurons** with an augmenting pattern; ► **pre-inspiratory neurons** (pre-I or I-E/I) whose activity starts before the onset of inspiration and continues during inspiration. The BötC, with predominately post-I and aug-E neurons, is considered a major source of expiratory activity. The adjacent, more caudal compartment, the pre-BötC, contains circuitry essential for generating inspiratory activity. The activity of bulbospinal inspiratory (ramp-I or E-AUG) neurons of the rVRG, projecting to the phrenic motoneurons, is driven by the pre-BötC and inhibited by the inhibitory expiratory neurons of BötC and cVRG. The pontine respiratory regions include the ► **Kölliker-Fuse (K-F) nucleus** and ► **parabrachial (PB) complex** in the ► **dorsolateral pons** and several areas in the ► **ventrolateral pons**. Neurons in these areas exhibit phasic or tonic activity with inspiratory, expiratory or phase-spanning modulation and are involved in control of the respiratory pattern. Mechanosensory feedback from lungs provides strong modulation of the respiratory rhythm and pattern by controlling the timing of phase transitions and durations of inspiration and expiration. Specifically, lung inflation activates ► **pulmonary stretch receptors (PSRs)** that project to the ► **pump (P) cells** in the ► **nucleus tractus solitarius (NTS)**, which transmit information on lung inflation to the VRC and pontine nuclei. This feedback provides the ► **Hering-Breuer reflex** consisting of shortening (advanced termination) of inspiration and prolongation of expiration.

### **Network Mechanisms for Respiratory Rhythm and Pattern Generation and Network Models**

Computational models of the respiratory network have been in development for several decades. Early computational models focused on the network interactions between different types of respiratory neurons and did not consider possible contributions of the intrinsic, biophysical properties of neurons. Generation of the respiratory rhythm in these models was based on a network concept suggesting that the respiratory rhythm results from sequential phase switchings, such as an inspiratory off-switch (IOS, transition from

inspiration to expiration) and an expiratory off-switch (EOS, transition from expiration to inspiration). These phase switchings were proposed to result from the reciprocal (mostly inhibitory) interactions among different types of respiratory neuron populations. The early network models employed relatively simple activity-based models of single neurons in which the output neuronal (or population) activity was described by single continuous variables representing the neuronal firing rate. For example, Duffin [1] proposed a model of the respiratory network consisting of two inhibitory (I-DEC and E-BÖT) and one excitatory (I-AUG) neurons, that generated two-phase (inspiration–expiration) oscillations based upon mutual inhibition between the I-DEC and E-BÖT neurons. Both phase switching mechanisms (IOS and EOS) in this model were based on the adaptive properties of the I-DEC neuron and the reciprocal interactions between the two inhibitory neurons.

A series of three-phase network models were developed based on a conceptual schematic proposed by Richter et al. [2] that postulated that the respiratory cycle consists of three phases: inspiration, postinspiration, and late expiration. The IOS mechanism in these models involved late-I neurons that started firing by the end of inspiration, reached peak activity at the transition from inspiration to expiration, and provided the initial inhibition of inspiratory neurons. The early three-phase models usually used the activity-based models of units for simulating single neurons or neural populations. The model proposed by Botros and Bruce [3] included five neuron populations: I (inspiratory with a ramp-I pattern); early-I; late-I, post-I and E (expiratory). The interconnections among these populations were assigned in accordance with the Richter scheme [2]. The model generated a stable respiratory rhythm and reproduced realistic activity profiles of all five neuron populations incorporated. Some effects of pulmonary mechanosensory feedback on the respiratory pattern were also reproduced.

Balis et al. [4] developed the first model of the respiratory network based on interacting populations of respiratory neurons using simplified, “spiking”, ► **integrate-and-fire models** of single neurons. Their network model contained six neuron populations: one excitatory (I-AUG type), four inhibitory (I-DEC, E-AUG, E-SYM, and E-DEC), and an additional I-E/I (pre-I) population. Some key connections in the model were assigned from a spike-train analysis of multiple recordings performed by the same group. Interestingly, depending on the model parameters the respiratory pattern could be generated with or without an involvement of the I-E/I population.

Rybak et al. [5] built a series of network models with more complicated, ► **conductance-based models** of single neurons and analyzed possible roles of intrinsic

neuronal properties in the genesis of the respiratory rhythm. Several distinct network schematics were comparatively investigated. One version of this model is shown in Fig. 1. The model includes six respiratory neurons: early-I, ramp-I, late-I, post-I, aug-E (or E2), and pre-I. The IOS mechanism operates via the late-I neuron as proposed by the Richter scheme [2]. The EOS mechanism involves the pre-I neuron, which is inhibited during expiration, but when released from inhibition provides an initial activation of early-I and ramp-I neurons; the early-I neuron then inhibits post-I and aug-E neurons, hence completing the switch to inspiration.

This model includes a simplified model of the lungs and PSRs that provide pulmonary feedback to the respiratory network (Fig. 1a). This feedback is excitatory to the late-I and post-I neurons and inhibitory to the early-I neuron, allowing the expression of the Hering–Breuer reflex. Disconnecting the vagal feedback (“▶vagotomy”) causes a prolongation of inspiration and an increase in the amplitude of integrated phrenic discharges (Fig. 1b).

The model generates a realistic respiratory pattern, reproduces membrane potential trajectories of individual respiratory neurons (Fig. 1b), and shows proper changes in the respiratory pattern and firing activities of individual respiratory neurons under different conditions, including vagotomy and application of various stimuli activating afferent nerves. At the same time, this model (as well as other network models, such as those described above) failed to reproduce some important behaviors obtained from in vitro studies of the neonatal rodent system, specifically the persistence of rhythmic activity after inhibition in the network was blocked (see below).

#### Pre-Bötzinger Complex and Rhythm Generation In Vitro

A fundamentally distinct concept of respiratory rhythm generation was derived from the neonatal in vitro studies. The important discovery has been that a subregion of the VRC, called the pre-Bötzinger Complex (pre-BötC), contains a population of excitatory interneurons that can intrinsically generate an inspiratory-like rhythm [6]. This rhythm was shown to persist after blockade of synaptic inhibition, indicating that the pre-BötC may contain special cells with intrinsic ▶bursting properties. Butera et al. [2] developed and analyzed a series of computational models of ▶bursting pacemaker neurons and populations of these neurons with mutual excitatory connections. In these models, the intrinsic bursting activity was based on a subthreshold activating, slowly inactivating ▶persistent sodium current ( $I_{\text{NaP}}$ ) as the essential burst-generating, inward cationic current. The rhythmic bursting cycle in these models was controlled by the slow kinetics of inactivation and recovery from inactivation of  $I_{\text{NaP}}$ . This kinetics was shown sufficient to generate

voltage-dependent oscillations with the frequency spanning the range of bursting frequencies observed experimentally. Simulations performed have shown that the excitatory synaptic interactions coupled with  $I_{\text{NaP}}$  activation can readily synchronize cellular bursts and produce population bursting (Fig. 2a, b). Generation of this rhythm does not require inhibitory interactions; this can explain the persistence of the in vitro oscillations after inhibitory synaptic transmission was blocked. It was also shown that even a small fraction of intrinsically bursting cells (5–10%) can produce a synchronized bursting activity of the entire population. Moreover, synchronized population rhythms may occur even if none of the cells are in the intrinsic bursting state [7]. Elevation of tonic drive to the population reduces burst duration and increases burst frequency (see Fig. 2c) and, finally, switches population activity from bursting to a regime of sustained asynchronous activity (Fig. 2d).

This and a series of other related models were able to reproduce many characteristics of the pre-BötC activity in vitro, including multiple modes of activity (silence, bursting, and tonic) and a voltage-dependency of burst frequency.

#### Network-Based Versus Pacemaker-Driven Mechanisms for Respiratory Rhythmogenesis and a Hybrid Pacemaker-Network Model

As described above, network models were able to reproduce many characteristics of the respiratory ▶CPG including the generation of a realistic respiratory motor pattern and its alteration under different conditions. However, these models have failed to reproduce some characteristic behaviors observed in the reduced in vitro preparations and, specifically, the maintenance of the respiratory rhythm after blockade of synaptic inhibition. Alternatively, the pacemaker-based models, developed to fit to in vitro data, could not explain many behaviors observed in vivo, such as the Hering–Breuer and other respiratory reflexes, and independent regulation of the duration of each respiratory phase. For example, the pacemaker-based model could not reproduce ▶apneusis, a breathing pattern characterized by a significantly prolonged inspiration (up to several seconds) alternating with short expiratory intervals. Moreover, the pattern of rhythmic inspiratory discharges obtained from the reduced in vitro preparations and reproduced by the pacemaker-based models was characterized by a decrementing shape of inspiratory discharges (see Fig. 2), which differed from the augmenting shape of phrenic discharges observed during eupneic breathing in vivo and rather resembled the decrementing bursts observed during ▶gaspings in vivo.

The contradiction between the network-based and pacemaker-based concepts and models can be resolved by postulating that: (i) the pre-BötC, while capable of bursting intrinsically when isolated, is embedded in the

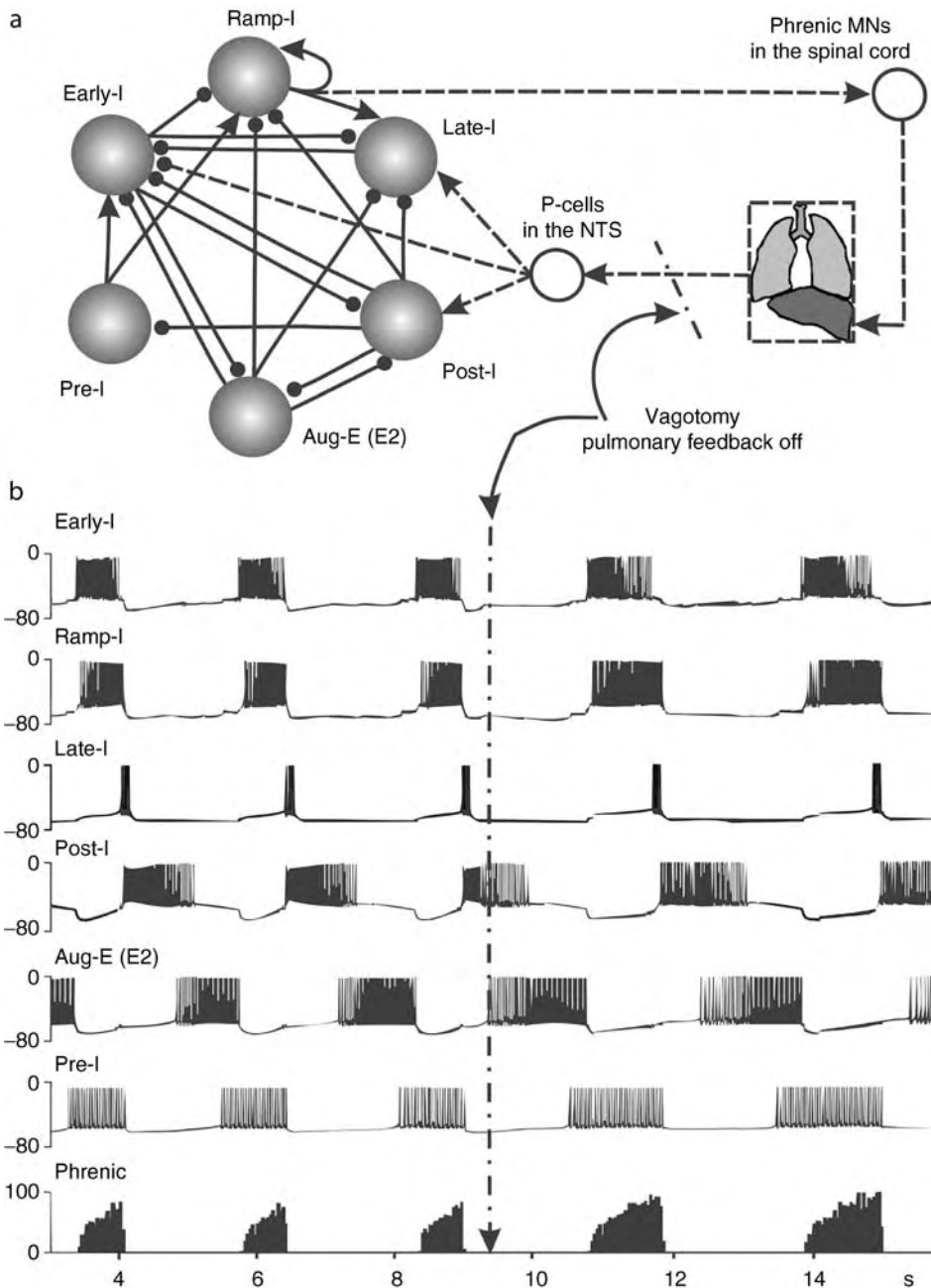

**Computational Modeling of the Respiratory Network. Figure 1** A network model of the respiratory CPG. (a) The schematic of a network model. Large spheres represent different respiratory neuron types. Excitatory and inhibitory synaptic connections are shown by arrows and small circles respectively. Each neuron also receives external excitatory drive (not shown). The pulmonary feedback loop that includes the lungs is shown by *dash lines*. (b) Model performance. All traces, except the bottom one, show membrane potential trajectory of particular respiratory neurons (indicated at *left*); the *bottom trace* shows the integrated phrenic activity. The *dash-dot line* indicates the moment of vagal feedback disconnection (“vagotomy”). Modified from [5] with permission.

larger brainstem respiratory network and its behavior as a part of the network becomes dependent on the interactions with other respiratory neural populations and (ii) the respiratory rhythmogenesis per se is state

dependent, and therefore the rhythm may be generated by either a network-based or pacemaker-driven mechanisms, or their specific combinations depending on the conditions [8–10].

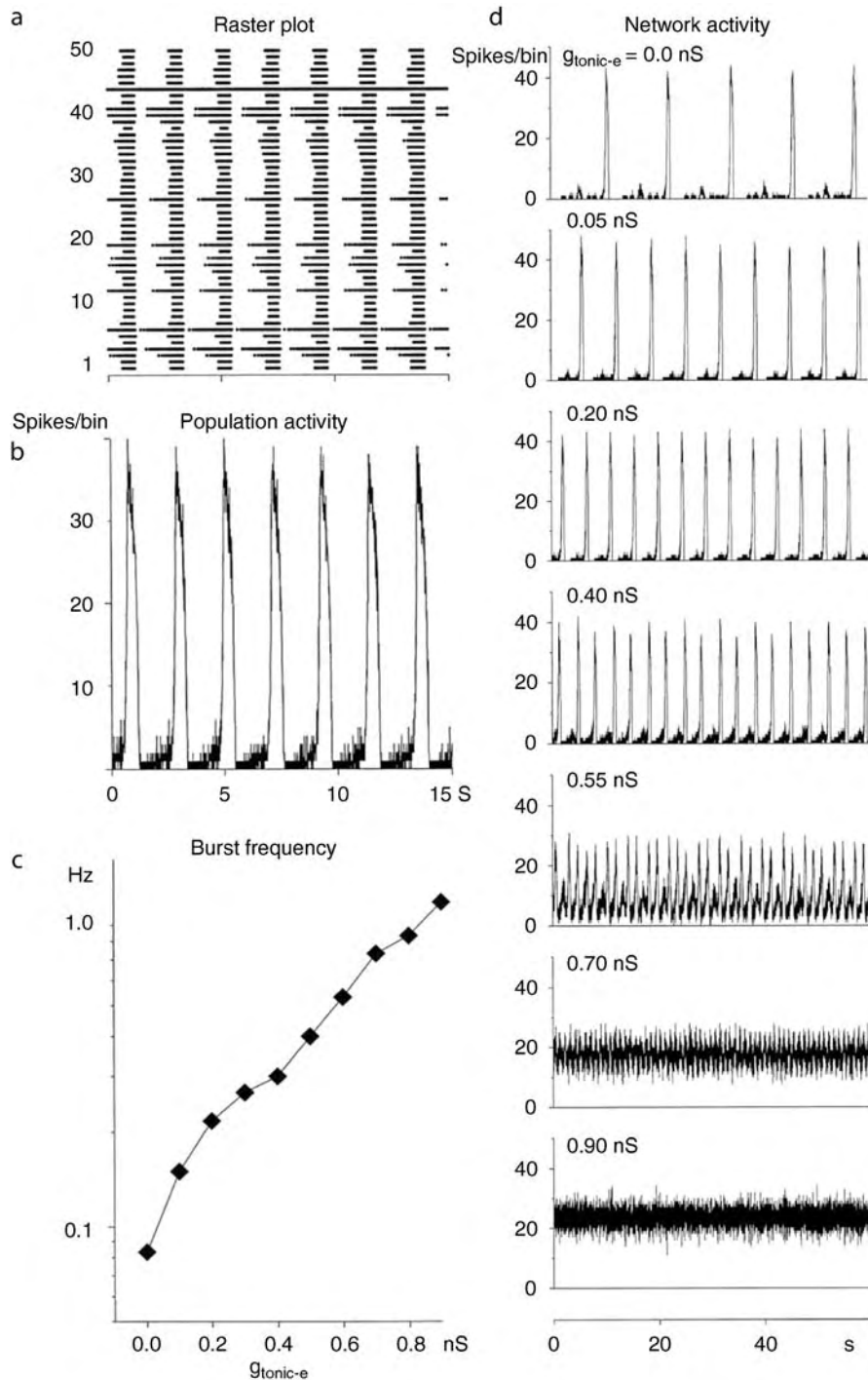

**Computational Modeling of the Respiratory Network. Figure 2** Modeling the intrinsic bursting activity of the pre-Bötzinger Complex in vitro. Simulations are shown for a heterogeneous population of 50 voltage-dependent bursting neurons (see raster plot at *left* in a) coupled by fast excitatory synaptic connections. All neurons incorporate the persistent (slowly inactivating) sodium current ( $I_{\text{NaP}}$ ). The population receives excitatory tonic drive. Heterogeneity and the cells' voltage-dependent properties result in temporal dispersion of spiking within the pre-BötC population. Population oscillations (b) generated by the model are similar to those recorded from the isolated pre-BötC in vitro. Population activity was obtained by calculating histograms (10 ms bins) of spike times across the 50 neurons. Control of pre-BötC population bursting frequency by tonic excitatory synaptic input ( $g_{\text{tonic-e}}$ ) is shown in (c) and (d). Elevation of this input (from *top to bottom* in d) increases burst frequency and, finally, switches the population activity from bursting to sustained asynchronous activity. Modified from [7] with permission.

Based on these ideas, Smith et al. [10] proposed a hybrid pacemaker-network model in which the pre-BötC excitatory kernel, with  $I_{NaP}$ -dependent bursting pacemaker properties, was embedded into an inhibitory network. The schematic of this model is shown in Fig. 3. The network model contains several populations of inspiratory and expiratory neurons (pre-I, early-I, ramp-I, late-I, post-I/biphasic-E, and late-E (aug-E or E-2)) simulated using populations of conductance-based single neuron models. It was shown that this model can operate in multiple rhythm-generating regimes depending on the expression of voltage-dependent pacemaker properties in the kernel cells and on the inhibitory network interactions. In the pacemaker (kernel)-driven mode, the inspiratory bursting activity in the pre-BötC results from the interactions between the pacemaker properties and tonic and phasic excitatory and inhibitory inputs. With the system operating in this mode, oscillation frequency is controlled by tonic

excitation/inhibition as in the isolated pre-BötC in vitro. In the network-driven mode, the kernel pacemaker neurons operate in the regime of sustained activity. In this state, the network feedback inhibition is required for ▶inspiratory phase termination. The inhibitory hyperpolarization resets  $I_{NaP}$  in the pre-BötC cells, allowing recovery from current inactivation, and the next inspiration is initiated when the inhibition declines. Analysis of the model has demonstrated that this hybrid model can be transformed dynamically between the above modes with specific changes in model parameters.

### State-Dependent Generation of the Respiratory Rhythm: The Ponto-Medullary Model

As described above, the functional state of the pre-BötC neurons with  $I_{NaP}$ -dependent bursting properties can be controlled by excitatory tonic drive and phasic synaptic inhibition (see also in [7]). Specifically, a relatively high excitatory drive can depolarize these neurons producing

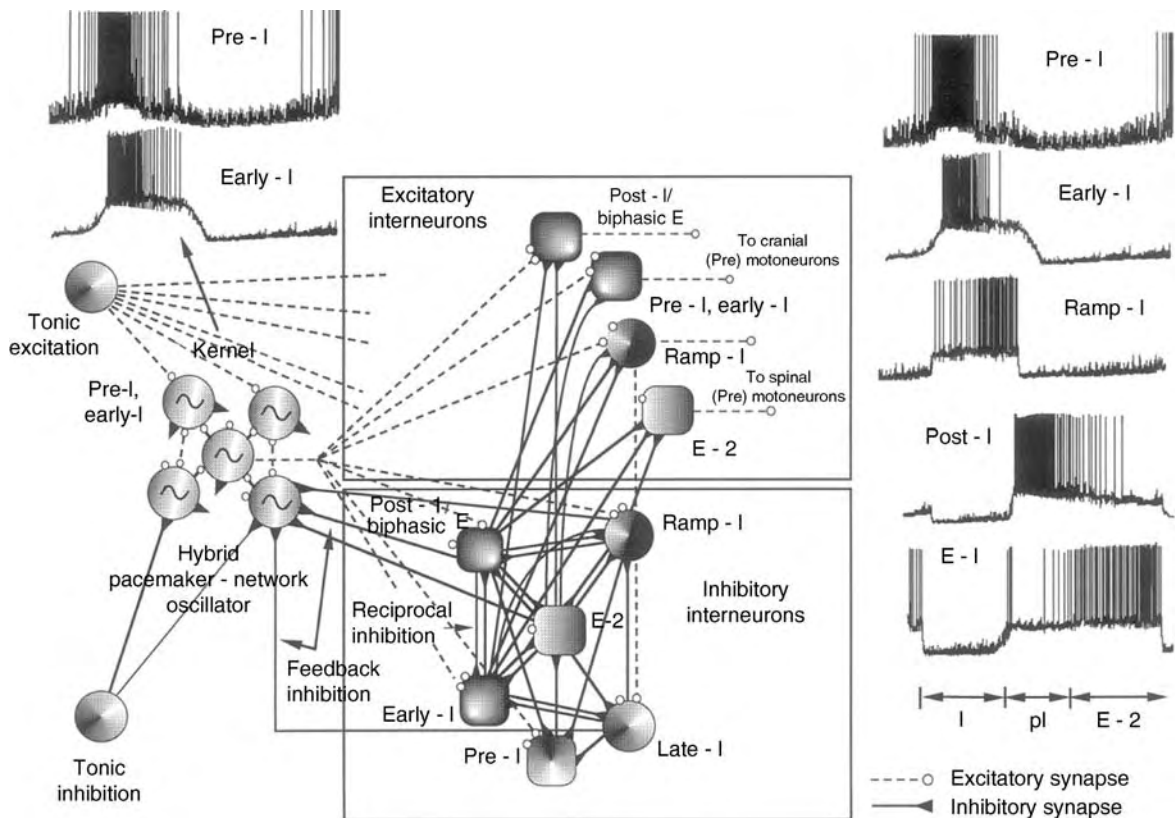

**Computational Modeling of the Respiratory Network. Figure 3** The hybrid pacemaker-network model. The respiratory network consists of interacting populations of different excitatory and inhibitory interneurons and incorporates the excitatory pacemaker-driven “kernel”, representing the pre-BötC that includes the populations of neurons (pre-I and early-I types) with  $I_{NaP}$  current (their activity is shown at the *top left*). Follower excitatory interneurons (see examples of activity patterns at the *top right*) generate synaptic drive via parallel transmission pathways to cranial and spinal (pre) motoneurons. Interconnected inhibitory interneurons generate temporal patterns of synaptic inhibition that project to the pre-BötC via feedback connections and the to the follower excitatory populations to sculpt pre-motor output activity. Modified from [10] with permission.



inactivation of  $I_{NaP}$  and putting these neurons to the state of tonic spiking. In addition, phasic inhibition can entrain a rhythmic rebound bursting resulting from the periodical disinhibition of pacemaker neurons. Hence tonic drive from supramedullary centers (e.g., from the ►pons) may control the functional state of the pre-BötC directly, via excitatory drive to the pre-BötC, as well as indirectly through the activation of post-I neurons providing phasic inhibition to the pre-BötC. As a result, pontine inputs to both the pre-BötC and BötC may change the operating rhythmogenesis mechanism via alteration of the functional state of pre-BötC neurons.

Rybak et al. [9] developed a model of the ponto-medullary respiratory network that employed the above state switching mechanism. Fig. 4 shows the schematic of this model and its performance under different conditions. The model consists of interacting populations of neurons modeled using conductance-based single neuron models. An attempt has been made to integrate known cellular-, network-, and system-level mechanisms contributing to respiratory rhythm generation and control, and accumulate all advantages of the previous models. Also in contrast to the previous models, this model has considered a spatial organization of “respiratory” compartments in the ►medulla (VRC) and pons by incorporating spatially separate compartments, such as rVRG, pre-BötC, BötC (all in VRC) as well as rostral (rPons) and caudal (cPons) parts of the pons. Each compartment includes neural populations known to be dominantly present in this region. Synaptic connections between neural populations within the VRC (i.e., between the ramp-I, early-I, late-I, post-I, aug-E and pre-I populations) define the basic circuitry for IOS and EOS mechanisms, which were similar to those operating in the network model shown in Fig. 1. At the same time, the pre-I population of the pre-BötC contains neurons with  $I_{NaP}$ -dependent pacemaker properties. Reciprocal excitatory connections between the medullary ramp-I and the pontine I-mod and IE-mod populations, and between the medullary post-I and the pontine IE-mod and E-mod populations, provide I-, IE- or E-modulation of the activity of the corresponding pontine populations. The model suggests that reticular neurons from the caudal pons (the tonic population) provide excitatory tonic drive to the majority of medullary respiratory neurons. Similar to the network model shown in Fig. 1, pulmonary mechanosensory feedback controls the activity of the key neural populations involved in IOS and EOS mechanisms (via activation of the late-I, post-I and ramp-I populations and inhibition of the early-I population) and hence contributes to regulation of the durations of respiratory phases through the Hering–Breuer reflex. In addition, this feedback suppresses the activity of the pontine neural populations that receive excitation from the medullary populations (I-mod, IE-mod, E-mod). Importantly, the

IOS and EOS mechanisms in this model operate under control of both pontine input and pulmonary feedback, which both are excitatory to the late-I, ramp-I and post-I populations.

The performance of the model under different conditions is shown in Fig. 4b–e. With pons intact, the model generates a stable “eupneic” respiratory rhythm and exhibits realistic firing patterns and membrane potential trajectories of respiratory neurons (see Fig. 4b). Specifically, the bursts of ramp-I neurons as well as phrenic discharges exhibit augmenting patterns. The pulmonary feedback to the medulla provides the Hering–Breuer reflex, so that disconnecting this feedback (“vagotomy”) produces an increase in the amplitude and duration of phrenic discharges (Fig. 4c) reflecting the loss of the Hering–Breuer reflex.

Disconnection of vagal feedback also eliminates the suppressing influence of vagal afferents upon the pontine I-mod, IE-mod and E-mod populations (Fig. 4a) and hence increases the role of these pontine populations in the control of respiratory phase switching. This control is provided via the same medullary IOS and EOS circuits that are controlled by pulmonary vagal feedback when the latter is intact.

As shown previously in cats and rats, a removal of the rostral pons or chemical blockade of respiration-related structures within this region produces apneusis, and a complete removal of the pons and rostral medullary structures in vivo can produce gasping-like phrenic bursts with decremting phrenic discharges. Similarly, a removal of rPons in this model converts the normal breathing pattern to apneusis (Fig. 4d), and a complete removal of the pons (additional removal of cPons) produces gasping-like (or in vitro-like) oscillations characterized by a decremting phrenic discharges (Fig. 4e). More recent versions also consider the regulatory role of inputs from rostral medullary neurons such as ►retrotrapezoid nucleus neurons, which have been proposed to convey tonic input related to chemosensory function.

This model (as well as the hybrid model described above) suggests that the operating rhythm-generating mechanism (network-based, pacemaker-driven or hybrid), particular that is engaged and expressed under conditions, depends on the functional states of the pre-BötC and other VRC compartments (e.g., BötC), which in turn are controlled by multiple network interactions within the medulla as well as by various supramedullary (e.g., pontine) and afferent (mechano- and chemosensory) inputs carrying information on the functional state and metabolic needs of the system.

### Synopsis

Although many cellular and network properties involved in respiratory rhythm and pattern generation remain unknown, there is an emerging understanding

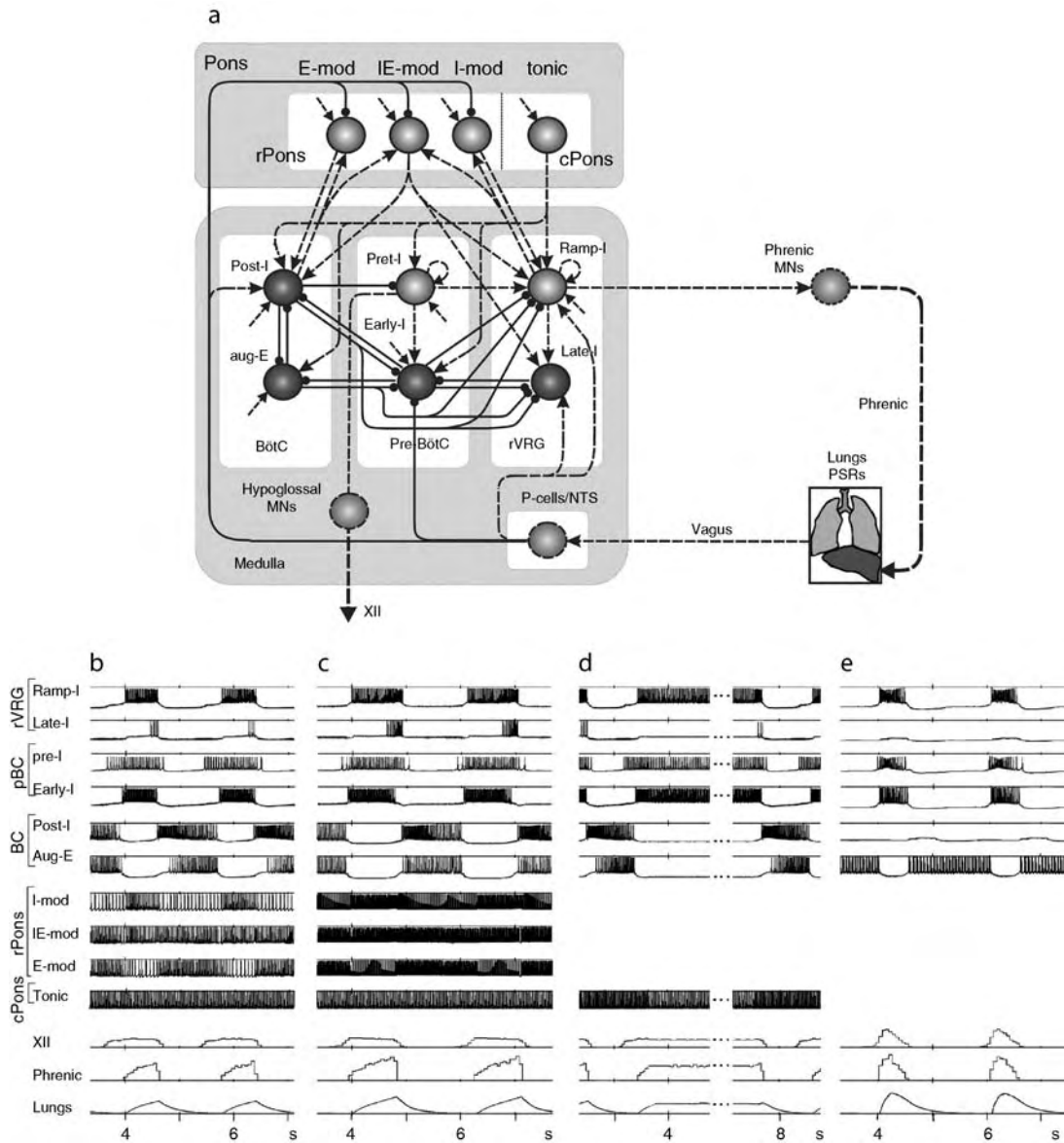

**Computational Modeling of the Respiratory Network. Figure 4** The ponto-medullary model of the respiratory CPG. (a) Model schematic. Each sphere represents a population of 50 neurons. *Dark and light large spheres* are excitatory and inhibitory populations respectively. *Dashed lines with arrows* represent excitatory synaptic connections and *solid lines* ended with small circles show inhibitory connections. *Additional arrows* at the population circles indicate external excitatory tonic drive to each population. (b–e) Model performance under different conditions. The *top traces* (except the bottom three) show membrane potential trajectory of one, randomly selected neuron from each population; the three *bottom traces* show integrated hypoglossal (XII) and phrenic activities and lung volume (the *bottom trace*). (b) The performance of the intact network (“eupnea”). (c) “Vagotomy” – the vagal feedback in the model is disconnected. (d) “Apneusis” produced by removal of rPons. (e) Complete removal of the pons switches the system to the state in which the rhythm in the network is completely driven by bursting pacemaker activity originating in the pre-BötC. Modified from [9] with permission.

that the operating neural mechanisms involved are state-dependent and entail complex cross-level interactions between multiple cellular-, network-, and system-level processes. Computational modeling at all levels of

complexity is expected to play an increasing role in analyzing the complex mechanisms underlying respiratory network function and the neural control of breathing.

## References

1. Duffin J (1991) A model of respiratory rhythm generation. *Neuroreport* 2:623–626
2. Richter D, Ballantyne D, Remmers JE (1986) How is the respiratory rhythm generated? A model. *News Physiol Sci* 1:109–112
3. Botros SM, Bruce EN (1990) Neural network implementation of the three-phase model of respiratory rhythm generation. *Biol Cybern* 63:143–153
4. Balis UJ, Morris KF, Koleski J, Lindsey BG (1994) Simulations of a ventrolateral medullary neural network for respiratory rhythmogenesis inferred spike train cross-correlation. *Biol Cybern* 70:311–327
5. Rybak IA, Paton JFR, Schwaber JS (1997) Modeling neural mechanisms for genesis of respiratory rhythm and pattern: II. Network models of the central respiratory pattern generator. *J Neurophysiol* 77:2007–2026
6. Smith JC, Ellenberger H, Ballanyi K, Richter DW, Feldman JL (1991) Pre-Bötzinger complex: a brain stem region that may generate respiratory rhythm in mammals. *Science* 254:726–729
7. Butera RJ, Rinzel JR, Smith JC (1999) Models of respiratory rhythm generation in the pre-Bötzinger complex: II. Populations of coupled pacemaker neurons. *J Neurophysiol* 82:398–415
8. Rybak IA, Paton JFR, Rogers RF, St.-John WM (2002) Generation of the respiratory rhythm: state-dependency and switching. *Neurocomputing* 44–46:603–612
9. Rybak IA, Shevtsova NA, Paton JFR, Dick TE, St.-John WM, Mörschel M, Dutschmann M (2004) Modeling the ponto-medullary respiratory network. *Respir Physiol Neurobiol* 143:307–319
10. Smith JC, Butera RJ, Koshiya N, Del Negro C, Wilson CG, Johnson SM (2000) Respiratory rhythm generation in neonatal and adult mammals: the hybrid pacemaker-network model. *Respir Physiol* 122:131–147

## Computational Motor Control: ERN

AMIR KARNIEL

Department of Biomedical Engineering, Ben-Gurion University of the Negev, Beer Sheva, Israel

The nervous system analyses sensory information (►Sensory systems) and orchestrates motor commands (►Motor control). Many artificially engineered systems face similar challenges. Following the notion of cybernetics, we strive to boost both scientific and technological research by exploring the differences between artificial control theory (►Adaptive control; ►Computer-neural hybrids; ►Control theory; ►Nonlinear control systems; ►Signals and systems) and the biological motor control.

Computational motor control covers all applications of quantitative engineering tools as well as other mathematical tools for the study of the biological movement control

system, which includes the joints, muscles, sensory organs and of course the nervous system.

For example, ►feedback control, ►adaptive control, and ►bayesian statistics, represent such computational tools that were employed in the study of the biological motor control system, see also [1–4].

The applications of computational motor control are bidirectional: on the one hand control theory knowledge is employed to generate new theories for the biological motor control and on the other hand we draw inspiration from the biological motor control in order to develop new control strategies for artificial devices.

In the following two sections we describe this interplay between science and technology and introduce the main concepts in the field of computational motor control that are further defined in the relevant keywords throughout the encyclopedia.

### Control Theory and Our Understanding of the Biological Motor Control System

Brain researchers have always used technical analogies stimulated by the status of the technology at the time of writing. For a recent review of insights from engineering theory that can shed some light on biological complexity see [5]. These analogies are very useful pedagogically and they could also be useful scientifically as long as they are accurately stated. The best way to accurately state an analogy is by means of a mathematical computational model. In the 50s the servo-mechanism was popular, and at that time Ragnar Granit [6] wrote that the concept of servo-control is practically as old as experimental physiology and could be traced back to Claude Bernard's idea about the *constancy of the internal environment* (1865). However, once the model is treated with a specific mathematical model, one can study the gain of the feedback and stability behavior, which are part of the feedback servo-mechanism control theory and were not existent at the time of Claude Bernard. The introduction of quantitative comparison of physiological data to the computational model paved the way to new discoveries, such as the time-varying gain [7] and the typically low gain and large delays [8] that generated new understandings and pushed researchers towards the notion of adaptive control.

Feedback Control (►Control) is the first technique taught in any control engineering class [9]. Computational motor control evolved as part of the field of biological cybernetics and the origin of the word cybernetics refers to feedback control and indeed in the early models for motor control, feedback control was the main analogy and modeling tool [7,10].

In parallel to the development of ►adaptive control theory, physiologists have noticed that the simple servo theory does not properly describe the biological motor control system since the gains are low and changeable,

and the delay does not enable proper control of rapid movements [8]. The delay problem is partially resolved by equilibrium theories (see ► [Equilibrium point control](#)) where the feedback is performed instantaneously by the muscle's impedance (► [Impedance control](#)).

Another prominent feature of the biological motor control system which is not addressed by the servo theory as well as by most modern engineering theories is the redundancy of the biological motor system [11] which enables obtaining the same goal by activating many possible muscle unit combinations (see ► [Coordination](#)).

Most notably, adaptive control theory was required in order to address the limitations of the servo theory and is being increasingly employed in many studies of the biological motor control system [12–16].

### The Hierarchy of Feedback Adaptation Learning and Evolution

Adaptation in the wide sense (WSA) is accommodation to the environment, in other words, any processing of sensory information that eventually changes the motor behavior in one way or the other. [Figure 1](#) presents a map of four instances of this phenomenon where the coordinates of this map are time-scale and majority of change. We start with a description of the system approach and then move to address each type of the WSA separately to clarify the scope of each part in this structural temporal hierarchy.

#### Structural Temporal Hierarchy

A prominent tool of the engineering approach is the block diagram and we use it here to describe the various notions in the proposed structural temporal hierarchy.

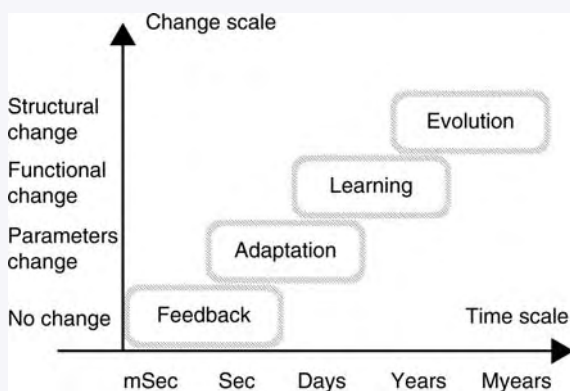

**Computational Motor Control: ERN. Figure 1** The temporal structural hierarchy of wide sense adaptation in the motor control system. Feedback, Adaptation, Learning and Evolution are instances of wide sense adaptation where sensory information is integrated and employed to change the control signal in various techniques and time scales.

[Figure 2](#) demonstrates such a diagram in which each block is an input-output system. The output is a function of the input. The term function is used here in the wide sense to include transfer function that implies the existence of dynamics and internal state variables within the system as well as stochastic function that implies the presence of noise or uncertainty.

When we think about a control problem we usually have at least two systems: The controller and the controlled system. For example if we wish to control the position of the hand, we have the controlled system on the one side, i.e., the relation between the neural command to the muscles and the position of the hand, and the controller on the other, i.e., the relation between the intended movement and the neural signals to the muscles implemented by the brain. (Other distinctions are possible, such as considering the muscles as part of the controller as discussed further in the next subsection).

A prominent feature of the biological system is to use the sensory information about the actual position of the hand in order to improve the control of its position. This simple idea was used by engineers from the beginning of cybernetics (in part following observations of nature) and was later developed to include adaptive control. We follow the engineering terminology and use it to define a hierarchy of methods to improve the control signal and then try to use it to describe the brain as it controls movements. The basic idea of this hierarchy was first presented in [4] and here we further extend and more accurately define and demonstrate it. The terms feedback, adaptation, learning and evolution that are used here to describe this hierarchy are overloaded with various meanings and interpretations, therefore it is crucial that we properly define what we mean by each part of the hierarchy. We start from choosing the appropriate definition from the dictionary and then further define and demonstrate what we mean in the context of the hierarchy and the engineering and biological control systems.

#### Feedback

According to the Miriam-Webster Dictionary: “the return to the input of a part of the output of a machine, system, or process (as for producing changes in an electronic circuit that improve performance or in an automatic control device that provide self-corrective action).”

According to the Oxford Dictionary: “a. Electr. The return of a fraction of the output signal from one stage of a circuit, amplifier, etc., to the input of the same or a preceding stage.”

We refer to a system as feedback control when sensory information is fed back to generate the control signal during the performance of the task (see [Fig. 2](#)). The signal flows from the sensory system to the control

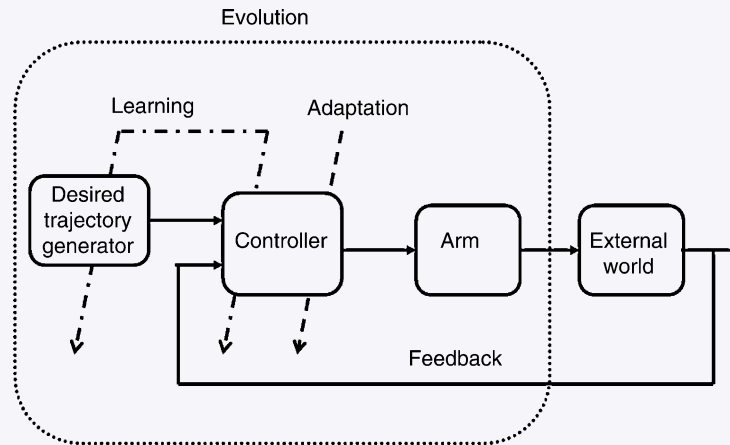

**Computational Motor Control: ERN. Figure 2** The hierarchy of wide sense adaptation in the control of arm movement. The biological motor control system is separated into three parts: the arm, which consists of the musculoskeletal system, the controller that may include internal models, state estimators as well as feedback controller, and the desired trajectory generator that represents higher brain functions. Feedback control changes only the control signals but does not change the functions of any part in the system. Adaptation may change the parameters of the controller, in particular parameters of the internal models. Learning may change the structure of the internal model and may also change the desired trajectory. Evolution can change each and every aspect of this system including the structure of the limb such as the number of joints in the arm. The external world influences the sensory feedback, which plays a crucial role in all these processes. Many studies manipulate the feedback by including force perturbations and altered visual feedback in order to excite these processes and analyze their properties. This diagram concentrates on the control of one arm movement, and therefore in this subsystem the external world is not influenced by the wide sense adaptation. However, in real life, outside the control experiments and rule-based games, the human brain has evolved to be capable of changing the environment and this capability is part of the learning process, therefore the learning process includes also changes in the strategy beyond changing the internal model and the desired trajectory, such as modifying the force perturbations by manipulating the environment.

system, this path could be long or short depending on the specific system; however, there is no change in the control system and the changes in the control signals are the result of changes in the sensory signals.

In the biological system the shortest path is typically described as the feedback reflex loop, which includes a monosynaptic pathway. However, there is a shorter pathway for feedback within the muscle. The simple mechanical property of stiffness (i.e. the force being proportional to the length of the muscle) could be referred to as feedback control, since the control signal (the force) is influenced by the outcome that is sensed by the length of the muscle. This last example demonstrates a limitation of the engineering approach, since the blocks usually hide the detailed structure, therefore if we define the control signal as neural input we would never note the internal feedback loops within the muscle and joint. In such block diagrams there is always a tradeoff between simplicity and accuracy and one should note that the hierarchy described here for a specific level of abstraction could be multiplied within each block.

Let us summarize this discussion with a formal definition of feedback control: Feedback Control: of a

given input-output system is the usage of the output signal in order to generate the control signal in real time, i.e., the time scale of changes in the control signals is determined by the propagation of signals through the channels and the control system.

Figure 1 captures the main properties of feedback: signal flow in real time without changes in the system.

### Adaptation

According to Miriam-Webster: “adjustment to environmental conditions: as (i) adjustment of a sense organ to the intensity or quality of stimulation (ii) modification of an organism or its parts that makes it more fit for existence under the conditions of its environment.”

According to the Oxford Dictionary: “2. a. The process of modifying a thing so as to suit new conditions: as, the modification of a piece of music to suit a different instrument or different purpose; the alteration of a dramatic composition to suit a different audience.”

Adaptive control is a control strategy where the controller can change its function to accommodate changes in the controlled system or in the environment. Here not only the signals are changed but also the control system is changed based on the sensory information

received. These changes in the system are typically slow compared to the time-scale of the feedback. The controller includes a finite set of adjustable parameters and a third system observes the flow of signals to and from the control system and determines how this set of parameters should change in order to improve some measure of performance.

**Adaptive control:** Changes in the parameters of the control system that are generated after observation of previous control and sensory signals in order to improve the future performance of the system over a well-defined task or measurements of performance.

### Learning

According to Miriam-Webster: “**1 a (1):** to gain knowledge or understanding of or skill in by study, instruction, or experience <learn a trade> [...] **b:** to come to be able <learn to dance>.”

According to the Oxford Dictionary: “1. The action of the vb. LEARN. a. The action of receiving instruction or acquiring knowledge; spec. in Psychol., a process which leads to the modification of behaviour or the acquisition of new abilities or responses, and which is additional to natural development by growth or maturation; (freq. opp. insight).”

While adaptation is a change in parameters of the controller that improves the performance in certain types of behavior, learning may generate a completely new behavior, as in skill acquisition, or may employ a new strategy to achieve the same task. In both cases the controller may change its structure. Such change in the biological system may include the recruitment of new brain areas or generation of a new neural circuit for a specific task. In artificial systems the controller may be replaced with another controller. At this point our technology does not provide an effective learning machine and it is highly possible that observing the biological system and modeling the neural control of movement may generate new control strategies that would later be used for artificial intelligent control, perfected by control engineers, and then return to serve as models for the brain.

**Learning Control:** change of the control system in order to generate a new type of behavior.

### Evolution

According to Miriam-Webster: “**2 c (1):** a process of continuous change from a lower, simpler, or worse to a higher, more complex, or better state; **4 b:** a theory that the various types of animals and plants have their origin in other preexisting types and that the distinguishable differences are due to modifications in successive generations.”

According to the Oxford Dictionary: “6. Biol. a. Of animal and vegetable organisms or their parts: The process of developing from a rudimentary to a mature

or complete state. c. The origination of species of animals and plants, as conceived by those who attribute it to a process of development from earlier forms, and not to a process of ‘special creation.’ Often in phrases doctrine, theory of evolution 7. The development or growth, according to its inherent tendencies, of anything that may be compared to a living organism (e.g. of a political constitution, science, language, etc.).”

In the proposed hierarchy, evolution is the last resort as it may take many years and it can potentially generate the largest change due to the evolution of a new species or in the engineering term, a new kind of controller.

**Evolution:** an arbitrary change in the controller that could include any change in structure, function, connectivity, parameter values, learning algorithms and adaptation protocols. The best change is chosen by survival of the fittest and therefore this process may be extremely long.

### An Engineering Example

Consider a controlled system:  $y = P(x, u)$ ;  $\dot{x} = g(x, u)$ , where  $y$  is the output,  $u$  is the input and  $x$  is the state, and a proportional controller  $u = k(y_d - y)$ , where  $y_d$  is the desired reference trajectory.

As long as  $k$  is constant, this is a simple feedback control. The sensed output  $y$  is used through the controller to change the control signal in real time, in this case immediately. Even if we introduced delay or dynamics to the controller, as long as the parameters of the controller are fixed this would still be called a feedback control system.

Now suppose that this feedback control that worked fine in the first design does not provide good performances due to changes in the control system or in the environment. We wish to choose  $k$  automatically to generate the best performance under this given structure. We may design an algorithm that observes the outputs and possibly also the inputs to the system and modify  $k$  accordingly. This scheme is called adaptive control and a typical requirement to avoid unstable behavior is that the time scale for the changes in the parameter is long compared to the time scale of the feedback loop. This is required in order to properly identify the system and adapt the parameters of the controller accordingly.

With this adaptive control we can face certain type of changes in the plant or the environment, however, a new task or severe changes in the plant or the environment (that would also be called new task) may require changes in the structure of the controller, e.g., one may consider adding integration or a lead or other elements from some given repertoire. In this example lets consider the repertoire of linear controller, i.e., finite number of poles and finite number of zeros in the transfer function of the controller.

An algorithm that would observe the inputs and outputs and would choose the optimal structure of the controller, i.e., the number of poles and number of zeroes, would be called a learning algorithm. Again this process should be slower than the typical time scale of adaptation in order to obtain enough information from the operation of the current controller to make a good decision.

Finally this whole framework of linear control might be wrong and a new generation could evolve based on gain scheduling or some neural network based controller (► [Neural Networks for control](#)).

Then again, after such an evolutionary process, e.g., in the case of neural network, the changes in the weights would be called adaptive control, changes in the connectivity, size and structure of the net would be called learning, and finally changes in the time of activation function or the underlying structure would be called evolution.

### A Neurophysiological Example

Consider a reaching movement from an initial position to a given target (► [Arm trajectory formation](#)).

The ► [equilibrium-point control](#) [17–19] suggests that the brain specifies the end point, namely the resting length of the muscles, and then the arm moves to its equilibrium according to the law of physics. As long as the hand is not at the target there is an error signal that pushes the hand towards the target. This would be a classical feedback control. Other versions of the equilibrium control [18,19] are also based on feedback control and account for equilibrium trajectory.

Suppose that the subject holds a robotic manipulator that exerts a velocity-dependent force perpendicular to the direction of movement [20]. In the first movement the subject generates a curved line and it seems that the feedback control is insufficient to generate a straight line. Then after practice the movement becomes straight and if the force field is stopped a curved movement in the other direction is generated, a phenomenon that was called after-effect. The after-effect is a clear sign that feedback was not the reason for the improved behavior and some change in the controller took place during this training period. We call such a change in parameters adaptation. The adaptive controller could be based on ► [internal models](#) [16] or on parametric changes in the Equilibrium-point (EP) signals or other control signals [21].

Now suppose that we introduce a completely new type of force field, which subjects are unable to adapt to within tens of trials, i.e. a force field, which is not within the natural repertoire of the adaptive control system. Two examples for such a force field are time-dependent forces and force fields that switch according to some sequence [22]. The natural adaptive control scheme is insufficient in order to compensate for such force fields, however,

some individuals after prolonged practice in a proper training plan with proper cues and motivation may be able to learn this task, probably by employing new neural circuits or generating a major structural change of the control strategy. This would be a learning process.

Finally the force field might be stronger than the physiological limitations of the muscles, much stronger than the one that could be learned by increasing the muscles mass through training. In such cases, only evolution of a new species might solve this task if this task was essential for the survival of the subject for a large number of generations.

The adaptive nature of the biological system addressed in this essay is indeed the core of computational motor control, however, one should note that many other computational models and control methods are being employed in the study of the biological motor control including optimal control (see ► [arm trajectory formation](#)), optimal feedback control, stochastic control, ► [information theory](#), ► [nonlinear control systems](#), etc.

As new engineering and computational techniques are being developed by engineers and mathematicians they are quickly employed to describe the nervous system, and on the other hand as new behavioral and physiological phenomena are being observed they quickly inspire engineers to incorporate them into artificial systems – this is the essence of cybernetics and computational motor control and therefore the specific definition and list of related topics are ever growing.

### References

1. Wolpert DM, Ghahramani Z (2000) Computational principles of movement neuroscience. *Nature Neuroscience* supplement, 3: pp 1212–1217
2. Jordan MI (1996) Computational aspects of motor control and motor learning, in Heuer and H. Keele, S. Handbook of Perception and Action: Motor Skills, Academic Press: New York
3. Shadmehr R, Wise SP (2005) *The Computational Neurobiology of Reaching and Pointing: A Foundation for Motor Learning*. MIT Press
4. Karniel A, Inbar GF (2000) Human motor control: Learning to control a time-varying, nonlinear, many-to-one system. *IEEE Transactions on Systems Man and Cybernetics Part C-Applications and Reviews*, 30(1): pp 1–11
5. Csete ME, Doyle JC (2002) Reverse engineering of biological complexity. *Science*, 295(5560): pp 1664–1669
6. Granit R (1955) *Receptors and sensory perception*. New Haven: Yale University Press
7. Marsden CD, Merton PA, Morton HB (1972) Servo action in human voluntary movement. *Nature*, 238 (5360): pp 140–143
8. Inbar GF (1972) Muscle spindles in muscle control. II. Analysis of muscle servo model. *Kybernetik*
9. Franklin GF, Powell JD, Emami-Naeini A (2002) *Feedback Control of Dynamic Systems*. 4th ed. Prentice Hall. Upper Saddle River, N.J.: 910

10. McRuer DT, Magdaleno RE, Moore GP (1968) A neuromuscular actuation system model. *IEEE Transactions on Man-Machine Systems*, MMS-9(3): pp 61–71
11. Bernstein N (1967) *The Coordination and Regulation of Movements*. Oxford: Pergamon Press
12. Inbar GF (1972) Muscle spindles in muscle control. 3. Analysis of adaptive system model. *Kybernetik*
13. Bhushan N, Shadmehr R (1999) Computational nature of human adaptive control during learning of reaching movements in force fields. *Biological Cybernetics*, 81: pp 39–60
14. Donchin O, Francis JT, Shadmehr R (2003) Quantifying generalization from trial-by-trial behavior of adaptive systems that learn with basis functions: Theory and experiments in human motor control. *Journal of Neuroscience*, 23(27): pp 9032–9045
15. Klaiman E, Karniel A (2006) Bimanual adaptation: internal representations of bimanual rhythmic movements. *Experimental Brain Research*, 171(2): pp 204–214
16. Kawato M (1999) Internal models for motor control and trajectory planning. *Current Opinion in Neurobiology*, 9: pp 718–727
17. Polit A, Bizzi E (1979) Characteristics of Motor Programs Underlying Arm Movements in Monkeys. *Journal of Neurophysiology*, 42(1): pp 183–194
18. Latash ML (1993) *Control of human movement*. Champaign: Human Kinetics
19. Feldman AG (2005) *Forty years of the equilibrium-point hypothesis*. Lachine, Quebec: Tristar Printing
20. Shadmehr R, Mussa-Ivaldi FA (1994) Adaptive representation of dynamics during learning of a motor task. *Journal of Neuroscience*, 14(5): pp 3208–3224
21. Gribble PL, Ostry DJ (2000) Compensation for loads during arm movements using equilibrium-point control. *Experimental Brain Research*, 135(4): pp 474–482
22. Karniel A, Mussa-Ivaldi FA (2003) Sequence, time, or state representation: how does the motor control system adapt to variable environments? *Biological Cybernetics*, 89(1): pp 10–21

## Computerized Stabilometry

► **Stabilometry**

## Computer-Neural Hybrids

VITTORIO SANGUINETI

Dipartimento di Informatica, Sistemistica e Telematica, Università di Genova, Genova, Italy

### Synonyms

Dynamic clamp; Neurally controlled animats; Hybrots; Embodied neural systems; Brain-machine interfaces; Brain-computer interfaces; Neuroprostheses

### Definition

Device or experimental apparatus in which living neurons exchange information in a bi-directional way with an artificial system – a computer simulation or a physical device.

Exchange may involve intra-cellular signals and occur within a single neuron, or between pairs of neurons. Alternatively, the neural component may be made of multiple neurons, an entire neural population or even a whole organism, with its own intact sensory and motor systems. In this latter case, signals are exchanged extra-cellularly, with multiple stimulation and recording sites.

The artificial part may consist of simulated neurons, thus resulting in a hybrid neural circuit. It may include artificial sensor or actuator systems, as in ► **neuro-prostheses** and ► **brain-computer interfaces**, or even consist of a whole physical or simulated body.

### Description of the Theory

#### Description of the Structure

In computer-neural hybrids at single neuron level, an ► **intra-cellular recording** of the ► **membrane potential** of a neuron is used to calculate a current, which is then injected into the same or another neuron. In this way, it is possible to simulate artificial voltage-gated (Fig. 1) and/or ► **synaptic conductances** (Fig. 2). Both voltage measurement and current injection are made with glass micropipette electrodes. This technique is known as dynamic clamp [1].

The artificial part of the dynamic clamp may consist of one or more simulated neurons. This would result in a hybrid neural circuit, made of both biological and artificial neurons. Dynamic clamp can be, and has been, implemented in various ways, ranging from analog circuits, to dedicated computer systems (e.g., digital signal processing boards), to software applications that exploit the computational power of modern computers.

In computer-neural hybrids that involve multiple neurons, both recording and stimulation usually occur extra-cellularly, through multiple electrodes or ► **microelectrode arrays**. Like in dynamic clamp, the multi-site neural signals are processed in real-time, but here the signal recorded from each electrode reflects the activity (population spikes and/or field potentials) of a small population of neurons. For this reason, the processing of the recorded neural signals often includes ► **spike sorting** modules, which result in multiple spike trains – one for each identified neuron in the population. Microelectrode arrays are also used to deliver electrical stimuli that excite the neural system by initiating action potentials in the neurons nearby (see Fig. 3).

As both recording and stimulation occur extra-cellularly, in these hybrids the computer-neural interaction is less direct than in dynamic clamp. Nevertheless, the collective activity of the neural population can be



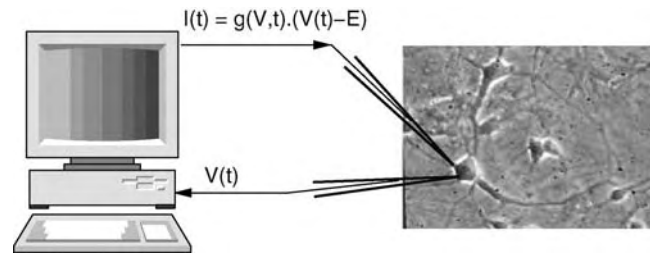

**Computer-Neural Hybrids. Figure 1** Dynamic clamp simulation of a membrane conductance. The membrane potential  $V(t)$  is sampled and the computer calculates the membrane current,  $I(t)$ , based on the model conductance  $g = g(V,t)$  and on its corresponding reversal potential,  $E$ .

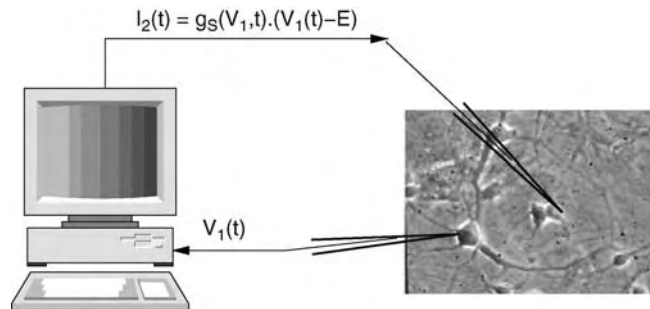

**Computer-Neural Hybrids. Figure 2** Dynamic clamp simulation of a synaptic conductance. The membrane potential of the pre-synaptic neuron,  $V_1(t)$ , is sampled, and the computer calculates the post-synaptic membrane current  $I_2(t)$  based on the model synaptic conductance,  $g_s = g(V_1,t)$  and on its corresponding reversal potential,  $E$ .

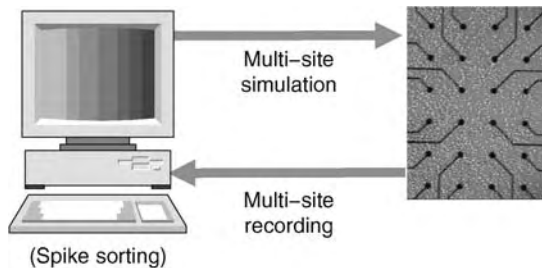

**Computer-Neural Hybrids. Figure 3** Computer-neural hybrid a population level. The multi-site electrical activity of a neural population is recorded extra-cellularly through an array of micro-electrodes. Spike trains are then extracted from the signal and transformed into a pattern of stimuli, which is applied to the same populations through selected micro-electrodes.

made to control the stimulation of the same population. Feedback may be used to maintain a specific dynamic regime, or to trigger adaptation phenomena.

### Higher Level Structures: Neural Interfaces and Embodied Neural Systems

A particular class of computer-neural hybrids at population level is that of brain-machine interfaces

(BMIs) or neural interfaces [2,3], in which an artificial device communicates directly with the nervous system with no direct participation of the sensory or the motor systems. Neural interfaces were first hypothesized in the early 60's to augment body functionalities in astronauts or pilots – the notion of cybernetic organism or **cyborg**. However, they became feasible with the progress in the technology of microelectrode arrays, which enabled the access to a neural system from multiple sites. Since then, they have become essential tools in the investigation of the dynamic and distributed nature of **neural coding**. Moreover, they have found an important area of application as aids for persons with sensory or motor disabilities.

There are two main types of neural interfaces: (i) brain-computer interfaces (BCIs), in which the activity of the nervous system is directly used to control external devices (computers, robots or prostheses); and (ii) neuroprostheses, in which physical devices are designed to induce spatio-temporal patterns of neural activity.

The aim of brain-computer interfaces is to use some measurement of the activity of the nervous system to control external devices, with no direct participation of peripheral nerves and muscles. More specifically, BCI technologies [4] use brain activity recorded

externally, i.e. on the scalp (►**electroencephalography**, EEG), or intra-cranially (epidural, sub-dural or intra-cortical), to control the movement of a cursor on a computer screen, or that of a robot.

Neuroprostheses aim at substituting for impaired sensory modalities, and always involve artificial replicas of the dysfunctional sensory receptors (or parts of them). Stimuli are applied to sensory nerves, thus mimicking the effect of natural sensory stimuli.

In BCIs, bi-directionality in the exchange of information is achieved through the sensory system (e.g., vision) that provides the brain informations on the outcome of the generated action. In neuroprostheses, bi-directionality is provided by the actions generated in response to the simulated sensory stimuli. Both types of neural interface require substantial training to allow subjects to either generate the correct action or correctly interpret sensor stimuli. Bi-directionality is essential to such training phase.

Embodied neural systems are a special class of computer-neural hybrids (Fig. 4), in which portions of nervous tissue are connected to either a “virtual,” computer-simulated [5], or a physical [6] body, equipped with sensors and actuators, thus forming an artificial/hybrid ►**autonomous system**. In these artefacts, also referred as **hybots** or **neurally controlled ►animats**, artificial sensory and motor systems allow the neural system to interact with the external world.

### Function

In neuroscience research, computer-neural hybrids can be seen as a method of investigation of complex neural systems, which falls midway between cellular and population electrophysiology experiments and simulations based on ►**computational models**. In a modeling

approach, one wants to investigate the effect of a specific component (a conductance, a synapse, a population of neurons, a sensory or motor system or even the whole body) on the whole neural system. However, while we may be able to model that specific component accurately, this may not be the case for the remaining parts of the system. The computer-neural hybrid method consists of replacing the well-modeled part with a computer-simulated computational model, in which all the details are under control, including the interaction with the external world. The model is then allowed to interact with the actual neural system, with all its complexity intact and the possibility of further manipulations. This experimental paradigm may potentially allow manipulations of the neural system under study that once were only possible with simulations on detailed, large scale computational models.

Dynamic clamp is now a well established technique in modern electrophysiology. It has been initially applied to the simulation of membrane ►**conductances** in single neurons. In this way, it is possible to observe the interaction between the added and the existing conductances, and compare the effect of simulated and actual conductances. Conductances may also be subtracted, i.e. it is possible to simulate negative conductances that cancel out existing ones.

The same technique may be used to simulate synaptic conductances between neurons. The current injected into a neuron can be made dependent on the membrane potential of a different neuron, as if there were a synapse among them. In this way, it is possible to investigate, for instance, the effect of the strength of the artificial synapse on the dynamic behavior of the hybrid neural circuit. An extension of this idea is to construct hybrid circuits that are made of both artificial and actual

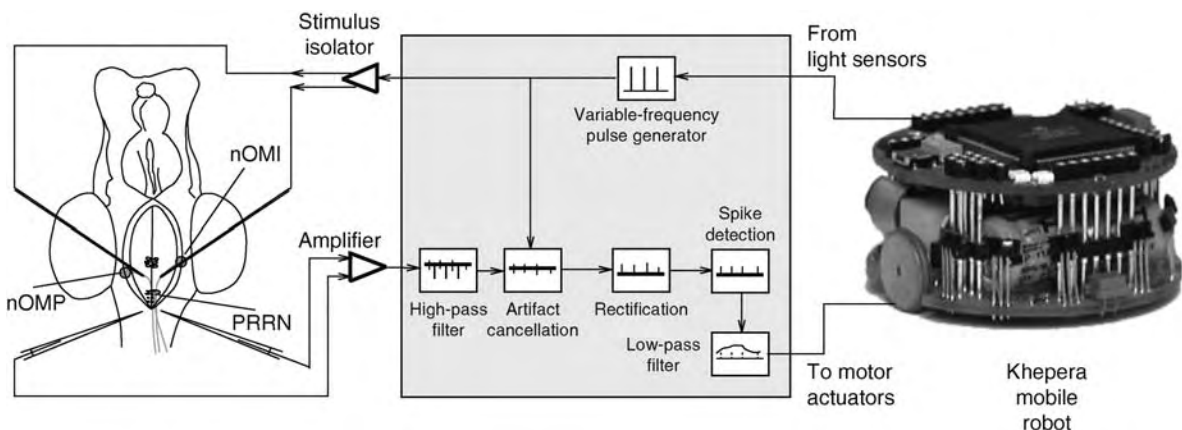

**Computer-Neural Hybrids. Figure 4** Example of an embodied computer-neural hybrid. The (multi-site) electrical activity of is recorded and decoded into a “motor command” which is used to control the artificial actuators. At the same time, the activity of the artificial sensors is coded into a set of stimuli that are delivered to the preparation through a stimulus isolator. The example refers to an experiment [5] in which the brainstem of a sea lamprey was connected to a small mobile robot.

neurons. For instance, hybrid combinations of biological and artificial neurons have been used to study and replicate a circuit involving retinal ganglion cells, ►reticular formation interneurons and thalamocortical neurons. Manipulation of the strength of the inhibitory synapse between the reticular interneuron and the thalamocortical neurons allowed to regulate the correlation between sensory input and thalamic activity, including the functional disconnection observed during sleep. Another example of application of dynamic clamp is the simulation of in-vivo synaptic inputs in an in-vitro slice preparation.

In computer-neural hybrids at population level, the same approach is extended to entire neural populations. Again, the artificial part of the hybrid provides a well-modeled environment for the neural system. For instance, a computer was used to control the dynamic regime of populations of ►culture of neurons [7] in closed-loop, and to induce a transition from synchronized bursting activity into a more sparse spiking behavior, similar to *in-vivo* awake cortical dynamics. Another application demonstrated the feasibility of “teaching” cultured neurons to reproduce a desired, target population activity [8].

BCIs have been investigated mainly as aids to patients with severe neuromuscular impairments (e.g., amyotrophic lateral sclerosis or ►spinal cord injury), but could in principle be used in different contexts. The key element in a BCI is a decoding algorithm, which converts the raw electrophysiological signal into an output that is suitable for controlling the external device. Most EEG-based BCIs require a prolonged learning phase to train subjects to “encode” the desired action into observable changes in their measured neural activity. For instance, subjects may be trained to control the amplitude of their  $\mu$ - or  $\beta$ -rhythms (portions of the EEG signal whose power spectrum is, respectively, in the 8–12 Hz and 18–25 Hz range), to control a cursor on a computer screen in one or two dimensions. State-of-art EEG-based BCIs have been estimated to have a maximum information transfer rate of 5–25 bit/min. Critical elements are the selection of the “relevant” features in the neural signal, i.e. the ones which allow the best selection/discrimination of the different actions, and the psychophysical and cognitive factors that affect the rate of learning for a particular application.

In intra-cortical BCIs, the neural activity of populations of cells in the motor areas of the brain cortex is recorded by means of chronically implanted ►micro-electrode arrays (MEA), and has been shown to be usable for predicting the intended movement and even to control a robot arm in real-time. In particular, the signals recorded from a population of neurons in the rat motor cortex were used to drive a mechanical lever which controlled the release of a food reward [9]. The

same cortical activity observed when a movement of the paw obtained the reward could also be maintained when the same reward was obtained by a movement of the mechanism and with the paw at rest. In experiments with monkeys [10], signals recorded from different motor areas have been demonstrated to predict the intended movement and of mimicking it by means of a robotic arm. Recently, intra-cortical BCIs have been experimented in restoring motor functions in human subjects.

As regards neuroprostheses, the existing implementations range in scope from experimental trials with single individuals, to commercially available devices. ►Cochlear implants are the best known examples of sensory prostheses. Widely used as aids for completely deaf patients, they consist of multi-channel electrodes, implanted in the internal ear and connected to an external processor, which translates and codes sounds into electrical pulse patterns. A similar but much more ambitious family of devices is that of ►retinal implants, for which clinical experimentation is just beginning.

The rationale underlying embodied neural systems is that the dynamic and adaptive properties of neural systems can be understood by looking at their interaction with their external environment, in a bi-directional closed-loop. If such an external environment is artificial, the points of interaction are well determined and therefore the modalities and patterns of interaction are fully observable. Moreover, the environment itself can be manipulated, and the changes in dynamic behavior that result from changes in the environment provide useful information for understanding the neural systems themselves. For instance [6], a bi-directional connection between a ►mobile robot and a lamprey ►brainstem, kept alive in-vitro, was used to investigate the functioning of neurons in the reticular formation, to quantify the complexity of neural dynamics and to investigate the dynamics of adaptation. In a similar application [5], a culture of dissociated neurons was connected to a computer-simulated body. Although they are little more than proofs of concept, embodied neural systems may help understanding how the collective properties of living neurons lead to learning, memory and the coding and processing of information, up to higher-level cognition and “intelligent” behavior.

The technologies enabling the interfacing of parts of the nervous system with artificial devices – electrodes, dedicated hardware for stimulation and recording – will open the way to entirely new approaches for investigating the brain and ultimately interacting with it therapeutically and/or prosthetically. Next-generation neuroprostheses, characterized by massive, possibly bi-directional interaction with the nervous system, would greatly benefit from low-power interfaces that support higher rates of information transfer, and

allow stimulation and recording at multiple sites. Flexible, general interfacing frameworks, possibly based on ►[neuromorphic device](#), will make the development of neuroprostheses cheaper, and more easily adaptable to the needs of individual users. Effective two-way interaction would also enable novel rehabilitation technologies, in which the recorded brain activity could be used to control the patterns of neural stimulation, thus inducing a reorganization of portions of the nervous system.

## References

1. Prinz AA, Abbott LF, Marder E (2004) The dynamic clamp comes of age. *Trends Neurosci* 27:218–224
2. Nicolelis MA (2003) Brain-machine interfaces to restore motor function and probe neural circuits. *Nat Rev Neurosci* 4:417–422.
3. Mussa-Ivaldi FA, Miller LE (2003) Brain-machine interfaces: computational demands and clinical needs meet basic neuroscience. *Trends Neurosci* 26:329–334
4. Wolpaw JR, Birbaumer N, McFarland DJ, Pfurtscheller G, Vaughan TM (2002) Brain-computer interfaces for communication and control. *Clin Neurophysiol* 113:767–791
5. DeMarse TB, Wagenaar DA, Blau AW, Potter SM (2001) The neurally controlled animat: biological brains acting with simulated bodies. *Autonomous Robots* 11:305–310
6. Karniel A, Kositsky M, Fleming KM, Chiappalone M, Sanguineti V, Alford ST, Mussa-Ivaldi FA (2005) Computational analysis in vitro: dynamics and plasticity of a neuro-robotic system. *J Neural Eng* 2:S250–S65
7. Wagenaar DA, Madhavan R, Pine J, Potter SM (2005) Controlling bursting in cortical cultures with closed-loop multi-electrode stimulation. *J Neurosci* 25:680–688
8. Shahaf G, Marom S (2001) Learning in networks of cortical neurons. *J Neurosci* 21:8782–8788
9. Chapin JK, Moxon KA, Markowitz RS, Nicolelis MAL (1999) Real-time control of a robot arm using simultaneously recorded neurons in the motor cortex. *Nat Neurosci* 2:664–670
10. Wessberg J, Stambaugh CR, Kralik JD, Beck PD, Laubach M, Chapin JK, Kim J, Biggs SJ, Srinivasan MA, Nicolelis MA (2000) Real-time prediction of hand trajectory by ensembles of cortical neurons in primates. *Nature* 408:361–365

## Concentration Gradient

### Definition

Denotes spatially distributed differences in the concentrations (parts per volume) of particles in solution.

►[Membrane Potential - Basics](#)

## Concentration Invariance

### Definition

Sensory systems can operate effectively over a very wide dynamic range of stimulus intensities. In the olfactory modality, the same odorant can be unambiguously recognized as the same perceptual entity over a broad spectrum of concentrations, a phenomenon termed concentration invariance.

►[Odor Coding](#)

## Concentric Contraction

### Definition

A period of muscle activity during which the length of the muscle fibers decreases.

►[Energy/Energetics](#)

## Concept

### Definition

Concept (or category) is a discrimination in which stimuli belonging to one concept are discriminated from other stimuli belonging to other concept. In other words, concept discrimination is generalization among all stimuli within a category and discrimination between the categories.

►[Discrimination](#)

## Concepts in Thinking

### Definition

Concepts are the representations that are employed in thinking. Concepts are supposed to be recombinable to a large extent, which accounts for the productivity and systematicity of thought.

►[The Knowledge Argument](#)

## Conceptual Analysis

### Definition

A conceptual analysis in a narrow sense is an investigation into the use of a concept word (for example “knowledge”) with the aim of finding (individually) necessary and (jointly) sufficient application conditions of that word. In a wider sense any investigation aiming at the clarification of a concept can be called a conceptual analysis.

► Knowledge

## Conceptual Role Semantics

### Definition

Conceptual role semantics (CRS), also called functional or inferential role semantics, claims that the meaning of a mental representation is its role in the cognitive economy of the agent, e.g. in perception, thought and decision-making. CRS is a version of the use theory of meaning, which holds that the way expressions are related to one another determines what they mean. The central idea is that the conceptual role of a particular representation is a matter of its causal relations to other states in reasoning and deliberation, and the way the expression combines and interacts with other representations to mediate between sensory inputs and behavioral outputs. It is associated with the functionalist approach to the mind, which characterizes mental states and their contents by their relations to sensory stimuli in terms of their causal interactions with input from the environment, other mental states and behavioral output.

► Theory Theory (Simulation Theory, Theory of Mind)

## Conceptualization

### Definition

Learning or understanding of abstract relations (e.g. more/less, same/different) to form categories, also termed “conceptual categorization”.

► Cognitive Elements in Animal Behavior

## Concha

### Definition

The bowl-shaped portion of the outer ear.

► Hearing Aids

## Concrete Entity

### Definition

Something that exists in space and time; a particular thing, e.g. a particular stone or horse.

► Possible World

## Concussion (Concussio Cerebri)

### Definition

Immediate but transient loss of consciousness due to a blunt impact on the skull or decelerating and accelerating of the brain within the skull. Mild symptoms are “star-struck” dazedness and brief ► [amnesia](#). More severe symptoms include faintness with hypotension, facial pallor, bradycardia, slow pupillary reaction or, at times, brief convulsions.

## Condensation

### Definition

Areas of a propagating sound pressure wave of maximal increased pressure (increase above the static pressure).

► Acoustics

## Conditional Burster

### Definition

A neuron that can generate rhythmic bursting activity in response to an excitatory input, but can only do so under the influence of a specific neuromodulator. Neurons

with endogenous bursting properties have a set of voltage-gated ion channels that enable them to produce oscillations of the membrane potential (i.e. alternating depolarizations and hyperpolarizations), which can drive bursts of action potentials.

However, in conditional bursters whilst these ion channels are present, they can not be activated sufficiently to generate membrane potential oscillations. The appropriate neuromodulator can enhance the function of these voltage-gated ion channels, so that they are able to respond with oscillations of the membrane potential in response to a prolonged excitatory drive.

- ▶ Central Pattern Generator
- ▶ Endogenous Burster

## Conditional Knockout

- ▶ Conditional Transgenics

## Conditional Overexpression

- ▶ Conditional Transgenics

## Conditional Pacemaker Neuron

### Definition

A neuron that generates pacemaker activity only in the presence of a neuromodulator.

- ▶ Bursting Pacemakers
- ▶ Conditional Burster
- ▶ Respiratory Pacemakers

## Conditional Place Avoidance (CPA)

### Definition

Animals learn to avoid a compartment or location that was previously paired with a noxious stimulus.

- ▶ Emotional/Affective Aspects of Pain

## Conditional Somatic Deletion

- ▶ Conditional Transgenics

## Conditional Transgenics

FIONA MANSERGH

Ocular Genetic Unit, Smurfit Institute of Genetics, Trinity College Dublin, Dublin 2, Ireland

### Synonyms

Conditional knockout; Conditional overexpression; Conditional somatic deletion; Recombinase mediated somatic cell mutagenesis; Tetracycline regulated transgenics

### Definition

Transgenesis refers to the genetic modification of an organism via the introduction of foreign or mutated DNA construct(s) not present in the ▶wild type of the species. A conditional transgenic is a genetically modified organism (GMO) in which the ▶transgene can be overexpressed, downregulated or deleted, depending on the presence (or absence) of an enzyme, pharmaceutical or hormonal analogue. In other words, a conditional transgenic contains a mutated gene that can be turned on or off, often in an organ specific fashion, depending on the needs of the investigator.

### Characteristics

#### Transgenic Mice

The first mammalian transgenics involved the introduction of non-native genes via injection of a DNA construct into fertilized mouse oocytes. However, this technology only permitted the addition of genetic material. Moreover, when using the same construct to generate different lines of transgenic mice, it became apparent that expression levels of the transgene could vary wildly. Depending on the genomic location into which the transgene integrated, its expression could be partially or wholly silenced. An advance on this method came with the discovery of mouse ▶embryonic stem cells (ES cells) [1].

### The Basics of Homologous Recombination (Gene Targeting)

Methods of culturing ES cells and of genetically modifying them advanced quickly, leading to the development of ▶homologous recombination, also

known as ►**gene targeting** [2]. Gene targeting relies on the cell's own capacity for recombination. ►**Targeting vectors** are generated, which contain homology to the gene that is to be modified, and one or more selection cassettes, which often encode resistance to a drug of choice (see Fig. 1).

Electroporation of targeting vector DNA results, in a small minority of cells, in a recombination event that integrates the targeting vector DNA into the gene of interest. This event results in ►**heterozygous** mutation of the gene of interest, incorporating drug resistance. Growth of electroporated cells in culture, using selection for drug resistance, should permit the growth of correctly targeted cells only. In practice, however, false positives usually outnumber targeted ES cell colonies and further screening (by long range ►**PCR** and/or ►**Southern blot**) is required in order to identify correctly targeted clones.

Targeted mice are then generated by injection of correctly targeted ES cells into mouse ►**blastocysts** or aggregation of the same cells with mouse ►**morulae**. Resultant hybrid embryos are inserted into the uteri

of ►**pseudopregnant** female mice, and brought to term. ES cells are often derived from agouti (brown) 129 mice (the strain most permissive for the isolation of ES cells). Targeted ES cells are then aggregated with, or microinjected into, embryos derived from a strain with a different coat color (often black C57Bl6/J mice). Resulting offspring have cells derived from both the ES lineage (brown) and the C57Bl6/J embryos (black), are referred to as chimaeras, and are easily identifiable by their mixed coat color. In the event that the ES cells have contributed to the chimaeric ►**germline**, subsequent breeding of these animals with more C57Bl6/J mice will result in some brown offspring (agouti is dominant to black). These are ES derived and approximately 50% will transmit the targeted allele. Crossbreeding of this generation will result in mice homozygous for the mutant gene (unless the mutation is ►**embryonic lethal**).

### The Need for Conditional Mutagenesis

Targeted mutagenesis has revolutionized biology; it has enabled us to study single gene function in mice by

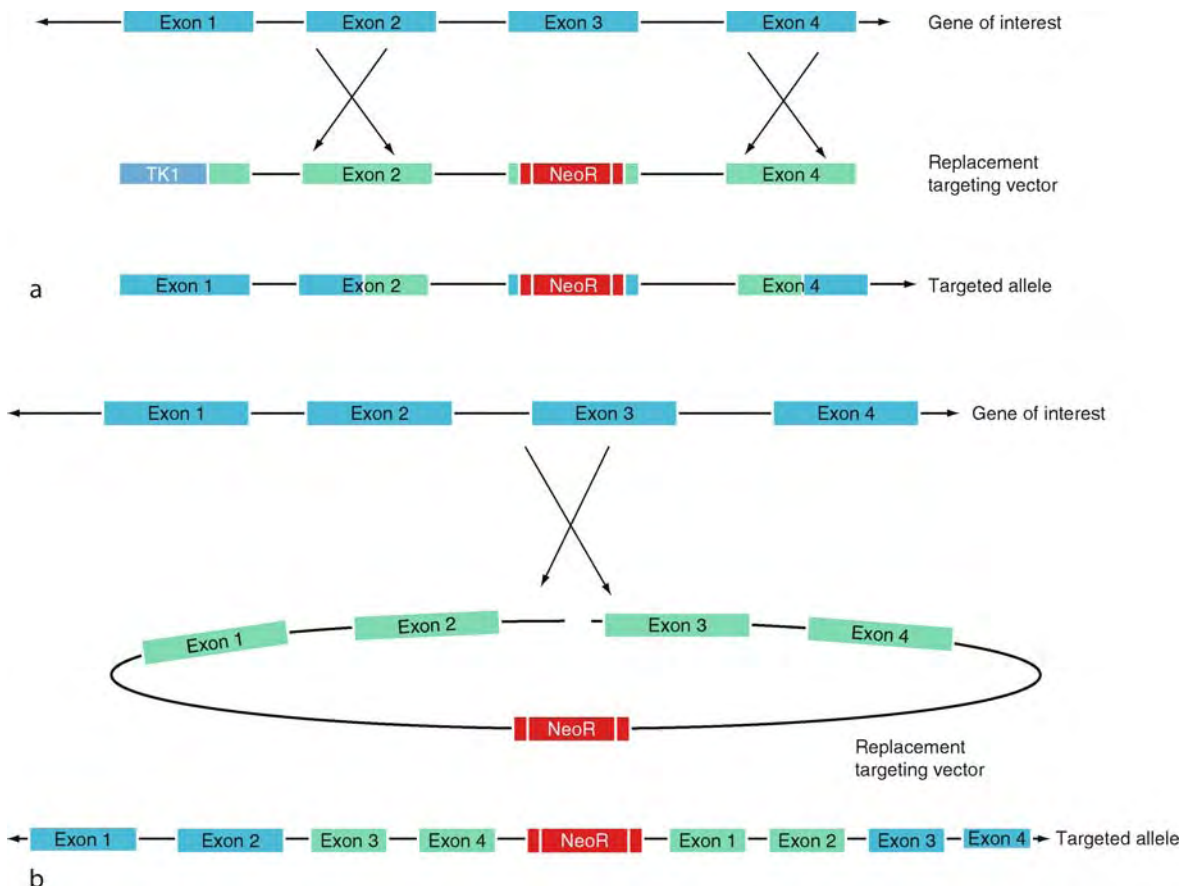

**Conditional Transgenics. Figure 1** Targeting vectors.

introducing precise mutations into the genome, in such a way that their expression is controlled. However, mutated genes are often embryonic lethal and recessive. This means that mice heterozygous for the targeted mutation are asymptomatic, while homozygotes do not survive gestation. While this demonstrates the essential function of that gene in a developmental process, it does not permit study of its function in later developmental events or in adults. This drawback led to the creation of various methods, whereby normal gene expression could be permitted during development, and then switched off in postnatal mice. Furthermore, modeling of disease can also require the overexpression of native genes, or of mutant versions thereof. Methods which can alter expression of a transgene in a temporally controlled and/or organ specific fashion are known collectively as conditional mutagenesis; mutant mice generated thereby are defined as conditional transgenics.

### Conditional Genetic Deletion, Cre/LoxP Mediated Somatic Cell Mutagenesis

This method of conditional mutagenesis relies on the ability of certain recombinases to invert or delete segments of DNA via site directed recombination. Cre and Flp, derived from the P1 bacteriophage and *Saccharomyces cerevisiae* respectively, are most often used for this purpose. Lox P sites are specifically recognized by Cre, while Flp recognizes FRT sites. Both LoxP and FRT sequences are 34bp in length, incorporating two 13bp palindromes separated by an 8bp asymmetric core. DNA strand exchange between two LoxP or FRT sites is mediated by the relevant recombinase and depending on the orientation of the two sites with respect to each other and the number of DNA molecules involved, can result in deletion, insertion, duplication, integration or translocation of DNA sequences [3].

The ►**Cre/LoxP system** is by far the most commonly used, and so will be described in more detail below (Fig. 2).

Conditional mutants are usually generated by introducing LoxP sites on either side of a vital exon of a gene of interest, via ►**homologous recombination**. When 2 LoxP sites are in cis (on the same DNA molecule) and in the same orientation (both 5'-3' or both 3'-5'), their recognition by Cre will result in deletion of the DNA between the two sites. On their own, however, without Cre, these sites (in combination with an intronic selection cassette) should result in a normal phenotype, even in homozygotes. A second, transgenic mouse line can then be generated, which expresses Cre under a tissue specific and/or inducible promoter. Crossbreeding can then be used to generate mice homozygous for the LoxP modified gene and that express Cre in specific cell types or inducibly. The DNA between the LoxP sites is then deleted, either in a tissue/cell specific

manner or inducibly, via administration of a drug. Transgenics expressing Cre under the control of various tissue specific promoters are catalogued at <http://nagy.mshri.on.ca/cre/> (Gfap, synapsin, TH, mlc and En2 mice are available for neuronal Cre expression). Promoters that can be induced by specific pharmaceuticals (e.g., RU486, a progesterone analogue) can also be used to more finely tune the timing of somatic deletion.

Cre/LoxP can also be used to restore gene expression; where a gene has been inactivated by the insertion of LoxP sites, expression of Cre can reduce the number of LoxP sites to one, and remove inserted, mutagenic sequence. This has to be carefully designed such that the remaining LoxP site is neutral with regard to gene expression, and results in the expression of a normal protein however [4].

In addition to organ specific mutagenesis, this system has been used to generate stable germ line mutations and for large chromosomal deletions. In the first instance, the Cre system can be used to generate “cleaner” knockout mutations. Drug selection cassettes can contribute to phenotype and interfere with the interpretation of results. By surrounding the positive selection cassette with Lox P sites in the same orientation, selecting and screening for targeted cells normally and then electroporating a construct that transiently expresses Cre into the cells prior to chimera formation, the cassette can be deleted prior to creation of the knockout line. Targeted ES cell colonies can then be screened for the absence of the resistance cassette.

This technique has the disadvantage, however, that overexpression of Cre in ES cells can result in non-specific recombination, compromising germline transmission of the ES cells [5]. This problem has been neatly overcome by the development of elegant selection cassettes such as pACN, which contains not only a neomycin resistance (neoR) gene, but also Cre recombinase, under the control of a testis specific promoter. Targeted cell lines are selected for and screened in the normal way. Cre is then transiently expressed in the germline of male chimaeras, deleting the ACN construct and itself and thereby limiting the potential for chromosomal damage [6]. The final mutation is an 80+ basepair insertion containing one LoxP site and stop codons in all 3 frames.

A further use of Cre/LoxP technology has been to generate large scale chromosomal deletions. ►**Loss of heterozygosity (LOH)** has long been known to contribute to the pathogenesis of many forms of cancer, moreover, many mental retardation syndromes result from the loss (►**Prader-Willi syndrome** and ►**Angelman syndrome**) or duplication (►**Down syndrome**) of megabases of DNA. Deletions larger than approximately 30kb are now typically achieved by sequential targeting of two LoxP containing vectors with



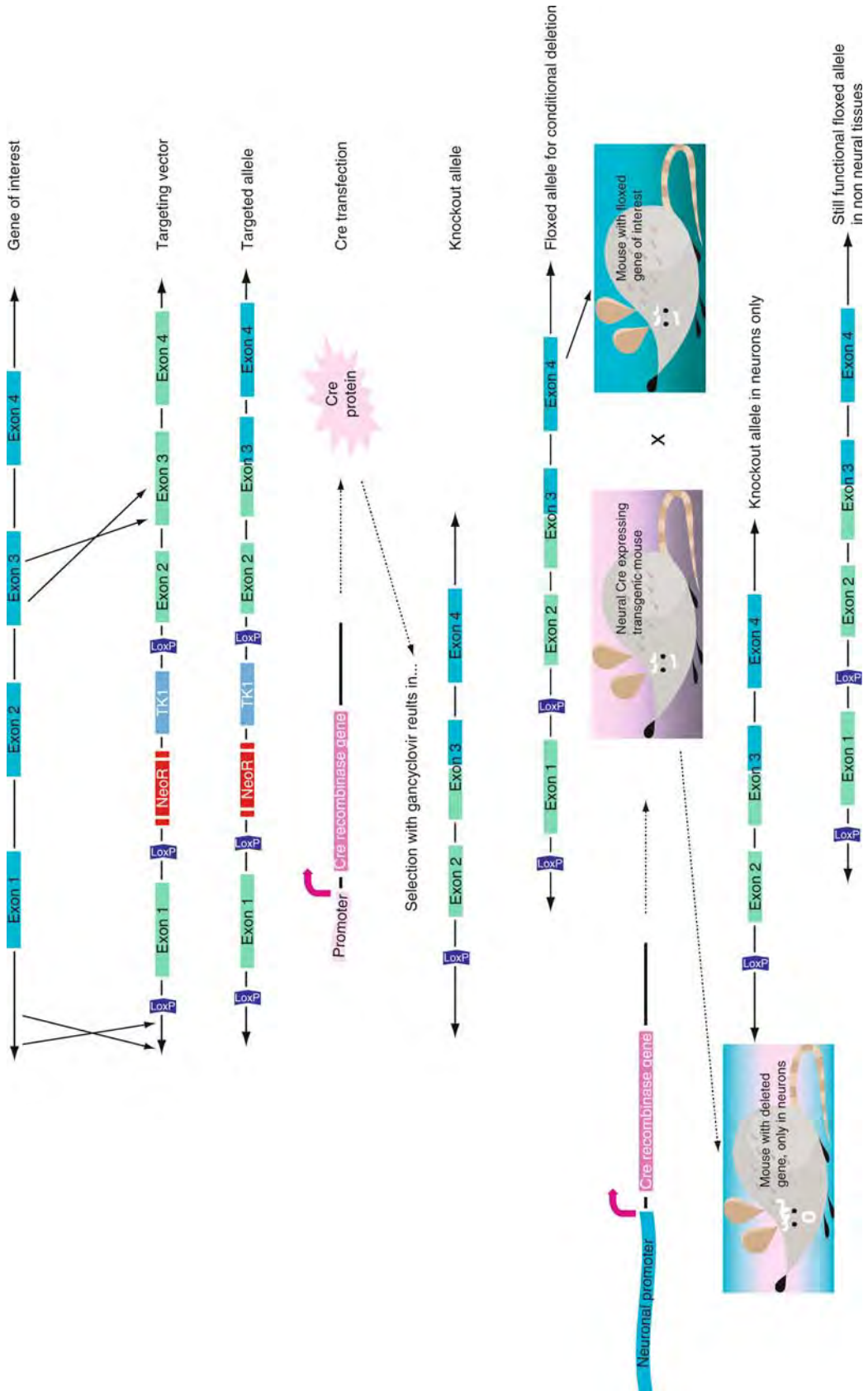

Conditional Transgenics. Figure 2 Cre/LoxP.

different drug resistance on either side of the region to be deleted. This system has been adapted to the genomic era by Allan Bradley and colleagues at the Sanger centre, who have developed a series of paired insertion targeting vectors, the MICER resource, that map all over the genome ([7], <http://www.sanger.ac.uk/PostGenomics/mousegenomics/>). Use of one vector alone can be used for simple gene targeting, should it map within a coding region. Use of 5' and 3' vectors that map within a few Mb of each other can be used to generate large scale deletions. These vector pairs each contain a neoR or puroR cassette, and the 3' or 5' half of an **Hprt minigene**; targeting is carried out sequentially in an Hprt<sup>-/-</sup> ES cell line, such as HM1 or AB2.2. Subsequent electroporation of a transient Cre can be used to mediate recombination between the LoxP sites in the two vectors, which, in the case of a deletion, will re-unite the two halves of Hprt. **HAT selection** can be used to isolate Hprt<sup>+</sup> colonies, some of which should contain the deletion of choice. This system could also be used conditionally, by crossing mice with the desired LoxP sites with those expressing a tissue specific Cre. Furthermore, use of 5' and 3' vectors on the same or different chromosomes could be used to model common disease causing inversions or translocations.

Disadvantages of Cre/LoxP (and Flp/Frt) include the fact that even the most tightly controlled of promoters can be less tissue specific (or biochemically inducible) than is strictly desirable, leading to low level Cre expression (and subsequent mutation), in tissues (or at times) other than intended. Furthermore, Cre driven mutation is often leaky, leading to a mosaic of cells, some of which contain the desired mutation and some of which do not. This has two consequences; firstly, the phenotype may be hypomorphic rather than null, secondly, in tissues that contain stem cells, undeleted stem cells may be selected to replace mutated cells that are possibly dying as a result of gene ablation. In this case, a transient phenotype may be followed by apparent recovery. Cre/loxP also relies on homologous recombination, which presently restricts its use to mice. Homologous recombination has been used to genetically modify bovine fibroblasts, followed by cloning, which has permitted the application of gene targeting to other animal species, holding out the possibility that the Cre/loxP system could be used for conditional mutagenesis. However, the handful of instances in which targeting has been used in sheep and cattle points to the fact that in most cases, technological complexity and cost may be prohibitive [8,9]. Finally, somatic cell deletion creates irreversible modifications to DNA, and is more useful in downregulating gene expression. Systems in which gene expression can be upregulated, or turned on and off repeatedly, are more useful under certain circumstances.

### Inducible Conditional Gene Expression

The tetracycline inducible system, known as Tet on/off, is the most commonly used inducible system (Fig. 3).

This system relies on manipulation of the control of tetracycline resistance gene expression, originally discovered in *E. coli*. The tetracycline resistance gene is constitutively repressed by the tetracycline repressor (tetR). This repressor binds to the tetracycline operator (tetO), a specific sequence in the tetracycline resistance gene promoter, which represses it. When tetracycline is present, it binds to tetR, which is then released from tetO, allowing expression of the tetracycline resistance gene.

This system has been modified for transgenic purposes. A CMV (cytomegalovirus) derived minimal promoter, fused with tetO sequences, is used to control gene expression. Meanwhile tetR has been fused with the activation domains of VP16 (an activator of herpes virus transcription). This results in a protein termed tTA (the tetracycline transcriptional activator), which activates tetO in the absence of tetracycline. Addition of tetracycline (or its analogues, doxycycline or anhydrotetracycline, which are less toxic), results in transcriptional repression, while gene expression can be turned on again once tetracycline has been cleared from the body. This system is known as tetOFF. Mutagenesis of tTA has resulted in reverse tTA (rtTA), which can only bind tetO in the presence of tetracycline (or analogues) and then activates transcription. In this case, addition of tetracycline activates transcription, while its removal results in downregulation (tetON) [3,10].

As with the Cre/LoxP system described above, using TetON/OFF systems in mice requires the crossbreeding of two strains, one carrying the transgene of interest, inserted downstream of the tetO/CMV promoter, and another carrying one of the tTA or rtTA genes (under the control of a tissue specific promoter, if required). Therefore, this system is extremely flexible; gene expression can be turned on or off upon multiple occasions, and can also, if desired, be restricted to certain organs or tissues. There are a number of disadvantages; leaky control of expression, toxicity or tetracycline insensitivity in certain cell types and unstable transcripts. Some tissues are more accessible to doxycycline than others; notably, doxycycline has limited access to the brain [4]. However, this system is highly accessible, owing to its commercial availability.

Similar inducible systems have been developed. One is based on induction of gene expression by ecdysone (which triggers insect metamorphosis), and also requires two lines of mice for activation. Another system uses the native Cyp1a1 enzyme promoter, which is induced by the administration of aryl hydrocarbons (such as indole-3-carbinol), and can be used to drive transgene expression [3]. This system has the advantage

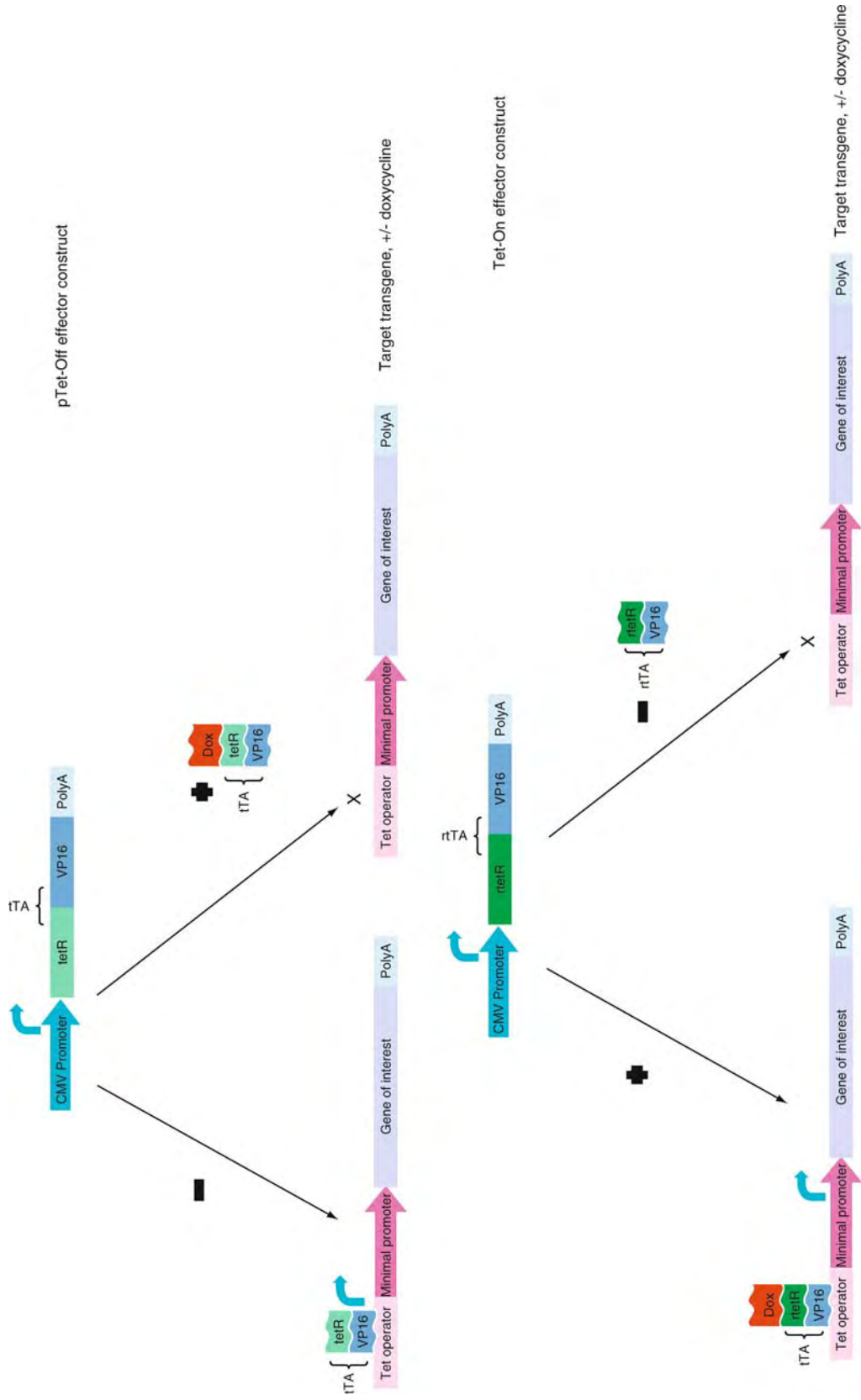

Conditional Transgenics. Figure 3 TetOn/Off.

of only requiring one line of transgenic mice for induction, but has limited tissue specificity. All of these systems rely on transgenic methods, meaning that their application is not limited to mice. However, the downside is that variable transgene expression, depending on the location of insertion in the genome, can affect results. However, the use of insulator sites, which block interaction between cis acting regulatory elements and can be used to protect transgenes from positional effects, can hopefully be used to improve transcriptional consistency [4]. Alternatively, ►knock-in technology, where homologous recombination can be used to place a sequence of interest into a locus with a known expression pattern, can be used effectively.

In conclusion, various options exist by which one can finely tune the expression of both normal and mutant alleles (►Zygosity). These systems have different advantages and disadvantages, but are powerful methods by which gene function can be further elucidated.

## References

1. Evans MJ, Kaufman MH (1981) Establishment in culture of pluripotential cells from mouse embryos. *Nature* 292:154–156
2. Mansour SL, Thomas KR, Capecchi MR (1988) Disruption of the proto-oncogene int-2 in mouse embryo derived stem cells: a general strategy for targeting mutations to non-selectable genes. *Nature* 336 (6197):348–352
3. Ryding ADS, Sharp MGF, Mullins JJ (2001) Conditional transgenic technologies. *J Endocrinology* 171:1–14
4. Lewandoski M (2001) Conditional control of gene expression in the mouse. *Nat Rev Genet* 2(10):743–755
5. Schmidt EE, Taylor DS, Prigge JR, Barnett S, Capecchi MR (2000) Illegitimate Cre-dependent chromosome rearrangements in transgenic mouse spermatids. *Proc Natl Acad Sci USA* 97(25):13702–13707
6. Bunting M, Bernstein KE, Greer JM, Capecchi MR, Thomas KR (1999) Targeting genes for self-excision in the germ line. *Genes Dev* 13(12):1524–1528
7. Adams DJ, Biggs PJ, Cox T, Davies R, van der Weyden L, Jonkers J, Smith J, Plumb B, Taylor R, Nishijima I, Yu Y, Rogers J, Bradley A (2004) Mutagenic insertion and chromosome engineering resource (MICER). *Nat Genet* 36(8):867–871
8. McCreath KJ, Howcroft J, Campbell KH, Colman A, Schnieke AE, Kind AJ (2000) Production of gene-targeted sheep by nuclear transfer from cultured somatic cells. *Nature* 405(6790):1066–1069. Erratum in: *Nature* 2000, 408(6808):120
9. Sendai Y, Sawada T, Urakawa M, Shinkai Y, Kubota K, Hoshi H, Aoyagi Y (2006) Alpha1,3-Galactosyltransferase-gene knockout in cattle using a single targeting vector with loxP sequences and cre-expressing adenovirus. *Transplantation* 81(5):760–766
10. Hickman-Davis JM, Davis IC (2006) Transgenic mice. *Paediatr Respir Rev* 7:49–53

## Conditioned Inhibition

### Definition

This learning occurs when a stimulus (conditioned inhibitor) signals that the outcome (or US) will not occur. The procedure for establishing conditioned inhibition involves training one stimulus (A) as a signal for the outcome and simultaneously training a compound of that stimulus and another stimulus (AX) as a signal for no outcome. X acquires the ability to suppress or inhibit the conditioned response normally elicited by A. The presence of conditioned inhibition is further confirmed by showing that X will transfer its suppressive properties to another stimulus (B) that has been paired with the outcome (summation test) and will resist being trained as a signal for that outcome (retardation test). In these tests, the effect of X is compared to a control stimulus (Y) which was presented alone and with no outcome during conditioned inhibition training.

►Theory on Classical Conditioning

## Conditioned Motivation

### Definition

One of two mechanisms (the other being the enhancing function) by which reinforcers cause changes in future behavior.

►Neuroethological Aspects of Learning

## Conditioned Reflexes

JONATHAN R. WOLPAW, DENNIS J. MCFARLAND  
Laboratory of Nervous System Disorders, Wadsworth Center, New York State Department of Health, Albany, NY, USA

### Definition

The word “reflex” is widely used in neuroscience and in psychology, as well as in every-day life, for different purposes and with different meanings. A definition that encompasses these different uses is: “A reflex is a behavior that reliably occurs at a characteristic latency

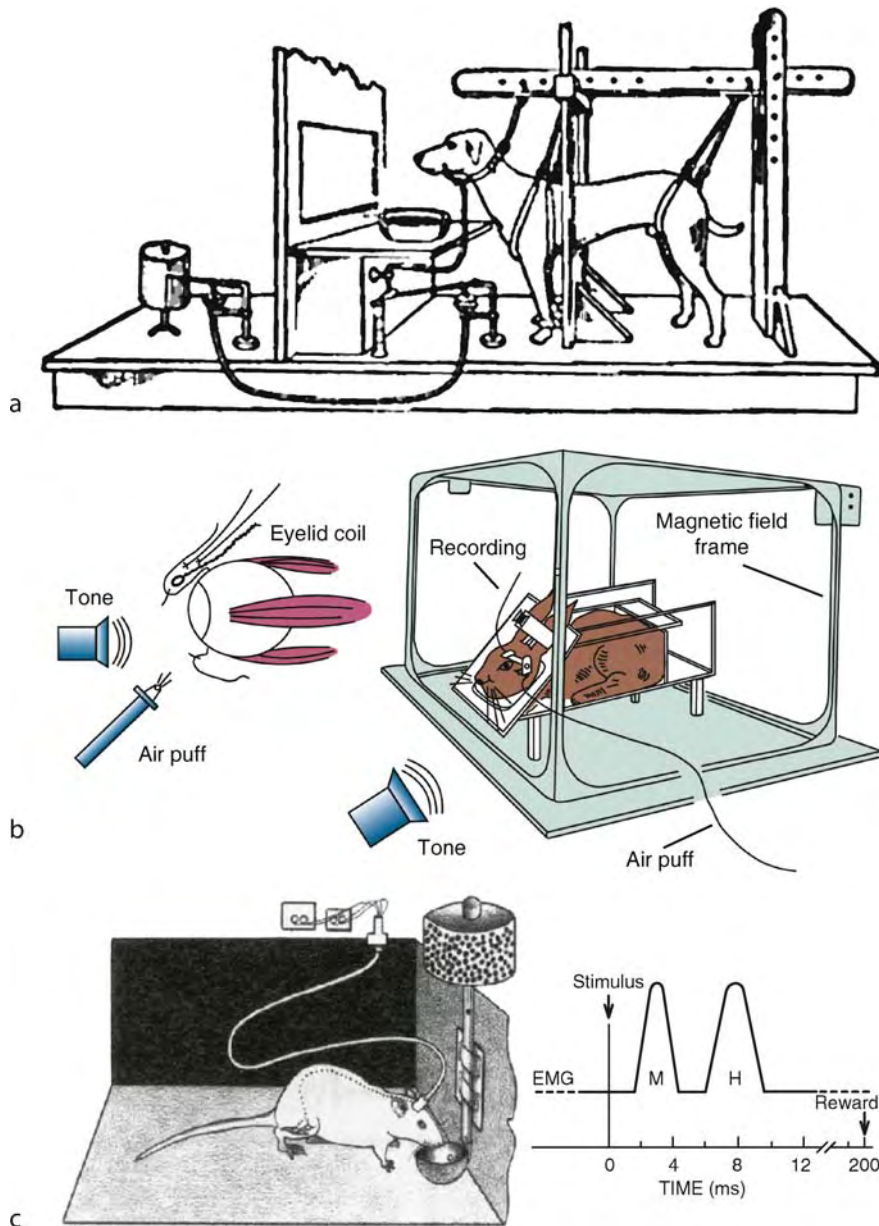

**Conditioned Reflexes. Figure 1** (a) Classical conditioning of salivation in a dog. The apparatus shown is similar to that used by Pavlov to study conditioned salivary reflexes. First, food (the “unconditioned stimulus” or US) is repeatedly preceded by a sound (the “conditioned stimulus” or CS), and elicits salivation (the “unconditioned reflex” or UR). Subsequently, delivery of the sound alone elicits salivation (the “conditioned reflex” or CR). Salivation is quantified by measuring flow rate in a capillary tube inserted in a salivary fistula. (From Yerkes RM, Morgulis S (1909) *The method of Pawlov in animal psychology*. *Psychol Bull* 6:257–273.) (b) Classical conditioning of eyelid closure in a rabbit. First, an air puff delivered to the cornea (the “unconditioned stimulus” or US) is repeatedly preceded by a tone (the “conditioned stimulus” or CS) and elicits eyelid closure (the “unconditioned reflex” or UR). Subsequently, the tone alone elicits eyelid closure (the “conditioned reflex” or CR). Eyelid closure is measured with a search-coil magnetic field technique. (From Delgado-Garcia JM, Gruart A (2006) *Building new motor responses: eyelid conditioning revisited*. *TINS* 29:330–338). (c) **Operant conditioning** of the H-reflex. Soleus EMG is monitored 24 h/day in a rat with chronically implanted electromyographic (EMG) electrodes and a tibial nerve cuff. The implant wires pass subcutaneously to a head-mounted connector and then through a flexible cable and a commutator to amplifiers and stimulator. The rat can move freely about the cage. Whenever the absolute value of soleus EMG stays in a specified range for a randomly varying 2.3–2.7 s period, a nerve-cuff stimulus elicits a threshold M response (i.e., a direct muscle response) and an H-reflex. For the first 10 days, the animal is exposed to the control mode, in which no reward

after a particular stimulus.” Reflexes are typically (though not always) simple behaviors elicited by simple stimuli. Some well-known examples are the knee-jerk reflex, in which sudden muscle stretch causes the muscle to contract, the flexion withdrawal reflex in which a painful stimulus to the skin elicits rapid withdrawal, the pupillary reflex in which a flash of light causes the iris to contract, the salivary reflex in which the taste of food triggers salivation, and the startle reflex in which a loud sound elicits widespread muscle contraction.

These examples, and other reflexes typically present in normal animals or humans, are called “▶unconditioned reflexes (URs).” The stimulus that elicits a UR is called the “unconditioned stimulus (US).” In contrast, a “▶conditioned reflex (CR)” is a reflex that has been created or modified through a particular training, or “conditioning,” experience. For example, a CR may be a behavior that is elicited by a stimulus that did not elicit it prior to the conditioning procedure. In this case, the newly effective stimulus is called a “conditioned stimulus (CS).”

### Characteristics

Historically, CRs have been created by two different kinds of training experiences: “classical” or “Pavlovian” conditioning and “operant” or “instrumental” conditioning. In the past, intense interest in these procedures was motivated by the idea that all forms of learning and complex human behavior could be reduced to these elementary processes [1]. More recently, the prevailing view is that a more complex taxonomy is needed to encompass all forms of ▶associative learning. For example, modifications of sensory cortex by experience may not be readily understood as either classical or operant conditioning. Nevertheless, researchers in the basic neurosciences continue to use them as valuable and tractable paradigms for exploring the biology of associative processes [2–4].

The traditional distinction between URs and CRs has also changed recently. In the past, URs were thought to reflect pre-determined patterns in the central nervous system. More recent views suggest that motor patterns arise through self-organization driven by complex interactions between genetic programs and environmental signals [5]. In association with these developments, the traditional sharp distinction between URs and CRs has broken down. It has come to be seen as a

largely artificial distinction imposed by an experimenter (see below).

B. F. Skinner originally held that operant procedures applied to reflexes of the skeletal motor system and classical procedures applied to reflexes of the autonomic system. It is now clear that the same reflex can be modified by either procedure. The distinction between these two methods is procedural: operant conditioning involves the association of responses and reinforcement while ▶classical conditioning involves the association of stimuli and reinforcement [6].

### Classically Conditioned Reflexes

Classical conditioning originated in Russia with the work of Sechenov and Pavlov. In a classical conditioning procedure, the stimulus that is to become the CS occurs (or begins) just before a US. After repeated presentations of this CS/US pairing, the UR, which previously had been elicited only by the US, can be elicited by the CS alone. When it is so elicited by the CS, it is called a conditioned reflex, or CR. Pavlov conditioned dogs by arranging that the sound of a bell always preceded application of meat powder to the mouth (Fig. 1a). Initially only the meat powder elicited salivation. After a number of such pairings, the dogs began to salivate to the sound of the bell alone.

Different subtypes of classical conditioning are distinguished by the exact relationships between the CS and the US, by whether the CR is an entirely new response to the CS, and/or by other features. Thus, in “delay conditioning” the US begins before the CS ends, while in “trace conditioning” the US does not begin until after the CS ends. In “ $\alpha$ -conditioning” the CR is not an entirely new response to the CS, but is rather an intensification of a response that the CS elicited prior to conditioning. These and other specifics of conditioning procedures are described more fully in Mackintosh [6].

Of critical importance in considering classical conditioning phenomena is the distinction between actual conditioning and other changes in the relationships between stimuli and the responses they elicit. A true CR results only from the repeated pairing (or association) of a CS and a US. When random presentation of the US and CS, or of the CS alone, elicits a CR-like response, the phenomenon is called “pseudoconditioning,” or “non-associative” conditioning.

In the years when conditioning was first defined and explored, there were attempts to interpret all or most

---

occurs and the H-reflex is simply measured to determine the size of the control reflex (the “unconditioned reflex” or UR). For the next 50 days, the rat is exposed to the up-conditioning or down-conditioning mode, in which a food-pellet reward is given if the H-reflex exceeds (up-mode) or falls below (down-mode) a criterion value. Background EMG and M response stay constant throughout. Successful conditioning (i.e., a change in H-reflex size of  $\geq 20\%$  in the rewarded direction) (a “conditioned reflex” or CR) develops in 75–80% of the rats (the others remain within 20% of control H-reflex size). (Modified from Wolpaw JR (1997) The complex structure of a simple memory. TINS 20:588–594.)

behaviors, even the most sophisticated human behaviors, as complex combinations of conditioned reflexes. Although such visions of conditioned reflexes as the basis of all behavior are no longer in fashion, experimental models based on conditioned reflexes play a prominent role in the increasingly reductionistic studies of the mechanisms of learning and memory.

These studies use a variety of different invertebrate and vertebrate models. Extensive studies in the marine snail, *Aplysia*, have clarified the cellular bases of classical conditioning. In the naive animal, a weak tactile stimulus (the CS) delivered to the siphon causes the gill to withdraw, while a painful stimulus (the US) delivered to the tail or head causes the gill to withdraw much more intensely (the UR). If the CS and the US are then paired repeatedly, the  $\alpha$  form of classical conditioning results: the CS comes to elicit intense gill withdrawal (the CR). This conditioning involves plasticity at multiple sites in the central nervous system. Attention has focused on the synapse in the abdominal ganglion between sensory neurons and gill motor neurons. The CR is explained in part by activity-dependent presynaptic facilitation that is specific to the pathway that conveys the CS. The molecular mechanisms of both the short-term and long-term forms of this facilitation are complex, and the long-term form has been linked to changes in gene expression. Full expositions of current understanding of the mechanisms of this ostensibly simple learning are available [7].

Studies in vertebrate models have begun to reveal the specific contributions of different brain regions to classical conditioning. Models based on the eyeblink reflex are widely used. In a typical protocol, the CS is a tone and the US is an air puff to the eye that in the naive animal evokes an eyeblink (the UR) (Fig. 1b). After repeated pairing of the CS and US, the CS alone comes to evoke an eyeblink (the CR). The cerebellar cortex and the interpositus nuclei play key roles in the plasticity underlying development of this CR [8]. Other brain areas may contribute as well. The hippocampus is essential when a trace conditioning protocol is used.

### Operantly Conditioned Reflexes

Operant conditioning originated in Britain and America with Bain, Morgan, and Thorndike [2,3]. In an operant conditioning procedure, the subject is presented with a particular stimulus or placed in a particular situation, and reinforcement, or reward, occurs when a particular response is made. After repeated exposures to this experience, the required response occurs more frequently and thereby increases the number of rewards. The neuronal and synaptic mechanisms of operant conditioning are likely to be even more complex than those now emerging from studies of classical conditioning. These mechanisms are being studied with

model systems that use operant procedures to change simple reflexes.

The ►H-reflex, the electrical analog of the “knee-jerk” reflex, is elicited by direct stimulation of sensory afferent fibers from the muscle spindle, which synapse in the spinal cord on the motoneurons serving the muscle and produce a contraction, the H-reflex. The H-reflex can be operantly conditioned: monkeys, humans, rats, and mice can increase or decrease it when reward is made contingent on its size (Fig. 1c) [9]. H-reflex change begins quickly and then continues at a much slower rate over days and weeks. The early change appears due to cortical influence on the spinal cord, while the gradual change reflects plasticity at multiple sites in the spinal cord that is gradually created by cortical influence. The cerebellum plays a key role. The spinal cord plasticity includes change in motoneuron firing threshold as well as in several synaptic populations. The H-reflex model is revealing how brain and spinal cord interact in a complex hierarchical fashion to produce operant conditioning of a simple reflex.

Model systems for studying the cellular basis of operant conditioning have been developed in several invertebrates. Comparisons of classical and operant conditioning in *Aplysia* have shown that the same biting reflex can be increased by either classical or instrumental conditioning. Furthermore, dopamine serves as the reinforcement transmitter in both forms [7]. Thus, the same neural circuits can be modified by both classical and operant conditioning. This suggests that similar mechanisms underlie both of these forms of associative learning.

### Reflex Conditioning is Important in Normal Life

Reflex conditioning is not limited to the laboratory. The concept of operant conditioning embraces phenomena produced by a wide variety of training experiences different from standard laboratory conditioning protocols. The gradual acquisition of any motor skill can be viewed as an operant conditioning procedure, in which improvements in performance serve as rewards that shape subsequent behavior. This process often includes changes in reflexes. The neuronal pathways responsible for reflexes such as the H-reflex participate in more complex behaviors, including standard motor skills such as posture and locomotion and the most sophisticated athletic and technical skills, as well as in the abnormal motor control associated with spinal cord injuries and other disorders [10]. Both laboratory and clinical studies indicate that reflex changes comparable to those produced by formal conditioning protocols occur as motor skills are acquired throughout life.

Spinally-mediated muscle stretch reflexes and ►flexion withdrawal reflexes, which are poorly focused and often inappropriate in newborn infants, become appropriately

focused during early life (Fig. 2a). This development depends on normal descending control from the brain. Later in life, muscle stretch reflexes and H-reflexes change gradually during skill acquisition (Fig. 2b). Furthermore,

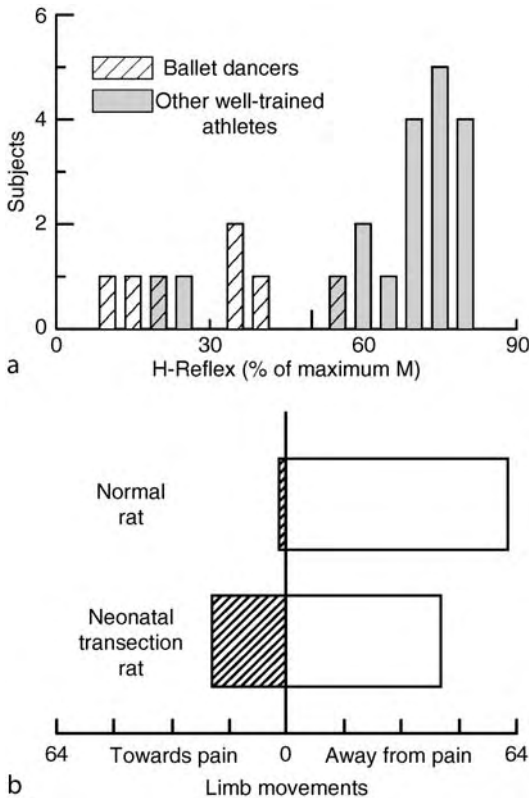

**Conditioned Reflexes. Figure 2** (a) Reflex conditioning associated with skill acquisition. Soleus H reflexes are much smaller in professional ballet dancers than in other well-trained athletes (e.g., runners, swimmers, cyclists). (H-reflexes of sedentary subjects fall in between.) It is likely that these reflex changes facilitate the precise cerebral control and the muscle co-contractions that are required in ballet. (Modified from Nielsen J, Crone C, Hultborn H (1993) H-reflexes are smaller in dancers from the Royal Danish Ballet than in well-trained athletes. *Eur J Appl Physiol* 66:116–121.) (b) Shaping of flexion withdrawal reflexes during development. Direction of limb movement produced by flexion withdrawal reflexes elicited by a nociceptive stimulus in normal adult rats and in adult rats that had undergone spinal cord transection just after birth. Direction is almost always appropriate, i.e., away from the stimulus, in normal adults, but is often inappropriate in transected adults. Neonatal transection prevents the normal shaping of flexion withdrawal reflexes that results from the interactions in the spinal cord of descending activity from the brain and peripheral sensory inputs from the limbs. (Modified from Levinsson A, Luo XL, Holmberg H, Schouenborg J (1999) Developmental tuning in a spinal nociceptive system: effects of neonatal spinalization. *J Neurosci* 19:10397–10403.)

reflex conditioning procedures might be used to help restore more effective function to people with spinal cord injuries or other severe impairments of motor function [9].

In sum, the reflex conditioning phenomena produced in the lab by classical and operant conditioning procedures are part of a broad spectrum of activity-dependent plasticity that plays an integral part in the acquisition and maintenance of motor skills throughout life and in the functional deficits and compensations seen with trauma or disease, and that might contribute to new methods for restoring function to the damaged nervous system.

### All Reflexes are Probably to Some Degree Conditioned Reflexes

Finally, the fact that reflexes are affected by activity-dependent plasticity throughout life (and even in utero) implies that the traditional distinction between unconditioned and conditioned reflexes is merely an artificial distinction imposed by an experimenter. In reality, most and probably all reflexes are conditioned in the sense that they have been shaped by activity. Those traditionally designated as “unconditioned,” such as the normal flexion withdrawal reflex that withdraws a limb from a painful stimulus, are reflexes that have undergone standard conditioning in the course of earlier life, and thus are similar in most normal individuals. In essence, “unconditioned reflexes” are simply reflexes that were conditioned before the experimenter began to observe them.

### References

1. Kimble GA (1961) Hilgard and Marquis' conditioning and learning, 2nd edn. Appleton-Century-Crofts, New York
2. Dudai Y (2002) Memory from A to Z. Oxford University Press, Oxford
3. Domjan MP (2003) The principles of learning and behavior, 5th edn. Thomson/Wadsworth, Belmont, CA
4. Moore JW (2002) A neuroscientist's guide to classical conditioning. Springer, Berlin Heidelberg, New York
5. Forssberg H (1999) Neural control of human motor development. *Curr Opin Neurobiol* 9:676–682
6. Mackintosh NJ (1974) The psychology of animal learning. Academic Press, London
7. Baxter DA, Byrne JH (2006) Feeding behavior of Aplysia: a model system for comparing cellular mechanisms of classical and operant conditioning. *Learn Mem* 13:669–680
8. Thompson RF (2005) In search of memory traces. *Ann Rev Psychol* 56:1–23
9. Wolpaw JR, Chen XY (2008) Operant conditioning of spinal cord reflexes. In: Squire L, Albright T, Bloom F, Gage F, Spitzer N (eds) New encyclopedia of neuroscience. Elsevier, Oxford
10. Wolpaw JR, Tennissen AM (2001) Activity-dependent spinal cord plasticity in health and disease. *Ann Rev Neurosci* 24:807–843



## Conditioned Response (CR)

### Definition

In classical conditioning, the conditioned response (CR) is a response evoked with time by the conditioned stimulus after repetitive pairing with the unconditioned stimulus. The CR is similar to the response evoked by the unconditioned stimulus.

► Classical Conditioning (Pavlovian Conditioning)

## Conditioned Stimulus (CS)

### Definition

In classical conditioning, the conditioned stimulus (CS) is a neutral stimulus at first and come to evoke a response (conditioned response) similar to the response (unconditioned response) evoked by the stimulus (unconditioned stimulus) that has been repetitively paired with the CS.

► Classical Conditioning (Pavlovian Conditioning)  
► Conditioned Taste Aversion

## Conditioned Taste Aversion

TAKASHI YAMAMOTO  
Department of Oral Physiology, Graduate School of  
Dentistry, Osaka University,  
Osaka, Japan

### Synonyms

Taste learning; CTA

### Definition

A kind of classical (Pavlovian) conditioning or association learning in which animals acquire an aversion to a tastant (conditioned stimulus, CS) that was followed by aversive internal symptoms induced by a toxic substance (unconditioned stimulus, US).

Conditioned taste aversion (CTA) is also a kind of fear learning to avoid subsequent intake of the “harmful” food by exhibiting aversive behavior to the taste of the food. Thus, CTA is a robust defense device

protecting animals against repeated consumption of toxic food [1]. When saccharin is used as a CS, the sweet and palatable taste is treated as an aversive taste after CTA acquisition. The quality itself may not change, while the perceived intensity may be enhanced to facilitate detection of the harmful substance, and a hedonic shift from positive to negative occurs. CTA is encountered at all levels of evolution, with similar forms of food aversion learning found in vertebrate and invertebrate species.

### Characteristics

In a typical paradigm to establish CTA in laboratory animals such as rats and mice, the animals mildly deprived of water are allowed to drink a novel palatable solution, e.g., 5 mM Na–saccharin as the CS for 20 min, followed soon by an intraperitoneal injection of 0.15 M LiCl (2% volume of the body weight), which is known to induce internal malaise as the US [2]. On the test day after 1-day recovery period, if the animals avoid ingesting the CS and/or show aversive reactivities to the reexposure to the CS, we can judge that the animals have acquired CTA to the CS.

CTA is a rapidly established and robust phenomenon and has the following characteristics that are not found in other forms of classical conditioning [3]: (i) robust CTA can be established after only one pairing of a CS that is followed by an US, (ii) successful CTA can develop after delays of as long as several hours between exposure to the CS and delivery of the US, and (iii) the association between the CS and the US can proceed under deep anesthesia.

### CTA as a Tool in Taste Research

Since CTA is considered to involve functions of the higher nervous system, the formation of CTA can be utilized as a tool to assess the functions of the higher gustatory centers. For example, the localization of a suggested cortical taste area of rat and hamster by the electrophysiological and anatomical methods was verified behaviorally using this technique, i.e., lesions of the relevant area disrupted the formation of CTA.

After acquisition of CTA, the animals remember the taste of the CS to show aversive responses to the CS, and this aversion is generalized to other taste stimuli with the similar taste. Therefore, examination of the generalization of CTA is an efficient method for determining how mammals classify taste stimuli. It is demonstrated that rats and hamsters categorize taste stimuli into four types corresponding to the four basic taste qualities such as sweet, salty, sour, and bitter, and mice (C57BL strain) can categorize the taste of monosodium glutamate into the fifth type corresponding to umami in humans. Such a behavioral categorization is utilized to elucidate the validity of neural coding hypotheses of taste quality such as the across-neuron response pattern theory and labeled-line theory [4].

### Neural Substrate of CTA

Electrophysiological, behavioral, pharmacological, and *c-fos* immunohistochemical studies have suggested brain regions responsible for the formation of CTA. A variety of brain regions including the parabrachial nucleus, amygdala, insular cortex, supramammillary nucleus, paraventricular thalamic nucleus, nucleus accumbens, and ventral pallidum are involved in different phases of CTA acquisition and expression. Concerning the role of amygdala, the enhanced taste sensitivity to facilitate detection of the CS may originate in the central nucleus of the amygdala (CeA), and the hedonic shift, from positive to negative, may originate in the basolateral nucleus of the amygdala (BLA) [5]. In accordance with this notion, although the previous studies have yielded inconsistent behavioral results, overall electrolytic or excitotoxic lesions show little, if any, involvement of the CeA in CTA, whereas the lesions of the BLA in many cases disrupted or attenuated CTA. The BLA may also play an important role in CS-US association and formation of fearful emotion, and this nucleus is suggested to be involved in neophobia requisite for CTA formation [6]. Recent studies have been demonstrating that the reward system including the ventral tegmental area, nucleus of accumbens, and ventral pallidum, which is known to play a mediating role in the rewarding effects of reward (e.g., drugs, food intake) also plays a role in CTA [5,7].

Although the hippocampus plays minor role in the acquisition of CTA, it has been suggested to mediate the effects seen in the aged animal. Rats show compromised effects (e.g., blocking and context learning), strengthened effects (e.g., long-delayed learning), and no effects (e.g., latent inhibition) with ageing. Many of these effects can be produced by hippocampal lesions, suggesting that changes in the hippocampus with ageing may mediate the effects seen in the aged animal [8].

### Molecular Mechanism of CTA

With the advantage of the characteristics of CTA as described above, CTA has been chosen as a good model for the study of molecular and biochemical mechanisms of plasticity and learning. It is conceivable that the CS presentation induces the formation of a short-term taste memory and that it is this trace that associates with the malaise-inducing US. The activation of muscarinic and glutamate receptors in the insular cortex and amygdala is crucial during the acquisition of CTA. This activation might be modulated by other neurotransmitter systems including the noradrenergic system [9]. Inhibition of protein synthesis with anisomycin in the insular cortex before and during CTA disrupts long-term but not short-term taste memory, indicating that the formation of CTA has a protein-synthesis-dependent phase. Concerning the biochemical level of the long-term taste memory, CTA is associated

with changes in the phosphorylated state of several proteins, including extracellular regulated kinase and the 2B subunit of the NMDA receptor [10].

### References

1. Garcia J, Kimmeldorf DJ, Koelling RA (1955) Conditioned aversion to saccharin resulting from exposure to gamma radiation. *Science* 122:157–158
2. Yamamoto T, Fujimoto Y, Shimura T, Sakai N (1995) Conditioned taste aversion in rats with excitotoxic brain lesions. *Neurosci Res* 22:31–49
3. Bures J, Bermudez-Rattoni F, Yamamoto T (1998) Conditioned taste aversion: memory of a special kind. Oxford University Press, Oxford
4. Yamamoto T, Yuyama N, Kato T, Kawamura Y (1985) Gustatory responses of cortical neurons in rats. III. Neural and behavioral measures compared. *J Neurophysiol* 53:1370–1386
5. Yamamoto T (2007) Brain regions responsible for the expression of conditioned taste aversion in rats. *Chem Senses* 32:105–109
6. Reilly S, Bornovalova MA (2005) Conditioned taste aversion and amygdala lesions in the rat: a critical review. *Neurosci Biobehav Rev* 29:1067–1088
7. Ramirez-Lugo L, Nunez-Jaramillo L, Bermudez-Rattoni F (2007) Taste memory formation: role of nucleus accumbens. *Chem Senses* 32:93–97
8. Manrique T, Moron I, Ballesteros M, Guerrero R, Gallo M (2007) Hippocampus, ageing, and taste memories. *Chem Senses* 32:111–117
9. Bermudez-Rattoni F (2004) Molecular mechanisms of taste-recognition memory. *Nat Rev Neurosci* 5:209–217
10. Rosenblum K, Berman DF, Hazvi S, Lamprecht R, Dudai Y (1997) NMDA receptor and the tyrosine phosphorylation of its 2B subunit in taste learning in the rat insular cortex. *J Neurosci* 17:5129–5135

## Conditioning

### Definition

Conditioning is method to train animals. One type of conditioning is respondent conditioning (classical or Pavlovian conditioning), in which a conditioned stimulus (CS) is paired with an unconditioned stimulus (UCS), which elicits behavior called the respondent or unconditioned response (UR). By conditioning or pairing CS with UCS, the CS begins to elicit conditioned response (CR). The other type of conditioning is operant conditioning (or instrumental conditioning) in which the outcome (reinforcement or punishment) of the behavioral response (operant) modifies the operant. A typical operant chamber for a rat is a small box with lever(s) and a food pellet dispenser. When the rat presses the lever, the dispenser

provides a food pellet. As a result, the rat learns to emit the lever-press behavior (operant) to get the food.

- ▶ Classical Conditioning (Pavlovian Conditioning)
- ▶ Operant Conditioning (Instrumental Learning)

---

## Conditioning Lesion

### Definition

One of two injuries, usually with a short period of time in between. The second injury “builds” upon the first one, and, as a result, the growth activity of the injured nerve cell is amplified.

- ▶ Neuronal Changes in Axonal Degeneration and Regeneration

---

## Conductance (Electrical)

### Definition

Conductance (electrical) is the measure of the ability of an electric circuit to conduct electricity and is the reciprocal of electrical resistance.

- ▶ Cable Theory
- ▶ Action Potential
- ▶ Membrane Potential: Basics
- ▶ Ohm’s Law

---

## Conductance-based Model

### Definition

A single-point neuron model taking into account ionic current flow through membrane channels of different types.

- ▶ Neural Networks

---

## Conduction Aphasia

### Definition

Also called Central Aphasia; Conduction aphasia results from lesions of the ▶ *arcuate fasciculus*, which

connects ▶ *Wernicke’s area* with ▶ *Broca’s area*, and is characterized by a severe deficit in repetition of what is heard or read, despite normal auditory comprehension, verbal fluency (which may be paraphasic) and writing.

- ▶ Broca’s Area
- ▶ Wernicke’s Area

---

## Conduction Velocity

### Definition

Velocity of action potential propagation along a nerve or muscle fiber.

- ▶ Action Potential Propagation

---

## Conductive Hearing Loss

### Definition

Hearing loss due to pathology of the outer and/or middle ear.

- ▶ Hearing Aids

---

## Cone

### Definition

Photoreceptor specialized for daylight vision, color and high acuity.

- ▶ Evolution of the Visual System: Mammals – Color Vision and the Function of Parallel Visual Pathways in Primates
- ▶ Photoreceptors

---

## Cone Opponent

### Definition

Wavelength-selective property of neural responses or human performance, produced when functional input

from one cone type is inhibited or “opposed” by input from a different cone type. Cone opponent neurons are typically excited by some wavelengths of light in the visible spectrum and inhibited by others.

- ▶ Color Processing
- ▶ Photoreceptors
- ▶ Retinal Color Vision in Primates

## Cone Pedicle

### Definition

Complex synaptic terminal of a cone photoreceptor that makes synapses with cone bipolar and horizontal cells.

- ▶ Photoreceptors
- ▶ Inherited Retinal Degenrations
- ▶ Retinal Bipolar Cells

## Cone Photoreceptor

### Definition

Cone-shaped photoreceptor cells of the vertebrate retina responsible for color vision under bright light. Based on peak spectral sensitivity, human cone cells are of three types; short wavelengths of light (437 nm), medium wavelengths of light (533 nm) or long wavelengths of light (564 nm).

- ▶ Photoreceptors

## Confabulations

### Definition

Faked and wrong reports and tales based on memory gaps and wrong memories with subsequent misinterpretations and inventions may occur within the ▶ amnesic syndrome (▶ Wernicke-Korsakoff syndrome), and as a result of various brain damages (arteriosclerosis, ▶ progressive paralysis (loss of muscle strength), brain injuries, alcoholism, poisoning).

- ▶ Wernicke-Korsakoff Syndrome

## Configural/Configurational

### Definition

Both terms are used as synonyms for synthetic odor mixture qualities.

- ▶ Olfactory Information

## Congenital Indifference to Pain

### Definition

Nav1.7-related congenital inability to experience pain is a very rare, autosomal recessive trait. These patients do not produce functional Nav1.7 channels and do not experience pain from normally painful acts such as inserting sharp objects in their hands or after bone fracture, tongue and lip biting, or walking on hot surfaces (burning coal). Heterozygous parents are asymptomatic suggesting that loss of functional Nav1.7 on one allele does not lead to haploinsufficiency.

- ▶ Voltage-gated Sodium Channels: Multiple Roles in the Pathophysiology of Pain

## Congenital Malformation

### Definition

Anatomical disorders with which the patient is born. Some congenital disorders are inherited.

## Congruent Taste and Smell

### Definition

Taste and smell that fit well together. Taste and smell usually encountered together in food in daily life.

- ▶ Flavor

## Conjugate Eye Movements

### Definition

These rotate the lines of sight of both eyes by the same amount and in the same direction (pure version as

opposed to vergence). They result from an equal innervation of functionally yoked pairs of extraocular muscles (e.g., right abducens and left medial rectus) emanating from a common source (Hering's law) and can be saccadic or smooth in nature; during saccades the coupling is not rigid, though, causing transient changes in vergence.

- ▶ Hering's Law
- ▶ Oculomotor Control
- ▶ Saccade, Saccadic Eye Movement
- ▶ Vergence Movements

---

## Conjunction Errors

### Definition

A mixture of details from different experiences, fused in memory.

- ▶ Memory Distortion

---

## Connectionism

DENIS MARESCAL, NADJA ALTHAUS  
Centre for Brain and Cognitive Development,  
Birkbeck, University of London, London, UK

### Synonyms

Artificial neural networks; Neural computation

### Definition

Connectionist models are computer models loosely based on the principles of neural information processing [1–3]. These typically take the form of artificial neural network simulations that embody general principles such as inhibition and excitation within a distributed, parallel distributed processing (PDP) system. The key idea is that of collective computation; although the behavior of the individual units in the network is simple, the behavior of the network as a whole can be very complex. They remain high-level information processing models and are not intended to model the functioning of individual neurons. They are intended to strike the balance between importing some of the key ideas from the neurosciences while maintaining sufficiently discrete and definable components to allow questions about behavior to be

formulated in terms of a high-level cognitive computational framework.

### Characteristics

#### The History of Connectionism

McCulloch and Pitts first proposed in 1943 that networks of simple neuron-like processing units could compute logical functions. Later, Hebb's theories of associative neural learning provided the basis for implementing learning in such artificial neural networks. The main concept behind this form of learning is that the connection between two units is strengthened according to the frequency with which both units are co-active. In the late 1950s, Rosenblatt developed the first neurocomputer (called a ▶perceptron) consisting of a simple neural network with a simple input and output layer. However, in 1969 Minsky and Papert [4] revealed that such networks were severely limited and could only compute linearly separable functions. In the late 1970s and early 80s new interest in the field was raised by the establishment of new, powerful learning algorithms for more complex models. These include the work by Hopfield, equating learning in connectionist nets to physical energy models, as well as Kohonen, who established models of self-organization. Another milestone of connectionist modelling research around that time was the emergence from the PDP (Parallel Distributed Processing) Research Group around Rumelhart and McClelland [1] who applied neural network principles to the understanding of cognitive functions. The discovery of the ▶backpropagation learning algorithm allowed multilayered networks to be trained and enabled an escape from the limitations previously raised by Minsky and Papert. A more detailed historical perspective can be found in [5].

#### Processing Principles in Connectionist Models

Connectionist models consist of a number of simple processing units with weighted connections between them, similar to an idealized network of neurons. Activation flows from unit to unit via the connections. A unit becomes active when the activation flowing into it is either larger than a threshold value or when it falls within a certain range. Typically, activation is taken to represent the average firing rate of the unit and processing proceeds through discrete time steps in which the activation of all units is updated. However, some networks incorporate real-time dynamics into their models. In such cases, unit activation is computed according to a differential equation relating the change in activation level of a specific unit to its net incoming activation and any loss of signal that naturally occurs over time. Such real-time units are sometimes called ▶leaky integrate and fire units.

Learning consists in adjusting the weights of the connections between the units. In *feedforward* networks

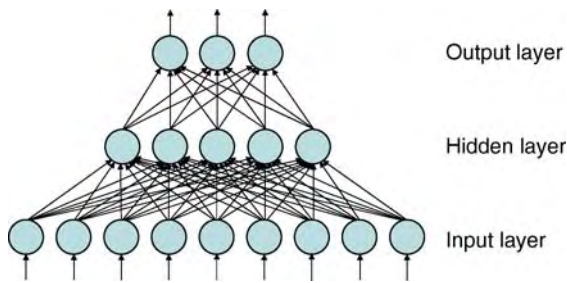

**Connectionism. Figure 1** A fully connected feedforward network with three layers of units: nine input units, four hidden and three output units. All connections (indicated by *arrows*) lead from lower to higher layers.

(Fig. 1), information is first encoded as a pattern of activation across the bank of input units.

That activation then filters up through a first layer of weights until it produces a pattern of activation across the band of hidden units. The pattern of activation produced across the hidden units constitutes an internal re-representation of the information originally presented to the network. The activation at the hidden units continues to flow through the network until it reaches the output layer. The pattern of activation produced at the output units is taken as the network's response to the initial input. *Recurrent* networks allow information to flow backwards such that later stages of processing feedback to influence ongoing lower levels of processing. The introduction of recurrent, feedback connections implements a form of memory that enables the network to process temporal information [6] such as that necessary to process language (Fig. 2).

### Learning in Connectionist Networks

There are four basic modes of training a connectionist network. In ► **supervised learning**, an external teaching signal is provided. The network gradually learns to associate a given input with this teaching signal by computing the discrepancy between its output and the teaching signal and adjusting the connection weights so as to minimize this discrepancy. The most frequently used algorithm for multilayer feedforward networks is backpropagation [1]. In this procedure, the sum of squared difference (output error) between a desired output (obtained from the teaching signal) and the actual output produced is propagated backwards through the net so that the weights of those connections that do not lead directly to the output layer can be adjusted appropriately. Because there is little biological evidence in support of error backpropagation, recent algorithms have tried to implement more biologically plausible forms of supervised learning. In ► **unsupervised learning** there is no teaching signal, and the task of the network is often to detect similarities between different inputs or to cluster the input data. Weights are

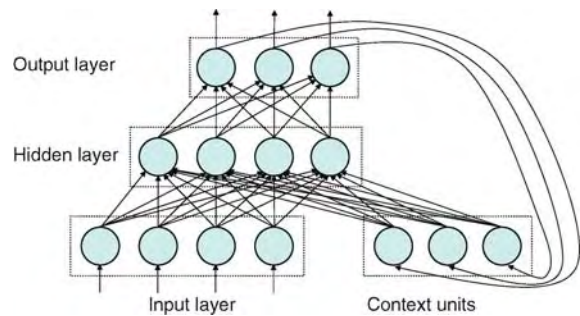

**Connectionism. Figure 2** A recurrent network: the hidden units receive input from both the input layer and the context nodes, which represent the output from previous steps.

adjusted until some internal constraint is satisfied. Kohonen maps, or self-organizing maps (SOMs), are common examples of unsupervised networks (Fig. 3).

In *reinforcement learning* there is no direct teaching signal but only feedback (reward) about the success of a task performed by the network. Finally, *self-supervised learning* is similar to supervised learning, but here the teaching signal is generated by the network itself rather than being external.

### Constructivist Connectionist models

One extension to the classical PDP model architecture is to let the network grow its own architecture as it learns. So-called “constructivist” networks start out with a very small number of units. This minimal network is trained until performance no longer improves. Once this point is reached, the existing architecture is adapted by adding new units and connections, or in some cases pruning existing structures. Cascade Correlation, illustrated in Fig. 4, is a wide-spread variant of this constructivist paradigm.

Such networks are particularly good at modelling cognitive development, in which the gradual accrual of cognitive capacity is an integral part of development [7]. In such models, the growing of new processing units is not taken to correspond to neurogenesis, but is interpreted at a more abstract level as relating to the construction of a network structure on the basis of adaptive learning.

### Examples of Connectionist Models

Connectionist models have had most impact in the domains of language (where they challenged traditional notions of Chomskyan linguistics) and cognitive development (where they provided tangible process models for how development could occur). Perhaps the most well-studied example of such models is in the acquisition of the English past tense. Regular English verbs can be put in the past tense by adding the suffix “-ed” to the end of a verb root, while irregular past tense forms are constructed in a different way. The pattern of

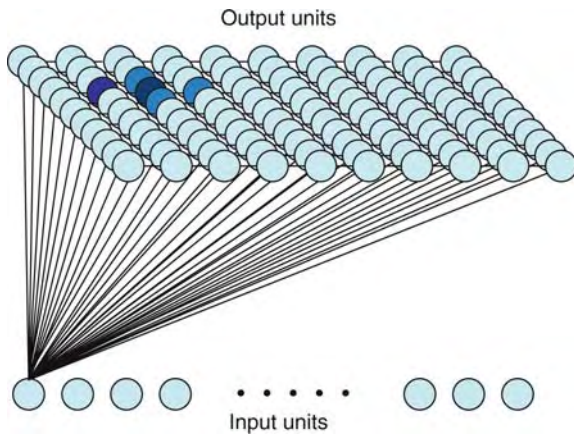

**Connectionism. Figure 3** Unsupervised learning: in self-organizing maps, an active unit partly distributes its activation to its neighbors. Eventually clusters of units emerge, representing a topological map of the input.

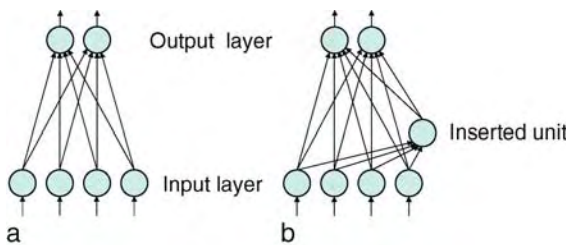

**Connectionism. Figure 4** A constructivist network: (a) the first stage, with the original set of only input and output units, (b) after inserting an additional unit.

errors observed in children learning the past tense had lead researchers to argue that the past tense was acquired through the formation of morphological rules. A series of connectionist simulations [1,2] showed that rule following was an emergent epiphenomenon and that learning in a parallel distributed system was a much more accurate reflection of how children learned the past tense.

Connectionist models have also been used to construct explanatory models of acquired disorders such as some forms of dyslexia [8]. Here connectionist models were trained to process written words and output their meaning. Once trained, they were damaged in different ways. Depending on where the damage occurred, the models reproduced error patterns observed in either deep dyslexics or surface dyslexics, suggesting that there was a single unified processing model that could account for a range of different reading disorders. More recently, connectionist models have also been used to explore the effects of damage occurring at different points during development on the ability to recover from a range of developmental disorders.

### Limitations of Connectionist Models

Feedforward connectionist networks have been shown to be universal approximators in the sense that, given an unlimited number of units, for any continuous input–output function there exists a network topology that can approximate it. However, while such an architecture may exist, there is no guarantee that the learning algorithms used to train networks will be able to discover it. Thus, connectionist networks are not universal learners. Indeed, many of the problems associated with connectionist networks relate to learning. The first problem is common to all statistical learning procedures: given a certain set of training data, i.e., inputs with associated teaching signal, the network may learn to perform perfectly on these, but still fail to generalize to novel data. This is known as **overfitting**: the function learned by the network is too specific. Overfitting can generally be avoided by providing a sufficiently large training set, or by refraining from extensive amounts of training. *Error minimization* is a second problem specific to the training algorithm. Mathematically, **gradient descent** algorithms such as backpropagation attempt to find a set of connection weights such as to minimize the network’s output error. Because they approach this minimum by making small, local changes to the overall setting of weights, this may result not in the global, but merely a local minimum of error (i.e., a partial solution that goes some way to solving the problem but is inconsistent with the full solution). In that case, network performance may fail to improve after some amount of training, despite the existence of a better setting. A third problem is **catastrophic interference** [9] in which a task currently being learned overwrites previous learning. As network weights are adjusted to improve performance on a new task, performance on a previous task that relied on the old set of weights decreases, often catastrophically.

One solution to the problem of catastrophic interference has been to propose a dual systems approach to knowledge accrual [10]. This approach posits that one function of *cortico-hippocampal interplay* is to overcome catastrophic interference in cortical neural networks. The neocortex is presumed to be a slow learning system with sensory input as well as indirect input via the hippocampus. The hippocampus is a fast learning system that develops internal representations over a much smaller time window from direct sensory input. It then provides a training signal used for gradual learning in the neocortex. Thus, although the hippocampal system is susceptible to catastrophic interference, learning in the neocortex is resistant to interference thanks to the gradual interleaved training signal coming from the hippocampal system.

Finally, connectionist models fail to capture the apparently systematic and compositional nature of conceptual and linguistic knowledge available to

human adults. Processing in connectionist networks is inherently context dependent. The meaning of any individual unit depends on the state of other units that may be active in the network at the same time. This does not appear to be the case in human conceptual systems in which elementary conceptual tokens can preserve their meaning over and above what other tokens may be present [2]. However, while representations in connectionist networks do not normally show compositionality and systematicity, it remains an open question whether human cognition really does.

### Acknowledgements

This work was supported by European Commission grants NEST-029088 (ANALOGY) and MEST-CT-2005-020725.

### References

1. Rumelhart DE, McClelland JL (1986) Parallel distributed processing: exploration in the microstructure of cognition, vols I and II. MIT, Cambridge, MA
2. Elman JL, Bates EA, Karmiloff-Smith A, Johnson MH, Parisi D, Plunkett K (1996) Rethinking innateness: connectionism in a developmental framework. MIT, Cambridge, MA
3. McLeod P, Plunkett K, Rolls T (1998) Introduction to connectionist modelling of cognitive processes. Oxford University Press, Oxford
4. Minsky M, Papert S (1969) Perceptrons. MIT, Cambridge, MA
5. Anderson JA, Rosenfeld E (eds) (1988) Neurocomputing: foundations of research. MIT, Cambridge, MA
6. Elman JL (1990) Finding structure in time. *Cogn Sci* 14:179–211
7. Shultz TR (2003) Computational developmental psychology. MIT, Cambridge, MA
8. Hinton GE, Shallice T (1991) Lesioning an attractor network: investigations of acquired dyslexia. *Psychol Rev* 98:74–95
9. French RM (1999) Catastrophic forgetting in connectionist networks. *Trends Cogn Sci* 3:128–135
10. McClelland JL, McNaughton BL, O'Reilly RC (1995) Why there are complementary learning systems in the hippocampus and neocortex: insights from the successes and failures of connectionist models of learning and memory. *Psychol Rev* 102:419–457

## Connectionist Architecture

### Definition

A cognitive system has a connectionist architecture if its cognitive processes or its intelligent behavior does not rely on structure-sensitive manipulations of symbols,

but on the activity of parallel distributed neural networks.

### ► Representation (Mental)

## Conscious Perception

### Definition

The reportable content of perception. A sensory stimulus has a better chance of reaching consciousness when attention is focused on it. While most of our thoughts and actions are guided by conscious perception, unconscious perception may nonetheless affect the quality of human performance and emotion.

### ► Attention

### ► Perception

## Consciousness, Intentional

### Definition

A person has intentional consciousness when she is living through a mental episode that is characterized by a certain content, i.e. by something the episode is of or about. Perceptual episodes are of or about particulars, while thoughts have propositional contents (Propositional attitudes). Phenomenologists insist that intentional consciousness is intrinsically “directed” to objects (Phenomenology). Alternatively, mental states may have a content in virtue of extrinsic causal relations.

### ► Argument

### ► Logic

## Consciousness, Phenomenal

### Definition

A person has phenomenal consciousness when she is living through a mental episode that has a characteristic feel, which is called a quale (pl. qualia). Being in pain or



having the sensory experience of something red are kinds of such episodes. It is somehow for the person to be in pain, and a person who has never had that kind of [□] experience cannot know what it is like to have it – or so many philosophers think.

- ▶ Argument
- ▶ Logic

---

## Consensual Light Reflex

### Definition

When one eye is illuminated, the pupil of the contralateral eye also constricts. This occurs as a result of bilateral projections from the pretectal neurons to the ipsilateral and contralateral neurons of the Edinger–Westphal nucleus.

- ▶ Neural Regulation of the Pupil

---

## Consensus Binding Motif

### Definition

Specific DNA oligonucleotide sequences recognized by a class of transcription factors or other DNA binding proteins. These binding motifs are usually localized to proximal promoters, but may also be found in intronic sequences and distal promoters that regulate target gene expression.

---

## Consensus Sequence

### Definition

A consensus sequence is determined by comparing aligned DNA sequences by using bioinformatic computer programs and identifying conserved sequence motifs. Usually the consensus sequence is shown indicating those nucleotides that are highly conserved and invariant and those that are more variable.

---

## Conservation Law

### Definition

A balance law in a case for which there is no change in the content of the corresponding physical quantity (such as can be the case for the mass content of a material body).

- ▶ Mechanics

---

## Consolidation of Motor Memory

### Definition

Process during which fresh motor memories, which are prone to various forms of interference, become interference resistant and thus long-term. Memory consolidation usually occurs in a confined period (window) of time following training, and generally involves protein synthesis.

- ▶ Motor Learning

---

## Conspecific

### Definition

(adj) from the same species as the animal being studied. The term is used extensively in the field of animal communication to distinguish communication signals originating from animals of the same species with those originating from other species (heterospecific) or from environmental sources.

---

## Constant Field Equation

### Definition

Is another expression for the Goldman-Hodgkin-Katz equation

- ▶ Membrane Potential - Basics

## Constant Internal Environment of an Organism

- ▶ Homeostasis

## Constant “Milieu Intérieur”

- ▶ Homeostasis

## Constant Routine (CR)

### Definition

An experimental protocol designed to allow for the accurate assessment of the human circadian rhythm of core body temperature by controlling the effect of exogenous variables such as light, ambient temperature, sleep, and activity. Subjects remain in bed in a semi-recumbent posture in a climate controlled laboratory suite under low light conditions for one or more circadian cycles. Meals are replaced by frequent isocaloric snacks and sleep is postponed until the end of the procedure.

- ▶ Circadian Cycle
- ▶ Circadian Rhythm
- ▶ Masking (Positive/Negative)

## Constitutive Law

### Definition

The statement of the response of a particular material (in terms of quantities such as stress and heat flux) to the history of the motion (in terms of quantities such as deformation and temperature). The quantitative aspects of constitutive laws are expressed in terms of constitutive equations.

- ▶ Mechanics

## Constitutive Route

### Definition

Constitutive route refers to the passage of vesicles which move directly, without being stored, from the Golgi apparatus to the cell membrane.

- ▶ Salivary Secretion Control

## Constitutive Theory

MARCELO EPSTEIN

Schulich School of Engineering, University of Calgary, Calgary, AB, Canada

### Definition

The statement of the response of a particular material (in terms of quantities such as ▶ stress and heat ▶ flux) to the history of the motion (in terms of quantities such as ▶ deformation and temperature). The quantitative aspects of ▶ constitutive laws are expressed in terms of constitutive equations.

### Description of the Theory

The ▶ kinematics of deformation and the ▶ balance laws of ▶ continuum mechanics (q.v.) apply to all ▶ material bodies, regardless of their physical constitution. They are equally valid for solids, liquids and gases of any kind. Even a cursory count of equations reveals that these laws are not sufficient to solve for all the fields involved. What is missing is a representation of the material response in a manner tailored to each material or class of materials. This tailoring is far from arbitrary. It must respect certain principles, the formulation of which is the aim of the constitutive theory.

If the *history* of a body is defined as its motion and its ▶ absolute temperature for all points of the body and for all past times up to and including the present, then the principles of *causality* and *determinism* assert that the history completely determines (by means of *constitutive functionals*) the present values of the stress tensor ( $\mathbf{T}$  or  $\mathbf{t}$ ), the heat-flux vector ( $\mathbf{Q}$  or  $\mathbf{q}$ ), the ▶ internal energy density ( $u$ ) and the ▶ entropy density ( $s$ ). It will be assumed (*principle of ▶ equipresence*) that the list of independent variables appearing in each of the functionals just mentioned is, a priori, the same. For example, if the temperature is a determining factor for the heat flux, then it should a priori be considered

determining for the stress as well. The theory of materials with memory (even fading memory) is beyond the scope of this article. Instead, only a few examples of classes of materials characterized by a dependence not on the whole history of the motion and the temperature but just on the present values of the ►deformation gradient, the temperature, its gradient and possibly their time derivatives will be presented. Moreover, it will be assumed that these materials are *local*, so that the fluxes and densities at a point depend only on the values of the independent variables (just listed) at that point. Even with these very restrictive assumptions (which, nevertheless, are general enough to encompass most material models in widespread use), it will be seen that the remaining two tenets of the constitutive theory, namely the *principle of ►material frame indifference* and the *principle of thermodynamic consistency*, are strong enough to impose severe restrictions upon the possible constitutive laws that might be measured in the laboratory. The general validity of the principle of material frame indifference and the particular methodology to implement thermodynamic consistency to be presented, have both been challenged on various grounds, which will not be discussed.

### The Principle of Material Frame-Indifference

A change of frame (►see kinematics of deformation) has an effect on all observable quantities, such as deformation gradients, vorticities, temperature gradients and so on, the exact effect depending on the intrinsic or assumed nature of the quantity at hand. The principle of material frame indifference asserts that, although the independent and dependent variable of a given constitutive equation may be affected by a change of frame, the constitutive functions themselves are not affected, regardless of whether or not the frames are inertially related. In plain words, what the principle is stating is that material properties such as the stiffness of a spring, the heat conductivity of a substance or the coefficient of thermal expansion can be determined in any laboratory frame. Before this important principle can be applied to particular cases, it must be established once and for all how the measurements of some of the most common physical quantities change under a change of frame. The most primitive quantity is the spatial distance between two simultaneous events. By construction, the most general change of frame involves just orthogonal spatial transformations, whence it follows that all observers agree on the distance between two simultaneous events. A scalar quantity, the result of whose measurement is independent of the frame, is called a *frame-indifferent scalar*. On physical grounds (for example, by claiming that the length of the mercury line of a thermometer is the distance between two

simultaneous events, or perhaps through a more sophisticated argument or assumption) it is established that the absolute temperature is a frame-indifferent scalar. Since observers agree on length, they must surely agree on volume and they certainly should agree on the “counting of particles”, so it is reasonable to assume that mass density is a frame indifferent scalar. On similar grounds it will be agreed that internal energy density and entropy density are frame-indifferent scalars.

Moving now to vector quantities and starting with the oriented segment  $\mathbf{d}$  joining two simultaneous events, two flashlights blinking together in the dark, as it were, a direct application of (17) of ►kinematics of deformation to the ends of the segment yields  $\mathbf{d}^* = \mathbf{Q}\mathbf{d}$ . A vector that transforms in this manner is called a *frame indifferent vector*. The unit normal  $\mathbf{n}$  to a spatial element of area is frame indifferent, since it can be thought of as an arrow of the type just described. The unit normal  $\mathbf{N}$  to a referential element of area, however, is not frame indifferent, since as far as the reference ►configuration is concerned, a change of frame has no consequence whatsoever. The ►velocity and ►acceleration of a particle are clearly not frame-indifferent. Moving now to tensors, a frame-indifferent tensor must be defined as a linear transformation that takes frame-indifferent vectors into frame indifferent vectors. It follows from this criterion that a tensor  $\mathbf{A}$  is frame-indifferent if it transforms according to the formula  $\mathbf{A}^* = \mathbf{Q}\mathbf{A}\mathbf{Q}^T$ . Assuming that spatial forces are frame indifferent, it follows, according to the definition above (since spatial normals are also frame-indifferent) that the ►Cauchy stress  $\mathbf{t}$  is a frame-indifferent tensor (►Cauchy’s Theorem). The deformation gradient transforms according to the formula  $\mathbf{F}^* = \mathbf{Q}\mathbf{F}$ , which shows that the deformation gradient is not frame indifferent. Its determinant  $J$ , however, is a frame-indifferent scalar. The ►first Piola-Kirchhoff stress tensor  $\mathbf{T}$  is not frame indifferent. It transforms according to  $\mathbf{T}^* = \mathbf{Q}\mathbf{T}$ . The ►velocity gradient  $\mathbf{L}$  is not frame indifferent since  $\mathbf{L}^* = \mathbf{Q}\mathbf{L}\mathbf{Q}^T + \dot{\mathbf{Q}}\mathbf{Q}^T$ . The principle of material frame indifference *does not* claim that the quantities involved in a constitutive law must be frame indifferent. Quite to the contrary, it affirms that, even though the quantities involved are in general not frame indifferent, nevertheless the constitutive functionals themselves are *invariant* under a change of frame.

As an example of the application of the principle of material frame indifference, consider ►elasticity. A material is said to be *elastic* if the stress at a point is a function of just the present value of the deformation gradient at that point, namely:

$$\mathbf{t} = \mathbf{f}(\mathbf{F}), \quad (1)$$

where  $\mathbf{f}$  is a tensor-valued function. Leaving aside the other constitutive functions (such as the internal

energy), what restrictions if any does the principle of material frame-indifference impose on this constitutive law? According to this principle, in another frame:

$$\mathbf{t}^* = \mathbf{f}(\mathbf{F}^*), \quad (2)$$

identically for all nonsingular tensors  $\mathbf{F}$ . Note the conspicuous absence of a star for the function  $\mathbf{f}$ , which is the whole point of the principle of frame indifference. According to previous comments about the way  $\mathbf{t}$  and  $\mathbf{F}$  change under a change of frame:

$$\mathbf{Q} \mathbf{f}(\mathbf{F}) \mathbf{Q}^T = \mathbf{f}(\mathbf{Q}\mathbf{F}), \quad (3)$$

an equation that the function  $\mathbf{f}$  must satisfy identically for all non-singular  $\mathbf{F}$  and all orthogonal  $\mathbf{Q}$ , certainly a severe restriction. To make this restriction more explicit, the **polar decomposition theorem** can be invoked (see kinematics of deformation) to write:

$$\mathbf{Q} \mathbf{f}(\mathbf{R}\mathbf{U}) \mathbf{Q}^T = \mathbf{f}(\mathbf{Q}\mathbf{R}\mathbf{U}). \quad (4)$$

Since this is an identity,  $\mathbf{Q} = \mathbf{R}^T$  can be chosen (at each instant) and, rearranging some terms, yields:

$$\mathbf{t} = \mathbf{R} \mathbf{f}(\mathbf{U}) \mathbf{R}^T. \quad (5)$$

This restriction means that the dependence of the Cauchy stress can be arbitrary as far as the **strain part** ( $\mathbf{U}$ ) of the deformation gradient is concerned, but the dependence on the rotational part is canonical.

### The Principle of Thermodynamic Consistency

The second law of thermodynamics is a restriction that Nature imposes on all observable phenomena; certain things simply cannot happen. The point of view adopted to ensure that those things that should not happen never come out as a solution of the equations of continuum mechanics, is the following. Any constitutive law for which, under any conceivable process, the **Clausius-Duhem inequality** might be violated, even instantaneously, will be excluded. In the classes of materials dealt with, this statement implies that the Clausius-Duhem inequality must hold true identically for any instantaneous combination of the independent variables and their space or time derivatives. The restrictions that are obtained from the principle of thermodynamic consistency for the case of *thermoelastic heat-conductors* will be explored. In this class of materials it is assumed, by definition, that the constitutive variables are functions of the deformation gradient, the temperature and the temperature gradient, namely (in the **Lagrangian description**):

$$T^{il} = T^{il}(F_J^j, \theta, \theta_{,J}), \quad (6)$$

$$Q^J = Q^J(F_J^j, \theta, \theta_{,J}), \quad (7)$$

$$s = s(F_J^j, \theta, \theta_{,J}), \quad (8)$$

$$\psi = \psi(F_J^j, \theta, \theta_{,J}), \quad (9)$$

using the notation of the balance laws. For convenience, the free energy  $\psi$  has been substituted for the internal energy  $u$ . Notice, by the way, an application of the principle of equipresence; exactly the same list of arguments has been assumed for all constitutive variables, letting thermodynamics indicate whether or not an argument should be excluded from a particular constitutive law. Equations (6)–(9) are plugged into (30) of balance laws, the chain rule is used and terms are grouped together to obtain the following result:

$$\begin{aligned} & \left( \rho_0 \frac{\partial \psi}{\partial F_J^j} - T_j^J \right) \dot{F}_J^j + \rho_0 \left( \frac{\partial \psi}{\partial \theta} + s \right) \dot{\theta} \\ & + \rho_0 \left( \frac{\partial \psi}{\partial \theta_{,J}} \right) \dot{\theta}_{,J} + \frac{1}{\theta} Q^J \theta_{,J} \leq 0, \end{aligned} \quad (10)$$

where the fact that  $v_{,J}^j = \dot{F}_J^j$ , by the symmetry of mixed partial derivatives is used. The inequality obtained should be valid identically for all values of  $F_J^j$ ,  $\dot{\theta}$ ,  $\theta_{,J}$  and  $\dot{\theta}_{,J}$ . But this inequality is *linear* in  $\dot{F}_J^j$ ,  $\dot{\theta}$  and  $\dot{\theta}_{,J}$ , since none of these variables appear, anywhere except as multipliers of other expressions. This is not the case for the variable  $\theta_{,J}$ , since the heat-flux vector that it multiplies may depend on it, according to the constitutive assumptions. Since a linear function cannot have a constant sign over its whole domain, it must be concluded that the identical satisfaction of the inequality demands the satisfaction of the following equations:

$$\rho_0 \frac{\partial \psi}{\partial F_J^j} = T_j^J \quad (11)$$

$$\frac{\partial \psi}{\partial \theta} = -s \quad (12)$$

$$\frac{\partial \psi}{\partial \theta_{,J}} = 0 \quad (13)$$

and the residual inequality:

$$Q^J \theta_{,J} \leq 0 \quad (14)$$

These remarkable restrictions can be summarized as follows. The **free energy (of Helmholtz) density** is independent of the temperature gradient and acts as a potential for the stress and the entropy density, both of which are, consequently, also independent of the temperature gradient. Eleven of the constitutive functions of departure boil down therefore, to a single scalar function  $\psi$ . Moreover, according to the residual inequality, heat cannot flow from lower to higher temperatures, since the heat-flux vector cannot form an acute angle with the temperature gradient! If, for example Fourier's law of conduction, which establishes that the heat-flux vector is proportional to the temperature

gradient, is postulated it is concluded that the constant of proportionality must be negative. The coefficient of heat conduction for real materials is in fact defined as the negative of this constant, so as to be positive.

An interesting by-product of the example just presented is that if attention is restricted to processes of a thermoelastic heat conductor that take place at a strictly constant and uniform temperature throughout the body, the heat flux vanishes identically, the processes are reversible and the first Piola-Kirchhoff stress is derivable from the free-energy function per unit referential volume,  $W = \rho_0 \psi$ . A material with this last property is called *hyperelastic* and the function  $W = W(\mathbf{F})$  in this context is sometimes called the *stored-energy function*.

## References

1. Truesdell C, Toupin R (1960) The classical field theories. In: Flügge S (ed) *Handbuch der Physik*, vol III/1. Springer-Verlag, Heidelberg
2. Truesdell C, Noll W (1965) The non-linear field theories of mechanics. In: Flügge S (ed) *Handbuch der Physik*, vol III/3. Springer-Verlag, Heidelberg
3. Eringen AC (ed) (1971) *Continuum physics*, vols I–IV. Academic, New York
4. Fung YC (1981) *Biomechanics*. Springer-Verlag, Heidelberg
5. Gurtin M (1982) *An introduction to continuum mechanics*. Academic Press, New York
6. Chadwick P (1999) *Continuum mechanics: concise theory and problems*, 2nd edn. Dover, New York

## Constructional Apraxia

### Definition

Disability in re-drawing (copying) a drawn figure.

## Consummatory Response

### Definition

A class of unconditioned responses that occur in response to delivery of a rewarding stimulus (usually food or water). Sucking, chewing, or swallowing might constitute examples of such responses.

► Value-based Learning

## Contact Mechanics

### Definition

The equilibrium or motion of bodies that are physically touching.

► Measurement Techniques (Pressure)

## Content-addressable Memory

► Associative Memory

## Context

### Definition

Context is the set of static, unchanging cues that define an environment. Cues that are commonly contextual include boundaries, such as wall and semi-distant landmarks (very distant objects, such as celestial objects, are not environment-specific). There are also non-spatial cues that contribute to context, such as permeating odors or persistent sounds. Contexts are important in learning. Contextual learning can be direct association (“in this room I get food rewards”) or configural (“if a red light turns on in this room I get food rewards”). Context has been extensively studied in fear conditioning and in the analysis of place cells.

► Hippocampus: Organization, Maturation, and Operation in Cognition and Pathological Conditions  
 ► Spatial Learning/Memory

## Context Conditioning

### Definition

Cues or stimuli (odors, tastes, sounds or images) from the environment where training occurs that come to be associated with the training, and can be used as cues to trigger memory of the training.

## Contextual Amnesia

### Definition

- ▶ Amnesia
- ▶ Source Amnesia

## Contextual Fear Conditioning

### Definition

Contextual fear-conditioning is a form of Pavlovian conditioning whereby a subject associates a neutral context with an aversive, unconditioned stimulus (US), such as electric footshock. While the shock elicits bouts of jumping and running followed by freezing, the context alone elicits freezing.

- ▶ Aversive Learning
- ▶ Classical Conditioning (Pavlovian Conditioning)

## Contextual Influences in Visual Processing

TAI SING LEE

Computer Science Department and Center for Neural Basis of Cognition, Carnegie Mellon University, Pittsburgh, PA, USA

### Synonyms

Surround influence; Contextual modulation; Local global interaction; Extra-classical receptive field modulation

### Definition

Vision is the analysis of patterns in visual images with the view to understanding the objects and the physical processes in the world that generate them. Locally, visual patterns are highly ambiguous and subject to multiple interpretations. Image structures surrounding the pattern being analyzed can provide additional constraints or context to disambiguate the interpretation. The resulting ▶contextual influences are ubiquitous in visual perception and manifest at the neuronal level as the modulation of the activity of neurons by image structures outside their ▶classical receptive fields.

### Characteristics

The study of contextual influences in visual processing has a long history in psychology and neuroscience [1]. Investigations of these effects in the visual system have focused on the ▶modulatory effect on the activity of a neuron by image structures outside its localized ▶receptive field. The classical approach employs the simplest stimuli such as bars and sinusoidal gratings to probe the interaction between the stimuli presented inside and outside a neuron's classical receptive field. A prevalent finding is that neurons in both the ▶primary visual cortex (striate cortex, V1) and the ▶extrastriate cortex exhibit ▶feature contrast enhancement, i.e., the cells respond better when the stimulus attributes in the area surrounding their receptive fields, such as bar orientation, are different from those inside their receptive fields (Fig. 1a).

Recent approaches seek to understand the neural basis of the perceptual interpretation of the local receptive field stimulus by changing the global image context (Fig. 1b). With this approach, a number of neural correlates of perception have been revealed, providing insights into the representation of subjective perceptual experience in the brain.

### Contextual Influences in the Primary Visual Cortex

Neurons in the primary visual cortex receive converging input from the ▶lateral geniculate nucleus (LGN). A neuron's classical receptive field, also known as the minimum responsive field, is the part of visual space in which the presence of appropriate features can excite the neuron. By definition, stimulating the visual space outside a neuron's classical receptive field cannot evoke a response. Modulation of neuronal activity by surround stimulation can be observed, however, only when the neuron is responding to a stimulus presented to its receptive field. This modulation is called the non-classical or ▶extra-classical receptive field effect. Such effects have been considered neural manifestations of contextual influences in visual perception.

A variety of extra-classical receptive field effects have been identified. A commonly reported phenomenon is called ▶surround suppression: the response of a neuron to an oriented bar or grating within its receptive field is suppressed when stimuli are simultaneously introduced to the surrounding area outside its receptive field. There are several types of surround suppression effects, mediated by a number of ▶local circuits as well as ▶recurrent feedback circuits [2]. The early phase of surround suppression is fast and is not sensitive to the exact parameters of the surround stimuli. However, the later phase of surround suppression is stimulus-specific. Simply put, while the neuron can detect the presence of stimuli in the surround immediately, its sensitivity to the precise nature of the surround stimulus or global context takes time to develop. The onset delay of this

sensitivity varies considerably depending on the types of the stimuli and the spatial extent of the contextual stimuli.

One well-known stimulus-specific surround suppression, observed with an onset delay, is called **iso-orientation suppression**. In this phenomenon, a neuron's response is stronger when the orientation of the surround stimulus is different from that of the center receptive field stimulus than when the orientations are the same. When the receptive field stimulus is a bar, iso-orientation suppression emerges at about 10 ms after the onset of the response to the receptive field stimulus [3]. When the receptive field stimulus is a part of an oriented texture region significantly larger than that of the receptive field, the later part of the neuron's response is inversely proportional to the size of the region – the larger the region, the smaller the response. This results in a relative enhancement of response when the neuron's receptive field is inside a smaller region than when it is in the larger background region. Interestingly, the enhancement is uniform across the surface of a compact region, with a sudden drop off at the region's border. Hence, it has been proposed to be a signal that could highlight a figure against its background and is called the **figure enhancement** effect [4]. According to most studies, the onset delay of this figure enhancement effect is proportional to the size of the region. When the receptive field is at the center of a region that is six times larger than its size, the onset delay is typically 40 ms relative to response onset on the average. The figure enhancement effect is more general than iso-orientation suppression as it has been observed in studies with motion or shape from shading stimuli without any orientation contrast between the receptive field stimulus and the surround [4,5].

Functionally, both iso-orientation suppression and figure enhancement can serve to enhance stimulus feature contrast, resulting in an increase in **perceptual saliency** of the representation of less expected or surprising visual events to facilitate further processing. Indeed, it has been demonstrated that this response enhancement is directly proportional to perceptual saliency of the visual pattern, as measured in terms of the reaction time for target detection, and it is dissociable from luminance contrast or orientation contrast in the stimulus (Fig. 1b) [5]. The broader spatial extent and the longer onset latency of the figure enhancement effect suggest that, while iso-orientation suppression might be mediated primarily by inhibitory **local circuits**, the figure enhancement or perceptual saliency effect likely involves additional long range facilitation circuits including recurrent **feedback** from the extrastriate cortex, as suggested by both anatomical and deactivation studies.

Surround interaction can be quite complex and can vary according to the luminance contrast or the spatial scale of the stimuli. While surround modulation tends to

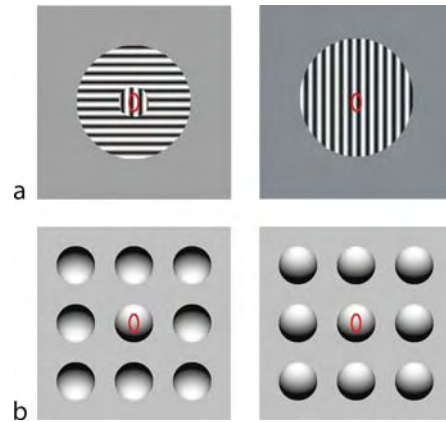

### Contextual Influences in Visual Processing.

**Figure 1** Stimuli used in contextual modulation studies. (a) Classic center-surround stimuli that have been typically used in neurophysiological studies on iso-orientation surround suppression [3]. Neurons tend to respond better when the orientations of the center and surround gratings are different (*left image*) than when they are the same (*right image*). The red ellipse outlines the spatial extent of the receptive field of the neuron. A similar effect observed in a larger center patch with a significantly longer delay is called figure enhancement [4]. (b) Surround context can change the perceptual saliency of the receptive field stimulus. The receptive field stimulus is said to pop out from the background on the left image, but not on the right image. This pop-out phenomenon depends on 3D interpretation of the stimulus elements. Early visual neurons' activity is correlated with the perceptual saliency of this pop-out phenomenon [5].

be suppressive when the luminance contrast of the stimulus is strong, it can become facilitatory when the luminance contrast is weak. Neuronal **adaptation**, well known in the **retina** and LGN, is sensitive to the absolute luminance and luminance contrast levels in the entire scene. In a dark and low-contrast environment, retinal and LGN neurons are known to expand their receptive fields temporally and spatially with a simultaneous increase in their sensitivity gains. Such a strategy serves to optimize feature detection in the presence of noise. The contrast dependence of surround influence likely results from V1 neurons inheriting and extending these adaptation or optimization strategies.

Perceptual computations supported by the complex machinery in V1 likely go beyond feature detection and feature contrast enhancement. From a computational perspective, contextual effects reflect the influence of computational constraints, realized by neuronal connectivity and interaction, necessary for solving visual inference problems. Surround interaction can bring in contextual information to improve local estimates

of visual cues, as evident in the observations that ►orientation tuning curves and ►disparity tuning curves tend to sharpen over time during the analysis of each visual image. The ►retinotopic organization, the connection infrastructure, and the tuning properties of neurons in V1 make it ideally suitable for supporting a variety of visual computations. One such computation is the grouping of edges into contours and features into coherent regions. There is some evidence that V1 plays an important role in this computation to be discussed below.

First, the activity of some V1 neurons is enhanced if the surrounding bars outside their receptive fields line up with the bar presented within their receptive fields to form a longer contour (Fig. 2a).

Moreover, some V1 neurons respond to the ►subjective contour of a ►Kanizsa figure, even when no feature is presented to their classical receptive fields (Fig. 2b). There is also evidence that neurons can interpolate contours across the blind spot or behind an occlusion. Furthermore, collinear contours have been

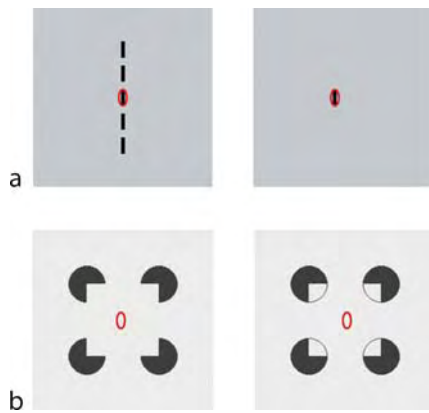

### Contextual Influences in Visual Processing.

**Figure 2** Neurophysiological evidence of contour completion in V1. (a) Oriented bars in the surround (*left image*), when aligned with the receptive field stimulus to form a contour, can increase a cell's response to its receptive field stimulus (*right image*) (Kapadia, Westheimer and Gilbert 2000). The *red ellipse* outlines the spatial extent of the receptive field of the neuron. (b) The subjective contour of a Kanizsa's illusory square can evoke response in a V1 neuron even when no stimulus feature is present in its receptive field (*red ellipse*) (Lee and Nguyen 2001). The subtle addition of thin circles on the right image changes the perceptual interpretation of the image from a white square occluding four black circular disks, with a vivid subjective contour over the receptive field (*left image*), to that of a white square in a background visible through four circular windows on a white wall in front (*right image*).

found to induce neuronal synchrony in V1 neurons of the same ►orientation selectivity. Recently, it was also found that neurons with different orientation tunings, when stimulated simultaneously by curved contours, also exhibit an increase in synchrony or ►effective connectivity, as revealed by multi-electrode recordings [6]. This dynamic change in effective connectivity between neurons as a function of stimulus is suggestive of a mechanism for ►contour completion.

In addition, similar changes in effective connectivity have also been observed among spatially disjoint ►disparity selective neurons when the 3D depth plane of the random dot stereogram stimulus intersects with the cells' optimal disparity tunings. This process appears to contribute to the gradual sharpening of the neurons' disparity tunings over time, providing a plausible mechanism for improving local estimates of visual cues based on global context. Such cooperative or mutual facilitatory mechanisms might also contribute to *surface association* by increasing the firing rates of the neurons analyzing different parts of the same visual surface simultaneously. The resulting enhanced and correlated activities, partly represented in the figure enhancement effect, can highlight the relevant coincident features in visual input as a group to provide a stronger drive for downstream neurons in the extrastriate cortex to learn explicit representations for higher order features and structures.

### Contextual Influences in the Extrastriate Visual Cortex

The extrastriate cortex, downstream from the striate or primary visual cortex, is partitioned into many different visual areas. The feature contrast enhancement effect observed in V1 is also prevalent in extrastriate visual areas, expressed in the respective feature dimensions that neurons in those areas are tuned to. In area ►MT (medial temporal), for example, the motion of surround stimuli has been shown to significantly modulate the response of a neuron to moving stimuli presented to its receptive field. The response of the neuron is suppressed when the direction of surround motion is the same as the motion detected in the neuron's receptive field. This is analogous to the iso-orientation suppression in V1 but in the motion domain. In addition, the disparity-tuned MT neurons also experience iso-disparity suppression.

The extrastriate cortical areas, however, exhibit some additional contextual effects that are rarely observed in the striate cortex. Many of these *new* contextual effects are concerned with the inference of 3D surfaces, their occlusion and depth ordering relationships, also known as ►figure-ground organization. In MT, it has been shown that the responses of direction-selective neurons to a motion stimulus are sensitive to the figure-ground context defined by the surrounding surface depth structures in a way that is consistent with ►Barber Pole illusion [7].



Several lines of evidence suggest that the computations underlying figure-ground segregation and 3D surface inference might start in visual area V2. First, a significant fraction of V2 neurons (and a small number of V1 neurons) have been shown to signal whether their receptive fields are at the left border or the right border of a figure in an image regardless of the polarity of contrast at the border (Fig. 3a).

A left-border-preferring neuron carries the information that the border within its receptive field belongs to (or is *owned* by) the surface or region to its right [8]. A complementary, right-border-preferring neuron exists at the same location, and both neurons could form a push-pull pair for every border orientation. The activity of a set of such pairs of ►border-ownership neurons in various orientations along the border of each region in an image can encode the depth-order relationship between the different image regions or inferred surfaces. Secondly, it has been found that neurons in V2, but not in V1, are sensitive to the mismatch in features between the images from each eye at visual locations where one surface occludes another [9]. The emergence of sensitivity to this surface occlusion cue in V2, known as the ►Da Vinci stereo, further suggests that 3D surfaces and their occlusions are explicitly represented in V2. The figure-ground context made explicit in V2 could feed back to constrain the computation in V1, resulting in, for example, the figure enhancement effect. However, it should be noted that the figure enhancement effect in V1 has not been conclusively demonstrated to depend solely on figure-ground organization.

The perception of surface attributes such as brightness, shading and color depends very strongly on the interpretation of the underlying 3D surface geometry and the illumination direction in the visual scene. Two observations suggest that these surface attributes might also be inferred and represented in V2 because of the dependence of such inference on 3D surface interpretation. First, the neural correlate of ►shape-from-shading pop-out, a perceptual phenomenon that crucially depends on 3D surface interpretation, is observed in V2 but not in V1 pre-attentively [4]. Second, the neural correlate of the ►Cornsweet-O'Brien illusion, an illusion in perceived brightness induced by edge contrast, which ultimately can be traced back to surface geometry and lighting direction interpretations in natural scenes, is observed in V2 but not V1 [10] (Fig. 3b). There has been, however, some evidence for brightness representation in V1 [1]. It is possible that the construction of brightness representation is a gradual and distributed process, computed first at V1 based on surround luminance contrast, but achieving a more abstract and invariant representation in V2 as the 3D surface representation is made explicit. In general, neuronal activities tend to become progressively more abstract and more correlated with our

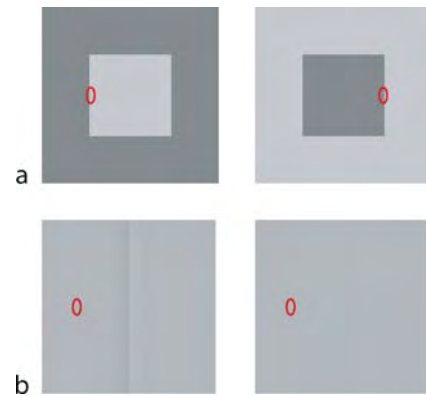

### Contextual Influences in Visual Processing.

**Figure 3** Neurophysiological evidence of surface inference in V2. (a) A left-border cell will respond more strongly when its receptive field (*red ellipse*) is analyzing the left border of a figure (*left image*) than when it is analyzing the right border of the figure (*right image*), even when the visual pattern on the receptive field and in its immediate surround is identical [8]. This class of cells, observed primarily in V2, is said to convey information about border-ownership or surface occlusion. (b) In the Cornsweet-O'Brien illusion, the presence of a contrast edge can change the perception of the brightness of a region. A V2 neuron that prefers darkness over brightness would respond better to the perceptually darker region (*left image*) than to the perceptually brighter region (*right image*) even though the physical luminance of the receptive field stimulus in the two cases is exactly the same [10].

subjective perceptual experience as one moves up the visual hierarchy.

In addition to global image structures, behavior, task demands and memory are also known to provide strong contextual information to influence visual perception and object recognition. ►Attentional modulation of neuronal responses has been widely observed and studied in the extrastriate cortex (see ►Visual Attention). Attentional effects in V1 are subtle and observable mostly when visual scenes are cluttered or in tasks that demand considerable spatial attention at precise locations such as the task of tracing a curve. Beyond V2, extrastriate neurons tend to have large receptive fields. Attentional modulation in neurons of these higher areas typically manifests as the selection of one relevant feature over the others present within their individual receptive fields. Attention can be voluntary, as in selecting a particular spatial location (spatial attention) or a particular feature (feature attention) in the receptive field for further analysis. But it can also be reflexive, driven or captured by the saliency of the stimuli computed automatically in early visual areas. The variety of ►feature contrast and perceptual saliency effects observed in V1 and in the extrastriate cortex likely serve as a part of this reflexive attention mechanism. Recently, higher-order non-spatial

contextual effects, such as context familiarity and associative memory, have also been shown to modify the activities of neurons in ►inferotemporal cortex (IT) and medial temporal (MT) respectively.

From the perspective that vision is a process for inferring the various underlying environmental causes of visual patterns such as the 3D geometry of surfaces, the identities of objects and the illumination direction in the scene, the extrastriate areas in the visual hierarchical system might be conceptualized as modules that provide explicit representation of these decomposable causes. Each extrastriate module furnishes an explanation on some aspect of the visual scene. The inference of the underlying causes involves integration of information across space and over time by neurons in the higher-order visual areas, which in turn provide a variety of context in which visual processing in the earlier visual areas can be refined. V1, with its neurons arranged in a spatially precise ►retinotopic map and endowed with small localized receptive fields capable of representing fine details in images, might serve as a *high resolution buffer* at which all the causes are combined together to synthesize an explanation of the visual input represented explicitly there. These interactive computations can bring about a very rich set of contextual influences in V1 and the extrastriate cortex. The long latency of many of the contextual effects observed suggests that a substantial amount of recurrent interaction could have taken place. Computations involving such recurrent interaction predict the *simultaneous* emergence of the perception-related signals in many visual and decision areas in the brain.

## References

- Albright TD, Stoner GR (2002) Contextual influences on visual processing. *Annu Rev Neurosci* 25:339–379
- Angelucci A, Levitt JB, Walton EJ, Hupe JM, Bullier J, Lund JS (2002) Circuits for local and global signal integration in primary visual cortex. *J Neurosci* 22 (19):8633–8646
- Knierim JJ, van Essen DC (1992) Neuronal responses to static texture patterns in area V1 of the alert macaque monkey. *J Neurophysiol* 67:961–980
- Lamme, VAF (1995) The neurophysiology of figure-ground segregation in primary visual cortex. *J Neurosci* 15:1605–1615
- Lee TS, Yang CF, Romero RD, Mumford D (2002) Neural activity in early visual cortex reflects behavioral experience and higher order perceptual saliency. *Nat Neurosci* 5:589–597
- Samonds JM, Zhou Z, Bernard MR, Bonds A (2006) Synchronous activity in cat visual cortex encodes collinear and cocircular contours. *J Neurophysiol* 95 (4):2602–2616
- Duncan RO, Albright TD, Stoner GR (2000) Occlusion and the interpretation of visual motion: perceptual and neuronal effects of context. *J Neurosci* 20:5885–5897
- Zhou H, Friedman HS, von der Heydt R (2000) Coding of border ownership in monkey visual cortex. *J Neurosci* 20:6594–6611
- Bakin JS, Nakayama K, Gilbert CD (2000). Visual responses in monkey areas V1 and V2 to three-dimensional surface configurations. *J Neurosci* 20:8188–8198
- Hung CP, Ramsden BM, Roe AW (2007) A functional circuitry for edge-induced brightness perception. *Nat Neurosci* 10(9):1185–1190

## Contextual Modulation

- Contextual Influences in Visual Processing

## Contextualist Theories of Knowledge

### Definition

Contextualist theories of knowledge (at least those in the narrow sense of the term) claim that, in order to answer the question whether or not S knows that p, the context of the person ascribing knowledge has to be taken into account. The consequence is that, according to these theories, there is no ascriber independent “fact of the matter” about knowledge.

- Knowledge

## Contig

### Definition

DNA sequence that is assembled from overlapping shorter sequences to form one large contiguous sequence.

## Continuity Equation

### Definition

A traditional name for the law of conservation of mass.

- Mechanics

## Continuous Growth and Remodeling

MARCELO EPSTEIN

Schulich School of Engineering, University of Calgary,  
Calgary, AB, Canada

### Definition

A process of growth consists of the addition or removal of mass from a ►material body. In a continuum framework, volumetric (or bulk) growth and surface growth can be distinguished. The term remodeling is applied to instances in which there is a reorganization of material particles without any net growth.

### Description of the Theory

The theories of continuous growth and remodeling, as well as more general theories of morphogenesis, are still in a stage of development and have not yet attained a definitive standard form. For this reason, this paper will be limited to the presentation of some fundamental theoretical notions based on a particular point of view (in line with ►continuum mechanics) and confined to certain types of phenomena. According to this point of view, growth and remodeling are particular instances of phenomena of ►material evolution in which the identities of the material particles, as well as their constitutive nature, are preserved. What changes, then, is the way they are mutually arranged in the body. These changes are not to be confused with the motion in space: they refer to a different type of “motion” taking place in the body itself. If material snapshots were possible, the body at different instants of time would still be seen as made of the same material, but would be busy accommodating the material neighborhoods relative to each other. Each snapshot might reveal the presence of continuous distributions of dislocations and it is this presence that can be seen as responsible for the development of, among other effects, residual ►stresses associated with the processes of growth and remodeling.

As a point of departure for a more general treatment, consider first a material body each of whose points abides by a purely elastic response. To make matters even simpler, assume that the body is *hyperelastic* as defined in the constitutive theory (q.v.), the mechanical response at each material point is completely characterized by a single scalar function  $W$  measuring the stored elastic energy per unit volume of a reference ►configuration. The independent variables of this function are the ►deformation gradient  $\mathbf{F}$  and the body point  $\mathbf{X}$ . The derivative of  $W$  with respect to  $\mathbf{F}$  at a point  $\mathbf{X}$  is equal to the ►first Piola-Kirchhoff stress tensor  $\mathbf{T}$  at that point. The first question that comes to mind is the following: given a function  $W = W(\mathbf{F}, \mathbf{X})$ , namely, a hyperelastic

material response with respect to some reference configuration, can it be unequivocally ascertained that all the points of the body are made of the same material? At first sight, the answer to this question seems to be that this will be the case if the response function  $W$  happens to be independent of the point  $\mathbf{X}$ . A moment's reflection, however, reveals that, although this condition is certainly sufficient, it is by no means necessary for a positive answer. To understand why this is the case, assume that there is indeed a reference configuration for which the response function  $W$  is independent of  $\mathbf{X}$ . If the reference configuration (as per Eq. 9 in ►kinematics of deformation (q.v.)), is now changed there would be a new expression for the stored-energy function  $W'$  per unit volume of the new reference configuration:

$$W'(\mathbf{F}, \mathbf{Y}) = J_H^{-1} W(\mathbf{F}\mathbf{H}(\mathbf{X})). \quad (1)$$

In this equation, the change of reference configuration is represented (as in Eq. 9 of kinematics of deformation) by a function  $\mathbf{Y} = \mathbf{Y}(\mathbf{X})$ , whose gradient is denoted by  $\mathbf{H}$ . The determinant  $J_H$  of  $\mathbf{H}$  appears in the equation because  $W'$  is evaluated per unit volume of the new reference configuration. The main point is that in the new reference configuration there is an *explicit dependence on the body point*  $\mathbf{Y}$ , even though the body is exactly the same as before! What this means is that a ►constitutive law may appear to indicate a dependence on the body point, but this may be due only to an unhappy choice of reference configuration. In some cases no happy choice exists and yet the material may be the same at all points of the body.

Inspired by Eq. 1, the concept of ►material isomorphism can be introduced. Two points,  $\mathbf{X}_1$  and  $\mathbf{X}_2$ , of a body with constitutive law  $W = W(\mathbf{F}, \mathbf{X})$  are said to be *materially isomorphic*, if there exists a non-singular two point tensor  $\mathbf{P}_{12}$  such that the equation:

$$W(\mathbf{F}, \mathbf{X}_2) = J_{P_{12}}^{-1} W(\mathbf{F}\mathbf{P}_{12}, \mathbf{X}_1) \quad (2)$$

is satisfied *identically* for all deformation gradients  $\mathbf{F}$ . From the physical point of view this formula has a very simple explanation: If a small neighborhood has been surgically cut around point  $\mathbf{X}_1$ , given a deformation  $\mathbf{P}_{12}$  and then implanted in place of a neighborhood of point  $\mathbf{X}_2$  and if, after performing this *transplant operation* it is impossible to detect by any mechanical experiment that the operation has taken place, then the material must have been the same at both points to begin with. Otherwise, such a perfect graft would not have been possible. A body is said to be *materially uniform* if all of its points are mutually materially isomorphic. In other words, material ►uniformity corresponds exactly to the positive answer to the question of departure. A function  $W$  that passes the test of material uniformity corresponds to a body that is made of the same (hyperelastic)

material at all points. Clearly, material isomorphism is an equivalence relation: (i) every point is materially isomorphic to itself (choosing  $\mathbf{P}_{11} = \mathbf{I}$ ); (ii) if  $\mathbf{X}_1$  is materially isomorphic to  $\mathbf{X}_2$ , then  $\mathbf{X}_2$  is materially isomorphic to  $\mathbf{X}_1$  (choosing  $\mathbf{P}_{21} = \mathbf{P}_{12}^{-1}$ ); (iii) if  $\mathbf{X}_1$  is materially isomorphic to  $\mathbf{X}_2$ , and  $\mathbf{X}_2$  is materially isomorphic to  $\mathbf{X}_3$ , then  $\mathbf{X}_1$  is materially isomorphic to  $\mathbf{X}_3$  (choosing  $\mathbf{P}_{13} = \mathbf{P}_{23} \mathbf{P}_{12}$ ). In other words, a materially uniform body can also be defined as one for which all of its points are materially isomorphic to a fixed reference point  $\mathbf{X}_0$ . Imagine that this reference point has been placed outside of the body as some kind of *archetype* or pattern that describes the generic behavior of all points of the body. Introducing the notation  $\mathbf{P}(\mathbf{X}) = \mathbf{P}_{0X}$  for the transplant operations from the archetype to an arbitrary point  $\mathbf{X}$  and denoting the archetypal stored energy function by  $\overline{W}$ , Eq. 2 may be rewritten as:

$$W(\mathbf{F}, \mathbf{X}) = J_{\mathbf{P}}^{-1} \overline{W}(\mathbf{F}\mathbf{P}(\mathbf{X})). \quad (3)$$

Thus, a body is uniform if there exists a *field of implants*  $\mathbf{P}(\mathbf{X})$  such that Eq. 3 is satisfied identically for all deformation gradients  $\mathbf{F}$ . This equation clearly shows that a dependence on material point in itself is not an indication of lack of material uniformity, as long as this dependence is restricted by the multiplicative composition indicated in Eq. 3.

A material point may be non-trivially materially isomorphic to itself. That is, there may exist material automorphisms  $\mathbf{G}_X = \mathbf{P}_{XX} \neq \mathbf{I}$ . Such tensors are called *material symmetries* of the point in question. For physical reasons, they are always assumed to have a unit determinant, since it is expected that the material response will always be affected by a change of volume. It is not difficult to verify that all material symmetries of a point form a group under the operation of matrix composition. This group, called the *symmetry group* of the point, is a subgroup of the *unimodular group*, namely, the group of matrices with unit determinant. An elastic material point is called an *elastic solid* if there exists a reference configuration for which the symmetry group is a subgroup of the orthogonal group. Such a configuration is called a *natural state*. If the symmetry group coincides with the orthogonal group, the solid is fully *isotropic* (its response is indifferent to any pre-imposed rotation). Clearly, if  $\mathbf{G}_1$  is a **material symmetry** of point  $\mathbf{X}_1$  and if  $\mathbf{P}_{12}$  is a material isomorphism between  $\mathbf{X}_1$  and  $\mathbf{X}_2$ , then the composition  $\mathbf{P}_{12}\mathbf{G}_1$  is also such a material isomorphism. In other words, the material isomorphisms between points of a uniform body are not unique if the points have a non-trivial symmetry group. As expected, the symmetry groups at different points of a uniform body are not independent of each other. Indeed, it is not difficult to verify that, with the same notation as above, the map  $\mathbf{G}_2 = \mathbf{P}_{12} \mathbf{G}_1 \mathbf{P}_{12}^{-1}$  is a symmetry at point  $\mathbf{X}_2$  and that all symmetries at this point can be obtained in this

way. Technically, the symmetry groups at all points are *conjugate* of each other and therefore, also conjugate to the symmetry group of the archetype.

Given a materially uniform body it may so happen that, in some reference configuration, there exists a trivial field of implants, namely, a field consisting just of a translation of the archetype to each point; the grafts are achieved without any distortion or rotation. If this is the case, the uniform body is said to be *globally homogeneous* and the special reference configuration is a *homogeneous configuration*. Without entering into the technical details, there exist uniform bodies that are not globally homogeneous (for example, a homogeneous bar that has been closed by perfectly welding its ends in a ring-like fashion, is not globally homogeneous; notice that in this example the lack of **homogeneity** manifests itself in the impossibility of releasing the stresses simultaneously at all points of the ring). One may think that a uniform body may always be considered as *locally homogeneous*, that is, homogeneous by pieces (the example of the ring seems to suggest so, since any piece of the ring can always be rectified, if not the complete ring). Unfortunately, this is not the case, and it is not difficult to construct examples of locally inhomogeneous uniform bodies. Physically, they correspond, for example, to bodies with continuous distributions of dislocations.

So as to link these ideas to the biological problems of growth and remodeling, imagine that the implants  $\mathbf{P}(\mathbf{X})$  are allowed to evolve in time, namely to become functions  $\mathbf{P}(\mathbf{X}, t)$ . This process is called a *material evolution*. It is critical to realize that, even though the material archetype remains always hyperelastic, the admission of a material evolution into the physical picture results in a non-elastic response of the different points of the body. The simplest image of what is going on is obtained by thinking of the body as an array of **linear springs**, all having the same stiffness constant. The implant operation  $\mathbf{P}(\mathbf{X})$  boils down in this case to a stretch of the archetypal spring before inserting it in each position within the body. A material evolution can then be interpreted as a change of resting length of the inserted spring as time goes on. This example should not be pushed too far, but it is certainly a good heuristic picture to keep in mind. If the material evolution takes place at a given point in such a way that the determinant of the implant keeps a constant value, it is said that *remodeling* is taking place. If, on the other hand, the determinant changes in time, a process of *volumetric growth or resorption* is also at play, since it is easy to verify that in this case the mass *is not conserved*. From the purely formal point of view, therefore, the various theories of growth and remodeling are similar to the theory of plasticity with finite **strains**. As evolution takes place, it is clear that even if the material body is

initially homogeneous it will in general cease to be so and internal stresses will in general appear due to the material rearrangement processes taking place. It is also possible for biological systems in particular to have a natural tendency to produce a material evolution that tends to eliminate these residual stresses in the long run.

To complete a theory of growth or remodeling, in addition to important modifications to be introduced into the conventional ►balance laws (q.v.), it is necessary to specify some *constitutive law of evolution* dictating, for example, how the first ►time-derivative of the implants is related to the stresses in the material. Although the details of the underlying constitutive theory are beyond the scope of this article, it is interesting to notice that if the stored-energy function is identified with the ►free energy (of Helmholtz) per unit volume, then it turns out that, in the same way as the derivative of Eq. 3 with respect to  $\mathbf{F}$  yields the first Piola-Kirchhoff stress, the derivative of the same equation with respect to the implant field  $\mathbf{P}(\mathbf{X})$  yields another measure of stress called the ►Eshelby stress. More specifically:

$$\frac{\partial W}{\partial \mathbf{P}} = \mathbf{P}^{-1}(-W \mathbf{I} + \mathbf{F}^T \mathbf{T}) \quad (4)$$

where the formula for the derivative of a determinant has been used. The quantity within parentheses, namely  $\mathbf{b} = -W \mathbf{I} + \mathbf{F}^T \mathbf{T}$ , which can be expressed in component form as:

$$b_j^i = -W \delta_j^i + F_j^i T_i^j, \quad (5)$$

is the Eshelby stress tensor. It is a purely referential tensor. From its derivation, it is clear that the Eshelby stress is a measure of the free energy per unit volume consumed in producing a material change in the body (such as growth or remodeling) and it is legitimate to identify it with some kind of *material or configurational force* in contradistinction with the spatial or Newtonian forces of conventional mechanics (►Newtonian Mechanics). Configurational forces of various kinds are the subject of intense research in present-day continuum mechanics.

The Eshelby stress is thus the thermodynamic dual of the material implant  $\mathbf{P}$ . A possible law of evolution may, therefore, have the form:

$$\dot{\mathbf{P}} = f(\mathbf{b}, \mathbf{P}), \quad (6)$$

where  $f$  is some tensor-valued function depending of the material and the phenomenon being modeled. By requiring that the form of the law be independent of the reference configuration used, this law can be reduced to the form:

$$\bar{\mathbf{L}}_P = f(\bar{\mathbf{b}}), \quad (7)$$

where

$$\bar{\mathbf{L}}_P = \mathbf{P}^{-1} \dot{\mathbf{P}} \quad (8)$$

is a measure of the velocity of remodeling, somewhat like a material counterpart of the spatial ►velocity gradient (although  $\bar{\mathbf{L}}_P$  is not a gradient in general). The overbar is meant to remind that this quantity is an automorphism of the archetype. Similarly, the argument  $\bar{\mathbf{b}}$  represents the Eshelby stress pulled back to the archetype, namely:

$$\bar{\mathbf{b}} = J_P \mathbf{P}^T \mathbf{b} \mathbf{P}^{-T}. \quad (9)$$

Thus, the evolution law, Eq. 7, depends only on the archetype chosen, as it should. There is still another restriction to the evolution law, which stems from the symmetry group of the material. This is called the *principle of actual evolution*. Recall that if  $\mathbf{P}$  is a material isomorphism between the archetype and some point in the body, so is the product  $\mathbf{P}\mathbf{G}$ , where  $\mathbf{G}$  is an arbitrary member of the symmetry group of the archetype. Thus, there is a certain degree of freedom in the choice of implant. If the symmetry group is continuous, therefore, it is possible that the form of the function  $f$  be such that the instantaneous change of implant prescribed by Eq. 7 may fall within this degree of freedom. In such a case, the evolution would be fictitious and would not represent a true material rearrangement. To avoid such a situation, the function  $f$  must provide a result, which is never equal to a “small” element of the symmetry group of the archetype. In other words, this function must always give a result that falls outside the Lie algebra of the symmetry group. As an example, consider the case of a fully isotropic solid. Assuming that the archetype is in a natural state, the symmetry group of the archetype is the orthogonal group. The Lie algebra consists of all skew-symmetric matrices (infinitesimal rotations). The tensor function  $f$ , therefore, must not be skew-symmetric. Put in a different way, the law of evolution must specify a non-vanishing evolution for the symmetric part of  $\bar{\mathbf{L}}_P$ . On the other hand, if the material is not fully isotropic (for example, if its symmetry group is discrete), then even a skew-symmetric function  $f$  represents a legitimate evolution.

## References

1. Epstein M, Maugin GA (1990) The energy-momentum tensor and material uniformity in finite elasticity. *Acta Mechanica* 83:127–133
2. Maugin GA (1993) *Mathematical inhomogeneities in elasticity*. Chapman Hall, London
3. Rodriguez EK, Hoger A, McCulloch AD (1994) Stress-dependent finite growth in soft elastic tissues. *J Biomechanics* 27:455–467
4. Taber LA (1995) *Biomechanics of growth, remodeling and morphogenesis*. *Appl Mech Rev* 48(8):487–545
5. Epstein M, Maugin GA (1996) On the geometrical material structure of anelasticity. *Acta Mechanica* 115:119–131

6. Epstein M (1999) Toward a complete second-order evolution law. *Math Mech Solids* 4(2):251–266
7. Gurtin ME (2000) *Configurational forces as basic concepts in continuum physics*. Springer, Berlin
8. Epstein M, Maugin GA (2000) Thermomechanics of volumetric growth in uniform bodies. *Int J Plast* 16:951–978
9. Epstein M (2002) The Eshelby tensor and the theory of continuous distributions of inhomogeneities. *Mech Res. Comm* 29(6):501–506

## Continuum Mechanics

MARCELO EPSTEIN

Schulich School of Engineering, University of Calgary, Calgary, AB, Canada

### Definition

Continuum **▶mechanics** studies the motion of material bodies taking into consideration their deformability. It does not make any a-priori distinction between different states of matter (solid, liquid, gaseous), but it does generally assume that the underlying medium is continuous. Technically speaking, the medium is assumed to be a **▶differentiable manifold**, so that smoothly varying *fields* can be defined on it (**▶velocity**, **▶stress**, temperature and so on). A more appropriate name for the discipline might have been continuum thermomechanics, since thermodynamical effects are an essential part of its scope.

### Description of the Theory

Although the historical origins of continuum mechanics can be traced back to, among others, Euler and Cauchy and although by the first half of the twentieth century a variety of particular theories (**▶elasticity**, fluid mechanics, plasticity, etcetera) had been successfully applied to many areas of engineering, it is commonly agreed that the term continuum mechanics refers to the rigorous unified treatment undertaken starting from the 1950's and still very much underway in today. The by now standard treatment of the subject can be neatly divided into three parts, **▶kinematics** of deformation **▶balance laws** and constitutive theory. While the first two parts enunciate general definitions and principles applicable to all bodies, the third part deals with the description of particular classes of ideal materials, whose behavior may be used to approximate the response of real materials, at least under certain restricted conditions (for example, relatively small **▶strains**, isothermal processes and so on). Nevertheless, whereas the range of applicability of an ideal material model to a particular

real material may be so restricted, one of the tenets of continuum mechanics is that, once the parameters of an ideal model have been established, no further limitations are to be imposed. To be more precise, ideal material models are formulated in terms of constitutive equations, which express the generic functional dependence of certain physical quantities (stress, heat flux, **▶internal energy**, etc) in terms of other quantities (motion, temperature, etc). An ideal material is completely characterized by the choice of these variables (for example, the present value of the temperature, rather than its whole past history may be considered), but their range is not limited a priori. For biomechanics in particular, the possibility of not avoiding (as would have been the case in the older treatments) the exploration of a wide range of deformability is of paramount importance and it can be said that biological systems constitute a natural source of material models that is and will continue to be behind much of the cutting edge activity in continuum mechanics. Apart from the more conventional theories, biological systems necessitate the application of **▶mixture theory** (with and without chemically reacting components), smart materials (activated by external agents) and theories of continuous **▶growth and remodeling** (involving laws of evolution driven by so-called **▶configurational forces**).

### References

1. Truesdell C, Toupin R (1960) The classical field theories. In: Flügge S (ed) *Handbuch der Physik*, vol III/1. Springer, Berlin, pp 226–793
2. Truesdell C, Noll W (1965) The non-linear field theories of mechanics. In: Flügge S (ed) *Handbuch der Physik*, vol III/3. Springer, Berlin, pp 1–602
3. Eringen AC (ed) (1971) *Continuum physics*, vols I–IV. Academic, New York
4. Fung YC (1981) *Biomechanics*. Springer, New York
5. Gurtin M (1982) *An introduction to continuum mechanics*. Academic, New York
6. Taber LA (1995) Biomechanics of growth, remodeling and morphogenesis. *Appl Mech Rev* 48(8):487–545
7. Chadwick P (1999) *Continuum mechanics: concise theory and problems*, 2nd edn. Dover, New York
8. Humphrey JD (2001) *Cardiovascular solid mechanics*. Springer, NY

## Contours

### Definition

**▶Form Perception**

## Contractile Element

### Definition

In muscle mechanics. A rheological element that can slide freely with no force unless it is “activated,” in which case the force is given by an ad hoc (experimentally based) law.

► Mechanics

## Contraction-induced Injury

### Definition

An experimental method of causing injury to an isolated skeletal muscle, typically dissected from a mouse or rat, to determine under what conditions the components of the muscle fibers will become injured when they are contracting while being stretched. It is a method suitable for comparing dystrophic versus non-dystrophic skeletal muscle integrity.

## Contralateral Visual Field

### Definition

The region of visual space that extends from the vertical meridian (which passes through the center of gaze) peripherally toward the side of the body opposite to the neuron or brain region studied. In general, each side of the brain processes information from the contralateral visual field.

► Visual Field

## Contrast

### Definition

In sensory systems, contrast is a measure of relative stimulus intensity at some point in relation to the average (background) intensity level.

► Sensory Systems

## Contrast Enhancement

THOMAS A. CLELAND

Department of Psychology, Cornell University, Ithaca, NY, USA

### Synonyms

Receptive field selectivity; Edge enhancement; Sharpening; Acutance; Unsharp masking; Selective feature enhancement; Decorrelation

### Definition

Contrast enhancement is a transformation of a sensory representation that results in an output representation in which regions of transition (e.g. “edges”) are selectively emphasized. The mechanisms mediating contrast enhancement in different systems are diverse, depending critically on the breadth of the contrast enhancement function as well as on the modality of the representation.

### Characteristics

#### Quantitative Description Across Modalities and Scales

The utility of contrast enhancement is broadly familiar from photography, particularly digital photography, in which it is employed to help compensate for the physical limitations of photographic equipment in comparison to the capacities of the human visual system. Indeed, several image processing techniques including contrast enhancement resemble stimulus-transformation processes embedded in animal sensory systems. Interestingly, the essential function of contrast enhancement is remarkably similar among sensory modalities (e.g. vision, audition, olfaction) as well as between these biological systems and photographic image processing, although the algorithms and neural mechanisms mediating this transformation differ substantially according to the differing constraints of these systems.

Contrast enhancement is a general term encompassing a range of related operations distinguished by *scale* (or *breadth*), which in this context refers to the maximum distance from any given point in an image or sensory representation at which local activity exerts an influence over the contrast enhancement operation. The simplest, smallest-scale contrast enhancement operation is edge enhancement (Figs. 1a–c).

Neighboring points in a sensory representation (or photographic image) that differ in intensity (e.g. brightness) are transformed so that these differences are accentuated. Specifically, local changes in intensity are emphasized by increasing *acutance*, the local derivative of intensity with respect to space. In digital photography, the most common algorithm for edge enhancement is the

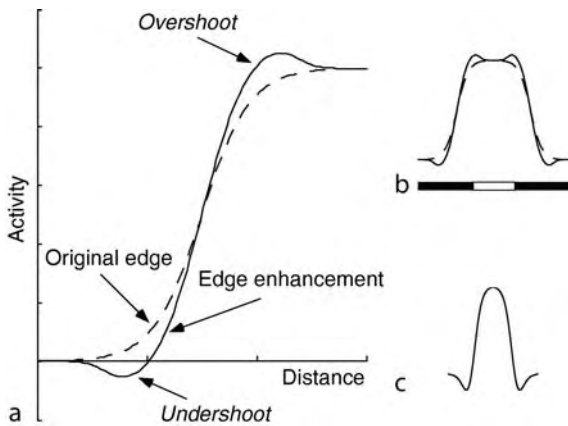

**Contrast Enhancement. Figure 1** Contrast enhancement functions. In all figures, the abscissa represents distance in the appropriate metric space (e.g. spatial location for visual retinotopy, frequency for audition, or odor similarity for olfaction), whereas the ordinate represents activity. (a) Edge enhancement. The original edge of the image or representation (dashed line) smoothly transitions from a low-activity (e.g. dark) region to a high-activity (e.g. bright) region. After edge enhancement (solid line), the acuteness (maximum slope of the curve) has been increased. Additionally, both unsharp masking and lateral inhibition can produce regions of overshoot adjacent to the edge, which further emphasize the transition. This is the basis for the perception of Mach bands. (b) The “Mexican hat” function representing on-center/inhibitory surround contrast enhancement, here depicted in one dimension. Dashed line: activity profile induced by a stimulus (white bar) on a blank background (dark bar). Solid line: activity profile after edge enhancement. (c) Another form of the Mexican hat function in which the activated region is smaller than the scale of the contrast enhancement function and hence can be approximated by a point. Consequently, this form of the function does not exhibit prominent overshoots, though it does exhibit undershoots (surround inhibition).

► **unsharp mask**, whereas in the retina of the eye (for example) this transformation is instead mediated by lateral inhibitory synaptic interactions among neighboring neurons. Because both these operations utilize only information from immediately adjacent locations within the representation, they are considered to operate on the smallest relevant scale. At the other extreme of scale, in which the unsharp mask is uniform or, equivalently, lateral inhibitory interactions are uniform in strength and connect all possible pairs of neurons irrespective of distance, the resulting transformation is a global normalization roughly comparable to a *z*-score [1]. Winner-take-all and winner-take-most algorithms are potential variants of this global-scale contrast enhancement operation.

Contrast enhancement operations acting at intermediate scales are of considerable computational interest in

neural systems. Potentially, they can address the global dynamic range problem created by sensory scenes in which different regions of potential interest exhibit substantially different mean intensities. Normally, in sensory scenes with distinct regions exhibiting widely different mean intensities, a simple optimization of the sensory system for the properties of one selected region renders it correspondingly poorly optimized for dissimilar regions. For example, setting a camera to capture the detail of a well-lit surface can result in the detail of darker regions within that photograph being lost. In digital image processing, local contrast enhancement, which operates on a scale between edge enhancement and global normalization, alleviates this problem by transforming images with respect to the intensity of a somewhat broader region surrounding each point. The underlying algorithm is typically a simple unsharp masking on a larger scale (i.e. greater blur distance) than is used for edge enhancement; however, superior results can be obtained by utilizing more complex, scene-dependent adaptive transfer functions integrating multiple independent samples. The analogous operations in biological sensory systems are topics of substantial interest and debate.

In each of these examples, an ordered topology among sensors is a necessary prerequisite for contrast enhancement computations. That is, the array of sensors must be somehow organized so that computations can be selectively performed among sensors with respect to the similarity (or degree of overlap) of their receptive fields. The degree of receptive field dissimilarity is referred to as *distance* – not necessarily based on physical space but rather on a distance ► **metric** based on this ordered topology of stimulus similarity. For example, in digital image processing, creating an unsharp mask requires specification of the blur distance, which in turn requires a metric with which to compute distance and proximity in visual space. In the retina, physically neighboring visual neurons mediate correspondingly similar spatial receptive fields; hence, physical proximity naturally reflects receptive field similarity. In the auditory modality, the analogous similarity metric is frequency. While frequency is not an intrinsically spatial stimulus feature, the ordered distribution of frequency selectivity along the cochlea again enables the physical proximity of higher-order sensory neurons to reflect the similarity of their receptive fields. That is, these two neural systems are organized specifically so as to be able to utilize physical proximity to represent receptive field similarity, which renders effective the use of neural algorithms dependent on physical proximity, such as nearest-neighbor lateral inhibition. This solution is not effective in all modalities, however, as is discussed below.

Contrast enhancement is in essence a nonuniform rescaling of intensity information across a sensory scene that accentuates certain features of the sensory



scene in exchange for a theoretical loss of absolute intensity information among those features. (This may result in little practical loss when the absolute range of intensities exceeds the instantaneous dynamic range of the sensory system). The scale of the contrast enhancement operation determines its function, which can range from edge enhancement at the smallest scales to global intensity normalization (e.g. exposure control) at the largest scale, with substantial potential at intermediate scales to contribute to selective feature extraction. While these definitions and principles are generally applicable, effective neural mechanisms for computing contrast enhancement operations depend critically on the properties and constraints of each sensory modality.

### Olfactory Contrast Enhancement

Contrast enhancement operations are clearly evident within the olfactory system. Specifically, they are directly observable in the activity profiles of second-order principal sensory neurons, known as mitral cells, located within the olfactory bulb [2] (Fig. 2a).

Odor stimuli evoke characteristic activity profiles across a broad range of different primary olfactory sensory neurons (OSNs); some OSNs become strongly activated by a given odorant while others are activated weakly or not at all. OSNs synapse directly onto mitral cell dendrites, as well as onto periglomerular cell spines which subsequently inhibit the same mitral cell dendrites (Fig. 2b). Consequently, mitral cell responses to odorants can be either predominantly excitatory or inhibitory, and have been shown to exhibit “Mexican hat” tuning curves for odor stimuli; i.e. odorants that are structurally and perceptually similar to those evoking peak activity in a given mitral cell evoke the strongest inhibitory responses from that cell (Figs. 1c and 2a). In other words, mitral cell response profiles exhibit “on-center, inhibitory surround” receptive fields, in which the metric that defines this “surround” is based on chemical similarity rather than on physical space. This unique similarity metric necessitates an underlying neural mechanism quite different from those utilized by the visual and auditory systems.

### Principles of Operation

Olfactory contrast enhancement and its underlying neural mechanisms exhibit important differences from their visual and auditory counterparts. First, of course, the similarity metric in olfaction is unique. In visual *retinotopy*, neuronal receptive fields naturally overlap in proportion to their spatial proximity; in audition, the cochleotopic mapping of auditory frequency selectivity accomplishes the same effect, enabling spatial proximity to be utilized as a proxy for receptive field similarity in subsequent neural computations. Consequently, nearest-neighbor lateral inhibitory synaptic interactions are able to mediate small-scale contrast

enhancement in both these systems, though in audition the similarity metric is defined along the single dimension of frequency rather than the two-dimensional matrix of retinotopic space. The similarity metric in olfaction is somewhat more complex. Primary olfactory receptivity is mediated by ligand-receptor interactions between odorant molecules and a population of hundreds of different cell surface receptors expressed (in vertebrates) in ciliary membranes lining the olfactory epithelium within the nasal cavity. The different classes of olfactory receptor each respond to a range of structurally related molecular epitopes (*odotopes*; [4]), and the chemical receptive fields of different receptor classes overlap substantially, such that even single-molecule odorant stimuli can evoke activity in a substantial number of differently-tuned sensory neurons. Because of these broad receptive fields, structurally similar odorant molecules evoke correspondingly overlapping patterns of activity in the olfactory bulb and their odors are perceived as correspondingly similar in quality [5]. However, because of the number of receptor classes, the similarity metric is also high-dimensional (in principle, the number of dimensions should correspond to the number of different odorant receptors expressed; [4]). Consequently, a distance matrix of odorant similarities, whether defined perceptually or in terms of neuronal activation profiles, cannot be continuously mapped onto a one- or two-dimensional surface as can the cochleotopic or retinotopic maps of the auditory and visual modalities. Rather, such **metric spaces** must be mapped discontinuously when mapped onto lower-dimensional spaces such as the two-dimensional cortical layer of the olfactory bulb, thereby exhibiting exactly the sort of fragmented topology exhibited in the glomerular layer of the olfactory bulb. Nearest-neighbor lateral inhibition is therefore ruled out as a possible underlying neural mechanism for olfactory contrast enhancement.

Olfactory contrast enhancement entails sharpening mitral cell receptive fields so that the population activated by a given odorant is more specific and the overlap between the representations of similar odorants is correspondingly reduced. That is, an operation must be performed that is analogous to lateral inhibition, but that is effective in a high-dimensional metric space. A non-topographical mechanism for olfactory contrast enhancement has been proposed that is independent of the proximity among activated neurons, combining a small-scale contrast enhancement mechanism with a qualitatively distinct global-scale mechanism mediating feedback normalization among activated mitral cells [1,3]. While the mechanisms are unrelated, the resulting transformation is comparable to that which would be mediated by a “lateral” inhibitory mechanism mapped directly onto the high-dimensional topology of similarity among OSN receptive fields.

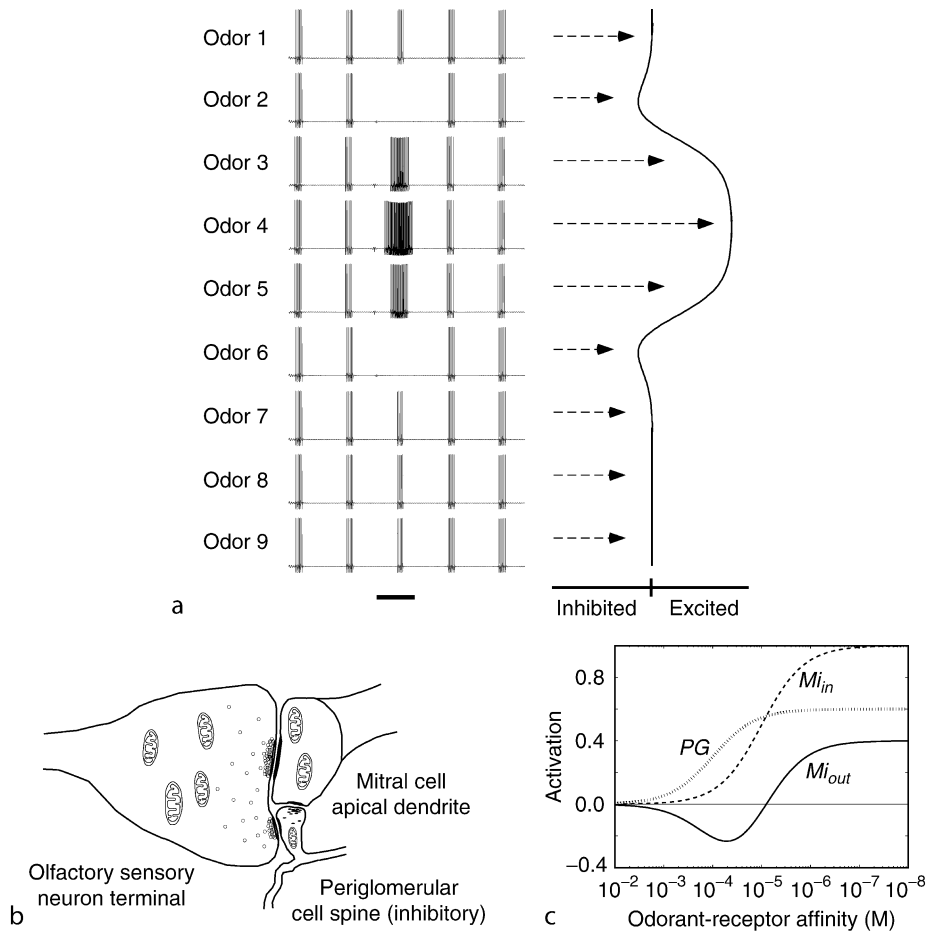

**Contrast Enhancement.** Figure 2 Features of olfactory contrast enhancement. (a) Computational model of non-topographical contrast enhancement [3] replicating the canonical demonstration of olfactory contrast enhancement among olfactory bulb mitral cells [2]. Activity from a single mitral cell is illustrated over five inhalation cycles; the cell exhibits weak periodic background activity in response to inhalation of room air. One 2-second odor stimulus is delivered during the third inhalation cycle (denoted by black bar). Nine different odors are presented that vary sequentially in structural and perceptual similarity (odors 1–9, corresponding to a homologous series of  $n$ -aliphatic aldehydes in [2]). Here, odor 4 is near the center of this cell's receptive field, with its neighboring odors also evoking activity and odors 2 and 6 evoking a net inhibition. This response profile reflects a Mexican hat contrast enhancement function, as illustrated to the right, based on a metric of odor similarity. (b) Illustration of the synaptic triad between OSN axonal terminals, mitral cell apical dendrites, and the spines of inhibitory periglomerular interneurons. OSN activity is communicated to the mitral cell both directly as excitation and via the periglomerular cell as inhibition. (c) Illustration of the central principle of non-topographical contrast enhancement [3]. The higher input resistance and smaller volume of periglomerular spines (PG) is proposed to generate a more sensitive voltage response to similar OSN inputs compared with mitral cell dendrites ( $Mi_{in}$ ), but also to saturate at a level that the latter can overcome. The result is a nonmonotonic "half-hat" response profile of mitral cells to odors of varying quality ( $Mi_{out} = Mi_{in} - PG$ ), in which high-affinity odors evoke excitation, medium-affinity odors evoke inhibition, and low-affinity odors evoke no response from mitral cells, yielding odor response profiles as shown in a. Further details in [1,3,4].

### Regulation of Olfactory Contrast Enhancement

Many factors – behavioral, situational, pharmacological, and genetic – affect the perceptual differentiation among similar odorants that is influenced by contrast enhancement. The clearest correspondence to date between such perceptual differentiation and the regulation of contrast enhancement at the neural circuit

level, however, is the neuromodulation of olfactory bulb circuitry by acetylcholine. Nicotinic cholinergic agonists excite both mitral and periglomerular neurons in the olfactory bulb [6], yielding a concerted response predicted by the non-topographical contrast enhancement model to sharpen mitral cell tuning curves. Indeed, infusion of cholinergic agonists into

the olfactory bulb evokes sharper behavioral differentiation among odorants [7]. The implication of this example is that olfactory contrast enhancement is plastic, with differentiation among odor representations dynamically regulated in accordance with variables such as learning, motivation and behavioral state.

### Contrast Enhancement and Olfactory Function

The function of contrast enhancement in any system is to differentially emphasize particular features within a sensory scene. Traditionally, this process of feature selection is discussed with reference to the physical attributes of sensory scenes: e.g. visual edges, or the relative differentiation among structurally similar odorant stimuli; however, this is not a requirement. Feature selectivity filters at any level comprise essentially the same operations as are here termed contrast enhancement. Of particular interest in the olfactory system are the potential contrast enhancement capabilities of the external plexiform layer – a deeper layer of the olfactory bulb in which mitral cell secondary dendrites interact reciprocally with inhibitory granule cells and hence indirectly with each other. That is, this layer mediates lateral inhibition among mitral cells, though the pattern of this inhibition does not appear to reflect a two-dimensional center-surround architecture [8,9]. While it has been argued that this processing layer lacks the full complement of afferent information necessary to mediate contrast enhancement with respect to physical stimulus attributes [3,4], it appears architecturally capable of manipulating high-dimensional stimulus representations, and hence of mediating feature-selective operations on odor representations using arbitrary scales and masks that are not constrained by the externally-defined odotope similarity metric. For example, these masks may reflect prior odor experience and olfactory learning and could contribute to complex processing such as the binding of multiple structurally-unrelated odorant features into unitary odor percepts. However, while the circuitry and synaptic interactions within this layer are clearly plastic and responsive to odor learning [10], the function of this post-glomerular circuitry remains unclear.

Contrast enhancement is a general term for what might in retrospect be more broadly referred to as selective feature enhancement, and is a ubiquitous process in sensory systems. While the operational principles are common across sensory modalities, the basic properties of the olfactory modality necessitate underlying mechanisms for contrast enhancement that are dissimilar from those operating in other sensory systems. Neuromodulatory regulation of receptive field stringency in second-order olfactory principal neurons, and the plasticity of bulbar circuitry in response to olfactory discrimination learning, identify these contrast enhancement mechanisms as a crucial part of the adaptive plasticity of an active sensory system.

## References

1. Cleland TA, Johnson BA, Leon M, Linster C (2007) Relational representation in the olfactory system. *Proc Natl Acad Sci USA* 104:1953–1958
2. Yokoi M, Mori K, Nakanishi S (1995) Refinement of odor molecule tuning by dendrodendritic synaptic inhibition in the olfactory bulb. *Proc Natl Acad Sci USA* 92:3371–3375
3. Cleland TA, Sethupathy P (2006) Non-topographical contrast enhancement in the olfactory bulb. *BMC Neurosci* 7:7
4. Cleland TA (2008) The construction of olfactory representations. In: Holscher C, Munk M (eds) *Mechanisms of information processing in the brain: encoding of information in neural populations*. Cambridge University Press, Cambridge, UK
5. Cleland TA, Morse A, Yue EL, Linster C (2002) Behavioral models of odor similarity. *Behav Neurosci* 116:222–231
6. Castillo PE, Carleton A, Vincent JD, Lledo PM (1999) Multiple and opposing roles of cholinergic transmission in the main olfactory bulb. *J Neurosci* 19:9180–9191
7. Mandairon N, Ferretti CJ, Stack CM, Rubin DB, Cleland TA, Linster C (2006) Cholinergic modulation in the olfactory bulb influences spontaneous olfactory discrimination in adult rats. *Eur J Neurosci* 24:3234–3244
8. Willhite DC, Nguyen KT, Masurkar AV, Greer CA, Shepherd GM, Chen WR (2006) Viral tracing identifies distributed columnar organization in the olfactory bulb. *Proc Natl Acad Sci USA* 103:12592–12597
9. Xiong W, Chen WR (2002) Dynamic gating of spike propagation in the mitral cell lateral dendrites. *Neuron* 34:115–126
10. Wilson DA, Stevenson RJ (2006) *Learning to smell: olfactory perception from neurobiology to behavior*. Johns Hopkins University Press, Baltimore, MD

## Contraversive

### Definition

Directed toward the contralateral side.

## Control

GRAHAM C. GOODWIN<sup>1</sup>, ARIE FEUER<sup>2</sup>  
<sup>1</sup>ARC Centre for Complex Dynamic Systems and Control, Department of Electrical and Computer Engineering, The University of Newcastle, NSW, Australia

<sup>2</sup>Electrical Engineering, Technion, Israel

### Definition

Control is a generic term used to describe the process of acting on a system to cause it to behave in some

desirable fashion [1,2]. A control system typically comprises of four components. These are the physical system to be controlled, ►sensors used to measure the current behavior of the system, ►actuators used to apply “forces” to the system to affect its behavior and an associated algorithm that commands the actuators. A typical control system combining these four components is shown in Fig. 1.

The “control law” in Fig. 1 can often be further decomposed into a “feedforward” component and a “►feedback” component as shown in Fig. 2.

### Description of the Theory

Control design consists of designing the algorithm. Typically, the algorithm uses both the desired behavior and the output of the sensors. The latter provides feedback of the current behavior.

Control systems appear in many areas including biology, industry, economy, etc. Three illustrative examples are:

1. In biology: We sense using our eyes; we use our hands as actuators and our brain implements the algorithm.
2. In automobile cruise control: We sense vehicle speed; we use the throttle as an actuator to cause the engine to deliver torque to the wheels that, in turn, changes the speed. The algorithm is typically implemented in a small on-board computer.
3. The human heart: This is an example of a complex biological control system with multiple interacting sensors and actuators that are part of the autonomic nervous system [3]. Actuation occurs via the parasympathetic and sympathetic nervous system. The former can release acetylcholine, which slows the rate of the heart whilst the latter can release nor-adrenaline, which can speed-up the heart beat. Blood flow to individual tissues is regulated by local control systems in a cascaded structure. When the overall demand exceeds the capacity of the pulmonary circuit then outer control loops come into play. Sensors measure  $O_2$ ,  $CO_2$  and pH (via

chemical receptors) and blood pressure (via stretch receptors).

The central nervous system uses this information to control breathing, heart rate and blood flow via “feedback” control systems. There also exist “feedforward” components, which respond to emotions and anticipation of future activity (flight or fight).

Control has a long history [4] in engineering, beginning with windmills that automatically pointed into the wind and clocks that regulated their speed. A boost to control theory occurred during the industrial revolution when steam power was harnessed to drive engines used in textiles and other manufacturing enterprises. A well-known invention from that period was the fly ball governor [4], which was a mechanism to regulate the speed of a steam engine under different load conditions. Referring to Fig. 1, in the fly ball governor, the engine speed was sensed by two fly balls that were thrown outwards by centripetal forces as the engine rotated. This action was connected via a system of levers (the “algorithm”) to a throttle valve (the actuator) which changed the flow of steam to the engine. The basic idea of this device was that, if the engine sped up, the fly balls would swing out and this would cause the throttle valve to close, thus delivering less steam to the engine thereby causing it to slow down, i.e., to return to the desired engine speed. One can well imagine that feedback mechanisms of this type can sometimes fail to yield satisfactory behavior. In particular, if the adjustments to the throttle are too large in comparison with the changes in speed, then one can obtain self-sustaining oscillation, or worse, the system can shut down or over-speed. Thus, science is needed to design the feedback gains so that the system operates properly.

### States, Controllability, Observability and Stability

Four key concepts that arise in the context of control are those of “►state,” “►controllability,” “►observability,” and “►stability” [1]. These ideas are briefly described below.

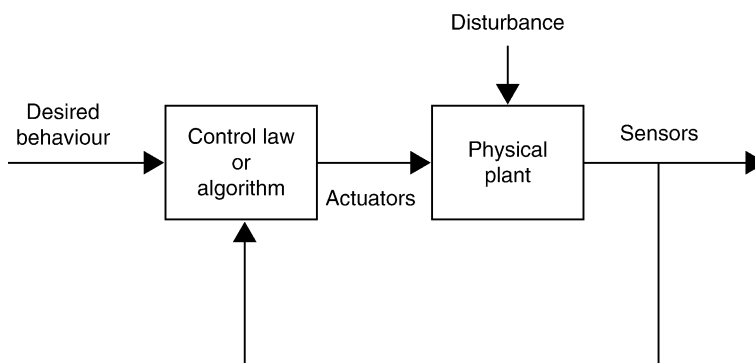

**Control. Figure 1** Control system.

The current state of a system describes the values of those variables, which together with the future inputs to the system uniquely define the subsequent response [1,5]. Thus, we sometimes loosely talk about the “state” of the economy. In engineering systems, the state is often a way of summarizing the current internal energy of a system. The state will typically consist of a multidimensional vector of quantities. Obviously, knowing the current state of a system is extremely helpful in determining what input trajectories to apply (via the actuators) to cause the subsequent response of the system to correspond to some desirable behavioral pattern.

In some cases, one has enough sensors available to measure the full state vector. This is the most desirable situation for a control system. In other cases, the available sensors will only give direct information about a sub-set of the states. However, by observing the available sensor data over a non-infinitesimal time interval, one can sometimes reconstruct (or calculate) the current state vector. If this is possible, then we say that the system is “observable” from the given sensors [5,6]. The property of “observability” has been well studied. For simple systems (i.e., those exhibiting linear time invariant behavior), simple ways exist of testing a model to see if it is observable for the given sensors [1,5].

A related question is the following: Say we know (or can estimate) the current state, does a sequence of input changes exist over a future time period (a few minutes, hours or days), which we can apply via the actuators to cause the state to go from its current value to some desirable value. This property is called “controllability” [5,6]. We say that a system is controllable (using the given actuators) if the state can be taken from one point to another. Obviously, controllability is a highly desirable property. We only need to think of the problem of dieting, i.e., does a program of food consumption exist that will cause our body’s state (weight, cholesterol levels, sugar levels, resting blood pressure) to go from some given initial value to some desired final value over a given period of time. Controllability is a very well studied question. For simple systems (i.e., those exhibiting linear time invariant behavior), simple ways exist of testing a model to see if it is controllable from the given actuators [1,5].

One may imagine that controllability and observability are important properties of a system. Indeed, many of the standard methods for control system design depend on the satisfaction of these core properties for their success [6,7].

Another core property of dynamical systems is that of stability [1,2]. A system is said to be stable if it returns to some equilibrium condition after it is perturbed. A system that is not stable can either oscillate or exhibit divergent behavior. We say that a physical

system is “open-loop stable” if it is stable when considered in isolation. We say that a feedback control system is “closed-loop stable” if the full control system acts in a stable fashion with the controller attached.

Feedback can be used to turn an open-loop unstable system into a stable closed-loop system. However, feedback, if inappropriately applied, can also have the contrary effect, i.e., feedback can lead to instability if the gains around the loop are too high. For example, readers may have experienced the high-pitched whistling sound that is often heard in concert halls when a high gain feedback loop is inadvertently formed from the loud speakers to the microphone and back to the speakers through the audio amplifiers. This is an example of an unstable feedback loop. This behavior is generally highly undesirable (unless one is deliberately trying to produce an oscillation). A notorious example of an unstable control system was the circumstances that led to the Chernobyl explosion. In engineering feedback control systems, one usually makes stability a major design objective.

### Internal Models in Control

Readers are referred to the companion article on “internal models.” For simple cases (e.g., systems that are open-loop stable and have linear time invariant dynamics) it can be shown that all control laws that yield a stable closed-loop must explicitly or implicitly contain an internal model of the system. Indeed, it can be shown that for the simple case referred to above, all stabilizing linear control loops can be redrawn as in Fig. 3, [1,8]. The components inside the dotted line in Fig. 3 represent the control law shown in Fig. 1. In this context, the art of control system design amounts to choosing the contents of block 1 and 2 in Fig. 2. These blocks typically contain a “good” approximation to the inverse of the model, where the term “good” at a minimum includes the fact that block 1 and block 2 must be stable when considered in isolation. Typical control system design methods described in the engineering literature ( $H_\infty$ , LQG, etc.) [1,6,7] are basically algorithms for choosing block 1 and block 2, so that they are good “approximations” to the inverse of the model (where “good” is measured by some specific criterion).

Thus, control laws also contain approximate “inverse models” [1].

### Further Properties of Control Systems

As mentioned above, closed-loop stability is a core requirement of most feedback control systems. Other desirable properties are as follows (here we refer to Fig. 3):

1. Insensitivity of the output response to errors in the model of the system

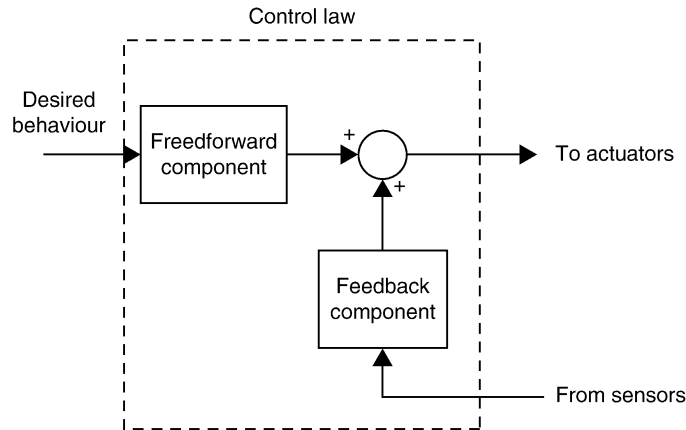

**Control. Figure 2** Decomposition of control law into feedforward and feedback components.

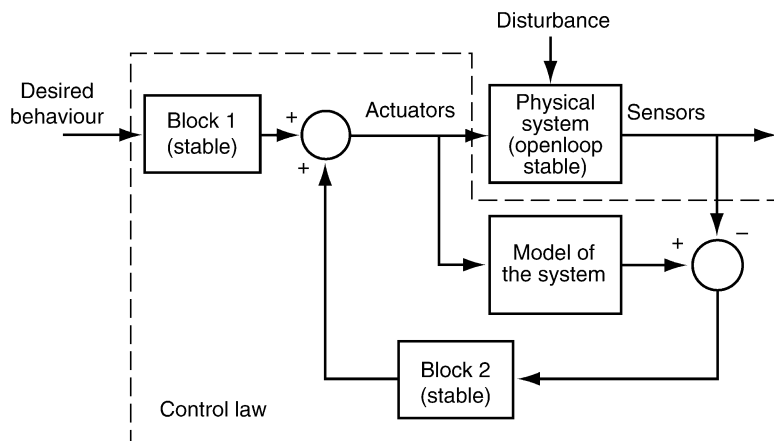

**Control. Figure 3** The control law in the Internal Model form.

2. Insensitivity of the output response to disturbances
3. Insensitivity to errors in block 1 or block 2

The feedforward component of a control law (see Fig. 2) is maximally sensitive to errors in the model, since its behavior is predetermined without “seeing” what actually happens. On the other hand, the feedback component of a control law (see Fig. 2) usually has reduced sensitivity, since the control actions (as applied to the actuators) are moderated by what actually happens (i.e., the sensors give immediate “feedback” on what is actually happening).

Indeed, one of the principal advantages of feedback is that it helps achieve reduced sensitivity [1]. In particular, provided closed-loop stability is retained, then output sensitivity typically decreases proportionally to the loop gain. (i.e., the product of all gains around the loop). The most common control law used in industry is a Proportional-Integral-Derivative (PID) controller [1,2,4]. These controllers have a key property

in that they have infinite gain in steady state (due to the integral term). Hence, the output response is total insensitivity to steady state disturbances when a PID controller is employed.

### Fundamental Limitations for Control Systems

In common with all physical systems, feedback control systems are subject to fundamental limitations, i.e., there are some things that just cannot be achieved based on the available sensors and actuators [9]. Issues that limit the achievable performance include:

1. Actuator amplitude limits and slew rate limits, i.e., there is usually a maximum input that can be applied and a maximal rate that an input can be changed [10].
2. Time delays in the sensor system – if the sensors give us “old data,” then we need to be very careful in applying large corrective forces via the actuators, since the system may have “moved on” making the

data from the sensors obsolete and hence potentially destabilizing [9].

3. Inverse response – many systems have the annoying property that they initially respond in the wrong direction. Inverse response limits how quickly a system can be forced to respond, since the magnitude of the response in the wrong direction typically increases as one tries to move the system faster [9]. (The reader can check this claim by balancing a stick on his/her hand. First notice that this system exhibits an inverse response, i.e., if you want to move the balancing position left then you must first move to the right. Also, notice that the faster you try to go left then the further you need to go in the inverse direction.)
4. Modeling errors, i.e., errors between the true system dynamics and the dynamics as captured in the “model.” Errors of this type will eventually lead to closed-loop stability being lost [7], since the control law implicitly takes for granted that the model is correct.

Unfortunately, biological and engineering systems often have the property that their characteristics change due to external influences (e.g., slow changes due to aging or more dramatic changes due to surgery or other interventions). For small changes, the control loop will continue to give satisfactory behavior due to the inherent capacity of feedback to adjust the inputs applied via the actuators to correct errors as seen by the sensors. However, for large changes in the system (i.e., major changes in the dynamics or gains), the control system may begin to exhibit erratic behavior including instability. In such cases, one needs to adjust the internal model used in the control system so that it better approximates the current system characteristics. This leads to the idea of an “adaptive controller” (see companion article).

## References

1. Goodwin GC, Graebe SF, Salgado ME (2001) Control systems design. Prentice Hall, Englewood Cliffs
2. Levine WS (1996) The control handbook. CRC, Boca Raton
3. Pervis WK, Orians GH, Heller HC (1992) Life: the science of biology. Sinauer, Sunderland, MA
4. Bennett S (1988) A history of control engineering: 1930–1955. The Institution of Engineers, Stevenage, UK
5. Kailath T (1980) Linear systems. Prentice Hall, Englewood Cliffs
6. Kwakernak H, Sivan R (1972) Linear optimal systems. Wiley-Interscience, New York
7. Zhou K, Doyle J, Glover K (1995) Robust and optimal control theory. Prentice Hall, Englewood Cliffs
8. Desoer C, Liu R, Murray R, Saini R (1980) Feedback systems design: the fractional representation approach to analysis and synthesis. IEEE Trans Automat Contr 25(3):399–412

9. Seron MM, Braslavsky JH, Goodwin GC (1997) Fundamental limitations in filtering and control. Springer, Berlin
10. Goodwin GC, Seron MM, De Dona JA (2004) Constrained control and estimation. Springer, New York

---

## Control System

- ▶ Feedback Control of Movement

---

## Control Theory

- ▶ Modeling of Human Postural Control

---

## Control Treatment

- ▶ Placebo Analgesic Response

---

## Control Variables (CVs), also Central Commands

### Definition

Neurophysiological parameters that, depending on the motor task, may be kept constant or changed by the nervous system; can be specified independently of state variables; effectively influence the latter thus producing intentional motor actions; represent different forms of threshold control.

- ▶ Equilibrium Point Control

---

## Controllability

### Definition

Controllability represents the ability to affect physical system behavior by means of the actuators connected to

it. In terms of system states, it is the ability to move the system from one arbitrary state to another.

► [Control](#)

---

## Controller

### Definition

The device which controls the plant.

► [Neural Networks for Control](#)

---

## Contusion

### Definition

A “brain bruise.” Injury occurring as a result of the brain colliding with the bony and dural surfaces of the skull. Pathologically contusion corresponds to the area of hemorrhagic necrosis on the surface of the cortical gyrus. The severity of the contusion depends on the location as well as mobility of the head during the impact. If the head is injured while immobile, the focus of the primary injury will be located at the impact site, a so called “coup” injury. When the head is struck while moving, the majority of the contusion may be located on the opposite side of the head from impact, a “contra coup” injury. The contusions are most frequently seen on the subfrontal and anterior temporal cortical surfaces, partly due to irregular architecture of the interior of the skull in these areas.

---

## Contusion Injury

### Definition

Spinal cord bruising initiating death of spinal cord cells, loss of spinal tissue.

---

## Contusion Injury Model

### Definition

Contusion injury model is a model of spinal cord injury (SCI) created in animals by bruising the spinal cord. It is

usually made by dropping weights from certain heights or by mechanically applying a certain force. The pathophysiology of contusion injuries is rather similar to that of SCI in humans. Other SCI models that have been established are the transection model (complete transection of the spinal cord), and the hemisection model (half cut model), etc.

---

## Convergence Neurons

► [Near Response Neurons](#)

---

## Convergent Eye Movement

### Definition

Adduction of the eyes to view a nearer target.

---

## Conversion Disorder

► [Hysteria](#)

---

## Convex Hull

### Definition

In two-dimensional systems, a minimum convex polygon.

► [Evolution and Brain-Body Allometry](#)

---

## Convolutions

### Definition

The gyri and sulci (“hills and valleys”) of the cerebral cortex.

► [Evolution of the Brain in Humans – Paleoneurology](#)



## Convulsant Drugs

### Definition

Group of drugs, which can induce ►seizures. These drugs include antagonists of ►glycine receptors (e.g., strychnine) and antagonists of the ►GABA<sub>A</sub> receptor (e.g., bicuculline and picrotoxin).

- GABA
- Glycine

## Coordinate Systems for Head Rotations

### Definition

Head angular rotations are usually described as rotations about cardinal axes. Rotations about the vertical axis are called yaw, those about the interaural axis pitch and those about naso-occipital axis roll.

## Coordination

MARK L. LATASH

The Pennsylvania State University, University Park, PA, USA

### Synonyms

Dexterity; Skill; Adroitness; Synergy

### Definition

The word “coordination” is used in two general meanings. First, as an ability to perform motor tasks in an efficient way (synonymous to dexterity or skill, e.g., “your child has good coordination”). Second, as a purposeful pattern of actions by a set of effectors (synonymous to ►synergy, e.g., “hand function depends on coordination of the digits”). Coordinated motor patterns have been viewed as resulting from an action by the central nervous system (CNS) confronted by the problem of *motor ►redundancy*, also known as the ►Bernstein problem [1,2], and constrained by factors related to the environment and the body mechanics [3]. Redundant motor systems can be described with elemental variables (►degrees-of-freedom, DOFs) whose number is larger than the number of constraints imposed

by typical motor tasks. Theoretically, such systems have an infinite number of solutions for specific motor tasks. Two major views on the origin of motor patterns observed in redundant systems have dominated the studies of motor coordination. First, that coordination results from elimination of the redundant DOFs by the CNS [1], possibly based on certain optimization criteria. Second, that no DOFs are ever eliminated, but they are all used to stabilize particular performance variables – the principle of ►abundance [4]. According to the latter view, coordination within multi-element systems has been assumed to result from organizing elements into ►synergies, defined as particular neural organizations of elemental variables that stabilizes a required value or a time profile of important performance variable(s). Within the ►dynamic systems approach, coordination has typically been viewed as a particular stable phase relation between actions of a set of effectors [2,5].

### Characteristics

#### Quantitative Description

Coordination has been notoriously hard to quantify, largely because of the lack of agreement on what constitutes coordination. In recent studies, coordination (synergies) has been quantified using measures of stability of motor patterns commonly applied to analysis of cyclic actions within the *dynamic systems* approach to movement studies [5], principal component analysis, comparison of actual and surrogate data sets created using patterns of elemental variables selected randomly from different attempts at a task [6], and analysis of co-variation of elemental variables within the framework of the ►uncontrolled manifold (UCM) hypothesis [7]. Within the last approach, variance in the state space of elemental variables is quantified within a subspace (a UCM), corresponding to a certain value of a hypothetically important performance variable and orthogonal to that subspace. Comparing the two variance magnitudes per DOF within each subspace allows to conclude whether the elemental variables are coordinated to stabilize the performance variable. This method has been used to quantify coordination in healthy young persons performing various motor tasks, as well as atypical coordination in special subpopulations, such as persons with Down syndrome, healthy elderly, and patients after stroke. It was also used to track changes in coordination that occur with practice.

#### Higher Level Structures

Coordination is a complex phenomenon that probably cannot be associated with a single neural structure or a subset of neural structures. Cerebellum has been traditionally viewed as a brain structure directly related to motor coordination [8], partly based on observations of impaired coordination in animals with cerebellar

lesions and patients with cerebellar disorders. However, coordinated limb movements can be observed in animals without the cerebellum, and even in animals whose spinal cord is surgically separated from the brain. Typical examples include spinal locomotion, wiping reflex, and scratch reflex. Apparently, different parts of the CNS are able to produce coordinated motor actions, and the natural coordination in intact animals is a result of a combined action of numerous structures within the CNS. This conclusion is indirectly supported by observations of impaired coordination in cases of virtually all neurological disorders.

### Lower Level Components

Coordinated action has been studied for groups of elements at different levels of description of the human behavior. Most studies of motor coordination analyzed it at the level of muscle interaction, joint interaction, or effector interaction during complex actions such as locomotion, vertical posture, ►prehension, and speech. However, coordination of motor actions at “higher” (inter-personal coordination, e.g., coordinated actions of players of a football team) and “lower” (e.g., coordination of motor units within a muscle) levels has been addressed. One of the most influential hypotheses of motor control, the ►equilibrium-point hypothesis [9], may be viewed as being associated with establishing a coordination law that stabilizes equilibrium states of the neuromotor system comprised of the organism and environment. According to this hypothesis, the CNS parametrizes the neuromotor system, and synergies emerge following the natural tendency of the system to reach a steady-state.

### Higher Level Processes

Coordination may be viewed at levels that transcend the motor function. In particular, grammar may be viewed as coordination of words within a language, inter-personal interactions may be viewed as governed by coordination laws, and even the world economy may be viewed as resulting from a (poorly) coordinated action of local economies. Studies of autism have suggested that this state may be associated with a disruption of coordination at a basic level reflected in impaired inter-personal, language, and motor abilities, possibly causally related to changes in the cerebellar function.

### Lower Level Processes

Coordination has typically been studied as relations within a set of variables (elements, effectors) selected by researchers, largely based on common sense and intuition. There is no unambiguous definition for an elemental variable. Depending on the level of analysis, elemental variables could be related to outputs of individual motor units, muscles, joints, limbs, digits of the hand, speech articulators, persons, etc. Elemental

variables can be characterized by a certain irreducible level of variability in their outputs. Coordination of several elemental variables implies that they contribute to a common task in a certain way (sharing), and deviations of their outputs from a preferred pattern co-vary to stabilize a pattern of an important task-related variable (error compensation). Correspondingly, synergies can be characterized by two indices related to sharing (relations among average patterns of elemental variables) and error compensation (relations among dispersions of elemental variables across several attempts at the same task). Variability of elemental variables may be viewed as consisting of two components, one of which affects a selected performance variable (“bad” or non-goal-equivalent variability) while the other does not (“good” or goal-equivalent variability). Synergies stabilize performance variables by making most of the variability of elemental variables “good.” Several performance variables may be stabilized simultaneously if a sufficient number of elemental variables are available. For example, studies of digit coordination during human prehension has shown the existence of at least two synergies (null-spaces) related to grasping the object with sufficient strength and ensuring its rotational equilibrium.

### Process Regulation

Task-specific co-variation of elemental variables, which stabilize important performance variables, may be viewed as a process of formation of corresponding null-spaces within the space of elemental variables by the CNS, and channeling most of the variability into the null-spaces. Neural processes participating in the formation of such null-spaces are unknown. An optimal feedback control mechanism has been suggested to ensure stabilization of performance variables by coordination of elemental variables [10]. Coordination can also be based on central back-coupling mechanisms, using efferent copies of outputs of neural elements directly related to elemental variables. Possible involvement of different neural structures including the spinal cord, the cerebellum, and the cortex of the large hemispheres into regulation of coordination has been documented using electrophysiological methods and brain imaging techniques. Developmental studies have shown that elements of motor coordination exist immediately after birth, but much of the repertoire of human coordinated actions is discovered by the CNS over the first months and years of life. Practice is a commonly used method to improve coordination or develop new coordinated actions. A decline in motor coordination is seen with advanced age.

### Function

Coordinated movements are expected to show two features that seem hardly compatible: Stability of performance in the presence of unavoidable unpredictable

changes in the environment and within the neuromotor system, and flexibility of performance in cases of quick modifications of the task and/or major changes in external conditions. The former aspect of coordination has dominated movement studies. Correspondingly, coordination has been frequently quantified using indices that describe stability of the system's behavior [5]. However, coordinated actions may be purposefully organized to destabilize aspects of motor behavior if the context requires quick modifications of important performance variables. Coordination may also have, as a goal, a perceptual effect (as in some sports such as figure skating and synchronized swimming) or a complex perceptual-motor effect that cannot easily be formalized (as in a stretching exercise).

### Pathology

Virtually all motor pathologies lead to problems with motor coordination. In particular, impaired coordination has been described for movements of patients suffering from cerebellar disorders, Parkinson's disease, systemic neurodegenerative disorders such as multiple sclerosis, peripheral disorders including peripheral neuropathies and myopathies, after stroke affecting the large hemispheres, and after spinal cord injury. Impaired coordination is also seen in atypically developing persons, such as those with cerebral palsy, Down syndrome, and with the Developmental Coordination Disorder, as well as in healthy elderly. Some of the changes in motor coordination may be viewed as adaptive to a pathology and optimal for the actual state of the person's central nervous system and the peripheral neuromotor apparatus.

### Therapy

Disorders of motor coordination have been notoriously difficult to correct. Pharmacological and invasive therapies (such as surgery and implantation of stimulators) typically address more basic and severe consequences of motor disorders including excessive involuntary movements (tremor, spasticity), weakness, inability to initiate actions, etc. Attempts to treat disordinated movements, in particular those observed in patients with dystonia, chorea, and cerebellar disorders have been largely unsuccessful. Physical and occupational therapy have been treatments of choice for coordination disorders. Along somewhat different lines, there has been substantial progress in the development of prosthetic devices such as artificial hands. However, these devices have a limited repertoire of possible actions that are marginally coordinated. The current superficial level of understanding of the neural mechanisms of coordination, has not yet allowed the development of prosthetic devices that would be controlled by the person's CNS, based on the same principles as it uses to control natural actions.

## References

1. Bernstein NA (1967) The co-ordination and regulation of movements. Pergamon, Oxford
2. Turvey MT (1990) Coordination. *Am Psychol* 45:938–953
3. Newell KM (1991) Motor skill acquisition. *Annu Rev Psychol* 42:213–237
4. Gelfand IM, Latash ML (2002) On the problem of adequate language in biology. In: Latash ML (ed) *Progress in motor control, vol 2: structure–function relations in voluntary movement*. Human Kinetics, Urbana, IL, pp 209–228
5. Kelso JAS (1995) *Dynamic patterns: the self-organization of brain and behavior*. MIT, Cambridge
6. Muller H, Sternad D (2004) Decomposition of variability in the execution of goal-oriented tasks: three components of skill improvement. *J Exp Psychol Hum Percept Perform* 30:212–233
7. Latash ML, Scholz JP, Schönner G (2002) Motor control strategies revealed in the structure of motor variability. *Exer Sport Sci Rev* 30:26–31
8. Houk JC, Gibson AR (1987) Sensorimotor processing through the cerebellum. In: King JS (ed) *New concepts in cerebellar neurobiology*. Liss, New York, pp 387–416
9. Feldman AG, Levin MF (1995) Positional frames of reference in motor control: their origin and use. *Behav Brain Sci* 18:723–806
10. Todorov E, Jordan MI (2002) Optimal feedback control as a theory of motor coordination. *Nat Neurosci* 5:1226–1235

---

## Cordotomy

### Definition

A surgical lesion of the anterolateral funiculus used in terminal patients with intractable pain. Prevents nociceptive signals from ascending to the brain by cutting the spinothalamic and other nociceptive pathways.

► [Ascending Nociceptive Pathways](#)

---

## Core and Shell SCN

### Definition

The suprachiasmatic nucleus (SCN) of hamsters, mice, rats and humans is comprised of two fundamentally different regions based on cell size, peptidergic phenotype and morphology, afferent and efferent connections, and patterns of expression of clock genes. The relationship between these two subdivisions is quite consistent among mammalian species. The core

lies closest to the optic chiasm, and the shell largely surrounds the core. The older term for core was ventrolateral and for shell it was dorsomedial. This terminology was based on studies on the rat, where these geographical locations held true. In other species, the SCN still has at least two distinctly different regions, but their location in space may differ from that of the rat, giving rise to the need for new descriptors.

- ▶ Suprachiasmatic Nucleus

## Corollary Discharge

### Definition

A term coined by Roger Sperry in 1950, who studied the opto-motor response in fish. It states that any eye motion that will cause displacement of the visual image on the retina will have “a corollary discharge into the visual centers to compensate for retinal displacement.” This allows the animal to determine whether image motions on the retina were caused by movements of the object or by eye movements of the animal itself. The same principle was simultaneously and independently discovered by Erich von Holst and Mittelstaedt termed “efference copy.” Specifically, the term refers to internal neural correlates of the descending motor command that are involved in the perception of force and in the decoding of muscle spindle responses. Also, in mormyrids, the electric organ corollary discharge (EOCD) is an internal reference of the timing of electric organ discharge (EOD) production.

- ▶ Auditory-Motor Interactions
- ▶ Proprioception: Role of Muscle Receptors
- ▶ Reafferent Control in Electric Communication

## Corollary Discharge Feedback

- ▶ SC – Local Feedback

## Corpora Quadrigemina

- ▶ Inferior Colliculus

## Corpus Callosum

### Definition

The largest commissure of the brain. Connects the two halves of the cerebrum and forms the floor of the longitudinal fissure of cerebrum. Consists of four parts: splenium, trunk, genu and rostrum.

- ▶ Telencephalon

## Corpus Striatum

### Definition

Corpus striatum denotes a heterogeneous collection of several deep telencephalic nuclei, including the caudate nucleus and putamen, which receive massive outputs from the cerebral neocortex and projections from some subcortical structures and the globus pallidus, to which the caudate and putamen project. The globus pallidus itself projects to a number of sites having to do with motor control, including the brainstem reticular formation and via a relay in the thalamus, motor staging areas of the cortex. Although properly including a number of additional structures, such as the amygdala and septal nuclei, the term basal ganglia is conventionally used to denote the corpus striatum and a number of related structures, such as the substantia nigra and subthalamic nucleus, said to comprise the extrapyramidal motor system. Damage to the corpus striatum results in the typically manifest symptoms of chorea, due to disinhibition of the globus pallidus and substantia nigra. Chorea is characterized at an advanced stage by hyperkinesia especially of the distal extremities' musculature and of the face. Dystonic syndrome (e.g., retrocollis, spastic torticollis) or athetosis are also encountered.

- ▶ Basal Ganglia
- ▶ Striatopallidum
- ▶ Telencephalon

## Corpusculum Lamellosum

- ▶ Pacinian Corpuscle Regeneration

## Corpusculum Tactus

- ▶ Meissner Corpuscle Regeneration

## Corrective Saccades

### Definition

These eliminate the remaining error relative to a target position after a primary, main saccade aimed at this position has failed to bring the eye close enough for foveal vision (error due to open-loop nature of saccades). Corrective saccade occur within approximately normal visual latency (200 ms) upon the end of the primary saccade if the error is small ( $\leq 3^\circ$ ) but can be much prompter (130–150 ms) with large errors. If the error is large, corrective secondary saccades can also occur in the absence of visual feedback (target invisible after primary saccade). These characteristics are attributed to the intervention of a non-visual feedback mechanism which, being less precise than visual signals, would be effective only with large errors.

- ▶ Oculomotor Control Saccade, Saccadic Eye Movement

## Correlation

### Definition

A linear measure of the association between two variables. Note that correlation does not imply causation. Correlation between a variable at a certain time instant and itself at other time instances is known as the auto-correlation, while the correlation between two variables is known as the cross-correlation.

- ▶ Signals and Systems

## Correlation Dimension

### Definition

Measure of the size of the attractors in a system. This measure is used to typify the complexity of chaotic systems.

- ▶ Signals and Systems

## Correlational Research

### Definition

An approach, which compares psychophysical and neuronal correlates of sensory performance on a quantitative, descriptive level, by establishing a correlative rather than a material or causal relationship between mental and brain processes. Correlation research was first established in the study of vision by Richard Jung and co-workers and has meanwhile become an established venue of research in modern neuroscience.

- ▶ Psychophysics

## Correlative Neuroanatomy

- ▶ Functional-Anatomical System

## Cortical

### Definition

Related to the cerebral cortex, the outermost layers of the brain.

## Cortical Areas

### Definition

The cerebral cortex in primates is divided into a large number of areas based on criteria such as cyto-, myelo- and/or chemoarchitecture, topographical organization, input-output and intracortical connections, electrophysiological properties of neurons and deficits resulting from local lesions or deactivation (Extrastriate visual cortex). Brodmann's (1909) classification of human cortical areas (Fig.1) is based on cyto- and myeloarchitecture. Von Bonin and Bailey's (1947) classification for monkeys is cruder than Brodmann's (1909) and names areas first according to their location in one of the major lobes (F, frontal; P, parietal; O, occipital;

T, temporal). The subsequent letter has no specific significance, but is one of the initial alphabetic characters. This scheme has been refined and led to further differentiations including, for example, anatomical designations such as “a” for anterior, “c” for caudal etc. For instance, “PGa” denotes the anterior portion of PG (area “G” in the parietal cortex), which is situated rostral to the lateral (Sylvian) fissure close to its posterior end, etc. Some areas are simply designated according to their form or anatomical location, e.g. AIP = anterior intraparietal, or according to their function, e.g. primary motor cortex (MI, M1). Unfortunately, these diverse nomenclatures are often used interchangeably, such that, e.g. Brodmann's area 17 = striate cortex = primary visual cortex = area V1, or Brodmann's area 4 = MI = F1.

## Cortical Atrophy

### Definition

Cortical atrophy refers to a number of neurodegenerative disorders of the ►cerebral cortex, including syndromes such as ►Alzheimer's disease, ►corticobasal degeneration, ►frontotemporal dementia, ►primary progressive aphasia, ►posterior cortical atrophy.

- Alzheimer's Disease
- Corticobasal Degeneration
- Frontotemporal Dementia
- Posterior Cortical Atrophy
- Primary Progressive Aphasia

## Cortical Development

OSCAR MARÍN

Instituto de Neurociencias de Alicante, Consejo Superior de Investigaciones Científicas and Universidad Miguel Hernández, Spain

### Synonyms

Cerebral cortex development

### Definition

Cortical development typically refers to the process by which the cerebral ►cortex is formed in mammals. The development of the cerebral cortex shares some common features with other cortical structures, such as

the cerebellum. However, some aspects of the development of the cerebral cortex are unique to this structure, the highest-order processor of neural function. Cortical development comprises several consecutive phases, which may temporally overlap to a certain extent: induction, patterning, neuronal migration, formation of axonal connections and functional maturation.

## Characteristics

### Higher Level Structures

The cerebral cortex develops from the dorsal region of the most anterior vesicle of the neural tube, the prosencephalon or ►forebrain (Fig. 1).

The anlage of the cortex, also known as the ►pallium, is organized in four main radial subdivisions, the medial, dorsal, lateral and ventral pallium [1]. All pallial domains form cortical structures (e.g. superficial laminar neuronal zones), but the lateral and ventral pallium parts also give rise to deep-lying nuclear structures, integrated in the claustror-amygdaloid complex. Hence not all derivatives of the pallium are part of the cerebral cortex. The medial pallium forms the hippocampal complex and subiculum; the dorsal pallium generates the ►mesocortex and the ►isocortex (also less appropriately known as neocortex); finally, the lateral pallium and ventral pallium are thought to give rise to the primary olfactory cortex, the dorsolateral claustrum and parts of the amygdala (basolateral nucleus, amygdalo-hippocampal area) and periamygdaloid cortex. The lateral pallium and the medial pallium fuse together around the dorsal pallium, forming the allocortical ring around the meso- and isocortex.

The distinct types of cortices are characterized by specific morphological features, among which the number of layers is the most distinctive. The hippocampus and the olfactory cortex consist of three layers each, whereas the isocortex is typically made of six layers. The axonal connections formed by different layers of the cortex are also different. For example, layer II-III pyramidal neurons form connections within the cortex, whereas layer V and layer VI target subcortical structures.

### Lower Level Components

The cerebral cortex contains two major classes of neurons, glutamatergic pyramidal cells and  $\gamma$ -aminobutyric containing (GABAergic) interneurons. The majority of cortical neurons are pyramidal cells (~80%), which are responsible for establishing long connections between different cortical areas and between the cortex and other subcortical regions (pyramidal cells are also known as cortical projection neurons). Interneurons, on the other hand, constitute a rather heterogeneous group of neurons responsible for establishing local circuits in the cortex.

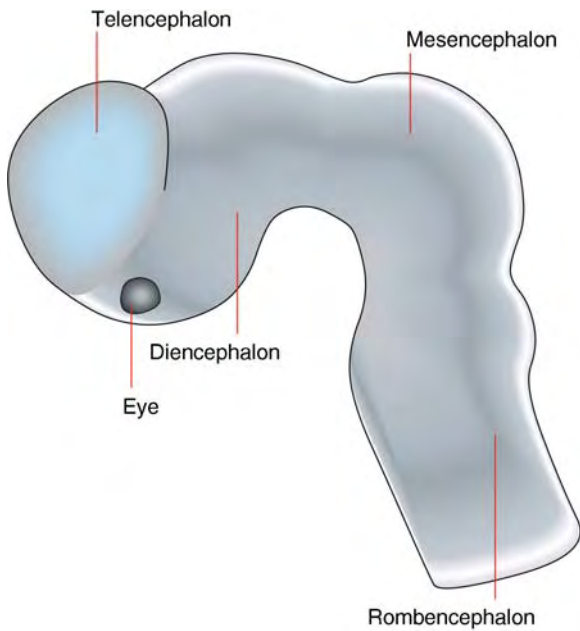

**Cortical Development. Figure 1** Schematic representation of a lateral view of the brain of a mouse embryo at around embryonic day 10, showing its main subdivisions.

### Higher Level Processes

As the cerebral cortex forms from the most anterior region of the neural tube, its development requires first the acquisition of anterior neural character in a process that involves signals emanated from the ►[node](#) and the anterior visceral endoderm. Since the anterior character is the default state of the early neural plate, inhibitors of factors that induce a posterior character are responsible for maintaining anterior neural identity. Additional patterning events specify within the anterior neural plate the territory occupied by the telencephalon, from which the cortex develops. This second patterning process requires signals from the anterior neural ridge, a group of cells located at the junction between the anterior neural and non-neural ectoderm. Subsequently, a dramatic set of morphogenetic movements accompanied by extensive proliferation lead to the transformation of the anterior neural plate into a set of paired vesicles. In parallel to this process, patterning events driven by the dorsal midline and the ►[prechordal plate](#) regionalize the telencephalon into distinct ventral (►[subpallium](#)) and dorsal (pallium) domains, with the later giving rise to the cerebral cortex ([Fig. 2](#)).

Such signaling centers lead to the induction of a combinatorial code of homeodomain and bHLH transcription factors within progenitors at different dorsoventral positions of the telencephalon [2]. In the pallium, this code defines the emergence of at least four distinct territories (ventral, lateral, dorsal and medial

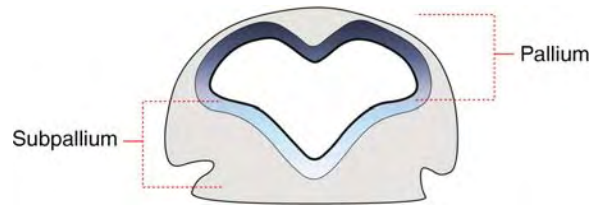

**Cortical Development. Figure 2** Schematic representation of a coronal section through the embryonic day 10 mouse telencephalon, in which the pallial and subpallial domains are delineated.

pallium), which will eventually give rise to different types of cortices.

Cortical projection neurons and interneurons follow largely different developmental programs [3]. In short, projection neurons originate throughout the ventricular zone of the different pallial regions and migrate radially to form the different types of cortices. Interneurons, on the other hand, originate in the ventricular zone of the subpallium and migrate tangentially to the pallium, where they eventually change their mode of migration to settle in specific layers of the cortex. Cell layers within the cortex are generally established according to an inside-out pattern. Accordingly, projection neurons produced simultaneously migrate and stop migrating roughly at the same time, so they all occupy the same cortical layer. GABAergic interneurons tend to adopt the same cortical layer as synchronically generated projection neurons, even though interneurons must migrate through much greater distances than projection neurons and thus require additional time to reach the pallium.

Our understanding of the mechanisms underlying the development of the circuitry that confers functional properties on the cerebral cortex is still relatively poor, although much is already known about the development of certain cortical connections, such as the reciprocal thalamocortical pathway. Thalamocortical and corticothalamic projections have to cross several boundary regions to reach their target, including the diencephalic-telencephalic boundary, the ventral telencephalon and the pallial-subpallial boundary. In addition to specific guidance molecules, thalamocortical and corticothalamic axons have been shown to interact with each other, at least at they cross the subpallium [4].

Neuronal circuits in the cerebral cortex are shaped by experience during specific periods of early postnatal life, named critical periods. In the cortex, this activity-dependent development is caused by the functional maturation of local inhibitory connections of specific subclasses of cortical interneurons.

### Lower Level Processes

Inhibitors of “posteriorizing” factors, such as the Wnt, BMP or Nodal signaling antagonists Cerberus and

Dickkopf, are involved in the early induction of the anterior neural plate. Other factors involved in the early induction of these territories are Chordin, Noggin and Follistatin. Subsequent patterning events, which define the territory occupied by the telencephalon, also require the inhibition of “posteriorizing” factors (in this case those that induce the development of the diencephalon), including but probably not limited to Wnt signaling. Dorsoventral patterning of the telencephalon largely depends on a balance between “dorsalizing” factors, such as Wnt and BMP signaling, and “ventralizing” activities, mostly Shh. The acquisition of a pallial fate by telencephalic cells involves the expression of specific transcription factors, such as *Pax6* and *Ngn2*. Furthermore, progenitor cells from the different pallial domains also express different combinations of transcription factors [5].

There has been considerable controversy over the mechanisms through which early subdivisions of the cerebral cortex are generated. One school proposed that mechanisms intrinsic to the cortex play a fundamental role in this process (the “protomap” model), whereas another suggested that regional identity is primarily controlled by the nature of thalamic axonal inputs that the different neocortical domains receive. A large body of evidence now supports the “protomap” hypothesis, according to which cues that specify particular areas act on cortical progenitor cells. Some of these cues are beginning to be identified [6].

Migration of cortical projection neurons and interneurons is largely controlled by different factors. Radial migration of cortical projection neurons depends on the Reelin pathway, and may also involve integrin signaling [7]. Tangential migration of cortical interneurons depends on several chemoattractive and chemorepellent molecules, including class III semaphorins, neurotrophic factors and Neuregulin-1 [8].

The development of axonal connections in the cerebral cortex involves multiple chemoattractive and chemorepellent molecules. For example, development of the corpus callosum requires Netrin-1, whereas the formation of corticofugal projections arising from layer V and layer VI neurons relies on Slits [9].

### Pathology

Disturbances of the inductive events involved in primary neurulation result in various errors of neural tube closure. Failure of anterior neural tube closure leads to anencephaly, which commonly involves the forebrain and variable amounts of upper brainstem. Defects in the formation of the forebrain at the rostral end of the neural tube range from the complete absence of the entire prosencephalon (aprosencephaly) or telencephalon (atelencephaly) to relatively mild disturbances of midline prosencephalic development (e.g. agenesis of the corpus callosum). Severe deviations from normal

prosencephalic development may also involve defects in prosencephalic cleavage that typically lead to holoprosencephaly, a condition in which the telencephalon develops as a single spherical structure.

There are multiple neuronal migration disorders in humans that affect the developing cerebral cortex. Because neuronal migration in the human cerebral cortex extends through a protracted period of time, typically between the 11th and the 24th weeks of gestation, the spectrum of migration disorder severity may extend from only a reduced number of heterotopic neurons, as observed in periventricular heterotopia, to complete laminar disorganization, as described in severe cases of lissencephaly. Nevertheless, migration disorders of the cerebral cortex are responsible for a large percentage of cases of mental retardation and epilepsy in children.

Despite making up a small percentage of the entire neuronal population, the activity of GABAergic interneurons is critical for cortical function, as they represent the basic elements that provide inhibition, synchronize and shape several types of cortical oscillations underlying various brain functions. Several lines of evidence suggest that abnormal development of GABAergic interneurons may underlie the development of important neurological disorders, from epilepsy and learning disabilities to schizophrenia [10].

### References

1. Puelles L, Kuwana E, Puelles E, Rubenstein JL (1999) Comparison of the mammalian and avian telencephalon from the perspective of gene expression data. *Eur J Morphol* 37:139–150
2. Campbell K (2003) Dorsal-ventral patterning in the mammalian telencephalon. *Curr Opin Neurobiol* 13:50–56
3. Marín O, Rubenstein JLR (2001) A long, remarkable journey: tangential migration in the telencephalon. *Nat Rev Neurosci* 2:780–790
4. López-Bendito G, Molnár Z (2003) Thalamocortical development: how are we going to get there? *Nat Rev Neurosci* 4:76–89
5. Rallu M, Corbin JG, Fishell G (2002) Parsing the prosencephalon. *Nat Rev Neurosci* 3:943–951
6. Rash BG, Grove EA (2006) Area and layer patterning in the developing cerebral cortex. *Curr Opin Neurobiol* 16:25–34
7. Marín O, Rubenstein JL (2003) Cell migration in the forebrain. *Annu Rev Neurosci* 26:441–483
8. Flames N, Marín O (2005) Developmental mechanisms underlying the generation of cortical interneuron diversity. *Neuron* 46:377–381
9. Price DJ, Kennedy H, Dehay C, Zhou L, Mercier M, Jossin Y, Goffinet AM, Tissir F, Blakey D, Molnár Z (2006) The development of cortical connections. *Eur J Neurosci* 23:910–920
10. Lewis DA, Hashimoto T, Volk DW (2005) Cortical inhibitory neurons and schizophrenia. *Nat Rev Neurosci* 6:12–24



## Cortical Development – Disorders

PAUL J. LUCASSEN<sup>1</sup>, KARIN BOEKHOORN<sup>1,2</sup>,  
FIONA FRANCIS<sup>3</sup>

<sup>1</sup>SILS Centre for Neuroscience, University of Amsterdam, GB Amsterdam, The Netherlands

<sup>2</sup>Neurosignalisation Moleculaire et Cellulaire, INSERM U706, Institut du Fer a Moulin, Paris, France

<sup>3</sup>Département Génétique, Développement et Pathologie Moléculaire, INSERM U567, CNRS UMR 8104, Institut Cochin, Paris, France

### Definition

Being discussed will be major disorders of cortical development: malformations arising from abnormal neural tube closure, congenital midline defects, abnormal neuronal proliferation and migration, and disorganized lamination and convolution. These severe disorders are associated with neonatal death or mental retardation and epilepsy.

### Characteristics

The ►neocortex originates from a very small population of ►stem cells. Through different phases of progenitor (►Neuronal progenitor) expansion and migration, these cells eventually form the six neuronal layers of the human neocortex. Genetic analysis of human disorders have highlighted various types of proteins that are critical for proper cortical development. Given the divergent nature and tight spatiotemporal orchestration of this complex process, early disruptions can cause aberrant progenitor expansion, migration or ectopic placement of neurons and produce severe malformations.

### Early Brain Development

Brain development is a complex and tightly controlled process (ERNS Chapter by Marin, 2008). The cerebral ►cortex consists of an outer layer of heavily interconnected neuronal tissue spanning the entire cerebrum. The human cortex importantly is responsible for many cognitive functions. When its development is disturbed, typically human disorders like aphasia, epilepsy, learning disabilities and mental retardation ensue.

### Development of the Neocortex

Neocortical development in the rodent involves the generation of postmitotic ►pyramidal neurons from a very small population of stem cells located in a region called the ventricular zone lining the lateral ventricles of the dorsal neocortex. These stem cells undergo successive phases of progenitor division and ►radial migration to reach their final laminar positions in a so-called “inside-out” manner. Interconnecting with the radially oriented, excitatory pyramidal neurons are

GABAergic inhibitory neurons, that originate from the ganglionic eminences and migrate tangentially (►Tangential migration) This results in six heavily interconnected neuronal layers with distinct identities and inputs [1,2] (Fig. 1).

Radial migration is accomplished through ►nuclear translocation and ►locomotion. ►Radial glia cells function as a scaffold enabling guidance of locomoting migratory neurons towards the outer ►pial surface. During early embryonic development migration occurs through glia-independent translocation that is characterized by movement of the soma and nucleus into a long leading process attached to the pial surface [2]. In addition to a role in guidance, radial glia produce almost all radially migrating neurons generated in the VZ. Hence, radial glia are neuronal precursors in corticogenesis [3].

### Neuronal Proliferation and Migration Disorders

Despite considerable progress, little is still known about the proteins controlling early cortical development. Various cytoskeletal-associated proteins have recently been implicated in processes like cell division, differentiation and neuronal migration [4] and also in cortical developmental disorders such as microcephaly, lissencephaly and doublecortex syndrome [5,6]. These genes may provide important insights not only into evolutionary aspects of variation in cortical thickness for example, but also into how normal human cortical development is controlled.

### Gyrencephaly/Microcephaly

Microcephaly is defined by a reduced head circumference and a significant diminution in brain volume. Microcephaly is divided into primary microcephaly, in which the brain fails to grow to the correct size during pregnancy, and secondary microcephaly, in which the brain is the expected size at birth but subsequently fails to grow normally. Current work suggests that primary microcephaly is caused by a decrease in the number of neurons generated during early ►neurogenesis [7], while in secondary microcephaly the number of dendritic processes and synaptic connections is reduced. Genetic but also non-genetic causes of primary microcephaly occur, such as maternal alcohol consumption during pregnancy, maternal syphilis infection, poor prenatal care and “non-accidental head injury.”

Individuals with autosomal recessive primary microcephaly (MCPH) are born with a significantly small head circumference and are mentally retarded. Brain scans show that the whole brain is reduced in size, with the cerebral cortex most severely affected. Four genes that cause MCPH have been identified, microcephalin, abnormal spindle in microcephaly (ASPM), CDK5RAP2 and CENPJ. All of the mutations are predicted to lead to a premature termination of the protein and for ASPM, there

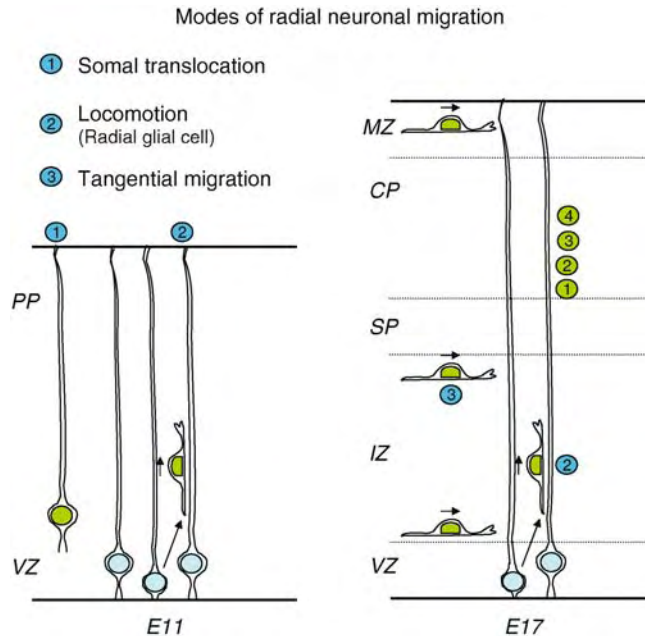

**Cortical Development – Disorders. Figure 1** Scheme depicting different forms and directions of neuronal migration during early cortical development. *Abbreviations:* MZ marginal zone; CP cortical plate; SP subplate; IZ intermediated zone; VZ ventricular zone; E11 embryonic day 11; E17 embryonic day 17.

is no correlation between the position of the mutation and the degree of microcephaly. Indeed nonsense mediated mRNA decay will almost certainly occur for each of these mutations and hence it is the functional absence of the ASPM protein that causes MCPH. ASPM is most probably involved in the organization of microtubules at mitotic spindle poles. Mutations in microcephalin lead to premature chromosome condensation and cell cycle defects. CDK5RAP2 and CENPJ have both been implicated in centrosomal function.

### Lissencephaly, Band and Nodular Heterotopia

Another set of proteins appears critical for neuronal migration to specific brain regions. Based on their phenotype, they can be divided in three groups. The first one encodes cytoskeletal molecules that play important roles during initiation and progression of neuronal movement. The second encodes signaling molecules for which homozygous mutations lead to an inverted cortex and a third group encodes enzymatic regulators of glycosylation that appear to delineate where neuronal migration will arrest [8].

### Periventricular Heterotopia (PVH)

Periventricular heterotopia (PVH) arises due to X-linked filamin A (FLNA) mutations. Affected females exhibit epilepsy and have visible malformations on MRI, consisting of nodules of heterotopic grey matter situated close to the cerebral ventricles [9]. In this X-linked form

of PVH, affected males are rare and usually die *in utero* or at birth. A second gene identified for rarer forms of PVH associated with microcephaly, is ARFGEF2 [9], a vesicle and membrane trafficking protein. In both these forms of PVH, the position of the heterotopic nodules situated close to the region where neurons are generated during development, suggests severely perturbed neuronal migration. FLNA is a well studied actin-binding protein, which also interacts with integrins and other transmembrane proteins. Thus FLNA is likely to play a role in anchoring such proteins to the cytoskeleton. Such functions could be quite consistent with a role in the first steps of neuronal migration, regulating the movement of a neuron along its substrate. However, alternative functions for FLNA have also been proposed. Data from recently described mouse knockout models show no apparent migration defects, but instead abnormal cell-cell and adherens junctions. Heterotopic nodules close to the ventricles in PVH could thus arise by disruption of neuroepithelial cell contacts at the ventricular lining [10].

### Lissencephaly/Doublecortex Syndrome

Also falling in the group of cytoskeletal associated proteins, mutations in ►microtubule associated proteins (MAPs) are correlated with lissencephaly [6]. The ongoing process of migration from the ventricular zone to the ►cortical plate is defective in both type I lissencephaly and in double-cortex syndrome

(DCS). Lissencephaly in humans is characterized by a lack of cortical folds on the brain surface (smooth brain) and a thicker cortex consisting of four layers of loosely packed cells with most cortical plate neurons found in the fourth layer. Type I lissencephaly and DCS are caused by mutations in the microtubule binding protein doublecortin (DCX). Neurons expressing a mutated DCX fail to migrate properly. Regulation of microtubule association occurs through phosphorylation that negatively regulates microtubule affinity [11]. Several kinases which phosphorylate DCX have been identified.

Essentially all missense mutations in DCX have been found in the two microtubule-binding DC repeats. In families with DCX mutations, affected males show lissencephaly whereas affected females show an apparently preserved six-layered outer cortex and a subcortical heterotopic band of neuronal tissue located in the cortical white matter (DCS) [5,6,11]. The mechanisms leading to heterotopia formation remain unclear, although since DCX is localized on the X chromosome, X inactivation may well generate such a mosaicism. Individuals with lissencephaly typically display severe mental retardation and intractable epilepsy, whereas individuals with DCS typically display mild to moderate mental retardation or normal cognitive abilities and less severe epilepsy.

Surprisingly, the cortex of DCX knockout male mice is morphologically normal, with proper cortical lamination. A second gene mutated in lissencephaly is LIS1 which is also associated with microtubules since it interacts with dynein. Interestingly, Lis1 mutant mice also display a rather subtle phenotype in the neocortex but show prominent hippocampal defects, suggesting the involvement of compensatory genes [5,6,12–14]. Nevertheless, interneuron defects are present in both models and also in the human disorder. In contrast to the traditional knockout, acute inactivation of DCX using siRNA in mice cortex hampered cortical migration and produced a subcortical heterotopic placement [6]. These data further suggest that functional compensation occurs in DCX knockout mice.

Another gene mutated in a form of lissencephaly is Reelin [5,12]. Studies in *reeler* mice and biochemical studies show that Reelin, an extracellular molecule, is involved in a signaling pathway (involving Reelin, VLDLR, APOER2 and Disabled I) which most probably controls the final steps of cortical neuronal migration [12,15].

### Cobblestone Lissencephaly

In cobblestone lissencephaly, the cortex lacks gyri and sulci and has a bumpy or cobblestone appearance. This type of malformation is thought to result from a defect in the limiting glial membrane that fails to transduce a stop signal, resulting in migratory neurons that have passed through the pia into the meninges inducing a mushroom

like appearance of the cortex. Also in the brain midline, neurons appear to migrate through both pial membranes and cross the midline into the opposite hemisphere. These disorders include muscle-eye-brain disorder, Walker-Walburg syndrome and Fukuyama congenital muscular dystrophy that are characterized by muscular dystrophy, eye abnormalities. Particularly glycosyltransferases are mutated in these disorders [5,6,8].

### References

1. Kriegstein AR, Castaneda-Castellanos DR, Noctor SC (2004) Patterns of cortical neurogenesis. *Clin Neurosci Res* 4:2–8
2. Nadarajah B, Parnavelas JG (2002) Modes of neuronal migration in the developing cerebral cortex. *Nat Rev Neurosci* 3(6):423–432
3. Fishell G, Kriegstein AR (2003) Neurons from radial glia: the consequences of asymmetric inheritance. *Curr Opin Neurobiol* 13(1):34–41
4. Vreugdenhil E, Kolk S, Boekhoorn K, Fitzsimons C, Schaaf M, Schouten T, Sarabdjitsingh A, Sibug R, Lucassen PJ (2007) Doublecortin-like, a microtubule associated protein expressed in radial glia cells is crucial for neuronal precursor division and radial process stability. *Eur J Neurosci* 25:635–648
5. Francis F, Meyer G, Fallet C, Moreno S, Kappeler C, Cabrera Socorro A, Phan Dinh Tuy F, Beldjord C, Chelly J (2006) Human disorders of cortical development: from past to present. *Eur J Neurosci* 23:877–893
6. LoTurco JJ, Bai J (2006) The multipolar stage and disruptions in neuronal migration. *Trends Neurosci* 29(7):407–413
7. Mochida GH, Walsh CA (2001) Molecular genetics of human microcephaly. *Curr Opin Neurol* 14:151–156
8. Bielas S, Higginbotham H, Koizumi H, Tanaka T, Gleeson JG (2004) Cortical neuronal migration mutants suggest separate but intersecting pathways. *Annu Rev Cell Dev Biol* 20:593–618
9. Lu J, Sheen V (2005) Periventricular heterotopia. *Epilepsy Behav* 7:143–149
10. Feng Y, Chen MH, Moskowitz IP, Mendonza AM, Vidali L, Nakamura F, Kwiatkowski DJ, Walsh CA (2006) Filamin A (FLNA) is required for cell-cell contact in vascular development and cardiac morphogenesis. *Proc Natl Acad Sci USA* 103(52):19836–19841
11. Moores CA, Perderiset M, Kappeler C, Kain S, Drummond D, Perkins SJ, Chelly J, Cross R, Houdusse A, Francis F (2006) Distinct roles of doublecortin modulating the microtubule cytoskeleton. *EMBO J* 25(19):4448–4457
12. D'Arcangelo G (2006) Reelin mouse mutants as models of cortical development disorders. *Epilepsy Behav* 8(1):81–90
13. Vallee RB, Tsai JW (2006) The cellular roles of the lissencephaly gene LIS1, and what they tell us about brain development. *Genes Dev* 20(11):1384–1393
14. Reiner O, Sapoznik S, Sapir T (2006) Lissencephaly I linking to multiple diseases: mental retardation, neurodegeneration, schizophrenia, male sterility, and more. *Neuromolecular Med* 8(4):547–566
15. Tissir F, Goffinet AM (2003) Reelin and brain development. *Nat Rev Neurosci* 4(6):496–505

## Cortical Frontal Eye Fields

### Definition

- ▶ Frontal Eye Fields
- ▶ Supplementary Eye Field

## Corticobasal Degeneration

### Definition

Corticobasal degeneration involves several neuropsychological impairments, such as limb ▶ **ataxia**, visuospatial problems, acalculia (inability to perform mathematical operations), and ▶ **aphasia**.

- ▶ Ataxia
- ▶ Aphasia

## Corticobulbar Tract

### Definition

Fibers coursing from cerebral cortex to brainstem (also called bulb).

- ▶ Pathways

## Corticofugal

### Definition

Referring to a neural pathway that originates within the cerebral cortex and project to other parts of the central nervous system (CNS), including other regions of the cortex.

## Corticonuclear Fibers

### Synonyms

- ▶ Fibrae corticonucleares

### Definition

On reaching the vicinity of their target region, the fibers of the pyramidal tract disengage themselves from the tract and form individual fibers, which are called corticonuclear fibers.

- ▶ Pathways

## Corticonuclear Tract

### Synonyms

Fibrae corticonucleares; Corticonuclear fibers

- ▶ Corticonuclear Fibers
- ▶ Pathways

## Corticospinal Neurons

### Definition

Neurons that have a cell body in layer V of the cerebral cortex and an axon that projects to the spinal cord. Most corticospinal neurons are found in motor areas of the frontal lobe and are involved in movement execution.

However, many corticospinal neurons are also found in somatosensory cortex and are involved in regulating the ascending flow of somatosensory information.

- ▶ Motor Cortex: Output Properties and Organization

## Corticospinal Tract

### Synonyms

Tractus corticospinal

- ▶ Pyramidal Tract
- ▶ Pathways

## Corticospinal Tract Lesions

### Definition

Lesions limited to the ▶ **pyramidal tract** produce a ▶ **Babinski sign** and ▶ **paresis** (i.e., negative symptoms

such as temporary weakness and loss of dexterity), but neither spastic ▶ *dystonia* nor permanent weakness.

▶ *Babinski Reflex*

## Corticosterone

### Definition

Major steroid hormone in rodents released from the adrenal cortex.

## Cortico-Subcortical Re-Entrant Circuit

HENK J. GROENEWEGEN

Institute for Clinical and Experimental Neurosciences, Department of Anatomy and Neurosciences, VU University medical center, Amsterdam, The Netherlands

### Synonyms

Basal ganglia-thalamocortical circuit; Cortical-basal ganglia circuit; Basal ganglia-thalamocortical loop

### Definition

Cortico-subcortical re-entrant circuits are composed of a series of connections that start in a particular part of the cerebral cortex and lead via subsequent steps in the basal ganglia and the thalamus back to the same part of the cortex. More in particular, cytoarchitectonically and functionally distinct cortical areas in the frontal lobe form the focal point of these circuits. Each frontal cortical area projects to a specific region of the striatum and that striatal region projects via the globus pallidus or substantia nigra to a particular thalamic nucleus or part thereof. This part of the thalamus, in turn, is in reciprocal connection with the original frontal cortical area, closing the circuit (Fig. 1).

These cortico-subcortical re-entrant circuits are also being indicated as the basal ganglia-thalamocortical circuits. Three “families” of cortico-subcortical re-entrant circuits have been described: sensory-motor, complex or cognitive and limbic or emotional-motivational circuits. The recognition of this circuitous arrangement between the cerebral cortex, basal ganglia and thalamus has had great impact on our understanding of the neuronal substrate of forebrain functions and the pathophysiological basis of various neurological and psychiatric disorders.

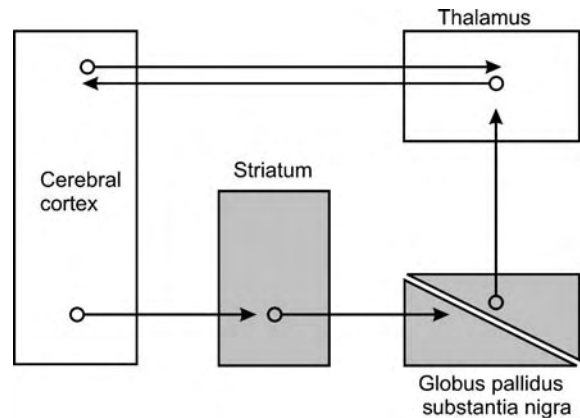

### Cortico-Subcortical Re-Entrant Circuit.

**Figure 1** Basic diagram of the architecture of cortico-subcortical re-entrant circuits that involve the different areas of the frontal cortex, the basal ganglia (gray boxes) and the thalamus.

### Characteristics

The connectional relationships between the cerebral cortex and the basal ganglia have been viewed in various ways in the past. Whereas initially it was thought that the basal ganglia send their output directly to lower brain structures such as the brainstem and spinal cord, Nauta and Mehler [1] showed that the basal ganglia mainly project to the thalamus. As a consequence, the influence of the basal ganglia reaches the cerebral cortex since the thalamus is reciprocally connected with the cortex. However, at that time the prevailing idea was that the basal ganglia, which themselves receive inputs from the cortex of the entire hemisphere, by subsequent steps of convergence, mainly direct their influence via the ventral anterior thalamic nucleus to the premotor cortex. In other words, the basal ganglia were considered to collect and integrate information from all functionally different cortical areas and direct their output via the thalamus to motor-related cortical areas, the basal ganglia in essence having an influence on the motor system. A major breakthrough was established with the landmark paper by Alexander and colleagues [2] who, on the basis of a reinterpretation of already existing neuroanatomical and electrophysiological data, proposed that the connections between the cerebral cortex, basal ganglia and thalamus are arranged in parallel, functionally segregated basal ganglia-thalamocortical loops or circuits. It became then generally accepted that, next to the premotor cortex, also extensive parts of the prefrontal cortex are under the influence of the basal ganglia and form part of cortico-subcortical re-entrant circuits. As a consequence, premotor and prefrontal cortices together with connectionally related parts of the basal ganglia and thalamus form a series of parallel,

partially closed circuits that subserve a wide range of motor, behavioral and emotional-motivational functions.

### Architecture of the Cortico-Subcortical Re-Entrant Circuits

The more detailed architecture of cortico-subcortical re-entrant circuits is as follows. Architecturally and functionally distinct frontal cortical areas form the starting and re-entrant point of the basal ganglia-thalamocortical circuits [2,3]. The projections from the cerebral cortex to the striatum are highly topographically organized. Motor and premotor, including oculo-motor cortical areas project to the dorsal and lateral parts of the caudate nucleus and putamen. Dorsolateral prefrontal cortical areas, involved in executive functions and working memory, project to intermediate, more ventrally located regions of the caudate-putamen complex. Finally, medial and orbital prefrontal areas, involved in emotional and motivational processes, project to the most ventral and medial parts of the striatum, including the ►nucleus accumbens (Fig. 2).

This corticostriatal topography forms the basis for three “families” of cortical basal ganglia-thalamocortical circuits, each consisting of several sub-circuits, that subserve sensory-motor, complex or cognitive and emotional-motivational behavioral functions. Next to these cortical inputs from the frontal lobe, the striatum receives projections from other cerebral cortical areas in more caudal parts of the hemisphere (parietal, occipital and temporal lobes), limbic structures, such as the amygdala and hippocampus, midline and intralaminar thalamic nuclei and the dopaminergic and serotonergic system. The striatum has therefore been designated as the input structure of the basal ganglia. Via different routes, the functionally different striatal regions reach distinct parts of the internal segment of the globus pallidus, the reticular part of the substantia nigra or the ventral pallidum that together form the output structures of the basal ganglia. These structures, in parallel, project to different thalamic nuclei that are in reciprocal contact with the original frontal cortical areas. Thus, the internal segment of the globus via specific parts of the

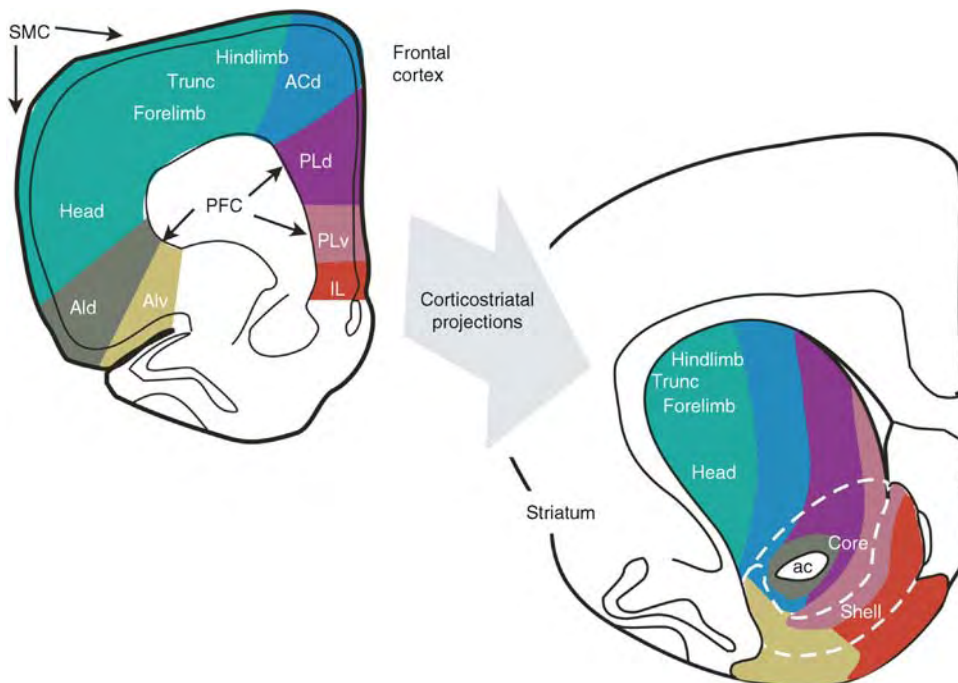

**Cortico-Subcortical Re-Entrant Circuit. Figure 2** Schematic representation of the organization of the corticostriatal projections in rats. At the left hand side different motor and prefrontal cortical regions in the frontal lobe are represented in different colors. The projections to the striatum at the right hand side are highly topographically organized providing for functionally different sectors in the striatum related to different cortical areas represented in the same color. Even though there is a distinct topography in the corticostriatal projections, there also exists overlap between the different projection areas. Abbreviations of the various prefrontal cortical areas in the rat: ACd, dorsal anterior cingulate area; Ald, dorsal agranular insular area; Alv, ventral agranular insular area, IL, infralimbic area; PLd, dorsal prelimbic area; PLv, ventral prelimbic area. Core and shell are distinct subregions of the nucleus accumbens in the ventral striatum.

ventral lateral and ventral anterior thalamic nuclei projects back to the premotor cortex, closing the so-called motor loop. The reticular part of the substantia nigra projects via specific parts of the ventral anterior and mediodorsal thalamic nuclei back to dorsolateral prefrontal areas, closing the so-called complex or cognitive loop. Finally, the ventral pallidum projects primarily to the mediodorsal thalamic nucleus which is connected to the medial and orbital prefrontal areas, closing the so-called limbic loop.

In the previous paragraph the basic architecture of the closed cortico-subcortical re-entrant circuits has been depicted. There are at least three aspects that are of interest in the context of our understanding of the structural and functional significance of these circuits.

First, the input and output structures of the basal ganglia are interconnected via two routes that have opposing effects on the basal ganglia output. The above-described striatal projections to the internal segment of the globus pallidus, the reticular part of the substantia nigra and the ventral pallidum form part of the so-called direct striatopallidal output pathway. The second, so-called indirect striatopallidal output pathway leads via subsequent synaptic interruptions in the external segment of the globus pallidus and the subthalamic nucleus to the basal ganglia output structures [3,4]. Stimulation of the direct pathway at the level of the striatum leads to a higher activity, stimulation of the indirect pathway to a lower activity at the level of the thalamocortical projections within a particular circuit. Interestingly, the direct and indirect striatal output pathways are modulated by dopamine D1 and D2 receptors, respectively. The direct pathway has been shown to facilitate, the indirect pathway to inhibit the expression of motor, cognitive and emotional behavioral output [4]. For normal functioning, a balance between the two output pathways is thought to be essential. Striatal dopamine levels have a strong influence on this balance, low levels leading to paucity and high levels to an excess of simple movements or complex behavioral output. The just described organization of the connections within a particular basal ganglia-thalamocortical circuit forms the neuronal basis for what is considered the basic function of the basal ganglia in relation to the cerebral cortex, i.e. the selection of an appropriate motor, cognitive or emotional behavioral output in a particular context [5].

Second, it is very likely that the contextual information necessary for such selection mechanisms that take place within the basal ganglia-thalamocortical circuits enters these circuits at the level of the striatum. Various cortical areas in the parietal, occipital and temporal lobes project in a topographical way to the striatum where they converge with functionally and connectionally related corticostriatal projections from the frontal lobe. For example, the ventral and medial parts of the striatum that form the limbic loop starting in the medial

and orbital prefrontal areas receive information from the hippocampus and amygdala. These two limbic structures feed information about the mnemonic and emotional aspects of the context in which a behavioral program must be selected. Interestingly, the hippocampus and amygdala not only project to the striatum, but also to the prefrontal cortical area that is the origin of the corticostriatal projections to the same part of the striatum. Similar arrangements exist for the projections of the midline and intralaminar thalamic nuclei to different parts of the striatum and frontal cortical areas (Fig. 3).

The midline and intralaminar receive primarily inputs from brainstem nuclei and are likely to determine the level of activity of individual basal ganglia-thalamocortical circuits [6]. The specific arrangements of cortical, limbic and thalamic inputs into basal ganglia-thalamocortical loops suggests that these circuits form part of larger distributed circuits that are involved in particular motor and behavioral functions.

Third, whereas the closed nature of the cortico-subcortical circuits has been emphasized, it is clear that there exist connections between these circuits that provide ways by which limbic and cognitive circuits might ultimately influence motor circuits. Indeed an ascending spiral of connections from limbic to motor circuits has been suggested on the basis striato-pallido-thalamic projections that shift from one loop to the other [7]. Likewise an ascending spiral from limbic via cognitive to motor loops has been described through the dopaminergic system [8]. Such arrangements of interconnections between circuits might form the basis for the gradual shift from unconditioned behaviors to conditioned behaviors to, finally, habit formation in the course of a behavioral learning process.

### Clinical Relevance

The recognition of the cortico-subcortical re-entrant circuits and the realization that these circuits subserve the wide range of sensory-motor to cognitive and emotional-motivational functions has had great impact on the interpretation and understanding of the pathophysiological basis of several neurological and psychiatric diseases [9,10]. Thus, disturbances of way stations of the dorsally located motor circuit lead to classical neurological symptoms [9]. An example is Parkinson's disease in which the clinical signs of bradykinesia, rigidity and tremor are associated with a degeneration of the dopaminergic innervation of the dorsolateral, sensory-motor related part of the striatum (mainly putamen). Disturbances in cortical and basal ganglia way stations of the cognitive or complex loop (centered on the dorsolateral prefrontal cortex) are associated with executive function deficits (e.g. schizophrenia). Finally, disturbances of one or more way stations in the limbic cortico-subcortical re-entrant circuit has been

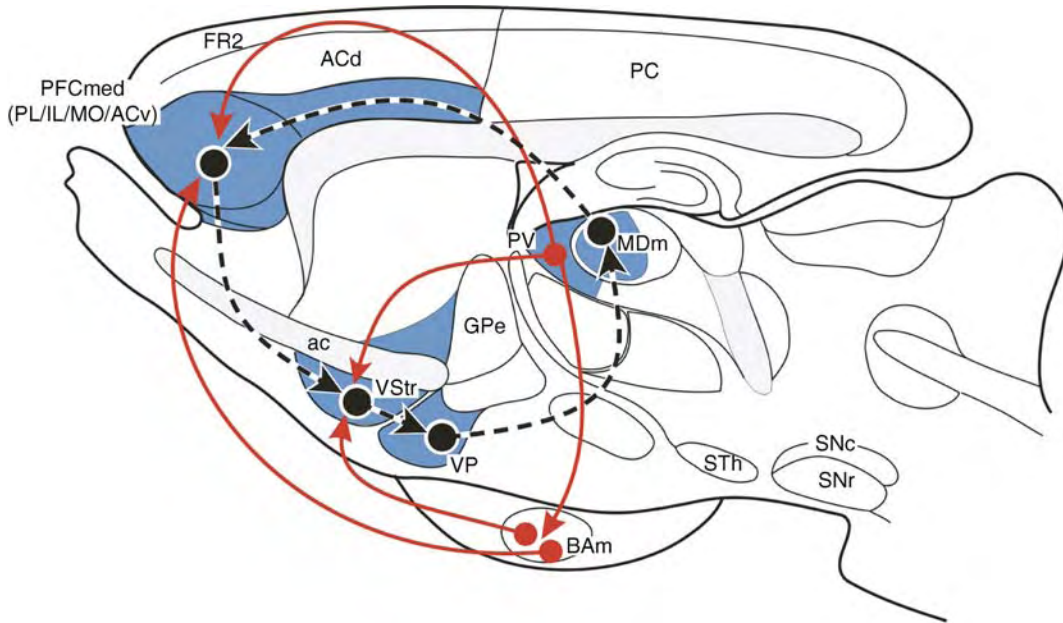

**Cortico-Subcortical Re-Entrant Circuit. Figure 3** Schematic representation in a midsagittal view of the rat brain of a cortical-subcortical re-entrant loop (black, stippled arrows) involving the prefrontal cortex, the mediodorsal thalamus and the ventral parts of the basal ganglia. In addition, the relationship of the projections of the midline thalamic nuclei and the amygdala with this loop are represented in this scheme (red arrows). The organization is as follows. Distinct basal amygdaloid subnuclei project to restricted parts of the prefrontal cortex and the ventral striatum that are both part of the same cortical-subcortical re-entrant loop. Likewise, distinct nuclei of the midline and intralaminar thalamic complex project to prefrontal cortical and ventral striatal areas that in turn are interconnected. In addition, the midline nuclei project to that part of the basal amygdala that is related to the same loop. This scheme represents a cortical-subcortical circuit that involves the medial prefrontal cortex, the ventral striatum and the medial segment of the mediodorsal thalamic nucleus. Similar arrangements exist for the relationships of midline/intralaminar thalamic nuclei and basal amygdaloid nuclei with other cortical-subcortical re-entrant circuits. Abbreviations: *ac*, anterior commissure; *ACv*, ventral anterior cingulate area; *BAm*, basal amygdaloid nucleus; *FR2*, frontal area 2; *GPe*, external segment of the globus pallidus; *MDm*, medial segment of the mediodorsal thalamic nucleus; *MO*, medial orbital area; *IL*, infralimbic area; *PFCmed*, medial prefrontal cortex; *PC*, posterior cingulate area; *PL*, prelimbic area; *PV*, paraventricular thalamic nucleus; *SNc*, substantia nigra pars compacta; *SNr*, substantia nigra pars reticulata; *STh*, subthalamic nucleus; *VP*, ventral pallidum; *VStr*, ventral striatum; Core and shell are distinct subregions of the nucleus accumbens in the ventral striatum.

associated with various other psychiatric disorders such as substance abuse, obsessive-compulsive disorder or mood disturbances like apathy.

## References

1. Nauta WJH, Mehler WR (1966) Projections of the lentiform nucleus in the monkey. *Brain Res* 1:3–42
2. Alexander GE, DeLong MR, Strick PL (1986) Parallel organization of functionally segregated circuits linking basal ganglia and cortex. *Annu Rev Neurosci* 9:357–381
3. Alexander GE, Crutcher MD, DeLong MR (1990) Basal ganglia-thalamocortical circuits: parallel substrates for motor, oculomotor, “prefrontal” and “limbic” functions. *Prog Brain Res* 85:119–146
4. Gerfen CR (1992) The neostriatal mosaic: multiple levels of compartmental organization in the basal ganglia. *Annu Rev Neurosci* 15:285–320
5. Mink JW (1996) The basal ganglia: focused selection and inhibition of competing motor programs. *Prog Neurobiol* 50:381–425
6. Groenewegen HJ, Berendse HW (1994) The specificity of the non-specific midline and intralaminar thalamic nuclei. *Trends Neurosci* 17:52–57
7. Zahm DS (2000) An integrative neuroanatomical perspective on some subcortical substrates of adaptive responding with emphasis on the nucleus accumbens. *Neurosci Biobehav Rev* 24:85–105
8. Haber SN, Fudge JL, McFarland NR (2000) Striatonigral pathways in primates form an ascending spiral from the shell to the dorsolateral striatum. *J Neurosci* 20:2369–2382
9. DeLong MR (1990) Primate models of movement disorders of basal ganglia origin. *Trends Neurosci* 13:281–285
10. Mega MS, Cummings JL (1994) Frontal-subcortical circuits and neuropsychiatric disorders. *J Neuropsychiatry Clin Neurosci* 6:358–370



## Corticotropes

### Definition

Cells in the anterior pituitary gland that secrete the stress hormone, adrenocorticotropin.

- ▶ Influence of  $\text{Ca}^{2+}$  Homeostasis on Neurosecretion

## Cortisol

### Definition

Major steroid hormone in humans released from the adrenal cortex.

## Cost Function

### Definition

The expression to be optimized in some objective function. The cost can correspond to some quantity we wish to minimize (e.g., energy, time) or maximize (e.g. smoothness), or to the degree to which the performance deviates from a mathematically defined criterion. Following the imposed constraints (e.g. at the beginning and end-points of a movement), minimizing the cost function with respect to its arguments enables us to predict the optimal performance in the desired context.

- ▶ Arm Trajectory Formation
- ▶ Neural Networks for Control

## Co-transmission

### Definition

Co-transmission refers to the release of more than one neurotransmitter from a single neuron. Co-transmitters may be released together or independently depending on their subcellular storage and the level of activation of the neuron. Often peptides are co-released with small molecules. The co-transmitters may have different release properties and can exert different effects on target neurons.

## Co-transporter

### Definition

Co-transporter (also called symporter) is a transmembrane protein that uses the energetically favorable transport of an ion down its electrochemical gradient to drive the uphill transport of other ion species in the same direction.

- ▶ Ion Transport

## Cough

- ▶ Respiratory Reflexes

## Coughing (Fishes)

- ▶ Odor-Sampling Behavior

## Coupling Coefficient

### Definition

The coupling coefficient is a measure of synaptic strength of an electrical synapse. It equals the ratio of the postsynaptic voltage response over the presynaptic voltage stimulus of two electrically coupled cells.

Because of the low-pass frequency filter characteristics of an electrical synapse, its coupling coefficient depends on the frequency characteristics of the stimulus. The steady-state coupling coefficient for direct current (DC) stimuli (i.e., stimulus frequency = 0) is a function of the electrical resistance of the gap junction and the input resistance of the postsynaptic cell. The non-steady state solution of the coupling coefficient for alternating current (AC) stimuli (i.e., stimulus frequency  $\neq 0$ ) includes capacitance terms represented by the membrane capacitance of the postsynaptic cell.

- ▶ Electrical Synapses

## Courtship

### Definition

The behavior of a male courting a female to seek sexual interaction.

## Covalent Regulation

### Definition

Control of enzyme activity by covalent bonding of phosphate group to sites other than the active site of the enzyme.

## Covert Shift of Attention

### Definition

In contrast to overt shifts of attention, in which the eyes or body is directed towards a new focus of attention, covert shifts of attention cannot be directly observed from a second person. Attention is directed from one location to another without overt behavior. Neural systems involved in covert and overt attentional shifts show strong overlap. Brain areas controlling covert shifts of attention include the posterior parietal cortex and frontal eye fields.

- ▶ Attention
- ▶ Frontal Eye Fields

## CPG

### Definition

- ▶ Central Pattern Generator

## CpG Dinucleotide

### Definition

The most common site of DNA methylation in adult somatic tissues.

## CpG Island

### Definition

CpG islands are regions of genomic DNA enriched for CG dinucleotides located in 35–50% of gene promoters.

## Cramps

### Definition

Cramps are spontaneous, paroxysmal, prolonged and painful contraction of one or more muscles.

## Cranial Nerves

### Synonyms

Nn. Craniales

### Definition

The cranial nerves are those nerves originating in the brainstem (midbrain, pons, and medulla) with the exception of the first and second cranial nerves, which are not true peripheral nerves but rather are fiber tracts of the brain. The 12 cranial nerves can be divided into sensory, motor or mixed nerves. Cranial nerves VII and IX carry parasympathetic innervation to the salivary glands.

- Olfactory nerve (I)
- Optic nerve (II)
- Oculomotor nerve (III)
- Trochlear nerve (IV)
- Trigeminal nerve (V)
- Abducens nerve (VI)
- Facial nerve (VII)
- Vestibulocochlear nerve (VIII)
- Glossopharyngeal nerve (IX)
- Vagus nerve (X)
- Accessory nerve (XI)
- Hypoglossal nerve (XII)

## CREB

### Definition

CREB is an activator that recognizes the consensus CRE site. It is also found at additional DNA sequences

(AP1 and GRE sites) in a complex containing other activators. The transcriptional activity of CREB is dynamically regulated by phosphorylation. The most well studied phosphorylation site is serine 133. Other phosphorylation events can repress its activity. CREB can be bound regardless of its phosphorylation state, however, for some genes CREB is only recruited to their CRE sites upon phosphorylation. CREB binds as a homodimer or heterodimer. Heterodimerization confers repressive activity of CREB as part of a larger complex of repressor proteins.

► Promoter

## Creep

### Definition

The phenomenon of increasing strain in time under constant stress.

► Mechanics

## c-Rel (REL)

► Nf-κB – Potential Role in Adult Neural Stem Cells

## Cresyl Violet Staining

### Definition

It is a common method of neuronal tissue staining. Cresyl violet, a basic dye, binds to the acidic component of cytoplasm, the RNA-rich ribosomes, nuclei and nucleoli, staining the cell bodies.

## Cretaceous

### Definition

The period approximately between 130 and 70 million years ago.

► Evolution of the Brain: At the Reptile-Bird Transition

## Creutzfeldt-Jakob Disease (CJD)

### Definition

Most common human subacute ► transmissible spongiform encephalopathy (► prion disease), and appears in several variants: sporadic, inherited or acquired (e.g., iatrogenic), the latter being due to the same agent responsible for Bovine Spongiform Encephalopathy in cattle (BSE or "mad cow disease"). Patients may initially present with non-specific symptoms, such as withdrawal, forgetfulness, asthenia and insomnia, with impairment of multiple neurological systems (visual, ► pyramidal, ► cerebellar and neurocognitive systems), spontaneous ► myoclonic jerks and occasionally ► progressive supranuclear palsy. The condition progresses to a totally dependent state within 10 to 12 months. Histological features include spongiform degeneration, neuronal cell loss and astrocytosis.

## Crimp

### Definition

Wave like pattern of the collagen fibrils in the superficial zone of articular cartilage.

► Articular Cartilage

## Cristae

### Definition

Sensory tissue of the semicircular canals. The three semicircular canals have swellings, called ampullae and within each ampulla is the sense organ, called the crista. In the cristae the hairs of the hair cells are embedded in a gelatinous mass, called the cupula, which extends across the ampulla.

► Semicircular Canals

► Vestibulospinal Responses

## Critical Period

### Definition

1. The time during which an organism acquires normal function if it is exposed to normal conditions (see also sensitive period).

2. A postnatal period in which experience induces a significant modulation of brain function and rearrangement of neural circuitry.

## Cross-adaptation in Sensory Systems

### Definition

Adaptation is the phenomenon whereby sustained or repeated exposure to a sensory stimulus results in a reduction in the sensory response. For a cell in a sensory system that responds to more than one stimulus, cross-adaptation refers to the effect of adaptation to one stimulus on the sensory responses to the other stimuli to which the cell responds.

## Cross-associative Memory

### Definition

Same as hetero-associative memory.

► Associative Memory

## Crossbridge

A crossbridge refers the binding of the contractile proteins myosin and actin to form actomyosin. The formation of crossbridges during a muscle contraction is essential to the generation of force and movement.

## Cross-bridge Theory

### Definition

The cross-bridge theory of muscle contraction states how force is produced, and how the filaments actin and myosin are moved relative to each other to produce muscle shortening. In the cross-bridge theory, side-pieces that are fixed in a regular pattern on the myosin filament (cross-bridges) are thought to undergo cyclic attachment and detachment to specific binding sites on the actin filament. During an attachment/detachment

cycle, the cross-bridge head is thought to undergo a rotation and so pull the actin filament relative to the myosin. Each of these cycles is associated with a relative movement of  $\approx 10$  nm and a force of about 2–10 pN. Furthermore, one cross-bridge cycle is thought to occur with the energy gained from the hydrolysis of one adenosine triphosphate (ATP). The cross-bridge theory was first formulated in a quantitative manner by Andrew Huxley in 1957. It has since undergone many changes and adaptations, but the basic principles put forward at that time still remain accepted in the scientific community today.

► Force Depression/Enhancement in Skeletal Muscles

## Cross-covariance

### Definition

A linear measure of the relationship between two variables. The cross-covariance is computed as the average of the products of the deviations of each variable from their respective mean.

► Signals and Systems

## Cross-generalization

### Definition

In sensory psychophysics this refers to generalization of a behavioral response from the stimulus on which an animal is trained to another stimulus. It is used to test similarities between stimuli.

## Cross-modal

### Definition

From two or more different sensory modalities. Used to refer to: (a) combinations of stimuli from different sensory modalities (e.g., a combination of light and sound) that normally evoke different subjective experiences, (b) the spatial register among the different receptive fields of a multisensory neuron, and (c) the spatial register among different sensory maps. Also

used to refer to tasks involving matching and/or transfer of information among modalities.

► Multimodal Integration

---

## Cross-modal Extinction

### Definition

A disorder that typically follows damage to the right hemisphere, in which patients are able to detect single tactile stimuli applied to the contralesional hand in isolation, but show impairments in detecting the same tactile stimuli when an additional visual stimulus is presented on the ipsilesional side.

► Multimodal Integration

---

## Crossmodal Integration

► Multimodal Integration

---

## Cross-modal Plasticity

### Definition

The neuroanatomical, neurophysiological, perceptual, and/or behavioral changes that may occur in one or more sensory modalities following damage to, or selective impairments in, another sensory modality.

For example, changes in auditory or tactile processing as a result of temporary or permanent blindness may be a result of crossmodal plasticity.

► Multimodal Integration

---

## Cross-modality Matching

### Definition

A psychophysical method that requires adjustment of the perceived strength of one sort of stimulus (e.g., light

intensity) so that it matches that of another sort of stimulus (e.g., sound intensity).

► Psychophysics

---

## Crossopterygian

### Definition

The coelacanth fish *Latimeria chalumnae*, a deep-sea fish of ancient lineage discovered in the ocean waters off the South African coast in the 1930s.

► Evolution of Brain: at Invertebrate–vertebrate Transition

---

## Cross-reactivity

### Definition

Antibody or T cell receptor interaction with more than one antigen. Cross-reactive lymphocytes are often activated by a foreign antigen that has similarities to another antigen, usually a self antigen.

► Anti-DNA Antibodies against Microbial and Non-Nucleic Acid Self-Antigens

---

## Cross-spectrum

### Definition

The linear relationship between two variables, expressed in the frequency domain.

► Signals and Systems

---

## Crotalidae

### Definition

A family of venomous snakes, comprising rattlesnakes, mokasen snake, bushmaster, etc. In some taxonomy it is a sub-family (Crotalinae) of Viperidae.

► Evolution of the Brain: At the Reptile–Bird Transition

## Cryophilic

### Definition

A preference for colder temperatures.

## Cryptochrome

### Definition

A family of proteins that form integral components of the core circadian clock machinery and/or the regulatory pathways for light entrainment of the molecular circadian clock in animals and plants. Cryptochromes are receptors for blue and ultraviolet light, which share structural similarity and evolutionary origin with DNA photolyases. In the *Drosophila* circadian clock, CRYPTOCHROME functions primarily in light entrainment; light stimulates interactions between CRYPTOCHROME and TIMELESS, which promotes degradation of TIMELESS and suppresses function of PERIOD-TIMELESS heterodimers to cause resetting of the circadian clock. In mammals, cryptochrome is an essential component of the negative arm of the circadian feedback loop. Plant cryptochromes also regulate response of the circadian clock to light.

Abbreviation: Cry.

► Clock

## Cryptochrome

### Definition

Class of potentially blue-light sensitive proteins related to the bacterial photolyases, which contain two chromophores (pterin and flavin). In mammals, they constitute together with the Period proteins the major repressive function during the dark phase.

► Clock-Controlled Genes

## CSP

### Definition

Cystein string proteins. Highly conserved synaptic vesicle proteins characterized by a central string of

cysteine residues (with multiple palmitoylations) and an N-terminal J-domain indicative of chaperone functions (e.g. facilitating folding or conformational changes of other critical proteins). Known to interact with voltage-gate  $Ca^{2+}$  channels.

► Synaptic Proteins and Regulated Exocytosis

## C-start Escape

### Definition

An escape response observed in many fishes and larval amphibians in response to sudden aversive stimuli. It consists of two phases: an initial tight bend away from the direction of the startling stimulus, causing a C-shaped curve in the body when observed from above. This C-shaped bend is followed by a rapid acceleration away from the animal's starting position. The C-start escape is typically initiated by a pair of large brainstem neurons, called Mauthner cells.

► Auditory-Motor Interactions

► Mauthner Cell

## CT

► Muscle Imaging Techniques: Computerized Tomography

## CT Afferents

► Tactile C Fibers

## CT Fibers

► Tactile C Fibers

## CTA

► [Conditioned Taste Aversion](#)

## Culmen

### Definition

Part of the vermis cerebelli lying above the primary fissure. Belongs to the anterior lobe. Like the entire vermis cerebelli, the culmen receives its afferents primarily from the spinal cord. Hence it is part of the so-called spinocerebellum = palaeocerebellum.

► [Cerebellum](#)

## Culture of Neurons

### Definition

Experimental preparation consisting of a layer of neuron cells, grown on a physical substrate which also contains electrodes for recording and stimulation. Cultures may be made from dissociated neurons, usually from cortical areas, thus resulting in a monolayer of cells which develop strong, random, mostly excitatory connections; or they may come from slices of nervous tissue – organotypic cultures, thus maintaining the basic anatomical features of the tissue of origin. Cultures of dissociated neurons can be kept in healthy conditions for a long time (several months) and their morphological and physiological properties resemble those of the tissue of origin, but cannot be directly compared to in-vivo preparations. Widespread, synchronous bursting activity is their normal mode of spontaneous response, reflecting their lack of afferent connections.

## Cuneate Fasciculus

### Definition

The cuneate fasciculus is a large bundle of axons running just lateral to the gracile fasciculus. Together the cuneate and gracile fasciculi form the dorsal columns in the dorsal medial part of the spinal cord.

The dorsal columns are formed by the axons of neurons in the dorsal root ganglia just outside the spinal cord and carry somatosensory information from the body to the caudal medulla. The cuneate fasciculus carries information from the arms and the upper trunk.

## Cuneate Nucleus

### Definition

The cuneate (Latin for wedge-shaped) nucleus is a nucleus in the caudal medulla that receives tactile, proprioceptive and vibratory input from the arm and upper trunk by way of the cuneate fasciculus. It is immediately lateral to the gracile (Latin for slender) nucleus (see below).

## Cuneus

### Definition

Part of the occipital lobe visible on the medial aspect of the hemisphere. Involved in the processing of visual information.

► [Telencephalon](#)

## Cupula

### Definition

A fluid-tight partition that lies above the crista and spans across the walls and roof of the ampulla in the semicircular canals. Cupula deflection by endolymph movement displaces the embedded stereocilia of the canal receptor cells.

► [Semicircular Canals](#)

► [The Peripheral Vestibular Apparatus](#)

## Curvature Equation

### Definition

A local measure of deviation from linearity of a curve. It is invariant under rotations and translations. Given a

planar curve in time ( $x(t)$ ,  $y(t)$ ), parameterized such that the speed  $V(t) > 0$ , the curvature at every point along the curve is expressed as follows: where dot means derivative with respect to time. Curvature is measured in units of  $1/\text{cm}$  and is dependent only on the path (regardless of the speed profile).

► Arm Trajectory Formation

## Cushing's Syndrome

### Definition

Endocrinological disorder characterized by consistently elevated levels of cortisol often resulting from tumors e.g., located in the pituitary (=Cushing's disease) or adrenal.

► Hypothalamo-Pituitary-Adrenal Axis, ► Stress and Depression

## Cutaneomuscular Reflexes

### Definition

Reflexes evoked by a variety of cutaneous, low and high threshold afferent fibers. Generally these are flexion reflexes; however, extension can occur when this pattern of muscle activation is required to remove the stimulated region of the skin from the stimulus, which is usually noxious.

## Cutaneous Mechanoreceptors, Anatomical Characteristics

HISASHI OGAWA

Department of Neurology, Kumamoto Kinoh Hospital;  
Department of Sensory and Cognitive Physiology,  
Kumamoto University, Honjo, Kumamoto, Japan

### Synonyms

Tactile (touch) receptors; Pressure receptors; Vibration receptors

### Definition

#### Morphology of Sensory Receptors in the Skin for Light Mechanical Stimulation

Light mechanical stimulation causes tactile, pressure or vibration sensations but not painful sensations. Sensory receptors for such light mechanical stimulation applied to skin are called cutaneous mechanoreceptors, and are located in the epidermis, dermis, or sometimes at subcutaneous tissue. They are innervated by nerve fibers with large to medium caliber. Almost all mechanoreceptors except one are the primary sensory cells, the nerve terminals specially evolved for receiving mechanical energy, surrounded by lamellae or accessory cells, however, the rest (Merkel cell) are probably secondary sensory cells, originated from the neural crest, making synapse like contacts with nerve endings, although there have been controversial debates on the functional role in mechanosensory transduction.

### Characteristics

#### Classification of Cutaneous Mechanoreceptors

Several mechanoreceptors can be differentiated in terms of the location in the skin and morphology. Included among them are Merkel cell-neurite complex, Ruffini endorgan, Meissner's corpuscle, hair follicle, and encapsulated corpuscles, such as, Krause ending, ► Pacinian corpuscle, and others. Merkel disk receptors (Glandry cells) and Herbst corpuscles, similar to Pacinian corpuscles, are found in lower animals such as birds. Anatomical characteristics of these receptors have been clarified electronmicroscopically, and they are now confirmed histochemically and immunochemically. Recent histochemical and immunochemical works are not referred to in this essay. The function of these receptors is found elsewhere in this Encyclopedia. Here, the detailed morphology is described.

#### Location of Cutaneous Mechanoreceptors

Different cutaneous mechanoreceptors are present between hairy and ► glabrous skin (Fig. 1).

In the hairy skin, Merkel cell-neurite complexes are seen at the base of touch dome, dome-like elevation of the skin, and hair follicles of guard and down hairs are also found in the dermis. In the glabrous skin, on the other hand, Merkel cell-neurite complexes locate at the rete of the papillary ridge and Meissner corpuscle (or Krause end bulb in cats) are found at the dermal papilla. In both skins, Ruffini endings are deep in the dermis and Pacinian corpuscles are in subcutaneous tissue. Merkel disk receptors and Herbst corpuscles are located at the dermis of some birds.

### Detailed Definition

#### Hair Follicle Receptors (Lanceolate Receptors)

In guard hairs and down hairs, the nerve endings run in parallel to the hair shaft and give rise to the lanceolate terminals immediately below the sebaceous glands. In



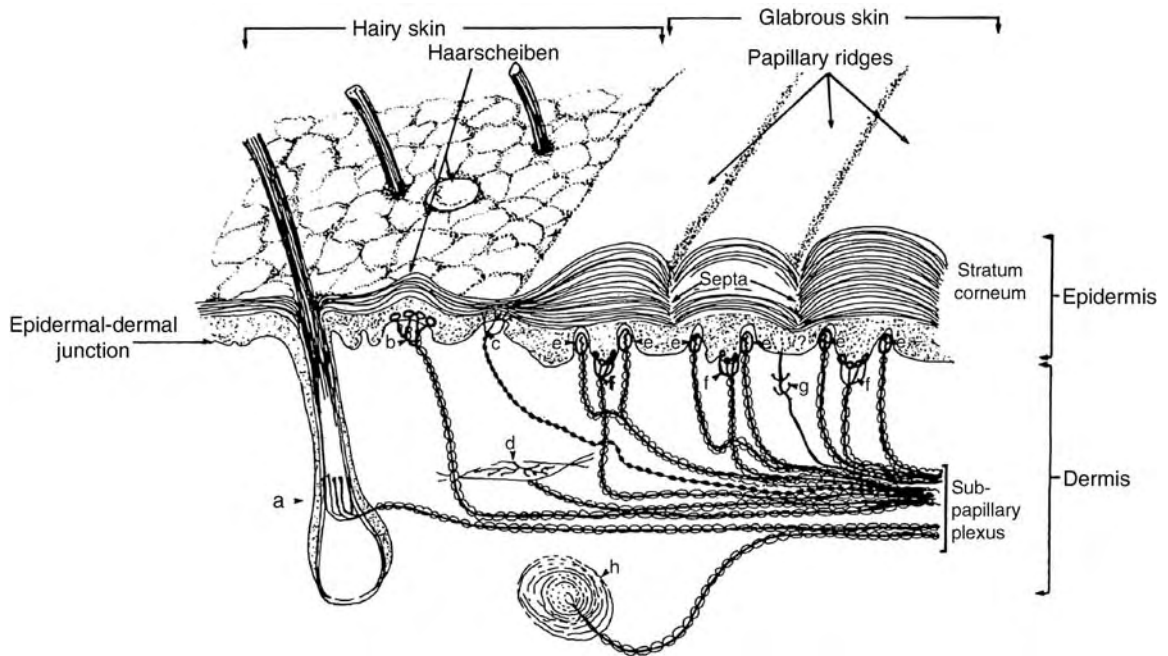

**Cutaneous Mechanoreceptors, Anatomical Characteristics. Figure 1** Location of low threshold cutaneous mechanoreceptors with some free nerve endings at hairy skin (left half) and glabrous skin (right half) of primate. A, hair follicle with “palisade” ending; b, “Haarscheiben” or touch dome with Merkel cell-neurite complexes at base; c, free nerve ending; d, Ruffini endings; e, Meissner corpuscle in dermal papillae; g, free nerve ending; h, Pacinian corpuscle (Reproduced from AR Light and ER Perl ‘Peripheral Sensory System’, In: PJ Dyck et al. (eds) *Peripheral Neuropathy*, vol.1, WB Saunders Company, Philadelphia, 1984, pp. 210–230, Fig. 9–3).

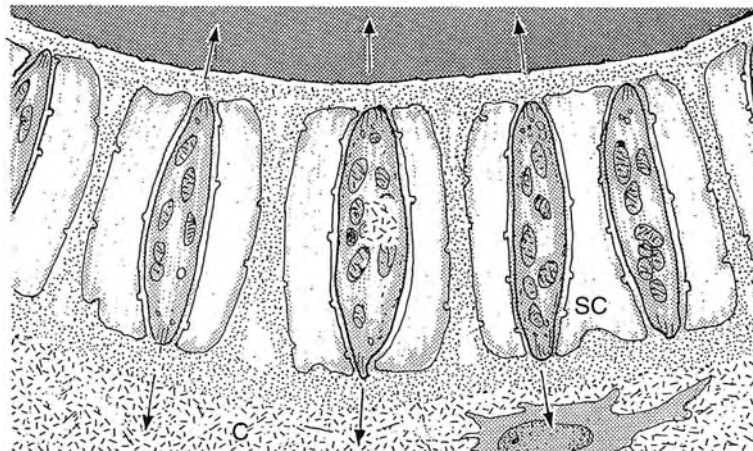

**Cutaneous Mechanoreceptors, Anatomical Characteristics. Figure 2** Schematic illustration of lanceolate endings in guard hair. C, cornium of hair follicle; SC, Schwann cell. (Reproduced from Andres and von Düring (1973) *Handbook of sensory physiology*, vol. 2 somatosensory system, (ed A Iggo), Springer, Berlin Heidelberg New York, Fig. 7a.)

an electronmicroscopic picture, they are seen in a circumferential array or palisade (Fig. 2) [1].

The terminals are covered by swollen ▶ Schwann cells except for narrow slits at their inner and

sides. In some nonsinus facial hair follicles, Ruffini-like spray terminations encircling the hair follicle just below the sebaceous gland have been reported and the term “pilo-Ruffini complex” is proposed [2].

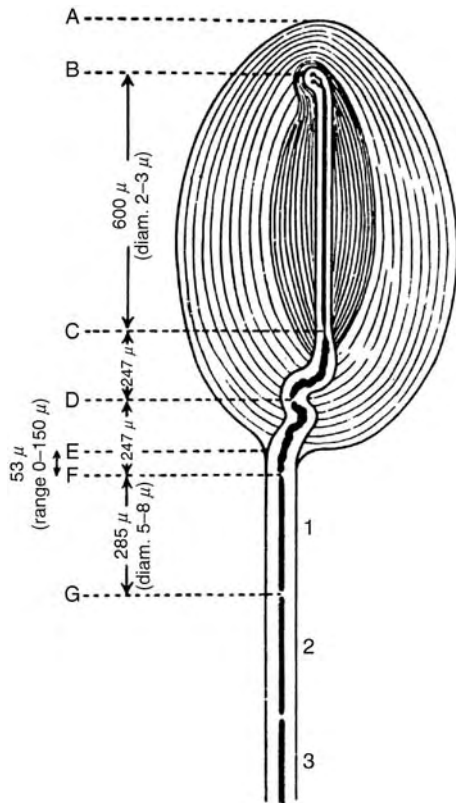

**Cutaneous Mechanoreceptors, Anatomical Characteristics. Figure 3** Schematic illustration of a lamellated corpuscle, representative of lamellated corpuscles. A single axon invades the lamellae to form a nerve ending. Two kinds of lamellae are identified; densely spaced lamellae, inner core, and loosely spaced ones, outer lamella. (Reproduced and modified from TA Quillian and M Sato (1955) The Distribution of Myelin on Nerve Fibres from Pacinian Corpuscles, *J. Physiol.* 129: 167–176, Fig. 8).

### Krause Endings

Two forms of small lamellated **end bulbs** were described by Krause (1880); the cylindrical form in non-primates, e.g., cats, and the globular or spherical form in man and monkeys. *Cylindrical end bulb of Krause* is present in the dermis, often very close to the epidermis but not usually in the dermal papillae or the glabrous skin in non-primates [3]. The cross section reveals the small-sized lamellated corpuscle (Fig. 3); that is the inner core consists of less than 10–30 sheets of Schwann cell lamellae which surround a nerve terminal and is separated from the capsule by a small capsular space.

There are morphological variations from simple unbranched terminals seen in the majority (51%) to branched [2]. The length ranges from 30 to 125  $\mu\text{m}$  and the mean diameter is 12.5 (ranging from 5 to 40)  $\mu\text{m}$  [3].

*Spherical end bulb of Krause* is, on the other hand, present at the mucous membrane such as oral mucosa, conjunctiva and genitalia. Their presence in glabrous skin of human extremities is also reported. So-called genital corpuscles in both primates and non-primates have morphological features similar to those of Krause's spherical end bulb. The typical end bulb is oval or spherical with a mean diameter of 100  $\mu\text{m}$ . It has a capsule made of two to six layers which surround the inner core without a distinct capsular space. In the inner core, nerve terminals covered with Schwann cell lamellae run in a tortuous manner [2].

### Meissner Corpuscles

These were originally described by Wagner and Meissner (1872). They are incompletely encapsulated corpuscles, occupying the dermal papilla in the glabrous skin [2]. The size is relatively large, 150  $\mu\text{m}$  long and 40–70  $\mu\text{m}$  in diameter. The capsule comprises of dispersed perineural lamellae and thick collagen fibers mainly encasing the basal side, but the capsular space is ill-defined. The inner core appears horizontally layered. It is composed of Schwann cells and nerve terminals, and these two components are arranged horizontally and alternatively layer by layer and lamellae of Schwann cells sandwich the oval or ellipsoidal nerve terminals. **Tonofibrils** are followed from the epidermal keratinocytes to collagen fibers in the dermis and some of them enter the upper part of the capsule and others are continuous with the endoneurial sheath of the basal half of the capsule [4]. Several myelinated **axons** enter the capsule.

### Merkel Cells

Merkel cells have been found in the skin of mammals and amphibians since Merkel (1875). When Merkel cells are associated with a neurite, the complex is often called a *Merkel cells-neurite complex* or rarely as a touch corpuscle. Merkel cells are characterized with a lobulated nucleus and distinct vesicles. In mammals, they are found in the epidermis of both glabrous and hairy skin (Fig. 4).

In hairy skin, they are situated at the bottom of the epidermis, in clusters of 50–70 cells, under the touch dome, a dome-like elevation, and is often associated with a guard hair called a Haarscheibe (hair disk). In the glabrous skin with ridging, Merkel cells are situated in a group in the rete of the epidermal ridge, including the bottom, through which the duct of the sebaceous gland passes. Merkel cells are  $6.9 \times 3.9 \mu\text{m}$ , and oriented so that the nuclei are horizontal, and make **desmosomes** with neighboring keratinocytes [5]. Cells have a number of cytoplasmic processes, **microvilli** (diameter, 0.14  $\mu\text{m}$ , length, ca 1  $\mu\text{m}$ ;  $n = 26$ ) [6] projecting into the invaginations of neighboring keratinocytes. A single myelinated nerve axon of a large

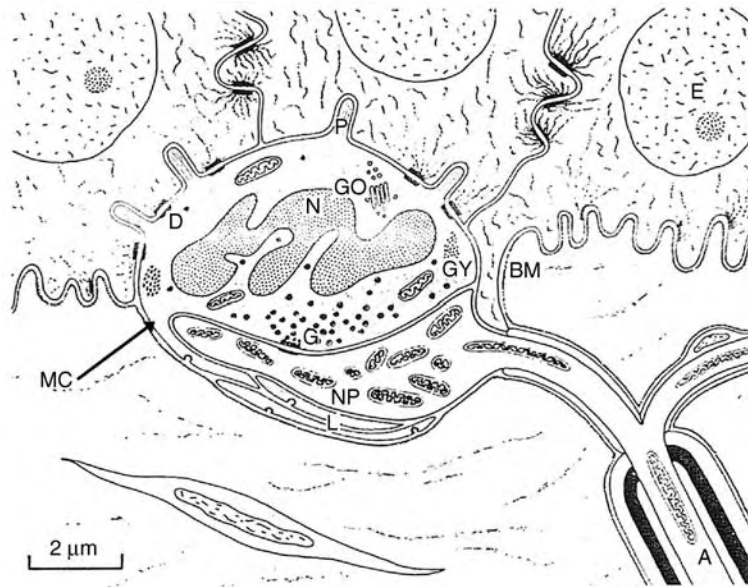

**Cutaneous Mechanoreceptors, Anatomical Characteristics. Figure 4** Schematic illustration of Merkel cell neurite complex. Axon; BM, basement membrane; D, desmosome; E, epithelial keratinocyte nucleus; G, granulated vesicles; GO, Golgi apparatus; GY, glycogen; L, lamellae underlying the nerve plate; MC, Merkel cell; N, multilobulated nucleus; NP, nerve plate; P, cytoplasmic process. (Reproduced from Iggo and Muir (1968) *J Physiol* 200:763–796, Text Fig. 2.)

diameter innervates Merkel cells in the field of about  $100 \times 300 \mu\text{m}$ , and their terminals make expanded and fattened disks (about  $7 \mu\text{m}$  in diameter and  $1 \mu\text{m}$  thick). The nerve disks are located on the dermal side of the Merkel cells, making synapse-like contacts with the latter. Merkel cells contain clear and dense-cored vesicles, mitochondria and Golgi apparatus in the cytoplasm, and vesicles (125,000–200,000) [2] are gathered between the nucleus and cell membrane facing the nerve disk, and the latter also contains mitochondria.

### Merkel Disk Receptors

Merkel disk receptors are encapsulated and often called *Grandry corpuscles* after Grandry (1869) who first described the receptor. They have been found in the dermis in the bill and tongue of aquatic birds, but are absent from Japanese quail and the domestic hen. The receptor is spherical with a mean diameter of  $30\text{--}80 \mu\text{m}$  and has a single-layered capsule. Two to seven Merkel cells (i.e., Grandry cells) or satellite cells (hemispherical,  $50 \times 15 \mu\text{m}$  in size) are present inside the capsule. The number of Merkel cells contained varies with different species [7]. The nerve terminal of a flattened disk form ( $40 \mu\text{m}$  in diameter  $\times$   $20 \mu\text{m}$  in thickness in duck) is sandwiched between two Merkel cells [8]. Merkel cells in this receptor show three morphological features similar to that of Merkel cells in the mammalian

Merkel cell-neurite complex, as follows; (i) there are numerous finger-like cytoplasmic protrusions on the hemispheric surface of the cell, the processes that interdigitate with Schwann satellite cells surrounding the cells. Merkel cells in this receptor have desmosome with Schwann cells but the desmosome is absent in the processes. (ii) The cytoplasm contains osmiophilic dense-cored vesicles ( $120\text{--}250 \text{ nm}$  in diameter) scattered throughout the cytoplasm, although the vesicles are concentrated adjacent to the nerve endings in the mammalian Merkel cells. (iii) Junctional zones are formed between the Merkel cell and the nerve terminal. It is argued to classify satellite cells in this receptor as Merkel cells, although they are differentiated on the basis of whether they are located in the epidermis or dermis and whether they are encapsulated or not [2].

### Pacinian Corpuscles

Lehman and Vater (1741) first described this corpuscle. The corpuscle is present deep in the subcutaneous tissue, at the interosseous membrane and at the mesentery in primates and non-primates. The perineural or outer lamella, made of  $20\text{--}70$  layers, forms a thick capsule and contains an inner core with many Schwann cells (inner lamella). An unmyelinated nerve terminal occupies the center of the inner core. The receptor is oval and rice-seed sized; the overall size ranges from  $0.5$  to  $2 \text{ mm}$  in length and is about  $0.7 \text{ mm}$  in diameter,

so large that it is visible when it presents at the mesentery or interosseous membrane. The lamellated structure looks like a section through an onion (Fig. 3). A single nerve fiber enters at one end of the corpuscle. After giving rise to a single Ranvier's node, it gets unmyelinated and travels to the other end of the corpuscle along the longitudinal in the inner core. The inner core lamella has a profile of semicircles with gaps between the half circles aligned so as to produce two clefts, with 180° apart, into which the unmyelinated nerve terminal with oval appearance at cross section projects the footlike extensions [9]. Nerve terminals are densely packed with a large number of mitochondria.

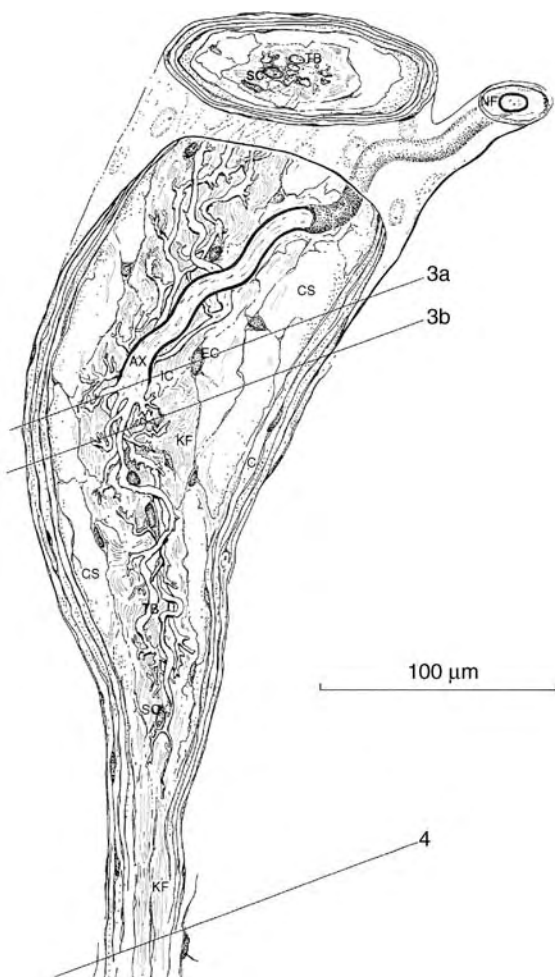

**Cutaneous Mechanoreceptors, Anatomical Characteristics.** Figure 5 Schematic illustration of Ruffini ending. AX, axon; cs, capsular space; KF, collagen fiber; IC, inner core; TB, terminal ramification of the axon. (Reproduced from Andres and von During (1973) *Handbook of sensory physiology*, vol. 2 somatosensory system, (ed. A Iggo), Springer Verlag, Berlin Heidelberg New York, Fig. 5).

### Ruffini Endings

These receptors were originally described by Ruffini (1983). Ruffini endings are spindle-shaped with the length ranging from 0.5 to 2 mm, and lie in the dermis both in the glabrous and hairy skin. A schematic illustration of the receptor is shown in Fig. 5.

The outer capsule of 3–5 lamella, originating from perineural cells, surrounds the fluid-filled space between the capsule and inner core, and the space is divided into several compartments. The inner core is filled with collagen fibers running continuously, and supplied by a large myelinated axon which breaks up to form a dense brush-work of fine branches and terminals [10]. A single axon innervates several endings.

### Sinus Hair Follicles

Sinus hairs are present in the skin of mammals: they are vibrissae or whiskers in the face, carpal sinus hairs on the foreleg, tactile hairs or **tylotrich hairs** in other parts of the body. They are characterized by their large diameter and the length of the hair, the presence of a vascular sinus in a large bulbous capsule, associated erectile muscles, and a rich innervation. Nerve terminals are present in the midregion of the follicle below the sebaceous gland. The four kinds of nerve terminals are noted in the facial sinus hairs [1]: (i) Merkel cells around the perimeter of the hair in the basal stratum adjacent to the glassy membrane, (ii) lanceolate nerve terminals lying in the inner hair follicle on the other side of the glassy membrane from the Merkel cells, (iii) small lamellate corpuscles, and (iv) fine nerve terminals. Carpal sinus hairs lack lanceolate nerve terminals but are associated with Pacinian corpuscles clustered around them. Tylotrich hairs have lanceolated nerve terminals but no Merkel cells, however, they are associated with Merkel cells in the epidermis to form hair disks.

### References

- Andres KH (1966) Ueber die Feinstruktur der Rezeptoren und Sinushaaren. *Z Zellforsch Mikrosk Anat* 75:339–365
- Iggo A, Andres KH (1982) Morphology of cutaneous receptors. *Annu Rev Neurosci* 5:1–31
- Iggo A, Ogawa H (1977) Correlative physiological and morphological studies of rapidly adapting mechanoreceptors in cat's glabrous skin. *J Physiol* 266:275–296
- Andres KH, von During M (1973) Morphology of cutaneous receptors. In: Iggo A (ed) *Handbook of sensory physiology*, vol 2, Somatosensory system. Springer, Berlin Heidelberg New York, pp 3–28
- Iggo A, Muir AR (1969) The structure and function of the slowly adapting touch corpuscle in hairy skin. *J Physiol* 200:763–796
- Yamashita Y, Toida K, Ogawa H (1993) Observation of Merkel cells with scanning electron microscopy. *Neurosci Lett* 159:155–158

7. Gottschaldt KM, Lausmann S (1974) The peripheral morphological basis of tactile sensibility in the beak of geese. *Cell Tissue Res* 153:477–496
8. Saxod R (1973) Organisation ultrastructurale des corpuscules sensoriels cutanes des oiseaux. *Sci Nat* 1:69–98
9. Hunt CC (1974) The Pacinian corpuscle. In: Hubbard JI (ed) *The peripheral nervous system*. Plenum Press, NY, pp 405–420
10. Chambers MR, Andres KH, von Duering M, Iggo A (1972) The structure and function of the slowly adapting type II mechanoreceptor in hairy skin. *Q J Exp Physiol* 57:417–445

## Cutaneous Mechanoreceptors, Functional Behavior

VAUGHAN G MACEFIELD<sup>1,2</sup>, INGVARIS BIRZNIKS<sup>2</sup>

<sup>1</sup>School of Medicine, University of Western Sydney, Sydney, NSW, Australia

<sup>2</sup>Prince of Wales Medical Research Institute, Sydney, NSW, Australia

### Synonyms

Tactile afferents; Low-threshold cutaneous mechanoreceptors; Cutaneous receptors

### Definition

The skin is the largest organ of the body and is richly supplied with specialized sensory endings of low mechanical threshold. These cutaneous mechanoreceptors allow us to feel the weak forces generated by a slight breeze and to differentiate between the textures and shapes of objects we touch and manipulate; they also contribute to ►[proprioception](#). Yet the tactile system subserves not only the sense of “touch” in the broadest interpretation of the word, which implies that a stimulus can be felt; cutaneous mechanoreceptors are also important in fine motor control (particularly of the hand), which – depending on the task – may or may not require conscious attention. The remarkable versatility of the human hand depends not just on its anatomical structure but, in particular, on the sophisticated neural machinery that controls it. We use our hands to explore the physical world within our reach and, with tools, the world beyond our reach, and to act on the world through manipulation of environmental objects. To control both the exploratory and manipulatory functions of the hand, the brain must obtain accurate descriptions of various mechanical events that take place when objects are brought into contact with the hand, or when the fingers make contact with an object. Cutaneous mechanoreceptors in the fingers play crucial roles in providing such information. The

glabrous (hairless) skin of the human hand contains approximately 17,000 low-threshold mechanoreceptors that provide us with our remarkable capacities to discriminate shape, texture and force [1]. This chapter deals only with the functional properties of human cutaneous mechanoreceptors, assessed via the technique of ►[microneurography](#).

## Characteristics

### Quantitative Description

#### Glabrous Skin

Four types of specialized mechanoreceptor terminal can be identified histologically in human hairless (glabrous) skin – two located superficially and two deeper [1]. In the upper layers of skin there are groups of expanded disc-like endings that arise from branched axons and which are closely associated with specialized cells in the basal layer of the epidermis (Merkel cell-neurite complexes); within the intradermal papillae lay ellipsoidal encapsulated endings (Meissner’s corpuscles), the long axis of which is oriented normal to the skin. In the subpapillary dermis one finds the encapsulated Ruffini and Pacinian corpuscles, both endings originating from a single axon. The Ruffini corpuscle, which is morphologically similar to the Golgi tendon organ, is oriented with its long axis in the plane of the skin and forms mechanical linkages with the longitudinally arranged collagen fibers that course through the dermis. The Pacinian corpuscle, which is composed of concentric lamellae around a central core, is situated in deeper layers of the dermis and subcutaneous tissues: the lamellae effectively serve as a high-pass filter, preventing all but the most brisk mechanical events from reaching the generator region of the axon terminal. As discussed below, it is terminal specializations like this that determine how a given sensory axon encodes mechanical stimuli. In addition to these specialized mechanoreceptors, however, free nerve endings – some of which have low thresholds to mechanical stimuli (►[tactile C fibers](#)) – are found within the epidermis and dermis. In support of the histological findings, microelectrode recordings from the median and ulnar nerves have also revealed the existence of four classes of low-threshold mechanosensitive afferent in the glabrous skin of the human hand, defined according to their responses to sustained indentation and to the sizes of their receptive fields: two classes of afferent adapt rapidly (►[rapidly-adapting afferents type I & II](#)) to a sustained indentation of the skin (“fast-adapting”) – types FAI and FAII – and two classes of afferent adapt slowly (►[slowly-adapting afferents type I & II](#)) and are referred to as SAI and SAII. Type I afferents possess small, well-defined receptive fields, whereas the receptive fields of the type II afferents are large with poorly defined borders. The most common class encountered in recordings from the median nerve,

which supplies most of the glabrous skin of the hand, is the FAI class, followed by (in descending order) the SAI, SAII and FAII classes [1]. Based on their behavioral similarities with afferents recorded in the cat and monkey it is believed that the FAI afferent – referred to as “RA” (rapidly adapting) in the cat and “QA” (quickly adapting) in the monkey – supplies the Meissner corpuscle, and the SAI afferent the Merkel cell-neurite complex. The receptors belonging to the FAII and SAII afferents are believed to correspond to the Pacinian corpuscle (“PC”) and Ruffini ending, respectively.

### **Non-Glabrous Skin**

The hairy skin covers much of the body, and the properties of cutaneous mechanoreceptors supplying this tissue are probably more representative of the “tactile sensory sheet” than those of the glabrous skin – which is rather more specialized. In agreement with the types of receptors found in hairy skin of the cat, five classes of myelinated tactile afferent have been recorded from the lateral antebrachial cutaneous nerve, which supplies the hairy skin of the human forearm: two types of slowly-adapting afferent (SAI & SAII) that can be classified in a similar fashion to those in the glabrous skin, and three types of rapidly-adapting afferent – hair units, field units and Pacinian units [2]. Hair units respond specifically to movements of individual hairs and air puffs onto the receptive field, whereas field units respond to actual skin contact; the behavior of the SAI, SAII and FAII units is similar to that observed in glabrous skin, with 80% of the SAII endings presenting a low-level background discharge in the absence of stimulation. The afferent innervation of the skin on the dorsum of the hand, which is supplied by the superficial branch of the radial nerve, is similar to that of the volar surface of the hand: SAI, SAII, FAI and FAII afferents have been identified [3]. However, differences do exist between the two cutaneous regions. Unlike glabrous skin, in which the dominant species of cutaneous afferent is the FAI afferent, two-thirds of the afferents in the hairy skin of the hand are slowly adapting. A further difference lies in the relative proportions of SAI and SAII afferents: in the glabrous skin there are more of the former, whereas there are equivalent numbers in the hairy skin. There are also difficulties in differentiating between SAI and SAII units in the hairy skin, whereas the classifications are quite distinct in glabrous skin. Although few endings associated with hairs have been recorded from the radial nerve this may simply reflect the lower density of hairs on the back of the hand compared with that of the forearm. Nevertheless, a common feature shared by glabrous and non-glabrous skin is the relative paucity of FAII afferents. Microelectrode recordings from the infraorbital nerve have demonstrated that the hairy skin of the human face

is innervated by rapidly-adapting and slowly adapting afferents with properties identical to those of the FAI and SAI afferents found in the hand [4]. A distinct population of slowly-adapting afferents that present a very regular discharge characteristic of SAII endings has also been found, although their responsiveness to skin stretch could not be tested. Interestingly, no FAII afferents were encountered; this suggests an absence of Pacinian corpuscles in the human face, and fits with the low sensitivity of the face to high-frequency vibration.

## **Lower Level Components**

### **Glabrous Skin**

Type I tactile afferents have small circular or ovoid receptive fields with distinct borders, and have a higher innervation density in the tips of the digits than more proximally within the hand [1]. In addition, receptive fields are smaller on the distal phalanx of the fingers than on the palm. The receptive field is composed of multiple “hot-spots” in which mechanosensitivity is maximal: FAI afferents contain 12–17 such zones – corresponding to the individual Meissner corpuscles supplied by a single axon – whereas SAI afferents contain only 4–7, corresponding to the individual Merkel cell neurite complexes. Type II afferents have large, poorly-defined receptive fields with obscure borders and, usually, a single zone of maximal sensitivity. In addition, their density is fairly uniform throughout the hand, with the exception of a specific representation of SAII afferents associated with the medial and lateral borders of the nail beds. As noted above, both classes of type II afferent can respond to stimuli applied outside their receptive field: FAII afferents respond to brisk mechanical stimuli and SAII afferents respond to lateral skin stretch; despite their small receptive fields, type I afferents can also respond to stimuli that do not directly engage their receptive field, such as stimuli that compress the finger pad. The mechanical thresholds of each class of afferent, as assessed with calibrated filaments (von Frey hairs), are fairly uniform throughout the glabrous area of the hand, but the rapidly adapting receptors have the lowest thresholds: median thresholds to punctate stimulation are lowest for the FAII (0.54 mN) and FAI (0.58 mN) afferents, and highest for the SAI (1.3 mN) and SAII (7.5 mN) afferents [1].

### **Non-Glabrous Skin**

Receptive field maps of four single cutaneous mechanoreceptors in the hairy skin of the forearm are illustrated in Fig. 1. The fields of the SAI afferents consist of 2–4 distinct islands of high sensitivity separated from each other by 3 mm on average; these spots presumably correspond to the touch domes overlying clusters of Merkel cells (Fig. 1a). On the dorsum of the hand, however, most of the SAI fields (like their

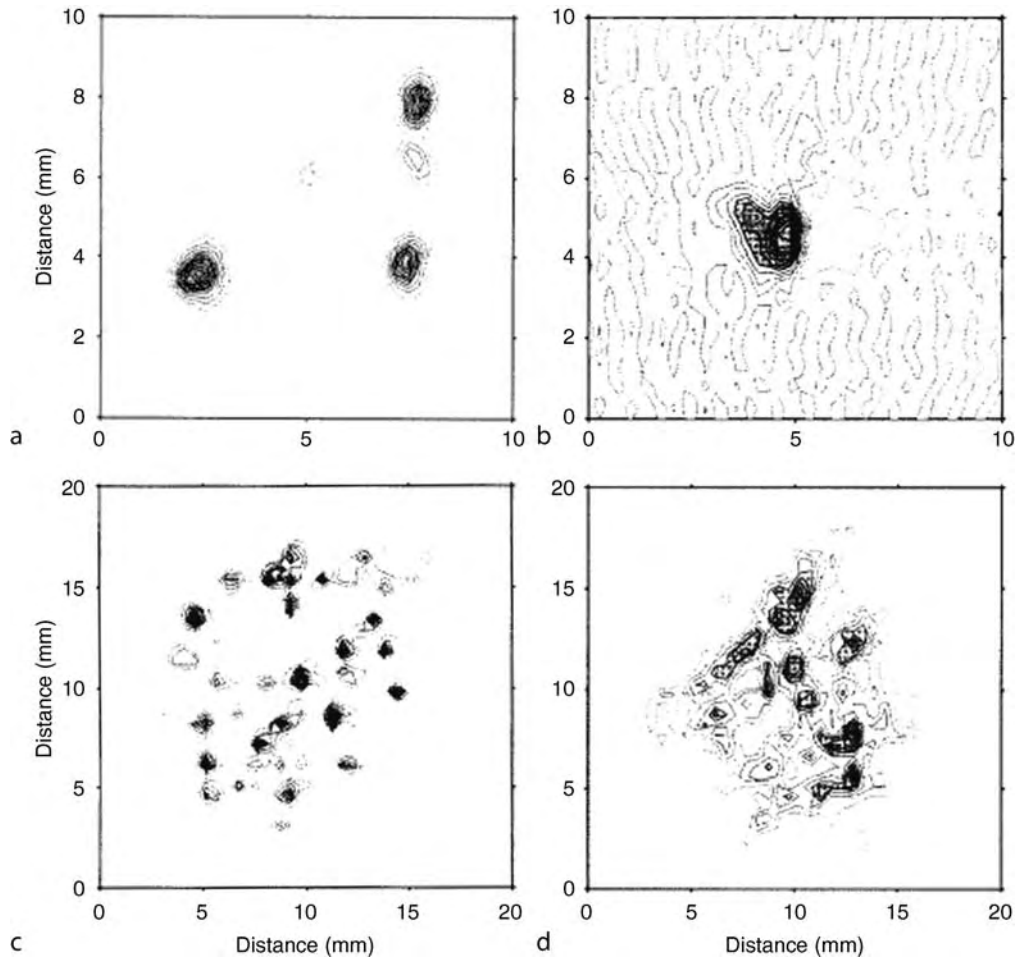

**Cutaneous Mechanoreceptors, Functional Behavior. Figure 1** Receptive field maps of single cutaneous mechanoreceptors in the hairy skin of the forearm: (a), SAI afferents with three zones of maximal sensitivity; (b), SAI afferent with single zone of maximal sensitivity; (c), hair unit and, (d), field unit with multiple zones of sensitivity. Note the different scales in C and D. Receptive fields were mapped by scanning the skin with a probe via a computer-controlled X-Y plotter. Reproduced from [2].

rapidly-adapting counterparts) consist of a single spot of maximal sensitivity. Overall, the number of these zones in the hairy skin is lower than in the glabrous skin. Apart from their higher representation in the hairy skin, the SAI afferents are similar to those in the glabrous skin, usually having a single zone of high sensitivity to punctate stimulation (Fig. 1b). Hair units have large ovoid or irregular receptive fields composed of multiple sensitive spots that corresponded to individual hairs (Fig. 1c). On average, each afferent innervates 20 hairs [2]. The field units show a similar arrangement of 10–12 high sensitivity spots encompassed by a similarly large area, although the individual spots are larger and less isolated than those of the hair units. By contrast, on the dorsum of the hand and the hairy skin of the face, the rapidly-adapting afferents have small receptive fields, usually with only a single zone of uniform sensitivity.

Mechanoreceptors in the hairy skin of the forearm are exquisitely sensitive, even more so than those in the glabrous skin: after the hair units the afferents with the lowest threshold to von Frey stimulation are the field units, with a median threshold of 0.1 mN; the SAI and SAI afferents have median thresholds of 0.45 and 1.30 mN, respectively [2]. Mechanical thresholds of afferents on the dorsum of the hand and on the face are similar to those in the glabrous skin of the hand [3,4].

#### Higher Level Processes

Selective stimulation (►microstimulation) of single FAI, FAII and SAI afferents innervating the glabrous skin of the hand evokes elementary sensations of a specific quality [5]. A single pulse delivered to a single FAI afferent can be detected if the subject's attention is directed to it, whereas an SAI afferent requires more

impulses and greater attention. This also fits with the lower mechanical threshold of FAI afferents and confirms an earlier interpretation of psychophysical thresholds that subjects can detect a single impulse generated by a single FAI receptor. Stimulating a single FAI afferent with a low frequency train generates a percept of intermittent tapping that, as the frequency of stimulation increases, becomes one of flutter or vibration; stimulation of a single FAII afferent with a train of pulses always generates a frequency-dependent perception of mechanical vibration. Percepts of sustained pressure can be evoked by selective stimulation of SAI afferents, the magnitude of which increases with increasing stimulation frequency. It would appear that the impulse codes utilized by rapidly and slowly adapting tactile afferents are quite distinct: increasing frequency of stimulation signaling increasing vibration with the former, and increasing pressure with the latter. Stimulation of a single SAI afferent with a train of pulses usually does not elicit a sensation.

## Function

### *Tactile Sensibility*

Because of their low mechanical thresholds, and functional specializations related to anatomic specializations of the receptor endings, tactile afferents contribute importantly to the sensory picture of the body. The afferent innervation of human skin is characterized by regional variations in receptor types and densities that indicate specializations of the “tactile sensory sheet.” In the glabrous skin of the hand the tips of the digits contain a high proportion of rapidly-adapting afferents (FAI) with small receptive fields, low mechanical thresholds, and – based on the robust perceptual responses to microstimulation – a secure transmission to the sensory cortex, whereas on the dorsum of the hand these afferents have a much lower representation. FAI afferents can be activated by discrete punctate stimuli in a small, well-defined area of skin; they are particularly sensitive to light stroking across the skin, responding to local shear forces and incipient or overt slips within the receptive field. The rapidly-adapting type II (FAII) afferents, like their PC counterparts in experimental animals, are exquisitely sensitive to brisk mechanical transients: typically, FAII afferents respond to tapping over areas remote from the site of maximal mechanosensitivity, or to blowing over the skin. Instantaneous firing rates are typically higher for the FAII afferents than for the FAI afferents. In all skin areas the numbers of FAII (Pacian) afferents is low, but given their large field sizes, low thresholds, exquisite sensitivity to mechanical transients and high security transmission to the sensory cortex, their number need not be so high anyway. The slowly-adapting type I afferents (SAI) characteristically have a high dynamic sensitivity to indentation stimuli applied to a discrete

area, and often respond with an off-discharge during release. In the glabrous skin of the hand, the SAI endings appear to be of particular importance in encoding shape and – together with the FAI afferents – in fine tactile discrimination. Furthermore, the SAI afferents in the finger pads signal with high fidelity the changes in grip force associated with manipulation of held objects. While the SAII afferents do respond to forces applied normal to the skin, a unique feature of these afferents is their capacity to respond also to lateral skin stretch. Many possess directional sensitivity, the discharge of some afferents increasing with stimuli applied in certain directions, but decreasing in others. And, because SAII afferents possess lower dynamic sensitivity, peak firing rates are typically lower for the SAII afferents than for the SAI afferents. A proportion of SAII afferents are spontaneously active at rest, presenting a characteristically regular discharge. Given their high sensitivity to forces tangential to the skin and poor capacity in spatial discrimination, it is reasonable to conclude that the specific contribution of SAII afferents may lie in signaling changes in conformation of the hand and the load forces (tangential to the skin) encountered during manipulation. The hairy skin of the forearm, which probably typifies the skin of much of the body, has its own specializations: in addition to two classes of very sensitive receptors with large receptive fields (hair units and field units), this region is endowed with non-myelinated mechanosensitive endings of very low threshold (▶tactile C fibers).

Although the two classes of rapidly adapting afferent have the lowest thresholds to mechanical stimulation, the slowly adapting type I afferent shares a property with the FAI afferents that effectively increases its mechanosensitivity: FAI and SAI afferents are especially sensitive to edges of a contact surface that crosses the afferent’s receptive field. The finger pads have the highest density of FAI and SAI endings; it is this property that endows the finger pads with their exquisite tactile discrimination, and the reason the finger pads are used for tactile exploration and manipulation.

Human subjects have a remarkable capacity to discriminate small differences in forces applied to the finger pad, forces of magnitudes typically associated with manipulation. Recent studies on the responses of tactile afferents in the finger to compression forces applied to the centre of the finger pad (Fig. 2) have emphasized the need to consider receptors in the entire terminal phalanx as providing tactile information on mechanical events in the centre of the pad [6]. Indeed, SAI and SAII endings, as well as FAI receptors, on the end and sides of the terminal phalanx can respond vigorously to stimuli applied at locations remote to their receptive fields, and each of these classes of tactile afferent can contribute to encoding the direction of fingertip forces [6] and the curvature of



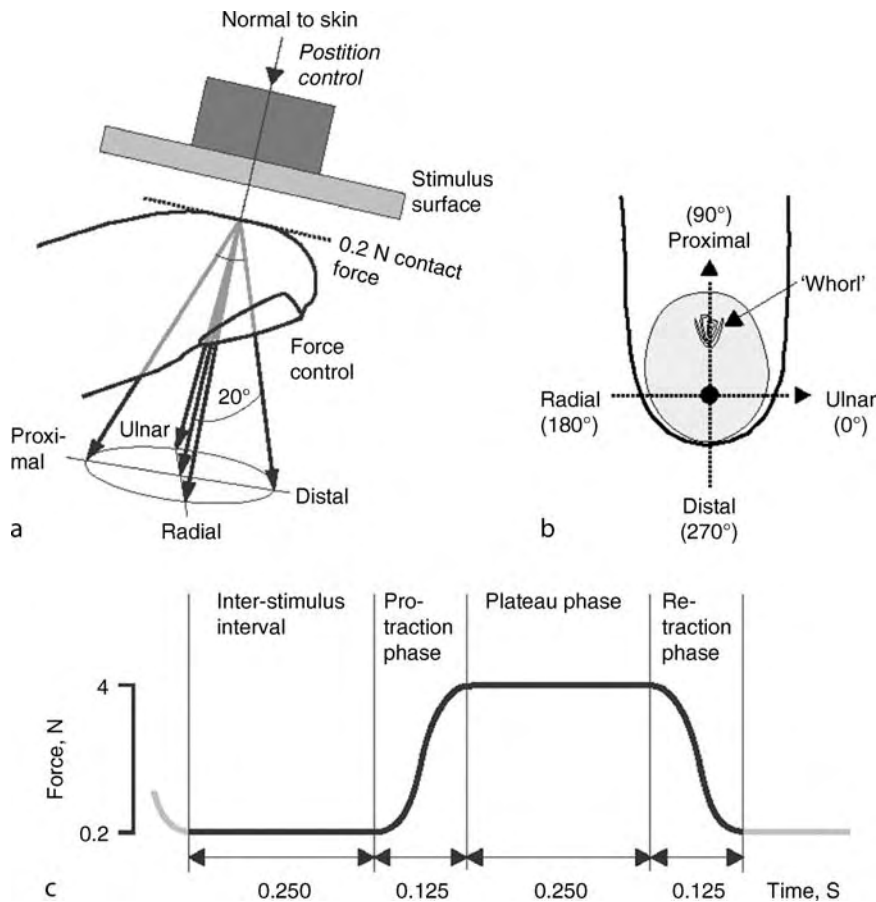

**Cutaneous Mechanoreceptors, Functional Behavior. Figure 2** Method of delivering forces to the fingertip in five different directions. (a), The stimulus surface was oriented parallel to the flat portion of skin at the fingertip. Force stimuli were superimposed on a 0.2 N background contact force and delivered in the normal direction and at an angle  $20^\circ$  to the normal with tangential components in the distal, radial, proximal, and ulnar directions as indicated by the *five arrows*; the normal force was always 4 N. (b), Outline of a generic finger showing the stimulation point and the approximate skin area (*shaded*) in contact with the stimulus surface for a 4 N normal force. (c), Temporal profile of the applied forces. Each stimulus consisted of a protraction phase, a plateau phase, and a retraction phase. Reproduced from [6].

objects applied to the finger pad [7]. Directional sensitivity has significant implications for functional specialization and, surprisingly, is present for each class of tactile afferent. Figure 3 show the directional sensitivity of FAI afferents in the distal phalanx of the finger to forces applied to the centre of the finger pad according to Fig. 2.

#### Sensorimotor Control of the Hand

Cutaneous mechanoreceptors in the fingers are critical for fine sensorimotor control of the hand. People with impaired tactile sensibility of the fingers (including that associated with aging) show clumsiness during object manipulation tasks: objects are frequently dropped, fragile objects may be crushed, and they have severe problems in stereognostic discrimination of objects. Most previous studies of afferents from the glabrous

skin of the human hand have addressed issues related to use of the hand in exploratory tasks, with comparatively little research devoted to the tactile encoding of the various mechanical fingertip events critical for the control of dextrous manipulation. The responses of human tactile afferents in relation to discrete motor control events were demonstrated for the first time during object lifting [8] and restraint tasks [9]. The neural programs involved in the sensorimotor control of manipulation are tuned parametrically to the physical properties of the object, whether this be surface friction and object mass, mass distribution or the shape of grasped surfaces. Through *Anticipatory Parameter Control* people use implicit memories from previous manipulatory experiences to retrieve internal models pertaining to the relevant properties of the target objects. Importantly, tactile signals from the

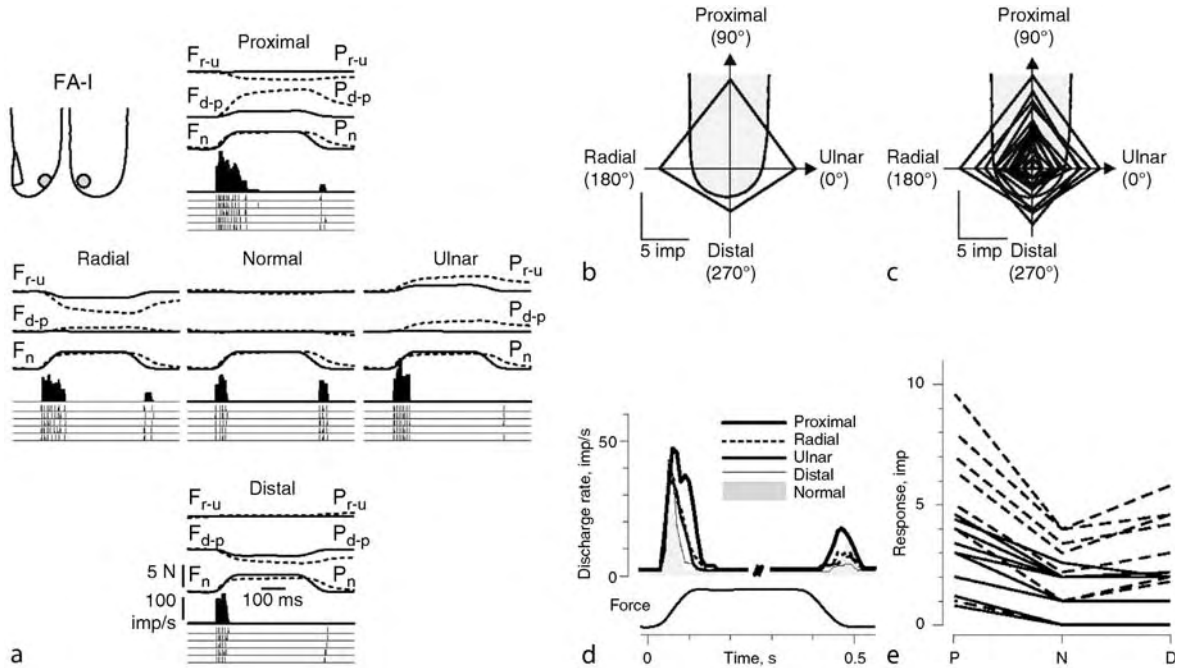

**Cutaneous Mechanoreceptors, Functional Behavior. Figure 3** Responses of FAI afferents to servo-controlled forces applied in five directions. (a), Responses of a single FAI afferent which responded preferentially to forces delivered in the proximal direction (b), The generic finger outline shows a polar plot for the afferent illustrated in A. (c–e), Data from 21 afferents for which response was greatest when the tangential component of force was in the proximal direction. (c), Overlaid polar plots, superimposed on the generic finger, for the 21 afferents for which responses were greatest when the tangential component of force was in the proximal direction. (d), Instantaneous firing rates, averaged over the five trials, for the same 21 afferents as in C, shown for forces with tangential components in the four directions and for normal force stimulation. (e), For each of the 21 afferents in C, lines join three data points representing the response, averaged over the five trials, to forces in the proximal (P), normal (N), and distal (D) directions. Reproduced from [6].

fingertips play a key role for the forming and updating those models. Through *Discrete Event, Sensory-driven Control* the time-varying tactile inflow is compared with an internal signal representing the predicted sensory outcomes (also generated by the active sensorimotor program). Disturbances in task execution due to erroneous parameter specification are reflected in a mismatch between predicted and actual sensory input; discrete tactile events may not occur when expected, or alternatively, they may occur unexpectedly. When such a mismatch is detected, pre-programmed patterns of corrective responses are triggered, along with an update of the parameter specification of the relevant internal model. For friction and aspects of object shape this updating primarily occurs during the initial contact with the object; tactile afferents in the finger pads provide this information.

An astonishing feature of sensorimotor control of hand is the speed with which motor commands are parametrically updated in response to discrete mechanical events during object manipulation. It appears that tactile information from the fingertips is

already available when most afferents would have had time to fire only one nerve impulse. Thus, besides traditional coding mechanisms based on rate codes requiring several or at least two impulses per afferent, a new much faster coding mechanism based on first spike latencies has been proposed [10]. This study demonstrated that the sequence in which different afferents initially discharge may provide information about the force directions and shape of grasped surfaces faster than any rate code and matches the speed with which this information is utilized by the sensorimotor control loops. Signals provided by FAI afferents are most efficient in this capacity, followed by the SAI afferents (Fig. 4).

When holding an object between the fingers and thumb there are two primary forces that act at the skin: a compressive component normal to the skin and a shear component tangential to the skin. The first is brought about by the grip forces exerted by the muscles acting on the digits, the second by the effect of gravity on the held object or any other net force imposed by the object or hand on the object. Johansson and colleagues

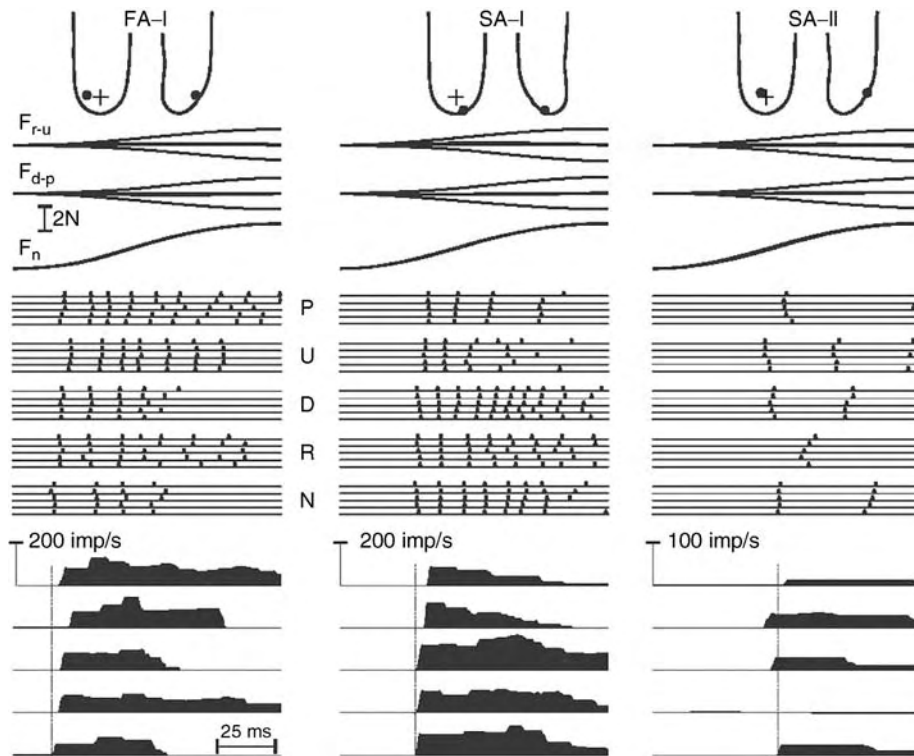

**Cutaneous Mechanoreceptors, Functional Behavior. Figure 4** Modulation of first spike latencies by direction of fingertip force. Responses of single afferents of each type to the proximal ("P"), ulnar ("U"), distal ("D"), radial ("R") direction and with normal force ("N") only (see stimuli in Fig. 2). Impulse ensembles show responses to the repeated stimuli ( $n = 5$ ). Traces above show the normal force ( $F_n$ ) and tangential forces in the radial-ulnar ( $F_{r-u}$ ) and distal-proximal ( $F_{d-p}$ ) directions, superimposed for all trials; traces below show the instantaneous discharge frequency averaged over the five trials. Vertical lines indicate the response onset latency for stimulation with normal force, i.e., the condition labeled "N." Symbols on the finger outlines indicate the centers of the afferents' receptive fields. Reproduced from [10].

have shown that cutaneous afferents in the glabrous skin of the digits are capable of encoding the grip and load forces associated with grasping and lifting an object, and that the information provided by tactile afferents to the central nervous system is of paramount importance in the fine coordination of load and grip forces [8]. When grasping and lifting a passive object between finger and thumb the type I afferents (FAI and SAI) in the tips of the digits respond with high firing rates at the moment of contact and in the early part of the loading phase, during which the grip force increases in parallel with the load force at a rate sufficient to prevent slipping of the object. The FAI and SAI afferents also respond to local mechanical disturbances during the lifting and hold phases, such as incipient or overt slips. FAII afferents respond to the mechanical transients associated with initial contact and release of the object, and they are especially sensitive to the acceleration (and deceleration) signals related to the start and end of a grip and lift (or replace) movement sequence. The SAII afferents generally respond to the grip force during the loading and hold

phases of the lift, and also to the tangential loads generated at the skin during the hold phase.

Similar behavior is observed when subjects attempt to prevent escape of a manipulandum from the grasp during unexpected increases or decreases in tangential force: the FAI, SAI and SAII afferents in the finger pads respond to the shear forces generated between the skin and the manipulandum, but the FAII afferents do not respond to these slow events. While the slowly-adapting afferents also respond during the subsequent increases in grip force that serve to restrain the manipulandum, as shown in Fig. 5, FAI afferents respond only during the dynamic phases of the stimulus, i.e., during the loading and unloading ramps, and less to the normal forces associated with the increase in grip force [9]. Tactile afferents also provide information on the rotational forces associated with manipulation of held objects. Indeed, torque loads tangential to the fingertips are common in the majority of natural manipulatory tasks. Everyday tasks, such as lifting a book from the shelf by its spine, would not be possible if the motor control system did not automatically coordinate grip forces with torsional

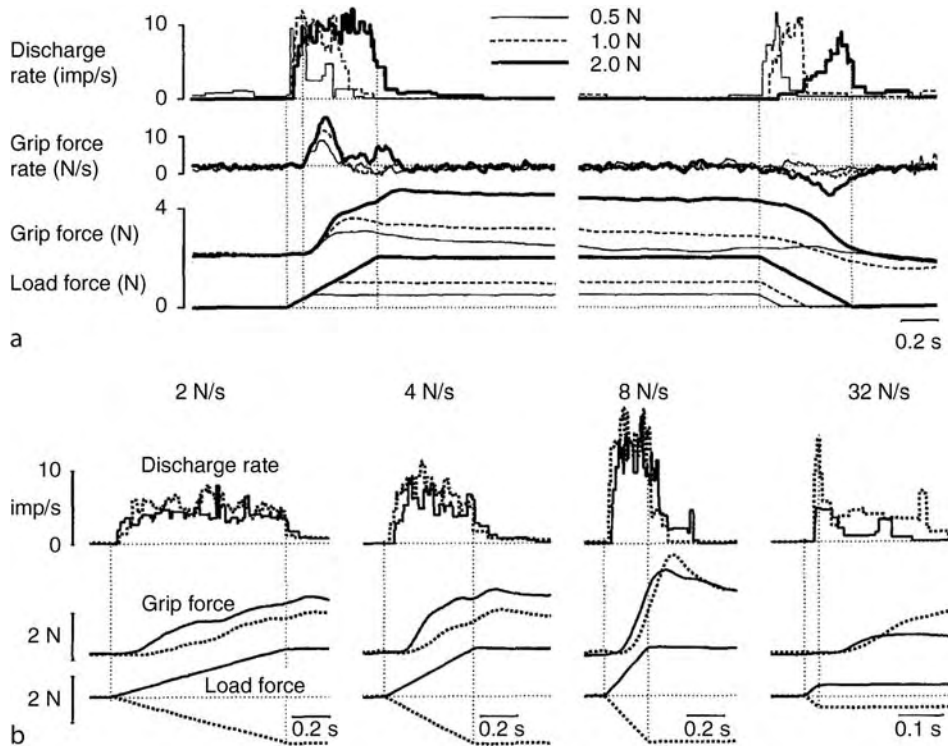

**Cutaneous Mechanoreceptors, Functional Behavior. Figure 5** Mean responses of 8 FAI afferents in the finger pads to tangential loads applied to the receptor-bearing digit at, (a), a constant ramp rate delivered at three different amplitudes (0.5–2.0 N) and, (b), at four ramp rates (2–32 N/s) delivered at a constant amplitude (2 N). Subjects gripped an instrumented manipulandum which delivered, at unexpected times, tangential loads in the distal (upward = pulling) or proximal (downward = pushing) direction. Reproduced from [9].

loads. Torque loads depend on rotational (torsional) friction between the fingertips and the object, which arises because the normal force is distributed across the skin-object contact area, rather than focused at a point. Thus, to prevent an object from slipping under combined linear force and torque loads, we need to apply a grip force that is higher than that required to prevent slips due to the linear load force only. Surface curvature parametrically scales the relationship between the grip force and tangential torque: the grip force at any given tangential torque increases with increasing surface convexity and thereby prevents rotational slips. Again, tactile afferents in the finger pads provide this information.

### Pathology

Loss of cutaneous (and proprioceptive) sensibility can occur in rare large-fiber sensory neuropathies. Patients lose all discriminative touch and their capacity for fine motor control, relying on vision as the only source of feedback. Nevertheless, in the hairy skin they do have preserved C-fiber function and, because of the low-threshold C-fibers (▶tactile C fibers), can sense light stroking on the skin.

### References

1. Johansson RS, Vallbo ÅB (1983) Tactile sensory coding in the glabrous skin of the human hand. *Trends Neurosci* 6:27–31
2. Vallbo ÅB, Olausson H, Wessberg J, Kakuda N (1995) Receptive field characteristics of tactile units with myelinated afferents in hairy skin of human subjects. *J Physiol* 183:783–795
3. Edin BB (1992) Quantitative analysis of static strain sensitivity in human mechanoreceptors from hairy skin. *J Neurophysiol* 67:1105–1113
4. Johansson RS, Trulsson M, Olsson KA, Abbs JH (1988) Mechanoreceptive afferent activity in the infraorbital nerve in man during speech and chewing movements. *Exp Brain Res* 72:209–214
5. Torebjörk HE, Vallbo ÅB, Ochoa JL (1987) Intraneural microstimulation in man. Its relation to specificity of tactile sensations. *Brain* 110:1509–1529
6. Birznieks I, Jenmalm P, Goodwin AW, Johansson RS (2001) Encoding of direction of fingertip forces by human tactile afferents. *J Neurosci* 21:8222–8237
7. Goodwin AW, Macefield VG, Bissley JW (1997) Encoding of object curvature by tactile afferents from human fingers. *J Neurophysiol* 78:2881–2888
8. Westling G, Johansson RS (1987) Responses in glabrous skin mechanoreceptors during precision grip in humans. *Exp Brain Res* 66:128–140

9. Macefield VG, Häger-Ross C, Johansson RS (1996) Control of grip force during restraint of an object held between finger and thumb: Responses of cutaneous afferents from the digits, *Exp Brain Res* 108:155–171
10. Johansson RS, Birznieks I (2004) First spikes in ensembles of human tactile afferents code complex spatial fingertip events. *Nat Neurosci* 7:170–177

---

## Cutaneous Reflexes

### Definition

An automatic and stereotypical response to cutaneous stimulation that is mediated through a polysynaptic set of interneurons in the spinal cord. A cutaneous reflex may be elicited by stimulation of any cutaneous sensory organs, broadly classified as innocuous mechanoreceptors, innocuous thermoreceptors, and nociceptors.

► Integration of Spinal Reflexes

---

## CVA Brain Attack

► Stroke

---

## Cyborg

### Definition

Contraction of Cybernetic Organism. Organism composed of a living and an artificial portion, in close bidirectional interaction. The term was first introduced in 1960 by Clynes and Kline in the context of the debate on humans colonizing space. If man in space, in addition to flying his vehicle, must continuously be checking on things and making adjustments merely in order to keep himself alive, he becomes a slave to the machine. The purpose of the Cyborg, as well as his own homeostatic systems, is to provide an organizational system in which such robot-like problems are taken care of automatically and unconsciously, leaving man free to explore, to create, to think, and to feel (Clynes & Kline 1960).

► Computer-Neural Hybrids

---

## Cycle

### Definition

The complete sequence of values of a periodic quantity that occur during a period.

---

## Cyclic AMP

### Definition

3-5-cyclic adenosine monophosphate (cAMP, formed from adenosine triphosphate, ATP, by the action of the enzyme adenylyl cyclase) is a second messenger, used for intra-cellular signal transduction of some inter-cellular messages (some hormones and neurotransmitters) or sensory messages such as odorants which cannot get through the cell membrane. These messages are also called “first messengers”.

---

## Cyclic AMP- and cGMP-dependent Protein Kinases (cAKs, cGKs)

### Definition

These enzymes are activated by the binding of cAMP or cGMP. When activated cAKs and cGKs phosphorylate specific serine or threonine residues in target proteins and thereby control the activity of these proteins.

► Cyclic Nucleotide-regulated Cation Channels

---

## Cyclic AMP-binding Guanine Nucleotide Exchange Factors (cAMP-GEFs)

### Definition

In the cAMP-bound conformation cAMP-GEFs specifically bind to Ras-like small G proteins and activate these proteins by profoundly accelerating the exchange of GDP for GTP.

► Cyclic Nucleotide-regulated Cation Channels

## Cyclic GMP

### Definition

Cyclic guanosine monophosphate (cGMP) is an intracellular second messenger generated by guanylyl cyclase from guanosine triphosphate (GTP).

## Cyclic GMP-regulated Phosphodiesterases

### Definition

Phosphodiesterases represent a multi-gene family of enzymes that hydrolyze the second messengers cGMP and cAMP. The hydrolytic activity of several sub-families of these enzymes is regulated in an allosteric manner by the binding of cGMP. Notably, the cyclic nucleotide binding site present in cGMP-regulated phosphodiesterases is not homologous to that found in most other cyclic nucleotide-binding proteins.

► Cyclic Nucleotide-regulated Cation Channels

## Cyclic Nucleotide-binding Domain (CNBD)

### Definition

In cyclic nucleotide-regulated channels this domain serves as a high-affinity binding site for 3–5 cyclic monophosphates. The CNBD of channels has significant sequence similarity to the CNBDs of most other classes of eukaryotic cyclic nucleotide receptors and to the CNBD of the prokaryotic catabolite activator protein (CAP). The primary sequence of CNBDs consists of approximately 120 amino acid residues forming three  $\alpha$ -helices ( $\alpha$ A– $\alpha$ C) and eight  $\beta$ -strands ( $\beta$ 1– $\beta$ 8).

► Cyclic Nucleotide-Regulated Cation Channels

## Cyclic Nucleotide-gated Cation Channel

### Definition

► Cyclic Nucleotide-regulated Cation Channels

## Cyclic Nucleotide-regulated Cation Channels

MARTIN BIEL

Department Pharmazie, Zentrum für Pharmaforschung, Ludwig-Maximilians- Universität München, München, Germany

### Synonyms

CNG channels; HCN channels

### Definition

Cyclic nucleotide-regulated cation channels are ion channels whose activation is regulated by the direct binding of cyclic AMP or cyclic GMP to the channel protein. Two families of channels regulated by cyclic nucleotides have been identified, the cyclic nucleotide-gated (CNG) channels [1,2] and the hyperpolarization-activated cyclic nucleotide-gated (HCN) channels [3–5]. CNG channels require the obligatory binding of a cyclic nucleotide in order to be activated. In contrast, HCN channels are activated by membrane hyperpolarization. Cyclic nucleotides enhance HCN channel activity by affecting the voltage-dependence of channel activation.

### Characteristics

Cyclic nucleotides exert their cellular effects by binding to four major classes of cellular receptors: ► Cyclic AMP- and cGMP-dependent protein kinases (cAKs, cGKs), ► Cyclic GMP-regulated phosphodiesterases, ► Cyclic AMP-binding guanine nucleotide exchange factors (cAMP-GEFs) and cyclic nucleotide-regulated cation (CNG and HCN) channels. Cyclic nucleotide-regulated cation channels are unique among these receptors because their activation is coupled to the influx of extracellular cations into the cytoplasm and to the depolarization of the plasma membrane. CNG channels pass monovalent cations, such as  $\text{Na}^+$  and  $\text{K}^+$ , but do not discriminate between them. Calcium is also permeable but at the same time acts as a voltage-dependent blocker of monovalent cation permeability. By providing an entry pathway for  $\text{Ca}^{2+}$ , CNG channels control a variety of cellular processes that are triggered by this cation. HCN channels conduct  $\text{Na}^+$  and  $\text{K}^+$  with permeability ratios of about 1:4 and are blocked by millimolar concentrations of  $\text{Cs}^+$ . Despite this preference for  $\text{K}^+$  conductance, HCN channels carry an inward  $\text{Na}^+$  current under physiological conditions. HCN channels can also conduct  $\text{Ca}^{2+}$ , but not as well as CNG channels. At 2.5 mM external  $\text{Ca}^{2+}$ , the fractional  $\text{Ca}^{2+}$  current of HCN2 and HCN4 is about 0.5%, whereas for native CNG channels it is in range between 10 and 80%.

CNG and HCN channels belong to the superfamily of **voltage-gated cation channels**. The proposed structure of the channels is shown in Fig. 1. The transmembrane channel core consists of six  $\alpha$ -helical segments (S1–S6) and an ion-conducting **pore loop** between the S5 and S6. The amino- and carboxy-termini are localized in the cytosol. CNG and HCN channels contain a positively charged S4 helix carrying three to nine regularly spaced arginine or lysine residues at every third position. In HCN channels, as in most other members of the channel superfamily, the S4 helix functions as “voltage-sensor” conferring voltage-dependent **gating**. In CNG channels, which are only slightly voltage-dependent, the specific role of S4 is

not known. In the carboxy-terminus, CNG and HCN channels contain a **cyclic nucleotide-binding domain (CNBD)** that is homologous to CNBDs of cAKs, cGKs and cAMP-GEFs. In CNG channels, the binding of cGMP or cAMP to the CNBD initiates a sequence of allosteric transitions that lead to the opening of the ion-conducting pore. In HCN channels, the binding of cyclic nucleotides is not required for activation. However, cyclic nucleotides shift the voltage-dependence of channel activation to a more positive membrane potential and thereby facilitate voltage-dependent channel activation. CNG and HCN channels are tetramers. In native tissue, HCN channel subunits can assemble to form either homo- or heteromeric complexes. By contrast, all known native CNG channels are heterotetramers.

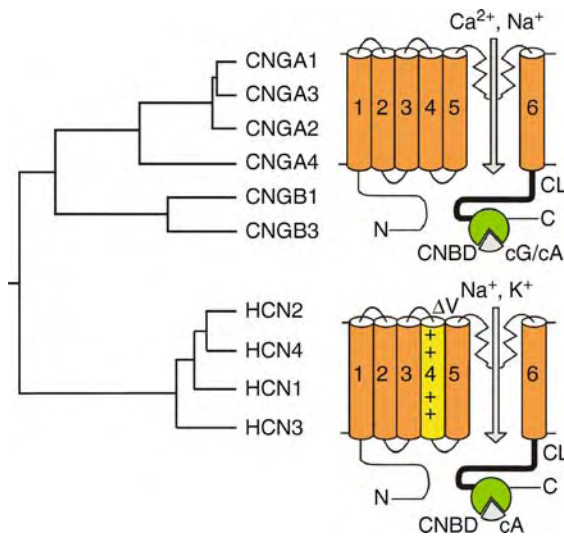

**Cyclic Nucleotide-regulated Cation Channels.** **Figure 1** Phylogenetic tree and structural model of cyclic nucleotide-regulated cation channels. The CNG channel family comprises six members, which are classified into A subunits (CNGA1–4) and B subunits (CNGB1 and CNGB3). A “CNGB2” subunit does not exist. The HCN channel family comprises four members (HCN1–4). CNG and HCN channels share the same transmembrane topology, consisting of six transmembrane segments (1–6), a pore loop and a cyclic nucleotide-binding domain (CNBD). CNG channels conduct  $\text{Ca}^{2+}$  and  $\text{Na}^+$  whereas HCN channel mainly conduct  $\text{Na}^+$  and  $\text{K}^+$ . CNG channel are activated *in vivo* by binding of either cAMP (cA) or cGMP (cG), depending on the channel type. HCN channels activate on membrane hyperpolarization ( $\Delta V$ ), and are enhanced by binding of cAMP. The positively charged amino acid residues in the S4 segment of HCN channels are indicated by + symbols. CL, C-linker involved in activation gating of CNG and HCN channels.

### CNG Channels

CNG channels are expressed in retinal photoreceptors and olfactory neurons and play a key role in visual and olfactory signal transduction. In addition, CNG channels are found at low density in some other cell types and tissues such as brain, testis and kidney. While the function of CNG channels in sensory neurons has been unequivocally demonstrated, the role of these channels in other cell types where expression has been observed remains to be established. Based on their phylogenetic relationship, the six CNG channels identified in mammals are divided in two subfamilies, the A-subunits (CNGA1–4) and the B-subunits (CNGB1 and CNGB3). When expressed in **heterologous expression systems**, A-subunits, with the exception of CNGA4, form functional homomeric channels. In contrast, B-subunits do not give rise to functional channels when expressed alone. However, together with CNGA1–3 they confer novel properties (e.g. single channel flickering, increased cAMP sensitivity) that are characteristic of native CNG channels. In native tissues, CNG channels are heterotetramers with different heteromers displaying distinct nucleotide sensitivity, ion selectivity and modulation by  $\text{Ca}^{2+}$ . Recent genetic studies in mice indicate that B-subunits play a key role in principal channel formation and channel targeting in native sensory neurons. For example, mice lacking the CNGB1 subunit fail to express substantial amounts of CNG channels in rod outer segments and olfactory cilia, respectively. The physiological role and subunit composition is known for three native channels: the rod and cone photoreceptor channels and the olfactory channel. The CNG channel of rod outer segment consists of the CNGA1 subunit and the CNGB1a subunit (3:1 stoichiometry). The cone photoreceptor channel consists of the CNGA3 and the CNGB3 subunit (2:2 stoichiometry). CNG channels control the membrane potential and the calcium concentration of

photoreceptors. In the dark, the channels are maintained in the open state by a high concentration of cGMP. The resulting influx of  $\text{Na}^+$  and  $\text{Ca}^{2+}$  (dark current) depolarizes the photoreceptor and promotes synaptic transmission. Light-induced hydrolysis of cGMP leads to the closure of CNG channels. As a result the photoreceptor hyperpolarizes and shuts off synaptic glutamate release. Mutations in human CNG channel genes have been linked to retinal diseases. Mutations in the *CNGA1* and *CNGB1* subunits have been identified in the genome of patients suffering from ►retinitis pigmentosa. The functional loss of either the *CNGA3* or the *CNGB3* subunit causes total color blindness (achromatopsia) and degeneration of cone photoreceptors.

The olfactory CNG channel consists of three different subunits: *CNGA2*, *CNGA4* and the *CNGB1b* subunit (2:1:1 stoichiometry). The channel is activated *in vivo* by cAMP which is synthesized in response to the binding of odorants to their cognate receptors. The olfactory CNG channel mainly conducts  $\text{Ca}^{2+}$  under physiological ionic conditions. The increase in cellular  $\text{Ca}^{2+}$  activates a  $\text{Ca}^{2+}$ -activated  $\text{Cl}^-$  channel which further depolarizes the cell membrane.  $\text{Ca}^{2+}$  is not only a permeating ion of the olfactory CNG channel, it also represents an important modulator of this channel. By forming a complex with calmodulin, which binds to the *CNGB1b* and *CNGA4* subunit,  $\text{Ca}^{2+}$  decreases sensitivity of the CNG channel to cAMP. The resulting inhibition of channel activity is the principal mechanism underlying fast odorant adaptation.

### HCN Channels

A cation current that is slowly activated by membrane hyperpolarization (termed  $I_h$ ,  $I_f$  or  $I_q$ ) is found in a variety of excitable cells including neurons, cardiac pacemaker cells and photoreceptors. The best understood function of  $I_h$  is to control heart rate and rhythm by acting as “pacemaker current” in the sinoatrial (SA) node.  $I_h$  is activated during membrane hyperpolarization following the termination of an action potential and provides an inward  $\text{Na}^+$  current that slowly depolarizes the plasma membrane. Sympathetic stimulation of SA node cells raises cAMP levels and increases  $I_h$  by a positive shift of the current activation curve, thus accelerating diastolic depolarization and heart rate. Stimulation of muscarinic receptors slows down heart rate by the opposite action. In neurons,  $I_h$  fulfills diverse functions, including generation of pacemaker potentials (neuronal pacemaking), control of membrane potential, generation of rebound depolarizations during light-induced hyperpolarizations of photoreceptors, dendritic integration, and synaptic transmission.

HCN channels represent the molecular correlate of the  $I_h$  current. In mammals, the HCN channel family

comprises four members (HCN1–4) that share about 60% sequence identity to each other and about 25% sequence identity to CNG channels. The highest degree of sequence homology between HCN and CNG channels is found in the CNBD. The crystal structure of this domain has been determined for HCN2 and a bacterial CNG channel. When expressed in heterologous systems all four HCN channels generate currents displaying the typical features of native  $I_h$ : (i) activation by membrane hyperpolarization, (ii) permeation of  $\text{Na}^+$  and  $\text{K}^+$  with a permeability ratio  $P_{\text{Na}}/P_{\text{K}}$  of about 0.2, (iii) modulation of voltage-dependence of channel activation by direct binding of cAMP, (iv) channel blockade by extracellular  $\text{Cs}^+$ .

HCN1–4 mainly differ from each other with regard to their speed of activation and the extent by which they are modulated by cAMP. HCN1 is the fastest channel, followed by HCN2, HCN3 and HCN4. Unlike HCN2 and HCN4, whose activation curves are shifted by about +15 mV by cAMP, HCN1 and HCN3 are only weakly, if at all, affected by cAMP.

Site-directed mutagenesis experiments have provided insight into the complex mechanism underlying dual HCN channel activation by voltage and cAMP. Like in other voltage-gated cation channels, activation of HCN channels is initiated by the movement of the positively charged S4 helix in the electric field. The resulting conformational change in the channel protein is allosterically coupled by other channel domains to the opening of the ion-conducting pore. Major determinants affecting channel activation are the intracellular S4–S5 loop, the S1 segment and the extracellular S1–S2 loop. The CNBD fulfills the role of an auto-inhibitory channel domain. In the absence of cAMP the cytoplasmic carboxy-terminus inhibits HCN channel gating by interacting with the channel core and, thereby, shifting the activation curve to more hyperpolarizing voltages. Binding of cAMP to the CNBD relieves this inhibition. Differences in the magnitude of the response to cAMP among the four HCN channel isoforms are largely due to differences in the extent to which the CNBD inhibits basal gating. It remains to be determined if the inhibitory effect of the CNBD is conferred by a direct physical interaction with the channel core domain or by some indirect pathway. There is evidence that the so-called C-linker, a peptide of about 80 amino acids that connects the last transmembrane helix (S6) to the CNBD plays an important role in this process. The C-linker was also shown to play a key role in the gating of CNG channels, suggesting that the functional role of this domain has been conserved during channel evolution.

HCN channels are found in neurons and heart cells. In mouse and rat brain all four HCN isoforms have been detected. The expression levels and the



regional distribution of the HCN channel mRNAs vary profoundly between the respective channel types. HCN2 is the most abundant neuronal channel and is found almost ubiquitously in the brain. In contrast, HCN1, HCN3 and HCN4 are enriched in specific regions of the brain such as thalamus (HCN4) hippocampus (HCN1) or olfactory bulb and hypothalamus (HCN3). HCN channels have also been detected in the retina and some peripheral neurons such as dorsal root ganglion neurons. In SA node cells, HCN4 represents the predominantly expressed HCN channel isoform. In addition, minor amounts of HCN2 and HCN1 are also present in these cells. Insights into the (patho) physiological relevance of HCN channels have been gained from the analysis of mouse lines lacking individual HCN channel isoforms. Disruption of HCN1 impairs motor learning but enhances spatial learning and memory. Deletion of HCN2 results in absence epilepsy, ataxia and sinus node dysfunction. Mice lacking HCN4 die *in utero* due to the failure to generate mature sinoatrial pacemaker cells. The key role of HCN4 in controlling heart rhythmicity is corroborated by genetic data from human patients. Mutations in the human HCN4 gene leading to mutated or truncated channel proteins have been found to be associated with sinus bradycardia (S672R, 573X) and complex cardiac arrhythmia (D552N).

### Drugs Acting on CNG Channels

Several drugs have been reported to block CNG channels. The most widely used among these drugs is *L-cis* diltiazem which blocks CNG channels in a voltage-dependent manner at micromolar concentrations. The *D-cis* enantiomer of diltiazem, which is an important therapeutic blocker of the L-type calcium channel, is much less effective than the *L-cis* enantiomer in blocking CNG channels. High affinity binding of *L-cis* diltiazem is only seen in heteromeric CNG channels containing the CNGB1 subunit. CNG channels are also moderately sensitive to blockage by some other inhibitors of the L-type calcium channel (e.g. nifedipine), the local anesthetic tetracaine and calmodulin antagonists. Interestingly, LY83583 [6-(phenylamino)-5,8-quinolinedione] blocks both the soluble guanylyl cyclase and some CNG channels at similar concentrations. H-8 [N-2-(methylamino)ethyl-5-isoquinolinesulfonamide], which has been widely used as a non-specific cyclic nucleotide-dependent protein kinase inhibitor, blocks CNG channels, though at significantly higher concentrations than needed to inhibit protein kinases. The most potent blocking agent for CNG channels is pseudoscorpion toxin. This toxin inhibits homomeric CNGA2 channels with a  $K_i$  of 5 nM and the homomeric CNGA1 channel with a  $K_i$  of 100 nM. The peptide is several

orders of magnitude less effective in blocking the heteromeric channels.

### Drugs Acting on HCN Channels

Given the key role of HCN channels in cardiac pacemaking, these channels are promising pharmacological targets for the development of drugs used in the treatment of cardiac arrhythmias and ischemic heart disease. HCN channels are not expressed in vascular and airway smooth muscle. As a consequence, specific HCN channel blockers are expected to have no side effect on the peripheral resistance. Importantly, unlike the well-established  $\beta$ -adrenoceptor blockers, HCN channel blockers would not impair pulmonary function in patients with asthma or obstructive pulmonary disease. Recently, ivabradine (S16257, Procoralan) was approved as the first therapeutic  $I_h$  blocker. Ivabradine blocks cardiac  $I_h$  at low micromolar concentrations and is used in the treatment of stable angina pectoris. Other known  $I_h$  blockers with blocking mechanisms related to that of ivabradine are ZD7288 [4-(N-ethyl-N-phenylamino)-1,2-dimethyl-6-(methylamino)pyrimidinium chloride], zatebradine and cilobradine. These blockers were not introduced into therapy because they either lacked specificity or exerted unacceptable side effects, in particular visual disturbances due to the inhibition of retinal  $I_h$ . Interestingly, the well-known  $\alpha_2$  adrenoceptor agonist clonidine also effectively blocks HCN channels. The block of cardiac  $I_h$  (mainly conferred by HCN4) contributes significantly to the bradycardic effect of clonidine. Modulation of  $I_h$  may also be a promising approach for treatment of disease processes in central and peripheral nervous system. For example,  $I_h$  is upregulated in dorsal root ganglion neurons in response to nerve injury making HCN channels interesting candidates for therapeutic modulation of inflammation and neuropathic pain. Moreover, agents acting on HCN channels may be utilized in the treatment of epilepsies. Finally, HCN1 and HCN2 channels are inhibited by clinically relevant concentrations ( $\leq 0.5$  mM) of the inhalational anesthetics halothane and isoflurane. Similarly, the intravenous anesthetic propofol inhibits and slows the activation of native and expressed HCN channels. Thus, modulation of  $I_h$  may contribute to clinical actions of anesthetic agents.

### References

1. Kaupp UB, Seifert R (2002) Cyclic nucleotide-gated ion channels. *Physiol Rev* 82:769–824
2. Craven KB, Zagotta WN (2006) CNG and HCN channels: two peas, one pod. *Annu Rev Physiol* 68:375–401
3. Baruscotti M, Bucchi A, DiFrancesco D (2005) Physiology and pharmacology of the cardiac pacemaker (funny) current. *Pharmacol Ther* 107:59–79

4. Biel M, Schneider A, Wahl C (2002) Cardiac HCN channels: structure, function and modulation. *Trends Cardiovasc Med* 12:206–213
5. Frère SGA, Kuisle M, Lüthi A (2004) Regulation of recombinant and native hyperpolarization-activated cation channels. *Mol Neurobiol* 30:279–305

- ▶ Glycine
- ▶ Ion Channels from Development to Disease
- ▶ Serotonin

## Cyclins

### Definition

Family of proteins that regulate the progress of cells through the cell cycle.

## Cyclooxygenase-2

### Definition

The cyclooxygenase (COX)-2 enzyme catalyzes the conversion of arachidonic acid into prostaglandins. The type-2 isoform of COX is induced during injury and infection. COX-2 generated prostaglandins induce inflammatory pathways, pain and fever.

- ▶ Central Nervous System Inflammation: Astroglia and Ethanol

## Cys-Loop Receptors

### Definition

Members of the Cys-loop receptor class are ligand-gated ion channels that open in response to binding of ACh, 5-HT (serotonin), Glycine, GABA. Cys loop receptor channels form from homo- or hetero-tetrameric arrangement of subunits surrounding an aqueous pore. Each subunit consists of an extracellular aminoterminal domain, followed by four transmembrane segments. They harbor a signature sequence of 13 residues flanked by cysteines which form a closed loop linking the extracellular ligand binding and channel domains.

- ▶ Acetylcholine
- ▶ GABA

## Cystometry

### Definition

Cystometry is the study of urinary bladder activity by recording the intravesical pressures exerted at varying degrees of bladder filling with water or gas.

- ▶ Micturition, Neurogenic Control

## Cytoarchitecture

### Definition

Refers to the morphological characteristics of cells.

- ▶ Evolution of the Brain: in Birds

## Cytokines

### Definition

The loose definition of cytokines is that they are proteins made by cells that affect the behavior of other cells through actions on specific cytokine receptors. The term is often used in a narrower sense as messages produced by white blood cells that affect the behavior of other blood cells and other non-blood cells. The term can therefore encompass neurotrophic factors, or may be used to refer only to cells released by lymphocytes, macrophages/microglia and polymorphs. In neurobiology the term is increasingly being used to refer to all small, low-molecular-weight (usually less than 30 kDa in size) protein messengers for inter-cell communication. Cytokines are also involved with inflammatory and hypersensitive reactions. They are critical to the functioning of both the innate and adaptive immune responses to injury in

many cell and tissue types. Usually cytokines are not produced at high levels in normal resting conditions but are rapidly and transiently up-regulated following appropriate stimuli. Cytokines exert their biological effect by interacting with high-affinity cell surface metabotropic receptors, leading to an intracellular cascade of signalling events and activation of transcription factors.

- ▶ Neurotrophic Factors

---

## Cytoplasmic mRNA Localization

- ▶ mRNA Targeting: Growth Cone Guidance

---

## Cytoskeleton

### Definition

The cytoskeleton of a cell is the framework that gives the cell its shape and integrity. It is also involved in the movement of organelles, and it plays an important role in cell division. Important cytoskeletal proteins are the microfilament actin, the intermediate sized neurofilament and the microtubules.

- ▶ Actin
- ▶ Microtubule
- ▶ Neurofilament

---

## Damping

### Definition

Damping denotes the proportionality constant for a linear dynamical system that relates the force (or torque) produced in response to an imposed velocity. The term viscosity is frequently used synonymously. In motor control, damping characterizes the ability of the system to attenuate the speed of deviation from an equilibrium or current position elicited by external perturbations; together with stiffness, damping is required for stability of posture and movement.

- ▶ Equilibrium Point Control
- ▶ Impedance Control

---

## Damping Ratio

### Definition

A parameter that indicates how quickly oscillations are attenuated following transient disturbances of a second-order linear dynamical system. It is defined as  $\zeta = B/2\sqrt{KI}$ , where  $B$  is damping,  $K$  is stiffness and  $I$  is inertia.

- ▶ Impedance Control

---

## Dandy-Walker Syndrome

### Definition

Characterized by enlargement of all four brain ventricles resulting from obstruction of the outflow of the cerebrospinal fluid from the fourth ventricles (through the foramina of Luschka and Magendie).

---

## Danger Signals

### Definition

Pathogens and toxic cell debris (apoptotic/necrotic cells) express molecules that will alert the innate immune response, the first line of defense of the host, against infection and tissue injury.

- ▶ Neurodegeneration and Neuroprotection – Innate Immune Response

---

## Dark-induced REM

### Definition

In certain strains of rats, rapid eye movement (REM) sleep can be triggered by turning off the environmental lights. The manner of testing is as simple as turning the room lights on for 30 min, followed by turning them off for 30 min for many hours, if desired. REM is initiated very shortly after the lights go off. Thus, light controls, at least to some degree, the expression of REM. It is not known what other brain structures connected to the pretectal regions responsible for dark-induced REM, although the IGL is a logical candidate.

- ▶ Rapid Eye Movement (REM) Sleep

---

## Darkness Hormone

- ▶ Melatonin

---

## De Novo Protein Synthesis

### Definition

The term “de novo protein synthesis” in neurons refers to protein synthesis that takes place outside the

boundaries of the soma or cell body. Such “extrasomal” protein synthesis can take place in both the dendritic and axonal compartments of neurons.

- ▶ Extrasomal Protein Synthesis in Neurons

---

## Deactivation

### Definition

Ion channels, such as sodium ion channels, have three structural states, open, close and inactivated. Deactivation is the direct change in state of an ion channel from open to close that does not involve the inactivation pathway. Unlike inactivation, there is no refractory period after deactivation which allows the channel to rapidly open and close.

- ▶ Action Potential
- ▶ Ion Channels from Development to Disease

---

## Dead Reckoning

### Definition

Synonym for path integration.

- ▶ Path Integration
- ▶ Spatial Learning/Memory

---

## Dead Zone

### Definition

Portion of the Phase Response Curve (PRC) during which light has no effect on rhythm phase. There are two major parts in the PRC derived from tests with light pulses. During the “subjective night,” light induces phase shifts (except at the “crossover” point), but during most of the “subjective day,” circadian rhythm phase is generally not modified by light. This portion of the PRC during which light has no effect on rhythm phase is known as the “dead zone.”

- ▶ Circadian Rhythm
- ▶ Phase Response Curve (PRC)

---

## Deafferentation

### Definition

Loss of sensory nerve input to the central nervous system.

- ▶ Proprioception: Effect of Neurological Disease

---

## Deafferentation Pain

- ▶ Central Pain

---

## Deafferented Subjects, Deafferentation

### Definition

Characterized by the loss or degeneration of afferent fibers carrying somatosensory and proprioceptive information to the spinal cord in humans; responsible for the lack of sensation of positions of body segments and marked motor deficits, especially in the absence of vision. Complete deafferentation is extremely rare.

- ▶ Equilibrium Point Control

---

## Debt

- ▶ Sleep Homeostasis

---

## Decerebrate Animals

### Definition

Animals with a complete section of the encephalon performed between the diencephalon and the midbrain

followed by removal of the whole anterior part of the brain. In this preparation the postural tone is abnormally high and the thermoregulation is abolished, while the control of blood pressure and breathing is preserved.

## Decerebrate Rigidity

### Definition

Characterized by extension of the elbows and wrists with pronation of the lower arm, indicating damage in the ►midbrain or caudal ►diencephalon. Strong spontaneous extensor rigidity occurs in ►metabolic encephalopathy, particularly after acute hypoxia.

►Encephalopathy (or Acute Organic Brain Syndrome)

## Decibel (dB)

### Definition

Ten times the log (base 10) of the ratio of two intensities, two powers, or two energies and 20 times the log of the ratio of two pressures.

►Acoustics

## Decision Neurons

### Definition

Neurons that are able by their discharge to discriminate between several behavioral options and to respond best to a specific stimulus.

## Decision-making Strategy

### Definition

A strategy for choosing action based on information about a current situation. A strategy often optimizes

certain criteria such as expected total reward in the future.

►Competitive Learning Theory

## Declarative Learning

### Definition

Learning events, facts and rules. Learning “that” rather than learning “how”. Declarative learning is typically contrasted with “procedural learning” or “knowing how”. In humans declarative learning is, roughly, learning that we can describe (declare) in language. Declarative learning is often subdivided into the learning of semantic information, facts, and the learning of episodic, autobiographical experiences. Because the definition and identification of declarative learning is tied to language, identifying declarative learning in animals is problematic. Amnesia is loss of declarative memory.

►Spatial Learning/Memory

## Declarative Memory

### Definition

Declarative memory refers to the everyday sense of memory, the learning and remembering of events and facts. Namely, declarative memory literally includes what can be declared or brought to mind as a proposition or an image. Declarative memory indicates memory for facts and events, which depends integrity of hippocampus and related structures.

►Amnesia  
 ►Long-Term Memory  
 ►Recognition Memory  
 ►Sensory Plasticity and Perceptual Learning

## Declive

### Definition

Part of the vermis cerebelli lying below the primary fissure. Belongs to the posterior lobe. Like the entire

vermis cerebelli, the declive receives its afferents primarily from the spinal cord. Hence it is part of the so-called spinocerebellum – palaeocerebellum.

► Cerebellum

---

## Decorrelation

► Contrast Enhancement

---

## Decorticate Rigidity

### Definition

Characterized by stereotyped arm and leg movements, spontaneous or in response to stimuli: flexion of the elbows and wrists and supination of the lower arm, suggesting severe bilateral brain damage above the ► midbrain.

---

## Decrease of Synaptic Effectiveness

► Presynaptic Inhibition

---

## Decussation

### Definition

A decussation (Latin for crosswise division in the shape of an X) refers to a crossing of fibers from one side of the brain to the other, e.g., the decussation of the superior cerebellar peduncle in the midbrain, or the pyramidal decussation in the medulla.

---

## Deep Somatic Pain

► Muscle Pain, Including Fibromyalgia

---

## Defecation Reflex

### Definition

The defecation reflex involves the evacuation of fecal material from the rectum in response to stimulation of afferent nerves in the distal bowel. Afferent activity is carried in the pelvic nerves to the sacral spinal cord where it stimulates parasympathetic reflex pathways to elicit a contraction of the smooth muscle of the colon and rectum. Simultaneous inhibition of somatic efferent pathways to the external anal sphincter permit concurrent opening of the anal canal.

---

## Defense

### Definition

Behavior to ward off danger by fight or flight; protection from harm.

---

## Defense Mechanism

### Definition

Defense mechanism denotes the special unconscious behavior used to protect the ego against emotions like anxiety, sense of guilt, shame or other psychical contents. There is a variety of available defense mechanisms, examples are: repression, displacement, projection, introjection, isolation, reaction formation, denial, intellectualization, negation, rationalization, reversal into the opposite, undoing.

► Personality Disorder

---

## Defense Musculaire

### Definition

Defense musculaire refers to rigidity of body wall muscle overlying painful viscera. Also known as “muscle guarding” or “muscular guarding,” this is a

familiar concomitant of disorders such as peritonitis and appendicitis. In pronounced cases, the rigidity is described as “board-like.” The term *defense musculaire* implies an adaptive function. Nonetheless, muscle hypertonicity may be relatively mild, even in the presence of significant visceral inflammation. The likely mechanisms of *defense musculaire* include spinally-mediated viscerosomatic reflexes. However, in the conscious patient, voluntary mechanisms also play a role.

## Defense Reaction

### Definition

The defense reaction is an “alerting” or “aversive” response to a threat and is characterized by coordinated changes in autonomic, respiratory, and other somatomotor functions, and by changes in the level of cortical arousal and attention to the external environment.

## Deflation Reflex

► Respiratory Reflexes

## Deformation

### Definition

A function specifying the correspondence between the positions of each particle of a material body in two different configurations.

► Mechanics

## Deformation Gradient

### Definition

The derivative of the deformation. Mathematically, it is represented by a tensor associated with each point of the body.

► Mechanics

## Degenerative

### Definition

In neurology, these are disorders in which there is a (usually unexplained and progressive) loss of neural tissue (e.g., cerebellar degenerations, Alzheimer's disease).

► Alzheimer's disease

## Degrees of Freedom

### Definition

The number of degrees of freedom of a mechanical system is given by the number of variables required to uniquely define the system's motion.

► Coordination

► The Distribution Problem in Biomechanics

## Degu

### Definition

*Octodon degus*, Order Rodentia, Suborder Histricomorpha, Family Octodontidae. A precocial species.

► Neural Correlates of Imprinting

## Deiter's Cell

### Definition

Deiter (a nineteenth century German anatomist) published a variety of materials on the inner ear. His name is attached to the outer phalangeal cell on the basilar membrane of the inner ear's Organ of Corti. It is also attached to the lateral vestibular nucleus of the 8th (cochleovestibular) cranial nerve.



## Déjérine's Syndrome

### Definition

(aka Medial medullary syndrome). Caused by occlusion of the vertebral or anterior spinal artery resulting in deviation of the tongue to the side of the lesion, weakness on the side of the body contralateral to the lesion without affecting the face, loss of vibration and proprioception on the side of the body ipsilateral to the lesion.

- ▶ Ischemic Stroke
- ▶ Stroke

## Dejours Test

### Definition

The magnitude of the ventilatory depression caused by hyperoxia, often used as an index of carotid body sensitivity.

- ▶ Carotid Body Chemoreceptors and Respiratory Drive
- ▶ Development of the Respiratory Network

## Delay Eyeblink Conditioning

### Definition

The eyeblink classical conditioning paradigm in which the conditioned stimulus is followed by and coterminates with the unconditioned stimulus. This paradigm is distinct from the trace conditioning paradigm in which the conditioned stimulus terminates before the onset of the unconditioned stimulus.

- ▶ Classical Conditioning (Pavlovian Conditioning)
- ▶ Motor Learning

## Delayed Depolarization

### Definition

- ▶ Action Potential

## Delayed Excitation

### Definition

After many neurons are hyperpolarized, they show a long delay with a slow repolarization, before they resume firing action potentials. The delay arises from activation of subthreshold potassium currents such as IA, while the excitation arises from subthreshold inward currents such as Ih, ICa(T) and INa(P).

- ▶ Action Potential
- ▶ Neuronal Potassium Channels
- ▶ Stomatogastric Ganglion

## Delayed Match-to-Sample Task

### Definition

Generally abbreviated as DMS, the delayed match-to-sample paradigm is often used in studies of working and recognition memory. The DMS task includes three distinct phases. In the first phase, a sample stimulus is studied. In the second phase, the encoded information must be maintained through a delay interval. The final, or choice, phase, requires the subject to indicate which of a series of choices matches the initially studied item.

- ▶ Recognition Memory

## Delayed Non-match-to-Sample Task

### Definition

Similar in design to the delayed match-to-sample (DMS) task, the delayed non-match-to-sample (DNMS) paradigm is employed in studies of working and recognition memory. Taking advantage of a general inherent preference for novelty found in both human and non-human species, experimenters using this paradigm ask subject to encode a sample object, remember it through a delay period, and then select the item that was not shown in the study phase.

- ▶ Recognition Memory

## Delayed Rectifier Current

### Definition

Depolarization-activated outward  $K^+$  current similar to that of the squid axon; it activates with a delay and relatively slowly, and inactivates minimally or very slowly. These channels may significantly contribute to the repolarizing phase of the nerve action potential.

- ▶ Action Potential
- ▶ Neuronal Potassium Channels

## Delayed-rectifier $K^+$ Channels

### Definition

Delayed-rectifier potassium channels activate with a delay and mediate outwardly-rectifying potassium currents. These channels may make a significant contribution to the repolarizing phase of nervous action potentials.

- ▶ Neuronal Potassium Channels

## Delayed Response Task

### Definition

A behavioral task in which a delay is interposed between when the cue is presented and the subsequent response is permitted. The cue is not present during the delay period so that this information must be stored in memory in order to guide future responding. Alterations in the duration of the delay period adjust the mnemonic load of the task.

## Delayed Saccade

### Definition

Delayed saccades are saccadic eye movements that are voluntarily withheld, after a targeting eccentric stimulus appears, until a central fixation stimulus is turned off. The temporal overlap between the time of target

appearance and the turning off of the fixation point is called the delay period.

- ▶ Saccade, Saccadic Eye Movement

## Delayed Saccade Task

### Definition

A visual target is presented and the subject is required to maintain fixation for a variable amount of time. Next, a second target is presented at another location, while the fixation target remains on. Finally, the fixation target is extinguished, and the subject must make a saccade to the location of the second target. This task is used to create a temporal dissociation between the visual target and the saccade.

- ▶ Saccade, Saccadic Eye Movement

## DeltaF/F

### Definition

Many functional imaging studies work with changing light. For example, a calcium -sensitive dye such as calcium green increases its fluorescence with increasing calcium concentration. However, the fluorescence increase also depends on the available quantity of dye in the first place. Therefore, the absolute change in fluorescence is not relevant, but the relative change is: and this magnitude is  $\Delta F/F$ , i.e. the absolute change in fluorescence ( $\Delta F$ ) divided by the background magnitude of fluorescence ( $F$ ).

- ▶ Functional Imaging

## Delta Function

### Definition

A signal whose integral over time is unity, while its width approaches zero (which implies that its height approaches infinity).

- ▶ Signals and Systems

## Delta Waves/Rhythms

### Definition

Slow oscillatory bursts of electroencephalogram (EEG) activity (1–4 Hz) observed during deep stages of non-REM sleep.

- ▶ Brain Rhythms
- ▶ Electroencephalography
- ▶ Non-REM Sleep

## Dementia

### Definition

A progressive neurodegenerative condition that compromises neurologic functioning in individuals who have attained adult levels of intact cognition.

- ▶ Memory and Dementia

## Dementia Paralytica

### Definition

Dementia paralytica results from diffuse chronic inflammation entailing degenerative sclerotic alterations in meninges, dura mater and brain with a predominance in the ▶ **frontal lobes**. The first symptom may be a generalized convulsion. Other main symptoms include headache, insomnia, personality changes (such as impaired judgment, altered emotional responses, delusions of greatness and tendencies towards sexual obscurities), slurring speech, tremors; later progress into dementia.

## Dementia Praecox

### Definition

This is the historic definition for psychotic diseases that was created by E. Kraepelin at the beginning of the last

century. It was later replaced by Bleuler with the term “schizophrenia.”

- ▶ Schizophrenia

## Demyelinating Neuropathies

### Definition

Subgroup of ▶ **peripheral neuropathies** and feature a degeneration of ▶ **myelin sheaths**, whereby the ▶ **conduction velocity** of the afflicted fibers is reduced, which in turn leads to many sensory and motor disturbances.

- ▶ Action Potential Propagation
- ▶ Large Fiber Sensory Neuropathy
- ▶ Myelin

## Demyelination

### Definition

Demyelination is the removal of an existing myelin sheath in the peripheral or central nervous system. It may be caused by immune processes, as in multiple sclerosis, by factors initiated by trauma, by the action of toxins, by genetic conditions and numerous other causes. The damaged myelin is usually removed by the action of macrophages/microglia and other cells, while the oligodendrocyte or Schwann cell may survive.

- ▶ Multiple Sclerosis
- ▶ Myelin
- ▶ Oligodendrocyte
- ▶ Schwann Cell

## Dendrite

### Definition

The dendrite (Greek for tree-like branching) is the branching process of the neuron that receives most of the synaptic input from axons of other neurons.

## Dendritic Field of Retinal Ganglion Cell

### Definition

Retinal ganglion cells collect light from photoreceptors (via bipolar retinal cells) through their dendrites, which extend away from the cell body. Since each class of retinal ganglion cells covers the entire retina, numerous cell types, such as the midget cell, have very small dendritic fields, whereas sparse cell types, like the P giant cell, have large dendritic fields.

- ▶ Retinal Bipolar Cells
- ▶ Photoreceptors
- ▶ Retinal Ganglion Cells
- ▶ Visual Processing Streams in Primates

## Dendritic Growth

SHIGEO OKABE

Department of Cellular Neurobiology, Graduate school of Medicine, University of Tokyo

### Definition

Increase in Total Length, Branching and Complexity of Dendritic Structures During Development and Reorganization of the Nervous System.

The basic pattern of morphological changes in dendrites in the course of nervous system development is described in this essay. After defining the four major stages in dendritic growth, the molecular mechanisms of growth regulation at each stage are discussed. The extent and pattern of dendritic growth show great variability among different cell types even within the same brain region. Specific patterns of dendritic growth have been used to illustrate the extent of divergence.

### Characteristics

#### Quantitative Description

The extent of dendritic growth is variable among different neuron types. The total dendritic length of typical CA1 pyramidal neurons in the rat hippocampus is 12–17 mm and they receive 30,000 excitatory and 2,000 inhibitory inputs after maturation (Fig. 1c) [1].

Immediately after the final mitosis in these cells in embryonic days 15–19, they have a few immature processes of lengths less than 50  $\mu\text{m}$  [2]. Postnatal dendritic growth is therefore a process of massive increases in surface area, in amount of cytoplasmic organelles and in synaptic junctions with other

excitatory and inhibitory neurons. Similar significant increases in the size and the complexity of dendrites are observed in a wide range of neuronal populations, including cortical pyramidal cells, ▶ cerebellar Purkinje cells, retinal ganglion cells and spinal cord motor neurons. There are several types of neurons showing less prominent dendritic growth. For example, some types of midget bipolar cells in the retina develop a few dendrites with individual processes of less than 20  $\mu\text{m}$  and receive synaptic input from only one to five photoreceptors (Fig. 1a). Cerebellar ▶ granule cells are another example of cells forming a simple dendritic structure (Fig. 1b). These cells have fewer than five short dendrites. The simple dendritic structure of granule cells contrasts with the highly branched dendrites of nearby Purkinje cells in the cerebellar cortex [3].

### Description of the Process

Dendritic growth involves multiple mechanisms, which tend to be in parallel operation even in a single neuron at a given time point [4]. However, to simplify the questions related to dendritic growth, it will be convenient to separate the time-course of dendritic growth into four essential stages. First, early postmitotic neurons (Fig. 2a) start to extend two types of processes, axons and dendrites (Fig. 2b).

Second, dendrites extend, branch and increase the volume they occupy (Fig. 2c). Third, dendrites interact with incoming axons and form synaptic junctions (Fig. 2d). Finally, dendrites stop their growth and are stabilized. They can even show regressive changes, frequently associated with functional competition among different afferents (Fig. 2e).

### Differentiation of Axons and Dendrites

Extensive culture studies of the rodent embryonic hippocampus identified the time-course of axon-dendrite differentiation in isolated neurons [2]. After the initial stage of slow outgrowth of several short processes from the cell body, a single process commences to elongate rapidly and later becomes the axon. Outgrowth of the other processes remains slower than that of the axon, but they branch more frequently to develop a typical dendritic structure.

It is generally accepted that a similar sequential differentiation of axons and dendrites takes place in vivo. Differential development of axons and dendrites is evident in specific neurons that extend their axons much earlier than the arrival of afferents at their dendrites, such as cerebellar Purkinje cells. The Purkinje cell axons already exist at birth in the rat, but dendrites grow slowly in postnatal days 4 to 21 [3].

### Process Extension and Branching

From short dendritic processes in immature neurons, a complex structure of highly branched dendrites

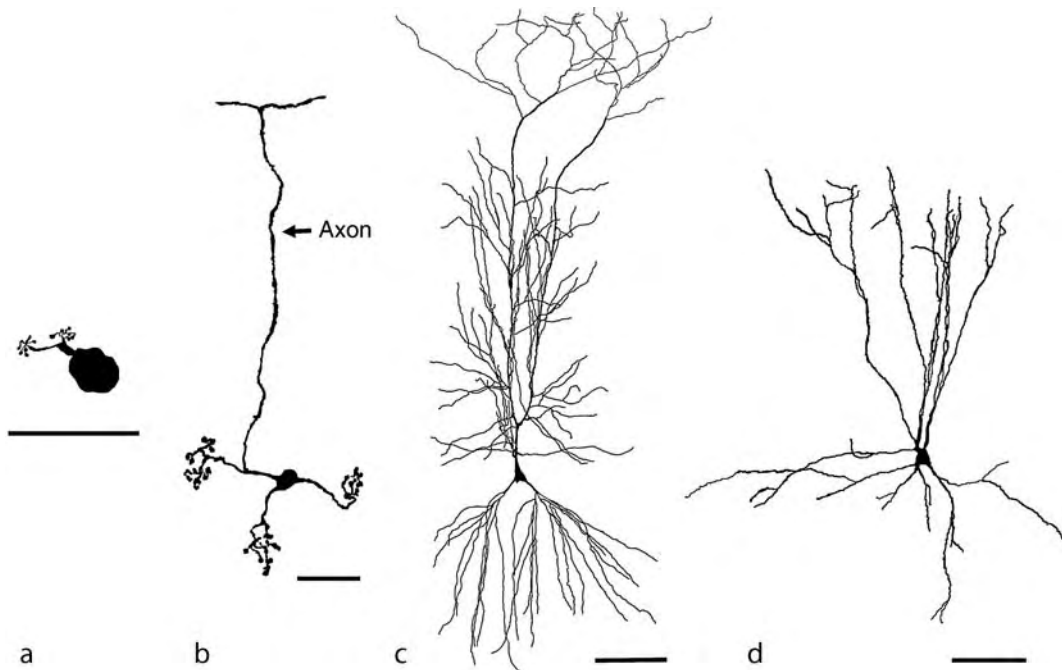

**Dendritic Growth. Figure 1** Diversity of dendritic structure for four different neuron types in three brain regions. (a) Morphology of a midget bipolar cell in the marmoset retina. Only the dendritic structure is shown and the axon is omitted from this drawing. The dendrite is short and bifurcated, contacting with two cone photoreceptors by multiple terminal branches. Bar, 20  $\mu\text{m}$ . (b) Morphology of a cat cerebellar granule cell. This neuron type contains less than five short dendrites with multiple terminal branches. These terminal branches contact with the mossy fiber terminals. Bar, 20  $\mu\text{m}$ . (c) Dendritic structure of a rat hippocampal CA1 pyramidal neuron. The cell body is a pyramidal shape and has both apical dendrites and basal dendrites. Both dendritic structures are highly branched. Bar, 100  $\mu\text{m}$ . (d) Dendritic structure of a rat hippocampal CA1 interneuron. This neuron belongs to a parvalbumin-immunopositive sub-class of hippocampal inhibitory neurons. Although the degree of extension of single dendritic branches is comparable to that of pyramidal neurons, the dendrites show less branching. Bar, 100  $\mu\text{m}$ .

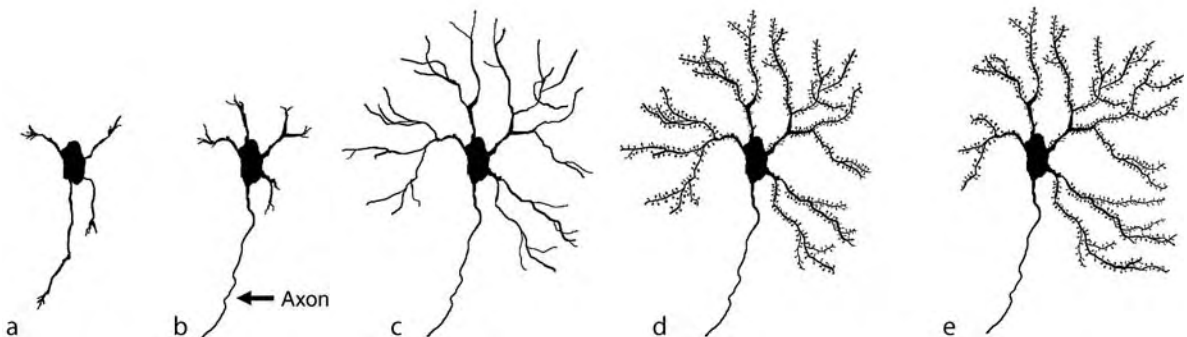

**Dendritic Growth. Figure 2** Developmental stages of dendritic growth. (a) Stage before determination of axons and dendrites. (b) Stage of axon/dendrite determination. A single neurite starts to extend rapidly and acquires features of the axon. (c) Stage of dendrite extension and branching. Massive increase in the dendritic cytoplasm takes place. (d) Stage of synapse formation. Dendrites start to make contact with incoming axons and form synapses. Synapse formation is often associated with formation of dendritic spines. (e) Stage of selective stabilization. Selective stabilization and additional growth of dendritic branches take place. Concomitantly, dendrites with less trophic support start to regress.

gradually develops. This structural development is driven by both increases in length of dendritic segments and in number of branching points. It should be emphasized that these two parameters determine the final size and shape of the dendritic arborization, which are specific for different types of neurons. The dendritic cytoplasm is the extension of the cell body. It contains the usual membrane organelles such as mitochondria, rough/smooth endoplasmic reticulum (ER), Golgi apparatus and free ribosomes. The presence of protein synthesis machinery in dendrites contrasts with the scarcity of ribosomes in axons. Another distinction between dendritic and axonal cytoplasm is the presence of microtubules with mixed polarity in the dendrites [4]. The axonal cytoplasm contains only microtubules with their plus ends distal to the cell body. The presence of microtubules with mixed polarity is important for dendritic morphogenesis, as suppression of a key molecule for the maintenance of the mixed polarity results in suppression of dendritic growth [4]. As in the case of growing axons, the tips of growing dendrites develop growth cones, which are highly motile structures with an enriched actin cytoskeleton. New dendritic branches are generated either by splitting of advancing dendritic growth cones or by de novo formation of processes in the middle of dendritic segments [5].

### Synapse Formation

In many brain regions, synapse formation occurs concomitantly with process extension and branching. A typical example is the synchronized formation of cerebellar Purkinje cell dendrites and their synaptic contacts with two distinct presynaptic components, the parallel fibers of granule cells and ▶[ascending fibers](#) from the ▶[inferior olive](#) [3]. The formation of specific types of synapses is known to be behind the peak of dendrite morphogenesis. For example in mossy fiber synapses onto the hippocampal CA3 pyramidal neurons [6], on postnatal day 7 the proximal segment of the apical dendrites is already established in the CA3 region. The development of presynaptic specialization in the incoming mossy fibers from the ▶[dentate gyrus granule cells](#) starts only after day 7 and the number of synaptic contacts increases gradually until postnatal day 21.

Synapse formation is associated with morphological changes in the dendritic surface. The most prominent morphological change is spine formation, which takes place in most of the excitatory neurons in the cortex and the hippocampus [7]. Spine formation is not restricted to excitatory neurons. Several GABAergic ▶[Golgi type I neurons](#), such as cerebellar Purkinje cells and striatal medium spiny neurons, also generate prominent spines with high density. Real-time imaging of pyramidal neuron dendrites in the neocortex in vivo and in slice preparations revealed rapid morphological change in

spines. This motility is driven by assembly/disassembly of filamentous actin, which is highly concentrated in the spine cytoplasm. Another characteristic structure on the surface of dendrites during the period of synaptogenesis are dendritic filopodia. A possible role of dendritic filopodia is to initiate contact with nearby axons. Stochastic extension and reabsorption of dendritic filopodia are consistent with their role in sampling the environment. The distinction between thin spines and filopodia with synaptic contacts is not self-evident and sometimes they are considered to be the same entity. Electron microscopic reconstruction studies revealed the appearance of dendritic filopodia at the early stage of synaptogenesis and their reduction at the later stage with an increase in dendritic spines. However, evidence for direct morphological transition from filopodia to spines is relatively scarce. Alternatively, dendritic filopodia can be stabilized by synaptic contacts and subsequently transformed into new dendritic shafts without losing the established synaptic contacts. This scenario has been confirmed by in vivo imaging of the postsynaptic specialization in zebra fish embryos [5].

### Growth Termination and Regression of Existing Dendrites

Extension of dendritic processes is usually limited at the border of brain territories. Apical dendrites of both CA1 pyramidal neurons and dentate granule cells receive inputs from the ▶[entorhinal cortex](#). These two types of apical dendrites extend toward the border of the stratum lacunosum-moleculare of CA1 and the stratum moleculare of the dentate gyrus in the opposite directions and there exists a clear demarcation between these dendritic fields [1]. Dendritic fields of individual neurons can also form clear borders in specific brain regions. For example, retinal ganglion cells stop extending dendritic processes once they make contact with adjacent ganglion cells to form mutually exclusive dendritic territories.

### Higher Level Processes

The pattern of dendritic growth is one of the key factors influencing the higher order organization and local connectivity in specific brain regions. As will be discussed in the following section, dendritic growth is regulated by multiple factors. Therefore, causal relationships between specific dendritic patterns and the overall organization of the local circuit are difficult to determine in many cases. Spiny neurons in the barrel field of the rodent somatosensory cortex show dendritic growth confined to individual barrel structures [8]. Development of barrel structure is dependent on the sensory afferents and activation of NMDA receptors in the sensory cortex. This is a clear example in which incoming axons and their synaptic connectivity control

postsynaptic dendritic growth. The barrel cortex is a typical example of topographic maps present in sensory systems and controlled growth of dendrites is important in proper processing of sensory information.

### Regulation of the Process

Dendritic growth is the product of both cell autonomous mechanisms and extrinsic influences. When neurons are placed in an artificial environment, such as in dissociated culture, they still grow to resemble their normal counterparts in vivo (Fig. 3) [1].

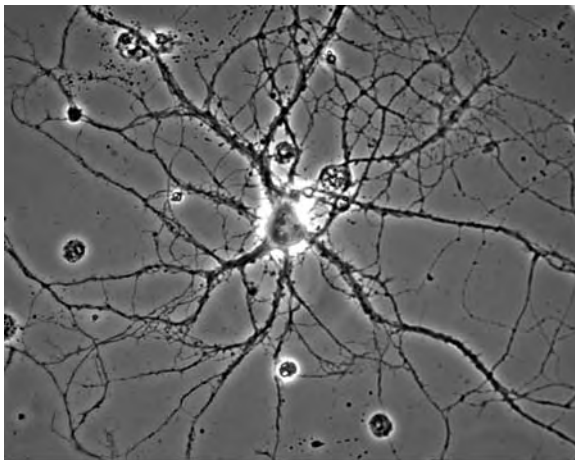

a

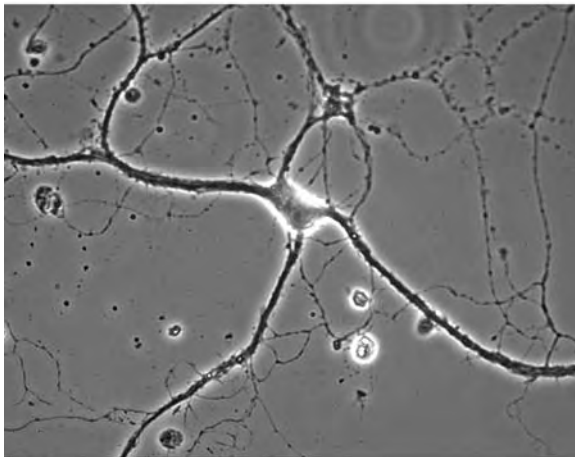

b

**Dendritic Growth. Figure 3** Dendritic morphology of hippocampal neurons maintained in dissociated culture. Without native cell-to-cell contacts, extracellular matrix and soluble factors, isolated neurons can establish the characteristic morphology of dendrites on culture substrate. Highly branched dendrites of a pyramidal shaped neuron (a) and less-branched straight dendrites of an inhibitory neuron (b) preserve the basic morphological characteristics of their in vivo counterparts shown in Fig. 1c,d.

On the other hand, detailed dendritic branching patterns of individual neurons with the same genetic composition and in close vicinity still show clear differences. Either intrinsic or extrinsic mechanisms or a combination of them play specific roles in certain stages of dendritic development [5].

### Intrinsic Mechanisms

Both extension of dendritic processes and branching are mediated by motile protrusions such as dendritic growth cones and filopodia. The actin cytoskeleton is enriched in these structures. Local assembly of the actin cytoskeleton is regulated by the Rho-family of small GTPases [7]. By increasing the activity of the small GTPase Rac1, initial growth of dendrites and dendrite branching are enhanced. Manipulation of Rac activity can also change the density of dendritic spines, where actin-dependent morphological change takes place. Another GTPase RhoA shows the opposite effects, reducing dendrite growth and branching. Dendritic growth is also mediated by assembly of microtubules, a major cytoskeletal component in the dendritic shaft. Proper organization of microtubules is also important for the addition of new plasma membrane, which is transported along the dendrites via microtubule-dependent motors. Dendritic cytoplasm contains abundant polyribosomes and protein synthesis within the dendritic compartment is another key factor for both dendritic growth and synapse maturation. Mutations affecting functions of several RNA-binding proteins impair dendritic growth and synapse formation.

### Exogenous Trophic Factors

A variety of soluble factors can influence the shape of dendrites [4]. *Sema 3A* was originally identified as having a collapsing activity on axonal growth cones. This collapsing effect can be reversed when the intracellular concentration of the cyclic nucleotide guanosine 3'/5'-monophosphate (cGMP) is elevated. *Sema 3A* attracts apical dendrites of neocortical pyramidal neurons, where the local cGMP level is high. Axons from the same pyramidal neurons show a repulsive response, because the local cGMP concentration is low. BDNF and NT-3, members of the neurotrophin family of growth factors, are important in promoting growth of dendrites from pyramidal neurons in specific cortical layers. Neurotrophins are synthesized in the cell body, transported down the axon and synaptically released to the postsynaptic neurons. The effect of BDNF on pyramidal neurons is also dependent on synaptic activity. This is one example of the interplay between distinct extrinsic signals on the growth of dendrites. Osteogenic protein 1 (OP-1), a member of the bone morphogenic protein (BMP) family, shows strong and specific effects on dendritic growth from sympathetic neurons.

### Cell-to-cell Interactions (Fig. 4)

As already mentioned, dendritic growth is coupled with synapse formation. In this sense, molecules involved in synapse formation also play important roles in dendrite morphogenesis. Cell adhesion molecules present on the postsynaptic membrane, such as N-cadherin ▶*synCAM* and neuroligin, are important in induction and/or maturation of synaptic structure [9]. N-cadherin and *synCAMs* are homophilic cell adhesion molecules. Neuroligin associates with presynaptic  $\beta$ -neurexin molecules to induce both presynaptic and postsynaptic specialization. Eph receptors are receptor tyrosine kinases (RTKs) activated by interaction with their ligands ephrins. Several members of both Eph receptor and ephrin ligand families are present in synaptic contact sites and positively regulate the process of synapse formation by accumulating key molecules such as NMDA receptors.

Several other membrane proteins, such as Notch and Flamingo, exert negative effects on dendrite outgrowth [4]. Notch is a cell surface protein originally identified in *Drosophila* as a regulator of cell fate specification. In the

mammalian neocortex, Notch is expressed in neurons and its activation by its ligand Delta or Jagged suppresses neurite extension. Flamingo is a ▶*seven-pass transmembrane protein* with the N-terminal extracellular domain homologous to cadherin molecules. In both *Drosophila* and mammalian neurons, the presence of Flamingo is important in proper morphogenesis of dendrites.

### Electrical Activity

Dendritic morphology is remarkably resistant to the treatments that reduce the overall level of synaptic activity or neuronal firing. In contrast, differential activity plays an important role in the process of competition among groups of afferents. For example, loss of sensory input from one eye dramatically alters the synaptic organization in the visual cortex. If input from both eyes is eliminated, the reorganization does not take place. Both synaptic activity and neuronal firing can induce an increase in intracellular calcium levels. Subsequent activation of intracellular effectors is responsible for the morphological alterations of dendrites [8]. As already mentioned, preferred

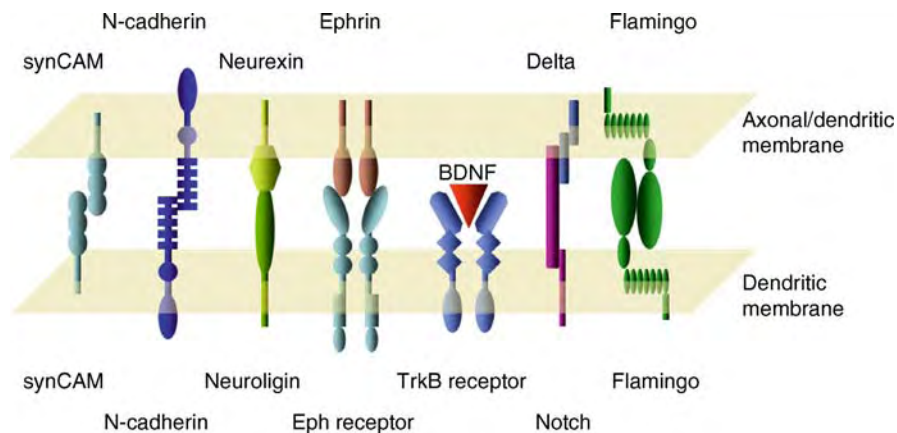

**Dendritic Growth. Figure 4** Membrane proteins involved in the regulation of dendritic growth. *SynCAM* belongs to the immunoglobulin superfamily of cell adhesion molecules. The extracellular region contains three immunoglobulin-like domains, which mediate calcium-independent homophilic interaction. The carboxy-terminal PDZ-binding motif of *synCAM* binds to synaptic PDZ domain-containing proteins. *N-cadherin* contains five cadherin repeats in the extracellular domain. The most amino-terminal cadherin repeat is responsible for the calcium-dependent homophilic interaction. The cytoplasmic domain of *N-cadherin* interacts with  $\alpha$ -catenin and  $\beta$ -catenin to organize the submembranous actin cytoskeleton. *Eph receptors* form a large group of receptor tyrosine kinases and show high affinity with their ligands, ephrin molecules. Eph receptors are divided into two sub-families, EphA and EphB. EphB receptors are localized at the postsynaptic membrane and their roles in synaptic functions have been extensively studied. EphB2 receptor activation can induce clustering of EphB2 together with NMDA receptors at the postsynaptic membrane. *TrkB receptors* are members of the Trk family of neurotrophin receptors. TrkB receptors belong to receptor tyrosine kinases and bind specifically to BDNF and NT-4/5. BDNF has been shown to be released from presynaptic terminals in an activity-dependent manner. *Notch* is a large membrane protein with 36 EGF-like domains in the extracellular region. The cytoplasmic domain of Notch is cleaved and transported to the nucleus to activate Notch-response genes. Delta is one of the Notch ligands and also contains EGF-like repeats in the extracellular region. *Flamingo* belongs to a family of seven-pass transmembrane proteins. The amino-terminal extracellular region of Flamingo contains eight cadherin domains, which are responsible for homophilic association. Knockdown of *Celsr2*, a mammalian homologue of *Drosophila* flamingo, impairs normal development of dendrites in cortical pyramidal neurons and cerebellar Purkinje cells.



development of dendrites within the barrel structure is dependent on the NMDA receptor, which is a major mediator of calcium influx. Calcium/calmodulin-dependent protein kinases (CaMKs) are one of the major targets of calcium influx. CaMKII $\alpha$  and CaMKII $\beta$  have opposing roles in dendritic growth. CaMKII $\alpha$  activation stabilizes dendrites and limits their growth. In contrast, CaMKII $\beta$  activation facilitates filopodia extension and dendrite development. A local increase in calcium in specific dendritic segments should be important in the process of competitive pruning, as dendritic segments receiving more active synaptic input should be selectively stabilized. Indeed, in retinal ganglion cell dendrites, a local increase in calcium in small dendritic segments specifically stabilizes developing dendrites [10]. Downstream signaling cascades involved in local stabilization of dendritic segments are not yet clarified, but selective activation of CaMKs is a candidate for this process.

## References

1. Johnston D, Amaral DG (2004) Hippocampus. In: Shepherd GM (eds) *The synaptic organization of the brain*. Oxford University Press, Oxford, pp 455–498
2. Goslin K, Asmussen H, Banker G (1998) Rat hippocampal neurons in low-density, serum-free culture. In: Banker G, Goslin K (eds) *Culturing nerve cells*. MIT, Cambridge, pp 339–370
3. Sotelo C (2004) Cellular and genetic regulation of the development of the cerebellar system. *Prog Neurobiol* 72:295–339
4. Scott EK, Luo L (2001) How do dendrites take their shape? *Nat Neurosci* 4:359–365
5. Niell CM, Meyer MP, Smith SJ (2004) In vivo imaging of synapse formation on a growing dendritic arbor. *Nat Neurosci* 7:254–260
6. Amaral DG, Dent JA (1981) Development of the mossy fibers of the dentate gyrus. I. A light and electron microscopic study of the mossy fibers and their expansions. *J Comp Neurol* 195:51–86
7. Ethell IM, Pasquale EB (2005) Molecular mechanisms of dendritic spine development and remodeling. *Prog Neurobiol* 75:161–205
8. Konur S, Ghosh A (2005) Calcium signaling and the control of dendritic development. *Neuron* 46:401–405
9. Yamagata M, Sanes JR, Weiner JA (2003) Synaptic adhesion molecules. *Curr Opin Cell Biol* 15:621–632
10. Lohmann C, Myhr KL, Wong RO (2002) Transmitter-evoked local calcium release stabilizes developing dendrites. *Nature* 418:177–181

## Dendritic Integration

► Synaptic Integration

## Dendritic Spike

### Definition

Dendritic spike denotes an action potential generated in dendrites of neurons on the basis of voltage-dependent ion conductances.

► Action Potential

## Dendritic Spines

### Definition

Dendritic spines are protuberances on the dendrites. These greatly increase the dendritic surface area for synaptic reception from axon terminals.

## Dendro-axonal Synapse

### Definition

Synapse formed between dendrite and axon.

► Synaptic Transmission: Model Systems

## Dendro-dendritic Synapse

### Definition

Synapse from one dendrite onto another. Examples of this type of synapse are in the retina and olfactory bulb.

► Olfactory Bulb

► Reciprocal Dendrodendritic Synapse

► Synaptic Transmission: Model Systems

## Denervation

Loss of nerve (innervation) to cell, tissue, organ.

## Dental Implant

### Definition

A replacement for lost root(s) of a tooth, upon which a new, artificial tooth is fabricated and attached.

► Tactile Sensation in Oral Region

## Dentate Gyrus

### Synonyms

Gyrus dentatus

### Definition

The dentate gyrus (dentate fascia) is an important part of the hippocampus, retrocommissural part. Rostrally, it joins Giancomini's band and caudally, the fasciolar gyrus. Afferents come from the hypothalamus and via the entorhinal area from the cerebral cortex. Efferents of the granular cells pass exclusively to the cell layers CA3 and CA4 of Ammon's horn, forming the dense mossy-fiber system.

► Telencephalon

## Dentate Nucleus

### Synonyms

Nucl. dentatus

### Definition

Measuring about 1 cm in length, the dentate nucleus is the largest cerebellar nucleus. With its typical, saw-toothed shape it lies in the medulla of the cerebellar hemisphere. Afferents: (i) Purkinje fibers of the cerebellar hemisphere, lateral part, (ii) collaterals of the pontocerebellar projection.

Efferents: via superior cerebellar peduncle to the ventral lateral thalamic nucleus. A few fibers terminate in the red nucleus.

► Cerebellum

## 2-Deoxy-Glucose Experiment

### Definition

Nerve cells need glucose as their source of energy. They take up 2-deoxy-glucose (2-DG) like normal glucose which, in contrast to normal glucose, is only slowly metabolized and therefore its degradation products are accumulated in the cell. Therefore radioactive 2-DG allows the visualization and measurement of the localized spontaneous or evoked activity of the whole brain by adequate electronic equipment, or by exposing radioactive brain slices of experimental animals to Xray film.

## Depolarization

### Definition

Depolarization is a change in the polarity of the membrane from changes in ionic distribution, that results in the membrane potential becoming more positive. A depolarization that raises the membrane potential above a threshold will fire action potentials. In many cases, depolarizations are generated by the influx of sodium ions through voltage-gated sodium channels, but the influx of calcium or potassium ions as a charge carrier can also cause depolarizations.

- Action Potential
- Action Potential Propagation
- Ion Channels from Development to Disease
- Membrane Potential - Basics

## Depolarization Block

### Definition

Depolarization block longer-lasting depolarizations may lead to accommodation which occur in a number of clinical conditions. These may come about, for example, by changes in ion concentration gradients across the cell membrane. An elevated extracellular  $K^+$  concentration (hyperkalemia) shifts the  $K^+$  equilibrium and the coupled resting membrane potential to

depolarized levels (for instance after crush injuries liberating great amounts of intracellular  $K^+$  into the extracellular space; during epileptic discharges, during impairment of the  $Na^+-K^+$  pump (Ion transport) by metabolic impairment, anoxia etc.; mistreatment by overinfusion of  $K^+$ ). In anesthesia and surgery, succinylcholine is used to depolarize the muscle fiber membrane and thus block the generation of action potentials for some time (depolarization block).

► Action Potential

## Depth Perception

### Definition

The ability to perceive that objects are positioned at different distances from the observer. There are monocular and binocular cues to provide absolute and relative depth information.

► Binocular Vision

## Depth Perception Disorders

### Definition

These patients are unable to perceive the three-dimensionality of the world and instead see all objects as flat. There is also a substantial proportion of people who cannot discriminate selectively “near” or “far” stimuli from monocular stimuli.

## Derived Characters/Traits

### Definition

Derived characters/traits are states of a character that are advanced over the primitive condition. Where such a trait is shared by one or more lineages it is said to be a synapomorphy.

► The Phylogeny and Evolution of Amniotes

## Dermatome

### Definition

The skin region supplied by the paired dorsal root nerves from one spinal segment.

► Somatosensory Projections to the Central Nervous System

## Dermatomyositis

### Definition

Acquired myopathy of unknown cause, characterized by rash (mostly in the face, on the chest and extensor surfaces of joints) and myopathic weakness primarily of proximal limb muscles, which may be mild or life-threatening.

## Dermis

### Definition

The inner, thickest layer of skin in which the Pacini corpuscles are located.

► Vibration Sense

## Descending Drive to Motorneuron Pool

► Sleep – Motor Changes

## Descending Modulation of Nociception

PEGGY MASON

Department of Neurobiology, Pharmacology and Physiology, University of Chicago, Chicago, IL, USA

### Synonyms

Nociceptive modulation; Pain modulation; Endogenous analgesia system; Descending pain modulation

## Definition

Descending pain modulation encompasses pathways that descend from the forebrain and brainstem to the spinal cord and trigeminal sensory complex to modify incoming somatosensory information so that the perception of and reactions to somatosensory stimuli are altered, resulting in either less or more pain.

## Characteristics

That mammalian sensory systems do not record the world faithfully is so obvious as to border on the cliché. Visual, auditory and somatosensory illusions are clear evidence that what we perceive differs from what exists externally. In the case of pain, a function absolutely critical to survival, it is remarkable that a given stimulus (or lack of stimulus) does not reliably evoke a predictable sensation. Under some circumstances, sensory perception is dominated by ascending nociceptive pathways as one may expect; however, there are a myriad of circumstances when sensory perception follows primarily from the effects of descending sensory modulation. Descending pain modulation can make one perceive and react to an innocuous stimulus as though it were painful. Holding a cold can of beer – the same can that felt ever so good on a hot summer day – in sub-freezing temperatures is unpleasant and even painful and chances are, you will drop the can. Pathological examples of “false positive” pains abound in the realm of the spontaneous pain that accompanies a number of neuropathic conditions, at least some of which depend on descending modulation for their initiation and maintenance. Examples of “false negatives” – noxious stimuli that fail to elicit a sensation of pain – also abound. One of the best articulated examples of this is David Livingstone’s feeling of “a sort of dreaminess, in which there was no sense of pain,” after being mauled by a lion (who Livingstone had just shot and injured), to the extent that his bone was splintered and skin permanently scarred [1]. These two examples represent two extremes on a continuum of sensitivity to cutaneous stimulation that ranges from insensitive (Livingstone) to inappropriately sensitive (holding cold beer on a freezing day).

The disconnect between the somatosensory worlds, outside and perceived, does not result from errors in the faithful, labeled-line, ascending sensory pathways, but rather from modulation of these same systems. Pain modulation happens at every level of the sensory pathway: at the peripheral terminal, the nerve, dorsal horn and on up the neuraxis. Touching one’s skin before and after basking in the sun for hours elicits very different sensations because a number of inflammatory chemicals modulate the sensitivity of peripheral afferents. Yet, the exquisite sensitivity to touch resulting from a sunburn is not very different under different contexts. In order for modulation to be context-specific,

the modulatory signal must arise from regions rostral to the spinal cord where information about context is available. Thus modulatory signals that alter nociceptive processing in accordance with context or meaning descend from the brainstem and forebrain. While some modulation ascends to modify thalamo-cortical processing of sensory input, it is clear that most pain modulation descends to the dorsal horn where it modifies the discharge of dorsal horn neurons that respond to nociceptor activation. In this way the dominant mode of pain modulation is to modify transmission at the earliest central synapses in the dorsal horn.

The primary direct (monosynaptic) sources of descending input to the dorsal horn arise from: (i) the medullary raphe magnus and adjacent reticular region; (ii) the locus coeruleus and neighboring catecholaminergic neurons in the dorsolateral pontine tegmentum; and (iii) motor cortex. Di- or oligo-synaptic connections from the midbrain periaqueductal gray, anterior hypothalamus and prefrontal cortex to the dorsal horn also figure prominently in the modulatory control of incoming sensory information. The raphe magnus and surrounding region, also known as the rostroventromedial medulla (RVM) or ventromedial medulla (VMM), has the strongest anatomical connection to the dorsal horn and receives input from virtually every other spinopetal afferent source. Thus, raphe magnus is considered to be the final common pathway for descending pain modulation and has been the focus of hundreds of studies. Much has been written about raphe magnus’ contributions to descending modulation and many reviews are available on the subject [2]. Therefore only a few key points will be discussed here:

- Raphe magnus can either inhibit or facilitate nociceptive transmission. Under normal circumstances and in healthy animals, the inhibitory effects predominate. However, descending facilitation from raphe magnus is a necessary component for certain neuropathic pain syndromes [3]. It is interesting to note that under these same circumstances, descending inhibitory influences from the medullary raphe also appear to be enhanced, perhaps in an attempt, albeit unsuccessful, to suppress the on-going neuropathic pain signal [4].
- The medullary raphe suppresses low threshold as well as nociceptive responses in dorsal horn neurons [5]. Raphe magnus stimulation also modulates thermoreceptive responses in the superficial dorsal horn [6]. Thus, descending modulation from raphe magnus likely targets a variety of sensory inputs rather than only nociceptive ones.
- Medullary raphe and ventral reticular neurons project heavily to the intermediate gray, including the thoracic and sacral intermedio-lateral and medial cell columns and to the central canal region. These cells also project oligosynaptically to

sympathetically- and parasympathetically-innervated tissues as well as to some somatomotor muscles, all of which are involved in maintaining homeostasis [7]. Activation of medullary raphe neurons results in a number of homeostatic adjustments, evidence for a role beyond one of simple sensory modulation.

Descending modulation from sensorimotor cortex warrants mention here as it is the most under-studied and unrecognized component of descending pain modulation. Contrary to the textbook version of corticospinal axons targeting one motoneuron pool and associated motor interneurons in order to control a muscle's activity, corticospinal axons collateralize in multiple spinal segments and in dorsal and intermediate gray as well as in ventral horn [8,9]. In fact, there is a strong projection from sensorimotor cortex to the medial superficial dorsal horn, laminae I and II, where cells have distal receptive fields. As Shinoda and colleagues speculate [9], this projection may be important in modulating sensory inputs during self-generated movements. Thus, anticipated sensory inputs, such as the brush of whiskers on the paw during grooming, can be suppressed whereas unexpected inputs, such as a sharp object on the heel, which would be particularly harmful if encountered while stepping down, could be facilitated to ensure a brisk withdrawal. The projection of corticospinal neurons to the superficial dorsal horn may be the neural substrate by which motor cortex stimulation provides pain relief to patients with intractable pain [10].

## References

- Livingstone D (1857) *Missionary travels and researches in South Africa*. John Murry, London
- Gebhart GF (2004) Descending modulation of pain. *Neurosci Biobehav Rev* 27:729–737
- Porreca F et al. (2001) Inhibition of neuropathic pain by selective ablation of brainstem medullary cells expressing the  $\mu$ -opioid receptor. *J Neurosci* 21:5281–5288
- Montagne-Clavel J, Oliveras JL (1994) Are ventromedial medulla neuronal properties modified by chronic peripheral inflammation? A single-unit study in the awake, freely moving polyarthritic rat. *Brain Res* 657: 92–104
- Gray BG, Dostrovsky JO (1983) Descending inhibitory influences from periaqueductal gray, nucleus raphe magnus, and adjacent reticular formation. I. Effects on lumbar spinal cord nociceptive and nonnociceptive neurons. *J Neurophysiol* 49:932–947
- Sato H (1993) Raphe-spinal and subcoeruleo-spinal modulation of temperature signal transmission in rats. *J Therm Biol* 18:211–221
- Mason P (2005) The ventromedial medulla: pain modulation and beyond. *J Comp Neurol* 493:2–8
- Casale EJ, Light AR, Rustioni A (1988) Direct projection of the corticospinal tract to the superficial laminae of the spinal cord in the rat. *J Comp Neurol* 278:275–286
- Shinoda Y, Yamaguchi T, Futami T (1986) Multiple axon collaterals of single corticospinal axons in the cat spinal cord. *J Neurophysiol* 55:425–448
- Lefaucheur JP et al. (2004) Neurogenic pain relief by repetitive transcranial magnetic cortical stimulation depends on the origin and the site of pain. *J Neurol Neurosurg Psychiatry* 75:612–616

---

## Descending Pain Modulation

- Descending Modulation of Nociception

---

## Descending Vestibular Nucleus

### Definition

Cluster of neurons located in the caudo-lateral region of the complex of the vestibular nuclei. It sends fibers to the spinal cord, the cerebellum and the brainstem reticular formation.

- Vestibular Nuclei
- Vestibulo-Spinal Reflexes

---

## Describing Function Analysis

### Definition

An approximate analysis method used to determine the possibility and parameters of persistent oscillations in a closed-loop (feedback) system.

- Nonlinear Control Systems

---

## Desmosome

### Definition

Disk-like machinery adhering neighboring two cells especially in the epidermis, to form a mechanically strong structure. Electron microscopically opaque.

- Cutaneous Mechanoreceptors, Anatomical Characteristics

## Desynchronization

### Definition

In the local field potential this refers to a decrease in periodicity of the signal. In human electroencephalography (EEG) it is used to refer to the waking state activity which does not show the prominent low frequency oscillations typical of some stages of sleep and relaxation.

- ▶ Brain Rhythms
- ▶ Electroencephalography

## Detection

### Definition

The subjective perception that an object is present (as opposed to absent).

- ▶ Sensory Plasticity and Perceptual Learning

## Detection of Tactile Stimuli

### Definition

Most tactile stimuli have multiple parameters each of which can be perceived separately from other parameters of the stimulus. For example, when we grasp an object, the position of the object on the skin and the contact force are perceived independently. The simplest judgment we can make is to detect the presence or absence of a particular stimulus or parameter. Psychophysics and clinical experiments have used von Frey monofilaments to establish absolute contact thresholds, sometimes referred to as touch thresholds. Another example of a tactile detection task is detecting the presence or absence of a micrometer sized raised bump when we rub our fingertips over a smooth surface. A higher level of judgment relates to the detection of a difference between two stimuli or discriminating the stimuli. Usually a difference in a single parameter is involved such as detecting a difference in the frequency of two vibrating probes (as opposed to a difference in their vibratory amplitude). An example of single parameter discrimination with a more complex

multi-dimensional stimulus is discriminating the ripeness (compliance) of two peaches by grasping them.

Once an object is detected, we can make judgments about the magnitude of each of the stimulus parameters. In psychophysics experiments this process is known as scaling. For example, when grasping a sphere, we can independently scale the curvature of the sphere and the grip force used.

- ▶ Processing of Tactile Stimuli

## Detection of Tactile Stimuli, Effects of Attention

### Definition

When relying solely on tactile information, spatially selective attention is not essential in simple tasks such as detecting the presence or absence of surface texture but it plays a role in more complex tasks such as discriminating differences in surface texture. In contrast, when attention is manipulated across sensory modalities, such as between touch and vision, tactile performance of both simple detection tasks and more complex discrimination tasks is affected. Tactile performance is faster and more accurate when attention is not misdirected toward another modality. Such attention diversion produces a genuine perceptual impairment.

- ▶ Processing of Tactile Stimuli
- ▶ Tactile Attention

## Detection Sensitivity

- ▶ Sensory Systems

## Detection Threshold

- ▶ Sensory Systems

## Detector Neurons

### Definition

Neurons that are able to detect, by their activity, the existence of a certain stimulus.

## Determinate, Overdeterminate and Indeterminate Mathematical Systems

### Definition

Mathematical systems are said to be determined, overdetermined and indeterminate when they have an equal number of system equations and unknowns, a greater number of system equations than unknowns, and a smaller number of system equations than unknowns, respectively.

► Distribution Problem in Biomechanics

## Determinate System

### Definition

A mathematical system is determinate if the number of equations equals the number of unknowns. A determinate system typically has one unique solution.

► Distribution Problem in Biomechanics

## Determinism

GEERT KEIL

Dept. of Philosophy, RWTH Aachen University,  
Germany

### Definition

Determinism is the metaphysical doctrine that the whole of world history is uniquely fixed by ► laws of nature and

initial conditions. In science, “deterministic” is an epithet of theories or of laws that describe the temporal behavior of physical systems as strictly regular.

### Description of the Theory

#### What is Determinism?

To a first approximation, determinism is the claim “that there is at any instant exactly one physically possible future” ([1] p 3). As such, determinism is a metaphysical doctrine about the course of the world as a whole, rather than a scientific theory. The French mathematician P. S. Laplace famously and vividly formulated metaphysical determinism in the early nineteenth century:

“An intelligence that, at a given instant, could comprehend all the forces by which nature is animated and the respective situation of the beings that make it up, if moreover it were vast enough to submit these data to analysis, would encompass in the same formula the movements of the greatest bodies of the universe and those of the lightest atoms. For such an intelligence nothing would be uncertain and the future, like the past, would be open to its eyes.” ([2] p 2).

In his appeal to a superhuman intelligence, later called *the Laplacean demon*, Laplace merged the idea that the future is definitely fixed with the idea that it can be predicted. Predictability, even predictability in principle, is an *epistemic* notion, which relates to the question what can be known, not to the question what is the case. It is advisable to disentangle the metaphysical claim of Laplacean determinism from the idea of predictability, because the latter poses additional problems. For example, the superhuman intelligence must not obtain his knowledge about the present state of the universe in the normal way. In the actual world, any detection of information involves the consumption of energy and thus would alter the physical data supposedly available to the demon. If the doctrine of determinism is not disentangled from predictability, then it can easily be shown to be untenable, as Popper did for what he called “scientific determinism” [3].

The Laplacean idea that the course of the world is fixed once and for all can be reformulated in the jargon of ► possible worlds. Following Montague, determinism has been defined as the doctrine that two possible worlds which instantiate the same laws are alike throughout all of time or never, “The world *W* is *Laplacean deterministic* just in case for any (possible world *W'* which satisfies the natural laws obtaining in the actual world), if *W* and *W'* agree at any time, then they agree for all times” ([4] p 13; cf [5]).

Laplacean determinism makes a *modal* claim, i.e., a claim about what *must* be the case, not simply a claim about what will in fact be the case. In this respect, it differs from so-called *logical determinism*, as encapsulated in the formula “Que sera, sera.” Being a tautology, this

dictum does not say what is *bound to happen*, as a matter of physical necessity. By contrast, Laplacean determinism does comprise an inevitability claim. It is taken to express a causal, physical or metaphysical kind of necessity, not a logical one. As to the question where its modal force stems from, there remains just one serious candidate. While *theological determinism*, i.e., the doctrine of divine predestination draws its modal force from God's intentions or commands, scientifically minded Laplacean determinism takes it from the laws of nature. If determinism is true, it owes its truth to the existence of certain laws that "govern" everything. Given this bond between determinism and lawfulness, some philosophers apply the epithet "deterministic" primarily to some sets of laws and only derivatively to the course of the world. The following definition, which echoes Earman's quoted above, reflects this idea: "A *deterministic* system of laws is one such that, whenever two possible worlds both obey the laws perfectly, then [...] they are alike always or never" ([6] p 37). The connection between the world related and the laws related formulations of determinism is provided by the deductive-nomological account, according to which deterministic laws, taken together with complete antecedent conditions, *logically entail* a description of the total state of the world at any other time.

Laplacean determinism is sometimes called *causal determinism*. While this locution helps to distinguish the doctrine from logical and from theological determinism, it is infelicitous in that it takes for granted a contentious conception of ►causality. Some authors simply equate determinism with the principle of universal causation, i.e. with the thesis that every event has a cause. This equation rests on the preconception that causality is a deterministic relation. But since nondeterministic accounts of causation have been developed, such an identification is inadvisable. Laplace himself chose a causal formulation when he suggested "consider[ing] the present state of the universe as the effect of its previous state and as the cause of that which is to follow" ([2] p 2). This view assumes an unusual conception of causal relations, according to which ►causal relations do not hold between ordinary events, but only between total states of the universe.

While determinism, in making a stronger claim about lawfulness, should not be identified with the principle that every event has a cause, it does exclude uncaused events, miracles and interventions by immaterial soul substances. Thus determinism is intimately linked with the principle of the ►causal closure of the physical domain (see also ►completeness of the physical domain). This association is due to the demand that one set of laws describe happenings completely and uniquely. If a miracle is defined as a violation of the laws of nature (Hume), it follows immediately that determinism rules out miracles. Whether determinism rules out *mental causation* is more

difficult to decide. Accounts of mental causation that do not contest the claim that one set of physical laws fixes the course of events uniquely, e.g., supervenience theories of the mental, should be compatible with determinism.

Determinism is closely linked with the ►physicalistic assumption that whatever happens must supervene on the lawful behavior of microphysical entities. While the principle of the nomological primacy of the micro-level as it may be dubbed, is arguably not part of the *meaning* of "determinism," it is hard to see how it could work the other way round, i.e., how higher level laws could uniquely fix the behavior of microphysical entities. Note, however, that microphysical laws do not *causally determine* the behavior of the systems they describe. Laws are abstract entities; they do not make anything happen. Causal determination is a relation in time, which holds between events or states that follow each other. To say that laws "govern" events is already metaphorical.

*Hard determinism* and *soft determinism* are not further variants of determinism, but views about the compatibility issue in the free will debate. Soft determinism holds that determinism and free will are compatible. Hard determinism denies it. It is widely agreed that no kind of determinism is compatible with one core element of a "strong" conception of freedom, the principle of alternative possibilities, according to which the agent could have acted otherwise under the same circumstances.

### Is Determinism True?

Is determinism a scientific or a metaphysical theory? The issue hinges on the kind of evidence available. The natural assumption is that any scientific evidence for Laplacean determinism must come from physics, the most fundamental science. Now the determinism problem is by no means a dead issue in the philosophy of physics. In recent years, long established assumptions have been called into question. It is no longer uncontroversial that classical mechanics is a deterministic theory, nor that quantum mechanics is indeterministic [4,8]. Since Newtonian mechanics knows no upper bound on the velocities of moving particles, it does not rule out objects which "escape to infinity" nor the inverse phenomenon of "space invaders." The latter at least violate determinism. Moreover, Newtonian mechanics does not yield empirically correct solutions for a number of collision phenomena. As for quantum theory, its orthodox interpretation is indeterministic, but in recent years, deterministic interpretations have been developed which also seem to be consistent.

How could physics prove or disprove Laplacean determinism? The main obstacle to a scientific test is the global character of the doctrine. Laplacean determinism says something about the course of the world as a whole. Now take the laws related formulation that a



deterministic system of laws is one such that whenever two ►possible worlds both obey these laws, they coincide throughout all of time or never. The question whether determinism is true then seems to boil down to the question whether the fundamental laws of physics or the theories of which they form part are deterministic in character or not. A law of physics is deterministic if it is strict, i.e., if it admits no exceptions, is not probabilistic and does not contain open ended *ceteris paribus* clauses. Given that the book of nature is written in mathematicalese, as Galileo proclaimed, a physical law's being deterministic is a mathematical property of certain sets of equations (roughly, the property of having a unique solution for future times). In quantum mechanics, for example, the Schrödinger equation, which describes the evolution of the wave function, is taken to express a deterministic law. However, the deterministic character of fundamental laws and the theories to which they belong does not by itself license the inference that the *world* is deterministic, i.e., that Laplacean determinism is true. The problem with this inference can be described as follows: "The best approach to the question whether a world is deterministic is to analyze the laws or theories that pertain to it. The claim that not only the theory but also the world it pertains to is deterministic (or indeterministic) is however a further claim that needs to be established separately, e.g., by arguing that the relevant theory describes the whole universe in all its detail" ([9] p 12). A deterministic theory would have to tell the *whole truth* about the course of the world. It would have to be a final "theory of everything." Unless it is such a complete theory, any regular succession of phenomena predicted by the theory is susceptible to interferences that are due to the superposition of physical forces about which the theory is silent. As Russell puts it: "All causal laws are liable to exceptions, if the cause is less than the whole state of the universe" ([10] p 230). Lacking an all-encompassing theory, deciding whether certain laws of a physical theory are deterministic or not is immaterial to the question of whether Laplacean determinism is true. There is "a large gap between the determinism of a given physical theory and the bolder, vague idea that motivated the traditional formulations, the idea that the world in itself is deterministic" ([8] p 33).

By the same token, the existence of counterinstances to alleged deterministic laws or theories does not by itself *refute* Laplacean determinism. In order to put Hume's principle "same cause, same effect" to the test, the antecedent conditions of the entire system, i.e., of the universe, would have to be the same on two occasions: "As long as it is not the case that the entire universe was in perfectly identical states  $t$  and  $t'$ , [an object]  $O$ 's different behavior at those two points in time can always be attributed to different causes acting on it. [...] Thus we could suggest that the doctrine of

determinism implies that if the total state of the universe was ever identical with a state that had obtained at any time in its past, the universe would from then onward go through eternally recurring cycles" ([7] p 341 f). This intimate connection between Laplacean determinism and the ancient doctrine of eternal recurrence was already acknowledged by J. S. Mill, who framed the hypothetical principle: "If the whole prior state of the universe could again recur, it would again be followed by the present state". Now as far as is known, history does not repeat itself. And worse yet, the more precisely the antecedent of an alleged law is specified, the less probable it is that such a state will be instantiated more than once. There is an inverse relation between exactness and repeatability, as described by Russell: "As soon as the antecedents have been given sufficiently fully to enable the consequent to be calculated with some exactitude, the antecedents have become so complicated that it is very unlikely they will ever recur" ([11] p 188). This being the case, the deterministic idea that like states follow like states after definite time intervals can only be preserved in a counterfactual version, as in Mill's principle, if a state of the universe *were* ever to recur, history *would* repeat itself down to the last detail.

Science has no option but to study systems that are not causally closed. Within the actual world, no physical system is completely isolated. The very procedures of taking measurements and making observations constitute causal interactions between the observed system and its environment. The above mentioned principle that the physical domain as a whole is causally closed does not change the situation, for even if the physical realm were a deterministic system, this property would not be passed on to partial systems within the physical. As a remedy, it has been suggested "to formulate determinism in terms of completely isolated systems," thinking of theories as "describing single completely isolated systems, each alone in the universe" ([8] p 36 f). This move is however just another version of Mill's escape to counterfactuality. Restricted to isolated systems, determinism would become a counterfactual claim and perhaps even a counter*legal* one, in devising worlds which are nomologically impossible. The salient point is that positing physical systems that are each alone in the universe would deny the existential presuppositions of the remaining laws of physics, thus making it impossible for all of the laws to hold in the same actual world ([12] p 778).

In sum, evidence from physics can neither conclusively verify nor falsify Laplacean determinism. Its assertion transcends empirical evidence and this is precisely what makes determinism a metaphysical doctrine.

Now what about the whole array of domain-relative determinisms? Talk of psychological, biological, genetic, historical, economic or cultural determinism

carries the suggestion that these respective factors strictly determine say, the nature and the behavior of human beings. Genetic determinism, for instance, has been described as the view that “human lives and actions are inevitable consequences of the biochemical properties of the cells that make up the individual and these characteristics are in turn uniquely determined by the constituents of the genes possessed by each individual” ([13] p 3). Now it is simply not the case that genetic factors fix human behavior uniquely. In order to make a domain-relative determinism true, strict, exceptionless laws would have to exist that link say, the genetic set up of individual organisms with their behavior. No weaker correlation would do. In particular, making the system *disposed* to react in a certain way does not constitute a deterministic relation. In the absence of such strict laws, either all these domain-relative determinisms are plainly false, or a weaker reading of “determinism” must be developed.

### Determinism in the Neurosciences

In the neurosciences, “determinism” is not a well-defined theory. Theories in the neurosciences can be called “deterministic” if they treat their objects of research, i.e., the brain or the neural system, as deterministic systems. What does it mean that the brain “works deterministically” or that it is a “▶deterministic automaton”? A deterministic automaton is one whose computational output is completely determined by the starting state, the input and the program. If the brain is such a system, its causal output must be fixed uniquely by these three factors. This could only be the case if the operation of the brain were causally isolated, i.e., if after the processing of some input begins, no further factor could ever disturb the dynamics of the brain from outside. Now surely more things can happen between brain input and output than are dreamt of in our neuroscientific textbooks. This is why neuroscience is hardly ever concerned with finding strict causal laws, i.e., causally sufficient conditions for the occurrence of a certain phenomenon. For example, the readiness potential, which “initiates” voluntary acts in the brain, according to B. Libet, is not a causally sufficient condition for the onset of movement and no one argues that it is. Just like any other physical system, the brain is susceptible to interferences of many kinds, including the sudden death of the organism that houses it, which ends all brain activity. Now systems that are not causally isolated cannot exhibit local determinism unless global Laplacean determinism is also true. (There is however one sense in which domain-relative determinisms could be true while Laplacean determinism is not; physical systems can be described at different levels and with different degrees of precision. If there is genuine randomness at the quantum level, this quantum indeterminacy may average out at the macro

level. In that restricted sense, the world could contain deterministic systems even if the course of events is fundamentally indeterministic.)

It has been suggested that biological systems, while not being causally or energetically closed, are “operationally” or “organizationally closed” (Maturana/Varela). ▶Operational closure means that certain relations and processes define the system as a unity, in determining the dynamics of interaction and transformations that the system may undergo. This kind of closure is however, immaterial to the issue of determinism. It is one thing to identify principles that restrict the number things that can happen within the system unless it is destroyed. It is another thing to reduce the number of possibilities to one. In order for the brain to be a deterministic system, its initial state, its input and its *modus operandi* would have to fix its causal output *uniquely* and as a matter of physical necessity.

The observation that neural activity is neither completely predictable nor purely random has led a number of authors to invoke the notion of ▶deterministic chaos to describe the dynamics of the brain. Deterministically chaotic systems are extremely sensitive to initial conditions, which makes their dynamics unpredictable in the long run, while they still instantiate deterministic laws. In such systems, same causes still have same effects, but similar causes do not have similar effects. The response of nerve cells to periodic stimulations for instance, has been described as such a deterministically chaotic process. The philosopher Robert Kane invokes chaotic neural processes sensitive to quantum events in order to explain the possibility of free, undetermined decisions [14].

In the life sciences, the notions of determinism and determination are often used in a loose, informal sense. For example, talk of “neural determinants” of thought and behavior typically does not commit the speaker to determinism proper. But while the verb “to determine” is an ordinary English term that is not associated with a particular philosophical or scientific theory, it is questionable whether a weak sense of “determinism” really exists or should be introduced. Insisting that the brain “works deterministically” often just has the function of indicating that no causal gaps, no miracles and no intrusions by immaterial soul substances should be expected. These views are better expressed without the notion of determinism. In particular, the view that all mental phenomena are physically *realized* in the brain has nothing to do with determinism, the latter describing a *temporal* relation. One can believe in the causal closure of the physical, reject Cartesian dualism and repudiate obscure pseudo-explanations without adhering to Laplacean or neurobiological determinism. Consciousness, thought and behavior arguably have neural correlates and even neural “determinants,” even if determinism is not true.

## References

1. van Inwagen P (1983) An essay on free will. OUP, Oxford
2. Laplace PS (1814) Philosophical essay on probabilities. Springer, Berlin Heidelberg New York, 1995
3. Popper KR (1982) The open universe. An argument for indeterminism. Hutchinson, London
4. Earman J (1986) A primer on determinism. Reidel, Dordrecht
5. Montague R (1974) Deterministic theories In: Thomason R (ed) Formal philosophy. Yale University Press, New Haven
6. Lewis D (1986) Philosophical papers, vol 2. OUP, New York
7. Schlesinger G (1987) Is determinism a vacuous doctrine? *Brit J Phil Sci* 38:339–346
8. Butterfield J (1998) Determinism and indeterminism. In: Craig E (ed) *Routledge encyclopedia of philosophy*, vol 3. Routledge, London, pp 33–39
9. Hüttemann A (2003) Introduction: determinism in physics and biology. In Hüttemann A (ed) *Determinism in physics and biology*. Mentis, Paderborn, pp 9–18
10. Russell B (1914) Our knowledge of the external world. Routledge, London, 1993
11. Russell B (1912) On the notion of cause. In: Russell B (ed) *Mysticism and logic*. Longmans, London, pp 180–208
12. Joseph G (1980) The many Sciences and the one world. *J Philos* 77:773–791
13. Rose S, Lewontin RC, Kamin LJ (1984) Not in our genes. Pantheon, New York
14. Kane R (1996) The significance of free will. OUP, Oxford

## Deterministic Automaton

### Definition

A deterministic automaton is a finite state computing system whose output is completely determined by the starting state, the input and the program.

► [Determinism](#)

## Deterministic Causation

### Definition

A relation between cause and effect such that a complete statement of the laws of nature together with a complete description of the condition of the entire universe at the time the cause occurs logically entails that the effect occurs.

► [Freedom of Will](#)

## Deterministic Chaos

### Definition

Deterministically chaotic systems are extremely sensitive to initial conditions. The dynamics of such systems is unpredictable in the long run, while they still instantiate deterministic laws.

► [Determinism](#)

## Detour Learning

### Definition

The ability to learn an efficient path to a goal that takes into account the presence of an obstacle or barrier to reaching the goal. This ability is difficult to explain by route navigation or dead reckoning navigation without a map. Similarly, route navigation and dead reckoning without a map make it difficult to take a newly available shortcut path to a goal. In contrast, a map-like representation of an environment contains the information that is needed for a subject to take efficient novel detour and shortcut paths. Thus the observation that rats can take detours and shortcuts was regarded as strong evidence that animals possessed an internal map-like representation of their environments. Such a representation is called a cognitive map and whether or not animals had one was the subject of the place versus response controversy.

► [Navigation](#)

► [Spatial Learning/Memory](#)

## Developing Nociceptive System

### Definition

An immature system in which the basic nociceptive connections (formed before birth) exhibit increased responsiveness in comparison to the adult animal. The conduction velocity of afferent fibers, action potential shape, receptor transduction, firing frequencies and receptive field properties change substantially over the postnatal period.

► [Development of Nociception](#)

► [Pain in Children](#)

## Development of Nociception

MARIA FITZGERALD

UCL Department of Anatomy and Developmental Biology, University College London, London, UK

### Synonyms

Developmental aspects of pain; spinal reflex; C fiber; nociceptor; spinal cord; neuropathic pain; chronic pain; medulla; cortex; receptive field; inhibitory circuits; hyperalgesia; analgesia

### Definition

The developmental aspects of pain concern the growth and maturation of neural pathways and mechanisms that result in nociceptive behavior and pain sensation in response to tissue damage in the fetus, infant and child.

Newborn infants show strong nociceptive behavior, but the nature of their pain sensation is poorly understood and as a result infant pain has, historically, been under-treated [1].

This essay will discuss our current understanding of mammalian pain development from both laboratory and clinical studies. It will show that

- Early pain behavior is restricted to reflex responses, but cortical pain responses are evident in the youngest preterm infants.
- Peripheral nociceptive neurons are specified early in development, and key molecular pathways that control this have been identified.
- Newborn nociceptive circuits are more excitable than in adults and receptive fields gradually become tuned during the postnatal period. This tuning arises from the refinement of afferent excitatory inputs and the maturation of inhibitory processes, both locally and descending from the brainstem.
- Nociception and ▶**primary hyperalgesia** can be observed at an earlier age than ▶**secondary hyperalgesia** and chronic ▶**neuropathic pain**, suggesting that ▶**central sensitization** pathways require postnatal maturation.
- Both non-noxious and noxious sensory activity can influence the development of pain processing.

### Characteristics

#### The Onset of Nociceptive Reflexes and Pain Processing

Nociceptive behavior in fetal life begins with the appearance of reflex reactions to noxious sensory stimuli. These responses are not, in themselves, evidence of pain perception or “feeling” pain, but do provide information about the ability of the fetal spinal cord and brainstem to respond to brief mechanical stimulation of the skin. These begin at 15 days of gestation in the rat

fetus (E15, where gestation is 21.5 days) and coincide with the onset of spontaneous movements in the absence of any obvious external stimulation. These spontaneous movements are first observed by real-time ultrasound at 7–8 weeks of fetal life in humans, but it is not known whether reflex responses to skin stimulation begins at the same stage. However, it is clear that the youngest premature babies, born at 22 weeks gestation, display robust reflex limb withdrawal to lancing the foot (for clinical blood sampling) as well as cardiovascular and hormonal responses, crying and facial expressions associated with pain. Recently ▶**near-infra red spectroscopy** has demonstrated neural activity in the contralateral somatosensory cortex in response to noxious stimulation in infants from 25 weeks showing that pain is potentially processed at cortical levels in very young infants [2,3]. (Fig. 1a) summarizes current methods of measuring pain in infants.

#### Postnatal Maturation of Nociceptive Behavior

Spinally-mediated nociceptive reflexes are exaggerated in magnitude and duration compared to the adult, but they lack functional precision [3]. Considerable fine tuning occurs over the postnatal period, and as a result reflex responses cannot be interpreted in exactly the same way at each stage of development. A noxious prick on the foot of a very young rat pup or human infant can cause movements of the whole body and simultaneous responses from all four limbs, but these gradually mature into restricted limb or foot movements over the postnatal period. This is because neonatal spinal withdrawal reflexes have lower ▶**cutaneous thresholds**, are easily sensitized by repeated stimulation and consist of more synchronized and prolonged muscle contractions than those of adults. Furthermore, reflex ▶**receptive fields** are large and disorganized such that the withdrawal itself can be evoked from a wider area of the limb and is not always appropriate to the stimulus. For the first 10 days after birth, rat pups have a 75% error rate in the direction of a tail flick to noxious stimulation of the tail, and this gradually improves to the adult rate of less than 10% by P21. Preterm human infant limb and abdominal ▶**withdrawal reflexes** show analogous lack of tuning [4]. This increased excitability and lack of focussed, directed response to a noxious stimulus in the newborn can be explained by the different sensory circuit properties in the infant spinal cord and brainstem. At birth, ▶**dorsal horn** cell cutaneous receptive fields, particularly those in the deep dorsal horn, are relatively larger than in adults and decrease rapidly in size over the first two postnatal weeks.

#### Development of Peripheral Nociceptors

Primary sensory neurons in the dorsal root ganglion are born early in embryonic life, but the small diameter

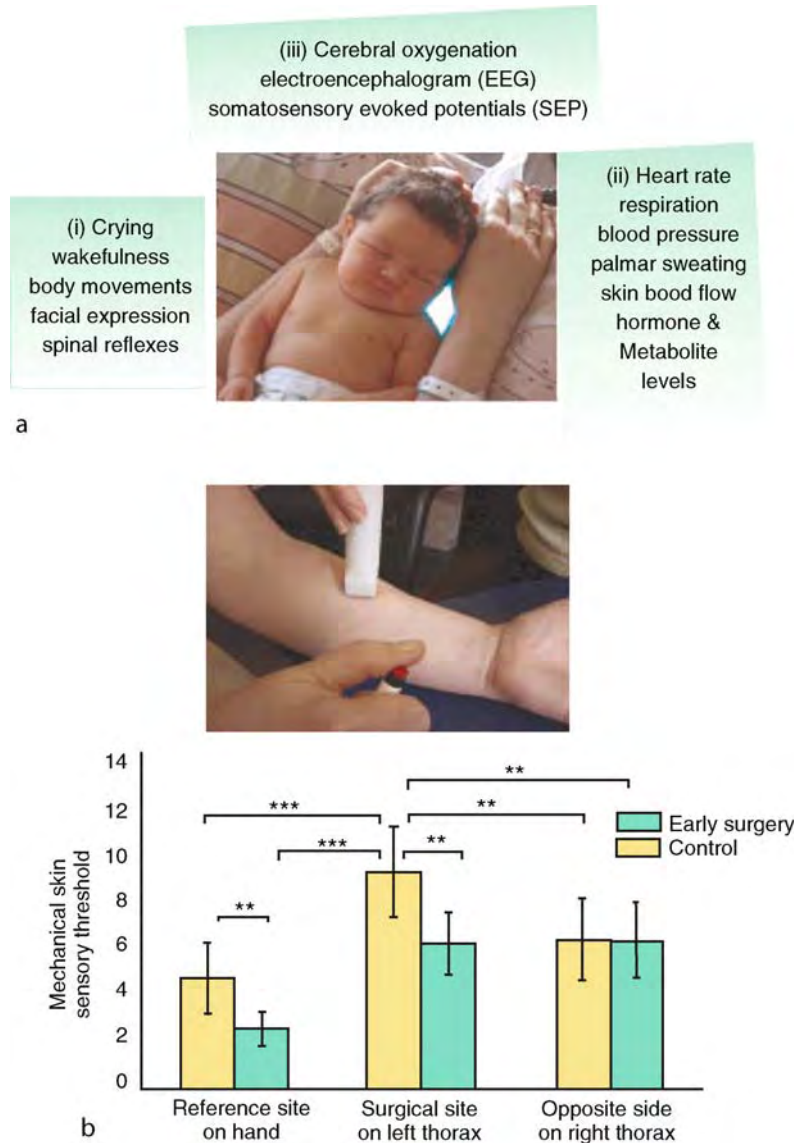

**Development of Nociception. Figure 1** (a) Measuring pain in human infants. Since infants cannot communicate their pain, other measures are used: (i) motor reflexes and behaviour (ii) automatic changes and hormonal levels and (iii) cortical activity. (b) Quantitative sensory testing in children. Children that have undergone early pain and surgery are less sensitive to mechanical skin stimulation than their age-matched controls. Upper panel shows skin temperatures sensitivity testing on a child. Lower panel shows the mean mechanical sensitivity in three skin areas in children that underwent thoracic surgery as neonates and age-matched controls. Note that the early surgery group have a higher threshold and are therefore are less sensitive to touch than the control group (adapted from ref 10).

C cells, most of which are future nociceptors, are in the last wave of neurogenesis. Their specification as a separate subgroup of sensory neurons is dependent on a member of the neurogenin family of **transcription factors**, *ngn1*. The final numbers of nociceptors are determined by the balance between cell birth and subsequent cell death, which in turn is regulated by access to peripheral neurotrophic factors that regulate the survival of immature nociceptors via signaling at receptor tyrosine kinases (**trks**). In early life, all

nociceptor neuron express *trkA* receptors and these require activation by the neurotrophin nerve growth factor (NGF) if the neurons are to survive. After birth, a subset of these neurons down-regulate *trkA* receptors and become dependent on a different neurotrophin called glial cell line-derived neurotrophic factor (GDNF) via the expression of the GDNF receptor *Ret*. The emergence of this sub-group of re-expressing nociceptors is coordinated by a Runt domain transcription factor, called *Runx1*. In this way, two clear

subgroups of nociceptors emerge over the perinatal period: the *trkA* expressing group, which contain the neuropeptides, substance P and calcitonin gene related peptide (CGRP), and the *ret* expressing group which do not contain neuropeptides [5]. Both are important for the full range of mechanical, thermal and chemical nociceptive transduction.

Mechanical, thermal and chemical nociceptive transduction depends upon expression of the TRP (transient receptor potential) channel family and the maturation of differential expression of these channels determines the functional heterogeneity of nociceptor responses. The sequence of development of different TRP channels determines the onset of heat sensitivity in the mouse at E12.5 followed by cold sensitivity at E16.5 and finally sensitivity to mustard oil, a pungent irritant [6].

### Development of Spinal Nociceptive Circuits

C fiber nociceptor terminals grow into the superficial laminae of the dorsal horn of the spinal cord just before birth in the rat and their arrival coincides with a period of rapid synaptic CNS growth and reorganization. The larger diameter, myelinated **A fibers**, which convey a sense of touch and pressure from peripheral tissues, have already grown into the cord and in doing so have formed widespread connections over much of the target area. The earlier maturation and widespread presence of functional A fiber terminals in the first weeks of life means that dorsal horn pathways which, in the adult, are only triggered by noxious inputs, can also be activated by touch and pressure in the newborn. As **C fiber** inputs proliferate and strengthen over the postnatal period, the influence of A fibers over nociceptive circuits declines through what appears to be a competitive mechanism and A fiber terminals gradually withdraw to deeper laminae [4].

The postnatal period is marked by important changes in excitatory and **inhibitory synaptic signaling** in immature nociceptive circuits. Synaptic inputs from nociceptive fibers are not simply getting stronger over the postnatal period, they are changing their signaling properties. The major excitatory neurotransmitter is glutamate and its receptors (AMPA, NMDA, kainate and metabotropic receptors) are made up of subunits that are all developmentally regulated over the postnatal period in the sensory circuits of the dorsal horn. Overall, glutamatergic activity in the newborn seems to lead to longer channel opening times and greater calcium influx than in adults, properties that are thought to be critical for growth and synaptogenesis, but will also impact upon nociceptive transmission. The development of inhibitory connections is as important as the excitatory input. The main inhibitory neurotransmitters, GABA and glycine and their receptors (GABAR and GlyR) are also postnatally regulated

in the postnatal dorsal horn. Initially, virtually all the inhibitory activity in the newborn dorsal horn is mediated by GABA, and there is little or no glycinergic activity, despite the presence of functional GlyR. Since glycinergic inputs mediate fast inhibitory events, their slow maturation relative to GABA inputs will affect the timing and synchronization of inhibition. In addition, GABA excitation is evident in the very newborn spinal cord, due to high intracellular  $Cl^-$  concentrations  $[Cl^-]$ ; in immature neurons, although inhibition predominates [7].

A further factor contributing to the balance of excitation and inhibition in spinal nociceptive circuits is descending activity from the brainstem. The brainstem is known to exert powerful descending control over spinal nociceptive processing in adults, largely through projections from the rostroventral medulla (RVM) and **periaqueductal grey (PAG)** traveling down the spinal cord in the dorsolateral funiculus (DLF). The role of this system in modulating spinal sensory processing in the neonate is less clear. Electrical activation of the periaqueductal gray (PAG) does not produce analgesia and stimulating the DLF does not inhibit the firing of dorsal horn neurons until at least P10. Recently, it has become evident that there is, in fact, powerful tonic supraspinal excitatory control over nociceptive circuits in the newborn, which shifts to inhibition after several postnatal weeks.

### Development of Persistent and Chronic Pain Mechanisms

Tissue injury and inflammation can lead to persistent pain and **hyperalgesia** that lasts for days, weeks or months due to sensitization of peripheral nociceptor terminals in the injured area and central sensitization of nociceptive neurons in the spinal cord and higher centers.

Hyperalgesia can also be produced by experimental inflammation in newborn rats and hypersensitivity to tissue damage can also be measured in human infants, where “tenderness” or a fall in reflex thresholds is established for days and weeks in the presence of local skin or deep visceral tissue injury. The effect is small in the youngest infants and increases with age in both rats and humans. Secondary hyperalgesia, which spreads into an area surrounding the original injury, appears to develop later than primary hyperalgesia in newborn rats [8].

Immature C fibers are capable of peripheral sensitization from before birth, but the release of the neurotransmitter substance P from their terminals is likely to be low in the neonate and substance P receptors (NK1) undergo substantial postnatal reorganization. In slice preparations, NMDA dependent C-fiber evoked depolarization of spinal cord cells and “wind-up” of cells to repeated C-fiber stimulation has been

demonstrated in the young (8–14 day) spinal cord, but it is not clear that it occurs earlier than that. In any event, it is evident that different protein kinase C-mediated pathways are triggered in the dorsal horn of young versus old rats by inflammation.

The development of neuropathic pain in infants and children is not well understood. Brachial plexus injuries occurring in infants during delivery do not appear to result in chronic neuropathic pain and peripheral nerve injuries do not evoke neuropathic pain behavior in neonatal rats in contrast to the pronounced behavioral changes seen in adults. Mechanisms underlying neuropathic pain, such as the activation of microglia in the dorsal horn, are absent in the early postnatal period and further studies of their development may aid our understanding of chronic pain in adults [9].

### Sensory Experience and the Development of Pain Processing

There is increasing evidence that the normal maturation of nociceptive systems is influenced by exposure of the infant to sensory stimulation. Sensory activity could arise from nociceptive or non-nociceptive inputs, but under normal physiological circumstances nociceptor activation would be rare in the first postnatal weeks while tactile stimulation would be considerable. Whereas daily noxious stimulation does not affect postnatal tuning of the nociceptive tail reflex, blocking low intensity tactile inputs from the tail with local anesthetic, during a critical ten day period, prevents it [6]. Regular tactile input can arise from spontaneous twitching during sleep in both rats and human infants and this has been proposed to be responsible for shaping nociceptive circuits in early life.

There is evidence that C fiber activity influences synaptic organization in the spinal dorsal horn. Neonatal destruction of C fibers by systemic administration of the neurotoxin capsaicin prevents or delays the development of a number of synaptic processes and increased C fiber input early in development is also likely to alter the normal development of nociceptive circuits [3]. The well-documented numerous invasive procedures that preterm infants undergo in intensive care, where it is not always possible to achieve adequate levels of analgesia, could produce increased C fiber activity, which in turn could alter the subsequent development of the nervous system. There are reports that children who were in intensive care as infants do have altered somatosensory processing [10] (Fig. 1b). In animal models, neonatal hindpaw inflammation has a pronounced effect on the central terminal fields of C fibers and the dorsal horn cell response to a second inflammatory challenge is increased well into adulthood. Similarly, neonatal skin wounds have

prolonged effect long after the wound has healed and the skin remains hypersensitive and dorsal horn receptive field sizes expanded for at least six weeks [3]. This is an area that requires more research before firm conclusions can be drawn.

### References

1. Howard RF (2003) Current status of pain management in children 2. *JAMA* 290:2464–2469
2. Slater R, Cantarella A, Gallella S, Worley A, Boyd S, Meek J, Fitzgerald M (2006) Cortical pain responses in human infants. *J Neurosci* 26:3662–3666
3. Fitzgerald M (2005) The development of nociceptive circuits. *Nat Rev Neurosci* 6:507–520
4. Waldenstrom A, Thelin J, Thimansson E, Levinsson A, Schouenborg J (2003) Developmental learning in a pain-related system: evidence for a cross-modality mechanism. *J Neurosci* 23:7719–7725
5. Zhong J, Pevny L, Snider WD (2006) “Runx”ing towards sensory differentiation. *Neuron* 49:325–327
6. Hjerling-Leffler J, Alqatari M, Ernfors P, Koltzenburg M (2007) Emergence of functional sensory subtypes as defined by transient receptor potential channel expression. *J Neurosci* 27:2435–2443
7. Bremner L, Fitzgerald M, Bacceti M (2006) Functional GABA(A)-receptor-mediated inhibition in the neonatal dorsal horn. *J Neurophysiol* 95:3893–3897
8. Walker SM, Meredith-Middleton J, Lickiss T, Moss A, Fitzgerald M (2007) Primary and secondary hyperalgesia can be differentiated by postnatal age and ERK activation in the spinal dorsal horn of the rat pup. *Pain* 128:157–168
9. Moss A, Beggs S, Vega-Avelaira D, Costigan M, Hathway GJ, Salter MW, Fitzgerald M (2007) Spinal microglia and neuropathic pain in young rats. *Pain* 128:215–224
10. Schmelzle-Lubiecki BM, Campbell KA, Howard RH, Franck L, Fitzgerald M (2007) Long-term consequences of early infant injury and trauma upon somatosensory processing. *Eur J Pain* 11:799–809

## Development of the Respiratory Network

HUGO LAGERCRANTZ, MALIN ROHDIN  
Karolinska Institute, Astrid Lindgren Children’s Hospital, Stockholm, Sweden

### Synonyms

Respiratory network growth and maturation

### Definition

The respiratory network consists of clusters of neurons in the brain stem that receives afferents from central

and peripheral chemoreceptors, mechanoreceptors in the lung and also from the cortex, hypothalamus and cerebellum. This structure generates the respiratory rhythm and forms the pattern of breathing movements. It used to be named the respiratory center. However, this term is not really appropriate since the forebrain, the hypothalamus and other suprapontine nuclei can override the respiratory network in the brain stem for example during talking and singing (Euler) [1].

### Characteristics

Respiratory movements can be observed by ultrasound already during the 11th gestational week in the human fetus. Respiratory related rhythm activity can be recorded from the isolated ►brainstem via C3 and C4 from the rat fetus at the 16th gestational day. These findings suggest that the respiratory rhythm generator localized in the ►pre-Bötzinger complex is developed at an early stage long before air breathing commences. However, the first respiratory-like activity is rather ataxic and a more rhythmic pattern emerges first after the inspiratory activity is inhibited by pontine structure, which is evident around E 18 in the rat fetus.

### Embryology/Anatomy

The respiratory rhythm generator is localized in the so-called pre-Bötzinger complex, which is a part of the nucleus tractus solitarius. The ►nucleus Ambiguus is also involved. The ►Kölliker-Fuse Nucleus, which is a part of the ►Locus Coeruleus, executes switching off the inspiration. Both clinical evidence and observations on transgenic mice indicate that inactivation of the genes encoding for the making of nuclei of the cranial nerves may cause aberrant respiratory patterns after birth [2].

### Neurochemistry

►Glutamergic neurons within the pre-Bötzinger complex can generate this activity. Glutamate seems to be essential for sharpening the central pattern generator acting via ►AMPA receptors and ►NMDA receptors. There are also subpopulations of neurons expressing opioid and substance P receptors in these structures. Substance P is the most abundant neuropeptide in the ►respiratory kernels and it has been found to affect the patterning of the respiration. ►GABA is an excitatory neurotransmitter in fetal life, but switches to an inhibitory neurotransmitter during maturation due to the expression of ►KCC2. Adenosine, prostaglandin and endogenous opioids inhibit breathing and may be responsible for suppression of breathing before and after birth. Blocking the action of endogenous adenosine is probably the mechanism by which theophylline and caffeine exert their clinical effects in the treatment of ►apnea of prematurity [3,4].

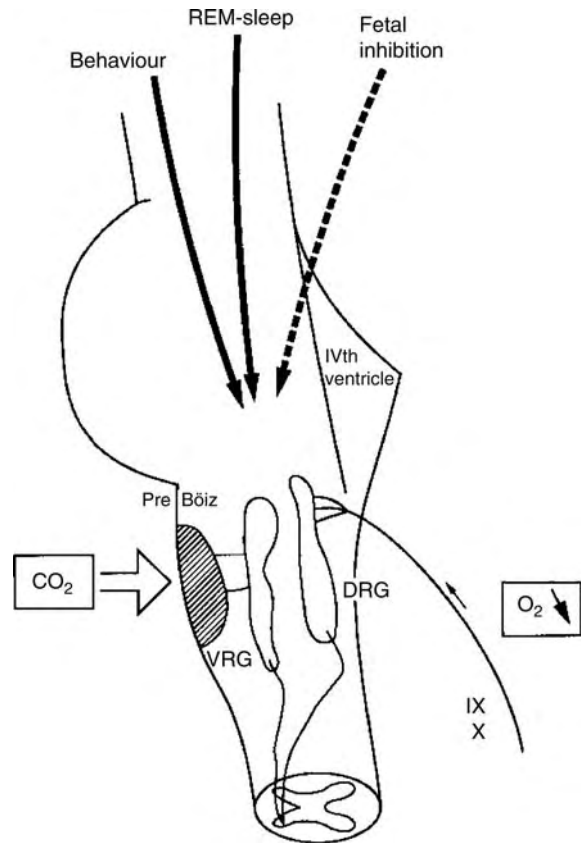

### Development of the Respiratory Network.

**Figure 1** Organization of the neuronal groups and drive mechanisms controlling respiration. The CO<sub>2</sub> drive is mediated by the central chemoreceptive area at the ventral surface. The hypoxic drive is mediated by the cranial nerves iX and X) which terminate at the dorsal respiratory group (DRG). The respiratory rhythm generator is assumed to be located in the pre-Bötzinger complex of the ventral respiratory group (VRG).

### Fetal Respiratory Movements

During the fetal period the respiratory system is fluid-filled and the fetus performs intermittent breathing efforts from 10 to 11 weeks of gestation [5]. Fetal respiratory movements are promoted by activity in the reticular system during rapid-eye-movement (REM) sleep, as identified by low-voltage cortical electrical activity [5]. In contrast, fetal breathing is inhibited during quiet sleep.

However, if the brainstem is transected above pons in the fetal sheep the breathing becomes continuous, indicating the existence of a suprapontine inhibition [5]. ►Hypoxemia also causes arrest of respiratory movements in the fetus due to central inhibition. Hypercapnia ►stimulates fetal breathing only during active sleep but has no effect during quiet sleep. The fetal respiratory movements are less frequent towards the end of gestation.



### Transition at Birth

The fetal respiratory movements are inhibited during labor, although severe hypoxemia may trigger gasps, which can lead to meconium aspiration. The mean time for the onset of respiratory effort is about 10 s, although there is great variability. The factors responsible for the onset of breathing can be divided into extrinsic (e.g. skin cooling and painful stimuli) and intrinsic influences (e.g. removal of respiratory inhibitory mechanisms including adenosine and ►prostaglandins, increased wakefulness, level of catecholamines and activation of CO<sub>2</sub> drive). The respiratory pattern is very irregular at birth, probably caused by incomplete neuronal interconnection and integration of signals.

Inspiratory pressure and volume are similar in newborn infants delivered by cesarean section compared to infants born vaginally. However, the expiratory and delivery pressures are often smaller and the functional residual capacity is formed less frequently after cesarean section than in the vaginal delivery. This is due to the fact that the lung liquid is less rapidly removed, probably caused by lower levels of catecholamines [3].

### Arousal and the Forebrain Drive

Respiration is governed by a number of regulating mechanisms hierarchically arranged to ensure behavioral and metabolic demands [1]. The breathing pattern during the awake state is rather irregular and influenced by sensory input and behavior. In contrast, the respiration is determined by the CO<sub>2</sub> drive during quiet sleep and by reticular firing during ►REM sleep.

### Thermodrive

The only way to elicit breathing movements in the fetal sheep during apnea is by cooling. There are also anecdotal evidences that cooling of the newborn infant, due to evaporation of the amniotic fluid, is an important trigger of the first breaths of air. Increasing the skin temperature of the preterm infant is a well-known factor causing apnea. It has also been assumed that some infants dying of ►SIDS have been too warm, particularly when they sleep in prone position.

### Central and Peripheral Chemoreceptor Drive

►Central chemoreceptors in the brain stem are continuously regulating the breathing through the partial pressure of carbon dioxide (PCO<sub>2</sub>) and pH in the blood. The partial pressure of oxygen (PO<sub>2</sub>) on the other hand, will only stimulate respiration when it reaches hypoxemic levels (PO<sub>2</sub> < 20 mmHg) through the ►peripheral chemoreceptors located in the carotid and aortic bodies. The peripheral receptors are set at a lower PO<sub>2</sub> level in the fetal sheep, probably adapted to the low O<sub>2</sub> in the fetus (Mount Everest in utero). The sensitivity is increased a few days after birth. This has

been tested by the so-called ►Dejours test, i.e. exposing the infants briefly for 100% oxygen. Normally, this results in a ~10% decrease of ventilation corresponding to the hypoxic drive. However, newborn infants do not respond until after a few days of age. Dopamine is probably involved in this process, since dopamine turnover decreases after birth.

### Respiratory Pattern

Maintenance of continuous, regular and effective breathing is dependent on a number of factors: the intricate balance of suprapontine influence on respiratory activity, chemoreceptor activity, neuromodulators, airway patency and stretch receptors in the lungs [1]. The precise integration of these various inputs is of particular importance to the infant [3].

In the neonatal period the breathing pattern is more influenced by respiratory reflexes than during childhood and adulthood. The respiratory reflexes are initiated by stretch receptors in the airways or the chest wall. Breuer and Hering found that inflation of the lung leads to apnea. The ►Hering-Breuer reflex prevents overinflation of the lungs and appears to be more important during the neonatal period than later in life. Pulmonary stretch receptors, present in the smooth muscle of the airways, respond to excessive stretching of the lung during large inspirations. The stretch receptors send action potentials to the apneustic center of the pons, inhibiting the inspiratory neurons present there, allowing expiration to occur. The Hering-Breuer reflex is active within tidal breathing range and increases progressively in strength from FRC to approximately 4 ml/kg above FRC. There is a significant relationship between strength of the reflex and respiratory rate, suggesting that the reflex modifies the breathing pattern in the neonatal period.

### Apnea

Apnea of prematurity represents a major medical concern in the neonatal population [6]. Clinical apnea in infants is defined as a pause in breathing for more than 20 s or a briefer pause if associated with bradycardia. Apneas are more common in preterm than in term infants [4], probably due to brainstem immaturity. The incidence of apnea of prematurity is inversely related to gestational age [7]. However, term infants apparently also have apnea exceeding 20 s, which has been detected by home monitoring.

Apneas can be divided into three different categories; central, obstructive and mixed apneas. Central apnea is defined as a complete cessation of inspiratory effort with no sign of obstruction of the upper airways. In the obstructive apnea, the infant tries to breathe against an obstructed upper airway resulting in chest wall/abdominal motion without nasal airflow. Mixed apnea is a combination of both

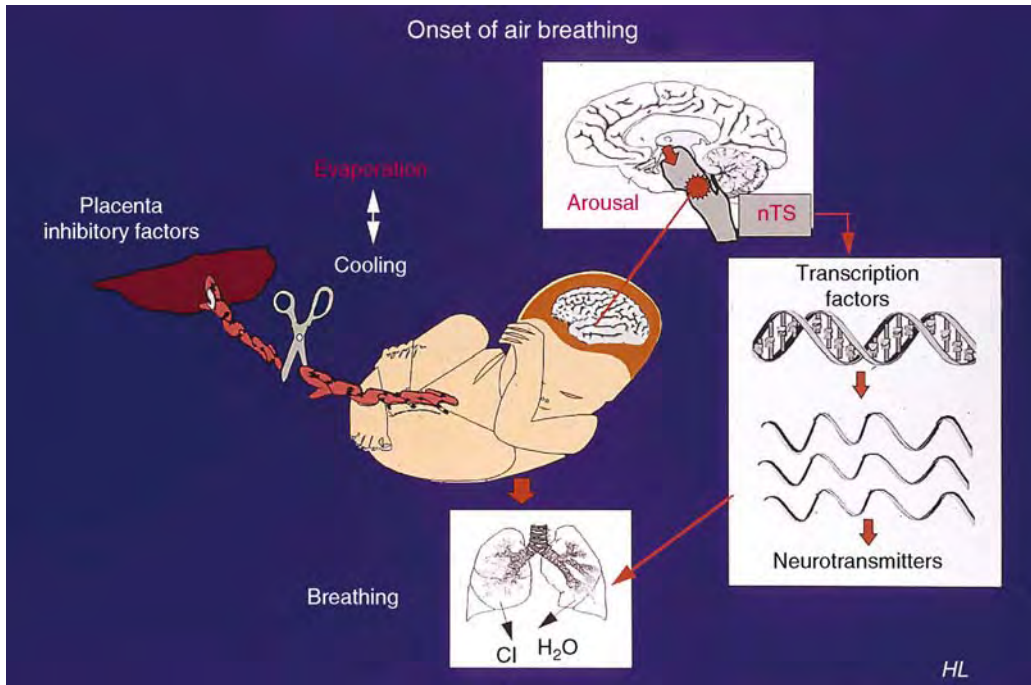

**Development of the Respiratory Network. Figure 2** Mechanisms involved in the initiation of the first breaths of air. Cooling at birth and arousal seem to be more important, than the CO<sub>2</sub> drive. Hypoxia inhibits the breathing of the fetus and the newborn, since the peripheral chemoreceptors are not yet adapted. Immediate early genes and genes encoding for Substance P and other respiratory stimulating neurotransmitters seem to be switched on at birth.

central and obstructive apnea. There is often a central respiratory pause followed by an obstructed respiratory effort.

### Sudden Infant Death Syndrome

Sudden infant death syndrome (SIDS) remains the most prevalent cause of post-neonatal infant mortality in developed countries. SIDS is defined as an abrupt death of an infant less than one year of age that remains unexplained after a thorough clinical history, death scene investigation and postmortem examination. Although the complete picture is yet to be drawn, a number of risk factors can be identified. SIDS is probably the result of an unfortunate combination of a critical time during maturational development, a congenital or acquired vulnerability and an acute stressor. SIDS occurs mainly during the first 6 months of age and the peak is between 2 and 4 months. Fetal exposure to nicotine seems to be the second most important risk factor. Nicotine affects the respiratory and arousal responses to hypoxia. It may also attenuate the ability to auto-resuscitate, possibly due to depleting of the catecholamine stores [8]. Failure of autoresuscitation mechanisms other than failure to initiate gasping may be characteristic of infants dying of SIDS. The most important environmental risk factor seems to

be prone sleeping. By the back-to-sleep campaign the incidence of SIDS has been reduced from about 1 case per 500–1,000 live-born to less than 1/4,000 in many countries [9]. The mechanism has not yet been clarified but it is possible that prone sleeping affects the heat dissipation and CO<sub>2</sub> removal. Another example of an acute stressor is an upper airway infection, which is a primary risk factor for SIDS, possibly mediated by interleukins, which inhibits breathing [10].

Sudden respiratory failure is currently viewed as the most likely cause of death in SIDS. Although sudden deaths in infants resulting from cardiac arrhythmias are well documented, these appear to account for no more than 5–10% of SIDS cases.

### References

1. Von Euler C (1986) Brain stem mechanisms for generation and control of breathing pattern. In: Cherniak NS, Widdicombe JG (eds). Handbook of physiology. The respiratory system, vol 2, Control of breathing. American Physiological Society, Bethesda, MD, pp 1–67
2. Borday C, Abadie V, Chatonnet F, Thoby-Brisson M, Champagnat J, Fortin G (2003) Developmental molecular switches regulating breathing patterns in CNS. *Respir Physiol Neurobiol* 135(2/3):121–132

3. Lagercrantz H, Milerad J, Walker DW (1991) Control of ventilation in the neonate. In: Crystal RG, West JB et al. (eds) *The Lung: scientific foundations*. Raven Press, New York, pp 1711–1722
4. Martin RJ, Abu-Shaweesh JM (2006) Control of breathing and neonatal apnea. *Biol Neonate* 87:288–295
5. Dawes GS (1984) The central control of fetal breathing on skeletal muscle movements. *J Physiol* 346:1–18
6. Rigatto H (2000) Breathing and sleep in preterm infants. In: Loughlin G, Carrol J, Marcus C, Lenfant C (eds) *Pediatric sleep disorders*, vol 147, Dekker, New York, pp 495–523
7. Henderson-Smart DJ, Cohen G (1986) Apnoea in the newborn infant. *Aust Paediatr J* 22(Suppl 1):63–6
8. Cohen G, Roux JC, Grailhe R, Malcolm G, Changeux JP, Lagercrantz H (2005) *Proc Natl Acad Sci USA* 102: 3817–3821
9. Fleming PJ, Gilbert R, Azaz Y, Berry PJ, Rudd PT, Stewart A, Hall E (1990) Interaction between bedding and sleeping position in the sudden infant death syndrome: a population based case-control study. *Br Med J* 301(6743):85–89
10. Hofstetter AO, Saha S, Siljehav V, Jakobsson PJ, Herlenius E (2007) The induced prostaglandin E2 pathway is a key regulator of the respiratory response to infection and hypoxia in neonates. *Proc Natl Acad Sci USA* 104:9894–9899

---

## Development of Thinking

- ▶ Cognitive Development

---

## Developmental Aspects of Pain

- ▶ Development of Nociception

---

## Developmental Cell Death

- ▶ Programmed Cell Death

---

## Developmental Disabilities

- ▶ Developmental Disorders

---

## Developmental Disorders

NORIO SAKAI<sup>1</sup>, MAKOTO SATO<sup>2</sup>

<sup>1</sup>Department of Developmental Medicine (Pediatrics), Osaka University Graduate School of Medicine, Yamadaoka, Suita, Osaka, Japan

<sup>2</sup>Division of Cell Biology and Neuroscience, Department of Morphological and Physiological Sciences, Faculty of Medical Sciences, University of Fukui, Matsuoka-Shimoaizuki, Eiheiji, Fukui, Japan

### Synonyms

Developmental disabilities

### Definition

Developmental Disorders are disorders that happen during infancy, childhood, or adolescence, and are typically accompanied with retarded development. They include psychological or physical disorders. In DSM-IV, the following disorders are listed; i) mental retardation, ii) learning disorders, iii) motor skills disorder, iv) communication disorders, v) pervasive developmental disorders, vi) attention-deficit and disruptive behavior disorders, vii) feeding and eating disorders of infancy or early childhood, viii) tic disorders, ix) elimination disorders, x) other disorders of infancy childhood, or adolescence [1].

### Characteristics

The neurodevelopmental disorders, whose primary causes are attributed to the nervous system, are focused on in this essay. Recently, molecular analyses of these disorders have achieved progress in cloning the causative genes. For example, methyl CpG-binding protein 2 (MeCP2) is responsible for Rett's disorder and SLITRK1 (Slit and Trk-like 1) for Tourette syndrome. DCDC2 (Doublecortin domain-containing 2), ROBO1 and KIAA0319 are likely to be responsible for dyslexia. A comprehensive list of genes useful for defining the diseases based on molecular understanding is not yet available.

In the subsequent chapters, the following neurodevelopmental disorders are discussed; i) mental retardation (MR), ii) learning disorders (LD), iii) pervasive developmental disorders (PDDs), and iv) attention-deficit hyperactivity disorder (AD/HD). In some cases, these disorders overlap with each other, and a single genetic mutation might present different clinical phenotypes in different persons. Some psychiatric diseases, including schizophrenia, whose onsets are considered to occur in the adolescent or adult period, are sometimes categorized into the developmental disorders, since their causes can be traced back into childhood.

Mental retardation (MR) is defined as a significant impairment of cognitive and adaptive function.

Intellectual developmental disorder, mental deficiency, and cognitive impairment are used as similar concepts. Learning disorders (LD) are defined as developmental impairment in a single area of development, such as reading, mathematics, or written expression. Pervasive developmental disorders (PDDs) are a class of neurodevelopmental disorders that emerge in childhood and involve impairments in the development of social reciprocity, communicative functioning, and/or a restricted range of interests and behaviors [2]. Five disorders are included in this category, namely i) Autistic Disorder, ii) Asperger's Disorder, iii) Rett's Disorder, iv) Childhood Disintegrative Disorder, and v) Pervasive Developmental Disorder Not Otherwise Specified (PDD-NOS). Age of onset, natural course, and individual symptom patterns are important for a precise diagnosis. Attention-deficit hyperactivity disorder (AD/HD), one category of attention-deficit and disruptive behavior disorders, results in symptoms of inability to maintain attention, impulsive behaviors and/or motor restlessness.

### Developmental Disorders: Mental Retardation (MR)

MR is diagnosed in individuals who have significantly subaverage intellectual function, existing concurrently with related limitations in two or more of the following applicable adaptive skill areas: communication, self-use, home living, social skills, community use, self-direction, health and safety, functional academics, leisure and work. IQ score is usually defined as lower than 70. It is called mild when IQ is 50–55 to 70, moderate when IQ is 35–40 to 50–55, severe when IQ is 20–25 to 30–40 and profound when IQ is below 20–25. It is subdivided into syndromic and non-specific when associated with distinct dysmorphic, neurological, behavioral or biometric abnormalities and when it is the only abnormality, respectively.

### Prevalence

1–3% of individuals in the general population. Sex ratio (male:female) is 1.5:1.

### Pathology

It is divided into four groups according to whether the causal diagnosis is i) genetic, ii) multifactorial, iii) environmental, or iv) unknown etiology. The most common known cause of MR is genetic etiology, which accounts for roughly 40% of the entire group. In this group, chromosomal abnormalities, including 21 trisomy, 18 trisomy, are the most common, and account for 20% of cases of MR. Other monogenic causes of MR include Fragile X syndrome, which is caused by FMR-1 gene mutations and occurs mainly in men, and Rett's syndrome, which is caused by mutations of the MECP2 gene in females. The latter disease is also classified as one of the PDDs, which are described later.

Hundreds of genetic diseases can cause MR. Among them, X-linked MR (XLMR) is important because it accounts for 10% of all MR. One-third of the estimated 165 genes associated with syndromic MR have been shown to reside on the X chromosome, and one-fourth of the estimated 100 genes causing non-specific MR are mapped on the X chromosome.

Multifactorial reasons have been suspected as causes of malformations of the central nervous system such as hydrocephalus and spina bifida. Drug-induced embryopathy and infection in the uterus are some of the possible environmental causes. Perinatal asphyxia causes 5% of all MR. In our present medical diagnostic situation, the largest part of MR (about 60% of all patients) is of unknown etiology. Two-thirds of them are syndromic and one-third is nonspecific. In the future, this category might be re-classified and include the former three groups.

### Learning Disorders (LD)

Specific ability, such as the mathematics ability, reading ability or writing ability, of individuals suffering from this LD is substantially below their expected potential.

Following the DSM-IV, the diagnostic criteria are as follows [1]

#### Reading Disorder

- A. Reading achievement, as measured by individually administered standardized tests of reading accuracy or comprehension, is substantially below that expected given the person's chronological age, measured intelligence, and age-appropriate education.
- B. The disturbance in Criterion A significantly interferes with academic achievement or activities of daily living that require reading skills.
- C. If a sensory deficit is present, the reading difficulties are in excess of those usually associated with it.

#### Mathematics Disorder

- A. Mathematical ability, as measured by individually administered standardized tests, is substantially below that expected given the person's chronological age, measured intelligence, and age-appropriate education.
- B. The disturbance in Criterion A significantly interferes with academic achievement or activities of daily living that require mathematical ability.
- C. If a sensory deficit is present, the difficulties in mathematical ability are in excess of those usually associated with it.

#### Disorder of Written Expression

- A. Writing skills, as measured by individually administered standardized tests (or functional assessments of writing skills), are substantially below those

expected given the person's chronological age, measured intelligence, and age-appropriate education.

- B. The disturbance in Criterion A significantly interferes with academic achievement or activities of daily living that require the composition of written texts (e.g., writing grammatically correct sentences and organized paragraphs).
- C. If a sensory deficit is present, the difficulties in writing skills are in excess of those usually associated with it.

### **Prevalence**

Approximately 2–10% of children.

### **Pathology**

Several genes have been reported as candidate genes for LD. FOXP2, mapped at 7q31, was mutated or duplicated in several families with speech and language impairment [3]. FOXP2 is a transcription factor containing the forkhead DNA-binding domain and is expressed broadly in the brain.

### **Pervasive Developmental Disorders (PDDs)**

The prevalence of PDDs is about 60 cases per 10,000 children. The largest proportion (~70%) of individuals with PDD have mild disorders—showing high IQ score, such as Asperger's Disorder and PDD-NOS. By contrast, the more severe regressive disorders (Childhood Disintegrative Disorder, Rett's Disorder) represent only about 2% of the cases of PDD.

#### **PDDs: Autistic Disorder**

This disorder is characterized by the following three features:

- (1) Deficits in social relating and reciprocity.
- (2) Impaired language and communication skills.
- (3) Restricted range of interests and activities.

Following the DSM-IV, the diagnostic criteria are as follows [1]

- A. A total of six (or more) items from (1), (2), and (3), with at least two from (1), and one each from (2) and (3): Qualitative impairment in social interaction, as manifested by at least two of the following: (i) marked impairment in the use of multiple nonverbal behaviors such as eye-to-eye gaze, facial expression, body postures, and gestures to regulate social interaction, (ii) failure to develop peer relationships appropriate to developmental level, (iii) a lack of spontaneous seeking to share enjoyment, interests, or achievements with other people (e.g., by a lack of showing, bringing, or pointing out objects of interest), (iv) lack of social or emotional reciprocity.

- (1) Qualitative impairments in communication, as manifested by at least one of the following: (i) delay in, or total lack of, the development of spoken language (not accompanied by an attempt to compensate through alternative modes of communication such as gesture or mime), (ii) in individuals with adequate speech, marked impairment in the ability to initiate or sustain a conversation with others, (iii) stereotyped and repetitive use of language or idiosyncratic language, (iv) lack of varied, spontaneous make-believe play or social imitative play appropriate to developmental level.
  - (2) Restricted repetitive and stereotyped patterns of behavior, interests, and activities, as manifested by at least one of the following: (i) encompassing preoccupation with one or more stereotyped and restricted patterns of interest that is abnormal either in intensity or focus, (ii) apparently inflexible adherence to specific, nonfunctional routines or rituals, (iii) stereotyped and repetitive motor mannerisms (e.g., hand or finger flapping or twisting, or complex whole-body movements), (iv) persistent preoccupation with parts of objects.
- B. Delays or abnormal functioning in at least one of the following areas, with onset prior to age 3 years: (i) social interaction, (ii) language as used in social communication, or (iii) symbolic or imaginative play.
  - C. The disturbance is not better accounted for by Rett's Disorder or Childhood Disintegrative Disorder.

### **Prevalence**

Autistic disorder develops before 36 months of age and is typically diagnosed by 18 months of age. Prevalence is approximately 20–60 per 10,000 births and 4–5 times more common in males than females.

### **Pathology**

Primary responsible region has not been identified, although deficits in the reticular activating system, structural cerebellar changes, forebrain hippocampal lesions, and neuroradiologic abnormalities in the prefrontal and temporal lobe areas, as well as the cingulate cortex, have been documented, and abnormal neurochemical findings have also been shown to be associated with autism, with dopamine, catecholamine, and serotonin levels or pathways implicated. However, the literature on brain structure and function in autistic children is conflicting and there is no diagnostic imaging or other test for autism at present.

The cause of autism is multifactorial [4]. There is a 60–90% concordance rate for monozygotic twins and less than 5% concordance rate for dizygotic twins. Anomalies have been reported in all but three chromosomes. Most promising may be the maternal but

not paternal duplication in chromosome 15q11-q13. Autism sometimes co-occurs with a variety of neurological disorders, such as tuberous sclerosis, phenylketonuria, fragile X syndrome, and neurofibromatosis. Approximately 25% of individuals with autism develop seizure disorders during their lifetime.

In addition, it has been reported that there are several symptoms associated with some patients with this spectrum; multisensory defects, selective dominance of visuospatial functions, high incidence of subthreshold EEG abnormalities, comorbidities with sleep-wake cycle anomalies, frank epilepsy (~15–25%) and MR (~50%) [5].

Individualized educational and behavioral treatments are essential for promoting optimal functioning for persons with autism. Recent research suggests that specialized early intervention (before 3 years old) can be extremely effective in promoting significant gains in social, communicative, and cognitive functioning. The TEACCH (Treatment and Education of Autistic and Communication Handicapped Children) model, which aims to improve the quality of the treatment program and the adaptation of individuals with autism with severe disabilities, was proposed and developed at Division TEACCH, University of North Carolina [6].

Antipsychotics, including haloperidol and risperidone, are the most widely studied drugs for reducing symptoms in children and adolescents with autism. When administered at relatively low dosages, antipsychotics have been shown to reduce repetitive behaviors and social withdrawal, as well as a number of related symptoms, such as hyperactivity, aggression, self-abusive behavior, temper tantrums, lability of mood and irritability [7].

#### **PDDs: Asperger's Disorder**

This disorder is characterized by the following three features:

- 1) Qualitative impairments in social interaction.
- 2) Restricted patterns of behavior or interests.
- 3) Average language and cognitive development.

Following the DSM-IV, the diagnostic criteria are as follows [1]

Qualitative impairment in social interaction, as manifested by at least two of the following: (i) marked impairment in the use of multiple nonverbal behaviors such as eye-to-eye gaze, facial expression, body postures, and gestures to regulate social interaction (ii) failure to develop peer relationships appropriate to developmental level (iii) a lack of spontaneous seeking to share enjoyment, interests, or achievements with other people (e.g., by a lack of showing, bringing, or pointing out objects of interest to other people) (iv) lack of social or emotional reciprocity.

- A. Restricted repetitive and stereotyped patterns of behavior, interests, and activities, as manifested by at least one of the following: (i) encompassing preoccupation with one or more stereotyped and restricted patterns of interest that is abnormal either in intensity or focus (ii) apparently inflexible adherence to specific, nonfunctional routines or rituals (iii) stereotyped and repetitive motor mannerisms (e.g., hand or finger flapping or twisting, or complex whole-body movements) (iv) persistent preoccupation with parts of objects.
- B. The disturbance causes clinically significant impairment in social, occupational, or other important areas of functioning.
- C. There is no clinically significant general delay in language (e.g., single words used by age 2 years, communicative phrases used by age 3 years).
- D. There is no clinically significant delay in cognitive development or in the development of age-appropriate self-help skills, adaptive behavior (other than in social interaction), and curiosity about the environment in childhood.
- E. Criteria are not met for another specific Pervasive Developmental Disorder or Schizophrenia.

#### **Prevalence**

Approximately 8–30 per 10,000 children, but the border between Asperger's disorder and autism is not clear and may cause an error in statistics.

#### **Pathology**

The diagnosis is mainly based on behavioral assessment and developmental history, therefore, it is usually made at least 5 years after birth. Group social skill training is an important therapy, although children with this disorder have a high risk for other psychiatric disorders.

#### **PDDs: Rett's Disorder**

This is a syndrome involving progressive psychomotor deterioration, stereotypic movements of the hands, loss of acquired language and decreased cranial growth. Several diagnostic criteria have been proposed [8].

#### **Pathology**

A gene that encodes the methyl CpG-binding protein 2 (MeCP2) on the X chromosome is the gene responsible for this disorder. Recently a second gene, CDKL5, responsible for the disease was reported.

#### **PDDs: Childhood Disintegrative Disorder**

Also called Heller dementia. Patients develop normally up to 2–4 years, and then exhibit severe deterioration of mental and social function. Language, social skills, and imagination are profoundly affected. Seizures are often present.

### **PDDs: Pervasive Developmental Disorder Not Otherwise Specified (PDDNOS)**

Individuals who have severe impairments in social relating and reciprocity, but who do not meet the diagnostic criteria for any of the other Pervasive Developmental Disorders. In addition to social deficits, patients with PDDNOS must demonstrate either impairments in communication development or restricted, repetitive interests and activities. The diagnosis of PDDNOS is based primarily on behavioral observations and developmental history. Educational and behavioral treatments are essential for promoting optimal functioning for persons with PDDNOS.

#### **Prevalence**

PDDNOS is the most common of the PDDs. Approximately 36 per 10,000 births.

### **Attention-Deficit Hyperactivity Disorder (AD/HD)**

Criteria for AD/HD according to DSM-IV are as follows [1]

#### **A. Either (1) or (2):**

- (1) Inattention: six (or more) of the following symptoms of inattention have persisted for at least six months to a degree that is maladaptive and inconsistent with developmental level: (i) often fails to give close attention to details or makes careless mistakes in schoolwork, work, or other activities. (ii) often has difficulty sustaining attention in tasks or play activities. (iii) often does not seem to listen when spoken to directly. (iv) often does not follow through on instructions and fails to finish school work, chores, or duties in the workplace (not due to oppositional behavior or failure to understand instructions). (v) often has difficulty organizing tasks and activities. (vi) often avoids, dislikes, or is reluctant to engage in tasks that require sustained mental effort (such as schoolwork or homework). (vii) often loses things necessary for tasks or activities (e.g., toys, school assignments, pencils, books, or tools). (viii) is often easily distracted by extraneous stimuli. (i) is often forgetful in daily activities.

- (2) Hyperactivity-impulsivity: six (or more) of the following symptoms of hyperactivity-impulsivity have persisted for at least six months to a degree that is maladaptive and inconsistent with the developmental level.

#### **Hyperactivity**

- (i) often fidgets with hands or feet or squirms in seat.
- (ii) often leaves seat in classroom or in other situations in which remaining seated is expected. (iii) often runs about or climbs excessively in situations in which it is inappropriate (in adolescents or adults, may be

limited to subjective feelings of restlessness). (iv) often has difficulty playing or engaging in leisure activities quietly. (v) is often “on the go” or often acts as if “driven by a motor.” (vi) often talks excessively. Impulsivity (vii) often blurts out answers before questions have been completed. (vii) often has difficulty awaiting turn. (i) often interrupts or intrudes on others (e.g., butts into conversations or games).

- B. Some hyperactive-impulsive or inattentive symptoms that caused impairment were present before age 7 years.
- C. Some impairment from the symptoms is present in two or more settings (e.g., at school [or work] and at home).
- D. There must be clear evidence of clinically significant impairment in social, academic, or occupational functioning.
- E. The symptoms do not occur exclusively during the course of a Pervasive Developmental Disorder, Schizophrenia, or other Psychotic Disorder and are not better accounted for by another mental disorder (e.g., Mood Disorder, Anxiety Disorder, Dissociative Disorders, or a Personality Disorder).

#### **Prevalence**

5–8% of children.

#### **Pathology**

Twin studies suggested substantial genetic influences ranging from 60 to 90%, and non-shared environmental influences ranging from 10 to 40% [9]. This disorder is also considered to be a polygenic trait. From clinical observations of drug effects, this disorder was proposed to result from dysregulation of dopamine and norepinephrine circuits. Based on association and linkage studies, a relationship with *DAT1* (the dopamine transporter gene), *DRD3* and *DRD4* (the dopamine receptor *D3* and *D4* genes), alpha 2A adrenergic receptor (*ADRA2A*), *HTR1β* (the serotonin 1β receptor gene), etc., was proposed; however, the strength of the relationship is not so evident at present.

Several drugs were tried historically, including stimulant drugs such as methylphenidate, as reviewed by Biederman and Faraone (2005) [10].

### **References**

1. DSM-IV (Diagnostic and statistical manual of mental disorders), 4th edn. American Psychiatric Association Washington D.C
2. Stone WL, Hepburn SL. Pervasive developmental disorders. Available at, ► [http://www.autismcolorado.org/wd\\_docs/autismguide/ascguide\\_pdd.doc](http://www.autismcolorado.org/wd_docs/autismguide/ascguide_pdd.doc)
3. Fisher SE (2005) On genes, speech, and language. *N Engl J Med* 353(16):1655–1657

4. Santangelo SL, Tsatsanis K (2005) What is known about autism: genes, brain, and behavior. *Am J Pharmacogenomics* 5(2):71–92
5. Levitt P (2005) Developmental neurobiology and clinical disorders: Lost in translation? *Neuron* 46:407–412
6. Van Bourgondien ME, Reichle NC, Schopler E (2003) Effects of a model treatment approach on adults with autism. *J Autism Dev Disord* 33(2):131–140
7. Malone RP, Gratz SS, Delaney MA, Hyman SB (2005) Advances in drug treatments for children and adolescents with autism and other pervasive developmental disorders. *CNS Drugs* 19(11):923–934
8. Hagberg B, Hanefeld F, Percy A, Skjeldal O (2002) An update on clinically applicable diagnostic criteria in Rett syndrome. Comments to Rett syndrome clinical criteria consensus panel satellite to European Paediatric Neurology Society Meeting, Baden Baden, Germany, 11 September 2001. *Eur J Paediatr Neurol* 6:293–297
9. Waldman ID, Gizer IR (2006) The genetics of attention deficit hyperactivity disorder. *Clin Psychol Rev* 26(4):396–432
10. Biederman J, Faraone SV (2005) Attention-deficit hyperactivity disorder. *LANCET* 366(9481):237–248

## Developmental Plasticity

### Definition

Neuronal plasticity accompanying developmental processes (to be distinguished from learning-induced and compensatory plasticity).

## Developmental Regulatory Genes

### Definition

Genes encoding transcription factors or signaling proteins that are expressed during development in specific spatiotemporal patterns and, by regulating the expression of other genes, control patterning and morphogenesis of specific body parts. In the brain, these genes are involved in patterning, specification, proliferation and/or differentiation processes. These regulatory genes act in cascades and networks that ultimately lead to a specific fate of the cells and tissue where they are expressed or where they act. The function of many of these genes has been inferred by experiments or mutations causing “lack of function” or “gain of function” of specific key genes (for example, in knockout or null mutant mice; or by morpholino injection or antisense electroporation in embryos).

► Evolution and Embryological Development of the Forebrain

## Deviation-detecting Neurons

### Definition

Neurons that are able to detect by their activity the deviation of an animal’s path from a fixation or reference point.

## Dexamethasone Suppression Test

### Definition

Clinical test interfering with HPA-axis feedback regulation; designed to diagnose and differentiate among the various types of Cushing’s syndrome and other hypercortisolaemic states like depression.

► Hypothalamo-Pituitary-Adrenal Axis, Stress and Depression

## Dexamethasone Suppression Test

### Definition

Designed to diagnose and differentiate among the various types of Cushing’s syndrome and other hypercortisolaemic states.

► Neuroendocrinology of Psychiatric Disorders

## Dexterity

► Coordination

## DGC Dystrophin Glycoprotein Complex

### Definition

Junction between the cytoskeleton (dystrophin) and the extracellular matrix (laminin) that involves members of the dystroglycan and sarcoglycan family as transmembrane components.

► Sarcomere Structural Proteins



## Dhh

### Definition

Dhh belongs to the Sonic hedgehog family of signaling molecules. It is expressed by Schwann cells and has an important role in controlling the formation of the perineurium and epineurium around peripheral nerves.

- ▶ Schwann Cells in Nerve Regeneration

## Diabetes Insipidus (DI)

### Definition

Diabetes insipidus (DI) is a disorder in which secretion of antidiuretic hormone (ADH) is impaired or absent (central DI), or kidney ADH receptors fail to respond normally to circulating ADH (nephrogenic DI). In both central and nephrogenic DI, patients present with polyuria and polydipsia. If allowed to progress unchecked, the disorder can result in marked hypernatremia, hypotension, and shock.

- ▶ Blood Volume Regulation
- ▶ Endocrine Disorders of Development and Growth
- ▶ Neuroendocrinology of Tumors

## Diabetes Mellitus

### Definition

Type I diabetes (insulin-dependent diabetes or juvenile diabetes) usually begins in childhood. It is caused by damage to the pancreas, which leads to insulin deficiency. Patients need to receive insulin throughout their lives. Type II diabetes usually starts later in life. It arises because the body is resistant to the insulin it makes. Treatment is aimed at stimulating the pancreas to produce more insulin and increase the other organ's sensitivity to insulin.

## Diacylglycerol (DAG)

### Definition

One of the enzymatic (e.g. phospholipase C) hydrolysis products of membrane phosphoinositides. One role for DAG as a second messenger is the activation of protein kinase C (PKC).

## Diagonal Band of Broca

### Definition

The magnocellular basal forebrain nuclei both contain the substantia innominata and the medial part of the horizontal limb of the diagonal band of Broca. Like other forebrain cortical structures, the main olfactory bulb receives strong cholinergic inputs from the horizontal limb of the diagonal band of Broca since the bulb itself is virtually devoid of intrinsic cholinergic neurons.

- ▶ Acetylcholine
- ▶ Neuromodulation in the Main Olfactory Bulb
- ▶ Olfactory Bulb

## Diaphragm

### Definition

Most powerful inspiratory muscle. Contraction of the diaphragm causes an upward and outward movement of the rib.

## Diapsida

### Definition

Clade incorporating those reptiles in which the postorbital region of the skull on each side contains two (upper and lower) openings (fenestrae), or a skull morphology derived from this condition. Living diapsids include lizards, crocodiles, snakes, birds and Sphenodon.

- ▶ Evolution of the Brain: At the Reptile-Bird Transition
- ▶ The Phylogeny and Evolution of Amniotes

## Diarthrodial Joint

### Definition

A joint encased in a ligamentous capsule including an articular cavity. The capsule is lined with a synovial

membrane that secretes synovial fluid into the cavity for lubricating the joint. The articular surfaces are smooth and covered with cartilage.

- ▶ Measurement Techniques (Pressure)

## Dichoptic Rivalry

- ▶ Binocular Rivalry

## Dichotomous Branching Tree

One in which only two branches may occur from any one node

- ▶ The Phylogeny and Evolution of Amniotes

## Dichromacy

### Definition

Type of color vision based on comparison of activity in two cone photoreceptor mechanisms (Photoreceptors). Human dichromats are sometimes referred to as “color blind,” but true color blindness (monochromacy) is very rare. Most human dichromats can make discriminations along the blue-yellow color dimension but fail to distinguish red from green objects, hence the common description “red-green color blind”.

- ▶ Color Processing
- ▶ Evolution of the Visual System in Mammals – Color Vision and the Function of Parallel Visual Pathways in Primates
- ▶ Evolution of the Visual System in Mammals – Comparative Evolutionary Aspects across Orders
- ▶ Photoreceptors
- ▶ Retinal Color Vision in Primates

## Diencephalic Syndrome

### Definition

Optic pathway glioma with emaciation in children.

- ▶ Neuroendocrinology of Eating Disorders
- ▶ Neuroendocrinology of Tumors

## Diencephalon

### Definition

The highest part of the brainstem, contains the tissue surrounding the third ventricle. To it belong the hypothalamus and the dorsal thalamic regions contiguous with the hypothalamus. Autonomic centers (hormone center) for regulating metabolism, heat and water balance, blood pressure and sweat secretion are encountered here as well as in the thalamic nuclear regions of the extrapyramidal system (e.g. globus pallidus).

- ▶ Evolution and Embryological Development of the Forebrain

## Difference Tones

### Definition

Tonal components at the output of a nonlinear system with frequencies equal to differences of the frequencies of the input tonal components.

- ▶ Acoustics

## Differentiable Manifold

### Definition

The mathematical counterpart of the physical notion of a continuum. Its properties are studied in the mathematical discipline known as differential geometry.

- ▶ Mechanics

## Differential Equation

### Definition

An equation containing differentials of a function or a variable.

- ▶ Signals and Systems

## Differential Threshold in Acoustics

### Definition

This refers to the smallest change in the stimulus (e.g. its frequency, intensity, duration, etc.) that a listener can reliably discriminate, and is sometimes referred to as the just-noticeable-difference or jnd.

- ▶ Psychoacoustics

## Diffraction

### Definition

A diffracted wave is one whose wave front has been changed in direction by an obstacle other than by reflection.

- ▶ Acoustics

## Diffuse Noxious Inhibitory Controls (DNIC)

### Definition

Counter-irritation technique whereby one concurrently applied noxious stimulus inhibits the perception of a second painful stimulus. This phenomenon is thought to reflect descending inhibition of pain signals. DNIC is presumed to operate through activation of descending supraspinal inhibitory pathways initiated by release of endogenous opioids.

- ▶ Descending Modulation of Nociception
- ▶ Gender/sex Differences in Pain

## Diffusion Equation

### Definition

A partial differential equation that describes the variation of the probability of finding a Brownian particle in a given region over time.

- ▶ Brownian Motions

## Digital Lamellated Corpuscle

- ▶ Meissner Corpuscle Regeneration

## Dim Light Melatonin Onset (DLMO)

### Definition

DLMO is the dim light melatonin onset. A common research tool and potential clinical test, plasma or saliva is collected usually every 30 min between about 6 p.m. and bedtime under conditions of dim light (<10–30 lux). The DLMO is commonly defined as the time when melatonin levels continuously rise above a threshold of 10 pg/ml in plasma (DMLO10) or 3 pg/ml in saliva (DMLO3). The DLMO designates circadian time (CT) 14. For low secretors, the DLMO2 and DLMO0.7 are used for plasma and saliva, respectively, and designated CT 13.

- ▶ Circadian Sleep Phase Syndromes

## Dim Red Light

### Definition

Lighting condition commonly used in circadian biology consisting of very low intensity of red light (620–750 nm wavelength), similar to the conditions found in dark rooms for photography. Dim red light is used in rooms where circadian experiments are conducted to allow

experimenters to perform maintenance, manipulations, or observations without affecting the circadian behavior of their subjects under study.

► Arrhythmicity/Rhythmicity

## Diplopia

### Definition

Double vision resulting from a misalignment of the eyes.

## Direct Inverse Learning

### Definition

An approach for training an inverse model based on random activation of the plant.

► Neural Networks for Control

## Direct Linear Transformation

### Definition

Camera calibration procedure for image-based motion analysis in which camera parameters are determined from the known locations of control points.

► Motion Analysis

## Direct Perception

### Definition

Direct realism is a theory of perception that claims that the senses provide us with direct awareness of the external world. The alternatives, indirect realism and

representationalism, claim that we are directly aware only of internal representations of the external world.

► Visual Illusions

## Direction of Attention

### Definition

Once attention has been disengaged from a location attention can move to another location. The movement and direction of attention is thought to be controlled by the superior colliculus. Spatial cues can direct attention from one location to another.

► Attention  
► Tactile Attention  
► Visual Attention

## Direction of Vestibular Stimulation

### Definition

This term indicates the direction of head linear or rotational movements employed in order to activate labyrinthine receptors. In order to define the direction of stimulation of a rotatory stimulus, it is necessary to identify the plane of rotation.

► Vestibulo-Spinal Reflexes

## Direction Processing of Visual Image Motion

### Definition

The extraction of information about the direction of two-dimensional image motion from the responses of a population of elementary motion detectors each sensitive to a particular axis of motion.

► Visual Motion Processing

## Direction-selective Ganglion Cell

### Definition

Retinal ganglion cell that fires vigorously to image motion across its receptive field in one direction (“preferred”), but stays silent for image motion in the opposite direction (“null”).

- ▶ Retinal Direction Selectivity and Starburst Amacrine Cells
- ▶ Retinal Ganglion Cells

## Direction Selectivity for Visual Image Motion

### Definition

The ability to detect and signal the direction of image motion.

- ▶ Retinal Direction Selectivity and Starburst Amacrine Cells

## Directional Burst Neurons

### Definition

Directional burst neurons discharge a burst of spikes for all saccadic eye movements into a particular hemifield (e.g., ipsilateral) with increasing discharge magnitude as saccade size increases. They fire little or not at all in the opposite direction, and don’t fire during fixations between saccades. Excitatory burst neurons typify this class of burst neurons.

- ▶ Burst Cells in Eye Movement
- ▶ Excitatory Burst Neurons (EBNs)
- ▶ Saccade, Saccadic Eye Movement

## Directional Hypokinesia (DH)

- ▶ Visual Space Representation for Reaching

## Directional Tuning

### Definition

A relation between a directional variable and the firing rate of a neuron tuned to that variable. For example, in many cortical areas involved in the control of reaching movements, the firing rate is maximal in one direction (preferred direction) and decays as the cosine of the angle between the movement direction and that direction.

- ▶ Reaching Movements

## Discharge

- ▶ Action Potential

## Disconnection Syndromes

### Definition

Disconnection syndromes result from damage to neural systems connecting different ▶ **cerebro-cortical** regions. A classical example is ▶ **conduction aphasia** supposed to result from interruption of the connection between ▶ **Wernicke’s** (sensory) language area and ▶ **Broca’s** (motor) language area via the ▶ **arcuate fasciculus**. This may be due to isolated lesions to sub-cortical fiber systems, but cortical gray matter is often damaged as well. Other syndromes result from damage or surgical lesions to the ▶ **corpus callosum** connecting the hemispheres, which - depending on the extent and location of the lesion – leads to various dysfunctions.

- ▶ Broca’s Area
- ▶ Wernicke’s Area

## Discrete Fourier Transform (DFT)

### Definition

A transformation of a discrete signal to the frequency domain. The fast algorithm used to compute this

transform is the Fast Fourier Transform (FFT). Similarly, the inverse DFT transforms the signal back to its original domain.

### ► Signals and Systems

## Discrimination

SHIGERU WATANABE

Department of Psychology, Keio University, Mita, Minato-Ku, Tokyo, Japan

### Definition

Discrimination refers to any difference in responding in the presence of different stimuli. Discrimination is learned through experience. Discrimination can be trained with either respondent or operant ► [conditioning](#).

### Characteristics

In respondent conditioning (classical conditioning or Pavlovian conditioning), a *conditioned stimulus* (CS) is paired with an *unconditioned stimulus* (UCS), which elicits behavior called the respondent or *unconditioned response* (UR). In respondent conditioning, the CS begins to elicit the respondent, now called the *conditioned response* (CR), without the UCS. The classic example is Pavlov's dog experiment, where a tone (CS) was paired with food (UCS) eliciting a salivary response (UR). After a certain amount of experience with the tone (CS) and food (UCS) being presented about the same time, the tone (CS) on its own made the dog drool (CR) without any food (UCS) being present. When one conditioned stimulus (CS+) is followed by the UCS but the other (CS-) is not, only the CS+ comes to elicit the CR. This is discrimination of respondent conditioning, which is also called *differentiation*. Because respondent conditioning involves the association of stimuli, theories about respondent conditioning are called *associative learning theories* [1]. When compound stimuli (CS1 + CS2) are conditioned after conditioning with CS1 alone, CS2 elicits a weak CR. This phenomenon is called *blocking*. Presentation of the CS alone without pairing with the UCS retards later conditioning with this CS. This phenomenon is called *latent inhibition*.

In operant conditioning (or instrumental conditioning), the outcome that immediately follows the behavioral response (the *operant*) modifies the operant. A typical operant chamber for a rat is a small box equipped with lever(s) and a food pellet dispenser. When the rat presses the lever, the dispenser provides a food pellet. As a result, the hungry rat learns to emit the lever-press behavior

(operant) to get the food (reinforcement). Discrimination or *stimulus control* training involves at least two stimuli as discriminative stimuli in operant conditioning. Responses to one of the stimuli are reinforced, while responses to the other are not reinforced, or extinguished. Two kinds of reinforcements are possible. When *positive reinforcement* immediately follows the response, the frequency of that response increases. An example of positive reinforcement is giving food after a lever press in an operant chamber. Removal of *negative reinforcement* immediately after the response increases the frequency of that response. An example of negative reinforcement is *escape* and *avoidance* of electric shock. Another type of training for discrimination involves *punishment*. Removal of a positive reinforcer after the response or presentation of a negative reinforcer after the response is punishment. *Passive avoidance*, where a rat receives an electric shock when it steps down to the floor from a platform, is a type of punishment. The rate of responding is decreased by punishment. Usually *partial reinforcement* is employed in operant conditioning to maintain responding rate. Responses are not continuously reinforced, but instead are reinforced depending on the time interval or rate of responding. Thus, only some correct responses would be reinforced, depending on the time or number of responses that had elapsed.

During the acquisition of the discrimination, the animal emits more responses to positive stimuli (S+) and fewer responses to negative stimuli (S-). The S+ and S- may be presented simultaneously (*simultaneous discrimination*) or successively (*successive discrimination*). Usually, the experimenter defines the criterion for the discrimination based on the relative responses to S+ and S- (see Fig. 1 left panel). Because the presence or absence of reinforcement gives information about positive and negative stimuli, discrimination is tested using an extinction procedure in which no reinforcement is available even for S+. An animal would continue to respond to S+ for a while even in this condition without reinforcement if it had learned the discrimination. This procedure is called *resistance to extinction*. Giving reinforcement to any response is another method that does not provide information about the discriminative stimuli. Responses to S- are reinforced in this condition, but the animal should emit fewer responses to S- if it had learned the discrimination. This procedure is called *resistance to reinforcement*.

*Animal psychophysics* is an applied area of operant discrimination [2]. Animals are first reinforced for responses to a certain brightness of light. For example, to measure the visual threshold, animals press a lever to answer "see" or another lever to answer "not see" and the brightness of the visual stimulus decreases or increases depending on the response of the animals. To assess

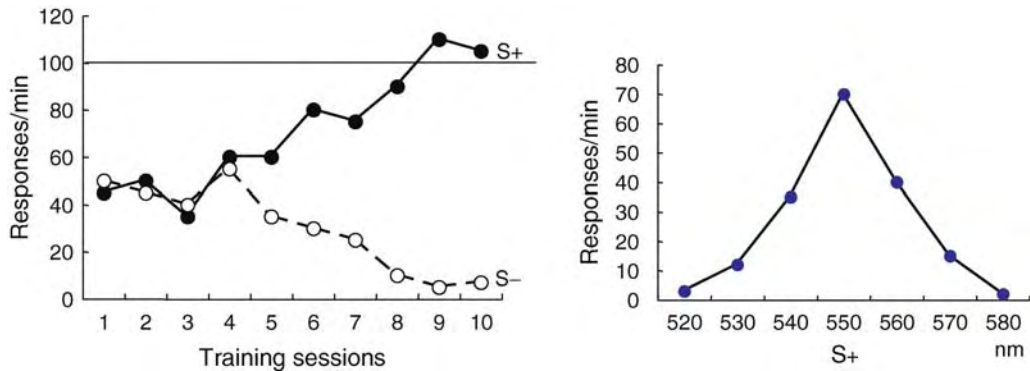

**Discrimination. Figure 1** Imaginary successive discriminative learning curve (*left*) and generalization gradient (*right*). During discrimination training animal gradually emitted more responses to S+ but less responses to S-. The training continues until the criterion of discrimination. After the training, animal emits response not only to S+ (550 nm) but also stimuli around the S+. Peak of response moves to direction away from S- when the S+ and S- are on the same stimulus dimension.

effects of drugs or brain lesions, it is useful to apply a signal detection theory (SDT) in which the sensory factor ( $d'$ ) is singled out from other factors.

Animals tend to respond not only to S+ but also to stimuli that are similar to S+. For example, a pigeon trained to peck a key illuminated by a 550 nm wavelength will usually peck at 560 or 540 nm also (see Fig. 1 right panel). This spread of the effect of discrimination training is called ►**generalization**. The rate of responding has a peak and a slope called the *generalization gradient*. The shape of gradients depends on the training procedures and the stimuli. The peak of responding usually moves from S+ in the direction away from S- along the stimulus dimension. This phenomenon is called a *peak shift*. The summation of the excitatory generalization gradients for S+ and the inhibitory generalization gradients for S- predicts the peak shift.

If redundant stimuli are involved in the discrimination training, for example discrimination between green-triangle vs. red-circle, then animals can learn this discrimination based on the color difference but also the difference in shape. Sometimes animals learn only one aspect, for example, color. This selective learning is an example of *attention* in animals [3]. The salience of the stimuli, predictability of reinforcement, and history of past discrimination influences the attention.

When animal was trained to choose a larger circle of two circles, and tested with the large circle and a new circle larger than the first one, it chooses the new larger circle. This phenomenon is called *transposition*. The transposition is discrimination based in relationship of two stimuli rather than absolute value of the stimuli.

When multiple exemplars are presented during discrimination training, animals can learn a category or ►**concept**. Using many different photographs, Herrnstein and Loveland [4] successfully trained pigeons to discriminate photographs with humans from

those without humans. The pigeons accurately discriminated photographs that had never been shown during the discriminative training. Pigeons have even learned to discriminate pictures by Monet from Picasso [5]. *Category discrimination* or *concept discrimination* indicates generalization within a category and discrimination between categories. Animals appear to have human-like visual concepts but the mechanism of concept formation may be different. People can use verbal descriptions to define or categorize a “triangle,” but pigeons learn the “concept of triangle” through discriminative training in which one type of shape is associated with reinforcement but the others are not (Fig. 2).

*Conditional discrimination* is discrimination based on an ‘IF–THEN’ structure. For example, there are two keys in an operant chamber and only a peck on the S+ key produces reinforcement. The conditional discrimination rule is: if the color is red, then the left key is S+; if the color is green, then the right key is S+. One application of conditional discrimination is *drug discrimination* in the field of behavioral pharmacology. A rat obtains reinforcement by pressing a left lever after injection of a drug but obtains reinforcement by pressing a right lever after injection of a vehicle. The rat learns this left-right conditional discrimination if the drug-induced internal state has a discriminative stimulus property. ►**Matching to sample** discrimination (MTS) is a kind of conditional discrimination. For example, a sample stimulus appears on the center key of three keys in an operant chamber, then two different choice stimuli appear on side keys. The animal has to choose the stimulus that is the same as the sample stimulus. In *matching-to-oddity discrimination* (MTO), animal has to choose the stimulus different from the sample stimulus. *Delayed matching to sample* (DMTS) uses a darkened delay period between the presentation of the sample stimulus and the choice stimuli, which

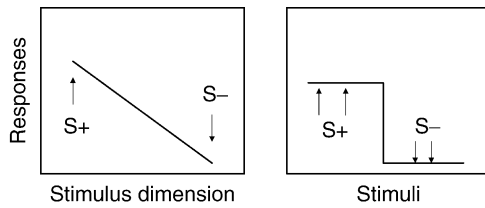

**Discrimination.** **Figure 2** Generalization and categorization. Generalization along one stimulus dimension shows a gradient. In concept or category discrimination, animal emits response to every stimulus belonging to one category but not to stimuli belonging to other category.

requires short-term memory. A more complicated discrimination is arbitrary or *symbolic matching to sample* training. The animal has to choose a particular stimulus after the presentation of one sample stimulus. For example, choose a triangle when the sample is red. This training can be considered as A- > B discrimination training. After learning the discriminations of A- > B and B- > C, human infants easily understand A- > C (*transitivity*) and C- > A (*stimulus equivalence*). This stimulus equivalence relationship is difficult for infrahuman animals to learn [6]. One exceptional result was obtained with sea lions [7]. Shusterman argued that the mother-infant bond among sea lions consists of different kinds of sensory stimuli, visual, auditory and olfactory cues, and that these experiences result in the learning of stimulus equivalence.

The relationship between S+ and S- is reversed after acquisition in *reversal discrimination* learning. In a *reversal ▶ learning set* paradigm, the reversal procedure is repeated until subjects show a steady number of trials to reach the criterion for each reversal. In the *learning set* paradigm, new stimuli are used in each simultaneous discrimination task. Performance in later tasks improves over successive tasks. Animals learn *how to learn* in these learning set paradigms. Because one of two stimuli is correct one, animal can choose correct stimulus in the second trial even if it failed in the first trial. In that case, performance in the second trial is expected more than 50%. Performance in the second trial and shape of learning curve of learning set show species difference.

## References

1. Rescolra RA, Wagner AR (1972) A theory of Pavlovian conditioning: variation in the effectiveness of reinforcement and non-reinforcement. In: Black H, Prokasy WF (eds) Classical conditioning II: current research and theory. Appleton-Century-Crofts, New York, pp 64–99
2. Stebbins WC (ed) (1970) Animal psychophysics: the design and conduct of sensory experiment. Appleton-Century-Crofts, New York
3. Reynolds GS (1961) Attention in the pigeon. J Exp Anal Behav 4:203–208

4. Herrnstein RJ, Loveland DH (1964) Complex visual concept in the pigeon. Science 146:549–551
5. Watanabe S, Wakita M, Sakamoto J (1995) Pigeons' discrimination of paintings by Monet and Picasso. J Exp Anal Behav 63:165–174
6. Sidman M (1994) Equivalence relation and behavior: a research story. Authors Cooperative, Boston
7. Schusterman RJ, Kastak D (1993) A California sea lion (*Zalophus californianus*) is capable of forming equivalence relations. Psychol Rec 43:823–839

## Disc-Shaped Cells

### Definition

The main neuron type in the central nucleus of the inferior colliculus.

▶ Inferior Colliculus

## Disease Markers

### Definition

Immunological markers associated with primary Sjögren's Syndrome (pSS) disease processes (e.g., high levels of anti-nuclear antibodies or rheumatoid factor), or markers of tissue damage or loss on central nervous system (CNS) images.

▶ Central Nervous System Disease in Primary Sjögren's Syndrome

## Disguising

▶ Masking (Positive/Negative)

## Dishabituation

### Definition

A quick restoration of a habituated response by applying a sensitizing stimulus.

▶ Learning



## Disjunction Problem

### Definition

Any crude causal account of meaning and content (which says that R means X, because it is X's which cause R's) faces this problem: If R's are also sometimes caused by Y's (=X's), then why does R mean X, and does not have the disjunctive content X-or-Y?

- ▶ Representation (Mental)

## Disjunctive Eye Movements

### Definition

Convergent and divergent eye movements.

- ▶ Divergence Neurons
- ▶ Vergence

## Disorders of the Labyrinth

- ▶ Disorders of the Vestibular Periphery

## Disorders of the Vestibular Periphery

LLOYD B. MINOR

Department of Otolaryngology – Head and Neck Surgery, The Johns Hopkins University School of Medicine, Baltimore, MD, USA

### Synonyms

Disorders of the labyrinth; Vestibular disorders; Inner ear disorder

### Definition

Disorders that cause abnormalities in the function of the labyrinth produce characteristic symptoms and signs that are dependent upon the endorgan(s) affected by the disorder and the effects of the pathology on the function of the labyrinth.

### Characteristics

▶ **Vertigo** (an illusion of motion) is a hallmark symptom that occurs as a consequence of many vestibular disorders. Vertigo can involve a sensation that objects are moving in the external environment or an illusion that the person is moving with respect to a stationary environment. Disorders affecting the semicircular canals often lead to rotatory vertigo with a spinning sensation whereas disorders affecting the otolith organs may cause a sensation of being tilted or pulled to one side. The vertigo associated with vestibular disorders is typically episodic with the duration and character of the episodes providing valuable insight into the nature of the disorder.

The history, clinical examination and results of specific laboratory tests as well as imaging studies can provide important information with regard to the diagnosis of the underlying disorder of the labyrinth. Information from the history often provides the most valuable insight into the etiology of the symptoms. The characteristics of the symptoms and in particular the duration of the episodes of vertigo provide a basis for classification of disorders of the labyrinth.

### Physiological Principles Underlying the Identification of Disorders of the Vestibular Periphery

Two fundamental principles of vestibular physiology provide the basis for understanding many of symptoms and findings on clinical examination that are associated with specific vestibular disorders. These principles pertain to the functional organization of the vestibulo-ocular reflex and were elucidated by Ewald more than a century ago [1]. Ewald's first law asserts that the eye moves in the plane of the semicircular canal that is affected by the stimulus. Thus, a pathological process affecting only the posterior semicircular canal will lead to an eye movement in the plane of that canal.

Ewald's second law asserts that although the vestibular system is a "push-pull" system, excitatory responses are encoded over a broader range of angular head movements than are inhibitory responses. When the head is moved to the right for example, there is an increase in the firing rate of afferent nerve fibers innervating the right horizontal semicircular canal and a decrease in the firing rate of afferents innervating the left horizontal canal. If these excitatory and inhibitory responses were reciprocal and symmetric, then there should be no consequence in terms of the function of angular vestibulo-ocular reflexes (VORs) associated with loss of function in one labyrinth. Many lines of evidence indicate that this is not the case.

### Unilateral Vestibular Hypofunction

Loss of function in one labyrinth leads to an enduring asymmetry in the vestibulo-ocular responses to rapid head movements. A rapid head movement resulting in excitation of semicircular canals on the intact side

evokes a relatively normal VOR. A diminished VOR is noted for rapid head movements that would, if vestibular function were intact, result in excitation of semicircular canal afferents on the side of the deficit. Such head movements in the case of unilateral vestibular hypofunction are encoded primarily by a reduction in firing rate (inhibition) of semicircular canal afferents on the intact side because there is little or no response of afferents on the side of the deficit. The consequence is a VOR that is not compensatory for the head movement. A rapid, resetting eye movement is required to bring the gaze back onto the target of interest. This diminished VOR with subsequent resetting rapid eye movement provides the basis for the head thrust (or head impulse) sign that is a characteristic finding in vestibular hypofunction [2].

► **Nystagmus** is a type of abnormal eye movement that often occurs in vestibular disorders. The jerk nystagmus that occurs in association with vestibular disorders involves a rapid, to-and-fro movement of the eyes with slow and fast components. The slow component of nystagmus reflects the underlying asymmetry in resting activity in vestibular-nerve afferents between the two labyrinths, whereas the fast component occurs because the limited range of motion of the eye necessitates a resetting of eye position towards the center of the oculomotor range. For example, sustained excitation of the right horizontal canal will lead to a nystagmus with slow phase components directed to the left and fast phase components bringing the eye back to the right.

### **Bilateral Vestibular Hypofunction**

Bilateral loss of vestibular function leads to oscillopsia (the apparent motion of objects that are known to be stationary) with head movements, as well as to disturbances of gait in varying severity. It is most commonly induced by the vestibulotoxic effects of aminoglycoside medications. It has been estimated that 3% of patients receiving systemic gentamicin for treatment of an infection develop some form of vestibular injury. The diagnosis is most often made after patients note gait ataxia when trying to return to normal activity after leaving the hospital. The ototoxicity from gentamicin can develop after only a single dose of the medication and vestibular toxicity can occur without damage to hearing.

Other causes of bilateral vestibular loss include degenerative diseases of the cerebellum, meningitis, systemic autoimmune diseases, trauma and bilateral ► **Ménière's disease**. No underlying cause is identified in about 20% of cases.

### **Benign Paroxysmal Positional Vertigo**

► **Benign paroxysmal positional vertigo (BPPV)** is probably the most common vestibular disorder. It has

been estimated that about 50% of people over the age of 70 will experience at least one episode of BPPV. The disorder is sometimes referred to as benign paroxysmal positioning vertigo because the symptoms and signs are brought on by changes in head position rather than by a sustained positional effect. The disorder occurs because otoconia (calcium carbonate crystals that are normally embedded in the otoconial membrane) become dislodged and pass through the endolymphatic space of the vestibule and into one of the semicircular canals. Causes of the release of otoconia include head trauma and the effects of aging. Once free floating in the endolymph, the most common location for the otoconia crystals to collect is the posterior semicircular canal, probably because this canal occupies the most dependent location in the labyrinth. Movement of these crystals within the posterior canal which occurs as a consequence of head movement (particularly head movement in the plane of the affected semicircular canal) results in the symptoms and signs which are characteristic of BPPV.

The pathognomic sign of posterior canal BPPV is a nystagmus in the plane of the affected posterior canal that is brought about by a positioning maneuver in the plane of that canal. Fig. 1 shows the sequence of head movements that evokes the characteristic symptoms and signs in a patient with right posterior canal BPPV.

The vertigo and nystagmus in posterior canal BPPV typically begin after a latency of 10–20 s following the head movement and subside over the course of about 30–60 s. The symptoms can be quite intense during this period of time. The treatment of posterior canal BPPV typically involves a repositioning maneuver as described by Epley [4] in which the head is rotated through the plane of the posterior canal in a manner that results in the otoconia crystals leaving the posterior canal and returning to the vestibule (Fig. 2). Note that the initial two head positions in the Epley maneuver are identical to the Dix-Hallpike maneuver.

### **Vestibular Neuritis**

► **Vestibular neuritis** is the second most common disorder affecting the labyrinth. It is thought to have a viral etiology with consequent inflammation of the vestibular nerve [5]. Selective damage to structures of the labyrinth innervated by the superior division of the vestibular nerve (horizontal canal, superior canal and utriculus) with preservation of endorgans innervated by the inferior division (posterior canal and sacculus) is common. Inflammation that is selective for the superior division of the vestibular nerve and anatomical differences in the course through bone of individual divisions of the vestibular nerve have been proposed as explanations for these differences in vulnerability.

Patients with vestibular neuritis typically experience the sudden onset of severe rotatory vertigo often

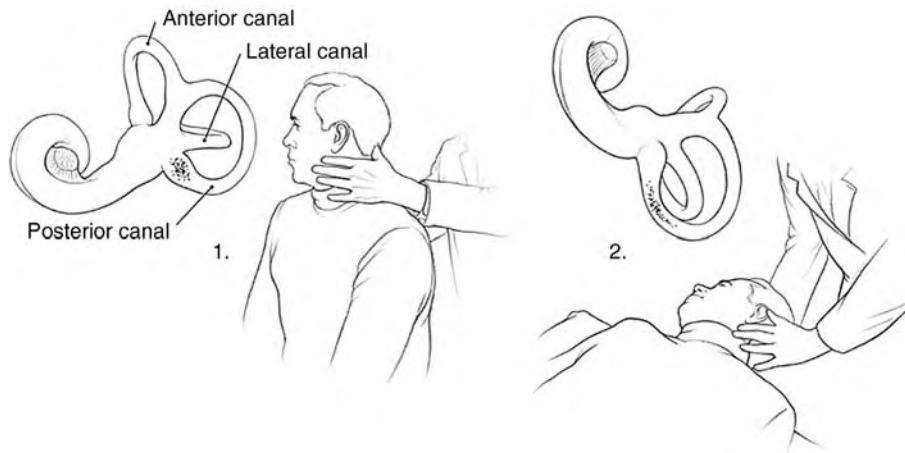

**Disorders of the Vestibular Periphery. Figure 1** The Dix-Hallpike maneuver for detection of BPPV affecting the right posterior canal. Lowering the patient's head backwards and to the side allows debris in the posterior canal (1) to fall to its lowest position, activating the canal and causing eye movements and vertigo (2). (From [3]).

accompanied by nausea and vomiting. The vertigo usually subsides over the course of several days although disequilibrium and unsteadiness may last for a longer period of time. The differential diagnosis of acute vertigo includes central causes such as cerebellar hemorrhage or infarction. Patients with vestibular neuritis can usually stand although they may be unsteady, whereas patients with acute vertigo due to central causes are often unable to walk or to maintain upright posture.

The clinical signs of vestibular neuritis include a spontaneous nystagmus and a diminished vestibulo-ocular reflex evoked by rapid head movements in the plane and direction that are excitatory for the affected semicircular canals on the side of vestibular hypofunction. Labyrinthitis refers to the simultaneous loss of hearing and balance function in an affected ear. These signs are manifestations of Ewald's laws. The axis of eye rotation during the spontaneous nystagmus has an orientation that is determined by the canals that have hypofunction. If there is diminished activity in the divisions of the vestibular nerve innervating all three semicircular canals in the affected labyrinth, then a horizontal-torsional nystagmus will result. The horizontal slow phase component will be directed toward the side of the lesion and the torsional slow phase component will involve motion of the superior pole of the eye towards the affected side. The spontaneous nystagmus that occurs with a vestibular lesion has three cardinal features, it is accentuated by gaze directed toward the side of the lesion, diminished by gaze directed away from the side of the lesion and suppressed by visual fixation [6].

Vestibular neuritis can lead to a reduction in vestibular function in the affected ear that is long lasting.

Analysis of the nystagmus evoked by warm or cold water or air delivered to the external auditory canal is the most widely used clinical test for comparison of function between the two labyrinths. The method is based upon the convective flow of endolymph that results from a temperature gradient across the horizontal semicircular canal as initially described by Bárány. This temperature gradient results in a density difference within the endolymph of the canal. When the horizontal canal is oriented in the plane of gravity (by elevating the head 30° from the supine position), the more dense fluid falls to the lower position in the canal, whereas the less dense fluid moves to the upper part of the canal (Fig. 3).

In the presence of gravity, there is a flow of endolymph from the cooler (more dense) region to the warmer (less dense) region. This convective flow of endolymph within the canal deflects the cupula, thereby leading to a change in the discharge rate of vestibular-nerve afferents. Endolymph flows toward the ampulla (an excitatory stimulus for the horizontal canal) for a warm stimulus and away from the ampulla (an inhibitory stimulus for the horizontal canal) for a cold stimulus.

### Ménière's Disease

Ménière's syndrome is an inner ear disorder marked by spontaneous attacks of vertigo, fluctuating sensorineural hearing loss, aural fullness and tinnitus. When the syndrome is idiopathic and not attributable to a specifically identified cause (such as syphilis), it is often referred to as Ménière's disease, which is considered to be the third most common disorder of the labyrinth. The duration of vertigo during an attack may vary from 20 to 30 min up to several hours.

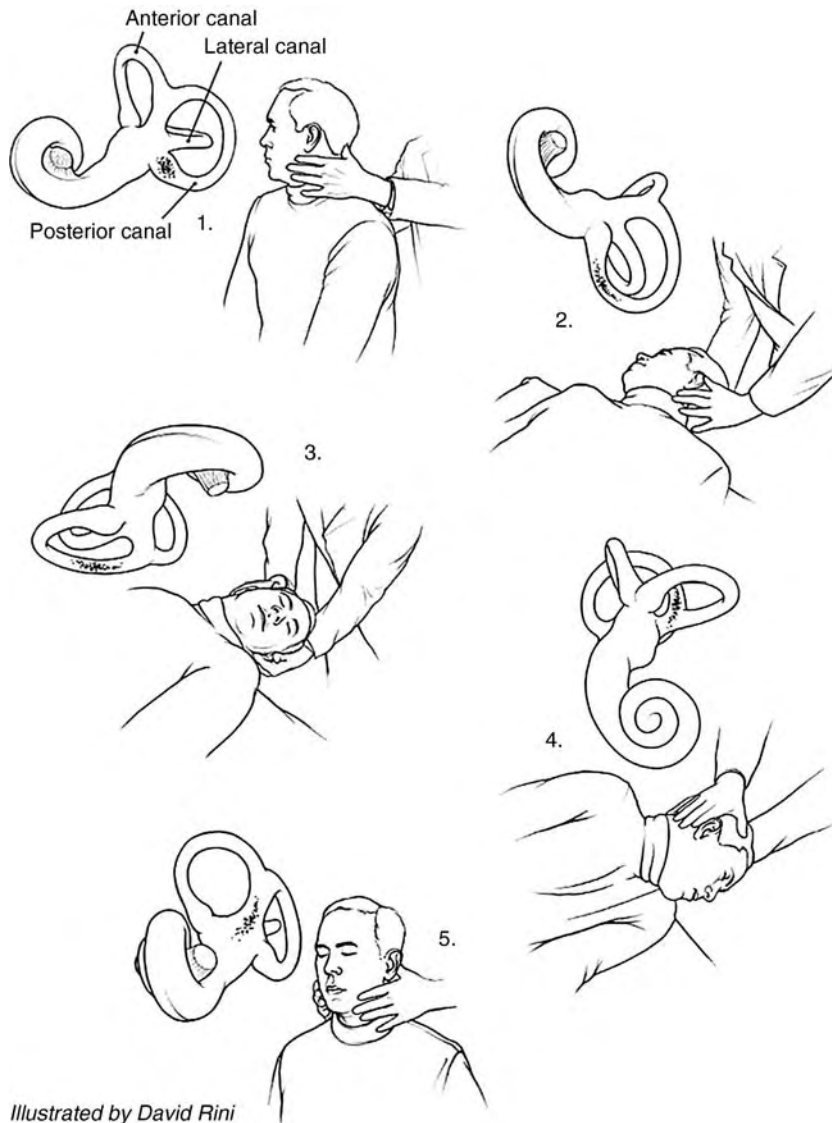

Illustrated by David Rini

**Disorders of the Vestibular Periphery. Figure 2** Canalith repositioning maneuver for treatment of benign paroxysmal positional vertigo (BPPV) affecting the posterior semicircular canal. *Panel 1* shows a patient with right posterior canal BPPV. The patient's head is turned to the right at the beginning of the canalith-repositioning maneuver. The *inset* shows the location of the debris near the ampulla of the posterior canal. The diagram of the head in each inset shows the orientation from which the labyrinth is viewed. In *panel 2*, the patient is brought into the supine position with the head extended below the level of the gurney. The debris falls toward the common crus as the head is moved backward. In *panel 3*, the head is moved approximately 180° to the left while keeping the neck extended with the head below the level of the gurney. Debris enters the common crus as the head is turned toward the contralateral side. In *panel 4*, the patient's head is further rotated to the left by rolling onto the left side until the patient's head faces down. Debris begins to enter the vestibule. In *panel 5*, the patient is brought back to the upright position. Debris collects in the vestibule. Illustration by David Rini. (From [3]).

Distortion of the membranous labyrinth with engorgement of the fluid-filled compartments containing endolymph (endolymphatic hydrops) is thought to be the pathological basis of Ménière's disease. The cause of the overproduction or failed absorption of endolymph remains uncertain. The specificity of the association between histological evidence of

endolymphatic hydrops and the clinical manifestations of Ménière's disease does not appear to be absolute. Temporal bone histopathological studies have revealed histological evidence of endolymphatic hydrops in specimens harvested at autopsy from subjects who did not have signs or symptoms of Ménière's disease during life [8].

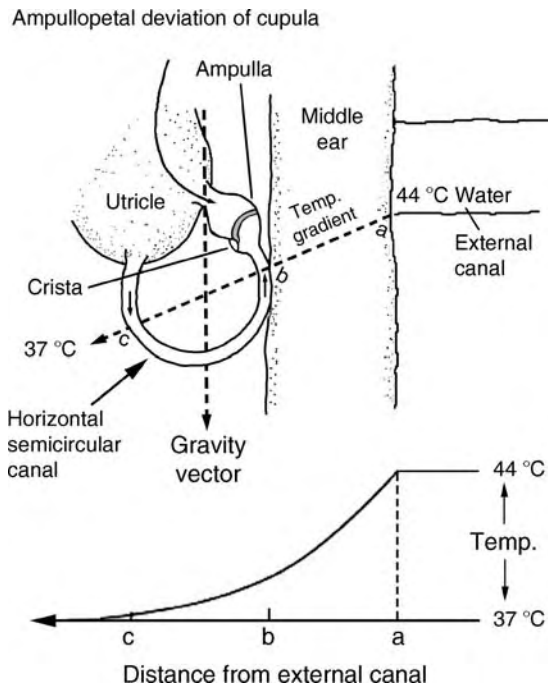

### Disorders of the Vestibular Periphery.

**Figure 3** Convective flow mechanism of the caloric response. Irrigation with warm or cold water (or air) results in a temperature gradient across the horizontal semicircular canal. With the horizontal canal oriented in the earth-vertical plane, gravity induces the convective flow of endolymph from the cooler area of the canal in which endolymph is more dense into the warmer area of the canal in which endolymph is less dense. For the warm caloric irrigation shown in this diagram, an ampullopetal deflection of the cupula results from this flow of endolymph. Ampullopetal deflection of the cupula refers to motion towards the vestibule where the utricle (an otolith organ) is located. Vestibular nerve afferents innervating the horizontal semicircular canal are excited and a horizontal nystagmus with slow components directed toward the opposite ear is produced. A cold caloric stimulus results in an oppositely directed response with ampulofugal deflection of the cupula, inhibition of horizontal canal afferents and a nystagmus with slow components directed toward the ear to which the cold caloric is applied. (From [7]).

There is no known cure for Ménière's disease and current therapy is directed at reduction of associated symptoms. Medical regimens aimed at prevention of vertigo are directed at decreasing the production and/or accumulation of endolymph. Salt restriction and diuresis are believed by many to be the best medical therapy for Ménière's disease. Vertigo persists despite optimal medical therapy in approximately 10% of patients. Treatment options in patients with intractable vertigo include surgical procedures to decompress the

endolymphatic sac or to drain fluid from it, surgical deafferentation of the affected ear with or without preservation of hearing, and intratympanic administration of aminoglycoside medications to produce selective reduction in vestibular function in the affected ear, typically with preservation of hearing.

### Superior Semicircular Canal Dehiscence Syndrome

Principles of vestibular physiology have been useful in identifying and determining the etiology of disorders of the labyrinth. An analysis of eye movements evoked by sound and/or pressure stimuli led to the identification of ▶superior semicircular canal dehiscence syndrome [9]. The vestibular abnormalities in this condition include vertigo and oscillopsia induced by loud noises or by stimuli that change middle ear or intracranial pressure. These patients may exhibit a Tullio phenomenon (eye movements induced by loud noises). The auditory abnormalities can include an apparent conductive hearing loss (manifested as an air-bone gap on audiometry that is not due to middle ear pathology), autophony (a sensation of increased loudness of the patient's own voice in the affected ear) and pulsatile tinnitus. The syndrome was identified based upon the observation that eye movements evoked by sound or pressure stimuli often align with the plane of the affected superior semicircular canal as predicted by Ewald's first law (Fig. 4).

The presence of a dehiscence (opening) in the bone overlying the superior canal (also referred to as the anterior canal) has been confirmed by temporal bone CT scans (Fig. 5).

Patients with superior semicircular canal dehiscence also have a lower than normal threshold for vestibular-evoked myogenic potentials [12].

The pathophysiology of superior canal dehiscence can be understood in terms of the effects of the dehiscence in creation of a "third mobile window" into the inner ear (Fig. 6).

Under normal circumstances, sound pressure enters the inner ear through the stapes footplate in the oval window and, after passing around the cochlea, exits through the round window. The presence of a dehiscence in the superior canal allows this canal to respond to sound and pressure stimuli. The direction of the evoked eye movements supports this mechanism. Loud sounds, positive pressure in the external auditory canal and the Valsalva maneuver against pinched nostrils cause ampulofugal deflection of the superior canal, which results in excitation of afferents innervating this canal. The evoked eye movements can involve a nystagmus that has slow components directed upward with torsional motion of the superior pole of the eye away from the affected ear. Conversely, negative pressure in the external canal, Valsalva against a closed glottis and jugular venous compression cause

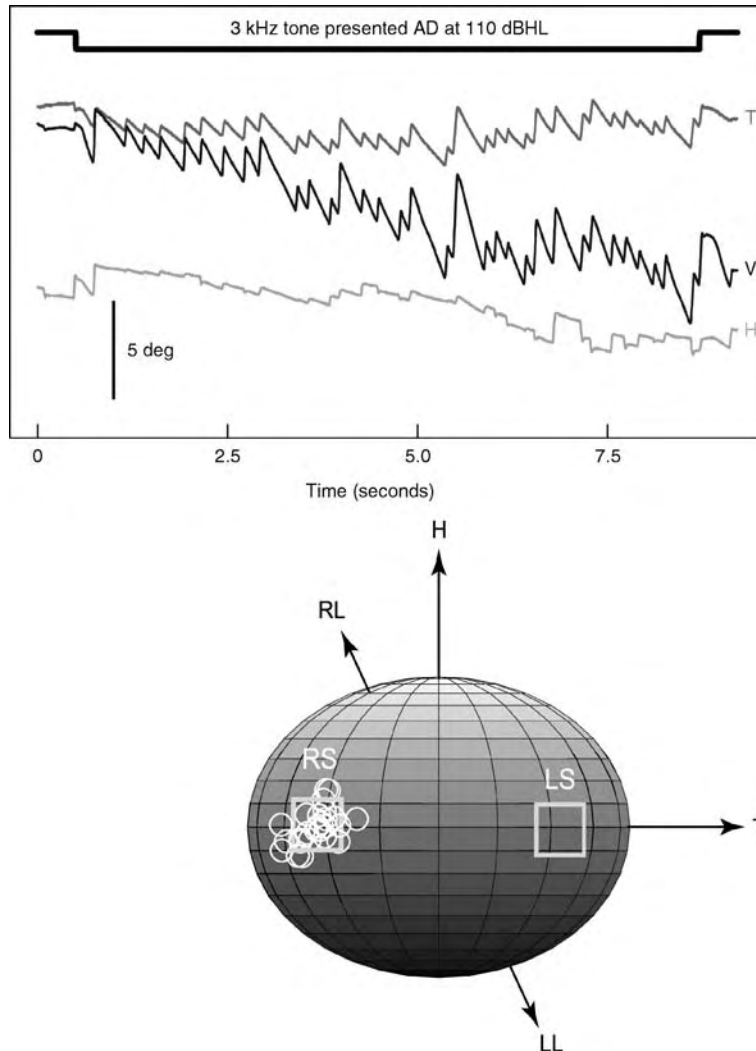

**Disorders of the Vestibular Periphery. Figure 4** Nystagmus induced by 3 kHz tone at an intensity of 110 dB in the right ear (AD) of a 33-year-old woman with right SCD syndrome. *Upper panel:* Torsional (*T*), vertical (*V*) and horizontal (*H*) eye position recorded with the scleral search coil technique from the right eye. The time during which the tone was presented is indicated by the stimulus marker at the top. Positive directions for the horizontal, vertical, and torsional axes are defined as left, down, and clockwise (rotation of the superior pole of the patient's eye toward her right side). In response to the tone in her right ear, the patient developed a nystagmus with upward, counterclockwise slow phases consistent with excitation of the right superior canal. *Lower panel:* The axis of slow phase eye velocity corresponding to the data plotted in the upper panel. The sphere represents the patient's head, as viewed from the right side. The positive direction of the horizontal axis (*H*) travels upward from the top of the head, the torsional axis (*T*) straight ahead from the patient's nose, and the vertical axis (which is obscured by the sphere) from the patient's left ear. The axis of the slow phase eye movement expected for excitation of each of the right superior (*RS*), left superior (*LS*), right lateral (*RL*) and left lateral (*LL*) semicircular canals is shown based upon the orientation of the canals. The box around the axis of each superior canal indicates the region ( $\pm 2$  SD) from the mean orientation of that axis. Each light circle represents the mean observed eye velocity axis for one slow phase of nystagmus. (From [10]).

ampullopetal deflection of the superior canal which results in inhibition of afferents innervating this canal. The evoked eye movements are typically in the plane of the superior canal but in the opposite direction

(downward with torsional motion of the superior pole of the eye toward the affected ear). Surgical plugging of the affected superior canal can be beneficial in patients with debilitating symptoms due to this disorder.

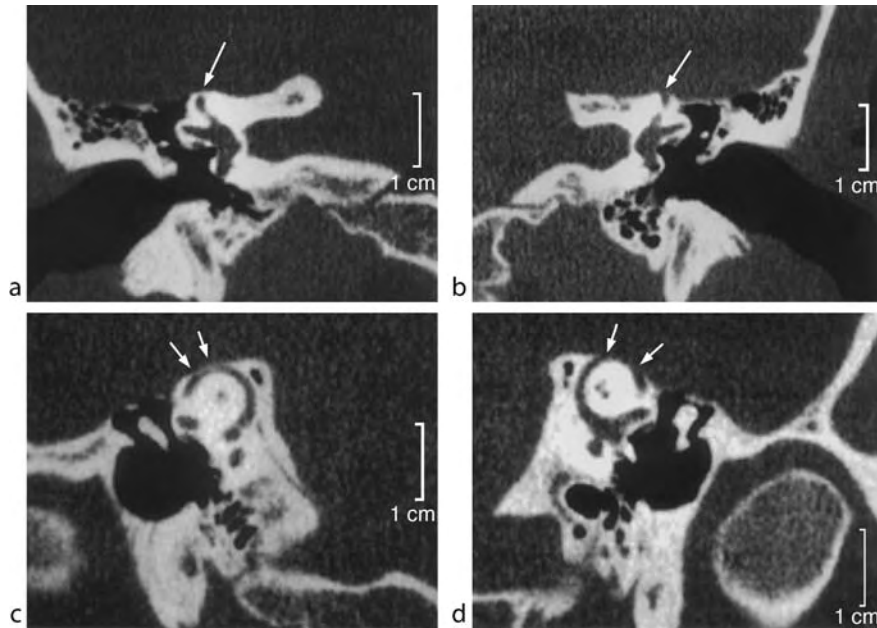

**Disorders of the Vestibular Periphery. Figure 5** CT images of the temporal bones in a 37-year-old man with left superior canal dehiscence syndrome. He developed vertigo, oscillopsia and eye movements in the plane of the left superior semicircular canal in response to tones of 500–1000 Hz at 110 dB HL in the left ear. Dehiscence of the bone over the left superior semicircular canal was confirmed at surgery. (a) Coronal 0.5-mm-collimated CT scan through right temporal bone demonstrates an intact layer of bone (*arrow*) over the superior canal. (b) Multiplanar reformation in an oblique sagittal orientation confirms the presence of an intact but thin layer of bone (*arrows*) over the right superior canal. (c) Coronal 0.5 mm-collimated CT scan through the left temporal bone demonstrates dehiscence of bone (*arrow*) over the left superior canal. (d) Multiplanar reformation in an oblique sagittal orientation through the left temporal bone demonstrates an area of dehiscence (*arrows*) over the left superior canal. (From [11]).

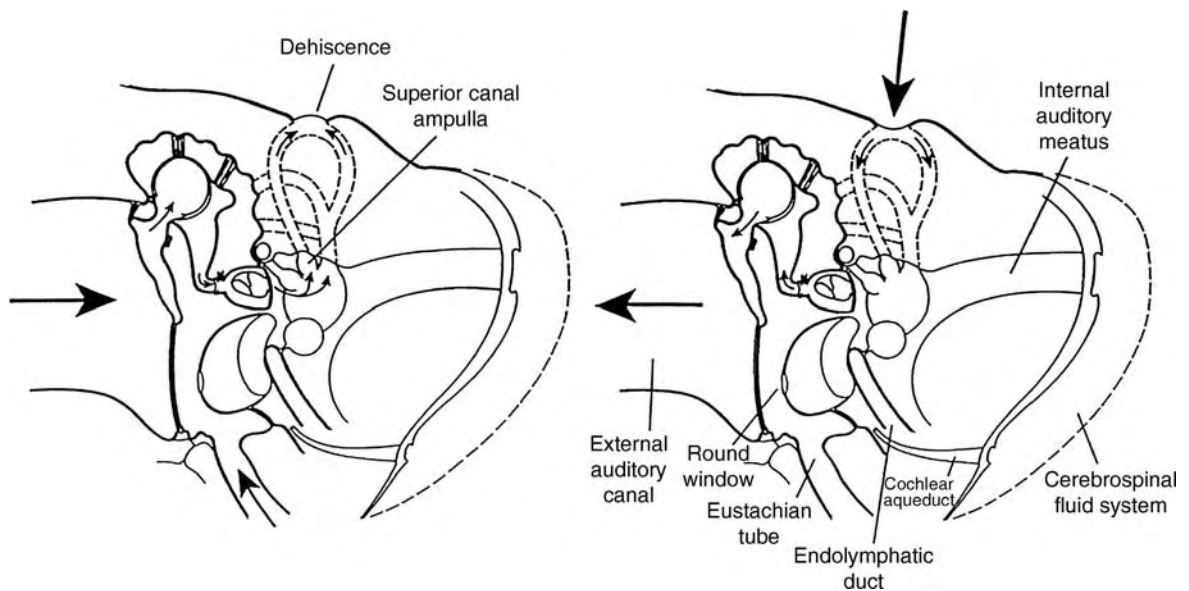

**Disorders of the Vestibular Periphery. Figure 6** Pressure changes inducing nystagmus in superior semicircular canal dehiscence syndrome. Positive pressure in the external auditory canal causes bulging of the membranous canal into the cranial cavity and ampullofugal flow. Negative pressure in the external auditory canal causes bulging of the cranial contents into the superior canal and ampullopetal flow. (From [9]).

### Disturbances of the Vascular Supply to the Inner Ear

Disruption of the blood supply to the inner ear can result in damage to the labyrinth and cochlea. The vertebro-basilar system provides blood supply to the inner ear, brainstem and cerebellum. The three major circumferential branches of this system are the posterior inferior cerebellar artery (PICA), the anterior inferior cerebellar artery (AICA) and the superior cerebellar artery (SCA). Occlusion of PICA and/or of the ipsilateral vertebral artery can result in lateral medullary infarction (Wallenberg's syndrome). The major symptoms and signs include vertigo, nausea, gait and ipsilateral limb ataxia, lateropulsion (saccadic eye movements overshoot to the side of the lesion) and abnormalities of smooth pursuit eye movements. Patients can also experience an ocular tilt reaction, a skew deviation of the eyes with the ipsilateral eye lower than the contralateral eye, head tilt towards the side of the lesion and ipsilateral cyclodeviation (top poles of the eyes rolling towards the affected side).

Ischemia in the territory of AICA results in lateral pontomedullary infarction. Unlike lateral medullary infarction, patients with an infarct in the AICA distribution often have severe hearing loss on the affected side. Ataxia, ipsilateral facial anesthesia and contralateral body anesthesia can also occur. Occlusion of the SCA may produce infarction of the superior lateral pons, superior cerebellar peduncle and superior cerebellar vermis and hemisphere, although the complete clinical syndrome is rare. Patients with this disorder often have contrapulsion with overshooting of saccades directed contralateral to the side of the lesion.

The internal auditory artery typically arises from AICA. The internal auditory artery divides into two branches, which supply the structures innervated by the two divisions of the vestibular nerve. The superior branch supplies the superior and horizontal semicircular canals as well as the utriculus. The inferior branch supplies the posterior semicircular canal, sacculus and cochlea. This relationship between the vascular supply and neural structures in the inner ear provides a basis for understanding conditions that may have a vascular etiology. For example, otoconia debris from the utriculus damaged by infarction of the superior branch of the internal auditory artery may settle into the posterior semicircular canal and cause BPPV in patients whose posterior canal function has been preserved.

### Other Conditions Affecting the Labyrinth

Schwannomas of the vestibular nerve can result in reduction of vestibular function in the affected ear(s). These tumors are slow growing and the vestibular abnormalities associated with them may be quite subtle. The diagnosis is most commonly made when

complaints of hearing loss or tinnitus lead to a gadolinium-enhanced cranial MRI, which identifies the tumor. For this reason, the tumors are often referred to as acoustic neuromas, although they rarely arise from the cochlear nerve.

Fractures of the bone of the labyrinthine capsule separating the inner ear from the middle ear and mastoid or disruption of the bone or membranes of the areas of the oval or round windows can lead to a perilymphatic fistula with consequent sensorineural hearing loss and episodic vertigo. Vestibular symptoms and signs in association with fluctuating hearing loss have led to the diagnosis of perilymphatic fistula in patients following trauma to the temporal bone, after surgical procedures such as stapedectomy and in association with congenital disorders of the cochlea and labyrinth such as Mondini deformity. More ambiguous situations are encountered when perilymphatic fistula is suspected in the absence of a clearly defined event that would be associated with these pathological entities. Criteria for exploration of the middle ear in search of a perilymphatic fistula have been difficult to establish because of the absence of an agreed diagnostic test that is sensitive and specific.

Acute alcohol intoxication leads to the rapid passage of alcohol into the cupula of each of the semicircular canals, which then become lighter than the surrounding endolymph (buoyancy hypothesis). These effects are noted when blood levels of alcohol approach 40 mg/dl. The cupula then becomes sensitive to gravity, which causes ►positional alcohol nystagmus and rotatory vertigo. The initial phase of PAN begins in humans within 30 min after ingestion of a moderate amount of alcohol and beats toward the lower ear when the subject is lying on his or her side with one ear down. Blood alcohol gradually diffuses into the endolymph, which leads to a period without PAN beginning between 3.5 and 5 h after cessation of alcohol ingestion. In the final stage, alcohol selectively diffuses out of the cupula before it leaves the endolymph. Phase II of PAN is initiated when the cupula becomes transiently denser than endolymph (5–10 h after cessation of drinking) and an oppositely directed positional nystagmus that beats towards the upper ear is noted [13].

### References

1. Ewald JR (1892) *Physiologische Untersuchungen über das Endorgan des Nervus Octavus*. Bergmann, Wiesbaden
2. Halmagyi GM, Curthoys IS (1988) A clinical sign of canal paresis. *Arch Neurol* 45:737–739
3. Hullar TE, Minor LB (2003) Vestibular physiology and disorders of the labyrinth. In: Glasscock ME, Gulya AJ (eds) *Surgery of the ear*, 5th edn, Chapter 4. Hamilton



4. Epley JM (1992) The canalith repositioning procedure: for treatment of benign paroxysmal positional vertigo. *Otolaryngol Head Neck Surg* 107:399–404
5. Baloh RW (2003) Vestibular neuritis. *New Engl J Med* 348:1027–1032
6. Alexander G (1919) In: *Handbuch der Kinderheilkunde*. Vogel, Leipzig, p 84
7. Baloh RW, Honrubia V (1990) *Clinical neurophysiology of the vestibular system*, 2nd edn. Davis, PA
8. Rauch SD, Merchant SN, Thedinger BA (1989) Ménière's syndrome and endolymphatic hydrops: double-blind temporal bone study. *Ann Otol Rhinol Laryngol* 98:873–883
9. Minor LB, Solomon D, Zinreich JS, Zee DS (1998) Sound- and/or pressure-induced vertigo due to bone dehiscence of the superior semicircular canal. *Arch Otolaryngol Head Neck Surg* 124:249–258
10. Minor LB, Cremer PD, Carey JP et al. (2001) Symptoms and signs in superior canal dehiscence syndrome. *Ann NY Acad Sci* 942:259–273
11. Belden CJ, Weg N, Minor LB et al. (2003) CT evaluation of bone dehiscence of the superior semicircular canal as a cause of sound- and/or pressure-induced vertigo. *Radiology* 226:337–343
12. Brantberg K, Bergenius J, Tribukait A (1999) Vestibular-evoked myogenic potentials in patients with dehiscence of the superior semicircular canal. *Acta Otolaryngol* 119:633–640
13. Fetter M, Haslwanter T, Bork M, Dichgans J (1999) New insights into positional alcohol nystagmus using three-dimensional eye-movement analysis. *Ann Neurol* 45:216–223

---

## Disorganized Schizophrenia

### Definition

Psychosis subtype in which thought disorder as well as disorganization of planning and behaviour prevails.

► Schizophrenia

---

## Dissection/Arterial Dissection

### Definition

A tear in the wall of a blood vessel that can happen spontaneously or be caused by trauma to that vessel.

► Ischemic Stroke  
► Stroke

---

## Disseminated Encephalomyelitis (DEM)

### Definition

Poly-symptomatic syndrome sharing some similarities with ► multiple sclerosis, but additionally including fever, altered states of ► consciousness, cognitive and ► aphasic symptoms, and meningism. In DEM, the ► thalamus or ► basal ganglia are often affected. The ► spinal cord lesions are longer than three vertebral segments.

---

## Dissociation

► Hysteria

---

## Distal Cues

### Definition

Distant landmarks. Typically contrasted with “local cues”.

► Spatial Learning/Memory

---

## Distal Supervised Learning

### Definition

An approach for training an inverse model which uses a forward model to propagate plant errors to errors of the inverse model.

► Neural Networks for Control

---

## Distortion Product Otoacoustic Emissions

### Definition

Sounds emitted by the ear in response to two simultaneous tones of different frequencies.

► Evolution of the Auditory System in Mammals

## Distribution Problem

### Definition

Calculation of the internal forces acting on the musculoskeletal system using the known resultant intersegmental forces and moments. The mathematical system describing the distribution problem is typically under- or indeterminate.

► [Distribution Problem in Biomechanics](#)

## Distribution Problem in Biomechanics

WALTER HERZOG

University of Calgary, Faculty of Kinesiology, Calgary, AB, Canada

### Synonyms

Force-sharing problem

### Definition

► The [distribution problem](#) in biomechanics deals with the determination of the ► [internal forces](#) acting on the musculoskeletal system. The distribution problem is most often used for calculating the muscle, ligament, and bone forces acting in and around joints. It is probably the most basic problem in biomechanics, as muscle forces determine the loading of joint structures, and also provide insight into the organization and control of voluntary movements.

The distribution problem can be defined as the calculation of the internal forces acting on the musculoskeletal system using the known resultant ► [intersegmental forces and moments](#). The ► [mathematical system](#) describing the distribution problem is typically a ► [under- or indeterminate system](#).

The distribution problem for human and animal joints is typically represented with an indeterminate set of system equations; that means there are more system unknowns than there are equations to solve the unknowns. In other words, a general joint has three rotational ► [degrees of freedom](#), is crossed by many muscles and ligaments, and often contains multiple bony contact points. Each degree of freedom can be used to write one system equation, and each muscle, ligament, or bony contact represents an unknown force. Therefore, the mathematical system representing a joint is indeterminate and cannot be solved in a unique way. In fact, it has an infinite number of possible solutions, and the

difficulty is to identify which of the solutions is (or approximates) the correct solution.

### Characteristics

#### Basic Concepts

When attempting to determine internal (=ligamentous, muscular, bony contact) forces in and around a biological joint from the known resultant joint forces and moments, certain modeling assumptions must be made. These assumptions include how a joint is defined and how forces are transmitted across the joint by internal structures.

A biological joint is typically defined as a point that may be associated with an anatomical landmark (e.g. the lateral malleolus for the ankle joint), or that may be defined mathematically and may move relative to the bones that make up the joint (e.g. the instantaneous centre of zero velocity concept). In mechanics, we typically think of a joint as a point that is “contained” in both segments that make up the joint. When performing an analysis of internal forces, a fictitious surface, which is not necessarily planar, is passed through the anatomical joint space, and this surface severs all tissues that transverse the joint. It is typically assumed that bony contact regions, muscles, and ligaments are the only structures that transmit non-negligible forces across a joint. Furthermore, for each structure that transmits force across a joint, the point of application of that force,  $Q$ , is chosen in such a way that the moment produced by that structure about point  $Q$  is zero ([Fig. 1](#)). Of course, each structure will produce a moment about points other than point  $Q$ , in particular about the joint centre,  $O$ .

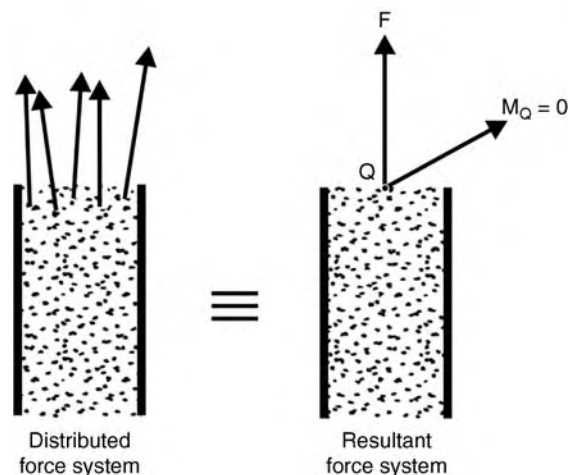

### Distribution Problem in Biomechanics.

**Figure 1** Equipollent replacement of a distributed force system (e.g., in a ligament attaching to a bone) by a resultant force and moment. In biomechanics, we tend to associate the point of application of the resultant force with a point,  $Q$ , where the resultant moment of the distributed force system is zero.

**Joint Equipollence Equations**

The ►joint equipollence equations relate the muscular, ligamentous, and bony contact forces to the resultant joint force and moment. Using the assumptions made above, the force and moment equipollence equations are as follows:

$$F = \sum_{i=1}^N (F_i^m) + \sum_{j=1}^P (F_j^l) + \sum_{k=1}^Q (F_k^c) \quad (1)$$

$$M_o = \sum_{i=1}^N (r_{i/o} \times F_i^m) + \sum_{j=1}^P (r_{j/o} \times F_j^l) + \sum_{k=1}^Q (r_{k/o} \times F_k^c) \quad (2)$$

where:

F = variable resultant external joint force

M<sub>o</sub> = variable resultant external joint moment

F<sup>m</sup> = internal muscular forces

F<sup>l</sup> = internal ligamentous forces

F<sup>c</sup> = internal bony contact forces

r<sub>i/o</sub> = location vector for muscular force i

r<sub>j/o</sub> = location vector for ligamentous force j

r<sub>k/o</sub> = location vector for bony contact force k

N = integer indicating the number of muscular forces

P = integer indicating the number of ligamentous forces

Q = integer indicating the number of bony contact forces

The resultant joint force, F, and joint moment, M<sub>o</sub>, may be obtained using the ►inverse dynamics approach [1]. Since equations (1) and (2) are two vector equations, they yield six scalar equations in a three-dimensional system. The unknowns include all muscular, ligamentous, and bony contact force vectors, as well as the corresponding location vectors. Therefore, the number of unknowns exceeds the number of system equations. Using anatomical information from cadaver or imaging studies, the unknown location vectors, as well as the direction of the muscular and ligamentous force vectors, may be determined or estimated. This anatomical information reduces the number of unknowns substantially, leaving just the magnitudes of all internal force vectors and the direction of the bony contact force vectors as unknowns. Therefore, the number of scalar unknowns (SU) in the system represented by equations (1) and (2) is equal to:

$$SU = N + P + 3Q$$

Where N, P, and Q represent the number of muscles, ligaments, and bony contact areas of the joint under consideration. In general, the number of unknowns will exceed the number of available system equations (i.e. six scalar equations in the three-dimensional case), or:

$$N + P + 3Q > 6$$

Therefore, the problem is mathematically indetermined.

**Solving Mathematically Indeterminate Systems using Optimization Theory**

Any mathematically indetermined system may be made determinate (►determinate system) by decreasing the number of unknowns, and/or increasing the number of system equations until the number of unknowns and system equations match. These approaches have been used to solve the indetermined distribution problem in biomechanics [2,7,8]. However, the approach used most often to solve the distribution problem is mathematical ►optimization. Optimization procedures are not only an elegant way of solving this type of mathematical problem, but are also believed to be good indicators of the physiology underlying force-sharing among internal structures. This belief goes as far back as Weber and Weber [3], who stated that locomotion is performed in such a way as to optimize (i.e. minimize) metabolic cost.

Optimization problems, in general, are defined by three quantities: the cost function, the design variables, and the constraint functions. The cost function is the function to be optimized. For the distribution problem in biomechanics, cost functions have been defined as:

Minimize  $\phi$  where:

$$\phi = \sum_{i=1}^N F_i^m \quad [6] \quad (3)$$

or:

$$\phi = \sum_{i=1}^N (F_i^m / pcsa_i)^3 \quad [7] \quad (4)$$

or:

$$\phi = \sum_{i=1}^N (F_i^m / M_{max\ i})^3 \quad [8] \quad (5)$$

where

F<sub>i</sub><sup>m</sup> = force magnitude of the ith-muscle

pcsa<sub>i</sub> = physiological cross-sectional area of the ith-muscle

M<sub>maxi</sub> = variable maximal moment that the ith-muscle can produce as a function of its instantaneous contractile conditions

N = total number of muscles considered

Design variables are the variables that are systematically changed until the cost function is optimized and all constraint functions are satisfied. The design variables must be contained in the cost function, and for the distribution problem, they typically are the magnitudes of the individual (muscle) forces.

The constraint functions restrict the solution of the optimization approach to certain boundary conditions. For example, in the distribution problem, typical inequality constraints are:

$$F_i^m \geq 0, \text{ for } i = 1, \dots, N \quad (6)$$

and typical equality constraints are:

$$M_o = \sum_{i=1}^N (r_{i/o} \times F_i^m) \quad (7)$$

Equations (6) and (7) indicate that muscular forces must always be zero or positive (tensile), and that resultant joint moments,  $M_o$ , are assumed to be satisfied by the vector sum of all moments produced by the muscular forces. An optimization problem may not have constraint functions, and is then referred to as an unconstrained problem.

#### Example Solution of a General Constrained Problem

The distribution problem in biomechanics is typically solved by minimizing the cost function of a **general constrained optimization** problem. Specifically, suppose we want to minimize  $f(x)$  subject to the constraints  $h_i(x) = 0$  ( $i = 1, 2, \dots, s$ ) where  $f$  and  $h_i$  are differentiable and  $x = (x_1, \dots, x_N)$  is a vector of design variables that are assumed to be non-negative. These non-negativity constraints  $x_j \geq 0$  ( $j = 1, 2, \dots, N$ ) make the problem of the “mathematical programming” type, and in certain cases, it can be solved via the Karush Kuhn-Tucker (KKT) conditions.

One such case, which we shall consider, is where  $f$  is convex and each  $h_i$  is affine, i.e.  $h_i(x) = a_i^T x + b_i$  for some (row) vector  $a_i$  and constant  $b_i$ . In this case, the KKT conditions are necessary and sufficient for a **global minimum**, and they admit the following interpretation.

First, select the design variables which are zero, and label them  $x_k$  (the other design variables are positive). Then solve the *equality* constrained problem of minimizing  $f(x)$  subject to:

$$\text{all } h_i(x) = 0 \text{ and all } x_k = 0 \quad (8)$$

This problem can be attacked by Lagrange multipliers  $\lambda_i$  and  $\mu_k$ . Let:

$$L(x) = f(x) + \sum_{i=1}^s \lambda_i h_i(x) + \sum_k \mu_k x_k \quad (9)$$

and solve the mathematical system consisting of the stationary point condition:

$$0 = \frac{\partial L}{\partial x_j}(x) \quad (j = 1, 2, \dots, N) \quad (10)$$

together with the equality constraints of equation (8).

If  $N$  is large, the task of selecting which design variables should be zero can be formidable. For a small  $N$ , however, the problem may be tackled as follows: first try the case where no  $x_k$  is zero (so all  $x_j$  are positive and the final summation is absent from  $L(x)$ ). If the system (i.e. equations 8 and 10) is soluble with all  $x_j \geq 0$ , then we have found the global minimum. If not, then we try the case where just one  $x_k$  is zero. There are  $N$  such possibilities, and if any of the resulting systems has a solution with all  $x_j \geq 0$ , then again we have found the minimum. If not, then we try those cases where exactly two of the  $x_k$  are zero, and so on.

## References

- Andrews JG (1974) Biomechanical analysis of human motion. *Kinesiol* 4:32–42
- Morrison JB (1968) Bioengineering analysis of force actions transmitted by the knee joint. *Biomed Eng* 3:164–170
- Paul JP (1965) Bioengineering studies of the forces transmitted by joints-II. Engineering analysis. In: Kenedi RM (ed) *Biomechanics and related bioengineering topics*. Pergamon Press, London
- Pierrynowski MR, Morrison JB (1985) A physiological model for the evaluation of muscular forces in human locomotion: Theoretical aspects. *Math Biosci* 75:69–101
- Weber W, Weber E (1836) *Mechanik der menschlichen Gehwerkzeuge*. W. Fischer-Verlag, Göttingen
- Seireg A, Arvikar RJ (1973) A mathematical model for evaluation of force in lower extremities of the musculoskeletal system. *J Biomech* 6:313–326
- Crowninshield RD, Brand RA (1981) A physiologically based criterion of muscle force prediction in locomotion. *J Biomech* 14:793–801
- Herzog W (1987) Individual muscle force estimations using a non-linear optimal design. *J Neurosci Methods* 21:167–179

## Di-Sulfide Linkages

### Definition

Covalent linkage formed between the thiol groups of cysteine residues of proteins.

## Divergent Eye Movement

### Definition

Abduction of the eyes to view a more distant target.

## DMD

- ▶ Duchenne Muscular Dystrophy

## DNA-binding Subunits of NF- $\kappa$ B

- ▶ Nf- $\kappa$ B – Potential Role in Adult Neural Stem Cells

## DNA Immunization

- ▶ Neuroinflammation – DNA Vaccination Against Autoimmune Neuroinflammation

## DNA Microarray

### Definition

A glass slides spotted of a large number of oligonucleotides corresponding to either genomic or cDNA sequences. By hybridizing with labeled probes, DNA microarrays allow for rapid measurement and visualization of differential expression among samples at the whole genome scale.

- ▶ Microarray Analysis of Molecular-Genetic Controls over Development of Neuronal Subtypes

## DNA Polymorphisms

### Definition

Alternate, but normal, usage of different nucleotide sequences at a given site in a DNA molecule across a

population of individuals. DNA polymorphisms may occur in exons or noncoding regions of genes. DNA polymorphisms are used extensively in genetic analyses when tracking the genes underlying familial disorders, including for example Huntington's disease. Single nucleotide polymorphisms (SNPs) occur at a single nucleotide, and because of degeneracy of the genetic code, do not necessarily result in changes in the amino acid sequence of the encoded protein. The presence of a particular SNP may not in itself cause a disease, but the presence of several SNPs across a region of the chromosome (haplotype) can affect the likelihood of a disease occurring, the severity of the disorder, and the response of a disease to chemical interventions.

## DNA Transcription

GABRIEL BERTOLESI, SARAH MCFARLANE  
The Hotchkiss Brain Institute, Department of Cell Biology and Anatomy, Faculty of Medicine, University of Calgary, Calgary, AB, Canada

### Synonyms

RNA synthesis

### Definition

▶ DNA Transcription is the process by which one strand of a ▶ DNA duplex serves as template to enzymatically generate a complementary strand of ▶ RNA. This reaction is catalyzed by enzymes called ▶ RNA polymerases.

Transcription refers to the conversion of a written source in another medium. For example, the digitization of a book is a transcription process since a specific written source is converted to a digitized one. In the context of the expression of genetic information, the conversion is from the template source of deoxynucleotides in the DNA, into a different form, ribonucleotides in the RNA. The stretch of DNA that is transcribed into an RNA molecule is called the ▶ transcription unit.

### Characteristics

#### RNA Polymerases Synthesize RNA From DNA

RNA polymerases are the enzymes responsible for RNA synthesis. Although RNA polymerases use double stranded DNA to make RNA, only one of the two stands of DNA acts as template as the double helix is transiently unwound. The RNA is complementary to the template strand. RNA polymerization proceeds only in the 5'→3' direction while the template DNA is read in the 3'→5' direction (Fig. 1).

RNA polymerases have a very modest proofreading mechanism compared with the DNA polymerase, which is compatible with the idea that the consequences of misincorporated nucleotides in RNA are much less significant than in DNA replication. This is because many copies of an RNA are made, degraded and replaced while the DNA that serves as template is unique.

RNA and DNA are made from four different types of nucleotide units linked together by phosphodiester bonds, but RNA chemically differs from DNA in two aspects:

1. ribose rather than deoxyribose is the sugar contained in the nucleotides and,
2. while the bases adenine (A), guanine (G) and cytosine (C) are present in both RNA and DNA, the base uracil (U) replaces thymine (T) in RNA (Fig. 1).

The transcription process is similar between prokaryotes and eukaryotes with two main differences:

1. There is only one RNA polymerase in bacteria, while at least three RNA polymerases are present in eukaryotes.
2. DNA transcription and protein synthesis are coupled in prokaryotes while it is compartmentalized in eukaryotes. Thus, in bacteria, newly transcribed RNA can interact with ribosomes while RNA polymerase is still synthesizing the RNA strand. In eukaryotes, transcription and translation are time separated and occur in the nucleus and cytosol/endoplasmic reticulum, respectively.

Eukaryotic transcription utilizes three RNA polymerases characterized by their RNA product:

1. RNA polymerase I generates the pre 45S ribosomal RNA, which matures into the three major components of RNA in the ribosome, the 28S, 18S and 5.8S ribosomal RNA (rRNA). Most of the DNA transcribed in cells corresponds to rRNA.
2. RNA polymerase II synthesizes the messenger RNA (►mRNA) and small nuclear RNA (snRNA). Although, mRNA comprises less than 5% of the total RNA in the cell, RNA polymerase II is the most studied of the three polymerases. It interacts with a wide range of ►transcription factors, which modify its affinity and selectivity for specific regions of the genes named ►promoters. Thus, RNA polymerase II is responsible for gene expression and ultimately for its regulation.
3. RNA polymerase III synthesizes transfer RNAs (tRNA); rRNA 5S and other snRNA.

Other RNA polymerases are found in mitochondria and chloroplasts of eukaryotic cells and resemble in some aspects the bacterial polymerase.

### Initiation, Elongation and Termination of Transcription

Transcription occurs in three stages, ►initiation, ►elongation and termination.

#### Initiation

The initiation step involves the binding of the RNA polymerase to the double strand DNA. The polymerase must recognize where to start transcription in the genome, and in a complex with multiple additional proteins determine which genes are to be transcribed and at what rate. In order to initiate transcription, RNA

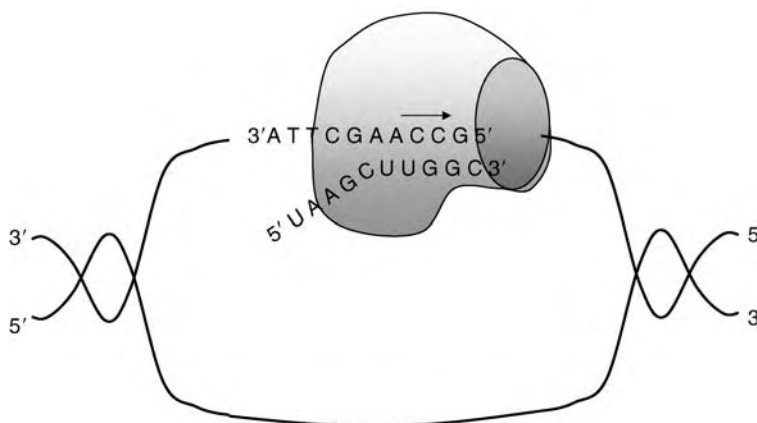

**DNA Transcription. Figure 1** RNA synthesis by the RNA polymerase. The RNA polymerase moves, unwinding the DNA helix. RNA synthesis occurs at the active site (shown as internal circle) generating the addition of new nucleotides at the 3' end. Thus, RNA polymerization occurs in the 5'→3' direction. The RNA is single stranded and complementary to one of the two DNA strands used as template. The base uracil (U) replaces thymine (T) in the ribonucleotides.

polymerases require the help of a large set of proteins called general **▶transcription factors**. These factors help the polymerase bind to the promoter, contribute to unwinding the DNA, and aid the transition of RNA polymerase II activities from initiation to elongation. General transcription factors are designated as TFII (transcription factors for polymerase II) plus an additional letter (TFIIA; TFIIIB etc) and are “general” because they participate in the assembly of transcription complexes on all promoters used by RNA polymerase II.

Other transcription factors are specific and form part of the transcription complex on some but not all promoters. Further, other gene regulatory proteins can bind the DNA even thousand of bases away from the promoter and influence the rate of transcription. Initiation is a critical step in the regulation of gene expression. An example in the nervous system of how transcriptional regulation at the initiation level may define neuronal properties involves the control of the expression of **▶Brain-Derived Neurotrophic Factor (▶BDNF)** by multiple promoters. BDNF is a member of the neurotrophin family that plays an important role in promoting neuronal survival, neuronal differentiation, and synaptic plasticity. Interestingly, four different

promoters regulate the transcription of BDNF, with expression under the control of each promoter differentially regulated by calcium signals [1].

### Elongation

This step involves the covalent addition of new ribonucleotides to the 3′ end of the growing RNA chain. The RNA synthesized by the RNA polymerase II in the nucleus of eukaryotes cells is called the **▶primary transcript**. Several of the modifications that occur on the primary transcript, commonly called “posttranscriptional modifications,” are really coupled to the elongation process. The three main modifications of the primary transcript are:

1. **▶5′ Cap:** The 5′ end of the RNA (the first to be synthesized during transcription) is capped by the addition of a methylated G nucleotide, a process that is important for protein synthesis and to protect RNA from degradation. The 5′ capping occurs almost immediately after the elongation of the first 30 nucleotides and protects the growing RNA transcript.
2. **▶3′ poly A tail:** The 3′ end of the RNA synthesized by polymerase II contains a poly-A- tail of about

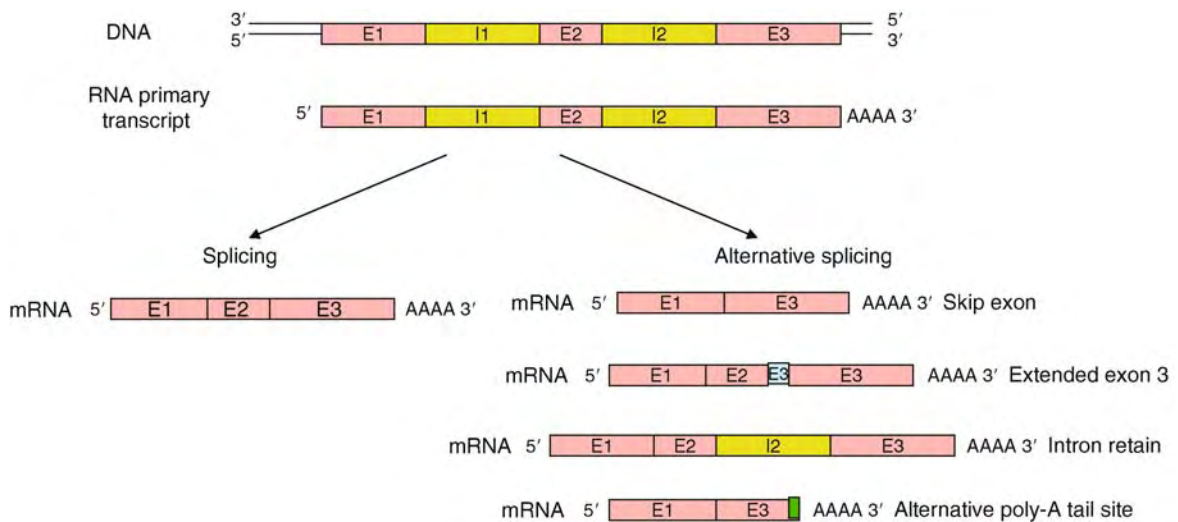

**DNA Transcription. Figure 2** Splicing and alternative splicing. The double strand DNA is transcribed to a single strand primary transcript containing both exons (pink) and introns (yellow). During the splicing process, introns are removed and the exon sequences (E1 to E3) are joined into a continuous coding sequence (*left side*). The primary transcript can also be spliced in different ways generating alternative splice variants with different coding sequences in different ways, generating (*right side*). Skipping exon: internal exons (E2) can be removed together with the introns generating a shorter coding sequence. Extended exons: During intron removal a “cryptic” sequence inside the intron is recognized as an “exon-intron” boundary, removing a shorter intron and leaving an additional region (light blue) as part of the next exon. Intron retained: During intron removal, a boundary exon-intron sequence is not recognized and the intron is retained in a coding sequence. Alternative poly-A tail site: a different sequence for poly-A addition is recognized. This may occur on the last or internal exons, generating a shorter coding sequence or sometimes changing the RNA stability.

100–200 nucleotides, which is added during elongation after recognition of a specific sequence and before termination of transcription. Additional nucleotides incorporated after synthesis of the poly-A-tail are later removed. The poly A tail is important for RNA stability, contributes to the export of RNA from the nucleus and is recognized by the ribosome for protein synthesis.

3. **▶Splicing:** The primary transcript is synthesized as a long molecule containing **▶exons** and **▶introns**. Splicing events occur in the nucleus and involve cutting the intronic sequence out of the RNA and joining the exons to produce an mRNA molecule that codes directly for a protein (Fig. 2).

The mature mRNA is exported to the cytoplasm only once the splicing process is completed. The splicing process is carried out by a multicomponent ribonucleoprotein complex, called the **▶spliceosome**, which recognizes the specific sequences that determine the boundary region between exons and introns.

In evolutionary terms, the splicing process allowed some genes to evolve from a combination of exons coming from different genes. This idea is supported by the presence of specific protein domains with similar function in many different proteins. Splicing also facilitates the diversity of proteins obtained from one gene. This concept becomes clear with an understanding of alternative splicing (Fig. 2), which expands exponentially the number of functionally distinct proteins. In humans, approximately 75% of the genes which contain multiple exons are subject to alternative splicing [2]. There are multiples examples of alternative splicing in neurons. For example, several potassium and calcium voltage channels with different electrophysiological properties are generated by alternative splicing. The expression of these splicing variant subtypes changes between cellular types, as well as during the development of neuronal cells [3].

### Termination

The RNA polymerase continues elongating the RNA until it finds a sequence in the DNA called the **▶terminator**. It then releases both the DNA template and the newly made RNA. These terminator sequences appear in the DNA as two fold symmetric sequences, which when transcribed into the RNA induce a secondary “hairpin” structure. The hairpin structure helps to destabilize the polymerase and the DNA-RNA hybrid, releasing the components. Because a large number of sequences have the potential to generate hairpin structures, terminator sequences are more heterogeneous and less well characterized than promoter sequences.

## References

1. Mamoru F, Akiko T, Masaaki T (2005) Transcriptional regulation of neuronal genes and its effect on neural functions: cumulative mRNA expression of PACAP and BDNF genes controlled by calcium and cAMP signals in neurons. *J Pharmacol Sci* 98:212–218
2. Johnson JM, Castle J, Garrett-Engle P, Kan Z, Lorech PM, Armour CD, Santos R, Schadt EE, Stoughton R, Shoemaker DD (2003) Genome-wide survey of human alternative pre-mRNA splicing with exon junction microarrays. *Science* 302:2141–2144
3. Lipscombe D (2005) Neuronal proteins custom designed by alternative splicing. *Curr Opin Neurobiol* 15 (3):358–363

## DNA Vaccination

### Definition

DNA vaccines are plasmid DNA that encodes for an antigen expressed under the control of a mammalian enhancer/promoter. DNA vaccines also contain certain DNA sequences, CpG DNA motifs, that act as adjuvants and are recognized by the innate immune system. The encoded antigen is transcribed and translated into protein in vivo after immunization, and antigen-specific immune responses are subsequently induced.

**▶Neuroinflammation – DNA Vaccination against Autoimmune Neuroinflammation**

## DNA Vaccination against Autoimmune Neuroinflammation

### Definition

To prevent or treat autoimmune neuroinflammation by vaccination with DNA encoding one or more autoantigen(s). The autoantigen, usually a myelin autoantigen, is transcribed and translated in vivo, processed and presented to T cells in the context of major histocompatibility complex after vaccination. Toll-like receptor 9 ligand CpG DNA within the plasmid backbone acts as adjuvant to activate the innate immune system. Presence of CpG DNA and the expressed autoantigen are both essential for the protective immune reaction to occur.

**▶Neuroinflammation – DNA Vaccination against Autoimmune Neuroinflammation**



---

## DOC2

### Definition

The vesicular double C2 protein, isoform 2; C2 is a highly conserved  $\text{Ca}^{2+}$ - and phospholipid-binding domain. DOC2 has been implicated in the regulation of late docking/priming steps of exocytosis, in part through its identified interaction with Munc18.

► Synaptic Proteins and Regulated Exocytosis

---

## Doing

► Action, Action-Theory

---

## Domain-general

### Definition

Concerning capacities for learning and/or reasoning applicable to various domains.

► Theory Theory (Simulation Theory, Theory of Mind)

---

## Domain-specific

### Definition

Specialized for a single type of information and not for others, and/or containing learning principles restricted to a particular domain.

► Theory Theory (Simulation Theory, Theory of Mind)

---

## Dominance Column

### Definition

In the primary visual cortex neurons receive information predominantly either from the left or the right eye. They are arranged in spatial regions which are called ocular dominance columns. In such a column cortical

cells respond to visual input from a receptive field of one eye while cells in the adjacent dominance column respond to visual input from a corresponding receptive field of the other eye.

► Striate Cortex Functions

---

## Dominant Allele

### Definition

Dominant allele – a gene that is expressed even when its allele on the other homologous chromosome is dominant or recessive.

► GAL4/UAS

---

## Dominant Inheritance

### Definition

Pattern of inheritance that causes disease by a faulty dominant gene which overpowers the normal gene.

---

## Dominant Negative

### Definition

A mutant form of a protein that when expressed at high levels in a cell will interact with the endogenous protein, or its interactors, and block or poison the function of the protein.

---

## Domoic Acid Neurotoxicity

DOUGLAS STEVEN KERR

Department of Pharmacology & Toxicology, University of Otago School of Medical Sciences, Dunedin, New Zealand

### Synonyms

Excitotoxin; Amnesic shellfish poison

## Definition

The term “neurotoxicity” refers to the process whereby a drug or toxin causes a temporary or lasting change in neuronal function leading to the disability or death of an organism. Neurotoxicity may involve a discrete alteration of neuronal activity which in turn leads to changes in physiological control mechanisms and subsequent loss of health, without any demonstrable damage to the neuron itself. The marine algal neurotoxin saxitoxin is a good example of a neurotoxin which does not directly damage neurons *per se*, but which blocks voltage-sensitive sodium channels and the propagation of action potentials, leading to profound paralysis and death. Conversely, neurotoxicity may involve a direct damaging effect on the neuron itself with subsequent physiological dysfunction(s) which lead to disability or death.

Domoic acid (also known as ►**Amnesic Shellfish Poison; ASP**) is a naturally occurring neurotoxin which, depending on dose and duration of exposure, can act by either of these two mechanisms. Domoic acid can cause a transient perturbation of neuronal function leading to cognitive disturbances, seizures and cardiac damage, or the neurotoxin can kill CNS neurons outright, leading to permanent and ongoing disabilities (epilepsy, anterograde amnesia) which persist even after the toxin has been cleared from the system. The following discussion will focus on domoic acid chemistry, toxicology, receptor sites and mechanisms of action, and central and peripheral pathophysiology. Interested readers are directed to recent reviews [1,2] for comprehensive treatments of the subject.

## Characteristics

### Source in the Environment and Chemistry of Domoic Acid

Domoic acid is produced by marine red algae in the genus *Chondria* and by marine diatoms in the genus *Pseudo-nitzschia*. In 1987 domoic acid was identified as the causative agent underlying an incident of human poisoning in Canada [3], and has since been responsible for episodes of pathological intoxication in animals as diverse as pelicans, sea lions and sea otters. Entry into food chains generally occurs during seasonal phytoplankton blooms, leading to bioaccumulation of domoic acid in numerous species of phytoplanktivorous shellfish, crustaceans and small finfish.

Domoic acid ((2S,3S,4R,5'R)-2-carboxy-4-(5'-carboxy-1'-methyl-1Z,3E-hexadienyl)-3-pyrrolidineacetic acid) is a tricarboxylic amino acid with structural homology to the endogenous CNS neurotransmitter glutamate and other excitotoxins, such as kainic acid (KA) and acromelic acid (from seaweed and fungi, respectively; Fig. 1). A number of natural isomers of domoic acid also exist (isodomoic acids-A through -H; Fig. 2). Although these isomers are generally detected in only

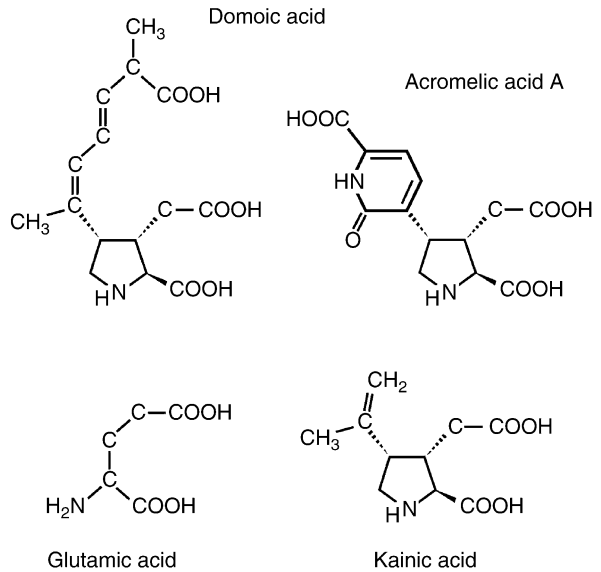

**Domoic Acid Neurotoxicity. Figure 1** Chemical structures of domoic acid and related compounds.

trace amounts in the food chain, isodomoic acids-A and -C have been recently identified in high concentrations in New Zealand shellfish. Not surprisingly, the appearance of DA and its isomers are of concern to commercial shellfish industries and food safety authorities alike, and monitoring programs are now in place worldwide.

## Pharmacokinetics

Following oral ingestion, domoic acid undergoes limited absorption from the mammalian gut with up to 98% excreted unchanged in the faeces (depending on the species). Animal studies indicate that the small percentage of domoic acid which is absorbed is not metabolized and undergoes full renal clearance within a few hours of ingestion. Movement from the blood is considerably limited by the blood-brain barrier with only 4–6% of an injected dose apparent in most brain regions at 1–2 h postinjection. Behavioral observations in rodents and primates following intravenous, intraperitoneal or subcutaneous administration of domoic acid indicate mild to strong neurotoxicity in the range of 1–4 mg/kg body weight. Oral administration in animals generally produces minimal adverse effects at doses 20- to 80-fold higher than those producing comparable activity by systemic administration. Humans appear to be much more sensitive to domoic acid following dietary exposure.

Clinical studies of humans and laboratory studies in rats confirm an age-related supersensitivity to domoic acid and related kainoids. Numerous studies have shown that aged rats suffer more severe symptoms of toxicity

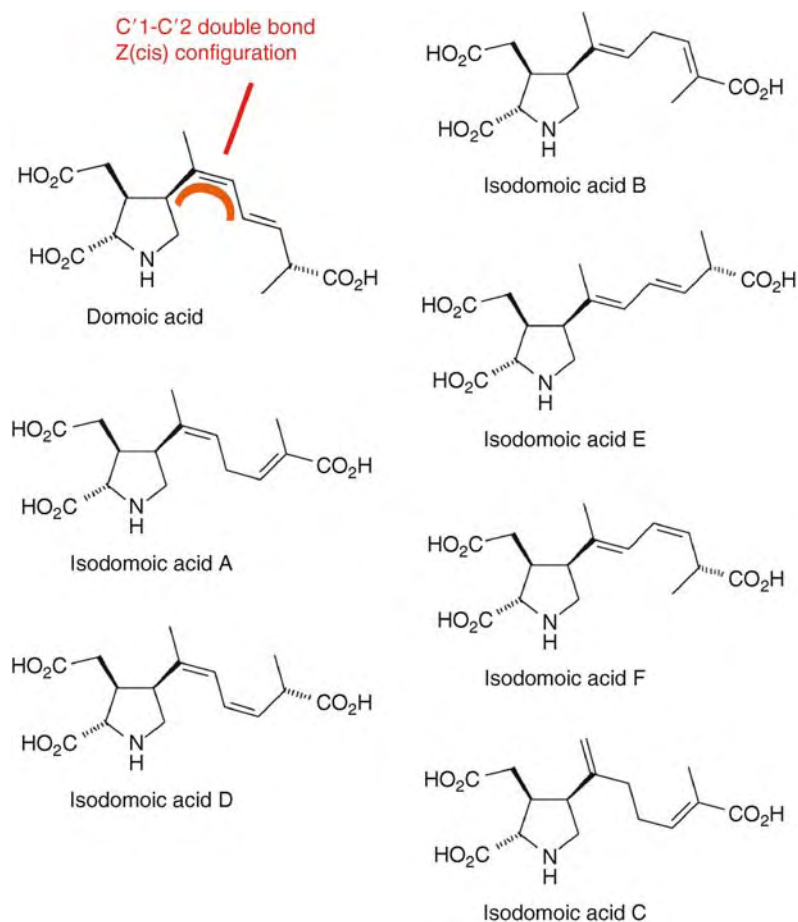

**Domoic Acid Neurotoxicity. Figure 2** Chemical structures of domoic acid and isodomoic acids A through F. The isoforms shown on the left (domoic acid, Iso-A and Iso-D) contain a C'1–C'2 double bond with a Z (cis) side-chain configuration; each of these exhibits strong neurotoxic potency. The isoforms on the right exhibit either no C'1–C'2 double bond (Iso-C) or a C'1–C'2 double bond with an E (trans) side-chain configuration (Iso-B, -E and -F) and collectively exhibit little or no functional potency.

following administration of kainic acid relative to young, and behavioral studies of domoic acid in neonatal, young-adult and aged rats have shown that neonatal and aged animals are markedly more susceptible to domoic acid-induced seizures relative to young-adults across a wide range of intraperitoneal doses. This increased susceptibility appears to be a result of impaired renal clearance as opposed to increased blood-brain barrier permeability or differences in absolute neuronal sensitivity to the neurotoxin [4]. Although the precise kinetics of domoic acid transfer across the placenta are not known, domoic acid has been shown to adversely affect postnatal development following exposure of pregnant animals to seizurogenic doses of the neurotoxin. In addition, domoic acid has been shown to appear in the milk of lactating rats and can be detected in low levels in suckling offspring. Interestingly, a number of studies in rats have shown that postnatal exposure to even small doses of domoic acid

can produce lasting changes in brain neurochemistry, anatomy and behavior which persist well into adulthood.

#### Receptor Sites of Action and Pharmacodynamics

Domoic acid is a potent agonist of ionotropic glutamate receptors, exhibiting high affinity to a subset of **▶KA receptors** and moderately high affinity to a subset of **▶AMPA receptors**. Neither the parent molecule nor its isomers bind to NMDA or metabotropic glutamate receptors (mGluR's), or to any of a wide range of other CNS neurotransmitter or ion channel sites [5]. The considerable selectivity of domoic acid at KA and AMPA receptors has been demonstrated by radioligand binding, electrophysiology and functional *in vitro* toxicity studies. Binding affinity ( $K_D$ ) at the KA receptor ranges from 1 to 5 nM and at the AMPA receptor from 10 to 100 nM, depending on receptor assay conditions. Whole cell neuronal recordings and *in vitro* cell culture studies have

confirmed this relative relationship for domoic acid potency (agonist activity) at KA and AMPA receptors.

A key feature leading to strong glutamate receptor binding by domoic acid and its isomers is a C'1–C'2 double bond with a Z (cis) side-chain configuration. In early radioligand binding studies, isodomoic acid-D and other cis-configuration isomers were shown to exhibit relatively high affinities for rat brain KA receptors, while isomers E and F (both trans-configuration) exhibited markedly lower affinities relative to DA [6]. The same relative structure-affinity relationship was recently shown for isodomoic acid-A (cis-configuration) and -C (trans-configuration) binding at KA receptors [7]. Studies of functional neurotoxicity in insects and recent electrophysiological analyses of isodomoic acids-A, -B and -C in rat brain, both *in vitro* and *in vivo* (8, and unpublished observations), have confirmed that strong agonist activity is associated with domoic acid isomers exhibiting a cis-configuration side chain.

### Mechanisms of Seizure Induction and Excitotoxicity

Because of its high affinity and potent agonist activity at KA and AMPA receptors, domoic acid readily produces seizure activity acutely and, at higher doses or following prolonged exposure, acts as a strong “excitotoxin” producing sustained ionotropic glutamate receptor activation, tonic dendritic depolarization, neuronal hyperexcitability, excessive Ca<sup>2+</sup> influx and ultimately, dendritic damage and neuronal loss. This excitotoxic cascade has been observed in a number of CNS regions, and is particularly pronounced in the mammalian hippocampus which is rich in AMPA and KA receptors. *In vitro* electrophysiological analyses in rat hippocampal slices have shown domoic acid to be 5–10 fold more potent than KA in the induction of epileptiform activity in region CA1, producing neuronal hyperexcitability within minutes of application and, with prolonged administration, a significant suppression of neuronal activity, presumably due to depolarization block of cell firing [8].

The hippocampus plays an important role in information processing, learning and memory and, in cases of animal or human epileptogenesis, is often a focus of limbic seizure activity. During a well-documented episode of domoic acid poisoning in Canada [3] a number of people suffered disorientation, seizures, convulsions, coma, and even death. Several people exhibited long-term anterograde amnesias consistent with excitotoxic lesions and neuronal loss from the hippocampus and associated limbic/median temporal structures. CAT, MRI and PET scans of individuals exhibiting severe amnesia, coupled with post-mortem tissue histopathology confirmed that significant neuronal degeneration had occurred in many of these brain regions [3]. In animals, behavioral indices of limbic seizures include “wet-dog shakes,” hypermotility, stereotypical scratching, head nodding, loss of balance, and mild facial clonus at lower

doses, followed by forelimb clonus, salivation and rearing (characteristic of *status epilepticus*) at higher doses. EEG analyses have yielded evidence of generalized bilateral seizures characterized by increased frequency and amplitude of electrographic spikes, a dominance of delta and theta activity, intermittent limbic paroxysmal burst discharges, and frontotemporal epileptiform activity in humans and animals suffering domoic acid poisoning. Of particular concern is the fact that acute seizure activity following domoic acid poisoning can lead to long-term epilepsy in humans, with onset delayed up to 1 year after the initial insult.

### Domoic Acid-Induced Cardiac Damage

During the 1987 case human domoic acid poisoning, hypertension and cardiac arrhythmias were seen in affected patients. More recently, cardiotoxicity has been documented in sea lions and sea otters exposed to domoic acid [9]. Cardiac lesions included myocardial pallor, myocardial haemorrhage and fibrinous epicarditis. In addition, lymphocytic myocarditis, gross lesions consistent with dilated cardiomyopathy, and congestive heart failure characterized by pulmonary oedema were evident in many animals. Whether cardiac injury is a direct or indirect effect of domoic acid is currently a subject of debate. As noted, animals exhibit strong, sustained seizure activity following domoic acid and it is possible that cardiac injury arises secondary to *status epilepticus* or during prolonged excitation of CNS cardiac control centers. Ictal tachycardias and/or bradycardias often arise during seizures, and most likely relate to propagation of electrical activity via insular cortex, amygdala and central nuclei to cardiorespiratory centers in the medulla. Furthermore, intracerebral kainate injection leads to myocardial necrosis in rats and intrahippocampal injection of picomole amounts of domoic acid produce sustained tachycardias (Sawant and Kerr, unpublished observations; Fig. 3).

However, while domoic acid-induced cardiac damage occurs downstream of autonomic “sympathetic storm,” domoic acid can also exert *direct* effects on cardiomyocytes. A number of studies have identified gene transcripts and proteins for ionotropic glutamate subunits in rat heart and, although precise mechanisms underlying excitotoxic insult within the myocardium have yet to be established, GluRs within the atrial/septal conducting fibres, ganglia cells, nerve fibers, intercalated discs and blood vessels may provide a means of modulating cardiac autonomicity, contractility and rhythmicity. Recent studies by our group indicate that treatment of isolated cardiac mitochondria with domoic acid results in a rapid uncoupling of mitochondrial respiration and specific damage to mitochondrial complex enzyme activity. We have also found that cultured H9c2 cardiomyocytes readily transport domoic acid into the intracellular compartment, and that mitochondrial respiratory activity

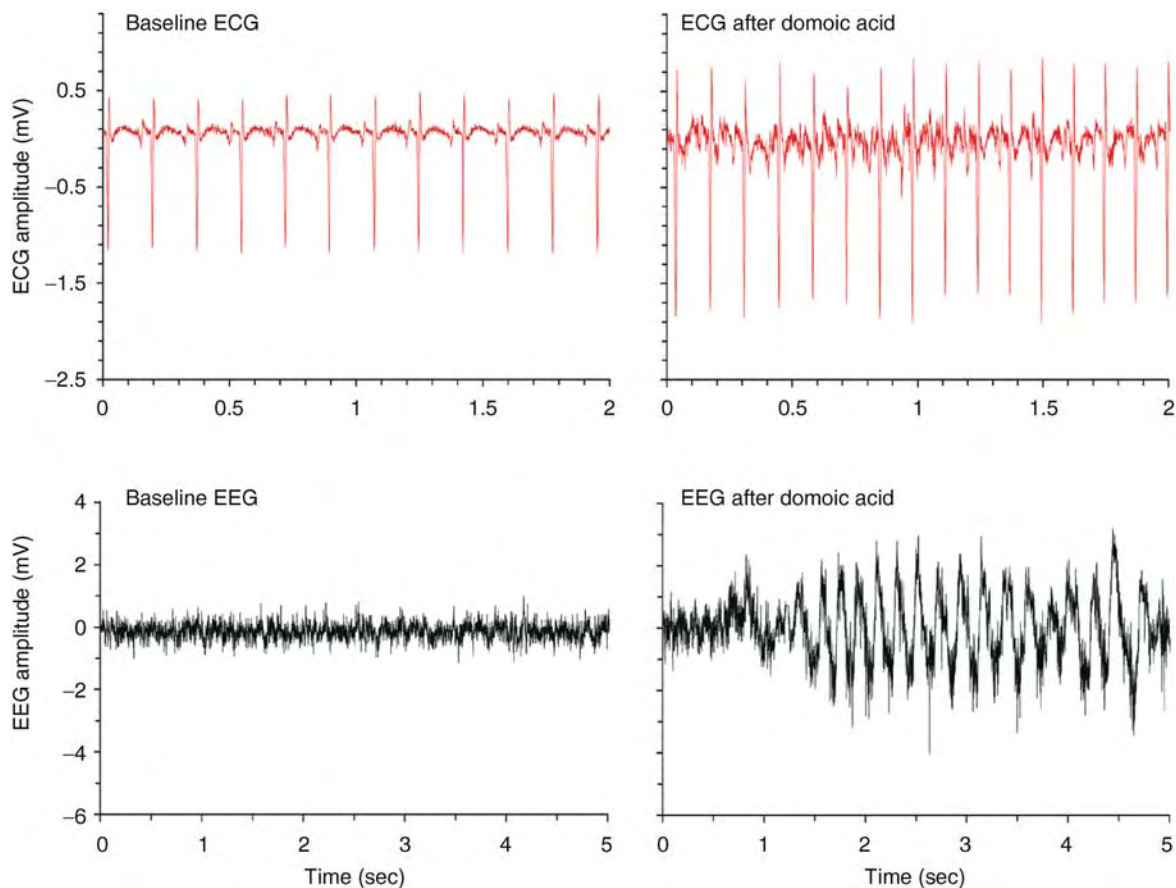

**Domoic Acid Neurotoxicity. Figure 3** Electrocardiograms (ECGs) and electroencephalograms (EEGs) from adult rat before (left panel; heart rate 330 bpm) and following intrahippocampal injection of 100 picomoles domoic acid (heart rate 450 bpm). (Sawant and Kerr, unpublished observations.)

is suppressed following *ex vivo* perfusion of intact hearts with domoic acid [10, and unpublished observations]. Interestingly, acute (20 min.) exposure to domoic acid does not alter Langendorff cardio-haemodynamics, suggesting that longer exposures, as occur naturally, may be required in the direct induction of cardiomyopathy. At this time it appears that cardiac damage involves direct actions of domoic acid on cardiac mitochondrial energetics in conjunction with indirect effects associated with excitation and/or damage to CNS autonomic control centers during domoic acid exposure. As such, seizure activity likely provokes or exacerbates gross and ultrastructural myocardial damage, consistent with pathology reported following domoic acid exposure.

## References

1. Jeffery B, Barlow T, Moizer K, Paul S, Boyle C (2004) Amnesic shellfish poison. *Food Chem Toxicol* 42:545–557
2. Ramsdell JS (2007) The molecular and integrative basis to domoic acid toxicity. In: Botana L (ed) *Phycotoxins: chemistry and biochemistry*, Blackwell Publishing Professional, Cambridge, MA, pp 223–250
3. Teitelbaum JS, Zatorre RJ, Carpenter S, Gendron D, Evans AC, Gjedde A, Cashman NR (1990) Neurologic sequelae of domoic acid intoxication due to the ingestion of contaminated mussels. *New Engl J Med* 322:1781–1787
4. Hesp BR, Clarkson A, Sawant PM, Kerr DS (2007) Domoic acid preconditioning and seizure induction in young and aged rats. *Epilepsy Res* 76:103–112
5. Crawford N, Lang TK, Kerr DS, de Vries D (2000) High affinity [ $^3$ H]-kainic acid binding to brain membranes: a re-evaluation of ligand potency and selectivity. *J Pharmacol Toxicol Methods* 42:121–125
6. Hampson DR, Huang XP, Wells GW, Walter JA, Wright JLC (1992) Interaction of domoic acid and several derivatives with kainic acid and AMPA binding sites in rat brain. *Eur J Pharmacol* 218:1–8
7. Sawant PM, Weare BA, Holland PT, Selwood AI, King KL, Mikulski CM, Doucette GJ, Mountfort DO, Kerr DS (2007) Isodomoic acids A and C exhibit low KA receptor affinity and reduced in vitro potency in hippocampal region CA1. *Toxicol* 50:627–638
8. Sari P, Kerr DS (2001) Domoic acid-induced hippocampal CA1 hyperexcitability independent of region CA3 activity. *Epilepsy Res* 47:65–76
9. Kreuder C, Miller MA, Lowenstine LJ, Conrad PA, Carpenter TE, Jessup DA, Mazet JA (2005) Evaluation

of cardiac lesions and risk factors associated with myocarditis and dilated cardiomyopathy in southern sea otters (*Enhydra lutris nereis*). *Am J Vet Res* 66:289–99

10. Tramoundanas AV, Harrison JC, Kerr DS, Sammut IA (2005) Domoic acid directly inhibits cardiac mitochondrial respiratory function. *N Z Med J* 118:1218

## Dopamine

### Definition

The catecholamine dopamine was first proposed to be a novel brain synaptic transmitter by Arvid Carlsson in the mid-1950's and the subsequent body of evidence, confirming this hypothesis and its relevance to several important brain disorders including Parkinson's disease and schizophrenia, earned him a Nobel prize in 2000.

Dopamine is synthesized from L-tyrosine. Dopamine acts via five distinct G protein-coupled metabotropic receptors which are categorized into two separate classes based on activation (D1-D5) adenylyl cyclase or reduction (D2,D3,D4) of cyclic AMP. There are six separate neural pathways containing dopamine as the primary synaptic transmitter, and two have particular relevance to systems neuroscience and higher order brain function. The nigrostriatal projection from the substantia nigra to dorsal striatum plays a critical role in initiation of movement and damage to this pathway leads to Parkinson's disease. The mesocorticolimbic projection arises from dopaminergic neurons in the ventral tegmental area and projects to regions of the limbic system and the prefrontal cortex. This pathway is essential for incentive motivation and reward function and is implicated in substance abuse and other forms of addiction. Dopamine activity in the prefrontal cortex has been linked to working memory and other aspects of executive function involved in predicting the outcome of subsequent behavior. Enhanced and reduced dopaminergic activity in the prefrontal cortex are both proposed as biochemical correlates of psychotic behavior.

► Parkinson's Disease

## Dopamine Receptors

### Definition

Dopamine acts via five distinct G protein-coupled metabotropic receptors which are categorized into two

separate classes based on activation (D1-D5) adenylyl cyclase or reduction (D2,D3,D4) of cyclic AMP.

► Dopamine

## Dopamine Transporter

### Definition

Dopamine Transporters (DAT) are present in dopamine nerve terminals and are critical for removing dopamine from the synapse. DA is then transported into vesicles by the monoamine transporter (VAT).

► Dopamine

## Dopamine- $\beta$ -hydroxylase (D $\beta$ H)

### Definition

Dopamine- $\beta$ -hydroxylase (D $\beta$ H) is the enzyme that converts dopamine to noradrenaline, in the pathway for catecholamine biosynthesis from the essential amino acids phenylalanine or tyrosine. D $\beta$ H in postganglionic autonomic neurons is synthesized in the cell body, and transported to the terminal varicosities in membrane bound vesicles. These vesicles take up dopamine, D $\beta$ H converts it to noradrenaline, and noradrenaline is stored in the vesicles prior to release (or, in amphibians, prior to its conversion to adrenaline).

- Adrenaline
- Dopamine
- Noradrenaline
- Postganglionic Neurotransmitter

## Dopaminergic Drugs

### Definition

Medications that either act as dopamine precursors (levodopa), dopamine mimickers (dopamine agonists), or dopamine level enhancers (monoamine oxidase-B inhibitors).

► Dopamine

## Dorsal Cap of the Inferior Olive (DC)

### Definition

A nucleus within the inferior olive that receives optokinetic information from the accessory optic system and eye movement-related information from the nucleus prepositus hypoglossi (NPH).

- ▶ Inferior Olivary Nucleus
- ▶ Vestibular Secondary Afferent Pathways

## Dorsal Cochlear Nucleus

### Definition

Major division of the cochlear nucleus.

- ▶ Cochlear Nucleus

## Dorsal Column

### Definition

The dorsal columns are composed of two bundles of afferent nerve fibers located on each side of the spinal cord behind the gray matter. They carry signals predominantly from mechanoreceptors in skin and deep tissues.

- ▶ Somatosensory Projections to the Central Nervous System

## Dorsal Column Ataxia

- ▶ Proprioception: Effect of Neurological Disease

## Dorsal Column Nuclei

### Definition

Nuclei that lie at the spinomedullary junction and receive projections from sensory afferent fibers carrying touch and position sense stimuli from the body. The medially lying nucleus gracilis carries this information from the lower limb and lower part of the

trunk, and the laterally neighboring nucleus cuneatus carries this information from the upper part of the trunk, the upper limb, and the neck. The dorsal column nuclei project to multiple sites in the brainstem, the most prominent of which is a dorsal thalamic nucleus, the nucleus ventralis posterolateralis of mammals and its homologues in other vertebrates.

- ▶ Evolution of the Somatosensory System in Nonmammalian Vertebrates
- ▶ Large Fiber Sensory Neuropathy
- ▶ Somatosensory Projections to the Central Nervous System

## Dorsal Cortical Pathway

### Definition

This prominent cortical pathway, dominated by input from parasol retinal ganglion cells, projects through cortical areas including MT, MST, LIP and VIP, and is thought to be crucial for motion and localization analysis.

- ▶ Extrastriate Visual Cortex
- ▶ Retinal Ganglion Cells
- ▶ Visual Motion Processing
- ▶ Visual Processing Streams in Primates

## Dorsal Horn

### Synonyms

Cornu posterius; Posterior horn of spinal cord; Posterior Horn

### Definition

Area of the spinal cord where sensory neurones relay information at a segmental level after entering the cord to other neurones.

## Dorsal Lateral Pontine Nuclei

### Definition

The dorsal lateral pontine nuclei relay smooth pursuit commands from the cerebrum to the cerebellar flocculus.

- ▶ Gaze Shift
- ▶ Smooth Pursuit Eye Movements

## Dorsal Lateral Thalamic Nucleus

### Synonyms

Nucl. lat. dors. thalami

### Definition

This thalamic nucleus of the lateral nuclear group is, like the anterior thalamic nucleus, reciprocally connected with the limbic cortex of the cingulate gyrus, retrosplenial area as well as the pre- and parasubiculum. Concomitantly, it receives afferents from the pretectal area and projects to the hippocampus, parietal lobe and retrosplenial cortex and is involved in somato-sensory-motor integration processes.

► Diencephalon

## Dorsal Longitudinal Fasciculus, (Schultz)

### Synonyms

Fasciculus longitudinalis post; Posterior longitudinal fasciculus

### Definition

The dorsal longitudinal fasciculus is a central axis of the autonomic nervous system, coupling the hypothalamus to the nuclei of the brainstem, primarily the parasympathetic nuclear regions, cranial nerve nuclei of the vagus nerve (X), trigeminal nerve (V), hypoglossal nerve (XII) and facial nerve (VII). Ascending fibers come from the solitary nucleus and the reticular formation, conveying predominantly gustatory information to the hypothalamus.

► Diencephalon

## Dorsal Motor Nucleus of the Vagus (DMV)

### Definition

Located ventral to the nucleus tractus solitarii (NTS) in the medulla oblongata, contains pre-ganglionic motor neurons innervating the gastro-intestinal tract. DMV

neurons have spontaneous pace-maker activity that is dampened by GABAergic NTS projections. More than 95% of DMV cells are cholinergic, the remaining neurons are catecholaminergic (mainly dopamine-containing) and nitrergic. Some portion of the DMV reside outside the blood brain barrier.

► Nucleus Tractus Solitarii

## Dorsal Nucleus of the Vagus Nerve

### Synonyms

Nucl post. n. vagi; Posterior nucleus of vagus nerve

### Definition

In this approximately 2 cm long nucleus, the preganglionic parasympathetic (GVE) fibers originate. The nucleus runs in the medulla somewhat parallel to the nucleus of the hypoglossal nerve, in the lower angle of the fourth ventricle (vagal trigone). Afferents are received by the nucleus from the solitary nucleus, dorsal tegmental nucleus and other structures.

The special visceromotor fibers in the vagus nerve originate in the nucleus ambiguus, as in the case of those from glossopharyngeal nerve (IX).

► Myelencephalon

## Dorsal Octavolateralis Nucleus

### Definition

Primary hindbrain recipient zone for electrosensory ampullary organ afferents in non-teleost fishes.

► Evolution of Mechanosensory and Electrosensory Lateral Line Systems

## Dorsal Raphé Nucleus (B7)

### Synonyms

Nucleus raphé dorsalis

► Raphé Nuclei



## Dorsal Respiratory Group

### Definition

A group of neurons in the ventrolateral portion of nucleus tractus solitarius that participates in generation of the respiratory rhythm, particularly inspiration.

- ▶ Motion Sickness

## Dorsal Root Ganglion (DRG)

### Definition

The dorsal root ganglion is situated on the spinal dorsal root and contains cell bodies of sensory afferent nerve fibers. Axons in the dorsal root convey somatosensory and viscerosensory information into the spinal cord and brain from the periphery.

## Dorsal Root of the Spinal Nerve

### Synonyms

N. spinalis, radix post; Posterior root of the spinal nerve

### Definition

Via the dorsal root, peripheral sensory nerve fibers enter the spinal cord. A distinction is made between various types of fibers (A, C fibers etc.)

- ▶ Medulla Spinalis

## Dorsal Root Potential (DRP)

### Definition

A prolonged negative potential recorded from the central stump of a cut dorsal root filament. These potentials are produced by electrotonic conduction of intraspinal depolarization of primary afferent fibers (primary afferent depolarization: PAD).

- ▶ Presynaptic Inhibition

## Dorsal Root Reflex (DRR)

### Definition

An action potential back-propagated into the axon when primary afferent terminals reach firing threshold as a result of primary afferent depolarization (PAD).

- ▶ Presynaptic Inhibition

## Dorsal Telencephalic Area

- ▶ Evolution of the Pallium: In Fishes

## Dorsal Telencephalon

- ▶ Evolution of the Pallium: In Fishes

## Dorsal Thalamus

### Definition

The part of the brain that receives sensory information and sends it to neocortex. The large dorsal cortex of mammals also receives inputs from other brain structures, such as the midbrain, including all of neocortex.

- ▶ Diencephalon
- ▶ Evolution, of the Brain, in Mammals

## Dorsal Vagal Complex (DVC)

### Definition

A collection of three neighboring nuclei in the caudal, dorsomedial medulla oblongata: (i) the nucleus of the solitary tract (NTS), a viscerosensory nucleus that

primarily integrates information from visceral structures such as the gut, the heart, and the lungs, which arrives primarily via the vagus nerve (cranial nerve X); (ii) the area postrema (AP), a circumventricular organ that protrudes into the fourth ventricle atop the NTS, and receives modest input from the vagus nerve; and (iii) the dorsal motor nucleus of the vagus (DMV, or DMX), which contains cholinergic visceral motor neurons that receive most of their input from the overlying NTS and directly innervate a variety of visceral structures, particularly the gut wall.

- ▶ Autonomic/Enteric Reflexes
- ▶ Encyclopedia of Neuroscience

## Dorsal Ventricular Ridge (DVR)

### Definition

A structure in the lateral telencephalon.

- ▶ Evolution of the Brain: in Birds

## Dorsolateral Cortex

- ▶ Prefrontal Cortex

## Dorsolateral Fasciculus of Spinal Cord (Lissauer)

### Synonyms

Tractus posterolat. (Lissauer); Posterolateral tract (Lissauer)

### Definition

Like the fasciculus proprius, Lissauer's tract contains primarily fibers for the intrinsic and reflex apparatus of the spinal cord.

- ▶ Medulla Spinalis

## Dorsolateral Placodes

### Definition

A series of epidermal thickenings found in all vertebrate embryos. These patches of cells give rise to the receptors, ganglion cells, and the glial and supporting cells of the octavolateralis systems.

- ▶ Evolution of Mechanosensory and Electrosensory Lateral Line Systems

## Dorsolateral Prefrontal Cortex

### Definition

A region in the prefrontal cortex that is thought to control working memory and attention.

- ▶ Attention
- ▶ Working Memory

## Dorsomedial Hypothalamic Nucleus

### Synonyms

Nucl dorsomed. hypothalami

### Definition

A diffusely organized hypothalamic nucleus implicated in eating behavior. Afferents from many subcortical areas. Efferents to the paraventricular nucleus, parvocellular part (influences neuroendocrine system). The motor nucleus of the vagus nerve (parasymp. effect on endocrine pancreas => insulin production), circumventricular organs (control of humoral factors from the blood).

- ▶ Diencephalon

## Dorsomedial Thalamic Nucleus

### Definition

A large collection of cells within the thalamus, a part of the forebrain. It plays a variety of roles in the regulation of rhythms and sleep.

- ▶ Nocturnal/Diurnal
- ▶ Thalamus

## Double Bouquet Cell

### Definition

A type of inhibitory cortical neuron with characteristic spiny dendrites oriented vertically. There are multiple subtypes defined neurochemically, and commonly are visualized with an antibody to calbindin.

succession. The offset of the central fixation target signals the subject to make saccades to the two peripheral targets, in the order in which they appear. Both targets, however, are extinguished shortly before saccade onset. The first saccade, of course, will change the position of the eyes so that the second saccade will not be directed to the same retinotopic location where the target had appeared.

► Saccade, Saccadic Eye Movement

## Double Dissociation

### Definition

A dissociation occurs when one factor, A, affects process 1 but not process 2; or, when another factor, B, affects process 2 but not process 1. A double dissociation occurs when both of these are true: when one factor, A, (whether an experimental manipulation or neural damage) affects process 1 but not process 2 while another factor, B, affects process 2 but not process 1.

► Visual Illusions

## Double Visceral Innervation

### Definition

Generally visceral organs of mammals are innervated by two kinds of nerves, sympathetic and parasympathetic, and this is referred to as double innervation. For example, the heart, stomach, pupils etc. are innervated by sympathetic and parasympathetic nerves, but sweat glands are not (they are only innervated by sympathetic nerves). Most of the visceral organs of the mammals are innervated by sympathetic and parasympathetic nerves, and muscles of the claw of the crab are innervated by facilitatory and inhibitory nerves.

► Parasympathetic Pathways

► Sympathetic Pathways

## Double Innervation

### Definition

Generally, visceral organs of mammals are innervated by two kinds of nerves, sympathetic and parasympathetic nerves, and is defined as double innervation. For example, the heart, stomach, pupil etc. are innervated by sympathetic and parasympathetic nerves, but the sweat gland is not (only innervated by the sympathetic nerve).

If an organ is innervated by two kinds of nerves, it is defined as double innervation. For example, most of the visceral organs of the mammals are innervated by sympathetic and parasympathetic nerves, and muscles of the claw of the crab are innervated by facilitatory and inhibitory nerves.

## Double Vision

### Definition

► Diplopia.

## Double Saccade Task

### Definition

After fixating a central target, the subject (human or monkey) is shown two peripheral visual targets in

## Down Syndrome Cell Adhesion Molecule

HUNG-HSIANG YU, TZUMIN LEE  
Department of Neurobiology, University of  
Massachusetts Medical School, Worcester, MA, USA

### Synonyms

DSCAM/Dscam

## Definition

DSCAM/Dscam, an immunoglobulin superfamily member primarily expressed in the nervous system of both vertebrates and flies, is broadly required in the *Drosophila* for neuronal morphogenesis, especially the proper segregation of neuronal branches that derive from the same neuron.

## Characteristics

### Mammalian DSCAMs as Immunoglobulin-Containing Neuronal Proteins

Down syndrome, the most common cause of genetic mental retardation, is strongly associated with trisomy of human chromosome 21, especially in the region of 21q22. One of the molecules located in this region is Down syndrome cell adhesion molecule (DSCAM). DSCAM and its paralog DSCAML1 are cell surface proteins with ten Immunoglobulin (Ig) domains and six fibronectin (FN) III domains on their extracellular region, a transmembrane domain and a cytoplasmic tail (Fig. 1) [1].

As revealed by in situ hybridization, both *DSCAM* and *DSCAML1* are dynamically expressed in the developing spinal cord and brain; and they are expressed in distinct

and/or complimentary patterns [1]. However, the function of DSCAM in the mammalian nervous system and whether over-expression or extra copies of DSCAM would lead to Down syndrome have not been elucidated.

### The Function of *Drosophila* Dscam and Dscam2 in the Neural Development

Four Dscams (Dscam and Dscam2–4) in the *Drosophila* genome are highly related to human DSCAM with the same number and organization of Ig and FNIII domains in their extracellular region, sharing about 30% sequence identity (Fig. 1) [2–4]. In contrast, the intracellular region of these *Drosophila* Dscams does not share similarity with their mammalian homologues. Dscam and Dscam2 are primarily expressed in the developing nervous system and, required for the formation of connections of various types of neurons during the development (Fig. 2) [2–4].

Dscam is important for assembling axon connectives and commissures of the embryonic central nervous system (CNS) and for correct axon projection of Bolwing's nerve (BN) [2]. BN is constituted by 12 photoreceptor neurons, whose axons navigate to their target in the brain at the embryonic and larval

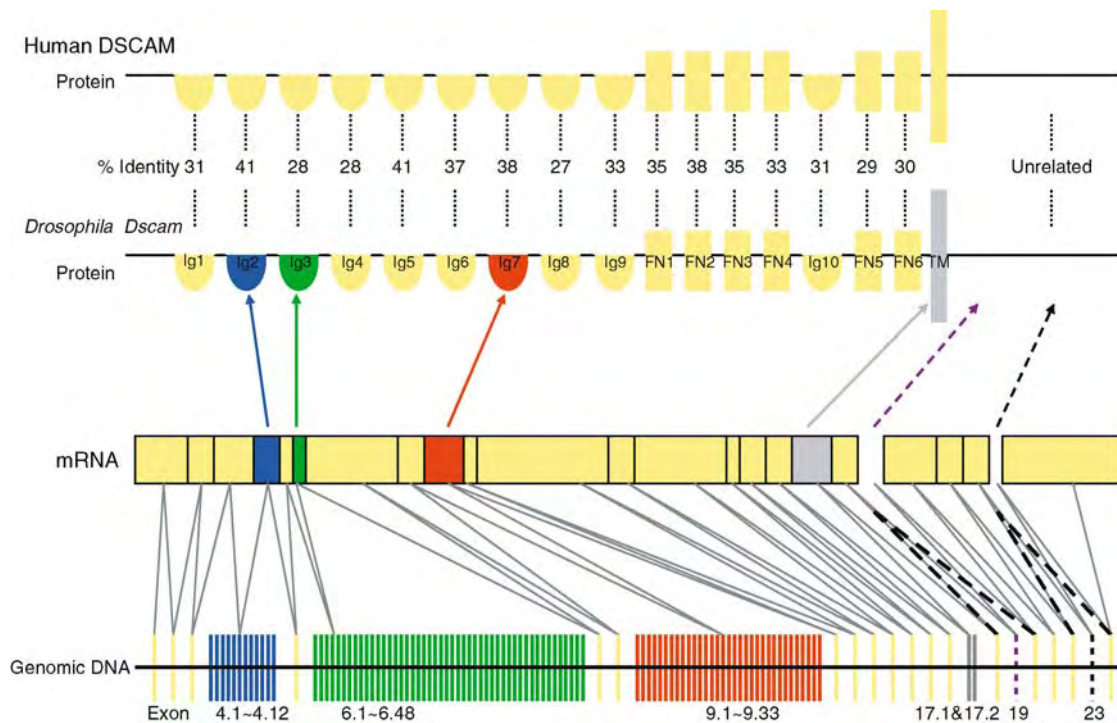

**Down Syndrome Cell Adhesion Molecule. Figure 1** The domain structures of human DSCAM and *Drosophila* Dscam are compared. Percentage identities of the compared domains are indicated in numbers between dashed lines. A large number of *Dscam* isoforms are produced by alternative splicing on multiple alternative exon clusters (exons 4, 6, 9 and 17). These alternative splicing exons are responsible for generating the variable regions on Ig2, Ig3, Ig7 and transmembrane domains of Dscam isoforms [2,3]. Additional variants, existing in the Dscam cytoplasmic domain, are generated from skipping exons 19 and/or 23 [7].

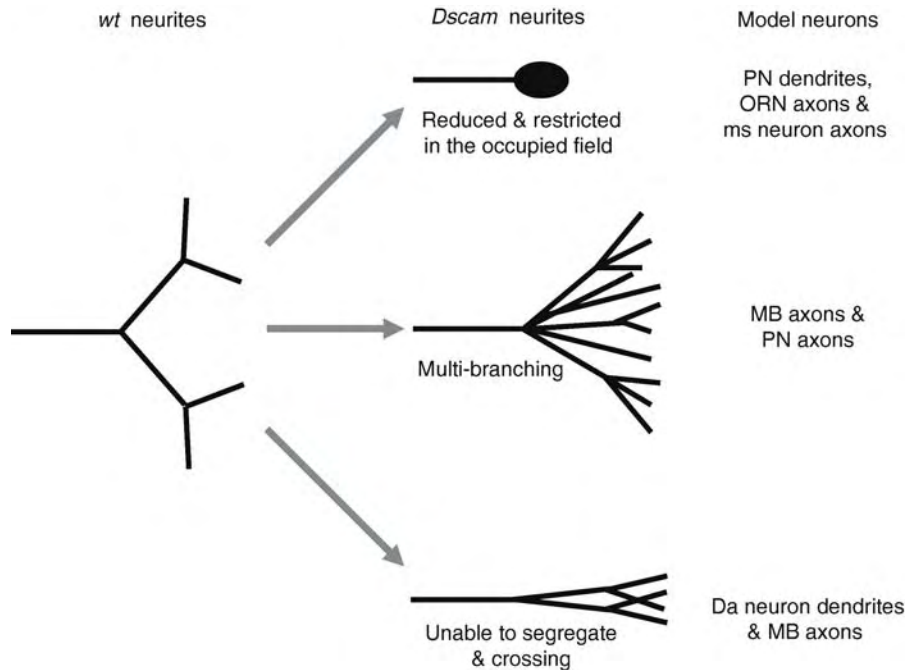

**Down Syndrome Cell Adhesion Molecule. Figure 2** A schematic illustration of hypothetical neurites summarizes the phenotypes observed in the wild-type and *Dscam* mutation. Phenotypes of different model neurons are indicated. PN, projection neuron; ORN, olfactory receptor neuron; ms, mechanosensory; MB, mushroom body; da, dendritic arborization [3,5,6].

stages. BN axons were often mistargeted and bypassed their intermediate target neuron in *Dscam* mutant embryos [2].

*Dscam* is crucial for constructing olfactory neural circuits in the *Drosophila* brain. Olfactory receptor neurons (ORNs), residing in two adult appendages (antennae and maxillary palps), project their axons and make the connections with dendrites of second-order projection neurons (PNs; equivalent to the mammalian mitral/tufted cells) in glomeruli of the antennal lobe (equivalent to the mammalian olfactory bulb). PNs send their axons to higher-order neurons in the mushroom body (MB) and lateral horn where the olfactory information is processed. When *Dscam* is deficient, mistargeted ORN axons were observed in ectopic sites within and outside the antennal lobe [3]. Compared to well elaborated wild-type ORN axonal branches within glomeruli of the antennal lobe, *Dscam*-deficient ORN axons tended to be restricted to the entry site of glomeruli of the antennal lobe. Similarly, removing *Dscam* specifically from the PNs resulted in clumped dendrites and reduced the dendritic field in glomeruli of the antennal lobe [5]. In single cell analyses, a *Dscam*-deficient DL1 PN axon became multiple branches after projecting into the region of the lateral horn in contrast to a single major axonal tract in the wild-type DL1 PN [5]. Furthermore, *Dscam* is essential for establishing the correct axonal pattern

during MB neuronal morphogenesis. Depleting *Dscam* from MB neurons led to an increase in axon branch number and/or a failure in segregation of sister branches [3].

Besides the functions in the CNS, *Dscam* is also required for generating proper axonal and dendritic patterns of *Drosophila* sensory neurons. Air flow- and touch-sensing mechanosensory (ms) neurons, innervating large bristles of the posterior thorax, have a remarkable stereotyped axonal branching pattern within the CNS. Axons of *Dscam*-deficient ms neurons frequently stalled near the CNS margin, resulting in a clumped axonal branch phenotype [3]. On the other hand, *Drosophila* dendritic arborization (da) neurons are peripheral sensory neurons with multiple dendritic projections, which spread their dendrites along the epidermis. Dendritic arbors within an individual single da neuron normally follow a “self-avoidance” rule to avoid contacting and crossing over each other. When *Dscam* was absent, dendrites of da neurons tended to bundle together and cross over each other [6].

In the *Drosophila* visual system, photoreceptor neurons from the ▶compound eye specifically innervate the lamina and medulla in the brain. For example, R7-R8 photoreceptor neurons extend their axons into the developing medulla columns where they make synaptic connections with lamina neurons (L1-L5). Normally, neurites of L1-L5 neurons are confined to their column unit in the medulla. A recent study of *Drosophila Dscam2*

on two lamina neurons, L1 and L2, has just started to reveal its function in the development of the visual system. *Dscam2* is required for restricting arbors of the L1 neuron, but not for L2 neuronal arbors, to a single column of the medulla. When *Dscam2* was deficient, L1 neurons were no longer able to limit their terminal structures within single columns [4].

### Extraordinary Molecular Diversity of *Drosophila Dscam*

A striking feature of *Drosophila Dscam* is its ability to produce a huge number of different isoforms [2], while no extensive isoform diversity can be found in mammalian DSCAMs and *Drosophila Dscam 2–4* [4]. This remarkable molecular diversity comes from the genomic organization of *Dscam*, which contains multiple cassettes of alternative splicing exons (Fig. 1). Mutually exclusive alternative splicing exon 4, 6, 9 and 17 clusters have 12, 48, 33 and 2 alternative exons, respectively, which correspond to the variable regions found in Ig2, Ig3, Ig7 and transmembrane domains of different *Dscam* isoforms [2]. Four additional variants, existing in the *Dscam* cytoplasmic domain, are generated from alternative splicing of exons 19 and 23 [7]. These alternative exons can potentially produce 152,064 *Dscam* isoforms.

The mechanism(s) underlying the mutually exclusive alternative splicing in the *Dscam* mRNAs is not entirely

clear. Comparative sequence analysis of the *Dscam* gene of 16 insect species led to identification of some RNA sequence elements that may control the mutually exclusive alternative splicing in the *Dscam* exon 6 cluster [8]. Two classes of conserved elements were recognized: the ►docking site, located in the intron downstream of constitutive exon 5, and the ►selector sequences complementary to a portion of the docking site, located upstream of each exon 6 variant (Fig. 3a).

The mutually exclusive nature of interactions of the docking site and selector sequence ensures that only one exon 6 variant is included in each *Dscam* mRNA. Similarly, two pairs of complementary sequences found on the *Dscam* intron 16–17.1 can form competing stem structures for mutually exclusive selection of one of exons 17.1 and 17.2 (Fig. 3b).

Since tremendous cellular and molecular diversity exists in the nervous system and *Dscam*, respectively, one interesting question is whether only a single *Dscam* isoform is expressed in any given neuron, endowing each neuron with its own identity. To address this question, a quantitative real-time PCR in combination with a customized oligonucleotide microarray, which contains sequences of all alternative exons from exon 4, 6 and 9 clusters, were used to analyze the usage of *Dscam* isoforms in distinct isolated neurons, including R3/R4 and R7 photoreceptors, MB neurons and ms

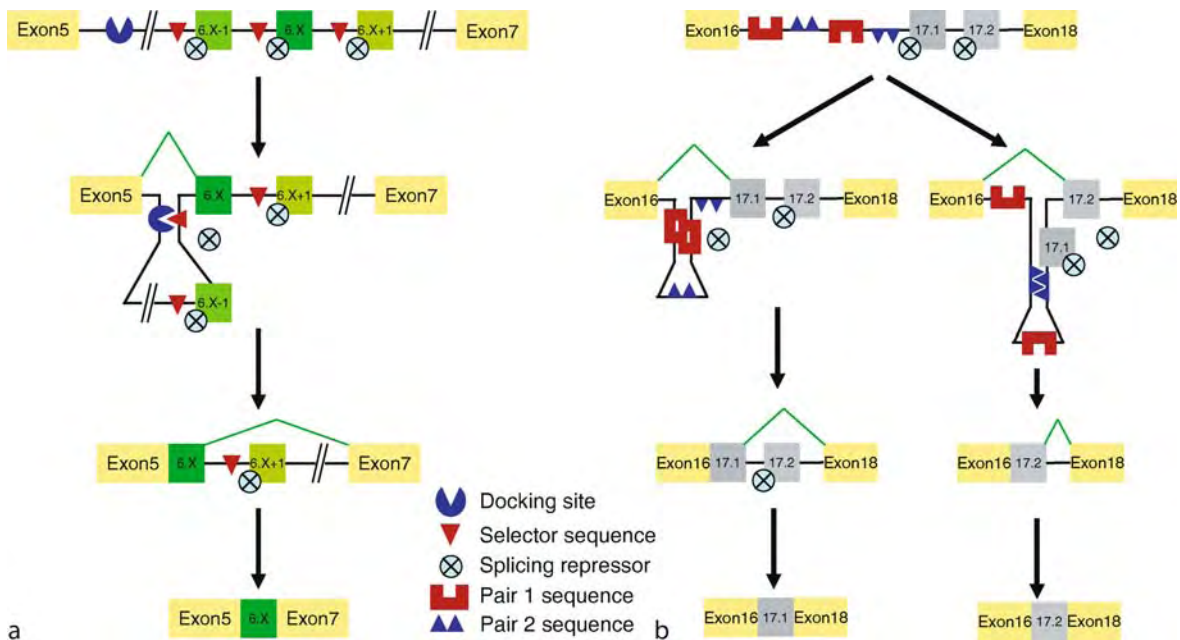

**Down Syndrome Cell Adhesion Molecule. Figure 3** The mechanism of mutually exclusive alternative splicing is proposed for how to choose a single exon on exon 6 (a) and exon 17 (b). Only three exons of the alternative exon 6 cluster are shown in A (x can be 2–47). Hypothetically unidentified splicing repressors normally prevent the splicing event from occurring. When a selector binds to the docking site (exon6) or complementary sequences bind to each other (exon 17), the splicing repressors are removed from pre-mRNA of *Dscam* in order to go on the mutually exclusive alternative splicing event [8].

neurons [3,9]. Such analyses revealed that individual neurons express around 10–50 distinct mRNA molecules chosen from thousands of splicing variants of *Dscam* isoforms in a stochastic yet biased fashion.

This stochastic yet biased *Dscam* expression raises another intriguing question: whether distinct *Dscam* isoforms have different specific functions. Two lines of evidence indicated that some *Dscam* isoforms have distinct functions in different types or sub-cellular regions of neurons. First, two deficiency lines with the deletion of exon 4.2–4.6 versus exon 4.4–4.8 of *Dscam* were used to examine axonal patterns of ms neurons. Interestingly, qualitatively different phenotypes were observed in these two deficiency lines [3], though no phenotype was detected in MB neurons lacking various subsets of exon 4s [7]. These results suggested that distinct *Dscam* exon 4 isoforms might mediate different neuronal morphogenesis at least in ms neurons (Fig. 4a).

Second, it has been reported that *Dscam* with exon 17.1 versus exon 17.2 is preferentially targeted to dendrites versus axons (Fig. 4b) [7]. Consistent with this notion, depleting exon 17.1-containing *Dscam*

selectively blocked PN dendritic morphogenesis while knocking down *Dscam* with exon 17.2 specifically disrupted axonal morphogenesis (Fig. 4b) [10].

#### Homophilic Binding Resulting in Repulsion

Like many Ig domain-containing proteins, mammalian DSCAMs and *Drosophila* Dscams are cell adhesion molecules which can promote aggregation between DSCAM/Dscam expressing cells [4]. Since *Drosophila Dscam* can produce a large number of isoforms that vary in the Ig domains, it is possible that different binding affinities may exist among distinct *Dscam* isoforms. A series of in vitro binding assays revealed that robust binding was restricted to identical Dscams, while no interaction was found in the heterophilic binding pairs (Fig. 5a) [3].

The homophilic binding region was further mapped to the variable Ig2, Ig3 and Ig7 domains. Varying the encoding exon for any of these three domains in *Dscam* drastically reduces the binding affinity among Dscams [3].

However, instead of mediating adhesion, three sets of experiments have shown that homophilic binding of

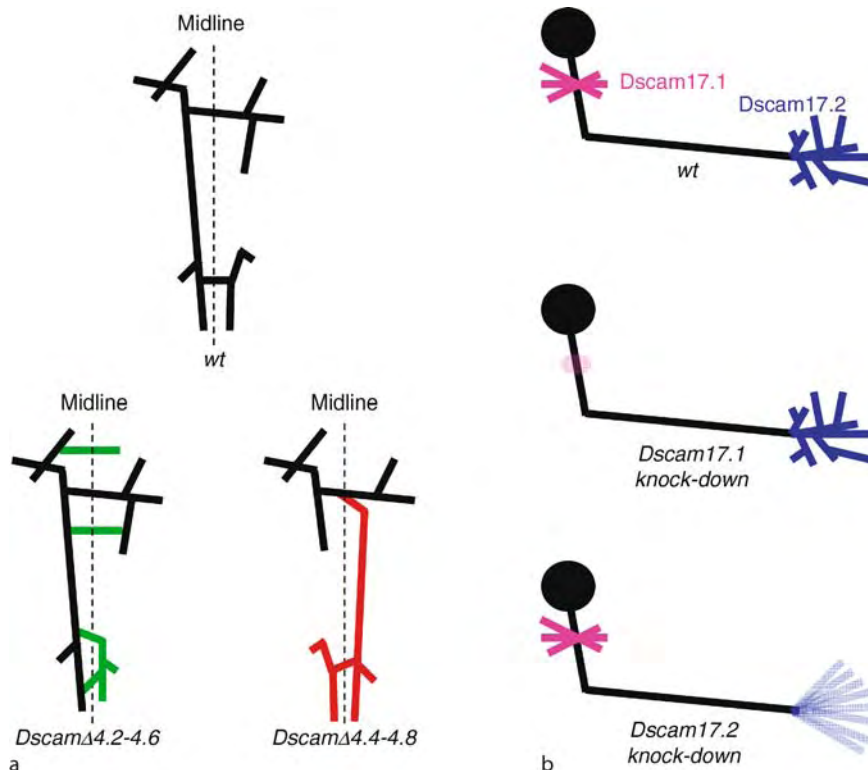

**Down Syndrome Cell Adhesion Molecule. Figure 4** Schematic illustrations depict phenotypes observed in ms neurons (a) and PNs (b) by removing subsets of *Dscam* exon 4 and exon 17 isoforms. Ectopic branches and misrouted contralateral projection were observed when exon 4.2–4.6 and exon 4.4–4.8, respectively, are deleted from the *Dscam* genomic region. *Dscam* exon 17.1 and exon 17.2 isoforms have preferential localization on dendrites and axons of PNs. Using a RNA interference technology to remove *Dscam* exon 17.1 and exon 17.2 isoforms from PNs results in distinct dendritic and axons phenotypes [3,7,10].

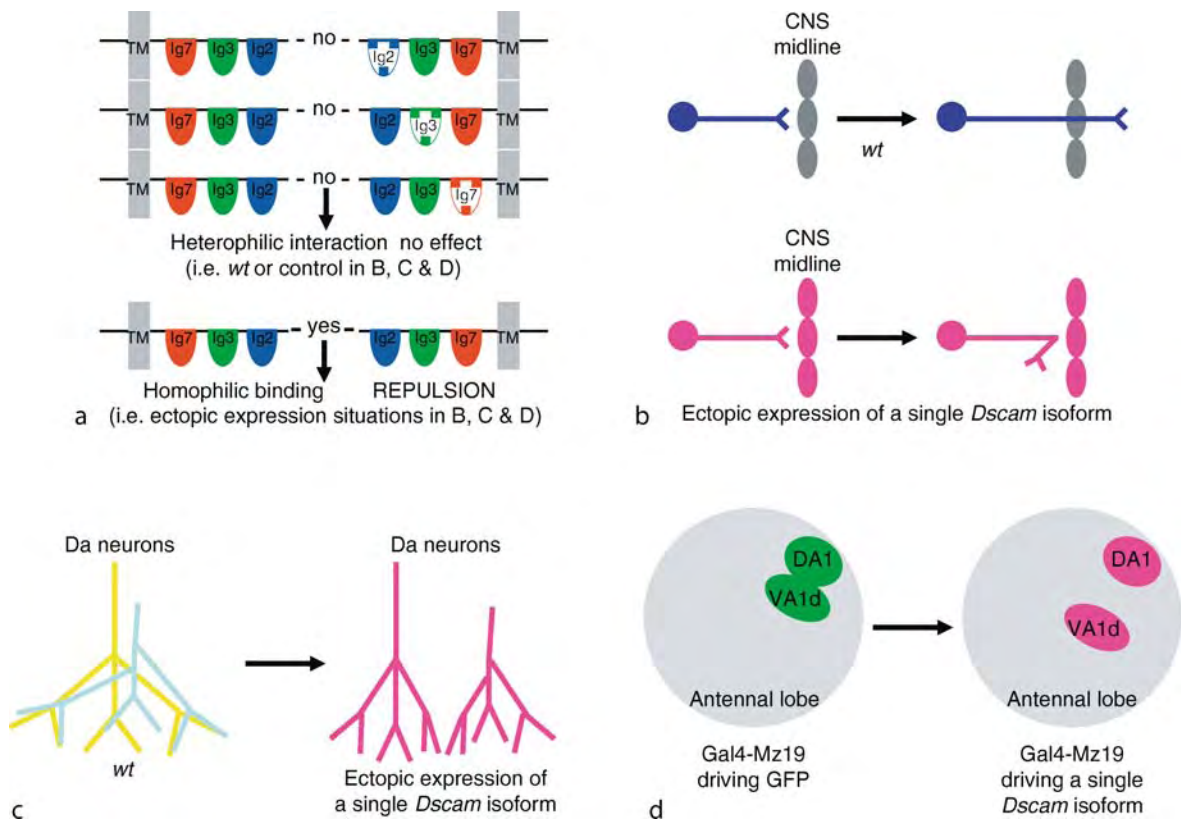

**Down Syndrome Cell Adhesion Molecule. Figure 5** Homophilic binding of identical *Dscam*s leads to repulsion of neurites, while heterophilic interaction of different *Dscam*s does not induce any biological effect. Neurites of embryonic interneurons (b), dendritic arborization neurons (c) and PN (d) can trigger the repulsive responses when a single *Dscam* isoform is over-expressed (shown in pink) [3,5,6].

*Drosophila* *Dscam* results in repulsion during the formation of neuronal connections. First, some embryonic CNS interneurons normally extend axons across midline cells during embryogenesis. However, axons of these embryonic interneurons failed to cross the CNS midline when *Dscam* was ectopically expressed in both the interneurons and midline cells (Fig. 5b) [3]. Second, four different classes of da neurons normally overlap with each other in their dendritic fields. Over-expression of a single *Dscam* isoform in da neurons led to dendritic recognition and avoidance, resulting in non-overlapping dendritic fields (Fig. 5c) [6]. Third, the wild-type DA1 and VA1d PN dendrites normally form two overlapping dendritic arbors adjacent to each other at the anterior surface of the antennal lobe. Using Gal4-Mz19 to over-express a single *Dscam* isoform in DA1 and VA1d PNs, VA1d dendrites were observed to shift to a more ventral position on the anterior surface and to be separated from DA1 dendrites by another glomerulus (Fig. 5d) [5].

Loss of such *Dscam*-dependent contact-mediated repulsion may underlie some *Dscam* loss-of-function phenotypes. For instance, *Dscam* mutant MB sister

branches often failed to extend away from each other [3]. In addition, aberrant bundling and crossing-over were frequently observed in *Dscam* mutant da neurons [6]. In both cases, removal of *Dscam* caused defects in self-avoidance, further supporting the model that homophilic binding of *Dscam* promotes repulsion of neuronal branches (Fig. 2).

## References

1. Barlow GM, Micales B, Chen XN, Lyons GE, Korenberg JR (2002) Mammalian DSCAMs: roles in the development of the spinal cord, cortex, and cerebellum? *Biochem Biophys Res Commun* 293:881–891
2. Schmucker D, Clemens JC, Shu H, Worby CA, Xiao J, Muda M, Dixon JE, Zipursky SL (2000) *Drosophila Dscam* is an axon guidance receptor exhibiting extraordinary molecular diversity. *Cell* 101:671–684
3. Zipursky SL, Wojtowicz WM, Hattori D (2006) Got diversity? Wiring the fly brain with *Dscam*. *Trends Biochem Sci* 31:581–588
4. Millard SS, Flanagan JJ, Pappu KS, Wu W, Zipursky SL (2007) *Dscam2* mediates axonal tiling in the *Drosophila* visual system. *Nature* 447:720–724



5. Zhu H, Hummel T, Clemens JC, Berdnik D, Zipursky SL, Luo L (2006) Dendritic patterning by Dscam and synaptic partner matching in the *Drosophila* antennal lobe. *Nat Neurosci* 9:349–355
6. Matthews BJ, Kim ME, Flanagan JJ, Hattori D, Clemens JC, Zipursky SL, Grueber WB (2007) Dendrite self-avoidance is controlled by Dscam. *Cell* 129:593–604
7. Wang J, Ma X, Yang JS, Zheng X, Zugates CT, Lee CH, Lee T (2004) Transmembrane/juxtamembrane domain-dependent Dscam distribution and function during mushroom body neuronal morphogenesis. *Neuron* 43:663–672
8. Graveley BR (2005) Mutually exclusive splicing of the insect Dscam pre-mRNA directed by competing intronic RNA secondary structures. *Cell* 123:65–73
9. Neves G, Zucker J, Daly M, Chess A (2004) Stochastic yet biased expression of multiple Dscam splice variants by individual cells. *Nat Genet* 36:240–246
10. Shi L, Yu HH, Yang JS, Lee T (2007) Specific *Drosophila* Dscam juxtamembrane variants control dendritic elaboration and axonal arborization. *J Neurosci* 27:6723–6728

---

## Down's Syndrome

### Synonyms

Trisomy 21 Syndrome

### Definition

Down's syndrome is due to an additional chromosome 21 or translocation of part thereof. Trisomy 21 is the only trisomy compatible with survival past infancy. Cardiac malformations (septal defects) may lead to early death, but some individuals live into old age and may reproduce. Brain weight is reduced and the ►cerebral cortex shows a simplified gyration. Mental retardation is common, older individuals often develop a premature ►Alzheimer's type of brain degeneration. Characteristic are eye and face changes, spots in the iris. The disease has a higher frequency of cataracts, periodontal disease, hyperextensibility of joints, and acute leukaemia.

---

## Downward Causation

### Definition

Exists if the system parts are to some degree constrained by the whole (which is a converse of the principle that

the microstructure of a system determines the system properties and dispositions).

### ► Emergence

---

## Dracomorph Lizards

### Definition

Large-sized lizards, e.g. Varanidae, Teiidae, Iguanidae, not a taxonomic term.

### ► Evolution of the Brain: At the Reptile-Bird Transition

---

## Dream Enactment

### Definition

In humans, dream enactment may involve complex and violent movements. In cats, lesions of the ventral ►locus coeruleus can produce ►REM sleep without the usually associated ►atonia.

### ► Rapid Eye Movement (REM) Sleep

### ► Locus coeruleus

---

## Dreaming

TORÉ A. NIELSEN

Dream & Nightmare Laboratory, Sleep Research Center, Hopital du Sacré-Coeur, QC, Canada; Psychiatry Department, Université de Montréal, Montreal, QC, Canada

### Synonyms

Sleep mentation; Dream imagery; Hypnagogic imagery; Oniric mentation; Nightmare

### Definition

Dreaming (see ►Dream) is the simulation, during sleep, of both the process and the contents of ►waking state experience. Experiential processes are largely simulated quite accurately, giving the impression that one perceives,

acts, feels and thinks in a manner indistinguishable from wakefulness. Experiential content, on the other hand, is not reliably simulated. Episodic memories are only rarely present and many classes of common behaviors (e.g., reading, typing, calculating) are infrequent. Elements of episodic memories do, however, contribute to dreaming, as do elements of more general semantic memories. Dreaming can be remembered, with effort, during the waking state but is more typically forgotten. The most vivid and most copious dreaming is recalled after awakenings from ►REM sleep, but it is also recalled, albeit less frequently and with less vividness, after awakenings from ►NREM sleep.

## Characteristics

### Dreaming Simulation of Experiential Process

The process or flow of experience during dreaming is indistinguishable in many key respects from that of typical waking state experience. Emotional sequences in ►dreams, for example, are for the most part true to their waking state counterparts. When they are present in laboratory REM dreams (70% of reports), subjects judge them to be appropriate to the dreamed situation over 80% of the time. Dreamed thinking is also relatively lifelike, with high prevalences of volition, inference, reflection, self-reflection, self-consciousness, choice and internal commentary [1]. One notable exception to this is the ability to detect bizarre dream contents; over half of the time dreaming subjects do not notice when bizarreness is present.

Perceptual activity is also reliably simulated. The subjective self is present in 95% of dream reports, perceived to be oriented normally within 3D space, and to be viewing the dream scene from an egocentric (own-eyes) point of view much more often (89%) than from a third person (other's-eyes) point of view (11%). When present, the self is also felt to be participating in dreamed actions over 90% of the time. Fictive movements within a dream usually respect the mechanical forces dictated by the 1g earth gravity field. This means that when the self moves about within a dreamed environment (90% of reports), it experiences apparently normal self-initiated movements of the trunk, face and limbs as well as normal, externally-imposed, movements such as being driven in a car. Further, the self's interactions with a succession of settings, objects and other living beings in the dreamed environment are experienced to be normal most of the time [1]. Basic perceptual features of this flow of environmental features display a relative constancy, e.g., size and shape are only rarely (<13%) distorted relative to reality.

The eye movements of REM sleep have been proposed to reflect perceptual activity of the visual system during dreaming, in particular, the "scanning" of fictive visual events. Evoked potential analyses of eye

movements during REM sleep do not support this proposition; however, new research reveals the existence of morphologically distinct types of eye movements, only some of which may reflect dream scanning.

In sum, phenomenological studies of dreaming suggest that rather remarkable simulations of the flow of waking state experience are achieved during sleep, reliably depicting the emotional, orientational and perceptual underpinnings of awareness. Such simulations are by no means perfect, however, and many of the exceptions contribute to dreaming's notoriety as a strange and surreal phenomenon. For example, a relatively familiar fallibility of orientation simulation is the suspension and distortion of gravity; illusions of falling, flying, floating and loss of balance are well-known. Such exceptions have been shown to occur more frequently when proprioception is disrupted during REM sleep either with external stimulation or because of vestibular disease. The induced bizarreness reveals the fragility of perceptual simulation in the absence of stable constant input from the multiplicity of external sense receptors active during wakefulness.

### Dreaming Simulation of Experiential Contents: Negative Findings

Despite the fidelity with which dreaming simulates experiential process, the specific contents of experience are not so reliably reproduced. First, dreams do not replay personal memories reliably and are thus not clearly a form of episodic narrative. In fact, only a small fraction (<2%) of dream reports describe complete episodic memories, in the sense that an ensemble of locations, objects, actions and characters specific to the memory are depicted. The episodic element most frequently absent from this ensemble is location; only 16% of dream reports contain locations that subjects confidently rate as reflecting an actual memory from wakefulness [2]. This dramatic absence of episodic replays stands in marked contrast to the replicative nightmares frequently reported by individuals with posttraumatic stress disorder; such nightmares replay, night after night, the individual's experience of a previously inflicted trauma.

Second, dreaming often fails to simulate many prominent waking state behaviors and objects. Research has found that about 90% of subjects "never" or "hardly ever" dream about reading, writing, typing and calculating even though they spend an average of 6 h per day engaged in these activities. Similarly, only 4% of subjects dream about using computers and only 7% of reading even though the prevalence of these activities during waking is significantly higher. We found surprisingly low percentages of first-year university students who had ever dreamed about the very common activities of seeing themselves in a mirror (16%) or

being at a movie (17%). Some common objects are also strangely missing from dreams; money, tools, food and drink all occur in <2% of reports [3]. Sensations of smell and touch are also much less prevalent during dreaming than would be expected from their importance to daytime experience. Findings from one study of 3,372 dream reports converge with those from several others in demonstrating that olfactory and gustatory experiences occur in 1% or less of all reports.

To summarize, while the experiential flow of waking awareness is largely preserved during dreaming, the contents of such experience are lacking in several important respects. Coherent episodic memories are virtually absent and many common behaviors and objects are underrepresented relative to their importance during wakefulness. Dreaming is clearly not a mirror that reflects waking existence in any simple fashion as the widely cited “continuity hypothesis” of dreaming would suggest. Rather, it is as if memory elements are selectively filtered for relevance before they are employed as contents during the dream formation process.

### **Dreaming Simulation of Experiential Contents: Episodic Referencing**

If dreaming does not typically simulate real episodic memories, it does draw heavily and consistently upon some components of such memories, and it does so in a rather disjunctive manner. This is amply demonstrated by studies that have presented subjects with distinctive stimuli, such as emotionally charged films or ego-threatening tasks, prior to sleep and then successfully tracked partial references to them in their subsequent dreams. The Fosse study cited above found that 65% of dream reports contain such partial references to previous episodic events – despite the overall low incidence of complete episodic narratives. One of the most common forms of episodic referencing seen by sleep researchers is the dreamed reoccurrence of laboratory features; they are observed in about a third of dreams on the first laboratory night. Such referencing of events from the prior day is but one example of the well-known “day residue” effect identified by Freud. A less well-known phenomenon is the referencing of events occurring approximately a week prior to the dream, the so-called “dream-lag effect.” Even more generally, episodic referencing is apparent in the frequent dream appearances of an individual’s friends, acquaintances and family members. Dreamed characters, excluding the self, are more often familiar than they are unfamiliar in both children’s dreams (70% vs. 30% respectively) and adults’ dreams (52% vs. 48%). Evidence also supports the presence of episodic referencing of waking state experiences such as social interactions and current concerns and everyday activities such as driving, watching TV and working.

Of course, dream contents do not consist only of rehashed episodic features. Dreaming draws also upon dissociated elements of more generalized knowledge, or semantic memories. Semantic memories concern meanings and general facts that are not connected to individual (episodic) experiences and are usually not temporally tagged. The occurrence of semantic knowledge during dreaming has not been systematically evaluated but the fact that thematic references to daytime experiences was the most frequent class of memory source of dreams (53%) in one study – even higher than that of objects (39%) or actions (41%) [2], indicates that such knowledge elements are prevalent indeed.

In sum, dreaming simulates the process or flow of experience quite dependably but it produces only inexact, partial simulations of the contents of such experience. The result is a sustained illusion of first-hand experience in which episodic elements such as people, places and objects are combined with semantic elements such as facts and other general knowledge in novel and unexpected ways. The dreamer’s thoughts and feelings about these events remain largely as they would be during the waking state. It may be this juxtaposition of accurate experiential process and selective, reorganized episodic and semantic content that underlies the surreal quality of dreaming (as it is remembered and evaluated from the perspective of wakefulness) and that is very likely responsible for judgments about its “bizarre” or “distorted” nature.

### **Neurophysiology**

The neurophysiological basis of dreaming as a general mental state has been widely linked to the state of REM sleep but the occurrence of dreaming reports in NREM sleep has left this equation controversial (for review see [4]). Some purportedly formal qualities of dreaming, such as its visual- and auditory-hallucinatory aspects, its coherence, or its portrayal of distorted and bizarre contents, have also been tied hypothetically to sub-processes of REM sleep, such as rapid eye movements, gamma oscillations or ►PGO waves [5]. Some evidence supports the contention that dream emotions are associated with variations in autonomic activity during sleep. However, very little research has succeeded in directly linking specific features of dream content with underlying neurophysiological events.

Even with the achievement of brain imaging during REM and NREM sleep, links between specific dream elements and specific brain regions have not yet been identified. However, this has not prevented much speculation about possible neurophysiological bases for dreaming. Neuroimaging studies reveal a pattern of characteristic activation and deactivation throughout the brain during REM sleep. In the case of brain activation, significant increases have been found in the mesopontine tegmentum, thalamic nuclei,

limbic/paralimbic areas (amygdaloid complexes, hippocampal formation, anterior cingulate cortex) and posterior cortices (temporo-occipital areas) [6]. With respect to brain deactivation, a meta-analysis of 207 PET scans revealed significantly less activity bilaterally in the temporo-parietal region, inferior lobule of the parietal cortex (below the intra-parietal sulcus) and inferior frontal gyrus and middle frontal gyrus (but neither superior frontal gyrus nor medial prefrontal cortex) [7].

Maquet suggests that the marked redistributions of frontal and parietal cortical activity during REM sleep constrains cognition in a unique fashion, and shapes the phenomenological nature of dreaming. For example, the deactivation of specific prefrontal and parietal regions may account for a lack of episodic narratives and a diminished capacity to formulate clear behavioral goals [7].

### Function

The functions of dreaming remain unknown although much recent speculation concerns the evolution of reality simulation during dreaming as a basis for successful human adaptation (see review in [8]). Simulated threat scenarios during nightmares and bad dreams are thought to have evolved to serve the basic function of rehearsing adaptive responses for threats encountered during wakefulness. Similarly, simulations of social interactions during dreaming may have evolved to serve broader, more polyvalent, functions of attachment and social cohesion, cognitive development and the formation of fear extinction memories. Other emerging theories stipulate a role for dreaming in the consolidation of memories and in psychological (e.g., emotional) adaptation.

In general, empirical research supporting these various theories of dream function is meager. However, substantial indirect support for the theories can be found in a growing body of research on the functions of REM sleep. Recent animal studies support the fear extinction memory model of dream function in demonstrating that REM sleep disruption leads to inhibition of fear extinction learning. Similarly, several human studies indicate that REM sleep deprivation impairs consolidation of new memories.

### Pathology

Many types of disturbed dreaming have been identified, the most common of which are nightmares and bad dreams. Both types are characterized by excessively real simulations of dysphoric emotion – typically fear – and varying degrees of associated waking distress. They are differentiated by the fact that nightmares produce awakenings from sleep while bad dreams do not. Replicative nightmares are often reported

by patients with PTSD and are distinguished from typical nightmares and bad dreams by the simulation of episodic narrative content, i.e., episodic replays of the individual's memory of a previously inflicted trauma.

The nature and frequency of dreaming may be altered dramatically by drugs and alcohol. Catecholaminergic agents (e.g., reserpine, thioridazine, levodopa), beta-blockers (e.g., betaxolol, metoprolol, propranolol), some barbiturates, non-benzodiazepine hypnotics (zolpidem), atypical antidepressants (bupropion), SSRIs (paroxetine, fluvoxamine), and tricyclic antidepressants all can induce nightmares and bizarre dreaming. The therapies most often associated with nightmares are sedative/hypnotics, beta-blockers, and amphetamines [9]. Alcoholic patients report vivid dreams and nightmares post-withdrawal, sometimes lasting for weeks, and can lead to resumed drinking. Withdrawal is associated with an increase in REM sleep “pressure” and predicts early relapse.

Dreaming may be disturbed in a variety of medical disorders (for review see [10]). At one extreme, primarily among neurological patients, there may occur a global cessation of dreaming. A related, but less severe disturbance, impoverished dreaming (reduced recall, vividness or complexity) is observed among alexithymic patients, PTSD and some brain syndromes. At the other extreme, there may occur excessive dreaming and a heightening of the experience simulation process to the point that dreaming is totally confused with reality. Some brain-damaged patients report increases in the frequency and vividness of dreaming or in the continuous occurrence of the same content throughout the night. Patients who spend prolonged periods of time in an intensive care unit (ICU) frequently experience “ICU dream delirium,” or the occurrence of persistent horrific nightmares that combine the reality of the ICU with macabre dream content; these may have a lasting traumatic effect [10]. A total confusion of dreaming and reality may occur among actively psychotic or borderline psychotic individuals and may lead to violent acting out. Dream realism is also frequently disturbed in a variety of sleep disorders, such as narcolepsy, ▶sleep paralysis and ▶REM behavior disorder or after severe sleep fragmentation, as with new mothers. In such conditions, highly realistic, even pseudo-hallucinatory dreams are commonplace; frequently, a vivid sense of presence of another person or entity in the bedroom is experienced.

To summarize, dreaming is an altered state of awareness characterized by an accurate simulation of experiential flow, a selective simulation of experiential contents and an admixture of various types of episodic and semantic elements. The neurophysiological changes characteristic of REM sleep have been proposed to constrain and shape the nature and content of dreaming, but no specific replicable correlates of

dream content have yet been reported. Possible functions of dreaming have been tied to this simulation process, with the suggestion that simulation enhances adaptation to threat, social cohesion, cognitive development and fear extinction. A variety of disorders of dreaming, too, often implicate either a weakening or a strengthening of the oniric reality simulation process.

## References

1. Snyder F (1970) The phenomenology of dreaming. In: Madow L, Snow LH (eds) *The psychoanalytic implications of the psychophysiological studies on dreams*. Charles Thomas, Springfield, Illinois, pp 124–151
2. Fosse MJ, Fosse R, Hobson JA, Stickgold RJ (2003) Dreaming and episodic memory: a functional dissociation? *J Cogn Neurosci* 15:1–9
3. Hall C, van de Castle RI (1966) *The content analysis of dreams*. Appleton-Century-Crofts, New York
4. Nielsen TA (2000) A review of mentation in REM and NREM sleep: “covert” REM sleep as a possible reconciliation of two opposing models [with reply to commentaries]. *Behav Brain Sci* 23:1040–1057
5. Pace-Schott EF (2005) Complex hallucinations in waking suggest mechanisms of dream construction. *Behav Brain Sci* 28:771–772
6. Maquet P (2000) Functional neuroimaging of normal human sleep by positron emission tomography. *J Sleep Res* 9:207–231
7. Maquet P, Ruby P, Maudoux A, Albouy G, Sterpenich V, ng-Vu T, Desseilles M, Boly M, Perrin F, Peigneux P, Laureys S (2005) Human cognition during REM sleep and the activity profile within frontal and parietal cortices: a reappraisal of functional neuroimaging data. *Prog Brain Res* 150:219–227
8. Nielsen TA, Lara-Carrasco J (2007) Nightmares, dreaming and emotion regulation: a review. In: Barrett D, McNamara P (eds) *The new science of dreams*. Praeger Greenwood, Westport, pp 253–284
9. Thompson DF, Pierce DR (1999) Drug-induced nightmares. *Ann Pharmacother* 33:93–98
10. Nielsen TA (2005) Disturbed dreaming in medical conditions. In: Kryger M, Roth N, Dement WC (eds) *Principles and practice of sleep medicine*. Elsevier Saunders, Philadelphia, pp 936–945

## Dreams

### Definition

Dream in the verb form refers to the involuntary process of simulating experience during sleep, as in “she dreams vividly.” In the noun form, dream refers to the product that ultimately results from an episode of dreaming, as in “to recall a dream.” A dream can be remembered, with some effort, during the waking state; however, for

most individuals, the majority of their dreams are quickly and irretrievably forgotten. Dreams accurately simulate the flow of waking state experience in most respects but only selectively simulate the contents of such experience.

### ► Dreaming

## Drinking

### Definition

Consuming fluids.

## Drinking Disorders and Osmoregulation

DICK F. SWAAB<sup>1</sup>, PAUL J. LUCASSEN<sup>2</sup>

<sup>1</sup>Netherlands Institute for Neuroscience, Amsterdam, The Netherlands

<sup>2</sup>Centre for Neuroscience, Swammerdam Institute of Life Sciences, University of Amsterdam, The Netherlands

### Definition

Subjects that consistently drink too much or too little suffer from disturbances in endocrine or central components of osmoregulation.

### Characteristics

The cause of these disorders may be on the level of the osmoreceptors, vasopressin (= antidiuretic hormone) production, release from the neurohypophysis, the sensitivity of the kidney to vasopressin or due to deficits in the circulation (for reviews see [3] and [4]).

### Quantitative Description and Description of the Process

Plasma osmolality is accurately maintained within a remarkably narrow range of 282–298 milliosmol/kg, which is achieved by the close integration of the antidiuretic action of vasopressin and a feedback regulation through the sensation of thirst. Plasma osmolality is the most important physiological determinant of vasopressin secretion, but blood pressure is also involved. Small changes in osmolality are rapidly detected in the circumventricular organs, specific brain

regions, characterized by the presence of fenestrated capillaries and endothelial cells, from which the blood brain barrier is largely absent. Primary monitoring takes place through osmoreceptors in the hypothalamic supraoptic and paraventricular nuclei (SON and PVN). The osmotic threshold above which secretion of vasopressin is triggered is 284.3 milliosmol/kg. Water reabsorption in the kidney conserves water and subsequently decreases osmolality. During drinking and fluid ingestion there is an almost instantaneous suppression of vasopressin secretion, probably due to the activation of oropharyngeal stretch receptors, which send inhibitory feedback signals that protect against overhydration. The osmotic threshold for thirst is similar to that for vasopressin release.

Decreases in blood pressure and blood volume are additional, although less powerful stimuli for vasopressin secretion. These conditions activate stretch sensitive baroreceptors in the atria of the heart that signal the hypothalamus to secrete vasopressin and conserve fluid. Animal experiments have further revealed a number of other peptides that modulate drinking behavior, such as angiotensin II and orexin-A. Histamine, produced in the tuberomammillary nucleus (TMN), elicits drinking, increases the release of vasopressin and decreases urine output via H1 and H2 receptors.

The kidney concentrates or dilutes urine under the influence of vasopressin. In the absence of vasopressin, the collecting duct of the kidney is impermeable to water. When vasopressin acts on the cell, water pores of the aquaporin family are inserted in the apical membrane of the collecting duct, which makes it permeable and causes water to move out of the lumen by osmosis. The segmental permeabilities in the nephron correlate with the expression of different members of the aquaporin family, seven members of which have been identified in the kidney. Vasopressin dependent expression of aquaporin-2 is particularly found in the apical membrane of the principal cells of the collecting tubes.

Vasopressin is released from the neurohypophysis, which is characterized by its rich vascularity, nerve endings and their swellings – the Herring bodies – and pituicytes, which are specialized astrocytes that can modulate neurohormone release. The capillaries have fenestrated endothelial cells and extensive perivascular spaces. Clinically, pathology of the neurohypophysis may lead to diabetes insipidus or to inappropriate secretion of vasopressin (Schwartz–Bartter syndrome). Pathology of the neurohypophysis includes congenital malformations, lymphocytic foci, hemorrhages, necrosis, inflammation, fibrosis, cysts, craniopharyngiomas and other tumors, metastatic carcinomas and granulomas. Hypovolemic shock of the mother at the time of delivery may not only cause pituitary necrosis, but also affect the tuber cinereum, pituitary stalk, SON and PVN, i.e. Sheehan's syndrome. Pathological

states of the neurohypophysis may be reflected in a disappearance of the MRI high intensity signal of the posterior pituitary, which is presumed to be caused by the neurosecretory granules containing vasopressin.

## Higher Processes

### *Diabetes Insipidus*

In diabetes insipidus, the mechanism that concentrates urine is inadequate or absent. Diabetes insipidus in familial cases may be due to a central vasopressin deficiency caused by a defect in the kidney receptors for vasopressin or to mutations in the vasopressin regulated water channel of the renal collecting duct aquaporin-2 in nephrogenic diabetes insipidus or to primary polydipsia. Inability to reabsorb water in the collecting ducts leads to excretion of large volumes of dilute urine. Consequently, thirst is the most prominent symptom of hypothalamic diabetes insipidus. The old treatment, pitressin in oil, given intramuscularly, was effective for 24 h, but the injection was often painful. Desmopressin (1-desamino-8-arginine vasopressin, DDAVP) however, does not have the pressor effect and is effective when given as a nasal spray twice daily. DDAVP is now also available in tablet form.

### *Familial Central Diabetes Insipidus*

Familial hypothalamic diabetes insipidus is a rare disease that accounts for about 5% of all cases of diabetes insipidus. It is transmitted as an autosomal dominant or X-linked recessive disorder. Affected individuals have low or undetectable levels of circulating vasopressin and suffer from polydipsia and polyuria. They respond to substitution therapy with exogenous vasopressin or analogues. Urine production may amount to some 20 l/day. Most mutations are presumed to impair the folding and intracellular trafficking of the prohormone for vasopressin. Some 40 different mutations have now been found, including six mutations in the part that encodes the signal peptide. The rest are in different loci in the neurophysin II moiety, i.e. in exon 1 or 2, including two in vasopressin itself, five nonsense mutations (premature stop codons) in exon 2 or 3 and one trinucleotide deletion in exon 2. All the dominant mutations contrast with the recessive mutation in vasopressin itself. The mutated form of vasopressin is a weak agonist with an approximately 30-fold reduced binding to the vasopressin receptor (V2) (Fig. 1).

The few available histological observations in post-mortem samples from families with hereditary hypothalamic diabetes insipidus point to severe neuronal death in the SON and PVN, associated with a loss of nerve fibers in the posterior pituitary. This suggests that the mutated product might be toxic to the neurosecretory cell. Slowly acting toxicity also explains why urine production is normal, often up to school age. Studies

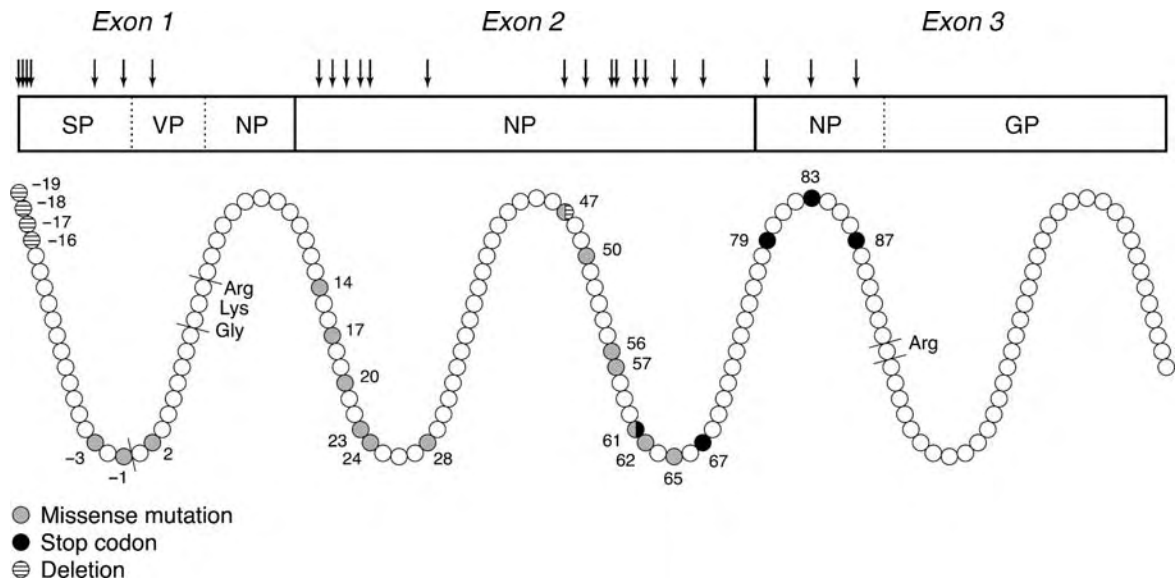

**Drinking Disorders and Osmoregulation. Figure 1** Schematic diagram of the coding regions of the arginine vasopressin–neurophysin II (AVP-NPII) gene and the primary structure of the preprohormone, showing the location and type of mutations identified in familial hypothalamic diabetes insipidus [1]. (Fig. 1 with permission).

in which various other human mutant vasopressin precursors were expressed in cell lines also showed an accumulation of the mutated vasopressin precursor in the endoplasmic reticulum, a reduced viability of the cells and a reduced vasopressin expression. The protein did not seem to reach the trans-Golgi network, probably because mutant vasopressin precursors do not fold correctly. The mutated proteins subsequently also interfere with the expression of the normal allele by their accumulation in the endoplasmic reticulum, explaining the dominant nature of the disease.

#### Autoimmune Diabetes Insipidus

Idiopathic diabetes insipidus is associated with autoimmunity in one third of the cases. It has not yet been established whether the autoantibodies observed in diabetes insipidus are indeed cytotoxic, nor whether they can destroy the vasopressin cell bodies, but ultimately their presence seems to go together with partial or complete diabetes insipidus. A dramatic improvement may take place following administration of corticosteroids. Patients with lymphocytic infundibuloneurohypophysitis presenting as diabetes insipidus may have autoantibodies to vasopressin and on MRI show a normal pituitary with focal nodular thickening of the infundibulum, stalk thickening and lack of a hyperintense signal from the neurohypophysis.

#### Pregnancy Induced Diabetes Insipidus

During pregnancy a transient form of diabetes insipidus sometimes occurs. The central form may respond to the analogue DDAVP but not to vasopressin itself, because

the former is much less susceptible to degradation by placental vasopressinase, which is the same enzyme as the cystine aminopeptidase or oxytocinase that is responsible for the fourfold increase in metabolic clearance of vasopressin during pregnancy. In addition, during pregnancy, thirst increases and more water is consumed. The lowering of the thirst threshold is accompanied by a similar lowering of the osmotic threshold for the release of vasopressin. As a result, pregnant women drink more water, which may subsequently be retained.

#### Nephrogenic Diabetes Insipidus

Nephrogenic diabetes insipidus is characterized by an inability to concentrate urine despite normal or elevated plasma vasopressin levels and insensitivity to exogenously administered vasopressin analogues. It may be partially controlled by thiazide diuretics, amiloride or indomethacin.

About 90–95% of patients with nephrogenic diabetes insipidus are males with the X-linked recessive form of the disease, who have mutations in the vasopressin receptor-2 gene, located on Xq28. The severe X-linked form is expressed in heterozygous boys, whereas heterozygous girls may have moderate expression to no symptoms at all. Over 155 mutations within the vasopressin receptor (V2) gene are known that may cause inherited nephrogenic diabetes insipidus (Fig. 2).

In less than 10% of the families, nephrogenic diabetes insipidus has an autosomal recessive or autosomal dominant mode of inheritance, caused by mutations on chromosome 12q13 in the gene of the water channel

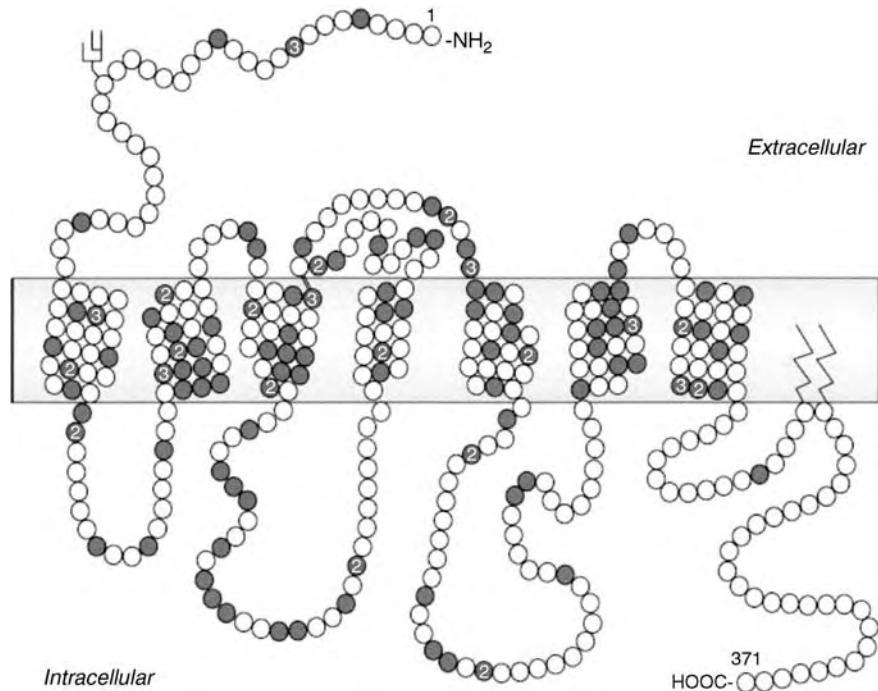

**Drinking Disorders and Osmoregulation. Figure 2** Schematic representation of the Vasopressin (V2) receptor and identification of 155 putative disease causing AVPR2 mutations. A solid circle indicates the location of (or the closest codon to) a mutation; a number indicates more than one mutation in the same codon. There are 78 missense mutations, 42 frameshift mutations, 6 in frame deletions or insertions and 3 splice site mutations. Eight large deletions and one complex mutation are not shown [2]. (Fig. 7 with permission).

protein aquaporin-2. Nephrogenic diabetes insipidus generally manifests a few days after birth (Fig. 3).

### Primary Polydipsia

Primary polydipsia is characterized by thirst, excessive fluid intake and hypotonic polyuria, despite preservation of the ability to secrete appropriate amounts of vasopressin in response to osmotic stimuli. Primary polydipsia may be associated with psychiatric disorders and is then generally termed “psychogenic polydipsia”. A physiological inhibition of vasopressin is present due to excessive drinking. Compulsive water drinking is sometimes also called dipsogenic diabetes insipidus. However, the term “dipsogenic polydipsia” is generally used for “somatic” patients who may e.g. suffer from damage to the hypothalamus after closed head trauma, neurosarcoidosis, infections, multiple sclerosis or medicines such as lithium or carbamazepine. Although the actual cause of the disorder is not yet established, it has been suggested that primary polydipsia is caused by abnormal function of the osmoreceptors that govern thirst.

### Adipsinogenic Disorders

In the case of inappropriate lack of thirst, with consequent failure to drink in order to correct

hyperosmolality, the patient denies thirst or does not drink spontaneously. The adipsogenic disorders are supposed to be based upon an osmoreceptor dysfunction and often associated with a defect in the osmoregulation of vasopressin secretion and diabetes insipidus.

### Vasopressin Hypersecretion in Diabetes Mellitus

Diabetes mellitus is associated with polyuria and polydipsia. In patients with diabetic ketoacidosis, plasma osmolality and vasopressin levels are increased, circulating volume is decreased and urinary excretion of the aquaporin-2 water channel is increased. Polyuria is classically said to be due to the osmotic diuresis caused by glucosuria. However, when hyperglycemia is improved by i.v. infusion of insulin and fluid, plasma vasopressin levels decrease promptly, i.e. within 6 h, although plasma osmolality remains high. This indicates that both osmotic and nonosmotic stimuli are involved in the hypersecretion of vasopressin.

### Syndrome of Inappropriate Secretion of Antidiuretic Hormone (Schwartz-Bartter Syndrome)

This syndrome is characterized by high vasopressin levels that can not be suppressed by acute water load. In addition there is renal sodium loss, hypotonic



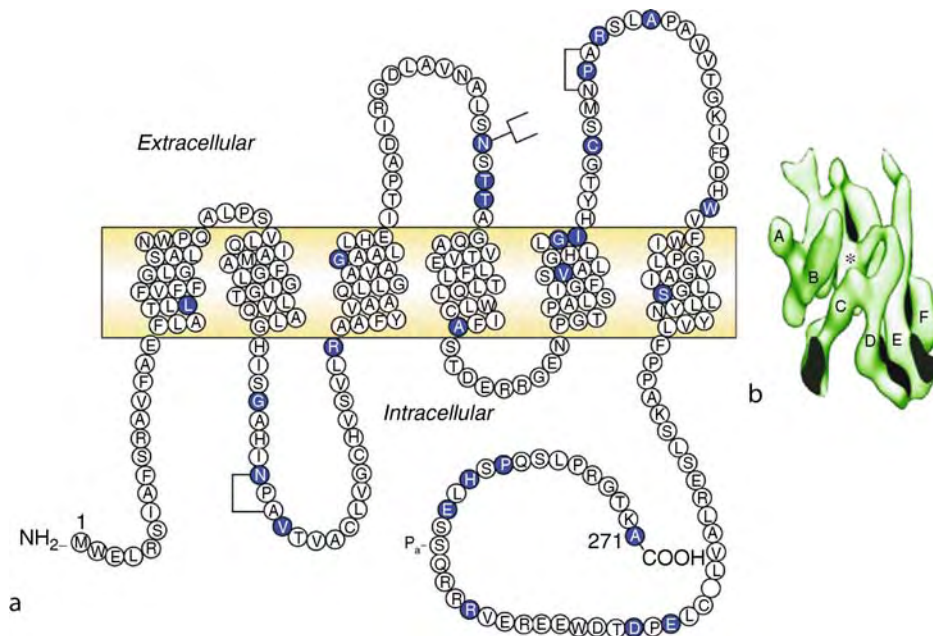

**Drinking Disorders and Osmoregulation. Figure 3** (a). Schematic representation of the aquaporin-2 (AQP-2) protein and identification of 26 putative disease causing AQP2 mutations. A monomer with six transmembrane helices is represented. The location of the protein kinase A phosphorylation site ( $P_a$ ) is indicated. This site is possibly involved in the arginine vasopressin induced trafficking of AQP2 from intracellular vesicles to the plasma membrane and in the subsequent stimulation of endocytosis. Solid circles indicate the locations of the mutations. (b) Representation of the six-helix barrel of the AQP1 protein viewed parallel to the bilayer [2].

hyponatremia and urine that is relatively or absolutely hyperosmolar to serum, i.e. greater than 300 milliosmol/kg. Plasma osmolality is below the osmotic threshold for thirst and drinking is minimal. The clinical features may include confusion, muscle cramps, seizures, fatigue, loss of appetite, nausea, vomiting, some clouding of consciousness and coma. Rapid correction of hyponatremia may lead to central pontine and extrapontine myelinolysis.

The syndrome was first described following exogenously administered pitressin and may be due to excessive vasopressin release from the posterior pituitary, despite hypo-osmolality. In cases of nonosmotic baroreceptor mediated stimulation of vasopressin release, as occurs in pulmonary hypertension due to heart failure or liver cirrhosis, there is a decrease in “effective” blood volume or arterial underfilling. Therefore the enhanced vasopressin release, lower plasma sodium levels and osmolality can in fact be considered as an appropriate reaction to a hemodynamic stimulus. The inappropriate vasopressin syndrome may also be due to ectopic production of vasopressin by extrahypophysial neoplasms, e.g. by a bronchus carcinoma. Other diseases which may be accompanied by increased vasopressin release include head injuries and central nervous system infections such as

pneumonia, exacerbations of multiple sclerosis, brain infarction, hematoma, traumata, subarachnoid hemorrhage, subdural hematoma, stroke, polyneuritis, asthma, hepatorenal syndrome and meningitis, in which IL-6 may be the mediator through which vasopressin secretion is stimulated. The syndrome has also been found in patients using psychotropic drugs. The treatment of inappropriate vasopressin secretion consists of fluid restriction, urea, furosemide or administration of a mineralocorticoid.

## References

1. Rittig S, Robertson GL, Siggaard C, Kovács L, Gregersen N, Nyborg J, Pedersen EB (1996) Identification of 13 new mutations in the vasopressin-neurophysin II gene in 17 kindreds with familial autosomal dominant neurohypophysial diabetes insipidus. *Am J Hum Genet* 58:107–117
2. Morello J-P, Bichet DG (2001) Nephrogenic diabetes insipidus. *Annu Rev Physiol* 63:607–630
3. Swaab DF (2003) The human hypothalamus. Basic and clinical aspects. pt 2: Neuropathology of the hypothalamus and adjacent brain structures. In: Aminoff MJ, Boller F, Swaab DF (eds) *Handbook of clinical neurology*. Elsevier, Amsterdam, Chapter 22
4. Verbalis JG (2003) Disorders of body water homeostasis. *Best Pract Res Clin Endocrinol Metab* 17:471–503

## Drive

### Definition

A internal state corresponding to a strong need or desire.

## Driving Point Impedance

### Definition

Mechanical impedance in the situation where the force drives the system and the velocity is that at the point of application of the force.

► Impedance Control

## Driving Potential

### Definition

(For an ion sort) denotes the difference between the actual membrane potential  $V$  and the equilibrium potential for the ion.

► Membrane Potential: Basics

## Drosophila Melanogaster

### Definition

*Drosophila melanogaster* or fruit flies, are commonly used as a model organism in development and in genetics research. They can be generated in large numbers, powerful techniques have been developed to modify gene function, and they have a short generation time and as such are amenable to genetic screens.

## Drugs

► Nootropic Drugs

## Drugs for Motor Disorders

TOMOMI SHINDOU, JEFFERY R. WICKENS

Neurobiology Research Unit, Okinawa Institute of Science and Technology, Uruma, Okinawa, Japan

### Synonyms

Drugs for movement disorders

### Definition

The term “motor disorders” encompasses a wide spectrum of disorders ranging from an inability to move normally to an inability to prevent unwanted involuntary movements. Parkinson’s disease is the most common of such disorders. Its symptoms include ►bradykinesia, ►tremor and rigidity. Other disorders include Huntington’s disease, which leads to motor symptoms including ►chorea, and disorders such as Tourette’s syndrome in which motor tics occur. This is a very selective list and many other syndromes occur. Importantly, motor disorders may occur as a side-effect of drugs, especially those used in the treatment of psychosis. For example, ►dystonia may occur as a side effect of treatment with dopamine blocking drugs, and ►tardive dyskinesia may also develop after exposure to dopamine receptor blocking agents.

### Characteristics

A diverse range of causes may lead to motor disorders, including genetic causes (as in Huntington’s disease or ►Wilson’s disease), drug side-effects (as in tardive dyskinesia or dystonia), and idopathic causes (as in Parkinson’s disease). The pathophysiology of motor disorders often involves the basal ganglia, and in particular is often associated with abnormal dopamine function in the striatum (caudate-putamen). Thus, dopamine agonists and antagonists feature prominently among the drugs for motor disorders. However, there are many non-dopaminergic neurotransmitters in the basal ganglia, and there is therefore great interest in the contribution of these other neurotransmitter systems to the pathophysiology of motor disorders, and their potential importance as novel targets for drug treatments.

Parkinson’s disease is the most common of such disorders and will be used to illustrate many of the important circuits and neurotransmitters involved in movement. We review the motor functions of the basal ganglia, the circuitry and neurotransmitters of the basal ganglia, and then consider the clinical features of Parkinson’s disease. Using this disease as a model, we consider the major classes of drugs used to treat motor disorders.

### Motor Functions of the Basal Ganglia

The basal ganglia are a group of subcortical structures comprising several interconnected nuclei: the striatum, the globus pallidus external segment (GPe), the globus pallidus internal segment (GPi), the substantia nigra pars reticulata (SNr), the substantia nigra pars compacta (SNc), and the subthalamic nucleus (STN). The anatomical connections of the basal ganglia mainly link it to elements of the motor apparatus of the brain, and the electrical activities of many basal ganglia neurons correlate with movements. In addition, dysfunction of the basal ganglia underlies the symptoms of Parkinson's disease, Huntington's disease, and several other motor neurological disorders. Thus, the major function of the basal ganglia is the control of movement. In addition to motor functions, the basal ganglia participate in some nonmotor aspects of behavior, such as cognition and reward processing. Current views based on experimental studies have indicated that the basal ganglia play a crucial part in the planning, initiation, and termination of movements with a complex cognitive dimension and motivational significance.

### Basal Ganglia Connections and Neurotransmitters

An overview of the anatomical structures and general circuitry making up the basal ganglia is provided (Fig. 1).

The striatum is the main input structure of the basal ganglia, receiving excitatory glutamatergic inputs from cerebral cortex and thalamus [1]. The STN also receives excitatory input from outside the basal ganglia. On the other hand, the outputs from basal ganglia arises from GPi and SNr, and their major targets are the thalamus and the midbrain and brainstem, which influence movement via direct or indirect connections with motor areas. These outputs are inhibitory GABAergic, and an increase in basal ganglia output leads to a reduction in the activity of its targets. The microcircuitry of the striatum was recently reviewed [1]. In addition to glutamatergic inputs from outside of the basal ganglia, the striatum and STN receive dopaminergic inputs from SNc. In the striatum, the great majority of neurons are GABAergic spiny projection neurons. These projection neurons can be divided into two, roughly equal groups, with little overlap: those that express dopamine D1 receptors and

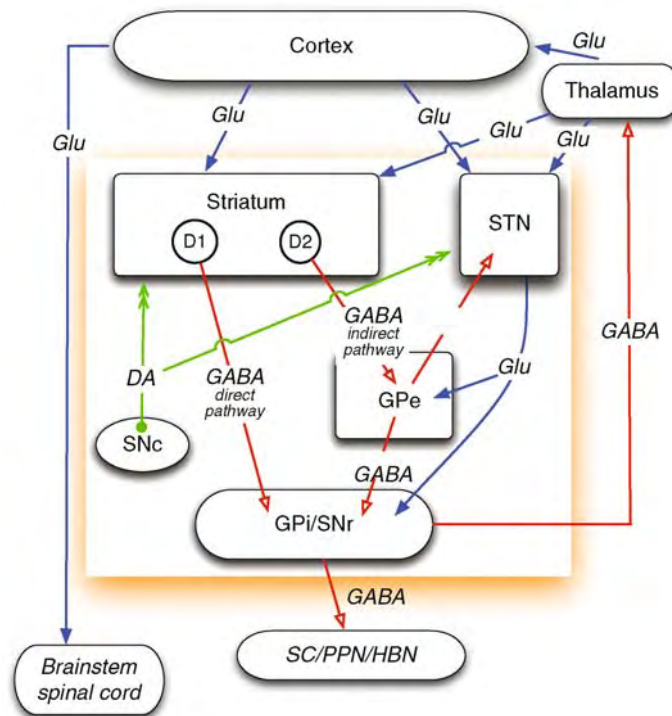

**Drugs for Motor Disorders. Figure 1** Simplified diagram of basal ganglia circuitry. The nuclei of the basal ganglia are included in the orange box. Excitatory (glutamatergic, Glu) and inhibitory (GABAergic) connections are indicated by blue and red, respectively. Dopaminergic projections are indicated by green. *GPe* globus pallidus external segments, *GPi* globus pallidus internal segments, *HBN* lateral habenula, *PPN* pedunculo-pontine nucleus, *SC* superior colliculus, *SNc* substantia nigra pars compacta, *SNr* substantia nigra pars reticulata *STN* subthalamic nucleus. D1 and D2 indicate dopamine D1 receptor- and dopamine D2 receptor-expressing striatal projection neurons, respectively.

project to the GPi and SNr (*direct pathway*); and those that express D2 receptors and project to the GPe (*indirect pathway*). The GPe gives rise to GABAergic axons to the STN, and then the STN projects excitatory (glutamatergic) outputs to the GPi and SNr. Thus, the output nuclei of the basal ganglia (GPi and SNr) receive striatal information not only directly (direct pathway) but also indirectly via GPe and STN (indirect pathway). Elucidation of these pathways over the past few decades has led to improved understanding of how to treat disorders of these structures, though much remains to be understood.

### Clinical Features of Parkinson's Disease

Parkinson's disease (PD) is the most common progressive neurodegenerative disorder after Alzheimer's disease with a mean age at onset of 55, and the incidence increases markedly with age. Patients with PD experience a number of motor symptoms including constant tremor at rest, muscle and limb rigidity, poverty of voluntary movement (akinesia), and slowness in performing voluntary movement (bradykinesia). Abnormalities of affect and cognition also accompany the motor symptoms frequently. Depression is common, and dementia is significantly more frequent in PD, especially in older patients.

In neuropathological terms, PD is characterized by the presence of intracytoplasmic inclusions from protein aggregates called Lewy bodies and the depletion of pigmented DA-containing neurons in the SNc. Approximately 60% of dopaminergic neurons in SN are already irreversibly destroyed when the first symptoms of PD become significantly visible. This degeneration of dopamine neurons in SNc with an accompanying loss of dopamine and its metabolism in the striatum cause the major motor symptoms in PD [2].

### Drugs for Treatment of Parkinson's Disease and Their Mechanisms

The motor symptoms of PD can be managed with several drugs in the initial years, but the disorder slowly progresses, eventually resulting in significant disability. Strategies for delaying onset or slowing progression of PD are important considerations in overall treatment approaches. The current management of PD is based on dopaminergic therapy aimed at reversing the effects of striatal dopamine depletion induced by the degeneration of dopaminergic neurons in SNc. L-DOPA, acting as a precursor of dopamine, and dopamine agonist drugs are the most effective drugs for the control of motor symptoms of PD [3]. However, long-term L-DOPA treatment causes a high level of motor complications including fluctuations of motor responses ('on-off' phenomena, 'off' means periods of return of PD symptoms when the medications' effects wears off), and ►**dyskinesia** (drug-induced involuntary movements including chorea and dystonia). To delay onset

of motor complications of L-DOPA, most patients begin treatment with a dopamine receptor agonist (e.g., bromocriptine, pergolide, pramipexole), but they need to add L-DOPA within a few years. The mechanisms of induction of the motor complications of L-DOPA treatments are still unclear, although several hypotheses have been proposed [4].

Catechol-O-methyltransferase (COMT) inhibitors (entacapone, tolcapone) are used mainly in combination with L-DOPA in order to increase the half-life of L-DOPA and reduce off time. COMT is one of the key enzymes that metabolizes catecholamines such as dopamine, and therefore, COMT inhibitors act to block endogenous dopamine degeneration and then enhance dopamine content in the synaptic cleft.

Amantadine, an antiviral agent, has been shown to have a mild efficacy against the motor symptoms of PD and also reduce dyskinesias. Amantadine is thought to have anti-dyskinesia actions by acting as an antagonist of glutamate receptors [5].

Monoamine oxidase (MAO)-B serves to break down dopamine, and MAO-B inhibitors (selegiline, rasagiline) act to increase striatal dopamine contents. MAO-B inhibitors improve motor features in early and late PD. In addition, MAO-B is involved in the oxidative pathway on dopaminergic neuronal degeneration. Antioxidants acting via MAO-B inhibition could delay progression of PD.

As indicated above, dopamine-replacement therapies with L-dopa and dopamine-related drugs are highly efficient for symptomatic management of PD, however, these treatments are associated with a series of long-term, treatment-related motor complications that increase in severity with disease progression. Novel non-dopaminergic approaches for management of PD are becoming available, that are designed to improve motor function of PD without inducing motor complications nor losing efficacy with disease progression. The adenosine  $A_{2A}$  receptor antagonist (istradefylline) is one of the leading candidates for non-dopaminergic treatments of PD [6]. Istradefylline provides modest symptomatic improvements without increasing troublesome dyskinesias.  $A_{2A}$  receptors selectively localise on the striatopallidal projection neurons, and serve to modulate the striatopallidal neuron via GABAergic modulation in the striatum and GP. Istradefylline can ameliorate the excessive activity of the striatopallidal pathway, which is caused by dopamine depletion in PD, then resulting in improving motor symptoms of PD.

### Other Movement Disorders

The list of other movement disorders is extensive and cannot be covered in this brief essay. However, it is reasonable to consider these disorders as arising from dysfunction in one or more of the various neurotransmitter systems in the basal ganglia. Among

the better understood neurotransmitter systems are acetylcholine, which is released by the large aspiny interneurons of the striatum, and gamma-aminobutyric acid (GABA), which is released by projection neurons and interneurons.

Centrally acting anticholinergic drugs have been used to treat dystonia, which may occur in a small number of syndromes in which the pathology is understood, idiopathically, or as a side effect of treatment with dopamine blocking drugs. Dystonia may also be treated with botulinum toxin [7]. GABA receptor agonist drugs, on the other hand, have been used to treat tardive dyskinesia. This is a movement disorder that may also develop after exposure to dopamine receptor blocking agents. Tardive dyskinesia may persist after discontinuing the drugs that triggered it. Several different tardive dystonia syndromes have been described, which have different pathophysiologies and treatments [8]. These drugs may act on the spiny projection neurons of the striatum or any of several types of GABA interneuron [9].

## References

1. Bolam JP et al. (2006) Molecules, microcircuits and motivated behaviour: microcircuits in the striatum. In: Grillner S (ed) *Microcircuits: the interface between neurons and global brain function* Dahlem Workshop Report 93. The MIT Press, Cambridge, MA
2. Marsden CD (1986) Basal ganglia disorders. *Lancet* 2:1141–1147
3. Hornykiewicz O (2002) L-DOPA: from a biologically inactive amino acid to a successful therapeutic agent. Historical review article. *Amino Acids* 23:65–70
4. Cenci MA (2007) Dopamine dysregulation of movement control in L-DOPA-induced dyskinesia. *Trends Neurosci* 30:236–243
5. Johnson JW, Kotermanski SE (2006) Mechanism of action of memantine. *Curr Opin Pharmacol* 6:61–67
6. Jenner P (2005) Istradefylline, a novel adenosine A2A receptor antagonist, for the treatment of Parkinson's disease. *Expert Opin Investig Drugs* 14:729–738
7. Jankovic J (2006) Treatment of dystonia. *Lancet Neurol* 5:864–872
8. Skidmore F, Reich SG (2005) Tardive dystonia. *Curr Treat Options Neurol* 7:231–236
9. Tepper JM, Koos T, Wilson CJ (2004) GABAergic microcircuits in the neostriatum. *Trends Neurosci* 27:662–669

---

## DSCAM/Dscam

► Down Syndrome Cell Adhesion Molecule

---

## DT-MRI, Diffusion Tensor Magnetic Resonance Imaging

### Definition

Diffusion Tensor MRI is based on measurements of water diffusion using diffusion weighted MRI (DWMRI) to calculate the diffusion tensor in each image voxel. With the aid of the diffusion tensor, information regarding diffusional anisotropy can be obtained together with information on the preferred direction of diffusion in tissues.

► Magnetic Resonance Imaging

---

## Dual Respiratory Center

### Definition

In vivo and in vitro studies on respiratory effects of opioids and anoxia indicate that two rhythmogenic interneuron groups, the preBötzinger Complex (pre-BötC) and the parafacial respiratory group (pFRG) constitute a dual (inspiratory-expiratory) center.

► Isolated Respiratory Center Functions  
 ► PreBötzinger Complex Inspiratory Neurons and Rhythm Generation  
 ► Respiratory Network Analysis  
 ► Isolated Respiratory Center Functions

---

## Dualism (Property Dualism, Substance dualism)

E. J. LOWE  
 University of Durham, Durham, United Kingdom

### Definition

► **Property dualism** is the doctrine that mental properties are distinct from and irreducible to physical properties, even if properties of both kinds may be possessed by the same thing, such as the human brain. ► **Substance dualism** is the doctrine that the things that possess mental properties are distinct from and irreducible to the things that possess physical properties – for example, that the

human mind or soul is distinct from and irreducible to the human body or any part of it, such as the brain.

### Description of the Theory

The most famous proponent of substance dualism was the French philosopher and scientist René Descartes (1591–1650), who maintained that there is a “real distinction” between the human mind or soul and the human body [1]. According to Descartes, the mind and the body are distinct and separable substances. (By a “substance” in this context, Descartes means an individual thing or object which possesses properties.) Descartes held that the mind and the body each have just one essential attribute – thought or consciousness in the case of the mind and ►spatial extension in the case of the body – and that all of the properties of each of these substances are modes of its essential attribute. Thus the body, he believed, has properties such as shape, size and spatial location but no mental properties, whereas the mind has properties such as belief, desire and volition but no physical properties. In support of his view, Descartes advanced two principal arguments – an argument from the conceivability of disembodiment, and an argument from the indivisibility of the mind or soul.

The ►conceivability argument may be reconstructed as follows. (i) It is clearly and distinctly conceivable that I (that is, my mind or soul) should exist without a body. (ii) What is clearly and distinctly conceivable is possible, because at least God can bring it about. (iii) Hence, it is possible that I should exist without a body. (iv) If it is possible that I should exist without a body, then I must be distinct and separable from my body. (v) Therefore, I am distinct and separable from my body. However, both of the premises (i) and (ii) are evidently open to challenge and for this reason the argument has generally been regarded as unpersuasive.

The ►divisibility argument may be reconstructed as follows. (i) My mind or soul contains no parts into which it is divisible. (ii) My body, being spatially extended, is necessarily divisible into parts. (iii) Hence, my mind or soul must be distinct from my body and cannot be spatially extended. Again, however, premise (i) is open to challenge and the argument has consequently failed to persuade philosophers who are not already sympathetic to substance dualism.

Even if Descartes’s arguments are unpersuasive, his position (Cartesian dualism) has considerable intuitive appeal and is in accord with the religious beliefs of many people. But it is widely regarded as being incompatible with our advancing scientific understanding of the workings of the human brain and nervous system. In particular, Cartesian dualism is thought to be faced with an insuperable problem regarding ►psycho-physical causation, that is, the causal interaction between mind and brain. Descartes believed that this interaction was centered on the pineal gland, where

the mind or soul was able to affect the motion of “animal spirits” and in turn be affected by such motion. (“Animal spirits” were thought to be subtle fluids flowing through nerve fibers.) However, this theory is apparently incompatible with physical conservation laws, notably the law of the conservation of momentum, as even some of Descartes’s own contemporaries perceived. As a consequence, interactionist substance dualism of the Cartesian variety fell out of favor, to be replaced by parallelist and epiphenomenalist versions, which deny that there is any causal action of the mind upon the body (the former also denying that there is any causal action of the body upon the mind). However, these versions of substance dualism are extremely counterintuitive, since we all have a strong conviction that our mental choices or decisions can have an effect upon our bodily behavior.

Substance dualism is a stronger theory than property dualism, in the sense that the former entails, but is not entailed by, the latter. Monistic property dualism is the view that substance dualism is false but that property dualism is true. One of the earliest versions of this view was advanced by Descartes’s contemporary, Baruch Spinoza (1632–1677), at least according to some interpretations of his position [2]. Spinoza denied that the mind and the body are distinct substances. Indeed, he denied that they are substances at all, holding that God or Nature – that is, the entire universe as a whole – is the only real substance, or fully independent thing. But he agreed with Descartes in distinguishing between the attributes of thought and extension, the modes of these attributes being mental and physical properties respectively. Where he differed from Descartes was in believing that the same substance or thing can possess both mental and physical properties. Most present-day versions of dualism are likewise versions of monistic property dualism [3,4], typically maintaining that the human brain possesses both mental and physical properties but that these properties are distinct and mutually irreducible.

Perhaps the most compelling case for monistic property dualism may be made by appeal to the apparently irreducible character of the properties of phenomenal consciousness, or so-called qualia, as revealed to us by introspection. It is hard to see how mental qualities such as the perceived redness of a rose or bitterness of a lemon could simply be physical properties of the brain or nervous system, such as complex patterns of neuronal activity. There seems to be an unbridgeable “explanatory gap” between such sensory qualia and the neurophysiological activity that seems to be correlated with them, which prevents us from either simply identifying the former with the latter or even somehow “reducing” the former to the latter [5]. The most that we seem to be able to say is that there is, as a matter of empirically confirmed fact, a causal correlation

between such mental properties and certain physical properties of the brain – but one which it seems impossible for us to explain.

However, physicalist philosophers of mind – those who are hostile to any form of dualism – protest that monistic property dualism suffers from at least some of the difficulties that are seen to beset substance dualism, in particular the problem of psychophysical causation. Such critics tend to appeal to the principle of the causal closure of the physical domain in advancing their objections [6]. This principle has a number of variants, but one popular one states that if we trace the causes of any physical effect backwards in time, we shall never encounter a chain of causation that takes us out of the domain of purely physical events. For example, if we trace back the causal antecedents of a certain bodily movement, such as a movement of my hand, we shall only ever encounter other physical events, such as neural events in my brain and nervous system. It seems most improbable to suppose that, at some point in such a causal chain, we shall find a physical event that has no other physical event as its immediate cause – in short, a point at which we might locate a purely mental event as its immediate cause, such as my experiencing the taste of a lemon or a twinge of pain. Consequently, such physicalists maintain, we must either regard such experiences as being merely epiphenomenal – that is, as having no effect upon the physical domain – or else maintain that, if indeed they really exist at all, they are in fact identical with, or somehow reducible to, physical occurrences of some kind, even if we cannot presently (and indeed may never) understand how. Against epiphenomenalism, however, they would argue that it leaves us with a mystery as to why mental properties should exist at all, given that they can have no effect upon the physical domain. In reply, some epiphenomenalists advance a panpsychist version of their theory, which maintains that it is a fundamental metaphysical fact about our universe that every physical occurrence is accompanied by a corresponding mental occurrence, as a matter of necessity. (In fact, Spinoza is often seen as any early proponent of this view.) To their opponents, however, this appears to be a wild speculation which is by its very nature incapable of being either confirmed or falsified empirically.

At present, physicalism is the dominant view in the philosophy of mind, with dualists of all kinds being very much in the minority and interactionist substance dualists [7,8] especially rare. However, physicalism has its difficulties too, as a consequence of which dualism is currently undergoing something of a revival. The main difficulty for physicalism is the “explanatory gap” mentioned earlier. We simply cannot see how mental properties might just be, or be reducible to, physical properties. Some physicalists urge that this is merely because our access to our own mental properties is

different from our access to the physical properties of other things, being via introspection rather than via our sensory organs, so that these properties appear to be different to us, when in fact they could be the same [9]. (This so-called “dual aspect” theory is sometimes attributed to Spinoza, as a rival to the interpretation of him as being a property dualist.) However, the idea that we can distinguish between “appearance” and “reality” in the case of mental properties such as pain is problematic, and this fact has been appealed to in support of dualism in recent times, notably by Saul Kripke [10].

Kripke invites us to consider the hypothesis that pain just is (that is, is identical with) a certain kind of physical activity, such as the firing of C-fibers, by analogy with the hypothesis – now accepted as true on empirical grounds – that heat just is the kinetic activity of molecules. Kripke argues that if such an identity obtains, then it does so necessarily, not just contingently. So, for example, given that heat is the kinetic activity of molecules, it could not have been anything else. He readily acknowledges that we seem to be able to imagine that it might have been something else, explaining this by the fact that there could have been a different kind of physical activity which had the same appearance as heat, that is, which gave rise to the same phenomenal experience as the kinetic activity of molecules gives rise to in us. But this is where the intended analogy inevitably breaks down, according to Kripke. For if pain just is the firing of C-fibers, say, then again this identity will have to be necessary rather than contingent, but we should likewise seem to be able to imagine that pain might have been something else. However, that would require the possibility of there being a kind of physical activity which had the appearance of pain without being pain, just as there could have been a kind of physical activity which had the appearance of heat without being heat. And it seems evident that there can be no such possibility, because whatever seems like pain is pain, even if not everything that seems like heat is heat.

Naturally, the debate, being a philosophical one, does not end there. What is fundamentally at issue in this debate is something that Descartes himself was intimately concerned with in his own defense of dualism, namely, the relation between what is possible and what is conceivable. Some present-day philosophers believe, like Descartes, that conceivability is a reliable guide to possibility and exploit this to argue in favor of property dualism, on the grounds that we can conceive of beings (“zombies”) who are physically just like us but lack properties of phenomenal consciousness [3]. Unsurprisingly, others dispute this. However, it is crucial to bear in mind that dualism and physicalism are rival metaphysical theories, not simply scientific theories amenable to empirical confirmation or refutation. As such, they are concerned with what is

necessarily the case and with what is merely possibly the case, rather than just with what is actually the case. Empirical evidence on its own, however, can at best only reveal to us what is actually the case. To go further than this, as metaphysics does, requires other sources of evidence or kinds of reasoning than those deployed by the empirical sciences. Unfortunately, metaphysicians themselves disagree, as scientists tend not to, about the methods of inquiry proper to their own discipline, with the result that their disputes are more intractable – but none the less interesting or important on that account.

## References

1. Descartes R (1984) *Meditations on first philosophy*. In: Cottingham J, Stoothoff R, Murdoch D (eds) *The philosophical writings of Descartes*. Cambridge University Press, Cambridge
2. Spinoza B (1994) *Ethics*, Curley E (ed) Princeton University Press, Harvard
3. Chalmers DJ (1996) *The conscious mind*. Oxford University Press, New York
4. Robinson WS (2004) *Understanding phenomenal consciousness*. Cambridge University Press, Cambridge
5. Levine J (2001) *Purple haze: the puzzle of consciousness*. Oxford University Press, New York
6. Kim J (1998) *Mind in a physical world*. MIT Press, Cambridge MA
7. Popper KR, Eccles JC (1977) *The self and its brain*. Springer International, Berlin
8. Swinburne R (1986) *The evolution of the soul*. Clarendon Press, Oxford
9. Papineau D (2002) *Thinking about consciousness*. Clarendon Press, Oxford
10. Kripke S (1980) *Naming and necessity*. Blackwell, Oxford

## Duchenne Muscular Dystrophy

KATI E. DRAPER, QIONG WANG,  
BRIAN O. WILLIAMS, ROBERT W. GRANGE  
Department of Human Nutrition, Foods and Exercise,  
Virginia Polytechnic Institute and State University,  
Blacksburg, VA, USA

### Synonyms

DMD

### Definition

►Muscular dystrophy describes a group of ~40 inherited heterogeneous disorders that result in progressive muscle weakness and muscle wasting [1,2]. The most common and fatal disorder is ►Duchenne

muscular dystrophy (DMD), first recognized in the mid 1800s and named for a French physician [3]. DMD is characterized by childhood onset, prevalence in boys, progressive muscle weakness, and abundant ►fibrosis and adipose tissue at later stages of the disease [3]. The genes associated with many but not all muscular dystrophies have been identified [1]. The ►genetic defects associated with DMD include deletions or non-sense mutations in the dystrophin gene, which result in the absence of the membrane-associated protein, dystrophin [4]. Although the genetic basis of the disease has been known for over ~20 years, the onset mechanism(s) of the disease is/are not yet clearly defined.

## Characteristics

### Quantitative Description

Gene: The gene for the protein dystrophin is ~2.4 million bases and is located on chromosome X at locus p21. It has 79 coding exons and 7 tissue-specific promoters for 7 protein isoforms. Three promoters produce “full-length” transcripts whose 427 kDa proteins only differ in their amino-terminal sequences. These isoforms are brain (B), muscle (M), which is expressed in skeletal and cardiac muscle, and Purkinje (P), which is expressed in both cerebellar Purkinje cells and skeletal muscle [5].

Protein: Dystrophin is expressed in both invertebrates and vertebrates. Vertebrate dystrophin is located at the cytoplasmic membrane of skeletal, cardiac and smooth muscle and at synapses in the central nervous system. The 427 kDa cytoskeletal isoform has 3,685 amino acids [6] and is a member of the  $\beta$ -spectrin/ $\alpha$ -actinin protein family [7]. Dystrophin has four separate domains: (1) an amino-terminal actin-binding domain; (2) a central rod domain; (3) a cysteine-rich domain; and (4) a carboxyl-terminal domain [5]. Dystrophin represents about 5% of sarcolemma proteins [6].

Incidence: Today, DMD is recognized as a severe X-linked muscle-wasting disease (►X-linked disease) that affects 1 in 3,500 boys [3]. One third of all DMD cases arise from a sporadic mutation in the dystrophin gene, most likely a result of its large size [4].

### Higher Level Structures

#### Dystrophin, Dystrophin Glycoprotein Complex, Costameres and Basal Lamina

The skeletal muscle isoform of dystrophin is considered a key structural element in the muscle fiber. It is a rod-like cytoskeletal protein localized to the inner surface of the skeletal muscle membrane, or sarcolemma. It forms part of the ►dystrophin glycoprotein complex (►DGC) that links the cytoskeleton and the basal lamina [2]. The DGC, along with additional proteins, form rib-like lattices on the cytoplasmic face of the



sarcolemma known as costameres, which facilitate force transmission between active and non-active fibers [8]. This complex of proteins also likely acts as a signaling conduit between the outside and inside of the fiber [1].

### Lower Level Components

The dystrophin glycoprotein complex is made up of several subcomplexes, including the dystroglycan complex, the sarcoglycan:sarcospan complex, and the peripheral proteins of the cytoplasmic dystrophin-containing domain. The amino or N-terminal of dystrophin binds cytoskeletal F-actin, and its carboxy or C-terminal region binds the dystroglycan complex, which is composed of  $\alpha$ - and  $\beta$ -dystroglycans.  $\beta$ -dystroglycan, an integral membrane protein, interacts with dystrophin in the cytosol and with  $\alpha$ -dystroglycan in the extracellular matrix, which in turn binds to laminin-2 in the basal lamina (Fig. 1). The sarcoglycan:sarcospan complex, composed of  $\alpha$ ,  $\beta$ ,  $\gamma$ , and  $\delta$  sarcoglycans and sarcospan, stabilizes the dystroglycan complex in the sarcolemma [2,5,7]. Additional proteins include  $\alpha$ -dystrobrevin and the syntrophins [1,7] (Fig. 1).

### Structural Regulation

Absence of expressed dystrophin in DMD leads to the complete loss of the DGC [2].

### Higher Level Processes

#### Effects of Dystrophin Deficiency

Mutations in the dystrophin gene result in premature stop codons that yield a truncated non-functioning protein. In the absence of dystrophin, the components

of the DGC are also absent from the membrane. Loss of the DGC is considered to render the sarcolemma membrane more fragile and to disrupt signaling [1,7].

### Process Regulation

#### Mechanisms of Muscle Degeneration

The mechanism, or mechanisms, of onset of DMD are not yet clearly defined.

One possibility is abnormal intracellular calcium regulation. The calcium hypothesis states the absence of dystrophin results in an influx of calcium through the sarcolemma, due to either abnormally functioning mechano-sensitive channels or cation-leak channels. The increased calcium entry would cause a rise in cytosolic free calcium, activate calcium-dependent  $\blacktriangleright$ proteases, and eventually lead to muscle fiber necrosis, including further degradation of the sarcolemma [9].

### Function

#### Structure and Signaling

The precise role(s) of dystrophin and the DGC at the membrane are incompletely understood at present, but they may play both structural and signaling roles [7]; it is therefore difficult to determine what processes are lost and/or changed when they are absent. Structural roles likely include maintaining the integrity of the membrane to ensure proper intracellular  $\text{Ca}^{2+}$  regulation, and stabilizing the sarcolemma from shear stresses imposed during eccentric muscle contractions [7,8]. However, in the absence of dystrophin and the DGC, skeletal muscles of older dystrophic animals are susceptible to  $\blacktriangleright$ contraction-induced injury, while skeletal muscles of maturing dystrophic mice are less

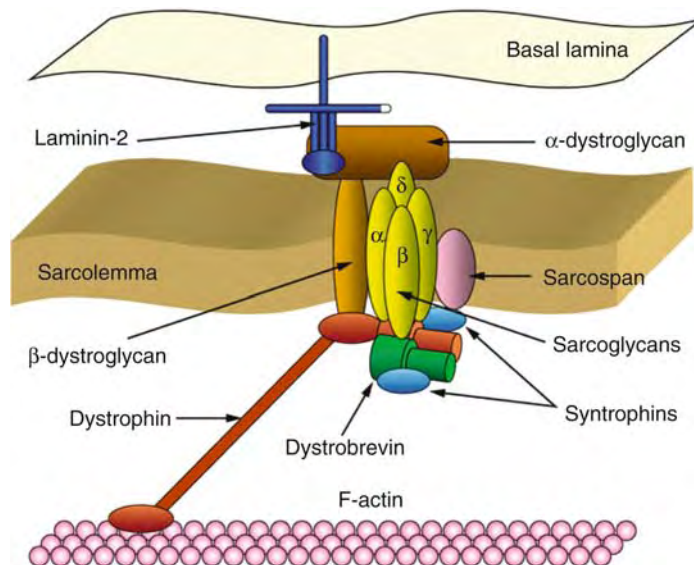

**Duchenne Muscular Dystrophy. Figure 1** Schematic of DGC with currently understood relationship of the components. (Roberts [7]).

susceptible [10]. Thus, the absence of dystrophin and the DGC in dystrophic membrane stability may change with maturation. There is increasing evidence that the DGC plays an important signaling role, such as the interaction between neuronal nitric oxide synthase (nNOS) and  $\alpha$ -syntrophin [1]. The nature of the signals that may be disrupted when the DGC is absent is still unclear.

## Pathology

### Characteristics of Muscle Pathophysiology

The two main features of DMD pathophysiology are: (i) progressive degeneration of muscle tissue, and (ii) progressive muscle weakness [2]. DMD muscles demonstrate grouped degenerating and necrotic fibers even before muscle weakness is clinically observed [5]. Necrotic fibers are infiltrated by inflammatory cells such as macrophages and CD4+ lymphocytes, while regenerating fibers are characterized by centralized nuclei. Eventually, regenerative capacity is lost and muscle fibers are replaced by adipose and fibrous connective tissue, giving rise to initial **pseudohypertrophy**, followed by atrophy [3]. Dystrophin-deficient muscle is characterized by increased permeability to endogenous macromolecules flowing in and out of the cell. Muscle fibers stain positively for endogenous extracellular proteins such as serum albumin (in to cell), and increased serum concentrations of cytosolic proteins such as creatine kinase are observed (out of cell) [5].

*Clinical Signs* Onset of DMD occurs at age ~3–5 years, with evident delays in speech and motor development. In the early stages, calf muscles are enlarged, some of which is due to adipose and connective tissue deposition (i.e. pseudohypertrophy). The muscle involvement is bilateral and symmetrical, first affecting the lower limbs. The proximal muscles are more affected than the distal muscles. Additional features are a waddling gait due to weakness in hip abductors, lumbar lordosis because of weak gluteal muscles, and the Gower's maneuver, which is difficulty rising from the floor or a chair, owing to weakened knee and hip extensors. One third of DMD patients also show intellectual impairment. By age 12, 95% of patients are confined to a wheelchair. Contractures occur at the elbows, knees, and hips and a severe kyphoscoliosis can develop. There is steady deterioration of pulmonary function. By age 20, 90% of DMD patients die, most from cardiac failure and respiratory insufficiency [3].

## Therapy

*Treatment* Specific treatments to significantly increase the lifespan of DMD patients are currently being developed including pharmacological and genetic therapies [6].

## References

1. Durbeej M, Campbell KP (2002) Muscular dystrophies involving the dystrophin-glycoprotein complex: an overview of current mouse models. *Curr Opin Genet Dev* 12:349–361
2. Straub V, Campbell KP (1997) Muscular dystrophies and the dystrophin-glycoprotein complex. *Curr Opin Neurol* 110:168–175
3. Emery AEH (1993) Duchenne muscular dystrophy, 2nd ed. Oxford University Press, New York
4. Petrof BJ (1998) The molecular basis of activity-induced muscle injury in Duchenne muscular dystrophy. *Mol Cell Biochem* 179:111–123
5. Blake DJ, Weir A, Sarall E, Davies KE (2002) Function and genetics of Dystrophin and dystrophin-related proteins in muscle. *Physiol Rev* 82:291–329
6. Kapsa R, Kornberg AJ, Byrne E (2003) Novel therapies for Duchenne muscular dystrophy. *Lancet Neurol* 2:299–310
7. Roberts RG (2001) Protein family review. Dystrophins and dystrobrevins. *Genome Biol* 2:3006.1–3006.7
8. Rybakova IN, Patel JR, Ervasti JM (2000) The dystrophin complex forms a mechanically strong link between the sarcolemma and costameric actin. *J Cell Biol* 150(5):1209–1214
9. Alderton JM, Steinhardt RA (2000) How calcium influx through calcium leak channels is responsible for the elevated levels of calcium-dependent proteolysis in dystrophic myotubes. *Trends in Cardiovasc Med* 10:268–272
10. Grange RW, Gainer TG, Marschner KM, Talmadge RJ, Stull JT (2002) Fast-twitch skeletal muscles of dystrophic mouse pups are resistant to injury from acute mechanical stress. *AmJ Physiol, Cell Physiol* 283:1090–1101

## Dummy Treatment

### ►Placebo Analgesic Response

## Dura Mater of Brain

### Synonyms

Dura mater cranialis; Cranial dura mater

### Definition

Pachymeninx. One of the three meninges. In the dura mater of brain it is closely connected with the periosteum of the calvaria, lined with the arachnoid on the inside. Consists of two layers which spread out

along the longitudinal fissure of cerebrum the falx cerebri (falx = sickle), and between cerebrum and cerebellum the tentorium cerebelli. Also forms blood sinuses such as the superior sagittal sinus and inferior sagittal sinus.

---

## DW-MRI, Diffusion Weighted Magnetic Resonance Imaging

### Definition

A modified magnetic resonance imaging technique that produces images for which the MR image signal intensity is sensitized to local differences in the diffusional movement of water.

- ▶ Magnetic Resonance Imaging

---

## Dyad

### Definition

Ribbon synapse made by bipolar axons in the inner plexiform layer onto two postsynaptic profiles.

- ▶ Retinal Bipolar Cells
- ▶ Retinal Ribbon Synapses

---

## Dynamic Clamp

- ▶ Computer-Neural Hybrids

---

## Dynamic Range

### Definition

Difference (in dB) between the threshold of audibility and the threshold of discomfort.

- ▶ Hearing Aids

---

## Dynamic Range in Acoustics

### Definition

Difference (in dB) between the threshold of audibility and the threshold of discomfort.

- ▶ Hearing Aids

---

## Dynamic Range of Neurons

### Definition

Range of intensity or amplitude of a stimulus that is encoded by a given property of a neural response. The neural code can for example be the rate of action potentials (spike rate) produced by a neuron.

---

## Dynamic Stiffness

### Definition

The proportionality constant for a linear dynamical system that relates the force (or torque) produced in response to an imposed displacement.

- ▶ Impedance Control

---

## Dynamical System

### Definition

A means of describing how one state develops into another state over the course of time. In engineering and mathematics, a dynamical system is a deterministic process in which a function's value changes over time according to a rule that is defined in terms of the function's current value. Simple nonlinear dynamical systems and even piecewise linear systems can exhibit a completely unpredictable behavior, which might seem

to be random. This unpredictable behavior has been called chaos.

► Emergence

## Dynein

### Definition

A class of motor proteins in cells that move proteins along microtubules, usually from the distal part of the cell towards its centre (i.e. in the direction of the minus end of the microtubule). This form of transport is known as retrograde transport.

► Microtubules  
► Retrograde Transport

## Dysarthria

### Definition

Articulatory speech deficit, usually due to cerebellar or brainstem disease.

► Central Vestibular Disorders

## Dyscalculia

### Definition

Inability to perform mathematical operations.

## Dysdiadokokinesia

### Definition

A neurological sign in which the patient is unable to perform rapidly alternating movements of the extremities. Classically, this sign results from pathology in the cerebellum.

► Cerebellar Functions

## Dysesthesia

### Definition

When an innocuous sensory stimulus is perceived as unpleasant or painful.

► Central Pain  
► Proprioception: Effect of Neurological Disease

## Dysgeusia

### Definition

Dysgeusia is a term referring to any distortion in the sense of taste. Dysgeusia can occur as a distortion in the perception of a tastant that is actually presented (e.g., a usually pleasant tastant is perceived as unpleasant) or as the perception of a taste in the absence of a tastant (e.g., persistent metallic taste). Dysgeusia may or may not be associated with loss of taste sensitivity and is usually caused by many of the same conditions that result in a pure reduction or loss of taste (see Ageusia for further details). Some authors refer to dysgeusia as a general term, encompassing all taste disturbances, both quantitative and qualitative. Thus, the term parageusia may be used to refer to distortions to the sense of taste, as described above.

► Ageusia  
► Gustation  
► Taste

## Dysgraphia

### Definition

Writing disability, despite maintained sensory and motor functions of the arm.

## Dyskinesia

### Definition

Literally means abnormal movement. However, the term has evolved to refer to abnormal drug-induced

involuntary movements, usually choreatic, dystonic, or a combination of both. Dyskinesia in patients with Parkinson disease results from the long-term complications of levodopa therapy. Tardive dyskinesia refers to choreo-dystonic movements secondary to long-term use of neuroleptic (antipsychotic) or anti-emetic medications, which have dopamine antagonist activity.

- ▶ Drugs for Motor Disorders
- ▶ Parkinson's Disease
- ▶ Tardive Dyskinesia

---

## Dysmetria

### Definition

A neurological deficit characterized by the inability to coordinate properly the extent and direction of goal-directed movements. Impaired trajectory movement of a limb towards an intended target, by undershooting or overshooting the target most commonly detected during the finger-nosefinger test in the upper limb, or the heel to shin test in the lower limb. Dysmetria is typically seen in disorders of cerebellar function and is part of the overall cerebellar ataxia syndrome.

- ▶ Cerebellar Functions

---

## Dysmetric Saccades

### Definition

Saccades that are not accurate. The term dysmetria is more often used to describe hypermetric saccades, i.e., saccades that overshoot the target, than hypometric saccades.

- ▶ Central Vestibular Disorders
- ▶ Saccade, Saccadic Eye Movement

---

## Dysosmia

- ▶ Smell Disorders

---

## Dysphagia

### Definition

- ▶ Disturbance in swallowing.

---

## Dysphasia

### Definition

- ▶ Aphasia.

---

## Dysphonia

### Definition

- ▶ Disturbance in vocalization due to weakness or incoordination of muscles controlling the vocal apparatus.

---

## Dysplasia

### Definition

Dysplasia (Greek dys- a combining term meaning difficult, painful, or abnormal, and plasia, a combining term meaning formation). Thus dysplasia is an abnormality of development.

---

## Dyssynergia

### Definition

A neurological sign characterized by the decomposition of movement reflecting the inadequate coordination of complex, multi-joint movements of the extremities.

- ▶ Cerebellar Functions

## Dystonia

### Definition

Abnormal sustained muscle contraction causing twisting or turning around one or multiple joints. It may affect the neck (cervical dystonia/torticollis), eyelids (blepharospasm), limbs (e.g. writer's cramp), trunk (segmental), or vocal cords (spasmodic dysphonia). Dystonia can be focal, segmental, or generalized. Generalized or multifocal dystonia affects multiple body parts.

- ▶ Complex Regional Pain Syndromes: Pathophysiological Mechanisms
- ▶ Drugs for Motor Disorders
- ▶ Proprioception: Effect of Neurological Disease

## Dystrophin Glycoprotein Complex (DGC)

### Definition

The complex of proteins associated with dystrophin that forms a link between the cytoskeleton of a muscle cell and the basal lamina outside the cell. It likely plays both structural and signaling roles for the cell. This complex is absent in Duchenne muscular dystrophy, and therefore structural and signaling functions are lost.

- ▶ Duchenne Muscular Dystrophy

---

## E2

- ▶ Long Loop Reflexes

---

## E Box

### Definition

DNA motif with the consensus sequence 5'-CACGTG-3' that constitutes a binding site for Clock (or NPas2) and Bmal1.

- ▶ Clock-Controlled Genes

---

## Early Selection

### Definition

A model, first proposed for attention, assuming that unattended signals are eliminated already on an early cortical level.

- ▶ Sensory Plasticity and Perceptual Learning

---

## Early Sensory Cortices

### Definition

Those parts of the cerebral cortex that receive direct input from sense organs, usually via the thalamus, i.e., the primary (and secondary) sensory cortices.

- ▶ Sensory Plasticity and Perceptual Learning

---

## Earmold

### Definition

A molded silicone, acrylic or vinyl mold worn in the ear.

- ▶ Hearing Aids

---

## Earth's Magnetic Field

- ▶ Geomagnetic Field

---

## Earth's Structure

### Definition

The planet Earth is layered. The subdivisions are crust (average thickness of continental crust: 35 km; oceanic average 6 km), mantle (35 – 2900 km depth), outer core (2900–5150 km depth), and inner core (5150 – 6371 km depth). The crust and mantle consist of solid rock, while the core is metallic. The inner core is solid, the outer core liquid.

- ▶ Geomagnetic Field

---

## Eating

### Definition

Eating is the process of taking food into the mouth, masticating the food and swallowing it.

## E-box

### Definition

Sequence of nucleotides that serves as DNA binding site for proteins involved in transcription. The consensus sequence is CANNTG and is found in the promoters of clock and clock-controlled genes.

- ▶ Clock Genes

---

## E-C Coupling

- ▶ Excitation-Contraction Coupling

---

## Eccentric Contraction

### Definition

A period of muscle activity during which the length of the muscle fibers increases.

- ▶ Energy/Energetics

---

## Echolocation

### Definition

A sensory system in bats, and toothed whales, in which usually high-frequency sounds are emitted and their echoes interpreted to determine the direction, and distance and shape of objects.

- ▶ Evolution of the Auditory System in Mammals

---

## Ecphory

### Definition

This term was originally introduced by German biologist Richard Semon, who used it in the sense of

“activation of a latent engram.” Subsequently, Canadian psychologist Endel Tulving used it to denote “the process by which the relevant information in the retrieval environment interacts with the information stored in a specific memory trace to produce conscious memory of certain aspects of the original event.”

- ▶ Episodic Memory

---

## Ectopia/Dystopia

### Definition

Congenital aberrant or inappropriate location of organs (such as the pituitary) or organ systems.

- ▶ Endocrine Disorders of Development and Growth

---

## Ectotherm

### Definition

An animal that relies on the surrounding temperature to regulate its body temperature. Animals in this group include fish, amphibians, and reptiles.

- ▶ Evolution of the Hypothalamus in Amniotes

---

## Edge Detectors

### Definition

- ▶ Visual Cortical and Subcortical Receptive Fields

---

## Edge Enhancement

- ▶ Contrast Enhancement



## Edinger-Westphal Nucleus

### Synonyms

Nuclei viscerates (Edinger-Westphal); Visceral nuclei (Edinger-Westphal); Accessory Nucleus of Oculomotor Nerve

## EDSS (Kurtzke Expanded Disability Status Score)

### Definition

The EDSS is a measure of neurologic impairment. It relies heavily on the ambulatory status of the patient and can provide a measurement of clinical status over time. The scale ranges from 0.0 (normal) to 10.0 (death due to multiple sclerosis, MS). Most patients with a score of <3.5 have RRMS and walk normally whereas patients with EDSS >5.5 need assistance to walk and may have progressive forms of MS.

- ▶ Multiple Sclerosis

## EEG

### Definition

Electroencephalogram, recording of brain wave activity.

- ▶ EEG in Sleep States

## EEG Delta Power

### Definition

The electrophysiological hallmark of non-REM (NREM) sleep. Electroencephalogram (EEG) slow waves (slow-wave activity, SWA) have a frequency within the delta frequency range between 1.0–4.0 and 0.75–4.5Hz. The prevalence and amplitude of slow or delta waves can be quantified by spectral analysis algorithms such as the Fourier transform. Because the delta frequency band is well defined (while the term

slow-waves is more ambivalent) and because the units of the Fourier output are power, the term EEG delta power is more precise although SWA is more widely used. EEG delta power is a measure of the depth of NREM sleep and its level is high when the duration of prior wakefulness was long and decreases over the course of a sleep episode.

- ▶ Electroencephalography
- ▶ Fourier Transform(ation)
- ▶ Non-REM Sleep
- ▶ Sleep Homeostasis

## EEG in Sleep States

KENNETH P. WRIGHT JR.

Sleep and Chronobiology Laboratory, Department of Integrative Physiology, University of Colorado at Boulder, Boulder, CO, USA

### Synonyms

Sleep electroencephalography (EEG); Sleep brain wave activity

### Definition

Recordings of the electrical activity of the brain during sleep.

### Characteristics

Sleep EEG activity can be recorded by placing sensors directly into brain tissue or onto the surface of the scalp. Brain wave activity can be recorded from individual cells, from populations of cells and from the surface of the brain and scalp. The EEG has been used in both research and clinical settings. Hans Berger was the first to report performing an EEG recording on a human subject in 1929. Loomis and colleagues were the first to report recordings of the human sleep EEG [1–3]. In humans, electrodes are typically placed on the scalp according to the international 10–20 system [4]. Brain wave activity recorded at the scalp generally represents cortical activity [5]. However, synchronization between cortical and sub-cortical structures influences the sleep EEG recorded at the scalp [6]. The features most commonly used to describe EEG waveforms are frequency, amplitude and morphology. Frequency is a measure of the number of cycles per second or Hertz (Hz). Amplitude is a measure of the height of the EEG waveform, commonly reported in micro volts ( $\mu\text{V}$ ) when measured on the scalp. Morphology is a description of the shape of the EEG waveform.

The EEG is commonly divided into bandwidths based on the assumption that the EEG within those bandwidths share common activity; the latter assumption may not always be accurate and thus some researchers examine EEG activity in single Hz [7]. The four primary EEG bandwidths include delta, theta, alpha and beta [7,8]. Different definitions of these bandwidths are found in the scientific and clinical

literature; however, the following can be used as a general guide. The delta band is commonly defined as the EEG rhythms between  $\sim 0.5$  and 3 Hz with amplitude of  $\sim 20$ – $200 \mu\text{V}$ . To be defined as delta sleep, the amplitude of the waveform must exceed  $75 \mu\text{V}$  [9]. Delta EEG activity is most common during synchronous slow wave sleep [8,9], also referred to as Delta or stage N3 sleep (Fig. 1), and is of highest

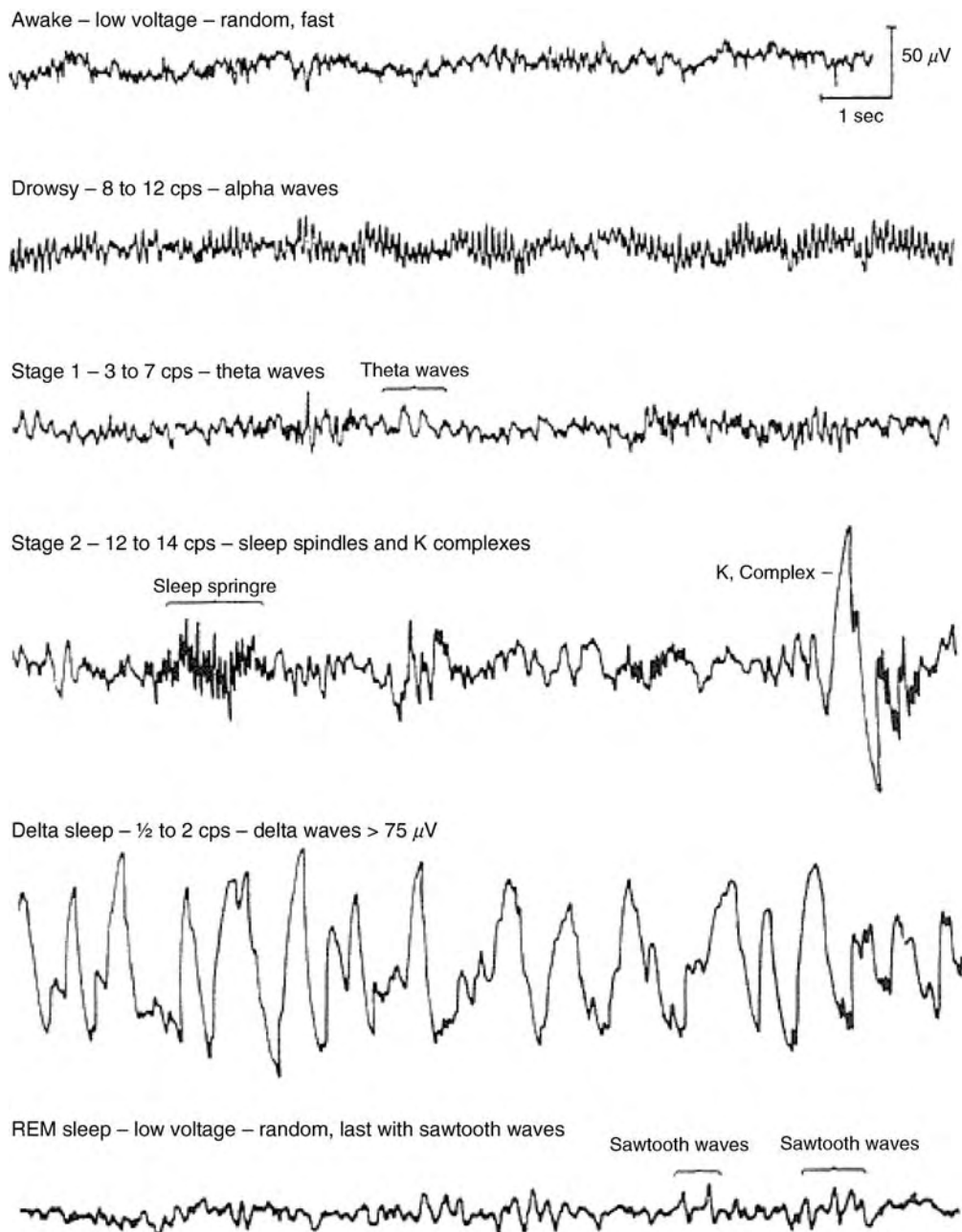

**EEG in Sleep States. Figure 1** EEG activity during wakefulness and sleep note due to nomenclature changes, stages 1, 2 and delta sleep are now referred to as stages N1, N2 and N3 sleep. Figure from <http://www.sleephomepages.org/sleepsyllabus/a.html> © Copyright 1997 Sleep Syllabus. Basics of Sleep Behavior. WebSciences International and Sleep Research Society (United States).

amplitude over the frontal cortex. The theta band is commonly defined as the EEG rhythms between  $\sim 4$  and 7 Hz and with amplitude of  $\sim 20$ – $200 \mu\text{V}$  [7–8]. Theta EEG activity is most commonly observed during the ►transition from wakefulness to sleep [7] and during sleep stages N1, N2 and REM [8]. Theta activity tends to be of highest amplitude over the central cortex. Theta EEG activity is also commonly recorded in non-humans in the hippocampus during REM sleep and wakefulness [10]. The alpha band is commonly defined as the EEG rhythms between  $\sim 8$  and 12 Hz with amplitude of  $\sim 20$ – $100 \mu\text{V}$  [7,8]. Alpha EEG activity is most commonly observed during quiet wakefulness, drowsiness, and the transition from wakefulness to sleep [7]. Alpha activity tends to be of highest amplitude over the occipital (visual) cortex of the brain, especially when eyes are closed [7]. The beta band is commonly defined as the EEG rhythms between  $\sim 15$  and 25 Hz with amplitude of  $\sim 2$ – $20 \mu\text{V}$ . Beta EEG activity is most commonly observed during active wakefulness. The 40 Hz rhythm associated with the gamma bandwidth is an EEG waveform reported to be associated with cognition.

Common EEG waveforms defined by their morphology include K-complexes, sleep spindles, vertex sharp waves, sawtooth waves, mu rhythm, and spike and sharp waves. The presence of K-complexes and sleep spindles define stage N2 sleep [9]. The K-complex is an EEG waveform having a well-delineated negative deflection immediately followed by a positive deflection with duration of  $\sim 0.5$  s (Fig. 1). The ►sleep spindle is an EEG waveform in the shape of a spindle with duration of  $\sim 0.5$  s (Fig. 1) [2]. Sleep spindles have frequencies between  $\sim 12$  and 14 Hz with highest amplitudes over the central cortex. Vertex sharp waves are EEG potentials occurring during the transition to sleep over the vertex of the central cortex. Sawtooth waves are a form of theta waves observed during REM sleep (Fig. 1). Saw-tooth theta waves have a shape like the blade of a saw [2]. The Mu rhythm is observed over the somatosensory cortex during wakefulness, with a frequency in the alpha bandwidth. Mu activity is morphologically different from alpha activity in that it has an arch-like shape like the letter m. Synchronous spike and sharp EEG waveforms maybe associated with epilepsy during sleep.

## References

1. Loomis AL, Harvey EN, Hobart G (1935) Potential rhythms of the cerebral cortex during sleep. *Science* 81: 597–598
2. Loomis AL, Harvey EN, Hobart (1935) Further observations on the potential rhythms of the cerebral cortex during sleep. *Science* 82:198–200
3. Davis H, Davis PA, Loomis AL, Harvey EN, Hobart G (1937) Changes in human brain potentials during the onset of sleep. *Science* 86:448–450

4. American Clinical Neurophysiology Society (2006) Guideline 5: guidelines for standard electrode position nomenclature. *J Clin Neurophysiol* 23:107–110
5. Olejniczak P (2006) Neurophysiologic basis of EEG. *J Clin Neurophysiol* 23:186–189
6. Steriade M (2005) Brain electrical activity and sensory processing during waking and sleep states. In: Kryger MH, Roth T, Dement WC (eds) *Principles and practice of sleep medicine*. W.B. Saunders Company, Philadelphia, PA, pp 101–119
7. Wright KP Jr, Badia P, Wauquier A (1995) Topographical and temporal patterns of brain activity during the transition from wakefulness to sleep. *Sleep* 18:880–889
8. Dijk DJ (1995) EEG slow waves and sleep spindles: windows on the sleeping brain. *Behav Brain Res* 69: 109–116
9. Carskadon MA, Dement WC (2005) Normal human sleep: an overview. In: Kryger MH, Roth T, Dement WC (eds) *Principles and practice of sleep medicine*. W.B. Saunders Company, Philadelphia, PA, pp 13–23
10. Poe GR, Nitz DA, McNaughton BL, Barnes CA (2000) Experience-dependent phase-reversal of hippocampal neuron firing during REM sleep. *Brain Res* 855:176–180

## EEG Sleep Stages

### Definition

Distinct electroencephalogram (EEG) patterns recorded from the sleeping human subject during different periods (stages) of his/ her sleep. There are four main sleep stages: 1st stage –drowsiness; 2nd stage – light sleep; 3rd and 4th stages –deep sleep. The resting alpha rhythm gradually attenuates during falling asleep and disappears in the 2nd stage. Sleep spindles (bursts of beta rhythm) and K complexes (slow waves associated with the spindles) characterize the 2nd stage. Slow-wave (delta) activity dominates during the 3rd stage and becomes more intensive in the 4th stage. After deep sleep, either the 2nd stage returns or rapid-eye-movement (REM) sleep may occur, associated with dreaming. The REM sleep apparently fills a rather specific place among the sleep stages and plays an important role for brain functioning.

- Electroencephalography
- Rapid Eye Movement (REM) Sleep

## EEG Waves

- Brain Rhythms

## E2F

### Definition

A family of transcription factors involved in regulation of the cell cycle in mammalian cells. E2Fs bind to consensus TTTCGCGC binding sites in target regulatory sequences.

► [Chromatin Immunoprecipitation and the Study of Gene Regulation in the Nervous System](#)

## Effector

### Definition

An element through which the controller affects the plant, e.g. arm muscle.

► [Neural Networks for Control](#)

## Effects of Alcohol on the Brain

NAOMI ETHERIDGE<sup>1</sup>, JUSTIN P. RIDGE<sup>1</sup>,  
JOANNE M. LEWOHL<sup>2</sup>, PETER R. DODD<sup>1</sup>

<sup>1</sup>School of Molecular and Microbial Sciences,  
University of Queensland, Brisbane, Queensland,  
Australia

<sup>2</sup>Genomics Research Centre, School of Medical  
Sciences, Griffith University, Southport, Queensland,  
Australia

### Synonyms

Alcoholic brain damage

### Definition

Alcohol misuse leads to cognitive, physiological, and structural changes in several cortical and sub-cortical structures. Neuroactive drugs such as ethanol influence neurotransmission to alter mood. Long-term alcohol use can lead to addiction, the compulsion to take the drug and loss of control over intake, or dependence, the need for continued drug exposure to avoid withdrawal.

Tolerance, where a reduced effect follows repeated exposure to a constant dose, or an increased dose is needed maintain the same effect, is also common (see ► [Tolerance and Dependence](#)). While research in this area is ongoing, the current understanding about the cellular and molecular mechanisms that bring about the multitude of changes is discussed in this essay.

## Characteristics Introduction

The present era has seen a tremendous upsurge in the misuse of psychoactive substances around the world. Despite the public attention lavished on illicit drugs, one of the greatest impacts on human health and societal well-being is exerted by a licit drug, alcohol. Alcohol causes 3.2% of total world-wide deaths, and a loss of 4% of all disability-adjusted life years (a standardised estimate of disease burden) [1]. Close to 40% of the alcohol-related disease load is caused by neuro-psychiatric conditions [1]. Figures are higher for men and markedly higher in special populations. Alcohol consumption has declined slowly in recent years in developed countries, but is growing steadily in developing countries. Although the prevalence of hazardous/harmful drinking varies from country to country, drinking behavior and alcohol-related problems show many common features. Major commonalities amongst all chronic alcohol abusers are patterns of hazardous drinking that exacerbate the harmful effects of alcohol on the brain. Understanding the mechanisms that constitute this harm is a major research priority.

### Acute Effects: Molecular Targets

Alcohol has diverse short-term effects on the brain, ranging from intoxication to sedation, analgesia and anesthesia. The dose of alcohol required to induce intoxication in humans is 10–20 mM, whereas the dose to produce anesthesia in experimental animals is 100–200 mM. Since a high concentration of alcohol is required to induce an effect, alcohol was thought to have a non-specific mechanism of action. However, in recent years, specific protein targets mediating the action of alcohol have been identified; many of these proteins have a role in neurotransmission. Specific binding sites for alcohol have been identified on a number of ionotropic (ligand-gated ion channel) neurotransmitter receptors [2,3]. In experimental animals, physiologically relevant concentrations of alcohol affect G-protein regulated inward-rectifier potassium channels (GIRKs), neurotransmitter transporters (DAT), anion channels gated by GABA and glycine (GABA<sub>A</sub> and Gly receptors; see ► [Anxiolytics and Hypnotics](#)), and cation channels gated by glutamate (► [NMDA receptors](#)), serotonin (5HT<sub>3</sub> receptors), nicotinic acetylcholine (nACh receptors) and ATP (P2X receptors). The action

of alcohol at each of these protein targets is thought to underlie the many behavioral effects of alcohol. For example, GIRK channels have been shown to mediate the analgesic effects of alcohol. Further research aims to identify the specific protein targets that underlie craving, reward, tolerance and dependence.

### The Path to Long-Term Effects: Gene and Protein Expression

Chronic exposure to alcohol has wide-ranging effects on gene expression in the brain leading to long-term changes in function. Microarray assays of mRNA transcripts, together with proteomic studies, have shown changes in the expression of numerous genes in the animal and human brain. Affected genes are involved in metabolism, the immune response, cell survival, cell communication, signal transduction and energy production [4]. In the human prefrontal cortex, genes encoding DNA-binding proteins, transcription factors and repair proteins are responsive to alcohol, and there is an overall down-regulation of genes encoding mitochondrial proteins. Genes involved in myelination and cell-adhesion are also affected; the majority are down-regulated [4]. These observations suggest that myelin formation and cell adhesion, both important processes in the development and plasticity of the CNS, could be severely impaired in the alcoholic brain. This proposition is supported by evidence of a change in cell-cell adhesion in an *in vitro* model. These broad-spectrum approaches highlight the large number of genes affected by long-term alcohol exposure that may lead to a generalized impairment of metabolism in affected cells.

In addition to the acute, short-term effects of alcohol on neurotransmitter receptor functions discussed above, long-term alcohol exposure affects the expression and composition of these receptors. Examples include NMDA receptors (NMDAR) and GABA<sub>A</sub> sites [2,3]. NMDARs are hetero-multimeric complexes consisting of NR1 and NR2 polypeptide subunits. Variations in the properties of NMDARs are generated through the incorporation of alternate versions of the NR1 and NR2 subunits. The NR1 subunit is encoded by a single gene that is expressed in eight alternate splice variants. NR2 subunits are encoded by four distinct genes giving rise to four alternate subunits, NR2A–D. NMDARs are reviewed in detail in [2].

Prolonged exposure to alcohol leads to an overall up-regulation of NMDARs in the rat brain, presumably to compensate for the reduction in ion flow caused by the action of ethanol on the receptor. In the same animal model, the level of NMDAR NR1 subunit mRNA expression was not significantly affected, although NR2B mRNA was significantly increased. In contrast, in the human autopsy brain we find that, although NR1

mRNA did not vary significantly, NR2B mRNA was unchanged in alcoholics without comorbid disease but was decreased in cirrhotic alcoholics.

GABA<sub>A</sub> sites are also significantly affected by chronic alcohol exposure. These are hetero-multimeric complexes consisting of five subunits permuted from several classes ( $\alpha$ ,  $\beta$ ,  $\gamma$ ,  $\delta$ ,  $\rho$  and  $\epsilon$ ), each of which has several isoforms. As with NMDARs, the level and subunit composition of GABA<sub>A</sub> sites are altered after prolonged alcohol exposure in an adaptive process. In an *in vivo* animal model the levels of  $\alpha$ 1,  $\alpha$ 2 and  $\alpha$ 4 subunit mRNA are significantly increased, and there are concurrent increases in the concentrations of the corresponding subunit proteins. In the human autopsy brain, significant regional differences in the expression of the  $\alpha$ 3 and  $\alpha$ 1 subunit transcripts and proteins were seen. The overall trend was toward an increase in  $\alpha$ 1 and a decrease in  $\alpha$ 3 in the alcoholic cases. GABA<sub>A</sub> sites are reviewed in detail in [3; see also ►Anxiolytics and Hypnotics].

It can be seen from this evidence that alcohol has a significant long-term influence on the expression and composition of, and in consequence the function of, NMDARs and GABA<sub>A</sub> sites. This influence is complex, and it is species-, region-, and comorbidity-dependent. However, the overall trend is for the tissue to adapt to higher levels of alcohol so as to compensate for its effects. This adaptation does appear to be reversible after time, but the altered levels and function of these receptors are thought to be primarily responsible for the neurological effects seen during withdrawal.

### Long-Term Effects: Neuropathology

Changes in gene and protein expression due to chronic alcohol misuse and dependence leads to significant brain damage (see ►Tolerance and Dependence). This is manifest clinically in characteristic neuropsychological behaviors, including impairment to executive functions, visuospatial abilities, judgment, insight, problem solving, motivation, and learning [5,6]. Alcoholism induces several types of brain damage that are confined to specific brain regions. Chronic alcohol misuse results in brain shrinkage, particularly of the frontal lobes, which is largely due to a reduction in volume of the cerebral ►white matter [7]. In contrast, ►grey matter is affected differentially. The evidence suggests that neurons in specific regions of the brain, such as cerebellar ►Purkinje cells and ►superior prefrontal gyrus pyramidal neurons, are selectively damaged [7]. The frontal cortex is important in judgement, decision-making and other executive functions; thus, the alterations in this area are in line with known changes in cognitive function, and correlate with findings of a retraction of dendrites and a reduction in synaptic density through ethanol toxicity.

Several other cortical regions, such as the motor or occipital cortices, do not show neuronal loss, but do show reduced dendritic arborisation [8]. Local differences in neuronal susceptibility may be a consequence of their possession of specific protein profiles [9]. The pathological changes may result from the direct neurotoxic actions of ethanol itself, or of one of its metabolites [5].

Alcoholics differ markedly in their neuropathological presentation, ranging from little or no damage to severe frontal lobe and/or cerebellar atrophy. The extent of atrophy can be correlated with estimates of lifetime alcohol consumption and is more severe in alcoholics who have comorbid diseases such as cirrhosis of the liver or the ►Wernicke–Korsakoff Syndrome [5]. These diseases are more prevalent with high rates of alcohol consumption so it appears that the pathology worsens with increasing disease severity.

Imaging studies utilizing computer-aided tomography (CAT), magnetic resonance imaging (MRI) and positron emission tomography (PET) have been instrumental in identifying the abstinence-induced reversibility of some types of alcoholic brain damage. Longitudinal studies have shown that even short term abstinence ameliorates neuropathological changes. Grey matter volume increases with one month's sobriety; longer-term abstinence is required for an increase of white matter and the partial recovery of ventricular size [6]. The recovery of certain parts of the brain suggests that the damage seen in chronic alcoholic misuse may be the result of a combination of irreversible axonal degeneration and neuronal death, and reversible changes in myelination. In is not clear from these analyses whether all brain damage associated with chronic alcoholism is reversible, or if there is a point of no return after which brain damage becomes permanent.

### Long-Term Effects: Mechanisms of Alcoholic Brain Damage

The cellular and molecular mechanisms behind alcohol-induced brain damage are poorly understood. As mentioned above, ligand-gated ion channels such as GABA<sub>A</sub> (inhibitory) and NMDA (excitatory) receptors mediate acute drug intoxication, but their roles in the long-term effects are still under investigation. Glutamate operates 67–73% of cortical synapses in the human brain and is the major excitatory transmitter: the influx of cations it mediates depolarizes post-synaptic cells, which have a negative internal polarity in the resting state. In contrast, the influx of anions mediated by GABA (and glycine) hyperpolarises the post-synaptic cell; GABA is used at 16–25% of cortical synapses, where it is the major inhibitor. Excitation-inhibition balance is a key determinant of neuronal viability: when tilted toward excessive excitation it is termed ►excitotoxicity (see ►Neurotoxicity).

In experimental studies, such a shift may be elicited in several ways. What is not clear is whether such mechanisms occur in the human brain in vivo, and how the localisation of pathology comes about. Plausible options include locally overactive NMDA or underactive ►GABA<sub>A</sub> receptors, and a diminished clearance of glutamate from the synaptic cleft [10]. Receptor and transporter pharmacology are determined by the expression of many genes; if some are switched off, and others switched on, profound changes in receptor function or transport capacity are brought about. It is thus of interest that the alcoholism risk is differentially associated with alleles of several transmission-related genes. The products of these genes (receptors, transporters) are targets for several drugs used to treat alcoholism. Genotype-phenotype interaction is a very active area in alcohol-misuse research.

### Acknowledgments

The authors wish to acknowledge the financial support provided by the National Institutes of Alcoholism and Alcohol Abuse (USA) under grant NIH AA12404 and the National Health and Medical Research Council (Australia) under grant #981723.

### References

1. WHO (2004) World Health Organization: global status report on alcohol. Geneva, Switzerland
2. Dodd PR, Beckmann AM, Davidson MS, Wilce PA (2000) Glutamate-mediated transmission, alcohol, and alcoholism. *Neurochem Int* 37:509–533
3. Grobin AC, Matthews DB, Devaud LL, Morrow AL (1998) The role of GABA(A) receptors in the acute and chronic effects of ethanol. *Psychopharmacology* 139:2–19
4. Flatscher-Bader T, van der Brug MP, Landis N, Hwang JW, Harrison E, Wilce PA (2006) Comparative gene expression in brain regions of human alcoholics. *Genes Brain Behav* 5:78–84
5. Harper C, Matsumoto I (2005) Ethanol and brain damage. *Curr Opin Pharmacol* 5:73–78
6. Sullivan EV, Pfefferbaum A (2005) Neurocircuitry in alcoholism: a substrate of disruption and repair. *Psychopharmacology* 180:583–594
7. Kril JJ, Halliday GM, Svoboda MD, Cartwright H (1997) The cerebral cortex is damaged in chronic alcoholics. *Neuroscience* 79:983–998
8. Harper C (1998) The neuropathology of alcohol-specific brain damage, or does alcohol damage the brain? *J Neuropathol Exp Neurol* 57:101–110
9. Dodd PR, Lewohl JM (1998) Cell death mediated by amino acid transmitter receptors in human alcoholic brain damage: conflicts in the evidence. *Neurochem Drugs Abuse: Ann NY Acad Sci* 844:50–58
10. Dodd PR (2002) Excited to death: different ways to lose your neurones. *Biogerontology* 3:51–56

## Efference Copy

### Definition

A negative copy of a motor command; defined by von Holst and Mittelstaedt in 1950 for the opto-motor response in flies. It is part of the Reafference Principle that describes how a sensory system can cope with self-induced (i.e., “re-afferent”) sensory input, such as image motions on the retina during eye-movements. If efference copy and re-afferent signal are of equal magnitude, the subtraction of the efference copy from the re-afference will cancel the sensory input signal. The same principle was simultaneously and independently discovered by Roger Sperry and termed “corollary discharge.”

- ▶ Auditory-Motor Interactions
- ▶ Corollary Discharge
- ▶ Movement Sequences
- ▶ Reafferent Control in Electric Communication
- ▶ SC – Local Feedback

## Efferent

### Definition

The term efferent (from Latin “ex” = out of and “ferre” = carry) refers to axons that relay information away from the central nervous system. The somatic motor system consists of efferent nerves that have muscles as targets and whose cell bodies are contained within the central nervous system. The autonomic motor system differs from the somatic in that the motor neurons are contained in ganglia outside the central nervous system. Efferent nerves from the autonomic motor system innervate diverse targets including sweat glands, cardiac muscle, and smooth muscle.

## Efficiency

### Definition

Ratio of the free energy increase in the driven process to the decrease in the driving process.

- ▶ Energy/Energetics

## Efficient Coding Hypothesis

### Definition

The efficient coding hypothesis was proposed by Horace Barlow in 1961 as a theoretical model of sensory coding in the brain. It posits that the spikes in the sensory system form a neural code for efficiently representing sensory information and that the number of spikes needed to transmit a given signal is minimized.

- ▶ Sensory Systems

## Egocentric Frame

### Definition

Also Visual space representation for reaching.

- ▶ Visual Space Representation for Reaching

## Egocentric Reference Frame

### Definition

Framework centered on body parts of the subject such as head or receptor surface such as retina.

- ▶ Spatial Memory

## Ehrenstein Illusion

### Definition

The Ehrenstein illusion is an optical illusion studied by the German psychologist Walter Ehrenstein in which the sides of a square placed inside a pattern of concentric circles take an apparent curved shape.

- ▶ Form Perception

## Eigenvector

### Definition

A vector whose direction is unchanged by an operator. During optokinetic after-nystagmus (OKAN), an eye velocity vector in three-dimensional space whose direction remains fixed along the stimulus velocity as the eye velocity declines toward zero. It has also been termed an “orientation vector.”

- ▶ Optokinetic After-Nystagmus (OKAN)
- ▶ Velocity Storage

## Eighth Cranial Nerve

- ▶ Auditory Nerve

## Eimer's Organ

### Definition

In the snout glabrous skin of the mole, the epidermis contains an abundance of Merkel cell-neurite complexes and well-developed intra-epidermal sensory axons almost reaching the surface of the epidermis. In addition, there are many lamellated corpuscles immediately beneath the epidermis. Eimer's organ is the composite unit of sensory nerves of different modality.

- ▶ Merkel Cell-Neurite Complex Regeneration

## Einstein Summation Convention

### Definition

A notational device whereby a monomial of indexed quantities is interpreted as a summation over every index that appears diagonally repeated.

- ▶ Mechanics

## Elastic Energy

### Definition

The energy stored in a stretched spring, related to its extension ( $x$ ) and spring stiffness ( $k$ ) by  $\frac{1}{2} k \cdot x^2$ .

- ▶ Energy/Energetics

## Elastic Energy Savings

- ▶ Muscle and Tendon Energy Storage

## Elasticity

### Definition

A material model whereby the stress tensor at a point is just a function of the (present value of the) deformation gradient at that point.

- ▶ Mechanics
- ▶ Muscular Stiffness

## Elderliness

- ▶ Olfaction and Gustation Aging

## Electric Communication and Electrolocation

BERND KRAMER

University of Regensburg, Institute of Zoology,  
Regensburg, Germany

### Synonyms

Electrocommunication



## Definition

**Electric Communication:** Via their electric organ discharges, which are under brain control, certain fish broadcast biologically relevant information into their environment. The information may include species, age, sex, or individual identity, and motivational state.

**Electrolocation:** The detection of usually weak electric fields of abiotic or biotic origin for orientation or object location, thanks to the electric sense that is present in all classes of lower aquatic vertebrates and monotreme mammals (platypus, echidna). Electrolocation is passive for ambient, extraneous electric fields. It is active when a weakly electric fish locates nearby objects that distort the fish's electric field.

## Characteristics

### Function

#### Electrocommunication

Electrocommunication differs greatly between the different taxa of electric fish [reviews 1–3].

#### **Batoidimorpha (Rays)**

**Torpedinidae (Electric Rays):** The exclusively marine electric rays, such as *Torpedo* or *Narcine* species, discharge their strong electric organs for prey capture or defense (see entry “Electric organ discharge”). As with all strong-electric fish, a communication function of the electric organ discharge cannot be excluded, but evidence for such a hypothesis is lacking.

**Rajidae (Skates):** The predominantly marine weakly electric skates carry electric organs in their tail filament, the only known function of which is communication. *Raja* skates discharge only rarely, not even when swimming; however, in social encounters, such as when lying on top of each other, discharge sequences were recorded quite often. Depending on the species, electric organ discharges of 70–217 ms pulse duration were recorded in trains of less than 100, at less than 8 Hz. Although a correlation between electric organ discharges and overt behavior has been observed, much remains to be studied in skates.

#### **Mormyriformes**

**Only Found in African Freshwater Bodies:** (i) Gymnarchidae: The only living representative of the Gymnarchidae, *Gymnarchus niloticus*, is a large, piscivorous predator with a constant-frequency wave discharge. Its social behavior in relation with electrocommunication is virtually unexplored. However, it displays a Jamming Avoidance Response (JAR), or frequency shift, to an electric A.C. wave stimulus (if sufficiently close to its electric organ discharge frequency), which resembles the JAR in the South American gymnotiform *Eigenmannia virescens* (with similar discharge). (ii) Mormyridae (snoutfish): All snoutfish (about 200 species) studied to date generate electric organ discharges of the

pulse type, waveform and duration of which are species-specific. Fish are active at night, when their electric organ discharge serves in group cohesion, at least in certain species [1].

Species and individual signature by electric organ discharge waveform. Electric organ discharge pulse waveforms that differ between syntopic sibling species point to their significance in communication, and aid in systematic research [4]. Despite an electric organ discharge duration far below 1 ms, trained, food-rewarded *Pollimyrus adspersus* discriminated between playback electric-organ discharge waveforms pre-recorded from another species, and even between different conspecific individuals. The intraspecific waveform variability is much greater than the fish's discrimination threshold, suggesting the electric organ discharge waveform is an individual signature (Fig. 1). The discrimination between electric organ discharge waveforms, as present in *P. adspersus*, relies on a purely temporal (and not spectral frequency) analysis, as demonstrated by using synthetic electric organ discharges of different waveforms but identical amplitude spectra [5].

Electric organ discharge waveform and sex. Although the electric organ discharge waveform in individual mormyrids varies within a species-specific range that may be quite wide for certain species, it is highly stable for an individual fish. In the males of certain species, the electric organ discharge waveform broadens with adolescence, or readiness for reproduction. A seasonal sexual dimorphism in electric organ discharge waveform is present in *Marcusenius altisambesi* (Upper Zambezi River), with a tenfold longer electric organ discharge duration in mature males than females; but in many other species, such as *P. adspersus* or *Petrocephalus catostoma* (Upper Zambezi form), only a statistically significant difference between the sexes with wide overlap is found. There is no difference at all between the sexes in still other species (Fig. 2).

The detection of such electric organ discharge waveform variation has been shown to be instrumental for one or more of the following functions: (i) recognition of mate identity during the many hours of a spawning night, with its hundreds of short female visits and retreats; (ii) female choice regarding male quality (that is, intersexual selection); and (iii) intrasexual selection among males competing for resources to gain access to gravid females. Runaway selection for still longer male *M. altisambesi* electric organ discharges is blocked by catfish predators, who detect male electric organ discharges the longer the better, with their low-frequency electroreceptor organs (during the famous “catfish runs” in the Okavango) [6] (Fig. 3). For evolutionary theory, particularly in South American setting, see [3].

**Sequence of Inter-Discharge Intervals:** The sequence of discharge intervals (SDI) fluctuates with the state

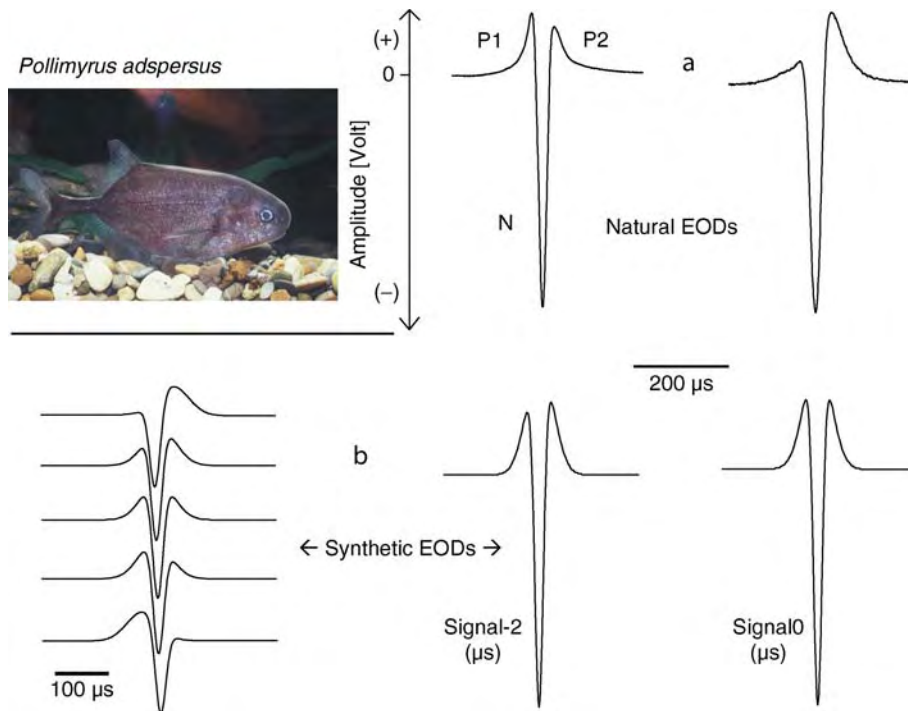

**Electric Communication and Electrolocation. Figure 1** (a) Electric organ discharge as an individual signature for two *Pollimyrus adspersus* snoutfish. Note difference in amplitude ratio of *P1* and *P2* phases; *N* head-negative phase. (b) A family of computer-generated stimulus pulses were used to determine the discrimination threshold for an *N* phase shift. The fish still discriminated the symmetrical Signal0 from Signal-2 with its *N* phase advanced by 2 μs. Discharges normalized to the same amplitude (peak-to-peak) [5].

of excitation in a mormyrid fish. Therefore, the SDI appears suitable for signaling motivational state, potentially in addition to all the information the electric organ discharge waveform is already transmitting [7]. The signaling of species identity by SDI was demonstrated in *Petrocephalus bovei*, when it showed spontaneous preference for conspecific playback SDIs over those from two other species (*Pollimyrus adspersus* and *Brienomyrus niger*, with electric organ discharge waveform excluded as a factor). Similar results were obtained with *Campylomormyrus rhynchophorus*, which “preferred” conspecific SDIs to those recorded from immature *C. tamandua*; the reverse experiment, however, was inconclusive (difference not statistically significant). The result shows that SDIs may indeed encode species identity, and perhaps sex or age; however, between sibling species, electric organ discharge waveform prevails [2].

**Agonistic Signaling:** An especially clear correlation of characteristic SDIs with overt behavior has been established for aggression and escape (agonistic behavior) in several species [2]. Overt attack is announced by a transient, short-lived, sharp increase in discharge rate that may be followed by a decrease (SID). The correlation of overt behavior with electric signaling is so strict in *Gnathonemus petersii* and *P. adspersus*

that the SID may be considered an integral part of the motor behavior attack, the two components apparently never occurring in isolation. In *G. petersii*, *P. adspersus*, and *Marcusenius pongolensis*, an attacking fish’s SID is often not followed by a decrease, but by a short period of a very high and stable discharge rate (SI-HD). This steady-state, high discharge rate component (HD) may last up to 4 s in *G. petersii*. During this period, *G. petersii* may either display a long sequence of the shortest possible interval for the species (ca. 8 ms), or an interval about twice its duration, or the two intervals may alternate in a sustained double pulse pattern. Any combination of these patterns may occur in a single SI-HD. An aggressive fish’s butt or bite of its opponent usually occurs at the end of the SID component, and the ensuing HD component is accompanied by a lateral (often antiparallel) display in close contact with the attacked fish. Compared to the discharge rate at the moment of physical contact, the HD component is usually twice that rate (up to 150 Hz). Multiple SI-HDs are observed in pairs of fish fighting about territorial dominance, with the HD component usually disappearing when one of the two opponents gives up.

In *G. petersii*, the loser of a fight usually increases its discharge rate during the moment of greatest danger

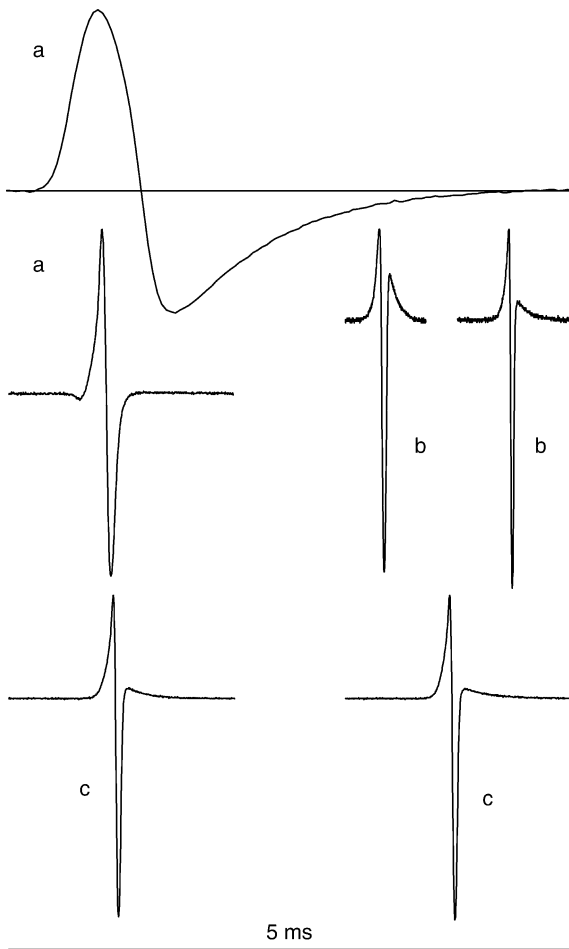

### Electric Communication and Electrolocation.

**Figure 2** Electric organ discharge waveform and sex, in three snoutfish species of southern Africa. All electric organ discharges represented as voltage over time, recorded in the field immediately after capture. Same time bar for all. (a) Sexual dimorphism in *Marcuseinius altisambesi* with two distinct waveforms. (b) Sex difference of only a statistical nature in *Petrocephalus catostoma* (Upper Zambezi form) with, in most males, a stronger second positive phase than in females, such as shown here. (c) *Petrocephalus wesselsi* (Sabie River, South Africa) with no difference between the sexes. *P. wesselsi* was recognized as distinct from *P. catostoma* only recently.

of being bitten by a dominant, attacking fish. In contrast to the aggressor, the subordinate fish's discharge rate remains well below the highest possible level. The increases given by a fish when actively escaping are preceded by a short electric organ discharge cessation of up to 1 s, contrasting strongly with the sequence of subsequent, short inter-discharge intervals (IDIs) of constant duration (at up to 55 Hz). As observed repeatedly in certain pairs of fish, these displays deter some aggressors' attacks. Therefore, they are thought

to represent threat displays, resulting from a conflict between aggression and escape tendencies.

Playback experiments contrasting "resting" electric organ discharge patterns with "aggression" electric organ discharge patterns (as pre-recorded from fish showing the appropriate behavior), established that the "aggression" pattern was more effective in evoking activity from the resident fish. The "aggression" pattern evoked full-fledged electric and motor behavior of aggression, including butts, bites, and lateral displays with correct orientation towards the dipole model, and with correlated SI-HDs of the highest intensity [2]. This shows that a simple, immobile electrical decoy bearing no physical resemblance with a real fish (except in electric field geometry) is sufficient to evoke the most complex, coordinated social behavior in this animal, as observed in territorial defense and reproduction (*M. pongolensis*). Agonistic signaling is clearly a function of the IDI code of communication in mormyrid fish, and has been confirmed in similar form in other mormyrid species.

*Signaling in Courtship and Spawning:* The nocturnal reproductive behavior was first observed in captive *P. adspersus* from West Africa. In addition to elaborate electrocommunication and motor behavior, the male produces complex songs at night ("advertisement calls"). A male with a territory and a nest attracts gravid females from a distance. An intensely singing male attacks a visiting female while also displaying attack-correlated SI-HDs. The female quickly escapes, but keeps repeating her short visits at about 2–3 per minute, and the male's aggression and singing slowly wane. Without discharging, the female briefly advances onto the bottom in the male's territory or right inside his hiding place, and rapid antiparallel circling at surprisingly low electric organ discharge rates follows until the female's quick retreat. This provokes courtship attacks and again intense singing from the male. After several repeats, eventually the female allows the male to move into a parallel position from behind, when both fish mechanically link their anal fins. Thus united, the pair performs a full, slow rotation (3–4 s), head-over-tail or tail-over-head both occur, accompanied by a low-rate electric signaling (medium uniform rate). For about 2–5 h on a spawning night, the pair carry on this courtship behavior while the male's singing slowly wanes; he is completely silent during the later stages of courtship and also during spawning. The behavior preliminary to a spawning bout is an abridged version of a courtship bout. On the female's arrival at the spawning site, the male immediately positions himself alongside, stimulating her anal fin region with a quivering motion of his anal fin, followed by oviposition (a few eggs per visit), fertilizing the eggs, and transporting the eggs to the nest. Head-to-tail circling and the elaborate rotation part are omitted. The female marks the end of

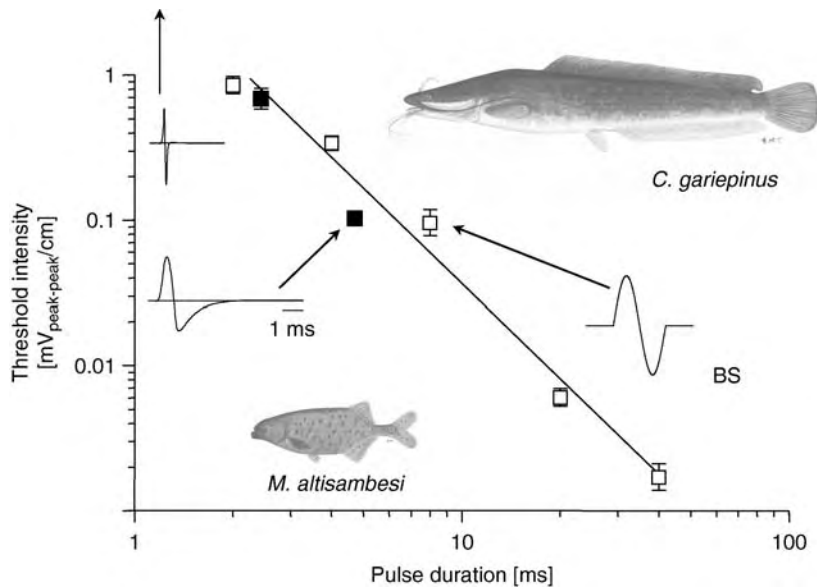

**Electric Communication and Electrolocation. Figure 3** Electrosensory thresholds of a snoutfish predator, the catfish *Clarias gariepinus* (ordinate), as a function of stimulus pulse duration (ms) (abscissa). Food-rewarded catfish detected stimulus pulses the longer the better. □ bipolar, single-cycle sine wave stimulus, ■ electric organ discharge of two male *Marcusenius altisambesi* with electric organ discharges of long duration (compared to females). Note that the thresholds for the two male electric organ discharges agree well with those for bipolar sine wave pulses of similar duration, whereas the brief female discharge was ineffective as a stimulus, and threshold was not reached [6] (Fish pictures from P. H. Skelton).

spawning by abruptly switching from a low and constant electric organ discharge rate to a pulse pattern that regularly alternates (at 2/s) between a low and a high electric organ discharge rate (that contrasts with all other patterns). The male's aggression returns immediately and is again accompanied by intense singing [2].

#### **Siluriformes (Catfish)**

Worldwide Occurring Freshwater Fish (Only a Few Marine): The African strong-electric catfish, *Malapterurus electricus*, stuns its prey and deters predators with its powerful discharges, and intraspecific electrocommunication is unknown in this fish (see the entry Electric Organ Discharge). Reports about weak electric potentials recorded from other African catfish (Mochokidae, squeakers, and the sharp-tooth catfish, *Clarias gariepinus*), suggestive of electric organs and electrocommunication, await confirmation or extension.

#### **Gymnotiformes (Electric Knifefishes)**

Only Found in South American Freshwater Bodies: The electric knifefish comprise perhaps 150 species, all of which seem to be nocturnal. All species known so far are weakly electric, except the electric eel, which is both strong and weakly electric (see entry Electric Organ Discharge). (i) *Pulse type knifefish*: Compared to the more erratically-discharging Mormyridae, pulse type knifefish generate electric organ discharges at either

fairly constant (e.g. *Gymnotus carapo*, 35–55 Hz at rest) or even highly constant pulse rates (e.g. *Steatogenys elegans*, ~60 Hz). The former will respond to most kinds of disturbances by electric organ discharge rate changes, and give SIDs during agonistic behavior and attack on prey. Social messages and/or changes of excitation are thus encoded as pulse rate modulations, similar to (if less varied and less specific than) mormyrids. Some species feature sex differences in electric organ discharge waveform [3]. The latter species will change their electric organ discharge rates exclusively to specific electrical stimuli, as occurring in social context. Effective pulse stimuli are of nearly (or exactly) the same rate, especially at specific phase relationships relative to the receiver's discharge cycle. (ii) *Wave type knifefish*: Wave knifefish are probably the most stable biological signal sources. The Sternopygidae (at least 24 species) discharge at about 15–800 Hz, the Apterontidae (at least 45 species) at about 500–1,800 Hz; a circadian rhythm does not seem to be present (unlike some pulse knifefish). Wave knifefish may signal to conspecifics by electric organ discharge waveform, by frequency modulations, by brief pauses that, especially when repeated, form a social signal, and by phase-locking to another fish's electric organ discharge cycle of identical frequency. As in pulse knifefish, much of the social behavior has yet to be explored. In *Eigenmannia virescens*, age and sex are encoded in electric organ

discharge waveform; the fish even detect a difference in waveform in artificial wave stimuli when spectral amplitude cues are lacking, a feat the human ear cannot repeat for acoustic signals [8]. A wave fish such as *E. virescens* (individual A), detects another wave fish's electric organ discharges (individual B) of slightly different frequency, when B's electric organ discharges rhythmically modulate A's own electric organ discharges in amplitude and phase, that is, when B's electric organ discharges beat against A's electric organ discharges. Fish A analyses such a beat pattern for (i) the frequency difference, including its sign, (ii) the intensity of the spectral component, or harmonic, closest to its own electric organ discharge fundamental, and (iii) waveform of B. If (i) is small in absolute terms, fish A may give a Jamming Avoidance Response, or frequency change, usually increasing the difference from B, in order to improve the resolution or speed of its signal analysis.

The strength of JAR increases with (ii), and strongly depends on motivation (age, sex, habituation, hunger, etc.). A trained, food-rewarded fish A is incapable of discriminating between two different stimulus waveforms of its own frequency, B and B', when an electronic frequency clamp is used that is designed to "frustrate" A's attempts of a JAR, by dynamically maintaining frequency identity of the stimulus with A's electric organ discharge. No sooner is the frequency clamp disabled than A (now successfully) performs a JAR and discriminates again. Stimulation experiments with a frequency clamp that, in addition to frequency identity of B with A, also controlled for a dynamically constant phase relationship of the B stimulus to the electric organ discharge cycle of A, showed that beat analysis is a purely temporal sensory mechanism, suggesting the involvement of only one kind of tuberous electroreceptor organs, the T units (Fig. 4).

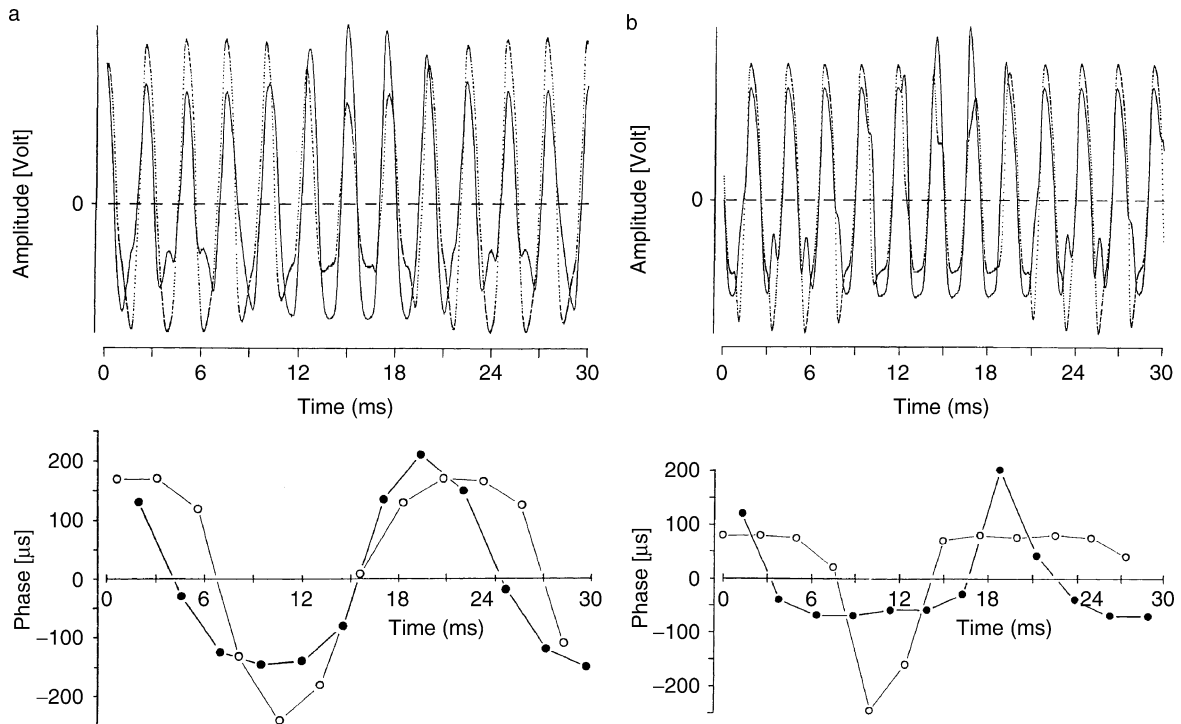

**Electric Communication and Electrolocation. Figure 4** Stimulus waveform detection by left-right comparison of beats (for the left and right body sides) in a wave gymnotiform, as mediated by its polarity-sensitive T electroreceptor units. (a) female *Eigenmannia virescens*' electric organ discharge (400 Hz) is superimposed by that of a close-by female in A, male in (b) (of both 30% amplitude and 450 Hz). *Top panels* additive superposition of signals (shown as *lines*) for one body side facing, say, the near pole of the stimulus source, subtractive ones facing the other pole (by curved field lines), *dotted* (representing the adequate stimuli for local T electroreceptor organs of the receiving fish's right and left body sides, respectively). One full beat cycle (20 ms) is shown centered. *Bottom panels* time disparities between the zero-crossings of the two curves (of *top panels*) as a function of time. Whether positive- (●) or negative-going (○) zero-crossings are chosen is irrelevant, as the time disparities between both represent the waveforms of the superimposing electric organ discharges in the same way and at greatly reduced speed (similar to using a stroboscope). The only difference is a 180° phase shift relative to the beat cycle. At such a high beat frequency as chosen here for illustration (50 Hz), the waveform reconstruction is rather crude; a more realistic beat frequency of 10 Hz (that is, a beat cycle of 100 ms) yields a fivefold better resolution [8].

The fish's threshold was lowest when the phase-locked stimulus evoked strong phase changes in a fish's electric organ discharge (measured as zero-crossings time shifts, detected by T units) but little amplitude change, and highest when amplitude change was strong (that is, optimal for the more "sloppy" amplitude-coding P units) but phase change minimal. Furthermore, with a free-running, not phase-locked, stimulus the JAR may already be evoked at stimulus detection threshold (that is determined by the sensitive T units), when the relatively insensitive P units are not responding.

## Electrolocation

### Passive Electrolocation

Ampullary electroreceptor organs detect weak electric fields of extraneous origin in the passive mode. This is true for both the common, primitive (or original) receptor organ type and its secondarily evolved replica that is found in certain teleosts, such as catfish ("small pit organs") and weakly electric fish. Geochemical and electromagnetic fields of sufficient strength to stimulate these receptor organs are found in natural waters; this is also true for the bioelectric fields that emanate from live organism, including prey. The spectral frequency content of these fields is usually low (or even D.C.), corresponding to the properties of ampullary receptor organs (both kinds). Famous examples are sharks that detect the electric fields

generated by their prey, such as flatfish buried under sand, using their ampullary electroreceptor organs, the ampullae of Lorenzini. The observed threshold sensitivities and attack distances were 5 nV/cm and 40 cm in marine sharks, and 5  $\mu$ V/cm at 5 cm distance in freshwater teleosts [9]. Electric fields may also be used for orientation. In the ocean, electric fields are generated by the flow of water through the vertical component of the earth's magnetic field, while in freshwater bodies fields of electrochemical, rather than electromagnetic origin prevail. These environmental fields are potential orientational cues, as indicated by the behavior of trained animals. In the sea, motional-electric fields of up to 500 nV/cm have been measured; they may inform elasmobranch fish about their drift with the water, or provide them with orientational cues during their movements in familiar territory. Captive freshwater fish (catfish and weakly electric fish) have been successfully trained to orient at field strengths of 1  $\mu$ V/cm.

### Active Electrolocation

Active object detection is an evolutionary feat only present in the Mormyriiformes and Gymnotiformes. It is based on a complex sensorimotor system comprising: (i) the generation of a test signal that is broadcast into the environment, the electric organ discharge; (ii) tuberous electroreceptor organs that are co-adapted

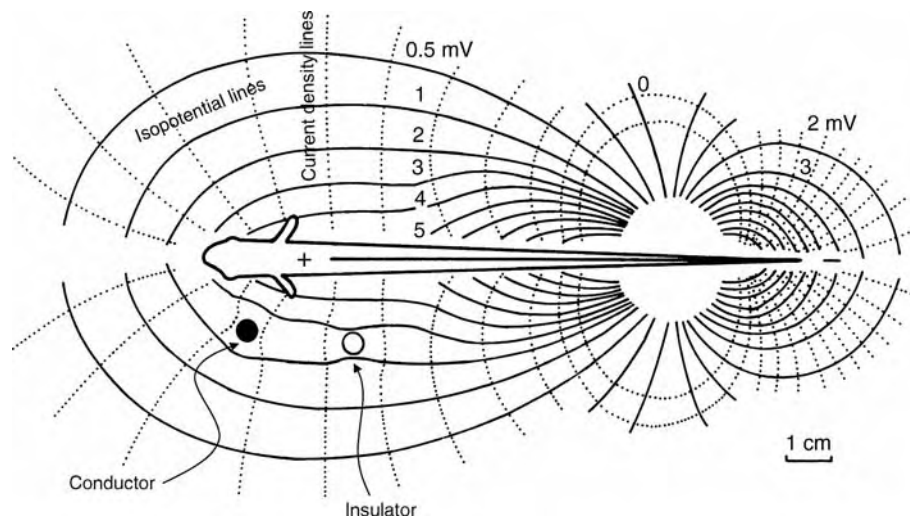

**Electric Communication and Electrolocation. Figure 5** Active electrolocation in a weakly electric fish. Horizontal section through the electric field generated by a fish's organ (indicated by *central line* in the fish's body and tail). The dipole field is shown as *lines of equal current density*, or lines of force (*dotted*), which are normal to the *isopotential lines* (solid, with mV figures). Note that an insulator (*white circle*) and a conductor (*black circle*) distort the fish's field in opposite ways. The fish "feels" the presence of an object as an increase or a decrease of current intensity that is stimulating its electroreceptor organs next to the object. (The current is, of course, generated by the electric organ discharge.) A conductor pushes away the isopotential lines, increasing their density (or voltage gradient) next to the skin. This causes an increase of current flowing across the skin that is detected by tuberous electroreceptor organs. An insulator does the opposite; it decreases the isopotential line density and therefore current intensity (modified from H. Scheich).

to the spectral properties of the electric organ discharge (usually of much higher frequencies than present in ambient electric fields); and (iii) huge brains with specialized areas and somatotopic maps for complex computations on the sensory feedback (reafference) received from autostimulation. In its function and complexity, this system is comparable to the echolocation, or SONAR, system of many bats; however, the reach of this active electric system is severely limited by physical constraints.

A weakly electric fish detects the presence of an object when it distorts the geometry of the electric dipole field the fish generates with each electric organ discharge (Fig. 5).

Nonconducting objects, such as stones, force the electric current to pass around, whereas conducting objects (such as live organisms) attract the electric current. Therefore, a local decrease of resistivity (relative to the tropical freshwater of high resistivity) causes the current passing through the fish's skin next to the object to increase (for conductors), whereas a local increase in resistivity causes a decrease (for nonconducting objects). The tuberous receptor organs embedded in the skin faithfully reflect these changes in the strength of reafference from autostimulation. Receptor organ position on the fish's body and receptor response pattern are mapped to the brain. In mormyrids, active electrolocation is mediated by tuberous receptor organs termed mormyromasts rather than Knollenorgan, in gymnotiforms, it is probably both types of tuberous electroreceptor organs that are involved (B and M units for pulse fish, T and P units for wave fish). In addition to the resistive impedance properties of an object, an electric fish may also detect its capacitive impedance (if present). As long as they are alive, all organisms have considerable capacitive properties that filter the discharge in phase, waveform and spectral properties, making it thus detectable for the fish [10].

## References

1. Moller P (1995) *Electric fishes: history and behavior*. Chapman & Hall, London
2. Kramer B (1996) *Electroreception and communication in fishes*. Gustav Fischer Verlag, Stuttgart, Jena, Lübeck, Ulm
3. Stoddard PK (2002) Electric signals: predation, sex, and environmental constraints. In: Slater PJB, Rosenblatt JS, Snowdon CT, Roper TJ (eds) *Advances in the study of behavior*, vol 31. Academic Press, London, pp 201–242
4. Kramer B, van der Bank FH, Wink M (2004) The *Hippopotamyrus ansorgii* species complex in the Upper Zambezi River System with a description of a new species, *H. szaboi* (Mormyridae). *Zoologica Scripta* 33:1–18
5. Paintner S, Kramer B (2003) Electrosensory basis for individual recognition in a weakly electric, mormyrid fish, *Pollimyrus adspersus* (Günther, 1866). *Behav Ecol Sociobiol* 55:197–208

6. Hanika S, Kramer B (2000) Electrosensory prey detection in the African sharptooth catfish, *Clarias gariepinus* (Clariidae), of a weakly electric mormyrid fish, the bulldog (*Marcusenius macrolepidotus*). *Behav Ecol Sociobiol* 48:218–228
7. Carlson BA, Hopkins CD (2004) Stereotyped temporal patterns in electrical communication. *Anim Behav* 68:867–878.
8. Kramer B (1999) Waveform discrimination, phase sensitivity and jamming avoidance in a wave-type electric fish. *J Exp Biol* 202:1387–1398
9. Kalmijn AJ, Gonzalez IF, McClune MC (2002) The physical nature of life. *J Physiol-Paris* 96:355–362
10. von der Emde G (2004) Distance and shape: perception of the 3-dimensional world by weakly electric fish. *J Physiol-Paris* 98:67–80

## Electric Field

### Definition

A space-filling force field around every electric charge or group of charges.

► [Electric Fish](#)

## Electric Fish

BERND KRAMER

University of Regensburg, Institute of Zoology, Regensburg, Germany

### Synonyms

Electrogenic fish

### Definition

Some fishes possess electric organs whose only known function is the generation of electricity outside their bodies. Strong organs are for defense and stunning prey, weak organs for active electrolocation and electrocommunication in nocturnal species.

### Characteristics

For more detailed reviews, see [1–3]. Any living tissue generates an electric field in its environment. The field is associated with the regulation of the tissue's ionic balance. These fields are D.C. or of low frequency, and, in animals, usually modulated by superimposed field potentials arising from normal nerve and muscle

cell activity. Relative to a distant electrode, potentials measured are up to 0.5 mV in marine species, and a few Millivolt in freshwater teleosts (see entry “►electric communication and electrolocation”).

In electric fishes, however, the generation of electricity is of another dimension, both in amplitude and regularity. These fishes’ electric organs are anatomically and physiologically specialized to generate electric organ discharges [4]. Electric organ discharges are precisely controlled in waveform, amplitude and frequency; electric organ discharges are species-characteristic and have even been used to tackle systematic and taxonomy problems. The electric organs are under the exclusive control of the brain [4]. The electric fields generated range from very weak (similar to the magnitude of incidental stray fields) to very strong (greater than 500 V).

All electrogenic species, except the stargazers, are also electroreceptive, and carry electroreceptor organs of at least one kind [5].

### Phylogeny

In the whole animal kingdom, it is only among two classes of jawed aquatic vertebrates (Pisces) that we find electrogenic members: the cartilaginous and the bony fishes (Chondrichthyes and Osteichthyes, respectively; Fig. 1).

Within the cartilaginous fishes, only some rays (Batoidomorpha) have electric organs; these include the weakly electric skates (190 species of Rajidae) and the exclusively marine, strongly electric rays (38 species of Torpedinidae). Among the bony fishes, it is only in four among the many orders and suborders of teleosts that we find electrogenic members. All of these are tropical freshwater fish, with the exception of the marine stargazers (3 species among the perches or Perciformes that are rather “weak” strong electric fish). The electrogenic tropical freshwater fish include the Mormyriiformes, the African weakly electric snoutfishes (about 200 species; Fig. 2); the Gymnotiformes,

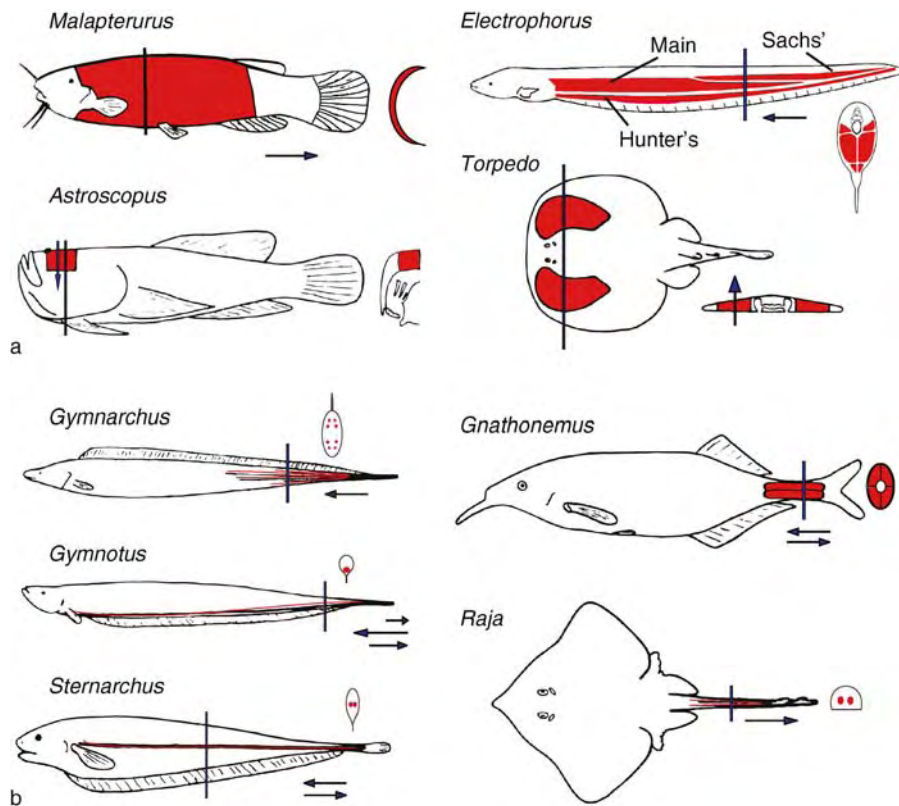

**Electric Fish. Figure 1** Schematically represented electric fish and their organs. (a) Strongly electric, (b) weakly electric. All are shown from the side except *Torpedo* and *Raja*, which are shown from the top. Electric organs shown by color. Cross-sectional plane as indicated by line. The arrows indicate the direction and sequence of current flows through the organs; the length of these arrows is proportional to the amplitude of the successive phases (if there is more than one). *Raja* and *Torpedo* species are cartilaginous fishes, all other fishes are bony fishes (subdivision teleosts). *Astroscopus*, several species of stargazers, are perches; *Malapterurus electricus*, the electric catfish; *Gnathonemus sp.*, a snoutfish, and *Gymnarchus niloticus* are Mormyriiformes; *Electrophorus electricus*, the electric eel, *Gymnotus sp.* and *Sternarchus sp.* are all gymnotiforms, or knifefish [modified from [4]; Srivastava, Szabo (1973); Libouban, Szabo, Ellis (1981)].



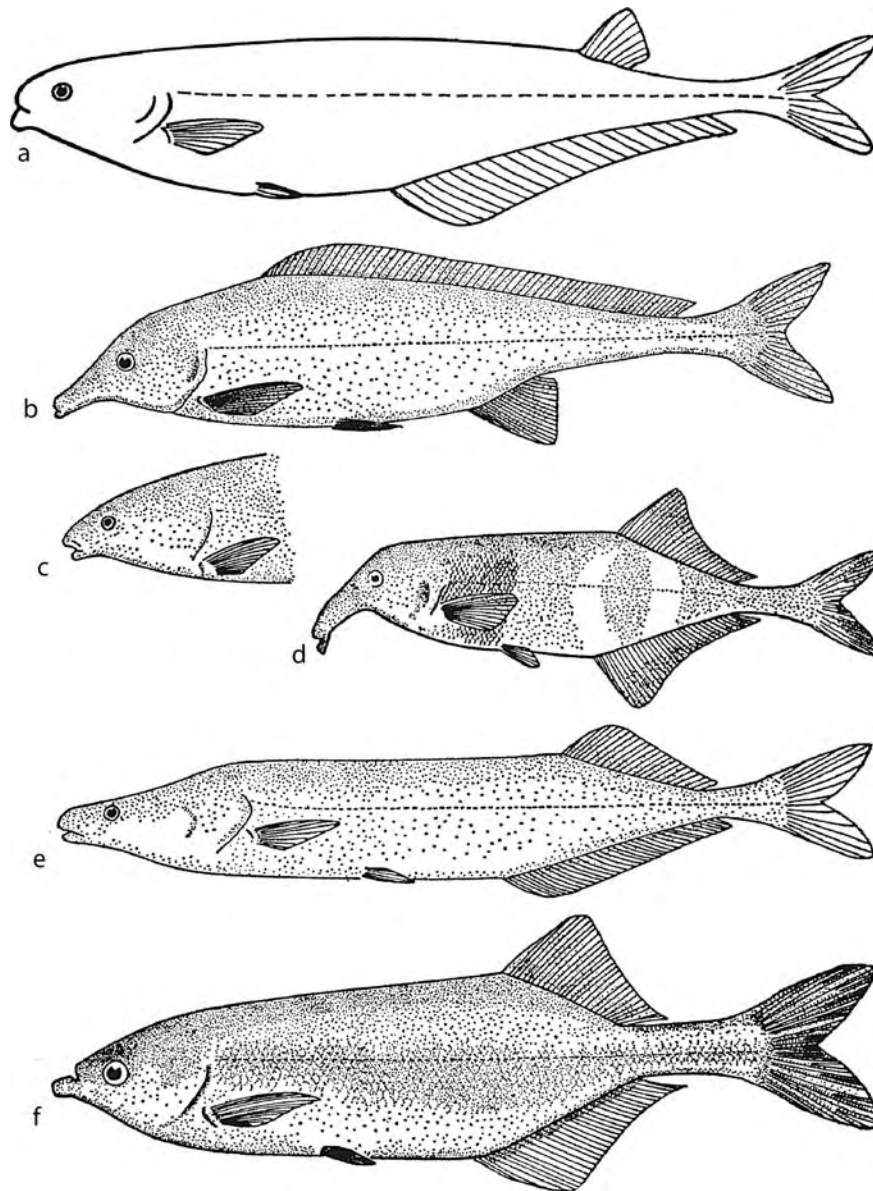

**Electric Fish. Figure 2** Several species of snoutfishes (Mormyridae) from the Sudanian ichthyological province, including West Africa. (a) *Hyperopisus bebe*. (b) *Mormyrus rume*. (c) Head of *Mormyrus hasselquistii*. (d) *Campylomormyrus tamandua*. (e) *Mormyrops deliciosus*. (f) *Marcusenius cyprinoides* [Daget, Durand (1981), modified].

the South American knifefishes that are all weakly electric except the electric eel with its powerful discharge (perhaps 150 species; Fig. 3); and the Siluriformes or catfishes, only very few, exclusively African members of which are electrogenic (including both strong and – less well confirmed – weak electric representatives).

Electric organs have evolved at least six times independently of each other: two times among the rays, and four times among the teleosts.

By independent evolution, electric organs are a derived group character for both Mormyriiformes and Gymnotiiformes, that is, present in all members of their group, but not in their respective sister groups (a synapomorphy). Perhaps a similar situation applies for the skates and the electric rays. This is in contrast to the large taxa catfish and perches, only very few members of which are known to possess electric organs. For a taxonomy of Mormyriiformes, see [6]; Gymnotiiformes, [7]; constantly up-dated is The Catalog of

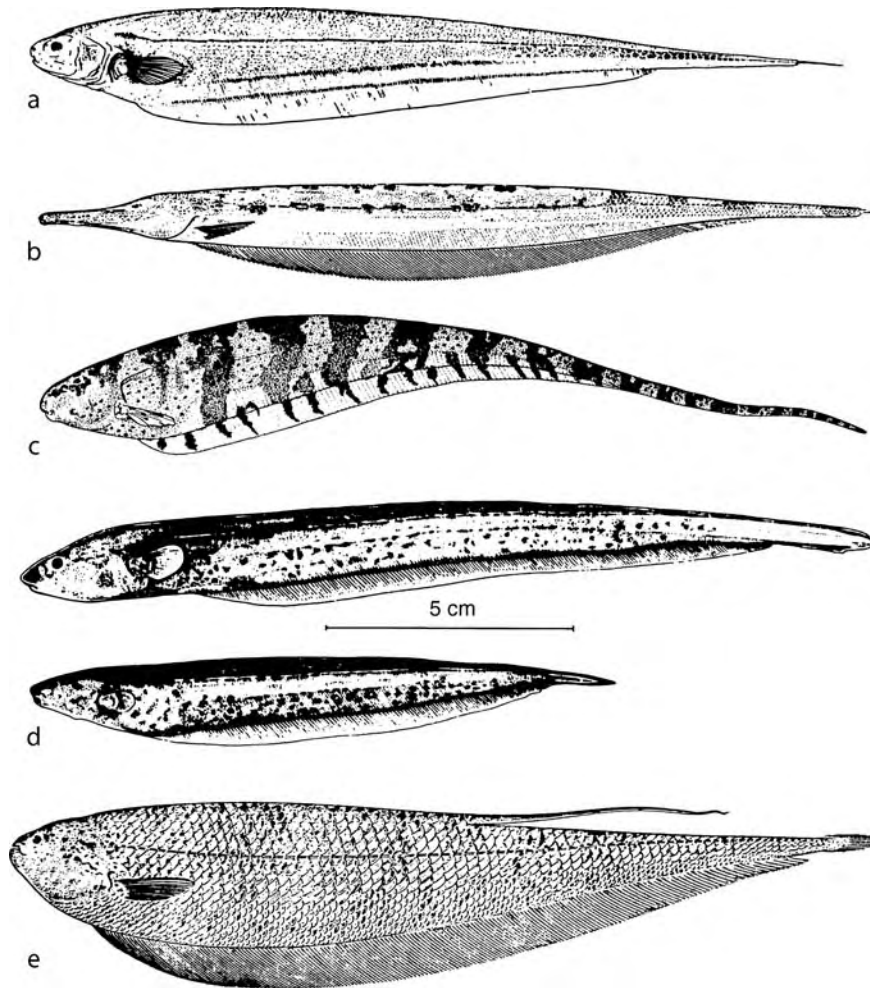

**Electric Fish. Figure 3** Several species of knifefishes (Gymnotiformes). (a) *Eigenmannia* sp. (b) the sandfish *Gymnorhamphichthys hypostomus*. (c) *Steatogenys elegans*. (d) Male (longer size) and female *Hypopomus occidentalis*. (e) *Adontosternarchus balaenops* ([3], after several authors).

Fishes, online at <http://www.calacademy.org/research/ichthyology/catalog/fishcatsearch.html>.

### Phenotypes

The terms strongly and weakly electric fish delineate alternative adaptations and behavioral strategies, or phenotypes, but do not correspond to phylogenetic categories; there is even one species, the South American electric eel, *Electrophorus electricus*, which is both strongly and weakly electric. “Strong” electric organs are discharged in pulse volleys for brief periods of time only, while attacking prey or during defense; these discharge volleys cause discomfort or pain to a human handling a fish [4]. A particularly strong discharge is that of an attacking or disturbed electric eel which is, according to historical notes from South American natives, capable of “knocking a man down” in its natural environment.

Weak electric organs operate continuously throughout life, and field intensities are usually below detection threshold for non-electroreceptive organisms. Weak electric organs form part of an information system, communication and active electrolocation (see entry “►electric communication and electrolocation”). There are a few intermediate cases, such as the stargazers, whose predatory attack is accompanied by discharge volleys, even though the discharges are much weaker than usual in strongly electric fish; on the other hand, the discharges of *Mormyrus hasselquistii* are unusually strong for a snoutfish, all weakly electric, and can also cause mild discomfort to a human handling this fish.

Among weakly electric, teleost freshwater fish, the Mormyriiformes and Gymnotiformes, there are two phenotypes of EOD, wave and pulse, both of which encode social signals as discharge rate modulations.

The pulse EODs of very few species resemble the monopolar time course or waveform of strong discharges; in most weakly electric pulse fish, EOD waveform is bipolar with two or more phases (reducing energy in the low-frequency range of the amplitude spectrum). The wave EODs of wave species are relatively broad pulses that are repeated at such a high and regular rate that they merge into a continuous A.C. wave. While a pulse fish, although discharging continuously, is silent most of the time (because the duration of an EOD is short compared to the inter-EOD interval), a wave fish's signal is always "on" (except on rare occasions, a brief "off" being a display of social significance).

While in Africa the wave discharge type is represented by a single species, *Gymnarchus niloticus*, the only living member of the Gymnarchidae (which is the sister family of the Mormyridae), there are two families of wave fishes in South America, the Sternopygidae, and the still larger family of Apterontidae (with their neurogenic electric organs). In contrast to Africa, in South America wave species are far more numerous than pulse species.

We are still unable to identify the selection pressures that shaped the ancestors of certain Mormyriiformes and Gymnotiiformes to discharge their organs either in pulse or in waveform, with only one living species known to date that may represent a transitional state (Fig. 3.18 in [3]). Wave and pulse fishes are found on both continents that are home to the Mormyriiformes in Africa, and the Gymnotiiformes in South America. The intricate pattern of speciation in the tropics, leading to the highest degree of biodiversity on earth, is a subject of prime interest for which weakly electric fish have proven to be particularly amenable (e.g. [8]).

In contrast to the monopolar EODs of strong-electric fish, the EODs of many weakly electric pulse and (as far as we know) all wave species lack energy in the D.C. and low-frequency range. This seems to be an adaptation to electroreceptive catfish, some of which are voracious, piscivorous predators (see entry "►electric communication and electrolocation"). Catfish are sensitive to low-frequency electric fields by their small pit organs (that are functionally equivalent to ampullary electroreceptor organs and often referred to by that name).

### Embryology of Electric Organs

Electric organs usually form from modified muscle cells, or electrocytes, which are unable to contract but are still capable of generating action potentials that are often unusually large [9]. In different species, electric organs are derived from the most diverse muscles and thus can be found almost anywhere in a fish's body. For example, in the mainly marine skates, the organs are located in a slender tail filament, while the strong electric organs of rays form part of the head region

of their flattened, disc-shaped bodies ("pectoral" position; Fig. 1).

In the snoutfishes (Mormyriiformes), two possible locations of electric organs are found: (i) a rather long and massive electric organ located posteriorly in the body trunk that arises from several columns of axial muscle (up to a third of a fish's length). This has been established in larval specimens for a few species of the family Mormyridae, and such a larval organ grows into the adult organ in the only representative of the Gymnarchidae, *Gymnarchus niloticus*. (ii) In the mormyrid species studied so far, the larval organ starts to degenerate when about 50 days old; while a compact adult organ starts to operate (simultaneous operation of the two organs for a short transition period). The adult organ is located more posteriorly in the caudal peduncle of the tail fin [10].

In the strongly electric catfish *Malapterurus electricus* from African freshwater bodies (the best-known among several, only recently discovered, new species), the electric organ forms from peripheral muscle cells (apparently pectoral), enclosing the body as a tight jacket. In a few members of small catfish, the squeakers (Mochokidae), an organ located dorsal to the swim bladder that may have formed from sonic muscles has been reported to generate very weak and irregular electricity.

In most South American knifefishes (Gymnotiiformes), the electric organ forms from several columns of axial muscle. The organ is very long, running from the tip of the tail to near the pectoral fins. Many gymnotiforms have accessory electric organs, the function of which is unclear. In one gymnotiform family, the Apterontidae, the electric organ forms from presynaptic endings of spinal motor nerves, even though larvae form a temporary organ of myogenic origin that degenerates early in life.

The dipole fields generated by electric organs are usually horizontally orientated, in a fish's long axis; so is the orientation of the electric organ. In a few cases, however, the field vector (that is, current flow) is vertically orientated; the same holds true for these fishes' electric organs. In the strongly electric rays and the stargazers, this is in agreement with these fishes' vertically directed prey capture behavior.

### Impedance Matching

Electric organs consist of closely packed, orderly arranged groups of cells, electrocytes, with each electrocyte innervated separately by a spinal electromotor neuron. As the whole organ is enclosed by a tight jacket of connective tissue, there are only little shunt currents, and the voltage differences generated by the individual electrocytes add up (like in a serial arrangement of batteries). The electric current generated by the organ is channeled such that it must leave the body in order to

return to the opposite pole of the source. This is important in freshwater fish with water conductivity far below the conductivity of body fluids (usually below 100  $\mu\text{S}/\text{cm}$  for tropical freshwaters vs. 5,000  $\mu\text{S}/\text{cm}$  for body fluids, or, in resistivity terms, 10  $\text{k}\Omega \times \text{cm}$  vs. 200  $\Omega \times \text{cm}$ , respectively) [4].

In strongly electric fish, impedance matching to the surrounding water is especially obvious, both on a gross morphological level and also regarding membrane physiology. In freshwater fish, such as the South American strongly electric eel, there are only about 70 columns arranged in parallel, consisting of about 6,000 electrocytes each. Therefore, in this fish, it is the voltage that is maximized (500 V or more). In a marine environment, this would not be possible; here, it is the current that should be maximized. Accordingly, in the strong electric rays, such as the *Torpedo* species, there are many relatively short columns arranged in parallel, yielding a low-voltage strong-current output. The number of columns is 500–1,000, the number of electrocytes per column about 1,000. The discharge amplitude is only 50 V in air, corresponding to a massive power output of greater than 1 kW at the peak of the pulse. For an unknown reason, marine electric fish generate (unusually large) postsynaptic potentials (PSPs) rather than muscle action potentials.

## References

- Moller P (1995) Electric fishes: history and behavior. Chapman & Hall, London
- Kramer B (1996) Electroreception and communication in fishes. Gustav Fischer Verlag, Stuttgart
- Kramer B (1990) Electrocommunication in teleost fishes: behavior and experiments. Springer, Berlin Heidelberg New York
- Bennett MVL (1971) Electric organs. In: Hoar WS, Randall DJ (eds) Fish physiology. Academic Press, London New York, pp 347–491
- Zakon HH (1988) The electroreceptors: diversity in structure and function. In: Atema J, Fay RR, Popper AN, Tavolga WN (eds) Sensory biology of aquatic animals. Springer, Berlin Heidelberg New York Tokyo, pp 813–850
- Gosse JP (1984) Mormyriiformes. In: Daget J, Gosse JP, Thys van den Audenaerde DFE (eds) Check-list of the freshwater fishes of Africa (CLOFFA). Office Rech Sci Tech Outre-Mer (ORSTOM), Bondy (France)/Mus R Afr Cent (MRAC), Tervuren (Belgium), pp 63–124
- Albert JS, Campos-da-Paz R (1998) Phylogenetic systematics of Gymnotiformes with diagnoses of 58 clades: a review of available data. In: Malabarba LR, Reis RE, Vari RP, Lucena ZM, Lucena CAS (eds) Phylogeny and classification of neotropical fishes. Edipucrs, Porto Alegre, pp 419–446
- Kramer B, van der Bank FH, Wink M (2004) The *Hippopotamyrus ansorgii* species complex in the Upper Zambezi River System with a description of a new species, *H. szaboi* (Mormyridae). Zoologica Scripta 33:1–18
- Zakon HH, Unguez GA (1999) Development and regeneration of the electric organ. J exp Biol 202:1427–1434
- Westby GWM, Kirschbaum F (1978) Emergence and development of the electric organ discharge in the mormyrid fish, *Pollimyrus isidori*. II. Replacement of the larval by the adult discharge. J Comp Physiol A 127:45–59

## Electric Organ

### Definition

So far only electric fishes are known to possess electric organs. In most cases myogenic organs generate electric fields. Some fishes, like the electric eel, use strong fields for prey catching or to ward off predators, while others use weak fields for electrolocation and communication.

Specialized organs in electrosensitive fishes – mostly derived from muscle tissue – that give off electrical discharges, both pulse-like and sinusoidal, under the control of the nervous system.

- ▶ [Electric Senses in Monotremes: Electroreception and Electrolocation in the Platypus and the Echidna](#)
- ▶ [Electrolocation](#)
- ▶ [Electroreceptor Organs](#)
- ▶ [Reafferent Control in Electric Communication](#)
- ▶ [Temporal Coding in Electroreception](#)

## Electric Organ Discharge

BERND KRAMER

University of Regensburg, Institute of Zoology, Regensburg, Germany

### Synonyms

EOD; organ discharge

### Definition

Certain fish possess an electric organ that, on brain command, generates a three-dimensional electric dipole field around their bodies. Compared to incidental stray fields as measured close to any organism [1], an electric organ discharge (EOD) is characterized by a stronger amplitude, higher temporal and spatial stability, and a

species-specific orientation that is adapted to its function.

## Characteristics

### Quantitative Description

Strongly electric fish all generate monopolar (D.C.) pulses. They are head-positive or head-negative in horizontally attacking fish, and dorsal-negative or dorsal-positive in vertically attacking fish. The time course of an individual EOD pulse is that of a muscle action potential, or of a postsynaptic potential (PSP) in the marine skates, rays, and stargazers (skates possess only weak organs). For the human touching a fish, perceived amplitudes range from mild discomfort associated with the EODs of the weakest strong-electric fish, the marine stargazers (up to 5 V with its dorsal surface in air), to intense pain caused by, for example, the electric catfish's (▶*Malapterurus electricus*) or the electric eel's EODs (▶*Electrophorus electricus*; several hundred Volts).

There are two phenotypes of weakly electric freshwater fish (Mormyriiformes, Gymnotiformes), pulse and wave species (Fig. 1).

Played through a loudspeaker, wave EODs sound tonal and are termed “hummers,” whereas pulse species are sometimes termed “buzzers.” In wave EODs, pulse duration and the inter-pulse interval are of about the same length, and merge into a constant-frequency wave. Frequencies range from about 50 to about 1,800 Hz. The amplitude spectrum of a wave EOD, such as that of ▶*Eigenmannia virescens*, shows a few

discrete frequency lines only where all the energy is concentrated. These frequencies are the fundamental frequency (which is the repetition frequency of the discharge “pulse,” or of a single signal period), and the higher harmonics which are integer multiples of the fundamental.

Pulse EODs are single-cycle clicks repeated at rates from below 1 to about 65 Hz at rest. Pulse discharges are separated by pauses that are long (and often variable) compared to the duration of an EOD. The amplitude spectrum of a single pulse shows energy over a broad and continuous frequency range with a flat peak region; that is, the signal is broadband. Frequencies of peak amplitude are usually below 10 kHz (but may be as high as 25 kHz). For intraspecific and interspecific waveform or frequency differences see the entry “electric communication and electrolocation.”

Wave EODs represent a continuous drain of energy for the sender; there are no strong-electric wave fish. Compared with most wave EODs, pulse EODs are of lower repetition rate and stronger amplitude. Pulse EODs may be detected over a greater distance because of their usually stronger amplitude. This would be an advantage for both communication and active electrolocation. However, wave EODs compensate for being weak by strongly contrasting from background noise by their harmonic structure. There is no or little D.C. component to the EOD of wave fishes (only a few studied), unlike that of many pulse species, making them less prone to detection by certain predators [2,3,4].

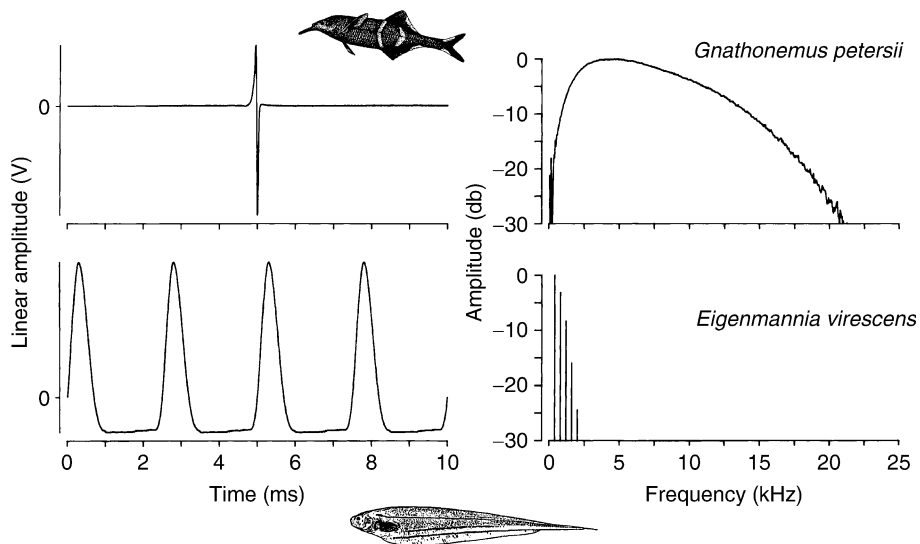

**Electric Organ Discharge. Figure 1** Pulse and wave discharges. *Left* Oscillograms of EODs (head-positivity is upwards); *right* amplitude spectra with the amplitudes expressed as dB attenuation relative to the strongest spectral component. Same time and frequency axes. Pulse EODs, such as that of the African snoutfish *Gnathonemus petersii*, are short and broad-band; they are repeated at highly variable rates. The wave EOD of the South American knifefish *Eigenmannia virescens* is of constant frequency and harmonically structured.

### Higher Level Structures

As two spike-generating membranes arranged in series with each other tend to desynchronize each other's activity, each electrocyte must be innervated separately to receive the central command synchronously [2]. The electric catfish probably has the simplest command system for controlling its electric organ. It consists of only two giant electromotoneurons ( $>100\ \mu\text{m}$  diameter) in the first spinal segment, one on either side. Both cells are closely coupled electrotonically by presynaptic fibres, and behave functionally as a unit. Each giant cell innervates the millions of electrocytes on its side of the body.

In gymnotiforms, the command system has four levels from peripheral to central: spinal electromotoneurons, medullary relay cells, medullary pacemaker cells, and mesencephalic prepacemaker cells. Pacemaker and relay cells either form two separate, but closely adjacent, midline nuclei (for example, in a *Hypopomus* pulse fish species), or are intermingled in a single nucleus, as in an *Eigenmannia* wave species [5].

Depending on the species, there are some 30–200 pacemaker cells activating about 50 large relay cells in gymnotiforms, and they project to hundreds or thousands of spinal electromotoneurons. In all gymnotiforms, except apteronotids, electromotoneurons innervate a number of electrocytes. In apteronotids, the electromotoneurons themselves generate the discharge. The connection of the command system to electroreceptive afferences is by the nucleus electrosensorius rostral from and connecting to the prepacemaker nucleus, which have been shown to modulate the pacemaker firing frequency.

At each level of the gymnotiform command system a single spike occurs for each organ discharge. However, in wave gymnotiforms the electromotor neurons have been observed continuing to firing at a similar frequency after completely cutting their input from relay cells by spinal section. Ringing seems to be an intrinsic property of all parts of the command system in these fish (and has even been observed in electroreceptor organs), and may somehow be necessary for generating the most stable biological rhythm, the wave discharge.

In mormyrids, the electromotoneurons that innervate the electrocytes of the organ form a nucleus in the caudal spinal cord [2,6]. They are driven by the cells of a medullary relay nucleus, a single midline structure, by chemical synapses. Electromotoneurons and relay neurons are coupled together electrically amongst each other. The medullary relay cells fire in “doublets” that evoke a triplet of spikes in the electromotoneurons. The three spikes are propagated out to the electrocyte stalk, where the first spike causes a small PSP, the second spike a greatly facilitated PSP, and the third spike reaches threshold. Thus, each volley of three

spikes (about 1 ms apart) evokes only a single discharge. The triplet can be recorded externally.

The pacemaker nucleus is a midline structure of 16–20 relatively small neurons located just ventrally to the medullary relay nucleus. The cells are functionally coupled by gap junctions. In contrast to the cells of the relay nucleus, their dendrites extend far beyond the confines of the nucleus, into the surrounding reticular formation and longitudinally running fibre tracts, where they are presumably contacted by the most diverse sources. It is probably these afferent inputs that mediate the effect of virtually any kind of sensory input on a mormyrid's discharge rate.

Command-associated corollary discharges “inform” afferent brain areas, such as the ELL (electrosensory lateral line lobe), of a reafference to be expected from the fish's own electroreceptor organs that is evoked by the fish's own EOD [7]. The corollary discharges greatly facilitate the task of separating reafferences from exafferences, by blanking “unwanted” sensory input. Reafferences to a fish's own EODs are the adequate response from mormyromast electroreceptor organs (in active electrolocation), and exafferences are the adequate response from the Knollenorgan, to another fish's EODs (in communication). Therefore, mormyromast afferences are facilitated when coincident with a corollary discharge, but blanked when not. For sensory feedback from Knollenorgans, the reversed situation holds: reafferences are blanked, and exafferences are facilitated.

### Lower Level Components

Electric organs are derived from muscle tissue (nerve terminals in Apterontidae), although different muscle groups are involved in different taxa. These muscle cells are unusual in that they do not twitch when neurally excited by transmitter substance (acetylcholine); various anomalies have been found in different groups that may explain why in electric organs the electromechanical coupling does not work.

Often these muscle cells, or electrocytes, form short cylinders and are stacked in series, an arrangement that increases the voltage. Several such columns in parallel increase the current, and are enclosed by a tight jacket of connective tissue. There is also connective tissue inside the columns, as well as blood vessels and nerve fibres. In general, the columns are orientated rostro-caudally, as is the potential difference and the direction of internal current flow. In the bottom-dwelling stargazers and the electric rays, the columns are orientated vertically (dorso-ventrally), in accordance with their upwards directed attacks on prey fish [review 4].

In contrast to all other electric fish, the apteronotids (Gymnotiformes) have neurogenic electric organs; their presynaptic nerve fibres have lost their contact with muscle cells and form the organ (larval apteronotids

have a temporary organ of myogenic origin; [8]). Apterotonids are outstanding for their very high discharge frequencies, up to 1,800 Hz in certain species. No ordinary nerve or muscle tissue comes close to even half that rate (at least not in sustained activity), and the explanation may reside, in part, in a command pathway with exclusively electrotonic synapses, and the specialized anatomy and physiology of the electric organ.

The ionic mechanisms of electrocyte membranes differ widely among species; these differences are the main source of the wide variation of organ discharge waveforms and frequencies among species [2,5]. The mechanism of the electric eel's discharge was the first to be elucidated (Fig. 2).

The electrocytes are innervated on their posterior face by spinal nerves that contact the cell primarily on short stalks. The anterior faces are uninnervated and have an increased surface area by a large number of papilli. The innervated face responds to depolarization by an overshooting spike of unusual amplitude (150 mV). The uninnervated face of very low resistance is unexcitable ( $0.2 \Omega\text{-cm}^2$  as compared with  $19 \Omega\text{-cm}^2$  for the innervated face, and about  $3000 \Omega\text{-cm}^2$  for frog twitch muscle). The two faces of the electrocyte are thus fairly matched in impedance, still more so when the innervated face becomes excited (and its resistance declines). This is clearly an organ adapted to maximum power output, because the circuit for all the  $\text{Na}^+$  inward current of a cell is completed by the external environment, and not by local opposing currents [2].

In contrast to freshwater fish, marine strong-electric fish, including the stargazer, generate exceptionally

large PSPs (of up to 90 mV amplitude) instead of spikes. Their membranes can only be excited neurochemically, not by depolarisation. The advantage of a PSP- over a spike-generating membrane in the marine environment is unknown.

Most weakly electric freshwater fishes tend to have little or no D.C. associated with their discharges, which allows them to have a more effectively dual electrosensory system: one for low-frequency voltages of primarily external origin, and another for monitoring the higher-frequency organ discharges. The wave fish ► *Gymnarchus niloticus* (perhaps also *Eigenmannia* species) achieves an organ discharge free from D.C. by modification of one electrocyte face (the uninnervated one) to pass current only capacitatively. This face has a large capacitance and a high resistance and is unexcitable [2]. Essentially, diphasic pulse fish, such as some *Hypopomus* species, *Gymnotus carapo*, and most mormyrids, have the opposed faces of their electrocytes act in sequence to achieve a similar effect. The uninnervated face is electrically excited to generate a spike that is slightly delayed compared to the spike of the innervated face. The net result is a diphasic potential, because the currents flow in opposite directions (with some cancellation in the shorter discharges).

In contrast to mormyrids, many gymnotiforms (excepting the sternopygids) have more than one organ, which are either anatomically distinct (as in the eel, and certain hypopomids and apteronotids that carry rostral accessory organs), or functionally heterogeneous (as in *G. carapo* where the dorsal portion of the organ is fired  $\frac{1}{2}$  ms early; in addition with reversed polarity because of its reversed pattern of innervation). This complexity is reflected in additional phases or inflexions to the basically diphasic discharge waveform, and additional deviations from the geometry of a dipole source at close range, making them species- or even individually specific signatures.

Mormyrids have more or less elaborate stalks of the innervated face of the electrocytes. The simplest (probably primitive) stage is that of ► *Mormyrus rume*, with multiple innervations on fine and numerous stalks. In species with shorter discharges, the number of innervation sites is reduced to the final limit of one, suggesting that more precise synchronization can be achieved with fewer innervation sites. Synchronization is especially important in these bi- or triphasic discharges, because slight out-of-phase firing would lead to cancellation. The stalks may, in certain species, penetrate the electrocyte and find their nerve on the “wrong”, usually the anterior, side of the cell, and this shows up in the overall organ discharge by an initial, weak head-negative potential in addition to the diphasic “main” discharge (Fig. 3).

In a few species, the stalks penetrate the cell twice so they contact their nerve on the “correct” side of the cell

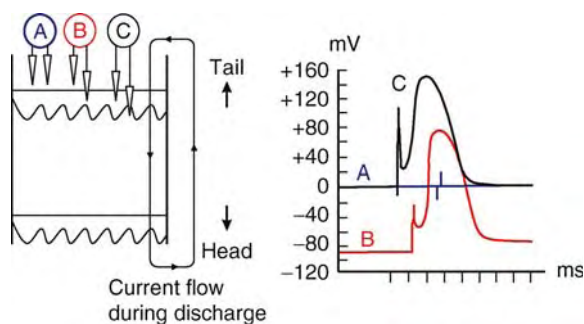

**Electric Organ Discharge. Figure 2** The mechanism of the electric eel's discharge. (A) A pair of recording electrodes external to the innervated face of an electrocyte records no response to a brief stimulus (blue; note a small, diphasic stimulus artifact). (B) One electrode is advanced into the cell. The inside negative resting potential of about 90 mV and an overshooting action potential of about 140 mV are recorded (red). (C) When the exploring electrode is advanced to outside the uninnervated face, the resting potential disappears, but the spike is essentially unchanged [after Keynes & Martins-Ferreira 1953, modified B. Markowski].

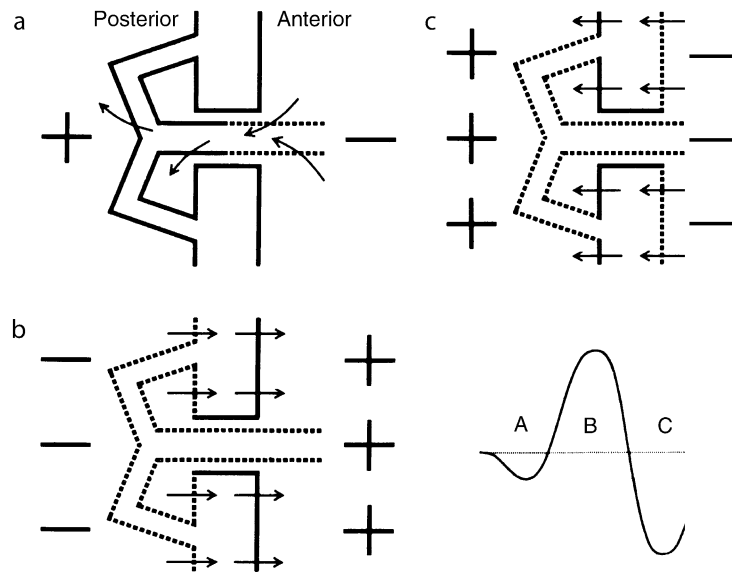

**Electric Organ Discharge. Figure 3** Schematic explanation of a diphasic electric organ discharge (EOD) of a mormyrid, which in certain species is preceded by a smaller prepotential (A in EOD diagram, lower right). Arrows show direction of current flow; active membranes are indicated by *dotted outlines* in order to show which stage in the excitation sequence (a, b, c) corresponds to which phase in the EOD waveform. A head-negative prepotential (A) is present when electrocyte stalks (formed by the posterior face) penetrate the electrocyte to contact the motor nerve from the “wrong” anterior face (such as here). The stalk potential invades the caudal face of the electrocyte, giving rise to the head-positive main phase of an EOD (B). The associated current flow through the electrocyte (b) triggers an action potential of the opposite, uninnervated cell face (c), giving rise to the head-negative main phase of an EOD (C). Evolving a bipolar EOD reduces the D.C. component detectable to catfish predators. The cost of a bipolar EOD is a loss of amplitude, especially in the many species that terminate the B phase early by fast triggering of C [2].

(usually the posterior one, just like in species with non-penetrating stalks). Some species have a combination of penetrating with non-penetrating stalks [2,3,9].

In some species such as *Pollimyrus adspersus* and *P. isidori*, the relatively long-lasting head-positive potential generated by the posterior face is split into two by an overriding, strong and brief spike of opposite polarity generated by the anterior face. Microsecond-timing of the second potential relative to the first is critical for the overall waveform within a relatively wide intraspecific variability (see “electric communication and electrolocation”).

### Structural Regulation

Impedance matching is clearly seen in marine and freshwater strongly electric fish, with both adapted to most efficient shocking in their respective environments. The marine species have flattened organs with many columns in parallel (500–1,000 columns, each with about 1,000 cells in series in ► *Torpedo* rays; 150–200 in the stargazer). Their organs generate a low-voltage strong-current output as is adequate for their conductive medium; for marine rays, 50 V measured in air, but >1 kW at the peak of a 5-ms pulse. In contrast, electric organs of freshwater species (teleosts) are

often long, generating a high-voltage, low-current field (>500 V), as indeed they must in a medium of high resistivity. The eel has about 6,000 electrocytes in series, and dorsoventrally about 35 (bilaterally) in parallel [2,3,9].

### Higher Level Processes

For the ionic mechanisms of firing rate in a pacemaker nucleus, see [5]. In wave gymnotiforms, androgen hormones affected the discharge frequency [5].

### Lower Level Processes

There are clear effects of androgen hormones on EOD waveform when administered to mormyrids, especially females that usually respond by increasing their pulse duration [3,9,10].

### Process Regulation

A sudden, strong decrease of water conductivity may cause complete or partial loss of a mormyrid’s head-negative EOD main phase (that is electrically evoked). The waveform is restored after a period of about two days, supposedly by the synthesis of additional ion channels [4,5].



## Function

*Electric communication and Electrolocation:* see the special entry on these topics.

*Prey capture and defence.* Strong-electric fish discharge for prey capture, defence, or related functions. Volleys of monopolar pulses lead to more effective shocking, irrespective of polarity. There is little or no evidence for an intraspecific communication or active electrolocation function in these fish; however, the negative evidence is compelling only in the non-electroreceptive stargazers.

*Torpedo marmorata* (electric ray). A ray is an ambush predator with a flattened, disc-shaped body with short tail that is usually buried under sand, with only its eyes and spiracles visible. A ray will start its predatory attack, accompanied by its deadly discharge volley, whenever a fish comes sufficiently close to the front rim of its body. Within half a second, the ray lifts itself up on its pectoral fins, jumping up and forward, landing on top of its prey in a successful attack. By rocking movements involving its tail, the ray tries to seize the head of its prey with its mouth and to swallow it; this takes from 7–24 s.

The electric organ is fired 80 ms after the onset of a ray's jumping attack. The duration of the discharge volley varies between 0.1 s (when the prey escaped) to 24 s, corresponding to 20–340 EODs. The discharge rate is high and stable up to the moment of landing (140–290 Hz); afterwards, when the ray tries to seize the prey with its mouth, the pulse rate is low and unstable (<10 Hz after 3 s of discharging).

The effect of a ray's electric discharge is quite devastating. Fish were partially immobilised, slowly turned black on one or both body sides, or had a broken spinal cord. Fish that closely managed to escape died one or a few days after. This is astonishing since the current density, as measured in seawater, was not particularly high (30 mA/cm<sup>2</sup>, at 15 V). Stimuli that effectively evoked an attack were touch and water current or pressure waves from objects passing by, at a distance not greater than ½ the diameter of a ray's disc.

*Malapterurus electricus* (electric catfish). This species of electric catfish is a large, strong-electric predator of up to 1.2 m (there are several new members of the genus in African freshwaters). Its head-negative EOD of 1.3 ms duration at 28°C is evoked by mechanical and gustatory stimuli. In an attack on prey, a feeding volley may be up to 562 EODs at 300 Hz; still longer volleys of still higher frequency were observed when defending itself against a superior predator (such as a conspecific or a *Clarias* catfish of bigger size). A surgically denervated catfish unable to discharge had a drastically lowered success rate in prey capture.

*Electrophorus electricus* (electric eel). The electric eel is the only South American knifefish having both a

weak and a strong discharge. There is evidence that the eel may prey largely on other gymnotiforms; unlike the electric catfish, the eel possesses, in addition, the high-frequency electroreceptor organs required for detecting many species' EODs. When roaming around its territory at night, it discharges its weak Sachs' organ at a very low rate (around 1/s or even below). The weak discharge may aid the fish in detecting obstacles etc. by active electrolocation, and warn other eels at a distance. Upon mechanical disturbance of any kind, including surface water waves when sufficiently close, or else a fellow gymnotiform's EOD, the eel strikes at the object with its wide and strong mouth. Concomitantly with an overt attack, the eel turns on its strong discharge (generated by the main organ, assisted by two weaker organs) at a very high rate (500 Hz or more) [2,3,4].

## Pathology

Very rarely, certain mormyrid specimens showed EOD waveforms that appeared totally deviant compared with all other specimens ever seen before or thereafter (e.g., *Brienomyrus niger*). An ontogenetic anomaly, or an imperfect regeneration after a predator's attack, are possible reasons for this malfunction. Electroreceptive predators of weakly electric fish are common in both South America (e.g., the electric eel and certain apteronotids) and Africa (several species of non-electrogenic catfish, such as *Clarias gariepinus*; the mormyrid *Gymnarchus niloticus*; the electric catfish). Especially in certain gymnotiforms, specimens sampled from their habitat quite commonly had regenerated or malformed tails.

Immediately after transfer into water of very low conductivity (such as 10 µS/cm, as found in certain tropical forest streams), very rarely certain mormyrid specimens tended to display EOD triplets, rather than one single strong discharge, per command (e.g., *G. petersii*). A propensity for EOD triplets has also been observed in one *Marcusenius macrolepidotus* individual even without conductivity stress.

## References

1. Peters RC, van Wessel T, van den Wollenberg BJW, Bretschneider F, Olijslagers AE (2002) The bioelectric field of the catfish *Ictalurus nebulosus*. *J Physiol Paris* 96:397–404
2. Bennett MVL (1971) Electric organs. In: Hoar WS, Randall DJ (eds) *Fish physiology*, vol 5. Academic, London, pp 347–491
3. Bass AH (1986) Electric organs revisited: evolution of a vertebrate communication and orientation organ. In: Bullock TH, Heiligenberg W (eds) *Electroreception*. Wiley, New York, pp 13–70
4. Kramer B (1996) *Electroreception and communication in fishes*. Gustav Fischer Verlag, Stuttgart

5. Stoddard PK, Zakon HH, Markham M, McAnelly L (2006) Regulation and modulation of electric waveforms in gymnotiform electric fish. *J Comp Physiol A* 192:613–624
6. Meek J, Nieuwenhuys R (1998) (The brains of) holo-steans and teleosts. In: Nieuwenhuys R, ten Donkelaar HJ, Nicholson C (eds) *The central nervous system of vertebrates*. Springer, Berlin Heidelberg New York, pp 759–937
7. Bell CC, Han VZ, Sugawara Y, Grant K (1999) Synaptic plasticity in the mormyrid electrosensory lobe. *J Exp Biol* 202:1339–1347
8. Kirschbaum F (1995) Reproduction and development in mormyrid and gymnotiform fishes. In: Moller P (ed) *Electric fishes: history and behavior*. Chapman & Hall Fish and Fisheries Series, vol. 17. Chapman & Hall, London, pp 267–301
9. Hopkins CD (1999) Design features for electric communication. *J Exp Biol* 202:1217–1228
10. Landsman RE (1995) Sources of plasticity in behavior and its physiology: sex, hormones, environment and the captivity model. In: Moller P (ed) *Electric fishes: history and behavior*. Chapman & Hall, London, pp 303–343

---

## Electric Orientation

### ►Magnetic and Electric Senses

---

## Electric Senses in Monotremes: Electroreception and Electrolocation in the Platypus and the Echidna

GERALD LANGNER<sup>1</sup>, HENNING SCHEICH<sup>2</sup>

<sup>1</sup>Neuroakustik, Fachbereich Biologie, TU Darmstadt, Darmstadt, Germany

<sup>2</sup>Leibniz-Institute for Neurobiology, Magdeburg, Germany

### Definition

The Australian platypus, *Ornithorhynchus anatinus*, and the two species of spine covered echidnas, *Tachyglossus aculeatus* and *Zaglossus brujnii*, are the only surviving species of ►monotremes. Among the three tribes of extant mammals, monotreme, marsupial and placental mammals, monotremes are the most primitive and limited to Eastern Australia, Tasmania, and New Guinea.

Since little is known about the role and function of the electric sense in echidnas this article focuses

mainly on the platypus. The nocturnally diving platypus subsists entirely on live food caught during nightly dives in lakes and streams. With eyes, nostrils, and ear canals closed underwater, its ability to locate and catch mobile prey like crayfish, shrimp, and small fish is unlikely to depend exclusively on the remaining tactile sense of the bill which has long been known to be covered with mechanoreceptor organs. Behavioral experiments have shown that the platypus can detect weak electric fields. It locates small living objects and avoids large obstacles provided they generate such fields. The legendary sixth sense of the platypus was shown to be electrical. Several lines of evidence suggest that electroreception in monotremes has evolved independently from the corresponding senses in fishes and amphibians.

### Characteristics

The platypus with a body length of about 45 cm is characterized by short legs, a flat tail, a dense fur with remnants of reptile scales, a duck-like bill of 15 cm length, small eyes, and a lack of pinnae. The male is slightly larger than the female. Aspects of its skull as well as its brain are reminiscent of those of reptiles. Its broad paws have five toes with sharp claws. A single poisonous hollow spur is exposed on the hind feet of the male. The urinal and genital tracts and rectum have a common opening (cloaca). Another unusual reptile-like characteristic of monotremes is that the platypus lays 2–3 eggs of about 2 cm. Embryos of 2.5 cm length hatch after a week, and are blind and nude. Their teeth are replaced by horn plates at a later stage of development. The platypus as well as the echidna are not endangered species, as their only natural enemies are snakes, crocodiles, marsupial foxes, and probably in former times the Tasmanian wolf.

The platypus lives in a self-made burrow, always near fresh water, which may be extremely long (10–20 m) and has its openings slightly above water level. It has adapted to catch small animals in water and roams about creeks and rivers in Eastern Australia and Tasmania. At dawn the animal swims and dives and then may stay under water for 5 min. It uses skin folds to close its eyes, ears, and nostrils, and relies totally on its somatosensory and electrical senses to feed on live prey, including several species of grubs, worms, decapod crustaceans, frogs, and small fishes. Typically the animal shows reflex-like head jerks when encountering transient electric fields in the millivolt range which may be generated by its prey.

### Quantitative Description

#### *Description of Structures, Processes, and Conditions*

As recently as 1986 a German–Australian team of biologists from the Universities of Darmstadt and Canberra discovered that the large bill of the platypus is not only a

mechanoreceptive feeding device, but also a highly sensitive electroreceptive organ [1]. The animal makes use of direct (d.c.) and alternating (a.c.) current fields in object location and avoidance. In a manner comparable to that of electro-sensitive fishes and amphibians, the platypus may use electric fields generated by live animals to find its food. The tail flicks of a local freshwater shrimp (*Macrobrachium australiense*), were found to be associated with compound muscle potentials that amount to 0.2–1 mV/cm at a distance of 5 cm. These potentials are well above the behavioral threshold of the platypus. Since a tail flick yields only a few centimeters of escape distance, the potentials are meaningful stimuli to guide prey catching. These myogenic alternating currents can lead the animal while it is probing blindly in the mud or among stones. The animal catches prey amounting to half its body weight during one day. When diving, a platypus usually performs 2–3 undulatory sweeps per second with its bill in parallel to the bottom. This “patrol phase” changes into a “search phase” when the bill contacts interesting objects or detects traces of food smell in the water (presumably mediated by the large ►vomero-nasal organ) and weak electric dipole fields. The search phase consists of erratic movements of the bill allowing the animal to home-in on a prey object. The sequence may be completed by an “attack phase” in which the object of interest is seized with rapid snaps of the bill.

The first evidence for an electrical sense in the platypus was the observation of a change from the patrol to the search phase of a diving platypus when in the vicinity of a small battery placed on the bottom of a pool [1]. Subsequently, animals could be easily trained to actively search for batteries baited with dead freshwater shrimp (Fig. 1).

More evidence came when electric fields generated by electrodes in the water were switched on, which elicited reflex movements of the heads and tails of the animals. Threshold values, when the animals were approximately in the centre of a homogeneous field, could be as low as 50  $\mu\text{V}/\text{cm}$  (equivalent to 4  $\text{nA}/\text{cm}^2$ ). Animals learned to avoid invisible plastic plates that had carbon electrodes attached at their ends. They made a detour around the plates at distances corresponding to a d.c. field gradient of  $<200 \mu\text{V}/\text{cm}$ , but regularly bumped into the plate when the field was switched off. There is still an unexplained discrepancy between these extremely low behavioral sensitivities and the threshold of individual ►electroreceptors, which is around 1 mV/cm [2].

The electrical sense in the echidna, or spiny anteater (*Tachyglossus aculeatus*), which together with the platypus belongs to the monotreme group, is the first and only example of electroreception in a purely terrestrial animal. Responses of dissected filaments of the trigeminal nerve to focal, low-voltage stimuli applied to the moist skin surface showed that the echidna has electroreceptors, and that receptive fields are restricted to small spots at the tip of the snout [2]. The skin is covered with large mucus-secreting glands similar to the ones in platypus. Trained animals discriminated between water-filled troughs with weak electric fields across them down to field strengths of 1.8 mV/cm, corresponding to the electro-physiological thresholds of the most sensitive receptors. A continuous nasal secretion always keeps the tip of the snout wet and may provide a low electrical resistance even under dry conditions. However, the behavioral significance of the electric sense in the echidna in its normal habitat remains largely speculative.



**Electric Senses in Monotremes: Electroreception and Electrolocation in the Platypus and the Echidna.**

**Figure 1** Left: A platypus attacking a battery half exposed between stones. Right: Resting on a wooden board in an experimental pool.

### Higher-Level Structures, Processes, and Conditions

Evoked cortical potentials in a platypus obtained with electrical stimulation of the bill had a threshold below 100  $\mu\text{V}/\text{cm}$  [1]. They revealed an electrosensory cortical field representing the contralateral bill about 5 mm ventral to the auditory cortical field [3]. Besides electric potentials mechanical waves traveling through the water from moving prey are detected by the bill which is densely covered with mechanoreceptors. Information from electroreceptors and mechanoreceptors probably converges in the same cortical field, as all electroreceptive neurons seem to receive mechanoreceptive input as well [4]. Behavioral and physiological experiments support the hypothesis that the platypus may be able to determine its distance from a target, by the difference in arrival times of electrical signals and mechanical waves produced by the prey [5]. It has been proposed that this is achieved by interfacing mechanosensory and electrosensory inputs in a type of cortical organization of alternating columns resembling the ocular **▶ dominance columns** of primates [6]. A columnar organization was already demonstrated by means of cortical mapping of electrical stimuli applied dorsoventrally across the left side of the bill in a **▶ 2-deoxy-glucose (2DG) experiment** [7]. The experiment revealed a large cortical map with the strongest contralateral stripe-like labeling having an extension of about 6–8 mm with inter-columnar distances of 1–2 mm (Fig. 2).

These columns actually do resemble the ocular dominance columns of some visual cortices. The strongly labeled contralateral columns are separated by gaps which spatially seem to fit into most of the weakly labeled columns in the ipsilateral hemisphere. Thus adjacent columns may integrate information from corresponding areas of the two sides of the bill. This would be compatible with the hypothesis that information about the distance from a source is available from the pattern of field decay across the bill [8]. The field decay should be identical for both sides of the bill when the electrical source is located directly ahead, a situation comparable to binocular processing. As cortical neurons were found to be bimodal [4], electroreceptive and mechanoreceptive input should be localized in the same cortical columns.

The dominance columns representing the spatial disparities of receptors across the surface bill together with the bimodal input within columns may indeed be the powerful tool used by the platypus to localize its underwater prey in three dimensions. The electroreceptors on the bill are organized as a directional antenna which is suitable for determining the azimuth and elevation of an electrical field source and enables the animal to generate accurate head saccades toward the prey [9].

### Lower Level Components

Already before the discovery of its electrosensory function the bill of the platypus was known to be covered with dense arrays of unusual receptor organs dissimilar to its numerous mechanoreceptors [10]. In electron microscope studies they were described as gland duct receptors of unknown function. These receptors are unique to the platypus but do also occur in echidnas in simpler form. Two kinds of gland duct receptors may be recognized from their morphology as potential electroreceptors because the association of skin pores with serous and mucous glands enables electric current to reach the trigeminal nerve endings. The approximately 40,000 mucous gland type electroreceptors of the platypus are arrayed in parasagittal rows on the surface of its bill, but also on the inner surfaces of its mandibles [5].

The epidermal ducts of the mucous glands are innervated by myelinated axons of trigeminal neurons with morphologically distinct axon terminals. The electroreceptors consist of small protoplasmatic protrusions from these axons which form filamentous processes extending into the ducts of the skin glands [10]. This arrangement is ideal for electroreception in a semi-aquatic animal. Because the epidermis of the bill dries out when the animal leaves the water, the glands help to preserve conductivity and to prevent damage to the electroreceptors by desiccation.

Electroreceptors which are sensitive enough to detect electrical signals generated by internal electrochemical processes of prey animals are well known in phylogenetically old fishes and some amphibians. In African mormyrid and South American gymnotiform fishes this sense has evolved to an additional active system using an **▶ electric organ** as a source for a.c. impedance measurement of the environment and for communication. All electroreceptors found in fishes and amphibians that do not have electric organs are of the ampullary receptor type and probably form part of the acoustico-lateralis system. In contrast, the electroreceptors in platypus belong to the trigeminal system. Their sensitivity to d.c. as well as to high-frequency pulses [2] contrasts with the mostly d.c. or low-frequency responsiveness of ampullary receptors, which are less well-adapted to detect rapid muscle action potentials.

The presence of ampullary-like electroreceptors of a unique structure connected to the trigeminal nerve indicates that electroreception has evolved independently in monotremes. This in turn emphasizes that monotremes are a highly evolved group which split off from the main mammalian stem a long time ago.

### Function

Since the discovery of the electric sense of the platypus in 1986 [1] an extensive series of behavioral

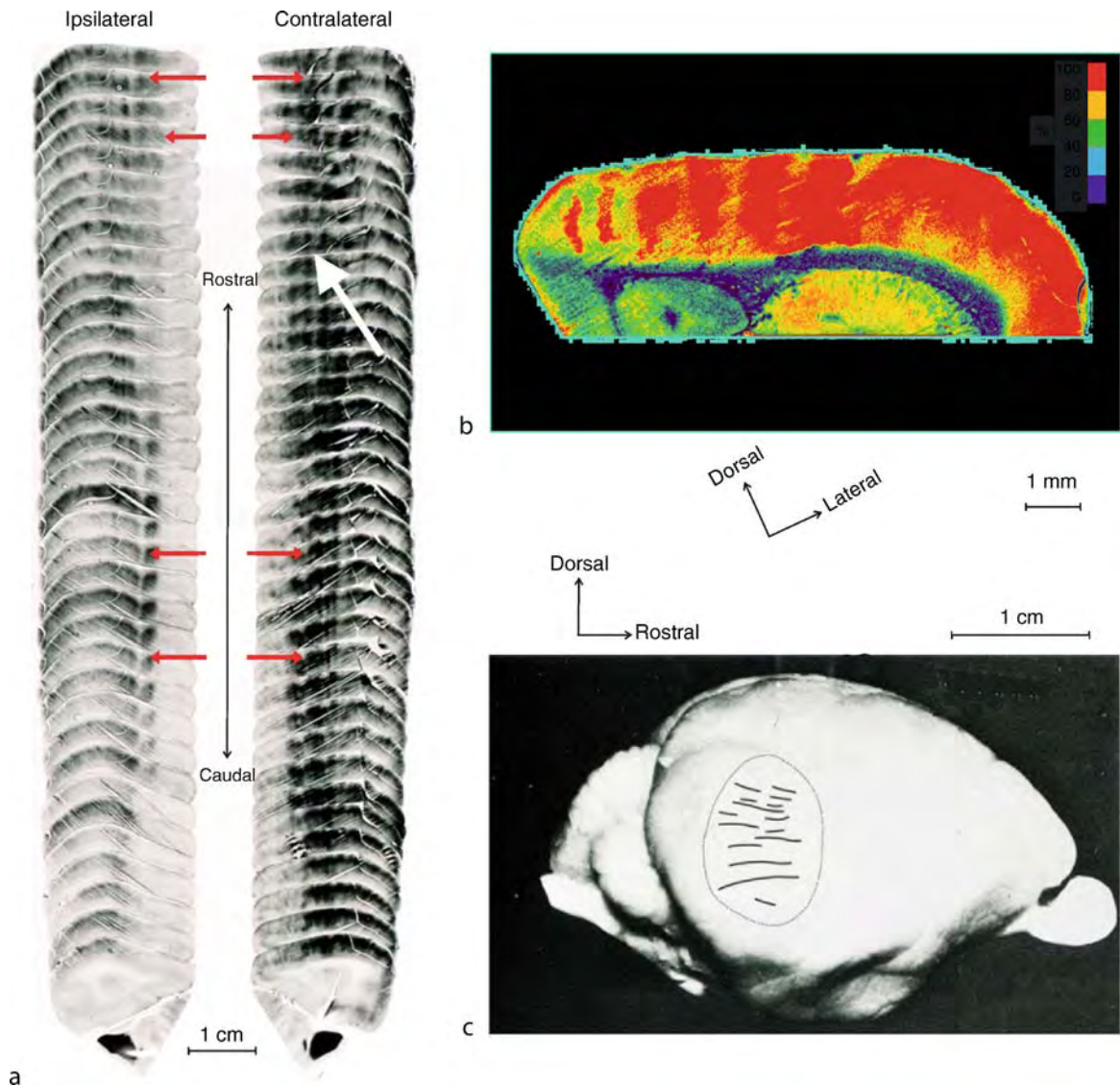

### Electric Senses in Monotremes: Electroreception and Electrolocation in the Platypus and the Echidna.

**Figure 2** [ $^{14}\text{C}$ ]2-deoxyglucose labeling of platypus cortex after 6-s stimulation with electrical pulses applied dorsoventrally across the right side of the bill through wet cotton (1 ms square pulses, 1 mV/cm). (a) Serial reconstruction of transverse sections, separate for left and right side, in the area of strongest contralateral labeling. Note the columnar arrangement with weakly labeled patches on the ipsilateral (*left side*) roughly corresponding to the gaps between the strongly labeled patches on the contralateral side (*right side*). *Red arrows* mark these spatial correspondences for some patches and gaps. (b) Color-coded labeling (indicated by the color scale) of patches in cortex layers 3–4 of one section in the area indicated in (a) by a *white arrow*. (c) Reconstruction of labeled columns from (a) superimposed on a platypus brain.

experiments has clarified how the animal uses electroreception together with mechanoreception, to locate aquatic prey in three-dimensional space [5,6]. The results showed that the platypus can detect weak electric dipoles and that it is able to locate moving prey by the electrical activity associated with its muscle contractions. All receptive fields mapped in the trigeminal nerve are located along the lateral border of the upper

bill and are characterized by a single spot of maximum sensitivity on the bill surface. Rapidly changing pulses are most effective in exciting receptors, indicating that the animal is adapted to detect moving prey by the electrical activity associated with muscle contraction. The skin of the bill also contains different kinds of mechanoreceptors that are highly sensitive to water waves. After 20 years of intensive behavioral,

physiological, and anatomical studies the conclusion has been reached that the platypus bill is indeed a mechano-electro-sensitive antenna [8].

## References

1. Scheich H, Langner G, Tidemann C, Coles RB, Guppy A (1986) Electroreception and electrolocation in platypus. *Nature* 319:401–402
2. Gregory JE, Iggo A, McIntyre AK, Proske U (1987) Responses of electroreceptors in the platypus bill to steady and alternating potentials. *J Physiol Lond* 408:391–404
3. Bohringer RC, Rowe MJ (1997) The organization of the sensory and motor areas of cerebral cortex in the platypus (*Ornithorhynchus anatinus*). *J Comp Neurol* 174:1–14
4. Krubitzer L, Manger PR, Pettigrew JD, Calford MB (1995) Organisation of somatosensory cortex in monotremes: in search of the prototypical plan. *J Comp Neurol* 352:261–306
5. Manger PR, Pettigrew JD (1996) Ultrastructure, number, distribution and innervation of electroreceptors and mechanoreceptors in the bill skin of the platypus, *Ornithorhynchus anatinus*. *Brain Behav Evol* 48:27–54
6. Pettigrew JD, Manger PR, Fine SLB (1998) The sensory world of the platypus. *Phil Trans R Soc Lond B* 353:1199–1210
7. Langner G, Scheich H (1986) Electroreceptive cortex of the platypus marked by 2-deoxyglucose. *First Int Congr Neuroethol Tokyo, Japan* 63
8. Fjällbrant TT, Manger PR, Pettigrew JD (1998) Some related aspects of platypus electroreception: temporal integration behaviour, electroreceptive thresholds and directionality of the bill acting as an antenna. *Phil Trans R Soc Lond B* 353:1211–1219
9. Proske U, Gregory JE (2003) Electrolocation in the platypus – some speculations. *Comp Biochem Physiol A* 4:821–825
10. Andres KH, von Düring M (1984) The platypus bill. A structural and functional model of a pattern-like arrangement of cutaneous sensory receptors. In: Hamann W, Iggo (eds) *Sensory receptor mechanisms*. World Scientific, Singapore, pp 81–89

## Electric Sensitivity

- ▶ Magnetic and Electric Senses

## Electrical Communication

- ▶ Reafferent Control in Electric Communication

## Electrical Coupling

### Definition

Electrical coupling refers to the coupling of membrane potentials of two cells. Usually electrical coupling is mediated by electrical synapses, which are formed by gap junctions. In less common cases, electrical coupling of cells can occur through ephaptic transmission, a process by which electrical activity in one cell affects the membrane potential of a neighboring cell through direct electrical field effects without the intervention of a synapse.

- ▶ Electrical Synapses
- ▶ Ephaptic Interaction

## Electrical Excitability

### Definition

Excitability refers to the capacity of nerves and other tissues to generate and sometimes propagate action potentials, i.e., signals that serve to control intracellular processes, such as muscle contraction, synaptic transmitter release or hormone secretion. Examples of excitable cells and tissues include neurons and glia, muscle and endocrine tissues. Examples of non-excitable cells and tissues include blood cells, most epithelia and connective tissues.

- ▶ Action Potential
- ▶ Action Potential Propagation
- ▶ Intrinsic Properties of Auditory Neurons

## Electrical Stimulation

### Definition

Electrical pulses may be used to activate cells. Currents must be large enough to elicit an action potential, but small enough to not damage the cells. Electrical stimulation is used, for example, in Parkinson patients to counter the akinesia.

## Electrical Synapses

WILLEM C. WILDERING

Department of Biological Sciences, Faculty of Science and Hotchkiss Brain Institute, University of Calgary, Calgary, AB, Canada

### Synonyms

Electrotonic synapse

### Definition

An electrical synapse is an electrically conductive junction between two cells formed by arrays of gap junction channels. Neighboring cells joined by such a junction are said to be electrically coupled because membrane potential changes can be directly transmitted between the partners without intervention of extracellular messenger molecules such as neurotransmitters.

### Characteristics of Electrical Synapses

#### Structural and Functional

► **Gap junctions** are structures consisting of one or more channel forming intercellular junctions between eukaryotic cells. The cytosolic bridges formed by gap junction channels allow direct cell-to-cell exchange of ions and small molecules up to a molecular mass of approximately 1 kDa such as second messengers and other intracellular metabolites, i.e. gap junctions allow cells to be both electrically and metabolically coupled.” Each gap junction channel is made from two mirror-image “half-channels,” traditionally called connexons or hemichannels (one provided by each of the partner cells) that align themselves in areas where the plasmamembrane of the partner cells closely appose each other (see Fig. 1).

Each of the hemichannels is composed of six homologous tetra-span integral membrane proteins that are called connexins (but see section on phylogenetic considerations). Each connexin molecule contains four membrane-spanning  $\alpha$ -helices connected by two extracellular loops, one cytoplasmic loop, and intracellular C and N termini [1]. The two extracellular loops contain several conserved cysteine residues that are thought to be essential in alignment and docking of contralateral hemichannel pairs [1,2]. The mammalian genome encodes over 20 connexin family members that may assemble in various homomeric and heteromeric combinations and instill gap junction channels with various physiological and pharmacological properties [3].

#### Phylogenetic Considerations

Gap junctions are found throughout the animal kingdom and support very similar functions in representatives of

all major animal taxonomic groups. Until quite recently it was thought that only members of the connexin family formed gap junctions. However, it is now evident that at least two, not directly related gene families, the connexins and the innexins, have evolved to fulfill the fundamental roles of gap junctions. Although the proteins encoded by members of these gene families have very different primary sequences, they nonetheless share many structural and functional features [1,2]. Both share the basic tetraspan transmembrane topology outlined above and both retain several positionally conserved cysteine residues in their extracellular loops and form functional gap junction channels [1,2]. All available genomic data indicates that the connexin family is confined to chordate lineages while the innexin family proper appears to be restricted to invertebrates. However, this dichotomy may be less absolutely than originally thought since distant innexin homologs, called pannexins, have been identified in the genomes of rat, mice, humans and other vertebrates [2]. This finding led to the proposal to reclassify innexins as members of a larger and phylogenetically broadly distributed family of pannexins [1]. Both the connexins and innexins/pannexins are members of large multigene families. Over 20 connexin genes were discovered in mammals in addition to three pannexins. The fruitfly *Drosophila melanogaster* genome codes for 8 innexin homologs, whereas the nematode *C. elegans* has 20 different innexin homologs supporting a variety of biological processes [1,2]. Dealing with these matters in more detail is beyond the scope of this introductory assay. For the current purpose, it suffices to conclude that despite their genetic diversity, gap junctions formed by connexins, innexins and pannexins share similar molecular organization and transmembrane topologies and, in neurophysiological terms, appear to instill very similar functions into electrically coupled cells.

#### Fundamental Electrophysiological Characteristics of Electrical Synapses

Ionic current flow across an electrical synapse is fundamentally a function of the voltage difference applied across the synapse (i.e., the transjunctional potential) and the number, unitary conductance, permeability and gating characteristics of the gap junction channels constituting the synapse. In principle, the cytosolic bridges provided by gap junctions allow exchange of molecular signals in both directions. In keeping with this bidirectionality, many gap junctions conduct ionic currents equally well in both directions. Moreover, the amount of junctional current flow is in many cases a linear function of the transjunctional potential, i.e., the synapse obeys Ohm’s current-voltage law. This kind of ► **electrical synapses** is called ► **non-rectifying gap junctions** to distinguish them from their

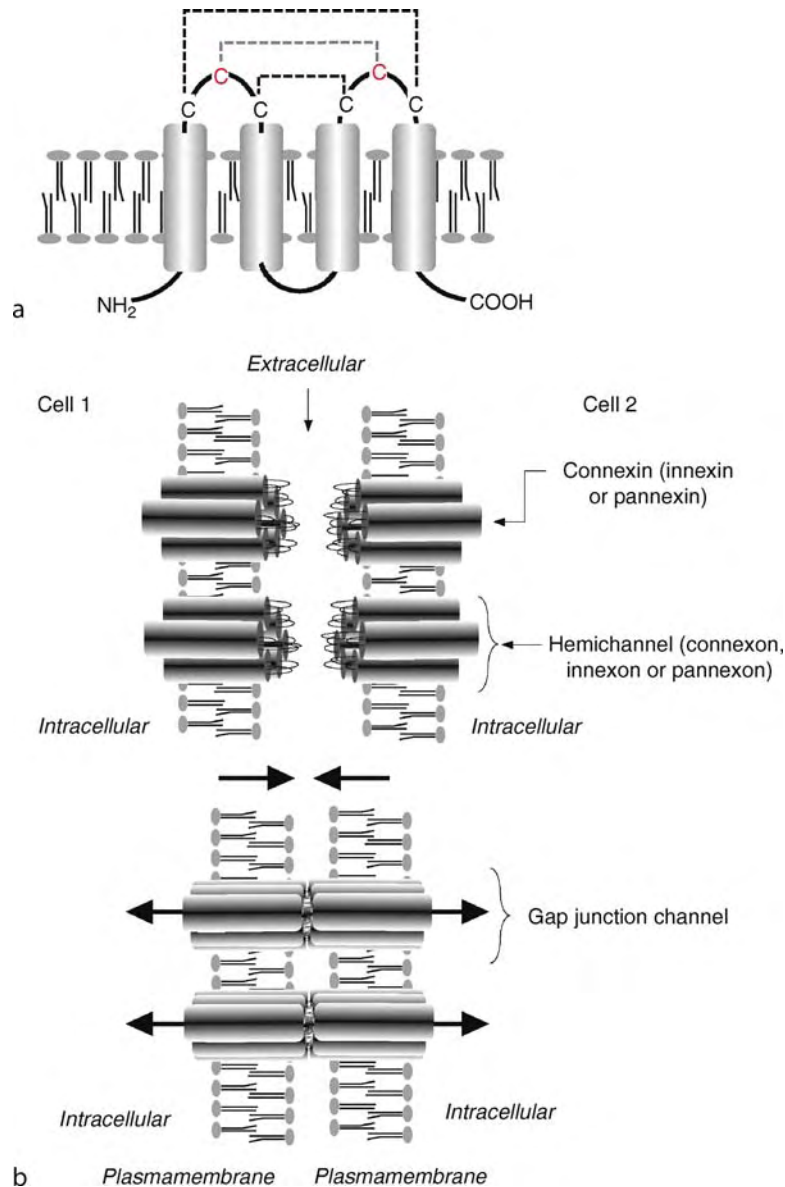

**Electrical Synapses. Figure 1** Generic structure of gap junctions and their protein components. (a) Gap junctions are homo- or heteromeric assemblies of members of the connexin, innexin or pannexin families. All three families of gap junction proteins have the same basic topology: four plasmamembrane spanning  $\alpha$ -helices coupled by two extracellular loops and one intracellular loop in addition to intracellular N and C-terminal amino acid chains. Connexins are further characterized by three conserved cysteine residues in each of their extracellular loops. Pannexins and innexins have two of these cysteine residues in each of their extracellular loops. Disulfide bridges between the extracellular cysteine residues of connexins as well as pannexins/innexins are thought to be essential in creating the extracellular topology that allow gap junction hemichannels of opposing cells to dock and align with each other. (b) Gap junction channels are formed when two hemichannels, one of each provided by the two apposing cells align themselves and dock with each other forming a continuous cytosolic bridge between the two cells. Depending on their phylogeny gap junction hemichannels are also known as connexons, innexons or pannexons. Each hemichannel is built from six tetraspan protein subunits known as connexins, innexins or pannexins (see (a)).

► **rectifying gap junctions** brethren. Rectifying electrical synapses conduct ionic currents better in one direction than the other, i.e., their conductive properties are a non-linear function of the transjunctional

potential. The rectification properties are a function of voltage-sensitive elements in some connexin family members and arise from asymmetries in hemichannel composition.



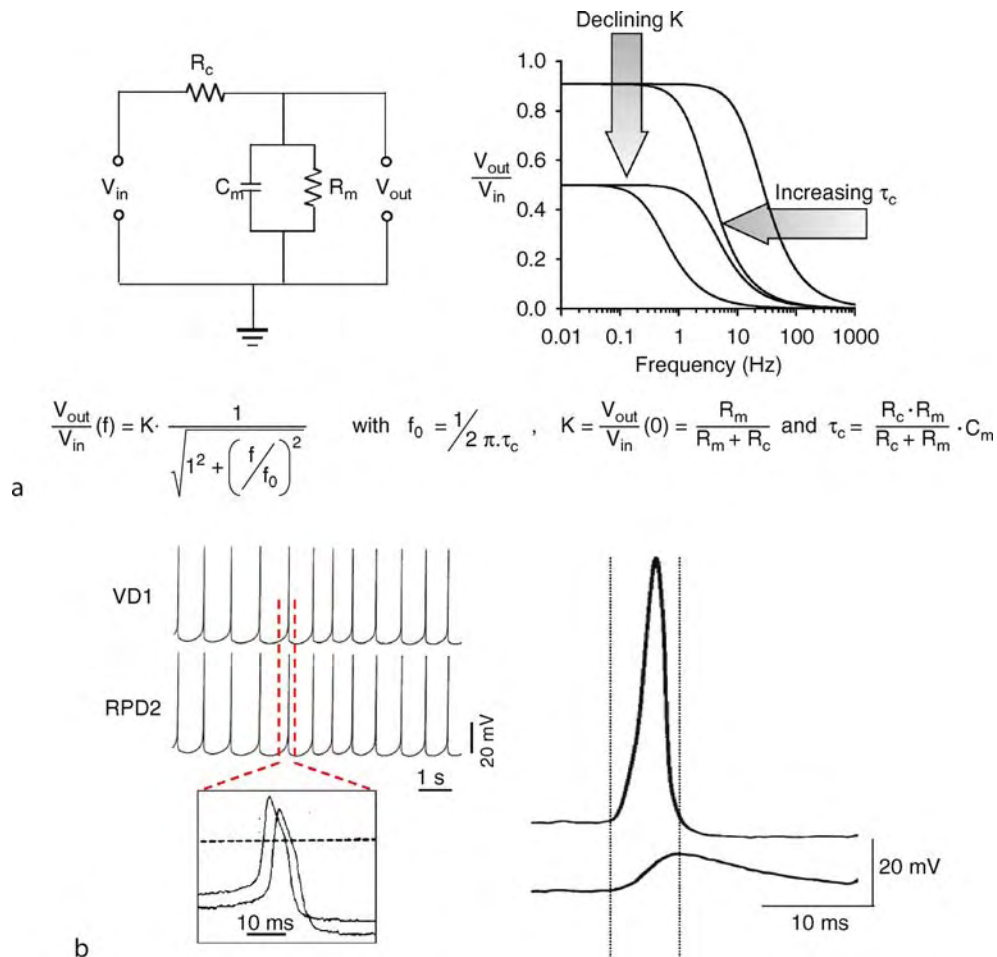

**Electrical Synapses. Figure 2** Fundamental electrical properties of electrical synapses. (a) Equivalent resistance/capacitance circuit modeling the passive membrane properties of two electrically coupled cells and its sinusoid voltage-transfer characteristics. In this simple circuit, electrical conductive properties of the electrical synapse are represented by an ohmic resistance ( $R_c$ ) standing in series with a parallel capacitance ( $C_m$ )/resistance ( $R_m$ ) circuit. The latter two variables represent the membrane capacitance ( $C_m$ ) and membrane resistance ( $R_m$ ) of the postsynaptic cell. For the current purpose the presynaptic cell is considered an ideal voltage source ( $V_{in}$ ). Although this model ignores intricacies arising from the usually much more complex cable-like structure of neurons, it does adequately illustrate the basic principles underlying the transmission characteristics of electrical synapses. The voltage transfer function ( $V_{out}/V_{in}$ ) is the product of the steady state coupling ratio ( $K$ ) and a frequency ( $f/f_0$ ) dependent term.  $K$  is a function of the resistive values  $R_m$  and  $R_c$  only. An increase in  $R_c$  or a decrease in  $R_m$  will lead to a decline in  $K$ . A decrease in  $R_c$  or an increase in  $R_m$  will lead to higher values of  $K$ . Because of the presence of  $C_m$ , electrical synapses act as low-pass frequency filters attenuating higher frequencies stronger than lower frequencies. The coupling time constant  $\tau_c$  relates this frequency dependent behavior to passive membrane properties of the coupled cells. The cutoff frequency  $f_0$  is inversely proportional to  $\tau_c$ . Hence, an increase in  $\tau_c$ , which may arise as a consequence of an increase in  $R_c$ ,  $R_m$  or  $C_m$ , will lower the coupling's cutoff frequency and make the coupling more restrictive. Lower values of  $\tau_c$  are associated with higher values of  $f_0$  and less restrictive high-frequency filtering. To illustrate the effects on the transmission characteristics of an electrical synapse, the plot in the *top right* panel shows four examples of voltage transfer functions with progressively smaller  $K$  (top to bottom) and larger  $\tau_c$  (right to left).

(b) Electrical synapses are often involved in the synchronization of electrical activity in groups of neurons. This figure shows synchronized action potential activity in two peptidergic neurons in the pond snail *Lymnaea stagnalis*. The cell named visceral dorsal 1 (VD1) is an intrinsic pacemaker. VD1 is coupled through an electrical synapse to the second cell called right parietal dorsal 2 (RPD2). The presence of an electrical synapse allows VD1 to drive RPD2's spiking rhythm in close synchrony (see *inset*). In the right panel RPD2 was hyperpolarized to reveal the postsynaptic potential (the smaller lower trace of the two) generated by an action potential in VD1 (the larger upper trace of the two). Note that in its transfer across the electrical synapses the action potential is attenuated and slowed down appreciable. This phenomenon arises from the fact that most of the action potentials power spectrum lies substantially above the cutoff frequency ( $f_0$ ) of this synapse.

Electrical synapses act as ►**low-pass frequency filters**, a feature arising from the fact that current flowing through the junction feeds into both the membrane capacitance and membrane resistance of the postsynaptic cell (for further explanation see equivalent RC circuit of electrically coupled cells in Fig. 2, see also [4]). The transmission characteristics of an electrical synapse and the influence of various junctional and non-junctional membrane properties thereon are easiest appreciated by considering a simplified equivalent RC-circuit (Fig. 2).

Since current flowing through the gap junction ( $R_c$  in Fig. 2) feeds into both membrane capacitance ( $C_m$  in Fig. 2) and resistance ( $R_m$  in Fig. 2) of the postsynaptic cell, the synapse behaves like a low-pass frequency filters with passband attenuation. That is, when the frequency of the input signals ( $V_{in}$ ) approaches 0, i.e., when a steady state has been accomplished, the transmission efficacy of the synapse ( $V_{out}/V_{in}$ ) will reach its maximum. This so-called steady state coupling ratio ( $K$  in Fig. 2) is a function of the resistive components of the coupled cells only ( $R_m$  and  $R_c$  in the equivalent circuit of Fig. 2; see also [4]). The extent to which non-steady state input signals (i.e., AC signals) are attenuated depends on their frequency relative to the so-called cutoff frequency of the synapse ( $f_0$  in Fig. 2). In simple situations resembling the equivalent RC-circuit shown in Fig. 2,  $f_0$  is a function of the passive membrane properties of the postsynaptic cell (i.e.,  $R_m$  and  $C_m$ ) and the electrical resistance of the junction ( $R_c$ ) which collectively determined the coupling time constant ( $\tau_c$  in Fig. 2). Thus, although the strength of an electrical synapse is traditionally expressed in terms of ►**coupling coefficient**, this value only expresses the transmission efficacy for signals substantially slower than the synapse's cutoff frequency (i.e.,  $\leq 5 \times f_0$ ). Clearly, few electrically coupled neurons have an electrotonic architecture simple enough to be accurately represented by a one compartment RC-network like the equivalent circuit shown in Fig. 2. However, the model does provide valuable insights in the operational constraints of electrical synapses. For example, an increase in  $R_m$  will increase the steady state coupling coefficient, but restrict the AC response of the synapse. An increase in  $R_c$  will attenuate both steady state and AC response characteristics of the synapse. Larger cell size, through increased larger membrane capacitance  $C_m$ , correlates with increasingly restrictive low pass filter characteristics. Thus, in order to obtain high steady state coupling ratio  $R_c \ll R_m$ . In addition, to obtain the fastest possible synaptic transmission through electrical synapses,  $C_m$  should be as low as possible.

Much of the attention on electrical synapses has focused on their role in fast synaptic transmission of impulse-like potentials such as action potentials. However, as outlined above electrical synapses act

as low-pass frequency filters. Most action potential waveforms are dominated by components substantially faster than a few Hz. However, many types of synaptic potentials, pacemaker potentials and other subthreshold membrane potentials have a substantial representation in this frequency range. Therefore, electrical synapses, particularly those combining a high steady state coupling ratio with low a cutoff frequency may have substantial impact on synaptic integration, rhythmogenesis and other integrative properties of coupled neurons while transmitting little of actual action potentials [5,6].

### Modulation of Electrical Synapses

The permeability characteristics of gap junctions and therefore the conductance characteristics of electrical synapses depend on various factors. For example, insertion or removal of gap junction channels from the membrane will affect overall conductance of the synapse. Also, depending on their subunit composition gap junction permeability, gating, electrical conductivity and selectivity characteristics may differ [4]. Furthermore, the conductance of many gap junction channels is modulated by intracellular signaling factors, including intracellular free  $Ca^{2+}$ , pH, cAMP, and in other cases, the transjunctional voltage [4]. In addition, since the electrical synapse's coupling coefficient is a function of both junctional and non-junctional membrane resistance, the strength of coupling can be altered by changing the gap junctional conductance itself as well as by changing the conductance of adjacent non-junctional membranes through for example chemical synaptic activity.

### Electrical Synapses and Gap Junctions in the Invertebrate Nervous System

Since their original description by Furshpan and Potter in crayfish in 1957, it has become abundantly clear that electrical synapses are not only quite common but also play various critical roles in the invertebrate brain. For example, due to their relative transmission speed and insensitivity to temperature, electrical synapses are frequently found in circuits controlling critical behavioral functions that require quick responses such as escape and defensive behaviors such as the crayfish tailflip escape response. A more general purpose of electrical synapses is to synchronize electrical activity among populations of neurons. For example, electrical synapses contribute to the synchronization of electrical activity of various populations of hormone secreting neurons in various invertebrates thereby facilitating a burst of hormone secretion into the circulation. Interestingly, electrical synapses serve similar roles in the synchronized release of neurohormones by several groups of mammalian hypothalamic and pituitary neurons.

## Electrical Synapses and Gap Junctions in the Vertebrate Nervous System

The significance of electrical and ►metabolic coupling mediated by gap junctions in development, morphogenesis and circuit formation in the mammalian brain has long been recognized. However, although the existence of electrical synapses in various areas of the mature mammalian brain has been known or suspected for quite a while, ►electrical coupling was until quite recently not considered of great importance in adult brain function [3]. Since the biochemical steps involved in chemical synaptic transmission proceed at a faster rate at the higher body temperatures, electrical synapses have less of a speed advantage over their chemical counterparts in homeotherms. This led to the idea that the contribution of gap junctions to processes requiring high-speed synaptic transmission was probably of lesser importance in warm-blooded mammals than in cold-blooded animals. Interestingly, consistent with this contention electrical synapses are a critical factor in the response characteristics of the Mauthner cell system, the neural circuit subserving the tail flick escape response of, obviously cold-blooded, teleost fish.

Recently, the significance of gap junctions in information processing in the adult mammalian brain is undergoing a substantial reappraisal. For example, a growing body of evidence indicate that gap junction coupling is a crucial factor in the temporal coordination of neuronal activity and the generation of endogenous neuronal ►network oscillations in various areas of the mammalian brain including the olfactory bulb, the ►olivocerebellar complex, thalamus, hippocampus and neocortex (reviewed by [3,4,8]). In addition, although the significance of electrical coupling in retinal signal processing has been known for a long time, transgenic model systems have been instrumental in confirming existing ideas and uncovering new insights in the significance of gap junctions in various aspects of retinal signal processing, including photoreceptor signal-to-noise characteristics, sensitivity, spatial resolution, determination of receptive field size (reviewed by [3]). Consistent with their new found functional importance, gap junctions are also increasingly implicated in various neurological disorders of the mature mammalian nervous system, including the progression of epileptic seizures, post ischemic damage and demyelinating diseases [8–10].

Non-neuronal roles of gap junctions in the nervous system – This essay focuses on the role of gap junctions in forming electrical synapses between neuronal cell populations. However, most macroglial cell types of the mammalian nervous system express specific sets of connexins and are extensively coupled through gap junctions organizing many of these cell types in distinct functional syncytiums [9,10]. Gap junctions support long-range metabolic coupling within several glial cell populations and is implicated in the brain's osmolarity

and global excitability regulation. Treatment of these topics is beyond the scope of this essay. However several good reviews are available [9,10].

## References

1. Panchin YV (2005) Evolution of gap junction proteins – the pannexin alternative. *J Exp Biol* 208:1415–1419
2. Phelan P (2005) Innexins: members of an evolutionarily conserved family of gap junctions. *Biochim Biophys Acta* 1711:225–245
3. Söhl G, Maxeiner S, Willecke K (2005) Expression and function of neuronal gap junctions. *Nat Rev Neurosci* 6:191–200
4. Bennett MVL, Zukin RS (2004) Electrical coupling and neuronal synchronization in the mammalian brain. *Neuron* 41:495–511
5. Berry MS, Pentreath VW (1977) The integrative properties of electrotonic synapses. *Comp Biochem Physiol A* 57:289–295
6. Marder E (1998) Electrical synapses: beyond speed and synchrony to computation. *Curr Biol* 8:R795–R797
7. Goodenough DA, Goliger JA, Paul DL (1996) Connexins, connexons and intercellular communication *Annu Rev Biochem* 65:475–502
8. Traub RD, Draguhn A, Whittington MA, Baldeweg T, Bibbig A, Buhl EH, Schmitz D (2002) Axonal gap junctions between principal neurons: a novel source of network oscillations, and perhaps epileptogenesis. *Rev Neurosci* 13:1–30
9. Spray DC, Ye ZC, Ransom BR (2006) Functional connexin “hemichannels”: a critical appraisal. *Glia* 54:758–773
10. Dermietzel R (1998) Diversification of gap junction proteins (connexins) in the central nervous system and the concept of functional compartments. *Cell Biol Int* 22:719–730

## Electrical Syncytium

### Definition

Gastric and intestinal smooth muscle behaves as an electrical syncytium due to the presence of junctions between neighboring muscle fibers permitting the electrical excitatory current to spread from muscle fiber to muscle fiber throughout the sheet of muscle.

►Autonomic/Enteric Reflexes

## Electrocardiogram

### Definition

A graphic produced by an electrocardiograph, which records the electrical activity of the heart over time.

## Electrochemical Equilibrium

### Definition

Denotes the equilibrium between opposing forces constituted by an electrical potential difference and a chemical concentration difference.

- ▶ Membrane Potential - Basics

## Electrochemical Gradient

### Definition

The free energy difference for an ion in the extracellular versus the intracellular aqueous solution of a cell, i.e. the transmembrane free energy difference. The direction of this electrochemical gradient will determine whether the ion will flow into or out of the cell through a transmembrane pathway such as a  $\text{Na}^+$  channel; the gradient magnitude is a major factor affecting the rate of this ion flux (hence it is sometimes called “the driving force” for an ion). The electrochemical gradient for an ion has both electrical (i.e. transmembrane voltage) and chemical components (i.e. the transmembrane concentration difference for the ion).

- ▶ Membrane Potential: Basics
- ▶ Sodium Channels

## Electrochemical Potential

### Definition

- ▶ Ion Transport
- ▶ Membrane Potential: Basics

## Electrocochleography (ECoChG or ECoG)

### Definition

A technique for measuring cochlear receptor potentials. An electrode, either a trans-tympanic needle electrode

or a “wick” electrode placed against the tympanic membrane, records cochlear microphonic, summing and action potentials. Abnormalities indicate cochlear hair cell dysfunction. ECoChG is commonly used in the diagnosis of such conditions as Meniere’s disease and endolymphatic hydrops.

- ▶ Auditory Evoked Potentials

## Electrocommunication

- ▶ Electric Communication and Electrolocation
- ▶ Magnetic and Electric Senses
- ▶ Reafferent Control in Electric Communication

## Electrocyte

### Definition

A cell derived from muscle tissue whose function is the generation of electrical current.

- ▶ Electric Organ
- ▶ Electric Organ Discharge (EOD)

## Electrode

### Definition

Electric-current-conducting contact between excitable tissue and electrical recording or stimulation apparatus.

- ▶ Extracellular Recording

## Electroencephalogram

### Definition

- ▶ Electroencephalography

## Electroencephalography

ALEXEY M. IVANITSKY, GEORGE A. IVANITSKY,  
ANDREY R. NIKOLAEV, OLGA V. SYSOEVA  
Laboratory of Human Higher Nervous Activity,  
Institute of Higher Nervous Activity and  
Neurophysiology, Russian Academy of Sciences,  
Moscow, Russia

### Definition

Electroencephalography (▶EEG) is a technique for recording brain electrical activity from the human (or animal) scalp for research and diagnostic purposes. The term “electroencephalogram” means the sample of the scalp record.

### Purpose

Electroencephalography is applied in a broad field of noninvasive studies of brain activity. Having as well as magnetoencephalography the highest time resolution among the brain imaging techniques, the EEG recordings are the most effective for tracking the rapid changes of the brain functional states. Such an important field of brain science as the study of the cortical connectivity is most usefully served by the analysis of ▶EEG synchrony. ▶Sleep stages (fast and slow sleep) are revealed and described by means of overnight EEG monitoring. EEG can reveal the impairment of the brain’s workings, in terms of both its functional and organic nature. Therefore, clinical electroencephalography is a widely used technique for diagnostics, particularly in neurology and psychiatry. EEG is especially efficient in the diagnosis of epilepsy, as EEG signs in this disease are rather specific (▶sharp waves/spikes and ▶slow wave complexes). Information about EEG changes in various brain pathologies can be obtained from special clinical EEG Handbooks [1,2]. EEG can also be used for external devices control, particularly in Brain-compute Interface.

### Principles

#### Physiological Basis of the EEG

The electrical brain potentials recorded by EEG are the primary effects of neural activity. The neuronal ▶action potentials are the real “language” of neuronal communication. However, scalp-recorded EEG does not directly reflect the action potentials as the intervening tissues sharply attenuate their fields. Instead, the slower ▶postsynaptic excitatory and ▶inhibitory potentials generated predominantly in the dendrites of pyramidal cells make the main contribution to the EEG [3]. The reason is that the pyramidal neurons possess a well-developed dendritic system and that these dendrites constitute masses of equally oriented fibers. When, during the generation of postsynaptic potentials, dendritic

currents flow inside these fibers, they acquire the properties of electric current dipoles. In the case of synchronous activity of masses of pyramidal cells, the co-oriented dendritic dipoles produce fairly large electrical potentials on the surface of the head. In contrast, the dendrites of smaller neurons display a random orientation and are not able to contribute significantly to the superficially measured EEG. Still, they can influence the EEG indirectly by modulating the discharge patterns of the pyramidal cells. ▶Volume conduction due to intervening dura, skull, and soft tissue acts as a spatial ▶low-pass filter and smears the electric potentials over rather large brain areas. Thus, the scalp-recorded EEG may be attributed to the activity of underlying neuroanatomical structures over about a 1 cm range. Despite these restrictions, the contemporary methods of EEG analysis provide valuable accounts about the brain’s workings. The analysis of EEG rhythms is indeed a key point for understanding the informational processing in the brain.

#### EEG Rhythms

In 1929, the founder of the method, Hans Berger, discovered that the EEG consists of rhythms. There are two reasons why EEG acquires rhythmical properties. Firstly, some ▶pacemaker neurons possess an intrinsic capability for rhythmic discharges. On the other hand, neuronal groups can synchronize their activity through excitatory and inhibitory connections in such a manner that they constitute networks with oscillatory properties. Such networks are called ▶neuronal oscillators.

The whole frequency range of EEG rhythms has traditionally been divided into several bands: delta (1–4 Hz), theta (4–8 Hz), alpha (8–13 Hz), beta (13–30 Hz), and gamma (>30 Hz). Moreover, the alpha band is often divided into the lower alpha (8–11 Hz) and the upper alpha (11–13 Hz).

The most prominent EEG rhythm is the alpha rhythm of rest (Berger’s rhythm), with a frequency of about 10 Hz. This rhythm is observed in about 85% of normal adults, and is mostly expressed in occipital and parietal recording sites with eyes closed. The alpha rhythm reduces when the subject perceives a visual signal or makes a mental effort, e.g., performs arithmetic calculations. This rhythm results from an interplay of thalamic and cortical ▶neuronal networks.

Other rhythms of alpha frequency are also distinguished. The 10 Hz ▶mu-rhythm (Rolandic rhythm) can be observed at central electrodes above the motor and supplementary motor cortices. It has a specific ‘spiky’ waveform and is blocked by movements or preparation for movements. The 10 Hz tau-rhythm is recorded under temporal electrodes (above the auditory ▶cortex) and is attenuated by sounds.

The slow-wave ▶delta rhythm appears in deep sleep, both natural and narcotic, and also in coma. Delta

activity in the awake condition in adults was formerly considered as a sign of brain pathology, but new data indicates that in frontal site delta wave can also appear in some mental load.

The ▶**theta rhythm** is normal in children and is replaced with ▶**alpha rhythm** at the age of about ten. The midline frontal theta rhythm in adults may accompany a short-term ▶**memory** load and cognitive effort, and is supposed to be related to the activity of the ▶**hippocampus**.

The beta rhythm is of a merely cortical origin and is believed to underlie cognitive processing.

The gamma rhythm probably reflects the retaining and processing of elementary informational patterns in local cortical structures, such as the coding of visual features in primary visual cortex. Most probably, the integrating role of gamma rhythms goes beyond mere sensory processing.

The amplitude of the EEG rhythms usually ranges from 0.5  $\mu\text{V}$  (gamma rhythm) to as large as 100  $\mu\text{V}$  (alpha rhythm at rest in some subjects and delta waves).

Recent studies have shown that the spatial and frequency distribution of EEG rhythms under cognitive loads form stable patterns that are specific for an individual and a task type. These patterns are preserved in time and constitute a ‘rhythmical portrait’ of a person.

The contemporary view of the functional role of the brain rhythms could be briefly sketched as follows. The brain rhythms may perform a threefold function (i) Gating, i.e., transforming the informational processes into discrete representations in the time domain. (ii) Retention of elementary parts of information in brain microstructures for a time necessary to associate informational elements with each other. This is achieved by reverberating the signal in inter-neuronal loops with excitatory and inhibitory connections. (iii) Synthesis of informational elements into an integrative whole. This is achieved by synchronizing rhythms in the appropriate brain loci.

As mentioned before, a mixture of electrical potentials produced by various cortical neuronal oscillators forms the superficially measured EEG. Oscillators may work independently (at different frequencies) or synchronously. The synchronization may be of two types: mass or selective. The mass synchronization, in which all oscillators of a macroscopic brain area work synchronously, results in an increased amplitude of the rhythm measured above this area and is considered as a sign of the area’s idleness. Under informational load, however, the oscillators in the area begin to work at different frequencies (desynchronize), which leads to a decrease in the wave amplitude. Thus, the desynchronization of a formerly massively synchronized brain area is a sign of the area’s activation (e.g., mu-rhythm blockade during the preparation to a movement). By contrast, the phenomenon of selective synchronization implies that neither all

oscillators work at the same frequency (as in the idling condition), nor do they all work independently. Instead, certain cortical oscillators are selectively and distantly synchronized. In particular, those oscillators that carry parts of the information to be associated with each other are synchronized, i.e., integrated into a whole. Thus, the selective synchronization underlies the informational link in the brain. Mikhail Livanov [4] was the first to experimentally prove this idea. In his experiments, the correlation coefficient between EEG signals recorded in the visual and the motor cortices of the rabbit were monitored. It appeared that the animal responded to a light flash with a paw movement only when this coefficient was sufficiently large. This approach is the major one in the study of cortical connectivity.

The framework of ▶**nonlinear dynamics**, which in recent years has been widely applied to EEG studies, extends the frequency-specific synchrony approach. It is supposed that the neuronal interactions may be both linear and nonlinear, with phase interdependences among brain areas across and between a wide range of frequencies. The resulting spatio-temporal patterns are labile and short-lived. To adapt to fast environmental changes, the patterns are created, destroyed and again recreated. In EEG dynamics, they may be seen as a rapid alternation (intermittency) of synchronized and desynchronized episodes. Therefore, the balance between synchronization and desynchronization is considered to be an important point for understanding the mechanism of adaptive cognitive functions.

### EEG Recording

An EEG acquisition system typically consists of electrodes, amplifier (electroencephalograph), ▶**analog-to-digital converter**, and a computer for storage, analysis and display of the obtained data.

EEG recording usually includes the following steps:

1. A subject is comfortably seated in a sound-, light-, and electromagnetic fields-proof room
2. Electrodes are placed according to a certain scheme
3. The reference electrodes are chosen
4. Parameters of the EEG acquisition system are set
5. To establish the exact amplitude of the EEG signal and to evaluate the amplifier noise, the acquisition system is calibrated
6. Non-biological artifacts (e.g., due to bad electrode placement or external electromagnetic sources) are detected and removed as far as possible
7. EEG is recorded (Figs. 1, 2)

### Recording Place

Modern EEG systems have been designed to provide clear recordings in almost any environment. Wireless (telemetric), portable electroencephalographs enables long-term EEG monitoring even at a subject’s location.

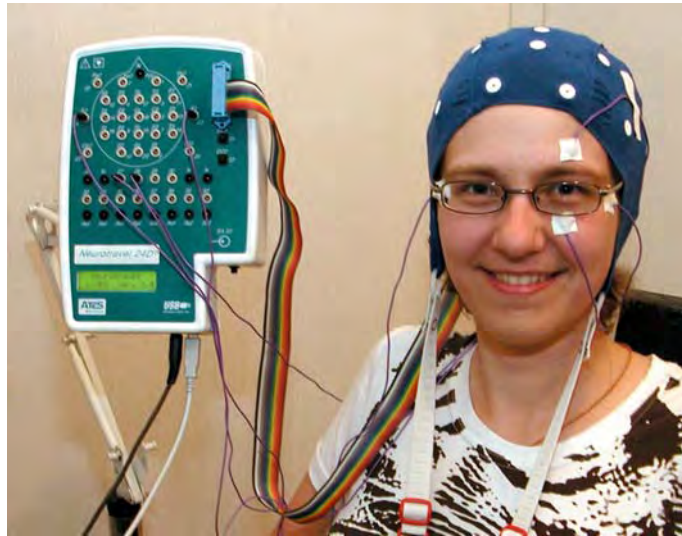

**Electroencephalography. Figure 1** The procedure of the EEG recording. The subject is sitting in a comfortable chair with an electrode cap on her head in a sound- and light-proof cabin, which is also shielded from electromagnetic fields. The electrodes for monitoring of possible artifacts from blinks and eye movements are placed above and below the left eye and on the outer canti of both eyes. The 32-channel EEG amplifier is situated on the *left side*. Smiling is not recommended because of possible muscle artifacts.

However, the removal of nearby electric devices is a usual requirement for the EEG recording place.

### Electrodes and Electrode Placement Schemes

Typical EEG electrodes are made from metal (gold, silver, or tin). A gel or salt solution is used to improve the conduction between skin and electrode surface. The acceptable scalp-electrode impedance depends on the type of amplifier used and ranges from 3 to 40 kOhms. Except for a specific goal, any electrode placement scheme is aimed to sample evenly the head surface. The traditional 10–20 system uses topographical markers for electrode position (such as inion, nasion, pre-auricular points), and is well situated for single-electrode

built-in electrodes makes topographical measurement for each electrode unnecessary. The caps allow the quick and accurate application of any number of electrodes (up to 256).

### Reference Electrode

As EEG measures the voltage, e.g., the difference in potential between an active and a reference site, the choice of the reference electrode is crucial. The reference electrode should be placed in the most ‘inactive’ site that is maximally distant from the brain sources of interest. For example, averaged signals from both earlobes are the most popular reference. Alternatively, the reference may be derived analytically after recording. The widespread solution is an average reference that is a mean of all electrodes. A ‘reference-free’ signal

may be obtained using surface Laplacian derivation, which is computed as the second derivative of the potential field at each electrode.

### Parameters for EEG Acquisition and Storage

To catch the frequencies of the main EEG rhythms (up to 100 Hz), the minimum **▶sampling rate** of the analog-to-digital conversion (ADC) has to be at least 200 samples/second. ADC should be done at a resolution of at least 12 bits in order to resolve the EEG signal down to 0.5  $\mu$ V. The low-pass filter should be set to 0.16 Hz or less to acquire slow wave activity. A 50–60 Hz **▶notch filter** should be available, but not routinely used, especially in studies of EEG rhythms in the gamma band [5].

### EEG Signal Analysis

(See [6] for details)

### Spectral Analysis

**▶Spectral analysis** is used to reveal frequency components of an EEG signal. Each frequency presumably reflects the activity of a particular oscillating neuronal group. The transformation of a signal from the time domain into the frequency domain may be done by means of the **▶Fourier transform (FT)**. It is based on the mathematical fact that any signal defined in a given time interval can be decomposed into a sum of sine waves of different frequencies, phases and amplitudes. The result of FT gives the information about the amplitude and the phase of the signal at each frequency for the whole

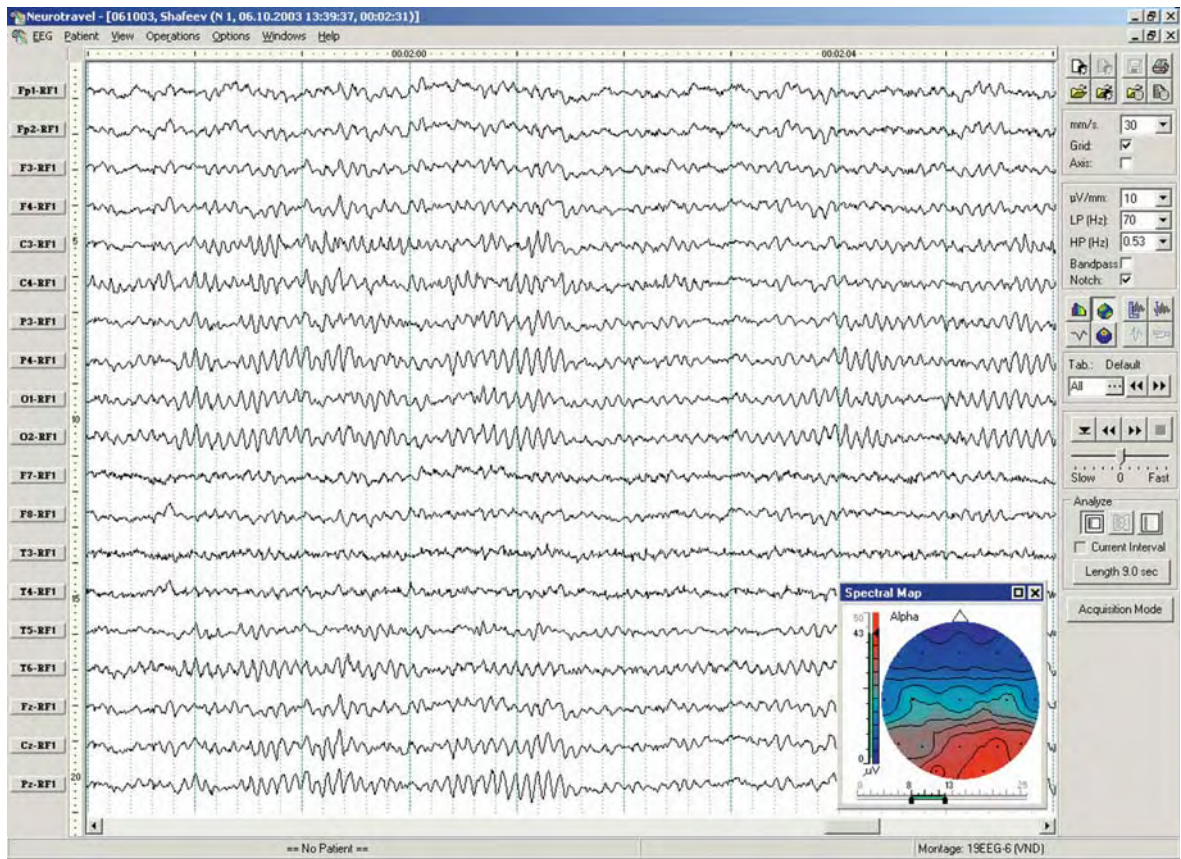

**Electroencephalography. Figure 2** Electroencephalogram and spectral map in the alpha band as they are seen on the monitor screen. Each line corresponds to one of 19 EEG channels (*marked on the left*) referenced to the common electrode RF1 (placed on the left earlap). On the right, in the menu table, the experimenter can choose the scale of the EEG visualization (i.e., it is set at 10  $\mu\text{V}/\text{mm}$ , 30 mm/s etc.). The menu for other types of EEG data analysis and presentation is also available. In the posterior channels, the synchronized bursts of alpha waves, of the amplitude of approximately 50–60  $\mu\text{V}$ , are visible. On the power spectral map in the right bottom corner, this activity may be localized with maximum in the occipital regions.

studied period of time. The frequency resolution of FT is the inverse of the width of the analyzed time window:  $\Delta f = 1/T$ . To estimate the time course of EEG spectra, the windowed FT is applied. In this method, the FT is calculated in a window of constant duration that moves along the EEG record. The discrete fast Fourier transform (FFT) is an algorithm, which is mostly used to efficiently compute the FT on a discrete grid of time points. To know the power of different frequency components, the power spectrum is used. It is the squared absolute value of the FT, and no longer contains the phase information. It is also possible to calculate the relation of power in different bands, spatial asymmetry of band power, peak frequencies, and peak asymmetries.

The ►wavelet transform (WT), like FT, enables the estimation of the amplitude and the phase for a set of frequency components of the EEG, but, in addition to traditional FT, it enables the tracing of the development of each frequency component in time. In the WT, the

template signal (“mother wavelet”) and its compressed or dilated copies are convolved with the EEG signal with successive time shifts, resulting in the time-frequency representation of the signal. The WT’s time resolution is inverse to the frequency – it is better for high frequencies than for low frequencies. This property makes WT especially useful for the analysis of high-frequency (gamma) EEG bands.

### EEG Long-Range Synchrony

►Coherence analysis provides a measure of the phase consistency of two signals, independently of these signals’ amplitudes. This measure is important, since a constant phase lag between oscillating EEG signals at different recording sites may be an index of these sites’ neural connection. The method is based on the calculation of the cross-spectrum of two EEG signals. This function contains information about the phase lag between the signals for each frequency component.



Obtaining the coherence measure is essentially an accumulative procedure. Accumulation is achieved by averaging the cross spectra of many EEG trials. If for some frequency component there is a consistency in phase difference between the two signals over many trials, the cross-spectrum value for this frequency will be high. To obtain the coherence function, the accumulated cross-spectrum is normalized to the product of the signals' power spectra, resulting in the coherence values lying in the range from 0 (randomly changing phase difference) to 1 (constant phase difference).

One drawback of the coherence analysis is the reverse side of its advantage: the coherence is strongly influenced by phase-shift changes between two interacting oscillators during the analysis epoch. However, one may propose that phase lag may change during the analysis epoch as it can determine both the neural connection mode (active vs. silent) and its direction.

To overcome this difficulty, a technique called ► **Intracortical interaction mapping** has been developed. This method is based on the same idea that the EEG spectral components reflect the activity of the main cortical oscillators, and that the coincidence in their

frequency properties reports on communication between cortical areas. It is proposed that this technique reveals the cortical connections that are invariant to transient phase shifts between the interacting cortical oscillators. After FT (or WT), the major spectral peaks are selected and the peaks coinciding in their frequency are determined. The coincidence of the frequency peaks in two or more brain areas can indicate that these areas are potentially connected. To verify whether the connection is significant, the usual procedure of the comparison of two experimental conditions (e.g., before and during some mental task) is performed (Fig. 3).

### Event-Related Synchronization and Desynchronization

Event-related desynchronization (ERD) is a short-lasting, topographically localized attenuation of rhythms within the alpha and lower beta band. It is considered as a sign of activation of cortical areas, while synchronization is characteristic for the relative rest. For quantitative estimation of ERD, the following formula has been proposed:  $ERD\% = 100\% \cdot (R-A)/R$ , where R is the average power of the band-filtered reference EEG trials,

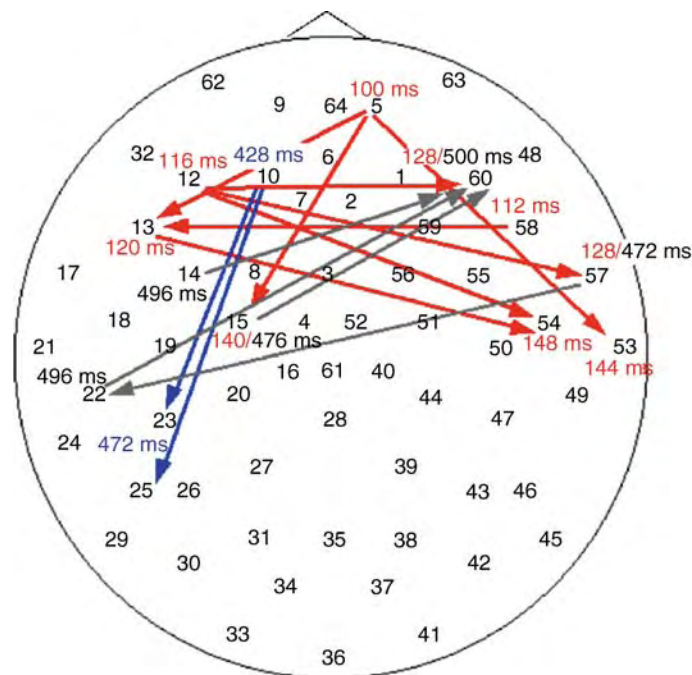

**Electroencephalography. Figure 3** Additional cortical connections in the search-for-word association task (i.e., “pen – write”) in comparison to the simple reading task. The connections were found by a version of the intracortical interaction mapping – calculation of the correlation coefficients between wavelet curves within consecutive time windows of 100 ms duration. Connections on the early, intermediate and late stages of the task solving were observed at 12–16, 17–19 and 21–24 Hz, correspondingly and presented with lines of different colors. The color digits indicate the time of the peaks in wavelet curves after the noun presentation on the monitor screen. The supposed direction of information transmission is indicated by arrows. Electrode numbers are in black. The frontal areas are in the *upper part* of the figure, and the occipital areas in the *lower part* of the figure.

and  $A$  is the same kind of average for the investigated trials. This approach efficiently reveals the activated cortical areas in numerous motor and cognitive tasks.

### Dipole Source Localization

As stated earlier, the electric currents generated by neural cells' dendrites are the principal physical sources of the EEG. Each of the active dendrites can be viewed as a microscopic electromotive force of dipolar nature. Any potential distribution instantaneously measured over a set of scalp electrodes is thus a sum of potentials produced by elementary dipole current sources. The goal of the inverse problem of electroencephalography is to find the distribution of dipoles in the brain that provides the potential distribution over the scalp as close as possible to the measured one. Due to its mathematical essentiality, the inverse problem of EEG has neither a unique, nor a precise solution. Instead, approximate solutions are searched for under certain assumptions and constraints.

The usefulness of the method is supported by several considerations. Firstly, in certain physiological conditions, neurons in a very local brain area may fire highly synchronously, thus surpassing the activity of all other neurons. An example is provided by ►epileptiform discharge. In this case, the one-dipole model is quite appropriate. On the other hand, it is obvious that in normal conditions, a great number of dipoles are simultaneously active. Nevertheless, in many situations, the measured potential can be well approximated by the influence of a few dipoles; these dipoles are then named the equivalent dipoles. Although the equivalent dipoles surely do not coincide with actual dipoles, the method may provide a robust, but useful, approximation of the activation sequence of brain areas, especially under some a priori assumptions on the expected active areas. A variety of complicated mathematical methods have now been elaborated to accomplish this task. The approach is effective both in research and in the localization of brain pathology.

### EEG Mapping

►EEG mapping is a presentation of EEG parameters on a schematic head surface, obtained by interpolating the data recorded at each single electrode site into inter-electrode space. This provides the researcher with a visual image presenting multi-channel ►EEG in the most integrative and illustrative form. In the clinic, the mapping helps reveal the exact site of pathological activity, for example, slow waves or epileptic spikes. The map can be an instant representation of the EEG signal amplitude, or its spectral value for the chosen period of time (Fig. 2). A valuable version of the EEG map is the connectivity map, when the coupled electrode sites are joined with lines (Fig. 3).

### Advantages and Disadvantages

Modern methods of studying brain functions, such as ►positron emission tomography (PET), ►functional magnetic resonance imaging (fMRI) and ►magnetoencephalography (MEG), have become very popular among neuroscientists. However, the EEG remains a widespread tool for research and diagnostic purposes because of its cheapness, simplicity in use, mobility (can be applied while the subject performs behavioral tasks, i.e., during professional activity and out of the laboratory as far as in space flight) and the possibility of long-term monitoring (e.g., during sleep). The current biofeedback studies show that the EEG signal can be used for the direct control of some devices, i.e., a cursor on the monitor screen or even a wheelchair.

The main advantage of EEG over PET and fMRI is based on the fact that electrical potentials are the primary effects of neural excitation, while metabolic changes in the brain tissue measured by PET/fMRI are secondary effects. Therefore, the EEG has a much higher temporal resolution and can reveal a most important parameter of neural activity – its rhythmic property. One might say that EEG shows not only “where” but also “how” information is processed in the brain. The main disadvantage of the EEG is its low spatial resolution, which, however, can be partly overcome by using dense arrays of electrodes and dipole modeling. Moreover, the combination of EEG and fMRI recording seems very promising.

The main difference of EEG compared to magnetoencephalography (MEG) is that the latter cannot record the radially oriented dipoles and deep sources of activity due to the property of magnetic fields. MEG is also much more expensive, bulky and complicated in use.

### References

1. Blume WT, Kaibara M, Young GB (2002) Atlas of adult electroencephalography, 2nd edn. Lippincott Williams & Wilkins, Philadelphia, PA, 546
2. Niedermeyer E, Lopes da Silva F (2004) Electroencephalography: Basic principles, clinical applications and related fields, 5th edn. Williams & Wilkins, Baltimore
3. Steriade M, Gloor P, Linas RR, Lopes de Silva FH, Mesulam MM (1990) Report of IFCN committee on basic mechanisms. Basic mechanisms of cortical rhythmic activity. *Electroencephalogr Clin Neurophysiol* 76:481–508
4. Livanov MN (1977) Spatial organization of cerebral processes. Wiley, New York
5. Nuwer MR, Comi G, Emerson R, Fuglsang-Frederiksen A, Guérit JM, Hinrichs H, Ikeda A, Luccas FJC, Rappelsberger P (1998) IFCN Standards for digital recording of clinical EEG. *Electroencephalogr Clin Neurophysiol* 106:259–261
6. Ivanitsky AM, Nikolaev AR, Ivanitsky GA (1999) Chapter 35. Electroencephalography. In: Windhorst U, Johansson H (eds) *Modern techniques in neuroscience research*. Springer, Berlin Heidelberg New York, pp 971–991

## Electrogenic Fish

- ▶ Electric Fish

## Electrolocation

### Definition

Detection of remote objects by sensation of the distortions in a self-generated electric field created by the object.

- ▶ Electric Communication and Electrolocation
- ▶ Evolution of Mechanosensory and Electrosensory Lateral Line Systems
- ▶ Magnetic and Electric Senses

## Electrolocation – Active

### Definition

Certain nocturnal teleost fishes of Africa (Mormyri-forms) and South America (Gymnotiforms) generate “weak” electric organ discharges to test the impedance properties of the surrounding water body. Any close-by object representing an impedance inhomogeneity relative to the water is detected by these fishes’ specialized electroreceptor system of the tuberous type. The adequate stimulus is an increase or a decrease of the strength of autostimulation that is associated with the presence of the object. Both an object’s resistive and capacitive properties are detected in the species studied.

- ▶ Electroreceptor Organs

## Electrolocation – Passive

### Definition

An electroreceptive fish detects an extraneous current source, provided the electric field is above threshold and within the frequency range of its receptor organs.

Examples are flatfish buried in sand that, like any live organism, generate strong DC fields that are associated with the regulation of the ionic balance of its tissues, and low-frequency field potentials from muscle and nerve activity. These fields are detected by the ampullary electroreceptor system (ampullae of Lorenzini) of sharks swimming over the sea floor. Another example are weakly electric fish, such as mormyrids or gymnotiforms, who generate electric organ discharges that can be located “passively” by conspecifics (usually with their tuberous electroreceptor organs), as well as by electroreceptive predators (ampullary or tuberous system, depending on the species).

- ▶ Electroreceptor Organs

## Electromagnetic Induction

### Definition

According to Faraday, charges crossing a stationary magnetic field experience a deflecting force perpendicular to the motion, and, if there is a conducting path (such as a wire) in this direction, a current is induced. A shark heading east or west in the ocean crosses the horizontal component of the earth’s magnetic field, leading to dorso-ventral potential differences of a magnitude detectable by the shark’s ampullary electroreceptor organs. By swimming and probing in different directions, the shark may thus derive magnetic compass orientation through its electroreceptive system.

- ▶ Electroreceptor Organs

## Electromotor Neuron/Cells

### Definition

In fishes that possess electric organs, electromotor neurons are the last neurons in the brain’s command chain that triggers a discharge. The cell bodies of these neurons are located in the spinal cord, and each one sends its axon to a different modified muscle cell, called electrocyte, many of which form an electric organ. In certain fishes, the ensemble of electromotor nerves themselves constitutes the electric organ by their terminal swellings (Apteronotidae). The electric catfish (*Malapterurus* species) has only two giant electromotor neurons in the first spinal segment.

## Electromotor System

### Definition

A system of electric organs and control circuits that creates an electrostatic field surrounding the possessing organism. Generally used in communication and electrolocation.

- ▶ Electrolocation
- ▶ Evolution of Mechanosensory and Electrosensory Lateral Line Systems

## Electromyogram

### Definition

EMG; A recording of the electrical activity of muscle obtained using electrodes that may be on skin over a muscle (e.g., in human recordings) or placed into the muscle. Because the electrical activity arises from action potentials in the muscle fibers, EMG activity can be a rough measure of the rate of activation of the muscle and of muscle force.

## Electromyography

MADELEINE LOWERY

Rehabilitation Institute of Chicago, Department of Physical Medicine and Rehabilitation, Northwestern University, Chicago, IL, USA

### Synonyms

EMG

### Definition

Electromyography (EMG) is the study of the electrical activity of muscle.

### Characteristics

#### Quantitative Description

The electromyogram, or EMG signal, is the electrical signal generated by contracting muscle fibers. It can be detected with electrodes placed on the skin surface

above the muscle of interest, or with indwelling intramuscular or subcutaneous electrodes. When a muscle fiber is stimulated, an action potential propagates along the fiber membrane in both directions away from the neuromuscular junction. The flow of current across the membrane produces an electric field that can be detected as a change in the electric potential or voltage at an electrode located in the surrounding tissue. As the action potentials propagate along the muscle fiber, the potential at the electrode varies, giving rise to a characteristic muscle fiber action potential waveform. Additional components, known as start-up and end-effects, due to the generation and extinction of the ▶ **transmembrane action potential**, may also be observed. The shape of the ▶ **single fiber action potential** depends on the fiber membrane properties, the electrical properties and geometry of the surrounding tissues, and on the electrode location and configuration. In general, the greater the distance between the muscle fiber and electrode, the lower the amplitude and frequency content of the propagating part of the action potential that will be detected. As the distance between the fiber and electrode is increased, high frequency components are attenuated and the action potential becomes increasingly low-pass filtered [1]. This phenomenon, known as spatial filtering, is not due to properties of the conducting tissues, but rather to the propagating nature of the action potential source. When the muscle fiber lies far from the electrode, the variation in potential as the action potential propagates along the muscle fiber is small, yielding a slowly varying, low frequency signal. For fibers located close to the electrode, there is a much sharper increase in potential as the action potential propagates beneath the electrode, yielding a high-frequency action potential. The stationary start-up and end-effect components are not subject to spatial filtering and, therefore, decay more slowly than the propagating part of the waveform, becoming more pronounced at large distances from the muscle fiber [2].

Under normal conditions muscle fibers do not contract individually, rather all fibers belonging to a single motor unit are simultaneously stimulated. The waveform detected when the fibers in a single motor unit are stimulated is termed the ▶ **motor unit action potential** (MUAP). Small delays between individual fiber action potentials occur due to differences in the locations of the neuromuscular junctions, the lengths and conduction velocities of terminal nerve branches and random variations in the excitation times of each fiber, known as jitter. The EMG signal detected during voluntary or electrically elicited contractions is comprised of the linear summation of MUAPs from all active motor units lying within the electrode pick-up volume.

## Surface EMG

Surface EMG is a non-invasive, easy-to-use method of measuring the electrical activity of a muscle. Due to the relatively large pick-up volume of the surface electrodes, surface EMG is suited to applications where information about the activity of the entire muscle is required, where activation timing is sought, or where EMG is used as a control signal, for example, in myoelectric prosthesis or biofeedback (Fig. 1a).

The main disadvantage of surface electrodes is that they can only be used to detect signals from muscles lying close to the skin surface, are not suited to recording from small muscles and may become contaminated with signals from neighboring muscles that are simultaneously active [3].

## Intramuscular EMG

Indwelling fine-wire or needle electrodes enable EMG signals to be recorded from a much smaller area than with surface EMG, facilitating the study of action potentials from single motor units (Fig. 1b), particularly during low-level contractions. Needle electrodes may be used in monopolar or bipolar configurations, with electrode surfaces mounted on the side of the needle or on wires placed inside the cannula. It is possible to adjust the position of the electrode using needle electrodes to get close to a particular muscle fiber. Fine-wire electrodes are inserted into the muscle using a needle that is then withdrawn, leaving the wires resting

within the muscle. The tips of the insulated wires are first exposed to form the recording surfaces of the electrodes. Fine-wire electrodes may also be inserted subcutaneously, at the interface of the muscle and the fat tissue. Intramuscular fine-wire electrodes may be implanted and withdrawn with relative ease and with less discomfort than needle electrodes. However, they have a tendency to migrate within the tissue as the muscle contracts [3].

## Electrode Configuration

EMG signals are usually recorded using a bipolar electrode configuration, whereby signals detected at two adjacent electrodes are differentially amplified. Signals from far away sources appear similar at both electrodes and are therefore attenuated, while those originating from fibers close to the electrodes are amplified. In the standard bipolar electrode configuration, the electrodes are generally aligned parallel to the muscle fiber direction to optimize selectivity, and are positioned mid-way between the muscle end-plate zone and the tendon to minimize the contribution of start-up and end-effects. More selective recordings can be obtained by further differentially amplifying the EMG signal, for example, using a double-differential configuration. With highly selective two-dimensional electrode arrays it is possible to obtain further selectivity and to examine single motor unit behavior [4], while linear arrays, comprised of a series of bar electrodes

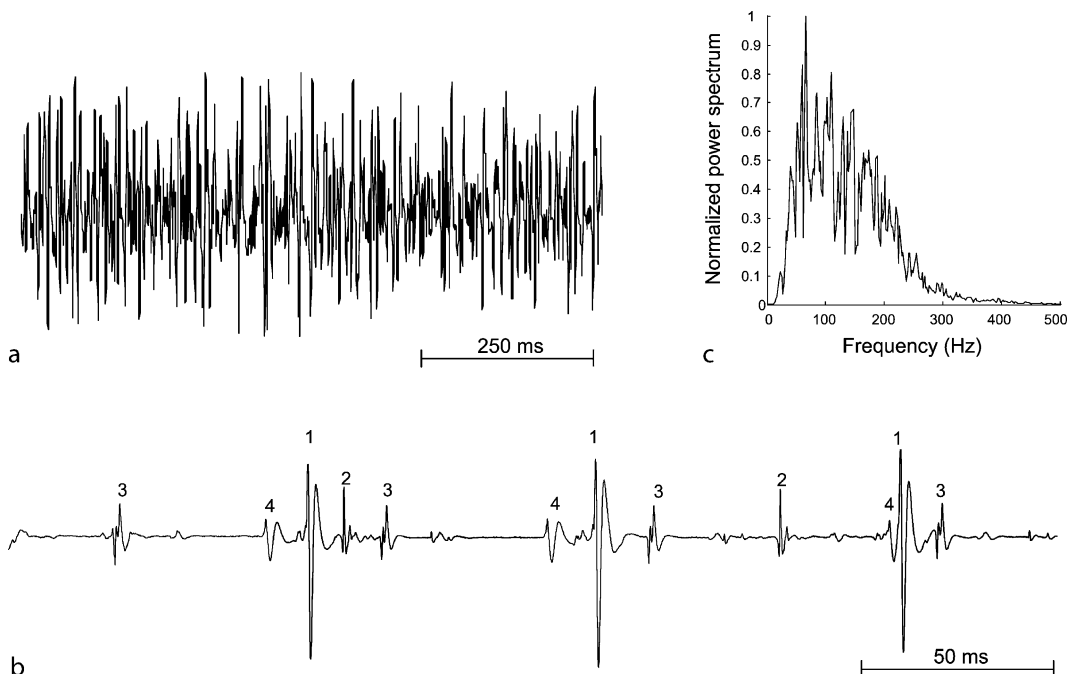

**Electromyography. Figure 1** (a) Sample bipolar surface EMG signal recorded from the first dorsal interosseous muscle. (b) Sample fine-wire EMG signal recorded from the brachioradialis muscle, indicating MUAPs from four different motor units. (c) Power spectral density of the surface EMG signal in A.

orientated perpendicular to the muscle fiber direction, can be used to estimate ►[muscle fiber conduction velocity](#) and the locations of the tendon and end-plate zone [5].

### **Amplitude Parameters**

The amplitude of the surface EMG signal is the most commonly investigated surface EMG parameter. It is generally quantified in terms of the average rectified (AR) value or the root mean square (RMS) value of the signal. At high levels of muscle activation, the surface EMG signal may be approximated as a band-limited Gaussian signal, for which the RMS value and AR value are directly proportional to one another. However, when the number of action potentials detected is low, there is no longer a simple relationship between the two parameters. For zero mean signals, the RMS value approximates the square root of the signal variance. If the firing times of individual motor units are uncorrelated, the variance of the EMG signal will be equal to the sum of the variances of the constituent MUAP trains. Under these conditions the RMS value, unlike the AR value, is not affected by the superposition or cancellation of MUAPs and is, therefore, considered a more reliable method of quantifying surface EMG amplitude.

The amplitude of the EMG signal is generally interpreted as an indication of the level of activity of the underlying muscle. The recruitment of additional motor units or increases in the firing rates of active units will cause the surface EMG amplitude signal to increase. The magnitude of this increase will vary depending on the location of the motor unit with respect to the electrodes. Short-term synchronization of motor units can also cause EMG amplitude to increase, while changes in muscle length, fatigue, the electrode-skin contact and temperature may further alter the amplitude of the EMG signal. The relationship between EMG amplitude and muscle force has been widely examined, with both linear and non-linear relationships observed [6]. While EMG amplitude reflects the level of activation of the motor unit pool, the complexity of the relationships between the motor unit activity, muscle force output and the surface EMG has precluded the establishment of a simple relationship between EMG amplitude and muscle force.

### **Frequency Parameters**

Due to the phenomenon of spatial filtering, the frequency content of the surface EMG signal lies below 300–500 Hz (Fig. 1c), whereas the intramuscular EMG signal may contain power up to several kilohertz. The shape of the power spectrum of the EMG signal is primarily determined by the spectra of the constituent MUAPs [1], but is also influenced by the motor unit firing statistics and synchronization between motor

unit firings. The most commonly employed EMG spectral parameters are the power spectrum median and mean frequency [7]. To obtain a more complete picture of the behavior of the EMG spectrum a range of characteristic frequencies throughout the spectrum should be examined. EMG frequency parameters are commonly used to track the progressive shift of the EMG spectrum towards lower frequencies that occur during muscle fatigue. The frequency content of the EMG signal has also been proposed as a means of detecting the recruitment of higher threshold motor units through their higher conduction velocities, however, this effect tends to be masked by other factors including motor unit location. To apply conventional spectral analysis methods, the EMG signal must be assumed to be stationary (statistically invariant over time). This may generally be assumed for EMG signals of 0.5–1 s duration during isometric contraction [7].

### **Cross-Talk**

EMG cross-talk, the detection of unwanted signals from muscles other than the muscle of interest, is one of the most significant limiting factors associated with surface EMG. Cross-talk increases with subcutaneous fat tissue thickness, due to the increased distance between the electrode and the active fibers [8]. Problems with EMG cross-talk can also arise when recording from small muscles, or concurrently active neighboring muscles. There is currently no reliable means of distinguishing between cross-talk signals and EMG signals originating in the muscle beneath the electrode. Previously suggested frequency-based methods such as high pass filtering of the EMG have been shown to be unsuitable when the signal is dominated by high-frequency ►[muscle fiber end-effects](#). The most effective means to reduce cross-talk remains the use of selective electrode recording configurations, such as a double differential or Laplacian electrode configuration [9].

### **EMG during Muscle Fatigue**

Changes in both the amplitude and frequency spectrum of the surface EMG signal are consistently observed during sustained fatiguing contraction. During sustained maximal voluntary contractions, a decrease in EMG amplitude is generally observed. In contrast, at submaximal force levels EMG amplitude is observed to increase. This increase is commonly attributed to the recruitment of additional motor units or an increase in motor unit firing rates to maintain force output, while the decrease in EMG amplitude at maximal force levels is associated with derecruitment and a reduction in mean firing rates. During sustained contraction, a progressive reduction in muscle fiber conduction velocity also occurs, causing the frequency content of the surface EMG signal to decrease and EMG amplitude to increase with increasing duration of the

extracellular action potentials [1]. The relationship between characteristic frequencies of the surface EMG spectrum and muscle fiber conduction velocity is approximately linear, but is also influenced by changes in motor unit firing rates and synchronization between motor units.

### EMG during Dynamic Contraction

When interpreting EMG signals recorded during dynamic contraction, several additional factors should be considered. As the length of the muscle fiber changes, the location of the electrodes with respect to the underlying fibers will also vary. Variations in the EMG signal may not necessarily reflect different levels of muscle activity, but rather changes in muscle fiber length and in the location of the fibers with respect to the electrodes. Furthermore, the condition of stationarity generally assumed during isometric contraction no longer holds, precluding the application of classical spectral analysis techniques. To overcome this limitation, time-frequency techniques can be applied. These are becoming increasingly popular methods of estimating EMG frequency parameters during dynamic contraction [10].

### References

1. Lindstrom LH, Magnusson RI (1977) Interpretation of myoelectric power spectra – model and its applications. *Proc IEEE* 65:653–662
2. Dimitrova NA, Dimitrov GV, Lateva ZC (1991) Influence of the fiber length on the power spectra of single muscle fiber extracellular potentials. *Electromyogr Clin Neurophysiol* 31:387–398
3. Basmajian JV, De Luca CJ (1985) *Muscles Alive*. 5th edn. Williams and Wilkins, Baltimore
4. Zwarts MJ, Stegeman DF (2003) Multichannel surface EMG: basic aspects and clinical utility. *Muscle Nerve* 28: 1–17
5. Merletti R, Farina D, Gazzoni M (2003) The linear electrode array: a useful tool with many applications. *J Electromyogr Kinesiol* 13:37–47
6. Lawrence JH, De Luca CJ (1983) Myoelectric signal versus force relationship in different human muscles. *J Appl Physiol* 54:1653–1659
7. Merletti R, Loconte LR (1995) Advances in Processing of Surface Myoelectric Signals I. *Med Biol Eng Comput* 33:362–372
8. Lowery MM, Stoykov NS, Kuiken TA (2003) A simulation study to examine the use of cross-correlation as an estimate of surface EMG cross talk. *J Appl Physiol* 94:1324–1334
9. Dimitrov GV, Disselhorst-Klug C, Dimitrova NA, Schulte, E, Rau G (2003) Simulation analysis of the ability of different types of multi-electrodes to increase selectivity of detection and to reduce cross-talk. *J Electromyogr Kinesiol* 13:125–138
10. Knaflitz M, Bonato P (1999) Time-frequency methods applied to muscle fatigue assessment during dynamic contractions. *J Electromyogr Kinesiol* 9:337–350

## Electron Microscopic Tomography

### Definition

A version of electron cryo-microscopy in which a sample is successively tilted and imaged and the resulting 2D images are assembled using specific mathematical procedures to yield a 3D reconstruction of the molecular landscape.

E

## Electronystagmography

### Definition

Is a test for the presence of nystagmus that is typically used in a clinical evaluation. The nystagmus might be spontaneously present as a result of pathology of the vestibular periphery or the central nervous system, or might be induced by controlled stimulation of the vestibular system. The device for measuring nystagmus usually relies on the electrooculogram for recording eye movements, plots the amplified signals on a moving paper plotter, and is AC-coupled, which accentuates the quick-phases and distorts the slow-phases of nystagmus.

- ▶ Central Vestibular Disorders
- ▶ Disorders of the Vestibular Periphery
- ▶ Nystagmus
- ▶ Vestibular Tests: Caloric Test
- ▶ Vestibular Tests: Galvanic Test

## Electrooculogram (EOG)

### Definition

This is an older method for measuring the movements of the eyes that is still used with human subjects because of its ease of use. Electrodes for measuring horizontal movements are typically placed bi-temporally near the canthus of each eye, and those for measuring vertical movements are placed over the bone above and below one eye. The method thereby depends on conjugacy of the two eyes, although other electrode placements can measure the movement of

one eye with less accuracy. The electrical signal recorded by the EOG is produced by an electrostatic dipole moment in each eye, which is in turn produced by the dark current in the retinal photoreceptors. The EOG signal is therefore greatest and most stable with the subjects adapted to very low light levels, while other conditions result in considerable drift and other changes in accuracy. With care and frequent calibration, eye movements can be measured with a resolution of about  $1^\circ$ .

► Photoreceptors

## Electroporation

### Definition

A gene transfer technique that uses electrical pulses to drive DNA, RNA or morpholino oligonucleotides into cells. This approach is commonly used in mouse, chick, zebrafish and *Xenopus* to assess the function of a gene in a developmental process.

## Electroreception

### Definition

A sense that detects the weak electric fields generated by an animal itself or other animals. Present in all taxa of lower aquatic vertebrates, including newts and salamanders, by common descent. Also present in the egg-laying monotreme mammals of Australia and New Guinea (such as the duckbill, or platypus) by independent evolution. The ancestors of a few sub-taxa of lower aquatic vertebrates, such as the Teleostei, have lost electroreception, but some of these have re-evolved electroreception. Electroreception is based on the possession of specialized electroreceptor organs that form part of the octavo-lateralis system (excepting the monotreme mammals), and sensory afferents connecting to specialized brain areas, and only works in water.

- Electric Communication and Electrolocation
- Electroreceptor Organs
- Magnetic and Electric Senses

## Electroreceptor

### Definition

Epidermal sensory organ responsive to minute fluctuations in voltage across the skin surface. Electroreceptors in vertebrates include ampullae of Lorenzini, teleost ampullary organs, and several kinds of tuberous organs.

- Electric Senses in Monotremes: Electroreception and Electrolocation in the Platypus and the Echidna
- Electroreceptor Organs
- Evolution of Mechanosensory and Electrosensory Lateral Line Systems

## Electroreceptor Organs

ROBERT C. PETERS

Department of Functional Neurobiology, Utrecht University, Utrecht, The Netherlands

### Synonyms

Electroreceptor organ; Electroreceptor; Microampullary organ; Small pit organ; Ampulla of Lorenzini; Tuberous organ; Mormyromast; Knollenorgan; Sensory mucous gland; Lateral line organ; Octavolateralis (Both terms *octavolateral* and *octavolateralis* are in use. *Octavolateralis* is used most often. The old term for *octavolateralis* is *acousticolateralis*) organ; Acousticolateralis organ; Hair cell organ

### Definition

► **Electroreceptor organs** are sensory organs adapted to detect electrical potential differences in aquatic environments. They are found in the skin of some species of fishes and amphibians, and on the bill of monotremata such as the platypus. In fishes and amphibians, they represent specializations of the ► **octavolateralis system**. Unlike the mechanosensitive specializations of the octavolateralis system – such as the sense of hearing, the sense of equilibrium, and the sense of rotation that respond to mechanical stimuli – they respond to electrical environmental stimuli. The lower detection level of the electroreceptive system approaches 10 nV/cm in media with a conductivity of 0.05 S/cm. Electroreceptor organs behave as band filters within the range of 0.1–10,000 Hz, the specific bandwidth depending on the type of organ. They give the organism access to electrical worlds, just as photoreceptor organs give the organism access to visual worlds. Electroreceptor organs were recognized as parts



of an electrosensory system in the middle of the twentieth century. Before then they were well known from morphological studies, but considered mechanosensory organs, or even glands.

## Characteristics

### Qualitative Description

Electroreceptor organs are, just like the mechanosensitive lateral line components, found in or immediately under the skin. There is a conspicuous dichotomy in appearance, related to the conductivity of the environment. All marine electrosensitive fishes have ampullae of Lorenzini, i.e. centimeters long, jelly-filled channels ending in innervated capsules (Figs. 1–3), whereas the freshwater fishes have microampullary organs (Figs. 4, 5) or tuberous organs (Fig. 6) within the skin.

Typical electroreceptor organs consist of open or closed invaginations of the skin. At the bottom of the invagination or cavity, receptor cells make contact with lateral line fibers. Open organs are called ampullary, closed organs tuberous. The recently discovered electroreceptor organs in Monotremata deviate from this general design in that they lack ▶secondary receptor cells. The sensitive structures here are specializations of the afferent trigeminal nerve endings. The nerve ending itself consists of highly convoluted plasma membranes inside a myelin capsule. From those capsules, unmyelinated axonal spines protrude in the direction of the lumen of the gland. Such receptor organs are found on the bill of the platypus, *Ornithorhynchus anatinus*, and the snout of the echidna, *Tachyglossus aculeatus*, and the long-nosed echidna *Zaglossus bruijnii*.

The majority of electroreceptor organs belong to either the ampullary or tuberous organs.

Of the ampullary organs, the ampullae of Lorenzini in marine fishes are jelly-filled subcutaneous canals

of less than 1 mm diameter and a length of several cm. The canals form a salt bridge between the receptor cells and the seawater. Thousands of receptor cells are clustered in capsules where they contact the endings of afferent lateral line nerves. Ampullae of Lorenzini occur in elasmobranch fishes like the dogfish *Scyliorhinus canicula*, the marine teleost catfish *Plotosus lineatus*, and the living coelacanth *Latimeria chalumnae*. The other type of ampullary organ is the microampullary organ, found in freshwater fishes and amphibians. These are microscopically small invaginations of the skin that do not extend beyond the dermis. One lateral line nerve fiber innervates some tens of secondary electroreceptor cells at the bottom of the ampulla. Microampullae are found in a variety of electrosensitive freshwater species like the catfish *Ameiurus nebulosus*, the lamprey *Petromyzon marinus*, the sturgeon *Acipenser* sp., and also in urodeles like for instance *Siren* sp.

The tuberous organs in freshwater fishes can be described as microampullary organs where a plug of cells closes the ampulla lumen. The receptor cells do not connect to the outer world directly. The receptor organs have the appearance of skin-deep cavities. There are various subtypes, usually innervated by several types of



**Electroreceptor Organs. Figure 1** Left view of the head of a 10 cm long specimen of the marine catfish *Plotosus lineatus*, a teleost, with the openings of the ampullae of Lorenzini just visible as light dots, e.g. near the rostrum in the dark area above the left barbel.

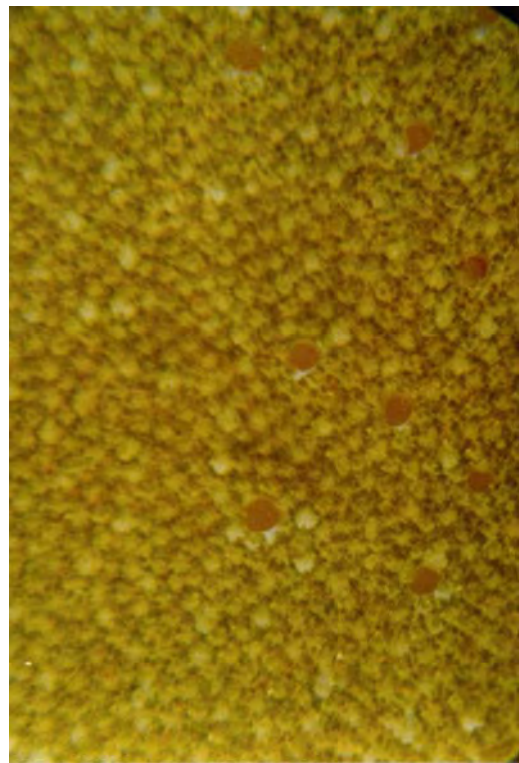

**Electroreceptor Organs. Figure 2** Top view of a piece of skin on the head of the marine dogfish *Scyliorhinus canicula*, a shark, with scales and circular openings of the ampullae of Lorenzini (diameter of openings 0.5–1 mm).

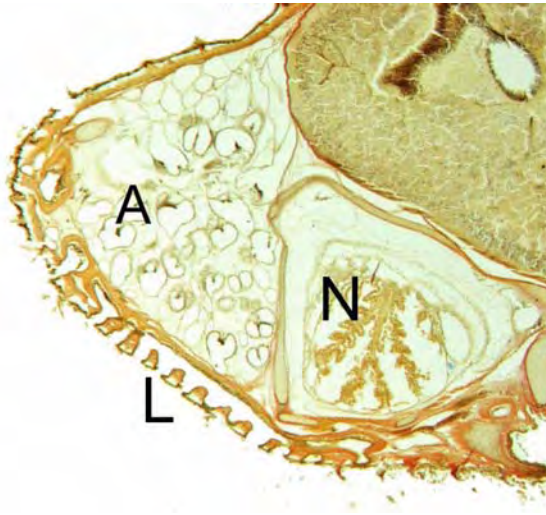

**Electroreceptor Organs. Figure 3** Sagittal section through the head region of a 9-cm long specimen of the marine dogfish *Scyliorhinus canicula*. Note the loose tissue in the rostrum (foremost part) representing the ampulla of Lorenzini. The section also shows a part of the mechanoreceptive lateral line system, a subcutaneous canal with openings to the exterior (Preparation: Wim J.G. Loos). Length of preparation 4 mm. A Ampulla capsule; L lateral line canal; N olfactory epithelium.

lateral line fibers. Tuberous organs occur in Mormyridae like *Gnathonemus petersii*, in Gymnarchidae like *Gymnarchus niloticus*, and in Gymnotiformes like *Eigenmannia virescens*. In the Mormyridae there are two subtypes, the Knollenorgans and the mormyromasts. They are tuned to discharges emitted by electric organs of the fish itself, respectively by conspecifics and other species with electric organs. Knollenorgans are also called rapid timing units, because they respond with a single spike to a single **electric organ** discharge. Mormyromasts are amplitude-modulated units, because they code the amplitude of the electric organ discharge in a spike train. In other Osteoglossiformes and Gymnotiformes, similar types of receptor organs exist. One type is involved in encoding timing, whereas another is involved in encoding strength.

Electroreceptor organs are found in the following subdivisions of the animal kingdom: Osteoglossiformes, Siluriformes, Gymnotiformes, Myxiniiformes, Petromyzontiformes, Chimaeriformes, Squaliformes, Rajiformes, Coelacanthiformes, Lepidosireniformes, Polypteriformes, Acipenseriformes, Semionotiformes, some Amphibia, and Monotremata.

### Higher Level Structures

Electroreceptor organs are innervated by lateral line nerves in all electrosensory species except for monotremes, where the trigeminal nerve is involved.

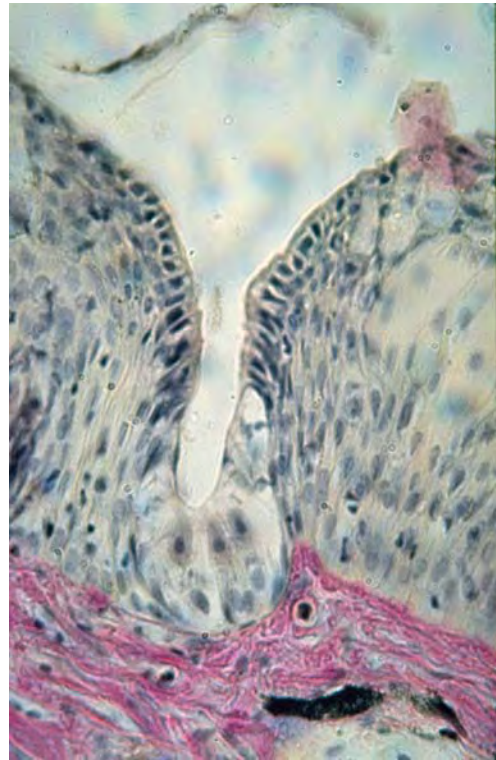

**Electroreceptor Organs. Figure 4** Transverse section through a microampullary organ of the tropical freshwater catfish *Clarias gariepinus*, which demonstrates why these organs are called ampullary. The invagination exposes the electroreceptor cells at the bottom to electrical potential differences over the skin. Red: collagenous tissue, large pinkish cells at the bottom of the ampulla: electroreceptor cells. Width of the ampulla about 0.1 mm.

The lateral line nerves in aquatic vertebrates are a well-developed set of cranial nerves, not found among the cranial nerves in terrestrial vertebrates. The lateral line nerves end in a specialized region of the rhombencephalon named the octavolateralis area. The ventral part of the octavolateralis area is involved in the processing of octavus information, the dorsal part in lateralis information. In teleosts, the medial zone of the dorsal (lateralis) part is mechanosensory, the lateral zone electroreceptive. The electroreceptive zone is called the Electrosensory Lateral Line Lobe (ELLL). From the ELLL, fibers run bilaterally to the pre-eminential nucleus, mainly contralateral, and to the torus semicircularis. Back projections have been demonstrated from the torus via the pre-eminential nucleus to the ELLL, and also directly to the inferior olive and caudal cerebellar lobe. A limited number of electrophysiological studies were performed in elasmobranch brains and in passive electrosensitive teleost brains. Two active electric teleost species have been investigated



**Electroreceptor Organs. Figure 5** Overview of a set of ampullary electroreceptor organs in the anal fin of the freshwater catfish *Kryptopterus bicirrhis* after exposure of one side to a 1% methylene blue solution. The electroreceptor cells of this side of the anal fin stand out as dark dots, whereas the cells at the other side of the fin are unstained. The large rod-like structures are fin rays. The thin wires between the ampullae are nerve fibers. Diameter of an ampulla about 0.1 mm.

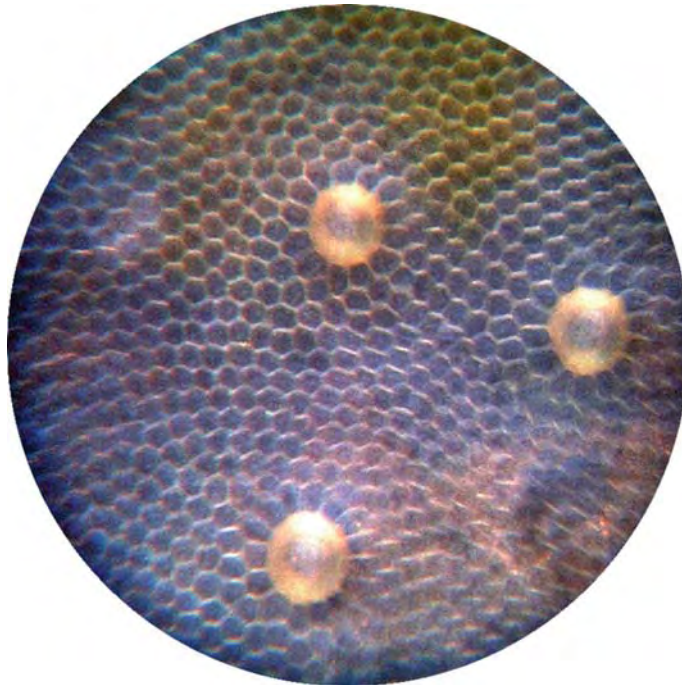

**Electroreceptor Organs. Figure 6** Photograph of a part of the skin of the electric freshwater fish *Gnathonemus petersii* with hexagonal epithelial cells and some tuberous organs. The tuberous organs stand out as white pearls against a dark background. The diameter of a tuberous organ is in the order of 0.2 mm.

extensively: (i) The ELLL of the Mormyrid representative *Gnathonemus petersii*, where separate processing of electrosensory information by the ampullary system, the Knollenorgan system and the mormyromast system takes place, and (ii) The ELLL of the gymnotiform

representative *Eigenmannia virescens*, where the neurophysiology of the [Jamming Avoidance Response](#) was unraveled. Up to the ELLL there is a large degree of somatotopy. ELLs excitatory and inhibitory electroreceptive units are found in both gymnotiforms and

Mormyrids involved in contrast enhancement via lateral inhibition mechanisms. Other examples of signal processing by the central nervous system are the suppression of respiratory common mode signals, the convergence-related sensitivity increase in second order neurons, and the existence of frequency and directionality maps.

### Lower Level Components

All electroreceptor organs, apart from monotreme organs, have secondary receptor cells that synapse to afferent fibers of the lateral line nerves. There is morphological and pharmacological evidence that the synapses are chemical and glutamatergic. Sensitivity of the synapse to the glutamate agonists kainate, quisqualate, AMPA, and NMDA has been demonstrated. Electrophysiological data do not exclude an electrical contact between receptor cell and nerve fiber.

The apical faces of the receptor cells bear microvilli or kinocilia. It is assumed that surface enlargement lowers the electrical resistance from environment to the basal face of the receptor cell, thus providing a low resistance path to the electrosensitive structures. In ampullary electroreceptor cells, which are more exposed to the outer world than the cells of tuberous organs, electron-dense inclusions are found consisting of paracrystalline substances.

### Lower Level Processes

The process understood best is probably the functioning of the chemical synapse. The synapse behaves as other glutamatergic synapses of the vertebrate brain. The synapses mediate in the generation of spontaneous activity and stimulus-evoked activity in the primary afferents. The spontaneous activity is more dependent on metabolic processes than is the stimulus-evoked response. The other lower-level processes in electroreceptor organs are less well understood. There are, however, strong experimental indications that the electroreceptor cell is under severe electrochemical stress. The apical face of the electroreceptor cell is exposed to the outer world, usually freshwater or seawater, the basal face to the body fluids. The apical face bears either kinocilia or villi, which are usually associated with surface enlargement and ion transport. Further, the electroreceptor cells provide a low-resistance path to external stimuli. Somehow the electroreceptor cells must cope with all these challenges of its homeostasis. Functional adaptations to the electrochemical stress might be high activity of membrane ATP-ases to maintain electrochemical homeostasis, and a well-developed intracellular detoxification process. Evidence for the latter is given by the presence of electron-dense bodies in the electroreceptor cell. Dense bodies are large paracrystalline inclusions that contain metal ions like Fe- and Cd-ions. Other

adaptations are perhaps the mucus containing invaginations that separate the electroreceptor cells from the outer world and may act as an electrochemical buffer. The temperature dependence of the action potential patterns reveals that an energy-consuming process in particular sustains the spontaneous activity.

### Process Regulation

Data of process regulation are scanty. The general presented view in textbooks and research articles is that electroreceptor organs are open loop systems that convert an electric stimulus into an action potential pattern. The stimulus transport process can, however, be modulated by the ion composition of the surrounding water. The glutamatergic synapse, with NMDA and AMPA receptors, can be modulated by glycine and serotonin. The transmission process is temperature dependent. Turnover of receptor cells is most likely, as in related mechanosensitive octavolateralis organs. It is inferred that the electrochemical homeostasis of the receptor cells is narrowly linked to the stimulus transduction process. How these two features are coupled was never investigated.

### Function

Electroreceptor organs serve to detect electrical fields in the aquatic environment. Different types serve different purposes. The tuberous organs are tuned to the detection of the Electric Organ Discharges (EOD). EODs are discharges generated by electric organs, which are under the control of motor neurons. EODs can be pulses of less than 1 ms duration and several volts of amplitude as in many mormyrids, or continuous sinusoidal discharges with frequencies ranging from 15 to 1,800 Hz as in many gymnotiforms. The ampullary organs are tuned stimuli other than EODs, i.e. electrical stimuli with frequencies from 1 to 100 Hz.

Of the tuberous organs of the Mormyridae, the Knollenorgans are specialized to detect the EODs of conspecifics. The mormyromasts in Mormyridae are used for measuring the distortions (deformations) of EODs by foreign bodies in the vicinity. These distortions represent objects with conductivities different from water, and thus allow object location. The ampullary organs are used for the detection of low-frequency electric fields representing respiratory potentials and standing dc potentials of aquatic organisms, and electrical fields related to redox processes in the bottom, or electromagnetic induction phenomena. The complete set of electroreceptor organs is used for prey detection, prey recognition, spatial orientation, navigation, intraspecific and interspecific communication.

In gymnotiform wave fishes, a similar specialization of electroreceptor organs exists. Tuberous T-organs are involved in the detection of the timing of the sinusoidal EODs, whereas the tuberous P-organs are involved

in the detection of the EOD strength. The ampullary organs serve the same purpose as those of the Mormyridae. Gymnotid fishes with EODs of almost equal frequencies would disturb each other's perception. To avoid unwanted interference of the EODs, the fish show a Jamming Avoidance Response (JAR), i.e. both fishes shift the frequency of the EODs slightly in opposite directions. The neural mechanisms behind the JAR response have been extensively studied.

Not all electrosensitive fishes have electric organs to give off electric discharges. Fishes *with* electric organs are said to use electroreception in the active mode, whereas fish without electric organs use electroreception in the passive mode. Fishes without electric organs use, as a rule, only ampullary systems to detect low-frequency electric fields emanating from prey or other aquatic organisms, and electrical fields related to geochemical features of the environment and water motion in the earth magnetic field.

Behavioral experiments have demonstrated unequivocally that the electric sense is a real sensory system that is used for everyday survival by making use of electrical cues from the environment. Electroreception is used for the detection and recognition of food, for spatial orientation and navigation, and for social interactions. Apart from being sensitive to electrical stimuli, the electroreceptor organs also respond to chemical, thermal, and magnetic stimuli. Stingrays have been conditioned to orientate with respect to the natural magnetic field of the earth. The ampullae of Lorenzini are assumed to be the magnetic detectors involved. Further, both the spontaneous activity and the stimulus-evoked responses of the electroreceptor organs in freshwater fishes respond to slight, naturally occurring, variations of the water ion composition. Electroreceptors also respond to temperature changes. Until now, however, no behavioral experiments support a thermoreceptive or a chemoreceptive function.

### Pathology

Electroreceptor organ pathology is only known from dysfunction due to the administration of drugs like cisplatin, vincristine and cytochalasin in pharmacological studies, or acriflavine and tryptaflavine in the fight against fin rot. Electroreceptor cells have been used as model systems for mechanosensitive hair cells of the vertebrate sense of hearing. The susceptibility of the electric sense as a whole to water pollution has been studied in order to develop early warning systems to monitor the quality of surface water.

### References

1. Peters RC, Denizot JP (2004) Transduction and transmission in electroreceptor organs. In: Frings S, Bradley J (eds) Transduction channels in sensory cells. Wiley-VCH, New York, pp 273–300

2. Collin SP, Marshall NJ (eds) (2003) Sensory processing in aquatic environments. Springer, New York, p 446
3. Nieuwenhuys R, ten Donkelaar HJ, Nicholson C (1998) The central nervous system of vertebrates. Springer, Berlin Heidelberg New York
4. Kramer B (1996) Electroreception and communication in fishes. In: Rathmayer W (ed), Progress in Zoology, vol. 42. Gustav Fischer, Stuttgart, p 119
5. Moller P (ed) (1995) Electric fishes, history and behavior. Fish and Fisheries Series. vol. 17. Chapman & Hall, London, Glasgow, p 584
6. Heiligenberg W (1993) Electroreception. In: Evans DH (ed) The physiology of fishes. CRC Press, Boca Raton, pp 137–160
7. Akeov GN, Andrianov YN (1993) Sensory hair cells. Synaptic transmission. Springer, Berlin Heidelberg New York, p 194
8. Bullock TH, Heiligenberg W (eds) (1986) Electroreception. In: Northcutt RG (ed) Wiley series in biology. Wiley & sons, New York, p 722

## Electrosense

- Evolution of the Mechanosensory and Electrosensory Lateral Line Systems

## Electrosensory Lateral Line Lobe (ELL)

### Definition

Primary recipient zone for teleost electroreceptors. Ampullary and tuberous organs each project to parallel somatotopically organized representations of the body surface. This region is not homologous to the DON of other fishes.

- Electroreceptor Organs
- Evolution of Mechanosensory and Electrosensory Lateral Line Systems

## Electrosensory Systems

### Definition

A system of cutaneous receptors which respond to voltage changes across the skin with changes in neural

activity. Electroductory systems have evolved multiple times within vertebrates.

► Evolution of Mechanosensory and Electroductory Lateral Line Systems

---

## Electrotonic Spread

### Definition

A change in membrane potential (e.g. a receptor potential or synaptic potential) originating in one region of a cell ( $\Delta V_0$ ) is associated with local transmembrane currents that distribute and flow intra- and extracellularly to adjacent membrane regions (at distance  $d$ ), where they in turn cause changes in membrane potential ( $\Delta V(d)$ ). However, the underlying currents get progressively smaller with distance because fractions of them are diverted through transmembrane ion leak channels. Thereby, the elicited adjacent membrane potential changes ( $\Delta V(d)$ ) are reduced in size and altered in shape (electrotonic decrement). In a cylindrical nerve or muscle fiber, the amplitude of the potential changes falls off exponentially with distance from the region where they have originated:  $\Delta V(d) = \Delta V_0 \cdot \exp(-d/\lambda)$ , where the length (space) constant  $\lambda$  is  $\sqrt{R_m/R_i}$ , defining the distance at which the original voltage change ( $\Delta V_0$ ) drops to a fraction of  $1/e \approx 0.37$ ,  $R_m$  is the membrane resistance and  $R_i$  the longitudinal intra-fiber resistance. Two important conclusions are that (i) the passive or electrotonic spread of local potentials across a cell membrane is no means for transmitting information over long distances; and (ii) a process of encoding is necessary to transform the local potential from a continuous graded potential to a discharge of action potentials which are able to propagate over longer distances.

► Action Potential Propagation  
 ► Cable Theory  
 ► Sensory Systems

---

## Electrotonic Synapse

► Electrical Synapses

---

## Elemental Mixture

### Definition

In odor mixture psychophysics, elemental mixtures are those that smell like their components.

► Olfactory Information

---

## Elementary Vestibulo-ocular Reflex Arc – Three-neuron Arc

► Vestibulo-Oculomotor Connections

---

## Eliminative Materialism

### Definition

A philosophical view, committed to the idea that all psychological explanations are false, because there are no mental states.

► Reductionism (Anti-Reductionism, Reductive Explanation)

---

## Eliminativism

### Definition

Mental phenomena do not exist. We believe that there are mental phenomena only because we adhere to a false theory (folk psychology), to be replaced by the neurosciences.

► Causality

---

## ELISA

### Definition

The Enzyme-Linked ImmunoSorbant Assay (ELISA) is a quantitative method used to detect an antigen or an

antibody in a sample (e.g., plasma, supernatant from tissue or cell extracts). Two antibodies are used, one specific to the antigen and the other one is coupled to an enzyme causing a signal in the presence of chromogenic or fluorigenic substrate.

► [Neuroinflammation – LPS-Induced Acute Neuroinflammation](#)

## ELKS

### Definition

A family of proteins highly enriched at the active zone; name is related to high content of glutamate (E), leucine (L), lysine (K), and serine (S) residues. Generally recognized as a synaptic scaffolding protein that is known to interact with Bassoon, Piccolo, Liprin- $\alpha$ , RIM, and Rab6 among other proteins. Also known as ERC or CAST proteins.

► [Synaptic Proteins and Regulated Exocytosis](#)

## Embodied Neural Systems

► [Computer-Neural Hybrids](#)

## Emboliform Nucleus

### Synonyms

Nucl. interpositus ant; Anterior interpositus nucleus

### Definition

The emboliform nucleus and globose nucleus are collectively known as the interpositus nucleus, since both receive their afferents from Purkinje cells of the cerebellar hemisphere, intermediate part and from collateral spino- and rubrocerebellar projections. Their efferents pass via the fiber bundle of the superior cerebellar peduncle primarily to the small-celled red nucleus, but with fewer going to the ventral lateral thalamic nucleus.

► [Cerebellum](#)

## Embryonic Stem (ES) Cells

### Definition

Embryonic stem cells are pluripotent cells derived from the epiblast tissue of the inner cell mass (ICM) of a blastocyst. A blastocyst is an early stage embryo – approximately 3–5 days old mammals – consisting of about 50–150 cells. ES cells possess two unique characteristics: pluripotency (see after) and an indefinite self-renewal capacity, remaining genetically stable even after 140 cycles of division. Improvements regarding the ES culturing protocols to generate largescale numbers of transplantable ES have recently been described. Feeder-independent growth of human ES cells (e.g., using protein components solely derived from recombinant sources or purified from human material) can be achieved as well as the in vitro propagation (through continuous asymmetric cell division) of ES cell-derived neural stem cells without accompanying differentiation. However, protocols for avoiding in vivo teratocarcinoma formation after ES (or ES-derived cells) cell transplantation are still lacking.

Transplantation of both ES cells and ES cell-derived neural (neuronal, glial) progenitors efficiently promotes CNS regeneration in preclinical models of stroke, myelin deficiency, acute spinal cord injury (SCI), and Parkinson's disease (PD). Because of their unique combined abilities of unlimited expansion and pluripotency, ES cells are a potential source for regenerative medicine and tissue replacement after injury or disease. To date, no approved clinical medical treatments have been derived from embryonic stem cell research.

► [Autoimmune Demyelinating Disorders: Stem Cell Therapy](#)

## Emergence

ACHIM STEPHAN

Institute of Cognitive Science, University of Osnabrück, Lower Saxony, Germany

### Definition

In ordinary language, the notions “to emerge” and “emergence” still bear the meaning of their Latin ancestor *se emergere*; they stand for “to appear” or “to show up,” and “appearance,” respectively. In scientific discourse, the term “emergent” is used to characterize

certain properties and structures, sometimes also laws. Three types of “emergence,” which are of different strength should be distinguished: *Strong (synchronic) emergence* refers to irreducible properties, *diachronic emergence* points to unpredictable structures and properties, and *weak (synchronic) emergence* refers to properties that are instantiated only on the systemic level, but are reducible in principle.

### Description of Theory

During the last two decades the concept of emergence has seen a strong revival in ►cognitive science and the philosophy of mind (see, e.g., [1,2]; for a historical survey cf. [3]). People associate with it the hope to both adequately classify philosophical problems such as the “►hard problem of consciousness” and to adequately characterize behaviors of artificial systems that are not programmed explicitly, but arise from self-organizing processes. A closer look, however, reveals that no unique notion of emergence is available that is apt for both issues: The classification of mental phenomena that resist reductive explanations necessitates a strong notion of emergence, which is significant for metaphysical issues in the philosophy of mind, but of low interest to the other areas of cognitive science (and to the natural sciences in general [4]). These disciplines focus on behaviors of complex ►dynamical systems that exhibit unprogrammed or unexpected patterns and regularities without being resistant to reductive explanations. They need notions of emergence that go without irreducibility. Hence, there is a need for specifying different notions of emergence.

### Varieties of Emergence

The more ambitious versions of emergentism are all based on a common weak theory from which they can be developed by adding further theses. The weak (synchronic) theory of emergence specifies the minimal criteria for emergent properties. Its three basic features – the thesis of *physical monism*, the thesis of *systemic (or collective) properties*, and the thesis of *synchronic determination* – are jointly compatible with current reductionist approaches.

The thesis of *physical monism* is about the nature of systems that have emergent properties or structures. It claims that the bearers of emergent features consist of physical entities only: All entities existing or coming into being in the universe consist solely of physical components; likewise, properties, behaviors, or structures classified as emergent are instantiated by systems consisting exclusively of physical entities. Thus, all substance-dualistic positions are rejected; for they base properties such as being alive or having cognitive states on supernatural bearers such as an ►entelechy or a ►res cogitans, respectively.

According to the second thesis, only *systemic (or collective) properties* are candidates for emergent properties. These are properties of a *general* type, which are instantiated by the system as such, but by no subsystem or component of it. It is uncontroversial that many systems exhibit systemic properties. Otherwise, one would have to maintain that *all* system properties are already instantiated by system parts.

The thesis of *synchronic determination* specifies the type of relationship that holds between the systemic properties of a system and its microstructure (*i.e.*, the specific arrangement of the system’s parts together with their properties): Systemic properties and dispositions depend nomologically on the microstructure of their bearers. There can be no difference in a system’s systemic properties without some difference in the properties or arrangement of its parts. Anyone who denies the thesis of *synchronic determination* either has to admit properties that are not bound to the microstructure of its bearer, or she has to suppose that some additional factors, e.g., non-natural entities, are responsible for differing dispositions of physically identical systems.

*Weak* emergentism is compatible with contemporary reductionist approaches without further ado. Particularly for this reason, philosopher of science Bunge [5] is emphatic on it, but also cognitive scientists, e.g., Varela, Thompson, and Rosch [6] adopt this position.

The essential claims of the two more ambitious theories of emergence are those of *irreducibility* (synchronic emergentism) and of *unpredictability* (diachronic emergentism). These are closely connected. Irreducible systemic properties are *eo ipso* unpredictable before their first appearance. Hence, synchronically emergent properties are also diachronically emergent, but not conversely. All diachronic theories of emergence are based on a thesis about the occurrence of *novelties* in evolution. According to this thesis, in the course of evolution exemplifications of genuine novelties occur again and again. Existing entities combine to new configurations and structures that constitute new entities with new properties and behaviors. However, the thesis of novelty does not by itself turn a weak theory of emergence into a strong one, since reductive physicalism remains compatible with it. Only the addition of the thesis of *unpredictability*, in principle, will lead to stronger forms of *diachronic* emergentism.

The structure of an arising new system can be unpredictable, in principle, for two reasons: Its arrangement may be a result of indeterministic processes, or it may be the result of deterministic, but chaotic processes. Within emergentism, only the second option is discussed. It is captured by the thesis of *structure unpredictability*, which claims that the rise of a novel structure is unpredictable, in principle, if its formation is governed by laws of deterministic chaos. Likewise, any property that is instantiated by such a novel structure is unpredictable, in principle.



Emergence as *structure unpredictability* has a great deal in common with an approach Clark has called emergence as *uncompressible unfolding* [7]. This expression refers to those macrostates of a system that can only be derived by *complete* simulations of all interactions at the component's level and the external influences on the system [8]. Such complete simulations of the underlying microdynamics would be necessary for long-term predictions of structure formation governed by deterministic chaos. Since these simulations are not available – information compressing short cuts are not adequate for longer intervals –, structure unpredictability as introduced above is unpredictability, in principle.

Strong (synchronic) emergence has its roots in Broad's theory of emergence [9]. It involves irreducibility, *i.e.*, the principled failure of explaining reductively a systemic property. For a reductive explanation to be successful, several conditions must be met: the property to be reduced must be functionally construable (or reconstruable); it must be shown that the specified **functional role** is filled by the system's parts and their mutual interactions; and the behavior of the system's parts must follow from the behavior they show in isolation or in simpler systems than the system in question. If all these conditions are met, the behavior of the system's parts in other contexts reveals what systemic properties the actual system has.

Since these three conditions are independent of each other, there are three different ways in which systemic properties may be irreducible and thus: strongly emergent. A systemic property is irreducible: if it is not functionally construable (or reconstruable); if it cannot be shown that the interactions between the system's parts fill the systemic property's construed or reconstructed functional role; or if the specific behavior of the system's components, over which the systemic property supervenes (**Supervenience**), does not follow from the component's behavior in isolation or in simpler arrangements (for further details, see [4]).

Hence, we have to distinguish three different types of strong synchronic emergence. Their consequences are also different. If a system property is irreducible due to the fact that the components' behavior is not reducible to the behavior they show in simpler systems given their current arrangement, then the system itself or its specific structure seems to exert some "downward causal influence" on its parts. However, such **downward causation** would not violate the principle of the **causal closure of the physical domain**. We would just have to accept additional types of causal influences within the physical domain besides the known types of mutual interactions.

On the other hand, if the behavior of the system's parts cannot fill the functional role adequately attributed to the corresponding systemic property this systemic property itself would have causal powers different

from those of the system's microstructure. If in addition, the systemic property were a nonphysical (mental) property with a causal influence on the physical world, we would have to admit a violation of the principle of the causal closure of the physical realm.

In contrast, the occurrence of properties that are not functionally construable does not imply any kind of downward causation. Systems with properties that admit of no functional analysis need not be constituted in such a way that their components' behavior is irreducible. Nor is it implied that the system's structure has a downward causal influence on the system's parts. Thus there is no reason to assume that properties that cannot be functionally analyzed have any causal influence on its bearer's parts. Rather, the question is how such properties might have any causal role at all.

### Applications

The debate about phenomenal **qualia** and consciousness shows that within the philosophy of mind there is need for a strong notion of emergence. Even if we would know everything about the neural correlates of consciousness, even if we could say how each single neuron and how each single synapse behave, we might not be able to reductively explain all mental properties correlated with these neural processes. In fact, such a failure would not be based on a lack of insight on the side of the neurosciences; rather it would come along with the conceptual impossibility to adequately reconstruct phenomenal qualities via their functional role.

In contrast, the notion of strong emergence has no application to cognitive science, except this discipline itself were concerned with phenomenal qualities, *e.g.*, with the question whether or not an artificial system might have a **first-person perspective** and conscious experiences. In all other branches, strong emergentism has no relevance for cognitive science: Connectionist networks (**Connectionism**), Artificial-Life colonies (**Artificial Life**) and robots exhibit behaviors and properties (*e.g.*, pattern recognition, flocking behavior, collecting cans, respectively) that are specified via their functional role. All of these are only *weakly* emergent, they are reductively explainable without residue [10]. However, it is not informative to learn that most properties of connectionist networks, robots, and *A-life*-creatures are weakly emergent, for there exist just too many properties which are instantiated at the system level only, and not at the level of the system's parts.

Rather, emergence as *structure unpredictability* or *uncompressible unfolding* is an alternative that cuts the *world of artifacts* in cognitive science at some interesting joints. Bedau has demonstrated the fruitfulness of this approach for *A-Life* research and the **Game of Life** [8]. In robotics and artificial intelligence, this approach to emergence might help particularly to characterize evolutionary and **hybrid**

**architectures:** quite often they develop in a way that is unpredictable, in principle.

## References

1. Beckermann A, Flohr H, Kim J (eds) (1992) Emergence or reduction? Essays on the prospects of nonreductive physicalism. de Gruyter, Berlin
2. Kim J (1999) Making sense of emergence. *Philos Studies* 95:3–36
3. Stephan A (1999) Emergenz. Von der Unvorhersagbarkeit zur Selbstorganisation. 3rd printing, mentis, Paderborn 2007. [An English translation will be published by Springer/Kluwer]
4. Boogerd FC, Bruggeman FJ, Richardson RC, Stephan A, Westerhoff HV (2005) Emergence and its place in nature: a case study of biochemical networks. *Synthese* 145:131–164
5. Bunge M (2003) Emergence and convergence. Qualitative novelty and the unity of knowledge. University of Toronto Press, Toronto, pp 9–25
6. Varela FJ, Thompson E, Rosch E (1991) The embodied mind. *Cognitive science and human experience*. MIT, Cambridge, MA, pp 85–103
7. Clark A (2001) *Mindware. An introduction to the philosophy of cognitive science*. OUP, Oxford, pp 112–117
8. Bedau M (1997) Weak emergence. *Philos Perspect* 11:375–399
9. Broad CD (1925) *The mind and its place in nature*. Kegan Paul, London, pp 43–94
10. Stephan A (2006) The dual role of “emergence” in the philosophy of mind and in cognitive science. *Synthese* 151:485–498  
(The page references in parentheses for No. 5 & 6 narrow down the pertinent parts of these books.)

## Emergency Response

The concept was first put forward by Walter B. Cannon who described that in a certain situation, such as under threat or in danger, the sympathetic-adrenal system is activated together as a whole, producing an increase in blood pressure, heart rate, cardiac contraction, hair erection (in hairy animals), salivary secretion, pupil dilation, and epinephrine secretion. In dogs and cats the response brings a picture of an angry animal. However, the sympathetic system is not always activated as a whole; in many other situations differential activation of the sympathetic nerves innervating various organs occurs.

- ▶ Homeostasis
- ▶ Sympathetic Nervous System
- ▶ Sympathetic Pathways

## Emergent Property

### Definition

An emergent property is a property resulting from the cooperative interactions of the neurons forming a neural network; not typically found at the single neuron level. The behavior of the network as a whole may exceed the sum of the contributions of its individual components.

## EMG

- ▶ Electromyography

## Eminentia Sagittalis

- ▶ Evolution of the Wulst

## Emotion

MEG WARACZYNSKI

Department of Psychology, University of Wisconsin – Whitewater, Whitewater, WI, USA

### Synonyms

Affect

### Definition

Physiological and behavioral responses to an important environmental object or event, typically mediated by the autonomic nervous system and ▶ **subcortical** brain structures. These responses are combined with cortically-mediated modulation and interpretation. One’s interpretation of emotional responses is often called a “feeling,” and is typically considered separately from those responses.

### Characteristics

#### Historical Perspective

Emotion has often been connected with ▶ **motivation**. Charles Darwin argued that emotions have the adaptive

value of communicating motivational states to other members of one's species or social group. ▶ **William James** also linked emotion to motivation, suggesting that emotions are a means of maintaining motivation in the absence of direct environmental input that would initiate and sustain it. The James-Lange theory of emotion, which combined James' ideas with those of Carl Lange, proposes that one's perception of an event or object stimulates physiological reactions and behavioral responses, the occurrence of which are interpreted by the brain as a feeling. To use James' famous example, we see a bear, become aroused, and then interpret that arousal as a feeling of fear.

Empirical investigations found problems with the James-Lange theory. For example, people whose brains cannot receive arousal cues from the ▶ **autonomic nervous system** because of spinal cord transection feel emotions nonetheless. Also, different emotional states produce identical behavioral and physiological arousal profiles, leaving it mysterious as to how the brain makes the appropriate interpretation. Consequently, the James-Lange theory was modified and extended by physiologists Walter Cannon and Phillip Bard, who proposed that one's perception of the arousing object or event simultaneously stimulates both subcortical mechanisms of physiological arousal and cortically-mediated feelings.

This perspective is echoed in Antonio Damasio's more contemporary somatic-marker hypothesis [1]. Damasio proposes that an individual contemplating a potential response to an emotionally significant event, or even to thoughts or memories of such events, experiences a bodily reaction to the perceived consequences of that response option. This bodily, or somatic, reaction marks the contemplated action with a positive or negative valence, and this marker goes on to influence one's choice of that response option; negative somatic markers devalue the associated response option, and positive somatic markers enhance it. Somatic markers then interact with one's (cortically-controlled) cognitive evaluation of one's options, leading to response selection and production.

### Neural Mechanisms of Emotional Responses:

#### ▶ Pavlovian Fear Conditioning

Functional neuroanatomical investigations have given us valuable insight into the neural mechanisms of emotion. Subcortically, important structures include the ▶ **thalamus**, which receives sensory input, the ▶ **amygdala**, which coordinates the behavioral and physiological responses to the input, as well as relaying information to the cortex for interpretation, and the ▶ **hypothalamus**, which controls many of the autonomic and ▶ **neuroendocrine** (hormonal) responses to emotionally-relevant stimuli. Our understanding of the subcortical mechanisms that mediate linkages between sensory input and emotional responding has been greatly

advanced by the work of LeDoux's research group on the neural mechanisms of fear conditioning in the rat [e.g. 2]. Although most of our knowledge about subcortical mechanisms of emotion has been gained from studying fear, there is ample evidence that the same processes and neural systems govern positive emotions as well [e.g. 3].

Fear conditioning is a specific case of Pavlovian or ▶ **classical conditioning** in which a stimulus that initially provokes no noticeable response (the conditioned stimulus or CS) is paired with a stimulus that provokes a fear response automatically (the unconditioned stimulus or US). In fear conditioning, the CS is typically a tone and the US is a slight electric shock to the rat's footpad. Sensory information about both of these is relayed by the thalamus and the sensory cortices to the basal and lateral nuclei of the amygdala. At the start of the conditioning experience, thalamic and cortical inputs that carry information about the tone do not induce any substantial response by the amygdala, while inputs carrying information about the footshock do induce a response. The basal and lateral amygdala respond to footshock input by activating connections with the central and medial nuclei of the amygdala. These nuclei in turn stimulate a constellation of behavioral and physiological reactions that we call a fear response. For example, the central and medial amygdala have connections with nuclei of the hypothalamus that initiate a series of reactions culminating in the release of adrenalin and ▶ **corticosteroid** ("stress") hormones from the adrenal glands. Outputs of the central and medial amygdala to other ▶ **brainstem** structures coordinate activation of the peripheral nervous system, and stimulate behavioral responses such as freezing and other defensive responses.

During fear conditioning, the tone CS is repeatedly presented with the footshock US, until, after several such training trials, the tone presented by itself provokes the same constellations of reactions provoked initially only by the footshock. This change in response to the CS is a result of ▶ **synaptic plasticity** in the neural connections between the thalamus and the basal and lateral amygdala. The connections between neurons of the thalamus that processed the tone input and neurons of the basal and lateral amygdala were initially weak at the start of the conditioning experience, too weak to provoke the amygdala-mediated responses provoked by the US. However, activating those weak inputs simultaneous with the strong inputs carrying footshock information led to strengthening of the initially weak connections, such that they could provoke the same response in the basal and lateral amygdala that was provoked by the strong footshock inputs.

#### The Adaptive Value of Emotional Reactions

Such mechanisms offer a neurobiological explanation of the valuable – although sometimes maladaptive – capacity of all animals to learn to have emotional

reactions to objects, events, or others that initially provoked no such response. In particular, reminiscent of James' ideas, animals can learn which environmental cues predict impending danger or reward and respond appropriately, even if the danger or reward is not immediately present.

In people, social concerns can also become associated with basic emotional responses, e.g. shame, guilt, and pride might all be seen as learned emotional reactions to sociocultural punishments or rewards. Also, given the reciprocal connections among the amygdala and the ►hippocampus, a structure critical to processing memories of episodes in one's past, one can respond emotionally to the *memories* of emotional events (see ►Emotional Learning and Memory).

### Cortical Mechanisms of Emotion

As Cannon and Bard pointed out, cortical structures are also involved in emotion. Cortical areas have been implicated in one's subjective interpretation of the subcortical arousals and reactions associated with an emotion (this interpretation is often called "feeling"), the capacity to perceive, comprehend, communicate, and recall emotional information accurately, and the ability to modulate emotional reactions.

Of the four major lobes of the cortex, the frontal lobe has been most closely linked to emotion. Its development is important to one's abilities to recognize and project emotion, to regulate emotion, and to coordinate emotional response with social and cultural expectations. For example, people suffering ►frontal cortex damage typically do not show autonomic arousal to pictures that most people judge as disturbing, while neurologically intact people show strong autonomic arousal to such images. (Based on such findings, some have speculated that sociopathy might derive from frontal cortex hypoactivity.) Other cortical areas have been associated with emotion. For example, people with ►temporal lobe epilepsy often report deeper, more intense feelings during seizures. Also, ►visual cortex in occipital and temporal lobe and ►somatosensory cortex in parietal lobe are relevant to recognizing emotional facial expressions, while auditory cortex in temporal lobe is relevant to recognizing emotional tone of voice. But most attention has focused on the role of frontal lobe areas in emotional information processing.

Data emerging from both human brain imaging studies and animal research suggest that ►prefrontal cortex, ►orbitofrontal cortex, and ►cingulate cortex are particularly implicated in emotional function. Both prefrontal and orbitofrontal cortex seem necessary to one's ability to recognize and discriminate among emotional facial expressions and vocal tones [4]. Medial prefrontal cortex is activated when an individual reevaluates how negative a negative event really was, and its

activation inhibits the amygdala, presumably degrading the degree to which the individual reacts to the event [5]. Prefrontal, orbitofrontal, and cingulate cortex all influence subcortical structures such as the amygdala, and are all invoked to modulate emotional reaction based on expectations and beliefs about impending dangers or rewards. For example, these systems seem to play a role in the fact that normally non-painful stimuli are perceived as painful if one is told to expect pain, and that anticipation of a reward can enhance that reward's subjective value [6]. There even seems to be a dorsoventral (top to bottom) differentiation of function within these areas: more ventral (lower) frontal cortex areas may be involved in emotionally evaluating an object or event based on its context, and in guiding response selection based on that evaluation. On the other hand, dorsal (upper) areas may be important to purposive regulation of emotional reactions [6,7], such as an individual's decision not to react to an insult with physical violence.

### Cortical and Subcortical Interactions

Cortex and subcortical structures such as the amygdala do not act independently. Rather, they interact to govern several aspects of emotion. For example, communication from the amygdala to sensory cortex can sharpen cortical cell responses to certain sensory inputs associated with emotionally-significant events. Amygdala input also appears to inform cortical activity involved in directing one's attention to potentially salient environmental events. The amygdala also seems to mediate hormonal activity that affects the consolidation of emotional memories within the hippocampus [see 8 for a more detailed discussion of these interactions]. Thus, emotion is a combination of subcortically- and autonomically-governed behavioral and physiological reactions to environmental events together with the cortical interpretation and modulation of such reactions.

### Lateralization and Asymmetry

The cortex is somewhat lateralized in its emotional function. That is, structures in the left brain hemisphere may process emotional information differently than do structures in the right hemisphere. People with right hemisphere damage are often unable to interpret others' emotional facial expressions or tones of voice, or to project their own emotions in their own expressions and intonations. Left hemisphere damage is more likely to affect one's ability to understand the emotional content of writing or speech or to correctly process information about emotions. For example, such damage might impair empathy or one's "theory of mind," i.e. the ability to understand what another person might be feeling.

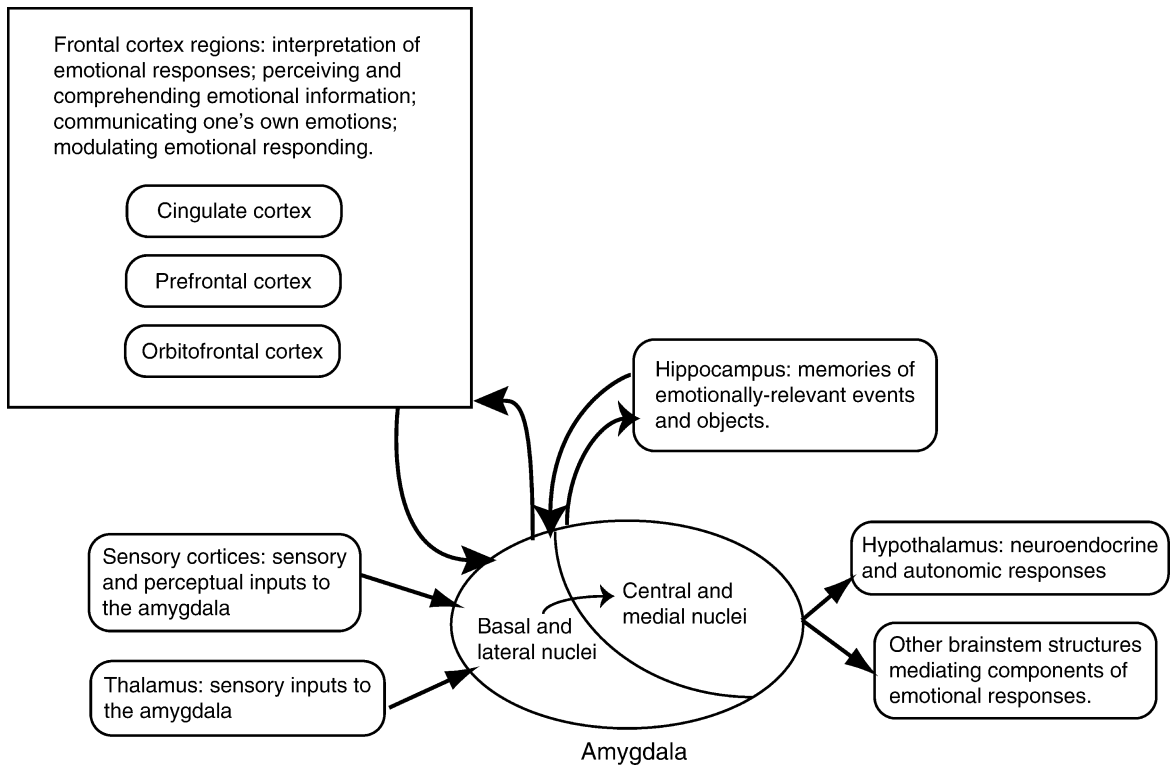

**Emotion. Figure 1** Schematic summary of major cortical and subcortical brain areas and their respective roles in emotion.

Similar ►[asymmetry](#) may obtain in the amygdala. Right amygdala may perceive and respond relatively quickly to more gross-grained, immediately identifiable information coming from the surrounding environment, and mediate broad or global emotional reactions. On the other hand, left amygdala may be involved in the relatively slow perception of and response to details of emotional stimuli, orchestrating more specific responses to particular features of the environmental event or object [9]. Although most human brain imaging studies suggest that the left amygdala responds more strongly to emotional information than does the right, this asymmetry may be an artifact of the time resolution of current brain imaging technology: Faster right amygdala responses might not always be as observable as slower left amygdala responses [10].

### Summary

The roles and interactions of several brain areas that are important to emotion are summarized in Fig. 1.

Emotional responses begin with the sensation and perception of relevant environmental objects, events, or others. Sensory and perceptual information is relayed to the amygdala, either immediately from thalamic nuclei

or following processing in sensory cortex. Amygdalar nuclei interact with the hypothalamus and other brainstem structures to coordinate the constellation of autonomic, behavioral, neuroendocrine, and other reactions that constitute the emotional response. Plasticity in synaptic inputs to and within the amygdala confers the ability to learn to respond emotionally to previously neutral environmental cues associated with emotional objects or events. Reciprocal connections between the amygdala and the hippocampus help mediate memory for emotional events, and allow the individual to respond emotionally to memories. Reciprocal connections between the amygdala and cortical areas, especially regions of the frontal cortex, mediate conscious, subjective interpretations of emotional arousal and also allow the individual to modulate emotional responding depending on the environmental context.

### References

1. Damasio AR (1994) *Descartes error*. HarperCollins, New York, NY
2. LeDoux J (2003) The emotional brain, fear, and the amygdala. *Cell Mol Neurobiol* 23:727–738

3. Everitt BJ, Cardinal RN, Parkinson JA, Robbins TW (2003) Appetitive behavior: impact of amygdala-dependent mechanisms of emotional learning. *Ann N Y Acad Sci* 985:233–250
4. Adolphs R (2002) Neural systems for recognizing emotion. *Curr Opin Neurobiol* 12:169–177
5. Quirk GJ, Beer JS (2006) Prefrontal involvement in the regulation of emotion: convergence of rat and human studies. *Curr Opin Neurobiol* 16:723–727
6. Ochsner KN, Gross JJ (2005) The cognitive control of emotion. *Trends Cogn Sci* 9:242–249
7. Phillips ML, Drevets WC, Rauch SL, Lane R (2003) Neurobiology of emotion perception I: the neural basis of normal emotional perception. *Biol Psychiatry* 54:504–514
8. Phelps EA, LeDoux J (2005) Contributions of the amygdala to emotion processing: from animal models to human behavior. *Neuron* 48:175–187
9. Gläscher J, Adolphs R (2003) Processing of the arousal of subliminal and supraliminal emotional stimuli by the human amygdala. *J Neurosci* 23:10274–10282
10. Baas D, Aleman A, Kahn RS (2004) Lateralization of amygdala activation: a systematic review of functional neuroimaging studies. *Brain Res Rev* 45:96–103

## Emotional/Affective Aspects of Pain

RICHARD H. GRACELY<sup>1,2</sup>, STEVEN E. HARTE<sup>2</sup>

<sup>1</sup>Internal Medicine-Rheumatology, University of Michigan, Ann Arbor, MI, USA

<sup>2</sup>Department of Neurology, University of Michigan; VA Ann Arbor Health System, Ann Arbor, MI, USA

### Synonyms

Pain unpleasantness; Pain distress

### Definition

1. The immediate unpleasantness ascribed to a painful sensation that motivates behaviors of escape and avoidance to minimize injury
2. Cognitively-mediated emotional and affective disturbances such as depression, anger, anxiety, and despair that can be associated with having pain; pain distress

### Characteristics

Pain sensation varies in intensity, location, quality and duration. In addition, the experience of pain contains a salient disagreeable aspect that powerfully motivates behaviors to eliminate or reduce this disagreeable aspect. This dual sensory/motivational nature of pain, combined with its functional role of avoiding or minimizing injury,

forms the basis for the formal definition of pain provided by the leading international pain organization, the International Association for the Study of Pain (IASP), “an unpleasant sensory and emotional experience associated with actual or potential tissue damage or described in terms of such damage.”

Pain affect contains at least two distinct components. The first component can be described as immediate unpleasantness. This disagreeable component is readily demonstrated in both animals and man. It motivates behaviors of escape and avoidance, as well as recuperation; it serves as an immediate “alarm of harm” that commands attention and action to minimize injury. In contrast, the second component is implicit in the terms “emotional/affective,” which imply a range of factors including anger, depression, hopelessness, anxiety, despair, and distress. These emotional and affective disturbances derive from cognitive evaluations of the meanings and consequences associated with having pain, especially if the pain is prolonged or chronic.

The immediate, unpleasantness component of pain shares many features with other sensory modalities such as temperature. Temperature sensations can be accompanied by unpleasant feelings that motivate behaviors (e.g., seeking warm or cool environments). The term “pain unpleasantness” is derived directly from human psychophysical studies of sensations such as taste and temperature that can be both intense and either pleasant or unpleasant. The study of human judgments of pleasantness and unpleasantness is termed “[▶hedonic psychophysics](#)” and the use of the term “unpleasantness” in pain emphasizes the immediate nature of the disagreeable component in contrast to the more cognitively-mediated [▶pain emotions](#) and pain-generated affect.

The separation of the pain experience into sensory, and unpleasant and/or affective, dimensions has a long history that has been formalized more recently in both influential reviews [1] and pain measurement instruments. The most widely used instrument is the McGill Pain Questionnaire (MPQ) published in 1975 [2]. Based on a study of pain language [3], the MPQ and its subsequent short form divides the pain experience into a number of sensory qualities, and into additional non-sensory “affective” dimensions and an “evaluative” dimension. The adjectives in these scales can be construed as describing degrees of unpleasantness (e.g., annoying, troublesome, unbearable, agonizing) or emotional reactions directly (e.g., sickening, fearful, exhausting) or indirectly by personifying the pain (e.g., vicious, cruel).

The MPQ distinguishes between differences in the quality of pain sensation and in dimensions that can be aligned with the unpleasantness of these sensations and the emotional reactions to them. [Figure 1](#) shows an alternative approach that measures the intensity of pain

20		20	
19		19	
18	Extremely intense	18	
17	Very intense	17	Very intolerable
16	Intense	16	Intolerable
15	Strong	15	
14		14	
13	Slightly intense	13	Very distressing
12	Barely strong	12	Slightly intolerable
11	Moderate	11	Very annoying
10		10	Distressing
9		9	Very unpleasant
8	Mild	8	Slightly distressing
7		7	Annoying
6	Very mild	6	unpleasant
5	Weak	6	Slightly annoying
4	Very weak	5	Slightly unpleasant
3		4	
2		3	
1	Faint	2	
0	No pain sensation	1	
		0	Neutral

**Emotional/Affective Aspects of Pain. Figure 1** The Gracely Box Scale measures pain intensity and unpleasantness directly by presenting adjectives that are scaled along these separate dimensions of pain. Respondents are instructed to focus on the words to determine their level of pain intensity or unpleasantness and then select the number that corresponds to this level.

sensations and unpleasantness directly by adjectives that are scaled along these dimensions. Other approaches use a pair of visual analog scales in which the dimensions are differentiated by instructions and by the labels used to describe the ends of the scale [4].

The outcomes of sensory and unpleasantness scales are often correlated, leading to questions of whether specific scales discriminate between dimensions or about the basic validity of the multidimensional approach. However, these dimensions can be both correlated and independent [5]. In this view, the amount of unpleasantness is determined by the intensity of the pain sensation and by another factor that can be thought of as an affective amplifier of sensory input with an affective gain control. This system is symbolized by an amplifier and the gain by a knob. From this figure, it is clear that the outputs of pain intensity and ▶pain unpleasantness would be correlated. Pain unpleasantness can be altered by changes in the input

signal related to the intensity of the pain sensation. However, the position of the knob on the affective amplifier, affective gain, is under central control and independent of sensory intensity. Manipulations that increase pain affect, such as anxiety, would do so by increasing the affective gain, resulting in more unpleasantness for a given pain sensation. Manipulations that decrease pain unpleasantness would likewise do so by decreasing the gain. In practice, pain intensity and unpleasantness can be measured by calculating the amount of unpleasantness for a given sensory intensity (e.g., ratio of unpleasantness to intensity responses). This calculated gain, which can be termed “▶relative unpleasantness,” together with the ratings of pain intensity, provides independent measures of both dimensions.

This system also depicts a second affective amplifier that receives input from cognitions associated with

the pain experience. It underlies the development of pain-related distress. A third affective amplifier receives input from cognitions unrelated to pain, for example, knowledge of a life-threatening disease. Feedback loops connect all of these systems to all gain controls (not shown). Thus, the overall emotional experience and suffering associated with human pain may reflect input from all three affective sources.

Several models of nociception have been developed to measure these affective reactions in animals. It is important to note that these assays differ from the more commonly used reflex measures that provide information only related to the sensory processing of noxious stimuli (intensity, location, duration). Furthermore, unlike most affective reactions, reflexive responses such as paw withdrawal and paw-licking do not require cerebral processing.

Animal models of pain affect can be divided into two types: those that directly measure unlearned or innate affective reactions to noxious stimulation (e.g., vocalizations) and those that indirectly measure pain affect by assessing learned responses of escape or avoidance. The audible vocalizations or cries emitted by rats *following* exposure to a noxious stimulus (►vocalization after discharges (VADs), ►Noxious stimulus evoked vocalizations) are considered a direct index of the unpleasantness associated with painful sensations [6]. Support for VADs as a valid rodent model of pain affect is derived from reports that VADs are suppressed by damage of or drug treatments into brain areas (anterior cingulate cortex, amygdala, hypothalamus, medial thalamus) implicated in the generation of pain unpleasantness in humans. These findings are consistent with serial transection studies indicating that the essential neural circuitry mediating the generation of VADs is organized at the level of the rhinencephalon (“smell-brain,” also included in the limbic system)-diencephalon. Drug treatments that preferentially suppress the disagreeable feelings of human pain also preferentially suppress VAD production in rats, and more importantly, elicitation of VADs is necessary for noxious stimulation to support fear conditioning.

In contrast to VADs, audible vocalizations of the rat that occur *during* noxious stimulation are not considered an index of pain unpleasantness. These vocal responses are organized within the brainstem and exhibit different spectrographic characteristics compared to VADs. Rodents also emit ultrasonic vocalizations that have been suggested to reflect negative hedonic states in general and pain unpleasantness in particular during a noxious event. However, the validity and usefulness of measuring ultrasonic vocalizations in studies of pain is debatable.

Indirect measures of pain affect evaluate learned responses related to the emotive attributes of a noxious stimulus. In ►conditional place avoidance (CPA) paradigms, rats learn to avoid a compartment that was previously paired with a noxious stimulus. This avoidance behavior is indicative of a conditional response that stems from the association of the contextual cues of the compartment with the immediate unpleasantness of the ►noxious stimulus that was experienced within that compartment. Recent evidence from studies using CPA suggests that the rostral extent of the anterior cingulate cortex (rACC) may be a critical region for encoding the unpleasantness component of a noxious stimulus. Johansen et al. [7] demonstrated that inactivation of the rACC impaired the acquisition of pain-induced CPA, but failed to attenuate both the production of acute pain behaviors and avoidance conditioning to an aversive, but non-nociceptive, stimulus. More recently, these investigators showed that chemical activation of rACC produces CPA in the absence of noxious stimulation.

Operant tests also are indirect measures of pain affect. In these assays, animals perform learned (motivated) responses to escape from or avoid noxious stimulation (see for example [8]). In one type of escape paradigm, noxious stimulation is delivered in either one of two sides of a testing chamber. To escape, animals must move from the noxious side of the chamber to the other, non-noxious side. In another operant approach, animals learn to perform behaviors (e.g., bar pressing) to avoid noxious stimulation. Lastly, in tests of motivational choice, animals can choose to voluntarily expose themselves to a noxious stimulus to receive a reward such as food. Thus, the motivational drive to acquire a desired reward must be evaluated against the motivational drive to avoid the unpleasantness of noxious stimulation.

Increasing evidence from clinical and preclinical (animal) studies using electrophysiological, neurosurgical, and functional imaging methods strongly suggests a neuroanatomical basis for independent sensory and unpleasantness processing (reviewed in [9,10]). The sensory attributes of pain appear to be encoded in a lateral pain system projecting through specific lateral thalamic nuclei to the primary and secondary somatosensory cortices. In contrast, pain unpleasantness may be determined within a medial pain system that projects through the reticular formation to terminate in medial/intralaminar thalamic nuclei. The medial thalamus in turn projects (often reciprocally) to limbic and forebrain regions that process emotional stimuli and unpleasantness in other sensory systems such as the amygdala, insula and anterior cingulate cortex. Processing of nociceptive input within this limbic-forebrain circuit is thought to contribute to the generation of innate



affective and autonomic reactions, the coordination of pain-related motor activity, and the development of fear conditioning.

## References

1. Melzack R, Casey KL (1968) Sensory, motivational, and central control determinants of pain. In: Kenshalo DR (ed) *The skin senses*. Charles C. Thomas, Springfield, IL, pp 423–443
2. Melzack R (1975) The McGill Pain Questionnaire: major properties and scoring methods. *Pain* 1:277–299
3. Melzack R, Torgerson WS (1971) On the language of pain. *Anesthesiology* 34:50–59
4. Price DD, Harkins SW, Baker C (1987) Sensory-affective relationships among different types of clinical and experimental pain. *Pain* 28:297–307
5. Gracely RH (1992) Affective dimensions of pain: how many and how measured? *APS J* 1:243–247
6. Borszcz GS (2006) Contribution of the ventromedial hypothalamus to generation of the affective dimension of pain. *Pain* 123:155–168
7. Johansen JP, Fields HL, Manning BH (2001) The affective component of pain in rodents: direct evidence for a contribution of the anterior cingulate cortex. *Proc Natl Acad Sci USA* 98:8077–8082
8. Mauderli AP, Acosta-Rua A, Vierck CJ (2000) An operant assay of thermal pain in conscious unrestrained rats. *J Neurosci Methods* 97:19–29
9. Treede RD, Kenshalo DR, Gracely RH, Jones AK (1999) The cortical representation of pain. *Pain* 79:105–111
10. Vogt BA, Sikes RW (2000) The medial pain system, cingulate cortex, and parallel processing of nociceptive information. *Prog Brain Res* 122:223–235

## Emotional Arousal

### Definition

The arousing of a feeling or response of fear, anger, joy or sadness.

► Emotional Learning/Memory

## Emotional Arousal-influenced Learning and Memory

► Emotional Learning/Memory

## Emotional Learning/Memory

BENNO ROOZENDAAL

Center for the Neurobiology of Learning and Memory, Department of Neurobiology and Behavior, University of California, Irvine, CA, USA

### Synonyms

Emotional arousal-influenced learning and memory

### Definition

Memories of emotionally arousing experiences are generally well retained. The term “emotional learning/memory” refers to the phenomenon that remembrance of emotionally arousing experiences is typically more enduring and more vivid than that of emotionally neutral experiences. Studies investigating the neurobiological mechanisms underlying this phenomenon indicate that emotionally significant experiences activate hormonal and brain systems that regulate the formation of the memory of such experiences. Arousal-activated modulatory systems not only influence neurobiological processes underlying the consolidation of new information; they also affect other mnemonic processes, including ► [memory retrieval](#) and ► [working memory](#).

### Characteristics

#### Description of the Process

##### *Stress Hormone Effects on Learning and Memory*

This essay describes how acutely released stress hormones mediate ► [emotional arousal](#) (Emotion) effects on cognition. In recent years significant advances have been made in understanding the neurobiological processes underlying the strengthening of such memory traces. Emotionally arousing experiences induce the release of ► [epinephrine](#) from the adrenal medulla and ► [cortisol](#) (► [corticosterone](#) in rodents) from the adrenal cortex (Stress response). These stress hormones serve a large number of physiological functions, including influences on brain activity in modulating learning and memory. Chronic stress or sustained elevated levels of stress hormones also affect learning and memory processes. These effects, which are predominantly memory impairing, are due to either direct actions of the hormones on mnemonic processes or on brain organization or atrophy. In contrast, research on the effects of acutely administered or released stress hormones indicates that they have different effects on distinct components or phases of memory.

1. *Memory consolidation*: Adrenal hormones released by emotionally arousing experiences influence long-term memory by modulating ►memory consolidation processes [1]. Systemic injections of epinephrine administered, to laboratory animals, within minutes after training produce dose-dependent effects on subsequent long-term retention. Low doses enhance retention, whereas high doses impair retention. Administration of low doses of corticosterone or synthetic ligands immediately after training also enhances long-term retention. The memory-enhancing effects of glucocorticoids are mediated via an activation of the low-affinity glucocorticoid receptor. As the administration of these hormones several hours after training does not enhance later retention, such evidence indicates that they influence time-dependent processes underlying memory consolidation. Epinephrine and glucocorticoids, as well as stressful conditions that stimulate their release, also enhance memory consolidation in human subjects when administered shortly before or after learning. Adrenal stress hormones do not enhance memory consolidation of all kinds of training, but interact with training-associated endogenous emotional arousal to preferentially modulate memory consolidation of emotionally arousing experiences. Hormones from the hypothalamus or pituitary, such as corticotropin-releasing factor, adrenocorticotropin, enkephalins, vasopressin and oxytocin, as well as gonadal hormones (testosterone and estrogens) are also released during emotionally arousing experiences and either modulate memory consolidation directly or interact with other stress hormones in influencing the consolidation of memory of emotionally arousing experiences.
2. *Memory retrieval and working memory*: In contrast to the enhancing effects on memory consolidation, stressful experiences or the administration of glucocorticoids generally impair short-term memory in laboratory animals and humans. Further, when administered shortly before retention testing, glucocorticoids also impair retrieval of long-term memory [2]. Similarly, high circulating levels of glucocorticoids impair working memory in both rodents and humans. As with memory consolidation, these effects are mediated via an activation of glucocorticoid receptors but, in contrast to consolidation, the emotional arousal-induced impairments in memory retrieval and working memory are temporary and subside when the hormone levels return to baseline. Memory retrieval is also influenced by systemic administration of drugs affecting several other modulatory systems, including epinephrine, adrenocorticotropin,  $\beta$ -endorphin and vasopressin.
3. *Memory acquisition and encoding*: Some findings suggest that glucocorticoids can facilitate sensory and information processing during memory acquisition and encoding [3]. These effects appear to depend on an activation of the mineralocorticoid receptor, an adrenal steroid receptor subtype with a high affinity for corticosterone and cortisol. It is currently unknown whether other hormones also influence memory acquisition and encoding.

### Higher Level Processes

#### *Involvement of the Basolateral Amygdala*

The modulating effects of stress hormones and emotional arousal on learning and memory are integrated through influences involving the amygdala [4] (►Amygdala). The ►basolateral amygdala (BLA) is the region of the amygdala that is critical for such integration. Permanent lesions or reversible inactivation of this brain region prevent the memory-modulating effects of administered stress hormones. Further, agonists for adrenoceptors or glucocorticoid receptors infused into the BLA enhance memory consolidation, whereas antagonists for these receptors impair memory when administered shortly after training. Drugs affecting other stress-activated neurotransmitter systems, including vasopressin, dopamine and corticotropin-releasing factor, also enhance memory consolidation when administered into the BLA, whereas the administration of opiates, gamma-aminobutyric acid (GABA) receptor agonists or benzodiazepines impair memory consolidation. There is also considerable evidence from human studies consistent with those of animal studies indicating that the enhancing influence of emotional arousal on memory consolidation involves activation of the amygdala [5]. In human studies, however, the experiments have not as yet investigated the possible selective involvement of the BLA. In human subjects with amygdala damage, unlike subjects with an intact amygdala, emotionally arousing stimulation does not enhance long-term memory. The involvement of amygdala activation in emotionally influenced memory has also been shown in healthy humans with studies using positron emission tomography (PET) (Positron emission tomography) and functional magnetic resonance imaging (fMRI). These studies indicated that activity of the amygdala assessed during the presentation of emotionally arousing stimuli correlates highly with memory of the stimuli tested weeks later. Further, the relationship between amygdala activity during encoding and subsequent long-term memory is greatest for the most emotionally arousing stimuli and does not depend on the emotional valence (i.e., positive or negative) of the stimuli.

### **Role of Norepinephrine in the Basolateral Amygdala**

As epinephrine passes the blood-brain barrier poorly, it does not directly affect amygdala activity in influencing memory consolidation. Epinephrine effects on memory consolidation are mediated by stimulation of peripheral  $\beta$ -adrenoceptors located on the ascending vagus nerve that innervates brain stem noradrenergic cell groups in the nucleus of the solitary tract and locus coeruleus (Noradrenergic drugs). Noradrenergic projections originating in these brain nuclei innervate brain regions involved in memory consolidation, including the BLA. Extensive evidence indicates that the memory-enhancing effects of peripheral epinephrine involve the release of norepinephrine and activation of postsynaptic  $\beta$ - and  $\alpha_1$ -adrenoceptors in the BLA [4]. Blockade of noradrenergic transmission in the BLA with infusions of adrenoceptor antagonists prevents the memory-enhancing effects of peripherally administered epinephrine. Norepinephrine-induced activation of adrenoceptors in the BLA results in the activation of the cAMP/protein kinase A intracellular signal transduction pathway. Blockade of this pathway also prevents the memory-enhancing effects of either epinephrine or norepinephrine. Studies using *in vivo* microdialysis techniques to assess norepinephrine levels in the amygdala provide additional evidence that noradrenergic activation within the amygdala is importantly involved in influencing memory consolidation. In rats, footshock stimulation of the kind typically used in fear-based training induces the release of norepinephrine in the amygdala and the amount of norepinephrine released varies directly with the footshock intensity. Further, the magnitude of training-induced increases in amygdala norepinephrine levels assessed shortly after training correlates very highly with the rats' subsequent long-term retention performance. Studies of human subjects indicate that the administration of  $\beta$ -adrenoceptor antagonists blocks the increase in amygdala activity and enhanced retention induced by emotional stimuli.

Noradrenergic activation of the BLA is also essential in enabling glucocorticoid **▶modulation of memory** consolidation [6]. Although glucocorticoids are lipophilic and, thus, can bind directly to intracellular receptors in brain to induce gene transcription and protein synthesis, such genomic actions alone are insufficient to enhance memory consolidation. Glucocorticoid-induced memory enhancement also requires interactions with arousal-activated noradrenergic mechanisms within the BLA. New findings suggest that glucocorticoids can bind to membrane-bound glucocorticoid receptors to activate the noradrenergic signaling cascade via G-protein mediated mechanisms. Such conditional effects of glucocorticoids on memory consolidation via interactions with arousal-associated

noradrenergic activation fit well with evidence from studies of both animal and human subjects indicating that glucocorticoid enhancement of memory consolidation may be limited to emotionally arousing conditions that induce the release of norepinephrine [6]. Several other neuromodulatory influences on memory consolidation are also mediated through converging influences on noradrenergic transmission within the BLA. The interaction of epinephrine and glucocorticoids with noradrenergic influences in the BLA is summarized in Fig. 1.

The impairing effects of glucocorticoids on memory retrieval and working memory, like those obtained in studies of memory consolidation, depend critically on an interaction with noradrenergic mechanisms. Blockade of noradrenergic neurotransmission with systemic administration of a  $\beta$ -adrenoceptor antagonist prevents the impairment of memory retrieval and working memory induced by concurrent injections of corticosterone. Furthermore, inactivation of the BLA with either permanent lesions or infusion of a  $\beta$ -adrenoceptor antagonist prevents glucocorticoid-induced impairment of these memory functions. Such evidence is consistent with that from studies on memory retrieval in humans indicating that glucocorticoids or psychosocial stress impair only the retrieval of emotionally arousing information or during emotionally arousing test conditions. Further, the glucocorticoid-induced impairment of memory retrieval in humans, as well as rats, is blocked by concurrent administration of a  $\beta$ -adrenoceptor antagonist.

### **Basolateral Amygdala Interactions with Other Brain Regions in Modulating Emotional Learning and Memory**

Extensive evidence suggests that a region of the BLA, the lateral nucleus, may be a locus of neural changes underlying **▶fear-based memories** [7]. However, although the BLA is a critical brain site for integrating adrenergic, glucocorticoid and other stress-activated influences on memory consolidation, the BLA is not the locus of the long-term memory processes modulated by stress hormones. There is abundant evidence that the BLA is involved not only in modulating memory of aversively motivated training, such as footshock training used in inhibitory avoidance and Pavlovian **▶fear conditioning**, but also modulates the consolidation of memory for many other kinds of training experiences. And, as these different training experiences are known to engage different brain systems both during training and during the consolidation occurring after training, the BLA-induced modulation no doubt involves influences on processing occurring in these other brain regions [4]. The findings of many

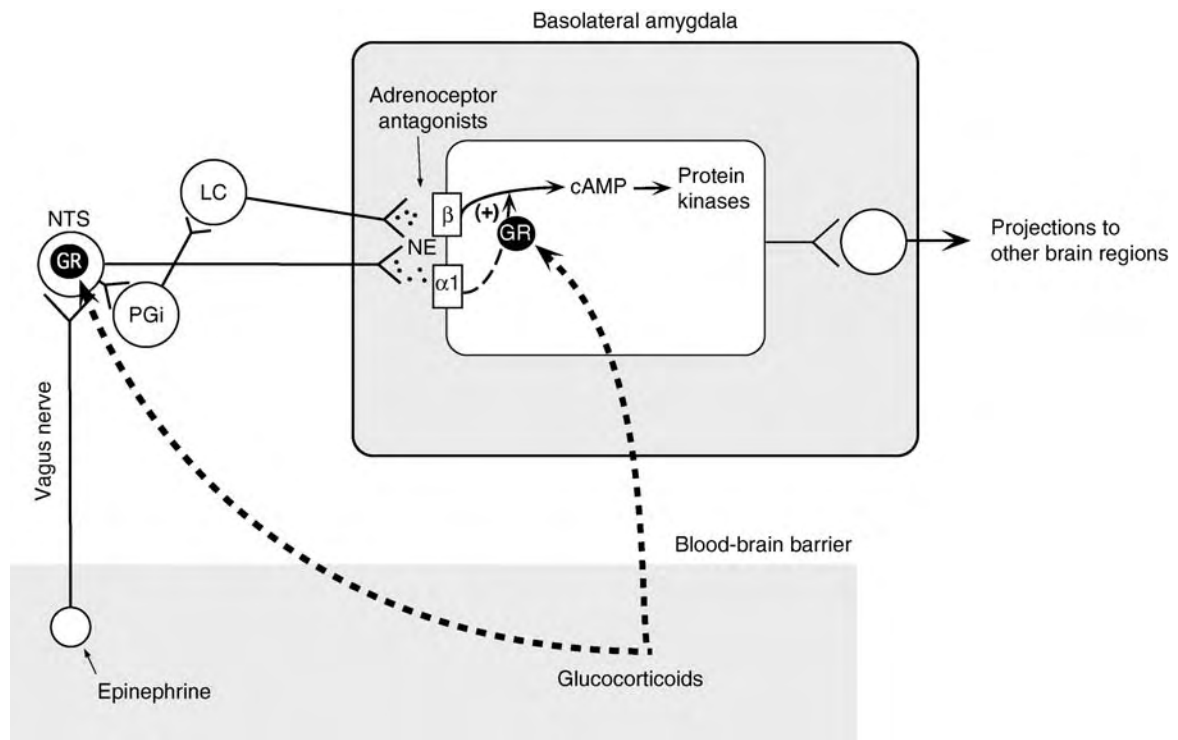

**Emotional Learning/Memory. Figure 1** Interactions of adrenal stress hormones with the noradrenergic system in the BLA in modulating memory consolidation. Epinephrine, which does not cross the blood-brain barrier, induces the release of norepinephrine (NE) in the BLA by activating vagal afferents to the nucleus of the solitary tract (NTS). Noradrenergic neurons in the NTS project directly to the BLA, and indirectly via the locus coeruleus (LC). Norepinephrine binds to both  $\beta$ -adrenoceptors and  $\alpha_1$ -adrenoceptors at postsynaptic sites and activates cAMP formation. Glucocorticoids freely enter the brain and bind to glucocorticoid receptors (GRs) in brainstem noradrenergic neurons to potentiate norepinephrine release in the BLA, as well as postsynaptically in BLA neurons to facilitate the norepinephrine signaling cascade. Glucocorticoids may influence the  $\beta$ -adrenoceptor-cAMP system via a coupling with  $\alpha_1$ -adrenoceptors.  $\alpha_1$  =  $\alpha_1$ -adrenoceptor;  $\beta$  =  $\beta$ -adrenoceptor; cAMP = adenosine 3',5'-cyclic monophosphate; PGi, nucleus paragigantocellularis. Reprinted with permission from Roozendaal B (2000) *Psychoneuroendocrinology* 25:213–238.

experiments provide strong evidence that BLA activation enhances memories of different types of experiences via interactions with a wide variety of brain regions. In rats, noradrenergic activation of the BLA enhances memory of training in many kinds of tasks, including water-maze spatial and cued tasks, inhibitory avoidance, contextual and cued fear conditioning, conditioned taste aversion and object recognition. These tasks are known to involve functioning of different brain regions. Conversely, inactivation of noradrenergic transmission in the BLA blocks the memory-modulating influences of drugs administered into the hippocampus (Hippocampal formation) or several cortical regions. Further, manipulation of BLA neuronal activity influences memory-associated changes in electrophysiological and molecular correlates of synaptic plasticity in a variety of efferent brain regions [8]. Other evidence suggests that synchronized oscillatory activity within the BLA may facilitate

cortical processes involved in memory consolidation [9]. An intact and functioning BLA is also required for regulating emotional arousal effects on the impairment of memory retrieval and working memory involving other brain regions [10]. Figure 2 summarizes the roles of adrenal stress hormones and BLA activation in modulating memory consolidation in other brain regions.

### Regulation of the Process

The effects of emotional stimulation on learning and memory are modulated by several factors, including age and gender. For example, stressful stimulation in female rats can, depending of the menstrual period, have opposite effects on eye-blink conditioning that it has in male rats. Females also appear to be less sensitive to the impairing effects of glucocorticoids on memory retrieval. In general, these differences tend to become smaller or disappear after menopause and, therefore, are thought to be mediated via modulating influences of

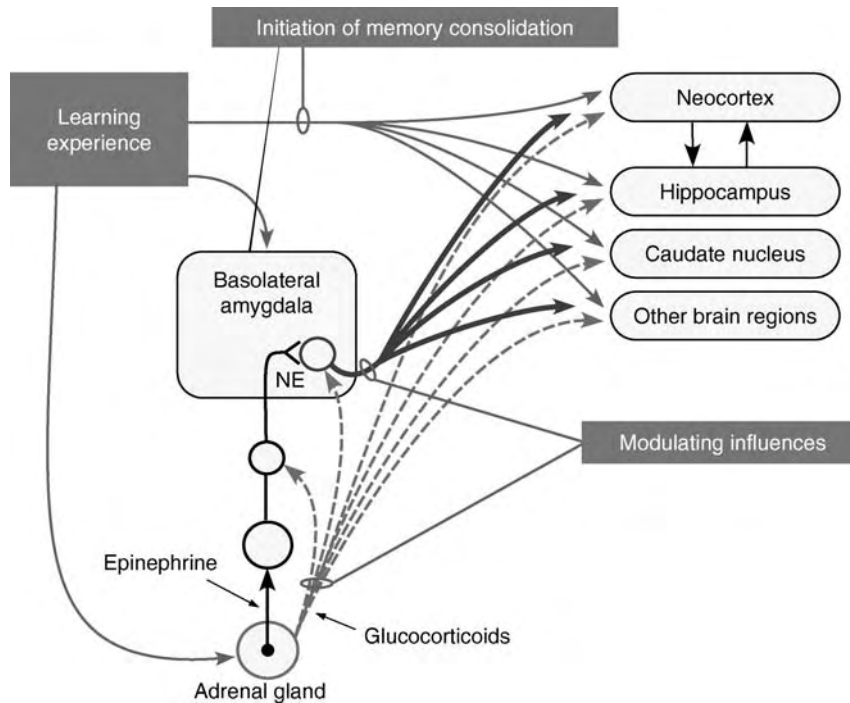

**Emotional Learning/Memory. Figure 2** Emotional arousal-induced modulation of memory consolidation. Experiences initiate memory storage in many brain regions involved in the forms of memory represented. Emotionally arousing experiences also release adrenal epinephrine and glucocorticoids and activate the release of norepinephrine in the BLA. The BLA modulates memory consolidation by influencing neuroplasticity in other brain regions. Reprinted with permission from McGaugh JL (2000) *Science* 287:248–251.

circulating estrogens. However, there are also permanent differences in brain organization between males and females in the processing of emotionally arousing information. A striking example is that exposure to emotionally arousing stimuli induces activation of the right amygdala in men, but of the left amygdala in women. Although the basis or consequences of such a hemispheric differentiation are not well understood, it has been proposed that gender-specific processing of either the details or gist of emotionally arousing information may play a crucial role.

### Function

It is, of course, essential for our adaptation and survival that we record and retain lasting memories of our significant experiences. The facilitating effects of emotional arousal and stress hormones on memory consolidation directly subserve this function. However, as indicated, emotional arousal also impairs memory retrieval and working memory. Such impairments may seem to be more difficult to reconcile with an adaptive function. Why do we have a modulatory system that makes us forget to remember during emotionally arousing test conditions such as stressful examinations or job interviews? One hypothesis suggests that a

temporary impairment of these memory functions may actually aid to an accurate consolidation of new information [10]. By impairing the retrieval of old information, this information is unable to interfere with the consolidation of new information, allowing this information to be stored without distortion. Thus, according to this hypothesis, the emotional arousal-induced impairment in memory retrieval and working memory also serves an adaptive function. But, stress hormones can also strengthen memories more than is necessary and create traumatic memories and post-traumatic stress disorder. Several lines of investigation indicate that understanding the neurobiological processes underlying emotional arousal effects on learning and memory may be useful in the development of new and efficacious therapies for stress-related memory disorders.

### References

1. McGaugh JL, Roozendaal B (2002) Role of adrenal stress hormones in forming lasting memories in the brain. *Curr Opin Neurobiol* 12:205–210
2. de Quervain DJ-F, Roozendaal B, McGaugh JL (1998) Stress and glucocorticoids impair retrieval of long-term spatial memory. *Nature* 394:787–790

3. Oitzl MS, de Kloet ER (1992) Selective corticosteroid antagonists modulate specific aspects of spatial orientation learning. *Behav Neurosci* 108:62–71
4. McGaugh JL (2003) *Memory and emotion: the making of lasting memories*. Columbia University Press, New York
5. Cahill L (2000) Modulation of long-term memory in humans by emotional arousal: adrenergic activation and the amygdala. In: Aggleton JP (ed) *The amygdala*. Oxford University Press, London, pp 425–446
6. Roozendaal B, Okuda S, Van der Zee EA, McGaugh JL (2006) Glucocorticoid enhancement of memory requires arousal-induced noradrenergic activation in the basolateral amygdala. *Proc Natl Acad Sci USA* 103:6741–6746
7. LeDoux JE (2000) Emotion circuits in the brain. *Annu Rev Neurosci* 23:155–184
8. Richter-Levin G, Akirav I (2003) Emotional tagging of memory formation – in the search for neural mechanisms. *Brain Res Rev* 43:247–256
9. Paré D (2003) Role of the basolateral amygdala in memory consolidation. *Prog Neurobiol* 70:409–420
10. Roozendaal B (2002) Stress and memory: opposing effects of glucocorticoids on memory consolidation and memory retrieval. *Neurobiol Learn Mem* 78:578–595

---

## Emotional Motor System

### Definition

In 1991, Gert Holstege suggested that three motor systems may be discerned in the central nervous system (CNS), the first, comprised by brainstem and spinal premotor interneurons, directly drives the cranial and spinal motoneurons responsible for muscle activation. The second (somatic) motor system acts mainly on the premotor neurons of “first motor system” to control the muscles of the head, neck, trunk, and limbs, with only limited direct synapses on motoneurons. Holstege’s third system or the “emotional motor system” targets diffuse projecting networks such as the locus coeruleus, raphe nuclei, and medial ventral tegmentum of the caudal pons which in turn increase motoneuron excitability and also modulate sensory afferents. Specific somatic and autonomic motor patterns are also elicited by the emotional motor system via projections to periaqueductal gray, and to the lateral tegmental fields of the caudal pons and medulla.

These include emotionally elicited movements of the head and eyes, emotional vocalizations, emotional modulation of respiratory and cardiovascular output, as well as emotional aspects of behaviors such as vomiting, swallowing, licking and chewing. Notably, the second and emotional motor systems have little direct anatomical interconnections at higher levels of the neural axis (with the possible exception of axons targeting locus coeruleus and the raphe nuclei), and

have topographically separate pathways to the premotor networks of the brainstem and spinal cord. These alternate projection corridors provide a rationale for the clinical observations of neural pathology that, for example, can preclude voluntary activation of facial muscles while leaving emotional activation of the same muscles intact (as with smiling or laughter). As a contrary example, in Parkinson’s disease emotional facial expression may be severely compromised (masklike facial expression), while voluntary activation of facial muscles may be demonstrated.

► [Extended Amygdala](#)

---

## Empty Sella

### Definition

Absence or strong atrophy of the pituitary gland.

► [Endocrine Disorders of Development and Growth](#)

---

## En bloc Preparations

### Definition

In vitro preparation of the brainstem and spinal cord containing brainstem respiratory-rhythmic neurons, spinal tracts and spinal nerve roots that innervate muscles of respiration.

► [Respiratory Network Analysis](#)

► [Isolated Respiratory Center Functions](#)

---

## En Passant Synapses

### Definition

An “en passant” (French for in passing) synapse is a non-terminal synaptic contact on another neuron made before the “passant” axon continues to its terminal synapse. (See bouton en passant above.)

## Enantiomers

### Definition

Compounds of identical molecular composition that differ only in the three-dimensional arrangement of their atomic groupings.

## Ena/VASP

### Definition

A family of proteins involved in actin filament nucleation and elongation. Ena/VASP proteins are substrates for the kinase PKA which is activated following neurotrophin binding. Ena/VASP enhances actin filament elongation by recruiting actin complexes to sites of active actin remodeling such as the tips of lamellipodia.

► [Neurotrophic Factors in Nerve Regeneration](#)

## Encephalitis

### Definition

An inflammation of the brain caused by infections. Cerebral edema accumulates, causing destruction of nerve cells, bleeding (intra-cerebral hemorrhage) and brain damage. Tight junction: an intercellular junction, which tightly occludes the intercellular space in order to limit or eliminate intercellular passage of molecules.

► [Neuronal Cell Death and Inflammation](#)

## Encephalization

### Definition

Those increases in brain size that cannot be accounted for by scaling to body size alone.

► [Evolution of the Brain: in Birds](#)

## Encephalomalacia

### Definition

A process of tissue softening within the brain. It can result from an old injury, due to degenerative process or after stroke.

► [Gliomas](#)  
 ► [Stroke](#)

## Encephalomyelitis

### Definition

An inflammation of the brain and spinal cord due to infectious or immune-related causes. The most common types of encephalomyelitis are acute disseminated encephalomyelitis (ADEM) – a demyelinating disease that most often affects children following a viral infection or vaccination; and viral encephalomyelitis.

Symptoms associated with encephalomyelitis depend upon the area of brain or spinal cord involved, but typically include change in level of consciousness or coma, seizures, weakness or paralysis, and loss of sensation in one or more limbs. Diagnosis is typically made by demonstration of abnormalities of the brain and spinal cord by magnetic resonance imaging.

► [Acute Disseminated Encephalomyelitis \(ADEM\)](#)

## Encephalon

### Synonyms

Brain

### Definition

Encephalon comprises the part of the CNS located in the calvaria.

► [General CNS](#)

## Encephalopathy

### Definition

Acute Organic Brain Syndrome; Acute diffuse or multifocal disturbance of the content aspect of consciousness as opposed to chronic impairment, which is called ▶ **dementia**. Encephalopathy may result from structural (injurious) or metabolic changes. The first often affect the ascending arousal system originating in the ▶ **brainstem reticular formation**. The second are consequences of effects on the ▶ **forebrain** of a long list of metabolic or toxic influences, including e.g. lack of nutrients and oxygen, changes in ionic and hormone concentrations, seizures, drugs, consequences of liver and renal failure, inflammation (▶ **encephalitis**, ▶ **meningitis**).

## Encoder

### Definition

Structure in a sensory receptor (and central and other neurons), which transforms graded, amplitude-modulated changes in membrane potential into series of action potentials.

▶ Sensory Systems

## Encoding Site

### Definition

In sensory receptors, the encoding site is the place where the generator potential gives rise to (is encoded into) a series of action potentials. It may be located in the receptive terminal or, in myelinated fibers, at the level of the first node of Ranvier (heminode)

▶ Sensory Systems

## Encoding Specificity

### Definition

The principle postulating that the ability to retrieve information in the episodic memory system depends on

the degree to which information in the cue was incorporated into the memory trace of the target event at the time of its original encoding.

▶ Episodic Memory

## Endbuds

### Definition

Putative electroreceptors of lampreys.

▶ Electroreceptor Organs  
▶ Evolution of Mechanosensory and Electrosensory Lateral Line Systems

## Endocast

### Definition

Cast made from the internal table of bone of the cranium.

▶ Evolution of the Brain in Humans – Paleoneurology

## Endocrine

### Definition

Referring to internal secretion; e.g. release and transport of hormones from glands into the blood and effective in specific target organs.

## Endocrine and Metabolic Myopathies

### Definition

These myopathies may manifest as muscle weakness or fatigue secondary to endocrine diseases such as thyroid, parathyroid, adrenal, ▶ **pituitary** disorders, and vitamin D deficiency.



## Endocrine Cells

### Definition

Cells specialized to synthesize and release hormones into the blood stream.

## Endocrine Disorders of Development and Growth

PAUL J. LUCASSEN<sup>1</sup>, DICK F. SWAAB<sup>2</sup>

<sup>1</sup>SILS Centre for Neuroscience, University of Amsterdam, Amsterdam, The Netherlands

<sup>2</sup>Netherlands Institute for Neuroscience, Meibergdreef, Amsterdam, The Netherlands

### Definition

Developmental hypothalamus related brain malformations are discussed.

### Characteristics

Development of the human brain is a complex and tightly controlled process. Given its divergent nature, early aberrations can cause major anomalies. Failure of proper neural tube closure or midline defects involve hypothalamic and pituitary related defects that result in severe and lasting neuroendocrine and other disorders [1].

### Anencephaly

Anencephaly is a rare but severe neural tube defect. Its etiology is heterogeneous; various agents and conditions such as maternal nutritional status and teratogens may cause anencephaly, whereas X-linked forms are also known. Anencephaly is thought to result from a failed fusion of the rostral neuropore around the second week after conception. An anencephalic child lacks any definable brain structure rostral of the brainstem (Fig. 1).

The neural tissue in the remaining areas including the hypothalamus is an amorphous mass of primitive nerve cells and blood vessels. Anencephalic fetuses hence display pituitary development in the absence of the hypothalamus, which can reveal functions of the fetal hypothalamus in intrauterine development and onset of birth.

Birth weight and placenta weight is reduced in anencephalic children, their gestational length is generally shorter due to hyrannios and the course of labor is protracted. Also intrauterine growth rate is lower

than in controls, suggesting that the fetal brain directly participates in the regulation of its own growth and timing of birth. This idea is consistent with previous observations where gestational length was for example increased in cattle with fetal pituitary aplasia or dystopia. Later studies demonstrated that the fetal hypothalamo-pituitary-adrenal axis is indeed actively involved in the initiation of labor, in particular in the normal timing of the moment of birth around 40 weeks of pregnancy. The marked release of fetal vasopressin from the hypothalamic paraventricular nucleus normally occurring in spontaneous labor and its absence in anencephalics, together with the large proportion of anencephalic children that die during the process of labor, point to the importance of intact fetal brain systems for withstanding the stress of birth. Fetal vasopressin may be involved in redistribution of the fetal circulation to the most vital organs during the process of birth.

### Congenital Midline Defects; Septo-optic Dysplasia (De Morsier's Syndrome)

Congenital midline defects are associated with an impaired midline cleavage of the embryonic forebrain and include various grades of severity of holoprosencephaly, schizencephaly, septo-optic dysplasia and dystopia of the neurohypophysis. Holoprosencephaly is the most common brain malformation in humans with different severities; alobar, semilobar and lobar forms are distinguished. In the first form, the prosencephalon fails to cleave sagittally into cerebral hemispheres, transversely into telencephalon and diencephalon and horizontally into olfactory tracts and bulbs. This results in an absence of large parts of the olfactory system, agenesis of the corpus callosum and hypopituitarism. The centrally located hypothalamus is one of the most severely affected structures and



**Endocrine Disorders of Development and Growth.** Figure 1 An anencephalic child showing the absence of definable brain structures rostral of the brain stem.

many holoprosencephalic children exhibit for example diabetes insipidus or anterior pituitary dysfunction.

Septo-optic dysplasia (De Morsier's syndrome) (Fig. 2) is a developmental anomaly of midline structures characterized by uni- or bi-lateral hypoplasia of the optic nerves, tracts and chiasm and by an absence of the septum pellucidum.

Children with optic nerve hypoplasia are blind in 20–50% of cases or severely visually impaired.

The homeobox gene HESX1 is implicated in a familial form of septo-optic dysplasia and hypopituitarism is an important component of this syndrome. The endocrine deficiencies vary from isolated growth-hormone (GH) deficiency to panhypopituitarism. Neuropathological studies have revealed that the optic nerves are severely affected. The hypothalamic supraoptic and paraventricular

nuclei are either absent or affected as well. This may explain the varying degrees of diabetes insipidus in these cases.

### Dystopia of the Neurohypophysis

Pituitary ectopias generally involve a disturbed developmental descent of the neurohypophysis. In true ectopia, the pituitary fossa only contains adenohypophysial tissue and lacks endocrine abnormalities. This condition is very rare and mostly not associated with clinical symptoms.

Acquired dystopia of the pituitary may result from perinatal injury causing stalk transection and subsequent regeneration of fiber tracts of the hypothalamo-neurohypophyseal system resulting in newly formed ectopic posterior lobe tissue at the proximal

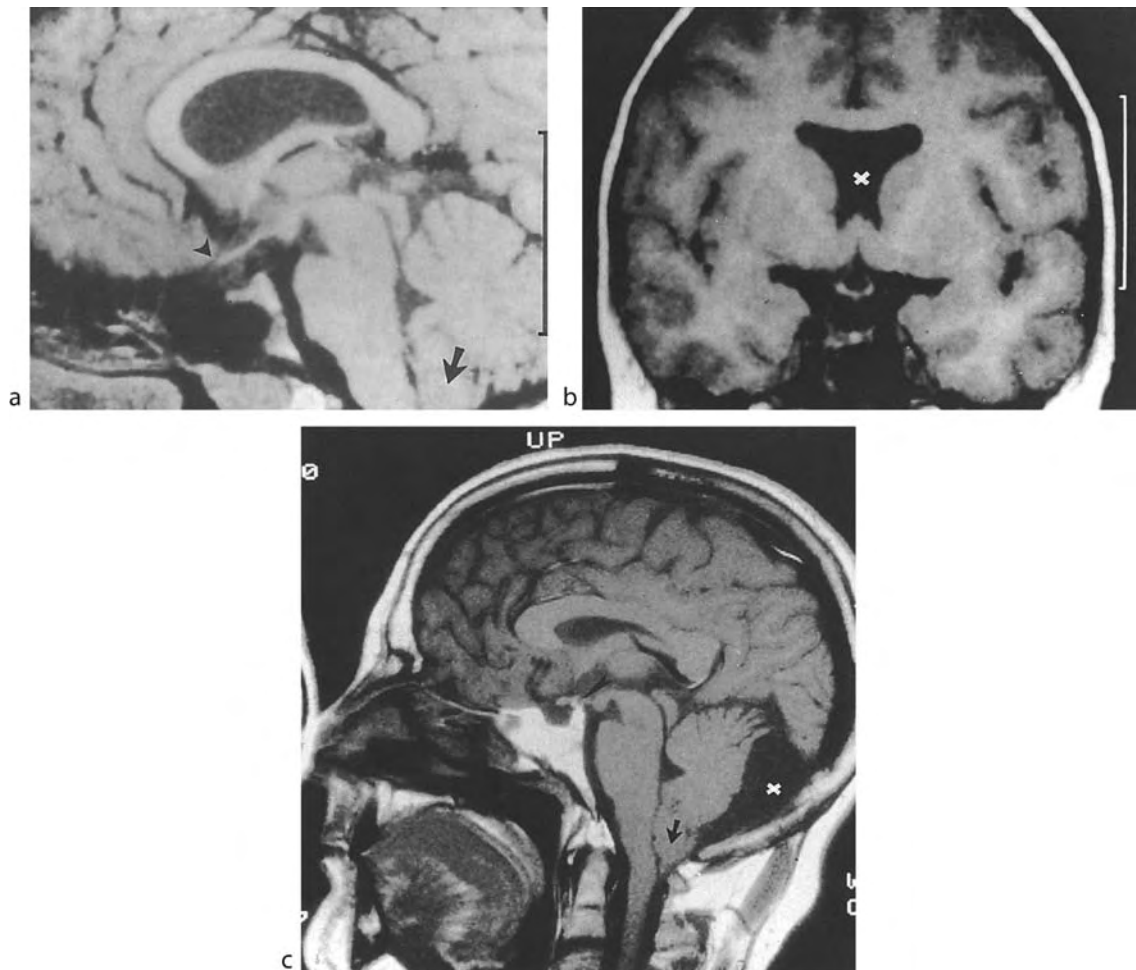

**Endocrine Disorders of Development and Growth. Figure 2** (a) Sagittal image of septo-optic dysplasia; severe hypoplasia of the pituitary gland, the stalk and the chiasma (*arrowhead*). Partial ectopy of the cerebellar tonsils in the foramen magnum (*arrow*). (b) Coronal image of septo-optic dysplasia; absence of the septum pellucidum indicated by the *cross*. (c) Sagittal image of posterior pituitary ectopia (*arrowhead*), hypoplastic anterior pituitary, ectopia of the cerebellar tonsils (*arrow*) and the arachnoid cysts, posterior of the cerebellar hemispheres (*cross*). From [2] figs. 2–4, with permission.

stump. Prenatal congenital disconnection defects that subsequently affect hypothalamo-pituitary function can also occur.

Dystopia of the neurohypophysis in individuals without clinical symptoms has to be distinguished from the dystopia in patients with anterior pituitary abnormalities like pituitary dwarfism (isolated growth hormone deficiency) or other pituitary hormone deficiencies like central diabetes insipidus. In addition, periventricular heterotopias may be present where the adenohypophysis can be hypoplastic, the infundibulum absent and the posterior lobe located ectopically.

A large majority of the patients with anterior pituitary abnormalities experienced perinatal problems. However, the perinatal problems do not seem to be causal, since the presence of several accompanying brain anomalies such as microcephaly, facial or sella abnormalities, an ectopic or absent neurohypophysis, periventricular heterotopias, a thin or absent pituitary stalk, optic nerve hypoplasia and a HESX1 mutation, together suggest primarily early congenital disconnection defects in at least some patients that are later followed by hypothalamo-pituitary anomalies. Because of the active role of the fetus in labor, such congenital developmental brain defects may contribute first to labor problems and later to for example growth hormone deficiency.

### Alterations in the Growth Hormone Axis in Development

Besides gross structural abnormalities, dysregulation of hypothalamic function can seriously impact growth of the body and brain. Growth hormone (GH) synthesis is regulated by several hypothalamic factors delivered to the pituitary gland. Growth hormone releasing hormone (GHRH) stimulates, whereas somatostatin (SOM) inhibits growth hormone production. In addition, GH secretion is controlled by autocrine connections. GHRH and SOM release are modulated by NPY, POMC, galanin, thyroid, gonadal and adrenal hormones as well as by acetylcholine, which inhibits SOM in the hypothalamus. Growth hormone releasing peptide (GHRP), ghrelin, which is involved in food intake, is an endogenous ligand for the GH secretagogue receptor and stimulates GHRH release. GH itself has further been implicated in feeding, sleep and learning and memory.

Shortly after birth, GHRH induces GH hyperresponsiveness caused by a reduced sensitivity of the pituitary to SOM. After the fourth decade, this response and the GH levels decline, but even when longitudinal growth has stopped, GH continues to affect regulation of body metabolism. Cases with previous hypothalamic or pituitary diseases or patients who are deficient in GH may suffer from adiposity and a reduced physical fitness, which are often paralleled by social phobia and depression. When put on replacement therapy, many patients report improvements, indicating lasting central

effects of GH in adulthood. Indeed, GH can act directly on the brain, since GH receptors are present.

### Noonan Syndrome

In 1963, Noonan and Ehmke described children with a typical facial appearance, i.e. hypertelorism, down slanting palpebral fistures, ptosis and low set posteriorly rotated ears. Both familial and sporadic cases exist. Polyhydramnios complicates 33% of the affected pregnancies. Growth rate is reduced, puberty is often delayed and there is hypotonia in young children. In 76% feeding difficulties occur, abnormal hearing is present in 40% and abnormal vision in 94% of affected children. GH secretion in Noonan syndrome is characterized by a low amplitude that is held responsible for the short stature and low growth rate.

### Multiple Pituitary Deficiencies, Isolated Growth Hormone Deficiency

Patients with multiple pituitary deficiencies, including GH deficiencies, generally have suprasellar damage that is paralleled by neuroendocrine changes such as a severe GH deficiency. Isolated growth hormone deficiency is characterized by a hypoplastic anterior pituitary lobe, an absent infundibulum and an ectopic posterior pituitary. Pediatric patients with mitochondrial myopathy, encephalopathy and lactic acidosis may also suffer from GH deficiency. Children with organic causes for GH deficiency such as congenital malformation, tumors or chemotherapy suffer from additional changes in their hypothalamo-pituitary-adrenal axis, possibly due to a disruption of central control pathways.

Children with GH deficiency are generally of normal intelligence, but do have learning and behavioral problems. These children are shy, withdrawn and have problems with mood and attention but these symptoms decline after GH replacement therapy. Early GH therapy leads to a rapid catch up of cranial growth.

Multiple pituitary deficiencies go together more frequently with empty sella (34%) than isolated GH deficiency (less than 10%), in which few abnormalities of the sellar region are found. Empty sella is considered to be of congenital origin but is also common in patients with benign intracranial hypertension where it may occur secondary to pituitary apoplexy. About 50% of the adult patients with primary empty sella have anti-pituitary antibodies indicative of previous autoimmune hypophysitis. Primary empty sella syndrome is frequently accompanied by GH deficiency and hypogonadotropic hypogonadism, but not by central hypothyroidism.

### Genetic Forms of GHRH Deficiency

An autosomal recessive form of hypothalamic GHRH deficiency exists. This is a genetically heterogeneous group of disorders that are generally inherited as an

autosomal recessive trait. The pituitary and hypothalamus appear normal.

1. Several families with GHRH resistance due to an inactivating mutation in the GHRH-receptor gene have been described as well. They resemble in many aspects the “little mouse” animal model that has a single base change (A to G) in the gene for the GHRH receptor. The clinical picture of homozygous individuals with the inactivating GHRH-receptor mutation largely resembles that of severe, isolated GH deficiency. The affected individuals look like miniature versions of normal people. Although intelligence appears normal, the skull is considerably smaller than that which has been described in classic GH deficiency. This is in agreement with the microcephalus described in the “little mouse”. The endocrine profile corresponds to that of isolated growth hormone deficiency.

In hereditary Gitelman disease, growth hormone deficiency is associated with a partial vasopressin deficiency, empty sella and a renal tubular disorder. It is caused by mutations in the sodium chloride transporter gene (TSC; SLC12A3). In Down’s syndrome, the neuronal control of GHRH secretion is impaired.

## References

1. Swaab DF (2003) The human hypothalamus. Basic and clinical aspects, pt. 2: Neuropathology of the hypothalamus and adjacent brain structures. In: Aminoff MJ, Boller F, Swaab DF, (eds) Handbook of clinical neurology. Elsevier, Amsterdam
2. Zucchini S, di Natale B, Ambrosetto P, De Angelis R, Cacciari E, Chiumello G (1995) Role of Magnetic resonance imaging in hypothalamic-pituitary disorders. *Horm Res.* 44 Suppl 3:8–14

---

## Endocytosis

### Definition

Endocytosis is the process of taking up extracellular components by folding in and pinching off short segments of the cell membrane to form intracellular vesicles.

---

## End-of-dose Wearing Off

### Definition

The wearing off of the beneficial effects of a dose of levodopa before the next dose takes effect. In this

situation, the patient with Parkinson disease feels the need for the next dose of levodopa before the next dose is due.

### ► Parkinson Disease

---

## Endogenous Analgesia System

### ► Descending Modulation of Nociception

---

## Endogenous Antipyretics

### Definition

Inherent mediators liberated both systemically and within the brain during fever that counter the formation or action of endogenous pyrogens, or inhibit the activity of neural circuits that modulate febrigenesis. They thus prevent the height of fever from reaching a potentially dangerous level. They include certain cytokines, neuropeptides, glucocorticoids, hormones, nitric oxide, and others.

### ► Endotoxic Fever

---

## Endogenous Burster

### Definition

A neuron that possesses the intrinsic ability to respond to a prolonged excitatory drive with an oscillation of the membrane potential (i.e. alternating depolarizations and hyperpolarizations) that can drive bursts of action potentials. The membrane potential oscillations are not caused by rhythmic synaptic inputs, but are the result of interactions between different types of voltage-gated ion channels. The depolarization at the beginning of a burst is often due to the activation of a persistent  $\text{Na}^+$  current or a low-voltage activated  $\text{Ca}^{2+}$  current. Activation of these currents can be self-sustaining as the depolarization caused by their activation is sufficient to keep these types of channels activated. Their prolonged activation leads to an increase in

intracellular  $\text{Ca}^{2+}$  or  $\text{Na}^+$  concentrations, which can activate  $\text{Ca}^{2+}$ - or  $\text{Na}^+$ -dependent  $\text{K}^+$  currents. Activation of these channels will terminate the depolarization and cause a hyperpolarization of the membrane potential. Alternatively, the depolarization can be terminated by a slow activating voltage-gated  $\text{K}^+$  current (e.g.  $I_A$ ). The hyperpolarization of the membrane potential at the end of the burst is self-limiting as it will remove the signal that activated the channels responsible for the hyperpolarization. A new burst can either be initiated if the excitatory drive is still present, or it can be triggered endogenously by the action of a slow hyperpolarization-activated inward current,  $I_h$ .  $I_h$  can be activated by the hyperpolarization at the end of a burst leading to a slow depolarization, activating voltage-gated ion channels responsible for the depolarization during a burst. Endogenous bursters are often also referred to as pacemaker neurons.

► Central Pattern Generator

## Endogenous Depression

► Major Depressive Disorder

## Endogenous Oscillations

### Definition

Molecular, physiological or behavioral rhythms that persist in constant conditions without any exogenous time information (free-running oscillations). Endogenous oscillations are generated by an intrinsic pacemaker or clock.

► Circadian Rhythm  
► Clock Coupling Factors

## Endogenous Receptor Agonists

► Respiratory Neurotransmitters and Neuromodulators

## Endolymph

### Definition

A unique fluid that resides inside the membranous labyrinth and consists of a solution similar to intracellular fluids with a high potassium and low sodium content.

► The Peripheral Vestibular Apparatus

## Endomysium

### Definition

The fascia that covers the full perimeter of each muscle fiber, with the exception of its ends. It forms the wall of a “tunnel” in which the muscle fiber operates.

► Intramuscular Myofascial Force Transmission  
► Skeletal Muscle Architecture

## Endoneurial Pathways

### Definition

Longitudinal basal lamina (equivalent to the basement membrane, with large components of laminin and fibronectin) profiles that provide a track for regenerating axons from the proximal nerve to use as they regrow within the distal nerve. These are synonymous to endoneurial tubes (see Bands of Bungner).

► Peripheral Nerve Regeneration and Nerve Repair

## Endorphins

### Definition

A group of endogenous (produced by the pituitary gland, the hypothalamus other brain areas) hormones (e.g. beta endorphin, met-enkephalin) that are chemically similar

to opiate drugs. Endorphins are involved in coping with acute stress and modulating the perception of pain; they may also have a role in mobilizing the immune system.

► Neuroendocrinology of Psychiatric Disorders

## Endosome

### Definition

Endosome is a membrane-bound compartment within a cell, which is often the target of protein-transporting endocytic membrane vesicles that pinch off from the cell membrane. From there proteins can be recycled back to the plasma membrane or targeted for degradation in lysosomes.

## Endothelial Cell

### Definition

Endothelial cells form the inner lining of blood vessels. The endothelial cell layer may be leaky, with gaps in the junctions between the cells, as in the glomeruli of the kidney, or the cells may be closely associated with one another to form a relatively impenetrable barrier between the blood and the surrounding tissue, as in the brain where the blood-brain barrier is mainly due to the tight association of endothelial cells. The cells have many transport molecules in both sides to allow molecules to be transferred from blood to tissue and vice versa. After injury endothelial cells may proliferate, and are one of the sources of granulation tissue.

► Blood-brain Barrier  
► Glial Scar

## Endothelial Nitric Oxide

### Definition

A substance produced and secreted by vascular endothelial cells, and is a potent regulator of vascular function. Nitric oxide diffuses from endothelial cells

into underlying smooth muscle, causing relaxation, which results in vasodilation.

## Endotherm

### Definition

An animal that maintains a constant body temperature regardless of the surrounding temperature. Animals in this group include birds and mammals.

► Evolution of the Hypothalamus in Amniotes

## Endothermy

### Definition

Indicative of a physiology in which heat is generated from internal body processes rather than obtained from external heat sources (ectothermy)

► The Phylogeny and Evolution of Amniotes

## Endotoxic Fever

CLARK M. BLATTEIS  
University of Tennessee Health Science Center,  
College of Medicine, Memphis,  
TN, USA

### Synonyms

Pyrexia, Hyperpyrexia

### Definition

The term ►fever specifically defines the elevation of body core temperature ( $T_c$ ) that characteristically occurs in most animals in response to the invasion of their body by infectious microorganisms such as bacteria (e.g. *Staphylococcus*, *Salmonella*), viruses (e.g. *influenza*), parasites (e.g. *filaria*), and fungi (e.g. *Candida*). It is also a frequent reaction to non-microbial illnesses, e.g. autoimmune and neoplastic diseases, some host-derived substances, e.g. antigen-antibody complexes,

as well as to certain synthetic products, e.g. antitumor agents and immunoadjuvants. The English word *fever* stems from the Latin word *febris*; pyrexia is a synonym derived from the Greek word *pyretos*. In humans,  $T_c$ s above  $38^\circ\text{C}$  are generally considered clinical fevers. The  $T_c$  rise is induced by fever-producing, host-derived mediators called *endogenous pyrogens*, resulting in an elevation of the ►set-point of  $T_c$ . Accordingly, the higher  $T_c$  is established and defended by the *active* cooperation of heat-producing (thermogenic; e.g. shivering, “chills”) and heat-dissipating (thermolytic; e.g. shift of blood flow to or away from the skin via cutaneous vasomotion) thermoeffectors. Fever is thus distinct from *hyperthermia*, a condition in which the  $T_c$  rise is the *unavoidable* consequence of the *passive* gain of heat (from external [e.g. warm environment] or internal [e.g. physical exercise] sources) in excess of the capability of *active* thermolytic effectors to dissipate it. The two terms should, therefore, not be used interchangeably. Magnitudes, durations and patterns of natural fevers vary, but an upper limit ( $40.5^\circ\text{C}$  in humans) is seldom exceeded. Hyperpyrexia is a medical emergency defined as a  $T_c$  over  $41.1^\circ\text{C}$ .

## Characteristics

### Description

The invasion of the body by infectious live or inanimate agents entrains, after a variable delay (termed the *latent* or *prodromal* period), the duration of which depends on the pathogen type, its amount and localization in the body, certain physiological variables of the host, and other conditions), an array of nonspecific, stereotyped, systemic reactions designed to combat the deleterious effects of the invading pathogens and to restore health to the afflicted host. These reactions are collectively termed the *acute-phase reaction* (APR) and comprise both autonomic [1] (e.g. changes in the levels of various plasma proteins [“acute-phase proteins”] and trace metals, in the secretion of certain pituitary hormones, in intermediary metabolism) and behavioral [2] (e.g. somnolence, anorexia, anhedonia) components. They constitute, therefore, the primary host defense response. Fever is the most manifest among these and consequently is regarded as the hallmark of infection; i.e. it is not the disease, but its clinical sign.

Our knowledge of the mechanisms underlying fever derives largely from studies using animals in which a low-to-moderate dose of a fever-producing (*pyrogenic*) agent is administered peripherally as a bolus. In most instances, this material is an extract of the outer wall of Gram-negative bacteria (*bacterial endotoxic lipopolysaccharide*, LPS); a biphasic rise in  $T_c$  is consequently generated that, due to its causative agent, typifies ►endotoxic fever. LPS and other fever-producing pathogens that originate outside of the body are termed *exogenous pyrogens*.

It is well established that the brain region that controls  $T_c$  is the preoptic area (POA) of the anterior hypothalamus. It receives thermal inputs from the periphery and from other brain regions, it is itself thermosensitive, and it modulates the coordinated effector activities that counteract deviations in  $T_c$  due to any cause. Furthermore, it is responsive to both local and peripheral pyrogenic stimuli [3]. The  $T_c$  rise of fever is attributed to a regulated change in the characteristics of this neural controller. The details of the neural circuits and molecular mechanisms that underlie the febrile response are, however, still incompletely known.

## The Febrile Process

### Afferent Pyrogen Signaling

Exogenous pyrogens that gain access to the body are not, as indicated earlier, the agents that directly induce fever and its non-thermal acute-phase correlates. Rather, these responses arise as the result of a phased sequence of interactions among soluble factors and cells that is initiated in the periphery by the presence of the exogenous pyrogens; relevant signals are transmitted to the POA, which modulates the febrile response. Thus, foreign materials that have penetrated the body are immediately recognized through their unique molecular patterns (“pathogen-associated molecular patterns,” PAMPs) by specialized receptors on the host’s immune cells. These receptors, called Toll-like receptors (TLRs), occur predominantly on mononuclear phagocytes (e.g. circulating and resident macrophages). Their activation transduces the pathogenic signals into intracellular molecular processes that eventuate in the concatenated production of endogenous factors that mediate the APR. LPS acts via the TLR4, bacterial (CpG) DNA via the TLR9, and viruses via the TLR3 receptors; other PAMPs activate other TLRs, but it would appear that the cascades of mediators thus produced are similar [4].

These mediators belong to the class of immunoregulatory, pleiotropic polypeptides called ►cytokines. Most prominent among these for fever induction are interleukins (IL)- $1\beta$  and IL-6, tumor necrosis factor (TNF)- $\alpha$ , and interferons (IFN)- $\alpha$  and IFN- $\gamma$ ; they are released into the extracellular fluid [5]. Following the intravenous (iv) administration of LPS, TNF- $\alpha$  normally appears in the bloodstream first, followed by IL- $1\beta$ , and lastly by IL-6; IFNs do not occur or occur late – they are induced predominantly in response to viruses and their products and partially to CpG DNA. The functional levels of these ►cytokines are modulated by the sequential, time-dependent release at different points along the febrile course of their own antagonists, e.g. specific target cell-surface antagonists (e.g. IL-1 receptor antagonist [IL-1Ra]), soluble blood-borne receptors (e.g. soluble TNF receptor type II), and

inhibitors of their synthesis (e.g. glucocorticoids) or their actions (e.g. arginine vasopressin in the brain). These ►**endogenous antipyretics** constitute an essential, autoregulatory feedback that serves to prevent an exaggerated fever from occurring during systemic infectious challenges [6].

The original concept of fever induction posited that these cytokines are transported to the POA by the bloodstream, to activate it. Indeed, they induce fever when microinjected into this site, whereas the administration of their antagonists suppresses it. Specifically, the pyrogenic cytokines inhibit the activity of warm-sensitive (probably by increasing the presynaptic release of GABA) and synaptically excite that of temperature-insensitive (and synaptically also of cold-sensitive) neurons located there, consistent with the diminished heat loss and enhanced heat production that these cells, respectively, mediate [3], suggesting therefore that they could be their direct targets. Subsequent research, however, has indicated that neuronal activity consistent with the generation of fever is more likely modulated by another mediator, prostaglandin (PG) $E_2$ , induced secondarily *de novo* by the cytokines in the POA. Further studies have established that its formation depends on the inducible isoforms of the enzymes cyclooxygenase-2 (COX-2) and microsomal PGE synthase-1 (mPGES-1). Indeed, drugs that inhibit PGE $_2$  synthesis, e.g. nonsteroidal anti-inflammatory drugs (NSAIDs; e.g. aspirin), are potent antipyretics. This concept of the process of infectious fever production, now classical, is illustrated in Fig. 1.

The plausibility of this sequence was questioned, however, when the molecular biology of these mediators became better understood. Thus, it was learned that pyrogenic cytokines are not expressed constitutively in phagocytic cells, but induced *de novo* in response to their activation by exogenous pyrogens; this synthetic process requires ~30–45 min. Indeed, cytokines appear in the bloodstream significantly later than the onset of fever induced by LPS injected iv (~10 min). Furthermore, their penetration into the brain became an issue when it was appreciated that, as large hydrophilic peptides, their free diffusion across the blood-brain barrier (BBB) was improbable. Finally in this context, it was found that the cytokine-induced upregulations of COX-2 and mPGES-1 in the POA require, in conscious rats at least, a minimum 45 min. Several alternatives were consequently proposed to counter these inconsistencies [7], but, although all were based on sound experimental data, they did not resolve the issue of the temporal discrepancy between the first appearance of cytokines in blood or of PGE $_2$  in the POA and the short latency of the febrile response to iv injected LPS. Another intermediary evoked by LPS more rapidly than cytokines should therefore be operating.

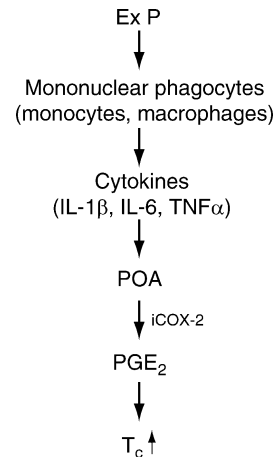

**Endotoxic Fever. Figure 1** The classical concept of the sequential mechanism of LPS fever induction. Exogenous pyrogens (Ex P) invading the body quickly encounter circulating and resident mononuclear phagocytes, stimulating them to produce pyrogenic cytokines. These mediators, in turn, are released into the bloodstream and transported to the POA, inducing there COX-2 and the consequent production of PGE $_2$ , the putative, final, central fever mediator. Modified from [10].

Indeed, this interposed peripheral mediator was very recently identified to be PGE $_2$ , produced by hepatic macrophages (Kupffer cells [Kc], the largest population of macrophages in the body) [8]. Its critical involvement is based on the following evidence: (i) the onset of endotoxic fever is best correlated with the first appearance of LPS in the liver, irrespective of its route of administration, (ii) the level of PGE $_2$  rises in hepatic venous blood very quickly after the peripheral administration of both exogenous (e.g. LPS) and endogenous (e.g. IL-1 $\beta$ ) pyrogens, and (iii) the febrile response to LPS is abrogated by the prior iv administration of a PGE $_2$  antibody. LPS stimulates Kc PGE $_2$  production by two means. The first is the anaphylatoxic complement (C) component C5a [9]. The C cascade is activated on contact with LPS via the alternative pathway (antibody-independent), resulting in the immediate production of all its components, including C5a; Kc express its receptor, C5aR $_1$ . The production of PGE $_2$  is initiated within 2 min after the addition of C5a; C depletion inhibits both its release and fever production. PGE $_2$  is generated under these conditions by the hydrolysis of membrane-associated phosphoinositide (PI, which has a high arachidonoyl chain content) by PI-specific phospholipase C (PI-PLC); arachidonic acid (AA, the substrate of COX) liberation by PI-PLC is tenfold more rapid (within seconds) than that mediated by group IV cytosolic phospholipase A $_2$  (cPLA $_2$ , the enzyme activated by LPS that catalyzes the release of AA from cell membrane phospholipids). Moreover,



PI-PLC is activated by C, but not by LPS or IL-1 $\beta$ , and the subsequent conversion of this AA to PGE<sub>2</sub> is unselectively catalyzed by COX-1 and/or COX-2, which are both constitutive in Kc. The second means is the TLR4-mediated, direct activation of Kc by LPS. However, the activation by LPS of cPLA<sub>2</sub> is slow. Also, as already mentioned, the increased synthesis of PGE<sub>2</sub> induced by LPS is selectively catalyzed by inducible COX-2 and mPGES-1, the upregulations of which require time. Hence, a second elevation of plasma PGE<sub>2</sub> occurs ~45 min after the first. It is not, however, the signal that triggers the febrile response, but it may sustain its course.

The mechanism by which the PGE<sub>2</sub> quickly released by Kc drives the febrile response is controversial. One concept holds that it is transported to the POA by the bloodstream and, being lipophilic, stimulates thermosensitive neurons in the POA either by crossing the BBB or diffusing to this site through the OVLT [8]. Although febrile responses to iv injected PGE<sub>2</sub> have been reported, it is, however, uncertain whether PGE<sub>2</sub> can simply diffuse from the blood into the brain. An alternative possibility, that the fever-mediating PGE<sub>2</sub> is produced by cerebral endothelial cells, although based on well substantiated evidence that circulating LPS and pyrogenic cytokines (particularly IL-6) induced by it upregulate the expressions of COX-2 and mPGES-1 in these cells, is weakened by the finding that the expression of endothelial cell COX-2 evoked by peripheral LPS is not POA-specific, but occurs throughout the brain microvasculature and, moreover, first appears significantly later than the onset of iv LPS-induced fever. Finally, although the rises of T<sub>c</sub> and preoptic PGE<sub>2</sub> levels caused by iv LPS are both abrogated by peripherally injected antipyretics, findings that they are also prevented by the intraPOA microinjection of COX-2 inhibitors (in quantities undetectable in the blood) indicate that it is more likely that the applicable PGE<sub>2</sub> is generated inside rather than outside the BBB.

Hence, another concept is that the fever-triggering message of peripheral PGE<sub>2</sub> is transmitted from the liver to the POA neurally rather than humorally. In support, sensory vagal afferents are distributed in the vicinity of the Kc, and bilateral subdiaphragmatic section of the vagus or of its hepatic branches prevents fever development. Furthermore, paraganglia on hepatic vagal branches bind IL-1Ra, and the electrical activity of the vagus is increased by the injection of IL-1 $\beta$  into the hepatic portal vein; the latter effect is blocked by indomethacin, a NSAID. In addition, the expression of *c-fos* is enhanced in the A2 cell group of the nucleus of the solitary tract (NTS, the primary projection area of the vagi) after iv and ip IL-1 $\beta$  and LPS, but prevented by subdiaphragmatic vagotomy; electrolytic lesions of the NTS also attenuate the febrile response to ip LPS [7].

Finally, abundant PGE<sub>2</sub> receptors of the EP<sub>3</sub> subtype, the class implicated by other studies as mediating the febrile response, occur in nodose ganglion neurons receiving information from the abdominal compartment. Very recently, the trigeminal nerve has also been implicated as a signaling pathway in acute periodontitis.

Thus, novel accumulating evidence suggests that endotoxic fever is initiated by the arrival of LPS in the liver and its uptake by Kc, causing virtually immediately the activation of the C cascade and, hence, the generation of the anaphylatoxin C5a. It, in turn, stimulates the Kc very rapidly to release constitutive COX-1- and COX-2-dependent PGE<sub>2</sub>. The released PGE<sub>2</sub> then most likely activates local sensory vagal terminals that project to the NTS. Fig. 2 summarizes the updated sequence of events that initiates the febrile response triggered in the periphery by the appearance of LPS.

### Central Integration

Various studies have demonstrated that the vagally transmitted pyrogenic signals proceed from the NTS to the POA by way of noradrenergic projections originating in the A2 region and arriving in the POA via the ventral noradrenergic bundle (VNB). The release of norepinephrine (NE) in the POA following the systemic administration of exogenous and endogenous pyrogens is well documented, and it has been shown in rats that subdiaphragmatic vagotomy blocks the ip IL-1 $\beta$ -induced reduction in hypothalamic NE. The involvement of the central noradrenergic system in thermoregulation has also been demonstrated; e.g. electrical stimulation of

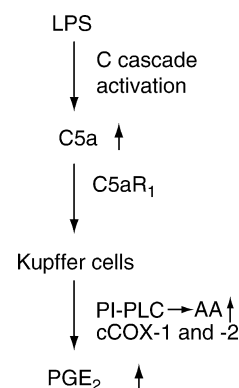

**Endotoxic Fever. Figure 2** The course of the production of PGE<sub>2</sub> by hepatic macrophages (Kupffer cells) activated by a pyrogenic dose of LPS. LPS activates the complement (C) cascade on contact, quickly generating the anaphylatoxin C5a, which binds to its receptors on Kupffer cells, stimulating PI-PLC and generating arachidonic acid (AA) from membrane phospholipids. Constitutive (c) COX-1 and COX-2 then catalyze its conversion into PGE<sub>2</sub>.

the ascending noradrenergic system in the brainstem of guinea pigs evokes a  $T_c$  rise whereas surgical or pharmacological lesions of this pathway abrogate this response. It has also been shown in the peripheral nervous system that the stimulation of noradrenergic neurons induces the postsynaptic release of  $PGE_2$ , which then limits the further presynaptic release of NE, thereby modulating the activity of noradrenergic neurons. NE also stimulates the release of  $PGE_2$  in POA minces *in vitro*, and the microdialysis of NE into the POA of conscious guinea pigs rapidly augments the local production of  $PGE_2$ . Accordingly, noradrenergic terminals in the POA, through their NE-induced local production of  $PGE_2$ , could mediate the febrile response to LPS.

Indeed, recent studies have confirmed that NE and its  $\alpha$ -adrenoceptor (AR) agonists microdialyzed into the POA of conscious guinea pigs or injected intracerebroventricularly (icv) into conscious mice evoke two distinct  $T_c$  rises: one is  $\alpha_1$ -AR-mediated, rapid in onset, and  $PGE_2$ -independent, and the other  $\alpha_2$ -AR-mediated, delayed, and COX-2/ $PGE_2$ -dependent. The  $\alpha_1$ -ARs are located on thermoregulatory neurons and the  $\alpha_2$ -ARs presumptively on perisynaptic astrocytes. The direct, quick,  $PGE_2$ -independent inhibition of warm-sensitive neurons by cirazoline, an  $\alpha_1$ -AR agonist, was recently reported in rat POA slices. It was likewise confirmed that the iv injection of a pyrogenic dose of LPS rapidly induces the appearance of NE in the POA interstitial fluid and the concomitant increases of  $T_c$  and preoptic  $PGE_2$ . Importantly, the level of NE culminates in 30 min, then gradually returns toward its control value; i.e. NE is released at the beginning of fever only. Pre-treatment with an  $\alpha_1$ -AR antagonist, prazosin, significantly slows the rate of rise of the first phase of fever and eliminates its first peak, but does not affect the onset latency of the response nor the magnitude and time of the second peak of fever. It also does not affect the initial, LPS-induced elevation of preoptic  $PGE_2$ . However, like NE, this increase is not sustained,  $PGE_2$  levels returning from their first highs at 30 min to their control values at 60 min. They then rise a second time and culminate not differently than in untreated counterparts and coincidentally with the second peak of fever. Pre-treatment with an  $\alpha_2$ -AR antagonist, yohimbine, by contrast, does not change the onset latency and rate of rise of the early febrile response, the first  $T_c$  peak reaching the same value and occurring at the same time as that of untreated controls; but it completely abrogates the second peak, consequently significantly reducing the overall magnitude of the febrile response by comparison to that of untreated controls. The fever, moreover, abates more slowly in this group than in controls. Remarkably, this treatment completely suppresses the LPS-induced rise in preoptic  $PGE_2$  levels. Collectively, these findings therefore indicate that:

(i) the onset of LPS fever is indeed associated with the intraPOA release of NE and accompanied by coincident increases in  $T_c$  and preoptic  $PGE_2$  levels, (ii) the initial  $T_c$  rise is mediated by the NE-induced activation of  $\alpha_1$ -AR and, its very onset excepted, the first phase of fever is maintained by the direct noradrenergic stimulation of the relevant neurons in the POA, without the intermediation of  $PGE_2$ , and (iii) the LPS fever of  $\alpha_2$ -AR-blocked guinea pigs is initiated, maintained, and even extended in the total absence of corresponding increases in POA  $PGE_2$  levels; hence, by deduction, it is mediated entirely by  $PGE_2$ -independent,  $\alpha_1$ -AR activation. The specific involvement of COX-2 in the formation of the  $\alpha_2$ -AR-mediated  $PGE_2$ -was verified by its blockade by selective COX inhibitors. The mechanism of its production under these specific conditions has not yet been determined, however. It has been shown in other systems that NE-stimulated postjunctional  $\alpha_2$ -ARs activate cPLA<sub>2</sub>; NE also binds to  $\alpha_2$ -ARs coupled to PI-PLC and D. Both these processes would generate AA. NE also induces the production of cyclic AMP, which is an activator of COX expression. In sum, NE released in the POA mediates the characteristically biphasic febrile responses of conscious animals to iv LPS by two consecutive processes, viz., the first via direct  $\alpha_1$ -AR stimulation not associated with  $PGE_2$  formation, and the second via  $\alpha_2$ -AR stimulation and the delayed production of COX-2-dependent  $PGE_2$  [10]. Since NE is present in the POA at the onset of fever only, it may be presumed that it activates both  $\alpha_1$ - and  $\alpha_2$ -ARs then; the delay in the response of the latter is most likely due to the time required for the upregulations of COX-2 and mPGES-1 and the consequent biosynthesis of  $PGE_2$ .

But what accounts for the initial rise in preoptic  $PGE_2$ , including in yohimbine-pretreated animals? The intraPOA microdialysis of selective COX-1, -2, and -3 inhibitors do not prevent it, suggesting that it could be induced by a COX-independent pathway, e.g. the non-enzymatic isoprostane pathway of free radical-catalyzed peroxidation of AA. Some indirect support for this notion comes from the finding that the intraPOA microdialysis of the antioxidant catechin throughout the febrile course has the same effect as pre-treatment with the  $\alpha_2$ -AR antagonist yohimbine, viz., suppression of both the LPS-induced early and late rises of preoptic  $PGE_2$  and of the second peak of fever; the latency of fever onset and its first peak are not affected, the fever continuing at its early phase high level until it abates normally. Hence, its course is sustained by  $\alpha_1$ -AR activation alone. The free radicals in this case could be generated by the auto-oxidation of NE and/or be nitric oxide (NO); the latter is also released locally in the POA after LPS administration (see below). Since the initial  $T_c$  rise provoked by the peripheral administration of LPS is evidently mediated by  $PGE_2$ -independent  $\alpha_1$ -AR

activation in the POA and since, moreover, the febrile rise can evidently be sustained by this mechanism alone until its normal abatement, the new question arises whether, in contrast to PGE<sub>2</sub> generated in the liver, PGE<sub>2</sub> in the POA, however it may occur there, is really material to the febrile response to LPS. It should be noted that other, putative endogenous pyrogens have also been implicated in the direct, PGE<sub>2</sub>-independent, central mediation of LPS fever, e.g. IL-8, macrophage-inflammatory protein-1, pre-formed pyrogenic factor, and endothelin-1 [7].

Finally, reports that the gaseous transmitter NO stimulates the biosynthesis of PGE<sub>2</sub> by increasing the activities of both isoforms of COX have prompted investigations into whether NO could also have a pyretic function in the central mediation of the febrile response. Indeed, the various isoforms of NO synthase (endothelial, neural, and inducible NOS), the enzyme that converts L-arginine into citrulline and NO, occur in the hypothalamus, and circulating LPS and cytokines stimulate the release of NO in the POA. Furthermore, as described above, NE induces the production of COX-2-dependent PGE<sub>2</sub> in the POA via an  $\alpha_2$ -AR-mediated mechanism, and others have shown that NE activates NOS. Hence, the existence of a pyrogenic NE-NO-PGE<sub>2</sub> cascade in the POA in response to iv LPS seems plausible. But the testing of this hypothesis revealed that, quite to the contrary, NO donors microdialyzed into the POA of conscious guinea pigs inhibit rather than promote the febrile response to iv LPS and that they do so by inhibiting the LPS-induced release of NE in the POA and consequently preventing the  $\alpha_2$ -AR-mediated activation of COX-2-dependent PGE<sub>2</sub> synthesis. NO scavengers microdialyzed into the POA have exactly the opposite effects. Indeed, previous data regarding a potential role of NO in fever have been conflicting, some indicating pyretic and others antipyretic effects. These results would indicate, therefore, that NO, presumptively released in the POA coincidentally with or very shortly after NE, serves as a local negative-regulatory modulator of NE secretion, i.e. it is a central endogenous antipyretic.

In summary, newly accumulated evidence indicates that the Kc-generated, vagally transmitted message of PGE<sub>2</sub> is conveyed from the NTS to the POA via the VNB. NE consequently secreted in the POA activates both local  $\alpha_1$ - and  $\alpha_2$ -AR. The stimulation of the first rapidly evokes an initial rise in T<sub>c</sub> which is associated with a decrease in the firing rates of preoptic warm-sensitive neurons, inhibiting heat loss and stimulating heat production, but is not accompanied by any change in the levels of preoptic PGE<sub>2</sub>. Stimulation of the second causes, after a significant delay, a second, more prolonged T<sub>c</sub> rise that is associated with a concurrent increase in preoptic COX-2/mPGES-1-dependent PGE<sub>2</sub> levels. Hence, two distinctly produced PGE<sub>2</sub>s

would appear to mediate the febrile response: one, generated in the liver, is the immediate distal trigger of the febrile response, and the other, produced in the POA, is its subsequent proximal, albeit not indispensable mediator. The second phase of fever is very likely also supported by meanwhile produced circulating cytokines and PGE<sub>2</sub> as well as PGE<sub>2</sub> generated by cerebral endothelial and/or other cells in the blood-brain interface.

Thus, the key, new findings regarding the initiation of LPS fever are: (i) peripheral PGE<sub>2</sub> rather than pyrogenic cytokines initiates the febrigenic process, (ii) NE propagates the pyrogenic signal forward within the POA, (iii) NO modulates its release in the POA and, hence, the intensity of the febrile response, and (iv) preoptic COX-2/mPGES-1-dependent PGE<sub>2</sub> mediates the late, but not the early phase of fever; the latter appears to be independent of COX-derived PGE<sub>2</sub>. The sequence of events occurring in the POA following the arrival of peripheral, PGE<sub>2</sub>-induced, vagally transmitted, pyrogenic signals is depicted in Fig. 3.

#### Pathways to the Effectors

As described earlier, the major effector systems mediating pyrogen-induced fever are the skeletal muscle mass (shivering thermogenesis) in adult animals, brown adipose tissue (BAT) nonshivering thermogenesis (NST) in neonates and rodents, and the cardiovascular system (cutaneous vasoconstriction, for heat conservation). Although these thermoeffector mechanisms are well characterized, the central efferent pathways controlling them are not yet fully known. Recent advances in immunohistochemical mapping and tracing methods have, however, allowed more progress to be made in this area [10].

The efferent signals that mediate shivering (a somatic response albeit that it is driven involuntarily) descend in the medial forebrain bundle (MFB) from the POA to the dorsomedial region of the posterior hypothalamus; stimulation of this region directly elicits shivering. From here, the signals travel caudally through the midbrain via reticulospinal neurons in the reticular formation dorsolateral to the red nucleus; some signals may also be relayed directly from the POA to these neurons. The pathway then courses close to the ventrolateral surfaces of the pons and medulla oblongata, and continues to the lateral columns of the spinal cord and, via the ventral horns, to the  $\alpha$ -motoneurons of skeletal muscle, stimulating their contraction.

The signals for BAT NST are transmitted from GABAergic, EP<sub>3</sub> receptor-expressing warm-sensitive neurons in the POA via the MFB to the rostral raphe pallidus and raphe magnus nuclei in the medulla oblongata; GABAergic neurons in the dorsomedial hypothalamus projecting directly to these nuclei appear also to lie in this pathway. These nuclei contain vesicular glutamate

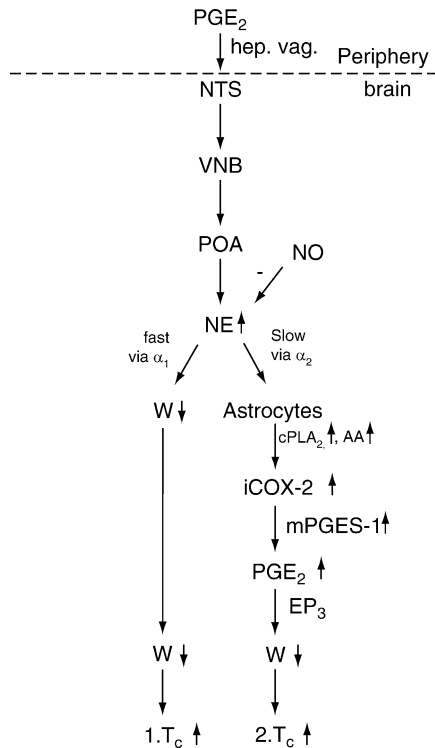

**Endotoxic Fever. Figure 3** The two-stage neural pathway of the induction of the biphasic (1. and 2.) febrile response to  $\text{PGE}_2$  generated by Kupffer cells in response to the peripheral bolus injection of a low-to-moderate pyrogenic dose of LPS.  $\text{PGE}_2$  generated by Kupffer cells in the liver activates hepatic vagal afferents, which then transmit its message to the POA via the nucleus tractus solitarius (NTS) in the medulla oblongata and the ventral noradrenergic bundle (VNB), culminating in the release of NE in the POA. NE then activates both  $\alpha_1$ - and  $\alpha_2$ -adrenoceptors. The stimulation of the first, located on preoptic warm-sensitive neurons, quickly and directly inhibits these, causing the first of the characteristic two core temperature ( $T_c$ ) rises induced by low-to-moderate doses of iv LPS. The stimulation of the second, presumably located on perisynaptic astrocytes, causes the generation of AA by an as yet indeterminate process and upregulates inducible (i) COX-2 and mPGES-1, resulting in the production of  $\text{PGE}_2$ . The latter then binds to its receptor ( $\text{EP}_3$ ) on warm-sensitive neurons, depressing their activity and inducing the second febrile rise. Modified from [10].

transporter 3-expressing neurons that project to the intermediolateral cell column of the spinal cord; this column contains sympathetic premotor neurons that innervate sympathetic preganglionic neurons exiting at various segments of the thoracic spinal cord. These, in turn, synapse on sympathetic postganglionic cells innervating BAT depots throughout the body. Since warm-sensitive neurons are activated by warmth, it follows that

their tonic influence on BAT thermogenesis is to inhibit it, probably via GABAergic inputs to the medullary raphe neurons; conversely, the inhibition of these neurons facilitates NST. As mentioned earlier, pyrogens inhibit these neurons and, consequently, the increased NST induced by these agents is presumptively mediated by a reduction in their inhibitory influence on BAT. Stimulation of the inferior olive and caudal periaqueductal gray has also been reported to activate BAT thermogenesis, but their specific roles in the circuitry controlling BAT activity are unclear. Tonic inhibitory areas may exist in the retrorubral field, pedunculo-pontine tegmental nucleus, and rubrospinal tract of the lower midbrain.

The efferents of the POA thermosensitive neurons controlling vasomotion also descend through the MFB, but to two different midbrain regions: one extends from the caudal edge of the lateral hypothalamus to the reticular formation and the periaqueductal gray, and the other to the ventral tegmental area. Preoptic warming excites the first, inducing skin vasodilation, and inhibits the second, hence mediating cutaneous vasoconstriction. Since pyrogens inhibit POA warm-sensitive neurons, the latter, presumably, is the efferent pathway consequently activated. The pathway continues from the ventral tegmental area to the sympathetic premotor neurons that control skin vasoconstriction. In cats, these are located predominantly in the rostral ventrolateral medulla, but in rats they are located in the caudal medullary raphe nuclei. From the medulla, the neurons project to the intermediolateral cell column of the spinal cord, exciting sympathetic preganglionic neurons and, thence, postganglionic vasoconstrictor neurons.

### Function

Fever has been recorded and associated with disease throughout history. From the beginning, it, or rather “fevers” were believed to be diseases in their own right, yet beneficial to the afflicted host, a view that persisted until the late nineteenth century when clinical observations and new techniques of quantitative measurements led to the gradual recognition that the observed rises in  $T_c$  were a response to rather than the cause of illness. It was considered, however, that while the heat of fever was probably useful for destroying infectious microorganisms, high or prolonged fevers were detrimental due to their wasting effects on the host’s body and, therefore, should be prevented. This, in turn, led to the general view that fever is harmful and should be suppressed, a goal that became practicable with the introduction in the late nineteenth century of salicylates. Indeed, the use of antipyretics became very popular, particularly since the reduction in  $T_c$  was also associated with the relief of the other untoward symptoms of sickness behavior, thus moderating the discomfort level

and consequently alleviating the anxiety of both the afflicted patients and their caregivers.

In the last two decades, however, this perspective has again shifted, based on new findings indicating that while, indeed, some pathogenic microbes are killed at febrile temperatures, more are not, and that, more importantly, the heat of fever serves as an adjuvant that enhances the effectiveness of certain stimulus-activated adaptive immune responses, thereby helping to compartmentalize the reactions to the infected site. But probably even more critically, there is evidence that fever modulates the temporal sequence of the co-induced generations of TNF $\alpha$ , IL-1 $\beta$  and IL-6 early during the innate immune response, thereby minimizing the risk of the potentially harmful effects that could result from their dysregulated expression. Indeed, it is now clear that fever and its associated, non-febrile events are a phylogenetically old phenomenon, existing not only in mammals and birds, but also in fishes, amphibians, and reptiles, suggesting therefore, teleologically at least, that it has important survival value. Nevertheless, the pros and cons of managing fever continue to be debated.

### Acknowledgments

The author's studies included herein were supported, in part, by National Institutes of Health grants numbers R01 NS-34857 and NS-38594.

### References

1. Gruys E, Toussaint MJM, Newold TA, Koopmans SJ (2005) Acute phase reaction and acute phase proteins. *J Zhejiang Univ SCI* 6B:1045–1056
2. Dantzer R, Kelley KW (2006) Twenty years of research on cytokine-induced sickness behavior. *Brain Behav Immun* 21:153–160
3. Boulant JA (2000) Role of the preoptic-anterior hypothalamus in thermoregulation and fever. *Clin Infect Dis* 31 (Suppl 5):S157–S161
4. Akira S, Uematsu S, Takeuchi O (2006) Pathogen recognition and innate immunity. *Cell* 14:783–801
5. Conti B, Tabarean I, Andrei C, Bartfai T (2004) Cytokines and fever. *Front Biosci* 9:1433–1449
6. Roth J (2006) Endogenous antipyretics. *Clin Chim Acta* 371:13–24
7. Roth J, Rummel C, Barth SW, Gerstberger R, Hubschle T (2006) Molecular aspects of fever and hyperthermia. *Neurol Clin* 24:421–439
8. Ivanov AI, Romanovsky AA (2004) Prostaglandin E<sub>2</sub> as a mediator of fever: synthesis and catabolism. *Front Biosci* 9:1977–1993
9. Blatteis CM, Li S, Li Z, Perlik V, Feleder C (2004) Signaling the brain in systemic inflammation: the role of complement. *Front Biosci* 9:915–931
10. Blatteis CM (2006) Endotoxic fever: new concepts of its regulation suggest new approaches to its management. *Pharmacol Ther* 111:194–223

## Endotoxin

### Definition

Denotes the inflammatory component of the cell wall of gram-negative bacteria (see Neuroimmunology and Lipopolysaccharide [LPS]).

- Endotoxic Fever

## Endplate

- Neuromuscular Junction

## End-to-side (ETS) Nerve Repair

### Definition

Connecting the distal part of an injured nerve in an end-to-side fashion to a neighbouring intact nerve trunk.

- Regeneration: Clinical Aspects

## Energizers

- Stimulants

## Energy Homeostasis

- Neuropeptides in Energy Balance

## Energy Sensing and Signal Transduction in Skeletal Muscle

JOHN A. HAWLEY

Exercise Metabolism Group, School of Medical Sciences, RMIT University, Bundoora, Victoria, Australia

### Definition

Control of energy metabolism and signal transduction in skeletal muscle.

### Characteristics

#### Quantitative Description

#### *Adenosine 5'-Triphosphate: The Metabolic Intermediary in Energy Metabolism*

The link between energy-producing and energy-utilizing pathways in skeletal muscle and other tissues is the nucleoside adenosine 5'-triphosphate (ATP). ATP is the only form of chemical energy that can be converted into other forms of energy utilized by living cells, and due to its unique role in energy homeostasis, has been termed the energy currency of the cell. ATP is broken down enzymatically to adenosine diphosphate (ADP) and inorganic phosphate (Pi) to yield energy for muscular activity (Fig. 1).

ATP is regenerated from ADP by the breakdown of fuel molecules, predominantly carbohydrates and lipids stored in skeletal muscle, liver and other locations in the body, via both anaerobic (oxygen-independent) and/or aerobic processes [1].

### Process Regulation

#### *Matching ATP Synthesis with ATP Demand*

One of the most fundamental parameters for any healthy cell is the maintenance of a high of ATP to ADP ratio

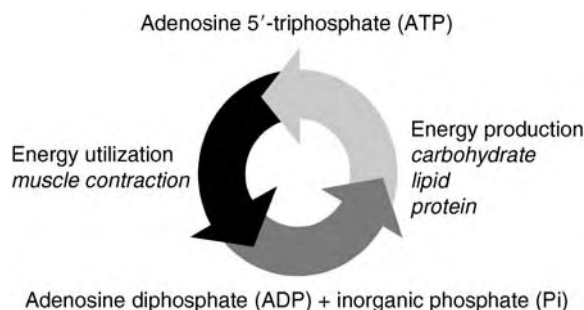

**Energy Sensing and Signal Transduction in Skeletal Muscle. Figure 1** The relationship between energy production and energy utilization in human skeletal muscle.

[2]. In cells with slow ATP-consuming reactions, resting [ATP] can be maintained by an acceleration of ATP-producing reactions, through the oxidation of carbohydrates and lipids. However, in the transition from rest to strenuous exercise, there is a dramatic increase in metabolic rate, such that the demand for ATP by active muscle can rise more than 100-fold. Nonetheless, such an increase in ATP turnover rate is accomplished with only minor perturbations in muscle [ATP]. This is because skeletal muscles have evolved a sensitive and sophisticated metabolic control system, one effect of which is to maintain a constant cellular [ATP]. The maximal rates of ATP resynthesis from aerobic and anaerobic processes and the “lag” time of these systems before their maximal rates are attained following contraction (i.e. whole body exercise) are displayed in Table 1.

#### *Metabolic Signals that Coordinate the Energy-Producing Pathways*

There are three major metabolic signals in the activation and coordination of the various energy-producing pathways during muscle contraction: (i) those initiated by changes in  $[Ca^{2+}]$ , (ii) those that respond to changes in the “energy charge” of the cell, and (iii) those that are influenced by the mitochondrial reduction/oxidation (redox) state of nicotinamide adenine dinucleotide ( $[NAD]/[NADH]$ ). Of these,  $Ca^{2+}$  release plays the most fundamental role in initiating muscle contraction and activating metabolism in a feed-forward or “early

**Energy Sensing and Signal Transduction in Skeletal Muscle. Table 1** Calculated maximal rates of adenosine 5'-triphosphate resynthesis from anaerobic and aerobic metabolism, along with the approximate lag time before maximal rates are attained following the onset of whole-body exercise

Metabolic process	Maximal rate of ATP resynthesis (mmol ATP/kg dm/s)	Lag time
PCr breakdown	9.0	Instantaneous
Glycolysis	4.5	5–10 s
Glycogen oxidation	2.8	Several minutes
Blood glucose oxidation	1.0	90 min
Lipid oxidation	1.0	>2 h

ATP, adenosine 5'-triphosphate; PCr, phosphocreatine; dm, dry mass.

warning” manner [1]. Calcium provides the trigger for force development and ATP hydrolysis, and contributes to the activation of glycogenolysis. Although the feed-forward  $\text{Ca}^{2+}$ -activated signals are important for events occurring early on in the excitation-coupling processes, the energy charge of the cell (i.e.  $[\text{ATP}]/[\text{ADP}][\text{Pi}]$ ) provides the rapid feedback signals that are necessary to balance ATP production with ATP consumption [3]. Finally, the redox state of the muscle activates numerous reactions in substrate/product or activator/inhibitor capacities [1]. All three types of signal are important in coordinating the up-regulation of enzymes that are vital for ATP production in mitochondrial and cytoplasmic compartments during contraction. During the past decade, strong evidence has emerged to suggest that one of the most important energy sensing/signaling proteins of the muscle involved in the regulation of metabolism during both acute contractions and chronic exercise training is the 5'-adenosine monophosphate-activated protein kinase (AMPK) pathway.

### The 5'-Adenosine Monophosphate-Activated Protein Kinase Pathway

AMPK is a protein consisting of three subunits, designated  $\alpha$ ,  $\beta$  and  $\gamma$ . The  $\alpha$  subunit, of which there are two isoforms ( $\alpha 1$  and  $\alpha 2$ ), contains the catalytic domain that transfers a high-energy phosphate from ATP to serine and threonine residues on a number of different target proteins [2]. There are also multiple isoforms of  $\beta$  ( $\beta 1$  and  $\beta 2$ ) and  $\gamma$  ( $\gamma 1$ ,  $\gamma 2$ ,  $\gamma 3$ ) regulatory subunits that are essential for full enzymatic activity, and also function in localizing the AMPK molecule within cells [4]. All the  $\alpha$  isoforms are found in skeletal muscle, with this subunit being most sensitive to AMP. Information about the distribution of the various subunits in different muscle fiber types is not currently available.

AMPK can be considered a protein that monitors the energy state of the muscle cell, triggering metabolic processes that, when activated, are designed to conserve and restore high-energy phosphate levels [2–4]. AMPK is rapidly activated by cellular stresses that deplete ATP (and concomitantly elevate AMP) either by accelerating ATP consumption (i.e. muscle contractions) or inhibiting ATP production (i.e. ischemia, hypoxia, pharmacological inhibition of glycolysis and oxidative phosphorylation). AMPK is activated allosterically by an increase in  $[\text{AMP}]$ , and inhibited by ATP and CP (Fig. 2), and by increases in fuel reserves, such as muscle glycogen. Once activated, the AMPK cascade switches on catabolic processes both acutely (by phosphorylation of downstream metabolic enzymes such as acetyl CoA carboxylase [ACC]), and chronically (by effects of gene expression), while concomitantly switching off ATP-consuming processes [5].

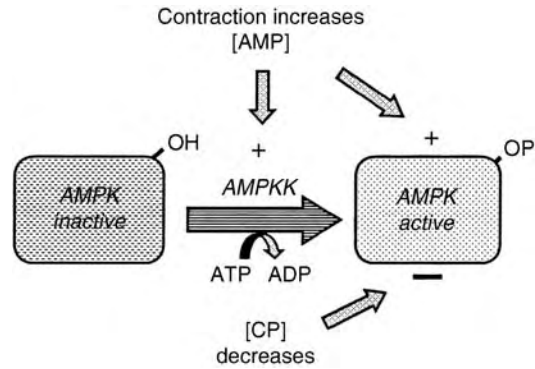

**Energy Sensing and Signal Transduction in Skeletal Muscle.** Figure 2 Activation of the 5'-adenosine monophosphate-activated protein kinase in skeletal muscle. From Winder WW (2001), Energy-sensing and signaling by AMPK-activated protein kinase in skeletal muscle. *J Appl Physiol* 91:1017–1028. Reproduced with permission of the American Physiological Society.

### Activation of AMPK by Muscle Contraction

The first evidence that AMPK was involved in the coordinated regulation of skeletal muscle metabolism was provided by Winder and Hardie [6]. These workers observed a two- to threefold increase in AMPK activity in the skeletal muscle of rats subjected to treadmill running, which was present 5 min after the onset of exercise. Of interest was that the increase in AMPK was work dependent, and that the activity remained elevated for up to 30 min post exercise, suggesting that AMPK might also be involved during the recovery of muscle energy reserves [6]. With regard to the effects of exercise in humans, low- to moderate intensity cycling in both untrained and trained individuals induces an isoform-specific and intensity-dependent increase in AMPK  $\alpha 2$ , but not  $\alpha 1$  associated activity [7]. Conversely, activation of the AMPK  $\alpha 1$  and  $\alpha 2$  isoforms occurs after sprint-type exercise [8]. It is likely that activation of the  $\alpha 1$  isoform after short-term anaerobic exercise is related to the rate of fuel utilization rather than the degree of substrate depletion, as no change in AMPK  $\alpha 1$  activity is observed after prolonged, continuous, low-intensity cycling leading to exhaustion and muscle glycogen depletion.

### Modulation of AMPK Response to Exercise by Muscle Fuel Status

Recent studies indicate that the glycogen content of skeletal muscle may modulate the AMPK response to contraction. Well-trained subjects have been studied under conditions of low- and high-glycogen concentration, at rest and subsequently during 60 min of moderate intensity cycling exercise [9]. At rest, both AMPK $\alpha 1$  and  $\alpha 2$  activities were elevated in the low- versus high-glycogen states. Low pre-exercise

glycogen content also increased AMPK $\alpha$ 2 activity and ACC phosphorylation during subsequent submaximal cycling. The low muscle glycogen state was also accompanied by significantly increased leg glucose and net fatty acid uptake, as well as increased plasma concentrations of catecholamines compared to the high-glycogen condition. Thus, AMPK activity during exercise would appear to be regulated by both fuel availability (i.e. the prevailing muscle glycogen content), as well as humoral factors (i.e. circulating hormones and substrates).

#### Effects of Exercise Training Status on AMPK

There are several lines of evidence to suggest that AMPK plays a role in mediating some of the adaptations to chronic muscle contraction (i.e. exercise training). For example, when AMPK is activated pharmacologically by the use of the chemical 5-aminoimidazole-4-carboxamide-riboside (AICAR), there are significant increases in the levels of several mitochondrial proteins, along with elevations in resting muscle glycogen content [4,10]. If AMPK does play a role in regulating some of the metabolic adaptations to training, then there should be a blunted response of AMPK to standardized exercise in trained versus untrained individuals. This is indeed the case. Several recent studies (reviewed in 5) have reported an attenuation in the rise in AMPK  $\alpha$ 2 activity in trained versus untrained subjects in response to intense cycling undertaken at the same relative power output. Despite higher absolute energy requirements during exercise in the trained individuals, the phosphorylation potential of the muscle (reflected by the difference in [PC]/[PCr + Cr] ratio) was better maintained in trained individuals. The results of these investigations provide strong evidence that AMPK activity is influenced more as a consequence of the metabolic perturbation induced by muscle contraction than the energy flux of the muscle cell.

#### Summary and Future Directions

Within the past decade, a growing body of evidence has emerged to suggest that AMPK plays a central role in regulating numerous metabolic processes in contracting human skeletal muscle. It appears that AMPK acts as a “fuel gauge” and can respond in an ultra-sensitive manner to changes in the energy status of the cell. Thus, the AMPK energy sensing and signaling system is involved in counteracting high-energy phosphate depletion during single bouts of exercise, and in the long-term, in inducing adaptations that play a role in up-regulating many of the exercise-induced responses in skeletal muscle that occur after repeated bouts of exercise. The biggest challenge for exercise physiologists in the future will be to link AMPK signaling to specific and defined metabolic responses in skeletal muscle that occur after exercise and other interventions.

## References

1. Meyer RA, Foley JM (1996) Cellular processes integrating the metabolic response to exercise. In: Rowell LB, Shepherd JT (eds) Handbook of physiology. Section 12: exercise: regulation and integration of multiple systems. New York: Oxford University Press, pp 841–869
2. Hardie DG, Carling D (1997) The AMP-activated protein kinase – fuel gauge of the mammalian cell? *Eur J Biochem* 246:259–273
3. Ramaiah A, Hathaway JA, Atkinson DE (1964) Adenylate as a metabolic regulator. Effect on yeast phosphofructokinase kinetics. *J Biol Chem* 239:3619–3622
4. Winder WW (2001) Energy-sensing and signalling by AMPK-activated protein kinase in skeletal muscle. *J Appl Physiol* 91:1017–1028
5. Hawley JA, Zierath JR (2004) Integration of metabolic and mitogenic signal transduction in skeletal muscle. *Exerc Sport Sci Rev* 32:4–8
6. Winder WW, Hardie DG (1996) Inactivation of acetyl-coA carboxylase and activation of AMP-activated protein kinase in muscle during exercise. *Am J Physiol Endocrinol Metab* 270:E299–E304
7. Wojtaszewski JFP, Nielsen JN, Hansen BF, Richter EA, Kiens B (2000) Isoform-specific and exercise intensity-dependent activation of 5'-AMP-activated protein kinase in human skeletal muscle. *J Physiol* 528:221–226
8. Chen ZP, McConell GK, Michell BJ, Snow RJ, Canny BJ, Kemp BE (2000) AMPK signaling in contracting human skeletal muscle: acetyl-CoA carboxylase and NO synthase phosphorylation. *Am J Physiol Endocrinol Metab* 279:E1202–E1206
9. Wojtaszewski JFP, Macdonald C, Nielsen JN, Hellstend Y, Hardie G, Kemp BE, Kiens B, Richter EA (2003) Regulation of 5'AMP-activated protein kinase activity and substrate utilization in exercising human skeletal muscle. *Am J Physiol Endocrinol Metab* 284:E813–E822
10. Aschenbach WG, Sakamoto K, Goodyear LJ (2004) 5' adenosine monophosphate-activated protein kinase, metabolism and exercise. *Sports Med* 34:91–103

## Energy State

### ► Neuropeptides in Energy Balance

## Energy/Energetics

RODGER WOLEDGE

Institute of Human Performance, University College London, London, UK

### Definition Energy

Energy is defined as a conserved quantity associated with the state of a system and indicative of the system's



capacity to impose change on other systems or to undergo change itself. The energy within a system exists in many forms. ▶ **The 1st Law of Thermodynamics** [1] states that energy can be converted from one form to another but the total energy remains constant. This is not a statement of the results of scientific observations but a statement of principle, a definition of the scientific use of the word energy.

In biomechanical studies on a macro scale (whole animal or body segment), the 1st Law can generally be satisfied by considering only these five forms of energy:

1. ▶ **Kinetic energy**. The energy associated with motion of an object.
2. ▶ **Elastic energy**. The energy stored in a stretched spring.
3. ▶ **Gravitational potential energy**. The energy associated with the vertical displacement of an object in a gravitational field.
4. ▶ **Chemical energy**. The energy associated with the chemical state of the matter in the system.
5. **Heat**. The energy associated with thermal motion of the system in all of its degrees of freedom.

In the bioenergetics of micro-scale processes, such as those occurring within the individual axon, chloroplast, mitochondrion or flagella, these further forms of energy will also be required:

6. ▶ **Osmotic energy**. The energy associated with a concentration gradient.
7. **Electrical potential energy**. The energy associated with the movement of an electrical charge ( $C$ ) through an electrical gradient ( $V$ ).

Other forms of energy exist, for example, nuclear energy or the energy associated with magnetic fields or large temperature gradients, but these are not known to be exploited in biological movement and need not be considered in biomechanical studies.

▶ **Free energy**. In principle, all forms of energy are inter-convertible by a suitable machine. However, the ▶ **2nd Law of Thermodynamics** [1] tells us that conversion of heat into any other form of energy is limited. The rule is that the maximum fraction of the heat that can be converted is equal to the ratio of the temperature gradient within the machine to its absolute temperature. This ratio would not exceed about 1% in a biological machine, and so it is not surprising that conversion of heat into other forms of energy has not been found in biological systems. Generally, the simplification is made that such systems operate at constant temperature and that no conversion of heat to other energy forms is possible. The conversion of energy into heat within a biological system is thus irreversible and the potential to convert it to another form is lost, for this reason the term energy dissipation is sometimes used for this conversion. In making an energy account, we must therefore distinguish between the part of the energy that cannot be converted to

another form, and the part that can be so converted, designated the free energy. Energy in kinetic, elastic, osmotic, electric or gravitational form can be considered entirely free energy: a perfect machine can convert all of it to another form. However, the energy of a chemical reaction is not in general the same as the free energy of the reaction, part of the energy change associated with the reaction cannot be converted to another form, it is an obligatory change in the heat content of the system [1]. Therefore, in considering chemical energy we have to distinguish between the free energy change and the total energy change, the sum of the measured heat and ▶ **work** changes, for which the term ▶ **enthalpy** is useful.

*Work*. A system may exchange energy with another system or with its environment. We distinguish between flows of energy as heat and as free energy, for which the term work is used. Since by definition the total energy of a system plus its environment remains constant, the change in the energy of the system can be observed by measuring the flows of heat and of work to/from the environment.

▶ **Efficiency**. The only changes that can occur in a system are those in which the total free energy, including any work done by or on the system decreases. Such changes in the simplest case involve the linkage (coupling) of two processes: one (the “driving” process) in which the free energy is decreasing, and another (the “driven” process) in which it is increasing. Efficiency is a term used to characterize the exchange of free energy between two systems, usually also two different forms of energy. It is ideally defined as the ratio of the free energy increase in the driven process to the decrease in the driving process. The efficiency so defined cannot exceed unity. Unfortunately, free energy flows are hard to measure and so other definitions of efficiency are often used, involving quantities that can be measured more easily (e.g. heat and work flow). With these definitions, the efficiency may not be constrained to a value less than unity. Efficiency calculations that give values greater than unity generally indicate that the identity of the driving process has not been established.

*Energetics*. The energetics of a system is a description of the flows of energy from one form to another during its operation. For example, the energetics of human walking is dominated by the exchange of energy between gravitational potential energy and kinetic energy, in addition to some conversion of chemical energy into mechanical energy. The experimental energetics of muscle contraction is the study of the flows of energy associated with muscle contraction under different conditions, and an enquiry into the nature of the processes causing these flows. The main experimental findings are summarized in the next section.

## Characteristics

On the macro scale, skeletal muscle contraction is the major driving process in animal movement, and the

following paragraphs address the energetics of muscle contraction.

When it is not being stimulated, muscle is merely a rather compliant spring and its contribution to the energetics of movement can usually be neglected. When it is stimulated by action potentials arriving from the motor nerve, muscle becomes “active” and operates energetically in two modes. When shortening, “concentric activity,” the muscle acts as a motor transforming chemical energy into heat and into the mechanical work that is done by shortening against any force acting to stretch the muscle. During “eccentric activity,” active muscle is made to elongate by the application of a sufficient external force. The muscle then acts as a brake absorbing the work done on it and converting it to heat. In an ► **isometric contraction**, muscle neither shortens nor lengthens and the energy output is as heat only.

*Series Elasticity.* Muscles, as identified anatomically, consist of muscle fibers and connective tissues connecting them to the anatomical tendon. These elements add a significant compliance in series with the muscle fibers known as the series elastic component (SEC). The SEC stores and releases elastic energy during muscle contractions, saving energy that would otherwise be dissipated as heat and reducing the need for chemical energy in the muscles. The energetics of muscle is much simplified if these processes are separated from those occurring in the muscle fibers themselves, which are described below. Typically, a period of muscle activity involves both eccentric and concentric phases; during the cyclic processes of locomotion, muscle/tendon units (MTU) often experience length changes of about 5–10% of the muscle fiber lengths. A common type of muscle activity would be for the muscle to be activated towards the end of the period of eccentric phase of the MTU, and for the period of activation to end towards the end of the concentric period. The consequence of this pattern of activity is that the length change in the muscle fibers is much less than that in the MTU, and they may remain almost isometric. The SEC can release stored work much more rapidly than work can be produced by the muscle fibers themselves, temporarily enhancing the power output of the muscles [2].

*Isometric contraction.* Energy is output as heat only. About 2/3 of this energy comes from the activities of the actin and myosin filaments within the muscle, and the remainder from the calcium turnover of the sarcoplasmic reticulum responsible for the activation and relaxation of the contractile system. In most muscles, the rate of energy output declines during a period of activation lasting several seconds, although the force exerted remains almost constant.

► **Concentric contractions.** Energy is output as both heat and work. The total rate of energy output

increases with speed of shortening to about 5 times the isometric rate.

► **Eccentric contractions.** Energy is input as work and output as heat. The rate of heat production exceeds the rate of work input, suggesting that chemical energy use is continuing, but at a rate below that in isometric contraction [3].

*Chemical Origin of the Heat and Work Produced.* Both the actomyosin system and the calcium turnover system of the SR use ATP as their energy source, splitting it to ADP and inorganic phosphate (Pi). The ADP produced is rapidly re-phosphorylated by the abundant phosphocreatine (PCr) in the muscle. The principle net chemical change *during* contraction is thus the splitting of phosphocreatine to creatine and Pi. Most of the energy output as heat and work can be explained by this reaction, but some is also probably derived from changes in the distribution of calcium within the muscle and changes within the actomyosin system itself. In some muscles, glycolysis occurs significantly even in short contractions and contributes to the energy output (see [2] for further information in this area).

After relaxation, PCr is rebuilt by oxidative phosphorylation in the following minutes. This process produces heat generally rather greater in amount than the energy output during the contraction itself.

*Muscle Efficiency.* As explained above, efficiency can only be determined unambiguously when the chemical source of the free energy is known. Considering the energy output both during and after contraction, the chemical source of the heat and work can be identified as oxidation of substrates. For this process, the free energy is closely similar to the enthalpy and the efficiency, therefore, is equal to the ratio of heat/(heat + work). Experimental values range from 20 to 40% depending on species used (see [2,4] for further information in this area).

When we consider only the processes occurring during contraction, the reported values of the ratio of heat to (heat + work) vary from 0.3 to 0.8 (see Table 2 in [4]). However, this overestimates the thermodynamic efficiency because the source of the heat + work is largely PCr splitting, for which the free energy change is about 50% greater than the amount of heat + work produced. The efficiency of the initial processes can be recalculated after taking account of this factor and allowing for the fact that part of the inefficiency is due to the use of ATP for calcium pumping, rather than for the mechanical processes themselves. The resulting values range from 25 to 65%, depending on fiber type and species of animal. The highest efficiency is found in the muscles of the tortoise, which have an unusually low power output. Efficiency can also be measured in skinned muscle fibers in which the source of energy is the ATP provided in the bathing solution and for which the free energy can be calculated. Results are in

the range of 14 to 40% (summarized with corrections in [4, Table 3]).

The values for efficiency of the recovery process itself, which is the transfer of free energy from oxidative phosphorylation to free energy of ATP splitting, is about 70% [4].

## References

1. Wilkie DR (1960) Thermodynamics and the interpretation of biological heat measurements. *Prog Biophys Mol Biol* 7:259–298
2. Woledge RC, Curtin NA, Homsher E (1985) Energetic aspects of muscle contraction. *Monographs of the Physiological Society*, vol 41. Academic Press, New York, pp 357
3. Linari M, Woledge RC, Curtin NA (2003) Energy storage during stretch of active single fibres from frog skeletal muscle. *J Physiol* 548:461–474
4. Smith NP, Barclay CJ, Loiselle DS (2004) The efficiency of muscle contraction. *Prog Biophys Mol Biol*
5. Galantis A, Woledge RC (2003) Theoretical limit to the power output of a muscle-tendon complex with inertial and gravitational loads. *Proc R Soc Lond B* 270:1493–1498

## ENGs (Electroneurographic Recordings)

### Definition

Extracellular recordings from a peripheral nerve. In many cases, the ENG is recorded from a peripheral nerve that innervates a particular muscle.

► [Extracellular Recording](#)

## Enhancer

### Definition

Enhancer is a short stretch of nucleotides that are bound by trans-activating factors that increase the levels of gene transcription. An enhancer does not need to be in close proximity in terms of nucleotide sequence, to the gene whose activity it regulates, but comes in close proximity to the DNA promoter when DNA is folded in the chromatin complex.

## Enhancer Trap

### Definition

Enhancer trap – an enhancer trap element is a mobile DNA element that is usually a P element. The P element can carry a reporter gene and an eye color marker as well as various bacterial elements necessary for cloning. Expression levels of the reporter require that the enhancer trap insert and come under control of an endogenous enhancer element.

► [GAL4/UAS](#)

## Enhancing Function

### Definition

One of two mechanisms (the other being conditioned motivation) by which reinforcers cause changes in future behavior.

► [Neuroethological Aspects of Learning](#)

## Enkephalin

### Definition

Enkephalin either of two closely related pentapeptides (methionine enkephalin and leucine enkephalin) having opiate-like qualities and occurring in the brain, spinal cord and other parts of the body. Binding to specific receptors, they may act as neuromodulators in a variety of brain structures, in some cases producing analgesic and sedative actions or affecting mood and motivation.

## Ensemble Code

### Definition

In this code many neurons together and not one neuron alone carry information.

## Enslavement

### Definition

Unintentional production of force by digits other than the digit with which a subject attempts to exert force voluntarily, as if the other digits slavishly follow the voluntarily activated digit.

► Motor Cortex – Hand Movements and Plasticity

## Entelechy

### Definition

In Greek an entity that “bears its goal within itself.” The vitalist Hans Driesch (1867–1941) reinvented the word to refer to a non-physical, non-spatial causal factor in living beings, which he claimed would direct the physical and chemical processes during an organism’s development.

► Emergence

## Enteric Dysfunction

### Definition

Enteric dysfunction is impairment of enteric functions such as motility, absorption and secretion. Enteric dysfunction is more prevalent with increasing age.

► Autonomic/Enteric Dysfunction

## Enteric Excitatory Musculomotor Neurons

### Definition

Enteric excitatory musculomotor neurons are motor neurons in the enteric nervous system that release

excitatory neurotransmitters to initiate contractions in the musculature of the digestive tract.

► Autonomic/Enteric Reflexes

## Enteric Inhibitory Musculomotor Neurons

### Definition

Enteric inhibitory musculomotor neurons are motor neurons in the enteric nervous system that release inhibitory neurotransmitters to inhibit contractile activity in the musculature of the digestive tract.

► Autonomic/Enteric Reflexes

## Enteric Nervous System

JOHN B. FURNESS

Department of Anatomy and Cell Biology and Centre for Neuroscience, University of Melbourne, Parkville, VIC, Australia

### Definition

A division of the autonomic nervous system whose component neurons lie within the walls of the digestive organs (esophagus, stomach, intestines, pancreas, gall bladder and pancreato-biliary ducts). The ►enteric nervous system (ENS) contains entire nerve circuits for digestive organ control, and can function autonomously.

The enteric nervous system is the intrinsic nervous system of the gastrointestinal tract through which gastrointestinal motility, gastrointestinal intramural blood flow and fluid movement across the mucosal lining of the intestine are controlled.

### Characteristics

#### Organization and Relationships

The enteric nervous system is composed of thousands of small ganglia that lie within the walls of the esophagus, stomach, small and large intestines, pancreas, gallbladder and biliary tree, the nerve fibers that connect these ganglia, and nerve fibers that supply the muscle of the gut wall, the mucosal epithelium, arterioles and other effector tissues [1,2,3]. Large

numbers of neurons are contained in the enteric nervous system, about 200–600 million in human. This is far more neurons than occurs in any other peripheral organ and is similar to the number of neurons in the spinal cord.

The ganglia contain nerve and glial cells, but not connective tissue elements, and in many respects are similar in structure to the central nervous system, except that there is no significant blood-enteric nervous system barrier. Nerve fiber bundles within the enteric nervous system consist of the axons of ►enteric neurons, axons of extrinsic neurons that project to the gut wall, and glial cells. Two major sets of ganglia are found, the myenteric ganglia between the external muscle layers, and the submucosal ganglia (Fig. 1).

The ►myenteric plexus forms a continuous network, extending from the upper esophagus to the internal anal sphincter. The ganglionated ►submucosal plexus is present in the small and large intestines, but is absent from the esophagus and contains only very few ganglia in the stomach.

The enteric nervous system originates from neural crest cells that colonize the gut during intra-uterine life. It becomes functional in the last third of gestation in human, and continues to develop following birth.

The enteric nervous system receives inputs from the parasympathetic and sympathetic parts of the nervous system, and the gastrointestinal tract also receives a plentiful supply of afferent nerve fibers, through the vagus nerves and spinal afferent pathways. Thus, there is a rich interaction, in both directions, between the

enteric nervous system, sympathetic prevertebral ganglia and the central nervous system.

The gastrointestinal tract also harbors an extensive endocrine signaling system, and many gastrointestinal functions are under dual neuronal and endocrine control [4]. Enteric neurons also interact with the extensive intrinsic immune system of the gastrointestinal tract.

### Types of Enteric Neurons

There are approximately 20 types of enteric neurons can be defined by their functions. Combinations of features (morphology, neurochemical properties, cell physiology and projections to targets) help to define each type. Amongst the 20 types, three classes can be identified, ►intrinsic primary afferent neurons (IPANs) [5], interneurons and motor neurons. IPANs detect the physical state of the organs (for example, tension in the gut wall and chemical features of the luminal contents). They react to these signals to initiate appropriate reflex control of motility, secretion and blood flow. IPANs connect with each other, with interneurons and directly with motor neurons; interneurons connect with other interneurons and with motor neurons. Amongst the motor neurons are muscle motor neurons, secretomotor neurons, secretomotor/vasodilator neurons and vasodilator neurons.

### Functions of the Enteric Nervous System

#### Control of Motility

The gastrointestinal tract has an external muscle coat whose purposes are to mix the food so that it is exposed

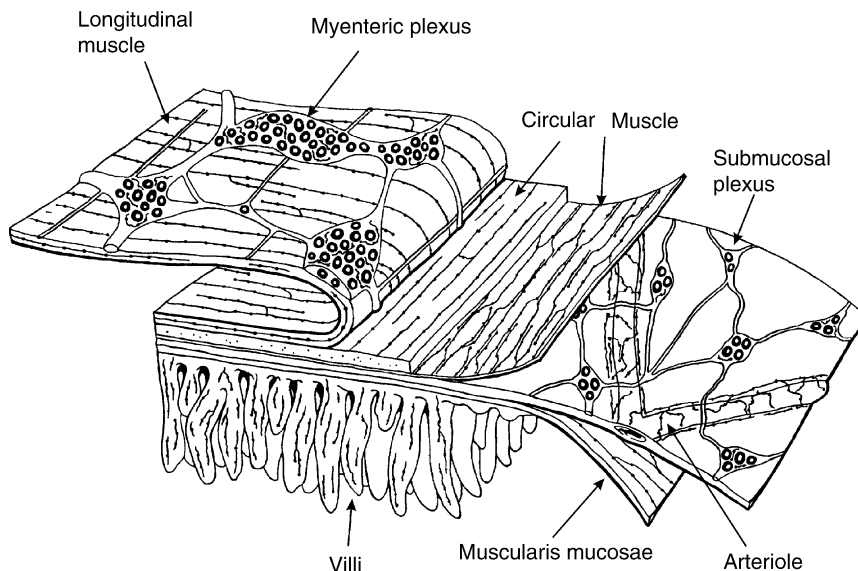

**Enteric Nervous System. Figure 1** The enteric plexuses of the small intestine. There are two plexuses that contain nerve cell bodies, the myenteric and submucosal plexuses, and plexuses of nerve fibers in the muscle, mucosa and around arterioles. Nerve cells are represented by the black circles in the myenteric and submucosal plexuses. The lines represent nerve fibers innervating the muscle, villi of the mucosa, arterioles and ganglia.

to digestive enzymes and to the absorptive lining of the intestine, and to propel the contents of the digestive tube. The muscle also relaxes to accommodate increased bulk of contents, notably in the stomach. The enteric reflex circuits regulate movement by controlling the activity of both excitatory and inhibitory neurons that innervate the muscle. These neurons have co-transmitters, for the excitatory neurons, acetylcholine and tachykinins, and for the inhibitory neurons nitric oxide, vasoactive intestinal peptide and ATP.

Intrinsic reflexes (► **Gastrointestinal reflexes**) of the enteric nervous system are essential to the generation of the patterns of motility of the small and large intestines. The major muscle movements in the small intestine are mixing, propulsive reflexes that travel for only small distances, the migrating myoelectric complex, peristaltic rushes and retropulsion associated with vomiting. The enteric nervous system is programmed to produce these different outcomes. In contrast to the intestine, peristalsis in the stomach is a consequence of conducted electrical events (slow waves) that are generated in the muscle. The intensity of contraction is determined by the actions of the vagus nerves, which form connections with enteric neurons in the gastric wall. The proximal stomach relaxes to accommodate the arrival of food. This relaxation is also mediated through vagus nerve connections with enteric neurons. Thus, the primary integrative centers for control of gastric motility are in the brain-stem, whereas those for control of the small and large intestines are in the enteric nervous system. In most mammals, the contractile tissue of the external wall of the esophagus is striated muscle, and in others, including humans, the proximal half or more is striated muscle. The striated muscle part of the esophagus is controlled, via the vagus, by an integrative circuitry in the brain stem. Thus, although the myenteric ganglia are prominent in the striated muscle part of the esophagus, they are modifiers, not essential control centers, for esophageal peristalsis.

The smooth muscle sphincters restrict and regulate the passage of the luminal contents between regions. In general, reflexes that are initiated proximal to the sphincters relax the sphincter muscle and facilitate the passage of the contents, whereas reflexes that are initiated distally restrict retrograde passage of contents into more proximal parts of the digestive tract.

The progress of the contents in an oral to anal direction is restricted when sympathetic nerve activity increases. To achieve this, transmission from enteric excitatory reflexes to the muscle is inhibited and the sphincters are contracted. The post-ganglionic sympathetic neurons utilize noradrenaline as a transmitter. Under resting conditions the sympathetic pathways exert little influence on motility. They come into action when protective reflexes are activated.

### **Regulation of Fluid Exchange and Local Blood Flow**

The enteric nervous system regulates the movement of water and electrolytes between the gut lumen and tissue fluid compartments. It does this by directing the activity of secretomotor neurons that innervate the mucosa in the small and large intestines and control its permeability. Neurotransmitters of secretomotor neurons are vasoactive intestinal peptide (VIP) and acetylcholine. Secretion is integrated with vasodilatation, which provides some of the fluid that is secreted. Most secretomotor neurons have cell bodies in submucosal ganglia.

Fluxes of fluid, greater than the total blood volume of the body, cross the epithelial surfaces of the gastrointestinal tract each day. Control of this fluid movement via the enteric nervous system is of prime importance for the maintenance of whole-body fluid and electrolyte balance. The largest fluxes are across the epithelium of the small intestine, with significant fluid movement also occurring in the large intestine, stomach, pancreas and gall-bladder. Water flows between the lumens of digestive organs and body fluid compartments in response to movement of osmotically active molecules. The greatest absorption of water, 8–9 l/day, accompanies inward flux of nutrient molecules and  $\text{Na}^+$ , and the greatest secretion accompanies outward fluxes of  $\text{Cl}^-$  and  $\text{HCO}_3^-$  in the small and large intestine, gall-bladder and pancreas. In each of these organs, fluid secretion is controlled by enteric reflexes. In the small intestine and most of the colon the reflex circuits are intrinsic, in the enteric nervous system. They balance secretion with absorptive fluxes, and draw water from the absorbed fluid and from the circulation. The activity of the secretomotor reflexes is under a physiologically important control from inhibitory sympathetic nerve pathways that respond to changes in blood pressure and blood volume through central reflex centers.

Local blood flow to the mucosa is regulated through enteric vasodilator neurons so that the mucosal blood flow is appropriate to balance the nutritive needs of the mucosa and to accommodate the fluid exchange between the vasculature, interstitial fluid and gut lumen. Overall blood flow to the gut is regulated from the central nervous system, via sympathetic vasoconstrictor neurons.

### **Regulation of Gastric and Pancreatic Secretion**

Gastric acid secretion is regulated both by neurons and by hormones. Neural regulation is through cholinergic neurons with cell bodies in the wall of the stomach. These receive excitatory inputs both from enteric sources and from the vagus nerves.

Gastric secretion of HCl and pepsinogen in the stomach, and secretion of pancreatic enzymes, is largely dependent on vago-vagal reflexes. Enteric motor neurons are the final common pathway, but the roles of intrinsic reflexes are minor. Pancreatic secretion of bicarbonate, to neutralize the duodenal contents, is

controlled by secretin, a hormone released from the duodenum, in synergy with activity of cholinergic and non-cholinergic enteric neurons. Secretion into the gall-bladder and bicarbonate secretion in the distal stomach are also nerve controlled.

### Regulation of Gastrointestinal Endocrine Cells

Nerve fibers run close to endocrine cells of the mucosa of the gastro-intestinal tract, some of which are under neural control. Gastrin cells in the antrum of the stomach are innervated by excitatory neurons that utilize gastrin releasing peptide as the primary neurotransmitter.

### Defense Reactions

Enteric neurons are involved in a number of defense reactions of the gut. Defense reactions include diarrhea to dilute and eliminate toxins, exaggerated propulsive activity that occurs when there are pathogens in the gut, and vomiting.

Fluid secretion is provoked by noxious stimuli, particularly by the intraluminal presence of certain viruses, bacteria and bacterial toxins. This secretion is due in large part to the stimulation of enteric secretomotor reflexes. The physiological purpose is undoubtedly to rid the body of pathogens and their products. However, if the pathogens overwhelm the body's ability to cope, the loss of fluid (diarrhea) can become a serious threat to the organism.

### Pathology

There are a large number of pathologies associated with the neural regulation of digestion, most of these arising from abnormalities of the enteric nervous system [6,7]. One neuropathology of the gut is Hirschprung's disease, in which an agenesis of the enteric nervous system, that extends proximally from the rectum for various distances, occurs. It is fatal if untreated. Other enteric neuropathologies include hypertrophic pyloric stenosis, esophageal atresia, gastroparesis, slow transit constipation, some cases of esophageal reflux, Chagas' disease and irritable bowel syndrome.

### References

1. Furness JB (2006) The enteric nervous system. Blackwell, Oxford, pp 1–274
2. Brookes SJH, Costa M (2002) Cellular organisation of the mammalian enteric nervous system. In: Brookes SJH, Costa M (eds) Innervation of the gastrointestinal tract. Taylor and Francis, London, pp 393–467
3. Gershon MD (2005) Nerves, reflexes, and the enteric nervous system. *J Clin Gastroenterol* 38:S184–S193
4. Furness JB, Kunze WAA, Clerc N (1999) Nutrient tasting and signaling mechanisms in the gut II. The intestine as a sensory organ: neural, endocrine, and immune responses. *Am J Physiol* 277:G922–G928

5. Furness JB, Jones C, Nurgali K, Clerc N (2004) Intrinsic primary afferent neurons and nerve circuits within the intestine. *Prog Neurobiol* 72:143–164
6. De Giorgio R, Camilleri M (2004) Human enteric neuropathies: morphology and molecular pathology. *Neurogastroenterol Motil* 16:515–531
7. Spiller R, Grundy D (2004) Pathophysiology of the enteric nervous system, a basis for understanding functional diseases. Blackwell, Oxford

## Enteric Neuron

### Definition

Two networks or plexuses of enteric neurons are embedded in the wall of the entire length of the digestive tract. The myenteric plexus is located between the circular and longitudinal layer of the muscularis externa, and is primarily involved with the control of gut motility. The submucous plexus, within the submucosa, is involved in the regulation of blood flow within the digestive tract and in the control of epithelial functions such as the secretion of enzymes, acid or mucous. Every neuron whose cell body is in the enteric nervous system is named as “enteric neuron.” The enteric neurons are classed in three groups: sensory neurons sending their sensory afferents to chemo- and mechanoreceptors in the gut wall, motor (either excitatory or inhibitory) neurons regulating gut activities, and interneurons forming synaptic linkages among enteric neurons. The enteric neurons are classified according to their electrophysiological/chemical properties and shapes; good correlations among these are established. Dogiel type I neurons, morphologically classified, correspond to S/Type 1 neurons, electrophysiologically identified, acting as motor and/or interneurons; while Dogiel type II neurons are AH/Type 2 neurons as afferent sensory neurons.

- ▶ Bowel Disorders
- ▶ Enteric Nervous System

## Enteroreceptive

### Definition

Receptors and senses receive stimuli arising within the body and comprise proprioception, and various other senses, such as deep thermosensibility and pain.

- ▶ Sensory Systems

## Entheogens

- ▶ Hallucinogens

## Entity

### Definition

Anything that exists.

- ▶ Property

## Entorhinal and Perirhinal Cortices

### Definition

The entorhinal and perirhinal cortices are situated in the parahippocampal gyrus and mark the transition from allocortex of the hippocampus to the cerebral cortex of the temporal lobe. The area stretches from the amygdaloid body to the prepiriform cortex and already features a 6-layered structure. Afferents: rhinencephalon, Ammon's horn, septum verum, cortex, thalamus.

Efferents: hippocampus, thalamus, tegmentum of

- ▶ Mesencephalon.
- ▶ Telencephalon

## Entorhinal Area (Cortex)

MENNO P. WITTER

Kavli Institute for System Neuroscience, Centre for the Biology of Memory, Department of Neuroscience, Norwegian, University of Science and Technology (NTNU), Trondheim, Norway; Institute for Clinical and Experimental Neurosciences, Department of Anatomy and Neurosciences, VU University medical center, Amsterdam, The Netherlands

### Synonyms

Brodman area 28

### Definition

The entorhinal (inside rhinal) area is a part of the cortex that is partially enclosed by the ▶rhinal (▶olfactory) ▶sulcus. It is a major part of the ▶medial temporal lobe memory system and constitutes the major gateway between the *hippocampal formation* and the *neocortex*. It is involved in higher-order cognitive processing, in particular in memory processes. The entorhinal area exhibits pathological and pathophysiological changes in a number of diseases including Alzheimer's disease, epilepsy, and schizophrenia.

### Characteristics

#### Anatomical Organization

The entorhinal area is part of a densely interconnected group of cortical areas that together form the ▶*para-hippocampal region*, an area closely associated with the *hippocampal formation*. The name of the entorhinal area, similar to that of other components of the parahippocampal region, is derived from the ▶rhinal sulcus, which can be distinguished in all mammals. However, its particular features differ quite a bit between species. Whereas in rats it is essentially the only distinguishable sulcus that runs along the rostro-caudal extent of the hemisphere, in humans it is only present in about 50% of the cases as a shallow and short indentation in the most medio-anterior temporal lobe.

The entorhinal area is uniquely positioned as an interface between the *neocortex* and the *hippocampal formation*. It is also closely associated with a larger group of cortices, referred to as *limbic cortex*. The entorhinal area is traditionally divided into the lateral and medial entorhinal area. Similar to other cortices, in the entorhinal area, neurons are grouped into different layers that are each characterized by a dominant cell type. Six layers are commonly distinguished, of which layers I and IV are relatively free of neurons. All remaining layers do contain a variety of neuronal subtypes that have been characterized on the basis of their anatomical and/or electrophysiological properties. The principal neurons of the entorhinal area, i.e. the neurons that are the main recipients of incoming axons and the major source of entorhinal output to a variety of cortical and subcortical structures are generally pyramidal cells or modified versions, the so-called stellate cells. These mainly utilize *glutamate* as an excitatory *neurotransmitter*. A second group of neurons are the interneurons that mainly provide intrinsic, local connections that use *GABA* as an inhibitory transmitter. Many of these interneurons are characterized by expressing a variety of different peptides in their cellbody [1,2] (Fig. 1).

#### Functional Organization

The entorhinal area is part of the cortical domain, called the *parahippocampal region* which in addition to the entorhinal area includes the perirhinal and



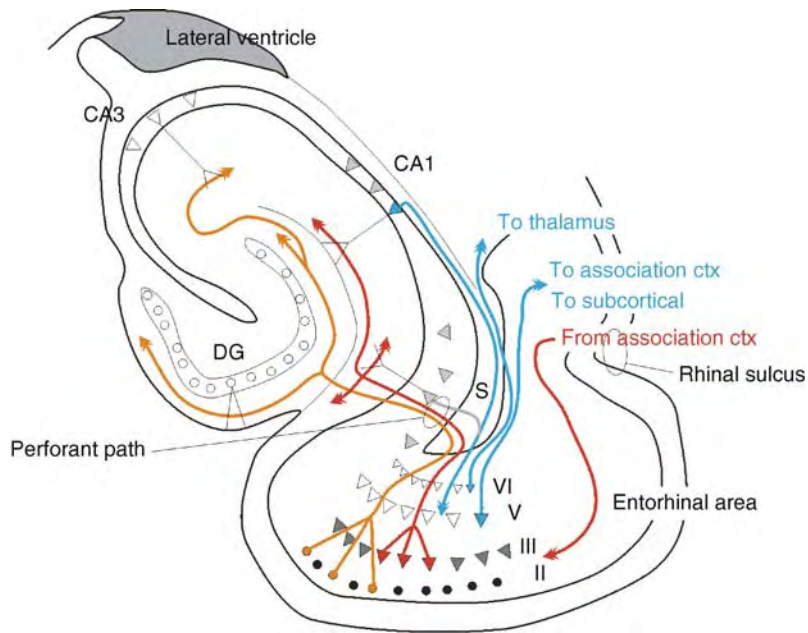

**Entorhinal Area (Cortex).** **Figure 1** Schematic representation of the entorhinal area and its main connectivity that puts it in a pivotal position to mediate the communication between the hippocampal formation and the association cortex. Dentate gyrus (DG), Cornu ammonis fields 3 and 1 (CA3, CA1) and the subiculum are components of the hippocampal formation.

parahippocampal (postrhinal) cortices and the pre- and parasubiculum. The parahippocampal region in turn is virtually inseparable from the *hippocampal formation*, and together they form the major constituents of the system mediating conscious (declarative) memory. Together these regions appear to specifically deal with the translation of neocortical exteroceptive information into higher order complex representations that, when combined with motivational and interoceptive representations, will serve cognitive functions, in particular conscious memory.

Since prominent species differences are apparent with respect to size and organization of cortical areas, also the organization of the entorhinal area may be expected to be different in for example primates and non-primates. However, despite considerable diversity of the majority of cortical regions, the anatomy and functional role of the entorhinal area appear to be largely conserved [3].

The entorhinal area receives a variety of cortical and subcortical inputs. The strongest cortical inputs arise from the adjacent cortical domains in the *parahippocampal region*. Additional inputs originate in other higher order association cortices such as prefrontal (▶prefrontal cortex), insular and ▶cingulate cortex. To a large extent, these cortical inputs terminate in the superficial layers II and III, providing inputs to neurons that give rise to the so-called ▶perforant path, projecting to the *hippocampal formation* [1]. Neurons

in layers II and III of the entorhinal area are the major source of cortical input to all of the different subfields within the hippocampal formation. Layer II neurons mainly project to the *dentate gyrus* and hippocampal field CA3, and cells in layer III distribute their axons largely to field CA1 and the *subiculum*. Cortical output of the *hippocampal formation* is preferentially distributed to layer V of the entorhinal area, which in turn is the origin of projections to the *parahippocampal region* and a number of other cortical regions. In addition, projections for layers V and VI target a number of subcortical structures including the *striatum*, the *amygdala* and the ▶thalamus. Overall, cortical inputs to superficial layers of the entorhinal area are reciprocated by projections from the deep entorhinal layers.

The overall connectivity of the entorhinal area shows a strong topography organized along a gradient that runs from its border with the rhinal sulcus towards the border between the entorhinal cortex and the adjoining hippocampal formation. Multimodal sensory cortex providing inputs from the outside world, such as those from the perirhinal and postrhinal cortex preferentially target a strip of entorhinal area which is adjacent to the rhinal sulcus. Parts of entorhinal area that are more distant from the rhinal sulcus receive information representing motivational or visceral dependent input, such as projections from ▶infralimbic cortex and almost all nuclei of the *amygdala*. Outputs of the entorhinal area follow a comparable gradient [1]. This

overall anatomical organization is reflected in results of lesion studies indicating that animals with lesions of the strip close to the rhinal sulcus show spatial memory problems, while animals with lesions of the more distant strip do not. These latter animals show altered fear-related behavior [4].

The lateral and medial entorhinal cortices differ with respect to their major inputs. The lateral entorhinal area receives considerable input from the perirhinal cortex, *olfactory* and *insular* cortex and the *amygdala*. The medial entorhinal area receives major inputs from the postrhinal cortex, the presubiculum, visual association cortex and *cingulate* and *parietal cortices* and the *anterior complex of the thalamus*. These overall differences in cortical connectivity are reflected in recent findings that the medial entorhinal area, but not the lateral, is a major hub in the brain's circuitry for spatial navigation [5]. A key component of this network is the *grid cell*. When rats run around in two-dimensional environments, grid cells fire selectively at

regularly spaced positions, such that for each cell, the multiple firing fields define a repeating triangular pattern that tiles the entire environment covered by the animal, almost like the cross points of graph paper, but with an equilateral triangle as the unit of the grid rather than a square. Grid cells are predominant in layer II of the entorhinal area, but exist also in layers III and V. Grid cells intermingle with *head-direction cells* as well as cells with conjunctive grid and head-direction properties. Directionally tuned cells are located primarily in layers III and V of the medial entorhinal cortex, which are major target areas of presubicular projections most likely conveying signals from the head direction cells in the presubiculum. It is of interest that neighboring grid cells in different layers show a striking coherence in the spacing and orientation, suggesting the presence of column-like modules that span across layers of the entorhinal area [5].

In the lateral entorhinal area, neurons exhibit little spatial modulation, and their precise functional correlates

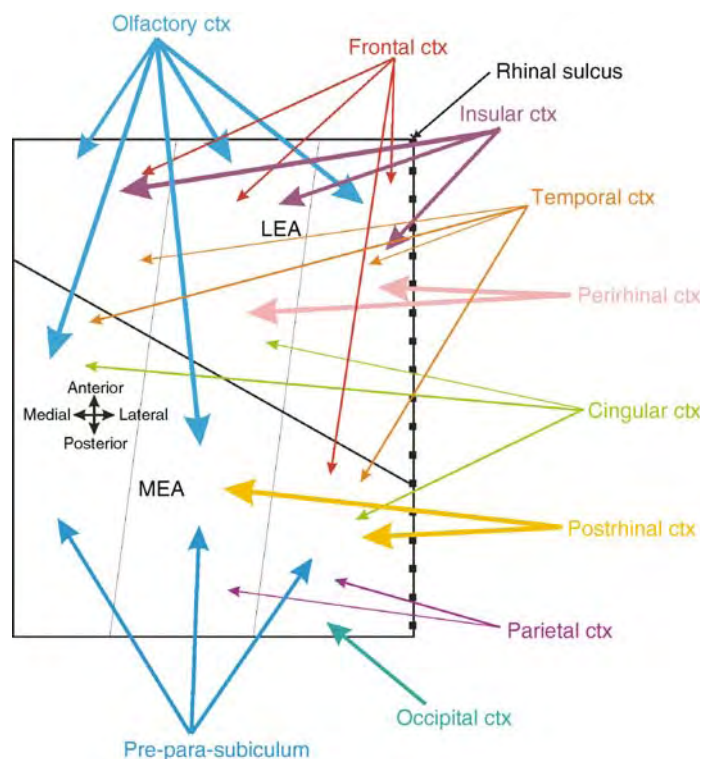

**Entorhinal Area (Cortex).** **Figure 2** Schematic representation of the major cortical inputs to the entorhinal area, emphasizing the differences between the lateral and medial entorhinal area, LEA and MEA respectively, and between the zones that are differently positioned in relation to the rhinal sulcus. Clear differences are apparent such that MEA receives preferentially visual-spatial information from occipital, parietal and postrhinal/parahippocampal cortices and pre-para-subiculum, whereas LEA receives stronger inputs from olfactory, insular (taste) and perirhinal cortices. Also note that most multimodal sensory association cortex reaches entorhinal cortex via adjacent zones of the parahippocampal region terminating preferentially in the entorhinal zone, directly adjacent to the rhinal sulcus, i.e. the most laterally positioned zone.

are not well understood [5]. Since it is likely that a comparable intrinsic and extrinsic column-like connective architecture is present in lateral and medial entorhinal area what needs to be established is whether a non-spatial counterpart for the grid cell in the medial entorhinal area exists in the lateral entorhinal area. This non-spatial counterpart, most likely is to be found within the domain of memory for single items and the association between them in view of findings that many cells in the lateral entorhinal area respond to memory cues such as odors or visual stimuli [3] or that the lateral entorhinal area is specifically involved in olfactory based conspecific recognition [6].

The notion of two functionally different parts of the entorhinal area should be tempered since the lateral and medial portions of the entorhinal area are strongly interconnected, as are two of the major input structures, the perirhinal and parahippocampal (postrhinal) cortices. It is thus likely that at the level of the entorhinal area relations between the two input components will already occur. This is in line with the finding that in the entorhinal area cells respond to both object and place stimuli and that lesions do not result in impairments in, for example, object recognition but do impair the relational organization of memory [7].

Entorhinal functions are most likely modulated by a number of subcortical inputs, including those from the *thalamus*, mainly originating from the midline structures, and *cholinergic* inputs. High levels of *acetylcholine* sets the appropriate dynamics to facilitate the storage of stimuli, whereas removal of the cholinergic inputs to the entorhinal area dramatically interfere with the memory performance of the animal [8]. These subcortical inputs also play an essential role in occurrence of oscillatory activity that is an elementary component of normal entorhinal function [1,2] (Fig. 2).

### Clinical Relevance

Severe alteration of the entorhinal area is associated with many disorders of the human brain, including *Alzheimer's disease*, ► *Picks disease*, *Huntington's disease temporal lobe epilepsy* and *schizophrenia* [1]. In case of Alzheimer, the initial pathological changes reportedly occur in layer II of the entorhinal area; *temporal lobe epilepsy* is associated with marked degeneration in layer III, whereas in case of *Huntington's disease* the most dramatic initial changes are seen in layer V with some additional but minor involvement of layers II and superficial III.

The widespread pathology throughout the cortex seen in later stages of Alzheimer's disease stands in marked contrast to the much more focal initial damage in the entorhinal area and other adjacent structures of the medial temporal lobe. Volume reduction of the entorhinal area is now considered a relevant and reliable measure to identify individuals at risk for Alzheimer's

disease [1]. Entorhinal atrophy is associated with mild memory loss as seen in individuals with mild cognitive impairment and it precedes hippocampal volume reduction seen in mild Alzheimer patients [9]. A comparable sequence of entorhinal atrophy before hippocampal alterations have been reported in case of temporal lobe epilepsy [10].

### References

1. Scharfman HE, Witter MP, Schwarcz R (eds) (2000) The parahippocampal region: implications for neurological and psychiatric diseases. *Ann NY Acad Sci* 911:9–13
2. Witter MP, Wouterlood FG (eds) (2002) The parahippocampal region: organization and role in cognitive functions. Oxford University Press, Oxford, UK
3. Manns JR, Eichenbaum H (2006) Evolution of declarative memory. *Hippocampus* 16:795–808
4. Steffenach HA, Witter M, Moser MB, Moser EI (2005) Spatial memory in the rat requires the dorsolateral band of the entorhinal cortex. *Neuron* 45:301–313
5. Witter MP, Moser EI (2006) Spatial representation and the architecture of the entorhinal cortex. *Trends Neurosci* 29:671–678
6. Petrusis A, Alvarez P, Eichenbaum H (2005) Neural correlates of social odor recognition and the representation of individual distinctive social odors within entorhinal cortex and ventral subiculum. *Neuroscience* 130:259–274
7. Buckmaster CA, Eichenbaum H, Amaral DG, Suzuki WA, Rapp PR (2004). Entorhinal cortex lesions disrupt the relational organization of memory in monkeys. *J Neurosci* 24:9811–9825
8. Hasselmo ME (2006) The role of acetylcholine in learning and memory. *Curr Opin Neurobiol* 16:710–715
9. Pennanen C, Kivipelto M, Tuomainen S, Hartikainen P, Hanninen T, Laakso MP, Hallikainen M, Vanhanen M, Nissinen A, Helkala EL, Vainio P, Vanninen R, Partanen K, Soininen H (2004) Hippocampus and entorhinal cortex in mild cognitive impairment and early AD. *Neurobiol Aging* 25:303–310
10. Bernasconi N, Bernasconi A, Caramanos Z, Dubeau F, Richardson J, Andermann F, Arnold DL (2001) Entorhinal cortex atrophy in epilepsy patients exhibiting normal hippocampal volumes. *Neurology* 56:1335–1339

## Entrain

### Definition

To synchronize an endogenous circadian rhythm to a rhythm in the environment.

- Circadian Rhythm
- Seasonality

## Entrainment

### Definition

The process by which a biological oscillator with a free-running period ( $\tau$ ) that is close to 24 h is adjusted to the exact 24-h period ( $T$ ) of the environment. When entrained, the period of the biological rhythm equals the period of the entraining stimuli and the two oscillations exhibit a stable phase relationship. The entraining stimuli can also alter the waveform of the processes driven by the circadian system. The daily cycle of light and dark is the dominant cue responsible for entrainment, though other environmental and social cues can play a role. The entraining cue is referred to as a “zeitgeber” (translated from German “time giver”). In order to establish that a periodic environmental signal is a zeitgeber, it is necessary to demonstrate that the period of the biological rhythm equals the period of the zeitgeber and that there is a stable phase relationship between the two rhythms. For example, in the most common case for circadian rhythms, there should be a fixed time interval between the peak of the biological rhythm and the time of lights-on or lights-off when the organism is held in a light/dark cycle. Upon releasing the biological oscillator into constant conditions, the phase of the endogenous oscillator must be shown to be determined by the phase of the previous zeitgeber cycle. In order for a biological oscillator to provide a reliable estimation of time in the external world, the oscillator must be entrained to the environment. Thus, entrainment is critical for one of the key adaptive functions of circadian clocks.

- ▶ Circadian Cycle
- ▶ Clock
- ▶ Phase Response Curve (PRC)

## Entropy

### Definition

A quantity postulated by the second law of thermodynamics. For a continuous body, it is given by the integral over the body of the entropy density, assumed to be a function of state of the system (that is a quantity specified via a constitutive law).

- ▶ Mechanics

## ENU Mutagenesis

### Definition

Mutagenesis using N-ethyl-N-nitrosourea (ENU). This chemical is an ethylating agent that is cytotoxic to mouse spermatogonial stem cells. It is injected intraperitoneally into male mice reaching maturity (G0 mice, 6–8 weeks of age). These mice are then used in breeding programs; G1 mice can be used to screen for dominant mutations, whereas the identification of recessive mutants requires further backcrossing. Large scale phenotypic screens are then used to identify interesting mutants.

- ▶ Bioinformatics

## EOD

- ▶ Electric Organ Discharge

## EP Element

### Definition

EP element – EP (enhancer/promoter) elements are P elements containing upstream activation sequences that drive GAL4-dependent transcription from an adjacent P element promoter through genomic DNA next to the site of insertion. Activation of transcription by GAL4 in targeted cells results in the overexpression of the downstream gene.

- ▶ GAL4/UAS

## Ependymal Cells

### Definition

Originate from the germinal layer of the neural tube, and functions as a blood-cerebrospinal fluid barrier and produces the majority of the cerebrospinal fluid. They

are also known to produce various kinds of trophic factors.

- ▶ Cerebrospinal Fluid (CSF)
- ▶ Neural Tube
- ▶ Regeneration of Optic Nerve

## Ependymoglia

### Definition

Less advanced glial type, the cell bodies are in the ependymal layer, which lines the brain ventricle, their long processes can span the brain wall.

- ▶ Evolution of the Brain: At the Reptile-Bird Transition

## Ependymomas

### Definition

Primary brain or spinal cord tumors arising from the cells lining the cerebro-spinal fluid (CSF) containing spaces of the nervous system. They may exhibit benign or malignant features and generally do not infiltrate normal brain tissue. Ependymomas typically spread along CSF spaces. Several different types of ependymomas are recognized. Some are amenable to surgery.

- ▶ Gliomas

## Ephapse

### Definition

An ephapse is a non-synaptic contact between nerve cells, which arises as a consequence of pathological processes (e.g., demyelination diseases) or is produced experimentally and enables non-physiological transfer of action potentials between cells.

- ▶ Action Potential Propagation

## Ephaptic Interactions

### Definition

The process whereby neighbouring neuronal processes affect each other through the passive spread of electrical current across intercellular space.

## Ephrins

### Definition

Membrane-bound repulsive molecules acting through Eph receptors. A-type and B-type ephrins play an important role in guidance of retinal ganglion cell axons during optic system development. Here, ephrins and their receptors are expressed to form complementary gradients that organize retinal axons in a topographic order.

- ▶ Growth Inhibitory Molecules in Nervous System Development and Regeneration
- ▶ Retinal Ganglion Cells

## EPI, Echo-Planar Imaging

### Definition

Echo-planar imaging is an ultra-fast method for acquiring MR images, which is typically used in functional MRI experiments to investigate functional organization of the human brain non-invasively. EPI permits an image acquisition time of 100 ms or less, which allows for MR scanning of the brain in 2–3 s with functional (BOLD) contrast.

- ▶ Magnetic Resonance Imaging

## Epidemic Encephalitis

### Definition

Infections of the brain caused by arthropod-borne viruses primarily from the families togaviridae,

flaviviridae, bunyaviridae, reoviridae and rhabdoviridae. The life cycles of these viruses are characterized by zoonoses, with birds and lower mammals serving as intermediate hosts; the virus is transmitted to humans by the bite of mosquitoes or ticks; clinical manifestations include fever, ►headache, alterations of mentation, focal neurologic deficits, and ►coma.

## Epilepsy

### Definition

A medical condition in an individual characterized by recurrent, unprovoked seizures. There are many different types and causes of epilepsy which are characterized and described by criteria established by the International League Against Epilepsy (<http://www.ilae-epilepsy.org/>).

► Anticonvulsants

## Epileptiform Pattern of EEG

Interictal discharge of brain activity in the EEG recording, which, based on its shape, may be divided into sharp waves, spikes, spike-and-slow-wave complexes, and multiple spike-and-slow-wave complexes. The epileptiform activity may be revealed in the majority of epileptic patients and, therefore, EEG is an important diagnostic tool for this disease.

► Electroencephalography

## Epimuscular Myofascial Force Transmission and Intermuscular Interaction

PETER A. HUIJING

Research Instituut Faculteit Bewegingswetenschappen, Vrije Universiteit, Amsterdam, The Netherlands

### Definition

Myofascial Force Transmission between the Intramuscular Stroma and Neighboring Structures. In the

accompanying essay of this Encyclopedia on ►intra-muscular myofascial force transmission, we have argued that this stroma functions as an integrator for force within a muscle.

►Epimuscular myofascial force transmission occurs if force is transmitted from or onto this stroma by paths other than the muscle's own tendons. In any case, such transmission will lead to differences in force exerted at proximal and distal tendons of a muscle (or other forms of its origin and insertion).

Two types of such force transmission are distinguished:

1. Intermuscular myofascial force transmission [1,2]: Force is transmitted between the connective tissue stromata of adjacent muscles, which can be viewed as continuous.
2. ►Extramuscular myofascial force transmission [3,2]: Force is transmitted between the connective tissue stroma and non-muscular tissues of a compartment.

A muscle is shown with connections to a neighboring muscle and to non-muscular structures.

1. Assumed initial positions of the extra- and intermuscular connections.
2. After distal lengthening exclusively of the muscle of interest, a distribution of lengths of linking elements (both extra- and intermuscular) is present. Distal links increase in length because this variable is influenced not only by the length change of the muscle part to which they are attached, but also by the cumulated sum of length changes of the more proximal muscle part, which causes displacement of distal muscle parts.
3. After exclusively changing the position of the muscle of interest, without changing its length. Note that the direction of the linking elements (both extra- and intermuscular) is reversed, as the distribution of their lengths is reversed. This would also reverse the direction of force transmission.

### Characteristics

#### Quantitative Description

In animal experiments under conditions of full recruitment, for fully activated muscle the absolute value proximo-distal force difference (i.e. percentage of muscle force transmitted by epimuscular pathways) varied from 0 to 40% of optimal force. Even for submaximally activated muscle (lower firing frequencies), this difference may reach maximal values as high 30% of the optimal force exerted for a specific firing frequency. Such values are an indication of the potential importance of epimuscular myofascial effects.

The magnitude of a proximo-distal force difference has been shown to be a function of muscle length

(Fig. 1), but also the relative position of a muscle with respect to its surroundings [4,5]. This means that as a muscle is moved relative to the structures surrounding it, its physiological properties will change (e.g. sarcomere lengths, stiffness of the intramuscular stroma) even if the length of the muscle has not (Fig. 2). Note that, depending on muscular relative position, the sign of the difference may change from positive to negative.

For passive muscle, the level of such force transmission (expressed in N) is of course much lower, but very substantial normalized proximo-distal force differences are found (e.g. ref. [3]).

## Higher Level Structures

### Relevant Connective Tissue Structures

The type of honeycomb-like structure, described for all levels of the intramuscular stroma (c.f. the accompanying article on intramuscular myofascial force transmission of this Encyclopedia: Fig. 3), repeats itself at higher levels of organization and size:

#### 1. Muscular compartments

The walls of a compartment containing a synergistic muscle group consist of the following connective tissue:

- Sheets covering the bones (►periost).
- Sheets connecting bones (intermuscular membrane, e.g. between tibia and fibula).
- Sheets separating two muscle groups (►intermuscular septum). It should be noted that these structures are suspended from bones and from ligaments crossing joints.

#### 2. The ►general fascia or whole body fascia

This is the highest level of the connective tissue structure, extending all the way from the endomysium surrounding one muscle fiber to whole body cover.

It should be noted that the compartment related structures described frequently form a major location of attachment of muscle fibers (e.g. ref. [6]). Therefore, these connective tissue structures act as an extension of the bony skeleton in this respect. It should also be noted that these structures form connections with or may even be continuous with the capsule and ligaments of the joints.

Within each compartment, besides muscles two additional potentially relevant structures are found [7]:

- Extramuscularly, the nerves and blood vessels remain embedded in a sheet or column of connective tissue that is called the ►neurovascular tract (Fig. 3). This structure can also be considered mechanically as some form of continuation of the intramuscular stroma. The neurovascular tract is also attached to elements that form the compartment walls and pass from

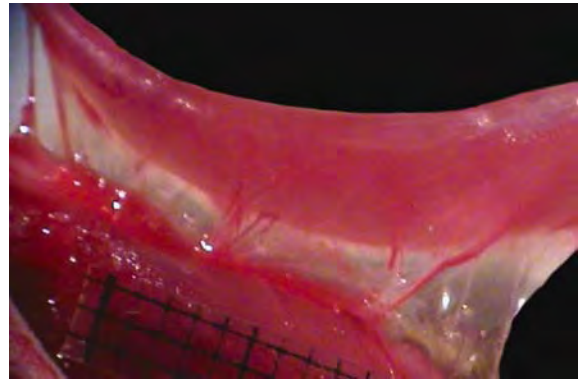

### Epimuscular Myofascial Force Transmission and Intermuscular Interaction. Figure 1

Typical example of the length dependence proximo-distal force differences in rat extensor digitorum longus muscle. EDL muscle-tendon complex length ( $l_{m+t}$ ) was changed by pulling on the proximal tendon. Active forces (black curves, use left vertical axis) are plotted for maximally activated muscle. Note that proximal and distal forces are only equal at one length (crossover point). Grey curves indicate passive forces (use right vertical axis).

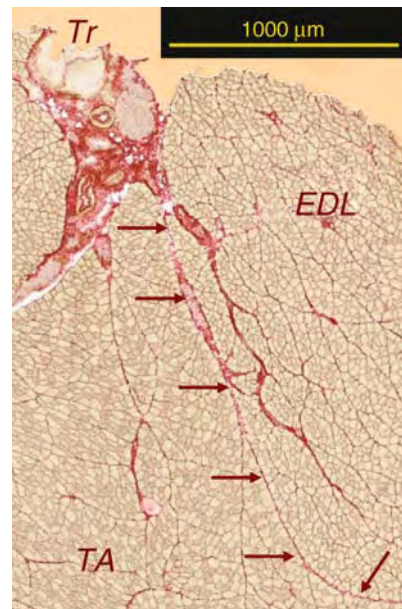

### Epimuscular Myofascial Force Transmission and Intermuscular Interaction. Figure 2

Schematic representation of effects of length change and relative position on the length of extra- and intermuscular connections.

- compartment to compartment via windows in the intermuscular septa or ►interosseal membrane (Fig. 4).
- The intramuscular connective tissue stromata of neighboring muscles are connected (Fig. 4). Even though this type of connective tissue is usually

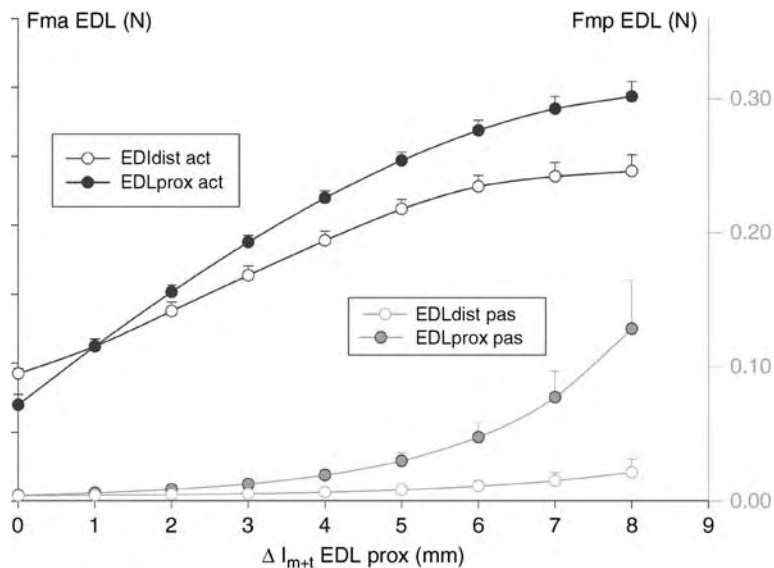

**Epimuscular Myofascial Force Transmission and Intermuscular Interaction. Figure 3** Schematic representation of effects of length change and relative position on the length of extra- and intermuscular connections.

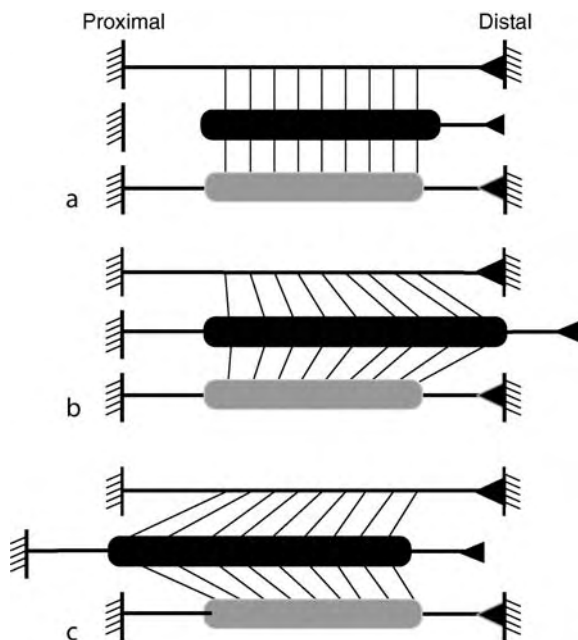

**Epimuscular Myofascial Force Transmission and Intermuscular Interaction. Figure 4** Schematic representation of effects of length change and relative position on the length of extra- and intermuscular connections.

labeled as “loose connective tissue,” we know very little of its stiffness under physiological loading. If it is stiff enough, it could potentially transmit force between adjacent muscles.

### Lower Level Components

The intramuscular stroma has been described in the accompanying essay on intramuscular myofascial force transmission of this Encyclopedia.

### Higher Level Processes

#### *Compartment Walls, Joint Stabilization and Extramuscular Myofascial Force Transmission*

As force is transmitted myofascially to extramuscular tissues including compartment walls, it will make these structures more stiff and stable. This should facilitate their function as origin or insertion for muscle fibers, which are not attached to bone.

As elements of these extramuscular structures are mechanically continuous with the joint capsule and joint ligaments (i.e. reinforcements of the capsule by concentrated collagen fibers within it), forces will be exerted at the joints. If coordinated appropriately, such forces may stabilize the joints during movement and static conditions.

#### *Extramuscular Myofascial Force Transmission will Affect Neural Receptors within Compartment Walls*

Force transmitted myofascially, or myotendinously for that matter, onto elements forming walls of **muscle compartments** from muscular and joint origins, will affect any mechanoreceptor or free ending of afferent nerves present there by straining or other specific stimuli. Even though not a great deal of effort has been devoted to describing receptors and nerve endings in such structures, it is clear that Pacinian corpuscles and free nerve endings do occur at substantial numbers at



specific sites within the periosteal, interosseal membranes and intermuscular septa [8,9,6]. In addition, Wal [6] argued that the specific locations of such receptors is related to global organization of connective tissue and muscles within the compartment.

### **Intermuscular Interaction through Myofascial Force Transmission**

#### **Between Synergistic Muscles**

In animal experiments, it has been shown that if one muscle is lengthened and neighboring muscle is kept at constant length, the force in the lengthened muscle increases at the tendon location of lengthening. In contrast, at the same side in neighboring muscle the force falls despite their constant length [4]. The two muscles interact mechanically through myofascial force transmission: Force originating from the active sarcomeres of one muscle is exerted at the tendon of a neighboring (synergistic) muscle. This can be understood as follows: Any active sarcomere will shorten until opposing forces prevent further shortening. The myotendinous junction may exert, via sarcomeres arranged in series, such an opposing force. Also, the inter- and extramuscular connective tissues transmit such forces from neighboring muscles or from non-muscular structures. As one of neighboring muscles is stretched, the length of linking structures will increase, as will their stiffness. Therefore, the length of some sarcomeres within the muscle kept at constant muscle-tendon complex length will decrease and force will fall. Some force that was exerted at the tendon of the constant length muscle will be transmitted to neighboring (lengthened) muscle and exerted at that tendon. We cannot presently distinguish the contributions of extramuscular and intermuscular paths for synergistic muscles within one compartment, but the arguments to be presented in the paragraph on antagonistic muscles do suggest that extramuscular pathways will prove to be important.

It should be realized that some relative movement of a muscle with respect to extramuscular tissues and even between synergistic muscles is a likely occurrence in vivo. Any differences between moment arms of adjacent muscles (which are not uncommon) will cause such relative movement of muscles. Even more important may be the effect of some muscles of a compartment being polyarticular. For example, if the ankle joint angle is kept constant and the knee joint angle is changed, changes of relative position and mechanical interaction will occur between several muscles of the lower limb, even if the muscles had identical moment arms at the ankle joint.

#### **Between Antagonistic Muscles**

By definition, antagonistic muscles (causing opposite movements at a given joint) are separated by an intermuscular septum or interosseal membrane, and

therefore do not have intermuscular connections between the connective tissue stromata.

Despite that fact, the same phenomenon of force decrease in a muscle, kept at constant muscle-tendon complex length, was found experimentally [4] as its antagonistic muscle was lengthened. In such a case, the mechanism is as described above, but an interaction between muscles mediated by myofascial transmission of force between muscles must be extramuscular in nature. The collagen fiber reinforcement of the neurovascular tract forms the most likely path for such transmission.

By definition, changes of muscular relative position for antagonistic muscles are the only possibility during movement: Shortening of the agonistic muscle (group) and lengthening of the antagonistic muscle (group), or vice versa, always accompanies joint movement. Changes of relative position of these muscles will be extreme, which makes substantial interaction by extramuscular myofascial force transmission very likely.

#### **Lower Level Processes**

Intramuscular myofascial force transmission has been described in the accompanying essay of this Encyclopedia.

#### **Process Regulation**

Considering the rather high number of potential paths for force transmission, the process that actually determines division of force across paths needs to be considered in some more detail. The rules for such division may be derived from biomechanics. For serial connections, the force borne must be equal. If force is exerted at a node of two serial paths of equal stiffness arranged in parallel, the force will be divided equally across the two. If the stiffness of two or more serial paths in parallel differs, more force will be borne by the stiffest path.

Therefore, the division of force across serial paths in parallel is governed by the relative stiffness of the available paths.

#### **Function**

In a classical view, muscles are independent generators of active and passive force. Epimuscular myofascial force transmission constitutes additional mechanisms of force transmission from muscle: Force is transmitted between the intramuscular stroma at the muscle level and the tissues of a higher level of organization. The latter acts as an integrator of forces exerted by different muscles and non-muscular structures. It has been concluded that the tissues of a compartment play an important role in modifying muscular properties. A major consequence is that muscles should no longer be considered as independent units, but may show

considerable interaction, even with antagonistic muscles. Such interaction is highly dependent on the relative position of a muscle with respect to surrounding muscular and non-muscular structures.

Even though not all force of a muscle may be exerted at the tendons, force transmitted via extramuscular structures should not be considered as lost for the creation of movement. It may actually be essential for the ability to move, as well as the use of specific muscles (whose myofibers do not attach to tendon or bone) to contribute efficiently to moments exerted at the joints.

Furthermore, the connective tissue stroma, acting as an integrator of force of the body, also provides locations for neural receptors or nerve endings, which provide global information to the central nervous system about the condition of the limbs, rather than information about very localized processes within muscles or extramuscular tissues.

From the above, visions emerge of motor control as a manipulation of the ratio of stiffness of different elements of the integrating connective tissue structures of a whole limb or body part, allowing the exertion of specific combinations of moments and forces at joints that would allow efficient specific desired movement. It is obvious that such hypotheses still require experimental verification.

### Pathology

Effects of epimuscular myofascial force transmission have also been shown for human muscle with experiments on patients undergoing tendon transfer surgery because of spasticity. For example, after distal tenotomy of flexor carpi ulnaris muscle (FCU), extension of the wrist still caused substantial lengthening of FCU, even though the muscle did not cross the wrist joint anymore [10]. After partial dissection of FCU from its surroundings, in similar groups of patients, length-force characteristics were not compatible with the idea that the limitation of movement was caused by elements of the muscle itself, but suggest the hypothesis that inter- and extramuscular connections may actually cause the limitations in range of joint movement in this group of patients with spastic muscles.

### References

1. Maas H, Baan GC, Huijing PA (2001) Intermuscular interaction via myofascial force transmission: effects of tibialis anterior and extensor digitorum longus length on force transmission from rat extensor digitorum longus muscle. *J Biomech* 34:927–940
2. Yucesoy CA, Koopman HFJM, Grootenboer HJ, Huijing PA (2003) Effects of inter- and extramuscular myofascial force transmission on adjacent synergistic muscles: assessment by experiments and finite-element modeling. *J Biomech* 36:1797–1811

3. Huijing PA, Baan GC (2001) Extramuscular myofascial force transmission within the rat anterior tibial compartment: proximo-distal differences in muscle force. *Acta Physiologica Scandinavica* 173:1–15
4. Huijing PA (2002) Intra-, extra- and intermuscular myofascial force transmission of synergists and antagonists: effects of muscle length as well as relative position International. *J Mech Med Biol* 2:1–15
5. Maas H, Baan GC, Huijing PA (2004) Muscle force is determined also by muscle relative position: isolated effects. *J Biomech* 37:99–110
6. Wal JCvd (1988) The organization of the substrate of proprioception in the elbow region of the rat (doctoral dissertation). University of Limburg, Maastricht, The Netherlands
7. Huijing PA (2003) Muscular force transmission necessitates a multilevel integrative approach to the analysis of function of skeletal muscle. *Exerc Sport Sci Rev* 31:167–175
8. Stilwell DL, Jr. (1957) Regional variations in the innervation of deep fasciae and aponeuroses. *Anat Rec* 127:635–653
9. Zelena J (1982) Survival of Pacinian corpuscles after denervation in adult rats. *Cell Tissue Res* 224:673–683
10. Kreulen M, Smeulders MJ, Hage JJ, Huijing PA (2003) Biomechanical effects of dissecting flexor carpi ulnaris. *J Bone Joint Surg Br* 85:856–859

## Epimysium

### Definition

The fascia that covers the full longitudinal perimeter of each muscle, but not its ends. It forms the wall of a “tunnel” in which the muscle operates. The epimysium is continuous with the endomysial-perimysial stroma of the muscle. It covers the aponeuroses of the muscle but is not attached to it, except at locations of muscle fiber attachment.

- ▶ Intramuscular myofascial force transmission
- ▶ Skeletal Muscle Architecture

## Epinephrine or Adrenaline

### Definition

Catecholaminergic hormone released from the adrenal medulla by stressful experiences.

- ▶ Adrenaline

## Epineurial Repair

### Definition

Adaptation of the ends of an injured nerve by suturing the epineurial sheath.

► **Regeneration: Clinical Aspects**

## Epineurium

### Definition

A connective tissue layer surrounding the fascicles, constituting the outer sheath of the nerve. The epineurium carries a longitudinal network of blood vessels.

► **Regeneration: Clinical Aspects**

## Epiphenomenalism

SVEN WALTER

Institute of Cognitive Science, University of Osnabrueck, Osnabrueck, Germany

### Synonyms

Epiphenomenalism; Automaton-theory; Automatism

### Definition

Epiphenomenalism holds that mental states or ► **events** are caused by physical states or events in the brain but do not themselves cause anything. Although mental events appear to bring about behavioral effects, thereby influencing the causal course of the physical world, psychobehavioral sequences are merely reflections of the real causal processes at the underlying physical level.

### Description of the Theory

An epiphenomenon is a *secondary symptom*, a mere “afterglow” of real phenomena. As a label for a philosophical theory of the mind, “epiphenomenalism” was coined by William James (see [1]) in his criticism of the position of the British biologist, physiologist and philosopher Thomas Henry Huxley. Huxley’s *Presidential Address to the British Association for the*

*Advancement of Science* from 1874 contains the most famous articulation of epiphenomenalism. Mental events are said to be caused by physical events in the brain but themselves incapable of causing anything. Just as the steam-whistle is an effect of the engine’s operations without any causal influence on it, mental events are causally inefficacious effects of the workings of neurophysiological mechanisms [2, p 240]. According to epiphenomenalism, for instance, a pain does not cause wincing; rather, the pain is caused by the same neurophysiological event that also causes the wincing. To assume that the regular successions of mental and physical events – volitions giving rise to appropriate behavior, momentary pangs resulting in one’s wincing etc. – reflect genuinely causal processes is to commit the fallacy of *post hoc, propter hoc*. Awareness of those regular successions cannot reveal their causal nature. Awareness of the psychological or psychophysical sequences that make up one’s everyday life is no more awareness of causal processes (or of the fact that these sequences reflect causal processes) than awareness of the sequence of shadows a moving car casts.

Epiphenomenalism is typically considered to be a wildly counterintuitive theory of last resort to which one is driven only because all alternatives are even less satisfying. The trust in ► *mental causation* – the mental’s ability to causally influence the physical – seems to be too much part and parcel of the common sense conception of human beings as freely deliberating agents who are the causal origins of their actions and do what they do because they have the beliefs and desires they do for epiphenomenalism to be true. Why, then, did reputable scientists ever take epiphenomenalism seriously?

Epiphenomenalism evolved in a particular intellectual climate in the late Nineteenth century in which classical ► **dualism** with respect to the mind and the body was as well received scientific wisdom as a decidedly scientific attitude with regard to the body. Epiphenomenalism resulted from the attempt to reconcile the scientific confidence that the world consists of purely physical causes governed by purely physical laws with the sustained trust that human minds are ultimately non-physical. Epiphenomenalists are would-be ► **materialists** who hold back from endorsing ► **materialism** because they do not want to give up the autonomy and uniqueness of the human mind.

To thinkers of the late Nineteenth century it seemed to be an obvious fact of experience that human beings are subjects of mental events which apparently resist incorporation into a materialist ► **ontology**. Thoughts, sensations, desires etc. just seem to be too dissimilar from physical events for them to be “nothing but” physical events. At the same time, however, a scientific naturalism evolved, motivated by the successes of a mechanistic physics and characterized by a desire to

identify the underlying causal structure of observed phenomena in terms of matter and motion alone. In particular, early neurophysiological research found no mental influence upon the brain (or the body), and eventually, with the demise of ►vitalism regarding the forces governing animate life, the ►causal closure of the physical was nearly universally accepted. The conception of the physical as a causally closed system in which physical forces are the only forces, combined with the naturalistic view that human beings are a part of the physical world and governed by its laws left no room for causally efficacious mental events. There simply seemed to be “no gaps” [3, p 278] in the causal mechanisms to be filled by mental events outside the physical domain.

The solution was epiphenomenalism. Human beings are part of the causally closed physical world and as such exhaustively governed by physical laws. Hence, no non-physical causes must be invoked to explain physical, e.g. behavioral, effects. But since human beings are also subjects of non-physical minds, the only conclusion was that these minds are incapable of exerting any causal influence. As Alex Hyslop has put it, “[t]he case for Epiphenomenalism is the case for Materialism, together with the case against Materialism. The case for Materialism is the Argument from Science, from a triumphant, or at least steadily triumphing Science. The case against Materialism is that there are features of our conscious experience that are not accounted for by Science” [4, p 61].

The dichotomy between mental and physical events characteristic of traditional epiphenomenalism is nowadays no longer uncontroversial. More and more philosophers endorse a psychophysical *event identity theory* according to which every concrete mental event is (identical to) a concrete physical event. On such a view, the question of traditional epiphenomenalism no longer arises because, say, pain is identical to (rather than caused by) the neurophysiological event which causes wincings and thus a cause of wincings, too. However, the threat of epiphenomenalism re-arose in a different guise. Although modern philosophy of mind tends to turn more and more of the mental over to the physical side, some dualistic residue – for example in form of *mental properties* – remains, and this mental residue threatens to become epiphenomenal. According to a forceful intuition, for instance, events cause what they cause in virtue of certain of their properties and not in virtue of others. Suppose a soprano sings the word “shatter” at a high pitch and amplitude, causing a window to shatter. The particular cause *c* of the shattering – the soprano’s singing – has the property *being a singing of a high C* and the property *being a singing of the word “shatter.”* Yet, *c*’s being a singing of the word “shatter,” in contrast to its being a singing of a high *C*, seems to be *causally irrelevant* for its causing

the shattering – no matter whether the soprano sung “shatter,” the window would have shattered as long as she sung a high *C*, but had she sung “shatter” with a lower pitch and amplitude, it would not have shattered.

If events cause their effects in virtue of their properties, it makes sense to ask whether mental events cause their effects in virtue of their mental, in virtue of their physical or in virtue of both kinds of properties. Some fear that mental properties (unless identical to physical properties) are as causally irrelevant for physical effects as the singing’s being a singing of the word “shatter” is for the shattering. If mental events cause their effects only in virtue of their physical properties, their being the kinds of mental events they are is causally irrelevant and mental *properties* are, in a sense, epiphenomena. Philosophers thus distinguish between *event-* and *property-epiphenomenalism* (see [3,5,6]). According to the former, physical events are causes, but mental events cannot cause anything; according to the latter, events are causes in virtue of physical properties, but no event is a cause in virtue of mental properties. If event-epiphenomenalism is wrong, mental events can be causally efficacious; but if they are causally efficacious solely in virtue of their physical properties, property-epiphenomenalism is correct, and some consider this to be no less disconcerting than Huxley’s original epiphenomenalism.

Epiphenomenalism undoubtedly appears to be at odds with the manifest image of the world; it appears incompatible with those features of human beings without which they would apparently not be the kind of being they are and without which they would apparently not be able to occupy the place in the world they occupy. Unless further specified, however, this is little more than the claim that epiphenomenalism is *counterintuitive*, and that is something its defenders should not find in the least problematic since a host of widely accepted and feted theories – like Einstein’s theory of special relativity or quantum mechanics – are riotously counterintuitive. Those who urge that epiphenomenalism is deeply problematic must say what precisely it is about epiphenomenalism that makes it incompatible with the manifest image of man.

It has been urged that epiphenomenalism undermines the ascription of *moral* or *legal responsibility*, Donald Davidson’s distinction between the reason(s) for which an action was performed and causally irrelevant *post hoc* rationalizations, the standard response to the ►*other minds problem*, and the application of epistemic norms like justification, warrant, or reasonableness to processes of belief formation. Apart from that, causal theories of *knowledge, meaning, reference* or *memory* have been said to entail that causally otiose mental phenomena cannot be subject of knowledge, reference, memory or meaningful statements. Finally, causally otiose mental phenomena could apparently not have endowed human

beings with an evolutionary advantage and thus not have evolved, and if one assumes that to be real is to have some causal powers, epiphenomenalism even appears to collapse into outright eliminativism. Yet, it is at least disputable whether any of these objections suffices to refute epiphenomenalism once and for all (for an overview over objections against epiphenomenalism and possible replies on behalf of it see [3,4,7]).

## References

1. James W (1890) *The principles of psychology*. Hold, New York
2. Huxley TH (1874) On the hypothesis that animals are automata, and its history. *Forth Rev* 22:555–580
3. Robinson W (2003) Epiphenomenalism. *Stanford Encyclopedia of Philosophy*. <http://plato.stanford.edu/entries/epiphenomenalism/> (January 11, 2003)
4. Hyslop A (1998) Methodological epiphenomenalism. *Australas J Philos* 76:61–70
5. McLaughlin B (1994) Epiphenomenalism. In: Guttenplan S (ed) *A companion to the philosophy of mind*. Blackwell, Oxford, pp 277–288
6. McLaughlin B (1989) Type epiphenomenalism, type dualism, and the causal priority of the physical. *Philoso Perspect* 3:109–135
7. Walter S (2009) Epiphenomenalism. In: McLaughlin, Beckermann, Walter (eds) *Oxford Handbook of Philosophy of Mind*. Oxford University Press, Oxford.

## Episodic Behavior

### Definition

A behavior which repeats without inherent regularity in the interval of time between adjacent events.

## Episodic Event

### Definition

A personally experienced event, generally occurring at a particular time and place and consisting of a coordinated sequence of scenes that are experienced as a unit. The term is rarely used, because it is synonymous with “episode” in the field of memory research.

► [Episodic Memory](#)

## Episodic Memory

TOSHIKATSU FUJII<sup>1</sup>, MAKI SUZUKI<sup>2</sup>

<sup>1</sup>Department of Behavioral Neurology and Cognitive Neuroscience, Tohoku University Graduated School of Medicine, Sendai, Japan

<sup>2</sup>Division of Cyclotron Nuclear Medicine, Cyclotron and Radioisotope Center, Tohoku University, Sendai, Japan

### Definition

Episodic memory is a type of long-term memory for personally experienced events occurring at particular times and in particular places.

### Characteristics

#### Episodic Memory as one of the Memory Systems

Memory refers to (i) the information retained in the mind/brain, (ii) the cognitive function of encoding, retention (storage), and retrieval of information about personal experiences, semantic knowledge, or skills, and (iii) the hypothesized system in the mind/brain that sustains memory function. On the basis of previous psychological, neuropsychological, and neurobiological evidence, researchers have classified memory into several types of memory systems (Fig. 1).

In this formulation, memory is divided into declarative memory and nondeclarative memory, episodic memory being a type of declarative memory [1–3]. Episodic memory is what most people mean when they use the term “memory.”

### Encoding of Episodic Memory

The encoding of episodic memory involves cognitive processes that lead to the formation of a unique ► [episodic representation](#) (a memory trace or an engram for an episode) for a personally experienced event such that it can subsequently support the conscious recollection of one’s past experiences. An experiencer, as an observer and also often as an actor, encodes all the information that is attended or consciously perceived if the brain regions responsible for the formation of the episodic representation are intact. Experiencers who have damage to the brain regions responsible for the formation of episodic representations are unable to make a complete episodic representation, although they can consciously experience the event while it is occurring.

The episodic representation for a personally experienced event as a whole is probably composed of several types of memory traces. Every ► [episodic event](#) we experience is considered to consist of a focal element and a setting [4]. The focal element refers to the salient occurrence within the setting (content information),

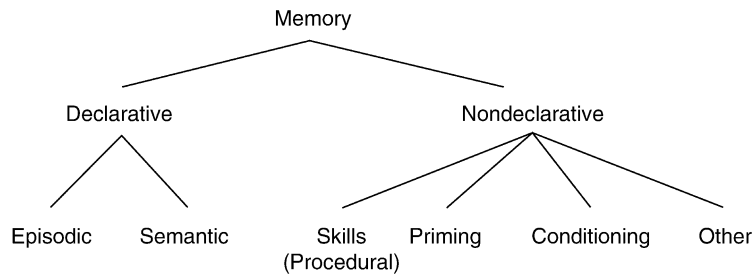

**Episodic Memory. Figure 1** A taxonomy of memory. The major distinction is between declarative memory and nondeclarative memory [1,2]. Declarative memory refers to memory that can be accessed consciously and is further classified into episodic memory and semantic memory [3]. Episodic memory is memory of personally experienced events that occurred in a certain place at a particular time; semantic memory is memory of organized knowledge about words, objects, facts, and concepts. In contrast, nondeclarative memory refers to memory that cannot be accessed consciously and demonstrated through performance. It includes skill (procedural) learning, priming, conditioning, etc.

whereas the setting refers to the time and place in which the individual experienced the event (contextual information).

The properties of the memory traces for focal elements are determined by the aspects to which the individual paid attention during a particular event. The focal elements comprise interactions between various animate (including the experiencer) and inanimate objects. These are typically experienced through several sensory modalities as a continuous series of gradually changing scenes, each of which is made up of several objects, including the experiencer and objects located in spatial positions relative to each other and to the experiencer, over a limited period of time. In addition, most of this sensory information about the objects and the interactions is likely to be automatically interpreted in terms of the individual's available semantic knowledge. Consequently, the memory traces for focal elements include very different kinds of information, such as visual information, auditory information, spatial information about the objects and the self, and automatically interpreted meanings of the objects and interactions. The experiencer may or may not be aware of the setting (a global spatio-temporal context) in which the events are experienced. However, the memory trace for the setting is required to make a unique episodic representation as a whole [5,6]. The successful retrieval of memory for contextual information is thought to be one of the most crucial characteristics of episodic memory retrieval, as discussed later. Furthermore, the individual's internal physical state (e.g. hunger or satiety) or mental state (e.g. mood or emotional aspects evoked by the event) is likely to be encoded [7]. In addition to the various memory traces described above, it is thought that there are various types of binding codes that are stored in the brain and enable the episodic representation to allow the experience to be brought back to mind.

### Retrieval of Episodic Memory

Retrieval of episodic memory refers to the cognitive processes that enable an individual to recover previously experienced events. This differs from the retrieval of semantic memory in that it requires access to information about focal elements that includes the individual perspective of the rememberer and where and when the event occurred.

Episodic retrieval is thought to involve an interaction between a retrieval cue (self-generated or provided by the environment) and a previously stored memory trace, leading to the reconstruction of certain aspects of the event represented by the memory trace. This interaction process is called **►ecphory** [4], and enables the memory traces for the focal elements (perceptual and semantic representations) and for the setting (spatial and temporal context) to be bound together with the individual's awareness of personal experiences, probably aided by binding codes.

There are two principal types of episodic retrieval: recall and recognition. In the recognition situation, a copy of the target item is generally presented as a retrieval cue, and the rememberer only needs to decide whether he/she has experienced a particular item before. In contrast, in the recall situation, either no specific cues or cues other than copy cues are provided, and the rememberer has to describe or reconstruct some aspect of the original item-event. Recognition is usually better than recall because it involves greater overlap between encoding and retrieval situations (see "**►encoding specificity**," described below). This means that remembering reflects the interaction between the encoding and retrieval processes.

### Interactions between Encoding and Retrieval

Whether or not episodic retrieval is successful is influenced by the cues available and the processes involved during the retrieval situation. The importance of retrieval cues is

emphasized in the principle of encoding specificity [4]. The encoding specificity principle states that the effectiveness of a retrieval cue is dependent on the extent to which information in the cue was incorporated into the memory trace of the target event at the time of its original encoding. The importance of processes engaged during the retrieval situation is emphasized in the concept of ►transfer-appropriate processing [8]. The concept of transfer-appropriate processing postulates that memory performance is a function of the degree to which the cognitive operations engaged at encoding are recapitulated at retrieval.

Specific examples of encoding specificity or transfer-appropriate processing are context-dependent memory and state-dependent memory [7]. As retrieval depends on the effectiveness of the cues available and the processes involved during the retrieval situation, it also depends on the congruity of the context or the individual's state between the encoding and retrieval situations. Context-dependent memory is based on the concept that people retrieve information better when they are asked to recall it in the same environmental setting (context) as that in which it was acquired. State-dependent memory is based on the concept that people retrieve information better when they are in the same physical or mental state as they were when they acquired it. (When a mental state is related to an individual's mood, this is called mood-dependent memory.) The context in which an event was encoded and the individual's internal state at the time of encoding appears to be two of the most powerful retrieval cues.

### Neural Substrates

In humans, disorders of episodic memory that cannot be explained by a state of delirium or dementia are often called amnesic syndrome. Patients with amnesic syndrome usually manifest both anterograde amnesia (the inability to encode or retrieve information acquired after the onset of brain damage) and retrograde amnesia (the inability to retrieve information acquired prior to the onset of brain damage). Unlike patients with dementia, those with amnesic syndrome usually have normal intelligence. This syndrome can result from focal damage to the medial temporal lobe (MTL), the medial diencephalon, or the ►basal forebrain [9] (Fig. 2).

The MTL includes the ►hippocampal complex and the amygdala; the former is considered to be an essential region for episodic memory and the latter for emotion and emotional modulation in episodic memory. The medial diencephalon includes various midline thalamic nuclei, the mamillothalamic tract, and the internal medullary lamina. The basal forebrain includes the septal area, the diagonal band nuclei, and the substantia innominata. The literature concerning patients with disorders in episodic memory indicates that the MTL and the medial diencephalon may have roles in both the encoding and

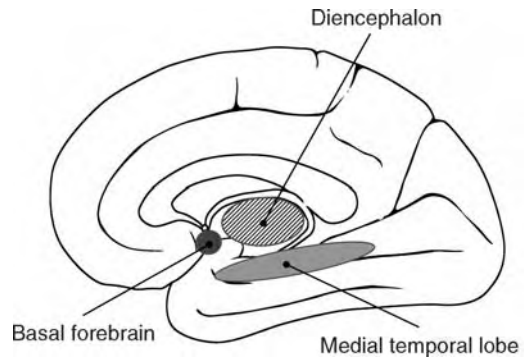

**Episodic Memory. Figure 2** Brain areas causing amnesic syndrome (an isolated disorder of episodic memory).

retrieval of episodic memory, and that the basal forebrain has a particular role in its retrieval. Recent functional neuroimaging studies also indicate that the MTL has a role in both the encoding and retrieval of episodic memory, and a few that the basal forebrain has a role in the retrieval of episodic memory. However, the precise roles of these three regions, or of subregions within each region for episodic encoding, storage, and retrieval, is not still well understood.

As for episodic representations for some focal elements of events, it is thought that these are retained as complex patterns of neural activity that are primarily located in sites within those parts of the posterior neocortex that represent both meaningfully interpreted and relatively uninterpreted sensory information. Recent functional neuroimaging studies support this view. It is likely that which of the specific posterior association cortices is involved in episodic representations relies on the nature of the focal elements and on the experiencer's mental processing of the focal elements. Within this context, some researchers have argued that the encoding of episodic memory entails the formation of a code embodied in the MTL that binds neurons in the posterior neocortex (heteromodal and unimodal association cortices) that represent the information attended to.

It is widely accepted that damage to the prefrontal cortex does not lead to memory disorders involving deficits in the storage and retention of information about focal elements of episodes. Such disorders are associated with damage to the MTL, medial diencephalon, and basal forebrain. Memory disorder following frontal lobe lesions seems to involve the strategic aspects of memory that are necessary for devising strategies for encoding, guiding search at retrieval, correctly placing retrieved memory in the setting in which the event was experienced, and other aspects of episodic memory [10]. Although the prefrontal cortex plays specific roles during the encoding and retrieval of episodic memory, future studies are required to

provide evidence of the roles of the various distinct areas within the prefrontal cortex.

## References

1. Squire LR (1987) Memory and brain. Oxford University Press, New York
2. Squire LR, Zola-Morgan S (1991) The medial temporal lobe memory system. *Science* 253:1380–1386
3. Tulving E (1972) Episodic and semantic memory. In: Tulving E, Donaldson W (eds) Organization of memory. Academic Press, New York, pp 382–402
4. Tulving E (1983) Elements of episodic memory. Oxford University Press, New York
5. Fujii T, Moscovitch M, Nadel L (2000) Memory consolidation, retrograde amnesia, and the temporal lobe. In: Boller F, Grafman J (eds) Handbook of neuropsychology, 2nd edn., vol 2. Elsevier, Amsterdam, pp 223–250
6. Mayes AR, Roberts N (2001) Theories of episodic memory. *Philos Trans R Soc Lond B* 356:1395–1408
7. Smith EE, Nolen-Hoeksema S, Fredrickson BL, Loftus GR (2003) Atkinson and Hilgard's introduction to psychology, 14th edn. Wadsworth/Thomson Learning, Belmont, pp 285–286
8. Morris DC, Bransford JD, Franks JJ (1977) Levels of processing versus transfer appropriate processing. *J Verb Learn Verb Behav* 16:519–533
9. Bauer RM, Grande L, Valenstein E (2003) Amnesic disorders. In: Heilman KM, Valenstein E (eds) Clinical neuropsychology, 4th edn. Oxford University Press, New York, pp 495–573
10. Moscovitch M, Winocur G (1992) Frontal lobes and memory. In: Squire LR (ed) Encyclopedia of learning and memory, Macmillan, New York, pp 182–187

## Episodic Representation

### Definition

A mental representation (or a presumed physiological alteration or process) of a personally experienced event that is made during encoding. Also called an engram or a memory trace for a personally experienced event.

► [Episodic Memory](#)

## Episomal

### Definition

DNA residing in the nucleus as additional genetic information, but not integrated into one of the chromosomes.

► [Gene Therapy for Neurological Diseases](#)

## Epistemology

VOLKER GADENNE

Department of Philosophy and Theory of Science,  
Johannes-Kepler-University, Linz, Austria

### Definition

Epistemology (from Greek “episteme”: knowledge): The study of the nature and the problems of knowledge, especially, the conditions, sources, and limits of knowledge.

### Characteristics

#### The Concept of Knowledge

According to a view already discussed by Plato, knowledge is *justified true belief*. That is, a person *x* knows that *p* if and only if (i) *x* believes that *p*, (ii) *p* is true, and (iii) *x* can justify her belief. Imagine that *x* believes she passed her exam, and that she really passed it, and was told so in a letter from the university. In this case we can say that *x* knows she passed her exam. Many philosophers still think that the “standard view” states the essence of the idea of knowledge. There are, however, counterexamples in which *x* seems to lack knowledge though she has a justified true belief. In those cases, *x*'s ► [justification](#) is not appropriately related to the facts that make *p* true. Epistemologists still try to solve this problem [1].

### Kinds of Knowledge

The standard view refers to cases in which a subject is (or can become) conscious of the proposition believed and the justifying reason(s). This is called *explicit* (declarative) knowledge. However, people do not only know *that* things are such and such, they also know *how to do* things, for example, how to drive a car, play the violin, or speak in accordance with the rules of grammar without being able to state them. Such *tacit* (implicit, procedural) knowledge plays an important role in all kinds of action. Until recently, epistemology was merely concerned with explicit knowledge.

With respect to the sources of knowledge, epistemology distinguishes knowledge that is justified independently of perceptual experience (*a priori*) from knowledge based on such experience (*a posteriori*). The standard case of the former is knowledge of logical and mathematical truths; as a standard case of the latter serves knowledge of physical objects and facts.

### The Concept of Truth

In the standard definition of knowledge, “truth” has usually been understood as *correspondence to* ► [reality](#). That is, a proposition *p* is true if and only if what *p* says is actually the case; otherwise it is



false. “Correspondence” must not be confused with “likeness” or “similarity.” There is of course no similarity between words (or concepts) and real objects. “Correspondence” simply means “agreement” between a proposition and some real situation. The correspondence ►theory of truth is the view of common sense and is still held by many philosophers. It has however not been generally accepted. Critics insist that the idea of correspondence has remained unclear. Some of them propose to relate truth and justification (in order to bridge the gap between them). In one version, truth is understood as *coherence* with some ideal background of beliefs. A further major account of truth is James’s ►pragmatic theory according to which true assumptions are, by definition, those that would be confirmed by experience in the long run. Closely related to the pragmatist view is a contemporary theory (due to Dummett and Putnam) that connects truth with ►verification: To say that p is true is to say that p would be *verified* by an appropriate procedure. All those alternatives to the correspondence theory of truth are faced with serious problems.

### Justification, Foundationalism, and Coherentism

According to *foundationalism* (Aristotle, Descartes, C. I. Lewis), we have to distinguish between *mediate* (indirect, inferential) and *immediate* (direct, non-inferential) justification. Many beliefs are mediately justified by some appropriate relation to other justified beliefs, e.g., by being (►deductively or ►inductively) inferred from, or based on them. The central thesis of foundationalism is that all mediately justified beliefs owe their justification ultimately to foundational ones, that is, to immediately justified beliefs [2]. There are, however, different views about which kinds of beliefs should count as foundational. Some construe immediate justification as *self-justification*. Others hold that foundational beliefs have their justification from non-belief mental states, especially, sensation, perception, and memory. For example, a ►scientific hypothesis may be regarded as mediately justified by some particular statements, which may in turn be immediately justified as based on *observation*. Foundationalists argue that, only by adopting some beliefs as immediately justified, one can escape an infinite regress or epistemic circularity. The main problem of foundationalism is how to avoid dogmatism.

*Coherentism* (Neurath, Sellars), the traditional competitor to foundationalism, holds that a belief is justified if it coheres with a background system of beliefs [3]. For example, a scientific hypothesis may be deemed justified because of its coherence with the laws of the leading ►paradigm (Kuhn), or with the total of statements expressing experimental results. A major problem of coherentism is to make plausible why mere coherence should be the ultimate source of justification, and should be regarded as a reason for accepting any belief as true.

### The Challenge of Skepticism

For more than 2000 years skeptics have held that knowledge does not and cannot exist. In order to justify a belief A, we have to accept another belief B. But now we have to justify B, which requires still another premise C. Thus we end up in a regress. The retreat to perception does not help either. There is illusion and hallucination. We can be sure that things appear such and such, but this does not guarantee that they really are how they appear. Consequently, no belief (about real things) can be better justified than any alternative belief, so that we should refrain from any claim to knowledge (Pyrrhon).

### Rationalism and Empiricism

Two attempts to meet the skeptical challenge were classical rationalism (Descartes, Leibniz, Spinoza) und British empiricism (Bacon, Locke, Berkeley, Hume), both movements being a reaction against traditional scholastic philosophy. According to rationalism, the only source of (certain) knowledge is (pure) reason [4]. Ideally our knowledge ought to be organized into a deductive system, in which all truths are derived from a small number of axioms whose truth is guaranteed by their self-evidence. In contrast, empiricists claimed that, prior to experience, the human mind is a “tabula rasa.” All knowledge about the world comes from sensory and perceptual experience, or has to be inferred from perceptual knowledge.

Both movements were very influential and obtained important insights. However, as attempts to overcome skepticism and demonstrate that certain knowledge is possible, they did not reach their ultimate goal. Rationalists could not prove that the self-evidence of axioms is a guarantee of their truth. Descartes was not successful in demonstrating a priori that there is an external world that is truly represented by our senses if we only make careful use of them. The empiricists, on the other hand, could not escape the conclusion that we can only know the contents of our own minds. In addition, Hume [5] denied the rationality of inductive reasoning, which had been considered the fundamental method of inference in the natural sciences. Classical empiricism ended up in a skeptical view about the aim to obtain knowledge of the real world and the laws of nature.

### Kant’s Epistemology

Kant tried to solve the problems left by rationalism and empiricism [6]. He started with the conviction that there are propositions about the world whose truth we know a priori. His central question was: How is such knowledge possible? His answer instituted his “Copernican Revolution” in epistemology: We have such knowledge because the objects depend on our cognitive faculties, especially our forms of intuition (space, time) and our categories (e.g. substance, cause). Kant explained the

features of appearances by reference to traits of the observer rather than traits of the objects themselves. For example, we know Euclid's laws a priori because these laws characterize the structure of our form of intuition that determines how objects in space appear to us. Nevertheless Kant deemed it necessary to assume a world of *things-in-themselves*. Since there are appearances, that is, objects of representation, there must be something that appears to us. But it follows from his premises that we cannot have knowledge of the things-in-themselves. We can only know the world as it appears to us.

However, Kant could not prove that his theory is the only possible explanation of how our mind works. Many objections have been raised against his view. For example, some critics have questioned his table of categories. A major objection refers to the rise of alternative geometries, which casts doubt on Kant's assumption that Euclidean geometry is necessarily true. Empiricists have insisted that we cannot have a priori knowledge about the world. Nevertheless Kant's theory had an enormous influence on epistemology.

### Realism and Anti-Realism

The main alternative to skepticism and Kant's philosophy is *realism* according to which we can and do have knowledge of the real, mind-independent world. Realism is the view of common sense, and has been maintained by many philosophers and scientists since the Presocratics. It was Kant who convinced many philosophers that realism is untenable. Few accept his system in all detail, but many adopt his central idea that the objects of knowledge are somehow *constituted* or *constructed* by us. However, while Kant considered the forms and categories that determine the appearances as fixed, contemporary anti-realists see them as variable ("anti-realism" is here understood as any view that rejects realism). They claim that the world we can know is a world that depends on some context: on language, social rules, forms of life, paradigms (Kuhn), or values (Putnam). Some also say that the world is a "social construction." "Radical ►constructivism" claims the world is a construction of the brain.

### Fallibilism, Justification, and Rationality

It turned out to be far more difficult to meet the challenge of skepticism than traditional epistemology had assumed. As a consequence, philosophers had to lower the claims associated with knowledge, justification, and truth. Most of them gave up the idea that the human mind can guarantee the truth of a belief beyond any doubt. Attempts to justify beliefs can never achieve certainty. All beliefs are fallible. *Fallibilism* was explicitly stated by pragmatists (Peirce, James). Popper made it a central principle of his *critical rationalism* [7]. Fallibilism was controversially discussed until some decades ago but seems now generally accepted in

philosophy as well as in science. Consequently, the traditional aim of certain knowledge had to be replaced by the aim of *conjectural knowledge*.

It is obvious that fallibilism is compatible with coherentism. But it is compatible with foundationalism as well? Contemporary foundationalists, unlike Descartes, separate claims to foundational justification from claims to certainty. To say that some beliefs are foundational is to say that they are justified though they can be criticized and eventually rejected. For example, observational statements may, other things being equal, be regarded as better justified than hypotheses, so that the latter can be tested with the help of the former. But observational statements, too, may be rejected if further observations prove them as erroneous.

Some philosophers believe that fallibilism is a reason to give up realism. But others think that both principles can be combined. Critical rationalism, e.g., holds that we can have *conjectural knowledge* of the *real world* [8]. Such knowledge is represented by observational statements, or by hypotheses (theories) that have withstood serious criticism.

### Naturalized Epistemology

On the traditional view, epistemology has to solve its problems independently of, and prior to, scientific research. (Descartes therefore called it "first philosophy.") Quine argued that this project was a failure. Instead, he proposed to make epistemology a branch of natural science that investigates with empirical means how people develop beliefs on the basis of sensory stimulation [9].

But how can natural science answer normative questions concerning justification and foundation? *Externalists* recommend giving up the justification condition in the traditional definition of knowledge and replacing it by a *causal* condition [1]. The idea is, roughly, that, in order to qualify as knowledge, a belief in *p* should be caused by the fact that makes *p* true, or that this belief should be brought about by a *reliable* process (not necessarily accessible to the believer's mind), that is, a process which produces true rather than false beliefs. For *internalists*, on the other hand, knowledge requires reasons that should be consciously accessible to the believer. Furthermore, internalists ask the critical question how it could be *justified* to qualify a process as "reliable," or truth-conducive.

An important kind of naturalist approach is *evolutionary epistemology* [10], which claims that our cognitive mechanisms are the result of natural selection (Konrad Lorenz) and that the development of human knowledge is governed by a process analogous to biological natural selection (Campbell, Popper).

Naturalist approaches to philosophical problems are controversially discussed. Most contemporary philosophers do not think that the traditional normative

questions can be reduced to questions of natural science. This, however, does not preclude interdisciplinary approaches to the problems of knowledge. More and more have become convinced that epistemology, even if not reducible to empirical science, needs and has to take into account its results, especially, those of cognitive science and neuroscience.

## References

1. Audi R (1998) *Epistemology*. Routledge, London
2. Lewis CI (1946) *An analysis of knowledge and valuation*. Open Court, La Salle
3. Lehrer K (1990) *Theory of knowledge*. Westview Press, Boulder
4. Descartes R (1641/1985) *Meditations on first philosophy*. In: Cottingham J, Stoothoff R, Murdoch D (eds) *The philosophical writings of Descartes*. Cambridge University Press, Cambridge
5. Hume D (1748/1975) *An enquiry concerning human understanding*. In: Selby-Bigge LA (ed) *Enquiries concerning human understanding and concerning the principles of morals*, 3rd edn (rev Nidditch PH). Clarendon Press, Oxford
6. Kant I (1781/1964) *Kritik der reinen Vernunft*. Trans. Kemp Smith N: *Critique of pure reason*. Macmillan, London
7. Popper KR (1959) *The logic of scientific discovery*. Hutchinson, London
8. Popper KR (1983) *The postskript to the logic of scientific discovery: realism and the aim of science*, vol 1. Rowman and Littlefield, Totowa, NJ
9. Quine WVO (1969) *Epistemology naturalized*. In: *Ontological relativity and other essays*. Columbia University Press, New York, pp 69–90
10. Vollmer G (1981) *Evolutionäre Erkenntnistheorie*. Hirzel, Stuttgart

## Epithalamus

### Definition

Part of diencephalon. Consists of pineal body and habenular nuclei.

► Diencephalon

## Epithelial Cells

### Definition

Epithelial cells form the surface layer of the body and the linings of the body cavities.

## EPSP

### Definition

An excitatory postsynaptic potential (EPSP) is due to a temporal increase in postsynaptic membrane potential caused by the flow of positively charged ions into the postsynaptic cell.

## Equilibrium Neurological Test

► Vestibular Tests: Romberg Test

## Equilibrium Point

### Definition

A multi-component variable characterizing a steady state in the interaction of the organism with the environment; comprised of values of mechanical and other state variables in such a state.

► Equilibrium Point Control

## Equilibrium Point Control

ANATOL G. FELDMAN

Neurological Science Research Center, Department of Physiology, University of Montreal, Montreal, QC, Canada

### Synonyms

Equilibrium point hypothesis; Set point control; The  $\lambda$  model; Threshold (position) control

### Definition

Originated from empirical studies in humans [1], the ► equilibrium point (EP) hypothesis describes basic rules underlying the control of ► motor actions. Such actions occur when the ► steady state of the system comprised of the organism and the environment is

disturbed, either by the environment (e.g., due to changes in external forces acting on the body) and/or by the organism itself following neural control influences on neuromuscular elements. These elements tend to minimize the imposed activity by establishing the same or another steady state, depending on internal and external constraints. The EP is a combination of variables (including the equilibrium positions of body segments *and* muscle forces or torques at these positions) characterizing the motor output of the system in a steady state. The neural **control variables** that shift the EP and thus elicit intentional actions are identified in the  $\lambda$  model [2], which also offers solutions to several classical problems in motor control.

## Description of the Theory

### The Essence of Control Processes

The behavior of the system obeys natural laws. These laws express the relationships between certain variables called **state variables** (SVs; e.g., forces and kinematic variables related by laws of motion). Constrained by natural laws, SVs, *including the EP*, cannot be specified directly by the nervous system.

Natural laws include **parameters**, some of which are not conditioned by these laws but define essential characteristics of the system's behavior under the action of the laws. Fig. 1 shows the difference between SVs and parameters in a simple physical system – a pendulum (a mass on a rope). This example illustrates a general physical rule: Although in an **equilibrium** (steady) **state** all forces are balanced, it is not forces (or other SVs) but the system's parameters that pre-determine where, in the torque-position space, this state can be achieved [2]. Therefore, in order to bring the system from one EP to another, neural control levels *must change parameters that are independent of SVs*. Our motor skills are thus based on the ability of the brain to organize, exercise, memorize, select in a task-specific way, and modify during learning **parametric control** of the system.

Control variables (CVs) are those parameters that can be altered by the nervous system in a task-specific way. In some tasks, CVs can be changed in relation to SVs but in other tasks, they can be changed independently of SVs or be kept constant. Such freedom of manipulation distinguishes CVs from SVs. By changing CVs, the nervous system may elicit and modulate motor actions, *thus taking advantage of natural laws without any knowledge of these laws*.

By specifying CVs, control levels reduce the range of possible EPs to a set called the invariant characteristic of the neuromuscular system. A specific EP from this still **redundant set** emerges in the process of interaction of the organism with the environment. Fig. 2 illustrates this point and summarizes known properties of EP shifts for reaching movements.

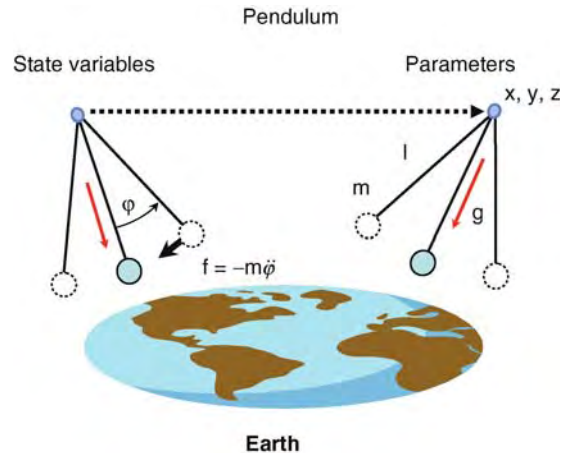

**Equilibrium Point Control.** Figure 1 State variables (SVs), parameters, and parametric control. Related by the law of mechanics,  $f = -m\ddot{\phi}$ , the force ( $f$ ) acting on the mass of the pendulum and kinematic variables (position,  $\phi$ , and its time derivatives) are SVs. The coordinates of the suspension point ( $x, y, z$ ), the length ( $l$ ) of the pendulum, the mass ( $m$ ) and the local direction of gravity (red arrows) are parameters, i.e., quantities that can be specified independently of SVs, for example by a person who made the pendulum. The system's behavior can be controlled without direct specification of forces or other SVs, by changing parameters, for example, the coordinates of the suspension point, thus transferring the oscillations to a new location in space (dashed arrow). Frequency of oscillations can be controlled by changing parameter  $l$ .

A central notion of the  $\lambda$  model is that all CVs represent various forms of one, empirically well-established phenomenon – **threshold control**.

### Threshold Control and a Solution to the Posture-Movement Problem

A given posture of the body or its segments is usually stabilized such that deviations from it are met with forces tending to restore that posture. In order to produce an intentional change in position, the system must readdress these stabilizing mechanisms to a new posture. Otherwise, the new posture would be seen as a deviation from the initial posture and the system would generate forces to resist it [2,5]. Studies in humans have shown that such readdressing is achieved by shifting the threshold position of body segments, i.e., the position at which all skeletal muscles spanning these segments are silent. Deviations from the threshold position result in the generation of muscle activity and resistive forces tending to restore it (Fig. 3) [2,5]. When the threshold position is shifted, the initial position of body segments appears as a deviation from the newly specified threshold position, and posture-stabilizing mechanisms provide forces driving the system to the new threshold

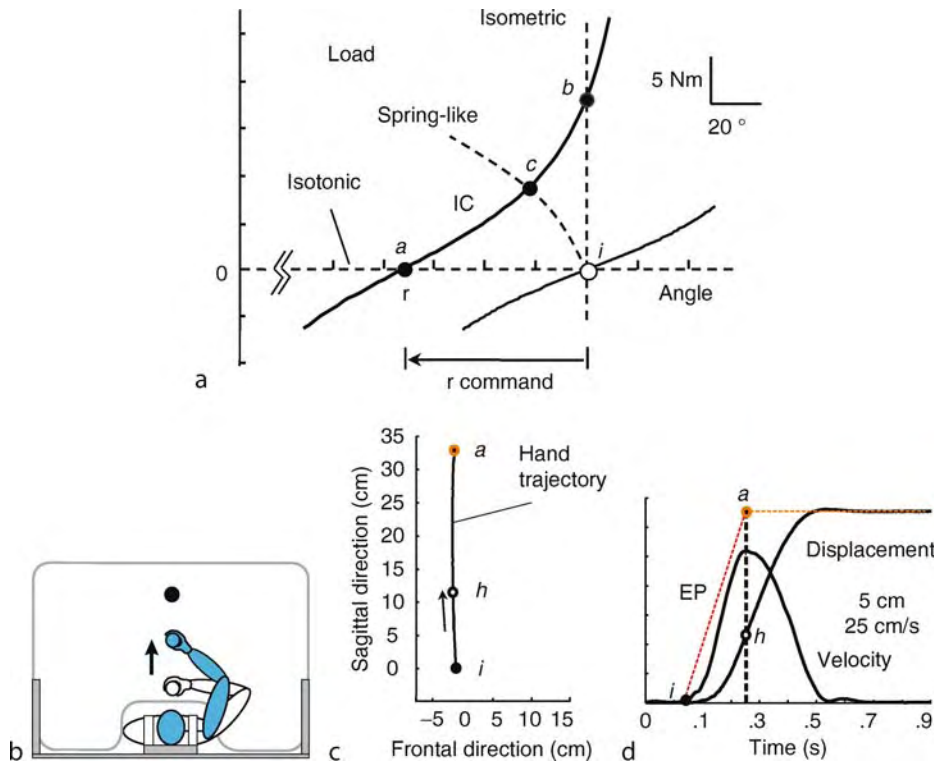

**Equilibrium Point Control. Figure 2** Relationship between control variables, equilibrium points and motor actions. Point *i* (*upper panel*) is the initial equilibrium point (EP) of a single joint in the absence of external forces. By changing a control variable, *r* (*arrow*), the nervous system replaces one set of possible EPs with another set of EPs comprising a curve called the invariant characteristic (IC; thick curve that passes through point *a*). The redundancy problem (a choice of one EP from this set) is solved through the interaction of the joint with the environment: Depending on the characteristic of external forces (*dashed lines*), different EPs are established (*a*, *b*, or *c*) resulting in different actions – a movement to a new position, isometric torque generation, or a transition of the joint to a new combination of position and torque, respectively. *Lower left panel* shows an experimental set in which subjects moved a handle along the surface of a table. In randomly selected trials, the movement was blocked at the initial position by activating an electromagnet embedded in the table, thus transforming the movement into isometric force production. It was found (*lower middle panel*) that the equilibrium position reaches its final destination (*a*) when the hand (*h*) has covered only about 1/3 of the total movement distance, about the time when the hand velocity is maximal (*lower right panel*). Thus, although the equilibrium and actual hand trajectories may be similar [3], they are not isochronal. Due to the distance between the actual and the equilibrium positions, agonist muscles generate substantial accelerating torques required for fast movement. The results imply that, to correct movement errors, the system may initiate new EP shifts while the motor response to the previous EP shifts continues. Rapid sequences of EP shifts can also be generated without waiting for the end of each motor response, an option that might be essential in piano playing, typing and speech. Adapted from Ghafouri and Feldman [4].

position. In such a way, intentional motor actions are harmonized with natural laws: the system not only eliminates resistance to movement from the previous posture, but actually *takes advantage of posture-stabilizing mechanisms to drive the body to a new posture*, as has been shown by simulations of different movements, including locomotion [2].

If the desired motor goal is not reached by the initial shifts, control levels may produce additional shifts in the threshold position in the same or repeated movements until the goal is reached. The correct pattern of shifts in thresholds can be stored in memory and

recalled to reproduce the motor action in similar conditions [2]. In this way, threshold control underlies intentional posture and movement regulation as well as motor learning.

### Physiological Origin of Threshold Control

For a single muscle or a motoneuron in the intact organism, the threshold position is identical to the threshold muscle length, a parameter that can be changed by descending input [10,11]. Note that control-descending signals are electrical in nature. The  $\lambda$  model explains how they are converted into a position-dimensional

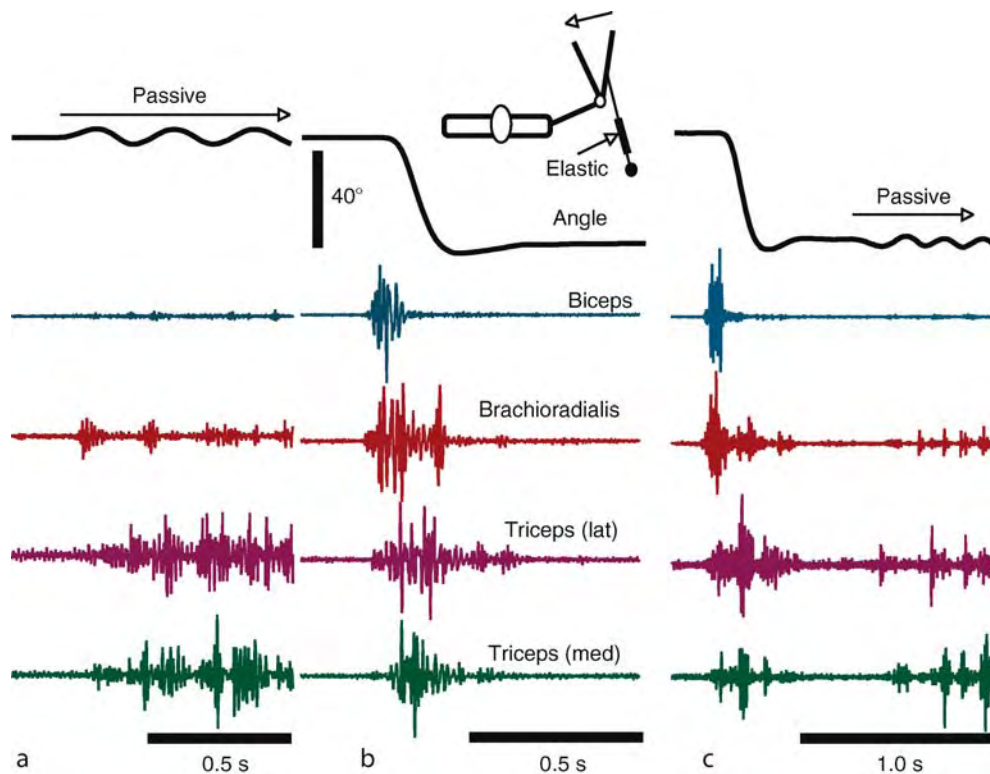

**Equilibrium Point Control. Figure 3** Threshold position resetting in rapid elbow flexion movement [7]. Note that the activity of elbow muscles (four lower traces in B) at the initial elbow position was practically zero (background noise level) and, after transient EMG bursts, returned to zero at the final position. Muscles were activated in response to passive oscillations of the arm at the initial (A) and final (C) positions, implying that motoneurons of these muscles were initially just in a sub-threshold state and that the threshold state was readdressed to the final position when the movement was made. To exclude the influence of external forces and small passive forces of inactive flexor muscles on the movement from the initial position of about  $140^\circ$ , the arm was placed on a horizontal manipulandum and an elastic connector (sketch in B) was used to compensate for the passive muscle forces. The compensation was unnecessary for the final position (about  $90^\circ$ ) since it is known that at this position the net torque of passive elbow muscles is zero.

quantity – the threshold muscle length. Figure 4 shows that the conversion is accomplished at the level of the motoneuronal membrane, in the presence of electrical threshold and proprioceptive feedback. Note also that the threshold length can be changed by independent control input, even if the electrical threshold of the motoneuron remains constant. It follows that *threshold control does not exist in proprioceptively deafferented subjects*. As a result, deafferentation causes substantial motor deficits.

Control levels must be able to elicit activation or, conversely, relaxation of the muscle at any length within the biomechanical range  $[x_-, x_+]$ . To meet these requirements, the threshold must be able to be regulated in a range  $[\lambda_-, \lambda_+]$  that exceeds the biomechanical range (Fig. 4). In some subjects with hemiparesis and cerebral palsy, the range of threshold regulation is reduced, resulting in weakness, spasticity, and inter-joint discoordination [8].

Central shifts in the activation threshold length are associated with sub-threshold changes in the membrane potentials of motoneuron (Fig. 4). Thus, control levels may influence essential characteristics of motor actions in advance, i.e., before these actions are actually initiated and accomplished. This implies that threshold control is ►feedforward in nature.

The threshold length is not entirely specified by control levels: It consists of several components and only one of them,  $\lambda$ , can be changed independently of other components by different descending systems via mono-, poly-, pre- or post-synaptic influences on  $\alpha$ -motoneurons or, indirectly, via  $\gamma$ -motoneurons or interneurons of proprioceptive loops (Fig. 4).

#### Threshold Control of Muscle Co-Activation, Damping, and Intermuscular Interaction

Not only the control of posture but also *other control processes must use threshold control to avoid a conflict*

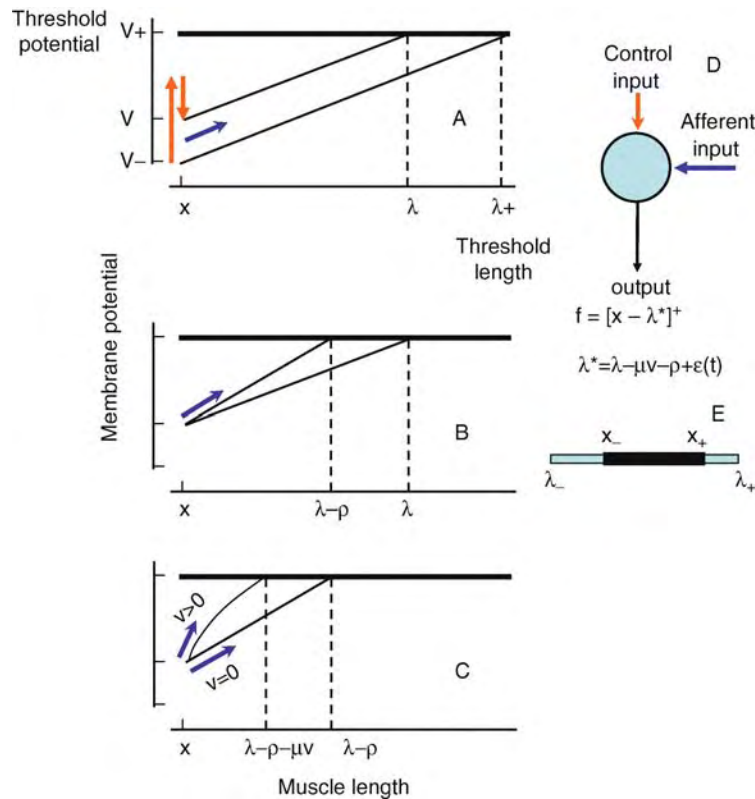

**Equilibrium Point Control. Figure 4** Physiological basis of threshold control. (a) Due to proprioceptive feedback, the motoneuronal membrane potential increases (lower diagonal line) when the muscle is stretched quasi-statically from an initial length,  $x$ . At some length,  $\lambda_+$ , (threshold length), the motoneuron begins to generate spikes at a frequency increasing with further muscle stretch. When independent control inputs are added at the same initial length (red arrows; up for depolarization and down for hyper-polarization), the threshold position is shifted to  $\lambda$ . Motoneurons thus equalize the dimensionality of their input electrical signals with that of a physical variable (muscle length) transmitted by afferent signals. Thereby the effect of independent, control inputs to motoneurons is measurable in terms of shifts in the threshold length. Motoneurons of single muscles are recruited sequentially, according to their individual threshold length. (b) Independent control influences can be transmitted by interneurons that also receive inputs from afferents of muscle spanning the same or other joints and terminate on the motoneuron (reflex intermuscular interaction). This interaction is responsible for an additional shift,  $\rho$ , in the threshold length. (c) Activity of muscle spindle afferents mediating proprioceptive feedback is velocity-dependent such that when the muscle is stretched at a non-zero velocity ( $v > 0$ ), the motoneuron is recruited at a shorter length (to a first approximation, by  $\mu v$ ) compared to the static threshold length. Factor  $\mu$  is controlled by  $\gamma$ -dynamic motoneurons, influencing damping of the system. (d) Summary diagram with formulas describing the output (f) of motoneurons. Note that the threshold length,  $\lambda^*$ , plays the role of a referent with which the actual length is compared, so that motoneuron is activated or not depending on the result of this comparison ( $[u]^+ = u$  if  $u > 0$  and 0 otherwise). Motoneurons thus recognize when the referent muscle length matches the physical muscle length and act accordingly. With respective referent and physical variables, this cognitive scheme may be valid for many other neurons. (e) The range of regulation,  $[\lambda_-, \lambda_+]$  of the central component,  $\lambda$ , of the threshold should exceed the biomechanical range  $[x_-, x_+]$  of muscle length,  $x$ , in order to meet the need to activate or relax muscles at any position within the biomechanical range.

with natural laws. In particular, this is the case for **damping** control. The muscle activation threshold is velocity-dependent (Fig. 4). The coefficient of this dependency ( $\mu$ ) is regulated by  $\gamma$ -dynamic motoneurons. Considered a CV in the  $\lambda$  model (command  $\mu$ ), the coefficient efficiently, although indirectly,

influences damping, which is also enhanced with muscle activation and **co-activation**.

Independent control influences may be transmitted to motoneurons via interneurons that also receive proprioceptive afferent inputs from muscles spanning the same or other joints (reflex intermuscular interaction;

Nichols [9]). These interneurons not only transmit changes in the independent component,  $\lambda$ , but are also responsible for a component,  $\rho$ , representing the contribution of intermuscular interaction to the total threshold,  $\lambda^*$ , of a given muscle (Fig. 4).

Co-activation of muscles can be produced to enhance resistance to deviations from the initial position. Threshold control allows the system to surround this position with a spatial zone in which muscles are co-activated, and to shift this zone to a new location when movement to a new posture is made (Fig. 5). In this way, the posture-stabilizing mechanisms amplified by muscle co-activation will not resist the deviation from the initial position and, instead, will assist in bringing the body or its segments to the new position.

### Action-Producing Frames of Reference

Not only motoneurons (Fig. 4), but also many other neurons may integrate sensory-dependent and independent signals. Due to threshold properties, neurons, like motoneurons, equalize the dimensionality of the independent, control input with that of variables delivered by sensory input and characterizing the physical world. Transformed in this way, the control input influences the threshold value that the sensory input should exceed in order to influence other neurons and muscles. Here is where the notion of the action-producing **frames of reference** (**FR**) emerges: The threshold can be considered as the origin of the FR in which the neuron functions. By shifting the origin, control levels delineate the area in the FR in which sensory input may influence groups of neurons and/or effectors, such

as muscles. Due to these actions, the FRs are called *action-producing* or *physical*, unlike formal, mathematical FRs for which shifting the origin modifies the description of the behavior of a system but not the behavior itself [2]. In particular, the threshold muscle length,  $\lambda^*$ , can be considered as the origin of a spatial FR,  $\{\lambda^*, x\}$ , in which motoneurons of the muscle may be silent or recruited depending on the difference between the actual ( $x$ ) and threshold muscle lengths. FRs can be different for different neurons depending on the combination of sensory inputs that neurons receive and the actions (motor or cognitive) that they produce. Fig. 5 and Table 1 give examples of physical FRs for different actions, including reaching and locomotion.

In addition to threshold positions defining the origins of spatial FRs, other parameters (CVs) can specify the metrics of FRs that define how strongly neurons and/or muscles are activated depending on the distance of each point in the FR from the origin. CVs may also define the orientation of one FR in another FR. FRs can be numerous, but one can assume that there are certain relationships between them, so that the whole set of FRs is analogous to a tree with the trunk representing hierarchically ordered *major* FRs, whereas branches of the tree represent FRs embedded within major FRs. Like FRs for muscles and motoneurons, other FRs are defined by the existing anatomical, neurophysiological, biochemical and biomechanical relations between elements of the neuromuscular system. Therefore, physical FRs appear to be tools always available for action production. Control levels may choose a FR that is most appropriate for the motor task (*leading* FR; Fig. 6) and

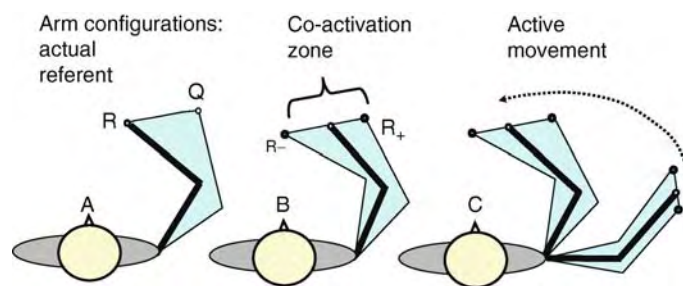

**Equilibrium Point Control. Figure 5** **Referent configuration** of the arm, spatial organization of co-activation of opposing muscle groups, and the cooperation of the two types of threshold control in the production of active arm movement. In the absence of co-activation of opposing muscle groups, the referent (R) configuration represent a threshold configuration at which all muscles of the arm are silent but generate activity (symbolized by blue in the *left panel*) and forces resisting deviations of the arm from it. By changing the thresholds of the two groups of muscles in opposite directions (*middle panel*) control levels create a range of referent configuration  $[R_-, R_+]$  surrounding the R configuration with a zone in which these groups are co-active. The absolute changes in the threshold may not be identical as long as they do not influence the net (zero) torque at position R. Active movement (*right panel, dashed arrow*) is produced by changing the R configuration that simultaneously relocates the co-activation zone. If necessary, the extent of the zone can also be changed. In this way, threshold control eliminates resistance to the deviation from the initial arm position and instead amplifies the forces driving the arm to a new position. Readdressed to a new arm position, muscle co-activation contributes to the speed of transition to this position while increasing damping of the system and thus suppressing terminal oscillations [2].



**Equilibrium Point Control. Table 1** Physical or action-producing frames of reference (examples)

Type of FR	Possible afferent systems involved	Examples of actions for which the FR may be leading
Body in the environment $\{E^*, F\}$	Vestibular, visual, somatosensory	Stabilization of vertical posture, single step, locomotion, jumps, somersaults
Hand in peripersonal space $\{H^*, S\}$	Vestibular, visual, somatosensory	Reaching for objects or other manual actions in the environment
Hand in relation to the body $\{h^*, s\}$	Somatosensory	Reaching for, touching, scratching body parts, and feeding
Body configurations $\{R^*, Q\}$	Somatosensory	Actions with a primary focus on body expressions, such as dancing
Body configurations in the limits $[R_-, R_+]$ defining co-activation (c) zone (Fig. 5) $\{R^*, Q_c\}$	Somatosensory	Re-location of the co-activation zone in order to accelerate movement and stabilize new position
Muscle; activated when muscle length $x$ exceeds threshold $\lambda^*$ of first recruited motoneuron $\{\lambda^*, x\}$	Proprioception	Actions specifically focused on muscle contraction
Motoneuron; activated when the muscle length, $x$ , exceeds the individual threshold, $\lambda_i^*$ , of this motoneuron	Proprioception	Control of single motor unit
Neuron; activated when variable $w$ signaled by afferent inputs exceeds threshold $u^*$ $\{u^*, w\}$	Neuron-specific	Cognitive processing

The first symbol in the brackets is the origin of the FR, i.e., the threshold values for coordinate(s) shown as the second symbol in the same brackets. Asterisk (\*) refers to the origins of FRs – dynamic values of the threshold modified, compared to its static value, be velocity of changes in the coordinate(s), as exemplified for the threshold muscle length in Fig. 4. Actions of neuromuscular elements associated with each FR result from shifts in its origin or/and changes in the coordinate(s) elicited, for example, by external forces.

switch comparatively rapidly to another FR when task requirements change, as has been shown by Ghafouri et al. [see 2]. New FRs may be formed during learning for tasks requiring integration of sensory stimuli not found in the available FRs.

### Principle of Neurological Minimization

Biological systems are not unique in the tendency to reach an EP. This tendency is an expression of optimization described in physics and characteristic of many non-biological systems (e.g., a pendulum). In contrast, threshold control of EP suggests optimization of behavior that is unique for neurophysiological systems. As described above, the activity of neuromuscular elements results from the difference between the referent and the actual values of physical variables. The reaction of neuromuscular elements to the imposed activity seems to be guided by the **principle of neurological minimization**: each element separately and in cooperation with other elements tends to drive the system to a state in which the difference between the referent and actual values of variables, and thus the overall activity in the system, becomes minimal, in the limits defined by the task constraints (cf. Gelfand and Tsetlin [10]). For muscles, the minimization is accomplished by: contraction in response to the initial activation; a subsequent decrease in the activity of motoneurons resulting from muscle shortening; reciprocal

inhibition of motoneurons of antagonist muscles. Threshold control temporarily enhancing muscle co-activation and readdressing it to a new position (see above) accelerates the achievement of the state when the activity of motoneurons and co-activation are minimized (Fig. 3). Indeed, when a movement is blocked, the minimization process is interrupted. However, the occurrence of substantial activity of muscles opposing the perturbation is indicative of the tendency to minimization: when the movement is allowed to proceed, the activity rapidly decreases.

The minimization process is global: neurons of the leading FR that is primarily used to produce a motor action cannot reach an activity minimum, unless neurons of subordinate FRs and eventually muscles and motoneurons also minimized their activity, to a level consistent with the task constraints (Fig. 6).

### Guiding Movements Without Redundancy Problems

Threshold control and the principle of neurological minimization provide a solution to the **redundancy problem** [2], by finding a unique way of coordinating abundant degrees of freedom of the body each time a motor action is produced. For example, reaching movement is produced by shifting the referent coordinates ( $R^*_h$ ) of the hand, by influencing neurons that receive afferent inputs related to actual coordinates ( $Q_h$ ) of the hand in space. The movement will proceed

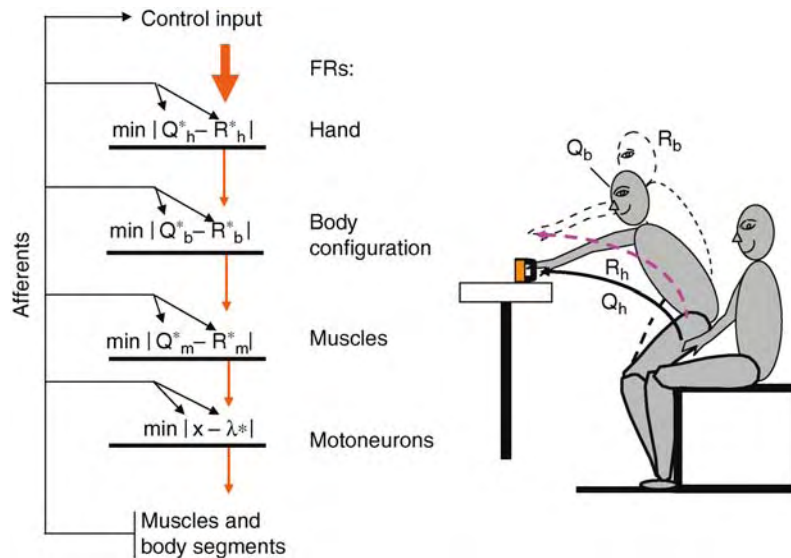

**Equilibrium Point Control. Figure 6** Principle of neurological minimization and its capacity to guide movements made by multiple muscles and degrees of freedom without redundancy problems (schematic diagrams). Some spinal and supraspinal neurons projecting to motoneurons mono- or poly-synaptically may integrate somatosensory, visual and vestibular inputs and proprioceptive signals from muscle, joints and skin receptors to receive information about coordinates ( $Q_h$ ) of the hand in an external frame of reference. Like for motoneurons, independent, control influences on these neurons can be measured by the amount of shifts in the threshold (referent) position ( $R_h^*$ ) of the hand. Such neurons may or may not be recruited depending on the difference between  $Q_h$  and  $R_h^*$ . In the task of reaching for a cup (*right panel*), control levels shift  $R_h^*$  to move the hand in the desired direction. This strategy is reminiscent of using the steering wheel to direct the car motion: the focus is on the direction of car motion, rather than on the means (turning the steering wheel) used to accomplish it. As long as the hand approaches the cup, it is not essential whether or not the actual ( $Q_h$ ) and referent ( $R_h$ ) trajectories of the hand coincide. In the *left panel*, reaching for a cup is controlled by shifting the origin  $R_h^*$  of the leading FR in which the hand position ( $Q_h$ ) is localized. The leading FR influences the origin ( $R_b^*$ ) of the body configuration FR. The output of the latter FR, in turn, influences the origins ( $R_m^*$ ) of FRs of individual muscles and eventually threshold lengths ( $\lambda^*$ ) of motoneurons. The activity of neural elements in each FR tends to minimize (min) the discrepancy between the actual and referent coordinates, forcing the arm and other body segments to move until the hand reaches a final position at which a global minimum in the system, in the limits of intrinsic and external constraints, is reached. Because of the weights of the body segments, the absolute minimum (zero activity) at all subordinated levels will not be reached: the body will continue to move until at some equilibrium position,  $Q$ , the activity of appropriate muscles will produce torques balancing the weight torques. Vertical brackets denote a measure of the distance between the variables inside the brackets, determining how strongly neural elements in each FR are activated.

until the difference between these variables become minimal, which occurs when neurons of subordinate levels, including motoneurons, also minimize their activity (Fig. 6). In each trial, there will be no uncertainty in choosing one coordination pattern of a set of many other patterns that meet the task demands – each time, the minimizing process will produce a unique coordination pattern. If necessary, with additional corrective shifts in  $H^*$ , the target will be reached. The coordination pattern can, indeed, naturally vary with task repetitions, history-dependent changes in the system (e.g., due to fatigue), task constraints (e.g., if the movement is obstructed), intentional involvements or restrictions of some degrees of freedom of the body. One prediction of this strategy – the invariance of the

hand ►trajectory regardless of the number of degrees of freedom involved in pointing movements – has been confirmed by Adamovich et al. [see 2]. Walking can be performed by choosing a FR in which a stable body posture in the environment is maintained (Table 1). By shifting the origin and thus translating this FR, control levels will provoke minimizing reactions of all systems, so that the initial body posture will be restored but at a new location in the environment, thus producing a step. Walking will emerge when the system continues shifts of the same FR.

Several minimization principles have been suggested for movement production (e.g., the smoothness criterion that well describes movement trajectories; Hogan and Flash [see 2]). Formulated in terms of SVs, these

principles lack an essential element, CVs. Therefore, their applicability and explanatory power are restricted, as would be the case if optimization of motor behavior implied by EP control were considered without identifying CVs. These principles may appear to be reduced forms of the more general principle of neurological minimization.

## References

1. Asatryan DG, Feldman AG (1965) Functional tuning of the nervous system with control of movements or maintenance of a steady posture: I. Mechanographic analysis of the work of the joint on execution of a postural tasks. *Biophysics USSR* 10:925–935
2. Feldman AG, Goussev V, Sangole A, Levin MF (2007) Threshold position control and the principle of minimal interaction in motor actions. *Prog Brain Res* 165:267–281
3. Won J, Hogan N (1995) Stability properties of human reaching movements. *Exp Brain Res* 107:125–136
4. Ghafouri M, Feldman AG (2001) The timing of control signals underlying fast point-to-point arm movements. *Exp Brain Res* 137:411–423
5. Ostry DJ, Feldman AG (2003) A critical evaluation of the force control hypothesis in motor control. *Exp Brain Res* 153:275–288
6. Matthews PBC (1959) The dependence of tension upon extension in the stretch reflex of the soleus muscle of the decerebrated cat. *J Physiol (London)* 147:52–46
7. Feldman AG, Orlovsky GN (1972) The influence of different descending systems on the tonic stretch reflex in the cat. *Exp Neurol* 37:481–494
8. Musampa NK, Mathieu PA, Levin MF (2007) Relationship between stretch reflex thresholds and voluntary arm muscle activation in patients with spasticity. *Exp Brain Res* 181:579–593
9. Nichols TR (1989) The organization of heterogenic reflexes among muscles crossing the ankle joint in the decerebrate cat. *J Physiol (London)* 410:463–477
10. Gelfand IM, Tsetlin ML (1971) On mathematical modeling of mechanisms of central nervous system. In: Gelfand IM, Gurfinkel VS, Fomin SV, Tsetlin ML (eds) *Models of the structural–functional organization of certain biological systems*. MIT, Cambridge, MA

## Equilibrium Point Hypothesis

### Definition

A hypothesis that the central nervous system controls voluntary actions by manipulating central variables treated to positional states of muscles, joints, effectors, and the whole body.

- ▶ Equilibrium Point Control
- ▶ Coordination

## Equilibrium Points

### Definition

In system theory, those points in the state space in which the time derivative of the state is null.

- ▶ Nonlinear Control Systems

## Equilibrium Potential

### Definition

- ▶ Membrane Potential - Basics

## Equipresence

### Definition

A heuristic principle according to which all constitutive quantities in a material model must, a priori, depend on the same independent variables.

- ▶ Mechanics

## Equivalent Acceleration due to Gravity

### Definition

Associated with the gravitational field, which pulls a mass towards the Earth is an equivalent acceleration in the opposite direction. This comes from Einstein's equivalency principle as stated in his General Theory of Relativity.

- ▶ Velocity Storage

## ER81

### Definition

A member of the ETS class of DNA-binding transcription factors. ER81 is phosphorylated and activated

by Ras via MAP kinase signaling pathways and regulate the expression of several genes in a variety of cell types.

---

## ErbB Receptors

### Definition

ErbB receptors are called epidermal growth factor receptors and are members of the tyrosine kinase family. They integrate external stimuli by binding to neuregulins, specific ligands, thus they integrate external stimuli with internal signal transduction pathways.

- ▶ Growth Factors

---

## Erectile Dysfunction

### Definition

A sexual dysfunction disorder in men that is a neurovascular disease produced by hormonal, local, biochemical and structural changes in the penis.

- ▶ Targeting Endothelial Dysfunction Through Treatment of Erectile Dysfunction: Current Pharmacological Treatment and Mechanism of Action

---

## Ergoline

### Definition

A tetracyclic molecule with an embedded tryptamine moiety that serves as the framework for the potent alkaloids produced by species of the ergot fungus (*Claviceps*), as well as the potent hallucinogen LSD.

- ▶ Hallucinogens

---

## Ergot

### Definition

Fungi of the genus *Claviceps* that typically infest grain crops such as rye and barley. They produce a series of alkaloids known as ergot alkaloids, which served as the basis for a number of medically-important products such as ergonovine and ergotamine.

- ▶ Hallucinogens

---

## ERP

- ▶ Auditory Evoked Potentials

---

## Error Detection

- ▶ Feedback Control of Movement

---

## Erythromelalgia

### Definition

Erythromelalgia (also called “burning feet syndrome”) is characterized by episodes of excruciating pain in the extremities and associated skin redness due to periodic blockage of blood vessels (usually in the lower extremities). Common triggers include mild heat, alcohol consumption, or exertion. Inherited erythromelalgia (IEM) (also known as erythermalgia) can start early in life with a mean age of onset of 3 years and typically affect feet and hands, whereas symptoms of adult-onset IEM typically start in mid-life. While early- and juvenile-onset IEM have been linked to mutations in *Nav1.7*, the genetic cause for adult-onset IEM remains to be identified (see Voltage-gated sodium channels: multiple roles in the pathophysiology of pain).

- ▶ Ion Channels from Development to Disease
- ▶ Voltage-gated sodium channels: Multiple roles in the pathophysiology of pain

## Escape Behavior

### ► Startle Response

## Eshelby Stress

### Definition

A particular combination of the Helmholtz free-energy density, the deformation gradient and the first Piola-Kirchhoff stress. The Eshelby stress is the thermodynamic dual of the evolution of the material isomorphisms and can therefore be considered as the driving force behind material evolution.

### ► Mechanics

## Essential Tremor

ALI SAMII

Department of Neurology, University of Washington, Seattle, WA, USA

### Synonyms

Benign essential tremor; Benign familial tremor

### Definition

A common movement disorder characterized by ► **action tremor** that is usually hereditary.

### Characteristics

#### Epidemiology and Clinical Features

In essential tremor, action tremor is the typical presentation, but other signs such as subtle gait disturbance and non-motor features including mild cognitive deficits and personality changes may accompany the tremor [1]. The extent to which subtle neurological findings other than action tremor are seen in essential tremor is debated, and the old view of essential tremor being a mono-symptomatic tremor syndrome is gradually changing into the view that it is a complex heterogeneous neurological disorder. Action tremor can be postural (hands in the outstretched position), intention (finger-nose-finger), or task-specific (seen while performing a specific activity, e.g., writing). Essential tremor is prevalent and is probably the second most common movement disorder behind restless legs

syndrome. The worldwide prevalence of essential tremor ranges from 0.41 to 3.92% based on studies that provided diagnostic criteria for essential tremor, defined it as an action tremor, and used community-based rather than service-based designs [2]. Tremor is present during action and involves the hands, head, and voice to variable degrees. Although it is labeled as “benign essential tremor,” it can be far from benign, quite disabling with devastating consequences for persons whose job and livelihood depend on manual dexterity. In addition, the social disability that it causes should not be underestimated. Persons with moderate to severe tremor avoid social events, such as eating in restaurants or social gatherings, because they cannot cut meat, eat soup, or drink out of a cup. The inability to sign checks or other legal documents poses another challenge. Essential tremor may also be a risk factor for alcoholism as alcohol is an effective means of dampening the tremor but with a short duration of action.

### Pathophysiology and Genetics

The etiology of essential tremor is unknown and the pathophysiologic mechanism of essential tremor is not well understood. Mechanical, reflex oscillators, and central neuronal circuits (e.g., ► **olivocerebellothalamic circuit**) have all been implicated in essential tremor [3]. Essential tremor is different from the tremor in Parkinson disease in two important ways: essential tremor is more symmetric than the tremor of Parkinson disease, and Parkinson tremor is more prominent while the arm is resting on the lap, while essential tremor is more pronounced with action. Rigidity and bradykinesia are not seen with essential tremor. The frequency of essential tremor is higher (8 Hz) than that of Parkinson disease, but decreases with age. In severe cases, essential tremor may be present at rest, making it quite difficult to differentiate from the tremor seen in Parkinson disease. Unlike Parkinson disease, essential tremor does not significantly improve with anti-Parkinson medications. A family history is positive in most patients with essential tremor, with a ► **dominant inheritance** pattern and variable ► **penetrance**. Three gene loci (ETM1 on 3q13, ETM2 on 2p24.1 and a locus on 6p23) have been identified in patients and families with essential tremor [4]. In rare cases, action tremor combined with gait ataxia in older men can be due to fragile X-associated tremor/ataxia syndrome [5]. This syndrome occurs in male carriers of pre-mutation alleles of the fragile X mental retardation gene. However, screening patients with essential tremor for the presence this pre-mutation allele has extremely low yield and is not cost effective [6].

### Treatment

Essential tremor is worsened by caffeine, stress, and associated medical disorders such as hyperthyroidism and it is relieved by alcohol. Essential tremor can be

exacerbated by certain medications such as lithium, valproate, cyclosporine, levothyroxine, and corticosteroids. Patients should minimize the use of caffeine and be warned about the risk of alcohol dependence in the setting of essential tremor. Medical therapy for essential tremor usually starts with either primidone or propranolol [7]. The usual therapeutic dose of propranolol is 60–320 mg daily. Potential adverse effects of propranolol include slow heart rate, low blood pressure, reduced exercise tolerance, impotence in men, fatigue, worsening of asthma or obstructive pulmonary disease, and depression. The usual therapeutic dose of primidone is 50–500 mg daily. Potential adverse effects of primidone include sedation, impaired cognition, fatigue, and unsteadiness of gait. Topiramate, gabapentin, and benzodiazepines may also relieve tremor. Topiramate may cause a sensation of diffuse body tingling (paresthesia), weight loss, cognitive impairment, unsteadiness of gait, and sedation. At higher doses, gabapentin and benzodiazepines can also cause sedation and unsteadiness of gait. Injections of botulinum toxin may help tremor in selected patients who have inadequate tremor control with drug therapy alone. Head and voice tremor may respond better to injections of botulinum toxin than hand tremor. When focal dystonia (such as writer's cramp or cervical dystonia) is superimposed on top of essential tremor, the first line therapy would be injection of botulinum toxin. In severe essential tremor intractable to medical therapy, unilateral ► **thalamotomy** (surgical destruction of a small part of the thalamus) improves contralateral tremor [8]. Bilateral thalamotomy is rarely performed as it can cause cognitive and gait disturbances [9]. Deep brain stimulation is a procedure whereby an electrode is placed into a deep target within the brain (e.g., thalamus) in order to electrically stimulate that target and “mimic” a lesion without destroying tissue. The mechanisms of action of deep brain stimulation are not well understood and most experts agree that the mechanism is much more complicated than simply mimicking a lesion effect through high frequency stimulation. Thalamic deep brain stimulation is considered safer than thalamotomy [10], presumably because there is no significant destruction of brain tissue, and the degree to which the target is “suppressed” is adjustable with variations in stimulation voltage, frequency, and pulse width. Serious surgical complications include symptomatic brain hemorrhage (usually less 3%) and death (usually less than 0.5%).

## References

1. Benito-León J, Louis ED (2006) Essential tremor: emerging views of a common disorder. *Nat Clin Pract Neurol* 2(12):666–678
2. Louis ED, Ottman R, Hauser WA (1998) How common is the most common adult movement disorder? Estimates of the prevalence of essential tremor throughout the world. *Mov Disord* 13(1):5–10

3. Lorenz D, Deuschl G (2007) Update on pathogenesis and treatment of essential tremor. *Curr Opin Neurol* 20(4):447–452
4. Deng H, Le W, Jankovic J (2007) Genetics of essential tremor. *Brain* 130(Pt 6):1456–1464
5. Jacquemont S, Hagerman RJ, Leehey MA, Hall DA, Levine RA, Brunberg JA, Zhang L, Jardini T, Gane LW, Harris SW, Herman K, Grigsby J, Greco CM, Berry-Kravis E, Tassone F, Hagerman PJ (2004) Penetrance of the fragile X-associated tremor/ataxia syndrome in a premutation carrier population. *JAMA* 291(4):460–469
6. Arocena Garcia Louis ED, Tassone F, Gilliam TC, Ottman R, Jacquemont S, Hagerman PJ (2004) Screen for expanded FMR1 alleles in patients with essential tremor. *Mov Disord* 19(8):930–933
7. Zesiewicz TA, Elble R, Louis ED, Hauser RA, Sullivan KL, Dewey RB Jr, Ondo WG, Gronseth GS, Weiner WJ (2005) Quality Standards Subcommittee of the American Academy of Neurology. Practice parameter: therapies for essential tremor: report of the Quality Standards Subcommittee of the American Academy of Neurology. *Neurology* 64(12):2008–2020
8. Zirh A, Reich SG, Dougherty PM, Lenz FA (1999) Stereotactic thalamotomy in the treatment of essential tremor of the upper extremity: reassessment including a blinded measure of outcome. *J Neurol Neurosurg Psychiatry* 66(6):772–775
9. Burchiel KJ (1995) Thalamotomy for movement disorders. *Neurosurg Clin N Am* 6(1):55–71
10. Schuurman PR, Bosch DA, Bossuyt PM, Bonsel GJ, van Someren EJ, de Bie RM, Merkus MP, Speelman JD (2000) A comparison of continuous thalamic stimulation and thalamotomy for suppression of severe tremor. *N Engl J Med* 342(7):461–468

## Essentialism

### Definition

The view that objects have some of their properties essentially, which means that they could not be these objects and lack those properties.

### ► Property

## EST

### Definition

Expressed sequence tag. These are derived from RNA from a particular source. RNA is reverse transcribed to cDNA and used to generate a plasmid library, which is then sequenced to determine which genes are expressed in cells or tissues of interest. EST sequences have been

databased and aligned with other ESTs to provide an approximation of full length gene sequences (UniGene database). ESTs can be aligned with the genome sequence in order to indicate which regions of the genome are actually expressed.

► Bioinformatics

## Ethogram

### Definition

The catalogue of all fixed action patterns exhibited by a species in the natural environment.

## Ethology

### Definition

The comparative study of the behavior of creatures, which include humans, living in their natural environment.

► Behavior

## N-Ethylmaleimide Sensitive Factor (NSF)

### Definition

A protein with ATPase activity and can interact with the SNARE complex which is important for the process of exocytosis.

► Non-synaptic Release

## Euler/Cardan Angle Decomposition

### Definition

Method for describing three-dimensional rotations as a sequence of rotations about coordinate system axes.

► Motion Analysis

## Eulerian Description

### Definition

A formulation of the equations of continuum mechanics in terms of fields whose independent variables are the spatial coordinates and time. Also called the spatial description.

► Mechanics

## Euler's Equations

### Definition

The equations of motion of a rigid body.

► Mechanics

## Eumelanin

### Definition

A dark brown or black polymeric pigment produced by melanocytic cells from dihydroxyindole and dihydroxyindole-1-carboxylic acid monomers derived from Ltyrosine.

► Melanin and Neuromelanin in the Nervous System

## Eumelanosomes

### Definition

Ellipsoidal organelles  $0.3 \mu\text{m} \times 0.9 \mu\text{m}$  found within melanocytes that compartmentalize eumelanin synthesis and storage.

► Melanin and Neuromelanin in the Nervous System

## Eupnea

### Definition

Eupnea is a regular, three-phasic discharge pattern of the phrenic nerve consisting of a steadily augmenting discharge during inspiration, a small and decrementing after-discharge (postinspiratory discharge) during stage 1 expiration (postinspiration) and a complete silence during stage 2 expiration.

► Respiratory Neurotransmitters and Neuromodulators

## Euthermia, Normothermia

### Definition

A body temperature state of endothermic animals following their “true” or “normal” temperature level (of about 35–37°C).

► Hibernation

## Evanescence Field Fluorescence Microscopy

DAVID ZENISEK  
Yale University School of Medicine, New Haven,  
CT, USA

### Synonyms

Evanescence field microscopy; Evanescence wave microscopy; Total internal fluorescence microscopy; TIRF, TIRFM

### Definition

#### Evanescence Field

Light traveling from a substance of one ► refractive index toward another refractive index is ► refracted based on ► Snell’s law

$$n_1 \sin(\theta_1) = n_2 \sin(\theta_2), \quad (1)$$

where  $\theta_1$  and  $\theta_2$  are the angles of the incident and refracted light defined, respectively, and  $n_1$  and  $n_2$  are

the refractive indices of the media that the incident and refracted beam travel in. Note that  $\theta_1$  and  $\theta_2$  are defined relative to the perpendicular of the interface of the two media (see Fig. 1). Snell’s law can be rearranged to solve the angle of the refracted light

$$\sin(\theta_2) = (n_1/n_2) \sin(\theta_1) \quad (2)$$

From (2), it is easy to see that for incident angles  $> \sin^{-1}(n_2/n_1)$ ,  $\sin(\theta_2) > 1$ . At these angles, light is no longer refracted, but instead is totally reflected internally within the incident medium.  $\sin^{-1}(n_2/n_1)$  is defined as the ► critical angle. Note that critical angles only exist (and total internal reflection can only occur) for situations where  $n_1 > n_2$ .

Although light does not propagate through the lower refractive index substance during total internal reflection, the light intensity does not drop to zero immediately at the interface of two substances. Instead, light in the lower refractive index substance drops off exponentially with distance from the interface. This thin layer of light is known as an “► evanescent field.” This evanescent field is described by (3)

$$I = I_0 \exp(-z/d), \quad (3)$$

where  $I$  is the intensity of the light,  $I_0$  is the intensity at the interface and  $z$  is the distance from the interface. The value  $d$  is a function of the angle of incidence and the relative refractive indices of the two media as detailed in (4)

$$d = \lambda/4\pi(n_1^2 \sin^2(\theta_1) - n_2^2)^{-0.5}, \quad (4)$$

where  $\lambda$  is the wavelength of light. From (4), one can see that the evanescent field becomes shallower with larger excitation angles and with more disparate refractive indices for the two substances.

### Evanescence Field Fluorescence Microscopy

Evanescence field fluorescence microscopy takes advantage of the thin “evanescent field” of light created during

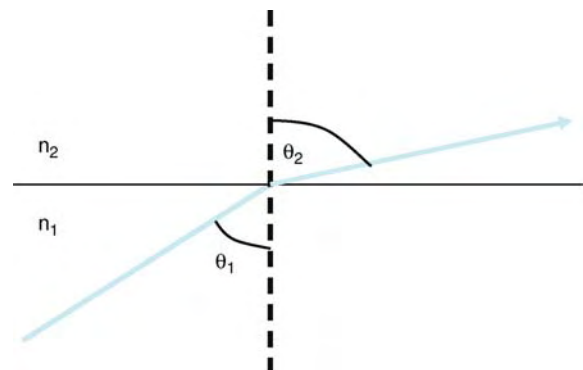

**Evanescence Field Fluorescence Microscopy.**  
Figure 1



total internal reflection, to preferentially excite fluorophores near the interface in the lower refractive index substrate. Typically, the evanescent field is set up such that the length constant of the evanescent field ( $d$  from (3) and (4)) is considerably shorter than the wavelength of light used, thus illuminating a much thinner section than is typical for other microscopy methods. This allows one to confine illumination to a smaller region than the focal plane of an objective lens, thus greatly reducing out-of-focus light. Evanescent field microscopy is typically performed using standard fluorescence microscopes modified for evanescent field illumination. The two most common methods for introducing excitation light for evanescent field microscopy are prism-type and objective-type evanescent field microscopy. These two methods are briefly discussed below. For more detailed descriptions of these techniques and other related methods, see Axelrod [1].

### Prism-Type Evanescent Field Microscopy

In order to generate an evanescent field, one needs to introduce light at an acute angle through a highly refractive substance. One way to achieve this is to introduce the light through a prism made of higher refractive material than your sample. For this method, light shown at an acute angle travels through the prism, a refractive index matched immersion fluid and coverslip to the interface between the sample and the coverslip, where it suffers total internal reflection. The evanescent field generated during total internal reflection is used to excite fluorophores in the sample, and the fluorescent light is collected using an objective lens and standard fluorescence microscope. Such a method can be employed using either an upright fluorescence microscope with excitation light introduced from below the sample, or with an inverted fluorescence microscope and light brought in from above. Using this method, the excitation light and the objective used for light collection are on opposite sides of the sample. Since most biological samples are studied in aqueous buffers, this technique requires either the use of water immersion objective lenses with lower **▶numerical aperture** and poorer light collection than oil immersion lenses or placing the sample between two layers of glass, which restricts access to the cell. To get around these problems, a second method, objective-type evanescent field microscopy [2], using a high numerical objective on an inverted microscope has become more popular since the introduction of very high numerical aperture objective lenses by several microscope companies.

### Objective-Type Evanescent Field Microscopy

A second technique often used for evanescent field illumination, through-the-objective type (or prismless) evanescent field illumination was pioneered by Stout and Axelrod [2]. This technique takes advantage of very

high numerical aperture objectives ( $NA = 1.4$  to  $1.65$ ) to introduce totally internally reflected light for evanescent field illumination. This is usually achieved in one of two different ways. (i) A laser beam is focused off-axis to the back focal plane of the objective. Light focused off-axis to the back focal plane emerges collimated at an angle that becomes more acute with increasing distance from the center of the back focal plane. (ii) An arc lamp is focused onto an opaque disk in the center of the conjugate back focal plane of the objective. This opaque disk is set up in such a way to block all subcritical angles of light.

### Purpose

#### Applications

Evanescent field microscopy has been used for a variety of applications including: the visualization of cell surface contacts (e.g., Weiss et al. [3]); visualizing single molecules [4] and events occurring at the cell surface such as endocytosis of clathrin coated pits [5], visualization of single secretory granules in neuroendocrine cells [6] and synaptic vesicles in dissociated neurons (e.g., Zenisek et al. [7]); and near membrane ionic transients (e.g., Omann and Axelrod [8], Zenisek et al. [9]).

### Advantages and Disadvantages

Evanescent field microscopy provides several advantages over conventional light microscopy. First, the very thin layer of excitation light illuminates a much smaller region than with other conventional techniques, thus eliminating the interference from fluorescent objects more distal to the glass–cell interface. In fact, the evanescent field can be much thinner than the focal plane of the objective lens, thereby theoretically eliminating out-of-focus excitation light from the image. In practice, however, scattered excitation and emission light prevents reaching this theoretical ideal. Second, the sharp drop in excitation light allows one to monitor subtle movements of an object by tracking its intensity over time. Third, since optical sectioning is provided by the excitation light rather than by introduction of a pinhole (as is the case for confocal microscopy), light collection is more efficient than with confocal.

The utility of evanescent field microscopy is limited to the visualization of structures within 500 nm of a highly refractive substrate. Within cells, such as neurons, it limits its uses to the study of processes within 200 nm of a membrane of a cell adherent to a coverslip. Structures deeper within cells or within tissue cannot be visualized with this technique.

### References

1. Axelrod D (2001) Total internal reflection fluorescence microscopy in cell biology. *Traffic* 2:764–769

2. Stout AL, Axelrod D (1989) Evanescent field excitation of fluorescence by epi-illumination microscopy. *Appl Optics* 28:5237–5242
3. Weis RM, Balakrishnan K, Smith B, McConnell HM (1982) Stimulation of fluorescence in a small contact region between rat basophil leukemia cells and planar lipid membrane targets by coherent evanescent radiation. *J Biol Chem* 257:6440–6445
4. Vale RD, Funatsu T, Pierce DW, Romberg L, Harada Y, Yanagida T (1996) Direct observation of single kinesin molecules moving along microtubules. *Nature* 380:451–453
5. Merrifield CJ, Feldman ME, Wan L, Almers W (2002) Imaging actin and dynamin recruitment during invagination of single clathrin-coated pits. *Nat Cell Biol* 4:691–698
6. Lang T, Wacker I, Steyer J, Kaether C, Wunderlich I, Soldati T, Gerdes H-H, Almers W (1997)  $\text{Ca}^{2+}$  triggered peptide secretion neurotechnique in single cells imaged with green fluorescent protein and evanescent-wave microscopy. *Neuron* 18:857–963
7. Zenisek D, Steyer JA, Almers W (2000) Transport, capture and exocytosis of single synaptic vesicles at active zones. *Nature* 406:849–854
8. Omann GM, Axelrod D (1996) Membrane proximal calcium transients in stimulated neutrophils seen by total internal reflection fluorescence. *Biophys J* 71:2885–2891
9. Zenisek D, Davila V, Wan L, Almers W (2003) Imaging calcium entry sites in two presynaptic cells. *J Neurosci* 23:2538–2548

---

## Evanescent Field Microscopy

- ▶ Evanescent Field Fluorescence Microscopy

---

## Evanescent Wave Microscopy

- ▶ Evanescent Field Fluorescence Microscopy

---

## Event-related Potentials

### Definition

Electrical response from the brain elicited by an event. Encephalographic (EEG) recordings are made following a stimulus presentation (sound, light, touch). Typically, event-related electrical activity is smaller

than ongoing spontaneous activity, thus signal averaging is employed to combine time-locked responses to multiple repetitions of the event.

- ▶ Auditory Evoked Potentials
- ▶ Electroencephalography

---

## Events

### Definition

Among the most prominent theories of *events* are Jaegwon Kim's account of events as structured entities constituted by objects, properties and times and Donald Davidson's account of events as concrete, datable and non-repeatable happenings. According to Kim, events are exemplifications by objects of properties at times. An event *e* is represented by an expression of the form “[*o*, *F*, *t*],” where *o* is *e*'s constitutive object, *F* is *e*'s constitutive property (exemplified by *o*), and *t* is *e*'s constitutive time (the time at which *o* exemplifies *F*). According to Davidson, events resemble ordinary objects; they are concrete, datable and non-repeatable happenings such as births, assassinations, excitations of neural areas or beliefs.

- ▶ Epiphenomenalism

---

## Evoked Potential (EP)

### Definition

Summed electric response of many cells recorded by surface electrodes and evoked by stimulation of some neural, including sensory, or skeleto-muscular structure. For instance, repeated electric shocks delivered to a peripheral cutaneous nerve evoke waveforms of potential changes in the electroencephalogram (EEG), which upon averaging yield averaged sensory EPs. So do brief stretches to muscles, brief light flashes delivered to the retina or acoustic clicks delivered to an ear. Likewise, repeated transcranial magnetic stimulation (TMS) evokes changes in electromyograms (EMGs).

- ▶ Electroencephalography
- ▶ Electromyography
- ▶ Extracellular Recording
- ▶ Transcranial Magnetic Stimulation

## Evolution and Brain-Body Allometry

HARRY J. JERISON

Department of Psychiatry & Biobehavioral Sciences,  
UCLA Health Sciences Center, Santa Monica,  
CA, USA

### Definition

Allometry is the relationship of size or weight between a particular part of the body or part of an organ and the size or weight of the body or organ itself, respectively.

### Characteristics

If you have weighed the brains and bodies of a lot of animals and want to know their relationship, a good place to begin is with a graph of your data on a scatter diagram. You would be beginning an allometric analysis. Brain-body allometry is a description of what you have done, a discussion of how and why you did it, and the theory, such as it is, of what is going on. You will quickly learn to work with logarithmic rather than linear data. You may undertake regression analyses to fit lines to your data showing how brain size is related to body size. You might, on the other hand, prefer a simpler description without the assumptions that go into a statistical regression analysis by drawing minimum convex polygons about your data. For many inferences it may be enough simply to inspect the graph. You can, in addition, try to relate your results to what is known about the geometry of living brains [1,2]. At the very least you will be able to describe the diversity of adaptations of brain size. If you also have estimated and graphed brain and body size in fossil animals, you would learn something about the evolution of the brain by comparing the fossils with living species.

### The Development of Brain-body Measurements and Their Theoretical Issues

The issue is ancient, beginning with one of Aristotle's many mistakes about the brain and what it does. In ►*The Parts of Animals*, Aristotle wrote that "of all animals, man has the largest brain in proportion to its size." He was prescient in placing man among the animals, but when people dissected moles and shrews they knew that Aristotle got the rest of it wrong, at least if "proportion" meant a simple ratio of brain weight to body weight. Snell [3] tried to correct the error by relating brain weight to the surface area of the body rather than its weight. This was enough to restore ►*Homo sapiens* to top rank, to be jostled only by dolphins (►*Tursiops truncatus*), which continue to challenge us for the glory. Snell's was, perhaps, the first clear statement of the allometric equation.

The classic story was reviewed some years ago [4] listing the main contributors to the field of brain-body analyses, especially Eugen Dubois, the discoverer of ►*Pithecanthropus erectus*." Dubois analyzed brain-body relations to determine where his ►*Pithecanthropus* belonged in human evolution.

Snell did not recognize that the equation relating brain size to body size must be dimensionally balanced. Bodies are three-dimensional objects as are brains. Snell's solution was to take the 2/3rds power of body size, which makes it a dimensional surface. He wrote the classic allometric equation, taking the allometric exponent,  $\alpha = 2/3$ :

$$E = k P^\alpha \quad (1)$$

E is brain size, P is body size, and k is a multiplier, which then has the *dimension*, length. The idea is that the dimensions are part of the equation; the balanced dimensional equation is: *volume* = *length* × *area*.

One usually works with the log transform, Eq. 1a, and rather than choosing 2/3 as the exponent it can be determined empirically, by fitting a line to your data. The log transform is a regression equation,  $\alpha$  is its slope and  $\log k$  is the Y-intercept.

$$\log E = \log k + \alpha \log P \quad (1a)$$

The dimensional approach is discussed in depth by Bridgman [5]. If one takes  $\alpha = 2/3$ , the dimension of  $k$  could refer to the depth of the cortex. It is a *length* and has to vary with the 1/3rd power of brain size. Cortical depth has not been studied in detail, but it is known to vary slightly with brain size across species, at about the 1/6th power.

In the scatter diagram,  $k$  is also the basis of a kind of encephalization quotient ( $EQ$ ), determined for each brain relative to the overall regression. The computed value of  $k$  in the regression equation, Eq. 1a, is a kind of average (by least-squares) of the deviations from the regression line. It could be calculated for each measured brain as the Y-intercept of a line parallel to the regression line, drawn through that measured brain-point. The computed  $EQ$  is thus the ratio of the measured brain size to the measured expected brain size at its body size (its X-value). It is a ratio rather than a difference or linear distance from the regression line because of log scaling: recall that  $\log y - \log x = \log (y/x)$ . Following this logic,  $EQ$  also has a dimension. For  $\alpha = 2/3$ , it is 1/3 minus a function of the depth of the cortex as related to body size. This feature of allometric analysis has not been formally explored.

Despite the unresolved dimensional problems with  $EQ$  and the multiplier  $k$ , there is some support for this approach [6], because the brain may be thought of as a mapping machine. Mapping is exemplified by the two-dimensional cortical maps of sensorimotor systems in mammals. The dimensional problem makes sense,

because the maps are sheets of brain tissue. Although very thin (about 1 mm thick, ranging from about 0.5 mm in the mouse to about 3.0 mm in humans), the cortex has a thickness and is a measurable depth.

Gould [7] has published a detailed discussion of the basic issues in allometric analysis. The “dictionary” by Medawar and Medawar [8] includes short essays on “allometric growth,” “form and mathematics,” “growth laws,” and “transformations,” which are excellent reviews. Martin ([9]: pp. 179–190) discusses it as applied to between-species data with emphasis on brain evolution. Perhaps the most novel development is based on Mandelbrot’s “fractal geometry of nature”; in his second edition [10] he discusses the brain briefly using data in Figure 4, below. Hofman [11] has analyzed the same surface-volume as Mandelbrot and can be read as an introduction to fractals as applied to brain-body analysis.

The idea that the brain is a mapping machine is one theoretical approach to the meaning of brain size and to allometric analysis of brain-body relations [12]. Another theoretical approach is based on fractals. In most reports, however, brain-body allometry is primarily a descriptive method to present data with few inferences about fundamental properties of brains. With the discovery of the empirical 3/4 exponent [9], there has been renewed interest in metabolic constraints on brain growth [13] and on deriving a theoretical allometric exponent from fractal geometry [14].

Snell’s use of  $\alpha = 2/3$  may define a fundamental constant reflecting the mapping of the body’s sensorimotor surfaces on the brain. However, as just noted, the empirical exponent for mammals from a statistical regression analysis of all available mammalian data is approximately 3/4. The issue is that for brain-body relations the exponent from empirical curve-fitting exercises does not account for the mapping phenomenon nor does fractal geometry. An important problem is to explain the difference between the empirical 3/4 and a theoretical 2/3 exponent.

### Data Handling

The remainder of this essay is concerned with handling the data after entering the numbers in a data sheet, independently of theoretical analysis. Two examples of the analysis will then be presented. One analysis is with minimum convex polygons, a nonparametric approach that illustrates the present diversity of brain size and is sufficient to describe several unusual aspects of brain evolution. The second is a regression analysis with implications for structural differences in the mammalian brain and illustrates the use of fractal geometry.

Computations with Eq. 1 are performed with logarithmically transformed data as indicated in Eq. 1a, which is a regression equation for bivariate data. Graphs

of data on brain sizes and body sizes drawn on log-log graph paper (Fig. 1) will produce a cloud of points for which Eq. 1a can be a best-fitting line. Fig. 1 compares linear with logarithmic scaling, and is one of the justifications for the latter. A “best-fitting” line determined by regression analysis applied to a very large sample of mammals results in  $\alpha$  as approximately 3/4 (Fig. 2 below). The usual method for determining the regression line, “reduced major axes,” is essentially the first principle component of multivariate analyses applied to bivariate data. Standard regression analysis assumes error-free body sizes and error only in the measures of brain sizes, and the residuals are then easier to work with. In brain-body data the residual for each species is the frequently used measure *EQ* (encephalization quotient). This is the ratio of measured brain size to expected brain size for a particular species at its body size according to the regression equation.

The main lesson so far is to graph the data using logarithmic scales for brain-body allometry and to be prepared to analyze the regression. It is reasonable to assume that brain size will vary as a function of body size, hence brain size is the dependent variable, the Y-coordinate, and body size is the independent variable, the X-coordinate. The units should be commensurate, such as in the centimeter-gram-second (cgs) system. Mixing scales, such as taking brain size in grams and body size in kilograms or mixing English and metric scales (ounces and grams) should not be done. Logarithms are the natural units for analyzing biological size, because they scale multiplicatively rather than additively [16], reflecting the role of cell division in growth and in determining adult size.

To emphasize logarithmic scaling, linear and logarithmic scales were compared for the same mammalian data in Fig. 1. In addition to being inappropriate for the analysis of biological size, the linearly scaled data were limited to mammals weighing less than 800 kg to keep the points on a manageable graph. With logarithmic coordinates the entire sample of 647 mammal species that had been measured could be placed on a single graph. One can confirm that Eq. 1a is an appropriate regression equation; for these mammalian data the best-fitting  $\alpha$  is about 3/4 (actually 0.74), a better fit than 2/3. Because there are good arguments for the choice of either exponent they are compared for didactic purposes in Fig. 2.

To return to the wherefore of the analysis, why does an allometric equation fit the data as well as it does? The answer can be that the instructions encoded in the genome of all mammals include a requirement that the peripheral sensorimotor cells, which communicate with the brain, be mapped on the brain. The size of the brain is determined by the size of the map, which in turn is determined by the number of cells in the

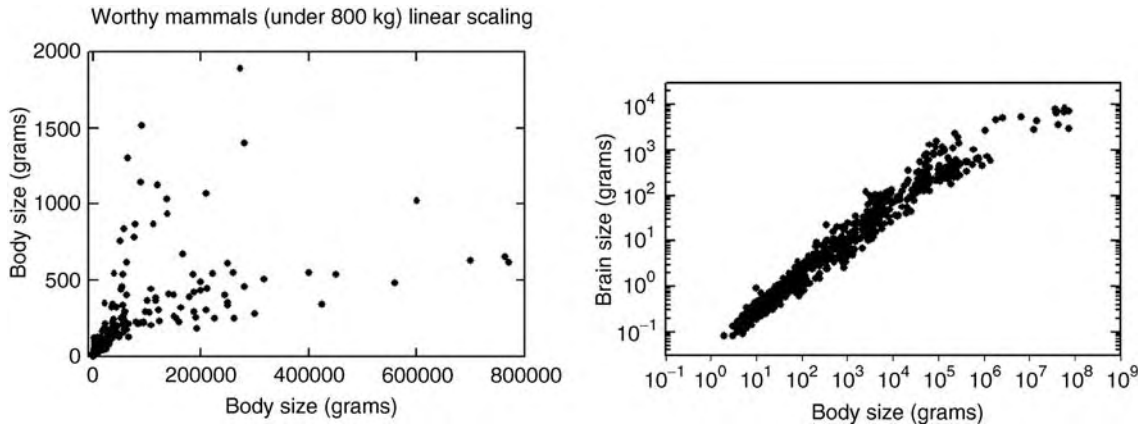

**Evolution and Brain-Body Allometry. Figure 1** Linear and logarithmic scales for brain-body weight data in mammals. Data from Worthy GAJ, Hickie JP [15].

brain map. This implies an allometric exponent  $\alpha = 2/3$ . The exponent of  $3/4$  has been related to a metabolic constraint on the size of a brain that can be supported by an animal programmed to grow to a particular body and organ size. This limits the growth of the brain, but within this constraint species can “grow” different sized brains at a given body size. As indicated in Fig. 2, either exponent could be correct.

Although curve fitting with regression analysis assumes that scatter in the cloud of points are random, in brain-body analysis the deviations from the regression (“residuals”) are not random. They are the effect of another factor that determines brain size in a species. Opossums, cats, and monkeys, each weighing about 5 kg, may typically have brains weighing 5, 30, and 60 g respectively. (The species could be ►*Didelphis virginiana*, ►*Felis catus*, and ►*Cebus capucinus*.) The difference in brain size relative to body size is a difference in ►encephalization. Cats are average living mammals in this respect, whereas opossums are small-brained and monkeys large-brained. When Snell discovered the allometric equation he recognized this difference and described it as reflecting a “psychic” factor. The term, “encephalization,” which is purely descriptive, is better.

### Minimum Convex Polygons for Brain-Body Ratios

A graphic analysis with little theorizing is enough to provide important insights into both the diversity of brain size and its evolution. It is not even necessary to calculate regression equations or to make precise judgments of encephalization in different species. It is enough to draw a minimum convex polygon (“convex hull”) about sets of points of special interest. Fig. 3 shows such an analysis for living and fossil amniotes. The method of measuring brain and body size in fossil species is beyond the scope of this article (see [4,6]).

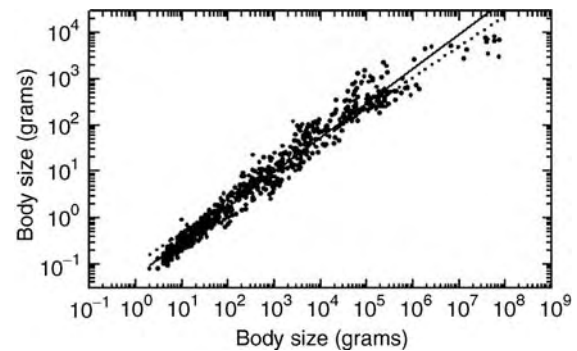

### Evolution and Brain-Body Allometry.

**Figure 2** Regression of brain size on body size (solid line), Eq. 1a,  $\alpha = 0.74$ ,  $k = 0.06$ . Dotted line is Eq. 1a, with  $\alpha = 2/3$  run through the centroid.

There are simple inferences from this nonparametric analysis. First, the polygons are oriented similarly about an upward slope within each class of vertebrates, which shows that brain size is determined significantly by body size. The vertical differences between the polygons show that birds and mammals are about equally encephalized and that both of these vertebrate classes are more encephalized than reptiles. A secondary point involves the present consensus that sees birds as surviving dinosaurs. This analysis is enough to show that with respect to brain size, dinosaurs were at a reptilian grade, whereas the earliest bird was at an avian grade of brain size. (Other fossil data on later bird brains supports the differentiation of an avian grade with respect to brain size.) Finally, adding the “archaic” mammals reported in Jerison [4] has them clustered about the bottom border of the living mammalian polygon, indicating that progressive encephalization was one of the features of mammalian brain evolution.

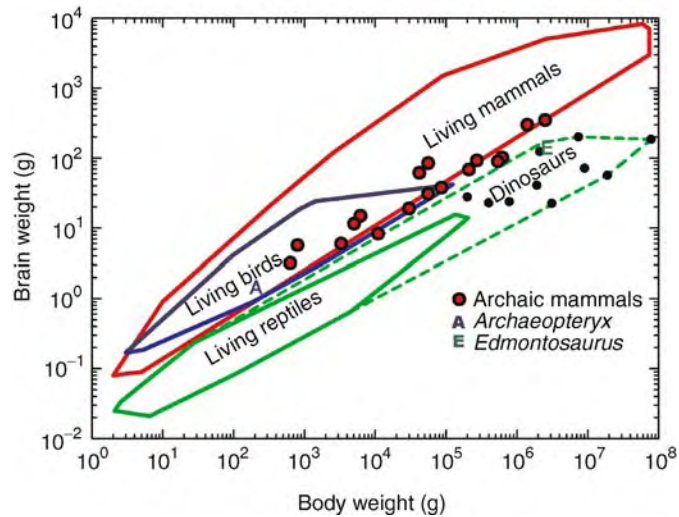

**Evolution and Brain-Body Allometry. Figure 3** Encephalization in living amniotes, with minimum convex polygons drawn about very large samples of mammal species ( $N = 647$ ), bird species ( $N = 219$ ), and reptile species ( $N = 59$ ). Data on the earliest bird, the Jurassic *Archaeopteryx*, 13 dinosaurs, and 17 archaic fossil mammals indicate trends in brain evolution.

The archaic species are from extinct orders of mammals that became extinct between 3 and 50 million years ago. Although this gross procedure does not permit a very fine analysis, it is fine enough to enable us to reach these conclusions about the diversity and evolution of brain size.

#### Regression Analysis Comparing Cortical Surface Area and Gross Brain Weight

The final case history is an allometric analysis in which regression analysis provides important clues about the organization of the brain. It is not a brain-body analysis but instead compares two measures of the brain in living mammals: cortical surface area and gross brain weight. Such surface-volume comparisons across mammalian brains are undertaken primarily to clarify the meaning of brain size for inferences about fossil “brains” that are known only as endocranial casts. Some have argued that cortical surface area is a measure of information processing capacity, contending that the number of neurons and of synapses in the cortex per unit area appears to be approximately constant across species of mammals. According to that argument, if volume estimates surface area then it estimates the information processing capacity of the brain for a species. Fig. 4 [12] shows that cortical area is indeed directly related to gross brain weight, a relationship that is in accord with the previous observation of the degree of gyrification of the cortical surface area with the gross body weight of a given species.

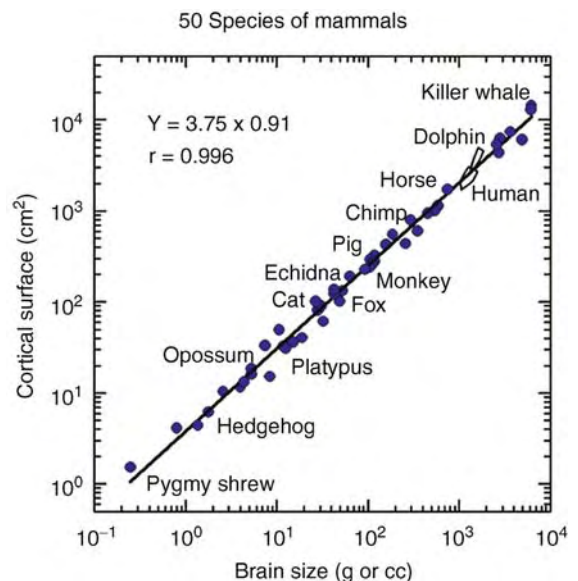

**Evolution and Brain-Body Allometry. Figure 4** The relation between cortical surface area and brain weight in 50 species of mammals. (From [12], by permission.)

The unusual feature in Fig. 4 is the slope, the allometric exponent, which is 0.91. This means that as mammal brains evolved to larger size, the surface area increased disproportionately. There was an orderly change of shape with increasing volume. Were shape constant the exponent would be exactly  $2/3$ . The change in shape took the form of the appearance of convolutions.

Mandelbrot's fractal geometry interprets this graph as indicating a fractal dimension of 2.70. Whether fractal analysis proves to be fruitful, or older approaches, such as the dimensional analysis of Bridgman [5], are preferable remains to be resolved. From the older perspective, an exponent of 0.91 for Fig. 4 implies a change of shape with increasing size, and the very high correlation coefficient, essentially 1.0, indicates that the change is very orderly. The change is, of course, the appearance of convolutions, i.e., gyri, as noted above, and the implication is that convolutedness of brains is almost entirely a function of brain size and does not necessarily signify increased intelligence. Resolving these issues is among the challenges for future research.

## References

1. Braitenberg V, Schüz A (1998) *Anatomy of the cortex: statistics and geometry*, 2nd edn. Springer Verlag, New York, Berlin, Heidelberg
2. Hofman MA (1989) On the evolution and geometry of the brain in mammals. *Prog Neurobiol* 32:137–158
3. Snell O (1891) Die Abhängigkeitangigkeit des Hirngewichtes von dem Körpergewicht und den geistigen Fähigkeiten. *Archiv für Psychiatrie und Nervenkrankheiten* 23:436–446
4. Jerison HJ (1973) *Evolution of the brain and intelligence*. Academic Press, New York, NY
5. Bridgman PW (1931) *Dimensional analysis*, rev edn. Yale University Press, New Haven, CT
6. Jerison HJ (2001) The study of primate brain evolution: where do we go from here? In: Falk D, Gibson K (eds) *Evolutionary anatomy of the primate cerebral cortex*. Cambridge University Press, Cambridge, England, pp 305–337
7. Gould SJ (1966) Allometry and size in ontogeny and phylogeny. *Biol Rev* 41:587–640
8. Medawar PB, Medawar JS (1983) *Aristotle to zoos: a philosophical dictionary of biology*. Harvard University Press, Cambridge, MA
9. Martin RD (1990) *Primate origins and evolution: a phylogenetic reconstruction*. Chapman & Hall, London
10. Mandelbrot BB (1983) *The fractal geometry of nature*, 2nd edn. Freeman, New York, NY
11. Hofman MA (1991) The fractal geometry of convoluted brains. *Journal für Hirnforschung* 32:103–111
12. Jerison HJ (1991) Brain size and the evolution of mind, 59th James Arthur lecture on the evolution of the human brain. American Museum of Natural History, New York
13. Aiello LC, Wheeler P (1995) The expensive-tissue hypothesis: the brain and the digestive system in human and primate evolution. *Curr Anthropol* 36:199–221
14. West GB, Brown JH, Enquist BJ (1998) The fourth dimension of life: fractal geometry and allometric scalings of organisms. *Science* 284:1677–1679
15. Worthy GAJ, Hickie JP (1986) Relative brain size in marine mammals. *Am Nat* 128:445–459
16. Stevens SS (1946) On the theory of scales and measurement. *Science* 103:677–680

## Evolution and Embryological Development of the Cortex in Amniotes

ALEXANDER A. POLLEN<sup>1,2</sup>,  
AMANDA F. P. CHEUNG<sup>1</sup>, ZOLTÁN MOLNÁR<sup>1</sup>

<sup>1</sup>Department of Physiology, Anatomy and Genetics  
University of Oxford, Oxford, UK

<sup>2</sup>Stanford University School of Medicine, Palo Alto,  
CA, USA

### Synonyms

Neurogenesis; Radial and tangential neuronal migration; Abventricular division; Ventricular zone; Subventricular zone

### Definition

The cortex in amniotes ranges from the relatively simple cytoarchitecture of three-layered reptilian dorsal cortex to the more complex six-layered neocortex (isocortex) of mammals and the pseudo-laminated but hypertrophied Wulst, or hyperpallium, of birds. New findings on the development of these pallial regions shed new light on how their cytoarchitectonic features evolved in the different amniote taxa that are extant today.

### Characteristics

The human neocortex supports many of our most advanced behaviors and cognitive abilities. Understanding the evolutionary processes that led to the enlargement of mammalian and the human brain is a major goal of neuroscience and evolutionary biology. Subcortical structures of the mammalian brain are largely similar to those of birds and reptiles [1]. However, several major qualitative differences distinguish the mammalian telencephalon from that of sauropsids: the laminar expansion of the cortex to six layers and the reorganization of the lateral region of the pallium. Within mammals, the massive tangential expansion of the neocortex is the hallmark of the primate brain, although it is also observed in several other orders. The goal of this article is to highlight the developmental processes that may underlie major changes in the telencephalon by reviewing elaborations of the amniote brain and recent comparative work on neurogenic compartments of the developing telencephalon [2–4]. In all amniotes, cortical excitatory neurons are produced by progenitors that divide along the ventricle surface. However, in mammals (and to a much lesser extent in birds) cortical excitatory neurons are also produced in the ►subventricular zone (SVZ), a zone superficial to the ventricle surface [5,6]. Recent work in primate and rodent revealed that the SVZ is

responsible for producing upper-layer neurons that are absent in the cortex of reptiles and birds [2,7]. Comparative developmental studies suggest that SVZ elaboration has contributed to tangential expansion of the cortex and the appearance of more elaborate cell types especially in supragranular layers. Future work on the molecular mechanisms that regulate the formation of the SVZ will provide insight on mammalian and primate brain evolution.

### Elaboration of the Telencephalon in Amniote Evolution

Major brain structures have largely been conserved in amniote evolution, but the telencephalon has diverged rapidly since the stem amniote [1]. In the common ancestor of all mammals, the cortex expanded from three to six layers and extended along the lateral region of the pallium. Within mammalian orders, the neocortex has also expanded tangentially, and cortical areas have been associated with advanced cognitive functions. Meanwhile, in sauropsids (reptiles and birds), the dorsal cortex has remained a three-layered structure, but in birds, the dorsal cortex (hyperpallium) has been elaborated into a pseudo-layered structure [8]. Additionally, the lateral region of the pallium of birds has been elaborated from the simple and presumed ancestral-like laminated structure in the tuatara, *Sphenodon punctatum*, to an enlarged dorsal ventricular ridge (DVR) [9]. In birds, the hyperpallium and nuclei of the DVR have been associated with advanced cognitive functions.

Evolution must have acted on developmental processes in order to produce these differences in amniote telencephalon structures. It is believed that there were some major transformations at the corticostriatal junctions [10–12], together with the generation of a new developmental process to increase cortical cell numbers to produce supragranular layers on a much larger cortex. This chapter briefly reviews the elaboration of the differences in the cortical lamination and tangential extension of the mammalian neocortex and reviews evidence that SVZ formation has been a critical developmental process enabling this laminar and tangential expansion of the mammalian cortex. The developmental processes underlying DVR elaboration are less well-understood, but it is interesting to note that a SVZ also forms during ►neurogenesis in the avian DVR.

### Differences in the Cortical Lamination and Tangential Expansion of the Mammalian Neocortex

Mammals uniquely possess a six-layered cortex (isocortex or neocortex), which develops in a strict inside-out pattern. In contrast, reptiles possess a three-layered cortex with considerable similarity to layers I, V and VI of mammals. The hyperpallium of birds also shares no homologues to layers II, III, and IV of

the mammalian cortex. However, based on morphology, connectivity, and neurotransmitters, it may have independently evolved cell populations that are at least analogous to these layers [1,8]. Thus, the laminar expansion of the cortex in mammals from the stem amniote required an increased number of neurons and cell types, and much debate exists about the developmental source of these neurons.

Harvey Karten originally proposed that the mammalian neocortex evolved from a rearrangement of elements already present in other vertebrates. He demonstrated that equivalent circuits are present in the visual and auditory pathways in avian and mammalian telencephali [13,14]. While these components are arranged into cortical layers in mammals, they are mostly situated in the DVR in birds, hinting that tangential migration could have been responsible for a cortical rearrangement in mammals. Initial reports that the mammalian subpallium, a region outside the cortical neuroepithelium, contributes tangentially migrating neurons to the mammalian cortex appeared to support Karten's theory [14,15]. However, tangentially migrating neurons are purely inhibitory (GABAergic). Additionally, tangential migration is not unique to mammalian brains, but occurs in birds and reptiles. Finally, tangentially migrating cells in all amniotes originate from the subpallium, which is not considered homologous to the DVR [16]. Therefore it is more conceivable that changes in the local dorsal cortical neurogenetic program, together with some major rearrangements at the corticostriatal junction [12], provided the foundation for remodeling the mammalian cortical lamination [2,17].

The tangential expansion of the cortex within mammals also required increased cortical neurogenesis. In contrast to the relatively constant features of mammalian radial columns [18], a more noticeable change in the evolution of the neocortex is the tangential expansion of the cortical sheet associated with the transformation of lissencephalic cortex typical of smaller brains, including those of some rodents, to the gyrencephalic cortex typical of larger brains, including those of some primates, cetaceans and other orders. The total surface area of the cerebral cortex has increased exponentially from lesser shrew (0.8 cm<sup>2</sup>), rat (6 cm<sup>2</sup>), and cat (83 cm<sup>2</sup>) to human (2,500 cm<sup>2</sup>), bottlenose dolphin (3,745 cm<sup>2</sup>), and African elephant (6,300 cm<sup>2</sup>).

### Evidence for Neurogenesis in the Subventricular Zone

Recent experiments suggest that the generation of neurons in the subventricular zone (SVZ) could have increased neural production in the neocortex of mammals. The majority of neurons in the adult brain are produced during embryonic development. In the amniote telencephalon, embryonic neurogenesis occurs at several sites. Early precursor cells and radial glia



produce neurons along the ►ventricular zone (VZ). Away from the ventricle, scattered abventricular cells also produce neurons. However, in mammals, but not in turtles and possibly other reptiles, cortical neurons are also generated by a discrete mitotic compartment called the SVZ that is located radially above the VZ [19].

The progenitor cells of the mammalian SVZ and of abventricular regions differ from progenitors in the VZ. In the VZ, neuroepithelial cells give rise to early born neurons and radial glia. The nuclei of radial glia undergo interkinetic migration, passing through S phase away from the ventricle surface and returning to the ventricle surface during M phase. At the ventricle, a radial glia cell divides asymmetrically to produce another radial glia and either a mature neuron or an intermediate progenitor cell that migrates to the SVZ. In contrast to radial glia, SVZ (intermediate) progenitors do not undergo interkinetic nuclear migration, and instead remain away from the ventricle surface where the cells divide symmetrically to produce two neurons, or occasionally, two daughter progenitors [5] (Fig. 1). Thus the two-step pattern of neurogenesis in which a radial glia cell produces a SVZ progenitor increases the overall rate of neurogenesis relative to the one-step pattern in which a radial glia cell produces a single neuron directly by asymmetric division.

The appearance of the cortical SVZ in the common ancestor of mammals coincides with the appearance of the six layered neocortex. Turtles and birds lack upper layer cortical neurons and also lack an SVZ in their pallial and Wulst (hyperpallium) regions, respectively [3,20]. This can be demonstrated by labeling sections from embryonic brains with an antibody against the mitotic marker phospho-histone H3. (Fig. 2a) shows that in both the pallium and subpallium of turtles, cell divisions occur along the VZ and in abventricular cells but never in an organized SVZ. Abventricular cell divisions may also increase the rate of neurogenesis,

But, the proportion of such divisions in the dorsal cortex remains small (less than 1/6th) and stable throughout neurogenesis, whereas in mammals, the proportion of SVZ and ►abventricular divisions dramatically increases [3,4,20]. Thus, the SVZ and a substantial role for intermediate progenitor cells appear in conjunction with the six-layered neocortex. However, this suggestion is based on a few species in the supramimate clade, Species from other order should be looked at before generalization could be made.

### Elaboration of Mitotic Compartments in the Avian Brains

Although reptiles and birds lack a SVZ in the dorsal cortex and hyperpallium respectively, a SVZ has been reported in ventral regions of the telencephalon in birds. Striedter and Keefer [22] described a 100–200  $\mu\text{m}$  thick band of labeled cells superficial to the VZ in the ventral telencephalon of E6 chick. The observed SVZ appeared to be prominent in subpallial regions. However, recent work indicates that the chick SVZ also extends across the entire DVR, terminating at the lateral edge of the cortex [4]. Thus, the entire VZ of the chick pallium commonly expresses transcription factors such as Pax6, and yet only the lateral portion produces a SVZ.

The SVZ in the embryonic DVR of the chick shares several similarities with the cortical SVZ of mammals. SVZ progenitors in both species are present during phases of neurogenesis. Additionally, in mammals, transcription factors such as Tbr2, Ngn1 and Ngn2 are locally expressed in the SVZ. Prior to the identification of the pallial SVZ in birds, Tbr2 expression was observed to reach the proliferative zone in the chick DVR, but not hyperpallium, and Ngn1 and Ngn2 were shown to be more strongly expressed in the DVR than hyperpallium [23,24]. These early results intimate that similar factors may regulate the formation of the SVZ in the chick and mouse.

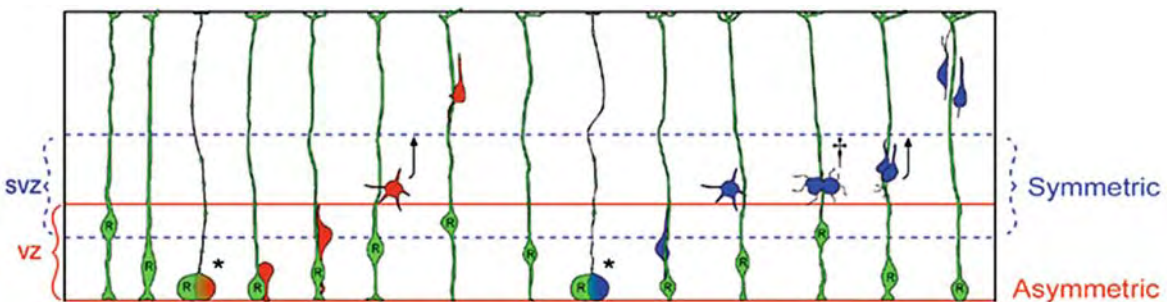

**Evolution and Embryological Development of the Cortex in Amniotes. Figure 1** A radial glial cell (green) in the ventricular zone (VZ) undergoes asymmetric division to produce two daughter cells of different fates (one radial glial cell plus one neuron (red), or one radial glial cell plus one intermediate progenitor cell (blue)). The intermediate progenitor cells then undergo symmetric division in the subventricular zone (SVZ) which produces either two neurons or two intermediate progenitor cells to replenish the cell pool. Reproduced with permission from ref. [5].

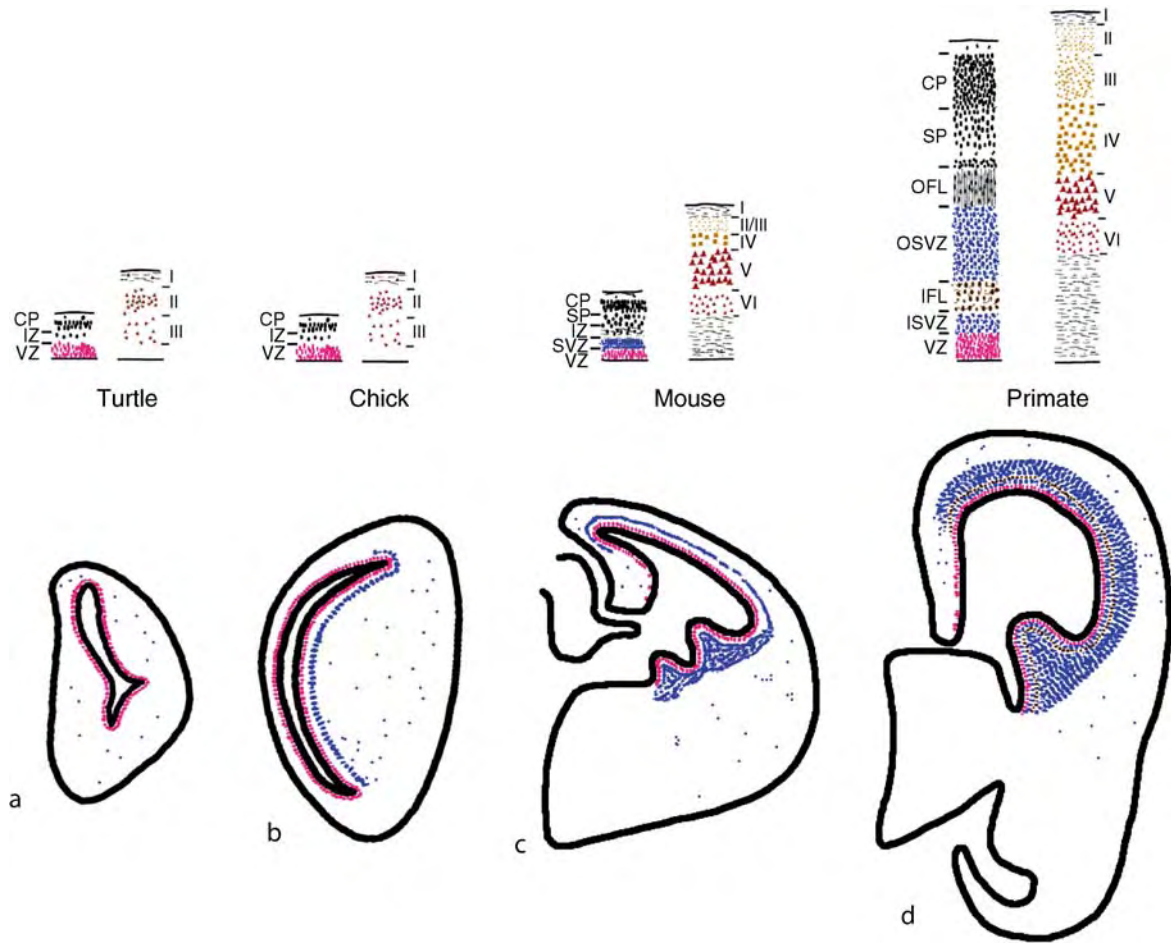

**Evolution and Embryological Development of the Cortex in Amniotes. Figure 2** In turtle (a), cell division occurs at the VZ (red) and in abventricular cells (blue), but an organized SVZ is absent. In chick (b), an organized SVZ is absent from the dorsal cortex (hyperpallium), shown here, but present in ventral pallial regions (DVR). In mouse (c) and primate (d), an SVZ is present in the dorsal cortex and in the ganglionic eminences. Upper panel demonstrates a correlation between the size of the SVZ and the increase in supragranular layer complexity in the adult cortex. In turtle and chick, the absence of an SVZ (upper panel a, b: left column) corresponds to an absence of supragranular layers in the adult (right column). In primate, the SVZ is much larger than in mouse (upper panel c, d: left column) and the supragranular layers are larger and more complex (right column). The compartmentalization of germinal zone might have increased the pool of neural progenitors and prolonged the period of neurogenesis during vertebrate evolution. Figure is reproduced with permission from ref. 4 using the data from refs. [3,17,21].

### Elaboration of Mitotic Compartments in the Primate Brains

The rodent-monkey (possibly lissencephalic-gyrencephalic) differences in the post-mitotic compartments are accompanied by major differences in the dimensions, configurations and developmental timing of the germinal zones. In rodents with small, lissencephalic brains, the VZ remains the major proliferative zone well past mid-corticogenesis [21] and the SVZ accounts for no more than 35% of the cortical proliferative population at E15 [25]. Accordingly, the supragranular layers occupy no more than a third of the thickness of the mature cortex (Fig. 3). In monkeys

with larger, gyrencephalic brains, SVZ cells are found at a relatively earlier stage in corticogenesis and show a much greater expansion compared to the rodent, so that by mid-corticogenesis the SVZ has become the predominant germinal zone [21]. This coincides with the predominance of supragranular layers in the mature, gyrencephalic primate cortex.

The primate SVZ also differs structurally from that of small sized rodents. From E65 onwards, a specialized component of the SVZ, the outer (O) SVZ emerges [21]. Histologically the OSVZ has very different features from the randomly organized cells that are typical of the SVZ described in rodents and the early pre-E65

SVZ in the monkey. The dense, radially orientated precursors of the OSVZ constitute a unique primate feature and birth-dating experiments show that the OSVZ generates the supragranular layers of the cortex [7]. The predominance of OSVZ in primates could be due to the increased importance of the cortico-cortical connections and therefore the supragranular layers in this order. It is possible that different micro-environmental cues in the SVZ compared to the VZ are responsible for creating certain neuronal subtypes. It is also possible that further compartmentalization of SVZ in primates is a correlate of higher neuronal diversity of supragranular layers. The contribution of the SVZ in neuronal production appears to grow in evolution as the complexity of the cortex increases (Fig. 3). The emergence of an additional proliferative zone and its diversification during cortical evolution might have been triggered by the necessity to produce more neuronal subtypes in different morphological compartments.

There are numerous unanswered questions concerning the embryonic compartments of the developing monkey cortex. For instance, the identity of the inner fiber layer that separates the inner (I) SVZ from the OSVZ is unknown. Smart et al. [21] showed that the outer fiber layer (OFL) houses the fibers from the lateral geniculate nucleus. Thus thalamic fibers may be much more closely connected to the germinal zone in monkeys compared to rodents and carnivores, intimating that the ascending pathways influence rates of proliferation in the cortex and ultimately contribute to establishing distinct proliferative programs in the germinal zone and distinct cortical cytoarchitecture in adults [7,27]. It is currently not clear whether the compartmentalization of the germinal zone mentioned above is a primate characteristic or similar partitioning occurs in the development of other gyrencephalic brains [17].

The expression pattern of transcription factors in the more elaborate primate germinal zone has not been studied in detail during embryonic development. It is conceivable that the new compartments enable novel combinatorial effects of the same transcription factors producing more variety of cell types. In rodent and primate, there also seem to be great differences in the proportion of GABAergic neurons generated locally in the pallium and the striatum/subpallium (lateral and medial ganglionic eminences). In human, gene expression evidence suggests that a substantial fraction (65%) of cortical interneurons are generated by the pallium whereas in rodents this estimate is only 5%, the rest having a subpallial origin [26].

### Presumed Role of the SVZ in Laminar and Tangential Expansion of the Cortex

The laminar expansion of the cortex that occurred in the common ancestor of all mammals and the tangential

expansion of the cortex that has occurred within several mammalian orders each required increased neuron production during embryonic neurogenesis. The two-step pattern of neurogenesis in the SVZ could have increased the rate and duration of neurogenesis, and recent studies provide evidence for a role of the SVZ in the laminar and tangential expansion of the cortex [6,20].

As mentioned earlier, the appearance of the cortical SVZ correlates with the appearance of upper layer pyramidal neurons. Additionally, progenitor cells of the SVZ play a direct role in generating upper cortical layers in mammals. Tarabykin et al. [28] linked SVZ progenitors to upper layer neurons because the expression of the gene *Svet1* was restricted to both sets of cells, and reduced expression of *Svet1* in the SVZ corresponded to the absence of upper layer pyramidal neurons in *Pax6* mutant mice. Since this proposal, time-lapse photography of GFP-labeled progenitor cells in cultured brain slices [5,6], and direct *in vivo* labeling of SVZ cells [29] have confirmed that SVZ cells are neurogenic and generate upper layer pyramidal neurons (Fig. 1). Taken together, these observations strongly suggest the appearance of the SVZ was integral to laminar expansion of the cortex.

The evidence for a contribution of the SVZ to the tangential expansion of the cortex is based on comparative studies. Martínez-Cerdeño et al. [20] compared progenitor cells in rats which have a smooth lissencephalic cortex and ferrets which have a folded gyrencephalic cortex. In ferrets, the proportion of total cell divisions that occur in the SVZ is higher and remains at peak levels for a longer duration than in rats. These data suggest that the increased proportion and duration of SVZ divisions could relate to the tangential expansion of the ferret cortex. Meanwhile, in the monkey, the SVZ has expanded to include the OSVZ which becomes the major proliferative component during development, and the primate cortex is disproportionately expanded compared with other mammals [21]. Thus comparative studies intimate a role for SVZ regulation in the tangential expansion of the cortex [2].

### Molecular Mechanisms of SVZ Regulation

Neurogenesis in the SVZ may have been involved with the formation and tangential expansion of the six layered neocortex in mammals. Thus the molecular mechanisms regulating SVZ formation may have played a major role in the diversification of the amniote telencephalon. However, the molecular mechanisms regulating SVZ formation are only beginning to be elucidated.

Descriptive studies demonstrate that progenitor cells in the cortical SVZ express several transcription factors that are absent or much less abundant in VZ progenitors. *Tbr2*, *Ngn2*, and *Svet1* are expressed early as progenitor cells approach the SVZ [6,28] followed by *NeuroD* and

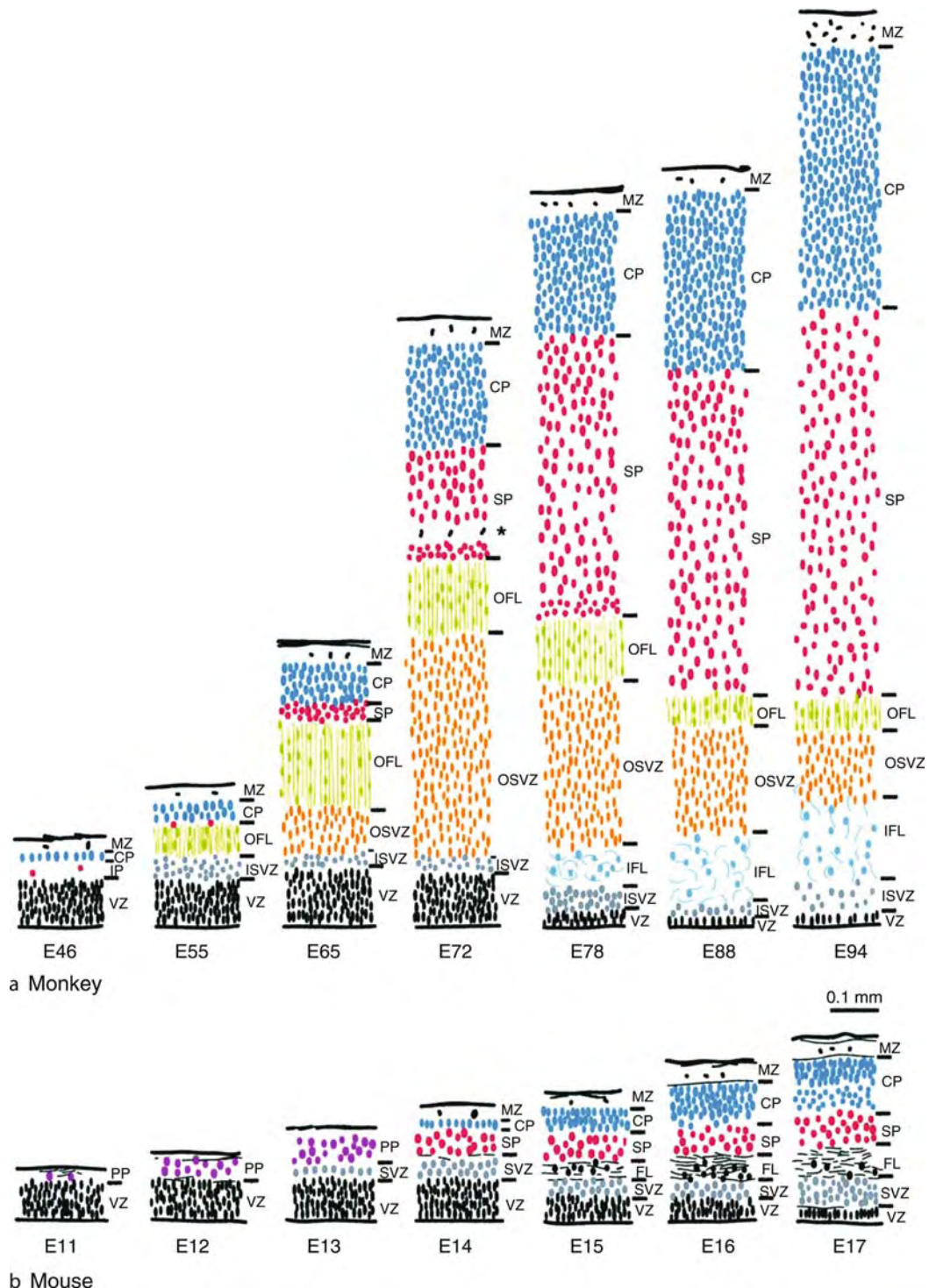

**Evolution and Embryological Development of the Cortex in Amniotes.** **Figure 3** Comparison of histological sequences in the developing mouse and monkey telencephalic wall. These drawings are of transects through putative area 17 in (a) monkey and (b) mouse at comparable developmental stages. The depth of each layer is drawn to a common scale. The internal detail of each layer is not to scale but depicts the orientation, shape and relative packing density of nuclei in each layer. The vertically aligned pairs have been chosen with reference to birthdating experiments so as to illustrate corticogenesis at equivalent developmental stages. Abbreviations: *CP* cortical plate; *IFL* inner fiber layer; *ISVZ* inner subventricular zone; *MZ* marginal zone; *OFL* outer fiber layer; *OSVZ* outer subventricular zone; *SP* subplate proper; *VZ* ventricular zone. Reproduced with permission from ref. [24].

other markers such as *Slc17a6* and *Cutl2* [30–32; Fig. 4] As a group, these transcription factors may be involved in the decision of SVZ cells to halt interkinetic nuclear migration, to divide symmetrically, and to differentiate into upper layer excitatory neurons. Miyata et al. [4] further observe that SVZ progenitor cells lose their apical contact with the ventricular surface prior to division in the SVZ.

Several functional studies have further explored factors influencing SVZ cell fate. Radial glia infected with a retrovirus containing the proneural gene *Ngn2* were more likely to produce SVZ progenitors than radial glia infected with a control virus [6]. Interestingly, *Ngn2* knockout mice, and double knockouts with *Ngn1* do not appear to have a reciprocal phenotype of a reduction in SVZ progenitors, but a null mutation in *Pax6* does reduce the SVZ progenitor population [33]. Future studies may reveal factors downstream of *Ngn2* and *Pax6* that induce cell division in the SVZ.

Magdalena Götz's lab has explored whether the basal and apical processes of radial glia are involved in SVZ formation. The basal process of radial glia contacts the pial surface. In three mutant strains of mice with defects in basal processes of radial glia, the proportion of VZ and SVZ progenitors remained normal and abnormalities only appeared later in the migration of neurons to the cortical plate [34].

However, apical processes appear important for normal SVZ regulation. Apical processes of radial glia form adherens junctions with the ventricle surface. Götz's lab genetically impaired adherens junction formation by creating a conditional knockout in the dorsal telencephalon for the rho-GTPase *cdc42*, an enzyme that indirectly regulates adherens junctions

with the ventricle surface. Adherens junctions deteriorated more quickly in the absence of *cdc42*, and overall, the number of SVZ cells, and the number of neurons produced increased [31]. The authors speculate that the loss of the apical process of radial glia affects interkinetic migration by reducing the pulling force of cells back to the ventricle and thereby freeing cells to divide in the SVZ. Interestingly, the expression of SVZ specific transcription factors including *Tbr2*, *NeuroD*, *Svet1* and others increased dramatically in the absence of *cdc42*, suggesting that cells were able to switch to an SVZ-like fate. Thus molecular pathways and cellular events are now being identified that influence SVZ formation, but many questions remain.

### Conclusion

The recent comparative studies on cortical development are beginning to provide insight into the events that enabled the expansion of the mammalian cerebral cortex. These data suggest that the regulation of the SVZ formation might have been a key factor in the increased neuronal production, contributing to the supragranular layers and to increased cortical surface areas. The key current questions include understanding the cellular and molecular mechanisms molecular mechanism regulating SVZ formation in different vertebrates. The understanding of this basic developmental process may provide clues about the genetic changes that have restructured the mammalian telencephalon and enlarged the primate neocortex.

### References

1. Butler AB, Hodos W (2005) Comparative vertebrate neuroanatomy, 2nd edn. Wiley, USA
2. Kriegstein AR, Noctor S, Martínez-Cerdeño V (2006) Patterns of neural stem and progenitor cell division may underlie evolutionary cortical expansion. *Nat Rev Neurosci* 7(11):883–890
3. Molnár Z, Tavaré A, Cheung AF (2006) The origin of neocortex: lessons from comparative embryology. Evolution of nervous system, vol 3. In: Krubitzer LA, Kaas JH (eds) The evolution of nervous systems in mammals, vol 4. Elsevier, UK, pp 13–26
4. Cheung AF, Pollen AA, Tavaré A, DeProto J, Molnár Z (2007) Comparative aspects of cortical neurogenesis in vertebrates. *J Anat* 211(2):164–176
5. Noctor SC, Martínez-Cerdeño V, Ivic L, Kriegstein AR (2004) Cortical neurons arise in symmetric and asymmetric division zones and migrate through specific phases. *Nat Neurosci* 7(2):136–144
6. Miyata T, Kawaguchi A, Saito K, Kawano M, Muto T, Ogawa M (2004) Asymmetric production of surface-dividing and non-surface-dividing cortical progenitor cells. *Development* 131(13):3133–3145
7. Lukaszewicz A, Savatier P, Cortay V, Giroud P, Huisoud C, Berland M, Kennedy H, Dehay C (2005) G1 phase regulation, area-specific cell cycle control, and cytoarchitectonics in the primate cortex. *Neuron* 47(3):353–364

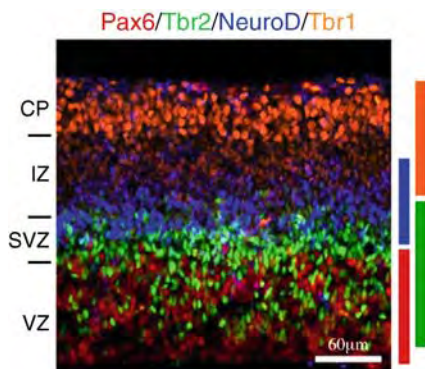

**Evolution and Embryological Development of the Cortex in Amniotes. Figure 4** Zonal expression of transcription factors Pax6 (red), Tbr2 (green), NeuroD (blue) and Tbr1 (orange) in embryonic murine cortex. By elucidating the sequential expression of fate-determining factors, we will be able to understand the specification of different projection neurons. Reproduced with permission from ref. [30].

8. Medina L, Reiner A (2000) Do birds possess homologues of mammalian primary visual, somatosensory and motor cortices? *Trends Neurosci* 23(1):1–12
9. Reiner A, Yamamoto K, Karten HJ (2005) Organization and evolution of the avian forebrain. *Anat Rec A Discov Mol Cell Evol Biol* 287:1080–1102
10. Striedter GF (1997) The telencephalon of tetrapods in evolution. *Brain Behav Evol* 49:179–213
11. Puelles L, Kuwana E, Puelles E, Bulfone A, Shimamura K, Keleher J, Smiga S, Rubenstein JL (2000) Pallial and subpallial derivatives in the embryonic chick and mouse telencephalon, traced by the expression of the genes *Dlx-2*, *Emx-1*, *Nkx-2.1*, *Pax-6*, and *Tbr-1*. *J Comp Neurol* 424(3):409–438
12. Molnár Z, Butler AB (2002) The corticostriatal junction: a crucial region for forebrain development and evolution. *Bioessays* 24(6):530–541
13. Karten HJ (1969) The organization of the avian telencephalon and some speculations on the phylogeny of the amniote telencephalon. In: Noback CR, Petras JM (eds) *Comparative and evolutionary aspects of vertebrate central nervous system*, vol 167. *Annals of the New York Academy of Sciences*, New York, pp 146–179
14. Karten HJ (1997) Evolutionary developmental biology meets the brain: the origins of mammalian cortex. *Proc Natl Acad Sci USA* 94:2800–2804
15. Anderson SA, Qiu M, Bulfone A, Eisenstat DD, Meneses J, Pedersen R, Rubenstein JL (1997) Mutations of the homeobox genes *Dlx-1* and *Dlx-2* disrupt the striatal subventricular zone and differentiation of late born striatal neurons. *Neuron* 19(1):27–37
16. Cobos I, Puelles L, Martínez S (2001) The avian telencephalic subpallium originates inhibitory neurons that invade tangentially the pallium (dorsal ventricular ridge and cortical areas). *Dev Biol* 239(1):30–45
17. Molnár Z, Metin C, Stoykova A, Tarabykin V, Price DJ, Francis F, Meyer G, Dehay C, Kennedy H (2006) Comparative aspects of cerebral cortical development. *Eur J Neurosci* 23(4):921–934
18. Rockel AJ, Hiorns RW, Powell TP (1980) The basic uniformity in structure of the neocortex. *Brain* 103:221–244
19. Sturrock RR, Smart IH (1980) A morphological study of the mouse subependymal layer from embryonic life to old age. *J Anat* 130(Pt 2):391–415
20. Martínez-Cerdeño V, Noctor SC, Kriegstein AR (2006) The role of intermediate progenitor cells in the evolutionary expansion of the cerebral cortex. *Cereb Cortex* 16 Suppl 1:i152–161
21. Smart IH, Dehay C, Giroud P, Berland M, Kennedy H (2002) Unique morphological features of the proliferative zones and postmitotic compartments of the neural epithelium giving rise to striate and extrastriate cortex in the monkey. *Cereb Cortex* 12(1):37–53
22. Striedter GF, Keefer BP (2000) Cell migration and aggregation in the developing telencephalon: pulse-labeling chick embryos with bromodeoxyuridine. *J Neurosci* 20(21):8021–8030
23. Bulfone A, Martínez S, Marigo V, Campanella M, Basile A, Quaderi N, Gattuso C, Rubenstein JL, Ballabio A (1999) Expression pattern of the *Tbr2* (Eomesodermin) gene during mouse and chick brain development. *Mech Dev* 84:133–138
24. Frowein J, Campbell K, Götz M (2002) Expression of *Ngn1*, *Ngn2*, *Cash1*, *Gsh2* and *Sfrp1* in the developing chick telencephalon. *Mech Dev* 110:249–252
25. Takahashi T, Nowakowski RS, Caviness VS Jr (1995) Early ontogeny of the secondary proliferative population of the embryonic murine cerebral wall. *J Neurosci* 15(9):6058–6068
26. Letinic K, Zoncu R, Rakic P (2002) Origin of GABAergic neurons in the human neocortex. *Nature* 417:645–649
27. Dehay C, Savatier P, Cortay V, Kennedy H (2001) Cell-cycle kinetics of neocortical precursors are influenced by embryonic thalamic axons. *J Neurosci* 21(1):201–214
28. Tarabykin V, Stoykova A, Usman N, Gruss P (2001) Cortical upper layer neurons derive from the subventricular zone as indicated by *Svet1* gene expression. *Development* 28(11):1983–1993
29. Wu SX, Goebbels S, Nakamura K, Nakamura K, Kometani K, Minato N, Kaneko T, Nave KA, Tamamaki N (2005) Pyramidal neurons of upper cortical layers generated by NEX-positive progenitor cells in the subventricular zone. *Proc Natl Acad Sci USA* 102(47):17172–17177
30. Hevner RF, Hodge RD, Daza RA, Englund C (2006) Transcription factors in glutamatergic neurogenesis: conserved programs in neocortex, cerebellum, and adult hippocampus. *Neurosci Res* 55(3):223–233
31. Cappello S, Attardo A, Wu X, Iwasato T, Itoharu S, Wilsch-Brauninger M, Eilken HM, Rieger MA, Schroeder TT, Huttner WB, Brakebusch C, Götz M (2006) The Rho-GTPase *cdc42* regulates neural progenitor fate at the apical surface. *Nat Neurosci* 9:1099–1107
32. Guillemot F, Molnár Z, Tarabykin V, Stoykova A (2006) Molecular mechanisms of cortical differentiation. *Eur J Neurosci* 23:857–868
33. Schuurmans C, Armant O, Nieto M, Stenman JM, Britz O, Klenin N, Brown C, Langevin LM, Seibt J, Tang H, Cunningham JM, Dyck R, Walsh C, Campbell K, Polleux F, Guillemot F (2004) Sequential phases of cortical specification involve Neurogenin-dependent and -independent pathways. *EMBO* 23:2892–2902
34. Haubst N, Georges-Labouesse E, De Arcangelis A, Mayer U, Götz M (2006) Basement membrane attachment is dispensable for radial glial cell fate and for proliferation, but affects positioning of neuronal subtypes. *Development* 133:3245–3254

---

## Evolution and Embryological Development of Forebrain

LORETA MEDINA

Department of Experimental Medicine,  
Faculty of Medicine, University of Lleida, Institut of  
Biomedical Research of Lleida (IRBLLEIDA), Lleida,  
Catalonia, Spain

### Synonyms

Prosencephalon (synonym of forebrain)

## Definition

Series of molecular, cellular and morphological gradual changes that take place in the anterior or rostral part of the neural tube during the course of embryonic development and in evolution, that lead to the morphological and functional complexity and diversity found in the forebrain of vertebrates.

## Characteristics

### The Forebrain: A Region Supporting Sophisticated Behaviors in Different Vertebrates

The forebrain is the most rostral and complex part of the brain and, in all vertebrates, includes the thalamus, the hypothalamus and the ▶telencephalon [1,2] (Fig. 1).

This part of the brain plays a key role in the control of motivated behavior (from motor control to decision-making) and the modulation of instinctive reflex-like behavior (ingestion, reproduction, defense) in response to external or internal stimuli. It is also the brain region responsible of our conscious thoughts, memories, learning capabilities, emotion, and social behavior, and it is the region that makes us unique as humans and confers each person individual attributes and capabilities. In spite of this, the basic subdivisions of the forebrain and many aspects of their organization are quite conserved in vertebrates. Moreover, from fish to mammals, the forebrain contains comparable centers that are apparently involved in similar basic aspects of behavior. For example, in most vertebrate groups the basal part of the telencephalon (or subpallium) includes a center called “basal ganglia” that shows similar neurochemical features, cell types and basic

connections, and appears to be involved in similar functions such as motor control, motivation and reward [3].

However, not everything is similar in the forebrain of different vertebrates, which reflects the existence of divergent evolution in the different lineages [2,3]. Divergent evolution of the forebrain has resulted in an increase in size and complexity of specific centers and their projections, and in the appearance of highly sophisticated behaviors in some vertebrate lineages, such as mammals or birds. For example, the telencephalon has independently evolved or elaborated centers and pathways related to song/vocalization learning and production in songbirds or parrots, or to language in humans.

What make us different from other vertebrates, or what differs between a zebrafish, a frog and a mouse, or between an owl, a chick and a parrot? It appears that, while the basic forebrain subdivisions are rather constant across vertebrates (but see below), different vertebrates differ in the degree of elaboration/complexity of these subdivisions. Each vertebrate group (or each species within a group) is characterized by elaboration of specific subdivisions and/or by differing degrees of elaboration of these subdivisions. For example, birds, reptiles and mammals show an important or extremely important development and elaboration of the telencephalic pallium (cortical region), but while mammals are characterized by the greatest development of the dorsal pallium (giving rise to the neocortex), birds and reptiles have primarily developed the ventrolateral pallium (producing a prominent pallial center called “dorsal ventricular ridge” or DVR). Among birds, owls

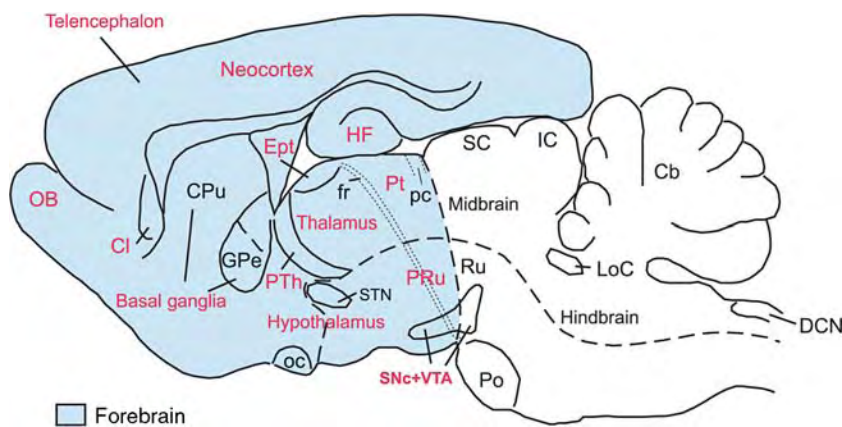

**Evolution and Embryological Development of Forebrain. Figure 1** Lateral schematic view of a rodent brain, showing the major regions and cell groups of the forebrain. Abbreviations: *Cb* cerebellum; *Cl* claustrum; *CPu* caudoputamen complex (dorsal striatum); *DCN* dorsal column nuclei; *Ept* epithalamus; *fr* fasciculus retroflexus; *GPe* globus pallidus, external or lateral part (dorsal pallidum); *IC* inferior colliculus; *LoC* locus coeruleus; *OB* olfactory bulb; *oc* optic chiasm; *pc* posterior commissure; *Pt* pretectum; *Po* pontine nuclei; *PRu* prerubral area; *PTh* prethalamus (ventral thalamus); *Ru* nucleus ruber (red nucleus); *SC* superior colliculus; *SNc* substantia nigra pars compacta (A9 dopaminergic cell group); *STN* subthalamic nucleus; *VTA* ventral tegmental area (A10 dopaminergic cell group).

are characterized not only by a great elaboration of the ventrolateral pallium but also by an important development of the dorsal pallium [2,3].

What produced either the conservation or divergence of forebrain regions and pathways in evolution? It is now clear that divergent evolution is the consequence of changes in developmental mechanisms. Non-lethal modifications in developmental mechanisms produce phenotypic variations that are then exposed to natural selection; but what developmental mechanisms produce forebrain complexity and how have these changed in evolution? These fundamental questions need to be answered in order to achieve a complete understanding of the forebrain. Although the questions are still far from being answered, below we consider some clues based on recent genetic and experimental evidence.

### Similar Mechanisms of Neural Induction and Formation of the Anterior Neural Plate in Vertebrates

In all vertebrates, the forebrain develops from the anterior part of the neural plate during gastrulation [4,5] (Fig. 2). The mechanisms responsible of its formation and subsequent patterning are highly conserved in evolution and result in the production of similar forebrain subdivisions/compartments along the rostro-caudal and dorsoventral axis (explained below).

It appears that a prospective neural plate is initially induced by FGF (fibroblastic growth factor) signals released from the ►node (a primary ►organizer), and its neural character is subsequently established by antagonists of BMP signaling that inhibit the formation of non-neural ectoderm [5,6]. This early neural plate is anterior in character and is going to become the forebrain. As the node regresses, caudal regions of the plate are formed (midbrain, hindbrain, spinal cord) due to exposure to caudalizing signals. The initial anteroposterior (AP) partition of the neural plate is rather crude, but it is subsequently refined due to later signals (as explained below).

### From Bidimensional Molecular Compartments in the Neuroepithelium to Tridimensional Radial Units in the Brain

The anterior neural plate is initially a simple sheet of neuroepithelium, but through different steps is going to become the most complex part of the brain. As a consequence of its highly complex morphogenesis, it is not easy to identify the basic units/subdivisions in the mature forebrain or to understand the topological relationships between units. This leads to serious difficulties in the comparison of basic forebrain units or cell groups in different vertebrates and greatly complicates forebrain evolution studies. As noted below, developmental studies are extremely important for unraveling forebrain organization and constitute a great support for comparative and evolution studies.

Recent molecular/genetic specification data together with fate-map experimental analysis in different vertebrates have indicated that divisions and subdivisions of the brain and, in particular, the forebrain, start to appear at neural plate stage, before they become morphologically visible [4]. Molecular specification data are based on the restricted, combinatorial expression and action of ►developmental regulatory genes (key or master control genes, encoding transcription factors or ►signaling proteins) that regulate important aspects of development. These data indicate the existence of distinct molecular domains at neural plate stages, and fate-map analysis indicates that each of these molecular domains correlates well with a specific fate (region/cell population) in the adult brain.

Each molecular subdivision of the neural plate/tube is thus characterized by the expression of a specific combination of developmental regulatory genes, and -by the action of these genes- is going to produce a specific set of brain derivatives. Therefore, each subdivision represents a true morphogenetic field or compartment. Based on genetic and embryological evidence, these are considered basic units of development, linking genotype to phenotype [7]. Since ►morphogenetic compartments are able to change independently of the surrounding fields, they also represent basic units of evolution.

Under the action of different combinations of regulatory genes, the neural plate (and later the tube) is going to become simultaneously subdivided into several dorsoventral (DV), longitudinal subdivisions and into a series of rostrocaudal (or anteroposterior; AP) subdivisions (Figs. 2 and 3).

This process is explained in detail below. Initially, the compartments are established at the neuroepithelial level and affect the proliferative neural cells. At the neuroepithelial level, each compartment shows clonal restriction. Following proliferation, most immature neurons born in each neuroepithelial compartment migrate into the mantle following primarily radial glial fibers (although examples of tangential cell migration are described in some regions, as explained below). Neuroepithelial compartments, initially established in a bidimensional coordinate system, are thus transformed into tridimensional radial units of the brain (Fig. 3).

Each molecular subdivision/compartment and derived radial unit occupies a specific position within the DV and AP brain axes (►topological position), which remains invariable independent of subsequent deformations due to differential growth of neighbor units (Fig. 3). The expression patterns of orthologous regulatory genes in the neural plate/tube are highly conserved throughout vertebrate phylogeny (with a few exceptions noted below), and so are the brain subdivisions/units and their molecular profile [4,7–9]. This facilitates one-to-one comparison of the molecular brain subdivisions/units



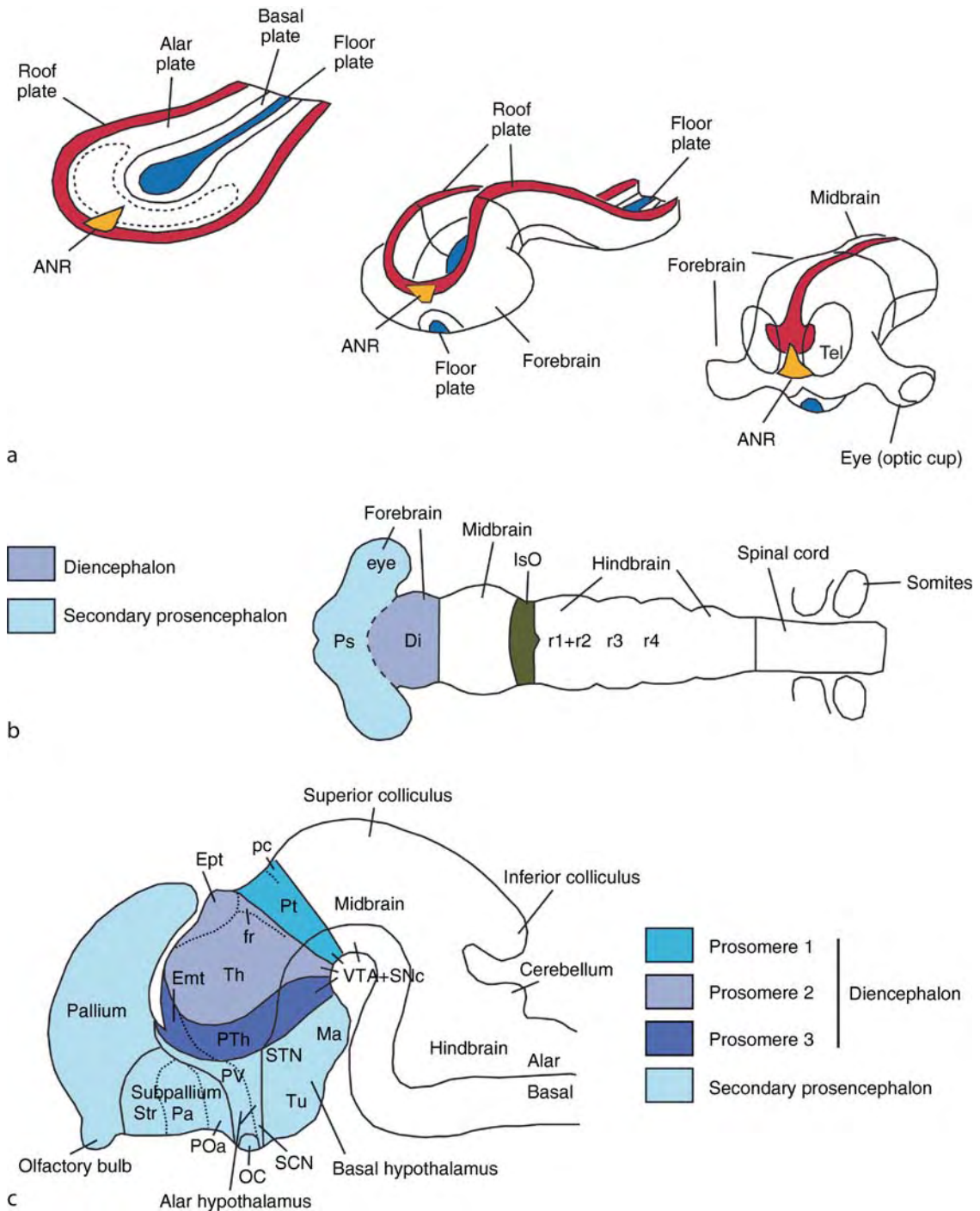

**Evolution and Embryological Development of Forebrain. Figure 2** (a) Schemes showing the anterior neural plate and some of the gradual changes that occur during neurulation and later, which lead to the formation of the early forebrain vesicle (modified from [4]). (b) Dorsal schematic view of the early developing brain, showing the two major divisions of the forebrain: the diencephalon proper (Di; caudally), and the secondary prosencephalon (ps; rostrally). Both the eye and telencephalic vesicles are paired evaginations from the secondary prosencephalon. (c) Lateral schematic view of a rodent brain during mid-embryonic development, showing the major divisions and subdivisions of the forebrain. Note that the diencephalon proper is subdivided into three major transverse segments, called prosomeres 1, 2 and 3. The dorsal (alar) parts of prosomeres 2 and 3 give rise to the thalamus and prethalamus, respectively. In contrast, the hypothalamus develops from the secondary prosencephalon (i.e., rostral to the diencephalon proper). Since the longitudinal axis is highly bended in the forebrain, the hypothalamus appears located

across vertebrates. Subdivisions/units with identical position and molecular profile in different vertebrate groups, if traced back to a common ancestor (using cladistic analysis), are considered field ►homologues [7]. Given that molecular brain subdivisions are the basic units of development and evolution, any homology consideration of specific cell groups should start by analyzing whether the neurons under study originate in the same molecular compartment or, in the adult, are located in the same radial unit. However, although less likely, the latter may have changed in evolution due to tangential migration. In that case, the embryological origin is a prevalent criterion for homology consideration.

### Formation and General Disposition of Major Forebrain Regions

During the course of development, the neural plate folds up and fuses dorsally forming the neural tube (a process called neurulation) (Figs. 3 and 4).

As a consequence, the lateral part of the neural plate is going to become dorsal, whereas the medial part of the neural plate becomes ventral in the neural tube. Shortly after neural tube closure, the anterior part of the neural tube starts to show three primary vesicles, forebrain, midbrain and hindbrain, which become morphologically visible due to differential growth; the forebrain constitutes the rostralmost of them (Fig. 2). The forebrain becomes later subdivided into the ►diencephalon proper (caudally) and the ►secondary prosencephalon (rostrally) (Fig. 2). Regardless the observation of a clear “forebrain vesicle” as defined by classical embryologists (this is clear in amniotes, but less so in fish), from a molecular point of view, the forebrain is the domain of the anterior neural plate/tube showing expression of Pax6 in the alar territory, a situation that is highly conserved in all vertebrates studied thus far, from the lamprey (a jawless fish) to the mouse [4,10].

Simultaneous to the appearance of the forebrain vesicle, the anterior neural plate/tube begins to subdivide through gradual steps into distinct longitudinal (DV) and transverse (AP) subdivisions, under the action of different regulatory signals and transcription factors (see below). Transverse and longitudinal subdivisions were initially

proposed in the forebrain based on classical embryological studies, but their existence has been unequivocally shown by modern genetic evidence and fate-map analysis [4,11]. All these data together have led to the proposal by Puelles and Rubenstein of a parcellation model for the forebrain, called the prosomeric model, according to which the forebrain of different vertebrates becomes subdivided during development into a comparable set of longitudinal and transverse subdivisions [reviewed in 4]. The same set of subdivisions has been observed in the forebrain of all vertebrates, from the lamprey to mouse and human, and subdivisions in different species with the same position and basic molecular features are considered field homologues [4]. Therefore, this parcellation model is not only very useful for understanding the anatomical and functional organization of the forebrain and its development, but also for studies of forebrain evolution. For example, by using the model one realizes that major fiber tracts usually follow trajectories parallel to boundaries between domains. Moreover, the model provides a framework for understanding gene expression patterns and the effects of null mutations of specific regulatory genes.

As in the rest of the neural tube, the major longitudinal (DV) subdivisions of the forebrain are the roof, alar, basal and floor plates (Fig. 2; see next section). Transverse domains or segments of the forebrain are the ►prosomeres (as initially called by Puelles, Rubenstein and colleagues in the prosomeric model). These are orthogonal to the longitudinal axis, which as explained below is highly bended in the forebrain [4] (Fig. 2). Each prosomere contains roof, alar, basal and floor subdivisions.

In the caudal forebrain, the diencephalon proper subdivides into three prosomeres, called prosomeres 1–3 [p1, p2, p3] from caudal to rostral (Fig. 2). The main derivatives of each subdivision are shown in Fig. 2. Briefly, the alar part of p1 includes the pretectum, the alar part of p2 includes the thalamus and epithalamus, whereas the alar part of p3 includes the prethalamus (previously called ventral thalamus) and the thalamic eminence. According to this model (supported by molecular and fate-map data), the thalamus and prethalamus are located caudal and rostral, respectively,

---

below the prethalamus, and the prethalamus below the thalamus. For this reason, in classical studies the hypothalamus is considered to represent the “ventral diencephalon,” the prethalamus is called the “ventral thalamus” and the thalamus is called “dorsal thalamus.” Developmental studies indicate that these conceptions are wrong. Instead, the prethalamus is located rostral to the thalamus, whereas the hypothalamus is rostral to the diencephalon proper. Abbreviations: *Emt* eminentia thalami; *Ept* epithalamus; *fr* fasciculus retroflexus; *Ma* mammillary hypothalamic region; *oc* optic chiasm; *Pa* pallidum; *pc* posterior commissure; *POa* anterior preoptic area; *Pt* pretectum; *PTH* prethalamus; *PV* paraventricular hypothalamic nucleus; *SCN* suprachiasmatic nucleus; *SNC* substantia nigra pars compacta (A9 dopaminergic cell group); *STN* subthalamic nucleus; *Str* striatum; *Th* thalamus; *Tu* tuberal hypothalamic region (it contains the ventromedial hypothalamic nucleus); *VTA* ventral tegmental area (A10 dopaminergic cell group).

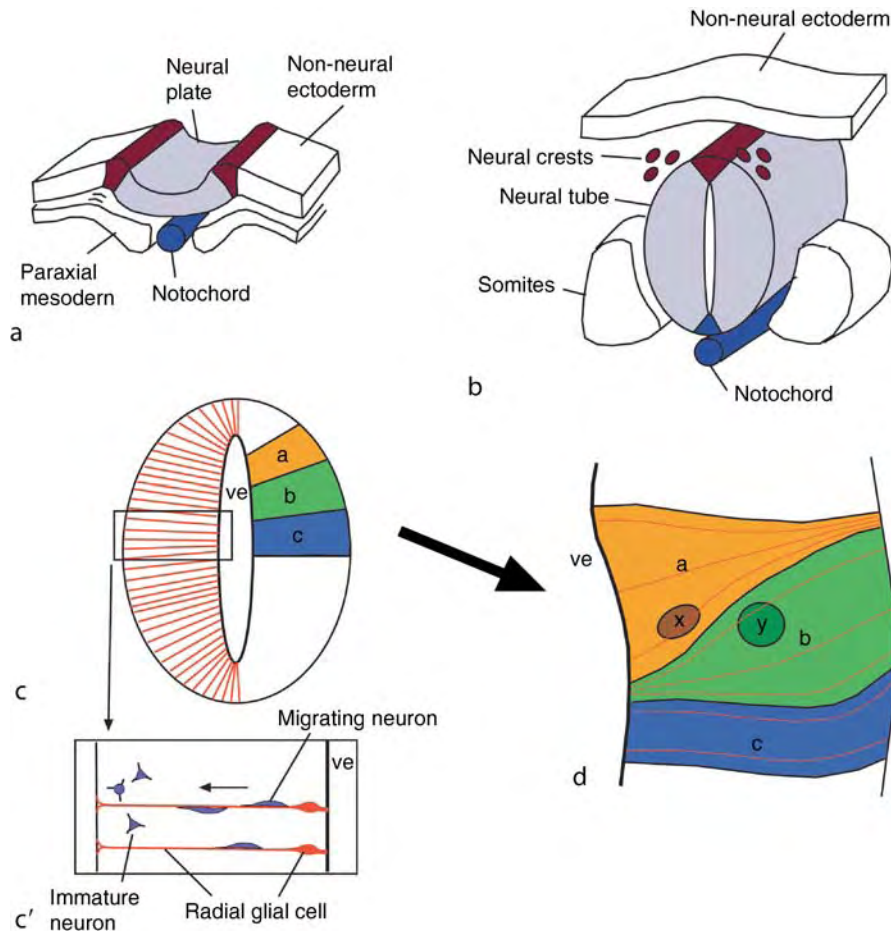

**Evolution and Embryological Development of Forebrain.** Figure 3 (a, b) Schemes showing the neural plate during the process of neurulation (a), and the neural tube after closure (b); (c, c', d) Formation of radial histogenetic domains. Morphogenetic compartments are initially established in the neuroepithelium along the anteroposterior (AP) and dorsoventral (DV) axis. Since cells produced in each compartment migrate into the mantle following primarily radial glial fibers (c, c'), the bidimensional compartments of the neuroepithelium are transformed into tridimensional radial units. The topological position of each unit (i.e. its relative position within the neural tube, and with respect to neighbour units) remains unvariable independent of deformations taking place during subsequent development (d). For example, if units a, b, and c (orange, green and blue in panel c) are initially located in dorsal, intermediate and ventral positions with respect to each other, this remains the same in the mature neural tube (panel d), and so do their derivatives (nucleus x is dorsal to nucleus y). In contrast, based only on topographic position, nucleus x is medial to nucleus y, providing a less accurate information on the real position of nuclei. Abbreviations: ve ventricle.

to the p2/p3 boundary (instead of dorsal and ventral, as classically considered). The roof plate also appears to produce specific cell groups at each rostrocaudal level, such as the subcommissural organ in p1, the pineal gland in p2 and choroid tissue in p3. The basal and floor plates of p1-p3 include several prerubral reticular groups and a major diencephalic part of the A9-A10 dopaminergic cell groups (i.e., a large part of the substantia nigra pars compacta and ventral tegmental area).

Rostral to the diencephalon proper is the secondary prosencephalon, giving rise to the hypothalamus ventrally, the eye vesicle dorsolaterally, and the telencephalon

dorsally (Fig. 2). It also produces the choroid tissue related to the lateral ventricles (in the telencephalon), which is a roof plate derivative, and the neurohypophysis, which derives from the floor plate. The hypothalamus includes alar and basal components, but the eye field and the telencephalon are exclusively derived from the alar region. The alar hypothalamus includes the supra-chiasmatic, supraoptic and paraventricular hypothalamic nuclei (among other nuclei). The basal hypothalamus includes the retrochiasmatic, ventromedial, and mammillary hypothalamic nuclei (among other). It also includes the subthalamic nucleus.

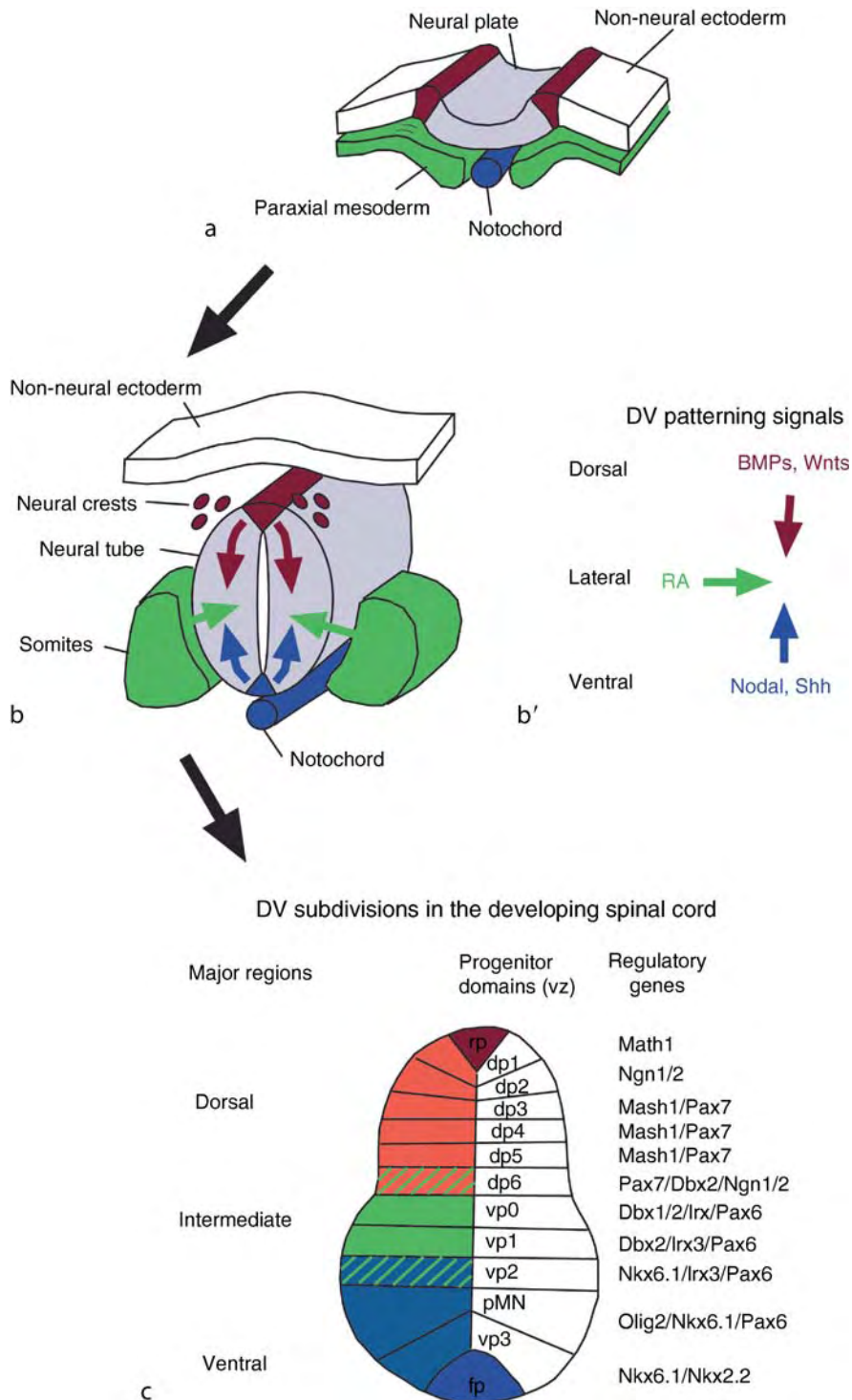

**Evolution and Embryological Development of Forebrain. Figure 4** Schemes representing the mechanisms of dorsoventral (DV) patterning and formation of compartments in the caudal neural tube. Patterning along the DV axis occurs by the confluence of ventral, dorsal and lateral signals (in the schemes, these are represented in blue, purple and green, respectively). Ventral signals initially originate in the ► notochord underlying the neural plate/tube and include nodal and Shh. Later, ventral signals of Shh also originate in the floor plate. Ventral signals induce the expression of specific transcription factors in the ventral tube, such as Nkx2.2 and Nkx6.1, which trigger the formation of specific ventral cell types (motoneurons or specific ventral interneurons). Dorsal signals (BMPs, Wnts) initially originate in the non-neural ectoderm and later also in the roof plate, and induce the expression of transcription

The telencephalon is located dorsal to the hypothalamus and includes two major subdivisions: pallium and subpallium (Fig. 2). The pallium gives rise to the cortical regions, olfactory bulb, claustrum and pallial amygdala in mammals, and to the cortical/pallial regions in non-mammals (including the dorsal ventricular ridge in birds and reptiles). In different vertebrates, the subpallium is going to produce the basal ganglia, the centromedial-extended amygdala, the cholinergic corticopetal cell groups of the basal telencephalon and most of the septum.

## DV Patterning

### Classical DV Subdivisions

Classically, the neural tube has been subdivided into four major longitudinal domains in all vertebrates: floor plate, basal plate, alar plate and roof plate (from ventral to dorsal; Fig. 4). In general, these major regions are morphologically distinct during development. For example, at caudal levels the roof and floor plates show negligible proliferation and include cells that will become glial. In contrast, the alar and basal plates show abundant proliferation and will produce numerous neuroblasts that, at caudal levels, will become either sensory or motor neurons, respectively [6]. Recent studies based on expression of developmental regulatory genes indicate that the classical DV subdivision of the neural tube is roughly true. For example, during development the roof plate is induced to express bone morphogenetic proteins (BMPs) and Wnts, most of the alar plate is generally characterized by expression of the transcription factor Pax7, an important part of the basal plate expresses Nkx (NK family) transcription factors, whereas the floor plate is induced to express Sonic hedgehog (Shh) (Fig. 4). Expression of regulatory genes also constitutes a great help for correctly identifying major DV subdivisions at forebrain levels, as explained in detail below [4].

However, genetic and experimental data indicate that the DV compartmentation of the neural tube is more complex than this, and it involves the confluence of different external signals that ultimately produce the formation of multiple compartments along the DV axis [6,12] (explained in the next section).

### Confluence of Dorsal, Lateral and Ventral Signals and Formation of Multiple Compartments

The initial stages of neural patterning are controlled by signaling proteins (morphogens) that are secreted from primary organizers (in the adjacent mesoderm or

non-neural ectoderm) and spread over variable distances across neural tissue [12]. Later, the signals are also produced locally from the roof and floor plates. These signals are going to induce, in the presence of specific receptors in the tissue, the expression of specific ►transcription factors in a concentration-dependent manner [6,12]. The induced transcription factors become the effectors for the specification and subsequent formation of specific neural domains. Induction also involves qualitative differences in the effects of distinct signaling proteins, as well as temporal changes in the response of the tissue. This process starts prior to neurulation and is remarkably similar in different vertebrates, from zebrafish to mouse [6,12]. It is also highly similar from caudal to rostral parts of the neural plate/tube.

The ventral signals initially originate from the ►notochord or the prechordal plate/rostral mesoderm (at rostral levels) underlying the neural plate, and later also in the ventral neural tube (floor plate and, at rostral levels, the basal plate), and include Sonic hedgehog (Shh) and Nodal [12] (Fig. 4). Dorsal signals originate in the non-neural ectoderm adjacent to the tube, and later also in the dorsal neural tube (roof plate) (Fig. 4), and include bone morphogenetic proteins (BMPs) and Wnt proteins (the latter are primarily involved in proliferation, but recent studies indicate that some Wnt proteins, such as Wnt1 or Wnt3a, also play a role in dorsal patterning, as recently reviewed by Victor Chizhikov and Kathleen Millen and also by Clifton Ragsdale and Elizabeth Grove) [6]. Lateral signals originate in the paraxial mesoderm (somites) or, at rostral levels, the ectoderm adjacent to the neural tube at early stages (including the olfactory placode, or mesenchymal cells inside it), and include retinoic acid (RA) [12] (Fig. 4). Ventral and lateral signals also include antagonists of BMP-mediated dorsal signals, such as noggin, chordin and follistatin. Shh induces the expression of Nkx transcription factors in the ventral tube, and is required for the ventral midline formation and for ventral neural fate specification. In the absence of Shh signals, spinal motoneurons and several ventral interneuron subtypes are not formed, and animals are born with cyclopia and holoprosencephaly (for example, in Shh-►knockout or null mutant mice, or in humans affected with a mutation disrupting Shh signaling) [12]. It appears that Shh acts by neutralizing the repressive form of Gli transcription factors (Gli3, which is promoted by BMPs), and by inducing the activating forms of Gli that mediate the subsequent

---

factors typical of the alar plate, such as Pax7. Lateral signals of retinoic acid (RA) originate in the paraxial mesoderm (somites), and induce the expression of Dbx1/2 and Iroquois 3 (Irx3) in an intermediate sector of the neural tube, thus triggering the formation of specific neurons in this position. Abbreviations: *dp1-dp6* dorsal progenitor domains 1 through 6; *pMN* motoneuron progenitor domain; *vp0-vp3* ventral progenitor domains 0 through 3.

molecular parcellation and specification of the ventral neural tube [12]. Once Gli3 is inactivated, the role of Shh for ventral specification is largely dispensable. Nodal acts upstream of Shh, and is responsible for the induction of Shh expression and specification of the most ventral part of the neural plate/tube [12]. Mutations disrupting Nodal signaling abolish Shh expression in the ventral neural tube and reproduce the phenotype of Shh null mutant. On the other hand, BMP dorsal signals promote expression of Pax7 and Msx1/2 in the dorsal region (among others), whereas RA lateral signals promote expression of Dbx1/2, Irx3 and Pax6 in an intermediate region in the caudal neural tube [6].

Thus, in general terms, the confluence of signals induces the formation of three major subdivisions located between the roof and floor plates, namely dorsal, intermediate and ventral regions, and these can be found from caudal to rostral regions of the neural tube [12]. However, more subdivisions are formed at caudal and rostral levels. For example, the concerted action of ventral, dorsal and lateral signals will ultimately produce the parcellation and specification of at least thirteen [13] distinct DV molecular sectors in the spinal cord, each characterized by a specific combination of transcription factors and producing a specific set of neurons [6,12] (Fig. 4).

As noted above, the molecular mechanisms for dorsoventral patterning are generally similar from caudal to rostral levels of the neural plate/tube (Fig. 5), and involve similar ventral, dorsal and lateral inductive signals from Shh/Nodal, BMP/Wnt and retinoid acid, respectively. However, although following a general rule, different transcription factors (sometimes different members of the same family) are induced along the rostrocaudal axis (Fig. 5), indicating intrinsic differences between rostral and caudal levels of the neuroepithelium and/or the existence of other signals acting on the rostrocaudal dimension (such as FGF8; see next section). In the forebrain, as in the caudal neural tube, signals from the roof plate (which include BMPs and Wnts) appear to be important for dorsal patterning and for the formation of roof specializations of the diencephalon and secondary prosencephalon (choroid plexus, pineal gland and subcommissural organ) (reviewed by Ragsdale and Grove, 2001; Chizhikov and Millen, 2005). In fish and mouse, these structures are not formed or are defective following diencephalic roof plate loss, or after abrogation of BMP or Wnt3a signaling in the telencephalon. In the diencephalon, this also produces downregulation of Pax6/7 in the adjacent alar plate. In the telencephalon, Wnt signals from the roof appear to be important for inducing Lhx2, Ngn2 and Pax6 in the adjacent dorsomedial pallium. Moreover, mice lacking Wnt3a (but not Wnt8b) have a near complete deletion of the

hippocampus. On the other hand, the basal forebrain expresses Nkx family transcription factors from rostral to caudal levels, which are induced by Shh ventral signals, resembling the situation at caudal levels [12]. Again, rostrocaudal differences in the expression of Nkx factors likely reflect the existence of additional signals acting on the AP dimension, as well as changes in the ventralizing signals along the AP axis (this is explained in more detail in a separate section).

In addition to dorsal and ventral signals, RA lateral signals appear to play a role in patterning an intermediate sector of the forebrain. In the telencephalon, RA signals induce the expression of Pax6 and Dlx transcription factors in the intermediate sector encompassing the ventral pallium and striatal subdivision (Dlx genes are induced in the striatal subdivision, whereas Pax6 is strongly induced in the ventrolateral pallium, with decreasing gradients towards the striatum and the dorsomedial pallium) [12]. As in the spinal cord, RA may also induce Dbx1 expression in the telencephalic ventral pallium. In the diencephalon, these signals may be important for induction of Pax6/7 in the alar plate (from the alar hypothalamus to the pretectum), Dlx in the prethalamus and part of alar hypothalamus, and Dbx1 in the thalamus and pretectum, although this needs to be investigated. The effect of different signals on telencephalic patterning will be explained in more detail in a separate section.

### **The Longitudinal Axis**

Analysis of molecular signals involved in DV patterning along the rostrocaudal axis, such as Shh, helps to understand the disposition of the longitudinal axis along the entire length of the neural tube (Fig. 5). This is particularly relevant in the forebrain, where the axis is extremely bended (specially in mammals and birds) obscuring the interpretation of anatomical data and the comparison across vertebrates. Mechanisms involved in DV patterning are highly similar across vertebrates, from fish to mammals [12], and so are the resulting DV brain domains. Therefore, the correct identification of the longitudinal axis and DV domains along the axis is extremely relevant for studying forebrain evolution and also for interpreting the action of patterning or other developmental regulatory genes. Due to the inclination of the longitudinal axis, the diencephalic vesicle (giving rise to the thalamus) is going to lie above the secondary prosencephalon (giving rise to the hypothalamus and telencephalon) (Fig. 5).

For this reason, classical studies have considered the thalamus as dorsal diencephalon and the hypothalamus as ventral diencephalon. This interpretation is now considered erroneous, and in the new scheme the diencephalon proper (including the thalamus) is caudal to the hypothalamus [4]. For this reason, and to keep partially with the classical terms, in some modern text

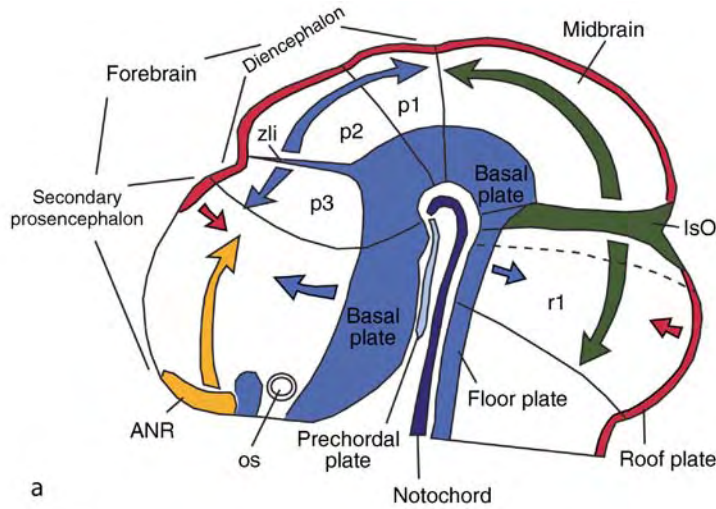

a

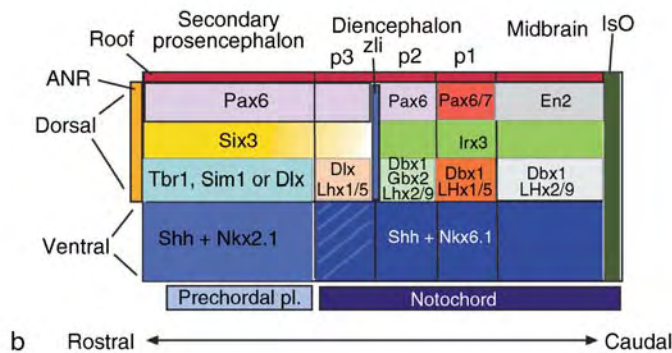

b

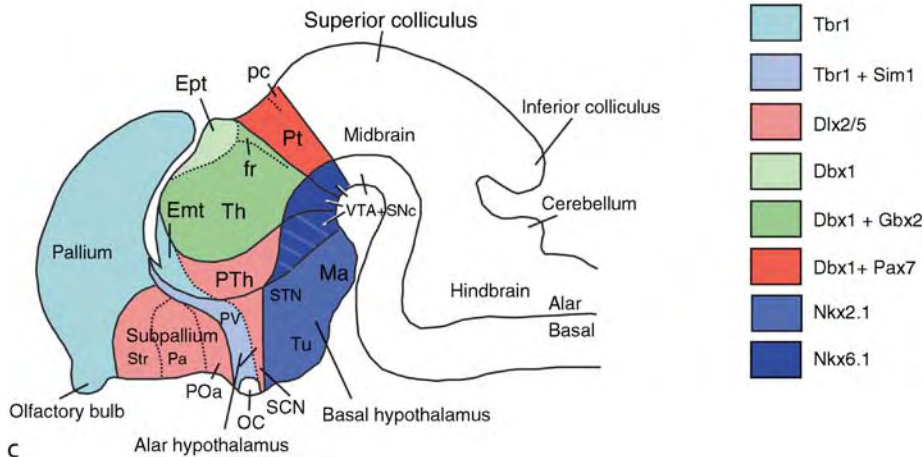

c

**Evolution and Embryological Development of Forebrain. Figure 5** (a) Lateral schematic view of the embryonic brain, representing some of the organizer centers and signals that operate for patterning the forebrain along the DV and AP axis. As at caudal levels, dorsal signals initially originate in the non-neural ectoderm and later in the roof plate, and include BMPs and Wnts (purple in the scheme). Ventral signals initially originate in the notochord (caudally) and prechordal plate (rostrally), and include Nodal and Shh. Nodal induces the expression of Shh in the ventral forebrain (first including both the floor and basal plate, but later only the basal plate), which becomes a secondary source of ventral signals (blue arrows in the scheme). Later, Shh signals extend dorsally in the zona limitans intrathalamica (*zli*), a secondary organizer center at the p2/p3 boundary, from which signals emanate caudally and rostrally. Rostral (anterior) signals originate in the anterior neural ridge or ANR and initially include Wnt antagonists (such as *Tlc*), which oppose to Wnts expressed in the caudal forebrain. These opposing gradients are going to induce the expression of *Irx3* caudally and *Six3* rostrally (see panel b). The boundary between *Irx3* and *Six3* expression domains

books or articles the hypothalamus is sometimes considered as the rostral diencephalon (although derived from the secondary prosencephalon and not from the diencephalic vesicle), whereas the thalamus is considered part of the caudal diencephalon. The disposition of forebrain subdivisions with respect to the AP axis is described in detail elsewhere in the text, and its patterning is explained in the following section.

### AP Patterning

From a molecular point of view, the forebrain parcellation along the AP axis occurs by two major factors: 1) the distinct action of prechordal plate versus notochord signals; 2) the action of signals derived from secondary organizers, such as the isthmic organizer (IsO), the zona limitans intrathalamica (zli) and the anterior neural ridge (ANR) [4,13] (Fig. 5).

It appears that signals derived from either the notochord or the prechordal plate are somewhat different and produce different effects on the expression of transcription factors in the overlying neural plate/tube. For example, it appears that Shh signals are primarily involved in patterning the caudal plate, whereas Nodal plays a dominant role in the anterior plate (recently reviewed by Marysia Placzek and James Briscoe). Interestingly, the transition from the notochord to the prechordal plate roughly coincides with a spike-like dorsal extension of basal molecular features, secondarily formed at the zona limitans intrathalamica (zli; the transverse boundary between thalamus and prethalamus) (Fig. 5). Actually, the zli is slightly caudal to the notochord-prechordal plate transition level, which is coincident with the boundary between p3 and the hypothalamus [4,11], as explained later in the text. The zli shows a core of Shh expression that is covered by a band (shell) of Nkx2.2 expression, which is typical of the basal plate [4,13]. Curiously, at this same position the dorsal signals typical of the diencephalic roof plate (such as Wnt1) show an opposed, although smaller ventral spike [4,13]. Thus, the zli constitutes a secondary organizer center from which signals emanate caudalwards and rostralwards, possibly inducing, modulating or refining the expression of specific transcription factors and subsequent parcellation in adjacent territories (Fig. 5).

Before the zli is formed, other local organizers are present, the ANR and the IsO, which produce signals

that contribute to the AP patterning of the forebrain, including the formation of the p3/p2 boundary and the zli (Fig. 5). It appears that early signals from the ANR play a key role. The earliest ANR signals include antagonists of Wnt proteins (secreted Frizzled-related proteins) such as Tlc, which are opposed to Wnt proteins produced in the caudal forebrain [5]. The secreted Frizzled-related proteins antagonize Wnt activity by binding to Wnt proteins and sequestering them. Wnt proteins are going to caudalize the forebrain (forming the diencephalon proper), whereas Wnt antagonists produced at the ANR are important for the formation of rostral forebrain, including the telencephalon, eye field and hypothalamus. Zebrafish embryos that carry a mutation affecting the intracellular Wnt pathway (Masterblind mutants) show loss of telencephalon and eyes, and expansion of the diencephalon proper to the front of the neural plate. That Wnt signal promote posterior forebrain fates (diencephalon proper) but suppresses anterior forebrain fates is also supported by studies in frog, chick and mouse [5].

Interestingly, during embryonic development, caudal and rostral forebrain regions express different transcription factors in response to Wnt signaling [5]. It appears that Iroquois 3 (Irx3) is expressed in response to high levels of Wnt in the caudal forebrain, and constitutes an important effector of Wnt signaling for posterior forebrain formation (Fig. 5). In contrast, the rostral forebrain is characterized by expression of the transcription factor Sine-oculis (Six; in particular Six3 and related proteins) (Fig. 5), which is extremely important for rostral forebrain formation, and is expressed in areas of low Wnt activity [5]. Removal of the ANR (the source of Wnt antagonists) or enhanced Wnt activity suppresses Six3 expression in the anterior neural plate.

Initially, Six3 expression shows a caudal boundary adjacent to the rostral limit of Irx3. It appears that the mutual repression of Six3 and Irx3 is going to determine the formation of the p3/p2 boundary (where the zli locates). The posterior border of Six3 expression is dynamic and regresses rostrally over time, leaving the prethalamus free of expression. As note above, it is likely that the zli is a source of signals (including Shh) that help to refine patterning of the alar diencephalon [5,13]. Signals from the zli possibly act in conjunction with other signals from the ANR (rostrally) and IsO

---

appears to determine the formation of the p2/p3 boundary, and perhaps the formation of the zona limitans intrathalamica (zli). Subsequently, the confluence of ANR versus zli signals rostrally, and zli versus isthmic organizer (IsO) signals caudally contribute to further parcellation of the forebrain. Later, the ANR produces FGF8 signals that are important for patterning the telencephalon. (b) Diagram representing the organizer centers and molecular compartments that are formed in the forebrain from rostral to caudal levels. (c) Lateral schematic view of the major molecular compartments observed in the mouse forebrain at mid-embryonic development. Each major compartment is characterized by expression of a specific combination of transcription factors, and is going to produce a specific set of neurons. For abbreviations see Figure 2 legend.



(caudally) and under the action of specific effector transcription factors are going to produce further partition of the forebrain in smaller subdivisions. Previous studies have indicated that IsO signals include FGF8 and Wnt1 and have an effect on patterning the territory rostral and caudal to isthmus [13]. The confluence of zli and IsO signals may be important for establishing the boundary between pretectum (diencephalon) and midbrain. On the other hand, the confluence of zli and ANR signals may be important for establishing the boundary between prethalamus and hypothalamus (or between p3 and secondary prosencephalon, in general).

In addition to Wnt antagonists, the ANR expresses FGF signals (including FGF8) that seem to be very important for patterning the telencephalon, eye and hypothalamus [5,12,13]. It appears that the expression of FGF by ANR is a downstream consequence of inhibition of Wnt activity by local antagonists [5]. The role of FGF on telencephalic patterning is explained in more detail in a separate section.

### **Patterning and Formation of Specific Cell Groups in the Forebrain Basal/Ventral Region. Evolutionary Trends and Questions**

The basal region of the forebrain shows two major subdivisions, characterized by distinct expression of transcription factors and by production of distinct cell groups. These two subdivisions are located caudal or rostral to the boundary between diencephalon and secondary prosencephalon (i.e. between p3 and hypothalamus).

The basal region (floor and basal plates) caudal to this boundary is epichordal, expresses Nkx6.1 [4], and produces dopaminergic neurons of the substantia nigra and ventral tegmental area (A9 and A10 groups) in different vertebrates (Figs. 5 and 6) [4,14; see also reviews by Marín et al., 1998, and Reiner et al., 1998].

The dopaminergic neurons in the meso-diencephalic tegmentum appear to be induced by cooperative signals of Shh from the floor plate/notochord and FGF8 from the IsO [14]. The differentiation of dopaminergic neurons requires the expression of the regulatory genes *Nurr1* and *Pitx3* [14]. *Pitx3* is highly conserved in vertebrates, but its relation to the differentiation of dopaminergic neurons in non-mammals requires further investigation. An interesting aspect of the dopaminergic neurons of this region is that in fish they are only formed in the diencephalon ventral to p2 (posterior tubercle) (Fig. 6). In amphibians, birds and mammals, these cells extend caudally and also form in the ventral parts of p1 and midbrain (Fig. 6). This suggests that rostral diencephalic dopaminergic cells are evolutionarily older. In mammals, the rostral dopaminergic cells are also observed at earlier developmental stages than the caudal ones. In some reptiles (such as the lizard

*Gallotia*), dopaminergic neurons are only formed in p1 and midbrain, and this is presumably due to secondary loss of the rostralmost group in evolution. Thus, dopaminergic cells of the meso-diencephalic tegmentum have undergone some changes in evolution regarding where they are formed, but it is currently unclear what has caused these changes.

The basal region rostral to the p3/hypothalamic boundary is primarily under the influence of prechordal plate/rostral mesendoderm signals, expresses Nkx2.1, and produces the ventral hypothalamus (including the neurohypophysis, and the ventromedial/tuberal, mammillary and tuberomammillary hypothalamic regions) (Figs. 5 and 6). Expression of Nkx2.1 in this ventral region is induced by prechordal Shh signals. Based on the effect of lack of function or hypofunction of Nkx2.1 in mouse and frog, this transcription factor appears to play a key role in the specification and formation of the ventral hypothalamus in different vertebrates [15,16]. In some fish, such as the teleost zebrafish, the ventral hypothalamus is greatly developed (relative to other forebrain domains). In adult teleosts, the ventral hypothalamus contains many specific centers related to the gustatory/visceral system (this system is greatly developed in ray-finned fishes, particularly in some teleost species). It is unknown what triggered the great development and growth of this forebrain region in these animals. It possibly was a multifactorial event, but it surely involved changes affecting the proliferation and morphogenesis in this region. In relation to this, it is noteworthy to mention that the prospective ventral hypothalamus expresses two copies of Nkx2.1 in zebrafish, Nkx2.1a and Nkx2.1b [15]. Since during early development these genes are expressed in the proliferative zone (ventricular zone), this may have resulted in changes in proliferation (higher proliferation rate or during a longer period), producing an overgrown region.

### **Patterning and Formation of the Dorsal Diencephalon and Hypothalamus. Evolutionary Trends and Questions**

As noted above, patterning of the alar diencephalon and hypothalamus is induced by confluence of dorsal signals from the roof plate (BMP, Wnt), lateral signals (possibly mediated by RA), anterior signals from the ANR (including Wnt antagonists and, later, FGF8), posterior signals from the IsO (Wnt, FGF8), and anterior/posterior signals from the zli (including Shh; Fig. 5) (see above). The confluence of these signals ultimately produces the parcellation of the alar territory into four major transverse subdivisions: alar hypothalamus and dorsal parts of p3, p2, and p1 (Fig. 5). These major subdivisions are present in all vertebrates, from jawless fish to mammals (Fig. 6). Each major subdivision is further subdivided into smaller longitudinal or transverse

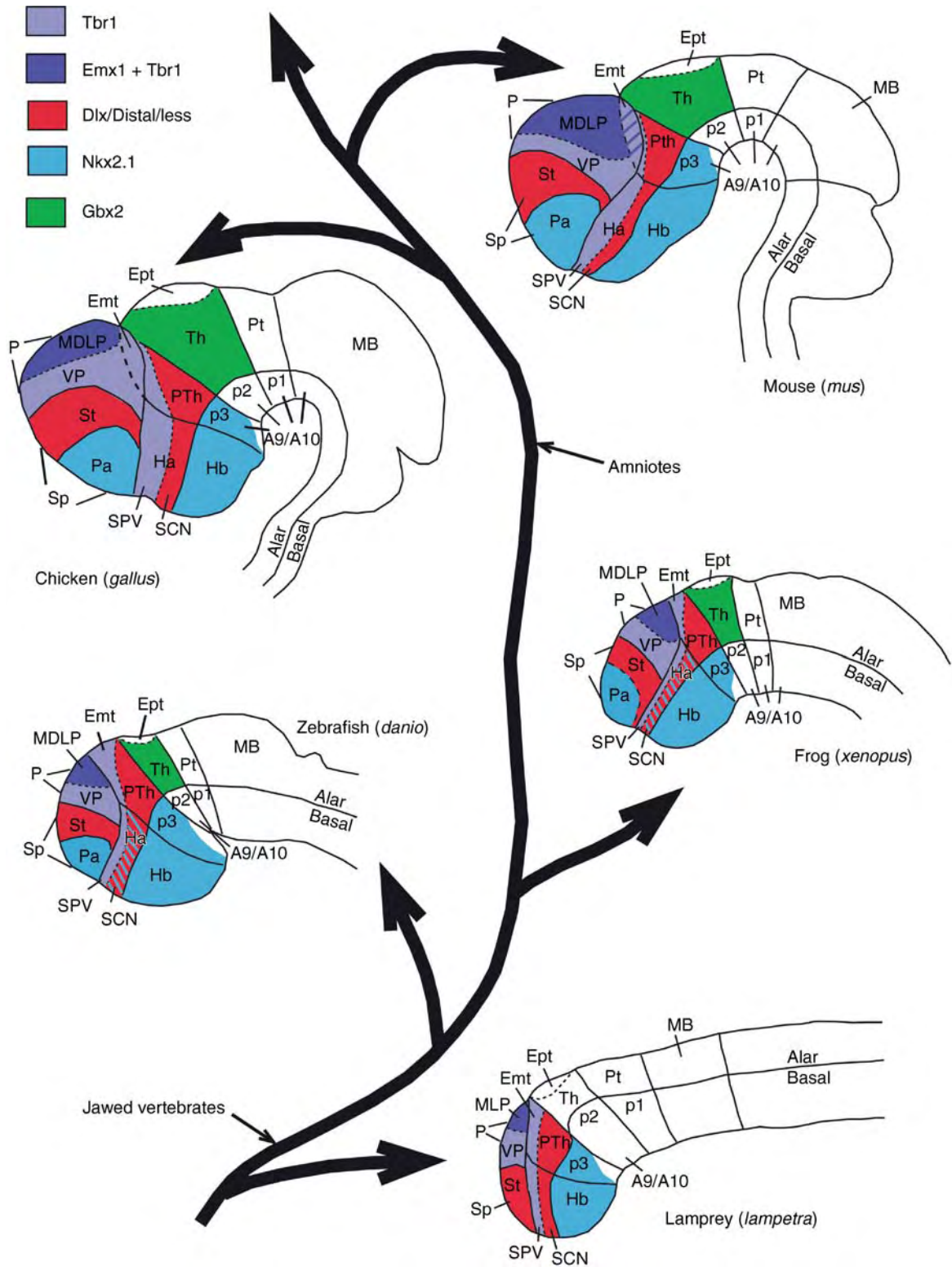

**Evolution and Embryological Development of Forebrain.** Figure 6 Phylogenetic diagram representing the embryonic forebrain of representative species of different vertebrate groups, including a jawless fish (the lamprey), a teleost fish (the zebrafish), an anuran amphibian (the frog *Xenopus*), a bird (the chicken), and a mammal (the mouse). In all species, the forebrain includes comparable molecular compartments, showing identical position and similar expression of transcription factors. Nevertheless, during subsequent development each compartment shows varying

subdomains, which show distinct gene expression. A similar set of these smaller subdomains appears to be present in all tetrapods (from amphibians to mammals), although their relative size changes depending on the group [17].

### Subdomains in the Alar Diencephalon

For example, in p3 there is a dorsal subdomain expressing *Tbr1* that gives rise to the eminentia thalami and a ventral subdomain expressing *Dlx2/5* that gives rise to the prethalamus [4,8] (Figs. 5 and 6). Like other forebrain regions expressing *Dlx* genes, the prethalamus is rich in GABAergic neurons, whereas the eminentia thalami contains glutamatergic neurons (as is typical in domains expressing *Tbr1*).

On the other hand, p2 shows several subdomains that give rise to the epithalamus and thalamus. The thalamus expresses *Gbx2* and *Lhx2/9* but lacks *Dlx* expression and is typically rich in glutamatergic neurons that project to the telencephalon (including the cortex/pallium) (Figs. 5 and 6). The thalamus is subdivided into even smaller subdomains that express different combinations of *Cadherin* genes or proteins, involved in later morphogenesis events [17]. Each thalamic subdomain produces cell populations that are going to project to a specific part of the telencephalic pallium/cortex [17]. For example, the dorsal thalamic subdomain gives rise to nuclei globally included in the “lemnithalamus” [18] and projects to the dorsomedial pallium. The intermediate and ventral thalamic subdivisions produce nuclei that globally correspond to the “collothalamus,” and project to the lateroventral pallium. In addition, the area adjacent to the *Shh*-expression of the *zli* is induced by *Shh* to express *Nkx2.2* (leading to secondary downregulation of *Pax6* expression), and this area has been proposed to be the source of the subpopulation of GABAergic interneurons observed in the thalamus [4]. Interestingly, the dorsal thalamic subdomain is greatly developed in mammals, and this is correlated to the great development of the dorsal pallium (neocortex) in these animals. In contrast, the great development of the intermediate/ventral subdomains in birds and reptiles is correlated with the great development of the ventrolateral pallium (DVR) in these sauropsids. Given this evidence, it would be tempting to suggest that the expansion of specific thalamic subdomains triggered the expansion of specific cortical/pallial subdivisions. However, patterning and

regionalization of the thalamus and the cortex/pallium appear to be primarily induced by local or intrinsic factors [16]. This is partially supported by the analysis of mice lacking *Gbx2*, in which thalamocortical axons fail to reach their target, but still the cerebral cortex is normally patterned. Nevertheless, it appears that growing thalamocortical axons release a mitogenic factor, which may affect the proliferation and growth of the targeted cortical areas.

When studying the development and organization of the thalamus in different vertebrates, two major questions are raised: 1) what produced the thalamic enlargement during evolution of amniotes, but specially in birds and mammals?, and 2) what produced the distinct expansion of different thalamic subdomains in different amniotes. Regarding the first question, a recent study has suggested that a reduction of the *Nkx2.1* expression in the alar hypothalamus during evolution to amniotes (see below) may have produced an expansion on the territory caudal to it, including the thalamus [15]. Regarding the second question, we are still far from understanding what produces the subdivision of the thalamus into smaller domains. Only after we understand this, we will be able to make testable proposals.

### Subdomains in the Alar Hypothalamus

Similar to the major subdivisions of the dorsal diencephalon, the alar hypothalamus also is subdivided into smaller subdomains, which show distinct molecular features and produce different cell groups. For example, it shows the following two major longitudinal subdomains (Figs. 5 and 6):

1. a dorsal subdomain adjacent to the subpallial preoptic area (ventral to it, from a topological point of view), that expresses the transcription factors *Tbr1*, *Sim1* (Singled-minded 1), and *Otp* (Orthopedia) and is rich in glutamatergic neurons (as typical of forebrain domains expressing *Tbr1*). This subdomain produces the paraventricular, supraoptic and anterior hypothalamic nuclei [4]. For this reason, this molecular subdomain is often referred to as the supraopto-paraventricular domain (SPV) and contains magnocellular neurons that produce oxytocin or vasopressin (vasotocin in non-mammals). These cells project to the neurohypophysis, forming the

degrees of growth and elaboration in the different species. In contrast to the subpallium of jawed vertebrates, the subpallium of jawless fish does not appear to be subdivided, based on the absence of *Nkx2.1* expression in the telencephalon. This is correlated with the absence of a pallidum in the basal telencephalon of these animals. See text for more details. Abbreviations: *A9-A10* A9 and A10 dopaminergic cell groups (substantia nigra pars compacta and ventral tegmental area); *Emt* eminentia thalami; *Ept* epithalamus; *Ha* alar hypothalamus; *Hb* basal hypothalamus; *MB* midbrain; *MDLP* medial, dorsal and lateral pallium; *MLP* medial and lateral pallium; *P* pallium; *Pa* pallidum; *Pt* preteetum; *PTh* prethalamus; *p1-p3* ▶ *prosomer*s 1–3; *SCN* suprachiasmatic domain; *Sp* subpallium; *SPV* supraopto-paraventricular hypothalamic domain; *St* striatum; *Th* thalamus; *VP* ventral pallium.

hypothalamo-neurohypophysial system. It appears that *Sim1* and *Otp* transcription factors are involved in the differentiation of oxytocin (isotocin in fish) and vasopressin producing cells of the SPV. These cells are missing in *Sim1* knockout mice, as well as in *Sim1* knockdown zebrafish, as recently found by Jennifer Eaton and Eric Glasgow, indicating that the mechanisms for their development are highly conserved in vertebrates.

2. a ventral subdomain that expresses *Dlx2/5* transcription factors but not *Tbr1/Otp/Sim1* and is located between the supraopto-paraventricular domain and the basal plate. This subdomain produces the suprachiasmatic nucleus, among other cell groups and is rich in GABAergic neurons (as other *Dlx*-expressing forebrain domains).

The same two main subdomains of the alar hypothalamus noted above are present in non-mammals, including chick, frog, and apparently zebrafish (Fig. 6). One interesting difference between groups recently noted is that the alar hypothalamus in frog and zebrafish shows expression of *Nkx2.1* (possibly overlapping the *Dlx*-expressing subdomain), but this transcription factor is either not expressed or done at a very low level in the alar hypothalamus of mouse and chick [15] (Fig. 6). This means that the expression of this transcription factor was greatly downregulated during evolution to birds and mammals. What was the consequence of this loss? This is no doubt a question difficult to answer because we cannot repeat evolution in a laboratory. However, knockdown experiments of *Nkx2.1* in frog embryos produce a shrinkage of the alar hypothalamus and an expansion of the thalamus, and based on these results it has been proposed that the loss or downregulation of this transcription factor during evolution was possibly one of the factors that triggered the great expansion of the thalamus in these animals [15]. Another consequence of the loss or reduction in the expression of *Nkx2.1* in the alar hypothalamus is that this may have involved a relative shrinkage of the domain that gives rise to the suprachiasmatic nucleus and the expansion of the adjacent SPV domain. This possibility requires further investigation, first by analyzing the relative importance of both domains throughout phylogeny. Meanwhile, it is interesting to note that the hypothalamo-hypophysial system (related to the SPV) is extremely important not only for homeostasis control, but also for social, sexual and maternal behaviors. Among vertebrates, social and maternal behaviors generally show the greatest development in mammals and birds, and this may be associated to a great development of SPV domain and the hypothalamo-hypophysial system. However, although most amniotes (including most fish) would consider their young and fish eggs simply a tasty food,

a few fish species show parental care behavior (for example, mouthbreeders). It would be interesting to analyze the SPV domain in these species relative to that of fishes that show no parental care.

## The Telencephalon: A Specialization of the Rostral and Dorsal Forebrain

### Molecular Definition

Regardless the existence of paired evaginated vesicles or not (or everted vesicles in ray-finned fishes), the telencephalon is present in all vertebrates, from jawless fish (such as the lamprey) to mammals. From zebrafish to mouse, it is characterized by expression of *BF1*, and animals carrying a null mutation in this gene lack a telencephalon. It shows two major divisions, pallium and subpallium (Fig. 6), which express different combinations of transcription factors. In different vertebrates, the pallium expresses *Emx1/2* and *Pax6* (Figs. 6 and 7), which are involved in specification, regionalization, and growth of the pallium.

It also expresses *Tbr1*, a transcription factor involved in differentiation of glutamatergic neurons, which are typical in the pallium in all vertebrates [16; see also recent articles by Isabelle Bachy and her colleagues and Aurora Brox and her colleagues]. On the other hand, the subpallium expresses *Dlx/Distal-less* transcription factors (Figs. 6 and 7), among many other (see below); *Dlx* transcription factors are involved in the acquisition of the GABAergic phenotype, which is typical in subpallial neurons and their projections [8]. Analysis of *BF1* and transcription factors typical of the subpallium (including *Dlx5*, *Nkx2.1*, *Lhx6* and *Lhx7/8*) indicates that the telencephalon includes the anterior preoptic region (POa). This includes a novel subpallial domain called the commissural preoptic area (POC), related to the anterior commissure [4,19]. Functional studies have usually linked the preoptic area with the hypothalamus, although classical anatomical studies in non-mammals considered the preoptic area as part of the telencephalon “impar,” which is a non-evaginated part of the telencephalon. Genetic developmental data support the classical view and indicate that at least part of the preoptic area belongs to the telencephalic subpallium.

### Major Telencephalic Subdivisions and Their Patterning. Evolutionary Trends and Questions

Each major division of the telencephalon contains at least four main subdivisions (4 in the pallium and 4 in the subpallium), and each is characterized by a specific combination of transcription factors and by the production of specific cell populations. The same major domains are apparently present in all tetrapods, from amphibians to mammals (Figs. 6–8). These are located in identical topological positions within the telencephalon, show

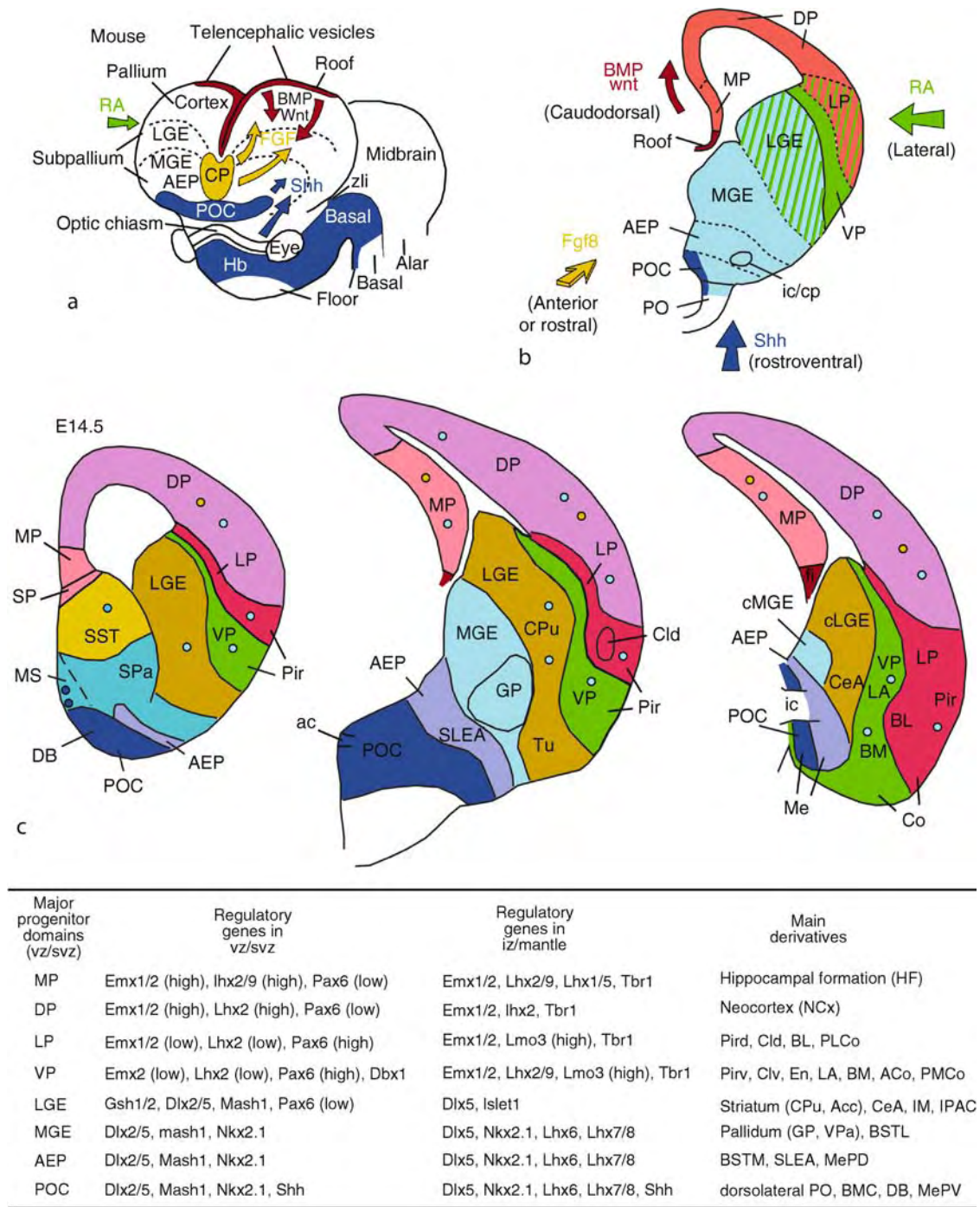

**Evolution and Embryological Development of Forebrain. Figure 7** (a, b) Schemes of the forebrain or a frontal telencephalic section of a mouse during early development, showing the organizers and signals involved in telencephalic patterning. These include dorsocaudal signals from the roof (BMP, Wnt; purple arrows); anteroventral signals from the ANR (FGF; yellow arrows), and from the ventral forebrain and later the commissural preoptic area or POC (Shh, blue arrows); and lateral signals (RA, perhaps from the olfactory placode or mesenchyme cells inside; green arrows). The confluence of these signals is going to produce the parcellation of the telencephalon into several pallial and subpallial compartments. The expression patterns and derivatives of each compartment are shown in panels c and d. (c) Schemes of frontal sections from rostral (*left*) to caudal (*right*) levels of the mouse telencephalon at a mid-embryonic stage, showing the different molecular compartments, and main derivatives. (d) Diagram showing

similar combinations of transcription factors, and can therefore be regarded as field homologues.

Based on molecular and anatomical features, the pallium appears to be subdivided into medial, dorsal, lateral and ventral pallial subdivisions in all tetrapods [4,8,20; see also recent, related articles by Luis Puelles and his colleagues, Isabelle Bachy and her colleagues, and Aurora Brox and her colleagues] (Figs. 7 and 8). Nevertheless, the dorsal pallium in amphibians, if present, appears to be very small. The dorsomedial pallial territories show strong expression of *Lhx2* and *Emx1/2* and lower expression of *Pax6*, whereas the lateroventral pallia show strong expression of *Pax6* and *Lhx9*, and low or no expression of *Emx1*. In particular, the ventral pallium of tetrapods is characterized by no expression of *Emx1* in the proliferative zone and by strong expression of *Pax6* and *Lhx9* in the mantle. In mammals, the ventral pallium is also characterized by expression of *Dbx1* in the proliferative zone (Yun et al., 2001; Medina et al., 2004), but this transcription factor is not found in the ventral pallium of non-mammals. Based on these expression patterns together with anatomical features, the medial subdivision gives rise to the hippocampal formation in different tetrapods, whereas the dorsal pallium gives rise to the neocortex in mammals, to a small dorsal cortex/dorsal pallium in reptiles and amphibians, and to the hyperpallium (Wulst) in birds (Figs. 7 and 8). In mammals, the lateral and ventral pallial subdivisions give rise to the piriform (olfactory cortex), claustrum and endopiriform nuclei, as well as the cortical areas and the basal complex of the amygdala (Fig. 7). In birds and reptiles, the lateral and ventral pallia also give rise to the piriform cortex, as well as to the dorsal ventricular ridge or DVR (the latter includes the nidopallium, mesopallium and arcopallium of birds) (Fig. 8). This implies that the claustrum, endopiriform nuclei and pallial amygdala of mammals are ►homologous as a field to the DVR of birds and reptiles and to the corresponding lateral and ventral

pallia of amphibians. Interestingly, the caudal part of the DVR in birds and reptiles, and the caudal part of the lateroventral pallia of amphibians have been proposed to include the pallial amygdala on the basis of position, neurochemistry and some basic connections [2,17; see also a related article by Laura Bruce and Timothy Neary, where the amygdalar comparison was first broached, and more recent articles by Luis Puelles and his colleagues and Fernando Martínez-García and his colleagues]. For example, the caudal DVR of reptiles and birds and the caudal ventral pallium of amphibians include an auditory area receiving input from the collothalamus, and this area appears comparable to the lateral amygdala of mammals (also a ventral pallial derivative), which receives input from medial geniculate nucleus of the mammalian collothalamus. A major question that remains to be answered is how much of the DVR is amygdalar-like. The finding of transcription factors restricted to the pallial amygdala, but avoiding other parts of the ventrolateral pallium, will help to resolve this issue.

On the other hand, the subpallium in mammals includes at least four molecularly and anatomically distinct subdivisions (Figs. 7 and 8): the striatal subdivision (lateral ganglionic eminence [LGE]); the pallidal subdivision (medial ganglionic eminence [MGE]); the anterior peduncular area (AEP) and the commissural preoptic area (POC) [4,19]. The LGE/striatal subdivision expresses *Dlx1/2/5*, *Gsh1/2*, and *Islet1* transcription factors and gives rise to the striatum and central amygdala in mammals. The MGE/pallidum, AEP and POC of mammals express *Dlx1/2/5*, *Nkx2.1*, *Lhx6/7/8*, and *Shh* (the latter is restricted to POC and derivatives), and give rise to the pallidum, extended amygdala (including most of the bed nucleus of the stria terminalis [BST] and medial amygdala), and the cholinergic corticopetal cell groups [19] (Fig. 7). In addition, the septum also contains septo-striatal and septo-pallidal domains that show combinatorial

---

the major progenitor domains of the embryonic telencephalon, the transcription factors that each expresses, and the main derivatives of each compartment. See text for more details. Abbreviations: *ac* anterior commissure; *Acc* nucleus accumbens; *ACo* anterior Co; *AEP* anterior peduncular area; *BL* basolateral amygdalar nucleus; *BM* basomedial amygdalar nucleus; *BMC* basal magnocellular complex; *BSTL* bed nucleus of the stria terminalis, lateral part; *BSTM* bed nucleus of the stria terminalis, medial part; *CeA* central amygdalar nucleus; *Cld* dorsolateral claustrum; *cLGE* caudal part of LGE ((in the caudal ganglionic eminence); *Clv* ventromedial claustrum; *cMGE* caudal part of MGE (in the caudal ganglionic eminence); *Co* cortical amygdalar areas; *cp* cerebral peduncle; *CP* commissural plate; *CPu* caudate-putamen complex; *DB* diagonal band nuclei; *DP* dorsal pallium; *En* endopiriform nuclei; *fi* fimbria; *GP* globus pallidus; *Hb* basal hypothalamus; *ic* internal capsule; *IM* main intercalated amygdalar masses; *IPAC* interstitial nucleus of the posterior limb of the anterior commissure; *LA* lateral amygdalar nucleus; *LGE* lateral ganglionic eminence; *LP* lateral pallium; *Me* medial amygdalar nucleus; *MePD* posterodorsal part of Me; *MePV* posteroventral part of Me; *MGE* medial ganglionic eminence; *MP* medial pallium; *MS* medial septal nucleus; *Pir* piriform cortex; *Pird* dorsal part of Pir; *Pirv* ventral part of Pir; *PLCo* posterolateral Co; *PMCo* posteromedial Co; *PO* preoptic area; *POC* commissural preoptic area; *SLEA* sublentiform extended amygdala; *SP* pallial part of the septum; *SPa* pallidal-like part of the septum; *SSt* striatal-like part of the septum; *Tu* olfactory tubercle; *VP* ventral pallium; *VPa* ventral pallidum; *zli* zona limitans intrathalamica.

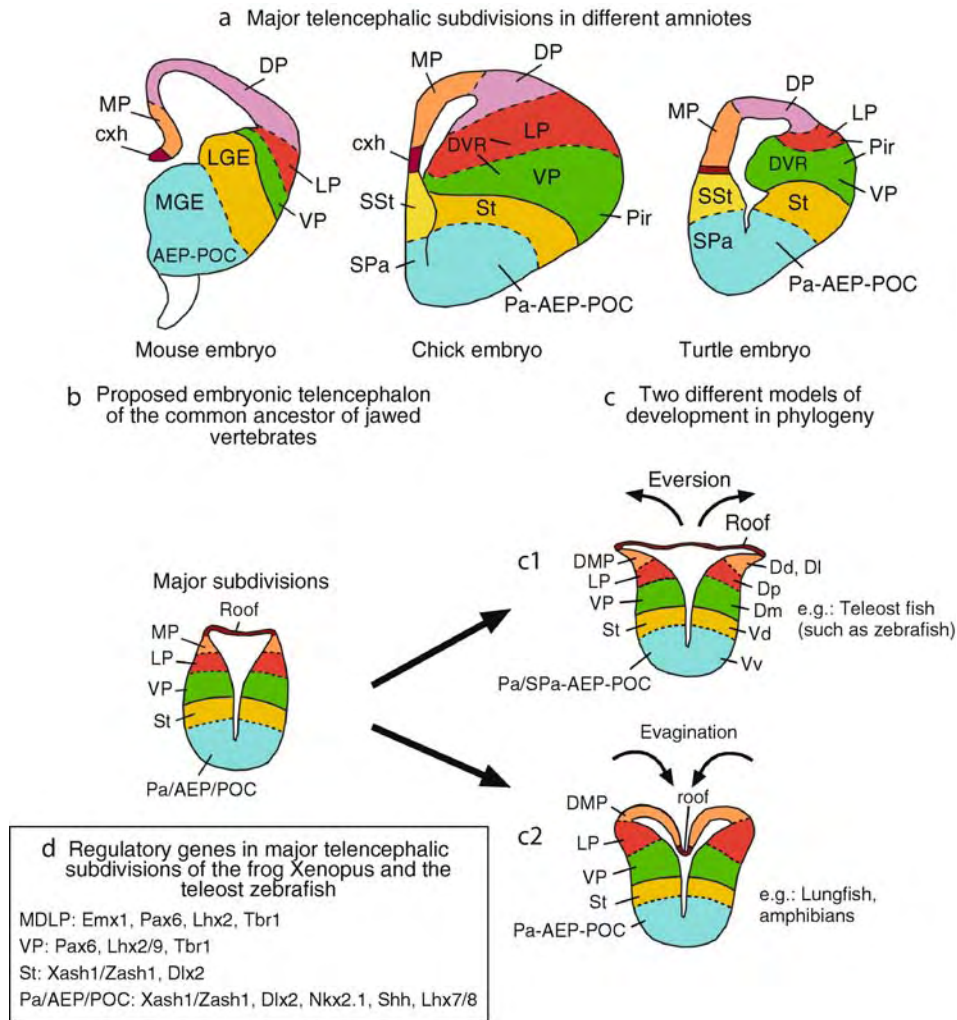

**Evolution and Embryological Development of Forebrain. Figure 8** (a) Schemes of frontal sections through the embryonic telencephalon of different amniotes (a turtle, a chicken and a mouse), showing the major molecular compartments. Basically, all groups show the same set of pallial and subpallial compartments, although their size and elaboration varies depending on the group. (b, c, c1, c2) Proposed model of the basic molecular compartments present in the embryonic telencephalon of the common ancestor of jawed vertebrates (b). From this basic organization scheme, the telencephalon underwent partial or almost complete eversion (B1) or evagination (B2) in different radiations. (d) Diagram showing the major telencephalic subdivisions and the regulatory genes they express in the frog *Xenopus* and the teleost zebrafish. Many of these are the same as in amniotes. Abbreviations: AEP anterior peduncular area; *cxh* cortical hem; *Dd, Dol, Dm, Dp* dorsal telencephalic area (pallium), dorsal, lateral, medial or posterior parts; *DP* dorsal pallium; *DMP* dorsomedial pallium; *DVR* dorsal ventricular ridge; *LP* lateral pallium; *MP* medial pallium; *Pa* pallidum; *Pir* piriform cortex; *POC* commissural preoptic area; *SPa* pallidal-like septum; *St* striatum; *SSt* striatal-like septum; *Vd* ventral telencephalic area (subpallium), dorsal part; *VP* ventral pallium; *Vv* ventral telencephalic area (subpallium), ventral part.

expression of regulatory genes comparable to those of either LGE or MGE/AEP/POC. The subpallium of non-mammals, from frog to chick, also shows striatal, pallidal, and AEP-POC molecular domains comparable to those of mammals, giving rise to striatal and pallidal parts of the basal ganglia and septum, to the extended amygdala, and the cholinergic cells groups of the basal telencephalon (Fig. 8).

How are these basic subdivisions of the telencephalon patterned? The answer to this question may also help to propose possible evolutionary changes that led to differential growth of subdivisions in each vertebrate lineage.

The telencephalon constitutes a dorsal specialization of the rostral forebrain and appears to be patterned by signaling mechanisms similar to those that operate in

DV and AP patterning of the diencephalon and caudal neural tube [4,5,12,16] (Fig. 7). However, it should be noted that, from a topological point of view, internal boundaries between telencephalic subdivisions do not fit well into the general scheme of AP or DV boundaries of the rest of the neural tube [4]. Nevertheless, pallium and subpallium develop from caudal or rostral domains of the anterior neural plate, respectively. In the telencephalon, BMPs and Wnt signals from the dorsal midline (roof plate, including the cortical hem; Fig. 7) induce the expression of *Lhx2* and *Emx2* in the adjacent dorsomedial pallium (with a decreasing gradient towards the lateroventral pallium), whereas RA induces expression of *Dlx2*, *Gsh2*, and *Pax6* in the lateral, intermediate region (*Dlx2* and *Gsh2* in LGE, and *Pax6* primarily in the lateroventral pallium, with decreasing gradients towards the medial pallium and the LGE) [12; also Ragsdale and Grove, 2001] (Fig. 7). In addition, FGF8 and Shh anteroventral signals induce the expression of *Nkx2.1* in the most basal telencephalic region (MGE and the most basal parts of the subpallium) (Fig. 7).

Initially, FGF8 signals from the ANR are extremely important for telencephalic patterning [12]. Ablation of ANR or blockage of the FGF8 signals eliminates or reduces *BF1* expression in the prospective telencephalon at neural plate stages, and this is rescued by FGF8-soaked heparin beads [13]. Moreover, FGF signals are able to induce the expression of genes typical of the subpallium, such as *Dlx2*, *Gsh2* and *Nkx2.1* [12]. Later in development, *Shh* starts to be expressed in a small subpallial domain in close relation to the ANR [13] (Fig. 7), and this new signal is also related to induction of subpallial marker genes [12]. Thus, both FGF8 and *Shh* induce the expression of subpallial marker genes. FGF8 also represses retinoid acid signaling in the developing telencephalon leading to the formation of MGE instead of LGE [12]. In addition, FGF8 signals - in conjunction with BMP/Wnt and RA - are important for cortical regionalization and area formation.

These mechanisms contribute to pattern the telencephalon in mammals and non-mammals (including zebrafish), and appear to be conserved in vertebrates. Based on this, perhaps differences in the relative proportion of dorsocaudal versus lateral versus anteroventral inducing signals triggered the great development of the ventral pallium in birds and reptiles (producing the DVR), or the great development of the dorsal pallium in mammals (giving rise to the neocortex).

#### Evolution of a Novel Morphogenetic Domain in the Subpallium

The major molecular domains observed in the telencephalon of tetrapods (from amphibians to mammals) are also present in zebrafish, suggesting that they were likely present in the telencephalon of stem jawed

vertebrates (Figs. 6–8). This includes a pallium and subpallium, and several subdivisions in each. For example, in the subpallium there are striatal and pallido-AEP-PO subdivisions, which express either *Distal-less/Dlx* or both *Dlx* and *Nkx2.1* transcription factors. These subdivisions appear to produce, respectively, striatal and pallidal cell groups described in the ventral telencephalic region of teleosts, although these may be mostly comparable to septal or limbic striatal and pallidal subdivisions of mammals [3] (Figs. 6 and 8). The pallido-AEP-PO subdivision also expresses *Shh* and is possibly related to the cholinergic neurons observed in the subpallium of teleosts. It is however unclear whether the pallido-AEP-PO domain can be further subdivided into separate pallidal, AEP and PO subdivisions in teleosts. Regarding the pallium, there are at least three major subdivisions comparable to the medial pallium, lateral pallium and ventral pallium in teleosts (the latter including the pallial amygdala) (Fig. 8). However, due to the eversion process that occurs during development of the telencephalon in teleosts, the topographic positions of these pallial subdivisions are shifted from lateral to medial (Fig. 8). Thus, the so-called dorsomedial pallium of teleosts really corresponds to the ventral pallium, whereas the true medial pallium (hippocampal) is located in a lateral position. Nevertheless, the topological relationships of each pallial subdomain (regarded with respect to intrinsic coordinates of the neural tube), remain unchanged in comparison with other vertebrates. For example, the true medial/hippocampal pallium of teleosts is immediately adjacent to the choroid tissue (roof derivative), which is typical of the medial pallium in all vertebrates (Fig. 8).

As that of jawed vertebrates, the subpallium of the lamprey (a jawless fish) expresses *Distal-less/Dlx* transcription factors [10]. However, the subpallium of the lamprey does not appear to be subdivided, based on the absence of expression of both *Shh* and *Nkx2.1* in the basal telencephalon of these animals [3,10,15; see also Osorio et al., 2005] (Fig. 6). In fact, the basal telencephalon of adult lampreys contains a structure suggested to be comparable to the basal ganglia, but this structure appears to show basically striatal features and there is no evidence for the presence of a pallidum in these animals [3]. This suggests that the evolution from jawless to jawed vertebrates involved the novel appearance of a pallido-AEP-PO subpallial domain, possibly as a consequence of the novel expression of *Shh* and *Nkx2.1* in the basal telencephalon. Possibly, the novel expression of *Nkx2.1* was induced by *Shh* and/or perhaps by FGF8. Alternatively or additionally, the novel expression of *Nkx2.1* in the basal telencephalon may be related to changes at the level of the regulatory region of the *Nkx2.1* gene, a possibility suggested recently on the basis of computer-based



sequence analysis of this gene in different vertebrates, from lamprey to human [15]. Another important question that remains to be answered is what triggered the appearance of the novel expression of Shh in the basal telencephalon.

The most obvious consequence of the novel expression of Shh and Nkx2.1 is the appearance of new cell populations in the basal telencephalon, including the pallidum and apparently the cholinergic cells that are typical of the basal telencephalon of jawed vertebrates [3]. In addition to this, the appearance of the new morphogenetic domain likely had consequences for the striatum and pallial/cortical regions, since in tetrapods (from amphibians to mammals) the MGE-AEP domain is a known major source of GABAergic interneurons that migrate tangentially to these regions.

### Function

Not applicable. See Thalamus, Hypothalamus, Telencephalon, Basal Ganglia, Cerebral Cortex, Hippocampus, Amygdala, Substantia Nigra, Ventral Tegmental Area, Dopaminergic Systems.

### Pathology

A number of neurological and neuropsychiatric disorders observed in humans, such as schizophrenia, some types of epilepsies, and autism (among other), are caused by developmental alterations, leading to abnormal formation of specific parts of the cerebral cortex and/or the amygdala. For example, in some cases of schizophrenia in humans there is a mutation in the neuroregulin-1 gene, encoding a molecule involved in the migration of GABAergic interneurons from the subpallium into the cortex, as Nuria Flames and her colleagues recently demonstrated. Other developmental alterations that lead to forebrain malformations produce cyclopia, holoprosencephaly, lissencephaly or callosal agenesis (among many others), which can be associated with mental retardation or other less severe cognitive deficits, as recently discussed by Lynn Paul and her colleagues. Knowing the developmental mechanisms and genes involved in forebrain formation can help to identify possible mutations or other causes of malformation, as a first step for a therapy design. An example of the value of this knowledge is found with the Nkx2.1 (or *Titf-1*) transcription factor, involved in the specification and formation of the basal hypothalamus and basal telencephalon, as well as in the formation of the thyroid gland and the lungs/bronchi. This was learned following analysis of Nkx2.1 null mutant mice. After reading about this, a group of physicians identified a number of patients with associated hypothyroidism, lung and motor (basal ganglia-related) problems, and decided to run a genetic test for possible mutations in the human Nkx2.1 gene; the test turned out to be positive.

### Therapy

Not applicable. See gene therapy, stem cell therapy.

### References

- Butler AB, Hodos W (2005) Comparative vertebrate neuroanatomy. Evolution and Adaptation, 2nd edn. John Wiley & Sons, Hoboken, NJ, USA
- Striedter GF (2005) Principles of brain evolution. Sinauer Associates Inc., Sunderland, MA, USA
- Medina L (2008) Basal ganglia: evolution. In: Squire L et al. (eds) The new encyclopedia of neuroscience. Elsevier, Oxford (in press)
- Puelles L, Martínez S, Martínez-de-la-Torre M, Rubenstein JLR (2004) Gene maps and related histogenetic domains in the forebrain and midbrain. In: Paxinos G (ed) The rat nervous system, 3rd edn. Elsevier, Amsterdam, pp 3–25
- Wilson SW, Houart C (2004) Early steps in the development of the forebrain. *Dev Cell* 6:167–181
- Wilson L, Maden M (2005) The mechanisms of dorsoventral patterning in the vertebrate neural tube. *Dev Biol* 282:1–13
- Medina L (2006) Field homologies. In: Kaas J, Striedter G, Rubenstein JLR (eds) Encyclopedia on evolution of nervous systems, vol 1: History of ideas, basic concepts and developmental mechanisms. Elsevier, Oxford, UK
- Brox A, Ferreira B, Puelles L, Medina L (2003) Expression of the genes *GAD-67* and *Distal-less-4* in the forebrain of the amphibian *Xenopus* confirms a common pattern in tetrapods. *J Comp Neurol* 461:370–393
- Wullimann MF, Mueller T (2004) Teleostean and mammalian forebrains contrasted: evidence from genes to behavior. *J Comp Neurol* 475:143–162
- Murakami Y, Ogasawara M, Sugahara F, Hirano S, Satoh N, Kuratani S (2001) Identification and expression of the lamprey *Pax6* gene: evolutionary origin of the segmented brain of vertebrates. *Development* 128:3521–3531
- García-López R, Vieira C, Echevarría D, Martínez S (2004) Fate map of the diencephalon and the zona limitans at the 10-somites stage in chick embryos. *Dev Biol* 268:514–530
- Lupo G, Harris WA, Lewis KE (2006) Mechanisms of ventral patterning in the vertebrate nervous system. *Nat Rev Neurosci* 7:103–114
- Echevarría D, Vieira C, Gimeno L, Martínez S (2003) Neuroepithelial secondary organizers and cell fate specification in the developing brain. *Brain Res Brain Res Reviews* 43:179–191
- Smits SM, Burbach JPH, Smidt MP (2006) Developmental origin and fate of meso-diencephalic dopamine neurons. *Prog Neurobiol* 78:1–16
- van den Akker WMR, Brox A, Puelles L, Durston AJ, Medina L (2008) Comparative functional analysis provides evidence for a crucial role for the homeobox gene *Nkx2.1/Titf-1* in forebrain evolution. *J Comp Neurol* 506:211–223
- Marín O, Rubenstein JLR (2002) Patterning, regionalization, and cell differentiation in the forebrain. In: Rossant J, Tam PPL (eds) Mouse development. Patterning, morphogenesis, and organogenesis. Academic Press, San Diego, CA, pp 75–106

17. Puelles L (2001) Thoughts on the development, structure and evolution of the mammalian and avian telencephalic pallium. *Philos Trans R Soc London B Biol Sci* 356:1583–1598
18. Butler AB (1994) The evolution of the dorsal thalamus of jawed vertebrates, including mammals: cladistic analysis and a new hypothesis. *Brain Res Brain Res Reviews* 19:29–65
19. García- López M, Abellán A, Legaz I, Rubenstein JLR, Puelles L, Medina L (2008) Histogenetic compartments of the mouse centromedial and extended amygdala based on gene expression patterns during development. *J Comp Neurol* 506:46–74
20. Moreno N, Bachy I, Rétaux S, González A (2004) LIM-homeodomain genes as developmental and adult genetic markers of *Xenopus* forebrain functional subdivisions. *J Comp Neurol* 472:52–72

## Evolution and Phylogeny of Amniotes

SUSAN E. EVANS

Research Department of cell and Developmental Biology, UCL, University College London, London, UK

### Definition

Amniotes (Amniota) form a monophyletic group that encompasses the last common ancestor of living mammals and reptiles, and all descendents of that ancestor. They are characterised by the possession of an amniote egg (or at least amniotic membranes in live-bearers) that contains the essentials for embryo development, but is protected by a leathery or calcareous outer shell. This key innovation enabled tetrapods to reproduce on land. Amniotes had larger brains and sense organs, better feeding systems, more mobile necks, and stronger limbs than their predecessors. As a result, amniotes rapidly came to dominate the terrestrial environment, and subsequently colonised the air and recolonised the water.

The classification used in this essay is cladistic and recognises only monophyletic groups (see *Phylogeny of Vertebrates* for a fuller explanation). Ages in millions of years before the present (Ma BP) are based on the most recent geological timescale [1] and the earliest records of occurrence, but should be understood to carry error bars.

### Characteristics

The first amniotes are recognised from the Carboniferous period (c. 320 Ma BP) based on skeletal characters (e.g. two sacral ribs, ankle structure), because until the development of calcareous shells, eggs were rarely fossilised. These early fossil amniotes were already split between two major clades, Synapsida and Sauropsida (Fig. 1). The latter is almost equivalent to Reptilia, and

this is used in subsequent discussion. However, under its cladistic definition, Reptilia is the monophyletic group that encompasses the last common ancestor of living lizards and snakes, crocodiles, birds and turtles, and all (but only) the descendents of that last common ancestor. In the past, and even in some recent literature, reptile was used in a paraphyletic sense equivalent to basal amniote (e.g. in the inaccurate term “mammal-like reptile” for early synapsids). Modern reptiles have a long independent evolutionary history and should not be used simplistically as morphological surrogates for the ancestral mammalian condition. For decades, understanding of mammalian ear evolution was obfuscated by attempts to derive the mammalian condition from that of a lizard. Only with the acceptance that the lizard and mammalian eardrums were not phylogenetically homologous (i.e. were not present in the last common ancestor of the two lineages, c. 320 Ma BP), was the problem resolved [2].

### Sauropsida

Reptilia sensu stricto includes living turtles and tortoises (Testudines), lizards, snakes and tuatara (Lepidosauria), and crocodiles and birds (Archosauria), as well as several important extinct groups such as the plesiosaurs, ichthyosaurs, and dinosaurs. Under this cladistic framework, birds (Aves) do not form a group distinct from reptiles – they are part of the monophyletic Reptilia.

Turtles are first recorded from the Late Triassic period (c. 310 Ma BP), but these fossils are already too highly specialised to shed much light on their immediate ancestry. There is general agreement that turtles are more closely related to lizards, crocodiles and birds than to mammals [3], but the details of that relationship remains unresolved. The traditional view is that turtles are the sister group of the ►*lepidosaurs* and ►*archosaurs* [4]. However, over the last decade increasing numbers of studies have suggested that turtles might be diapsid derivatives, related either to ►*lepidosaurs* [3] or ►*archosaurs* (most molecular analyses, e.g. [5]).

Lepidosauria and Archosauria, with their immediate ancestors, constitute the Diapsida. (The term diapsid refers to the presence of two bony fenestrae in the temporal region of the skull.) Lepidosauria today encompasses two unequal clades – Rhynchocephalia and Squamata. Once a globally widespread group, Rhynchocephalia is now represented by a single surviving genus, *Sphenodon*, restricted to a few islands off the coast of New Zealand. *Sphenodon* has been much misunderstood, regarded as a “living fossil” and sometimes cast into the role of archetypal primitive reptile. Over the last 25 years, our knowledge of extinct Rhynchocephalia has improved considerably. Within Rhynchocephalia, *Sphenodon* is a relatively derived form. Many of the skull characters previously used to

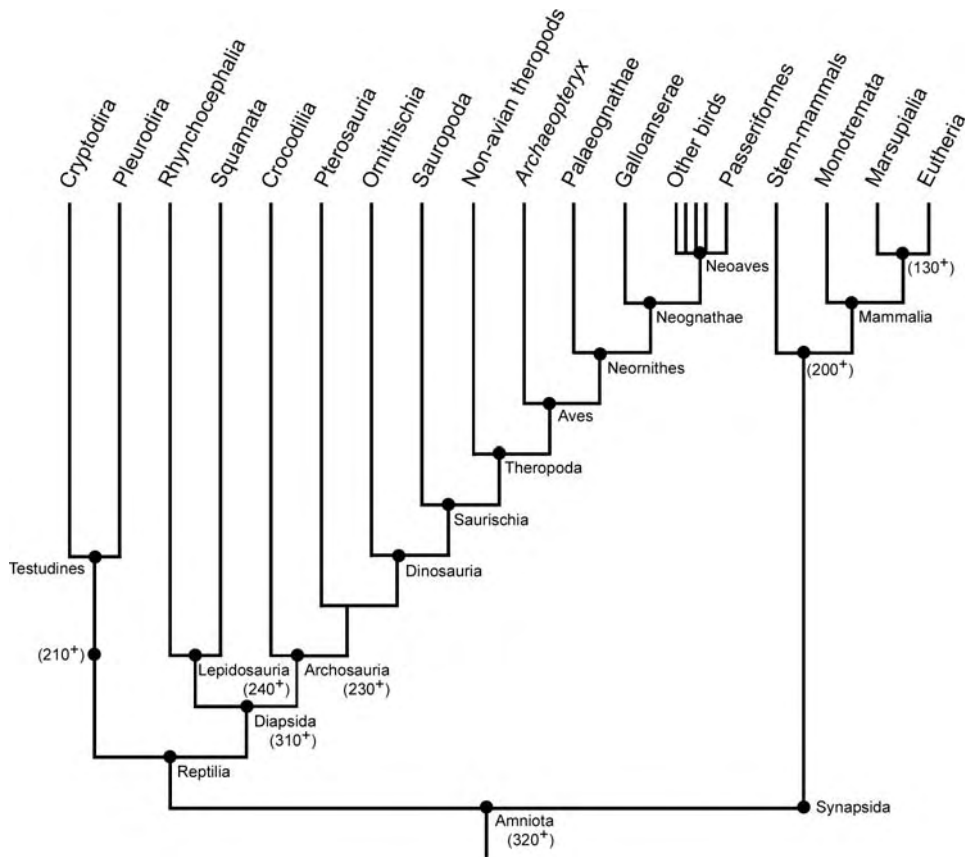

**Evolution and Phylogeny of Amniotes. Figure 1** Tree showing relationships amongst major amniote groups. Clade names have been added to appropriate nodes. The numbers at some nodes represent the minimum age estimates (in millions of years) for the last common ancestor of the descendant lineages.

argue for a primitive position are now recognised as secondary specialisations. Nonetheless, compared to lizards, *Sphenodon* does show some apparently primitive features, as well as a low basal metabolic rate and a longevity rivalling that of turtles. The last common lepidosaurian ancestor of squamates and rhynchocephalians lived around 240 Ma BP, and both lineages have undergone evolution in the interim, although squamates diversified more rapidly than other reptiles. This may explain why *Sphenodon* sometimes groups with other reptilian clades in molecular analyses [6].

Squamata is a highly successful clade, with more than 7,000 living species of lizards, amphisbaenians and snakes. There is common agreement that snakes (*Serpentes*) and “worm lizards” (*Amphisbaenia*) each constitute monophyletic groups, but that “lizards” are simply squamates that are neither snakes nor amphisbaenians. For this reason formal names like “*Lacertilia*” should not be used for them. Within squamates, most morphologists recognise four distinct clades, *Iguania* (iguanas, chameleons, agamas), *Gekkota* (geckos and their relatives), *Scincomorpha* (e.g. *Lacerta*, *Scincus*) and *Anguimorpha* (e.g. *Varanus*, *Anguis*), with a

fundamental early split (c. 200 Ma BP) between *Iguania* on one side and all other squamates (= *Scleroglossa*) on the other. Snakes typically group within *Anguimorpha*, but amphisbaenians are more problematic [7]. To complicate matters further, recent molecular analyses have proposed that *Scleroglossa* is not monophyletic and that *Iguania* is nested within it [8].

The earliest definitive archosaurs (*Archosauria*) arose more than 230 Ma BP, but their separation from the ancestors of lepidosaurs occurred before this. Archosaurs were the dominant group throughout the Mesozoic (250–265 myrs), culminating in three major clades – crocodylians, pterosaurs, and the dinosaurs/birds. However, extant birds and crocodylians represent end points of lineages that separated at least 230 Ma BP. Modern crocodiles are amphibious but early forms were small terrestrial reptiles with a parasagittal quadrupedal gait. In contrast, the first dinosaurs were small active bipeds. These diversified into the herbivorous *Ornithischia* (e.g. *Stegosaurus*, *Triceratops*, *Iguanodon*) and the *Saurischia*. The latter group, in turn, split to produce the quadrupedal herbivorous sauropods (e.g. *Diplodocus*, *Brachiosaurus*) and the bipedal,

predominantly carnivorous, theropods (e.g. *Tyrannosaurus*). One group of theropods evolved into a clade of active, small-bodied, large brained raptors (e.g. *Velociraptor*) that were the direct ancestors of birds.

The earliest recorded bird (*Aves*) is *Archaeopteryx* (c. 140 Ma BP). In many respects this animal was more like its dinosaurian forebears than modern birds (teeth, claws, bony tail), except that it was capable of flight (and had a brain to match). Modern birds seem to have undergone an explosive radiation around 50 Ma BP, and most modern groups (*Neornithes*) can be traced back to at least that time, or earlier [9]. The most primitive living birds are the ratites (*Palaeognathae*, e.g. ostriches, emus). Of “higher” birds (*Neognathae*, e.g. the group that encompasses ducks, geese and pheasants (*Galloanserae*) is thought to be basal [9], with a postulated divergence time of about 90 Ma BP. The remaining birds (*Neoaves*) fall into a series of groups for which the relationships are poorly resolved, but the large and diverse *Passeriformes* (e.g. sparrows, black-birds, robins) is probably the most derived.

### Synapsida

Synapsida, the second amniote division, is represented today by the mammals, but includes a wide range of extinct stem taxa. (Synapsida may be defined as incorporating all amniotes more closely related to living mammals than to living reptiles and birds; the term synapsid refers to the presence of one bony fenestra in the temporal region of the skull.) Indeed, the synapsids seem to have undergone the first successful amniote radiation, dominating early terrestrial ecosystems for more than 50 Ma. By 250 Ma BP, some of the most derived synapsids resembled mammals in having a parasagittal stance (that is with the body held upright on limbs that move parallel to the midline of the body, in contrast to the sprawling gait of many small reptiles and amphibians), a differentiated dentition, a hard palate to separate air and food, and bone histology suggestive of at least incipient endothermy. However, the end of the Permian period (c. 250 Ma) was marked by a cataclysmic extinction that destroyed about 80–96% of species, including many lineages of synapsids. In the period that followed, reptiles (and particularly archosaurs) gained the upper hand. Small synapsids survived, perhaps by adopting more nocturnal habits (driving the further evolution of mammalian endothermy, more acute hearing, dark-adapted cone rich retinae, and improved olfaction). A second major extinction at the end of the Cretaceous (65 Ma BP) decimated the reptile lineages and mammals regained control.

Living mammals fall into three major groups – the egg-laying *Monotremata*, the pouched *Marsupialia*, and the placentals (*Eutheria*), and thus *Mammalia* in the strict sense encompasses the last common ancestor of these three groups and all descendents of that

ancestor. *Monotremes* (*Platypus*, *Echidnas*) were once more widespread (e.g. South America) but are today restricted to Australia (earliest record c. 110 Ma BP), surviving on a continent that was not colonised by placentals until relatively recently. On the basis of fossil evidence (supported by molecular analyses), marsupials and placentals separated at least 130 Ma BP. Marsupials are today are restricted to Australia except for the American opossums (e.g. *Didelphis*), which probably separated c. 68–72 Ma BP. Placentals are more diverse. Morphological data suggests that the *Xenarthra* (sloths, armadillos, anteaters) are the most basal of living lineages, but several recent molecular studies instead recognise a basal African clade, *Afrotheria*, including elephants, tenrecs, elephant shrews, aardvarks and sirenians [10].

### References

1. Gradstein FM, Ogg JG (2004) Geological time scale 2004 – why, how and where next. *LETHAIA* 37:175–181
2. Allin EF (1975) Evolution of the mammalian ear. *J Morphol* 147:403–437
3. Rieppel O, de Braga M (1996) Turtles as diapsid reptiles. *Nature* 384:453–455
4. Lee MSY (1993) The origin of the turtle body plan: bridging a famous morphological gap. *Science* 261:1716–1721
5. Zardoya R, Meyer A (2001) The evolutionary position of turtles revised. *Naturwissenschaften* 88:193–200
6. Hedges SB, Poling LL (1999) A molecular phylogeny of reptiles. *Science* 283:998–1001
7. Kearney M, Stuart BL (2004) Repeated evolution of limblessness and digging heads in worm lizards revealed by DNA from old bones. *Proc R Soc B* 271:1677–1683
8. Townsend TM, Larson A, Louis E, Macey JR (2004) Molecular phylogenetics of Squamata: the position of snakes, amphisbaenians, and dibamids, and the root of the squamate tree. *Syst Biol* 53:735–757
9. Pereira SL, Baker AJ (2006) A molecular timescale for galliform birds accounting for uncertainty in time estimates and heterogeneity of rates of DNA substitutions across lineages and sites. *Mol Phylogenet Evol* 38:499–509
10. Asher RJ, Novacek MJ, Geisler JH (2003) Relationships of endemic African mammals and their fossil relatives based on morphological and molecular evidence. *J Mamm Evol* 10:131–194

---

## Evolution and Phylogeny of Vertebrates

SUSAN E. EVANS

Research Department of Cell and Developmental Biology, UCL, University College London, London, UK

### Synonyms

Evolution of vertebrates; Phylogeny

## Definition

The phylogeny of a group, in this case back-boned animals (vertebrates), represents the course of evolutionary change undergone by that group over time. It is typically represented in the form of a ▶ **dichotomous branching tree** in which the vertical axis represents time and the horizontal axis represents closeness of relationship (Fig. 1).

## Characteristics

### Underlying Methodology

The framework used here is cladistic. Groups must be monophyletic (including the common ancestor and all its descendents) and are diagnosed on the basis of shared ▶ **derived characters**. Only monophyletic groups are given formal scientific names. The primitive absence of a derived trait (e.g. the absence of jaws, absence of hair) cannot be used to group organisms. The use of paraphyletic, gradal, groups confuses the discussion of morphological evolution. For example, the old view that reptiles gave rise to mammals (instead of being their ▶ **sister group**) left many comparative anatomists trying to derive mammalian structures (e.g. the middle ear) directly from those of living reptiles, despite more than 300 million years of independent history.

Ages in millions of years before present (Ma BP) are based on the most recent geological timescale [1], but

should be regarded as minimum estimates reflecting the earliest known occurrence of a fossil group or its phylogenetic sister taxon. Given that individual geological strata cannot always be dated with precision, such dates should also be understood to carry error bars.

## Vertebrates

Vertebrates (backboned animals) are part of the wider group Chordata (see ▶ **Phylogeny and Evolution of Chordates**), characterized by the possession of an axial stiffening rod (notochord), a perforated pharynx, a dorsal hollow nerve cord, and a post-anal tail. Chordata has a long fossil record, the earliest known representatives occurring some 570 Ma BP. Today, only two groups of basal chordates survive – the Urochordata (e.g. ▶ *Ciona*) and the Cephalochordata (e.g. the lancelet, ▶ *Branchiostoma*). All remaining chordates are craniates (Craniata). The name acknowledges the common possession of an organized head with a brain, well-developed sense organs, cranial nerves, and the beginning of a skull (all linked to the evolution of ectodermal placodes and migratory neural crest).

Craniates are divided informally into ▶ **agnathans** and ▶ **Gnathostomata**. Agnathans are a gradal concept rather than a valid monophyletic group since they include a range of primitive craniates (mostly now extinct) that lack jaws. Some agnathans (e.g. the

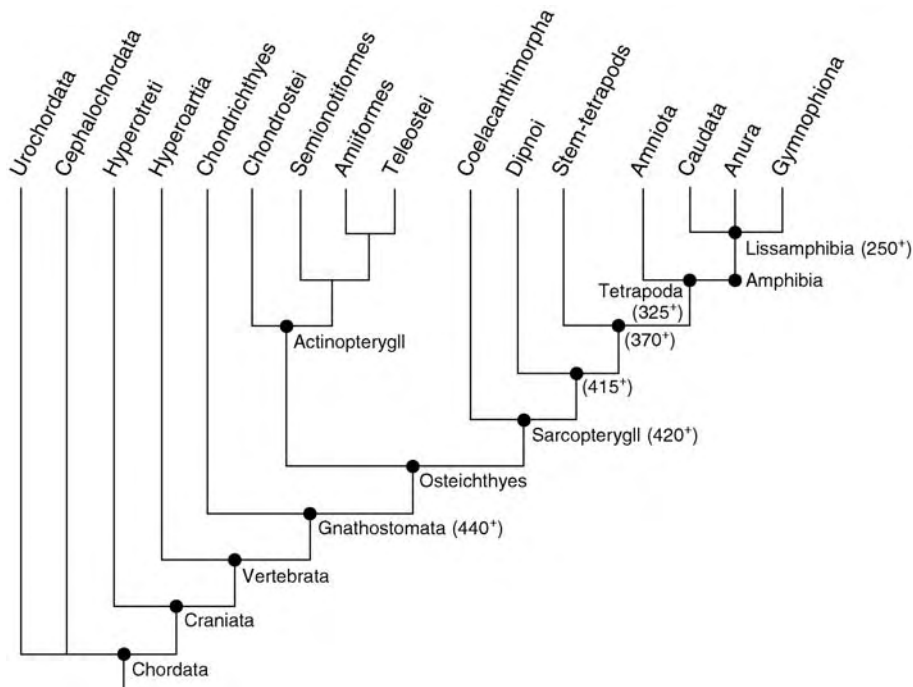

**Evolution and Phylogeny of Vertebrates. Figure 1** Tree showing relationships amongst major vertebrate groups. Clade names have been added to appropriate nodes. The numbers at some nodes represent the minimum age estimates (in millions of years) for the last common ancestor of the descendant lineages.

extinct ▶*osteostracans*) are more closely related to derived vertebrates (gnathostomes) than are others (e.g. lampreys). Today, only two agnathan lineages survive – the primitive hagfish (Hyperotreti) and the lampreys (Hyperoartia). However, researchers are divided as to whether lampreys are more closely related to hagfish (to form a monophyletic Cyclostomi [2,3]) or to gnathostomes [4]. Under the second hypothesis, lampreys and gnathostomes form the Vertebrata, while hagfish would be considered craniates but not vertebrates. Under the first, Craniata and Vertebrata are synonymous [2]. Fig. 1 illustrates the second hypothesis in order to clarify the conceptual distinction between craniate and vertebrate, but with the recognition that a monophyletic Cyclostomi is more widely accepted amongst neontologists.

### Gnathostomes

The evolution of jaws from gill arch (branchial arch) cartilages occurred at least 440 Ma BP. Unlike their predecessors, early gnathostomes were adapted to an active predatory niche, with paired pectoral and pelvic fins and a streamlined body shape. Aquatic fusiform gill-breathing gnathostomes are traditionally, and colloquially, called fish (and were once grouped as Pisces), but “fish” do not form a monophyletic group. A zebrafish is more closely related to a human than either is to a shark. All living “fish” are grouped into one of two major clades – the Chondrichthyes (with a cartilaginous skeleton, like sharks, rays [Elasmobranchii] and parrot-fish [Holocephali]), and Osteichthyes (with true bone). The monophyletic Osteichthyes includes ALL vertebrates with a bony endoskeleton, ranging from goldfish and lungfish through to dinosaurs, birds and monkeys.

Living osteichthyans are themselves subdivided, based on fin type, into Actinopterygii and Sarcopterygii that separated at least 420 Ma BP. Actinopterygii are the ray-finned fish. As the name suggests, this group encompasses fish in which the fins consist of a fan of delicate rays. The most derived actinopterygians are the teleosts (e.g. zebrafish, cod, tuna), but some members of more ancient stem clades have also survived, including Amiiformes (the bowfin, ▶*Amia*), Semionotiformes (gars, e.g., *Lepisosteus*), and Chondrostei (paddlefish, e.g., ▶*Polyodon*, and sturgeons, e.g., ▶*Acipenser*).

### Sarcopterygians

The Sarcopterygii, or lobe-fins, differ from actinopterygians in having a skeletal axis to the pectoral and pelvic appendages. The largest living group of sarcopterygians is comprised, of course, of the tetrapods, but two extant fish groups also fall into this clade – the Coelacanthimorpha or ▶*coelacanth*s (▶*Latimeria*) and the Dipnoi or lungfish (▶*Lepisodiren*, ▶*Neoceratodus*, ▶*Protopterus*). The freshwater lungfish, as the name suggests, have functional lungs, internal nostrils, and a pulmonary

circulation. Both lineages (lungfish and coelacanth) go back more than 415 Ma, but of the two, lungfish are probably the more closely related to tetrapods [but see 5], although not on the tetrapod stem. Paleontological and molecular evidence suggests a rapid diversification of the major sarcopterygian lineages, including the immediate fossil ancestors of tetrapods, within a relatively short space of time around 420–400 Ma BP [5].

### Tetrapods

In common parlance, a tetrapod is an animal with four limbs (tetra-pod), but Tetrapoda ▶*sensu stricto* encompasses the last common ancestor of living amphibians and living amniotes, and all descendants of that ancestor. This definition omits some of the earliest truly limbed vertebrates and these are best termed ▶*stem-tetrapods*. The earliest known stem-tetrapods date from the later part of the Devonian period, around 370 Ma (e.g. ▶*Acanthostega*, ▶*Ichthyostega*, [6]). They were still aquatic, using a combination of lung and gill breathing, like the living Australian lungfish, ▶*Neoceratodus*.

The main vertebrate colonization of the land appears to have begun during the Carboniferous (c. 340–320 Ma BP), perhaps coinciding with a sharp rise in atmospheric oxygen levels, and the fossil record documenting a gradual radiation of stem-tetrapods into available ▶*niches*. The phylogenetic tree is rather “bushy” at this stage, but two major lineages emerged: amphibians and amniotes. The latter clade includes all truly terrestrial groups (e.g. birds, tortoises, lizards and snakes, mammals) that possess an ▶*amniote egg* (or a derivative structure such as the placenta). This group is covered in more detail elsewhere (see ▶*The Phylogeny and Evolution of Amniota*). Amphibians are rather more challenging. Under traditional usage, Amphibia is a paraphyletic group for tetrapods that are not amniotes, but under a cladistic definition, Amphibia encompasses those tetrapods that are more closely related to living amphibians (frogs, salamanders, caecilians) than to amniotes. Unlike amniotes, they still generally require water to reproduce, typically have an aquatic larva, and undergo ▶*metamorphosis*. Paleontologists do not agree as to the ancestry of living forms. For neontologists, this is relatively unimportant except that it impacts on the timing of the divergence between the ancestors of Amphibia and of Amniota. Nonetheless, by any estimate, the last common ancestor of amniotes and amphibians lived more than 325 Ma BP [7].

Modern amphibians comprise of the Lissamphibia: frogs, salamanders and the limbless caecilians. The relationships of the three living clades are not fully resolved. Many workers place frogs (Salientia) and salamanders (Caudata) as close sister taxa but others argue for separate origins from distinct fossil lineages [7]. Caecilians are even more problematic: they may be the sister group of frogs plus salamanders (most

morphological analyses and some molecular ones), they may be the sister group of salamanders alone, or they may be unrelated [7]. This affects estimated divergence times for the three major groups (325–200 Ma BP). The earliest known fossil stem-frogs are recorded from c. 245 Ma BP, while the equivalent dates for salamanders and caecilians are 170 Ma BP and 190 Ma BP respectively [7,8].

Amongst living frogs, the North American ▶ *Asca-phus* and New Zealand ▶ *Leiopelma* represent the oldest and most basal lineages, followed by discoglossids (e.g. ▶ *Alytes*, *Discoglossus*), and then pipids (e.g. ▶ *Xenopus*), pelobatids and rhinophrynids. The most diverse and derived frog clade is the Neobatrachia (e.g. ▶ *Bufo*, *Hyla*, *Rana*). Fossil ascaphids have not been identified with certainty, but discoglossids are recorded with confidence from around 145 Ma BP, basal pipids from 120 Ma BP, and early neobatrachians from at least 80 Ma BP, these dates giving the latest possible divergence times for each lineage [9]. Living salamanders fall into two major groups, Cryptobranchioidea (e.g. ▶ *Cryptobranchus*, *Hynobius*) and Salamandroidea (e.g. ▶ *Salamandra*, *Ambystoma*) and, judging from recent fossil finds in China and the USA, these groups had already separated by at least 145 Ma BP. Nonetheless, the position of sirenids (e.g. ▶ *Siren*) is still uncertain (basal or highly derived, [6]), as are the interrelationships of living families. The fossil record of caecilians is extremely poor and no certain representative of modern families has been recovered from Mesozoic deposits.

## References

1. Gradstein FM, Ogg JG (2004) Geological time scale 2004—why, how and where next. *Lethaia* 37:75–181
2. Furlong RF, Holland PWH (2002) Bayesian phylogenetic analysis supports monophyly of Ambulacraria and of cyclostomes. *Zool Sci* 19:593–599
3. Takezaki N, Figueroa F, Zaleska-Rutczynska Z, Klein J (2003) Molecular phylogenetics of early vertebrates: monophyly of the agnathans as revealed by sequences of 35 genes. *Mol Biol Evol* 20:287–292
4. Janvier P (1996) The dawn of vertebrates: characters versus common ascent in current vertebrate phylogenies. *Palaeontology* 39:259–287
5. Takezaki N, Figueroa F, Zaleska-Rutczynska Z, Takahata N, Klein J (2004) The phylogenetic relationship of tetrapod, coelacanth and lungfish revealed by the sequences of 44 nuclear genes. *Mol Biol Evol* 21:1512–1524
6. Clack JA (2002) Gaining ground: the origin and evolution of tetrapods. Indiana University Press, Bloomington, Indiana
7. Frost DR, Grant T, Faivovich J, Bain RH, Haas A, Haddad CFB, de Sá RO, Channing A, Wilkinson M, Donnellan SC, Raxworthy CJ, Campbell JA, Blotto BL, Moler P, Drewes RC, Nussbaum RA, Lynch JD, Green DM, Wheeler WC (2006) The amphibian tree of life. *Bull Am Mus Nat Hist* 297:370 pp
8. Zhang P, Chen Y-Q, Zhou H, Wang X-L, Qu LH (2003) The complete mitochondrial genome of a relic salamander, *Ranodon sibiricus* (Amphibia, Caudata) and implications for amphibian phylogeny. *Mol Phylogenet Evol* 28:620–626
9. Roček Z (2000) Mesozoic anurans. In: Heatwole H, Carroll RL (eds) *Amphibian biology*, vol 4: Palaeontology. Surrey Beatty and Sons, Australia, pp 1295–1331

## Evolution and Phylogeny of Primates

ANN M. PALKOVICH

Krasnow Institute for Advanced Study, Department of Sociology and Anthropology, George Mason University, Fairfax, VA, USA

### Definition

The evolutionary lineage of arboreal placental mammals exhibiting sociality and stereoscopic, color vision as primary adaptations, taxonomically designated as “primates”.

### Characteristics

Primates represent a taxonomic order within the class Mammalia. Primates are characterized by a generalized mammalian limb structure including retention of pentadactylism (five digit hands and feet), a tendency toward vertical body posture and extensive head rotation ability. Limb mobility is facilitated by the unfused radius and ulna that maximizes forearm rotation, dorsally located scapulae accommodating free-swinging and suspensory arm motions and ball-and-socket joints of the hip accommodating climbing, quadrupedal and bipedal locomotion. Most primate species have tails (except great apes), with Platyrrhines (New World monkeys) exhibiting prehensile tails able to hold and manipulate objects. Hands and feet display enhanced grasping ability with friction skin on finger and palmer surfaces, sensitive tactile pads at fingertips, flat nails rather than rigid claws and varying degrees of thumb opposability. Eyes are generally enlarged compared to other mammals and enclosed in a complete bony ring with front-facing stereoscopic vision and varying degrees of sensitivity to low light levels. Color vision is also variable, being uniformly trichromatic in Catarrhines—Old World monkeys, great apes, and humans—but variably dichromatic or trichromatic among Platyrrhines [1]. Heterodont dentition (incisors, canines, premolars and molars) and a tooth count reduced from that of primitive mammals are features exhibited by all primates as are complete bony orbits. Reduced prognathism (i.e. projecting muzzle) of the lower face and jaws appears to be associated with a

marked disruption (circa 30%) in olfactory receptor genes, particularly in Old World monkeys and apes. The percentage of disrupted genes that disable olfactory receptors reaches nearly 60% in humans [2]. Strong selection for binocular color vision at the expense of smell may have enhanced preferential exploitation of fruits and flowers for catherhine and some platyrrhine primates subsisting in arboreal niches. The auditory bulla (forming the osseous case of the inner and middle ears) forms as an expansion of the petrous portion of the temporal bone rather than from a separate ossification center, a developmental feature apparently unique to primates. Sociality is characteristic of all primate species and is associated with longer gestation periods than most mammals, a lengthened period of maturation, low reproductive rate, parental care of offspring and a relatively long life span [3,4,5,6].

### Primate Origins Hypotheses

Two complementary hypotheses of primate origins stress the selective advantages of primates as visual predators. Cartmill's visual predation hypothesis states that the optic convergence of stereoscopic vision and dexterous extremities equip primates to focus on and capture insects and other small prey. He suggests primates became insect-hunting specialists rather than another arboreal mammalian lineage [7,8]. Alternatively, Sussman notes that some bats exhibit analogous primate-like visual systems yet subsist primarily on angiosperms rather than insects. With the burgeoning angiosperm diversity during the Paleocene filling tropical forests with abundant flowers and fruits, Sussman proposes that in tiny mammals depth-perception and color acuity combined with grasping ability proved highly successful in exploiting fruits and flowers on small terminal branches [9]. This angiosperm hypothesis accounts for the combination of early primate specializations equally well, leading other researchers to suggest a combined angiosperm-insect exploitation hypothesis. Emphasis on visual predation, small body size, exploitation of arboreal habitats and manipulative abilities of extremities suggest early primates depended on visual acuity to identify color distinctions in flowers and fruits on the small branches of trees while opportunistically eating insects drawn to these same food resources.

### Primate Phylogeny

Current interpretations identify two semiorders within the order Primates, the Euprimates (true primates) and the Plesiadapiformes (extinct and archaic predecessors to the Euprimates). DNA dating places the divergence of the order Primates from other placental animals around 90 million years ago. The Paleocene fossil *Purgatorius* (68 million years BP) is cited by some researchers as the earliest primate, predating the

Euprimates [10]. Plesiadapiformes or archaic primates exhibit primate-like molars yet have long, low crania lacking postorbital bars and procumbent rodent-like incisors. They also lack grasping hands and feet and retain rigid claws. These fossil species appear to exhibit adaptations distinct from later Euprimates. Having no extant counterparts, Plesiadapiformes have been placed taxonomically as a semiorder within the order Primates; however, their intermediate morphological status could easily place them in their own separate order. There is also speculation whether Plesiadapiformes are ancestral to Euprimates or whether they represent a sister lineage. Current fossil evidence does not allow us to unequivocally identify the ancestral primate lineage before the Eocene (55 million years ago). How closely related Euprimates may be to other mammalian orders [Scandentia (tree shrews), Chiroptera (bats) or Dermoptera (colugos or flying lemurs)] is also unknown, leading some scholars to lump these orders into an archontan clade [4,5,11,12].

The semiorder Euprimates is believed to have appeared during the early Eocene (approximately 55 myr), coincident with the appearance of other arboreal mammals. However, Euprimate fossils that clearly exhibit the suite of traits seen in extant primates are documented only from about 35 myr. Euprimates appear globally as an adaptive radiation. North American Euprimate forms only persist through the end of the Eocene before becoming extinct, while living primates are believed to represent descendant lineages that were established in Africa and Asia [3,5,11,12].

Two suborders—Strepsirhines and Haplorhines—are established by 53 myr (though some scholars place this divergence at approximately 25 myr). Strepsirhines ("wet-nosed" primates) are a cluster of small primates represented by four living families of lemurs and three additional families including lorises, pottos and galagos. The family Daubentoniidae is also included among the Strepsirhines, though its taxonomic history within the suborder is debated. Strepsirhines are characterized by long muzzles and sensory whiskers (tactile vibrissae), a mandibular toothcomb, relatively large olfactory lobes for their body size and a smaller brain to body ratio than Haplorhines. Strepsirhines also exhibit a frenulum that serves to anchor the upper lip to the face, thus limiting the range of facial expression in these species. Many Strepsirhines are also nocturnal, show enlarged eyes for their body size and have a light-reflecting retinal layer. All Strepsirhines exhibit a postorbital bar that serves to form a bony eye socket. Tarsiers have been previously classified along with lemurs, lorises, pottos and galagos in the suborder Prosimii (prosimians). It has since been demonstrated that tarsiers share an extensive list of traits with simians and thus have been reclassified into the Anthropoidea



with other monkeys and apes. However, tarsiers retain unfused mandibular symphyses, a three-cusp upper molar pattern, some clawed toes and nonopposable thumbs, which are characteristics of Strepsirhines. Cladistic coherence and a common ancestry for the Strepsirhines, which also places tarsiers as a distinct genetic outlier has also been recently demonstrated by mitochondrial sequence analyses and retroposon analyses (presence/absence analysis of RNA derived transposable elements which episodically insert at DNA locations within the genome) [13]. As a result, the suborder Strepsirhine now includes only non-tarsier forms once considered Prosimians [4,5,11,12,14,15].

Haplorhines (“dry-nosed” primates) represent the tarsiers (hyporder Tarsiiformes) and monkeys and apes (hyporder Anthropoidea), which are further organized into two infraorders, New World monkeys (Platyrrhini) and Old World monkeys and apes (Catarrhini). New World and Old World monkeys diverged as separate lineages during the Oligocene (35–40 myr). Haplorhines are characterized by shorter muzzles that lack prominent sensory whiskers, anterior dentition proportional to other teeth thus lacking a toothcomb, reduced olfactory lobes and a mobile upper lip with a greatly reduced or absent frenulum, which permits an enhanced range of facial expressions. Most Haplorhines are diurnal, lack a light-reflecting retinal layer and exhibit a retinal fovea, which heightens visual acuity. Haplorhines exhibit a complete bony orbit in contrast to the postorbital bar seen in Strepsirhines. Haplorhines also exhibit fused frontal bones, fused mandibular symphyses and a larger brain to body size ratio. Larger social groups exhibit more complex social interactions and a longer period of maternal dependence by offspring.

Living Platyrrhines (found in tropical Central and South America) are distinguished by round, lateral facing nostrils, three premolars in each dental quadrant and a body size intermediate between Strepsirhines and Catarrhines. Trichromatic or dichromatic color vision occurs for individuals within some species based on the particular complement of cone opsin genes [1]. Some cebus monkeys also have prehensile tails, while some callitrichid monkeys exhibit specialized compressed nails that form pseudoclaws [15]. Living Catarrhines (found in tropical Africa, India, Asia, Australia and nearby island chains) are distinguished by narrow anterior facing nostrils, two premolars in each dental quadrant and larger body size. A more limited range of shoulder movement is distinct from the hominoid arm swing and is related to the habitual quadrupedal arboreal locomotion of most smaller monkeys [4,5,6,11,12,15].

The superfamily Hominoidea are the largest bodied primates that appeared during the early Miocene (25 myr) and are represented by *Proconsul* and *Morotopithecus*

in the fossil record. They exhibit shorter torsos in comparison to limbs, broad chests, scapulae located dorsally and a broad range of motion in limbs that variously accommodates suspensory arboreal movement and brachiation as well as bipedality. Hominoids have no tails, exhibit the flattest facial profiles of all primates, have five cusp mandibular molars and show the greatest reduction in olfactory lobes. A higher brain to body size ratio, more highly convoluted cerebral cortex, more complex social behaviors, greater developmental immaturity of infants at birth, insight learning and self-recognition among hominids distinguish these species from other primates [4,5,6,11]. Molecular evidence shows Hylobatidae (gibbons and siamangs) experienced the earliest divergence from the Hominoid common ancestor at approximately 17 myr and subsequently show the strongest selection for arboreal life as a medium bodied brachiator. Divergence from a common lineage for other extant great apes based on DNA-DNA hybridization branching times places orangutans at 12 myr, gorillas at 9 myr and the ►*Pan-Homo* split at 7 myr. Molecular evidence also shows much closer phylogenetic affinities among great ape species that has led researchers to place all great apes into the family Hominidae. Taxonomic distinctions within Hominidae now parallel times of divergence, placing orangutans (subfamily Ponginae; genus *Pongo*) and gorillas (subfamily Gorillinae; genus *Gorilla*) into separate categories, acknowledging the close genetic similarities among chimpanzees, bonobos and humans (subfamily Homininae) and differentiating chimpanzees and bonobos (tribe Panini; genus *Pan*) from humans (tribe Hominini; genus *Homo*) at the taxonomic level of tribe. Divergence between chimpanzee and bonobo lineages appears to occur around 5 myr, shortly after the split with the genus *Homo* [12].

Retrogenes, also known as retrotransposons or processed pseudogenes are providing new insights into primate phylogeny and evolution. Retrogenes are common genetic elements in ancestral primates, as is generally true of mammalian genomes. At approximately 40 million years BP, retrotranspositional substitutions in ancestral primates accelerated to 30–200 times the rate observed for the previous 10 million years. This retrogene explosion appears to mark the beginning of the main adaptive radiation of higher primates (hyporder Anthropoidea), and occurs just prior to the establishment of Platyrrhines (New World monkeys) and Catarrhines (Old World monkeys) as separate infraorders [16,17,18,19]. These novel retrogene combinations may have promoted new simian phenotypes and lineages, as well as the appearance of new varieties of morphological complexity through domain specific positive selection. Recent studies also suggest that this abundance of new gene combinations may play a role in the rapid appearance of hominin

phenotypes through inactivating (or down regulating) conserved ancestral primate traits. For example, inactivation of the myosin heavy chain (MYH) associated with substantial reductions in masticatory muscles appears to have occurred at approximately 2.4 million years BP, thus removing contractile force constraints on craniofacial morphology [20]. Similar selective inactivation of the common mammalian sialic acid gene in brain tissue (hydroxylase inactivating substitution of CMP-Neu5Ac for CMP-Neu5Gc) occurs at approximately 2.8 million years BP [21,22]. Both of these proteomic events are coincident with a surge in hominin encephalization.

Monkeys most commonly used in scientific experimentation include baboons, marmosets, various species of macaques, capuchins and African green monkeys. Chimpanzees as well as bonobos, gorillas and orangutans continue to be used in biomedical and neuroscience experimentation despite the endangered status of these non-human great apes.

The following primate taxonomy represents current consensus among researchers for the phylogenetic and adaptative relationships among primates. Details and even broad characterizations of any taxonomy undergo continual review as additional fossils are recovered and new molecular studies reveal previous unknown phylogenetic relationships.

#### ORDER PRIMATES [4,22]

- Semi-Order Plesiadapiformes: archaic, extinct primate predecessors
  - Superfamily Paramomyoidea
  - Family Paromomyidae
  - Family Picrodontidae
  - Superfamily Plesiadapoidea
  - Family Plesiadapidae
  - Family Carpolestidae
  - Family Saxonellidae
- Semi-Order Euprimates
  - Suborder Strepsirhini lemurs, lorises, pottos, galagos, Aye-Aye
  - Infraorder Lemuriformes
  - Superfamily Lemuroidea
  - Family Lemuridae: lemurs
  - Family Lepilemuridae: sportive lemurs
  - Superfamily Indriodea
  - Family Indriidae: woolly lemurs
  - Family Lepilemuridae: sportive lemur
  - Family Daubentonidae: Aye-aye
  - Superfamily Lorisiformes
  - Family Lorisidae: lorises, pottos and allies
  - Family Galagidae: galagos
  - Family Cheirogaleidae: dwarf lemurs and mouse-lemurs
  - Suborder Haplorhini: tarsiers, monkeys and apes
    - Hyporder Tarsiiformes
    - Family Tarsiidae: tarsiers
    - Hyporder Anthropeoidea
    - Infraorder Platyrrhini: New World monkeys
    - Family Cebidae: marmosets, tamarins, capuchins and squirrel monkeys
    - Family Atelidae: howler, spider, sakis, owl monkeys and woolly monkeys
    - Infraorder Catarrhini
    - Superfamily Cercopithecoidea
    - Family Cercopithecidae: Old World monkeys (21 genera including macaques, colobus, langurs, baboons)
    - Superfamily Hominoidea
    - Family Hylobatidae: gibbons, siamangs
    - Family Hominidae: bonobos, chimpanzees, orangutans, gorillas, humans, all ancestral hominin fossils

#### References

1. Jacobs GH (2004) Comparative color vision. In: Chalupa LM, Werner JS (eds) *The visual neurosciences*. MIT, Cambridge, pp 962–973
2. Gilad Y, Wiebe V, Przeworski M, Lancett D, Paabo S (2004) Loss of olfactory receptor genes coincide with the acquisition of full trichromatic vision in primates. *Public Library of Science Biol* 2:120–125
3. Conroy G (1990) *Primate evolution*. Norton, New York
4. Delson E (2000) Classification of the primates. In: Delson E, Tattersall I, Van Couvering J, Brooks A (eds) *Encyclopedia of human evolution and prehistory*, 2nd edn. Garland, New York, pp 23–27
5. Delson E, Tattersall I (2000) Primates. In: Delson E, Tattersall I, Van Couvering J, Brooks A (eds) *Encyclopedia of human evolution and prehistory*, 2nd edn. Garland, New York, pp 590–595
6. Martin R (1990) *Primate origins and evolution*. Princeton University Press, Princeton
7. Cartmill M (1974) Rethinking primate origins. *Science* 184:436–443
8. Cartmill M (1992) New views on primate origins. *Evol Anthropol* 1:105–111
9. Sussman R (1991) Primate origins and the evolution of angiosperms. *Am J Primatol* 23:209–223
10. Tavare S, Marshall C, Will O, Solige C, Martin R (2000) Using the fossil record to estimate the age of the last common ancestor of extant primates. *Nature* 416:726–729
11. Grove C (2001) *Primate taxonomy*. Smithsonian Institution, Washington
12. Hartwig W (ed) (2002) *The primate fossil record*. Cambridge University Press, Cambridge
13. Roos C, Schmitz J, Zischler H (2003) Primate jumping genes elucidate strepsirrhine phylogeny. *Proc Natl Acad Sci USA* 101:10650–10654
14. Martin (2003) Combing the primate record. *Nature* 422:388–391
15. Sargis E (2002) Primate origins nailed. *Science* 298:1564–1565

16. Enard W, Khaitovich P, Klose J, Zollner S, Heissig F, Giavalisco P, Nieselt-Struwe K, Muchmore E, Varki A, Ravid R, Doxiadis G, Bontrop R, Paabo S (2002) Intra- and interspecific variation in primate gene expression patterns. *Science* 296(5566):340–343
17. Ohshima K, Hattori M, Yada T, Gojobori T, Sakaki Y, Okada N (2003) Whole-genome screening indicates a possible burst of formation of processed pseudogenes and Alu repeats by particular L1 subfamilies in ancestral primates. *Genome Biol* 4(11):R74–R84
18. Sonnenburg J, Altheide T, Varki A (2004) A uniquely human consequence of domain-specific functional adaptation in a sialic acid-binding receptor. *Glycobiol* 14(4): 339–346
19. Vallender E, Lahn B (2004) Positive selection on human genome. *Hum Mol Genet* 13(2):R245–R254
20. Hansell S, Kozyak B, Nelson A, Thesier D, Su L, Low D, Bridges C, Shrager J, Minugh-Purvis N, Mitchell N (2004) Myosin gene mutation correlates with anatomical changes in the human lineage. *Nature* 428 (6981):415–418
21. Chou H, Takematsu H, Diaz S, Iber J, Nickerson E, Wright K, Muchmore E, Nelson D, Warren S, Varki A (1998) A mutation in human CMP-sialic acid hydroxylase occurred after the Homo-Pan divergence. *Proc Natl Acad Sci USA* 95:11751–11756
22. Chou H, Hayakawa T, Diaz S, Krings M, Indriati E, Leakey M, Paabo S, Satta Y, Takahata N, Varki A (2002) Inactivation of CMP-N-acetylneuraminic acid hydroxylase occurred prior to brain expansions during human evolution. *Proc Natl Acad Sci USA* 99:11736–11741

## Evolution and Phylogeny of Chordates

JON MALLATT

School of Biological Sciences, Washington State University, Pullman, Washington, WA, USA

### Synonyms

Phylogeny; Phylogeny and evolution of chordates

### Definition

Chordates are the group of animals to which vertebrates including humans belong. Like so many other phyla of ► *bilaterian animals*, they originated in the ocean over 520 million years ago, before or during the Cambrian period. Their early evolution is of interest to neuroscientists because this was when the basic structure of the vertebrate brain and spinal cord was assembled. Early chordates were soft-bodied so they seldom fossilized, but we reconstruct their origin using the modern chordates and their relatives plus some miraculously preserved fossils.

Living chordates consist of three subgroups: (i) the vertebrates (informally, the fishes, amphibians, reptiles

and mammals), (ii) cephalochordates (also known as amphioxus or lancelets) and (iii) tunicates (or urochordates, including “sea squirts”). Representatives of these three subgroups are shown in [Figs. 1](#) and [2](#). The chordates belong to a larger group of animals called deuterostomes, whose other members are the hemichordates (such as enteropneusts or “acorn worms:” [Fig. 1h](#)), echinoderms (the crinoid sea lilies, the sea stars, sea urchins, etc.), and a rare worm-like animal called *Xenoturbella* ([Fig. 2](#)) [[3](#)].

### Characteristics

#### Descriptions of the Structures and Animals

##### Structures

At some time in their life cycle, all chordates have five major structures, some of which they share with the other deuterostome animals. These chordate-defining structures are: (i) a dorsal, hollow nerve cord, (ii) a notochord, (iii) pharyngeal slits or pouches, (iv) an endostyle or thyroid gland and (v) a tail behind the anus. These are shown in the various chordates in [Fig. 1](#) and will now be considered.

The dorsal, hollow nerve cord develops from the ectoderm layer of the back in chordate embryos, usually as a tubular invagination, and then becomes the brain in the head and the spinal cord in the neck and trunk. The brain is associated with special sensory receptors that detect light and other stimuli.

The notochord is a turgid stiffening rod in the back. In vertebrates, the notochord forms in the embryo, marks the position of the backbone and is then mostly replaced by the vertebrae. However, in the invertebrate chordates and in a few fishes that do not develop complete vertebrae, the notochord remains complete throughout life and is important for swimming. Not compressible from front to back but bendable from side to side, it allows swimming by lateral undulations of the body. Incidentally, human biologists might be interested to know that the human notochord forms the springy nucleus pulposus in each intervertebral disc of the backbone; this nucleus bursts out in the common back injury called a herniated or slipped disc.

In the primitively aquatic chordates (tunicates, cephalochordates, fishes and larval amphibians), the pharyngeal slits allow water that has entered the mouth to leave the body through the pharynx. This function is important for ventilation in fishes, but it is also a part of suspension feeding (filtering tiny algae, bacteria and detritus particles from the ventilatory water), which is the feeding mode of all the invertebrate chordates. In chordate embryos, the pharyngeal slits form as openings in lateral outpocketings of the pharynx, the pharyngeal pouches. Land vertebrates do not have gills or gill slits, but they form pharyngeal pouches ([Fig. 1a](#)), which develop into structures such as the middle ear, a tonsil, the thymus and the parathyroid glands.

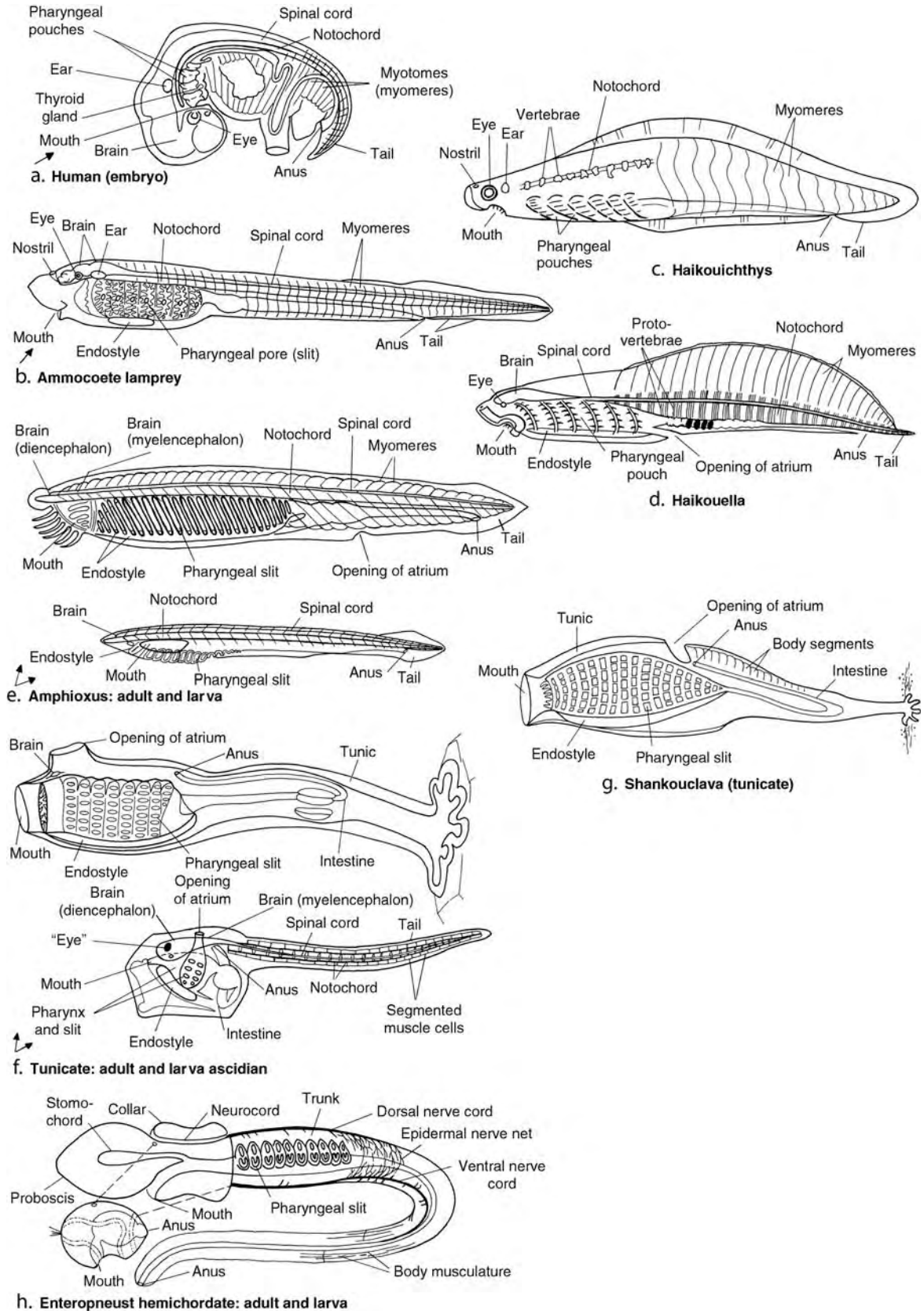

Evolution and Phylogeny of Chordates. Figure 1 (Continued)

The endostyle is a longitudinal groove in the midline of the floor of the pharynx in the primitively suspension-feeding chordates (Fig. 1b, d–g). A kind of salivary gland, it secretes food-trapping mucus and digestive enzymes for suspension feeding, but it also gathers iodine, makes thyroid hormone and is ►*homologous* to the thyroid gland of vertebrates.

The chordate tail, projecting posterior to the anus, is muscular and participates in swimming and other movements of the body.

In addition to their five main structures, all chordate groups have muscle segments along each side of the body and in most groups these segments contract in series to propel the animal by lateral undulation. In the tunicates, these segments are so small that each is just one muscle cell (see the discussion of tunicate larvae below), but in all other chordates the segments are larger blocks of muscle called myomeres (Fig. 1). The primitively aquatic chordates also have vertical ►*fins* which are related to their swimming movements.

The different groups of chordates, in which the above structures are developed to a greater or lesser degree, will be considered next [6, 7, 8, 9].

### Animals

**Vertebrates** Humans possess all the chordate structures, as best seen in a human embryo in the fifth week of development (Fig. 1a). For exploring chordate origins, however, the vertebrates are better represented by a jawless fish, a young lamprey. This is the ammocoete ►*larva* (Fig. 1b), and it is not an embryo but a life-stage that lasts several years before it metamorphoses into an adult lamprey. The ammocoete lives burrowed in the sediment of streams, is a suspension feeder and has all the chordate structures. It also has the structures that are unique to the vertebrates, including a skull, fish gills, paired lateral eyes, ear structures, an olfactory organ and a vertebrate brain that includes a telencephalon and mesencephalon as well as a diencephalon and myelencephalon. Most of these vertebrate-specific structures develop from embryonic “neural folds” [10], which are absent from the invertebrate chordates (see ►*Evolution of neural crest and neurogenic placodes*).

Vertebrates also have ►*vertebrae*, segmented pieces of skeleton that lie along, or mostly replace, the notochord. Such vertebral elements form when the ammocoete lamprey becomes an adult, but more

significantly, they are also present in the oldest known vertebrate animal, the jawless fossil fish, ►*Haikouichthys* (Fig. 1c) [11]. *Haikouichthys* is from the Maotianshan shale of South China. This shale dates to the Early Cambrian, 520 or 530 million years ago. It was laid down in the shallow ocean and documents the first appearance of whole-body fossils of various phyla in the fossil record. Thus, *Haikouichthys* shows that the first vertebrates did possess the defining structures of the vertebrate group.

**Haikouella** Another fossil animal from the Maotianshan shale is *Haikouella lanceolatum* (Fig. 1d) [12], not to be confused with the similarly named *Haikouichthys* above. *Haikouella* is represented by many remarkably preserved specimens that reveal its anatomical structures in exceptional detail. Its well-developed head resembles that of an ammocoete lamprey. All the chordate-defining structures can be identified in *Haikouella*, plus a remarkably large brain, gills and “proto-vertebrae” that suggest vertebrae evolved early in the line to vertebrates. However, *Haikouella* lacks some features of vertebrates, such as a skull, ear and large telencephalon, so phylogenetic studies show it to be the nearest-known relative of vertebrates rather than a true vertebrate. Details of its mouth and pharynx indicate it was a suspension feeder, as are all other invertebrate chordates.

**Cephalochordates** Amphioxus (Fig. 1e) is a fish-like invertebrate that lives burrowed in coarse sands in the shallow ocean, suspension feeding on particles in the water that flows between the sand grains. Able to undulate through the sediment and to swim rapidly in the water column if dug up, amphioxus has all the chordate structures, including the locomotory myomeres, notochord and tail [6]. Its brain, head region and cranial sensory organs are much less developed than those of vertebrates. In fact, the brain is only a slightly widened part of the nerve cord and was not confirmed as a real, chordate brain until the 1990s, when ultrastructural and developmental studies showed it to consist of a diencephalon and a myelencephalon [13].

Despite some candidate fossils, cephalochordates have not been identified with certainty in the fossil record [7].

**Urochordates** Tunicates are highly specialized chordates and in many ways, the most unusual [5, 6]. They are covered by a tunic, which is a living, growing, vascularized coat of proteins and of carbohydrates that

**Evolution and Phylogeny of Chordates. Figure 1** Various chordates, with some of their larvae and relatives. Living animals are in the *left* column, and fossil animals from the Early Cambrian are in the *right* column. Redrawn from various sources. The tunicates shown in part f are ascidians, of the aplousobranchiate subgroup. In part h, *dashed lines* are used to show corresponding points on the bodies of the adult and larval hemichordates. Recent studies [1,2] confirm that the dorsoventral axis of chordates is inverted compared to that of hemichordates, so the enteropneust (h) should be flipped over for comparison with the chordates (a–g). To give some idea of sizes, all the adult animals shown here are several centimeters long in life and were drawn to roughly the same scale.

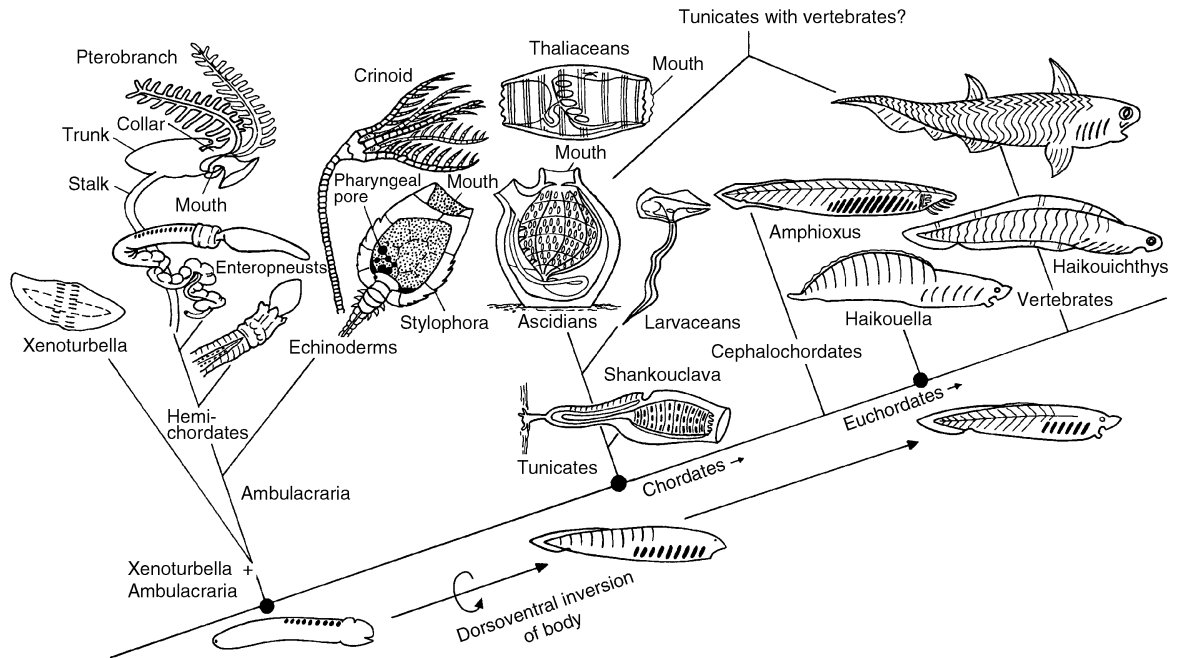

**Evolution and Phylogeny of Chordates. Figure 2** Phylogenetic tree showing the relationships among deuterostomes and chordates. This tree was derived from morphological and molecular-phylogenetic evidence [e.g., in 3, 4]. Three hypothetical, reconstructed ancestors are shown along the backbone of the tree, at the bottom and correspond to the three nodes at the large black dots. All the other animals are real except for the un-named fish at the **far upper right**, which is a reconstruction of the first jawed vertebrate. The bodies of all the animals are oriented with their cranial/mouth end pointing to the **right**, except for the ascidian tunicate, whose mouth points **upward**. “Euchordates” comprise the cephalochordates, **Haikouella**, and vertebrates; however, some recent evidence suggests instead that tunicates are closer to vertebrates (and to **Haikouella**) than are cephalochordates [5]. The various animals are not drawn to the same scale.

resemble plant cellulose in most tunicate groups. The group of tunicates that is most comparable to other chordates is the ascidians (Fig. 1f). Adult ascidians are sessile, not capable of real locomotion and live anchored to ocean substrates as they suspension-feed with their large pharyngeal basket. As adults (Fig. 1f, top), they have only a remnant of the brain (a cerebral ganglion and “neural gland”) and no spinal cord, notochord, muscle segments or tail. As motile, swimming larvae, however, they have all these chordate structures (Fig. 1f, bottom). Furthermore, the brain of some ascidian larvae (the aplousobranchiates) is rather elaborate, with external bulges that define diencephalon and myelencephalon parts [13].

Besides ascidians, tunicates have two other subgroups, thaliaceans and larvaceans (Fig. 2).

Both of these are motile, but neither resembles other chordates as closely as ascidians do. The barrel-shaped thaliaceans (which include the salps) evolved from ascidians, as indicated by sequence data from their genes [4]. The small larvaceans are rapidly developing and short-lived in the extreme. Despite their tadpole-shape and swimming tail, their anatomy and genome are so

unusual that it seems best to view larvaceans as derived and specialized animals, not as models of the ancestral chordates as some scientists have done in the past.

Recently, a convincing fossil tunicate was discovered, *Shankouclava*, from the Cambrian Maotianshan shale (Fig. 1g) [14]. Significantly, it resembles aplousobranchiate ascidians (Fig. 1f), whose bodies are longer and less pharynx-dominated than those of other ascidians. Most intriguingly, although the *Shankouclava* specimens are adults, they show segments along the dorsal body, reminiscent of myomeres (although the true nature of these segments cannot be discerned from the fossil material). Overall, *Shankouclava* suggests that tunicates evolved from an ancestor with a more elongate and more typically chordate body.

**Other Deuterostomes** Hemichordates are not chordates, but are related deuterostomes that have a few chordate structures [6, 15]. Their body is divided into three parts, which are called the proboscis, collar and trunk in the major group of hemichordates, the enteropneust worms (Fig. 1h). Enteropneusts live on the ocean bottom, many in burrows and others under shells or rocks. They are motile and can crawl; some

deep-sea species forage for food particles along the ocean floor. Enteropneusts include both suspension feeders and deposit feeders.

It is debatable whether hemichordates have a dorsal, hollow nerve cord. Their nervous system consists of a net of neurons in the epidermis over the entire body (Fig. 1h). This net includes both a dorsal and a ventral nerve cord, but these cords are solid rather than hollow. In the collar region, however, the dorsal cord folds inward to form a tubular neurocord or collar cord, suggesting it corresponds to the chordate nerve cord, which develops in the same way. Unlike the nerve cord, however, the neurocord is restricted in location and seems only to conduct signals rather than to process information. Given these differences, most authorities do not equate the hemichordate neurocord with the chordate nerve cord [15].

Hemichordates also have a notochord-like structure, the stomochord, which projects from the roof of the oral cavity into the proboscis (Fig. 1h). The notochord of chordates similarly develops from the roof of the digestive tube and its microscopic anatomy resembles that of the stomochord in considerable detail; both are collections of vacuolated cells surrounded by a sheath of connective tissue. Even so, the stomochord and notochord have different locations relative to nearby vascular and nervous structures and do not express the same genes as they develop [2], raising doubt as to whether they are homologous structures.

Actually, these questions of homology are answered by recent studies of embryonic development of enteropneust hemichordates. These studies, by Christopher J. Lowe and others [1, 2, 9], mapped the expression domains of the genes that pattern the dorsoventral arrangement of the body (especially, of genes for bone-morphogenic proteins and for chordin). The findings revealed that the ventral side of the hemichordate body corresponds to the dorsal side of the chordate body, and vice-versa (even though the anteroposterior pattern of development defining the head and tail ends is the same in the two groups of animals). What's more, the dorsoventral pattern of the hemichordate body matches that of all other bilaterian animals, so this pattern must be ancestral, and the chordates must have turned over so that their original back surface became their belly surface. This upholds the fundamental correctness of an old and controversial idea that chordates are "upside-down" compared to arthropods and other non-chordate invertebrates (see [1] for references). All this means that the stomochord and neurocord of hemichordates are not on the same side of the body as are the notochord and nerve cord of chordates, so these structures cannot be homologous in the two groups of animals. Other implications of the apparent flip in the dorsoventral orientation of chordates will be considered later in this essay.

Hemichordates do have the chordate character of a pharynx pierced by pharyngeal slits. These slits and the pharyngeal bars between them are remarkably similar to those of cephalochordates. No iodine-binding endostyle exists in hemichordates, however.

The body musculature of enteropneusts mostly runs longitudinally and is not divided into segments. These worms move by shortening and lengthening their body and proboscis, not by undulation. Juveniles of some species have a tail behind the anus [2] but no adult enteropneust has a post-anal tail.

Besides the enteropneust worms, the other group of hemichordates is the pterobranchs ("sea angels;" Fig. 2) [6]. These are tiny animals, minimally mobile or sessile, that live in colonies in a network of cuticular tubes, mostly in the deep ocean. The body of a pterobranch resembles a bag on a stalk, with tentacled, filtering arms projecting from the collar region of the bag. The gill slits are reduced, with some pterobranchs having a single pair, others having none. Phylogenetic studies based on ribosomal rRNA genes suggest that pterobranchs evolved from one subgroup of enteropneust worms [4].

No body fossils of hemichordates are known, although the tubes of some pterobranchs are known from the Paleozoic Era about 500 to 300 million years ago and are named graptolites.

Hemichordates were long thought to be the closest relatives of chordates, but recent developmental and molecular-phylogenetic studies indicate they are closer to echinoderms instead [4, 7]. The name for this "hemichordate and echinoderm" group is Ambulacraria (Fig. 2). This grouping could mean that echinoderms evolved from enteropneust-like worms, and indeed, some fossil echinoderms from the Early Paleozoic, called Stylophora, had pharyngeal slits or pores and bodies that were more elongated and closer to bilaterally symmetrical than the bodies of later echinoderms (Fig. 2). The idea that the common ancestor of echinoderms and hemichordates was a worm is supported by the fact that *Xenoturbella*, recently found to be the closest relative of these Ambulacraria [3], is itself wormlike (Fig. 2).

## Higher Level Processes

### Steps in the Origin of the Chordates

Throughout most of the twentieth century, biologists focused on the facts that many of the deuterostome groups are inactive, sessile animals shaped like sacs (pterobranchs, echinoderms represented by the crinoid sea lilies and adult ascidians) and that the swimming, streamlined larvae of ascidian tunicates have all the chordate-locomotory structures that adult ascidians lack (Fig. 1f). This focus led such scientists as W. Garstang, N.J. Berrill and A.S. Romer to conclude that ▶larval evolution was the key to the origin of the chordates and

the vertebrates [4, 8]. That is, adults of pre-chordates and early chordates were said to have been sessile “sacs” but then a swimming tunicate-larva gained the ability to reproduce (through ▶*progenesis*) and thus became a swimming adult; the original, sessile adult stage was eliminated and this tunicate gave rise to the mobile cephalochordates and vertebrates. In this view, studying the evolution of the nervous system involved a straightforward exploration of how the simpler system of hemichordates could have evolved into the slightly more complex and centralized system of larval tunicates and then into the increasingly complex systems of cephalochordates and vertebrates. This approach was not very successful, however, because the nervous systems of hemichordates and chordates are too dissimilar to compare easily and because it was not yet known that tunicates and cephalochordates have true brains. Another problem with the idea that vertebrates evolved from larval tunicates is that the latter do not express certain genes needed to form the body plan of bilaterian animals, implying that tunicates could not give rise to the vertebrate body [16].

The current understanding of deuterostome inter-relationships, built on molecular-phylogenetic data as well as anatomical evidence, suggests a different scenario for the origin of chordates (Fig. 2). As documented in the figure, most of the deuterostomes with sessile adults are more derived than was previously expected; that is, the pterobranchs, echinoderms and modern ascidians are high up at the end branches of the tree and do not represent basal or “primitive” animals, as was formerly believed. Instead, mobile worm-like and fish-like animals occupy these basal positions, as reconstructed at the three black dots in Fig. 2.

This leads to a simpler story of chordate and vertebrate evolution, as it occurred right before the Cambrian Period [10, 16]. At first, ancestral deuterostomes were mobile, bottom-dwelling, suspension-feeding worms with pharyngeal slits (roughly resembling enteropneusts); interestingly, at this time the ocean bottoms throughout the world were covered with a thick film or suspension of bacteria and other microorganisms (a “microbial mat”) that could have supplied the food for such worms. Next, some of these early deuterostomes became more active and able to swim through the water above the ocean bottom, perhaps traveling back and forth among the most food-rich spots of the microbial mat. These swimmers were the first chordates, roughly resembling amphioxus in body form. They then gave rise to cephalochordates and the highly active vertebrates. Although the animals along the main line became progressively more active, many offshoots by contrast became less active or sessile, at least as adults: e.g., the echinoderms, pterobranchs, the sessile ascidians and even the cephalochordates when they became burrowers.

To this scenario must be added an explanation of why pre-chordates flipped their body dorsoventrally when evolving into chordates [1, 2]. This is better explained in terms of gradual adaptive changes in the life style of the lineage rather than being attributed to some abrupt, macro-evolutionary shift in developmental patterning. Three possible explanations come to mind. First, pre-chordate worms may have gone through a stage where they stopped lying and moving horizontally on the ocean floor but shifted to live only in vertical burrows. After eons of time, when the animals once again came to lie horizontally, they did so by chance on the opposite side of their body [1]. However, the special features of the chordate body do not suggest adaptation for extreme burrowing but instead for better swimming, raising a second possibility, i.e. that the first chordates, when they began swimming in the water column, swam on their backs. A modern analogy is that many branchiopod crustaceans such as fairy shrimps do swim belly-up like this. A third possibility is that in the original, worm-like deuterostomes and pre-chordates the dorsal and ventral surfaces of the body did not differ much from one another in their anatomy, so it made little difference how these animals lay on the ocean floor, whether on their bellies, backs or sides and it was only by chance that the chordate line began to orient their originally lower surface upward.

Actually, the difficult part of explaining the dorso-ventral inversion of chordates involves the mouth [1, 17]. The mouths of hemichordates and most non-chordate bilaterians are on the ventral surface of their body, so the inversion should have placed the chordate mouth dorsally – but this did not happen, as the mouth of chordates is ventral. To resolve this contradiction, most workers proposed that after the body inverted the chordate mouth moved around or through the body from dorsal to ventral [1, 17], perhaps to make room for the evolving and enlarging brain, or that there was an intermediate stage with two mouths, both a dorsal and a ventral one. A simpler explanation, however, is that the original mouth of ancestral deuterostomes and pre-chordates was neither dorsal nor ventral but terminal, lying at the very anterior end of the worm’s body. Only later did it migrate to the ventral location, independently in the chordates and non-chordates. This would solve the conundrum and an ancestrally terminal mouth is not impossible, given that many known worms do have terminal mouths (e.g., earthworms and nematodes).

Another thing should be noted about the scenario of chordate origins proposed here (Fig. 2). It views suspension feeding as a constant feature of all the early deuterostome and chordate groups. That is, all were suspension feeders until much later in the evolutionary radiation when advanced vertebrates and echinoderms adopted predation or other feeding modes.



### Implications of the Model

A scenario of chordate origins in which chordates evolved from hemichordate-like worms, rather than from tunicate larvae, has been presented. How does this new view affect understanding of the early evolution of chordate structures, especially of the nervous system? First, it shifts the focus from larval tunicates (old view) to amphioxus as the best proxy for the first chordate animal. Second, it implies that the nervous system of adult and larval tunicates is secondarily modified or simplified, so a straight line cannot be drawn from enteropneusts to tunicates to amphioxus in reconstructing the evolution of nervous structures.

As amphioxus moves to center stage, it is worth noting that the near-vertebrate *Haikouella* shares several body structures with amphioxus (e.g., see the “opening of atrium” in Fig. 1d, e), as well as having many vertebrate structures. This implies that amphioxus is not only a good model for the first chordates, but also for the ancestor of ►vertebrates. However, we must not jump to the conclusion that either one of these ancestors was exactly like amphioxus, because our scenario also implies the cephalochordate line lost some of its neural complexity when it switched from free-swimming to burrowing and living in sediment. The brain and cranial-sensory organs of amphioxus could have been secondarily reduced by an amount that is difficult to determine.

New ►phylogenomic studies that compare large numbers of genes across deuterostomes suggest that tunicates, although their body is highly modified, are actually more closely related to the vertebrates than is amphioxus [3, 5]. The problem is still under investigation, but if the proposed grouping of tunicates with vertebrates proves true, it will shift cephalochordates one step farther down the tree (Fig. 2) and will reinforce the current view that amphioxus resembles the earliest chordates.

Although the idea that amphioxus approximates the ancestral chordate will help to direct future research, it also reveals a disappointing gap in the available evidence. In reconstructing the initial evolution of Chordata, one is now forced to derive an amphioxus-like body from that of a (inverted) hemichordate and with no fossils to help. Although these two animals show similarities in their pharynx and in the development of their mesoderm, they differ from one another in most other organ systems (Fig. 1). These evolutionary gaps may be too wide for scientists to fill with any certainty. Most frustrating is the gap between their nervous systems: Except in very general terms it could prove too difficult to reconstruct how an extended, epidermal nerve net like that in hemichordates evolved into the highly organized and condensed central nervous system of amphioxus and other chordates.

This barrier to reconstructing the evolution of the chordate nervous system could be removed by recent

findings from non-deuterostome annelid worms [18], which indicate that the common ancestor of all bilaterian animals already had a complex central nervous system (CNS), with specific neuron types shared by both chordates and annelids. This finding implies that the hemichordate line uniquely lost this CNS in favor of a secondarily simplified nerve net, making hemichordates irrelevant to the question of interest. Instead, key information on the origin of the chordate CNS could be found in the non-deuterostome invertebrates after all.

The topic of nervous-system evolution is considered further and from a different perspective in ►Evolution of the brain: at the invertebrate-vertebrate transition.

### References

1. Lowe CJ, Terasaki M, Wu M et al (2006) Dorsoventral patterning in hemichordates: insights into early chordate evolution. *P LoS Biol* 4:1603–1619
2. Gerhart J (2006) The deuterostome ancestor. *J cell Physiol* 209:677–685
3. Bourlat SJ, Juliusdottir T, Lowe CJ et al (2006) Deuterostome phylogeny reveals monophyletic chordates and the new phylum Xenoturbellida. *Nature* 444:85–88
4. Winchell CJ, Sullivan J, Cameron CB, Swalla B, Mallatt J (2002) Evaluating hypotheses of deuterostome phylogeny and chordate evolution with new LSU and SSU ribosomal DNA data. *Mol Biol Evol* 19:762–776
5. Delsuc F, Brinkmann H, Chourrout D, Philippe H (2006) Tunicates and not cephalochordates are the closest living relatives of vertebrates. *Nature* 439:965–968
6. Harrison FW, Ruppert EE (eds) (1997) *Microscopic anatomy of invertebrates*, vol 15. Wiley, New York
7. Holland ND (2005) Chordates. *Curr Biol* 15:R911–R914
8. Kardong KV (2006) *Vertebrates: comparative anatomy, function, evolution*, 4th edn. McGraw Hill, Boston
9. Ruppert EE, Fox RS, Barnes RD (2004) *Invertebrate zoology, a functional evolutionary approach*, 7th edn. Thomson Brooks/Cole, Belmont
10. Northcutt RG (2005) The new head hypothesis revisited. *J Exp Zool* 304B:274–297
11. Shu DG, Conway Morris S, Han J, Zhang ZF, Yasul K, Janvier P, Chen L, Zhang XL, Liu JN, Li Y, Liu HQ (2003) Head and backbone of the Early Cambrian vertebrate *Haikouichthys*. *Nature* 421:526–529
12. Mallatt J, Chen JY (2003) Fossil sister group of craniates: predicted and found. *J Morphol* 258:1–32
13. LaCalli TC (2001) New perspectives on the evolution of protochordate sensory and locomotory systems, and the origin of brains and heads. *Philos Trans R Soc Lond B Biol Sci* 356:1565–1572
14. Chen JY, Huang DY, Peng QQ, Chi HM, Wang XQ, Feng M (2004) The first tunicate from the Early Cambrian of South China. *Proc Natl Acad Sci USA* 100:8314–8318
15. Ruppert EE (2005) Key characters uniting hemichordates and chordates: homologies or homoplasies? *Can J Zool* 83:8–23
16. LaCalli TC (2005) Protochordate body plan and the evolutionary role of larvae: old controversies resolved? *Can J Zool* 83:216–224

17. LaCalli TC (2008) Basic features of the ancestral chordate brain. *Brain Res Bull* 75:319–323
18. Denes AS, Jékely G, Steinmetz PRH et al (2007) Molecular architecture of annelid nerve cord supports common origin of nervous system centralization in Bilateria. *Cell* 129:277–288

## Evolution and the Concept of Homology

ANN B. BUTLER

Department of Molecular Neuroscience, Krasnow Institute for Advanced Study, George Mason University, Fairfax, VA, USA

### Definition

Homology was originally defined by Richard Owen in 1843 as “the same organ in different animals under every variety of form and function” [1]. Its current most common usage is in the sense of phylogenetic homology, which requires presence of the phenotypic character (or trait) in the common ancestor and continuity of its expression along an evolutionary lineage and across the members of the taxon. Other definitions that focus on continuity of information, i.e., the genetic and developmental bases for a given character, are coming into use as the close relationships between evolution and embryological development are increasingly appreciated.

### Characteristics

#### The Concept of Homology

While the term analogy refers to similarity of function and can be applied regardless of phylogenetic relationships, the term homology is predominantly applied to structural characters, irrespective of possible functional differences but tied, in one way or another, to the phylogenetic relationships of the animals in which they are present. Richard Owen’s use of the word “same” in his pre-Darwinian, 1843 definition of homology [1], “the same organ in different animals under every variety of form and function,” recently has come to be appreciated from a new perspective due to the wealth of new developmental data on gene expression patterns now available.

Consider, for example, the word “eye.” This word has been applied to the paired, complexly structured ommatidial photoreceptor apparatuses on the heads of insects as well as to the paired, retinal photoreceptor apparatuses on the heads of vertebrates, which are also complexly structured but in a substantially different

way. That both these sets of structures have the same name implies sameness in some manner, and, indeed, they share a number of common features including relative location on the head and similar structural components albeit differently arranged. However, while it is now known that the genetic specification at the top part of the cascade for the embryological generation of eyes is shared across vertebrates and invertebrates alike [2] (and see Evolution, of Eyes), the lack of eyes (as whole eyes) in the postulated common ancestor precludes the eyes of insects and the eyes of vertebrates as being considered homologous, at least in the historical, or phylogenetic, sense, which is by far the most common application of the concept. While the common ancestor likely had a simple, paired or unpaired, photoreceptor apparatus on the head region, consisting of one or a few receptor cells, the gain of large and complexly structured photoreceptor apparatuses – whole eyes – in insects and vertebrates occurred independently within each lineage. Thus, in the historical sense of homology, these independent gains would represent an example of homoplasy – either parallelism or convergence. These concepts will be examined, and then an alternative, conceptual approach to the issue of sameness, that of generative homology, or syngeny [3], based on the inheritance of common genetic bases, will be considered.

### Historical, or Phylogenetic, Homology

One of the more commonly cited definitions of historical homology is that of Wiley [4]: “A character of two or more taxa is homologous if this character is found in the common ancestor of these taxa, or, two characters (or a linear sequence of characters) are homologous if one is directly (or sequentially) derived from the other(s).” Historical homology thus requires that the phenotypic character was present in the common ancestor and was expressed in the phenotypes along the descendant lineage and is best applicable to characters that are reliably and consistently expressed in the phenotype. Historical homology addresses character distribution and is concerned with the reconstruction of phylogenetic relationships and the recognition of monophyletic groups.

Similarity of multiple features and to a minute degree [5] is often used to both recognize and evaluate the occurrence of historical homology. Since similarity is not a requirement, however, some instances of homology may be missed when marked variation of features has occurred. For example, two of the three middle ear bones in mammals, the malleus and incus, would not be recognizable as homologues of the articular and quadrate bones, respectively, of reptiles without the sequential evidence of change revealed by the fossil record, since their morphology and location are so different.

Most but not all historically homologous characters are produced by homologous generative systems. In a number of cases, characters that exhibit multiple points of similarity and phylogenetically congruent distributions are produced by generative systems that are different to some extent. Examples include that of Meckel's cartilage, which is induced by different tissues in different tetrapods, the columella (middle ear bone) of chicks, which is variably derived from either ectoderm or mesoderm, and development of the lens of the eye from ectoderm in the normal situation but regeneration of it from dedifferentiated iris tissue in salamanders.

### Homoplasy

The opposite of historical homology is homoplasy, which is similarity of a character in two or more taxa that is not the result of inheritance from a common ancestor. The term was coined by Lankester in 1870 to refer to the independent gain of similar characters in different taxa [1]. Homoplasy comprises three types: parallelism, reversal, and convergence. In the former two, the similarities may be multiple and minute, in some cases resulting in an incorrect hypothesis of historical homology. In the latter, similarities are usually only superficial.

### Parallelism

Wiley [4] defined parallelism as "the independent development of similar characters from the same plesiomorphic [i.e., precursor] character." While the presence of such a precursor character in the common ancestor is not universally considered to be essential, it is generally agreed that some basis for it, such as the genetic basis, be shared. Wake [6], for example, defined parallelism as "the production of apparently identical traits by the same generative system." The sharing of a generative basis for traits not present in a common ancestor has also been called latent homology by de Beer [7], meant to imply a "genetically based homology" for traits not expressed in the common ancestor as "visible phenotypic" traits, and a variety of terms by other authors, including deep homology, or homoiology, unique inside parallelism, and underlying synapomorphy.

### Reversal

Reversal refers to the reappearance, within a single lineage, of a character that was not phenotypically apparent in intermediate members of that lineage. Multiple reversals can occur along a lineage for loss, regain, loss again, regain again, and so forth of a character. The regain of a character in this manner is, as in the case of parallelism, presumably due to the same generative basis [8].

### Convergence

Wiley [4] defined convergence as "the development of similar characters from different preexisting characters." Wake [9] has noted that convergence may frequently be the result of design constraints. Since such characters typically are similar only to a superficial degree and occur in widely divergent taxa, it is generally agreed that convergence involves the deployment of nonhomologous generative systems.

### Specification of Homology

A crucial but sometimes neglected step in formulating a hypothesis of homology is to specify the level of the homology [10]. As discussed above, the eyes, as whole eyes, of insects are not historically homologous to those of vertebrates. The phrase "as whole eyes" specifies the level of the homology. In contrast, the eyes, as rostral head, pigmented cell structures, are homologous across all invertebrates and vertebrates, since parsimony supports that such a structure was present in the common ancestor.

Another commonly cited example is that of wings. One can state that the wings of birds and bats are not homologous. One can also state that they are. Neither of these statements makes sense, however, until they are specified. The wings of birds and bats are not homologous as wings. The wings of birds and bats are homologous as forelimbs. In a number of cases, the specification is obvious, and in these cases, it is not necessary to spell it out: for example, the dorsal lateral geniculate nucleus of birds is homologous to the dorsal lateral geniculate nucleus of mammals. Even in such cases, however, caution is advised. While the nucleus in this example can be presumed to be compared as the whole nucleus, its subdivisions, even just within mammals, are not homologous in terms of one-to-one comparison.

### Tests for Homology

Patterson [11] suggested three tests for homology that comprise a formidable methodology for evaluating hypotheses of it. The first test, that of similarity, is widely applied. The second test, that of congruence, is the methodology of cladistic analysis and also widely applied. It is the crucial test for historical homology. The third test, that of conjunction, is less commonly invoked but is highly useful in some circumstances.

### Similarity

Similarity is the most salient of the criteria used to assess homology. As noted above, Simpson [5] specified that most if not all homologous characters can be expected to exhibit similarity of multiple features and to a minute degree. While extensive similarity is not a required criterion, it supports hypotheses of homology where present.

### **Congruence: Parsimony and Cladistical Analysis**

The principle of parsimony is used in the analysis of the distribution of characters, whether they are phenotypic or generative. The hypothesis that involves the least number of changes along lineages and across taxa is formulated and then tested. Without using parsimony, more elaborate and thus less likely hypotheses could be generated. Although parsimony does not guarantee correctness of any hypothesis, the use of it in formulating hypotheses provides a reasonably efficient working methodology.

Since the nervous system leaves little trace in the fossil record, other than for its surface features in some cases, hypotheses about the neural traits of ancestral taxa must be formulated based on the distribution of characters across extant taxa. Cladistic analysis examines the distribution of a given character, such as the presence of a particular nucleus in the brain, across a phylogeny that itself is determined using multiple, unrelated, i.e., non-neural, traits. If a neural character is present in all or most members of a taxon, it is parsimonious to hypothesize that the character was also present in the common ancestor and is thus historically homologous. If, in contrast, the character is present in only one or a few members of the taxon, it is likely that it was gained independently in those members. In the latter case, a hypothesis that posits the presence of the character in the common ancestor followed by loss of it in most members would require more changes than positing its ancestral absence followed by a few instances of its subsequent gain.

### **Conjunction**

This criterion is rarely invoked but can be highly important in some circumstances. As Patterson [11] stated, “If two structures are supposed to be homologous, that hypothesis can be conclusively refuted by finding both structures in one organism.” For example, if a particular structure in one taxon is proposed to be homologous to a structure in another taxon, identifying the former as well as the latter in the second taxon would nullify the hypothesis of homology.

### **Alternative Approaches to the Concept of Sameness**

A more general definition of homology than Wiley’s [4] is that of Van Valen [12]: “resemblance caused by a continuity of information.” As information on the generative bases for many different characters has accumulated, the concept of homology is being reevaluated.

### **Biological Homology**

A concept referred to as biological homology was introduced by Roth [13], who recognized that “the basis of homology in the broad sense is the sharing of pathways of development, which are controlled by

genealogically-related genes.” In a key insight, Roth realized that one must “tolerate some ambiguity” between [historical] homology and parallelism. Wagner [14] applied the concept of biological homology to structures that “share a set of developmental constraints, caused by locally acting self-regulatory mechanisms of organ differentiation [that] are thus developmentally individualized parts of the phenotype,” and Müller and Wagner [15] more recently as “the establishment and conservation of individualized structural units in organismal evolution.” Biological homology thus focuses on developmental mechanisms and addresses mechanisms of character evolution. Most biologically homologous characters are also historically homologous ones.

### **Generative Homology, or Syngeny**

The concept of generative homology, or syngeny (literally meaning “same genes”) [3,16] focuses specifically on phenotypic (or developmental) characters produced by shared generative systems, inherited with continuity from a common ancestor. It groups characters differently than in the system of historical homology versus homoplasy. Rather, syngenous characters are all those that are produced by shared generative systems, which include (i) most historically homologous characters and cases of (ii) parallelism and (iii) reversal. An example of syngeny is that of eyes across many invertebrate taxa as well as in vertebrates, as whole eyes and to the extent that they are produced by shared patterning genes, including *Pax6* [2]. The opposite of syngeny is allogeny (literally meaning “different genes”) [3]. All cases of convergence and a few cases of historical homology (such as the examples noted above) are cases of allogeny.

This concept is thus aligned with the new, evolutionary-developmental biological approach to evolution. In the same vein, Meyer [17] noted “that the biological basis for these seemingly disparate kinds of “sameness” in evolution [including all forms of homoplasy] may in some, or even most, instances not be all that different and may be based on the same principle – the long evolutionary retention of genes, gene interactions and developmental mechanisms.... Therefore, the biological basis of both [historically] homologous traits (those that are evolutionarily always expressed) and homoplasious traits (those that are not always “on,” but are “re-awakened” during evolution) might not be so different, and the distinction between homology and some forms of homoplasy may be somewhat artificial.”

### **Forms of Homology**

Multiple forms of homology can be recognized. Hobart Smith [18] published succinct and clear definitions of the most commonly encountered forms, on which the following explications are based.

### Discrete Homology

Discrete homology, also referred to as one-to-one homology or strict homology, refers to specific structures that can be regarded as unitary, at least at the level of specification of the homology. The wing of a bat, specified either as a wing or as a forelimb, is an example of a discrete homology.

### Field Homology

Field homology applies to sets of structures that are derived from the same, i.e., homologous, ontogenetic source. For example, the developmental field that gives rise to the five main layers of the dorsal lateral geniculate nucleus (DLGN) in carnivores is homologous to the developmental field that gives rise to the six main layers of this nucleus in primates. The set of five main layers of the carnivore DLGN are homologous, as derivatives of that developmental field, to the set of six layers in the primate DLGN, even though the layers themselves cannot be homologized in a discrete manner. Since a developmental field may give rise to a different number of derivatives, including zero, in various taxa, this concept of homology allows the sets of derivatives to be compared. An interesting example of this involves comparing the zero (non-existent) forelimbs of snakes to those of other tetrapods.

### Serial Homology

Serial homology is often called iterative homology or, rarely, homonymy. A commonly cited example is that of the vertebrae, either as those of one part of the spinal column or as those of the entire column: the C2 vertebra is serially homologous to the C4 vertebra, as cervical vertebrae, and to the L5 vertebra, simply as vertebrae. Some scientists, such as Wake [19] make the distinction that iteration is simply that, and iterated structures are thus not suitable material for application of the homology concept.

### Partial Homology

Partial homology is a highly controversial concept [17]. As data on patterning genes and developmental specification of morphological characters continue to accumulate, this concept gains in credibility. Wake [19] cites the system of *Hox* patterning genes in defending it, noting that “all homology among genealogical entities is partial at some level, except between the closest relatives.” As discussed above, the concept of generative homology, or syngeny, is fully in accord with the concept of partial homology.

### Evolution of the Concept of Homology

The concept of homology continues to evolve as information on the generative bases for characters and their phenotypic expression increases. Concepts such as historical homology, biological homology, and

generative homology often overlap and imply each other, but in some crucial aspects, they are independent. Historical homology is the most common application of Owen’s original idea of sameness and is the entrenched basis for phylogenetic reconstruction based on phenotypic traits; nonetheless, some of its most strongly supported hypotheses have been overturned by genetic studies – for example, the relationships of the major groups of sauropsids to each other, with lizards and snakes alone forming the outgroup to crocodiles, birds, turtles, and the tuatara *Sphenodon* [20].

Biological homology and generative homology, in contrast, both more directly address and recognize the importance of the generative pathways for characters. While biological homology focuses the variational tendencies of characters and the mechanisms for character evolution, generative homology focuses on the evolution of the generative pathways themselves and specifies their shared usage as the basis for character classification [see 3]. The inheritance of generative systems as the basis for shared character expression is now recognized as the fundamental foundation of evolution. Whether the character is consistently (as required for historical homology) or sporadically expressed across or along a lineage is of less import than previously credited.

### References

1. Panchen AL (1999) Homology – history of a concept. In: Bock GR, Cardew G (eds) Homology, novartis foundation symposium 222, Wiley, Chichester, UK, pp 5–18
2. Quiring R, Walldorf U, Kolter U, Gehring WJ (1994) Homology of the *eyeless* gene of *Drosophila* to the *Small eye* gene in mice and *Aniridia* in humans. *Science* 265:785–789
3. Butler AB, Saitel WM (2000) Defining sameness: historical, biological, and generative homology. *BioEssays* 22:846–853
4. Wiley EO (1981) Phylogenetics. Wiley-Liss, New York
5. Simpson GG (1961) Principles of animal taxonomy. Columbia University Press, New York
6. Wake DB (1996) Introduction. In: Sanderson MJ, Hufford L (eds) Homoplasy: the recurrence of similarity in evolution. Academic Press, San Diego, CA, pp xvii–xxv
7. de Beer G (1971) Homology, an unsolved problem. *Oxford biology readers*, vol 11. Oxford University Press, London
8. Hennig W (1966) Phylogenetic systematics. University of Illinois Press, Urbana, IL
9. Wake DB (1991) Homoplasy: the result of natural selection or evidence of design limitations? *Am Nat* 138:543–567
10. Campbell CBG, Hodos W (1970) The concept of homology and the evolution of the nervous system. *Brain Behav Evol* 3:353–367
11. Patterson C (1982) Morphological characters and homology. In: Joysey KA, Friday AE (eds) Problems of phylogenetic reconstruction. Academic Press, London, pp 21–74

12. Van Valen LM (1982) Homology and causes. *J Morphol* 173:305–312
13. Roth VL (1984) On homology. *Biol J Linn Soc* 22:13–29
14. Wagner GP (1989) The biological homology concept. *Ann Rev Ecol Syst* 20:51–69
15. Müller GB, Wagner GP (1996) Homology, *hox* genes, and developmental integration. *Am Zool* 36:4–13
16. Butler AB, Hodos W (2005) *Comparative vertebrate neuroanatomy: evolution and adaptation*, 2nd edn. Wiley, Hoboken, NJ
17. Meyer A (1999) Homology and homoplasy: the retention of genetic programmes. In: Bock GR Cardew G (eds) *Homology, novartis foundation symposium 222*. Wiley, Chichester, UK, pp 141–153
18. Smith HM (1967) Biological similarities and homologies. *Syst Zool* 16: 101–102
19. Wake DB (1999) Homoplasy, homology and the problem of “sameness” in biology. In: Bock GR, Cardew G (eds) *Homology*. Wiley, Chichester, UK, pp 24–33
20. Hedges SB, Poling LL (1999) A molecular phylogeny of reptiles. *Science* 283:998–1001

## Evolution and the Scala Naturae

WILLIAM HODOS

Department of Psychology, University of Maryland,  
College Park, MD, USA

### Synonyms

Scale of nature; Phylogenetic scale; Evolutionary scale

### Definition

A hierarchical ranking of animals based on Aristotelian notions of perfection, with humans at the top. It has often been used incorrectly as a model for vertebrate evolution.

### Characteristics

In seeking to find order and relationship in the biological world, the Greek scientist and philosopher, Aristotle (384–322 B.C.) devised a classification scheme for animals that came to be known as the *scala naturae* in its Latin translation from Greek. In Latin, *scala* means “ladder” or “flight of steps” and *naturae* means “of nature” or “of the universe”. Aristotle’s idea was that living things could be assigned a hierarchical position on this metaphorical ladder that would represent their degree of perfection [1,2,3]. He placed humans on the top rung and other creatures of the known world on progressively lower rungs. He based his classification system on various biological characteristics that he could observe, such as whether the creatures were oviparous (egg bearing, such as birds or

fishes) or viviparous (live bearing, such as mammals), the number of legs, etc. Although he did not produce a classification that would be useful to scientists in the post-Darwinian era, as did Carolus Linnaeus (1707–1778), the creator of the system of classification of animals and plants that is used today, Aristotle’s work was, nevertheless, a landmark event for its time that influenced theologians, philosophers, and scientists for many centuries to come. Its influence can still be found in some contemporary writings about brain evolution.

In the Middle Ages, and even into the nineteenth century, the *scala naturae* was a feature of religious ideas of a hierarchy of living things with the deity at the top as the most perfect being, angels next as slightly less perfect, humans still more imperfect, and then apes, monkeys, etc., down the scale to those creatures at the bottom that lacked any symmetry or regular form [4,5], **Figure 1** shows a *scala naturae* of some familiar animals. It shows humans at the top of the ladder; i.e., at the pinnacle of perfection. Below them are progressively less perfect animals: apes and monkeys and then cats and dogs. Still lower down are the rodents (rats, mice, squirrels) and at the bottom of the ladder are the least perfect creatures: insects, worms, and sponges.

With the advent of the Darwinian revolution and the gradual acceptance of the concept of evolution in the second half of nineteenth century and early twentieth century, the *scala naturae*, which was already well established in the popular mind, offered a simplistic framework for evolutionary conceptualization by the

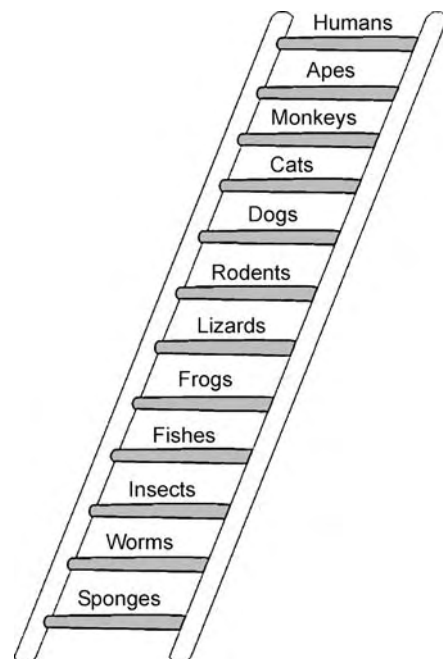

**Evolution and the Scala Naturae. Figure 1** A *scala naturae* of some familiar animals.

general public and by some scientists (including neuroscientists) who had little knowledge of the work of paleontologists on the actual lines of descent of living animals from ancestral forms. Thus, it was not uncommon to find neuroanatomists, neurophysiologists, or behaviorists reporting results from comparative studies of aggregations of animals such as monkeys, cats, and rats, and concluding that they were replicating actual historical sequences in the evolutionary history of mammals [4].

### The Phylogenetic Scale

In the post-Darwinian era, the *scala naturae* was transformed into the phylogenetic scale, which is sometimes known as the evolutionary scale or the evolutionary ladder. Although these terms sound more scientific, they are nothing more than a renaming of the *scala naturae* to suggest that it has something to do with evolution. The phylogenetic scale has nothing more to do with evolution than does the *scala naturae*. What terms such as “phylogenetic” or “evolutionary” do, however, is to add to the *scala naturae* implications about ancestor-descendent relationships that were not present in Aristotle’s original formulation. The word “scale” suggests a unilinear organization in which those animals at the top of the ladder are descendents of those animals on the lower rungs and that by “climbing” this ladder, sponges and worms could somehow be transformed into humans [4,6,7].

A further disservice that the phylogenetic scale does to conceptualizations of the relationships among animals is to perpetuate the notion of higher and lower species. Those near the top of the scale are the so-called “higher” animals, which have superior characteristics and those closer to the bottom are the “lower” animals, which are more “primitive,” less “advanced,” and in general are expected to have inferior characteristics [4]. Closely related to the ideas of higher and lower animals is the conception that the phylogenetic scale is also a scale of complexity. This is the result of conflating the *scala naturae* with the erroneous notion that evolution always proceeds from the simple to the complex. Thus, the phylogenetic scale also connotes increasing complexity with ascent from bottom to top. This idea gained support from some early comparative studies in which the selection of a limited range of species supported the impression of a trend from simple to complex when comparing “lower” animals with “higher.” While there are many examples of actual evolutionary lineages being associated with increased complexity of structures or systems from ancestors to descendents, there are also many examples of evolution resulting in increased simplification. The error was to assume that all early vertebrate ancestors were crude, primitive versions of later, descendent species. Many of the earliest vertebrates had actually adapted quite well

to their environments and had evolved considerable complexity that enabled them to survive and even exploit the world around them [7,8,9,10].

### The Phylogenetic Tree

Figure 2 shows that the history of vertebrate evolution is very much more complex than a simple ladder or staircase model would suggest. A more accurate model is that of a tree with many branches radiating out from a single stem that is rooted in the ancient past. The branches of the tree are based on actual historical data, such as the geologically dated record of fossils and studies of genetic relatedness based on DNA analyses.

Each main branch of the tree further bifurcates into subsidiary branches as the tree advances through time until we arrive at the top of the tree, which represents those animals that are alive today. The tree shown in Fig. 2 is highly simplified for purposes of this illustration in that it shows the lineage of only a handful of well-known species. Moreover, the tree in Fig. 2 also omits the many lineages, such as the dinosaurs, that became extinct and thus did not survive to the present era, although it is now well established that birds are the living descendants of the dinosaurs. Note there is also no hierarchical arrangement of the animals within tree. They are merely descendents of different branches of the vertebrate family tree.

In contrast to the phylogenetic tree, the phylogenetic scale is an entirely metaphorical concept; it has no scientific basis. You can search the evolution and classification literature and find many phylogenetic trees and detailed classification schemes, but you will search in vain for a definitive listing of the phylogenetic scale to answer questions such as: “Are dogs higher animals than cats?” or “Are bears higher animals than wolves?”

### Anagenesis

In the middle of the twentieth century, the concept of anagenesis entered the literature of comparative biology and eventually appeared in the comparative psychology literature as well. Anagenesis means a progressive improvement of a structure or system through time in a genealogical lineage [11,12]. Unlike the *scala naturae*, anagenesis was firmly based on evolutionary data, but it unfortunately was also deeply rooted in theories of the superiority of the European body type and features, especially facial features, over those of other races. Such ideas had been prevalent in Europe since at least the fifteenth century along with ideas of the superiority of European religion, culture, and social systems.

At the heart of anagenesis is the notion of “progress,” which suggests an advancement from simple to complex; i.e., that the more recent forms are the more advanced. Unfortunately, the determination of what is

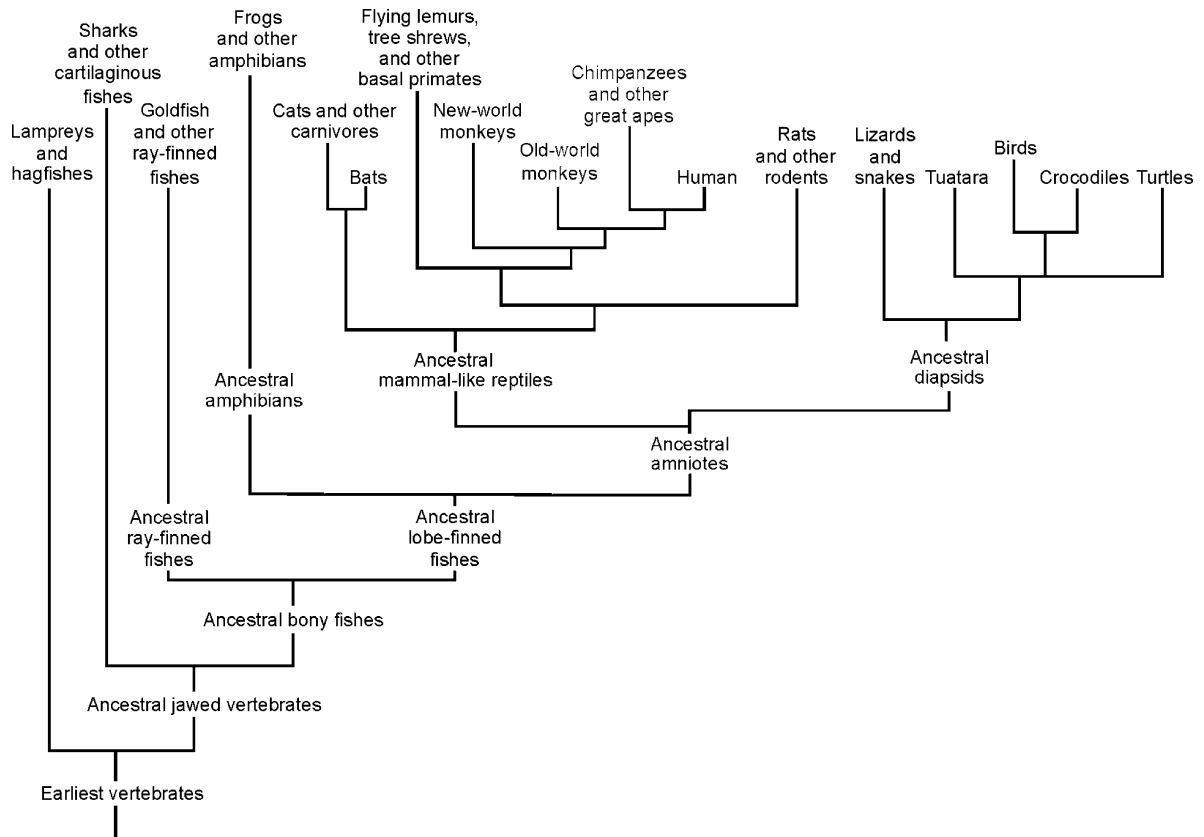

**Evolution and the Scala Naturae. Figure 2** A phylogenetic tree that shows the genealogical relationships of the major vertebrate groups. The earliest vertebrates are at the bottom and living vertebrates are at the top. Adapted from Butler and Hodos [7] with permission of John Wiley & Sons.

progress often depends on value judgments by the observer rather than objective science [13]. Evolution is an opportunistic process, and the only determiner of success is survival of the species. If the environment changes, the same adaptation that led to increased number of individuals or increased numbers of species (some of the criteria of evolutionary success) previously could now become a handicap and start the lineage down an inexorable course towards extinction. Thus, what would be evolutionary “progress” in one environmental circumstance could prove to be a disastrous trend in another. In other words, it is the relationship between the adaptation and the environment that determines progress or efficiency rather than absolute properties of the adaptation itself.

The unit of advancement by anagenesis is the “grade,” which is a stage of progressive improvement of a characteristic within a specified lineage. Although grades can be quite useful in comparative analysis to analyze the relationship between structure and function, some investigators have fallen into the *scala naturae* trap and have concluded that by merely arranging grades in a sequence of complexity, without careful reference to ancestor-descendent relationships, they have also

represented an historical sequence in the evolution of the character or process being investigated [13].

## References

1. Aristotle (1910) *Historia Animalium*. Clarendon Press, Oxford, UK (Translated by W Ogle)
2. Aristotle (1912) *De Partibus Animalium*. Clarendon Press, Oxford, UK (Translated by W Ogle)
3. Aristotle (1912) *De Generatione Animalium*. Clarendon Press, Oxford, UK (Translated by A Platt)
4. Hodos W, Campbell CBG (1969) *Scala naturae*: why there is no theory in comparative psychology. *Psych Rev* 76:337–350
5. Lovejoy AO (1936) *The great chain of being*. Harvard University Press, Cambridge, MA
6. Hodos W, Campbell CBG (1990) Evolutionary scales and comparative studies of cognition. In: Kesner R, Olton D (eds) *Animal cognition*. Erlbaum, Hillsdale, NJ, pp 1–21
7. Butler AB, Hodos W (2005) *Comparative vertebrate neuroanatomy: evolution and adaptation*, 2nd edn. Wiley-Liss, Hoboken, NJ
8. Hofman MA (2001) Evolution and complexity of the human brain: some organizing principles. In: RothG, Wullimann ME (eds) *Brain evolution and cognition*. Wiley, New York, pp 501–521



9. Jerison HJ (2001) The evolution of neural complexity. In: Roth G, Wullimann ME (eds) Brain evolution and cognition. Wiley, New York, pp 521–553
10. Carroll RL (1988) Vertebrate paleontology and evolution. Freeman, New York
11. Ayala EJ (1988) Can “progress” be defined as a biological concept? In: Nitecki MH (ed) Evolutionary progress. University of Chicago Press, Chicago Press, IL, pp 75–96
12. Gould SJ (1988) On replacing the idea of progress with an operational notion of directionality. In: Nitecki MH (ed) Evolutionary progress. University of Chicago Press, Chicago, IL, pp 319–338
13. Campbell CBG, Hodos W (1991) The *scala naturae* revisited: anagenesis and evolutionary scales in comparative psychology. *J Comp Psych* 105:211–221

## Evolution of Association Pallial Areas: In Birds

JONAS ROSE, ONUR GÜNTÜRKÜN, JANINA KIRSCH  
Biopsychology, Institute of Cognitive Neuroscience,  
Ruhr-University Bochum, Bochum, Germany

### Definition

This essay describes a case of ►homoplasy of mammalian and avian brains. Both mammals and birds can organize their behavior flexibly over time. In mammals, the mental operations generating this ability are called executive functions and are associated with the prefrontal cortex. The corresponding structure in birds is the ►nidopallium caudolaterale. Anatomical, neurochemical, electrophysiological and behavioral studies show these structures to be highly similar. The avian forebrain displays no lamination that corresponds to the mammalian neocortex; hence lamination does not seem to be a requirement for higher cognitive functions. Because all other aspects of the neural architecture of the mammalian and the avian prefrontal areas are extremely comparable, the freedom to create different neural architectures that generate prefrontal functions seems to be very limited.

### Characteristics

Behavior defines the frontier along which animals interact with evolutionary selection pressures. Therefore, neural architectures are shaped during evolution to produce certain behavioral traits that are required to stand the race for fitness. If species from different lineages are faced with the same selection pressure they might react with the same solution at the behavioral level. But how many degrees of freedom are there on the neural level to achieve the same behavioral

solutions? In other words, can differently organized brains implement the same set of behaviors? In the following, a case of ►homoplasy between mammals and birds will be discussed, contrasting the behavioral skills employed by both orders as well as the neural structures that enable these skills.

### Behavioral Skills of Birds and Mammals

The order of mammals is phylogenetically very successful. Mammals like humans, macaques or rats are able to adjust their behavior flexibly to changing demands. They are able to reverse-learn behavioral choices, select appropriate responses according to contextual information and withhold actions until a suitable situation occurs. In short, they optimally organize their behavior with time [1,2]. Birds represent an about equally successful vertebrate order and a vast literature testifies that birds are able to generate many of the same cognitive functions [1,2]. Pigeons, for example, are able to memorize up to 725 different visual patterns, reverse-learn contingencies, learn to categorize images as “human-made” or “natural” or rank patterns using transitive inference [3]. The evolution of these abilities is an example of ►homoplasy that enables birds and mammals to utilize a very similar repertoire of behavioral skills. These skills were not inherited from a common ancestor, however, but rather were evolved independently [3]. Furthermore, corvids in particular have developed cognitive skills to a degree that can only otherwise be found in primates. The level of corvid cognitive abilities is indicated by feats such as causal reasoning, prospection and the ability to use experience in predicting the behavior of conspecifics. Another domain in which birds stand out is the use of tools. New Caledonian crows use different types of tools for different purposes; they manufacture specific tools to standardized patterns and carry them while foraging. In the laboratory they are reported to use analogy with previous experience when using unknown materials to manufacture novel tools [4]. Another example of the vast behavioral repertoire of birds is ►episodic-like memory. Many corvids store food items and recover them often months later for consumption. In caching food items, corvids are known to show ►episodic-like memory; they remember *where* and *when* they stored *what* food item. This enables the birds to retrieve perishable food earlier, while non-perishable items can be left in storage or to recache food that might be pilfered by another bird. In sum, these abilities place corvids amongst the cognitively most developed species, finding a match only in a very few primate species [4].

### Neuroarchitecture of Birds and Mammals

A sharp contrast to the numerous similarities of mammals and birds on the behavioral level is the great evolutionary distance and therefore the substantially different organization of avian and mammalian forebrains. The lines of

birds and mammals separated about 300 million years ago. This evolutionary distance resulted in a number of crucial organizational differences on the neural level, the most notable being the lack of a laminated cortex in the avian telencephalon [1,2].

In recent years our understanding of the evolution of vertebrate brains and the homologies between avian and mammalian brains has advanced substantially. To reflect this new understanding, The Avian Brain Consortium, a group of leading experts in the field, has proposed changes to the avian brain nomenclature and renamed many avian telencephalic structures [3,5]. The classical avian brain nomenclature dated back to 1900 and was based on Edinger's model of brain evolution. According to his formulation, vertebrate brain evolution consisted of a series of additions of new brain entities, with the mammalian neocortex being the last and most advanced step. In mammals, the cortex, including neo- archi- and paleo-cortical components, together with the claustrum and lateral parts of the amygdala, constitutes the forebrain pallium. Pallium and subpallial structures, including the striatum and pallidum, make up the cerebrum. While the organization of the striatum is highly conserved among birds and mammals, pallial organization is rather different. The mammalian pallium mainly follows a laminar organization, while the avian pallium is organized in nuclei. The absence of a laminated component within the avian cerebrum led Edinger to assume that birds have virtually no pallium but an enormously hypertrophied striatum instead. Based on neurochemical, histological, behavioral, embryological and genetic studies, this view had to be rejected. Birds do indeed possess a large pallium, which consists of four main subdivisions, the hyper-, meso-, nido- and arco-pallium (Fig. 1).

The field homologies between these different subdivisions and corresponding mammalian structures are a topic of active research. For most divisions, consensus, if ever possible, has not yet been reached.

It is well known that the cognitive skills of mammals depend on their pallial association structures. These areas are organized following a general principle. Primary sensory structures project to the surrounding unimodal association areas, which in turn project to polysensory association structures. The sensory projections of the avian pallium are organized according to the same principle (Fig. 2).

Within the visual system, the afferent fibers entering the pallium project either to the visual Wulst, a subdivision of the hyperpallium or to the entopallium, a subdivision of the nidopallium. The thalamofugal (Wulst) and the tectofugal (entopallium) systems correspond to the mammalian geniculo-cortical and extrageniculate pathways, respectively. The visual Wulst shows a pseudolamination, with a primary visual layer located ventrally and a unimodal association layer located dorsally. The

entopallium is organized in a primary visual core and a surrounding belt, which is a unimodal association structure called the perientopallium [6]. This organization into primary sensory core and surrounding unimodal associative belt is shared by the somatosensory Wulst, the auditory field L and the trigeminal-recipient nucleus basorostralis pallii of the nidopallium. The primary sensory areas project to the corresponding unimodal association areas that, in turn, send afferents to polysensory association structures. In birds, until now only the ►nidopallium caudolaterale (NCL) has been described as receiving polysensory input and participating in cognitive functions.

### Functions of the Avian and Mammalian "Prefrontal Cortex"

In the following the focus will be on the NCL, the functional equivalent of the mammalian prefrontal cortex (PFC) for two reasons. First, the NCL is one of the best-understood avian pallial structures and analogy to the mammalian PFC has been established satisfactorily; second, NCL and PFC are the crucial structures in mediation of many of the behaviors mentioned above [2]. The function of the PFC is commonly described with the terms "executive functions" and "►working memory." ►Working memory (WM) has been defined in parallel and rather independently in pigeons and humans. The non-human and the human definitions of ►working memory differ only with respect to the presence of a language-component in humans. Not only is WM behavior very similar between mammals and birds but the neural processes generating WM also seem to be identical in both orders. WM is based on the active maintenance and manipulation of stimulus information. These processes are mediated by neurons that show an elevated firing rate during delay periods of WM tasks. In other words, the representation of a physically absent stimulus is actively maintained over a delay. Disruption of this activation leads to a loss of the information, i.e. to forgetting. In mammals, this activation was first described in the PFC. Lesions to the PFC result in a disruption of WM. The same type of neuronal activity has been reported in the avian equivalent of the PFC, the NCL [7]. As in the case of the PFC, lesions to NCL lead to a decrease in WM-performance. In mammals, the release of ►dopamine (DA) within PFC and the subsequent activation of D1-receptors play a major role in sustained activity levels of delay cells and the animals' performance in ►working memory tasks. In pigeons, the local blockade of D1-receptors within NCL selectively disrupts ►working memory performance [2].

Apart from stimulus maintenance, the PFC takes part in the selection of behavioral goals. In reversal tasks, for instance, animals learn to associate the response to one stimulus with reward and the response to an alternative stimulus with punishment. When the animals have

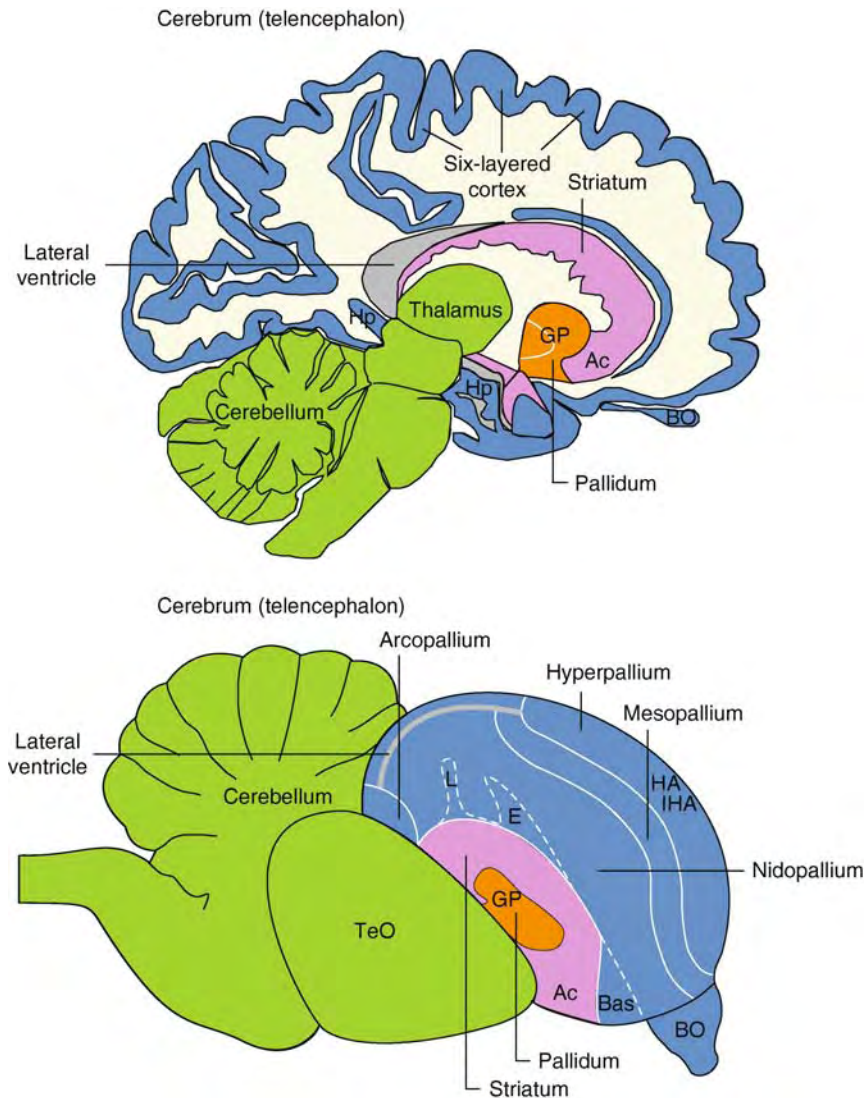

**Evolution of Association Pallial Areas: In Birds. Figure 1** The new understanding of avian and mammalian brain relationships. Sagittal view of a human (*top*) and a pigeon (*bottom*) brain. Pallial structures are marked in blue, striatal structures in pink and pallidal structures in orange. Abbreviations: Ac nucleus accumbens; Bas nucleus basorostralis pallii; BO bulbus olfactorius; E entopallium; GP globus pallidus; HA hyperpallium apicale; IHA interstitial hyperpallium apicale; Hp hippocampus; L field L; TeO tectum opticum, NCL nidopallium caudolaterale.

established these associations, the contingencies are reversed, responses to the previously rewarded stimulus are now punished and vice versa. In order to master this task the animal has to monitor the success of its actions and reverse its behavior if the actions are unsuccessful. This flexibility in adapting to changing demands is severely disrupted in mammals with lesions to the PFC and the same holds for birds with NCL lesions or blockade of D1- [1] or NMDA-receptors in this area [8].

In order to plan goal-directed actions effectively and to decide between alternative strategies, it is crucial to integrate information about the costs and benefits of different actions. In other words, it is crucial to adjust

the effort to obtain a reward to the value of that reward. Transient pharmacological lesions to the NCL disrupt this ability and such animals will put as much effort into obtaining a small reward as into obtaining a large reward [9]. In line with this data, a recent study showed that neurons in the NCL reflect an animal's preference for a reward, based not only on the features of the reward but also on the delay until the reward is obtained [10].

The most straightforward example of a neural correlate of executive control reported in any species thus far has recently been provided by a single-cell study in pigeons. Pigeons were trained on a WM task during which the animals were informed that

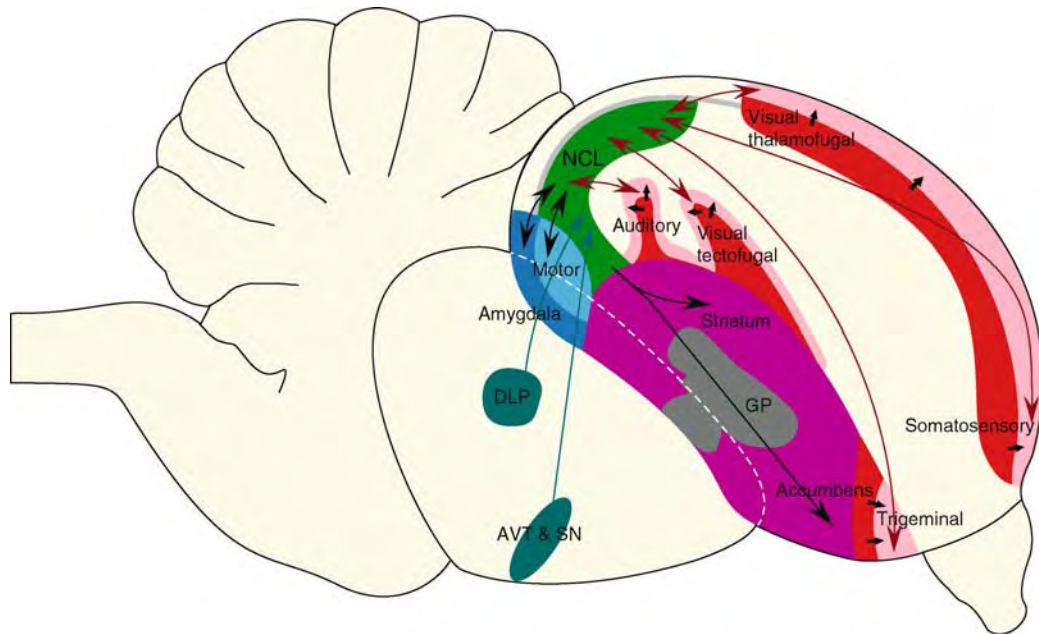

**Evolution of Association Pallial Areas: In Birds. Figure 2** Afferent and efferent connections of the ►nidopallium caudolaterale. Primary sensory areas are depicted in red, secondary and tertiary areas in pink. The primary sensory areas project to secondary and tertiary structures (*small black arrows*), which have reciprocal connections with the ncl (*red arrows*). The visual thalamofugal and tectofugal systems correspond to the geniculocortical and colliculo-pulvino-extrastriate systems of mammals, respectively. The area labeled “motor” is the arcopallium, which has descending projections to various motor and premotor structures. Thalamic afferents arise from the nucleus dorsolateralis posterior thalami. Dopaminergic afferents stem from the area ventralis tegmentalis and the substantia nigra. Abbreviations: AVT area ventralis tegmenti; DLP nucleus dorsolateralis posterior thalami; GP globus pallidus; SN substantia nigra.

remembering a stimulus was necessary in order to obtain a reward. The animals were able to use this information, memorizing only relevant stimuli. Most importantly, this selectivity was reflected in the memory-period activity of NCL neurons. The vast majority of neurons showed memory related activity when the birds chose to remember; however, this activity was suppressed as soon as the birds knew that memorizing a stimulus was not required. This decision process, controlling the neural mechanisms that govern ►working memory, is a prime example of executive functions as attributed to the mammalian PFC [11]. In spite of the great phylogenetical distance, the avian NCL and the mammalian PFC generate the same set of behaviors.

### Connectivity of the “Prefrontal Cortex”

Returning to the initial question, how many degrees of freedom are there on the neural level to generate the same set of behaviors, structural differences and similarities between PFC and NCL will now be described. The PFC of mammals is densely innervated by dopaminergic fibers from the ventral tegmental area and the substantia nigra. This dopaminergic innervation

was usually taken as a characterizing element of the PFC. Ivan Divac and colleagues showed that the NCL is densely innervated by catecholaminergic fibers of probably dopaminergic nature. Subsequent studies demonstrated that NCL is indeed one of the main termination areas of dopaminergic fibers from the ventral tegmental area and the substantia nigra. The architecture of the dopaminergic terminals within the NCL closely resembles that of the PFC [1,2].

The NCL is comparable to the PFC in that it is a center of higher-order sensory integration. Sensory input reaches the NCL via a set of interconnected pathways that show a considerable overlap of different modalities (Fig. 2). The primary sensory area of each modality projects first to an adjacent area that then projects not only to the next modality-specific association area in line but also to the NCL, which in turn reciprocates by sending fibers back to the projecting area. In addition, NCL projects to most parts of the somatic and limbic striatum, as well as to motor output structures. Thus, identically to PFC, the avian NCL is a convergence zone between the ascending sensory and the descending motor systems. In addition, NCL and PFC resemble each other in terms of their

connections with the amygdala, nucleus accumbens, visceral structures and diverse chemically defined afferent systems. One difference between the connectivity of NCL and PFC is, however, the thalamic input. The mammalian PFC receives afferents from the mediodorsal (MD) nucleus of the thalamus. Thalamic afferents to the NCL arise mainly from the dorsolateral posterior nucleus, which is not homologous to MD but still seems to serve similar functions [1,2].

A comparison of the anatomical network defining NCL and PFC shows a large number of similarities with only a few differences. Like the PFC, the avian NCL is a multimodal forebrain area that is located at the convergence zone from sensation to action, is modulated by dopaminergic fibers and is tightly interrelated with structures serving limbic, visceral and memory-related functions.

### Concluding Remarks

We have shown that birds are capable of generating complex behaviors that, in some cases, outperform the skills of most mammals. Given the phylogenetic distance between birds and mammals, it can be assumed that a number of these skills have evolved independently. On the neural level, it can be said that the avian and mammalian pallium seem to be homologous with respect to their phylogenetic continuity, but this does not necessarily hold for the different pallial domains, which could also be a product of ►homoplasy. Discussion focused on the equivalence between PFC and NCL and showed that both structures generate the same set of cognitive functions using surprisingly similar systems. These structural similarities are most evident in the case of stimulus maintenance, as discussed in detail by Güntürkün [2]. Among the few obvious differences between avian and mammalian pallia is the lack of lamination, but this is evidently not a prerequisite in generating higher cognitive functions.

### References

- Güntürkün O (2005) The avian ‘prefrontal cortex’ and cognition. *Curr Opin Neurobiol* 15:686–693
- Güntürkün O (2005) Avian and mammalian “prefrontal cortices”: limited degrees of freedom in the evolution of the neural mechanisms of goal-state maintenance. *Brain Res Bull* 66:311–316
- Jarvis ED, Güntürkün O, Bruce LL, Csillag A, Karten H, Kuenzel W, Medina L, Paxinos G, Perkel DJ, Shimizu T, Striedter GF, Wild JM, Ball GF, Douglas-Ford J, Durand SE, Hough G, Husband S, Kubikova L, Lee DW, Mello CV, Powers A, Siang C, Smulders TV, Wada K, White SA, Yamamoto K, Yu J, Reiner A, Butler AB (2005) Avian brains and a new understanding of vertebrate brain evolution. *Nat Rev Neurosci* 6:151–159
- Emery NJ, Clayton NS (2004) The mentality of crows: convergent evolution of intelligence in corvids and apes. *Science* 306:1903–1907

- Reiner A, Perkel DJ, Bruce LL, Butler AB, Csillag A, Kuenzel W, Medina L, Paxinos G, Shimizu T, Striedter GF, Wild M, Ball G, Durand S, Güntürkün O, Lee DW, Mello CV, Powers A, White SA, Hough G, Kubikova L, Smulders TV, Wada K, Douglas-Ford J, Husband S, Yamamoto K, Yu J, Siang C, Jarvis ED (2004) Revised nomenclature for avian telencephalon and some related brainstem nuclei. *J Comp Neurol* 473: 377–414
- Krützfeldt NO, Wild JM (2004) Definition and connections of the entopallium in the zebra finch (*Taeniopygia guttata*). *J Comp Neurol* 468:452–465
- Kalt T, Diekamp B, Güntürkün O (1999) Single unit activity during a Go/NoGo task in the “prefrontal cortex” of pigeons. *Brain Res* 839:263–278
- Lissek S, Diekamp B, Güntürkün O (2002) Impaired learning of a color reversal task after NMDA receptor blockade in the pigeon (*Columba livia*) associative forebrain (neostriatum caudolaterale). *Behav Neurosci* 116:523–529
- Kalenscher T, Diekamp B, Güntürkün O (2003) Neural architecture of choice behaviour in a concurrent interval schedule. *Eur J Neurosci* 18:2627–2637
- Kalenscher T, Windmann S, Rose J, Diekamp B, Güntürkün O, Colombo M (2005) Single units in the pigeon brain integrate reward amount and time-to-reward in an impulsive choice task. *Curr Biol* 15:594–602
- Rose J, Colombo M (2005) Neural correlates of executive control in the avian brain. *PLoS Biol* 3:e190

## Evolution of Association Pallial Areas: In Reptiles

FERNANDO MARTÍNEZ-GARCÍA<sup>1</sup>,  
ENRIQUE LANUZA<sup>2</sup>

<sup>1</sup>Dpt. de Biología Funcional;

<sup>2</sup>Biología Cel.lular, Fac. Ciències Biològiques, Universitat de València. C. Dr. Moliner, Burjassot, Spain

### Synonyms

Association = Multimodal or polymodal sensory convergence; Pallium = Dorsal part of telencephalon

### Definition

#### Associative Pallium

The adult ►pallium includes areas that receive inputs from nuclei in the dorsal thalamus relaying unimodal sensory information, namely visual, auditory or somatosensory (and gustatory-visceroceptive). In most vertebrates, intrapallial connections allow multimodal convergence in some areas that constitute the associative pallial areas. Multimodal convergence might also occur at lower levels in the *neuroaxis*. For instance, some thalamic areas receive convergent afferents from

brainstem regions processing different kinds of stimuli. The ascending projections of these thalamic multimodal areas terminate in pallial areas that should also be considered associative.

## Characteristics

### The Pallium of Reptiles

The reptilian pallium is composed of four main cortical areas plus the so-called ►dorsal ventricular ridge. The architecture of the cortex differs slightly among the different reptilian groups. Squamate reptiles (lizards and snakes) possess a three-layered cortex, with a well-organized cell layer surrounded by inner and outer plexiform (or molecular) layers, in which four areas are easily distinguished, namely the medial (MC), dorsomedial (DMC), dorsal (DC) and lateral (LC) cortices (Fig. 1). In turtles and crocodiles, the layering and the regionalization of the cortex are not so clear-cut. In squamate reptiles and turtles, the lateral aspect of the anterior dorsal cortex shows no clear boundaries with the pallial thickening, which is usually considered an additional area of the reptilian cortex (Fig. 1).

Moreover, the pallium of all reptiles (and of birds) possesses a bulge of nervous tissue that protrudes into the lateral ventricle and is therefore called the dorsal ventricular ridge (DVR). The DVR of reptiles is usually divided into an anterior (ADVR) and a posterior (PDVR) or basal portion. Although not very clear, the DVR shows a layering composed of a juxtaventricular cell-free area, a layer of cell clusters the size of which varies from medial to lateral and a deep stratum with loose, scattered cells. In the ADVR (but not in the PDVR), the layer of cell clusters shows continuity with the cell layer of the ventral lateral cortex. In addition, the ADVR shows a clear-cut separation with the subpallium due to the presence of a cell-free zona limitans [1]. The DVR derives from the lateral and ventral portions of the embryonic pallium that are ►topologically lateral to the lateral pallium, i.e. interposed between the lateral pallium and the subpallium [2,3].

A volumetric analysis of the cerebral hemispheres of the old-world lizard ►*Podarcis hispanica* indicates that the pallium constitutes about 67% of the telencephalon.

### Associative Areas of the Reptilian Cerebral Cortex

In all the studied reptiles, the main olfactory bulb, which receives a direct projection from the olfactory epithelium, projects to the LC and to portions of the superficial amygdala (Fig. 2). The accessory olfactory bulb, the vomeronasal portion of the bulb, projects to a structure of the caudal cortex that, in squamate reptiles, is called the ►nucleus sphericus. Therefore, the LC and NS represent the primary ►olfactory and vomeronasal cortices, respectively. In addition, studies of the afferent connections to the cerebral cortex in lizards and turtles indicate that the lateral aspect of the dorsal cortex plus

the pallial thickening constitute the *visual cortex of reptiles* [4,5,6]. There is no evidence of any other unimodal input to the cerebral cortex in reptiles [7].

In contrast, the MC, DMC and most of the DC of reptiles receive a massive input from a thalamic cell group called the dorsolateral anterior thalamic nucleus (DLA) [4,5,8]. The DLA is a peculiar cell group [8] that apparently receives direct spinal and (minor) retinal inputs. In addition, DLA projection cells have long dendrites that extend out of the cytoarchitectonic boundaries of the nucleus and reach neighboring nuclei that receive retinal (lateral geniculate nucleus), auditory (medial anterior nucleus) or somatosensory afferents. The multimodal nature of the thalamic projection to the MC and DC has been demonstrated using physiological techniques [9].

In addition, the MC and DC also receive a direct input from the lateral cortex [4, 10], which, in turn, is the main target of the projections from the main olfactory bulb and of the nucleus sphericus [11,12]. Therefore, the anatomical data available in lizards indicate that the dorsal and medial cortices receive convergent sensory inputs from the chemosensory (olfactory and vomeronasal) lateral cortex and from a multimodal (visual, auditory and somatosensory) thalamic cell group (DLA).

As a conclusion, the MC, DMC and DC constitute together the associative cortex of the reptilian pallium. In the lizard *Podarcis hispanica*, the MC, DMC and DC represent about 56% of the pallium and 37% of the whole cerebral hemispheres.

### Associative Areas of the DVR of Reptiles

The PDVR (Fig. 3) receives convergent projections from the medial, intermediate and lateral portions of the ADVR [1], which in turn are the targets of the three main sensory nuclei in the dorsal thalamus of reptiles [13,14], the medial anterior thalamic nucleus (auditory), the posteromedial and posterocentral nuclei (somatosensory) and the nucleus rotundus (visual, tecto-receptive).

Additional afferents to the PDVR include another multimodal thalamic cell group (the dorsomedial anterior nucleus), the ventral portion of the LC (chemosensory) and the DC [1], which is also a multimodal pallial region. Studies of the efferent projections of the ADVR [15], the dorsomedial anterior thalamic nucleus [1], the LC [16] and DC [17] indicate that all these areas also project to an ill-defined cell group in the vicinity of the PDVR named the lateral amygdala. Some of these afferents also project to another neighboring cell group called the dorsolateral amygdaloid nucleus.

These data indicate the presence of a second associative area in the pallium of reptiles, composed at least of the PDVR and the lateral and the dorsolateral

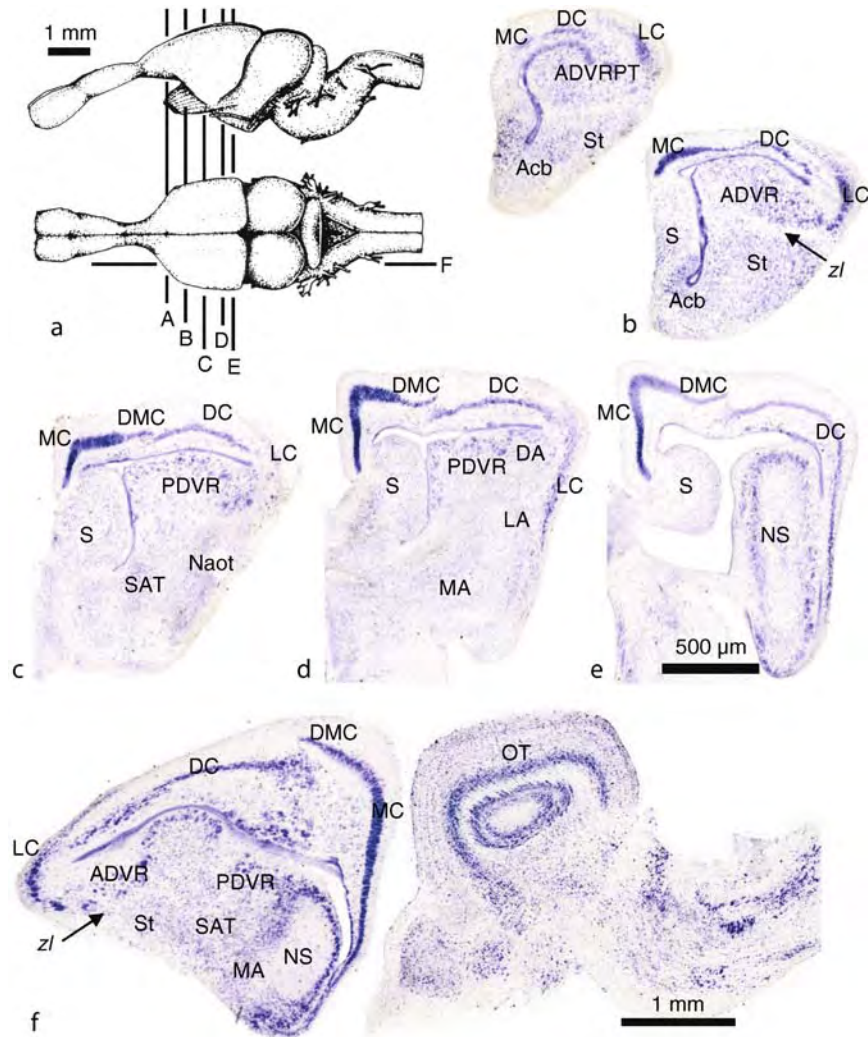

**Evolution of Association Pallial Areas: In Reptiles. Figure 1** Pallial structures in the brain of a reptile, the old world lizard *Podarcis hispanica*. The lateral (*up*) and dorsal (*down*) views of the brain of *P. hispanica* show well-developed olfactory bulbs, typical of squamate reptiles, and two medium-sized cerebral hemispheres. Frontal sections through the telencephalon (a–e) and a sagittal section of the brain (f) show a big pallium that consists of the cortex (medial, dorsomedial, dorsal and lateral areas) and the dorsal ventricular ridge (anterior and posterior parts), as well as several other adjoining structures. As a whole, the pallium constitutes 67% of the cerebral hemispheres. The subpallium is mainly composed of the septum, the striatum, and the nucleus accumbens. At the level of the anterior dorsal ventricular ridge, the pallium and subpallium are separated by a cell-free *zona limitans* (*zl*). Abbreviations (in alphabetical order): *Acb*: nucleus accumbens (ventral striatum); *ADVR*: anterior dorsal ventricular ridge; *DA*: dorsolateral amygdala; *DC*: dorsal cortex; *DMC*: dorsomedial cortex; *LA*: lateral amygdala; *LC*: lateral cortex; *MA*: medial amygdala; *MC*: medial cortex; *Naot*: nucleus of the accessory olfactory tract; *NS*: nucleus sphericus; *OT*: optic tectum (midbrain tectum); *PDVR*: posterior dorsal ventricular ridge; *PT*: pallial thickening; *S*: septum; *SAT*: striato-amygdaloid transition area; *Str.* (dorsal) striatum; *zl*: *zona limitans*.

amygdaloid nuclei. In *Podarcis hispanica*, these structures represent about 7.3% of the pallium and nearly 5% of the cerebral hemispheres.

### The Hippocampal Formation of Reptiles

The MC, DMC and DC of reptiles not only share their inputs from the DLA and lateral cortex. The MC gives

rise to massive, ►zinc-enriched projections to the DMC and DC [10]. In turn, the DMC and DC project back to the MC. This is a bilateral projection, the contralateral part of which courses through the pallial commissures [18]. In addition, both the MC and DC also give rise to a zinc-enriched, ordered projection to the (lateral) septum [10]. Finally, the dorsal cortex is the origin of a long

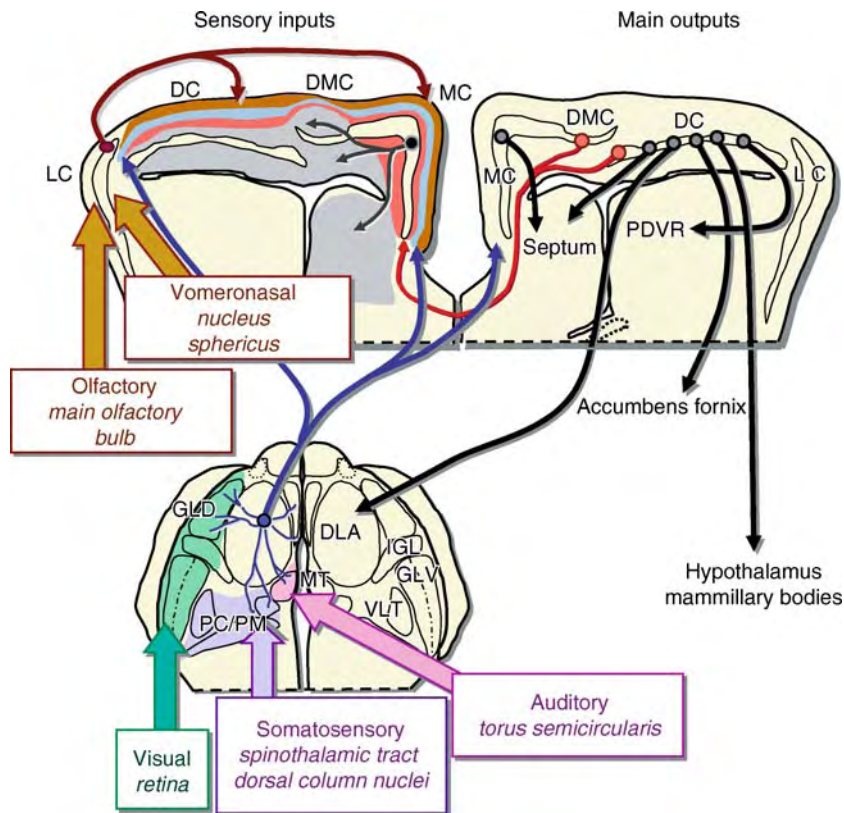

**Evolution of Association Pallial Areas: In Reptiles. Figure 2** The medio-dorsal cortex: an associative cortex in the reptilian cerebral hemispheres. Schematic view of the cerebral cortex of reptiles with indication of the main sources of sensory inputs (*left*), as well as its main efferent pathways (*right*). In reptiles, the main thalamo-cortical pathway arises in the dorsolateral anterior nucleus of the thalamus (*DLA*) and terminates in the medial and dorsomedial cortices and most of the dorsal cortex (jointly known as medio-dorsal cortex). This is a multimodal pathway, due mainly to synaptic convergence on the long dendrites of the *DLA* projection cells, which invade adjacent sensory (visual, auditory, and somatosensory) nuclei of the dorsal thalamus. In addition, the fourth cortical area, the lateral cortex, which receives direct olfactory and indirect vomeronasal inputs, also projects onto the medial-dorsal cortex. Other intrinsic and commissural cortico-cortical projections are also illustrated. As depicted, in reptiles the main afferents of the medio-dorsal cortex terminate in a nicely layered fashion. The main efferents of the medio-dorsal cortex terminate in the *PDVR* (amygdala), septum, nucleus accumbens and hypothalamus. These and other features of these cortical areas strongly suggest that they constitute the hippocampal formation of the reptilian brain. Abbreviations (in alphabetic order): *DLA*: dorsolateral anterior thalamic nucleus; *GLD*: dorsal lateral geniculate nucleus; *GLV*: ventral lateral geniculate nucleus; *IGL*: intergeniculate leaflet; *MT*: anterior medial thalamic nucleus; *PC*: postero-central thalamic nucleus; *PM*: posteromedial thalamic nucleus; *VLT*: ventrolateral thalamus. For other abbreviations, see Fig. 1.

descending projection to parts of the hypothalamus through the fornix [17].

This set of connections and histochemical features, together with a topological analysis of the reptilian pallium, strongly suggests that its medial aspect including the *MC*, *DMC* and part of the *DC* constitutes the hippocampal formation of reptiles. This indicates that, although mammals and reptiles share a hippocampal formation that receives all kinds of chemosensory and non-chemosensory stimuli, there are important differences in the pathways providing this sensory information in the two classes of vertebrates. In

mammals, an enormous isocortex that includes several primary and secondary sensory areas relays highly processed sensory information to the hippocampal cortex through the entorhinal cortex, in turn an associative area. In contrast, reptiles receive a chemosensory (olfactory and vomeronasal) input from the lateral cortex, plus a multimodal non-chemosensory thalamic afferent from the *DLA*. Whereas the thalamic afferents to the mammalian hippocampus, arising mainly from the nucleus reuniens, are relatively scarce, the projection from the *DLA* to the medial-dorsal cortex of reptiles is massive (Fig. 2).



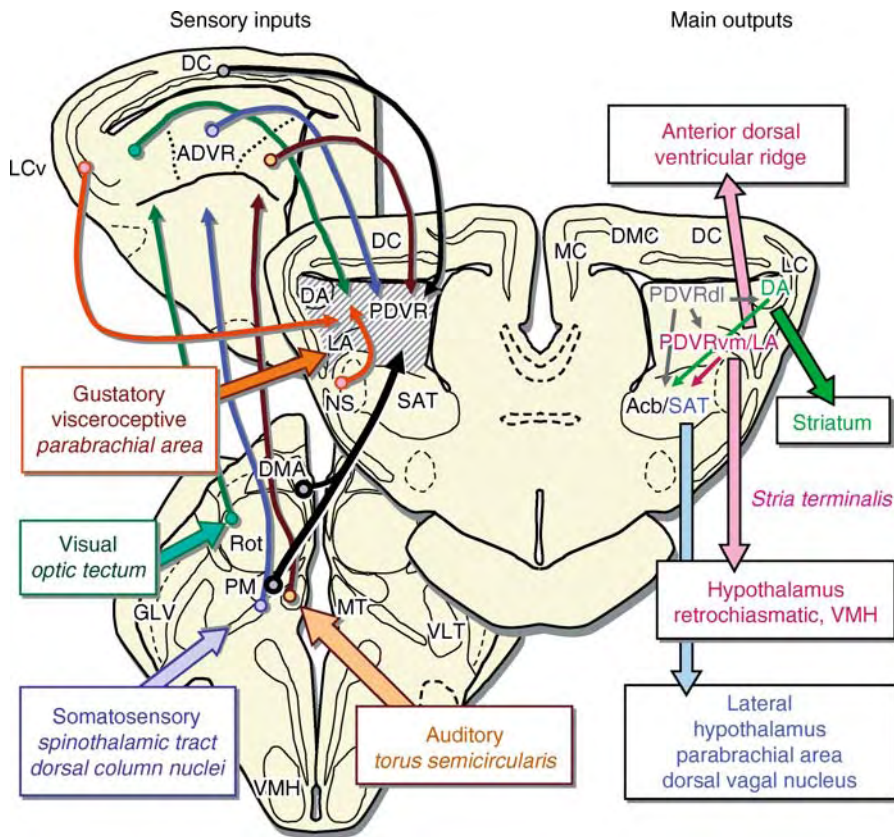

**Evolution of Association Pallial Areas: In Reptiles. Figure 3** An additional associative area in the posterior dorsal ventricular ridge: the putative amygdala of reptiles. Schematic view of the PDVR and adjoining pallial area of reptiles, with indication of the main sources of sensory inputs (*left*), as well as their main efferent pathways (*right*). The PDVR, the lateral amygdala (LA) and, to a lesser extent, the dorsolateral amygdala (DA), are the target for multimodal pathways (*thick, black arrows*) from the dorsal cortex and from two thalamic cell groups, the medial posteromedial thalamic nucleus (PM) and the dorsomedial anterior thalamic nucleus (DMA). In addition, they receive convergent projections from the auditory (*orange*), somatosensory (*bluish grey*), and visual (*green*) areas of the ADVR, which in turn, are targeted by ascending projections from the main sensory nuclei of the dorsal thalamus (*coloured arrows*). Finally, the PDVR and adjoining pallium also receives chemosensory information by means of direct afferents from the parabrachial area (which probably also conveys viscerosensitive inputs), from the ventral part of the lateral cortex (olfactory), and from the nucleus sphericus (vomeronasal). The projections of the PDVR and adjoining areas are suggestive of an amygdaloid nature of this area of the reptilian pallium. Thus, the ventromedial PDVR (*PDVRvm*) and the LA display a prominent projection to the ventral and medial hypothalamus through the *stria terminalis*, whereas the DA projects to the striatum. The dorsolateral PDVR (*PDVRdl*) is mainly engaged in intrinsic projections, whereas the whole system projects to the nucleus accumbens and to the striato-amygdaloid area (SAT). The SAT gives rise to long-distance descending projections to centers of the hypothalamus and brainstem that probably are involved in the expression of fear-related behaviors. Finally, the LA projects back to the ADVR. Abbreviations (in alphabetic order): *PDVRdl*: dorsolateral part of the posterior dorsal ventricular ridge; *PDVRvm*: ventromedial part of the PDVR; *Rot*: nucleus rotundus; *VMH*: ventromedial nucleus of the hypothalamus. For other abbreviation see [Figs. 1 and 2](#).

### The Reptilian Amygdala

Data on the connections of the PDVR and adjacent areas strongly suggest that they constitute the basolateral amygdala of reptiles [1]. Thus, like its mammalian counterpart, this multimodal area of the reptilian pallium projects to different parts of the ventromedial hypothalamus, through the *stria terminalis* and to the dorsal and ventral striatum. The latter projection

includes a pathway targeting the caudal portion of the ventral striatum, the so-called striato-amygdaloid transition, for which a homology with the central extended amygdala has been proposed.

The amygdaloid nature of the PDVR and adjacent areas is also supported by topological data. Like the basolateral amygdala of mammals, the PDVR is a portion of the ventral pallium [3] topologically deep to

the caudal olfactory and vomeronasal cortex (nucleus sphericus).

### Functional Aspects

#### Medial, Dorsomedial and Dorsal Cortices

Functional studies in turtles and lizards indicate that the MC-DC are involved in spatial learning [19,20]. Lesions of the medial aspect of the cortex impair the capacity to locate the goal in a maze or arena if animals need to rely on distal (extra-maze) cues (►*spatial learning*). In contrast, these lesions elicit no substantial behavioral deficits when the animals can orient themselves using local (intra-maze) cues (cue-related learning). These data suggests that the MC/DC of lizards, like the mammalian hippocampus, is involved in processing multimodal information to construct (►*allocentric maps* vs egocentric maps) (based on objects external to the subject) of the environment to guide navigation.

#### Role of the PDVR and Its Circuitry in Behavior

As shown above, the PDVR seems to be part of the reptilian amygdala. Although there are few functional studies of the cerebral hemispheres of reptiles, some data indicate a role of the PDVR and adjoining areas in the expression of *fear*-related behaviors, a feature typical of the mammalian amygdala. Thus, lesions of the caudal cerebral hemispheres, including the striato-amygdaloid area or comparable areas in lizards [21] and crocodiles [22] result in a decrease in attack-retreat reactions and social interactions as well as in shortened ►*tonic immobility* and ►*antipredator behaviours*, reminiscent of the effects of amygdaloid lesions on fear reactions in mammals. In addition, electrical stimulation of the caudolateral cerebral hemispheres in freely moving crocodiles results in what resembles escape behavior, sometimes accompanied by vocalizations, respiratory changes and micturition [22].

In conclusion, the reptilian cerebral hemispheres include two different pallial associative areas that apparently comprise their hippocampal and amygdaloid formations. As in mammals, these areas seem to be involved in *spatial memory* and in the expression of emotional behaviors (e.g. fear) respectively. It is unlikely that reptiles also possess additional associative areas mediating complex functions similar to the ones found in the areas of the mammalian cortex (parietal, temporal and frontal lobes), since the rest ( $\approx 37\%$ ) of the pallium is mostly composed of primary sensory areas (LC, nucleus sphericus, pallial thickening and ADVR).

### Acknowledgements

This work has been funded by the Spanish Ministry of Education and Science-FEDER (BFU2004-04272), the Valencian Government (Conselleria d'Empresa,

Universitats i Ciència, ACOMP06/258) and the Junta de Comunidades de Castilla-La Mancha (PAC-05-007-2).

### References

1. Lanuza E, Belekhova M, Martínez-Marcos A, Font C, Martínez-García F (1998) Identification of the reptilian basolateral amygdala: an anatomical investigation of the afferents to the posterior dorsal ventricular ridge of the lizard *Podarcis hispanica*. Eur J Neurosci 10:3517-3343
2. Fernandez AS, Pieau C, Repérant J, Boncinelli E, Wassef M (1998) Expression of the Emx-1 and Dlx-1 homeobox genes define three molecularly distinct domains in the telencephalon of mouse, chick, turtle and frog embryos: implications for the evolution of telencephalic subdivisions in amniotes. Development 125:2099-2111
3. Martínez-García F, Martínez-Marcos A, Lanuza E (2002) The pallial amygdala of amniote vertebrates: evolution of the concept, evolution of the structure. Brain Res Bull 57:463-469
4. Bruce LL, Butler AB (1984) Telencephalic connections in lizards. I. Projections to cortex. J Comp Neurol 229:585-601
5. Desan PH (1988) Organization of the cerebral cortex in turtle. In: Schwerdtfeger WK, Smeets WJAJ (eds) The forebrain of Reptiles. Current concepts on structure and function. Karger, Basel, pp 1-11
6. Ulinski PS (1988) Functional architecture of turtle visual cortex. In: Schwerdtfeger WK, Smeets WJAJ (eds) The forebrain of reptiles. Current concepts on structure and function. Karger, Basel, pp 151-161
7. Martínez-García F (2003) The origin of the amniote sensory and motor cortices. Behav Brain Sci 26:562-564
8. Martínez-García F, Lorente MJ (1990) Thalamo-cortical projections in the lizard *Podarcis hispanica*. In: Schwerdtfeger WK, Germroth P (eds) The forebrain in nonmammals. New aspects of structure and development. Springer, Berlin Heidelberg New York, pp 93-102
9. Belekhova MG, Ivazov NI (1983) Analysis of the conduction of visual, somatic and audiovibrational sensory information of the hippocampal cortex in the lizard. Neurofiziologija 15:153-160
10. Martínez-García F, Olucha FE (1988) Afferent projections to the Timm-positive cortical areas of the telencephalon of lizards. In: Schwerdtfeger WK, Smeets WJAJ (eds) The forebrain of reptiles. Current concepts on structure and function. Karger, Basel, pp 30-40
11. Martínez-García F, Olucha FE, Teruel V, Lorente MJ (1993) Fiber connections of the amygdaloid formation of the lizard *Podarcis hispanica*. Brain Behav Evol 41:156-162
12. Lanuza E, Halpern M (1997) Afferent and efferent connections of the nucleus sphericus in the snake *Thamnophis sirtalis*: convergence of olfactory and vomeronasal information in the lateral cortex and the amygdala. J Comp Neurol 385:627-640
13. Ulinski PS (1983) Dorsal ventricular ridge. A treatise on forebrain organization in reptiles and birds. Wiley, New York
14. Bruce LL, Butler AB (1984) Telencephalic connections in lizards. II. Projections to anterior dorsal ventricular ridge. J Comp Neurol 229:602-615

15. Andreu MJ, Dávila JC, Real MA, Guirado S (1996) Intrinsic connections in the anterior dorsal ventricular ridge of the lizard *Psammotrochus algirus*. *J Comp Neurol* 372:49–58
16. Hoogland PV, Vermeulen-Vanderzee E (1995) Efferent connections of the lateral cortex of the lizard Gekko gekko: evidence for separate origins of medial and lateral pathways from the lateral cortex to the hypothalamus. *J Comp Neurol* 352:469–480
17. Hoogland PV, Vermeulen-Vanderzee E (1989) Efferent connections of the dorsal cortex of the lizard *Gekko gekko* studied with *Phaseolus vulgaris*-leucoagglutinin. *J Comp Neurol* 285:289–303
18. Martínez-García F, Amiguet M, Schwerdtfeger WK, Olucha FE, Lorente MJ (1990) Interhemispheric connections through the pallial commissures in the brain of *Podarcis hispanica* and *Gallotia stehlinii* (Reptilia, Lacertidae). *J Morphol* 205:17–31
19. Rodríguez F, López JC, Vargas JP, Gómez Y, Broglio C, Salas C (2002) Conservation of spatial memory function in the pallial forebrain of reptiles and ray-finned fishes. *J Neurosci* 22:2894–2903
20. Day LB, Crews D, Wilczynski W (2001) Effects of medial and dorsal cortex lesions on spatial memory in lizards. *Behav Brain Res* 118:27–42
21. Davies DC, Martínez-García F, Lanuza E, Novejarque A (2002) Striato-amygdaloid transition area lesions reduce the duration of tonic immobility in the lizard *Podarcis hispanica*. *Brain Res Bull* 57:537–541
22. Keating EG, Kormann LA, Horel JA (1970) The behavioral effects of stimulating and ablating the reptilian amygdala (*Caiman sklerops*). *Physiol Behav* 5:55–59

## Evolution of Association Pallial Areas: Parietal Association Areas in Mammals

LEAH KRUBITZER<sup>1,2</sup>, JEFFREY PADBERG<sup>1</sup>

<sup>1</sup>Center for Neuroscience, University of California, Davis, CA, USA

<sup>2</sup>Department of Psychology, University of California, Davis, CA, USA

### Definition

Posterior parietal cortex is a large region of cortex that lies between somatosensory and primary cortices. In some mammals such as primates, it contains a number of cortical fields whose functions include coding the spatial location of objects within both egocentric and extrinsic frames of reference, and in generating an internal representation of the body that contributes to a “sense of self,” “body schema,” or “body image.” While the posterior parietal association areas are well developed in primates, likely in conjunction with specialized

hand use, some of these areas may be present in a primitive form in other mammals. A similarly located region of cortex has been identified in rodents, carnivores, hedgehogs, tenrecs, and opossums.

### Characteristics

All mammals actively explore their environment with specialized body parts that contain unique arrangements of various types of sensory receptors. It has been proposed that the complex motor sequences involved in exploration require an internal representation of the body, a knowledge of what constitutes the body or self, and a knowledge of what constitutes the external world, which includes animate and inanimate objects (see [1]). The region of the neocortex that is thought to generate these complex abilities is the posterior parietal association cortex, which has greatly expanded in human and nonhuman primates. Because an internal representation of the body is necessary in order to interact appropriately with the external environment, it is likely that all mammals have portions of their brain devoted to generating such an internal representation. Unfortunately, little is known about posterior parietal association cortex in mammals other than primates and whether there are fundamental features of the mammalian neocortex that give rise to this internal framework or “sense of self.”

### Introduction: Posterior Parietal Cortex as an Association Area

The neocortex is a uniquely mammalian structure that comprises a large portion of the brain and is responsible for the higher order sensory, perceptual, and cognitive behaviors. In several lines of descent such as primates, cetaceans, and elephants the neocortex has disproportionately expanded compared to the rest of the brain, and much of this expansion appears to be due to an increase in the number of higher-order association areas. Traditionally the mammalian neocortex has been divided into three broad categories including motor cortex, sensory cortex, and association cortex. Association cortex, as defined by many modern text books, includes temporal, prefrontal, and posterior parietal cortex, and is hypothesized to mediate complex behaviors such as perception, attention, cognition, and other high level mental functions. The definition of what constitutes association cortex is based on the premise, which emerged from earlier mapping studies of Woolsey [2] (e.g., 1958), that the amount of cortex that could not be defined as unimodal sensory cortex in primates was relatively large compared to other mammals (Fig. 1).

Because primates are thought to have a larger repertoire of higher level or cognitive behaviors than other mammals, this expanded cortex became associated with higher mental processes and was considered a primate phenomenon.

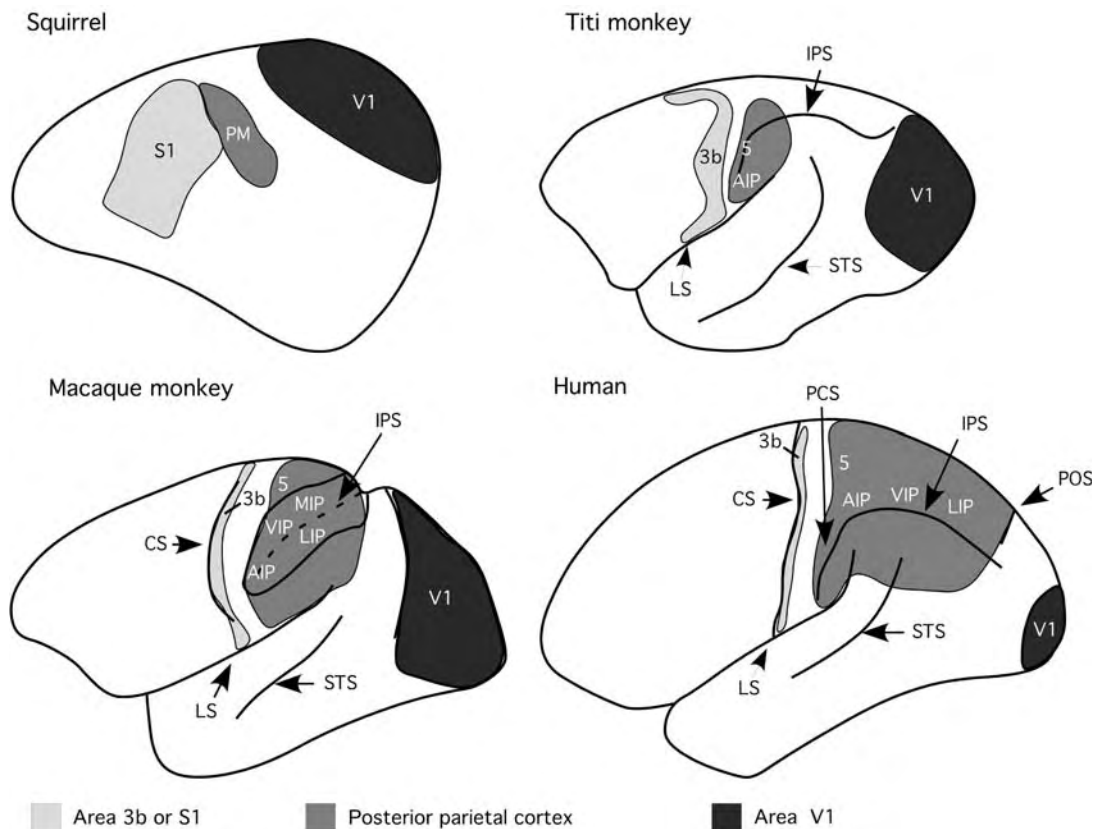

**Evolution of Association Pallial Areas: Parietal Association Areas in Mammals. Figure 1** Illustrations of the location of posterior parietal cortex, PP (dark grey), in several different mammals including squirrels, non-human primates and humans. Although the relative location of PP, between S1 (light grey) and V1 (black), is maintained in the different species, the amount of cortex devoted to PP, and the number of subdivisions within PP has changed in different mammals. Further, this cortex has greatly expanded in anthropoid primates including macaque monkeys and humans.

However, the early mapping studies, which provided support for these ideas, were hampered by technical problems, which made it difficult to elicit responses from neurons in cortex other than primary and secondary sensory fields. Despite these limitations, these early studies generated several long held tenants regarding sensory and association cortex. Probably the most noteworthy was that primary fields are evolutionarily older, and that association cortex is a new evolutionary phenomenon found mainly in human and non-human primates. Thus, the expansion of association cortex was proposed to be the hallmark of human brain evolution.

The view of a hugely expanded association cortex in primates was upended by work in the early 1970s by Allman and Kaas [3] who demonstrated that much of extrastriate cortex in non-human primates that was considered to be association cortex actually contained a number of unimodal visual areas. Somewhat later, portions of parietal and temporal cortex previously thought to be association regions were similarly

reassigned as unimodal somatosensory and auditory cortical fields, respectively (see [4] for review). Although we now appreciate that much of the expanded neocortex in mammals such as primates actually contains sensory areas, there are still a few regions of the neocortex that are considered to be association areas, one of which is the posterior parietal cortex.

Posterior parietal cortex appears to be involved in coding the spatial location of objects within both egocentric and extrinsic frames of reference (e.g., [5]). Much of the region traditionally defined as posterior parietal association cortex has likely evolved in primates for the generation of specialized hand use, such as manual dexterity, bimanual coordination, and visually-guided reaching and grasping. Such behavior requires an internal representation of the body that allows some species-specific effector, such as the hand in primates, to interact with objects in their surroundings. This internal coordinate system of the body contributes to what has variously been termed “sense of self,” “body schema,” and “body image.” Currently it is unclear whether other mammals

possess neocortical areas homologous to the posterior parietal areas in primates.

### Posterior Parietal Cortex in Primates

Posterior parietal cortex in primates is located within and around the intraparietal sulcus, approximately midway between primary visual cortex (V1) and primary somatosensory cortex (3b; Fig. 1). Most work on posterior parietal areas comes from studies in macaque monkeys. In these primates, posterior parietal fields including areas 5, 7, the medial intraparietal area (MIP), the lateral intraparietal area (LIP), and the ventral intraparietal area (VIP) are thought to be involved in visuospatial processing including monitoring limb location during visually guided reaching tasks, converting sensory locations into motor coordinates for intentional movement, and perceiving the movements of the body in extrapersonal space (e.g., [5–7]). Multiunit electrophysiological studies indicate that neurons in area 5 respond to stimulation of deep receptors of the contralateral and sometimes ipsilateral body, and that area 5 is dominated by the representation of the hand and forelimb, (Fig. 3; e.g., [8]).

Some posterior parietal areas, including area 5, are more densely connected with motor cortical fields than with somatosensory or visual cortical fields. (e.g., [6,8]; Rizzolatti et al., 1998). Indeed, recent work by Stepniewska et al. [9] has shown that posterior parietal association cortex has important motor functions. Microstimulation of rostral regions of posterior parietal cortex in galagos, including area 5, evoked what the authors term “ethologically significant behaviors.” These behaviors included defensive behavior, reaching, hand to mouth movements, and aggressive behaviors. It is apparent from these studies that posterior parietal areas may be specialized motor integrators that allow the internal or animal-centered states to interface with and explore the external world.

Work in posterior parietal cortex of other primates besides macaques is restricted to a few species, but most studies indicate that New World Monkeys and prosimians have significantly less posterior parietal cortex than Old World macaque monkeys (Fig. 1; [10]). Posterior parietal areas caudal to area 3b in galagos and marmosets are less extensive than those of macaques (e.g., [10,11]). Recent work in titi monkeys indicates that area 5 appears to be present, but the amount of cortex it occupies is relatively small compared to macaque monkeys [8]. One common feature of posterior parietal cortex, specifically area 5, in all primates, is an increased representation or cortical magnification of ecologically relevant effectors, such as the hand (Fig. 2).

Another feature that most primates share is dense connectivity between posterior parietal, motor, and premotor areas, and orbitofrontal cortex and the lateral posterior and lateral dorsal nuclei of the thalamus.

### Posterior Parietal Cortex in Non-Primate Mammals

Although the organization of posterior parietal cortex, defined here as cortex caudal to primary somatosensory cortex (S1) and rostral to the second visual area (V2), is not well understood in most non-primate mammals, the existing data indicate that multimodal cortex is present in the same general region as posterior parietal cortex in primates (Fig. 3).

Recent studies in rodents demonstrate that they are capable of dexterous manipulations of objects (for review, Whishaw, [12] 2003). These manipulations include reaching for items in front of the animal, and using combinations of digits to hold and orient food items. It has been suggested that skilled forelimb movements may in fact be a phylogenetically old behavior that developed in early tetrapods (e.g., [12]). If this is the case, then the neural substrate for these skilled forelimb movements, which in primates appears to be posterior parietal cortex, must also be phylogenetically old, and should be observed in a wide range of mammalian species other than primates.

Studies of cortical regions in rodents that may be involved in these behaviors are limited to rats and squirrels. In rats, anatomical studies indicate that there is a posterior parietal area termed PPC (Fig. 3), and that thalamocortical connections of PPC originate from nuclei such as the lateral posterior and lateral dorsal nucleus (e.g., [13]). Homologous thalamic nuclei project to posterior parietal cortex in primates (e.g., [14]). In addition to projections from sensory areas of the neocortex, PPC in rats receives inputs from other association cortical areas such as the ventrolateral and medial orbital areas, and medial agranular cortex.

In squirrels, a region of cortex caudal to S1, termed the posterior medial (PM) area, is interconnected with S1 and contains neurons that respond to stimulation of deep receptors (Fig. 3). Further, PM/PPC is dominated by the representation of the forelimb (e.g., [15]). Based upon location, connections, and neural responsiveness, it seems likely that this region in rodents is involved in at least some of the intentional and skilled behaviors of the forepaw studied by Whishaw and colleagues.

In addition to primates and rodents, there is evidence that posterior parietal cortex has common features across all mammalian taxa (Fig. 3). For example, in carnivores such as ferrets, overlapping maps of visual and somatosensory responsiveness within a rostral posterior parietal zone have been described [16]. In cats, a zone of cortex caudal to area 3b contains neurons that respond to both deep and cutaneous somatosensory stimulation, and an area 5 similar to that observed in primates has been described (e.g., [17]).

In marsupials such as the short tailed opossum, striped possum, native cat and Virginia opossum, a small multimodal band of cortex is present between S1 and V1, and is termed C or SC (e.g., [18,19]). Likewise in

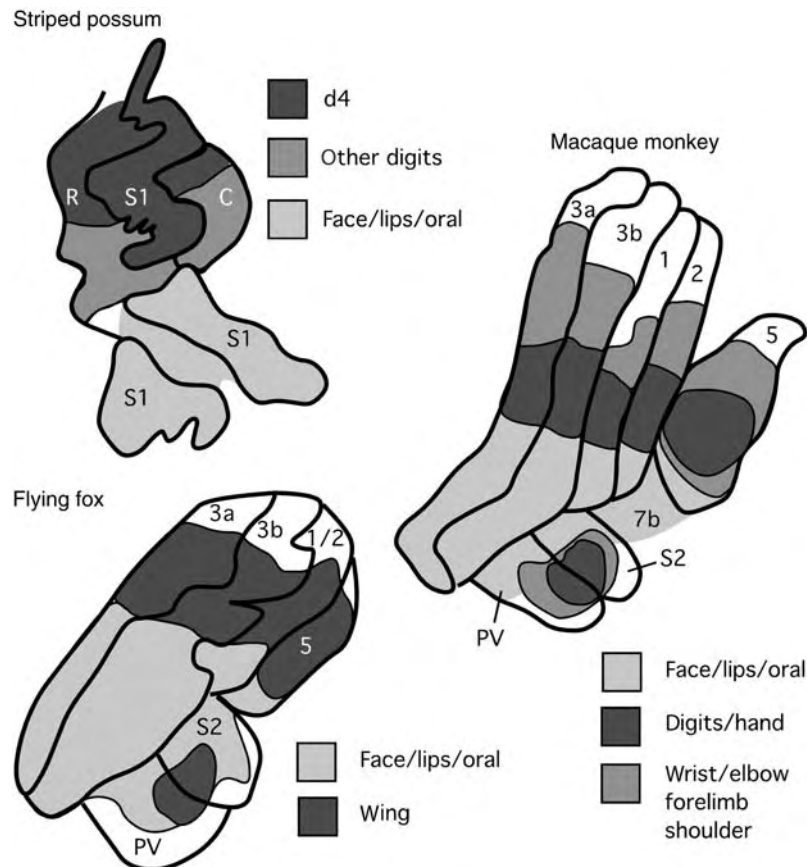

**Evolution of Association Pallial Areas: Parietal Association Areas in Mammals. Figure 2** The somatotopic organization of anterior (3a, 3b, 1 and 2) and posterior parietal area 5 in several species of mammals. Although some mammals have increased the number of somatosensory areas such as area 3a, 1 and 2 in primates, all mammals have similar features of organization of anterior and posterior parietal area. The most noteworthy feature here is an expanded representation of behaviorally relevant body structures (noted in different species by different shades of grey). These include D4 and oral structures in the striped possum, the wing and oral structures in the flying fox, and the hand, shoulder and oral structures in the macaque monkey.

hedgehogs and tenrecs, a narrow band of cortex in the location of posterior parietal cortex has been identified, and neurons in this region respond to visual and/or to auditory stimulation, to stimulation of cutaneous somatosensory receptors (i.e., deflection of quills), and/or to visual stimulation [20]. Species such as the flying fox have a cortical field termed PP, which is immediately caudal to area 1/2. Neurons in PP respond to stimulation of deep receptors as well as to visual stimulation, and PP has connections with area 1/2 (e.g., [21]).

As with area 5 in primates, electrophysiological recording studies of posterior parietal cortex in other mammals indicate that there is an extreme magnification of ecologically relevant body parts (Fig. 2). For example, in rats and squirrels, this cortex is dominated by the representation of the forepaw. In marsupials such as the striped possum, with its specialized fourth digit, this cortex contains a large representation of D4 [19].

Another feature common to PPC and area 5 is that neurons in this region of cortex respond to stimulation of deep somatic receptors and often to visual stimulation as well. Finally, as in primates, in the few studies in which the connections of PPC have been investigated in non-primates, strong connections are observed with motor cortex, orbitofrontal cortex, and the lateral posterior and lateral dorsal nuclei of the thalamus.

#### The Evolution of Posterior Parietal Cortex

The presence of PPC in both New World and Old World monkeys, and a rudimentary form of PPC in most non-primate mammals studied suggests that this region of cortex arose early in mammalian evolution and has been retained in most or all species of this class (Fig. 4). If this is the case, then the long-held belief that PPC is a newly evolved region of cortex observed only in primates needs to be re-evaluated.

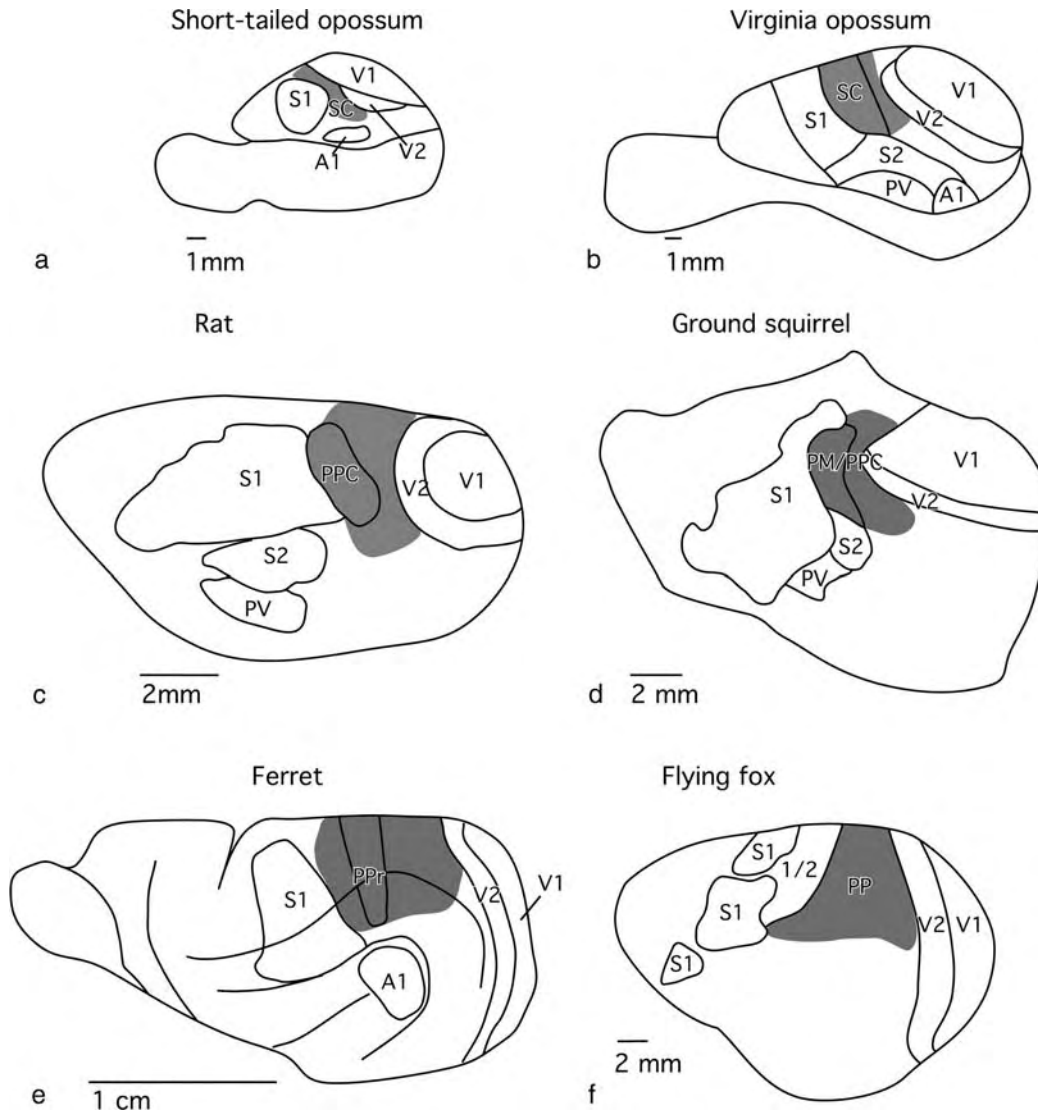

**Evolution of Association Pallial Areas: Parietal Association Areas in Mammals. Figure 3** The location of the proposed homologue of PP (grey) in different non-primate mammals. In marsupials such as the short-tailed opossums (a) and the *Virginia opossum* (b) a field termed SC resides between S1 and V1 and neurons here are responsive to somatic and visual stimulation. In rodents such as rats (c) and ground squirrels (d) a field termed PPC and PR respectively is located just adjacent to S1 and as in marsupials, neurons in this region are responsive to visual and somatic stimulation. Posterior parietal cortex has been less well explored in other species such as ferrets (e) and flying foxes (f), but limited data indicate that these animals also have PP. Note that in small brained animals, PP is immediately adjacent to S1 and V1, and in mammals with larger brains such as ferrets, the PP does not appear to abut primary sensory areas.

While all mammals, including primates, appear to have regions of the neocortex associated with generating an internal frame of reference, in primates, new sensory areas such as anterior parietal fields 1 and 2 (Fig. 4) have been added, new connections have formed, and existing posterior parietal cortical areas associated with visually guided hand use have been elaborated.

All of these factors may ultimately have led to the emergence of a more refined internal representation of

self and increased the ways in which this internal representation interacts with objects in extra-personal space via the hands. Thus, the evolution of multiple sensory areas and an expansion of cortex devoted to hand use may be the hallmark of primate evolution. This species-specific internal representation is not a property that emerged in anthropoid primates alone but is a dynamic sensorimotor loop that all mammals possess in a derived form based on their morphological

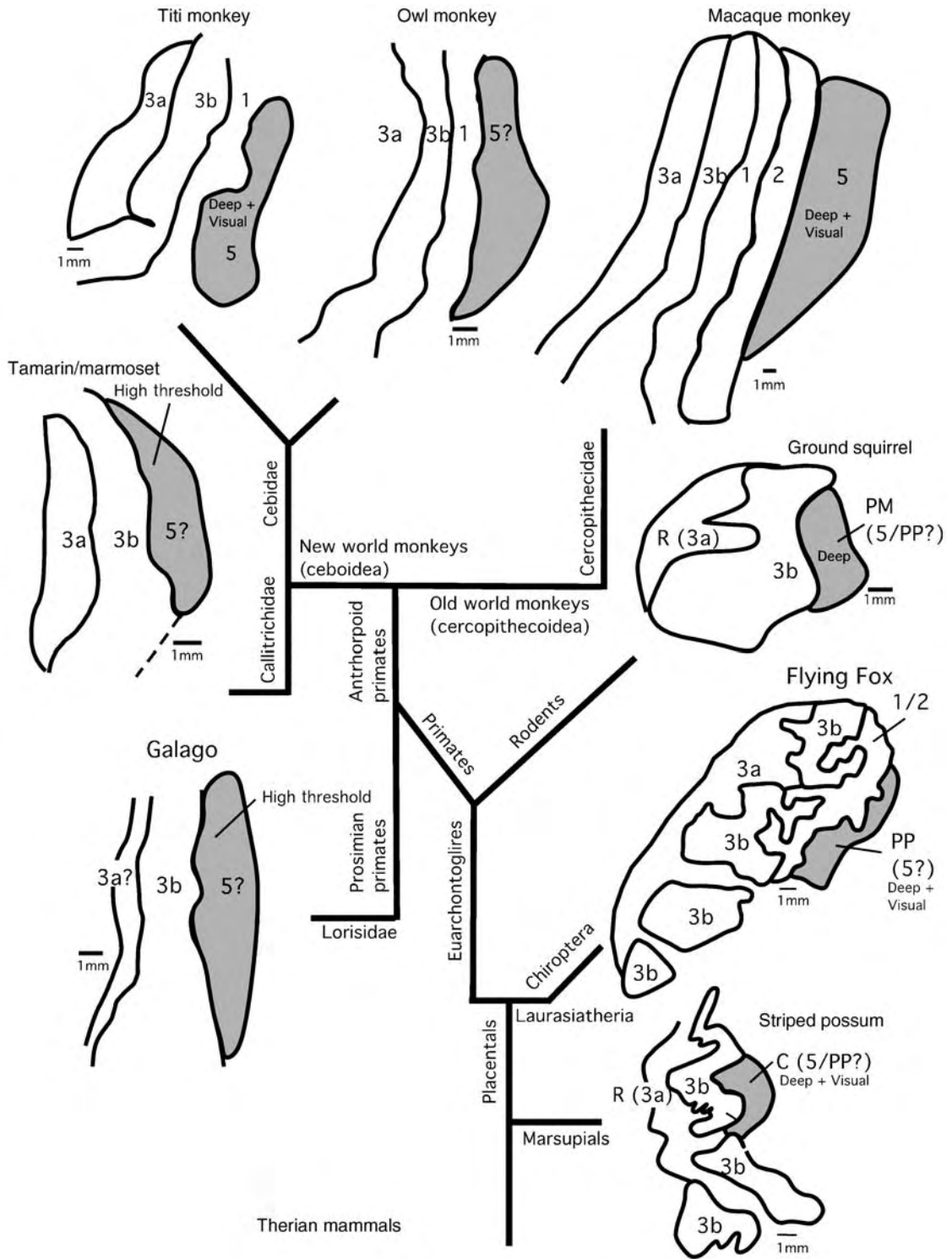

**Evolution of Association Pallial Areas: Parietal Association Areas in Mammals. Figure 4** A cladogram depicting the phylogenetic relationship of different species and the location of posterior parietal area 5 (grey) relative to anterior parietal fields. Note that in New World and Old World monkeys such as titi, owl and macaque monkeys, new sensory areas have been interspersed between evolutionary older fields such as 3b (S1) and posterior parietal areas (PP or area 5).



distinctions and distribution of sensory receptors. In primates and some rodents, the morphology in question is that of the hands and the behaviors associated with the use of the hands to explore and interact with the external environment. In other mammals, exploratory behavior may involve morphological structures such as a snout, bill, or nose follicle. Regardless of the effector organ, all of these behaviors require an internal frame of reference and specialized motor programs that allow efficient interface between the effector and the external world. Studies of connections as well as electrophysiological recording data indicate that PPC does have strong interconnections with motor areas of the cortex. This suggests that the motor system plays a critical role in generating an internal frame of reference which enables all animals to distinguish self from non-self, an attribute traditionally delegated solely to association cortex in primates.

## References

- Krubitzer L, Disbrow E (2007) The evolution of parietal areas involved in hand use in primates. In: Kaas J, Gardner E (eds) *The senses: a comprehensive reference*, vol 5, Somatosensation, Academic Press, Oxford
- Woolsey CN (1958) Organization of somatic sensory and motor areas of the cerebral cortex. In: Harlow HF, Woolsey CN (eds): *Biological and biochemical bases of behavior*. University of Wisconsin Press, Madison, pp 63–82
- Allman JM, Kaas JH (1971) A representation of the visual field in the caudal third of the middle temporal gyrus of the owl monkey (*Aotus trivirgatus*). *Brain Res* 31:85–105
- Kaas JH, Collins CE (2004) The resurrection of multimodal cortex in primates: connection patterns that integrate modalities. In: Calvert G, Spence C, Stein BE (eds) *Handbook of multisensory processing*. MIT Press, Cambridge
- Peseran B, Nelson MJ, Andersen RA (2006) Dorsal premotor neurons encode the relative position of the hand, eye, and goal during reach planning. *Neuron* 51:125–134
- Kalaska JF (1995) Parietal cortex area 5 and visuomotor behavior. *Can J Physiol Pharmacol* 74:483–498
- Fogassi L, Luppino G (2005) Motor functions of the parietal lobe. *Curr Opin Neurobiol* 15:626–631
- Padberg J, Disbrow E, Krubitzer L (2005) The organization and connections of anterior and posterior parietal cortex in titi monkeys: do new world monkeys have an area 2? *Cereb Cortex* 15:1938–1963
- Rizzolatti G, Luppino G, Matelli M (1998) The organization of the cortical motor system: new concepts. *Electroenceph clin Neurophysiol* 106:282–296
- Stepniewska I, Fang PC, Kaas JH (2005) Microstimulation reveals specialized subregions for different complex movements in posterior parietal cortex of prosimian galagos. *Proc Natl Acad Sci USA* 102(13):4878–4883
- Huffman KH, Krubitzer L (2001) Area 3a: topographic organization and cortical connections in marmoset monkeys. *J Comp Neurol* 435:291–310
- Whishaw IQ (2003) Did a change in sensory control of skilled movements stimulate the evolution of the primate frontal cortex? *Behav Brain Res* 146:31–41
- Reep RL, Chandler HC, King V, Corwin JV (1994) Rat posterior parietal cortex: topography of corticocortical and thalamic connections. *Exp Brain Res* 100:67–84
- Yeterian EH, Pandya DN (1985) Corticothalamic connections of the posterior parietal cortex in the rhesus monkey. *J Comp Neurol* 237:408–426
- Slutsky DA, Manger PR, Krubitzer L (2000) Multiple somatosensory areas in the anterior parietal cortex of the California ground squirrel (*Spermophilus beecheyii*). *J Comp Neurol* 416:521–539
- Manger PR, Masiello I, Innocenti GM (2002) Areal organization of the posterior parietal cortex of the ferret (*Mustela putorius*). *Cereb Cortex* 12:1280–1297
- Dykes RW, Rasmusson DD, Hoeltzell PB (1980) Organization of primary somatosensory cortex in the cat. *J Neurophysiol* 43:1527–1546
- Beck PD, Pospichal MW, Kaas JH (1996) Topography, architecture, and connections of somatosensory cortex in opossums: Evidence for five somatosensory areas. *J Comp Neurol* 366:109–133
- Huffman K, Nelson J, Clarey J, Krubitzer L (1999) The organization of somatosensory cortex in three species of marsupials, *Dasyurus hallucatus*, *Dactylopsila trivirgata*, and *Monodelphis domestica*: Neural correlates of morphological specializations. *J Comp Neurol* 403:5–32
- Krubitzer LA, Künzle H, Kaas JH (1997) Organization of sensory cortex in a Madagascan insectivore, the tenrec (*Echinops telfairi*). *J Comp Neurol* 379:399–414
- Krubitzer LA, Calford MB, Schmid LM (1993) Connections of somatosensory cortex in megachiropteran bats: the evolution of cortical fields in mammals. *J Comp Neurol* 327:472–506

## Evolution of Auditory System in Anamniotes

CATHERINE A. MCCORMICK,

MARK R. BRAFORD JR

Departments of Biology and Neuroscience, Oberlin College, Oberlin, Ohio, OH, USA

### Definition

The ascending auditory system comprises the receptor apparatuses, sensory ganglia and central pathways that detect and convey auditory stimuli into and through the brain. It is not known whether jawless fishes (lampreys and hagfishes) hear. Across jawed vertebrates, the auditory system exhibits diversity in its auditory receptors and central nuclei but a common pattern of organization of its central ascending pathways (Fig. 1). Jawed fishes hear using ► **otolith endorgans** – the saccule, lagena and utricle – and the non-otolithic macula neglecta may

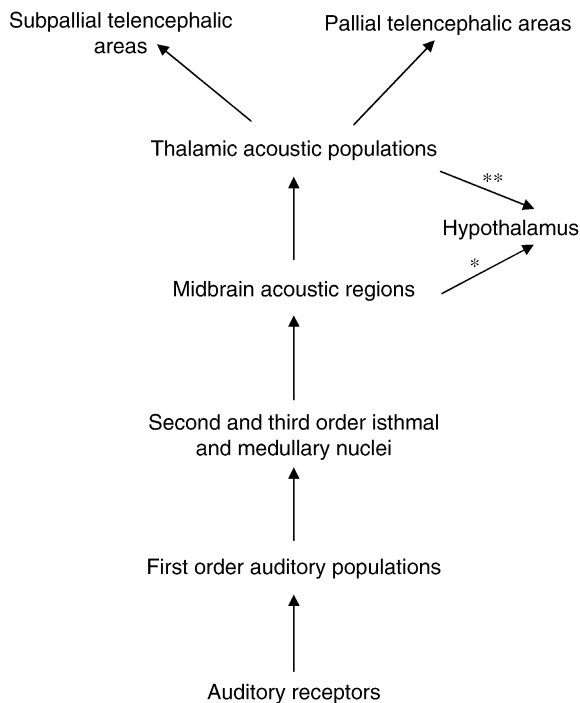

### Evolution of Auditory System in Anamniotes.

**Figure 1** Basic organization of the ascending auditory pathways in jawed vertebrates. \* connections from the auditory midbrain to the hypothalamus present in at least some bony fish. \*\* connections from auditory thalamic structures to the hypothalamus present in at least some anurans.

also be auditory in some ►cartilaginous fishes [1]. Amphibians retain auditory function in the saccule and lagena and also have evolved new sound pressure receptors – the amphibian and basilar papillae [2].

The mechanosensory lateral line system, present only in anamniotes, potentially contributes to hearing in fish and those aquatic amphibians that retain it [3]. Because little is definitively known about the role of the lateral line in sound processing, it will not be discussed further. The Mauthner neuron responds to sound but does not contribute to the ascending auditory pathway [4]. Likewise, possible first-order acoustic input to the reticular formation is involved in motor activity. Other characteristics of the central auditory pathways of fish and amphibians not addressed in this chapter include (i) extensive commissural connections at many if not all levels and (ii) extensive and complex descending connections [4,5,6,7,8,9].

### Characteristics

#### Ascending Auditory Pathway in Fish Brainstem Auditory Structures

The three otolith endorgans in bony and cartilaginous (jawed) fish may function both as hearing and as

gravistatic organs [1]. Each endorgan thus gives rise to a branch of the statoacoustic nerve that may have auditory and vestibular components. The central auditory pathways have been studied in relatively few species; among the ►bony fishes information is available for only the ray-finned fishes (actinopterygians). Auditory fibers segregate from otolith endorgan vestibular fibers and supply auditory regions within functionally mixed (auditory-vestibular) first-order octaval nuclei [4]. In certain cartilaginous fish auditory macula neglecta fibers also terminate in these regions [4].

Four first-order nuclei receive inner ear input in cartilaginous and the ray-finned bony fishes, the anterior, descending, magnocellular and posterior octaval nuclei (Fig. 2a). ►Teleost fish, which comprise the majority of bony fish, have an additional nucleus tangentialis. The dorsal division of the descending nucleus is the major first-order auditory center and contributes the majority of input to the auditory midbrain and other higher-order brainstem auditory structures [4]. The dorsal division of the less prominent anterior nucleus provides input to the auditory midbrain in some, but not all, species [4,10].

Within the auditory division of the descending and anterior nuclei, the otolith endorgans and, in cartilaginous fish the macula neglecta, have partially overlapping terminal zones. Fibers from the saccule, lagena and utricle usually terminate in medial to lateral locations respectively [4].

The auditory portion of the descending nucleus varies in size and morphology among fishes. Although it is largest in bony fish species specialized for sound pressure detection, there is an incomplete understanding of the functional significance of the three morphological variations that have been described [4]. The saccule in certain teleosts is specialized for sound pressure detection [1] and in these species the saccule has a very prominent, medially located terminal zone in the dorsal descending nucleus [4,8,11]. In clupeids, a teleost group in which a portion of the utricle is specialized for sound pressure detection, it is the utricular projection that prominently supplies the most medial terminal zone in the descending nucleus [4]. These comparative data suggest that in bony fish specialized for sound pressure detection, the medial portion of the dorsal descending nucleus processes the pressure component of sound and that other auditory areas of the nucleus process the particle motion component of sound.

Information about auditory processing in the anterior nucleus is lacking, but there is further information about the descending nucleus. Anatomical data from two distantly related species suggest that initial computations underlying sound localization potentially occur in the descending nucleus [12,13]. In the sonic batrachoidid teleosts, a region of the descending nucleus

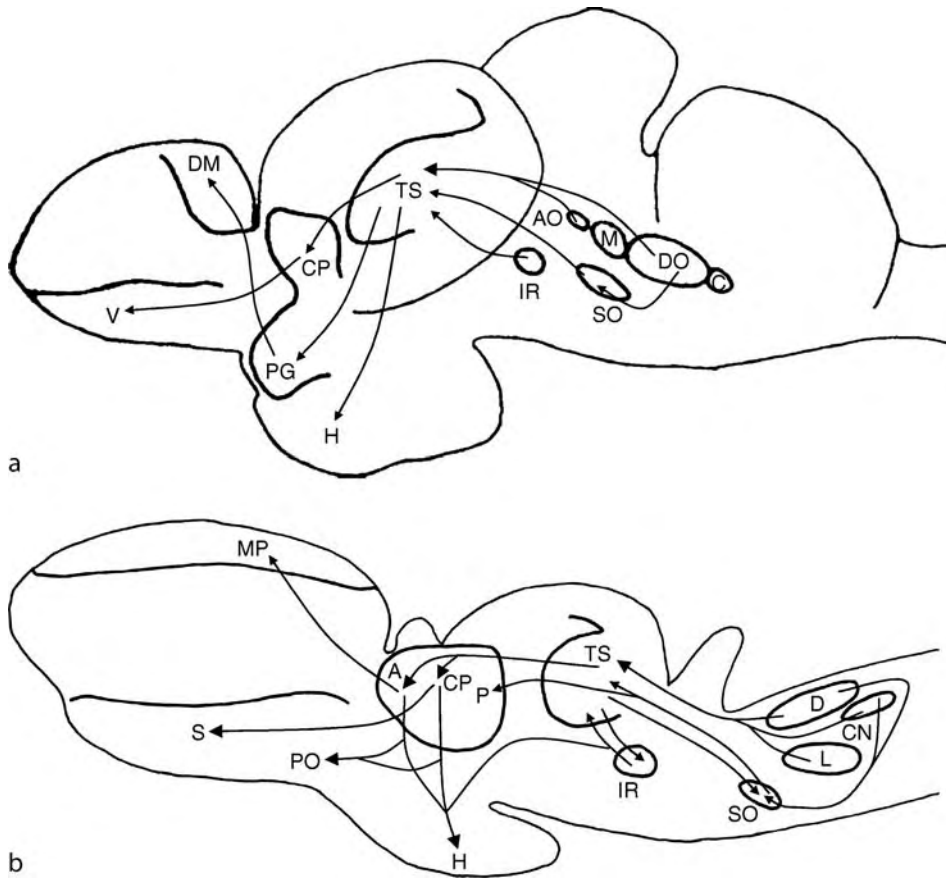

**Evolution of Auditory System in Anamniotes. Figure 2** Lateral view of the brain of a goldfish and b frog schematically showing major components of the ascending auditory pathway. See text for additional auditory structures. Abbreviations: *A* anterior nucleus of the thalamus; *AO* anterior (octaval) nucleus; *C* caudal (octaval) nucleus; *CN* caudal/medial “vestibular” nucleus; *CP* central posterior nucleus of the thalamus; *D* dorsolateral (dorsal medullary) nucleus; *DM* dorsomedial area of the pallium of the telencephalon; *DO* descending (octaval) nucleus; *H* hypothalamus; *IR* isthmoreticular nucleus; *L* lateral “vestibular” nucleus; *M* magnocellular (octaval) nucleus; *MP* medial pallium; *P* posterior nucleus of the thalamus; *PG* pregglomerular nuclei; *PO* preoptic area; *S*, striatum; *SO* secondary octaval nucleus (fish); superior olivary nucleus (anurans); *TS*, torus semicircularis; *V*, area ventralis (subpallium) of the telencephalon.

(along with adjacent second-order neurons) may be a vocal-acoustic integration site [10].

The auditory divisions of the descending and in some species, the anterior nuclei give rise to the lateral lemniscus (Fig. 2a). This fiber bundle has a major output to the auditory midbrain bilaterally, usually with contralateral predominance [4,8,10,11]. In bony fish the auditory midbrain comprises the nucleus centralis of the torus semicircularis (TSc; or mediodorsal nucleus of mormyrids). In some species a medial pretoral nucleus is closely allied and interconnected with the TS and other auditory structures in the diencephalon and brainstem [4,8,10]. The medioventral nucleus of the lateral mesencephalic complex in cartilaginous fish is the possible homologue of the TSc [4]. The TS as a whole also includes lateral line and

probably somatosensory subdivisions and is classically considered to be homologous to the mammalian inferior colliculus. Functional studies in various teleost species implicate the TS in sound localization and recognition of species-typical vocalization, relying heavily on temporal rather than spectral cues [14]. A loose tonotopic organization has been reported in two teleost species [14].

Other brainstem components of the ascending auditory pathway are best known in bony fishes; their functional roles are unknown. In the medulla, a secondary octaval population (Fig. 2a) composed of two or three distinct divisions receives input from the dorsal descending nucleus and projects bilaterally to the TSc [4,8,10,11] and in *otophysan* teleosts to the medial pretoral nucleus [8]. In cartilaginous fish, the relatively unstudied cell

plates C1–C3 may include a group comparable to the secondary octaval population [4]. Populations associated with the lateral lemniscus also project to the TSc. Among these, the paralemniscular/paralemniscal nucleus and possibly the isthmoreticular nucleus (Fig. 2a) receive input from the secondary octaval nucleus in ►otophysan teleosts [8].

### Ascending Auditory Pathway in Fish: Forebrain

Anatomical information on forebrain auditory pathways is limited in bony fish and absent in cartilaginous fish. Auditory structures and patterns of connectivity appear to vary among bony fish taxa [4]. Connectional differences have even been reported among closely related species. Combining data across species, it can be generally stated that nuclei in each of four regions of the diencephalon receive input from the acoustic midbrain as well as from other sensory systems in some or all species studied to date [4]. Thus, sound is processed in (i) the central posterior nucleus of the dorsal thalamus, (ii) the ventromedial nucleus of the ventral thalamus, (iii) one or more of the nuclei within the preglomerular complex of the posterior tuberculum and (iv) the anterior tuberal nucleus or other regions of the hypothalamus. Some of the mostly unimodal neurons in the central posterior nucleus of the goldfish (an otophysan teleost) are auditory [15]. Most anterior tuberal neurons in goldfish are multimodal; units responding to sound can also respond to light, to hydrodynamic (lateral line) stimuli or to both [15].

Neurophysiological analyses of the area dorsalis of the telencephalon (the pallium) have identified an auditory population within the dorsomedial area (DM) [4,16]. Anatomical studies have revealed that the bulk of the auditory input to DM arises from one or more nuclei, variously named in different species, within the preglomerular complex [4,6,9,17]. DM gets only a minor input from the central posterior and anterior tuberal nuclei and has strong descending connections to the latter [4,6,18]. DM has been hypothesized to be homologous to the pallial amygdala [6,18] or alternatively to the auditory isocortex [9]. Anatomical studies also suggest the presence of one or more auditory regions in the area ventralis (subpallium) based on input from the central posterior nucleus [4,19].

### Amphibian Ascending Auditory Brainstem Pathways Overview of the Auditory Periphery

Amphibians retain the otolith endorgans, the lagena and in particular the saccule are auditory [2]. Amphibians also have one or two endorgans with hair cells that are covered by a membrane or tectorium, the ubiquitous amphibian papilla and the variably present basilar papilla. ►Urodeles, ►apodans and certain ►anurans lack a tympanic membrane and thus seismic stimuli may

be the dominant acoustic signal. Most anurans have a tympanic membrane, are thus very sensitive to airborne sound in addition to substrate vibrations and have all four acoustic organs [2].

### Brainstem Auditory Structures

In all amphibians studied to date, acoustic fibers from the conserved otolith endorgans and the newly evolved papillar organs converge in presumed acoustic populations in the dorsal portions of mixed auditory-vestibular nuclei. This pattern of organization thus resembles that of fishes. Homologies between these mixed-modality nuclei in fish and amphibians have been suggested but are not established [20]. Little is known about the function of these populations, but in anurans the lateral vestibular and caudal/medial vestibular nuclei project directly to one or more higher-order auditory areas [20]. Anurans have in addition evolved a first-order nucleus dedicated to auditory processing, the dorsolateral nucleus or dorsal medullary nucleus. It is tonotopically organized with a high frequency dorsomedial zone that receives basilar papilla input and a lateral zone that receives the lower frequency amphibian papilla input [7]. The lagena and saccule, both low frequency receptors, project respectively to the lateral zone of the dorsolateral nucleus [4] and to a neuropil ventrally adjacent to the dorsolateral nucleus [4,7,20].

Connections beyond the first-order level are known primarily from studies on anurans. As in fish, the lateral lemniscus conveys auditory input from lower levels of the neuraxis to the midbrain torus semicircularis (TS), a structure thought to be homologous to the mammalian inferior colliculus (Fig. 2b). The TS has a complex nuclear organization that is interpreted variously in the literature. Five toral subdivisions are generally recognized in ranid anurans, three of which are involved in sound processing, the magnocellular nucleus/ventral zone, laminar nucleus and principal nucleus [7]. The TS in the clawed toad *Xenopus* is hypertrophied and differently organized, probably due to the presence of a lateral line mechanosensory area [21]. Nevertheless, a common theme in the TS of both groups of anurans is the presence of (a) a main acoustic recipient zone – in ►ranids the ventral toral zone/magnocellular nucleus and in *Xenopus* the laminar nucleus – and (b) mixed modality zones. The anuran TS also receives a somatosensory projection, contains multimodal sensory areas and sends fibers to the deep layers of the optic tectum [7].

In anurans, the dorsolateral nucleus projects bilaterally to the TS (Fig. 2b) [7]. The superior olive (SO), located in the medulla, receives bilateral input from the dorsolateral nucleus and from the mixed-modality caudal/medial vestibular nucleus and projects bilaterally to the acoustic midbrain – the torus semicircularis (Fig. 2b) [7,20]. Like the dorsolateral nucleus, the SO and TS are tonotopically

organized [14]. All three structures additionally contain some neurons that are sensitive to interaural time and intensity differences [14]. The superficial reticular nucleus, located in the isthmus, receives contralateral input from the dorsolateral nucleus and ipsilateral input from the SO and projects bilaterally to the TS (Fig. 2b) [7]. In ranids, the main auditory area in the TS is reciprocally connected to the secondary isthmal nucleus/nucleus of the lateral lemniscus [7]. Because the secondary isthmal nucleus also projects to the ventral hypothalamus along with some of the acoustic thalamic nuclei, it may be involved in circuitry that links vocalizations and reproductive behavior [5].

### Forebrain Auditory Structures

As is the case in fish, the anuran TS has widespread connections to the diencephalon. Many of these nuclei are multimodal, and not all are auditory. Two dorsal thalamic nuclei – the caudal portion of the central posterior nucleus and the posterior thalamic nucleus (Fig. 2b) – appear to contain subpopulations that are exclusively or largely focused on auditory processing [5]. The anterior nucleus (Fig. 2b) is an acoustically responsive multimodal region of the dorsal thalamus that also receives visual and somatosensory input [5].

The central posterior nucleus is reciprocally connected with the main auditory toral region, the ventral zone/magnocellular nucleus (Fig. 2b) [5]. The posterior thalamic nucleus receives input from the SO, the central posterior nucleus and the TS ventral zone [5]. The central posterior and posterior thalamic nuclei may be components of parallel circuits that process temporal and spectral components of sound respectively [4]. Both of these nuclei project to the striatum (Fig. 2b) [4,5].

The central posterior nucleus and the anterior nucleus additionally provide input to acoustically responsive areas in the preoptic area and ventral hypothalamus (Fig. 2b); acoustic input potentially influences vocalization and the hormonal control of reproductive behavior via this pathway [5]. The anterior thalamic nucleus receives a small direct input from the TS and a larger indirect toral input via the pretectal gray in addition to visual and somatosensory inputs [5]. Acoustic responses have been recorded from one of its telencephalic targets, the medial pallium (Fig. 2b) [5]. The medial pallium may contain homologues of the hippocampus and non-olfactory sensory cortices [22].

### Evolutionary Overview

The ascending auditory pathways of fish and amphibians share a common pattern of information flow – a multisynaptic, ascending system that begins in the medulla and terminates in the forebrain (Fig. 1). At each level of this circuit, various taxa have evolved unique specializations. For example, among fish, the organization of otolith endorgan inputs into the acoustic

region of the main auditory nucleus varies. Among amphibians, anurans uniquely evolved a dedicated auditory processing nucleus but also have mixed auditory-vestibular nuclei present in other amphibians and fish. Anurans and at least some groups of fish have significant inputs of the auditory system to the hypothalamus, but the circuits are organized differently. Forebrain auditory pathways are particularly variable. It is noteworthy that the general pattern of auditory information flow in fish and amphibians is also present in ►amniotes. This may reflect conservation of a primitive pattern established at least as early as the evolution of the first jawed vertebrates, if not earlier [4]. Whereas the ascending auditory pathway in mammals terminates mainly in auditory isocortex with smaller inputs to the striatum and amygdala, in fish and amphibians this pathway terminates in the striatum and in pallial areas of uncertain homology.

### References

1. Ladich F, Popper AN (2004) Parallel evolution in fish hearing organs. In: Manley GA, Popper AN, Fay RR (eds) Evolution of the vertebrate auditory system. Springer, Berlin Heidelberg New York, pp 95–127
2. Smotherman M, Narins R (2004) Evolution of the amphibian ear. In: Manley GA, Popper AN, Fay RR (eds) Evolution of the vertebrate auditory system. Springer, Berlin Heidelberg New York, pp 164–199
3. Braun CB, Coombs S (2000) The overlapping roles of the inner ear and lateral line: the active space of dipole source detection. *Philos Trans R Soc Lond B Biol Sci* 355:1115–1119
4. McCormick CA (1999) Anatomy of the central auditory pathways of fish and amphibians. In: Fay RR, Popper AN (eds) Comparative hearing: fish and amphibians. Springer, Berlin Heidelberg New York, pp 155–217
5. Neary TJ (1988) Forebrain auditory pathways in ranid frogs. In: Fritzsche B, Ryan MJ, Wilczynski W, Hetherington TE, Walkowiak W (eds) The evolution of the amphibian auditory system. Wiley, New York, pp 233–252
6. Northcutt RG (2006) Connections of the lateral and medial divisions of the goldfish telencephalic pallium. *J Comp Neurol* 494:903–943
7. Wilczynski W (1988) Brainstem auditory pathways in anuran amphibians. In: Fritzsche B, Ryan MJ, Wilczynski W, Hetherington TE, Walkowiak W (eds) The evolution of the amphibian auditory system. Wiley, New York, pp 209–231
8. Yamamoto N, Ito H (2005) Fiber connections of the central nucleus of the semicircular torus in cyprinids. *J Comp Neurol* 491:186–211
9. Yamamoto N, Ito H (2005) Fiber connections of the anterior preglomerular nucleus on cyprinids with notes on telencephalic connections of the preglomerular complex. *J Comp Neurol* 491:212–233
10. Bass AH, Bodnar DA, Marchaterre MA (2000) Midbrain acoustic circuitry in a vocalizing fish. *J Comp Neurol* 419:505–531

11. Kozloski J, Crawford JD (1998) Functional neuroanatomy of auditory pathways in the sound-producing fish *Pollimyrus*. *J Comp Neurol* 401:227–252
12. Edds-Walton PL (1998) Anatomical evidence for binaural processing in the descending octaval nucleus of the toadfish (*Opsanus tau*). *Hearing Res* 123:41–54
13. Tomchik SM, Lu Z (2005) Octavolateral projections and organization in the medulla of teleost fish, the sleeper goby (*Dormitator latifrons*). *J Comp Neurol* 481: 96–117
14. Feng AS, Schellart NAM (1999) Central auditory processing in fish and amphibians. In: Fay RR, Popper AN (eds) *Comparative hearing: fish and amphibians*. Springer, Berlin Heidelberg New York, pp 218–268
15. Kirsch JA, Hofmann MH, Mogdans J, Bleckmann H (2002) Response properties of diencephalic neurons to visual, acoustic and hydrodynamic stimulation in the goldfish, *Carassius auratus*. *Zoology (Jena)* 105:61–70
16. Precht JC, von der Emde G, Wolfart J, Karamursel S, Akoev GN, Andrianov YN, Bullock TH (1998) Sensory processing in the pallium of a mormyrid fish. *J Neurosci* 18:7381–7393
17. von der Emde G, Precht JC (1999) Anatomical connections of auditory and lateral line areas of the dorsal telencephalon (Dm) in the osteoglossomorph teleost, *Gnathonemus petersii*. *Brain Res* 818:355–367
18. Braford MR Jr (1995) Comparative aspects of forebrain organization in the ray-finned fishes: touchstones or not? *Brain Behav Evol* 46:259–274
19. Wong CJH (1997) Connections of the basal forebrain of the weakly electric fish, *Eigenmannia virescens*. *J Comp Neurol* 389:49–64
20. Will U (1988) Organization and projections of the area octavolateralis in amphibians. In: Fritzsche B, Ryan MJ, Wilczynski W, Hetherington TE, Walkowiak W (eds) *The evolution of the amphibian auditory system*. Wiley, New York, pp 185–208
21. Edwards CJ, Kelley DB (2001) Auditory and lateral line inputs to the midbrain of an aquatic anuran; neuroanatomic studies in *Xenopus laevis*. *J Comp Neurol* 438:148–162
22. Bruce LL, Neary TJ (1995) The limbic system of tetrapods: a comparative analysis of cortical and amygdalar populations. *Brain Behav Evol* 46:224–234

## Evolution of Brain: At Invertebrate–Vertebrate Transition

ANN B. BUTLER

Department of Molecular Neuroscience, Krasnow Institute for Advanced Study, George Mason University, Fairfax, VA, USA

### Definition

Evolution of the brain in the earliest vertebrates from their invertebrate chordate ancestor.

### Characteristics

#### Phylogenetic Relationships

The earliest vertebrates evolved from ancestral, invertebrate chordates. Vertebrates (= craniates) are defined here as including among their extant members the jawless vertebrates (agnathans) – both hagfishes and lampreys – and jawed vertebrates (gnathostomes). The latter comprise cartilaginous fishes (Chondrichthyes) and the bony fish (Osteichthyes) radiation. Osteichthyes includes ray-finned fishes (actinopterygians) and the sarcopterygian radiation of lungfishes, crossopterygians, and tetrapods (amphibians, mammals, reptiles, and birds). Vertebrates have long been classified as one of three groups of chordates, which also include cephalochordates (the lancelets, i.e., amphioxus, or *Branchiostoma*) and urochordates (tunicates, or sea squirts). The hemichordates (acorn worms) have long been recognized as the sister group to the chordates, with echinoderms (starfishes, sea urchins, etc.) being the outgroup to the group of both hemichordates and chordates. The echinoderms, hemichordates, and chordates comprise the extant deuterostomes, which are distinguished from protostomes (most invertebrate taxa) by embryological differences early in development.

Recent molecular evidence [1–3] has prompted a revision of the cladogram for deuterostomes such that it now contains four phyla (Fig. 1) – Xenoturbellida (which comprises the single species *Xenoturbella bocki*), Ambulacraria (which comprise both the echinoderms and the hemichordates), Cephalochordata (the lancelets), and Olfactores (the urochordates and vertebrates). This new phylogeny includes a displacement of cephalochordates, long regarded as the sister group of vertebrates, to the sister group of the Olfactores, with urochordates (tunicates) being the closest extant lineage to vertebrates (see ► [Evolution and Phylogeny of Chordates](#)).

Recent hypotheses on how the brains and heads of the earliest vertebrates evolved have been based on the previous phylogenetic hypothesis that placed lancelets as the sister group. The tenets of these hypotheses are nonetheless well supported in light of the new phylogenetic interpretation, because additional recent findings about the nervous system in ascidian larvae reveal that it is much more similar to that of lancelets and vertebrates than previously realized.

### New Head Hypothesis of Northcutt and Gans

In 1983, Northcutt and Gans [4] published a major breakthrough for our understanding of vertebrate evolution with their New Head Hypothesis. Among its several new insights was the realization that tissues derived from neural crest (cells that arise next to the neural tube and give rise to multiple tissues, including some neurons) and neurogenic placodes (neighboring neurogenic epithelial regions) accounted for most of the features that uniquely occur in vertebrates, and thus the

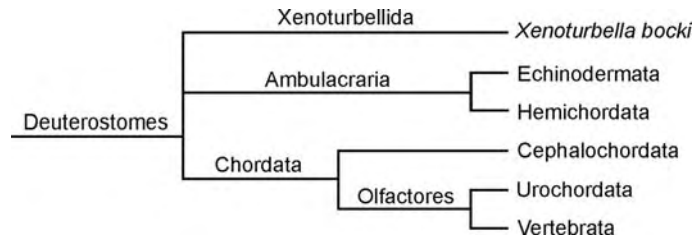

**Evolution of Brain: At Invertebrate–Vertebrate Transition. Figure 1** Dendrogram showing the relationships of the deuterostomes, based primarily on Bourlat et al. [1] and other references as cited in the text.

E

origin and elaboration of these tissues had played a crucial role in their evolution. Neurogenic placodes contribute sensory neurons to many of the cranial nerve sensory ganglia as does neural crest, while the latter also gives rise to a host of other tissues, including structural components of the gill arches, dermal skull, teeth, and pigment cells. Some indication of the presence of neural crest derivatives and placodes has been found in the invertebrate chordates, particularly in ascidians (urochordates), as discussed by Holland and Holland [5] and Northcutt [6], and Jeffery [7] has recently bolstered his assertion that neural crest-like cells that give rise to pigment cells are present in numerous ascidians. Nevertheless, the main point of Northcutt and Gans's insight stands in that the elaboration, if not the completely novel evolutionary gain, of these two tissues was one of the most significant and catapulting events in the evolutionary origin of the vertebrate subphylum.

Northcutt [6] recently reassessed the New Head Hypothesis. As noted above, its recognition of substantial elaboration of neural crest and neurogenic placodes in the earliest vertebrates (even if these tissues are not unique to vertebrates) has been supported. A second claim of the New Head Hypothesis, that the elaboration of the neural crest and placodes allowed a shift from filter feeding to active predation is likewise supported by the accumulated data, as will be discussed further below.

### The Nervous Systems of Cephalochordates and Urochordates

In a seminal series of papers, Lacalli and his co-workers [8–10] illuminated the details of the rostral part of the central nervous system (CNS) of cephalochordates, as studied in the larval lancelet, *Branchiostoma* (amphioxus), by doing meticulous 3D reconstructions from serial sections at the level of the electron microscope. Using this methodology, they definitively demonstrated for the first time that a brain with distinct subdivisions and several recognizable homologues of vertebrate CNS structures is present in the cephalochordates (Fig. 2). Among the vertebrate homologues is a rostrally located pigment spot and associated neurons that likely

comprise a homologue of the paired eyes of vertebrates, a structure called the lamellar body, which is thought to be homologous to the vertebrate pineal, and a so-called balance organ that actually is a homologue of at least part of the vertebrate hypothalamus. Farther caudally is a collection of motor neurons, called the primary motor center, that is regarded as the rostral-most population of hindbrain motor neuron pools.

Recent work also has provided new insights into the structure of the rostral part of the neural tube in urochordates, as studied in the larval tadpole form of *Ciona*. These animals have a sensory vesicle that is separated by a so-called neck region from a visceral, or trunk, ganglion, which contains motor neurons, in the trunk, as well as a caudally extending nerve cord. The sensory vesicle contains two pigment spots, an otolith and a more dorsocaudally situated ocellus, the latter possibly associated with photoreceptor cells [12]. Homeobox gene expression data support the morphological comparisons for urochordates (Fig. 2). Based on the work of Dufour et al. [11] and Imai and Meinertzhagen [11], the picture now emerging is that, as is likely also the case in amphioxus, the brain in ascidian larvae lacks a midbrain region. Rather, they have a clearly identifiable forebrain region that is divided from a rather small hindbrain by a midbrain-hindbrain boundary, the latter also identifiable in vertebrate brains. These components all lie within the sensory vesicle, while the trunk ganglion comprises the neuronal populations that correspond to the spinal cord.

### Vertebrate Eye Evolution Considered

In considering the New Head Hypothesis, the question arose as to whether the full elaboration of all sensory systems, brain, and the vertebrate head could have occurred as essentially simultaneous events or whether a sequential scenario might account for the transition to the earliest definitive vertebrates [13, 14; and see 15, 16]. If the neural crest and neurogenic placodal sensory systems of the head, i.e., the peripheral senses – the olfactory, trigeminal, facial, lateral line, auditory, vestibular, glossopharyngeal, and vagal – had elaborated before the brain also elaborated, they would not be

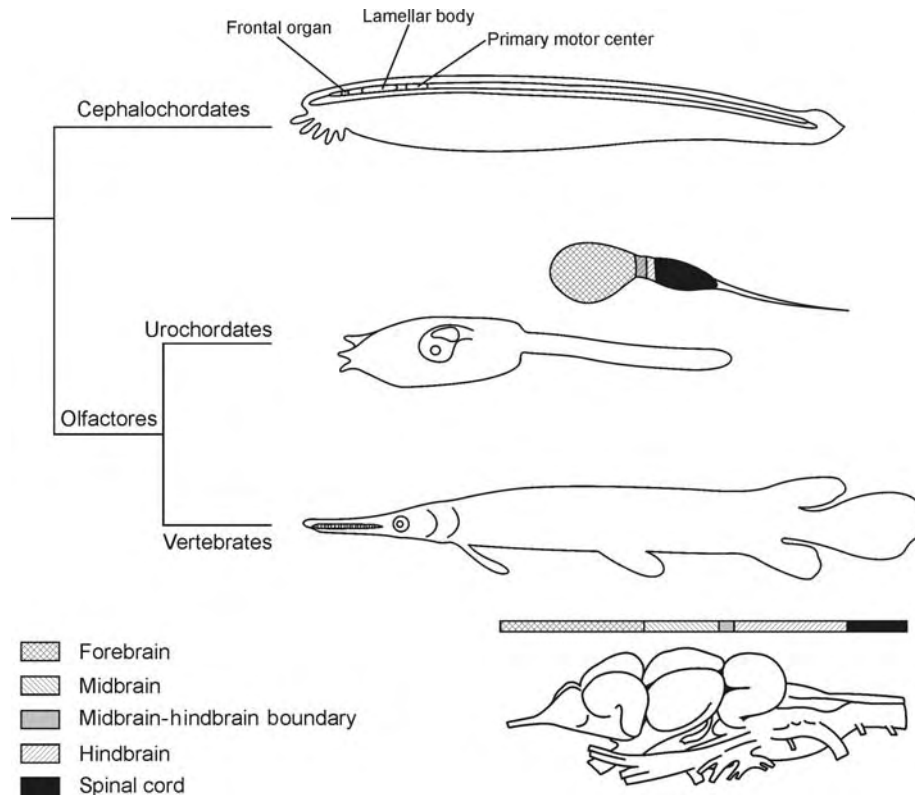

**Evolution of Brain: At Invertebrate–Vertebrate Transition. Figure 2** Drawings, from top to bottom, of a cephalochordate (lancelet), a urochordate (represented here by larval *Ciona intestinalis*), and a vertebrate (gar), with the brains drawn separately and offset to the right for the latter two. Rostrocaudal regions, from left to right and indicated by colors, of the urochordate brain (sensory vesicle) and their correspondence to regions of the vertebrate brain are based on the interpretation of Dufour et al. [11]. Similarly, for the lancelet brain, the frontal organ and lamellar body are components of the forebrain, while the region of the primary motor center most likely corresponds to the midbrain-hindbrain boundary and/or hindbrain.

potentially adaptive without the brain circuitry to take advantage of their sensory inputs.

In contrast, if the brain had undergone elaboration first, including the gain of the paired vertebrate eyes as an elaborated part of the diencephalon, such an event would be advantageous, due to the enhanced visual input, even without the elaboration of the neural crest and neurogenic placodal tissues. Their subsequent elaboration would be adaptive, however, since their inputs could be processed and utilized by the already elaborated brain. Further elaboration of both the peripheral senses and of the brain, including the visual system, would then quite rapidly follow. While the brain and paired eyes elaborated in the earliest vertebrates, the telencephalon would not have appeared until the subsequent elaboration of the olfactory system. This idea is called the “Cephalate” or the “Serial Transformation” Hypothesis [13,14,16].

#### Fossil Evidence: Answers From *Haikouella*

The discovery of a wealth of fossil material in part of Haikou, China has provided numerous data that support

the key tenets of the New Head Hypothesis, as well as the Serial Transformation Hypothesis that the paired eyes and an elaborated brainstem, including the diencephalon, were gained before much of the elaboration of the neural crest and all or most placodal sensory systems. Recent cladistic analysis by Mallatt and Chen [17] indicates that this extinct species, *Haikouella lanceolatum*, is the closest known sister group of vertebrates (Fig. 3). If this interpretation is correct, it provides an unusually clear picture of vertebrate origins.

In 1996, from analysis of the then available evidence on living and fossil fishes, Mallatt [18] had proposed that the basal vertebrate ancestor would have been a true vertebrate (craniate) with a skull, as well as with many of the neural features predicted by the New Head Hypothesis, including the presence of at least some peripheral sensory systems, such as the olfactory and auditory/vestibular systems, and a telencephalon in addition to the rest of the brain. The external features of *Haikouella*'s head and body are remarkably like Mallatt's [18] prediction, including the presence of



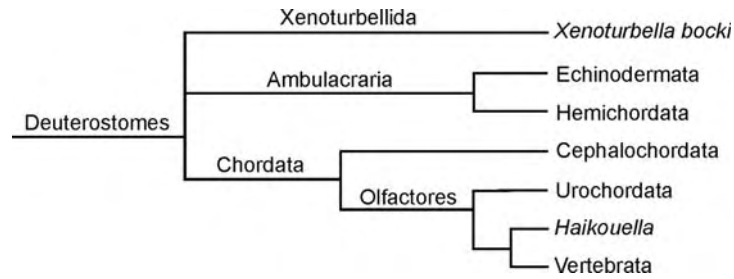

**Evolution of Brain: At Invertebrate–Vertebrate Transition. Figure 3** Dendrogram showing the relationships of the deuterostomes, based primarily on Bourlat et al. [1] and other references as cited in the text, with the addition of *Haikouella* as the sister group of vertebrates, based on Mallatt and Chen [17].

branchial bars (to which neural crest substantially contributes), a circular mouth surrounded by an oral ring and tentacles, lips, and a premandibular oral cavity. Present on the body are myomeres and a series of bands on the notochord, which may be indicative of protovertebrae. *Haikouella* also has paired eyes, as predicted by both Mallatt [18] and Butler [13,14,16], but, also as Butler predicted, *Haikouella* fossils do not indicate the presence of most peripheral sensory systems, including the ear and/or a lateral line system, derived from neural crest and neurogenic placodes. The fossil material is ambiguous as to the presence of nostrils, but, while the paired eyes are clearly evident, the rostral part of the brain appears to comprise only a diencephalon, with a telencephalic region mostly or completely absent. Nonetheless, the brain-body ratio appears to be comparable to that of extent lampreys, indicating substantial elaboration of the brain in comparison to lancelets, let alone urochordates.

### Summary and Conclusions

The evidence now available from *Haikouella* [17], in conjunction with the previous predictions and other evidence, indicates that the earliest vertebrates arose because of some neural crest elaboration that resulted in the gain of branchial bars and the crucial switch from filter feeding to active predation, as predicted by Northcutt and Gans [4] in their New Head Hypothesis, as well as the gain of at least some components of the vertebrate skull, also mostly a neural crest derivative, as also predicted by Mallatt [17,18]. Possibly like *Haikouella*, these earliest vertebrates may have had mesodermally-derived protovertebrae, consistent with their increased mobility for active predation. Also, these earliest vertebrates would have had paired eyes and an elaborated brainstem, including the diencephalon, as consistent with the Serial Transformation Hypothesis [13,14]. That step was followed by substantial further elaboration of the neural crest and neurogenic placodes for the gain of most of the peripheral sensory systems, as also predicted by the New Head Hypothesis [4], if not necessarily as effectively simultaneous acquisitions.

Among the latter, the olfactory system was elaborated (or further elaborated), and in conjunction with it, the telencephalon also was elaborated. At this stage, the definitive taxon of vertebrates, with a new head and the shared, basic divisions of the brain—a prosencephalon, or forebrain, comprising telencephalon rostrally and diencephalon caudally, including paired eyes; a definitive mesencephalon, or midbrain; and a rhombencephalon, or hindbrain, comprising the metencephalon rostrally (pons and cerebellum of mammals, for example) and myelencephalon caudally (medulla oblongata)—as well as the basal set of peripheral cranial nerves, was established.

### References

1. Bourlat SJ, Juliusdottir T, Lowe CJ, Freeman R, Aronowicz J, Krischner M, Lander ES, Thorndike M, Nakano H, Kohn AB, Heyland A, Moroz LL, Copley RR, Telford MJ (2006) Deuterostome phylogeny reveals monophyletic chordates and the new phylum Xenoturbellida. *Nature* 444:85–88
2. Delsuc F, Brinkmann H, Chourrout D, Hervé P (2006) Tunicates and not cephalochordates are the closest living relatives of vertebrates. *Nature* 439:965–968
3. Vienne A, Pontarotti P (2006) Metaphylogeny of 82 gene families sheds a new light on chordate evolution. *Int J Biol Sci* 2:32–37
4. Northcutt RG, Gans C (1983) The genesis of neural crest and epidermal placodes: a reinterpretation of vertebrate origins. *Q Rev Biol* 58:1–28
5. Holland LZ, Holland ND (2001) Evolution of neural crest and placodes: amphioxus as a model for the ancestral vertebrate? *J Anat* 199:85–98
6. Northcutt RG (2005) The new head hypothesis revisited. *J Exp Zool Mol Dev Evol* 304B:274–297
7. Jeffery WR (2006) Ascidian neural crest-like cells: phylogenetic distribution, relationship to larval complexity, and pigment cell fate. *J Exp Zool Mol Dev Evol* 306B:470–480
8. Lacalli TC (1996) Frontal eye circuitry, rostral sensory pathways and brain organization in amphioxus larvae: evidence from 3D reconstructions. *Philos Trans Royal Soc Lond B* 351:243–263
9. Lacalli TC, Holland ND, West JE (1994) Landmarks in the anterior central nervous system of amphioxus larvae. *Philos Trans Royal Soc Lond B* 344:165–185

10. Lacalli TC, Kelly SJ (2000) In fundibular balance organ in amphioxus larvae and related aspects of cerebral vesicle organization. *Acta Zool* 81:37–48
11. Dufour HD, Chettouh Z, Deyts C, de Rosa R, Goridis C, Joly J-S, Brunet J-F (2006) Precrinate origin of cranial motoneurons. *Proc Natl Acad Sci U S A* 103:8727–8732
12. Imai JH, Meinertzhagen IA (2007) Neurons of the ascidian larval nervous system in *Ciona intestinalis*. I. central nervous system. *J Comp Neurol* 501:316–334
13. Butler AB (2000a) Chordate evolution and the origin of craniates: an old brain in a new head. *Anat Rec* 261:111–125
14. Butler AB (2000b) Sensory system evolution at the origin of craniates. *Philos Proc Royal Soc Lond* 355:1309–1313
15. Butler AB, Hodos W (2005) Comparative vertebrate neuroanatomy: evolution and adaptation, 2nd edn. Wiley-Liss, Hoboken, NJ
16. Butler AB (2006) The serial transformation hypothesis of vertebrate origins: comment on “The new head hypothesis revisited.” *J Exp Zool Mol Dev Evol* 306B:419–424
17. Mallatt J, Chen J-Y (2003) Fossil sister groups of craniates: predicted and found. *J Morphol* 258:1–31
18. Mallatt J (1996) Ventilation and the origin of jawed vertebrates: a new mouth. *Zool J Linn Soc* 117:329–404

## Evolution of Cerebellum

WILLIAM HODOS

Department of Psychology, University of Maryland,  
College Park, MD, USA

### Definition

The cerebellum is a major subdivision of the hindbrain that is involved in various sensory-motor functions, especially those involving the vestibular and somato-sensory systems, and electroreception in certain ray-finned fishes. It has also been reported to play a role in certain cognitive processes.

### Characteristics

The cerebellum is a major feature of the vertebrate hindbrain. It varies widely in its shape and in its size relative to other major brain components such as the cerebrum [1,2]. In shape, it most often is roughly spherical, but it also can be a flattened sphere or even a flat plate. Typically, the cerebellum is smaller than the cerebrum; hence its name, which means “little brain” in Latin. In some fishes, however, such as the Mormyrid fishes, which have an exquisitely developed system of ▶electroreception, the cerebellum assumes gigantic proportions and can be as large or larger than the rest of the brain [3]. This may be seen in Fig. 1 which is a simplified ▶cladogram of vertebrate evolution

with figurines representing the brains of each of the animals shown.

The brains have all been scaled to have the same size brain stem; i.e., the brain stem of a relatively small ray-finned fish, such as a trout or a carp is shown as the same size as that of a human or sheep. Thus, in the Fig. 1, the size of the cerebellum relative to the size of other major brain regions, such as the cerebral hemisphere, can be seen. The majority of ▶ray-finned fishes (which lack electroreception), as well as lampreys and amphibians, have cerebella that are relatively small in comparison to the total size of the brain or to the cerebrum. Among the amniotes (mammals, reptiles, and birds), reptiles also have a relatively small cerebellum, which is in the form of a flat plate that often is curved [4,5]. Apart from the electroreceptive fishes, mammals and birds have the largest cerebellum relative to the rest of the brain [1,2].

The major components of the cerebellum that can be found in most vertebrates are the corpus cerebelli (the main body of the cerebellum) and the cerebellar auricle (“little ear”), which is also known as the flocculus in ▶tetrapod vertebrates [1,2]. Although some cerebellar folding is present in the cerebellum of many vertebrate taxa (and extreme cerebellar folding occurs in the cerebella of the electroreceptive Mormyrid fishes, the surface of the cerebellum tends to be relatively smooth. In birds and mammals, however, the cerebellum becomes quite ▶foliated [1,2]. In addition, in mammals, the corpus cerebelli becomes compressed into a narrow, worm-like midline structure called the vermis (“worm” in Latin) and a large, foliated, hemispheric extension called the neocerebellum appears on both sides of the vermis. Rather than being a new addition to the cerebellum, as its name implies, the neocerebellum appears instead to be merely a lateral expansion of the corpus cerebelli. An additional cerebellar structure, the valvula cerebelli, is unique to ray-finned fishes [6].

Figure 2 shows schematic illustrations of the cerebellum in a number of vertebrates. The corpus cerebelli and auricle are shown in each. Hagfishes lack any trace of a cerebellum, and in lampreys, the cerebellum is small and rudimentary. Its relationship to the corpus cerebelli of the other vertebrates is not clear at the present time. In contrast, all jawed vertebrates have a clearly discernable corpus cerebelli and auricle. The narrow midline structure in the mammal’s cerebellum is the vermis and the so-called neocerebellum is shown on either side of it.

### Pre-Cerebellar Nuclei

The neuronal groups that supply input to the cerebellum are sometimes known as the precerebellar nuclei. In addition to its ▶somatosensory and ▶vestibular inputs, the cerebellum receives important projections

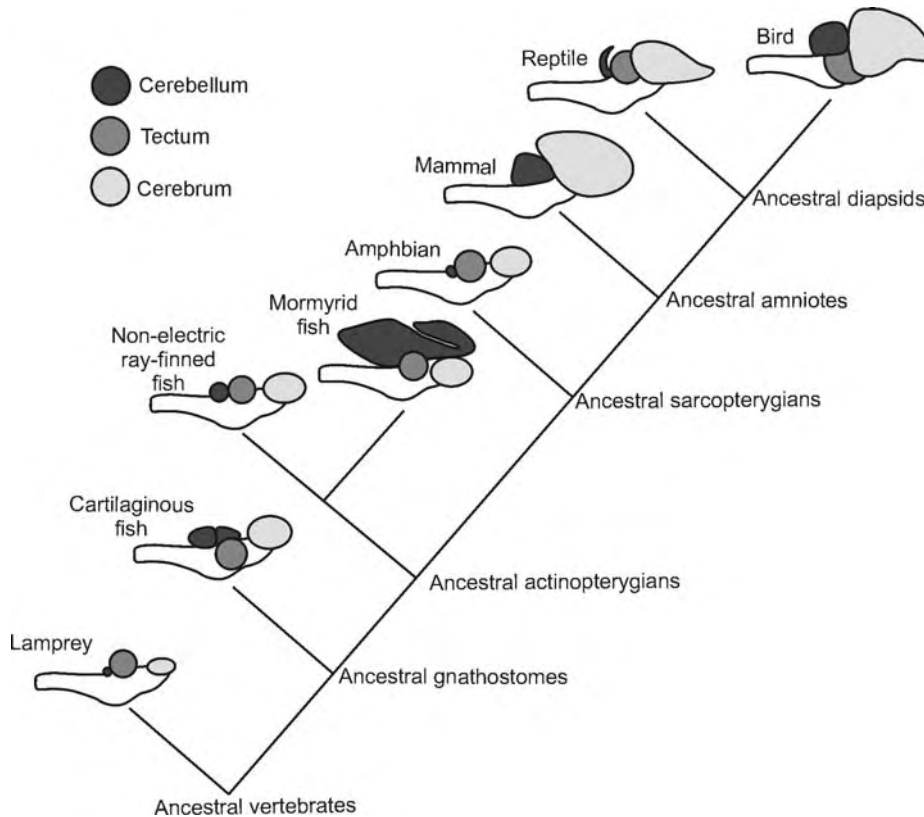

**Evolution of Cerebellum. Figure 1** A cladogram of vertebrate evolution showing the changes in the size and shape of the cerebellum in various classes of vertebrates. All of the representations of brains have been scaled to the same size to facilitate relative size comparisons. Also shown are the cerebrum and optic tectum. Reproduced from Butler and Hodos [1] with permission of John Wiley and Sons.

from other precerebellar neuronal groups [7]. These include nuclei of the ►reticular formation, the ►inferior olivary nucleus [8], which is present in all vertebrates with a cerebellum and varies in size with the size of the cerebellum, and the ►pontine nuclei, which are present in birds and mammals [1,2]. In addition, ray-finned fishes have a nucleus lateralis valvulae, which is very well developed in electrosensory fishes with a gigantic cerebellum, and many species also have a nucleus paracommissuralis [1,2].

### Cerebellar Cortex

The corpus cerebelli and the auricle are covered by a layer of neurons known as the cerebellar cortex [1,2,7]. It has an organization that bears some similarities to the cerebral cortex, but with different cell types and a different organization. The most superficial layer is the molecular layer and the deepest layer is the cerebellar white matter. Between these two are the layer of densely packed granule cells and the layer of Purkinje cells.

Although there are important differences in the cerebellar cortex among the various vertebrate classes, there also are many similarities. In general, the two

main types of cells of the cerebellar cortex are the Purkinje cells and the granule cells. Granule cells are remarkably similar in appearance across vertebrate classes. They are very small cells with relatively few dendrites. The dendrites are characterized by claw-like or knob-like endings. These cells are the most numerous and most densely packed of any cells in the central nervous system.

In contrast to the granule cells, the Purkinje cells are quite variable in their form across vertebrate taxa. They can however, easily be recognized in most cases by their large cell bodies, which are located along the margin of the granule cell layer and from which emerge a large, candelabra-shaped dendritic tree oriented towards the surface of the cortex. The Purkinje cell bodies are quite large and often are arranged in a layer that is only one cell body thick.

The outermost layer of the cortex is the molecular layer, which contains a variety of small inhibitory neurons that exert negative feedback over the granule cells and Purkinje cells. The Purkinje cell dendrites rise into the molecular layer and spread out like the branches of a tree. The axons of the granule cells also

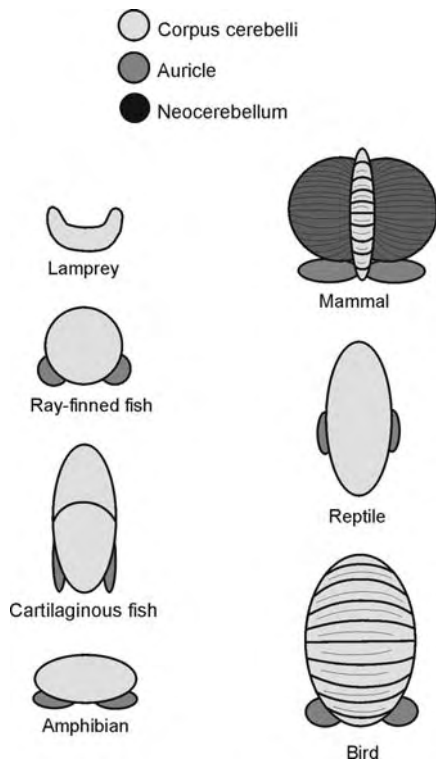

**Evolution of Cerebellum. Figure 2** Schematic diagrams of the major components of the cerebellum in various groups of vertebrates. The brains have been scaled to the same size to facilitate relative size comparisons. Adapted from Butler and Hodos [1] with permission of John Wiley and Sons.

ascend into the molecular layer, form a T-shaped junction and pass through the Purkinje cell dendrites like telephone wires passing through the branches of a tree. These granule cell axons in the molecular layer are known as parallel fibers [9].

The deepest layer of the cortex is the white matter, which consists of the axons of neurons entering the cortex and those of the Purkinje cells leaving the cortex. Embedded within the white matter are one or more deep cerebellar nuclei, which are the destination of the axons of the Purkinje cells. The deep nucleus or nuclei send their axons to multiple targets, including the red nucleus in the midbrain tegmentum and the dorsal thalamus (e.g., its ventral lateral nucleus in mammals). A notable exception to this pattern are the Purkinje cells of ray-finned fishes, which differ from typical vertebrate Purkinje cells in several ways: first, they may be scattered throughout the molecular layer in parts of the cerebellum, and second, they do not terminate in a deep cerebellar nucleus. Instead their terminations are intrinsic to the cortex. The cortical efferents are carried instead by eurydendroid cells [1,2], not to a deep cerebellar nucleus, which they lack, but directly to

neuron groups in the brain stem and spinal cord that affect movement or other processes.

### Connections of the Cerebellum

The connections of the cerebellum to other brain regions are roughly the same in all vertebrate classes [1,2,7]. In general, the cerebellum has major connections with parts of the brain that are involved in balance and movement or other responses of the body, such as the generation of electric discharges in fishes that are electroreceptive. The cerebellum also receives major inputs from the somatosensory system of the spinal cord and from the vestibular system of the hindbrain as well as from the visual system and other senses. The afferents to the cerebellum are of two sorts: climbing fibers, which climb the Purkinje cell dendrites like a vine climbing the branches of a tree and originate in the inferior olivary nucleus, and mossy fibers, which arise in the other sources of cerebellar input. In birds and mammals, the major source of mossy fibers is the pontine nuclei.

Efferents of the cerebellum are via the deep cerebellar nuclei in most taxa, as noted above, and typically are to the vestibular nuclei, reticular formation, pontine nuclei, and inferior olivary nucleus of the pons region of the hindbrain as well as to the red nucleus of the midbrain and, in amniotes, the dorsal thalamus. Although some cerebellar efferents pass directly to the spinal cord, the cerebellum mainly controls movement via pathways to the spinal cord from the red nucleus, vestibular nuclei, and the reticular formation.

### Cerebelloid Structures

A number of brain structures of non-tetrapods that traditionally have been regarded as separate entities have an organization that resembles that of the cerebellar cortex. Among these are:

1. The crista cerebellaris (cerebellar crest), which is continuous with the molecular layer of the cortex and indeed resembles it. It is present in cartilaginous as well as ray-finned fishes. It contains parallel fibers from nearby granule cells and dendrites from nearby Purkinje-like cells [1,2].
2. The torus longitudinalis, which is located on the roof of the cerebral ventricle in the depths of the optic tectum of ray-finned fishes. It is continuous with the granule cell layer of the cerebellum [1,2,10].
3. The electrosensory lateral line lobe of electrosensory fishes that consists of a molecular layer, a granule cell layer, and a series of additional layers. It receives its input from electrosensory receptor organs on the skin and from the inferior olive, which is also a major source of input to the cerebellum [1,2,11].

In addition to these structures found in fishes, the dorsal cochlear nucleus of mammals, which is

one of the neuronal groups that receives the incoming axons of the auditory nerve, also has a structure very similar to that of the cerebellar cortex complete with granule cells that form parallel fibers, efferent cells that send their dendrites into the layer of parallel fibers and many other characteristics of the cerebellum [1,12].

### Evolution of the Cerebellum

Although there are some striking differences between and even within vertebrate classes, the cerebellum generally has remained relatively conservative in its evolution. Some of the major changes in the cerebellum that accompanied the transition to land have been the appearance of new types of inhibitory cells, the development of multiple deep cerebellar nuclei, and the elaboration and expansion of the corpus cerebelli in mammals and birds [1,2].

### References

1. Butler AB, Hodos W (2005) Comparative vertebrate neuroanatomy: evolution and adaptation, 2nd edn. Wiley-Liss, Hoboken, NJ
2. Nieuwenhuys R, ten Donkelaar HJ, Nicholson C (1998) The central nervous system of vertebrates. Springer, Berlin Heidelberg New York
3. Bullock TH, Heiligenberg W (1986) Electoreception. Wiley, New York
4. Ten Donkelaar HJ, Bangma GC (1991) The cerebellum. In: Gans C (ed) Biology of the Reptilia. University of Chicago Press, Chicago, IL, pp 496–586
5. Meek J (1992) Comparative aspects of cerebellar organization. From mormyrids to mammals. Eur J Morphol 30:37–51
6. Wullimann ME, Northcutt RG (1994) Afferent connections of the valvula cerebelli in two teleosts, the common goldfish and the green sunfish. J Comp Neurol 289:554–567
7. Llinás RR, Sotello C (eds) The cerebellum revisited. Springer, Berlin Heidelberg New York
8. Straka H, Dieringer N (1992) Chemical identification and morphological characterization of the inferior olive in the frog. Neurosci Lett 140:67–70
9. Meek J (1992) Why do parallel fibers run parallel? Teleostean purkinje cells as possible coincidence detectors in a timing device subserving spatial coding of temporal differences. Neurosci 48:249–283
10. Wullimann ME, Roth GE (1994) Descending telencephalic information reaches the torus longitudinalis via the dorsal preglomerular nucleus in the teleost fish *Pantodon buchholzi*: a case of neural preadaptation? Brain Behav Evol 44:338–352
11. Han VZ, Bell CC, Grant K, Sugawara Y (1999) Mormyrid electrosensory lobe in vitro: morphology of cells and circuits. J Comp Neurol 404:3595–374
12. Mugnaini E, Olsen KK, Dahl AL, Friedrich VL, Korte G (1980) Fine structure of granule cells and related interneurons (called Golgi cells) in the cochlear complex of cat, rat, and mouse. J Neurocytol 9:537–570

## Evolution of Cranial Nerves

- ▶ Evolution of Auditory System: in Anamniotes
- ▶ Evolution of Auditory System: in Mammals
- ▶ Evolution of Auditory System: in Reptiles and Birds
- ▶ Evolution of Mechanosensory and Electrosensory Lateral Line Systems
- ▶ Evolution of Hindbrain
- ▶ Evolution of Oculomotor System
- ▶ Evolution of Olfactory and Vomeronasal Systems
- ▶ Evolution of Terminal Nerve
- ▶ Evolution of the Trigeminal Sensory System and Its Specializations
- ▶ Evolution of Vestibular System

## Evolution of Corticospinal Motor Systems

- ▶ Evolution of Motor Systems: Corticospinal, Reticulospinal, Rubrospinal and Vestibulospinal Systems

## Evolution of Eyes

RUSSELL D. FERNALD

Department of Biology, Stanford University, Stanford, CA, USA

### Synonyms

Eye evolution; Phototransduction; Lens evolution; Opsin evolution

### Definition

Eye evolution is the process through which eyes evolved in the animal kingdom. Eyes are organs that compare light from different directions to produce an image. Information carried by light is transduced by specialized photoreceptor cells in the eye into neural information to be used by the brain. Many eyes have lenses that serve to collect and focus light, and these proteins have an independent evolutionary history.

### Characteristics

Light has been exploited by organisms for energy via photosynthesis and information through the evolution

of photoreceptors and ultimately eyes in animals. Darwin first wondered how such a remarkable organ as the eye could have evolved. We now know that the many adaptations of different eye types among widely different organisms concealed some interesting constraints on eye evolution. Morphological comparisons of differences in eye structures first suggested eyes are polyphyletic, evolving possibly 40–60 times, but studies of eye development identified some molecules used to build eyes in many species, suggesting eyes are monophyletic. Most studies compared eyes using ciliary photoreceptors found primarily in vertebrates with eyes using microvillar photoreceptors found primarily in invertebrates. Each eye type uses different members of the rhodopsin (type 2) protein for phototransduction and have remarkably different molecular cascades that convert photons into information. Recently, this controversy has been resolved with evidence that both primary eye types existed in ancestral bilaterians, and both are present in extant vertebrates and invertebrates. This means that at least these two eye types and probably many more were present in the urbilateria, prior to the Cambrian explosive speciation. Moreover, the novel functional photodetection system, the cryptochromes that exist widely in both plants and animals is as ancient. Thus, the eyes we know are certainly polyphyletic in origin and more surprises await us.

### Constraints on Eye Evolution from Physical Laws

Although there seems to be a large variety of eyes in the animal kingdom, physical laws have constrained solutions for collecting and focusing light to just eight types of eye optics [1].

Animal eyes are not simply photon detectors but organs that produce an image by comparing light from different directions using pinholes, lenses or mirrors to focus an image on photoreceptors. Light travels in straight lines and information is carried by wavelength, intensity and/or polarization, setting limits on eye dimensions and detection systems. Of ca. 33 animal phyla, about one-third have no specialized organ for detecting light, one-third have light sensitive organs, and the rest are animals with what we would consider eyes. Image-forming eyes appeared in six of the 33 extant metazoan phyla (*Cnidaria*, *Mollusca*, *Annelida*, *Onychophora*, *Arthropoda*, and *Chordata*), and these six contribute about 96% of the known species alive today.

Since earliest evolution occurred in water which transmits only a limited range of wavelengths, the mechanisms for photon response converged on biochemical solutions that set the course for subsequent evolution [1]. The evolution of eyes very likely proceeded in stages. First were eye-spots, found in nearly all major animal groups, with a small number of receptors in an open cup of screening pigment. Eye-spots are able

to distinguish light from dark but cannot represent complex light patterns. Second, invagination of this eyespot into a pit adds the capacity to detect the direction of incident light. Third, increasing the number of receptors, either by adding them in an existing pit or duplicating the pit in its entirety, probably led in two directions: adding receptors may have led to a chambered eye, while duplication of receptors may have led to a compound eye [1]. Fourth, adding an optical system that increases light collection and produces an image significantly increases the usefulness of an eye. Early in the Cambrian period (570–500 million years ago), very simple eyespots, useful for detecting light but not for processing directional information, were present. Explosive speciation, or the “Big Bang” of animal evolution, happened during the Cambrian period, and existing eye types improved radically, coincident with the appearance of carnivory and predation. Whereas primitive eyes can inform about light intensity and direction, more advanced eyes deliver more sophisticated information about wavelength, contrast and polarity.

### Other Photodetection Systems

In addition, a second family of photodetection is found in archaea and eukaryotic microbes based on an independently evolved family of rhodopsin molecules (rhodopsin 1). Evolution produced this solution for harvesting light for energy, guiding phototaxis and serving other yet undiscovered functions. Genetic sequencing of organisms in large water samples has increased the number of known type 1 opsins (>800). Despite remarkable convergence in molecular details of their function, there is no phylogenetic relationship between the gene sequences of opsin types 1 and 2. Nonetheless, both are seven transmembrane domain proteins, both use an associated retinal moiety to capture light and, in both, retinal is attached in a Schiff base linkage via a lysine residue in the seventh helix. However, type 1 opsins function within the membrane to pump ions or signal other integral membrane proteins as opposed to signaling via intracellular G proteins. Finally, the two retinal molecules are photoisomerized quite differently. Progenitors of the type 1 opsins probably existed in earliest evolution before the divergence of archaea, eubacteria and eukaryotes, meaning that a light driven ion transport mechanism for deriving energy used in association with opsin 1 preceded the evolution of photosynthesis as a means for using the sun’s energy. These photodetection systems can trigger movement in response to light direction and intensity and thus might be considered “proto-eyes.” Comparing these two opsin systems reveals the power of natural selection to generate independent inventions which, when coupled with strong functional constraints, yield complex, convergent biological systems.

## Capturing Photons

The transduction of photons into neural signals uses seven-transmembrane opsin proteins (30–50 kDa) combined with a photon sensitive vitamin A-derived non-protein retinal chromophore attached via a specialized binding pocket. These opsin proteins, or visual pigments, which control sensitivity to light of different wavelengths, appeared before eyes and evolved into seven or eight distinct families, diverging from an ancestral type before fish split from other vertebrates (Fig. 1). It is now clear that all animals have multiple opsin types, and opsin was present before deuterostomes split from protostomes suggesting that a common ancestor had multiple opsin genes, a surmise recently verified. Multiple new opsin genes, as well as new genes for other photo transduction specific families (e.g., G proteins, nucleotide-gated channels etc.) arose early in vertebrate evolution during extensive chromosome duplications and very likely facilitated retinal specializations, providing the raw material for natural selection. For example, opsin gene duplication was responsible for the independent evolution of three color (trichromatic) vision in both Old and New World primates, and opsin gene duplications in lepidoptera (butterflies) followed by increased rate of evolution produced a diversity of pigments sensitive to visual spectra important for specific species. Photoreceptor wavelength absorption spectra are exquisitely modulated by a small collection of amino acid side groups adjacent to the chromophore binding site in the seventh transmembrane domain of opsins where the effects of natural selection are now most evident.

An example of how color vision shapes cone opsin evolution is in the visual systems of cichlid fishes in the East African lakes. In one riverine species, ancestral

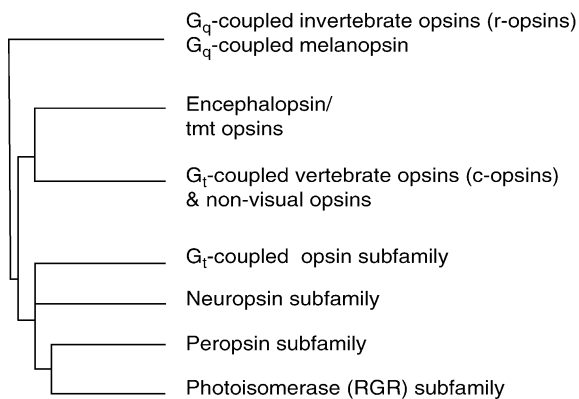

**Evolution of Eyes. Figure 1** A schematic molecular phylogenetic tree inferred by the neighbor-joining method showing the seven known opsin subfamilies [Simplified from Terakita A. (2005) *The opsins*. *Genome Biology* 6:213.1–213.9].

to the lake species, seven cone opsin genes are present due to gene duplications. Though only four cone opsins are found in the adult retina and hence can contribute to wavelength discrimination by the animal, the rest are expressed variously during ontogeny. This preservation of opsin genes may offer a substrate for rapid selection of different visual chromatic sensitivities in response to selective pressures.

The two best known photoreceptor types use distinct families of opsins packed in quite different membrane specializations and, importantly, use different mechanisms of transduction (Fig. 2).

Vertebrate photoreceptors use members of the ciliary opsin (c-opsin) family named because they are incorporated into specialized cilia, while invertebrate photoreceptors use members of the rhabdomeric opsins (r-opsin) that are typically formed into structures called rhabdoms. Each receptor type uses different heterotrimeric guanine nucleotide-binding proteins (G protein), named transducin in vertebrates, and the Gq family in invertebrates. Vertebrate photoreceptors produce hyperpolarizing potentials via a phosphodiesterase cascade while invertebrate photoreceptors are depolarizing and use a phospholipase C cascade. The site of biochemical signal amplification is quite different between these receptor types, as are the mechanisms for terminating the response. Moreover, opsins in invertebrates are fixed to their membranes, allowing polarization detection while those in vertebrates are not. It is clear that these photoreceptor types arose independently and co-existed in urbilateria before bilateria arose.

Eyes have evolved to extract information about the environment exploiting the same properties of light: intensity differences produce contrast, and wavelength differences produce hue. However, no unique neural solutions exist for extracting this information, and specializations that evolved to process intensity and wavelength differ among species, reflecting how natural selection can solve similar problems via diverse mechanisms. For example, mammals and bees use long wavelength photoreceptors for intensity and color vision, while flies and birds have evolved separate sets of photoreceptors for these two purposes. Similarly, blowfly and monkey photoreceptors are equally effective in compressing a wide range of light intensities and in converting detected intensity variations into useful visual contrast using vastly different mechanisms. Thus, blowfly and monkey photoreceptors evolved independently, use different molecular mechanisms, signal processing and other physiological steps, yet essential information about the world delivered to the nervous system is nearly identical. These few examples reveal the different routes natural selection has taken during the evolution of eyes in response to the information available in light.

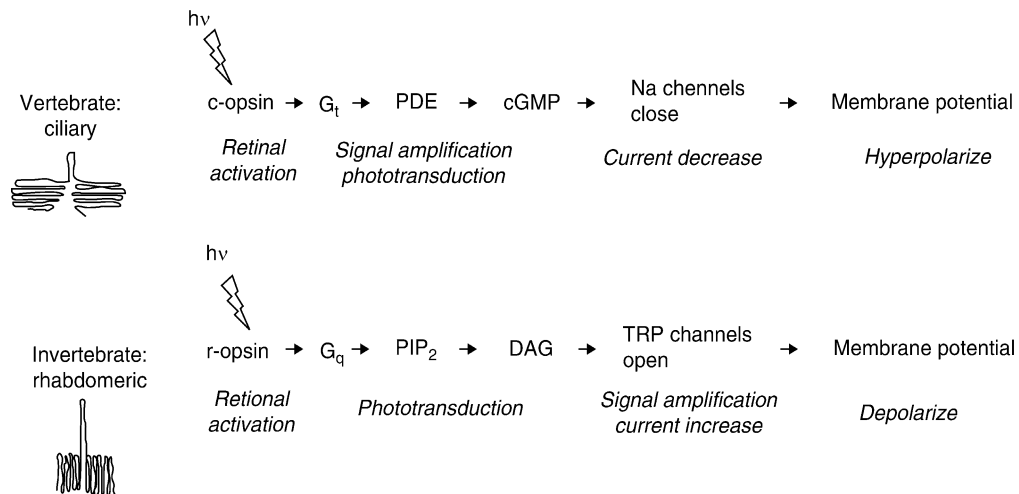

**Evolution of Eyes. Figure 2** Schematic illustration showing the key differences between a simplified representation of: (TOP) canonical vertebrate ciliary phototransduction and: (BOTTOM) invertebrate rhabdomeric phototransduction where  $h\nu$  represents incident photon energy. The two different opsin types (c-opsin and r-opsin) are contained in distinctly different membrane types, ciliary and rhabdomeric. The opsins are coupled to different families of G proteins that act via different types of transduction cascades. Amplification occurs during phototransduction in ciliary receptors and during channel opening in rhabdomeric receptors. These cascades produce signals of different sign.  $G_t$ , transducin; PDE, phosphodiesterase; cGMP, cyclic guanosylmophosphate;  $G_q$ , guanine nucleotide binding protein  $\alpha 15$ ;  $PIP_2$ , phosphatidylinositol-4,5-biphosphate; DAG, diacylglycerol.

## Lenses

Eye lenses collect and focus light, leading to increased sensitivity and allowing information to be spatially resolved. More advanced eyes collect light through an aperture and focus it with a lens onto a layer of photoreceptor cells. Lenses are made from proteins, so could their phylogenetic relationships provide insight into eye evolution?

Vertebrate lenses contain high concentrations of soluble proteins called crystallins because they maintain transparency while lens proteins of most invertebrate eyes are secreted by specialized cells. Three major gene families of crystallins are widely expressed in vertebrate lenses and account for most of the protein in aquatic and terrestrial vertebrates:  $\alpha$ -crystallins [2–3],  $\beta$ -crystallins (6+) and  $\gamma$ -crystallins [2–16]. Though it was once thought that these proteins had uniquely evolved to function as lenses, some are found expressed in heart, brain and other tissues of the eye. The remaining vertebrate lens proteins are a diverse, non-conserved group, several of which serve as enzymes elsewhere in the body having been co-opted from other functions, such as enzymes, and typically the same gene encodes both the enzyme and lens protein. This molecular opportunism has also occurred both in cephalopods (octopus, cuttlefishes, etc.) and in *Drosophila* [1]. The common strategy of assembling lenses from diverse proteins seems to be a convergent evolutionary solution that has occurred independently

many times in vertebrates with the source of protein quite variable.

Functionally, the exquisite gradient of refractive index necessary to allow spherical lenses to focus light [2] is a convergent solution that has evolved in water-dwelling vertebrates and invertebrates alike. What remains unknown is how genetic programs assemble differing amounts of diverse proteins to preserve the essential functional properties of lenses and whether there is any rhyme or reason to which specific proteins are used in different taxa.

## Origins of Eyes

In the past 100 years, ideas about whether eyes evolved from many origins (polyphyletic) to one origin (monophyletic) have switched back and forth. Originally, it was thought that there could have been many origins of eyes, but when it was discovered that opsin proteins were central to phototransduction in all eyes, a monophyletic origin was posited. Subsequent morphological comparisons suggested that eyes evolved 40 or more times independently based on, among other things, the distinct ontogenetic origins of eyes in different species. For example, the vertebrate retina arises from neural ectoderm and induces head ectoderm to form the lens, while cephalopod retinas result from invaginations of lateral head ectoderm, ultimately producing an eye without a cornea. These observations and many others suggested eyes had multiple origins



that converged onto a limited number of forms dictated by the physics of light.

Multiple origins were also supported by the apparent ease of eye evolution, shown by an elegant simulation model [3]. Starting from a patch of light-sensitive epithelium, the simulation, under selection for improved visual acuity, produced a focused camera-type eye in less than  $4 \times 10^5$  generations. For animals with generation times less than a year, this would be less than a half million years.

The idea that eyes arose multiple times independently was challenged by the discovery that a single developmental gene, *pax6*, could initiate eye construction in diverse species. However, subsequent work has shown that *pax6* does not act alone, but that building an eye requires many interacting genes. Nonetheless, discussion about eye origins was invigorated by the discovery that homologous genes can trigger construction of paralogous systems for photodetection, just as homologous *hox* genes do for paralogous body parts across phyla.

Eye development proceeds via morphological transformations of newly generated tissue that are regulated by multiple genes with expression patterns that overlap in time and space. Identifying clear control pathways is difficult because gene products are tightly regulated, and many are used repeatedly. Functions for at least 15 transcription factors and several signaling molecules have been described for human and mouse eye development, many of which are also widely expressed in other tissues. For *Drosophila* photoreceptor arrays, it is now known that seven genes, encoding transcription factors and two signaling molecules, collaborate. These genes [(*eyeless* (*ey*), *twin of eyeless* (*toy*) (both of which are *pax6* homologs), *sine oculus* (*so*), *eyes absent* (*eya*), *dachshund* (*dac*), *eye gone* (*eyg*) and *optix*] and signaling systems, including the Notch and receptor tyrosine kinase pathways, act via a complex regulatory network. Deletion of any one of these genes causes radical reduction or complete loss of the *Drosophila* eye. Yet in collaboration with certain signaling molecules, any one of these genes, except *sine oculus*, can also cause ectopic expression of an eye. Like other developmental cascades, a network of genes is required for organogenesis. Notably, *Six1*, *Dach* and *Eya* are important in the formation of the kidney, muscle, and inner ear, as well as eyes, suggesting that this suite of genetically interacting gene products may have been recruited repeatedly during evolution for organogenesis of other structures.

It seems highly probable that photodetection systems came first in evolution. Appearance of photodetection probably happened many, possibly hundreds of times until selection produced at the very least the two independent, main types of photoreceptor types known today – ciliary and rhabdomeric (e.g., Fig. 2). Clearly,

though, the other opsin families also have photodetection capacities mediated by unknown structures for functions also unknown. Although these two main photoreceptor types were thought to be strictly segregated in vertebrate animals (ciliary) and invertebrate animals (rhabdomeric), recent studies show that elements of both photoreceptor types probably co-exist in most organisms.

An overlooked hint about the existence of multiple photodetection systems came from the discovery of both depolarizing and hyperpolarizing responses to light stimuli from cells located in different layers of a scallop retina (*Pecten irradians*). Depolarizing potentials, characteristic of invertebrate photoreception, arise from the proximal layer, and hyperpolarizing potentials, characteristic of vertebrate photoreception, arise from the distal layer. In 2004, Arendt and colleagues found that the polychete ragworm (*Platynereis dumerilii*) had ciliary photoreceptors in the brain in addition to rhabdomeric photoreceptors in its eyes [4]. The canonical opsins associated with each photoreceptor type were localized only with its type (e.g., vertebrate c-opsin with ciliary receptors in the brain and invertebrate r-opsin with rhabdomeric receptors in the eye). Thus both main types of “eyes” exist in a worm. Correspondingly, in vertebrates, Berson and colleagues [5] had found a small population of intrinsically photosensitive retinal ganglion cells (the neural output of the retina), use melanopsin, a member of the r-opsin family. Melanopsin in these neurons, functions via transduction pathways like those in invertebrates and signals presence or absence of light in parallel to and collaboration with the well known image-forming visual system.

Arendt and colleagues also proposed that rhabdomeric photoreceptors might be the evolutionary ancestors of vertebrate ganglion cells based on use of r-opsin and the expression of a constellation of transcription factors including *pax6*, *Math5*, *Brn3* and *BarH*. Further, they suggested that other retinal processing neurons, horizontal and amacrine cells, might also share in this rhabdomeric photoreceptor ancestry but have lost photosensitivity. Taken together, these data show that at least two kinds of photoreception existed in the Urbilateria, before the split into three Bilateria branches at the Cambrian. Moreover, each branch of the family tree still carries versions of both of these photoreceptor types, along with other opsin dependent photo detection systems yet to be fully described. In the course of evolution, vertebrate vision favored ciliary photodetection for the pathway that delivers images, while invertebrates favored rhabdomeric photodetection for their main eyes, although why this might be remains unknown. Along both evolutionary paths, secondary photodetection systems remained to give additional information about light, possibly to instruct circadian

rhythms, phototaxis or other light dependent behaviors. But, if vertebrates are an example, these two photo-detection systems functioned together rather than remaining separate. Although the remaining five families of opsins have not been fully characterized, it seems probable that they also respond to light, and organisms use the information they provide. Understanding whether and how they extract information from light and how animals use that information is now a major challenge.

## References

1. Fernald RD (2006) Casting a genetic light on the evolution of eyes. *Science* 313:1914–1918
2. Kroeger RHH, Campbell MCW, Fernald RD, Wagner HJ (1999) Multifocal lenses compensate for chromatic defocus in vertebrate eyes. *J Comp Physiol A* 184:361–369
3. Nilsson DE, Pelger S (1994) A pessimistic estimate of the time required for an eye to evolve. *Proc R Soc Lond B Biol Sci* 256:53–58
4. Arendt DK, Tessmar-Raible Snyman H, Dorresteyn AW, Wittbrodt J (2004) A Ciliary photoreceptors with a vertebrate-type opsin in an invertebrate brain. *Science* 306:869–871
5. Berson DM, Dunn FA, Takao M (2002) Phototransduction by retinal ganglion cells that set the circadian clock. *Science* 295:1070–1073

## Evolution of Forebrain

► Evolution and Embryological Development, of Forebrain

## Evolution of Midbrain

► Evolution of Optic Tectum in Anamniotes  
 ► Evolution of Optic Tectum: in Amniotes

## Evolution of Motor Systems: Basal Ganglia

► Evolution and Embryological Development, of Forebrain

## Evolution of Motor Systems: Corticospinal, Reticulospinal, Rubrospinal and Vestibulospinal Systems

HANS J. TEN DONKELAAR

Department of Neurology, Radboud University Nijmegen Medical Centre, Nijmegen, The Netherlands

### Synonyms

Evolution of corticospinal motor systems; Evolution of reticulospinal motor systems; Evolution of rubrospinal motor systems; Evolution of vestibulospinal motor systems

### Definition

The descending pathways from the forebrain and brainstem to the spinal cord represent the instruments by which the central nervous system (CNS) steers movements of the trunk, the tail and the extremities. All vertebrates have a certain repertoire of descending brainstem pathways in common [1–3]. ► **Reticulospinal projections** form the most ancestral descending motor system by which the vertebrate brain exerts control over movements in all classes from cyclostomes to mammals. ► **Vestibulospinal projections** were also present early in evolution for control of equilibrium and postural activities. With the appearance of extremities, the development of an adequate neural control system for the steering of limb movements became apparent. It is likely that the ► **rubrospinal tract** plays an important role in this mechanism [4]. Goal-directed limb movements are controlled mainly by the rubrospinal tract, and in mammals also by the corticospinal tract.

### Characteristics

#### Reticulospinal Projections

The ancestral vertebrate motor system included myomeric axial musculature, spinal motoneurons, a spinal network composed of at least two types of interneurons (excitatory interneurons and inhibitory commissural interneurons) and reticulospinal neurons to activate the spinal networks [5]. Throughout vertebrates, reticulospinal neurons are large. Their coarse axons conduct rapidly and make direct contact with spinal motoneurons and interneurons [6]. For rapid escape movements, a pair of specialized very large cells in the brainstem, the Mauthner cells, has been formed. These features of the early motor system were retained in living anamniotes. Major changes occur among amniotes such as the break-up of the myomeres into a large number of discrete axial

muscles, the development of paired fins and limbs with associated muscles and the development of a topographic map of the motor column onto the embryonic myotome. Tract-tracing studies have shown that a basic pattern in the organization of descending pathways is present throughout vertebrates, with a dominant role for reticulospinal projections (Fig. 1).

Reticulospinal projections arise from the mesencephalon (the nucleus of the fasciculus longitudinalis medialis, giving rise to the interstitiospinal tract) and throughout the rhombencephalic reticular formation. Moreover, serotonergic raphe-spinal and noradrenergic coeruleospinal projections are common to all vertebrates. Locomotor activity can be initiated by stimulation of reticulospinal pathways, as elegantly shown in for instance lampreys [7].

The likely ancestors of the land vertebrates, i.e. the lobe-finned rhipidistian crossopterygians, presumably used their paired fins to “walk” on the bottom as the modern lungfish do. For locomotion on land an increased

efficiency of the limbs was necessary. Limb-moving generators were developed in the spinal cord, one for each limb. These central pattern generators (CPGs) are driven from a brainstem locomotor region in the caudal part of the mesencephalon [8, 9]. Reticulospinal neurons serve as a final common supraspinal pathway for locomotion.

### Vestibulospinal Projections

Vestibulospinal projections arise from the vestibular nuclear complex in the medulla oblongata and are involved in the control of equilibrium and postural activities. With the reticulospinal formation, vestibulospinal or octavomotor neurons give rise to the bulk of the descending motor pathways in anamniotes (Fig. 1). Ipsilateral vestibulospinal projections arise in the large-celled lateral vestibular nucleus or its equivalent, whereas contralateral vestibulospinal projections arise in other vestibular nuclei.

Tract-tracing data from amphibians, reptiles, birds and mammals show that throughout terrestrial vertebrate’s

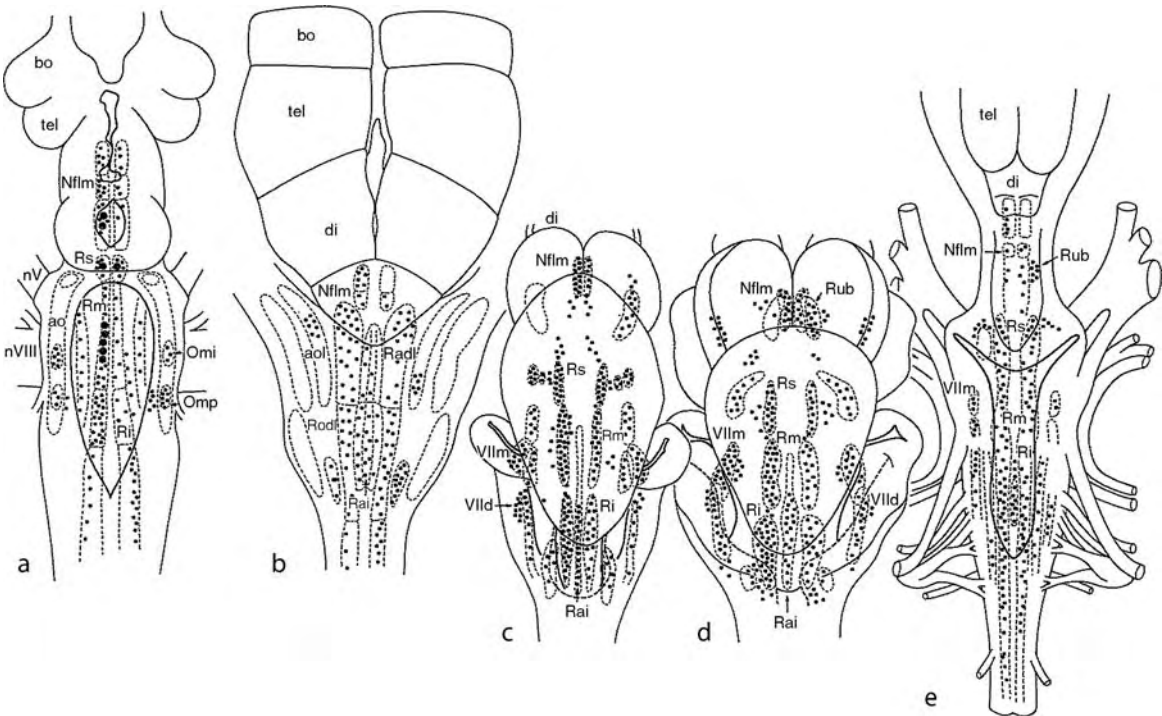

### Evolution of Motor Systems: Corticospinal, Reticulospinal, Rubrospinal and Vestibulospinal Systems.

**Figure 1** The distribution of retrogradely labeled cells in the brainstem after horseradish peroxidase injections into the left side of the spinal cord in (a) the silver lamprey, *Ichthyomyzon unicuspis*, (b) the Pacific hagfish, *Eptatretus stouti*, (c) the spotted dogfish, *Scyliorhinus canicula*, (d) the ray *Raja clavata*, (e) the African lungfish, *Protopterus amphibians* (after ten Donkelaar [3]). In a the large dots indicate large reticulospinal (Müller) cells, and the asterisk marks the Mauthner cell. Abbreviations: *aol*, area octavolateralis; *bo*, bulbus olfactorius; *di*, diencephalon; *Nflm*, nucleus of the fasciculus longitudinalis medialis; *nV*, nervus trigeminus; *nVIII*, nervus octavus; *Omi*, *Omp*, intermediate and posterior octavomotor (vestibular) nuclei; *Radl*, dorsolateral part of nucleus reticularis anterior; *Rai*, nucleus raphes inferior; *Ri*, *Rm*, *Rs*, nucleus reticularis inferior, medius and superior; *RpdI*, dorsolateral part of nucleus reticularis posterior; *Rub*, nucleus ruber; *tel*, telencephalon; *VIIId*, *VIIIIm*, descending and magnocellular vestibular nuclei.

►medial and ►lateral systems of descending brainstem pathways as advocated by Kuypers [10] can be distinguished. Interstitiospinal, reticulospinal and vestibulospinal pathways pass via the ventral funiculus and the ventral part of the lateral funiculus and terminate in the mediodorsal part of the ventral horn and in the adjacent parts of the intermediate zone (Fig. 2).

This ►medial system is functionally related to postural activities and progression and constitutes a basic system by which the brainstem exerts control over movements. The ►lateral system consists of fibers occupying a lateral position in the lower brainstem and descending into the lateral funiculus of the spinal cord. This system is mainly composed of rubrospinal fibers that terminate in lateral and dorsal parts of the intermediate zone.

### Rubrospinal Projections

In anamniotes, a red nucleus (or nucleus ruber) is indistinct or cannot be identified cytoarchitectonically. In gnathostomes, a small, unspecialized red nucleus may possibly have originated with paired appendages. Apparently, some of its connections were lost again in some fish species. Criteria used to identify a structure as a (primordial) red nucleus are, apart from its relative position in the midbrain tegmentum, the mesencephalic site of termination of the brachium conjunctivum and its contralateral spinal projection [4]. Based on such criteria, a crossed rubrospinal tract could be unequivocally identified in the thornback ray, *Raja clavata*, in the common goldfish, *Carassius auratus*, in the African lungfish, *Protopterus amphibians* and in amphibians with limbs (Fig. 3).

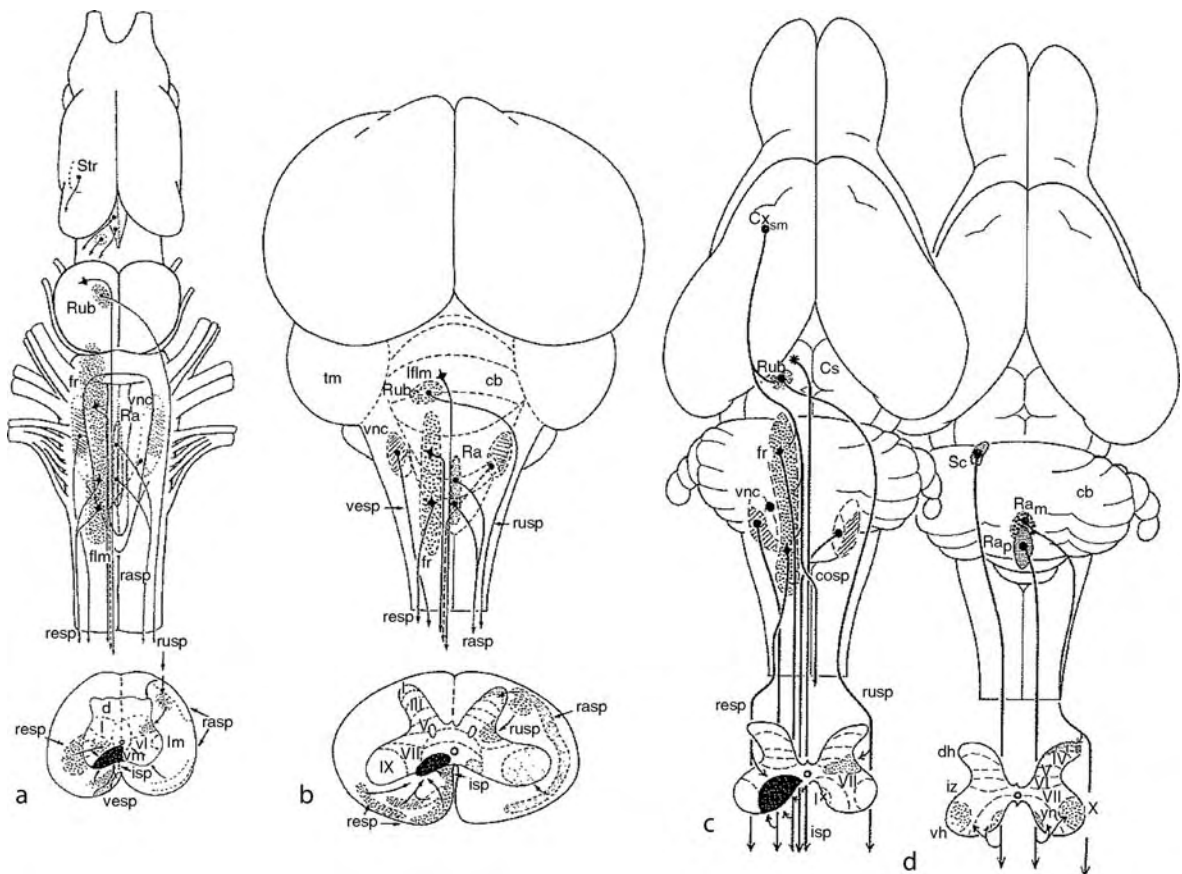

### Evolution of Motor Systems: Corticospinal, Reticulospinal, Rubrospinal and Vestibulospinal Systems.

**Figure 2** Summary of experimental data on descending supraspinal pathways a the clawed toad, *Xenopus laevis* b the pigeon, *Columba livia*, c, d the North American opossum, *Didelphis virginiana* (after ten Donkelaar [2]).

Abbreviations: *cb*, cerebellum; *cosp*, corticospinal tract; *Cs*, colliculus superior; *Cx<sub>sm</sub>*, somatomotor cortex; *d*, *l*, *lm*, *vl*, *vm*, dorsal, lateral, lateral motor, ventrolateral and ventromedial fields of spinal grey matter; *dh*, dorsal horn; *flm*, fasciculus longitudinalis medialis; *fr*, formatio reticularis; *flm*, interstitial nucleus of the *flm*; *isp*, interstitiospinal tract; *iz*, intermediate zone; *Ra*, raphe nucleus; *Ra<sub>m</sub>*, nucleus raphes magnus; *Ra<sub>p</sub>*, nucleus raphes pallidus; *rasp*, raphespinal projections; *resp*, reticulospinal projections; *Rub*, nucleus ruber; *rusp*, rubrospinal tract; *Sc*, subcoeruleus area; *Str*, striatum; *tm*, tectum mesencephali; *vesp*, vestibulospinal projections; *vh*, ventral horn; *vnc*, vestibular nuclear complex; *I-X*, laminar subdivision of spinal grey matter.

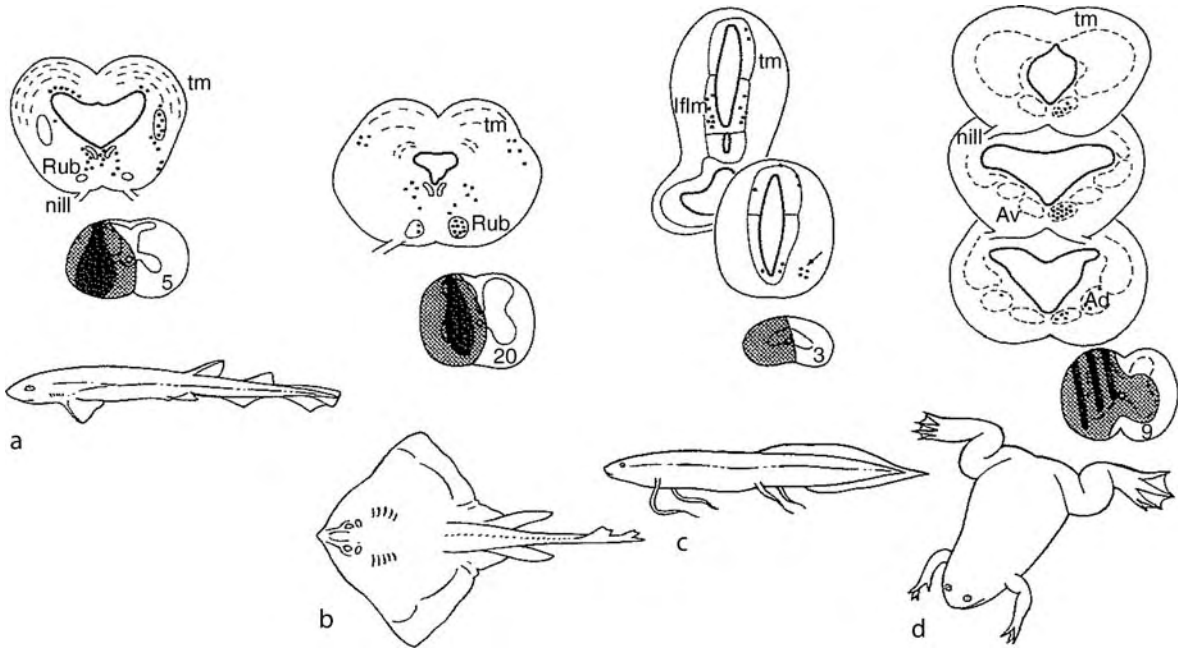

### Evolution of Motor Systems: Corticospinal, Reticulospinal, Rubrospinal and Vestibulospinal Systems.

**Figure 3** The distribution of retrogradely labeled neurons in the mesencephalon at the level of the oculomotor nerve after horseradish peroxidase injections into the spinal cord. (a) a shark, the spotted dogfish *Scylliorhinus canicula*. (b) the thornback ray, *Raja clavata*. (c) the African lungfish, *Protopterus amphibians*. (d) the clawed toad, *Xenopus laevis* (after ten Donkelaar [4]). Abbreviations: Ad, Av, anterodorsal and anteroventral tegmental nuclei; IfIm, interstitial nucleus of fasciculus longitudinalis medialis; nIII, oculomotor nerve; Rub, nucleus ruber; tm, tectum mesencephali. Numbers refer to spinal segments.

No rubrospinal tract could be identified in a shark or in a limbless amphibian, the apodan *Ichthyophis kohtaoensis*. These data suggested that the presence of a rubrospinal tract is related to the presence of paired appendages. The thornback ray uses its enlarged pectoral fins for locomotion. In teleosts, paired fins are used for postural stability and steering control but also to maneuver and propel the body at low speed. In a more recent study in the gymnophionan *Dermophis mexicanus*, Sánchez-Camacho et al. [11] identified a loosely arranged mesencephalic cell group that projects to the contralateral spinal cord and identified it as the caecilian red nucleus.

In reptiles, in general a well-developed red nucleus is found. In freshwater pond turtles, Houk and co-workers extensively studied the functional role of a cerebellorubrospinal circuit in goal-directed limb movements [12, 13]. The red nucleus, cerebellum, and their extensive interconnections form a premotor network for controlling limb movements. Snakes have presumably lost their rubrospinal tract secondarily, since in boid snakes no rubrospinal tract could be demonstrated [14]. They retain a nucleus ruber with a distinct rubrobulbar projection however, which is presumably involved in the neural control of mastication. Birds and mammals have a well-developed red nucleus, the magnocellular part of which gives rise to the

rubrospinal tract. The parvocellular part of the red nucleus in amniotes innervates the ipsilateral inferior olive and is involved in a cerebellar loop. In monkeys, neurons of the magnocellular red nucleus are preferentially related to movements of the hand and fingers [15]. Particularly in anthropoid primates such as the gibbon, the magnocellular part is much reduced [16]. In humans, the rubrospinal tract is very small. Only a few fibers reach the spinal cord and these do not usually extend beyond the upper cervical segments [17].

### Corticospinal Projections

Although minor telencephalospinal projections are found in some sharks and birds, a **corticospinal tract** is a derived feature of mammals. Its emergence appears to be associated with the acquisition of dexterous motor skills [10]. For prehensile extremities and tails, corticospinal projections are essential. The sensorimotor capacities of the hand for exploring the visible world develop best in primates. Direct **corticomotoneuronal** connections from the sensorimotor cortex to motoneurons innervating hand, finger, foot or tail muscles are found only in primates and a few specialized carnivores such as raccoons, which are capable of some form of precision grip. In birds, a unique sensorimotor circuit is present that is related to the handling or 'mandibulation'

of food [18]. Its anatomical organization is analogous to that of the sensorimotor pathways controlling the forelimbs of mammals.

The corticospinal tract arises invariably from layer V pyramidal cells, particularly from rostral, frontal parts of the cerebral cortex. Both motor and somatosensory cortices give rise to corticospinal projections. The somatosensory cortex innervates the dorsal horn of the spinal cord and the dorsal column nuclei. The corticospinal projection is predominantly contralateral, but in many insectivores such as moles largely ipsilateral. Moles have dense corticospinal projections from the forelimb presentation of the somatosensory and motor

cortices that may reflect sensorimotor specializations related to digging [19]. With regard to the terminal distribution of corticospinal fibers, the various mammals tend to fall into four groups that show an increasingly wider distribution area of corticospinal fibers in the spinal grey matter (Fig. 4).

By ranking the motor skill of the hands of 69 different mammals from one to seven, Heffner and Masterton [20] concluded that the extent and the site of termination of the corticospinal tract most closely correspond with dexterity. Direct corticomotoneuronal connections to motoneurons innervating hand and finger muscles are only found in primates and a few

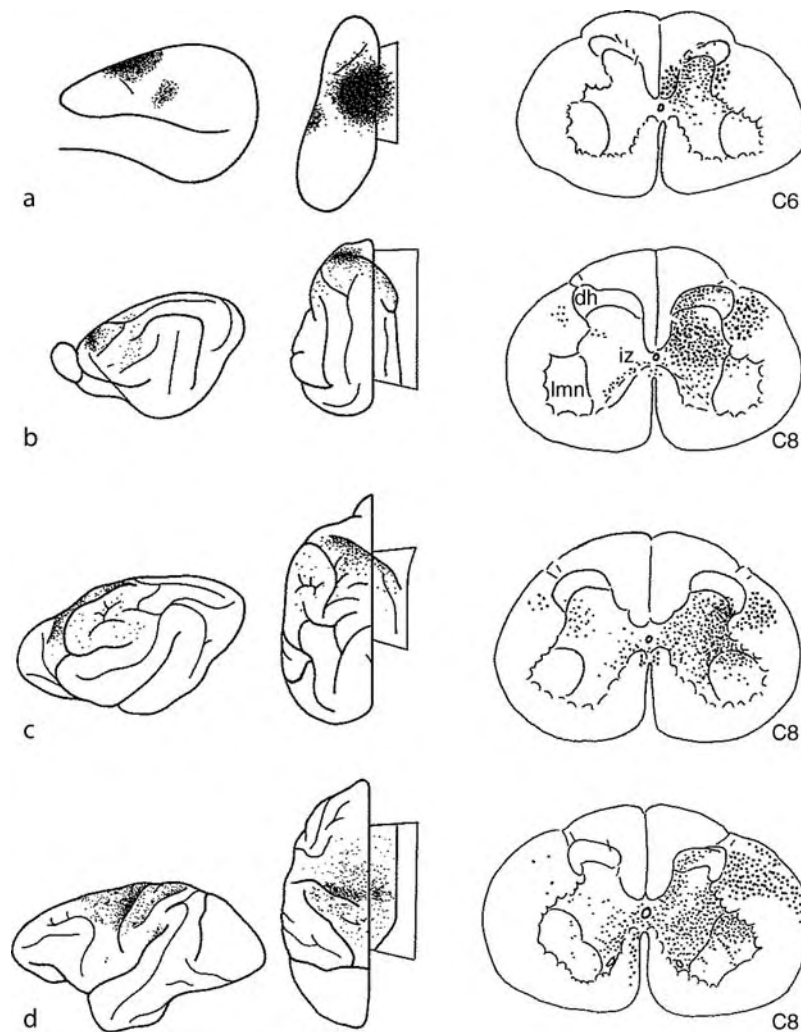

#### Evolution of Motor Systems: Corticospinal, Reticulospinal, Rubrospinal and Vestibulospinal Systems.

**Figure 4** The distribution of the cells of origin of the corticospinal tract shown in lateral and dorsal views of the brain. (a) the North American opossum, *Didephis virginiana*. (b) the domestic cat, *Felis catus*. (c) the raccoon, *Procyon lotor*. (d) the rhesus monkey, *Macaca mulatta*. Also shown are the sites of termination of the corticospinal tract in the cervical enlargement of the spinal cord (based on various sources, after ten Donkelaar [2]). Abbreviations: *dh*, dorsal horn; *iz*, intermediate zone; *lmc*, lateral motoneuron column.

carnivores such as raccoons and kinkajous [10]. This suggests that the presence of direct corticomotoneuronal connections is a derived characteristic that has evolved independently, along with manual dexterity, in both primates and carnivores [20]. Direct corticomotoneuronal projections are not restricted to forelimb motoneurons however. In many monkeys, the motor cortex also projects to hind limb motoneurons, and in spider (*Ateles*) and woolly (*Lagothrix*) monkeys even to motoneurons innervating the muscles of the prehensile tail [21].

Telencephalic projections to the spinal cord are not restricted to mammals. Minor telencephalospinal projections were found in the nurse shark, *Ginglymostoma cirratum* [22]. Using intracranial electrical microstimulation mapping and simultaneous recording of the evoked body movements in goldfish, Salas and co-workers [23] showed that a primary somatomotor pallial area is present in the most caudal part of the telencephalon, reminiscent of the somatosensory cortex in mammals. This motor pallium innervates premotor centers in the reticular formation of the brainstem. Early, rather crude electrical stimulation studies in reptiles in search of a motor pallial area suggested the presence of a “motor cortex” in turtles [24]. Later studies, however, showed that the motor responses reported after cortical stimulation in turtles and also in alligators probably resulted from current spread to underlying, striatal structures [25]. The evidence for one or more pallial areas in reptiles that elicit movements of restricted body parts following electrical stimulation is therefore not convincing.

In birds, at least three descending pallial efferent systems have access to the brainstem [26]. Birds use their beaks for the manipulation of the environment. The beak functions in reaching, grasping and manipulation analogously with the forelimb of mammals and the primate hand [18]. The sensorimotor circuit involved includes tactile information from mechanoreceptors in the beak passed via the trigeminal system to the nucleus basorostralis pallii (formerly known as nucleus basalis), which forms part of the dorsal ventricular ridge (DVR). The DVR, a large intraventricular protrusion, and the Wulst, a swelling present on the dorsal surface of the avian telencephalon, contain cell groups that may be homologous to those in the mammalian neocortex [27, 28], although the hypothesis of the neocortical homology of the DVR is currently under debate (See: ▶[Evolution of the Forebrain: Embryological Development and Evolution of the Telencephalon: in Amniotes.](#)). Both of these pallial structures, including their association areas, comprise end stations of ascending systems and telencephalic motor output areas. Via a relay in the hyperstriatum ventrale, the nucleus basalis innervates the rostral part

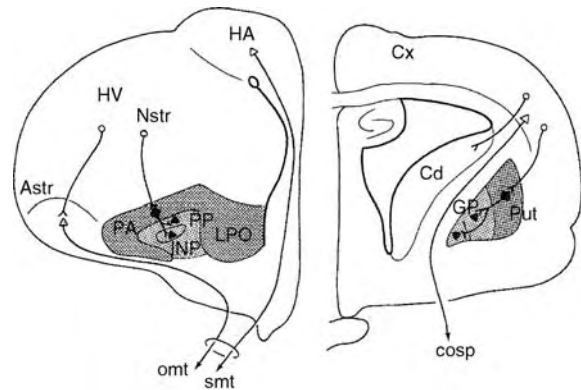

**Evolution of Motor Systems: Corticospinal, Reticulospinal, Rubrospinal and Vestibulospinal Systems.** **Figure 5** Origins of somatomotor projections in birds (left panel) and mammals (right panel). The corresponding parts of the basal ganglia are shown by shading (after Karten and Dubbeldam [27]).

Abbreviations: *Astr*, archistriatum (rostral part); *Cd*, caudate nucleus; *cosp*, corticospinal tract; *Cx*, cerebral cortex; *GP*, globus pallidus; *HA*, hyperstriatum accessorium (part of Wulst); *HV*, hyperstriatum ventrale (part of dorsal ventricular ridge); *INP*, interpeduncular nucleus; *LPO*, lobus parolfactorius; *Nstr*, neostriatum; *omt*, occipitomesencephalic tract; *PA*, paleostriatum augmentatum; *PP*, paleostriatum primitivum; *Put*, putamen; *smt*, septomesencephalic tract.

of the archistriatum (Fig. 5) which gives rise to the ▶[occipitomesencephalic tract](#).

This major pallial efferent pathway projects to various brainstem nuclei including premotor groups in the reticular formation that innervate the motor nucleus of the jaw muscles [29, 18]. In pigeons and ducks, the occipitomesencephalic tract extends to the rostral part of the spinal cord [29]. This tract represents the telencephalic output channel for the trigeminal feeding circuit and resembles the corticobulbar tract found in mammals.

In birds, another corticobulbar pathway, the ▶[septomesencephalic tract](#), arises from the Wulst. The caudal, visual part of the Wulst plays a role in modulating the activity of tectal projections to premotor structures in the brainstem reticular formation. The rostral, somatosensory part of the avian Wulst innervates the red nucleus, pontine nuclei, dorsal column nuclei and rostral spinal cord [30]. In parrots, which possess brains with the most highly developed telencephala among birds, the basal branch of the septomesencephalic tract reaches the cervical cord. In zebra and green finches, rather extensive projections to the cervical spinal cord are present [30]. In other prehensile birds such as cockatoos and rosellas however, no telencephalospinal projections have been found. Therefore, in birds there is no general direct palliospinal control of refined motor skills of the extremities.

## References

- ten Donkelaar HJ (1982) Organization of descending pathways to the spinal cord in amphibians and reptiles. *Progr Brain Res* 57:25–67
- ten Donkelaar HT (2000) Development and regenerative capacity of descending supraspinal pathways in tetrapods: a comparative approach. *Adv Anat Embryol Cell Biol* 154:1–145
- ten Donkelaar HJ (2001) Evolution of vertebrate motor systems. In: Roth G, Wullimann MF (eds) *Brain evolution and cognition*. Wiley, New York, pp 77–112
- ten Donkelaar HJ (1988) Evolution of the red nucleus and rubrospinal tract. *Behav Brain Res* 28:9–20
- Fetcho JR (1992) The spinal motor system in early vertebrates and some of its evolutionary changes. *Brain Behav Evol* 40:82–97
- Shapovalov AI (1975) Neuronal organization and synaptic mechanisms of supraspinal motor control in vertebrates. *Rev Physiol Biochem Pharmacol* 72:1–54
- Grillner S, Matsushima T (1991) The neural network underlying locomotion in lamprey – synaptic and cellular mechanisms. *Neuron* 7:1–15
- Rossignol S (1996) Neural control of stereotypic limb movements. In: Rowell LB, Sheperd JT (eds) *Motor control Handbook of physiology-exercise: regulation and integration of multiple systems*. American Physiology Society, Bethesda, MD pp 173–216
- Shik ML, Severin EV, Orlovsky GN (1966) Control of walking and running by means of electrical stimulation of the midbrain. *Biophysics* 11:756–765
- Kuypers HGJM (1981) Anatomy of the descending pathways. In: Brookhart JM, Mountcastle VB (eds) *Motor control. Handbook of physiology—the nervous system, vol 2*. American Physiology Society, Bethesda, MD pp 597–666
- Sánchez-Camacho C, Marín O, ten Donkelaar HJ, González A (2001) Descending supraspinal pathways in amphibians. I. A dextran-amine tracing study of their cells of origin. *J Comp Neurol* 434:186–208
- Houk JC, Keifer J, Barto AG (1993) Distributed motor commands in the limb premotor network. *Trends Neurosci* 16:27–33
- Keifer J, Houk JC (1994) Motor functions of the cerebellorubrospinal system. *Physiol Review* 74:509–542
- ten Donkelaar HJ, Bangma GC (1983) A crossed rubrobulbar projection in the snake *Python regius*. *Brain Res* 279:22–232
- Cheney PD, Fetz EE, Mewes K (1991) Neural mechanisms underlying corticospinal and rubrospinal control of limb movements. *Progr Brain Res* 87:213–252
- Padel Y, Angaut P, Massion J, Sedan R (1981) Comparative study of the posterior red nucleus in baboons and gibbons. *J Comp Neurol* 202:421–438
- Nathan PW, Smith MC (1982) The rubrospinal and central tegmental tracts in man. *Brain* 105:223–269
- Wild JM, Arends JJA, Zeigler HP (1985) Telencephalic connections of the trigeminal system in the pigeon (*Columba livia*): a trigeminal sensorimotor circuit. *J Comp Neurol* 234:441–464
- Catania KC, Kaas JH (1997) Organization of somatosensory cortex and distribution of corticospinal neurons in the Eastern mole (*Scalopus aquaticus*). *J Comp Neurol* 378:337–353
- Heffner R, Masterton RB (1983) The role of the corticospinal tract in the evolution of human digital dexterity. *Brain Behav Evol* 23:165–183
- Petras JM (1968) Corticospinal fibers in new world and old world simians. *Brain Res* 8:206–208
- Ebbesson SOE, Schroeder DM (1971) Connections of the nurse shark's telencephalon. *Science* 173:254–256
- Salas C, Jiménez-Moya F, Durán E, Ocaña F, Gómez A, Álvarez E, Torres B, Broglio C, Rodríguez F (2004) The motor pallium of the teleost fish. In Abstracts 4th European conference on comparative neurobiology, Oxford, 15–17 April 2004, p 23
- Johnston JB (1916) Evidence of a motor pallium in the forebrain of reptiles. *J Comp Neurol* 26:475–479
- ten Donkelaar HJ (1998) Reptiles. In: Nieuwenhuys R, ten Donkelaar HJ, Nicholson C (eds) *The central nervous system of vertebrates*. Springer, New York, pp 1315–1524
- Dubbeldam J (1998) Birds. In: Nieuwenhuys R, ten Donkelaar HJ, Nicholson R (eds) *The central nervous system of vertebrates*. Springer, Berlin, pp 1525–1636
- Karten HJ, Dubbeldam J (1973) The organization and projections of the paleostriatal complex in the pigeon (*Columba livia*). *J Comp Neurol* 148:61–90
- Nauta WJH, Karten HJ (1970) A general profile of the vertebrate brain, with sidelights on the ancestry of cerebral cortex. In: Schmitt FO (eds) *The neurosciences: second study program*. Rockefeller University Press, New York, pp 7–26
- Dubbeldam JL, den Boer-Visser AM, Bout RG (1997) Organization and efferent connections of the archistriatum of the mallard, *Anas platyrhynchos* L: an anterograde and retrograde tracing study. *J Comp Neurol* 388:632–657
- Wild JM, Williams MN (2000) Rostral Wulst in passerine birds. I. Origin, course and terminations of an avian pyramidal tract. *J Comp Neurol* 429:429–450

---

## Evolution of Motor Systems: Vocal and Song Systems of Birds

DAVID J. PERKEL

Departments of Biology & Otolaryngology, University of Washington, Seattle, WA

### Definition

Vocal learning, the ability to mimic sounds made by other individuals, is a very common feature of birds. It has arisen independently in three avian taxa, the oscine songbirds, the parrots and the hummingbirds, together comprising more than half of all extant bird species. In oscine songbirds, song learning is essential for territory defense and mate attraction, and thus probably for reproductive success. The brain circuit underlying oscine vocal learning consists of discrete,



interconnected forebrain nuclei forming a descending motor pathway and a basal ganglia pathway essential for learning. These structures share properties with their surrounding brain regions, and thus could have evolved via relatively minor specializations of pre-existing circuits.

## Characteristics

### Avian Vocal Behavior (Calls and Songs)

There are approximately 9,000 extant species of birds (class *Aves*). Birds produce a wide variety of vocalizations that are used for communication. In general, these vocalizations can be classified into two broad categories: calls and songs. All bird species generate calls. Although there are exceptions, calls tend to be relatively simple and unlearned. They can carry a variety of meanings, from desire for food (e.g. begging calls) to expression of danger (e.g. alarm calls). The meaning of some calls is unknown. In contrast, songs tend to be more complex, and are used for courtship, territory defense, mate selection and mate recognition. In temperate regions, males are the predominant or exclusive singers, while in tropical species, duetting is more common.

### Vocal Learning in Three Bird Taxa

Current evidence supports vocal learning in three taxa of birds. Vocal learning, as used here, means the production of sounds heard through experience. In the vast majority of natural cases, this involves learning to produce sounds produced by other individuals of the same species. The largest group of vocal learners is the oscine songbirds (Order *Passeriformes*), which make up approximately half of bird species. Behavioral studies have shown that song learning in oscines occurs in two main phases. During a sensitive period early in life, a bird hears and memorizes the song(s) of another bird, often called the tutor. This is called the sensory phase of song learning. Later, through practice involving a large number of trials, he gradually learns to produce sounds that are a good match to the memorized song(s). This is termed the sensorimotor phase of learning, because it requires that the bird be able to hear himself vocalize while practicing. When he can sing a good copy of the tutor song, the song becomes highly stereotyped, and the bird has a much-reduced ability to memorize songs of other birds.

This basic pattern holds across the oscine songbirds, but there is also substantial variation in aspects of this process [1]. For example, some species learn a single, relatively simple song, while others learn large repertoires comprising hundreds of songs. Some species learn only once during juvenile development, while others relearn parts of their repertoire seasonally or continuously through adulthood. This diversity provides experimentalists a wide variety of study

species with different capabilities. It also highlights an important aspect of the evolution of vocal learning, namely that it is plastic, while maintaining a core set of behavioral features.

In addition, parrots and parakeets (Order *Psittaciformes*) are also well-known vocal mimics, and some of these species are able to produce sounds closely resembling those of human speech. In addition, some hummingbirds (Family *Trochilidae*) have been found to exhibit learning abilities. Far less is known about the behavioral aspects of song learning in parrots and hummingbirds than in songbirds. Nonetheless, given how rare vocal learning is in mammals, it is an interesting and fundamental question how three avian taxa have evolved the capacity for learned vocalizations.

In contrast to the thousands of avian species exhibiting vocal learning, this capacity has been demonstrated in only one species of primates, *Homo sapiens*, in some marine mammals and may occur in some bats.

### Song System of Oscine Songbirds

The variety of vocal learning and performance capabilities of birds, and their appearance in three bird taxa, raise the question of how song learning arose and whether there are similarities in mechanism among the three clades. Answers to such questions in general depend on comparative analyses of a variety of species, including representatives of outgroups of the taxa of interest. In addition, the fossil record could be consulted for intermediate stages to help determine when specific features arose. In this case however, in which vocal learning likely reflects changes solely within the central nervous system, which leaves essentially no fossil evidence, we are left only with comparative analysis of the brains of extant species, which we can examine using neuroanatomical and neurophysiological techniques [2].

The neural substrates of avian vocal learning and production have been best studied in oscine songbirds [3]. Examination of their brains reveals a set of discrete clusters of neuronal cell bodies that stand out from the surrounding tissue by virtue of their larger cell bodies, denser packing or other cellular features [4]. These clusters, known as nuclei, are found in oscine songbirds, but not in non-oscine species. A variety of studies have implicated these nuclei in the control, learning and perception of song, and they have come to be known collectively as the song system. Neural tracing studies have delineated interconnections among these nuclei. A simplified schematic diagram of these structures is shown in (Fig. 1).

Studies involving localized brain lesions, electrophysiological recording, examination of gene expression and electrical stimulation have provided evidence for different functional roles for different portions of this circuit. For example, the pathway from nucleus

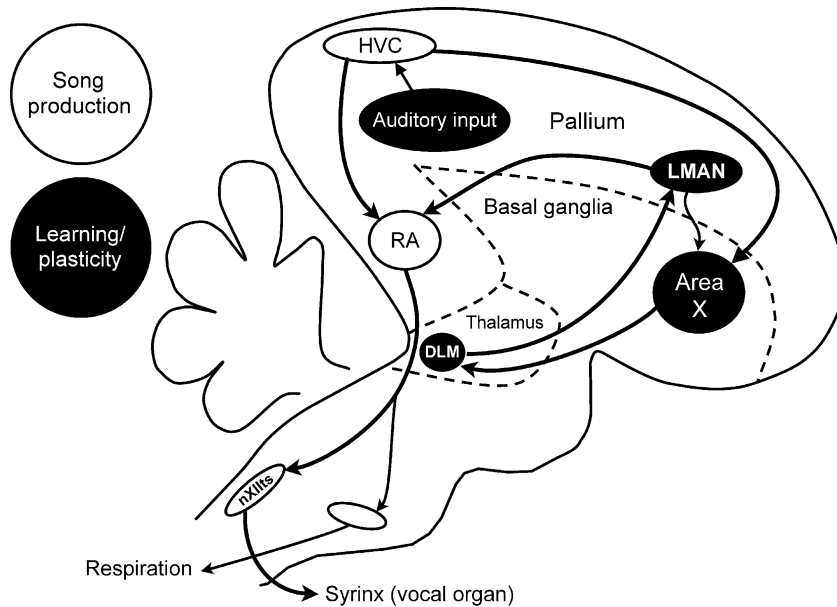

**Evolution of Motor Systems: Vocal and Song Systems of Birds. Figure 1** Simplified schematic diagram of the oscine song system. The descending motor system includes nucleus HVC (used as the proper name), which projects to nucleus RA (robust nucleus of the arcopallium) which projects to the tracheosyringeal portion of the hypoglossal motor nucleus (nXIIts) and to respiratory premotor nuclei in the medulla. HVC receives auditory input and projects to Area X, a large nucleus in the basal ganglia. Area X projects to the medial portion of the dorsolateral nucleus of the thalamus (DLM), which projects to the lateral magnocellular nucleus of the anterior nidopallium (LMAN). LMAN projects to RA, and sends axon collaterals to Area X.

HVC (see figure legend for descriptions of names) to nucleus RA to the hypoglossal motor nucleus is an obligatory descending motor pathway essential for song production. An indirect connection from HVC to RA, known as the anterior forebrain pathway (AFP), travels by way of Area X in the basal ganglia, the thalamic nucleus DLM and the pallial nucleus LMAN to RA. The AFP is not essential for song production, although this pathway can contribute somewhat to trial-to-trial song variability. The AFP is crucial for song learning, however; lesions to LMAN or Area X, even after song memorization has occurred, dramatically disrupt song learning. In addition, lesions to LMAN prevent some forms of adult song plasticity that have been examined. Precisely how the AFP contributes to learning is currently a question being actively investigated.

Non-oscine birds do not show evidence for such song nuclei.

### Vocal Control Systems in Parrots and Hummingbirds Parrot Nuclei and Tracing

Examination of the parrot brain reveals nuclei in the forebrain in locations roughly corresponding to the song system of oscine songbirds. It was thus initially thought that these nuclei might have existed in a common ancestor of oscines and psittacines. Indeed,

two posterior forebrain nuclei appear to form a descending motor pathway, and two anterior nuclei are important for song plasticity. However, careful analysis of the connections among the vocal control nuclei in parakeets has shown important differences from the oscine song system [5]. It seems very difficult to reconcile current data with a common origin of vocal learning in these two taxa.

### Immediate Early Genes in Parrots and Hummingbirds

When they are highly active, many neurons transiently increase the expression of certain genes, known as immediate early genes (IEGs). Examining expression of IEGs in the 30–60 min after bouts of intense vocal production has revealed increased IEG levels in several song nuclei in oscine songbirds [6]. Use of the same technique in psittacines and hummingbirds has also revealed the presence of nuclei with increased levels of IEGs in more-or-less comparable locations as in songbirds [7,8]. This similarity of nucleus location suggests that similar networks of vocal-control nuclei might underlie vocal learning and production in these three taxa, and could be used to support the hypothesis that song learning evolved once in an ancestral lineage common to songbirds, parrots and hummingbirds, and has since been lost in intervening taxa.

While this possibility is intriguing, and while it remains impossible to eliminate firmly the hypothesis of shared evolution of avian vocal-control nuclei, it seems most plausible at this time to hypothesize three independent evolutionary events in which vocal learning arose.

### Similarities with Mammals

Although early comparative neuroanatomists thought that most of the avian forebrain resembled the basal ganglia (deep grey matter) of mammalian brains, it is now clear that the forebrains of birds and mammals share similar architecture, though there are clearly some important differences [9,10]. In both birds and mammals, the ventral approximately two thirds of the forebrain consists of basal ganglia, while the dorsal one third arises from pallial origin, and includes such structures as the hippocampus and parts of the amygdala. In mammals, the pallium also includes the cortex. Birds do not possess cortex *per se*, but their pallial tissue arises from the same developmental precursor. The oscine songbird nucleus Area X lies within the basal ganglia. The neurons of Area X, as well as surrounding basal ganglia exhibit strong similarities in cellular electrophysiological and morphological properties to their counterparts in mammalian basal ganglia [11,12]. Moreover, the basal ganglia of a non-oscine bird, the domestic chicken, has neurons with very similar properties [13]. Together, these results suggest that the AFP arose as a specialization from pre-existing basal ganglia circuits shared by all birds and indeed by mammals as well.

### Hypothesized Evolutionary Steps to Explain Both Similarities and Differences Among Birds

All birds that have been tested can use sensory feedback to guide the learning of subsequent motor acts. It seems that a relatively simple set of steps can account for the evolution of vocal-control systems. First, a descending motor system must arise or come to be in place to control the vocal and respiratory musculature, but since there is abundant evidence in even non-vocal learning species for descending, topographic forebrain control of body musculature in general, this requires only access to vocal and respiratory musculature. In addition, circuitry must be present to compare the bird's own vocalizations with that of a target song. Initially, that target need not have been memorized, but could have been an innate program for a species-typical vocalization. Finally, some means is needed to convey the output of that comparison to the motor system to allow for changes in subsequent songs. All of these elements are common to, or easily obtained through, small modifications of the typical vertebrate forebrain-wiring diagram.

The general architectural similarities between bird and mammal brain organization, combined with the

conservation of cellular properties in the basal ganglia, suggests a way to reconcile the similarities among the nuclei identified in all three avian taxa that exhibit vocal learning with independent evolution of this process in those taxa. If each "invention" of vocal learning involved pre-existing basal ganglia circuits, perhaps with slightly different ways in which those circuits connected to the motor system, then the three resulting neural circuits for vocal learning could have deep similarities. These similarities would be due to homologies among these circuits as basal ganglia circuits rather than as vocal learning circuits [14]. In this way, then, it is even possible that vocal learning circuits in humans could resemble those in songbirds in fundamental ways, without them necessarily being evolutionarily homologous as vocal learning circuits.

### References

1. Brenowitz EA, Beecher MD (2005) Song learning in birds: diversity and plasticity, opportunities and challenges. *Trends Neurosci* 28(3):127–132
2. Farries MA (2001) The oscine song system considered in the context of the avian brain: lessons learned from comparative neurobiology. *Brain Behav Evol* 58:80–100
3. Zeigler HP, Marler P (2004) Behavioral neurobiology of bird song. New York Academy of Sciences, New York
4. Nottebohm F, Stokes TM, Leonard CM (1976) Central control of song in the canary, *Serinus canarius*. *J Comp Neurol* 165:457–486
5. Striedter GF (1994) The vocal control pathways in budgerigars differ from those in songbirds. *J Comp Neurol* 343:35–56
6. Jarvis ED, Nottebohm F (1997) Motor-driven gene expression. *Proc Natl Acad Sci USA* 94(8):4097–4102
7. Jarvis ED, Mello CV (2000) Molecular mapping of brain areas involved in parrot vocal communication. *J Comp Neurol* 419(1):1–31
8. Jarvis ED, Ribeiro S, da Silva ML, Ventura D, Vielliard J, Mello CV (2000) Behaviourally driven gene expression reveals song nuclei in hummingbird brain. *Nature* 406(6796):628–632
9. Reiner A, Perkel DJ, Bruce LL, Butler AB, Csillag A, Kuenzel WJ, Medina L, Paxinos G, Shimizu T, Striedter GF, Wild JM, Ball GF, Durand SE, Gunturkun O, Lee DW, Mello CV, Powers AS, White SA, Hough G, Kubikova L, Smulders TV, Wada K, Dugas-Ford J, Husband S, Yamamoto K, Yu J, Siang C, Jarvis ED (2004) Revised nomenclature for avian telencephalon and some related brainstem nuclei. *J Comp Neurol* 473:377–414
10. Jarvis ED, Gunturkun O, Bruce L, Csillag A, Karten H, Kuenzel W, Medina L, Paxinos G, Perkel DJ, Shimizu T, Striedter G, Wild JM, Ball GF, Dugas-Ford J, Durand SE, Hough GE, Husband S, Kubikova L, Lee DW, Mello CV, Powers A, Siang C, Smulders TV, Wada K, White SA, Yamamoto K, Yu J, Reiner A, Butler AB (2005) Avian brains and a new understanding of vertebrate brain evolution. *Nat Rev Neurosci* 6(2):151–159
11. Farries MA, Perkel DJ (2000) Electrophysiological properties of avian basal ganglia neurons recorded in vitro. *J Neurophysiol* 84:2502–2513

12. Farries MA, Perkel DJ (2002) A telencephalic nucleus essential for song learning contains neurons with physiological characteristics of both striatum and globus pallidus. *J Neurosci* 22:3776–3787
13. Farries MA, Meitzen J, Perkel DJ (2005) Electrophysiological properties of neurons in the basal ganglia of the domestic chick: conservation and divergence in the evolution of the avian basal ganglia. *J Neurophysiol* 94(1):454–467
14. Butler AB, Hodos W (2005) Comparative vertebrate neuroanatomy: evolution and adaptation, 2nd edn. Wiley-Liss, Hoboken, NJ

## Evolution of Nucleus Isthmi

ELIZABETH DUDKIN<sup>1</sup>, EDWARD GRUBERG<sup>2</sup>

<sup>1</sup>Penn State University, Media, PA, USA

<sup>2</sup>Biology Department, Temple University, Philadelphia, PA, USA

### Definition

The nucleus isthmi is a nucleus that lies within the region of the midbrain-hindbrain junction of many vertebrates. It is reciprocally connected with the ipsilateral optic tectum. The nucleus isthmus has a high ►acetylcholinesterase activity.

### Characteristics

#### Location of Nucleus Isthmi

The isthmic region of vertebrates connects the hindbrain to the midbrain. In this region is a visually driven bilateral cell group called the nucleus isthmi. The nucleus isthmi is found in bony fish, amphibians, mammals, reptiles and birds. In mammals it is called the ►parabigeminal nucleus. For economy, this cell group will be referred to as “n. isthmi” except in the case of mammals.

#### Reciprocal Isthmotectal Connections

The common characteristic of the n. isthmi in all species studied so far is their strong reciprocal connections with the much larger ipsilateral midbrain structure, the optic tectum (homologous with the mammalian superior colliculus). This tecto-isthmo-tectal connection is a feedback loop for the tectum and thus the n. isthmi can influence tectal function. The optic tectum is an important target of retinal ganglion cells. Retinotectal fibers terminate in superficial layers of the tectum where they form a ►visuotopic map, i.e. adjacent points in visual space are represented at adjacent points in laminae of the optic tectum. Isthmotectal fibers tend to terminate in the same layers or adjacent layers of the tectum as retinotectal fibers. The isthmotectal fibers also form a

visuotopic map and usually it is in alignment with the retinotectal visuotopic map [1–3]. The nucleus isthmi should not be confused with another isthmic nucleus, the ►isthmo-optic nucleus, which is found in reptiles and birds. The isthmo-optic nucleus receives input from the optic tectum and projects to the retina.

### Other Inputs

Depending on the species, the n. isthmi may also receive input, with fewer fibers, from non-tectal areas of the brain. In some frog species (anurans) but not others, there are scattered cells in the tegmental anterodorsal nucleus that project to the contralateral n. isthmi. In the ray-finned fish, ►*Navodon modestus*, the diencephalic nucleus pretectalis (= the magnocellular superficial pretectal nucleus) projects to the ipsilateral n. isthmi [4]. In the weakly electric fish ►*Apteronotus*, the dorsal torus semicircularis, an electrosensitive area, makes reciprocal connections with the n. isthmi [5].

### Histochemical Character

The nucleus isthmus is further characterized by having high acetylcholinesterase (AChE) activity, (the enzyme that hydrolyzes acetylcholine). Most isthmotectal fibers have been shown to be cholinergic and their tectal terminal zones have high AChE activity and high ►choline acetyltransferase (ChAT) activity (the enzyme that synthesizes acetylcholine). The frog n. isthmi also contains high ChAT activity not only in perikarya but also in adjacent neuropil [6]. This suggests that tectoisthmal fibers, at least in frogs, may be cholinergic also.

### One, Several Nuclei Isthmi

While a single n. isthmi on each side of the midline is recognizable in amphibians, mammals and fish, birds have evolved several distinct n. isthmi, all with reciprocal connections with the tectum and each with high AChE activity. These nuclei are nucleus isthmi pars parvocellularis (Ipc), nucleus isthmi pars magnocellularis (Imc) and nucleus semilunaris (SLu) [7]. Ipc and SLu make precise reciprocal topographic maps with the optic tectum; both Ipc-tectal fibers and SLu-tectal fibers are cholinergic and terminate in both retinoreceptive layers and deeper layers. Imc-tectal fibers use  $\gamma$ -amino butyric acid (GABA) as their neurotransmitter and form a more diffuse map restricted to the deeper layers of the tectum. Other neurons in Imc project widely to Ipc and SLu without any obvious topography. Turtles have both an Ipc (called “Imc” in turtle) and an Imc (called “Imc” in turtle) with tectal connectivity similar to that in birds [8]. As in birds, turtle Imc projects to Ipc nontopographically. Lizards have two isthmic structures that make reciprocal connections with the ipsilateral tectum, the Imc and nucleus profundus mesencephali (NPM), which may respectively correspond to the Imc and Imp of turtles [9].

### Appearance of Nucleus Isthmi

In many species, the n. isthmi can be recognized in ►Nissl stained material. In mammals, the parabigeminal nucleus is clearly identifiable as a dense cluster of cells located on the lateral superficial wall of the isthmic region [2]. In birds, all three isthmic nuclei are recognizable [7]. In anurans, the nucleus stands out as a discrete area with a high density of cortical cells demarcating much of the outer edge of the nucleus and a lower density of cells in a core medullary area [3,10]. In urodele amphibians, the nucleus is not clearly distinguishable from adjacent tegmental tissue. In ray-finned fish, the n. isthmi is distinguishable by having a cortical layer of cells and a non-cellular medullary region.

### Morphology of Isthmi Cells

The nucleus isthmi in frogs is made up of several neuronal cell types [11]. In the cortex, there are mostly piriform cells with a single large apical dendrite, either straight or curved, from which several secondary dendrites begin. The axon originates from the primary dendrite or the soma. Both cortical and medullary cells have no basal processes. In the medulla there are several different types of cells; most common are cells that have several dendrites arising from the soma. Roughly speaking, the size of dendritic spread as a proportion of the size of nucleus is greater in frog species with poorer vision (fewer optic nerve fibers). In ray-finned fish, single apical dendrites of n. isthmi cells extend from the outer shell into the noncellular core where they branch. The axons arise from the cell bodies that possess many spiny processes [12]. In birds, Ipc and SLu soma are round, have relatively uniform diameter and emit multiple dendrites. Bird Imc soma are quite variable in both size and shape and are multipolar. The size of dendritic spread is variable [13].

### Feed-Forward Connections

In addition to the reciprocal connections between n. isthmi and ipsilateral tectum, the n. isthmi projects in topographic order to the contralateral tectum in amphibians [3,10] and mammals [2]. In urodele amphibians, n. isthmi cells project to both tecta. There are apparently no significant n. isthmi projections to the contralateral tectum in reptiles, birds or bony fish.

The projection from eye to tectum is almost entirely crossed in most anurans, yet information from the ipsilateral eye reaches the optic tectum. For example, the pathway that originates in the left eye and eventually reaches the left tectum is from the left eye to the right tectum to the right nucleus isthmi to the left tectum (the pathway from the right eye to the right tectum being mirror symmetrical) [3]. ►Ablation of the right nucleus isthmi eliminates the response in the left tectum to left eye visual stimulation [14]. The isthmotectal fibers projecting to the contralateral tectum follow a remarkable

rostral route from the n. isthmi along the lateral wall of the ipsilateral midbrain and diencephalon [3]. Depending on the species, the contralaterally projecting isthmotectal fibers cross the midline ventrally, either in the caudal part of the optic chiasm or immediately posterior in the postoptic commissure. The fibers then course dorsocaudally to the tectum. A similar path and crossing pattern is seen in mammals [2].

### Map Anomalies

The isthmotectal visuotopic map and the retinotectal visuotopic map are not necessarily in register throughout the tectum. Almost all animals have a frontal part of the visual field seen by both eyes (the binocular visual field) and left and right lateral areas of the visual field seen exclusively by left and right eyes, respectively (the monocular visual fields).

In anurans, the visual projection from, e.g. the left eye onto the right tectum encompasses the binocular field and the monocular field of the left eye. This visual projection covers the entire surface of the right tectum. Those two fields are also represented in the right n. isthmi. In turn, the right n. isthmi projects back to the right tectum, where the isthmic and tectal maps are in register. However, the right n. isthmi also projects to the left tectum. The left tectum receives a direct visual projection from the right eye encompassing the binocular region and also the monocular field of the right eye across the entire surface of the left tectum [10]. The binocular region of each tectum thus consists of two binocular maps that are in register, one from each eye, one direct and one indirect via the nucleus isthmi. In the monocular region of the tectum, there are also two visual maps of monocular visual space. However, these maps are the superimposed fields of left eye and right eye monocular visual space. These maps cannot be in register but rather each point in this part of the tectum corresponds to mirror image locations in monocular visual space of the two eyes [15].

### Other Centrifugal Connections of Nucleus Isthmi

In mammals, the parabigeminal nucleus projects to the dorsal lateral geniculate nucleus [2]. Depending on the species, this projection is ipsilateral (primates), bilateral (cats) or contralateral (rodents, gophers, tree shrews and marsupials). In birds, the SLu subdivision of n. isthmi projects to the nucleus rotundus and the lateral spiriform nucleus, both of which lie within the dorsal thalamus [16]. Neither of the latter two nuclei is homologous to the dorsal lateral geniculate nucleus of mammals, however.

Electrical recording in the n. isthmi is generally consistent with the topographic tectoisthmal projection. A recording microelectrode systematically moved to different locations in the nucleus will record electrical responses to stimuli placed in anatomically determined

visual field locations. This is true in mammals, amphibians and birds. However, in the bony fish, sunfish and goldfish, electrical responses are evoked at any n. isthmi location wherever the stimulus is placed in the visual field [17]. Thus, there is no apparent physiological correlate to the neuroanatomically determined visuotopy in the n. isthmi of at least some fishes. This apparent lack of visuotopy could be due to electrical coupling between cells of n. isthmi, since it is known that fish n. isthmi cells are interconnected via gap junctions.

### Isthmotectal Physiology

In amphibians and reptiles, most tectal neurons are excited by isthmic electrical stimulation whereas a minority of tectal cells are inhibited by isthmic stimulation [18]. In birds, there is a complex interaction between Ipc, Imc and the tectum. Tectal bipolar “shepherd crook” cells (so called because of the characteristic 180° bend of their axons as they emerge from their cells) have narrow dendritic spread and project visuotopically to Ipc cells. In turn, Ipc neurons project back to the same visuotopic locations with excitatory cholinergic axonal terminations (“paintbrush” terminals) as part of a

narrowly spread axonal tree extending in a radial column over many superficial tectal layers [19]. Imc receives a coarser visuotopic input from tectal bipolar cells. In turn, Imc cells project to both Ipc and to tectum with GABAergic inhibitory terminals in a heterotopic manner. Their projections spread widely but not to the visual location in Ipc and tectum from which the Imc cells receive their input from the tectum. The effect is perhaps to provide an excitatory center and inhibitory surround to tectal cells. In other avian studies, it has been shown that blocking activity in Imc reduces the firing rate of tectal cells after visual stimulation. Conversely, Ipc appears to have an inhibitory effect on most tectal cells and a brief excitatory effect on other tectal cells followed by inhibition. The inhibition is apparently contributed directly by GABAergic Ipc cells and by excitation of tectal interneurons that are in turn GABAergic.

In frogs, cholinergic isthmotectal fibers have a modulatory effect on frog retinotectal fibers that express acetylcholine receptors on their surface [20]. Calcium uptake (and indirectly, release of neurotransmitter) into retinotectal fibers is significantly enhanced when there is near simultaneous electrical input from retina and ipsilateral n. isthmi compared to input from retina alone.

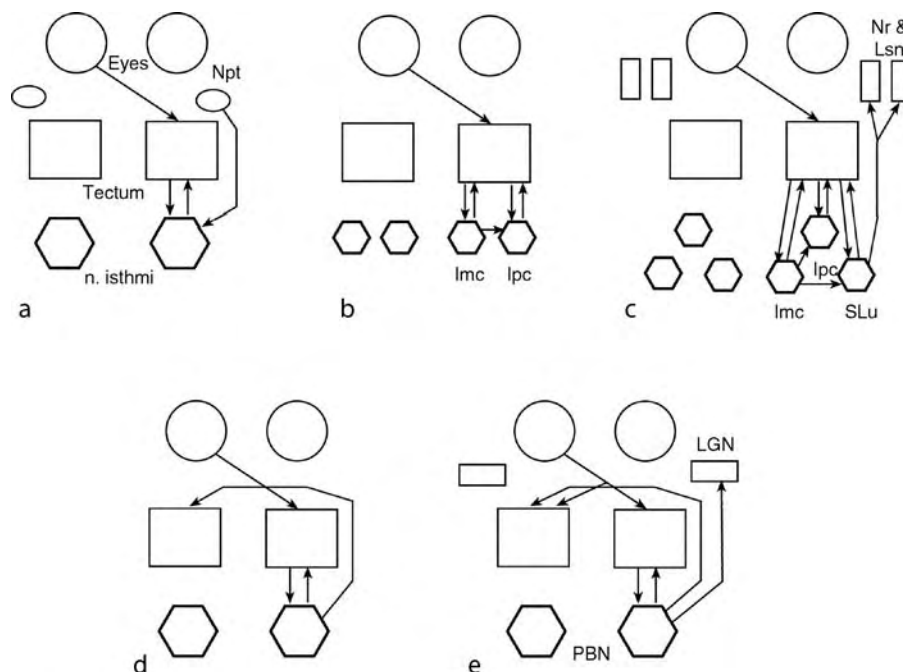

**Evolution of Nucleus Isthmi. Figure 1** Basic connections of right n. isthmi in (a) bony fish, (b) reptiles, (c) birds, (d) amphibians and (e) mammals. In all these animals there are reciprocal connections between the tectum and ipsilateral nucleus isthmi. With the exception of mammals, the projection from the eye to the tectum is mostly crossed. Amphibians and mammals also have a crossed projection from nucleus isthmi to the tectum. The fibers of this projection cross the midline in or near the optic chiasm. Reptiles and birds have more than one nucleus isthmi. Abbreviations: *Imc* nucleus isthmi pars magnocellularis; *Ipc* nucleus isthmi pars parvocellularis; *LGN* lateral geniculate nucleus; *Lsn* lateral spiriform nucleus; *Npt* nucleus pretectalis; *Nr* nucleus rotundus; *PBN* parabigeminal nucleus; *SLu* nucleus semilunaris.

Electrical input from n. isthmi alone has no effect on calcium uptake into retinotectal fibers.

There are reports that the n. isthmi has a respiratory function. Injection of lidocaine or kainic acid solutions into frog n. isthmi results in changes in breathing rate [21]. The results are problematic given that the volumes injected are large enough to spread over much of the isthmic region and so could affect other isthmic structures. Also, there is no obvious anatomical connection between n. isthmi and known brainstem respiratory areas.

### Behavior

The superior colliculus plays a role in directed eye and head movements in mammals, and this is reflected in parabigeminal function. In awake cats trained to move their eyes to fixate points on moving targets, the level of response of parabigeminal cells is a function of how far the center of gaze is away from the target. The parabigeminal nucleus thus provides error signals to the superior colliculus [1].

In frogs, unilateral ablation of n. isthmi results in a ►scotoma to prey and looming stimuli in the contralateral monocular visual field. The scotoma has the quality of “visual neglect” [14]. That is, within the scotoma zone, the animal is not completely unresponsive to visual stimuli, but the likelihood of response is very low. Partial ablation of the nucleus isthmi causes a smaller scotoma in the same monocular visual field region, but the scotomas always include the temporal most part of the contralateral field. Thus, the scotomas are not isomorphic with the part of the visual field map that has been ablated. In contrast, partial ablation of the optic tectum results in a scotoma commensurate with the tectal visual representation [15]. Another consequence of ablation of frog n. isthmi is an increase in the size of visually evoked multiunit receptive fields recorded from the tectum [14]. Thus, the visuotopic map degrades as if retinotectal axonal terminals are less stabilized in the absence of isthmotectal input.

### Functional Role

In fish, given the non-topographic responsiveness of n. isthmi, it may play a role as a sentinel, alerting the system that something is moving in the visual field rather than directing the animal to a particular object or to a particular point in space. In amphibians and birds, the system could act as a “winner-take-all” module, selecting a particular object for attention [7,15,22]. In mammals, the parabigeminal nucleus mediates visuomotor tracking by computing error signals [1].

The tectum serves the visual needs of particular species in different ways such as tracking visual objects, discriminating between different classes of objects, selecting (or attending to) one of several objects, and directing movement of eye or head or body. The nucleus

isthmi appears to be an important modulator and facilitator of tectal function (Fig. 1) [23].

### References

1. Cui H, Malpeli JG (2003) Activity in the parabigeminal nucleus during eye movements directed at moving and stationary targets. *J Neurophysiol* 89:3128–3142
2. Graybiel AM (1978) A satellite system of the superior colliculus: the parabigeminal nucleus and its projections to the superficial collicular layers. *Brain Res* 145:365–374
3. Gruberg ER, Udin SB (1978) Topographic projections between the nucleus isthmi and the tectum of the frog, *Rana pipiens*. *J Comp Neurol* 179:487–500
4. Ito H, Tanaka H, Sakamoto N, Morita Y (1981) Isthmic afferent neurons identified by the retrograde HRP method in a teleost, *Navodon modestus*. *Brain Res* 207:163–169
5. Sas E, Maler L (1986) Identification of a nucleus isthmi in the weakly electric fish *Apteronotus leptorhynchus* (Gymnotiformes). *Brain Behav Evol* 28:170–185
6. Desan PH, Gruberg ER, Grewell KM, Eckenstein F (1987) Cholinergic innervation of the optic tectum in the frog, *Rana pipiens*. *Brain Res* 413:344–349
7. Wang Y, Luksch H, Brecha NC, Karten HJ (2006) Columnar projections from the cholinergic nucleus isthmi to the optic tectum in chicks (*Gallus gallus*): a possible substrate for synchronizing tectal channels. *J Comp Neurol* 494:7–35
8. Sereno MI, Ulinski PS (1987) Caudal topographic nucleus isthmi and the rostral nontopographic nucleus isthmi in the turtle, *Pseudemys scripta*. *J Neurol* 261:319–346
9. Wang SR, Yan K, Wang YT, Jiang SY, Wang XS (1983) Neuroanatomy and electrophysiology of the lacertilian nucleus isthmi. *Brain Res* 275:355–360
10. Grobstein P, Comer C (1983) The nucleus isthmi as an intertectal relay for the ipsilateral oculotectal projection in the frog, *Rana pipiens*. *J Comp Neurol* 217:54–74
11. Tóth P, Lázár G, Wang SR, Li TB, Xu J, Pál E, Straznický C (1994) The contralaterally projecting neurons of the isthmic nucleus in five anuran species: a retrograde tracing study with HRP and cobalt. *J Comp Neurol* 346:306–320
12. Ito H, Sakamoto N, Takatsuji K (1982) Cytoarchitecture, fiber connections, and ultrastructure of nucleus isthmi in a teleost (*Navodon modestus*) with a special reference to degenerating isthmic afferents from optic tectum and nucleus pretectalis. *J Comp Neurol* 205:299–311
13. Wang Y, Major DE, Karten HJ (2004) Morphology and connections of nucleus isthmi pars magnocellularis in chicks (*Gallus gallus*). *J Comp Neurol* 469:275–297
14. Gruberg ER, Wallace MT, Caine HS, Mote MI (1991) Behavioral and physiological consequences of unilateral ablation of the nucleus isthmi in the leopard frog. *Brain Behav Evol* 37:92–103
15. Winkowski DE, Gruberg ER (2005) Superimposed maps of the monocular visual fields in the caudolateral optic tectum in the frog, *Rana pipiens*. *Vis Neurosci* 22:101–109
16. Hellmann B, Manns M, Güntürkün O (2001) Nucleus isthmi, pars semilunaris as a key component of the tectofugal visual system in pigeons. *J Comp Neurol* 436:153–166

17. Northmore DP, Gallagher SP (2003) Functional relationship between nucleus isthmi and tectum in teleosts: synchrony but no topography. *Visual Neurosci* 20:335–348
18. Wang SR (2003) The nucleus isthmi and dual modulation of the receptive field of tectal neurons in non-mammals. *Brain Res Rev* 41:13–25
19. Marín G, Mpodozis J, Sentis E, Ossandon T, Letelier JC (2005) Oscillatory bursts in the optic tectum of birds represent re-entrant signals from the nucleus isthmi pars parvocellularis. *J Neurosci* 25:7081–7089
20. Dudkin EA, Gruberg ER (2003) Nucleus isthmi enhances calcium influx into optic nerve fiber terminals in *Rana pipiens*. *Brain Res* 969:44–52
21. Gargaglioni LH, Coimbra NC, Branco LG (2002) Chemical lesions of the nucleus isthmi increase the hypoxic and hypercarbic drive to breathing of toads. *Respir Physiol Neurobiol* 132:289–299
22. Marín G, Salas C, Sentis E, Rojas X, Letelier JC, Mpodozis J (2007) A cholinergic gating mechanism controlled by competitive interactions in the optic tectum of the pigeon. *J Neurosci* 27:8112–8121
23. Gruberg E, Dudkin E, Wang Y, Marín G, Salas C, Sentis E, Letelier JC, Mpodozis J, Malpeli J, Cui H, Ma R, Northmore D, Udin S (2007) Influencing and interpreting visual input: the role of a visual feedback system. *J Neurosci* 26:10368–10371

that innervates the ciliary ganglion. The ciliary ganglion, together with the sympathetic fibers from the superior cervical ganglion, innervates the internal eye muscles for pupillary control and accommodation.

In its basic form, the oculomotor system is driven by information from the vestibular system to keep the eye on target through any and all head movements. For this, the ocular motoneurons receive input from the vestibular nuclei, which in turn receive information from the inner ear about head movements through the vestibular neurons of the ear.

This chapter will analyze how each of the components of this three neuron reflex arc (vestibular hair cell, vestibular neuron, vestibular nucleus neuron, ocular motoneuron, ocular muscle) evolved and how they achieved their functional interactions as described above for mammals.

### Characteristics

Six ocular muscles move the eye in the orbit. Ocular muscle fibers are unique in several respects; they have both fast twitch fibers for rapid eye movements and slow, tonic fibers to maintain position without fatigue. Ocular muscles have very small motor units. This feature evolved early and was largely maintained [1]. Several vertebrates have seven eye muscles, one of which retracts the eye into the orbit and/or moves a membrane across the cornea and/or closes the eyelids. However, some vertebrates have no ocular muscles and some have lost and/or transformed individual muscles to generate weak electric signals.

Ocular motoneurons have been referred to as “somatic motoneurons” as they are under conscious control. However, neither the molecular basis of their development [2] nor their overall evolution [3] fits this assumption. It is possible that trochlear and oculomotor neurons co-evolved with the mid/hindbrain barrier as they depend critically on molecules necessary for the formation of this barrier [4,5].

Four to five vestibular nuclei have been characterized in vertebrates [6,7]. Each nucleus receives a unique complement of input from the ear and other senses and relates the processed information to higher centers such as the ocular motoneurons [7]. Additional vestibular information processing is in the cerebellum, which modifies the vestibular output. In addition, brainstem and midbrain centers for horizontal and vertical gaze control exist and can be activated by higher centers such as the midbrain tectum or the cortex.

The ear has two different sets of sensors, the canals with their associated sensory epithelia to measure rotation and gravistatic sensors with associated otoconia/otoliths to measure position in space [8]. The information from the ear is related to the vestibular nuclei and the cerebellum in discrete but partially overlapping vestibular afferent fiber tracts [9].

## Evolution of Oculomotor System

BERND FRITZSCH

Department of Biomedical Sciences, Omaha, NE, USA;  
Department of Biology, University of Iowa, Iowa City, USA

### Synonyms

Eye movement system; Vestibular-ocular reflex system; Oculomotor systems

### Definition

The oculomotor system consists in mammals of three functionally interconnected motoneuron populations, the oculomotor, trochlear and abducens motoneurons. These three motoneuron populations innervate all six ocular muscles such that the oculomotor nerve (cranial nerve III) innervates four ocular muscles (superior rectus, inferior rectus, medial rectus, inferior oblique) the trochlearis nerve (cranial nerve IV) innervates one muscle (superior oblique) and the abducens nerve innervates one muscle (lateral rectus) and, if present, the retractor bulbi. In mammals, the oculomotor nerve also innervates the levator palpebrae muscle that lifts the upper eyelid. All jawed vertebrates have a parasympathetic component of the oculomotor nerve (the Eddinger-Westphal nucleus)



## Description of the Process

Evolution has changed ocular muscle patterns, innervation of ocular muscles, connection of vestibular nuclei to ocular motoneurons, input of the ear to the vestibular nuclei and the ear. We will describe the process, starting from the ocular muscles and finishing with the ear.

Hagfish have no ocular muscles and a reduced eye. This condition may be primitive as vertebrate outgroups have no eyes or ocular muscles. Lampreys, which together with hagfish form the taxon agnatha, or jawless fish, have six ocular muscles. However, ocular muscles are oriented differently in the orbit of lampreys and have a unique pattern of innervation [10]; two muscles are innervated by the abducens, one by the trochlearis and three by the oculomotor. In jawed vertebrates there are two patterns of six to seven eye muscles and their innervation. Four muscles are innervated by the oculomotor, one by the trochlear, one by the abducens and the seventh muscle (if present) is also innervated by the abducens. Sharks and other elasmobranchs have an innervation of the nasal rectus by an oculomotor branch that passes dorsally around the optic nerve. In contrast, all bony fish and land vertebrates have an oculomotor twig to the medial rectus muscle that passes ventrally around the optic nerve. How the new nasal/medial rectus muscle relates to the oculomotor nerve innervated ocular muscles of lampreys is unknown. Most interesting is the seventh ocular muscle. This muscle can be used to retract the eye into the orbit (retractor bulbi), can retract the eye and move a nictitating membrane across the cornea, can close the eyelid or is completely detached from the eye. In the last case this muscle may function as a retractor for a tentacle [11] or may move a mobile anterior part of the skull [12]. In many mammals, including man, the retractor bulbi is lost and facial nerve innervated muscles close the eyelids.

Hagfish have no ocular motoneurons. Lampreys have ocular motoneurons but they are peculiar in several respects. The trochlear motoneurons are in the cerebellum [10] apparently through migration away from their site of origin [13]. Abducens motoneurons exit not as a ventral motor root but rather with the trigeminal motoneurons [3]. Abducens motoneurons extend from rhombomere 6 through 5 and into the caudal half of 4, thus are next to the most caudal trigeminal motoneurons [3,6,14]. Some variation of abducens position occurs in jawed vertebrates with the most notable change being the restriction to only rhombomere 5 in mammals whereas birds have abducens motoneurons in both rhombomeres 5 and 6 [15,16,7].

Much less is known of the evolution of vestibular projections to ocular motoneurons, which appears to be highly conserved across vertebrates with only minor changes [17,6,7].

The ear shows two canals for vertical rotation detection in hagfish and lampreys and three canals in

jawed vertebrates [8]. Since canal input is the main input into ocular motoneurons, evolution of the ear should allow understanding of the sensory input that controls the motor output. Jawed vertebrates evolved a third canal, the horizontal or lateral canal, apparently through incorporation of at least two new genes into ear development, *Foxg1* for the formation of the horizontal canal sensory epithelium and *Otx1* for the formation of the horizontal canal [18]. Whether changes in ear development preceded evolution of eye muscle arrangements and their innervation as previously proposed [6] remains unknown.

## Regulation of the Process

The general assumption for evolution is that mutations cause alterations in gene expression (promoter mutations) or gene function and thus alterations in development. How a complex interconnected system evolves is still a matter of conjecture. For the vestibulo-ocular reflex system, it appears that alterations in the ear (formation of vertical canals, formation of the horizontal canal) precede changes in the eye muscle innervation. Whether evolution of a horizontal canal is upstream to eye muscle geometry and innervation changes or whether both changes are driven by changes in the same unrelated developmental event (evolution of jaws and appendages) remains to be resolved, once the latter changes are mechanically understood in terms of sequence of genetic changes.

## Function

The vestibular-ocular system functions to stabilize gaze on target. The reflex can be supplemented by several higher order inputs to provide control of eye movements beyond simple reflexes.

## Pathology

Strabismus is a pathological misalignment of eyes that can result in amblyopia. Numerous pathologies of eye muscles, summarized as congenital cranial dysinnervation disorders, are known. An atypical consequence of the congenital absence of proper innervation is fibrotic muscle degeneration, known as congenital fibrosis of the extraocular muscles [19]. Several genes have been identified which in humans and in mouse mutants cause strabismus or congenital fibrosis syndrome [4,20]. Many of these genes (*Phox2a*, *Hoxa1*, *Krox20*) are known to be essential for some ocular motoneuron population development and were probably important for ocular motor axis evolution.

## References

1. Fritsch B, Sonntag R (1988) The trochlear motoneurons of lampreys (*Lampetra fluviatilis*): location, morphology and numbers as revealed with horseradish peroxidase. *Cell Tissue Res* 252:223–229

2. Brunet JF, Pattyn A (2002) Phox2 genes – from patterning to connectivity. *Curr Opin Genet Dev* 12:435–440
3. Fritzsich B, Northcutt RG (1993) Cranial and spinal nerve organization in amphioxus and lampreys: evidence for an ancestral craniate pattern. *Acta Anat (Basel)* 148:96–109
4. Fritzsich B, Nichols DH, Echelard Y, McMahon AP (1995) Development of midbrain and anterior hindbrain ocular motoneurons in normal and Wnt-1 knockout mice. *J Neurobiol* 27:457–469
5. Lee SM, Danielian PS, Fritzsich B, McMahon AP (1997) Evidence that FGF8 signalling from the midbrain-hindbrain junction regulates growth and polarity in the developing midbrain. *Development* 124:959–969
6. Fritzsich B (1998) Evolution of the vestibulo-ocular system. *Otolaryngol Head Neck Surg* 119:182–192
7. Straka H, Baker R, Gilland E (2002) The frog as a unique vertebrate model for studying the rhombomeric organization of functionally identified hindbrain neurons. *Brain Res Bull* 57:301–305
8. Lewis ER, Leverenz EL, Bialek WS (1985) The vertebrate inner ear. CRC, Boca Raton
9. Maklad A, Fritzsich B (2003) Development of vestibular afferent projections into the hindbrain and their central targets. *Brain Res Bull* 60:497–510
10. Fritzsich B, Sonntag R, Dubuc R, Ohta Y, Grillner S (1990) Organization of the six motor nuclei innervating the ocular muscles in lamprey. *J Comp Neurol* 294:491–506
11. O'Reilly JC, Nussbaum RA, Boone D (1996) Vertebrate with protrusible eyes. *Nature* 382:33
12. Northcutt RG, Bemis WE (1993) Cranial nerves of the coelacanth, *Latimeria chalumnae* [Osteichthyes: Sarcopterygii: Actinistia], and comparisons with other craniata. *Brain Behav Evol* 42 Suppl 1:1–76
13. Fritzsich B, Northcutt RG (1993) Origin and migration of trochlear, oculomotor and abducent motor neurons in *Petromyzon marinus* L. *Brain Res Dev Brain Res* 74:122–126
14. Murakami Y, Pasqualetti M, Takio Y, Hirano S, Rijli FM, Kuratani S (2004) Segmental development of reticulospinal and branchiomotor neurons in lamprey: insights into the evolution of the vertebrate hindbrain. *Development* 131:983–995
15. Gilland E, Baker R (1993) Conservation of neuroepithelial and mesodermal segments in the embryonic vertebrate head. *Acta Anat (Basel)* 148:110–123
16. Murakami Y, Uchida K, Rijli FM, Kuratani S (2005) Evolution of the brain developmental plan: insights from agnathans. *Dev Biol* 280:249–259
17. Baker R (1998) From genes to behavior in the vestibular system. *Otolaryngol Head Neck Surg* 119:263–275
18. Fritzsich B, Signore M, Simeone A (2001) *Otx1* null mutant mice show partial segregation of sensory epithelia comparable to lamprey ears. *Dev Genes Evol* 211:388–396
19. Engle EC (2002) The molecular basis of the congenital fibrosis syndromes. *Strabismus* 10:125–128
20. Pieh C, Goebel HH, Engle EC, Gottlob I (2003) Congenital fibrosis syndrome associated with central nervous system abnormalities. *Graefes Arch Clin Exp Ophthalmol* 241:546–553

## Evolution of Olfactory and Vomeronasal Systems

ALINO MARTÍNEZ-MARCOS, MIMI HALPERN  
Facultad de Medicina and Centro Regional de Investigaciones Biomédicas (CRIB) Universidad de Castilla-La Mancha, Albacete, Spain

### Synonyms

Vomeronasal organ; Vomeronasal system (Accessory Olfactory system); Accessory olfactory system

### Definition

The olfactory and ►vomeronasal systems (Accessory olfactory system) are the main nasal chemosensory systems in vertebrates. Both are composed of chemosensory epithelia, olfactory bulbs and olfactory- and ►vomeronasal-recipient (Vomeronasal-amygdala) structures in the basal telencephalon. The ►olfactory system is present in virtually all major groups of vertebrates, whereas the vomeronasal system is thought to first appear in amphibians.

### Characteristics

#### Structure of the Olfactory and Vomeronasal Systems

The olfactory and vomeronasal systems are the primary nasal chemosensory systems in vertebrates. The olfactory system is sensitive to volatile airborne odorants, whereas the vomeronasal system is primarily sensitive to non-volatile molecules or volatile molecules bound to carrier (usually protein) molecules such as ►pheromones [1,2,3].

Among vertebrates, the olfactory and vomeronasal systems are remarkably conserved, having similar structures and functions in virtually all groups. The olfactory system is present in all vertebrates (except some cetacean mammals), whereas the vomeronasal system appears in amphibians, some, but not all, reptiles and mammals [4]. The olfactory system consists of a peripherally located ►olfactory epithelium lining portions of the nasal cavity, a ►main olfactory bulb, located in the most anterior (rostral) portion of the brain and several ►olfactory-recipient structures more centrally located in the brain, which serve as neural networks controlling responses to olfactory information [1,2] (Fig. 1).

The vomeronasal system, structurally similar to the olfactory system, is composed of a ►vomeronasal organ (Jacobson's organ) that contains a ►vomeronasal epithelium, an ►accessory olfactory bulb that is located rostrally in the brain (usually posterior to the main olfactory bulb) and several more caudally situated brain

vomeronasal-recipient structures involved in orchestrating the behavioral and endocrinological responses to vomeronasal stimuli [3] (Fig. 1).

### Olfactory Epithelium and Vomeronasal Organ

The olfactory epithelium of most vertebrates consists of a relatively thin layer of cells surmounted by a mucous layer. Three types of cells are found in the epithelium – basal, receptor and supporting cells (Fig. 2). The receptor cells are bipolar neurons whose axons leave the epithelium and terminate in the main olfactory bulb. Receptor cell dendrites reach the apical surface of the epithelium and contain enlargements, called olfactory vesicles, from which cilia emanate. It is on these cilia that the receptor proteins that bind odorants are located. Supporting cells are situated adjacent to the receptor cells. They are thought to be

involved in removal of substances from the epithelial surface and perhaps contribute to the mucous layer. Basal cells are stem cells that periodically undergo mitosis and are the source of new receptor cells during the periodic turnover of the epithelial constituents [5].

The vomeronasal epithelium is located in the vomeronasal organ, which in many, but not all, vertebrates is located at the base of the nasal septum. In different vertebrates, the organ opens into the nasal cavity (e.g., salamanders and frogs), the oral cavity (e.g., snakes and lizards) or both (e.g., many mammals) (Fig. 1). No separate vomeronasal organ is present in agnathans (jawless fishes), gnathostomes (jawed fishes), turtles, crocodiles, the tuatara *Sphenodon*, birds, cetaceans and sirenians (dugongs and manatees) [4]. As in the olfactory epithelium, the vomeronasal sensory epithelium consists of three types of cells – supporting, receptor and basal

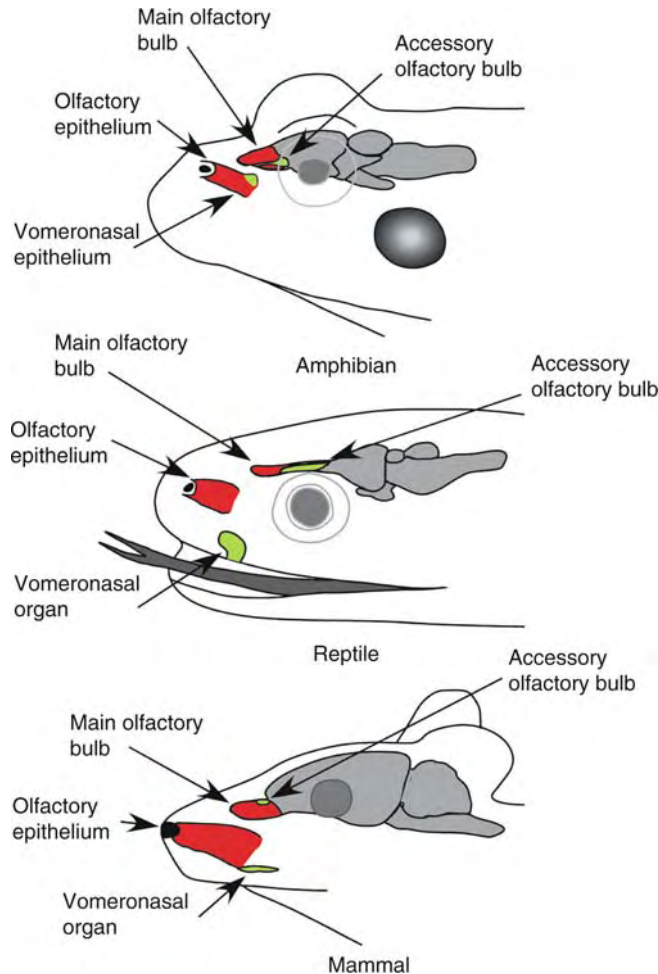

**Evolution of Olfactory and Vomeronasal Systems. Figure 1** Schematic diagram showing the organization of the olfactory (red) and vomeronasal (green) epithelia and the main (red) and accessory (green) olfactory bulbs in amphibians, reptiles (lizards and snakes) and mammals.

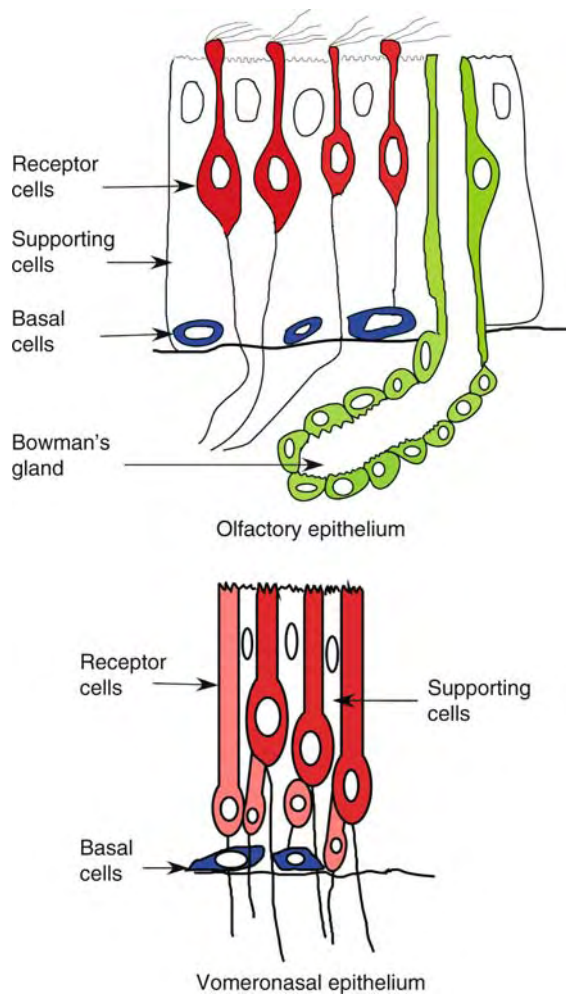

**Evolution of Olfactory and Vomeronasal Systems.**  
**Figure 2** Schematic diagrams showing the cellular organization of the olfactory and vomeronasal epithelia.

cells (Fig. 2). The vomeronasal receptor cells (with a few exceptions) differ from those of the olfactory epithelium in lacking cilia on their dendritic surfaces, which are covered instead with microvilli. The receptor proteins that bind vomeronasal stimuli are presumably located on these microvilli. As in the olfactory epithelium but less frequently, basal cells periodically undergo mitosis and generate new receptor cells to replace receptor cells that are dying or have died. Again as in the olfactory epithelium, the function of supporting cells is unclear [3].

### Evolution of Chemosensory Receptors

Little was known about chemosensory receptors prior to 1991 when a multigene family encoding mammalian olfactory receptors (OR) was identified [6]. This

discovery provided a molecular basis for olfactory recognition and it was awarded the Nobel Prize in 2004. The olfactory receptor family includes about 1,000 genes that encode 7-transmembrane domain G-protein coupled receptors expressed in the membrane of olfactory cilia. Subsequently, two different families of vomeronasal receptors (V1R and V2R) were cloned [3]. These gene families (about 100 genes each) also encoded 7-transmembrane domain G-protein coupled receptors, but are only distantly related to each other and to the olfactory receptor family. The V1R and V2R families are expressed in the microvilli of apically and basally located vomeronasal receptor cells respectively (Fig. 2). They also have different molecular structures indicating that they could recognize different vomeronasal stimuli.

Apart from OR, V1R and V2R, two additional families of mammalian taste receptors (T1R and T2R) have been cloned. All of these five families belong to a superfamily of G-protein coupled chemosensory receptors. A group of V1Rs is distantly related to T2Rs, suggesting that all these genes could have evolved from a common ancestor possessing cells detecting water-soluble substances. In fact, in fishes – where a single chemosensory epithelium exists – two different gene families encoding chemosensory receptors have been found. One is similar to mammalian ORs, whereas the other is similar to mammalian V2Rs [7]. All of these data support the hypothesis that the separate olfactory and vomeronasal epithelia of terrestrial vertebrates arose in evolution by segregation of distinct classes of neurons that were already present in the olfactory epithelium of an aquatic vertebrate precursor [3].

### Signal Transduction in Chemosensory Receptor Cells

Signal transduction refers to a process whereby a physical stimulus (e.g., light, sound, odor, hormone) is transformed into a cellular signal. In chemosensory neurons, signal transduction occurs when chemical stimuli bind to specific cell-surface receptors, which then transmit the information that they have bound the chemical signal to intracellular or membrane-bound proteins that initiate processes that eventually result in membrane voltage changes.

In the cilia of olfactory receptor neurons, odor binding to a G-protein coupled receptor (typically  $G_{olf}$ ) results in activation of the enzyme adenylyl cyclase, which in turn stimulates the production adenosine 3',5'-cyclic monophosphate (cAMP). cAMP targets cyclic nucleotide calcium-permeable channels in the cell membrane resulting in calcium influx into the cell and depolarization of the cell membrane. In addition to this second messenger system, odorant binding to G-protein coupled receptors linked to the enzyme phospholipase C has been reported to increase intracellular concentrations of inositol-1,4,5-trisphosphate

(IP<sub>3</sub>). IP<sub>3</sub> targets IP<sub>3</sub>-gated channels that in turn allow calcium entry into the cell with a consequent depolarization of the cell membrane. This latter mechanism is less common in olfactory system transduction [1,2].

In the microvilli of vomeronasal receptor neurons, stimulus binding to G-protein coupled receptors activates phospholipase C, which in turn stimulates the production of IP<sub>3</sub> and diacylglycerol (DAG). In mammals, current evidence suggests that IP<sub>3</sub> and DAG target IP<sub>3</sub>- and DAG-gated transient receptor protein channels (TRPC2) in the microvillar membrane, resulting in increases in intracellular calcium and membrane depolarization. In snakes, the data indicate that increases in intracellular IP<sub>3</sub> result in both influx of extracellular calcium and release of calcium from intracellular stores, the combined effect of which is to produce membrane depolarization [3].

### Primary Olfactory and Vomeronasal Projections

In contrast to some other sensory systems, olfactory and vomeronasal receptor cells are true neurons that generate action potentials that are transmitted along the entire length of their axons in response to chemical stimuli. Axons group into olfactory and vomeronasal nerves that terminate in the main and accessory olfactory bulbs respectively.

In fishes, extrabulbar projections from the olfactory epithelium to telencephalic and diencephalic targets other than the olfactory bulb have been reported. Ciliated and microvillous receptor cells differentially project to the olfactory bulb. In salamanders, vomeronasal axons run separately along the lateral edge of the olfactory nerve. In frogs, the vomeronasal nerve is located first medial to and then ventral to the olfactory nerve prior to reaching the cranial cavity. In all reptiles, olfactory axons pierce the cribiform plate of the ethmoid bone; in lizards and snakes vomeronasal axons form the vomeronasal nerve, which is located along the nasal septum and also penetrates the cribiform plate. In mammals, both olfactory and vomeronasal axons cross the cribiform plate, the latter occupying a more medial position. Olfactory receptor cells express four different types of olfactory receptors that project specifically to given glomeruli of the main olfactory bulb [8]. Vomeronasal receptor neurons located apically and basally in the epithelium express different vomeronasal receptors (V1R and V2R) and G proteins (G<sub>i2α</sub> and G<sub>oα</sub>) and project to the anterior and posterior portions of the accessory olfactory bulb respectively [3,8].

### Main and Accessory Olfactory Bulbs

The olfactory bulbs are located in the most rostral portion of the brain in most vertebrates, except in some groups such as primates where the frontal cortex has expanded more rostrally and cetaceans in which the bulbs are absent. In amphibians, the accessory olfactory

bulb is located caudo-lateral to the main olfactory bulb, in lizards and snakes it is caudal to the main olfactory bulb and in mammals it is located dorso-caudal to the main olfactory bulb [1,2,9] (Fig. 1).

Relative to brain size, the olfactory bulbs constitute an important portion of the telencephalon of fishes, amphibians and reptiles; they are more reduced in many mammals and comparatively insignificant in birds and primates. The relative size of the main and accessory olfactory bulbs also varies across taxa and species. The accessory olfactory bulb is more than twice as large as the main olfactory bulb in snakes, it varies considerably among lizards and it is smaller than the main olfactory bulb in amphibians. In mammals, the accessory olfactory bulb is in general much smaller than the main olfactory bulb [1,2,3,9] (Fig. 1).

In vertebrates, the main and accessory olfactory bulbs are laminated structures with similar structural features. The most external layer is composed of the axons of receptor neurons, forming the nerve layer. The axons terminate in the adjacent, more internal, glomerular layer. Below the glomerular layer are located, in order from superficial to deep, external plexiform, mitral (or mitral/tufted) cell, internal plexiform and granule cell layers. The neural circuitry of the bulbs involves synaptic terminations of receptor cell axons onto mitral (mitral/tufted) cell dendrites and reciprocal synapses between the dendrites of mitral cells and the dendrites of granule cells. Periglomerular cells and short axon cells are also involved in modulation of this basic pattern. The axons of mitral (mitral/tufted) cells project out of the bulbs to targets in the forebrain [1,2,3].

### Projections from the Main and Accessory Olfactory Bulbs

In vertebrates, axons from mitral cells form a main bundle, the lateral olfactory tract, which reaches olfactory-recipient cortical areas of the telencephalon. In some groups, a comparatively minor medial olfactory tract is present. In tetrapods that have the vomeronasal system, axons from mitral/tufted cells form the accessory olfactory tract that terminates in vomeronasal-recipient structures. Olfactory and vomeronasal-recipient areas of the telencephalon are adjacent structures with minor overlap between them [3,10].

In fishes, the axons of mitral cells form the lateral olfactory tract, which terminates in the ventral telencephalon. In amphibians, the lateral olfactory tract ends in the lateral pallium, whereas the accessory olfactory tract travels to the medial amygdala. In reptiles, the lateral olfactory tract projects to the lateral cortex and olfactory amygdala; additionally in lizards and snakes, the accessory olfactory tract projects to the nucleus sphericus, a conspicuous structure of the vomeronasal amygdala. In mammals, the lateral olfactory tract carries

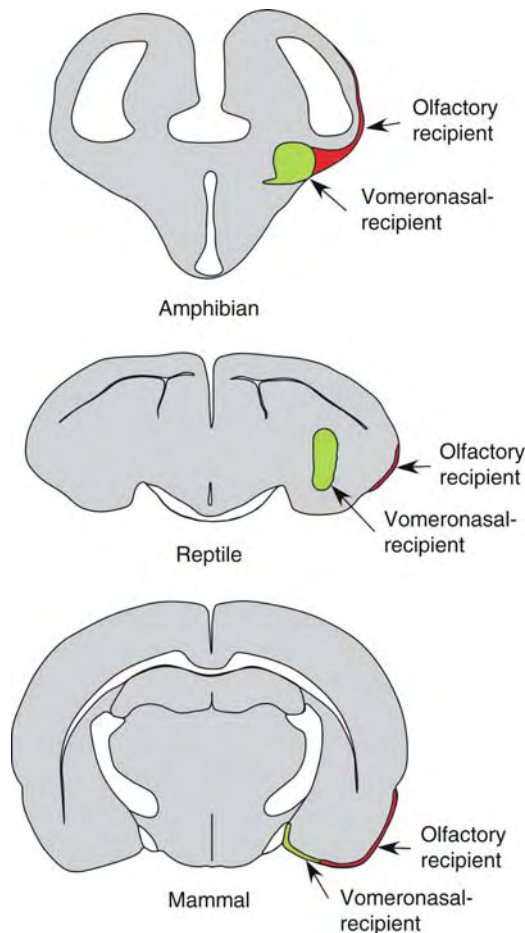

**Evolution of Olfactory and Vomeronasal Systems.**  
**Figure 3** Schematic diagrams showing the olfactory- (red) and vomeronasal-recipient (green) areas of the telencephalon of amphibians, reptiles (lizards and snakes) and mammals.

axons to a number of cortical structures, including the olfactory amygdala, piriform cortex and a portion of the entorhinal cortex. The accessory olfactory tract also ends in vomeronasal cortical structures such as the medial and posteromedial cortical nuclei [1,2,3,9,10] (Fig. 3).

#### Plasticity in the Olfactory and Vomeronasal Systems

The olfactory and vomeronasal systems are plastic mainly at two levels, the epithelium and the bulb. In the olfactory and vomeronasal epithelia, receptor neurons become apoptotic and die periodically. Basal stem cells divide, migrate and mature to become neurons and replace senescent cells. How axons of these new cells reach appropriate glomeruli in the bulb is not fully understood [3,5]. In addition, there is a portion of the telencephalic ventricular wall (anterior subventricular

zone) that generates stem cells that migrate rostrally (rostral migratory stream) to the main and accessory bulbs. There, these cells differentiate into granule and periglomerular cells. What the function of these new cells is or how they are incorporated into the circuitry of the bulbs are matters yet to be resolved [3].

#### Functions of the Olfactory and Vomeronasal Systems

It is critically important for animals to respond to their chemical environments for safety (avoidance of predators or fire), nourishment (identification of life-sustaining nutrients) and reproduction (selection of sexually appropriate mates). Both olfactory and vomeronasal systems participate in these chemically mediated behaviors. In addition, in macrosomatic animals (those with well developed olfactory systems), individual recognition and identification of conspecifics is frequently mediated by the nasal chemical senses [1,3,9].

In general, the behavioral purview of the olfactory system is to identify and respond appropriately to airborne odorants. Potential prey will, upon sensing the odor of a predator, become restless and eventually seek cover. The successful predator remains “down wind” from his prey to avoid detection. Prey without a functional olfactory system will be unable to detect the proximity of a predator and therefore risk capture.

For many animals, odor, as well as taste, dictates the choice of nutrients. In those cases where odor is a major source of information about the location of suitable food, the olfactory system is essential for its identification and localization. In animals where carrion represents the main diet component, the smell of rotting flesh is the cue to its presence; conversely, the same odor may result in the avoidance of the same food by animals for whom consumption of rotting meat is a health risk. In humans, the odor of food serves as a motivational stimulus, both positive and negative. Whereas in most animals identification and consumption of foods is associated with gustatory and olfactory functions, in snakes (and perhaps lizards) identification of prey and their consumption is primarily a vomeronasal function [3,9].

Reproductive behavior is a complex set of responses to multiple external and internal signals, only some of which are mediated by the nasal chemical senses. Chemical signals secreted or excreted by one animal and responded to by another animal of the same species are usually termed “pheromones.” Over the years it has been common to associate pheromonal communication with the vomeronasal system, since pheromone molecules are typically large complex molecules or small volatiles bound to larger molecules such as proteins. Interestingly, detection of the pheromones that subserv individual recognition, at least in hamsters, appears to depend on a functional olfactory system and not a

functional vomeronasal system. Many, but not all, of the chemical signals that signal reproductive state are mediated by the vomeronasal system. Thus, the nipple-search pheromone used by nursing rabbit pups to attach to the maternal nipple is detected by the olfactory system. Similarly, response of female pigs to androstenone, a pheromone in boar saliva, is detected by the olfactory and not by the vomeronasal system. Rodent pheromones that mediate induction of estrus, male-induced acceleration of puberty and strange male-induced implantation failure among others, all depend on a functional vomeronasal system. The female snake sex pheromone to which males respond with avid courtship is also detected by the vomeronasal organ. It is therefore important to remember that although the vomeronasal system detects and responds to many pheromones, it is a misnomer to consider it as the only pheromone detecting system [1,3,9].

### Origins of the Olfactory and Vomeronasal Systems

Attraction (food sources) or repulsion (toxins) by chemical substances (chemotropisms) is one of the oldest and more conserved behaviors present in all groups of animals – even in bacteria. Among vertebrates, the olfactory system is present in all groups and the vomeronasal system in some tetrapods.

The olfactory epithelium of some fishes contains ciliated as well as microvillar receptor cells. These latter cells could be evolutionary precursors of vomeronasal receptor neurons. They express G-proteins and receptor genes similar to mammalian vomeronasal receptor genes. These microvillar cells tend to group separately from the ciliated ones and project differentially to the bulb. This evidence suggests that the aquatic ancestor of tetrapods possessed both cell populations and that thereafter they segregated into separate olfactory and vomeronasal epithelia and distinct chambers. This idea is supported by the observation that the vomeronasal system is well developed in fully aquatic amphibians and also by the fact that the vomeronasal organ of terrestrial vertebrates is fluid-filled and responds to non-volatile odors, frequently in a liquid state. This thesis argues against the idea of the vomeronasal system as an adaptation to terrestrial life. The presence of the olfactory system in most vertebrates and the vomeronasal system in most tetrapods suggest that these systems were lost during the past history of some groups or species that no longer possess olfactory and/or vomeronasal systems [4].

### References

1. Finger TE, Silver WL, Restrepo D (2000) The neurobiology of taste and smell, 2nd edn. Wiley-Liss, New York
2. Doty RL (2003) Handbook of olfaction and gestation, 2nd edn. Marcel Dekker, New York

3. Halpern M, Martinez-Marcos A (2003) Structure and function of the vomeronasal system: an update. *Prog Neurobiol* 70:245–318
4. Eisthen HL (1997) Evolution of vertebrate olfactory systems. *Brain Behav Evol* 50:222–233
5. Farbman AI (1992) Cell biology of olfaction. Cambridge University Press, New York
6. Buck L, Axel R (1991) A novel multigene family may encode odorant receptors: a molecular basis for odor recognition. *Cell* 65:175–187
7. Mombaerts P (1999) Molecular biology of odorant receptors in vertebrates. *Annu Rev Neurosci* 22:487–509
8. Mori K, von Campenhouse H, Yoshihara Y (2000) Zonal organization of the mammalian main and accessory olfactory system. *Philos Trans R Soc Lond B Biol Sci* 355:1801–1812
9. Halpern M (1992) Nasal chemical senses in reptiles: structure and function. In: Gans C, Crews D (eds) *Hormones, brain and behavior. Biology of the Reptilia*. 18. University of Chicago Press, Chicago, p. 423–523
10. Moreno N, Gonzalez A (2006) The common organization of the amygdaloid complex in tetrapods: new concepts based on developmental, hodological and neurochemical data in anuran amphibians. *Prog Neurobiol* 78:61–90

## Evolution of Parabigeminal Nuclei

- Evolution of Nucleus Isthmi

## Evolution of Reticospinal Motor Systems

- Evolution of Motor Systems: Corticospinal, Reticulospinal, Rubrospinal and Vestibulospinal Systems

## Evolution of Rubrospinal Motor Systems

- Evolution of Motor Systems: Corticospinal, Reticulospinal, Rubrospinal and Vestibulospinal Systems

## Evolution of Septal Nuclei

ENRIQUE LANUZA<sup>1</sup>,

FERNANDO MARTÍNEZ-GARCÍA<sup>2</sup>

<sup>1</sup>Depts of Biología Cel·lular i Parasitologia, Facultat de Ciències Biològiques, Universitat de València, Burjassot, Spain

<sup>2</sup>Biología Funcional i Antropología Física, Facultat de Ciències Biològiques, Universitat de València, Burjassot, Spain

### Synonyms

Septal nuclei; Septum; Septal region; Septal complex

### Definition

The septal nuclei constitute a subcortical (i.e. subpallial) telencephalic structure that lies at the base of a dorsally extending wall (“septum”) in the midline that separates the lateral ventricles of the two cerebral hemispheres and is known as the septum pellucidum or septum lucidum (Figs. 1–3). The latter structure is mostly composed of glial cells. The septal nuclei are an evolutionarily well-conserved part of the limbic system, present in all vertebrate groups. Among their most conserved features are a massive excitatory input from the hippocampus and major interconnections with the hypothalamus.

### Characteristics

Septal nuclei or their homologues may be present in all or most vertebrates. A septal region or septal nuclei have been identified in ray-finned and cartilaginous fishes and tentatively in hagfishes. However, little information is yet available on the details of the connections and neurochemistry of these nuclei in fishes, so this essay focuses mainly on the septal nuclei in tetrapods.

### The Septal Nuclei in Tetrapod Vertebrates

The septal region has long been thought to be a subcortical structure of the limbic system deeply interconnected with the hippocampus and the hypothalamus. However, recent data on the expression of homeotic genes during development indicate that, in both mammals and non-mammalian tetrapods, pallial, striatal and pallidal divisions can be distinguished within the septal complex [1], with the striatal and pallidal divisions being the major structures of the septal region. In fact, Swanson and Risold (see [2]) consider that the septal region constitutes the medial division of the striato-pallidal complex in the cerebral hemispheres.

### Pallial, Striatal and Pallidal Territories in the Septal Region

The identity of the pallial division of the septum is currently a matter of debate. During some embryonic developmental stages, a small dorsally located area of the medial wall of the cerebral hemispheres shows expression of pallial genetic markers such as *pax-6*, *tbr-1* and *emx-1* (at least in mice and chicks [1]). In the adult however, these markers are no longer expressed and the pallio-subpallial boundary has no obvious landmark within the septal region (Figs. 1–3). Therefore the location and extent of the pallial septum is still an open issue.

The striatal division is characterized by a strong expression of the striatal marker *Dlx-2* [1,3]. It corresponds to what is usually named lateral septal complex (Figs. 1a–c, 2a–c, 3a–c), with the possible exception of its dorsal most part, which may be a pallial derivative. In all tetrapod vertebrates the lateral septal complex receives a dense and topographically organized zinc-enriched excitatory input (Figs. 1d–e, 3d) from the hippocampal formation, gives rise to topographical projections to the pallidal septum and has extensive bidirectional connections with the hypothalamus (Fig. 3i).

The pallidal division corresponds to the complex formed by the medial septum (called in reptiles the nucleus of the medial forebrain bundle) and the diagonal band. It is characterized by the expression of *Nkx 2.1* [1], receives a substantial topographically organized input from the several nuclei of the lateral septal complex and gives rise to a projection back to the hippocampal formation that partially arises from cholinergic cells (Figs. 1f, 2f, g, 3e). Therefore, the main circuitry of the septo-hippocampal complex includes a pallio-striato-pallido-pallial loop, with glutamatergic pallio-striatal projections, GABAergic striato-pallidal projections and cholinergic pallido-pallial projections [4].

### Neurochemistry and Hodology of the Septal Divisions

The patterns of gene expression during embryonic development, together with recent data on neurochemistry and ►hodology in the adult allow detailed comparisons of subdivisions of the septal complex among rodents [5], birds [6,7,8], reptiles [9,10,11] and amphibians [12,13,14] (see Table 1 and Figs. 1–3). In teleost fishes, the septal nuclei are considered to be represented by the ventral nucleus of the ventral telencephalon, but subdivisions similar to those present in the tetrapod septum have not been recognized [15].

As discussed above, the lateral septal complex is a well-conserved structure that has been described in the four classes of tetrapod vertebrates. It consists of two major groups of nuclei, the lateral septum and the posterior septum (Figs. 1–3; [5]; Table 1), the latter being a set of cell groups apparently associated with the



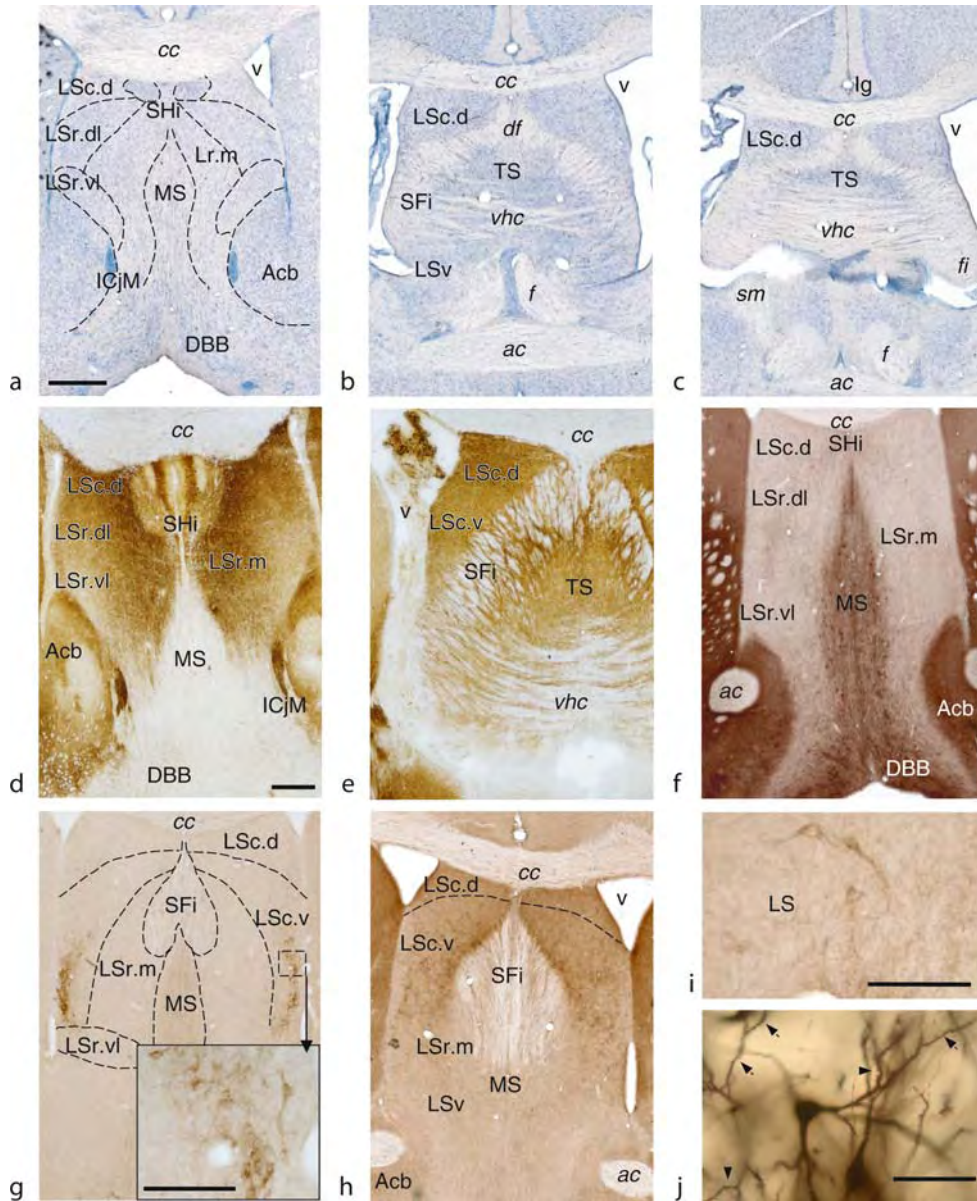

**Evolution of Septal Nuclei. Figure 1** The septal region in rodents. (a–c) Nissl-stained transverse sections of the mouse brain through the rostral, commissural and postcommissural levels of the septum illustrating the cytoarchitectonic complexity of this structure. (d–e) Timm staining in the rat septum showing the zinc-enriched terminal field of the hippocampal projection to the lateral septum at rostral (d) and caudal (e) levels. Note the remarkable lack of staining in the medial septum-diagonal band complex. (f) The histochemical detection of acetylcholinesterase activity in the mouse rostral septum reveals that the medial septum and the diagonal band are cholinergic structures and are enriched in cholinesterase-positive cells. In contrast, the lateral septum lacks cholinergic cells and is nearly devoid of cholinesterase activity. (g) Immunohistochemical detection of CGRP in a rostral level of the lateral septum of the mouse. A high magnification view of the pericellular nests is shown in the inset. (h) Immunohistochemical detection of tyrosine hydroxylase in a caudal level of the lateral septum of the mouse. (i) High magnification photomicrograph of the tyrosine hydroxylase-immunopositive pericellular nests in the mouse lateral septum. (j) High magnification photomicrograph of a Golgi-stained spiny stellate cell of the lateral septum of a rat in which the numerous dendritic spines (arrowheads) can be observed. Calibration bar in a: 400  $\mu$ m, valid for b, c, f, g, h. Calibration bar in d: 500  $\mu$ m, valid for e. Calibration bars in g (*inset*) and i: 100  $\mu$ m. Calibration bar in j: 50  $\mu$ m. (d, f courtesy of Jeús Perez-Clausell, Universitat de Barcelona). Abbreviations: *ac* anterior commissure; *Acb* nucleus accumbens; *cc* corpus callosum; *DBB* nucleus of the diagonal band of Broca; *df* dorsal fornix; *f* fornix;

hippocampal (pallial) commissure and the fornix (the main hippocampofugal tract). In mammals, the lateral septum is characterized by a massive and topographically organized glutamatergic afferent from the hippocampal formation (Ammon's horn and subiculum) that is enriched in zinc (Fig. 1d, e). In addition, it receives ascending projections from peptidergic (Fig. 1g) and monoaminergic (Fig. 1h, i) cell groups in the hypothalamus (mainly from mammillary levels), tegmentum and brainstem, as well as from the midline thalamus. Whereas the hippocampal input gives rise to synapses on dendritic spines of the septal cells, the ascending afferents from the hypothalamus and brainstem display terminal axonal arborizations that form nests around septal cell bodies and proximal dendritic shafts ([5]; see Fig. 1g–i). This kind of afferent innervation includes a vasopressinergic projection that mainly arises from the amygdala and parts of the bed nucleus of the stria terminalis and that terminates in a specific region of the lateral septal complex [16]. This amygdalo-septal projection is sexually dimorphic and sensitive to sexual steroids. Other afferents, either identified with specific markers or by means of anterograde tracing techniques, also show a great specificity for distinct regions of the lateral septum.

The main efferent projections of the mammalian lateral septum innervate the medial septal complex and the hypothalamus and ventral midbrain. These projections arise from spiny stellate cells (Fig. 1j) that use GABA as a neurotransmitter. Therefore, the principal cell of the striatal septum is an inhibitory medium-sized spiny neuron, following the same pattern of organization found in other striatal regions [4,5].

The pattern of afferent and efferent connections of the mammalian lateral septum described above is similar to the one observed in amphibians [12,14], reptiles (Fig. 3; [10,11]) and birds (Fig. 2; [6,8,17]). As can be observed in Figs. 2 and 3, the lateral septum of non-mammalian amniotes also receives a zinc-enriched glutamatergic afferent input (Fig. 3d) from the hippocampal formation and ascending projections that terminate in pericellular nests arising from peptidergic (e.g. CGRPergic, Figs. 2d, 3f) and monoaminergic (e.g. dopaminergic, Figs. 2e, 3g) cell groups located in the hypothalamus, tegmentum and brainstem. These anatomical data suggest that the lateral septum has undergone a conservative evolution and therefore, it very likely plays a key role in the control of the physiology and behavior across tetrapods (see below).

Based on chemoarchitectonic information, Goodson et al. [7] have suggested that the dorsal zone of the caudal part of the lateral septum of birds and mammals (Figs. 1a–c, 2a–c) are comparable structures that apparently correspond to the pallial septum. However, the neurochemical properties of topographically equivalent structures in the septum of reptiles (Sdl, Fig. 3a–c; [9]) and amphibians (Sld, [13]) only partially coincide with those of mammals and birds. Therefore, further evidence is needed to confirm or discard the pallial origin of these structures.

In contrast to the lateral septum, the connections of the nuclei that compose the posterior septum are poorly studied. In the four classes of tetrapods, its main output reaches the epithalamus (amphibians [12], reptiles [11], birds [8], mammals [5]). The main afferents of the posterior septum have been studied in amphibians [14] and reptiles [10]. In these animals it receives non-topographical afferents from the hippocampal (medio-dorsal) cortex. At least in reptiles this projection is poor in zinc [9]. In addition, like the lateral septum, the posterior septum seems to receive ascending thalamic and hypothalamic inputs.

The pallidal division of the septal region, the medial septal complex, has not been studied as extensively as the lateral septal complex (at least in non-mammalian vertebrates). It is composed of the medial septal nucleus (or nucleus of the medial forebrain bundle in reptiles) and the diagonal band in the four classes of tetrapod vertebrates. One of its defining features is the presence of cholinergic cells (Figs. 1d, 2f–g, 3f) projecting to the hippocampal cortex. Although present in all the studied vertebrates, the size of this cell population shows a substantial variability even within a single class (see [7] and references therein). Another significant characteristic of the pallidal septum is an important population of GABAergic cells that gives rise to ascending projections to the hippocampal formation (and other pallial areas) as well as to descending projections to the hypothalamus and brainstem [5]. In addition, the medial septum-diagonal band complex is innervated by a dense plexus of substance P-positive fibers (Figs. 2h, 3h). As can be observed in Figs. 2 and 3, the pallidal septum in birds and reptiles is not in a medial position, but it is located ventral to the lateral septum, adjacent to the diagonal band mainly at rostral (precommissural) levels. Regarding its afferents, the massive projections of the medial septal complex to the

*fi* fimbria; *lcjM* major island of Calleja; *lg* indusium griseum; *LS* lateral septal nucleus; *LSc* caudal part of *LS*; *LSc.d* dorsal zone of *LSc*; *LSc.v* ventral zone of *LSc*; *LSr* rostral part of *LS*; *LSr.dl* dorsolateral zone of *LSr*; *LSr.m* medial zone of *LSr*; *LSr.vl* ventrolateral zone of *LSr*; *LSv* ventral part of *LS*; *lv* lateral ventricle; *MS* medial septal nucleus; *SFi* septofimbrial nucleus; *SHi* septohippocampal nucleus; *sm* stria medullaris; *TS* triangular septal nucleus; *vhc* ventral hippocampal commissure.

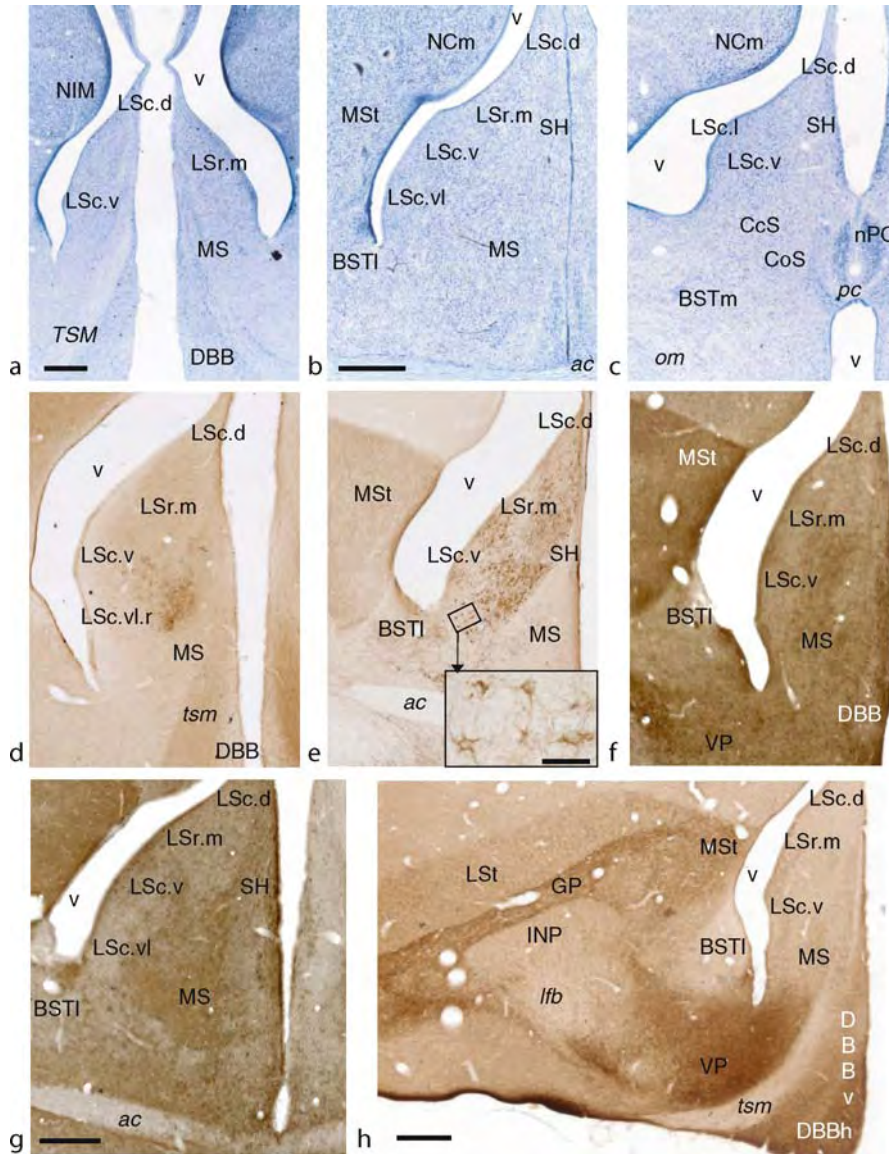

**Evolution of Septal Nuclei. Figure 2** The septal region of birds. (a–c) Nissl-stained transverse sections through the rostral, commissural and postcommissural levels of the septum of a chick brain showing the main cytoarchitectonic divisions of this structure. (d) Immunohistochemical detection of CGRP in a rostral level of the lateral septum of the chick. (e) Immunohistochemical detection of tyrosine hydroxylase in a caudal level of the lateral septum of an adult quail. The *inset* shows a high magnification photomicrograph of the tyrosine hydroxylase-immunopositive pericellular nests. (f–g) Histochemical detection of acetyl cholinesterase activity in the chick septum at rostral (f) and commissural (g) levels showing the enriched cholinergic structures in the medial septum-diagonal band complex. (h) Low-magnification photomicrograph of a rostral section through the septal region of a chick brain, immunolabelled for substance P. Note the rich plexus of positive fibers in the pallidal structures, such as the globus pallidus, the ventral pallidum and the diagonal band of Broca. The medial septum is only slightly immunoreactive. Calibration bars in a, b (valid also for c–f, g, h): 500  $\mu$ m. Calibration bar in e (*inset*): 50  $\mu$ m. Abbreviations: *ac* anterior commissure; *BSTl* lateral bed nucleus of the stria terminalis; *BSTm* medial bed nucleus of the stria terminalis; *CcS* caudocentral septum; *CoS* commissural septal nucleus; *DBB* nucleus of the diagonal band of Broca; *DBBh* horizontal limb of the *DBB*; *DBBv* vertical limb of the *DBB*; *LS* lateral septal nucleus; *GP* globus pallidus; *INP* intrapeduncular nucleus; *lfb* lateral forebrain bundle; *LSc* caudal part of *LS*; *LSc.d* dorsal zone of *LSc*; *LSc.l* lateral zone of *LSc*; *LSc.v* ventral zone of *LSc*; *LSc.vl* ventrolateral zone of *LSc*; *LSc.vl.r* rostral region of *LSc.vl*; *LSr.m* rostral part of *LS*; *LSr.m* medial zone of *LSr*; *LSt* lateral striatum; *MS* medial septal nucleus; *MSt* medial striatum; *NCm* caudal medial nidopallium; *NIM* intermediate medial nidopallium; *nPC* nucleus of the pallial commissure; *om* occipitomesencephalic tract; *pc* pallial commissure; *SH* septohippocampal nucleus; *tsm* septomesencephalic tract; *v* lateral ventricle; *VP* ventral pallidum.

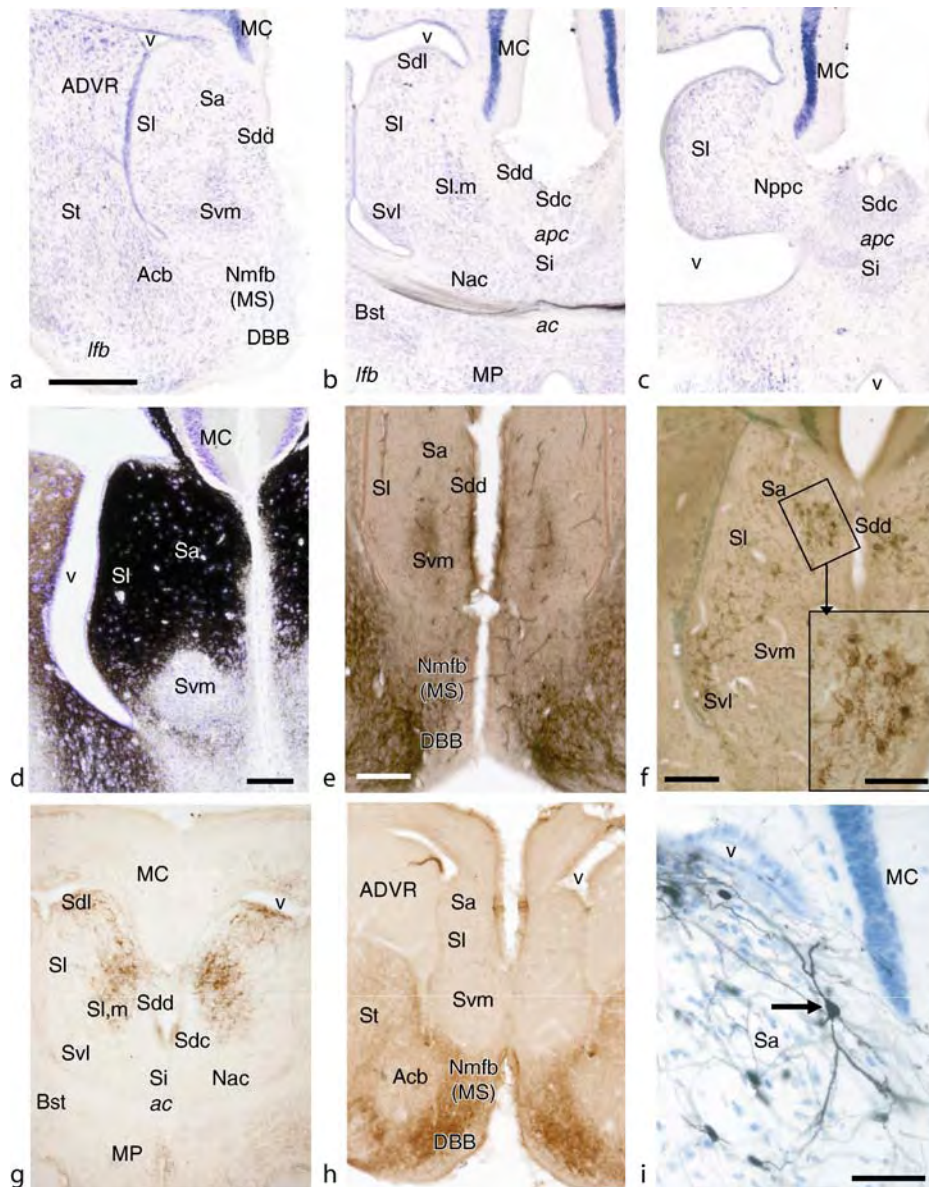

**Evolution of Septal Nuclei. Figure 3** The septal region of the lizard *Podarcis hispanica*. (a–c) Nissl stained transverse sections through the rostral, commissural and postcommissural levels of the septum illustrating the cytoarchitectonic compartmentalization of this structure. The anterior commissure in (b) shows axons stained in a tracing experiment. (d) Timm staining showing the zinc-enriched terminal field of the hippocampal projection to the lateral septum. Nissl counterstaining. (e) The histochemical detection of acetyl cholinesterase activity reveals the difference between the lateral (striatal) septum, which is devoid of labelling with the exception of the neuropile of the ventromedial septal nucleus and the medial (pallidal) septal divisions, which are densely stained and include a population of cholinergic cells. (f) Immunohistochemical detection of CGRP in a rostral level of the lateral septum. The section is very lightly counterstained with the Nissl technique. *Inset*: High magnification photomicrograph of the CGRP-immunopositive pericellular nests. (g) Immunohistochemical detection of tyrosine hydroxylase in a caudal level of the lateral septum. (h) The immunohistochemical detection of substance P corroborates the difference between the lateral (striatal) and the medial (pallidal) septal divisions, confirming that the medial septum corresponds to the area usually called nucleus of the medial forebrain bundle. (i) High magnification photomicrograph of a septo-hypothalamic projection neuron (*arrow*) of the lateral septum retrogradely labelled in a tracing experiment. Note the multipolar morphology and the numerous dendritic spines of this cell type. Nissl counterstaining. Calibration bars in a (valid also for b, c): 250  $\mu$ m. Calibration bars in d and f: 100  $\mu$ m. Calibration bar in f (*inset*): 50  $\mu$ m. Calibration bar in e (valid also for g and h): 200  $\mu$ m. Calibration bar in i: 50  $\mu$ m. (d, courtesy of Jesús Perez-Clausell,

**Evolution of Septal Nuclei. Table 1** Detailed comparison of the different septal nuclei among the four classes of tetrapodian vertebrates based on the neurochemistry and some particular connections (see text for details)

Major divisions	Amphibians	Reptiles	Birds	Mammals
Lateral Septum	Sd (rostral)	Sa	LS, rostral part, dorsolateral zone	LS, rostral part, dorsolateral zone
	Sc	SI (including SI.m)	LS, rostral part, medial zone	LS, rostral part, medial zone
			LS, caudal part, ventrolateral zone, rostral region	LS, rostral part, ventrolateral zone
	Sld	Sdl	LS, caudal part, dorsal zone	LS, caudal part, dorsal zone
		Svl	LS, caudal part, ventral zone	LS, caudal part, ventral zone
Slv	Svm	LS, caudal part, ventrolateral zone, caudal region	LS, ventral part	
Posterior Septum	caudal Sd/Sm; BN	Sd	nPC/caudocentral septum	Septofimbrial and triangular nuclei
		Si		
		Nppc		
Medial Septal Complex	Sm	Nmfb	MS	MS
	DBB	DBB	DBB	DBB

Abbreviations Amphibians: *BN* bed nucleus of the pallial commissure; *DBB* diagonal band nucleus; *Sd* dorsal septal nucleus; *Sld* dorsolateral septal nucleus; *Slv* ventrolateral septal nucleus; *Sm* medial septal nucleus; Reptiles: *DBB* diagonal band nucleus; *Nmfb* nucleus of the medial forebrain bundle; *Nppc* nucleus of the posterior pallial commissure; *Sa* anterior septal nucleus; *Sd* dorsal septal nucleus; *Sdl* dorsolateral septal nucleus; *Si* nucleus septalis impar; *SI* lateral septal nucleus; *SI.m* medial nucleus of the lateral septum; *Svl* ventrolateral septal nucleus; *Svm* ventromedial septal nucleus; Birds and Mammals: *DBB* diagonal band nucleus; *LS* lateral septal nucleus; *MS* medial septal nucleus; *nPC* nucleus of the pallial commissure.

posterior hypothalamus and the brainstem are bi-directional. Moreover, the medial septal complex is also characterized by a topographical projection from the lateral septum [5].

### Evolution of the Septal Function

The analysis of the connectivity and chemical neuroanatomy of the septal region described above reveals that it is composed of three major divisions (lateral, medial and posterior septum) that can be recognized in the four classes of tetrapod vertebrates, where they show remarkable similarities. It is therefore reasonable to suggest that the function of the septal region should also be conserved and consequently the septum is probably implicated in neural mechanisms that are essential for the survival and reproduction of the animals. It is not known, however, whether the three

major divisions of the septum are involved in a unitary function. From the anatomical point of view, the lateral and medial septal divisions are strongly interconnected (Fig. 4; [5]), and therefore it is likely that the structures are functionally interdependent. In contrast, the posterior septum is only moderately interconnected with the rest of the septal regions. Although earlier studies based on lesion data suggested that the posterior septum played a role in water intake, it seems that this function is actually carried out by the subfornical organ [11], which is located next to the posterior septum. In fact, the role of the posterior septum in water balance appears inconsistent with its main differential feature, the efferent projection to the habenula, a structure that has been recently shown to be functionally related to the hippocampus and the nucleus accumbens in mediating higher cognitive functions [18].

Universitat de Barcelona). Abbreviations: *ac* anterior commissure; *apc* anterior pallial commissure; *Acb* nucleus accumbens; *ADVR* anterior dorsal ventricular ridge; *Bst* bed nucleus of the stria terminalis; *DBB* nucleus of the diagonal band of Broca; *lfb* lateral forebrain bundle; *MC* medial cortex; *MP* medial preoptic hypothalamus; *MS* medial septal nucleus; *Nac* nucleus of the anterior commissure; *Nppc* nucleus of the posterior pallial commissure; *Sa* anterior septal nucleus; *Sd* dorsal septal nucleus; *Sdc* central part of *Sdc*; *Sd* dorsal part of *Sd*; *Sdl* dorsolateral septal nucleus; *Si* nucleus septalis impar; *SI* lateral septal nucleus; *SI.m* medial nucleus of the lateral septum; *Svl* ventrolateral septal nucleus; *Svm* ventromedial septal nucleus; *St* striatum; *v* lateral ventricle.

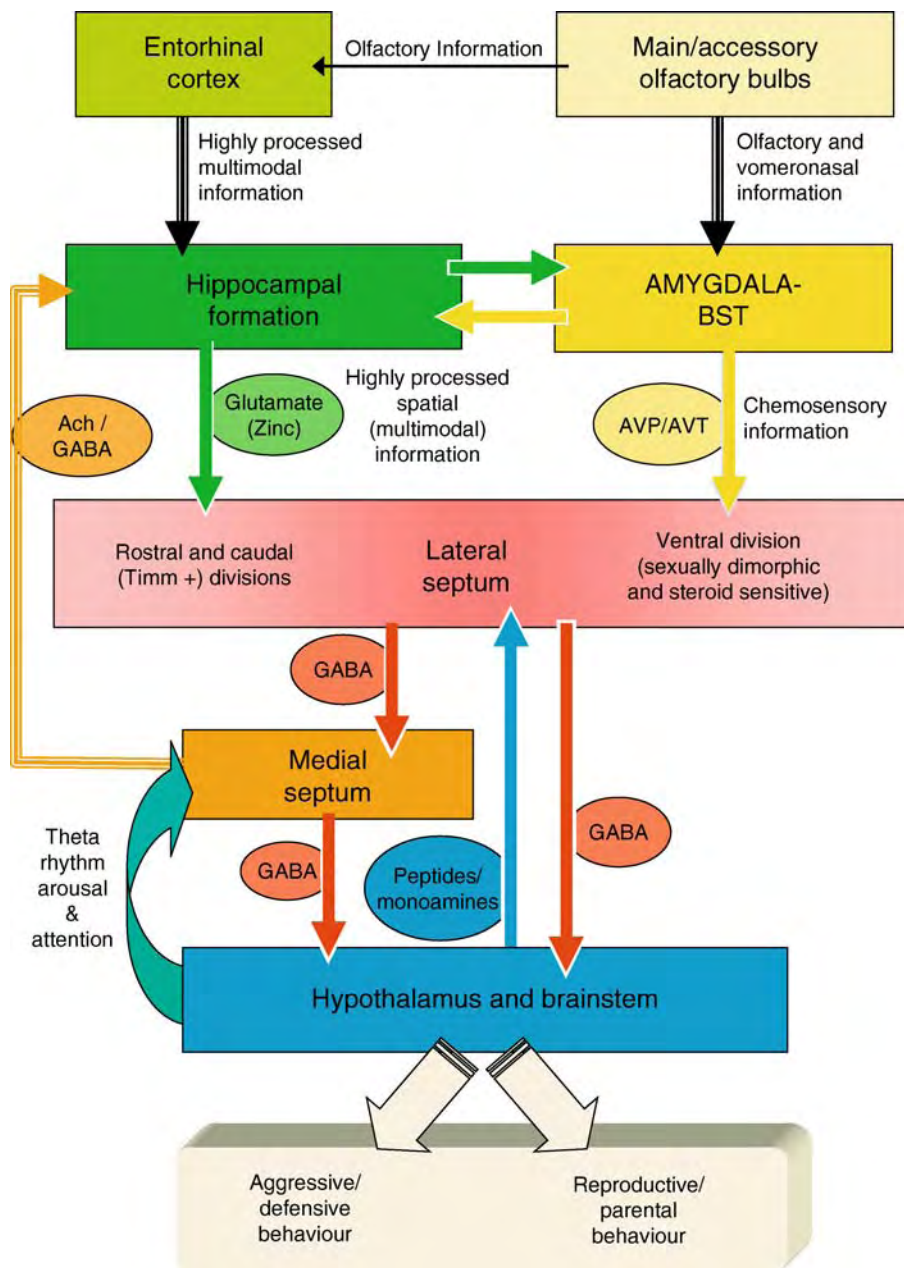

**Evolution of Septal Nuclei. Figure 4** Diagram of the functional neuroanatomy of the septal complex, which includes the neurochemical properties of those connections that are more relevant for both functional and comparative purposes. Abbreviations: *Ach* acetylcholine; *AVP/AVT* vasopressin/vasotocin.

#### **Functional Organization of the Lateral Septum and the Medial Septal Complex**

Data derived from lesion studies and pharmacological manipulations have demonstrated that the lateral septum is involved in social memory, parental behavior, intraspecific aggression, dominant-subordinate relationships and territoriality (see [2]). Therefore, the

lateral septum is usually considered a key node of the ►social behavior network [19,20] and its main connections can be interpreted in this context.

The efferent projections of the lateral septum (directly and indirectly through the medial septal complex) target the social behavior network in the hypothalamus and brainstem, which control both reproductive and

defensive/▶agonistic behaviors [21] (Fig. 4). The reproductive network includes the medial preoptic nucleus and parts of the ventromedial tuberal hypothalamus, together with the ventral premammillary and tubermammillary nuclei. On the other hand, the defensive network includes the anterior hypothalamus, parts of the ventromedial hypothalamus, the dorsal premammillary nucleus and periaqueductal grey. Additional projections to the midline thalamus and reticular formation might subservise attentional processes common to both kinds of social behaviors.

The main afferent input to the lateral septum, which arises from the hippocampal formation (Fig. 4), provides contextual information (including spatial and non-spatial cues). Therefore, the lateral and medial septal divisions should play a key role in initiating the appropriate reproductive/defensive/aggressive behavior as a function of the contextual situation of the animal [11,20], thus constituting a pivotal center for ▶territorial motivation. A crucial aspect of the context is the animal's location in its territory or in a competitor's territory. In fact, the behavioral response of an animal to a conspecific may vary from aggressive (when the animal is located within its own territory) to defensive/submissive (when it is located outside its territory). In rodents, and in many other territorial species where chemical signals are used for territorial marking, olfactory and vomeronasal information relayed to the septum might reveal the presence of competitors and give information on its sexual identity and social status. There are two possible neural pathways. On the one hand, the hippocampus receives its main input from the entorhinal cortex, which in turn is directly targeted by the efferent projections from the main olfactory bulbs (Fig. 4). On the other hand, the ventral part of the lateral septum receives a direct projection from the amygdala and the bed nucleus of the stria terminalis that probably conveys both olfactory and vomeronasal information (Fig. 4). Therefore it is reasonable that the lateral septum be involved in social recognition and social memory (see [2]). In conclusion, the great variety of behaviors elicited by electrical stimulation of the lateral septum, as well as the inconsistent effects that lesioning this structure has in behavioral tests in the laboratory, may be explained by the role of the lateral septum as distributor of behaviors as a function of variables such as territoriality and social context, which are difficult to control in the laboratory.

Although the medial septum has not been implicated in social behavior, it is deeply interconnected and thus functionally interdependent with the lateral septum and hippocampus (Fig. 4). In fact, in mammals the medial septum is known to function as a pacemaker that synchronizes the neural activity of hippocampal (and entorhinal) cells by means of its GABAergic and

cholinergic projections (see [2]), giving rise to the generation of the theta rhythm. Although the function of the theta rhythm is not clear, it is expressed during exploratory behavior and voluntary motor activity (as well as REM sleep) and the activity of place cells is in phase with the theta rhythm [22]. This suggests a role of the medial septum in sensory processing by the hippocampus that would, in turn, have a strong influence on the hippocampo-septal pathways controlling the social behavior network. In this respect, the functional interdependence of the medial and lateral septal divisions is further indicated by the important projections from the caudal aspect of the lateral septum onto the supramammillary nucleus [5], which is the main interface between the brainstem reticular formation and the medial septum. Therefore, the influence of the lateral septum on the activity of medial septal cells (both by direct projections and indirect modulation through the supramammillary nucleus) provides anatomical evidence of a joint role of the medial and lateral septum on attentional processes related to acquisition of spatial memory during exploration of the territory. Consequently, it is not surprising that lesions of the medial complex in mammals result in complex deficits in behavioral paradigms requiring attention and memory [2,5]. In conclusion, the septum is a key node in the social behavior network that initiates the appropriate reproductive/defensive/aggressive responses as a function of the territorial motivation.

### Acknowledgements

This work has been funded by the Spanish Ministry of Education and Science-FEDER (BFU2004-04272), the Valencian Government (Conselleria d'Empresa, Universitat i Ciència, ACOMP06/258) and the Junta de Comunidades de Castilla-La Mancha (PAC-05-007-2).

### References

1. Puelles L, Kuwana E, Puelles E, Bulfone A, Shimamura K, Keleher J, Smiga S, Rubenstein JL (2000) Pallial and subpallial derivatives in the embryonic chick and mouse telencephalon, traced by the expression of the genes *Dlx-2*, *Emx-1*, *Nkx-2.1*, *Pax-6*, and *Tbr-1*. *J Comp Neurol* 424:409-438
2. Numan R (ed) (2000) *The behavioral neuroscience of the septal region*. Springer-Verlag, New York, NY
3. Brox A, Puelles L, Ferreiro B, Medina L (2003) Expression of the genes *GAD67* and *Distal-less-4* in the forebrain of *Xenopus laevis* confirms a common pattern in tetrapods. *J Comp Neurol* 461:370-393
4. Lanuza E, Novejarque A, Moncho-Bogani J, Hernandez A, Martinez-Garcia F (2002) Understanding the basic circuitry of the cerebral hemispheres: the case of lizards and its implications in the evolution of the telencephalon. *Brain Res Bull* 57:471-473

5. Risold PY (2004) The septal region. In: Paxinos G (ed) The rat nervous system, 3rd edn. Elsevier, San Diego, CA, pp 605–632
6. Atoji Y, Wild JM (2004) Fiber connections of the hippocampal formation and septum and subdivisions of the hippocampal formation in the pigeon as revealed by tract tracing and kainic acid lesions. *J Comp Neurol* 475:426–461
7. Goodson JL, Evans AK, Lindberg L (2004) Chemoarchitectonic subdivisions of the songbird septum and a comparative overview of septum chemical anatomy in jawed vertebrates. *J Comp Neurol* 473:293–314
8. Montagnese CM, Szekely AD, Adam A, Csillag A (2004) Efferent connections of septal nuclei of the domestic chick (*Gallus domesticus*): An anterograde pathway tracing study with a bearing on functional circuits. *J Comp Neurol* 469:437–456
9. Font C, Hoogland PV, Vermeulen-Van Der Zee E, Pérez-Clausell J, Martínez-García F (1995) The septal complex of the telencephalon of the lizard *Podarcis hispanica*: I. Chemoarchitectonical organization. *J Comp Neurol* 359:117–130
10. Font C, Martínez-Marcos A, Lanuza E, Hoogland PV, Martínez-García F (1997) Septal complex of the telencephalon of the lizard *Podarcis hispanica*: II. Afferent connections. *J Comp Neurol* 383:489–511
11. Font C, Lanuza E, Martínez-Marcos A, Hoogland PV, Martínez-García F (1998) Septal complex of the telencephalon of lizards: III. Efferent connections and general discussion. *J Comp Neurol* 401:525–548
12. Endepols H, Roden K, Walkowiak W (2005) Hodological characterization of the septum in anuran amphibians. II. Efferent connections. *J Comp Neurol* 483:437–457
13. Endepols H, Mühlenbrock-Lenter S, Roth G, Walkowiak W (2006) The septal complex of the fire-bellied toad *Bombina orientalis*: chemoarchitecture. *J Chem Neuroanat* 31:59–76
14. Roden K, Endepols H, Walkowiak W (2005) Hodological characterization of the septum in anuran amphibians. I. Afferent connections. *J Comp Neurol* 483:415–436
15. Rink E, Wullmann MF (2004) Connections of the ventral telencephalon (subpallium) in the zebrafish (*Danio rerio*). *Brain Res* 1011:206–220
16. De Vries GJ, Panzica GC (2006) Sexual differentiation of central vasopressin and vasotocin systems in vertebrates: different mechanisms, similar endpoints. *Neuroscience* 138:947–955
17. Krayniak PF, Siegel A (1978) Efferent connections of the septal area in the pigeon. *Brain Behav Evol* 15:389–404
18. Lecourtier L, Deschaux O, Arnaud C, Chessel A, Kelly PH, Garcia R (2006) Habenula lesions alter synaptic plasticity within the fimbria-accumbens pathway in the rat. *Neuroscience* (in press)
19. Newman SW (1999) The medial extended amygdala in male reproductive behavior. A node in the mammalian social behavior network. *Ann N Y Acad Sci* 877:242–257
20. Goodson JL (2005) The vertebrate social behavior network: Evolutionary themes and variations. *Horm Behav* 48:11–22
21. Swanson LW (2000) Cerebral hemisphere regulation of motivated behavior. *Brain Res.* 886:113–164
22. Hasselmo ME (2005) What is the function of hippocampal theta rhythm? Linking behavioral data to phasic properties of field potential and unit recording data. *Hippocampus* 15:936–949

## Evolution of Subpallial Cholinergic Cell Groups

ALICE SCHADE POWERS

Department of Psychology, St. John's University,  
Jamaica, NY, USA

### Synonyms

Nucleus basalis; diagonal band; medial septum; Ch1; Ch2; Ch3; Ch4

### Definition

Cells that make *acetylcholine* and are located primarily in the basal forebrain.

### Characteristics

Cells that make *acetylcholine* have been found in the basal forebrain throughout tetrapod phylogeny. In cyclostomes and fishes, cholinergic cell groups have also been identified, but the equivalence of those cell groups to the cell groups found in tetrapods is not always clear. These issues are reviewed below.

Cholinergic cells can be identified by immunohistochemistry using an antibody against *choline acetyltransferase* (ChAT). The alternative method of identifying cells that contain *acetylcholinesterase* (AChE) is not accurate because AChE is known to be located in non-cholinergic cells as well as cholinergic ones [e.g., 1]. The studies to be reviewed below all used ChAT immunohistochemistry to identify cholinergic cells.

### Mammals

In placental mammals, three broad groups of cholinergic cells can be recognized in the basal forebrain, the *medial septum*, the *diagonal band of Broca* and the *nucleus basalis of Meynert*, which lies within the *substantia innominata* and is called the *nucleus basalis magnocellularis* in many nonprimate species. These cells, which have also been called Ch1 (*medial septum*), Ch2 and Ch3 (vertical and horizontal limb of the *diagonal band of Broca*) and Ch4 (*nucleus basalis of Meynert*), form a continuous band from rostromedial to caudolateral in the basal forebrain [1]. Cholinergic interneurons are also found in the dorsal striatum or caudate-putamen of mammals, but these cells will not be treated in detail here because they are considered to be components of the basal ganglia. In addition to this group of nuclei, cholinergic cells are seen in the nucleus accumbens and olfactory tubercle. In some mammalian species, cholinergic cells can also be identified in the *lateral septum* [2], medial nucleus of the amygdala and bed nucleus of the stria terminalis, but these are not consistently seen.

The cells in the *medial septum* project to the hippocampus. Cells in the diagonal band project to



the hippocampus, hypothalamus, olfactory bulb and cortex. Cells in the nucleus basalis project to the cerebral cortex and amygdala [1].

In a study of the monotremes platypus (*Ornithorhynchus anatinus*) and echidna (*Tachyglossus aculeatus*) [3], cholinergic cells were described in the nucleus basalis and ventral pallidum and in the *medial septum*, but not in the diagonal band. Cholinergic cells were also found in nucleus accumbens. A few cells were described in the amygdala, but the area in which they were located was not clear.

### Fishes

In cyclostomes, few cholinergic cells are found in the forebrain. A few cells have been seen in the area thought to be the striatum of *Petromyzon marinus*, the sea lamprey [4], but none in *Lampetra fluviatilis*, the river lamprey [4].

Similarly, in the dogfish *Scyliorhinus canicula*, a member of the class Chondrichthyes or cartilaginous fishes, no cholinergic cells were found in the basal forebrain [5]. In this species, however, a large number of small cholinergic cells were found in the superficial dorsal pallium [5]. This finding of *acetylcholine* cells in the pallium is rare among vertebrates and, because no other species of Chondrichthyes has been studied, whether it is characteristic of this class or unique to the dogfish is unknown.

In the class Osteichthyes, or bony fishes, representatives of two superorders within the subclass actinopterygians, Acipenseriformes and Teleostii, have been studied. Like the dogfish, the sturgeon ► *Acipenser baeri*, a member of the Acipenseriformes, does not have cholinergic cells in the telencephalon [6]. The first consistent evidence of cholinergic cells in the basal forebrain appears in the teleosts [7]. The fish that have been studied are the midshipman ► *Porichthys notatus* [8], two species of trout (*Oncorhynchus mykiss* and *Salmo trutta fario*) [9], the cyprinids *Danio rerio* and *Tinca tinca* [10,11] and the European minnow *Phoxinus phoxinus* [12]. The cholinergic cells found in the telencephalons of these fish are located in different subdivisions. *Phoxinus* has small ChAT-positive neurons in the area ventralis lateralis (VI) and nowhere else in the telencephalon [12]. This area may be equivalent to the olfactory tubercle [12,13,14]. Cholinergic cells in VI were also found in two species of trout [9]. Although they reported no ChAT-positive cells in the telencephalon in one study of the cyprinid *Danio rerio* [10], Clemente et al. [11] later found cholinergic cells in the “lateralmost area of the central nucleus within the ventral telencephalic area” in both *Danio rerio* and *Tinca tinca*. This region again appears to be VI. In contrast, Brantley and Bass [8] described cholinergic neurons in the ventral zone of area ventralis (Vv) in the teleost fish *Porichthys notatus*, the midshipman. The

Vv has been thought to be equivalent to the septal area or perhaps to a broader basal forebrain region of tetrapods, including the septum, nucleus accumbens and the *nucleus basalis magnocellularis* [13]. Brantley and Bass [8] saw no cholinergic cells in the lateral zone of the area ventralis (VI), where cholinergic cells have been found in other teleost species. Thus, the basal forebrain of teleost fish clearly contains cholinergic cells, but these cells are not always found in the same location, and their homologues in tetrapods are not clear.

### Amphibians

In amphibians, a consistent pattern similar to that seen in mammals can be discerned. Representatives of all three orders of amphibians have been studied, anurans (the frogs *Rana perezi* and *Xenopus laevis* [15,16] and the fire-bellied toad *Bombina orientalis* [17]), pleurodires (the Iberian ribbed newt *Pleurodeles waltl* [16]), and gymnophionans (the Mexican caecilian *Dermophis mexicanus* [18]). In all three orders, cholinergic cells are found in the basal forebrain, but some differences have been found. In anurans, cholinergic cells are found in the *medial septum* but not the *lateral septum* (a few cells were reported in the rostral *lateral septum* of *Rana perezi* [15]). No ChAT-positive cells were found in the septum of the single urodele that has been studied and in the only gymnophionan, such cells were seen in the lateral but not the *medial septum*. Anurans have been shown to have cells in the *diagonal band of Broca*, but these cells were not seen in either the urodele or the gymnophionan species. In the ventral pallidum however, all three groups have cholinergic cells. These cells have been variously identified as being in the lateral amygdala or medial amygdala, but Sanchez-Camacho et al. [16], using the newer nomenclature of Marin et al. [15], found ChAT-positive cells in the ventral pallidum and medial amygdala of *Rana*. In urodeles, cells are found in the same region, which is probably equivalent to the ventral pallidum and medial amygdala, but the terminology has not been revised for this group. Similarly, in the gymnophionan *Dermophis*, cells are seen in the basal forebrain and in a region called the amygdala, pars lateralis, but the true equivalence of the latter to areas in other groups is not known.

### Reptiles

In reptiles, studies have been done on the cholinergic cells in the forebrain of the turtles *Chrysemys picta* and *Pseudemys scripta* [19], the lizards *Gallotia galloti* [20] and *Gekko gekko* [21] and the crocodilian *Caiman crocodilus* [22]. All show cholinergic cells in the basal forebrain, in the characteristic mammalian pattern of cells extending from the septum to the diagonal band to the ventral pallidum. Turtles and caiman have cholinergic cells in all three subdivisions; the lizards *Gallotia galloti* and *Gekko gekko* were reported not to have

cholinergic cells in the *medial septum*, but the medial wall of the hemisphere in *Gallotia galloti* did contain cholinergic cells. Cholinergic cells were seen in the nucleus accumbens in all reptiles. Some cells were also seen in the bed nucleus of the stria terminalis in the lizard *Gallotia* and in the amygdala in turtles.

### Birds

A similar pattern is seen in birds. Studies have been done of the pigeon *Columba livia* [23] and budgerigar *Melopsittacus undulatus* [24,25] and of the septal area of songbirds [26]. All birds studied have cholinergic cells in the ventral pallidum, which was recently renamed the *nucleus basalis magnocellularis*, and the diagonal band. The *medial septum* in the budgerigar *Melopsittacus undulatus* is reported not to contain cholinergic cells, but the *medial septum* of pigeons and songbirds does contain such cells. The nucleus taeniae, thought to be the homologue of the medial amygdala, contains cholinergic cells in pigeons [Reiner A, 2006, personal communication] and parrots. The bed nucleus of the stria terminalis in pigeons and the nucleus accumbens in both pigeons and parrots have also been reported to contain cholinergic cells.

In addition, the cholinergic system has been studied in the song control nuclei of zebra finches [27,28,29] and budgerigars [24]. Cholinergic perikarya are found in area X of zebra finches and the equivalent magnocellular nucleus of the medial striatum (MStm—formerly LPOm) of budgerigars. No other song-control nucleus contains somata labeled by ChAT-immunohistochemistry. Other song control nuclei in both groups, the higher vocal center (HVC) of zebra finches and the equivalent NLC (central nucleus of the lateral nidopallium) of budgerigars, are innervated by cholinergic fibers and these projections were shown in the zebra finch to originate in the ventral pallidum [27], as do projections to the robust nucleus of the arcopallium (RA).

### Comparative Aspects Across Vertebrates

Thus cholinergic areas in the basal forebrain are found consistently in amniotes and the forerunners of such cholinergic areas are found in amphibians. Cholinergic cells are found in the basal forebrain of fish, but the exact homologues of these areas with those of amniotes are not clear. Inconsistencies are found among amniote groups only in whether cholinergic cells are found in the *medial septum* (a few groups do not have them), the *lateral septum* (the common pattern is that cholinergic cells are not found, but a few groups have them), and in whether the amygdala, nucleus accumbens and bed nucleus of the stria terminalis contain cholinergic cells.

Semba [3] has suggested that the cholinergic neurons of the basal forebrain may have changed their function over the course of evolution, beginning as part of the olfactory system, but moving caudally in the brain to

supply *acetylcholine* to the pallium (the hippocampus and cerebral cortex in mammals) and to function in learning, memory and attention. Although evidence for their early function in olfaction is weak, the evidence for their function in cognitive tasks is strong in mammals and they have been shown to have this function in at least one group of reptiles, the turtles [30].

### References

1. Mesulam M-M, Mufson EJ, Levey AI, Wainer BH (1983) Cholinergic innervation of cortex by the basal forebrain: cytochemistry and cortical connections of the septal area, diagonal band nuclei, nucleus basalis (substantia innominata), and hypothalamus in the rhesus monkey. *J Comp Neurol* 214:170–197
2. Semba K (2004) Phylogenetic and ontogenetic aspects of the basal forebrain cholinergic neurons and their innervation of the cerebral cortex. *Prog Brain Res* 145:3–43
3. Manger PR, Fahringer HM, Pettigrew JD, Siegel JM (2002) The distribution and morphological characteristics of cholinergic cells in the brain of monotremes as revealed by ChAT immunohistochemistry. *Brain Behav Evol* 60:275–297
4. Pombal MA, Marin O, Gonzalez A (2001) Distribution of choline acetyltransferase-immunoreactive structures in the lamprey brain. *J Comp Neurol* 431:105–126
5. Anadón R, Molist P, Rodríguez-Moldes I, López JM, Quintela I, Cerviño MC, Barja P, González A (2000) Distribution of choline acetyltransferase immunoreactivity in the brain of an elasmobranch, the less spotted dogfish (*Scyliorhinus canicula*). *J Comp Neurol* 420:139–170
6. Adrio F, Anadón R, Rodríguez-Moldes I (2000) Distribution of choline acetyltransferase (ChAT) immunoreactivity in the central nervous system of a chondrosteian, the Siberian sturgeon (*Acipenser baeri*). *J Comp Neurol* 426:602–621
7. Rodríguez-Moldes I, Molist P, Adrio F, Pombal MA, Pérez SE, Yáñez J, Mandado M, Marín O, López JM, González A, Anadón R (2002) Organization of cholinergic systems in the brain of different fish groups: a comparative analysis. *Brain Res Bull* 57:331–334
8. Brantley RK, Bass AH (1988) Cholinergic neurons in the brain of a teleost fish (*Porichthys notatus*) located with a monoclonal antibody to choline acetyltransferase. *J Comp Neurol* 275:87–105
9. Pérez SE, Yáñez J, Marín O, Anadón R, González A, Rodríguez-Moldes I (2000) Distribution of choline acetyltransferase (ChAT) immunoreactivity in the brain of the adult trout and tract-tracing observations on the connections of the nuclei of the isthmus. *J Comp Neurol* 428:450–474
10. Clemente D, Porteros A, Weruaga E, Alonso JR, Arenzana FJ, Aijón J, Arévalo R (2004) Cholinergic elements in the zebrafish central nervous system: histochemical and immunohistochemical analysis. *J Comp Neurol* 474:75–107
11. Clemente D, Arenzana FJ, Sánchez-González R, Porteros A, Aijón J, Arévalo R (2005) Comparative analysis of the distribution of choline acetyltransferase in the central nervous system of cyprinids. *Brain Res Bull* 66:546–549

12. Ekström P (1987) Distribution of choline acetyltransferase-immunoreactive neurons in the brain of a cyprinid teleost (*Phoxinus phoxinus* L.). *J Comp Neurol* 256:494–515
13. Northcutt RG, Davis RE (1983) Telencephalic organization in ray-finned fishes. In: Davis RE, Northcutt RG (eds) *Fish neurobiology*, vol 2. Higher brain areas and functions. University of Michigan Press, Ann Arbor, pp 203–236
14. Reiner A, Northcutt RG (1992) An immunohistochemical study of the telencephalon of the Senegal bichir (*Polypterus senegalus*). *J Comp Neurol* 319:359–386
15. Marin O, Smeets WJAJ, González A (1997) Distribution of choline acetyltransferase immunoreactivity in the brain of anuran (*Rana perezi*, *Xenopus laevis*) and urodele (*Pleurodeles waltl*) amphibians. *J Comp Neurol* 382:499–534
16. Sánchez-Camacho C, López JM, González A (2006) Basal forebrain cholinergic system of the anuran amphibian *Rana perezi*: evidence for a shared organization pattern with amniotes. *J Comp Neurol* 494:961–975
17. Endepols H, Mühlbrock-Lenter S, Roth G, Walkowiak W (2006) The septal complex of the fire-bellied toad *Bombina orientalis*: chemoarchitecture. *J Chem Neuroanat* 31:59–76
18. González A, López JM, Sánchez-Camacho C, Marin O (2002) Localization of choline acetyltransferase (ChAT) immunoreactivity in the brain of a caecilian amphibian, *Dermophis mexicanus* (Amphibia: Gymnophiona). *J Comp Neurol* 448:249–267
19. Powers AS, Reiner A (1993) The distribution of cholinergic neurons in the central nervous system of
20. Medina L, Smeets WJAJ, Hoogland PV, Puelles L (1993) Distribution of choline acetyltransferase immunoreactivity in the brain of the lizard *Gallotia galloti*. *J Comp Neurol* 331:261–285
21. Hoogland PV, Vermeulen-VanderZee E (1990) Distribution of choline acetyltransferase immunoreactivity in the telencephalon of the lizard *Gekko gecko*. *Brain Behav Evol* 36:378–390
22. Brauth SE, Kitt CA, Price DL, Wainer BH (1985) Cholinergic neurons in the telencephalon of the reptile *Caiman crocodilus*. *Neurosci Lett* 58:235–240
23. Medina L, Reiner A (1994) Distribution of choline acetyltransferase immunoreactivity in the pigeon brain. *J Comp Neurol* 342:497–537
24. Cookson KK, Hall WS, Heaton JT, Brauth SE (1996) Distribution of choline acetyltransferase and acetylcholinesterase in vocal control nuclei of the budgerigar (*Melopsittacus undulatus*). *J Comp Neurol* 369:220–235
25. Roberts TF, Hall WS, Brauth SE (2002) Organization of the avian basal forebrain: chemical anatomy in the parrot (*Melopsittacus undulatus*). *J Comp Neurol* 454:383–408
26. Goodson JL, Evans AK, Lindberg L (2004) Chemoarchitectonic subdivisions of the songbird septum and a comparative overview of septum chemical anatomy in jawed vertebrates. *J Comp Neurol* 473:293–314
27. Li R, Sakaguchi H (1997) Cholinergic innervation of the song control nucleus by the ventral paleostriatum in the zebra finch: a double-labeling study with retrograde fluorescent tracers and choline acetyltransferase immunohistochemistry. *Brain Res* 763:239–246
28. Sakaguchi H, Saito N (1991) Developmental change of cholinergic activity in the forebrain of the zebra finch during song learning. *Dev Brain Res* 62:223–228
29. Zuschratter W, Scheich H (1990) Distribution of choline acetyltransferase and acetylcholinesterase in the vocal motor system of zebra finches. *Brain Res* 513:193–201
30. Petrillo M, Ritter CA, Powers AS (1994) A role for acetylcholine in spatial memory in turtles. *Physiol Behav* 56:135–141

## Evolution of Telencephalon: in Amniotes

- ▶ Evolution and Embryological Development, of Forebrain
- ▶ Evolution of the Brain: in Mammals
- ▶ Evolution of the Somatosensory System: in Mammals
- ▶ Evolution of the Visual System: in Mammals—Comparative Aspects across Orders
- ▶ Evolution of the Visual System: in Mammals—Color Vision and Parallel Visual Pathways in Primates
- ▶ Evolution of Auditory System: in Mammals
- ▶ Evolution of Association Pallial Areas: Parietal Association Areas in Mammals
- ▶ Evolution of Septal Nuclei
- ▶ Evolution of Association Pallial Areas: in Reptiles
- ▶ Evolution of Hippocampal Formation
- ▶ Evolution of the Brain: in Reptiles
- ▶ Evolution of the Visual System: in Reptiles and Birds
- ▶ Evolution of Subpallial Cholinergic Cell Groups
- ▶ Evolution of the Auditory System: in Reptiles and Birds
- ▶ Evolution of Amygdala: in Tetrapods
- ▶ Evolution of Association Pallial Areas: in Birds
- ▶ Evolution of the Brain: in Humans—Specializations in the Comparative Perspective
- ▶ Evolution of the Brain: in Humans—Paleoneurology
- ▶ Evolution of the Pallium: in Reptiles and Birds
- ▶ Evolution of the Brain: at the Reptile-bird Transition
- ▶ Evolution of Motor Systems: Vocal and Song Systems of Birds
- ▶ Evolution of Motor Systems: Corticospinal, Reticulospinal, Rubrospinal, and Vestibulospinal Systems
- ▶ Evolution of the Brain: in Birds; Evolution, of the Wulst

## Evolution of Vomeronasal System

- ▶ Evolution of Olfactory and Vomeronasal Systems

## Evolution of the Amygdala: Tetrapods

AGUSTÍN GONZÁLEZ, NEREA MORENO  
Dept. Biología Celular, Fac. Biología, Univ.  
Complutense, Madrid, Spain

### Synonyms

Amygdaloid complex; Extended amygdala; Tetrapods

### Definition

In mammals, the amygdaloid complex is a group of nuclei topographically situated in the ventrolateral caudal telencephalic region. It has four major divisions, two of which are mostly pallial and receive major inputs from the olfactory system, one of which is likewise pallial, receives sensory inputs and is highly interconnected with other pallial areas and the fourth of which is subpallial and closely interconnected with the autonomic nervous system. The amygdala is present across tetrapods, with a variety of shapes, sizes and component parts depending on the tetrapod studied.

### Characteristics

#### Overview of the Amygdala in Tetrapods

The amygdala was first identified by Burdach in the early nineteenth century as an almond shaped mass of gray matter through the temporal pole of the human cerebral hemispheres. Subsequently, with the progressive achievement of new technical approaches, it was observed that the amygdala of diverse mammalian species is a complicated structure consisting of an extended continuum of nuclei and the term “amygdaloid complex” was commonly used. This complex is located within the basal telencephalon and extends rostrally to reach the caudal tip of the shell portion of the nucleus accumbens. Diverse studies have demonstrated that the distinct divisions of the amygdala in all tetrapods (amphibians, reptiles, birds and mammals) show a common histochemical and hodological organization that includes an intricate set of intra-amygdaloid connections and a common embryological origin, supporting the idea of a highly conserved structure in the telencephalon of vertebrates [1,2]. However, there are differences due to specific features in the brain of each vertebrate class, such as is the case for birds, which possess a huge dorsal ventricular ridge of uncertain comparative significance, a poorly developed olfactory system and a virtual lack of the vomeronasal system [3].

Nevertheless, there are several key features of amygdaloid complex organization shared by most of the studied tetrapods. These are (i) its location in the ventrolateral caudal telencephalic hemispheres, (ii) a common embryological origin with components from lateral and ventral pallial territories (the latter organized

into cortical and deep amygdaloid components) and components embryologically derived from the lateral and medial ganglionic eminences of the subpallium (Fig. 1), (iii) strong vomeronasal (with the exception of birds) and olfactory inputs that are mainly relayed to the hypothalamus and autonomic centers, thus defining different functional systems in the amygdaloid complex, vomeronasal, olfactory, autonomic and multimodal, all four strongly related by an intricate intra-amygdaloid network, (iv) the presence of a main output center involved in the autonomic system and therefore influencing the behavioral final response of the animal, (v) the ▶*stria terminalis* as the main fiber tract connecting the amygdaloid complex with basal telencephalic populations and with the hypothalamus, (vi) abundant local circuit neurons within the amygdaloid nuclei, (vii) important and distinct inputs from dorsal thalamic multisensorial areas (Fig. 2) and (viii) a strong peptidergic input from hypothalamic and midbrain centers. Due to its close relation to different sensory systems, the amygdaloid complex changes in distinct vertebrate groups with individual environmental adaptations, e.g. snakes possess a highly developed vomeronasal system and a ▶*vomeronasal amygdala*, strikingly larger than in other reptiles, whereas in birds the absence of a vomeronasal system has reduced this amygdaloid area [4].

#### Description of the Structure

Among tetrapods, the expression pattern of different homeotic genes during development and in the adult supports a new interpretation of the ▶*homology* between different amygdaloid territories [1,5,6] (Fig. 1). The current view of the amygdaloid complex of tetrapods considers pallial and subpallial components based on their distinct ontogenetic origin. Derivatives of the lateral and ventral pallial regions form the “▶*pallial amygdala*,” whereas derivatives of the lateral and medial ganglionic eminences (origin of the striatum and the pallidum, respectively) constitute the “▶*subpallial amygdala*” (Fig. 1). In addition, the amygdala in amniotes is formed by two kinds of pallial structures, (i) the *cortical amygdala* that shows a laminar organization, a superficial position and is dominated by massive inputs from the olfactory bulbs [7] and (ii) those pallial derivatives deep in the cortical amygdala that constitute the *basolateral amygdala*, are in general indirectly related to the olfactory system and constitute an important relay center for the multisensorial thalamic information [4,7]. In contrast, the amphibian pallial amygdala does not possess cortical structures [1] and is formed by the putative homologues of the amniote deep pallial amygdaloid components [2]. However, the subpallial amygdala in all tetrapods is composed of the *centromedial amygdaloid* area, represented by the central nucleus of the amygdala, which is a striatal derivative and the main component of the autonomic amygdaloid subdivision and the *medial*

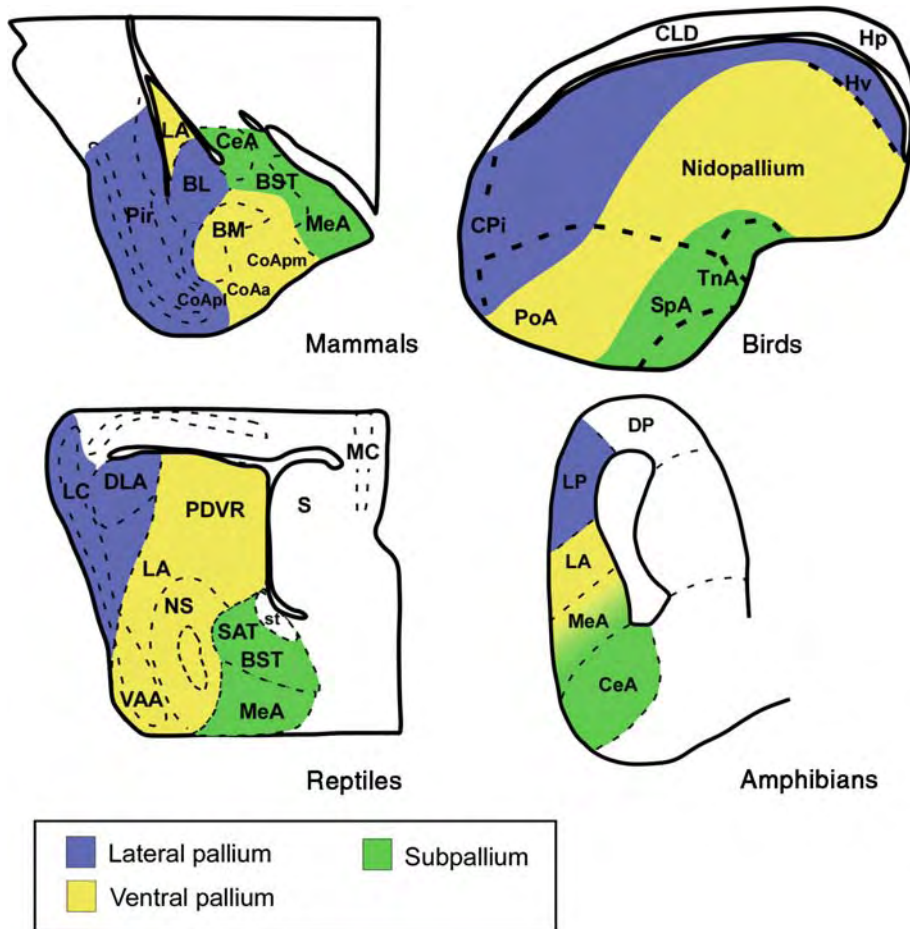

**Evolution of the Amygdala: Tetrapods. Figure 1** Schematic drawings of transverse sections illustrating the localization of amygdaloid structures in relation to their embryological origin in the brain of mammals, birds, reptiles and amphibians. Abbreviations: *Acc*, accumbens; *ADVR*, anterior dorsal ventricular ridge; *AOB*, accessory olfactory bulb; *BL*, basolateral amygdaloid nucleus; *BM*, basomedial amygdaloid nucleus; *BST*, bed nucleus of the stria terminalis; *CeA*, central amygdala; *CoAa*, anterior cortical amygdaloid nucleus; *CoApl*, posterolateral cortical amygdaloid nucleus; *CoApm*, posteromedial cortical amygdaloid nucleus; *DLA*, dorsolateral amygdala; *DP*, dorsal pallium; *Dth*, dorsal thalamus; *ExA*, external amygdala; *LA*, lateral amygdala; *LC*, lateral cortex; *LP*, lateral pallium; *MC*, medial cortex; *MeA*, medial amygdala; *MOB*, main olfactory bulb; *NS*, nucleus sphericus; *PB*, parabrachial nucleus; *PDVR*, posterior dorsal ventricular ridge; *Pir*, piriform cortex; *S*, septum; *SAT*, striatoamygdaloid transition area; *st*, stria terminalis; *Str*, Striatum; *VAA*, ventral anterior amygdala; *VH*, ventral hypothalamus; *VTA*, ventral tegmental area.

*amygdala*, which is an important secondary vomeronasal center [1]. Thus, in general, the amygdala seems to be formed by areas acquired at different moments in evolution, with the subpallial components being the most conserved areas, present in all tetrapods with the same basic features. In contrast, the cortical amygdala seems to be a newly evolved area, originating during the anamniote-amniote transition.

### Evolution of the Tetrapod Amygdala

In amniotes, the different subdivisions of the amygdaloid complex were identified on the basis of their

distinct connectivity, i.e. those with long descending projections, those receiving olfactory information, those that do not receive direct olfactory information but project to the hypothalamus and those receiving ascending thalamic information [4]. Significantly differently in amphibians (anamniotes), a single ventropallial structure receives direct olfactory information and projects massively to the ventral hypothalamus through the *stria terminalis* [1]. It seems that during the transition from water living to earth living animals, the brain of ancestral tetrapods developed an elaborated amygdaloid complex in response to the new requirements.

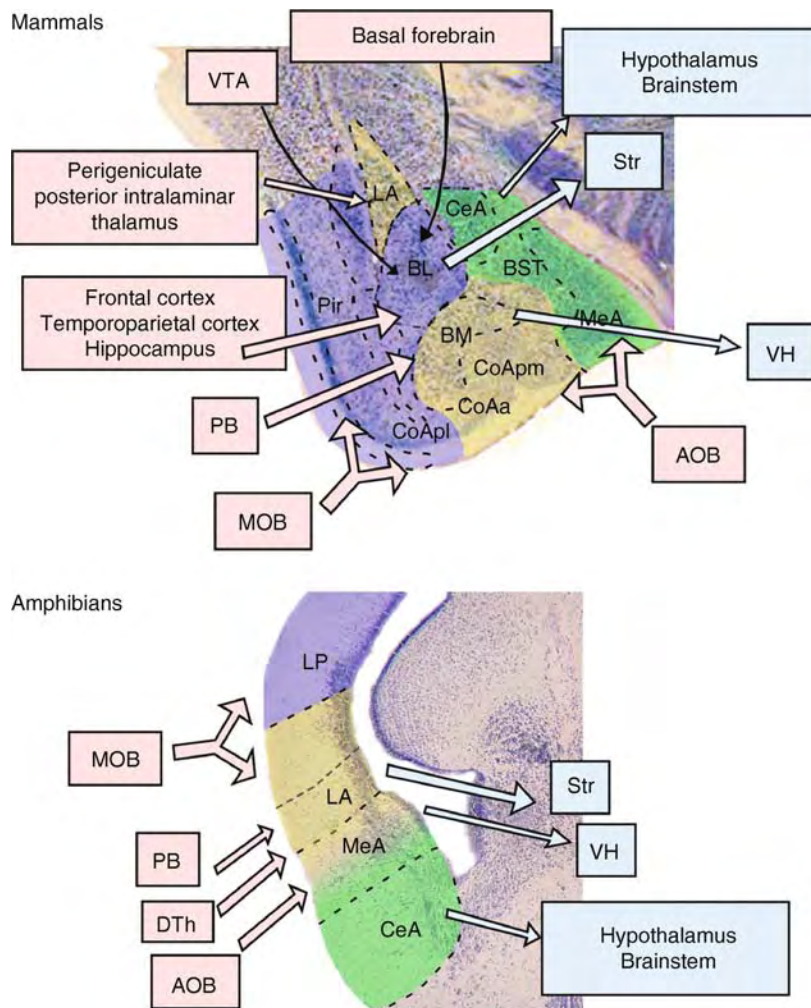

**Evolution of the Amygdala: Tetrapods. Figure 2** Schematic drawings over representative transverse sections of the mouse and anuran telencephalon illustrating the embryological origin of the different amygdaloid nuclei and their main hodological (and thus functional) relationships. For abbreviations see Fig. 1.

The basic organization of this brain system is still recognizable in all extant tetrapods. During the evolution of tetrapods, the pallium was enormously expanded in amniotes and thus the medial, dorsal, lateral and ventral areas dramatically increased in size (Fig. 1). As a consequence of the acquisition of large new superficial areas, the current spatial arrangement of the mammalian amygdaloid complex reflects a re-localization of the central, medial (autonomic, vomeronasal) and basolateral (multisensory) nuclei, which in the ancestral condition could occupy a superficial ventrolateral position in the caudal telencephalon, as is still the condition in living anurans (Figs. 1 and 2). The “new evolutionary nuclei” (cortical regions) could have pushed the “more conserved nuclei” medially, explaining why in mammals the central and medial nuclei occupy the most medial position, followed by the basolateral complex, whereas the cortical amygdaloid nuclei occupy the most

lateral position. Thus, the mammalian amygdala may be composed of evolutionarily old centromedial and basolateral regions and new cortical regions, the latter being missing in the anuran brain. The evolutionarily old brain structures have been conserved through evolution, maintaining a pattern of organization shared by all tetrapods. The developmental, hodological and neurochemical features common to the amygdaloid complex of all tetrapods are those needed to fulfill its multiple vital functions (such as survival and reproduction), which have been conserved over the course of evolution.

#### Higher Level

The ►forebrain, in general, shows a relative diversity among tetrapods, more so than the brainstem or the spinal cord which appear much more conserved. However, indications of the existence of a basic plan, “bauplan,” in the origin, regionalization and organization of the

forebrain in tetrapods are increasing, as for example in the amygdaloid complex and the basal ganglia.

### Function

On the basis of its heterogeneous origin, chemoarchitecture and hodology, the amygdaloid complex represents a number of different, unrelated anatomical structures, with pallial and subpallial derivatives belonging to different functional systems, the olfactory, vomeronasal, autonomic and the frontotemporal cortical systems [7]. The summation of all these systems by means of an intricate intraamygdaloid network allows the multimodal integration that occurs in the amygdaloid complex, which is the basis for the acquisition of “emotional memory.” This has as its final response “emotional behavior,” i.e. responses that occur to promote the survival of individuals and their species as, for instance, in defense against danger, in the interaction with sexual partners or in fighting with an enemy [8]. It allows the association of different stimuli – olfactory/vomeronasal, acoustic, painful, pleasant and so on – that are important in terms of survival and reproduction with the emotions that occur at the same time, thus resulting in an emotional labeling of these stimuli with important somatosensory and autonomic components.

The vomeronasal system, also known as the accessory olfactory system, plays a crucial role in the detection of chemical molecules, i.e. pheromones, and is therefore crucial in co-specific recognition and reproductive processes in most terrestrial vertebrates. This system is present in representatives of amphibians, reptiles and mammals, but is absent in birds. In turn, the olfactory system is present in almost all tetrapods and detects volatile chemical molecules. The olfactory/vomeronasal information passes via the olfactory bulbs to the “olfactory” and “vomeronasal amygdala” [7]. This olfactory/multimodal amygdaloid system consists of distinct cortical and deep amygdaloid areas in amniotes but only the deep portion is present in amphibians [1]. All parts of the vomeronasal amygdala receive direct information via the accessory olfactory bulb (Fig. 2), whereas cortical structures of the ►**olfactory amygdala** receive direct inputs from the olfactory bulb. The deep pallial components receive indirect information through the intricate intra-amygdaloid network [7]. In addition, a variety of sensory inputs reach a major integrative center of the amygdala (mainly from the dorsal thalamic nuclei), which, after integration of these diverse inputs, conveys sensory information to other amygdaloid nuclei for further processing. This system of connections comprises an important component of the multimodal amygdala which is strongly implicated in emotional behavior.

Abundant behavioral studies indicate that the amygdala profoundly influences numerous responses, as well as

the expression of instinctive and conditioned behaviors with motivational and/or emotional components, which could be mediated, at least in part, by projections to the hypothalamus. Given its importance, there have been many studies of the amygdalo-hypothalamic projection and it is of particular interest in an evolutionary perspective since it seems to be extremely conserved across tetrapods [9]. Actually, the major similarities among the amygdala in amniotes are highlighted when analyzing their hypothalamic projections via the *stria terminalis*. The *stria terminalis* (or a homologous amygdalo-hypothalamic fiber tract) is a prominent fiber bundle found in all tetrapods which interconnects the amygdala with the rostromedial forebrain and the hypothalamus. Physiological evidence indicates that the amygdala also influences a variety of visceromotor responses that could be mediated, at least in part, by projections from the amygdala to the lower brainstem. Thus, in all tetrapods a striatal component can be detected which is strongly related to the autonomic system [5]. It constitutes the main output nucleus of the amygdaloid complex, which receives convergent information from several other amygdaloid regions and generates behavioral responses that presumably reflect the sum of neuronal activity produced by different amygdaloid nuclei [10]. Hence it is considered to be the main integrative center in the amygdaloid complex and, due to its connections with autonomic brainstem centers and with forebrain limbic regions (and according to physiological data), it is involved in the modulation of autonomic, somatic and endocrine functions [7]. Furthermore, it has been related to the integration of emotional and motor components of behavior and to the mediation of conditioning oriented responses, behavioral responses to nociceptive and conditioned aversive stimuli and to the visceral and behavioral responses to stressful stimuli.

### References

1. Bruce LL, Neary TJ (1995) The limbic system of tetrapods: a comparative analysis of cortical and amygdalar populations. *Brain Behav Evol* 46:224–234
2. Moreno N, González A (2006) The common organization of the amygdaloid complex in tetrapods: new concepts based on developmental, hodological and neurochemical data in anuran amphibians. *Prog Neurobiol* 78:61–90
3. Reiner A (2005) A new avian brain nomenclature: why, how and what. *Brain Res Bull* 66:317–331
4. Martínez-García F, Martínez-Marcos A, Lanuza E (2002) The pallial amygdala of amniote vertebrates: evolution of the concept, evolution of the structure. *Brain Res Bull* 57:463–469
5. Puelles L, Kuwana E, Puelles E, Bulfone A, Shimamura K, Keleher J, Smiga S, Rubenstein JLR (2000) Pallial and subpallial derivatives in the embryonic chick and mouse telencephalon, traced by the expression of the genes *Dlx-2*,

- Emx-1, Nkx-2.1, Pax-6, and Tbr-1. *J Comp Neurol* 424:409–438
6. Medina L, Legaz I, González G, De Castro F, Rubenstein JLR, Puelles L (2004) Expression of Dbx1, Neurogenin 2, Semaphorin 5A, Cadherin 8, and Emx1 distinguish ventral and lateral pallial histogenetic divisions in the developing mouse claustramygdaloid complex. *J Comp Neurol* 474:504–523
  7. Swanson LW, Petrovich GD (1998) What is the amygdala? *Trends Neurosci* 21:323–331
  8. LeDoux JE (2000) Emotion circuits in the brain. *Annu Rev Neurosci* 23:155–184
  9. Moreno N, González A (2005) Forebrain projections to the hypothalamus are topographically organized in anurans: conservative traits as compared with amniotes. *European J Neurosci* 21:1895–1910
  10. Sah P, Faber ES, Lopez De Armentia M, Power J (2003) The amygdaloid complex: anatomy and physiology. *Physiol Rev* 83:803–834

## Evolution of the Auditory System

SUSANNE J. STERBING-D'ANGELO  
Department of Psychology, Vanderbilt University,  
Nashville, TN, USA

### Definition

Sensory systems are inevitably the adaptive products of natural selection. In some mammalian species certain specializations of the auditory periphery can be correlated with ecological niches. Examples of niches that require special adaptations of the auditory system would be underwater hearing (e.g., whales and dolphins), ►**echolocation** (bats), or orientation in underground environment (e.g., mole rats). In addition to ecologically driven adaptations, physical constraints (e.g., limitations of the size of the tympanic membrane) and ►**phylogenetic** precondition, as well as non-auditory factors like body or head size have to be considered. While the special adaptations to environmental parameters are quite obvious for the auditory periphery, such adaptations are less obvious in the central auditory system. Here, adaptations are manifested in more general parameters like relative volume/size of auditory structures versus overall brain size, relative size of individual auditory nuclei that are specialized for the processing of different sound parameters, or differentiation/number of auditory cortical fields and their connectivity [1].

### Characteristics

The evolution of the auditory system has been traditionally regarded as a gradual process of change from a “primitive” amphibian to the “advanced” mammalian

auditory system driven by the transition from life in water to life on land. In congruence with this idea, auditory brain structures between e.g., sauropsids (reptiles and birds) and mammals were homologized based on location and connections. However, more recent paleozoological research revealed that, e.g., middle ear structures of modern amphibians, sauropsids, and mammals developed independently. Also long-accepted homology between nuclei of the auditory pathway, e.g., the homology between the nucleus laminaris of sauropsids and the mammalian medial superior olive, recently have been questioned because of differences in potassium channel distribution and differences in inhibitory inputs [2]. However, both structures are involved in sound localization, specifically in the coding of interaural time differences, which are the differences in arrival time of sound waves between the two ears for lateralized sound sources. While there are many similarities in the function of ►**auditory brainstem** nuclei of sauropsids and mammals, there are also distinct differences. In contrast to amphibians and sauropsids, most non-aquatic and non-subterranean mammals possess a “pinna.” The pinna, the visible part of the external ear, is typically complex in shape and can be quite mobile. The angle of sound incidence upon the ridges and folds of the pinna causes certain frequencies to be amplified while others are attenuated. Therefore, these pinna cues provide information about the location of sound in space, which distinguishes the localization ability of mammals from nonmammalian vertebrates. Also, adaptations of the middle ear and inner ear anatomy reflect the different environmental pressure imposed on specialized species of mammals. For example, the middle ear cavity is enlarged to a “bulla tympanica” in some small mammals that are specialized for low frequencies (e.g., chinchilla, guinea pig [3]). Another example is the anatomical specialization of the cochlea of bats, which allows the perception of very high frequencies, enabling bats to echolocate, i.e., to actively use the auditory system for obstacle avoidance and prey detection during flight in complete darkness.

To shed light on the questions of the evolution of the mammalian auditory system, it is worthwhile to look at the paleozoological findings [4,5]. About 190 million years ago, during the age of dinosaurs, the first primitive mammals (prototheria) evolved from mammal-like amniotes. The first true mammals were probably represented by the genera *Hadrocodium*, *Repenomamus* and *Gobiconodon*, which filled an intermediate position between the basal mammal *Morganucodon* and the earliest therian (marsupial and placental mammals), such as *Triconodon* [6]. *Triconodon* was about the size of a Virginia opossum. Unfortunately, the fossils cannot provide much information about the function of the auditory system, because soft tissues are not preserved [4]. Fortunately, the primitive mammals still have living



descendants in the monotremes, i.e., the egg-laying duckbilled platypus and the spiny anteater of Australia. Studying the extant monotremes, which are regarded as inhabiting an intermediate position between therapsid amniotes and therian mammals, might therefore provide key insight into the evolution of the auditory system. In many primitive mammals, like the monotremes and some insectivores, the middle ear cavities are not bony, but are in part covered by cartilage and connective tissue. Physiological data are quite sparse and were mostly obtained from the auditory periphery via cochlear microphonic potentials, cochlear **▶distortion product otoacoustic emissions**, or auditory brainstem potentials (ABR) [7,8]. Although some anatomical aspects of the peripheral hearing system in monotremes appear bird-like or reptile-like, e.g., the relatively short, demilunar shape of the cochlea and the **▶columella**-like stapes, the functional properties of the cochlea and the ABR are comparable to those of advanced mammals, albeit with a compressed frequency range. Monotremes also have the mammalian neocortex (see below), although it is not differentiated into as many areas. Furthermore, the corpus callosum, the massive bundle of fibers that connects the two cortical hemispheres in placentals, is absent. At this time, behavioral data on hearing are lacking for monotremes.

About 135 million years ago, marsupials (metatheria) branched off from true placental mammals (eutheria). An extensive comparison of the morphometry of the central auditory system across 53 mammalian species (marsupials and placentals) has been published by Glendenning and Masterton [9]. The smallest species studied was the mole, the largest species the human. While the absolute size of the auditory system varies more than 139-fold among the species, the logarithmic volume of the auditory system is closely correlated to the logarithmic brain weight ( $r = 0.903$ ). However, compared to rather primitive mammals like the marmosa opossum, the kangaroo rat, and bats, humans have the smallest auditory system relative to brain size. A detailed analysis of similarity for the entire ascending auditory pathway resulted in a rank order of species from “least deviant” to “most deviant” to the average auditory system. Surprisingly, species from the same taxonomic group could show up at either end of this spectrum. For example, marsupials: the ring-tail possum has the least deviant auditory system in the tested group of 53 mammals, while the Virginia opossum has one of the ten most deviant. The same holds for the rodents: while the prairie dog has one of the least deviant systems, the mouse has the most deviant of the tested mammals. However, if only a subsystem that is involved in a specific hearing task was compared, the rank orders looked substantially different. One example is the nuclei of the superior olivary complex (SOC), which are involved in sound

localization. The least deviant group of mammals in regards to the SOC comprised mostly marsupials, insectivores, bats and rodents. The most deviant group contained mostly primates and predators. The conclusion of the authors is that the overall form of the subcortical auditory system has been relatively unchanged for 135 million years, while some subsystems might have developed into different directions in adaptation to the ecological niches of each species [10].

So far, only the evolutionary aspects of the auditory periphery and the auditory brainstem nuclei have been discussed. How did the auditory cortex evolve? The origin of the mammalian neocortex, in which the auditory cortex is located, has been discussed controversially. For quite some time part of the neocortex was regarded as a **▶homologue** of the reptilian “dorsal ventricular ridge,” which receives auditory and visual inputs from the thalamus. In contrast, more recent studies suggest that all of the mammalian neocortex evolved from the “dorsal pallium” of reptiles, which is mainly a visual and somatosensory structure. This new insight is supported by molecular and developmental evidence [11]. Consequently, the mammalian neocortex would be a “new” target – in an evolutionary sense – for projections from the auditory thalamus. The evolution of the neocortex is paralleled by a gradual general expansion of the brain. This is evident from fossil skull endocasts (molds) of early mammals, e.g., *Hadrocodium* and *Morganucodon*. The enlargement of the neocortex has also been associated with the evolution of a “modern” middle ear, which makes sound transmission more effective. Whether these two structures dependently coevolved is questionable. While most early mammals with an enlarged neocortex indeed had a fully evolved middle ear, the reverse is not true. Not every mammal with a “modern” middle ear also has an enlarged neocortex. This makes inconclusive the theory that the enlargement of the neocortex was caused chiefly by more demand for sound processing.

In sauropsids, particularly birds, the auditory part of the pallium has subdivisions with complex interconnections for auditory processing (see **▶Evolution, of the Auditory System: in Reptiles and Birds**), as is also the case in most mammals. However, the auditory cortex of placental mammals offers even more neural substrates for processing. An evolutionarily “new” neuronal substrate that placentals have is the presence of additional thalamic inputs that bypass the primary auditory cortex (A1) but target certain secondary cortical areas. In primates for example, the caudo-medial area of the belt region of the auditory cortex is serially activated by the primary auditory cortex. However, it receives additional extralemnisal and possibly also additional **▶lemniscal** projections from parts of the auditory thalamus other than the ventral medial geniculate body (MGv), which is the primary projection to A1. Such additional inputs (e.g., MGd) might indicate

a specialization of this area for the processing of certain sound attributes.

Another evolutionary new layer of neuronal processing would be provided the connection between the cortical hemispheres via the corpus callosum. Monotremes and marsupials lack the corpus callosum. Their interhemispheric connections run through the ventrally located anterior commissure, and hence have to cross over a long distance. However, large-brained marsupials like the kangaroo developed interhemispheric cortical fibers (“fasciculus aberrans”), which descend from the subcortical white matter along the internal capsule and then reach the anterior commissure, thus significantly shortening the traveling distance [12]. Nevertheless, the corpus callosum of the placental mammals allows information to travel much more efficiently between the hemispheres, especially between higher-order cortical areas.

To summarize, the relative contribution of different areas of the auditory cortex has not been studied in enough species to clearly reveal an evolutionary trend of specialization for certain sound parameters. However, all mammalian species studied so far (e.g., carnivores, rodents, bats and primates) have in common that the auditory cortex can be divided into a core region of two or three areas and a belt region with additional areas. This seems to be the basic organization retained from a common ancestor. The number of areas varies remarkably across species. Furthermore their relative location and their connections vary. Finally, different physiological properties, especially in highly specialized bat species [13], make it likely that the complex cortical processing system has developed in a quite independent fashion across mammalian taxa. The evolution of the mammalian auditory system in general seems to be driven by ecological needs independent of taxon and common ancestry.

## References

- Grothe B, Carr CE, Casseday JH, Fritsch B, Köppl C (2004) The evolution of central pathways and their neural processing patterns. In: Manley GA, Popper AN, Fay RR (eds) Evolution of the vertebrate auditory system (Springer handbook of auditory research). Springer, Berlin Heidelberg New York
- Carr CE, Soares D (2002) Evolutionary convergence and shared computational principles in the auditory system. *Brain Behav Evol* 59:294–311
- Webster DB, Plassmann W (1992) Parallel evolution of low-frequency sensitivity in old world and new world desert rodents. In: Webster DB, Fay RR, Popper AN (eds) The evolutionary biology of hearing. Springer, Berlin Heidelberg New York
- Allin EF, Hopson JA (1992) Evolution of the auditory system in synapsida (“mammal-like reptiles” and primitive mammals) as seen in the fossil record. In: Webster DB, Fay RR, Popper AN (eds) The evolutionary biology of hearing. Springer, Berlin Heidelberg New York
- Vater M, Meng J, Fox RC (2004) Hearing organ evolution and Specialization: Early and later mammals. In: Manley GA, Popper AN, Fay RR (eds) Evolution of the vertebrate auditory system (Springer handbook of auditory research). Springer, Berlin Heidelberg New York
- Rowe T (1996) Coevolution of the mammalian middle ear and neocortex. *Science* 273:651–654
- Gates GR, Saunders JC, Bock GR, Aitkin LM, Elliott MA (1974) Peripheral auditory function in platypus, *Ornithorhynchus anatinus*. *J Acoust Soc Am* 56:152–156
- Mills DM, Shepherd RK (2001) Distortion product otoacoustic emission and auditory brainstem responses in the echidna (*Tachyglossus aculeatus*). *J Assoc Res Otolaryngol* 2:130–146
- Glendenning KK, Masterton RB (1998) Comparative morphometry of mammalian central auditory systems: variation in nuclei and form of the ascending system. *Brain Behav Evol* 51:59–89
- Popper AN, Fay RR (1997) Evolution of the ear and hearing: issues and questions. *Brain Behav Evol* 50:213–221
- Aboitiz F, Morales D, Montiel J (2003) The evolutionary origin of the mammalian isocortex: Towards an integrated developmental and functional approach. *Behav Brain Sci* 26:535–586
- Abbie AA (1939) The origin of the corpus callosum and the fate of the structures related to it. *J Comp Neurol* 70:9–44
- Pearson JM, Crocker WD, Fitzpatrick DC (2007) Connections of functional areas in the mustached bat’s auditory cortex with the auditory thalamus. *J Comp Neurol* 500: 401–418

## Evolution of the Auditory System: In Reptiles and Birds

CATHERINE CARR<sup>1</sup>,

JAKOB CHRISTENSEN-DALSGAARD<sup>2</sup>

<sup>1</sup>Department of Biology, University of Maryland, College Park, MD, USA

<sup>2</sup>Institute of Biology, University of Southern Denmark, Odense, Denmark

### Definition

The anatomical organization of the central auditory system is similar across the Reptilia (turtles, lizards, snakes, crocodiles and birds) and physiological studies reveal similar responses to sound. Tonotopic organization, emergence of binaural comparisons, feature detection, convergence of sensory modalities and descending modulation all characterize the reptilian auditory system and are probably ancestral properties. The central auditory systems of both modern reptiles and mammals show

examples of parallel solutions to similar problems of neural coding.

### Characteristics

Whereas the animals traditionally identified as “reptiles” form a paraphyletic or invalid group, Reptilia is a valid clade that includes the snakes and lizards (Lepidosauria), turtles (Testudines), crocodiles (Crocodylia) and birds (Aves) and their most recent ancestors [1]. In Reptilia, the birds, crocodiles and the extinct dinosaurs belong to the group Archosauria and the turtles are a sister group to the archosaurs [2]. The modern consensus is that birds descend from theropod dinosaurs and Aves is therefore a subgroup within Dinosauria. Most extant archosaurs are vocal and birds have provided a major model for studies of complex sound processing and vocal communication. Sensitive, well-developed ears are, however, also found in non-vocal reptilians such as the lizards.

Tympanic ears appear to have evolved independently at least five times in the lines leading to mammals, lepidosaurs, archosaurs, probably turtles and amphibians [3]. The ancestral, atympanic ear would have responded to sound, but the evolution of the tympanic ear increased the sensitivity and high-frequency response of the ears to airborne sound [4]. The emergence of this increased sensitivity to airborne sound would have influenced the organization of ascending auditory information in the central nervous system. The central auditory system is organized similarly in all vertebrates, presumably because it evolved from an ancestral sensory system sensitive to vibration or gravistatic stimuli.

### Auditory Endorgans

Reptilians usually have an external ear and tympanum and one middle ear bone, the columella, which connects the tympanum and the oval window. The eardrums are connected through the interaural canal or mouth cavity and thus can act as pressure gradient receivers. The strongest acoustical coupling of the eardrums is found in lizards and probably reflects the condition of the ancestral tympanic ear [4,5]. Acoustical coupling allows sounds from each ear to interact at the tympanum and leads to the strongly directional responses of the lizard eardrum [5,6]. Since binaural interaction is already found at the tympanum, every neuron of the auditory system, including the auditory nerve, is binaural. The reduced acoustical coupling found in some birds and all mammals is the result of increasing isolation of the middle ear. Middle ear isolation appears to be a derived feature and profoundly changes the operation of the system. Since the ears are now independent and non-directional, direction must be computed by the central auditory system based on binaural cues generated by neural interaction.

The reptilian ear has a new feature, the elongate basilar membrane. The stereotypical papilla of modern

amniotes appears to have begun with the stem amniotes [7]. The papilla is a strip of membrane populated by tonotopically-organized hair cells. Salient features in papilla evolution include lengthening and curvature of the sensory epithelia; features thought to both enhance sensitivity and extend the audible frequency range. Lizards also display a varied and unique population of freestanding hair cells not associated with a tectorial membrane. These freestanding hair cells are thought to be an adaptation that enables lizards to respond to higher frequencies. The low-frequency population of hair cells in lizards is generally similar to that of other amniotes and is probably ancestral [7].

Variation in hair cell type characterize both mammals and archosaurs. The avian and crocodylian basilar membranes do not contain the two types of hair cells found in mammals but instead have hair cells that change continuously in length from short to tall across the papilla. Tall hair cells on the neural edge receive the major afferent innervation [7]. Birds hear higher frequencies than turtles, snakes and lizards [8]. Most birds hear up to 5–6 kHz, while the barn owl has exceptional high frequency hearing, with characteristic frequencies of 9–10 kHz in the auditory nerve, probably as a consequence of specialization for localization of high-frequency sound.

### Central Auditory Pathway Overview

In Reptilia, the auditory nerve enters the brain and divides into two to project to a column of first order auditory nuclei. These projections are tonotopically organized and mediate the emergence of coding for different aspects of the auditory stimulus, such as sound timing and level in birds [9]. The ascending branch of the nerve largely terminates in the nucleus angularis and the descending branch in the nucleus magnocellularis. The nucleus magnocellularis projects to the nucleus laminaris, which in turn projects to the superior olive, to the lemniscal nuclei and to the central nucleus of the auditory midbrain, termed the torus semicircularis or the inferior colliculus. The nucleus angularis projects to the superior olive, to the lemniscal nuclei and to the central nucleus of the auditory midbrain. Thus, the first order nucleus projections contribute to two ascending streams, one binaural combining information from the two ears and the other monaural. The binaural stream is formed when projections from the ipsi- and contralateral nuclei converge on second-order nucleus laminaris that project in parallel with the monaural nuclei to the midbrain. The auditory midbrain receives ascending inputs from both monaural and binaural hindbrain nuclei and physiological studies have revealed the emergence of complex response properties there. The midbrain projects to the thalamus, which in turn projects to auditory structures in the telencephalon. The organization of the telencephalon is structurally and

functionally diverse. In all vertebrate clades, the telencephalon exhibits large changes associated with the increased use of sound for communication. In addition to these ascending pathways, the central auditory system is characterized by multiple descending projections.

### Anatomical Components and Their Physiological Responses in the Central Auditory System

Tonotopic organization is a key feature of the reptilian central auditory system, probably reflecting the tonotopic organization of the auditory papillae. Each point on the basilar membrane projects to an iso-frequency plane across the extent of the first order auditory nuclei. Thus, the cochlear place representation is expanded into a second dimension in the brain, unlike the visual and somatosensory systems, which are point-to-point.

The first order auditory nuclei process parallel ascending streams of auditory information, which will be described starting from the primary auditory nuclei (reviews in [9,10]). In archosaurs, the nucleus magnocellularis is the origin of a neural pathway that processes timing information, while a parallel pathway for processing sound level information originates with the nucleus angularis. Auditory responses in the nucleus angularis in the barn owl include primary-like, onset, chopper and complex type IV responses. Recordings in the chicken cochlear nuclei have found a similar but less clear segregation of function. The similarities between the owl and the chicken suggest that the functional separation of time and level coding is a common feature of the avian auditory system. The anatomical divisions into angular and magnocellular nuclei characterize turtles, lizards and archosaurs [9]. In lizards as in the anurans, the available data suggest that time and level information is not processed in separate streams, maybe due to the strong, but frequency-dependent directional input generated by the acoustically coupled ears [6].

The auditory system uses phase-locked spikes (firing at a certain phase of the stimulus) to encode the temporal parameters of sound. All vertebrate auditory nerve fibers phase-lock to low-frequency stimuli, but the upper frequency limit of phase locking varies from approximately 1–2 kHz in lizards to 9 kHz in the barn owl. The preservation of the phase-locking information in the CNS mediates accurate detection of temporal information. The specialized endbulb terminal in the nucleus magnocellularis, termed an endbulb of Held, has been documented in mammals, birds and lizards and conveys the phase-locked discharge of the auditory nerve fibers to its postsynaptic targets in the nucleus magnocellularis [11]. AMPA-type glutamate receptors contribute to the rapid response of the postsynaptic cell by virtue of their rapid desensitization kinetics [12,11]. In birds, the nucleus magnocellularis projects to the nucleus laminaris, where sensitivity to interaural time differences (ITDs) emerges.

ITD is the principal cue for auditory azimuth representation in birds. There are two stages to ITD computation. It begins with binaural interactions in the nucleus laminaris. There, neurons generate interaural phase difference (IPD) selectivity by coincidence detection between binaural excitatory inputs and encode IPD in a place map according to the Jeffress model [13]. IPDs are an ambiguous coding of ITD, since ITDs that vary by integer multiples of cycle time have identical IPDs. The second stage of ITD computation occurs in the inferior colliculus, where across-frequency integration filters phase-ambiguous side peaks, forming neurons that respond mainly to the true ITD [14]. ITD computations are modulated inhibitory feedback via the superior olive. Both the nucleus laminaris and the nucleus angularis project to the superior olive, the lemniscal nuclei and the inferior colliculus. The superior olive projects to the inferior colliculus and also provides inhibitory GABAergic feedback to the nucleus magnocellularis, the nucleus laminaris, and the nucleus angularis. This olivary input appears to provide tonic inhibition, in contrast to the inhibitory projections of the mammalian MSO that provide phase locked inhibition [13]. The GABAergic input in birds appears to maintain the coincidence detector in the optimal range of operation.

The interaural level difference pathway begins with the nucleus angularis, whose neurons respond to changing sound level over about a 30 dB range. The nucleus angularis sends an excitatory projection to the contralateral dorsal lemniscal nucleus, which also receives an inhibitory projection from the opposite dorsal lemniscal nucleus. In the barn owl, this dorsal lemniscal nucleus (also called VLVp) mediates detection of interaural level differences. Sensitivity to interaural level differences emerges through the interaction between the excitatory and inhibitory inputs to neurons of the dorsal lemniscal nucleus. These neurons do not encode elevation unambiguously and are therefore described as sensitive to interaural level difference. More selective responses arise in the auditory midbrain [14]. There are two identified lemniscal nuclei in lizards and turtles (dorsal and ventral) and three in birds (dorsal, intermediate and ventral). They receive input from the first order auditory nuclei and from the nucleus laminaris and project to midbrain, thalamic and telencephalic targets [9].

The reptilian auditory midbrain is termed the torus semicircularis or inferior colliculus and is homologous to similarly named structures in all other vertebrates. It receives ascending input and projects to the thalamus. In birds the auditory midbrain is surrounded rostrally and laterally by an intercollicular area that receives descending input from the forebrain arcopallium [15]. The inferior colliculus is a major center for auditory processing, while the intercollicular area appears to mediate vocalization and other auditory-motor

behaviors. The inferior colliculus is divided into an external nucleus and a central nucleus that receives ascending projections from the nucleus angularis, the lemniscal nuclei and the nucleus laminaris [15]. Interaural time difference and interaural level difference signals are combined and the combinations conveyed to the external nucleus, which in the barn owl contains a map of auditory space [14]. Studies of the owl auditory midbrain have shown that most neurons are binaural, excited by inputs from the contralateral ear and inhibited by the ipsilateral ear, although bilateral excitation and contralateral excitation are also present. Many neurons are sensitive to changes in interaural level and time difference. The tonotopic organization in birds is consistent with that observed in lizards and crocodiles, with low best frequencies being represented dorsally.

Recordings from the midbrain in barn owls and songbirds show the emergence of biologically relevant responses. Barn owls are nocturnal predators with excellent sound localization ability [16] and their midbrain responses are dominated by computations directed to localization. Most barn owl inferior colliculus neurons are binaural and many are sensitive to changes in interaural level and time differences. Physiological properties are subdivision specific and reflect the inputs to each subdivision. The central nucleus projects to both the auditory thalamus and the external nucleus. Space-specific responses emerge in the external nucleus [14,16]. The external nucleus projects topographically to the optic tectum, which contains aligned maps of visual and auditory space. Activity in the tectum directs the rapid head movements made by the owl in response to auditory and visual stimuli [17]. In the zebra finch midbrain, recordings show strong onset responses and encoding of temporally modulated signals and it appears that selectivity for specific song-related spectrotemporal properties emerges in the midbrain [15].

The central nucleus of the auditory midbrain projects bilaterally to a dorsal thalamic region made up of a central nucleus surrounded by a shell [10]. The core and shell receive ascending input from the central nucleus and from the lemniscal nuclei, respectively. In both birds and crocodylians, the core and shell thalamic regions project to separate, non-overlapping regions of the telencephalon, suggesting a basic division of auditory input to the telencephalon into two separate streams. Although the connections and dorsal thalamic locations are consistent throughout amniote phylogeny, suggesting that these structures are homologous, the anatomical terminology differs. The dorsal thalamus is called nucleus reuniens in turtles, nucleus medialis in lizards and crocodylians and nucleus ovoidalis in birds. The nucleus ovoidalis is tonotopically organized, with high best frequencies located dorsally and low best frequencies ventrally. In the barn owl, all divisions of the central nucleus project

to the nucleus ovoidalis and the physiological responses in the ovoidalis reflect this diverse array of inputs. Most neurons respond to interaural time difference and/or interaural level difference at stimulus frequencies similar to those found in the midbrain. In contrast to the mapping found in the midbrain however, the nucleus ovoidalis contains no systematic representation of sound localization cues. Nevertheless, sound localization and gaze control are mediated in parallel in the midbrain and forebrain of the barn owl [14].

In birds, Field L is the principal telencephalic target of ascending input from ovoidalis [18]. It is a component of the nidopallium and is divided into three parallel layers, L1, L2 and L3. Auditory units in L2 generally have narrow tuning curves with inhibitory sidebands, which might be expected from their direct input from the dorsal thalamus, while the cells of L1 and L3 exhibit more complex responses in the guinea fowl. The general avian pattern is that Field L projects to the adjacent nidopallium and to other nuclei of the caudal nidopallium. Auditory targets of Field L (direct and indirect) include dorsal nidopallium in the pigeon, HVC in songbirds and ventrolateral nidopallium in budgerigars. These nidopallial nuclei project to the auditory areas of the arcopallium (AIVM, RA), which project back down to the auditory thalamus and midbrain [9].

### Forebrain and Birdsong

Song systems have evolved in parallel in songbirds, parrots and hummingbirds. In all groups, the dependence on auditory learning has led to changes in telencephalic structures that have been related to song learning and production. In oscine songbirds the song system is composed of an anterior and a posterior pathway. The posterior pathway is required throughout life for song production and is composed of a circuit from HVC (the higher vocal center) to the robust nucleus of the arcopallium and then down to the motor nuclei that control the syrinx and respiration. The anterior forebrain pathway is a basal ganglia-forebrain circuit critical for both song learning and adult modification of vocal output. It projects to the posterior pathway and provides a guiding influence on the developing vocal motor program. A revision of the avian anatomical nomenclature has provided a common language for studying the function of the cortical-basal-ganglia-cortical loop, enabling neuroscientists to take advantage of the specialization of basal ganglia areas in various birds [19]. In both birds and mammals, the basal ganglia contain similar cell types, which project to the midbrain substantia nigra and globus pallidus and receive a major glutamatergic input from the overlying pallium, dopaminergic input from midbrain and a lesser glutamatergic input from thalamus. These two types of striatal projection neurons, a substantia nigra and a globus pallidus are present in all jawed vertebrates, supporting the idea that the basal

ganglia performs a fundamental role in telencephalic function [20]. Studies of the role of the anterior pathway in auditory learning are illuminating the interaction between sensory, motor and reward signals in the basal ganglia and the function of these signals in task learning and execution.

## References

- Modesto S, Anderson J (2004) The phylogenetic definition of reptilia. *Syst Biol* 53:815–821
- Hedges SB, Poling LL (1999) A molecular phylogeny of reptiles. *Science* 283:998–1001
- Clack JA (1997) The evolution of tetrapod ears and the fossil record. *Brain Behav Evol* 50:198–212
- Christensen-Dalsgaard J (2005) Directional hearing in non-mammalian vertebrates. In: Popper AN, Fay RR (eds) *Sound source localization*. Springer-Verlag, New York, pp 67–123
- Christensen-Dalsgaard J, Manley GA (2005) Directionality of the lizard ear. *J Exp Biol* 208:1209–1217
- Feng AS and Christensen-Dalsgaard J (2008) Interconnections between the Ears in Nonmammalian vertebrates. In: Allan I, Basbaum, Akimichi Kaneko, Gordon M, Shepherd, Gerald Westheimer (eds) *The Senses: A Comprehensive Reference, Vol 3, Audition*, Peter Dallos and Donata Oertel. San Diego: Academic Press, pp 217–224
- Manley GA (2005) Advances and perspectives in the study of vertebrate ear evolution. In: Manley GA, Popper A, Fay RR (eds) *Evolution of the vertebrate auditory system*. Springer, New York, pp 360–368
- Klump G (2000) Sound localization in birds. In: Dooling RJ, Fay RR, Popper AN (eds) *Comparative hearing: birds and reptiles*. Springer Verlag, New York, pp 249–307
- Carr CE, Code RA (2000) The central auditory system of reptiles and birds. In: Dooling RJ, Fay RR, Popper AN (eds) *Comparative hearing: birds and reptiles*. Springer, New York, pp 197–248
- Grothe B, Carr CE, Casseday JH, Fritsch B, Köppl C (2005) The evolution of central pathways and their neural processing patterns. In: Manley GA, Popper AN, Fay RR (eds) *Evolution of the vertebrate auditory system*, Springer, New York, pp 289–359
- Trussell LO (1999) Synaptic mechanisms for coding timing in auditory neurons. *Annu Rev Physiol* 61:477–496
- Parks TN (2000) The AMPA receptors of auditory neurons. *Hearing Res* 147:77–91
- Burger R, Rubel EW (2007) Encoding of interaural timing for binaural hearing. In: Kaas J (ed) *Evolution of nervous systems*. Elsevier, New York
- Konishi M (2003) Coding of auditory space. *Annu Rev Neurosci* 26:31–55
- Covey E, Carr CE (2005) The auditory midbrain in bats and birds. In: Schreiner C, Winer JA (eds) *The inferior colliculus*. Springer, New York, pp 493–536
- Takahashi TT, Bala AD, Spitzer MW, Euston DR, Spezio ML, Keller CH (2003) The synthesis and use of the owl's auditory space map. *Biol Cybern* 89:378–387
- Knudsen EI, Zheng W, DeBello WM (2000) Traces of learning in the auditory localization pathway. *Proc Natl Acad Sci USA* 97:11815–11820
- Reiner A, Yamamoto K, Karten HJ (2005) Organization and evolution of the avian forebrain. *The Anatomical Record Part A: Discoveries in Molecular, Cellular, and Evolutionary Biology*, vol 287, 1080–1102
- Jarvis ED, Güntürkün O, Bruce L, Csillag A, Karten H, Kuenzel W, Medina L, Paxinos G, Perkel DJ, Shimizu T, Striedter G, Wild JM, Ball GF, Dugas-Ford J, Durand SE, Hough GE, Husband S, Kubikova L, Lee DW, Mello CV, Powers A, Siang C, Smulders TV, Wada K, White SA, Yamamoto K, Yu J, Reiner A, Butler AB (2005) Avian brains and a new understanding of vertebrate brain evolution. *Nat Rev Neurosci* 6:151–159
- Doupe AJ, Perkel DJ, Reiner A, Stern EA (2005) Birdbrains could teach basal ganglia research a new song. *Trends Neurosci* 28:353–363

## Evolution of the Brain in Mammals

JON H. KAAS

Department of Psychology, Vanderbilt University, Nashville, TN, USA

### Definition

The brain is the part of the central nervous system that is inside the skull. Major parts include the hindbrain, midbrain, and forebrain. In mammals, the neocortex comprises the largest portion of the rostral part of the forebrain, the telencephalon, and, with its distinctive six layers and particular cytoarchitecture, is the hallmark of the mammalian brain. Other parts of the mammalian brain, including the diencephalon and cerebellum, are also enlarged and elaborated in comparison to the brains of most other vertebrate groups. In contrast, the more basal parts of the midbrain and hindbrain have been more conservative in their evolution.

### Characteristics

The brain is the part of the nervous system that is enlarged and elaborated in mammals compared to other amniotes. This enlargement and elaboration is especially great in some lines of mammalian evolution, and the enlargement mostly involves the forebrain, especially the neocortex. Thus, the neocortex is a part of the brain that varies greatly in size across mammals. In addition, the neocortex is subdivided into a number of functionally distinct regions called areas. Mammals with the smallest brains have an estimated 15–20 cortical areas, while humans have as many as 150. While the mammalian brain has evolved in many other ways, the most dramatic changes have involved a disproportionate enlargement of the forebrain,

especially neocortex, and a ten-fold increase in number of functionally distinct areas.

### The Brains of Early Mammals

Early mammals, some 150–200 million years ago (mya) were generally small, cat-to-mouse sized, and nocturnal. Their brains were small, as brain size scales with body size, but their brains were especially small for mammals [1]. Over the course of over 200 million years of mammalian evolution, a common trend has been toward an increase in brain size relative to body size. In some lines of evolution, the increase has been dramatic, while in a few lines of evolution the brain appears to have enlarged little, if at all. What we know about the sizes of the brains of early mammals comes from the fossil record, as the internal shape of the skull, that is the brain case, closely reflects the size and shape of the brain in mammals [2]. However, as the soft tissue of the brain itself is not preserved in the fossil record, internal organizations of the brains of early mammals cannot be known directly, but only inferred from the brain features present in the species of mammals that exist today. In practice, the brains of those species of mammals that have retained a small brain, much like the brains of early mammals in size, appear to provide the closest picture of the internal organizations of early mammal brains. The accepted formal approach in evaluating this assumption is called a cladistic character analysis in which brain features or characters are compared across a group of related species to estimate which of the features have been retained from an early, common ancestor [3,4].

The brain of a small tenrec, a nocturnally active insectivore-like mammal from the island of Madagascar in the superorder Afrotheria, serves as a model of the brain of an early mammal (Fig. 1).

In this dorsolateral view of the brain, the peripheral nerves and spinal cord have been removed so that the main parts of the brain can be more easily appreciated. Only the caudal part of the brainstem (where it was separated from the spinal cord), that is, the hindbrain, and the roof (tectum) of the midbrain are apparent, as the cerebellum covers much of the lower brainstem (hindbrain). The tectum of the midbrain includes the sensory processing stations, the inferior colliculus for auditory processing and the superior colliculus for visual processing. The midbrain is adjoined rostrally by the diencephalon, which includes the thalamus and the basal ganglia, which are within the ventral part of the telencephalon and are covered by the cortex, and thus, cannot be seen in this external view. The rostral end of the brain is formed by the olfactory bulbs.

Because the proportions of brain parts and the size of the brain relative to body size in tenrecs closely compare to those estimated from the fossils of early mammals, many of which were also nocturnal or

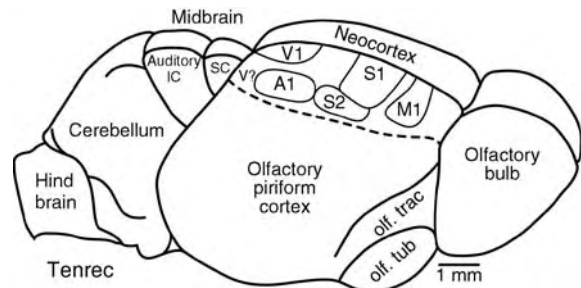

### Evolution of the Brain in Mammals.

**Figure 1** A dorsolateral view of the brain of a Madagascar tenrec (*Echinops telfairi*) a small Afrotherian mammal. In this mammal, the forebrain is dominated by a large olfactory bulb and a large (relative to the rest of the brain) olfactory (piriform) cortex. Note also the olfactory (olf.) tract and tubercle (tub.). Piriform cortex is capped by a small expanse of neocortex, which contains several functionally distinct areas, including primary visual cortex, V1, the second visual area, V2, a primary somatosensory area, S1, a second somatosensory area, S2, a primary motor area, M1, and a primary auditory area, A1. There are other, less well-identified areas; perhaps 15 areas exist in this mammal. As the neocortex is small, it does not extend caudally to cover the midbrain, as it does in most mammals, so the inferior colliculus (IC) and superior colliculus (SC) of the tectum (roof) of the midbrain can be seen. The cerebellum covers the mid portion of the brainstem. Based on Krubitzer et al. [5].

crepuscular, some general conclusions about the brains of early mammals are justified. Most notably, early mammals devoted much of their brain to processing olfactory information. Thus, the olfactory bulb and the more caudal olfactory (piriform) cortex are very large in proportion to the rest of the brain. Olfaction was and remains important for many mammals [6] particularly in the nocturnal environment, for being able to find food and mates, while detecting predators and competitors.

In addition, neocortex was a proportionately small part of the brain in early mammals. This is especially relevant because primates in general, and humans in particular, have devoted a huge proportion of their brains to neocortex [7]. Neocortex is a multilayered sheet of tissue that evolved from a simpler structure in stem amniotes that is homologous, at least in part, to the dorsal cortex of reptiles, to become the most variable part of the brain in mammals [8]. In all mammals, neocortex is divided into functionally distinct regions, the cortical areas. Comparative studies of extant mammals indicate that some of these areas, 15–20, were present in early mammals. These areas include the primary and secondary visual areas, V1 and V2, primary and secondary somatosensory areas,

S1 and S2, and at least one auditory area, A1. Although these areas, as well as subdivisions of cingulate cortex and orbital frontal cortex, existed, they were not well differentiated into layers and specialized cell types, suggesting little functional specialization. Surprisingly, a primary motor cortex apparently was not present and did not appear until the evolution of placental (Eutherian) mammals [9]. The dorsal thalamus, which is directly interconnected with neocortex, providing the sensory activation of neocortex, was also less extensively differentiated. Thus, early mammals did not depend much on neocortex, which was devoted to rather simple sensory-perceptual functions. The minor role that neocortex had in motor control was mediated through somatosensory areas.

Other parts of the brains of early mammals were small but not remarkably so in relation to body size. The brainstem, especially, is often used as an index for the disproportionate growth of other parts of the brain. This is because it maintains a roughly similar size in proportion to the size of the mammal in evolution, although structural modifications have occurred. The midbrain size varies, with an emphasis on the size of the inferior colliculus in mammals relying most on hearing, as in echolocating bats, and an emphasis on the size of the superior colliculus in some visually dependent mammals, such as squirrels where the superior colliculus is ten times larger than expected for their body size. However, major changes in the proportions of the midbrain are unusual. The cerebellum, with functional ties to the neocortex varies in size with neocortex. Although, as they both increase in size, the size of the cerebellum increases less than that of the neocortex. However, the small sizes of the micro-neurons (granule cells) of the cerebellum, allows the number of neurons in the cerebellum and neocortex to remain roughly proportional with increases in cortical size. This is because mammals with larger brains have greater increases the sizes of cortical neurons than cerebellar neurons [10].

### **How Brains have Evolved in the Great Mammalian Radiation**

Over the last 200 million years or so, mammals have differentiated into six major superorders [11], and approximately 4,500 extant species. The fossil record indicates that over much of their early history, mammals did not change very much. While forming the body plans of the major divisions (monotremes, marsupials, and placentals), the brains did not enlarge or specialize in many ways. However, with the extinction of the “ruling reptiles,” 65 mya, many environments became open to mammals, allowing for rapid diversification, as modifications in their brains, especially in neocortex, allowed them to exploit the many new opportunities.

Many of the changes involved specializations of sensory systems that involved only modest overall increases in brain size. Thus, echolocating bats became successful as their auditory system evolved to become sensitive to echo frequencies, and specialized cortical areas emerged to analyze the information obtained from these echoes. Many other mammals exploited the information obtained from bending hairs on the surface of the body, and used long vibrissal hairs on the face, or on other parts of the body to detect objects at short distances. They used this information via computations in specialized somatosensory systems to guide prey capture, as in cats, or environmental exploration, as in rats. The nose was modified in the line leading to the star-nosed mole to produce 22 fleshy and mobile appendages covered with specialized receptors, Eimer’s organs, that activate a highly specialized sensorimotor system used to detect and capture small prey [12]. The strange Australian mammal, the platypus, which is a monotreme, evolved receptors for electroreception on its bill-like snout, and modified the somatosensory system and cortex for electroreception to find prey in murky streams [13]. Likewise, the other genus of monotremes, echidnas, also has electroreceptors on their snouts [14]. Tarsiers, survivors of an early branch of primate evolution, depend on extremely large eyes to see in dim light, and a highly differentiated and proportionately large primary visual cortex to mediate its unique primate roll as a visual predator of small invertebrates and vertebrates [15].

In these and other examples, specializations within a system and their related neocortical components have occurred, rather than global changes in the brain. The specializations include enlargements of the behaviorally relevant parts of the systems, and structural differentiations of the relevant parts so that neuron types, modules of neurons and classes of layers emerge to expand and vary functions of the systems. In addition, new connections, new cortical areas, and subcortical nuclei, may be added to the systems.

In other instances, brain changes have been more global, as brains evolved to permit behavior that is more flexible. The larger brains of primates are characterized by a proportionately larger neocortex, especially in humans and other highly social primates [7]. This suggests that much of neocortex in these primates is not just processing sensory information for immediate action, and programming the skillful movements needed in the actions, but is involved in calculating the benefits of various alternative behaviors in a complex social environment. Many types of information have to be extracted from the ongoing behaviors of others and related to past behaviors. Primates seem to have accomplished this by greatly expanding some parts of the brain, mainly by adding a great number of processing areas, thereby increasing the steps in serial



processing sequences, and increasing the number of pathways through variously specialized processing systems (areas and nuclei). The number of cortical areas devoted to processing mainly visual information increased from 4–5 in early mammals, to 15–20 in prosimian primates, to 30–40 in macaque monkeys, and to over 50 or so in humans [16]. Especially in social primates, the frontal lobe expanded and subdivided, allowing for planning for the future [17]. The frontal motor system became enlarged and more complex with the addition of premotor and cingulate motor areas, fields were added to somatosensory cortex, and posterior parietal cortex became large and subdivided into motor planning areas, especially those for using the valuable visual information that guides the social behavior of primates [18]. To some extent, similar changes took place in other social mammals, such as wolves, but they were less extensive.

### Conclusions

In summary, the brains of mammals have differentiated from those of early mammal ancestors in many ways. Various brain parts have selectively enlarged, and whole brain regions have enlarged. Parts have differentiated by the gain of new neuron types and aggregates of interconnected neuron modules and layers enabling specialized subfunctions. New areas and nuclei have been added to systems, most probably by differentiation from existing structures. Connections between structures have changed, sometimes via losses [19] and sometimes by invading other parts of the brain. While the local modifications in brain organization are the most notable, these changes imply widespread alterations in brain structure and function. As sensory-perceptual systems become more sophisticated, the use of the additional information requires modification in memory systems, motor control, motor programs, and decision-making circuits. The less changed brainstem circuits are likely to be altered along with the more modified cortex, as both brain regions contribute to the integrated systems guiding behavior.

### References

1. Allman J (1999) *Evolving brains*. W.H. Freeman & Co, New York
2. Jerison HJ (1973) *Evolution of the brain and intelligence*. Academic, New York
3. Hennig W (1966) *Phylogenetic systematics*. University of Illinois Press, Urbana, IL
4. Wiley EO (1981) *Phylogenetics: the theory and practice of phylogenetic systematics*. Wiley, New York
5. Krubitzer LA, Kunzle H, Kaas JH (1997) The organization of sensory cortex in a Madagascan insectivore (*Echinops telfairi*). *J Comp Neurol* 378:1–16
6. Kaas JH (2004) Evolution of somatosensory and motor cortex in primates. *Anat Rec* 281A:1148–1156

7. Kaas JH, Preuss TM (2003) Human brain evolution. In: Squire LR (ed) *Fundamental Neuroscience*. Academic, San Diego, pp 1147–1166
8. Northcutt RG, Kaas JH (1995) The emergence and evolution of mammalian neocortex. *Trends Neurosci* 18:373–379
9. Beck PD, Pospichal MW, Kaas JH (1996) Topography, architecture, and connections of somatosensory cortex in opossums: evidence for five somatosensory areas. *J Comp Neurol* 366:109–133
10. Herculano-Houzel S, Mota B, Lent R (2006) Cellular scaling rules for rodent brains. *Proceedings of the National Academy of Sciences USA* 103:12138–12143
11. Murphy WJ, Eizirik E, O'Brien SJ, Madsen O, Scally M, Douady CJ, Teeling E, Ryder OA, Stanhope MJ, de Jong WW, Springer MS (2001) Resolution of the early placental mammal radiation using Bayesian phylogenetics. *Science* 294:2348–2351
12. Catania KC, Kaas JH (1996) The unusual nose and brain of the star-nosed mole. *Bioscience* 46:578–586
13. Krubitzer LA, Manger P, Pettigrew JD, Calford M (1995) The organization of somatosensory cortex in monotremes: in search of the prototypical plan. *J Comp Neurol* 351:261–306
14. Gregory JE, Iggo A, McIntyre AK, Proske U (1989) Response of electroreceptors in the snout of the echidna. *J Physiol* 414: 521–538
15. Collins CE, Hendrickson A, Kaas JH (2005) Overview of the visual system of tarsius. *Anat Rec* 287A:1013–1025
16. Kaas JH (2003) The evolution of the visual system in primates. In: Chalupa LM, Werner JS (eds) *The Visual Neurosciences*. MIT, Cambridge, pp 1563–1572
17. Rilling JK (2006) Human and non-human primate brains: Are they allometrically scaled versions of the same design? *Evol Anthropol* 15:65–77
18. Kaas JH (2004) The evolution of the large, complex sensorimotor systems of anthropoid primates. *Int J Comp Psychol* 17:34–52
19. Ebesson SOE (1984) Evolution and ontogeny of neural circuits. *Behav Brain Sci* 7:321–366

## Evolution of the Brain in Reptiles

LAURA L. BRUCE

Department of Biomedical Sciences, School of Medicine, Creighton University, Omaha, NE, USA

### Definition

The brain consists of a forebrain, midbrain, and hindbrain. Among reptiles, the degree to which the forebrain, particularly its upper part, the pallium, is elaborated varies. Turtles, the tuatara *Sphenodon*, and some lizards have relatively modest pallial specializations; snakes and other lizards have a greater degree; and crocodiles exhibit the most specialized pallium. The roof of the midbrain, the tectum, is well developed

in all reptiles, whereas the roof of the hindbrain, the cerebellum, is much more modestly developed than it is in mammals and birds.

### Characteristics

The major regions of the brain are the hindbrain, midbrain, and forebrain; the latter is composed of the diencephalon and telencephalon (Fig. 1).

These regions are present in all tetrapods and probably in all vertebrates, although interspecies comparisons reveal anatomic and physiologic diversity. Among tetrapods, there has been an evolutionary trend of increased size and complexity in thalamic and telencephalic regions since the transition of amphibians to stem amniotes. As a result, hypotheses about the homologues of thalamic and pallial regions in amphibians, reptiles, and birds are in general agreement, but comparisons with mammalian regions have proven more difficult and more controversial. This difficulty comparing homologous forebrain regions between mammals and other tetrapods may be related to their divergent evolutionary history. The anapsid line of stem amniotes gave rise to two independent lineages, first the synapsid line to mammals and later the diapsid reptilian line, which gave rise to all living reptiles and birds (see ► *Evolution*, and ► *Phylogeny of Amniotes*). The following paragraphs describe some of the characteristics of reptilian brains and their relationships to other vertebrates.

### Hindbrain

The organization of the reptilian hindbrain is fairly similar to that of amphibians, birds, and mammals. The same major components, including sensory and motor cranial nerve nuclei and reticular nuclei, are found in all tetrapods. The nuclei vary, however, in their size and rostral to caudal spread. For example, the

rostral limit of each motor nucleus is similar, but the caudal limit may differ by one or more rhombomeres. Comparisons of motor nuclei suggest that the trigeminal (V), facial (VII), and octavolateral efferents (VIII) are particularly variable (see ► *Evolution*, ► *of the Hindbrain*, ► *Evolution*, of the Cranial Nerves).

One notable brainstem specialization is unique to infrared-detecting snakes [1]. In pythons and rattlesnakes infrared is detected by pit organs near the mouth, which are innervated by branches of the trigeminal nerve. This infrared information reaches a unique brainstem region, nucleus calorici, which evolved as a specialized region of the brainstem reticular formation.

### Midbrain

In reptiles the roof, or tectum, of the midbrain (Fig. 2) includes three regions that integrate sensory information: the optic tectum (with visual information superficially and somatosensory information in deeper layers), the somatosensory subdivision of torus semicircularis, and the auditory subdivision of torus semicircularis. Homologues of all three regions have been identified in amphibians, birds, and mammals.

The reptilian optic tectum is homologous to the mammalian superior colliculus. The superficial neurons receive a direct retinal projection and are exclusively visual. The deeper neurons integrate visual information with somatosensory, and probably auditory and limbic, information. In rattlesnakes, the optic tectum contains neurons that respond to infrared stimuli, related to their infrared-detecting specializations [1]. Stimulation of the optic tectum elicits directional head movements, indicating that it contains a motor map in addition to the sensory maps. The reptilian optic tectum sends sensory information to two thalamic nuclei, a minor projection to nucleus dorsolateralis and a robust projection to nucleus rotundus (Figs. 2, 3b) [2,3,4,5]. The auditory and

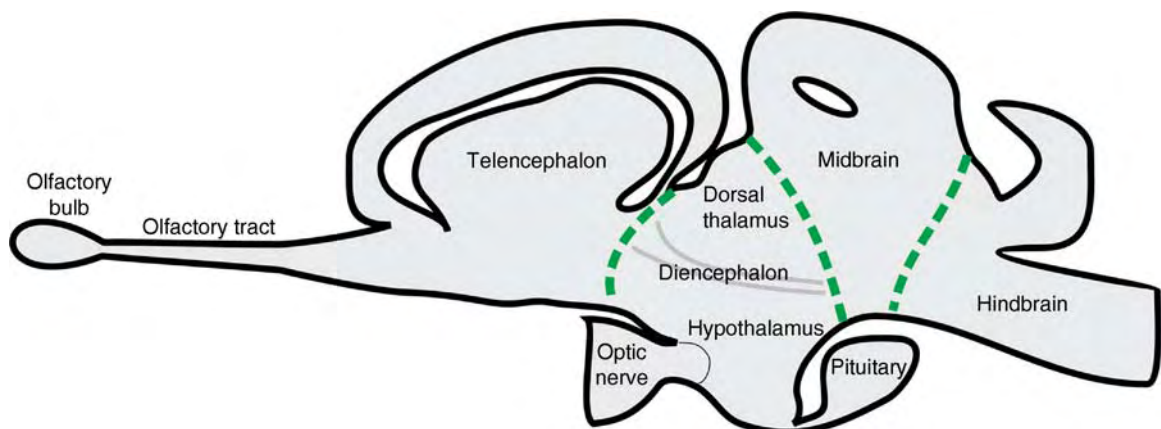

**Evolution of the Brain in Reptiles. Figure 1** A sagittal section through a lizard brain, illustrating the major regions and subdivisions.

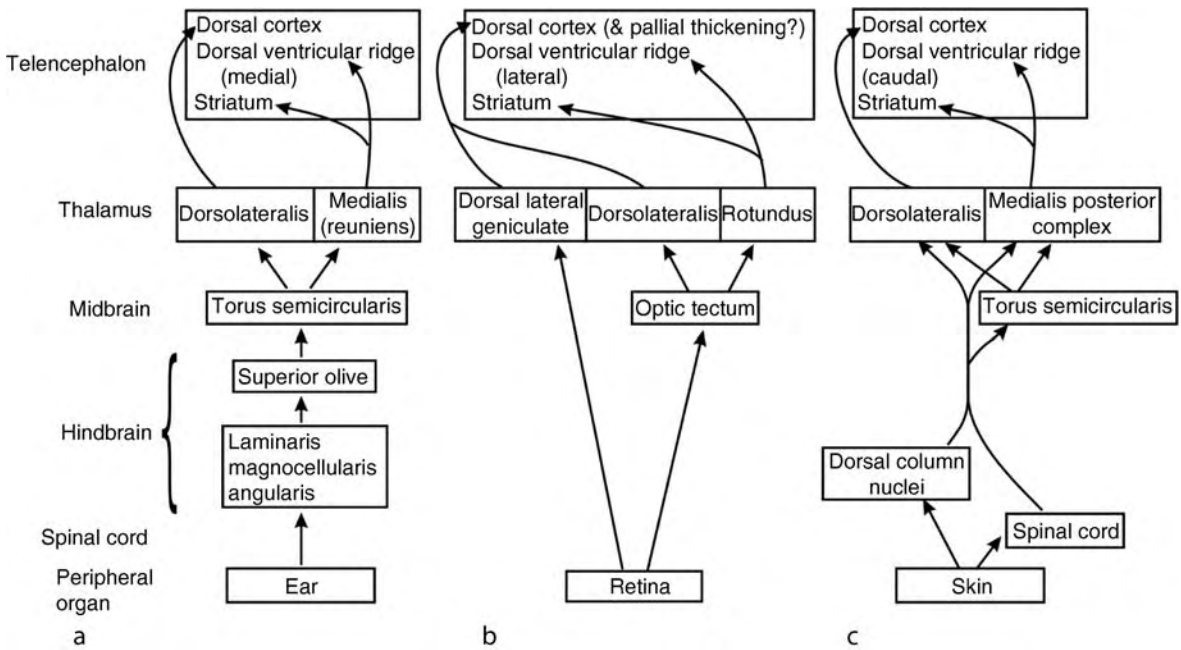

**Evolution of the Brain in Reptiles. Figure 3** Schematic representation of the auditory, visual, and somatosensory pathways to the telencephalon in reptiles.

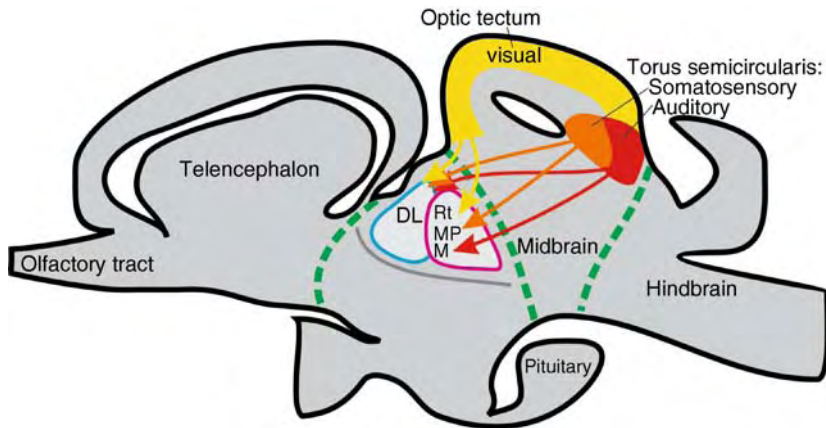

**Evolution of the Brain in Reptiles. Figure 2** A sagittal section through a lizard brain, illustrating the organization of the sensory midbrain regions, and their projections to the dorsal thalamus. Abbreviations: DL, nucleus dorsolateralis; M, nucleus medialis; MP, nucleus medialis posterior; Rt, nucleus rotundus.

somatosensory parts of torus semicircularis also project to two thalamic targets. The auditory torus projects sparsely to the nucleus dorsolateralis and robustly to nucleus medialis (Figs. 2, 3a), and the somatosensory part of torus projects to nucleus dorsolateralis and nucleus medialis posterior (Figs. 2, 3c) 2,3,4,5].

**Diencephalon**

The reptilian diencephalon consists of the epithalamus, dorsal thalamus (sometimes called thalamus), ventral

thalamus, and hypothalamus. This section focuses on the hypothalamus and dorsal thalamus, which have been studied extensively.

**Hypothalamus**

The reptilian hypothalamus contains multiple neuronal groups with diverse functions. It is crucial for regulating behaviors and involuntary functions that are essential for survival. These functions include feeding, temperature regulation, body fluid homeostasis, diurnal rhythms,

autonomic responses, and reproductive behaviors. The same major functional and anatomical regions identified in the reptilian hypothalamus are also present in birds and mammals, as are the histochemical expression patterns and the interconnections with other parts of the brain, notably the amygdala, septum, and brainstem. These critical hypothalamic systems apparently evolved in earlier vertebrates and then were largely conserved through subsequent evolutionary stages (see ► [Evolution, of the Hypothalamus: in Amniotes](#), ► [Evolution, of the Hypothalamus: in Anamniotes](#)).

### Dorsal Thalamus

The dorsal thalamus consists of nuclei that are connected with the telencephalon (Figs. 3, 4).

Their homologues in amphibians and birds are commonly agreed upon, but the mammalian homologues are more controversial. There are two main hypotheses of dorsal thalamic evolution (Table 1), which are based mainly on divergent interpretations of some of the telencephalic targets of two major sensory thalamic groups in reptiles and mammals. Hypothesis A compares the reptilian dorsal cortex to some sensory and all limbic cortical regions in mammals, and the DVR to the mammalian lateral sensory cortical areas [6,7]. Hypothesis B considers the reptilian dorsal cortex to be the homologue of all mammalian cortical areas except the hippocampus and olfactory cortices, and the reptilian dorsal ventricular ridge (DVR) the homologue of the mammalian pallial amygdala [8,9]. The identification of thalamic homologues is consistent with the telencephalic homologues proposed by each hypothesis.

General organization of the thalamus. The reptilian dorsal thalamus consists of three major groups, as

well as several smaller groups. The three major groups can be characterized by their connections [2,4,5,8,10] as follows (Figs. 2, 3 and 4).

- (1) A visual nucleus that receives a direct retinal projection and projects to the dorsal cortex, called the dorsal lateral geniculate nucleus.
- (2) Nuclei that predominantly receive projections directly from the spinal cord, dorsal columns, trigeminal nuclei, and hypothalamus, as well as sparse projections from the midbrain tectum and torus semicircularis, and in turn project mainly to the dorsal cortex in the pallium. The nucleus dorsolateralis is the main component of this group in reptiles.
- (3) Nuclei that receive robust visual, somatosensory, and auditory projections from the midbrain roof (tectum and torus semicircularis) and in turn project mainly to the striatum and dorsal ventricular ridge in the pallium. Nuclei rotundus, medialis posterior, and medialis (called reuniens in turtles and crocodiles) are the main components of this group in reptiles.

Evolutionary considerations of thalamic homologues. Most comparative neurologists consider the dorsal lateral geniculate (LGD, group 1) to be homologous to the mammalian dorsal lateral geniculate [10]. There are, however, two divergent hypotheses about the mammalian homologues of thalamic groups 2 and 3 (Table 1). These are based mainly on the interpretations of some of the telencephalic targets of two major sensory thalamic groups in reptiles and mammals.

Hypothesis A, proposed by Butler [6,7], compares the reptilian cortex to all motor and limbic cortical regions and to only the primary sensory visual and

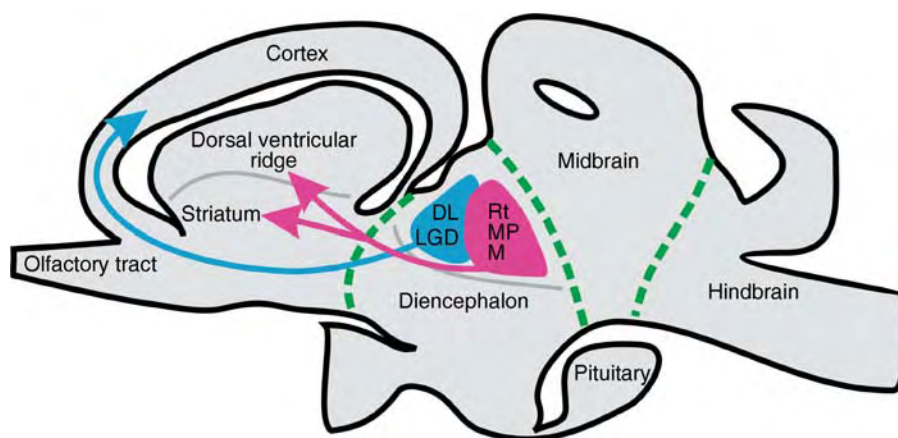

**Evolution of the Brain in Reptiles. Figure 4** A sagittal section through the brain of a lizard, illustrating the main sensory thalamic groups and their projections to the striatum, dorsal ventricular ridge, and cortex. Abbreviations: DL, nucleus dorsolateralis; LGD, dorsal lateral geniculate nucleus; M, nucleus medialis; MP, nucleus medialis posterior; Rt, nucleus rotundus.

**Evolution of the Brain in Reptiles. Table 1** Comparisons of dorsal thalamic nuclei in tetrapods

Amphibian	Reptile lizard	Reptile crocodilian	Reptile turtle	Birds	Mammal (rodent) Hypothesis A	Mammal (rodent) Hypothesis B
Anterior	Dorsal lateral geniculate	<sup>a</sup>	Dorsal lateral geniculate	Dorsal lateral geniculate	<sup>b</sup> Dorsal lateral geniculate	Dorsal lateral geniculate
Anterior	DL	<sup>a</sup>	DMA, DL	DIVA, DLA, Superficialis parvocellularis	<sup>b</sup> Anterior, Reuniens, VPL, VPM	Anterior, LP, MGd, MGv, Posterior, Reuniens, VPL, VPM
<sup>a</sup>	<sup>a</sup>	<sup>a</sup>	?*	Ventral intermediate area	<sup>b</sup> VA, VL	VA, VL
<sup>a</sup>	DM	<sup>a</sup> ?*	DM	DIP, DMA, DMP, DLM, DLP, SHL	<sup>b</sup> Medial, Rostral intralaminar, <sup>c</sup> Caudal intralaminar	Medial, Rostral intralaminar, Caudal intralaminar
Lateral	Rotundus	Rotundus	Rotundus	Rotundus	<sup>c</sup> LP, Perigeniculate group	Perigeniculate: suprageniculate
Central	Medialis posterior, Posterocentral	Medialis complex	Caudalis	Subrotundus	<sup>c</sup> Posterior, Perigeniculate group	Perigeniculate: posterior intralaminar
Central	Medialis	Reuniens	Reuniens	Ovoidalis	<sup>c</sup> MGd, MGm, MGv	Perigeniculate: MGm

<sup>a</sup>Corresponding nuclei have not yet been identified.

<sup>b</sup>and <sup>c</sup>designate the lemnothalamic nuclei and collothalamic nuclei, respectively, which are proposed to arise from separate thalamic areas, according to hypothesis A.

Abbreviations: Reptiles: *DLA* dorsolateralis anterior; *DLP* dorsolateralis posterior; *DM* dorsomedial; *DMA* Dorsomedial anterior. Birds: *DIP* dorsointermedius posterior; *DIVA* dorsalis intermedius ventralis anterior; *DLA* dorsolateralis anterior; *DLP* nucleus dorsolateralis posterior; *DMA* dorsomedialis anterior; *DMP* dorsomedialis posterior; *SHL* subhabenularis lateralis. Mammals: *LP* lateral posterior; *MGd* medial geniculate, dorsal part; *MGm* medial geniculate, medial part; *MGv* medial geniculate, ventral part; reuniens, *VA* ventral anterior; *VL* ventral lateral; *VPL* ventral posterior lateral; *VPM* ventral posterior medial.

somatosensory cortical areas of mammals, and compares the DVR to the primary sensory auditory area and to visual, somatosensory, and auditory association areas of the mammalian cortex, plus the mammalian pallial amygdala. Thus, Butler includes both the reptilian nucleus dorsolateralis (thalamic group 2) and nucleus dorsomedialis in the same thalamic group and compares them to the mammalian anterior, ventral, and medial thalamic nuclei. Along with the LGD, she names these the “lemnothalamic nuclei” because they receive mainly direct sensory and limbic projections. Butler also compares the predominantly tectal and toral recipient nuclei (thalamic group 3) to the mammalian lateral posterior, posterior, medial geniculate, and amygdalar-projecting (perigeniculate) thalamic areas. She names these the “collothalamic nuclei” because of their predominant input from the midbrain colliculus (tectum).

Hypothesis B, originally proposed by Bruce and Neary [8,9], considers the reptilian cortex to be comparable to all mammalian cortical areas, and the reptilian dorsal ventricular ridge (DVR) to be comparable to the mammalian pallial amygdala. This hypothesis proposes that the reptilian nucleus dorsolateralis

(thalamic group 2) is homologous to the mammalian anterior, ventral posterior, lateral posterior, and posterior, plus the parts of the medial geniculate that project to the cortex (Table 1).

Furthermore, the predominantly tectal and toral-recipient thalamic nuclei (rotundus, medialis, and medialis posterior; thalamic group 3) are comparable to the mammalian perigeniculate sensory thalamic groups that project to the pallial amygdala. Further studies of the development of thalamic regions and their connections are required in order to resolve which of these two hypotheses is correct.

### Telencephalon

The reptilian telencephalon is composed of pallial and subpallial regions; the latter includes striatal and pallidal components. The major components of the pallium include the medial cortex, dorsal cortex, lateral cortex, and dorsal ventricular ridge.

### Subpallium

The subpallial telencephalon includes the striatal area and the pallidum laterally and the septal nuclei medially. The striatal area contains homologues of

the mammalian striatum and central amygdaloid nucleus, and the pallidum includes homologues of the mammalian globus pallidus and ventral pallidum. The reptilian striatum and globus pallidus are organized similarly to those of birds and mammals. They have similar connectional, developmental, and histochemical characteristics in all amniotes [11]. However, they are much larger than in the amphibian condition, suggesting that they increased dramatically in size from their anamniote ancestral condition. The septal nuclei are largely comparable across amniotes and other vertebrates (see ►Evolution, ►of Septal Nuclei).

### Pallium

The medial, dorsal, and lateral cortices are comparable to the mammalian hippocampus, general cortex (including part or all of neocortex), and olfactory cortex, respectively. Although the dorsal cortex of reptiles lacks the discrete lamination pattern seen in mammalian neocortex, it is the target of ascending auditory, visual, and somatosensory pathways (Fig. 3) and has similar connectional, developmental, and neurochemical expression patterns as neocortex. The reptilian dorsal cortex is the homologue of the avian Wulst plus the adjacent dorsolateral corticoid area. The dorsal cortex receives visual, somatomotor, auditory, and limbic inputs from the thalamus (Fig. 3, 4). The reptilian DVR contains auditory, visual, and somatosensory regions, as well as a region that projects to the ventromedial hypothalamus, and another that projects to the lateral hypothalamus [2,4,5,9]. The dorsal ventricular ridge (DVR) of reptiles is clearly homologous to the ventral part of the lateral pallium in amphibians and to the nidopallium in birds [8,9,12,13], but its relationship to the mammalian brain remains controversial.

Two distinct patterns of neural organization occur in the DVR of living reptiles [2,5]. The ancestral type is characterized by a plate of neurons adjacent to the ventricle and a central core with few neurons, typical of most turtles, rhynchocephalians (tuatara), and some lizards, including geckos, lacertids, anguids, and skinks. In the derived type, neurons are scattered throughout, and there is no distinct cell plate. This condition occurs in iguanas, chameleons, varanids, snakes, and crocodylians and also in birds; it thus evolved independently in at least two lineages, one lineage leading to crocodylians and birds, the thecodonts, and another, within squamates, to some lizards and snakes.

Evolutionary considerations of pallial homologies. The reptilian dorsal cortex is considered to be homologous to some or all of the mammalian neocortex by most comparative neurologists. However the mammalian homologues of the reptilian dorsal ventricular ridge (DVR) are highly controversial. There are three distinct hypotheses that are widely discussed by comparative neurologists: the cortical layer

hypothesis, the lateral cortex hypothesis, and the amygdalar hypothesis.

The cortical layer hypothesis, first proposed by Karten in 1969 [14], suggests that large groups of neurons within the DVR are homologous to neurons located in particular layers of the mammalian cortex. Thus, neurons in the DVR that receive thalamic projections resemble those of mammalian cortical layer IV, neurons in the rostral DVR that receive inputs from the latter and project to the posterior DVR resemble intercortical neurons of mammalian cortical layers II-III, and the latter in turn project to neurons in the posterior DVR that project to the thalamus and brainstem and therefore resemble those in mammalian cortical layers V and VI. The lateral cortex hypothesis, first proposed by Butler [7,15], contends that the DVR is homologous to the developmentally lateral parts of neocortex. These include auditory, extrastriate visual, and association insular cortices, which are the predominant targets of the tectal-recipient thalamic nuclei, as well as parts of the pallial amygdala. The DVR-pallial amygdala hypothesis, first proposed by Bruce and Neary [8,9,12,13], argues that the parts of the DVR receiving sensory thalamic input are homologous to the mammalian lateral amygdaloid nucleus, which also receives sensory thalamic input, whereas the parts of the DVR projecting to diencephalon and brainstem are homologous to the basomedial and basolateral amygdaloid nuclei. This hypothesis is based on the numerous connectional, neurochemical, gene expression, and topological similarities between the reptilian and avian DVR and the mammalian pallial amygdaloid nuclei. Further comparative studies using a combination developmental, genetic, and neurochemical approaches are needed to determine the evolutionary history of the reptilian pallium.

### References

1. Stanford LR, Schroeder DM, Hartline PH (1981) The ascending projection of the nucleus of the lateral descending trigeminal tract: a nucleus in the infrared system of the rattlesnake, *Crotalus viridis*. *J Comp Neurol* 201:161-173
2. Butler AB, Hodos W (2005) Comparative vertebrate neuroanatomy: evolution and adaptation, 2nd edn. Wiley, Hoboken, NJ
3. Desfilis E, Font E, Belekova M, Kenigfest N (2002) Afferent and efferent projections of the dorsal anterior thalamic nuclei in the lizard *Podarcis hispanica* (Sauria, Lacertidae). *Brain Res Bull* 57:447-450
4. Pritz MB (1995) The thalamus of reptiles and mammals: similarities and differences. *Brain Behav Evol* 46:197-208
5. Ulinski PS (1983) The dorsal ventricular ridge: a treatise on forebrain organization in reptiles and birds. Wiley, New York

6. Butler AB (1994) The evolution of the dorsal thalamus of jawed vertebrates, including mammals: cladistic analysis and a new hypothesis. *Brain Res Rev* 19:29–65
7. Butler AB (1994) The evolution of the dorsal pallium in the telencephalon of amniotes: cladistic analysis and a new hypothesis. *Brain Res Rev* 19:66–101
8. Bruce LL (2006) Evolution of the nervous system in reptiles. In: Kaas JH (ed) *Evolution of nervous systems, vol II. The evolution of nervous systems in non-mammalian vertebrates*. Elsevier, pp 125–156
9. Bruce LL, Neary TJ (1995) The limbic system of tetrapods: a comparative analysis of cortical and amygdalar populations. *Brain Behav Evol* 46:224–234
10. Kenigfest N, Martínez-Marcos A, Belekhova M, Font C, Lanuza E, Desfilis E, Martínez-García F (1997) A lacertilian dorsal retinorecipient thalamus: a re-investigation in the Old-world lizard *Podarcis hispanica*. *Brain Behav Evol* 50:313–334
11. Reiner A, Medina L, Veenman CL (1998) Structural and functional evolution of the basal ganglia in vertebrates. *Brain Res Rev* 28:235–285
12. Fernandez AS, Pieau C, Repérant J, Boncinelli E, Wassef M (1998) Expression of the Emx-1 and Dlx-1 homeobox genes define three molecularly distinct domains in the telencephalon mouse, of chick, turtle and frog embryos: implications for the evolution of telencephalic subdivisions in amniotes. *Development* 125:2099–2111
13. Puelles L, Kuwana E, Puelles E, Bulfone A, Shimamura K, Keleher J, Smiga S, Rubenstein JL (2000) Pallial and subpallial derivatives in the embryonic chick and telencephalon, mouse traced by the expression of the genes Dlx-2, Emx-1, Nkx-2.1, Pax-6, and Tbr-1. *J Comp Neurol* 424:409–438
14. Karten HJ and Shimizu T (1989) The origins of neocortex: connections and lamination as distinct events in evolution. *J Cogn Neurosci* 1:291–301
15. Reiner AJ (2000) A hypothesis as to the organization of cerebral cortex in the common amniote ancestor of modern reptiles and mammals. *Novartis Found Symp* 228:83–102

## Evolution of the Brain in Amphibians

WALTER WILCZYNSKI

Center for Behavioral Neuroscience and Department of Psychology, Georgia State University, Atlanta, GA, USA

### Synonyms

Amphibians; Brain evolution

### Definition

The general structure and functional organization of the amphibian brain includes several apparently primitive features (such as a small size and relatively little cell migration and areal differentiation, these being less

severe in ►anurans than in other amphibians) as well as the standard major brain areas and basic connective patterns found in all vertebrates. Evolutionary specializations are also apparent, especially in anurans where expanded visual and auditory midbrain areas are present. The forebrain contains many of the basic vertebrate systems and general organization of connections, but the functional organization of sensory systems is quite different from the familiar pattern seen in mammals, birds and reptiles.

### Characteristics

Modern day amphibians are represented by three groups, the anurans, i.e., the frogs and toads, the ►urodeles, i.e., the tailed amphibians including salamanders and newts and the ►apodans or ►gymnophiones, an unusual and relatively small group of legless amphibians [1]. The groups are similar in having (at least) two distinct life stages including an early aquatic tadpole stage followed by metamorphosis into a radically different adult form. As adults the three amphibian groups have quite different body forms and behavioral ecology characteristics that are, no doubt, reflected in neural specializations. For example, all anurans with the exception of the most primitive have their adult social behavior driven by acoustic signals, while urodele social interactions are guided by olfactory and visual communication. Locomotion is highly specialized in anurans and the burrowing, fossorial apodans. Despite specialized features, common structural characteristics mark all amphibian brains, including a small brain to body ratio as well as less cell migration in most brain divisions and less differentiation into distinct structural and functional divisions than in larger brained vertebrates. Interestingly, amphibians share these characteristics with the lobe-finned lungfish and the most primitive ray-finned bony fish and sharks. Because of this, and because of the amphibians' position as living representatives of the ancestral vertebrates giving rise to reptiles, birds and mammals, amphibian brains have often been used as surrogates for the primitive condition from which the more advanced brains of amniotes evolved. In broad anatomical terms, there is probably some validity to this. In terms of the fine structure and the physiological and functional organization that go with it, such assumptions are riskier. Both the anurans and the apodans are highly derived vertebrate groups and therefore considering any particular brain character found in either as primitive should be done with extreme caution.

### Brain Size and General Structure

Overall brain size (relative to body size) in amphibians is small compared to that of mammals and birds, falling within the range of other amniotes such as fish [2]. Salamanders and newts have exceptionally small brains even for amphibians and seem to have undergone

an evolutionary reduction in brain size [2]. The amphibian brain has an elongated appearance in which the major vertebrate brain divisions are clearly visible (Fig. 1).

The medulla lies caudally and has the usual complement of motor and sensory areas. The cerebellum is apparent between the medulla and midbrain. It is curiously small in all amphibians. It is not clear whether this is a primitive trait or the result of a secondary reduction. These brain areas are relatively conserved across amphibian groups in their size and general appearance. The midbrain is large in anurans relative to the other amphibian groups due to an expanded optic tectum and torus semicircularis, which are homologous to the mammalian superior and inferior colliculus respectively. The forebrain, with diencephalic and telencephalic divisions, occupies the most rostral portion of the brain. The telencephalic hemispheres appear as

elongated cylinders with prominent ventricles, extending rostrally to terminate in main and accessory olfactory bulbs. Although older texts often present amphibian brains as being dominated by the midbrain with a small olfactory telencephalon, the forebrain (telencephalon and diencephalon, excluding olfactory bulbs) in fact represents about 40% of the total brain volume in anurans and about 56% in urodeles (Fig. 2).

Olfactory input into telencephalic areas is indeed extensive, but amphibians have the normal complement of vertebrate sensory systems, all of which make connections to diencephalic nuclei and ultimately the telencephalon. It is true that the functional organization may be quite different in amphibians compared to other tetrapods (see below), but the basic pattern of multiple sensory inputs – vision, hearing, somatosensory – reaching the forebrain along with olfaction is now recognized as common to all vertebrates.

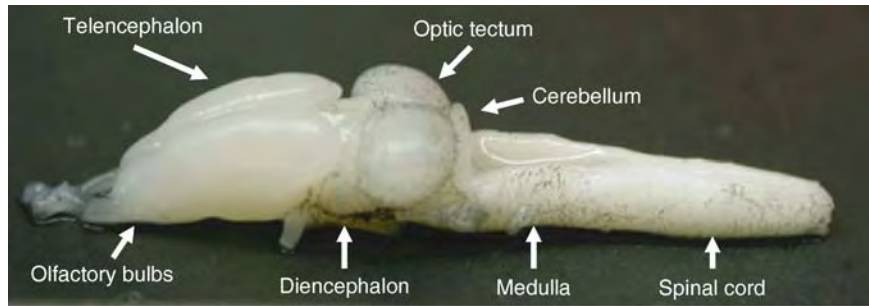

**Evolution of the Brain in Amphibians. Figure 1** Photograph of an anuran brain (the green treefrog, *Hyla cinerea*). Major brain divisions are indicated.

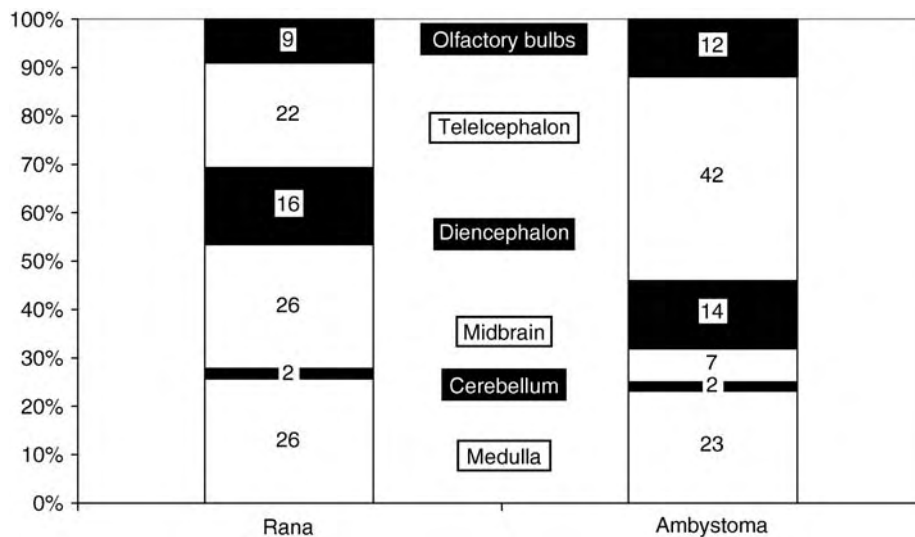

**Evolution of the Brain in Amphibians. Figure 2** Relative sizes of brain divisions in an advanced anuran (the bullfrog, *Rana catesbeiana*) and a urodele (*Ambystoma* sp.). Percent of total brain volume is indicated by the numbers in the boxes. Data from Northcutt et al. [3].



The general structure of the forebrain is, at a gross level, so clearly organized into the fundamental divisions familiar to all neuroanatomists that it has often been viewed as a representation of a primitive vertebrate ▶bauplan. The diencephalon is composed of four divisions oriented dorsal to ventral along a prominent, midline third ventricle. The clearly defined habenula comprises the epithalamus at the dorsal apex of the diencephalon. Beneath that is a dorsal thalamic division that is indirectly [4, 5] in receipt of ascending sensory input. Next is a ventral thalamic division with a mixture of ascending and descending outputs. The hypothalamus forms the floor of the diencephalon, with various divisions containing neurosecretory neurons and associated centers important in a variety of visceral, endocrine and behavioral functions. These are adult divisions; see Puelles et al. [6] for a discussion of their complex embryological origins.

A complex transition zone joins the diencephalon to the telencephalic hemispheres. Each hemisphere can be bisected into a dorsal pallial and a ventral subpallial zone, each in turn with lateral and medial components, resulting in four basic quadrants to the amphibian telencephalon. The lateral subpallium or striatum is embryologically, connectionally and histochemically similar to the basal ganglia of mammals, while the medial subpallium is equivalent to the septal area and related secondary olfactory nuclei. The lateral quadrant of the pallium has two divisions. The lateral pallium is dominated by olfactory input and as such is similar to the various olfactory cortices of mammals. A dorsal pallium above it has been considered the likeliest site of homologies to mammalian neocortical areas. The medial pallial area is similar to the hippocampus and associated limbic cortices. See Butler and Hodos [7] for a more thorough discussion.

The majority of neurons throughout the brain are situated close to the ventricles, with fiber tracts and terminal fields occupying the areas peripheral to them. As cell proliferation zones are located around the ventricles, this suggests less cell migration during development than is seen in reptiles and birds or mammals or even teleost fish and advanced sharks. Furthermore, differentiation of cell populations into discrete nuclei is less apparent in amphibians, especially urodeles, than in these other vertebrates [2, 7, 8]. There are some exceptions in anurans. The midbrain roof contains a complexly laminated optic tectum and an auditory torus semicircularis with several nuclei (Fig. 3).

Secondly, the anuran diencephalon is clearly divisible into multiple nuclei within three of its four divisions, the epithalamus, dorsal thalamus and ventral thalamus. Most hypothalamic cells remain very close to the ventricles. Thirdly, the medial halves of the telencephalic hemispheres are more expanded and differentiated than the lateral halves and the subpallial portion

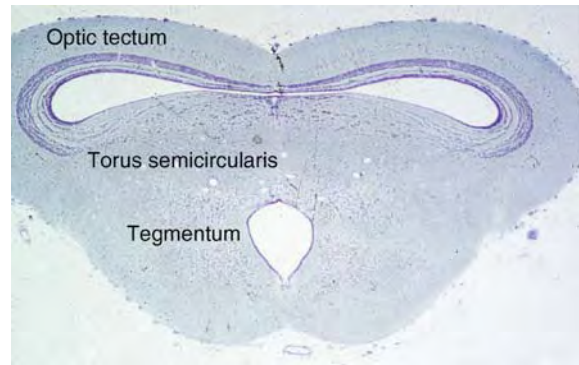

**Evolution of the Brain in Amphibians. Figure 3** Cross section through the midbrain of a bullfrog (*Rana catesbeiana*) showing the multilaminated optic tectum and the torus semicircularis beneath the tectal ventricle. The relatively undifferentiated reticular nuclei of the tegmentum can also be seen. Note that even in this expanded region of anurans, cell density is low and most neurons remain clustered near ventricles.

contains several distinct, migrated nuclei. In all three areas, urodeles and apodans have far less differentiated brains, with nearly all neurons occupying periventricular positions.

### Brainstem Areas and Cranial Nerves

The organization of the cranial nerves is highly conserved across all vertebrates, including amphibians. In addition to the standard tetrapod twelve identified pairs and their motor and sensory nuclei, lateral line nerves and nuclei such as those in aquatic vertebrates are present in tadpole stages and in the adult stages of those amphibian species that retain an aquatic life style following metamorphosis. The cranial nerves of amphibians that are also present in amniotes include the so-called special senses such as taste, hearing and vestibular systems as well as the general somatic sensory systems mediated by the trigeminal nerve and its three brainstem nuclei. All contribute to ascending sensory pathways that reach the diencephalon along with ascending somatosensory pathways from the spinal cord in a pattern recognizable in all vertebrates. Individual nuclei can be quite difficult to recognize, but overall what has been seen in the amphibian brainstem suggests that this area of the brain follows a conserved and probably primitive vertebrate plan.

The major exception to the simplicity and relatively undifferentiated structure of the brainstem is the midbrain roof of anuran amphibians (Fig. 3). There the optic tectum expands to form paired multilaminated dorsal lobes. This large and complex structure represents an important visual processing structure in the anuran brain related to the specialized visual predation characterizing frogs and toads. Some urodeles share this specialized feature [9].

The second expanded structure of the midbrain roof is the torus semicircularis. It lies caudal to the optic tectum in primitive frogs such as the pipids but is folded beneath the optic tectum in advanced frogs and toads as the increased expansion of both the tectum and torus rotates it underneath the tectal ventricle. The multiple nuclei of the torus serve as points of convergence for ascending auditory pathways, as well as an important motor interface between ascending auditory and descending forebrain inputs and outputs to various motor centers associated with vocal production [10]. The toral expansion in anurans coincides with this group's specialization of the auditory system for use in reproductive social behavior [11].

### Forebrain Organization

Virtually all of the detailed connectional anatomy of the amphibian forebrain has been done in anurans, although enough is known in urodeles to suggest that the basic anuran organization represents a general amphibian condition. The expansion and differentiation of diencephalic areas and medial parts of the telencephalic hemispheres are derived conditions in anurans however, as they are not shared by the other amphibian groups.

All ascending sensory pathways that have been investigated in any detail have been shown to reach thalamic nuclei. This includes visual input, both directly from the retina and from the optic tectum, auditory input from the torus semicircularis and somatosensory input from the spinal cord, dorsal column area and trigeminal nuclei. All have extensive connections to a variety of thalamic nuclei. There is very little if any olfactory representation in dorsal or ventral thalamic areas.

In terms of the input it receives therefore, the amphibian thalamus is similar in some respects to that seen in other tetrapods. One difference however, is that none of the thalamic nuclei are clearly dedicated to a single sensory modality, with the possible exception of the retinal recipient targets that lie along the lateral margins of the thalamus embedded within the optic tracts, the nucleus of Bellonci and the corpus geniculatum, both of which are ventral thalamic nuclei. A second difference concerns the pattern of termination of the direct retinal and somatosensory projections; while in fish and in amniotes these projections terminate within the anterior part of the dorsal thalamus (nucleus anterior), in amphibians they terminate within ventral thalamic nuclei, which then in turn project to the anterior part of the dorsal thalamus [4,5].

Dorsal and ventral thalamic nuclei are major relay centers sending their output to the telencephalon, hypothalamus and midbrain areas. Telencephalic connections from the middle and posterior portions of the thalamus terminate heavily in the basal ganglia region termed the striatum. The thalamo-striatal pathway is

the predominant ascending thalamic connection to the amphibian telencephalon. Anterior portions of the thalamus target instead telencephalic limbic regions, the medial pallium and septal nuclei. At least a small component of these connections reaches the dorsal part of the pallial division.

From these connections it can be seen that all sensory systems not just olfaction reach large areas of the telencephalon. In this general way, amphibians are similar to other tetrapods, notwithstanding that the inputs are dominated by a very heavy middle thalamic input to the striatum. The details however, reveal a quite different functional organization from that which might be expected [10]. The telencephalic targets of ascending sensory pathways are all multimodal. There is no evidence for separate representations for each sensory system, no indication of a topographically preserved projection from any thalamic nucleus to any telencephalic area and no physiological evidence for a sensory (or for that matter motor) map. In essence, there is no evidence for the distinct, unimodal, mapped sensory representations that are so prominent in the mammalian cortex. A possible exception may be the core olfactory-recipient region of the lateral pallium. That is not to say that there is or is not a homologue of mammalian neocortex within the amphibian telencephalon, but there are certainly no functional equivalents for the well-mapped, pure sensory zones that are so prominent in mammals and are significant telencephalic components in reptiles and birds.

A major question in vertebrate evolution is what happened at the transition from anamniotes to the true land vertebrates. Crucial to understanding this is deciding whether the structural and functional organization of the anuran telencephalon represents the primitive tetrapod condition or reflects the specialized functions of vision and hearing in these vertebrates. It is not easy to resolve this without extensive investigations in other primitive vertebrates.

### References

1. Duellman WE, Trueb L (1986) *Biology of the amphibians*. McGraw-Hill, New York
2. Striedter GF (2005) *Principles of brain evolution*. Sinauer, Sunderland
3. Northcutt RG, Neary TJ, Senn DG (1978) Observations on the brain of the coelacanth *Latimeria chalumnae*: external anatomy and quantitative analysis. *J Morphol* 155:181–192
4. Roth G, Grunwald W, Dicke U (2003) Morphology, axonal projection pattern, and responses to optic nerve stimulation of thalamic neurons in the fire-bellied toad *Bombina orientalis*. *J Comp Neurol* 461:91–110
5. Westhoff G, Roth G, Straka H (2004) Topographic representation of vestibular and somatosensory signals in the anuran thalamus. *Neuroscience* 124:669–683

6. Puelles L, Milán FJ, Martínez-de-la-Torre M (1996) A segmental map of architectonic subdivisions in the diencephalon of the frog *Rana perezi*: acetylcholinesterase-histochemical observations. *Brain Behav Evol* 47:279–310
7. Butler AB, Hodos W (2005) *Comparative vertebrate neuroanatomy: evolution and adaptation*, 2nd edn. Wiley-Liss, Hoboken
8. Wicht H, Northcutt RG (1992) The forebrain of the Pacific hagfish: a cladistic reconstruction of the ancestral craniate forebrain. *Brain Behav Evol* 40:25–64
9. Roth G (1987) *Visual behavior in salamanders*. Springer, Berlin
10. Wilczynski W, Endepols H (2007) Central auditory pathways in anuran amphibians: the anatomical basis of hearing and sound communication. In: Narins PM, Feng AS, Fay RR, Popper AN (eds) *Hearing and sound communication in amphibians*. Springer, Berlin, pp 221–249
11. Narins PM, Feng AS, Fay RR, Popper AN (eds) (2007) *Hearing and sound communication in amphibians*. Springer, Berlin

## Evolution of the Brain: At the Reptile-Bird Transition

MIHALY KALMAN

1st Department of Anatomy, Semmelweis University, School of Medicine, Budapest, Hungary

### Definition

Enlargement and elaboration of many brain features occurred independently in the diapsid line leading to modern reptiles and birds and separately in the synapsid line leading to modern mammals. Within the diapsid line, birds, which arose from the archosaur line that includes crocodiles, show the most elaboration of a number of their brain structures. They have the greatest number of distinct thalamic nuclei, particularly for the visual and somatomotor systems, correspondingly expanded areas of the telencephalic pallium for sensory, motor, and associative areas; elaborated cerebellar and basal ganglia circuitry for motor control; and the “astrocytic” glial system. All of these features are also present in mammalian brains, independently gained.

### Characteristics

#### Evolutionary Relations

The amniotes form three major groups: ► **Anapsida**, Synapsida, and Diapsida. Mammals are synapsids, whereas birds are diapsids, as well as the extant reptiles. Turtles were regarded formerly as anapsids, i.e. closest extant relatives of the ancestral, stock amniotes. Recent studies suggest, however, that the turtles are also

diapsids (see [1]). Major diapsid groups are the Archosauria (crocodiles, ► **pterosaurs**, dinosaurs, birds, and probably turtles) and Lepidosauria (Squamata: lizards and snakes). The closest extant relatives of birds are the crocodylians.

### External Morphology

Like in other tetrapods, the telencephalon consists of paired, evaginated hemispheres and an unevaginated telencephalon impar. In most reptiles the telencephalon is elongated, but rather rounded in the crocodiles and birds, and in the birds there is a rostromedial eminence (“Wulst,” Fig. 1).

The hemispheres cover the olfactory tracts in turtles, and, frequently, even the olfactory bulbs in birds. The major reptile/bird difference lies within the cerebellum. In the birds it is similar to that of mammals in size and foliation, but there are no distinct vermis and hemispheres. The optic lobes are pushed down, into dorso-lateral or even ventrolateral position by the large cerebellum. The crocodile cerebellum has a fissura prima and a fissura secunda; therefore, anterior, middle, and posterior lobes are separated. Otherwise the cerebellum is only a lamina, which curves backward in turtles but forward in lizards [2,3].

The birds have brain weights 6–10 times larger than reptiles (as related to the body weight) (see ► **Evolution, and Brain-Body Allometry**). One might suppose that these larger brains are necessary for a well-coordinated flight, but the cranial volume of pterosaurs was within the reptilian range (although near the upper border). The fossil bird, *Archaeopteryx*, from the late ► **Jurassic** already had a brain weight in the border range between birds and reptiles. The intense brain enlargement probably occurred before the late Eocene, as calculated from skull endocasts [1–3].

### Inner Structure and Cytoarchitectonics

In the spinal cord a characteristic structure of birds is the so-called lumbosacral sinus, which is filled with the jelly-like glycoide body. In the brainstem the reticular formation in crocodiles is more complex than in the other reptiles but less complex than in birds. In the cerebellum, despite the difference in size, the basic neuronal network is similar, except that basket cells are more numerous in birds than in reptiles. Reptiles have two deep cerebellar nuclei, whereas birds also have a third one [1,2].

The layering of the optic tectum in birds is more crisp demarcated than in reptiles, although its neuronal types are similar. Fifteen layers of the optic tectum are generally recognized in birds. The extra layer is recognized within the layers 2–8, whereas in reptiles only six layers, 8–13, constitute the same part of the tectum. (Note that, by convention, the layers of the avian tectum are numbered from superficial to deep, but in

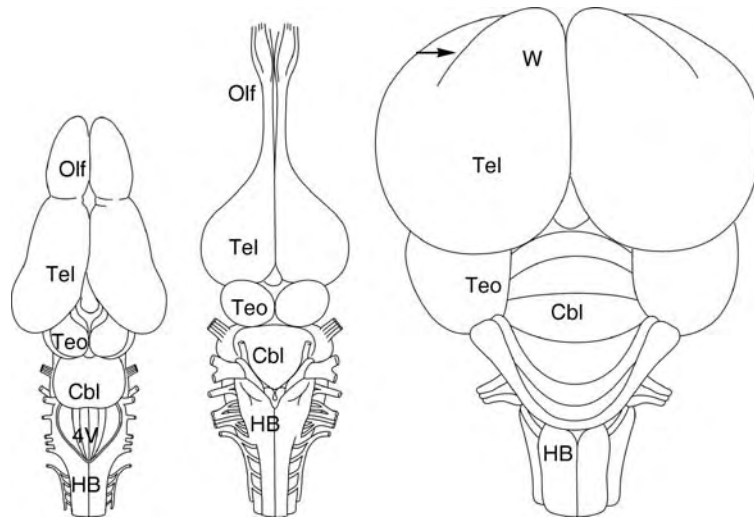

**Evolution of the Brain: At the Reptile-Bird Transition. Figure 1** Comparative sketches of turtle (a), crocodilian (b), and bird (c) brains. Note the conspicuous differences: Size and position of olfactory (Olf) tract and bulb; Size and shape of cerebellum (Cbl); The position of the optic tectum (TeO); HB hindbrain; Tel telencephalon; W “Wulst,” arrow points to the vallicule, i.e. the furrow bordering laterally, 4V fourth ventricle.

reptiles in the opposite way. When comparing the avian and reptilian tecta, a disparity exists in the placement of the boundary between the superficial and central zones). In reptiles the torus semicircularis is clearly distinct, whereas in birds it is not conspicuous, and hence named as nucleus mesencephali lateralis. A comparison of reptilian and avian diencephalic nuclei will be discussed below [1,2].

In both groups the telencephalic hemispheres consist of pallium and subpallium; the latter comprises the septum (discussed below with the limbic system) and the striato-pallidal complexes (Fig. 2).

In the subpallium magnocellular and parvocellular areas, corresponding to the pallidum and striatum, can be distinguished in reptiles. In birds, the striatum is more differentiated, with lateral and medial subdivisions of the dorsal striatum that are clearly distinct [1,2].

The pallium consists of medial, dorsal and lateral pallia, and the dorsal ventricular ridge (DVR), which bulges into the ventricle (Fig. 2). The DVR is characteristic of the brains of both reptiles and birds. Anterior and posterior parts are distinguished (ADVR, PDVR), and this structure is now known to be pallial rather than striatal, as previously believed. However, there is no general consensus as to whether it derives from the lateral or dorsal pallium or from the recently described ventral pallium [4]. The avian forebrain is reminiscent of that of reptiles, but three areas evolved substantially: the dorsal pallium, the DVR, and the medial pallium.

The dorsal (general) cortex of reptiles consists of the three main layers, deep and superficial cell-poor plexiform layers, and a middle neuron-rich layer.

Dorsolaterally a pallial thickening is found (Fig. 2a). In birds the layered arrangement dissolved into an irregularly scattered but markedly expanded neuronal population. In the rostromedial part of the dorsal pallium a thickening, the hyperpallium or Wulst (German for “hump,” Figs. 1c and 2c) evolved. Cytoarchitectonically it comprises three perpendicular arranged areas: hyperpallium apicale, intercalatum, and densocellulare. The “intercalatum” contains small granular cells, not yet found in reptiles [1,2]. Note that the new revised terminology of the avian brain (based on the recommendations of the Avian Brain Nomenclature Forum) is followed here, as in numerous recent publications, but not in the previous literature.

In turtles ADVR is separated from the dorsal pallium and the striatum by the dorsal and medial ventricular sulci (Fig. 2a). In the other groups the ADVR expanded (and the ventricle narrowed) to the point where it is difficult to recognize boundaries. In the crocodiles the ADVR lies immediately dorsal to the striatum (Fig. 2b), and in birds, is closely juxtaposed to the dorsal pallium, so only the medullary laminae (dorsal and superior frontal) mark the borders (Fig. 2c). In reptiles, there are only less distinct areas (dorsolateral and intermedio-lateral in the pallium, whereas the ventrolateral area corresponds to the striatum). In birds the ADVR comprises the so-called meso-, and nidopallium; within the latter there are further areas such as entopallium, Field L, and nucleus basorostralis. PDVR is also less distinct in birds; here the arcopallium and amygdalar complex are found, although their correspondence to the PDVR regions in reptiles is not yet resolved [1,2].

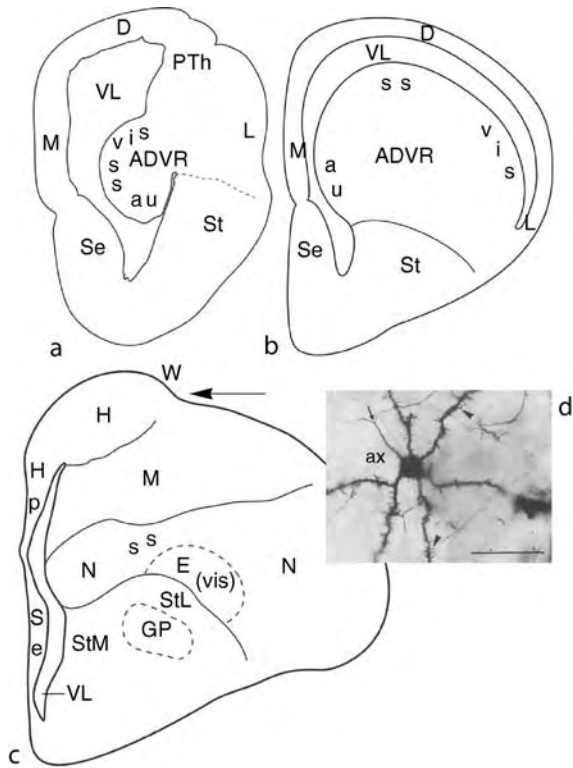

### Evolution of the Brain: At the Reptile-Bird Transition.

**Figure 2** Comparative sketches of telencephalic coronary sections (a,b,c – as in Fig. 1). Note the differences in the size, inner structure of DVR, and its connection to the other parts of the telencephalon. The continuous *thin lines* inside the drawings represent medullary laminae, while the *dashed lines* are cytoarchitectonical borders. (d) “Spiny” neuron from chicken entopallium. Ax axon (arrow points to branching), *arrowheads* – “spines” (small dendritic protrusions to receive synapsizing axons). Bar 50  $\mu$ m. (Photomicrograph of T. Tömböl.) ADVR anterior dorsal ventricular ridge; *au* auditory area; *D* dorsal pallium; *E* entopallium; *GP* pallidum dorsalis része (globus pallidus), *H* hyperpallium (its emergence forms the “Wulst,” *W*, arrow points to the vallicule, see also in Fig. 1c), *Hp* hippocampus; *L* lateral pallium; *M* medial pallium in (a) and (b), but mesopallium in (c), *N* nidopallium; *S* septum; *ss* somatosensory area; *St*, *StL*, *STM* striatum, mediale and laterale; *PTh* pallial thickening; *vis* visual area; *VL* lateral ventricle. In birds (c), the auditory area (field L) is caudo-medial to the somatosensory area (ss), i.e. it is not in the plane of section.

The reptilian ADVR has two basic cytoarchitectonic patterns, based on the distribution of neurons – type I or type II [5]. Type I occurs in the tuatara, turtles, and some lizards, whereas type II occurs in other lizards, snakes, and crocodiles, as well as in birds. The type I ADVR configuration has three relatively distinct zones: an outer, narrow cell-poor zone, with periventricular

neurons, their dendrites extending concentrically with the ventricular surface; the second zone has a relative large number of clustered neurons; whereas in the third zone there are scattered neurons, occasional clusters. The neurons are spiny or non-spiny, and the axons are radially arranged in the latter two layers. The more distributed type II configuration lacks zonal organization; instead it contains scattered clusters of neurons, which are almost all spiny (Fig. 2d) [1,2].

The medial pallium of reptiles (Fig. 3a) has also a three-layered cortical lamina, divided into medial and dorsomedial parts. Due to their cytoarchitectonics and connections, the medial cortex has been compared with the dentate gyrus and the dorsomedial cortex with Ammon’s horn. The medial part of the dorsal cortex may correspond to the limbic parts bordering the Ammon’s horn (subiculum, entorhinal cortex). The topological order of these parts is similar in mammals and reptiles [1].

In birds, the relationships of parts of the medial pallium to those in reptiles have been controversial (Fig. 3b). The avian medial pallium ends in a V-shape that contains two layers of neurons – ventromedial (Vm) and ventrolateral (VI) – collectively referred to as hippocampus, and a region of scattered neurons called parahippocampal area. Five different regions within the hippocampal formation have been recognized. The hippocampus has subdivisions VI and Vm, and the parahippocampal area has dorsolateral (DL), dorsal dorsomedial (DMd), and ventral dorsomedial (DMv) ones. VI and Vm have been argued to represent the Ammon’s-horn, and DL, DMd and DMv the dentate gyrus, subiculum and entorhinal cortex, respectively [1,6]. However, more recent work [7] has illuminated in the intrinsic connections and established homology of the V-shaped Vm and VI regions with the dentate gyrus of mammals and of DM to Ammon’s horn. The septal areas are similar in reptiles and birds. The main difference is that a direct septal-interpeduncular connection is missing from birds, but present in reptiles [1,2].

### Sensory Systems

There are two types of pathways to the corresponding thalamic relay nuclei: directly (so-called lemnthalamic pathways, referring to the direct sensory pathway as ribbon-like, as the word lemniscus means, or through the tectum (collothalamic, referring to the colliculi of the mammalian tectum). In the optic tectum, the superficial layers belong to the visual system (completely contralateral from the retina in birds, but with an ipsilateral component in some reptiles), whereas the deeper layers are multisensory, mainly somatosensory. The auditory pathway is represented in the torus semicircularis in reptiles, and the nucleus mesencephali lateralis in birds; only a collothalamic pathway has been reported for this system [1,2,8].

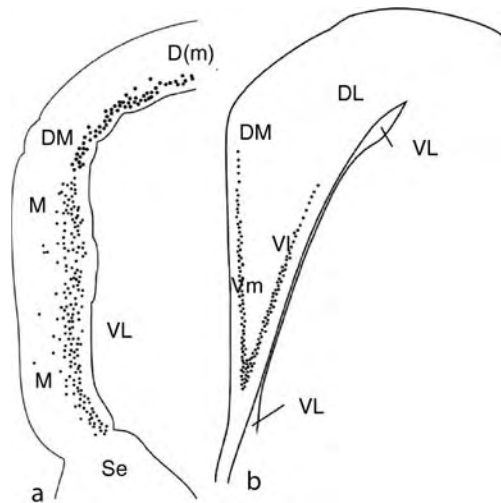

### Evolution of the Brain: At the Reptile-Bird Transition.

**Figure 3** Turtle (a) and avian (b) hippocampal formations. Note the varied subdivisions, and the position of the layer of large cells: DM in (a), V in (b). *D(m)* dorsal pallium, medial part; *DM* dorsomedial pallium in (a), the dorsomedial part of the hippocampal formation in (b); *DL* the dorsolateral part of the hippocampal formation; *M* medial pallium; *S* septum; *Vm,l* ventral medial and lateral areas of the hippocampal formation.

The collothalamic nuclei of reptiles are: nucleus rotundus (visual), nucleus medialis (auditory, called nucleus reuniens in crocodiles and turtles), and for the somatosensory sensory system a nucleus termed nucleus caudalis in turtles, nucleus medialis posterior in lizards, or as the medialis complex in crocodiles, where via the nucleus reuniens pars diffusa a secondary pathway also emerges. In birds, the nucleus triangularis is mentioned beside the rotundus in the visual representation, the somatosensory nuclei comprise nuclei dorsolateralis posterior pars caudalis and semilunaris parovoidalis (in some species: ovoidalis pars ventralis); the nucleus ovoidalis is auditory [1,2,8].

The lemnothalamic nuclei of reptiles are: the geniculatum laterale pars dorsalis (visual), and the dorsolateralis anterior and dorsomedialis (so-called perirotundal nuclei). These latter two are multi- rather than only somatosensory, having connections (mainly the dorsomedial) with viscerosensory, limbic, motor, etc. systems. In birds, the visual nucleus (opticus principalis thalami) is a complex of small nuclei, now called the dorsal lateral geniculate nucleus (DLGN). Somatosensory input is received by several nuclei: the dorsalis intermedius ventralis anterior (DIVA), the area ventralis intermedia (VIA), and a set of nuclei called the dorsal thalamic zone (DTZ), which have different functions. The latter two nuclei communicate with the motor and limbic systems, respectively. Comparing the thalamic

systems across sauropsids, the main difference seems to be that in birds more discrete nuclei are present, so that the different functions belong to specialized nuclei rather than multifunctional ones [1,2,8].

The thalamic sensory relay nuclei project to both the striatum and pallium, mainly ipsilaterally. The collothalamic pathways terminate in turtles in three neighboring areas (dorsal visual, medial somatosensory, ventral acoustic) which fill almost completely the AVDR, leaving free only the central area, for the incoming axons of the lateral forebrain bundle (Fig. 2a). In crocodiles the arrangement is less tight (Fig. 2b). In birds, the target areas are also derivatives of DVR: entopallium (visual, Fig. 2c), field L (acoustic), intermediate part of the nidopallium (somatosensory, Fig. 2c), which, however, leave large areas of DVR free. The lemnothalamic pathways project to the dorsal pallium (this area is called “lemnopallium”): in reptiles to the pallial thickening. In the avian dorsal pallium, the hyperpallium (also known as the Wulst, Figs. 1c and 2c) emerged to receive the somatosensory projections (from DIVA) and visual projections from DLGN, in distinct areas. Within the hyperpallium cytoarchitectonic “pseudolayers” (hyperpallium apicale, intercalatum, and densocellulare, see above) enhance the analysis. The thalamic and pallial representations are somatotopic (retino-, tonotopic) in birds, but, as for reptiles, this is only found in the somatosensory lemnothalamic pathway of crocodiles, more or less. In the hyperpallium the representations are bilateral, allowing for stereoscopic vision [1,2,8].

There is an especially important somatosensory system for the head, the trigeminal. It collects information from the oral and nasal regions, by which the animals can explore the environment actively. In reptiles, the somatosensory representation of head region is related to a lemnothalamic pathway that originates from both trigeminal sensory nuclei (principal and spinal), and projects to the nucleus dorsolateralis anterior thalami, which also receives the somatosensory input from the body. In birds, the head representation is rather separate from that of body. Whether it is comparable to the lemnothalamic trigeminal pathways in reptiles is yet to be determined. The pathway, the quintofrontal tract, originates in the principal trigeminal nucleus of the pons, lacks relay in either the midbrain or the thalamus, and terminates within the nucleus basorostalis pallii, in the nidopallium (i.e. in a collopallial area). Its evolution is not clear, though a relationship to the reptilian nucleus tractus olfactorii lateralis has been mentioned. The terminals of the basorostral pallial nucleus reach two areas of the nidopallium: frontale pars trigeminalis and caudale pars trigeminalis. The basorostral nucleus contains somatotopic representations [1,2,8].

Both the isthmo-optic, and isthmo-tectal nuclei, which help the early analysis of visual information, and the pretectal and other systems organizing the

oculomotor responses (mainly the nucleus lentiformis mesencephali) are more evolved, and have more extended connections in birds, than in reptiles [1].

The parietal eye (►Parietal organ) occurs in lizards (except for some equatorial species) but it was lost from most of snakes, most of turtles, crocodiles (which have not even pineal gland), and birds. The ►vomeronasal organ and the accessory olfactory bulb are also found in squamatae but were lost in other reptiles and birds. Occurrence of accessory olfactory bulb is accompanied by its sensory center, the nucleus sphericus in the PDVR of squamatae [1,2,8].

### Motor Systems

The reptile-bird transition involved a number of modifications in the motor control of limbs and head. Instead of the “wriggling” movement inherited from amphibians (such as Urodela) and used by squamate reptiles, walking with a limb-supported body evolved in dinosaurs and birds, with crocodiles representing more or less an intermediate stage. Evolving flight in birds (as well as in certain mammals and reptiles) separated the coordination between the anterior and posterior limbs.

Both in reptiles and birds the main motor pathways descend to the motoneurons from the deep layers of the tectum, the nucleus ruber, and the reticular formation. Notably, in birds the tectum has no direct connection to the spinal cord, only *via* the reticular formation. These systems in reptiles are controlled mainly by the striatum, *via*: (i) pretectum (mainly the nucleus of the posterior commissure), and (ii) the substantia nigra. Apart from a minor corticotectal projection, projections from the pallium to the striatum, rather than to the brainstem have been demonstrated. The cerebellum receives spinal, vestibular, and retinal inputs (via the pretectal nucleus of posterior commissure); its output targets are mainly the vestibular nuclei and, to a lesser extent, the nucleus interstitialis fasciculus longitudinalis medialis, nucleus ruber, and the thalamic subpeduncular nucleus. In reptiles, there is an apparent absence of striato-thalamo-cortico-striatal loops and of similar thalamic loops involving the cerebellum [1,2,9].

In birds the motor system consists mainly of (i) pallial efferents (ii) feedback loops involving the thalamus, and (iii) the additional elaboration of a cerebellar feedback loop. Concerning the pallial efferents, the somatosensory/motor part of the Wulst projects to the red nucleus and the reticular formation, the tectum, and presumably (at least in several species) to the contralateral spinal cord, resembling the pyramidal tract, but usually extending only to the cervical segments [10]. Another pathway, the occipitomesencephalic tract descends from the temporoparieto-occipital pallium, the anterior part of the arcopallium. This tract terminates, among others, on the tectum, the tegmentum, the lateral reticular

formation, and the rostral spinal cord. The pathway is related to the ascending pathway from the trigeminal system to the nucleus basorostralis palii: some efferents of the latter nucleus terminate in a region of the arcopallium, which in turn gives rise to descending projections to the spinal nucleus of trigeminal nerve [1,2,11]. From the striatum and pallidum, there are thalamic feedback systems by VIA to the Wulst, and by DTZ to the nidopallium and in turn to the arcopallium. The cerebellum receives new inputs, mainly from the pallium: from the Wulst *via* the pontine nuclei and the inferior olive and from the arcopallium *via* the lateral pontine nuclei and the pretectal nucleus spiriformis medialis. A new acquisition is also the cerebellothalamic connection, through VIA [1,8]. Specialized thalamic nuclei of these functions cannot be recognized in reptiles, although parts of other thalamic nuclei (periround nuclei, area ventralis) may have similar functions, mainly in crocodiles, which have also a pretectal input to the cerebellum [1].

Relatively little research has been done on the vocal control mechanism of reptiles. In the general case for birds the telencephalic auditory center, Field L, and the nucleus dorsomedialis posterior pars caudalis have efferents to the arcopallium pars ventralis, from which the vocal-respiratory pathway originates, which supplies the oral, respiratory, and larynx muscles. In songbirds the pathways involved in the regulation of vocal behavior are more complex. The ►syrinx is controlled by the tracheosyringeal division of the hypoglossal nucleus (nucleus XIIIts). The nucleus basorostralis also participates in these regulatory processes [1].

### Higher Cerebral Functions, Behavior

Numerous behavioral phenomena indicate a high evolutionary level of the avian brain, in some respects comparable, or even superior to that of most mammals (for reviews see [12,13]). Such key elements are visual acuity, color and stereoscopic vision, cognitive and learning abilities, elaborate vocalization, communication, imitation, advanced social behavior, nesting and nursing, prolonged family partnership, migration and homing, colony formation, ►food-storing. In reptiles, similar phenomena are absent, or rather infrequent and less elaborate (crocodilians: vocal signals, nesting and nursing, pelagic turtles: homing to the nesting shore).

The behavioral advances of birds can be attributed to the facts that large pallial areas remain free between the primary sensory and motor areas for associative tasks. In consequence, the intrapallial connections are also more extended (e.g. the fronto-arcopallial tract). The nidopallium caudolaterale has been proposed to be responsible for cognitive abilities, similar to those of the prefrontal cortex of mammals [14]. The temporo-occipital and lateral corticoid areas are also candidates of behavioral regulation [5]. The hippocampal

formation has more distinct subdivisions in birds (see Fig. 3), and distinct thalamic nuclei in the DTZ have become specialized for communication with the limbic system.

### The Glial System

Whereas brain structure, cytoarchitectonics and hodology are rather similar in reptiles and birds, most strikingly, their glial architecture is completely different (Figs. 4a, b, d, f vs. c, e, g). Birds share with mammals the general features of glial architecture and ►GFAP

distribution. These are: (i) predominance of astrocytes (stellate-shape cells, Figs. 4c and g), (ii) absent or limited GFAP-immunopositivity of several brain areas (Fig. 4e), and (iii) a distinct glial architecture of several brain areas. Radial fibers in the mature avian brain are found only along the telencephalic medullary laminae, in the hippocampus, and hypothalamus [1,14,15].

In reptiles, radially arranged ►ependymoglia is the predominant glial element, like in amphibia and fishes. Radial processes form the submeningeal ►glia limitans and the end-feet on the blood vessels (Figs. 4f and g).

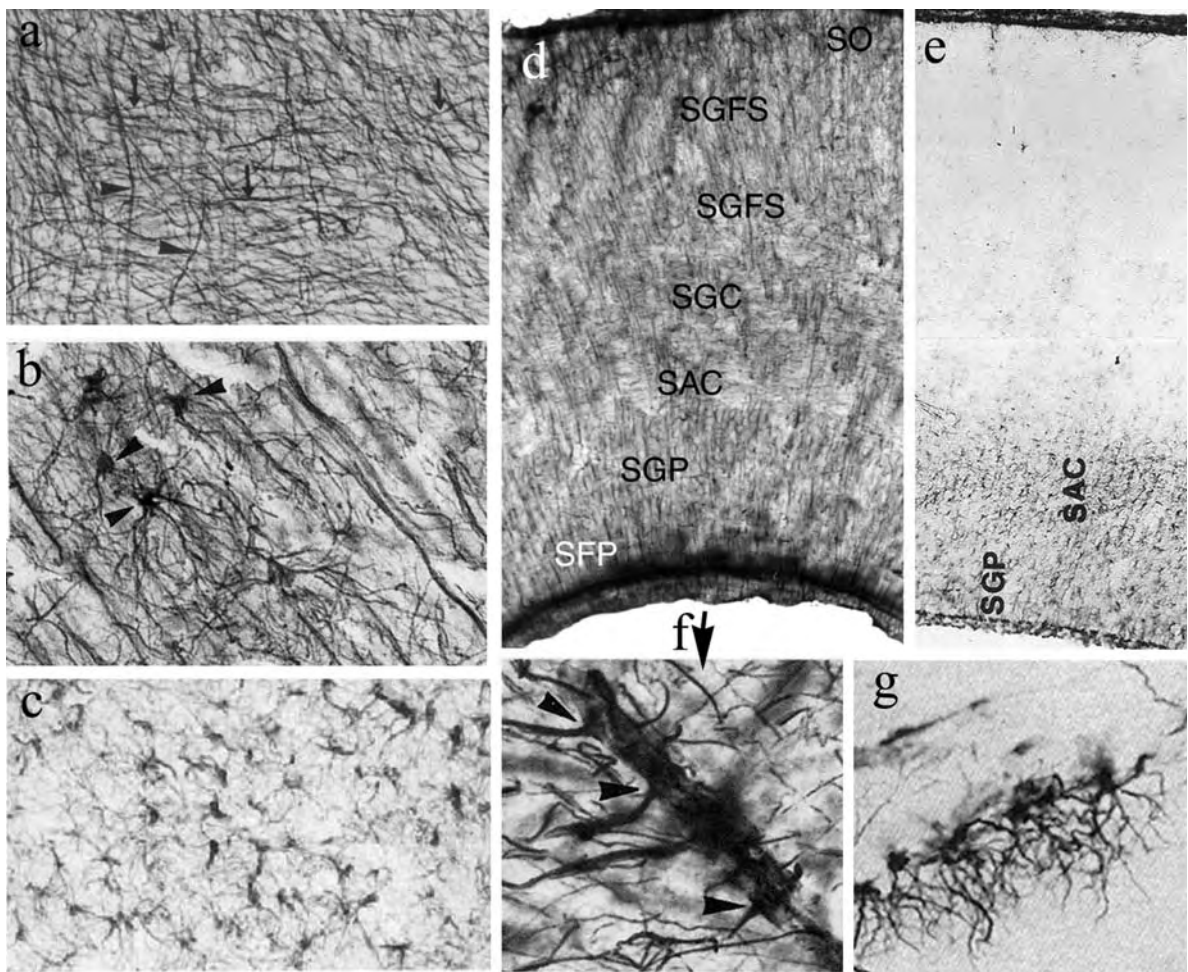

**Evolution of the Brain: At the Reptile-Bird Transition. Figure 4** Comparison of reptilian and avian glial system (immunohistochemical staining of GFAP). (a) Turtle; the radial processes (*arrowheads*) are almost completely masked by other processes (*small arrows*). (b) Caiman, between the radial cells astrocytes are also occur as complementary elements (*arrows*). (c) Chicken, the predominant elements are astrocytes. (d) Turtle tectum. Almost evenly distributed, immunopositive radial glia. SAC stratum album centrale; SFP stratum fibrosum periventriculare; SGFS stratum griseum et fibrosum superficiale; SGC stratum griseum centrale; SGP stratum griseum periventriculare; SO stratum opticum. (e) Chicken tectum: astrocytes, but immunopositive only in the deeper layers (therefore layers are only here recognizable). (f) Caiman, perivascular endfeet at the end of a long process (*arrowhead*). (g) Bird, perivascular astrocytes. (Photomicrophotographs of M. Kalman.)



The radial glia are interwoven with a number of fine non-radial processes. Except for some major tracts, no brain area is devoid of GFAP-immunopositivity. A comparison of the glial structures of the reptilian and avian tectal walls demonstrates the differences (Figs. 4d and e). Astrocytes have also been demonstrated in certain areas in snakes and lizards but not in turtles (Figs. 4a and b). In crocodiles, astrocytes are found in every major brain part but nowhere as a predominant glial element. No ►astrocyte was found in a perivascular or subpial position. Only in crocodiles were some nuclei (e.g. magnocellularis cochlearis) recognizable by their glial structure [15–17]. Oligodendrocytes, myelin sheaths, satellite glial cells, and microglia are similar in both groups.

### Lesion and Regeneration

The avian brain responds to lesions like the mammalian brain: after a critical stage of development no axonal regeneration is observed, and ►glial reaction is formed [18]. Neurogenesis in the adults is confined to some special areas, mainly those responsible for song-learning [19]. The glial reactivity and regenerative capability of reptiles has not been estimated with certainty, although there are data on post-lesion glial reaction (at least an intense GFAP expression), neuron production, and axonal regeneration. The latter phenomena may be attributed to the persistence of radially oriented ependymoglia, which preserves the original axonal pathways and may produce neurons, at least according to the recent data [17,20].

### Divergent Evolution of Squamates

Here only those features are summarized in brief, which were acquired (or lost) by snakes and/or lizards probably after their divergence from other reptiles. Their ancient features were mentioned above. In the visual system there were two tendencies. In the ►dracomorph lizards the visual system surpassed that of other reptiles, both in the tectum, which became ►iguanaid (type) from the most common ►lacertid (type), and in the extended visual area of ADVR. The other tendency is a moderate reduction of the visual system, in most snakes (e.g. ►ophiid (type) of tectum, poor pretectal nuclei), and a progressive reduction in ►burrowing lizards and snakes (►amphisbenid (type) of tectum, disappearance of some visual nuclei and pathways). In some snakes (Boidae and ►Crotalidae) a thermosensitive “►pit organ” evolved. This organ is innervated by the trigeminal nerve, and in these snakes the tectum is well-developed, like in most reptiles [1,2].

In snakes the motor system also has specific features. The spinal cord has no intumescenciae. To help the horizontal movement of the trunk, a separate vestibular nucleus evolved. ►Pythons (but not the snakes in general, see e.g. ►Colubridae) lack the rubrospinal tract [1,2].

### Interspecies Avian Differences

There are particular modifications associated with behavioral adaptation within the various clades. Songbirds (oscine perching birds) surpass the other birds in several fields. The food-storing songbirds have a high capability of memory based on a well-developed medial pallium. All songbirds have an elaborate vocal control system, organized around the higher vocal center (HVC). A part of this system, Area X, occurs only in males. In the HVC there is a seasonal reproduction and reorganization of neurons. Parrots have also high capability of cognition and learning and elaborate vocal control (note their imitation activity), but these abilities are based on a different neural organization [1].

The birds of prey have a large and well-developed visual hyperpallium and a descending system related specifically to the motor control of the talons. In owls it is accompanied with an elaborated spatial representation of auditory space. An expansion of the nucleus basalis is associated with the use of the beak as a tactile organ in wading birds. The neurobiological basis of the capability of homing has not yet been found, but olfactory, magnetic field sensitivity, and visual functions are supposed to play a role [1].

### Conclusion: Convergent Evolution with Mammals

Summarizing the advanced cerebral features of birds – the separation of functions in distinct nuclei, distinct and somatotopically organized thalamic and pallial sensory representations, stereoscopic and colored vision, the extended functions of telencephalon, its direct effects on the lower motor centers, the pallio-ponto-cerebellar connection, the striato-pallido-thalamo-pallio-striatal circuitry, the highly enlarged cerebellum, the extended associative pallial areas, and the “astrocytic” glial system – are also characteristic of mammals. These features evolved independently, despite the long-separated phylogeny, fundamentally different lifestyles, and rather different pallial morphogenesis and cytoarchitectonics of birds and mammals.

### Dinosaur Evolution or Reptile/Bird Transition?

Recent data suggest that many of the avian behavioral features were most probably also shown by some dinosaurs. Since birds’ ancestors were within the dinosaur clade, the question arises as to whether the avian behavioral features and cerebral structures that are advanced in comparison to those of reptiles evolved in dinosaurs or only in their avian descendants. Skull endocasts demonstrate, however, that most dinosaur brains were within the range of reptilian brains (as related to the body weight), except for some small ostrich-like, carnivorous dinosaurs (*Stenonychosaurus* and *Dromiceiomimus*). These latter ones appear to have had remarkably large brains falling into the range of

birds' brains. Such highly advanced dinosaurs, however, including those (mainly hadrosaurs) that left fossil marks of "bird-like" behavior, are recorded to the upper ►Cretaceous, whereas the bird-dinosaur divergence is supposed to have taken place in the (upper?) Jurassic. Therefore, the avian brain represents its own evolutionary line [1,2].

## References

- Butler AB, Hodos W (2005) Vertebrate neuroanatomy. Evolution and adaptation, 2nd edn. Wiley, New York
- Nieuwenhuys R, Ten Donkelaar HJ, Nicholson C (1997) The central nervous system of vertebrates. Springer, Heidelberg
- Northcutt RG (1981) Evolution of the telencephalon in nonmammals. *Annu Rev Neurosci* 4:301–350
- Puelles L, Kuwana E, Puelles E, Bulfone A, Shimamura K, Keleher J, Smiga S, Rubenstein JLR (2000) Pallial and subpallial derivatives in the embryonic chick and mouse telencephalon, traced by the expression of the genes *Dlx-2*, *Emx-1*, *Nkx-2.1*, *Pax-6*, *Tbr-1*. *J Comp Neurol* 424:409–438
- Ulinski PS (1983) The dorsal ventricular ridge: a treatise on forebrain organization in reptiles and birds. Wiley, New York
- Székely AD (1999) The avian hippocampal formation: subdivisions and connectivity. *Behav Brain Res* 98:219–225
- Atoji Y, Wild JM (2006) Anatomy of the avian hippocampal formation. *Rev Neurosci* 17:3–15
- Butler AB (1994) The evolution of the dorsal thalamus of jawed vertebrates, including mammals: cladistic analysis and a new hypothesis. *Brain Res Rev* 19:29–65
- Smeets WJA, Marin O, González A (2000) Evolution of the basal ganglia: new perspectives through a comparative approach. *J Anat* 196:501–517
- Wild JM, Williams MN (2000) Rostral Wulst in passerine birds. I. Origin, course, and terminations of an avian pyramidal tract. *J Comp Neurol* 416:429–450
- Wild JM, Farabaugh SM (1996) Organization of afferent and efferent projections of the nucleus basalis prosencephali in a passerine, *Taeniopygia guttata*. *J Comp Neurol* 365:306–328
- Butler AB, Cotterill RMJ (2006) Mammalian and avian neuroanatomy and the question of consciousness in birds. *Biol Bull* 211:106–127
- Butler AB, Manger PR, Lindahl IB, Århem P (2005) Evolution of the neural basis of consciousness: a bird-mammal comparison. *Bioessays* 27:923–936
- Güntürkün O (1997) Cognitive impairments after lesions of the neostriatum caudolaterale and its thalamic afferent in pigeons: functional similarities to the mammalian prefrontal cortex? *J Hirnforsch* 38:133–143
- Kálmán M (2002) GFAP expression withdraws – a trend of glial evolution? *Brain Res Bull* 57:509–511
- Kálmán M, Pritz MB (2001) Glial fibrillary acidic protein-immunopositive structures in the brain of a crocodylian, *Caiman crocodylus*, and its bearing on the evolution of astroglia. *J Comp Neurol* 431:460–480
- Romero-Alemann MM, Monzon-Mayor M, Yanes C, Lang D (2004) Radial glial cells, proliferating periventricular cells and microglia might contribute to successful structural repair in the cerebral cortex of the lizard *Gallotia galloti*. *Exp Neurol* 188:74–85
- Hasan SJ, Keirstead HS, Muir GD, Steeves JD (1993) Axonal regeneration contributes to repair of injured brainstem-spinal neurons in embryonic chick. *J Neurosci* 13:492–507
- Alvarez-Buylla A (1990) Mechanism of neurogenesis in adult avian brain. *Experientia* 46:948–955
- Font E, Desfillis E, Perez-Canellas MM, Garcia-Verdugo JM (2001) Neurogenesis and neuronal regeneration in the adult reptilian brain. *Brain Behav Evol* 58:276–295

## Evolution of the Brain in Birds

M. FABIANA KUBKE, J. MARTIN WILD  
Department of Anatomy with Radiology, Faculty of Medical and Health Sciences, University of Auckland, Auckland, New Zealand

### Definition

Birds share large brain–body ratios with mammals, although enlargement of their forebrain is more variable across species, and innovations in various parts of the brainstem have also occurred. The diencephalon and telencephalon both show enlargement and elaboration as compared with reptiles, particularly including the dorsal ventricular ridge (DVR) and Wulst regions of the pallium. The latter occupies much more of the telencephalic territory than previously realized. While possible homologies with mammalian brain structures are unresolved, the avian pallium similarly is in receipt of the major ascending sensory pathways, gives rise to descending corticospinal-like pathways, and is involved in motor control circuits with the basal ganglia and cerebellum. Further, avian brains exhibit considerable lability, as evidenced by the presence of novel nuclei for the vocalization (e.g., song) system.

### Characteristics

#### Origin and Evolution of Avian Brains

The prevailing view of the evolutionary origins of birds (*Aves*) is that they are derived from small theropod dinosaurs of the Middle to Late Jurassic, roughly 150 mya. However, our knowledge of the structure and function of the brains of modern birds has accumulated only within the last 100 years or so and predominantly in the last 35, due to the rise of contemporary techniques for the analysis of neuronal connections, gene expression, cladistic relationships, immunohistochemistry, and electrophysiology. From the evolutionary point of view, birds in general are considered to be flying

reptiles with a brain similar to that of modern, and presumably also to that of ancient, crocodylians (Archosaurs). The little we know about the brains of pre-Tertiary birds derives from studies of cranial endocasts, which suggest that *Archaeopteryx* exhibited a “bird-like” brain that was probably adapted for flight. Modern comparative neuroanatomy has, however, more frequently sought to compare avian and mammalian brains, rather than avian and reptilian brains, probably because of the disproportionate wealth of knowledge of the brains of mammals and the relatively modern view that birds and reptiles constitute a monophyletic group (Sauropsids).

### Quantitative Description

A classic approach to quantifying variation in brains is to look at how their size (or the size of brain regions) varies in relation to body weight. Principally, brain size varies with body size in a way that can be described by the allometric function:  $\text{brain weight} = a \times \text{body weight}^b$  [1], where  $a$  is the normalization constant and  $b$  is the scaling exponent. Differences in brain size are thought to result from two contributing factors – those changes in size directly related to differences in body size and increases in size due to encephalization [1]. Despite the close phylogenetic relationship between birds and

reptiles, the brains of birds are significantly larger than those of their close relatives and instead are more similar in size to the brains of mammals of similar body size. This suggests a strong evolutionary drive toward increasing brain size in the avian lineage, similar to that seen in mammals (Fig. 1).

Changes in brain size are the result of two types of brain evolution, which have been referred to as passive (easy) and active (difficult) modes [2]. The passive mode refers to global increases in brain size, whereas the active mode refers to enlargement of specific cell groups that are not accompanied by a concomitant enlargement of their containing structure. Variations in the relative sizes of brains and of brain regions have been extensively reported in the literature, for both birds and mammals. Despite the similarity in the relative brain size seen in birds and mammals, there are two important differences in the regulation of brain size in these two groups. First, the final brain size of adult birds depends on the developmental mode of the species under study (see later). Second, increases in brain size appear to be more homogeneous in birds than in mammals. While enlargement in the brain size of mammals is associated with a relatively greater enlargement of the forebrain, this is less pronounced in birds, and preferential enlargement of the forebrain may not

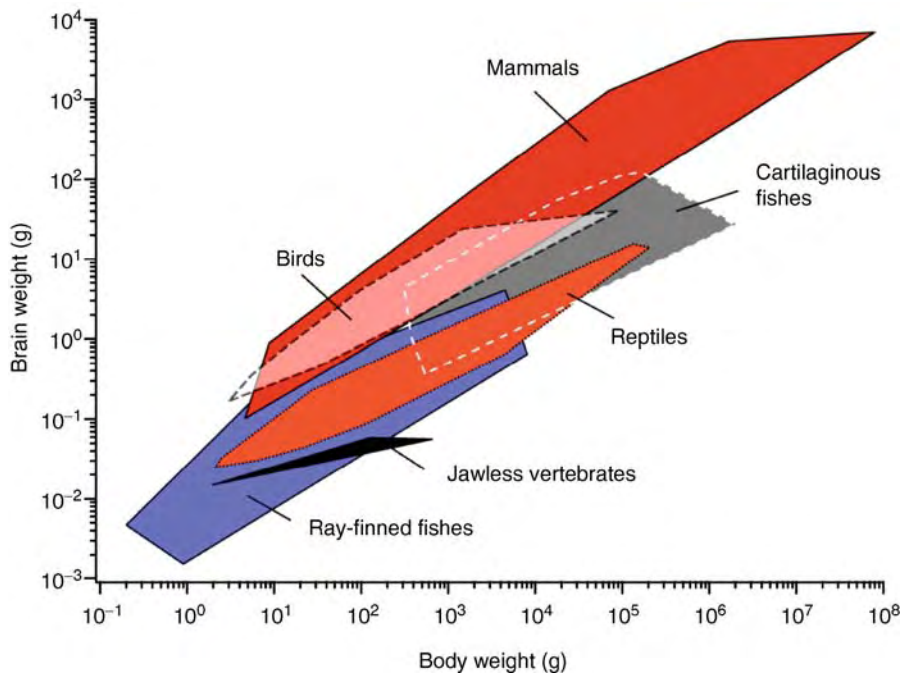

**Evolution of the Brain in Birds. Figure 1** Brain to body scaling in major vertebrate groups. Minimum convex polygon plots for mammals, birds, reptiles, and fishes. Despite the close phylogenetic relationship between birds and reptiles, the brain to body size relationship is more similar to that of mammals (Reproduced with permission from Georg Striedter, University of California, Irvine [2]).

be common to all birds, and may indeed be quite variable even within given orders. This suggests that the increase in total brain size in birds, unlike that in mammals, does not necessarily result from a predominant increase in the size of the telencephalon.

Enlargement of brain size (or brain regions) in mammals can be accounted for by protracted neurogenesis, that is, larger structures are achieved by delaying the birth date of constituent neurons, which may lead to an exponential increase in the number of progenitor cells [2]. It has been argued that increases in the size of specific mammalian brain regions occur at the expense of accompanying increases in size of related structures, but recent studies suggest that components of functional systems can also evolve together and independently of size changes in the rest of the brain (mosaic evolution or active mode) [2]. Evidence for mosaic evolution in birds has also been recently shown by several authors. Bennett and Harvey failed to see a correlation between specific brain structures and the specific niche occupied by the species and concluded that there appears to be no correlation between, for example, the size of the optic tectum (OT) and diurnal versus nocturnal habits. In contrast, Cobb showed variation in the ratio of the sizes of the optic tectum to auditory midbrain in different species, suggesting that in birds, too, variation in the size of separate functional structures can occur in the absence of global increases in the size of the brain (or the brainstem in this case). It has been suggested, for example, that auditory structures are enlarged in auditory specialists such as owls and that visual areas (e.g., the OT) are reduced in the nocturnal kiwi [3]. Thus, mosaic evolution can occur in avian brains; that is, variation in the relative size of the neuronal assemblies can occur in the absence of a parallel variation in relative size of the entire structure. Yet, although mosaic evolution may be evident in some individual species, i.e., at the level at which natural selection acts, it may not be a general trend in birds.

The variation seen in the relative number of neurons in the auditory nuclei of auditory specialists may also be dependent on body size. Since larger birds have larger brains, overall increases in brain regions may be achieved by simply scaling to body size. Relative increases, however, must by definition be the result of mosaic evolution. The relative enlargement (hyperplasia) of auditory areas may be less pronounced in auditory specialists of larger body size. We can propose that if a given neuronal computation requires a minimum number of neurons, larger birds may achieve sufficiently large nuclei simply as a result of the scaling of the brain to body size. Smaller sized birds may have limits on brain weight and may therefore require a relative increase in cell number (hyperplasia) in order to acquire an equally enlarged brain region.

Size changes in the avian hippocampus have been reported in relation to spatial orienting behavior and

in oscine song nuclei in relation to vocal repertoire [2]. Since these nuclei are subject to adult neurogenesis, variation in size may result from changes in adult neuron survival rather than from changes in developmental programs.

Thus, mechanisms other than those that underlie the general increases in brain size can operate to produce hyper- or hypoplasia of brain regions, and mosaic evolution can also be seen within functional units in the brains of birds.

### Description of the Structural Diversity of Avian Brains *Structural Diversity in the Avian Brainstem*

Although the structure of the brainstem of birds may at first glance appear constant and surprisingly reminiscent of that of a mammal, rather than that of a reptile [4], there is sufficient evidence that innovation in the avian brainstem can indeed occur. For example, the auditory nucleus laminaris, which appears to have evolved in the Archosauria and may not be present in other reptiles, exhibits morphological variation between bird species at both the histological and ►cytoarchitectonic levels, whereas the morphology of other auditory structures (with the exception perhaps of the nucleus angularis) appears to be quite conserved. The nucleus angularis in ratites and chickens has a medial region that extends dorsally toward the midline, which is absent in all other bird lineages examined (parrots, songbirds, pigeons). Since this medial region of nucleus angularis is seen in reptiles as well, it probably represents the plesiomorphic (ancestral) condition. Brainstems in the avian lineage also appear to lack a cerebellar-like structure (such as the dorsal cochlear nucleus of mammals or the dorsal octavolateral nucleus of fish), a characteristic found in most other vertebrate lineages.

Variation is not limited to the structure of nuclei, but is also expressed in the way in which different brain regions are interconnected. For instance, there appears to be significant variation in the way somatosensory pathways are organized in the brainstem of different species. A three-station projection system from the periphery to the rostral Wulst via the dorsal column nucleus and dorsal thalamus is probably present in all species for the mediation of tactile input from the body. This is accompanied by a separate, disynaptic projection system from the beak and oral cavity to the forebrain nucleus basorostralis pallii (Bas), via the principal sensory trigeminal nucleus (PrV). However, in some species, e.g., budgerigars, there is in addition a complete representation of the head and body in Bas, which is mediated by disynaptic projections via PrV (for the beak) and an adjacent subprincipal nucleus (for the body). In other species, e.g., the barn owl, a complete body representation in Bas is mediated both by a disynaptic projection via PrV (for the beak) and a trisynaptic projection via the dorsal column

nucleus and a large lateral pontine nucleus known as pontis externus (for the body) [5].

These examples show that variation in the brainstem can occur, including changes in relative size, lamination, and cytoarchitecture. This variation may be related to specific sensory specializations associated with loss or gain of function. Finally, although not specifically mentioned in the literature, there may be significant differences in the size of the brainstem in males versus females of some species (Wild, unpublished observations).

### **Structural Diversity in the Avian Forebrain**

Information from spinal and cranial nerves (with the exception of olfactory inputs) can be processed locally at the level of reflex arcs or can be routed for further processing in the forebrain. As in mammals, a significant number of inputs are routed through different thalamic nuclei dedicated to specific sensory or multimodal processing. However, unlike the case in mammals, the thalamus is not an obligatory relay to the forebrain in birds. Rather, several ascending systems, including an auditory and a somatosensory component, bypass the thalamus to innervate the nucleus basorostalis (Bas), which does not receive thalamic inputs. This suggests that two integration pathways (thalamic and nonthalamic) occur in the avian forebrain and it is not known to what extent (if any) these two pathways converge. It is, therefore, not surprising that it is in the organization of the telencephalon that the most obvious anatomical differences between birds and mammals are observed.

The common reference to “grey matter” highlights one of the most intriguing differences between the brains of birds and mammals, for while bird brains are full of “grey matter” – i.e., nerve cell bodies – these are not organized in the same way as are those that make up the “grey matter” of the mammalian cortex (Fig. 2). A hexalaminated and, roughly according to brain size, convoluted neocortex is the hallmark of the mammalian pallium (i.e., the dorsal part of the telencephalon), although it is sobering to remember that for the most part this cortex is no more than 2-mm thick. Other large, but nonlaminated collections of grey matter in a nuclear arrangement are located in the subpallium, where they are known as basal ganglia. Prior to the 1960s, it was thought that the great majority of the telencephala of birds, including large dorsal and ventroposterior parts then known as neostriatum, ectostriatum, hyperstriatum, and archistriatum, were collectively equivalent to the striatum of mammals, with only relatively thin portions of the medial and dorsal telencephalic walls being similar to the hippocampal and dorsal cortices, respectively, of other amniotes (Fig. 2). This erroneous assumption prevailed long after it was shown neurochemically that only those basal parts of the avian

telencephalon lying ventral to the lamina medularis dorsalis (LMD, as it was then known) are similar to mammalian basal ganglia [6]. Modern studies of the regional expression of genes regulating telencephalic development have confirmed the location of the basal ganglia, which develop from a ventral territory known as the subpallium [2]. To correct the terminology for neural territories dorsal to LMD, the Avian Brain Nomenclature Forum held at Duke University (USA) in 2002 replaced the names of structures having the suffix “striatum” with names having the suffix “pallium,” thus, nidopallium, entopallium, hyperpallium, and arcopallium [7].

Analogies can be made between avian and mammalian brains, regardless of their homologous relationship. Thus, the Wulst, which is largely a visual structure receiving a major thalamic input from the equivalent of the dorsal lateral geniculate nucleus of mammals, can be said to be analogous to mammalian neocortex and is often said to be homologous to it. That is, it is generally recognized that the same simple cortical structure that was probably present in stem amniotes gave rise to the superior part of the neocortex in mammals and to the Wulst in birds. However, the large part of the pallium that derives from the underlying DVR can also be considered analogous to mammalian neocortex, in that it receives major visual, auditory, and somatosensory inputs from discrete thalamic nuclei. The idea that components of the DVR are homologous to mammalian neocortex continues to be debated in comparative neuroanatomy [6]. The major point of contention focuses on the origin of the mammalian temporal cortex, this being thought to arise either de novo in the mammalian lineage or to be derived from a part of the dorsal cortex of stem amniotes that gives rise to at least rostral parts of the DVR in birds. Karten proposed that the primary sensory areas of the DVR are made up of neurons equivalent to those in layer IV of corresponding regions of mammalian neocortex (although such areas are now known to contain other types of neurons as well, for instance those that project to the striatum [6,8]). Other workers, basing their ideas on embryological and genetic expression analyses, are of the opinion that the sauropsid DVR derives from a subcortical pallial region in stem amniotes that in mammals gives rise to the claustrum, endopiriform region and/or pallial amygdala [2]. The evidence for and against these viewpoints has been thoroughly discussed [2,6].

### **Structural Diversity Associated with Behavioral Specializations**

Birds also have the ability to invent new nuclei as they see fit; that is, avian brains are labile to innovation. For example, birds that have evolved the ability to learn their vocalizations (e.g., song) have specialized

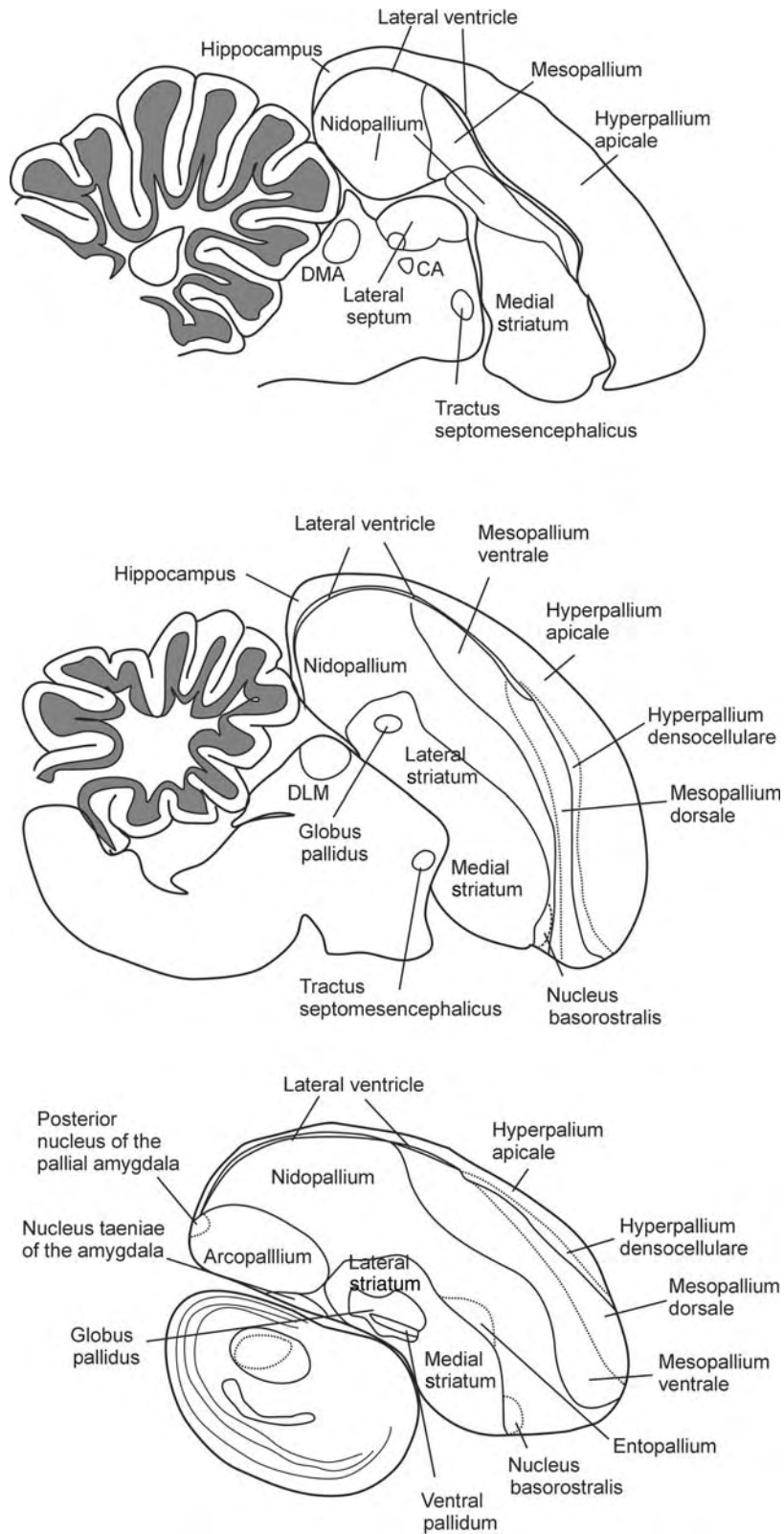

**Evolution of the Brain in Birds. Figure 2** Organization of the avian telencephalon. Medial to lateral series of schematics of sagittal sections of a brain of a zebra finch, illustrating the major components of the forebrain (Reproduced with permission from C. Siang and E. Jarvis, Duke University).

nuclei in their telencephalon that are not present in nonvocal learning species, even in the suboscine passerines; in vocal learners, these nuclei appear to have evolved independently at least three times during avian evolution, viz, in oscines, parrots, and some hummingbirds [5]. Because vocal learning is dependent on auditory feedback, some of these specialized nuclei in vocal learners are thought to have “grown out of” regions in the brains of ancestral species that gave rise to areas involved in higher level auditory processing in both vocal learners and nonvocal learners. In vocal learners [9], however, the specialized nuclei participate in auditory-vocal processing and integration and eventually give rise to a unique, major descending pathway from the telencephalon that directly innervates vocal motor neurons and respiratory premotor neurons in the medulla for the control of vocal production (song).

In other cases, birds appear to have evolved extreme behavioral specializations that may be mediated by novel brain structures or neural mechanisms remaining to be identified. For instance, the New Caledonian crow (*Corvus moneduloides*) manufactures tools from leaves to extract grubs from trees, a highly sophisticated and culturally transmissible trait that appears to exceed in intelligence the intellectual abilities of many primates (Fig. 3) [10]. The New Zealand kea, a notoriously



**Evolution of the Brain in Birds. Figure 3** New Caledonian crows manufacture and use tools. Photograph of a New Caledonian crow (*Corvus moneduloides*) holding a recently manufactured tool (Reproduced from Gavin Hunt and Russell Gray, University of Auckland).

mischievous parrot, also possesses a high level of intelligence evidenced by high-level problem solving, often involving social cooperation. However, since we do not understand the neural basis of human intellectual variation, it may be just as difficult to understand similar variations amongst birds and other animals, unless the behavior in question happens to be mediated by specialized nuclei as song learning is in songbirds.

#### **Developmental Mechanisms Underlying the Evolution of Avian Brains**

In birds, but not in mammals, relative brain size depends upon developmental mode. Precocial birds (those that are relatively mature in their development at birth) are born with larger brains with respect to body weight and grow to have proportionately smaller brains. The opposite is true for altricial birds (those that are relatively immature in their development at birth). Altriciality may be an evolutionary prerequisite for birds to attain larger brains, where altriciality is a necessary (but not sufficient) condition associated with increases in brain size. This is not true for mammals; brain size is not dependent on the species' developmental mode. Thus, the differences in the allometric relationships between different brain regions in birds and the dependency of total brain size on avian developmental mode would imply that the mechanisms that underlie the regulation of brain size in birds may be quite different to those proposed for mammals.

Increases in brain size must ultimately be brought about by increases in neurogenesis. This may be achieved by increasing the rate at which neuronal precursors are produced, increasing the length of time over which they are produced, decreasing the extent of neuronal death or a combination thereof. For example, a late neurogenesis thought to occur in altricial avian species may contribute to the relative enlargement of the brain. Indeed, Finlay and Darlington have proposed that in mammals protracted neurogenesis underlies the increase in the neuronal precursor population and an overall increase in the number of neurons and may be a mechanism by which specific brain regions can be enlarged [2]. Altriciality in birds may be accompanied by changes in neurogenetic times. Thus, studies similar to those of Finlay et al. need to be performed in birds.

Histological and cytoarchitectural changes are also the result of changes in developmental programs. Thus, the variation seen in the organization of avian brains must be brought about by diverging developmental programs that lead to the diversification of brains at different levels of organization. The developmental programs that give rise to the avian brain are not too different from those of other vertebrates. However, despite these common mechanisms, downstream cascades of gene action must certainly be regulated differentially to give rise on the one hand to brains that

look very different from those of other vertebrates and on the other to brains within different bird species that also differ markedly among themselves.

### Acknowledgments

We are grateful to G. Striedter for useful comments on an earlier version of this manuscript.

### References

1. Jerison HJ (1973) Evolution of the brain and intelligence. Academic, New York
2. Striedter G (2005) Principles of brain evolution. Sinauer, Sunderland
3. Craigie EH (1930) Studies on the brain of the kiwi (*Apteryx australis*). J Comp Neurol 49:223–357
4. Ariëns Kappers CU, Huber GC, Crosby EC (1936) The comparative anatomy of the nervous system of vertebrates, including man, 1st edn. MacMillan, New York
5. Butler AB, Hodos W (2005) Comparative vertebrate neuroanatomy: evolution and adaptation, 2nd edn. Wiley-Liss, Hoboken
6. Reiner A, Yamamoto K, Karten HJ (2005) Organization and evolution of the avian forebrain. Anat Rec A Discov Mol Cell Evol Biol 287:1080–1102
7. Reiner A, Perkel DJ, Bruce LL, Butler AB, Csillag A, Kuenzel W, Medina L, Paxinos G, Shimizu T, Striedter G, Wild M, Ball GF, Durand S, Güntürkün O, Lee DW, Mello CV, Powers A, White SA, Hough G, Kubikova L, Smulders TV, Wada K, Dugas-Ford J, Husband S, Yamamoto K, Yu J, Siang C, Jarvis ED (2004) Revised nomenclature for avian telencephalon and some related brainstem nuclei. J Comp Neurol 473:377–414
8. Krützfeldt NO, Wild JM (2005) Definition and novel connections of the entopallium in the pigeon (*Columba livia*). J Comp Neurol 490:40–56
9. Farries MA (2001) The oscine song system considered in the context of the avian brain: lessons learned from comparative neurobiology. Brain Behav Evol 58:80–100
10. Hunt GR (1996) Manufacture and use of hook tools by New Caledonian crows. Nature 379:249–251

## Evolution of the Brain in Fishes

MARIO F. WULLIMANN<sup>1</sup>, PHILIPPE VERNIER<sup>2</sup>

<sup>1</sup>Ludwig-Maximilians-University, Department of Biology II-Neurobiology, Planegg-Martinsried, Germany

<sup>2</sup>CNRS, Institute of Neurobiology A. Fessard, Gif sur Yvette Cedex, France

### Definition

Study of brain evolution across and within each of the major radiations of fishes reveals a Bauplan

or morphotype of the fish brain that exhibits many common ancestral neural traits – e.g. cranial nerves, brain subdivisions and the basic organization of ascending sensory pathways and of neurochemical phenotype distribution – shared by all craniates/vertebrates. At the same time many variations are revealed. The latter include substantial differences in pallial cytoarchitecture, tectal and cerebellar organization and emphasis of primary sensory centers. In sum, these findings are not consistent with the previously held notion of a linear *Scala naturae* in vertebrate brain evolution but rather with an appreciation of independent evolutionary events that have occurred on the foundations of the morphotype across and within different vertebrate radiations.

### Characteristics

#### Quantitative Description

The phyletic (cladistic) method of establishing ancestral and derived brain characters using data from modern functional neuroanatomical and chemoarchitectonic studies of fish brains supports the view of a largely conservative neural organization throughout the craniate/vertebrate neuraxis in which many specializations may be detected. For example, ascending sensory pathways into the telencephalic pallium, motor output systems and modulatory systems (dopamine, noradrenaline, serotonin, acetylcholine) of lampreys, cartilaginous fishes and actinopterygian fishes share many commonalities still present in tetrapods. Hagfishes also have many of these vertebrate traits, but they lack external eye muscles and their innervating cranial nerves, as well as a cerebellum. The characteristics that are shared across all extant fishes are those likely to have been present in the common ancestor of all craniates/vertebrates and thus form its Bauplan or morphotype.

#### Systematics/Species Diversity

Extant vertebrate (or craniate) fish groups (Fig. 1a; after Forey and Janvier [1]; Lauder and Liem [2]) include the two ►agnathan (jawless) or cyclostome, taxa of myxinooids (hagfishes: 32 species) and petromyzontids (lampreys: 41 species) and many gnathostome (jawed) vertebrate taxa.

The latter comprise three major taxa: (i) ►chondrichthyans (cartilaginous fishes), with roughly 1,000 extant species including holocephalans, sharks and batoids (rays and skates), (ii) actinopterygians (ray-finned fishes), which comprise slightly more than half of all living vertebrate species (i.e. 24,000) and (iii) ►sarcopterygians (lobe-finned fishes). The sarcopterygian radiation (Fig. 1a) includes two clades of fishes– the African, Australian and South American lungfishes (Dipnoi: six species) as well as the Comoran



E

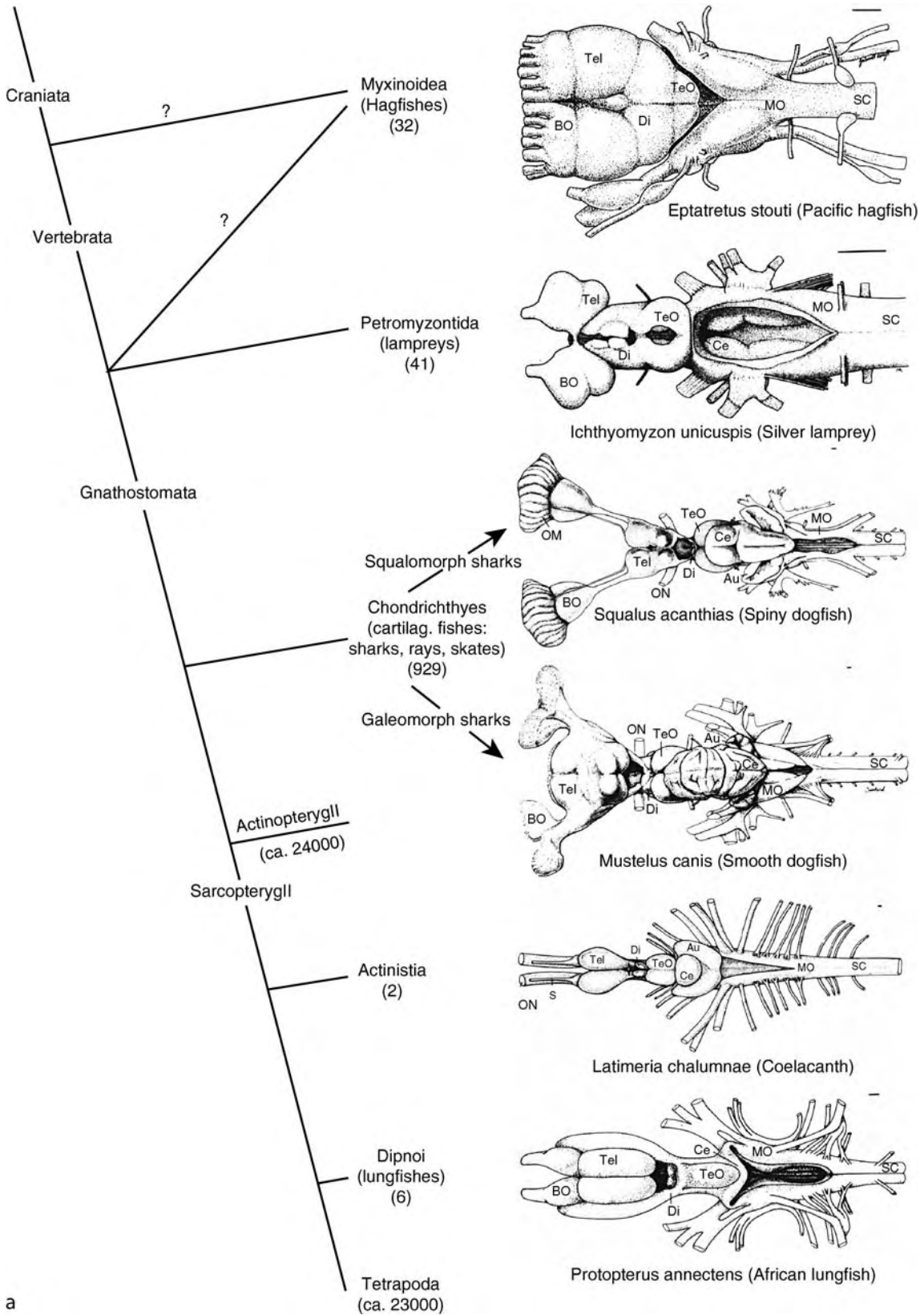

Evolution of the Brain in Fishes. Figure 1 Continued.

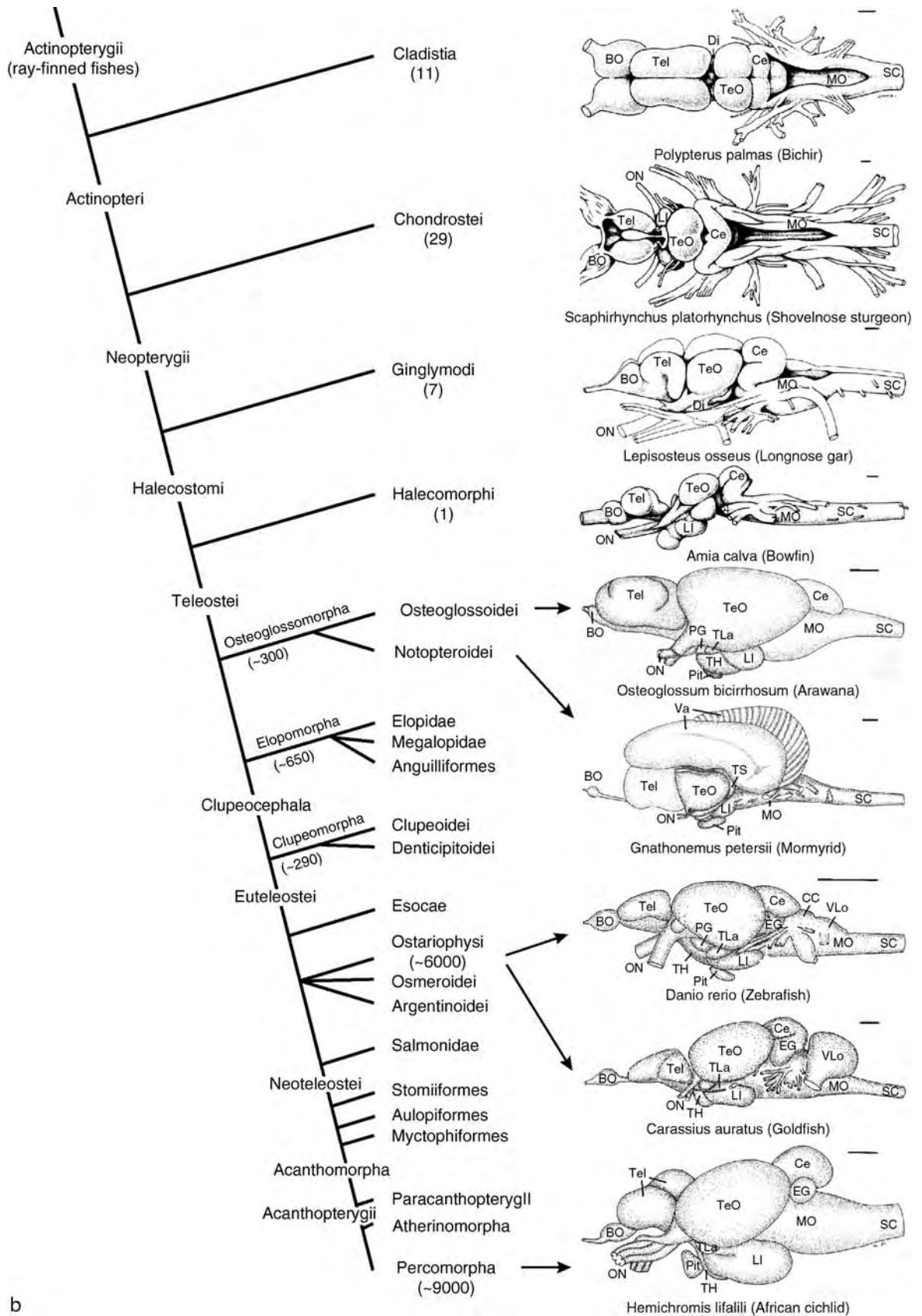

b

and Indonesian coelacanth (Actinistia; two species of *Latimeria*) – and also the large clade of the tetrapods (amphibians, mammals, sauropsids).

There are two major hypotheses about the systematic relationship of the two agnathan taxa with the ►gnathostomes (Fig. 1a). Morphological and paleontological data support the theory that the myxinooids (hagfishes) form an outgroup to gnathostomes and petromyzontids (lampreys), the latter two would then represent the vertebrates. Molecular genetic analyses [3,4] provide new evidence for the (classic) hypothesis that hagfishes and lampreys form a ►monophyletic taxon (the cyclostomes); hagfishes would thus be included in the vertebrate taxon. Consequently, their lack of vertebrate characters (for some in the nervous system, see below) would be due to secondary losses within the myxinooid taxon).

Of all extant fish taxa, actinopterygians comprise by far the largest radiation (Fig. 1b). Basal actinopterygian groups (bichirs, sturgeons, gars and bowfin) are small in extant species numbers, in contrast to their fossil representatives, the paleozoic chondrosteans (especially the palaeoniscoids) and mesozoic “holosteans”. These fossil radiations independently gave rise to many forms apparently adapted to all sorts of environments, probably from deep sea and free water to coral reefs. The three most basal living teleost groups are osteoglossomorphs (e.g. the African mormyrids and freshwater butterflyfish *Pantodon buchholzi* or the South American arapaima and arawana), elopomorphs (tenpounders, tarpons and eels) and clupeomorphs (herring-like fishes) and they include at present more species than non-teleost actinopterygians. The pinnacle of recent teleost species diversity is reached by more derived euteleosts, the largest groups among them being the ostariophysans (6,000 mostly freshwater species, including the cypriniforms, characiforms and siluroids) and the percomorphs (9,000 mostly marine species, including many coral reef forms). The fossil origin of teleosts lies in the early Mesozoic (late Triassic, free-water fish swarms, pholidophorids, leptolepids). However, teleost speciation, in particular that of acanthomorphs (which include percomorphs), increased tremendously towards and after the Cretaceous-Tertiary

boundary. A double duplication of the whole genome of a chordate ancestor (the 2R hypothesis) may have been instrumental in the emergence of vertebrates (or craniates), more than 500 million years ago and an additional round of genome duplication occurred between nonteleost actinopterygians and teleosts around 335–404 million years ago [5]. This genetic complexity of teleosts may have been critical for their tremendous species diversification, leading to the invasion of all aquatic environments, which cover 80% of the earth’s surface.

### Brain Weight-Body Weight Data

Vertebrate brain size/weight increases on average at a coefficient of 0.66 of the body weight, i.e. the steepness of the regression line reveals negative allometric growth of brain versus body weight [6,7]. Relative brain size (degree of encephalization) is indicated by real brain weight over expected brain weight (if real brain weight is on the regression line, the ratio has a value of 1). A comparison of the value for humans (6.45) with that of some actinopterygians, e.g. trout (1.2), goldfish (2.2) or the African electric fish *Gnathonemus petersii* (5.5), reveals independent increases in relative brain weight between and also within major vertebrate taxa (see Wullimann and Vernier [8]). Similar brain value diversity is seen in chondrichthyans. In particular, galeomorph sharks and myliobatiforms (stingrays) among batoids show independent brain enlargement [9].

Minimum convex polygons visualize total brain weight/body weight relationships between major taxonomic groups (Fig. 2). Polygons for mammals and birds lie above those of agnathans, amphibians and reptiles, i.e. mammalian and avian brains are consistently much larger for a given body weight (Fig. 2a). However, if cartilaginous and ray-finned fishes (in particular mormyrids) brain weights are added, their polygons overlap considerably with those of birds and mammals (Fig. 2b). This may largely but not exclusively be accounted for by disproportional growth of the cerebellum [9]. Clearly, early diverging (anamniote) vertebrate groups are not intrinsically constrained to have small relative brain weights. Brain weight-body

---

**Evolution of the Brain in Fishes. Figure 1** Cladograms depict systematics and species numbers of extant a craniates b actinopterygians (after [2]) combined with lateral or dorsal views of representative brains. Some drawings courtesy of Helmut Wicht (*Eptatretus*) and R. Glenn Northcutt (*Ichthyomyzon*, cartilaginous fishes, sarcopterygians, non-teleost actinopterygians). *Au* auricle; *BO* olfactory bulb; *CC* crista cerebellaris; *Ce* cerebellum; *Di* diencephalon; *EG* eminentia granularis; *LI* hypothalamic inferior lobe; *LL* lateral line nerves; *MO* medulla oblongata; *OM* olfactory mucosa; *ON* optic nerve; *PSP* parvocellular superficial pretectal nucleus; *Pit* pituitary; *PG* preglomerular area; *S* secondary olfactory peduncle; *SC* spinal cord; *SV* saccus vasculosus; *T* tegmentum; *TeI* telencephalon; *TeO* optic tectum; *TH* tuberal hypothalamus; *TLa* torus lateralis; *TS* torus semicircularis; *Va* valvula cerebelli; *VLo* vagal lobe.

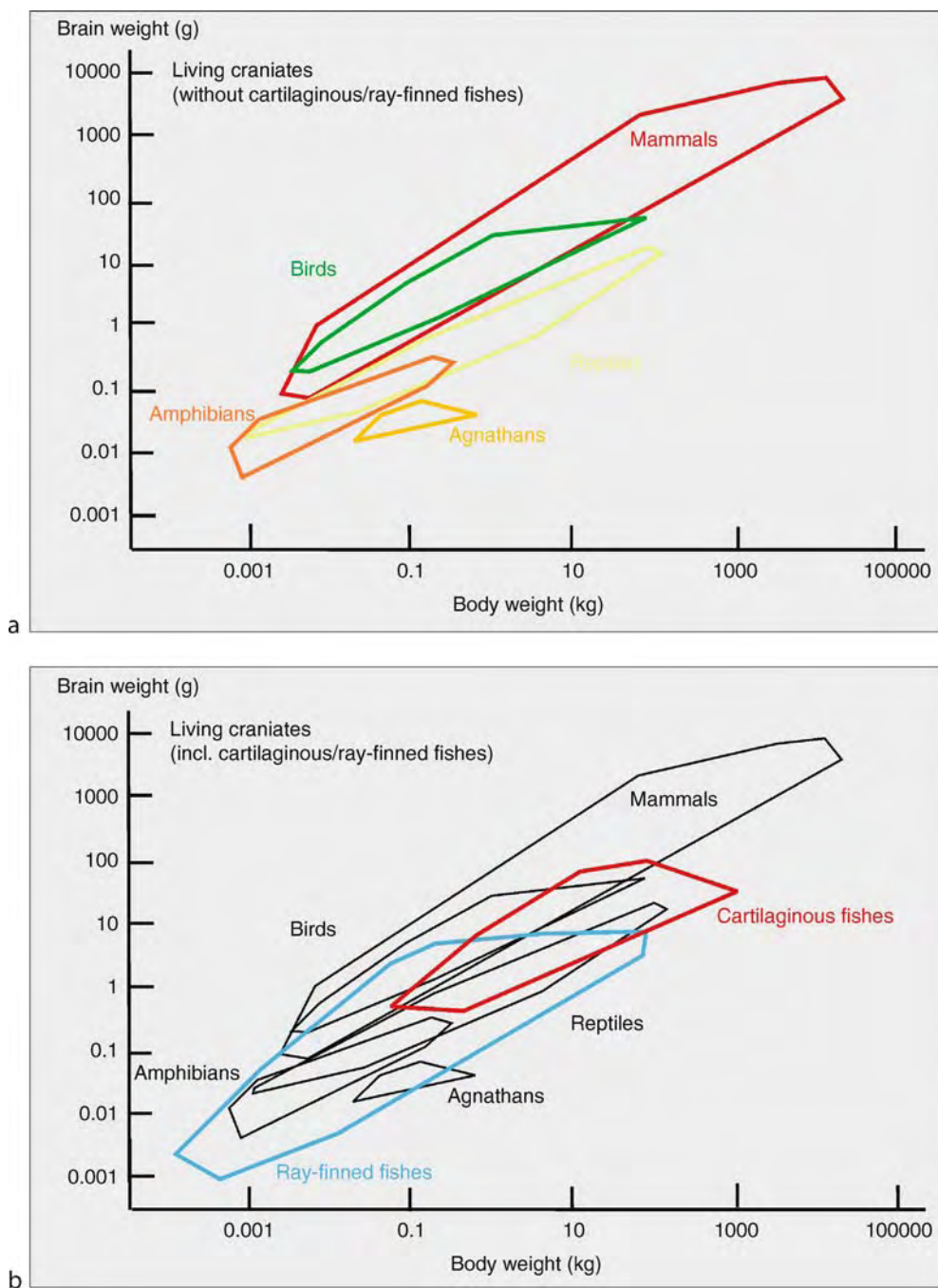

**Evolution of the Brain in Fishes. Figure 2** Brain weight/body weight relationships of living craniates (after [6]) without a and with b cartilaginous and ray-finned fishes. Note that their polygons overlap greatly with those of mammals and birds in comparable body size ranges.

weight data show that relative brain enlargement in evolution occurred several times each in cartilaginous and ray-finned fishes independently of that in mammals and birds. This homoplastic (convergent) evolution of vertebrate brain enlargement falsifies the common ladder-notion of *Scala naturae* [10].

#### Phyletic Analysis

To assess vertebrate brain evolution, the comparative (cladistic) method for establishing the evolutionary polarity of brain traits is used. It analyzes single organismic characters instead of entire organisms or their entire brains, leading to the identification of

ancestral (plesiomorphic) or derived (apomorphic) neural characters through the usage of well-supported ►cladograms (Fig. 1). Cladograms are exclusively based on shared derived characters (synapomorphies). Sister groups, such as sarcopterygians/actinopterygians (Fig. 1a) are characterized by synapomorphies inherited from their last common ancestor, distinguishing them from outgroup taxa (e.g. cartilaginous fishes in Fig. 1a). The outgroup comparison determines the evolutionary polarity of particular neural characters. If two conditions occur in sister groups [such as evagination of telencephalic hemispheres in sarcopterygians and eversion in actinopterygians (discussed below)], the condition in the outgroups is investigated (evagination in cartilaginous fishes), which, for reasons of parsimony (i.e. principle of choosing the simplest explanation), is considered to represent the ancestral condition.

### The Shared Ancestral Craniate/Vertebrate Brain Morphotype (Bauplan)

Instead of stepwise addition of brain parts at the rostral pole of the neuraxis during evolution, a craniate/vertebrate ►Bauplan of basic brain parts appears to have been initially present from which novelties arose

[10–13]. All craniate/vertebrate brains (exemplified for the zebrafish in (Fig. 3) exhibit in rostrocaudal order a telencephalon, a diencephalon (these two together comprise the prosencephalon or forebrain), a mesencephalon (midbrain) and a rhombencephalon (or hindbrain).

In gnathostomes, the hindbrain includes the metencephalon, (which contains the cerebellum) and the myelencephalon. The craniate/vertebrate mesencephalon includes a dorsally lying optic tectum (a visual-multisensory structure that corresponds to the mammalian superior colliculus) and torus semicircularis (a lateral line-auditory structure in fishes, amphibians and sauropsids that corresponds to the mammalian inferior colliculus), as well as a ventrally lying tegmentum. Three major divisions of the diencephalon, i.e. pretectum, dorsal thalamus and ventral thalamus (new: prethalamus) – classically considered a dorsoventral series – are now seen as a caudostral sequence of three transverse forebrain neural tube units (prosomeres) along the longitudinal brain axis (following the ►neuromeric model of Puelles and Rubenstein [14]), with the posterior tuberculum representing basal portions of prosomeres 2 and 3 and the region of the nucleus of the medial longitudinal fasciculus being

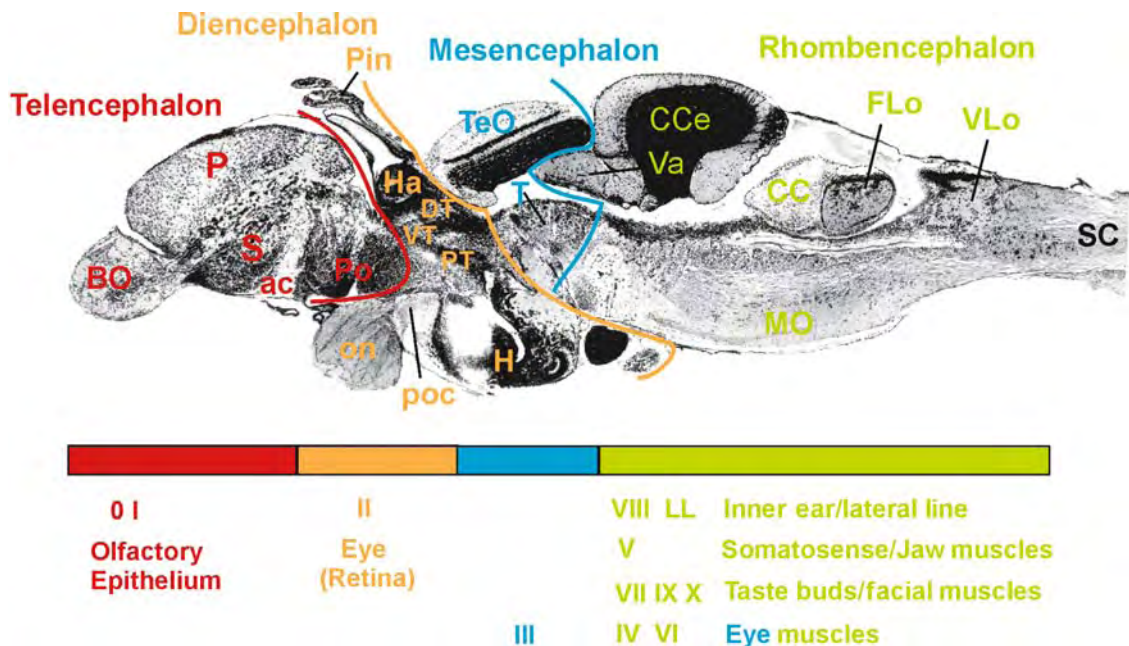

**Evolution of the Brain in Fishes. Figure 3** Sagittal section of adult zebrafish brain exemplifies gnathostome brain Bauplan (modified after Wullimann, M.F., B. Rupp and H. Reichert: Neuroanatomy of the zebrafish brain, Birkhäuser, Basel, 1996). Cranial nerves and their associated organs are listed at figure bottom. *ac* anterior commissure; *BO* olfactory bulb; *CC* crista cerebellaris; *CCe* corpus cerebelli; *DT* dorsal thalamus; *FLo* facial lobe; *H* hypothalamus; *Ha* habenula; *MO* medulla oblongata; *MON* medial octavolateralis nucleus; *on* optic nerve; *P* pallium; *Pin* pineal organ; *Po* preoptic region; *poc* postoptic commissure; *PT* posterior tuberculum; *S* subpallium; *SC* spinal cord; *T* tegmentum; *Tel* telencephalon; *TeO* optic tectum; *Va* valvula cerebelli; *VLo* vagal lobe; *VT* ventral thalamus (prethalamus).

the basal portion of prosomere 1. The craniate/vertebrate telencephalon includes a pallium (which includes the isocortex [neocortex] in mammals as well as other components) and a subpallium (which includes the striatum, pallidum and most components of the septum in mammals) representing together with the hypothalamus (as well as the eminentia thalami and preoptic region) the most rostral and prechordal part of the neural tube.

### Cranial Nerves

Two of twelve cranial nerves traditionally recognized in human neuroanatomy, the hypoglossal (XII, motor innervation of tongue) and spinal accessory nerve (XI, motor innervation of some neck muscles) are unique to tetrapods. The remaining ten nerves, as well as an additional one (the terminal nerve), characterize almost all vertebrates. Thus, in lampreys and gnathostome fishes, the olfactory nerve (I) enters the olfactory bulb at the rostral pallial pole of the telencephalon; the terminal nerve (0) is also associated with the telencephalon. The optic nerve (II) enters the vertebrate diencephalon at the ventral boundary region of preoptic region and hypothalamus. The oculomotor nerve (III) exits the mesencephalic tegmentum. The vertebrate rhombencephalon is ancestrally characterized by its association with the majority of cranial nerves and their primary motor and sensory centers, i.e. the trochlear (IV), trigeminal (V), abducens (VI), facial (VII), otic (VIII), glossopharyngeal (IX) and vagal (X) nerves (see ►[Evolution of the Hindbrain](#); ►[Evolution of the Oculomotor System](#)). Additionally, fishes and some amphibians have lateral line nerves (including a mechanoreceptive component – and in some taxa an electroreceptive component). Myxinoids generally share this pattern but lack external eye muscles and thus the associated cranial motor nerves (i.e. III, IV and VI), as well as a terminal nerve and the electroreceptive – but not the mechanoreceptive – component of the lateral line nerves [8,10,15,16]. As discussed above, the absence of these and additional neural characters (cerebellum, see above) is either due to secondary reduction within this taxon [3] or alternatively represents the ancestral craniate condition [1]. The sensory organs and motor structures subserved by craniate cranial nerves are listed for the zebra fish in Fig. 3.

### “New Head” Hypothesis

This hypothesis explains in developmental terms the evolution of the considerable increase in complexity of the craniate/vertebrate head compared to protochordates [17]. In addition to neural tube (all central nervous system somatomotor and visceromotor nerve components) and neural crest (peripheral nervous system

sensory and visceromotor nerve components) – that are both involved in spinal nerve development as well – another set of neuroectodermal structures, the placodes (epidermal thickenings with neurogenic fate), gives rise to some of the cranial nerve components in the head and to most special sense head organs. Although primordia of neural crest and placodes have been described in cephalochordates and urochordates [18,19], the New Head of craniates relies on the emergence of new organizing centers at the cephalic animal pole, which are maintained and regulated by placodes and migratory neural crest. This New Head hypothesis gives a clear definition of sensory cranial nerves including distinct placodal origin, resulting peripheral ganglion and sensory receptor structures and most importantly separate primary central nervous projection nuclei. It falsifies the so-called octavolateralis hypothesis, which assumed that lateral line mechanoreceptors on the fish body surface were internalized in evolution into the labyrinth to serve tetrapod auditory function, as well as the related concept of a primary sensory octavolateralis region in fishes where lateral line and otic nerve input overlap. The ancestral condition for vertebrate fishes is from dorsal to ventral, three separate sensory medullary columns dedicated to receiving segregated lateral line electrosensory, mechanosensory and otic nerve information [20].

### Ascending Central Nervous Sensory Pathways

The previously held smell-brain theory suggested that the fish telencephalon is dominated or even exclusively reached by secondary olfactory input from the olfactory bulb. Thus, a multisensory telencephalon or pallium was seen as a derived amniote or mammalian feature. However, the synaptic relay from primary sensory centers throughout the ascending neuraxis into subpallium and/or pallium in all fishes reveals general similarity to the situation in amniotes.

### Actinopterygians

In teleosts, almost all sensory pathways have been neuronally traced from primary sensory centers into the telencephalon (review Wullimann, [21]), which definitely receives largely non-overlapping information from all sensory systems (see ►[Evolution of the Telencephalon: in Anamniotes](#)). Secondary olfactory input reaches a limited pallial territory (i.e. the homologue of the lateral pallium or olfactory cortex) and most subpallial areas. The teleostean visual system exhibits a direct retino-thalamofugal and an indirect retino-tecto-thalamofugal system with synaptic relays in the dorsal thalamus, both of which may be terminating in the subpallium and not in the pallium. However, in certain teleosts, tectofugal visual information reaches the pallium via the preglomerular region, a complex of migrated nuclei lateral to the

posterior tuberculum (see below). The auditory and lateral line mechanoreceptive systems ascend multisynaptically in the lateral longitudinal fascicle via mesencephalic torus semicircularis and diencephalon to the pallium, i.e. they are very similar to the lateral lemniscal system of tetrapods. The same organizational scheme applies to the electroreceptive system, which is lost in neopterygians (Ginglymodi, Halecomorphi and Teleostei; see Fig. 1b), but re-appears in certain teleost groups, i.e. in osteoglossomorph African mormyrids and in South American knife-fishes and catfishes (the later two both ostariophysans). Gustatory information in teleosts reaches the diencephalon and telencephalon via a medullary secondary gustatory nucleus, comparable to the parabrachial nuclear region of mammals. Finally, teleosts possess a direct spinal ascending somatosensory system similar to the mammalian anterolateral (protopathic) system in addition to indirect spinal ascending projections which are relayed at the obex level, comparable to the mammalian medial lemniscal (epicritic) system.

A general, notable difference between teleost and amniote ascending sensory circuitry is that the predominant diencephalic targets of teleostean ascending sensory projections are not in the dorsal thalamus, but rather in the preglomerular nuclei located in the lateral periphery of the posterior tuberculum (see ►[Evolution of the Telencephalon: in Anamniotes](#)). This preglomerular region has striking functional similarity to the amniote dorsal thalamus, as both make up a large proportion of the diencephalon, are subdivided into many nuclei associated with specific sensory systems and have reciprocal connections with the pallium. A hallmark of teleosts is that they evolved into sensory specialists for all modalities, which is prominently displayed in functional neuroanatomy [10,21].

### Chondrichthyans

Except for the little investigated gustatory system, the available information for the remaining sensory systems in cartilaginous fishes reveals that there is an ancestral condition of ascending sensory pathways and centers common to all gnathostomes (see ►[Evolution of the Telencephalon: in Anamniotes](#)). These data in cartilaginous fishes suggest that a dual innervation of the diencephalon (dorsal thalamus/posterior tubercular region) by at least some ascending sensory systems is the ancestral pattern for gnathostomes. Also, the chondrichthyan telencephalon is clearly multisensory in nature. Together, the findings for actinopterygians and chondrichthyans disqualify the smell-brain theory because they demonstrate that ascending pathways of most if not all sensory systems reach the telencephalon and thus that this condition was also most probably present in the ancestral gnathostomes.

### Agnathans

Although the telencephalon, including the pallium, is far more dominated by secondary olfactory input in hagfishes and lampreys (see ►[Evolution of the Telencephalon in Anamniotes](#)) than in gnathostome fishes, this condition does not revive the smell-brain theory. Extant agnathans differ much from their ancestors in morphology and life habits that are seemingly very specialized for olfactory orientation, possibly representing adaptive novelties. Moreover, both in lampreys and myxinooids, the telencephalon (and pallium) is of a multisensory nature, not, as the smell-brain theory would predict, of an exclusively olfactory nature.

### Integrative/Motor Centers

The cytoarchitectonic and modular organization of the craniate/vertebrate optic tectum, its segregated multimodal input and the topographical representation of this input and output to the reticular formation very probably provide an ancestral neuronal machinery apparently exquisitely designed for integrative orientation tasks such as object identification and location and coordinated motor control. In contrast, a cerebellum exhibiting the typical three-layered cortex with comparable cell types and internal circuits is only seen in gnathostomes, probably already in the ancestral stock, with functions in motor learning and coordination. Both the optic tectum and the cerebellum act on the motor structures with descending projections to medullary and spinal levels, i.e. reticular formation, caudal (inferior) raphe region, vestibular and sensory trigeminal nuclei and the nucleus of the medial longitudinal fasciculus.

### Neurochemical Organization

Studies on neurotransmitter/neuromodulatory systems largely confirm the existence of a common Bauplan of brain organization in craniates/vertebrates [8]. In particular, the neurochemical anatomy of fish neuromodulatory systems, i.e. dopamine, noradrenaline, serotonin, histamine and acetylcholine, reveals a conserved picture. In addition to their role in motor programming and sensory processing, these neuromodulators participate in the ascending modulatory systems involved with more specific behavioral processes such as reward and motivation, awareness, aggression or escape, sleep, thirst and hunger. Accordingly, many projections course rostrally in a very divergent manner, probably accompanying the evolutionary invention of the telencephalon in craniates. Among those systems that were probably ancestrally present are a noradrenergic locus coeruleus, serotonergic superior raphe nuclei, dopaminergic basal diencephalic (all craniates/vertebrates) and mesencephalic (all except actinopterygians) and possibly both brainstem and basal forebrain cholinergic populations as seen in amniotes.

## References

- Forey P, Janvier P (1994) Agnathans and the origin of jawed vertebrates. *Nature* 361:129–134
- Lauder GV, Liem KF (1983) The evolution and interrelationships of the actinopterygian fishes. *Bull Museum Comp Zool* 150:95–197
- Furlong R, Holland PWH (2002) Bayesian phylogenetic analysis supports monophyly of Ambulacraria and of cyclostomes. *Zool Sci* 19:593–599
- Mallat J, Sullivan J (1998) 28S and 18S rDNA sequences support the monophyly of lampreys and hagfishes. *Mol Biol Evol* 15:1706–1718
- Hoegg S, Brinkmann H, Taylor JS, Meyer A (2004) Phylogenetic timing of the fish-specific genome duplication correlates with phenotypic and taxonomic diversification in fishes. *J Molecular Evol* 59:190–203
- Jerison H (2001) The evolution of neural and behavioral complexity. In: Roth G, Wullimann MF (eds) *Brain evolution and cognition*. Spektrum Akademischer Verlag/Wiley, Berlin, pp 523–554
- van Dongen PAM (1998) Brain size in vertebrates. In: Nieuwenhuys R, ten Donkelaar HJ, Nicholson C (eds) *The central nervous system of vertebrates*, Springer, Berlin Heidelberg New York, pp 2099–2134
- Wullimann MF, Vernier P (2007) Evolution of the nervous system in fishes. In: Kaas J (ed) *Evolution of nervous systems*, vol 3: *Evolution of nervous systems in non-mammalian vertebrates*, Elsevier, Amsterdam, pp 39–60
- Northcutt RG (1978) Brain organization in the cartilaginous fishes. In: Hodgson ES, Mathewson RF (eds) *Sensory biology of sharks, skates, and rays*. Office of Naval Research, Department of the Navy, Arlington, pp 117–193
- Butler AB, Hodoss W (2005) *Comparative vertebrate neuroanatomy: evolution and adaptation*, 2nd edn. Wiley, New York
- Nieuwenhuys R, ten Donkelaar HJ, Nicholson C (1998) *The central nervous system of vertebrates*. Springer, New York
- Northcutt RG (1981) Evolution of the telencephalon in nonmammals. *Annu Rev Neurosci* 4:301–350
- Striedter G (2005) *Principles of brain evolution*. Sinauer, Sunderland
- Puelles L, Rubenstein JLR (1993) Expression patterns of homeobox and other putative regulatory genes in the embryonic mouse forebrain suggests a neuromeric organization. *Trends Neurosci* 16:472–479
- Braun CB (1996) The sensory biology of lampreys and hagfishes: a phylogenetic assessment. *Brain Behav Evol* 48:262–276
- Bullock TH, Bodznick DA, Northcutt RG (1983) The phylogenetic distribution of electroreception: evidence for convergent evolution of a primitive vertebrate sensory modality. *Brain Res Rev* 6:25–46
- Northcutt RG, Gans C (1983) The genesis of neural crest and epidermal placodes: a reinterpretation of vertebrate head origins. *Q Rev Biol* 58:1–28
- Jeffery WR (2006) Ascidian neural crest-like cells: phylogenetic distribution, relationship to larval complexity, and pigment cell fate. *J Exp Zool B Mol Dev Evol* 306:470–480
- Mazet F, Shimeld SM (2005) Molecular evidence from ascidians for the evolutionary origin of vertebrate cranial sensory placodes. *J Exp Zool B Mol Dev Evol* 304:340–346
- McCormick CA (1992) Evolution of central auditory pathways in anamniotes. In: Webster DB, Fay RR, Popper AN (eds) *The evolutionary biology of hearing*. Springer Verlag, New York, p 323
- Wullimann MF (1998) The central nervous system. In: Evans DH (ed) *Physiology of fishes*. CRC, Boca Raton, FL, p 245–282

## Evolution of the Brain in Humans – Paleoneurology

RALPH L. HOLLOWAY<sup>1</sup>, CHET C. SHERWOOD<sup>2</sup>, PATRICK R. HOF<sup>3</sup>, JAMES K. RILLING<sup>4</sup>

<sup>1</sup>Department of Anthropology, Columbia University, New York, NY, USA

<sup>2</sup>Department of Anthropology and Biomedical Sciences, Kent State University, Kent, OH, USA

<sup>3</sup>Department of Neuroscience, Mount Sinai School of Medicine, New York, NY, USA

<sup>4</sup>Department of Anthropology, Emory University, Atlanta, GA, USA

### Definition

The evolution of the human brain from hominids existing perhaps 3–5 MYA (million years ago) to the present has been a mosaic process of size increases intercalated with episodes of ►reorganization of the cerebral cortex. The fossil evidence shows that reorganization preceded large-scale brain size increase, whether ►allometric or not, by about 2–3 MYA and again around 1 MYA, involving a reduction of primary visual cortex and cerebral asymmetries, including those within Broca's region. These changes were followed by nearly a tripling of brain size.

### Characteristics

#### What is Paleoneurology?

►Paleoneurology is the study of the fossil evidence for brain evolution and is, at present, the only direct line of evidence as to how different animals' brains have evolved through time. Paleoneurology is not a new branch of paleontological study as earlier publications go back to those of Oken, who found petrified mud in a crocodylian skull in 1819, as mentioned by Owen in 1841. Tilly Edinger wrote a valuable monograph on the evolution of the horse brain and her 1929 [1] and 1949 [2] papers on the history of paleoneurology are an important critique of comparative neurology's mistaken notions of human evolution. Kochetkova's [3] treatise



on ►endocasts is another valuable source, both for history and methods, as well as descriptions of some of the fossil hominids.

### What are Endocasts?

The objects studied are called endocasts. These are simply casts that are made from the inside table of bone of crania. It is particularly important to realize that the endocasts are just that; they are *not* casts of brains, because in life, the brain is surrounded by three meningeal layers, the dura mater, arachnoid tissue and cerebrospinal fluid and lastly the pia mater, a thin investing tissue directly overlying the brain. With death, these tissues as well as the brain dissolve, leaving a cranium that will in time fossilize.

### How does Paleoneurology Differ from Comparative Neurology?

Comparative neuroscience studies the brains of living animal species and is a particularly rich source of data from a microscopic level to that of whole brains. These data are essential to the understanding of the relationships between structure, function and behavior. In other words, how the brain varies in terms of its cellular makeup, cytoarchitecture, fiber systems, neural nuclei, axons and dendrites and the supporting matrix of glial cells, neurotransmitters and neuroreceptors can hopefully be related to variability of behavior. Paleoneurology is correspondingly exceedingly poor in data, as only the surface features of the once living and pulsating brain can be observed if – and only if – they are imprinted onto the internal table of bone. The drawback of comparative studies is that each species is currently an end product of its own separate line of evolution and therefore cannot provide any real time depth to past evolutionary events that affected the brain. Nevertheless, without comparative studies, there would be no possibility of correctly identifying and interpreting those surface features of the endocast that may have changed during evolutionary time from species to species.

### How are Endocasts Made?

First, it is necessary to appreciate that the data obtainable from endocasts depend on the completeness and quality of the endocast and this will be affected by how the endocast has been made. Some endocasts are natural, i.e., made by fine sediments collecting (through the foramina of the cranium) in the cranium of the deceased animal and with time being compacted and eventually turned to stone. Some of these endocasts can obtain an almost jewel-like quality. At least three endocasts of our ancestral hominid australopithecine line of 2–4 MYA were made in this way (e.g., Taung, Sts 60, Sk 1585, Type 2; see [4] for descriptions).

Endocasts can also be man-made, by directly covering the surface of the internal bony table with a casting medium, such as latex rubber or various forms of silicon rubber (Figs. 1 and 2). Endocasts can also be made from the data collected during CT scans, which can be rendered as a “virtual” endocast on the computer. This data set, in turn, can be sent to a machine that will literally carve out an endocast from a block of plastic, producing what is called a stereolithic endocast. For example, the recent “hobbit” endocast of the putative *Homo floresiensis* hominid was made this way [5], as was the virtual endocast for Saccopastore, a Neandertal from Italy [6]. Increasingly, CT scans are used for endocranial analyses.

### What Data can Endocasts Provide?

#### Overall Brain Volume

The most useful data gleaned from endocasts is the size of the once living brain, usually determined by either water displacement of the endocast or by a computer algorithm which simply adds sections taken from a CT scan of either the endocast or the cranium. Endocast volumes are somewhat larger, by about 8–12%, than the actual once-living brain, as the endocranial volume (ECV) includes meninges, cerebral fluid (including cisternae) and cranial nerves. Fossil hominids, of which we are the present-day terminal end products, had brain sizes varying from roughly 385 ml to 1700 ml, while the average for our own species is about 1400 ml. If the body weight is known from estimates made from measuring postcranial bones, then it is possible to calculate some derived statistics that may have some epistemological value. For example, “relative brain size” (RBS) would be the weight of the brain divided by body weight. Modern humans have an RBS of roughly 2%, and this value is neither the smallest nor largest in the animal kingdom or even in the primate order. It is also possible, when body and brain sizes are known, to calculate a statistic called the “encephalization quotient” (EQ). An EQ’s value depends on the database used to make the calculation. For example, equations derived from two different data sets appear below, with the corresponding modern human value:

EQ(1) = Brain weight (of any species)/0.12 × Body weight<sup>0.66</sup> [7]

The human value is 6.91, 4.02 for chimpanzee and 1.8 for gorilla.

EQ(2) = Brain weight/1.0 Body weight<sup>0.64</sup>

This is the “homocentric” equation of Holloway and Post [8], which then expresses each EQ as a direct percentage of the human value, taken as 100%. The chimpanzee EQ is 39.5% and the gorilla 19.1%.

While these values appear very different, the relative position within the primate order is almost static, the rank order correlation being about 0.9 [8].

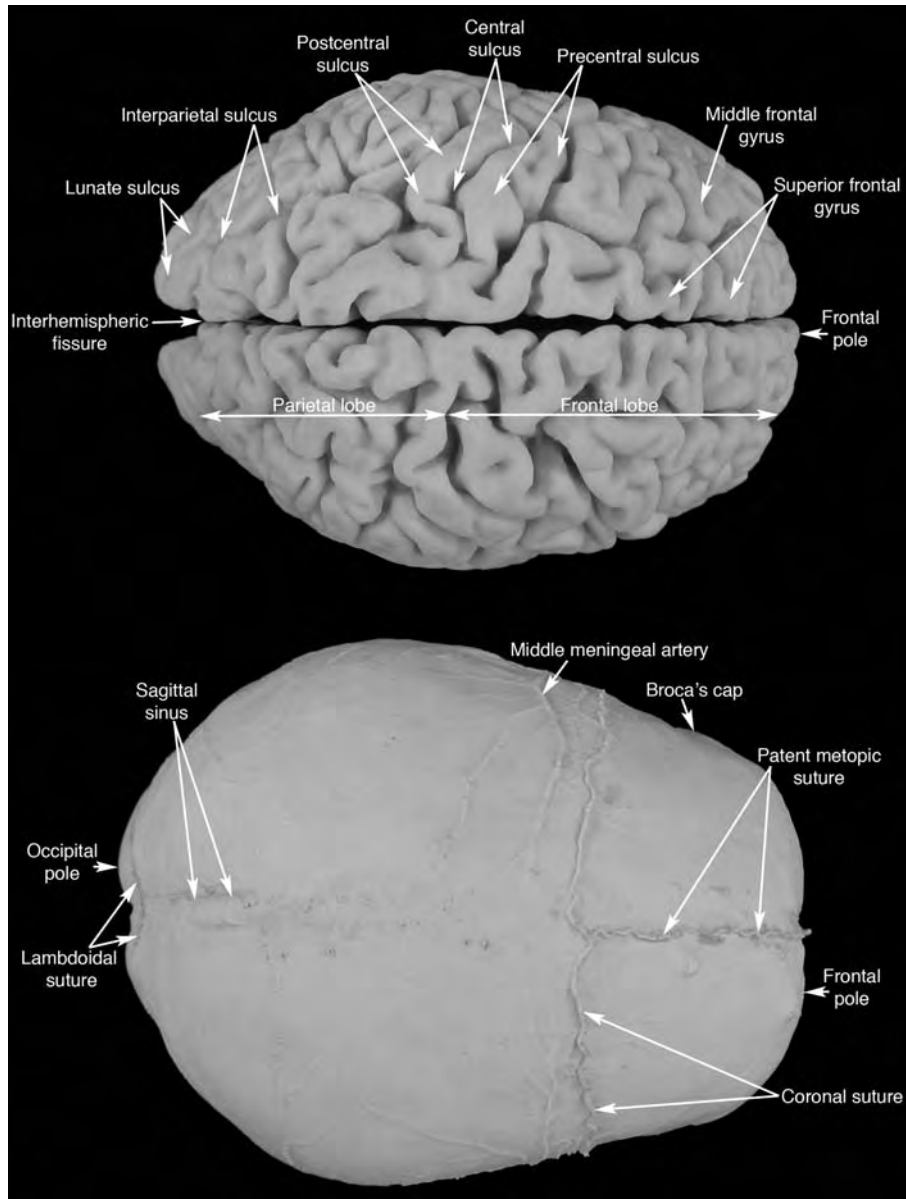

**Evolution of the Brain in Humans – Paleoneurology. Figure 1** A dorsal view of a cast of a modern human brain and its accompanying endocranium. Note that the left occipital lobe is wider and projects more posteriorly than the right side and that the right frontal lobe width is slightly larger than the left. This is typical of the torque petalial pattern associated with right-handedness.

### **Relative Sizes of Lobes**

Endocrania provide a very rough idea of the relative sizes of the lobes of the cerebral cortex. It is rough because all the sulci on a primate endocranium, particularly a hominid one, cannot be seen. It is thus not possible to find the central sulcus accurately in order to delineate the frontal lobe or to find the precentral sulcus to delineate the prefrontal lobe.

### **Convolution Pattern**

Endocrania do provide glimpses of the underlying ►convolution (gyri and sulci) pattern, depending both upon the state of preservation of the endocranium and the faithfulness of convolutional imprinting on the internal table of bone. Alas, this is seldom complete and such incompleteness often leads to controversy, at least within paleoanthropology. For example, the Taung

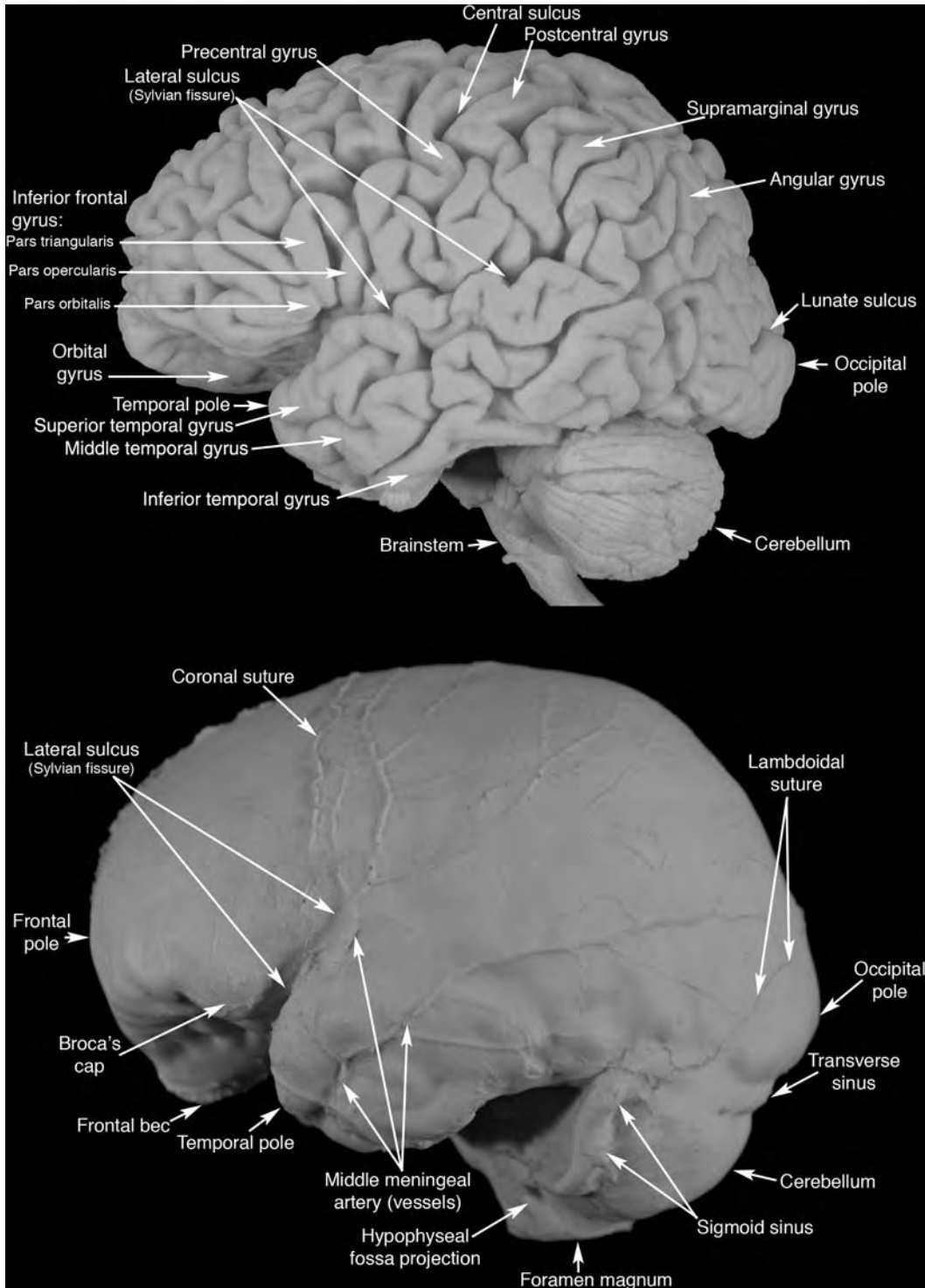

**Evolution of the Brain in Humans – Paleoneurology. Figure 2** The same brain and endocast in lateral view, showing the difference in details between a cast of the brain and its endocast.

endocast (natural), found with the partial cranium and jaw of *Australopithecus africanus* and described by Raymond Dart in 1925, showed a depression taken by Dart to represent the lunate sulcus or what would have

been the approximate anterior limit of primary visual cortex (V1). This appeared to Dart to be in a relatively posterior position, signaling that, even in this early representative of hominids, the brain was organized

differently from that of any ape and was moving toward a more human-like condition (Fig. 3). This depression was in the same region as the lambdoid suture and thus could not be definitively recognized. Putting a lunate in the position expected of an ape such as the chimpanzee or gorilla would violate the existing morphology and the placement of the lunate sulcus even anterior to this would result in a position comparable to an Old World monkey. It was not until 2005 that a description of a posteriorly-placed lunate on the Stw 505 *A. africanus* specimen was made by Holloway et al. [4], effectively settling this controversial issue as to whether the hominid brain had to enlarge before cortical reorganization took place.

### Asymmetry

Endocasts, depending on completeness (both halves necessary) and relative lack of distortion, show varying degrees of asymmetry of the once throbbing cerebral hemispheres and these asymmetries become interesting for their relationship to cerebral specializations, including possible handedness and language. For example, when the endocasts show a bulging left hemispheric projection of the occipital lobe posteriorly (and often laterally), combined with a wider right frontal bulge (these bulges are called petalias), this pattern matches what we know from modern human endocasts and radiography to be the result of a torque-like growth pattern. [see 9–11]. Modern humans also show asymmetries in the Broca's cap regions of the third inferior convolution of the frontal cortex. These asymmetries probably differ by handedness as well as by unknown functional relationships. Such asymmetries are present in Neandertals and even earlier on some *Homo erectus*

specimens (indeed they are clear on the 1.8 million year-old *Homo rudolfensis* specimen, KNM-ER 1470). They cannot prove that this or that hominid had language, but if these asymmetries are homologous to those found in modern humans, well, why not? What is curious is that scientists speculating about the origins of language never bother to look at the paleoneurological evidence [e.g., 12].

### Statistical Analyses

Endocasts have shapes and are thus amenable to measurements that can be taken with calipers or from CT scans. Such data sets can then be statistically analyzed using a variety of multivariate statistical techniques.

### Blood Supply Patterns

The blood supplies to the meninges show different patterns in different hominid taxa and thus might be useful, in some cases, for identifying hominid phyletic lines [13].

### Human Brain Evolution as Seen from Paleoneurology

It is important to keep in mind that roughly 4 MY of evolutionary time has existed for hominid evolution to date and that the number of brain endocasts for hominids that provide reliable data either for size or cerebral organization is very small, numbering no more than about 160, including modern *Homo sapiens* from the end of the Pleistocene (See Holloway et al. [4] Appendix, for a complete listing up to that date). In essence, there is one brain endocast for every 235,000+ years of evolutionary time. Nevertheless, we believe we

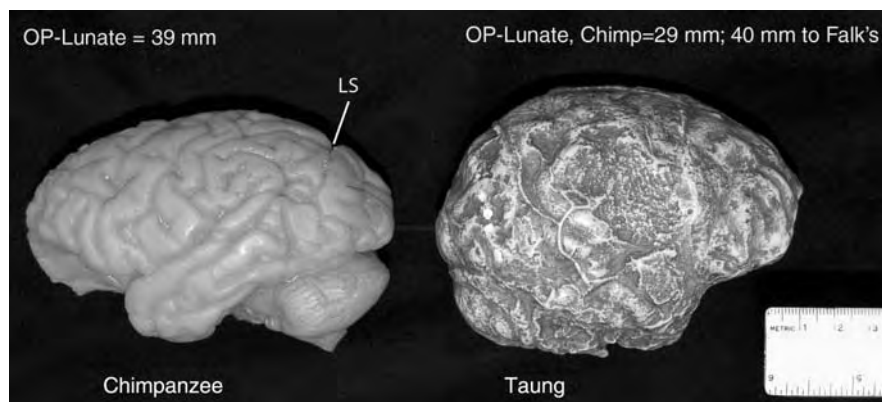

**Evolution of the Brain in Humans – Paleoneurology. Figure 3** Lateral views of a chimpanzee brain cast, and the hominid Taung *Australopithecus africanus* endocast. The lunate sulcus (LS) of the chimpanzee lies much farther anteriorly than on the Taung endocast. The dots on the Taung endocast show where a typical chimpanzee LS would lie, if Taung showed a typical ape-like pattern. The distance from the occipital pole (OP) to the LS is roughly 30–40 mm on chimpanzee brains. The measurement from OP to Falk's LS line on the Taung endocast is about 40 mm. Both the typical chimpanzee LS placement and that of Falk violate the sulcus morphology on the Taung endocast.

can perceive a mosaic of brain evolutionary events that involve size increases interspersed with elements of cerebral organization, as shown in Tables 1, 2 and 3. At least two important reorganizational events occurred rather early in hominid evolution, (i) a reduction in the relative volume of primary visual striate cortex (PVC, area 17 of Brodmann), which occurred early in australopithecine taxa, perhaps as early as 3.5 MYA and

(ii) a configuration of Broca’s region (Brodmann areas 44, 45, and 47) that appears human-like rather than ape-like by about 1.8 MYA. At roughly this same time, cerebral asymmetries, as discussed above, are clearly present in early *Homo* taxa, starting with KNM-ER 1470, *Homo rudolfensis*.

The first change suggests that the relative reduction in PVC was accompanied by a relative increase, most



**Evolution of the Brain in Humans – Paleoneurology. Table 1** A Table showing the reorganizational changes based on the paleoneurological record of hominid endocasts

Brain changes (Reorganization)	Taxa	Time (MYA)	Endocast evidence
(1) Reduction of primary visual striate cortex, area 17, and relative increase in posterior parietal cortex	<i>A. afarensis</i>	3.5–3.0	AL 162–28 endocast
	<i>A. africanus</i>	3.0–2.0	Taung child, Stw 505 endocast
	<i>A. robustus</i>	ca. 2.0	SK 1585 endocast
(2) Reorganization of frontal lobe (Third inferior frontal convolution, Broca’s area, widening prefrontal)	<i>Homo rudolfensis</i>	2.0–1.8	KNM-ER 1470 endocast
	<i>Homo habilis</i>		Indonesian endocasts
	<i>Homo erectus</i>		
(3) Cerebral asymmetries, left occipital, right-frontal petalias	<i>Homo rudolfensis</i>	”	KNM-ER 1470 endocast
	<i>H. habilis</i> , <i>H. erectus</i>		Indonesian endocasts
(4) Refinements in cortical organization to a modern Homo pattern	? <i>Homo erectus</i> Present ?	1.5–10	<i>Homo</i> endocasts ( <i>erectus</i> , <i>neanderthalensis</i> , <i>sapiens</i> )

Changes in the reorganization of the hominid brain based on endocasts (after [14]).

**Evolution of the Brain in Humans – Paleoneurology. Table 2** A Table showing the major allometric and non-allometric increases in brain size based on the hominid endocasts

Brain changes	Taxa	Time (MYA)	Evidence
(1) Small increase, Allometric*	<i>A. afarensis</i> to <i>A. africanus</i>	3.0–2.5	Brain size increases from 400 ml to 450 ml., 500+ ml.
	<i>A. africanus</i> to <i>Homo habilis</i>	2.5–1.8	KNM-1470, 752 ml (Ca 300 ml)
(3) Small allometric increase in brain size to 800 ml-1000 ml (Assumes <i>habilis</i> was KNM 1470-like)	<i>Homo habilis</i> to <i>Homo erectus</i>	1.8–0.5	<i>Homo erectus</i> Brain Endocasts and postcranial Bones, e.g., KNM-ER 17000
	<i>Homo erectus</i> to <i>Homo sapiens</i>	0.5–0.10	Archaic <i>homo</i> and Neandertal endocasts
	<i>Homo sapiens</i> <i>neanderthalensis</i>		1200–1700 + ml
(5) Small reduction in brain size among modern homo sapiens, which was allometric	<i>Homo s. sapiens</i>	0.015 to present	Modern endocranial capacities

Major size changes in human brain evolution (after [14]).

(\* NOTE: Allometric means related to body size increase or decrease, while non-allometric refers to brain size increase without a concomitant body-size increase.)

**Evolution of the Brain in Humans – Paleoneurology. Table 3** A table showing the major cortical areas (Brodmann's) involved in reorganization changes

Cortical regions	Brodmann's areas	Functions
Primary visual striate cortex	17	Primary visual
Posterior parietal and anterior occipital (peri- and parastriate cortex)	18, 19	Secondary and tertiary visual integration with area 17
Posterior Parietal, Superior Lobule	5, 7	Secondary somatosensory
Posterior parietal, inferior lobule (mostly right side. left side processes symbolic-analytical)	39	Angular gyrus perception of spatial relations among objects, face recognition
Posterior parietal, inferior lobule (mostly right side. See above)	40	Supramarginal gyrus spatial ability
Posterior superior temporal cortex	22	Wernicke's area, posterior superior temporal gyrus. Comprehension of language.
Posterior Inferior Temporal	37	polymodal integration, visual, auditory. Perception and memory of objects' qualities.
Lateral prefrontal cortex (including mirror neurons)	44, 45, 47	Broca's area (Broca's Cap)
	(also 8, 9, 10, 13, 46)	Motor control of vocalization, language Complex cognitive functioning Memory, inhibitor of impulse, foresight, etc

Major cortical regions involved in early hominid evolution (With major emphasis on the evolution of social behavior, and adapting to expanding environments) (after [14]).

**Evolution of the Brain in Humans – Paleoneurology. Table 4** A table showing the average statistics for different hominid taxa

Taxon	Mean volume	Number	Range	Mean MYA	Body mass	EQMARTIN	EQHOMO
<i>A. afarensis</i>	445.80	5.00	387–550	3.11	37.00	4.87	42.79
<i>A. africanus</i>	462.33	9.00	400–560	2.66	35.50	5.21	45.58
<i>P. ethiopicus</i>	431.75	4.00	400–490	2.09	37.60	4.66	41.01
<i>A. garhi</i>	450.00	1.00	450.00	2.50	NA	NA	NA
<i>H. erectus</i>	941.44	20.00	727–1220	0.81	57.80	7.32	67.64
<i>H. ergaster</i>	800.67	2.00	750–848	1.74	57.50	6.25	57.72
<i>H. habilis</i>	610.00	6.00	510–687	1.76	34.30	7.06	61.50
<i>H. heidelbergensis</i>	1,265.75	12.00	1150–1450	0.27	68.70	8.64	81.30
<i>H. rudolfensis</i>	788.50	2.00	752–825	1.87	45.60	7.35	66.08
<i>H. neanderthalensis</i>	1,487.50	28.00	1200–1700	0.08	64.90	10.60	99.14
<i>H. sapiens</i>	1,330.00	23.00	1250–1730	0.01	63.50	9.63	89.90
<i>H. soloensis</i>	1,155.86	7.00	1013–1250	0.06	NA	NA	NA
<i>P. robustus</i>	493.33	3.00	450–530	1.50	36.10	5.49	48.11
<i>P. boisei</i>	515.00	6.00	475–545	1.65	41.30	5.17	46.02
<i>P. troglodytes</i>	405.00	350–450	NA	0.01	46.00	3.75	33.75
<i>G. gorilla</i>	500.00	400–685	NA	0.01	105.00	2.47	24.39

Average Statistics for Different Hominid Taxa (after [14]).

likely in the inferior parietal and posterior temporal lobes. Exactly what selective forces led to this shift can only be guessed, but following the archaeological record of stone tool development at roughly 2.6 MYA,

these changes are perhaps best explained as a response to an expanding ecological niche, where scavenging, some small game hunting and a vegetarian food base necessitated a more complex appreciation of

environmental resources, as well as social behavioral stimuli within foraging hominid groups. A positive feedback model for these and other interacting variables was suggested by Holloway [15,16].

Certainly, the second reorganizational pattern, involving Broca’s region, cerebral asymmetries of a modern human type and perhaps prefrontal lobe enlargement, strongly suggests selection operating on a more cohesive and cooperative social behavioral repertoire, with primitive language a clear possibility. By *Homo erectus* times, ca. 1.6–1.7 MYA, the body plan is essentially that of modern *Homo sapiens* – perhaps somewhat more lean-muscled bodies but statures and body weights within the modern human range. This finding indicates that relative brain size was not yet at the modern human peak and also indicates that not all of hominid brain evolution was a simple allometric exercise. Again, this pattern reflects the

mosaic nature of human brain evolution. Neandertals were present at least 200,000 years ago, and those known from Western Europe, Eastern Europe and the Middle East have brain volumes that on average exceeded those of modern man, yet with bodies that appear more massive (lean body mass). The only difference between Neandertal and modern human endocasts is that the former are larger and more flattened. Most importantly, the Neandertal prefrontal lobe does not appear more primitive. Table 4 provides a brief statistical description of the major hominid taxa and their respective sample sizes, endocranial volumetric means and ranges. The EQ values that accompany this Table were calculated using Holloway and Post’s [8] homocentric equation (see Holloway et al. [4] p. 13–14 for a more detailed explanation) as well as Martin’s EQ’s based on a mammalian sample. Figure 4 presents a plot of endocranial volumes against time.

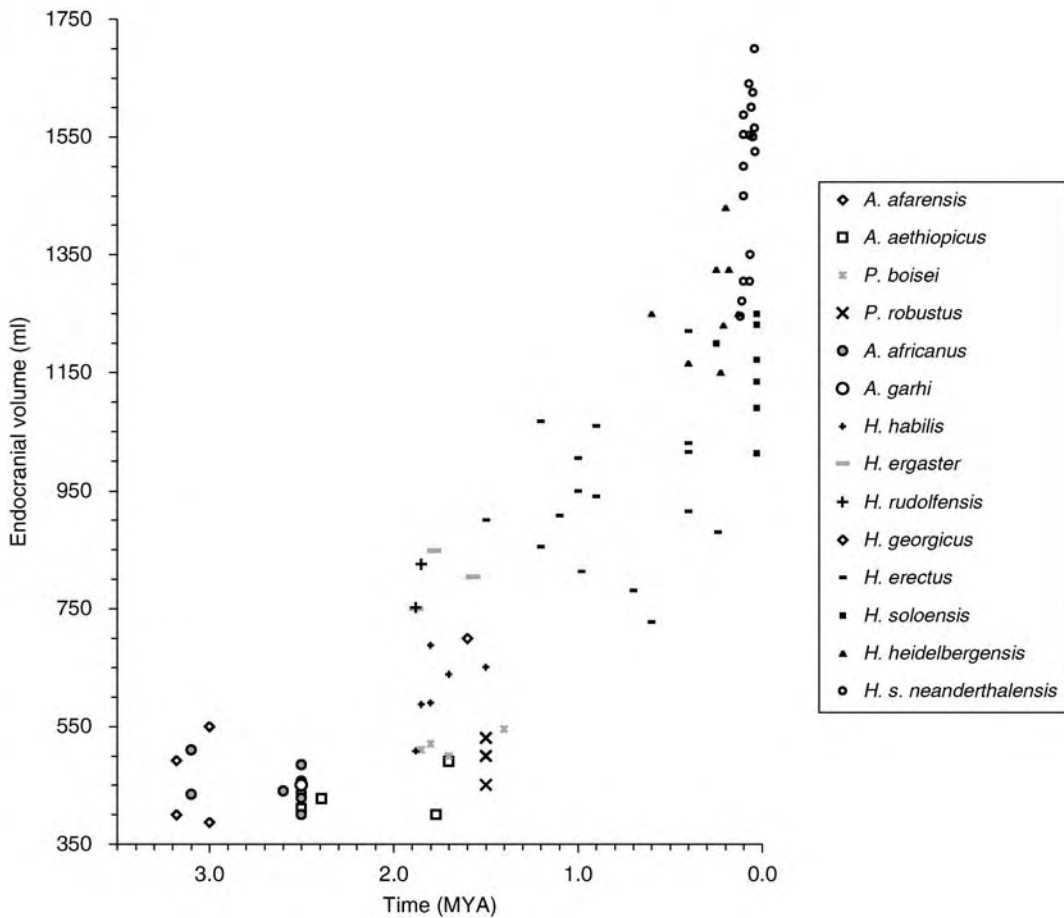

**Evolution of the Brain in Humans – Paleoneurology. Figure 4** Graph showing increase in brain size during the past 3 million years from the fossil hominid endocasts available. While the graph appears smooth and continuous, it should be remembered that each symbol represents several thousand years, and such a graph cannot accurately portray all of the details of brain size changes with time, particularly given the incompleteness of the fossil record. After Holloway et al. [14].

### Concluding Comments

Comparative neurology provides neuroscientists with the basic understanding of neural structural variation and correlated behavioral patterns [17]. Paleoneurology provides the direct evidence for hominid brain evolution but is extremely constrained in its evidentiary details, largely thanks to the meninges that surround the surface of the cerebral cortex. In time, growing understanding of molecular neural genetics may help to pinpoint more of the evolutionary differences between modern man and other primates and may even reliably date some of the key organizational and size changes that occurred in mosaic fashion in the human line. It seems that the most essential aspects of human behavior – strong cooperative (and competitive) social behavioral adaptation, far in advance of any ape, centered within and controlled by language and cognitive abilities involving multi-way interactions between predictive prefrontal and analytic parietal/temporal lobes – emerged relatively early in hominid evolution, setting the stage for positive feedback relationships between growing cerebral size and behavioral complexity, which involved a complex interaction between regulatory gene events and changes in the genes themselves.

### References

1. Edinger T (1929) Die fossilen Gehirne. *Ergebnisse der Anatomie und Entwicklungsgeschichte* 28:1–221
2. Edinger T (1949) Paleoneurology versus comparative brain anatomy. *Confinia Neurologica Separatum* 9:5–24
3. Kochetkova V (1978) Paleoneurology. Winston, Washington DC
4. Holloway RL, Clarke RJ, Tobias PV (2004) Posterior lunate sulcus in *Australopithecus africanus*: was Dart right? *Am J Phys Anthropol* 3:287–293
5. Falk D, Hildebolt C, Smith K, Morwood MJ, Sutikna T, Brown P, JatmikoSaptomo EW, Brunnsden B, Prior F (2005) The brain of LB1, *Homo floresiensis*. *Science* 308:242–245
6. Bruner E (2003) Geometric morphometrics and paleoneurology: brain shape evolution in the genus *Homo*. *J Human Evol* 47:279–303
7. Jerison HJ (1973) *Evolution of the brain and intelligence*. Academic, New York
8. Holloway RL, Post DG (1982) The relativity of relative brain measures and hominid mosaic evolution. In: Armstrong E, Falk D (eds) *Primate brain evolution: methods and concepts*. Plenum, New York, pp 57–76
9. Galaburda AM, LeMay M, Kemper TL, Geschwind N (1978) Right-left asymmetries in the brain. *Science* 199:852–856
10. Holloway RL, de Lacoste-Lareymondie MC (1982) Brain endocast asymmetry in pongids and hominids: some preliminary findings on the paleontology of cerebral dominance. *Am J Phys Anthropol* 58:101–110
11. LeMay M (1976) Morphological cerebral asymmetries of modern man, and nonhuman primates. *Ann NY Acad Sci* 280:349–366
12. Klein RG (1999) *The human career: human biological and cultural origins*. University of Chicago Press, Chicago
13. Grimaud-Hervé D (2004) Endocranial vasculature. In: Holloway RL, Broadfield DC, Yuan MS (eds) *The human fossil record, vol 3. Brain endocasts: the paleoneurological evidence*. Wiley-Liss, New York, pp 273–282
14. Holloway RL, Broadfield DC, Yuan MS (2004) *The human fossil record, vol 3. Brain endocasts: the paleoneurological evidence*. Wiley-Liss, New York
15. Holloway RL (1967) The evolution of the human brain: some notes toward a synthesis between neural structure and the evolution of complex behavior. *Gen Syst* 12:3–19
16. Holloway RL (1996) Evolution of the human brain. In: Locke A, Peters C (eds) *Handbook of human symbolic evolution*. Oxford University Press, New York, pp 74–116
17. Rilling JK (2006) Human and nonhuman primate brains: are they allometrically scaled versions of the same design? *Evol Anthropol* 15:65–77

## Evolution of the Brain in Humans – Specializations in a Comparative Perspective

CHET C. SHERWOOD<sup>1</sup>, JAMES K. RILLING<sup>2</sup>,  
RALPH L. HOLLOWAY<sup>3</sup>, PATRICK R. HOF<sup>4</sup>

<sup>1</sup>Department of Anthropology, The George Washington University, Washington, DC, USA

<sup>2</sup>Department of Anthropology, Emory University, Atlanta, GA, USA

<sup>3</sup>Department of Anthropology, Columbia University, USA

<sup>4</sup>Department of Neuroscience, Mount Sinai School of Medicine, New York, NY, USA

### Definition

The cognitive and linguistic capacities of humans are exceptional in comparison to other animals. To understand the neural bases of uniquely human behavioral traits, it is necessary to compare brain structure in humans to close primate relatives, particularly the great apes.

### Characteristics

#### The Comparative Approach

Humans express dramatically divergent behavioral attributes compared to other animals in terms of language, social cognition and the manufacture of technology. To discover the human brain specializations that subservise these behavioral capacities, it is necessary to consider neural structure and function in



comparison to humanity's closest relatives. Despite pronounced morphological and behavioral differences between humans and other primates, genetic evidence clearly indicates that humans share close phylogenetic affinities with the great apes (orangutans, gorillas, bonobos and chimpanzees). Indeed, humans and chimpanzees are more closely related to each other than either is to gorillas. In light of these phylogenetic relationships, comparisons of human brains to those of chimpanzees and other great apes hold the potential to unveil the neural substrates of human cognitive specializations that have evolved in the 6–8 million years since the last common ancestor (Fig. 1).

### Size and Morphology

One of the most remarkable features of the human brain is its large size in both absolute and relative terms. Humans have the largest brain of any primate (~1,400 g), being about three times bigger than those of the great apes. Although larger absolute brain sizes can be found among whales and elephants, humans show the greatest deviation among mammals in having exceptionally large brains after controlling for overall body size (Fig. 2) Fossil evidence, furthermore, indicates that the period of most dramatic brain expansion occurred within the human lineage in the last two million years, long after the evolution of other human-specific traits like bipedal walking [1].

It is less obvious, however, whether brain enlargement in humans has been accompanied by disproportionate increases in particular regions. Some alterations of internal organization may be expected because of developmental, functional or architectural constraints that necessitate redesign with changes in total brain size. For example, in comparison to other primates there is

more white matter underneath the neocortex in humans. The proportion of neocortical white matter volume in humans, however, conforms to **allometric scaling** expectations based on the demands for interconnections of gray matter at human brain size [2, 3]. Additionally, the human neocortex (gray and white matter combined) occupies a larger fraction of total brain size than it does in great apes. While much of this extra neocortical growth may be explained by evolutionarily conserved schedules of neurogenesis [4], it is significant that the size of the human neocortex actually exceeds what would be predicted for an anthropoid primate of the same brain size [2].

The neocortex is heterogeneous with respect to architecture and function. Therefore, it is also important to consider whether the human neocortex shows regional modifications in organization. The overall degree of cortical folding or gyrification generally increases with larger brain size in primates and the human brain fits this pattern. Nonetheless, the prefrontal part of the neocortex in humans displays a greater amount of **gyrification** than would be expected for an anthropoid primate of the same size [2]. This suggests that relatively more cortical tissue is buried within sulci in the human prefrontal cortex, which may correlate with enhancement of the cognitive functions mediated by this neocortical region. However, studies that have directly examined whether the prefrontal cortex is enlarged in humans have yielded somewhat contradictory results. While it seems that total frontal cortex size in humans is no greater than expected based on apelike scaling trends for brain size [5], further data may be necessary to resolve whether the prefrontal cortex or any of its constituent cytoarchitectural areas show disproportionate enlargement in humans.

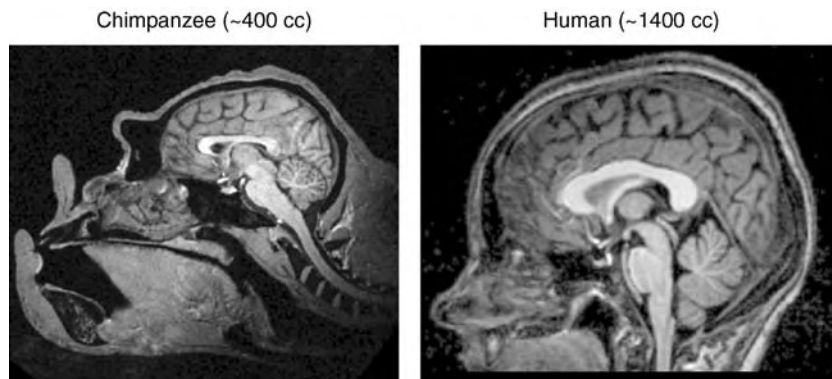

**Evolution of the Brain in Humans – Specializations in a Comparative Perspective. Figure 1** Midsagittal magnetic resonance image sections of chimpanzee and human heads. In comparison to the chimpanzee, the human brain is dramatically enlarged relative to other cranial components. From this view, it is also clear that the majority of human brain expansion is due to enlargement of a subset of structures, including the neocortex and cerebellum, whereas others, like the brainstem, are relatively unmodified.

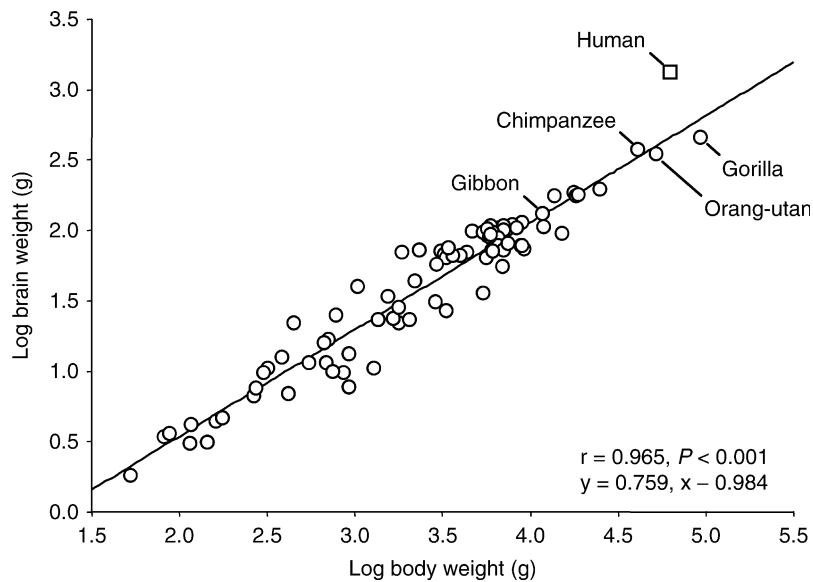

**Evolution of the Brain in Humans – Specializations in a Comparative Perspective. Figure 2** The allometric scaling relationship between mean brain weight and body weight among 85 primate species based on data presented in Holloway [7]. A least-squares regression line is fitted to the nonhuman primate data ( $y = 0.759, x - 0.984, r = 0.965, P < 0.001$ ). Note that the value for human brain size is the greatest departure from the allometric scaling trend seen in all other primates.

Beyond the prefrontal cortex, there is evidence of human-specific reorganization of the size of other cortical areas. The primary visual cortex (Brodmann's area 17 or V1) and the primary motor cortex (area 4) are quite similar in absolute volume in humans and great apes, despite vastly different brain size among these species [6]. In fact, the primary visual cortex in humans is substantially smaller than predicted for total brain size [7], probably because it scales closely to the size of the eye rather than the brain. These data suggest that human neocortical enlargement entailed selective expansion of certain "association" areas of the parietal, temporal and prefrontal cortex, whereas primary sensory and motor areas remained more closely correlated with direct inputs and outputs from the periphery. The hypothesis of regional modification in human neocortical evolution is further supported by the observation that human temporal lobes, especially the underlying white matter, are enlarged beyond allometric predictions based on apes [8]. It is also interesting that a subset of thalamic nuclei in humans show differences from apes. After taking scaling into account, humans have more neurons than other hominoids in the anterior principal (anteroventral) nucleus, mediodorsal nucleus and pulvinar, while neuron numbers in sensory relay nuclei are generally conservative [9]. This suggests that the "association" regions of the neocortex have expanded in humans in parallel with the specific thalamic nuclei that furnish them with reciprocal connections. Taken together, the studies reviewed above

indicate that some regions within the human neocortex have become selectively modified in size.

The neocortex is not the only brain structure that is uniquely expanded in humans. After the neocortex, the human cerebellum shows the next greatest degree of enlargement relative to body size. This is not surprising given the extensive connections that link neocortex and cerebellum. In fact, the two structures appear to have evolved in tandem as a coordinated system in primates, although fossil endocast data suggest that recent human evolution was characterized by a burst of cerebellar expansion that was unmatched by a parallel increase in neocortex size. Beyond relative cerebellar size, humans also differ from other primates in the size and shape of the cerebellar dentate nucleus. In particular, the ventral portion, believed to send outputs to non-motor regions of the frontal lobe by way of the ventrolateral thalamus, is better developed in humans than in great apes. These connections may be the anatomical substrate supporting the postulated cerebellar involvement in cognition, beyond its traditionally recognized role in motor coordination [8].

### Asymmetry

Human brains exhibit structural and functional lateralization in a number of different respects. Humans have a unique capacity for the generation and communication of symbolic thinking in the form of language. Concomitantly, a majority of humans show left hemisphere

dominance for language functions and display associated anatomical asymmetries of the brain. Human brains are especially asymmetric in the region of cortex along the sylvian fissure [10]. In most human brains, the left sylvian fissure is longer and more superiorly oriented than the right. In addition, the ►**planum temporale**, located on the superior temporal plane between Heschl's gyrus and the termination of the sylvian fissure, is larger on the left in most human brains. These asymmetries may be significant for language lateralization because this region of posterior temporal cortex corresponds to cytoarchitectural area Tpt, a site that has been identified as a major component of Wernicke's area. Whether or not these asymmetries can be considered human evolutionary specializations can only be determined in reference to great apes. Notably, the sylvian fissure and planum temporale have been demonstrated to display humanlike left dominant asymmetry in chimpanzees, gorillas and orangutans [11]. The full extent to which these gross anatomical asymmetries in great apes reflect underlying microstructural differences in circuitry between the left and the right is not yet clear. However a comparative study of area Tpt cytoarchitecture demonstrated that humans have left dominance in terms of greater spacing between minicolumns and more overall neuropil volume, allowing for interconnectivity among cells [12]. It is interesting that these histological asymmetries are absent in macaque monkeys and chimpanzees.

The gyri of the inferior frontal cortex in the location of Broca's area exhibit morphological asymmetries in humans. Although it has been claimed that similar anatomical asymmetries of the inferior frontal gyrus exist in African great apes (gorillas, bonobos and chimpanzees), the poor correspondence between cytoarchitectural boundaries and the location of sulci makes it difficult to assess the significance of external landmarks for revealing asymmetries of Brodmann's areas 44 and 45 [13]. At the histological level, Broca's area in humans displays lateralization of pyramidal neuron dendritic arborization and overall neuron packing densities. However, it is not yet known whether comparable microstructural lateralization exists in the homologous areas of great apes.

A further aspect of human cerebral asymmetry can be observed as greater width and protrusion of the left occipital pole and right frontal pole, called ►**petalias** [7]. In humans, this typical petalia torque pattern is most strongly observed in right-handed individuals. The characteristic humanlike pattern of left occipital-right frontal petalias is not expressed in great apes to the same degree.

### **Histology and Connectivity of the Neocortex**

More subtle alterations of histological architecture in the absence of large-scale volumetric reorganization

also have occurred in the course of human brain evolution. For example, the human primary visual cortex shows modifications of dendritic compartments and interneurons in layer IVA relative to great apes, which might relate to changes in the way that humans process motion information [6]. The anterior cingulate and paracingulate cortex have also undergone modifications in histological organization at various times along the evolutionary lineage leading to humans. Very large ►**spindle-shaped neurons**, also known as Von Economo neurons, located in layer Vb are present in the anterior cingulate cortex of humans and great apes, but not that of any other primates [14]. In comparison to other species, in humans these unusual neurons are especially large in size, more numerous and aggregated in clusters. Because their distinctive morphology derives from the presence of thick singular apical and basal dendrites, these neurons might be specialized to transmit rapid outputs to subcortical targets. In addition to the spindle-shaped neurons, great apes and humans are also unique among primates in displaying calretinin-containing pyramidal cells in layer V of anterior cingulate cortex [15]. The location of these two classes of specialized neurons in the anterior cingulate cortex suggests that great ape and human brains are adapted for the integration of emotion and cognition. In particular, it is possible that these connections are involved in the rapid processing of judgments in circumstances of social uncertainty. Furthermore, it is interesting that calretinin-containing pyramidal neurons are also found in the anterior paracingulate cortex (area 32) only in humans, but not great apes. This area is implicated in "theory of mind," a cognitive capacity that is exceptionally well developed in humans.

Finally, although there are extremely few comparative data on connectivity patterns in humans and great apes, a set of intriguing results from axon degeneration studies suggest that the human brain is distinguished among primates in having direct projections from neurons in the primary motor cortex to the motoneurons of the larynx in the nucleus ambiguus [16]. These direct cortico-motoneuron connections would be situated to provide enhanced voluntary motor control for speech production. Additionally, a recent comparative study used diffusion tensor imaging to show that the arcuate fasciculus language tract has a much larger projection to the middle and inferior temporal cortex in humans compared with chimpanzees or macaques.

### **Evidence from Gene Expression and Gene Sequence Evolution**

Distinctive aspects of the human brain phenotype arise from alterations to the genes that direct processes involved in neural development, physiology and

structure. Several genes that participate in orchestrating brain development show evidence of natural selection in the lineage leading to humans [17]. For example, the genes *ASPM* and *MCPHI* have undergone high rates of nonsynonymous amino acid substitution at different branch points in the evolutionary history of apes, including a marked upsurge in humans since the last common ancestor with chimpanzees. Because the proteins encoded by these genes are involved in neuroblast proliferation during embryonic development and mutations within these genes can cause pathological reduction in brain volume (microcephaly), these data suggest that some part of human brain enlargement may be related to their evolution. The transcription factor *FOXP2* also displays evidence of sequence changes in human evolution [18]. Specific linguistic impairment, intellectual deficits, orofacial dyspraxia and structural abnormalities of language-related brain areas have been shown to occur in members of a single human family that share a point mutation in the *FOXP2* gene. The *FOXP2* transcription factor is highly conserved across mammals, with identical amino acid sequences in rhesus macaques, gorillas and chimpanzees. Humans however, have mutations that yield two amino acid substitutions in comparison to other primates, suggesting that this gene may be involved in the evolution of language and speech.

Several studies of gene expression in the brain using microarray techniques broadly agree in showing that the human cortex is distinguished from that of chimpanzees and other primates in displaying up-regulation of the expression of many genes related to neuronal signaling, plasticity, and activity [19]. These observations are further supported by findings that genes that encode various subunits of the mitochondrial electron transport chain show evidence of natural selection in the human lineage [20]. These changes would presumably enhance the aerobic energy producing capabilities of cells that have high metabolic rates, such as neurons.

### Conclusions

Research efforts directed at understanding the human brain in comparative perspective are still in their infancy. As more data accumulate to articulate the phenotypic differences between human brains and those of humanity's close relatives, greater insights will be gained into how neuroanatomical and genetic changes translate to human behavioral specializations.

### References

- Holloway RL, Broadfield DC, Yuan MS (2004) The human fossil record, vol 3, Brain endocasts: the paleoneurological evidence. Wiley, New York
- Rilling JK, Glasser MF, Preuss TM, Ma X, Zhao T, Hu X, Behrens TE (2008) The evolution of the arcuate fasciculus revealed with comparative DTI. *Nat Neurosci* 11:426–428
- Zhang K, Sejnowski TJ (2000) A universal scaling law between gray matter and white matter of cerebral cortex. *Proc Natl Acad Sci USA* 97:5621–5626
- Finlay BL, Darlington RB (1995) Linked regularities in the development and evolution of mammalian brains. *Science* 268:1578–1584
- Semendeferi K, Lu A, Schenker N, Damasio H (2002) Humans and great apes share a large frontal cortex. *Nat Neurosci* 5:272–276
- Preuss TM (2004) What is it like to be a human? In: Gazzaniga MS (ed) *The cognitive neurosciences III*. MIT, Cambridge, CA, pp 58–22
- Holloway RL (1996) Evolution of the human brain. In: Lock A, Peters CR (eds) *Handbook of human symbolic evolution*. Oxford University Press, Oxford, pp 74–114
- Rilling JK Human and nonhuman primate brains: are they allometrically scaled versions of the same design? *Evol Anthropol* 15:65–77
- Armstrong E (1982) Mosaic evolution in the primate brain: differences and similarities in the hominoid thalamus. In: Armstrong E, Falk D (eds) *Primate brain evolution: methods and concepts*. Plenum, New York, pp 131–162
- Toga AW, Thompson PM (2003) Mapping brain asymmetry. *Nat Rev Neurosci* 4:37–48
- Cantalupo C, Pilcher DL, Hopkins WD (2003) Are planum temporale and sylvian fissure asymmetries directly related? A MRI study in great apes. *Neuropsychologia* 41:1975–1981
- Buxhoeveden DP, Switala AE, Litaker M, Roy E, Casanova MF (2001) Lateralization of minicolumns in human planum temporale is absent in nonhuman primate cortex. *Brain Behav Evol* 57:349–358
- Sherwood CC, Broadfield DC, Gannon PJ, Holloway RL, Hof PR (2003) Variability of Broca's area homologue in African great apes: implications for language evolution. *Anat Rec* 71A:276–285
- Nimchinsky EA, Gilissen E, Allman JM, Perl DP, Erwin JM and Hof PR (1999) A neuronal morphologic type unique to humans and great apes. *Proc Natl Acad Sci USA* 96:5268–5273
- Hof PR, Nimchinsky EA, Perl DP, Erwin JM (2001) An unusual population of pyramidal neurons in the anterior cingulate cortex of hominids contains the calcium-binding protein calretinin. *Neurosci Lett* 307:139–142
- Kuypers HGJM (1958) Corticobulbar connections to the pons and lower brainstem in man. *Brain* 81:364–388
- Gilbert SL, Dobyns WB, Lahn BT (2005) Genetic links between brain development and brain evolution. *Nat Rev Genet* 6:581–590
- Enard W, Przeworski M, Fisher SE, Lai CS, Wiebe V, Kitano T, Monaco AP, Pääbo S (2002) Molecular evolution of *FOXP2*, a gene involved in speech and language. *Nature* 418:869–872
- Preuss TM, Caceres M, Oldham MC, Geschwind DH (2004) Human brain evolution: insights from microarrays. *Nat Rev Genet* 5:850–860
- Goodman M, Grossman LI, Wildman DE (2005) Moving primate genomics beyond the chimpanzee genome. *Trends Genet* 21:511–517

## Evolution of the Brain in Urbilateria

SIMON G. SPRECHER

Department of Biology, Center for Developmental Genetics, New York University, New York, NY, USA

### Synonyms

Brain evolution; Urbilateria

### Definition

Morphological and neuroanatomical properties of the brains of phylogenetically distantly related animal phyla differ in many aspects. However, using molecular genetic techniques to study the process of brain development, it has become evident that the fundamental genetic program underlying brain development has been largely conserved throughout evolution. It has therefore been proposed that the last common ancestor of all bilaterian animals, the ►Urbilateria, possessed a brain-like structure defined by an ancestral developmental genetic program.

### Characteristics

#### Phylogenetic Implications

In classical phylogenetics, major criteria for classification involved morphological and anatomical characteristics. For example, the presence of a secondary body cavity called the coelom had importance in determining where to place a given animal phylum within the phylogeny. Similarly, animal phyla sharing major morphological characteristics in their body plan, such as the obvious segmental organization of annelids and arthropods, were often grouped in closely related clades. However, advances in molecular genetic analysis during the last decade have led to the proposal of a novel molecular based phylogeny [1,2]. This phylogenetic tree is largely based on ribosomal and Hox gene sequence analysis. One of the most striking implications of this revised phylogeny is that none of the bilaterian phyla present today represents a truly ancestral, basal state (Fig. 1).

Therefore, the characteristics of the ►urbilaterian ancestor, at the base of all bilaterally symmetrical metazoan animal phyla, cannot be directly derived from currently existing animal phyla. Previously basally located and/or out-grouped phyla such as the Platyhelminthes (“flatworms”) are now placed among highly evolved phyla such as arthropods and annelids. Molecular genetic features, which act in a comparable manner in ►protostome phyla and ►deuterostome phyla, presumably existed in the urbilaterian ancestor. Studies of the molecular basis of brain development in animal model systems as different as the mouse and the fruit fly

(*Drosophila melanogaster*) provide insights into the way in which the urbilaterian brain may have evolved [3,4].

### Dorsoventral Patterning System

A major difference between the central nervous systems (CNS) of invertebrates and vertebrates is that their relative locations along the body axis are dorsoventrally inverted; the CNS of invertebrates is located ventrally, whereas the CNS of vertebrates is dorsal. Possible scenarios leading to the opposite location of the CNS in these animal groups have been the center of a debate for almost two centuries. Accordingly, animal phyla were grouped together into Gastroneuralia (e.g., insects, containing a ventrally lying CNS) and Notoneuralia (e.g., chordates, containing a dorsally lying CNS). Nevertheless, the major patterning systems that are responsible for specifying the neurogenic region and subdividing the CNS into longitudinal columns are surprisingly similar in insects and vertebrates. In vertebrates the opposing action of the two signaling molecules Chordin (dorsal) and BMP4 (ventral) is required for the specification of the neurectoderm, where Chordin promotes and BMP4 inhibits neurogenic cell fate. In contrast, during early embryogenesis in *Drosophila*, the Chordin homolog Short gastrulation (Sog) is expressed ventrally and the BMP4 homolog Decapentaplegic (Dpp) is expressed dorsally. Nevertheless, Dpp also act to inhibit neurogenic cell fate, whereas Sog promotes neurectoderm formation [3,4]. A set of three homeobox genes, the columnar patterning genes *ventral nervous system defective* (*vnd*, ventral column), *intermediate nervous system defective* (*ind*, intermediate column) and *muscle specific homeobox* (*msh*, lateral column), subdivide the insect neurectoderm into three longitudinal stripes. These columnar patterning genes are essential for the formation of neuronal stem cells as well as for the specification of their identity. In vertebrates the genes *Nkx2*, *Gsh* and *Msx* (homologs of the *Drosophila* genes *vnd*, *ind* and *msh* respectively) act in a similar way in the developing spinal cord [5]. However, their relative expression along the body axis is dorsoventrally inverted (Fig. 2).

In addition to the comparable columnar subdivision of the CNS in insects and vertebrates, the developmental fate of precursors and the neurons produced within a specific columnar domain are sometimes similar. For example, in both animal phyla, precursors of the medial column give rise to interneurons that pioneer the medial longitudinal fascicles and to motoneurons that exit via the lateral nerve root.

The Dpp/Sog and BMP4/Chordin interactions and the expression of columnar patterning genes are both inverted in a dorsoventral manner between insects and vertebrates. It has therefore been proposed that the ventral neurectoderm of insects may correspond to the dorsal neurectoderm of vertebrates. The evolutionarily

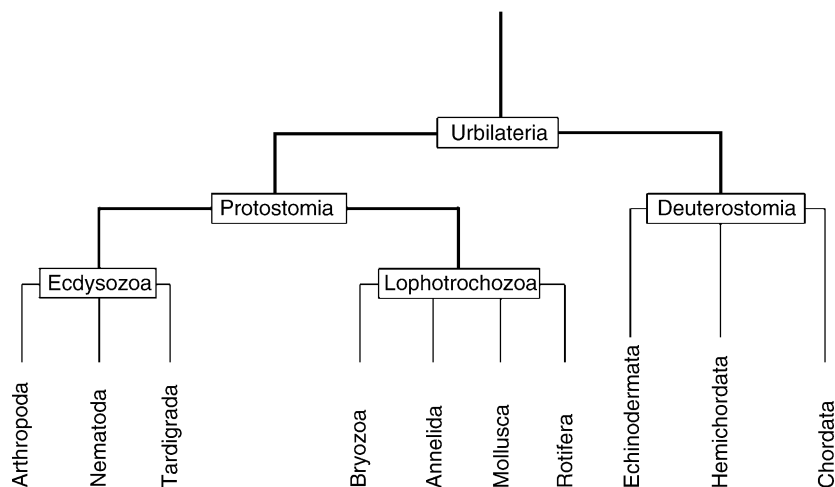

**Evolution of the Brain in Urbilateria. Figure 1** Phylogeny of the bilaterians mainly based on molecular data. Note that phyla which have previously been considered as “primitive” such as the Platyhelminthes are now placed among the Lophotrochozoa and no longer represented as an out-group. Therefore characteristics present in distantly related groups with molecular resemblance argue for monophyletic origin of these features. For simplification, not all phyla are included.

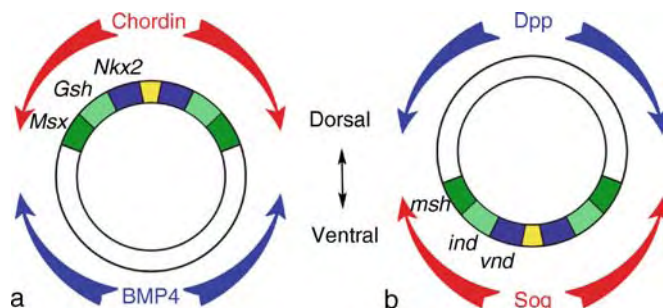

**Evolution of the Brain in Urbilateria. Figure 2** Induction and subdivision of the neurogenic region in vertebrates (a) and insects (b). Schematic diagram shows the opposing action of the signaling molecules Dpp/BMP4 (blue) and Sog/Chordin (red), which define the neurogenic region. Columnar subdivision of the neuroectoderm requires the homeobox genes *msh*/*Msx* (ventrolateral/dorsolateral), *ind*/*Gsh* (intermediate) and *vnd*/*Nkx2* (ventromedial/dorsomedial). The action of the signaling molecules as well as the columnar sub-organization of the neurepithelium is dorsoventrally inverted in insects and vertebrates.

conserved action of signaling molecules that specify the neurogenic region and the homologous set of homeobox genes that subdivide the neuroectoderm into longitudinal columns imply that these molecular mechanisms are ancestral features and might have been already present in urbilaterians [3,4].

### Anteroposterior Patterning System

Studying the basic body plan of insects has led to the identification of important molecular patterning systems, including many transcription factor cascades and major signaling pathways. Among these

transcription factors, the homeotic or ► **Hox genes** are of great interest, since they specify segmental identity along the anteroposterior body axis. Interestingly, the expression of ► **homeotic genes** in the brain along the anteroposterior axis is virtually identical between vertebrates and insects. In the developing brain of *Drosophila* the homeotic gene *labial* (*lab*) is expressed in the tritocerebral ► **neuromere**. In *lab* mutant *Drosophila* embryos, neuronal stem cells are generated and proliferate correctly; however their progeny fails to express neuron specific markers. Thus, *lab* is required for the specification of neuronal identity. The mouse

homologs of *lab*, *Hoxa-1* and *Hoxb-1*, play a comparable role in the development of the vertebrate hindbrain. In *Hox1* mutant mouse embryos formation of rhombomere 4 (r4) is defective. Double knockout of *Hoxa-1* and *Hoxb-1* causes a reduced size of r4 and additionally a loss of expression of r4 specific markers, resulting in a domain of unknown identity between r3 and r5. In both invertebrates and vertebrates, Hox gene action is necessary for the development of the posterior part of the brain [3,4]. In more anterior regions another set of transcription factors are involved in brain development. Insect “cephalic gap genes,” such as *orthodenticle* (*otd*) and *empty spiracles* (*ems*), are essential for brain development and are involved in the formation of neuronal stem cells. In *otd* mutant embryos large parts of the neuronal stem cells of the anterior brain primordium do not develop, resulting in a large deletion of the anterior embryonic brain. A similar defect is seen in *ems* mutant embryos where large parts of anterior brain neuromeres are deleted. Defects observed in *ems* mutants locate slightly posterior to the defects seen in *otd* mutants. The mouse homologous genes of *otd* and *ems*, *Otx2* and *Emx2*, have similar functions in the development of the anterior vertebrate brain. The *Otx2* gene is expressed during early stages in the anterior visceral endoderm, where it is involved in the fundamental processes of anterior neurepithelium patterning. In *Otx2* mutant mouse embryos the rostral neurectoderm, which gives rise to the forebrain, midbrain and rostral hindbrain, does not get specified. *Emx2* is expressed in the ventricular zone of the developing cerebral cortex. In *Emx2* mutant mouse embryos the cerebral hemispheres and hippocampus are severely reduced in size and lack the dentate gyrus. Thus, in both mouse and *Drosophila*, *otd/Otx* and *ems/Emx* gene families are essential in the processes of patterning the anterior brain region.

Cross phylum rescues carried out in both *Drosophila* and mouse showed that *otd* and *Otx* genes were able to functionally replace each other during embryonic brain development. Neuronal specification defects in the brain of *otd* mutant *Drosophila* embryos ubiquitously expressing the mouse *Otx2* gene were largely restored. Similarly, the ubiquitous expression of *Emx2* in *ems* mutant *Drosophila* embryos rescued during early brain development results in a largely normal anterior brain region. In mouse the expression of the *Drosophila otd* gene was able to rescue the forebrain and midbrain patterning defects caused by the *Otx2* mutation. These observations support the notion that the function of *otd/Otx* and *ems/Emx* genes in brain development is evolutionarily conserved between protostomes and deuterostomes. Both gene families might therefore have been involved in patterning the anterior brain region of the urbilaterian ancestor.

### Tripartite Organization of the Brain

Genetic analysis of major developmental patterning genes suggests that the embryonic vertebrate brain consists of a tripartite basic organization. This ground plan consists of an anterior forebrain/ midbrain region, an intermediate midbrain/hindbrain boundary region (MHB) and a posterior hindbrain region. These developing brain regions are characterized by the specific expression domains of *Otx*, *Pax2/5/8* and Hox genes respectively. In both insects and vertebrates, it has been shown that the anterior brain regions depend on *otd/Otx* gene action and the posterior regions upon Hox gene activity (see above). In vertebrates the MHB is specified at the interface of an anterior *Otx2* expression domain and a posterior *Gbx2* expression domain, where the *Pax2/5/8* genes are expressed. Similarly, in *Drosophila* the expression domain of the *Gbx2* homolog *unplugged* (*unpg*) abuts an anterior *otd* expression domain. As in vertebrates, the expression of the two *Pax2/5/8* orthologs *Pax2* and *Pox neuro* (*Poxn*) coincides with the *unpg-otd* interface. Thus, as in vertebrates, the expression of *otd* adjacent to *unpg*, in combination with *Pax2/Poxn* genes expression, subdivides the embryonic *Drosophila* brain into three parts [6]. A specific feature of the vertebrate MHB is that at the interface, the expression of *Otx2* and *Gbx2* are antagonistic and orchestrate the expression of downstream factors [7]. When *Otx2* is mutated, *Gbx2* expression shifts into more anterior regions, whereas if *Gbx2* is mutated, *Otx2* expression extends posteriorly. Similarly, in *Drosophila* the expression of *otd* extends into more posterior regions in *unpg* mutants, whereas *unpg* extends anteriorly in *otd* mutant embryos [8]. This cross-repressive interaction of *otd/Otx2* and *unpg/Gbx2* seems to be evolutionarily conserved and is probably an ancestral feature of this brain region (Fig. 3).

Therefore, not only is the tripartite organization of the embryonic brain conserved between insects and vertebrates, but the genetic interaction of the major patterning genes and their developmental roles is also at least partially conserved.

Thus, mammalian and insect dorsoventral and anteroposterior patterning systems and the tripartite organization of the brain show close similarities in distantly related animal phyla. Even though vertebrate and insect brains differ significantly in their neuroarchitecture, it seems likely they have a common evolutionary origin in a brain-like structure that may have existed before the split of deuterostomes and protostomes. Moreover, key elements of the ancestral molecular genetic program that controlled the development of the brain in urbilaterians are likely to be evolutionarily conserved and therefore common to the development of the brain of all bilaterian animals including our own.

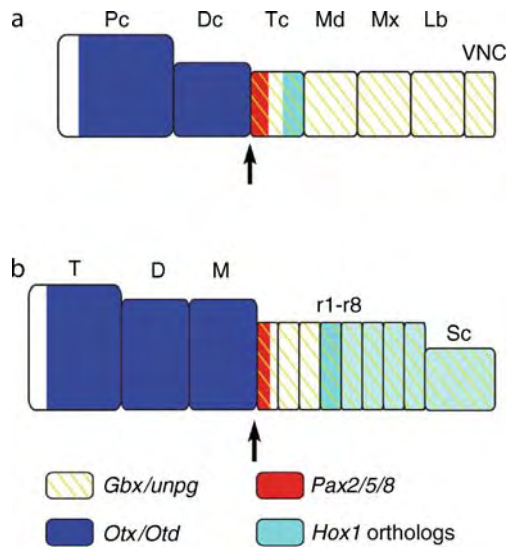

### Evolution of the Brain in Urbilateria.

**Figure 3** Tripartite organization of the brain in insects (a) and vertebrates (b). Schematic representation shows expression domains of *Otx/otd* (blue), *Gbx/unpg* (yellow hatched), *Hox1* (green) and *Pax2/5/8* (red). In both animal groups the expression domain of *Pax2/5/8* genes is located at the interface of the *otd-unpg/Otx-Gbx*, anterior to the *Hox1* expression territory resulting in a tripartite organization of the brain (arrow). Diagram shows the embryonic brain of *Drosophila* (a) subdivided into protocerebrum (Pc), deutocerebrum (Dc), tritocerebrum (Tc), mandibular neuromere (Md), maxillary neuromere (Mx), labial neuromere (Lb) and ventral nerve cord (VNC). Schematic representation of the embryonic mouse brain (b) subdivided into telencephalon (T), diencephalon (D), mesencephalon (M), rhombomeres 1–8 (r1–r8) and spinal cord (Sc).

### References

- Adoutte A, Balavoine G, Lartillot N, Lespinet O, Prud'homme B, de Rosa R (2000) The new animal phylogeny: reliability and implications. *Proc Natl Acad Sci USA* 97:4453–4456
- Adoutte A, Balavoine G, Lartillot N, de Rosa R (1999) Animal evolution: the end of the intermediate taxa? *Trends Genet* 15:104–108
- Sprecher S, Reichert H (2003) The urbilaterian brain: developmental insights into the evolutionary origin of the brain in insects and vertebrates. *Arthropod Struct Dev* 32:141–156
- Lichtneckert R, Reichert H (2005) Insights into the urbilaterian brain: conserved genetic patterning mechanisms in insect and vertebrate brain development. *Heredity* 94:1–13
- Cornell RA, von Ohlen TV (2000) *Vnd/nkx*, *ind/gsh*, and *msh/msx*: conserved regulators of dorsoventral neural patterning? *Curr Opin Neurobiol* 10:63–71
- Reichert H (2005) A tripartite organization of the urbilaterian brain: developmental genetic evidence from *Drosophila*. *Brain Res Bull* 66:491–494
- Nakamura H, Katahira T, Matsunaga E, Sato T (2005) Isthmus organizer for midbrain and hindbrain development. *Brain Res Rev* 49:120–126
- Hirth F, Kammermeier L, Frei E, Walldorf U, Noll M, Reichert H (2003) An urbilaterian origin of the tripartite brain: developmental genetic insights from *Drosophila*. *Development* 130:2365–2373

## Evolution of the Diencephalon

ANN B. BUTLER

Department of Molecular Neuroscience, Krasnow Institute for Advanced Study, George Mason University, Fairfax, VA, USA

### Definition

The diencephalon is the more caudal of the two divisions of the forebrain. It lies between the more rostral division of the forebrain, the telencephalon, and the rostral end of the midbrain. The diencephalon comprises four divisions in its major, rostral part – the epithalamus, dorsal thalamus, ventral thalamus (or subthalamus), and hypothalamus – as well as the more caudally lying prepectum and, in some vertebrates, the posterior tuberculum.

### Characteristics

The diencephalon varies substantially in the degree of elaboration of its various components – epithalamus, dorsal thalamus, ventral thalamus, hypothalamus, prepectum, and the migrated nuclei of the posterior tuberculum – across vertebrates. The hypothalamus, prepectum, and posterior tubercular nuclei are arguably most complex in most taxa of ray-finned fishes, while the dorsal thalamus and ventral thalamus are most elaborated in amniotes. The more dorsal part of the epithalamus is also quite variable, while its habenular portion is relatively conservative, at least in some of its features.

### Epithalamus

The epithalamus comprises two main divisions – that of the habenular complex and related nuclei and that of its roof, the epiphysis, which is the more variable in terms of evolutionary specializations across the various vertebrate taxa.

### Epiphysis: Pineal/parietal and other Specializations of the Epithalamic Roof Plate

The epiphysis has been identified in lampreys and jawed vertebrates and is generally involved in the



regulation of diurnal rhythms [1,2]. While absent in extant hagfishes, the fossil evidence indicates that the epiphysis was present in ancestral vertebrates. A pineal component, which in most cases is directly photoreceptive, is the most commonly occurring epiphyseal structure, present in lampreys and all jawed vertebrate taxa except crocodiles. Pineal projections vary to some degree across vertebrates, but its most common central target (particularly in ray-finned fishes and tetrapods) is the habenula. A more rostral epiphyseal structure, the parapineal organ, is present only very sporadically across vertebrate taxa – having been identified only in lampreys, trout, and the crossopterygian fish *Latimeria*. Like the pineal, it is also photoreceptive, and the parietal eye of lizards and the tuatara *Sphenodon*, which has a pigmented, retinal structure, may likewise be a parapineal outgrowth. Frogs also have a rostral epiphyseal outgrowth called the frontal organ. In birds, the pineal may be light-receptive, since its cells have opsin-containing membraneous segments, whereas in mammals, the pineal is blocked from direct light reception by the overlying cortex and skull. In both birds and mammals, the pineal is known to receive sympathetic innervation.

### Habenula

The habenular nuclei are a strikingly constant feature of vertebrate brains [1,2]. In all vertebrates studied to date (including a good sampling across fishes and tetrapods), the major afferent and efferent connections are similar. The two major afferent inputs arise from the basal ganglia, motor-control parts of the subpallium, the more ventral part of the telencephalon (particularly from the internal segment of the globus pallidus and its homologues), and from limbic (predominantly septal and hypothalamic) sources related to visceral and related functions, the latter coming into the habenular nuclei via the stria medullaris. The major output is via the fasciculus retroflexus to the interpeduncular nuclei.

The habenular nuclear complex is prominent in most fishes (lampreys, hagfishes, and cartilaginous and ray-finned fishes) and across tetrapods. In mammals, two additional nuclei have been classified as part of the epithalamus, the anterior and posterior paraventricular nuclei [3], but whether these nuclei also have homologues in other vertebrates is unknown. In most vertebrates, the habenular nuclei are markedly asymmetric in size, but the significance of this feature, if any, is unknown.

### Dorsal Thalamus

In mammals, the dorsal thalamus comprises a diverse set of nuclei, most of which are organized into groups and including multiple specific sensory relay nuclei, nuclei that are predominantly interconnected with

limbic system structures, motor-system related relay nuclei, and intralaminar nuclei with widespread cortical projections. In nonmammalian amniotes, homologues of many of these nuclei have been identified. In contrast, in anamniotes, the dorsal thalamus is a relatively smaller part of the diencephalon with rostral and caudal portions distinguishable on the basis of their location and amount of afferent input from the midbrain roof. Despite marked differences in the degree of elaboration and many hodological differences, the basic organization of two rostrocaudally aligned divisions also applies to the amniote dorsal thalamus and allows its evolutionary history to be illuminated.

### Overview of Dorsal Thalamic Divisions and Evolution

The organization and evolution of the dorsal thalamus, particularly in mammals, which have a large number of different nuclear groups, was long regarded as difficult to fathom, since comparisons between mammals and other amniotes and between amniotes and anamniotes were difficult to make. The pioneering work of Karten and his colleagues in the 1960s and 1970s, establishing that ascending auditory and visual pathways [4] are present in birds that are similar to those in mammals represented a major breakthrough in understanding dorsal thalamic organization. The large number of nuclear groups present in mammals still did not allow for comparisons of most of their nuclei across amniotes. Nonetheless, the visual system pathways, one through the dorsal lateral geniculate nucleus (nucleus opticus principalis thalami, or OPT) and the other through nucleus rotundus, demonstrated a basic dichotomy between parts of the thalamus that Butler [5] subsequently generalized across other sensory systems and that revealed a basic thalamic organization of two divisions.

The two divisions of the dorsal thalamus, present in all vertebrates, are (i) a developmentally more rostral part that receives its predominant inputs directly, or lemniscally (in reference to a direct, ribbon-like pathway), called the lemnothalamus, and (ii) a more caudal part that receives its predominant inputs via a less direct route through the midbrain roof (the colliculi in mammals), called the collothalamus [5]. These divisions are consistent with the embryological development of the dorsal thalamus in mammals [6]. Across amniotes, the two divisions underwent different evolutionary histories: in early mammals, the lemnothalamus became elaborated first, particularly in regard to the elaboration of the limbic, visual, and somatosensory systems, followed by elaboration of the collothalamus in several orders, while the reverse sequence occurred in the sauropsid line that led to modern birds [5]. These elaborations of the thalamic divisions occurred in conjunction with corresponding elaboration of their respective targets in the pallium (the more dorsal,

sensory-receptive and integrative part of the telencephalon), the lemnopallium and collopallium [1].

### **Dorsal Thalamic Organization Across Vertebrates**

Rostral, lemnothalamic and caudal, collothalamal divisions are generally present in fishes. In hagfishes, the dorsal thalamus and pallium have become elaborated in an apparently unique way, and the identity of the various thalamic nuclei and pallial areas remains obscure. In most other fishes, however, the lemnothalamic nucleus anterior predominantly receives a direct retinal input, while the more caudal part of the dorsal thalamus predominantly receives tectal (midbrain roof) inputs [1,2].

In contrast to other vertebrates, thalamic and pallial organization differs in amphibians in some particulars. The lemnothalamus does not receive direct retinal [7] or somatosensory [8] projections but rather indirect ones via the ventral thalamus; it is heavily interconnected with the limbic, medial pallium [9]. The collothalamus, while in receipt of tectal projections, projects predominantly to the striatum (a component of the basal ganglia) within the subpallium, rather than to the pallium [9]. Thus, the lemnothalamus of amphibians appears to correspond to the limbic-related parts of the lemnothalamus of amniotes rather than to its visual and/or somatosensory system components, and while collothalamal projections to the striatum correspond to those in amniotes, the major collothalamal-pallial projections present in amniotes are lacking. Whether these differences reflect secondary evolutionary events within the amphibian lineage or characterized the common tetrapod ancestral condition is unknown.

Within amniotes, the lemnothalamus comprises the nuclei that receive direct visual and somatosensory inputs as well as motor feedback pathways and also limbic system-related nuclei and the diffusely projecting, rostral set of intralaminar nuclei. In mammals, these include the anterior, medial, rostral intralaminar, and ventral nuclear groups as well as the dorsal lateral geniculate nucleus, and similar nuclei have been identified in sauropsids [5,10–13]. In mammals, the collothalamus comprises the lateral, posterior, and posterior intralaminar nuclear groups, as well as the medial geniculate nucleus [5], and similar nuclei have been identified in sauropsids, although debate continues as to the more individual nuclear comparisons with mammals. For more information on dorsal thalamic evolution, see: Butler, Evolution, of Dorsal Thalamus, this volume.

### **Ventral Thalamus**

In amniotes, the ventral thalamus, often called the subthalamus in mammals, mainly consists of a visual system component and motor system-related nuclei that are involved in circuitry with the basal ganglia. An additional ventral thalamic component is the thalamic

reticular nucleus, a GABAergic cell group of importance in palliothalamic loops. In amniotes, several ventral thalamic nuclei are present – called nuclei ventrolateralis, ventromedialis, and intermedius in ray-finned fishes [1], for example – that are known to be retinorecipient, but their efferent projections have not yet been described. In frogs, two prominent structures called the nucleus and neuropil of Bellonci are, likewise, retinorecipient ventral thalamic components [7].

### **Ventral Thalamic Visual Nuclei**

In sauropsids (reptiles and birds), the ventral lateral geniculate nucleus is a retinorecipient nucleus of marked prominence that lies ventral to the dorsal lateral geniculate nucleus along the medial margin of the optic tract [1]. It is connected with other brainstem nuclei that participate in the production and regulation of eye movements. In mammals, the position and relative size of this nucleus varies considerably; it is called the pregeniculate nucleus in primates. An additional, visual, ventral thalamic component present across amniotes is the intergeniculate leaflet [10], which is also connected with other brainstem visual structures.

### **Motor Ventral Thalamus**

Nuclei of the ventral thalamus that participate in basal ganglia-related circuitry have not yet been identified in any amniotes and may be uniquely involved in amniotes in relation to motor system functions for their terrestrial, tetrapodal niche. In mammals, the most salient of the ventral thalamic nuclei is the subthalamal nucleus, which receives inhibitory (GABAergic) input from the external segment of the globus pallidus (GPe) and provides excitatory (glutamatergic) input to the internal segment of the globus pallidus (GPi). The latter is inhibitory to the ventral anterior and ventral lateral nuclei of the dorsal thalamus, so activity in the subthalamal nucleus promotes inhibition of these dorsal thalamic nuclei via GPi. Similar circuitry is present in reptiles and birds [14]. In birds, the subthalamal nucleus (previously called the anterior nucleus of the ansa lenticularis) receives homologous pallidal input and projects to homologous dorsal thalamic nuclei [15].

### **Thalamic Reticular Nucleus**

The thalamic reticular nucleus (TRN) appears to be most robustly developed in mammals, where it is involved in thalamocortical loop circuitry and may be a crucial part of the neural basis for the generation of consciousness [3,16,17]. The mammalian TRN comprises populations of GABAergic neurons that are reciprocally connected in topographical manner with thalamic nuclei and likewise receive ordered inputs from neocortical areas that are interconnected with the same thalamic nuclei. A homologous TRN is present in birds (previously called the pars dorsalis of the superior

reticular nucleus), comprising a ventral thalamic, GABAergic population of neurons that has circuitry similar to that of the TRN of mammals [18]. Among reptiles, a homologous nucleus with like features has been found in turtles [19]. In contrast, in crocodiles, a TRN may be present, but it contains few GABAergic neurons [20].

### Hypothalamus

The hypothalamus is a highly complex part of the diencephalon, primarily involved in the regulation of a host of visceral and limbic-related functions [1,2]. In many fishes, the hypothalamus includes a large, ventral lobe that is interconnected with various sensory systems, particularly the visual system via projections from pretectal nuclei, and that may be involved in the motor control of feeding behavior. In all vertebrates, the hypothalamus is interconnected with the pituitary gland and is involved with regulation of many functions via the autonomic nervous system.

In mammals, the hypothalamus is organized into sets of nuclei in three medial to lateral zones – periventricular, medial, and lateral – with preoptic, supraoptic, tuberal, and mammillary regions in rostral to caudal order through those zones, and this basic organizational scheme is discernable in other vertebrates as well. Across all vertebrates, the hypothalamus is highly interconnected with both limbic and visceral regulatory systems. For more information on the evolution of the hypothalamus, see: Bruce, *Evolution, of the Hypothalamus: in Amniotes*; and Hodos, *Evolution of the Hypothalamus: in Anamniotes*, this volume.

### Pretectum

The pretectum forms a transitional region between the dorsal thalamus and the roof of the midbrain. The pretectal nuclei are variously elaborated in different vertebrate taxa but share a predominant relationship to the visual system. Some of the pretectal nuclei are highly interconnected with the vestibular system and with tegmental nuclei that form the accessory optic system; these pathways are involved in the regulation and control of eye movements.

In all vertebrates, the pretectal nuclei can be grouped into superficial, central, and periventricular sets, although this organization is most salient in fishes. Among the latter, the pretectum is particularly well developed in teleosts [1,2]. In teleosts, various pretectal nuclei receive retinal and tectal inputs and are connected with other pretectal nuclei that in turn project to parts of the hypothalamus; these circuits may be involved in feeding behavior. Among amniotes, the pretectum is elaborated to a greater degree in sauropsids (reptiles and birds) than in mammals. Some probable homologies can be recognized across amniotes, such as the area pretectalis of birds and the olivary pretectal nucleus of mammals,

which regulate pupillary constriction via projections to the Edinger-Westphal nucleus of the oculomotor nuclear complex. Various other nuclei share some characteristics but not others, indicating that some independent evolution of pretectal nuclei may have occurred within the sauropsid and mammalian lineages.

### Migrated Posterior Tuberculum

The posterior tuberculum is a caudal diencephalic region that is most clearly recognizable in anamniotes (see Vernier and Wullimann, *Evolution, of the Posterior Tuberculum and the Preglomerular Nuclear Complex*, this volume). Its unmigrated portion is in the tegmental region and contains some dopaminergic neurons. Its migrated portion is classified as a caudal diencephalic component, mainly because its several nuclei are involved in the relay of various sensory system inputs from the sensory nuclei to the telencephalon [1]. Thus, the migrated nuclei of the posterior tuberculum mimic some of the dorsal thalamic nuclei of amniotes. The migrated nuclei of the posterior tuberculum have been most studied in ray-finned fishes, particularly teleosts, in which they form a complex known as the preglomerular nuclear complex. These nuclei relay ascending sensory information – particularly lateral line (electrosensory and mechanosensory) and gustatory – to various parts of the telencephalon. For more information on the evolution of the lateral line systems, see: Braun, *Evolution, of the Mechanosensory and Electrosensory Lateral Line Systems*.

### References

1. Butler AB, Hodos W (2005) *Comparative vertebrate neuroanatomy: evolution and adaptation*. Wiley-Liss, Hoboken, NJ
2. Nieuwenhuys R, ten Donkehaar HJ, Nicholson C (1998) *The central nervous system of vertebrates*. Springer, Berlin, Heidelberg, New York
3. Jones EG (2007) *The thalamus*, 2nd edn. Cambridge University Press, Cambridge UK
4. Karten HJ (1969) The organization of the avian telencephalon and some speculations on the phylogeny of the amniote telencephalon. *Ann N Y Acad Sci* 167:164–179
5. Butler AB (1994) The evolution of the dorsal thalamus of jawed vertebrates, including mammals: cladistic analysis and a new hypothesis. *Brain Res Rev* 19:29–65
6. González G, Puelles L, Medina L (2002) Organization of the mouse dorsal thalamus based on topology, calretinin immunostaining, and gene expression. *Brain Res Bull* 57:451–454
7. Roth G, Grunwald W, Dicke U (2003) Morphology, axonal projection pattern, and responses to optic nerve stimulation of thalamic neurons in the fire-bellied toad *Bombina orientalis*. *J Comp Neurol* 461:91–110
8. Westhoff G, Roth G, Straka H (2004) Topographic representation of vestibular and somatosensory signals in the anuran thalamus. *Neuroscience* 124:669–683

9. Northcutt RG, Kicliter E (1980) Organization of the amphibian telencephalon. In: Ebbesson SOE (ed) *Comparative neurology of the telencephalon*. Plenum, New York, pp 203–255
10. Kenigfest N, Martínez-Marcos A, Belekova M, Font C, Lanuza E, Desfilis E, Martínez-García F (1997) A lacertilian dorsal retinorecipient thalamus: a re-investigation in the Old-world lizard *Podarcis hispanica*. *Brain Behav Evol* 50:313–334
11. Medina L, Veenman CL, Reiner A (1997) Evidence for a possible avian dorsal thalamic region comparable to the mammalian ventral anterior, ventral lateral, and oral ventroposterolateral nuclei. *J Comp Neurol* 384:86–108
12. Veenman CL, Medina L, Reiner A (1997) The avian homologues of the mammalian intralaminar, mediodorsal and midline thalamic nuclei: immunohistochemical and hodological evidence. *Brain Behav Evol* 48:78–98
13. Wild JM (1997) The avian somatosensory system: the pathway from wing to Wulst in a passerine (*Chloris chloris*). *Brain Res* 759:122–134
14. Reiner A, Medina L, Veenman CL (1998) Structural and functional evolution of the basal ganglia in vertebrates. *Brain Res Brain Res Rev* 28:235–285
15. Jiao Y, Medina L, Veenman CL, Toledo C, Puelles L, Reiner A (2000) Identification of the anterior nucleus of the ansa lenticularis as the homolog of the mammalian subthalamic nucleus. *J Neurosci* 20:6998–7010
16. Llinás R, Ribary U, Contreras D, Pedroarena C (1998) The neuronal basis for consciousness. *Philosophical Proceedings of the Royal Society of London B*. 353: 1841–1849
17. Steriade M (2006) Grouping of brain rhythms in corticothalamic systems. *Neuroscience* 137:1087–1106
18. Sun Z, Wang HB, Laverghetta A, Yamamoto K, Reiner A (2005) The distribution and cellular localization of glutamic acid decarboxylase-65 (GAD65) mRNA in the forebrain and midbrain of domestic chick. *J Chem Neuroanat* 29:265–281
19. Kenigfest N, Belekova M, Repérant J, Rio JP, Ward R, Vesselkin N (2005) The turtle thalamic anterior entopeduncular nucleus shares connectional and neurochemical characteristics with the mammalian thalamic reticular nucleus. *J Chem Neuroanat* 30:129–143
20. Pritz MB, Stritzel ME (1993) Neuronal subpopulations in a reptilian thalamic reticular nucleus. *Neuroreport* 4:791–794

It comprises a number of nuclei that relay sensory inputs and other information to the telencephalon, the more rostral forebrain component. It has two divisions, based on their predominant sources of afferent input, that can be identified across all jawed vertebrate groups – the lemnothalamus, which receives predominantly direct (lemniscal) inputs, and the collothalamus, which receives its predominant inputs via a relay through the midbrain roof (called the colliculi in mammals).

### Characteristics

The dorsal thalamus contains only three nuclei in most fishes and amphibians, a rostrally lying nucleus called nucleus anterior and two (or sometimes several) nuclei that lie more caudally. The latter nuclei receive their predominant input from the midbrain roof, while in fishes, nucleus anterior is the direct target of retinal projections. The dorsal thalamus of reptiles and birds contains numerous nuclei, and in most mammals these nuclei are even more numerous and comprise a number of nuclear groups.

Despite the relative complexity of the dorsal thalamus in amniotes, Butler [1,2] realized that a rostral, lemnothalamic division and a caudal, collothalamic division can be recognized across at least all jawed vertebrates, based on commonalities of input patterns, projection patterns, and embryological development. The prefix “lemno-” in the term for the rostral division refers to a ribbon, indicating a ribbon-like, i.e., direct, input of afferent sensory projections. (In mammals, a number of such direct pathways have this flat, ribbon-like shape, e.g., the medial lemniscus and the trigeminal lemniscus). The prefix “collo-” in the term for the caudal division refers to the midbrain colliculi of mammals, which form the roof of the midbrain. The organization of the dorsal thalamus will be discussed in these terms in the present essay; for an alternative view see Bruce, *Evolution, of the Brain: in Reptiles*, this volume.

In mammals, dorsal thalamic sensory relay nuclei are the exclusive relay system for this information to the telencephalon, a situation that, as far as is currently known, is also the case in reptiles and amphibians. A markedly different arrangement occurs in ray-finned and cartilaginous fishes, in which some laterally migrated nuclei of a more caudal diencephalic division, the posterior tuberculum, as well as, in some instances, parts of the hypothalamus and ventral thalamus, participate in sensory relay pathways to the telencephalon that are in addition to the sensory relays through the dorsal thalamic nuclei. In birds, while most sensory relay to the telencephalon occurs through dorsal thalamic nuclei, an exception occurs within their trigeminal system: the principal trigeminal nucleus projects directly to a part of the telencephalic pallium (the more dorsal part of the telencephalon), bypassing the dorsal thalamus.

Variation also occurs in the telencephalic targets of collothalamic (and/or posterior tubercular nuclei)

## Evolution of the Dorsal Thalamus

ANN B. BUTLER

Department of Molecular Neuroscience, Krasnow  
Institute for Advanced Study, George Mason  
University, Fairfax, VA, USA

### Definition

The dorsal thalamus is a part of the diencephalon, the more caudal of the two components of the forebrain.

across different vertebrate groups. In fishes, the location and input patterns of the migrated nuclei of the posterior tuberculum, most frequently referred to as the pregglomerular nuclear complex (see Vernier and Wullmann, Evolution, of the Posterior Tuberculum and Pregglomerular Nuclear Complex, this volume), are similar to that of the collothalamus. The collothalamus generally projects to the lateral aspects of the pallium (ventral and lateral pallia and/or the lateral part of the dorsal pallium) and also to the striatum (a motor-control region) within the subpallium (the more ventral part of the telencephalon). Likewise, their projections of the pregglomerular nuclear complex are generally to the more lateral aspects of the pallium (“lateral” being in used here in reference to original position embryologically, regardless of position in the adult case, as discussed below). While in amniotes, the collothalamic nuclei generally project also to the lateral aspects of the pallium as well as to the striatum, in amphibians, the collothalamus projects almost exclusively to the striatum, with only a very minor projection to the lateral-most edge of the pallium. Whether the latter condition is a specialization within the amphibian lineage or representative of the primitive tetrapod condition is currently unresolved.

Similar variation occurs in the telencephalic targets of lemnothalamic nuclei across different vertebrate groups. In fishes, while the picture is somewhat cloudy, the general case appears to be that the lemnothalamus projects to the more medial aspects of the pallium (“medial” also used here in reference to the original position during embryological development). In amphibians, the projections of the lemnothalamus are robust and strongly to the medial pallium, which is somewhat elaborated in contrast to the very poorly developed other pallial regions. In amniotes, the lemnothalamic nuclei project only sparsely to the medial pallium (hippocampus) but robustly to various parts of the medial part of the dorsal pallium. In mammals and birds, projections to the striatum from the rostral intralaminar nuclei have also been gained. Further, variation in inputs to the lemnothalamus varies significantly between amphibians and amniotes. Thus, relative to amphibians, shifts in the afferentation of the lemnothalamus and in both the lemnothalamic and collothalamic projection patterns occur, in conjunction with dramatic differences in the elaboration of the various pallial areas that receive them.

### Collothalamus

In fishes and amphibians, the caudal portion of the dorsal thalamus, composed of two or several nuclei, receives its predominant input from the midbrain roof. This portion of the dorsal thalamus also generally projects to the more lateral aspects of the pallium and/or to the striatum. Likewise, several nuclei are present in the more caudal part of the dorsal thalamus of reptiles, birds, and mammals that receive similar predominant

inputs from the midbrain roof and project to the more lateral aspects of the pallium and to the striatum. Further the projections from these nuclei to the telencephalon are exclusively ipsilateral across all taxa.

The evolutionary relationship of this set of predominantly midbrain roof-recipient nuclei was not difficult to interpret, based on this major shared feature of afferent input. Beginning in the 1960s, Harvey Karten and his colleagues [3] identified major ascending sensory pathways in a bird (the pigeon *Columba livia*) for both the auditory and visual systems that were relayed through the midbrain roof to the dorsal thalamus and thence to the telencephalic pallium. During the same period of time, Irving Diamond and his colleagues [4] identified multiple visual pathways in mammals that likewise are relayed through the superior colliculus to subdivisions of the lateral posterior/pulvinar complex (LP/pul) within the dorsal thalamus and thence to extrastriate visual cortices. The auditory system pathway through the inferior colliculus to subdivisions of the medial geniculate body and thence to auditory cortices was already well known at that time [5]. (Note that, in regard to terminology as used here, the lateral lemniscus is part of the collothalamic auditory system in spite of its “lemniscal” name, because it is a direct path to the midbrain roof, not to the thalamus). In birds, the comparable auditory pathway is relayed through a dorsal thalamic nucleus called nucleus ovoidalis to a part of the nidopallium (then called neostriatum) called Field L, and the comparable visual pathway is through nucleus rotundus to the entopallium (then called ectostriatum). During the next decade or so, similar pathways were found in a variety of reptiles, including turtles, lizards, and crocodiles.

Thus, while some controversy continues regarding specific, one-to-one homologies, it is widely accepted that the various, predominantly midbrain roof-recipient nuclei in reptiles, birds, and mammals are homologous to each other as a group and are evolutionarily derived from a shared set of nuclei in the common amniote ancestor and likewise homologous to the several predominantly midbrain roof-recipient nuclei in anamniotes. That these nuclei comprise one of two fundamental divisions of the dorsal thalamus could be appreciated only with understanding that there are just the two divisions, i.e., recognizing the fundamental unity and evolutionary continuity of the constituents of the lemnothalamus and that the collothalamic and lemnothalamic divisions comprise all of the dorsal thalamic nuclei/nuclear groups in anamniotes and amniotes alike [1,2].

### Lemnothalamus

Before the lemnothalamus, i.e. the developmentally rostral part of the dorsal thalamus that does not receive its predominant inputs by way of relay from the midbrain roof, was identified as a unitary division of the dorsal thalamus, the evolutionary source of many

of the dorsal thalamic nuclei/nuclear groups in amniotes was not understood. The nucleus anterior of fishes receives a substantial and direct projection from the retina, indicating that it might be homologous to the dorsal lateral geniculate nucleus (DLGN) of mammals and the equivalent cell group in reptiles [6] and birds, referred to by a variety of terms, including the nucleus opticus principalis thalami (OPT) in birds [3], but which will be referred to here in all amniotes as the dorsal lateral geniculate nucleus.

In contrast to the single nucleus anterior present in the rostral part of the dorsal thalamus in both fishes and amphibians, reptiles have several nuclei in that region [6], including nucleus dorsolateralis anterior (DLA), nucleus dorsomedialis, and perirotundal nuclei, in addition to the more laterally situated, retinorecipient DLGN [7]. Birds have even more individual nuclei within this part of the dorsal thalamus [8–10]. For most mammals, the situation is even more complex, with placental mammals (and marsupials and monotremes to a lesser but nonetheless substantial extent) having multiple nuclear groups in addition to the DLGN, including the medial, anterior, rostral intralaminar, and ventral nuclear groups. The question of how these various nuclei in sauropsids and nuclear groups in mammals were related evolutionarily to each other, to the DLGN, and to the more caudal, predominantly midbrain roof-recipient nuclei was resolved by recognizing commonalities of development and partially overlapping patterns of connectivity across them. In brief, the direct retinal projections overlap to varying degrees with somatosensory (spinal and/or dorsal column), raphe, hypothalamic, and minor (as opposed to predominant) tectal inputs across these nuclei in amniotes [1], while in fishes, nucleus anterior receives direct retinal input, as noted above, and also the minor tectal and raphe inputs. At the time that the lemnothalamic division of the dorsal thalamus was recognized [1], it was thought that the nucleus anterior of amphibians also received direct retinal and somatosensory inputs, which thus also fit the pattern in both fishes and amniotes. Recent work of Gerhard Roth and his colleagues [11,12] has shown that, instead, these inputs end on ventral thalamic nuclei that in turn project to nucleus anterior, and, also in contrast to the situation in other vertebrates, these inputs appear to be inhibitory, rather than the excitatory inputs of the directly projecting sensory systems. Nonetheless, nucleus anterior of amphibians clearly comprises the lemnothalamus and is homologous to its namesake in fishes. The pattern of projections to it in amphibians may be a specialization within that lineage rather than characteristic of the ancestral tetrapod lineage. Studies of these projections in lungfish may help to resolve this question.

Additional data that support viewing the above noted nuclei in amniotes as lemnothalamic and homologous as an entire group to nucleus anterior of anamniotes

are their shared pattern of projections to the telencephalon. Projections from some of the lemnothalamic nuclei are bilateral, in all vertebrate groups examined including mammals [13,14], rather than being solely ipsilateral<sup>1</sup> like the collothamic nuclei. Also, they tend to be to the medial pallium and/or medial part of the dorsal pallium rather than to the lateral aspects of the hemisphere. Additionally, they do not project to or give off any collateral branches to the striatum.

### Developmental Perspectives on the Lemnothalamus and Collothalamus

The above analysis of shared patterns of connections, both afferent and efferent, was enlightened by a much earlier study of the embryological development of the dorsal thalamus in a rabbit, carried out by Rose [15] (Fig. 1a). Rose identified five neuronal masses in the developing dorsal thalamus of 50-mm rabbit embryos. A medial geniculate pronucleus gives rise to the medial geniculate body, and a single dorsal pronucleus gives rise to both the posterior nuclear group and the lateral posterior/pulvinar complex. The latter two pronuclei thus constitute the embryonic collothalamus. The three other pronuclei comprise the medial pronucleus, which gives rise to the medial nuclear group, the central pronucleus, which gives rise to the anterior, (rostral) intralaminar, and ventral nuclear groups, and a dorsal lateral geniculate pronucleus, which gives rise to the DLGN.

The developmental affinity of the anterior, (rostral) intralaminar, and ventral nuclear groups was an additional clue in the identification of the lemnothalamus as a unitary, rostral thalamic division. Further, the caudal and lateral position of the DLGN in most adult mammals is explicable as the result of the expansion of the derivatives of the medial and central pronuclei [15].

Recent developmental findings have supported the idea of a bipartite dorsal thalamus. In developing mice embryos, calretinin is expressed in the collothalamus but not in the lemnothalamus, and the gene *Math4a* has

<sup>1</sup> Butler 1> originally included all intralaminar nuclei as part of the lemnothalamus. Based on a detailed analysis of dorsal thalamic connectivity in birds, Veenman et al. 10> cogently argued that while the set of rostral intralaminar nuclei across amniotes are indeed a lemnothalamic component, the posterior and more laterally lying intralaminar nuclei, including the parafascicular, paracentral, and central lateral nuclei of mammals, should be considered collothamic, based on multiple factors, including their substantial tectal input and striatal projections. Bilateral projections to the pallium have been found in mammals that originate from the parafascicular and paracentral nuclei 13,14>, but in these studies, the retrogradely labeled neurons on the contralateral side are quite few and are restricted to the medialmost portions of these nuclei. Thus, it is highly likely that this entire medial thalamic region of mammals, including the medialmost portions of the parafascicular and paracentral nuclei, is part of the collothalamus.

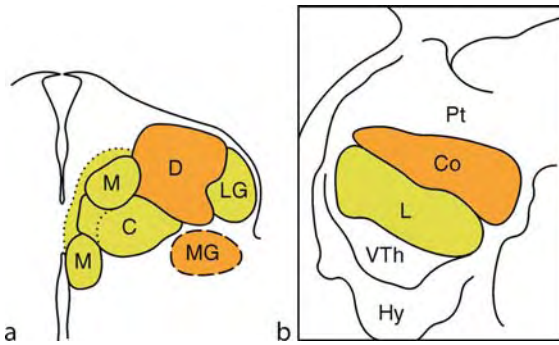

**Evolution of the Dorsal Thalamus. Figure 1 a.** Developing pronuclei in the dorsal thalamus of a rabbit, based on data from [15], shown in a semi-schematic drawing of a rostrally compressed, transverse hemisection through the diencephalon on the right side. Collothalamic nuclei are shown in tan and lemniothalamic nuclei in green. The border of the medial geniculate pronucleus is shown in dashed lines, since it actually lies caudal to this level. The more rostrally present continuity between the two poles of the medial pronucleus is indicated by the dotted lines connecting them and the unlabeled green area that bridges them. **b.** Distribution of calretinin in the collothalamus, shown in tan, and *Math4a* in the lemniothalamus, shown in green, in a semi-schematic drawing of a parasagittal section through the diencephalon of the developing mouse, with rostral toward the left. Data from [16]. Abbreviations: C, central pronucleus; Co, collothalamus; D, dorsal pronucleus; Hy, hypothalamus; L, lemniothalamus; LG, dorsal lateral geniculate pronucleus; M, medial pronucleus; MG, medial geniculate pronucleus; Pt, pretectum; VTh, ventral thalamus.

the opposite pattern, being expressed in the lemniothalamus but not in the collothalamus [16] (Fig. 1b).

### Differential Evolution of the Lemniothalamus and Collothalamus Across Amniotes

The basic features of the lemniothalamus that are shared across most major vertebrate taxa are thus (i) a developmentally rostral position, (ii) a mixture of sensory and other inputs, most of which come directly to the lemniothalamic nuclei rather than being relayed through the midbrain roof, (iii) projections to the more medial aspects of the telencephalon that are (iv) either ipsilateral or bilateral, and (v) a lack of any projections to the striatum. The basic features of the collothalamus that are likewise shared across most major vertebrate taxa are that it is (i) developmentally caudal in position, (ii) receives its predominant inputs via relay through the midbrain roof, (iii) projects to the more lateral aspects of the telencephalon but (iv) exclusively ipsilaterally, and (v) also projects to the striatum.

Against the backdrop of this basic set of features, substantial variation occurs in these two thalamic

divisions across vertebrate taxa and most dramatically within amniotes. As noted above, the set of features seen in modern amphibians for each of these divisions may or may not be similar to the ancestral tetrapod pattern for the afferent pattern to the lemniothalamus and for the efferent projections of both divisions to the telencephalon. Nonetheless, both divisions themselves were clearly present in the common tetrapod and common amniote ancestors, and differential elaboration of each division occurred in the ancestral mammalian line on the one hand and in the ancestral reptilian line on the other.

In ancestral reptiles, which subsequently gave rise to modern reptiles, including birds, the collothalamus was most likely elaborated to a much greater extent than the lemniothalamus (Fig. 2). As is the case in modern reptiles, nucleus rotundus is the largest dorsal thalamic nucleus, and it and the other collothalamic nuclei occupy a larger volume of the thalamus than do the lemniothalamic nuclei. This is reflected in the volume of the pallium occupied by the respective targets of these nuclei. While in some reptiles, such as turtles and snakes, neither the dorsal ventricular ridge (collothalamic target) or the dorsal cortex (or general cortex/pallial thickening) are greatly expanded, in others, such as crocodiles and some lizards, the dorsal ventricular ridge is relatively very large and is populated with multiple, migrated cell groups. In birds, the dorsal ventricular ridge (its main components now called mesopallium, nidopallium, and arcopallium) reaches its greatest development in both size and complexity. Within the sauropsid line, comparative analysis indicates that elaboration of the lemniothalamus then secondarily occurred in birds. Birds thus have some lemniothalamic nuclei that appear to be homologous in a one-to-one fashion with corresponding nuclei in mammals, such as the dorsal column-recipient nucleus dorsalis intermedius ventralis anterior (DIVA) in birds and the ventroposterior lateral nucleus of mammals [17]. However, such comparisons must be restricted to the level of a field homology, since in reptiles, and thus probably in the common sauropsid ancestor, this cell group is contained within the DLA-DM-perirotundal complex of nuclei rather than as a discrete nucleus [6].

In ancestral mammals, the opposite scenario appears to have occurred, such that the lemniothalamus was elaborated to a much greater extent than the collothalamus. As is the case in modern monotremes and to a lesser degree in marsupials, and thus probably the case in the stem, ancestral mammals, the lemniothalamic nuclei were expanded and elaborated to a greater degree than the collothalamic nuclei, likely in conjunction with selective pressures for increased spatial mapping abilities (anterior nuclear group), elaboration of the somatosensory system with the loss of scales and gain

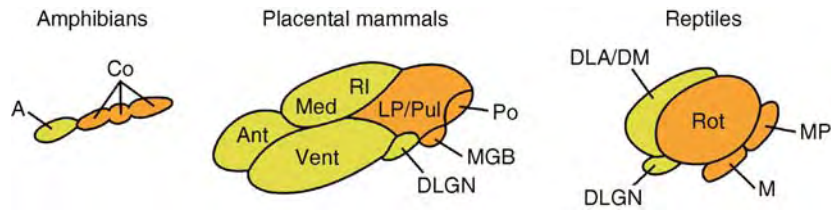

**Evolution of the Dorsal Thalamus. Figure 2** Schematic comparison of lemnothalamic (green) and collothalamic (tan) regions in the brains of an amphibian, a placental mammal, and a reptile. Rostral is towards the left for comparison with Fig. 1b. In amphibians and probably in the most basal, ancestral amniote condition, the caudally lying collothalamus and the rostrally lying lemnothalamus are both rather small and lie in a periventricular (nonmigrated) position. In amniotes, these two thalamic divisions both contain multiple nuclei. In early mammals (not shown here), the lemnothalamus was elaborated to a greater extent than the collothalamus, with some elaboration of the collothalamus occurring secondarily, and to a large extent independently, in a number of orders of placental mammals. The large expansion of the rostral part of the lemnothalamus accounts for the relatively caudal position of the dorsal lateral geniculate nucleus in adult placental mammals. In ancestral and modern reptiles, the collothalamus was elaborated initially to a greater extent than the lemnothalamus. Secondary elaboration of a number of lemnothalamic components has occurred in birds (not shown here). Abbreviations: *A*, nucleus anterior; *Ant*, anterior nuclear group; *Co*, collothalamic nuclei; *DLA/DM*, dorsolateral anterior and dorsomedial nuclei (and peritotundal nuclei); *DLGN*, dorsal lateral geniculate nucleus; *M*, nucleus medialis; *MP*, nucleus medialis posterior; *Med*, medial nuclear group; *MGB*, medial geniculate body; *LP/Pul*, lateral posterior/pulvinar complex; *Po*, posterior nuclear group and posterior intralaminar nuclei; *RI*, rostral intralaminar nuclei; *Rot*, nucleus rotundus. Note that in actuality not all of the nuclear groups represented for mammals or reptiles would be visible on the lateral surface of the thalamus, as represented here.

of body hair (ventral nuclear group), importance of the visual system (dorsal lateral geniculate nucleus), elaboration of the prefrontal cortex (medial nuclear group), and continuation of the importance of the reticular activating system (intralaminar nuclear group). Correspondingly, the pallial areas in receipt of lemnothalamic projections are relatively extensive in modern monotremes, while those receiving collothalamic projections are quite small [18].

Within a number of orders of placental mammals, it is thus most likely that elaboration of collothalamic components occurred secondarily, with corresponding elaboration of their telencephalic targets, both pallial and subpallial. In general, collothalamic nuclei in mammals project to two major pallial targets – both the lateral nucleus of the pallial amygdala and one or more areas of neocortex – as well as to the striatum. While the medial geniculate body, with its several subdivisions, and its telencephalic targets is relatively constant across different orders of mammals, the projections of the posterior nuclear group are arguably more variable, and the projections of the lateral posterior/pulvinar complex are markedly so. The latter set of neuronal cell groups and their pallial targets have dramatically increased in complexity and number within several mammalian orders, particularly carnivores and primates [18,19].

Thus, while both lemnothalamic and collothalamic components are expanded and elaborated in both birds and various orders of mammals, the ancestral divergence of the reptilian and mammalian lines was

apparently characterized by different evolutionary strategies. Within the ancestral reptilian line, elaboration of the collothalamus and its telencephalic targets was strongly selected for, while in the ancestral mammalian line, elaboration of the lemnothalamus was strongly selected for. Subsequently, in some but not all descendants of each of these lineages, the other division of the dorsal thalamus was likewise elaborated.

## References

1. Butler AB (1994) The evolution of the dorsal thalamus of jawed vertebrates, including mammals: cladistic analysis and a new hypothesis. *Brain Res Rev* 19:29–65
2. Butler AB, Hodos W (2005) Comparative vertebrate neuroanatomy: evolution and adaptation. Wiley-Liss, Hoboken, NJ
3. Karten HJ (1969) The organization of the avian telencephalon and some speculations on the phylogeny of the amniote telencephalon. *Ann NY Acad Sci* 167:164–179
4. Harting JK, Glendenning KK, Diamond IT, Kaas JH (1973) Evolution of the primate visual system: anterograde degeneration studies of the tecto-pulvinar system. *Am J Phys Anthropol* 38:383–392
5. Jones EG (2007) The thalamus, 2nd edn. Cambridge University Press, Cambridge, UK
6. Desfilis E, Font E, Belekova M, Kenigfest N (2002) Afferent and efferent projections of the dorsal anterior thalamic nuclei in the lizard *Podarcis hispanica* (Sauria, Lacertidae). *Brain Res Bull* 57:447–450
7. Kenigfest N, Martínez-Marcos A, Belekova M, Font C, Lanuza E, Desfilis E, Martínez-García F (1997) A



lacertilian dorsal retinorecipient thalamus: a re-investigation in the old-world lizard *Podarcis hispanica*. *Brain Behav Evol* 50:313–334

8. Csillag A, Montagnese CM (2005) Thalamotelencephalic organization in birds. *Brain Res Bull* 66:303–310
9. Medina L, Veenman CL, Reiner A (1997) Evidence for a possible avian dorsal thalamic region comparable to the mammalian ventral anterior, ventral lateral, and oral ventroposterolateral nuclei. *J Comp Neurol* 384:86–108
10. Veenman CL, Medina L, Reiner A (1997) The avian homologues of the mammalian intralaminar, mediodorsal and midline thalamic nuclei: immunohistochemical and hodological evidence. *Brain Behav Evol* 48:78–98
11. Roth G, Grunwald W, Dicke U (2003) Morphology, axonal projection pattern, and responses to optic nerve stimulation of thalamic neurons in the fire-bellied toad *Bombina orientalis*. *J Comp Neurol* 461:91–110
12. Westhoff G, Roth G, Straka H (2004) Topographic representation of vestibular and somatosensory signals in the anuran thalamus. *Neuroscience* 124:669–683
13. Carretta D, Sbriccoli A, Santarelli M, Pinto F, Granato A, Minciacchi D (1996) Crossed thalamo-cortical and cortico-thalamic projections in adult mice. *Neurosci Lett* 204:69–72
14. Dermon CR, Barbas H (1994) Contralateral thalamic projections predominantly reach transitional cortices in rhesus monkey. *J Comp Neurol* 344:508–531
15. Rose JE (1940) The ontogenetic development of the rabbit's diencephalon. *J Comp Neurol* 77:61–129
16. González G, Puelles L, Medina L (2002) Organization of the mouse dorsal thalamus based on topology, calretinin immunostaining, and gene expression. *Brain Res Bull* 57:451–454
17. Wild JM (1997) The avian somatosensory system: the pathway from wing to Wulst in a passerine (*Chloris chloris*). *Brain Res* 759:122–134
18. Krubitzer LA (2000) How does evolution build a complex brain? In: Bock GR, Cardew G (eds) *Evolutionary developmental biology of the cerebral cortex*. Wiley, Chichester, UK, pp 206–220
19. Kaas JH (1995) The evolution of isocortex. *Brain Behav Evol* 46:187–196

## Evolution of the Hindbrain

BERND FRITZSCH<sup>1,3</sup>, DAVE NICHOLS<sup>1</sup>,  
GARY O. GAUFO<sup>2</sup>

<sup>1</sup>Department of Biomedical Sciences, Creighton University, Omaha, NE, USA

<sup>2</sup>Department of Biology, University of Texas at San Antonio, Texas, TX, USA

<sup>3</sup>Department of Biology, University of Iowa, Iowa City, IA, USA

### Synonyms

Rhombencephalon; pons + medulla oblongata; brainstem (with midbrain); Hindbrain

### Definition

The hindbrain is wedged between the midbrain and the spinal cord. It consists of the pons (rostrally) and the medulla oblongata (caudally). Because of the unique shape of the ventricle within the developing hindbrain, it is referred to as the “rhombencephalon.” The border with the midbrain is defined dorsally by the crossing of the trochlear nerve and ventrally by the superior pontine sulcus (in mammals). In developmental/comparative terms, this boundary is marked by the midbrain-hindbrain-boundary of gene expression. The transition to the spinal cord is marked dorsally by the closure of the IVth ventricle and ventrally by the decussating cortico-spinal tract (in mammals). In lampreys it is characterized by the sharp transition from hindbrain branchial motoneurons to spinal somatic motoneurons. The brainstem receives all mixed cranial nerve sensory information and provides information processing for fast reactions as well as change of attention and vegetative functions through the reticular formation. The area around the midbrain-hindbrain boundary develops into the cerebellum, an evolutionarily diverse part of the hindbrain (see Evolution, of the Cerebellum).

### Characteristics

As with the spinal cord, the hindbrain is composed of an alar plate, receiving and processing sensory information and a basal plate, harboring cholinergic motoneurons and the transmitter rich, reticular formation (see Evolution, of the Reticular Formation). The roof plate is extended and attenuated to form the choroid plexus of the fourth (IVth) ventricle. Formation of the IVth ventricle commences through a complex morphogenetic movement of the alar plates into lateral positions. In some vertebrates (= craniates as used here) with little developed cerebellum and forebrain, the hindbrain makes up nearly 40% of the total brain (e.g., lamprey). However, while its absolute size increases in more complex brains, its relative size is reduced compared to forebrain and cerebellum. Although notably conserved in its overall form and basic content, there are noteworthy gains and losses in the motor and sensory components of the hindbrain of vertebrates, the molecular basis for which is now beginning to be understood.

Within the central nervous system, the hindbrain contains all of the mixed cranial nerves (the trigeminal, facial, glossopharyngeus, and vagus nerves), the one cranial nerve with only branchial motoneurons (BM; the accessory nerve), and three of the four cranial nerves with only somatic motoneurons (SM; the hypoglossus, abducens and trochlearis nerves). The cranial nerve nuclei of the hindbrain receive general somatosensory information from the face (via the trigeminal, facial, and vagal nerves), special visceral afferents (taste information via the facial, glossopharyngeus, and vagus nerves) and some special somatic afferents (vestibular and

auditory information via the vestibulocochlear nerve and, if present, lateral line mechanosensory and electroreceptive information via the lateral line nerves). The hindbrain provides almost all input to the cerebellum via inferior olive, pontine nuclei (if present), vestibular primary and secondary fibers and part of the dorsal spinocerebellar tract (from the external cuneate nucleus). Almost all sensory information crosses in the hindbrain to the contralateral side, providing an intricate topography that leads to unique phenotypes of defects with regional lesions (see pathology).

### **Branchiomotor Motoneurons (BMs): Features, Development and Evolution**

BMs (formerly misnamed as special visceral motoneurons) are a defining component of the vertebrate hindbrain, because they are present throughout and only in the hindbrain [1]. BMs innervate muscle associated with the branchial arches. BMs are different from somatic motoneurons (SMs) in that they project through dorsal roots rather than forming distinct ventral roots. In contrast to spinal nerves, where dorsal and ventral roots converge to form a mixed spinal nerve, in the hindbrain BMs form together with the sensory neurons a mixed dorsal root. The trigeminal BMs apparently require the sensory fiber root to exit the brain, whereas the facial BMs of mammals are unique in that they form an apparently segregated root. Such intermediate and segregated roots are also known for the accessory nerve that originates in the cervical spinal cord. This feature indicates that the apparently primitive motor fiber association with the sensory fibers can be secondarily segregated in evolution.

In contrast to the spinal cord, where overlapping distributed somatic motoneurons project through distinct rootlets to form a single ventral root, BMs form discrete aggregates in a regular pattern that relates to the embryonic development of hindbrain compartments, the rhombomeres [2]. For example, trigeminal BMs of mammals form in rhombomere 2 (r2) and r3, facial BMs in r4, glossopharyngeal BMs in r6, and vagal BMs in r7. While the rhombomeric patterning appears to be conserved across vertebrates, no other chordate has such units and the content of these rhombomeres appears to change somewhat across different vertebrate groups. For example, in the lamprey the trigeminal BMs extend from r2 into the first half of r4, facial BMs are found in the second half of r4 and all of r5 [3].

BMs become postmitotic near the floor plate and generally migrate more laterally to form a column of motoneurons that in its topology resembles the intermediate column of visceral motoneurons (VMs) in the intermediate column of the thoracic spinal cord. This topology has been long known, and it has been conjectured that BMs develop out of generalized VMs. It was also assumed that these neurons innervate

muscles derived from the lateral plate mesoderm (hypomere), which was later shown to be wrong. Combined with a relatively late evolution of VMs in the hindbrain, as compared to the appearance of hindbrain visceral motoneurons only after parasympathetic ganglia evolved in ancestral jawed vertebrates, this evolutionary scenario suggests that BMs are a distinct and unique class of motoneurons only present in the hindbrain.

One unique feature of BMs is their rather variable topology and adult distribution. This feature results from longitudinal as well as radial migrations that are not observed for any other class of motoneurons [1]. Facial BMs migrate, for example, only laterally in lampreys, some ray-finned fish, frogs and birds. However, they show extensive longitudinal migrations to settle in a more caudal rhombomere in cartilaginous fish, some ray-finned fish, salamanders and mammals. While we begin to understand the molecular basis for this migration [4], the functional significance of this process remains enigmatic.

One unique population of neurons, apparently derived from facial BMs, are the so-called inner ear efferents [5]. Unlike any other motoneuron, these neurons innervate placodally derived hair cells and sensory neurons of the ear rather than facial muscle fibers or neural crest derived autonomic neurons. Like facial BMs, inner ear efferents derive from r4 but segregate from BMs as a result of differential migration in many, but not all, vertebrates. In mammals, these neurons appear to activate a unique contractile system that allows length changes of outer hair cells to adjust to sound intensity.

### **Visceromotor Motoneurons (VMs): Features, Development and Evolution**

Hindbrain VMs form three discrete aggregates of preganglionic parasympathetic neurons that are associated with the facial (superior salivatory nucleus), the glossopharyngeal (inferior salivatory nucleus) and the vagus (dorsal motor nucleus of the vagus) nerves. The only other places in the central nervous system that contains preganglionic parasympathetic VMs are the midbrain (Eddinger–Westphal component of the oculomotor nucleus) and the sacral spinal cord. VMs of the hindbrain project to cranial visceral ganglia, which, in turn, innervate glands (facial nerve to the sphenopalatine ganglion to the lacrimal gland; facial nerve to the submandibular ganglion to the submandibular and sublingual glands, and the glossopharyngeus nerve to the otic ganglion to the parotid gland) or abdominal viscera (vagus nerve to the parasympathetic postganglionic neurons to the viscera). Cranial parasympathetic ganglia and VMs are absent in cyclostomes (lampreys and hagfishes) and may have evolved with terrestrial vertebrates [1], possibly with the evolution of

parasympathetic ganglia from the neural crest. VMs derive from rhombomeres 5–7 and thus form a column that parallels the special visceral sensory (taste) nucleus of the solitary tract. VMs typically show only lateral migration with a limited additional migration away from the IVth ventricle. Neither the origin of the parasympathetic ganglia nor of VMs innervating them is understood at the molecular level.

### **Somatomotor Motoneurons (SMs): Features, Development and Evolution**

Mammalian descriptive neuroanatomy recognizes three SM nuclei in the hindbrain — the hypoglossus, which innervates intrinsic muscles of the tongue, the abducens, which innervates the lateral rectus muscle of the eyes and the trochlearis, which innervates the superior oblique muscle of the eye. All these motoneurons are classically considered to be rostral continuations of spinal SMs. Indeed, they share with the SMs an overall topology near the floor plate and the discrete exit independent of sensory roots. However, SMs of hindbrain do not form mixed nerves with sensory fibers.

Although this terminology is accepted in the mammalian literature, comparative neuroanatomy questions that any of the hindbrain SMs can be compared to spinal SMs. After all, in contrast to the spinal cord, SMs coexist with BMs in the hindbrain. In addition, lampreys and hagfish, being jawless, have no tongue and the most rostral spinal motoneurons that might have evolved into the hypoglossal SMs are immediately caudal to the last BMs of the vagus. Therefore, the caudal rhombomeres of lampreys and hagfish do not develop SMs, suggesting that the evolution of the hypoglossus as a part of the hindbrain is tied into the evolution of jaws and tongues. As with the hypoglossus, the abducens of jawed vertebrates is clearly identified as an SM, but this nucleus does not exist in hagfish. In lampreys, it is organized like a BM population that projects rostrally to exit through the trigeminal nerve. Whether these unique features of the lamprey abducens reflect a primitive condition, lost in hagfish, or signify a parallel evolution to the similarly named nucleus of jawed vertebrates, remains unresolved. The last SM of the hindbrain, the trochlearis, is unique in several aspects. For one thing, its axons extend dorsally to exit to the contralateral orbit, the only motoneuron to do this. Secondly, the neurons may migrate dorsally to remain near their root in lampreys, a feature unknown in any other vertebrate. Lastly, the trochlearis SMs are the only motoneurons that form in r1 and depend critically on the development of the midbrain-hindbrain boundary for their development [6]. Combined, these data suggest that the ancestral vertebrate brainstem may not have had any SMs but evolved them by recruiting SMs of the rostral spinal cord (hypoglossus), diverting a BM population to assume a

SM phenotype (abducens) and/or evolving a unique motoneuron population with the evolution of the midbrain-hindbrain boundary (trochlearis).

### **Somatosensory Nuclei: Features, Development and Evolution**

The somatosensory nuclei of the brainstem and the central projections of the predominantly neural crest-derived cranial and spinal ganglia are rostral extensions of the substantia gelatinosa (lamina II) of the spinal cord and Lissauer's tract from the dorsal root ganglia, respectively. This continuity is most obvious in the continuation of spinal Lissauer's tract. The topography of central projections from the three subdivisions of the trigeminal ganglion are conserved across vertebrates, except for hagfish where the central projection is expanded and dorso-ventrally reversed. As with spinal somatosensory information, second order somatosensory neurons project mostly to the contralateral side, reaching mostly the thalamus in parallel with the spinal second order projection (see Evolution of the Trigeminal Sensory System).

Primary afferents reach the hindbrain from neural crest-derived cranial ganglia, which require the bHLH gene ▶*Neurogenin1* for development, whereas both ▶*Neurogenin 1* and ▶*Neurogenin 2* are required for spinal ganglia [7]. In lampreys, cranial ganglia appear to derive solely from placodes, whereas in jawed vertebrates, placodes other than epibranchial placodes (see below) contribute a subpopulation of cells only to the trigeminal ganglion [8]. It remains unclear whether this evolutionary change in developmental origin of seemingly identical sensory neurons is related to the multiplication of neurogenins in jawed vertebrates [9] or indicates that the neural crest contribution to cranial ganglia evolved after placodes formed cranial ganglia. The topography of the central projections is defined by rhombomere-specific expression of hox genes [10] and depends on retinoic acid expression.

Unique features of the spinal trigeminal nuclei of cyclostomes are the dorsal cells. These cells appear to be functionally equivalent to the mesencephalic nucleus of jawed vertebrates [1]. However, since jawless vertebrates have no specialized muscle spindles, it remains unclear whether these cells contact proprioceptors.

### **Sensory Nuclei for Taste and Viscerosensory Perception: Features, Development and Evolution**

Taste, in most vertebrates, is localized to specialized organs in the oral cavity that are innervated by three cranial nerves — the facial, glossopharyngeus and vagus nerves. However, in hagfish, taste bud like organs are distributed over the body and are innervated by both cranial and spinal nerves. In addition, many bony fish and other aquatic vertebrates have single chemosensory cells that respond to various stimuli in the aquatic

environment and have taste buds distributed over the body [11]. Cranial nerves innervating the taste buds show an unusual central projection that suggests that this system is uniquely derived in hagfish and differs in many respects from all other vertebrates. In lampreys and jawed vertebrates, the central taste projection is a medial addition to the trigeminal projection targeted to a unique nucleus, the rostral portion of the nucleus of the solitary tract, also known as the gustatory nucleus. Taste bud-innervating neurons derive from unique embryonic anlage, the epibranchial placodes. In mammals, these placodes are dependent on the bHLH gene *Neurogenin 2*. Developmental of the central solitary nucleus critically depends on specific genes [12]. Taste is part of the viscerosensory component of cranial nerves and may be the evolutionarily oldest part of it [1]. It clearly existed prior to the formation of the autonomic motor system. How other viscerosensory components of cranial nerves evolved to innervate the viscera and the heart is unclear.

Peripheral taste organization varies most in bony fish and may show expansion of the facial nerve to innervate taste buds outside the oral cavity. In some species, taste receptors project centrally into a greatly enlarged component of the solitary tract nucleus. In others, their central projections may have enlarged the taste system related to the glossopharyngeus and have evolved a lobed, multilayered nucleus in hindbrain that rivals the cellular complexity of the electrosensory and auditory nuclei of other vertebrates [11].

#### **Octavolateral Sensory Nuclei: Features, Development and Evolution**

A unique feature of the hindbrain, without an apparent equivalent in the spinal cord, is the set of octavolateral nuclei that receive the primary afferents of the vestibular part of the ear, and, if present, of the auditory part of the ear and the mechanosensory lateral line and electrosensory organs. Of all the nuclei in the hindbrain, the electrosensory nuclei of bony fish and the auditory nuclei of terrestrial vertebrates (see Evolution, of Mechanosensory and Electrosensory Lateral Line Systems, Evolution, of the Auditory System: Reptiles and Birds, Evolution, of Auditory System: Anamniotes, Evolution, of Auditory System: Mammals) show the most expansion, indicating a unique level of plasticity not found in other, evolutionarily conserved, parts of the hindbrain (except for the cerebellum). These diversifications seem to correlate with the appearance and functional expansion of multiple electrosensory organs in bony fish and diversification of sound pressure receptors in terrestrial vertebrates. Interestingly, the basic organization of the central projections of electrosensory and mechanosensory lateral line and vestibular neurons to second order nuclei follows a stereotypic order along the dorsoventral axis of

the hindbrain alar plate in jawless vertebrates [1]. In dorsal-to-ventral order, it consists of electrosensory lateral line, mechanosensory lateral line and vestibular nuclei and their projections to their respective second order nuclei. This arrangement suggests that central nuclei evolve in relationship to numerical and structural diversification of the periphery. During development, the specific projections seem to develop on a staggered time table with the more ventral projections developing before the more dorsal projections. In the auditory system, specialized receptors evolve in the auditory periphery prior to the formation of discrete second order nuclei. However, the evolution of central nuclei is required for the development of distinct central projections [13]. Recent work suggests that formation of mammalian auditory nuclei depends on the bHLH gene Atonal homolog 1 (*Atoh1*) [14]. In the spinal cord, *Atoh1*-expressing precursors form only a small contingent of second order proprioceptor neurons, whereas in the hindbrain its transcription is essential for the formation of the two largest and evolutionarily most diverse areas, the cerebellum and the auditory nuclei [15]. Combined, these data suggest that evolution of these areas may result from expansion of a small population of cells, a mechanism that may be applicable for most allometric growth of nuclei in brain evolution. It remains to be shown whether the expansion of electrosensory nuclei in teleost fish is also related to the expansion of *Atoh1*-expressing cell populations. An interesting aspect of the evolution of the octavolateral area is the frequent loss of some systems (mechanosensory lateral line and electrosensory system) and gain of others (sound pressure reception system). This situation has led to the suggestion that loss of one set of systems permitted the expansion of the other in terrestrial vertebrates. While this idea has been ruled out for the mechanosensory lateral line that co-exists in some anurans with a sound pressure receiving system, there is a possibility that the loss of electroreception could, in terrestrial vertebrates, have led to or allowed the rapid expansion of the central auditory nuclei sources. More molecular data on development of salamander and frog hindbrains are needed to provide a mechanistic basis for this speculation.

#### **Molecular and Evolutionary Developmental Conservation and Changes in the Hindbrain**

Overall, the basic dorso-ventral patterning of the hindbrain resembles that of the spinal cord and depends on long range diffusible factors such as sonic hedgehog (*Shh*) formed in the floor plate and its interactions with more dorsally expressed gene products such as *Bmp4*, *Gli3* and *Wnt1*. Within these expression gradients, discrete regions of the neural tube are specified to express discrete sets of genes such as bHLH genes. These bHLH genes work, either alone or

in combination with other genes, to specify cell fate in a region specific fashion [16].

In contrast to the spinal cord, the hindbrain shows not only a clear dorso-ventral specification gradient but also a rostro-caudal gradient that specifies discrete dorso-ventral cellular populations to adopt unique rostro-caudal fates [17]. In the central sensory nuclei this situation is most obvious in the ►*Atoh1* expressing area. ►*Atoh1* is required for formation of the external cuneate nucleus that relates spinal cord proprioception to the cerebellum [15]. More rostrally, the equivalent area has been found to give rise to neurons that migrate to form the pontine nuclei. Even more rostrally, the same ►*Atoh1* expressing population forms the auditory nuclei, and, more rostral still, the cerebellum forms [18]. This sequence suggests both the DV and AP patterning processes are interlaced in the hindbrain. Thus, a single dorso-ventral population, specified by ►*Atoh1*, is diversified by its relationship to a rostro-caudal gradient likely reflected in the Hox code.

### Function

Except for the variable presence of electrosensory/mechanosensory lateral line, auditory systems and the expansion of taste-specific area and the cerebellum, the hindbrain is fairly stable across evolution. Most important exceptions to this stability are related to the expansion of ►*Atoh1*-dependent precursor populations. Likewise, the expansion of taste nuclei may relate to another bHLH gene, ►*Mash1* [19]. How an expanded sensory periphery relates to expanded central nuclei and these in turn to an expanded reliance on such a modality for communication with conspecifics or the environment remains unclear. Likewise, in the motor system, there is variation in migration of BMs that, in extreme cases, can move motoneurons from their origin in rhombomere 4 into the rostral spinal cord. Although speculations about the functional significance of such migrations abound, proper testing of them will require functional interference with such migrations [4] and establishing specific losses in function.

### Pathology

Evolution must ultimately occur as a result of selected alterations to the genetic mechanisms responsible for morphogenesis. These same mechanisms malfunction in hindbrain related pathologies. Mutations to the *Zic* family of zinc finger transcription factors have been implicated in instances of the human Dandy–Walker malformation (DWM) and its phenocopy in mice [20]. Although DWM is characterized by its cerebellar phenotype, the *Zic* genes are expressed throughout the dorsal hindbrain. Alterations to the precerebellar nuclei of the hindbrain are thus to be suspected as well. Similarly, while no specific human pathology has yet be identified, mutation to the ►*Atoh1* (►*Math1*) gene

results in the neonatal death of mouse pups from what appears to be respiratory arrest resulting from the absence of relevant hindbrain neuronal populations.

### References

1. Fritzscht B, Northcutt RG (1993) Cranial and spinal nerve organization in amphioxus and lampreys: evidence for an ancestral craniate pattern. *Acta Anat (Basel)* 148:96–109
2. Lumsden A, Keynes R (1989) Segmental patterns of neuronal development in the chick hindbrain. *Nature* 337:424–428
3. Murakami Y, Uchida K, Rijli FM, Kuratani S (2005) Evolution of the brain developmental plan: insights from agnathans. *Dev Biol* 280:249–259
4. Muller M, Jabs N, Lork DE, Fritzscht B, Sander M (2003) *Nkx6.1* controls migration and axon pathfinding of cranial branchio-motoneurons. *Development* 130:5815–5826
5. Fritzscht B (1999) Ontogenetic and evolutionary evidence for the motoneuron nature of vestibular and cochlear efferents. In: Berlin CI (ed) *The efferent auditory system: basic science and clinical applications*, San Diego, Singular Publishing, pp 31–59
6. Fritzscht B, Nichols DH, Echelard Y, McMahon AP (1995) Development of midbrain and anterior hindbrain ocular motoneurons in normal and *Wnt-1* knockout mice. *J Neurobiol* 27:457–469
7. Ma Q, Chen Z, del Barco Barrantes I, de la Pompa JL, Anderson DJ (1998) *Neurogenin1* is essential for the determination of neuronal precursors for proximal cranial sensory ganglia. *Neuron* 20:469–482
8. McCauley DW, Bronner-Fraser M (2003) Neural crest contributions to the lamprey head. *Development* 130:2317–2327
9. Furlong RF, Graham A (2005) Vertebrate neurogenin evolution: long-term maintenance of redundant duplicates. *Dev Genes Evol* 215:639–644
10. Oury F, Murakami Y, Renaud JS, Pasqualetti M, Charnay P, Ren SY, Rijli FM (2006) *Hoxa2*- and rhombomere-dependent development of the mouse facial somatosensory map. *Science* 313:1408–1413
11. Finger TE, Bottger B, Hansen A, Anderson KT, Alimohammadi H, Silver WL (2003) Solitary chemoreceptor cells in the nasal cavity serve as sentinels of respiration. *Proc Natl Acad Sci U S A* 100:8981–8986
12. Qian Y, Fritzscht B, Shirasawa S, Chen CL, Choi Y, Ma Q (2001) Formation of brainstem (nor) adrenergic centers and first-order relay visceral sensory neurons is dependent on homeodomain protein *Rnx/Tlx3*. *Genes Dev* 15:2533–2545
13. Maklad A, Fritzscht B (2003) Development of vestibular afferent projections into the hindbrain and their central targets. *Brain Res Bull* 60:497–510
14. Fritzscht B, Pauley S, Feng F, Matei V, Nichols DH (2006) The evolution of the vertebrate auditory system: transformations of vestibular mechanosensory cells for sound processing is combined with newly generated central processing neurons. *Int J Comp Psychol* 19:1–24
15. Bermingham NA, Hassan BA, Wang VY, Fernandez M, Banfi S, Bellen HJ, Fritzscht B, Zoghbi HY (2001) Proprioceptor pathway development is dependent on *Math1*. *Neuron* 30:411–422

16. Lee SK, Lee B, Ruiz EC, Pfaff SL (2005) Olig2 and Ngn2 function in opposition to modulate gene expression in motor neuron progenitor cells. *Genes Dev* 19:282–294
17. Dasen JS, Tice BC, Brenner-Morton S, Jessell TM (2005) A Hox regulatory network establishes motor neuron pool identity and target-muscle connectivity. *Cell* 123:477–491
18. Wang VY, Rose MF, Zoghbi HY (2005) Math1 expression redefines the rhombic lip derivatives and reveals novel lineages within the brainstem and cerebellum. *Neuron* 48:31–43
19. Gaufo GO, Wu S, Capecchi MR (2004) Contribution of Hox genes to the diversity of the hindbrain sensory system. *Development* 131:1259–1266
20. Grinberg I, Millen KJ (2005) The ZIC gene family in development and disease. *Clin Genet* 67:290–296

## Evolution of the Hippocampus

VERNER P. BINGMAN<sup>1</sup>, COSME SALAS<sup>2</sup>,  
FERNANDO RODRIGUEZ<sup>2</sup>

<sup>1</sup>Department of Psychology and J.P. Scott Center for Neuroscience, Mind and Behavior, Bowling Green State University, Bowling Green, OH, USA

<sup>2</sup>Laboratory of Psychobiology, University of Sevilla, Spain

### Synonyms

Medial pallium; Ammon's horn; Hippocampus

### Definition

The hippocampus or ►**medial pallium** is a part of the cerebral cortex that develops from the medial edge of telencephalic ►**pallium** (from the distal, anterior portion of the embryonic telencephalic ►**alar plate**). The medial pallium, which is present in all vertebrates, has a long evolutionary history (Fig. 1) characterized by features some of which are conserved, such as many of its connections to other brain regions, and others which are divergent, such as the striking variation in cytoarchitectural organization across vertebrate groups. The hippocampus is important for memory representations of space that can guide navigation and, in some animal groups, the encoding of episodic memory.

### Characteristics

#### Mammals

The well-described mammalian hippocampus (Fig. 2) is generally viewed as a three layered structure consisting of three major subdivisions: the dentate gyrus, the

Ammon's horn (fields CA1, CA2 and CA3) and the subiculum [1,2,3,4]. There are two major pathways that connect the hippocampus with the rest of the brain. One, via the neighboring parahippocampal regions (e.g. entorhinal cortex), connects it to higher order, sensory associational regions of the neo(iso)cortex. The other mainly connects the hippocampus with subcortical structures via the fornix. The distinctive principal granule cell and pyramidal cell layers of the dentate gyrus and Ammon's horn respectively, participate in a prevalently feed-forward series of connections that enable the hippocampus to participate critically in a neural system that supports navigation and memory processes that include space as a defining feature, e.g. episodic memory.

#### Birds

The medial pallium and ►**dorsomedial pallium** (collectively referred to as HF below) of birds (Fig. 2) was considered the homologue of the mammalian hippocampus by early twentieth century comparative neuroanatomists [2,3,4]. Both develop from the same portion of the enlarging prosencephalon and both display a similar pattern of developmental gene expression. Although the distinctive cytoarchitectural organization of a mammalian dentate gyrus and Ammon's horn is not readily detectable, the avian HF has a suggestive layered organization, most evident near the "V" shaped cell layers in medial HF. Bitufted spinous neurons, which resemble mammalian hippocampus pyramidal cells, populate the "V" layer. Multipolar spinous neurons populate more dorsomedial regions.

Despite the apparent differences in cytoarchitectural organization between the mammalian hippocampus and HF, across other neurobiological dimensions noteworthy similarity can be found [5]. Shared extra-HF/hippocampal connectivity includes similarly organized connections with the septum, lateral hypothalamus, amygdala (archipallium in birds), brainstem monoaminergic nuclei and telencephalic sensory processing regions. A discernable intra-HF/hippocampal feed-forward processing circuit, which resembles the trisynaptic circuit in the mammalian hippocampus, has been described in HF, including a robust commissural projection to the contralateral HF. However, interpretation of internal connectivity in terms of explicit comparisons between avian and mammalian hippocampal subdivisions is not yet fully resolved [6,7]. The avian HF and mammalian hippocampus also share a generally similar neurochemical profile.

At the electrophysiological level, both the mammalian hippocampus and avian HF display NMDA-dependent and NMDA-independent changes in synaptic efficacy referred to as ►**long-term potentiation**. However, it has been suggested by some researchers that one type of NMDA-independent long-term potentiation

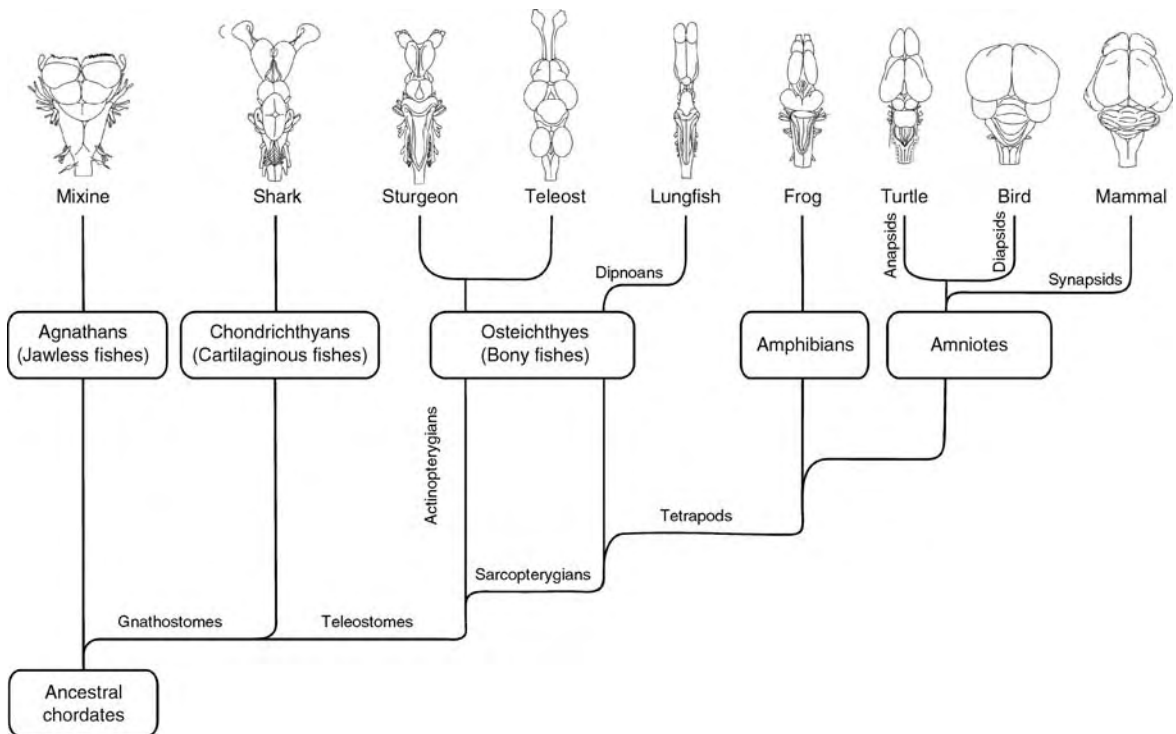

**Evolution of the Hippocampus. Figure 1** Cladogram illustrating the phylogenetic relationship among the main groups of extant vertebrates.

observed in the avian HF is not found in mammals. Field potential recordings of the mammalian hippocampus and avian HF have revealed similar slow-wave oscillations in the theta range, the so-called **▶theta rhythm**. Contrasting the spatial response properties of hippocampal/HF neurons recorded from freely moving rats and homing pigeons is particularly interesting [8]. The spatial response properties of pigeon and rat HF neurons reveal surprising similarity in the contribution of position, direction and trajectory toward explaining spatial variation in firing rate. By contrast, the asymmetrical distribution of spatial response properties of neurons in the left and right HF of homing pigeons, but not the hippocampus of rats, indicates a difference in network organization. This pattern of differences and similarities suggests that the evolution of hippocampal/HF organization may be characterized by inertia with respect to the combination of spatial dimensions that can determine variation in a neuron's action potential firing rate, but considerable plasticity in how neurons with different spatial response properties are organized into functional networks.

The hippocampus of modern mammals and the HF of modern birds are separated by about 300 million years of independent evolution. It is therefore remarkable that despite this “evolutionary distance”, the

hippocampus/HF of modern mammals and birds plays a remarkably similar role in the map-like or relational representation of space [5]. This is best illustrated by studies in which control and hippocampus/HF lesioned rats and homing pigeons were trained on tasks in which alternative spatial representational strategies could be used to navigate to a goal location. One strategy was a route-like strategy based on the association of the goal direction with fixed orientation response to a landmark (s). The other was a map-like strategy based on learning the spatial relationship among landmarks distributed in space and using that relational representation to navigate to the goal. It was shown that in both rats and pigeons the map-like strategy was abolished by HF lesion while the route-like strategy was unaffected.

### Reptiles

The medial pallium of reptiles (Fig. 2) is considered homologous to the avian and mammalian hippocampal formation [2,3,4,9]. In reptiles, the **▶medial (limbic) ▶pallium** is a three-layered cortex, which is comprised of medial (MC) and dorsomedial (DMC) subdivisions. The reptilian MC and DMC are thought to be homologous to the dentate gyrus and Ammon's horn of the mammalian HF, respectively. In addition, the adjacent medial portion of dorsal cortex (DC) has been compared

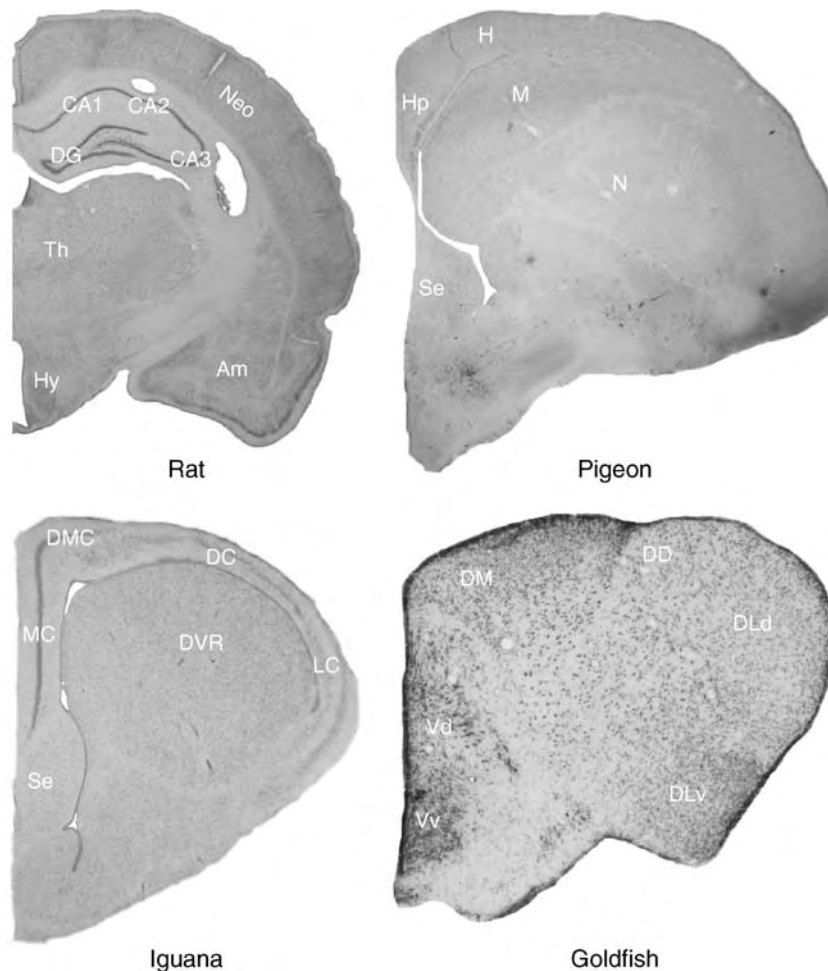

**Evolution of the Hippocampus. Figure 2** Photomicrographs of mid-telencephalic, transverse brain sections in representative species of four different vertebrate groups showing the position of the medial pallium (hippocampus). Abbreviations (see text). *Rat*: Am, amygdala; CA1, CA2 and CA3, fields 1, 2 and 3 of Ammon's horn; DG, dentate gyrus; Hy, hypothalamus; Neo, neocortex; Th, thalamus. *Pigeon*: Hp, hippocampus; H, hyperpallium; M, mesopallium, N, nidopallium; Se, septum. *Iguana*: DC, dorsal cortex; DMC, dorsomedial cortex; DVR, dorsal ventricular ridge; LC, lateral cortex; MC, medial cortex; Se, septum. *Goldfish*: DD, dorsal division of area dorsalis (the area dorsalis is the pallium.); DLd, dorsal subdivision of the lateral division of the area dorsalis; DLv, ventral subdivision of the lateral division of the area dorsalis; DM, medial subdivision of the area dorsalis; Vd, dorsal nucleus of the area ventralis (the area ventralis is the subpallium.); Vv, ventral nucleus of area ventralis.

with the transitional entorhinal cortex that borders the mammalian hippocampus.

MC contains small neurons, whereas DMC contains large neurons. As in mammals and birds, pyramidal-like, bitufted spinous neurons are present in the reptilian medial pallium and this characteristic seems to be an apomorphic (derived) feature of amniotes, because this cell type has not been found in anamniotes [10]. The pattern of connectivity of the medial cortex of reptiles resembles the hippocampus of mammals and HF of birds. The MC receives afferent projections from the DMC, DC and lateral (olfactory) cortex and projects

back reciprocally to the DMC and DC. Thus, whereas the MC of reptiles receives afferent projections from several telencephalic cortical regions, the DMC is primarily connected with just the MC. In addition to reciprocal connections with MC, there is a substantial commissural connection between the DMCs of the two hemispheres. Both MC and DMC are reciprocally connected with the septum and receive ascending projections from the anterior dorsomedial nucleus of the dorsal thalamus, the mammillary and periventricular regions of the hypothalamus, the raphe nuclei, the locus coeruleus and the reticular formation.



At a functional level, recent evidence indicates that the medial pallium, like the hippocampus of mammals and HF of birds, is important for some types of spatial learning and memory [9]. The MC of turtles is specifically involved in what has been called map-like, allocentric or relational spatial representations of the environment. Lesions to MC in turtles produce deficits in a variety of map-like, relational spatial tasks but not in cue learning and other egocentrically referenced learning tasks. In addition, although the available data are still scarce, medial pallial dependent learning and memory may be based on some conserved cellular/molecular mechanisms. For example, as observed in mammals and birds, both NMDA-dependent and NMDA-independent long-term potentiation has been reported in the MC of turtles.

In summary, the medial pallium or hippocampus of amniotes is partially characterized by divergence in cytoarchitectural organization (the distinctive dentate gyrus and hippocampus of mammals, a V-shaped large-cell layer in the HF of birds, a cell layer in the MC of lizards and a scarcity of lamination in turtles). These variations suggest some independent evolutionary elaboration in each separate radiation. However, there are perhaps even more evident similarities. Conserved histochemical, physiological and functional characteristics, as well as some aspects of anatomical connectivity, indicate that these traits were present in the ancestral group of amniotes that gave rise to extant mammals, birds and reptiles. As the amniotes appear to be a monophyletic group that diverged from primitive tetrapods during the early Carboniferous, it is reasonable to assume that medial pallial (hippocampal) dependent spatial cognition is an ancient brain-behavior property present in the stem reptilian ancestor of modern amniotes that was retained during the independent evolution of each extant lineage.

### Anamniotes

A hippocampal-like medial pallium is also present in amphibians, lungfishes, ray-finned fishes, cartilaginous fishes and agnathans [3,11,9,10,12]. In amphibians, the medial pallium is hypertrophied relative to other pallial regions and the medial pallium of lungfishes. The medial pallium of amphibians and lungfishes can be divided into three subdivisions based on cytoarchitectural and histochemical criteria, but the subdivisions are not necessarily comparable between the two groups or with specific subdivisions of the amniote medial pallium. In frogs, intra-telencephalic connections of the medial pallium include reciprocal, extensive connections with the dorsal and lateral pallia, the septal nuclei, the nucleus of the diagonal band, the amygdala and the nucleus accumbens, as well as commissural connections with the contralateral medial pallium. Extra-telencephalic connections include a fornix-like projection

to the ventral thalamus, preoptic area and hypothalamus, as well as inputs from the anterior nucleus of the dorsal thalamus and a serotonergic projection from the raphe area. Thus, the extrinsic connectivity of the medial pallium of amphibians [10] is strikingly similar to that of amniotes, with the notable exception of a robust dorsal thalamic non-olfactory-sensory projection into the amphibian medial pallium. Furthermore, the pattern of expression of LIM-homeodomain genes in the pallium of amphibians strongly supports homology with the medial pallium of amniotes.

The degree of cytoarchitectural complexity varies from relatively simple to highly elaborate in the ►telencephalon of squalomorph and galeomorph sharks, skates and rays. The medial pallium (the topological equivalent of the hippocampus) of cartilaginous fishes receives inputs from the ►dorsal pallium and the septal nucleus, and sensory information is relayed from the thalamus and other diencephalic areas.

In agnathans, the elaboration and complexity of cell masses in the telencephalon varies from relatively simple in lampreys to complex in hagfishes. In lampreys, the medial pallium receives inputs from other pallial areas, the septum and various areas of the diencephalon; it projects to a variety of telencephalic, diencephalic and brainstem areas. The presence of a medial pallium and associated pallial and subpallial structures in agnathans indicates that a hippocampal-like structure is a primitive feature of the vertebrate telencephalon, dating back close to the origin of vertebrates.

The telencephalon of ray-finned fishes (actinopterygian fishes) constitutes a special case among vertebrates (Fig. 2). The telencephalon of ray-finned fishes develops by a process of eversion (bending outward of the embryonic prosencephalic alar plate) instead of evagination as occurs in every other vertebrate group. As a consequence of this particular developmental process, the medial-to-lateral topography of the pallial areas observed in other vertebrate groups is reversed in ray-finned fishes. Accordingly, the pallial area most probably homologous to the hippocampus is located laterally in the telencephalon [9].

Among the ray-finned fishes, the teleosts have been most intensively studied. The topography, connections and histochemistry of the ►lateral pallium of teleost fish are remarkably similar to the medial pallium of vertebrates with a developmentally evaginated telencephalon. The lateral area of the teleost pallium (DI) is characterized by extensive intra-telencephalic connections. DI has widespread reciprocal connections with other pallial areas, as well as with the contralateral DI by means of commissural projections. DI is also reciprocally connected with the ventral nucleus of the area ventralis (Vv), considered to be homologous with the septal nuclei of amniotes. Like the septal formation of amniotes, the Vv of teleost fish sends a large

projection to the midline hypothalamus and cholinergic input to DI. DI has reciprocal connections with the preglomerular complex of the posterior tuberculum in the diencephalon, from which it receives a number of multi-sensory inputs (rather than from the dorsal thalamus). DI also projects to the preoptic area and other diencephalic regions and receives inputs from the preoptic area, the locus coeruleus and the superior raphe. Within DI, the ventral subdivision (Dlv) is a candidate for a specific homologue of the tetrapod medial pallium. It occupies a distal topological position in the pallium and has extensive interconnections with the suspected homologues of the septal nuclei and preoptic area. The homology of Dlv with the medial pallium is supported also by the distribution pattern of several histochemical and molecular markers. For example, the dopamine receptor subtype D1B, which is characteristic of the mammalian hippocampus, is selectively expressed in the Dlv subdivision of the teleost pallium. The pattern of connectivity and multi-sensory functional organization of the dorsal subdivision of DI (Dld) also resembles amniote medial pallium. The primary target of descending projections from Dld is the caudal hypothalamus, a projection that resembles the post-commissural fornix in tetrapods.

A considerable amount of functional evidence indicates that, like the amniote medial pallium, the lateral pallium of teleost fish selectively supports spatial cognition [9]. For example, training goldfish in a spatial task produces a significant and restricted increase in neuronal protein synthesis activity in the lateral pallium compared to fish trained in cue learning or control procedures. In addition, lateral pallial lesions in goldfish produce a dramatic impairment in a variety of spatial learning tasks. By contrast, medial or dorsal pallial lesions do not produce any observable deficit in the same spatial tasks. Moreover, like the medial pallium of amniotes, the lateral pallium of teleost fish seems to be selectively involved in map-like or relational representations of space, as lateral pallial lesions do not affect cue-learning or non-relational, egocentric spatial behavior. Thus, the effects of lateral pallial damage in teleost fish are similar to those observed in amniotes following medial pallial lesions. Like amniotes, LTP mechanisms are present in the pallium of teleost fish and spatial memory formation involves NMDA receptors.

### Hippocampus Evolution: Synthesis

From agnathans to mammals, the medial (lateral in actinopterygians) pallium (hippocampus) of all extant vertebrates shares a suite of developmental and connectivity characteristics, as well as some less studied neurochemical and electrophysiological properties. The similarities indicate a common evolutionary ancestry. Thus, it is reasonable to assume that some basic

organizational properties of the medial pallium-hippocampus evolved early in vertebrate phylogenesis – properties that were generally conserved during the independent evolution of the different vertebrate radiations. The conserved properties probably explain the universal role of the medial pallium-hippocampus in spatial cognition. Nonetheless, across vertebrate groups the medial pallium-hippocampus, together with neighboring brain regions, is characterized by considerable variation in morphological and cytoarchitectonic organization, as well as some aspects of intrinsic connectivity. Therefore, the medial pallium-hippocampus in any extant group of vertebrates should be viewed as a composite of both conserved and derived characteristics collectively adapted in part to the spatial ecology of that group and the evolved properties of connected brain regions.

### References

1. Amaral DG, Witter MP (1995) Hippocampal formation. In: Paxinos G (ed) The rat nervous system. Academic, New York, pp 443–493
2. Butler AB, Hodos W (2005) Comparative vertebrate neuroanatomy: evolution and adaptation, 2nd edn. Wiley, Hoboken
3. Nieuwenhuys R, ten Donkelaar HJ, Nicholson C (1998) The central nervous system of vertebrates. Springer-Verlag, Berlin
4. Striedter GF (2005) Principles of brain evolution. Sinauer, Sunderland
5. Bingman VP, Hough GE II, Kahn MC, Siegel JJ (2003) The homing pigeon hippocampus and space: in search of adaptive specialization. *Brain Behav Evol* 62:117–127
6. Atoji Y, Wild JM (2004) Fiber connections of the hippocampal formation and septum and subdivisions of the hippocampal formation in the pigeon as revealed by tract tracing and kainic acid lesions. *J Comp Neurol* 475:426–461
7. Kahn MC, Hough GE II, Ten Eyck GR, Bingman VP (2003) Internal connectivity of the homing pigeon (*Columba livia*) hippocampal formation: an anterograde and retrograde tracer study. *J Comp Neurol* 459:127–141
8. Siegel JJ, Nitz D, Bingman VP (2006) Lateralized functional components of spatial cognition in the avian hippocampal formation: evidence from single-unit recordings in freely moving homing pigeons. *Hippocampus* 16:125–140
9. Salas C, Broglio C, Rodríguez F (2003) Evolution of forebrain and spatial cognition in vertebrates: conservation across diversity. *Brain Behav Evol* 62:72–82
10. Westhoff G, Roth G (2002) Morphology and projection pattern of medial and dorsal pallial neurons in the frog *Discoglossus pictus* and the salamander *Plethodon jordani*. *J Comp Neurol* 445:97–121
11. Northcutt RG (1995) The forebrain of gnathostomes: in search of a morphotype. *Brain Behav Evol* 46:275–318
12. Wulliman MF, Mueller T (2004) Teleostean and mammalian forebrains contrasted: evidence from genes to behavior. *J Comp Neurol* 475:143–162

## Evolution of the Hypothalamus in Anamniotes

WILLIAM HODOS

Department of Psychology, University of Maryland,  
College Park, MD, USA

### Definition

The hypothalamus is a specialized region of the ventral diencephalon that is involved in regulation of the endocrine system, the autonomic nervous system, and related brain systems. It is concerned with various visceral functions and behavioral processes such as reproductive and parental behavior, temperature regulation, territory management, and biological rhythms. The anamniote hypothalamus has many similarities to that of amniotes, but it also has some important differences.

### Characteristics

The hypothalamus occupies most of the ventral region of the diencephalon. It is a relatively large and well developed region in many anamniote vertebrates, such as jawless fishes, cartilaginous fishes (chiaemaras, sharks, skates, and rays), ray-finned fishes, and amphibians. It consists of a preoptic area at its rostral end and a hypothalamus proper. In cartilaginous and ray-finned fishes, the latter contains a ventral region known as the inferior lobe. The hypothalamus proper consists of specialized cell groups known as nuclei or areas that have many connections within the diencephalon, the telencephalon, and the hindbrain. It also receives a modest axonal pathway from the retina that plays a role in daily and seasonal photoperiodic biological rhythms and behaviors that are linked to these rhythms, such as seasonal breeding and migration. Other sensory systems, such as the gustatory and auditory systems, have input into the hypothalamus as well. The hypothalamus is also involved in a variety of other survival behaviors such as feeding, defense, and escape [1].

### Circumventricular Organs

In anamniotes, the third ventricle of the brain extends into the hypothalamus to form a hypothalamic ventricle. In some localized areas, the ependymal lining of the ventricles is thickened into specialized structures called circumventricular organs, some of which secrete hormones and other neuroactive substances into the cerebrospinal fluid that fills the ventricles and some of which detect the presence of neuroactive substances in the cerebrospinal fluid, which acts as a chemical transport system similar to the cardiovascular system. In anamniotes, the circumventricular organs include the area postrema, the subcommissural organ, the pineal, the

median eminence and posterior pituitary, and the paraventricular organ [1].

### Saccus Vasculosus

In many anamniote species, including teleost fishes and sharks, the hypothalamic ventricle protrudes ventrally to form the saccus vasculosus. Among the hypotheses for the functions of this organ are sensory (depth detection and chemical detection), osmoregulation, ionic transport, skeletal growth, tooth regeneration, and a variety of visceral functions [2]. The saccus is innervated by the tractus sacci vasculosi, which terminates in the nucleus sacci vasculosi in the posterior tuberculum [1].

### The Hypophysis

One of the major functions of the hypothalamus is control of the endocrine system via the hypophysis (pituitary), which is attached to the floor of the hypothalamus by the median eminence. The hypophysis consists of a neural zone (the neurohypophysis) and a glandular zone (the adenohypophysis), the latter of which is further subdivided into a distal part and an intermediate part.

The neurohypophysis is innervated by axonal pathways from the hypothalamus that transport to it the hormones oxytocin, isotocin, and argentine vasotocin, which are produced in the hypothalamus [3,4]. These are secreted into the general circulation from the neurohypophysis. These hormones affect such functions as blood pressure, kidney filtration, and contractions of the oviduct that affect movement of the ova.

The adenohypophysis is controlled by a local circulatory system, the hypophyseal portal system, which carries releasing and inhibiting hormones to it from the hypothalamus. These releasing and inhibiting hormones in turn regulate the release (or inhibition) of trophic hormones from the adenohypophysis into the general circulation where they affect the production of hormones from the various endocrine glands, such as the gonads and [1,5]. Unlike the adenohypophysis of amniotes, the adenohypophysis in sharks and teleosts contain finger-like projections of the hypothalamus through which hypothalamic neuronal processes enter [1].

Another role of the neuroendocrine system is the control of skin coloration by melanocyte stimulating hormone (MSH), which affects the dispersion of melanin granules in the melanocyte organs of the skin. Neurons from the preoptic area and hypothalamus regulate the release of MSH from the intermediate division of the adenohypophysis which results in skin darkening, which can serve as camouflage or as a social display [1].

### The Preoptic Area

The preoptic area is a transition zone between the diencephalon and the telencephalon. In ray-finned fishes, it is important, along with the posterior region of the

hypothalamus, for the maintenance of body temperature, whether by internal physiological mechanisms or by behavioral means; i.e., moving from a region that is too warm or cold to a location that is within a satisfactory thermal range for the animal. Regulation of body temperature is especially important for aquatic animals because of the effects of temperature on various respiratory gasses, and also because temperatures outside of the animal's optimal range can affect the rate at which important metabolic chemical reactions occur [1].

The preoptic area is present in all fishes. Among jawless fishes, it is less developed in lampreys than in hagfishes, in which it is particularly well developed and consists of four nuclei: dorsal, external, periventricular, and intermediate. This area is also well developed in ray-finned fishes and comprises anterior and posterior parvocellular nuclei and a magnocellular nucleus that contains both large-celled and small-celled subdivisions. The preoptic area is not particularly well developed in lungfishes and salamanders, but in frogs it contains an anterior preoptic area and a magnocellular nucleus. [1,3].

Among anamniotes, the functions of the preoptic area have probably been best studied in ray-finned fishes, where it has been reported to be involved in reproductive and parental behaviors such as courtship, nest building, and sperm and egg release and related social behaviors such as aggressive displays. Other functions of the preoptic area in fishes include a role in heart rate and respiration [1].

### Connections of the Preoptic Area

The preoptic area receives epithalamic projections from the epiphysis (pineal) and habenula [1,7]. Other inputs are from the lateral pallium [6]. The preoptic area sends efferent axons to most of the telencephalon, including the olfactory bulb, and also to the habenula and the periglomerular complex [3,7,8], which is an aggregation of nuclei in the posterior tuberculum (a posterior part of the diencephalon unique to fishes) that receive gustatory, visual, and auditory inputs and relay them to the midbrain tectum and the telencephalon. In amphibians, the preoptic area receives input from limbic system structures such as the septum and amygdala, as well as from the hypothalamus, retina, and pineal. Its efferents are to the striatum of the telencephalon, hypothalamus, and spinal cord [1].

### Hypothalamus

In lampreys, the hypothalamus consists of a thin shell around the third ventricle and is comprised of dorsal and ventral divisions. The hypothalamus of hagfishes also is poorly developed. In contrast, the hypothalamus of sharks is well developed into distinct nuclei. In addition to the suprachiasmatic nucleus, it contains a nucleus medius, as well as a periventricular nucleus, and a nucleus lateralis tuberis, which seems to be related to the

hypophysis. Also present is a nucleus lobi lateralis which is present in the lateral lobe, a lateral expansion of the ventral hypothalamic region. This nucleus is connected to various subpallial structures of the telencephalon by the basal forebrain bundle and to the pallium by the tractus pallii [1].

In ray-finned fishes, the hypothalamus consists of a dorsal and a ventral division as well as distinct nuclei such as ventral, lateral, and anterior tuberal nuclei in the region of attachment of the hypophysis. The inferior lobe contains a diffuse nucleus and a compact nucleus known as the central nucleus of the inferior lobe. Also contained within the inferior lobe of cyprinid fishes (goldfish and other carps as well as catfishes), which are fishes that are highly specialized for gustation, is a structure called the mammillary body, so named for its superficial resemblance to the mammillary body of the amniote hypothalamus. In these fishes, however, this cell group appears to be specialized for gustatory input to the hypothalamus; it receives axons from the secondary gustatory nucleus and sends its output to other regions of the inferior lobe [8,9].

In lungfishes and salamanders, the hypothalamus is relatively undifferentiated into distinct nuclei. The hypothalamus in frogs, however, is differentiated into dorsal and ventral regions and a lateral hypothalamic nucleus that may be comparable to the inferior lobes of sharks and ray-finned fishes [1].

Nearby to the preoptic area in many anamniotes is the suprachiasmatic nucleus, a cell group that is a hypothalamic target of axons from the retina and that sends its output to other regions of the hypothalamus and to the periglomerular nuclear complex [1,10,11]. The suprachiasmatic nucleus has been reported to play an important role in biological rhythms that depend on the daily light cycle and its seasonal changes in anamniotes as well as amniotes.

### Connections of the Hypothalamus

The connections of the hypothalamus in anamniotes have not been as well studied as those of mammals. The inferior lobe of fishes receives inputs from a wide variety of sources including the gustatory nuclei [10], preoptic area, dorsal thalamic area, the posterior thalamic nucleus, and parts of the periglomerular nuclear complex [6,9,10,11]. Additionally, it receives visual inputs relayed through pretectal nuclei (the posterior pretectal nucleus in nonteleost ray-finned fishes and two comparable nuclei, nucleus pretectalis superficialis pars intermedius and nucleus glomerulosus, in teleosts) that may be involved in feeding behavior [1]. Its efferents are to the central zone of the pallium, dorsal hypothalamus, mammillary body, and posterior thalamic nucleus [10,12–15].

As in amniotes, an important function of the hypothalamus in anamniotes is the autonomic control of the viscera by way of the hindbrain. A main pathway

for this control is the tractus lobo-bulbaris from the inferior lobe to the reticular formation and motor nuclei of the hindbrain. The inferior lobe also interacts with the cerebellum via the tractus lobocerebellaris. Other connections of the inferior lobe are with the midbrain tegmentum [1].

In amphibians, the hypothalamus receives inputs from the preoptic area, components of the limbic system such as the amygdala and septum, and various thalamic nuclei such as the anterior and central nuclei. Other afferents are from the midbrain including the tegmentum, optic tectum, and torus semicircularis. It efferent targets include the amygdala, preoptic area, and the anterior and posterior nuclei of the dorsal thalamus [1].

In summary, taken together, the preoptic area and the hypothalamus form a complex interface between sensory systems, visceromotor systems, and the endocrine system [1,11,12,15]. The details of their connections vary substantially across the major vertebrate taxa, both anamniote and amniote, according to the variable elaboration of different parts of the neuraxis and the different niches they occupy.

## References

- Butler AB, Hodos W (2005) Comparative vertebrate neuroanatomy: evolution and adaptation, 2nd edn. Wiley, Hoboken, NJ
- Devlin AJ, Danks AJ, Faulkner MK, Power DM, Canario AV, Martin TJ, Ingleton PM (1996) Immunohistochemical detection of parathyroid hormone-related protein in the saccus vasculosus of a teleost fish. *Gen Comp Endocrinol* 101:83–90
- Saito D, Komatsuda M, Urano A (2004) Functional organization of preoptic vasotocin and isotocin neurons in the brain of rainbow trout: central and neurohypophysial projections in single neurons. *Neuroscience* 124:973–984
- Goodson JI, Bass AH (2000) Vasotocin innervation and modulation of vocal acoustic circuitry in the teleost *Porichthys notatus*. *J Comp Neurol* 422:363–379
- Yamamoto N (2003) Three gonadotropin-releasing hormone neuronal groups with special reference to teleosts. *Anat Sci Int* 78:139–155
- Folgueira M, Anadón R, Yáñez J (2004) Experimental study of the connections of the telencephalon in the rainbow trout (*Oncorhynchus mykiss*). II: Dorsal area and preoptic region. *J Comp Neurol* 480:204–233
- Yáñez J, Anadón R (1996) Afferent and efferent connections of the habenula in the rainbow trout (*Oncorhynchus mykiss*): an indocarbocyanine dye (DiI) study. *J Comp Neurol* 372:529–543
- Folgueira M, Anadón R, Yáñez J (2005) Experimental study of the connections of the preglomerular nuclei and corpus mamillare in the rainbow trout (*Oncorhynchus mykiss*). *Brain Res Bull* 66:361–364
- Sawai N, Yamamoto N, Yoshimoto M, Ito H (2000) Fiber connections of the corpus mamillare in a percomorph teleost, tilapia *Oreochromis niloticus*. *Brain Behav Evol* 55:1–13
- Ahrens K, Wullimann MF (2002) Hypothalamic inferior lobe and lateral torus connections in a percomorph teleost, the red cichlid (*Hemichromis lifalili*). *J Comp Neurol* 449:43–64
- Yamamoto N, Ito H (2005) Fiber connections of the anterior preglomerular nucleus in cyprinids with notes on telencephalic connections of the preglomerular complex. *J Comp Neurol* 491:212–233
- Rink E, Wullimann MF (1998) Some forebrain connections of the gustatory system in the goldfish *Carassius auratus* visualized by separate DiI application to the hypothalamic inferior lobe and the torus lateralis. *J Comp Neurol* 394:152–170
- Lamb CF, Caprio J (1993) Diencephalic gustatory connections in the channel catfish. *J Comp Neurol* 337:400–418
- Northcutt RG (2006) Connections of the lateral and medial divisions of the goldfish telencephalic pallium. *J Comp Neurol* 494:903–943
- Shimizu M, Yamamoto N, Yoshimoto M, Ito H (1999) Fiber Connections of the Inferior Lobe in a Percomorph Teleost, *Thamnaconus (Navodon) modestus*. *Brain Behav Evol* 54:127–146

## Evolution of the Hypothalamus in Amniotes

LAURA L BRUCE

Department of Biomedical Sciences, School of Medicine, Creighton University, Omaha, NE, USA

### Definition

The amniote hypothalamus is located in the ventral part of the diencephalon. It consists of multiple cell groups that regulate diverse functions, including feeding, temperature regulation, diurnal rhythms, autonomic responses and procreation.

### Characteristics

The hypothalamus consists of multiple cell groups with diverse functions, most of which help to regulate survival of the individual (e.g. feeding, temperature regulation, diurnal rhythms, autonomic responses) or survival of the species (e.g. procreation). Many of the nuclei and their neurochemical characteristics are present in all amniotes, suggesting that they were present in the common amniote ancestor.

### Introduction

The amniote hypothalamus is located in the ventral part of the diencephalon or thalamus, forming the walls and floor of the third ventricle (Fig. 1).

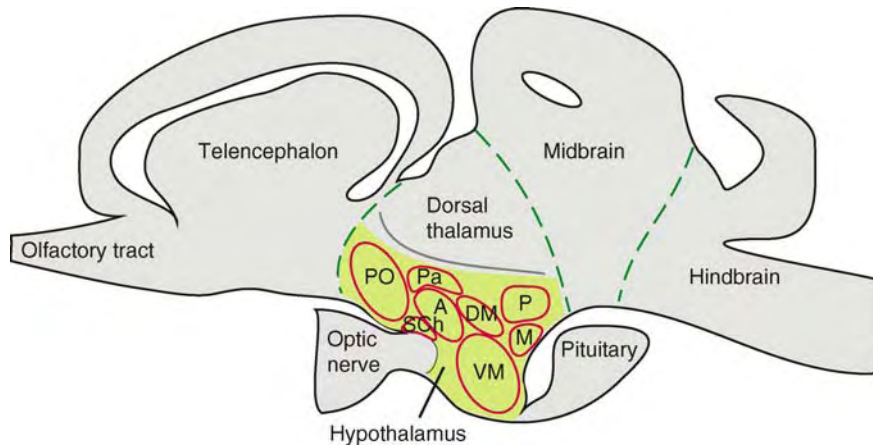

**Evolution of the Hypothalamus in Amniotes. Figure 1** The location of the hypothalamus (light green) and some of the major hypothalamic nuclei (red outline) relative to other major brain regions is illustrated in a sagittal section through a reptilian brain. Rostral is to the right and dorsal is up. Abbreviations: *A*, anterior hypothalamic nucleus; *DM*, dorsomedial hypothalamic nucleus; *M*, mammillary body; *Pa*, paraventricular nucleus; *PO*, preoptic area; *SCh*, suprachiasmatic nucleus; *VM*, ventromedial hypothalamic nucleus; *P*, posterior hypothalamic area.

The rostral midline of the hypothalamus is formed by the lamina terminalis, which also forms the rostral wall of the third ventricle and is associated with a vascular organ. The functions of the hypothalamic nuclei are usually essential for survival and thus it is perhaps to be expected that, once evolved, these nuclei would be retained during the further evolution of species.

### General Organization of the Hypothalamus

In all amniotes the hypothalamus is divided into three longitudinal zones: periventricular, medial, and lateral (Fig. 2).

Many of the cell groups in the periventricular zone project to the pituitary and thus regulate the secretion of pituitary hormones. The groups of the medial zone receive sensory information through major connections from the limbic regions in the telencephalon, such as the septum and amygdala. The output of the medial zone regulates the expression of survival and reproductive behaviors. The lateral zone is traversed by the medial forebrain bundle, which interconnects this zone with the brainstem, cortex and amygdala. The medial zone is organized rostrocaudally into four regions, the preoptic, anterior, medial (or tuberal) and posterior (or mammillary) regions. These divisions can be extended into the periventricular and lateral zones, thus dividing the hypothalamus into 12 compartments. The major nuclei of these compartments can be recognized in all reptiles, birds, and mammals (Fig. 2). The following descriptions emphasize nuclei that have been identified in all amniote classes. Comparable connective, histochemical or functional studies have not been performed yet in some classes and so the lack of data should not be interpreted as absence of homology.

### Functions Associated with Hypothalamic Nuclei

The functions associated with the major hypothalamic nuclei will be addressed in a rostral to caudal and medial to lateral sequence.

#### Body Fluid Homeostasis

The hypothalamic vascular organ, together with the nucleus paraventricularis, is involved in osmoregulation. Both angiotensin II and the antidiuretic vasotocin are located in these nuclei and are involved in osmoregulation. Angiotensin II has been shown to elevate blood pressure in birds.

A hypothalamic periventricular organ is present in all vertebrates except mammals. It is located dorsal to the dorsomedial hypothalamus. The cells of this organ are in direct contact with the fluid of the third ventricle and appear to accumulate dopamine and noradrenalin from the cerebral spinal fluid of the third ventricle. The function of this organ is not clear, but it is probably affected by the cerebral spinal fluid and thus may regulate body fluid homeostasis. It is considered to be a primitive trait that was lost in mammals.

#### Temperature Regulation

In all amniotes the hypothalamus has a critical role in regulating behaviors and physiology relevant to thermoregulation. The medial preoptic area and anterior hypothalamic region activate mechanisms that enhance heat loss (shallow breathing, sweating, vasodilation). Temperature-sensitive neurons are scattered in the medial preoptic and the anterior hypothalamic nuclei. These neurons respond to cooling or warming of either the skin or the surrounding brain tissue. They appear to regulate body temperature through behavioral and

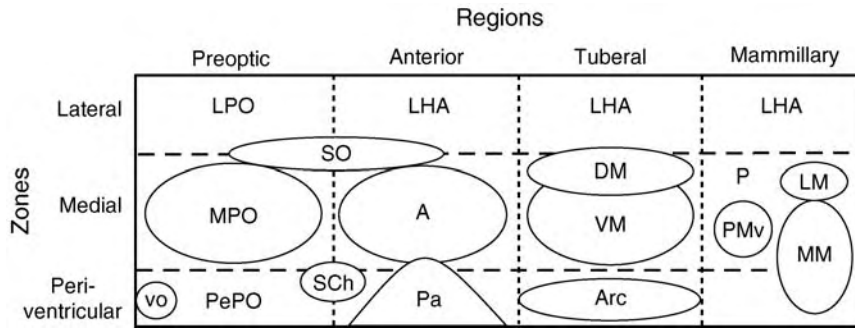

**Evolution of the Hypothalamus in Amniotes. Figure 2** Relative positions of major hypothalamic nuclei.

A simplified two-dimensional representation of the right side of the hypothalamus showing the relative positions of major nuclei within the zones and regions that have been identified in all amniotes. Rostral is to the left, lateral is to the top, and the third ventricle (midline) is at the bottom. Abbreviations: A, anterior hypothalamic nucleus; Arc, arcuate nucleus; DM, dorsomedial hypothalamic nucleus; LHA, lateral hypothalamic area; LM, lateral mammillary nucleus; LPO, lateral preoptic area; MM, medial mammillary nucleus; MPO, medial preoptic area; P, posterior hypothalamic area; Pa, paraventricular nucleus; PePO, preoptic periventricular nucleus; PMv, ventral premammillary nucleus; Sch, supra-chiasmatic nucleus; SO, supraoptic nucleus; VM, ventromedial hypothalamic nucleus; vo, vascular organ of the lamina terminalis. Modified from Simerly [1].

involuntary means, including panting and changes in peripheral blood flow. The mechanisms for hypothalamic temperature control are present in both ectotherms (reptiles) and endotherms (mammals and birds). In addition, endotherms rely on insulation by fat bodies and a high, variable metabolic rate, which probably function independently from hypothalamic regulation. Neurons in the anterior and medial preoptic nuclei also respond to hormones, suggesting that reproduction and body temperature may be closely linked physiologically, although it is unclear where they are integrated. Vasotocin (or arginine-vasotocin) acts in the hypothalamus to reduce shivering and body temperature.

### Reproductive Behaviors

Reptiles have proven to be excellent models for studying the role of the hypothalamus in the regulation of sexually dimorphic behaviors. Many reptilian species exhibit temperature-dependent sex determination (i.e. the incubation temperature of the egg determines the gonadal sex of the individual), whereas other species are parthenogenetic (female-only species in which individuals display both male-like pseudocopulation and female-like receptivity) and in others sex is determined genetically.

Sexually dimorphic behaviors appear to involve neural pathways that express the androgen, estrogen and/or progesterin receptors. These pathways appear to regulate hormone-dependent, sex-typical reproductive and agonistic behaviors and have been highly conserved throughout vertebrate evolution, although further studies are needed in birds. In amniotes, these behaviors are regulated by the medial preoptic area, anterior hypothalamic nucleus and ventromedial hypothalamic nucleus.

The medial preoptic area and the anterior hypothalamic nucleus are involved in expression of masculine sexual behaviors in all amniotes, particularly the regulation of male-typical mounting and intromission behaviors. In some mammals the central portion of the medial preoptic nucleus is larger and contains a greater number of neurons in males compared to females. Androgen-receptor expressing cells are more abundant in the preoptic area of males than females. Progesterin and estrogen receptors are also present in the preoptic and anterior hypothalamic regions. These hypothalamic areas are strongly influenced by olfactory and vomeronasal amygdalar connections, as well as those from parts of the subiculum and septal nuclei, which provide a route for sensory cortical information to influence the masculine sexual behaviors. The preoptic region also regulates parental behaviors in birds and mammals and involves the activation of progesterin receptors there.

The ventromedial hypothalamic nucleus regulates estrogen-dependent receptive behaviors, in particular female-typical receptivity. Its lateral part contains abundant receptors for estrogen, progesterin and androgen. In lizards the volume of the ventromedial hypothalamic nucleus is larger in females than in males. It receives massive inputs from the amygdala (particularly the lateral amygdalar nucleus, which is homologous with the mammalian accessory basal amygdala) and ventral subiculum, which provide information about all sensory modalities. The reptilian nucleus premammillaris and the mammalian ventral premammillary nucleus both label densely with androgen probes and slightly with estrogen probes, indicating a possible homology. The connections of these nuclei in both reptiles and mammals are similar

to those of the ventromedial hypothalamus, suggesting that they may contribute to the regulation of similar behaviors.

### **Circadian Rhythms**

The suprachiasmatic nucleus lies above the optic chiasm close to the midline in reptiles and mammals. In birds it includes a medial and lateral subdivision that extends laterally along the optic tract. In all amniotes, the suprachiasmatic nucleus receives visual input directly from the ganglion cells in the retina. In mammals, it appears to be responsible for the maintenance of circadian rhythms of sleep, locomotion, feeding and drinking, adrenal corticosterone secretion and pineal activity and cyclicity of ovarian activity. It is likely that it serves similar functions in other amniotes.

### **Neuroendocrine Control**

The periventricular hypothalamus is largely involved in controlling the lobes of the pituitary gland and in this sense contains the motoneurons of the neuroendocrine system. Magnocellular nuclei control the posterior pituitary, whereas parvocellular nuclei control the anterior pituitary.

### **Magnocellular Neurosecretory System**

Large neurons in the supraoptic and paraventricular nuclei comprise the magnocellular neurosecretory system, which is present in all amniotes. These large neurons synthesize the hormones vasopressin and oxytocin in mammals and produce very similar hormones in birds and reptiles. In mammals these neurons send axons to the posterior pituitary, where the hormones are released into the bloodstream. In mammals oxytocin is responsible for lactation, labor, nausea and gastric distention and both arginine-vasopressin (AVP) and oxytocin regulate water balance and blood pressure.

### **Parvocellular Neurosecretory System**

Small neurons located in a variety of hypothalamic nuclei form the parvocellular neurosecretory system, which regulates the function of the anterior pituitary gland. The neurons are located mainly in the periventricular zone and are particularly numerous in the paraventricular and arcuate nuclei. These neurons contain a variety of stimulatory and inhibitory factors that travel via axons to the median eminence (at the top of the pituitary stalk). There the factors are released into portal veins, which form a venous capillary system between the median eminence and the anterior pituitary lobe. These factors thus reach the anterior lobe, where they stimulate or inhibit cells to release their hormones. In mammals, the hormones include growth hormone (GH), thyroid-stimulating hormone (TSH), adrenocorticotrophic hormone (ACTH), prolactin, luteinizing hormone (LH) and follicle stimulating hormone (FSH).

Homologues of many of the mammalian hypothalamic factors and pituitary hormones have been identified in reptiles and birds. Thus, it appears that the parvocellular neurosecretory system was well established in the common amniote ancestor.

Corticotropin releasing hormone (CRH) and its non-mammalian homologue are involved in the stress response. CRH is located in small neurons of the paraventricular nucleus, where it is part of the parvocellular neurosecretory system. CRH is the major physiological stimulus for secretion of adrenocorticotrophic hormone (ACTH), or a homologue. ACTH is important in controlling blood pressure and a variety of other functions that will also affect body fluid homeostasis.

### **Feeding**

The dorsomedial hypothalamus and adjacent regions are involved in regulation of ingestive behaviors. Its connections have been identified in mammals and reptiles and are consistent with this function. It receives connections from many brainstem nuclei, including the parabrachial nuclei and the nucleus of the solitary tract, which are involved in gustatory functions. Vomeronasal and olfactory information strongly influence feeding behaviors, and consistent with this, this hypothalamic feeding region receives such input from the bed nucleus of the stria terminalis. It also receives many intrahypothalamic projections, notably including the ventromedial hypothalamus. The ventromedial hypothalamus and adjacent lateral regions influence metabolism and ingestive behaviors and thus weight regulation. In mammals the lateral hypothalamus is important in appetite and probably serves a similar function in birds and reptiles, although further studies are needed.

### **Autonomic Regulation**

Neurons in the paraventricular, dorsomedial, lateral and posterior hypothalamic nuclei influence both the sympathetic and parasympathetic divisions of the autonomic nervous system. In mammals neurons in these nuclei project to preganglionic parasympathetic nuclei in the brainstem and spinal cord. Similar hypothalamo-spinal projections have been reported in reptiles suggesting that this pathway is present in all amniotes.

### **Spatial Learning**

The mammillary body includes the medial and lateral mammillary nuclei. In mammals the mammillary body is commonly believed to be important in spatial learning tasks and in the interaction between emotion and memory. It is strongly influenced by visual and auditory information. A major input to the mammillary body arises from the subicular region of the hippocampal formation via the fornix. It then projects to tegmental nuclei in the brainstem and to the anterior thalamic complex. The latter in turn projects to the limbic cortex



and then to the hippocampus. Although functional studies of the mammillary body have not been performed in reptiles and birds, connectional studies suggest that a similar structure exists. In particular the connections between the mammillary body and the hippocampal formation have been documented.

## Reference

1. Simerly RB (1995) Anatomical substrates of hypothalamic integration. In: Paxinos G (ed) *The rat nervous system*, 2nd edn. Academic, San Diego, pp 353–376

## Further Reading

1. Bruce LL, Neary TJ (1995) The limbic system of tetrapods: a comparative analysis of cortical and amygdalar populations. *Brain Behav Evol* 46:224–234
2. Butler AB, Hodos W (2005) *Comparative vertebrate neuroanatomy: evolution and adaptation*. Wiley-Liss, Hoboken
3. Crews D (2005) Evolution of neuroendocrine mechanisms that regulate sexual behavior. *Trends Endocrinol Metab* 16:354–361
4. Grigg GC, Beard LA, Augee ML (2004) The evolution of endothermy and its diversity in mammals and birds. *Physiol Biochem Zool* 77:982–997
5. Nieuwenhuys R, ten Donkelaar H, Nicholson C (1998) *The central nervous system of vertebrates*. Springer-Verlag, Berlin
6. Swanson LW (1987) The hypothalamus. In: Björklund A, Hökfelt T, Swanson LW (eds) *Handbook of chemical neuroanatomy*, vol 5. Integrated systems of the CNS, Part I. Elsevier, the Netherlands, pp 1–124
7. Young LJ, Lopreato GF, Horan K, Crews D (1994) Cloning and *in situ* hybridization analysis of estrogen receptor, progesterone receptor, and androgen receptor expression in the brain of whiptail lizards (*Cnemidophorus uniparens* and *C. inornatus*). *J Comp Neurol* 347:288–300

## Evolution of the Mechanosensory and Electrosensory Lateral Line Systems

CHRISTOPHER B. BRAUN

Department of Psychology, Hunter College, City University of New York (CUNY), NY, USA; Programs in Biopsychology and Behavioral Neuroscience, and Ecology Evolution and Behavior, Graduate Center, City University of New York (CUNY), NY, USA

## Synonyms

Octavolateralis system; Acousticolateralis system; Lateral line; Electrosense; Mechanosense

## Definition

The ▶**mechanoreceptive** and ▶**electroreceptive lateral line systems** are components of the vertebrate ▶**octavolateralis system**, a collection of sensory systems derived from embryonic thickenings called ▶**dorsolateral placodes**. Octavolateralis derivatives include all sensory organs of the ▶**inner ear**, both ▶**acoustic** and ▶**vestibular**, and the hydrodynamic and electric sensors on the body surface termed ▶**neuromasts** and ▶**electroreceptors**, respectively. The term octavolateralis is derived from the combination of *octaval* (eighth) and *lateralis* (lateral) because the inner ear and eighth cranial nerves are the earliest components of the dorsolateral placodes to develop embryonically and are the most prominent aspect of the system in many adult forms. They are the only derivatives found in amniotes. The earliest craniates possessed a mechanosensory octavolateralis system comprised of both an inner ear and spatially distributed ▶**mechanoreceptors** in the integument of the head and trunk. These components are present in all living anamniotic vertebrates, including the aquatic life-stages of most amphibians. The ▶**electrosensory systems** are more diverse and have slightly more recent origins. Lampreys, cartilaginous fishes, non-neopterygian bony fishes, and some urodele (salamanders) and apodan (caecilians) amphibians retain the primitive electrosense. Electrosensory octavolateralis systems were lost during the history of bony fishes, but electroreception appears to have independently re-evolved from octavolateralis precursors multiple times in unrelated groups of teleost fishes.

## Characteristics

### Overview

The mechanosensory and electrosensory lateral line systems are components of a larger suite of craniate sensors that also include the inner ear and vestibular systems (Figs. 1 and 2).

The mechanoreceptive lateral line and the inner ear appear to have arisen simultaneously in the ancestral craniate [1]. Electroreceptive systems arose later, with the origin of the vertebrates and have been lost and re-evolved several times independently [2]. The mechanosensory lateral line is composed of neuromasts (see Fig. 3), sensors that detect hydrodynamic disturbances and spatio-temporal patterns of nearby water movements.

The inner ear originally detected hydrodynamic rather than acoustic sources as well, detecting low frequency water disturbances, including the hydrodynamic ▶**nearfield** surrounding sound sources [3]. True acoustic sensitivity (detection of pressure disturbances) has arisen multiple times later in vertebrate history [4]. The earliest electrosensory systems were composed of epidermal ▶**ampullary organs** (see Fig. 3) that

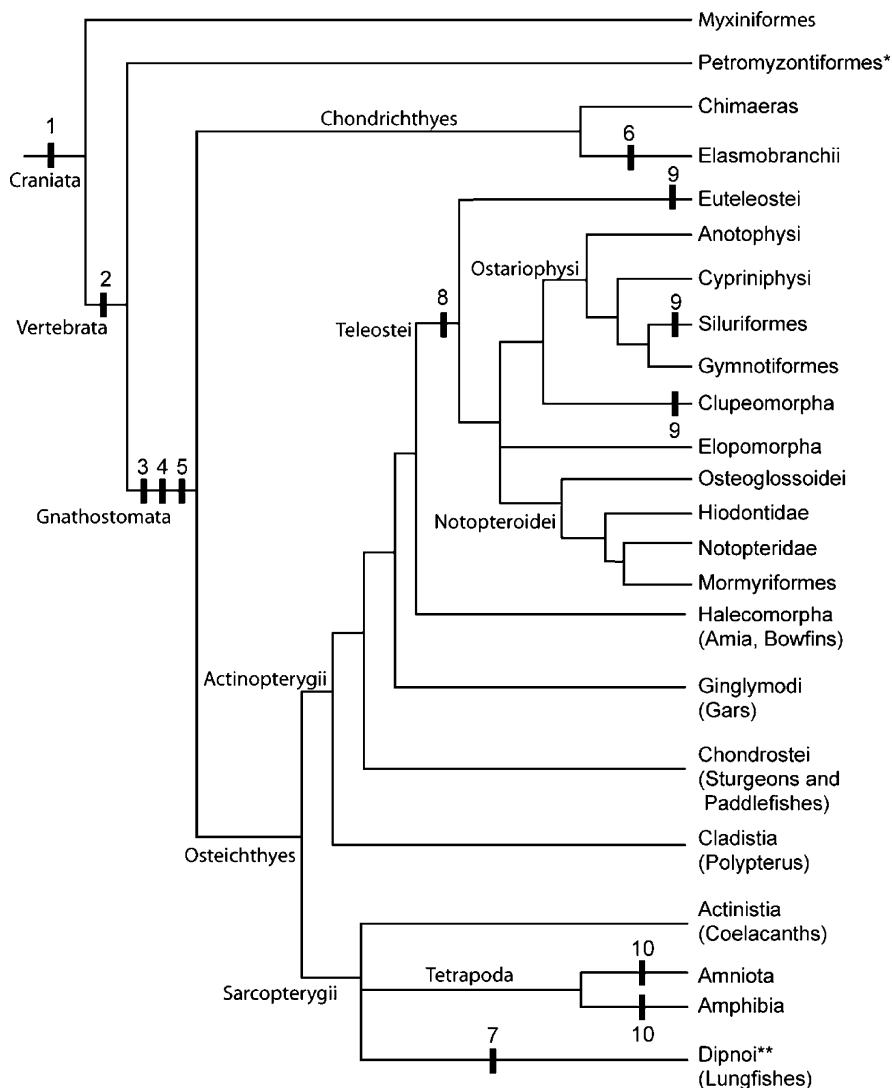

**Evolution of the Mechanosensory and Electrosensory Lateral Line Systems. Figure 1** Branching diagram displaying the phylogenetic relationships of the major craniate groups. Evolutionary events in the history of mechanoreceptive octavolateralis systems are shown as numbered bars. 1) Mechanoreceptive octavolateralis system consists of inner ear and lateral line system in the integument. 2) Multiple lines of neuromast organs on the head and trunk. 3) Multiple classes of neuromasts, canal and pit types. 4) Presence of Cupulae. 5) Some neuromasts receive efferent innervation. 6) Elongated neuromasts fuse creating continuous sensory strip in canals. 7) Multiple neuromasts found between canal pores 8) Large numbers of supernumerary neuromasts. 9) Lateral line canal system functionally linked to gas bladder. 10) Loss of lateral line system in some or all taxa. Recent molecular studies [Mallat J and J Sullivan (1998) *Mol Biol Evol* 15: 1706–1718; Furlong, RF and PWH Holland (2002) *Zool Sci* 19: 593–598] have argued for a sister group relationship between lampreys and hagfishes (Petromyzontiformes + Myxiniformes), which would necessitate re-optimization of characters 1–5. Existing molecular phylogenetic studies of craniate relationship have been based on small subsets of craniate taxa and the bulk of morphological evidence still suggests that lampreys are more closely related to gnathostomes than either is to hagfishes however, so this hypothesis is shown retained herein. \*Petromyzontiformes (lampreys) may be secondarily simplified, as some fossil taxa suggest that character 3 may have arisen earlier than the origin of the gnathostomes. \*\*Multiple neuromasts between canal pores occur in some lungfish taxa only. Linkage between lateral line and gas bladder occurs in clupeomorph fishes [Best ACG and JAB Gray (1980) *J Mar Biol Assoc U.K.*, 60: p. 703–715.], chaetodontid butterfly fishes [Webb JF and WL Smith (2000). *Phil Trans Roy Soc Lond B*, 355: p. 1125–1129.] and loricaroid catfishes [Aquino AE and SA Schaefer (2002), *Zoologischer Anzeiger*, 241: p. 223–244.].

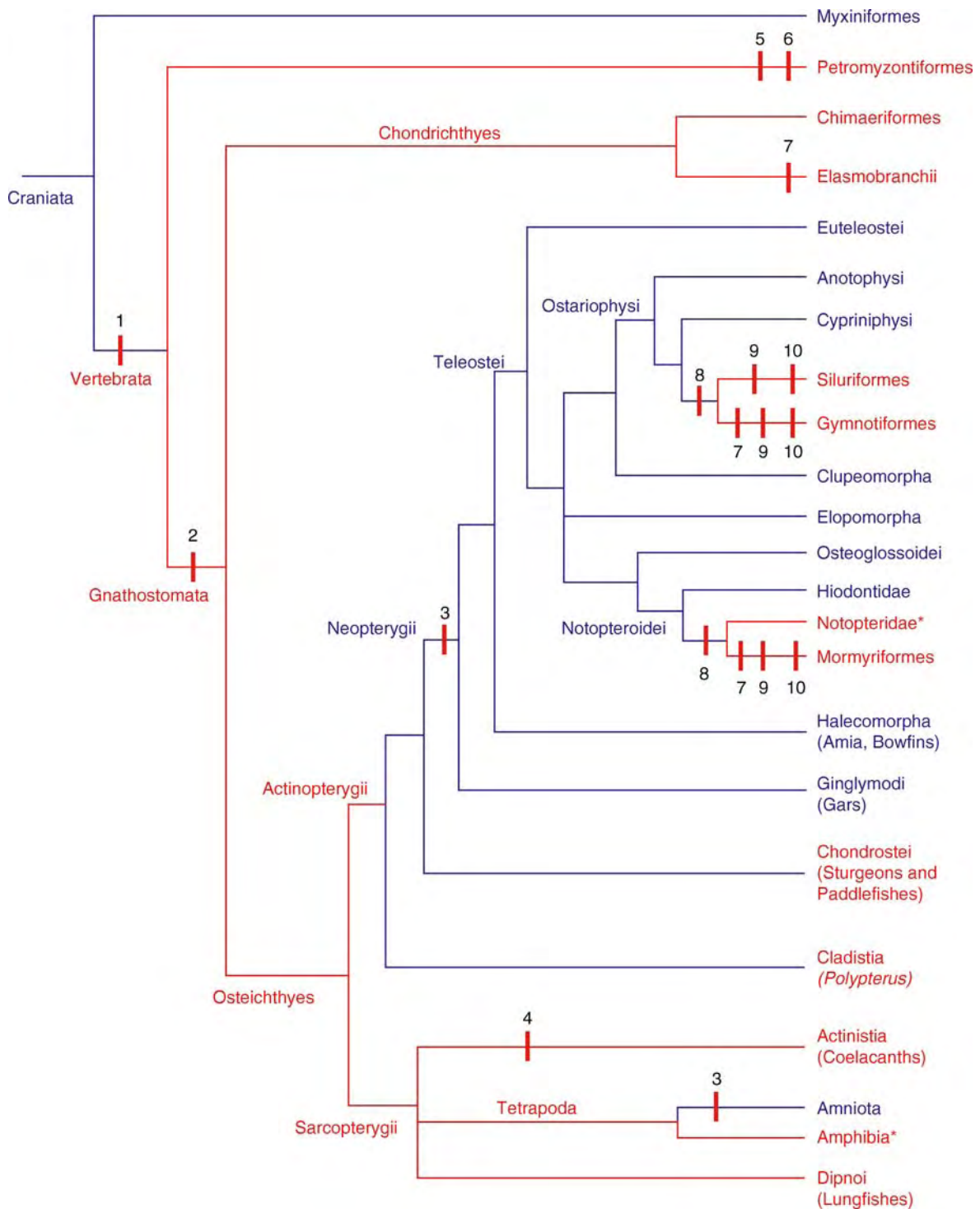

E

**Evolution of the Mechanosensory and Electrosensory Lateral Line Systems. Figure 2** Branching diagram displaying the phylogenetic relationships of the major craniate groups. Electrosensitive lineages are plotted in red and shown in boldface type. Non electrosensitive lineages are plotted in blue. Evolutionary events in the history of the electrosensitive system are plotted as numbered bars. 1) Sensitive to electric fields. 2) Cathodally excited ampullary organs. 3) Loss of electroreceptors, corresponding nerves, and brain regions. 4) Electroreceptors present in Rostral Organ only. 5) Endbud organs. 6) Photoreceptive lateral line. 7) Electrogenic organ. 8) Independent re-evolution of electroreception. 9) Anodally excited ampullary organs. 10) Tuberous electroreceptors. \*Only some amphibian and notopterid taxa are electrosensitive.

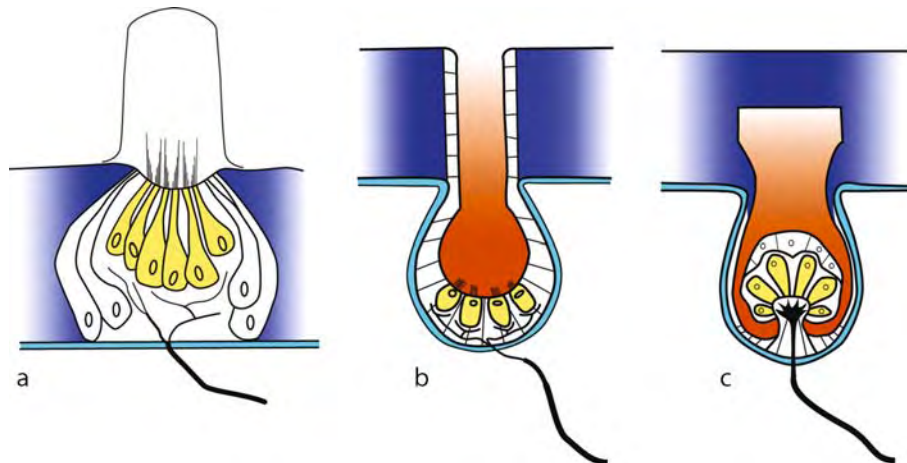

**Evolution of the Mechanosensory and Electrosensory Lateral Line Systems. Figure 3** Schematic organization of octavolateralis organs. (a) Neuromast. Hair cell receptors (in yellow) are found nestled within support cells and project apical cilia into a gelatinous cupula. (b) Ampullary organ. Ciliated receptors (yellow) project their apical surface into a jelly filled ampulla that is electrically continuous with the outside environment (shaded). (c) Tuberous organs. Ciliated receptors (yellow) are found in a crypt within the epidermis. The crypt communicates electrically with the external environment via a column of loosely packed epidermal cells (shaded).

were sensitive to DC and very low frequency electric fields. This system of electroreceptors was lost with the origin of neopterygian fishes (teleosts, gar and bowfins). Several groups of teleost fishes subsequently re-evolved electroreceptive systems, with multiple classes of receptors sensitive to a wider and higher range of frequencies [5]. Some of these electrosensitive fishes also evolved an ►electromotor system capable of generating weak electric fields. These self-generated fields are used in communication and as a sensory carrier for sensing electrically conductive or resistive objects. Electrogenic fishes also possess a second class of electroreceptive organs, ►tuberous receptors, which are specialized for detection of their own electric organ discharge, as well as those of conspecifics. In living fishes, the electroreceptive and mechanosensory lateral line systems are used in all behavioral contexts, general orientation and navigation, intraspecific communication and mate choice, predation, and predator-avoidance [6,7].

### Receptor Complement

The principal receptor organ of the ►mechanosensory lateral line is the ►neuromast (Fig. 3a). The basic organization of neuromasts, onion-shaped aggregations of ciliated receptor cells, support cells and mantle cells, is remarkably consistent across vertebrates. The surfaces of the receptor cells bear a single true cilium (the kinocilium) flanked by an array of microvilli typically arranged in stair-step descending heights (the stereocilia). In most instances, these hair cells occur in pairs, with each member of the pair bearing oppositely aligned apical bundles. Within a neuromast, all pairs of

hair cells are aligned such that each member of the pair faces the opposite pole of a single axis of best sensitivity for the neuromast as a whole. Hair cell responses are highly directionally specific, such that deflection of the apical bundle towards the kinocilium depolarizes the cell's membrane potential and movement away from the kinocilium causes hyperpolarization. The transduction mechanism is primarily mechanical: cytoplasmic bridges, called tip-links, connect the kinocilium and microvilli and are stretched and relaxed by motion of the hair-cell bundle. This change in tension within the apical bundle begins a mechano-electric transduction cascade that alters the membrane potential of the hair cell [8].

The apical bundles are enmeshed in a gelatinous cupula which projects outward from the skin surface. Cupular morphology is poorly documented, and appears to be variable. The most common arrangement is a keel-shaped cupula with a long axis parallel to the axis of the underlying hair cell bundles. The cupula is friction-coupled to the surrounding water, pulled along the surface of the neuromast with local fluid flow, rather than bending or being deflected by water striking its longest face. The combination of friction-coupling provided by cupular morphology and the apical polarity of the receptor cells makes neuromasts highly directionally specific. Lateral line ganglion neurons respond proportionally to the cosine of the angle of incident flow. Ganglionic responses are either inhibitory or excitatory (ganglion cells always display spontaneous activity), depending on which half of the paired population of hair cells are innervated by any particular ganglion cell.

There are three basic types of neuromast organ found in vertebrates. ►**Canal neuromasts** are those which were primitively found within dermal canals on the head and trunk. In some living vertebrates, homologous neuromasts are found in similar locations superficially, in the absence of canals, in which case they are called ►**replacement neuromasts** [9]. Such replacement neuromasts may be found in place of all neuromasts (as in salamanders), or they may replace individual neuromast lines or segments (as in many teleosts). The second type of neuromast is the ►**pit organ**, which are smaller than canal or replacement neuromasts and may have distinctive response properties [10]. Pit organs are found in small lines of neuromasts on the head and trunk of most fishes and were a component of the earliest vertebrate octavolateralis systems [11]. The individual pit organs may be housed in pits, grooves, or short canal segments, depending on the species. Pit organs may be difficult to identify in many teleost fishes, because these fishes also possess large numbers of small superficial neuromasts distributed in clusters or uniform densities across the head and body surface (Fig. 4). These latter neuromasts have been called ►**accessory neuromasts** [9], and they likely have distinct functions and patterns of innervation [12]. Accessory organs are only found in teleost fishes.

The receptor organs of the electrosensory lateral line are more diverse [5]. Primitively, jawed vertebrates (Gnathostomata) possessed small epidermal organs called ampullary organs (or Ampullae of Lorenzini in cartilaginous fishes). These consist of an epidermal canal stretching from the skin surface into deeper layers of the integument (Fig. 3b). A small crypt containing as many as several hundred ciliated receptor cells is present at the base of this ampulla, and the apical portions of the receptor cells protrude into the crypt and

canal. The crypt and canals are filled with a gelatinous substance that is matched to the resistance of the ambient medium. The receptor cells respond with exquisite sensitivity to changes in voltage across the epidermal surface, i.e., voltage gradients on the order of 1 microvolt/cm or less. Primitive ampullary receptor cells are depolarized by negative external voltages (relative to the interior of the animal) and hyperpolarized by positive external voltages. The electroreceptive octavolateralis system was lost sometime in the lineage leading to neopterygian fishes (Fig. 2). Most neopterygian fishes do not possess electroreceptors of any kind. Two groups of teleost fishes subsequently re-evolved electroreceptive systems, still drawing developmentally from dorsolateral placodes. Electroreceptive teleosts possess ampullary organs much like those of primitive vertebrates, however the polarity of excitation is exactly opposite: teleost receptor cells are excited by positive voltages and inhibited by negative voltages. Both teleost and primitive ampullary organs are most sensitive to DC and low-frequency electrostatic fields, generally less than 50 Hz [2].

A second broad category of electroreceptive organs is the ►**tuberous organs** found in weakly-electric fishes of South America (Gymnotiformes) and Africa (Mormyriiformes). It appears that although these organs share many attributes, they have evolved convergently [2]. These organs are also comprised of an epidermal crypt containing receptor cells (Fig. 3c). Unlike ampullary organs, however, the apical canal is typically loosely packed with epidermal cells. This region of flattened cells with large extracellular spaces acts functionally like the canal of ampullary organs, conducting current through the epidermis to the lumen of the tuberous organ crypt. Several distinct types of tuberous organs are found in each group of electroreceptive teleosts

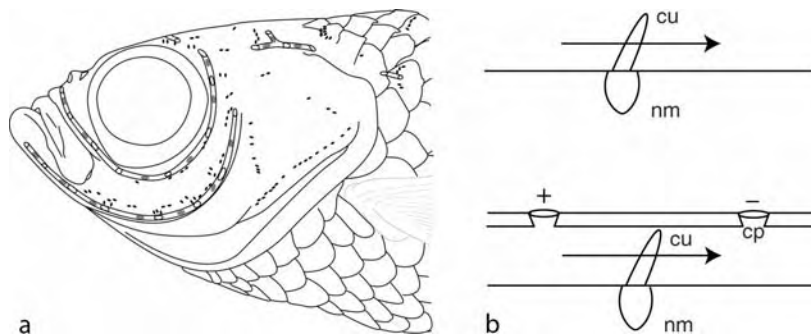

**Evolution of the Mechanosensory and Electrosensory Lateral Line Systems. Figure 4** Generalized pattern of neuromast distribution in a teleost fish. Large numbers of supernumerary accessory neuromasts are depicted as small black ovals. The larger canal neuromasts are shown as grey ovals within dermal canals that open to the surface through pores (open circles). B. Neuromast (nm) responses depend on accessory structures. Superficial neuromasts (above) respond in proportion to the velocity of fluid past the cupula (cu). Canal neuromasts (below) respond similarly, but the velocity of fluid within the canal is proportional to the pressure difference (+/-) at adjacent canal pores (cp).

and reflect the complex information processing demands of a system used for both communication and active sensing [5]. The multiple classes have been best described physiologically, but there are also gross morphological differences between organ types. Nonetheless, all tuberous organs appear to be tuned to higher frequency ranges than ampullary organs (up to several thousand Hz, depending on the species and are only found in species that produce electric fields. Unsurprisingly, tuberous organs function in the detection of self-generated electric signals and those generated by conspecifics. In any given electric fish species, two tuberous organ types detect different aspects of electric signals, usually functionally distinguished by responsiveness to either temporal or amplitude cues. In Gymnotiformes, both functional classes of tuberous organs are involved in both communication and ►**electrolocation** based on self-generated electric fields. In Mormyriiformes, however, the time coding tuberous organs, ►**Knollenorgans**, are used to detect the electric fields produced by other fishes, but their input to the brain is cancelled during production of the animal's own electric field. Distortions in the animal's self-generated field are used in electrolocation, and these distortions are sensed by the other class of tuberous organ, the ►**mormyromasts**. Although mormyromasts are less sensitive than Knollenorgans, and Knollenorgans are clearly specialized for communication, the distinction is not completely clear-cut, as mormyromasts may also be used to detect conspecifics during agonistic and other close-range encounters [7].

Curiously, the living coelocanth (*Latimeria*) does not possess any of these types of electroreceptors, including ampullary organs. Instead, a series of subdermal chambers, called the ►**rostral organ**, is found in the snout, with three pairs of external pores on the rostrum. The epithelial lining of these pouches contains putative electroreceptor cells and receives innervation from octavolateralis cranial nerves. The physiological properties and relevant stimuli of these receptors are unknown. It is not known if any extinct coelocanth also lacked ampullary organs, but evidence of a rostral organ has been found in fossil taxa [13].

### **Agnathan Octavolateralis Receptor Complement**

The sensory organs described above are widespread in gnathostome vertebrates, but the antecedent systems were more diverse and are less well-understood in agnathan vertebrates (currently represented by extant lampreys and hagfishes). Lampreys, a putative sister group to the living jawed vertebrates, possess slightly unusual neuromasts, most distinguished by the lack of a cupula and an absence of efferent innervation. In hagfishes, the putative sister taxon to the remaining vertebrates, one family lacks any trace of a mechanosensory lateral line system, and the other appears

to have a degenerate system composed of disorganized trenches filled with isolated ciliated receptor cells [14].

There is no trace of any electroreceptive system in hagfishes, and a most unusual system is found in lampreys. Adult lampreys are electroreceptive but do not possess ampullary organs. Instead, small clusters of sensory cells are grouped into organs with an apical microvillar surface rather than a tubular ampulla within the epidermis. These organs, called ►**endbuds** in the older literature, are innervated by lateral line cranial nerves and are similar in their responses to ampullary organs. That is, they respond to very minute electric fields, on the order of microvolts per centimeter, and are excited by cathodal stimulation, as are primitive ampullary organs. Although it is likely that electroreceptors of some kind were found in the ancestor of lampreys and gnathostomes (Fig. 2), it is not known if they were of the lamprey endbud type, or were more like ampullary organs of gnathostomes. There is evidence of electroreceptive pores (i.e., remnants of ampullae) in the bony armor of some groups of extinct jawless fishes, so it is possible that ampullary organs are the primitive form of electroreceptor [1].

Complicating matters, larval lampreys (ammocoetes) possess a gnathostome-like brainstem circuitry and cranial nerves for electroreception and electroreceptive units in these structures have been demonstrated physiologically. Strikingly, however, they do not possess end-buds. The peripheral electroreceptive elements are unknown in ammocoetes. Individual sensory cells are present in the epidermis of larval lampreys, in isolated clusters of two to four cells, without supporting cell types. These are termed ►**multivillous cells** and they are similar to the receptor cell type found in adult endbuds. These clusters of cells have been suggested to mediate a well-documented extra-ocular photosensory response in ammocoetes. This response is mediated by unknown cutaneous sensors innervated by ganglion cells in the posterior lateral line nerve. Photoreceptive units have also been demonstrated in the medial octavolateralis nucleus (the primary site of *mechanoreceptive* afferents). Multivillous cells contain unique cytoplasmic structures that could conceivably support photopigment deposition, but there is no evidence that these cells mediate the cutaneous photoresponse. The photoresponse and electrosense are clearly mediated by different systems and terminate in medial and ►**dorsal octavolateralis nuclei** respectively. Thus one receptor type is the only known possible sensor for two distinct modalities [1]. Future research should examine the source of innervation of multivillous cells and their central representation to resolve this question.

### **Accessory Structures and the Functions of Neuromasts**

Mechanoreceptive neuromasts are found with a variety of supporting structures with biophysical filter

properties that dramatically affect stimulus transduction [12]. Superficial neuromasts on the surface of the integument have cupulae that are directly impacted by fluid velocity at the body surface (Fig. 4).

In many cases, small ridges are found near superficial neuromasts and these could act as directional or spatial filters for fluid flow past the cupulae. Superficial neuromasts may also be found within grooves, trenches or pits, all of which alter the relationship between the cupula and the boundary layer of fluid at the body surface. Superficial neuromasts are generally physiologically responsive to the velocity magnitude past the cupula, but grooves and trenches may alter this relationship, particularly at low frequencies [6,9,12].

In many species, neuromasts are also found deep within the dermis, in epithelial canals that open to the body surface through pores (Fig. 4). These canals develop embryonically from lines of superficial neuromasts as the grooves surrounding them deepen and invaginate into the integument. The morphology of these canals varies greatly across vertebrates, from simple trenches to tubes to highly branched canals with elaborate lattices of pores at the surface. The canal walls vary greatly in diameter, stiffness and in the presence of surface constrictions. The pores themselves may be simple, varying primarily in size and shape, or the pore may also be covered with a membrane or tympanum. All of these variations have significant filter properties that alter the relevant stimulus to the neuromast, that is, fluid-flow within the canal. In all cases, it is believed that the canal itself acts as an acceleration-to-velocity transducer. That is, the velocity of fluid motion within the canal (the proximate stimulus to the neuromast) is proportional to the acceleration (or pressure gradient) across the adjacent canal pores. This transduction process renders the canal neuromast system acceleration-sensitive [3]. Generally, the canal also acts as a high pass filter, reducing the amplitude of fluid motion at low frequencies. The high-pass cutoff point is an inverse function of canal diameter: small diameter canals attenuate low frequency accelerations more intensely than wide canals. It may be difficult to apply this generalization however as limited regions of constriction can impart high-pass properties to otherwise wide-diameter canals [12]. The pores act as sampling points, so pore number and placements affect the spatial receptive properties of each neuromast. A neuromast within a branched canal, where each neuromast is flanked by multiple pores will sample water motions over a wider spatial zone than a neuromast in an unbranched canal with a single pore. Although there are few empirical data on neuromast responsiveness in complex canal systems, it is likely that such spatial averaging result in an increased signal-to-noise operating ratio at a cost of reduced spatial acuity [12].

### Phylogenetic Overview of Receptor Distribution

The distribution of electroreceptors is relatively conservative. Most electroreceptive animals have a high concentration of ampullary receptors on head, which was probably the primitive condition for bony fishes [13]. Ampullary organs are also present on the trunk (primarily dorsally) in lungfishes and in electroreceptive teleosts. The total number of receptors generally ranges from several hundred to several thousand. These receptors are mapped somatotopically in the ►electrosensory lateral line lobe or dorsal octaval nucleus. Tuberos receptors are only found in electrogenic teleost species, but have a similar distribution on the body surface, with highest densities on the snout and dorsal body surface. There are generally fewer tuberos receptors (several hundred) than ampullary organs (several thousand or more) in any given species. Some species have specialized “electrosensory appendages,” such as the proboscis of so-called elephant-nose mormyrids (actually an extension of the jaws) or the dorsal filament of some apteronotid gymnotiforms, and these probe-like structures have a high density of electroreceptors [7].

The primitive distribution of mechanosensory octavolateralis sensors appears to be multiple arrays of canal neuromasts on the head and trunk [11,15]. A second class of smaller neuromasts grouped into three to six lines on the head and dorsal trunk were also present in the earliest vertebrates, although these may be found in pits or grooves in many taxa. These are the ►pit lines, which in most living vertebrates are found in superficial pits [15]. All gnathostome groups with the mechanosensory octavolateralis system possess both a main system of (usually canal-based) lines and a pit line system [11]. The main canal system is typically comprised of canals above and below the eye (supra- and infraorbital canals), and a mandibular-preopercular canal (see Fig. 4). These canals connect through a temporal canal caudal to the eye and this temporal canal may continue caudally as a trunk canal. Several short canal segments (either contiguous with this main array or not) are also usually present on the rostral snout and dorsal head, including two or more commissural canals. This pattern is so consistent across taxa that a similar distribution must have characterized the earliest vertebrates. The number of canals on the trunk is more uncertain. All living vertebrates have a line of neuromasts running down the trunk and they are most often contained within a canal. In most vertebrate groups, a ventral canal is also usually present, running along the ventral body surface. A third canal is also present dorsally, although this group of neuromasts typically does not extend the entire body length. In many taxa, these canals are reduced or eliminated and phylogenetically homologous lines of superficial neuromasts are present on the head and trunk. Canal

reduction can occur globally, as in amphibians, which lack any canals at all; or locally, as is the case in many teleosts, where individual segments of canals have been replaced by superficial lines of neuromasts. These are called ►replacement neuromasts, to distinguish them from other superficial organs and recognize their phylogenetic lineage as canal organs [9].

In many taxa (e.g., teleosts), individual neuromasts are found between each pair of canal pores. In other taxa, (Chondrichthyes and lepidosiren and protopterid lungfish), the neuromasts proliferate or grow within the canals and multiple neuromasts are present between each pair of pores [15]. In some sharks, these neuromasts may even fuse, forming a continuous sensory epithelium lining the canal. This pattern of neuromasts distribution likely affects spatial processing, but nearly all behavioral and physiological studies of canal neuromast function have been performed using animals with a single neuromast between canal pores, so one can only speculate as to how this impacts mechanosensory function. Although the vast majority of living taxa have a single neuromast between canal pores, the phylogenetic distribution of multiple neuromasts suggests that multiple neuromasts may have actually been the primitive state [15].

Teleost fishes are unique in possessing large numbers of superficial neuromasts, called ►accessory neuromasts. These neuromasts are typically found in clusters rather than lines, and are often associated with or surrounding the canal pores on the head and trunk. There may also be thousands of them widely distributed across the body surface. These neuromasts are typically smaller than canal or replacement neuromasts, and are innervated by diverging sensory neurons. A single sensory afferent may contact a cluster of neuromasts (all with a similar apical orientation), whereas canal neuromasts have an exclusive innervation (a sensory afferent only innervates a single canal neuromast). It has been shown that teleosts use superficial neuromasts to orient to the direction of current flow (rheotaxis), and it is likely that this behavior is mediated by accessory rather than replacement or pit neuromasts [12].

### Central Pathways

The inner ear endorgans, mechanosensory lateral line, and electrosensory systems are each innervated by exclusive populations of cranial ganglion cells. Despite many differences in the physical nature of relevant stimuli and the somewhat independent processing pathways, the central anatomy of octavolateralis systems share many similar features, as depicted in Fig. 5 [14,16].

This likely reflects their shared developmental and evolutionary origins, but also reflects commonalities in information-processing requirements [16]. All octavolateralis systems analyze spatial, temporal, or spectral

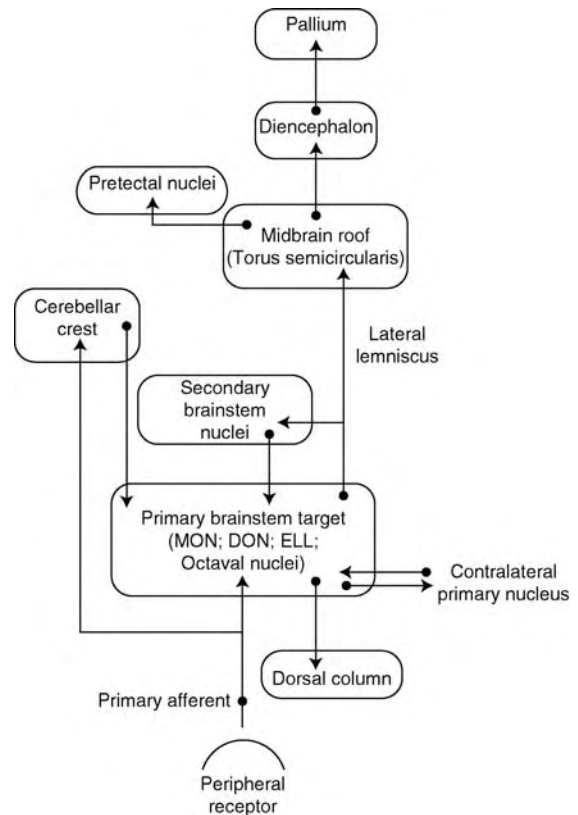

### Evolution of the Mechanosensory and Electrosensory Lateral Line Systems.

**Figure 5** Generalized pattern of octavolateralis central pathways, modified after [1 and 12]. DON: dorsal octavolateralis nucleus; ELL: electrosensory lateral line lobe; MON: medial octavolateralis nucleus. Not all connections are shown, but note that the cerebellar crest (or eminentia granularis) also receives inputs from somatosensory afferents and descending inputs from multiple higher brain regions.

discontinuities in a stimulus field (sonic, hydrodynamic, or electrostatic), and this has resulted in similar neural structures and pathways. Each octaval modality has a distinct primary hindbrain target and most primary afferents also send collaterals to a rhombic lip region called the eminentia granularis or the cerebellar crest (see Fig. 5). These regions issue parallel fibers that overlie the primary brainstem nucleus and form a cerebellum-like circuit that adaptively filters and processes primary inputs [14,16]. Each primary nucleus is organized topographically, although inner ear and/or lateral line projections are coarsely organized in some or all species. Electroreceptive afferents terminate somatotopically, and when multiple classes of electroreceptors are present, each class of afferent forms a parallel somatotopic map in a specific hindbrain region. Afferents from the inner ear maculae and semicircular



canal cristae terminate in a complex of nuclei called the ►**octaval nuclei** (anterior, descending, magnocellular, and posterior), each of which receives inputs from all the inner ear end organs. The dorsomedial region of the descending nucleus receives the heaviest projections from putatively ►**acoustic** end organs and its efferents form an ascending lemniscal pathway to the midbrain. Mechanosensory lateral line afferents project primarily to a dorsal medullary nucleus called the ►**medial octavolateralis nucleus (MON)**. Primitive ampullary organs are represented in a region just dorsal to the MON, called the dorsal octavolateralis nucleus ►**(DON)**. In teleosts, which lack the primitive electro-sense, but have re-evolved ampullary organs, these sensors are represented in a non-homologous brainstem region called the electrosensory lateral line lobe (ELL). Where multiple classes of electroreceptors are present (i.e., gymnotiforms and mormyrids), each class is represented in a separate segment of the ELL.

The brainstem primary nuclei project to other brainstem nuclei (e.g., olivary nuclei) and to midbrain nuclei through the ►**lateral lemniscus**. Each modality is represented in distinct regions of the ►**torus semicircularis**, and each of these toral regions have unique efferent targets. Although there is an opportunity for the convergence of modalities in the hindbrain (through the parallel fiber pathways and a small degree of overlap of primary afferents), the integration of modalities appears to first occur in the midbrain tectum. Diencephalic targets may be uni-modal, particularly in the electrosensory pathway, but at least some thalamic nuclei and most pallial areas appear to receive inputs from multiple octavolateralis pathways [14,16].

## References

- Braun CB (1996) The sensory biology of the living jawless fishes: a phylogenetic assessment. *Brain Behav Evol* 48:262–276
- Bullock TH, Bodznick DA, Northcutt RG (1983) The phylogenetic distribution of electroreception: evidence for convergent evolution of a primitive vertebrate sense modality. *Brain Res Rev* 6:25–46
- Kalmijn AJ (1989) Functional evolution of lateral line and inner ear sensory systems. In: Coombs S, Görner P, Münz H (eds) *The mechanosensory lateral line: neurobiology and evolution*. Springer, Berlin Heidelberg New York, pp 187–216
- Braun CB, Grande T (2007) Evolution of Peripheral Mechanisms for the Enhancement of Sound Reception. In: Popper AN, Fay RR, Webb JA (eds) *Fish bioacoustics*. Springer, Berlin Heidelberg New York (in Print)
- Bullock TH, Hopkins CD, Popper AN, Fay RR (eds) (2005) *Electroreception*. Springer handbook of auditory research (SHAR), vol 21. Springer, Berlin Heidelberg New York
- Coombs S, Montgomery JC (1999) The enigmatic lateral line system. In: Fay RR, Popper AN (eds) *Comparative hearing: fish and amphibians*. Springer, Berlin Heidelberg New York, pp 319–362
- Moller P (1995) *Electric fishes: history and behavior*. Fish and fisheries, vol 17. Chapman and Hall, London
- Hackney CM, Furness DN (1995) Mechanotransduction in vertebrate hair cells: structure and function of the stereociliary bundle. *Am J Physiol* 268:C1–C13
- Coombs S, Janssen J, Montgomery J (1992) Functional and evolutionary implications of peripheral diversity in lateral line systems. In: Fay RR, Popper AN (eds) *Evolutionary biology of hearing*. Springer, Berlin Heidelberg New York, pp 267–294
- Northcutt RG, Bleckmann H (1993) Pit organs in axolotls: a second class of lateral line neuromasts. *J Comp Physiol A* 172:439–446
- Northcutt RG (1989) The phylogenetic distribution and innervation of craniate mechanoreceptive lateral lines. In: Coombs S, Görner P, Münz H (eds) *The mechanosensory lateral line: neurobiology and evolution*. Springer, Berlin Heidelberg New York, pp 17–78
- Coombs S, Braun CB (2003) Information processing by the lateral line system. In: Collin SP, Marshall NJ (eds) *Sensory processing in aquatic environments*. Springer, Berlin Heidelberg New York, pp 122–138
- Northcutt RG (1986) Electroreception in non-teleost bony fishes. In: Bullock TH, Heiligenberg W (eds) *Electroreception*. Wiley, New York, pp 257–286
- Bell CC, Maler L (2005) Central neuroanatomy of electro-sensory systems in fish. In: Bullock TH, Hopkins CD, Popper AN, Fay RR (eds) *Electroreception*. Springer Handbook of Auditory Research (SHAR), vol 21. Springer, Berlin Heidelberg New York, pp 68–153
- Webb JA, Northcutt RG (1997) Morphology and distribution of pit organs and canal neuromasts in non-teleost bony fishes. *Brain Behav Evol* 50:139–151
- Montgomery JC, Coombs S, Conley RA, Bodznick D (1995) Hindbrain sensory processing in lateral line, electrosensory, and auditory systems: a comparative overview of anatomical and functional similarities. *Aud Neurosci* 1:207–231

## Evolution of the Optic Tectum in Amniotes

SALVADOR GUIRADO, JOSÉ CARLOS DÁVILA  
Departamento de Biología Celular, Genética y Fisiología, Facultad de Ciencias, Universidad de Málaga, Málaga, Spain

### Definition

The optic tectum in amniotes is a laminated structure located in the roof of the mesencephalon. It consists of various layers of cells and fibers, the number and thickness of which varies among reptiles, birds and mammals. Generally speaking, numerous cells localized to distinct depths of the optic tectum are

characterized by radially oriented dendritic trees that are in regions with a variety of sensory afferent fibers coursing parallel to the mesencephalic surface, whereas other cells with horizontal morphologies are exposed to a lesser variety of sensory afferent inputs. As a result, the mesencephalon is provided with a 3D sensory map of the external world and, through its efferent connections to motor centers, elicits a number of motor responses such as escape, freezing, or orientation. These motor responses may be selected or inhibited by a further evaluation of the sensory input through neural circuits involving the ascending connections of the optic tectum to the thalamus and telencephalon.

## Characteristics

### Structure of the Optic Tectum in Reptiles

From the pioneering studies of Pedro Ramón y Cajal (Santiago Ramón y Cajal's brother, usually known as P. Ramón as he appeared in many of his papers), 14 layers have been recognized in the reptilian optic tectum. Following the descriptions in the original paper of P. Ramón on the structure of the chameleon brain [1], layers are numbered from the ventricle to the pial surface: (i) epithelial zone; (ii) molecular zone; (iii) cellular zone; (iv) molecular zone; (v) cellular zone; (vi) central fiber zone; (vii) central cellular zone; (viii) cellular zone; (ix) molecular zone; (x) cellular zone; (xi) molecular zone; (xii) cellular and optic fiber zone; (xiii) molecular zone and (xiv) optic fiber zone. Among reptiles, lizards are the group where the 14 layers are most clearly delimited. These 14 layers were later regrouped into six strata [2]: (i) the *stratum opticum*, which contains the fibers from the optic tract and is located superficially; (ii) the *stratum fibrosum et griseum superficiale*, with loosely arranged small cells and fibers; (iii) the *stratum griseum centrale*, a thick layer with densely packed cells; (iv) the *stratum album centrale*, consisting mainly of the axons of the *stratum griseum centrale* cells; (v) the *stratum griseum periventriculare*, with loosely arranged small and medium-sized cells and (vi) the *stratum fibrosum periventriculare*, the innermost fiber layer (Figs. 1 and 2).

### Cells

Golgi and cell-labeling studies in reptiles have shown a variety of cell types in the optic tectum. One type of tectal neuron displays dendrites extending radially across the tectal laminae; thus they are referred to as radial cells (but also as pyramidal or piriform cells) (Fig. 3).

These radial cells are found in all layers of the tectum but are most common in the intermediate and deep layers. Another type is the horizontal cell, with dendrites arranged parallel to the pial surface and mostly found in the superficial layers. Yet another prominent type of tectal neuron is the ganglion cell, a large neuron



### Evolution of the Optic Tectum in Amniotes.

**Figure 1** Transverse hemisection through the midbrain of a lizard (*Psammotromus algirus*) stained with the reduced silver nitrate method of Cajal.

with extensive dendrites that extend toward the pial surface. Many of these ganglionic neurons are localized to the *stratum griseum centrale* and display apical dendritic tufts within the superficial retinorecipient layers [3].

### Afferences

The optic tectum in reptiles receives visual, somatosensory and auditory inputs, as well as non-sensory inputs from brainstem, diencephalic and telencephalic centers. Retinal projections to the optic tectum are bilateral, although predominantly contralateral in most reptiles. Retinal fibers innervate the superficial tectal layers, where a heavy projection is found, primarily to layers 9, 11 and 13. Neurophysiological studies reveal a precise retinotopic projection on the optic tectum; the nasotemporal visual axis is represented along the rostrocaudal tectal axis and the dorsoventral visual axis along the mediolateral tectal axis. The reptilian optic tectum also receives direct projections from the telencephalic visual cortex.

Other sensory systems project to the deeper tectal layers. Somatosensory inputs from both spinotectal and trigeminotectal pathways reach the intermediate and deep layers of the optic tectum. Auditory inputs reach the deeper tectal layers after a relay in the torus semicircularis and nucleus intercollicularis. Various pathways also link the optic tectum with the basal

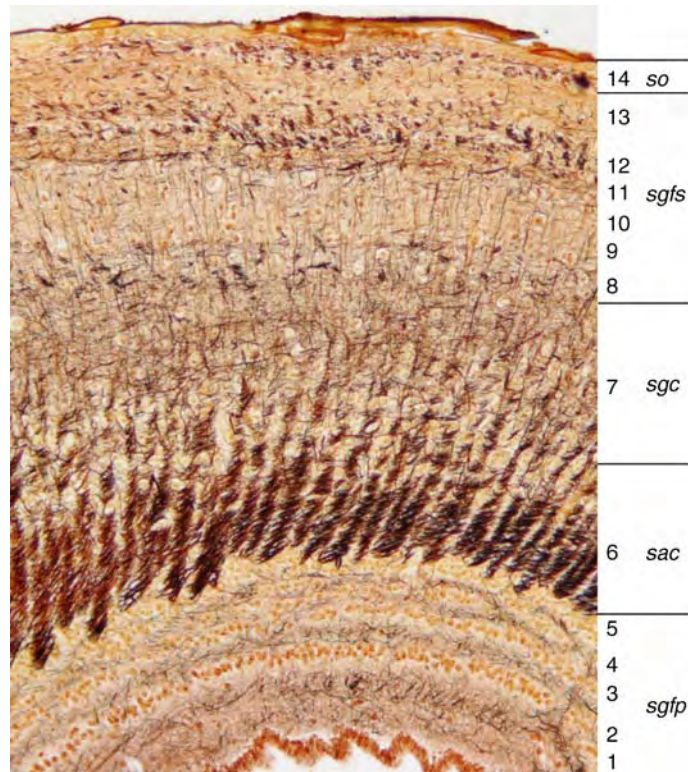

**Evolution of the Optic Tectum in Amniotes. Figure 2** Detail of a portion of the optic tectum of a lizard (*Psammotromus algirus*) showing the tectal lamination. Reduced silver nitrate stain. Abbreviations: *so*, *stratum opticum*; *sgfs*, *stratum griseum et fibrosum superficiale*; *sgc*, *stratum griseum centrale*; *sac*, *stratum album centrale*; *sgfp*, *stratum griseum et fibrosum periventriculare*. Numbers (1–14) indicate layers.

ganglia, since diencephalic and mesencephalic regions receiving striatal projections, which include the nucleus of the posterior commissure, the posterior entopeduncular nucleus and the substantia nigra, project to the optic tectum.

#### Efferences

Tectal neurons give rise to bilateral ascending projections to the pretectum and thalamus, commissural projections to the contralateral tectum and descending projections to the brainstem. In most reptiles, the thalamic nucleus rotundus receives the largest ascending tectal input, which arises almost exclusively from neurons in the *stratum griseum centrale* [4]. The tectal projections to the dorsal geniculate nucleus are very scarce compared with the tecto-rotundal ones and originate from neurons localized mostly to the *stratum fibrosum et griseum superficiale* [5].

The reptilian optic tectum projects to different rostrocaudal parts of the brainstem reticular formation through the dorsal, intermediate and ventral tectobulbar tracts. These descending fibers arise mainly from neurons in the *stratum griseum centrale*, with minor contributions from the superficial tectal layers and from the *stratum griseum periventriculare*.

#### Structure of the Optic Tectum in Birds

Fifteen layers are generally recognized in the avian optic tectum and are numbered from superficial to deep (the most superficial tectal layer is layer 1 and the deepest layer is layer 15, following in this case the descriptions of Santiago Ramón y Cajal [3]). A grouping of avian tectal layers into superficial, central and periventricular strata like the reptilian counterparts is commonly used [6]. This avoids misconceptions about layers' numbers due to the original distinct descriptions in birds and reptiles and simplifies comparison among vertebrates. These strata are (i) the *stratum opticum* (corresponding to layer 1), (ii) the *stratum fibrosum et griseum superficiale* (corresponding to layers 2–12), (iii) the *stratum griseum centrale* (corresponding to layer 13), (iv) the *stratum album centrale* (corresponding to layer 14) and (v) the *stratum griseum et fibrosum periventriculare* (corresponding to layer 15) (Fig. 4).

#### Cells

The cellular organization of the avian optic tectum is similar to the reptilian one. Deeper lying neurons have their dendrites oriented perpendicular to the surface of the tectum, whereas neurons localized to the superficial layers display horizontal dendritic trees.

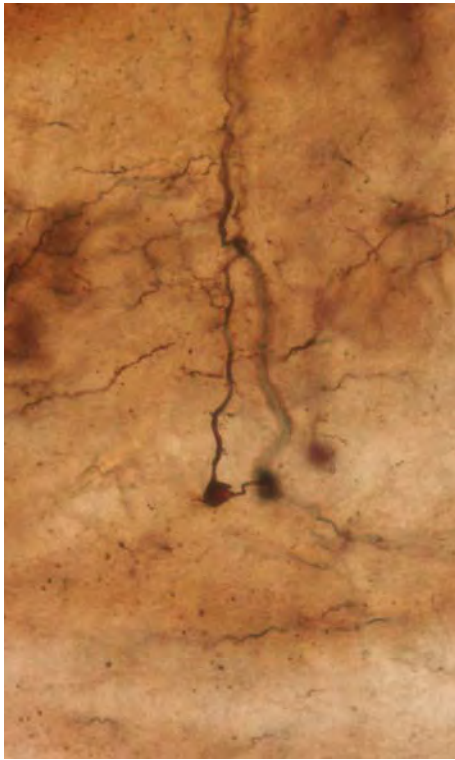

**Evolution of the Optic Tectum in Amniotes. Figure 3**  
A typical radial pyramidal-shaped neuron localized to the intermediate tectal layers of the lizard *Psammotriton*. Golgi-Hortega method.

Layer 13 is characterized by large multipolar ganglionic cells with wide dendritic fields. Most of these ganglionic neurons display bottlebrush endings at their distal dendritic branches, which extend into the superficial tectal layers [7].

#### Afferences

The avian optic tectum, like the reptilian tectum, receives visual, somatosensory and auditory inputs, as well as non-sensory projections from a great variety of centers in the telencephalon, diencephalon and brainstem. The retinal projection is entirely contralateral and retinotopically organized. Retinal afferent projections terminate specifically in layers 2–5 and 7. Telencephalic visual pallial regions project directly to the avian optic tectum, mainly to layers 11–13. Inputs from other sources, including somatosensory input, terminate predominantly in deeper layers of the tectum. As they do in reptiles, nuclei receiving striatal projections, such as the nucleus spiriformis lateralis or the substantia nigra, project to the deeper tectal layers.

#### Efferences

Efferent tectal connections include ascending projections to a number of thalamic and pretectal nuclei,

commissural projections to the contralateral tectum and descending projections to brainstem centers.

The most prominent ascending system arises from layer 13 neurons, which project bilaterally to the thalamic nucleus rotundus (and to various pretectal nuclei). Other ascending projections reach the retino-recipient lateral geniculate nucleus. This tecto-geniculate projection originates exclusively from neurons localized to the *stratum fibrosum et griseum superficiale* [8].

Various descending pathways from the optic tectum reach parts of the brainstem reticular formation, pontine nuclei and isthmus nuclei. A crossed tectobulbar pathway originates mainly from layer 13 neurons, with minor contributions from layers 11–12 and 14–15. The ipsilateral tectopontine system originates mainly from layers 9–10 and 13–15.

#### Structure of the Optic Tectum in Mammals

The mammalian optic tectum, which is generally referred to as the superior colliculus, is also a laminated structure. It consists of eight layers, which correspond, as a whole, to the full set of tectal layers in reptiles and birds and can be grouped into superficial, intermediate (or central) and deep zones. The superficial zone consists of the *stratum zonale*, the *stratum griseum superficiale* and the *stratum opticum*; the intermediate zone comprises the *stratum griseum intermediale* and the *stratum album intermediale* and the deep zone consists of the *stratum griseum profundum*, the *stratum album profundum* and the *central gray*. The deepest layer, the central gray or periaqueductal gray (PAG), is usually regarded separately and is not considered by some to be a layer of the superior colliculus.

#### Cells

Various different morphological cell types are present throughout the tectal layers, including neurons with radially oriented dendrites, neurons with horizontal dendritic trees and large multipolar neurons with bottlebrush dendritic endings [9].

#### Afferences

The mammalian superior colliculus receives sensory inputs (visual, somatosensory and auditory), as well as non-sensory projections from numerous telencephalic, diencephalic and brainstem centers.

Superficial layers are dominated by the direct visual input from the retina. Retinal afferences terminate topographically in the *stratum griseum superficiale*, mainly in the outermost of its three sublayers. In mammals, the visual cortex projects directly to the superficial layers of the optic tectum.

The spinal trigeminal nucleus projects to intermediate layers, providing topographic representation of somatosensory input from the face. Other sources of projections to the intermediate and deep collicular layers include telencephalic cortical areas, hypothalamic nuclei, the

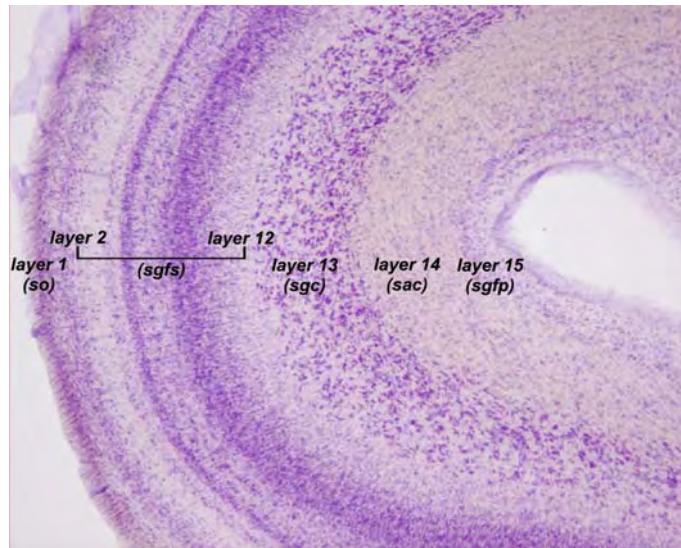

**Evolution of the Optic Tectum in Amniotes. Figure 4** Detail of a portion of the optic tectum of the chicken (*Gallus gallus*) showing the tectal lamination. Nissl stain. Abbreviations: so, *stratum opticum*; sgfs, *stratum griseum et fibrosum superficiale*; sgc, *stratum griseum centrale*; sac, *stratum album centrale*.

substantia nigra and the posterior pretectal nucleus (which receives striatopallidal inputs), the reticular formation, the spinal cord and other brainstem sites.

#### Efferences

Superior collicular neurons give rise to ascending, commissural and descending projections.

Neurons in the superficial layers give rise to ascending connections with “visual” thalamic nuclei. Neurons localized mainly to the deepest sublayer of the *stratum griseum superficiale* give rise to the ascending projection to the lateral posterior-pulvinar (LP/pulvinar) complex in the dorsal thalamus. Neurons located at the superficial layers also project to the retino-recipient dorsal lateral geniculate nucleus. Neurons in the *stratum griseum intermediale*, as well as in deeper or more superficial layers, give rise to ascending pathways to the intralaminar nuclei and to the posterior nuclear group of the dorsal thalamus (Fig. 5).

Neurons located in the intermediate/deep layers give rise to descending pathways to numerous sites, including the reticular formation, extraocular motor nuclei and the spinal cord, in addition to commissural connections to the contralateral superior colliculus.

#### Function

The optic tectum is one of the most conservative structures in the vertebrate brain [10], displaying many similarities in intrinsic radial organization, neuronal types and major inputs and outputs among amniotes. Although the number and thickness of the tectal layers varies among reptiles, birds and mammals, in all three classes of amniotes a similar tectal lamination pattern may be recognized, with superficial layers dominated

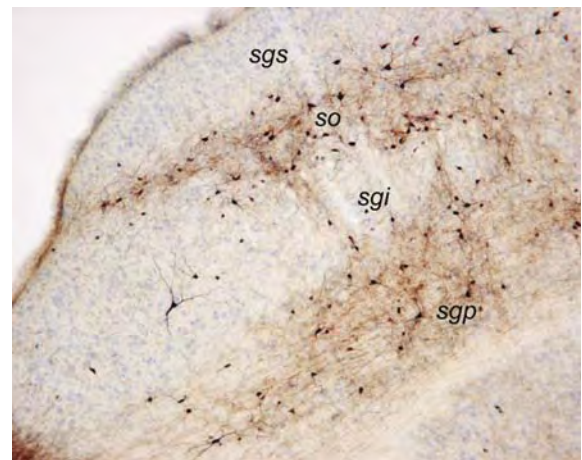

**Evolution of the Optic Tectum in Amniotes. Figure 5** Detail of a portion of the mouse superior colliculus showing retrogradely labeled neurons in various tectal layers, after a tracer injection in the suprageniculate nucleus of the dorsal thalamus. Abbreviations: sgs, *stratum griseum superficiale*; so, *stratum opticum*; sgi, *stratum griseum intermediale*; sgp, *stratum griseum profundum*.

by visual inputs and intermediate and deep layers receiving other sensory modalities as well as non-sensory inputs. Neurons located at these intermediate and deep layers are, by means of their radially oriented dendrites that ascend to superficial layers, also in a position to receive a visual input. Thus, neurons in the deeper layers respond to auditory, somatosensory or visual stimuli, and many of them may receive converging multimodal inputs.

Another common feature of the amniote optic tectum is the topographic organization of the sensory afferences, producing a representation of the sensory space for each sensory modality (sensory maps) along the optic tectum. In addition, the different modality-specific sensory maps are aligned, allowing multimodal deeper neurons to integrate two or more stimuli (for example, visual and auditory) from the same region of the sensory space [11].

Neurons localized to the deeper layers of the optic tectum are the main source of the descending projections to premotor and motor centers of the brainstem and spinal cord and the organization of these “motor” neurons mirrors the overlapping maps of the sensory space. This alignment of sensory and motor maps in the optic tectum provides a means by which different sensory cues can be rapidly transformed into motor commands for orienting movement of the eyes, head and body.

In addition, neurons in the intermediate and deep tectal layers, unimodally or multimodally driven, give rise to ascending projections to the dorsal thalamus in reptiles, birds and mammals. There exists an ongoing debate about the homology of dorsal thalamic nuclei receiving a major tectal projection in sauropsids (birds and reptiles) and mammals. Thus, while the sauropsidian nucleus rotundus has been considered homologous to the mammalian lateral posterior/pulvinar nucleus, mainly on the basis of a massive projection from visually driven tectal neurons [7,9,12], an alternative hypothesis, based on topological, chemoarchitectonic and hodological criteria, considers that the sauropsidian nucleus rotundus is the homologue of the mammalian posterior/intralaminar thalamic complex, a thalamic field which also receives visual as well as multimodal projections from the same tectal layers as the nucleus rotundus [13,14]. In any case, tectorecipient thalamic nuclei project in turn to the telencephalon, to both subpallial (basal ganglia) and pallial (amygdala and cortex) regions. By means of this tecto-thalamo-telencephalic pathway, telencephalic centers that participate in the elaboration of orientation and defense responses are supplied with direct spatiotopic sensory information. This ascending pathway, and therefore the corresponding motor responses elicited, can be modulated by way of the basal ganglia-tectum loop, since these structures are reciprocally connected.

## References

- Ramón P (1896) Estructura del encéfalo del camaleón. *Revista Trimestral Micrográfica* 1:46–82
- Huber GC, Crosby EC (1933) The reptilian optic tectum. *J Comp Neurol* 57:57–163
- Ramón y Cajal S (1904) *Textura del sistema nervioso del hombre y de los vertebrados*, vol 2. Moya, Madrid
- Reiner A (1994) Laminar distribution of the cells of origin of ascending and descending tectofugal pathways in turtles: implications for the evolution of tectal lamination. *Brain Behav Evol* 43:254–292
- Belekhova M, Kenigfest N, Rio JP, Repérant J, Ward R, Vesselkin N, Karamian O (2003) Tectothalamic visual projections in turtles: their cells of origin revealed by tracing methods. *J Comp Neurol* 457:37–56
- Ariëns Kappers CU, Huber GC, Crosby EC (1967) *The comparative anatomy of the nervous system of vertebrates, including man*, vol 2. Hafner, New York
- Luksch H, Cox K, Karten HJ (1998) Bottlebrush dendritic endings and large dendritic fields: motion-detecting neurons in the tectofugal pathway. *J Comp Neurol* 396:399–414
- Wild JM (1989) Pretectal and tectal projections to the homologue of the dorsal lateral geniculate nucleus in the pigeon: an anterograde and retrograde tracing study with cholera toxin conjugated to horseradish peroxidase. *Brain Res* 479:130–137
- Major DE, Luksch H, Karten HJ (2000) Bottlebrush dendritic endings and large dendritic fields: motion-detecting neurons in the mammalian tectum. *J Comp Neurol* 423:243–260
- Butler AB, Hodos W (2005) *Comparative vertebrate neuroanatomy: evolution and adaptation*, 2nd edn. Wiley-Liss, Hoboken
- Stein BE, Meredith MA (1993) *The merging of the senses*. MIT, Cambridge MA
- Karten HJ, Cox K, Mpodozis J (1997) Two distinct populations of tectal neurons have unique connections within the retinotectorotundal pathway of the pigeon (*Columba livia*). *J Comp Neurol* 387:449–465
- Dávila JC, Andreu MJ, Real MA, Puelles L, Guirado S (2002) Mesencephalic and diencephalic afferent connections to the thalamic nucleus rotundus in the lizard *Psammmodromus algirus*. *Eur J Neurosci* 16:267–282
- Guirado S, Real MA, Dávila JC (2005) The ascending tectofugal visual system in amniotes: new insights. *Brain Res Bull* 66:290–296

## Evolution of the Optic Tectum in Anamniotes

WILLIAM M. SAIDEL  
Department of Biology, Rutgers, the State University of New Jersey, Camden, NJ

### Synonyms

Midbrain roof

### Definition

The mesencephalic optic tectum is the midbrain roof of poikilothermic vertebrates. It is of a highly organized, three-dimensional array of neural tissue reflecting or mapping environmental space as defined by sensory information. In poikilothermic vertebrates, the retina

provides the major input to the optic tectum and reflects the visuotopic organization of the retina. Thus, the tectum is organized according to the geometry of the world as seen by the retina. The tissue is defined by both tangential and radial axes, by defined lamina and by spatial homogeneities and inhomogeneities.

The functional role of the tectum is reflected in its topographic organization in which motor behaviors are directed in space. The computations result from tectal cells that are positionally defined in visual space by the topography of retinal input. In addition, mechanoreception and electroreception (if present) also provide spatial information to different tectal layers. The tectum is connected to rostral and caudal divisions of the brain, which, in part, reflects functional divisions of the tectum. The retinotopic translation of the geometry of the visual world underlies its fundamental spatial organization in surface dimensions (mediolateral and rostrocaudal). The topographic geometry of the retina, within limits, is faithfully preserved in its tangential extent, while in its depth, it is organized into numerous cell rich, fiber poor and fiber rich, cell poor layers.

## Characteristics

The poikilothermic taxon considered here extends from the jawless aquatic vertebrates, the agnathans, to the amphibians. The cladogram (Fig. 1) represents speciation of organisms that correlate with two global lifestyle transitions.

Phylogenetically early in the cladogram, jaws were acquired. Late in the cladogram, aquatic animals transitioned onto land with descendants acquiring a

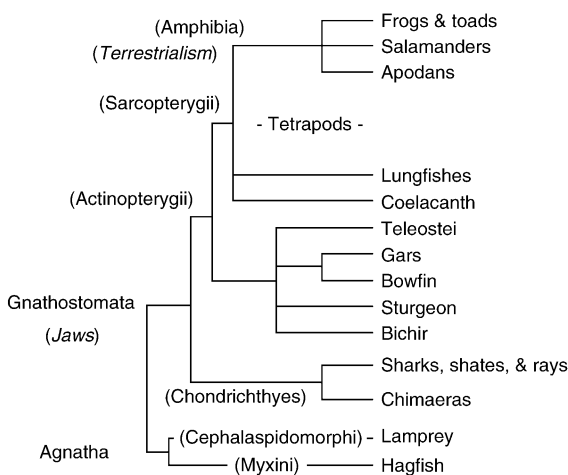

## Evolution of the Optic Tectum in Anamniotes.

**Figure 1** cladogram from branchiostoma to amphibians Superclass and class (in parenthesis) of species discussed in this article are identified (after Nelson, 3rd edn, Fishes of the world). The two ecologically important transitions are positioned appropriately.

terrestrial life-style. Both transitions represent dramatically important adaptations for the vertebrate life-history in that they entailed significant adaptative constraints for behavior. Jaws permitted a lifestyle change from a rambling meander through a three-dimensional environment to one that utilized active movement for food acquisition. The other, terrestrialism, illustrates an expansion of potential habitats outside an aquatic environment that was accompanied by a general reduction in the geometry of movement from three- to two-dimensions.

The adaptation for active, directed behavior is basic to any consideration of the role of the optic tectum for studies in many animals, and has revealed that tectal function is involved with spatiomotor activities. For the animals considered here, the tectum performs visuotopic tasks. That is, to understand the evolution of the tectum given its phylogenetic history, one should understand the potential tasks done by an animal that involve the tectum.

The cephalochordates (the lancelet, *Branchiostoma lanceolatum*) predate the Agnatha. Since *Branchiostoma* lacks a brain, the appearance of a midbrain tectum occurred only with the advance to the agnathans. All subsequent vertebrates display the three major divisions found in modern animals: the hindbrain, the midbrain, and a forebrain. Even the braincase of extinct ostracoderm fishes shows a three-part central brain. If modern agnathans, the lampreys and hagfishes, reflect brain organization of ancestral agnathans, then the latter also possessed well developed, compartmentalized brains.

## The Optic Tectum in Agnathans (Jawless Fishes)

The optic tectum of the hagfish possesses a crudely laminar structure. Four strata are distinguishable from the surface: the stratum marginale (SM), a stratum cellulare et fibrosum (SCF), a stratum periventriculare (SP) and a stratum ependymale (SE) [1]. Three years later, Iwahori and colleagues identified eight tectal layers in the cyclostome, *Lampetra japonica*. From the surface, they are the thin stratum marginale, the stratum opticum, the main terminal area of the optic nerve, the stratum cellulare et fibrosum externum, the stratum fibrosum centrale, the stratum cellulare et fibrosum internum, the stratum fibrosum periventriculare (SP) and the stratum ependymale (SE).

## Cells

Cells in the SE of hagfishes are of two sorts. One with pyriform, fusiform or irregular-shaped soma has its main dendrites relatively radial in orientation. Cells of the SP contain pyriform or fusiform neurons with dendrites extending in any direction, but mostly radial. Cells in the SCF are densely packed and of many morphologies. Their dendrites tend to mark a limited territory. Cells of the SM are relatively medium and

small and are fusiform or triangular with obliquely oriented dendrites.

In lampreys, several rows of ependymal cells form the SE. Neurons whose dendrites are oriented radially inhabit the stratum cellulare periventriculare. The stratum fibrosum periventriculare is thin and contains a few vertical neurons. Several alternating cellular and fibrous layers with a variety of radial and tangential neurons inhabit the stratum cellulare et fibrosum internum. Tangential fiber bundles make the stratum fibrosum centrale with a small number of tangentially oriented cells. In the stratum cellulare et fibrosum externum, numerous fibers run horizontally in a loosely organized plexus with various types of vertical, horizontal and stellate neurons distributed among these fibers. The stratum opticum is the main terminal area of the optic nerve. Within this layer are some stellate and horizontal neurons. The stratum marginale is thin with sparse distribution of radial and tangential neurons.

#### Tectal Afferent Connections

The SCF of the hagfish tectum receives visual input from its subepidermal eyes. Other sensory inputs in *Eptatretus burgeri* arise from the trigeminal sensory nucleus and the area acoustico-lateralis. Central sources of tectal afferents include (ipsilaterally) the

hypothalamus, the pars ventralis thalami of Jansen, nucleus reticularis mesencephali, and (contralaterally), the tectum, nucleus sensorius, and the so-called nucleus funiculi dorsalis [2] (Fig. 2).

In the lamprey, retinal fibers incompletely cross in the optic chiasm, with the majority terminating contralaterally. In the adult lamprey, only the superficial zone of the SCF is retinorecipient. Unlike in the teleosts, the SM is fiber sparse. Other targets are: a bilateral projection to a neuropil in the caudodorsal thalamus, contralateral projections to a cell group in the dorsomedial thalamus and the superficial pretectum. Ipsilateral retinal projections include spatially distinct regions of the superficial rostral tectum and deeper layers of the caudal and ventrolateral tectum.

Neurons projecting to the tectum (or whose axons pass through the tectum) are found in four areas of the telencephalon [pallium, subhippocampal lobe, striatum, preoptic area], multiple areas of the diencephalon [bilaterally in prethalamic eminence, ventral geniculate nucleus, periventricular prethalamic nucleus, periventricular pretectal nucleus, precommissural nucleus, magnocellular and parvocellular nuclei of the posterior commissure and pretectal nucleus; ipsilaterally in nucleus of Bellonci, periventricular thalamic nucleus, nucleus of the tuberculum posterior, subpretectal tegmentum,

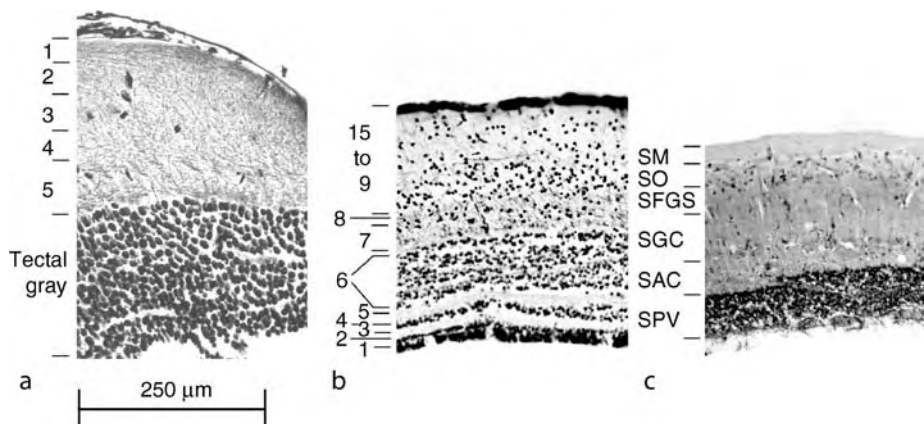

**Evolution of the Optic Tectum in Anamniotes. Figure 2** Cross section of tectum:(a) Salamander. The 5-layer scheme of the tectal white originates from Herrick (J Comp Neurol 149:463–476, 1942) and Gruberg and Solish (J Comp Neurol 157:137–150, 1978). Layer 1: superficial layer (visual input) Layer 2: intermediate neuropil (visual input) Layer 3: intermediate fiber layer (somatosensory input) Layer 4: commissural fiber layer Layer 5: deep neuropil Tectal gray: cell bodies (b) Rana The layering scheme of the frog tectum arises from Pedro Ramón's 1984 study of *Rana catesbeiana* and its update in Potter, J. Comp. Neuro., 136:203–232, 1969. The deep zone comprises layers 1 through 6; and the superficial zone comprises layers 7 through 15. In the deep zone, layers 1,2, 4 and 6 are primarily cellular, 3 and 5 are fibers of various sorts. In the superficial zone, layer 7 is a complicated layer of fibers intermixed with cells although the deepest aspect of the layer is primarily fibers. Layer 8 is a distinct small cell layer and Ramon's layers 9 through 15, according to Potter, lack a clear laminar cellular organization. (c) Teleost-Pantodon buchholzi, the African Butterfly Fish SM stratum marginale SO stratum opticum SFGS stratum fibrosum et griseum superficiale SGC stratum griseum centrale SAC stratum album centrale SPV stratum periventriculare. Parts a & b courtesy of Dr. E. Gruberg, Temple University, Philadelphia, PA; Part c, an original image from the author.



and pineal organ], the mesencephalon [bilaterally in dorsal and lateral isthmic nuclei, ipsilateral torus semicircularis, contralateral optic tectum, and bilaterally in the mesencephalic reticular formation, plus the retinopetal nuclei] and rhombencephalon [octavolateral area, sensory nucleus of the descending trigeminal tract, dorsal column nucleus and reticular formation]. Recently, De Arriba and Pombal, found a small projection from the rostral spinal cord.

### The Optic Tectum in Chondrichthys (Cartilaginous Fishes)

The tectum of the dogfish shark has been divided into six layers [3], [the stratum medullare externum, the zona externa of the stratum cellulare externum, the zona interna of the stratum cellulare externum, the stratum medullare internum, the stratum cellulare internum and a layer of fibers parallel to the ependymal layer of the mesencephalic ventricle], or historically, seven [the stratum marginale (SM), stratum fibrosum et griseum superficiale (SFGSs and SFGSi), stratum griseum superficiale (SGC), stratum fibrosum et griseum centrale (SFGC), stratum album centrale (SAC), stratum griseum periventriculare (SGP), stratum fibrosum periventriculare (SFP)].

### Cells

At least eight types of Golgi-defined neurons have been identified in the tectum [3]. No single type of cell was restricted to only one layer. All cell types possessed dendrites that were either radial or tangential with respect to the different layers.

### Tectal Afferent Connections

Retinal ganglion cells primarily terminate in the stratum medullare externum of *Scyliorhinus* (or the SFGS and SGS, superficial zone) while the zona externa of the stratum cellulare externum is the primary terminal zone in *Raja*. An ipsilateral terminal zone is also found in the anterior SFGS and a small caudomedial zone of the SFGS.

The tectum of cartilaginous fishes receives afferents from numerous nuclei extending from the cervical spinal cord to the telencephalon. Diffuse cells in the dorsal cervical cord, the rhomencephalic reticular formation, rhombencephalic cells in the nucleus cerebelli, nucleus vestibularis superior, nucleus funiculi lateralis, nucleus tractus descendens nervi trigemini, and the dorsal and intermedius octavolateralis areas have been reported to project to the tectum. From the mesencephalon, cells in the contralateral tectum, nucleus tegmentalis lateralis, the red nucleus, and the ventrolateral tegmentum provide afferents to a tectum. In the forebrain, diencephalic neurons in the nuclei thalamus dorsalis pars medialis, thalamus ventralis pars

lateralis, and medius infundibuli and in the pretectal area contribute afferents, as do telencephalic neurons in the caudal pallium [4].

### Tectal Efferent Connections

Three distinct pathways emerge from the tectum of the shark *Scyliorhinus* and the skate *Raja* [5]: a bilateral rostral pathway to the pretectal area, the dorsomedial thalamus and the lateral geniculate; a commissural pathway to the contralateral tectum and the intercollicular nucleus; and a descending projection to the rhombencephalic reticular formation with fibers terminating in the intercollicular nucleus, the nucleus reticularis isthmi, and the medial and median reticular formation.

### Optic Tectum in Ray-finned Fishes

Many aspects of tectal anatomy and physiology in ray-finned fishes, particularly their largest taxon the bony fishes, or teleosts, have been covered in significant reviews [6–9]. In general, the layering of the tectum in the teleosts is conservative, although one must be reminded that variations correlate with unusual aspects to an eye in a species, of which there are more than 20,000. However, in most teleosts, the tectum is comprised of six tangential layers with subdivisions. The composition of these layers is differentiated by their fiber and cell constituents, and the details of individual layers show some ecological correlations related to visual abilities and to eye structure. From the pia mater to the ventricle, the layers are typically named stratum fibrosum marginale (SM), stratum opticum (SO), stratum fibrosum et griseum superficiale, stratum griseum centrale, stratum album centrale, and stratum griseum periventriculare (SPV) [9,10]. The SPV is predominantly composed of cells, while the SM is predominantly composed of unmyelinated axons. The other layers contain cells scattered among neurites from different sources.

### Cells

Although mostly defined by Golgi studies of neurons in the goldfish *Carassius*, the majority of tectal neurons correspond to one of about 15 types of cells [7,10]. A majority of cells are pyriform neurons whose soma is located in the SPV with an apical (or radial) dendrite that extends from the soma either radially or tangentially into the SGC and perhaps up to the SO. Both pyramidal and fusiform cells are found in the SFGS and SGC with dendrites that span multiple neurite-containing layers. These cells possess from one to three tangential dendrites emerging from a radial dendrite, each in a different layer of the tectum. Small and large multipolar neurons are found predominantly in the central SGC and SFGS with a smattering in the SM or SO.

### **Afferent Connections**

The stratified input to the tectum organizes afferent inputs from different sensory systems and nuclei. The unmyelinated axons of the SM originate from the torus longitudinalis. The SO and the SFGS receive the bulk of the retinal terminals although, depending upon species, regions of the SGC and the SAC may also receive retinal. Mechanoreceptive information reaches the layers SGC and SAC of the tectum from the torus semicircularis, which is the recipient of lateral line and eighth nerve input. Of those fishes that are electroreceptive, electroreceptive information also reaches the SGC in spatial register with the more superficial retinal afferents.

The telencephalon provides input to the SGC (ipsilaterally and possible contralaterally). Collateral axons from the cells of origin of the nerve terminalis (the most rostral cranial nerve) may also terminate within the tectum. From the diencephalon, numerous pretectal, thalamic, and hypothalamic nuclei contribute inputs to the tectum. In some cases, the details appear to depend upon the species studied. Pretectal nuclei, the torus semicircularis, the torus longitudinalis, the nucleus isthmi, and a tegmental nucleus provide mesencephalic input as do cells in a rostral rhombencephalic reticular nucleus.

### **Efferent Connections**

Numerous nuclei and areas within the pretectum, the mesencephalon, and the rhombencephalon are recipient of tectal efferents, forming direct and indirect visual circuitry and visuo-cerebellar circuitry. Particular to goldfish, these are nucleus pretectalis, area pretectalis, the parvocellular part of the superficial pretectum, and the magnocellular part of the superficial pretectum, while others have been described with respect to other species (see [7]). Commissural efferents exist to the contralateral tectum and the torus longitudinalis. Descending projections to the mesencephalic torus semicircularis, nucleus isthmi, a tegmental dorsolateral nucleus, lateral reticular formation (ipsilaterally), medial reticular formation (contralaterally), and, in the rhombencephalon, the cerebellar-connecting nucleus lateralis valvulae and the facial and vagal lobes.

### **Function of Individual Neurons**

Meek's [10] theoretical analysis of the role of the tectal laminar structure highlights synaptic integration by single neurons. The targets of specific types of tectal neurons also have been summarized [7]. Various properties have been recorded using electrophysiological techniques including binocularity, light responsiveness to part or the entirety of a receptive field with center-surround structure or not, chromaticity, movement sensitivity, and directionality [6]. A limited number of studies have combined anatomical identification of tectal neurons in

teleosts with a description of their response properties. As expected, some cells are light responsive with large, center-surround receptive fields, possess sustained and transient responses to light stimulation, and/or are bimodally sensitive [6].

### **Expressions of Tectal Inhomogeneity: Anatomy and Behavior**

The optic tecta of anamniotes resemble each other in that they are similarly constructed and function for orientation and spatial motor tasks. However, three kinds of experiments reveal that the anatomy and functional consequences of tectal processing in teleosts is not spatially homogeneous. The type and direction of movement depends upon stimulation locus in both depth and visuotopic position for (i) eye movements and (ii) body orientation and is reflected by (iii) detailed afferent connectivity.

#### **Eye Movements**

Local stimulation of the anteromedial tectum evokes convergent eye movements, while stimulation of the anteromedial, medial and caudal zones evokes conjugate eye movements of different sorts [11].

#### **Body Orientation**

Similarly, stimulation of different regions of the tectum in freely moving or restrained fishes resulted in body reorientation, turning, or rolling to one side or the other plus other movements indicative of reorientation and possibly escape movements [11].

### **The Optic Tectum in Amphibians**

The study of the tectum in frogs (anurans) has an extensive history. The most modern interpretations of it are as a structure with 15 distinct layers or four zones: the deep zones (layers 1–6), a deep nearly cell-free medullary lamina (deep region of lamina 7), a multipolar cell lamina (superficial region of lamina 7 or G), and a superficial zone (layers 8 and 9 or fiber layers A-F) [12,13]. The layers are distinguished by the presence, shapes, and sizes of neurons, and between the cellular layers, concentric laminae of fibers run parallel to the cell layers. In the superficial tectum, at least four distinct layers represent retinal input of myelinated and unmyelinated axons and deeper, somatosensory input.

The tectum of salamanders (urodeles) reflects a simpler variation in structure. It is characterized by a large and deep cell layer surrounded by a superficial large cell-free neuropil. The neuropil has been divided into five layers, numbered from the pial surface 1 through 5. Gruberg [14] showed that the superficial half of the neuropil represents the layers of retinal fiber terminations, and later found that the inner half of the neuropil contains somatosensory afferents.

### Cells

Many cell types have been characterized in the anuran tectum. The deep tectal cells are described as ganglionic/ or candelabra cells (layer 6 & 7) and pyramidal cells (layers 6). Their dendritic extensions are wide and relatively narrow, respectively. In the superficial layer, granule cells near the pia have numerous dendrites [13]. Among the ascending efferent neurons are small and large piriform neurons of layer 8, ganglionic and fusiform neurons of layer 7, and piriform and pyramidal cells of layer 6. Descending neurons include ganglionic cells and large piriform and pyramidal cells of layers 6 and 7 [12].

### Afferent Connections

In anurans, sources of direct afferent input to the tectum arise from all divisions of the brain except the telencephalon (which is indirectly afferent): the diencephalon [pretectum, the ventromedial thalamic nucleus, the ventrolateral thalamic nucleus, the supra-chiasmatic nucleus and from within the central and anterior thalamic nuclei], midbrain [the contralateral tectum, nucleus isthmi, areas of the posteroventral tegmental field, the posterior tuberculum], and rhombencephalon [cervical spinal cord]. Some specificity of termination on the dendrites of tectal neurons exists to separate each sensory input. The nucleus reticularis tegmenti projects to the deep tectal layers [15].

In salamanders, tectal afferents from the telencephalon, the contralateral tectum, and the medulla are sparse and branched widely. Projections of the telencephalon and all diencephalic nuclei terminate deep in the rostral tectum. Projections of the medulla terminate preferentially deep in the caudal tectum. The isthmo-tectal projection innervates the whole tectum opticum on the ipsilateral side and is highly topographic [16].

Cells afferent to the optic tectum are located within the telencephalon [the ventral part of the lateral pallium, and the posterior strio-amygdalar complex], diencephalon [ventral and dorsal thalamus, nucleus of Darkschewitsch, and the preoptico-hypothalamic complex], midbrain [the pretectal nucleus, contralateral tectum, dorsal tegmentum, and nucleus isthmi] and brainstem [nucleus reticularis medius, nucleus vestibularis magnocellularis, and area octavo lateralis]. Ipsilateral projections arise from as far caudal as the dorsal gray columns of the cervical spinal cord [17].

### Efferent Connections

In anurans, efferent tectal projections terminate in dorsal diencephalic nuclei (the dorsal thalamic neuropil and nucleus anterior) and the pretectum, in midbrain nuclei (including the contralateral tectum, the nucleus isthmi, regions of the tegmentum and reticular formation, in some rhombencephalic nuclei, and the rostral

spinal cord. Specifically neurons within the superficial tectal layer 8 project to the posterior lateral dorsal nucleus, the corpus geniculatum, and the nucleus lentiformis mesencephali. Other defined outputs of the tectum include axons of ganglionic and pyriform neurons of layer 8 terminate in the posterior lateral ventral nucleus and anterior lateral nucleus of the thalamus. Descending efferents forming the tectobulbospinal tract arise from ganglionic cells in layer 7 and layer 6.

In salamanders, rostral efferent projections of the tectum terminate in the ipsilateral pretectal area, the ipsilateral dorsal and ventral thalamus, and the contralateral tectum. The tecto-isthmic projection is highly topographic forming a layered terminal field lateral to the nucleus isthmi. Caudal efferents form the bilaterally organized tecto-bulbar tracts innervating the rhombencephalon.

### Detailed Afferent Connectivity

Different turning movements may be elicited from different depths of the tectum. In addition, regions of the tectum defined by elicitation of conjugate versus convergent eye movements suggest differences in tectal connectivity with other brain regions. Neuroanatomically, telencephalic afferents terminate in the antero-medial tectal zone; supra-chiasmatic and preoptic nuclei project preferentially to the anteromedial tectum, while thalamic and pretectal nuclei are afferent to the entire tectum. The tecto-tectal relationship is homotopic, while the medial and posterior tectal zones receive afferents from the medial and inferior reticular formation respectively. The superior reticular formation, like the thalamus and pretectal inputs, does not differentiate to particular areas of the tectum [18]. However, the uniform or non-uniform distribution of intrinsic cells within different layers has been minimally explored.

Although unexplored in detail, limited evidence suggests that the anuran tectum is not a homogeneous structure. The relationship between efferents from the nucleus isthmi to the tectum depends upon the spatial position within the tectum [19] as does the distribution of neurons immunoreactive to somatostatin, substance P, and serotonin antibodies within the tectum [20].

### Tectal Function

At this point we might ask, what role does the midbrain tectum play? It is undeniable that the tectum instigates and guides visually-driven movements. It is reasonable to assume that its central role is the translation of processed sensory signals into meta-control signals for appropriate life-sustaining behaviors, especially those involved with feeding and escape or, to rephrase, approach and avoidance. Among poikilothermic

vertebrates, the tectum has a coordinated map of space resulting from at least two if not more senses that contribute to the transformation of synaptic connections into a sensory map. The tectum might be considered as a two-dimensional whose coordinate points, determined from the visual field, both specify the external influences and personal space so that the appropriate action is spatially determined. This would be the underlying basis for orientation behavior. Whether the action is towards or away is a property of internal tectal networks under pretectal influence.

From lampreys to teleosts, or salamanders to anurans, a number of structural features exist in common to provide a substrate upon which appropriate behavior is contextually computed. The generalized structure represents the intersection of a developmental process, an informational sink, and a successful computational device. Although many, many details about intrinsic structure and connectivity have been revealed, the study of the underlying algorithms for a detailed functional analysis of intratectal networks and how they relate to behavior is still in its infancy (Fig. 3).

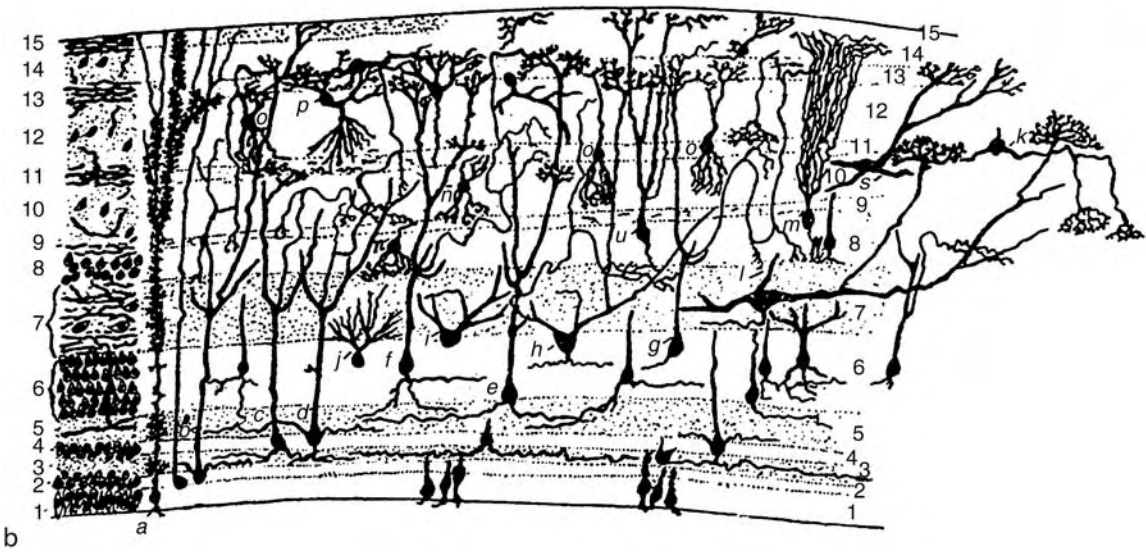
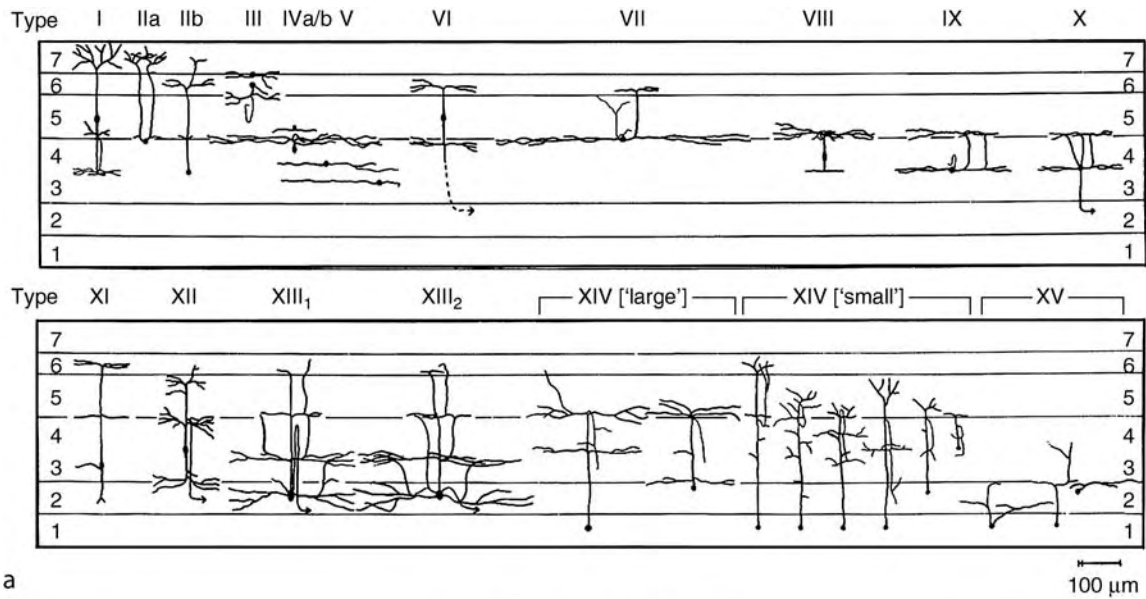

**Evolution of the Optic Tectum in Anamniotes.** Figure 3 (a) The neurons of the teleost tectum have been characterized into 15 distinct types (After figure 19 of Meek, Schellart (1978) A golgi study of goldfish optic tectum. *J Comp Neurol* 182:89–122). (b) The neurons of the bullfrog tectum have also been characterized by a variety of methods into a large number of layer- distinct cells (after figure 1, Potter, 1969).

## References

- Iwahori N, Nakamura K, Tsuda A (1996) Neuronal organization of the optic tectum in the hagfish, *Eptatretus burgeri*: a Golgi study. *Anat Embryol* 193:271–279
- Amemiya F (1983) Afferent connections to the tectum mesencephali in the hagfish, *Eptatretus burgeri*: an HRP study. *J Hirnforsch* 24:225–236
- Manso MJ, Anadon R (1991) The optic tectum of the dogfish *Scyliorhinus canicula* L.: a Golgi study. *J Comp Neurol* 307:335–349
- Smeets WJAJ (1982) The afferent connections of the tectum mesencephali in two chondrichthyans, the shark *Scyliorhinus canicula* and the ray *Raja clavata*. *J comp Neurol* 205:139–152
- Smeets WJAJ (1981) Efferent tectal pathways in two chondrichthyans, the shark *Scyliorhinus canicula* and the ray *Raja clavata*. *J comp Neurol* 195:13–23
- Guthrie S (DM) (1990) The physiology of the teleostean optic tectum. In: Douglas RH, Djamgoz MBA (eds) *The visual system of fish*, Chapman and Hall, London, pp 279–343
- Meek HJ (1990) Tectal morphology: connections, neurones and synapses. In: Douglas RH, Djamgoz MBA (eds) *The visual system of fish*, Chapman and Hall, London, pp 239–277
- Northcutt RG (1983) Evolution of the optic tectum in ray-finned fishes. In: Davis RE, Northcutt RG (eds) *Fish neurobiology*, vol 2: Higher brain areas and functions, The University of Michigan Press, Ann Arbor, MI, pp 1–42
- Vanegas H, Ito H (1983) Morphological aspects of the teleostean visual system: a review. *Brain Res Rev* 6:117–137
- Meek J (1983) Functional anatomy of the tectum mesencephali of the goldfish. An explorative analysis of the functional implications of the laminar structural organization of the tectum. *Brain Res Rev* 6:247–297
- Herrero L, Rodriguez F, Salas C, Torres B (1998) Tail and eye movements evoked by electrical microstimulation of the optic tectum in goldfish. *Exp Brain Res* 120:291–305
- Lázár GY, Tóth P, Csank Gy, Kicliter E (1983) Morphology and location of tectal projection neurons in frogs: a study with HRP and cobalt-filling. *J Comp Neurol* 215:108–120
- Potter HD (1969) Structural characteristics of cell and fiber populations in the optic tectum of the frog (*Rana catesbeiana*). *J Comp Neurol* 136:203–232
- Gruberg, ER (1973) Optic fiber projections of the tiger salamander *Ambystoma tigrinum*. *J Hirnforsch* 14(4):399–411
- Montgomery NM, Fite KV (1991) Organization of ascending projections from the optic tectum and mesencephalic pretectal gray in *Rana pipiens*. *Vis Neurosci* 7:459–478
- Rettig G (1988) Connections of the tectum opticum in two urodeles, *Salamandra salamandra* and *Bolitoglossa subpalmata*, with special reference to the nucleus isthmi. *J Hirnforsch* 29:5–16
- Finkenstadt T, Ebbesson SO, Ewert JP (1983) Projections to the midbrain tectum in *Salamandra salamandra* L. *Cell Tissue Res* 234:39–55
- Pérez-Pérez MP, Luque MA, Herrero L, Núñez-Abades, PA, Torres B (2003) Afferent connectivity to different functional zones of the optic tectum in goldfish. *Vis Neurosci* 20:397–410
- Dudkin EA, Gruberg ER (1999) Relative number of cells projecting from contralateral and ipsilateral nucleus isthmi to loci in the optic tectum is dependent on visuotopic location: horseradish peroxidase study in the leopard frog. *J Comp Neurol* 414:212–216
- Debski EA, Liu Q, Chapman AM (1995) Non-uniform distribution of cellular phenotypes in the optic tectum of the leopard frog. *J Comp Neurol* 360(4):671–684

## Evolution of the Pallium in Amphibians

S. MÜHLENBROCK-LENTER, GERHARD ROTH, FRÉDÉRIC LABERGE  
Brain Research Institute, University of Bremen, Bremen, Germany

### Synonyms

Amphibian cerebral cortex; Pallial primordia; Paleopallium and archipallium; Primordium hippocampi; Pallia dorsale and piriforme

### Definition

The amphibian pallium consists of the dorsomedial, dorsal and dorsolateral part of the paired telencephalic hemispheres. It is composed of a periventricular cellular layer and a superficial fiber layer, the latter of which consists of three laminae (Fig. 1). A medial, dorsal, lateral and ►ventral pallium can be distinguished representing the ancestral condition of jawed vertebrates [1,2]. Dorsal and medial regions receive multimodal sensory and limbic afferents predominantly from the anterior dorsal thalamus, but – in contrast to amniotes (at least to birds and mammals) – no unimodal “lemnthalamic” input. The lateral and ventral pallia receive predominantly olfactory and vomeronasal input. Unlike derivatives of the ventral pallium in other tetrapods (i.e., parts of dorsal ventricular ridge in sauropsids, basolateral amygdala components in mammals), a substantial visual, auditory and somatosensory input from the dorsal thalamus as well as connections with the dorsal pallium are lacking. The function of the amphibian pallial areas appears to consist of unimodal olfactory (lateral and ventral pallia), multimodal-associative (medial and dorsal pallia) and limbic information processing, including memory extinction (medial and posterior lateral pallia).

### Characteristics

**Structure.** The amphibian pallium forms the dorsomedial, dorsal and dorsolateral part of the cerebral

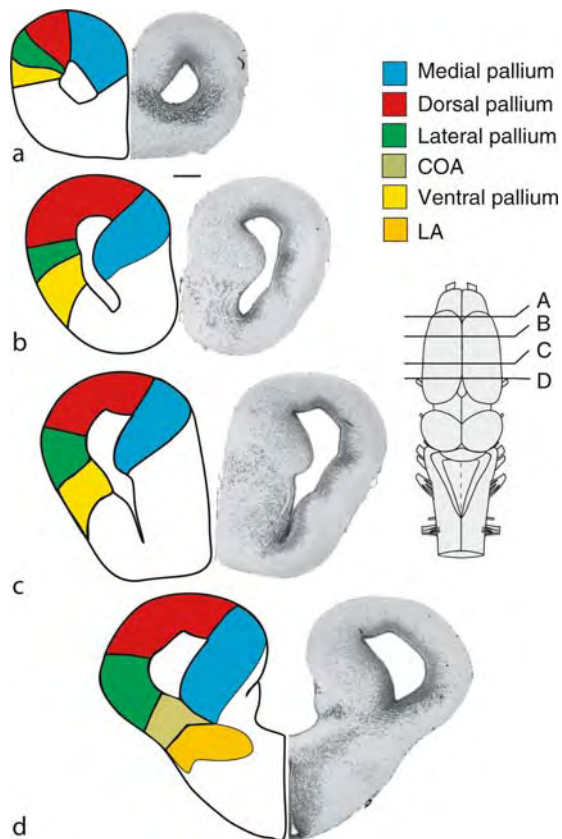

### Evolution of the Pallium in Amphibians.

**Figure 1** Transverse sections through the telencephalon of *Bombina orientalis* at levels indicated in *inset*. *Right*: Klüver-Barrera staining, *left*: pallial zones. COA: cortical olfactory amygdala, LA: lateral (vomeronasal) amygdala. Bar for transverse sections indicates 500  $\mu$ m.

hemispheres of the telencephalon, while the subpallium forms the ventral part of the telencephalon. The medial, dorsal, lateral and ventral pallia are confluent with each other and mostly distinguished by differences in afferent and efferent connectivity. Medially, the pallium is separated from the subpallial septum by a cell-free zone, the *zona limitans medialis*, while laterally the pallium merges with the striatum via a transitional zone, the *striato-pallial transition area* ( $\blacktriangleright$ SPTA). Rostrally, it is confined by the main olfactory bulbs, while the caudal tip of the hemispheres exceeds the lamina terminalis and extends above the diencephalon dorsally.

The pallium generally exhibits a two-layered structure, *viz.* a periventricular cellular layer of variable thicknesses and a superficial fiber layer. Substantial cell migration occurs only in the intermediate and dorsal portions of the medial pallium, without generating a clear lamination outside the periventricular layer. Besides small Golgi type II and horizontal neurons, the bulk of neurons have spherical or triangular somata and

extend their dendrites peripherally in a fan-like fashion; the dendrites are often densely covered with spines. These pallial neurons are assumed to be precursors of cortical pyramidal neurons in reptiles and mammals [3]. The superficial fiber layer consists of a deep lamina carrying intrinsic-associative fibers, an intermediate lamina containing extrinsic afferents and an outer, subpial zone occupied by the large dorsal association tract [4, p 1933]. Presumably, some pattern of alternating cellular and fiber laminae in the pallium is a plesiomorphic feature of all tetrapods, because in the pallium of the non-paedomorphic dipnoan *Neoceratodus* there is a tripartite lamination similar to the situation found in the cortex of turtles and lizards [cf. 4]. Because many traits of the amphibian brain have undergone secondary simplification [5,6], it is possible that the pallium of the amphibian-like ancestor of tetrapods had three layers, unlike the situation in extant amphibians.

**Medial pallium.** The medial pallium is generally considered homologous to Ammon's horn and the subiculum of the mammalian hippocampus, while a dentate gyrus is believed to be absent. Ascending and descending fibers extend in a periventricular position via the intrahippocampal fornix and via a subpial hippocampal fimbria tract. Strong reciprocal connections of the medial pallium with the septal nuclei exist [7–9] and include a cholinergic component as in mammals [10]. Polysynaptic multi-modal sensory and limbic afferents originate in the anterior thalamic nucleus and terminate in the medial, dorsal and lateral pallia, especially in their rostral parts [11–15, G. Roth, unpublished observations]. On the other hand, the dorsal striato-pallidal complex receives input from the central dorsal thalamic nucleus. The medial pallium is connected with the dorsal and lateral pallia, postolfactory eminence, nucleus accumbens, subpallial (medial most) and vomeronasal amygdala, dorsal and ventral thalamus, dorsal and ventral hypothalamus, tegmentum, tuberculum posterius, nucleus entopeduncularis posterior and raphe nuclei [8,16, personal observations]. The rostral most part of the medial pallium differs from the caudal part in its reciprocal connection with the olfactory bulb and its projection to the dorsal striatum and dorsal pallidum [17, personal observations], thus resembling orbito-, infra- and pre- limbic cortices in mammals. The striatum as well as the nucleus accumbens in turn projects directly or indirectly (via the ventral thalamus) to the anterior and central dorsal thalamus, which – as mentioned before – project to the pallium and striatum, respectively [18]. Thus, as in mammals, pathways equivalent to a dorsal and a ventral “executive loop” may exist in amphibians.

**Dorsal pallium.** The dorsal pallium differs from the medial pallium in the absence of contralateral connections and substantially fewer extratelencephalic targets; septum, nucleus accumbens and the eminentia thalami

are the only extra-pallial and extra-telencephalic targets. It is strongly interconnected with the medial and lateral pallia, but not with the ventral pallium and thus appears to represent an integrative-associative limbic pallium [16]. Thalamic afferents arise from the anterior nuclei and reach the dorsal pallium via the dorsal association tract. With respect to its connectivity, the dorsal pallium is difficult to compare with cortices of amniote tetrapods. According to the “outgroup hypothesis” and in correspondence with gene expression data (for discussion see [1,2]), the dorsal pallium of amphibians appears to be homologous with the dorsal cortex/Wulst of sauropsids and the mammalian neocortex.

*Lateral and ventral pallium.* The lateral-ventral pallium of amphibians is marked by the lateral olfactory tract running in a superficial position and giving off collaterals along its course. Its most ventral portion, the SPTA, contains the accessory olfactory tract, which in anurans runs inside the periventricular cellular layer and in salamanders occupies a superficial position. Traditionally, the lateral pallium is divided into a dorsal and a lateral portion [cf. [19] separated by the rhinal sulcus and the lateral pallial cellular prominence. However, recent data on developmental regulatory genes corroborate the view that these parts have to be considered separate types of pallium called lateral and ventral pallium (cf. [2,20–22]), the former of which is considered a fore-runner of the olfactory cortex in mammals and the latter a fore-runner of the mammalian claustror-amygdaloid complex including cortical, basal and lateral amygdala nuclei [23]. The ventral pallium of amphibians terminates at the level of the lamina terminalis and the pallial commissures, where it neighbors the cortical olfactory amygdala [18], while the lateral pallium extends beyond the commissures to the caudal pole of the hemispheres. There is only weak thalamic input to the lateral pallium via the medial forebrain bundle and dorsal association tract and only scattered thalamic afferents reach the cellular layer of the caudal SPTA via the lateral forebrain bundle (for review see [4,13,14]). The lateral and ventral pallia have distinctly different projections in the sense that the lateral, but not the ventral, pallium is closely connected to the postolfactory eminence, the dorsal and medial pallia and the septum, mostly in its medial part [7,9,18]. The anterior ventral pallium and to a lesser extent the lateral pallium are reciprocally connected with the olfactory bulb. Accordingly, this rostral region could be considered as olfactory pallium corresponding to the mammalian piriform cortex and the lateral cortex of sauropsids respectively [4,24,25]. At caudal levels, the lateral and ventral pallia differ from the dorsal regions by massive projections to the hypothalamus and form both the vomeronasal and olfactory (cortical) amygdala [18,26]. It is disputed whether the amphibian lateral and ventral pallium represents structures homologous

to the basolateral amygdala complex of mammals (for discussion see [26]). Based on connections and topology it is reasonable to consider the most posterior lateral pallium as a forerunner of the mammalian entorhinal cortex.

*Function of the amphibian pallium.* Little is known about the precise function of the amphibian pallium except for a few studies using brain lesion experiments and histological demonstration of glucose utilization (<sup>14</sup>C-2DG study), which suggest that the amphibian ventral medial pallium as well as the lateral pallium and lateral (vomeronasal) amygdala are involved in memory extinction [16,27,28]. Anatomical and electrophysiological investigations suggest that the dorsal and lateral pallium are involved in olfactory processing. The anterior medial pallium as well as the neighboring dorsal pallium receive sensory input from all modalities, which likens them to the mammalian hippocampal formation or limbic frontal cortex. Thus, the amphibian pallium comprises areas corresponding to the mammalian olfactory cortices and cortical amygdalar nuclei, to the hippocampus (at least Ammon’s horn and subiculum), entorhinal cortex and maybe even the limbic frontal cortex.

## References

1. Northcutt RG, Kaas JH (1995) The emergence and evolution of mammalian neocortex. *Trends Neurosci* 18:373–379
2. Puelles L (2001) Brain segmentation and forebrain development in amniotes. *Brain Res Bull* 55:695–710
3. Sanides F, Sanides D 1972 The “extraverted neurons” of the mammalian cerebral cortex. *Zeitschrift für Anatomie und Entwicklungsgeschichte* 136(3):272–293
4. Nieuwenhuys R, ten Donkelaar HJ, Nicholson C (1998) *The central nervous system of vertebrates*. Springer, Berlin
5. Dicke U, Roth G (2006) *Evolution of the nervous system in amphibians*. Wiley, New York
6. Roth G, Nishikawa C, Wake DB (1997) Genome size, secondary simplification, and the evolution of the salamander brain. *Brain Behav Evol* 50:50–59
7. Endepols H, Roden K, Walkowiak W (2005) Hodological characterization of the septum in anuran amphibians: II. Efferent connections. *J Comp Neurol* 483:437–457
8. Northcutt RG, Ronan M (1992) Afferent and efferent connections of the bullfrog medial pallium. *Brain Behav Evol* 40:1–16
9. Roden K, Endepols H, Walkowiak W (2005) Hodological characterization of the septum in anuran amphibians: I. Afferent connections. *J Comp Neurol* 483:415–436
10. González A, Lopez JM, Sánchez-Camacho C, Marín O (2002) Regional expression of the homeobox gene NKX2–1 defines pallidal and interneuronal populations in the basal ganglia of amphibians. *Neuroscience* 114:567–575
11. Kicliter E (1979) Some telencephalic connections in the frog, *Rana pipiens*. *J Comp Neurol* 185:75–86

12. Neary TJ (1984) Anterior thalamic nucleus projections to the dorsal pallium in ranid frogs. *Neurosci Lett* 51:213–218
13. Roth G, Dicke U, Grunwald W (2003) Morphology, axonal projection pattern and responses to optic nerve stimulation of thalamic neurons in the fire-bellied toad *Bombina orientalis*. *J Comp Neurol* 461:91–110
14. Roth G, Grunwald W (2000) Morphology, axonal projection pattern, and responses to optic nerve stimulation of thalamic neurons in the salamander *Plethodon jordani*. *J Comp Neurol* 428:543–557
15. Vesselkin NP, Agayan AC, Nomokonova LM (1971) A study of thalamotelencephalic afferent systems in frogs. *Brain Behav Evol* 4:295–306
16. Westhoff G, Roth G (2002) Morphology and projection pattern of medial and dorsal pallial neurons in the frog *Discoglossus pictus* and the salamander *Plethodon jordani*. *J Comp Neurol* 445:97–121
17. Sassoe Pognetto M, Pairault C, Clairambault P, Fasolo A (1991) The connections of the anterior pallium in *Pleurodeles waltl* and *Triturus carnifex*: an HRP study. *J für Hirnforschung* 32:397–407
18. Roth G, Mühlbrock-Lenter S, Grunwald W, Laberge F (2004) Morphology and axonal projection pattern of neurons in the telencephalon of the fire-bellied toad *Bombina orientalis*: an anterograde, retrograde and intracellular biocytin labeling study. *J Comp Neurol* 478:35–61
19. Kicliter E, Ebbesson SOE (1976) Organization of the “nonolfactory” telencephalon. In: Llinás R, Precht W (eds) *Frog neurobiology*. Springer, Berlin, pp 946–972
20. Brox A, Puelles L, Ferreiro B, Medina L (2004) Expression of the genes *Emx1*, *Tbr1*, and *Eomes* (*Tbr2*) in the telencephalon of *Xenopus laevis* confirms the existence of a ventral pallial division in all tetrapods. *J Comp Neurol* 474:562–577
21. Fernandez AS, Pieau C, Reperant J, Boncinelli E, Wassef M (1998) Expression of the *Emx-1* and *Dlx-1* homeobox genes define three molecularly distinct domains in the telencephalon of mouse, chick, turtle and frog embryos: implications for the evolution of telencephalic subdivisions in amniotes. *Development* 125:2099–2111
22. Puelles L, Kuwana E, Puelles E, Bulfone A, Shimamura K, Keleher J, Smiga S, Rubenstein JLR (2000) Pallial and subpallial derivatives in the embryonic chick and mouse telencephalon, traced by the expression of the genes *Dlx-2*, *Emx-1*, *Nkx-2.1*, *Pax-6*, and *Tbr-1*. *J Comp Neurol* 424:409–438
23. Medina L, Legaz I, Gonzalez G, De Castro F, Rubenstein JL, Puelles L (2004) Expression of *Dbx1*, *Neurogenin 2*, *Semaphorin 5A*, *Cadherin 8*, and *Emx1* distinguish ventral and lateral pallial histogenetic divisions in the developing mouse claustroramygdaloid complex. *J Comp Neurol* 474:504–523
24. Northcutt RG, Royce GJ (1975) Olfactory bulb projections in the bullfrog *Rana catesbeiana*. *J Morphol* 145:251–267
25. Ragimova NG, Kratskin IL (1984) Telencephalic sources of the afferents of the main olfactory bulb in the frog *Rana temporaria*. *Žurnal evoljucionnoj biochimii i fiziologii* 20:380–385
26. Laberge F, Mühlbrock-Lenter S, Grunwald W, Roth G (2006) Evolution of the amygdala: New insights from studies in amphibians. *Brain Behav Evol* 67:177–187
27. Finkenstädt T, Ewert JP (1988) Effects of visual associative conditioning on behavior and cerebral metabolic activity in toads. *Naturwissenschaften* 75:95–97
28. Papini MR, Muzio RN, Segura ET (1995) Instrumental learning in toads (*Bufo arenarum*): reinforcer magnitude and the medial pallium. *Brain Behav Evol* 46:61–71
29. Wenz E, Himstedt W (1990) Telencephalic structures are involved in learning and memory in the newt *Triturus alpestris*. *Naturwissenschaften* 77:239–240

## Evolution of the Pallium in Birds and Reptiles

ERICH D. JARVIS

Department of Neurobiology, Duke University Medical Center, Durham, NC, USA

### Definition

The telencephalon of amniotes (reptiles, birds, and mammals) consists of two major subdivisions: the pallium and the subpallium. The subpallium, also called the basal ganglia, is further divided into two main subdivisions: the striatum and pallidum (Fig. 1). The striatum and pallidum are also thought to contribute to the septum and subpallial amygdala (central and medial nuclei). The subpallial components are relatively conserved in its organization among amniotes (Fig. 1). The pallium, however, which is the topic of this essay, is relatively diverse in its organization. The bird pallium consists of four major subdivisions – hyperpallium (hypertrophied pallium), mesopallium (middle pallium), nidopallium (nest pallium), and arcopallium (arched pallium)- as well as olfactory, hippocampal, and pallial amygdala regions (Fig. 1b) as defined in the new avian brain nomenclature [1,2]. The organization of the reptile pallium is not yet as well defined, but it consists of what has been called the dorsal cortex and the dorsal ventricular ridge (DVR), as well as olfactory, hippocampal, and pallial amygdala regions (Fig. 1a). Various hypotheses have been proposed for similarities and differences in the organization of the reptile, bird, and mammalian pallia, which contribute towards an understanding of the evolution of the pallium [1,2].

### Characteristics

Reptiles and birds belong to the vertebrate class called sauropsids (Fig. 2). Although birds are now sometimes classified as reptiles, birds and reptiles are referred to here as separate groups belonging to sauropsids, one group with feathers and the other with scales, respectively. The sauropsids belong to the larger group



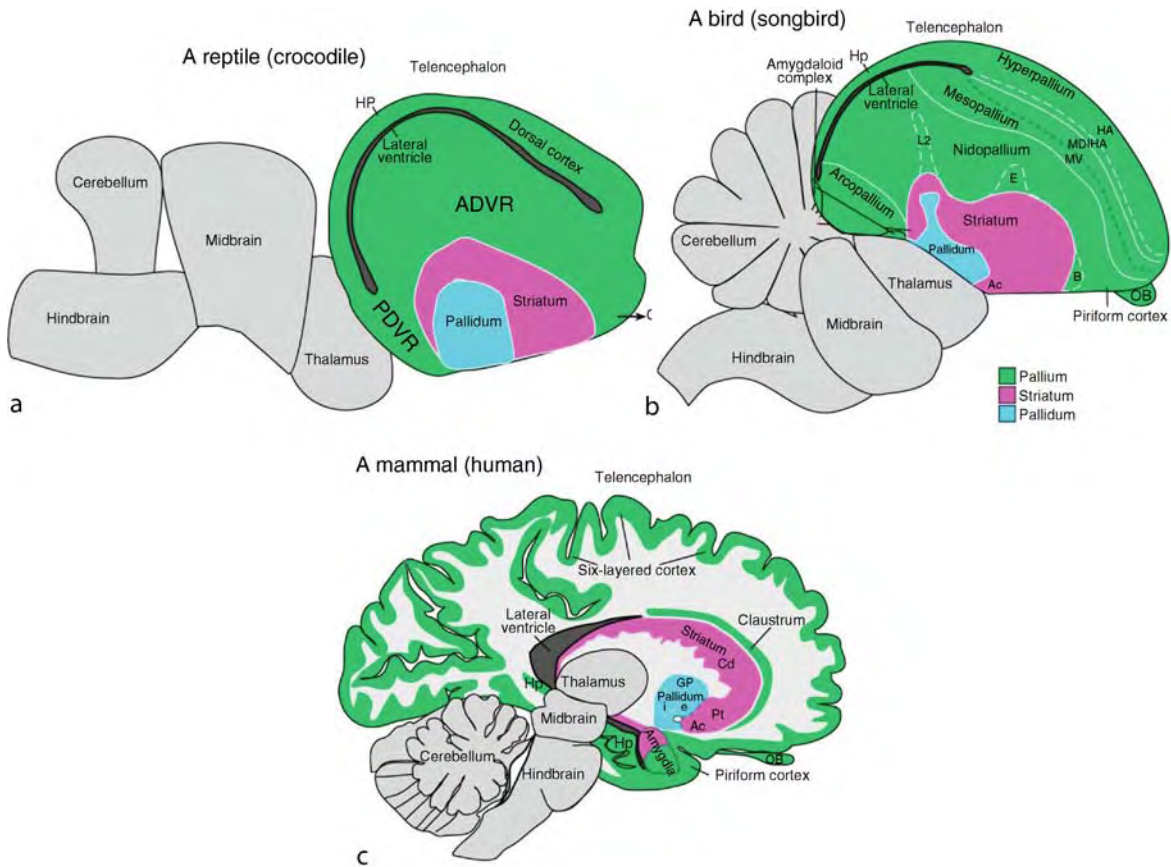

**Evolution of the Pallium in Birds and Reptiles. Figure 1** Comparable organization of adult telencephalon of reptiles (a), birds (b), and mammals (c). Shown are sagittal views. Color-coding indicates pallial, striatal, and pallidal telencephalic domains. Pallial organization is well known for birds and mammals but not yet for most reptiles. The schematics represent the modern and recently revised view of vertebrate brain organization and evolution [1,2]. Abbreviations: *Ac* accumbens; *B* basorostralis; *Cd* caudate; *E* entopallium; *GP* globus pallidus, internal (i) and external (e) segments; *IHA* interstitial hyperpallium apicale; *HA* hyperpallium apicale; *Hp* hippocampus; *L2* field L2; *MD* dorsal mesopallium; *MV* ventral mesopallium; *OB* olfactory bulb; *Pt* putamen. For birds, some confusion exists in the literature as to whether the MD is hyperpallium densocellulare (HD) or is a separate structure.

called amniotes and share a stem amniote ancestor with mammals (Fig. 2). The pallia in developing embryos of reptiles, birds, and mammals are more similar than they are in their adult forms, consisting of a ventricular zone (VZ) and, in birds and mammals, a sub-ventricular zone (SVZ; Fig. 3), from which most pallial neurons emerge [3]. In the adult form, however, major differences are found in sauropsids relative to mammals. In sauropsids, the pallium is mostly nuclear in cellular organization, whereas in mammals it is mostly layered (Fig. 1) [1]. Among sauropsids, there are several types of nuclear organizations: type I found in turtles and some lizards, where neurons are relatively uniformly distributed within each brain subdivision, and type II found in other lizards, birds and crocodiles, where neurons are more concentrically organized relative to the lateral ventricle within brain subdivisions (Fig. 4) [4]. Despite these organizational differences,

neural connectivity and/or gene expression profiles indicate shared features in the type I and type II pallia of birds and reptiles and with the pallium of mammals. The shared features with mammals have led to investigators to propose differing hypotheses on the evolution of pallial subdivisions or neuron types from the stem amniote ancestor of birds and reptiles with mammals [1]. These features and hypotheses are discussed in this essay.

### Development

The embryonic pallium of reptiles (studied mostly in turtles), birds, and mammals consists of a neurogenic zone near the lateral ventricle, the VZ (Fig. 3). Stem cells in the VZ divide to give rise to daughter stem cells, neurons, and glia. The neurons and glia migrate away from the VZ to make up the pallial parenchyma. In addition, mammals have a transient SVZ, and birds

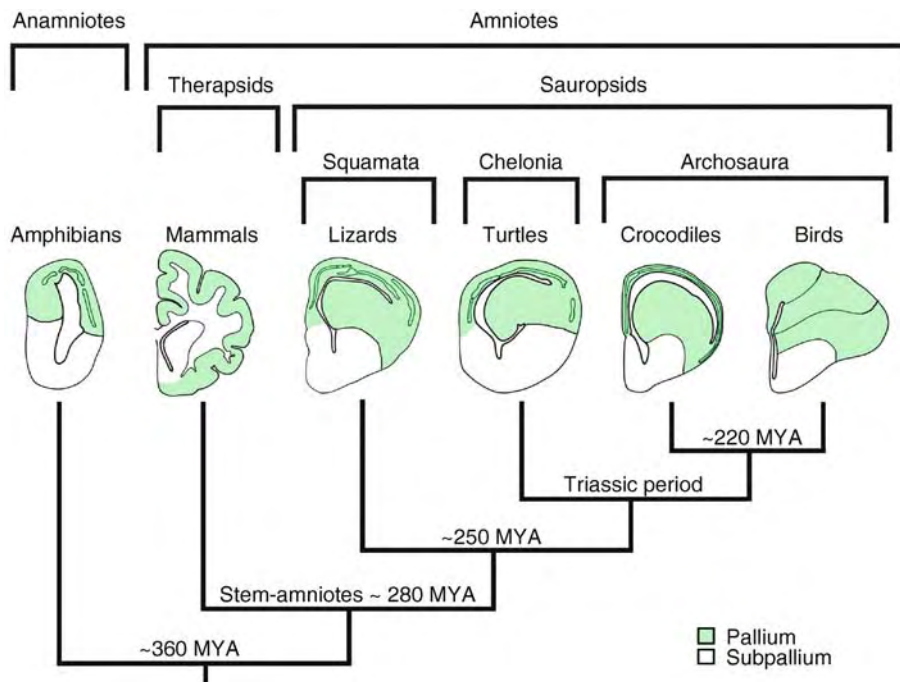

**Evolution of the Pallium in Birds and Reptiles. Figure 2** Simplified modern view of tetrapod vertebrate evolution and general pallial shape in examples of living forms. As indicated by the phylogenetic trees, ancestral tetrapods are thought to have given rise to amphibians and to stem amniotes. Stem amniotes then split into at least two groups: the synapsid line leading to therapsids, which, through a series of now-extinct intermediate forms, evolved into mammals, and the diapsid line to sauropsids, which gave rise to all modern reptiles and birds. Among sauropsids, birds and crocodiles comprise the archosaurs and, along with the tuatara (not shown) and turtles, constitute one major clade, while the squamates, snakes (not shown) and lizards constitute the other major clade. This tree represents a recently revised view of reptilian phylogeny [8,9]. MYA, million years ago. For the brain examples, frontal views of anterior right hemispheres are shown; medial is left, dorsal is up. Note that the pallium (green) for large mammals (as shown here) is folded and thin; that of sauropsids below the lateral ventricle (open space) is nuclear and thick. For the sauropsids, only well-defined pallial subdivisions are known for birds. The subpallium in this plane of section includes the striatum (right of ventricle) and septum (left of ventricle, which is also thought to consist of striatal and pallidal parts). Figure modified from [10], with revisions based upon [1,2,8].

have a long-lasting SVZ located  $\sim 100 \mu\text{m}$  away from the VZ that also gives rise to new neurons that contribute to the pallium. In mammals, the SVZ is present in pallial regions dorsal and ventral to the lateral ventricle and is transient, whereas in birds it is mainly ventral to the lateral ventricle and lasts throughout adulthood. In mammals, the thicker the SVZ, the larger the brain and cortical folding that develops, and this may also be the case for birds since their pallia tend to be relatively larger than many reptiles (Fig. 3) [3]. These findings suggest that either the SVZ evolved independently in birds and mammals or was lost in at least type I reptile (turtle) pallia. Neurons from the pallial VZ of developing birds and reptiles (and from the pallial SVZ of birds) are added to the pallium in an *outside-in* pattern as the pallium expands away from the lateral ventricle, with oldest neurons situated farthest away from the ventricle. In mammals, neurons are added instead in an *inside-out* pattern, with the oldest neurons

situated closest to the ventricle. These findings lead to the view that the similar connectivity and gene expression patterns found in adult avian and mammalian pallium may be the result of convergent evolution instead of features inherited from a common stem amniote ancestor [5].

Despite these differences in how the developing pallium is organized, developmentally regulated transcription factors have been used to demonstrate that the dorsal part of the telencephalon is homologous as pallium across vertebrates (Fig. 2). These transcription factors mostly have been studied in the brains of birds and mammals [6], but several also have been studied in reptiles [3,7]. The T-box transcription factor 2 (Tbr2) appears to be expressed in the pallial SVZ of both developing chicks and mice, whereas Tbr1 is expressed in more peripheral parts of the pallium lateral to the ventricle. In these peripheral parts, Tbr1 is lower in the later developing avian arcopallium and mammalian

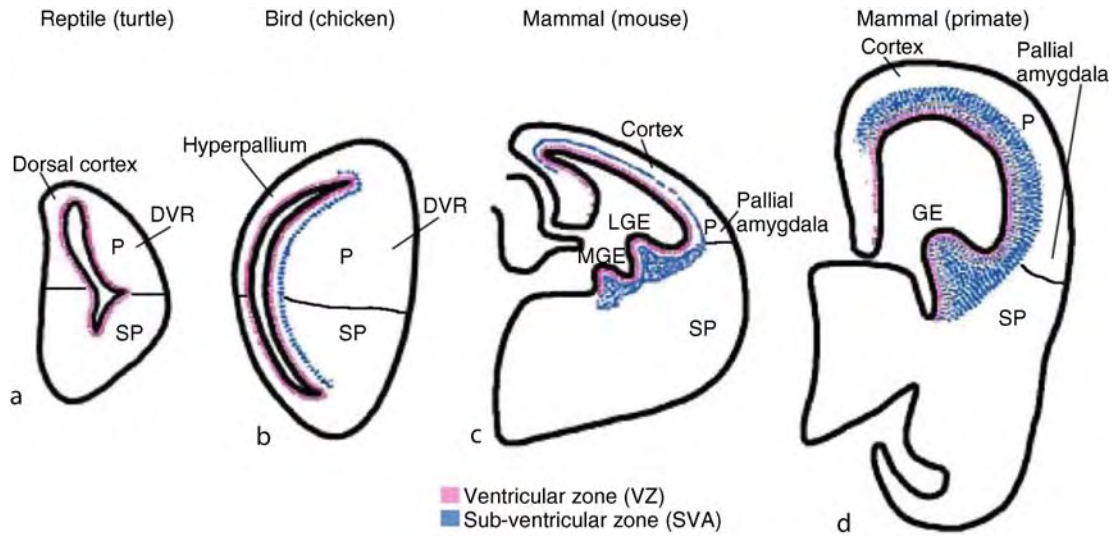

**Evolution of the Pallium in Birds and Reptiles. Figure 3** Comparable organization of embryonic telencephalon of reptiles (a), birds (b), and mammals (c and d) highlighting the ventricular zone (VZ) and the subventricular zone (SVZ). Shown are frontal views of the right hemisphere; medial is left, dorsal is up. A positive correlation exists between the presence and size of the SVZ and the size of the adjacent pallial regions. Labels outside of the telencephalons are the presumed adult regions to which these embryonic regions give rise. These and related findings were used to propose that the amygdala (and adjacent claustrum) of mammals is homologous to the DVR of reptiles and birds and that the six-layered cortex of mammals is homologous to the dorsal cortex of reptiles and hyperpallium of birds. The LGE and MGE in rodents give rise to the striatal and pallidal neuron types, respectively; in primates, the LGE and MGE are fused to form the GE. Abbreviations: DVR, dorsal ventricular ridge; GE, ganglionic eminence; LGE, lateral ganglionic eminence; MGE, medial ganglionic eminence; P, pallium; SP, subpallium. Figure modified from [3]; the medial part of the bird telencephalon is more vertically orientated than that shown, as in other species.

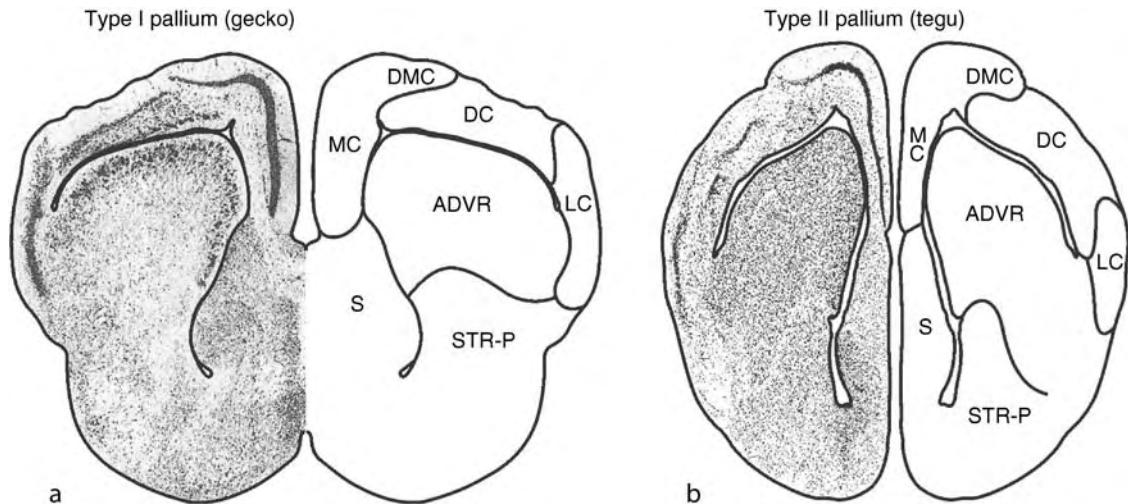

**Evolution of the Pallium in Birds and Reptiles. Figure 4** Examples of type I and type II reptile pallia. Shown are frontal sections with mirror-image drawings through the telencephalon of a type I lizard (a, the gecko) and a type II lizard (b, the black tegu). Note the differences in the pallium, the ADVR, of each. Type I species have a high density of cells clustered near the ventricle surface. Abbreviations: ADVR, anterior dorsal ventricular ridge; DC, dorsal cortex; DMC, dorsal medial cortex; LC, lateral cortex; MC, medial cortex; S, septum; STR-P, Striatal-pallidal region. Figure from [9, figs.19–21] and used with permission.

pallial amygdala. The empty spiracles 1 (Emx1) homeobox transcription factor is expressed in dorsal pallial regions during development in chick, turtles, and mice, but appears to be absent in the later stages of embryonic avian nidopallium, mammalian claustrum, and parts of reptile pallium. The paired box 6 (Pax6) transcription factor is expressed along the entire developing pallial VZ in birds, reptiles, and mammals, but it is also differentially expressed in other forebrain areas among these groups. These findings have led some investigators to conclude that the avian arcopallium or parts of the avian arcopallium and a similar posterior pallial region in reptiles is homologous to the mammalian pallial amygdala, and that the avian nidopallium and parts of the mesopallium are homologous to mammalian claustrum, if not to other parts of the pallial amygdala [6,7]. I call this the nuclear-to-claustrum/amygdala hypothesis [1], which is described in further detail at the end of this essay.

### Adult Organization

The organization of the adult avian pallium has been well studied and that of reptiles somewhat studied. Based upon Nissl staining patterns of embryonic and adult brains, Ulinksi and others defined a general organization of the bird and reptile pallia [4]. This includes a dorsal part, called the dorsal cortex in reptiles and the Wulst or hyperpallium in birds, and a lateroventral part called the dorsal ventricular ridge (DVR) that grows into the lateral ventricle (Fig. 1a and 1b). In birds the ventricular space between the DVR and hyperpallium is fused during development; in reptiles, the DVR and dorsal cortex remain separate into adulthood (Fig. 1a and b). Ulinksi further subdivided the DVR into anterior (ADVR) and posterior (PDVR) parts (Fig. 1a). He then defined two types of ADVR: type I, which consists of concentrically organized neurons with a higher density nearer the lateral ventricle, as found in turtles, the tuatara (the rhynchocephalian *Sphenodon*), and some lizards (such as the gecko; Fig. 4a); and type II, which consists of more uniformly distributed neurons, as found in birds, crocodiles, snakes, and other lizards (such as black tegu; Fig. 4b). As a result, the type II pallium is thought to have been derived multiple times independently (see ►Evolution, of the Brain: in Reptiles).

Which pallial subdivisions constitute the ADVR, PDVR, and dorsal cortex in birds is not clear, although it is often reported as clearly defined. For reptiles, detailed subdivision definitions have not yet been clearly delineated for any species, due in part to more diffuse Nissl staining of boundaries relative to birds [6]. Thus we do not yet know which pallial subdivisions in birds truly constitute presumably homologous subdivisions in reptiles. Approximate comparisons, however, have been given. One view holds that the homologue of the reptilian dorsal cortex is the highly differentiated

avian hyperpallium (including the hyperpallium apicale [HA], intercalated hyperpallium apicale [IHA], and hyperpallium densocellulare [HD]), that the homologue of the reptilian ADVR is the avian mesopallium and nidopallium, and that the homologue of the reptilian PDVR is the avian arcopallium [1,4]. However, this view may be too simplistic [4]. Comparative gene expression studies indicate that crocodiles like birds have a mesopallium [11], but that in both the mesopallium may consist of dorsal and ventral parts above and below the ventricle, as described further below. Differences certainly exist between birds and some reptiles. For example, snakes and lizards have a relatively unique feature in the medial part of their PDVR called the nucleus sphericus, which is involved in accessory olfactory bulb function and is not found in avians, crocodylians, or turtles [4,9]; nucleus sphericus is thought to be the homologue of portions of mammalian pallial amygdala nuclei (basal lateral amygdala and lateral amygdala) that receives input from the accessory olfactory bulb. Additional studies are needed to determine further similarities and differences in pallial organization between birds and reptiles, especially with the advent of the new avian brain nomenclature [1,2].

### Connectivity: Sensory and Motor Pathways

Comparative analyses of sensory pathways in birds and various reptile species indicate that all have sensory pathways that reach the pallium [4,9]. These consist of at least two visual pathways, two somatosensory pathways, and one or possibly two auditory pathways. Two different types of sensory pathways have been defined as either collothamalic (sensory input serially connecting to midbrain to thalamus to pallium) or lemnothamalic (sensory input skipping midbrain serially connecting thalamus to pallium).

The auditory pathway is collothamalic, where in birds, crocodiles, turtles, and lizards, a midbrain auditory nucleus projects to the thalamic auditory nucleus, which in turn projects to a defined cell population in the caudomedial pallium (Fig. 5a and b). The exact location of this cell population differs across species of mammals, but it also differs across species of birds [12], where the subsequent connectivity has been well studied [13]. This pallial, thalamo-recipient cell population in birds is called field L2, which then projects to surrounding caudomedial nidopallium (NCM), which in turn projects to the caudomedial mesopallium (CM, in the ventral mesopallium). The surrounding nidopallium also has a descending auditory pathway to the arcopallium and thence to the surrounding shell regions of the thalamic and midbrain auditory nuclei. This descending auditory system is similar in connectivity to a descending auditory pathway found in mammals. The collothamalic visual pathway has a similar organization as the auditory pathway, as found in birds, crocodiles, turtles, and lizard,

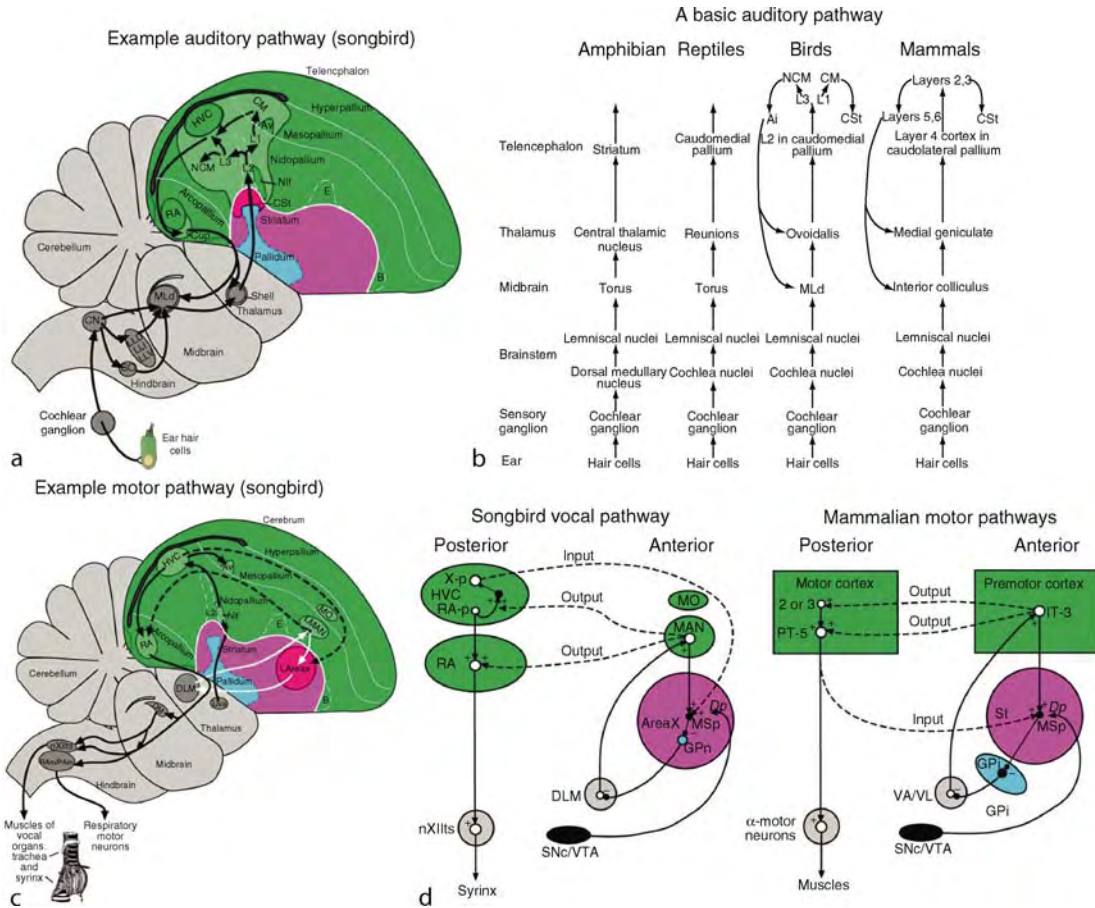

**Evolution of the Pallium in Birds and Reptiles. Figure 5** Example sensory (auditory) and motor (vocal) pathways in songbirds, in comparison with other vertebrates. (a) Auditory pathway in the songbird showing ascending and descending input. (b) Similar auditory pathways, but sometimes with different nomenclature used for individual nuclei, can be found for all amniotes examined. Only a sub-pathway through the cochlea and lateral lemniscal nuclei are shown. Once in the telencephalon, parallels can be found in cell type connectivity, although the pallial organizations are different and projections in amphibians are mostly to the striatum. (c) Vocal pathway of songbirds consisting of the vocal motor pathway (*black arrows*), the vocal pallial-basal-ganglia-thalamic loop (*white arrows*), and the connections between the two (*dashed arrows*). (d and e) Comparisons of cell types and connectivity of the vocal pathway in songbirds and forebrain motor pathways in mammals. Also shown is dopaminergic input from the SNc/VTA. Abbreviations: Av avalanche; B basorostralis; CM caudal mesopallium; CN cochlear nucleus; CSt caudal striatum; DLM dorsal lateral nucleus of the medial thalamus; DM dorsal medial nucleus; E entopallium; GPi globus pallidus, internal segment; HVC (a letter-based name); L1, L2, L3 fields L1, L2 and L3; LAreaX lateral AreaX of the striatum; LLD lateral lemniscus, dorsal nucleus; LLI lateral lemniscus, intermediate nucleus; LLV lateral lemniscus, ventral nucleus; LMAN lateral magnocellular nucleus of the anterior nidopallium; MO oval nucleus of the mesopallium; MLd dorsal lateral nucleus of the mesencephalon; NCM caudal medial nidopallium; Nif interfacial nucleus of the nidopallium; nXIIIts Nucleus XII, tracheosyringeal part; Ov ovoidalis; PAm para-ambiguus; RA robust nucleus of the arcopallium; RAM retroambiguus; SO superior olive; Uva nucleus uvaeformis. For panels (d) and (e) – + excitatory neurons; – inhibitory neurons; MSp medium spiny neuron; GPn globus pallidus-like neuron in songbird AreaX; X-p X-projecting neuron of HVC; RA-p RA-projecting neuron of HVC; PT-5 pyramidal tract neuron of motor cortex layer 5; IT-3 intratelencephalic projecting neuron of layer 3. (a) and (c) modified from [1]; (b) and (d) modified from [12].

with the projection field of all suaropsids tested located more anteriorly within the nidopallium adjacent or near to the striatum; the specific pallial, thalamo-recipient target is called the entopallium in birds (Fig. 6a). A

pseudo-collothalamic somatosensory pathway exists in birds, from the trigeminal sensory nucleus, innervated by the upper neck and face. The ascending trigeminal somatosensory pathway in birds does not involve a



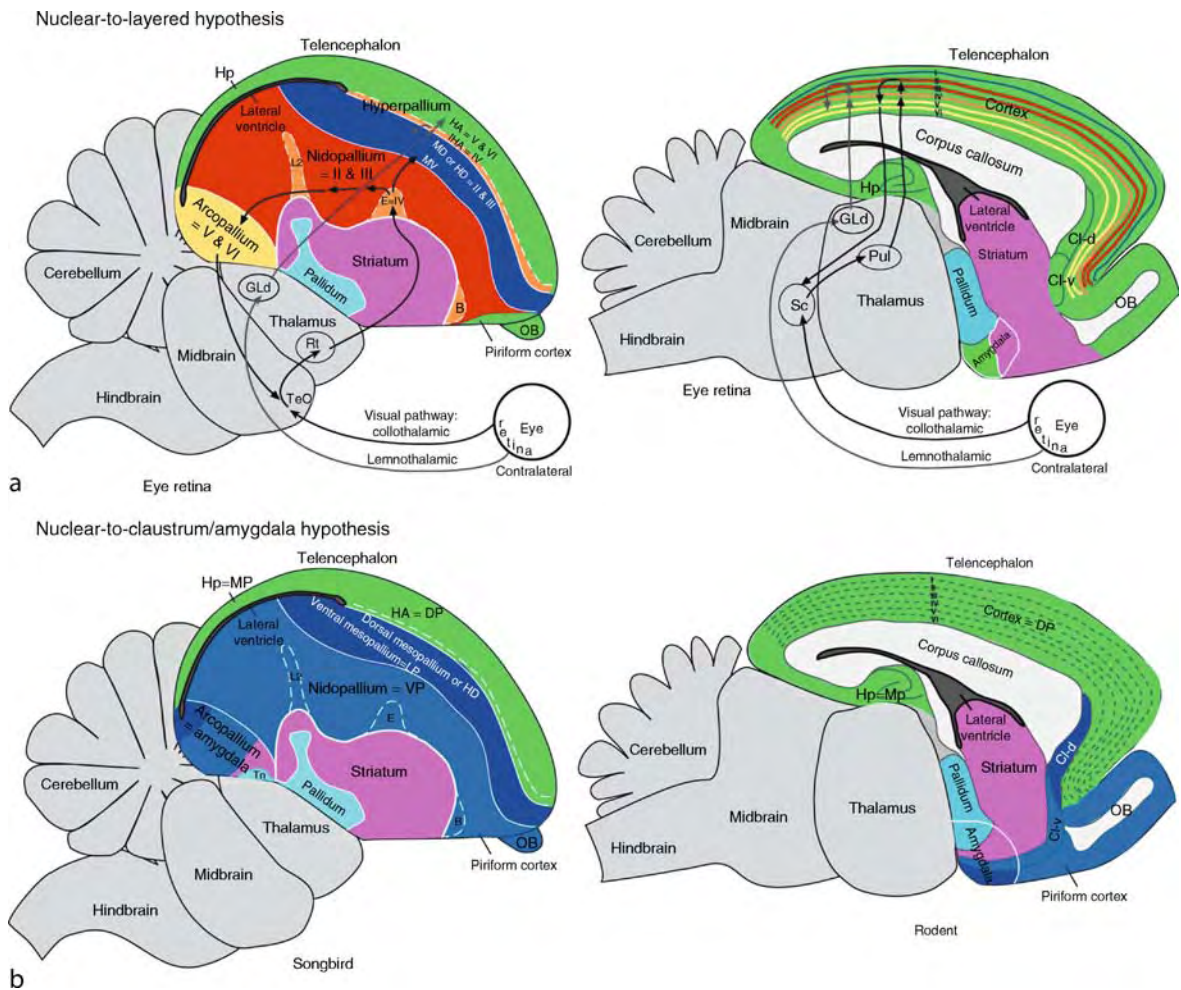

**Evolution of the Pallium in Birds and Reptiles. Figure 6** One-to-one homology hypotheses between avian and mammalian brains in the context of the new avian brain nomenclature. (a) An example of a nuclear-to-layered hypothesis. Connectivity of collothalamic and lemnothalamic visual pathways in avian (*left*) and mammalian (*right*) brains are shown. The hypothesis illustrated is a combination of Karten [18] and Medina and Reiner [5]. (b) An example of a nuclear-to-claustrum/amygdala nuclei hypothesis. The hypothesis illustrated is that of Puelles et al. [6]. In both hypotheses, color-coding indicates proposed homologies between birds and mammals, but the relationship of the newly named mesopallium needs further study and clarification. Abbreviations: I–VI cortical layers I–VI; B basorostralis; Cl-d claustrum, dorsal part; Cl-v claustrum, ventral part; DP dorsal pallium; E entopallium; GLd dorsal lateral geniculate nucleus; HA hyperpallium apicale; HD hyperpallium densocellulare; Hp hippocampus; IHA interstitial hyperpallium apicale; L2 field L2; LP lateral pallium; MD dorsal mesopallium; MP medial pallium; MV ventral mesopallium; OB olfactory bulb; Pul pulvinar nucleus; Rt nucleus rotundus; Sc superior colliculus; TeO optic tectum; Tn nucleus taenia; VP ventral pallium. Figure updated from Jarvis et al. [1].

connection through the midbrain or dorsal thalamus. But like collothalamic pathways, its pallial target, basorostralis, is within the nidopallium (Fig. 5a). The connectivity from basorostralis is similar thereafter to the collothalamic auditory and visual pathways. In contrast, in mammals, the trigeminal somatosensory pathway for the face and neck regions is clearly lemnothalamic; its connections in reptiles are unknown.

The lemnothalamic visual pathway projects directly from a thalamic nucleus to the posterior part of the

IHA lamina within the Wulst in birds (Fig. 6a) and to the outer layer of the dorsal cortex as well to an adjacent lateral region called the pallial thickening in turtles. After reaching the dorsal telencephalon, there are significant differences in intra-pallial connectivity between birds and turtles, suggesting that they evolved divergent pallial connectivity for the lemnothalamic visual pathway [5]. A lemnothalamic somatosensory pathway projects from the body receptors to the dorsal column nuclei to the somatosensory thalamus to the anterior IHA within

the Wulst in birds, and to part of the dorsal cortex in turtles and lizards. Very little is known for intra-pallial sensory pathway connectivity in reptiles, and thus further comparisons with birds will have to await further studies. Ulinksi [4] proposed, however, that type II ADVRs in reptiles (like in birds) have more discrete sensory projections into the pallium than type I ADVRs, which have more diffuse projections that radiate out from a central recipient zone. Thus, there could be several types of sensory pathway organization in the reptile pallium.

As for the motor pathways of the pallium, very little is known for birds and reptiles. A pyramidal tract-like pathway from the anterior HA has been identified in birds, but it is suggested to possibly be a modulatory feedback projection to somatosensory nuclei of the spinal cord [14]. The best known sauropsid motor pathway is the songbird vocal pathway. This pathway consists of two sub-pathways: (i) a posterior vocal motor pathway that connects a series of nuclei in the ventral mesopallium, nidopallium, and arcopallium, which then projects to the vocal motor neurons of the medulla that control the syrinx; and (ii) an anterior vocal pathway that forms a pallial-basal-ganglia thalamic loop through the anterior nidopallium (and possibly ventral mesopallium) to the anterior striatum to anterior dorsal thalamus and back to the anterior nidopallium (Fig. 6c) [1]. This pathway is used for vocal learning of songs. A similar vocal pathway is found in the forebrain of parrots, and similar connectivity is found adjacent to the vocal nuclei in songbirds [15]. These and many other findings have led to the theory that the vocal learning systems may be motor pathways that evolved out of pre-existing non-vocal motor pathway in birds [12,16] (Feenders et al. unpublished observations). The songbird arcopallium adjacent to the arcopallial vocal nucleus projects to medullary reticular premotor neurons that in other avian orders have been shown to control wing and leg movements [17].

The above findings suggest that birds inherited their existing auditory, visual, and somatosensory pathways from their reptilian ancestor. A similar, but not identical auditory pathway exist in amphibians (Fig. 6b) [9]; a major difference is that the thalamic nuclei project heavily to the striatum, and only weakly to the medial pallium. This medial pallium region is thought to be the homologue of the mammalian hippocampus, but it could also include homologues of sensory areas (►Evolution of the Auditory System in Anamniotes). This suggests that sauropsids may have inherited a rudimentary form of their forebrain auditory pathway from their common stem amniote ancestor. As for the visual pathways, differences between birds and reptiles in the pallial connectivity of the lemnothalamic visual pathway suggest that they diverged after the split of birds from their common reptilian ancestor. As for the motor pathways, the posterior vocal pathways of

avian vocal learners have been noted to be similar to descending motor pathways of mammals, and the anterior vocal pathway is similar to motor cortico-basal-ganglia-thalamic loops of mammals (Fig. 6d) [12], indicating possible inheritance from the stem amniote ancestor. It has been recently said that reptiles lack such loops (►Evolution, of the Brain: At the Reptile-Bird Transition), but Ulinksi discovered their existence in turtles and lizards [4] before they were popularly studied in mammals. Therefore, if Ulinksi is correct, the presence of such forebrain loops in reptiles, birds, and mammals indicate that they may have been inherited from their common stem amniote ancestor.

Harvey Karten noted that the sensory pathways to the pallium in birds share similarities with sensory pathways in mammals, and based upon these findings he and others proposed a hypothesis on the cellular homologies in pallial neuron types of birds with mammals (Fig. 5a) [5,18]. This hypothesis states that the primary thalamic recipient zones in bird pallium is homologous to layer IV neurons of primary auditory, visual, and somatosensory cortices; the second order neurons in the surrounding nidopallium are homologous to layers II and III; the third order neurons of the arcopallium that also send descending projections out of the telencephalon is homologous to layer V. I call this the nuclear-to-layered hypothesis [1], which is described in further detail at the end of this essay.

### Molecular Profiles

Not many studies have compared molecular gene expression profiles of adult pallia in their fully differentiated forms between birds and reptiles. We compared the expression of the fork-head transcription factors FoxP1 and FoxP2 in adult birds and crocodiles [11]. FoxP2 is implicated in spoken language function in humans and in vocal learning in birds, and it is highly expressed in the striatum of both birds and mammals. We found similarly enriched FoxP2 expression in the striatum of crocodiles. FoxP1 is also expressed in the striatum in birds and mammals, but is further enriched in the avian mesopallium and mammalian cortical layer VI neurons. In crocodiles, FoxP1 expression shows very similar profiles, including enrichment in a pallial region similar to the avian ventral and dorsal mesopallium, with the ventral part below the lateral ventricle and the dorsal part above it. These findings suggest that mesopallium was inherited in birds from a common reptilian archosaur ancestor with at least crocodiles and that pallial organization of archosaurs may be very similar, although difficult to detect in the crocodile brain with Nissl staining. They also support an idea that the dorsal cortex and the ADVR may be continuous structures 6, where the lateral ventricle is not a functional boundary between brain subdivisions. Further gene expression studies are necessary to test these ideas and to determine the

similarities and differences in the organization of avian, crocodylian, and other reptilian pallia.

### Function

The connectivity findings are supported by electrophysiology and lesion studies in birds and reptiles, and activity-dependent gene expression studies in birds. They show that there are auditory processing neurons in the caudal pallium, visual processing neurons in anterior and dorsal pallium regions of the two visual pathways, and somatosensory processing neurons in anterior and dorsal pallium regions of the two somatosensory pathways [4,9,12] (Feenders et al. unpublished observations). It is not yet clear whether these pathways in birds and reptiles process their sensory modality-specific information in the same manner. As for possible motor pathways, stimulation of the arcopallium in birds can induce crouching or running movements [4]. Stimulation of ADVR regions in reptiles leads to modulation of movements. However, lesions of ADVR in reptiles and anterior nidopallium in birds indicate that these regions are not essential for the generation of movement. These types of studies parallel the more detailed findings on the songbird vocal pathway, where lesions of the posterior vocal pathway nuclei show that they are necessary for the production of learned song, whereas the lesions of the anterior vocal pathway nuclei show that they are not necessary for song production but are necessary for song learning and the generation of variability in song production [12]. Further experiments are necessary to define non-vocal motor pathways of the pallium in birds and reptiles.

### Evolution Hypotheses on Homologies with Mammals

Based upon comparative neurobiology studies, modern hypotheses on avian (as well as reptilian) brain homologies with mammals fall into two categories that I named nuclear-to-layered and nuclear-to-claustrum/amygdala hypotheses (Fig. 5) [1]. These hypotheses are sometimes presented as final in the literature, but each has its strengths and weaknesses, and thus each needs further testing. Both hypotheses agree on pallial regions that are widely recognized to be homologous among birds, reptiles, mammals and other vertebrates: the hippocampus, olfactory cortex, and olfactory bulb – brain regions covered in other essays (see ► [Evolution, of the Hippocampus](#); ► [Martínez-Marcos and Halpern, Evolution, of Olfactory and Vomeronasal Systems](#)). They disagree, however, on homologies of other pallial regions. To appreciate these disagreements, it is useful to consider general organization principles that appear to be unique to each vertebrate group. The avian hyperpallium possesses a more semi-layered organization not found in reptile dorsal cortex to date and thus might have evolved complexity more recently than the mammalian six-layered cortex, since birds evolved well

after mammals [by ~50–100 million years (Fig. 2)]. The DVR, with its nuclear organization, is found only in birds and reptiles and thus may have evolved after sauropsids split from stem amniotes. The six-layered cortex is a pallial organization found only in mammals (monotremes, marsupials, and placentals), and thus it was presumably inherited from their common therapsid ancestor over 200 million years ago (Fig. 2). As all non-mammalian therapsids are now extinct, it is difficult to trace from stem amniotes to mammals the evolutionary history of mammalian pallial organization – layered, nuclear, or otherwise. Thus, the reptilian nuclear pallial organization cannot be assumed to represent the ancestral condition for mammals, as it is for birds. The evidence suggests that in contrast to conserved striatal and pallial domains, there are fewer constraints on how the pallium can be organized [1].

### Nuclear-to-Layered Hypotheses

First proposed by Karten [18], this hypothesis states that the common ancestor of birds, reptiles, and mammals possessed a nuclear pallium that was transformed into a layered pallium early in the mammalian lineage, maintaining connectivity of the ancestral nuclear network. In this regard, he argued that the avian pallium is divided into three sets of serially connected types of neurons – thalamo-recipient neurons (Field L2, entopallium, and basorostralis), pallio-pallial neurons (other parts of nidopallium) and extra-telencephalic projection neurons (arcopallium), with cell types and interconnectivity similar to those of mammalian cortical layers IV, II-III, and V-VI, respectively. Similar arguments were made by others for the avian hyperpallium divisions (Fig. 6a) [5]. Supporting this hypothesis, gene expression studies on adult brains have shown that avian thalamo-recipient nuclear fields (L2, entopallium, basorostralis, and IHA) and the mammalian thalamo-recipient layer IV of cortex selectively express some of the same genes. Avian extra-telencephalic projection neurons (in the arcopallium, but not in the hyperpallium) and mammalian extra-telencephalic projection neurons (layer V neurons of cortex) both selectively express some of the same genes [1]. Thus, although the avian pallium is not organized cytoarchitecturally into layers, its nuclear subdivisions bear marked similarities in connectivity and some molecular profiles to different layers of the mammalian cortex. A weakness of this hypothesis is that developmental neural fate mapping studies have not revealed that the specific neurons precursors that give rise to the different layers of the mammalian six-layered cortex also give rise to the different pallial subdivisions of the avian telencephalon [6]; such studies have also not been able to falsify the hypothesis. Another weakness is that since the avian hyperpallium organization appears to be different than the turtle, it is possible that the hyperpallium



organization is novel instead of inherited from a common ancestor with mammals. Falsifying the nuclear-to-layered hypothesis may require the use of novel gene manipulation and fate mapping tools to determine if precursor nuclear-specific neurons or genes of sauropsids and layer-specific neurons or genes of mammals will be incorporated into each other's palliums in the expected manner according to the hypothesis.

### **Nuclear-to-Clastrum/Amygdala Hypotheses**

First proposed by Bruce and Neary [19], these hypotheses propose that the DVR represents an elaboration of parts of the mammalian pallial amygdala and claustrum, and that the connectivity that the avian DVR shares with the six-layered cortex evolved independently. This view is based on findings that both the avian DVR and mammalian claustrum-amygdala are nuclear in organization, that both the avian DVR and part of the mammalian pallial amygdala have similar connections, and that both have conserved developmental expression patterns of regulatory genes that play key roles in brain regionalization and morphogenesis. Based on these gene expression patterns, Puelles et al. [6] and Smith-Fernandez et al. [7] proposed that the avian mesopallium and the mammalian dorsal claustrum and basolateral amygdala develop from the lateral pallium and are homologous structures, that the avian nidopallium and the mammalian ventral claustrum and lateral anterior amygdala arose from the ventral pallium and are homologous structures, and that the avian arcopallium and mammalian amygdala consists of pallial and subpallial parts derived from striatal and pallidal cell groups and are homologous to the mammalian amygdala (Fig. 6b). Weaknesses of these hypotheses are that the details vary greatly from author to author, from including only a part of the arcopallium to the entire DVR as the homologue of the mammalian amygdala/claustrum, that there is as yet no clear definition of the amygdala in birds or reptiles, that definitions of the amygdala in mammals varies (e.g. Fig. 6a vs. Fig. 6b.), and that some developmental fate mapping studies have been ambiguous in the context of the new avian brain nomenclature. For example, the expression of *Emx1* gene (*I note here*) is restricted to the newly defined embryonic mesopallium and arcopallium, but not hyperpallium and nidopallium, which would then lead to revisions of the proposed homologies between birds and mammals. Falsifying the nuclear-to-claustrum/amygdala hypothesis may also require the same novel tools and experiments as mentioned above for falsifying the nuclear-to-layered hypothesis.

It is possible that both hypotheses are partially correct. The mammalian amygdala and claustrum share many similarities with the six-layered cortex and as such has been proposed to be extensions of the

six-layered cortex [20]. If true, then the similarities of pallial regions shared with birds and possibly with reptiles would indicate that either the sauropsid pallium has both six-layered and amygdala/claustrum mammalian homologues that are extensions of each other within each brain subdivision or that the sauropsid and mammalian palliums use a pre-existing neural substrate present in their embryonic forms that then diverged into different pallial organizations in their adult forms but maintain basic principles. These hypotheses are testable.

### **References**

1. Jarvis ED, Güntürkün O, Bruce L, Csillag A, Karten H, Kuenzel W, Medina L, Paxinos G, Perkel DJ, Shimizu T, Striedter G, Wild JM, Ball GF, Dugas-Ford J, Durand SE, Hough GE, Husband S, Kubikova L, Lee DW, Mello CV, Powers A, Siang C, Smulders TV, Wada K, White SA, Yamamoto K, Yu J, Reiner A, Butler AB (2005) Avian brains and a new understanding of vertebrate brain evolution. *Nat Rev Neurosci* 6:151–159
2. Reiner A, Perkel DJ, Bruce LL, Butler AB, Csillag A, Kuenzel W, Medina L, Paxinos G, Shimizu T, Striedter G, Wild M, Ball GF, Durand S, Güntürkün O, Lee DW, Mello CV, Powers A, White SA, Hough G, Kubikova L, Smulders TV, Wada K, Dugas-Ford J, Husband S, Yamamoto K, Yu J, Siang C, Jarvis ED (2004) Revised nomenclature for avian telencephalon and some related brainstem nuclei. *J Comp Neurol* 473:377–414
3. Cheung AF, Pollen AA, Tavare A, DeProto J, Molnár Z (2007) Comparative aspects of cortical neurogenesis in vertebrates. *J Anat* 211:164–176
4. Ulinski PS (1983) Dorsal ventricular ridge: a treatise on forebrain organization in reptiles and birds, Wiley, New York
5. Medina L, Reiner A (2000) Do birds possess homologues of mammalian primary visual, somatosensory and motor cortices? *Trends Neurosci* 23:1–12
6. Puelles L, Kuwana E, Puelles E, Bulfone A, Shimamura K, Keleher J, Smiga S, Rubenstein J (2000) Pallial and subpallial derivatives in the embryonic chick and mouse telencephalon, traced by the expression of the genes *Dlx-2*, *Emx-1*, *Nkx-2.1*, *Pax-6*, and *Tbr-1*. *J Comp Neurol* 424:409–438
7. Smith-Fernandez AS, Pieau C, Repérant J, Boncinelli E, Wassef M (1998) Expression of the *Emx-1* and *Dlx-1* homeobox genes define three molecularly distinct domains in the telencephalon of mouse, chick, turtle and frog embryos: implications for the evolution of telencephalic subdivisions in amniotes. *Development* 125:2099–2111
8. Iwabe N, Hara Y, Kumazawa Y, Shibamoto K, Saito Y, Miyata T, Katoh K (2005) Sister group relationship of turtles to the bird-crocodylian clade revealed by nuclear DNA-coded proteins. *Mol Biol Evol* 22:810–813
9. Butler AB, Hodos W (2005) Comparative vertebrate neuroanatomy, 2nd edn. Wiley-Interscience, Hoboken, NJ, p 715
10. Aboitiz F, Morales D, Montiel J (2003) The evolutionary origin of the mammalian isocortex: towards an integrated

- developmental and functional approach. *Behav Brain Sci* 26:535–552
11. Haesler S, Wada K, Nshdejan A, Morrisey EE, Lints T, Jarvis ED, Scharff C (2004) FoxP2 expression in avian vocal learners and non-learners. *J Neurosci* 24:3164–3175
  12. Jarvis ED (2004) Learned birdsong and the neurobiology of human language. *Ann N Y Acad Sci* 1016:749–777
  13. Mello CV, Vates GE, Okuhata S, Nottebohm F (1998) Descending auditory pathways in the adult male zebra finch (*Taeniopygia guttata*). *J Comp Neurol* 395:137–160
  14. Wild JM, Williams MN (2000) Rostral wulst in passerine birds. I. Origin, course, and terminations of an avian pyramidal tract. *J Comp Neurol* 416:429–450
  15. Bottjer SW, Brady JD, Cribbs B (2000) Connections of a motor cortical region in zebra finches: relation to pathways for vocal learning. *J Comp Neurol* 420:244–260
  16. Farries MA (2004) The avian song system in comparative perspective. *Ann N Y Acad Sci* 1016:61–76
  17. Sholomenko GN, Funk GD, Steeves JD (1991) Avian locomotion activated by brainstem infusion of neurotransmitter agonists and antagonists. I. Acetylcholine excitatory amino acids and substance P. *Exp Brain Res* 85:659–673
  18. Karten HJ (1991) Homology and evolutionary origins of the “neocortex”. *Brain Behav Evol* 38:264–272
  19. Bruce LL, Neary TJ (1995) The limbic system of trepods: a comparative analysis of cortical and amygdalar populations. *Brain Behav Evol* 46:224–234
  20. Swanson LW (2000) Cerebral hemisphere regulation of motivated behavior. *Brain Res* 886:113–164

## Evolution of the Pallium in Fishes

GEMA HUESA<sup>1</sup>, RAMÓN ANADÓN<sup>2</sup>,  
MÓNICA FOLGUEIRA<sup>3</sup>, JULIÁN YÁÑEZ<sup>3</sup>

<sup>1</sup>Institute of Neurosciences, University Autónoma of Barcelona, Campus of Bellaterra, Bellaterra, Spain

<sup>2</sup>University of Santiago de Compostela, Campus Sur, Santiago de Compostela, Spain

<sup>3</sup>University of A Coruña, Campus A Zapateira, A Coruña, Spain

### Synonyms

Dorsal telencephalic area; Dorsal telencephalon

### Definition

The pallium is the dorsal part of the telencephalic lobes. In the telencephalon of vertebrates two main regions have been distinguished, the olfactory bulbs and the telencephalic lobes. The telencephalic lobes consist of a dorsal region or pallium and a ventral region or subpallium. Cytoarchitecture, histochemistry, hodology (connections) and/or gene expression are currently

used for setting the boundaries with the ventral part of the telencephalic lobe (subpallium) and between the various pallial regions.

The term “fishes” applies to living representatives of jawless vertebrates, the Agnathans (Petromyzontids or lampreys and Myxinoids or hagfish) and to various groups of jawed fishes (Gnathostomata) included in the large radiations of Chondrichthyes (cartilaginous fishes) and of Osteichthyes (bony fishes). Cartilaginous fishes include the ratfish (holocephali), and sharks, skates and rays (elasmobranchs). Bony fishes include the Actinopterygians, or ►ray-finned fishes (Cladistia or bichirs, sturgeons, garfish and a large number of modern species, the teleosts) and the Sarcopterygians, which include the ►lobe-finned fishes (the coelacanth *Latimeria* and the lungfishes), living fossils thought to be closely related to primitive land vertebrates, as well as the land vertebrates, amphibians and amniotes. Fig. 1 depicts a simplified schema of phylogeny of fishes and the morphology of their telencephalic lobes.

## Characteristics

### The Pallium in Fishes

The long evolutionary history of fishes has resulted in the pallium being very heterogeneous in appearance in the different lines (Fig. 1). For most groups, relevant information on its development, neurochemistry and connections is scant and knowledge on evolution of the pallium is quite incomplete. Modern studies of the telencephalon are centered on a few species of fishes, mainly teleosts, cartilaginous fishes, lampreys and lungs. Neurogenetic studies support the distinction between pallium and subpallium in fishes based on a gene expression program similar to the one observed in other vertebrates. Thus, in early embryo stages of species as different as lampreys, dogfish, zebrafish, frog, chick and mouse, the pallium and subpallium express similar transcription factors. The *Emx1/3* genes are expressed in the primordium of the pallium, whereas *Dlx-1/2* genes characterize the primordium of the subpallium [1,2]. Further distinction of pallium regions by genetic markers in developing fishes is lacking. In the Future paragraphs will describe some of the characteristics of the pallium of fishes using the phylogenetic schema presented above.

### Agnathans

*Hagfish* The forebrain of adult hagfish is well-differentiated cytoarchitecturally but lacks a well-developed ventricular system, which obscures the location of the pallial–subpallial boundary. The pallium lies over a massive “central prosencephalic complex,” a structure unique to hagfishes that some authors have interpreted as medial pallium, striatum or even as thalamus. The pallium consists of a superficial “cortical” mantle of gray matter that is subdivided into

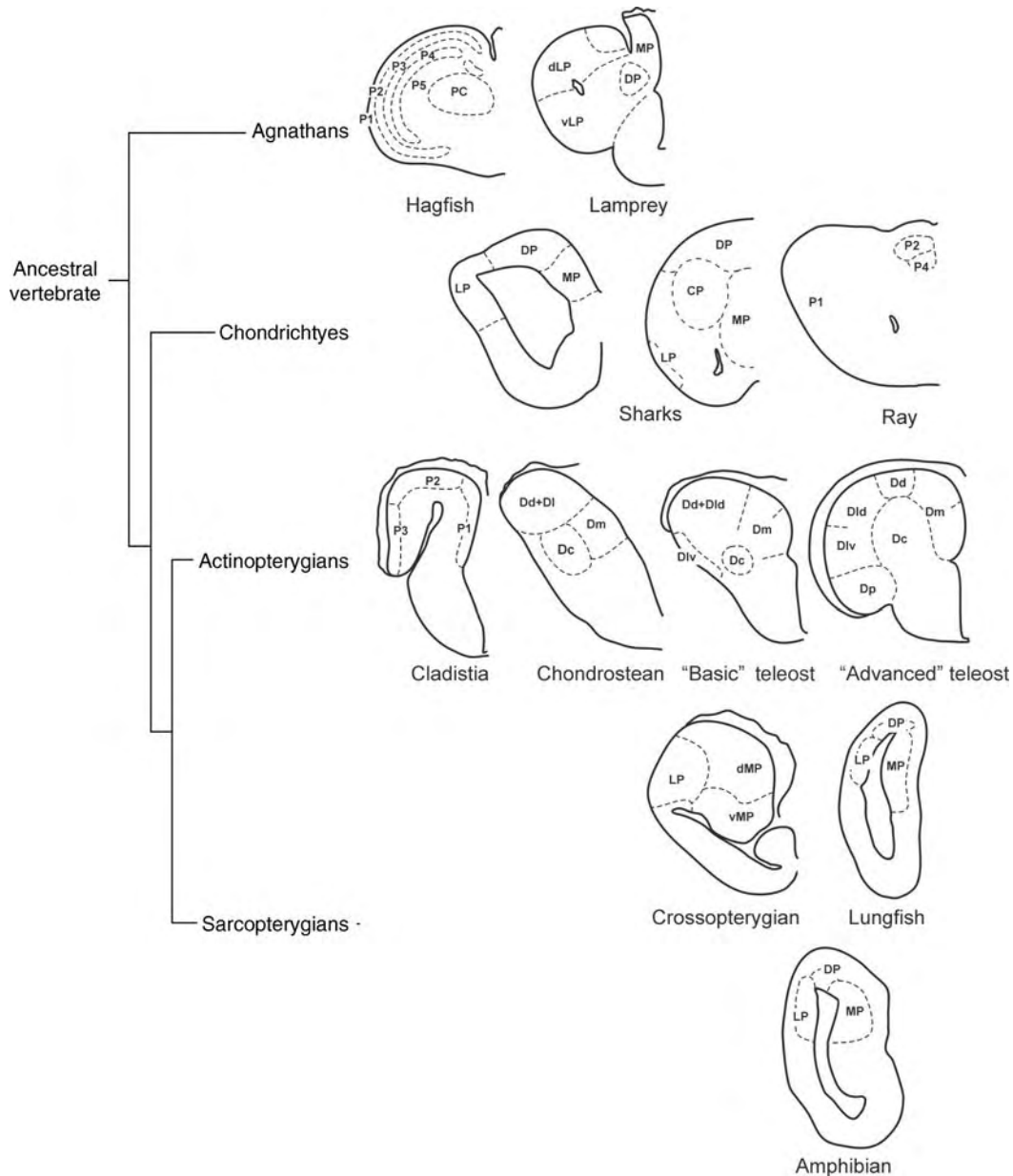

**Evolution of the Pallium in Fishes. Figure 1** Simplified phylogenetic tree of fishes, showing its relation with tetrapods. At the right, exemplificative schematic drawings of transverse sections through one telencephalic lobe, showing the main neuroanatomical areas of the pallium of some fishes. Abbreviations: CP central nucleus of the pallium; D dorsal telencephalon or pallium; Dc central area of D; Dd dorsal area of D; DI lateral area of D; Dld dorsal region of DI; dLP dorsolateral pallium; Div ventral region of DI; dMP dorsal region of MP; Dp posterior area of D; DP dorsal pallium; dP dorsal pallium (= subhippocampal lobe); LP lateral pallium; MP medial pallium; P1–5 pallial areas or layers 1–5; PC central prosencephalic nucleus; vLP ventrolateral pallium; vMP ventral region of MP.

two main cellular strata parallel to the surface (layers 2 and 4) separated by layers of fibers and cells (layers 1, 3 and 5). Many cells of these two cellular strata are bipolar and tripolar, and are arranged perpendicularly to the layers. A heterogeneous distribution of substance P- and enkephalin-positive neurons has been reported in

layer 2. There is no clear correspondence between the subdivisions of the hagfish pallium and those of other craniates [3]. The entire pallium of hagfishes receives extensive secondary olfactory projections [3]. Other pallium afferents arise from the contralateral pallium, the dorsal thalamic nuclei, the preoptic region and the

► **posterior tubercle.** Ascending thalamic and secondary olfactory projections overlap throughout the pallium. Ascending nonolfactory sensory information may reach the pallium via a tectal-thalamic-telencephalic route. The pallium projects to the olfactory bulbs, preoptic region, the dorsal thalamus and the mesencephalic tectum [3].

*Lampreys* The pallium of lampreys consists of lateral and medial parts that differ in development, organization and connections [4]. The lateral pallium makes an early appearance, but the medial pallium is only well-organized in adults. The lateral pallium forms the evaginated lateral hemispheres around the lateral ventricles and is continuous with the olfactory bulbs. The medial pallium lines the impar telencephalic ventricle and extends caudally to the habenular region. The lateral pallium does not have clear laminar organization, and many neurons are multipolar. Some of them are GABAergic, but most are probably glutamatergic. This area is richly innervated by serotonergic fibers and also receives fairly abundant dopaminergic fibers. The medial pallium consists of a dense periventricular cell layer with pear-shaped cells that extend dendrites in a wide lateral region of neuropil and scattered cells. The lateral region shows some GABAergic neurons and abundant serotonergic and cholinergic fibers in superficial regions.

Secondary olfactory projections reach all pallial fields, as in hagfish [4]. The lateral pallium of both hemispheres is interconnected through the habenular commissure and also has reciprocal connections with the olfactory bulbs and striatum. Diencephalic afferents to the lateral pallium are very scarce. Instead, in addition to telencephalic afferents (olfactory bulbs, septum, striatum), the medial pallium receives a substantial input from diencephalic and mesencephalic tegmentum and dorsal isthmus cell groups. The medial pallium projects to the pretectum and optic tectum [4]. The connections of the lateral and medial pallium of lampreys suggest specialization of these regions in olfactory and visual functions, respectively.

Some authors also include in the lamprey pallium the “dorsal pallium” (= subhippocampal lobe), a caudal region located below the medial pallium and the striatum. This cell group mainly projects to the habenula and is comparable to the entopeduncular nucleus of teleosts.

### Cartilaginous Fishes (Chondrichthyes)

The cartilaginous fishes are the sister-group of bony fishes. Some elasmobranchs (primitive sharks, some dogfishes and ratfish) have hollow telencephalic lobes, but in most elasmobranchs (some sharks, skates, rays, guitarfish and electric rays), the reduction of the lateral ventricles and midline fusion of both lobes during development gives rise to massive telencephala with hardly distinguishable boundaries [5]. In the dogfish

*Scyliorhinus*, three main pallium regions, medial, dorsal and lateral, are distinguished topographically, without obvious laminar organization.

The cells of the elasmobranch pallium are morphologically and neurochemically heterogeneous. The dorsal pallium is the richest in neuron types, whereas the medial pallium is the most homogeneous. The pallium of dogfishes is characterized by the presence of numerous small GABAergic cells, dopaminergic cells, cholinergic cells and cells expressing leuencephalin, somatostatin, neuropeptide Y, FMRF-amide and thyrotropin-releasing hormone. Fibers immunoreactive to these neuropeptides and to serotonin and substance P are abundant in the pallium.

The secondary olfactory tracts in dogfishes project heavily to the pallium and some fibers cross contralaterally in the olfactory commissures. In the spiny dogfish, *Squalus acanthias*, retrogradely labeled cells from the medial pallium were found in the superficial part of the dorsal pallium, the medial pallium, the septal area and in the posterior tubercle and posterior lateral thalamic nucleus. Electrophysiological studies in a guitarfish have mapped the mechanosensory and electrosensory pathways from the lateral line nerves that ascend via the thalamus to the medial region of the pallium.

The massive central nucleus of the pallium of the nurse shark receives afferents from the contralateral central thalamic nucleus, the lateral geniculate nucleus, the ventrolateral optic nucleus, periventricular gray, the ventral mesencephalic tegmentum and the superior raphe nucleus. Experimental studies in sharks reveal that the central nucleus of the pallium is involved in control of visually guided behavior. Telencephalic neurons that project to the optic tectum were observed in the caudal part of the pallium.

### Ray-Finned Fishes (Actinopterygians): Eversion of the Pallium

A developmental feature shared by actinopterygians is the “►eversion” of their telencephalon, in contrast to the evagination of the telencephalon of other vertebrates (Fig. 2). A result of eversion is that the lateral part of the actinopterygian pallium corresponds topologically to the medial pallium of other vertebrates and vice versa [2,5,6]. The degree of eversion varies from basal to ►advanced teleost groups, which can be appreciated by noting the insertion line of the ►choroid plexus.

*Cladistia* In *Polypterus* (Cladistia) the pallium is an externally curved C-shaped lamina, which is poorly organized, consisting of a thin sheet of neurons in a periventricular location and a wide superficial region of neuropil and fibers. The pallium has been subdivided into two primary regions, dorsomedial (P1) and dorsolateral (P2–P3). P1 receives strong olfactory input, whereas P2–P3 receives inputs mainly from the

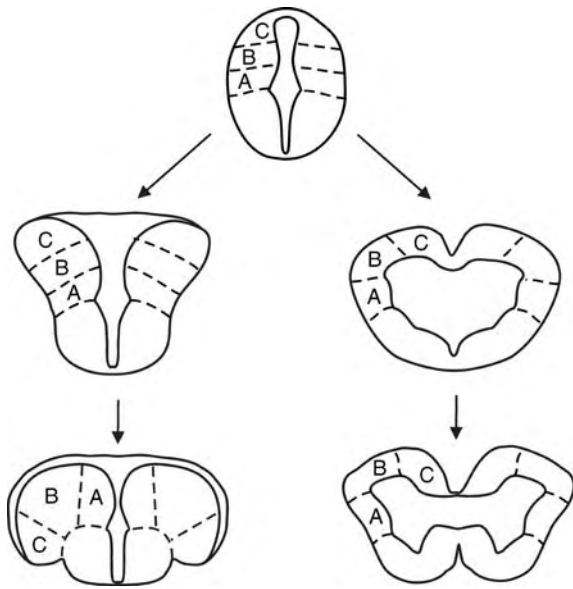

**Evolution of the Pallium in Fishes. Figure 2**  
Schematic drawings showing the eversion process of actinopterygian fishes (on the left) versus the evagination process of most vertebrates (on the right).

subpallium, and from the nucleus medianus of the posterior tubercle that in turn receives projections from the optic tectum [5]. Evoked potentials have been recorded in the dorsolateral pallium of *Polypterus* in response to light flashes, which supports the existence of visual projections to the pallium via the optic tectum and nucleus medianus.

**Chondrosteans** Studies on the pallium of sturgeons (chondrosteans) are scant. The pallium of the sturgeon *Acipenser* can be subdivided by using cytoarchitectonic criteria, acetylcholinesterase histochemistry and calretinin immunohistochemistry, into four subregions [7], the medial and the dorsal plus lateral zones, a central zone more laterally and the posterior zone caudally. The central zone contains scattered catecholaminergic (dopaminergic) cells and the pallium receives fairly abundant serotonergic fibers. The posterior zone is the main olfactory pallial region, whereas the fibers from the median nucleus of the posterior tubercle, dorsal and ventral thalamus reach mainly to the central zone, suggesting segregation between olfactory and ascending sensory inputs [7]. The medial and the dorsal plus lateral zones of the pallium are also interconnected.

**Teleosts** In teleosts, the most numerous vertebrates in number of species, the organization of the pallium is far more complex than in primitive actinopterygians and varies in the number and extension of subdivisions [5,8,9,10]. Studies on the pallium have been performed in numerous species, including catfishes (channel catfish), cyprinids (goldfish, carp, zebra fish), eel, trout and some percomorphs (*Sebastiscus*, *Poecilia*,

*Lepomis*, *Oreochromis*). In most teleosts, the pallium (dorsal telencephalic area) can be subdivided cytoarchitectonically into medial (Dm), dorsal (Dd), lateral (Dl), posterior (Dp), and central (Dc) regions. Dm can be divided into subzones on the basis of cytoarchitecture, fiber connections and/or calretinin immunoreactivity. Distinction between Dd and Dl and of subregions within Dl is not clear in trout, but in many species Dd is well separated from Dl and Dl is clearly subdivided into dorsal (Dld), ventral (Dlv), and posterior (Dlp) subzones. Dc consists of large multipolar neurons and in many species consists of several differentiated groups. The pallium contains scattered GABAergic neurons and in some species cells immunoreactive to somatostatin and dopamine. Rich innervation by fibers immunoreactive to somatostatin, neuropeptide Y, thyrotropin releasing hormone, gonadotropin releasing hormone and cholecystokinin was reported in some pallial regions of teleosts.

Experimental studies in *Sebastiscus*, trout and goldfish indicate that the regions of the pallium are connected with a number of telencephalic and extratelencephalic centers [9,10]. Studies in trout [9] reveal that Dd + Dl receives afferents from the subpallium and different nuclei of the diencephalon and rhombencephalon and projects to Dc and diencephalic areas. Dm maintains reciprocal connections with the preglomerular nuclei and the mammillary body and also receives afferents from several diencephalic and rhombencephalic nuclei. Dc receives fibers mainly from Dd + Dld, the preoptic nucleus, the ►preglomerular complex and the torus semicircularis and projects to several extratelencephalic centers. Dp is mainly connected with the olfactory bulbs, subpallium and diencephalic centers and projects to hypothalamic and posterior tubercular regions. Though some pallial connections of trout differ from those reported for *Sebastiscus* and goldfish, together these studies reveal a much richer connectivity of the pallium in teleosts than in other groups of fishes.

Behavioral studies after bilateral lesions of the Dm or Dlv in goldfish indicate that Dm is involved in emotional learning whereas Dlv is involved in spatial learning [6]. These teleost pallial zones are hence functionally similar to the mammalian amygdala and hippocampus respectively, suggesting a general homology with these regions.

### Lobe-Finned Fishes (Sarcopterygians)

Lobe-finned fishes are the sister-group of ray-finned fishes. They include a few "living fossil" species, the lungfishes (Dipnoa) and coelacanths (*Latimeria*: Crossopterygians), which diverged from lines leading to amphibians about 400 million years ago. Lungfishes are the sister group of tetrapods (land vertebrates).

**Lungfishes** The telencephalic hemispheres of the African lungfish (*Protopterus*) are tubular structures

organized around the paired telencephalic ventricles that show a surprising amphibian-like appearance in transverse sections [11]. The dorsal telencephalon (pallium) has been subdivided into lateral, dorsal and medial regions using cytological and immunohistochemical criteria. The dorsal and lateral pallia receive olfactory projections and together may correspond to the olfactory pallium (P1) of *Polypterus* (Cladistia). The medial pallium was found to consist of three immunohistochemically distinct subdivisions, dorsal, intermediate and ventral cell groups, though its correspondence to the medial pallium of land vertebrates is unclear. The dorsomedial telencephalon of *Protopterus* has been intermediated by some authors as a subpallial (septal) structure on the basis of its staining by acetylcholinesterase histochemistry. However, medial parts of the dorsal telencephalon of sturgeon, teleosts and frogs exhibit strong acetylcholinesterase activity, so it is probable that this marker is unreliable for distinguishing pallial from subpallial structures.

**Crossopterygians** The pallium of *Latimeria* is represented by a thickened, solid body covered by a membranous roof resembling the pallium of actinopterygians [5]. The pallium has been subdivided into dorsomedial, ventromedial and lateral on topographical grounds, but correspondence to pallial regions of other vertebrates is not known.

In conclusion, there is no direct line of pallial evolution “from fish to man.” The earlier scenario of pallial evolution held that primitive piscine pallia were entirely dominated by secondary olfactory projections. An invasion of dorsal thalamic fibers into the pallium was thought to have occurred in tetrapods, thus giving rise to the sensory pallial areas characteristic of mammals. This scenario however, had to be rejected on the basis of modern comparative data [5].

## References

1. Myojin M, Ueki T, Sugahara F, Murakami Y, Shigetani Y, Aizawa S, Hirano S, Kuratani S (2001) Isolation of *Dlx* and *Emx* gene cognates in an agnathan species, *Lampetra japonica*, and their expression patterns during embryonic and larval development: conserved and diversified regulatory patterns of homeobox genes in vertebrate head evolution. *J Exp Zool* 291:68–84
2. Wullimann MF, Mueller T (2004) Teleostean and mammalian forebrains contrasted: evidence from genes to behavior. *J Comp Neurol* 475:143–162
3. Wicht H, Northcutt RG (1998) Telencephalic connections in the Pacific hagfish (*Eptatretus stouti*), with special reference to the thalamopallial system. *J Comp Neurol* 395:245–260
4. Northcutt RG, Wicht H (1997) Afferent and efferent connections of the lateral and medial pallia of the silver lamprey. *Brain Behav Evol* 49:1–19
5. Northcutt RG (1995) The forebrain of gnathostomes: in search of a morphotype. *Brain Behav Evol* 46:275–318
6. Broglio C, Gómez A, Durán E, Ocaña FM, Jiménez-Moya F, Rodríguez F, Salas C (2005) Hallmarks of a common forebrain vertebrate plan: specialized pallial areas for spatial, temporal and emotional memory in actinopterygian fish. *Brain Res Bull* 66:277–281
7. Huesa G, Anadón R, Yáñez J (2006) Topography and connections of the telencephalon in a chondrosteian, *Acipenser baeri*: an experimental study. *J Comp Neurol* 497:519–541
8. Castro A, Becerra M, Manso MJ, Anadón R (2006) Calretinin immunoreactivity in the brain of the zebrafish, *Danio rerio*: distribution and comparison with some neuropeptides and neurotransmitter-synthesizing enzymes. I: olfactory organ and forebrain. *J Comp Neurol* 494:435–459
9. Folgueira M, Anadón R, Yáñez J (2004) An experimental study of the connections of the telencephalon in the rainbow trout (*Oncorhynchus mykiss*). II: dorsal area and preoptic region. *J Comp Neurol* 480:204–233
10. Murakami T, Morita Y, Ito H (1983) Extrinsic and intrinsic fiber connections of the telencephalon in a teleost, *Sebastiscus marmoratus*. *J Comp Neurol* 216:115–131
11. Reiner A, Northcutt RG (1987) An immunohistochemical study of the telencephalon of the African lungfish, *Protopterus annectens*. *J Comp Neurol* 256:463–481

## Evolution of the Posterior Tuberculum and Preglomerular Nuclear Complex

PHILIPPE VERNIER<sup>1</sup>, MARIO F. WULLIMANN<sup>2</sup>

<sup>1</sup>Institute of Neurobiology A. Fessard, CNRS, Gif sur Yvette Cedex, France

<sup>2</sup>Department of Biology II–Neurobiology Biocenter, Ludwig-Maximilians-University, Planegg-Martinsried, Germany

### Definition

The posterior tuberculum is part of the ventral area of the caudal diencephalon, arising from the basal plate of the neural tube. It comprises a periventricular area that contains an important contingent of dopaminergic neurons implicated in sensori-motor control. In actinopterygians (ray-finned fishes) and chondrichthyans (cartilaginous fishes), but not in tetrapods (amphibians, reptiles, birds, and mammals), the posterior tuberculum also includes laterally lying, migrated nuclei, which relay sensory inputs to the telencephalon.

### Characteristics

The posterior tuberculum was initially recognized on a cytoarchitectonic basis as a caudobasal division of the diencephalon posterior to the hypothalamus, but

anterior to the area of the medial longitudinal fascicle and named *area* or *pars tuberculi posterioris* by Harry Bergquist in the 1930s, who compared its extent and anatomical complexity in all representative anamniote (fishes and amphibians), and some amniote (reptiles and mammals) vertebrate species (reviewed in [1]). Subsequently, the posterior tuberculum was similarly presented as the basal part of the thalamus (but including also the most posterior part of hypothalamus, the mammillary bodies, plus, explicitly, the migrated preglomerular masses present in teleosts (modern bony fishes, which are the largest clade of the ray-finned fish radiation) [1,2]. In any case, the posterior tuberculum is clearly distinct from the two main alar plate (dorsal part of the neural tube)-derived thalamic divisions (dorsal and ventral) and includes large migrated cell groups that are best developed in teleost fishes. Thus, although the posterior tuberculum was traditionally well recognized in anamniotes, its definition in mammalian or avian brains remained elusive and the notion of a posterior tuberculum is rarely used in amniotes (Fig. 1).

More recently, neurochemical approaches revealed the presence of several populations of dopamine-synthesizing neurons in the periventricular region of the posterior tuberculum in fishes. This observation became the hallmark of the posterior tuberculum. Since many of these dopaminergic neurons project to the ventral telencephalon (striatal component) and likely also to the pallium in anamniotes, they have been proposed to be homologous to at least a part of the substantia nigra/ventral tegmental area of amniotes. The latter, however, are mostly localized in the ventral mesencephalon (reviewed in [3]; see discussion below). Accordingly, the notion of posterior tuberculum is often synonymous of the presence of dopamine neurons in this location in comparative neurosciences [2].

This view has significantly changed during the last twenty years, when the definition of the posterior tuberculum began to take into account the antero-posterior transverse divisions (neuromeres) and dorso-ventral divisions (longitudinal zones or plates) of the brain. These divisions are defined by precise morphogenetic cues, and form the Bauplan (basic design) of the neural tube [4,5]. A clear and more general definition (which extends to amniotes) of the posterior tuberculum can now be proposed on the basis of neuromeres [anteroposterior (rostrocaudal) neural segments] and longitudinal zones. It also helps to integrate embryological, genetic and anatomical observations [4,6]. In this neuromeric view of the neural tube, the posterior tuberculum is defined as the basal plate (ventral part of the neural tube) of prosomeres (forebrain segments) 1 through 3 (the posterior forebrain). These neuromeres share many developmental and anatomical characteristics with each other and with the midbrain tegmentum as well (Fig. 2; see below).

Although the posterior tuberculum has been characterized either on cytoarchitectonical, neurochemical or segmental criteria, these different views are not irreconcilable. In the following section, before examining specific aspects of the posterior tuberculum, we summarize comparative embryological data that shed light on the origin and definition of the posterior tuberculum.

### Developmental Origin of the Posterior Tuberculum

A general consensus asserts that the posterior tuberculum is derived from the basal plate of the posterior part of the diencephalic neural tube. The analyses of proliferation patterns and of expression territories of genes involved in defining (basal) longitudinal zones and in region-specific neurogenesis/differentiation broadly support this assumption. Islands of neural progenitor cells, radial glia and gene expression (the posterior limit of the *Otp* gene, or the anterior limit of *Neurogenin1/2* and *NeuroD* expression, for example) mark the limit between the posterior hypothalamus and the retromammillary area/Forel fields in amniotes, or the hypothalamus and ventral (=anterior) part of the posterior tuberculum in teleosts [4,5]. In the postero-basal diencephalon of zebrafish and rat, clusters of neurogenesis clearly identify three zones in front of the mesencephalic tegmentum, corresponding to the ventral components of p1 (synencephalon), of p2 (par-encephalon posterius), and of p3 (par-encephalon anterior) [4,5]. Thus, they are respectively ventral to (alar) pretegmentum, dorsal thalamus and ventral thalamus. In the early prosomeric literature, only the basal p2 is referred to as the posterior tuberculum [4,5], except in amniotes where the basal components of p2 and p3 are named dorsal and ventral part of the posterior tuberculum [4]. It should be stressed that these prosomeric clusters of neurogenesis are in register at longitudinal levels with the neurogenic clusters of the (basal plate) midbrain tegmentum.

In addition to specific islands of neurogenesis, the basal plate of the caudal diencephalon is characterized by the expression of specific genes involved in different steps of regionalization of the neural tube, neurogenesis or neural differentiation. Several genes such as *Shh* or *axial/hfn3b/foxA2* are expressed in the basal plate portions of the three first prosomeres and the mesencephalon. Other genes have variable anteroposterior expression domains in different vertebrate groups. In mouse, *NeuroD* is abundant in the p2-p3 prosomeres, but at a much lower level in p1 and in the tegmentum mesencephali. *Neurogenin 1/2* is expressed in the three first prosomeres of the basal plate, with a sharp anterior limit towards the posterobasal hypothalamus, and extends into the basal mesencephalon, with a clear-cut posterior limit at the isthmus [10]. Thus, based on neurogenetic patterns and expression of proneural genes, the basal plate of the diencephalon in amniotes

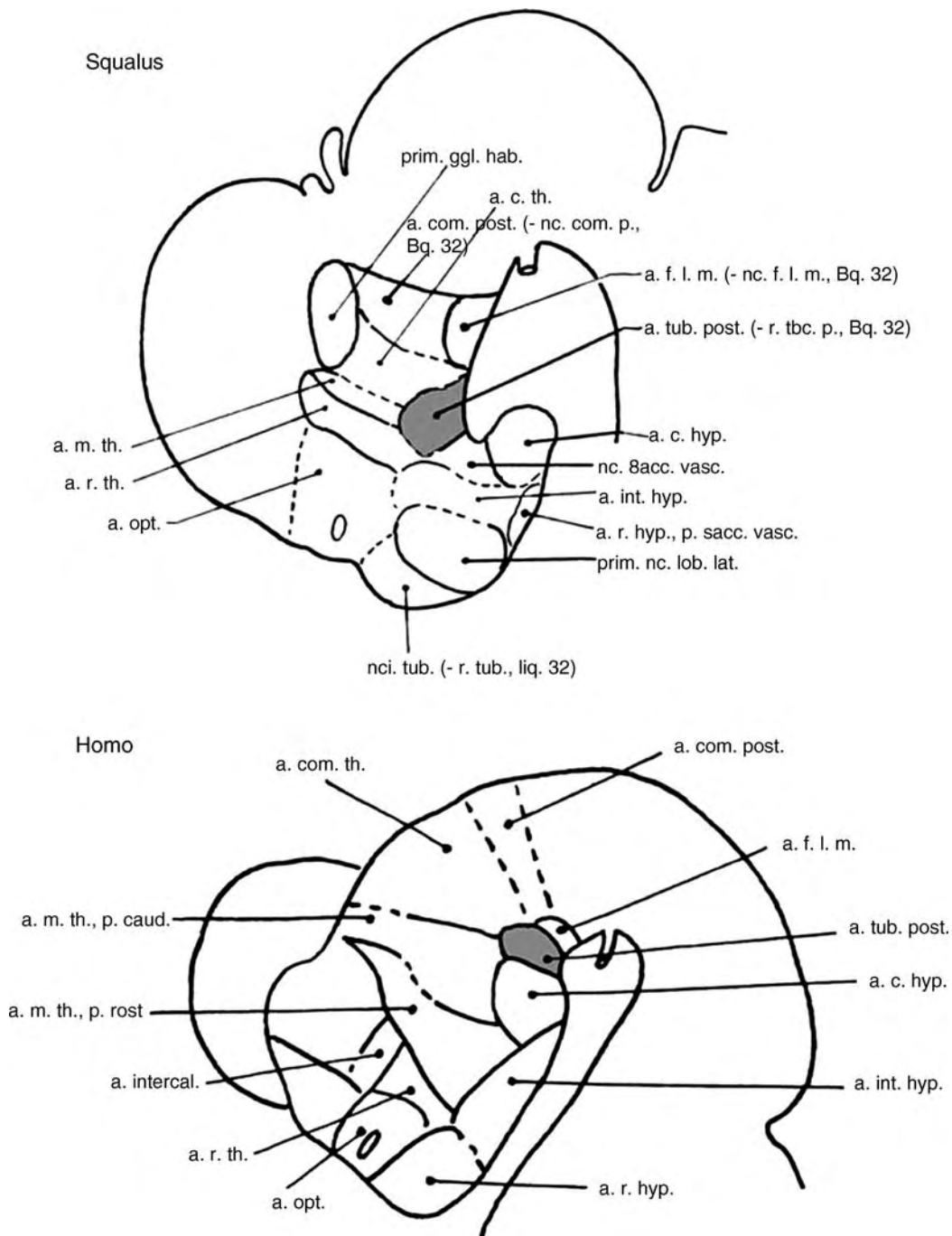

**Evolution of the Posterior Tuberculum and Preglomerular Nuclear Complex. Figure 1** Modified from original figures in a paper by Bergquist, published in 1954, depicting sagittal brain drawings of an embryonic (a) shark (*Squalus acanthias*) and a (b) human embryo. The proposed posterior tuberculum is shaded in grey. Some abbreviations: *a. c. th.*, area caudalis thalami; *a. f.l.m.*, area fasciculi longitudinalalis medialis; *a. tub. post.*, area tuberculi posterioris.

and anamniotes can be divided into three different morphogenetic units, which share many commonalities in terms of genetic specification. This is particularly true for the expression of dopaminergic markers in this

area. Indeed, the genes coding for tyrosine hydroxylase (TH), or for the dopamine transporter (DAT) are not only expressed in the mesencephalic basal plate but also in the three first prosomeres in mouse, rat, human,



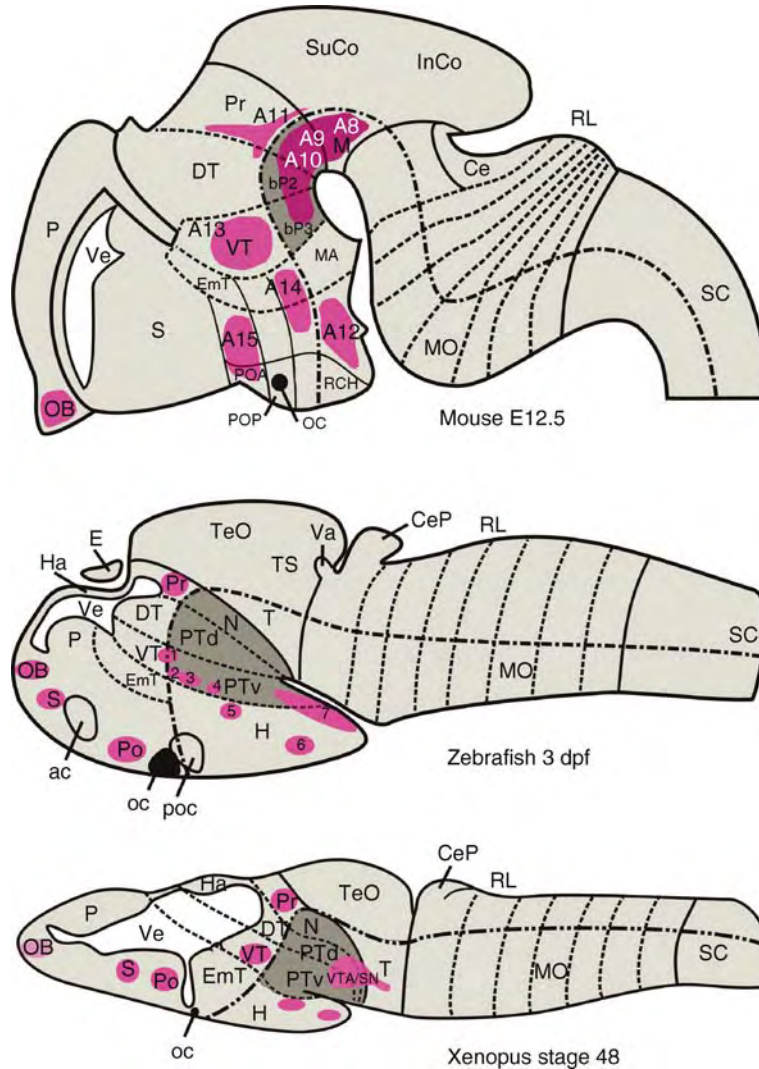

**Evolution of the Posterior Tuberculum and Preglomerular Nuclear Complex. Figure 2** Schematics of brains from mouse (*Mus musculus*) at embryonic day 12,5 (a), zebrafish (*Danio rerio*) at 3 days postfertilization (b), and xenopus (*Xenopus laevis*) at embryonic stage 48 (c) in lateral views showing the distribution of the most important dopamine cell nuclei (in pink). The organization of the dopamine nuclei is interpreted with respect to the neuromeric divisions of the brain. The limits between the antero-posterior neuromeres are marked by interrupted lines, and alar plate (dorsal) and basal plate (ventral) are separated by a dotted line, which also indicates the bent anteroposterior axis. For the mouse, the A8-A15 dopamine cell groups correspond to the nomenclature of [3,7]. For the zebrafish, the numbers of the groups of dopamine cells are taken from [8]. For the xenopus, dopamine nuclei are described according to [3,9]. Abbreviations: *ac*, anterior commissure; *bP*, basal part of the prosomere; *Ce*, cerebellum; *CeP*, cerebellar plate; *DT*, dorsal thalamus; *E*, epiphysis; *EmT*, eminentia thalami; *H*, hypothalamus; *Ha*, habenula; *InCo*, inferior colliculus; *MA*, mammillary hypothalamus; *MO*, medulla oblongata; *N*, area of the nucleus of the medial longitudinal fascicle; *OB*, olfactory bulb; *oc*, optic chiasm; *P*, pallium; *poc*, postoptic commissure; *Pr*, pretectum; *PTd*, dorsal posterior tuberculum; *PTv*, ventral posterior tuberculum; *Po*, preoptic area; *POA*, anterior preoptic area; *Pr*, pretectum; *RCH*, retrochiasmatic hypothalamus; *RL*, rhombic lip; *S*, subpallium; *SC*, spinal cord; *SuCo*, superior colliculus; *T*, tegmentum mesencephali; *TeO*, tectum opticum; *Va*, valvula cerebelli; *Ve*, brain ventricle; *VT*, ventral thalamus; *VTA/S*, ventral tegmental area/substantia nigra.

chicken and amphibians [6,7,9,11]. In contrast, the same genes in teleost fishes are expressed in the basal part of p3 only [8,12,13]. Thus, the differentiation of dopaminergic cells is variably occurring in different

vertebrates from mesencephalon to posterior tuberculum up to p3. A parsimonious and simple definition of the posterior tuberculum would be that it is the basal plate of the three first prosomeres (Fig. 2).

In teleost fishes, the posterior tuberculum was proposed to include the preglomerular complex and also the lateral torus, which were interpreted as having migrated toward a lateral position within the posterior tuberculum [1,2] and, thus, being derivatives of the posterior tuberculum. More recent developmental data reveal that the early preglomerular complex (named M2; [4]) undergoes ongoing neurogenesis, with proliferative cells likely originating from the periventricular posterior tuberculum. In contrast, the analysis of the concomitant expression of specific developmental genes (*Pax6*, *Dlx2*, *NeuroD*) suggests that the preglomerular complex may derive, at least in part, from the alar plate of the diencephalon, and not from the basal plate [4,14]. Thus, the preglomerular complex and the dorsal thalamus in amniotes, which are the major diencephalic sensory relay centers to the pallium in teleosts and amniotes, respectively, may have partly the same embryological origin. If this observation will be further supported by precise fate studies, it will render the organization of diencephalic sensory systems more conserved across vertebrates than originally thought.

### The Periventricular Nuclei and Dopaminergic Neurons of the Posterior Tuberculum

In anamniotes, the posterior tuberculum contains conspicuous neuronal populations synthesizing the modulatory neurotransmitter dopamine. Strong evidence supports that these dopamine cell populations are homologous to the ventral tegmental area/substantia nigra of amniotes. This contention is based on developmental, hodological and neurochemical characters. The differentiation of these neurons depends on a well-conserved gene network induced by the ventral signals *Nodal* and *Shh* and by *Fgf8* produced at the midbrain-hindbrain boundary. The network comprises genes activated in a sequential manner from committed progenitors to differentiated neurons, namely *Ash1*, *Ngn1/2* and *Lmx1a/b*, then *FoxA2*, *Nurr1/NR4A2*, and finally *En1/2* and *Pitx3*, these latter being required for the maintenance of the phenotype throughout adulthood.

The dopamine neurons of the posterior tuberculum project anteriorly via the medial forebrain bundle to the telencephalon, mostly to the striatum, but also to the pallium, with large variation across the various vertebrate clades. In addition, the dopamine neurons of the posterior tuberculum exhibit, as those of the ventral tegmental area/substantia nigra (VTA/SN), a specific phenotype defined by the presence of a combination of molecules involved in dopamine neurotransmission [7].

These dopamine-synthesizing neurons express TH, the limiting enzyme of catecholamine synthesis, and aromatic amino acid decarboxylase, which transforms L-DOPA into dopamine. They also contain the vesicular monoamine transporter VMAT2 and the membrane

dopamine transporter DAT, required to respectively store dopamine into vesicles and to clear dopamine from the extracellular space. Finally, monoamine oxydase, the main degrading enzyme, and the dopamine D2 receptor are also found in a conserved manner in amniotes as well as in teleost fishes [3].

### Jawless Fishes

In agnathans (or cyclostomes, the jawless vertebrates/craniates), the petromyzontids (lampreys) have TH-positive, dopamine-containing cells in the nucleus tuberculi posterioris, which projects anteriorly, mostly to the subpallium (striatum/septum) and occasionally to the pallium [15]. In myxinoids (pacific hagfish), TH-positive neurons are located in the lateral nucleus of the posterior tuberculum, which emits long processes toward the basal telencephalon [16].

### Jawed Fishes

In chondrichthyans (the cartilaginous fishes), the situation differs between holocephalians (chimeras) and elasmobranchs (sharks, skates, and rays). In at least some sharks, two dopamine cell populations lie in the midbrain tegmentum, at the level of the third cranial nerve. The first one, located medially and anterior to the interpeduncular nucleus, is called ventral tegmental area, and the second, scattered around the red nucleus, is named substantia nigra. Both populations display a clear anterior extension into the posterior tuberculum. A very similar situation has been described in rays, with two mesencephalic dopamine cell components, plus posterior tubercular components, and this is probably true for most elasmobranchs. However, in holocephalians, dopamine cells are found in the posterior tuberculum, but not more caudally in the mesencephalic tegmentum, as in agnathans and teleost fishes [17].

### Actinopterygians

In actinopterygians (the large radiation of ray-finned fishes that include the teleost fishes), the periventricular area of the posterior tuberculum exhibits three identifiable components: the nucleus of the posterior tuberculum (TPp), the paraventricular organ (PVO), mainly ependymal cells, which, in anamniotes, exhibit a specific differentiation in continuity with the hypothalamic periventricular wall, and a third nucleus made of larger cells, the nucleus tuberis posterior or posterior tuberal nucleus. These dopaminergic neurons are all housed in the basal third prosomere and do not extend more caudally. It is generally believed that dopaminergic neurons are not present in the mesencephalon, although some evidence exists for the presence of dopamine-containing cells in the tegmentum mesencephali of *Lepisosteus*, a non-teleost actinopterygian fishes (reviewed in [3]). With this possible exception in mind, ray-finned fishes show TH cell groups in

the posterior tuberculum only, where the neurons of the adult ascending dopaminergic system are located. In the bichir, a most basal actinopterygian fish, TH-positive cells have been described in the TPP, and were proposed to project to the dorsal nucleus of the subpallium, a probable homologue of the amniote striatum [3,8]. In teleosts, only TH-positive (small and large) cells of the TPP give rise to ascending projections toward the subpallial area, as demonstrated in the adult zebrafish [8]. In another teleost, the medaka, these posterior tubercular cells express the *Nurr1/NR4A2* gene, which is mandatory for the development and maintenance of mammalian basal midbrain dopaminergic cells [13]. This further substantiates the recognition of the teleostean posterior tubercular dopamine cells as homologous to the VTA/SN of other vertebrates (Fig. 2).

The other populations of TH-positive neurons in teleosts, classified according to their shapes and projections, are located either in liquor-contacting cells of the PVO (or of the more anteriorly located hypothalamus), or in the posterior tuberal nucleus [8]. The cell bodies of dopamine neurons projecting to the spinal cord are also located in the posterior tuberculum. Although it may differ for details, this picture prevails in all the teleosts studied so far (Fig. 2; see [3]).

In lungfishes, which are members of the sarcopterygian radiation, or lobe-finned fishes, that ancestrally gave rise to tetrapods, there is a significant population of TH-positive cells in the mesencephalic tegmentum, comparable to the substantia nigra, which projects to the lateral and medial pallium [2,3].

### Tetrapods

In amphibians, as in most fishes, a well-developed posterior tuberculum exists, which hosts dopamine-synthesizing neurons that give rise to ascending projections mostly to the striatum and scarcely to the pallium. This cell group occupies the dorsomedial and ventrolateral portions of the posterior tuberculum, within the three first prosomeres. It extends caudally into the mesencephalon but much less than in amniotes. In all the amphibian groups, the dopaminergic neurons cannot be separated into distinct VTA and substantia nigra populations (Fig. 2). Only in *Siren*, a urodele, TH-positive cells appear much more numerous in the posterior tuberculum than in the tegmentum mesencephali (reviewed in [9]).

In reptiles and birds, dopamine-synthesizing neurons are very numerous in the basal mesencephalon, but also extend into the basal plate of the three first prosomeres. In birds, the VTA lies rostral to the interpeduncular nucleus and medial to the red nucleus. The SN includes cells lateral and posterior to the VTA, and another group similar to the retrorubral population of mammals can be recognized in chick and pigeon. This finding led to a classification as A10, A9, A8

respectively, as in mammals (see below; reviewed in [3]). In lizards, snakes, and turtles, the dopamine neurons of VTA/SN and retrorubral field constitute the largest population of dopamine neurons in the brain [18]. In all these species, TH-positive cells of the mesencephalon extend into the basal diencephalon, homologous to the posterior tuberculum of anamniotes, at least up to the second prosomere (the posterior parencephalon) [3,18].

In mammals, the dopamine neurons of the diencephalo-mesencephalic area have been classified into three groups by Dahlström and Fuxe with histochemical methods (see [3,7]). The retrorubral component (A8) is exclusively located in the mesencephalon, whereas SN (A9) and VTA (A10) extend in a respective lateral and medial position from the mesencephalon to the three first prosomeres [7,11]. Neurons from the A8-A10 area give rise to three main projections pathways, namely meso-striatal, meso-cortical and meso-limbic (Fig. 2). There is no clear distinction of the projections arising from the VTA or the SN, which both contribute to the innervation of striatal or pallial areas, with several species-specific features. (see [7] for review). They also innervate pallidal areas, as well as other nuclei of the basal telencephalon and diencephalon. Dopamine neurons of the VTA/SN are particularly numerous in human, in a proportion that exceeds the regular allometry of brain nuclei. Their degeneration is one of the hallmark of Parkinson's disease and the cause of its most disabling symptoms [3,7].

### The Migrated Nuclei of the Posterior Tuberculum

The posterior tuberculum of ray-finned fishes and cartilaginous fishes exhibits migrated sensory nuclei, the nature and origin of which has been problematic for decades. Difficulty in analyzing these nuclei stems from their variation in size and location among species and from highly confusing terminology. It is now well accepted that these nuclei collectively form the preglomerular nuclear complex in teleosts. These neurons relay sensory information to the telencephalon, mostly from the lateral line and gustatory systems. The lateral torus also has been included into the migrated nuclei of the teleostean posterior tuberculum. A similar situation exists in cartilaginous fishes (see below). These pathways through the migrated nuclei of the posterior tuberculum are similar to the sensory pathways through the dorsal thalamic nuclei of amniotes. However, a direct homology to any known dorsal thalamic nuclei in tetrapods is still difficult to establish, mostly because of the unresolved developmental origin (Fig. 3).

### Jawless Fishes

In hagfishes, but apparently not in lampreys, the posterior tuberculum contains a migrated nucleus [16],

the lateral nucleus of the posterior tuberculum which does project to the pallium and, thus, it bears some resemblance to migrated nuclei of the posterior tuberculum of teleosts/chondrichthyans.

### **Jawed Fishes**

In cartilaginous fishes (elasmobranchs), a posterior lateral and central thalamic nucleus, located lateral to the periventricular part of the posterior tuberculum, relay electrosensory and mechanosensory input, respectively, from the lateral lemniscal system to the telencephalon. This contrasts with the other sensory systems, which make synapses in the dorsal thalamus, for relay to the telencephalon [6].

In teleosts, several migrated (preglomerular) nuclei are present in the lateral posterior tuberculum, and they display a large anatomical complexity and interspecific variability. These nuclei provide the major diencephalic input to the pallial zones of the area dorsalis telencephali. Specific sensory preglomerular nuclei exist for the auditory, lateral line mechanosensory, lateral line electrosensory (when present), and the gustatory systems, and for components of the somatosensory and visual systems (Fig. 3); [1,2,6,12,19].

Ascending inputs from the mechanosensory lateral line reach the torus semicircularis from where they are relayed to the (lateral) preglomerular region. The latter projects in turn both to medial and lateral zones of the teleostean pallium. The electrosensory system of gymnotids and silurids is more complex, with a projection going from the torus semicircularis to a nucleus electrosensorius in the pretectum before reaching the preglomerular complex, from where this input then reaches the pallium. In electrosensory osteoglossomorphs (mormyrids), electrosensation and mechanosensation exhibit significantly different ascending pathways to the preglomerular complex. Electrosensory efferents from the torus semicircularis project to the dorsal part of the preglomerular complex. This area also receives inputs from the dorsal pallium and optic tectum and projects to the cerebellum. Mechanosensory inputs, instead, project from the torus semicircularis to a ventral part of the preglomerular complex, which is probably homologous to the lateral preglomerular nucleus in non-electroreceptive teleosts. Accordingly, this preglomerular nucleus then projects to the pallium. In contrast, acoustic pathways relay mostly through the dorsal thalamus (from where they reach the subpallium), but also in the anterior and lateral nuclei of the preglomerular complex, at least in some teleosts. Auditory inputs from the latter reach the medial and lateral zones of the dorsal pallium.

Gustatory pathways are rather diverse, with a varying degree of complexity among teleosts. Sometimes, the medullary secondary gustatory nucleus projects to

preglomerular and hypothalamic nuclei for direct relay to the pallium (mostly the medial zone of the dorsal pallium). In some species, such as goldfish, gustatory diencephalo-telencephalic pathways are more indirect but also involve the preglomerular area.

Visual pathways relay partially (tectofugal visual information) through the preglomerular complex in some teleosts. Most visual inputs reach the telencephalon via a direct retino-thalamic and an indirect retino-tecto-thalamic pathway. However, in contrast to amniotes, the major visual telencephalic target in teleosts is the subpallium rather than the pallium.

In certain teleost species, a few other migrated nuclei of the posterior tuberculum are found in the vicinity of the preglomerular complex, the so-called caudal “mammillary body” (although probably not homologous to the mammillary area of mammals), a nucleus subglomerulosus, and a lateral (=posterior) thalamic nucleus.

To conclude, similar to cartilaginous fishes, the predominant diencephalic targets of teleostean ascending sensory projections are in the preglomerular region located in the lateral periphery of the posterior tuberculum rather than in the dorsal thalamus as in amniotes [6,12,19]. Although the homology of sensory pathways between teleosts and tetrapods is not certain in each single case, the functional similarities between the teleostean preglomerular region and the amniote dorsal thalamus are striking: both make up a large proportion of the diencephalon, are subdivided into many nuclei associated with specific sensory systems, and, further, most of them have reciprocal connections with the pallium (Fig. 3).

### **Evolutionary Variations of the Posterior Tuberculum**

The discussion of the evolution of characteristics of the posterior tuberculum is necessarily based on our current knowledge of the phylogenetic relationships of vertebrates (craniates). (For review see [2,6]). Current embryological data, mostly from teleosts (zebrafish and medaka), amphibians (*Xenopus*) and mammals (mouse and human) support the hypothesis that the posterior tuberculum corresponds to the basal component of the three first (caudal) prosomeres. In addition, in jawed vertebrates, commonalities in neuronal specification exist between the dopaminergic neurons of the posterior tuberculum and of the mesencephalic VTA/SN, which can be considered as derivatives of the same embryological field. Since only posterior tubercular dopaminergic neurons are present in jawless vertebrates/craniates, and only the full extent of dopaminergic neurons from the three first prosomeres to the posterior limit of midbrain tegmentum is observed in amniotes, it could be hypothesized that the localization of the dopaminergic neurons in the posterior tuberculum is the ancestral situation and

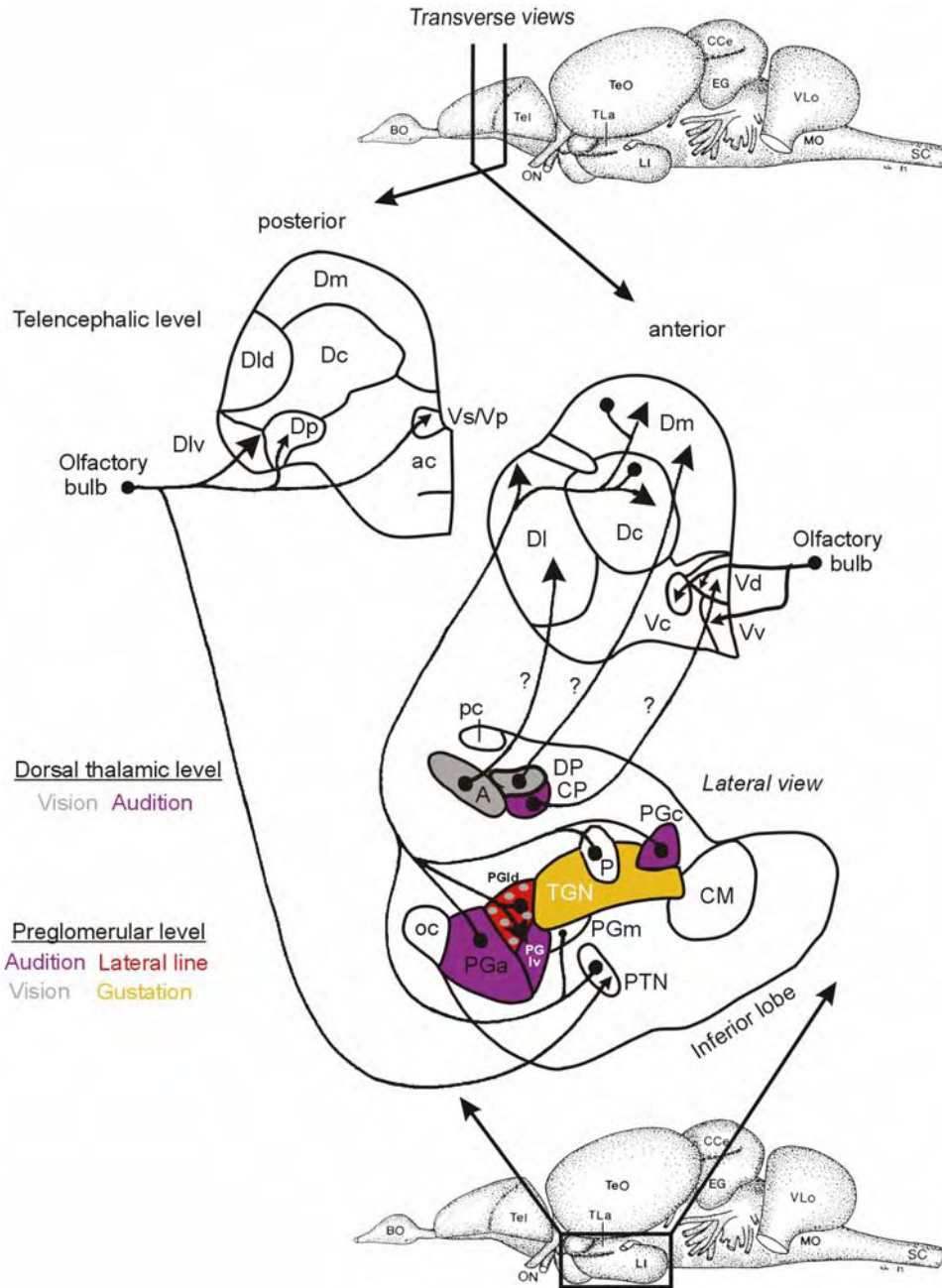

**Evolution of the Posterior Tuberculum and Preglomerular Nuclear Complex.** Figure 3 Sensory circuits in the brain of the goldfish (*Carassius auratus*). Arrows between preglomerular complex (PG) and pallium (DI, Dc, Dm) illustrate mechanosensory lateral line inputs (red), auditory inputs, (violet), and visual inputs (gray) originating from the preglomerular complex and the thalamus (audition/vision, which more likely terminate in the subpallium). TGN, P and PGm are gustatory-involved nuclei. Pallial input from PGI is to DI and Dm, while PGa, PGm and PGc project only to Dm. Exact pallial input terminations from P as well as from PTN, remain tentative. Abbreviations: A, anterior nucleus of dorsal thalamus; ac, anterior commissure; BO, olfactory bub; CCe, corpus cerebelli; CM, corpus mamillare; CP, central posterior nucleus of dorsal thalamus; Dc, l, m, p, area dorsalis telencephali, central, lateral, medial, posterior zones; DP, dorsal posterior nucleus of dorsal thalamus; EG, eminentia granularis; LI, lobus inferior; pc, posterior commissure; MO, medulla oblongata; oc, optic chiasm; ON, optic nerve; P, posterior thalamic nucleus; PGa, c, l, m, preglomerular nucleus, anterior, caudal, lateral, medial nucleus; PTN, posterior tuberal nucleus; SC, spinal cord; Tel, telencephalon; TeO, tectum opticum; TGN, tertiary gustatory nucleus; TLa, torus lateralis; Vc, d, p, s, v, area ventralis telencephali, centralis, dorsalis, postcommissural, supracommissural, ventral nucleus. Redrawn from [12], including new data from [19].

that, subsequently, associated with the allometric growth of the forebrain (pallium and subpallium), the diencephalo-mesencephalic dopaminergic neurons become more numerous and populate the whole basal plate from p3 to the isthmus. However, since dopaminergic neurons also are present in the midbrain tegmentum of elasmobranchs, lungfishes, and amphibians, in addition to amniotes, it can neither be said that the invasion of the mesencephalon by dopaminergic cells is correlated to the emergence of amniotes nor to the acquisition of terrestrial life. Thus, the multi-segmental origin of VTA/SN dopaminergic neurons is a plesiomorphy (evolutionarily basal condition) of jawed vertebrates, and the numerous variations in the details of their connections among species is likely to reflect strong functional adaptation to different life styles.

Regarding the presence and origin of the migrated preglomerular complex in teleosts, it is probably ancestrally present in jawed vertebrates and perhaps in all vertebrates/craniates, based on hodological and embryological evidences [6,12,20]. A comparison of cartilaginous and bony fishes suggests that a dual innervation of the diencephalon (dorsal thalamus/posterior tubercular region) by at least some ascending sensory systems may be the ancestral situation for gnathostomes. Interestingly, in both cartilaginous and bony fishes, hair cell sensory organs of the cochlea and the labyrinth (audition, equilibration) project to the dorsal thalamus. In contrast, the other hair cell sensory organs (mechanoreception, electroreception) project to the posterior tubercular region. Thus, dual sensory pathways may be a gnathostome plesiomorphy. If so, the evolutionary loss of the latter sensory systems in amniotes may directly explain the dominance of the dorsal thalamus as diencephalic sensory relay region in amniotes. For years, the posterior tuberculum was viewed essentially as a fish peculiarity. Rejuvenation of this concept by developmental biology and its extension to the whole craniate/vertebrate phylum promises to shed new light on the important neuronal structures present in this hinge region of the brain.

## References

1. Braford MR Jr, Northcutt RG (1983) Organization of the diencephalon and preteectum of the ray-finned fishes. In: Davis RE, Northcutt RG (eds) Higher brain areas and functions. Fish neurobiology, vol 2. University of Michigan Press, Ann Arbor, pp 117–140
2. Butler AB, Hodos W (2005) Comparative vertebrate neuroanatomy: evolution and adaptation, 2nd edn. Wiley-Liss, Hoboken, NJ
3. Smeets WJ, González A (2000) Catecholamine systems in the brain of vertebrates: new perspectives through a comparative approach. *Brain Res Brain Res Rev* 33:308–379
4. Mueller T, Wullimann MF (2005) Atlas of early zebrafish brain development: a tool for molecular neurogenetics. Elsevier Publishing Company, Amsterdam
5. Puelles L, Rubenstein JL (2003) Forebrain gene expression domains and the evolving prosomeric model. *Trends Neurosci* 26:469–476
6. Wullimann MF, Vernier P (2006) Evolution of the nervous system in fishes. In: Kaas J (ed) Evolution of nervous systems, vol 1. Academic Press, London, pp 39–60
7. Björklund A, Dunnett SB (2007) Dopamine neuron systems in the brain: an update. *Trends Neurosci* 30:194–202
8. Rink E, Wullimann MF (2001) The teleostean (zebrafish) dopaminergic system ascending to the subpallium (striatum) is located in the basal diencephalon (posterior tuberculum). *Brain Res* 889:316–330
9. González A, Smeets WJAJ (1994) Catecholamine systems in the CNS of amphibians. In: Smeets WJAJ, Reiner A (eds) Phylogeny and development of catecholamine systems in the CNS of vertebrates. Cambridge University Press, Cambridge, pp 77–102
10. Sommer L, Ma Q, Anderson DJ (1996) Neurogenins, a novel family of atonal-related bHLH transcription factors, are putative mammalian neuronal determination genes that reveal progenitor cell heterogeneity in the developing CNS and PNS. *Mol Cell Neurosci* 8:221–241
11. Marín F, Herrero MT, Vyas S, Puelles L (2005) Ontogeny of tyrosine hydroxylase mRNA expression in mid- and forebrain: neuromeric pattern and novel positive regions. *Dev Dyn* 234:709–717
12. Wullimann MF, Mueller T (2004) Teleostean and mammalian forebrains contrasted: evidence from genes to behavior. *J Comp Neurol* 475:143–162
13. Kapsimali M, Bourrat F, Vernier P (2001) Distribution of the orphan nuclear receptor *Nurr1* in medaka (*Oryzias latipes*): cues to the definition of homologous territories in the vertebrate brain. *J Comp Neurol* 431:276–292
14. Ishikawa Y, Yamamoto N, Yoshimoto M, Yasuda T, Maruyama K, Kage T, Takeda H, Ito H (2007) Developmental origin of diencephalic sensory relay nuclei in teleosts. *Brain Behav Evol* 69:87–95
15. Pombal MA, El Manira A, Grillner S (1997) Afferents of the lamprey striatum with special reference to the dopaminergic system: a combined tracing and immunohistochemical study. *J Comp Neurol* 386:71–91
16. Wicht H, Northcutt RG (1994) An immunohistochemical study of the telencephalon and the diencephalon in a myxinooid jawless fish, the Pacific hagfish, *Eptatretus stouti*. *Brain Behav Evol* 43:140–161
17. Stuesse, SL, Cruce, WLR, Northcutt RG (1994) Localization of catecholamines in the brain of Chondrichthyes (cartilaginous fishes). In: Smeets WJAJ, Reiner A (eds) Phylogeny and development of catecholamine systems in the CNS of vertebrates. Cambridge University Press, Cambridge, pp 21–49
18. Smeets WJAJ (1994) Catecholamines in the CNS of reptiles: structure and functional correlation. In: Smeets WJAJ, Reiner A (eds) Phylogeny and development of catecholamine systems in the CNS of vertebrates. Cambridge University Press, Cambridge, pp 103–133.

19. Northcutt RG (2006) Connections of the lateral and medial divisions of the goldfish telencephalic pallium. *J Comp Neurol* 494:903–943
20. Murakami Y, Uchida K, Rijli FM, Kuratani S (2005) Evolution of the brain developmental plan: Insights from agnathans. *Dev Biol* 80:249–259

## Evolution of the Reticular Formation

PAUL R. MANGER

School of Anatomical Sciences, Faculty of Health Sciences, University of the Witwatersrand, Johannesburg, Republic of South Africa

### Definition

The reticular formation encompasses a wide variety of neurons found predominately in the adult derivative of the basal plate of the brainstem but extending to the forebrain. It is involved in the regulation, control and coordination of a variety of neural and neuromuscular processes.

### Characteristics

#### Organization of the Reticular Formation

The term reticular formation is used to encompass a large expanse of neurons scattered throughout the central nervous system, from the spinal cord to the forebrain. This distribution makes the definition and delineation of this neural system a difficult task, especially across species, as traditionally, the majority of studies of this formation have been restricted to mammals, with differing terminology used across the various vertebrate classes and no clear homology of this formation in the invertebrate brain. Within the brainstem (the midbrain, pons and medulla oblongata), the reticular formation can be divided into three major rostro-caudally oriented cell columns—the raphe column located either side of the midline, the magnocellular/gigantocellular column located just lateral to the raphe column and the parvocellular column occupying the most lateral position. These columns can be subdivided according to cell size and type and their connectivity with other parts of the brain. The parvocellular or small-celled column tends to be the region that receives axons from sensory systems of the brainstem and spinal cord. The magnocellular/gigantocellular or large-celled column tends to be the region creating the output of the reticular formation, sending axons to the motor neurons of the spinal cord and brainstem or to higher levels of the brain.

The neurons of the reticular formation are mostly characterized by having long straight dendrites (of the ► isodendritic type) and axons that project, often over a

large distance in the brain, to other neuronal groups. This neuronal morphology allows the reticular formation to interact with axons traversing the brainstem, whether these are ascending axons from the spinal cord or cranial nerves or are descending axons from more dorsal portions of the brain. The long axons of these neurons often collateralize significantly (except in the lamprey), innervating distant portions of the brain as well as other subdivisions of the reticular formation to allow the subdivisions to act in concert.

A variety of nomenclatures have been applied to the reticular formation and numerous subdivisions either included or excluded from this formation by different authors (see Butler and Hodos [1] for a conciliation of this terminology). Within the diencephalon lies the most rostral portion of the reticular formation, this being the reticular nucleus of the dorsal thalamus. A reticular nucleus associated with the dorsal thalamus (or something similar) appears to be present in most vertebrate classes. Within the diencephalon and brainstem there are many subdivisions of the reticular formation that have been identified across many vertebrate species using immunohistochemical techniques, due to the specific neurotransmitters produced (including noradrenalin, adrenalin, serotonin, acetylcholine, GABA and several others). These neuronal groups are known to be involved in the sleep-wake cycle (see below) and may be the easiest parts with which to determine the evolutionary trajectory of the reticular formation (see below). Many of the immunohistochemically identifiable subdivisions project great distances over the brain and spinal cord. Within the midbrain of most vertebrate species two subdivisions of the reticular formation, the nuclei cuneiformis and subcuneiformis (or mesencephalic division in less complex brains) are commonly found lying dorsal to the substantia nigra within the midbrain tegmentum. Within the pons, the two major components of the reticular formation regularly identified are the nucleus pontis oralis, which lies anterior to the second subdivision, the nucleus pontis caudalis. Neuronal groups within the pons that produce specific neurotransmitters include the noradrenergic locus coeruleus complex, the serotonergic dorsal raphe and the cholinergic pedunculo-pontine and lateral dorsal tegmental nuclei. Within the medulla oblongata, the three columns of the reticular formation are clearest, with the midline serotonergic raphe nuclei, various subdivisions of the gigantocellular column and the subdivisions of the parvocellular column apparent. These subdivisions are accompanied by the adrenergic neurons of the area postrema. The number and location of the subdivisions of the medullary reticular formation differ across vertebrate species, but there is a great deal of conservation in particular nuclei, which can be recognized across classes.

### Functional Aspects of the Reticular Formation

The functional organization of the reticular formation can be appreciated based on the resultant effects of its two major sets of efferent pathways – the “ascending” pathways that project to the diencephalon and telencephalon and the “descending” pathways that project to the cranial nerve motor nuclei and spinal cord, the ►reticulobulbar and ►reticulospinal pathways respectively. The descending pathways are mainly involved in the regulation, coordination and organization of movement, as well as in the maintenance of muscle tone. Thus the descending pathways act in concert with those parts of the brain that enable rhythmic pattern generation of movements such as respiration, swimming, walking, flying, chewing and, in electric fish, the repetitive discharge of the electric organs. The ascending pathways are involved in processes such as the sleep-wake cycle [and the various phases of this cycle such as arousal, slow wave sleep (SWS) and rapid eye movement sleep (REM)] and attention (the ability to focus upon a particular stimulus while filtering out input from other stimuli). An intriguing example of the differing end effects (or post-synaptic actions) comes from studies of the serotonergic raphe system of the reticular formation. The pontine serotonergic neurons mainly project upon the forebrain and result in inhibition of the post-synaptic neurons (during wake), while the medullary serotonergic neurons mainly project upon the spinal cord and result in excitation of the post-synaptic neurons (the loss of this excitation in REM sleep is partly responsible for the lack of muscle tone in this state). While the majority of research on reticular formation function has been undertaken in mammals, there is good evidence that this system has similar functional roles in non-mammalian amniotes (bird and reptiles) and anamniotes (amphibians and fish), as well as possibly in invertebrates (although, for example, the serotonergic component may be represented by a single neuron). Perhaps the simplest way to encompass the vast variety of functions in which the reticular formation is involved is to consider that the descending pathways are involved in the global coordination and tone of the activities of the musculo-skeletal system and the ascending pathways are involved in the global coordination and tone of the neural activity of the forebrain.

The functional roles of the reticular formation in vertebrates were summarized [1] to include:

- the coordination of movements of the head and body by facilitation and inhibition of both voluntary and reflex movements
- alteration of respiration and blood pressure
- serving as a “gate” to block out sensory inputs, including pain

- psychological processes such as arousal and attention
- sleep and dreaming
- regulation of muscle tone

### Immunohistochemically Identifiable Subdivisions and Evolution of the Reticular Formation

In terms of understanding the evolution of the reticular formation, perhaps the parts of this formation that have been studied with the most clarity across species are the immunohistochemically identifiable portions, three of which are the catecholaminergic [2], cholinergic [3] and serotonergic systems [4]. These studies have, for the most part, concentrated on differences between classes of vertebrates and found an increased complexity, in terms of numbers of homologous subdivisions of these systems, increased neuronal numbers and increased branching patterns associated with larger, and ostensibly more complex brains. These studies, however, provide a somewhat limited view of brain evolution, have restricted the analysis of the data to a gradualistic, or neo-Darwinian approach (►gradualistic evolution) and have not forwarded any specific hypotheses regarding the evolution of these systems and of the reticular formation in general. More recently Manger [5], based on earlier observations in various mammals [6,7,8,9,10], proposed that changes in the complexity (the number of homologous nuclei) of these immunohistochemically identifiable neuronal systems might only occur at the genesis of a new mammalian order (►constrained evolution). For example, in both species of monotremes studied, 52 directly homologous subdivisions (and no others) of these systems were found, despite a 3-fold difference in brain size, an over 50 million year divergence and extremely different phenotypes and life histories. It has also been noted that the locus coeruleus of the 1,500 g bottlenose dolphin brain contains fewer subdivisions than the 1 g mouse brain. As a last example, the extreme regression of the visual system in the African common molerat does not lead to a reduction in the number of components of these systems, even those related to the visual system, in comparison to normally sighted rodents [11]. These observations indicate that it is highly likely that at the level of neural organization termed the systems level there may be understandable patterns in the evolution of the reticular formation. This pattern is rather conservative as it appears that changes at the systems level of organization of the reticular formation may only occur during (or be constrained to) the evolutionary events leading to the formation of a new order and not at other times. There are yet to be any substantive evolutionary observations made at other levels of organization of the reticular system; however, it does appear that this system may be one of the most conservative parts of the brain in terms of evolutionary change, at least in vertebrates.



## The Reticular Formation and the Evolution of Sleep and Dreaming

As mentioned above, the reticular formation plays a major role in the regulation and timing of the sleep-wake cycle, including changes in the level of alertness or drowsiness when awake, changes during sleep between the different stages of slow wave sleep (SWS) and changes between slow wave sleep and rapid eye movement sleep (REM). Many of the components of the reticular formation involved in the control of the sleep-wake cycle have been identified immunohistochemically. These components comprise two major neuronal groupings located in the basal forebrain plus hypothalamus (GABAergic, cholinergic, hypocretinergic and histaminergic neurons) and the pontine tegmentum (GABAergic, glutamatergic, noradrenergic, cholinergic and serotonergic neurons) [12]. Their connections include local ones within and between the individual components as well as those with other parts of the brain. How these components relate to the evolution of ►sleep phenomenology is not yet fully understood, however.

Sleep is a vital function for all vertebrates and sleep-like states have been documented for invertebrates, with a sleep-like state being recently reported for jellyfish [13]. There are differences in the way the various vertebrates sleep, particularly in the clear occurrence of REM sleep in mammals and birds but not in reptiles, amphibians or fish. There is also a conservative aspect to sleep evolution, with SWS being found in all classes of vertebrates. One interesting example of sleep evolution is derived from studies of the monotremes, where it has been shown that the forebrain shows classical signs of SWS while the brainstem and body exhibit signs of REM sleep [14,15,16]. These observations fit well with the lack of cholinergic neurons in the anterior hypothalamus of the monotremes [6] and implicate the cholinergic system in the global coordination of brain state, this coordination being split into two parts in the monotremes. This is interesting in a further light regarding the evolution of dreaming. Dreaming is for the most part associated with the desynchronized activity of the forebrain during REM sleep. During SWS dreaming also occurs, but these dreams are very simple dreams and quite different from the intense dreams of REM sleep. As said above, REM sleep does not occur in reptiles and in birds it occurs only in short bursts, but in mammals REM can last for periods of up to 30 mins. In the monotremes, REM sleep occurs in the brainstem but not the forebrain. So do the monotremes dream? It is likely that they have dreams similar to those that occur in SWS in other mammals (including humans) but that they don't have the intense dreams associated with REM in humans and other mammals. Thus, it might be concluded that dreaming, as a memorable cognitive event, did not evolve until after

the monotreme divergence from the remainder of the mammals, and this may be linked to an altered anatomy of the reticular formation in the monotremes.

## References

1. Butler AB, Hodos W (2005) Comparative vertebrate neuroanatomy: evolution and adaptation 2nd edn. Wiley, Hoboken
2. Smeets WJAJ, González A (2000) Catecholamine systems in the brain of vertebrates: new perspectives through a comparative approach. *Brain Res Rev* 33:308–379
3. Rodríguez-Moldes I, Molist P, Adrio F, Pombal MA, Pérez SE, Yáñez J, Mandado M, Marín O, López JM, González A, Anadón R (2002) Organization of cholinergic systems in the brain of different fish groups: a comparative analysis. *Brain Res Bull* 57:331–334
4. Bjarkam CR, Sorensen JC, Geneser FA (1997) Distribution and morphology of serotonin-immunoreactive neurons in the brainstem of the New Zealand white rabbit. *J Comp Neurol* 380:507–519
5. Manger PR (2005) Establishing order at the systems level in mammalian brain evolution. *Brain Res Bull* 66:282–289
6. Manger PR, Fahringer HM, Pettigrew JD, Siegel JM (2002) The distribution and morphological characteristics of cholinergic cells in the brain of monotremes as revealed by ChAT immunohistochemistry. *Brain Behav Evol* 60:275–297
7. Manger PR, Fahringer HM, Pettigrew JD, Siegel JM (2002) The distribution and morphological characteristics of catecholaminergic cells in the brain of monotremes as revealed by tyrosine hydroxylase immunohistochemistry. *Brain Behav Evol* 60:298–314
8. Manger PR, Fahringer HM, Pettigrew JD, Siegel JM (2002) The distribution and morphological characteristics of serotonergic cells in the brain of monotremes. *Brain Behav Evol* 60:315–332
9. Manger PR, Ridgway SH, Siegel JM (2003) The locus coeruleus complex of the bottlenose dolphin (*Tursiops truncatus*) as revealed by tyrosine hydroxylase immunohistochemistry. *J Sleep Res* 12:149–155
10. Manger PR, Fuxe K, Ridgway SH, Siegel JM (2004) The distribution and morphological characteristics of catecholaminergic cells in the diencephalon and midbrain of the bottlenose dolphin (*Tursiops truncatus*). *Brain Behav Evol* 64:42–60
11. Da Silva JN, Fuxe K, Manger PR (2006) Nuclear parcellation of certain immunohistochemically identifiable neuronal systems in the midbrain and pons of the Highveld mole rat (*Cryptomys hottentotus*). *J Chem Neuroanat* 31:37–50
12. Siegel JM (2004) The neurotransmitters of sleep. *J Clin Psychiatry* 65 (suppl 16):4–7
13. Kavanau JL (2006) Is sleep's "supreme mystery" unraveling? An evolutionary analysis of sleep encounters no mystery; nor does life's earliest sleep, recently discovered in jellyfish. *Med Hypotheses* 66:3–9
14. Siegel JM, Manger PR, Nienhuis R, Fahringer HM, Pettigrew JD (1996) The echidna *Tachyglossus aculeatus* combines REM and non-REM aspects in a single

- sleep state: implications for the evolution of sleep. *J Neurosci* 16:3500–3506
15. Siegel JM, Manger PR, Nienhuis R, Fahringer HM, Pettigrew JD (1998) Monotremes and the evolution of rapid eye movement sleep. *Philos Trans R Soc Lond B* 353:1147–1157
  16. Siegel JM, Manger PR, Nienhuis R, Fahringer HM, Shalita T, Pettigrew JD (1999) Sleep in the platypus. *Neuroscience* 91:391–400

## Evolution of the Somatosensory System in Mammals

JON H. KAAS

Department of Psychology, Vanderbilt University, Nashville, TN, USA

### Definition

The somatosensory system comprises multiple ascending pathways that relay information about touch, position sense, nociceptive stimuli (pain) and temperature to various sites in the brainstem, diencephalon and pallium.

### Characteristics

Across vertebrates, the somatosensory system is most elaborated in amniotes, particularly mammals. In addition, the system is variable in complexity, details of organization and function across mammalian taxa. Some of these complexities are discussed here, but the focus is on the basic organization of the mammalian somatosensory system (Fig. 1).

The components of the system that are common to all or most mammals are those that were probably present in the first mammals.

### Somatosensory Receptors

The somatosensory system of mammals is activated by receptors in the skin and in deeper tissues. Most of these receptor types were most likely retained from stem amniote ancestors, including rapidly adapting (RA) and slowly adapting (SA) cutaneous mechanoreceptors mediating touch, muscle spindle and joint receptors for position sense and receptors sensitive to noxious stimuli (pain) and temperature [1]. The interesting difference is that mammals are characterized by having hair and hairs can act as levers so that moving them distorts and activates touch mechanoreceptors in the skin. To take advantage of this characteristic, mammals evolved various types of sensory hairs, often on the face, but also on other parts of the body, to increase sensitivity and to detect objects slightly distant from the body. Thus, cats

use mystacial vibrissa to sense the position of prey and guide killing bites and rats use their vibrissa to make a wide range of discriminations of objects near the body. Bats use sensory hairs to guide flight and seals use vibrissa movements due to water flow to find prey. Specialization of receptors has occurred in the non-hairy glabrous skin of mammals as well. Most notably, the glabrous skin of the nose of the star-nosed mole is packed with over 25,000 specialized receptor arrays called Eimer's organs [2]. The aquatic monotreme mammal, the platypus, has evolved electroreceptors in its bill that activate parallel pathways in the somatosensory system [3] and such receptors are also present, although to a lesser extent, on the snout of the other monotreme taxon, the echidna. These and other specializations in the peripheral anatomy of the receptor arrays represent one of the ways in which mammals have varied as they have evolved to adapt to different environmental niches.

### Ascending Somatosensory System Pathways to Midbrain and Thalamus

The receptors activate peripheral nerve afferents that project to second-order neurons in the spinal cord and brainstem. Second-order neurons include those in the dorsal horn of the spinal cord and the hindbrain or brainstem complex of nuclei in the medulla and pons. Some of these second-order neurons access local circuit neurons that mediate reflexes, and others project to a higher target. Some of the second-order neurons project to the cerebellum, providing sensory guidance for adjusting and conducting motor behavior. Others project to the superior colliculus to help direct eye movements to targets of interest and to the zona incerta of the upper brainstem, which projects to other targets including the superior colliculus and even the cerebral cortex to influence the functions of these structures. However, the projections that have been most intensively studied are those to the dorsal thalamus. The rapidly conducting, low threshold cutaneous mechanoreceptors that relay in the hindbrain complex project to the ventroposterior nucleus (VP), a nucleus found in all mammals.

By tradition, two subnuclei have been distinguished as 'nuclei' in VP. The ventroposterior medial subnucleus, VPM, forms the largest target component of VP in most mammals as it receives information carried by branches of the trigeminal nerve from the contralateral face and both ipsilateral and contralateral receptors of the teeth, tongue and other surfaces of the oral cavity. Information from the facial vibrissa and from the receptors of the tongue and teeth guiding food processing [4] are very important for mammals, hence the large size of the VPM portion of VP. The ventroposterior lateral subnucleus, VPL, represents the rest of the contralateral body, mediated through

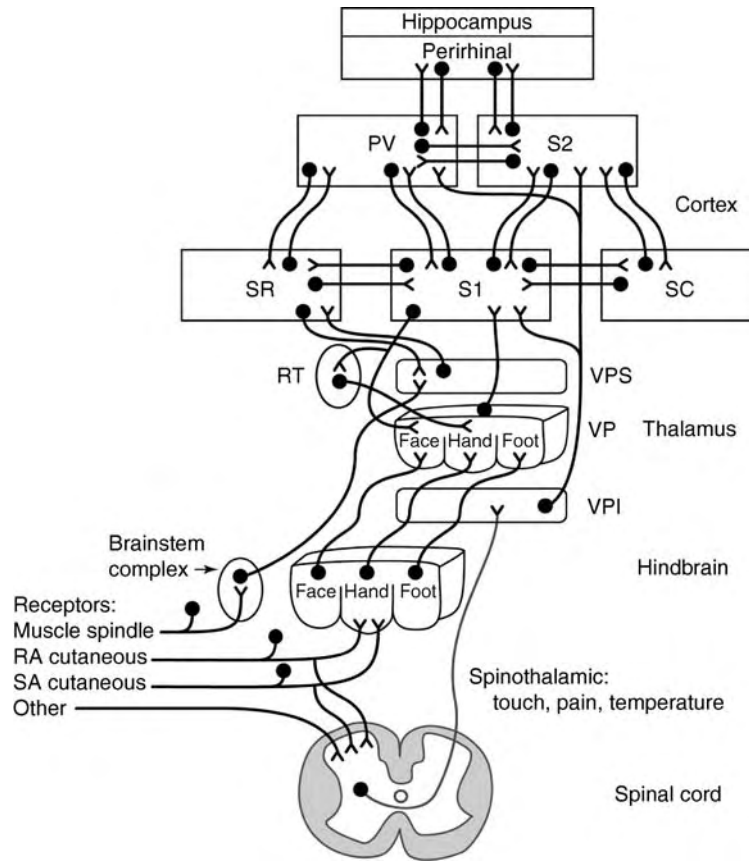

**Evolution of the Somatosensory System in Mammals. Figure 1** A diagram of the basic organization of the somatosensory system of early mammals. These nuclei and areas are those that have been retained in most extant mammals. Not all of the connections and structures are shown. For example, the posterior nucleus or anterior pulvinar is not included (see text). Processing starts with receptors in the skin, muscles and other deep tissues. Other receptors include those mediating pain and crude touch. Rapidly and slowly adapting receptors (RA and SA) mediate aspects of touch. The hindbrain, or brainstem, complex (also called the trigeminal-dorsal column complex) in the lower brainstem includes trigeminal, cuneate and gracile subnuclei for the face, forelimb and hindlimb, respectively. Separate nuclei in the complex relay muscle spindle receptor information to the cerebellum (not shown) and thalamus. Terminations in the spinal cord activate neurons that project contralaterally to form the spinothalamic tract. The somatosensory thalamus includes the ventroposterior nucleus (VP), the ventroposterior inferior nucleus (VPI) that is not recognized in most mammals and the ventroposterior superior nucleus (VPS) that is otherwise named or unrecognized in non-primate mammals. The thalamic reticular nucleus of the ventral thalamus receives inputs from VP and somatosensory cortex, while having inhibitory neurons that project to VP. Primary somatosensory cortex (S1), the second somatosensory area (S2) and the parietal ventral area (PV) are the targets of VP. VPS projects to the somatosensory rostral belt (SR), identified as area 3a in primates, while VPI projects broadly to somatosensory cortex. SC, the somatosensory caudal belt is in the position of area 1 of primates. For long-term memory, the somatosensory system accesses perirhinal cortex and the hippocampus.

the dorsal column systems. In some mammals such as humans, a large representation of the receptors of the glabrous hand is found, as the hand (forepaw) has become an important tactile surface. Those monkeys with a glabrous surface on a prehensile tail have a larger representation of the tail in VPL. The basic principle is that skin regions with dense arrays of receptors have larger representations in the somatosensory system, including VP. The skin regions that are over-represented are species variable.

Muscle spindle afferents from the body also project to the somatosensory thalamus after relaying in contralateral subnuclei of the medullary complex, but the thalamic target of this relay has not been consistently identified and named. In primates, these proprioceptive inputs terminate in a nucleus on the dorsal (superior) margin of VP that has been called the ventroposterior superior nucleus (VPS) [5,6]. A similar nucleus has been identified in many other mammals, where it has been given different names or considered part of VP. Other second-order neurons in the

spinal cord and spinal divisions of the trigeminal complex project to the contralateral thalamus in and around VP. These projections have many functions and they appear to terminate in more than one nucleus, but these nuclei are usually poorly defined. However, in primates a nucleus with these spinothalamic and medullary inputs just ventral to VP has been defined as the ventroposterior inferior nucleus, VPI.

### Somatosensory Cortical Areas

VP relays to primary somatosensory cortex, S1, also termed area 3b in primates [7], as well as to two second-level areas, the second somatosensory area (S2) and the parietal ventral area (PV) [8]. In monkeys and probably other anthropoid primates, the projections to PV and S2 have been lost, while projections to two caudal belt (secondary) areas, termed area 1 and area 2, have been gained [1]. VPS or its homologue projects to the rostral belt between S1 and the motor cortex, termed area 3a in primates and identified as dysgranular cortex in rats. In monkeys, VPS also projects to area 2. Finally, VPI projects broadly to many areas of cortex, but densely to S2 and PV. These VPI projections are thought to modulate ongoing activity.

The thalamic region dorsal and somewhat caudal to VP has been identified as the posterior nucleus (or complex) in some mammals such as rats and as the anterior pulvinar in primates. By position and connections with somatosensory cortex, these regions may contain homologous nuclei, but this remains uncertain. Another nucleus, the somatosensory portion of the reticular nucleus of the ventral thalamus has connections with the somatosensory dorsal thalamus and somatosensory cortex. This nucleus and the anterior pulvinar-posterior nucleus appear to modulate the responses of neurons in somatosensory cortex and VP.

All mammals have a primary somatosensory area S1, adjoining narrow rostral and caudal belts of secondary cortex that have been given various names or ignored, at least S2 and often PV (Fig. 2).

It is uncertain whether PV is missing in some mammals or that the evidence has simply not been collected. Thus, early mammals probably had four or five somatosensory areas [5]. S1 projects to all three to four of the other areas, providing the inputs that drive neurons. There are also feedback connections to S1 and S1 sends feedback to the thalamus. The cortical areas further interconnect with each other to form an interactive network. In most mammals, some of these areas also project to a narrow adjoining strip of posterior parietal cortex that is multi-sensory. In placental mammals with a primary motor area and one or more premotor areas, areas of somatosensory cortex, especially PV and S2, access motor areas of the frontal lobe. PV and S2 also project to the perirhinal cortex and gain access to the hippocampus and parahippocampal cortex for long-term memory functions.

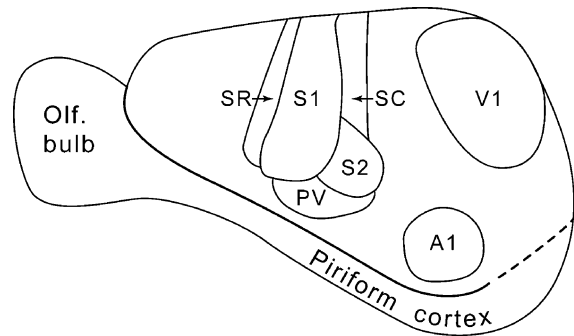

### Evolution of the Somatosensory System

**in Mammals. Figure 2** The arrangement of somatosensory areas typical of small-brained mammals with less complex somatosensory systems. The largest area is the primary somatosensory area, S1, which is bordered laterally by the second somatosensory area, S2 and the parietal ventral area, PV. The somatosensory rostral (SR) and caudal (SC) belt areas also border S1. Primary auditory (A1) and visual (V1) areas are shown for reference. Olf. bulb, olfactory bulb. The brain is a dorsolateral view of the left cerebral hemisphere.

Other outputs are to the basal ganglia, the superior colliculus, the lower brainstem and the upper spinal cord for motor and sensory functions.

In some mammals with larger, more complex brains, such as cats and primates, a number of other somatosensory areas have been added to the basic five. Anthropoid primates have four areas, organized somatotopically, in anterior parietal cortex, area 3a, 3b (S1 of other mammals), 1 and 2 [9]. In addition, these primates have an uncertain number of areas in and around PV and S2 within the lateral sulcus and a number of areas in a greatly expanded posterior parietal cortex, the caudal half of which is predominantly visual in function and the rostral half of which combines visual and somatosensory information to guide motor behavior via projections to M1 and premotor areas.

In summary, many different somatosensory systems have evolved in mammals. Here, the focus has been on describing a basic framework that applies widely to mammals, while only briefly suggesting the great diversity that has emerged across mammalian taxa. This diversity includes variations in the receptor array, including the evolution of specialized sensory hairs and other sensory organs that instruct the development of the rest of the somatosensory systems so that all components are compatible. The components of the central somatosensory system vary in how they represent receptors, their connections with other structures and their structural organization. The somatosensory systems of mammals vary in number of component nuclei and areas and types of modular organization within these areas and nuclei.

The variable organization of somatosensory systems has allowed mammals to be successful in a great range of environmental niches, including the tactile prey detection system of star-nosed moles, the flight guiding system of bats, the system for detecting aquatic prey in swimming mammals and even the addition of an electroreceptive component in monotremes. Humans can thank the system for the skillful use of the hands in tool manufacture and use that has transformed their way of life.

## References

1. Kaas JH (2004) Somatosensory System. In: Paxinos G, Mai JK (eds) *The human nervous system*, 2nd edn. Elsevier, New York, pp 1059–1092
2. Catania KC, Kaas JH (1996) The unusual nose and brain of the star-nosed mole. *BioScience* 46:578–586
3. Krubitzer L, Manger P, Pettigrew J, Calford M (1995) Organization of somatosensory cortex in monotremes: in search of the prototypical plan. *J Comp Neurol* 351:261–306
4. Kaas JH, Qi HX, Iyengar S (2006) Cortical network for representing the teeth and tongue in primates. *Anat Rec* 288A:182–190
5. Kaas JH (2004) Evolution of somatosensory cortex in primates. Special Issue: The evolution of primate sensory systems. *Anat Rec* 281A:1148–1156
6. Krubitzer LA, Kaas JH (1992) The somatosensory thalamus of monkeys: cortical connections and a redefinition of nuclei in marmosets. *J Comp Neurol* 319:123–140
7. Kaas JH (1983) What, if anything, is S1? The organization of the ‘first somatosensory area’ of cortex. *Physiol Rev* 63:206–231
8. Krubitzer LA, Kaas JH (1987) Thalamic connections of three representations of the body surface in somatosensory cortex in grey squirrels. *J Comp Neurol* 265:549–580
9. Kaas JH, Nelson RJ, Sur M, Lin C-S, Merzenich MM (1979) Multiple representations of the body within S-I of primates. *Science* 204:521–523

## Evolution of the Somatosensory System in Nonmammalian Vertebrates

ANN B. BUTLER

Department of Molecular Neuroscience, Krasnow Institute for Advanced Study, George Mason University, Fairfax, VA, USA

### Definition

The somatosensory system in both mammals and nonmammals comprises multiple ascending pathways that relay information about touch, position sense, nociceptive stimuli (pain), and temperature to various sites in the brainstem, diencephalon (the more caudal

component of the forebrain), and pallium (the more dorsal part of the telencephalon, which is the more rostral component of the forebrain).

### Characteristics

Although the somatosensory system is most elaborated in mammals, at least some of the basic ascending pathways have been identified across most of the other major groups of vertebrates. While in fishes, a substantial amount of exteroceptive sensory information is conveyed to the brain via the lateral line system (see Braun, Evolution, of mechanosensory and electroreceptive lateral line systems) that has receptors distributed over head and body regions, ascending spinal, dorsal column, and trigeminal systems are also present and have been studied in some taxa. The trigeminal nerve exhibits a number of diverse specializations across vertebrates, most of which occur in amniotes – from infrared heat sensing in some snakes to electroreception in monotremes to magnetoreception in birds. For a discussion of these adaptations and the anatomy of the system in general in amniotes, see: Manger, Evolution, of the trigeminal sensory system and its specializations.

### Somatosensory System in Fishes

Ascending somatosensory pathways have not been well studied in ray-finned fishes (which include the very large radiation of bony fishes, or teleosts) or cartilaginous fishes (chimaeras and the sharks, skates and rays), so the available information for these taxa is spotty at best [1]. In at least one species of teleost fish, ascending fibers from all levels of the spinal cord project to part of the reticular formation and cerebellum. This pathway has some similarities to the ventral spinocerebellar system of mammals but also several differences. Trigeminal nerve projections have been studied in a relatively basal ray-finned fish, the sturgeon *Acipenser* [2], which has all four of the trigeminal components found in amniotes – principal (medial) (for touch and position sense) and descending (for pain and temperature) sensory nuclei, the motor nucleus (for jaw muscles), and the mesencephalic nucleus (for jaw muscle proprioception). In trout, Walker et al. [3] have found that the trigeminal nerve is involved in magnetoreception: branches of the superficial ophthalmic nerve innervate magnetite-based magnetoreceptor cells located in the olfactory lamellae and are responsive to magnetic field stimuli.

The mesencephalic nucleus of the trigeminal is readily identifiable in most ray-finned fishes, due to the characteristic globular shape of its neuron cell bodies and their constant position along the periventricular cell layers of the optic tectum [1]. This nucleus is extremely large in some fishes, such as the tarpon *Elops*, which is a large fish with powerful jaws, popular with sport fishermen.

More information on the connections of the various somatosensory systems is available in jawless vertebrates [1]. In both hagfishes and lampreys, ascending spinal and dorsal column systems are present. Spinal projections are mainly to the reticular formation, with some fibers reaching as far rostrally as the mesencephalic tegmentum and/or the deep part of the optic tectum, and dorsal funicular fibers also project to sensory, dorsal column nuclei within the medulla. The latter also project to the reticular formation and contain both excitatory and inhibitory cell populations.

The trigeminal system is also present in both hagfishes and lampreys [1]. In the latter, five cell columns receive trigeminal input. Lampreys have nuclei identifiable as homologous to the primary and descending sensory nuclei and the trigeminal motor nucleus of amniotes. Cells within the descending nucleus project to the reticular formation. Consistent with their jawless condition, lampreys lack the tectal-level mesencephalic trigeminal cells found in jawed vertebrates. They may have a homologue of the mesencephalic nucleus in their medulla, and the so-called dorsal cells, or Rohen-Beard cells, which are migrated spinal ganglion cells that lie within the dorsal half of the spinal cord, likewise may be serial homologues of the mesencephalic trigeminal nucleus of other vertebrates.

### Somatosensory System in Amphibians

Dorsal column nuclei are present in amphibians [4]. These nuclei give rise to a medial lemniscus that ascends through the brainstem and projects to sites including the reticular formation, midbrain roof (torus semicircularis and, sparsely in some species, deep layers of the optic tectum), and nuclei within the thalamus [4,5]. A spinothalamic system and a homologue of the mammalian lateral cervical nucleus, which receives ascending spinal inputs and projects to the contralateral thalamus, have also been identified in amphibians [5]. Trigeminal nuclei, similar to those in other vertebrates, include principle and descending sensory nuclei and a trigeminal motor nucleus.

Ascending somatosensory systems may not be relayed through the dorsal thalamus in a manner similar to that in amniotes, however. Westhoff et al. [6] have found that in a toad (*Bombina orientalis*), most somatosensory input to the diencephalon is confined to the ventral thalamus and posterior tuberculum. Within the dorsal thalamus, input is very sparse and appears to be confined to the more caudally lying central thalamic nucleus, rather than to the more rostral part of the thalamus, the latter thought to be homologous as a field to the rostral part of the amniote thalamus, or lemnothalamus [1], that includes the ventral nuclear group. Thus, as Westhoff et al. [6] discuss, amphibians may lack a disynaptic somatosensory

pathway to telencephalic pallium via the dorsal thalamus, as they similarly lack a disynaptic, dorsal thalamic visual pathway. Since amphibians also lack any substantive collothamic pathways to the pallium (relayed through the midbrain roof and then the dorsal thalamus [1], either these pathways are unique to amniotes or have been secondarily lost in amphibians.

### Somatosensory System in Reptiles

In reptiles, only limited information is available on the somatosensory pathways. A projection from the dorsal column nuclei (DCN) to nucleus dorsolateralis anterior (DLA) of the dorsal thalamus has been demonstrated in a lizard [7], but this same study found only a few retrogradely labeled neurons within the cervical spinal cord and only after injections that involved additional dorsal thalamic nuclei. Thus, a spinothalamic system may be essentially absent in lizards. The dorsal column information that reaches DLA is relayed to the dorsal cortex, and reciprocal projections from the cortex to DLA are also present [7]. Since this pathway is not relayed through the midbrain roof, it constitutes a lemnothalamic pathway [1], homologous to the dorsal column-thalamocortical pathway of mammals. The homologue of the ventroposterior nucleus of mammals lies within the reptilian DLA [7].

Reptiles also have a collothamic somatosensory pathway [1] relayed through the midbrain roof. In crocodiles, this pathway arises from the dorsal column nuclei [8], although from a separate subdivision than that containing the directly thalamic-projecting neurons, and its axons terminate within the deep, somatosensory part optic tectum (the homologue of the mammalian superior colliculus). The somatosensory part of the tectum projects to the medialis complex within the dorsal thalamus, which in turn projects to a restricted part of the dorsal ventricular ridge in the telencephalic pallium [8]. The medialis complex of crocodiles has homologues called by different names in other reptiles – the nucleus medialis posterior and nucleus postero-centralis of lizards, which both also project to the dorsal ventricular ridge [1], and the nucleus caudalis of turtles.

The ascending trigeminal system of reptiles comprises all four components present in other vertebrates – motor, mesencephalic, and two sensory nuclei. Both the descending and the principal sensory trigeminal nuclei give rise to projections to DLA, which relays these inputs to cortex along with those from the dorsal column nuclei [7]. As in mammals, the pathway from the trigeminal nuclei to the dorsal thalamus is bilateral, with the contralateral component predominating.

### Somatosensory System in Birds

In birds, both lemnothalamic and collothamic somatosensory pathways [1] that arise from the dorsal column

nuclei are present. The former involves a relay through nucleus dorsalis intermedius ventralis anterior (DIVA) of the dorsal thalamus, which projects to the somatosensory part of the Wulst (the anterior part of the hyperpallium apicale) within the telencephalic pallium [9]. The latter pathway is via the deeper layers of the optic tectum, which project to two dorsal thalamic nuclei – the caudal part of nucleus dorsolateralis posterior (cDLP) and nucleus semilunaris parovoidalis – which in turn relay the information to part of the avian dorsal ventricular ridge within the nidopallium intermedium.

Like reptiles, mammals, and anamniotes, birds also have a trigeminal system. However, the ascending projections from the principal sensory trigeminal nucleus are highly unusual. Rather than projecting to a nucleus within the dorsal thalamus, the principal nucleus of V projects directly to a target within the nidopallium of the telencephalon, the nucleus basorostralis pallii (previously called nucleus basalis prosencephali) [10]. This direct pathway is known as the quinfrofrontal tract.

## References

1. Butler AB, Hodos W (2005) Comparative vertebrate neuroanatomy: evolution and adaptation, 2nd edn. Wiley, Hoboken, NJ
2. New JG, Northcutt RG (1984) Primary projections of the trigeminal nerve in two species of sturgeon: *Acipenser oxyrinchus*. and *Scaphirhynchus platyrhynchus*. *J Morphol* 182:125–136
3. Walker MM, Diebel CE, Haugh CV, Pankhurst PM, Montgomery JC, Green CR (1997) Structure and function of the vertebrate magnetic sense. *Nature* 390:371–376
4. Muñoz M, Muñoz A, González A, ten Donkelaar HJ (1995) Anuran dorsal column nucleus: organization, immunohistochemical characterization, and fiber connections in *Rana perezi* and *Xenopus laevis*. *J Comp Neurol* 363:197–220
5. Dicke U, Mühlenbrock-Lenter S (1998) Primary and secondary somatosensory projections in direct-developing plethodontid salamanders. *J Morphol* 238:307–326
6. Westhoff G, Roth G, Straka H (2004) Topographic representation of vestibular and somatosensory signals in the anuran thalamus. *Neuroscience* 124:669–683
7. Desfilis E, Font E, Belekova M, Kenigfest N (2002) Afferent and efferent projections of the dorsal anterior thalamic nucleus in the lizard *Podarcis hispanica* (Sauria, Lacertidae). *Brain Res Bull* 57:447–450
8. Pritz MB, Stritzel ME (1994) Anatomical identification of a telencephalic somatosensory area in a reptile, *Caiman crocodylus*. *Brain Behav Evol* 43:107–127
9. Wild JM (1997) The avian somatosensory system: the pathway from wing to Wulst in a passerine (*Chloris chloris*). *Brain Res* 759:122–134
10. Wild JM, Farabaugh SM (1996) Organization of afferent and efferent projections of the nucleus basalis prosencephali in a passerine, *Taeniopygia guttata*. *J Comp Neurol* 365:306–328

## Evolution of the Spinal Cord

WILLIAM HODOS

Department of Psychology, University of Maryland, College Park, MD, USA

### Definition

One of the two major divisions of the central nervous system, the other being the brain. The spinal cord is involved in the integration of sensations from the body region (both internal and external) with somatic motor and visceral motor processes. It also responds to commands from the brain that involve both voluntary and reflex behavior.

### Characteristics

The vertebrate central nervous system is divided into two great regions: the brain, which is involved in using sensory information to affect behavior, and the spinal cord, which controls the musculoskeletal system of the body to move the body through space. Both the brain and spinal cord are also important in the control and regulation of the body's internal organs, also known as the viscera.

### Locomotion

For most animals that live entirely or partly in an aquatic environment, locomotion through the water is by rhythmic, undulatory movements of the body. These movements are augmented by paddling movements of fins or legs and sometimes undulatory movements of fins. Some exceptions to this generalization are aquatic birds, such as ducks and gulls that float on the surface and paddle only with their feet, diving birds that paddle with their wings, and turtles that paddle with their limbs. In contrast, the great majority of land animals (also known as tetrapods, meaning having four legs) move by means of their limbs accompanied by some movements of the trunk [1]. These rhythmic movements, whether of the trunk, fins, or limbs, are controlled by groups of neurons located within the spinal cord called *central pattern generators*. These in turn are controlled by neuronal networks, called *command generators*, that are located within the ► **hindbrain** and ► **midbrain** [2–4].

### Reflexes

Another function of the spinal cord is to perform rapid, automatic reactions in response to either external or internal stimuli. These reactions are known as reflexes. External stimuli result in reflex alterations of body posture or location; internal stimuli result in reflexes that affect, heart rate, respiration, digestion, or other visceral functions.

### Spinal Nerves, Roots, and Ganglia

The spinal cord is connected to the internal or external organs that it controls by means of nerves known as spinal nerves. In general, the nerves entering the dorsal portion of the spinal cord carry sensory information from the external or internal environments into the cord. Those exiting on the ventral surface of the cord carry motor commands to operate muscles or internal organs. These entering and exiting nerves are known as spinal roots. In most vertebrates, the spinal roots eventually converge to form a common mixed nerve. A feature of the dorsal root is the dorsal root ganglion, which contains the cell bodies of the incoming sensory neurons. Located on the common sensory-motor spinal nerve root, is another ganglion, which contains the cell bodies of neurons that send their axons to the viscera. These are part of a semi-autonomous visceral regulatory system known as the autonomic nervous system. It is partly a spinal system and partly a hindbrain system [2,5].

In most vertebrates, the spinal cord runs the entire length of the vertebral column, the series of bony rings that form the backbone. The spinal nerves pass between the vertebrae en route to their destinations in muscles or viscera [6]. In some vertebrates, however, such as adult humans, and some fishes, such as the angler fish (*Lophius piscatorius*), the cord does not extend the entire length of the vertebral column. Nevertheless, the spinal nerves continue on to exit between their appropriate vertebrae. This results in the lower levels of the ►spinal column being filled with nerves only and no spinal cord. This shaggy collection of nerves is known as the cauda equina, which is Latin for horse's tail, which it resembles [2,5].

### Organization of the Spinal Cord

The spinal cord is organized into local regions known as spinal segments, each corresponding to a ►vertebra. Each segment is responsible for the reflexes that involve the sensory and motor nerves that enter and exit that segment. The neurons that form these reflex circuits within a single segment are called intrasegmental neurons. In addition, there is a longitudinal organization that coordinates the activities of several adjacent segments, which are known as extrasegmental or intersegmental reflexes. The command generators of the midbrain and hindbrain organize the reflex activities of many spinal segments and are called suprasegmental reflexes.

Some reflexes of the spinal cord involve only two neurons (a sensory and a motor) and a single synapse between them. These are called monosynaptic reflexes. Most reflexes, however, are polysynaptic and involve one or more additional neurons between the sensory and motor neurons.

### Spinal Autonomy

In mammals, the spinal cord is autonomous of the brain for some rhythmic responses, postural reflexes, and some autonomic reflexes, such as those of the gut. However, in non-mammals, the spinal cord has considerably more autonomy. Thus, in non-mammals, the spinal cord tends to carry out many of its postural and locomotor activities independently of the brain. For example, in the event that the brain detects a potential predator, the spinal cord is capable of executing precise and sophisticated escape routines. Likewise, a decapitated bird, such a chicken, in which much of the brain has been removed but the respiratory and cardiac control regions of the hindbrain left intact, is quite capable of maintaining an upright posture and locomotion [2,5].

### Longitudinal Cell Body and Axon Columns of the Spinal Cord

In general, the neuron cell bodies that are present in one segment of the spinal cord are in line with those of adjacent segments [2,5,6]. Thus, these cell bodies form longitudinal columns within the spinal cord. These cells tend to congregate at the core of the spinal cord and are known as the grey matter.

The grey matter has elongated extensions that are known as horns. Those that protrude dorsally are called the dorsal horns, and those that protrude ventrally are the ventral horns. Some species also have lateral horns in certain regions of the cord. In general, the ventral horns contain the cell bodies of the motor neurons and the dorsal horns contain neurons that receive the incoming axons of the sensory neurons. Various types of interneurons are also present that form the neural networks that are the basis of reflexes and coordinated movement of body segments and appendages. An unusual spinal cord component are the electromotor neurons that innervate the ►electric organs in electric fishes, such the weakly electric Mormyrids, which use their electric fields mainly for communication and as a kind of sonar to navigate murky waters, and the strongly electric fishes such as the electric eel, which use their more powerful electric fields to stun prey or for defense [7].

Also present in the spinal cord are the neurons that regulate the various internal organs. The lateral horns, where present, contain the preganglionic cell bodies of the autonomic nervous system. In the thoracic and upper lumbar segments, where lateral horns are present, they contain the cell bodies of the sympathetic part of this system and are called the intermediolateral columns. A lateral horn is also present in the sacral part of the cord, where it contains parasympathetic preganglionic neurons.

Not all neurons lie within the grey matter; a small number of cells occur within the white matter at the periphery of the spinal cord. These cells are called edge



cells or marginal cells and are probably involved in detection of flexion or bending of the spinal cord itself. A canal, the central canal, which contains cerebrospinal fluid, runs through the center of the grey matter [2,5].

The more superficial regions of the cord consist mainly of intersegmental axons and suprasegmental axons of spinal grey matter that ascend and descend within the cord as well as descending axons from the brain. These axon columns are known as the white matter columns. The axon columns also form larger sets, which are called the lateral, ventral, and dorsal white matter columns, or funiculi. Fig. 1 shows a transverse section through the spinal cord of a lamprey. It shows many of the cell and axon columns of the non-tetrapod cord. These are similar in many ways to those of tetrapods.

Some non-tetrapods, however, possess a number of features not found in the tetrapod spinal cord, such as the axons of the giant Mauthner cell and the axons of the Müller cells. The Müller cell bodies are located in the midbrain and hindbrain in jawless fishes and some ray-finned fishes. They control both normal swimming movements and changes in body orientation to acceleration and gravity. Their axons, which are quite large, are located in the ventral white matter columns. The giant Mauthner axon arises from a gigantic, banana-shaped cell body in the medulla. Only one Mauthner cell body is present on each side of the brain. It is present in jawless fishes, ►ray-finned fishes and some amphibians. It plays a crucial role in escape reflexes by bending the body into a C-shape that quickly points it away from the predator to allow the animal to make a swift change in its direction of locomotion [2,5,8].

### Tetrapod Spinal Cords

The transition from the aquatic environment to the land required limbs capable of supporting the animal's weight in response to the pull of gravity and to move

the animal across the land. In most tetrapods, additional sensory and motor neurons that serve the limbs are present in two regions of the spinal cord: the caudal part of the cervical region in the neck and the lumbar region in the abdominal area. These neurons are present in addition to those that move the trunk in these levels of the spinal cord and hence cause bulges in the cord known as the cervical and lumbar enlargements.

Fig. 2 shows the cervical and lumbar enlargements (or the lack of them) in several groups of tetrapods that vary in their use of limb and trunk muscles.

Also shown are the major levels of the spinal cord: cervical (neck), thoracic (chest), lumbar (abdominal), and sacral (pelvic). In animals with both well developed trunk muscles and well developed limbs, such as lizards, alligators and mammals, the spinal cord has clearly defined cervical and lumbar enlargements [2,5,9,10]. In contrast, snakes, which have exceptionally powerful trunk muscles but no limbs, lack these enlargements. Turtles, on the other hand, have powerful limbs, but lack trunk muscles within their shell. Their spinal cords have clearly defined cervical and lumbar enlargements, but are very thin in the thoracic region where it mainly consists of visceral neurons and longitudinal axon columns [11]. Birds that fly have spinal cords similar to turtles because they lack an extensive system of longitudinal axon columns, since there is little need to coordinate the action of the wings and the legs. In flight, the legs are held motionless and close to the body as are the wings on land.

### Evolution of the Spinal Cord

The spinal cord has been a relatively stable region of the central nervous system during vertebrate evolution. The major changes have occurred during the transition from aquatic locomotion with its emphasis on propulsion by body and tail undulation (with some assistance from

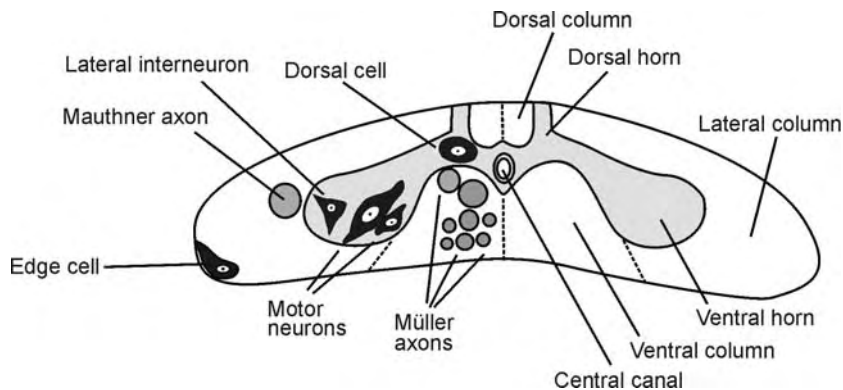

**Evolution of the Spinal Cord. Figure 1** A transverse section through the spinal cord of a lamprey. The right side of the figure shows the grey matter horns and the columns of axons. The left side shows some of the major cell types, the giant Müller axons and the single giant Mauthner axon. From Butler and Hodos [2] and used with permission of John Wiley and Sons.

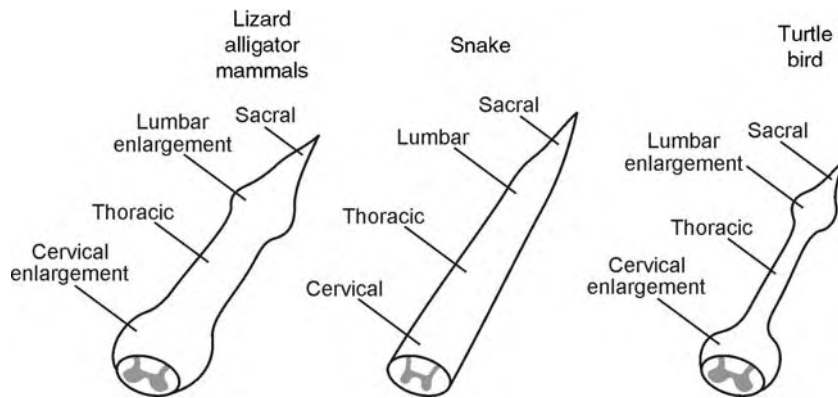

**Evolution of the Spinal Cord. Figure 2** Three types of tetrapod spinal cord. *Left*: A typical spinal cord with both cervical and lumbar enlargements. *Center*: The spinal cord of a snake that is uniformly thick throughout its length and lacks both cervical and lumbar enlargements. *Right*: A spinal cord typical of birds and snakes, which has both cervical and lumbar enlargements, but a thin thoracic region. From Butler and Hodos [2] and used with permission of John Wiley and Sons.

fins) to rhythmic movements of limbs that support the weight of the body in air [2,5,12]. This shift coincided with changes in local connections within the cord and the enlargement of the grey matter columns in the tetrapod cord along with enlargements in the cervical and lumbar regions, especially in animals with moveable digits on the limbs that can manipulate objects [13]. Another major feature of the tetrapod spinal cord is the development of increased numbers of ascending and descending connections between the brain and levels of the spinal cord [14], particularly in species that manipulate objects with their limb digits.

## References

- Liem KF, Bemis WE, Walker WF, Grande L (2001) Functional anatomy of the vertebrates. Harcourt, Fort Worth, TX
- Butler AB, Hodos W (2005) Comparative vertebrate neuroanatomy: evolution and adaptation, 2nd edn. Wiley-Liss, Hoboken, NJ
- Sirota MG, di Prisco FV, Duboc R (2000) Stimulation of the mesencephalic locomotor region elicits controlled swimming in semi-intact lampreys. *Eur J Neurosci* 12:4081–4092
- Zelenin PV, Grillner S, Orlovsky GN, Deliagina TG (2001) Heterogeneity of the population of command neurons in the lamprey. *J Neurosci* 21:793–803
- Nieuwenhuys R, ten Donkelaar HJ, Nicholson C (1998) The central nervous system of vertebrates. Springer, Berlin, Heidelberg, New York
- Lumsden A (1990) The cellular basis of segmentation in the developing hindbrain. *Trends in Neurosci* 13:329–335
- Wong RY, Hopkins CD (2007) Electrical and behavioral courtship displays in the mormyrid fish *Brienomyrus brachyistius*. *J Exp Biol* 210:2244–2252
- Preuss T, Osei-Bonsu PE, Weiss SA, Wang C, Faber DS (2006) Neural representation of object approach in a decision-making motor circuit. *J Neurosci* 26:3454–3464
- Earhart GM, Stein PS (2000) Step, swim, and scratch motor patterns in the turtle. *J Neurophys* 84:2181–2190
- Matez C, Kulik A, Baksai T (2002) Ascending and descending projections of the lateral vestibular nucleus in the frog. *J comp Neurol* 444:115–128
- Currie SN, Gonsalves GG (1999) Reciprocal interaction in the turtle hindlimb enlargement contribute to scratch rhythmogenesis. *J Neurophys* 81:2977–2987
- Wagner GP, Chiu C (2003) Genetic and epigenetic factors in the origin of the tetrapod limb. In: Müller GB, Newman SA (eds) *Origination of organismal form*. MIT Press, Cambridge, MA, pp 265–285
- Sanchez-Camacho C, Marin O, ten Donkelaar HJ, González A (2001) Descending supraspinal pathways in amphibians: II. Distribution and origin of catecholaminergic innervation of the spinal cord. *J Comp Neurol* 434:209–232
- Yamamoto M, Akita M, Imagawa T, Uchara M (2001) Laterality of the spinocerebellar axons and location of cells projecting to the anterior and posterior cerebellum in the chicken spinal cord. *Brain Res Bull* 54:159–165

## Evolution of the Telencephalon in Anamniotes

MARIO F. WULLIMANN<sup>1</sup>, PHILIPPE VERNIER<sup>2</sup>

<sup>1</sup>Ludwig Maximilians-University, Department Biology II – Neurobiology, Planegg-Martinsried, Germany

<sup>2</sup>Institute of Neurobiology A. Fessard, Gif sur Yvette Cedex, France

### Definition

The telencephalon is the most anterodorsal craniate/vertebrate brain division and forms with its anteroventral

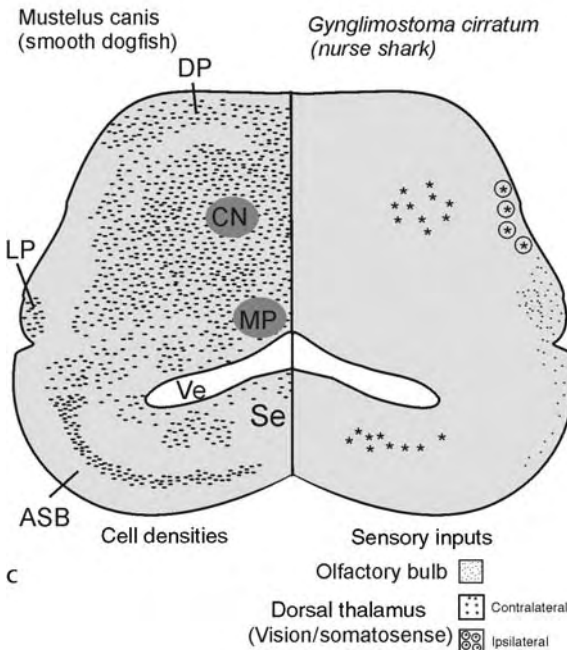
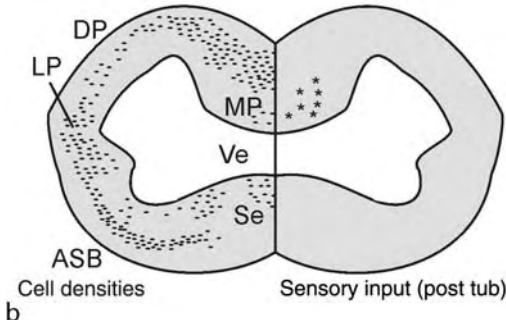
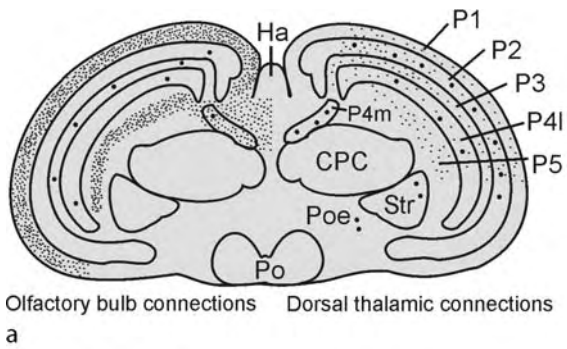

**Evolution of the Telencephalon in Anamniotes.**

**Figure 1** Telencephalic sensory input and output relationships in various fish taxa. (a) *Eptatretus stouti* (Pacific hagfish). *Left side*: Olfactory bulb input to two pallial layers throughout most of their mediolateral extent. *Right side*: Dorsal thalamic input to all pallial layers. Note also reciprocity of connections with both sources of sensory input (after [1]). (b) *Squalus acanthias* (spiny dogfish, a squalomorph shark). *Left side*: Medial, dorsal and lateral pallial divisions dorsal to the subpallium. *Right side*: Multimodal sensory input from posterior tuberculum to medial pallium (see [2] for

complement, the hypothalamus, the most rostral portion of the neural tube. The telencephalon represents part of the ancestral craniate (and, thus, anamniote) brain ►Bauplan (morphotype). The craniate telencephalon includes ventrally a subpallial region (medially: septum; laterally: striatum) and dorsally a pallial region. In addition to olfactory bulb input, the pallium receives ascending sensory information in all craniates, with largely separate pallial terminations in all jawed vertebrates (►gnathostomes). While it is likely that a lateral pallium (olfactory cortex homologue) and a medial pallium (hippocampus homologue) arose at the latest with the gnathostomes (and likely are ancestral for craniates), a dorsal pallium may have arisen several times independently in ►chondrichthyans, teleosts and amniotes. A separate pallial subdivision of the craniate striatal formation may only have evolved with the gnathostomes.

**Characteristics**

**Systematics/Species Diversity**

For systematic relationships and species diversity of extant craniate fish groups, see Essay: Evolution of the Brain in Fishes by Wullimann and Vernier (including Figs. 1a and b).

Craniates include the agnathan myxinioids (hagfishes) and petromyzontids (lampreys), as well as all gnathostomes (jawed vertebrates), but the phylogenetic relationships of these three groups is still a matter of debate, with petromyzontids and gnathostomes either constituting the vertebrates, or myxinioids and petromyzontids forming the ►monophyletic cyclostomes [3]. Gnathostomes include three taxa: (i) Chondrichthyans (cartilaginous fishes), including holocephalans (chimaerans), sharks, and batoids (rays and skates); (ii) ►Actinopterygians (ray-finned fishes), including basal groups, i.e., cladistians (bichirs), chondrosteans (sturgeons), ginglymodes (gars) and halecomorphs (bowfin), as well as the more derived teleosts, including three basal taxa, i.e., osteoglossomorphs (arawanas, arapaimas, etc.), elopomorphs (tenpounders, tarpons and eels) and clupeomorphs (herring-like fishes), plus

Original literature). (c) *Mustelus canis* (smooth dogfish, a galeomorph shark). *Left side*: A large pallial central nucleus is recognized in addition to three conventional pallial divisions. *Right side*: Telencephalic sensory input (established in another galeomorph, the nurse shark *Ginglymostoma cirratum*) (see [2] for original literature). Abbreviations: ASB area superficialis basalis; CN central nucleus; CPC central prosencephalic complex; DP dorsal pallium; Ha habenula; hoc horizontal commissure; LP lateral pallium; MP medial pallium; P1-5 pallial layers; Po preoptic region; Poe external preoptic region; Se septum; Str striatum; TH tuberal hypothalamus; Ve ventricle.

E

the more advanced euteleosts, such as ostariophysans (including cypriniforms, characiforms and siluroids) and percomorphs (perches); (iii) ► **Sarcopterygians** (lobe-finned fishes) include actinistians (coelacanths), dipnoans (lungfishes) and tetrapods, which include (anamniote) amphibians and amniotes. Amphibians (ca. 4,000 extant species) include frogs (anurans), salamanders (caudates, urodeles) and caecilians (gymnophionans, apodans). Thus, unlike amniotes, anamniotes (i.e., all craniates except amniotes) do not comprise all descendants of a hypothetical last common ancestor, because the term, by definition, excludes amniotes. Anamniotes are therefore a paraphyletic group. These systematic relationships are of paramount importance for the discussion of the evolution of telencephalic characteristics in anamniotes [4; and see below].

### Brain Weight-Body Weight Data

For a summary of brain weight-body weight data in anamniotes and amniotes, see Essay: Evolution of the Brain in Fishes by Wullmann and Vernier (including Fig. 2).

### Phyletic Analysis

For a summary of the comparative (cladistic) method for establishing the evolutionary polarity of brain traits, see Essay: Evolution of the Brain in Fishes by Wullmann and Vernier (including Fig. 1a and b).

### The Telencephalon is Part of a Shared Ancestral Craniate/Vertebrate Brain Morphotype (Bauplan)

Instead of stepwise addition of brain parts at the anterior pole of the neuraxis during evolution, a craniate Bauplan of basic brain parts appears to have been initially present from which novelties arose (see Essay: Evolution of the Brain in Fishes by Wullmann and Vernier; including Fig. 3).

In this Bauplan, the telencephalon occupies the most anterodorsal pole and represents, together with the anteroventrally located hypothalamus (as well as eminentia thalami and preoptic region), the most anterior, prechordal part of the neural tube. The craniate telencephalon includes a pallium (cortex in mammals) and a subpallium (including striatum, pallidum, septum in mammals).

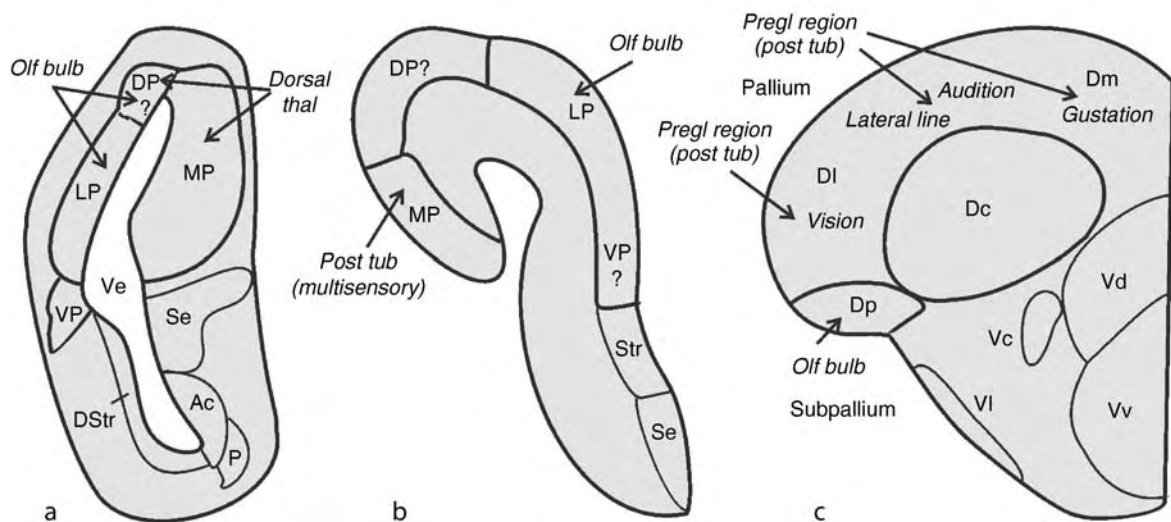

**Evolution of the Telencephalon in Anamniotes. Figure 2** Pallial sensory input and output relationships in amphibians and ray-finned fishes. Sketches of *left* telencephalic hemispheres of: (a) frog. Pallial locations of olfactory bulb and dorsal thalamic inputs are indicated (data from various species) [5,6]. (b) bichir (*Polypterus palmas*). Pallial locations of olfactory bulb and multisensory posterior tubercular inputs are indicated (after [7]). (c) Zebrafish (*Danio rerio*). Pallial locations of olfactory bulb (olf), visual, lateral line mechanosensory, auditory and gustatory inputs (originating in preglomerular nuclei lateral to the posterior tuberculum) as established in various teleost species (for details, see [8,10]). Abbreviations: Ac nucleus accumbens; Dc, Dl, Dm, Dp central, lateral, medial, posterior zones of area dorsalis telencephali (pallium); DIL diffuse nucleus of inferior lobe; DP dorsal pallium; DStr dorsal striatum; LP lateral pallium; MP medial pallium; P Pallidum; Se septum; Str striatum; Vc, Vd, VI, Vv central, dorsal, lateral, ventral nuclei of area ventralis telencephali (subpallium); Ve ventricle; VP ventral pallium.

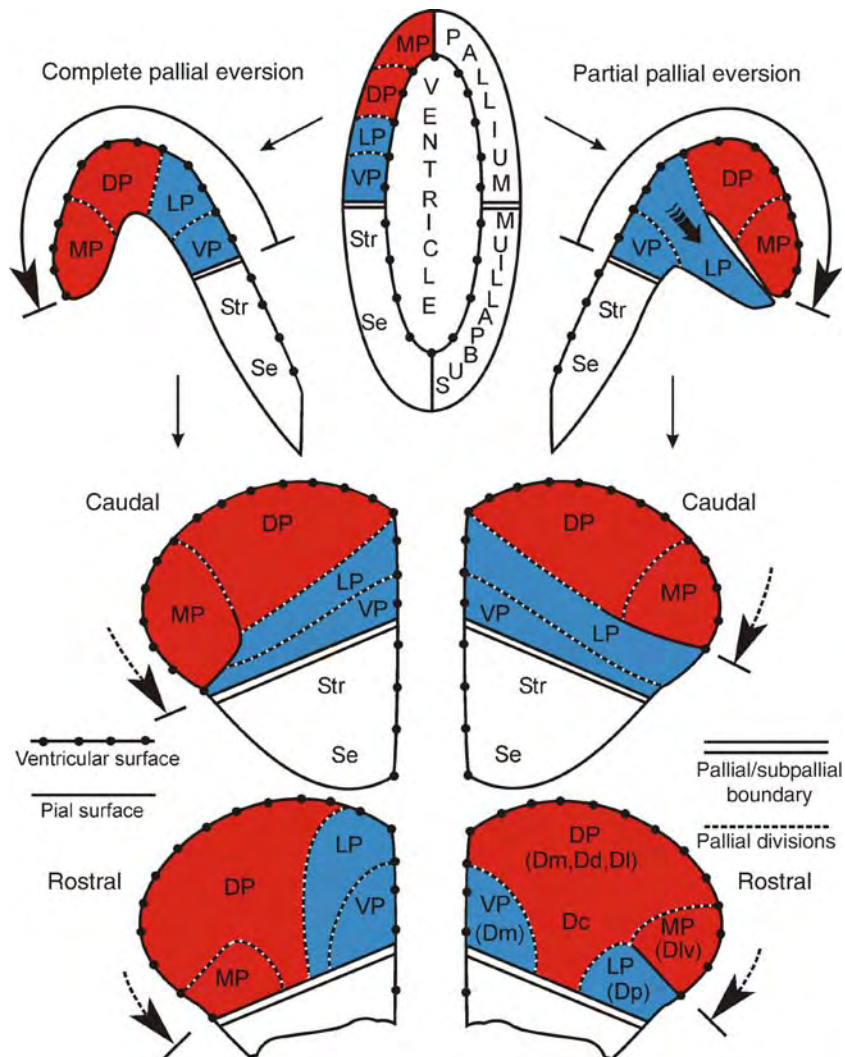

**Evolution of the Telencephalon in Anamniotes.** Figure 3 (after [20]) Complete (*left side*) versus partial pallial eversion model (*right side*) in teleosts and hypothetical relationship of four (medial, dorsal, lateral, ventral) pallial zones in tetrapods to adult teleostean pallial zones. Abbreviations as in Fig. 2.

### Ascending Sensory Pathways Reach Telencephalon in all Craniates

Historically, the smell-brain theory suggested that the fish telencephalon is dominated or even exclusively reached by secondary olfactory input from the olfactory bulb. Thus, a multisensory telencephalon or pallium has been interpreted as a derived amniote or mammalian feature. However, the synaptic relay from diverse primary sensory centers throughout the ascending neuraxis into subpallium and/or pallium in all anamniotes reveals general similarity to the situation in amniotes [4].

### Agnathans

In both the petromyzontid and myxinoïd telencephalon, subpallial (striatum/septum) and pallial divisions

may be recognized. However, at least in myxinoïds (Pacific hagfish; Fig. 1a), the pallium does not appear to exhibit three pallial divisions typical of gnathostomes (i.e., lateral, dorsal and medial pallium; see below), but rather has a homogeneously organized pallial cortex with five distinct neuronal layers throughout [1]. Olfactory bulb input reaches most of the mediolateral extent of the hagfish pallium, but it remains restricted to two pallial layers (P1, P5; Fig. 1a). However, all hagfish pallial layers receive additional dorsal thalamic input [1]. Furthermore, there are reciprocal connections both with the olfactory bulb and, importantly, with the dorsal thalamus. Rather extensive secondary olfactory projections also reach the pallium in petromyzontids (lampreys), but again, these are complemented by dorsal thalamic input to the pallium [9].

Although an outgroup comparison reveals that both agnathan groups have a more olfactory dominated telencephalon or pallium than gnathostome vertebrates, the smell-brain theory is not supported for two reasons. Extant **▶agnathans** differ much from their ancestors in morphology and life habits that are seemingly very specialized for olfactory orientation, possibly representing adaptive novelties. More importantly, both in lampreys and myxinooids, the telencephalon (including the pallium) is of multisensory, and not of exclusive olfactory nature, as the smell-brain theory would predict.

### Chondrichthyans

Cartilaginous fish display paired evaginated telencephalic hemispheres around a central ventricle with medial, dorsal and lateral pallial divisions located dorsal to the subpallium, which includes (medial) septal and (lateral) striatal components (spiny dogfish: Fig. 1b) as discussed by Glenn Northcutt in the early 1980s. Independent telencephalic enlargement occurs in some batoids and sharks (for original literature, see [2]). For example, galeomorph sharks (smooth dogfish; Fig. 1c, left) display a conspicuous large central nucleus in the dorsal pallium.

#### Sensory Systems in Chondrichthyan Pallium

Pioneer discoveries by Sven Ebbesson and colleagues in the early 1980s revealed (i) that the galeomorph telencephalon (nurse shark) receives only very restricted secondary olfactory bulb projections to pallial (lateral pallium) and subpallial territories (Fig. 1c, right) and, (ii), that the central pallial nucleus receives substantial contralateral dorsal thalamic input and the lateral dorsal pallium receives ipsilateral dorsal thalamic input (unspecified modality). The input to the central pallial nucleus was later recognized as visual, somatosensory and mechanosensory (lateral line) by tract tracing and electrophysiology. Furthermore, the medial pallium of the squalomorph spiny dogfish receives multisensory (vision, electrosense; Fig. 1b, right) dorsal thalamic, as well as posterior tubercular inputs (for original literature, see [2]). These findings falsify the smell-brain theory because they show that the ancestral situation for gnathostome vertebrates already is characterized by ascending pathways of most if not all sensory systems reaching the telencephalon.

#### Sensory Systems in Chondrichthyan Diencephalon

Apart from the largely unknown gustatory system, most other sensory systems in cartilaginous fishes have been demonstrated to reach the dorsal thalamus, i.e., vision (retinothalamic and retinotectothalamic pathways), lateral line mechanosensation, somatosensation, and probably audition. Electrosensation ascends via the lateral lemniscal system to the lateral posterior

tuberculum (as also, additionally, lateral line mechanosensation) and to a hypothalamic nucleus, and both nuclei project to the telencephalon (for original literature, see [2]).

These data in cartilaginous fishes suggest that a dual innervation of the diencephalon (dorsal thalamus/posterior tubercular region) by at least some ascending sensory systems is the ancestral pattern for gnathostomes. Furthermore, it may be a gnathostome plesiomorphy that hair cell sensory organs in the labyrinth (audition, vestibular sense) are represented in the dorsal thalamus and the remaining hair cell sensory organs (mechanoreception, electroreception) are present in the posterior tubercular region. If so, the evolutionary loss of the latter sensory systems in amniotes may directly explain the dominance of the dorsal thalamus as the diencephalic sensory region in amniotes.

### Actinopterygians

The actinopterygian telencephalon is divided into a subpallial ventral telencephalic (septum/striatum) and a pallial dorsal telencephalic area (bichir, Fig. 2b; zebrafish, Fig. 2c). Different from the usual vertebrate location of medial, dorsal and lateral pallia, which results from evagination of bilateral telencephalic hemispheres (e.g., in sharks, Figs. 1b, c and amphibians, Fig. 2a), actinopterygian pallial masses are everted [10], as further discussed below and clearly represent an evolutionarily derived situation among vertebrates. Eversion results in altered topology of pallial masses, best illustrated in basal actinopterygians (bichir; Fig. 2b), where the medial pallium (which receives multisensory posterior tubercular input, but not olfactory bulb input) comes to lie laterally, while the lateral pallium (receiving a dense olfactory bulb input) is medially located. In teleosts, the posterior zone of the dorsal telencephalic area (Dp) is the major recipient of secondary olfactory input and is considered the lateral pallium (or olfactory cortex) homologue. The teleostean pallial lateral zone (Dl) has been described as a visual area, the lateral, central (Dc) and medial (Dm) zones as lateral line mechanosensory, the lateral and medial zones as auditory, the medial and central zones as somatosensory, and the medial zone as gustatory-recipient in various teleost species (for original literature, see [2,4,8,10]).

In teleosts, the synaptic relay of almost all sensory system pathways has been neuronally traced from primary sensory centers into the telencephalon (see above). Although the homology of sensory pathways between teleosts and tetrapods is not certain in each single case, the degree of similarity is nevertheless of great functional and evolutionary interest. Vision reaches the telencephalon via a direct retino-thalamic and an indirect retino-tecto-thalamic pathway. In contrast to amniotes, the major telencephalic target is

the subpallium. However, tectofugal visual information reaches the pallium in certain teleosts via the preglomerular region, a complex of migrated nuclei lateral to the posterior tuberculum. The sensory systems which ascend multisynaptically in the lateral longitudinal fascicle (audition, lateral line mechanoreception and electroreception) to the mesencephalon reach the pallium mostly via nuclei in the preglomerular complex and, possibly, dorsal thalamus (only audition). Gustation in teleosts reaches the pallium via a medullary secondary gustatory nucleus and diencephalic preglomerular (and hypothalamic) nuclei. Finally, teleosts possess direct and indirect spinal ascending somatosensory system reaching the dorsal thalamus and preglomerular region.

Thus, similar to cartilaginous fishes the predominant diencephalic targets of teleostean ascending sensory projections are in the preglomerular region located in the lateral periphery of the posterior tuberculum, not in the dorsal thalamus as in amniotes [2,8]. Specific teleostean sensory preglomerular nuclei exist for the auditory, the lateral line mechanosensory, the electro-sensory, the gustatory, the somatosensory, and the visual systems. These preglomerular nuclei have a high degree of cytoarchitectonic differentiation and they - not the dorsal thalamic ones - provide the major diencephalic input to the pallial zones of the area dorsalis telencephali (Fig. 2c). Thus, the functional similarities between the teleostean preglomerular region and the amniote dorsal thalamus are striking: both make up a large proportion of the diencephalon, are subdivided into many nuclei associated with specific sensory systems and, further, most of them have reciprocal connections with the pallium.

### Amphibians

Typically, amphibians have paired evaginated telencephalic hemispheres around a central ventricle and medial, dorsal and lateral pallial divisions have been recognized dorsal to the subpallium, which displays (medial) septal and (lateral) striatal components (frog: Fig. 2a) [5–6]. The olfactory bulb provides heavy input to the lateral pallium, extending also into the dorsal pallium. The medial pallium receives sensory input from the dorsal thalamus (visual, auditory) that also extends into the dorsal pallium. Although ascending sensory input reaches the amphibian posterior tuberculum, its projection to the pallium has not received enough attention, unfortunately. The existence of a separately definable dorsal pallium in amphibians is controversial (see below), although homologies with the mammalian cortex have been evidenced [12,11].

### Evolutionary Origin of Dorsal Pallium and Ventral Pallium

A major current debate relates to the ancestral condition of the craniate/vertebrate pallium. Undoubtedly, both lateral (olfactory cortex homologue) and medial pallia

(hippocampus homologue) are ancestrally present in gnathostomes, and probably in all craniates, based on hodological and embryological evidences [14–17]. However, the existence of a dorsal pallium [neocortex (isocortex) homologue] has recently again been questioned both in amphibians [5] and basal actinopterygians [7]. If so, dorsal pallial territories (characterized by absence of olfactory input typical for lateral pallium and sensory input functionally separable from that to medial pallium) would have evolved separately in chondrichthyans, teleosts, and amniotes.

Interestingly, embryological approaches have established the existence of a fourth craniate/vertebrate pallial division, the ventral pallium (homologue of parts of the amniote pallial amygdala, endopiriform nuclei and claustrum), which is a genetically and functionally definable histogenetic unit in all tetrapods (and likely in all craniates/vertebrates) [16].

### Subpallium

The craniate subpallium has striatal and septal divisions ancestrally. Detailed information recently has been accumulated for the anamniote tetrapod subpallium (e.g., basal ganglia), because homologues of mammalian striatal motor centers (caudatoputamen, nucleus accumbens, pallidum) were identified in amphibians where functional emphasis of basal ganglia is rather on descending motor control than on re-entrant circuits to the pallium (Fig. 2a, [6]). There is also considerable evidence that the dorsal nucleus of the ventral telencephalic area represents both striatum and pallidum in teleosts (Fig. 2c) [8] and that the ventral nucleus represents the septum. Although both striatum and septum appear to exist in chondrichthyans, the exact situation remains elusive because of a lack of functional neuroanatomy and modern developmental work. In contrast, embryological and gene expression data in the ventral telencephalon of lampreys suggest that a pallidal subdivision (in mammals: the derivative of the medial ganglionic eminence) is absent in agnathans and may only originate in gnathostome ancestors [13,15].

### Neurochemical Organization

For a summary of the neurotransmitter/neuromodulatory – i.e. dopamine, noradrenaline, serotonin, histamine, and acetylcholine – systems and their relationship to the telencephalon, see Essay: Evolution of the Brain in Fishes by Wullimann and Vernier, and [2].

### Telencephalic Eversion Versus Evagination

Independent of the problematic ancestral condition of pallial divisions in craniates (see above) is that different modes of telencephalic hemisphere development – eversion in ray-finned fishes versus evagination in all other vertebrates (Figs. 2 and 3) – obscure the comparative interpretation of actinopterygian telencephalic

subdivisions (e.g., subpallial septal and striatal formations, amygdala, or medial, dorsal, lateral and ventral pallial formations seen in tetrapods; as discussed by Mark Braford and Glenn Northcutt in the early 1980s (and see [8,10]). As discussed above, the situation is best grasped in a comparison of basal actinopterygians (bichir; Fig. 2b) with amphibians (frog; Fig. 2a). Also in teleosts, the medial pallium (hippocampus homologue) must be concluded to be dislocated by eversion somewhere to the adult lateral telencephalic periphery. However, the most lateral teleostean pallial division (the posterior zone of area dorsalis, Dp; Fig. 2c) receives the densest secondary olfactory input, typical for the tetrapod lateral pallium (olfactory cortex homologue). Thus, complete topological eversion of the entire teleostean pallium seems doubtful (Fig. 3; left). Recently, a new model of partial pallial eversion (Fig. 3; right) has been suggested [20] where the teleostean Dp is interpreted as a non-everted pallial division, with its main, non-everted portion in the ventrocaudal pallial neural tube wall near the midline (similar to the situation in bichirs; Fig. 2b). A minor anterolateral portion of the teleostean Dp (Fig. 3; lowest right panel) accordingly represents a rostrally laterally dislocated (but also uneverted) portion continuous with the more caudally situated main mass of the lateral pallium. Thus, only dorsal and medial – but not lateral and ventral – pallia would be everted.

There is substantial support for the identification of the teleostean medial pallium (hippocampus homolog) directly dorsal to Dp, i.e., a ventral division of the lateral zone of the dorsal telencephalic area (Dlv), and of the teleostean ventral pallium (e.g., pallial amygdala homologue) in the most medioventral part of the medial zone of the dorsal telencephalic area [18,19]. Dlv is involved in learning and memory of spatial maps because focal Dlv lesions in goldfish lead to a specific deficit in place - but not other - tasks, similar to hippocampus lesioned amniotes. In contrast, lesions in the ventromedial Dm in goldfish result in behavioral deficits comparable to amygdala-like lesions observed in amniotes [18], speaking strongly for the identification of the teleostean pallial amygdala in the medioventral Dm. These behavioral data are in accord with the location of medial and ventral pallium predicted by the partial eversion model (Fig. 3). While functional similarity is not necessarily a valid criterion for homology, these functional commonalities of pallial regions in fishes and mammals together with topological correspondences are striking.

Accordingly, the homologue of the tetrapod dorsal pallium (e.g., mammalian neocortex) would then occupy remaining portions of the teleostean dorsal telencephalic area (i.e., most of medial Dl, all of Dd, Dc, and dorsolateral Dm). Comparing the extent of these areas to the rather small dorsal pallium of

amphibians, one must conclude that the teleostean situation cannot be ancestral, even if considering possible pedomorphic reduction effects in amphibians. Whether basal actinopterygians show a less elaborated dorsal pallium remains an open question at present [7, and see above]. In any case, the development, functional neuroanatomy and evolution of the large zones likely representing the dorsal pallium of teleosts remain fruitful fields to be investigated.

## References

1. Wicht H, Northcutt RG (1998) Telencephalic connections in the Pacific hagfish (*Eptatretus stouti*), with special reference to the thalamopallial system. *J Comp Neurol* 395:245–260
2. Wullimann MF, Vernier P (2007) Evolution of the nervous system in fishes. In: Kaas J (ed) ?Evolution of nervous systems, vol 3: Evolution of nervous systems in non-mammalian vertebrates. Elsevier, Amsterdam, pp 39–60
3. Kuraku S, Kuratani S (2006) Timescale for cyclostome evolution inferred with a phylogenetic diagnosis of hagfish and lamprey cDNA sequences. *Zool Sci* 23:1053–1064
4. Butler AB, Hodos W (2005) Comparative vertebrate neuroanatomy: evolution and adaptation, 2nd edn. Wiley-Liss, Hoboken, NJ
5. Bruce LL, Neary TJ (1995) The limbic system of tetrapods: a comparative analysis of cortical and amygdalar populations. *Brain Behav Evol* 46:224–234
6. Marín O, Smeets WJAJ, González A (1998) Basal ganglia organization in amphibians: evidence for a common pattern in tetrapods. *Prog Neurobiol* 55: 363–397
7. Holmes PH, Northcutt RG (2003) Connections of the pallial telencephalon in the Senegal bichir, *Polypterus*. *Brain Behav Evol* 61:113–147
8. Northcutt RG (2006) Connections of the lateral and medial divisions of the goldfish telencephalic pallium. *J Comp Neurol* 494:903–943
9. Polenova OA, Vesselkin NP (1993) Olfactory and nonolfactory projections in the river lamprey (*Lampetra fluviatilis*) telencephalon. *J Hirnforsch* 34:261–279
10. Meek J, Nieuwenhuys R (1998) Holosteans and teleosts. Nieuwenhuys R, ten Donkelaar HJ, Nicholson C (eds) The central nervous system of vertebrates. Springer, Berlin Heidelberg New York, pp 759–937
11. Laberge F, Roth G (2007) Organization of the sensory input to the telencephalon in the fire-bellied toad, *Bombina orientalis*. *J Comp Neurol* 502:55–74
12. Roth G, Laberge F, Mühlenbrock-Lenter S, Grunwald W (2007) Organization of the pallium in the fire-bellied toad *Bombina orientalis*. I. Morphology and axonal projection pattern of neurons revealed by intracellular biocytin labeling. *J Comp Neurol* 501:443–464
13. Murakami Y, Uchida K, Rijli FM, Kuratani S (2005) Evolution of the brain developmental plan: insights from agnathans. *Dev Biol* 280:249–259
14. Northcutt RG, Wicht H (1997) Afferent and efferent connections of the lateral and medial pallia of the silver lamprey. *Brain Behav Evol* 49:1–19



15. Osório J, Mazan S, Rétaux S (2005) Organization of the lamprey (*Lampetra fluviatilis*) embryonic brain: insights from LIM-homeodomain, *Pax* and *hedgehog* genes. *Dev Biol* 288:100–112
16. Puelles L, Kuwana E, Puelles E, Bulfone A, Shimamura K, Keleher J, Smiga S, Rubenstein JLR (2000) Pallial and subpallial derivatives in the embryonic chick and mouse telencephalon, traced by the expression of the genes *Dlx-2*, *Emx-1*, *Nkx-2.1*, *Pax-6*, and *Tbr-1*. *J Comp Neurol* 424:409–438
17. Striedter GF (1997) The telencephalon of tetrapods in evolution. *Brain Behav Evol* 49:179–213
18. Portavella M, Vargas JP, Torres B, Salas C (2002) The effects of telencephalic pallial lesions on spatial, temporal, and emotional learning in goldfish. *Brain Res Bull* 57:397–399
19. Salas C, Broglio C, Rodríguez F (2003) Evolution of forebrain and spatial cognition in vertebrates: conservation across diversity. *Brain Behav Evol* 62:72–82
20. Wullimann MF, Mueller T (2004) Teleostean and mammalian forebrains contrasted: evidence from genes to behavior. *J Comp Neurol* 475:143–162

## Evolution of the Terminal Nerve

KATHLEEN WHITLOCK

Department of Molecular Biology & Genetics, Cornell University, Ithaca, NY, USA

Departamento de Neurociencia Facultad de Ciencias, Universidad de Valparaiso, Valparaiso, Chile

### Synonyms

Nervus terminalis

### Definitions

The terminal nerve is one of the three most rostral ►cranial nerves and is characterized by neurons that contain ►gonadotropin releasing-hormone (GnRH). While its modality is not yet completely understood, it may play a role in reproductive behavior.

### Characteristics

This essay on the evolution of the terminal nerve presents as its foundation the premise that understanding the embryonic origin(s) of the terminal nerve provides information about the potential evolutionary origin of this cranial nerve. The terminal nerve is characterized as containing neuroactive peptides including the decapeptide gonadotropin releasing-hormone (GnRH), the presence of which is conserved across vertebrates. Analyses of these GnRH-containing cells of the terminal nerve present two possibilities:

1. The terminal nerve arises from the olfactory placode, a structure that gives rise to the olfactory sensory neurons
2. The terminal nerve arises from the ►cranial neural crest, a group of cells known to give rise to neuroendocrine cells in the vertebrates.

### Structure of the Terminal Nerve

The terminal nerve or nervus terminalis is the last identified of the cranial nerves of the peripheral nervous system in vertebrates. The terminal nerve (TN) is found in all jawed vertebrates including humans, although its axonal projection pattern and cell body location vary widely among the vertebrate animals. The TN is associated with the olfactory nerve, has processes extending into the region of the olfactory epithelium and has ganglia located at various points along its projections that run through the ventral olfactory bulb/telencephalon. The more posterior extent of this ganglionic distribution has been termed the nucleus olfactoretinalis (NOR) in some fishes. The NOR, whose cell bodies are generally located posterior to the junction of the olfactory bulb and the telencephalon, has been considered as a structure distinct from the TN in some analyses. In general, comparative analyses suggest that the NOR is in fact the most posterior part of the TN ganglionic distribution (see for review [1]).

The morphology and distribution of the TN ganglionic cells differs across species. Elasmobranchs and teleosts tend to have compact discrete clusters of cells located in the region of the olfactory nerve junction with the olfactory bulbs and at the junction of the olfactory bulbs with the telencephalon. In mammals the TN neurons are more distributed, with less distinct ganglia. The cells of the mammalian TN are often smaller and fusiform-shaped as opposed to the larger round cells observed in the aquatic species. In all animals the cells are predominantly bipolar with one axon process extending toward the peripheral olfactory system and the other one toward the central nervous system.

The axonal projection patterns of the TN vary across vertebrates (Fig. 1). In fishes the TN has a distinct axonal projection to the inner plexiform layer of the retina, a projection that appears also to be present in amphibians [2]. Based on studies in fishes (goldfish), the TN has been shown to have two separate sets of projections, one that extends to the retina but does not have any connections to the olfactory epithelium (Fig. 1, blue) and a second set of projections associated with the olfactory epithelium with extensions in the central nervous system but not to the retina [3] (Fig. 1).

The TN contains neuroactive peptides, such as neuropeptide Y (NPY) and FMRFamide and acetylcholine (as assayed using acetylcholinesterase and choline acetyltransferase markers) [2]. A notable characteristic of the TN is that it contains the neuroendocrine decapeptide

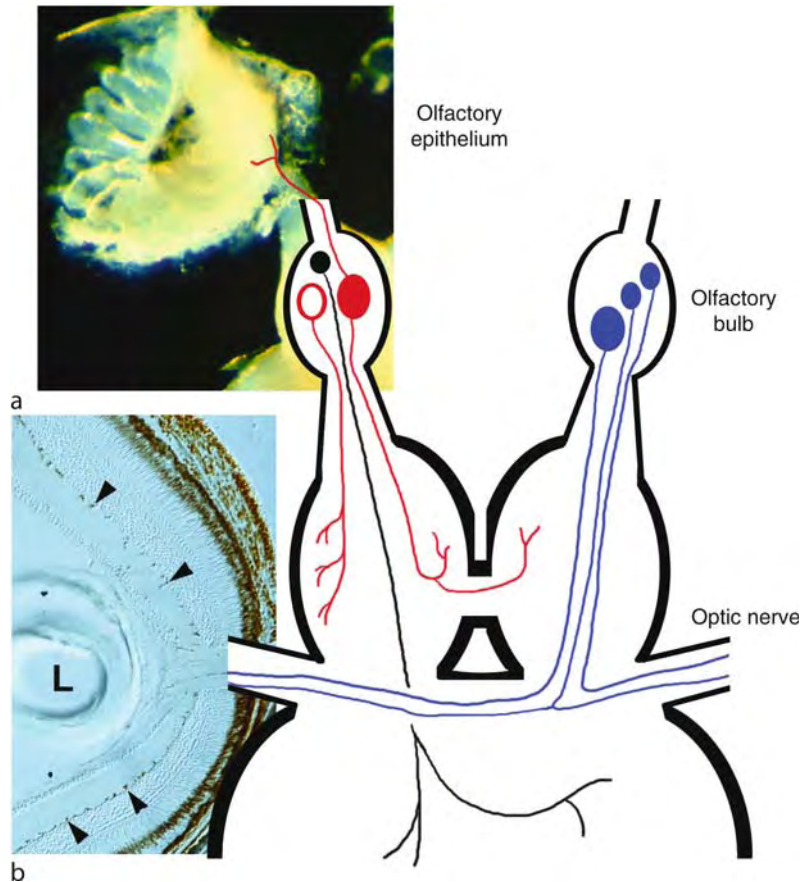

**Evolution of the Terminal Nerve. Figure 1** Diagram depicting the projections of the terminal nerve within the olfactory and visual system. Adapted from Stell et al. [3]. The TN has several types of axonal projections within the olfactory system (*red*), one of which consists of bipolar neurons with axons extending to the olfactory epithelium/mucosa (*red closed circle*). In addition there are projections to the retina (*blue*) and ventral forebrain (*black*). The TN neurons in zebrafish are recognized by an anti-GnRH antibody (LRH13), express *GnRH3* and have axons extending both anteriorly and posteriorly. (a) Olfactory rosette of the adult zebrafish. (b) Section of zebrafish retina depicting GnRH-positive axons and terminals (*arrowheads*) of the TN. L = lens of the eye.

gonadotropin-releasing hormone (GnRH). The presence of GnRH (or luteinizing hormone releasing hormone, LHRH) was first described in 1980 in the guinea pig using immunocytochemical methods [4]. This finding allowed for subsequent studies in which GnRH positive cells were identified in a variety of vertebrate species including mammals, fishes and birds [5]. Reptiles contain FMRF positive cells suggesting that they too may have GnRH positive cells in the TN. Through molecular analysis, it has been shown that there are multiple (three) forms of GnRH in vertebrates based on amino acid sequence. In fishes the form of GnRH found in the terminal nerve (“salmon GnRH” or GnRH3) is often distinct from that found in the hypothalamus (see for review [6,7]). This separation of GnRH cell populations does not appear to be generally true for other animals, although the data are clouded by use of cross-reactive antibodies. Until gene expression, using probes specific

for the sequence of the GnRH genes, is more carefully analyzed across the vertebrate groups, it is difficult to say with certainty whether the fishes are the only animals showing a unique TN-specific form of GnRH.

#### Function of Terminal Nerve

The identification of GnRH positive cells in the TN of gnathostomes provided a valuable tool in the analysis of the function and evolution of the TN. GnRH is a highly conserved neuroendocrine decapeptide that has been identified in all Chordata subphyla – Urochordata, Cephalochordata and Vertebrata – thus suggesting its presence in the ancestral root protochordates. The presence of GnRH positive cells in the TN has been identified in every class of vertebrates except for the silver lamprey [8]. The presence of neurons containing GnRH within the TN suggests a function in reproduction, but this appears to be neuromodulatory and

distinct from the hypothalamic populations of GnRH cells that play a role in release of gonadotropins from the anterior pituitary.

The TN has axonal projections to the olfactory sensory system where the axons terminate near the basement membrane between the lamina propria and olfactory epithelium, although in some cases GnRH positive endings have been observed in the olfactory epithelium [1]. In fishes the TN has axonal projections extending into the retina, of which a subset contain GnRH. The TN has been reported to have functional roles in olfactory and retinal physiology, reproductive function, sexual behavior and interactions with the pineal system, indicating that there is no clear consensus as to the function of the TN.

### Association of Terminal Nerve and Olfactory System

Because the TN ganglionic cells are found in association with the olfactory sensory system, typically embedded in the olfactory nerve, and because some studies propose that the TN arises from the medial olfactory placode, the implicit assumption is that these two nerves are inexorably linked in development and function. The TN is generally present throughout the life of the organism in fishes. In contrast, in mammals the TN is present in all species thus far examined, but it is not uncommon for the TN to be prominent in fetal stages then become less distinct and reduced in the adults. For example, in microsmatic insectivorous bats the TN is present in the early stages of development, but as development proceeds the TN is lost in adults [9]. Interestingly these bats do not have a vomeronasal organ, the part of the olfactory sensory system associated with the TN in mammals.

Evidence suggesting that the TN and the olfactory sensory system are not functionally interdependent is gleaned from studies in the toothed whales, whose nares are displaced to the dorsal surface of the head and are anosmatic. The TN in adult odontocetes is large and contains GnRH positive neurons. The developmental association between the TN and the olfactory epithelium has been analyzed in these animals, since their embryos have an olfactory epithelium, a vomeronasal organ and a TN system, although the vomeronasal system is extremely rudimentary. As development proceeds, the olfactory epithelium degenerates as does the vomeronasal epithelium yet the TN remains [10]. The olfactory epithelium actually regresses prior to the appearance of the future terminal nerve ganglion. The retention of the TN in the adult suggests that olfaction is dispensable in whales, but the function of the TN is necessary to the survival of this group of animals. Because the olfactory placode and TN appear to have separable developmental origins (see below), function may in fact be more readily gained or lost in an independent manner.

### Cranial Nerves are Derived from Neural Crest and Sensory Placodes

Ontogeny recapitulates phylogeny in the sense of the general to the specific; thus, the developmental origin of the TN is informative as to its potential evolutionary origin. The cranial nerves of the nonvisual paired sense organs of the head (nose, taste buds, ears, etc.) have their embryonic origins in the thickenings of the neuroectoderm (placodes) and in neural crest, as exemplified by the olfactory, vomeronasal, trigeminal, facial, vestibulocochlear, glossopharyngeal and vagal nerves [11]. Shortly after the discovery of the TN, it was suggested that the TN arose from cranial neural crest. This proposal was based on observations that the TN was identifiable while the cranial neural crest vanished on either side of the neuropore and that the appearance of these cells in many sections suggested a neural crest origin in elasmobranchs. Observations by Johnston in the early 1900s also noted the close association of the neuropore, developing TN and neural crest and suggested a neural crest origin for the TN (for review see [12]). After the identification of GnRH as a marker for the TN, studies in the developing mouse embryos showed that there are GnRH positive cells associated with the olfactory sensory system, thus supporting the hypothesis that the TN originates in the olfactory placode [13,14]. Thus, the reported close proximity of GnRH-positive cells to the developing olfactory placode and subsequent localization to the TN suggested that the TN arises in part or entirely from the olfactory placode. More recently it was proposed that the ganglionic cells of the TN are of multiple embryonic origins, with the GnRH positive cells proposed to arise from the medial olfactory placode and the catecholaminergic cells from mesencephalic neural crest [11].

Operating on the model that the olfactory placode generates the GnRH containing cells of the TN, a single cell fate map was made in the zebrafish embryo prior to olfactory placode formation and no precursors of GnRH cells (either the TN or hypothalamus) were uncovered [15]. Because neural crest cells contribute to the structural elements of the frontal nasal process by moving anteriorly and surrounding the olfactory placode as it forms (Fig. 2), the possibility that the neural crest contributed to the TN was further explored [16].

The olfactory placode field and pre-migratory neural crest domains are recognizable using gene markers that share a common border (Fig. 2a). Using a combination of dye labeling and single cell lineage tracing, it was demonstrated that GnRH positive cells of the TN originate in cranial neural crest in zebrafish [17]. Subsequently it has been demonstrated that decrement in function of two genes important for neural crest development, *sox10* and *jdk6*, leads to loss of the GnRH cells of the TN as well as those of the midbrain [18]. Thus, the adjacent neural crest and olfactory placode

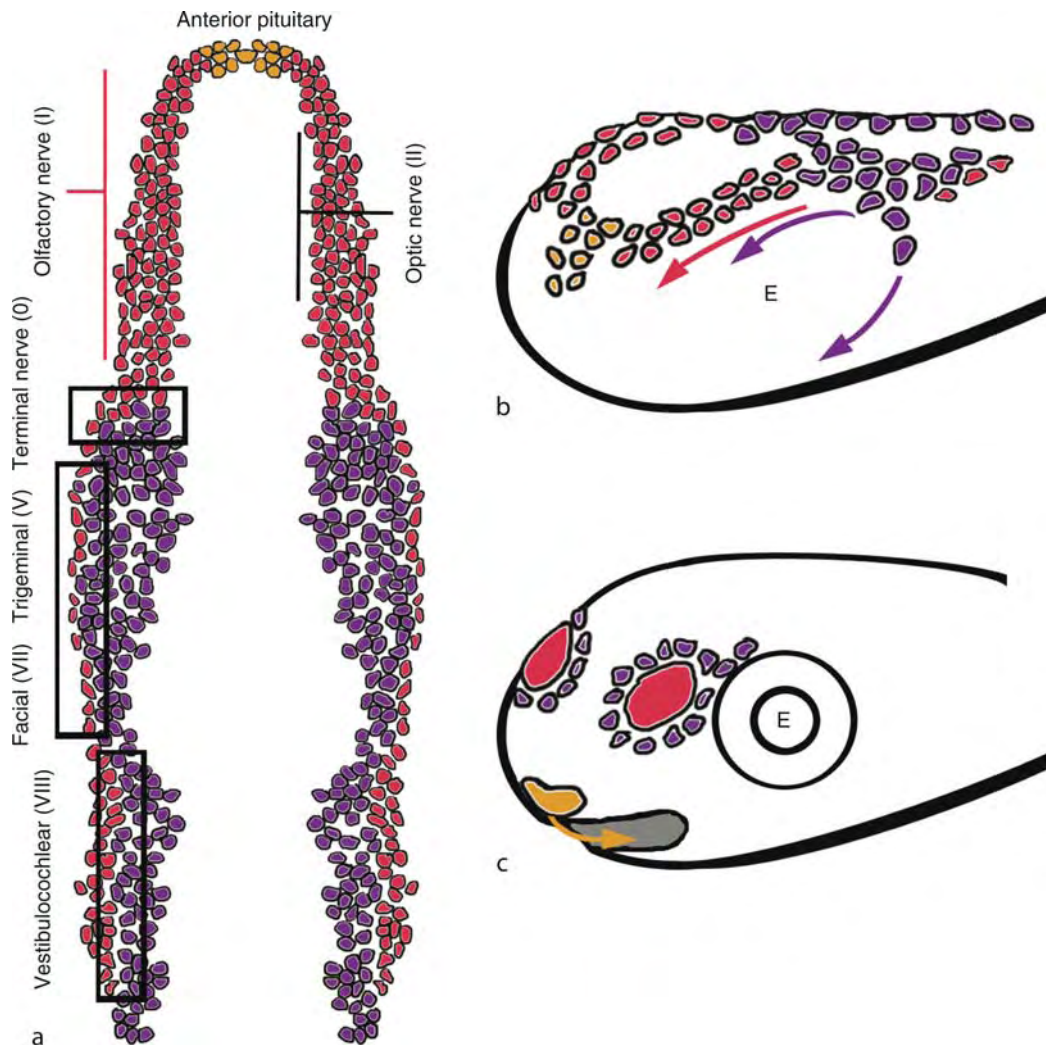

**Evolution of the Terminal Nerve. Figure 2** Cell movements resulting in formation of olfactory placode and TN. (a) Diagrammatic depiction of neural crest (*purple*) and **▶sensory placode** (*red*) domains in the developing neural plate (dorsal view anterior toward the top of the page). Cranial nerves thought to arise from neural crest and sensory placodes: vestibulocochlear (VIII), facial (VII), trigeminal (V), and terminal (0) [11]. The olfactory nerve arises from the olfactory placode domain, although glia may be neural crest derived, and the optic nerve arises from the neural tube. The TN arises from the most anterior cranial neural crest that interfaces with the olfactory placode. These cells will migrate anteriorly resulting in neural crest cells surrounding the newly formed olfactory placode (b, c). E = lens of the eye.

domains sort into cranial neural crest- and olfactory placode-derived structures as they migrate anteriorly to form the frontal mass and associated neural tissues. The association of the TN with the forming olfactory placode (Fig. 3) appears to be secondary.

### Conclusions

In examining the evolution of animals, the visual system is a highly conserved sensory structure. Paired eyes have appeared in many different types of animals and the molecular signaling pathways controlling the development of eyes are highly conserved. In contrast,

head and neural crest are cell populations that have appeared only once in chordates (for review see [19]). The embryonic origin of the TN, whether partially or wholly derived from neural crest, suggests that it post-dates the appearance of eyes in vertebrates. The TN is ontogenetically separable from the olfactory placode both by lineage and by genetic pathways. These findings, coupled with the observations that phylogenetically the TN is not absolutely correlated with the presence or absence of olfactory epithelia across species, suggests an origin independent of, but coordinated with, the appearance of the olfactory placodes.

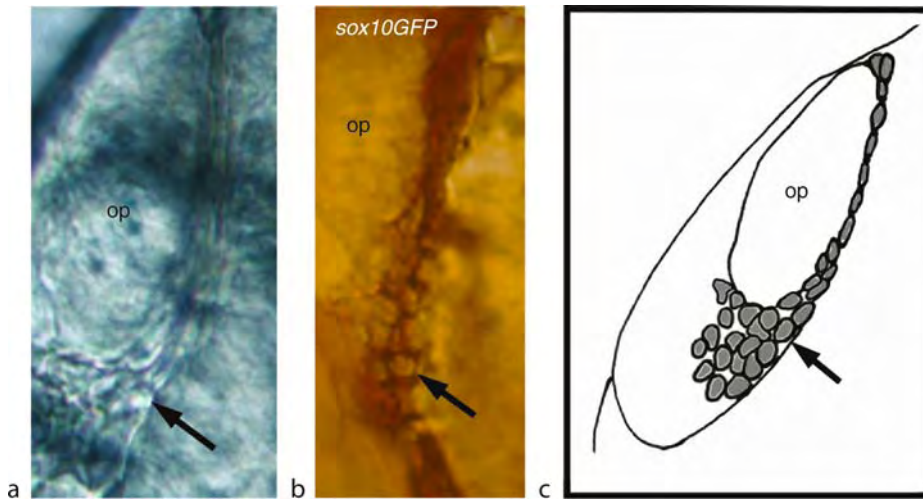

**Evolution of the Terminal Nerve. Figure 3** Visualization of association of cranial neural crest cells with the olfactory placode in the zebrafish embryo. (a) Olfactory placode (*op*) in living zebrafish embryo. (b) Localization of *sox10*-GFP neural crest marker to cells (*arrow*) associated with the olfactory placode (*op*). (c) Cells proposed to be precursors on TN (*arrow*) located at antero-medial aspect of the olfactory placode.

Because cells of the TN contain GnRH, a neuroendocrine decapeptide and this feature appears to be conserved across vertebrates at least in early development, it can be argued that the ancestral precursor of the TN contained GnRH. The lungfish has a distinct TN that projects to the telencephalon, as well as a second nerve (nervus preopticus) that originates near the nostril and extends to the preoptic area. The lungfish TN does not contain GnRH and the “nervus preopticus does contain GnRH positive cells” [20]. The latter has been called the “posterior root” of the TN. These observations led to the suggestion that the TN may have arisen from the fusion of two separate cranial nerves over evolutionary time.

## References

- Demski LS (1993) Terminal nerve complex. *Acta Anat* 148:81–95
- Wirsig-Wiechmann CR, Wiechmann AF, Eisthen HL (2002) What defines the nervus terminalis? Neurochemical, developmental, and anatomical criteria. *Prog Brain Res* 141:45–58
- Stell WK, Walker SE, Ball AK (1987) Functional-anatomical studies on the terminal nerve projection to the retina of bony fishes. *Ann NY Acad Sci* 519:80–96
- Schwanzel-Fukuda M, Silverman AJ (1980) The nervus terminalis of the guinea pig: A new luteinizing hormone-releasing hormone (LHRH) neuronal system. *J Comp Neurol* 191:213–225
- Demski LS (1987) Phylogeny of luteinizing hormone-releasing hormone systems in protochordates and vertebrates. *Ann NY Acad Sci* 519:1–14
- Dubois EA, Zandbergen MA, Peute J, Goos HJ (2002) Evolutionary development of three gonadotropin-releasing hormone (GnRH) systems in vertebrates. *Brain Res Bull* 57:413–418
- Whitlock KE (2005) Origin and development of GnRH Neurons. *Trends Endocrinol Metab* 16:145–151
- Eisthen HL, Northcutt RG (1996) Silver lampreys (*Ichthyomyzon unicuspis*) lack a gonadotropin-releasing hormone- and FMRFamide-immunoreactive terminal nerve. *J Comp Neurol* 370:159–172
- Brown JW (1987) The nervus terminalis in insectivorous bat embryos and notes on its presence during human ontogeny. *Ann NY Acad Sci* 519:184–200
- Buhl EH, Oelschläger HA (1986) Ontogenetic development of the nervus terminalis in toothed whales Evidence for its non-olfactory nature. *Anat Embryol* 173:285–294
- Northcutt RG (1993) A reassessment of Goodrich’s model of cranial nerve phylogeny. *Acta Anat* 148:71–80
- Whitlock KE (2004) Development of the nervus terminalis: Origin and migration. *Microsc Res Tech* 65:2–12
- Schwanzel-Fukuda M, Pfaff DW (1989) Origin of luteinizing hormone-releasing hormone neurons. *Nature* 338:161–163
- Wray S, Nieburgs A, Elkabes S (1989) Spatiotemporal cell expression of luteinizing hormone-releasing hormone in the prenatal mouse: Evidence for an embryonic origin in the olfactory placode. *Brain Res Dev Brain Res* 46:309–318
- Whitlock KE, Westerfield M (2000) The olfactory placode of the zebrafish form by convergence of cellular fields at the edge of the neural plate. *Development* 127:3645–3653
- Whitlock KE (2004) A new model for olfactory placode development. *Brain Behav Evol* 64:1–11

17. Whitlock KE, Wolf CD, Boyce ML (2003) Gonadotropin-releasing hormone (GnRH) cells arise from cranial neural crest and adenohypophyseal regions of the neural plate in the zebrafish, *Danio rerio*. *Dev Biol* 257:140–152
18. Whitlock KE, Smith KM, Kim H, Harden MR (2005) A role for *foxd3* and *sox10* in the differentiation of gonadotropin-releasing hormone (GnRH) cells in the zebrafish, *Danio rerio*. *Development* 132:5491–5502
19. Butler AB (2000) Chordate evolution and the origin of craniates: An old brain in a new head. *Anat Rec* 261:111–125
20. von Bartheld CS, Claas B, Munz H, Meyer DL (1988) Primary olfactory projections and the nervus terminalis in the African lungfish: implications for the phylogeny of cranial nerves. *Am J Anat* 182:325–334

## Evolution of the Trigeminal Sensory System and its Specializations

PAUL R. MANGER

School of Anatomical Sciences, Faculty of Health Sciences, University of the Witwatersrand, Johannesburg, Republic of South Africa

### Synonyms

Somatosensory trigeminal system; Evolution of trigeminal nerve

### Definition

The ►*trigeminal nerve* or fifth cranial nerve carries sensory information from the head to the brainstem, from whence it is passed to more rostral portions of the brain. In vertebrates several unique sensory systems subserved by the trigeminal nerve have evolved.

### Characteristics

#### Basic Structure of the Trigeminal Sensory System Peripheral Nerve Pathways

The trigeminal nerve carries sensory information from the cutaneous surface of the head (including the oral cavity) and jaws as well as the muscles of the jaw. As its name suggests, the trigeminal nerve has three main branches, the ophthalmic branch innervating the skin on the anterior part of the head, the maxillary branch that innervates the upper jaw, upper teeth, the roof of the mouth and the upper lip and the mandibular branch that innervates the lower jaw, lower teeth, the floor of the mouth and the lower lip. The trigeminal nerve is large in animals that have a well-developed snout and face, and is significantly expanded in animals that have associated sensory specializations of the face (see below). The three major branches of the trigeminal nerve are

found in all vertebrates and are similar in distribution (although they differ in size), but in many of the non-mammalian vertebrates a profundus division of the trigeminal nerve has been identified, which appears to correspond to the ophthalmic division of the mammalian trigeminal nerve [1].

#### Central Nervous System Pathways of the Trigeminal Nerve

Within vertebrates the central terminations and pathways of the trigeminal nerve are quite consistent. The three major branches of the trigeminal nerve form synapses with two locations within the central nervous system: (i) the descending or spinal nucleus of the trigeminal nerve, which is found within the somatic afferent column of the lateral medulla oblongata and continues into the dorsal horn of the spinal cord and (ii) the principal nucleus of the trigeminal nerve, which is seen to be a rostral expansion of the lateral somatic afferent column located within the pons. In both these sites there are topographic maps of the various incoming sensory inputs. From these two sites, the sensory information is conveyed to the dorsal thalamus and thence to the somatosensory cortex (of mammals) or the somatosensory pallium of other vertebrates. This pathway is the largest central pathway of the trigeminal nerve. A lesser sized branch of the ascending trigeminal pathway projects to the intermediate gray layer of the superior colliculus in mammals or the optic tectum in other vertebrates. This smaller projection, along with projections from the spinal cord, forms the topographic somatic input to the tectum (see ►*magnetoreception* below). There are two main variations on these pathways.

In birds, the target of the rostral projection of the principal trigeminal nucleus is not the dorsal thalamus but a group of neurons in the telencephalon called the nucleus basorostralis pallii, which in turn sends axons to the somatosensory pallium. It is unclear whether the nucleus basorostralis pallii is a homologue of the somatosensory dorsal thalamic nucleus of mammals (the ventral posterior medial nucleus, first described in the platypus by Hines [2]). A second unusual morphology of the trigeminal nerve is the mesencephalic nucleus of the trigeminal nerve (or mesencephalic V). This nucleus is found between the commissures of the tectum and the periaqueductal gray matter. The cell bodies are large and readily visible and are in fact ganglionic cell bodies that are embryologically derived from neural crest and have migrated into the central nervous system. In jawed vertebrates, all other neural crest-derived ganglionic cell bodies are located outside the CNS. The neurons of mesencephalic V carry proprioceptive information about the muscles of the jaw, the connective tissue surrounding the teeth and in mammals and amphibians about the extraocular eye muscles. The neurons of this nucleus project upon the trigeminal motor nucleus, thus playing a role in

the opening and closing of the jaw. Interestingly, the mesencephalic V neurons are not found in jawless vertebrates (agnathans), but they may have serially homologous counterparts in the spinal cord of agnathans [1].

### The Various Sensory Modalities of the Trigeminal Nerve

#### *Infrared Detection in Snakes*

One of the many unusual sensory systems that have evolved and are associated with the trigeminal nerve is the ability of certain snakes to detect infrared radiation (►*Infrared detection*) [3]. This sensibility has evolved in two families of snakes, the boids (pythons and boa constrictors) and the crotalids or pit vipers (rattlesnakes, water moccasins, bushmasters, fer-de-lances, etc.). The actual sensory receptor is a pit located on the face of the snake, either as a single pit below the eye (crotalids), or as a row of pits lining the lips (boids). These pits are lined with a sheet of photoreceptors that are sensitive to the infrared radiation (which is out of the visible range of humans) and are supplied by the maxillary branch of the trigeminal nerve. Infrared radiation (IR) is emitted by all objects that have any form of warmth and emissions are especially high from the warm-blooded mammals and birds that form a large part of the snakes' diet. The infrared detectors of the rattlesnake have been shown to be sensitive to differences in temperature of around 0.003°C, which is approximately the heat radiated by a human hand at around 50 cm.

The maxillary nerve fibers that transmit the IR sensory information terminate in a special subdivision of the trigeminal sensory nuclei in the brainstem called the lateral trigeminal nucleus – a subdivision not found in snakes that don't detect IR. The neurons of this nucleus respond to IR sensory information in a manner not dissimilar to the way neurons that process visual information respond to visible light. From here, the IR information is sent to the nucleus reticularis caloris of the reticular formation (again a specialized subdivision only found in IR sensitive snakes) and onto the tectum of the midbrain, where a topographic map is found. Whether IR information is then passed onto the pallium via the dorsal thalamus is presently unknown.

#### *Magnetoreception in Fish, Birds and Molerats*

The ability to detect magnetic fields has been described behaviorally in six different vertebrate classes, the most intensively studied models of magnetoreceptive behavior being homing in migratory birds, sea turtles, molerats, newts and salmonid fish [4]. The behavioral responses to magnetic fields and their role in orientation are well understood; in contrast, the biophysical and neurological mechanisms underlying magnetoreception are still poorly understood, although studies using new neurological tools are improving this situation [5]. The primary ►*magnetoreceptor* is still yet to be definitively

identified; however, candidates include photopigments in the retina and pineal gland and magnetite-based magnetoreceptive structures that have been found in the olfactory lamellae of the nose of the trout and the cutis of the upper beak of pigeons. The magnetite-based candidate magnetoreceptors are light independent in action. It has been demonstrated that these putative magnetoreceptors are innervated by the ophthalmic branch of the trigeminal nerve. Thus, one can conclude that the portions of the brain that process magnetic field information derived from these magnetite-based magnetoreceptors must be involved with the trigeminal system.

Electrophysiological recording from neurons of the ophthalmic branch of the trigeminal nerve and the trigeminal ganglion in birds and fish have shown sensitivities to alterations in magnetic fields that would allow them to fix their position with an error of less than a few tens of kilometers [4]. As yet, higher neural centers processing magnetic information have not been identified in birds or fish, even though the trigeminal pathways within the brains of these species are known. In the molerats, the use of inducible transcription factors, such as Jun, Fos and Krox, has provided more detail regarding the central processing of magnetic information and has shown that a discrete sublayer of the superior colliculus plays an important role in orientation to magnetic field alterations [6]. This sublayer of the superior colliculus (specifically the outer sublayer of its intermediate gray layer) is dominated by trigeminal input in other mammals, which makes it likely that the behavioral orientation to magnetic stimuli in molerats is subserved by the trigeminal nerve. These experiments indicated that, like other sensory systems, there is a topographic arrangement or magnetotopic map within the superior colliculus, which may be aligned and integrated with other collicular maps as occurs in most vertebrates. Further experimentation using these techniques is likely to reveal other regions of the brain that process magnetic information. One particularly interesting open question is whether this information is passed on to the thalamo-cortical system, as this may indicate an awareness of changes in the magnetic field and thus bring the magnetosensory system into the realm of cognition, conscious experience and decision making on the basis of magnetic information.

#### *Mechanoreception*

The mechanical receptors (►*Mechanoreception*) supplied by the trigeminal nerve exhibit a great variety of forms, from basic free nerve endings, typical sensory cell type receptor endings and normal hair follicle receptors through specialized ►*vibrissae* (or whiskers) in mammals and specialized feathers at the base of the bill in birds to the complex array of multiple

mechanoreceptors found in the bill-tip organ of several species of birds, the Eimer's organ of insectivores and the push-rod mechanoreceptors of the monotremes. Given that the trigeminal nerve supplies the skin of the face and the oral cavity, the range of mechanoreceptors found in vertebrates is perhaps not surprising, as this is generally the region of the body that is involved in the detection and ingestion of food. Most interestingly, there are a few cases of convergent evolution in the form of the specialized mechanoreceptor complexes that are quite spectacular in nature.

*Vibrissae* or whiskers, which are a specialized hair follicle receptor, are a common feature of the lateral maxillary skin region of the therian (marsupial and placental) mammals. Amongst the therian mammals, those possessing vibrissae with associated central nervous system specialization (see below) include the metatherian possums and gliders and the eutherian rodents [7,8]. The possums, gliders and rodents use the vibrissae to navigate in the darkness and also to investigate objects of interest. One of the more spectacular cases of central nervous system convergent evolution is found in the representation of the vibrissae in the primary somatosensory cortex of these species, which are heavily reliant on vibrissae information. This central morphological similarity is referred to as "barrel" cortex due to the manner in which the cells of the cerebral cortex are clustered. The barrels exhibit two distinct forms, termed hollow and solid [7,8] due to the location of the neuronal bodies in the barrel-shaped formation that occurs in the cerebral cortex. That these barrels occur in several taxa, many of which are distantly related (for example the African porcupine of the eutherian Rodentia and the sugar glider of the metatherian *Diprotodontia*) and in different forms in more closely related taxa (for example the rat has solid barrels with the cells forming a cluster in the middle of a sheath of myelinated axons and the mouse has hollow barrels with a bundle of myelinated axons being surrounded by a shell of neuronal bodies) is an excellent example of convergent or divergent morphology in the central processing of sensory information from similarly specialized peripheral sensory receptors.

► *Mechanoreceptor epidermal rod complexes*, such as bill-tip organs in birds, Eimer's organs in moles and the push-rod mechanoreceptors of the monotremes, provide another example of convergent evolution, as they occur in distantly related taxa but have a very similar form and a similar function, i.e., extremely sensitive somatosensation involved in the location of food. These complexes are found within a column of epidermal cells, forming a rod that traverses the epidermis from the skin surface (the tip of the rod being visible under the dissecting microscope) to the dermis, in the skin of the rhinarium. In mammals there are usually three type of tactile receptors localized within

the complex: (i) one to three paciniform or encapsulated receptors that are sensitive to vibration, located deeper in the dermis than the epidermal rod, (ii) Merkel cells (one to twelve) that are slowly adapting light touch sensitive receptors, found within but at the base of the epidermal rod and (iii) a series of vesicle-chain neural processes that traverse the rod from its base to its tip, forming free nerve endings very close to the surface of the skin (the physiology of these vesicle chains is unknown, but it is presumed that they are very sensitive to light tactile stimulation, probably of a shearing nature). Of the mammals possessing these epidermal rod complexes, that of the platypus is perhaps the most complex, typically exhibiting two or three paciniform receptors, up to 12 Merkel cells, and upward of 40 vesicles chains, with a total of around 46,500 of these complexes arranged over the bill [9]. In the birds, a series of Herbst (similar to mammalian paciniform corpuscles) and Grandry (similar to Merkel cells) corpuscles are found in varying number and location throughout the rod, along with terminal cell column receptors and branched nerve endings with terminal cells toward the tip of the rod. The Herbst corpuscles detect vibratory stimuli, the Grandry corpuscles and terminal cell column receptors encode the velocity of the mechanical stimulus and the branched nerve endings the static stimulus components [10]. The central representation of these receptors is also specialized, especially in the primary somatosensory cortex of mammals, where stripes relating to the peripheral location and distribution of these receptors have been recognized (e.g., platypus [11]; star-nosed mole [12]).

#### *Electroreception in the Monotremes*

Perhaps the most intriguing sensory system associated with the trigeminal nerve is the electroreceptive system of the monotremes, first discovered by Scheich and colleagues [13]. In the two species of echidna, the electroreceptive system is not extensively expressed in comparison to that of the platypus [14]. In the platypus, two types of ► *electroreceptor*, one associated with a mucous gland the other with a serous gland, are found within the skin of the bill. The mucous gland electroreceptors are arranged in rostro-caudally oriented stripes along the bill and number in the region of 40,000 per individual platypus, while the serous gland electroreceptors are found most densely along the edges of the bill and number in the region of 13,000 [9]. The striped array of the mucous gland electroreceptors probably underlies the ability of the platypus to detect the origin of an electrical field and move its bill toward this field, as electrical fields decay exponentially as they pass through freshwater [15]. The mucous gland electroreceptor is a complex receptor organ, made up of a ring of up to 16 free nerve endings surrounding the duct of the mucous gland at the dermal-epidermal



junction. Each free nerve ending has a small neural protrusion piercing a layer of tightly joined keratinocytes that surround the epidermal duct of the mucous gland, presumably forming electrical insulation. From each of these neural protrusions there are small side branches that appear to connect (probably through a gap junction) to similar branches from neighboring nerve terminals. This pattern of peripheral interconnectivity probably serves a function in enhancing the signal to noise ratio [16]. The mucous gland electroreceptor is also innervated by several autonomic and C-fibers. The autonomic fibers are found surrounding the mucous gland in the dermis and a series of actin containing keratinocytes that form something akin to a sphincter lie around the upper epidermal portion of the duct [17]. The C-fibers are found traversing the epidermis peripheral to the mucous gland to within a few cells of the skin surface. These C-fibers are probably thermo- or wet-sensitive and appear to initiate an autonomic reflex loop, which when wet initiates secretion by the mucous gland and relaxation of the actin sphincter (which allows the rose-like arrangement of superficial keratinocytes around the duct pore to open). Personal observations of comfortable captive platypus indicate that prior to entering the water they immerse the bill in water for a few seconds, two to three times. This presumably prepares the bill for ►electroreception prior to full immersion and swimming by the platypus, this being somewhat akin to the rubbing of eyes on waking up. Interestingly, the push-rod mechanoreceptors and serous gland electroreceptors display similar actin rings and C-fiber innervation, indicating that both these structures are activated in water. The push-rod mechanoreceptors would have their tips freed up and become more sensitive. Presumably, as the bill dries, the actin sphincters tighten and the glands cease secretion.

This initiation of electroreception in the water and the increased tactile sensitivity in water may play an important role in the detection of food for the platypus. Firstly, the distribution of the mucous gland electroreceptors allows them to act as an antenna, providing the platypus with knowledge of the source of a bioelectric field and thus the direction in which to move the bill to capture the prey. The loosened push-rod mechanoreceptor may be sensitive enough to detect water pressure waves. At a distance of around 10 cm, the water pressure wave generated by the tail-flick of a freshwater shrimp (a natural prey item of the platypus) arrives approximately 5 ms later than the electrical wave created by the muscular contraction [18]. Using this time delay in the arrival of the pressure wave, the platypus will be able to compute the distance from the bill to the source of the bioelectric potential. This synergy between electrical and tactile processing provides the platypus with an accurate 3D locality for

its prey item. A nice analogy to this capacity of the platypus was first described by Jack Pettigrew as the “thunder and lightning” hypothesis of platypus prey location [19]. On seeing lightning, the seconds until the arrival of the thunder are counted to gauge the distance of the storm. Pettigrew postulated that the platypus might be doing a similar calculation, only in the range of milliseconds and centimeters, not seconds and kilometers. This processing would take place in the primary somatosensory cortex of the platypus, where a stripe-like arrangement of specialized neurons, responsive to both tactile and electrical stimulation could detail the decay of the electrical field across the bill and the time delay in arrival of the pressure wave.

## References

1. Butler AB, Hodos W (2005) Comparative vertebrate neuroanatomy: evolution and adaptation, 2nd edn. Wiley-Liss, Hoboken
2. Hines M (1929) The brain of *Ornithorhynchus anatinus*. Philos Trans R Soc Lond B Biol Sci 217:155–287
3. Hartline P (1974) Thermoreception in snakes. In: Fessard A (ed) Electroreceptors and other specialised receptors. Handbook of sensory physiology, vol 3. Springer, Berlin Heidelberg New York, pp 297–312
4. Wiltshcko R, Wiltshcko W (2006) Magnetoreception. Bioessays 28:157–168
5. Němec P, Burda H, Oelschläger HH (2005) Towards the neural basis of magnetoreception: a neuroanatomical approach. Naturwissenschaften 92:151–157
6. Němec P, Altmann J, Marhold S, Burda H, Oelschläger HH (2001) Neuroanatomy of magnetoreception: the superior colliculus involved in magnetic orientation in a mammal. Science 294:366–368
7. Weller WL (1993) SmI cortical barrels in an Australian marsupial, *Trichosurus vulpecula* (brush-tailed possum): structural organisation, patterned distribution, and somatotopic relationships. J Comp Neurol 337:471–492
8. Woolsey TA, Welker C, Schwartz RH (1975) Comparative anatomical studies of the SmL face cortex with special reference to the occurrence of “barrels” in layer IV. J Comp Neurol 164:79–94
9. Manger PR, Pettigrew JD (1996) Ultrastructure, number, distribution and innervation of electroreceptors and mechanoreceptors in the bill skin of the platypus, *Ornithorhynchus anatinus*. Brain Behav Evol 48:27–54
10. Gottschaldt KM (1985) Structure and function of avian somatosensory receptors. In: King AS, McLelland J (eds) Form and function in birds. Academic, London, 446–461
11. Krubitzer LA, Manger PR, Pettigrew JD, Calford MB (1995) Organization of somatosensory cortex in monotremes: in search of the prototypical plan. J Comp Neurol 351:261–306
12. Catania KC (2005) Evolution of sensory specializations in insectivores. Anat Rec A Discov Mol Cell Evol Biol 287:1038–1050
13. Scheich H, Langner G, Tidemann C, Coles RB, Guppy A (1986) Electroreception and electrolocation in platypus. Nature 319:401–402

14. Manger PR, Collins R, Pettigrew JD (1997) Histology of presumed electroreceptors and mechanoreceptors in the beak skin of the Nui Gini echidna, *Zaglossus bruijnii*. Proc R Soc Lond Biol Sci 264:165–172
15. Manger PR, Pettigrew JD (1995) Electroreception and the feeding behaviour of the platypus. Philos Trans R Soc Lond B Biol Sci 347:359–381
16. Manger PR, Pettigrew JD, Keast JR, Bauer A (1995) Nerve terminals of mucous gland electroreceptors in the platypus (*Ornithorhynchus anatinus*). Proc R Soc Lond Biol Sci 260:13–19
17. Manger PR, Keast JR, Pettigrew JD, Troutt L (1998) Distribution and putative function of autonomic nerve fibres in the bill skin of the platypus (*Ornithorhynchus anatinus*). Philos Trans R Soc Lond B Biol Sci 353:1159–1170
18. Pettigrew JD, Manger PR, Fine SL (1998) The sensory world of the platypus. Philos Trans R Soc Lond B Biol Sci 353:1199–1210
19. Pettigrew JD (2004) Bi-sensory, striped representations: comparative insights from owl and platypus. J Physiol Paris 98:113–124

## Evolution of the Vestibular System

WERNER M. GRAF

Department of Physiology & Biophysics, Howard University College of Medicine, Washington, DC, USA

### Synonyms

Vestibular system; Labyrinth; Sense of balance; Sense of equilibrium

### Definition

The sense of balance, the vestibular system, is our unknown sense. We recognize its existence only under pathological conditions, such as seasickness, dizziness, vertigo, etc. Among the classical five senses, i.e., vision, taste, smell, touch, hearing, our sense of balance is not mentioned. Quite often, the sense of balance is just considered as an appendix of the auditory sense due to the anatomical unity of cochlea and vestibular apparatus, the so-called inner ear. The inner ear is really a fabulous example of the “engineering” capabilities of nature and evolution being one of the most complex anatomical structures in vertebrate history: in humans, we find two hyper-sensitive hyper-precise sensory organs housed within the space equivalent to that of an aspirin tablet – the auditory sense and the sense of balance. Moreover, under normal life conditions, we are not even aware of the latter’s existence. The sense of balance could thus be considered our sixth sense, and its functions are manifold. At least four different and vital functions should be mentioned:

(i) postural control and postural stabilization, (ii) reflex movements, (iii) perception of self-movement, and (iv) autonomous control.

## Characteristics

### Anatomy

The inner ear is a bilateral organ. It is located inside the petrosal bone of the temporal bone of the cranium. The balance organ is part of the inner ear and consists of the ►semicircular canals and the ►otoliths (Fig. 1).

At first sight, the twisted and three-dimensional structure of the inner ear looks quite complicated and has earned the balance organ the name *labyrinth*.

Semicircular canals and otoliths are sense organs, which detect accelerations. The semicircular canals detect angular accelerations (rotations), the otoliths linear accelerations (translations). An example for a ubiquitous and permanent linear acceleration is earth gravity (gravity vector). Under normal living conditions, we rarely spend a thought about gravity, but when gravity becomes absent, the effects can be dramatic, as during space flight under micro-gravity conditions with resulting space motion sickness.

### The Semicircular Canals

The operational mode of the semicircular canals is independent of gravity. The canals are filled with a fluid, the so-called endolymph, which, during a given head movement, causes a so-called endolymph current, which displaces receptor cells inside a specialized area of the canal lumen, the so-called ►ampulla [1]. An important characteristic of the macroscopic anatomy of the semicircular canals is their three-dimensional orientation. The ensemble of the six canals, three on each side forms a physical coordinate system to detect angular accelerations in three-dimensional space. The semicircular canal system on each side of the head consists of a horizontal (lateral) canal, and two vertical canals (one anterior and one posterior canal) (Fig. 2). The horizontal canal is lightly tipped upward (about 30° in humans) at normal head resting posture. The vertical canals are oriented about 45° off the mid-sagittal plane of the head (Fig. 2).

The orientation of the semicircular canals in the head follows three interdependent functional principles: (i) bilateral symmetry: both labyrinths are mirror symmetric; (ii) reciprocal operational mode: during head rotations receptors in a given canal will be excited, while the receptors in the contralateral coplanar canal will be inhibited; so-called push-pull system; (iii) mutual orthogonality of canals: the functional planes of the canals enclose angles of 90°, or close to that value (Fig. 2). The semicircular canal system thus constitutes an intrinsic sensory reference frame system, which provides a blueprint for the spatial coordination of a number of reflex functions and sensory interactions.

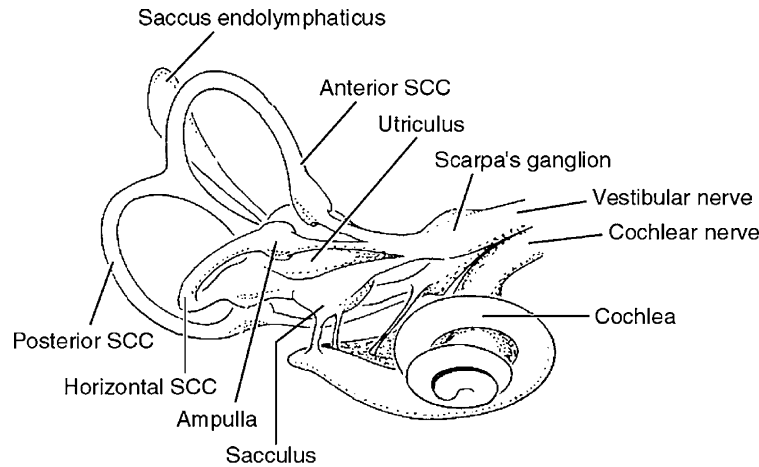

**Evolution of the Vestibular System. Figure 1** Anatomy of the organ of the sense of balance. Lateral view of the right human labyrinth in the approximate normal resting position of the head showing the portions of the sense of balance (semicircular canals, SCC, and otoliths) and of the sense of hearing (cochlea).

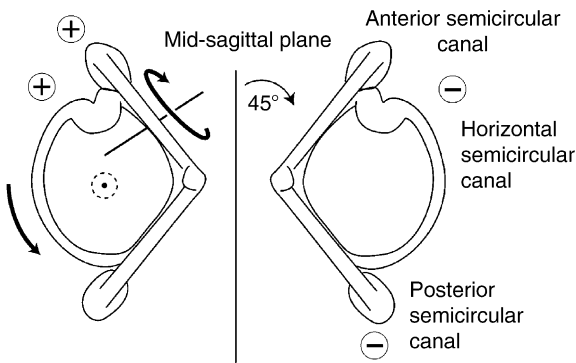

**Evolution of the Vestibular System. Figure 2** Spatial orientation of an idealized semicircular canal system (top view). Anterior and posterior canals are oriented vertically, horizontal canals are oriented horizontally. The vertical canals are oriented 45° off the midsagittal axis (“diagonal” orientation). Note bilateral symmetry, mutual orthogonality between canals, and the push-pull operational mode illustrated for the right posterior and the left anterior canals, and the right and left horizontal canals. When one canal becomes excited (+), its coplanar counterpart becomes inhibited (-). Canal on-directions are indicated by the directions of the arrows about the canal rotation axes. The combined excitatory and inhibitory responses of all canals during head movements produce a meaningful activity pattern in the afferent nerves and recipient brain nuclei to represent a movement vector in physical space (Figure modified after [2]).

**The Otoliths**

By contrast to the semicircular canals, the otoliths are receptors that depend on the presence of gravity (“graviceptors”). They detect linear accelerations, and

do not function in microgravity. Most ►vertebrates, including humans, possess two otoliths on each side, the horizontal utricle and the vertical saccule. At normal resting posture of the head, the utricle seems to be oriented earth horizontally. The receptor cells of the otoliths are embedded in the so-called otolith membrane, which contains the ►otoconia. During a displacement of the head from normal upright position, the otoconia will slide across the otolith membrane and produce a shear force upon the receptor cells.

**Evolutionary History of the Labyrinth**

The phylogenetic origins of the vertebrate labyrinth are not known. The only living proto-chordate, *Amphioxus*, possesses a median eye but no candidate for a homologue of the vestibular apparatus. Furthermore, only fragmentary fossil records exist that testify to the beginning of vertebrate life in Cambrian times, more than 500 million years ago. However, there now seem to be indications from molecular biology data for a common ancestor regarding mechanoreceptor cell evolution between *Drosophila* and vertebrates, i.e., ►hair cells [3]. Although for a long time, the balance organ had been thought to have evolved from the ►lateral line system, recent evidence based on multiple out-group comparison suggests, that the inner ear of vertebrates evolved as a statolithic system before the lateral line system and before semicircular canals appeared.

The fossil record becomes more complete only during the middle of the Paleozoic era, the Devonian period (400–350 million years ago). The first record that demonstrates the existence of semicircular canals comes from jawless vertebrates, agnathan species of the Devonian and Silurian times, the ostracoderms. They possessed vertical but not horizontal canals (Fig. 3).

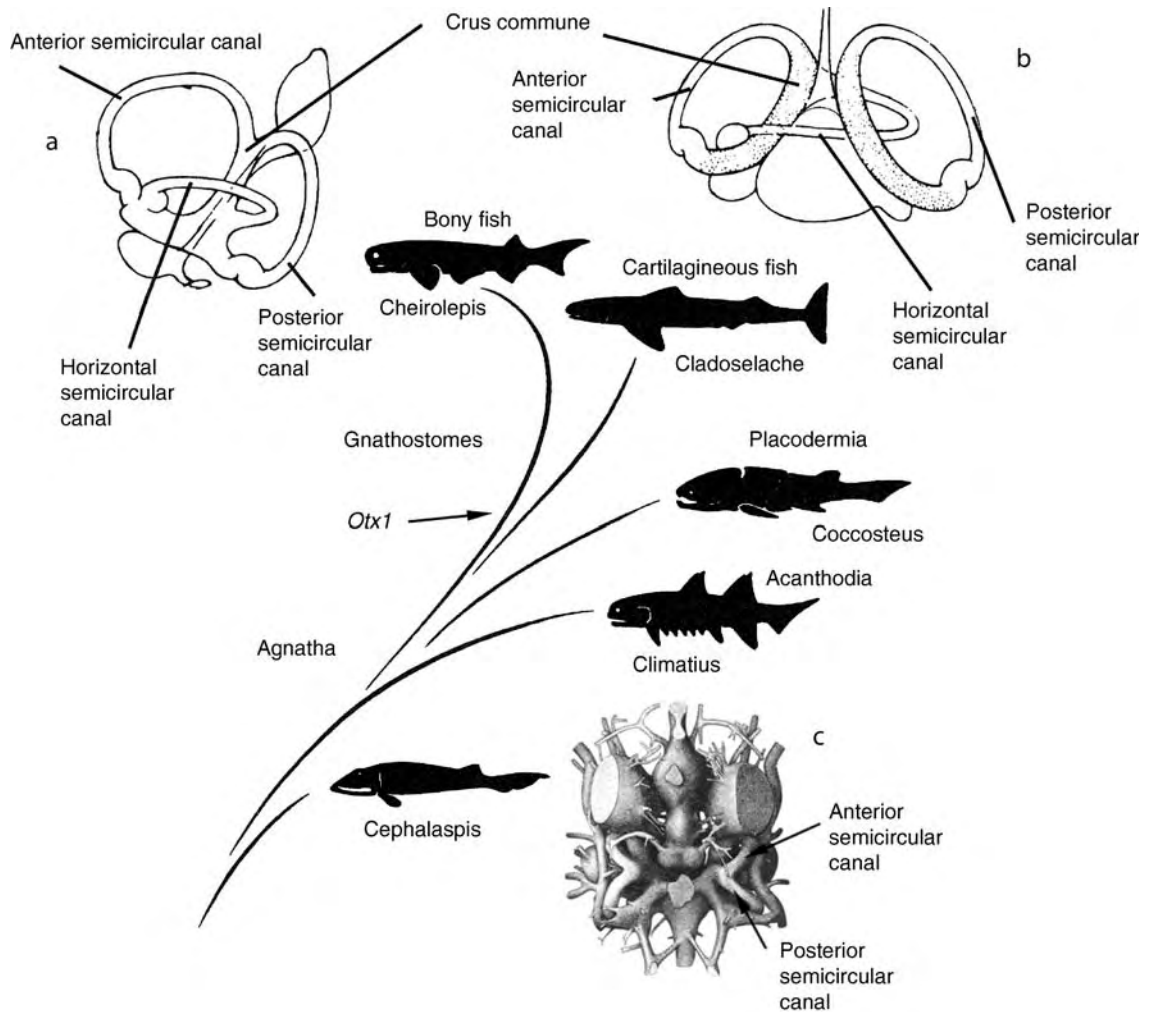

**Evolution of the Vestibular System. Figure 3** Phylogenetic relationship of early agnathans and gnathostomes (bony fishes, cartilaginous fishes, placoderms, and acanthodians) (modified after [4]), including prototypical vertebrate labyrinth characteristics. (a) Human labyrinth (after [2]). (b) Shark labyrinth, *Chlamydoselachus* (after [2]). (c) Ostracoderm labyrinth without horizontal canals (after [5]). Horizontal semicircular canals appear in bony fishes and cartilaginous fishes coinciding with the appearance of the  $\blacktriangleright$ *Otx1* gene. In bony fishes through humans, the anterior and the posterior canal form a common crus. In cartilaginous fishes there is no common crus between the anterior and the posterior canal. All labyrinths display a similar (“diagonal”) orientation of the vertical semicircular canals in the head.

Their vertical canals were oriented in the head as described before [5] (Fig. 2). The ostracoderm labyrinth was similar to the  $\blacktriangleright$ semicircular canal system of lampreys, the extant forms of their once-abundant ancestors. The Devonian period also marks the advent of jawed vertebrates (gnathostomes), bony and cartilaginous fishes (osteichthyes and chondrichthyes, respectively; Fig. 3). We know nothing about the labyrinth structure of the immediate ancestors of these newly appeared animals, but their modern successors display a new acquisition: horizontal semicircular canals. Thus, the vertebrate labyrinth now spans all

three dimensions of physical space. The circumstances that led to the development of a horizontal semicircular canal system are unknown, but its presence most certainly introduced distinct advantages for the detection of three-dimensional space in comparison to the four canal system in the agnatha. The acquisition of horizontal semicircular canals coincides with the expression of the vertebrate-specific gene  $\blacktriangleright$ *Otx1*. Knock-out mutants who do not express *Otx1* do not develop horizontal semicircular canals [6]. One could speculate that the appearance of horizontal semicircular canals, allowing an optimal solution, i.e., best and most

economical high signal-to-noise-ratio, for movement detection in three-dimensional space constituted one prerequisite for the success of vertebrates later on in phylogeny. At any rate, it certainly provided one further advantage.

Interestingly enough, there are two main lines of labyrinthine development in the surviving radiations, namely what we will refer to as the “bony fish/tetrapod line” (Osteichthyes) and the “cartilaginous fish line” (Chondrichthyes) (Fig. 3) (we are using the term “bony fish/tetrapod” in the following to delineate vertebrate species between bony fish and the two living amniote clades, mammals and sauropsids, the latter comprising reptiles and birds). Unfortunately, no fossil record testifies to the labyrinth structures of earlier radiations that became extinct (e.g., acanthodians, placoderms).

In viewing a typical vertebrate labyrinth of the bony fish/tetrapod line, in this case a human labyrinth (Fig. 3a), we observe that it consists of three canals, one anterior, one posterior, and one horizontal canal. Typically for this type of labyrinth, the anterior and the posterior canal form a so-called ▶ **common crus**; that is, they share a segment of their circular structure. The typical cartilaginous fish labyrinth, in this case from a shark (Fig. 3b) also possesses anterior, posterior and horizontal canals that display the same orientation in the head as the bony fish/tetrapod labyrinth type. However, there is no common crus between the anterior and the posterior canals. The posterior canal is separate and has a communication with the sacculus, whereas a common crus-like structure is formed between the horizontal and the anterior canals. This particular difference in labyrinth structure between bony fishes and cartilaginous fishes leads to the intriguing question of whether the phylogenesis of horizontal canals was monophyletic or polyphyletic in vertebrates.

### Comparative Anatomy

A great variety of movement and position detectors, so-called ▶ **statocysts** are found in vertebrates, and we will introduce only the most pertinent examples here. One type is found in cephalopods that are fast moving – squid and cuttlefish – while a second type is found in the slower moving cephalopods such as octopus. The third type is typified by the semicircular canals of crabs. Their characteristics show convergent evolution with the arrangements found in vertebrates for solving three-dimensional space orientation challenges.

The statocysts of the fast moving squid and cuttlefish (Fig. 4a) include grooves, which, similar to the vertebrate semicircular canals of vertebrates, direct endolymph flow towards a sensory crista with a ▶ **cupula** [7].

These invertebrate semicircular canals are oriented in space in a roughly orthogonal three-dimensional planar arrangement (Fig. 4b). Four canals on each side can be distinguished, which are oriented approximately

in the main planes of the body (Fig. 4d), in contrast to the vertebrate arrangement (Fig. 4c). Sensory receptors detect movements in the transverse plane of the body, with excitation occurring during ipsilateral upward roll movements, in the longitudinal plane of the body, with receptors detecting pitch-up and pitch-down movements, and in the horizontal plane with receptors being excited during contraversive rotation (Fig. 4d). Some receptors also detect linear accelerations [7]. The squid semicircular canal system can thus monitor three-dimensional angular accelerations just like the idealized vertebrate semicircular canal system with bilateral symmetry, orthogonality and push-pull operational mode. Orthogonality of the semicircular canals would provide an optimal signal-to-noise ratio, but in order to achieve paired orthogonality, the vertical semicircular canals need not necessarily be arranged in the familiar diagonal fashion. The one (and only) alternative arrangement is pairs in coronal, parasagittal and horizontal planes as shown in Fig. 4d. The squid/cuttlefish semicircular canal system could thus be termed a “principal axes” system, in contrast to the “diagonal” vertebrate arrangement.

In the octopus (Fig. 4e), the sensory receptor organ on each side consists of nine subsections, and is divided into three main planes which are approximately orthogonal to each other. The arrangement of the subsections suggests an angular acceleration detection system similar to that of vertebrates. Interestingly, the extraocular muscle arrangement of the octopus resembles closely that of lateral-eyed vertebrates [8] (Fig. 4f).

The third type of “semicircular canal” system introduced here in invertebrates of interest is found in crabs (Fig. 4g), which possess one horizontal and one vertical toroid structure on each side. Depending on the species, these “toroids” can either be open or can form a closed canal system [9]. In freely moving crabs, the horizontal canals are held earth horizontally, and since the horizontal and the vertical canals are close to orthogonal, the vertical canals are nearly vertical. Each vertical canal lies at an angle of 45° to the midsagittal plane in a configuration comparable to that of the anterior semicircular canals in vertebrates. Although there is only one vertical canal on each side, each one responds preferentially to movements about orthogonal axes, and thus the canals of crabs are collectively capable of accurately transducing three-dimensional angular accelerations [9].

Comparison of vertebrate and invertebrate solutions about how to “build” movement detection systems shows a remarkable uniformity to an idealized three-dimensional geometry of optimal decomposition of all given rotation vectors. The semicircular canal systems of vertebrate and invertebrates are thus prime examples of convergent evolution.

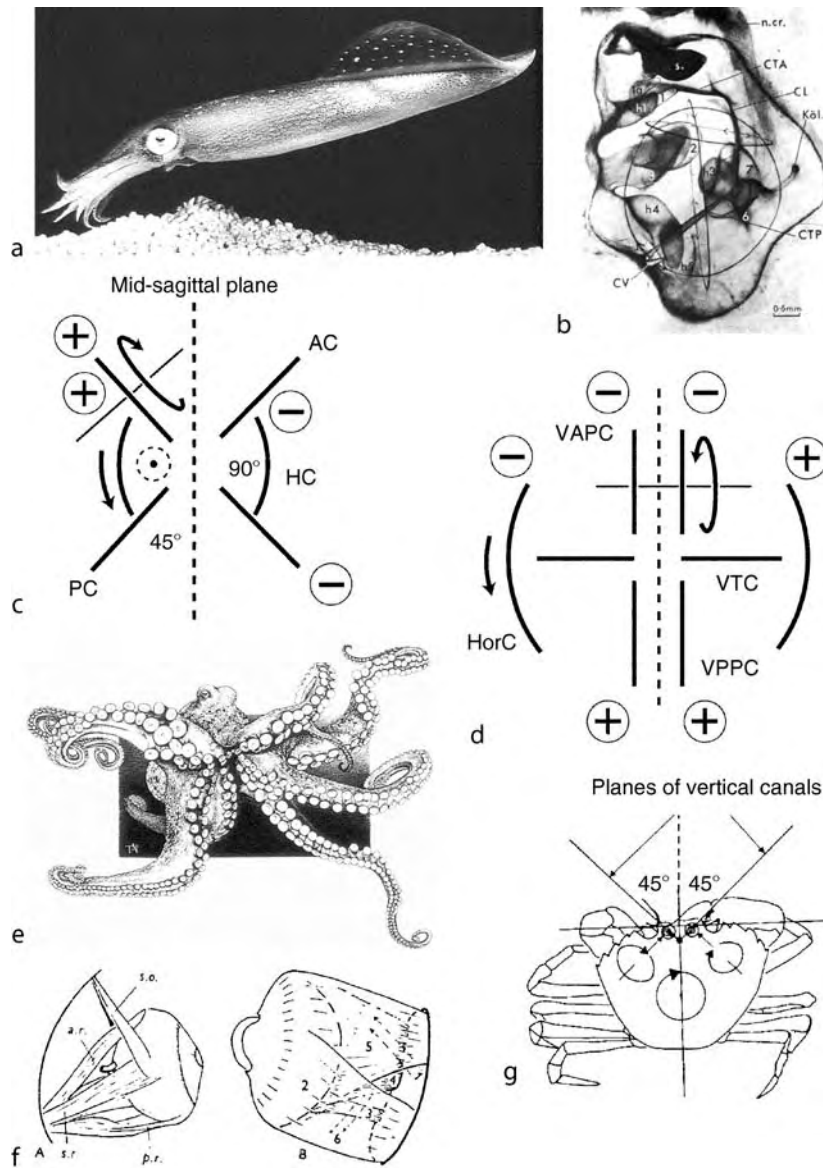

**Evolution of the Vestibular System. Figure 4** Convergent evolution of movement detection systems. (a) Photo of a squid. The animal propuls itself rapidly backwards by ejection of a jet of water. (b) Retouched photograph of a squid statocyst indicating the orientations of the toroid planes [from [7]]. (c) Comparison of the “diagonal” vertebrate semicircular canal system, and the “principal axes” system of squids (d) The squid system also fulfills the three criteria of orthogonality, bilateral symmetry, and push-pull operational mode. However, instead of six canals, it has eight toroid structures, and the on-directions of the sensory receptors are just about opposite to that of vertebrates. Nevertheless, the squid movement detection system functions according to the same operational principles as the vertebrate semicircular canal system). (e) Drawing of an octopus. Despite its seemingly amorphous body structure, the octopus possesses a well-defined three-dimensional movement detection system similar to vertebrates. (f) Comparison of the extraocular muscles in a shark, left, and in the octopus, right. Note similar “diagonal” spatial arrangement in the two animals [from [8]]. (g) Spatial arrangement of the semicircular canal system in crabs. Although there are only four canals in crabs, the vertical canals are oriented just like the anterior canals of vertebrates, as are the horizontal canals (after [9]).

### Ontogeny and Phylogeny of the Labyrinth

The vertebrate labyrinth develops from an enlargement of the ectoderm, the ►otic placode, which invaginates to form the so-called ►otocyst [10]. A number of

genes and induction molecules play a role for the complicated morphogenesis of the labyrinth. There are genes that are necessary for the differentiation of various organ- and system developments and others that

are labyrinth-specific. Many genes work in parallel or are redundant. Gene duplication, or multiplication of genes during the progress of evolution has to be taken into consideration as well [3]. The differentiation of the main structures of the labyrinth is guided by independent genes, which will be introduced below.

Although many vertebrate genes are ▶homologous with *Drosophila* genes, the vertebrate labyrinth is a development of chordates and without precedent in other animal groups. Flies do not possess balance organs *per se*, but rely on relative movement of body parts (▶halteres) to orient in gravity. Homologies with other animal groups seem to be restricted to the development of receptor cells, which transform mechanical stimuli into electrical impulses (mechano-electrical transduction). The receptors of the labyrinth are important examples for the general question of the origin of mechano-electrical transduction at the level of receptor cells. For many years, it was believed by evolutionary biologists that the labyrinth was derived from the ▶neuromast cells of the lateral line organ of aquatic vertebrates. Meanwhile, however, functional interrelations between the pressure receptors of the nematode *C. elegans* and the sensory bristle receptors and proprioceptors of the fruit fly *Drosophila* on one hand and vertebrate hair cells on the other have been described [3]. The description of a mechano-electrical transduction channel in *Drosophila* and *C. elegans* points to an early development of a mechano-electrical receptor in evolution. The original receptors might have consisted of a ▶cilia-like structure including support cells. Thus, receptor cells seem to have been an important evolutionary component for the development of the sense of balance of vertebrates, but it was not the structure *per se* that led to the macroscopic expression of ▶analogous sense organs. Interestingly, inner ear hair cells develop without involvement and influence of the neural crest, which normally guides the development of most of the sensory neurons of the peripheral nervous system of chordates.

The actual morphogenesis of the ear is governed by numerous genes, which also play a role in the development of lungs, kidneys and extremities. Embryogenesis and morphogenesis occur during particular periods in ontogenesis, when certain genes are switched on or off, and when certain organs and characteristics are being developed. The development of sense organs is embedded into the general process of structurization and position specification. In this process, proneural genes will be activated, which are determining the precursors of the elements of sensory organs, such as support cells, glia, and portions of the actual sensory cells. Two mechano-sensory bHLH genes (basic helix-loop-helix) are expressed in the ear, *Neurogenin 1* (*ngn1*) and mammalian *atonal* homologue 1 (*Math1*). In insects, *atonal* (*ato*) is important, whose vertebrate

homologue *Math1* is indispensable for the development of hair cells. Knock-out mutants without *Math1* develop support cells and primary neurons, but no hair cells. For the development of primary neurons, another bHLH homologue is required, i.e., *ngn1*, one of three so-called neurogenin genes.

For further labyrinth development, the so-called FGF and FGFR genes play an indispensable role (FGF, fibroblast growth factor; FGFR, tyrosine kinase receptor family). In particular, FGF19 seems to be a fundamental element for the induction of ear development in chickens, and which is activated together with *Wnt8c*. The interplay between FGFs and FGF-receptors in vertebrates seems to induce the budding out of the growth zones of lungs, extremities and of the ear placode. With regard to inner ear development, the receptor FGFR-2(IIIb) is essential for the development of the semicircular canals, the endolymphatic duct and the cochlea. Besides the FGF genes, BMP, Pax, POU and zinc-finger genes were shown to be present in the ear. POU4f3 knock-out mutants form a labyrinth with hair cells that are later lost. Missing the Pax2 gene results in an ear without cochlea, however, with semicircular canals and otoliths [6,17].

While all thus mentioned genes have been shown to exist in insects, some vertebrate-specific genes are noteworthy, such as the above-mentioned *Otx1*, which regulates the development of the horizontal semicircular canals (Fig. 3). Vertebrates without horizontal canals do not express this gene in the ear.

### The Extraocular Muscle Apparatus

The extraocular muscle apparatus can be considered as a prime example for the efficiency of biological systems. The spatial orientation of the extraocular muscles, in particular, illustrates in an almost ideal fashion, how evolution solved a complicated problem of sensory-motor transformation.

The six extraocular muscles move the eye in a reference frame that corresponds to the spatial geometry of the vestibular semicircular canals, i.e., the typical diagonal, 45° off the midsagittal plane orientation of vertical canals, is reflected in the pulling direction of the vertical eye muscles (Fig. 5).

The vertical eye muscles are superior rectus (SR), inferior rectus (IR), superior oblique (SO) and inferior oblique (IO); the horizontal eye muscles are lateral rectus (LR) and medial rectus (MR). These anatomical designations give the impression of a distinct separation between “straight” and “oblique” eye muscles. In the true sense of the word, only lateral rectus and medial rectus are “straight” eye muscles, whereas all vertical eye muscles, including superior rectus and inferior rectus, are in reality “oblique” muscles. The illustrated example drawing of the human vestibulo-ocular system (Fig. 5) demonstrates this fact very clearly.

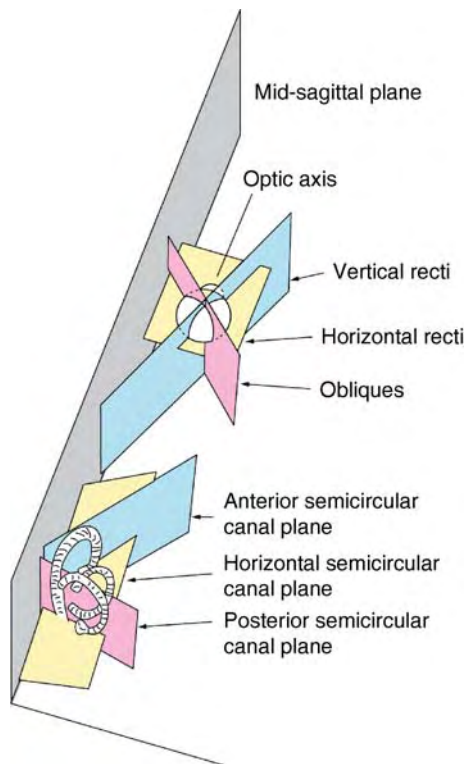

**Evolution of the Vestibular System. Figure 5**  
Three-dimensional orientation of semicircular canal planes and extraocular muscle pulling directions in man. Note alignment of certain eye muscle pulling directions with particular canal planes, forming an intrinsic reference frame system.

### Vestibular Output and Postural Control

Some of the earliest motor control systems of vertebrates are the tecto-spinal and the vestibulo-spinal pathways. Tecto-spinal connections underlie visually based orienting and control mechanisms. Vestibulo-spinal pathways essentially provide tonic postural and balance control. This function can be impressively demonstrated following ablation of one entire labyrinth (►[hemilabyrinthectomy](#)), or components there of [11,12]). In essence, the horizontal semicircular canals provide the straight-ahead direction of the head, whereas the utricles assure the upright posture of the entire head-neck ensemble in the midsagittal plane, at least in birds and mammals. The sacculi seem to play a similar role regarding lateral tilt displacements of the head [12]. In this context, we have to mention the fact that mammals in general possess a vertical cervical vertebral column, regardless of bipedal or quadrupedal locomotion. The transition to bipedalism from quadrupedalism in mammals thus requires bringing the thoracic vertebral column into an upright position and

modifications at the cervico-thoracic junction and the lumbar level but not within the cervical vertebral column or the atlanto-occipital articulation.

### The “New Wave” of Vestibular Interest

The intriguing geometry and three-dimensionality of the vertebrate labyrinth has fascinated scientists since the beginning of modern science, i.e., Antonio Scarpa in 1789, and numerous comparative studies have dealt with the expression of labyrinthine structures in basically almost all known vertebrates. While all these studies used invasive methods to visualize ear structures, modern imaging methods have now opened a way to study them non-invasively in living tissue, and also fossilized heads have become accessible to large-scale investigations. These possibilities led to a number of interesting morphological discoveries that added to the vast data set already available.

In general, there were no surprises regarding the spatial orientation of the semicircular canals. These followed the familiar pattern (see Fig. 2) [13]. A number of authors also sought to make use of their new investigative tool to re-interpret the functional context of vestibular system by putting it into the sole context of locomotion [13,14]. These authors argued that the dimensional morphology of the semicircular canals gave an indication about the locomotor capabilities of their owners. Thus, conclusions were drawn as to the point of effective bipedalism in certain hominids [13] or the agility of Neanderthal man [14]. We had argued against such interpretations based on a number of known facts and characteristics of the vestibular system [15]. In essence, the former authors had based their arguments largely on the size differences in the circumference of semicircular canals within one species and across different species. However, canal fluid dynamics affecting sensitivity are also largely governed by the lumen of the canal, i.e., its cross-section. Furthermore, to base locomotor activities solely on peripheral morphology means ignoring any well known adaptive mechanisms at the receptor level, ion channel dynamics, and above all, the vast apparatus of the neuronal processing machinery that make use of vestibular signals from the brainstem and cerebellum to the cortex. Focusing on locomotion alone also ignores all the other important and vital functions subserved by the vestibular system, notably compensatory eye movements and perceptual mechanisms. Without compensatory eye movements, in particular, we would not be able to have unblurred vision during any movement. In addition, during active movements, a number of postural reflexes become suppressed, which is reflected in elimination or attenuation of vestibular movement signals in the vestibular nuclei. Arguments about vestibular canal size have even been forwarded to explain the behavior of cetaceans and pterosaurs,



proposing a link between apparent extreme aquatic and aerial acrobatic capabilities of these animals, respectively. Although these arguments received wide acclaim in the popularized science literature, the “vestibular” argument again did not take into consideration all aspects of vestibular function or the entirety of a biological system. Against the aerial capabilities of pterosaurs could be brought forward, for instance, the size and shape of their cerebellum given the fact that the cerebellum plays an eminent role in motor coordination. Pterosaur cerebella resemble closely that of certain bats [16], and bats are not the very best flyers. As we have seen, postural control, locomotion and eye movements are closely related to vestibular output, and there is a lot more to consider than meets the eye at first glance.

### Summary and Conclusions

The semicircular canals of the labyrinth of vertebrates provide one way of motion detection in three-dimensional space. The fully developed form of the vertebrate labyrinth consists of six semicircular canals, three on each side of the head, whose spatial arrangement (vertical canals are placed diagonally in the head, horizontal canals are oriented earth horizontally) follows three interconnected principles: (i) bilateral symmetry, (ii) mutual orthogonality, (iii) push-pull operational mode. Motor systems related to the vestibular reflexes such as the extraocular muscles, or the neck muscles, share the same geometrical framework. This framework is also reflected in the anatomical networks mediating compensatory eye- and head movements, linking each of the semicircular canals to a particular set of extraocular muscles (so-called principal ►vestibulo-ocular reflex connections to yoke muscles) and to particular head-neck muscles. These connections are identical across species throughout evolution.

The particular spatial arrangement of the vertical semicircular canals is already present in fossil ostracoderms, who, however, lacked horizontal canals. The fully developed vertebrate labyrinth with its six semicircular canals displays distinct differences that are obvious when comparing different taxa (e.g., elasmobranchs vs. other vertebrates). Whereas the common crus of the semicircular canals in teleosts through mammals is formed between the anterior and the posterior semicircular canal, it occurs between the anterior and the horizontal canal in elasmobranchs. However, despite this morphological difference, these two vertebrate labyrinth prototypes constitute a functionally identical solution. A similar analysis holds for certain invertebrate species (squid, octopus, crab), which display an even wider variety in the physical expression of movement detection systems when compared to vertebrates. Although the physical expressions of motion detection systems differ in the animal

kingdom, the functional solutions (providing the best signal-to-noise ratio) with adherence to bilateral symmetry, mutual orthogonality and push-pull operational mode are identical. Furthermore, this functional principle is reflected in the intrinsic organization of related motor systems.

The evolution of the sense of balance of vertebrates and analogous systems in invertebrates suggest a number of important features of brain operations. We also observe conserved vestibulo-motor organizations and circuitry in vertebrates after the development of one optimal solution, when arrangements have been preserved throughout subsequent vertebrate history. In contrast to the many different morphological types of eyes, for instance, only two basic types of three-dimensional movement detectors have been retained, the “diagonal” ones of vertebrates, octopus, and crabs, and the “principal axes” ones of squids and cuttle fish. Each one of the two possibilities constitutes an ideal physical solution, with optimal signal-to-noise ratio. The early appearance of a viable and up-to-date conserved vertebrate vestibular system, in tandem with systems of similar geometry in certain invertebrates may suggest that close to ideal physical solutions developed early in vertebrate history.

### Acknowledgments

This work was supported by a grant from the European Union (QLK6-CT-2002-00151: EUROKINESIS) and the Specialized Neuroscience Research Program (SNRP: NIH/NINDS). The author wishes to thank France Maloumian for help with the illustrations.

### References

1. Wilson VJ, Melvill Jones G (1979) Mammalian vestibular physiology. Plenum, New York
2. Werner CIF (1960) Das Gehörorgan der Wirbeltiere und des Menschen. VEB Georg Thieme, Leipzig
3. Fritzschn B, Beisel KW, Bermingham NA (2000) Developmental evolutionary biology of the vertebrate ear: conserving mechanoelectric transduction and developmental pathways in diverging morphologies. *NeuroReport* 11: R35–R44
4. Colbert EH (1980) Evolution of the vertebrates, 3rd edn. Wiley, New York
5. Stensiö EA (1927) The dextonian and devonian vertebrates of spitsbergen, Part 1. Family cephalaspidae. *Skr. om Svalbard og Nordisshavet* Nr. 12, Norske Vidensk. Akad.: Oslo Arbok
6. Fekete DM (1999) Development of the vertebrate ear: insights from knockouts and mutants. *Trends Neurosci* 22:263–269
7. Stephens PR, Young JZ (1978) Semicircular canals in squids. *Nature* 271:444–445
8. Packard A (1972) Cephalopods and fish: the limits of convergence. *Biol. Rev.* 47:241–307
9. Fraser PJ (1981) Semicircular canal morphology and function in crabs. In: Gualtierotti T (ed) *The vestibular*

system: function and morphology. Springer, Berlin Heidelberg New York

10. Romand R, Varela-Nieto I (2003) Development of auditory and vestibular systems-3. Molecular development of the inner ear. *Curr Top Dev Biol* 57:1–481
11. De Waele C, Graf W, Josset P, Vidal PP (1989) A radiological analysis of the postural syndromes following hemilabyrinthectomy and selective canal and otolith lesions in the guinea pig. *Exp Brain Res* 77:166–182
12. Graf W, Wang DH, De Waele C, Vidal PP (1992) The role of otoliths in maintaining the upright posture of the head-neck system in the guinea pig. In: Shimazu H, Shinoda Y (eds) *Vestibular and brain stem control of eye, head and body movements*. Japan Scientific Societies Press, Tokyo, pp 79–90
13. Spoor F, Wood B, Zonneveld F (1994) Implications of early hominid labyrinthine morphology for evolution of human bipedal locomotion. *Nature* 369:645–648
14. Spoor F, Hublin JJ, Braun M, Zonneveld F (2003) The bony labyrinth of Neanderthals. *J Human Evol* 44:141–165
15. Graf W, Vidal PP (1995) Semicircular canal size and upright stance are not interrelated. *J. Hum Evol* 30:175–181
16. Baron G, Stephan H, Frahm HD (1996) *Comparative Neurobiology in Chiroptera*, vol 1, Macromorphology, brain structures, tables and atlases. Birkhäuser Verlag, Basel
17. Fekete DM, Wu DK (2002) Revisiting cell fate specification in the inner ear. *Curr Opin Neurobiol* 12:35–42

## Evolution of the Visual System in Mammals – Comparative Evolutionary Aspects across Orders

JAMIE D. BOYD<sup>1</sup>, ILYA KHAYTIN<sup>2,5</sup>,  
VIVIEN. A. CASAGRANDE<sup>2,3,4</sup>

<sup>1</sup>Department of Neurosciences, Medical University of South Carolina, Charleston, SC, USA

<sup>2</sup>Department of Cell and Developmental Biology, Nashville, TN, USA

<sup>3</sup>Department of Psychology, Nashville, TN, USA

<sup>4</sup>Department of Ophthalmology and Visual Sciences, Nashville, TN, USA

<sup>5</sup>Medical Scientist Training Program Vanderbilt University, Nashville, TN, USA

### Synonyms

V1, primary visual cortex, also referred to as striate cortex or Brodmann's area 17; V2, secondary visual cortex; LGN when used without classifier dorsal or ventral usually means dorsal LGN; Neocortex, Isocortex

### Definition

The visual system of mammals consists of a complex interconnected network of subcortical and cortical areas that are considered “visual” because cells in these areas respond to input from the ►retina. All mammals share a similar retinal organization. The output cells (►ganglion cells) of the retina send axons to the brain. These ►retinal ganglion cells are specialized to convey different aspects of the visual scene, such as object detail or motion, to a number of subcortical target areas and to provide each of these areas with a map of visual space. Most of the subcortical targets of the retina can be found in all mammals. Mammals also have a number of cortical visual areas, some of which can also be identified in all mammals. However, variation exists in the detailed organization of subcortical targets and in the number of cortical visual areas across mammals. Evolution has progressed independently in different mammalian lines by addition and deletion of characteristics at all levels of the visual system.

### Characteristics

Studying the evolution of visual structures within the brain poses more challenges than studying the evolution of other structures such as wings or hooves because soft tissue does not fossilize. Skulls may be preserved, or sediments may solidify within a brain case forming an ►endocast, but these give only a general idea of the size and shape of the brain. While useful, this information provides few clues to the internal organization of brain structures, which is more relevant than mere size, especially where the visual system is concerned.

The main tool we have to infer the evolutionary relationships of visual brain structures and their organization is comparison of the brains of modern species using a cladistic approach, that is, by comparing brains of closely and distantly related species [1,2]. A ►clade is a group of all organisms at any phylogenetic level that share a common ancestor, such that all members of the clade are more closely related to each other than to any organisms not in the clade. Mammals, carnivores, and felines are examples of clades. A characteristic present in all members of a clade can be assumed to have been present in the last common ancestor of the clade, i.e., to be ►homologous. If a characteristic is present in only some, but not all, members of two distantly related clades, the possibility must be considered that the characteristic arose independently in each clade by ►homoplasy (parallel evolution). Since unrelated animals can adapt to the same niche, especially one that places particular demands on the visual system (becoming ►nocturnal, or ►arboreal, etc.), their brains may show similar evolutionary changes. In making these determinations, we follow the principle of parsimony, the minimization of the number of gains or losses of a characteristic in a hypothetical evolutionary scenario.

It is noteworthy that, due to incomplete data on brain organization across taxa, these determinations are often based on data from a limited number of carefully chosen species.

In order to chart evolutionary changes in the brain with a cladistic approach, it is necessary to have valid clades. Molecular genetics helps define the phylogenetic trees used to infer evolutionary changes [3,4]. Molecular ►phylogeny classifies extant mammals into six super-orders: Monotremes (e.g., the duck-billed platypus and echidna), Marsupials (e.g., the kangaroo and opossum), and, among the eutherians, Afrotheria (e.g., the aardvark, elephant and manatee), Xenartha (e.g., the armadillo, anteater and sloth), Laurasiatheria (e.g., insectivores, carnivores, and ungulates), and Euarchontoglires (e.g., primates, treeshrews, and rodents). Knowledge of these relationships, in conjunction with comparative information on brain structure and function, enables the determination of which characteristics of the visual system are present across many groups, and therefore, which were likely to be present in the earliest mammals or were present only in certain groups and therefore likely were derived independently during the course of evolution.

### Cross-Species Comparisons at Successive Levels of the Visual System

The visual system of all mammals has the same basic structures (Fig. 1).

The retina sends axons to a number of subcortical targets, which include: (i) the ►suprachiasmatic nucleus of the hypothalamus, (ii) the ventral lateral geniculate nucleus (pregeniculate nucleus of primates) of the ventral ►thalamus, (iii) the dorsal ►lateral geniculate nucleus (LGN) of the dorsal thalamus, (iv) the pretectum and

►superior colliculus of the ►midbrain and (v) the accessory optic nuclei of the midbrain and ►hindbrain. Each of these nuclei receives axons from a specialized subset of retinal ganglion cells and has a network of connections with different areas of the brain. The retinal axons also project to their subcortical targets in an orderly manner so that each target area has a map of the visual world. Many of these subcortical retinal targets have homologues in non-mammals, such as the optic tectum of non-mammals, which is homologous with the superior colliculus of mammals [5]. The LGN is important in mammals as it provides the most direct pathway for retinal signals to reach the cortex. With minor exceptions none of the other subcortical targets of the retina sends axons directly to the cortex. In all mammals the LGN sends axons to the primary visual cortex (also called V1, striate cortex or area 17) located in the occipital lobe. V1, in turn, sends axons to several ►extrastriate cortical areas located in regions that tend to lie in more anterior zones of the cortex. These extrastriate areas, located in occipital, temporal and parietal areas, are connected, directly or indirectly, to the ►frontal cortex and ►hippocampus, allowing integration of visual information with other aspects of behavior.

**Retina.** The neural organization of the retina is similar across all vertebrates and contains at least five main cell types organized into layers. Light activates the receptors, rods and ►cones. Rods are specialized for night vision and cones for daylight vision, and where two or more cone types are present, color vision. From the receptors neural signals are processed through the retinal network before leaving the retina for the brain via the axons of retinal ganglion cells. In mammals, the proportion of rods to cones and number of cone types

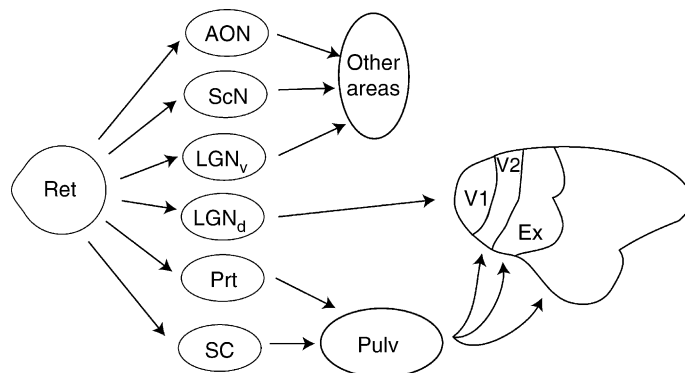

### Evolution of the Visual System in Mammals – Comparative Evolutionary Aspects across Orders. Figure 1

The retina (Ret) forwards information (via axons of retinal ganglion cells) to several subcortical structures including the accessory optic nuclei (AON), suprachiasmatic nucleus (ScN), the ventral lateral geniculate nucleus (LGN<sub>v</sub>), also called the pregeniculate in primates, the pretectal (Prt) nuclei, the dorsal lateral geniculate nucleus (LGN<sub>d</sub>), and the superior colliculus (SC). Of these structures only the LGN<sub>d</sub> has direct access to the visual cortex projecting to V1 in all mammals, and V2 in some mammals, such as carnivores. SC and Prt project to pulvinar (Pulv), which in turn projects to variety of subcortical and cortical structures including extrastriate visual cortex. The remaining subcortical nuclei project to a diverse array of brain areas.

varies across different species based primarily on visual niche, not phylogeny. Photopigment genetics suggests that ►opsins in all vertebrates are homologous, and that the primitive condition was four opsins. Ancestral mammals were ►dichromats; they lost two of their four ancestral pigments, possibly during a nocturnal bottleneck, leaving the short and medium wavelength opsins. Some extant nocturnal mammals (e.g., bush babies, owl monkeys, kinkajous) and some aquatic mammals (e.g., sea lions) have more recently and independently lost the short wavelength opsin. ►Old World primates and some ►New World primates have independently become ►trichromats, by duplication and divergence of the genes for the medium wavelength opsin in Old World Primates, and by a sex-linked polymorphism in the New World primates and some prosimians, such that only females, with two X chromosomes, have the potential for trichromatic color vision. All other mammals are thought to be dichromats [3,6; but see 7].

One of the main elaborations of visual processing in mammals is the expansion of areas devoted to vision at the cortical level and the parallel processing streams to visual cortex that begin in the retina from classes of retinal ganglion cells with different physiological responses and projections [1,4,8]. These classes of ganglion cells include cells that convey information about visual detail (higher spatial frequencies) and respond in a more sustained manner to the continued presence of an appropriate visual stimulus, cells that respond transiently to visual stimuli and respond well to high temporal frequencies (fast movement), and cells with slowly conducting axons and heterogeneous response properties. In carnivores such as cats and ferrets, these classes correspond to the X, Y, and W neuron classes, respectively. In primates, they correspond to the ►parvocellular (P), ►magnocellular (M), and ►konio-cellular neuron (K) classes [9,10]. Similar retinal ganglion cell triads are present in ►tree shrews, squirrels, rats, and rabbits, and are suggested from less complete studies in other species. Considering that physiologically and anatomically distinct classes of ganglion cells have been described in reptiles and birds [5], as well as all mammals so far examined, it seems likely that the presence of parallel retinal streams is a primitive condition in mammals; however, it is not completely clear how, or even if, the parallel streams in different mammals are homologous.

In carnivores and primates, the two groups for which we have the most data, both the cat's Y pathway and the primate's M pathway originate from the largest retinal ganglion cells with wide dendritic arbours and fast-conducting axons, while the cat's X and the primate's P pathways originate from smaller retinal ganglion cells, with small dendritic arbours and more slowly-conducting axons. The W and K retinal ganglion cells

both have small cell bodies, thin but extensive dendrites, and the thinnest, and most slowly conducting axons in the optic tract [9].

Physiologically, both Y cells and M cells have larger receptive fields, lower preferred spatial frequencies, higher preferred temporal frequencies, and higher contrast sensitivities than their X/P counterparts. Because of these similarities, it has been proposed that M and P cells are homologous to Y and X cells, respectively [3,6]. An alternative hypothesis, based partially on the fact that P cells have ►chromatic opponency while X cells do not, is that cat X and Y cells correspond to subgroups of M cells, and that the P pathway is primate-specific. As mentioned previously, however, many primates including some prosimian primates are dichromats and lack long-wave length cones. Their P cells, like cat X cells, lack chromatic opponency suggesting that chromatic opponency evolved in the P pathway of some primates and not others. Chromatic opponency, however, does appear to exist in a subset of W and K cells in all mammals where this has been examined.

**Retino-Recipient Nuclei.** As previously noted, the retina projects to many central targets, which are conserved in vertebrate evolution. The relative development of retinal targets differs in mammals. In non-mammals, the optic tectum appears to be the main target of the retina, whereas in mammals the retinal input to the superior colliculus is either balanced by input to the LGN as in tree shrews, or dominated by input to the LGN as in primates [5]. Also, in non-mammals retinal input is almost completely crossed; the right eye sends axons to the left hemisphere whereas the left eye sends axons to the right hemisphere. Binocular combination is achieved in some non-mammals either via pathways to the telencephalon or optic tectum that do not appear to exist in mammals.

In mammals, the LGN has undergone a wide array of structural changes in different mammalian lineages, due to segregation of retinal afferents of different functional class and eye specificity (Fig. 2).

The simplest plan of LGN lamination, which is found in at least some of mammals, is basically three layered, with two layers receiving inputs from the contralateral eye (crossed input) sandwiching a single layer receiving ipsilateral eye (uncrossed) input. The size of the ipsilateral LGN layer varies with the position of the eyes in the head of the mammals and therefore, in proportion to the amount of binocular overlap between the eyes, being positively cryptic in laterally-eyed rats and fully formed in binocular cats. These layers can also be subdivided in various ways in different species [3,4,6].

In even the simplest LGNs, there is some segregation according to fiber type. The most external layer (nearest the optic tract) is always enriched in input from retinal ganglion cells with thin axons (W or K cells in cats and primates, respectively) whereas the other layers tend to

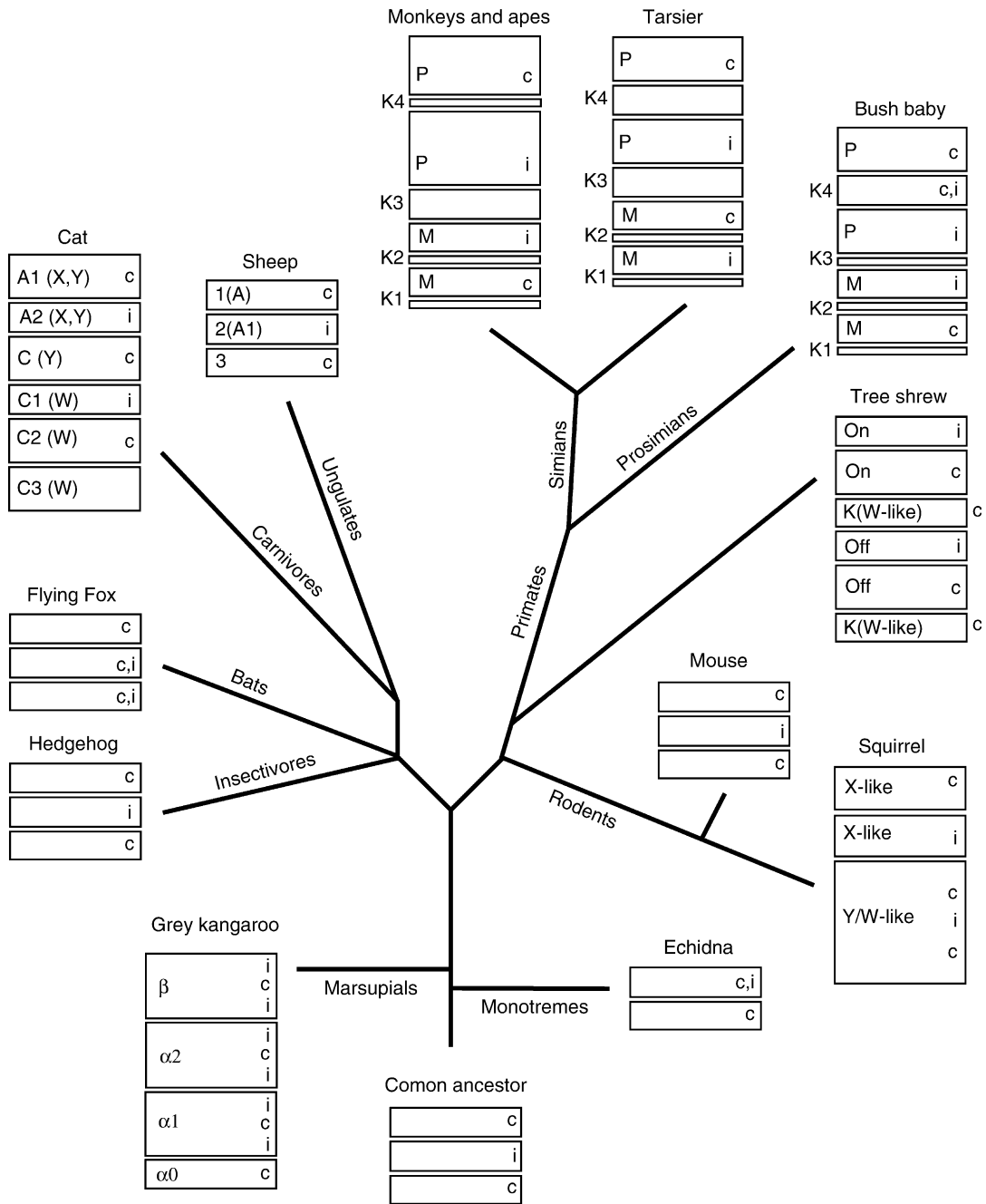

E

**Evolution of the Visual System in Mammals – Comparative Evolutionary Aspects across Orders. Figure 2** As with the primary and secondary cortical visual areas, there is a common theme governing the pattern of retinal input to the LGNd. In the presumed common ancestor the cells of the LGNd can be divided into layers based on their retinal input. In the presumed common ancestor there were three layers, two of which received crossed input from the contralateral (c) retina and one of which received uncrossed input from the ipsilateral (i) retina. This basic three layer plan underwent expansion during evolution, with the addition of more layers. In addition to layers devoted to each eye, some species also have LGNd layers that receive input from functionally distinct retinal ganglion cell classes such as the parvocellular (P), magnocellular (M) and koniocellular (K) cells in primates or the X, Y, and W or ON and OFF cells in some non-primates. For instance while most primates acquired the basic two P, and two M layers separated by variable numbers of K layers, their close relative the tree shrew has subdivisions into ON and OFF layers instead. Some animal groups, like primates, demonstrate clear separation of eye specific layers while, others, like rodents, can have extensive mixing of the inputs from both eyes. Only major subdivisions of LGNd are shown. Ungulates, carnivores, and to some extent bats, have an additional LGNd subdivision, the medial interlaminar nucleus (MIN).

get input from retinal ganglion cells that are more rapidly conducting (X, Y or P, M). Further segregation according to fiber type appears to have occurred in parallel in different mammalian lines. The LGN of carnivores and ungulates, for instance, consists of two main layers, A (contralateral) and A1 (ipsilateral), receiving X and Y cell input, and layer C, subdivided into large (Y) and several small (W) cell sublayers. In primates, the segregation of different functional classes is most complete, with separate M (external) and P (internal) layers for each eye, and K layers between or ventral to each of the P and M layers.

The P layers in the representation of the central visual field split into four layers in many primates, and up to six in some humans. A general rule is that larger LGNs have more layers, and not all layers need correspond to a unique combination of eye and functional class. In this light, it is interesting to note that some marsupials have evolved laminated LGNs independently of eutherian mammals, and large diurnal kangaroos have more layers in their LGN than their smaller relatives.

Although the position and number of K/W layers is rather variable, geniculate projections of K/W retinal ganglion cells in all mammals are to small-celled layers that are either next to the optic tract or intercalated between the main layers. Neurochemically, these small-celled layers have been identified in many species using antibodies to the calcium binding protein calbindin [3,6].

Interestingly, the tree shrew has a unique LGN organization, with 2 layers containing W-like cells, and 4 layers segregated by both eye input and contrast sign (ON center vs OFF center). Projections from sustained and transient retinal ganglion cells do not appear to segregate into different LGN layers. The tree shrew thus appears to have an LGN with many derived characteristics not shared with its primate sister group. This example reminds us that considerable evolutionary variation exists among mammals even in the primary target nuclei of the retina.

The midbrain targets of the retina, the superior colliculus and the pretectum, are also conserved in vertebrate evolution, and their inputs and outputs in mammals are similar to other vertebrates [5]. Supporting the hypothesis that W and K ganglion cells are homologous in primates is the fact that subclasses of these cells project to the superior colliculus in many mammals. In turn, the superior colliculus sends axons to layers of the LGN that receive K/W cell input in a variety of mammals.

In all vertebrates, the superior colliculus also projects to dorsal thalamic nuclei that receive no or minor input from the retina (►collothalamic nuclei, as opposed to the ►lemniothalamic nuclei, such as the LGN, which receive direct projections from ascending sensory pathways) [5]. These collothalamic nuclei, unlike the LGN, project to extrastriate visual areas of cortex

instead of V1. They also receive projections from V1 (at least in the placental mammals that have been examined), providing an indirect pathway to extrastriate cortex. Subdivisions of these nuclei appear to have arisen independently in different mammalian lines, and there is no straightforward way to homologize between them, e.g., the various subdivisions of the lateral posterior nuclei in cats and the components of the pulvinar in primates.

As to the other nuclei, each can be recognized in a variety of mammals. Thus, the suprachiasmatic nucleus, which appears to be important for circadian rhythms in mammals, has been recognized in a variety of mammals. Many of the pretectal nuclei such as the nucleus of the optic tract can be identified in a variety of mammals, but the relative development of others varies greatly across mammals. The same holds true for the ventral lateral geniculate nucleus which is as large as the dorsal LGN in many mammals but almost non-existent in primates.

**Primary Visual Cortex.** In all mammals V1 can be recognized by its projection from the LGN, its position on the caudal pole of the cortex, its single inverted map of visual space, and its distinctive architecture [3,6,11,12] (Fig. 3).

Birds and reptiles also have an area in the telencephalon that receives input from the visual thalamus, the dorsal cortex, which has been proposed to be homologous to mammalian isocortex [5]. Dorsal cortex has a simple three-layered structure, while six layers can be recognized in the isocortex of all mammals, including marsupials, suggesting that the six-layered organization originated very early in mammalian evolution. Although dolphins and whales lack a granular layer 4, it is suggested here that this may be a secondary reduction in neuronal packing density of neurons as an adaptation to limited oxygen availability during long dives.

Projections of the different cell classes in the LGN onto the visual cortex are similar in all mammals so far examined, with X/P and Y/M cells terminating in layer 4, and W/K cells terminating in layers 1 and 3. There is a trend towards a sublaminar segregation within layer 4, with Y/M cells tending to project to the upper portion of layer 4, and X/P cells tending to project to the lower portion of layer 4 [3,6]. This segregation pattern is most obvious in primates. Also, as at the level of the LGN, the segregation of ocular and functional inputs is most obvious in primates although relatively few mammals have been examined. Outputs of primary visual cortex are also similar across mammals, with layer 3 providing most of the outputs to extrastriate cortex, layer 5 projecting to the superior colliculus, layer 6 projecting to the LGN, and both 5 and 6 projecting to other visual thalamic nuclei. Although isocortex has six layers across mammals and is presumed to be homologous, sublaminar within the

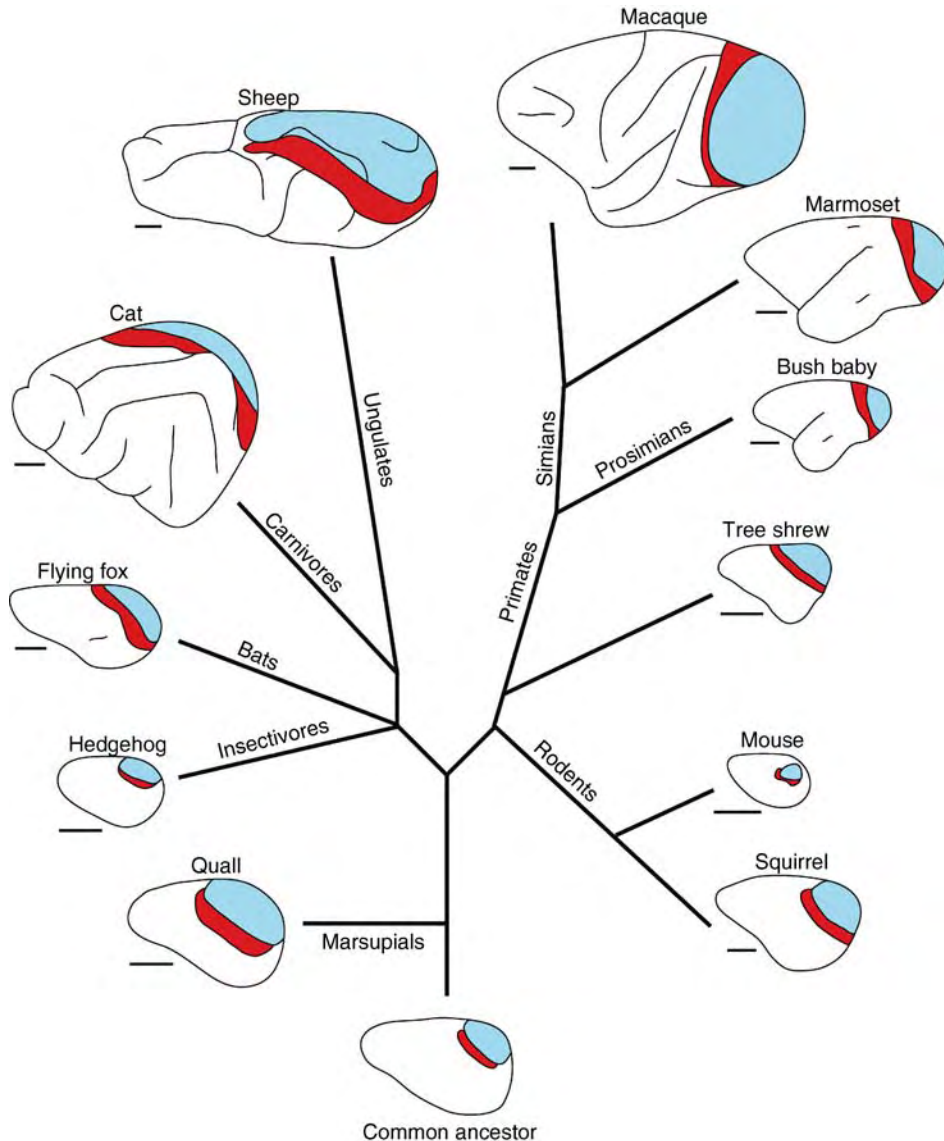

**Evolution of the Visual System in Mammals – Comparative Evolutionary Aspects across Orders. Figure 3** There is a clear commonality in the organization of cortical visual pathways in mammals. The primary visual area (V1, area 17, striate cortex) marked in blue is always located at the posterior aspect of occipital lobe. Its relative size and exact location depend on how “visual” the particular animal is. There is a tendency for primary visual cortex to be pushed toward posterior and medial aspect of the hemispheres as the relative size of the brain increases. Next to primary visual cortex lies the secondary visual area (V2, area 18) marked in red. Further anterior lie various extrastriate visual areas; no general consensus exists, however, concerning which extrastriate areas are present in which animals and how homologous areas are to each other. (Modified with permission from Rosa and Krubitzer, *TINS* 22(6) 1999) Scale bars = 5mm.

different layers has evolved independently in different lines of descent, as for example, the sublayers of layer 3 in primates and squirrels.

Visual cortex in many mammals is marked by a ►columnar organization of response properties and anatomical connectivity. How these columnar systems are related in different mammals is unclear. Segregation of inputs driven by the two eyes creates ocular

dominance (OD) columns, which are found, to a lesser or greater extent, in most mammals with substantial binocular overlap. It is likely that OD columns evolved independently in different mammalian lines as they evolved frontal vision. In primates, some New World monkeys lack OD columns, raising the possibility that Old and New World primates evolved OD columns independently, but recent work indicates that New

World species formerly thought lacking OD columns have them, albeit variable and poorly segregated, so OD columns need only have evolved once in primates. It seems likely that ocular segregation evolved independently in several lines of mammalian descent given that close relatives of primates, tree shrews, show a laminar, not a columnar segregation of ocular inputs to V1. Selectivity for stimulus orientation is another feature organized into columns in some mammals (e.g., carnivores, primates and tree shrews) but not in others (e.g., rodents and lagomorphs). Similar to LGN lamination, there is the possibility that increasing cortex area may lead to increased segregation into columns, independent of any contribution of columns to cortical processing. Counter to this argument is the fact that in squirrels V1 is equal in size to V1 in tree shrews yet does not show a columnar pattern for orientation suggesting that perhaps other factors besides size drive the development of this form of organization.

In some carnivores (cats) and primates, the metabolic enzyme cytochrome oxidase (CO) marks “blobs” of high activity in layer 3 that correspond to input zones of W/K LGN terminals, and also to segregation of projection neurons to extrastriate areas [3,6,9]. If blobs in cats and primates are homologous, they should exist in the Laurasiatherian relatives of cats and the Euarchontogliresian relatives of primates. Although blobs have been seen in ferrets, they have not been seen in tree shrews or rodents, and it is currently more parsimonious to conclude that blobs in carnivores and primates are a parallel homoplasy. Since blobs were more difficult to demonstrate in cats than in primates [9], it is possible that a cryptic columnar segregation of inputs and outputs may exist in other mammals, homologous to CO blobs, even if not readily visualized by CO content.

**Extrastriate Cortex.** Beyond V1, visual information is analyzed by a variety of different cortical areas, and it is unclear to what extent these extrastriate areas are homologous across species. Fossil evidence indicates that brain size and, hence, cortical area increased independently in different mammalian groups. Early mammals likely had few extrastriate areas; thus, few extrastriate areas can be common to all extant mammals.

Nearly all mammals have a narrow secondary visual area, V2, that wraps around V1 laterally and receives direct input from V1 [8,11] (Fig. 3). In rats and mice, it has been suggested that V1 is instead bordered by multiple small retinotopically defined areas, with perhaps the largest of these being homologous to V2 in other mammals. It has also been suggested that these small areas are actually modules within a single V2. Alternatively, a *bona fide* V2, narrow and easily overlooked, may be interspersed between V1 and these areas. In carnivores, V2 is a primary visual area,

receiving as strong an input from the LGN as does V1, and having a granular layer 4. Either the invasion of V2 by LGN axons induced a V1-like cytoarchitecture, or carnivore V2 is not homologous to V2 in other mammals. In the latter case, V2 may represent a duplication and divergence of V1, with laterally adjacent area V3 being the V2 homologue. It is not yet known if related Laurasiatherian groups such as ungulates have a carnivore-like V2 or a primate-like V2.

Beyond V2, extrastriate cortex in large, highly visual mammals such as cats and primates has expanded independently in evolution, with more than 10 extrastriate areas in cats and potentially over 30 in Old World primates. Even within primates, it is difficult to compare visual areas [4,13], and solid evidence in all studied primates exists for only three homologous areas, V1, V2, and the middle temporal area (MT), although it appears that smaller primates may have less extrastriate areas than larger ones. Likewise in carnivores, cats may have more visual areas than smaller brained ferrets.

In primates, it has been proposed that extrastriate areas can be divided into two streams for visual information processing, a dorsal stream to the parietal lobe involved in spatial vision, and a ventral stream to the temporal lobe involving object vision. Hierarchical chains of connections can be traced through multiple visual areas for each of these streams [3,4,6,10]. For the dorsal stream, V1 and V2 project to MT, which projects to parietal areas adjacent to and interconnected with premotor areas important for visually guided behaviors. For the ventral stream, V1 and V2 project through other intermediate areas, eventually reaching temporal cortex adjacent to and interconnected with perirhinal cortex and hippocampus, important for object recognition and encoding visual memories. Connectional, physiological, and behavioral evidence in cats suggests a similar functional specialization of dorsal and temporal visual areas, and similar specialization has been claimed for the multiple extrastriate areas of rodents as well [3,9]. Dorsal and ventral streams may be present in all mammals, as the targets of these streams, motor cortex and hippocampus, are present in all mammals. In this scenario, V1/V2 in early mammals would have direct projections to only a few areas that, in turn connected to motor cortex and to perirhinal cortex/hippocampus. Independently in different lines of descent, additional extrastriate areas for each stream would be inserted laterally to V2, more parietally (closer to motor cortex) for dorsal stream areas, and more temporal (closer to hippocampus) for ventral stream areas.

### Summary

Early mammals shared a similar retinal organization with specialized retinal ganglion cells sending axons in parallel to several subcortical targets with segregation



and differentiation of these pathways evolving separately in different evolutionary lines but with each target maintaining a map of visual space.

Early mammals had an LGN with projections to a 6 layered primary visual cortex. These mammals likely also had at least two types of LGN cells that projected in parallel to cortex. Orientation and ocular dominance columns likely evolved independently in different lines.

Early mammals had little extrastriate cortex and few extrastriate areas, which increased in size and number separately in different lines. A basic distinction between dorsal (motor-related) and ventral (hippocampal-related) processing was likely present in early mammals.

## References

1. Kaas JH (2002) Convergences in the modular and areal organization of the forebrain of mammals: implications for the reconstruction of forebrain evolution. *Brain Behav Evol* 59:262–72
2. Northcutt RG (2002) Understanding vertebrate brain evolution. *Integr Comp Biol* 42:743–756
3. Casagrande VA, Khaytin I, Boyd JD (2006) The evolution of parallel visual pathways in primates. In: Preuss TM, Kaas JH (eds) *Evolution of the nervous system*. Elsevier, London, GB
4. Kaas JH (2004) The evolution of the visual system in primates. In: Chalupa LM, Werner JS (eds) *The visual neurosciences*. MIT, Cambridge, MA, pp 1563–1572
5. Butler AB, Hodos W (2005) *Comparative Vertebrate Neuroanatomy: Evolution and Adaptation*, 2nd Edn. Wiley, Hoboken, NJ
6. Casagrande VA, Xu X (2004) Parallel visual pathways: a comparative perspective. In: Chalupa L, Werner JS (eds) *The visual neurosciences*. MIT, Cambridge, MA, pp 494506
7. Arrese CA, Oddy AY, Runham PB, Hart NS, Shand J, Hunt DM, Beazley LD (2005) Cone topography and spectral sensitivity in two potentially trichromatic marsupials, the quokka (*Setonix brachyurus*) and quenda (*Isoodon obesulus*). *Proc Biol Sci* 272:791–796
8. Krubitzer L (1995) The organization of neocortex in mammals: are species differences really so different? *Trends Neurosci* 18:408–417
9. Matsubara JA, Boyd JD (2002) Relationship of LGN afferents and cortical efferents to cytochrome oxidase blobs. In: Payne BR, Peters A (eds) *The cat primary visual cortex*. Academic, New York, pp 221–258
10. Sincich LC, Horton JC (2004) *The Circuitry of V1 and V2: Integration of Color, Form, and Motion*. *Annu Rev Neurosci*
11. Rosa MG, Krubitzer LA (1999) The evolution of visual cortex: where is V2? *Trends Neurosci* 22:242–8
12. Sereno MI, Allman JM (1991) Cortical visual areas in mammals. In: Leventhal AG (ed) *Vision and visual dysfunction: the neural basis of visual function*. Macmillan, London, pp 160–172
13. Rosa MG, Manger PR (2005) Clarifying homologies in the mammalian cerebral cortex: the case of the third visual area (V3). *Clin Exp Pharmacol Physiol* 32:327–339

## Evolution of the Visual System in Amphibians

URSULA DICKE, GERHARD ROTH  
Brain Research Institute, University of Bremen,  
Bremen, Germany

### Definition

The amphibian visual system like that of other vertebrates is anatomically organized into two ascending visual pathways, namely the retino-thalamo-telencephalic and the retino-tecto-thalamo-telencephalic pathways. In contrast to the situation in mammals, the dorsal thalamus does not contain a visual relay nucleus that receives direct retinal input and projects monosynaptically to the cortex. Primary and topographically organized visual areas are likewise absent in the pallium of amphibians. The thalamic and telencephalic centers involved in visual processing exert a modulatory rather than a primary sensory role. An additional pathway, the retino-tectal-pretectal system, processes localization and recognition of objects and depth perception and controls visual behavior. Visual processing takes place in essentially the same way as in amniotes; it is based on population coding and occurs in a parallel-distributed fashion simultaneously and subsequently by interaction with several visual centers.

### Characteristics

#### The Retina and Functional Anatomy of Retinal Ganglion Cells

The amphibian retina shows a five-layered structure typical of the vertebrate eye. The outer and inner nuclear layer and the layer of retinal ganglion cells (RGC) are separated by two fiber layers, viz. the outer plexiform layer and the much thicker inner plexiform layer. These two layers are the main sites of synaptic contacts between retinal cells, i.e. photoreceptors, amacrine cells, bipolar cells, horizontal cells and ganglion cells [1]. The outer nuclear layer contains the inner segments of the photoreceptors (rods, cones and double-cones) and their nuclei. Amphibians have no specialized intraretinal structures like the fovea of primates or birds. In some frog species, a streak of high cell density exists in the RGC layer along the naso-temporal meridian of the retina. Three major classes of RGCs exist in amphibians. ► **Small-field cells** respond either to moving or non-moving objects and require relatively high visual contrast; subclasses differ in color sensitivity and in responses to light “On/Off”. This cell type is comparable to X-cells in cats and to P-cells in primates. ► **Medium-field cells** respond to small changes in contrast and small dislocations of edges and

thus to movement; these cells correspond to Y-cells in cats and M cells in primates. ▶ **Large-field cells** respond well to large objects and to changes in illumination in larger parts of the visual field [for an extended overview see 2]. The axons of RGC form bundles and the majority of them cross in the optic chiasm.

The projections of RGCs are topographically organized and reach targets in the contralateral diencephalon and mesencephalon. Four thalamic neuropils are formed by their terminals: the neuropil of Bellonci (NB), the corpus geniculatum thalamicum (CGT), the nucleus preopticus, and the posterior thalamic neuropil, which is divided into a laterally situated pretectal neuropil and a medially situated uncinata field [3,4]. In the mesencephalon, the superficial fiber layer and part of the deeper fiber layers of the tectum receive extensive visual afferents forming three to four laminae [5,6]. Another terminal site of retinal afferents is the ▶ **basal optic neuropil** situated in the tegmentum. Axons of RGCs often form multiple terminal structures in the tectum and in the thalamic neuropils.

### The Tectum Mesencephali as the Main Visual Center

In amphibians, as in all anamniote vertebrates, in reptiles and partly in birds, the tectum is the major brain center for integrating visual perception and visuomotor functions. In the amphibian tectum, localization and recognition of objects and depth perception takes place. Three separate retino-tectal subsystems for object recognition exist, which process information about (i) size and shape, (ii) velocity and movement pattern and (iii) changes in ambient illumination. These kinds of information are processed at the level of different types of retinal ganglion cells and tectal neurons in close interaction with neurons in other visual centers (Fig. 1).

The tectum has substantial reciprocal connections with the ventral thalamus, the ▶ **pretectum**, the dorsal tegmental nucleus, the ▶ **nucleus isthmi** [see ▶ **Evolution, of Nucleus Isthmi**] and the middle reticular nucleus of the medulla. Transmitter-specific input originates from the cholinergic nucleus isthmi and from cholinergic tectal cells (only in salamanders), the serotonergic nucleus raphe and serotonergic tectal cells (only in frogs) or from the glycinergic middle reticular nucleus of the medulla (in salamanders), which modulate retino-tectal transmission and/or postsynaptic tectal processing [7–10].

Nine layers are distinguished in the tectum of frogs, while the tectum of salamanders consists only of a periventricular cellular layer and a superficial white matter with only few migrated neurons. During ontogeny, tectal cells originate in the periventricular germinal zone and then migrate toward the surface. In salamanders, this late ontogenetic migration process is either strongly reduced or completely abolished

due to secondary simplification as a consequence of ▶ **paedomorphosis** [11], while the functional organization of the tectum is essentially the same in frogs and in salamanders [12–14]. The salamander tectum contains on average 100,000 cells and this number is 2–17 times larger in frogs. Glutamate is found in the majority of tectal neurons. However, cells containing only GABA comprise at least one-third of the total population of neurons. The bulk of tectal neurons represent local interneurons and only roughly 5% are projection neurons. Separate tectal pathways descend to premotor and motor centers in the brainstem and cervical spinal cord that are involved in the guidance of visual behavior.

At least four types of neurons with medium- or large-sized dendritic arbors located in different tectal layers give rise to one crossed descending tract and several uncrossed descending tracts. The descending fibers of the different tracts form distinct terminal fields in the tegmentum and/or the medulla. The descending projectional system of the amphibian tectum corresponds to that found in other vertebrates as regards neuronal types and projection sites. Ascending tectal pathways run bilaterally to the dorsal and ventral thalamus, which in turn are connected with telencephalic associative (pallial) and limbic centers (amygdala and septum) and the striato-pallidum. These ascending pathways are formed by small-field tectal neurons with only ascending projections, as well as by two types of wide-field neurons with ascending and descending projections. The former neurons constitute the majority of ascending tectal projection neurons; they give rise to a retinotopic tectal projection to the thalamus. In contrast, the latter two types of neurons appear to give rise to a non-retinotopic tectal projection to the thalamus. Accordingly, in amphibians the ascending pathways may be divided into two functional systems, viz. a retinotopically organized one and a non-retinotopically organized one. This is comparable to the situation found in reptiles and birds.

Unlike other jawed vertebrates, the amphibian tectum includes no saccadic system, because eye movements do not exist in adult amphibians. This is probably due to a secondary loss, because eye movements are present during ontogeny of amphibians with aquatic or semi-aquatic life styles. In addition, directionally selective neurons are absent in the amphibian tectum, in contrast to their presence in all amniotes.

### The Visual Thalamus

Visual afferents to the thalamus include primary afferents from the optic nerve and secondary afferents from the tectum. The optic tract forms two neuropils in the thalamus, i.e. the neuropil of Bellonci (NB) and the corpus geniculatum thalamicum (CGT), which occupy most of the lateral region of the thalamus. Afferents from

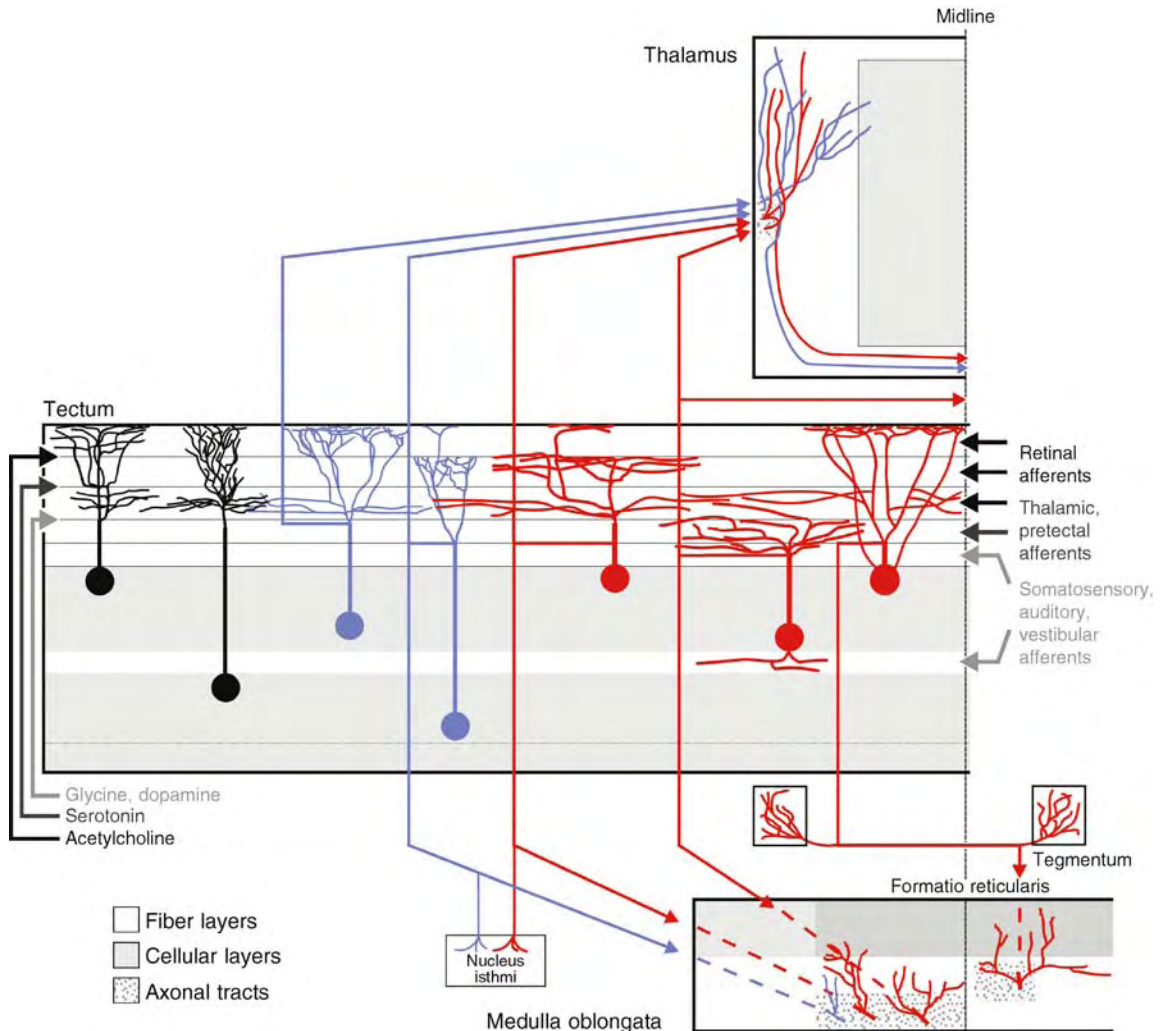

**Evolution of the Visual System in Amphibians. Figure 1** Summary diagram of the tectum and its layers, afferent input and types of tectal neurons. Local interneurons are drawn in black, small-field and large-field projection neurons are drawn in blue and red, respectively. Only ascending projections to the thalamus and descending projections to the tegmentum and medulla oblongata are shown.

the tectum terminate in the medial portion of the neuropil area. Thalamic neurons with only descending projections have dendritic trees that arborize in restricted parts of retinal afferents, while those with only ascending projections to telencephalic targets have dendritic trees that do not, or not substantially, contact retinal afferents. With electrical stimulation of the optic nerve, neurons in the ventral thalamus exhibit mostly excitatory responses at short latencies and thus appear to be mono- or oligo-synaptically driven by retinal afferents, while those of the dorsal thalamus respond with inhibition or excitation at long latencies and are regarded as poly-synaptically driven by retinal afferents [15,16].

A remarkable difference between amphibians and mammals is the absence in the dorsal thalamus of

amphibians of a visual relay nucleus that receives direct retinal input and projects mono-synaptically to the cortex. Another difference is the absence from the pallium of amphibians of primary and topographically organized visual areas such as are present in the striate cortex of mammals. Birds possess two visual pathways, viz. a retinotopically organized pathway from the retina to the nucleus geniculatus lateralis pars dorsalis, which in turn projects to the visual Wulst of the hyperpallium and is comparable to the retino-thalamo-cortical pathway in mammals and a non-retinotopically organized pathway from the tectum via the thalamic nucleus rotundus to the entopallium (formerly ectostriatum), the homology of which in mammals is currently a subject of debate [see Evolution, of the Telencephalon: in

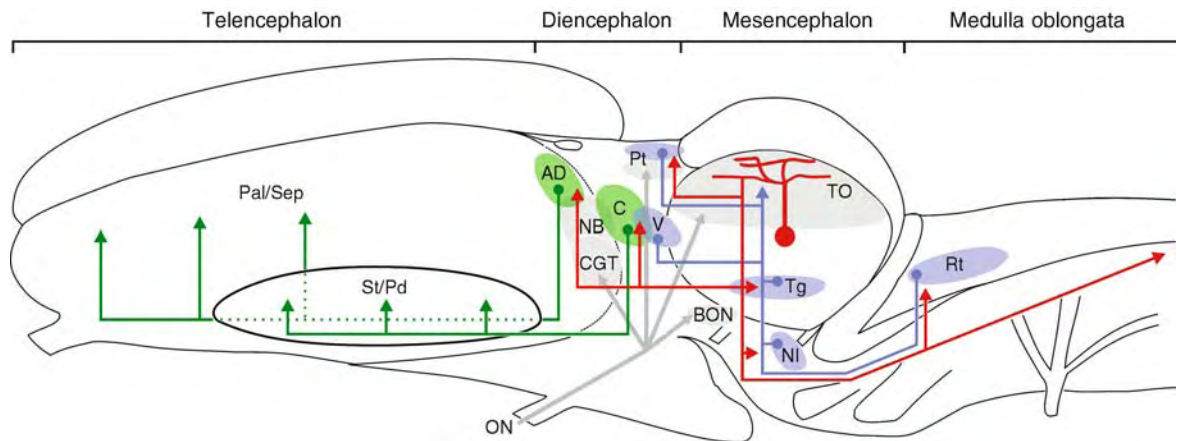

**Evolution of the Visual System in Amphibians. Figure 2** Schematic diagram of the visual pathways in the amphibian brain. An outline of the salamander brain is shown. Gray lines denote the optic nerve (ON), gray areas refer to the terminal fields of the axons of retinal ganglion cells in the neuropil Bellonci (NB) and corpus geniculatum thalamicum (CGT) inside the thalamus, the pretectum (Pt), the basal optic neuropil (BON) inside the tegmentum, and within the layers of the tectum (TO). A schematized tectal neuron and the efferent pathways of tectal cells are drawn in red; axons run to the ventral and dorsal thalamus, pretectum, tegmentum, isthmus region, reticular medullar zone and cervical spinal cord. Feedback connections (blue lines) exist between tectum and ventral thalamus (V), Pt, dorsal tegmental nucleus (Tg), nucleus isthmi (NI) and reticular nuclei (Rt). Ascending pathways (green lines) extend from the central dorsal thalamic nucleus (C) to the striato-pallidum (St/Pd), and from the anterior dorsal thalamic nucleus (AD) to the amygdala, pallium and septum (Pal/Sep). Descending projections from the telencephalon to the thalamus, tegmentum and medulla are omitted for the sake of clarity.

Amniotes and Evolution, of the Forebrain: Embryological Development]. The situation in turtles and squamates is somewhat intermediate, because although on the one hand a lateral geniculate nucleus exists, receives direct retinal input and projects both to the dorsal cortex and the pallial thickening, on the other hand, in neither area are retinotopically arranged visual areas found [17].

### Functional and Comparative Aspects

The major visual system differences that exist between amphibians on the one hand and mammals and birds on the other can be summarized as follows: (i) in amphibians, visual object recognition and visual guidance of behavior is mostly exerted by the retino-tecto-pretectal system, (ii) a unimodal visual thalamo-telencephalic system characteristic of mammals and birds is absent in amphibians and poorly developed in reptiles, (iii) the visual pallial area in amphibians is not topographically organized and (iv) in amphibians, thalamic and telencephalic centers appear to exert a modulatory but no primary sensory role.

On the basis of tract tracing and intracellular and extracellular recording experiments, it appears that besides the above mentioned differences, the amphibian visual system is organized in essentially the same way as that of amniotes in the sense that object recognition is based on population coding and occurs in a parallel

distributed fashion simultaneously and subsequently at several to many visual centers [18,19]. Interaction and modulation between these centers occurs to a large extent, because they are interconnected by several feedback loops and top-down influences are most likely (Fig. 2).

This pattern of interaction is supported by a complex chemoarchitecture [20–21]. At least three major streams of information converge at premotor and motor levels in order to elicit the various steps of visually guided behavior: (i) information about properties of the object perceived concerning size, contrast, color, shape, velocity, movement pattern etc. and (ii) information about the precise location of that object. Pathways (i) and (ii) need to interact in order to fully identify visual objects including their absolute size. Additionally, information about the level of motivation, most probably coming from limbic telencephalic regions (amygdala, nucleus accumbens/ventral striato-pallidum) and the hypothalamus, affects the behavior.

### References

1. Dowling JE, Werblin FS (1969) Organization of retina of the mudpuppy, *Necturus maculosus*. I. Synaptic structure. *J Neurophysiol* 32:315–338
2. Roth G, Dicke U, Wiggers W (1998) Vision. In: Heatwole H, Dawley EM *Amphibian biology*, vol 3: Sensory perception. Surrey Beatty, Chipping Norton, pp 783–878

3. Montgomery N, Fite KV (1989) Retinotopic organization of central optic projections in *Rana pipiens*. *J Comp Neurol* 283:526–540
4. Rettig G, Roth G (1986) Retinofugal projections in salamanders of the family Plethodontidae. *Cell Tissue Res* 243:385–396
5. Hughes TE (1990) Light and electron microscopical investigations of the optic tectum of the frog, *Rana pipiens*. I. The retinal axons. *Vis Neurosci* 4:499–518
6. Wiggers W (1999) Projections of single retinal ganglion cells to the visual centers: an intracellular staining study in a plethodontid salamander. *Vis Neurosci* 16:435–447
7. Dudkin EA, Gruberg ER (2003) Nucleus isthmi enhances calcium influx into optic nerve fiber terminals in *Rana pipiens*. *Brain Res* 969:44–52
8. Landwehr S, Dicke U (2005) The distribution of GABA, glycine and glutamate in neurons of the medulla oblongata and their projections to the midbrain tectum in plethodontid salamanders. *J Comp Neurol* 490:145–162
9. Malayev AA, Debski EA (1998) Serotonin modulates induced synaptic activity in the optic tectum of the frog. *Brain Res* 781:167–181
10. Yu CJ, Debski EA (2003) The effects of nicotinic and muscarinic receptor activation on patch-clamped cells in the optic tectum of *Rana pipiens*. *Neuroscience* 118:135–144
11. Roth G, Naujoks-Manteuffel C, Nishikawa K, Schmidt A, Wake DB (1993) The salamander nervous system as a secondarily simplified, paedomorphic system. *Brain Behav Evol* 42:137–170
12. Antal M, Matsumoto N, Székely G (1986) Tectal neurons of the frog: intracellular recording and labeling with cobalt electrodes. *J Comp Neurol* 246:238–253
13. Dicke U (1999) Morphology, axonal projection pattern, and response types of tectal neurons in plethodontid salamanders. I. Tracer study of projection neurons and their pathways. *J Comp Neurol* 404:473–488
14. Roth G, Dicke U, Grunwald W (1999) Morphology, axonal projection pattern and response types of tectal neurons in plethodontid salamanders. II. Intracellular recording and labeling experiments. *J Comp Neurol* 404:489–504
15. Roth G, Grunwald W (2000) Morphology, axonal projection pattern and responses to optic nerve stimulation of thalamic neurons in the salamander *Plethodon jordani*. *J Comp Neurol* 428:543–557
16. Roth G, Grunwald W, Dicke U (2003) Morphology, axonal projection pattern and responses to optic nerve stimulation of thalamic neurons in the fire-bellied toad *Bombina orientalis*. *J Comp Neurol* 461:91–110
17. Dicke U, Roth G (2007) Evolution of the amphibian nervous system. In: Kaas JH, Bullock TH, Krubitzer LA, Preuss TM, Rubenstein JLR, Strausfeld NJ, Striedter GF (eds) *Evolution of nervous systems*, vol. 2. Academic Press, Oxford, pp 61–124
18. Schuelert N, Dicke U (2005) Dynamic response properties of visual neurons and context-dependent surround effects on receptive fields in the tectum of the salamander *Plethodon shermani*. *Neuroscience* 134:617–632
19. Winkowski DE, Gruberg ER (2005) Superimposed maps of the monocular visual fields in the caudolateral optic tectum in the frog, *Rana pipiens*. *Vis Neurosci* 22:101–109
20. Debski EA (2001) Distribution and regulation of substance P-related peptide in the frog visual system. *Microsc Res Tech* 54:220–228
21. Li Z, Fite KV (2001) GABAergic visual pathways in the frog *Rana pipiens*. *Vis Neurosci* 18:457–464

## Evolution of the Visual System in Fishes

E

SHAUN P. COLLIN

Sensory Neurobiology Group, School of Biomedical Sciences, The University of Queensland, Brisbane, QLD, Australia

### Synonyms

Fishes; Visual systems

### Definition

The evolution of the visual system can be defined as the series of changes in the structure and function of the eye and visual input to the brain that has occurred as a result of selection pressures over a relatively long time period. The visual system of fishes comprises the optical apparatus (cornea, iris and lens), the neural retina (converting an optical image into an electrical image) and the optic nerve (conveying visual information to the brain). Primitive fishes are either jawless (Agnatha) or jawed (Elasmobranchii and Osteichthyes) and are remarkably diverse, occupying a large range of aquatic environments.

### Characteristics

The extant jawless fishes (hagfishes and lampreys) represent the earliest stage in vertebrate evolution. Lamprey-like animals are represented in fossil deposits dating back approximately 540 million years. The jawed fishes (cartilaginous and bony) evolved approximately 400 million years ago and occupy a diverse range of habitats and lifestyles. At present, about 25,000 species within almost 500 families and 60 orders of fishes exist (85 jawless, 850 cartilaginous sharks, skates, rays and chimaeras and 24,000 bony fishes). However, the visual systems of only a small percentage of these species have been examined. Many of their ocular features have been shown to be under environmental, rather than phylogenetic, selection pressures.

### The Eye

#### *The Evolution of the Eye in Fish*

The single-chambered chordate eye appears to have evolved not long after the Cambrian explosion, a period

in evolutionary history that generated many of the animal phyla in existence today. The evolution of an image-forming eye in conodont animals provided spatial vision and the opportunity for predation, a strong selection pressure that was to greatly influence eye design. The vertebrate retina is derived from the neural epithelium of the central nervous system, while the lens is derived from an invagination of the epidermal epithelium. The evolution of the eye from a region of photosensitive skin to an eyecup with retinal elements and a lens is considered to have taken less than 400,000 generations or less than half a million years [1]. Given the enormous range of visual environments occupied by various species of fish, it is therefore not surprising that their eyes have evolved a plethora of mechanisms to increase sensitivity and/or spatial resolution. The size and position of the eyes within the head and the extent of the ►visual field also varies and governs visual behavior.

### The Cornea

The cornea is the first optical interface in the eye and acts as a protective goggle predominantly comprising collagen fibers (stroma) interposed between an epithelium and an endothelium. The fish cornea confers little if any refractive power due to the comparable refractive indices of the cornea and the surrounding aquatic media. In early fishes, the cornea was split into dermal (continuous with the skin) and scleral (continuous with the eyecup) components, which, in some amphibious or burrowing species, allows the underlying globe to move freely. The evolution of the dermal cornea or secondary spectacle is thought to streamline the head and, in benthic species, protects the eye from abrasion. Colored pigments within the cornea (and lens) also act as short wavelength absorbing filters to minimize chromatic aberration and to tune the light reaching the retinal photoreceptors. These intraocular filters have been described in the corneas of agnathans and in cartilaginous and bony fishes. In some pelagic species of bony fishes, a fusion of horizontal or vertical eyelids has resulted in an intraconjunctival space (termed a tertiary spectacle by Walls [2]). In agnathans and elasmobranchs, ►sutural fibers inhibit the corneal stroma from swelling in response to low temperatures and changes in osmotic pressure associated with moving between salt water and freshwater.

Multilayered stacks of materials (such as connective tissue, modified ►rough endoplasmic reticulum, collagen fibrils and cytoplasmic plates) with different refractive indices are common inclusions in bony fishes (Osteichthyes) and produce iridescence [3]. The result of constructive interference, the wavelength and intensity of the reflected iridescence depends upon the thickness, spacing and the angle of incidence of the light on the cornea. Iridescence may reduce intraocular

flare produced by bright down welling light, act as a birefringent filter and provide camouflage for the pupil. Given the diversity of iridescent structures, its appearance may represent convergent evolution.

### The Lens

In water, and in the absence of any corneal refraction, the refractive power of the fish eye lies solely with the lens. In order to reduce the focal length and improve the quality of the image focused on the retina, a lens with a small radius of curvature is required. Therefore, the fish lens is generally spherical (Figs. 1, 2).

However, this presents the optical problem of spherical aberration. This type of aberration is produced by light rays refracting (bending) too much at the spherical surface of the lens, thereby not bringing all rays to a single focus and producing a blurred image. In order to overcome spherical aberration, and in contrast to terrestrial lenses, the fish lens has a graded refractive index from the lens center to the periphery. The result is that the lens periphery bends the light less and all rays are brought to a single focus on the neural retina. The graded refractive index is lacking in young sea lampreys, which exhibit positive spherical aberration until they mature.

Some species of fishes have evolved mechanisms to alter the refractive power of either the lens or cornea or both. In amphibious fishes (e.g. mudskippers and flying fish), the cornea has become flattened to compensate for the increase in corneal power in air. The sandlance, a minute bony fish with independent turret-like eyes, has evolved a highly refractive corneal lenticle with increased power (balanced by a flattened lens with decreased power) in water (Fig. 2). This unique optical design moves the nodal point of the eye forward, thereby providing new information about a prey object's location against a background, without translations of the head or body [4]. The four-eyed fish is able to see in both air and in water by sitting at the water's surface with the dorsal half of the eye out of the water facing upwards and the ventral half of the eye submerged and facing downwards. Clear vision in both aerial and aquatic axes is accomplished simultaneously with a lens that has different radii of curvature (Fig. 2).

Unfortunately for biological lenses, short wavelengths of light are refracted more than long wavelengths of light (chromatic aberration). This results in blue light focusing closer to the lens than red light. However, interruptions to the otherwise smooth refractive index gradients of the lens in lampreys, lungfish and teleosts bring the focal length of the light spectrum back to a single focus on the retina. These multifocal lenses allow the incident light to be focused on a single layer of retinal photoreceptors, thereby optimizing the capture of light by multiple cone types involved in mediating color vision [5].

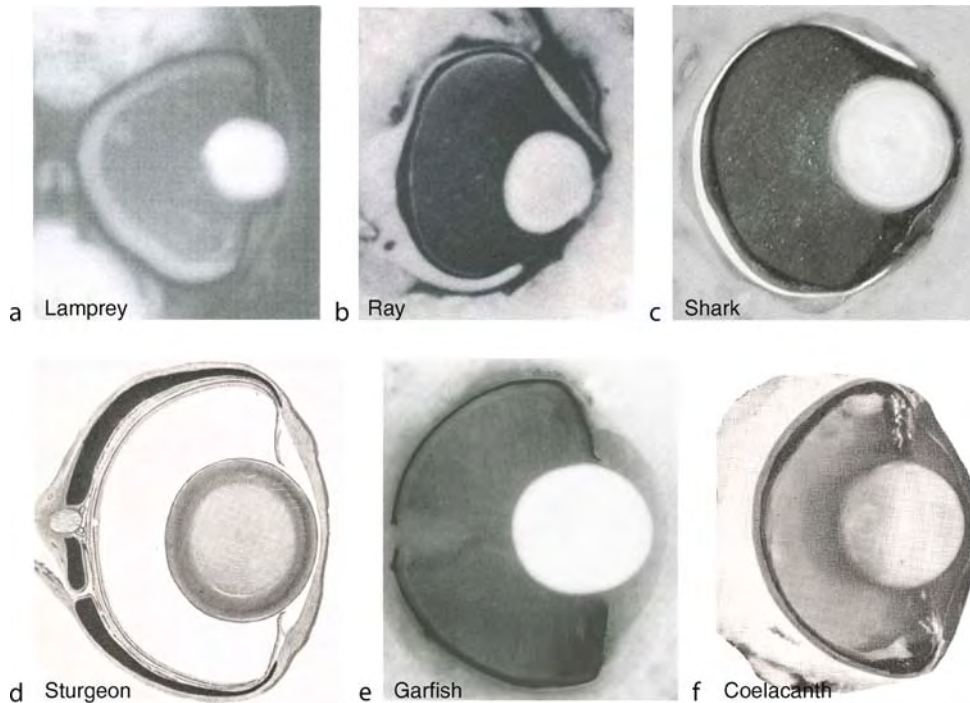

**Evolution of the Visual System in Fishes. Figure 1** Transverse frozen sections of the eyes of a range of primitive fishes. a The lamprey, *Geotria australis*, Agnatha [adapted from 23]. b The bluntnose stingray, *Dasyatis sayi*, Elasmobranchi [adapted from 26]. c The bamboo shark, *Chiloscyllium punctatum* Elasmobranchi. d The sturgeon, *Acipenser ruthenus*, Chondrostei [adapted from 24]. e The Florida garfish, *Lepisosteus platyrhinchus*, Neopterygii [adapted from 22]. f The coelacanth, *Latimeria chalumnae*, Sarcopterygii [adapted from 24].

The size of the pupillary aperture can improve the level of spherical aberration by reducing the number of rays passing through the lens periphery. The shape and size of the pupil varies across fishes from a circular to a U- or W-shaped with multiple apertures to a slit. Lampreys possess little, if any, active movement of the iris, while most elasmobranchs elicit rapid changes in pupil shape in response to ambient light levels. Teleosts predominantly do not possess pupillary movements, although some benthic catfishes use the constricted pupil to camouflage their eyes [6].

#### Accommodatory Apparatus

With a spherical shape of fixed focal length, the fish lens must be physically moved back and forward to focus on near and far objects within the visual field. Accommodatory mechanisms have been subject to appreciable selection pressure in fishes and vary across many of the groups [7]. Many hagfishes do not possess a lens. However, in other agnathans (the lampreys), a cornealis muscle lying in the head next to the eye is thought to retract the cornea and thereby the closely apposed lens towards the retina during accommodation. However, stimulation of the cornealis muscle does not elicit lens movement in some species of lampreys and other static forms of accommodation i.e. a multifocal

lens and a variable distance between the photoreceptor plane and the lens center, may provide a focused image on the retina (Fig. 1). In lampreys, some batoid elasmobranchs and developing teleosts, the eyes are not symmetrical, the dorsal retina sitting closer to the lens than the ventral retina. This “ramped retina” allows both near and far objects to be focused on the retina simultaneously (Fig. 1). Cartilaginous fishes and bony fishes possess a protractor and a retractor lentis muscle, respectively. These intraocular lens muscles within the ventral papillae of the ciliary body move the spherical lens anteriorly (towards the cornea accommodating for near objects) and posteriorly (toward the retina accommodating for distant objects). Two species of teleost, the sandlance and the deep-sea pearleye, possess corneal accommodation, where a striated cornealis muscle flattens the corneal curvature thereby retracting the lens towards the retina.

#### The Retina and Photoreception

With the exception of the hagfish retina, which appears undifferentiated, the retina of both primitive and advanced fishes possesses all of the major retinal neurons found in other vertebrates. These include photoreceptors, horizontal, bipolar, amacrine and ganglion cells, which are arranged into three nuclear layers

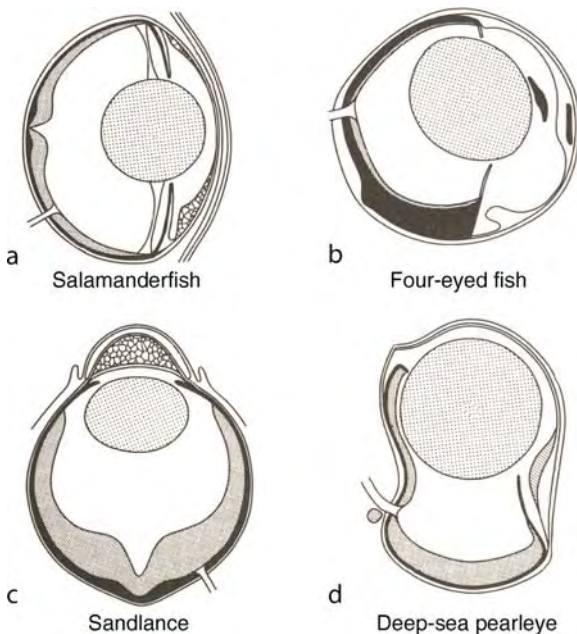

**Evolution of the Visual System in Fishes. Figure 2** Schematic eyes of a range of teleost fishes. a The salamanderfish, *Lepidogalaxias salamandroides*. b The four-eyed fish, *Anableps anableps*. c The sandlance, *Limnichthyes fasciatus*. d The deep-sea pearleye, *Scopelarchus michaelsarsi*. Note the diverse range of corneal, lenticular and retinal specializations [adapted from 21].

and two plexiform (synaptic) layers. In lampreys, most (75%) of the ganglion cells lie within the inner nuclear layer. Axons of these “ectopic” ganglion cells join those lying within the ganglion cell layer to exit the retina at the boundary of the inner nuclear and inner plexiform layers at the optic nerve head, effectively negating the blind spot [8]. In elasmobranchs and teleosts, most of the ganglion cells lie within the ganglion cell layer, with a small proportion “displaced” to the inner nuclear layer. Their axons traverse the retina within the nerve fiber layer abutting the inner limiting membrane. A great deal of work still remains to be done on the evolution of the inner retina in fishes, but it appears that lampreys possess a population of biplexiform ganglion cells that make direct connections with the photoreceptors and inner nuclear layer cells.

The photoreceptors within the outer retina of a range of extant species of fishes have received more attention. Their visual pigments phototransduce light energy into electrical impulses that trigger a cascade of enzymatic reactions that amplify the signal and ultimately change the rate of neurotransmitter release from their synaptic terminals. The signals are conveyed to the ganglion cells via bipolar interneurons. The visual pigments comprise a chromophore based on either vitamin A<sub>1</sub> (rhodopsin) or A<sub>2</sub> (porphyropsin) covalently bonded to

an opsin protein, comprised of seven transmembrane alpha helices embedded within the outer segment discs. The amino acid sequence of the opsin protein and the type of chromophore used in fishes determines the spectral sensitivity/tuning of the visual pigment and therefore the range of wavelengths to which each species is sensitive. Rods mediate dim light (scotopic) vision and cones mediate bright light (photopic) vision. In jawed vertebrates, rod visual pigments are classified as Rh1, while cone visual pigments fall into four classes (long wavelength-sensitive or LWS, ultraviolet-sensitive or SWS1, blue wavelength-sensitive or SWS2 and medium wavelength sensitive or Rh2). Cones may be also characterized on size and whether they are single or double (although triple and quadruple cones have also been described). Single cones can be divided into at least four classes based on size and the class of visual pigment. Double cones are closely apposed cones that are morphologically distinct (with principal and accessory components) or indistinct (twin cones). The presence of more than one cone type, each with a different (but overlapping) spectral sensitivity, provides the basis for color vision.

While hagfishes, possess at least two photoreceptor types, lampreys possess up to five morphologically distinct photoreceptor types, all of which possess cone-like characteristics and contain a different visual pigment (LWS, SWS1, SWS2, RhA and RhB), providing the basis for pentachromatic vision [9]. Three of these opsin genes are orthologous to the visual pigment classes of gnathostomatous (jawed) vertebrates but the other two (RhA and RhB) have evolved by an independent gene duplication event, which occurred within the agnathan lineage. Given the absence of the Rh1 opsin gene within the agnathan lineage, scotopic vision may have evolved exclusively within the gnathostomatous lineage prior to the evolution of the cartilaginous fishes. The functional characterization of rods and cones requires further examination in the early vertebrates at both the physiological and the biochemical levels. Multiple cone types have been retained within the cartilaginous (3 cone types) [10], dipnoan (4 cone types) [11], early ray-finned (3 cone types) [12] and teleostean (up to 7 cone types) [13] fishes. Therefore, it appears that all vertebrate classes possess the potential for color vision, although this has not yet been confirmed behaviorally in the non-actinopterygian fishes. The comoran coelacanth appears to have lost the SWS1, SWS2 and LWS opsin genes and retained the Rh1 and Rh2 opsin genes that are tuned to detect the full spectrum of light available at the depth it inhabits (200 m) [14].

#### Spectral Filters

Filtering mechanisms in fishes are common and typically comprise the accumulation of short wavelength-absorbing pigment within the ocular media



(cornea, lens and vitreous humor) [15] and within the inner regions of some photoreceptor types (myoidal pigment and oil droplets). These spectral filters narrow the absorption spectrum of the visual pigment housed in the outer segment of the photoreceptors, shift the peak absorption of the visual pigment towards longer wavelengths and decrease the absorption efficiency. Accumulations of yellow myoidal pigment exist in lampreys, the Australian lungfish and in reptiles. Oil droplets exist in the lobe-finned (lungfish and coelacanth) [11] and early ray-finned (sturgeon and paddlefish) [12] fishes and may be red or colorless. Oil droplets allow the discrimination of more colors under bright light conditions. Intracellular structures resembling oil droplets lie within the photoreceptor inner segments in a single species of lamprey and some teleostean cyprinids. Termed ellipsosomes based on their elliptical shape, these structures are of mitochondrial origin and may either contain a heme pigment, thereby acting as a spectral filter (cyprinids) or lack any light-absorbing pigment and may act as an intracellular focusing device.

### Tapeta

A mirror or tapetum located behind the retina for increasing sensitivity by reflecting light back onto the photoreceptors is an early invention in vertebrate evolution. Of the 33 species of lampreys described, a single species (*Mordacia mordax*) possesses a mixture of reflective needles and pigment granules within the retinal pigment epithelium, which elicits a yellow eye shine. Retinal tapeta have been also described in garfishes and several species of teleosts. These comprise spheres containing astaxanthin, phenolic compounds or lipids packed into a hexagonal array within the confines of the retinal pigment epithelial cell membrane. All these spheres are reflective and elicit a colored reflex produced by diffuse scattering. Choroidal tapeta, typically with guanine as the reflector, are found in cartilaginous fishes (sharks, skates, rays and ratfishes), Polypteriformes (bichirs), Ginglymodi (gars), Acipenseridae (sturgeons), Dipnoi (lungfishes), the coelacanth and a few nocturnal ray-finned fishes. In cartilaginous fishes, the choroidal tapetum is occlusable, masking the mirrored surface with pigment granules in bright light.

Another way of increasing sensitivity to a range of ambient light conditions is to differentially place the rod photoreceptors adapted for dim light vision closer to the incident light (at the outer limiting membrane). Under these conditions, the cone photoreceptors migrate towards the back of the retina. The opposite occurs in bright light, where the cones adopt a position at the outer limiting membrane and the rods are masked by the migration of the melanosomes within the retinal pigment epithelium. In teleosts, not all photoreceptor types undergo photomechanical movements. There

appears to be a trade-off between the level of photomechanical retinomotor movements (inherently slow) and the evolution of more rapid pupillary movements. In evolutionary terms, pupillary and retinomotor movements appear to be most developed within the elasmobranchs and teleosts, respectively.

In contrast to optimizing sensitivity with either retinomotor movements or a tapetum, many fishes are specialized for acute vision, sampling a particular part of their visual field with high **spatial resolving power**. The lamprey retina is specialized for acute vision, where both the photoreceptor and ganglion cell densities increase to form an area centralis in the central retina [8]. All of the fishes examined thus far, irrespective of their phylogenetic origins, possess some form of retinal specialization, which may be in the form of a concentric increase in cell density (area centralis) or an elongated increase in cell density across the retinal meridian (horizontal streak). Environmental cues and the symmetry of each species' perceived world play a large role in the topography of retinal cells rather than any phylogenetic relationships. The first appearance of a retinal invagination or foveal pit in predatory fishes appears to be in the euteleosts, i.e. in the seahorse and the sandlance (Fig. 2).

### Central Visual Pathways

The optical image formed by the visual apparatus is transformed into an electrical image by the retina, which is conveyed to the visual centers of the brain via the optic nerve. The optic nerve comprises the axons of the retinal ganglion cells and **efferent fibers**. In lampreys, the optic nerve is avascular and contains an ependymal core and unmyelinated axons. However, typically, the axons of gnathostomatous (jawed) fishes are myelinated and form fascicles or bundles subdivided by astroglia. The optic nerves from the left and right eyes cross (decussate) at the optic chiasm crossing as separate nerves (most teleosts) or where one optic nerve is interlaced with the other (cartilaginous fishes and a few teleosts). In most fishes, contralateral and ipsilateral projections from the eyes terminate in the suprachiasmatic nucleus, the posterior parvocellular preoptic nucleus, the anterior nucleus of the thalamus, the pretectal nuclei and the optic tectum. In all species examined, retinal input to the optic tectum is retinotopic and is restricted to the stratum opticum (SO), the stratum fibrosum et griseum superficiale (SFGS), the stratum griseum centrale (SGC) and the junction between the stratum album centrale (SAC) and the stratum periventriculare (SPV), although some phylogenetic variation exists.

### Laterality

Ipsilateral (non-decussating) input to the visual centers of the brain is thought to be an inherent component of

the visual pathway in all vertebrates, including hagfishes and lampreys. However, the relationship between ipsilaterally projecting ganglion cells and the extent of the binocular visual field is not well understood in early fishes. The optic tracts in both hagfishes and lampreys project bilaterally to the preoptic, thalamic and pretectal nuclei and terminate in the mesencephalic optic tectum [16]. In garfishes, the mediorostral and ventrolateral regions of the optic tectum receive ipsilateral input from the retina and subtend the dorsal and ventral binocular fields, respectively [17]. Discrete ipsilateral input to the entire optic tectum is found in the Australian lungfish and juvenile teleosts suggesting that there may be phylogenetic differences in binocular partitioning (when compared to most modern teleosts). Ipsilateral input via the intertectal and posterior commissures does not appear to occur in all non-actinopterygian fishes and appears to have evolved independently many times [25].

#### **Ascending Pathways to the Telencephalon**

Visual information is relayed to the telencephalon through several different routes in various fishes [18]. While little is known about the ascending pathways in agnathans, these pathways have been studied in both cartilaginous and bony fishes. In some sharks and in skates, the retina projects to the nucleus anterior in the rostral thalamus, which in turn projects to part of the pallium. The retina also projects to the optic tectum, which in turn projects to a more caudal part of the dorsal thalamus, the dorsal posterior nucleus, which also projects to the pallium and additionally robustly to part of the subpallium. More detailed information is needed on these two pathways in cartilaginous fishes and their respective terminal fields within the pallium. In ray-finned fishes, the nucleus anterior within the rostral part of the dorsal thalamus likewise receives retinal input, but whether it projects to part of the pallium or not remains controversial. Ray-finned fishes do have an ascending tectal-dorsal thalamic-pallial pathway, via the dorsal posterior nucleus and this pathway terminates predominantly in the medial part of the pallial region (which compares topographically to the lateral pallium of most other vertebrates due to the developmental process of eversion [see ►Evolution: of the Pallium Fishes]).

#### **Pretectal Elaboration in Ray-finned Fishes**

The pretectum reaches a high degree of elaboration in ray-finned fishes, particularly among teleosts [18]. In all fishes, three zones from superficial to deep can be recognized in this region — superficial, intermediate and periventricular. In all teleosts, generally comparable nuclei are present in the latter two zones, but marked variation occurs in the degree of elaboration of the superficial zone. In three of the four major teleost

radiations (osteoglossomorphs, elopomorphs and clupeomorphs) the superficial zone comprises the parvocellular superficial pretectal nucleus (P<sub>Sp</sub>), the magnocellular superficial pretectal nucleus (P<sub>Sm</sub>), the nucleus corticalis (NC) and a posterior pretectal nucleus (PO). The PO attains a very large size in some taxa, such as some osteoglossomorphs. In teleosts, P<sub>Sp</sub>, P<sub>Sm</sub>, and NC are present, but instead of a single additional nucleus (PO), two different nuclei are present; the intermediate superficial pretectal nucleus (P<sub>Si</sub>) and the nucleus glomerulosus (NG). Based on connections, location and other indications, these two nuclei appear to have differentiated out of the same field that gives rise only to PO in other teleosts. NG is a highly elaborate nucleus with neuronal clusters and afferent fibers forming a ring of glomeruli around its periphery. These nuclei are involved in what may be a feeding circuit. Visual input from the retina is relayed through P<sub>Sp</sub> to either PO or, in euteleosts, to P<sub>Si</sub> and then to NG. PO and NG both project to the inferior lobe of the hypothalamus, which may be involved in controlling motor aspects of feeding.

#### **The Nucleus Rostrolateralis of Ray-finned Fishes**

An additional apparently unique feature of ray-finned fishes is the presence of a nucleus in the rostral and lateral part of the diencephalon, which is thus named the nucleus rostromedialis. This receives visual inputs, a modest input from the retina and a robust projection from the optic tectum [18]. The nucleus does not appear to project to the telencephalon but rather may be involved with more caudal, tegmental visual pathways. The nucleus is striking for its very widespread but sporadic phylogenetic distribution, having been found in clusters of several closely related species within several taxa (from gars to some euteleosts to date), which themselves are very distantly related, but being absent from the phylogenetically intermediate species that have been examined. Remarkably, in the four-eyed fish, *Anableps*, each half of the diencephalon contains two rostromedial nuclei, one for each half of the retina, for the visual space in and out of the water from each eye.

Efferents within the optic nerve of ray-finned fishes form the centrifugal system. Neurons located in the olfactoretinal nucleus, located at the junction of the telencephalon and the olfactory bulb, the pretectal nuclear complex, the dorsomedial optic nucleus and the optic tectum project directly to the retina and synapse upon dopaminergic interplexiform cells located within the inner nuclear layer. In both lampreys and hagfishes, two tegmental cell groups (the reticular mesencephalic area and the nucleus M5 of Schober) give rise to centrifugal fibers and, as in teleosts, also make contact with bipolar, horizontal and ganglion cells. The centrifugal system responds to chemical cues such as sex pheromones and regulates visually mediated sexual

and reproductive behavior in addition to altering ganglion cell responses to color contrast.

### Adaptations

Extant eyes are extremely variable and reflect a high degree of evolutionary change. Although restricted within the confines of the vertebrate camera-type eye design, the evolution of the visual system is regulated by the light environment, the ecological niche occupied by each species and their visual demands for survival. The proportion of rods and cones and their retinal distribution is determined largely by ambient light intensity and spectral composition (dictated by the amount of attenuation and absorption throughout the water column), which play an important role in the spectral sensitivity and tuning of the photoreceptor visual pigments [19]. Some teleost species have a labile mechanism for varying spectral sensitivity, with many cichlids possessing up to seven opsin genes in response to the behavioral demands of feeding and reproductive success [13]. The duplex nature of the retina and the visual demands of predation and predator avoidance also affect retinal processing and ultimately behavioral outcomes. It appears that the visual system can respond very rapidly to evolutionary changes in lifestyle [1]. The selective pressure on the phenotype of the retinal photoreceptors for example can be measured by examining the rates of synonymous (no effect on the encoded proteins) and non-synonymous (affects the protein) nucleotide substitution of the opsin genes [20]. In this way, a measure of the regulation of the molecular evolutionary clock may be gained at least over comparable time frames where a fossil record is available or where data is available for other vertebrate phylogenies.

Evolutionary and developmental changes in the visual system of fishes has ensured that each species is adapted to their often changing environment. Avoiding predation, successfully feeding and finding reproductive partners is ultimately the function of the visual system. Although in concert with a battery of other senses, vision remains a crucial modality for survival in an aquatic environment. The diverse range of adaptive specializations and the high degree of developmental plasticity reflects intense selection pressure to maintain and optimize visual sampling within a range of environments [27].

### References

1. Nilsson D-E, Pelger S (1994) A pessimistic estimate of the time required for an eye to evolve. *Proc R Soc Lond B* 256:53–58
2. Walls GL (1963) *The vertebrate eye and its adaptive radiation*. Hafner, New York
3. Collin SP, Collin HB (2001) The fish cornea: adaptations for different aquatic environments. In: Kapoor BG, Hara TJ *Sensory biology of jawed fishes: new insights*. Science Publishers, Enfield, USA, pp 57–96
4. Pettigrew JD, Collin SP, Ott M (1999) Convergence of specialised behaviour, eye movements and visual optics in the sandlance (Teleostei) and the chameleon (Reptilia). *Curr Biol* 9:421–424
5. Kröger RHH, Campbell MCW, Fernald RD, Wagner H-J (1999) Multifocal lenses compensate for chromatic defocus in vertebrate eyes. *J Comp Physiol A* 184:361–369
6. Douglas RH, Collin SP, Corrigan J (2002) The eyes of suckermouth armoured catfish (Loricariidae, subfamily Hypostomus): pupil response, lenticular longitudinal spherical aberration and retinal topography. *J Exp Biol* 205:3425–3433
7. Ott M (2006) Visual accommodation in vertebrates: mechanisms, physiological response and stimuli. *J Comp Physiol A* 192:97–111
8. Fritzsche B, Collin SP (1990) The distribution and dendritic fields of two populations of ganglion cells and the retinopetal fibers in the retina of the lamprey, *Ichthyomyzon unicuspis*. *Vis Neurosci* 4:533–545
9. Collin SP, Knight MA, Davies WL, Potter IC, Hunt DM, Trezise AE (2003) Ancient colour vision: multiple opsin genes in the ancestral vertebrates. *Curr Biol* 13: R864–R865
10. Hart NS, Lisney TJ, Marshall NJ, Collin SP (2004) Multiple cone visual pigments and the potential for trichromatic colour vision in two species of elasmobranch. *J Exp Biol* 207:4587–4594
11. Bailes HJ, Robinson SR, Trezise AEO, Collin SP (2006) Morphology, characterisation and distribution of retinal photoreceptors in the Australian lungfish *Neoceratodus forsteri* (Krefft, 1870). *J Comp Neurol* 494:381–397
12. Sillman AJ, O’Leary CJ, Tarantino CD, Loew ER (1999) The photoreceptors and visual pigments of two species of Acipenseriformes, the shovelnose sturgeon (*Scaphirhynchus platorynchus*) and the paddlefish (*Polyodon spathula*). *J Comp Physiol A* 184:37–47
13. Parry JW, Carleton KL, Spady T, Carboo A, Hunt DM, Bowmaker J (2005) Mix and match colour vision: tuning spectral sensitivity by differential opsin gene expression in Lake Malawi cichlids *Curr Biol* 15:1734–1739
14. Yokoyama S, Zhang H, Radlwimmer FB, Blow NS (1999) Adaptive evolution of color vision of the comoran coelacanth (*Latimeria chalumnae*). *Proc Natl Acad Sci USA* 96:6279–6284
15. Siebeck UE, Marshall NJ (2001) Ocular media transmission of coral reef fish – can coral reef fish see ultraviolet? *Vision Res* 41:133–149
16. Wicht H, Northcutt RG (1990) Retinofugal and retinopetal projections in the Pacific hagfish, *Eptatretus stouti*. *Brain Behav Evol* 36:315–328
17. Collin SP, Northcutt RG (1995) The visual system of the Florida garfish, *Lepisosteus platyrhincus* (Ginglymodi): IV. Bilateral projections and the binocular visual field. *Brain Behav Evol* 45:34–53
18. Butler AB, Hodos W (2005) *Comparative vertebrate neuroanatomy: evolution and adaptation*, 2nd edn. Wiley, Hoboken
19. Hunt DM, Fitzgibbon J, Slobodyanyuk SJ, Bowmaker JK (1996) Spectral tuning and molecular evolution of rod visual pigments in the species flock of cottoid fish in Lake Baikal. *Vision Res* 36:1217–1224

20. Nei M, Gojobori T (1986) Simple methods for estimating synonymous and non-synonymous nucleotide substitutions. *Mol Biol Evol* 3:418–426
21. Collin SP (1997) Specialisations of the teleost visual system: adaptive diversity from shallow-water to deep-sea. *Acta Phys Scand* 161, Suppl 638:5–24
22. Collin SP, Collin HB (1993) The visual system of the Florida garfish, *Lepisosteus platyrhincus* (Ginglymodi): II. Cornea and lens. *Brain Behav Evol* 42:98–115
23. Collin SP, Potter IC, Braekevelt C (1999) The ocular morphology of the southern hemisphere lamprey *Geotria australis* Gray, with special reference to the characterisation and phylogeny of photoreceptor types. *Brain Behav Evol* 54:96–118
24. Duke-Elder S (1958) The eye in evolution, vol 1. System of ophthalmology. Henry Kimpton, London
25. Northcutt RG, Butler AB (1992) Retinofugal and retinopetal projections in the green sunfish, *Lepomis cyanellus*. *Brain Behav Evol* 37:333–354
26. Sivak JG (1976) The accommodative significance of the “ramp” retina of the eye of the stingray. *Vision Res* 16:945–950
27. Lamb TD, Collin SP, Pugh EN Jr (2007) Evolution of the vertebrate eye: opsins, photoreceptors, retina and eye cup. *Nature Reviews Neuroscience* 8:960–975

## Evolution of the Visual System in Reptiles and Birds

TORU SHIMIZU<sup>1</sup>, TADD B. PATTON<sup>1</sup>,  
GABRIELLE SZAFRANSKI<sup>1</sup>, ANN B. BUTLER<sup>2</sup>

<sup>1</sup>Department of Psychology, University of South Florida, Tampa, Florida, USA

<sup>2</sup>Department of Molecular Neuroscience, Krasnow Institute for Advanced Study, George Mason University, Fairfax, VA, USA

### Definition

Reptiles and birds (sauropsids) depend heavily on the sense of vision to detect danger, find food, defend territory, and select a mate, and vision is of course essential for birds to fly in the air. Sauropsids have well-developed eyes, midbrains, and forebrains for visual processing. Among sauropsids, many avian species have excellent visual abilities, including color vision, visual acuity, motion perception, and visual memory.

### Characteristics Reptilian Eye

**Features:** As in other vertebrates including birds, the eyes of reptiles consist of an outer, fibrous and tough layer of sclera, a vascular layer called the choroid, and an inner, thin pigment epithelium that is applied to the outer surface of the neural retina. The choroid supplies

oxygen and nutrition to the retina of many reptiles, but in lizards and to a lesser extent in snakes, an additional cone-shaped structure is present that supplements this function [1]. This structure is called the conus papillaris [2] and is homologous to the pecten of birds, which is discussed below.

The sclera is also somewhat specialized in reptiles. In most taxa, it includes cartilaginous elements, and, in its anterior region, it contains about 14 scleral ossicles that form a ring around the cornea. These bones are also present in birds, as discussed further below, but they are absent in extant crocodiles and snakes.

The scleral ossicles are involved in the process of accommodation of the eye in those reptiles that possess them [1]. For accommodation to occur, the lens must become rounder, i.e., assume a shape that gives it greater depth from front to back. Rather than acting to relax the tension on the lens ligaments as occurs in mammals, allowing the lens to assume a more spherical shape, the ciliary muscles in reptiles contract in such a way as to press the ciliary body against the sides of the lens, causing it to lengthen from front to back. Also, as the lens pushes against the rim of the cornea, the scleral ossicles assist in maintaining the pressure supplied by the ciliary body. As discussed below, the latter mechanism is greatly augmented in some diving birds.

**Visual Fields:** In most reptiles – crocodiles, land tortoises, and most diurnal lizards – the eyes are laterally placed on the head, resulting in mostly monocular visual fields with only a small region of binocular overlap. In contrast, some freshwater turtles and snakes have a more extensive binocular overlap, up to 30° or more [1]. Chameleons (such as *Chamaeleo vulgaris*) have the exceptional ability to independently move their eyes, such that the eyes can swivel up to about 180° in the horizontal plane and up to about 90° in the vertical plane. At times, a chameleon may have each eye directed laterally for monocular vision to each side, while at other times one eye may be directed forward and the other backward. For a wide field of binocular vision, both eyes may be directed forward [1].

**Retina:** Reptiles have a variety of specializations with regard to the retina, depending upon their particular niche or other factors [1]. Retinas that contain both rods and cones occur in many reptiles, including some turtles, crocodiles, and the tuatara (the rhynchocephalian *Sphenodon*). Diurnal lizards, however, lack rods. Unusual for lizards, anoles (which are iguanids) have two foveas in each eye rather than just one. In contrast, nocturnal lizards, such as geckos, have retinal receptor cells that resemble rods, which (as in some other taxa) may actually be a derived form of cone cell. The retina of snakes reflects their convoluted evolutionary history of a period of assuming a fossorial niche and then subsequently

reemerging to a surface niche. The retinas of snakes exhibit marked variations in their rod and cone types.

### Avian Eye

**Features:** A striking feature of the avian eye is the presence of the **pecten**. It is a comb-like, pigmented, and highly vascularized structure, standing in the posterior chamber of the eye, and is much more elaborate in its size and development than the similar cone-shaped structure, the *conus papillaris*, in lizards and snakes. Although various possible functions of the pecten have been suggested, evidence indicates that it is probably involved in the nutrition of the internal parts of the eye. In the avian eye, unlike the human eyes, there are no surface retinal blood vessels. Instead, the vascularized tissue of the pecten may serve as an agitator to propel nutrients and oxygen into the retina [3].

Although the overall design of the avian eye is similar to those of other vertebrates, there are some important differences. As in reptiles, the avian sclera is specialized in terms of the presence of the scleral ossicles, with particular specializations of these elements having occurred in some species of shore birds [see 6]. Some shore birds, including herring gulls, pelicans, and some species of ducks, lack specialization of their scleral ossicles, and therefore have reduced ability to accommodate under water. Other birds, including cormorants, merganser ducks, and guillemots, have specialized scleral ossicles and ciliary muscles that provide accommodation of the lens when under water as well as in air, allowing them to dive to pursue and catch fish and other prey under water without the benefit of goggles. These species have exceptionally large ciliary muscles and heavily ossified scleral elements that form a rigid ring around the cornea. When diving, the ciliary muscles compress and hold the lens against the scleral ring, causing its front portion to partially herniate through the ring and become almost spherical in shape, thus allowing excellent vision under water. Penguins have a similar adaptation.

Another major distinguishing characteristic of the avian eye is its huge size relative to the brain and head. Human eyes occupy about 5% of the cranial volume, whereas the eyes of birds usually occupy over 50% [4]. Indeed, the largest eyes of all land animals belong to the ostrich, whose eyes are approximately 5 cm in diameter, compared to human eyes that are about 2.5 cm in diameter. The large eye-size can be advantageous for visual acuity, which is a measure of the ability to see fine details. The larger the eyes, the longer the focal length (the distance between the lens and retina), so that images projected on to the retina are magnified for the detection of details.

The overall shape of the eye varies widely among avian species. There are at least three types of eye

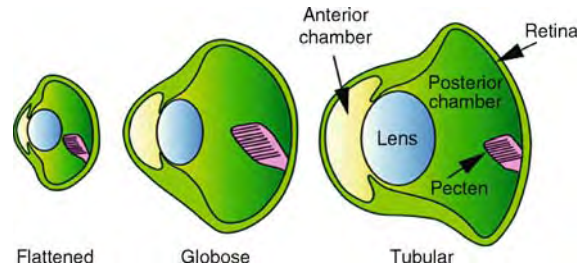

### Evolution of the Visual System in Reptiles and Birds.

**Figure 1** Schematic images of the three types of avian eyes, which are categorized based on shape: flattened (swan), globose (eagle), and tubular (owl). Adapted from [6].

shape: flattened, globose, and tubular [5] (Fig. 1). The eyes of many birds with not-so-sharp vision (e.g., quail, chickens) are of the flattened type. The short focal length of the flattened eye is not ideal to see details, but it can provide a wide field of vision, which may be essential to detect approaching predators. Birds of prey with sharp vision (e.g., hawks, eagles) have the globose-type of eyes with a similar length and width. The longer focal length of a globose shape helps to produce a larger retinal image, which is presumably important to find small prey. Nocturnal birds (e.g., owls) have the tubular type of eyes, which include exceptionally large pupils relative to the focal length. The characteristics of tubular eyes enable nocturnal birds to gather a maximum amount of light in a dark environment.

**Visual Fields:** In most birds, as in reptiles, the eyes are placed on the bilateral sides of the head, enabling a large monocular visual field but a small binocular field. Without moving their heads, pigeons can see over  $300^\circ$  in the lateral fields, and American woodcocks can survey  $360^\circ$  [4]. The large visual field may be critical for birds that need to be vigilant for approaching predators. On the other hand, the lateral placement of the eyes appears to sacrifice binocular vision, which is important for adequate depth perception. However, many birds have excellent eye movements and can transiently increase binocular overlap by convergence. They also have extremely flexible, fast-turning necks and can easily turn their heads with great speed without repositioning their bodies. Many predatory or nocturnal birds (e.g., owls) have eyes that are placed more frontally. They are less concerned about approaching predators, resulting in selection for smaller monocular fields and a relatively larger binocular field.

**Retina:** The basic anatomical circuitry and constituent neurons in the avian retina are similar to those of other vertebrates. However, the avian retina is characterized by its thickness due to a high cell density and connectivity within the retina [5]. This indicates that a significant amount of visual information is processed at

the level of the retina before reaching the brain. As in humans, birds have cone receptor cells for color vision and rod receptor cells for night vision. Humans have approximately 200,000 cones per square millimeter in the fovea whereas small sunbirds have about 380,000 cells per square millimeter [7]. The peak density of rods is about 180,000 rods per square millimeter in humans whereas nocturnal oilbirds have a million cells per square millimeter [8].

Photoreceptor cells are not distributed evenly within the avian retina. Some areas have more photoreceptor, as well as bipolar and ganglion cells, which serve to enhance acuity in the certain sectors of the visual field. Most birds with lateral eyes have two areas of high cell density in the retina: one in the central area and the other in the more temporal area. The central retina is presumably important for monocular vision in the lateral visual fields, whereas the temporal retina is used for binocular vision in the frontal visual field. In contrast, birds with frontal eyes, such as owls, have a single retinal area with a high cell density, which may assist binocular viewing of objects in the frontal field. The single area of high cell density in nocturnal birds may be important for collecting the maximum amount of light in an environment with a low light level [3].

### Visual Pathways in Reptiles

*Midbrain:* The decussation of the optic nerve in reptiles is almost but not entirely complete [9]. The optic tracts project to sites in the diencephalon and midbrain, within the latter principally to the optic tectum [See: Evolution, of the Optic Tectum: in Amniotes]. The reptilian optic tectum is well developed and highly laminated. Retinal fibers terminate in the superficial layers of the tectum [10]. The optic tectum gives rise to several sets of efferent pathways, including descending projections to the brainstem, a major ascending projection that principally targets a large, centrally located nucleus in the dorsal thalamus, nucleus rotundus, and a projection to two nuclei within the nearby isthmal region: nucleus isthmi [See: Evolution, of Nucleus Isthmi], which contains cholinergic neurons and projects reciprocally back to the optic tectum, and the isthmo-optic nucleus [10]. The latter projects centrifugally to the retina and is present in crocodiles, turtles, and, to a lesser degree in lizards, but is apparently absent in snakes [11].

*Forebrain:* As noted above, one of the major targets of the optic tectum is nucleus rotundus. This dorsal thalamic nucleus [See: Evolution, of the Dorsal Thalamus] projects to the visual part of a large structure in the telencephalon called the dorsal ventricular ridge (DVR) [See: Evolution, of the Telencephalon: in Amniotes]. The anatomy of the DVR varies substantially across reptiles [12]. In turtles, the rhynchocephalian *Sphenodon*, and some lizards, it consists of a cell plate, often formed by a series of clumps, or clusters, of the neuron cell bodies, with a more central

portion that is mostly neuropil. In other lizards and in snakes and crocodiles, as well as in birds, the DVR is larger and consists of many neurons that are migrated away from the ventricular surface to form various nuclear groups. This pathway – from the retina to the optic tectum to nucleus rotundus to the visual part of the DVR – is sometimes referred to as a collothamic pathway, due to its substantial relay through the midbrain roof [see 6]. Like in birds, the tectorotundal projection in reptiles is bilateral, and the projection from nucleus rotundus to the DVR is entirely ipsilateral.

A second major visual nucleus of the dorsal thalamus is the dorsal lateral geniculate nucleus (DLGN), as identified by Kenigfest et al. [13]. This nucleus receives its predominant input directly from the retina and projects to a part of the dorsal cortex. In turtles, this projection is to the dorsal cortex itself, referred to in this taxon as the general cortex, while in lizards it is to a rostral portion of the dorsal cortex called the pallial thickening. This cortical, pallial target of the DLGN across all reptiles is thought to be homologous to the visual part of the Wulst in birds and to the primary visual cortex – the striate cortex – of mammals. This thalamofugal pathway is sometimes referred to as a lemnothalamic pathway, in regard to the predominantly direct (or “ribbon-like”) input from the retina to the thalamus rather than by relay through the midbrain roof [see 6]. It should be noted that the geniculopallial pathway in reptiles is entirely ipsilateral, in contrast to the situation in birds as discussed below.

*Variations in the Visual System of Snakes:* Just as is the case for their rod and cone types, as discussed above, snakes exhibit variation in their visual thalamus. Several studies have investigated the major visual pathways in snakes, particularly the tectofugal, or collothamic, pathway [12,14–17], and some interesting variation has been found in their visual thalamic nuclei in comparison to other reptiles. In at least some species such as the water snake *Natrix*, the DLGN is substantially larger than nucleus rotundus, which is dramatically small in relation to all other dorsal thalamic nuclei and in comparison to its dominant thalamic presence in other reptiles and in birds [6,18]. This observation supports the hypothesis of Walls [5] that snakes evolved from an ancestral line of fossorial lizards, in which the eyes and the entire visual system were markedly reduced. As their descendants resumed a surface habitat, the visual sense again became important, but the lemnothalamic portion of it was favored by selective pressures and re-enlarged. In line with this hypothesis, it is of particular interest to note that in the water snake *Natrix*, in which nucleus rotundus is markedly reduced, the optic tectum projects robustly to the DLGN [6] – a highly unusual shift in the collothamic pathway from the tectum to the primary lemnothalamic nucleus.

## Visual Pathways in Birds

**Midbrain:** In all birds, as in reptiles, visual information from the retina is sent almost exclusively, but not completely, to the contralateral hemispheres. Although several structures in the midbrain and forebrain receive retinal output, the major target among them is the optic tectum of the midbrain [19,20] (Fig. 2). The avian optic tectum is a large, round-shaped structure protruding laterally, visible between the cerebrum and cerebellum. It is highly laminated, with the superficial layers receiving retinotopically-organized input and the deeper layers giving rise to tectal efferents. As in reptiles, these efferents are categorized into at least three groups based on the targets. The tectum sends a descending projection to motor-related nuclei in the brainstem and the spinal cord to control skeletal movements. The tectum also sends a major ascending projection (tectofugal or collothamic pathway) to the nucleus rotundus, which is the largest cell group in the avian dorsal thalamus. Finally, the optic tectum sends a projection to several nuclei within the nearby isthmal region. One of these projections is to a small midbrain nucleus called the isthmo-optic nucleus adjacent to the tectum [21]. This nucleus is a part of the feedback loop that sends a projection to the retina. The feedback system from the brain to the retina is not unique to birds, but is found in many other vertebrates. Although the exact role in birds has not been clarified, the feedback system has been suggested to be associated with the selective attention mechanism. The optic tectum also has reciprocal connections with three other isthmal nuclei, rather than with just one such nucleus as in reptiles – the parvocellular, magnocellular, and semilunar isthmal nuclei. Two of the latter nuclei, the

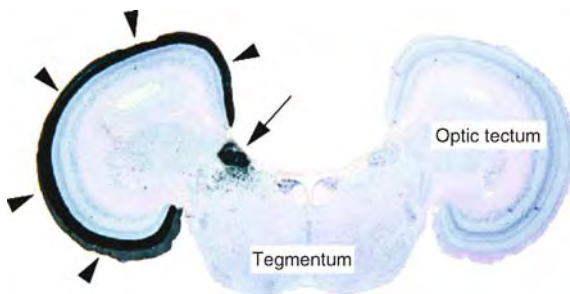

### Evolution of the Visual System in Reptiles and Birds.

**Figure 2** Transverse section of the pigeon midbrain, consisting of the large optic tectum and tegmentum. Dark staining in the left brain indicates labeling after the tract-tracing chemical cholera toxin was injected into the right eye. Such labeling is visible in the surface layers of the left optic tectum (arrow heads), where the retinal fibers primarily terminate. Also labeled is a region adjacent to the tectum (arrow), where a group of neurons (the isthmo-optic nucleus) sends a projection to the contralateral retina.

parvocellular and semilunar, contain cholinergic neurons, as does the nucleus isthmi of reptiles, while the magnocellular contains GABAergic neurons.

**Forebrain:** In the thalamus of birds, as in reptiles, two nuclei are directly associated with visual information processing, one of which is the nucleus rotundus of the tectofugal, or collothamic, pathway. In birds, the various subdivisions of the extremely large DVR are most frequently referred to as the mesopallium, nidopallium, and arcopallium [22,23]. The telencephalic target of nucleus rotundus is a specific subdivision of the nidopallium, called the entopallium [22,23]. The entopallium in turn sends direct and indirect projections to multiple cerebral structures, including the avian equivalents of the basal ganglia and the prefrontal cortex. The mammalian homologues of the nucleus rotundus and entopallium are still unclear, although possible candidates include part of the pulvinar for the nucleus rotundus and part of the extrastriate cortex, claustrum, or amygdala for the entopallium [20].

The other major thalamic cell group associated with visual processing is the principal optic thalamic nucleus (OPT), which is considered to be the avian equivalent of the dorsal lateral geniculate nucleus of mammals and the nucleus of the same name in reptiles [10,19]. As is true for mammals and reptiles, the avian OPT receives direct retinal input and sends a projection to the cerebrum for further processing. The target of the OPT projection is called the visual **Wulst** (the German word for “bump”), or visual hyperpallium, and is located in the mediodorsal cerebrum. The visual Wulst is presumably a homologue of the mammalian primary visual cortex. This retina-thalamus-Wulst route is called the thalamofugal or lemnthalamic pathway and is comparable to the retina-geniculate-visual cortex pathway in mammals.

In birds with frontal eyes (e.g., owls), the visual Wulst plays a critical role for binocular integration of the large binocular field [24]. These birds have a well-developed OPT and visual Wulst compared to those with laterally located eyes. In order to accomplish binocular integration, other animals with frontal eyes (e.g., cats) have a partial **optic decussation** so that each brain hemisphere receives information from both ipsilateral and contralateral eyes (Fig. 3). In contrast, birds have an almost complete decussation from the retina to OPT, and thus OPT in each hemisphere receives information only from the contralateral eye. However, the visual Wulst can still perform binocular processing because OPT of each hemisphere sends bilateral projections to the Wulst and therefore necessary information from the ipsilateral eye can re-cross to reach the Wulst.

In birds with lateral eyes, especially pigeons, many lesion studies have been conducted to investigate lesion effects on various visual discrimination tasks. The

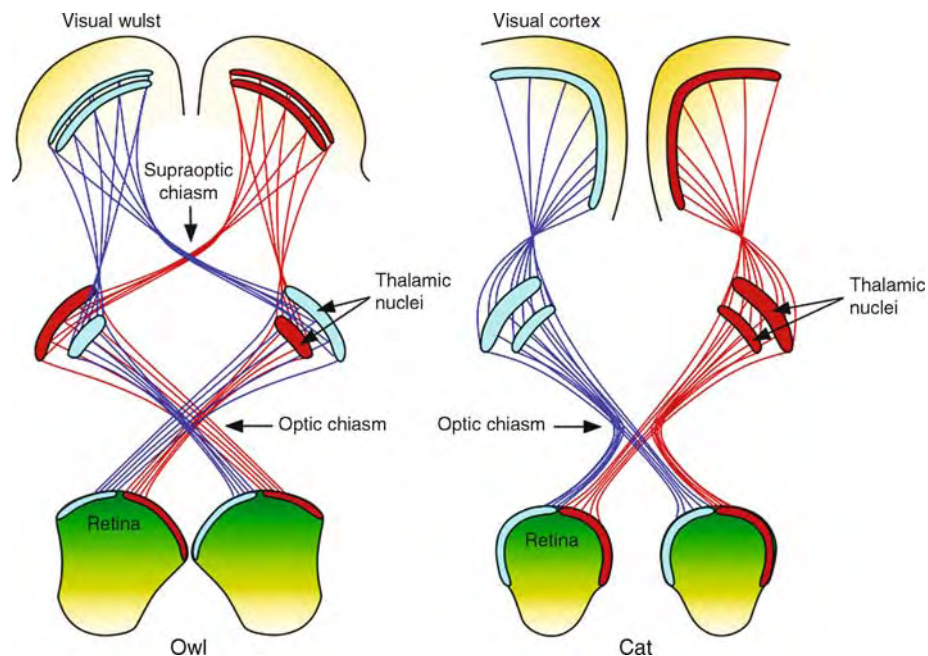

**Evolution of the Visual System in Reptiles and Birds. Figure 3** Schematic representation of visual pathways in owls and cats. In both animals, the cerebrum can accomplish binocular integration by receiving visual information from the temporal retina of the ipsilateral eye and the nasal retina of the contralateral eye. However, the pathway organizations from the retina to the cerebrum are different between the two animals. In cats (right), binocular convergence occurs at the thalamic level due to partial decussation from the retina at the optic chiasm. In owls (left), binocular convergence does not occur at the thalamic level due to an almost complete optic decussation. Instead, thalamic fibers representing the ipsilateral eye re-cross in the supraoptic chiasm. Adapted from [3].

results suggest that lesions in the tectofugal pathway, more so than lesions in the thalamofugal pathway (the avian equivalent of the geniculovisual cortex pathway), cause serious deficits in the discrimination of brightness, pattern, and color [25]. This contrasts to the observation that the geniculovisual cortex pathway in humans is a major visual processing system, lesions in which cause severe effects on conscious vision. The functional significance of the avian tectofugal pathway corresponds to the well-developed and differentiated organization of the avian tectum and its subsequent visual centers in the forebrain.

### The Exceptional Visual Capabilities of Birds

**Color Vision:** Colorful ornaments in their plumage indicate that many birds have excellent color vision, as do humans. However, avian color perception may be quite different from human color perception [26]. Birds have at least four kinds of cone photopigments, instead of the three primary-color system found in humans. Three of the avian pigments can detect the wavelength ranges seen by humans. The additional photopigment in birds is sensitive to ultraviolet or near ultraviolet light,

which humans and other primates are not able to perceive. This ultraviolet sensitivity may be useful for detecting optical markers on plants during foraging, as well as recognizing sexual ornaments during mate selection [27].

**Visual Acuity:** ▶ **Raptors**, such as falcons and eagles, have extremely keen vision which is most likely necessary for successful foraging. For instance, the visual acuity of American kestrels (46 cycles/degree, 28) is quite superior to that of normal human observers (30 cycles/degree). To accomplish the high visual acuity, raptor eyes are globose-shaped with a long focal length and have a very high density of photoreceptors in the retina. In contrast, other birds, such as ground-feeding quail with more flattened eyes, have poorer vision (6.8 cycles/degree, 29) than do humans.

Visual acuity also varies depending on the specific visual field. For example, raptors have better vision in the lower visual fields [4] and must tilt their heads to view objects in higher visual fields. Ground-feeding birds are near-sighted for the lower frontal visual field, which enables them to see close objects on the ground. They are also far-sighted for lateral vision, which



enables them to see possible predators far in the lateral visual fields.

**Motion Perception:** Flying birds, which are among the fastest moving animals, can detect motion much better than can humans. Birds have the excellent ability to resolve quickly changing images. In pigeons, the temporal resolution threshold can reach up to 100 Hz [30], compared to about 60 Hz by humans. This superb motion sensitivity is partly attributable to the high density of photoreceptors and complex connections within the retina. In addition, the midbrain and forebrain contain many neurons sensitive to moving stimuli. Some neurons of the nucleus rotundus are particularly intriguing in that they selectively detect approaching objects on a collision course. This looming detection ability is essential for flying birds in order to avoid obstacles before imminent collision while flying.

**Visual Cognition:** Field observations and laboratory studies have demonstrated that birds have excellent cognitive ability associated with vision [31]. New Caledonian crows use twigs to fetch insects hiding in trees; in fact, the crows will actually trim the twigs to make hooks that improve their efficiency. During the fall, Clark's nutcrackers hide tens of thousands of seeds in thousands of locations. Months later, they can retrieve the seeds to survive the winter. In laboratories, pigeons have repeatedly demonstrated their ability to learn the categories of numerous pictures of both natural objects (e.g., person, flower) and man-made objects (e.g., alphabet, car). The African grey parrot, Alex, learned to name the color, shape, and size of more than 100 objects using English words [32].

## References

- Bellaïrs A (1970) *The Life of Reptiles*, vol. 2. Universe Books, New York
- Braekevelt CR (1989) Fine structure of the conus papillaris in the bobtail goanna (*Tiliqua rugosa*). *Histol Histopathol* 4:287–293
- Nalbach HO, Wolf-Oberhollenzer F, Remy M (1993) Exploring the image. In: Zeigler HP, Bischof H-J (eds) *Vision, brain and behavior in birds*. MIT Press, Cambridge, MA, pp 25–46
- Waldvogel JA (1990) The bird's eye view. *Am Sci* 78:342–353
- Walls GL (1942) *The vertebrate eye*. Cranbrook Institute of Science, Bloomfield Hills, MI
- Ulinski PS (1977) Tectal efferents in the banded water snake, *Natrix sipedon*. *J Comp Neurol* 173:251–274
- Fite KV, Rosenfield-Wessels S (1975) A comparative study of deep avian foveas. *Brain Behav Evol* 12:97–115
- Martin G, Rojas LM, Ramirez Y, McNeil R (2004) The eyes of oilbirds (*Steatornis caripensis*): pushing at the limits of sensitivity. *Naturwissenschaften* 91:26–29
- Butler AB, Northcutt RG (1971) Retinal projections in *Iguana iguana* and *Anolis carolinensis*. *Brain Res* 26:1–13
- Butler AB, Hodos W (2005) *Comparative vertebrate neuroanatomy: evolution and adaptation*. Wiley-Liss, Hoboken, NJ
- Médina M, Repérant J, Ward R, Miceli D (2004) Centrifugal visual system of *Crocodilus niloticus*: a hodological, histochemical, and immunocytochemical study. *J Comp Neurol* 468:65–85
- Ulinski PS (1983) *Dorsal ventricular ridge: a treatise on forebrain organization in reptiles and birds*. Wiley, New York
- Kenigfest N, Martínez-Marcos A, Belekova M, Font C, Lanuza E, Desfilis E, Martínez-García F (1997) A lacertilian dorsal retinorecipient thalamus: a re-investigation in the old-world lizard *Podarcis hispanica*. *Brain Behav Evol* 50:313–334
- Berson DM, Hartline PH (1988) A tecto-rotundo-telencephalic pathway in the rattlesnake: evidence for a forebrain representation of the infrared sense. *J Neurosci* 8:1,074–1,088
- Dacey DM, Ulinski PS (1983) Nucleus rotundus in a snake, *Thamnophis sirtalis*: an analysis of a nonretinotopic projection. *J Comp Neurol* 216:175–191
- Repérant J, Miceli D, Rio JP, Weidner C (1987) The primary optic system in a microphthalmic snake (*Calabaria reinhardti*). *Brain Res* 408:233–238
- Repérant J, Peyrichoux J, Weidner C, Miceli D, Rio JP (1980) The centrifugal visual system in *Vipera aspis*. An experimental study using retrograde axonal transport of HRP and [<sup>3</sup>H] adenosine. *Brain Res* 183:435–441
- Northcutt RG, Butler AB (1974) Retinal projections in the northern water snake *Natrix sipedon sipedon* (L.). *J Morphol* 142:117–136
- Güntürkün O (2000) Sensory physiology: vision. In: Whittow GC (ed) *Sturkie's avian physiology* (5th edn). Academic Press, New York, pp 1–19
- Shimizu T (2001) Evolution of the forebrain in tetrapods. In: Roth G, Wulliman, MF (eds) *Brain evolution and cognition*. Wiley/Spektrum, New York, pp 135–184
- Uchiyama H (1989) Centrifugal pathways to the retina: influence of the optic tectum. *Vis Neurosci* 3:183–206
- Avian Brain Nomenclature Consortium: Jarvis ED, Güntürkün O, Bruce L, Csillag A, Karten T, Kuenzel W, Medina L, Paxinos G, Perkel DJ, Shimizu T, Striedter G, Wild JM, Ball GF, Dugas-Ford J, Durand SE, Hough GE, Husband S, Kubikova L, Lee DW, Mello CV, Powers A, Siang C, Smulders TV, Wada K, White SA, Yamamoto K, Yu J, Reiner A, Butler AB (2005) Avian brains and a new understanding of vertebrate brain evolution. *Nat Rev Neurosci* 6:151–159
- Reiner A, Perkel DJ, Bruce LL, Butler AB, Csillag A, Kuenzel W, Medina L, Paxinos G, Shimizu T, Striedter G, Wild M, Ball GF, Durand S, Güntürkün O, Lee DW, Mello CV, Powers A, White SA, Hough G, Kubikova L, Smulders TV, Wada K, Dugas-Ford J, Husband S, Yamamoto K, Yu J, Siang C, and Jarvis ED (2004) Revised nomenclature for avian telencephalon and some related brainstem nuclei. *J Comp Neurol* 473:377–414
- Pettigrew JD, Konishi M (1976) Neurons selective for orientation and binocular disparity in the visual wulst of the barn owl (*Tyto alba*). *Science* 193:675–678
- Hodos W (1993) Visual capabilities of birds. In: Zeigler HP, Bischof H-J (eds) *Vision, brain and behavior in birds*. MIT Press, Cambridge, MA, pp 63–76
- Goldsmith TH (2006) What birds see. *Sci Am* 295:68–75

27. Bennett ATD, Cuthill IC, Partridge JC, Maier EJ (1996) Ultraviolet vision and mate choice in zebra finches. *Nature* 380:433–435
28. Gaffney MF, Hodos W (2003) The visual acuity and refractive state of the American kestrel (*Falco sparverius*). *Vis Res* 43:2,053–2,059
29. Hodos W, Miller RF, Fite KV, Porciatti V, Holden AL, Lee JY, Djamgoz MBA (1991) Life-span changes in the visual acuity and retina in birds. In: Bagnoli P, Hodos W (eds) *The changing visual system*. Plenum Press, New York, pp 137–148
30. Hodos W, Potocki A, Ghim MM, Gaffney M (2003) Temporal modulation of spatial contrast vision in pigeons (*Columba livia*). *Vis Res* 43:761–767.
31. Cook RG (2001) Avian Visual Cognition. [Online] <http://www.pigeon.psy.tufts.edu/avc/>
32. Pepperberg IM (1999) *The alex studies: cognitive and communicative abilities of grey parrots*. Harvard University Press, Cambridge, MA

**geniculate nucleus (LGN)** of the ► **thalamus**. The LGN is critical for vision in mammals because all visual information from the ► **retina** that is utilized for conscious visual perception passes through this nucleus. LGN cells can also be divided into cell classes based on physiology and morphology. Different LGN cell classes receive input from different classes of retinal ganglion cells and send signals via parallel channels to the ► **primary visual cortex**, also called V1, striate cortex or area 17. Although there is general agreement that parallel visual pathways from retina to cortex (via LGN) exist in mammals, there is considerable controversy over the homology and function of these pathways. In this chapter we argue that recent research on the evolution of color vision can provide potential insights into both the homology and function of parallel visual pathways in primates.

### Color Channels

Color plays an important role in the perception of objects in many mammals. The ability to see color derives from the ability to compare wavelengths. Retinal ganglion cells, which can distinguish between wavelength signals they receive from different retinal receptors (cones) via the ► **bipolar cells** of the retina, can “see” color and can then transmit this message to the brain. Most mammals, including many primates, are ► **dichromatic**, meaning that they have only two types of cones in the retina, a ► **cone** sensitive to the shorter (S, blue) visible wavelengths of light and another sensitive to either midrange (M, green) wavelengths or longer (L, red) wavelengths. Early vertebrates are thought to have had four opsin types, L, M, S and ultraviolet (UV). Early mammals lost one of the UV and S opsins, and one of the L and M opsins [1,2]. Regardless, it is generally agreed that early mammals had S cones [3]. It has been proposed, therefore, that the earliest color pathway in mammals compared S cones with M/L cones to create the ability to distinguish blue from green or yellow [4]. In non-primates, such as ground squirrels, it has been proposed that specific retinal ganglion cells code for color [5]. In cats also, S and M cones are compared only in one class of ganglion cell, the W cell, to provide the basis of color vision in this species [6]. In primates the situation concerning the evolution of color vision is complicated by the proposal that ancestral primates were nocturnal [7–9]. Since some present day nocturnal prosimians are monochromatic and have only a single M cone it has been proposed that this was the condition of primate ancestors [7,8,10]. Regardless of whether the earliest primates were nocturnal, it is likely that they already had an S cone gene since all extant primates examined appear to have this gene including those primates that are nocturnal [4,8]. Whether this gene is functional in nocturnal primates is a separate issue, given that nocturnal members of other mammalian

## Evolution of the Visual System in Mammals – Color Vision and the Function of Parallel Visual Pathways in Primates

VIVIEN A. CASAGRANDE<sup>1</sup>, ILYA KHAYTIN<sup>1</sup>,  
JAMIE BOYD<sup>2</sup>

<sup>1</sup>Department of Cell & Developmental Biology,  
Vanderbilt University Medical School, U3218 Learned  
Lab, Nashville, TN, USA

<sup>2</sup>Department of Biological Sciences, Simon Fraser  
University, Burnaby, BC, Canada

### Synonyms

V1; Primary visual cortex; also referred to as striate cortex or Brodmann’s area 17

### Definition

Visual information is transmitted from the retina through the thalamus to cortex via parallel anatomical and functional pathways. One of the controversies surrounding existence of these parallel pathways is whether color is transmitted via an independent pathway and, if so, which pathway.

### Characteristics

All mammals with good vision have retinal ganglion cells that are specialized to encode different aspects of the visual scene. In well-studied mammals, such as cats and some primates, it has been shown that specific classes of retinal ganglion cells send information in parallel to separate classes of cells in the ► **lateral**

orders have also been shown to lack S opsins even when the S opsin gene is present in the ancestor [4]. Additionally, it is clear that a number of diurnal prosimians have color vision and at least two cone types [8] (Fig. 1).

As mentioned, most existing primates are dichromats and have only two cone types like cats and ground squirrels. There are, however, primates that have three cone types. In Old World simian primates such as ourselves and macaque monkeys, gene duplication on the X chromosome has led to trichromacy with both L and M cone genes represented on single X chromosomes. In New World simians and some prosimian lorises and lemurs, the X chromosome has only one M cone gene but gene polymorphism in some members of these primate groups has allowed females with two X chromosomes to develop trichromacy. Since males have only one X chromosome, all the male members of the latter primate groups are dichromats like cats and ground squirrels.

### Parallel Pathway Function

Although most primates are dichromatic, macaque monkeys, which are trichromats, have generally been used as models of primate visual system functional organization. In fact, most textbooks diagram the visual system based on work in macaque monkeys. These diagrams generally show two pathways extending from retina to cortex via the LGN, namely, the magnocellular and parvocellular pathways. In all studied primates these magnocellular and parvocellular pathways originate in the retina in separate classes of ganglion cells, the parasol and midget ganglion cells, respectively. These parasol and midget ganglion cells send axons to magnocellular and ▶parvocellular cells of the LGN, that, in turn, project to separate sublayers of the primary visual cortex, V1 [11]. Based in part on the physiological properties of parasol and midget ganglion cells in macaque monkeys and the fact that V1 cells send axonal output to two hierarchies of ▶extrastriate cortical visual areas concerned with either motion (or action) or object identification, it has been proposed that the magnocellular pathway is important for motion vision while the parvocellular pathway is essential for form and color vision. This view is supported by evidence in macaque monkeys showing that most magnocellular LGN cells respond transiently and are sensitive to high temporal frequencies (fast motion) while some parvocellular cells show red/green color selectivity and are sensitive to higher spatial frequencies (i.e. detail) [12].

Here is the problem. In well-studied mammals such as dichromatic cats, the cells in the LGN that are most likely to carry information relevant to detail vision, namely X cells, are color blind. This does not mean that they lack cone input, but simply that they do not receive input from two classes of cones arranged in an opponent

fashion, either center surround (e.g. S center, M surround) or sign of contrast (e.g. S on, M off). In most other respects, X cells in cats respond in ways that are similar to parvocellular cells in macaque monkeys; they have small receptive fields, respond in a sustained manner to the presence of an appropriate stimulus and outnumber other cell classes at the level of the LGN [12]. The color blindness of X cells in cats has led some to propose that the parvocellular pathway from retina to cortex in primates is not homologous to the X cell pathway of cats. Instead, it has been proposed that the parvocellular pathway evolved either as a specialization of primate vision or from a W-like cell pathway simply because W cells in cats are the only cells that could support color vision in this species since they receive opponent input from S and M cones [13]. This scenario seems unlikely for the following reasons. First, in New World ▶trichromatic female marmosets all red/green color selective cells are parvocellular cells [14]. In dichromatic males of the same species all parvocellular cells are color blind (Fig. 1). Nevertheless, parvocellular cells in all studied primates have higher acuity, on average, for luminance defined gratings than ▶magnocellular cells [12], suggesting that the parvocellular pathway evolved first to represent detail and secondarily came to represent color in some primates. Second, in both marmosets and macaque monkeys, S cones send their information via a separate ▶retinal ganglion cell pathway to some koniocellular LGN cells [15 for review]. These ▶koniocellular cells also can receive opposing input from other existing cones to create a separate blue/yellow or blue/green color channel. Koniocellular cells share other (non color) physiological and morphological characteristics with cat W cells [16, 17, see also above] suggesting that some koniocellular and W cells could represent part of a homologous pathway. It is noteworthy that even in distant relatives of primates, ▶tree shrews, there are LGN cells that resemble primate koniocellular and cat W cells anatomically and physiologically [18]. Whether such LGN cells in tree shrews uniquely carry signals from S cones or provide the substrate for color vision in this dichromatic species is unknown. In ground squirrels, S cones also appear to project via dedicated retinal channels where they are combined in different ways that suggest that they support three vision channels, a koniocellular or W-like color channel, a channel devoted to luminance where two cones are mixed just as is the case for magnocellular LGN cells in primates and a channel that receives input only from single M-cones just as parvocellular LGN cells do in dichromatic primates and X cells do in cats [5].

### The S Cone Pathway in Primates

As we have seen above, the evolution of color vision in mammals can provide additional clues as to the basic

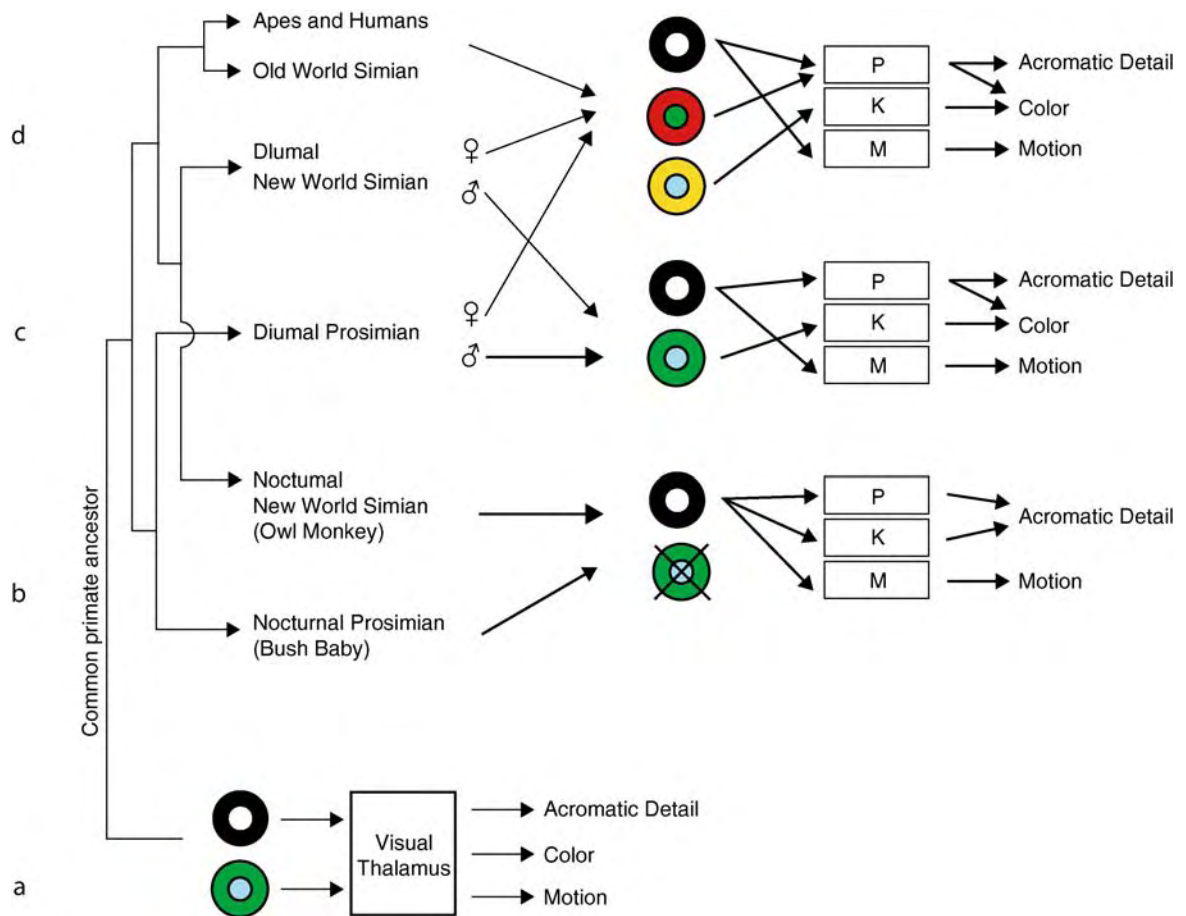

### Evolution of the Visual System in Mammals – Color Vision and the Function of Parallel Visual Pathways in Primates. Figure 1

Evolution in primates of parallel pathways for color, achromatic detail and motion vision. The white disc on a black background represents retinal ganglion cell types without chromatic opponency. The blue disc on a green background represents retinal circuitry, present in the last common primate ancestor and maintained in all diurnal primates, creating retinal ganglion cells with short wavelength sensitive centers and medium wavelength sensitive surrounds. The pale blue disc on a green background with a cross through it represents the loss of the short wavelength sensitive cone type in some nocturnal prosimians and in the owl monkey. The green disc on a red background and blue disc on a yellow background represent the color opponent channels made possible in Old World primates by duplication and divergence and in female New World primates by polymorphism of the gene on the X chromosome for the medium wavelength sensitive opsin. Note that for each channel shown there is also an opposing channel not shown in this diagram (e.g. black disc on a white background) “M”, “P”, and “K” represent, respectively, the magnocellular, parvocellular and koniocellular layers of the lateral geniculate nucleus. See text for details.

functions of parallel visual pathways in primates. By the same token differences in the color vision pathways of extant primates can provide clues about ancestry. The fact that S cone genes exist in all studied primates and are of ancient origin [3] and that all primates have at least one other functional gene for either M or L cones argues strongly for a diurnal origin for primates [see also 8] rather than a nocturnal bottle neck, especially considering the fact that the closest living relatives of primates, tree shrews (*Tupaiaidea*) are also diurnal.

S cone pathways in primates also show interesting differences that argue for the idea that the parallel

pathways supporting color vision in apes and monkeys may have diverged early in evolution from their prosimian ancestry. In macaque monkeys, recent work suggests that the main layer receiving S cone input from the LGN in V1 is cortical layer IIIB $\beta$  (IVA of Brodmann) [19]. Since thalamic axons project to layer IIIB $\beta$  in many diurnal simians but not in the prosimian bush baby or in apes (chimpanzee) or in man, this pathway appears to be a specialization of some primates and not others [20]. These findings indicate that apes and man may have diverged from a primate ancestor where the koniocellular pathway carrying S cone input

did not innervate layer IIIB $\beta$ . These findings support the hypothesis that components of the K pathway could have either been lost in the evolution of apes and man or that their common ancestor showed a parallel pathway organization more like that of present day prosimians where the thalamus does not project to layer IIIB $\beta$ .

### Summary

The evolution of color vision genes and pathways in mammals argues that the primate parvocellular and magnocellular pathways evolved to support detail vision and motion vision, respectively not color vision. Evidence indicates that color vision is supported mainly by the koniocellular pathway in primates and by a similar W-like pathway in dichromatic mammals.

### References

1. Yokoyama S (2002) Molecular evolution of color vision in vertebrates. *Gene* 300:69–78
2. Collin SP, Trezise AE (2004) The origins of colour vision in vertebrates. *Clin Exp Optom* 87:217–223
3. Calkins DJ (2001) Seeing with S cones. *Prog Retin Eye Res* 20:255–287
4. Jacobs GH (2002) Progress toward understanding the evolution of primate color vision. *Evol Anthropol* 11:132–135
5. Li W, Devries SH (2006) Bipolar cell pathways for color and luminance vision in a dichromatic mammalian retina. *Nat Neurosci* 9:669–675
6. Daw NW (1972) Color-coded cells in goldfish, cat, and rhesus monkey. *Invest Ophthalmol* 11:411–417
7. Ross CF (2000) Into the light: the origin of Anthroidea. *Annu Rev Anthropol* 29:147–194
8. Tan Y, Li WH (1999) Trichromatic vision in prosimians. *Nature* 402:36
9. Casagrande VA, Khaytin I, Boyd JD (2006) The evolution of parallel visual pathways in primates. In: Preuss TM, Kaas JH Evolution of the nervous system. Elsevier, London
10. Jacobs GH, Deegan JF (1992) Cone photopigments in nocturnal and diurnal procyonids. *J Comp Physiol [A]* 171:351–358
11. Casagrande VA, Ichida JM (2002) The lateral geniculate nucleus. In: Kaufman PL, Alm A (eds) *Adler's physiology of the eye*. Mosby, St. Louise, pp 351–668
12. Casagrande VA, Norton TT (1991) Lateral geniculate nucleus: a review of its physiology and function. In: Leventhal AG (eds) *The neural basis of visual function*. Macmillan, London, pp 41–84
13. Shapley R, Perry VH (1986) Cat and monkey retinal ganglion cells and their visual functional roles. *Trends in Neurosciences* 9:229–235
14. White AJ, Wilder HD, Goodchild AK, Sefton AJ, Martin PR (1998) Segregation of receptive field properties in the lateral geniculate nucleus of a New-World monkey, the marmoset *Callithrix jacchus*. *J Neurophysiol* 80: 2063–2076
15. Hendry SHC, Reid RC (2000) The koniocellular pathway in primate vision. *Annu Rev Neurosci* 23:127–153
16. Irvin GE, Norton TT, Sesma MA, Casagrande VA (1986) W-like response properties of interlaminar zone cells in the lateral geniculate nucleus of a primate (*Galago crassicaudatus*). *Brain Res* 362:254–270
17. Norton TT, Casagrande VA, Irvin GE, Sesma MA, Petry HM (1988) Contrast-sensitivity functions of W-, X-, and Y-like relay cells in the lateral geniculate nucleus of bush baby, *Galago crassicaudatus*. *J Neurophysiol* 59:1639–1656
18. Diamond IT, Fitzpatrick D, Schmechel D (1993) Calcium binding proteins distinguish large and small cells of the ventral posterior and lateral geniculate nuclei of the prosimian galago and the tree shrew (*Tupaia belangeri*). *Proc Natl Acad Sci USA* 90:1425–1429
19. Chatterjee S, Callaway EM (2003) Parallel colour-opponent pathways to primary visual cortex. *Nature* 426:668–671
20. Preuss TM, Coleman GQ (2002) Human-specific organization of primary visual cortex: alternating compartments of dense Cat-301 and calbindin immunoreactivity in layer 4A. *Cereb Cortex* 12:671–691

## Evolution of the Wulst

J. M. WILD

Department of Anatomy, Faculty of Medical and Health Sciences, University of Auckland, Auckland, New Zealand

### Synonyms

Eminentia sagittalis

### Definition

The Wulst is a part of the ►telencephalic pallium in birds that forms an elevated protuberance on the dorsomedial surface of the cerebral hemisphere. It has caudal and rostral divisions that are in receipt of ascending visual and somatosensory information respectively. The rostral division also gives rise to a motor tract that closely resembles the ►pyramidal tract of mammals.

### Characteristics

#### Anatomy and Connections of the Wulst

The Wulst is a bulge or swelling on the dorsomedial aspect of the brains of birds. It is bounded laterally by a groove called the valleculla (Fig. 1), in which runs a prominent blood vessel. The valleculla extends from the frontal pole of the brain, a variable distance posteriorly in different species, indicating that the Wulst itself varies in extent accordingly. The largest, posterior part of the Wulst forms the end station of the thalamofugal visual system, one of two major visual projection systems in the avian brain (Fig. 1).

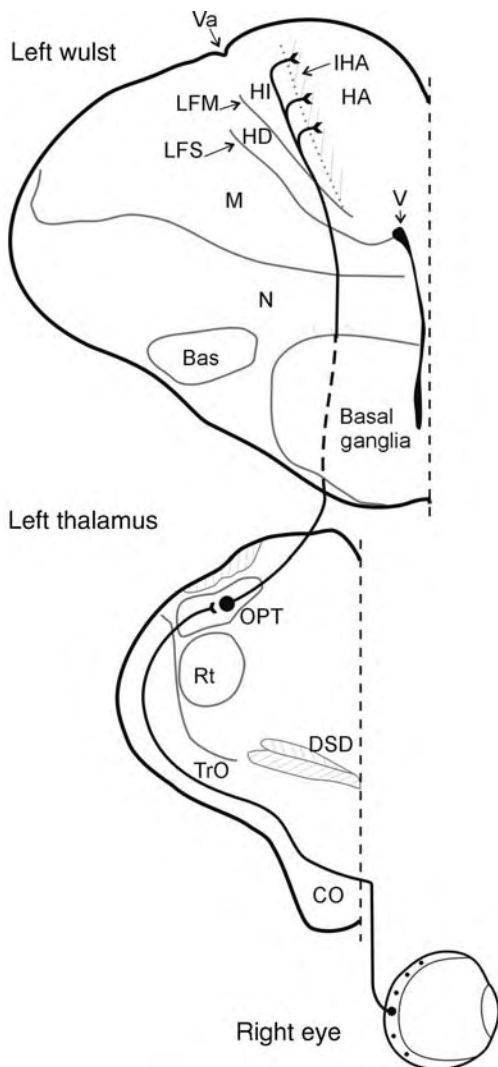

**Evolution of the Wulst. Figure 1** The avian thalamofugal visual system, as represented in a pigeon. Abbreviations: *Bas* nucleus basorostralis pallii; *CO* optic chiasm; *DSD* dorsal supra-optic decussation; *OPT* principal optic nuclei; *HA* hyperpallium apicale; *HD* hyperpallium densocellulare; *HI* hyperpallium intercalatum; *IHA* interstitial nucleus of the hyperpallium apicale; *LFM* supreme frontal lamina; *LFS* superior frontal lamina; *M* mesopallium; *N* nidopallium; *Rt* nucleus rotundus; *TrO* optic tract; *V* lateral ventricle; *Va* vallecula.

The visual Wulst receives its thalamofugal input from the various subnuclei of the principal optic nuclear complex (OPT) of the dorsal thalamus, one or more of which are considered the avian equivalent of the mammalian dorsal lateral geniculate nucleus (dLGN). Unlike the dLGN, however, the OPT in birds receives its input directly from retinal ganglion cells solely in the contralateral eye. This does not mean that the Wulst receives input only from the contralateral eye, for

depending on the species, some OPT cells project ipsilaterally to the Wulst, some project contralaterally (via the supra-optic decussation) and possibly a few project bilaterally. There is a double decussation in the avian thalamofugal visual system, a complete decussation at the optic chiasm and a partial decussation of OPT fibers projecting to the Wulst.

The size of the Wulst is greatest and its internal differentiation most distinctive in those predatory species with frontally placed eyes such as owls and in those species with the largest eye size to brain size ratio, e.g. the emu. In the barn and burrowing owls for instance, the Wulst forms a massive bulge on the dorsum of the brain (Fig. 2a), made up of a number of neuronal layers arranged concentrically from the pial surface dorsally to the mesopallium ventrally [1] (Fig. 2b).

These layers, sometimes referred to as pseudolayers [2] are unlike those of mammalian neocortex – although they are together considered homologous to them – in that there are fewer of them (four vs. six), they are generated from different regions of the ventricular zone during embryogenesis, they are generally thicker, they lack pyramidal neurons and as far as is known they lack the interlaminar connections of the type afforded by the radially organized dendritic trees of mammalian neocortical neurons. In owls the hyperpallium apicale (HA) [3] forms the thickest and most superficial layer, then comes a bilayer making up the interstitial HA (IHA) and then a layer of dispersed cells, the intercalated hyperpallium (HI), separated from the underlying densocellular hyperpallium (HD) by the supreme frontal lamina (LFM). In turn, the HD is separated from the mesopallium by the superior frontal lamina (LFS). Analogously to the dLGN input to layer IV of mammalian visual cortex, the OPT input terminates most densely in the granule cell layer IHA, with other inputs terminating in HD. The laminar-specific terminations from individual OPT nuclei however, remain to be elucidated.

In contrast to the concentric organization of the Wulst laminae in owls, the Wulst laminae in columbiformes (e.g. pigeons) and passerines (e.g. finches) tend to be arranged diagonally on a dorsolateral to ventromedial axis, especially rostrally, with the result that the whole Wulst forms a wedge shaped structure having its wide base at the surface of the brain and its narrow apex ventromedially, where it converges on the dorsal tip of the lateral ventricle (Fig. 1).

Although the Wulst is largely a visual structure, its most rostral portion is somatosensory in nature, this being exemplified again in the barn owl, in which the representation of the claw is confined to a specialized small bulge anterior to the much larger bulge of the visual Wulst [4] (Fig. 2a). In pigeons and finches the IHA and to a lesser extent HA of the somatosensory Wulst receives its thalamic input from

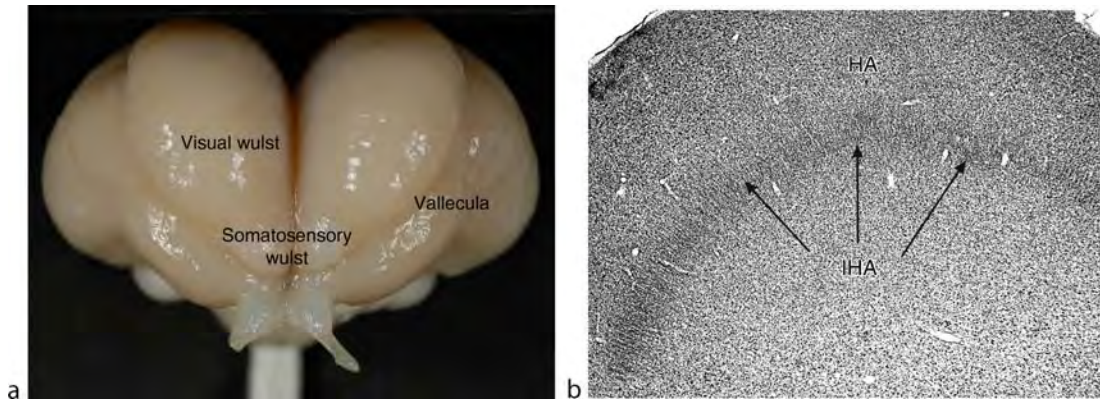

**Evolution of the Wulst. Figure 2** (a) Frontal view of the brain of a barn owl. (b) frontal section through the visual Wulst of a barn owl showing the hyperstriatum apicale (*HA*) and the interstitial nucleus of the hyperpallium apicale (*IHA*), which receives the bulk of the thalamic afferents [1].

the nucleus dorsalis intermedialis ventralis anterior (*DIVA*), which in turn receives its input predominantly from the contralateral dorsal column nuclei [5]. No auditory projections to the Wulst have been identified anatomically.

Another thalamic input to the more medial HD of the Wulst arises from the dorsomedial anterior thalamic nucleus [1]. This input is likely to be limbic in nature, in view of the fact that the HD projects to the hippocampal formation [6].

The greater part of the output from the Wulst arises from the *HA*, which receives much of its input from other Wulst lamina, the *IHA* in particular. From the visual Wulst, axons of *HA* cells exit primarily in three directions, ventrolaterally to the frontal ▶*nidopallium*, ventromedially to the basal ganglia and medially into the so-called septomesencephalic tract (*TSM*). This tract (*TSM*) courses ventrally adjacent to the midline and exits the telencephalon to supply a host of visual structures in the di- and mes-encephalon, including the *OPT*, the ventral lateral geniculate nucleus, the pretectal nuclei, the retinorecipient layers of the optic tectum and accessory optic and isthmo-optic nuclei [1,6,7]. These extratelen-cephalic projections are in general remarkably similar to those of the striate cortex in mammals. Within the ▶*telencephalon* of the burrowing owl, Wulst fibers were also traced to the ▶*perientopallium*, thereby potentially linking the thalamofugal and tectofugal visual pathways. Such a link in other avian species however, has yet to be defined unequivocally.

From the *HA* of the rostral somatosensory Wulst arises an avian equivalent of the mammalian pyramidal tract, which exits the telencephalon via the basal branch of *TSM* and terminates in the medial spiriform nucleus (which then projects to the cerebellum), the red nucleus and throughout extensive regions of the rhombencephalic lateral reticular formation. In the medulla it targets the dorsal column and external cuneate nuclei

bilaterally and terminates in lamina IV of the dorsal horn of upper cervical spinal cord segments contralaterally [8]. Like the mammalian ▶*pyramidal* tract, the avian “pyramidal tract” can therefore control sensory input and motor output, the latter predominantly via the red nucleus, which projects to all levels of the spinal cord and to the cerebellum.

### Physiological Properties of the Wulst

A thorough analysis of the visual properties of Wulst neurons in owls shows a remarkable similarity to those of striate cortical neurons in mammals; the visuotopic representation of space within the Wulst is also similar, with the vertical meridian represented at the lateral edge, adjacent to the vallecule [9]. *IHA* neurons are monocular and have concentrically organized receptive fields, whereas more dorsally located cells tend to be binocular and more closely resemble those in the mammalian extrastriate area 18, with increasingly stringent requirements for stimulus orientation, movement and binocular disparity – which suggested to Jack Pettigrew [9] that the visual Wulst of owls might be analogous to both striate and extrastriate areas of cats and monkeys. However, because of the very different strategies of optic decussation in birds and mammals, the total absence of pyramidal neurons in the avian Wulst and the anatomically and functionally differentiated nature of the owl Wulst compared with that of other avian species, Pettigrew was of the opinion that the owl Wulst and mammalian striate cortex are not homologous as visual structures, i.e. are not likely to be derived from a neural antecedent possessed by an ancestor common to both birds and mammals. Instead, he thought that the similarity of owl Wulst and mammalian striate cortex was more likely to be an example of convergent evolution, possibly reflecting a unique solution to the problem of stereopsis. This opinion contrasts with the more generally accepted view that the Wulst in birds is

probably derived from the same simple cortical structure in stem amniotes that gave rise to the superior part of the neocortex in mammals, which includes the target of dLGN projections.

The retinotopic and receptive field organization of the Wulst in other species such as chickens and pigeons, which have eyes placed on the side of the head instead of in front, may be quite different from that in owls [e.g. 10]. In these and other non-raptorial species there is generally a small and variable degree of binocular overlap, so that the inputs to the two eyes are largely independent, except when the eyes converge, e.g. during pecking. Even so, the OPT (in the pigeon) receives its strictly contralateral input from ganglion cells only in that part of the retina that looks laterally into the monocular visual field [11]. This implies that binocular fusion is not a significant function of the Wulst in this and other species with laterally placed eyes (compared with the geniculostriate system of mammals). How such birds cope behaviorally with the input from completely different parts of the visual world to the largely separate sides of the thalamofugal system is an interesting question for which there is as yet no satisfactory answer.

Given the undisputed visual nature of the greater part of the Wulst, it might be expected that lesions in this structure would cause severe visual deficits. Surprisingly, this is not always the case, as is evidenced by the results of many studies using color, brightness or pattern discriminations, although reversal learning tasks tend to be more affected. One suspects that the visual Wulst has functions that remain to be discovered. If the Wulst is analogous as well as homologous to the striate cortex of mammals, then as Harvey Karten has suggested it might be suspected that a major function of the Wulst is the control of certain kinds of eye movements, probably via the projections to the optic tectum and its descending projections to the brainstem [cf 12]. The effects of lesions of the somatosensory Wulst have not been assessed.

## References

1. Karten HJ, Hodos W, Nauta WJH, Revzin AM (1973) Neural connections of the “visual wulst” of the avian telencephalon. Experimental studies in the pigeon (*Columba livia*) and owl (*Speotyto cunicularia*). *J Comp Neurol* 150:253–278
2. Medina L, Reiner R (2000) Do birds possess homologues of primary visual, somatosensory and motor cortices? *Trends Neurosci* 23:1–12
3. Reiner A, Perkel DJ, Bruce LL, Butler AB, Csillag A, Kuenzel W, Medina L, Paxinos G, Shimizu T, Striedter GF, Wild M, Ball G, Durand S, Güntürkün O, Lee DW, Mello CV, Powers A, White SA, Hough G, Kubikova L, Smulders TV, Wada K, Douglas-Ford J, Husband S, Yamamoto K, Yu J, Siang C, Jarvis ED (2004) Revised

nomenclature for avian telencephalon and some related brainstem nuclei. *J Comp Neurol* 473:377–414

4. Manger PR, Elston GN, Pettigrew JD (2002) Multiple maps and activity-dependent representational plasticity in the anterior Wulst of the adult barn owl (*Tyto alba*). *Eur J Neurosci* 16:743–750
5. Wild JM (1997) The avian somatosensory system: the pathway from wing to Wulst in a passerine (*Chloris chloris*). *Brain Res* 759:122–134
6. Shimizu T, Cox K, Karten HJ (1995) Intratelencephalic projections of the visual Wulst in pigeons (*Columba livia*). *J Comp Neurol* 359:551–572
7. Reiner A, Karten HJ (1983) The laminar source of efferent projections from the avian Wulst. *Brain Res* 275:349–354
8. Wild JM, Williams NM (2000) The rostral Wulst in passerine birds. I. Origin, course, and terminations of an avian “pyramidal tract.” *J Comp Neurol* 416:429–450
9. Pettigrew JD (1979) Binocular visual processing in the owl’s telencephalon. *Proc R Soc Lond B* 204:435–454
10. Wilson P (1980) The organization of the visual hyperstriatum in the domestic chick. I. Topology and topography of the visual projection. *Brain Res* 188:319–332
11. Remy M, Güntürkün O (1991) Retinal afferents to the optic tectum and the nucleus opticus principalis thalami in the pigeon. *J Comp Neurol* 305:57–70
12. Schiller PH, Tehovnic EJ (2001) Look and see: how the brain moves your eyes about. *Prog Brain Res* 134:127–142

---

## Evolution of Trigeminal Nerve

- Evolution of the Trigeminal Sensory System and its Specializations

---

## Evolution of Vertebrates

- Evolution and Phylogeny of Vertebrates

---

## Evolution of Vestibulospinal Motor Systems

- Evolution of Motor Systems: Corticospinal, Reticulospinal, Rubrospinal and Vestibulospinal Systems



## Evolutionary Scale

- Evolution and the Scala Naturae

## Exchanger

### Definition

Exchanger (also called antiporter) is a transmembrane protein that uses the energetically favorable transport of an ion down its electrochemical gradient to drive the uphill transport of other ion species in the opposite direction (see also Ion transport).

- Ion Transport

## Excitable Cells

### Definition

Excitable cells are cells that contain voltage-gated channels which enables them to transmit action potentials in response to depolarizing stimuli. Examples of excitable cells include skeletal muscle, cardiac muscle and neurons.

- Action Potential

## Excitable Dendrite

### Definition

Dendrite endowed with active, voltage-gated ion conductances that may generate a dendritic spike.

- Action Potential

## Excitants

- Stimulants

## Excitation

### Definition

The change in membrane potential of neurons that moves it closer to the threshold for action potentials.

- Action Potential

## Excitation-Contraction Coupling

A. RUSSELL TUPLING

Department of Kinesiology, University of Waterloo, Waterloo, ON, Canada

### Synonyms

E-C coupling; voltage-dependent calcium release

### Definition

The series of events linking depolarization of the sarcolemma and t-tubule membrane to the release of messenger calcium ( $\text{Ca}^{2+}$ ) from the sarcoplasmic reticulum (SR), resulting in muscle contraction [1].

### Characteristics

**Quantitative Description:** Force production in muscle primarily depends on the level of intracellular free  $[\text{Ca}^{2+}]_i$  ( $[\text{Ca}^{2+}]_i$ ) achieved in excitation-contraction (E-C) coupling. The steady-state relationship between force and  $[\text{Ca}^{2+}]_i$  is shown in Fig. 1.

Within a single motor unit or single muscle fiber, the major factor that determines the  $[\text{Ca}^{2+}]_i$  achieved in E-C coupling, and thus force, is motor unit firing frequency or stimulation frequency (see accompanying essay on the force-frequency relation of this Encyclopedia). At low stimulation frequencies (i.e. 1–20 Hz), there is sufficient time between successive action potentials for  $\text{Ca}^{2+}$  to be taken back up into the SR by the sarco(endo)plasmic reticulum  $\text{Ca}^{2+}$ -ATPase (SERCA) or  $\text{Ca}^{2+}$  pump, which limits the amount of  $[\text{Ca}^{2+}]_i$  and force that can be achieved (i.e. unfused tetanus). At high stimulation frequencies (i.e. 50–100 Hz for human muscle; 100–200 Hz for rodent muscle), maximum or saturating  $[\text{Ca}^{2+}]_i$  and maximum force (i.e. fused tetanus) are achieved because there is not enough time between successive action potentials for any appreciable SR  $\text{Ca}^{2+}$  uptake to occur. The important role of SR  $\text{Ca}^{2+}$  uptake in determining the  $[\text{Ca}^{2+}]_i$  achieved in E-C coupling can be illustrated with the following two examples: (i) The

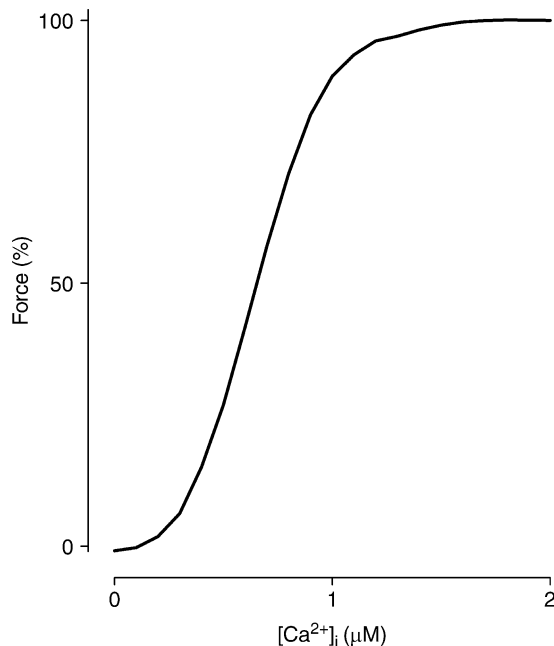

**Excitation-Contraction Coupling. Figure 1** The steady-state force- $[Ca^{2+}]_i$  relationship. The resting  $[Ca^{2+}]_i$  in skeletal muscle is approximately 100 nM, which is largely determined by the activity of the SR  $Ca^{2+}$  pump. During high-frequency stimulation,  $[Ca^{2+}]_i$  reaches  $\sim 1\text{--}10\ \mu\text{M}$ , which maximally activates the contractile apparatus resulting in a fused tetanic contraction [2]. At low stimulation frequencies, force falls on the steep part of the relationship, meaning that small changes in  $[Ca^{2+}]_i$  will result in a marked change in force. This relationship is fit by the Hill equation, which describes the cooperative nature of  $Ca^{2+}$  activation [2].

stimulation frequency required to obtain a fused tetanic contraction is significantly lower in slow-twitch (Type I) muscle (i.e. 100 Hz for mouse soleus) compared with fast-twitch (Type II) muscle (i.e.  $>150$  Hz for mouse extensor digitorum longus), due to a slower  $Ca^{2+}$  uptake rate in slow-twitch muscle (A.R. Tupling, unpublished observations); (ii) Pharmacologic block of SR  $Ca^{2+}$  uptake results in higher  $[Ca^{2+}]_i$  and force at low stimulation frequencies [2].

**Higher Level Structures:** The SR is a membranous structure in all muscle cells that closely and completely surrounds each myofibril forming part of the pathway of E-C coupling. In skeletal muscle, the SR is segmented and the segments are defined by their association with the t-tubules, which are continuous with the sarcolemmal membrane and run across the muscle fiber at the ends of the A-band regions of each sarcomere. Discrete junctional domains of the SR (terminal cisternae) appose either side of a t-tubule segment forming a triad. Communication between the t-tubule membrane and SR terminal cisternae membrane occurs at specific structures called calcium

release units (CRUs) [1]. These structures contain two major proteins identified as key elements in E-C coupling, namely dihydropyridine receptors (DHPRs), located in the t-tubule and ryanodine receptors (RyRs) or  $Ca^{2+}$  release channels located in the junctional SR membrane. The latter are visible as “feet” in electron micrographs from thin section [1]. The junctional domains of SR and t-tubular membranes are separated from each other by nonjunctional domains of the sarcolemma and SR membranes. The major protein located in the non-junctional SR is the  $Ca^{2+}$  pump.

### Lower Level Components

**DHPR** – In skeletal muscle, the DHPR (L-type  $Ca^{2+}$  channel) consists of five protein subunits:  $\alpha 1$ ,  $\alpha 2$ ,  $\beta$ ,  $\gamma$ , and  $\delta$  [3]. This protein complex is responsible for the L-type  $Ca^{2+}$  current and serves as the voltage sensor for E-C coupling. Being the principal functional DHPR subunit, the  $\alpha 1$  subunit of 170 kDa, which contains the  $Ca^{2+}$  pore, is the receptor for  $Ca^{2+}$  antagonists (i.e.  $Ca^{2+}$  channel blockers) and also functions as the voltage sensor which regulates opening of the channel in response to changes in the electrical potential across the cell membrane, permitting  $Ca^{2+}$  entry from extracellular spaces. The  $\alpha 1$  subunit contains four homologous transmembrane domains and the loop linking domains II and III interacts closely with the RyR of the SR [3]. The other subunits have regulatory functions.

**RyR** – The predominant RyR isoform expressed in skeletal muscle is RyR1. RyRs are extremely large homotetrameric proteins consisting of identical subunits of 565 kDa. Isolated RyR1, viewed by electron microscopy, is seen to be composed of four equal subunits, with the hydrophobic parts of the subunits forming a membrane-spanning base plate, and the more hydrophilic segments forming a cytoplasmic domain which bridges the 12 nm gap between the t-tubular and SR membranes [4]. The opening of RyRs is modulated by two RyR binding proteins, namely the FK506 binding protein (FKBP12) and calmodulin [4].

**Calsequestrin (CSQ)** – CSQ, a relatively low-affinity  $Ca^{2+}$ -storage protein capable of binding and releasing large quantities of  $Ca^{2+}$  rapidly, which is located within the lumen of the SR terminal cisternae. CSQ binds about 40–50  $Ca^{2+}$  ions with a binding constant of about 1 mM under physiological conditions [4]. With  $Ca^{2+}$  bound, CSQ polymerizes, forming linear ribbon-like structures that are associated with RyR1 through a supramolecular complex that involves CSQ binding to the lemmal domains of triadin and/or junctin (Fig. 2) [4].

This network of interacting proteins assures that high concentrations of  $Ca^{2+}$  are stored very near to the site of  $Ca^{2+}$  release.

**Structural Regulation:** In skeletal muscle, DHPRs are grouped into tetrads, or clusters of four DHPRs, which form ordered arrays in the t-tubular membrane. DHPR

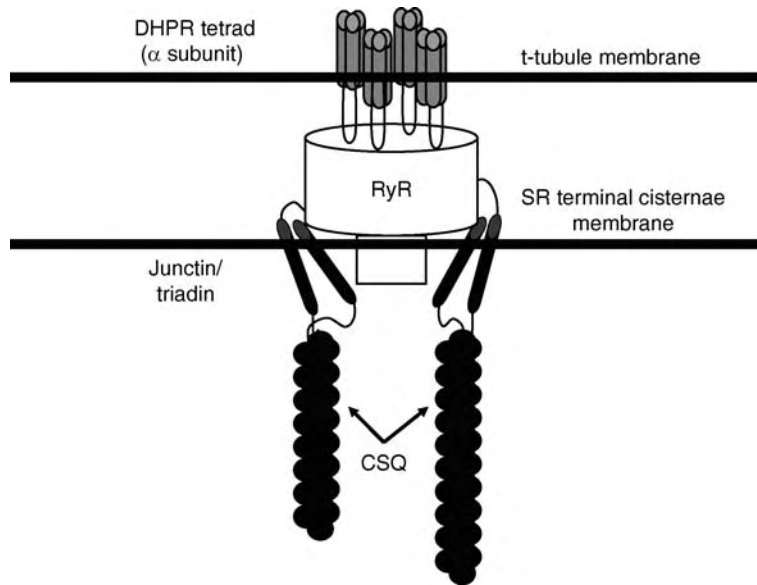

**Excitation-Contraction Coupling. Figure 2** Schematic model demonstrating the location and interaction between key proteins involved in E-C coupling. The DHPRs are grouped into tetrads in the t-tubule membrane, and the  $\alpha 1$  subunit II-III loop of each DHPR interacts closely with one of the four underlying RyR subunits located in the SR terminal cisternae membrane [3]. CSQ is a  $\text{Ca}^{2+}$ -binding protein located in the lumen of the SR that polymerizes upon binding  $\text{Ca}^{2+}$ , and is associated with the RyR through a supramolecular complex that involves CSQ binding to the lumenal domains of triadin and/or junctin [4]. During E-C coupling, the DHPR II-III loop allosterically activates the underlying RyR to open and release  $\text{Ca}^{2+}$ . Conformational changes in CSQ also occur during E-C coupling, suggesting that DHPR-induced conformational changes in RyRs are transmitted to CSQ, probably through triadin and/or junctin, and that the conformational changes in CSQ are likely involved in regulating  $\text{Ca}^{2+}$  release [5].

tetrads face ordered arrays of RyRs in such a way that each of the four DHPRs composing a tetrad appears to be linked ( $\alpha 1$  subunit II-III loop) to one of the four underlying RyR subunits. Every other RyR in the array is associated with a DHPR tetrad [1]. This distinct morphology of CRUs in skeletal muscle forms the structural basis underlying the so-called “mechanical” hypothesis of E-C coupling for skeletal muscle. This hypothesis proposes that DHPRs sense membrane depolarization and affect calcium release from the SR by a direct molecular interaction [1].

Until recently, it was believed that RyRs adjacent to a DHPR-linked RyR were probably activated by the  $\text{Ca}^{2+}$  released by the DHPR-linked RyR through a  $\text{Ca}^{2+}$ -induced  $\text{Ca}^{2+}$  release mechanism [6]. However, new evidence suggests that a functional grouping of RyRs, DHPRs and other junctional SR proteins (triadin, junctin, CSQ) may act in concert to release  $\text{Ca}^{2+}$  during E-C coupling. This functional grouping of CRUs is referred to as a couplon [7]. In skeletal muscle, a triad contains two couplons, one on either side of the t-tubule, which act independently of each other. Therefore, a new model suggests that adjacent RyRs within a couplon are mechanically linked, and that the linked RyRs open and close simultaneously during E-C coupling [6].

**Higher Level Processes:** In the relaxed muscle, RyRs are closed and a potential difference is generated across the t-tubular membrane (positive outside; negative inside) by the  $\text{Na}^+/\text{K}^+$ -ATPase [3]. The entry of  $\text{Na}^+$  following stimulatory events at the neuromuscular junction initiates a muscle action potential that travels along the sarcolemma and enters the t-tubular system (see accompanying essay on the neuromuscular junction of this Encyclopedia). The electrical signal is transmitted from the t-tubules to the SR terminal cisternae, which causes  $\text{Ca}^{2+}$  release from the SR.  $\text{Ca}^{2+}$  released into the cytoplasm binds to troponin C, resulting in a conformational change that alters the interactions between tropomyosin and the contractile machinery allowing actin and myosin to interact, leading to muscle contraction.

**Lower Level Processes:** Signal transmission between the t-tubule membrane and the SR terminal cisternae membrane during E-C coupling occurs through a direct molecular interaction between the DHPR located in the t-tubule and the RyR located in the SR terminal cisternae. Depolarization of the t-tubules is thought to destabilize positively charged transmembrane helices in the  $\alpha 1$  subunit of the DHPR, causing them to shift in the lipid bilayer and move toward the more negative

exterior [3]. As a result of this conformational change in the DHPR, the DHPR II-III loop allosterically activates the underlying RyR to open and release  $\text{Ca}^{2+}$ . Conformational changes in CSQ also occur during E-C coupling, after t-tubule depolarization and before  $\text{Ca}^{2+}$  release from the SR, suggesting that the E-C coupling signal is transmitted to CSQ and that it is somehow involved in regulating  $\text{Ca}^{2+}$  release [5]. These conformational changes probably lead to release of  $\text{Ca}^{2+}$  ions from CSQ, which raises the luminal free  $\text{Ca}^{2+}$  concentration, thus increasing the driving flux ( $\text{Ca}^{2+}$  gradient) for rapid  $\text{Ca}^{2+}$  release. However, another model has been proposed where CSQ acts as a  $\text{Ca}^{2+}$  wire that conducts  $\text{Ca}^{2+}$  into the  $\text{Ca}^{2+}$  release channel during E-C coupling [4]. Thus,  $\text{Ca}^{2+}$  diffusion from CSQ to the RyR would involve surface diffusion, which is a more rapid process than diffusion through liquid [4].

**Process Regulation:** The  $\text{Ca}^{2+}$  release process during E-C coupling is a DHPR-mediated process; however, this process is modulated by various cytoplasmic (and SR luminal) ligands such as ATP,  $\text{Mg}^{2+}$  and  $\text{Ca}^{2+}$ . Significant insights into the regulation of E-C coupling in skeletal muscle have transpired from experiments using the mechanically skinned fiber preparation [8]. As these fibers retain the normal voltage-dependent E-C coupling mechanism, and because the intracellular environment can be easily manipulated in these fibers, it is possible to investigate which factors influence normal E-C coupling and which do not. From these experiments, it was found that ATP has to be bound to the RyRs for them to be activated by DHPRs [8]. Presumably, ATP binds to a regulatory site on the RyR and stimulates depolarization-induced  $\text{Ca}^{2+}$  release [8]. It is known that a glycogenolytic complex, consisting of glycogen and several metabolic enzymes from glycolysis, is associated with the terminal cisternae membrane and is capable of synthesizing ATP [9]. This metabolic complex may serve as a source of local ATP within the triad membrane region that is important for the regulation of E-C coupling.

Cytoplasmic  $\text{Mg}^{2+}$  is also an important regulator of RyRs in muscle.  $\text{Mg}^{2+}$  acts as a  $\text{Ca}^{2+}$  release antagonist even at physiological resting free [ $\text{Mg}^{2+}$ ] (1 mM) and has a dual inhibitory effect: (i)  $\text{Mg}^{2+}$  binding to a low-affinity  $\text{Ca}^{2+}/\text{Mg}^{2+}$ -inhibition site in RyRs inhibits channel opening, and (ii)  $\text{Mg}^{2+}$  binding to a high-affinity  $\text{Ca}^{2+}$ -activation site in RyRs not only prevents  $\text{Ca}^{2+}$  activation of the channel but also directly inhibits channel opening [8]. Therefore, DHPR activation of RyRs during E-C coupling must overcome the inhibitory effect of  $\text{Mg}^{2+}$  on RyRs at rest, given that RyRs are near maximally activated during action potential stimulation [8]. It is proposed that allosteric activation of RyRs by DHPRs, resulting in a conformational change in RyRs, reduces RyR affinity

for  $\text{Mg}^{2+}$  at both the  $\text{Ca}^{2+}$ -activation site and the low-affinity  $\text{Ca}^{2+}/\text{Mg}^{2+}$  site [8]. Removing a resting inhibition of RyRs by  $\text{Mg}^{2+}$  would allow cytoplasmic ATP to activate the channel and the released  $\text{Ca}^{2+}$  would also be able to reinforce this activation [8]. The regulatory role of cytoplasmic factors in E-C coupling is particularly relevant to the basis of muscle fatigue under some conditions.

**Function:** The primary function of muscle is to do mechanical work. It is well known that repetitive muscle contraction unavoidably results in a progressive decline in mechanical performance known simply as fatigue (see accompanying essay on muscle fatigue of this Encyclopedia). The mechanistic basis of fatigue is complex and likely involves multiple etiologies, however; it is increasingly apparent that intense or continuous muscle contraction leads to alterations in E-C coupling processes, resulting in lower activating intracellular free  $\text{Ca}^{2+}$  levels and reduced force [2]. Experiments with mechanically skinned fibers have shown that changes in the level of specific substances in the cellular environment that mimic changes seen in fatigued muscle, directly impair muscle contractility either by altering the regulation of E-C coupling or by altering the physical interaction between DHPRs and RyRs [8].

Two factors that play a role in the regulation of E-C coupling that are likely to be important in muscle fatigue in some circumstances are: (i) a decrease in cytoplasmic [ATP] in the vicinity of the RyRs in the triad membrane compartment, and (ii) the associated increase in free [ $\text{Mg}^{2+}$ ] since the hydrolysis products of ATP, namely ADP and AMP, have a far lower affinity for  $\text{Mg}^{2+}$  than ATP [8]. With intense muscle activity, [ATP] can drop to <1 mM ([ATP] is ~6 mM at rest) and free [ $\text{Mg}^{2+}$ ] can increase more than twofold in mammalian fast-twitch fibers [8]. Decreasing [ATP] and increasing [ $\text{Mg}^{2+}$ ] to these levels inhibits voltage-dependent  $\text{Ca}^{2+}$  release in mechanically skinned fibers, and this is exacerbated by increases in ADP and AMP [8]. Under some conditions such as low-frequency fatigue, long-term interruption of the coupling between DHPRs and RyRs can occur. Under these conditions, it appears that elevated cytoplasmic [ $\text{Ca}^{2+}$ ] for prolonged periods could be responsible for the E-C coupling failure due to physical disruption of the triad junction [8].

**Pathology:** Malignant hyperthermia (MH) and central core disease (CCD) are inherited diseases of E-C coupling. MH susceptible individuals undergo an uncontrollable skeletal muscle hypermetabolism when exposed to potent inhalational anesthetics or depolarizing skeletal muscle relaxants due to excessive release of  $\text{Ca}^{2+}$  from the SR into the cytoplasm, thereby triggering sustained muscle contracture [10]. The incidence of MH during anesthesia is about 1 in 15,000 children and

about 1 in 50,000–100,000 adults [10]. The clinical symptoms of MH include muscle rigidity, tachycardia, hyperkalemia, hypoxia, lactic acidosis and eventually fever. If not treated immediately with the  $\text{Ca}^{2+}$  release inhibitor dantrolene, the patient may die within minutes from ventricular fibrillation, within hours from pulmonary edema or within days from post anoxic neurological damage or renal failure [10]. More than 50 different mutations in the *RYR1* gene have so far been associated with MH, and abnormalities of the  $\alpha 1$  subunit of the DHPR are also linked to MH [10].

Closely related to MH is CCD, which is a rare skeletal muscle myopathy that is characterized by hypotonia, delayed motor development and muscle weakness [10]. Diagnosis of CCD is based on histological examination, which shows the lack of oxidative enzymes in the central regions (cores) of skeletal muscle cells and electron microscopic analysis reveals unstructured myofibrils and enlarged, but less well structured, SR and t-tubular systems [10]. It is hypothesized that cytoplasmic  $\text{Ca}^{2+}$  overload due to a mutation in RyR1 is responsible for the mitochondrial damage that would lead to a reduction in ATP production. The decreased metabolic activity might therefore be the underlying cause of the muscle weakness observed in CCD [10].

## References

1. Franzini-Armstrong C, Protasi F (1997) Ryanodine receptors of striated muscles: a complex channel capable of multiple interactions. *Physiol Rev* 77:699–729
2. Allen DG, Lannergren J, Westerblad H (1995) Muscle cell function during prolonged activity: cellular mechanisms of fatigue. *Exp Physiol* 80:497–527
3. Leong P, MacLennan DH (1998) Complex interactions between skeletal muscle ryanodine receptor and dihydropyridine receptor proteins. *Biochem Cell Biol* 76:681–694
4. MacLennan DH, Abu-Abed M, Kang C (2002) Structure-function relationships in  $\text{Ca}^{2+}$  cycling proteins. *J Mol Cell Cardiol* 34:897–918
5. Beard NA, Laver DR, Dulhunty AF (2004) Calsequestrin and the calcium release channel of skeletal and cardiac muscle. *Prog Biophys Mol Biol* 85:33–69
6. Bers DM, Fill M (1998) Coordinated feet and the dance of ryanodine receptors. *Science* 281:790–791
7. Stern MD, Pizzaro G, Rios E (1997) Local control model of excitation-contraction coupling in skeletal muscle. *J Gen Physiol* 110:415–440
8. Lamb GD (2002) Voltage-sensor control of  $\text{Ca}^{2+}$  release in skeletal muscle: insights from skinned fibers. *Front Biosci* 7:d834–d842
9. Melzer W, Herrmann-Frank A, Lüttgau HC (1995) The role of  $\text{Ca}^{2+}$  ions in excitation-contraction coupling of skeletal muscle fibres. *Biochim Biophys Acta* 1241:59–116
10. MacLennan DH (2000)  $\text{Ca}^{2+}$  signalling and muscle disease. *Eur J Biochem* 267:5291–5297

## Excitation-transcription Coupling

- Calcium Channels: Regulation of Gene Transcription

## Excitatory Burst Neurons (EBNs)

E

### Definition

Neurons that exhibit a burst of spikes beginning no more than 15 ms before the onset of ipsiversive saccades, but are silent or nearly silent during fixation or slow eye movements. Excitatory burst neurons make excitatory connections with ipsilateral abducens motoneurons and interneurons, with ipsilateral prepositus nucleus neurons, and with ipsilateral inhibitory burst neurons.

- Brainstem Burst Generator
- Burst Cells – Medium Lead – Horizontal
- Burst Cells – Medium Lead – Vertical
- Saccade, Saccadic Eye Movement

## Excitatory CPG Interneurons

ABDELJABBAR EL MANIRA  
Department of Neuroscience  
Karolinska Institutet, Stockholm, Sweden

### Synonyms

Pre-motor interneurons; glutamatergic interneurons; network interneurons

### Definition

Rhythmic ►motor patterns are generated by networks of neurons within the CNS, these networks are referred to as ►central pattern generators (CPGs). They consist of populations of neurons that produce a motor output underlying a specific motor behavior such as locomotion, respiration, or mastication. The locomotor CPG is located in the spinal cord, and can generate the basic locomotor pattern that consists of alternation of ►excitation and ►inhibition.

The spinal CPG is a functional entity that can generate and sustain rhythmic locomotor patterns in the absence of descending and sensory inputs [1–3]. Normally, however, the activity of the spinal locomotor CPG is initiated by descending excitatory inputs

from the brainstem [2–4]. Also, the ongoing locomotor pattern can be adjusted to environmental demands via movement-related sensory feedback [2].

The locomotor CPG contains an intrinsic source of excitation that is composed of excitatory CPG interneurons. These interneurons are an essential component of the locomotor network. They provide the phasic synaptic excitatory drive to motoneurons that in turn produce the appropriate sequence of muscle contractions allowing the animal to swim, walk or fly. In addition, they also provide excitation to inhibitory CPG interneurons responsible for the alternation of activity in antagonistic motoneurons.

The excitatory CPG interneurons use glutamate as their synaptic transmitter, which is stored in their presynaptic terminals. The electrical activity of the excitatory CPG interneurons releases glutamate from their terminals, which diffuses in the synaptic region and activates glutamatergic receptors located on the postsynaptic target neurons (motoneurons and CPG interneurons). Activation of **▶ionotropic receptors** by glutamate leads to the depolarization of the membrane potential of the postsynaptic neurons. These synaptic potentials are mediated by activation of AMPA and NMDA receptors, and produce the phasic excitatory drive occurring during each locomotor cycle in motoneurons and interneurons. Release of glutamate from excitatory CPG interneurons also activates **▶metabotropic ▶receptors** (modulatory receptors) that underlie modulatory actions at the short and long time scales.

To be considered as CPG neurons (1) the excitatory interneurons need to be activated first during the locomotor cycle enabling them to drive the activity of other locomotor CPG neurons; (2) they should project ipsilaterally direct or indirect synaptic connections with motoneurons and CPG interneurons (excitatory and inhibitory), and (3) they should receive synaptic inputs from the command centers responsible for the initiation of locomotor activity, and sensory afferents to adjust the locomotor pattern to the environment.

## Characteristics

### Quantitative Description

Excitatory CPG interneurons can be characterized by: (1) their ipsilateral axonal projections, (2) monosynaptic connections with motoneurons and other **▶network interneurons**, and (3) their glutamatergic synaptic transmission.

The first indications for the existence of excitatory CPG interneurons were derived from the existence of depolarizing synaptic potentials in motoneurons in the lamprey and tadpole spinal cord. These excitatory potentials have their source within the spinal cord, and are due to activation of interneurons in the same segment or adjacent segments. Following these observations, it was possible to characterize excitatory CPG interneurons

using paired intracellular recordings. Excitatory CPG interneurons in the lamprey and tadpole spinal cord make monosynaptic connections with motoneurons and inhibitory interneurons responsible for left/right alternations. They also provide mutual excitation to one another. Stimulation of presynaptic excitatory interneurons elicits monosynaptic excitatory potentials in motoneurons or other network interneurons that are mediated by activation of NMDA and AMPA receptors [5,6]. Ipsilateral excitatory interneurons have also been identified in the mammalian spinal cord, but their role in locomotion has not yet been determined [7,8].

### Higher Level Structures

Locomotor activity is initiated by descending inputs from command centers in the brain. Stimulation of specific regions in the brainstem (mesencephalic locomotor region, MLR) or diencephalon (diencephalic locomotor region, DLR) can elicit coordinated locomotor patterns through an action mediated by reticulospinal neurons [4,9]. These regions are conserved in all vertebrates. To be able to trigger the activity of the spinal locomotor CPG, signals from the command centers need to activate the excitatory CPG interneurons. Indeed, the available data from lamprey shows that excitatory CPG interneurons receive monosynaptic excitatory inputs from reticulospinal neurons located in the different areas in the brainstem. Once these interneurons are activated they in turn excite motoneurons and inhibitory interneurons, and thereby a rhythmic locomotor pattern is generated. The inputs from the command centers not only trigger the activity of the spinal locomotor CPG, but they also regulate the level of activity resulting in changes in the frequency of the locomotor rhythm. The descending control of the activity of the excitatory CPG interneurons plays an important role in regulating the activity of the locomotor CPG, and thus enables the CPG to integrate influences from different parts of the CNS.

### Lower Level Structures

In the lamprey and tadpole CPG, the excitatory CPG interneurons provide synaptic inputs to each other via excitation within the pool of interneurons. Here they represent the first level of processing within the locomotor CPG that result in rhythmic activity. In addition, excitatory interneurons provide the excitatory drive to inhibitory interneurons, which project to the contralateral side and inhibit excitatory interneurons on the opposite side of the spinal cord ensuring left/right alternation of locomotor activity. Finally, excitatory CPG interneurons provide excitation to motoneurons that receive excitatory inputs from several excitatory interneurons that cause action potentials, which lead to muscle contraction. As the mammalian CPG has not been characterized in detail, no data from mammals is available.

The excitatory CPG interneurons are not only essential for the generation of a coordinated locomotor pattern, they are also important for the precise recruitment of different types of motoneurons. In the lamprey spinal cord, the analysis of synaptic connections between excitatory interneurons and motoneurons has shown that each motoneuron receives excitation from a small proportion of interneurons. In this preparation, stimulation of a single excitatory interneuron can elicit activity in the ventral root, but it is unable to produce a sustained rhythm. The excitatory CPG interneurons are likely to be subdivided into groups, which may enable different motor functions. For example, motoneurons responsible for movement around different joints (hip, knee and ankle) may be controlled by separate groups of excitatory interneurons [1].

### Structural Regulation

The activity of excitatory CPG interneurons is triggered by descending inputs from command centers. To account for the full locomotory repertoire, the spinal CPG also has to integrate sensory feedback generated by the movements being performed. These effects are mediated via synaptic connections between sensory afferents and interneurons within the locomotor CPG. By modulating the activity of excitatory CPG interneurons, sensory feedback can affect the overall locomotor pattern.

Overall, excitatory CPG interneurons are a pivotal player within the spinal locomotor network. They provide the intrinsic excitatory drive in the spinal cord and act as an integrating entity to adapt the ongoing locomotor rhythm to central commands and peripheral changes in the environment.

### Lower Level Processing

In the spinal locomotor network, excitatory CPG interneurons provide excitation to ipsilateral motoneurons and interneurons. The characteristic alternation of activity is ensured by inhibitory CPG interneurons that project to the contralateral side and inhibit both motoneurons and interneurons. As the basic locomotor pattern is dependent on synaptic interactions involving excitation and inhibition, the question was raised regarding the extent to which the excitation alone is able to produce rhythmic locomotor activity. To address this, experiments have been done in which the reciprocal inhibitory synaptic transmission is disrupted either pharmacologically or by a surgical approach. Thus, locomotor activity can be induced *in vitro* with left/right alternation, and flexor-extensor activity is blocked by blocking inhibitory synaptic transmission by adding an antagonist of glycine receptors. When the glycinergic reciprocal inhibition is blocked, the locomotor pattern switches from the characteristic alternation of left/right root activity to synchronous bursting. Although

synchronous, the rhythmic pattern of ventral root activity is not abolished by the glycine receptor antagonist. Moreover, the section of the spinal cord along the midline does not interrupt the rhythm. This rhythmicity does not depend on inhibitory synaptic transmission within each hemi spinal cord, because ventral root bursting continued to occur even when inhibition is blocked.

Each hemi-segment is thus able to independently generate rhythmic motor activity in the absence of inhibitory transmission. This suggests that the excitatory CPG interneurons on each side of the spinal cord form a neural network through excitatory interactions that is responsible for the basic motor activity. These interneurons make mutual excitatory connections with each other and form the kernel of the locomotor CPG. When the excitatory CPG interneurons are activated they synchronize their firing and drive the motoneurons. Their activity is terminated by mechanisms independent of active synaptic inhibition. These may include intrinsic membrane properties, such as activation or inactivation of specific ion channels that hyperpolarize the membrane potential of excitatory CPG interneurons and stop their firing.

In mammals, genetic manipulations promoting abnormal projections of excitatory CPG interneurons to the contralateral spinal cord, that otherwise do not occur in normal conditions, resulted in a synchronous activation of left and right sides [10]. In these mice, instead of alternating limb movements, a rabbit-gait with a hopping pattern develops. The cellular analysis in the isolated spinal cord showed abnormal axonal projections from excitatory CPG interneurons to the contralateral side. The crossed excitation thus dominates over inhibition, explaining the synchronous activation of both sides of the spinal cord. The normal locomotor pattern with alternating left/right activity could be restored experimentally by increasing inhibitory transmission or decreasing crossing excitation.

In conclusion, excitatory CPG interneurons seem to form the basic network in each side of the spinal cord and generate rhythmic motor activity via excitatory synaptic interactions. The two sides are connected to each other mainly via crossing inhibitory interneurons that are responsible for left/right alternation, which is characteristic for the locomotor movements from lower vertebrates to primates, including humans.

### Process Regulation

The firing frequency of excitatory CPG interneurons and their transmitter release can be modulated by various modulatory receptors that act on a slow timescale [11,12]. The postsynaptic modulation affects the electrical processing of these interneurons by changing specific conductances. The presynaptic modulation is mediated by receptors located on the axonal terminals of these interneurons that, when activated, can regulate

the amount of transmitter released and thus the response in the target neurons. During locomotor activity, synaptic transmission from excitatory CPG interneurons is phasically modulated via presynaptic inhibition. In addition, there are a number of modulatory receptors that change the frequency of the locomotor rhythm by acting on cellular and synaptic processing in excitatory CPG interneurons. Due to their central role in locomotor pattern generation, the excitatory CPG interneurons represent a critical target for modulatory inputs that trigger, maintain and regulate the locomotor behavior.

### Function

Based on the results for the lamprey and tadpole spinal cord, it can be suggested that the excitatory CPG interneurons represent the first order interneurons within the spinal locomotor network. They are important for starting the activity of the locomotor network and drive the motoneurons and inhibitory CPG interneurons. They also integrate sensory and descending inputs from descending commands allowing adaptation of the ongoing motor activity. The organization and synaptic processing of excitatory interneurons in mammalian spinal cord remains to be determined.

### Therapy

The excitatory CPG interneurons are the only source of excitation inherent to the spinal locomotor network. Understanding the mechanisms used by these interneurons to generate locomotor rhythm will allow the designing of novel pharmacological therapies and rehabilitation strategies, which may help to restore locomotor and postural function following spinal cord injury or disease affecting the spinal network.

### References

1. Grillner S (1981) Control of locomotion in bipeds, tetrapods, and fish. In: Brookhart JM, Mountcastle VB (eds) *Handbook of physiology. The nervous system II*, Am Physiol Soc. Bethesda, Maryland, pp 1179–1236
2. Pearson KG (2004) Generating the walking gait: role of sensory feedback. *Prog Brain Res* 143:123–129
3. Rossignol S (1996) Neural control of stereotypic limb movements. In: Rowell LB, Shepherd JT (eds) *Handbook of physiology. Exercise: regulation and integration of multiple systems*. Oxford University Press, New York, pp 173–216
4. Jordan LM (1998) Initiation of locomotion in mammals. *Ann NY Acad Sci* 860:83–93
5. Buchanan JT, Grillner S (1987) Newly identified ‘glutamate interneurons’ and their role in locomotion in the lamprey spinal cord. *Science* 236:312–314
6. Dale N, Roberts A (1985) Dual-component amino-acid-mediated synaptic potentials: excitatory drive for swimming in *Xenopus* embryos. *J Physiol* 363:35–59
7. Cavallari P, Edgley SA, Jankowska E (1987) Postsynaptic actions of midlumbar interneurons on motoneurons of hind-limb muscles in the cat. *J Physiol* 389:675–689
8. Wilson JM, Hartley R, Maxwell DJ, Todd AJ, Lieberam I, Kaltschmidt JA, Yoshida Y, Jessell TM, Brownstone RM (2005) Conditional rhythmicity of ventral spinal interneurons defined by expression of the Hb9 homeodomain protein. *J Neurosci* 25:5710–5719
9. Grillner S (2003) The motor infrastructure: from ion channels to neuronal networks. *Nat Rev Neurosci* 4:573–586
10. Kiehn O, Kullander K (2004) Central pattern generators deciphered by molecular genetics. *Neuron* 41:317–321
11. El Manira A, Kettunen P, Hess D, Krieger P (2002) Metabotropic glutamate receptors provide intrinsic modulation of the lamprey locomotor network. *Brain Res Brain Res Rev* 40:9–18
12. Nusbaum MP, Blitz DM, Swensen AM, Wood D, Marder E (2001) The roles of co-transmission in neural network modulation. *Trends Neurosci* 24:146–154

## Excitatory GABA

► Chloride Homeostasis and Development

## Excitatory Postsynaptic Potential (EPSP)

### Definition

Depolarization of the postsynaptic membrane potential by the action of a synaptically released neurotransmitter. Usually reflects release from a population of presynaptic fibers but it can be evoked by a single presynaptic fiber.

► Synaptic Transmission: Model Systems

## Excitatory Synapse

### Definition

The synapse exhibits the feature that presynaptic stimulation increases the excitability of a postsynaptic cell. At excitatory synapses, transmitter binds to the postsynaptic receptors, allows cations to enter the cell, and drives the membrane potential toward the threshold.

► Synaptic Transmission: Model Systems



## Excitotoxic Lesions

### Definition

Excitotoxins are analogues of glutamate that bind to glutamate receptors and cause unregulated influx of calcium into neurons, killing them. Different excitotoxins bind to the various different glutamate receptors – which excitotoxin will be most effective in a given brain area will depend upon the prevalence of different glutamate receptor types there. The value of excitotoxins is that, because glutamate receptors are found on the somatic not axonal portions of neurons, they make lesions of neurons while sparing fibers of passage in the region of effect.

► Mesopontine Tegmentum

## Excitotoxicity

### Definition

Neurodegeneration caused by over-activation of excitatory neurotransmitter-gated ion-channels (such as the glutamate-gated NMDA receptor), which then permits lethal levels of ions to enter the cell.

► Effects of Alcohol on the Brain

## Excitotoxin

► Domoic Acid Neurotoxicity

## Executive Attention

### Definition

Executive attention is a part of the attentional control system. Many models of executive attention assume a set of schemas with goals and actions that can be executed without interference of executive attention. Executive attention interferes with ongoing activity of these schemas, when the schemas fail to reach the goal, errors are made, preset responses have to be inhibited. If two or more tasks have to be executed at the same time, executive attention is also involved. Executive attention is thought to

have a limited capacity and be coordinated by neurons in the cingulate gyrus and dorsolateral prefrontal cortex.

► Attention

## Exercise

### Definition

Exercise can be defined as physical activity that is a planned, structured movement of the body designed to enhance physical fitness. Regimented or purposeful exercise consists of a program that includes 20–60 min of activity at least 3–5 days a week. Some examples of this type of activity include walking, running, cycling, or swimming. For athletes, exercise training programs are sport-specific and are considered according to intensity and volume. Scientists investigated “acute” or “chronic” exercise effects. Exercise may be classified in one of two categories, anaerobic and aerobic, depending on where energy is derived from. There is a distinct difference between the two, and specific training techniques are used to enhance both. Anaerobic exercise does not require oxygen for energy. This is due to the intensity and duration of anaerobic events, which typically are high intensity and last only a few seconds to a minute or two. These activities range from a tennis serve to an 800-m run. Aerobic exercise does require oxygen for energy. This is observed during exercise that is less intense but of longer duration. This energy system is primarily used during events lasting longer than several minutes, such as a 2-mile run or the Tour de France bicycle race or prolonged running races. The potential does exist that one can use both systems, as in soccer, where a match requires 90 min of continual activity with short intense bursts of effort.

► Autonomic Function and Exercise

► Stress Effects During Intense Training on Cellular Immunity

## Exocyst Complex

### Definition

A large protein complex (e.g. single copies of eight different subunits) required for polarized exocytosis, likely functioning at the stages of vesicle targeting/tethering.

► Synaptic Proteins and Regulated Exocytosis

## Exocytosis

MASAMI TAKAHASHI, TERUO ABE  
Department of Cellular Neurobiology, Brain Research  
Institute, Niigata University, Niigata, Japan

### Definition

A process in which the membrane of a membrane vesicle fuses with the plasma membrane, resulting in secretion of the vesicle content to the cell exterior. In this process, the lipids in the two membranes mix with each other, eventually forming a single membrane. The content of the vesicle varies from cell to cell: small organic molecules, peptides, proteins and other molecules. These secreted molecules could be used for communicating with other cells or could just be unwanted or harmful materials. From yeast to human, most, if not all, cells are capable of exocytosis, demonstrating that the process is important for the cell. Importantly, recent studies have shown that exocytosis is involved in the insertion of plasma membrane proteins.

### Characteristics

#### Quantitative Description

Small synaptic vesicles fuse with the plasma membrane and release their contents (neurotransmitters) in less than 1 ms of the arrival of an action potential at the nerve terminal. ► **Synaptic vesicle** (SV) exocytosis is triggered by  $\text{Ca}^{2+}$ -influx through voltage-sensitive Ca channels [1]. A major part of the above time is spent for Ca channel opening.

#### Higher Level Structures

Nerve terminal.

#### Lower Level Components

SVs, presynaptic membrane, active zone.

#### Higher Level Processes

Synaptic transmission.

#### Lower Level Processes

Exocytosis consists of four steps: ► **docking**, ► **priming**, fusion and recycling [1].

#### Docking

SVs must first be attached to the plasma membrane (docking). The molecular mechanism of this docking is unknown. Since SVs are only attached to the plasma membrane at the active zone, some component(s) of the active zone must be involved in docking. However, such component(s) have not yet been identified. The cytosolic protein nSec1/Munc18-, which binds to

► **syntaxin 1** seems to contribute to synaptic vesicle docking, as docked SVs are decreased in mice lacking the protein. In many CNS synapses, less than 10 SVs are docked per active zone, and only 0 to a few SVs are released at a time.

#### Priming

Docked SVs are not immediately available for exocytosis. They need to be activated to become fusion-competent. This process is called priming. Although the mechanism of priming is not clarified, it possibly involves conformational changes of ► **SNARE** proteins (syntaxin 1, ► **SNAP-25** and VAMP/syntaxin, referred to as VAMP hereafter) that are directly involved in synaptic vesicle exocytosis. In the closed conformation, N-terminal autoinhibitory domain masks the region consisting of about 70 amino acid residues (SNARE motif) adjacent to the transmembrane segment at the C-terminal. SNARE motifs are critical to SNARE complex formation and subsequent ► **membrane fusion**. The cytosolic protein nSec1/Munc18-1 is proposed to keep syntaxin 1 in this closed conformation, preventing complex formation between syntaxin 1 and the other two SNARE proteins [2]. The closed conformation can be converted to the open conformation by the active zone protein Munc13-1 by exposing the SNARE motif, enabling syntaxin 1 to interact with SNARE motifs of SNAP-25 and VAMP. The complex of syntaxin/SNAP-25/VAMP in the molar ratio of 1:1:1, called the ternary or core complex, plays a pivotal role in membrane fusion.

#### Fusion

One SNARE motif from each of syntaxin 1 and VAMP, and two motifs from SNAP-25 form a parallel four-bundle helix (trans-SNARE complex) [3] (Fig. 1).

It is generally postulated that helix bundle formation starts from the N-terminal regions, extending toward the C-termini of the three proteins like a zipper. This zipper-like, very stable structure pulls the SV membrane and the plasma membrane together, eventually leading to membrane fusion. In the presence of the cytoplasmic domain of ► **synaptotagmin 1** (a  $\text{Ca}^{2+}$ -binding protein in the SV membrane), liposomes containing syntaxin 1/SNAP-25, and those containing VAMP fuse with each other in a  $\text{Ca}^{2+}$ -dependent manner, suggesting that these proteins represent minimal machinery for membrane fusion in  $\text{Ca}^{2+}$ -triggered SV exocytosis [4,5]. However, it cannot be excluded that some other protein(s) also participate in the fusion reaction in vivo. The small cytosolic protein ► **complexin (synaphin)** that binds to the SNARE complex promotes membrane fusion, possibly by stabilizing or oligomerizing it. Very recent studies indicate that SVs in the CNS synapses exhibit at

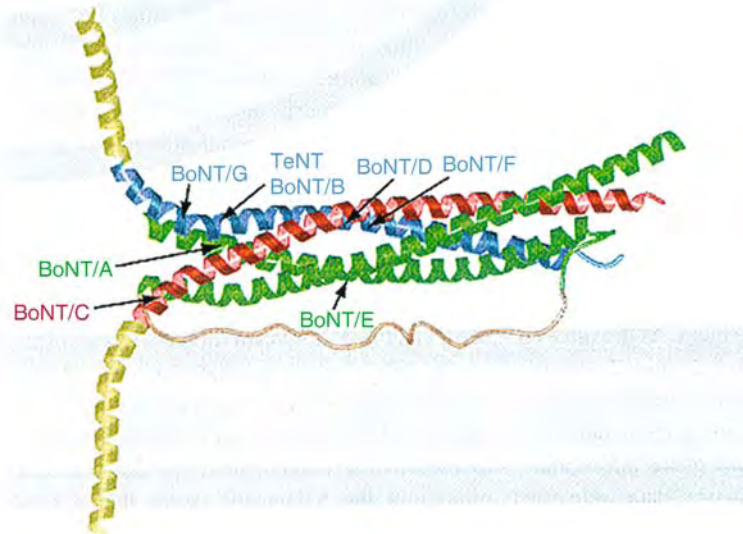

**Exocytosis. Figure 1** A model of ternary complex of SNARE proteins at the synapse. SNARE motifs are shown in *blue* (synaptobrevin/VAMP), *red* (syntaxin 1) and *green* (SNAP-25). Lipid bilayers of synaptic vesicle membrane (*above*) and presynaptic terminal plasma membrane (*below*) are depicted in gray. The sites cleaved by botulinum neurotoxin (BoNT, type A to G) and tetanus toxin (TeNT) are also shown. These neurotoxins are  $Zn^{2+}$ -metalloproteases that potently inhibit neurotransmitter release by specifically cleaving the SNARE proteins. Reproduced from [3] with permission.

least two types of exocytosis: full fusion and kiss-and-run [6,7]. In the latter, a small tube-like structure (►fusion pore with a diameter of 1–2 nm) temporarily forms between a SV and the plasma membrane. This aqueous fusion pore subsequently closes and SVs go back to the cytoplasm without fully collapsing into the plasma membrane. Although the fusion pore is rather small, they are sufficient to allow intravesicular small components (e.g. neurotransmitters like glutamate, GABA, norepinephrine, epinephrine, acetylcholine etc.) to leave SVs. Whether these fusion pores contain proteins in addition to lipids is not established. The kiss-and-run mechanism has a definite advantage of very rapid recycling of SVs.

### **Ca<sup>2+</sup>-Triggering of Release**

Depolarization of the nerve terminal opens voltage-sensitive Ca channels. In many synapses, Ca<sup>2+</sup> influx through P/Q- and/or N-type Ca channels are responsible for instantaneous rise of Ca<sup>2+</sup> concentration around the active zone that triggers SV exocytosis. Ca<sup>2+</sup> concentrations required for triggering neurotransmitter release vary from synapse to synapse in the range of 1  $\mu$ M to tens of  $\mu$ M. How do calcium ions trigger SV exocytosis? Synaptotagmin 1 (synaptotagmin 2 in some

synapses) acts as a major Ca sensor in the release process in the brain [8]. Synaptotagmin 1 binds SNARE complexes in a Ca<sup>2+</sup>-dependent manner. C2A and C2B domains of the protein bind three and two calcium ions, respectively. Low Ca<sup>2+</sup> affinities of the C2 domains dramatically increase when they bind phospholipids, roughly matching those required for SV exocytosis. However, the Ca<sup>2+</sup>-dependent binding of synaptotagmin 1 to SNARE complex may not be essential for triggering SV exocytosis, because strontium ions that do not facilitate SNARE complex binding of synaptotagmin 1 can trigger SV exocytosis [8]. None of the Ca<sup>2+</sup>-dependence of synaptotagmin functions including membrane insertion, oligomerization and SNARE binding exactly matches that of the neurotransmitter release rate [9]. Thus, the mechanism of synaptotagmin 1 action leading to SV exocytosis remains unclear.

### **Recycling Function**

After exocytosis, the cytosolic proteins ►NSF (N-ethylmaleimide-sensitive factor) and ►alpha-snap (alpha-soluble NSF attachment protein) bind to the cis-SNARE complex, and dissociate each SNARE protein

for reuse. In this reaction, ATPase activity of NSF is required. Exocytosed SVs are recovered by endocytosis. At least three mechanisms of SV endocytosis exist: very rapid endocytosis without endosomal intermediate, and clathrin-coated pathway with or without endosomal intermediate. SVs become refilled with neurotransmitter molecules by vesicular transporters, and regenerated SVs can be used again.

Function: SV exocytosis releases neurotransmitters towards postsynaptic receptors, thereby transmitting information to the postsynaptic cell. Thus, it links presynaptic action potentials to postsynaptic neurotransmitter receptors by means of chemical substances.

### Advantages of Exocytosis

Two types of secretion by exocytosis occur in the cell: constitutive and regulated. The former takes place constantly, and the latter is triggered only when a specific external or internal stimulus is given. Neurotransmitter release from the nerve terminal is an example of regulated secretion. It is triggered by the influx of external  $\text{Ca}^{2+}$ . Membrane vesicles to be exocytosed contain large amounts of specific, physiologically active substances. Trapped in membrane vesicles, these substances are protected from modifications by cell components. Thus, membrane vesicles to be exocytosed could serve as safe reservoirs for such substances. Since many membrane vesicles that contain the same substances usually exist in a cell and are released by exocytosis, the cell can liberate a large amount of such substances in a very short time, especially in regulated exocytosis. Thus, exocytosis could quickly achieve a high external concentration of such substances, facilitating rapid reaction(s) in target cells.

### Intracellular Membrane Vesicle Transport

Membrane proteins are transported in small membrane vesicles from their site of synthesis to the place where they function. For instance, plasma membrane proteins are usually transported from endoplasmic reticulum to Golgi apparatus to plasma membrane. At each of these compartments, a part of membrane containing a set of particular plasma membrane proteins buds from the membrane and form vesicles. These vesicles are transported to the next compartment, and fuse with its membrane, transferring the proteins to the compartment. This fusion, though a purely intracellular event independent of  $\text{Ca}^{2+}$ , takes place in a very similar manner as that between an intracellular vesicle with the plasma membrane. In fact, NSF, snaps and SNARE proteins were identified as components of transport systems in the studies on intracellular membrane transport [10]. In other words, SV exocytosis can be regarded as a specific form of intracellular membrane

transport. Many isoforms of syntaxin and VAMP exist, and one of these isoforms acts in each transport route. However, only SNAP-23 exists as an isoform of SNAP-25. Combinations of these SNARE proteins seem to specify the transport route.

### Pathology

In Lambert-Eaton myasthenic syndrome (LEMS), antibodies against P/Q-type Ca channels of the motor nerve terminal are produced. These antibodies decrease  $\text{Ca}^{2+}$ -influx, resulting in impaired neurotransmitter (acetylcholine) release. LEMS is often associated with small cell lung cancer.

### ► Non-Synaptic Release

## References

1. Katz B (1969) The release of neural transmitter substances. Liverpool University Press, Liverpool
2. Dulvova I, Sugita S, Hill S, Hosaka M, Fernandez I, Sudhof TC, Rizo J (1999) A conformational switch in syntaxin during exocytosis: role of munc18. *EMBO J* 18:4372–4382
3. Sutton RB, Fasshauer D, Jahn R, Brunger AT (1998) Crystal structure of a SNARE complex involved in synaptic exocytosis at 2.4 Å resolution. *Nature* 395:347–353
4. Weber T, Zemelman BV, McNew JA, Westermann B, Gmachl M, Parlati F, Sollner TH, Rothman JE (1998) SNAREpins: minimal machinery for membrane fusion. *Cell* 92:759–772
5. Weber T, Chapman ER (2004) Reconstitution of  $\text{Ca}^{2+}$ -regulated membrane fusion by synaptotagmin and SNAREs. *Science* 304: 435–438
6. Gandhi SP, Stevens CF (2003) Three modes of vesicular recycling revealed by single-vesicle imaging. *Nature* 423: 607–613
7. Aravanis AM, Pyle JL, Tsien RW (2003) Single synaptic vesicles fusing transiently and successively without loss of identity. *Nature* 423: 643–647
8. Sudhof TC (2004) The synaptic vesicle cycle. *Annu Rev Neurosci* 27:509–547
9. Augustine GJ (2001) How does calcium trigger neurotransmitter release? *Curr Opin Neurobiol* 11: 320–326
10. Sollner T, Whiteheart SW, Brunner M, Erdjument-Bromage H, Geromanos S, Tempest P, Rothman JE (1993) SNAP receptors implicated in vesicle targeting and fusion. *Nature* 362:318–324

## Exocytotic Cycle

### ► Synaptic Proteins and Regulated Exocytosis

## Exon

### Definition

Exon is protein encoding DNA sequence. Any DNA sequence that is transcribed and not spliced out of the final mRNA message.

Exon is protein encoding DNA sequence. Any DNA sequence that is transcribed and not spliced out of the final mRNA message.

## Expectancy Effect

► [Placebo Analgesic Response](#)

## Expectation Maximization

### Definition

A principle of statistical estimation from data with missing values proposed by A. P. Dempster. The maximum likelihood estimate is incrementally obtained by repeating the expectation step (e-step) and the maximization step (m-step).

► [Competitive Learning Theory](#)

## Experience

### Definition

Experience in a phenomenal sense is a conscious event such as a feeling of pain or a sensation of something red. Experience in a cognitive sense is knowledge that results from the conceptual processing of a perceptual input, e.g. the experiential knowledge that there are seven bottles of beer in the fridge. The acquisition of experiential knowledge may also be called experience. Empiricism is the view that all knowledge is due to experience.

- [Argument](#)
- [Consciousness, Phenomenal](#)
- [Logic](#)

## Experience with Natural Images as a Basis for Vision

DALE PURVES

Center for Cognitive Neuroscience and Department of Neurobiology, Duke University, Durham, NC, USA

### Definition

The phrase “natural images” refers to ► [images](#) projected onto the ► [retina](#) by light reflected from objects in typical visual environments.

### Characteristics

#### Defining the Problem

Despite much effort over the last century, visual perception is not understood in either psychological or neurobiological terms. Most thinking about this issue has been predicated on the seemingly obvious intuition that the ► [visual system](#) detects, represents and reports the physical features of stimuli and their sources in the world.

However, a growing body of evidence suggests that ► [visual percepts](#) may be generated in a quite different way. The alternative concept is that visual percepts depend on and ultimately represent accumulated ► [empirical](#) experience with light stimuli arising from natural scenes rather than the physical characteristics of the stimuli or their sources as such. The basis of this perspective is the inevitable ambiguity of information in retinal images, and the fundamental challenge presented by this “inverse optics problem” (Fig. 1).

Historically, exploring vision in terms of ► [feature detection](#) has used simple stimuli presented to anesthetized cats or monkeys in the laboratory while recording the electrophysiological responses of single neurons at different levels of the visual system. In contrast, exploring vision in empirical terms has depended on reports of what human subjects actually see, using analyses of natural images to predict perceptual functions. The purpose of this article is to compare and contrast these approaches to explaining vision, which must eventually be brought together if vision is to be understood.

#### Vision Explained in Terms of Feature Detection

The classical studies of David Hubel and Torsten Wiesel begun in the late 1950s and proceeding through the early 1980s showed that neurons in the primary visual pathway (which includes the retina, ► [lateral geniculate nucleus](#) of the ► [thalamus](#) and the ► [primary visual cortex](#) in the ► [occipital lobe](#)) respond selectively to stimuli with particular characteristics [2]. These neuronal properties define each cell’s ► [receptive field](#).

Investigators have now studied the receptive field characteristics of visual neurons at different levels of the visual system in a variety of species, focusing on non-human primates such as rhesus monkeys. Neurons in the primary and higher order visual cortices of such animals respond selectively to stimulus orientation, direction of movement, speed of movement, spectral characteristics and ►binocular disparity.

Moreover, some neurons in visual cortical areas in the ►temporal lobe respond selectively to more complex stimulus characteristics such as shape and texture, and even to patterns associated with specific objects such as faces. These studies have all reinforced the idea that the primary function of visual neurons is to detect and represent stimulus features in retinal images.

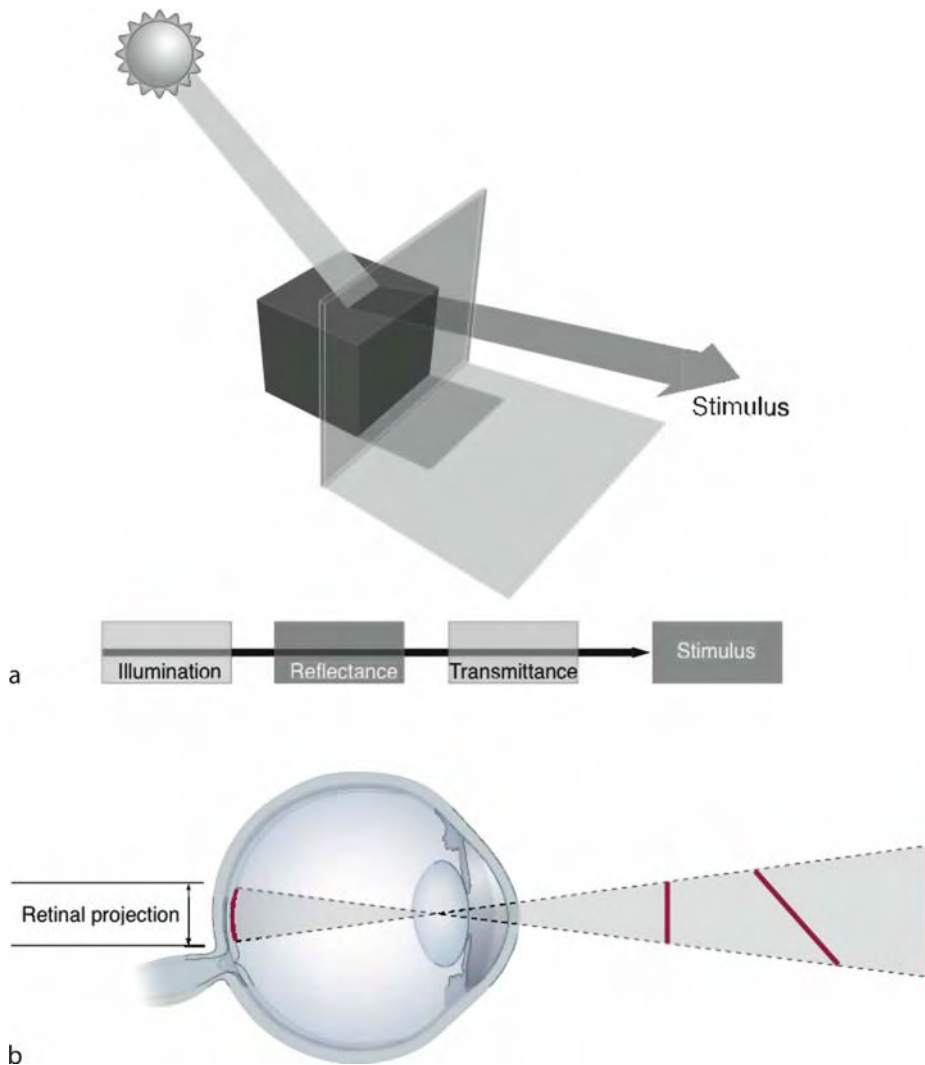

**Experience with Natural Images as a Basis for Vision. Figure 1** A fundamental problem in biological vision is the necessarily uncertain relationship between the information in the images that fall on the retina and their real-world sources. (a) Conflation of the factors that determine the amount and spectral quality of light falling on the retina. Illumination depends on the properties of a source like the sun; the reflectance of objects depends on their physical composition; and transmittance depends on the amount and quality of the atmosphere intervening between an object and the observer (as well as between the source of illumination and the illuminated objects). These basic factors that together determine the luminance and spectral distribution of any stimulus at the eye cannot be disentangled by analysis of the retinal image as such. (b) The problem is much the same in the perception of geometry, since the spatial properties of three-dimensional objects are also conflated when the light reflected from them is projected onto a plane. The diagram shows that the same retinal projection can be generated by objects of different sizes at different distances from the observer, and in different orientations. Again, there is no logical way to disentangle these factors by analysis of the retinal image [1].

### Vision Explained in Terms of Filters

A somewhat different and not mutually exclusive approach to understanding receptive field properties is based on the idea that visual neurons act as filters. This line of thought was initiated by Fergus Campbell and John Robson in the late 1960s and is predicated on Fourier's theorem [3]. This theorem shows that any continuous periodic function can be decomposed into a set of sinusoids and that the original function can be reconstructed from this set. ► **Fourier analysis** had been used to explain how the basilar membrane of the inner ear extracts frequency components from complex sound signals, and, as Campbell and Robson recognized, the same idea can be applied to images. Any image can be decomposed into a set of sinusoidal gratings with different spatial frequencies, and by reversing the process the image can be reconstructed from this spectrum.

This conception of neuronal function seemed promising in that it explained some otherwise puzzling psychophysical findings and suggested how the visual system might actually analyze complex natural images. For example, when human observers are presented with image patterns of alternating dark and light stripes, the minimal level of ► **contrast** between the stripes required to detect the pattern varies according to the spatial frequency of the stripes, defining the so-called

“contrast sensitivity function.” In this framework, the function would arise from the different contrast sensitivities of these filters. Visual neurons would thus encode the spatial frequency of the area of the image falling within their receptive fields, operating as Fourier analyzers. This result, together with evidence that cells in the primary visual cortex are tuned to different spatial frequencies, supported the idea that the local spatial frequency analyzers (filters) are important in visual processing. This conception has been extended to moving stimuli by the further suggestion that motion selective neurons function as spatio-temporal filters, thus analyzing the frequency structure of the retinal stimulus over time as well as space.

### Vision Explained in Terms of Past Experience with Natural Images

Despite these advances, explaining visual percepts in terms of receptive field properties has been frustrated by the persistent inability to relate the electrophysiological responses of visual neurons to the range and peculiarity of the psychophysical functions that have been established over the years. An example is the odd way humans perceive the lightness of a surface or the brightness of a light source, which has repeatedly found to be dependent on the detailed context of the surface or source being examined. As shown in Fig. 2, this

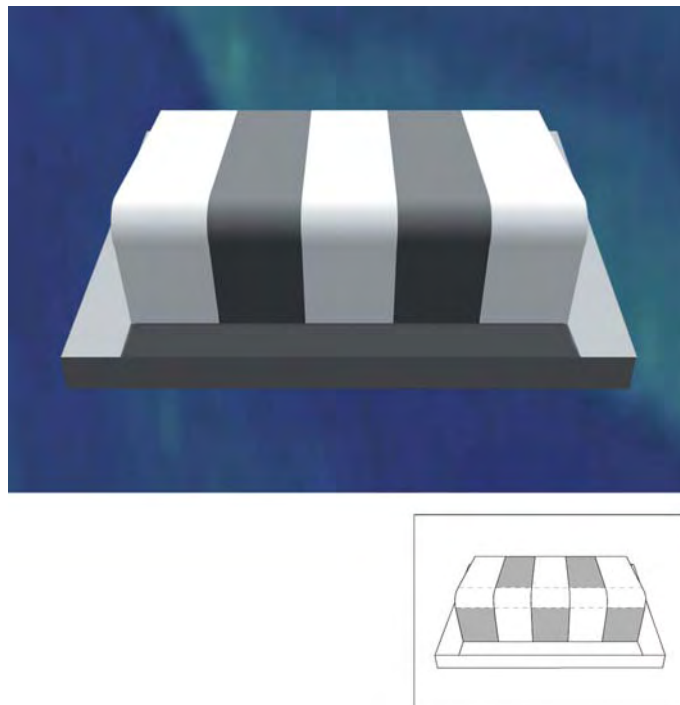

**Experience with Natural Images as a Basis for Vision. Figure 2** The dependence of visual perception on the contextual relationships in scenes. Although the indicated patches in the inset are physically identical, a dramatic perceptual difference between them is generated by empirical information in the scene [4].

dependence can make the same gray surface in a stimulus look either nearly black or nearly white. Although some specific lightness or brightness effects can be explained on an ad hoc basis, there has been no consensus about how such perceptual phenomena in general are linked to the receptive field properties of neurons at the various processing stations of the visual system.

Given this impasse, another approach to rationalizing visual percepts has focused on the challenge of the quandary illustrated in Fig. 1, and the possible ways the visual system could relate natural images to their real-world sources as a means of contending with the inverse problem [1,4,5]. In this framework the concept of vision as detecting and representing image features is abandoned in favor of the idea that the connectivity of the visual system has evolved to link images, their sources and visually guided responses on a wholly empirical basis. The supposition is that the percept elicited by any particular stimulus parameter (e.g., the lightness or brightness elicited by the luminance of a stimulus; see Fig. 2) corresponds to the relative frequency of occurrence of the relevant stimulus parameter (e.g., the luminance of any part of a natural scene) in relation to all other instances of that parameter experienced in the past.

Thus the lightness perceived in response to the luminance of a surface in a visual scene would be determined by how often the specific luminance had occurred relative to all the other luminance values experienced in that context. Visual percepts are thus conceived as statistical constructs that have no direct correspondence to the possible real-world sources of a stimulus; they are subjective sensations that link visual stimuli to the empirical significance of their sources according to the success or failure of visually guided behavior in the past.

A number of neurobiological observations suggest that visual circuitry could indeed be subserving this sort of empirical strategy as a way of contending with the inverse problem [6,7,8,9]. For example, enhanced responses to contrast boundaries as well as color responses are correlated with the basis functions of efficient statistical representations of natural images. Moreover, some anatomical characteristics of the primary visual cortex, e.g., preferential horizontal connections between neurons tuned to similar orientations, are also consistent with the incorporation of natural image-source statistics. Recent evidence suggests that neurons involved in decision making in other brain regions also operate probabilistically [10].

### Implications

The challenge of the inverse problem presents visual systems with a daunting problem: humans or other highly visual animals must extract behaviorally useful information from images whose sources can't be known directly. This quandary implies that biological visual

systems must take advantage of the empirical links between the inherently ambiguous images and their possible generative sources in the real world. In this view, this empirical information is gradually accumulated in the structure and function of evolving visual system circuitry as a result of the benefits of successful visually guided behavior. As a result, patterns of light on the retina activate circuitry that, over the millennia, has come to represent biologically useful constructs elicited as reflex responses to stimuli. The experimental support for this way of understanding vision is simply its ability to predict anomalous percepts of brightness, color, form and motion that have been difficult to explain in any other way. If this concept of vision is correct, then the detailed structure and function of visual system circuitry gleaned over the last half-century – i.e., the receptive field properties of visual neurons – will need to be rationalized in terms of this framework, which appears to be demanded by the challenge of the inverse problem.

### References

1. Howe CQ, Purves D (2005) *Perceiving geometry: geometrical illusions explained by natural scene statistics*. Springer, Berlin Heidelberg New York
2. Hubel DH, Wiesel TN (2006) *Brain and visual perception: the story of a 25-year collaboration*. Oxford University Press, Oxford
3. Campbell FW, Robson JG (1968) Application of Fourier analysis to the visibility of gratings. *J Physiol* 197:551–566
4. Purves D, Lotto B (2003) *Why we see what we do: an empirical theory of vision*. Sinauer, Sunderland, MA
5. Howe CQ, Lotto RB, Purves D (2006) Empirical approaches to understanding visual perception. *J Theor Biol* 241:866–875
6. Olshausen BA, Field DJ (1996) Emergence of simple-cell receptive field properties by learning a sparse code for natural images. *Nature* 381:607–609
7. Bell AJ, Sejnowski TJ (1997) The “independent components” of natural scenes are edge filters. *Vision Res* 37:3327–3338
8. Simoncelli EP, Olshausen BA (2001) Natural image statistics and neural representation. *Annu Rev Neurosci* 24:1193–1216
9. Wachtler T, Lee TW, Sejnowski TJ (2001) Chromatic structure of natural scenes. *J Opt Soc Am* 18:65–77
10. Yang T, Shadlen MN (2007) Probabilistic reasoning by neurons. *Nature* 447:1075–1080

---

## Experimental Allergic Encephalomyelitis (EAE)

### Definition

► Experimental Autoimmune Encephalomyelitis (EAE)



## Experimental Autoimmune Encephalomyelitis (EAE)

### Definition

Experimental autoimmune encephalomyelitis (EAE) is a widely used animal model of the human demyelinating disease multiple sclerosis (MS). EAE is generally induced in rodents or primates by either immunization with myelin antigens [e.g., myelin oligodendrocyte glycoprotein (MOG), proteolipidic protein (PLP), myelin basic protein (MBP), etc.] in adjuvant (active induction) or adoptive transfer of myelin-specific T cells (passive induction), resulting in inflammatory infiltrates, demyelination and axonal loss in the central nervous system (CNS). Induction of EAE typically results in ascending flaccid paralysis of limbs with inflammation and tissue damage primarily targeting the spinal cord.

- ▶ Autoimmune Demyelinating Disorders: Stem Cell Therapy
- ▶ Multiple Sclerosis
- ▶ Neuroendocrinology of Multiple Sclerosis

## Expiratory Neurons

### Definition

Respiratory neurons that receive phasic synaptic inhibition during the inspiratory motor phase of respiratory rhythm but otherwise discharge tonically in the interval between cranial (e.g., XII) or spinal (e.g., phrenic) nerve output.

- ▶ Anatomy and Function in the Respiratory Network

## Explanation (Deductive-Nomological, Mereological, Reductive)

MICHAEL ESFELD  
Department of Philosophy, University of Lausanne,  
Lausanne Switzerland

### Definition

An explanation seeks to enable us to understand a given phenomenon by indicating its cause or by tracing it

back to some general structure or pattern. The standard conception of explanation used to be the ▶ **deductive-nomological** model of covering laws. According to that conception, a given phenomenon is explained by deducing its description from a law plus a description of the particular circumstances in which the phenomenon in question occurs. The main conceptions today are explanation by referring to the ▶ **relevant causal factors** that bring about the phenomenon in question as well as ▶ **unificationism**: a phenomenon is explained by integrating its description into a general pattern of argument. Overall ▶ **unification** is achieved by reducing the number of independently acceptable hypotheses or argument patterns that one needs to explain the phenomena in the world.

A widespread idea how to explain phenomena and how to achieve the unification of descriptions at different levels is ▶ **mereological explanation**: the behavior of a system as a whole is explained by the intrinsic properties of its parts. Mereological explanation is a special case of ▶ **reductive explanation**: according to the ▶ **classical conception** of reduction, a theory of a higher level is reduced to a more fundamental theory by translating its concepts into the concepts of the more fundamental theory and then deducing its laws from the laws of the more fundamental theory. The multiple realization of higher level properties is the main objection to that conception. ▶ **Functional reduction** takes into account multiple realization by providing for a case by case reductive explanation of a higher level property by reference to the arrangement of lower level properties that realizes the higher level property in question on a given occasion.

### Description of the theory

#### Deductive-Nomological Explanation

The deductive-nomological model used to be the standard conception of explanation: one explains a phenomenon by deducing the description of the phenomenon from a law and a description of the particular circumstances in which the phenomenon in question occurs. This model has been developed within the context of the philosophy of science of logical empiricism, notably by Carl Gustav Hempel (1905–2001) ([1], Chap. 12, Sect. 2). It takes the following form:

$C_1, C_2, \dots, C_k$  Statements describing particular conditions

$L_1, L_2, \dots, L_k$  Statements of laws of nature

$E$  Statements describing the phenomenon to be explained (the explanandum)

The law statements are of universal application. They do not contain any terms referring to individuals. In order to derive from them a description of individual phenomena, a description referring to a particular situation is necessary. One may envisage applying the

deductive-nomological model to the law statements themselves, thus seeking to explain phenomenological laws, such as the one in the example mentioned above, by more general laws; it is, however, questionable whether the deductive-nomological model permits in general an explanation of the laws themselves (compare [1], Chap. 10, p 273 note 33).

### Problems of the Deductive-Nomological Model

The deductive-nomological model faces a number of problems.

1. First, it presupposes a clear distinction between statements of laws and statements of accidental regularities. Consider the following example:

- (a) This thing is a cube of gold (Au).
- (b) All cubes of gold (Au) have a diameter of less than hundred meters.
- (c) This thing has a diameter of less than hundred meters.

The fact that the thing in question is made of gold does not explain its size. The deductive-nomological model of explanation cannot distinguish between statements of laws and statements of accidental regularities (such as the one about the diameter of gold cubes), for the logical form of both these types of statements is the same. It therefore simply has to presuppose that a distinction between statements of laws and statements of accidental regularities is available that does not reside in the logical form of these statements.

2. Even if the second premise of the mentioned example were a law, the problem would not have been solved. For the law to be explanatory it has to be relevant to the phenomenon that is to be explained without stating anything that is not relevant. Consider the following example:

- (a) This stick is partially submerged in water.
- (b) All sticks partially submerged in water look bent.
- (c) This stick looks bent.

Suppose that on a given occasion, a stick is partially submerged in water that has been blessed by a priest. Adding this fact contributes nothing to the explanation, but fits the deductive-nomological model:

- (a) This stick is partially submerged in a container of water blessed by a priest.
- (b) All sticks partially submerged in water blessed by a priest look bent.
- (c) This stick looks bent.

3. Moreover, explanation is asymmetric. If *A* explains *B*, *B* cannot explain *A*. However, the deductive-nomological model does not satisfy this condition. Consider the following example: a flagpole of a certain height casts a shadow of a certain length. Given the position of the sun and laws about the rectilinear propagation of light, the height of the flagpole explains the

length of the shadow. However, given the position of the sun, the relevant laws and the length of the shadow, we can also deduce the height of the flagpole. But the length of the shadow does not explain the height of the flagpole.

In view of these problems the deductive-nomological model is accepted as a starting point, but all sides agree that changes to this model are called for.

### Corrections of the Deductive-Nomological Model

There are three main types of changes suggested in the contemporary literature that may supersede the deductive-nomological model:

1. **Causal explanation:** an explanation has to mention the causally relevant factors that bring about the phenomenon to be explained, and only these factors [2]. For instance, in the examples mentioned above, the height of the flagpole causes the shadow, but the shadow does not cause the height of the flagpole, and the fact that a priest blessed the water is causally irrelevant to the stick looking bent. In what way this conception of causally relevant factors is worked out depends on the view that one takes in the metaphysics of causation. If one regards causation as being tied to laws, the causal conception of explanation can be seen as an amendment of the deductive-nomological model: the covering law has to be a causal law that refers to the causally relevant factors that produce the phenomenon that is to be explained.
2. **Unification:** the ultimate aim of explanation is unification. A phenomenon is explained by integrating its description into a general pattern of argument. For instance, Newton's three laws of motion and his universal law of gravitation explain a lot of phenomena, including the laws of earlier theories such as Kepler's, by showing how they fit into one general pattern. Thus, explanation by unification can be conceived as reducing the number of acceptable argument patterns ([3], Sect. 4). Explanation by unification is also conceived as reducing the number of independent phenomena that we have to accept as ultimate ([4], pp 14–15). Since these argument patterns involve laws, the view of explanation by unification can be seen as an improvement of the deductive-nomological model: the laws that figure in an explanation have to be such that they permit a unification.

Explanation by citing the causally relevant factors and explanation by unification capture salient features of explanation, but it is not the case that all explanations are causal or that all explanations proceed by unification. However, if it turns out to be possible to bring these two approaches together (as suggested by [2], Chap. 4), this may lead to a satisfactory theory of explanation.

3. ► *Pragmatic explanation*: any explanation is relative to the context in which the phenomenon that is to be explained occurs, including the interest and the knowledge of those who call for the explanation ([5], Chap. 5).

This third position in the current literature takes the objections to the deductive-nomological model to suggest that the search for a general scheme of explanation is futile. It thus stands in opposition to the two other mentioned positions.

### Mereological Explanation

According to a widespread view, we understand a complex system by considering the things which are its parts taken separately. This is mereological explanation (derived from the Latin word “meros,” that is to say, “part”). This conception can be traced back at least to Thomas Hobbes, notably the preface to *De cive* (1642).

The idea is that (i) by considering the parts taken separately, that is, by considering their intrinsic properties, we can understand the way in which the parts interact and that (ii) if we understand the way in which the parts interact, we can understand the properties of the whole. This idea presupposes that (i) the relations among the parts supervene on their intrinsic properties and that (ii) the properties of the whole supervene on the relations among the parts and their intrinsic properties.

Both these presuppositions are called into question in contemporary philosophy of science. As regards the first presupposition, it is evident that the properties of the whole depend on the spatial arrangement of the parts, but the spatial arrangement of the parts does not supervene on their intrinsic properties. Furthermore, it is questionable whether causal relations supervene on intrinsic properties (this depends on whether these relations can be traced back to dispositions and whether dispositions are – or supervene on – intrinsic properties). Moreover, our current most fundamental physical theory, quantum theory, is widely received as showing that the fundamental properties of physical systems are not intrinsic properties, but consist in certain relations, namely the relations of quantum entanglement.

As regards the second presupposition, a number of properties of a complex system depend not only on the properties of the parts, but also on the environment of the system. For instance, the biological property of fitness of an organism crucially depends on the environment. Two organisms that are alike internally can differ in fitness because they live in different environments. For these reasons, mereological explanation in the narrow sense that can be traced back to Hobbes is not a viable option.

### Reductive Explanation

Mereological explanation is a kind of reductive explanation. But the notion of reductive explanation is wider than the mentioned one of mereological explanation. It is not committed to the view of basic properties that are intrinsic properties. Reductive explanation concerns in the first place the relation between the concepts of different theories. The ultimate aim is to achieve theory unification. There is a theory  $T_1$  that explains one class of phenomena and we wonder how this theory is related to another theory  $T_2$  that explains a wider range of phenomena.  $T_2$  hence is a more fundamental theory that covers the domain of  $T_1$  as a special case. In the last resort,  $T_2$  is a fundamental and universal theory of physics. According to the classical conception of theory reduction ([6], Chap. 11), we reduce  $T_1$  to  $T_2$  by (i) constructing biconditional links between the concepts of  $T_1$  and concepts of  $T_2$  and by (ii) deducing the laws of  $T_1$  from the laws of  $T_2$ . In order to gain biconditioned links, bridge principles are needed that establish an identity of extension between the concepts of  $T_1$  and concepts that can be defined within  $T_2$ .

The main objection to this conception is that no such identity of extension can be achieved due to the multiple realization of higher level properties. Higher level properties – such as biological properties, neurophysiological properties, psychological properties – typically are functional properties, that is, properties which are defined by the characteristic causes and effects of their instantiations. Functional properties admit of multiple realization. That is to say, one and the same functional property can be implemented by arrangements that are composed in different manners of – in the last resort – instantiations of fundamental physical properties. Thus, for instance, the same type of gene can be realized by different sequences of bases in the DNA (or the RNA), a mental property such as pain may be realized by neural states of type  $N$  in humans, but it is realized in a different way in octopuses, etc. [7].

Nonetheless, there is a conception of reductive explanation available that accommodates multiple realization, namely functional reduction [8]. It is in principle possible to identify in each case the realizer of a given instantiation of a functional property. That realizer may include the environment of the system. The way in which the parts of the realizer interact explains how there can be an instantiation of a certain functional property, explaining how there can be the cause and effects that characterize the functional property in question. This is a reductive explanation without an overall theory reduction.

However, on that basis, attempts have been made in recent years to develop functional reduction into a fully-fledged theory reduction. (i) The stream known as

new wave reductionism seeks to construct for each higher-level theory of a special science several physical theories that wrap the special science theory in question for a particular domain or species; consequently, the higher-level theory can be replaced by these physical theories [9]. Furthermore, (ii) one can seek to make the higher-level functional concepts more precise so that functional sub-types are gained that are no longer multiply realizable; the aim there is to get to a conservative theory reduction by means of biconditional links [10]. In any case, explanation by theory reduction against the background of functionalism is one of the central topics of the current discussion.

## References

1. Hempel CG (1965) Aspects of scientific explanation. In: Hempel CG (ed) Aspects of scientific explanation and other essays in the philosophy of science. Free Press, New York, pp 331–496
2. Salmon WC (1998) Causality and explanation. Oxford University Press, Oxford
3. Kitcher P (1989) Explanatory unification and the causal structure of the world. In: Kitcher P, Salmon WC (eds) Minnesota studies in the philosophy of science, vol. XIII: Scientific explanation. University of Minnesota Press, Minneapolis, pp 410–505
4. Friedman M (1974) Explanation and scientific understanding. *J Philos* 71:5–19
5. van Fraassen BC (1980) The scientific image. Oxford University Press, Oxford
6. Nagel E (1961) The structure of science. Problems in the logic of scientific explanation. Routledge, London
7. Fodor JA (1974) Special sciences (or: The disunity of science as a working hypothesis). *Synthese* 28:97–115
8. Lewis D (1994) Lewis, David: Reduction of mind. In: Guttenplan, SH (ed) A companion to the philosophy of mind. Blackwell, Oxford, pp 412–413
9. Bickle J (1998) Psychoneural reduction: the new wave. MIT press, Cambridge (Massachusetts)
10. Esfeld M, Sachse C (2007) Theory reduction by means of functional sub-types. *International studies in the philosophy of science* 21:1–17

---

## Explanatory Gap

MICHAEL PAUEN  
 Institut für Philosophie, Humboldt-Universität zu  
 Berlin, Berlin, Germany

## Synonyms

Hard problem of consciousness

## Definitions

The “explanatory gap” [1] opens up between scientific explanations of neural processes on the one hand and conscious experience on the other, such that it is impossible, in principle, to account for the very existence and the specific quality of the latter in terms of the former. It is an ► *epistemic* problem that does not concern the relation between mental and neural processes themselves but, rather, the relation between ► *knowledge* concerning mental processes and ► *knowledge* concerning neural processes. Therefore, an explanatory gap may exist even if mental states are in fact physical states.

## Description of the theory

It seems intuitively highly plausible that the specific quality of mental experience, like the way it is to feel a pain or to have a sensation of red, cannot be accounted for in terms of knowledge about neural activity. The problem does not result from the imperfection of current neuroscience. Rather, it is a problem for neuroscientific knowledge in general. It would persist, even if we knew everything that can be known with respect to neurobiology.

The underlying intuition has already been articulated in ancient philosophy, it can be found in Leibniz’s Monadology and later in the work of the nineteenth century German physiologist Emil Du Bois-Reymond.

The recent discussion in the philosophy of mind has focused on two questions: (i) Can the underlying intuition be transformed into an intelligible claim and, if so, (ii) is it possible to reconstruct this claim as the conclusion of a sound argument? One of the basic difficulties that such an argument has to overcome is that it must hold, no matter how far scientific progress will reach in some distant future.

(i) It is now widely accepted that the central question is, whether a reductive explanation of mental properties in terms of general laws concerning the underlying physical properties can be given [2]. Reductive explanations account for the higher level properties of a system in terms of lower level laws that refer to the elements of the system. Thus, the freezing of water can be reductively explained in terms of general micro-physical laws concerning H<sub>2</sub>O-molecules. Reductive explanations of this sort face a general difficulty: They often try to account for higher-level properties which play no role in the lower-level laws they appeal to. As a consequence, so called “bridge laws” are needed in order to link the higher-level properties in the explanandum to the lower-level laws in the explanans.

Consequently, reductive explanations consist of two steps [2]. In the first step, the higher level property in the explanandum has to be linked by a bridge law to some lower level property that figures in the explanans. In a

second step, an explanation for the lower-level property in question has to be provided.

Bridge laws must not be empirical correlations because such correlations call for an explanation themselves, so the problem would only be transferred. What is needed is a conceptual connection between higher- and lower-level properties in a neutral language that applies to both levels of description. Given that causes and effects play a central role on all levels of scientific description, a so called “functional” account of the higher level property in terms of its typical causes and effects appears as the most promising candidate for such a bridge law [2]. So the functional description, say, of the freezing of water might mention that freezing is an effect of temperatures below 0°C, that it makes water less penetrable, that it prevents water from adapting to the walls of a receptacle it might be in etc. This list is certainly only the beginning of what might be a full blown functional account of “freezing,” but we have no reason to believe that such an account is impossible, in principle. Given such an account, any lower level property, say of H<sub>2</sub>O-molecules, that meets the functional criteria in question would have to be counted as a case of freezing.

In order to take the second step, the property in question would have to be explained with reference to some lower-level laws. Since such explanations are daily business in science, this step should raise no particular philosophical problems. The functional account would then provide the bridge law that links the higher-level property to be explained with the lower-level laws that figure in the explanation. This would complete the reductive explanation of the higher level property.

The answer to the first question regarding the central claim of the explanatory gap argument should therefore be clear: According to this claim, it is impossible, in principle, to provide a reductive explanation for the qualitative features of mental properties.

(ii) But what would be a sound argument in support of this claim? According to the above considerations, reductive explanations require bridge laws, and bridge laws, in turn, call for a functional account of the higher-level properties to be explained. If it can be demonstrated that certain mental properties cannot be captured by such a functional account, then this would result in an argument to the effect that these properties cannot be reductively explained. Given that this would be a purely conceptual argument which does not depend on the deficits of current scientific knowledge, the argument would seem to be unaffected by scientific progress.

Many proponents of the Explanatory Gap argument have argued that this is true for the qualitative or phenomenal character of mental states, the so called “qualia.” According to their view, it is impossible, in principle, to give a functional account of these qualia,

that is, of the way it is like to have a pain feeling or a red experience [1–5].

The evidence for this claim comes from a number of well known thought experiments which appeal to our conceptual intuitions with respect to phenomenal properties. Typically, these experiments demonstrate that the phenomenal aspects of mental states can be dissociated completely from their functional aspects. It is therefore impossible, in principle, to account for the phenomenal character in functional terms.

So, according to the “inverted spectrum” thought-experiment, it is conceptually possible that a physically and functionally identical twin of a person with normal color-vision has an inverted color experience, such that the inversion-twin has a green experience when she looks at a ripe tomato and a red experience when she looks at a cucumber. Note that these differences will in no way affect the inversion-twin’s behavior, not even with respect to color-discrimination: The twin, after all, has learned to describe the color of ripe tomatoes as “red” and the color of cucumbers as “green.” So given that there is no functional difference whatsoever that would allow us to discriminate between the person with normal-vision and the inversion-twin, it seems to follow that it is impossible, in principle, to capture the respective phenomenal experience in functional terms.

In a similar vein, it has been argued that the physical-functional twin of a conscious person may be a “zombie” who has no conscious experience at all. Given that there is no functional difference by definition between the conscious person and her zombie-twin, this would support the intuition that mental properties cannot be accounted for by functional properties.

It should be kept in mind that these thought experiments are only intended to explore our conceptual intuitions. Nobody believes, of course, in the existence of zombies and inversion twins. The claim is only that our phenomenal concepts are such that they permit these dissociations and therefore cannot be captured in functional terms.

Given that a functional account is required by a reductive explanation, it could be concluded that such an explanation is possible, no matter how far scientific progress might go.

## Conclusions

While it is almost uncontroversial that the failure of a reductive explanation of phenomenal properties would pose a problem for ►physicalism [1,3], it is unclear how severe the consequences might be. Nagel and particularly Levine concede that the problem might render physicalism less plausible, still they insist that this does not force us to reject it. This is so because physicalism makes a *metaphysical* claim about the entities that exist in our world. The explanatory gap argument, by

contrast, makes an *epistemic* claim about certain failures of the theories that try to explain those entities. Given that our theories or their conceptual framework may happen to be inadequate for whatever reasons, the failure of low level theories to account for high level properties would not permit the conclusion that the high level properties are no physical properties – provided, of course, that we have independent reasons to accept physicalism.

Other authors, however, argue that the problem leads to a rejection of physicalism. According to Jackson's ►[knowledge-argument](#) [4], physical knowledge does not comprise phenomenal properties. That is why Jackson thought that they cannot be physical properties. Another line of reasoning attacks the physicalist assumption that mental entities are identical with certain physical entities. As it has been demonstrated by Kripke, identity claims like the claim of psychophysical identity that employ rigid designators are either *necessarily* true or false. Given that the dissociation thought experiments show that psychophysical identity claims are not necessarily true, so the argument continues, they must be false and physicalism has to be given up.

### Objections

Several objections have been brought forward against the explanatory gap argument. According to the most radical objection, no such problem exists, to begin with. This may be so, because the existence of ►[qualia](#) is denied so that there is nothing left to be explained [6]. Those who accept the existence of qualia have tried to show that the alleged problem is based on a confusion that can be dissolved as soon as we understand an important implication of identity claims [7]: These claims need justification but there is no need and not even a possibility for explanation – how should we explain why something is itself? Others claim that the whole problem is based on an fallacious “argument from ignorance” that fails to account for future scientific developments. These developments might provide us with those explanations that now seem impossible [8]. Another line of attack tries to undermine the dissociation thought experiments. If psychophysical dissociations are possible, then they can affect any individual. However, given that the abilities to remember and recognize are certainly functional features, variations of phenomenal properties in the absence of any variation of functional features would make no difference to our memory. It would follow that we would be unable to remember and recognize those variations, no matter how often they occur. Apart from leading to absurd consequences, this would clearly undermine any knowledge with respect to phenomenal properties. But how could we ask for an explanation of properties that we have no knowledge of? [9] Finally, it is controversial whether reductive explanations of high-level properties

really are a standard in science. If they are not, then nothing really follows from our inability to provide reductive explanations for phenomenal properties [10].

### References

1. Levine J (1983) Materialism and qualia: the explanatory gap. *Pac Philos Q* 64:354–361
2. Kim J (1998) *Mind in a physical world. An essay on the mind-body problem and mental causation.* MIT Press, Cambridge, MA
3. Nagel T (1974) What is it like to be a bat? *Philos Rev* 83:435–450
4. Jackson F (1982) Epiphenomenal qualia. *Philos Q* 32:127–136
5. Chalmers DJ (1996) The conscious mind. In: Chalmers DJ (ed) *Search of a fundamental theory.* Oxford University Press, New York, Oxford
6. Dennett DC (1993) Quining qualia. In: Goldman AI (ed) *Readings in philosophy and cognitive science.* MIT Press, Cambridge MA, pp 381–414
7. Papineau D (1998) Mind the gap. *Nous* 32:373–388
8. Churchland PS (1996) The Hornswoggle problem. *J Consciousness Stud* 3:402–408
9. Pauen M (2006) Feeling causes. *J Consciousness Stud* 13(1–2):129–152
10. Block N, Stalnaker R (1999) Conceptual analysis and the explanatory gap. *Philos Rev* 108:1–46

---

## Explicit Memory

### Definition

Explicit memory refers to a memory with conscious recollection for specific facts and episodes. Difference between explicit or implicit memory depends on consciousness when retrieving information from the storage. Information examined by formal test of recall or recognition belongs to explicit memory. Explicit memory is synonymous with declarative memory.

- [Long-Term Memory](#)
- [Recognition Memory](#)

---

## Exploratory Behavior

### Definition

A constellation of behaviors that are expressed in a novel environment or when features of a familiar

environment are rearranged or otherwise changed. In a novel environment an animal will rear frequently, navigate around the boundaries and spend time near objects.

► Spatial Learning/Memory

## Exportin

### Definition

Exportin is a class of molecules involved in transporting molecules, in particular mRNA, out of the nucleus.

## Express Saccades

### Definition

A saccade elicited by the appearance of a new target after a distinctively shorter time ( $\approx 100$  ms) than regular saccades ( $>150$  ms) and yet having approximately normal accuracy. Their frequency of occurrence is idiosyncratic but mostly quite low in standard situations (current target disappearing upon presentation of new one) but can be primed by a gap period (current target off about 200 ms before new target appears) and by reduced uncertainty about target location. The study of express saccades supports the notion that an important, and time consuming, step among the processes leading to the generation of a new saccade is the release of attention and fixation from their current focus.

► Oculomotor Control

► Saccade, Saccadic Eye Movement

## Expression Profiling

### Definition

Expression profiling using microarrays the complement of genes expressed in a specific tissue or cell type can be compared between samples that differ by some critical variable (e.g. age, drug treatment, disease state, loss or gain of a gene's function).

## Extended Amygdala

GEORGE F. ALHEID

Department of Physiology, Northwestern University, Feinberg School of Medicine, Chicago, IL, USA

### Definition

The extended amygdala describes a large ►basal forebrain macrostructure encompassing a contiguous but heterogeneous collection in excess of 16 interconnected and functionally related neuronal aggregates, or subnuclei, extending from the centromedial amygdala to the bed nucleus of the stria terminalis. It is important to note that the definition of the extended amygdala does not encompass the large lateral-basolateral complex of the amygdala nor the superficial cortical amygdaloid nuclei, although the extended amygdala is one of the most important recipients of afferent input from these structures.

### Characteristics

#### Historical

On the basis of comparative and embryological studies (including human embryos) J. B. Johnston [1] proposed in 1923 that the centromedial amygdala, the bed nucleus of the stria terminalis, and neurons accompanying the stria terminalis formed a continuum in the basal forebrain of mammals, that was homologous to neurons accompanying the lateral forebrain longitudinal association bundle he observed in embryos and non-mammalian vertebrates. Embedded within Johnston's extensive treatise on the comparative anatomy of the amygdala and basal forebrain, this proposal did not persist in the anatomical literature, but was later revived and extended by de Olmos and colleagues in the 1980s. In addition to neurons accompanying the stria terminalis, the latter authors asserted that interconnecting neurons below the globus pallidus should be included as part of this lateral forebrain continuum, conceptualized as an "extension" of the central and medial amygdala into the basal forebrain [2], or alternatively as the "extended amygdala" [3].

### Functional Neuroanatomy

The central and medial nuclei of the amygdala lie just below the caudate putamen and globus pallidus (together the lenticular nuclei) in the medial part of the temporal lobe of mammals (Fig. 1). Rostrally, the borders of the central and medial amygdaloid nuclei are indistinct, and they merge dorsomedially with corridors of neurons in the "sublenticular" area that in turn merge with ventrolateral portions of the bed nucleus of the stria terminalis (Figs. 1 and 2). Neurons related to the amygdala accompany the stria terminalis as clusters, or interrupted columns of cells (the supracapsular bed nucleus of the

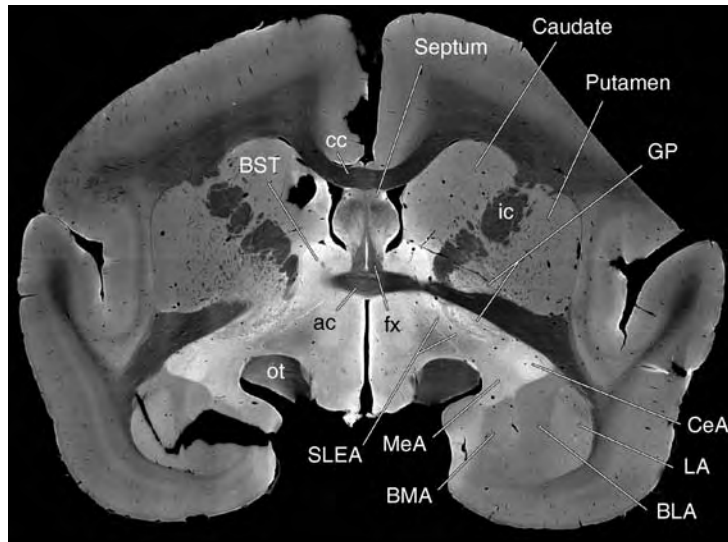

**Extended Amygdala. Figure 1** Extended amygdala in the primate brain. Depicted is a direct photographic print of a coronal section from the brain of a tamarin monkey that has been stained for secretoneurin (white areas). In rodents and humans this peptide is highly expressed in the region of the extended amygdala and serves to graphically depict its extent. Note the continuous field of secretoneurin immunoreactivity between the bed nucleus of the stria terminalis and central and medial amygdala.

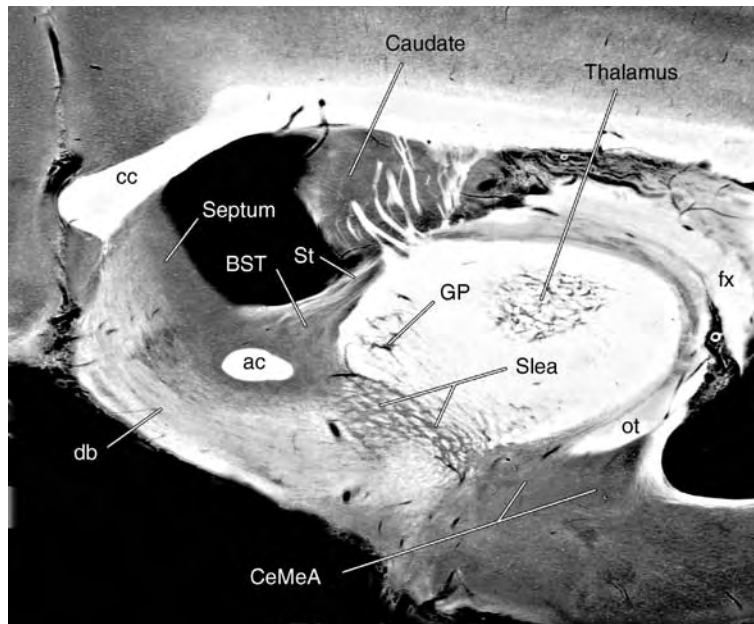

**Extended Amygdala. Figure 2** Extended amygdala in the rat brain. This figure is a direct photographic print of an unstained section of a rat brain cut parallel to the main rostrocaudal plane of the extended amygdala. Note the distorted circle formed by the bed nucleus of the stria terminalis (BST), the sublenticular extended amygdala (SLEA), the centromedial amygdala (CeMeA) and the arcing fibers of the stria terminalis (st).

stria terminalis). An additional corridor of amygdala-like neurons accompany the posterior limb of the anterior commissure (the interstitial nucleus of the posterior limb of the anterior commissure; "IPAC") as it courses

rostromedially from the amygdala. IPAC crosses the rostral face of the ventral pallidum (i.e. across the caudal surface of the nucleus accumbens), and eventually merges with lateral portions of the bed nucleus of the



stria terminalis. In primates, and particularly in the human brain where the ventral pallidum is represented by a more dispersed archipelago of neurons (when compared with non-primate mammalian species) it is not clear that a separate column of cells representing the primate homologue of IPAC exists.

### Two major Groups of Subnuclei, Medial and Central make up the Extended Amygdala

1. The medial nucleus of the amygdala is contiguous with the medial part of the bed nucleus of the stria terminalis via neurons scattered within the medial part of stria terminalis (medial supracapsular bed nucleus of the stria terminalis), and by neurons traversing a caudal and ventral corridor in the sublenticular area. These regions are collectively termed the “*medial division of extended amygdala*” (Fig. 3a) and are particularly characterized by reciprocal connections with medial hypothalamic nuclei. Most of the structures composing the medial division of extended amygdala have been implicated in aspects of social and reproductive behaviors. These include

mediation of reproductive behaviors (including parenting), of related psychoendocrine responses, and intra- and inter-specific aggression.

2. The “*central division of extended amygdala*” (Fig. 3b) takes its name from the central amygdaloid nucleus, its largest and most characteristic component. The central nucleus of the amygdala is contiguous with the lateral part of the bed nucleus of the stria terminalis via neuronal corridors in anterior and dorsal portions of the sublenticular area and via IPAC. The central extended amygdala has robust, generally reciprocal connections with hypothalamus (particularly lateral hypothalamus), mesencephalic tegmentum, dorsolateral pons and medulla. It targets potential premotor areas such as in the lateral pontine and medullary reticular formations as well as in more complex sensory-motor regions such as the periaqueductal gray, parabrachial complex, and the nucleus of the solitary tract. Theoretically important targets of the central extended amygdala include the dopamine cells in the ventral tegmentum of the mesencephalon, as well as serotonergic and

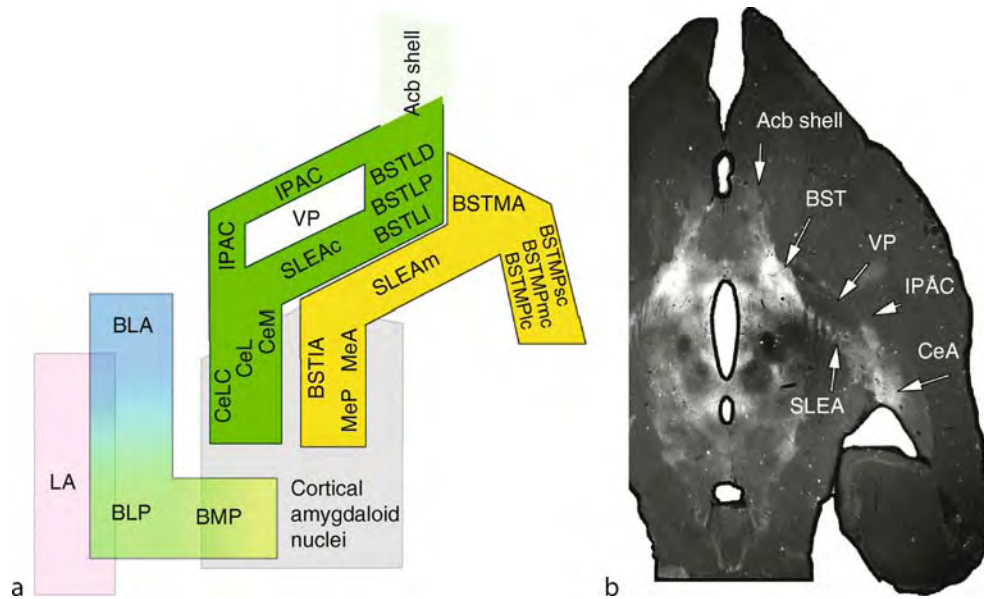

**Extended Amygdala. Figure 3** Elements of extended amygdala. The Schematic horizontal diagram of the rat extended amygdala in 2A outlines the central (green) and medial divisions (yellow) of extended amygdala. The central division surrounds the ventral pallidum which is distinct histochemically and connectionally from the central division of extended amygdala. The definition of extended amygdala *does not* include the lateral amygdaloid nucleus (pink) basolateral (blue-green) complex, or the superficial cortical amygdaloid nuclei (gray). 2B is a direct photographic print of a horizontal section of the rat brain immunolabeled for the peptide angiotensin II. This peptide is prominent in both subdivisions of extended amygdala, but not the ventral pallidum or striatum, with the exception being the most caudal portions of shell of nucleus accumbens. Note the prominent amygdala related band (SLEA) caudomedial to ventral pallidum traversing the sublenticular region between the centromedial amygdala and the bed nucleus of the stria terminalis. Although it is not evident in this view, it should be noted that IPAC is also continuous across the rostral face of ventral pallidum and joins the ventrolateral quadrant of the lateral bed nucleus of the stria terminalis. (Modified from Alheid (2003) [4], with permission from Blackwell Publishing).

noradrenergic neurons in the pons. Behavioral data has implicated central extended amygdala neurons in the motor, endocrine, and autonomic responses conditioned to stimuli associated with fear, anxiety, and unavoidable stress. Mediation of positive emotional/motivational stimuli or the rewarding impact of drugs of abuse has also been associated with modulation of dopamine or GABA neurotransmitters in the central division of the extended amygdala. As a consequence, it is included as a focus of research aimed at understanding the biological substrates of drug abuse.

### Extended Amygdala and Nucleus Accumbens

Just rostral to extended amygdala, the “shell” area of nucleus accumbens has been the main focus for studies on structures mediating the central rewards and the rewarding effects of drugs of abuse. It has been suggested that caudal portions of the accumbens shell region might represent transitional areas with extended amygdala where neurons from both structures are incompletely separated. Recent evidence has, in fact,

indicated that some neurons scattered in caudal parts of the accumbens appear to derive developmentally from a “caudal ganglionic eminence” in the lateral forebrain of the embryo which also gives rise to the lateral bed nucleus of the stria terminalis and central nucleus of the amygdala [5]. On the other hand, various studies, particularly those by Zahm and coworkers (e.g., [6]), have amply demonstrated the particularly striatal nature of the shell of the accumbens, including its caudal portions. It is, therefore, not accurate to treat the accumbens shell as simply the rostral most portion of extended amygdala.

### Parallel Processing in Basal Forebrain

It has been argued that much of the forebrain may be understood as parallel anatomical corridors through the basal ganglia (striatum and globus pallidus) that process efferents of functionally unique cortical zones [3]. In some respects the organization characterizing the cortico-striato-pallidal system may be used to model relations in nearly the entire basal forebrain (Fig. 4), including extended amygdala, and even the medially

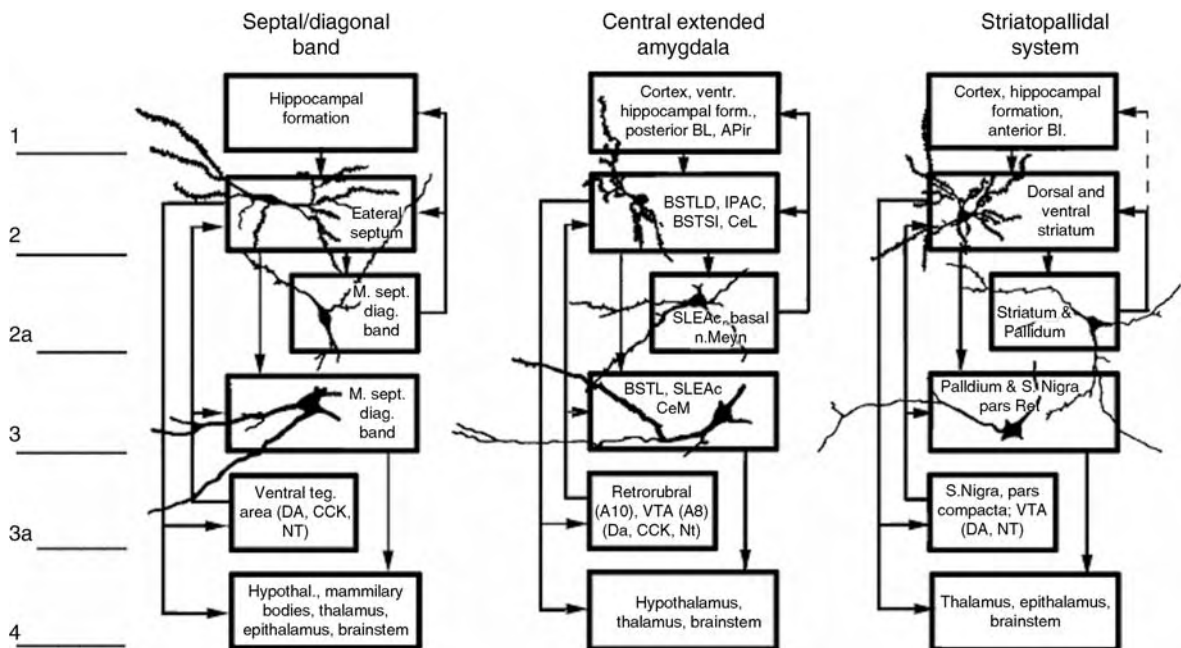

**Extended Amygdala. Figure 4** Basal forebrain columns. Three major cortical-subcortical corridors in basal forebrain (i.e. hippocampal septal-diagonal-band; central extended amygdala; cortico-striato-pallidal). Note that comparable processing steps are not depicted for the medial extended amygdala but such a scheme might be attempted. Basically, in all three systems shown, glutaminergic (level 1) cortical neurons and cortical-like amygdala neurons project to GABAergic medium sized spiny neurons (level 2). These in turn project to projection neurons with long slender dendrites (leptodendritic) (level 3) in the diagonal band nuclei, in central extended amygdala, but also to downstream targets such as the ventral tegmental dopamine neurons (level 3A). The leptodendritic neurons provide a massive output to (level 4) hypothalamus, thalamus, and brainstem. Large leptodendritic interneurons (level 2A) receive input from medium spiny neurons and from thalamus, but more rarely from cortex. To varying degrees these provide feedback locally to medium spiny neurons, but also back to cortical areas that were the original source of the input to the medium spiny neurons. (From Alheid (2003) [4], with permission from Blackwell Publishing).

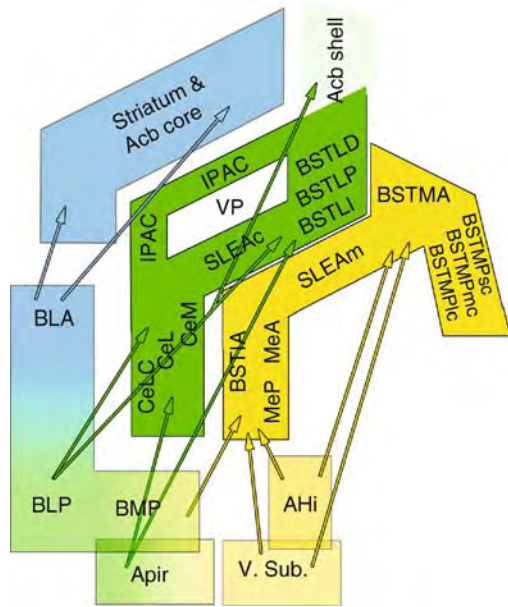

**Extended Amygdala. Figure 5** Multiple corridors in the projections of the basolateral amygdala to extended amygdala and striatum. In the rat, anterior basolateral amygdala selectively targets striatum and posterior basolateral amygdala projects to extended amygdala. Cortical-like excitatory projections from anterior or posterior segments of the basolateral amygdala more or less exclusively target separate parts of the forebrain, the striatum or central division of extended amygdala respectively. To some extent, the projection from posterior basolateral amygdala to the extended amygdala is mirrored by afferents from lateral portions of the amygdalopiriform area. A similarly focused input to medial extended amygdala originates from basomedial, amygdalohippocampal, and ventral subicular projections and to some degree form. *ac* anterior commissure; *Acb Shell* shell region of the nucleus accumbens; *AHi* amygdalohippocampal transition area; *APir* amygdalopiriform transition area; *BLA* anterior basolateral amygdaloid nucleus; *BLP* posterior basolateral amygdaloid nucleus; *BMP* posterior basomedial amygdaloid nucleus; *BST* bed nucleus of the stria terminalis; *BSTIA* intraamygdaloid bed nucleus of the stria terminalis; *BSTLD* dorsolateral part of the lateral BST; *BSTLI* intermediate part of the lateral BST; *BSTLP* posterior part of the lateral BST; *BSTMA* medial anterior part of the medial BST; *BSTMPic* large-celled lateral column of the medial posterior part of the BST; *BSTMPme* medium-celled intermediate column of the medial posterior part of the BST; *BSTMPsc* small-celled medial column of the medial posterior part of the BST; *cc* corpus callosum; *CeA* central amygdaloid nucleus; *CeLC* lateral capsular part of CeA; *CeL* lateral CeA; *CeM* medial part of CeA; *CeMeA* centromedial amygdala; *CCK* cholecystokinin; *DA* dopamine; *db* diagonal band; *fx* fornix; *GP* globus pallidus; *ic* internal capsule; *IPAC* interstitial nucleus of the posterior limb of the anterior commissure; *La* lateral amygdaloid nucleus;

adjacent hippocampal-septal system. In each forebrain corridor, glutamatergic pyramidal neurons in a cortical area (Level I, Fig. 4) target GABAergic medium sized spiny neurons in the basal forebrain (Level II) and these, in turn, send axon terminals to sparsely spiny GABAergic output neurons such as those found in pallidal areas. Additional elements that appear to be represented in all basal forebrain systems include large cholinergic and non-cholinergic (e.g. somatostatin) neurons providing either intrinsic (in striatum) or cortical feedback (septum/diagonal band and extended amygdala). Mesencephalic dopamine neurons also appear to be reciprocally connected with most basal forebrain regions in a loose topographical fashion.

### Parallel Projections from Basolateral Amygdala to Extended Amygdala and Basal Ganglia

A major source of afferents to the extended amygdala is the basolateral amygdala, a cortical-like structure with glutamatergic pyramidal neurons, but little evidence of a layered structure. The basolateral amygdala has been implicated both in conditioned fear (as an efferent relay from the lateral nucleus of the amygdala) and in the rewarding effects of drugs of abuse. In the context of parallel processing in basal forebrain, it is significant that the small-celled part of the basolateral amygdala (posterior part in the rat nomenclature) projects mainly to extended amygdala and to the shell area of nucleus accumbens, while the large-celled part of the basolateral amygdala (anterior part in the rat) projects mainly to striatum and to the core of nucleus accumbens, but not to extended amygdala (Fig. 5). As yet, few functional studies have capitalized on this distinction. In one set of experiments comparing chemical inactivation of anterior vs. posterior basolateral amygdala in the rat, the reinstatement of behavioral responses normally rewarded by cocaine administration was blocked by lidocaine deactivation of the posterior basolateral amygdala, when test injections of cocaine itself was the cue. On the other hand, reinstatement of drug rewarded behaviors was dependant on ongoing activity in anterior basolateral amygdala when reinstatement was prompted by environmental cues rather than by the drug itself [7]. These observations are consistent with

*M. Sept* medial septum; *MeA* anterior part of the medial amygdaloid nucleus; *MeP* posterior part of the medial amygdaloid nucleus; *Nt* neurotensin; *ot* optic tract; *S. Nigra pars ret.* substantia nigra pars reticulata; *SLEA* sublenticular extended amygdala; *SLEAc* central division of the sublenticular part of extended amygdala; *SLEAm* medial division of the sublenticular part of extended amygdala; *st* stria terminalis; *VP* ventral pallidum; *V. Sub.* ventral subiculum.

mediation by the extended amygdala and shell of the accumbens of the physiological consequences of natural rewards, including behavioral arousal, while the striatum and core of the accumbens appear to be more important in mediating the adaptive behavioral procedures elicited by learned cues signaling the availability of rewards.

In the final analysis, any gross generalization about the functional impact of the extended amygdala is qualified by the complex collection of subnuclei that compose its major divisions. These multiple subnuclei with their distinctive cortical and subcortical afferents, including their afferents from the remaining cortical-like nuclei of the amygdala proper, bespeak a substantial number of differentiated functional-anatomical systems accessing a broad range of neuroendocrine, autonomic, and somatomotor responses. This underscores the importance of the ongoing behavioral and physiological analyses that recognize the specific functional attributes of the many individual components of the amygdala, extended amygdala and basal forebrain in general.

## References

1. Johnston JB (1923) Further contributions to the study of the evolution of the forebrain. *J Comp Neurol* 35:337–481
2. de Olmos JS, Alheid GF, Beltramino CA (1985) The amygdala. In: Paxinos G (ed) *The rat nervous system: Vol 1 Forebrain and midbrain*. Academic Press, Sydney, pp 223–334
3. Alheid GF, Heimer L (1988) New perspectives in basal forebrain organization of special relevance for neuropsychiatric disorders; The striatopallidal amygdaloid and corticopetal components of substantia innominata. *Neuroscience* 27:1–39
4. Alheid GF (2003) Extended amygdala and basal forebrain. *Ann NY Acad Sci* 985:185–205
5. Nery S, Fishell G, Corbin JG (2002) The caudal ganglionic eminence is a source of distinct cortical and subcortical cell populations. *Nat Neurosci* 5:1279–1287
6. Reynolds SM, Zahm DS (2005) Specificity in the projections of prefrontal and insular cortex to ventral striatopallidum and extended amygdala. *J Neurosci* 25:11757–11567
7. Kantak KM, Black Y, Valencia E, Green-Jordan K, Eichenbaum HB (2002) Dissociable effects of lidocaine inactivation of the rostral and caudal basolateral amygdala on the maintenance and reinstatement of cocaine-seeking behavior in rats. *J Neurosci* 22(3):1126–1136
8. de Olmos J, Beltramino CA, Alheid GF (2004) Amygdala and extended amygdala of the rat: a cytoarchitectonical, fibroarchitectonical, and chemoarchitectonical survey. In: Paxinos G (ed) *The rat nervous system*, 3rd ed. Elsevier Academic Press, San Diego, pp 510–601
9. Heimer L, de Olmos JS, Alheid GF, Sakamoto N, Pearson JC, Marksteiner J, Switzer RC III (1999) The human basal forebrain, part II. In: Bloom F, Björklund A, Hökfelt T (eds) *The primate nervous system, Part II, Vol 13, Handbook of chemical neuroanatomy*. Elsevier, Amsterdam, pp 57–226

## External Capsule

### Synonyms

► Capsula externa

### Definition

The external capsule is a fiber layer running between claustrum and putamen. It contains projection fibers from the frontoparietal operculum and other parietal cortical

► Telencephalon

## External Tendon

► Tendon

## External Tufted Cells

### Definition

Cells in the glomerular layer of the olfactory bulb, which provide glutamatergic excitation from one glomerulus onto the GABAergic cells surrounding another glomerulus.

► Olfactory Bulb

► Olfactory Information

## Externalism

SVEN BERNECKER

Department of Philosophy, University of California at Irvine, Irvine, CA, USA

### Synonyms

Content externalism, Semantic externalism, Anti-individualism, Social externalism, Causal-essentialist externalism, Informational semantics

## Definition

“Externalism” is used in different philosophical disciplines. In the philosophy of action, externalism refers to the view that there are objective reasons for action that are not dependent on the agent’s desires, and thus external to him. In epistemology, externalism refers to the view that the factors required for a belief to be epistemically justified may be cognitively inaccessible to the epistemic subject, and thus external to his mind.

This essay is concerned with externalism in the philosophy of mind and in the philosophy of language. In this context, externalism is the view that the contents of an individual’s thoughts and the meanings of his words depend on systematic relations that the individual bears to aspects of his environment. Mental contents and word meanings are individuation-dependent on aspects of the physical and social environment of their subjects.

## Description of the Theory

The main road leading to externalism, proposed by Putnam [1] and Burge [2], draws on the semantic analysis of the truth conditions of that-clauses used to ascribe beliefs and other mental states.

## Twin-Earth Thought Experiments

Putnam asks us to consider the following ► [twin earth thought experiment](#) (cf. [3]): suppose S is an English speaker who uses the word “water” as much as anyone in his linguistic community. He doesn’t have any considerable knowledge of the chemical properties of water. Suppose that there exists somewhere in a nearby galaxy a planet called “twin earth,” which is a molecule-for-molecule duplicate of earth. The only difference between the two planets is that no water is present on twin earth. What is found there instead is a liquid which looks, tastes, and behaves like water but has the chemical composition XYZ and not H<sub>2</sub>O. Like each one of us, S has a molecular duplicate on twin earth. Twin S has endured experiences that are just like S’s, except that where S has encountered water, he has encountered XYZ; and neither of them is aware of the constitution of the liquids they refer to as “water.”

At this point Putnam introduces two common assumptions about the meaning of mental states and their relation to language. Firstly, there is the assumption that the meaning of terms in a language is determined by the mental states of the speaker who uses them. Thus, the meaning of the term “water” is determined by the speaker’s concept of water. Secondly, there is the assumption that reference is a component of the meaning of a term. So the meaning

of “water” contains not only an intentional description of the character or stereotype of water, but also the referent, H<sub>2</sub>O.

The reference of S’s “water” expression is different from the reference of his twin’s “water” expression. S’s expression refers to H<sub>2</sub>O while twin S’s refers to XYZ. Given that reference is part of the meaning, the meaning of S’s “water” expressions is distinct from the meaning of twin S’s “water” expressions. Also, if the meaning of an expression is determined by the concepts of the speaker, then the concept expressed by S’s term “water” is different from the concept expressed by twin S’s term “water.” To translate the concept expressed by the twin earthian word “water” into English we have to coin a new word, perhaps “twater.” Due to the difference in concepts, S and twin S express different thoughts when both of them utter, for example, “Gee, water is wet!”. Putnam concludes that mental states involving natural kind terms don’t supervene on physical states of our brains but on the physical states of our environment.

Putnam’s twin earth example exploits the fact that in the case of a natural kind term such as “water,” the nature of the referent plays an essential role in individuating the concept associated with the word. Burge [2], Dretske [4], Fodor [5] and others have developed versions of the twin-earth thought experiment that are not limited to natural kind terms.

## Varieties of Externalism

The numerous types of externalism can be classified according to two criteria. Firstly, different forms of externalism take different aspects of the environment to be constitutive for the individuation of mental content. Secondly, the dependency relation between brain states and environmental states, which is said to be constitutive of mental content, comes in various strengths. The first criterion concerns the supervenience base of contents, and the second criterion concerns the nature of the supervenience relation.

Different versions of externalism take different kinds environmental facts as responsible for the determination of thought content. According to Putnam’s causal-essentialist externalism, it is the (chemical) structure of the designated objects that determines the meaning of natural kind terms. Burge’s social externalism suggests that it is the linguistic norms of society which determine thought content. In Davidson’s [6] view, the thought contents of a speaker are determined by the physical and social properties with which both the speaker and his interpreter are in contact. According to Dretske’s [4] informational semantics, thought content is dependent on the informational states. What links the belief about water to water is that, under normal conditions, water causally contributes to one’s having beliefs about water.

The supervenience relation between mental states and environmental states comes in different strengths. One sort of externalism (e.g. [2]) insists that you could not have, say, a belief that water is wet unless there was some relation between you and water. Had you never come across water, beliefs about water would not be available to you. But this doesn't mean that there was necessarily a time when you were in the presence of water. It might be that water was described to you by others who have been in contact with it or that you simply theorize about the chemical composition of an illusionary substance called "water." This version of externalism entails only the weakest kind of supervenience. Other externalists (e.g. [4]) hold that for you to have beliefs about water (assuming "water" is a simple concept), you must have had some causal contact with water during your lifetime. An even stronger version might hold that you need to be in direct contact with water to have beliefs about water.

### Objections to Externalism

One objection to externalism concerns action explanation. Since your twin on twin earth is a molecule-for-molecule duplicate of you, the two of you perform the same kind of behavior. When you are thirsty, you may say "I would like to drink some water"; when your twin on twin earth is thirsty he will say the same thing. Your verbal expressions are identical.

It seems reasonable to suppose that the parallelism of behavior indicates a parallelism of action and of intentional states. For if the behavioral output is the same why should the intentional input be different? The problem, however, is that given externalism, you and your twin entertain different intentions when both of you say "I would like to drink some water." Your twin wants to drink twater, you want to drink water. The difference between twater-thoughts and water-thoughts is therefore a difference that, behaviorally speaking, makes no difference. The externalist notion of content seems to drop out as part of the theoretical apparatus of behavior causation and action explanation.

Externalists have tried to respond to this challenge by arguing that you and your twin's behavior is in fact different. When your twin and you desire to drink "water" and believe the glass in front of you to be filled with "water," both of you perform the same bodily movements – you take the glass and empty it. But even though the bodily movements are the same, the behavior is different. Behavior has to do with why one does what one does. Whereas your twin intends to drink twater, you intend to drink water (cf. [7,8]).

Another objection to externalism comes from the intuition that we can know, just by reflection (or a priori), about our own mental contents. Suppose you hold a belief that you express by saying "water is wet."

Given externalism, the content of your belief depends on the kind of entity designated by "water." But then it seems you can know the content of your belief only if you know what substance you are in contact with – H<sub>2</sub>O, XYZ, or whatever else. Knowledge of your own thought contents seems to require investigation of external content-determining circumstances. Hence, if mental contents are determined by environmental states, then, since reflection can reveal only intrinsic properties of mental states, a priori knowledge of one's mental contents seems to be impossible.

In response to this objection, some philosophers have tried to render externalism compatible with the idea that we know about our thought contents just by reflection. Consider the first-order thought "water is wet" and the simultaneously entertained self-referential thought "I believe that water is wet." The content of the first-order thought is contained (or included) in the content of the second-order thought, and the contents of both thoughts are determined by the same causal relations of which one may be ignorant. No matter which environment one lives in, the content of the second-order thought cannot come apart from the first-order thought by which it is causally sustained. For this reason, some proponents of externalism claim that their theory does not have the consequence that knowledge of one's thought contents requires the investigation of one's environment (cf. [8,9,10]). For a comprehensive and up-to-date defense of externalism see Brown [11] and Goldberg [12].

### References

1. Putnam H (1975) The meaning of 'meaning'. In: Putnam H (ed) *Mind, language and reality*. Cambridge University Press, Cambridge, pp 215–271
2. Burge T (1979) Individualism and the mental. *Midwest Stud Philos* 4:73–121
3. Pessin A, Goldberg S (eds) (1996) *The twin earth chronicles*. Sharpe, Armonk, NY
4. Dretske F (1981) *Knowledge and the flow of information*. MIT Press, Cambridge, MA
5. Fodor J (1990) *A theory of content*. MIT Press, Cambridge, MA
6. Davidson D (1989) What is present in the mind? *Grazer Philosophische Studien* 36:3–18
7. Dretske F (1988) *Explaining behavior*. MIT Press, Cambridge, MA
8. Edwards S (1994) *Externalism in the philosophy of mind*. Avebury, Aldershot, UK
9. Ludlow P, Martin N (eds) (1998) *Externalism and self-knowledge*. CSLI, Stanford, CA
10. Nuccetelli S (ed) (2003) *New essays on semantic externalism and self-knowledge*. MIT Press, Cambridge, MA
11. Brown J (2004) *Anti-individualism and knowledge*. MIT Press, Cambridge, MA
12. Goldberg S (2007) *Anti-individualism: mind and language, knowledge and justification*. Cambridge University Press, Cambridge

## Exteroceptive

### Definition

Receptors and senses receive stimuli from the world external to the body and comprise vision, electric senses and magnetic senses, audition (hearing), gustation (taste) and olfaction (smell).

- ▶ Sensory Systems

## Extinction

### Definition

This learning occurs when a conditioned stimulus (CS) that used to signal the unconditioned stimulus (US) now signals omission of that US. The standard procedure for extinguishing a CS involves suspending all presentations of the US. Extinction is typically indexed by a decline in conditioned responding to the CS. Phenomena such as spontaneous recovery of the conditioned response (CR) and disinhibition of the CR have supported accounts that attribute the loss of conditioned responding during extinction to a masking process such as inhibition rather than to erasure of the original association between the CS and the US.

- ▶ Classical Conditioning (Pavlovian Conditioning)
- ▶ Theory on Classical Conditioning

## Extinction Learning

### Definition

A form of inhibitory learning, in which conditioned responses to conditioned stimuli decrease.

- ▶ Learning and Extinction

## Extinction Memory

### Definition

The associative or cellular processes responsible for the decrease in conditioned responding observed after extinction.

- ▶ Learning and Extinction

## Extinction Training

### Definition

The experimental procedure of extinction, characterized by the presentation of the conditioned stimulus in the absence of the unconditioned stimulus, that leads to a decrease in conditioned responses.

- ▶ Learning and Extinction

E

## Extracellular

### Definition

Literally means outside the cell. In all cells, a cell membrane exists which separates the intracellular and extracellular compartments. Partly due to the presence of transporters and ion channels within the cell membrane the extracellular concentrations of many ions is different compared to the intracellular environment.

- ▶ Membrane Biophysics
- ▶ Membrane Potential: Basics

## Extracellular Fluid (ECF)

### Definition

The extracellular or interstitial fluid surrounds the cells and is a component of the extracellular matrix.

## Extracellular Matrix

### Definition

A matrix composed of various proteins, sugar residues and lipids surrounding cells.

## Extracellular Protease

YASUYUKI ISHIKAWA, SADA O SHIOSAKA  
Nara Institute of Science and Technology (NAIST),  
Structural Cell Biology, Nara, Japan

### Synonyms

Extracellular proteinase

### Definition

► **Neuronal plasticity**-related extracellular protease.

Secretory proteases or membrane-anchored proteases that catalyze hydrolysis of peptide bonds in extracellular proteins.

### Characteristics

#### Quantitative Description

Almost all extracellular serine proteases are rather small proteins, ranging from 30 to 70 kDa, but some are large. Approximate molecular weights are 30 kDa (neuropsin), 70 kDa (tissue plasminogen activator: tPA), 85 kDa (plasmin), 97 kDa (neurotrypsin), and 400 kDa (reelin). Matrix metalloproteases (MMPs) are between 50 and 100 kDa; i.e. 65 kDa (MMP24), 72 kDa (MMP2), and 97 kDa (MMP9).

### Higher Level Structures

Protease or proteinase.

### Lower Level Components

Serine Proteases:

- Tissue plasminogen activator (tPA)
- Plasmin
- Neuropsin (KLK8, ovasin, TADG-14, kallikrein hK8, PRSS19)
- Protease M/neurosin/zyme (KLK6, hK6)
- Neurotrypsin (brain-specific serine protease BSSP-3, leydin, motopsin, PRSS12).
- Reelin

Matrix Metalloproteases:

Matrix metalloprotease 2 (MMP2, gelatinase A, gelatinase Type IV collagenase)  
Matrix metalloprotease 3 (MMP3, stromelysin-1, proteoglycanase)  
Matrix metalloprotease 9 (MMP9, gelatinase B)  
Matrix metalloprotease 24 (MMP24, MT5-MMP)

### tPA and Plasmin

tPA is a serine protease that catalyzes the conversion of plasminogen (zymogen) into plasmin, a serine protease with broad substrate specificity. The *tPA* gene is localized

to chromosome 8p12 in humans and chromosome 8A2 in mice. tPA activity is regulated via inactivation by its inhibitor PAI-1. Modulation of the extracellular matrix may be related to hippocampal neural plasticity, such as learning and memory. Plasmin can degrade fibrin, factor X and a variety of extracellular matrix proteins (► **extracellular matrix (ECM) proteins**) such as ► **laminin**, vitronectin and DSD-1-PG/phosphocan. tPA and plasmin are well known proteases that are involved in the blood fibrinolytic system.

### Neuropsin (KLK8)

Neuropsin is a secretory serine protease, and the human *neuropsin* gene is encoded in a gene cluster of the big kallikrein-like multigene family (19q13.3-4; *KLK* genes). The precursor form of neuropsin (proneuropsin) has a presumed signal peptide sequence and is released extracellularly via both regulated and constitutional pathways in the mouse. This non-active precursor is stored in the extracellular spaces, probably mostly in the ► **synaptic cleft**. ► **Long-Term Potentiation (LTP)**-associated synaptic excitation results in the activation of proneuropsin by an as yet unknown endoprotease.

### Protease M/neurosin/zyme (KLK6)

Similar to neuropsin, protease M/neurosin/zyme is encoded in the same gene cluster as the kallikrein-like multigene (19q13.3-4; *KLK* genes). This enzyme has potential functions in the CNS, such as remodeling in brain injury. The enzymatic activity of KLK6 appears to be regulated by an autoactivation/autoinactivation mechanism. Mature KLK6 displays a trypsin-like activity and efficiently cleaves fibrinogen, collagen types I and IV, and alpha-synuclein *in vitro*.

### Neurotrypsin

Neurotrypsin is a secreted protein of 875 amino acids, belonging to the subfamily of trypsin-like serine proteases. The neurotrypsin gene is localized to chromosome 4q25-q26 in humans. The enzymatic character is still unknown.

### Reelin

Reelin was found as an extracellular matrix protein that relates to neuronal migration during development. Reelin is essential for proper cytoarchitectonic organization during CNS development. The *reeler* mutant mouse, with spontaneous Reelin null mutations, has defects in the cerebral cortex, hippocampus, cerebellum, and brainstem nuclei and gives rise to functional deficits, such as an ataxic gait and trembling. According to *in vitro* studies, Reelin has proteolytic activity that can degrade extracellular matrix molecules such as ► **fibronectin** and laminin. The effect of Reelin on neuronal migration may be mediated by its ability to modulate cell adhesion through its proteolytic activity.



### MMP2, 3, 9 and 24

Among a big family consisting of at least 25 MMPs, only 4 members, MMP2, 3, 9 and 24 are so far presumed to be involved in neural plasticity. Proteolysis of extracellular matrix molecules by MMPs may perform a permissive or inductive role in fiber remodeling and synaptogenesis initiated by deafferentation. MMP2 can degrade collagen type IV, the major structural component of basement membranes. MMP3 has a rather wide spectrum of substrate specificities and can degrade collagens (II, IV and IX), gelatin, aggrecan, perlecan, decorin, laminin, elastin, casein, osteonectin, ovostatin, entactin, plasminogen, myelin basic protein and IL-1 $\beta$ , and can also activate precursors of MMP3 and 9. MMP9 can degrade gelatin, a denatured collagen. As for physiological substrates, MMP9 can degrade elastin,  $\alpha$ 1-proteinase inhibitor, tissue factor pathway inhibitor (TFPI), myelin basic protein, CTAP-III, PF-4, gro- $\alpha$  and activational processing of IL-8. MMP24 is a membrane-type MMP and can cleave fibronectin, but not collagen type I nor laminin.

### Higher Level Processes

Transcription, translation, and secretion.

### Process Regulation

Major regulation occurs in transcription, translation or secretion. Processing of tPA is regulated in a synaptic activity-dependent manner at the transcription level. Neuropilin is secreted as a precursor form with a constitutional and regulatory pathway. The proneuropilin is activated by synaptic depolarization. It is also known that the activity of extracellular matrix proteases is regulated by protease inhibitors such as serpins and TIMPs. A membrane type MMP (MMP24) is down-regulated by shedding by a furin-type convertase.

### Function

Some extracellular matrix proteases are involved in neuronal plasticity, neuronal degeneration and regeneration.

A number of extracellular proteases are known to be involved in neural plasticity in development. Adaptive synaptic change controlling complex neuronal circuits might be a basis for the neural plasticity. Recently, it has been reported that extracellular proteases and their inhibitors play a crucial role in the development and maintenance of dynamic synaptic connections. Indeed, some serine- and metalloproteases contribute to cell migration, axonal outgrowth and elongation, and elimination of overproduced synapses during ontogenesis.

A mechanical change in synaptic morphology is hypothesized for the acquisition, consolidation and retention of long-lasting memory [1]. Even in adults, they play roles in the processing of neuroactive proteins,

and synaptic plasticity such as learning and memory processes. As meshwork matrix proteins and adhesion molecules that fill the synaptic cleft might form a solid connection of pre- and post-synaptic structures, the synapses may not be so freely altered in the non-stimulated or even in the excited state of the neurons. Therefore, some special mechanisms to regulate the synaptic morphology and/or synaptic movement in terms of plasticity might be necessary. As a plausible mechanism for the structural plasticity, a proteolysis system of extracellular matrix proteins was hypothesized [2]. Perhaps, an extracellular proteolysis system permits morphological changes in synapses, such as perforation, enlargement, angular change and synaptic movement in the contacting active sites, and, thereby, the synaptic machinery may control the acquisition and stabilization of learning (Fig. 1).

Some extracellular proteases are involved in the regulation of neuronal survival and death, probably through the degradation of extracellular matrix proteins (ex. tPA, neuropilin).

### tPA and Plasmin

tPA inhibitors can block the function of tPA in late phase-long term potentiation ( $\blacktriangleright$ late-phase LTP (L-LTP)). Consistently, the *tPA* gene-knockout mouse shows selective interference of the L-LTP in the hippocampus [3]. tPA contributes to L-LTP with the activation of cAMP-dependent protein kinase and the cleavage of  $\blacktriangleright$ NMDA receptors. Zhuo et al. [4] have demonstrated that the binding of tPA to its cell surface receptor, the  $\blacktriangleright$ low-density lipoprotein receptor-related protein (LRP), activates PKA, which plays a key role in L-LTP. More interestingly, tPA, by activating the extracellular protease plasmin, converts the precursor proBDNF to the mature  $\blacktriangleright$ brain-derived neurotrophic factor (BDNF), and such a conversion is critical for L-LTP expression in the mouse hippocampus [5]. The tPA-dependent proteolysis of the extracellular matrix could intensify learning and memory behaviors, because increased proteolytic activity of tPA showed enhanced synaptic plasticity, as examined by magnified LTP and improved performance in spatial learning. Recently, Mataga et al. [6] reported that tPA has a permissive role for functional ocular dominance plasticity downstream of the excitatory-inhibitory balance that triggers it. In addition, tPA triggers experience-dependent  $\blacktriangleright$ spine loss. Thus, physiological plasticity in the visual cortex may gradually induce morphological refinements through the tPA-plasmin system. tPA is highly expressed not only in the hippocampus but also in the amygdala. Although the role of tPA in the hippocampus has been well studied, its role in the amygdala has not often been addressed. A group demonstrated that tPA promotes stress-induced neuronal remodeling in this region, and that tPA is critical for the development of anxiety-like behavior following stress.

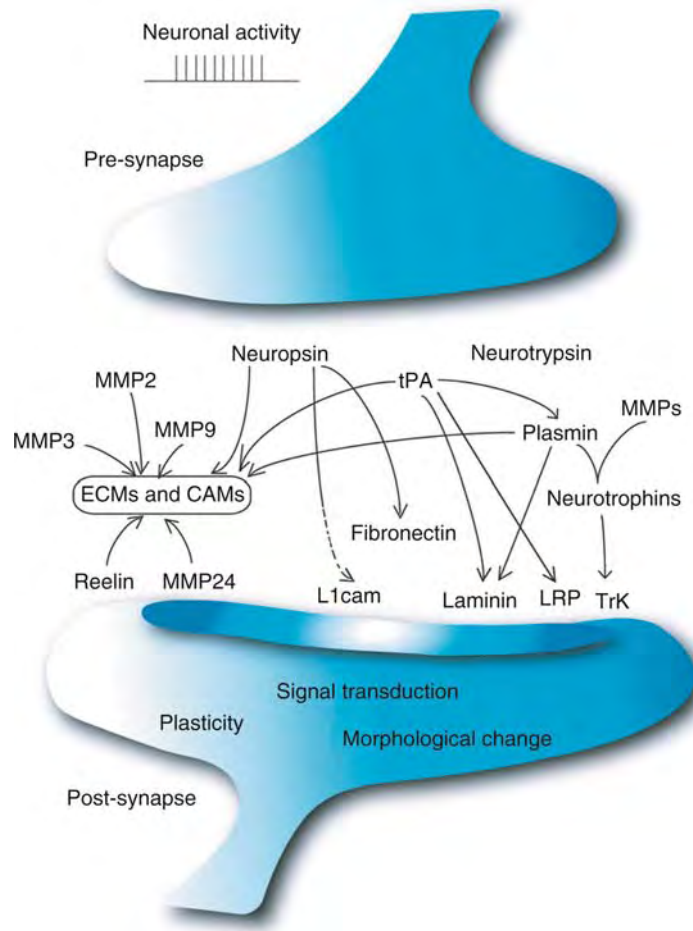

**Extracellular Protease. Figure 1** Schematic representation of synaptic extracellular proteases.

### Neuropsin

Neuropsin is a secreted serine protease and is expressed in the hippocampus and amygdala. Neuropsin mRNA is expressed with high density in the pyramidal or magnocellular neurons of the hippocampal CA1-3 subfields, lateral amygdaloid and basolateral amygdaloid nucleus and at a very low density in the entorhinal cortex, medial septal and Meynert's nucleus. Therefore, it is conceivable that neuropsin is implicated in the modulation of neuronal function and plasticity. Indeed, the activation of neuropsin induced the cleavage of fibronectin and  $\blacktriangleright$ L1cam. Both fibronectin and L1cam are involved in the modulation of synaptic plasticity. The application of recombinant neuropsin significantly promoted  $\blacktriangleright$ early-phase LTP (E-LTP) induction and the anti-neuropsin antibody reduced potentiation. Therefore, neuropsin plays an important role in the modulation of LTP, especially in E-LTP. Further, activation processing of stored-zymogen occurs extracellularly by removing only four amino acids. This process indicates stringent regulation of plasticity in the synaptic

machinery. These data suggest that neuropsin plays an important role in synaptic function through modifying extracellular environments [7]. Interestingly, it was reported that there are hominoid-specific isoforms derived from RNA splicing, neuropsin type II and its possible involvement in the brightness of the hominoid.

### Neurotrypsin

The most prominent expression of neurotrypsin is found in the cerebral cortex, the hippocampus and the amygdala. These structures are involved in the processing and storage of learned behaviors and memories. Using immuno-electronmicroscopy, neurotrypsin was localized in the presynaptic membrane and the presynaptic active zone of both excitatory and inhibitory synapses. Neurotrypsin is regarded as a candidate gene in synapse maturation and neural plasticity.

### Reelin

Reelin is essential for proper cytoarchitectonic organization during CNS development. Mutations of the *reelin*

gene in the mouse disrupt neuronal migration in several brain regions and give rise to functional deficits, such as ataxic gait and trembling. Thus, reelin is thought to regulate cell–cell interactions critical for cell positioning in the brain. Its function in the adult brain is far less well understood, but altered brain and blood reelin levels have been reported in some psychiatric disorders. An involvement of the reelin signaling pathway in neurodegeneration has been suggested.

#### **MMP2, 3, 9 and 24**

MMPs constitute a large family of extracellular enzymes, which function to remodel the pericellular environment, primarily through the cleavage of extracellular matrix proteins. The balance between MMPs and their inhibitors [tissue inhibitors of metalloproteinases (TIMPs)] in the pericellular environment determines the significant proteolytic events in tissue remodeling. Particularly, experimental evidence has shown that MMP2 and 9 have potential functions of plasticity in the CNS. Remodeling the nerve and neuromuscular junctions accompanied by nerve crush or axotomy induces the activation of MMP2 and 9. MMP-9-blocking antibody affects granular cell axonal outgrowth and migration in the developing cerebellum. MMP9 is known to be related to process outgrowth of oligodendroglia. Nerve growth factor, laminin or retinoic acid, which are strong inducers of axonal outgrowth enhanced expression of MMP2, 3 and 9 in dorsal root ganglion cells. MMP24, a nongelatinase-type isoform, is predominantly expressed in differentiated neurons and regulates axonal growth.

#### **Pathology**

tPA causes excitotoxic neuronal death, probably through the degradation of laminin. Laminins are extracellular matrix proteins that participate in neuronal development, survival and regeneration. tPA-deficient mice have been demonstrated to be resistant to excitotoxin-induced neuronal degeneration in the hippocampus and have an elevated threshold for seizure [8,9], indicating that the degradation of extracellular matrix, laminin, by the PA-plasmin system is a critical event in excitotoxic neuronal death. Laminins appear to be important components of the extracellular matrix in the CNS, and are critical for neuronal survival, as the loss of the laminin foundation can predispose neurons to excitotoxic death.

Neurotrophin appears to be involved in nerve injury, because its mRNA in oligodendrocytes is increased after kainite injection in the central nervous system or knife cut injury of the optic nerve. Neurotrophin is involved in the demyelination process accompanying injury. Of particular interest is the possible involvement of kallikreins in the pathogenesis of ▶ Alzheimer's

disease (AD). Protease M/neurosin/zyme mRNA is down-regulated, while neurotrophin mRNA is up-regulated in the hippocampus of Alzheimer's disease patients. MMPs are probably associated with Alzheimer's disease. Some data represented that MMPs are involved in the cleavage of ▶ amyloid precursor protein due to their  $\alpha$ -secretase-like activity. MMP-9-deficient mice displayed delayed granular precursors and reduced programmed cell death. MMP9 is also related to the disruption of the blood brain barrier initiated by the intense neuronal and glial depolarization during stroke, head trauma and migraine.

Four-base pair deletion in the neurotrophin gene was associated with autosomal recessive nonsyndromic mental retardation (MR). The 4bp deletion is most likely a null allele, as it is predicted to result in a shortened protein lacking the catalytic domain. These findings, therefore, indicate neurotrophin as the first gene to be identified as the cause of a nonsyndromic autosomal recessive form of MR [10].

#### **References**

1. Lamprecht R, LeDoux J (2004) Structural plasticity and memory. *Nat Rev Neurosci* 5:45–54
2. Shiosaka S, Yoshida S (2000) Synaptic microenvironments—structural plasticity, adhesion molecules, proteases and their inhibitors. *Neurosci Res* 37:85–89
3. Huang YY, Bach ME, Lipp HP, Zhuo M, Wolfer DP, Hawkins RD, Schoonjans L, Kandel ER, Godfraind JM, Mulligan R, Collen D, Carmeliet P (1996) Mice lacking the gene encoding tissue-type plasminogen activator show a selective interference with late-phase long-term potentiation in both Schaffer collateral and mossy fiber pathways. *Proc Natl Acad Sci USA* 93:8699–8704
4. Zhuo M, Holtzman DM, Li Y, Osaka H, DeMarco J, Jacquin M, Bu G (2000) Role of tissue plasminogen activator receptor LRP in hippocampal long-term potentiation. *J Neurosci* 20:542–549
5. Pang PT, Teng HK, Zaitsev E, Woo NT, Sakata K, Zhen S, Teng KK, Yung WH, Hempstead BL, Lu B (2004) Cleavage of proBDNF by tPA/plasmin is essential for long-term hippocampal plasticity. *Science* 306:487–491
6. Mataga N, Mizuguchi Y, Hensch TK (2004) Experience-dependent pruning of dendritic spines in visual cortex by tissue plasminogen activator. *Neuron* 44:1031–1041
7. Shiosaka S (2004) Serine proteases regulating synaptic plasticity. *Anat Sci Int* 79:137–144
8. Tsirka SE, Rogove AD, Bugge TH, Degen JL, Strickland S (1997) An extracellular proteolytic cascade promotes neuronal degeneration in the mouse hippocampus. *J Neurosci* 17:543–552
9. Chen ZL, Strickland S (1997) Neuronal death in the hippocampus is promoted by plasmin-catalyzed degradation of laminin. *Cell* 91:917–925
10. Molinari F, Rio M, Meskenaite V, Encha-Razavi F, Auge J, Bacq D, Briault S, Vekemans M, Munnich A, Attie-Bitach T, Sonderegger P, Colleaux L (2002) Truncating neurotrophin mutation in autosomal recessive nonsyndromic mental retardation. *Science* 298:1779–1781

## Extracellular Proteinase

### ► Synaptogenesis

## Extracellular Recording

UWE WINDHORST  
Göttingen, Germany

### Definition

Assessment of the electrical activity of nerve, glial and muscle cells by means of ► **electrodes** positioned in the extracellular vicinity of the cells.

### Purpose

Assessment of the electrical activity of nerve, glial and muscle cells in research and clinical settings, for analyzing the bioelectrical properties and function of such cells in various conditions and contexts.

### Principles

Changes in local transmembrane potentials ► **membrane potential-basics** reflect intra- and extracellular currents, which can be picked up by appropriately positioned electrodes, amplified and processed by means of electronic equipment in various ways. For example, when at an instant of time an ► **action potential** occurs in a nerve or muscle fiber, the membrane potential is reversed from negative interior to positive interior over a small area of membrane, whose extent depends linearly on ► **conduction velocity**. These local changes in intra- and extracellular potentials lead to potential differences with other non-excited membrane areas both on the inner and outer membrane sides. The differences, in turn, induce intra- and extracellular current flows along the fiber. Portions of the extracellular flow can be picked up by a pair of nearby electrodes (► **bipolar recording**) or a single nearby electrode with a reference electrode placed far away (► **mono- or unipolar recording**) [1].

With modifications, these principles apply to recordings made under the following circumstances:

- *Recordings from intact nerve trunks* (► **neurograms**) or *muscles* (► **electromyograms**). Such recordings almost always yield ► **interference patterns** of the superimposed activities of many cells (units), thus yielding ► **multi-unit activity**, and unless that is the objective, recording of ► **single-unit activity** requires specific

recording and data processing techniques to isolate the activity of individual units. In many applications, compound (summed) multi-unit activity is recorded from these multi-stranded structures in response to electrical, magnetic or mechanical or other stimulation, which yields ► **evoked potentials**. Such investigations are frequent in neurology to determine whether neuronal pathways are interrupted or compound conduction velocities are normal or reduced. Such recordings can be acute or chronic, in the latter case by means of chronically implanted nerve electrodes (see below).

- *Recordings from filaments* in peripheral nerves, spinal roots or central tracts split down to thin filaments in acute animal preparations and humans. Again, such filaments often contain several active fibers, so that the recording consists of an *interference pattern* of superimposed action potential trains from several fibers (multi-unit activity).
- *Recordings from individual cells or groups of cells* in the peripheral or central nervous system, and muscles, by means of microelectrodes. Such recordings may yield single-unit activity from individual cells, or compound activity of pools of neurons (► **field potentials**) elicited by short electrical or magnetic or other stimulation of their axons or synaptic inputs.

### Electrodes

Depending on the purpose, extracellular electrode forms and recording methods show a large variability (e.g., [1]).

*Wire electrodes.* Nerves or filaments may be positioned on fairly rigid wire electrodes, or flexible wires may be inserted into nervous tissues, nerves, spinal roots or muscles.

*Suction electrodes.* It is often not technically feasible to mount long filaments on rigid wire electrodes, for instance when nerve or spinal root stumps are short. Using negative pressure, these stumps can then be sucked into a glass pipette or other fine tube filled with an electrolyte to make electrical contact [2]. With the suction electrode, extracellular recordings can easily be obtained from very small hearts (e.g., of insects), intestinal nerves and neurons, and muscles can be stimulated by an electrical pulse to the neurons innervating them. It is also possible to record from moving tissue using a plastic tube instead of glass.

*Chronically implanted nerve electrodes.* A number of electrode systems have been developed, which can be implanted chronically in animals or humans. They can be used to record from, electrically stimulate and/or pharmacologically modulate various nervous structures, ranging from peripheral nerves to spinal roots, central nervous tracts and nuclei. Among these systems are nerve cuffs, longitudinally implanted intrafascicular

electrodes (LIFEs) and wires implanted in spinal roots and/or tracts. Arrays of wires are now routinely being implanted into central structures to record simultaneously from several single neurons ([1,3]; also below).

**Microelectrodes.** ▶ **Single-unit recordings** have been routinely performed with fine-tip microelectrodes of sufficiently high resistance and low ▶ **noise**, which are made of several types of metal or carbon-fiber electrodes or glass micropipettes filled with electrolytes. Microelectrodes of different sorts can be adapted to various uses, and can be combined into *multi-electrode arrays*. They can be used for several purposes, e.g., to record from many different neurons simultaneously or from a neuron while drugs are simultaneously applied nearby. *Metal electrodes* are produced from stainless steel, platinum or iridium and coated, except for the tip, with various insulating materials. They have the advantages of stability and flexibility, low noise and sampling bias. They lend themselves particularly well to recordings in chronic preparations, for example from the monkey cortex, which must be reached by driving the electrode through the intact dura mater, or from individual fibers or small groups of fibers in human nerves (▶ **microneurography**), which must be reached by driving the electrode through the skin and deeper tissues. Metal electrodes may be combined with micropipettes used for iontophoretic application (▶ **micro-iontophoresis**) or ▶ **pressure ejection** of drugs. *Carbon-fiber electrodes* have the advantages of low impedance, integration into multi-barrel arrays with some of the barrels devoted to local iontophoresis and some (those containing a carbon fiber) to recording, marking of the extracellular recording site, and scanning the chemical environment of the cell via ▶ **voltammetry** [1].

### Multi-Electrode Recordings

Essential operations of the nervous system are executed by the interactions of many neurons, i.e., at the level of neuronal networks. To gain a deeper insight into these cooperative interactions requires the simultaneous recording from large, statistically representative samples of the constituent neurons. Many attempts at such multiple single-unit recordings have been made, using various configurations with fixed electrode arrays or with sets of independently movable wire or fiber electrodes [4,5]. Newer developments include implantable electrode arrays for ▶ **multi-unit recordings** in behaving animals, such as the tetrode technology and the micro-machined silicon-based electrode arrays.

**Tetrode technology.** Instead of using a single sharp-tip electrode of high impedance, the use of four spaced wires (tetrodes) increases the yield of units and enables low-impedance recording, which diminishes the risk of movement-induced artifacts in naturally

moving animals [6]. Lightweight, implantable assemblies of independently movable tetrodes, whose *in situ* positions can be determined by ▶ **magnetic resonance imaging** (MRI), are available for recording of neuronal ensembles in behaving animals [7].

*Micro-machined silicon-based electrode arrays* with multiple recording sites are smaller than tetrodes and cause less tissue damage. The geometrically precise distribution of recording sites on multiple shanks allows for the recording of as many as a hundred well-separated neurons, and the determination of the spatial relationships of the isolated single neurons [8].

### Marking of Electrode Tracks

In many studies, it is important to be able to correlate neurophysiological recordings with neuroanatomy, i.e., to localize the neurons whose activities have been recorded. This problem is nontrivial, especially in chronic preparations where multiple electrode penetrations are made over many weeks or months. Various methods have been used to mark electrode tracks. *Electrolytic lesions* are the most common way of marking an electrode track, either at several places along the way or at the end. To make these lesions, small constant currents (5–10 mA) need to be applied for several seconds, say 20 s. These lesions can be seen in unstained histological sections, even after several months when the tissue is stained for markers of glial reactions such as cytochrome oxidase. On the other hand, lesions can cause extensive tissue damage and are often difficult to separate and identify in closely spaced multiple tracks. Stainless steel electrodes are particularly useful for marking the electrode tip position by depositing iron. The deposit is made visible as a Prussian blue spot by perfusing the animal with potassium ferrocyanide at the end of the experiment. Other methods involve stains such as thionin (Nissl stain), cytochrome oxidase and immunological staining using an antibody against glial fibrillary acidic protein [1].

### Attempts at Assessing Intracellular Events with Extracellular Electrodes

As ▶ **intracellular recording** with microelectrodes may be difficult or impossible, various methods have been used to assess transmembrane potentials with extracellular electrodes. One method of recording transmembrane potentials from elongated structures such as axons is the *sucrose gap technique* [1]. A second example is the *estimation of* ▶ **post-synaptic potentials** elicited by spike trains. Since intracellular recordings are difficult to achieve in freely moving animals and in humans (at least under normal circumstances), methods have been developed to indirectly assess ▶ **excitatory postsynaptic potentials**

(EPSPs) and ►inhibitory postsynaptic potentials (IPSPs) from extracellular recordings. The idea is that in a discharging neuron, the probability of postsynaptic discharge is in part due to membrane potential changes such as EPSPs and IPSPs. That is, an EPSP will transiently increase the firing probability and an IPSP will decrease it. However, the precise relationship between firing probabilities and potential changes is not straightforward because of the nonlinearity of the ►encoder transforming potential changes into discharge [1].

## Advantages and Disadvantages

### Advantages

In general, extracellular recording poses fewer problems than does intracellular recording. For single-unit recording, therefore, the selection of the microelectrode is not that critical. Moreover, the possibility of combining various types of electrodes into arrays allows for the simultaneous study of several questions. Thus, extracellular recording can be used for the following purposes.

*Neuron characterization and identification.* One goal of extracellular recording is to identify and characterize neurons. In this context, several parameters are of use [1]:

- *Location.* In invertebrate ganglia, individual neurons can be reproducibly identified from one animal to the next. In the *in situ* vertebrate CNS, this is not possible for individual cells, but certain classes of cells, such as the pyramidal cells of the cortex, can often be identified with the help of additional criteria such as their responsiveness to the electrical stimulation of particular fiber bundles (such as the cerebral peduncles in the case of pyramidal cells) or the depth of the electrode tip.
- *Response profiles.* The major impact of extracellular recording has been the description of the discharge patterns of neurons as they relate to sensory inputs and motor acts. This work has generated most of the presently available knowledge about the signal traffic through sensory-motor and other systems.
- *Pharmacological sensitivity.* Recording electrodes can be combined with micropipettes for micro-iontophoresis or pressure ejection of drugs, which enables the determination of the recorded neuron's pharmacological characteristics, or to simply make it discharge.

*Functional connections.* Extracellular recording can be used to infer functional connections between neurons. This pertains to both inputs and outputs of a neuron. The afferent connections of a neuron can be studied in several ways [1]:

- *Stimulation of afferent pathways.* One very common method is to electrically, magnetically or otherwise stimulate afferent pathways (e.g., peripheral nerves

or central tracts or nuclei) and record from the postsynaptic neuron. The latencies of postsynaptic discharge may give some indication of the number of synapses interposed between the stimulated and the responding neurons.

- ►*Cross-correlation of the discharges of presynaptic and postsynaptic cells.* Another way is to use two (or more) extracellular electrodes to simultaneously record from presynaptic and postsynaptic neurons. Using cross-correlation techniques, connections between the neurons can be indirectly inferred. This method requires that all recorded neurons produce discharges at rather modest discharge rates. If they do not do so on their own, discharges can be evoked by iontophoretic application of excitatory substances, such as excitatory amino acids.

The *efferent projection* of a cell can be studied by electrically stimulating a cell's axon in some anatomical structure and recording the evoked (►antidromically conducted) action potential from the soma. The evoked action potentials should (i) have constant latencies, (ii) follow repetitive stimuli at high rate, and (iii) collide with ►orthodromic action potentials. Combined with distance measurements, this method may yield estimates of the cell's conduction velocity.

*Operation of neuronal networks.* Recordings by means of multi-electrode arrangements enable the study of cooperative interactions among large ensembles of neurons, even in behaving animals.

### Disadvantages

*Tissue damage* inflicted by electrodes inserted into nervous tissue is a serious limitation of any electrode or electrode arrangement and should be minimized as much as possible by appropriate design and configuration.

*Sampling bias.* Despite its relative ease and the importance of the results it provides, extracellular recordings pose certain problems. One is the *sampling problem*. Since large neurons produce more current than small ones, the larger the cells the easier it is for extracellular electrodes to pick up the currents produced by them. This leads to a sampling bias that favors bigger cells at the expense of smaller ones. In addition, unless there is a way of activating all cells, only spontaneously active neurons are sampled. Another factor may be the presence, type and dose of the anesthetic employed, which can be expected to influence the number and identity of spontaneously responsive neurons. These factors can result in an incorrect estimate of the proportions of different kinds of cells in a sample. This is particularly disturbing when their estimation is one of the motives for performing the study.

*Absence of sub-threshold intracellular events.* Extracellular recording yields much less information about signal processing within a cell than does intracellular

recording. For instance, slower membrane potential changes and postsynaptic potentials are not seen, and can only be estimated using very indirect statistical methods [1].

## References

1. Lalley PM, Moschovakis AK, Windhorst U (1999) Chapter 6: Electrical activity of individual neurons in situ: extra- and intracellular recording. In: Windhorst U, Johansson H (eds) *Modern techniques in neuroscience research*. Springer-Verlag; Berlin, Heidelberg, New York, pp 127–172
2. Snodderly DM Jr (1973) Extracellular single unit recording. In: Thompson RF, Patterson MM (eds) *Bioelectric recording techniques. Part A. Cellular processes and brain potentials*. Academic Press, New York, pp 137–163
3. Sinkjaer T, Haugland M, Struijk J, Riso R (1999) Long-term cuff electrode recordings from peripheral nerves in animals and humans. In: Windhorst U, Johansson H (eds) *Modern techniques in neuroscience research*. Springer-Verlag; Berlin, Heidelberg, New York, pp 787–802
4. Eckhorn R, Thomas U (1993) A new method for the insertion of multiple microprobes into neural and muscular tissue, including fiber electrodes, fine wires, needles, and microsensors. *J Neurosci Methods* 49:175–179
5. Krueger J (1983) Simultaneous individual recordings from many cerebral neurons: techniques and results. *Rev Biochem Physiol Pharmacol* 98:177–233
6. Wilson MA, Mc Naughton BL (1993) Dynamics of the hippocampal ensemble code for space. *Science* 261:1055–1058
7. Jog MS, Connolly CI, Kubota Y, Iyengar DR, Garrido L, Harlan R, Graybiel AM (2002) Tetrode technology: advances in implantable hardware, neuroimaging, and data analysis techniques. *J Neurosci Methods* 117:141–152
8. Buzsáki G (2004) Large-scale recording of neuronal ensembles. *Nature Neurosci* 7:446–451

## Extracellular Stress-regulated Kinase (Erk)

### Definition

A member of the mitogen-activated protein kinases (MAPKs), a family of serine/threonine-specific protein kinases that upon activation by growth factors regulate gene expression, mitosis, differentiation, and cell survival/apoptosis.

- ▶ Neurotrophic Factors
- ▶ Neurotrophic Factors in Nerve Regeneration

## Extra-classical Receptive Field Modulation

- ▶ Contextual Influences in Visual Processing

## Extramuscular Myofascial Force Transmission

### Definition

The specific case of epimuscular myofascial force transmission, in which force is transmitted between the unit of muscle fibers – connective tissue stroma of a muscle and non-muscular structures such as the neurovascular tract, intermuscular septum, interosseal membrane or periost.

- ▶ Epimuscular Myofascial Force Transmission and Intermuscular Interaction
- ▶ Intramuscular Myofascial Force Transmission

## Extraocular Motor Neurons

STEPHEN M. HIGHSTEIN

Department of Otolaryngology, Anatomy and Neurobiology, Washington University Medical School, St. Louis, MO, USA

### Definition

Extraocular motor neurons (EOMs) innervate the muscles that move the eyes. There are six extraocular muscles inserted upon the eyeball bilaterally, and thus there are six subgroups of extraocular motor neurons bilaterally. Four subgroups reside in the midbrain oculomotor or third nucleus, namely the superior, medial, and inferior recti, and the inferior oblique. The superior oblique motor neurons reside in the midbrain trochlear or fourth nucleus, and the abducens or lateral rectus motor neurons are located within the abducens or sixth nucleus at the ponto-medullary junction. Extraocular motor neurons of the superior rectus and superior

oblique are contralateral to the muscles they innervate; the remaining four subgroups are ipsilateral.

► **Internuclear neurons (INTs)** are a group of neurons resident largely within the rostral half of the abducens nucleus. INTs send their axons across the midline at the level of their cell bodies to travel in the contralateral median longitudinal fasciculus (MLF). These axons terminate monosynaptically with excitatory synapses upon contralateral medial rectus motor neurons. Additionally, they emit axon collaterals that terminate within the midline intermediate, caudal and rostral nuclei of the MLF.

## Characteristics

### Quantitative Description

Motor neurons and internuclear neurons fire spontaneously when the eyes are at rest, and discharge with higher or lower frequency during eye movements. Their discharge frequency controls the length and tension of the extra ocular muscles, which translates into a rate-eye position sensitivity constant or “k” and a rate-velocity constant or “r.” While k can be described as a linear function of eye position in the orbit versus firing frequency, r can only be described as a linear function for small eye movements. For eye movements larger than say  $5^{\circ}$ – $7^{\circ}$ , motor neuronal firing does not add an equal increment of firing increase for each increment of increase in the size of the eye movement. Thus, as far as eye velocity is concerned, extraocular motor neurons are usually firing in a non-linear range. Even though the neuronal firing rate that causes muscle fusion frequency is around 400 impulses/s, higher frequency bursts of up to 1,000 Hz serve to reach fusion more rapidly than slower bursts, translating into faster eye movements.

**Figure 1** illustrates the firing properties of abducens motor neurons and internuclear neurons for horizontal eye movements. The tonic rate of both types of cell increases as the eye position deviates ipsilaterally. These neurons also have spontaneous firing activity when the eyes are at rest, and discharge with higher or lower frequency during eye movements.

**Figure 2** a and b plots the relationships of tonic firing rate to eye position for motor and internuclear neurons, respectively, while C, D illustrates examples for populations of such neurons. Rate-position slopes of internuclear neurons are generally steeper than those of their motor neuronal counterparts, i.e. the sensitivity of internuclear neurons to static eye position is greater than that of motor neurons. Both cell types burst for rapid eye movements (saccades or quick phase of nystagmus) in their on-directions, and pause for such movements in their off directions. The greater sensitivity to both eye position and eye velocity of internuclear neurons might be due in part to the smaller size of the somata of these cells when compared to motor neurons. However, causality has yet to be strongly established [1].

### Lower Level Components

**Figures 3** and **4** illustrate the morphology of abducens motor neurons and internuclear neurons.

**Figure 3** focuses on the somata and proximal dendrites of a typical motor (A) and internuclear (B) neuron. Generally, the internuclear cells are smaller with less complex dendritic trees. However, as illustrated in **Figs. 3** and **4**, internuclear neuronal dendrites of INTs are thicker than those of motor neurons of similar somatic size, and are generally straighter, and less highly branched than their motor neuronal counterparts [2].

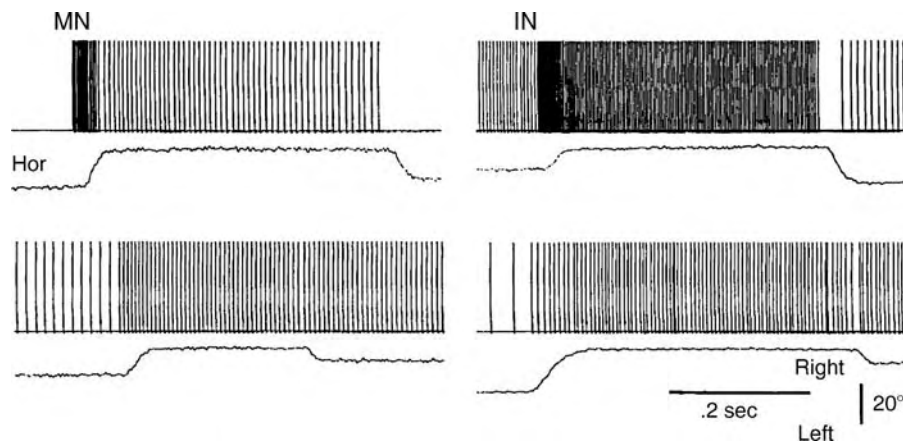

**Extraocular Motor Neurons. Figure 1** Firing patterns of two motor neurons (MN left) and two internuclear neurons (IN right). The top two neurons had a high saccadic eye velocity sensitivity, while the lower cells had a low sensitivity (modified from [1]).



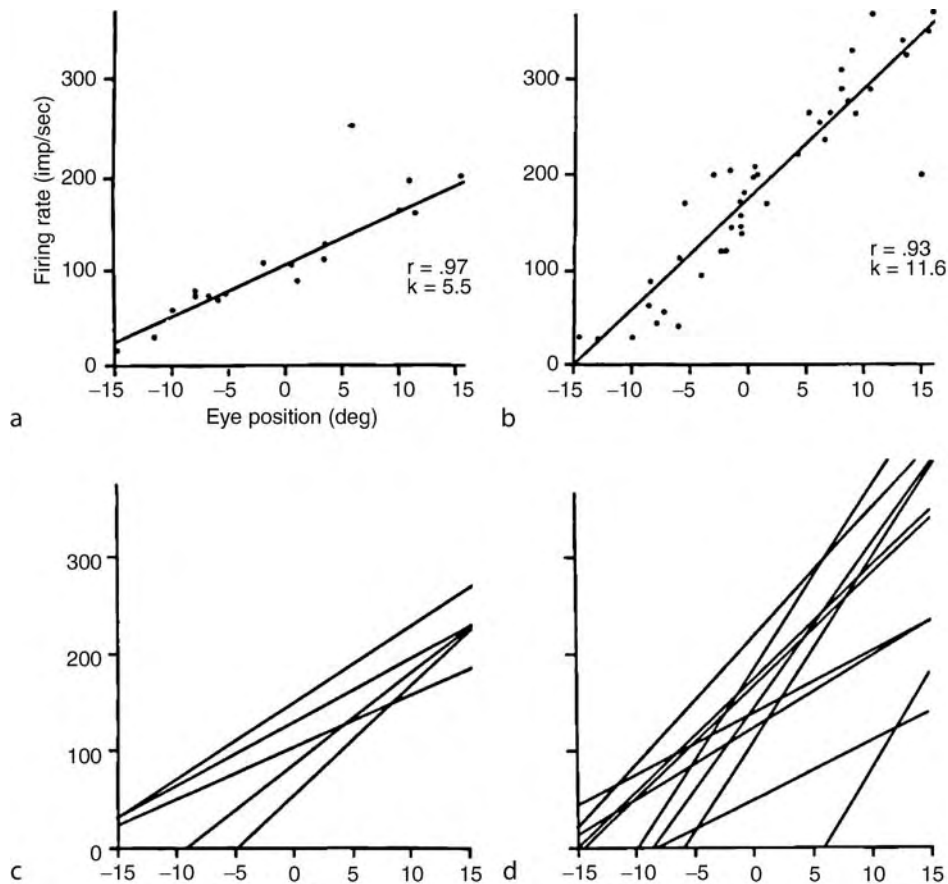

**Extraocular Motor Neurons. Figure 2** Eye position sensitivity of motor neurons (a, c) and internuclear neurons (b, d). The plots (a, b) illustrate the firing rate and eye position relationship for a motor and internuclear neuron, respectively. Eye positions ipsilateral to the neuronal somata are positive. The correlation coefficient ( $r$ ) of the linear regression line and the slope of that line ( $k$ ) in spikes/degree are indicated. (c, d) are similar plots for several other motor and internuclear neurons, respectively (modified from [1]).

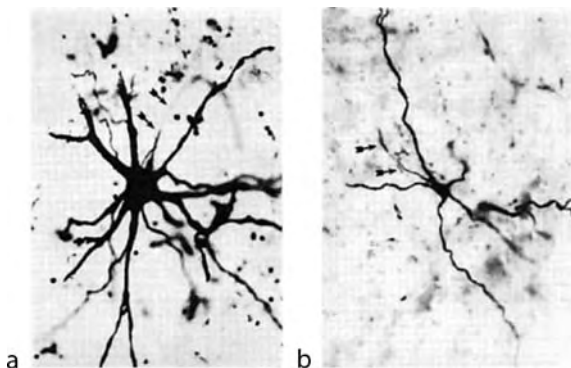

**Extraocular Motor Neurons. Figure 3** Photomicrographs of (a) an abducens motor neuron and (b) an internuclear neuron soma and proximal dendrites. The motor neuron somata measures roughly  $34 \times 47 \mu$  while the internuclear neuron somata measures approximately  $8 \times 30 \mu$  (modified from [2]).

Jean Buttner-Ennever [3] pioneered studies on groups of small motor neurons that surround the main nuclei. The C-subgroup of the medial rectus is a case in point. These neurons have been shown to be more involved in fixation and slow eye movements than in rapid eye movements such as saccades. Research on the functional roles of these small EOMs is ongoing.

### Pathology

For many years it was thought that the motor nuclei within the brainstem contained only motor neurons whose axons terminated in muscle causing its contraction. Thus, it was surprising when Graybiel and Hartweig [4] demonstrated with anatomical techniques, that a sub-population of abducens or lateral rectus motor neurons had axons that crossed the midline to terminate within the contralateral oculomotor or third nucleus. Subsequently Highstein and Baker [5]

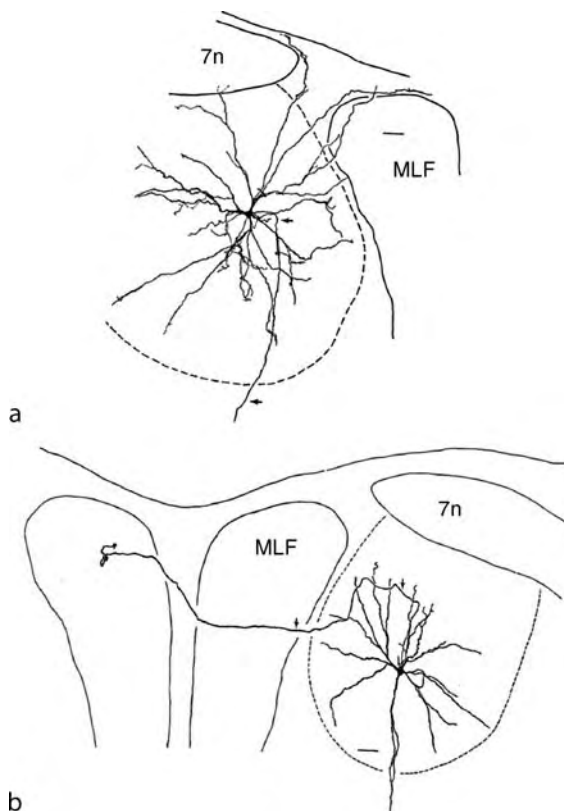

**Extraocular Motor Neurons. Figure 4** Coronal reconstruction of an abducens motor neuron (a) and an internuclear neuron (b). Arrows indicate axons. Neurons paired on the basis of soma shape. 7n, facial nerve; MLF, medial longitudinal fasciculus. Scale; 100  $\mu$ m (modified from [2]).

demonstrated that these neurons carried the ascending commands for conjugate eye movements to the opposite medial rectus extraocular motor neurons (Fig. 5).

A conjugate eye movement requires the co-contraction or co-relaxation of the ipsilateral lateral rectus and the contralateral medial rectus extraocular muscles. These neurons that link the lateral and medial recti were therefore named internuclear neurons. Interruption of their axons causes a well-defined syndrome called **internuclear ophthalmoplegia**. Patients affected by this syndrome have dysconjugate eye movements upon lateral gaze. Namely, with a left-sided syndrome, when attempting to look to the right the left eye does not cross the midline due to a failure of the medial rectus muscle to contract. The X in Fig. 5 indicates a lesion in the left MLF track. Rightward movement of the left eye is normally due to contraction of the left medial rectus muscle. However, the syndrome has removed the conjugate command innervation to this muscle carried

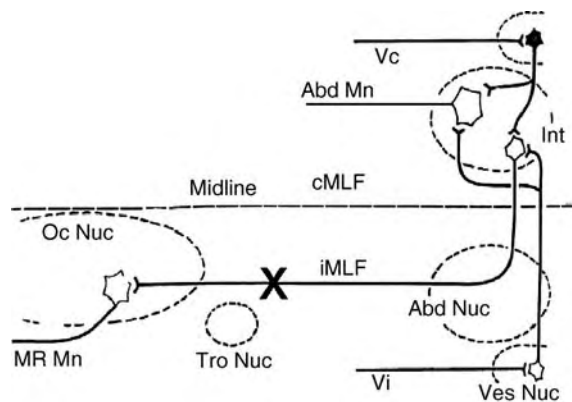

**Extraocular Motor Neurons. Figure 5** Schematic of the organization of abducens motor and internuclear neurons. Axons of Ints cross the midline to travel within the MLF and ultimately terminate monosynaptically upon contralateral medial rectus motor neurons (MR Mn). Filled neuronal somata have an inhibitory synaptic sign, and open somata terminate with excitation upon their targets. Vc and Vi, contralateral and ipsilateral VIIIth nerves, respectively. Abd Mn, abducens motor neuron; c and iMLF, contralateral and ipsilateral median longitudinal fasciculi, respectively; Ves Nuc, vestibular nuclei; Abd nuc, abducens nuclei; Tro Nuc, trochlear nuclei; Oc Nuc, oculomotor nuclei. X indicates the site of a putative MLF lesion.

by the axons of the internuclear neurons that ascend in the medial longitudinal fasciculus opposite to the side of their cell bodies of origin.

## References

1. McCrea RA, Strassman A, Highstein SM (1986) Morphology and physiology of abducens motoneurons and internuclear neurons intracellularly injected with horseradish peroxidase in alert squirrel monkeys. *J Comp Neurol* 243:291–308
2. Highstein SM, Karabelas A, Baker R, McCrea RA (1982) Comparison of the morphology of physiologically identified abducens motor and internuclear neurons in the cat: a light microscopic study employing the intracellular injection of horseradish peroxidase. *J Comp Neurol* 208:369–381
3. Buttner-Ennever JA, Akert K (1981) Medial rectus subgroups of the oculomotor nucleus and their abducens internuclear input in the monkey. *J Comp Neurol* 197:17–27
4. Graybiel AM, Hartweg EA (1974) Some afferent connections of the oculomotor complex in the cat: an experimental study with tracer techniques. *Brain Res* 81:543–551
5. Highstein SM, Baker R (1978) Excitatory termination of abducens internuclear neurons on medial rectus motoneurons: relationship to syndrome of internuclear ophthalmoplegia. *J Neurophysiol* 41:1647–1661

## Extraocular Muscle

### Definition

There are six extraocular muscles which act to rotate an eye about its vertical, horizontal, and antero-posterior axes: the medial rectus, the lateral rectus, the superior rectus, the inferior rectus, the superior oblique, and the inferior oblique. A given extraocular muscle moves an eye in a specific manner. For horizontal rapid eye movements, lateral rectus (LR) moves the eye away from the nose, while medial rectus (MR) moves the eye toward the nose.

► [Extraocular Motor Neurons](#)

## Extra-retinal Signals

### Definition

Non-visual signals used by the central nervous system to encode the position of the eyes in orbit. The brain must further combine these extra-retinal signals with visual (retinal) signals to allow the position of a visual target to be encoded with respect to any non-retinal coordinate system (head, trunk, body or gravio-inertial coordinate systems) useful for the programming of goal-directed movements. The relative contribution of efferent (oculomotor-related) and afferent (proprioceptive input) information to extra-retinal signals is still debated and varies with the behavioral task.

## Extrasomal Protein Synthesis in Neurons

JAN VAN MINNEN

Department Cell Biology & Anatomy, University of Calgary, Calgary, AB, Canada

### Synonyms

Extrasomal protein synthesis – local protein synthesis, axonal protein synthesis, dendritic protein synthesis; Soma or cell body; mRNA, transcript

### Definition

Extrasomal protein synthesis describes the ability of ► [neurons](#) to synthesize proteins in micro-domains of neurons, located outside the cell body or ► [soma](#).

### Characteristics

#### Introduction and Overview of Extrasomal Protein Synthesis

Neurons are the most polymorphous of all cell types in the animal kingdom. The cell body, or soma, extends many fine processes, which either receive (the ► [dendrites](#)) or transmit information onto other cells (the ► [axons](#)). Typically, a neuron contains many dendrites, but only one axon. Information gathering, processing and transmission are the most important task of neurons, and tiny structures called ► [synapses](#) are central to this process. A synapse is the point of functional contact between two neurons where information is generally carried by a chemical compound, the transmitter, from the presynaptic cell to the postsynaptic target. An electrical impulse invading a presynaptic terminal invokes calcium influx, which in turn facilitates transmitter release. The diffused transmitter (e.g., glutamate, dopamine, etc.) in turn binds to its respective receptors located on the postsynaptic membrane to alter its excitability. One neuron may contain many thousands of synapses which undergo dramatic structural and functional changes in response to either neuronal activity or various extrinsic factors (such as ► [neurotransmitters](#), trophic factors, etc.). These changes could either be short or long-term and they form the basis for all forms of learning and memory. It is generally believed that only long-term changes in synaptic structure and function require new protein synthesis, however the precise source of this protein synthesis (soma or locally) remains controversial.

During the last decade, it has become clear that the synapses are extremely complicated structures. As mentioned above, they consist of a pre and postsynaptic element, where literally thousands of different molecules interact in a coordinated fashion to transmit the electrical signals from one cell to another. Changes in the molecular composition of the network of proteins in both pre- and postsynaptic neurons will result in either strengthening or weakening of the synaptic structure and hence the underlying transmission. Since a neuron may contain thousands of synapses, how does it modulate the synaptic strength of a particular subset of synapses? A number of years ago, Frey and Morris formulated the “synaptic tagging” hypothesis, using the well established model for synaptic strengthening and weakening, long term potentiation (LTP) and long term depression (LTD), respectively. They showed that long lasting (L)-LTP induction at a subset of synapses stimulates the synthesis of new plasticity related proteins (PRPs), that subsequently could be captured at

a second set of synapses, which had received a single stimulus that normally leads early (E)-LTP. The capture of these PRPS converted the E-LTP into L-LTP. They hypothesized that the single stimulus generates a “tag” at the synapse, which captures the PRPs, that are synthesized by the neuron [1]. These experiments raised questions concerning the origin and nature of the molecules that are responsible for the synaptic tagging. Going back to earlier findings by Steward and Levy in 1982, who detected the key component of protein synthesis, ►polyribosomes, near synaptic sites [2] opened the attractive possibility that proteins could be synthesized on site – in response to synaptic activity. Furthermore, this mechanism would also spatially restrict protein synthesis within a neuron to those synapses that were stimulated, thus allowing individual synapses to regulate their efficacy and morphology in a protein synthesis-dependent manner.

It is now well established that ►mRNAs localize to (activated) synapses and that translation of these mRNAs leads to synaptic plasticity. Most studies have been conducted on dendrites, but it is becoming more and more evident that in the presynaptic (axonal) compartment protein synthesis does also occur. Here, a number of topics relating to pre- and post-synaptic protein synthesis will be described briefly. For a comprehensive description of the many aspects relating to extrasomal protein synthesis, the reader is referred to a number of recent reviews [3–5].

### Dendritic Protein Synthesis *mRNAs in Dendrites*

One of the first mRNAs detected in dendrites was the microtubule-associated protein 2 (MAP2) mRNA. In the years to follow, many transcripts have been added to the list, and depending upon the methods used, it is estimated that there are somewhere between 40 (using *in situ* hybridization) and 400 (using array and PCR-based strategies) dendritically localized mRNAs. These mRNAs include cytoskeletal proteins, enzymes, integral membrane proteins and molecules involved in protein modification and degradation. Interestingly, a number of reports have identified transcripts coding for proteins involved in local protein synthesis, such as ribosomal proteins and translation initiation factors. These data suggest that dendrites can synthesize, at least in part, molecules that are required for their own dendritic protein synthesis, but the exact mechanism by which this is accomplished remains to be determined.

The dendritic mRNA population is dependent on synaptic activity and the developmental stage of the animal. Many mRNAs, present for instance in growth cones and branch points during development may be absent in mature dendrites. Furthermore, presence or absence of mRNAs is dependent on synaptic activity. A well known example is the upregulation and

translocation to hippocampal dendrites of Arc mRNA in response to receptor activation. This dependency on activity and developmental phase raises questions concerning the mechanisms that are involved in the targeting of mRNAs. A number of these mechanisms will be described in the next paragraph.

### *Targeting of Dendritic mRNAs*

Both somal and extrasomal mRNAs are synthesized in the nucleus and subsequently transported to the cytoplasm. What factors determine whether an mRNA is to be exported to extracellular domains, or retained in the cell body? It is now clear that trans-acting RNA binding proteins that primarily bind to RNA stretches in the 3′-untranslated region (UTR) of mRNA are the key players. One of the best characterized mRNA binding proteins is the ►zip code binding protein 1 (ZBP1). Studies on fibroblasts showed that ZBP1 binds to a 51-nucleotide long stretch (“zip code”) in the 3′ UTR of β-actin mRNA. In neurons, ZBP1 binds β-actin mRNA in the nucleus and moves into the cytoplasm, where it represses translation. ZBP1 belongs to the heterogeneous nuclear ribonucleoprotein (hnRNP) family of proteins. Other members are hnRNP A2 and the fragile X mental retardation protein (FMRP). In the cytoplasm, the mRNA binding proteins and bound mRNAs are packaged into RNA transport granules. These granules contain in addition to mRNA, ►ribosomes and other translational components, mRNA binding proteins, motor proteins and hnRNPs (e.g., ZBP1 and FMRP) [6]. Next, the mRNA granules are transported along the microtubule network to their destinations in the dendritic compartment. Other proteins with a role in mRNA transport in neurons are Staufen 1 and Staufen 2. Staufen was first characterized in the *Drosophila* oocyte as an mRNA binding protein, which emphasizes that mRNA translocation to direct localized protein synthesis is a well conserved mechanism in evolution.

### *Regulation of Translation of Dendritic mRNAs*

Once the complexes of mRNA and mRNA binding proteins have reached their destination in the dendritic compartment, the mRNAs have to be released from their translational repression in a coordinate fashion so that the resultant proteins meet the need of the activated synapse. This is likely accomplished by diverse patterns of synaptic activity that stimulate distinct signaling cascades. These cascades differentially target specific mRNA binding proteins to release their mRNAs. After this, the mRNAs are translated by the dendritic protein synthesis machinery. Probably the best described mechanism underlying the regulated translation of specific mRNAs involves the cytoplasmic polyadenylation element binding protein 1 (CPEB1). CPEB1 is involved in regulating LTP and is localized in dendrites and post-synaptic densities (PSD). CPEB1 recognizes a

cis-element in the 3' UTR of a target mRNA and forms a complex with the 5' cap mRNA which prevents the formation of the translation initiation complex. In response to extracellular stimuli, CPEB1 is phosphorylated and recruits polyA-binding protein and elongation factor (eIF) 4G. This recruitment leads to polyadenylation and translation initiation. Presently, two proteins have been identified whose (dendritic) translation is regulated by CPEB1, CamKII and tissue plasminogen activator, but the translation of other mRNAs is likely to be controlled by CPEB1.

Another well-studied repressor of mRNA translation is the fragile X mental retardation protein (FMRP). Fragile X mental retardation is caused by a complete absence of the gene, or by a mutation in the mRNA binding domains which are localized in the 3' UTR. Fragile X patients and mouse models of the syndrome have an altered spine number and morphology that may be the cause of the mental retardation. Functionally, FMRP is involved in the establishment of metabolic glutamate-receptor (mGluR) dependent LTD. The precise mechanism of how this is accomplished is still largely unresolved, but it has been shown that FMRP represses translation of its mRNA targets, whereas upon synaptic stimulation it may support translation of the mRNAs in the FMRP complex. Surprisingly, FMRP mRNA is also present in dendrites, and FMRP is locally synthesized upon mGluR stimulation, which, as mentioned above, leads to mGluR dependent LTD.

A second mechanism by which mRNA translation in dendrites can be regulated is through stabilization of specific mRNAs. For instance, HuD, an Elav (embryonic lethal abnormal vision)-like protein binds to an AU rich segment in the 3' UTR of GAP-43 mRNA. This leads to stabilization of the mRNA, and it was demonstrated that this mechanism is involved in the formation of spatial memory in the hippocampus.

### Role of Dendritic Protein Synthesis

As mentioned above, dendritic protein synthesis plays a key role in synaptic plasticity. For the generation of L-LTP, transcriptional activity is required and therefore early studies focused on the role of translational control in the soma [1]. In 1996 the Schuman laboratory showed that protein synthesis in the dendritic field alone is sufficient to potentiate synaptic transmission. These authors used a hippocampal slice preparation in which the dendritic fields had been surgically isolated from their somata. After application of brain-derived ►neurotrophic factor (BDNF) they demonstrated that the synaptic transmission was potentiated between the CA3-CA1 synapses. This potentiation was sensitive to protein synthesis inhibitors, from which the authors concluded local dendritic protein synthesis was responsible for the strengthening of the synapses [7]). A similar study, using the same slice preparation,

showed that mGluR1 stimulation resulted in LTD, which required dendritic, but not somatic protein synthesis. A challenge for the future will be to determine what proteins are synthesized and how they interact to mediate the long-term changes, given the fact that the synaptic proteome contains over 1,000 different proteins. Also, these studies assume that all synaptic protein synthesis takes place in the dendritic compartment, and ignore the possibility that protein synthesis may also occur in the presynaptic terminal. As will be described below, the axonal compartments, to which these presynaptic structures belong, have also the potential to synthesize proteins.

There are only a few examples in which the dendritic synthesis of a given protein has been directly related to changes in synaptic efficacy. In 2002, the Mayford laboratory created mice that lacked the dendritic targeting element of the CAMKII $\alpha$  mRNA. This resulted in an almost complete absence of the CAMKII $\alpha$  transcript in the dendritic compartment, whereas somal levels of mRNA and protein were only moderately affected. However, the postsynaptic density (PSD) of these animals contained only about 20% of the CAMKII $\alpha$  protein. Behaviorally, these mice showed an impaired stabilization of synaptic plasticity and memory consolidation, in that they showed a reduced performance in the Morris water maze and contextual fear conditioning. Moreover, hippocampal slice preparations from these animals showed a diminished late-phase LTP.

In summary, it is now well established that mRNA translocation and subsequent regulated dendritic protein synthesis plays a crucial role in modulating synaptic efficacy and may thus form the basis for important brain functions such as learning and memory formation.

### Axonal Protein Synthesis

There are considerable differences in the morphology and molecular make-up of the axon compared to the dendritic compartment. As there are many dendrites, a neuron possesses only one axon, the length of which in large vertebrates may exceed several meters. Considering the enormous differences in volume between cell body versus axon (a conservative calculation shows that in a 1 m long axon it's volume exceeds that of the cell body at least 300 times) and the distance separating cellular components, it almost is a miracle that the distal axon not only survives but also performs autonomous functions.

The initial idea of how to provide axons with the necessary components to maintain the axonal integrity, such as e.g., cytoskeletal proteins, was that axonal proteins are transported anterogradely to the far reaches of axons. This possibility overlooked several constraints that are imposed by the extreme morphology of axons. If the soma is responsible for the supply, the

transport rate and capacity are the limiting factors. Axon transport has a fast and slow component, and the fastest rate reported is about 40 cm per day. Microtubule-based, fast axon transport carries vesicles and vesicle-associated proteins, such as receptor proteins. However, most cytosolic proteins, including cytoskeletal proteins, are transported at much slower rates, varying between 0.1 and 4 mm per day. (for review see [8]). Thus, cytoskeletal proteins would take at least 300 days to travel 1 m. Considering the half-life of proteins (e.g., tubulin  $t_{1/2} \approx 1$  week), it is hard to imagine that these proteins could reach the distal axon in sufficient quantities to be of biological significance. Indeed, studies by Nixon in 1980, using radioactive precursors, demonstrated that some cell body synthesized proteins destined for the peripheral axon are degraded in the first few millimeters of the mouse optic nerve. This means that the neuron must either spend significant energy to generate extra proteins to account for degradation during transport or it has other means to replenish proteins that are lost during transport. Moreover, as mentioned above, the volume of the axon is about 300× that of the cell body, where all the synthetic machinery is located. To supply such an excess of volume intuitively seems an almost impossible task.

An alternative mechanism to provide the distal axon with proteins was suggested Lasek and colleagues. They demonstrated that ►glia cells supply axons with proteins. However, these studies did not provide an answer to how neuronal specific proteins, such as ►neurofilaments, are supplied to the axon. Theoretically, a simple and economical way for the axon would be to synthesize some of its own proteins. Such localized protein synthesis is now a generally accepted mechanism in dendrites (see above), however for axons this mechanism was dismissed for a long time by much of the neuroscience community. Nevertheless, a small group of researchers have supported the idea of axonal protein synthesis for over 40 years (for reviews see [3,8]), and have performed groundbreaking experiments. Many of these “axonal” studies were initially carried out in two model systems, the Mauthner axon of the goldfish and the giant axon of the squid, where the large caliber axons (40–80 μm and up to 1 mm diameter, respectively) provided pure ►axoplasm for biochemical and molecular analyses. To date, with the recent advancements in sensitivity of molecular biological and biochemical techniques, axons from higher vertebrates have now become more amenable for analysis.

### mRNAs in Axons

In 1987 Capano and colleagues reported a complex, heterogeneous population of mRNAs (over 200 different transcripts) to be present in the squid giant

axon. Later studies showed axonal mRNAs included those encoding neurofilament, β-actin, β-tubulin, kinesin, enolase, nuclear-encoded mitochondrial proteins, heat-shock proteins and neuropeptides (for review, see [5]). Surprisingly, among the list of axonal mRNAs are species encoding ribosomal proteins and other components of the protein synthesizing machinery, such as translation initiation factors and chaperone proteins of the endoplasmic reticulum. These findings suggest that the axon, like dendrites (see above) can synthesize components of its own protein synthesizing and trafficking machinery.

### Targeting of Axonal mRNAs

β-actin mRNA has consistently been detected in many different axonal mRNA preparations (see above). The Singer laboratory showed differential localization of actin mRNAs in cortical neurons, with β-actin extending into axons and γ-actin being restricted to the cell body. The axonal targeting mechanism of the β-actin mRNA is comparable to the dendritic targeting described above, involving ZBP and a zip code in the transcript's 3' UTR. This zip code is absent in γ-actin mRNA. It is not clear what mechanisms may drive other neuronal mRNAs into axons, but for a number of axonal transcripts it has been demonstrated that the targeting sequence resides in the 3'UTR. For instance for Tau mRNA, which localizes to developing axonal processes, a *cis*-element resides in the 3' UTR that is recognized by RNA binding proteins including the Elav protein HuD. In other transcripts the zip code resides in the 5' UTR, as was shown for the κ-opioid receptor mRNAs. There appears to be no consensus sequence in the 5' or 3' UTRs that dictates axonal mRNA localization, but rather secondary and tertiary structure of the mRNA determines its interaction with RNA binding proteins.

The translocation of mRNAs can be differentially stimulated by external factors. The Twiss and van Minnen laboratories showed that treatment of dorsal root ganglion (DRG) cultures with nerve growth factor (NGF) or BDNF increases the transport of β-actin, vimentin and peripherin mRNA into axons, whereas the transport of the majority of the other axonally localized mRNAs was not affected by these growth factors. Imaging studies indicate that mRNAs can be transported at rates approaching that of fast anterograde transport of cell body-derived vesicular proteins, about 10 cm/day for actin mRNA. The rapid delivery of mRNAs encoding cytoskeletal proteins to distal axons could easily exceed the rate of delivery of the proteins that are synthesized in the cell body, which are moved by slow ►axonal transport velocity. Thus, translocation of mRNAs offers an attractive alternative possibility for the delivery of cytoskeletal proteins to the distal reaches of axonal compartment.

### Identification and Functions of Axonally Synthesized Proteins

Work from Koenig's group demonstrated that mature vertebrate axons contain components of the translational machinery and as, noted earlier, localized protein synthesis in mature axons was hypothesized to replenish proteins that are degraded during transport [8]. However, the actual function of this localized protein synthesis remained speculative without any means to test this hypothesis, due to the inability to isolate "pure" axonal preparation from mature nerves. As a consequence, most of our knowledge on the role of axonal protein synthesis comes from *in vitro*, developmental and regeneration studies.

An emerging concept is that locally synthesized proteins play a key role in axonal growth and support the developing axons to reach their target tissues. Studies using *in vitro* preparations of isolated axons demonstrated that local synthesis is required for chemotropic turning and growth cone collapse, and that guidance cues induce rapid synthesis of proteins such as  $\beta$ -actin, cofilin,  $\beta$ -thymosin and RhoA in the growth cone. Also, local synthesis is required for resensitization in responding to gradients of guidance cues [9]. Extracellular stimuli that regulate this axonal synthesis include Netrin-1, semaphorin 3A (Sema3A), and BDNF. The intracellular signaling cascades that lead to translational regulation in response to these axonal guidance cues have recently been identified. Erk 1/2 and p38<sup>MAPK</sup> are activated by axonal guidance cues and these signals can differentially regulate axonal protein synthesis. Sema3A locally activates Erk 1/2 leading to protein synthesis dependent turning of axons, while Netrin-1 activates both Erk 1/2 and p38<sup>MAPK</sup> leading to protein synthesis and proteolysis-dependent turning of axons. Furthermore, the involvement of CPEB to regulate localized translation of EphA2 mRNA in commissural axons should be mentioned. These data further strengthen the notion that axons and dendrites are likely to use similar mechanisms to regulate targeting and translation of mRNAs.

In addition to support axonal growth in developing axons, local synthesis plays a key role in regeneration. Using an *in vivo* peripheral nerve injury model, it was suggested that localized protein synthesis is required for axonal regeneration. The use of a culture preparation of dissociated injury-conditioned rat dorsal root ganglion neurons, made it possible to verify the potential of axons to synthesize proteins and to address their functionality. Axons isolated from these neurons synthesize proteins in culture and their growth cones rapidly retract upon inhibition of protein synthesis. A proteomics-based analyses of proteins translated by these isolated axons showed that a large number of different proteins are synthesized locally. Presently, the list of axonally synthesized proteins includes cytoskeletal proteins, neuropeptides, integral

membrane proteins, heat-shock- and other chaperone proteins, anti-oxidant proteins, metabolic proteins, nuclear-encoded mitochondrial proteins as well as proteins that have been linked to neurodegenerative disorders [5].

A surprising new role of local axonal synthesis was recently described by the Fainzilber laboratory. They showed protein synthesis at the site of an axonal injury serves as a way to signal the cell body. Following a nerve crush, a signaling complex is assembled in axons immediately proximal to the site of the injury. The formation of this complex requires synthesis of importin  $\beta$ 1 and vimentin, after which the newly synthesized proteins assemble into a retrograde signaling complex. Vimentin is subsequently proteolyzed and the cleaved vimentin serves as a scaffold to retrogradely transport activated Erk to the cell body where it initiates a regenerative response. A comparable mechanism of localized synthesis of importin with signaling to the nucleus was reported for dendrites of hippocampal neurons after NMDA receptor stimulation. This lends further support to the notion that plasticity and injury share common mechanisms and that axons and dendrites are likely to share common molecular mechanisms of localized mRNA translation.

The fact that axons and dendrites are capable of synthesizing a sizable portion of their own proteins raises questions about the basic biology of this process. It is a mystery how axons and dendrites can target locally synthesized proteins for membrane insertion, given that **RER** and **Golgi apparatus** are not ultrastructurally visualized in these domains [10]. In spite of this, membrane targeting of receptor proteins has been demonstrated. Spencer and colleagues injected an exogenous mRNA encoding a G-protein coupled receptor into axons separated from their cell body. The injected axons translated the mRNA, inserted the newly synthesized protein into the axonal membrane, and exhibited ligand-induced depolarization. Another example for localized translation and insertion of the integral membrane protein EphA2 was provided by the Flannagan laboratory. It will however be of great interest to delineate the mechanism(s) of protein synthesis and trafficking into axonal membrane. As further understanding of axonal protein synthesis is gained, the cellular mechanisms regulating this process may provide additional targets for modulating growth and repair of the injured nervous system.

From the above studies, it can be concluded that the axonal compartments of both vertebrate and invertebrate axons have the ability to synthesize proteins. The amount of axonal protein synthesis may vary from species to species, and may depend on the size or physiological state of the axon. To generalize, in large vertebrate (Mauthner) and invertebrate (molluscan) axons, protein synthesis appears to proceed at a higher rate than in mature mammalian axons. This assumption

is based on the facts that ribosomes, mRNAs and translational machinery are readily detectable in these axons, whereas they are very scanty in adult mammalian axons. Mammalian axons however are able to invoke the ability to synthesize proteins under particular conditions, such as injury and regeneration. Understanding the mechanisms by which axons acquire the ability to recruit the synthetic machinery and translocate specific mRNAs to the axonal domain holds great promise for the future to manipulate these processes.

### Unifying Principles of Dendritic and Axonal Protein Synthesis

Both the dendritic and axonal compartments of neurons have the ability to synthesize proteins. Most emphasis in dendrites has been on how localized protein synthesis impacts on synaptic strength and learning and memory formation, whereas in axons the focus was more on the significance in development and regeneration. Yet both dendrites and axons use similar principles to target and locally translate mRNAs, use similar RNA binding proteins, translate overlapping populations of mRNAs and translation can be regulated by similar intracellular and extracellular stimuli. It appears that axonal and dendritic translation are two sides of the same coin, and that the ability to locally synthesize proteins is an inherent property of the neuron which goes back to developmental mechanisms that initially shaped the nervous system.

### References

1. Frey U, Morris RG (1997) Synaptic tagging and long-term potentiation. *Nature* 385:533–536
2. Steward O, Levy WB (1982) Preferential localization of polyribosomes under the base of dendritic spines in granule cells of the dentate gyrus. *J Neurosci* 2:284–291
3. Giuditta A, Kaplan BB, van Minnen J, Alvarez J, Koenig E (2002) Axonal and presynaptic protein synthesis: new insights into the biology of the neuron. *Trends in Neurosci* 25:401–404
4. Sutton MA, Schuman EM (2006) Dendritic protein synthesis, synaptic plasticity, and memory. *Cell* 127:49–58
5. Twiss JL, van Minnen J (2006) New insights into neuronal regeneration: the role of axonal protein synthesis in pathfinding and axonal extension. *J Neurotrauma* 23:295–308
6. Sossin WS, DesGroseillers L (2006) Intracellular trafficking of RNA in neurons. *Traffic* 7:1581–1589
7. Kang H, Schuman EM (1996) A requirement for local protein synthesis in neurotrophin-induced hippocampal synaptic plasticity. *Science* 273:1402–1406
8. Alvarez J (2001) The autonomous axon: a model based on local synthesis of proteins. *Biol Res* 34:103–109
9. Piper M, Holt C (2004) RNA translation in axons. *Annu Rev Cell Dev Biol* 20:505–523
10. Peters A, Palay SL, Webster FW (1991) *The fine anatomy of the nervous system*, 3rd edn. Oxford University Press, Oxford

## Extrasomatic Translation

- mRNA Targeting: Growth Cone Guidance

## Extrastriate

### Definition

Located in cortical regions lying outside striate cortex (primary visual cortex or V1).

- Evolution of the Visual System: Mammals – Color Vision and the Function of Parallel Visual Pathways in Primates

## Extrastriate Cortex

### Definition

Areas of the visual cortex lying outside primary visual cortex, also referred to as prestriate cortex, i.e., in front of striate cortex.

- Extrastriate Visual Cortex

## Extrastriate Visual Cortex

DANIEL J. FELLEMAN

Department of Neurobiology and Anatomy, University of Texas Medical School-Houston, Houston, TX, USA

### Synonyms

Visual association cortex; Visual psychic cortex

### Definition

Extrastriate visual cortex refers to a large number of well-defined cortical areas and less well defined cortical zones that are located anterior to ►primary visual cortex (►area V1 or ►striate cortex) which are implicated in visual function on the basis of their physiology, cortical connections, and/or behavioral contributions to visual perception.



## Characteristics

### Extrastriate Cortical Areas

Visual cortex of primates consists of a large number of discrete cortical areas and less well defined cortical zones. Traditionally, cortical areas are defined according to a number of criteria; cyto-, myelo-, and/or chemoarchitecture, topographic organization, cortical connections, electrophysiological properties of their constituent neurons, and behavioral deficits following lesions or deactivation [1,2]. Although individual areas are generally not identified by a single criterion, most well recognized areas are defined on the basis of three or more of these criteria. Accordingly, visual cortex of macaque monkeys has been subdivided into at least 35 discrete areas distributed across the occipital, parietal, temporal, and frontal lobes (see Fig. 1). In addition, several expanses of visual cortex retain the distinction of cortical zones since they have not been well characterized, and may eventually be recognized as new cortical areas or be recognized as being part of larger cortical areas characterized by anatomical or functional heterogeneity. In Fig. 1, areas visible on the slightly exploded view of the lateral view of the cerebral hemisphere are illustrated in panel A and the full, unfolded, cortical surface is illustrated in panel B. In addition, the division of cortical areas into well recognized cortical streams and functional modules are illustrated by their color (►Color) and pattern designations (see below).

The occipital lobe contains a large number of extrastriate visual cortical areas that have been previously attributed to occipital architectonic areas 18 and 19 of Brodmann [3] or areas OA, OB, OC of von Bonin and Bailey [4]. The occipital lobe contains areas V2, V3 (V3d), VP (V3v), V3A, V4, V4Ad, V4Av, PIP, CIP, PO, V4t, and MT. A large number of extrastriate areas occupy temporal lobe cortex previously described as areas 20 and 21 of Brodmann [3] or TEO, TE, TEa/TEM of von Bonin and Bailey [4]. Currently recognized extrastriate temporal lobe areas include: PITd, PITv, CITv, CITd, AITpv, AITpd, AITav, AITad, FST, and one or more subdivisions of the anterior lateral bank of the STS (e.g. ALSTS and PLSTS). Parietal cortex contains a large number of extrastriate visual areas that participate in visual spatial analysis and visually guided eye and arm movements (►Visual space representation for action, ►Visual space representation for reaching). These parietal areas include areas LIPd, LIPv, VIPm, VIPI, AIP, MDP, MIP, V6, V6A, DP, and 7a. Frontal cortex contains several cortical areas that are implicated in various aspects of visual processing. Most posteriorly, area 8, the ►frontal eye fields, is involved in the generation of volitional ►saccadic eye movements. More anteriorly, area 46 is implicated in several aspects of visual memory, learning, and motor planning. In addition, areas 11, 12, and 13, on the orbital surface of

the frontal lobe, are involved in the representation of the affective qualities of visual stimuli, which are conveyed to several visual subdivisions of the medial and lateral temporal lobe.

### Extrastriate Cortical Modules

Extrastriate cortical areas have often been described as containing discrete anatomical or functional modules. Area V2 contains the best-studied example of anatomical modules that reflect distinct physiological processes [5]. The anatomical basis for modularity in V2 was first revealed by the stripe-like pattern in tangentially sectioned tissue stained for the metabolic enzyme cytochrome oxidase. This anatomical stain reveals three parallel, stripe-like modules referred to as the cytochrome oxidase thick, pale, and interstripes (Fig. 2b). A multitude of anatomical pathway tracing studies revealed that these V2 stripes receive specific, largely parallel input from modular elements in V1; V1 cytochrome oxidase blobs project to V2 thin stripes, V1 inter-blobs project to V2 interstripes, and V1 layer 4B projects to V2 thick stripes. Similarly, these V2 modules project, in parallel, to several extrastriate areas and thus provide evidence for one type of functional streaming in visual cortex (see below). The anatomical organization and segregated inputs to these V2 functional modules are also reflected in the functional properties of their constituent neurons. Specifically, V2 thin stripes contain spatially organized maps of hue and luminance change [6] (see Fig. 2c), V2 interstripes contain spatially organized maps of contour orientation [7], and V2 thick stripes contain spatially organized maps of contour orientation and binocular disparity [7] (see Fig. 2d).

Additional evidence for the modular organization of extrastriate cortical areas comes from electrophysiological, anatomical, and functional imaging studies of area MT in owl and macaque monkeys. Area MT is a well-defined area whose neurons are almost exclusively selective for the direction of visual motion (►Visual motion processing). Early electrophysiological studies recognized the systematic order of preferred direction that changed with tangential movement of the recording microelectrode. Functional imaging in owl monkeys revealed the complete pattern of preferred direction and its relationship to orientation preference maps. Furthermore, neurons in MT are selective for binocular disparity (►Binocular vision) and it is believed that disparity, orientation, and direction are systematically mapped within MT functional modules. Finally, MT contains an additional form of modularity that appears to reflect the segregation of neurons on the basis of the degree of wide field surround suppression.

Evidence for a modular organization in area V4 has come chiefly from investigations of the clustered patterns of cortical connections linking it with well



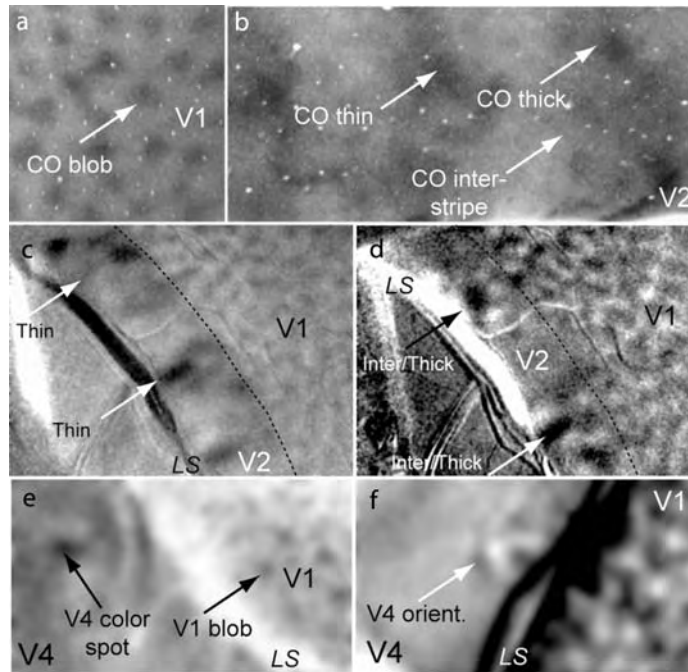

**Extrastriate Visual Cortex. Figure 2** Anatomical and Functional Modules in Areas V1 and V2. (a) Cytochrome oxidase blobs in area V1. (b) Cytochrome oxidase dense thin and thick stripes and pale interstripes in area V2. (c) Differential intrinsic optical image (*red/green – luminance*) indicating the color-prefering thin stripes (*dark regions*) in V2. Luminance-prefering domains in V2 thin stripes are bright. (d) Differential intrinsic optical image (*luminance 45°: dark regions – luminance 135°: bright regions*) indicating the orientation-prefering thick and interstripes in V2 that flank the thin stripes. (e) Differential intrinsic optical image (*red-green-luminance*) demonstrating color-prefering blobs in V1 and color spots in V2. (f) Differential optical image (*luminance 45–135°*) of orientation-prefering domains in V1 and V4.

defined modules in V2 and less well defined regions of posterior inferotemporal cortex. Following paired injections of distinguishable anterograde tracers restricted to individual V2 thin stripe and interstripe modules, labeled axon arbors were observed in largely segregated domains [8]. Unlike areas V1 and V2 that have distinctive cytochrome oxidase architecture, these large, segregated terminal fields provided clear evidence that the modular architecture observed in V2 was relayed and retained in area V4. In addition, paired distinguishable retrograde tracer injections in V4 that revealed segregated inputs from either thin or interstripes also demonstrated segregated modular domains in posterior inferotemporal cortex [9]. These anatomical experiments suggest that similar functional module types are present from V1 to intermediate levels of cortical processing in posterior inferotemporal cortex. Functional imaging studies have also demonstrated V4 cortical modules, but the precise correspondence of these modules to the thin and interstripe inputs from V2 remain to be determined. Nevertheless, V4 consists of a modular array of color-prefering (e.g. Fig. 2e) and orientation-prefering (e.g. Fig. 2f) modules somewhat similar to that observed in area V2.

A different type of modular architecture has been described for anterior inferotemporal cortex where neurons appear to be clustered by their selectivity for similar complex objects or shapes ([▶ Visual object representation](#)). Furthermore, adjacent “object modules” appear to represent similar, but functionally distinct complex shapes. These cortical modules, demonstrated by both standard electrophysiological recording and intrinsic optical recording techniques, may represent the highest form of functional module in the constellation of extrastriate cortical areas that subservise object recognition and perhaps visual memory.

### Extrastriate Functional Streams

It has long been recognized that extrastriate cortex of primates can be viewed as consisting of separate object recognition and spatial processing cortical streams [10] ([▶ Visual processing streams in primates](#)). This dichotomy was first based on behavioral observations following cortical lesions that suggested that temporal lobe areas were essential for object, “what” processing, while parietal lobe areas were essential for object, “where” processing. This basic dichotomy has received further support from electrophysiological studies of

receptive field properties (► [Visual receptive fields](#)) and anatomical studies of cortical pathways. More recently, the notion of separate “what” and “where” streams has been challenged by observations of rich interconnections between parietal and temporal lobe areas and by the demonstration of position selectivity in temporal lobe receptive fields and object form selectivity in parietal lobe neurons.

Initially, this high-level dichotomy was attributed to the parallel thalamo-cortical streams (► [Geniculo-striate pathways](#)) or their re-emergence from area V2. However, subsequent studies have recognized that these parallel inputs to V1 (parvocellular, koniocellular, and magnocellular lateral geniculate nucleus, LGN) are recombined in V1 to form three new streams. First, a magnocellular-dominated stream emerges from layer 4B in area V1 to provide input to V2 thick stripes, V3, and area MT. Second, the koniocellular stream is combined with elements of the magnocellular and parvocellular streams to form the color-preferring “blob” stream. Third, the parvocellular and magnocellular streams are combined to form the orientation-preferring “interblob” stream.

The blob and interblob streams of V1 project in a parallel and largely segregated manner to the cytochrome oxidase-defined thin and interstripes of V2. Although there is no doubt some crosstalk between streams via intrinsic connections within V2, these streams emerge to provide largely parallel, segregated inputs to discrete domains in V4 ([Fig. 3](#); yellow and black domains). Furthermore, anatomical studies demonstrate that larger domains in posterior inferotemporal cortex (PITd and PITv) receive segregated inputs from these V4 compartments thus demonstrating the continuance of these parallel streams into temporal lobe “what” processing areas.

According to the earliest views of cortical streams, the motion/direction-selective stream arising from layer 4B of V1 and directed to V2 thick stripes, V3, and MT is utilized solely for the analysis of three-dimensional location necessary for the “where” stream. This narrow view of MT function has been revised by anatomical and physiological studies that demonstrated a modular organization within MT (see above) that serves to segregate neurons according to their degree of surround inhibition (local versus wide-field motion selectivity) and to segregate neurons according to their cortical projections. According to this view, neurons selective for local movement are segregated into bands in area MT that project to temporal lobe area FST, while wide-field bands project to the ► [MST-complex](#) that relays this information to several subdivisions of parietal cortex. The significance of the MT projection to FST and subsequent areas (e.g. LST) is exemplified by the observation of robust motion-defined object selectivity through many areas within the lateral bank of the STS in the temporal lobe.

A further distinction of cortical streams within parietal cortex has come from recent studies that demonstrate parallel sets of areas and cortical connections that subservise goal directed eye and arm/hand movements. According to this view, a subset of parietal areas, including areas LIPd/v are closely interconnected with frontal area 8Ac to provide spatial information necessary to guide saccadic eye movements. In contrast, a different subset of areas, culminating in area AIP are closely interconnected with hand and arm subdivisions of motor cortex and provide information necessary for object shape-guided hand and arm movements into extra-personal space (► [Visual space representation for reaching](#)).

### Hierarchical Organization

It has been a longstanding belief that the visual system is organized hierarchically such that, at its lowest level, thalamic inputs enter through primary visual cortex, V1, and that the highest levels of visual processing take place in the temporal and frontal lobes. This notion is supported by the study of receptive field properties that demonstrate local processing of a small number of visual properties in V1 and selectivity for complex objects at the highest processing levels of the temporal and frontal lobes. The search for “step-wise” increases in complexity of properties has been directed at intermediate levels of processing (e.g. V2, V4, MT, MST complex, etc.), but despite certain properties that support this simple hierarchy theory, it has remained somewhat obscure what properties change across these intermediate areas.

An alternative approach to the study of hierarchical processing in visual cortex comes from anatomical studies of the laminar origins and terminations of cortical pathways that interlink the 30 or more extrastriate visual areas [1]. Although there are some exceptions, it is largely agreed that three types of cortico-cortical pathways can be observed. Feedforward pathways arise from cells located in the supragranular cortical layers and their axons terminate in layer 4 and deep layer 3. Feedback pathways arise from infragranular layers and terminate outside of layer 4, usually in layers 1 and 6. Lateral pathways, thought to link cortical areas at the same hierarchical level, arise from both supragranular and infragranular layers and usually terminate in a column spanning all cortical layers. An overall cortical hierarchy is then constructed by making pairwise comparisons of the reciprocal pathways interlinking all cortical areas and placing each area one level above each area that provides it feedforward input. When this process is iteratively applied to all known visual cortical pathways it is possible to assign the more than thirty visual cortical areas to one of 7 (or more) distinct hierarchical levels. [Figure 3](#) illustrates a subset of areas in macaque visual cortex and their hierarchical position according to

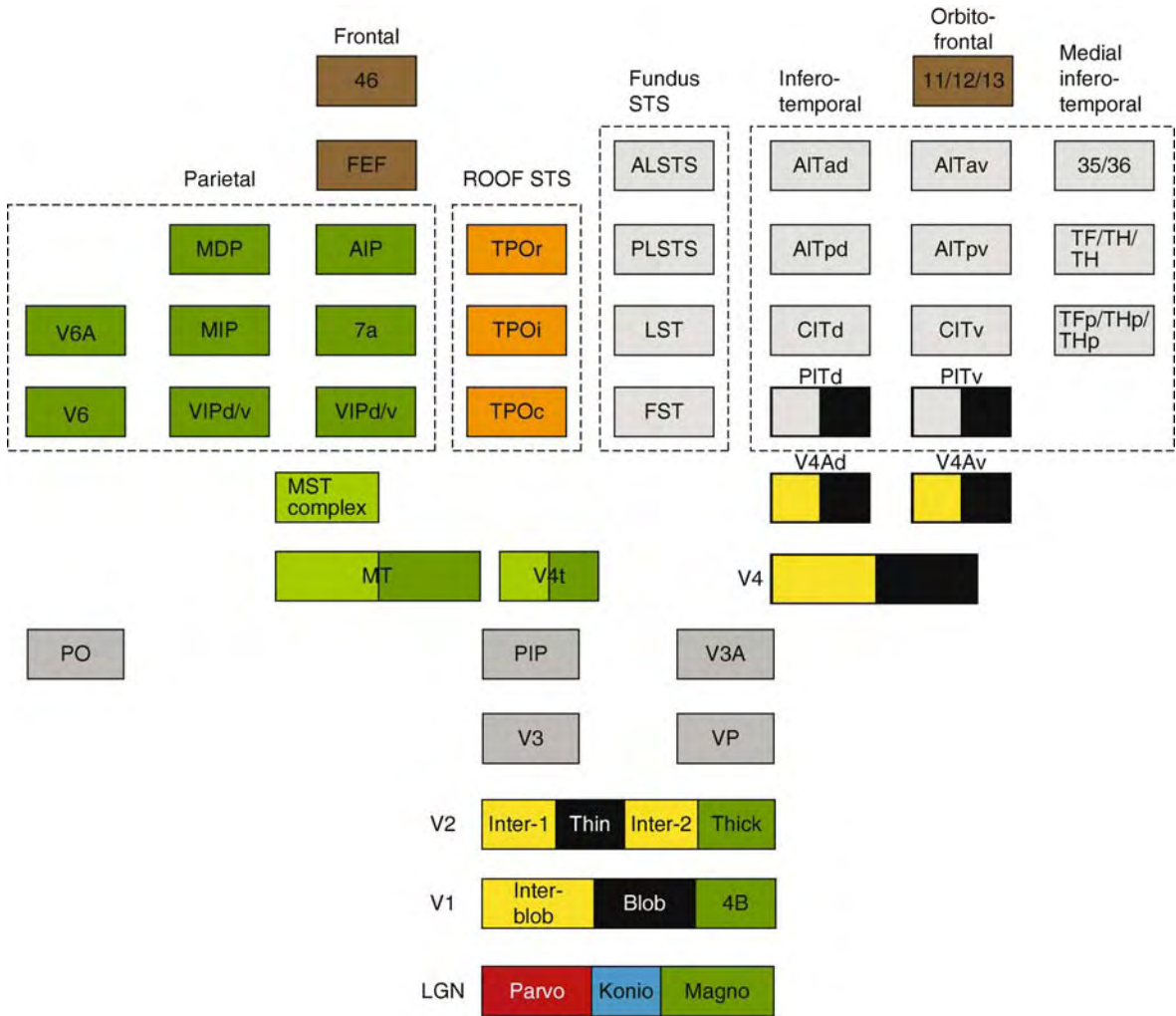

E

**Extrastriate Visual Cortex. Figure 3** Hierarchical organization of macaque visual cortex. Anatomical hierarchy of visual cortex based on the laminar patterns of cell bodies and axonal terminations of interconnected areas. Multiple-colored areas reflect modular subdivisions within areas V1, V2, V4, V4Ad, V4Av, PITv, PITd, MT, and V4t. The locations of extrastriate areas in parietal, frontal, and temporal lobes are indicated by solid colors as depicted in Fig. 1. This hierarchical array of a subset of visual cortical areas illustrates low level cortical modules and streams as well as the parcellations of higher cortical areas into larger domains. The areas enclosed by dashed boxes appear to reflect functional distinctions within the lateral and medial inferotemporal cortex, floor of the superior temporal sulcus, roof of the superior temporal sulcus, and parietal cortex.

this scheme. Recently, quantitative methods have been used to characterize the laminar patterns of origin for cortical pathways among the lower visual areas. This scheme introduces an anatomical distance metric between areas based on the proportion of supragranular cells in a given pathway. This analysis yields a hierarchy that in many ways is similar to the qualitative hierarchy described above, but differs in the assignment of a few areas.

It is important to reiterate that the above-described cortical hierarchy is based solely on anatomical principles and does not necessarily reflect notions of “stepwise” increases in functional complexity as one

ascends the anatomical hierarchy. The lack of direct correspondence between the anatomical hierarchy and notions of stepwise increases in functional complexity can be due to many factors including cortical pathways that span many discrete hierarchical levels, convergent input from areas at multiple levels onto a given cortical area, as well as incomplete knowledge about which functional properties to assess stepwise hierarchical change. The hierarchical position of area MT provides a useful focus for consideration of many of these factors. First, MT is located at the fifth level, but receives feedforward inputs that span many hierarchical levels. For example, MT receives a direct feedforward input

from cells in layer 4B of V1 (level 1), from thick stripes in V2 (level 2), from areas V3 and VP (level 3), and from area V3A (level 4). Thus, in some anatomical and perhaps functional sense, MT could be considered only one level higher than each of these areas. The second point, that MT receives convergent input from multiple areas at different hierarchical levels might suggest that each of these areas provides MT neurons with different types of input that may not simply be described by obvious differences in “stepwise” complexity. Thus, the inputs from V1 may reflect local motion cues while the V2 thick stripe input might convey specific binocular disparity information. The third point about uncertainty in the right functional questions to ask may be related to the second point about convergent inputs. For example, comparison of receptive field properties of layer 4B and MT neurons with respect to simple motion and direction selectivity may not reveal differences that might be expected on the basis of their separation by four hierarchical levels. However, comparisons of receptive field properties on the basis of higher order motion processing (e.g. shape from motion) might reveal a fundamental difference that is constructed over multiple discrete hierarchical steps.

A related dimension underlying the interpretations of the visual cortical anatomical hierarchy concerns the timing of information flow through the hierarchy. At one level of analysis, the latency to initial activation in each cortical area might simply be related to the number of synapses between a given extrastriate cell and the input from V1. Using area MT as an example, an extrastriate latency hierarchy might place MT at the same level as V2 and V3, given each of these areas is only one synapse away from V1. Closer scrutiny of this issue suggests that extrastriate response latency is determined by a number of additional factors including the density of feedforward inputs, the axonal caliber of all associated “lower” cortical pathways, and the efficacy of any given visual stimulus to activate “lower” visual neurons. This analysis thus underscores the difficulties in interpreting neuronal latency data and indicates the necessity for evaluating and understanding the changes in neuronal functional properties at different levels of the visual cortical hierarchy.

## References

1. Felleman DJ, Van Essen DC (1991) Distributed hierarchical processing in the primate cerebral cortex. *Cerebral Cortex* 1:1–47
2. Lewis JW, Van Essen DC (2000) Mapping of architectonic subdivisions in the macaque monkey, with emphasis on parieto-occipital cortex. *J Comp Neurol* 428:79–111
3. Brodmann K (1909) *Vergleichende Lokalisationslehre der Grosshirnrinde in ihren Prinzipien dargestellt aufgrund des Zellenbaues*. Leipzig, J.A. Barth

4. von Bonin G, Bailey P (1947) *The neocortex of macaca mulatta*. Urbana, IL, University of Illinois
5. Hubel DH, Livingstone MS (1987) Segregation of form, color, and stereopsis in primate area 18. *J Neurosci* 7 (11):3378–3415
6. Xiao Y, Wang Y, Felleman DJ (2003). Spatially organized representation of hue in macaque V2. *Nature* 421:535–539
7. Ts'o DY, Roe AW, Gilbert CD (2001) A hierarchy of the functional organization for color, form, and disparity in primate visual area V2. *Vision Res* 41:1333–1349
8. Xiao Y, Zych A, Felleman DJ (1999) Segregation and convergence of functionally defined V2 thin stripe and interstripe compartment projections to area V4 of macaques. *Cerebral Cortex* 9:792–804
9. Felleman DJ, Xiao Y, McClendon E (1997) Modular organization of occipito-temporal pathways: cortical connections between areas V2, V4, and PITv in macaques. *J Neurosci* 17:3185–3200
10. Ungerleider LG, Mishkin M (1982) Two cortical visual systems. In: Ingle DJ, Goodale MA, Mansfield RJQ (eds) *Analysis of visual behavior*. Cambridge, MA, MIT Press, pp 549–586

---

## Eye

### Synonyms

Musculi externi bulbi oculi; Extra-ocular muscles

### Definition

The extra-ocular muscles are compared with the intra-ocular muscles. The former provide for movement of the eyeball, while the latter are involved in adaptation (via the iris) and accommodation (via lens).

---

## Eye Evolution

### ► Evolution of Eyes

---

## Eye Movement System

### ► Evolution of Oculomotor System

## Eye Movements

### Definition

Any change of orientation of the eyes with respect to the head. They can be fast (e.g., “Saccades”) or slow (e.g., “smooth pursuit”), “conjugate,” or “disjunctive” and their goal can be either to shift the line of sight from one point of the visible world to another (e.g., “Saccades”) or to stabilize the visual image on the retina (e.g., the “vestibulo-ocular reflex”). They are caused by the combined activation/relaxation of six extraocular muscles (see “Eye Muscles”).

► Eye Movements Field

## Eye Muscle

### Synonyms

Extraocular Muscles

### Definition

Eye muscles are the six muscles (also known as extraocular muscles or EOMs) that rotate the eye. Horizontal eye rotations, usually referred to as horizontal eye movements, are produced mainly by the lateral and medial rectus muscles (also known as the horizontal recti). Vertical and torsional eye movements are produced mainly by the superior and inferior rectus muscles (vertical recti) in combination with the superior and inferior oblique muscles (obliques).

► Eye Orbital Mechanics

► Extraocular Muscle

## Eye Orbital Mechanics

PAUL DEAN, JOHN PORRILL

Department of Psychology, University of Sheffield,  
Sheffield, UK

### Synonyms

Oculomotor plant

### Definition

Mechanics of the ► eye muscles in combination with the connective and fatty tissues of the orbit (► orbital tissues) that surround the eyeball.

### Description of the Theory

#### Introduction

Neural signals from the ocular motoneurons (OMNs) control eye position and velocity. They do so by producing forces via the eye muscles (extraocular muscles, EOMs), which act on the eyeball and surrounding orbital tissues to move the eye. The mechanics of the EOMs and orbital tissues determine the relation between the neural input and eye-movement output, and are therefore of interest to clinicians as a possible contributor to eye-movement disorders, to experimental neuroscientists as a prerequisite for understanding neuronal firing patterns in the oculomotor system, and to computational neuroscientists concerned with general principles of biological motor control.

We start with the mechanics of horizontal eye movements, which are simpler to understand as they are produced by rotation about a single (vertical) axis. We further simplify the problem by assuming that only the ► lateral and ► medial rectus muscles contribute to horizontal movements. Evidence supporting that assumption is considered later. We follow the convention of ignoring movements of the centre of mass of the eye relative to the orbit, so that the term *eye position* refers to the angle of rotation of the eyeball around its centre of mass.

#### Orbital Mechanics in One Dimension

The equation of motion for rotation of a rigid body about a fixed axis is:

$$J\ddot{\theta} = G$$

where  $G$  is the torque around the axis,  $\theta$  is the angular position so  $\ddot{\theta}$  is the angular acceleration, and  $J$  is the moment of inertia of the rigid body. In the case of the eyeball the torque has two constituents, one ( $G_m$ ) exerted by the EOMs, and the other ( $G_{OT}$ ) by connective and other tissues in the orbit, which act to restore the eyeball to its resting position.

$$J\ddot{\theta} = G_m + G_{OT} \quad (1)$$

Assuming the torques are produced by forces that act tangentially to the surface of the eyeball in the horizontal plane, at a fixed distance  $r$  (= radius) from the vertical axis, then

$$J\ddot{\theta} = rF_m - rF_{OT} \quad (2)$$

where  $F_m$  is net muscle force and  $F_{OT}$  the orbital tissue restoring force.

It is helpful first to consider orbital mechanics in the static case, because this simplifies the problem in three ways: (i) the acceleration term is zero, (ii) the orbital-tissue force is dependent only on the elasticity of the orbital tissue, and (iii) the muscle force is unaffected by velocity terms.

**Orbital Statics in One Dimension**

Figure 1a shows the left eye from above, rotated  $\theta^\circ$  around the vertical axis from its resting position.

When the eye is static, the eq. of motion (1) becomes a force-balance equation  $rF_m - rF_{OT} = 0$  so that

$$F_{LR} - F_{MR} = F_{OT} \tag{3}$$

where  $F_{LR}$  is the counterclockwise force produced by the agonist lateral rectus muscle,  $F_{MR}$  the clockwise force of the antagonist medial rectus muscle, and  $F_{OT}$

the elastic restoring force produced by the orbital tissue. These forces have been measured in human subjects as a function of eye position (Fig. 1b). The muscle forces change with eye rotation in a complex way, because muscle force  $F_m$  is a function of both muscle length  $l_m$  (which in turn depends on eye-position  $\theta$ ), and the neural command  $N_m$ .

$$F_m = f(\theta, N_m) \tag{4}$$

The nature of this function is illustrated in Fig. 1c, which is derived from measurements of force in detached horizontal rectus muscles while the intact eye fixated on a series of targets at a range of horizontal eccentricities [3]. In these circumstances, neural command  $N_m$  refers to the neural command corresponding to the intact eye's position. It can be seen that muscle force increases as the neural command increases, or as

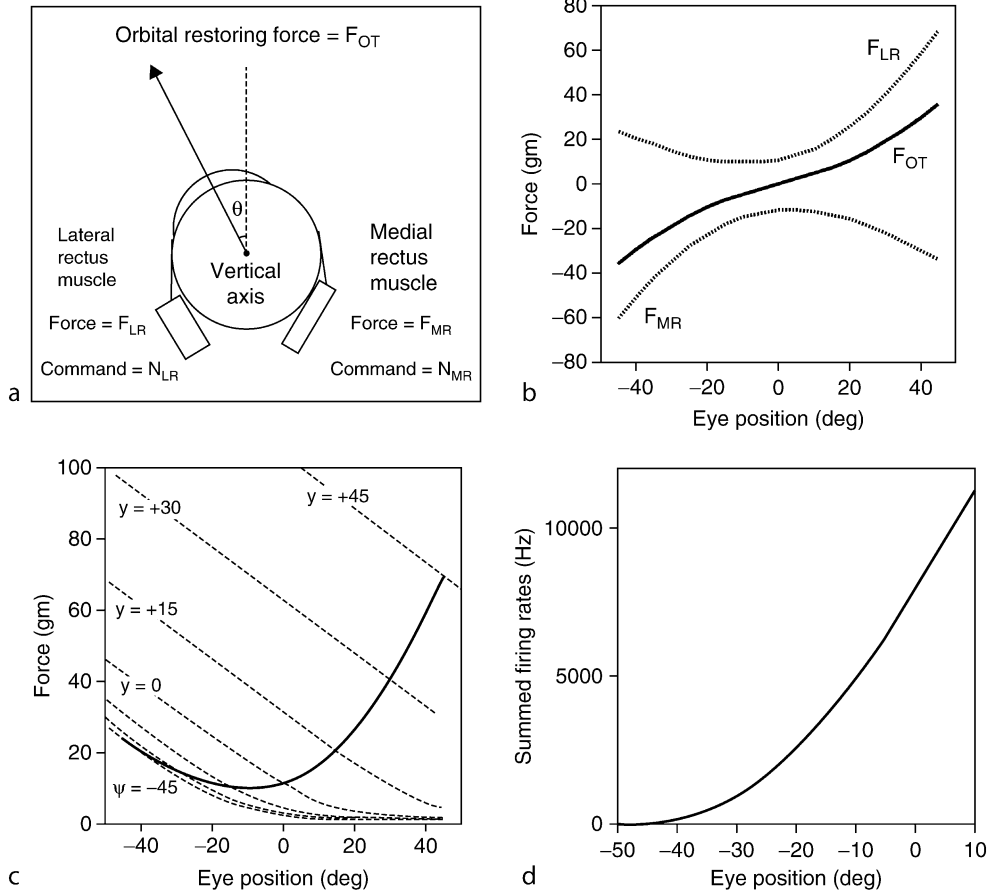

**Eye Orbital Mechanics. Figure 1** (a) Diagram of eyeball stationary at  $\theta^\circ$ . from its resting position, in the on-direction of the lateral rectus muscle. The agonist force  $F_{LR}$  is balanced by the antagonist force  $F_{MR}$  and the orbital restoring force  $F_{OT}$ . (b) The forces  $F_{LR}$ ,  $F_{MR}$  and  $F_{OT}$  plotted against eye position. (c) Length-tension curves (...) for a horizontal rectus muscle (with muscle length specified by eye-position) for different levels of innervation  $\psi$ . The innervation is operationally defined as the OMN firing corresponding to eye position  $\psi$  in normal conditions. The solid line joins those points for which muscle-length equals  $\psi$ , thus representing the tension in the muscle during normal behaviour. (d) Summed firing rates for a sample of horizontal rectus OMNs plotted against eye-position. Adapted from Fig. 2, 5 and 11 in Dean, Porrill and Warren [2].



muscle length increases. However, in the intact system, as the neural command increases and the eye rotates, the muscle shortens. The complex interaction between the two opposing factors of increasing neural command and shortening muscle is shown in Fig. 1c, and corresponds to the muscle force plots in Fig. 1b.

The final panel of the figure (Fig. 1d) indicates how innervation level varies with eye position. It is well known from recordings of single OMNs in alert monkeys that each OMN has an eye-position threshold below which it does not fire. The range of thresholds is large: some neurons fire throughout the oculomotor range (i.e. their thresholds are less than  $\sim 40^\circ$  in the off-direction of the relevant muscle), whereas others have thresholds more than  $10^\circ$  in the on-direction. Thus, as the position of the eye changes in the appropriate direction, the number of OMNs that are firing increases, a process known as recruitment. Since the firing rate of an individual OMN varies linearly with eye position above threshold, the *sum* of OMN firing rates must be non-linearly related to eye position [2].

Overall, Fig. 1 illustrates the complexities of orbital mechanics for even the simplest case of eye-position control in one dimension. In particular, the mechanical properties of each eye muscle alter with eye position (Fig. 1c), both as the muscle changes length and as the number of recruited motor units varies. These complexities require explicit modelling. Two main types of model have been distinguished, labeled “biomechanically correct” and “idealized plant” models [4].

Biomechanically correct models start from the full version of eq. (3)

$$F_{LR}(\theta, N_{LR}) - F_{MR}(\theta, N_{MR}) = F_{OT}(\theta) \quad (5)$$

and derive values for each of the terms by simulating the processes that underlie force-generation in muscles and orbital tissue. They are based on the pioneering work of Robinson [1]. One development has been to replace the lumped neural command shown in Fig. 1d with the firing rates of individual OMNs. By incorporating the behaviour of individual motor units, such distributed models can address general aspects of muscle control such as recruitment and the size principle, and also problems of motor control in general such as redundancy, when there are more commands available than variables to be controlled [2].

Idealized plant models simplify eq. (5) in order to clarify the basic tasks of eye-position control. A common strategy is to treat the two muscles as one (which requires only a single neural command) and then linearise the forces so that

$$\begin{aligned} F_{OT} &= k_{OT}\theta \\ F_m &= z_m N_m + k_m \theta \end{aligned} \quad (6)$$

where  $k_{OT}$  is the elasticity of orbital tissue,  $k_m$  the elasticity of the combined muscle, and  $z_m$  the strength of the combined muscle (defined as change in isometric force produced by unit change in neural command). Overall eq. (5) becomes

$$z_m N_m = k_{tot} \theta \quad (7)$$

where  $k_{tot}$  is the total elasticity of muscles and orbital tissue. This idealised plant model has a control signal that is simply proportional to the desired eye position and is the basis for related models of ID dynamics and 3D statics discussed further below.

### Orbital Dynamics in One Dimension

When the eye is moving, the static eq. (3) needs to be replaced by the full eq. of motion (2) for rotations around the vertical axis. Each force term is now more complex than in eq. (2).

$$\frac{J}{r} \ddot{\theta} = F_{LR}(\theta, \dot{\theta}, N_{LR}) - F_{MR}(\theta, \dot{\theta}, N_{MR}) - F_{OT}(\theta, \dot{\theta})$$

The orbital force is viscoelastic, i.e. it is dependent upon both eye position and velocity, and the EOM forces are determined by neural command, muscle length, and rate of change of muscle length (which in turn are determined by eye position and velocity).

It would be natural to expect here an equivalent of Fig. 1, showing the force measurements relevant to the dynamic case. However, although the need for these measurements has been recognised for many years [5] there are still few data available, particularly for EOM forces as a function of muscle shortening or lengthening. It is therefore difficult at present to extend the available biomechanically correct models of orbital mechanics for the static case to the control of eye movement.

Progress has, however, been made with idealised plant models. In these, the globe’s inertia is ignored and the mechanics of orbital tissue are approximated by ►Voigt elements (Fig. 2a).

A Voigt element consists of a linear viscosity ( $c_{OT}$ ) and linear elasticity ( $k_{OT}$ ) in parallel, which gives the equation of motion

$$F_{OT} = k_{OT}\theta + c_{OT}\dot{\theta}$$

In the simplest case, where orbital tissue is treated as a single Voigt element, the restoring force  $F_{OT}$  is split into independent elastic and viscous components. If each muscle is also treated as a single Voigt element, eq. (7) can be extended to become

$$z_m N_m = k_{tot} \theta + c_{tot} \dot{\theta} \quad (8)$$

where  $c_{tot}$  is the combined viscosity of the muscles and orbital tissue. This new equation illustrates two important points about the control of eye movements [5].

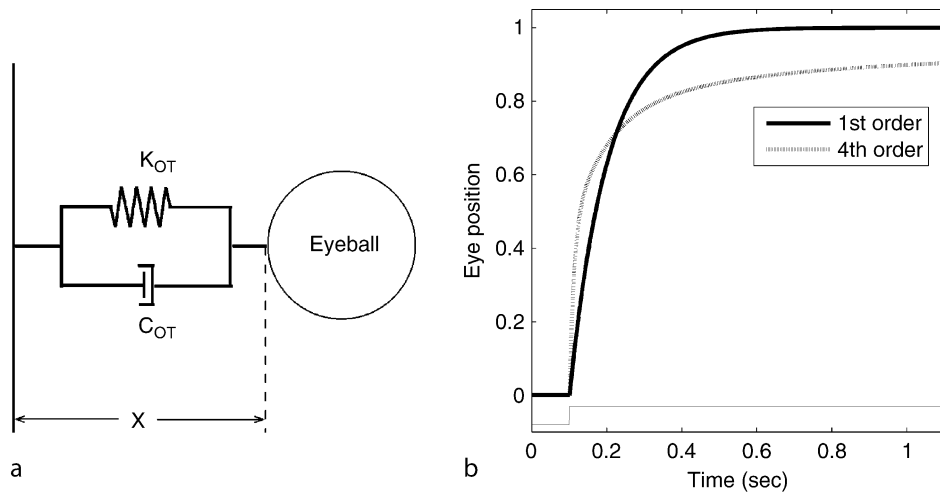

**Eye Orbital Mechanics. Figure 2** (a) Diagram of eyeball (*right*) attached to orbital wall (*left*) by a Voigt element, consisting of an elasticity  $k$  in parallel with a viscosity  $c$ . The length  $x$  of the element is defined relative to length = 0 at the primary position and is proportional to eye position  $\theta$ . (b) Behaviour of Voigt element (“first order”) in response to a unit step change in applied force (bottom trace). The length changes as an exponential function of time  $1/k(1-e^{-t/T})$  with time constant  $T = c/k$ , which in the case illustrated is 0.1 s. Also shown is behaviour of four Voigt elements in series (“fourth order”) with time constants of 0.01, 0.1, 1 and 10 s [5].

1. Gaze stabilizing reflexes such as the vestibulo-ocular reflex (VOR) and optokinetic reflex (OKR) require the eye to be moved at a particular velocity. Eq. (8) shows that if the oculomotor plant had no elasticity, its velocity would simply be proportional to the neural command sent to it. The presence of the elastic term requires an additional force to offset it, which could be generated by the integration (and appropriate weighting) of a velocity command. Hence the idea of a neural integrator, which has proved extremely influential.
2. The viscous resistance of the plant means that a step change in neural command produces only a gradual change in eye position (Fig. 2b). To produce as rapid a change in eye-position as possible, an additional pulse of neural command is required to overcome this viscous resistance. The combination of the two signals is the classical “pulse-step” command that generates saccades.

In fact, orbital tissue is better approximated by four Voigt elements in series, which respond to a step input as shown in Fig. 2b. A simple velocity command now has to be adjusted in a more complex way than by integration, and the saccadic control signal will consist of pulse, step, and multiple slide terms that may last for several seconds. These changes mean that the actual firing patterns of OMNs are explained more accurately by a four element than one element model [1].

### Orbital Mechanics in Three Dimensions

A convenient way of representing rotations about a fixed axis in 3D is to specify (i) the axis as a vector  $\mathbf{n}$

(bold symbols are used to denote vectors) in a head-fixed coordinate frame (Fig. 3), and (ii) the angle of rotation  $\theta$  around that axis, as indicated in Fig. 1a.

In this angle-axis representation, the rotations considered so far would all have been about the vertical axis  $[0,1,0]$ . As in the case of 1D mechanics, we start with the control of eye position.

### Orbital Statics in Three Dimensions

For each position in 3D, the net torque exerted by the muscles ( $\mathbf{G}_M$ ) must balance the restoring torque of orbital elasticity ( $\mathbf{G}_{OT}$ )

$$\mathbf{G}_M(\theta, \mathbf{n}) + \mathbf{G}_{OT}(\theta, \mathbf{n}) = 0$$

Both of these torques are functions of 3D eye position  $(\theta, \mathbf{n})$ . The problem of producing the required muscle torque is simplified by the restriction that only a subset of possible eye positions (Fig. 3) are used for fixation. All these positions (termed Listing’s positions) can be reached from the primary position by rotation around some axis that lies in a plane (Listing’s plane), which is close to the frontal (x-y) plane through the centre of the eyeball when the head is upright (Fig. 3).

The muscle torque  $\mathbf{G}_M$  is produced by six EOMs, whose pulling directions are shown in Fig. 4.

As in the 1D case, the net torque exerted on the eyeball is a function of the force in each EOM, together with the direction in which it pulls.

$$\mathbf{G}_M(\theta, \mathbf{n}) = r \sum_{i=1}^6 F_i(\theta, \mathbf{n}, N_i) \mathbf{m}_i(\theta, \mathbf{n}) \quad (9)$$

The magnitude of the force for an individual muscle ( $F_i$ ) depends on its neural command  $N_i$ , and on its length as

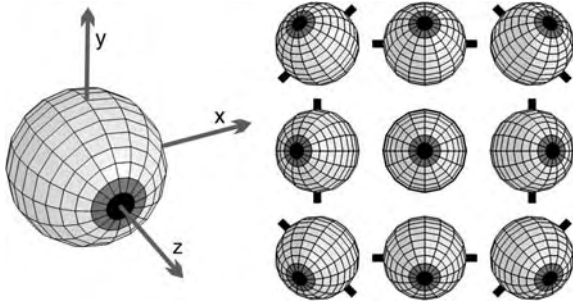

**Eye Orbital Mechanics. Figure 3** Left panel shows the coordinate system associated with the eye in primary position. This coordinate system does not move with the eye, but stays fixed relative to the head. Right panel illustrates Listing's law. The central globe represents the eye in primary position. In order to fixate horizontal or vertical ►secondary positions (here 30°.) from the primary position, the eye must rotate about the y-axis or the x-axis, respectively. In order to fixate tertiary positions from the primary position the eye rotates about oblique axes which still lie in the x-y plane. This plane is called Listing's plane. Changes in fixation which do not pass through the primary position (e.g. top left to top right) require an axis of rotation which lies out of Listing's plane. Redrawn from Fig. 1 of Tweed, Vilis (1990) Geometric relations of eye position and velocity vectors during saccades. Vision Res 30:111–127.

determined by eye position ( $\theta, \mathbf{n}$ ), according to the geometrical arrangement of the muscles (cf Fig. 4). The torque generated by this force has magnitude  $F_{ir}$ , and acts about the axis  $\mathbf{m}_i$  normal to the plane of action (this plane contains the centre of rotation of the eyeball, muscle insertion and direction of action of muscle at the insertion). This axis is also a function of eye position, as determined by muscle geometry.

The orbital-tissue torque  $\mathbf{G}_{OT}$  is produced by the elasticity of the orbital tissue, which is mechanically more complex in 3D than 1D.

$$\begin{pmatrix} G_x \\ G_y \\ G_z \end{pmatrix} = \begin{bmatrix} k_{xx} & k_{xy} & k_{xz} \\ k_{yx} & k_{yy} & k_{yz} \\ k_{zx} & k_{zy} & k_{zz} \end{bmatrix} \begin{pmatrix} \theta_x \\ \theta_y \\ \theta_z \end{pmatrix}$$

This equation relates  $\mathbf{G}_{OT}$  (with components  $G_x, G_y, G_z$  around the axes of Fig. 3), to eye position  $\boldsymbol{\theta}$  (with components  $\theta_x, \theta_y, \theta_z$  around the axes of Fig. 3), using 3D elasticity  $K_{OT}$ . It can be seen that  $K_{OT}$  is a 3×3 matrix (in fact the “elasticity tensor”), with terms representing the effects of rotation around one axis on torque around another (“off-diagonal” terms). Moreover, each term in the matrix could in principle itself vary as a function of eye rotation.

The first attempt at a biomechanically correct model of orbital statics in 3D was described by Robinson [1], and subsequently developed by Miller

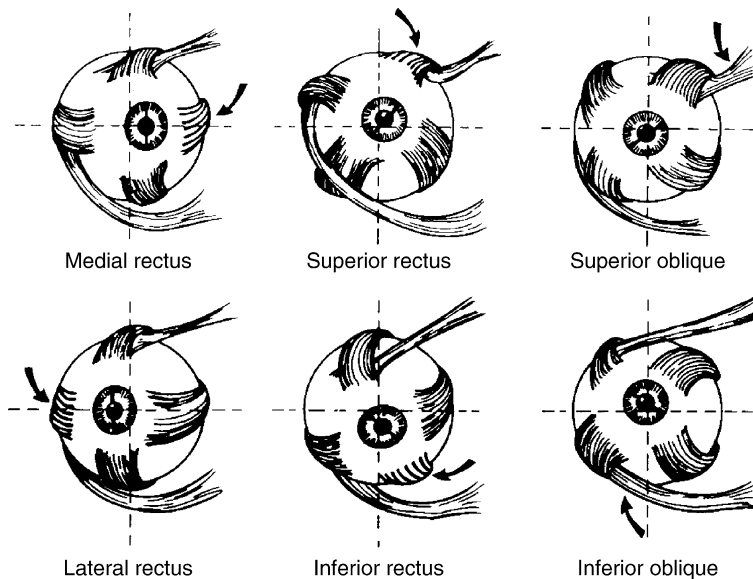

**Eye Orbital Mechanics. Figure 4** Schematic representation of the action of the extraocular muscles. If muscles are innervated individually at the primary position, then the lateral and medial recti produce approximately horizontal movement, the superior and inferior recti produce vertical movement with a small component of ►torsion, and the superior and inferior oblique muscles produce torsional movement with a small component of elevation. (Reproduced from Carpenter RHS (1988). ►Movements of the eyes. Pion, London). To satisfy the torsional constraint of Listing's law, the neural commands to the vertical recti and the oblique muscles must be yoked.

[6]. However, there are two important differences between using these models for 3D eye-position, and for horizontal eye positions only. First, the measurements needed to characterise the 3D elasticity tensor are not available, so the models use a simplified version in which the off-diagonal terms are set to zero:

$$K_{OT} = \begin{bmatrix} k_x(\theta_x) & 0 & 0 \\ 0 & k_y(\theta_y) & 0 \\ 0 & 0 & k_z(\theta_z) \end{bmatrix}$$

In addition, the elasticity is assumed to be ►isotropic in Listing's plane (i.e.  $k_x(\theta_x) = k_y(\theta_y)$ ). Secondly, the appropriate data for OMN firing rates in ►tertiary positions is surprisingly sparse [7], which means that crucial inputs to the model are undefined.

This second limitation requires that the model itself [6] be used to predict the patterns of neural commands that correspond to Listing's positions [8]. According to these predictions, the commands for horizontal fixations up to  $\sim 40^\circ$  either side of the primary position are little affected by the eye's elevation, and similarly commands for vertical fixations are little affected by horizontal position. The horizontal and vertical commands are thus separable, making the system easy to control. The model's behavior indicates that vertical eye-positions are achieved by yoking together the neural commands to the ►inferior rectus and ►superior oblique muscles, and to the ►superior rectus and ►inferior oblique muscles; and that separability depends upon the presence of "►pulleys" (Fig. 5), that is restrictions on the paths of EOMs identified in scans of the orbit and attributed to rings of connective tissue around the EOMs [9].

These restrictions alter the direction of the net torque exerted by the six EOMs, so that it tends to move with the eyeball (Fig. 5b) rather than remaining fixed relative to the head (Fig. 5a).

Unfortunately, idealised plant models in 3D have so far proved much less useful than their one dimensional (1D) counterparts. Since muscle length depends on 3D eye-position in a complex way, these models have ignored muscle elasticity altogether, so that equation (6) is reduced to

$$F_m = z_m N_m$$

However, the effects of muscle elasticity on EOM force are in fact substantial (Fig. 1c), and as a consequence the idealised plant models behave unrealistically, for example, producing Listing's positions with no neural commands to the oblique muscles [10].

### Orbital Dynamics in Three Dimensions

Extending orbital statics in 3D to orbital dynamics encounters two problems. First, some eye movements in 3D (e.g. those resulting from the VOR) generate eye

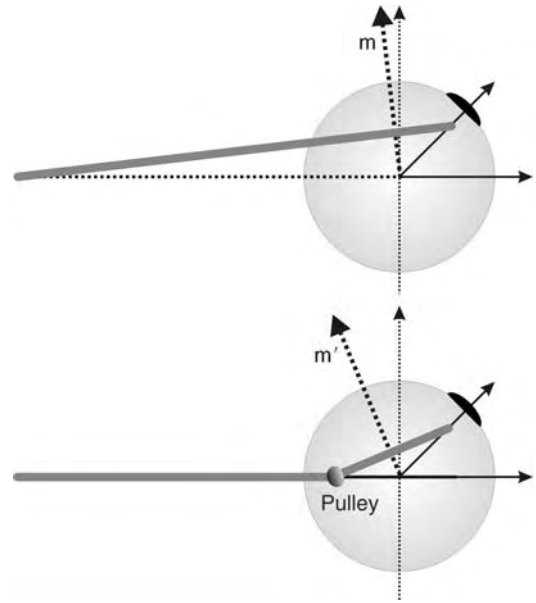

**Eye Orbital Mechanics. Figure 5** The top panel shows a schematic side view of the plane of the action of a horizontal muscle when its motion is not constrained by a pulley. Since the origin of the muscle is well behind the globe both its plane of action and hence the moment vector  $\mathbf{m}$  normal to the plane of action of the muscle change relatively little (relative to the head) as the eye elevates. The bottom panel shows the effect of constraining the muscle by a fixed pulley closer to the globe. The effect is to magnify the effect of eye elevation on the rotation of the plane of action and hence on the moment vector  $\mathbf{m}'$  to the plane of action of the muscle. Both plane of action and moment vector tend to move with the eye.

positions that are not Listing's positions [4]. Secondly, whereas the static case dealt only with the muscle torques and neural commands required to maintain Listing's positions, the dynamic case has to consider the actual paths taken between Listing's positions.

Fortunately, it can be shown theoretically that any Listing's position can be reached from any other Listing's position by a rotation about a fixed axis, and that all the intermediate positions produced by such a rotation are also Listing's positions. Moreover, in practice saccadic and smooth pursuit movements follow these paths. However, the requisite axis of rotation only lies in Listing's plane for rotations that pass through the ►primary position. Other movements, for example, from the top left Listing's position in Fig. 4 to the top right position, have rotation axes that do not lie in Listing's plane. It can be shown that the rotation axis for this example is tilted  $(\alpha/2)^\circ$  from Listing's plane, where  $\alpha$  is the elevation of the eye in the initial position, and that in general displacements through Listing's positions obey the "half-angle rule" [4].

This geometrical fact has serious implications for neural control. In the restricted case of rotations about a fixed axis the angular velocity  $\boldsymbol{\omega}$  is given by

$$\boldsymbol{\omega} = \dot{\theta} \mathbf{n}$$

The resistive torque due to orbital tissue viscosity is proportional to  $\boldsymbol{\omega}$ , so if the axis of rotation  $\mathbf{n}$  lies outside Listing's plane, so will the resistive viscous torque. The elastic restoring force, however, acts around an axis in Listing's plane. Thus, for fixation, the control signal always has to generate a torque in Listing's plane, whereas for some saccades and smooth pursuit movements the control signal must generate a torque that is not in Listing's plane. How can the controller achieve this?

Unfortunately, neither biomechanically correct nor idealised plant models in their current versions are of much help in answering this question. Extending the relevant equation of motion (1) for the 1D case to 3D gives

$$J\dot{\boldsymbol{\omega}} = \mathbf{G}_m(\boldsymbol{\theta}, \boldsymbol{\omega}) + \mathbf{G}_{OT}(\boldsymbol{\theta}, \boldsymbol{\omega})$$

$$\mathbf{G}_m(\boldsymbol{\theta}, \boldsymbol{\omega}) = r \sum_{i=1}^6 F_i(\boldsymbol{\theta}, \boldsymbol{\omega}, N_i) \mathbf{m}_i(\boldsymbol{\theta})$$

The torques exerted by the EOMs ( $\mathbf{G}_m$ ) and orbital tissue ( $\mathbf{G}_{OT}$ ) are now functions of both eye position (here denoted by  $\boldsymbol{\theta}$  for convenience) and angular velocity  $\boldsymbol{\omega}$ . Measurements of neither muscle dynamics nor 3D orbital tissue viscosity are available. Nor indeed have the OMN firing patterns for saccades and smooth pursuit between ►tertiary Listing's positions been well-characterised. Development of biomechanically correct models of 3D orbital dynamics is thus crucially hindered by absence of data.

On the other hand, idealised plant models of 3D dynamics have inherited the inadequacies of their static counterparts, and in addition ignored muscle viscosity. Thus, claims from these models that control of saccades and smooth pursuit could be simplified by appropriate movement of pulleys (cf Fig. 5) are difficult to evaluate. However, it should be noted that recent results from hybrid models suggest that pulley movement may act instead to keep the EOMs tangent to the eyeball [10]. Moreover, a scheme that requires six additional neural signals to move pulleys appropriately would not appear to qualify as simplified [7].

## Conclusions

This brief survey outlines the achievements and limitations of current models of orbital mechanics. Although some of the limitations arise because certain models ignore relevant data that are available, a more general problem is lack of appropriate measurements - despite their acknowledged clinical, experimental and theoretical importance. Three areas in particular merit further investigation:

1. The elasticity and viscosity of orbital tissue in 3D. Better understanding of these will underpin development of models of orbital tissue, using for example finite-element modelling techniques.
2. The dynamics of EOMs. These are poorly understood even for whole muscle, let alone at the level of the individual motor unit. Yet current genetic and histochemical studies emphasise the heterogeneity of EOM structure.
3. The firing patterns of EOMs for 3D fixations and movements. Until these are properly characterised, key issues such as neural versus mechanical contributions to eye-movement control, and pre-motor processing of neural commands, cannot be adequately addressed [7].

## References

1. Robinson DA (1975) A quantitative analysis of extraocular muscle cooperation and squint. *Invest Ophthalmol* 14:801–825
2. Dean P, Porrill J, Warren PA (1999) Optimality of static force control by horizontal eye muscles: a test of the minimum norm rule. *J Neurophysiol* 81:735–757
3. Haslwanter T (2002) Mechanics of eye movements: implications of the “orbital revolution”. *Ann NY Acad Sci* 956:33–41
4. Robinson DA (1981) Models of the mechanics of eye movements. In: Zuber BL (ed) *Models of oculomotor behavior*. CRC Press, Boca Raton, FL, pp 21–41
5. Sklavos S, Porrill J, Kaneko CRS, Dean P (2005) Evidence for a wide range of time scales in oculomotor plant dynamics: implications for models of eye-movement control. *Vision Res* 45:1525–1542
6. Miller JM (2000) Biomechanical models of strabismus. In: Lennerstrand G, Ygge J (eds) *Advances in strabismus research: basic and clinical aspects*. Portland Press, London, pp 181–193
7. Angelaki DE, Hess BJM (2004) Control of eye orientation: where does the brain's role end and the muscle's begin? *Eur J Neurosci* 19:1–10
8. Porrill J, Warren PA, Dean P (2000) A simple control law generates Listing's positions in a detailed model of the extraocular muscle system. *Vision Res* 40:3743–3758
9. Demer JL (2002) The orbital pulley system: a revolution in concepts of orbital anatomy. *Ann NY Acad Sci* 956:17–32
10. Quaia C, Optican LM (2003) Dynamic eye plant models and the control of eye movements. *Strabismus* 11:17–31

## Eye-Blink Conditioning

### Definition

Eye blink conditioning is one type of classical conditioning. Application of air puff to an eye makes

the eyelid close to prevent injury of the eyeball. This is a simple defensive reflex and air puff is called unconditioned stimulus. When sound is made before application of the air puff several times, the animal becomes to close eyes only hearing the sound. This phenomenon is the eye blink conditioning, and the sound is called conditioned stimulus.

► Sensory Motor Learning/Memory and Cerebellum

## Eye-Hand Coordination – Planning and Neural Structures

DENIS PELISSON, CLAUDE PRABLANC  
Espace et Action Unité 864, INSERM/Université  
Claude Bernard – Lyon, IFR19 Institut Fédératif des  
Neurosciences de Lyon, Bron, France

### Synonyms

Eye-hand coupling; Visuo-manual coordination; Oculo-manual synergy

### Definition

Goal-directed movements of the upper limb are assumed by a number of neural mechanisms extending from the detection of the target to the execution and on-line guidance of the hand trajectory. Due to its organization, the visual system supplies the hand motor system with signals which depend upon the position fixated by the subject in 3-D space. Thus, the performance of the limb response depends strongly on eye movements, combining saccadic eye movements (2-D changes of the direction of the line of sight) and vergence eye movements (changes in depth of the distance of the fixation point). Eye-hand coordination refers to the various mechanisms which regulate the temporal coupling between eye and hand movements and thereby allow, through eye movements, the capture and the transfer of visual information to the limb motor system at appropriate time periods. Eye-hand coordination also refers to the outcome of these mechanisms on the performance of the two motor responses which is expressed by the spatial coupling between eye and hand.

### Characteristics

#### Upstream Event/Conditions

During each behavioral phase (► Movement (or motor) planning and ► movement (or motor) programming phases, movement phase and error correction terminal phase), the limb motor system is provided with key

visual information related to the subject's environment (ultimate goal, intermediate targets, distractors, obstacles, visual background...) and to the body and limb posture. The visual system is endowed with properties whereby visual detection and localization of a stationary target in 3-D space are best achieved in the central part of the visual field, whereas the detection of the speed and particularly of the direction of object motion are preferentially achieved in ► peripheral vision. Given these features, an optimal visual control of limb movements is expected to strongly rely on co-ordinated orienting movements of the line of sight toward the hand movement goal [1]. Such fast movements of the line of sight (► Gaze shifts) are achieved by saccadic eye movements, often accompanied by a head rotation and, when the target is located at a distance closer or further from the original point of gaze fixation, by disconjugate (vergence) eye movements. Thus, a strong impact of oculomotor control is expected for all types of visually-guided movements of the arm, such as discrete movements of the limb to a stationary object (pointing and reach-to-grasp responses) and continuous arm movements to track or catch a moving target. However, most studies directly investigating eye-hand coordination processes have been performed in relation to pointing responses.

When a subject moves his arm in order to point to an object, the line of sight also quickly moves in a saccadic fashion, most often without any conscious knowledge from the subject. When both the speed and the accuracy of the limb response are emphasized (speed accuracy trade-off), the eyes appear to lead the hand motion and to land on the target nearly at the time the hand starts moving, i.e. too late for the arm motor program to use post-saccadic (updated) visual information. It has been demonstrated that at least under such conditions, the motor commands driving the eyes and the limb muscles are initiated in parallel, the shorter reaction time and movement time of the eye being accounted for by a much lower inertia as compared to that of the limb [2]. Note that this parallel planning strategy of eye and hand movements is more advantageous than any sequential strategy in terms of overall response time, but is *a priori* disadvantageous with regard to hand movement accuracy because such a planning is based on low resolution target position signals detected under peripheral vision, when the eyes have not yet foveated (► Foveation) the target. Thus, to achieve good performance both in the temporal and spatial domains, the parallel planning strategy requires that correction mechanisms are able to efficiently control on-line the limb trajectory during the movement phase. Note that these correction mechanisms also require precise knowledge of initial conditions and more specifically of vision of the initial posture of the arm [2].

## Downstream Event/Conditions

### Temporal Coupling

Due to its functional advantage, the parallel planning of eye and limb response is likely to result from some dedicated coordinative mechanisms. A possible link between eye and limb motor systems is based on visual attention. Both eye saccade and hand pointing responses, when performed separately, are associated with an automatic – temporally and spatially specific – shift of visual attention to the target [3]. Moreover, in a combined eye-hand response task, gaze stays anchored on the target and cannot move towards another target until the hand pointing movement is nearly completed [1,4]. Altogether, these data suggest that the limited attentional resources focused on the visual target are shared by eye and hand motor systems and can hence contribute to eye-hand coordination.

Another aspect of temporal coupling has recently been described: in the monkey, saccades associated with a hand movement are faster than saccades generated separately from any hand motion. In this case, the information appears to flow from the hand to the eye motor systems. Whereas its functional advantage is uncertain, this effect on saccade speed – and the associated increased oculomotor drive – is a signature of dedicated neural coordinative mechanisms which come into play specifically when a combined eye-hand response is required.

### Spatial Coupling

In contrast to temporal coupling, there is no definitive evidence for a strong spatial coupling between eye and hand responses. The first approach has been to look for a correlation between the achieved (final) positions of eye and hand when subjects point in the dark towards either the remembered position of a visual target or towards a briefly flashed target. There have been some controversies between the results of the different studies, but the current bottom line agreement is that the correlation is quite weak [5]. Since in these conditions no visual control of the hand trajectory is possible, this suggests that, although triggered in parallel, the planning of eye and hand movements do not necessarily result from common spatial information. This also indicates that the direction of gaze in the dark *per se* does not provide useful information for hand movement guidance. Further studies have indeed indicated that a retinal stimulation should be combined with – and act as a gate for – ►extra-retinal signals of eye position [2]. The second approach is to search whether temporal or spatial dissociations between the eye and hand responses interfere with the spatial performance of the latter. This kind of dissociation is typically achieved by asking subjects to initiate and execute their hand movement to the target without moving gaze. The

hand inaccuracy observed in this condition is a direct consequence of the poor spatial resolution of hand- and target-related visual signals encoded under peripheral vision (note that a decreased hand accuracy is also observed when only the head is prevented from moving as compared to a free eye-head-hand task, showing that a gaze position signal conveys more accurate information when based upon simultaneous orientation of eye and head than when based upon an eye movement alone). It can thus be expected that in the reverse situation, i.e. delaying hand response until the time the orienting saccade has been allowed to update target-related visual signals, the hand achieves maximal accuracy. Interestingly, however, this turns out to be true only when corrections of the on-going hand trajectory are prevented by turning the target off at movement onset [5]. This demonstrates that in this parallel strategy, which is used by default when the subject achieves a speed-accuracy trade-off (see above), the mechanisms allowing an on-line guidance of the hand trajectory are very efficient, owing to the saccade-contingent updated visual information. Concerning the effect of spatial dissociations, recent results indicate that hand movements are larger when the amplitude of the concomitant saccade increases by asking the subject to initiate it from a fixation point more eccentric than the initial hand position, and suggest that the parietal cortex integrates signals related to saccade amplitude with limb movement information. Other studies using two simultaneous targets, targets presented against an illusory background, or targets presented among distractors, have shown that eye and hand responses are usually affected by these stimulation conditions in a similar way but not necessarily by the same amount. In conclusion, current knowledge indicates that although the hand is not a slave to the eyes, gaze anchoring on the target during hand reaching contributes to a better hand accuracy under normal circumstances of parallel eye-hand planning.

### Involved Structures

Whereas definitive experimental evidence is still being searched at the behavioral level, eye-hand coupling is supported by numerous neurophysiological data. First, bi-modal (eye and hand) neural responses and effects of eye position on limb-related neuronal activity have been found repeatedly [6]. Second, studies of neurological patients and neurophysiological studies of normal subjects and animal models have further implicated some cerebral structures in eye-hand coordination. On the one hand, the cerebellum is involved in the temporal aspects of motor control in general and in the temporal coupling of eye and hand movements in particular. This cerebellar involvement has been demonstrated most clearly for visuo-manual tracking tasks [7].

On the other hand, the first electrophysiological recordings in the awake animal have suggested that, among the other structures participating in visuomotor transformations such as the basal ganglia and cerebellum, prefrontal and premotor cortices, the parietal cortex plays a central role in eye-hand coordination. Recent studies have confirmed and substantiated this hypothesis by delineating in this structure a number of neural processes which contribute to the temporal or spatial coordination between eye and hand. Indeed, as a multimodal integration node within the fast dorsal route from the occipital visual cortex to the motor cortex, the posterior parietal cortex is involved in sensory-motor transformation and in coordinates transformation for both eye and limb responses. The posterior parietal cortex is the neural centre where a linear modulation by gaze position (► **Gain fields**) of the target-related visual responses of neurons was first discovered [8]. Later, gain fields (► **Gain modulation (gain field)**) for arm movement-related activities have also been described in parietal areas as well as in the frontal lobe. The posterior parietal cortex is also involved in the control of shifts of visual attention and of the anticipatory displacement of visual receptive fields in relation to the generation of saccadic eye movements (► **Saccade remapping**: [9]). Recently, a specific role of the posterior parietal cortex in the automatic guidance of the limb movement trajectory toward a visual target has been suggested based on converging lines of evidence in human subjects [10]. Indeed, automatic corrections of the on-going hand trajectory performed by human subjects when pointing at a stepping target (non-consciously detected perturbation) are: (i) associated with activity in a parieto-cerebello-frontal network, and (ii) disrupted when the function of the posterior parietal cortex is transiently (application of transcranial magnetic stimulation) or permanently (► **Optic ataxia patient**) impaired. Other neural centers may additionally be involved. Among those is the superior colliculus, a subcortical structure whose role in the production of orienting eye and head movements is well-known, and which has recently been involved in the visual control of limb movements based on unit recording and electrical stimulation studies in animals.

### Methods to Measure This Event/Condition

Eye-hand coordination is a built-in property of the sensory-motor system. A privileged way to investigate eye-hand coordination is to experimentally dissociate eye and hand responses and to measure the effects of this dissociation relative to the baseline (no dissociation) condition. The dissociation can be made either or both in the temporal or spatial domain, and the effects measured at the behavioral and/or neural level. Behavioral measures involve the analysis of movement reaction time, movement duration and speed, terminal

accuracy and, in rhythmic tasks, phase relationships between eye and hand. To evaluate the capability to guide the hand response trajectory on-line, i.e. a good measure of eye-hand coordination, experimental protocols based on the perturbation of the target or of the moving limb have been designed. These perturbations, which permit the opening of different feedback loops at critical times of the saccade or of the hand movement, are a powerful tool for the evaluation of the different control processes and sources of static and dynamic information (visual, kinesthetic, efferent copy) influencing the accuracy of an aimed movement. Neural measures are the recording of neuronal activity in trained behaving animals and the recording of functional cerebral activation in human subjects, complemented by the analysis of movement deficits after lesion/inactivation in animal models and human patients.

### Acknowledgments

We are very grateful to Drs. C. Tilikete and Y. Rossetti for their critical reading of the manuscript.

### References

1. Johansson RS, Westling G, Backstrom A, Flanagan JR (2001) Eye-hand coordination in object manipulation. *J Neurosci* 21:6917–6932
2. Desmurget M, Pelisson D, Rossetti Y, Prablanc C (1998) From eye to hand: planning goal-directed movements. *Neurosci Biobehav Rev* 22:761–788
3. Schneider WX, Deubel H (2002) Selection-for-perception and selection-for-spatial-motor-action are coupled by visual attention: a review of recent findings and new evidence from stimulus-driven saccade control. In: Prinz W, Hommel B (eds) *Common mechanisms in perception and action (Attention and Performance XIX)* Oxford University Press, Oxford, pp 609–627
4. Neggers SF, Bekkering H (2001) Gaze anchoring to a pointing target is present during the entire pointing movement and is driven by a non-visual signal. *J Neurophysiol* 86:961–970
5. Prablanc C, Desmurget M, Grea H (2003) Neural control of on-line guidance of hand reaching movements. *Prog Brain Res* 142:155–170
6. Batista AP, Buneo CA, Snyder LH, Andersen RA (1999) Reach plans in eye-centered coordinates. *Science* 285:257–260
7. Miall RC, Reckess GZ, Imamizu H (2001) The cerebellum coordinates eye and hand tracking movements. *Nat Neurosci* 4:638–644
8. Andersen RA, Snyder LH, Bradley DC, Xing J (1997) Multimodal representation of space in the posterior parietal cortex and its use in planning movements. *Annu Rev Neurosci* 20:303–330
9. Colby CL, Duhamel JR, Goldberg ME (1995) Oculocentric spatial representation in parietal cortex. *Cereb Cortex* 5:470–481
10. Rossetti Y, Pisella L, Vighetto A (2003) Optic ataxia revisited: visually guided action versus immediate visuomotor control. *Exp Brain Res* 153:171–910



## Eye-Hand Coordination – Timing and Reference Frames

JOHN F. SOECHTING

Department of Neuroscience, University of Minnesota,  
Minneapolis, MN, USA

### Definition

The static (stationary) target of a hand movement is typically defined by visual information, and most commonly, the target is foveated before or at the time the hand movement is initiated. This behavior raises two issues in motor control. First, is the timing of hand and eye movements in this situation coordinated, and if so, what is the pattern of coordination? Second, since the eyes can move in the head and the head can move relative to the trunk, in what frame of reference is the spatial locus of the target defined? In other instances, a target may be moving, such as in tracking or interception tasks. In these cases, the eyes and the hand are both in motion, the trajectories of eye and hand movements being similar in the case of pursuit tracking and conceivably quite distinct in the case of interception, such as catching a ball.

### Characteristics

#### Eye-Hand Coordination for Static Targets

The temporal coordination of eye and hand movements to static targets has been shown to be task-dependent [1,2]. In the most simple case of a reaching movement to a single target, the target is initially foveated with a saccade, followed by a reaching movement to the target. In a reaction-time task, where the target is presented suddenly and the subject is instructed to move as soon as possible, hand and eye movements have nearly synchronous onsets. Since saccadic eye movements are much faster than hand movements, even then the eye arrives at the target before the hand and it has been claimed that gaze is locked onto the target until the hand arrives there. However, this strict temporal coupling between eye and hand movements is not obligatory, especially in more complex tasks involving sequential movements and requiring the manipulation of the object. For example, when subjects are required to transport a stack of blocks from one place to another while avoiding obstacles along the way, gaze is directed to salient landmarks: the blocks, the target location, and the obstacle [3]. In many instances, gaze is redirected to the subsequent target in the sequence, prior to the arrival of the hand at the landmark. Furthermore, the pattern of coordination between the eyes and the hand can change as subjects learn a novel motor task, such as using a manipulandum to control the motion of a cursor on a

screen [2]. Initially, as the task was being learned and the motion of the cursor was essentially unpredictable, the cursor's motion was pursued visually. However, once the task was mastered, predictive saccadic eye movements to target locations were used here as well to define the goal of the movement.

In summary, findings on the temporal coupling between eye movements and hand movements emphasize the role of vision in defining the spatial goal of intended limb movements. Since it has been found that the eye often departs the target before the hand arrives there, this pattern of coordination also suggests that vision may play a secondary role in mediating online corrections to limb movements, compared to the role of somatosensory information.

#### Visually-defined Frames of Reference for Pointing

Ultimately, the goal of an arm movement must be defined in a frame of reference that is fixed to the trunk, since the mechanical actions of muscles, dependent on the posture of the arm, are defined in such a frame of reference [4]. Based on behavioral data, a shoulder-centered reference frame to define target location was proposed and it was suggested that there was a transformation of visual information about target location from a retinocentric frame of reference into a shoulder-centered one [5]. There, information about target location would be combined with information about limb posture, derived proprioceptively, to define a hand movement vector, i.e., the direction and amplitude of the movement that was required. In primary motor cortex, this movement vector is indeed defined in a frame of reference that is independent of gaze.

However, more recent results suggest that this hand movement vector is initially encoded in posterior parietal cortex in an eye-fixed frame of reference. Some of the evidence comes from behavioral data [1]. For example, subjects make errors in pointing to targets that are located eccentrically on the retina, overestimating the target's eccentricity. Importantly, this error is also made when subjects initially foveate the target, and saccade away from it before pointing to the remembered location of the target. Neural substrates for such an encoding of target location have been identified in an area of posterior parietal cortex related to arm movements [6]. Neural activity in that area is tuned for the retinal locus of a target, irrespective of where the target is relative to the body. Furthermore, the cells' responses remain best for a particular retinal locus of the target, irrespective of the initial posture of the hand. Changing the initial posture of the hand does alter the overall gain of the target-related activity, in a manner that suggests that hand location is also encoded in an eye-fixed frame of reference.

All of these observations have been made under static conditions, where the location of the target relative

to the subject and its location relative to the direction of gaze do not change with time. It is not known whether these observations generalize to conditions where the target is in motion.

### Eye-Hand Coordination Under Dynamic Conditions

Situations where the target is in motion are not uncommon in everyday life. In some instances, the eyes and the hand move in concert, for example when tracking an object. In other cases, such as catching a ball, the two movements are disparate, the eyes tracking the target while the hand moves to intercept it. Finally, in some cases, the spatial goals of the two movements can be quite different. For example, when one drives along a winding road, the eyes tend to track the tangent point of the inside of a curve. It has been proposed that the heading of the car relative to this gaze angle defines the amount by which the steering wheel must be turned [7].

Conceivably, eye and hand movements could be controlled in parallel by independent channels. Certainly, the cortical areas associated with the control of hand movements are distinct from the areas driving eye movements. Nevertheless, there is considerable evidence that the kinematic profiles of eye and hand movements differ when the eyes and the hand move together, compared to when only one or the other modality is invoked [1,8]. For example, ocular tracking is more accurate when one tracks the motion of one's own arm compared to instances where the arm is moved by external means. Interventions that alter the gain of visual tracking affect the gain of manual tracking, and vice versa. Response latencies of eye and hand movements are also altered, depending on whether subjects use one or both modalities to track a moving target.

The interdependencies of eye and hand movements could arise from reciprocal connections between brain centers that control the two types of movements. However, they could also arise if part of the neural substrate responsible for controlling the two types of movements is shared by both. Interacting with moving objects, visually or manually, requires prediction and it is very likely that the mechanisms responsible for predicting target motion are shared by both modalities. The role of prediction has been studied most extensively for eye movements and it is known that the latency of smooth pursuit can decrease substantially from its normal value of 100 ms if the target motion is predictable; smooth pursuit may actually lead target motion in some instances [9]. Prediction can involve the timing of the onset of the motion, as well as the speed and direction of ongoing motion, for example when the target disappears transiently. In fact, as illustrated in Fig. 1, motion along a curve has been shown to be extrapolated [10].

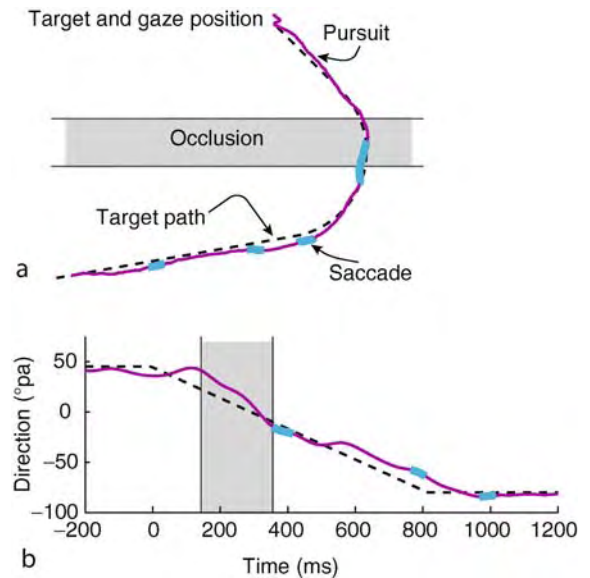

### Eye-Hand Coordination – Timing and Reference

**Frames. Figure 1** Prediction during eye tracking. Subject tracked a target that initially followed a straight path and then followed the arc of a circle. The target was occluded shortly after it began to follow the curved path (a). Note that pursuit eye movements continued to curve throughout the occluded portion of the path, as can be seen in the plot of eye movement direction as a function of time (b). Adapted from [10].

Predictive mechanisms governing hand motion are not as well understood, but one might expect the quality of prediction to be the same for hand and eye movements.

### References

1. Crawford JD, Medendorp WP, Marotta JJ (2004) Spatial transformations for eye-hand coordination. *J Neurophysiol* 92:10–19
2. Flanagan JR, Bowman MC, Johansson RS (2006) Control strategies in object manipulation tasks. *Curr Opin Neurobiol* 16:650–659
3. Johansson RS, Westling G, Bäckström A, Flanagan JR (2001) Eye-hand coordination in object manipulation. *J Neurosci* 21:6917–6932
4. Buneo CA, Soechting JF, Flanders M (1997) Postural dependence of muscle actions: implications for neural control. *J Neurosci* 17:2128–2142
5. Flanders M, Helms Tillery SI, Soechting JF (1992) Early stages in a sensorimotor transformation. *Behav Brain Sci* 15:309–320
6. Buneo CA, Andersen RA (2006) The posterior parietal cortex: sensorimotor interface for the planning and online control of visually guided movements. *Neuropsychologia* 44:2594–2606
7. Land MF, Lee DN (1994) Where we look when we steer. *Nature* 369:742–744

8. Engel KC, Soechting JF (2003) Interactions between ocular motor and manual responses during two-dimensional tracking. *Prog Brain Res* 142:141–153
9. Kowler E (1990) The role of visual and cognitive processes in the control of eye movement. *Rev Oculomotor Res* 4:1–70
10. Mrotek LA, Soechting JF (2006) Predicting curvilinear target motion through an occlusion. *Exp Brain Res* 178(1):99–114

## Eye-Head Coordination

DENIS PELISSON<sup>1</sup>, ALAIN GUILLAUME<sup>2</sup>

<sup>1</sup>Espace et Action Unité 864, INSERM/Université Claude Bernard – Lyon, IFR19 Institut Fédératif des Neurosciences de Lyon, Bron, France

<sup>2</sup>Institut des Sciences du Mouvement, UMR H6233 CNRS/Université de la Méditerranée, Marseille, France

### Synonyms

Eye-head coupling; Gaze control; Eye-neck synergy

### Definition

The control of the line of sight by the central nervous system is part of a larger visuomotor system allowing us to perceive, localize and recognize objects in the outside world. It is therefore an important research topic, and eye-head coordination further represents a good model for the study of the sensory-motor transformation mechanisms involved in the control of any multi-joint system. Eye-head coordination refers to the various mechanisms which contribute to orienting movements or to stabilization of the line of sight in space. This paper focuses on orienting movements and considers temporal and spatial coupling mechanisms, regulating respectively when and how much the ocular and cephalic body platforms move.

### Characteristics

#### Upstream Event/Conditions

Orienting movements of the visual axis (gaze) are continuously required when animals visually explore their environment. A simple reason is that, in animals lacking panoramic vision, the visual field does not cover the whole surrounding space and furthermore, in higher mammals, the specialization of the central part of the retina (fovea) allows an optimal analysis of only a very small part of the central visual field. Thus, exploration of our visual environment requires frequent ►gaze shifts to foveate (►Foveation) objects of interest, separated by periods of active gaze stabilization during which visual analysis is performed. The

eyes and the head are the two main body effectors, sometimes assisted by the trunk, that contribute synergistically to this gaze orientation and stabilization behavior. The low inertia eyeballs achieve fast and accurate orienting movements (saccades) to catch visual targets and to keep them in the foveal region of the visual field. As the desired amplitude of gaze movement increases, the amplitude of the eye saccade saturates and the contribution of the head becomes more prominent. The head is slower to move but has a larger operating range, allowing re-centering of the eyes in the orbit after each large ►gaze shift. This eye-head coordination pattern varies quantitatively between species as a function of the possible range of eye movements in the orbit (e.g. the oculomotor range of a cat is smaller than that of primates, leading to a larger contribution of the head to the gaze shift), but its qualitative features remain constant across species. Thus, the motor behavior yielding appropriate analysis of our visual environment involves precisely controlled and coordinated eye and head movements, involving for each platform all three degrees of freedom and additionally for the eyes, both conjugate and disconjugate movements. For simplification, we will focus on conjugate 2-D eye movements combined with 2-D head movements.

The neural control of combined eye-head gaze saccades is less well understood than the control of saccadic eye movements performed when the head is restrained [1]. A first issue of eye-head coordination concerns the relative timing between eye and head movement-initiation [2]. Behavioral investigations have revealed that this eye-head temporal coupling can vary according to experimental conditions. However, on average, for gaze shifts larger than 15°–20°, the head starts to move close to the eye saccade onset and therefore contributes significantly to the gaze shift (Figure 1). Note that the nearly concomitant initiation of eye and head displacements is the best strategy in terms of overall response time, but puts higher constraints on the neural processes controlling eye-head coordination. A second issue then concerns mechanisms by which the central nervous system regulates the size of each eye and head motor command in an appropriate way to bring gaze accurately onto the target [3]. This spatial coupling problem, involving a neural decomposition of a desired gaze displacement signal into eye and head motor commands, is complex because it must take into account both the very different mechanical properties of the eye and head platforms and the possible reflex interactions between them. Particularly, it supposes that the two antagonistic oculomotor responses – eye saccade and ►vestibuloocular reflex (VOR) – are precisely coordinated. Indeed, the gaze shift phase must be followed by perfect gaze stabilization as soon as the fovea is aligned with the target. This stabilization is due to the VOR which compensates for any residual head movement by

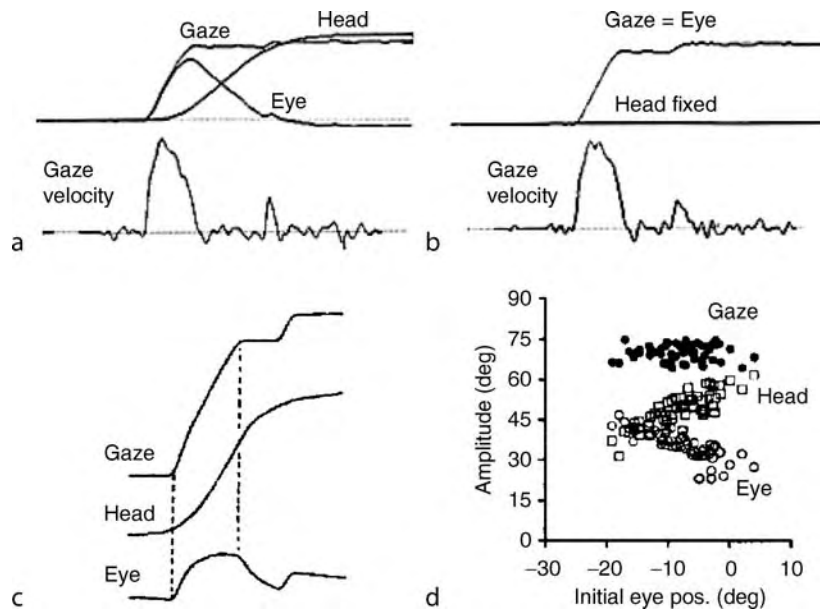

**Eye-Head Coordination. Figure 1** Kinematics of combined eye-head gaze shifts. (a–c) typical horizontal movement trajectories for  $40^\circ$  gaze shifts recorded in man (a) head free, (b) head fixed, and a  $100^\circ$  gaze shift in monkey (c). (d) effect of initial eye position on the coordination between eye and head for gaze shifts of nearly  $70^\circ$  in the monkey. The plot shows the amplitude of gaze shifts (filled circles), and of their eye (open circles) and head movement (open squares) components against initial eye position. Panels (a) and (b) are redrawn from Pelisson et al. JNP (1988), panel (c) from Guitton TINS (1992) and panel (d) from Freedman and Sparks JNP (1997).

producing a counter-rotation of the eyes (Figure 1). The accuracy of gaze shifts thus requires a very precisely timed switch between saccadic activity and VOR response.

### Downstream Event/Conditions

#### Temporal Coupling of Eye and Head Movement Initiation

The general pattern of eye-head temporal coupling can be predicted from the different properties of the ocular and the cephalic mechanical systems. Indeed, the larger inertia of the head relative to the eye can account for the 10–20 ms average lag of the head in the initiation of natural orienting movements, since the same lag has been observed for movements evoked experimentally by electrical microstimulation of gaze-encoding structures like the **►superior colliculus (SC)**. However, on top of this average head lag, a number of factors have been shown to affect the precise temporal synchronization of eye and head movement initiation (sensory modality of the target, target predictability, size and direction of gaze shift, initial eye and head positions, verbal instructions, see [2]): the head lag tends to decrease or even reverses to a head lead for non visual or highly predictive targets, for vertical as compared to horizontal gaze shifts, when the head is initially deviated away from the intended gaze shift direction, and when subjects are specifically asked to align their head with the target. These changes in eye-head initiation pattern imply significant variations in the relative timing of eye and head neural commands (due

in large part to variations of the latter), which in turn can be accounted for by the fact that the motor systems controlling each of the two platforms are not simply gated by a common mechanism. More specifically, head motor commands, including task-dependent intentional signals, can be sent to the spinal cord level while the pre-oculomotor neurons are still gated off by the omnipause neurons in the brainstem reticular formation, or conversely can be delayed – or suppressed – relative to the triggering of pre-oculomotor neurons.

#### Spatial Coupling

A central question has been how the two antagonistic ocular responses – the orienting saccade and the compensatory VOR response – combine during the gaze shift. Stated differently, the problem is whether the VOR continuously operates, despite being counterproductive, during the orienting gaze shift. A first hypothesis postulated that the continuously operating VOR led to the central cancellation of the physical head contribution to the gaze shift. It is now quite firmly established that this **►linear summation hypothesis** [4] does not hold, and that the VOR is inhibited during the gaze shift by the saccadic commands. Data to refute the summation hypothesis have been provided both by behavioral and neurophysiological experiments. The former demonstrated that head-unrestrained gaze shifts are faster than gaze shifts of the same size performed with the head fixed, which indicated that the head movement

contribution is not cancelled centrally by the VOR. In addition, specific head perturbation paradigms have been used to show that the modifications of the head trajectory during a gaze shift also affect gaze trajectory but not gaze final accuracy, owing to an ocular compensation unrelated to VOR. These observations indicate first that the VOR response does not adequately compensate for the head perturbations, signaling a momentary reduction of its gain during the gaze shift, and second that a central control of desired gaze displacement, independent of the status of the VOR, is involved in maintaining gaze terminal accuracy [5]. Thus, both the speed and the accuracy of gaze shifts can be optimized, leading to a performance compatible with the high functional value of orienting gaze shifts in everyday life. This conclusion is also supported by neurophysiological data. On the one hand, recordings from the so-called position-vestibular-pause (PVP) neurons, which constitute the intermediate link of the VOR 3-neurons arc, have shown a specific reduction of these neurons' head sensitivity during the saccadic part of gaze shifts in monkey [6]. Earlier data have indicated that a similar class of vestibular neurons in the cat are inhibited by saccadic burst neurons. On the other hand, several categories of neurons previously known to discharge in relation to saccadic eye movements in the head restrained condition have been shown to actually encode the total displacement of gaze (eye + head) in space: this has been shown for some saccadic burst neurons and omnipause neurons of the reticular formation, and for all burst neurons and fixation neurons of the superior colliculus. Although these findings are consistent with the ►gaze feedback hypothesis that was initially proposed to account for the maintenance of gaze accuracy despite VOR inhibition, the existence and neural implementation of such gaze feedback is still highly debated [7].

To summarize, gaze orientation towards a target of interest is based on a desired gaze displacement command, which has to be decomposed in separate commands for eye and head. The VOR response is inhibited during the saccadic part of the gaze shift and the gaze trajectory is controlled by internal feedback. The termination of the saccadic pulse generator activity, due to this feedback control, and the resumption of a unity VOR gain are both involved in the accurate termination of the gaze shift on the target, and in the subsequent gaze stabilization independently of any residual head movement.

### Involved Structures

To a large extent, the search for mechanisms responsible for eye-head coordination has so far focused on the brainstem, the superior colliculus and the cerebellum. As already stated above, a candidate neural substrate of the intra-saccadic VOR inhibition has been found at the brainstem level, involving an inhibition of PVPs neurons during saccades, likely arising directly

from saccadic burst neurons. Note also that another pathway, this time excitatory and running in the opposite direction (from the vestibular complex to saccadic burst neurons), has been suggested in the cat to contribute to the triggering of an eye saccade and/or the acceleration of the eyes during head movement. Although these particular burster-driving neurons have not yet been found in monkey, this type of excitatory, anticomensatory, vestibulo-ocular pathway is probably required in all animals for the triggering of saccade during head movements when there is no explicit target (quick phases of vestibular nystagmus). The superior colliculus is another brainstem structure that has been intensively investigated in different animal species. Since nearly 40 years ago, we have known that saccadic eye movements produced by head-restrained animals are topographically encoded at the level of the deeper collicular layers. More recently, studies in the head-unrestrained cat or monkey have shown that this collicular motor map in fact encodes the saccadic shift of gaze in space rather than the displacement of the eyes in the orbit. Indeed, unit recording, electrical microstimulation and anatomical studies have demonstrated that the SC contains a gaze motor map, and proposed that the SC provides the brainstem pre-motor centers with a desired gaze displacement command [3,8,9]. A remaining question that has not yet found a consensual answer is how and where in the cerebello-reticular network this collicular gaze displacement drive is decomposed into separate commands for the eyes and head. Does this decomposition occur downstream from a gaze pulse generator controlled by a single gaze feedback loop, as postulated in the original gaze feedback hypothesis, or does it occur ahead of two separate (eye and head) generators each controlled by its own feedback loop? Does it occur before or after the level of the spatio-temporal transform (i.e. of the transformation between the neuronal population code used by the SC to represent the desired gaze displacement and the frequency code used by motoneurons)? Gaze-related SC output neurons have been shown to project to the reticular formation both to the eye-related bursters and to the ►reticulo-spinal neurons (RSNs). RSNs in turn send collateral projections to the eye-related premotor neurons and to the spinal pre-cephalomotor neurons. Thus, RSNs are ideally suited to carry this eye-head decomposition process, but additional research is necessary to understand what the specific role of the different subtypes of RSNs is [10]. In any case, the SC is viewed as a major sensory-motor interface between cortical centers, where the appropriate goal for gaze is selected and encoded topographically in gaze coordinates, and the brainstem reticular formation, where different neuronal populations use a frequency code to represent the individual eye and head components in their respective coordinate frames.

### Methods to Measure This Event/Condition

The neurophysiological description of eye-head coordination mechanisms has long been hampered by the difficult task of recording unit neuronal activities in the head-unrestrained animal; thus, although increasing recently, the amount of data collected in this condition is still modest relative to the vast amount of information on the oculomotor and the vestibular systems collected in the head restrained condition. The situation is even worse for human subjects, since the available neurophysiological methods (neuroimaging and transcranial magnetic stimulation) all require firm stabilization of the subject's head. At the behavioral level, however, several methods are now available to record eye and head movements simultaneously. Beyond describing natural eye-head coordination, behavioral approaches have allowed the development of mechanical head perturbation tests which constitute a privileged way to investigate eye-head coordination. These tests are now increasingly associated with neural recordings in animal studies, allowing us to resolve important issues like the saccade-related inhibition of vestibulo-ocular neurons, and the frame of reference used by oculomotor centers to encode saccadic commands.

### References

1. Scudder CA, Kaneko CS, Fuchs AF (2002) The brainstem burst generator for saccadic eye movements. A modern synthesis. *Exp Brain Res* 142:439–462
2. Fuller JH (1992) Head movement propensity. *Exp Brain Res* 92:152–164
3. Sparks DL (1999) Conceptual issues related to the role of the superior colliculus in the control of gaze. *Curr Opin Neurobiol* 9:698–707
4. Bizzi E (1975) Motor coordination: central and peripheral control during eye-head movement. In: Gazzaniga MS, Blakemore C (eds) *Handbook of psychobiology*. Academic, New York, pp 427–437
5. Pélisson D, Prablanc C, Urquizar C (1988) Vestibulo-ocular reflex inhibition and gaze saccade control characteristics during eye-head orientation in humans. *J Neurophysiol* 59:997–1013
6. Roy JE, Cullen KE (1998) A neural correlate for vestibulo-ocular reflex suppression during voluntary eye-head gaze shifts. *Nat Neurosci* 1:404–410
7. Matsuo S, Bergeron A, Guitton D (2004) Evidence for gaze feedback to the cat superior colliculus: discharges reflect gaze trajectory perturbations. *J Neurosci* 24:2760–2773
8. Guitton D (1999) Gaze shifts in three-dimensional space: a closer look at the superior colliculus. *J Comp Neurol* 413:77–82
9. Guillaume A, Pélisson D (2001) Gaze shifts evoked by electrical stimulation of the superior colliculus in the head-unrestrained cat. I. Effect of the locus and of the parameters of stimulation. *Eur J Neurosci* 14:1331–1344
10. Grantyn A, Moschovakis AK, Kitama T (2004) Control of orienting movements: role of multiple tectal projections to the lower brainstem. *Prog Brain Res* 143:423–438

## Eye-head Coupling

### ► Eye-Head Coordination

## Eye-Head Tracking

### Definition

The term “tracking” is used here in a general sense to describe the movement of gaze when the subject actively follows a moving target. When target motion is relatively slow, the term “gaze pursuit” is used more frequently than “tracking.” During gaze pursuit eyes make a catch-up saccade shortly after the initiation of target motion and begin a smooth pursuit movement (cf. Smooth pursuit eye movements). The head starts its movement at a longer latency and accelerates to match the target velocity. During this time eye velocity falls to nearly zero and gaze pursuit is accomplished by the head while the eyes make only small corrective movements. The contribution of the head is however smaller if the target reverses periodically its direction. Tracking at high velocities consists of a head movement and a sequence of saccadic eye movements. Head movement is usually not smooth and shows accelerations synchronous with eye saccades. In spite of repetitive saccades orbital position of the eyes (relative to the head) remains close to the resting position because of the counter-rolling induced by the vestibulo-ocular reflex (VOR). Gaze movement in space and time resembles therefore a staircase of gaze saccades with steady gaze positions in between.

- Gaze
- Gaze Shift
- Gaze Pursuit
- Saccade, Saccadic Eye Movement
- Vestibuloocular Reflexes

## Eye-neck Synergy

### ► Eye-Head Coordination

---

## Face Expression

►Face Processing in Different Brain Areas

---

## Face Hallucinations

### Definition

Face hallucinations may result from hyperexcitability and spontaneous activity in the face-specialized ►fusiform gyrus.

---

## Face Identity

►Face Processing in Different Brain Areas

---

## Face Processing in Different Brain Areas

EDMUND T. ROLLS  
University of Oxford, Department of Experimental Psychology, Oxford, England

### Synonyms

Face expression; Face identity; Inferior temporal visual cortex; Orbitofrontal cortex; Spatial frequency, attention; Invariance

### Definition

Face processing in the brain.

## Characteristics

### Neuronal Responses to Faces in Different Temporal Lobe Cortex Visual Areas

Visual pathways project by a number of cortico-cortical stages from the primary visual cortex (Brodmann's area 17, striate cortex, area V1; ►Striate cortex functions) until they reach the ►temporal lobe visual cortical areas in which some neurons that respond selectively to faces are found [1–4]. The inferior temporal visual cortex, area TE (►cerebro-cortical area TE), is divided on the basis of cytoarchitecture, myeloarchitecture, and afferent input into areas TEa (►cerebro-cortical area TEa), TEm (►cerebro-cortical area TEm), TE3 (►cerebro-cortical area TE3), TE2 (►cerebro-cortical area TE2) and TE1 (►cerebro-cortical area TE1). In addition there is a set of different areas in the cortex in the superior temporal sulcus (►STS) [5] (see Fig. 1).

Of these latter areas, area TPO (►cerebro-cortical area TPO) receives inputs from temporal, parietal and occipital cortex; areas PGa (►cerebro-cortical area PGa) and IPa (►cerebro-cortical area IPa) from parietal and temporal cortex; and areas TS (►cerebro-cortical area TS) and TAa (►cerebro-cortical area TAa) primarily from auditory areas.

Considerable specialization of function was found in recordings made from more than 2,600 neurons in the architectonically defined areas [5]. Areas TPO, PGa and IPa are multimodal, with neurons that respond to visual, auditory and/or somatosensory inputs; the inferior temporal gyrus and adjacent areas (TE3, TE2, TE1, TEa and TEm) are primarily unimodal visual areas; areas in the cortex in the anterior and dorsal part of the superior temporal sulcus [e.g. TPO, IPa and IPg (►cerebro-cortical area IPg)] have neurons specialized for the analysis of moving visual stimuli; and neurons responsive primarily to faces are found more frequently in areas TPO, TEa and TEm, where they comprise approximately 20% of the visual neurons responsive to stationary stimuli, in contrast to the other temporal cortical areas in which they comprise 4–10%. Moreover, neurons with responses related to facial expression, movement, and gesture are more likely to be found in the cortex in the superior temporal sulcus, whereas neurons with activity related to facial identity are more likely to be found in the TE areas [3].

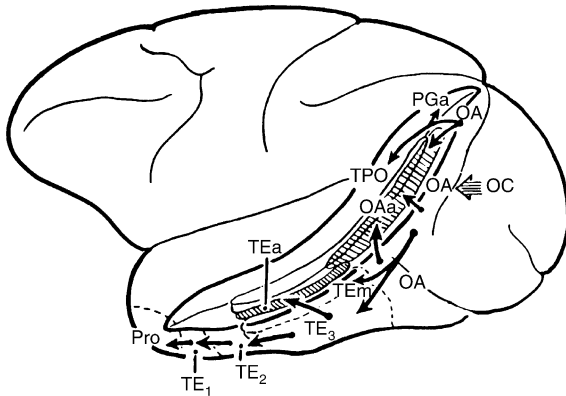

### Face Processing in Different Brain Areas.

**Figure 1** Lateral view of the macaque brain (*left*) and coronal section (*right*) showing the different architectonic areas (e.g. TEm, TPO) in and bordering the anterior part of the superior temporal sulcus (STS) of the macaque (see text).

In human ►fMRI studies, evidence for specialization of function is also described [6,7] related to face processing (in the ►fusiform gyrus face area, which may correspond to parts of the macaque inferior temporal visual cortex in which face neurons are common); to face expression and gesture (i.e. moving faces) (in the cortex in the superior temporal sulcus, which corresponds to the macaque cortex in the superior temporal sulcus); to objects (in an area that may correspond to the macaque inferior temporal cortex in which object but not face representations are common, as described above) (►Visual object representation); and to spatial scenes (in a parahippocampal area which probably corresponds to the macaque ►parahippocampal gyrus areas in which neurons are tuned to spatial view and to combinations of objects and the places in which they are located [3,4]. However, there is much debate arising from these human fMRI studies about how specific each region is for a different type of function. The single neuron studies in macaques described above and below show that individual neurons can be highly tuned in that they convey information about face identity, or about face expression, or about objects, or about spatial view. The recording studies show that within these different classes, individual neurons by responding differently to different members of the class convey information about whose face it is, what the face expression is, etc., using a sparse distributed code with an approximately exponential firing rate probability distribution. The neuronal recording studies also show that each cytoarchitecturally defined area contains different proportions of face identity vs. object neurons, but that the proportion of face-selective neurons in any one area is not higher than 20% of the visually responsive

neurons in a cytoarchitecturally defined area, so that considerable intermixing of specifically tuned neurons is the rule [5]. The neuronal recording studies also show that at the fine spatial scale, *clusters of neurons* extending for approximately 0.5–1 mm with tuning to one aspect of stimuli are common (e.g. face identity, or the visual texture of stimuli, or a particular class of head motion), and this can be understood as resulting from self-organizing mapping based on local cortical connectivity when a high-dimensional space of objects, faces etc must be represented on a two-dimensional cortical sheet (►Computational mechanisms for object and face recognition) [2,4]. Consistent with self-organizing map principles, there is a high concentration of face-selective neurons within a patch identified by fMRI [8], though face areas may be interspersed with non-face areas consistent with the neurophysiology.

### The Selectivity of One Population of Neurons for Faces

The neurons described in our studies as having responses selective for faces are selective in that they respond 2–20 times more (and statistically significantly more) to faces than to a wide range of gratings, simple geometrical stimuli, or complex 3-D objects [3]. These neurons are specialized to provide information about faces in that they provide much more information (on average 0.4 bits) about which (of 20) face stimuli is being seen than about which (of 20) non-face stimuli is being seen (on average 0.07 bits) [3,4]. These information-theoretic (►Information theory) procedures provide an objective and quantitative way to show what is “represented” by a particular population of neurons.

### Neurons Selective for Individual Face Features or for Combinations of Face Features

Masking out or presenting parts of the face (e.g. eyes, mouth, or hair) in isolation reveal that different cells respond to different features or subsets of features, and some require all the features to be present in the correct spatial configuration (i.e. not jumbled) [1,3,4].

### Distributed Encoding of Face Identity

An important question for understanding brain function is whether a particular object (or face) is represented in the brain by the firing of one or a few ►gnostic (or “grandmother”) cells, or whether instead the firing of a group or ensemble of cells each with different profiles of responsiveness to the stimuli provides the representation. It has been shown that the representation of which particular face is present is distributed. For example, in a study using 23 faces and 45 non-face natural images a distributed representation was found, with rather few stimuli producing high firing rates, and increasingly large numbers of stimuli producing lower and lower firing rates (see Fig. 2).



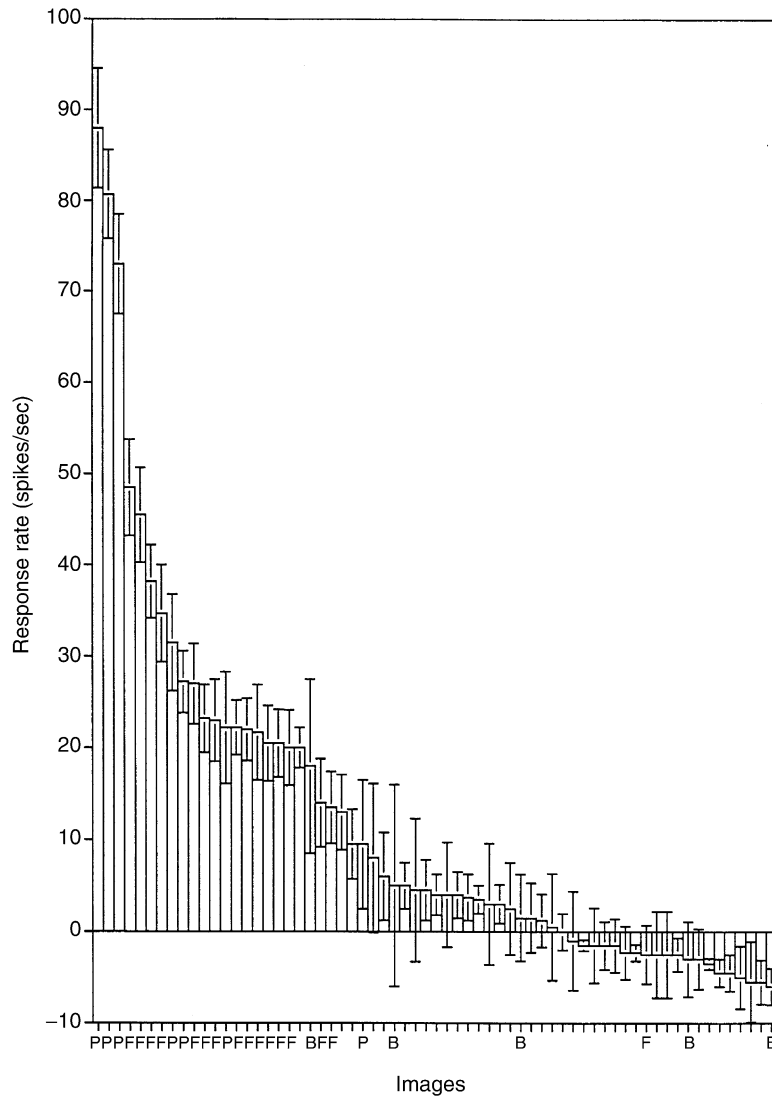

**Face Processing in Different Brain Areas. Figure 2** Firing rate distribution of a single neuron in the temporal visual cortex to a set of 23 face (F) and 45 non-face images of natural scenes. The firing rate to each of the 68 stimuli is shown. P indicates a face profile stimulus, a B a body part stimulus such as a hand. (See refs [3,4]).

Indeed, the firing rate probability distribution of many neurons is approximately exponential [3,4].

Complementary evidence comes from applying information theory to analyze how information is represented by a population of these neurons. The information required to identify which of  $S$  equiprobable events occurred (or stimuli were shown) is  $\log_2 S$  bits. (Thus 1 bit is required to specify which of two stimuli was shown, 2 bits to specify which of four stimuli was shown, 3 bits to specify which of eight stimuli was shown, etc.) The important point for the present purposes is that if the encoding was local (or grandmother cell-like), the number of stimuli encoded by a population of neurons would be expected to rise approximately linearly with

the number of neurons in the population. In contrast, with distributed encoding, provided that the neuronal responses are sufficiently independent, and are sufficiently reliable (not too noisy), the number of stimuli encodable by the population of neurons might be expected to rise exponentially as the number of neurons in the sample of the population was increased. The information available about which of 20 equiprobable faces had been shown that was available from the responses of different numbers of these neurons increases approximately linearly with the number of neurons in the population (see Fig. 3), and thus the representational capacity increases exponentially with the number of neurons in the ensemble (Fig. 4) [3,4].

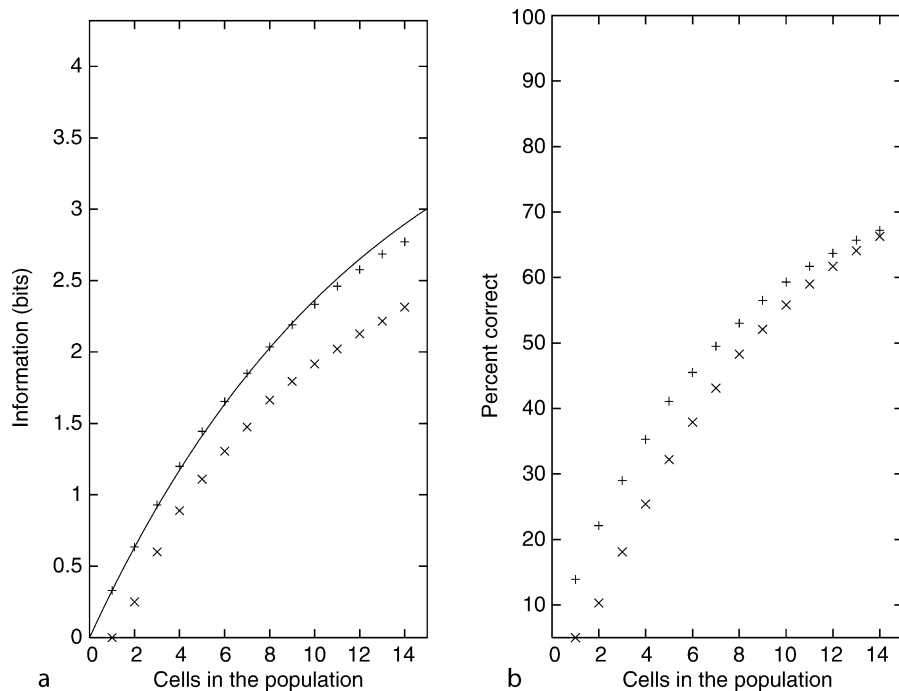

**Face Processing in Different Brain Areas. Figure 3** (a) The values for the average information available in the responses of different numbers of these neurons on each trial, about which of a set of 20 face stimuli has been shown. The decoding method was Dot Product (DP, x) or Probability Estimation (PE, +), and the effects obtained with cross validation procedures utilizing 50% of the trials as test trials are shown. The remainder of the trials in the cross-validation procedure were used as training trials. The full line indicates the amount of information expected from populations of increasing size, when assuming random correlations within the constraint given by the ceiling (the information in the stimulus set,  $I = 4.32$  bits). (b) The percent correct for the corresponding data to those shown in Fig. 3a. (See refs [3,4]).

This is further evidence for distributed encoding, and for the power of the code used.

The code that is used in the inferior temporal visual cortex is primarily the number of spikes from each neuron (i.e. a rate code), for very little (not more than approximately 5% of the total information) was available from stimulus-dependent synchrony [3,4]. The same result was found in natural scenes in which two test images had to be segmented from a complex background, the features of each object had to be bound together, and the monkey had to use top-down attention (►Visual attention) to search for one of two images in a complex scene [3,4].

The advantages of the code that has been found include exponentially high coding capacity, readability by a neuronally plausible (synaptically) weighted sum of the firing rates of different neurons, resistance to noise, generalization, completion, graceful degradation or fault tolerance, and speed of readout of the information, as described elsewhere [3,4].

### Invariant Representations

One of the major problems that must be solved by a visual system is the building of a representation of

visual information, which allows recognition to occur relatively independently of size, contrast, spatial frequency, position on the retina, angle of view, etc. This is required so that if the receiving associative networks (in e.g. the ►amygdala, ►orbitofrontal cortex and ►hippocampus) learn about one view, position, etc. of the object, the organism generalizes correctly to other positions, views etc. of the object. It has been shown that the majority of face-selective inferior temporal cortex neurons have responses that are relatively invariant with respect to the size of the stimulus [3,4], and the exact position of the face on the retina (translation invariance). Interestingly, the receptive fields become smaller (and still include the fovea) when faces or objects are seen against a complex natural background, and this helps with the ►binding problem [3,4]. It makes the interface to action simpler, in that what is at the fovea can be interpreted (e.g. by an ►associative memory in the orbitofrontal cortex or amygdala) partly independently of the surroundings, and choices and actions can be directed if appropriate to what is at the fovea [2–4]. Some neurons have view-invariant responses to faces (which would be useful for ►face recognition, and indeed these neurons tend to be tuned to face identity). Other neurons

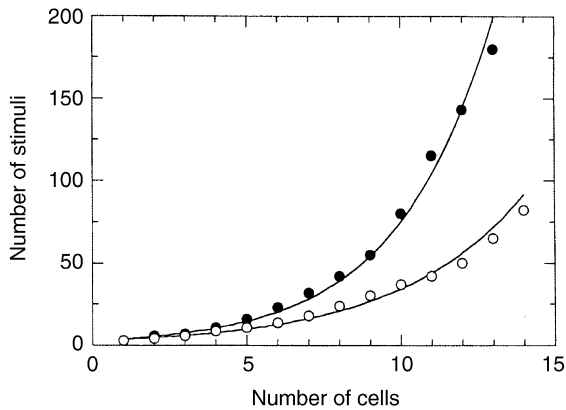

### Face Processing in Different Brain Areas.

**Figure 4** The number of stimuli (in this case from a set of 20 faces) that are encoded in the responses of different numbers of neurons in the temporal lobe visual cortex, based on the results shown in Fig. 3. The decoding method was Dot Product (DP, open circle) or Probability Estimation (PE, filled circle.) (See refs [3,4]).

have view-specific responses (which would be useful in social interactions), and indeed are found in the cortex in the superior temporal sulcus where some neurons are tuned to face expression, also useful in social interactions [3,4].

Possible computational mechanisms in the visual cortex for face recognition are described in the article by Deco and Rolls in this Encyclopedia (Computational mechanisms for object and face recognition), and elsewhere [2,4,9].

### A Representation of Faces in the Amygdala

Outputs from the temporal cortical visual areas reach the amygdala, and evidence is accumulating that these brain areas are involved in social and emotional responses to faces [10]. For example, we have identified a population of neurons with face-selective responses in the primate amygdala, some of which may respond to facial and body gesture. In humans, amygdala damage can impair the recognition of fear face expressions, and

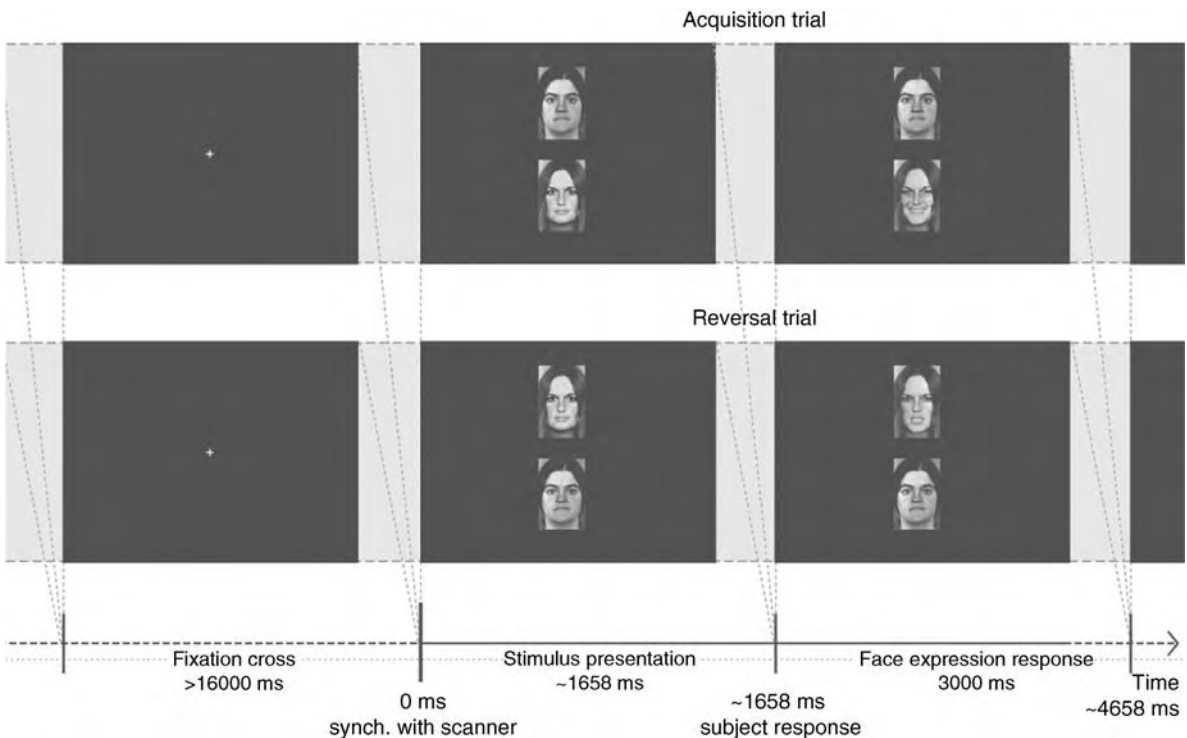

**Face Processing in Different Brain Areas. Figure 5** Social reversal task: The trial starts synchronized with the scanner and two people with neutral face expressions are presented to the subject. The subject has to select one of the people by pressing the corresponding button, and the person will then either smile or show an angry face expression for 3,000 ms depending on the current mood of the person. The task for the subject is to keep track of the mood of each person and choose the “happy” person as much as possible (*upper row*). Over time (after between 4 and 8 correct trials) this will change so that the “happy” person becomes “angry” and vice versa, and the subject has to learn to adapt her choices accordingly (*bottom row*). Randomly intermixed trials with either two men, or two women, were used to control for possible gender and identification effects, and a fixation cross was presented between trials for at least 16,000 ms. (After Kringelbach, Rolls (2003) Neural correlates of rapid reversal learning in a simple model of human social interaction. *Neuroimage* 20:1371–1383).

extraversion influences whether activations will be found to happy faces [10].

### A Representation of Faces in the Orbitofrontal Cortex

Rolls, Critchley, Browning and Inoue have found a number of face-responsive neurons in the orbitofrontal cortex, and they are also present in adjacent ►prefrontal cortical areas [3,4]. The orbitofrontal cortex face-responsive neurons, first observed by Thorpe, Rolls, and Maddison in 1982, tend to respond with longer latencies than temporal lobe neurons (140–200 ms typically, compared with 80–100 ms); and can convey information about which face is being seen, by having different responses to different faces. Some of the orbitofrontal cortex face-selective neurons

are responsive to face gesture or movement, and others to face expression [3,4]. The findings are consistent with the likelihood that these neurons are activated via the inputs from the temporal cortical visual areas in which face-selective neurons are found. The significance of the neurons is likely to be related to the fact that faces convey information that is important in social reinforcement, both by conveying face expression, which can indicate reinforcement, and by encoding information about which individual is present, also important in evaluating and utilizing reinforcing inputs in social situations [10].

We have also been able to obtain evidence that non-reward used as a signal to reverse behavioral choice is represented in the human orbitofrontal cortex (see [10]).

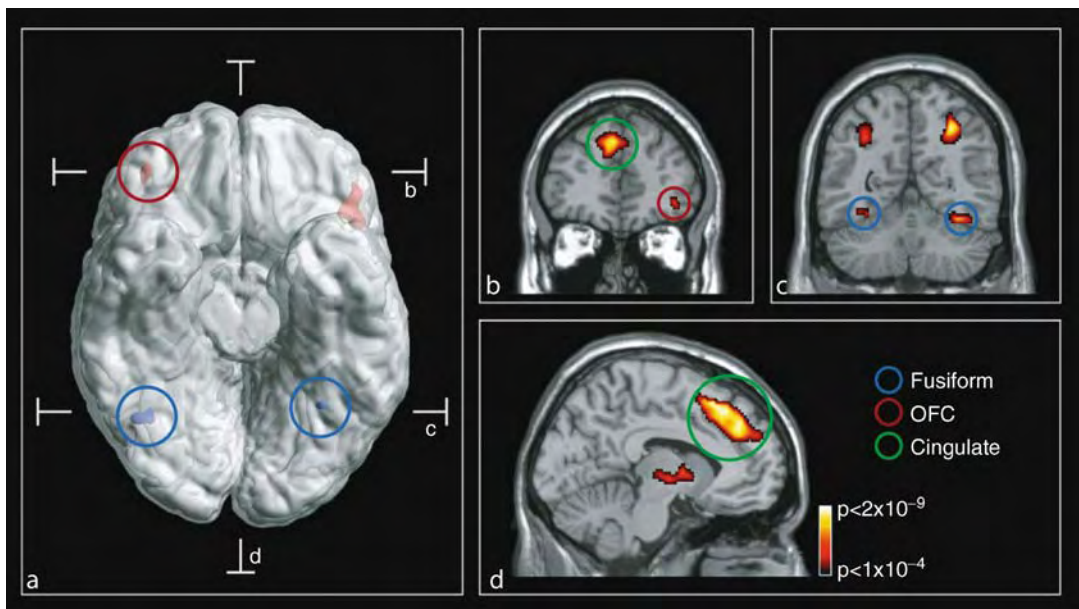

**Face Processing in Different Brain Areas. Figure 6** Social reversal: Composite figure showing that changing behavior based on face expression is correlated with increased brain activity in the human orbitofrontal cortex. (a) The figure is based on two different group statistical contrasts from the neuroimaging data which are superimposed on a ventral view of the human brain with the ►cerebellum removed, and with indication of the location of the two coronal slices (b, c) and the transverse slice (d). The red activations in the orbitofrontal cortex (denoted OFC, maximal activation:  $Z = 4.94: 42, 42, -8$ ; and  $Z = 5.51; x, y, z = -46, 30, -8$ ) shown on the rendered brain arise from a comparison of reversal events with stable acquisition events, while the blue activations in the fusiform gyrus (denoted Fusiform, maximal activation:  $Z > 8; 36, -60, -20$  and  $Z = 7.80; -30, -56, -16$ ) arise from the main effects of face expression. (b) The coronal slice through the frontal part of the brain shows the cluster in the right orbitofrontal cortex across all nine subjects when comparing reversal events with stable acquisition events. Significant activity was also seen in an extended area of the anterior ►cingulate/paracingulate cortex (denoted Cingulate, maximal activation:  $Z = 6.88; -8, 22, 52$ ; green circle). (c) The coronal slice through the posterior part of the brain shows the brain response to the main effects of face expression with significant activation in the fusiform gyrus and the cortex in the ►intraparietal sulcus (maximal activation:  $Z > 8; 32, -60, 46$ ; and  $Z > 8; -32, -60, 44$ ). (d) The transverse slice shows the extent of the activation in the anterior cingulate/paracingulate cortex when comparing reversal events with stable acquisition events. Group statistical results are superimposed on a ventral view of the human brain with the cerebellum removed, and on coronal and transverse slices of the same template brain (activations are thresholded at  $P = 0.0001$  for purposes of illustration to show their extent). (After Kringelbach, Rolls (2003) Neural correlates of rapid reversal learning in a simple model of human social interaction. *Neuroimage* 20:1371–1383).

Kringelbach and Rolls used the faces of two different people, and if one face was selected then that face smiled, and if the other was selected, the face showed an angry expression. After good performance was acquired, there were repeated reversals of the visual discrimination task. Kringelbach and Rolls found that activation of a lateral part of the orbitofrontal cortex in the fMRI study was produced on the error trials, that is when the human chose a face, and did not obtain the expected reward (see Figs. 5 and 6).

An interesting aspect of this study that makes it relevant to human social behavior is that the conditioned stimuli were faces of particular individuals, and the unconditioned stimuli were face expressions. Moreover, the study reveals that the human orbitofrontal cortex is very sensitive to social feedback when it must be used to change behavior (see [3,4,10]).

To investigate the possible significance of the neurons in the orbitofrontal cortex with face-related inputs, we also tested the responses to faces of patients with orbitofrontal cortex damage. We included tests of face (and also voice) expression decoding, because these are ways in which the reinforcing quality of individuals is often indicated. Impairments in the identification of facial and vocal emotional expression were demonstrated in a group of patients with ventral frontal lobe damage who had socially inappropriate behavior (see [3,4,10]). The expression identification impairments could occur independently of perceptual impairments in facial recognition, voice discrimination, or environmental sound recognition. The face and voice expression problems did not necessarily occur together in the same patients, providing an indication of separate processing.

To obtain clear evidence that the changes in face and voice expression identification, emotional behavior, and subjective emotional state were related to orbitofrontal cortex damage itself, and not to damage to surrounding areas which is present in many closed head injury patients, we performed further assessments in patients with circumscribed lesions made surgically in the course of treatment [3,4]. We found that some patients with bilateral lesions of the orbitofrontal cortex had deficits in voice and face expression identification [3,4]. (The same group of patients had deficits on a probabilistic monetary reward reversal task, indicating that they have difficulty not only in representing reinforcers such as face expression, but also in using reinforcers (such as monetary reward) to influence behavior.) Some patients with unilateral damage restricted to the orbitofrontal cortex also had deficits in voice expression identification. Patients with unilateral lesions of the antero-ventral part of the anterior cingulate cortex and/or medial prefrontal cortex area BA9 were in some cases impaired on voice and face expression identification.

## References

1. Perrett DI, Rolls ET, Caan W (1982) Visual neurons responsive to faces in the monkey temporal cortex. *Exp Brain Res* 47:329–342
2. Rolls ET, Deco G (2002) *Computational neuroscience of vision*. Oxford University Press, Oxford
3. Rolls ET (2007) The representation of information about faces in the temporal and frontal lobes. *Neuropsychologia* 45:125–143
4. Rolls ET (2008) *Memory, attention, and decision-making: a unifying computational neuroscience approach*. Oxford University Press, Oxford
5. Baylis GC, Rolls ET, Leonard CM (1987) Functional subdivisions of the temporal lobe neocortex. *J Neurosci* 7:330–342
6. Haxby JV, Hoffman EA, Gobbini MI (2002) Human neural systems for face recognition and social communication. *Biol Psychiatry* 51:59–67
7. Spiridon M, Fischl B, Kanwisher N (2006) Location and spatial profile of category-specific regions in human extrastriate cortex. *Human Brain Mapp* 27:77–89
8. Tsao DY, Freiwald WA, Tootell RB, Livingstone MS (2006) A cortical region consisting entirely of face-selective cells. *Science* 311:617–618
9. Rolls ET, Stringer SM (2006) Invariant visual object recognition: a model, with lighting invariance. *J Physiol Paris* 100:43–62
10. Rolls ET (2005) *Emotion explained*. Oxford University Press, Oxford

## Facial Nerve (VII)

### Synonyms

N. facialis (N.VII)

### Definition

The facial nerve conducts three qualities:

- Motor efferents for innervating the mimetic muscles: Nucleus: nucleus of the facial nerve
- Visceromotor control: parasympathetic innervation of salivary and lacrimal glands. Nucleus: salivatory nuclei
- Somatosensory control: sensory innervation of the tongue (anterior 2/3) and of the external ear

Qualities (2) and (3) are mediated by the intermediate maxillary nerve (V2) which is a permanent part of the facial nerve. Skull: internal acoustic meatus. Peripheral damage to the facial nerve leads to facial paresis. Depending on the localization of the lesion, symptoms with different degrees of expression are manifest even including complete paralysis of the ipsilateral facial musculature.

► Nerves

## Facilitation of Synaptic Transmission

### Definition

The increase in postsynaptic response to presynaptic release of neurotransmitter that occurs during trains of stimuli. At the neuromuscular junction as well as other synapses, facilitation is thought to be due to increased release of neurotransmitter from the presynaptic terminal.

► Neuromuscular Junction

## Facioscapulohumeral Dystrophy

### Definition

Inherited, autosomal dominant, relatively mild muscular dystrophy that affects both sexes, usually starts in adolescence and affects face and shoulder girdle.

## Faintness

### Definition

Lack of strength with a feeling of giddiness, swaying of ground or surrounding objects, and impending loss of consciousness (pre-syncope; see ► [syncope](#)).

## False-Belief Tasks

### Definition

Tasks which require a child to attribute a belief to another that differs from his own, e.g. a false belief.

Young three-year-olds and autistic children with a verbal age under 5 years regularly fail these standard tests, while normally developing four-year-olds pass, because they understand that people have false beliefs and act on them.

► Theory Theory (Simulation Theory, Theory of Mind)

## False Memories

### Definition

Memories for details or entire events that never occurred.

► Memory Distortion

## False Memory

► Memory Distortion

## Falsification

### Definition

Falsification is an operation to be performed on theories. A theory is said to be falsified or refuted if it (i) contradicts an observation sentence and (ii) the truth of this observation sentence has been established.

► Information

## Falx Cerebelli

### Definition

The tuber vermi and pyramid vermis are located quite deep between the two cerebellar hemispheres. Into this cleft, resting on the occipital bone, protrudes an evagination of dura mater, which, shaped like a sickle, follows the course of this groove. This sickle-shaped evagination of the dura mater is called the falx cerebelli. Its bigger counterpart is called the falx cerebri. This divides the two cerebral hemispheres.

► Cerebellum

## Falx Cerebri

### Definition

The dura mater forms a tough, sickle-shaped (falx – sickle) layer of tissue that stretches over the entire

length and depth of the longitudinal fissure of cerebrum.

At the cranium it forms a cavity, the superior sagittal sinus, and likewise at its free end: inferior sagittal sinus.

►Meninges & Cisterns

## Familial Hemiplegic Migraine (FHM)

### Definition

Rare subtype of ►migraine with aura (MA) and is caused by three genes: CACNA1A (FHM1), ATP1A2 (FHM2), and SCN1A (FHM3). It is unclear at present how these mutations may trigger migraine attacks as well as, in particular, the accompanying ►hemiplegic features and, in some families, paroxysmal or progressive ►ataxia and ►epileptic seizures. Possibly, mutations in CACNA1A alter  $\text{Ca}^{2+}$  influx and currents in neurons, possible factors of cortical ►spreading depression, which could underlie the migraine aura. Also, abnormal intracellular  $\text{Ca}^{2+}$  concentrations could alter ►neurotransmitter release. ATP1A2 mutations might entail faulty ► $\text{Na}^+/\text{K}^+$  exchange leading to abnormal  $\text{K}^+$  concentrations and subsequent depolarization and increased tendency for spreading depression, and/or abnormal  $\text{Ca}^{2+}$  concentrations because of the concomitant activation of the  $\text{Na}^+/\text{Ca}^{2+}$  exchanger.

►Headache

## Familial Periodic Paralysis

### Definition

Familial periodic paralysis comprise a group of hereditary diseases resulting from ►channelopathies (dysfunctions of ion channel proteins) and characterized by repetitive attacks of flaccid muscle weakness (potentially cardiac arrhythmias), a third of the patients developing permanent muscle weakness and degeneration at older age. In ►hyperkalemic periodic paralysis (loss of muscle strength) and ►hypokalemic periodic paralysis, mutations affect the ►voltage-gated  $\text{Na}^+$  and  $\text{Ca}^{2+}$  channels (essential for ►action potential generation and muscle ►excitation-contraction coupling). Slow, long-lasting depolarization of the sarcolemma during the attacks appears to inactivate  $\text{Na}^+$  channels, prevent the initiation of action potentials and leading to ►electromyographic silence. In the Andersen

syndrome, the gene defect also affects the heart muscle, raising the danger of ventricular arrhythmias.

- Action Potential
- Electromyography
- Excitation-contraction Coupling
- Hyperkalemic Periodic Paralysis
- Hypokalemic Periodic Paralysis
- Calcium Channels – an Overview
- Sodium Channels

## Familial Spastic Paraplegia

### Definition

Familial spastic paraplegia refers to a group of genetic disorders of the central nervous system affecting primarily the upper motor neuron pathways. They are characterized by slowly progressive disability associated with hyperactive tendon reflexes and increased muscle tone in the legs with Babinski responses. There are more than 30 different genetic subtypes inherited as autosomal dominant, autosomal recessive, or x-linked disorders. They may be uncomplicated or complicated (associated with other phenomena such as mental retardation, ataxia, or seizures).

►Neurogenetic Diseases

## Familiarity

### Definition

Familiarity is psychological experience of sensing that a stimulus or event as has previously been experienced.

The feeling of familiarity is generally distinguished from the concomitant recollection of the contextual details in which the stimulus was originally encountered.

►Recognition Memory

## Familiarization

### Definition

Process through which the novelty of a sensory stimulus (and more generally of a context, device, or cognitive

task), and related reflex-like actions of the organism, are decreased. Familiarization influences the encoding of a stimulus at several levels of the sensory pathway, and therefore modifies the neurophysiological and behavioral responses to the stimulus already experienced. It may also interfere with subsequent learning events involving that stimulus (such as Pavlovian conditioning). In reducing the reactivity to familiar cues, this process indirectly contributes to orient the attention towards other information from the surroundings. Familiarization differs from habituation, which only occurs after a sustained repeated exposure to a stimulus.

- ▶ Attention
- ▶ Classical Conditioning (Pavlovian Conditioning)

---

## Farad (F)

### Definition

Farad (F) is the unit of capacitance: capacity of a condenser to carry a charge of one coulomb with a potential difference of 1 V between two plates.

---

## Fascia

### Definition

A collagen fiber reinforced sheet of connective tissue. It contains collagen fibers running in many directions.

- ▶ Intramuscular Myofascial Force Transmission

---

## Fascicle

### Definition

A bundle of axons surrounded by a multicellular laminated perineurial sheath. Axons are loosely packed inside fascicles within the endoneurial connective tissue. Also, a group of muscle fibers surrounded by perimysium.

- ▶ Skeletal Muscle Architecture

---

## Fasciculations

### Definition

Visible, fine, rapid flickerings of skeletal muscle occurring in neurogenic ▶muscle dystrophies, reflecting synchronous contractions of all muscle fibers in a ▶motor unit whose ▶motoneurons are progressively degenerating.

---

## Fast and Slow Twitch Muscle Fibers

### Definition

Whole muscle is comprised of individual cells known as muscle fibers. Differences in twitch properties and fatigability delineate muscle fiber types. Fibers classed as “slow twitch” exhibit low speeds of shortening and tend to be fatigue resistant. Fibers classed as “fast twitch” exhibit high speeds of shortening and tend to be fatigue sensitive. In addition, fast twitch fibers tend to display PTP.

- ▶ Force Potentiation in Skeletal Muscle
- ▶ Motor Units

---

## Fast Fourier Transform

### Definition

An efficient algorithm for computing the Discrete Fourier Transform.

- ▶ Signals and Systems

---

## Fast Spiking

### Definition

Some neurons are capable of high-rate repetitive discharge with little decrease in rate upon prolonged stimulation.

- ▶ Action Potential



## Fastigial Nucleus

### Synonyms

► Nucl fastigii

### Definition

The fastigial nucleus receives its afferents (i) from the Purkinje fibers of the vermis cerebelli, (ii) directly from the vestibular apparatus and (iii) via collaterals from the vestibular nucleus. Its efferents course as the uncinate fasciculus via the inferior cerebellar peduncle to the vestibular nuclei and the reticular formation on the contralateral side.

► Cerebellum

## Fastigial Oculomotor Region (FOR)

### Definition

A part of the caudal fastigial nucleus (the most medial of the deep cerebellar nuclei) that participates in the control of saccadic and smooth-pursuit eye movements.

The FOR receives input from the oculomotor vermis (vermal portions of lobules VIc and VII) and various brainstem nuclei.

► Cerebellum – Fastigial Oculomotor Region (FOR)  
 ► Cerebellum – Role in Eye Movements

## Fastigium

### Definition

The cerebellum rests on the roof the fourth ventricle. Endowed with a sharp gable, this roof penetrates deeply into the trunk of the arbor vitae.

This gable-shaped extension is called the fastigium. It is also an eponymous designation for the fastigial nuclei situated in the cerebellum.

► Cerebellum

## Fatal Familial Insomnia (FFI)

### Definition

A rare, hereditary brain disease characterized by disrupted sleep (insomnia), motor abnormalities, and hyperactivation of the autonomic nervous system caused by a dual mutation in the gene encoding prion protein (PrP). The mutant protein aggregates to cause plaque development in the thalamus. The disease progresses into complete sleeplessness, is untreatable, and ultimately fatal between 7 and 36 months from onset. It was first detected by the Italian doctor Ignazio Roiter in 1979.

► Sleep Homeostasis

## Fatigue

### Definition

The reversible decline in the muscle performance due to prolonged or intense muscle activity. Fatigue due to metabolic and/or ionic changes in the working muscle itself is known as “peripheral” fatigue.

► Force Potentiation in Skeletal Muscle

## Fatty Acid Amide Hydrolase or FAAH

### Definition

Fatty acid amide hydrolase or FAAH is an enzyme that hydrolyzes bioactive amides including the endogenous cannabinoid anandamide to free arachidonic acid and ethanolamine. It is therefore viewed as an attractive drug target. FAAH was cloned in 1996 by Ben Cravatt at The Scripps Research Institute.

► Cannabinoids

## FDG

### Definition

The fluorinated analogue of glucose, labeled with fluorine-18 (18F); 2-[18F]-fluoro-2-deoxy-D-glucose;

the most common radiotracer for Positron Emission Tomography (PET).

► Positron Emission Tomography

---

## Fear Conditioning

### Definition

A learning task in which an initially neutral stimulus (the conditioned stimulus) acquires the capacity to elicit defensive responses after it has been associated or paired with a noxious stimulus (the unconditioned stimulus).

► Emotional Learning/Memory

---

## Fear Extinction

### Definition

A decrease in conditioned fear responses to a conditioned stimulus previously associated with an aversive unconditioned stimulus. Studies of fear extinction have been prominent in determining the neural circuitry of extinction.

► Learning and Extinction

---

## Fear Memory

### Definition

Memory of an event that evoked fear-based responses.

► Emotional Learning/Memory

---

## Feature-based Attention in Vision

### Definition

Feature-based attention refers to mechanisms by which a particular feature (e.g. a color, or shape of an object) is

selected for further processing and its evoked response is enhanced in the visual system. Feature-based attention can select either an entire feature dimension such as color versus motion or an aspect within a feature dimension such as red versus green. At the neural level, feature-based attention is a global mechanism that enhances processing of the selected feature regardless of where attention is directed spatially.

► Visual Attention

---

## Feature Extraction

### Definition

The process by which nervous systems detect the occurrence of specific stimulus features.

---

## Feedback

### Definition

Feedback reflects the use of system measurements (sensors outputs) to determine system actions (actuator inputs).

► Control

---

## Feedback Control of Movement

ARTHUR PROCHAZKA  
Centre for Neuroscience, University of Alberta,  
Edmonton, AB, Canada

### Synonyms

Reflex; Reaction; Report; Error detection; Control system

### Definition

Information about the output of a process derived from sensors and delivered as an input to a controller of that process.

## Characteristics

The word *feedback* was coined in 1948 by Norbet Wiener for the emerging field of *Cybernetics*. It is used extensively in engineering, generally in relation to *control systems*. In neurophysiology it is used to describe the signals entering the central nervous system (CNS) from sensory afferents. The CNS uses these signals to control a large number of bodily functions. For example, feedback from arterial baroreceptors is used by neural networks in the brainstem to control blood pressure via the heart and vasoconstrictor muscles. Many of these bodily functions maintain constancy of the internal environment, a process termed ►*homeostasis*.

With regard to the control of bodily movement, signals from a variety of receptors are involved, including mechanoreceptors in muscles, joints and skin, as well as higher-order receptor organs such as the eyes, ears and vestibular apparatus. All levels of the CNS from the spinal cord to the cerebellum and cerebral cortex receive feedback from mechanoreceptors and all these levels are involved to some extent in controlling even the simplest limb movements.

Historically, the study of movement control began with observations in the eighteenth and nineteenth centuries on simple responses to limb perturbations in animals in which the spinal cord had been severed, thereby eliminating supraspinal mechanisms. The underlying premise, first explicitly stated in 1864 by Ivan Sechenov in his book *Reflexes of the brain*, was that all movements, no matter how complex, could be broken down into elemental sensori-motor reactions called reflexes. By studying many types of reflex, one would eventually understand complex motor control. It is interesting to note that the Roman poet Ovid used the word *reflex* in the sense of *bring back*. Substitute *feed* for *bring* and we have *feedback*. Various types of feedback system exist in technology and whenever a new variant is developed, it is not long before a parallel is drawn with a CNS control function. The main types of feedback control are:

1. Finite state control (arguably the simplest form of feedback control). A sensor monitors a variable (e.g. the angular position of gearwheel in a clock). When the variable reaches a pre-set value, a new state in the process is initiated (e.g. a bell rings). In 1874, A. Freusberg found that when the hind-limb of a spinally-transected dog was dropped from a flexed position, at some point in the descent, the flexor muscles were suddenly activated and the limb flexed upward again. If the downward movement was stopped before this point, no reflex flexion occurred, indicating that a pre-set amount of extension was required to trigger the flexion phase. Later it was shown that during locomotion, it is not only the amount of extension or flexion, but also the amount

of force being generated that determines when the spinal cord switches between the stance and swing phases of locomotion [1]. In finite-state control, sensory thresholds, actuator states and state-transition rules are rigidly defined. Movement control in animals is no doubt more flexible than this.

2. Proportional control (►*Servo control*). This is a continuous form of feedback in which a comparator continuously computes the difference (*mismatch or error*) between a sensed variable (*output*) and the desired value of that variable (*input*) and causes an actuator (e.g. muscle) to minimize this error. The output is thereby made to follow variations in the input or command signal. Furthermore, external perturbations that cause an error are automatically resisted. The error computation is equivalent to subtracting the feedback signal from the input signal, hence “negative feedback.” The spinal feedback loop comprising ►*muscle spindles*, motoneurons and the muscles they innervate (Fig. 1) is often likened to a proportional negative feedback loop. The advantage of proportional feedback control is that variations in muscle function, e.g. fatigue, are automatically compensated for, because the feedback loop minimizes the error between output and input by appropriately modulating the drive to the muscle. The higher the loop gain (the product of the gains of all the elements in the loop) the better the error correction, but if there are significant delays around the loop and if the loop gain is high, uncontrolled oscillation can develop at a cycle period of two times the delay. The feedback signal effectively adds an error rather than subtracting from it, hence the term “positive feedback.”
3. Compensated control. When nonlinear properties of the actuator and load are known, it is advantageous to include components in the forward and feedback pathways of the control loop that compensate for these nonlinearities. This can improve response time and accuracy by allowing a larger loop gain before instability occurs. Numerous types of compensators have been developed in technology. The type commonly used as an analogy of biological control is the proportional integral differential (PID) controller, which is a proportional controller with additional differentiating and integrating elements in either the forward or feedback pathway (Fig. 1b). In *self-organizing* or *adaptive* compensators, the compensation parameters, e.g. the coefficients  $K_p$ ,  $K_i$  and  $K_d$  in Fig. 1b, are continuously updated on the basis of performance assessments. Because there are many ways to assess performance and to change parameters, adaptive controller design is an art form. The neurophysiological term for the adjustment or updating of transmission parameters is *plasticity*.

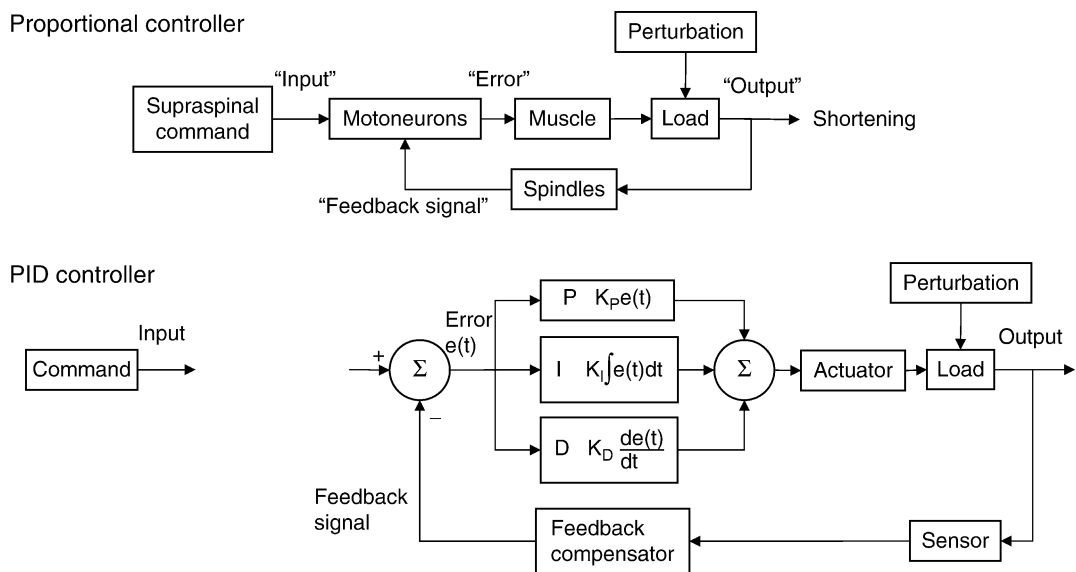

**Feedback Control of Movement. Figure 1** (a) A simple proportional feedback loop used as an analogy for the stretch reflex. Note that spindle input caused by muscle lengthening excites motoneurons which causes muscles to shorten, so this is an example of a negative feedback loop. (b) The general schema of a proportional-integral-differential controller. The three parallel elements (P, I, D) have separate gains that are adjusted to best compensate for inadequacies of the load-moving actuator.

4. Predictive control. If imminent loading and obstacles can be predicted it is often advantageous to alter the command with an element that provides feedforward compensation (Fig. 2). Another form of prediction that compensates for a known delay in the forward path is implemented with an internal feedback loop that models the actuator and load, but without a delay (Fig. 2). This internal loop can therefore have a high loop gain without becoming unstable. The actual delayed response (output) is compared to the internally delayed modeled response. The residual error is passed back into the internal loop for follow-up correction. This type of controller is called a Smith predictor [2], and it has been suggested as a model for the cerebellar control of movement.
5. Probabilistic control (e.g. Fuzzy logic, Kalman filters, Bayesian controllers etc). In these, sensory inputs are weighted according to past experience. The weighted sensory inputs then essentially “vote” for a particular direction and size of change in the actuators. Fuzzy logic controllers allow multiple inputs to control multiple outputs (MIMO control) in a manner that is understandable in linguistic terms. The weights (membership functions) are “hand-crafted” by the designer according to knowledge of the task and actuator properties. Bayesian controllers use an algorithm to predict sensory inputs according to the statistics of previous trials. Probabilistic control has also been proposed for the cerebellum.
6. Artificial neural nets. Commands and sensory signals are delivered to an input layer of computing elements, each of which assigns weighting factors to them and delivers its output through multiple connections to computing elements in the next layer, which assigns further weights. The final output layer, whose elements may be likened to motoneurons, controls multiple actuators. Layers between the input and output layers are called hidden layers and their elements may be likened to interneurons. The weighting factors are “learned” or progressively adjusted to reduce performance errors in successive iterations. Various methods of adjustment have been tried, including the best known one, back-propagation, whereby weights are adjusted according to “cost” (i.e. performance error). The adjustments proceed from the output layer backward through the successive hidden layers to the input layer. Artificial neural nets show some of the structural organization of biological neural systems and like neural systems they are capable of adaptation. A key biological insight they have provided is that hidden layer elements (interneurons) can show activity patterns that are not related to inputs or outputs in obvious ways, yet contribute to overall performance. This provides a plausible explanation for the finding that the activity of many neurons in the motor cortex of monkeys performing motor tasks is not obviously task-related even though these neurons probably contribute to the control of the task.

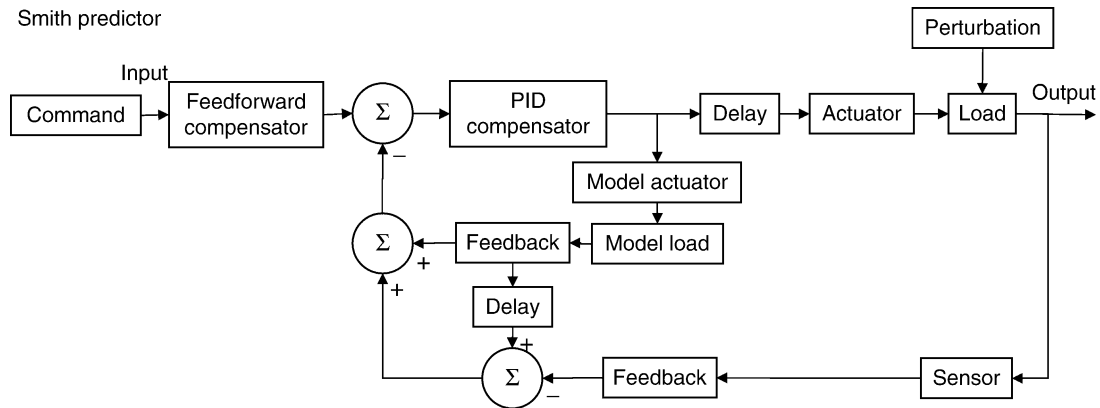

**Feedback Control of Movement. Figure 2** General schema of a feedforward predictor combined with a Smith predictor.

Over the last two decades the following developments have changed the way neurophysiologists think of feedback in the control of movement

1. The formalization of the concept of “internal models” whereby multimodal sensory input is processed to produce muscle commands based on internal predictions of the biomechanical consequence of these commands [3]. The *Smith predictor* (Fig. 2) is a good example of a controller having an explicit internal model.
2. Input from muscle receptors causes the abrupt phase-switching between stance and swing in the step cycle. Finite-state rules have been proposed, that describe these phase transitions in a variety of animal species. Fuzzy logic, which uses combinations of weighted sensory inputs rather than sets of fixed thresholds, may provide a more realistic analogy [4].
3. The discovery of positive force feedback during locomotion. During static posture, feedback from **tendon organs**, the force-sensing receptors in a muscle, reflexly inhibits the motoneurons of the muscle. During locomotion, tendon organ inhibition switches to excitation. This is positive force feedback. Unlike in a linear PID system, positive force feedback of muscles remains stable because when muscles shorten they produce less force for a given change in input, thus automatically limiting loop gain [5].
4. During locomotion, the portion of muscle activation attributable to spinal reflexes mediated by muscle receptors is smaller and more delayed than previously assumed. The stretch reflex contribution is only really significant when the centrally generated activation is weak [6].
5. In the presence of vision, locomotor movements are adjusted to terrain two or three steps in advance [7]. Firing of motor cortical neurons is correlated with these predictive changes. This suggests that predictive control is extremely important, at least for human gait.
6. The notion has emerged of the cerebellum being a state analyzer, performing probabilistic operations on sensory input analogous to Bayesian statistics or Kalman filtering [8].

### Concluding Remarks

Systems that combine central pattern generation (internal models), finite-state rules and PID control of limbs are now commonly used to control walking robots [9]. Presently the most advanced walking robot, the Honda Asimo humanoid robot, has three levels of control: (i) local PID control about individual joints, (ii) finite-state phase switching and hazard rules and (iii) a global command comprising a moving target of ground reaction force against which the actual ground reaction vector is compared. Models incorporating these feedback control systems have been used successfully to analyze human locomotion [10].

### References

1. Prochazka A (1993) Comparison of natural and artificial control of movement. *IEEE Trans Rehabil Eng* 1:7–17
2. Smith OJM (1959) A controller to overcome dead time. *Instrumentation Soc Am J* 6:28–33
3. Shadmehr R, Mussa-Ivaldi FA (1994) Adaptive representation of dynamics during learning of a motor task. *J Neurosci* 14(5 Pt 2):3208–3224
4. Prochazka A (1996) Proprioceptive feedback and movement regulation. In: Rowell L, Sheperd JT (eds) *Handbook of physiology, section 12. Exercise: regulation and integration of multiple systems*. American Physiological Society, New York, pp 89–127
5. Prochazka A, Gillard D, Bennett DJ (1997) Implications of positive feedback in the control of movement. *J Neurophysiol* 77(6):3237–3251
6. Yakovenko S, Gritsenko V, Prochazka A (2004) Contribution of stretch reflexes to locomotor control: a modeling study. *Biol Cybern* 90(2):146–155

7. Patla AE, Prentice SD, Rietdyk S, Allard F, Martin C (1999) What guides the selection of alternate foot placement during locomotion in humans. *Exp Brain Res* 128:441–450
8. Bower JM (1997) Control of sensory data acquisition. *Int Rev Neurobiol* 41:489–513
9. Kimura H, Fukuoka Y, Cohen AH (2007) Biologically inspired adaptive walking of a quadruped robot. *Philos Transact A Math Phys Eng Sci* 365:153–170
10. Taga G (1998) A model of the neuro-musculo-skeletal system for anticipatory adjustment of human locomotion during obstacle avoidance. *Biol Cybern* 78:9–17

---

## Feedback Error Learning

### Definition

Learning or training of internal inverse models by approximating a teacher signal with feedback control signals. Supervised learning becomes problematic when a teacher signal is provided in a coordinate system different from that of inverse-model outputs, the problem known as a distal teacher problem. Specifically, for motor learning, an error in a movement consequence is usually evaluated in the visual or proprioceptive coordinate, whereas a teacher signal for inverse models should be in the motor-command coordinate. The idea behind feedback error learning is that feedback control signal, though delayed due to sluggish sensory transmission, can approximate a teacher signal in the motor-command coordinate and can hence be used for training inverse models. Recent physiological and human brain imaging studies showed that the cerebellar circuit indeed realizes a certain type of feedback error learning.

- ▶ Neural Networks for Control
- ▶ Theories on Motor Learning

---

## Feedback Gain

### Definition

The ratio of the output of a feedback loop to its input. When a feedback loop contributes to joint impedance, the gain is frequently represented as the ratio of the force produced by the output of the feedback loop to the displacement or velocity of the imposed motion.

- ▶ Impedance Control

---

## Feedback Linearization

### Definition

- ▶ Global Linearization
- ▶ Nonlinear Control Systems

---

## Feedback Loops in Chronobiology

GIANLUCA TOSINI

Circadian Rhythms and Sleep Disorders Program,  
Neuroscience Institute, Morehouse School of Medicine,  
Atlanta, GA, USA

### Definition

Feedback is a process in which part of an output signal is passed to the input and, thus, contributes to the regulation of a system. A negative feedback loop tends to slow down a process, whereas a positive one produces an acceleration of a process. In this essay we will describe examples of feedback loops in the field of chronobiology at three different organizational levels: molecular, cellular and organismal.

### Characteristics

#### Molecular Feedback Loops: The Autoregulatory Transcription-Translation Feedback Loops

The molecular mechanism that generates the circadian ▶rhythmicity involves two interlocking transcription-translation feedback loops, which consist of positive and negative components (Fig. 1).

The autoregulatory feedback loops begin when two basic helix-loop-helix-PAS domain transcription factors, ▶CLOCK and ▶BMAL1, form heterodimers, bind to specific DNA regions (▶E-boxes), and activate the transcription of ▶Periods and ▶Cryptochromes genes. Once the CRYPTOCHROME and PERIOD proteins in the cytoplasm have reached predetermined levels, they begin to form heterodimers. Then they translocate into the nucleus to inhibit the transcription of the Cryptochromes and Periods genes by blocking CLOCK/BMAL1-mediated trans-activation (negative feedback loop). This inhibition leads to the decrease of PERIODS and CRYPTOCHROMES levels in the cytoplasm and, thus, to a decrease in the formation of the heterodimers until the levels of these heterodimers are insufficient to inhibit the transcription of the Periods and Cryptochromes genes [1]. Another positive feedback loop involves the products of two orphan nuclear receptors (*Rev-Erba* and *Rora*). These two proteins

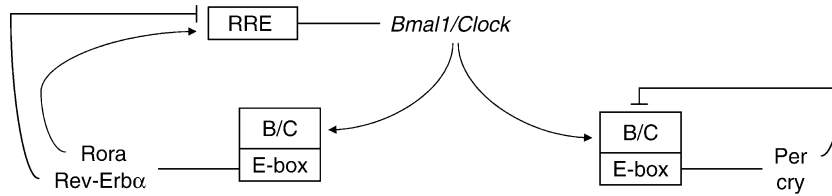

**Feedback Loops in Chronobiology. Figure 1** In mammals the autoregulatory feedback loop is composed of two independent feedback loops. The positive feedback loop involves the transcription factors *Bmal1* and *Clock*, which form heterodimers and activate the transcription of *Period* (*Per*) and *Cryptochrome* (*Cry*) genes. In the cytoplasm, PERIOD and CRYPTOCHROME proteins form heterodimers that enter the nucleus and interact with BMAL1/CLOCK (B/C), thus inhibiting the transcription (negative feedback). BMAL1 and CLOCK also stimulate the transcription of *Rev-Erba* and *Rora*. REV-ERB $\alpha$  protein inhibits *Bmal1* transcription whereas RORA protein enhances *Bmal1* transcription.

regulate the rhythmic transcription of *Bmal1* by competing for the binding of the *Rev-erb/Ror* (RRE) elements present on the promoter region of the *Bmal1* gene. REV-ERB $\alpha$  represses *Bmal1* transcription, whereas ROR $\alpha$  activates *Bmal1* transcription [2].

### Cellular Feedback Loops: The Retinal Circadian Clock System

A series of studies over the last two decades has shown that the vertebrate ►retina (mammals included) contains an intrinsic circadian clock that controls many functions within the tissue. Several investigations have also shown that circadian rhythmicity in many of these functions is maintained *in vivo* after lesion of the ►suprachiasmatic nuclei (SCN), the master circadian clock located in the brain of the hypothalamus and, in a few cases, *in vitro*. ►Melatonin, visual processing and disk-shedding are among the retinal circadian rhythms that may persist *in vitro* or after the lesion of the master ►circadian pacemaker located in the hypothalamus [3].

Melatonin and dopamine play opposing roles in the regulation of retinal adaptive physiology. Dopamine functions as a signal for light and, thus, is involved in the phenomenon of light-adaptation, whereas melatonin mediates dark adaptations. The synthesis and release of both melatonin and dopamine are under circadian control, with melatonin released at night and dopamine during the daytime. Melatonin inhibits the release of dopamine via its action on melatonin receptors, while dopamine inhibits the synthesis and release of melatonin by acting on dopamine receptors present on the melatonin-synthesizing cells. Therefore, the melatonin synthesizing photoreceptor cells and the dopaminergic amacrine cells form a cellular “feedback loop” that regulates circadian retinal physiology (Fig. 2).

Until recently, the working of this “feedback loop” was unclear, but in the last few years many details about the working of this cellular feedback loop have been revealed. Recent experimental evidence has demonstrated that dopamine rhythmicity in the retina is not required for the generation of circadian rhythmicity in

the melanergic system since a circadian rhythm in melatonin levels persists following destruction of the inner retina or in isolated photoreceptor layers [4]. Such a result demonstrates that the generation of the circadian rhythms in melatonin levels is independent, although it can be modulated by dopamine. Conversely, it seems that dopamine rhythmicity is dependent upon the presence of melatonin since retinal dopamine content and metabolism are in circadian melatonin-proficient mice, but not in melatonin-deficient mice [5]. Moreover, daily administration of melatonin restores the circadian rhythms in the dopaminergic system in melatonin-deficient mice [5]. Similarly, administration of Luzindole (a melatonin antagonist) to cultured retina abolishes the circadian rhythm of dopamine [6].

Therefore, it can be concluded that, in the mammalian retina, the pacemaker is likely to be located in the photoreceptors, and it appears to be necessary to generate the circadian rhythm in the dopaminergic system. In contrast, the circadian rhythmicity of the dopaminergic system is not necessary for the generation of the melatonin circadian rhythm in photoreceptors. However, the removal of the dopaminergic inputs may affect the phase of the circadian oscillation, thus demonstrating that the feedback from the dopaminergic cells is important to stabilize and determine that phase of the retinal circadian system.

### System Feedback Loop (The Birds’ Neuroendocrine Loop)

The circadian organization of birds is rather complex since these organisms possess multiple photoreceptive structures and circadian pacemakers. In some species, the ►pineal gland plays a dominant role as circadian pacemaker, whereas in other species, the eyes may be more important. In some instances, the generation of circadian rhythm requires inputs from the hypothalamic pacemaker. (See [7] for a recent review.) Early studies on house sparrow reported that overt circadian rhythms could not be sustained in animals in which the pineal gland had been removed. However, these studies also revealed that the avian SCN possesses oscillatory

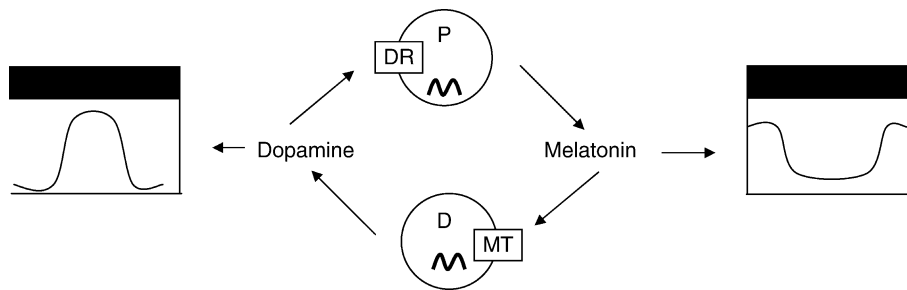

**Feedback Loops in Chronobiology. Figure 2** Melatonin is synthesized from the photoreceptors (P) during the night and acts on melatonin receptors (MT) located on dopaminergic neurons (D) in the inner retina to inhibit dopamine release. Conversely, dopamine inhibits melatonin synthesis via dopamine receptors (DR) located on the photoreceptors. Therefore, in the retina, melatonin forms an autoregulatory feedback loop.

properties. For example, circadian rhythms can be observed for a few days – and in some case for weeks – after the pineal gland or the eyes have been removed; in some cases, a single light pulse could restore rhythmicity for a few circadian cycles (six or seven) in pinealectomized sparrow held in constant darkness. Similarly, cyclic light conditions or administration of melatonin restored rhythmicity in behaviorally arrhythmic pinealectomized birds [8].

These experimental data led to the hypothesis that none of the components of the bird circadian system are capable of generating long-term self-sustained rhythmicity, but self-sustained circadian rhythmicity is generated by the mutual interaction between and among the different components of the birds' circadian system (Fig. 3).

This hypothesis, known as the “neuroendocrine feedback loop,” was proposed by Menaker and Cassone [9] to explain the sparrow's circadian organization. According to this model, during the day, the SCN, via a neural connection, inhibits pineal melatonin synthesis while, at night, the pineal *via* melatonin inhibits SCN neuronal activity. In this model removal of one of the oscillators and its feedback will lead to the damp-out of the remaining oscillator and, thus, to the abolishment of circadian rhythms at the organismal level. Therefore, this neuroendocrine loop synchronizes the different structures that contribute to the stability and precision of the system.

Experimental data suggest that this model can also be applied, with some modifications, to other species of birds in which the ocular pacemaker may play a key role for the maintenance of rhythmicity. For example, in pigeons, removal of the eyes alone, or pinealectomy alone, does not abolish circadian rhythms, whereas pinealectomy combined with blinding abolishes the circadian rhythms of locomotor activity and body temperature [7]. Daily infusion of melatonin may restore circadian rhythmicity. In the Japanese quail, enucleation renders the bird arrhythmic, while pinealectomy does not significantly affect the circadian

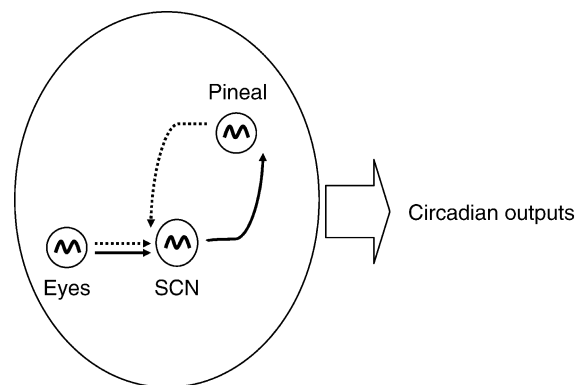

**Feedback Loops in Chronobiology. Figure 3** In birds, circadian oscillators are present in the pineal gland, eyes, and the SCN. The pineal gland plays its role on the SCN via melatonin (dashed line), while the SCN acts on the pineal gland via a neural connection (solid line). The eyes can act *via* melatonin and *via* neural connection on the SCN. Removal of one of these organs may induce a dampening of circadian rhythmicity in the organisms.

rhythm of body temperature and/or locomotor activity. Bilateral resection of the optic nerves affect circadian rhythmicity only in a small number of birds, suggesting that humoral (melatonin) and neural outputs from the eyes play an important role in the circadian system of this species [7].

Although this model has been proposed for the bird, other investigations have reported that a similar feedback system organization may also be present in reptiles [10].

## References

1. Reppert SM, Weaver DR (2002) Coordination of circadian timing in mammals. *Nature* 418:935–941
2. Lowrey PL, Takahashi JS (2004) Mammalian circadian biology: elucidating genome-wide levels of temporal



organization. *Ann Rev Genomics Hum Genet* 5:407–441

3. Iuvone PM, Tosini G, Haque R, Klein DC, Chaurasia SS (2005) Circadian clocks, clock-controlled genes and melatonin biosynthesis in the retina. *Prog Retin Eye Res* 24:433–456
4. Tosini G, Davidson AJ, Fukuhara C, Kasamatsu M, Castanon-Cervantes O (2007) Localization of a circadian clock in mammalian photoreceptors. *FASEB J* 21 (14):3866–3871
5. Doyle SE, Grace MS, McIvor W, Menaker M (2002) Circadian rhythms of dopamine in mouse retina: the role of melatonin. *Visual Neurosci* 19:593–601
6. Ribelayga C, Wang Y, Mangel SC (2004) A circadian clock in the fish retina regulates dopamine release via activation of melatonin receptors. *J Physiol* 554:467–482
7. Underwood U, Steele CT, Zivkovic B (2001) Circadian organization and the role of pineal birds. *Microsc Res Tech* 53:48–62
8. Lu J, Cassone VM (1993) Daily administration synchronizes circadian patterns of brain metabolism and behavior in pinealectomized house sparrow, *Passer domesticus*. *J Comp Physiol A* 173:765–782
9. Cassone VM, Menaker M (1994) Is the avian circadian system a neuroendocrine loop? *J Exp Zool* 232:539–549
10. Tosini G, Foa A, Bertolucci C (2001) The circadian system of reptiles: a truly multioscillatory and multi-photoreceptive system. *Physiol Behav* 72:461–471

## Feedback Networks

### Definition

Networks composed of mutually connected neurons, which are also called recurrent networks.

► Neural Networks

## Feedback System (Negative)

### Definition

The regulatory systems operating for maintenance of fixed levels of body variables are called negative feedback systems. They function such that, with any disturbance, the system is brought back to the desired level or reference value (set point).

► Homeostasis

## Feedforward Control

### Definition

The ability of the nervous system to influence some characteristics of motor actions in advance, before they are started or accomplished; in the  $\lambda$  model for motor control, it is achieved at the level of motoneuronal membrane.

► Equilibrium Point Control

## Feedforward Network

### Definition

A layered neural network architecture in which intralayer connections are absent, while inter-layer connections are strictly feed-forward without feed-back loops.

► Neural Networks

## Feedforward Networks

### Definition

Networks in which activity cannot travel in loops.

► Neural Networks for Control

## Feedforward (Open-loop) Controller

### Definition

A controller which does not use online sensory feedback.

► Neural Networks for Control

## Feedforward Postural Control

### Definition

Activation of postural muscles prior to any sensory feedback indicating postural instability.

- ▶ Anticipatory Postural Responses

dopamine and noradrenaline) in brain. The drug has been used clinically as an appetite suppressant but was withdrawn because of serious side effects.

- ▶ Dopamine
- ▶ Noradrenaline
- ▶ Serotonin
- ▶ Stimulants

## Feedforward Processing

### Definition

Information is processed in a set of subsequent stages.

Activation propagates unidirectionally through these stages from the input to the output. No feedback loops are involved.

- ▶ The Binding Problem

## Fenton Reaction

### Definition

The reaction in which  $\text{Fe}^{2+}$  ions react with hydrogen peroxide ( $\text{H}_2\text{O}_2$ ) to produce hydroxyl radicals and hydroxide ion:  $\text{Fe}^{2+} + \text{H}_2\text{O}_2 \rightarrow \text{Fe}^{3+} + \text{HO}\cdot + \text{OH}^-$ .  $\text{Fe}^{3+}$  can be regenerated to  $\text{Fe}^{2+}$  by hydrogen peroxide, producing additional peroxy radicals:  $\text{Fe}^{3+} + \text{H}_2\text{O}_2 \rightarrow \text{Fe}^{2+} + \text{HOO}\cdot + \text{H}^+$ . The Fenton reaction utilizes small amounts of  $\text{Fe}^{2+}$ , acting as a catalyst, to convert hydrogen peroxide to more reactive oxygen radicals.

## Feeding

### Definition

Consuming food.

## Ferguson Reflex

During normal delivery, stretching of the lower birth canal triggers the secretion of oxytocin by the pituitary gland, which results in strong expulsive uterine contractions.

- ▶ The Hypothalamo Neurohypophysial System
- ▶ Neurohypophysis, Corticosteroids, and Aquaporin-2 Channel
- ▶ Hypothalamo-Pituitary-Adrenal Axis
- ▶ Stress and Depression

## Feeling or Sense of What's Up And What's Down

- ▶ Verticality Perception

## Ferrimagnet

### Definition

A crystal that consists of two magnetic sublattices of different spontaneous magnetization, which are polarized in a direction opposite to one another so that they neutralize each other partially, but not completely. The

## Fenfluramine

### Definition

Fenfluramine is a stimulant drug that preferentially causes release of the neurotransmitter serotonin (vs.

resultant magnetization gives rise to a strong magnetism similar to that of a ferromagnet (such as metallic iron).

► Magnetic Bacteria

## Ferrimagnetism

### Definition

While ferromagnetism is due to a direct exchange between adjacent atoms in a lattice, ferrimagnetism is due to an indirect exchange between metallic ions mediated by non-metallic anions such as  $O^{2-}$  or  $S^{2-}$  (superexchange). Direct exchange in ferrites is weak because of the relatively large distance between the metallic ions. Ferrimagnetism requires two magnetic sublattices.

► Magnetite

## Fetal Brain Injury

► Prenatal Brain Injury by Chronic Endotoxin Exposure

## Fetal Mesencephalic Tissue

### Definition

Tissue from the midbrain (mesencephalon) of aborted fetuses used for transplantation into the brains of patients with Parkinson disease.

► Parkinson Disease

## Fetal Programming

### Definition

Maternal or environmental factors (undernutrition, chemicals) that influence fetal brain development and so affect brain structure and function for life.

► Neuroendocrinology of Eating Disorders

## Feynman Ratchet and Pawl

### Definition

A thought experiment about an apparent perpetual motion machine, postulated by Richard Feynman in his physics lectures, demonstrating the subtleties of the second law of thermodynamics.

► Brownian Ratchet

## FFR

► Force-Frequency Relation of Skeletal Muscle

## Fiber Type Grouping

### Definition

A common and striking finding in muscles that undergo continuous denervation and reinnervation. Fiber Type Grouping occurs as a result of a loss of functioning motor units followed by collateral sprouting, and leads to a reorganization of the motor units and fiber type distribution, with smaller or larger groups of muscle fibers of the same type. It is a common finding in muscles of patients with neurogenic muscle disorders such as motor neuron disease and peripheral neuropathies, but can also be seen in muscles from older individuals.

► Motor Units

► Muscle – Age-Related Changes

► Peripheral Neuropathies

## Fibrillations

### Definition

Spontaneous activity of individual muscle fibers not visible by clinical inspection.

## Fibrocartilage

### Definition

A type of cartilage characterized by its fibrous microscopic appearance; often the form of tissue found around the edges of joints (labrum) and intra-articular discs (menisci) that tend to increase the depth or congruence of joints.

► Joints

## Fibro-dendritic Laminae

### Definition

Layers in the central nucleus of the inferior colliculus composed of disc-shaped neurons whose dendritic fields are parallel and layers of axons.

► Inferior Colliculus

## Fibromyalgia

► Muscle Pain Including Fibromyalgia

## Fibromyalgic Syndrome

### Definition

Fibromyalgic Syndrome is characterized by musculo-skeletal pain, fatigue, neuro-vegetative symptoms and sleep disturbances.

► Neuroendocrinology of Psychiatric Disorders

## Fibronectin

### Definition

Contributes to the composition of the extracellular matrix and is known to play an important role in cell

adhesion as well as neural migration. Fibronectin is a glycoprotein dimer made of two structurally similar peptides held together by disulfide bonds. It is able to interact with numerous molecules including type IV collagens, fibrin, heparin as well as some membrane receptors such as integrins.

## Fibrosis

### Definition

Deposits of collagen, a connective tissue, in a wound or at sites of chronic inflammation.

## Fick's First Law

### Definition

In 1855 the German physiologist Adolf Eugen Fick introduced Fick's law of diffusion, which describes the diffusion of a gas across a fluid membrane:

$$J_{diff} = -D\partial[C]\partial x$$

$J$  is the diffusion flux (molecules  $s^{-1}cm^{-2}$ );  $D$  is the diffusion coefficient ( $cm^2 s^{-1}$ ) and  $[C]$  is the concentration of ion (molecules  $cm^{-3}$ ).

► Ion Transport

## Fictive Locomotion

### Definition

Stepping-like rhythmic activity recorded in ventral roots or peripheral nerves in paralyzed and deafferented animals, i.e. in the absence of sensory information.

## Fictive Motor Pattern

### Definition

The activation pattern of motor neurons (usually recorded with ENG) observed in a preparation without movement. Movement may be prevented either by

removal of all muscles or by neuromuscular chemical blockade.

- ▶ ENGs (Electroneurographic Recordings)
- ▶ Scratching

## Fictive Movements

### Definition

The pattern of motor commands produced by activated central pattern generators (CPGs) while output to muscles is prevented.

- ▶ Central Pattern Generator (CPG)
- ▶ Mastication

## Field Potential

### Definition

Summed electric response of many cells recorded by invasive microelectrodes in the CNS and evoked by short electric or magnetic stimulation of their axons or synaptic inputs.

- ▶ Extracellular Recording

## Fight-or-Flight Response

### Definition

Fight-or-flight response is the response of animals to acute stress. As first described by Walter Cannon in 1939, is the reaction to a threat or strong emotion. Is a motor behavior accompanied and sustained by a generalized activation of the sympathetic nervous system. This response was later considered the first stage of a general adaptation syndrome that regulates stress responses in vertebrates and other organisms.

- ▶ Autonomic Nervous System
- ▶ Sympathetic Nervous System

## Figure-Ground Perception

### Definition

- ▶ Form Perception

## Fila Olfactoria

### Synonyms

Olfactory nerves

- ▶ Olfactory Nerve (I)
- ▶ Pathways

## Filiform Papillae

### Definition

(Papilla: small protuberance, Filum: thread) Filiform papillae are keratinous structures emerging from the surface of the tongue epithelium. They are densely packed on the central axis and more sparse on the lateral edges. Filiform papillae cover the dorsal tongue from the sulcus terminalis to the tip. There are two types of morphologically distinguishable filiform papillae: those composed of a base shaped like a dome (primary papilla) surmounted by 5–30 elongated conical spikes (secondary papillae) and those composed of a single conical spike (solitary papilla). These structures which do not contain taste buds are made of layers of epithelial cells expressing keratins. Defective desquamation of some cells composing the conical spikes is associated with a condition called “black hairy tongue” characterized by the transformation of filiform papillae into “hairlike” elongated cornified spines.

- ▶ Taste

## Filopodium

### Definition

The extension of a long, slender cytoplasmic expansion supported by a microfilament core, found on a

migrating cell or neuronal growth cone. Filopodia may contain many receptors on their surface allowing them to sense the local environment. Their elongation and retraction movements can occur rapidly owing to the fast polymerization and depolymerization of the supporting actin filaments.

► Axonal Pathfinding and Network Assembly

---

## Filter

### Definition

An algorithm or a component that reshapes a signal to achieve a given performance goal in some domain, usually the frequency or the time domain.

► Signals and Systems

---

## Final Common Pathway

### Definition

The integration of all information reaching a skeletal muscle.

---

## Finite Difference Method

### Definition

A numerical method for solving the physical equations used in cardiovascular mechanics, particularly those governing fluid flow. In this case a Taylor series approximation of the governing Navier-Stokes partial differential equations produces a system of discrete equations for computation.

► Cardiovascular Mechanics

---

## Finite Element Method

### Definition

A numerical method for solving continuum equations such as those governing the large deformations that

occur in blood vessel walls and the heart walls. The material domain (such as the heart wall) is divided into small blocks or “elements.” Discrete variables defined at points called “nodes,” located at the corners of these elements, are used to interpolate fields that vary continuously within the elements and across the element boundaries.

► Cardiovascular Mechanics

---

## Firing Field

### Definition

A discrete region of an environment where a place cell exhibits a high firing rate. A place cell can have zero, one or several firing fields in an environment. Place field is a synonym.

► Spatial Learning/Memory

---

## Firing Patterns

► Temporal Coding

---

## Firing Rate

### Definition

The number of action potentials or spikes generated per unit of time in neurons.

---

## First- and Second-Order Cues

### Definition

First-order stimuli are defined by luminance or color and can be detected by Fourier analysis. Second-order

stimuli are defined by cues such as texture, disparity or contrast and cannot be detected by Fourier analyses.

There is disagreement as to whether these two types of stimuli are processed by common mechanisms, entirely different mechanisms, or whether the mechanisms are initially separate but combine after some nonlinear process (e.g., half-wave or full-wave rectification).

► Visual Illusions

## First Cranial Nerve

► Olfactory Nerve

## First-Person Authority

### Definition

The idea of first-person authority is that there is something special about knowing our own minds. For example, the way Mary knows what she herself thinks and feels is notably different from the way she knows what her sister Alice feels and thinks. Traditionally, this was tried to spell out in terms of the infallibility and incorrigibility of judgments about one's own mind.

► Behaviorism  
► Logical

## First-Person Perspective

### Definition

First-person perspective is constitutive for consciousness, processed in an egocentric reference frame and centered upon one's own body as opposed to the thirdperson perspective, from which an organism has access to the behavior of others.

► Emergence

## First Piola-Kirchhoff Stress

### Definition

The flux tensor corresponding to the flux of linear momentum (i.e. the surface traction) in the Lagrangian formulation. Also called Piola stress.

► Mechanics

## First Somatosensory Cortex, SI

► Somatosensory Cortex I

## Fishes

► Evolution of the Visual System: in Fishes

## Fission

### Definition

The regulated separate of two bilayer membranes resulting in a "pinching-off" that produces two separate membrane-bound compartments. The opposite of membrane fusion, and thus the defining step of endocytosis or vesicle retrieval from the plasma membrane; facilitated by the protein dynamin.

► Synaptic Proteins and Regulated Exocytosis

## Fitness

### Definition

The ability of an animal to produce offspring, i.e. to pass on its genes to the next generation.

A discrimination is made between direct (own offspring) and indirect or inclusive fitness (offspring produced by relatives).

---

## Fitts' Law

### Definition

A relationship that defines a tradeoff between movement time and accuracy, originally proposed by Fitts in 1954. It is based on the premise that the rate at which information is transmitted by the central nervous system is limited.

- ▶ Eye-Hand Coordination
- ▶ Movement Sequences

---

## Fixation

### Definition

The act of holding the visual axis relatively immobile on a location in space, usually for the purpose of exploring a visual scene. To see during fixation, ocular micro-movements are necessary to assure that the visual image is never perfectly stable on the fovea. Overt (covert) attention occurs when attention is (is not) directed at the fixated location.

- ▶ Fixation System

---

## Fixation Neurons

### Definition

They discharge during fixation of targets and pause for saccades, both ipsiversive and contraversive. Also called tectal pause neurons (TPNs).

- ▶ Saccade, Saccadic Eye Movement
- ▶ SC – Tectal Long-Lead Burst Neurons

---

## Fixation Point

### Definition

Usually a fixated spot of light, a terminology used most often in laboratory experiments (Fig. 1a of essay Fixation System).

- ▶ Fixation System

---

## Fixation-related Neurons

### Definition

Neurons whose discharge is specifically related to the act of fixating a location in space, irrespective of whether fixation occurs in the light or dark.

- ▶ Fixation System

---

## Fixation System

DANIEL GUITTON

Montreal Neurological Institute, McGill University,  
Montreal, QC, Canada

### Definition

To inspect our surroundings we use a sequence of rapid displacements of the eyes, called saccades, interspersed by ▶ [fixation](#) periods in which the fovea is aimed at specific locations on the visual scene (▶ [visual fixation](#)). During fixation periods, the eye is not completely immobile but is subjected to very small drifts and resetting micro-saccades – essential for accurate perception – each responsible for eye position changes with an overall standard deviation of  $\sim 0.1^\circ$  in each of the horizontal and vertical planes [1]. This essay is concerned with the putative ▶ [fixation system](#) – not with ocular micro-movements – that maintains, though not perfectly, the line of sight on a particular location in visual space.

When we search for a specific feature in a visual scene, we clearly need to attend to what we fixate. However, fixation and attention are not obligatorily linked; we can fixate on a point in space while attending to another. For example, during a search task for a



specific item within a spatially-distributed set of items, we can simplify the search by attending to a subgroup of items, based on a specific feature of this subgroup such as color. We can then select an object, within that color group, for further fixation and analysis, even if it is not currently being fixated. At the other extreme, we can fixate idly without attending to anything at all in the external world.

Brain imaging reveals regions implicated in attentive fixation, compared to idle fixation [2]. Further evidence for an active fixation system is that: (i) In patients suffering from the “spasm of fixation” syndrome, saccade generation is impaired in the presence of a foveal ►fixation point, but it is normal when no fixation point is present [3]. (ii) Saccade reaction times are longer when a subject must first break active fixation rather than start from an idle state [4]. (iii) Frontal lobe lesions can result in the inability to maintain fixation and suppress reflex saccades in the anti-saccade task [5]. (iv) Attentive fixation elevates the threshold for evoking saccades by electrically stimulating several oculomotor areas of the brain (e.g. [6]). (v) Neurons exist with fixation-related activity, which I shall review below.

## Description of the Theory

### Brainstem Motor Mechanisms for Holding the Eye Immobile

#### Circuits in the Pons

During fixation periods between saccades, any unwanted discharges, or “noise,” in burst neurons could cause unwanted variations in eye position and this would hinder precise fixation control. Such unwanted discharges in burst neurons are inhibited by “omnipause” neurons (OPNs), which fire steadily during fixation periods and “permit” saccades by ceasing to discharge for the duration of eye saccades made head-fixed, and gaze saccades made head-unrestrained. Hence OPNs are part of a motor fixation system; their tonic discharge that suppresses saccades is independent of whether the eyes are involved in either idle or active fixation.

#### The Midbrain’s Superior Colliculus and Fixation Control

Burst and omnipause neurons are “go-no-go” elements in saccade control, and their supervision by higher level structures is thought to require a major contribution by the midbrain’s superior colliculus (SC). The SC is a layered structure whose superficial layers contain visually-responsive neurons organized as a retinotopically coded visual map, with the foveal representation in the rostral pole and with increasingly eccentric positions in the visual field represented progressively more caudally. By comparison, the deeper layers are organized into a motor map – coextensive with the visual map above – that encodes the vector of saccadic eye-head gaze shifts. Large gaze shifts are driven by

neurons in the caudal parts of the motor map, whereas smaller gaze shifts are encoded more rostrally.

In the rostral pole of the motor map, is the so-called ►fixation zone containing cells with fixation-related discharges [7,8]. Some of these cells (Fig. 1b, Tonic foveal visual neurons) have foveal receptive fields and discharge tonically when the monkey fixates a light spot (FS), and cease discharging when FS is momentarily turned off (the “gap” in Fig. 1a), even though a monkey is attentively fixating the same location in the dark. Other cells (Fig. 1c, Pure fixation neurons, also called ►superior colliculus fixation neurons, SCFNs) fire tonically, beginning when the animal attentively foveates a discrete light spot and keep discharging during the gap.

The gap discharge can be higher, the same, or lower than the tonic fixation firing frequency (Fig. 1c, shaded outline). By comparison these cells do not discharge during idle fixation. The activity of eye fixation neurons pauses, like OPNs, during both eye and gaze saccades in head-fixed and head-unrestrained animals, respectively.

SCFNs project to, and excite, OPNs that themselves inhibit the eye saccade generator (e.g. [9]). Furthermore, SCFNs may inhibit the SC motor map as shown by electrical stimulation and by the response of neurons on the motor map (having off-foveal receptive fields), whose discharge is decreased when a monkey attentively fixates a foveal light spot [7]. This and other evidence suggests that SCFNs are part of an active motor fixation system that prevents the occurrence of unwanted saccades by gating eye or gaze saccades. However, the timing of SCFN reactivation at saccade end is too late to stop saccades and other, yet unknown, mechanisms are required.

### Fixation-Related Signals in Frontal Brain Structures

#### Frontal Eye Field (Fef)

There is an FEF fixation zone situated in about the rostral bank of the inferior arcuate sulcus, near the zone encoding small saccade vectors [10]. This FEF zone is similar to the SC fixation zone in that it contains pure fixation neurons and stimulation there suppresses saccades directed both contralaterally and ipsilaterally. However, FEF fixation-related cells (►fixation-related neurons) are also scattered throughout the FEF territory [11,12]. These authors have shown that the FEF sends saccade-related and fixation activity to the SC, a projection important in the control of voluntary saccades. According to ref. 12, there are four types of FEF neurons that project fixation-related activity to the SC. Three are illustrated in Fig. 1, using a slightly different nomenclature than they proposed: (i) Tonic foveal visual neurons (Fig. 1b) and (ii) Pure fixation neurons (Fig. 1c, similar to SCFNs in the rostral SC) each project about equally to the rostral and caudal SC, suggesting that they do not drive SCFNs. (iii) Neurons

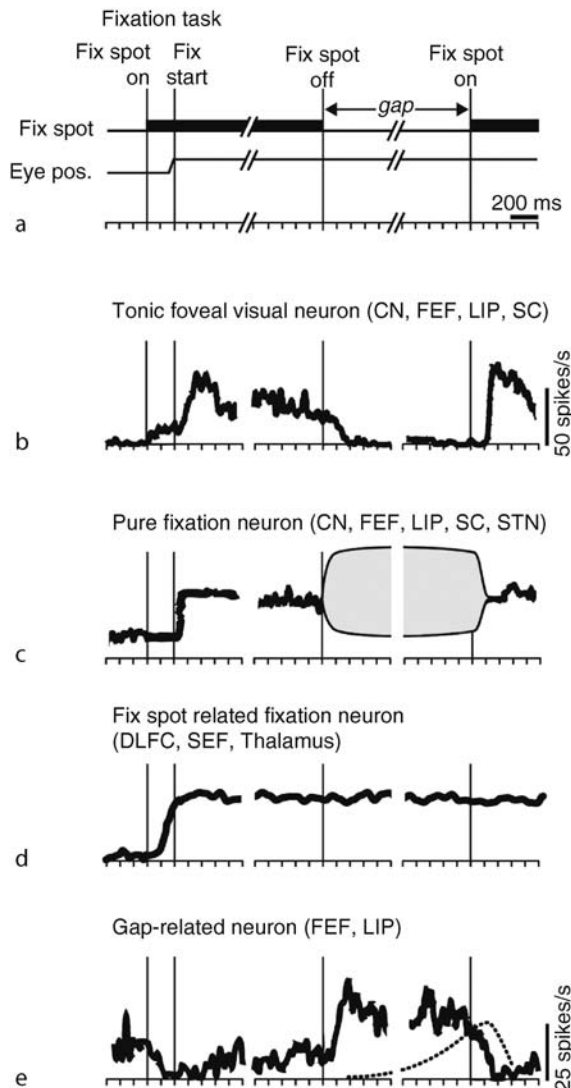

**Fixation System. Figure 1** Schematic representation of different types of fixation-related firing frequency profiles found in different monkey brain regions (adapted from Fig. 4 in Ref [12]). The traces and firing frequency scales in panels b and e are examples of FEF neuron discharges taken from Fig. 4 in Ref [12]. The nomenclature is novel and attempts to capture essential features of the different fixation discharge patterns found throughout the brain. (a) Fixation task: a monkey makes a saccade (Eye position trace) to foveate the fixation spot (FS), shortly after its presentation. FS remains on for a random time and then is briefly extinguished (the “gap”) for a random time, typically of about 500 ms and then turned on again. Monkey is required to maintain fixation of the FS or its remembered location in the dark, during the gap. (b) Tonic foveal visual neuron fires only when monkey foveates the visible FS. This example is from a FEF neuron [12]. (c) Pure fixation neuron (in superior colliculus, called superior colliculus fixation neuron, SCFN). These cells discharge just after the saccade that brings the fovea into the FS and firing

with a gap-related signal (Fig. 1e) are the main type of FEF-SC projection neuron and are nearly silent while the monkey attentively fixates a visible FS, and fire specifically during the gap (Fig. 1a) when the monkey is required to maintain fixation, in the dark, on the location occupied previously by FS. (iv) Other neurons have a foveal visual receptive field, a presaccadic pause in activity and elevated firing at saccade termination.

### Supplementary Eye Field (SEF)

Fixation spot – related fixation neurons (Fig. 1d) are the main type of fixation-related neuron found in the SEF, a frontal region implicated in controlling eye and gaze saccades. Unlike pure fixation neurons, the fixation related discharge of these neurons is triggered by the onset of FS and begins before and lasts throughout the saccade to FS. Some increase, others decrease their activity with attentive fixation [13]. The fixation-related tonic firing frequency is modulated by eye position during attentive fixation. This discharge property is also present in the posterior parietal cortex (see section below). However, while it is the visual activity of parietal neurons that is mostly affected by eye-position changes, the SEF fixation neurons are more implicated in encoding motor space [14]. The information carried by these neurons could permit the internal representation of the position of attended targets, relative to the head (or body), for the purpose of controlling target-directed motor behavior in 3D space. Interestingly, focal stimulation of the SEF evokes saccades that are directed to a location in the orbit corresponding to the eye position preferred by cells recorded at the stimulated site [14].

### Other Regions of Frontal Cortex

Other studies have reported neurons with fixation-related activity that resembles “fixation spot related fixation neurons” (Fig. 1d) in regions extending beyond the classical boundaries of the FEF and SEF [15,16].

frequency continues steadily during fixation. Some neurons maintain this discharge rate steadily during the gap; others either increase or decrease their gap firing frequency in the range indicated by the shaded area. (d) Fix spot related fixation neuron begins firing soon after FS on, and continues throughout saccade to FS and when FS is either on or in gap. Gap-related firing frequency profile may vary (not illustrated), as for SC. In SEF, DLFC and thalamus these neurons also encode eye position. (e) Gap-related neuron has little foveal visual response, but is strongly activated when monkey fixates attentively in the dark. This example is from a FEF neuron [12]. Dotted line shows response of LIP gap-buildup cell [19]. Abbreviations CN, DLFC, FEF, LIP, SC, SEF, STN refer to brain areas (see text) where fixation-related activity, of the type illustrated, is found.

Activity in some of these cells was induced when the monkey fixated a stimulus linked to reinforcement, also an important component of fixation-related discharges in the basal ganglia (see below).

### **Fixation-Related Signals in the Parietal Lobe**

Neurons in area 7a, with large visual receptive fields that include the fovea, can have enhanced visually-evoked discharges to para and extra-foveal targets during attentive fixation of either a light spot or in the dark (as in Fig. 1b) [17]. Their firing rate can also encode gaze position in 3D space even in the dark [18]. As noted above for SEF, these neurons as a population could encode the spatial position of targets of interest.

Fixation-related activity in area LIP has been studied in a task similar to that in Fig. 1a [19]. Cells were found with firing frequency profiles similar to those shown in Figs. 1b, c and e. The gap-related firing frequency profile (Fig. 1e) either rises abruptly after gap onset (followed by a slow decay) or increases slowly. The “abrupt” type has been found in the FEF, but not in SC. In LIP, as in SC and FEF, the tonic activity of pure fixation neurons pauses during saccades, but the timing of the pause is more loosely related to saccade onset and end, suggesting that LIP is not implicated in driving fixation-related cells in FEF and SC.

### **The Basal Ganglia and Subthalamic Nucleus Caudate Nucleus (Cn)**

Regions of the primate CN are implicated in linking cognitive and motivational sets to the generation of appropriate saccade commands. The CN receives cortical inputs, notably from FEF, SEF and LIP, as well as limbic structures and substantia nigra (reviewed in [20]). CN discharge properties are complex, being related to either/ or combinations of, expectation of target, expectation of reward, spatial location of target, fixation, breaking of fixation, and type of motor response (e.g. eye or limb).

Some CN neurons resemble pure fixation neurons (Fig. 1c) except that their discharge requires the fixation behavior to lead to reward [20]; they do not discharge when a non-rewarded spot is attentively fixated. During the gap (Fig. 1a), their activity decreases substantially but does not entirely subside. Other CN neurons display visually-evoked discharges when the monkey is fixating a light spot (Fig. 1b) – even if this behavior is not directly rewarded – and pause during saccades from one visible spot to another. The discharge of some of these visual cells is spatially selective to fixations of a light spot located in a specific zone on the screen facing the monkey. Such cells are silent in the dark even if fixation is rewarded.

### **Substantia Nigra Pars Reticulata (Snr)**

The SNr is a major output structure of the basal ganglia, and is implicated in controlling saccadic eye

movements via an inhibitory projection to the SC. A decrease in SNr tonic discharge has been reported in response to a visual stimulus or saccade [21]. Some SNr cells have large bilateral visual receptive fields that are most sensitive to a foveal stimulus. The fixation-related responses of these cells are complex, context-dependent and have not been tested in the paradigm of Fig. 1a. Their task-selective activity decrease was proposed to specifically facilitate saccades to remembered targets or to newly appearing targets by disinhibiting selective regions of the motor map of the SC. There are sustained increases in SNr firing during fixation [22], a property compatible with increased inhibition of the SC motor map. None of these discharge patterns seem compatible with SNr projections to SCFNs.

### **The Subthalamic Nucleus (Stn)**

Neurons in the ventral STN participate in visuo-oculomotor behavior and receive projections from FEF, SEF and CN. The same STN region projects to the SNr and back to CN [reviewed in 22]. Some visually driven STN neurons have fixation-related activity similar to that in Fig. 1b [22]. There is no eye position sensitivity. Other reward-related pure fixation neurons, with activity that declines in the gap period, discharge specifically when the animal fixates a target, or its location in the dark (Fig. 1c), and the discharge does not depend on whether eye or limb is used to obtain the reward. STN fixation-related discharges are similar to those in the CN and could be due to CN or frontal inputs.

### **The Thalamus**

Fixation spot related fixation neurons (Fig. 1d) have been found in the central thalamus [23] and subdivided about equally into two types whose firing patterns, when a FS is turned on, are mirror images of each other; one with increased tonic firing (fix+), the other with decreased firing (fix-). When the monkey looks away from the FS, the tonic firing frequency of fix + cells decreases before the saccade that breaks fixation. Thalamic fixation cells do not encode eye position in space.

### **Overview**

The maintenance of stable fixation is a prerequisite for performing saccade tasks. I have overviewed evidence supporting the existence of an active neural fixation system, whose function is polyvalent (see also [24]) and still needs much research to be fully elucidated. So far, the motor correlates of fixation-related discharges seem most clear in the SEF, FEF and SC and most certainly in OPNs. As discussed in previous sections, a reasonable hypothesis is that fixation-related discharges in FEF, SC and OPNs function to suppress the saccadic eye movement system, to assure that off-foveal distractor stimuli do not divert gaze away from a foveal target of interest. By comparison, fixation related activity in

parietal cortex and SEF could be important in salient target selection and localization at the visual and motor ends of the sensory-motor transformation spectrum, respectively. Activity in the basal ganglia, subthalamic nucleus and parts of frontal cortex seem implicated in linking fixation behavior to the receipt of reward, but how these regions contribute to fixation is unclear.

## References

- Martinez-Conde S, Macknik SL, Hubel DH (2004) The role of fixational eye movements in visual perception. *Nat Rev Neurosci* 5:229–240
- Petit L, Dubois S, Tzourio N, DeJardin S, Crivello F, Michel C, Etard O, Denise P, Roucoux A, Mazoyer B (1999) PET study of the human foveal fixation system. *Human Brain Mapp* 8:28–43
- Johnston JL, Sharpe JA, Morrow MJ (1992) Spasm of fixation: a quantitative study. *J Neurol Sci* 107:166–171
- Boch R, Fischer B (1986) Further observations on the occurrence of express-saccades in the monkey. *Exp Brain Res* 63:487–494
- Guitton D, Buchtel HA, Douglas RM (1985) Frontal lobe lesions in man cause difficulties in suppressing reflexive glances and in generating goal-directed saccades. *Exp Brain Res* 58:455–472
- Goldberg ME, Bushnell MC, Bruce CJ (1986) The effect of attentive fixation on eye movements evoked by electrical stimulation of the frontal eye fields. *Exp Brain Res* 61:579–584
- Munoz DP, Guitton D (1991) Control of orienting gaze shifts by the tectoreticulospinal system in the head-free cat. II. Sustained discharges during motor preparation and fixation. *J Neurophysiol* 66:1624–1641
- Munoz DP, Wurtz RH (1993) Fixation cells in monkey superior colliculus. I. Characteristics of cell discharge. *J Neurophysiol* 70:559–575
- Sugiuchi Y, Izawa Y, Takahashi M, Na J, Shinoda Y (2005) Physiological characterization of synaptic inputs to inhibitory burst neurons from the rostral and caudal superior colliculus. *J Neurophysiol* 93:697–712
- Izawa Y, Suzuki H, Shinoda Y (2004) Suppression of visually and memory-guided saccades induced by electrical stimulation of the monkey frontal eye field. II. Suppression of bilateral saccades. *J Neurophysiol* 92:2261–2273
- Segraves MA, Goldberg ME (1987) Functional properties of corticotectal neurons in the monkey's frontal eye field. *J Neurophysiol* 58:1387–1419
- Sommer MA, Wurtz RH (2000) Composition and topographic organization of signals sent from the frontal eye field to the superior colliculus. *J Neurophysiol* 83:1979–2001
- Schlag J, Schlag-Rey M, Pigarev I (1992) Supplementary eye field: influence of eye position on neural signals of fixation. *Exp Brain Res* 90:302–306
- Lee K, Tehovnik EJ (1995) Topographic distribution of fixation-related units in the dorsomedial frontal cortex of the rhesus monkey. *Eur J Neurosci* 7:1005–1011
- Bon L, Lucchetti C (1992) The dorsomedial frontal cortex of the macaca monkey: fixation and saccade-related activity. *Exp Brain Res* 89:517–580
- Suzuki H, Azuma M (1977) Prefrontal neuronal activity during gazing at a light spot in the monkey. *Brain Res* 126:497–508
- Mountcastle VB, Andersen RA, Motter BC (1981) The influence of attentive fixation upon the excitability of the light-sensitive neurons of the posterior parietal cortex. *J Neurosci* 1:1218–1235
- Sakata H, Shibutani H, Kawano K (1980) Spatial properties of visual fixation neurons in posterior parietal association cortex of the monkey. *J Neurophysiol* 43:1654–1672
- Ben Hamed S, Duhamel JR (2002) Ocular fixation and visual activity in the monkey lateral intraparietal area. *Exp Brain Res* 142:512–528
- Hikosaka O, Sakamoto M, Usui S (1989) Functional properties of monkey caudate neurons. III. Activities related to expectation of target and reward. *J Neurophysiol* 61:814–832
- Hikosaka O, Wurtz RH (1983) Visual and oculomotor functions of monkey substantia nigra pars reticulata. II. Visual responses related to fixation of gaze. *J Neurophysiol* 49:1254–1267
- Matsumura M, Kojima J, Gardiner TW, Hikosaka O (1992) Visual and oculomotor functions of monkey subthalamic nucleus. *J Neurophysiol* 67:1615–1632
- Schlag J, Schlag-Rey M (1984) Visuomotor functions of central thalamus in monkey. II. Unit activity related to visual events, targeting, and fixation. *J Neurophysiol* 51:1175–1195
- Bender DB, Youakim M (2001) Effect of attentive fixation in macaque thalamus and cortex. *J Neurophysiol* 85:219–234

---

## Fixation Zone

### Definition

A sub-region of a brain area/structure containing neurons with fixation-related discharges; e.g. there are fixation cells (Fig. 1b of essay Fixation System) in the fixation zone of the rostral superior colliculus.

### ► Fixation System

---

## Fixational Eye Movements

### Definition

Small involuntary movements of the eye that incessantly occur during visual fixation. Usually classified into three types: microsaccades, miniature saccadic jumps produced a few times per second; drift, slow random

gaze fluctuations between successive micros; tremor, high-frequency oscillations of very small amplitude superimposed on drift.

- ▶ Microsaccades
- ▶ Ocular Drift

---

## Fixed Support Strategy

### Definition

A reaction to postural perturbation in which the feet (and/or upper limbs) remain in contact with the supporting surface (or surfaces). Also commonly referred to as “in place” or “feet in place” reactions.

- ▶ Postural Strategies

---

## Fixing a Position by Sighting

### Definition

Observing size and relations among distant landmarks from a stationary location, to determine one’s location on a map. The concept is taken from ship navigation and applied to animal navigation.

- ▶ Spatial Learning/Memory

---

## FK506 Binding Protein (FKBP12, Calstabin1)

### Definition

An isomerase enzyme that binds specifically to RyR1 (4 molecules per tetrameric channel or 1 molecule per RyR monomer), the sarcoplasmic reticulum  $\text{Ca}^{2+}$  release channel in skeletal muscle, that stabilizes the closed state of the channel and facilitates coupled gating

between neighboring channels that enhances the  $\text{Ca}^{2+}$  transient during excitation-contraction coupling.

- ▶ Excitation-Contraction Coupling

---

## Flaccidity

### Definition

Softening and extreme yielding of skeletal muscle to stretch.

---

## Flash-Bulb Memory

### Definition

A strong and long-lasting memory of an emotionally arousing experience.

- ▶ Emotional Learning/Memory

---

## Flashing Ratchet

### Definition

The phenomenon that a Brownian particle that switches between two, directionally biased, potentials can undergo directed motion.

- ▶ Brownian Ratchet

---

## Flat Contact

### Definition

Synaptic contact between cone photoreceptors and mainly OFF bipolar cells, located at the base of the cone pedicle.

- ▶ Photoreceptors
- ▶ Retinal Bipolar Cells

## Flavor

THIERRY THOMAS-DANGUIN

Flavour Perception Group: Peri-receptor Events and Sensory Interactions, UMR1129 FLAVIC, ENESAD, INRA, Université de Bourgogne, Dijon Cedex, France

### Synonyms

Flavour

### Definition

The flavor is a sensory percept induced by food or beverage tasting. It relies mainly on the functional integration of information transmitted by the chemical senses: olfaction, gustation and oral and nasal ►**somatosensory** inputs. For a food item, there is a qualitative fusion of the different sensory inputs to form a single perceptual unit which is the food item's flavor. Flavor may be influenced by other sensory inputs such as texture or color.

### Characteristics

#### Quantitative Description

During food consumption and when food is not yet in the mouth, the olfactory system and nasal trigeminal system can detect volatile compounds released by the food matrix. Once in the mouth and during food matrix breakdown, tastants, odorants and ►**chemesthetic substances** are mixed with saliva while volatile compounds are released into the oral headspace. Tastants and chemesthetic substances reach mucosal papillae and can be detected by gustatory and trigeminal systems. In the meantime, odorants and volatile chemesthetic substances reach the nasopharynx and olfactory mucosa retronasally. They can then be detected by the olfactory and nasal trigeminal systems.

All physico-chemical aspects of oral stimuli interact with oral and olfactory surfaces, which transduce these properties. It is thus expected that many interactions among sensations from the oral cavity occur at a peripheral level [1]. However, the two sensory modalities of olfaction and gustation are clearly distinct in the periphery. Thus, integration may not occur until the level of the cortex [2]. Central or peripheral multisensory integration is obvious through perceptual interactions observed between the chemical senses.

Odorants and volatile chemesthetic substances reaching the nasal cavity and the olfactory mucosa, orthonasally or retronasally, can stimulate both olfactory receptor cells and other chemoreceptors of the trigeminal nerve. Therefore, the trigeminal nerve often contributes to an irritating attribute to odors. Odors were also shown to inhibit irritation and conversely, chemesthetic irritant

substances could decrease the perception of odors. This occurred without attenuation even when an irritant entered one nostril and an odorant the other [3]. These results revealed that odor–irritation interactions may take place centrally in the nervous system.

Similarly, in the mouth, tastants and chemesthetic substances can stimulate both gustatory receptor cells and oral endings of the trigeminal nerve. Several tastants become irritants when their concentration increases and trigeminal inputs may contribute to taste quality. Taste–irritant interactions can rely on multiple routes. Trigeminal activation can affect the physiology of the lingual epithelium through the release of substance P from peripheral terminals of ►**nociceptors**. It could also affect the activity in the ►**NTS** (►**nucleus of the solitary tract**, also innervated by the ►**chorda tympani**) via direct afferent inputs and/or via modulatory effects possibly mediated via ►**substance P** release in the NTS.

►**Psychophysical** studies in Human showing interactions between odors and tastes, when they are experienced in mixtures, clearly evidence integration between these two distinct modalities. Central cross-modal integration was reported for subthreshold taste and smell [4]. Human subjects, exposed to a ►**subthreshold concentration** of a tasteless cherry-almond odorant (benzaldehyde) associated with a subthreshold concentration of an odorless sweet tastant (sodium saccharin), were able to detect the combination. This cross-modal summation of subthreshold concentration demonstrates that neural integration of taste and smell inputs is occurring. However, this summation has been reported only for ►**congruent taste and smell** pairs. Indeed integration between benzaldehyde and monosodium glutamate (umami taste) does not occur, suggesting that experience with the paired taste and odor stimuli is necessary for integration to occur [5]. At a ►**suprathreshold** level perceptual interactions between taste and smell were also observed. In general, taste–odor interactions are strongest when they are congruent. Taste can thus enhance odor intensity or the reverse. When a sucrose solution contains a tasteless sweet-congruent odor, the rating of sweetness is higher than that of the sucrose solution by itself [6].

For the taste–odor enhancement effect to occur, the odor and taste components need to be perceptually congruent. This perceptual congruency is especially revealed when people attributed differences in the olfactory component of foods as a gustatory difference. Odor-induced taste interaction phenomena appeared to share several characteristics with ►**synesthesia**, in which a stimulus in one sensory modality reliably elicits a consistent corresponding stimulus in another modality [7]. The basis for this synesthesia may be odor–taste learning, which occurs via simultaneous repeated exposure to both odor and taste. This learning appears to be implicit and highly resistant to extinction

and interference. It is interesting to notice that to be so efficient, only a single taste–odor association is necessary for the learned synesthesia to be established. In such a view, the unitary flavor percept is built over time by repeated experience of sensory phenomenon appearing to originate from the oral cavity [8]. This phenomenon may rely on autoassociation neural networks (autocorrelation memory), implicated in episodic and short-term memory. Indeed, such networks can retrieve the full learned activation pattern upon presentation of only a part (e.g., an odor) of a previously learned input signal (odor–taste pair). The ►hippocampus is a classical biological example of this type of network and can be involved in taste–odor pairings. However, it has also been argued that the putative autoassociative network is part of the olfactory system itself. Taste–odor synesthesia, which can be learned implicitly, may involve recurrent attractor autoassociation networks in which the ►pyriform cortex, ►insula and ►orbitofrontal cortex (OFC), and possibly ►entorhinal cortex and hippocampal formation. These structures are thus suspected to play a critical integrative role as hubs [1].

Neuroimaging studies were performed in order to find neurophysiological correlates of flavor perception. The main aim of these studies was to isolate a network of regions that are likely to be responsible for taste/odor integration. Independent presentation of a tastant or an odorant produces overlapping activation in regions of the insula and ►operculum, the orbitofrontal cortex (OFC), and the anterior cingulate cortex. It is noteworthy that the insula, operculum, OFC and anterior ►cingulate cortex are also sensitive to somatosensory stimulation of the oral cavity.

Single-cell recording studies in monkeys indicated that integration across sensory modalities is reflected in the presence of multimodal neurons that receive converging sensory information [2]. It was especially suggested that the orbitofrontal cortex may act as a region for convergence of multiple sensory modalities including chemosensation. Neurons of the orbitofrontal cortex of the macaque were thus found to respond to stimulation of the taste, olfactory, or visual system. Many of these neurons were unimodal, but were found in close proximity to each other. Some single neurons showed convergence, responding for example to taste and visual inputs, taste and olfactory inputs and olfactory and visual inputs. Some of these multimodal single neurons had corresponding sensitivities in the two modalities, in that they responded to sweet taste, and in an olfactory discrimination task to fruit odor. The different types of neurons (unimodal in different modalities, and multimodal) were frequently found close to one another [9]. Taste and smell-responsive cells were also found in the insula/operculum. The presence of unimodal representation of taste, odor, and oral touch in the insula, frontal operculum, and OFC

of the human and nonhuman primate suggests that these regions play a key role in integrating the disparate sensory inputs that give rise to the flavor perception. This integration relies not only upon multimodal neurons but also upon the information coded across networks of unimodal neurons [8].

Several of the neuroimaging studies have been performed in Humans in order to compare unimodal stimulation with a taste or an odor to bimodal (simultaneous) presentation of the same tastes and odors. The results indicated activation in the frontal operculum, ventral insula/caudal OFC, and anterior cingulate cortex to a taste/odor mixture. In some studies the response was even found to be supra-additive, in that greater activity was observed when the subjects received a taste/odor mixture compared to the summed neural activation evoked by independent stimulation with the taste and the odor components. Importantly, the ventral insula/caudal OFC region is likely analogous to the area where multimodal neurons were reported in monkeys.

These neurophysiological studies clearly indicate that odor–taste integration does occur at the neural level. Taste–odor integration occurs at earlier stages of processing and is likely to be influenced by experience and affective factors such as the physiological significance of a given stimulus, since learning and affective processing are the primary functions of this cortical zone. The possibility of a very early cortical integration of the sensory components of flavor is consistent with the fact that taste perception is almost always accompanied by oral somatosensation and ►retronasal olfaction [8].

Many studies have highlighted the importance of spatial or temporal contiguity in facilitating cross-modal sensory integration. Indeed, temporal and spatial contiguity may be crucial determinants of odor/taste integration because they promote perception of disparate taste, odor, and oral somatosensations as a common object. It has been especially argued that the perception of smell through the retronasal route, as compared to the ►orthonasal one, could be a key factor for odor/taste integration to occur. Indeed during food or beverage consumption, taste perception is almost always accompanied by oral somatosensation and retronasal olfaction. It would thus not be surprising that the mode of olfactory stimulation (i.e., orthonasal vs. retronasal olfaction) may be important in the formation and perception of food flavor. Similarly, an artificial delay imposed between odor and taste perception is not favorable for an odor/taste mixture to be perceived as a single entity [8].

The flavor may be influenced by sound in relation to texture perception, but also several somatosensory perceptions (temperature, texture) and vision (color and shape). For example a study tested both naïve and experienced subjects on red and white wines. Both groups classified the wines according to the contrasting

tastes of red and white wines. However, the reds included whites that had been colored red, showing that the color had an overriding effect on the perceived flavor and especially the terms chosen for the descriptions of the flavor of the wines [10]. Moreover, it is likely that visceral and other satiety-related signals reach the orbitofrontal cortex and modulate the representation of food flavor.

All these observations highlight the unitary nature of the flavor perception. Moreover, it has also been reported that when odors and tastes are sufficiently integrated as flavors, they are resistant to attentional manipulations. That is the reason why several scientists proposed that flavor perception relies on a functional sensory system with inputs from somatosensation, gustation, and olfaction, where the key is the meaning of the sensation rather than its precise organ or site of origin [8].

## References

1. Verhagen JV, Engelen L (2006) The neurocognitive bases of human multimodal food perception: sensory integration. *Neurosci Biobehav Rev* 30(5):613–650
2. Rolls ET, Baylis LL (1994) Gustatory, olfactory, and visual convergence within the primate orbitofrontal cortex. *J Neurosci* 14(9):5437–5452
3. Cain WS, Murphy CL (1980) Interaction between chemoreceptive modalities of odour and irritation. *Nature* 284(5753):255–257
4. Dalton P, Doolittle N, Nagata H, Breslin PAS (2000) The merging of the senses: integration of subthreshold taste and smell. *Nat Neurosci* 3(5):431–432
5. Delwiche J (2004) The impact of perceptual interactions on perceived flavor. *Food Qual Prefer* 15(2):137–146
6. Stevenson RJ, Prescott J, Boakes RA (1999) Confusing tastes and smells: how odours can influence the perception of sweet and sour tastes. *Chem Senses* 24(6):627–635
7. Stevenson RJ, Tomiczek C (2007) Olfactory-induced synesthesias: a review and model. *Psychol Bull* 133(2):294–309
8. Small DM, Prescott J (2005) Odor/taste integration and the perception of flavor. *Exp Brain Res* 166(3–4):345–357
9. Rolls ET (2005) Taste, olfactory, and food texture processing in the brain, and the control of food intake. *Physiol Behav* 85(1):45–56
10. Morrot G, Brochet F, Dubourdiou D (2001) The color of odors. *Brain Lang* 79(2):309–320

---

## Flavor

The sense of “taste,” combining smell, taste, touch, hearing and vision.

- ▶ The Proust Effect

---

## Flexible Behavior

- ▶ Cognitive Elements in Animal Behavior

---

## Flexion Reflex

### Definition

A flexion reflex (or “flexion (or flexor) withdrawal reflex”) is a contraction of limb flexor muscles that is evoked by a nociceptive stimulus and that withdraws the limb from the stimulus. A flexion reflex is entirely spinally mediated. Excitation of cutaneous nociceptive afferents activates oligosynaptic spinal interneuronal pathways that excite flexor muscles and concurrently inhibit antagonist extensor muscles. Flexion reflexes are often exaggerated when disorders of spinal cord or brain disturb supraspinal control of spinal cord pathways.

- ▶ Conditioned Reflexes

---

## Flexor Reflex Afferents

### Definition

Flexor reflex afferents refer to the group of nociceptive afferent neurones that transmit information via A $\delta$  and C afferent fibers and produce the flexor withdrawal reflex.

These afferents make polysynaptic connects that are excitatory to flexors and inhibitory to extensors. They also make widespread connections throughout the spinal cord that have the opposite effect, i.e., excitation of extensors and inhibition of flexors. The later connections are typically made to heterogenous muscles that control other joints primarily for the control posture.

- ▶ Flexion Reflex
- ▶ Integration of Spinal Reflexes

---

## Flicking Behavior (Crustaceans)

- ▶ Odor-Sampling Behavior



## Floccular Lobe

### Definition

The flocculus and ventral paraflocculus.

## Flocculonodular Lobe

### Synonyms

► Lobus flocculonodularis

### Definition

The vermis segment nodulus and the hemisphere segment flocculus together form the flocculonodular lobe.

Phylogenetically it is very old and is thus called the archicerebellum. Since its afferents come mainly from the vestibular nuclei (vestibulocerebellar tract), the “vestibulocerebellum” is another synonym.

► Cerebellum

## Flocculus

### Definition

A part of the vestibulocerebellum adjacent to the cerebellar hemispheres and overlying the eighth cranial nerve. This is the phylogenetically oldest part of the cerebellum, and its structure is archetypical of the cerebellar cortex. Its major neuron is the Purkinje cell whose axon is the sole cortical output and employs the transmitter gamma-amino butyric acid or GABA. It receives two inputs: (i) from mossy fibers and (ii) from climbing fibers. Mossy fibers are the axon terminals of cerebellar-projecting brain stem neurons and excite the dendrites of granule cells that, in turn, give rise to parallel fibers that excite Purkinje cell dendrites. Each Purkinje cell dendritic tree receives hundreds of thousands of parallel fiber synapses. In the flocculus, mossy fiber discharges signal head velocity and eye velocity and position. Climbing fibers originate from the inferior olivary complex in the medulla and provide a powerful excitatory input to the Purkinje cell.

Each Purkinje cell receives only one climbing fiber. Climbing fiber spikes contain complex signals, some of which are related to retinal slip. Floccular Purkinje cell

axons terminate upon vestibular nucleus neurons that, in turn project to extra ocular motor neurons innervating the extra ocular muscles. The flocculus participates in the generation of smooth pursuit eye movements and control of the vestibuloocular reflex (VOR).

- Cerebellum – Role in Eye Movements
- Purkinje Cell, Neuron
- Vestibular Nuclei
- Vestibulocerebellum
- Vestibuloocular Reflexes
- Flocculonodular Lobe
- Cerebellum

## Flocculus Hypothesis

### Definition

Proposed by Ito, and according to it, the flocculus is a recalibration device for the vestibuloocular reflex (VOR). The VOR exemplifies a feed forward control system, because there is no immediate feedback to correct any faulty outcome of its resultant eye movements. Inadequate performance of the VOR would therefore result in slippage of the visual image on the retina, degrading vision. Without some internal mechanism to correct this error, performance might remain inadequate or worsen.

The credence of this hypothesis was strengthened when Maekawa and Simpson demonstrated that the flocculus was the recipient of visual signals via the climbing fiber pathway that monitored the constancy of visual images. Ito proposed that the climbing fiber spikes provided an error signal that gradually corrected the VOR performance, until it was near perfect. This progressive change in the internal floccular parameters was termed “motor learning” and it was supposed that the VOR would be improved by an adaptive modification of its performance by the visual information contained in climbing fiber discharges. This hypothesis was in good agreement with Marr’s proposal that the cerebellum was intimately involved in motor learning.

Marr theorized that the climbing fiber discharge contained an error signal that acted as a teacher to the mossy fiber-granule cell-Purkinje cell pathway. This error signal might change the character or gain of the parallel fiber to Purkinje cell synaptic transmission that, in turn might modify the motor output. Thus the VOR side path through the cerebellar flocculus serves to modify the gain of the VOR. When Ito discovered cerebellar long-term depression (LTD) he added a further corollary to the hypothesis that speculated that

LTD was the mechanism that controlled synaptic transmission and the VOR gain.

- ▶ Cerebellum – Flocculus Target Neurons
- ▶ Cerebellum – Role in Eye Movements
- ▶ Purkinje Cell, Neuron
- ▶ Vestibuloocular Reflex (VOR)

## Floor Plate

ATSUSHI TAMADA

Laboratory for Neuronal Growth Mechanisms, RIKEN Brain Science Institute, Wako, Saitama, Japan

### Synonyms

Ventral plate; Septum medullae

### Definition

Transient thin neuroepithelial structure located along the ventral midline of the central nervous system of vertebrates.

### Characteristics

#### Description of the Structure/Process/Conditions

The central nervous system of the vertebrates derives from an embryonic hollow columnar structure called the neural tube. The neural tube can be dorsoventrally divided into four fundamental regions, the roof, alar, basal and floor plates on the basis of morphological appearance (Fig. 1a).

The floor plate is a thin and narrow structure situated along the ventral midline [1]. It is connected with laterally located basal plates, separating the left and right halves of the neural tube. The floor plate consists of neuroepithelial cells with radial fibers extending from the ventricle to the ventral pial surface. The expression pattern of molecular markers indicates that the floor plate is composed of two distinct cell populations, the medial and lateral floor plate cells [2]. Anteroposteriorly, the floor plate exists at all levels of the neural tube from the forebrain to the spinal cord (Fig. 1b). It is closely associated with the underlying ▶notochord, a rod-like mesodermal structure. Since the typical morphological appearance is lost in the anterior brain regions, the anterior limit of the floor plate is not so clear. Molecular expression patterns suggest that the floor plate extends at least to the caudal diencephalon, where the notochord terminates. Although many marker molecules are uniformly expressed in the floor plate, some of them are differentially expressed along

the anteroposterior axis, implying the anteroposterior heterogeneity of the floor plate [3].

The floor plate itself is a non-neurogenic structure, whereas the adjacent basal plate and the alar plate are highly neurogenic. These regions generate a variety of neurons during development. Some of them project their axons across the ventral midline floor plate to targets on the contralateral side of the neural tube. Thus the floor plate is the site of the decussation of the contralaterally projecting axons. The floor plate is a thin and distinct structure at early embryonic stages, but it gets thick and indistinct by overwhelming cell growth in the basal plate and formation of axon decussation. It gradually disappears during development, remaining as a rudimentary structure called the septum medullae.

### Regulation of the Structure/Process/Conditions

Although the origin of the floor plate and the mechanism of its formation have been extensively studied, they are still controversial [2–4]. In the prevailing view, the floor plate is considered to originate from the neural ectoderm, which is ectoderm determined to become a neural tissue. However, fate-mapping studies indicate that the floor plate originates from both the ectoderm and the ▶node, the axial mesoderm generating the notochord [2–4]. Recent studies further demonstrated that ectoderm-derived cells contribute to the anterior floor plate whereas node-derived cells contribute the posterior floor plate. Thus the floor plate seems to have a dual origin from both the ectoderm and the mesoderm. The floor plate and the notochord could share the same precursor cells located in the node.

The floor plate appears at the stage of neurulation, when the flat neural plate is converted into a hollow neural tube (Fig. 1c). Neurulation accompanies a series of dynamic morphogenetic events. At first, the neural ectoderm thickens to form the neural plate. The neural plate folds inward at its median hinge point, which later becomes the floor plate. During this morphological change, the presumptive floor plate stays closely associated with the notochord. Then the lateral margins of the neural plate fuse at the dorsal midline, which becomes the roof plate. Finally, the closed neural tube is pinched off from the epidermal ectoderm that surrounds the neural plate.

The mechanisms of floor plate specification have been extensively studied. In the classical induction model [5], notochord cells are the source of an instructive inducing signal that mediates floor plate differentiation in the overlying central neural plate cells (Fig. 1c). In vitro and grafting experiments demonstrated that an additional floor plate was induced in the lateral neural plate when a supernumerary notochord was placed adjacently. Conversely, removal of the notochord resulted in the absence of the floor plate. This induction model was further supported by identification of a secreted molecule, Sonic

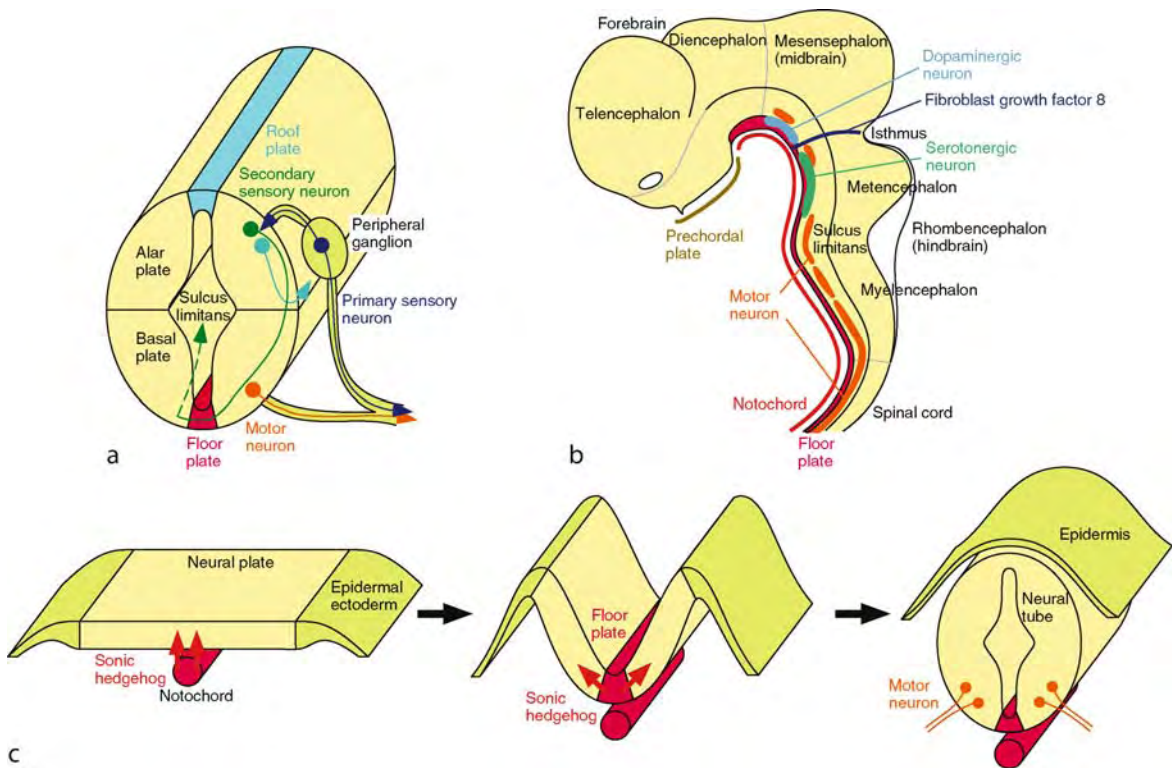

**Floor Plate. Figure 1** Schematic view of developing vertebrate central nervous system. (a) Columnar organization of the neural tube. (b) Longitudinal organization of the neural tube. Positions of neurons induced by the floor plate are indicated. (c) Morphogenetic events and Shh signaling during neural tube formation.

hedgehog (Shh), as a mediator of the inductive signal. Shh was originally identified as a vertebrate homologue of the *Drosophila* segment polarity gene hedgehog. Gain-of-function and loss-of-function experiments in chickens and mice suggested that Shh plays a crucial role in floor plate induction. However, induction by notochord and Shh cannot explain the findings in zebra fish [2,3]. Floor plate cells are present in several mutants lacking the notochord, whereas floor plate cells are greatly deficient in mutants that lack the ►prechordal plate but possess a differentiated notochord. In fish, Nodal, a member of the transforming growth factor  $\beta$  (TGF $\beta$ ) family, which is expressed in the prechordal plate, appears to play a major role in floor plate differentiation. A dual model in which notochord-derived Shh signaling induces posterior floor plate whereas prechordal plate-derived Nodal signaling induces anterior floor plate has recently been postulated to explain these conflicting findings.

### Function

The mechanism of floor plate specification is still controversial as described above, but the function of the floor plate seems to be well conserved among vertebrate species. Although the floor plate is a small and transient structure, it has multiple functions as an organizing

center for the development of the brain and the spinal cord. It plays crucial roles in dorsoventral patterning of cell differentiation, positive and negative guidance of axon growth and regulation of cell migration at and near the ventral midline.

### Patterning of Cell Differentiation

The neural tube generates a variety of cells depending on the position along the dorsoventral axis. In the spinal cord, motor neurons that project their axons to peripheral targets differentiate in the basal plate, whereas secondary sensory interneurons that receive peripheral inputs from axons of the peripheral ganglia differentiate in the alar plate (Fig. 1a). Grafting and *in vitro* experiments have demonstrated that the notochord can induce motor neurons as well as the floor plate as described in the previous section [5]. While floor plate cells were induced in the region adjacent to the ectopic notochord, motor neurons were induced in a region a short distance away. At a slightly later stage, the floor plate itself acquires the same inductive activity as the notochord (Fig. 1c). The floor plate can induce motor neurons and homogenetically induce itself. Molecular studies have indicated that a single molecule, Shh, can account for both floor plate induction and

motor neuron induction [5]. Shh can elicit ectopic floor plate and motor neuron development. Conversely, disruption of Shh results in the absence of the floor plate and motor neurons. Moreover, the choice of responding cell fate appears to be dependent on the concentration of Shh. Differentiation into the floor plate requires higher concentration of Shh than differentiation into motor neurons.

The ability of floor plate-derived Shh signal to control the differentiation of the ventral cell types is not restricted to the spinal cord. It can also induce motor neurons in the midbrain and the hindbrain, which have a similar dorsoventral organization to that of the spinal cord (Fig. 1b). Furthermore, Shh is involved in the development of region-specific neuronal populations that develop near the floor plate. Floor plate-derived Shh signals play crucial roles in the differentiation of two types of monoaminergic neurons, dopaminergic neurons of the substantia nigra in the midbrain and serotonergic neurons of the dorsal raphe nucleus in the hindbrain (Fig. 1b) [6]. In this case, *Fgf8*, a member of the fibroblast growth factors expressed by the isthmus another organizing center between the midbrain and the hindbrain, collaborates with Shh in determination of the cell fate. The floor plate-derived Shh signal can also induce oligodendrocytes, which later migrate to be distributed throughout the central nervous system.

### Axon Guidance

Another important function of the floor plate is to regulate the growth of axons [7]. Based on the bilaterally symmetrical organization of the neural tube, axonal projections can be divided into ipsilateral projections to

the targets on the same side and contralateral projections to those on the opposite side. The ventral midline floor plate is an intermediate target of contralateral projections. Many neurons formed in the alar plate project their axons to the contralateral targets in a stereotyped pattern (Fig. 2a).

These axons initially grow ventrally along the circumferential axis, grow toward and across the ventral midline floor plate, turn at a right angle on the contralateral side and finally grow anteroposteriorly along the longitudinal axis toward the targets. These neurons include spinal cord commissural neurons, secondary sensory neurons in the caudal hindbrain and the deep cerebellar neurons in the rostral hindbrain. It has been demonstrated that the floor plate releases diffusible molecules that guide these commissural axons toward their source. Such mechanism is called chemoattraction. A molecule that mediates the chemoattraction by the floor plate was identified as a laminin-related secreted molecule, *Nerin-1*. Later, it was found that Shh also functions as another chemoattractant to the commissural axons.

Unlike contralateral projections, specific mechanisms do not seem to be required in the floor plate for formation of ipsilateral projections. However, in some cases, the floor plate actively regulates the axon guidance of the ipsilateral projections. The floor plate has an activity to repel these axons at a distance. Such a mechanism is called chemorepulsion, an opposite mechanism to chemoattraction. Floor plate chemorepulsion appears to function against two types of ipsilaterally projecting axons. One is an axon that originates near the floor plate and grows dorsally away from the floor plate. The other is an axon that

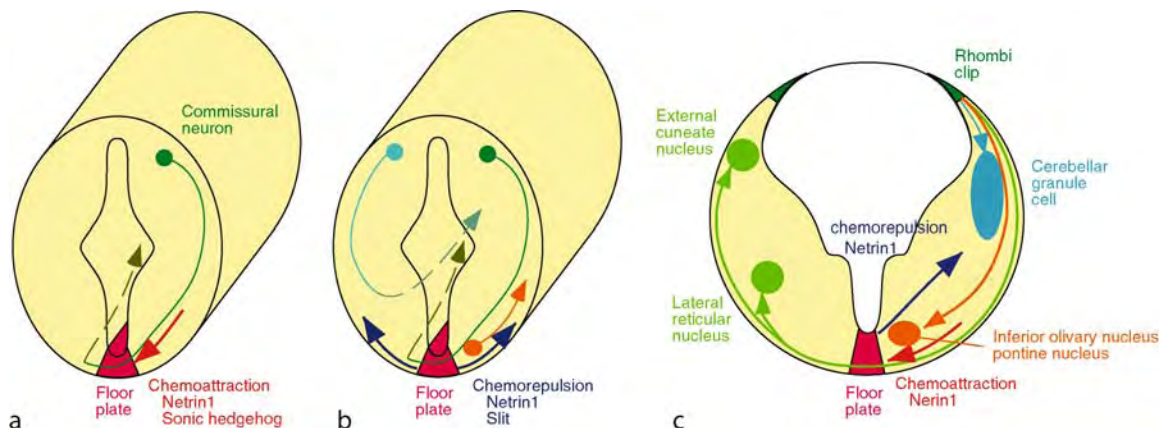

**Floor Plate. Figure 2** Role of the floor plate in axon guidance and cell migration. (a) Floor plate ► chemoattraction is involved in the guidance of commissural axons. (b) Floor plate ► chemorepulsion plays roles in guidance of ipsilaterally projecting axons by pushing axons dorsally away from the midline (orange) and preventing ventrally growing axons from crossing the midline (light blue). Chemorepulsion also appears to prevent re-crossing of commissural axons (green). (c) The floor plate is involved in tangential migration of cerebellar and precerebellar neurons.

initially grows ventrally toward the floor plate but later changes growth direction before reaching the floor plate (Fig. 2b). Chemorepellents, molecules mediating chemorepulsion, have been identified in the floor plate. Netrin-1, which acts as a bifunctional molecule, repels subsets of motor axons. Later, Slits, another family of secreted proteins containing leucine-rich repeats and EGF-like motifs, were found to function as a chemorepellent at the floor plate.

Commissural axons, once guided to the floor plate by chemoattractants, should grow beyond the floor plate without being captured by the same cues. Commissural axons lose responsiveness to the chemoattractant Netrin-1 after reaching the floor plate. Instead, they appear to acquire responsiveness to the chemorepellent Slits, which may prevent re-crossing into the floor plate (Fig. 2b) [8].

In addition to chemoattractants and chemorepellents, the floor plate also expresses a variety of contact-mediated axon guidance molecules. They include F-spondin and cell adhesion molecules of the immunoglobulin superfamily. It has been demonstrated that floor plate guides commissural axons across the midline in a contact-dependent manner via an interaction between two immunoglobulin superfamily cell adhesion molecules, TAG-1 and NrCAM [9].

### Cell Migration

It has recently been suggested that cell migration shares common mechanisms with axon guidance. The rhombic lip, the structure located at the dorsal margin of the alar plate of the hindbrain, generates a variety of cells that migrate tangentially along the circumferential axis (Fig. 2c). The rhombic lip in the rostral hindbrain generates cerebellar granule cell precursors. These cells are repulsed by Netrin-1, which appears to prevent their ventral migration out of the cerebellum. The rhombic lip in the middle and caudal hindbrain generates neurons of precerebellar nuclei that project axons to the cerebellum. These include pontine, inferior olivary, lateral reticular and external cuneate nuclei. All of these neurons migrate tangentially toward the floor plate. Some of them stop before reaching the floor plate, whereas the others migrate across the floor plate and settle on the contralateral side. It has been demonstrated that floor plate chemoattraction plays crucial roles in migration of these neurons toward the ventral midline [10].

### References

1. Kingsbury BF (1930) The developmental significance of the floor-plate of the brain and spinal cord. *J Comp Neurol* 50:177–207
2. Strähle U, Lam CS, Ertzer R, Rastegar S (2004) Vertebrate floor-plate specification: variations on common themes. *Trends Genet* 20:155–162
3. Placzek M, Briscoe J (2005) The floor plate: multiple cells, multiple signals. *Nat Rev Neurosci* 6:230–240
4. Le Douarin NM, Halpern ME (2000) Origin and specification of the neural tube floor plate: insights from the chick and zebrafish. *Curr Opin Neurobiol* 10:23–30
5. Tanabe Y, Jessel TM (1996) Diversity and pattern in the developing spinal cord. *Science* 274:1115–1123
6. Hynes M, Rosenthal A (1999) Specification of dopaminergic and serotonergic neurons in the vertebrate CNS. *Curr Opin Neurobiol* 9:26–36
7. Colamarino SA, Tessier-Lavigne M (1995) The role of the floor plate in axon guidance. *Annu Rev Neurosci* 18:497–529
8. Dickson BJ, Gilestro GF (2006) Regulation of commissural axon pathfinding by Slit and its Robo receptors. *Annu Rev Cell Dev Biol* 22:651–675
9. Stoeckli ET, Landmesser LT (1998) Axon guidance at choice points. *Curr Opin Neurobiol* 8:73–79
10. Bloch-Gallego E, Causeret F, Ezan F, Backer S, Hidalgo-Sánchez M (2005) Development of precerebellar nuclei: instructive factors and intracellular mediators in neuronal migration, survival and axon pathfinding. *Brain Res Rev* 49:253–266

## Fluctuation-Dissipation Relationship

### Definition

A relationship, discovered by Einstein (1905), which relates the diffusion of a Brownian particle in a medium to the viscosity and the temperature of the medium.

### ► Brownian Motions

## Fluid Homeostasis

### Definition

Total body water (TBW) is approximately 60% of the total body weight in a young adult human male and approximately 50% of the total body weight in a young adult human female. The prototypical 70-kg male has approximately 42 l of TBW (60% of 70 kg). Of these 42 l, approximately 60% (~25 l) is intracellular, and 40% (~17 l) is extracellular. Extracellular fluid is composed of blood plasma, interstitial fluid, and transcellular fluid. Total body fluid volume is determined by the rate of fluid intake and loss from the organism. The equilibrium between intake and loss is essential for long-term survival. The volumes of all the compartments of the body are determined by

many factors involved in the control of the cellular and extracellular electrolyte concentrations. Ion concentration gradients and fluxes, hydrostatic and osmotic pressures, neuralendocrine- paracrine factors, and physical factors determine the total volumes within the various compartments.

► Blood Volume Regulation

## Fluorescence

### Definition

Fluorescent molecules capture the energy of photons (light), and release part of it as photons with less energy (i.e. light with a longer wavelength). For example, green fluorescent molecules absorb blue light, and emit green light.

► Functional Imaging

## Fluorescence-activated Cell Sorting (FACS)

### Definition

A method to separate a heterogeneous mixture of biological cells into two or more containers, one cell at a time, based upon the specific light scattering and fluorescent characteristics of each cell. For example, by labeling a specific neuronal subtype with fluorescent proteins (e.g. GFP or YFP) under a specific promoter, labeled neurons can be sorted by FACS.

► Microarray Analysis of Molecular-Genetic Controls over Development of Neuronal Subtypes

## Fluorescence Dye

### Definition

Chemical compound having fluorescence.

## Fluorescence Histochemical Techniques

### Definition

These are procedures for binding a fluorescent molecule to a target molecule to visualize its location and distribution in cells or tissue.

## Fluorescence Recovery After Photobleaching (FRAP)

### Definition

A microscopic technique to measure mobility of fluorescence-labeled molecules and organelles from the recovery of fluorescence after photobleaching.

## Fluorescence Resonance Energy Transfer (FRET)

### Definition

Fluorescence resonance energy transfer is a distance-dependent interaction between the electronic excited states of two dye molecules in which excitation is transferred from a donor molecule to an acceptor molecule without emission of a photon.

## Fluorescent Tracers

### Definition

Neuroanatomical tracers (see below) visualized in tissue because they emit light at a particular wavelength when illuminated with light of another wavelength, i.e., they fluoresce.

## Flux

### Definition

In a balance equation, the flux term accounts for the distributed input or output per unit area of the boundary

and per unit time. If the conditions of Cauchy's theorem are satisfied, the flux term can be expressed in terms of a linear operator on the normal to the boundary, called the flux tensor.

► **Mechanics**

## Fly

### Definition

Insect of the order Diptera. Flies have a highly developed visual system and flight apparatus. Flies are used as model systems for analyzing visual capabilities of insects and for investigating mechanisms of flight (see essay on "Neuroethology of fly vision").

## FM1-43

MASAMI TAKAHASHI

Department of Biochemistry, Kitasato University  
School of Medicine, Japan

### Synonyms

N-(3-Triethylammoniumpropyl)-4-(4-(dibutylamino)styryl) pyridinium dibromide

### Definition

Synthetic ► **fluorescence dye**.

### Purpose

The size of ► **synaptic vesicles** and secretory vesicles are so small, it is difficult to follow the vesicle recycling in real time. FM dyes including FM1-43 are used for the real-time measurement of ► **exocytosis** and ► **endocytosis** in living neurons as well as in many kinds of cells.

### Principles

FM1-43 is an amphiphilic molecule consisting of a lipophilic tail linked to a positively charged head through a double-bond bridge. Various analogues having different structures and properties have been constructed (Fig. 1).

The length of the lipophilic tail determines the affinity of the dye to lipid membranes, and FM1-43 having a four-carbon tail needs a longer washout

time than that of FM2-10 with two-carbon tail. Dyes with shorter tails stain membranes less brightly than those with longer tails. The fluorescent properties of the dye are governed by the double-bond bridge and the excitation and emission of FM4-64 having three double bonds that are both red-shifted.

The following characteristic features of FM dyes are useful for the study of exocytosis, endocytosis, and vesicle trafficking: (i) FM dyes are incorporated into membranes reversibly. When dye is applied in the extracellular solution, all surface membranes become stained and the cell can be destained by washing with dye-free medium. (ii) FM dyes selectively stain only the external leaflet of the lipid bilayer since they do not "flip-flop" across membranes. Permanent plus charge in their hydrophilic head prevent these dyes becoming diffused through membranes, and thus they will not stain membranes in cytoplasm. (iii) FM dyes are almost nonfluorescent in water, and their quantum yield increases dramatically when they are incorporated into membranes 1–3).

Extracellular membrane is stained with FM dye by incubating the cells with FM dyes (Fig. 2, step 1). On stimulation, vesicular membrane is fused with cellular membrane and is further stained with FM dye (step 2).

In preparations including nonneuronal cells where recycling of secretory membrane is less apparent, the process of exocytosis can be monitored from an overall increase in surface fluorescence. In neuronal preparations where recycling of secretory membrane is apparent, exocytosis can be monitored as dye is released from prestained vesicles through destaining. After the membranes are endocytosed, the cells are washed out with dye-free solution, the extracellular membranes are then destained, however, the endocytosed membrane is still stained since the dye concentration in vesicles is still high. Thus, only endocytosed vesicles are stained with FM dye in this step (step 3). Second stimulation induced exocytosis of FM dyes in the vesicles, which induces a release of FM dye in the vesicle membrane (step 4).

### Advantages

1. FM dyes are excellent specific markers of presynaptic function.

Although immunocytochemical analysis reveals the existence of exocytotic proteins, it is not possible to see whether the site is functionally active or not. FM dye is quite useful as a marker of presynaptic release sites in cultured neurons as well as brain slice preparations in living state. The background fluorescence may raise a problem in thick preparations, however, various useful methods have been developed to reduce the background. Cyclodextrins are toroidal molecules with a hydrophilic exterior and hydrophilic interior, and efficiently binds free

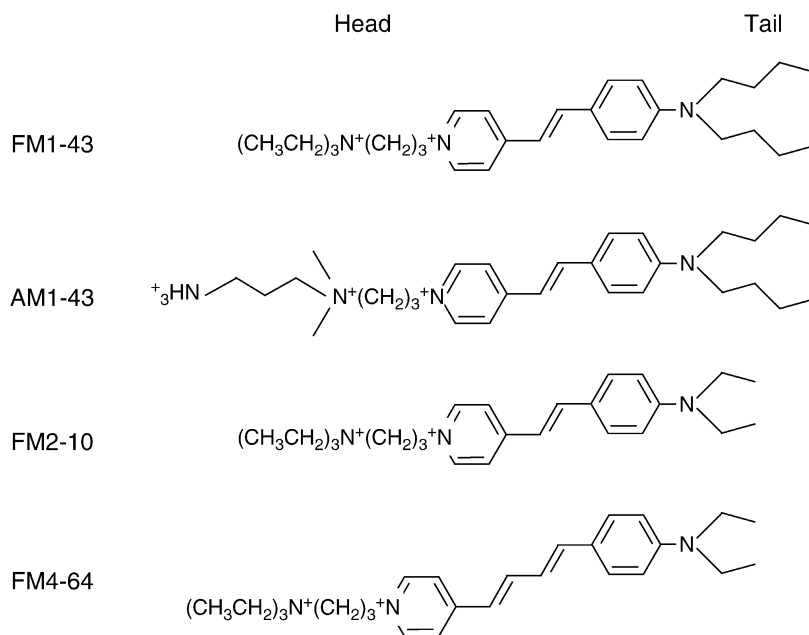

**FM1-43. Figure 1** Molecular structures of FM1-43 and its derivatives.

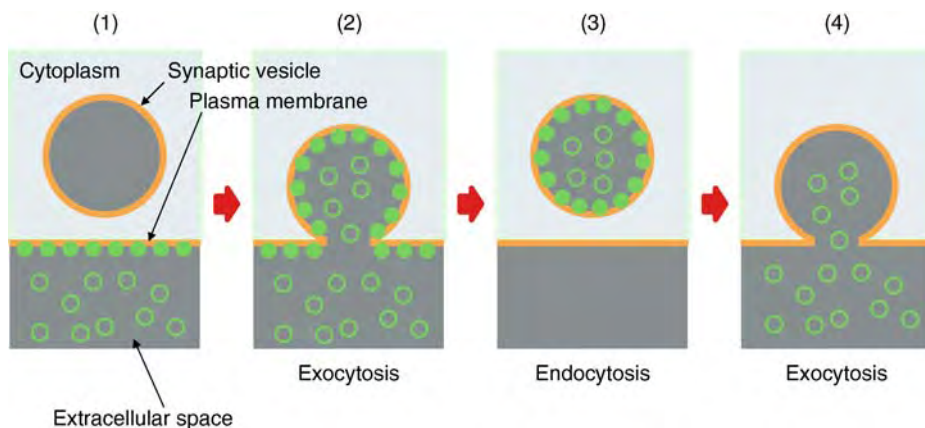

**FM1-43. Figure 2** Measurement of exocytosis with FM dyes. *Open green circles* represent free FM dyes in water which are almost nonfluorescent. *Filled green circles* represent FM dyes incorporated into external leaflet of the lipid bilayer. They are highly fluorescent in the hydrophobic environment.

FM dye. Since it is water soluble, FM dyes remaining in the extracellular solution can be readily washed out. Sulforhodamine 101 (S-Rhd) is also used to quench FM1-43 fluorescence via [fluorescence resonance energy transfer \(FRET\)](#).

AM1-43, in which an aldehyde-reactive amine has been added to the hydrophilic tail, is useful for the co-application of immunohistochemistry on fixed and permeabilized cells. Since AM1-43 is more amenable than FM1-43 to standard aldehyde fixation and detergent permeabilization protocols, it is well

preserved in sections for immunocytochemistry. The localization of FM dye is also analyzed on an electron microscopic level by a photoconversion of FM dye in the presence of diaminobenzidine (DAB).

2. FM dyes are useful to reveal properties and distribution of various vesicle pools.

Physiological studies show the existence of different functional “pools” of vesicles in presynaptic terminals as well as in [endocrine cells](#). Different vesicle pools are visualized either by electron microscopy using FA1-43 photoconversion in central [synapse](#)



or by fluorescence images in ► [neuromuscular junctions](#). ► [Fluorescence recovery after photobleaching \(FRAP\)](#) is also used to monitor movement of vesicles within clusters.

3. FM dyes are useful to measure exocytosis and endocytosis separately.

Exocytosis and endocytosis are accompanied with a change in cell membrane surface area, which can be monitored by a change in cell capacitance (► [Capacitance measurement](#)). However, it is not possible to measure these phenomena separately. The combination of whole cell capacitance recording with FM1-43 imaging allows simultaneous, independent measurements of exocytosis and endocytosis. Green Fluorescent Protein (GFP)-tagged proteins have been used extensively to monitor secretory vesicle biogenesis, trafficking, and secretion. If cells are transfected with a releasable GFP-tagged secretory granule protein and also stained with FM4-64, it is possible to monitor individual secretory granules before, during, and after membrane fusion.

4. FM dyes are useful to study exocytosis of nonneuronal cells.

Recently, it has been shown that various cells which had not been identified as secretory cells release various hormones, growth factors and cytokines by regulated exocytosis. FM dyes have been successfully used to study the exocytosis of various non-neuronal cells such as glial cells, brown fat adipocytes and eggs.

5. FM dyes could be used to detect some difference in membrane properties.

FM1-43 fluoresces with different colors depending on its microscopic environment. For example, when a frog nerve-muscle preparation is stained with FM1-43, Schwann cell vacuoles fluoresce orange-red, myelin appears green, and synaptic vesicles are yellow-orange. Quantum yield of FM dyes change depending on the microscopic environment. The plasma membrane lipid composition is asymmetric and most of the phosphatidylserine resides on the inner leaflet. FM dye is incorporated on the outer leaflet. Membrane asymmetry is disrupted in apoptosis, which causes a large increase in FM1-43 quantum yield. Thus, FM dye can be used to monitor membrane disruption accompanied with apoptosis.

### Disadvantages

In some cases, the fluorescence change of FM dyes may not reflect membrane recycling.

As described above, the fluorescence intensity and spectrum of FM dye may not change by exocytosis and endocytosis, but by other changes in membrane properties. Thus, special caution might be necessary in some cases.

## References

1. Angleson JK, Betz WJ (1997) Monitoring secretion in real time: capacitance, amperometry and fluorescence compared. *Trends Neurosci* 20:281–287
2. Brumback AC, Lieber JL, Angleson JK, Betz WJ (2004) Using FM1-43 to study neuropeptide granule dynamics and exocytosis. *Methods* 33:287–294
3. Cochilla AJ, Angleson JK, Betz WJ (1999) Monitoring secretory membrane with FM1-43 fluorescence. *Annu Rev Neurosci* 22:1–10

## fMRI

### Definition

► [Functional Magnetic Resonance Imaging \(fMRI\)](#)

## FMZ

### Definition

18F-labeled flumazenil; a well-known antagonist of central benzodiazepine receptors (BZR), used in Positron Emission Tomography (PET) imaging of epileptic foci.

► [Positron Emission Tomography](#)

## Focal Adhesions

► [Integrin-dependent Adhesion Contacts](#)

## Focal Complexes

► [Integrin-dependent Adhesion Contacts](#)

## Focal Contacts

### Definition

Focal contacts are transmembrane anchorage sites that link the actin cytoskeleton of the cell to other cells or

extracellular matrix. Cell adhesion molecules (CAMs), the transmembrane proteins of focal contacts, are divided into three structural families: (i) integrins, (ii) cadherins, and (iii) IgCams. These proteins allow the growth cone to form adhesive contacts with the surrounding substratum. Signaling proteins, such as FAK, Rho and Src, are also localized at focal contacts in growth cones.

- ▶ Growth Cones
- ▶ Integrin-dependent Adhesion Contacts

---

## Focal Dystonia

### Definition

Focal dystonia is a motor disorder often leading to loss of motor control of one or more fingers. It is frequently observed in musicians like pianists or string players, but can generally be found in people who do extensively repetitive, synchronous movements of their fingers, e.g. type writing.

- ▶ Somatosensory Reorganization

---

## Focus of Expansion

### Definition

A point in the optic flow from which all visual motion seems to emanate and which lies in the direction of forward motion. The focus of expansion only exists for purely linear forward motion. Optic flow that arises from combinations of linear motion with rotations such as eye movements or movement in a curve does not contain a focus of expansion.

- ▶ Optic Flow

---

## Fokker-Planck Equation

### Definition

A partial differential equation that describes the variation of the probability of finding a Brownian

particle that is subjected to a given potential in a given region over time.

- ▶ Brownian Ratchet

---

## Foliate Papillae

### Definition

(Papilla: small protuberance, Folium: leaf) These structures are bilaterally located on the posterior edges of the tongue which are made of a succession of up to 20 ridges or fissures embedded in the tongue epithelium.

The lateral walls of some of the more central invaginations are filed with taste buds opening into these clefts where saliva can penetrate. Ducts emanating from the lateral lingual glands are in contact with the bottom of some clefts. The number of taste buds found in human foliate papillae varies widely between individuals from 15 to 1,500. Foliate taste papillae have the appearance of a leaf, hence their name.

- ▶ Taste

---

## Foliated

### Definition

Folded.

---

## Folium Vermis

### Synonyms

- ▶ Folium of vermis

### Definition

Summit of the vermis cerebelli. It separates the declive and tuber vermis. Like the entire vermis cerebelli, the declive also receives its afferents primarily from the spinal cord, thus making it part of the so-called spinocerebellum = palaeocerebellum.

- ▶ Cerebellum

## Folk Psychology

HOLM TETENS

Institut für Philosophie, Freie Universität Berlin,  
Berlin, Germany

### Definition

In everyday life, we constantly ascribe mental states, such as perceptions, sensations, feelings, ideas, beliefs, desires and dreams, to ourselves and other people and describe, explain, criticize, justify and judge, with reference to the mental states ascribed to a person, their observable behavior and actions on the one hand and their internal states and character on the other hand. For example, we often explain the fact that a person P acts in manner a by referring to the practical syllogism: (i) P wants to bring about state Z. (ii) P believes himself to be in situation S and furthermore believes that action a is the best means in situation S to bring about Z. (iii) So P acts in manner a. Or we predict, for example, that person P will be afraid in a certain situation S by referring to the fact that P has already shown fear in similar situations and, on other occasions, has expressed the belief of being afraid of situations of type S. *Folk psychology* can in the first instance be understood as the aforementioned mutual ascription of mental states and the resulting description, explanation, prediction and justification of behavior, action and the internal states of persons.

In a certain respect, the philosophical and academic mind-body problem would not exist without folk psychology. For the human sciences, especially brain science, attempt to describe and explain human behavior and action solely as processes controlled by neurons. Mental states as understood by folk psychology do not figure in the explanans of these neuroscientific explanations and, in accordance with theoretical standards, should not appear there. Hence the fundamental problem of how the folk psychological and neuroscientific descriptions and explanations of a person relate to each other arises. Is folk psychology compatible with the findings of neuroscience, or are they mutually exclusive? Or is it possible that they complement each other and only provide a comprehensive and satisfactory description and explanation of persons when they are combined? All three positions are held in the controversial debate about the relation between folk psychology and scientific theories.

Against the background of the question of how folk psychological and scientific descriptions and explanations of persons relate to each other, it becomes understandable that the *status of folk psychology* is at the centre of the debate in the philosophy of mind. One of the main points of discussion is *whether folk psychology should be regarded as a theory or whether it*

*constitutes something completely different.* Two other controversial questions ensue, namely whether folk psychology is *completely or mainly true or completely or mainly false* and *whether folk psychology can be replaced by a scientific, in particular a neuroscientific theory, or not.*

### Descriptions of the Theory

How folk psychology and scientific theories about human beings relate to each other hinges fundamentally on the question of whether folk psychology is a theory at all. Many philosophers of mind answer in the affirmative [1,2]. According to this view, folk psychology consists of concepts, rules of their correct use, (possibly) folk psychological laws, standards of correct description and explanation and rules of confirmation and falsification. When describing, explaining or predicting another person's or one's own behavior in everyday life, one uses this set of concepts, laws and methodological standards in exactly the same way scientists use their theories. This, as it is called, "theory-theory" is opposed by the "simulation theory" [3]. According to the simulation theory, folk psychology is based on practical abilities and decision procedures. In order to predict what a person will do, we put ourselves in their position and then decide what we would do in such a situation ourselves.

It is, however, not clear whether there is a real opposition between the theory-theory and the simulation theory [4]. Presumably both views merely emphasize or overemphasize different aspects of folk psychology. From a functional point of view folk psychology with its descriptions, explanations and predictions exhibits all the characteristics of a theory. In that respect, the theory-theory gets it right. However, in contrast to our scientific theories, which are learned and further developed explicitly as theories only by a minority of experts, folk psychology is mastered by everybody and is, in any case, not acquired explicitly as a theory. Instead, we are introduced to folk psychology in the course of our socialization and thereby acquire the practical abilities to interact appropriately and communicate with others on the basis of our folk psychological language. That speaks in favor of the simulation theory. Furthermore, the debate about whether folk psychology is a theory possibly constitutes a rather fruitless controversy insofar as folk psychology not only serves the theoretical purposes of description, explanation and prediction, but also comes into play when we judge, criticize and justify our behavior, or even our character, coordinate our social lives through communication and organize it in general.

Can folk psychology be replaced by scientific theories and, indeed, should it be replaced by them? The most radical answer has been given by proponents of eliminative materialism [5,6]. According to the eliminative materialists, folk psychology is a theory, as it attempts to describe, explain and predict a person's behavior.

However, they regard folk psychology as a theory that is largely false and entirely inadequate and which can offer at best a partial explanation of many phenomena, but most often no explanation at all. Eliminative materialists like to compare folk psychology to magical beliefs or medieval belief in witchcraft. Just as magical beliefs and belief in witchcraft were completely replaced by scientific theories, folk psychology will turn out to be an explanatorily and prognostically false and hopelessly inferior theory as the human sciences, especially neuroscience, advance, and will therefore have to give way to these far superior theories.

Most philosophers of mind believe that eliminative materialism goes too far in its criticism of folk psychology. There are various reasons for this, the most important of which is probably that it can hardly be denied that we successfully explain certain phenomena observed in others or ourselves using the means of folk psychology, and, to a certain extent, even predict them successfully [1,7–9]. If folk psychology really failed prognostically to the extent claimed by the eliminative materialists, it would be completely incomprehensible how human interaction, that relies fundamentally on successful prediction of human behavior, can to this day still be based on folk psychology. For it is a fact that cannot be overemphasized that all our social practices, even those within the domain of science and research itself, are organized in accordance with folk psychology. This is not to say that one should, as some philosophers of mind tend to do as a reaction to eliminative materialism, regard folk psychology as a theory that is almost completely true [1], but it can surely, to a certain extent, be regarded as a correct and explanatorily and prognostically successful theory. This view is not contradicted by the fact that many phenomena, such as perception and motion or psychiatric conditions cannot be described, explained or even predicted correctly in terms of folk psychology. With regard to these phenomena folk psychology has always had to give way to undeniably more adequate scientific theories, and will probably have to do so even more in the future.

To this day there has been no final and uncontroversial answer to the question of how folk psychological descriptions and explanations relate to the scientific descriptions and explanations of persons. However, this controversial open-endedness of the debate should not come as a surprise; quite the contrary – the opposite would be surprising. For if we were able to give a final and unanimous answer, that would amount to nothing less than the final solution of the philosophical mind-body problem. Let us take a look at an example. Suppose the identity theory, according to which mental states are identical to brain states, were correct. Then one would have to be able to make plausible that, whenever we talk about mental states in terms of folk psychology, we are

really referring to brain states. Folk psychological explanations would have to be transformable into neuroscientific explanations. If such a transformation were successful, it would have been proved that folk psychological and neuroscientific descriptions and explanations of a person are compatible with each other. However, to date the identity theory has neither been proved nor refuted in the philosophy of mind. And the situation regarding the other proposed solutions to the mind-body problem is much the same.

But regardless of how the relation between folk psychology and scientific theory has been described or how it will be described in the future, the following should be clear from the outset: If the human sciences claim to be able to describe and explain human behavior in its entirety, they will also have to, at least in principle, be able to describe and explain how folk psychology itself evolved and why human societies with all their cultural variants are successfully based on it. For the latter is a fact that is confirmed for each of us every day in numerous encounters with others.

In the philosophy of mind and the public debate about the mind-body problem and its consequences, it is often overlooked or not sufficiently emphasized that, because of the points made above, the question of whether scientific theories are able to replace folk psychology is not an entirely theoretical question, but also has a far-reaching normative dimension. Our everyday life, even our entire human culture, is still based on folk psychology. To pick out just one aspect: fiction, theatre, music and painting, cultural and social sciences and the arts, even wide areas of academic psychology and medicine are unthinkable without folk psychology and its language. Nobody can seriously imagine what our everyday lives or, indeed, a humane and acceptable civilization would look like without folk psychology, and how scientific theories, such as theories about the brain, could fulfill these functions adequately. Even if, one day, it should emerge that scientific theories are able to describe, explain and predict all aspects of a person better than folk psychology, the question would nevertheless remain of whether we really want to completely replace folk psychology with scientific theories and whether we can accept the moral consequences.

#### ► Theory Theory (Simulation Theory, Theory of Mind)

## References

1. Fodor J (1975) *The language of thought*. MIT Press, Cambridge, Mass
2. Horgan T, Woodward J (1985) Folk psychology is here to stay. *Philos Rev* 94:89–106
3. Gordon R (1986) Folk psychology as simulation. *Mind Lang* 1:158–171

4. Stich SP, Nichols S (1992) Folk psychology: simulation or tacit theory. *Lang mind* 7:35–71
5. Churchland PM (1979) *Scientific realism and the plasticity of mind*. Cambridge University Press, Cambridge
6. Churchland PS (1986) *Neurophilosophy: towards a unified science of the mind/brain*. MIT Press, Cambridge, Mass
7. Baker LR (1970) *Saving belief*. Princeton University Press, Princeton
8. Graham GL, Horgan T (1988) How to be realistic about folk psychology. *Philos Psychol* 1:69–81
9. Von Eckard B (1993) *What is cognitive Science?* MIT Press, Cambridge, Mass

## Food Anticipation

► Food Entrainment

## Food-anticipatory Activity

### Definition

Circadian rhythms of behaviors such as wheel running, general activity or operant responding that occur in the hours immediately preceding a scheduled daily meal.

► Food-Entrainment

## Food-entrainable Oscillator (FEO)

### Definition

An oscillator that generates endogenous circadian rhythms that can be shifted and entrained by periodic presentation of food.

► Food Entrainment  
► Nocturnal/Diurnal

## Food-entrainable Pacemaker (FEP)

► Food Entrainment

## Food-entrainable Rhythms

► Food Entrainment

## Food Entrainment

RALPH MISTLBERGER

Department of Psychology, Simon Fraser University, Burnaby BC, Canada

### Synonyms

Food anticipation; Circadian food anticipatory activity (FAA); Food-entrainable rhythms; Food-entrainable pacemaker (FEP); Food-entrainable oscillators (FEO)

### Definition

► Phase and period control of endogenous circadian (24-h) oscillators and overt rhythms by daily schedules of food availability.

### Characteristics

#### Circadian Rhythms, Oscillators and Entrainment

Daily rhythms of biochemistry, physiology or behavior expressed by most living organisms are generated by endogenous, cell-autonomous (intracellular) ► oscillators cycling with a periodicity that closely approximates the solar day (hence “circadian”, L. about a day). To ensure optimal coordination of circadian rhythms both internally and with local environmental time, ► circadian oscillators can be synchronized (entrained) by periodic environmental or physiological stimuli (“► zeitgebers”, G. time-givers). The dominant environmental zeitgeber for most organisms is the daily ► light-dark (LD) cycle.

Light acutely delays circadian rhythms at dusk and early night, and advances circadian rhythms at late night through dawn. These phase adjustments serve to offset small differences in the duration (“► period”) of the circadian and LD cycles, and ensure a characteristic phase relationship between circadian rhythms and local time, manifest as ► nocturnal (night-active) and ► diurnal (day-active) “chronotypes”. In mammals, circadian rhythms are coordinated by a master ► circadian pacemaker, comprised of a population of neuronal circadian oscillators (“► clock cells”) located in the ► suprachiasmatic nuclei (► SCN), a region of the mediobasal hypothalamus directly innervated by the ► retina.

In many organisms, circadian rhythms can also be entrained by ► non-photic stimuli, which may include

daily cycles of temperature, social or nonspecific arousal, or food availability. While ►**entrainment** by food has been demonstrated in a variety of vertebrate species, its properties and mechanisms have been well-characterized in only a few species of mammals, primarily rats, mice and hamsters.

### Formal Properties of Food-Entrainment in Mammals

Circadian rhythms persist (“►**free-run**”) in constant light or dark, a property that is fundamental to the concept of endogenous, self-sustaining circadian oscillators. If food availability is restricted to a fixed time of day (e.g. a 4-h meal alternating with a 20-h fast) for a week or more, ►**free-running rhythms** may entrain to mealtime, typically with the daily active phase (denoted by the Greek letter “ $\alpha$ ”) of the circadian rest-activity cycle beginning prior to (anticipating) mealtime [1,2]. If food is then unrestricted, circadian rhythms resume free-running from the apparent phase of entrainment. In these cases, common in Syrian hamsters (e.g. Fig. 1a) and some marsupials and mouse strains, the SCN master circadian pacemaker appears to be entrained, and with it all behavioral and physiological rhythms. Food availability, or some correlate, thus can act analogously to light by entraining (setting the phase and period) of the entire circadian system. The phase of entrainment is adaptive, by ensuring that animals are

awake and active prior to mealtime, and metabolically prepared for food ingestion, digestion and absorption.

In other species or in the presence of a LD cycle, the response to daily schedules of food-availability is typically more complex, and reveals an underlying multi-oscillator circadian system in which one pacemaker (the SCN) is entrained primarily or exclusively by light, while most circadian oscillators elsewhere in the brain and body are entrained by food [3,4,1,5]. This uncoupling of circadian oscillators and rhythms by restricted feeding may also occur in constant light or dark, such that the light-entrainable, SCN pacemaker free-runs, while ►**food-entrainable oscillators** remain synchronized with mealtime. An additional layer of complexity is that some variables (e.g. locomotor activity) appear to be jointly controlled by both light-entrainable and food-entrainable oscillators, while others (e.g. ►**pineal melatonin secretion**) may be directly regulated by only one.

These complex responses were first discovered and remain best illustrated in common strains of the laboratory rat, *Rattus norvegicus* (hereafter “the rat”). Rats of this species are nocturnal, preferring to forage and feed at night. They are also opportunistic; wild rats will exploit a source of food that is available in the day, and laboratory rats will adapt to an exclusively daytime feeding schedule. Adaptation is facilitated by apparently loose coupling between light-entrainable and

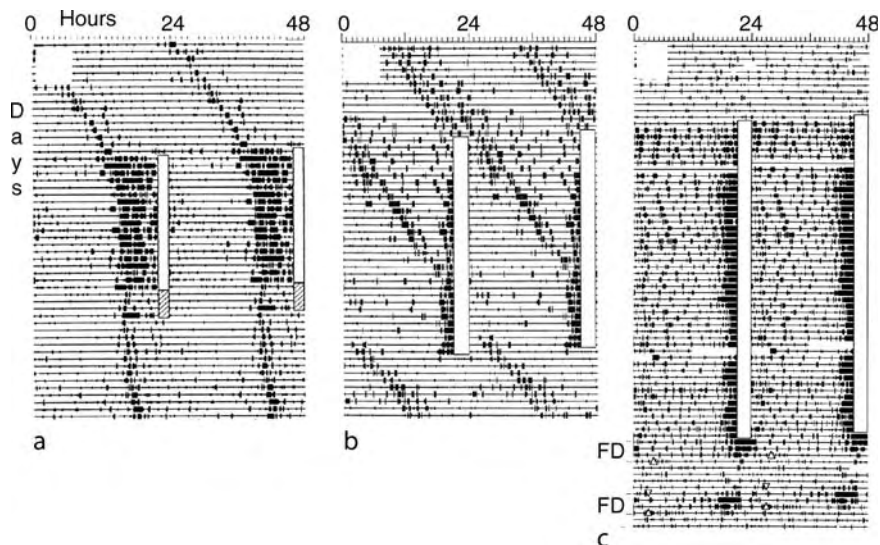

**Food Entrainment. Figure 1** Wheel running activity rhythms of rodents subjected to restricted daily feeding schedules, in standard “raster” or “actogram” format. Each panel represents activity of a single animal. Time within a day is plotted in 10 min bins from left to right. Consecutive days are aligned both horizontally and vertically (i.e. the record is double-plotted). Vertical deflections on the lines indicate time bins when activity counts were registered. During restricted feeding, mealtime is indicated by the opaque vertical bar. The beginning and end of bouts of total food deprivation are indicated by inverted and upright triangles, respectively. (a) Syrian hamster in constant dim light, with food and water access restricted to 3-h/day. (b) Rat in constant dim light with food restricted to 3-h/day. (c) Rat with complete SCN-ablation in constant dim light, with food restricted to 3-h/day, or food deprived for 72-h (FD). Note that SCN-ablation eliminates circadian rhythms when food is available ad-libitum.

food-entrainable oscillators in this species, as can be inferred from rhythm dissociations in rats exposed to both LD and feeding schedules. Lab rats entrained to a LD cycle and restricted to a single 2–4 h meal in the middle of the light period (the rest phase of the circadian cycle in nocturnal species, designated “ $\rho$ ”) within a few days exhibit increased locomotor activity beginning 1–3 h before mealtime (Fig. 2). The waveform of this bout of “▶food-anticipatory activity” (FAA) shows a steep positive slope until mealtime, and stabilizes within 1–3 weeks (Fig. 3a). In rats, nocturnal activity persists, but typically at a lower level.

The magnitude of FAA and the direction of change of nocturnal activity are dependent on both the species and the specific behavior measured. In the absence of a LD cycle, the previously nocturnal bout of activity free-runs with a species-specific circadian periodicity, while FAA emerges or persists with a periodicity of exactly 24 h (Fig. 1b). Again, the likelihood of such dissociation is greater in rats than hamsters and mice, but examples exist for all of these species. Expression of two circadian rhythms with different periods indicates joint control of activity by separate light- and food-entrainable oscillators. Body temperature also exhibits food- and light-entrainable components, while circadian rhythms of

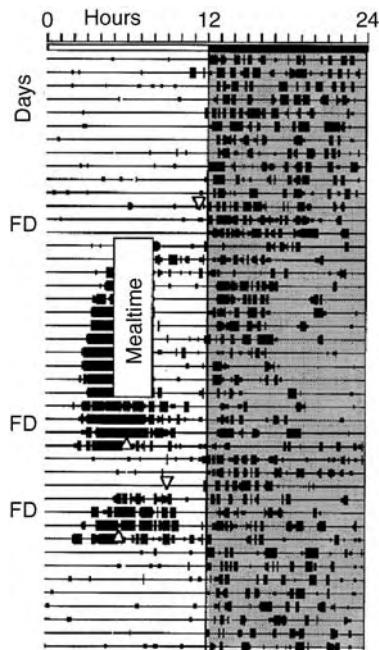

**Food Entrainment. Figure 2** Wheel running activity rhythm of a rat in a light-dark cycle subjected to total food deprivation (FD) for 2–4 days and to restricted daytime feeding (3-h/day). The daily dark period is denoted by shading. The beginning and end of bouts of total food deprivation are indicated by inverted and upright triangles, respectively.

pancreatic and hepatic enzymes, insulin and glucocorticoids appear to be predominantly regulated by food, with levels rising prior to mealtime. Pineal melatonin secretion is the only strong example of a circadian rhythm that appears to be exclusively light-entrainable.

A simple explanation for FAA is that it reflects an hourglass process, whereby premeal activity is triggered each day when energy depletion (hunger) reaches some threshold. However, food-deprived rats

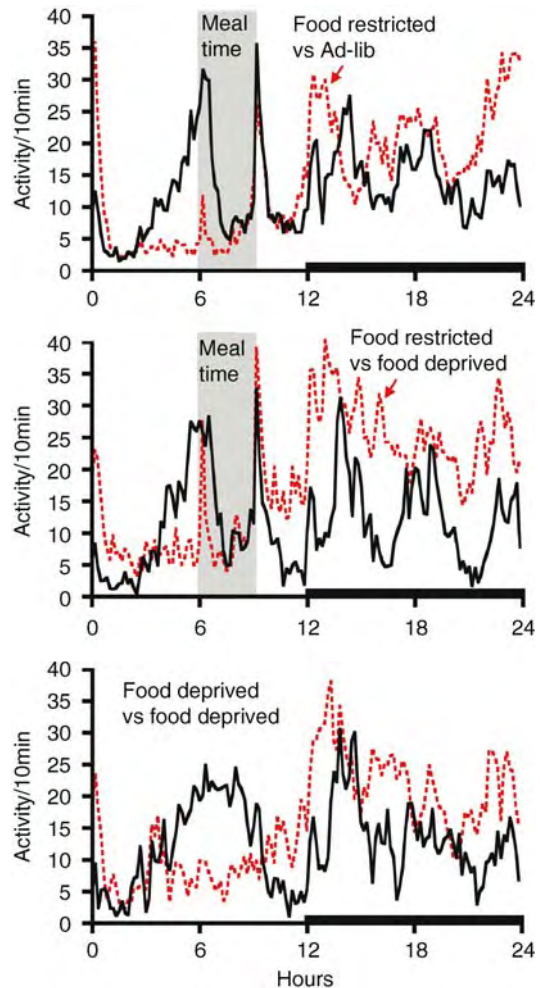

**Food Entrainment. Figure 3** Group mean average waveforms of general cage activity (recorded by infra-red motion sensors) in rats under different feeding conditions. (a) Rats anticipating a 3-h midday meal (solid line) or with free-access to food throughout the day (dashed red line). (b). Rats anticipating a 3-h midday meal (solid line) or subjected to 72-h with no food (dashed red line, no prior experience with midday feeding). (c) Rats subjected to 72-h food deprivation, either immediately after 3 weeks of midday feeding (solid line), or with no experience of restricted midday feeding (dashed red line). Lights-off is denoted by the heavy bar along the x-axis.

that have not experienced a regular mid-day feeding time do not exhibit an activity waveform similar to food-entrained rats (Fig. 3b). General activity levels may increase with prolonged deprivation, but the timing of this activity is non-specific, and the intensity of activity does not accelerate to a mid-day peak. Moreover, once a food anticipatory rhythm is established, it persists during prolonged (3–5 day) bouts of total food deprivation, and reappears at the same time of day during subsequent bouts of total food deprivation after a few days or more of ad-libitum food access (Figs. 1c, 2).

Another explanation for FAA is that it is the outcome of an associative learning process, whereby rats learn that certain phases of their light-entrainable circadian pacemaker are predictive of food availability. However, food-anticipatory rhythms emerge and persist normally in rats with complete SCN-ablation and also in constant light or dark (Fig. 1c).

Careful experimentation with different feeding schedules has revealed that FAA exhibits all of the canonical properties of an entrained, circadian clock-controlled rhythm [3,4,1,5]. If meal intervals are outside of the circadian range (~22–31 h), anticipatory rhythms do not emerge (so-called “▶limits to entrainment”); however, in rare but instructive instances, if already established, anticipatory rhythms may uncouple and free-run. Within this range, the duration of FAA (conceptualized as the ▶phase-angle of entrainment) varies systematically with the period of the feeding cycle. If mealtime is acutely shifted by 6–12 h, FAA shifts gradually, not immediately. These properties are evident in both intact and SCN-ablated rats, and indicate that FAA is driven by a physically separate circadian oscillator that is self-sustaining and entrainable by feeding-related stimuli.

### Molecular and Neural Mechanisms of Food-Entrainment

Circadian oscillations in SCN clock neurons are currently thought to be generated by interlocking negative and positive transcriptional-posttranslational feedback loops of so-called circadian clock genes and their protein products, including the *period* genes (*per1* and *per2*), the *cryptochromes* (*cry1* and *cry2*), ▶clock, ▶*Bmal1*, and ▶*rev-erba* [6]. The discovery of clock genes in the SCN was quickly followed by recognition that these genes are also expressed rhythmically in many brain regions outside of the SCN, and in most if not all peripheral organs and tissues [6,7]. Clock gene rhythms in the SCN are reset (and thereby entrained) by light (transduced by photosensitive ▶retinal ganglion cells that release ▶glutamate and ▶PACAP in the SCN) and in the presence of a LD cycle are not shifted by restricted daily feeding schedules that generate FAA. By contrast, clock gene rhythms in most peripheral organs are readily uncoupled from LD cycles and fully reset by daily feeding schedules. Numerous brain regions also exhibit

clock gene rhythms reset by feeding time. A working conceptual model is that circadian rhythms in mammals are regulated by a hierarchically organized, distributed population of neural and peripheral oscillators driving local brain and organ functions (Fig. 4).

The SCN master pacemaker sits at the top of this hierarchy, and under normal circumstances regulates the phase and period of oscillators elsewhere, thereby synchronizing rhythms within and between physiological systems, and coordinating the ensemble of oscillating tissues with local time by its sensitivity to LD cues. When food intake is controlled by the environment instead of by the SCN, ▶peripheral oscillators and many neural oscillators shift to maintain synchrony of behavior and physiology with mealtime. Feeding-related signals that mediate entrainment of neural and peripheral oscillators remain to be identified.

The locations of oscillators and neural circuits that generate food-anticipatory behavioral rhythms are not yet conclusively identified. Peripheral oscillators entrained to feeding schedules could conceivably drive circadian rhythms of FAA via autonomic afferents or hormones acting on the brain. Evidence to date suggests that peripheral oscillators do not serve this function, because the phase of these oscillators can be dissociated from behavioral food anticipatory rhythms by several days of ad-lib food access interposed between 3–4 day bouts of total food deprivation in rats previously entrained to a daytime meal [8]. During food deprivation, the behavioral rhythm reappears with its former daytime peak (Figs. 1c, 2), while the peripheral rhythms revert to a nocturnal phase, presumably reset by SCN-dependent nocturnal food intake when food is freely available. Also, in mice bearing a mutation of the *Clock* gene, the food anticipatory behavioral rhythm persists robustly during a 2-day food deprivation, while food-entrained rhythms of gene expression in at least two peripheral tissues, liver and heart, damp out [9].

Conversely, *Per2<sup>brdm1</sup>* mutant mice exhibit normal entrainment of peripheral oscillators to restricted daytime feeding, but lose food-anticipatory behavioral and temperature rhythms [10].

Loss of food-anticipatory rhythms in *Per2<sup>brdm1</sup>* mutant mice confirms a critical role for circadian clock genes, and provides a target for brain mapping studies to locate potential sites of FAA-generating clock neurons. Clock gene rhythms induced or reset by daily feeding schedules have been identified in numerous brain regions, including neocortex, limbic and extrapyramidal systems, thalamus and hypothalamus [10,7]. Lesions of many of these areas have no effects on food anticipatory rhythms [1,8,10]. Ablation of the dorsomedial hypothalamus (DMH), nucleus accumbens or nucleus of the solitary tract has been reported to attenuate or prevent food-anticipation in one study each, but not in other studies. Paraventricular



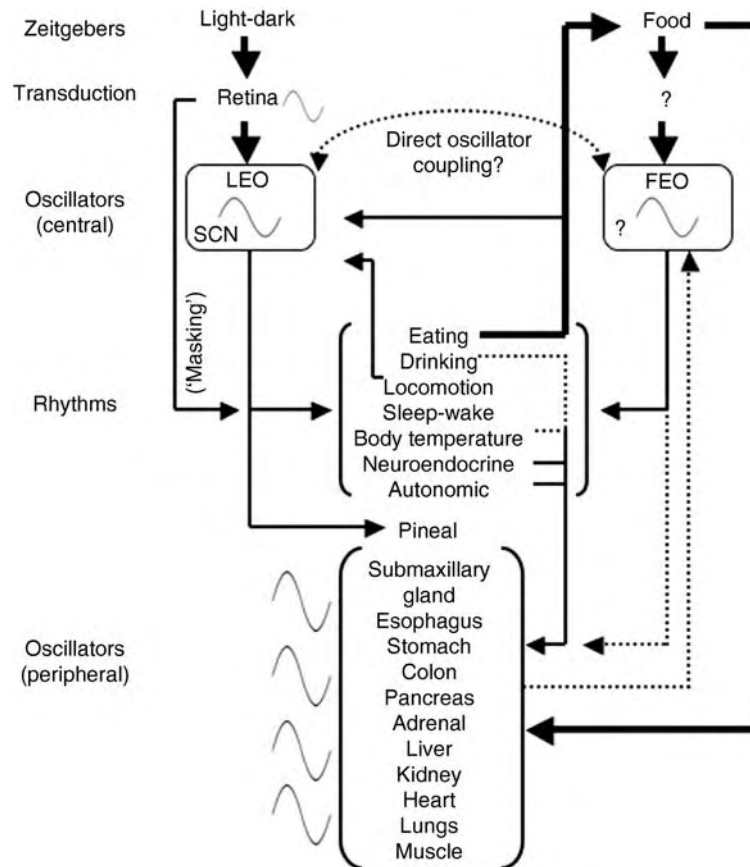

**Food Entrainment. Figure 4** Elements of the mammalian circadian timekeeping system, illustrating known sites of circadian oscillators (denoted by sine-waves), and known (*solid lines*) or potential (*dashed*) routes of coupling between zeitgebers (timing signals) and oscillators, and among oscillators. Heavier arrows indicate stronger entraining signal, relative to other entraining signals. Zeitgebers can be environmental (light) or behavioral (food ingestion, locomotor activity). *LEO* light-entrainable oscillator (or pacemaker); *SCN* suprachiasmatic nucleus; *FEO* food-entrainable oscillator (or pacemaker), which may be a collection of oscillators distributed across different brain regions, with different groups controlling different output rhythms.

hypothalamic lesions can attenuate food anticipation in one measure of behavior but not another, while ablation of the DMH, infralimbic cortex or hypophysis can eliminate the premeal rise of body temperature, without blocking behavioral anticipation. Entrainment of behavioral and autonomic rhythms by feeding may involve a distributed population of neuronal circadian clock cells, with different sites contributing to different rhythms, and multiple sites contributing to behavioral rhythms.

Elaboration of the neural and molecular mechanisms of food-entrainment may provide targets for the development of novel ▶**chronobiotics**. More generally, the profound effect of temporally restricted feeding schedules on circadian organization of physiology raises the possibility that disruption of normal eating patterns, secondary to eating disorders, other disease processes, aging, and ▶**shiftwork**, may account for some of the health consequences of these conditions.

## References

1. Mistlberger RE (1994) Circadian food anticipatory activity: Formal models and physiological mechanisms. *Neurosci Biobehav Rev* 18:171–195
2. Castillo MR, Hochstetler KJ, Tavernier RJ Jr, Greene DM, Bult-Itto A (2004) Entrainment of the master circadian clock by scheduled feeding. *Am J Physiol Regul Integr Comp Physiol* 287:R551–R555
3. Boulos Z, Terman M (1980) Food availability and daily biological rhythms. *Neurosci Biobehav Rev* 4:119–131
4. Aschoff J (1986) Anticipation of a daily meal: a process of “learning” due to entrainment. *Mon Zool Ital* 20:195–219
5. Stephan FK (2002) The “other” circadian system: food as a Zeitgeber. *J Biol Rhythms* 17:284–292
6. Ko CH, Takahashi JS (2006) Molecular components of the mammalian circadian clock. *Hum Mol Gen* 15: R271–R277
7. Guilding C, Piggins HD (2007) Challenging the omnipotence of the suprachiasmatic timekeeper: are circadian oscillators present throughout the mammalian brain? *Eur J Neurosci* 25:3195–216

8. Davidson AJ (2006) Search for the feeding-entrainable circadian oscillator: a complex proposition. *Am J Physiol Regul Integr Comp Physiol* 290:R1524–R1526
9. Horikawa K, Minami Y, Iijima M, Akiyama M, Shibata S (2005) Rapid damping of food-entrained circadian rhythm of Clock gene expression in clock-defective peripheral tissues under fasting conditions. *Neuroscience* 134:335–343
10. Feillet CA, Albrecht U, Challet E (2006) Feeding time for the brain: a matter of clocks. *J Physiol Paris* 100 (5–6):252–260

---

## Food Intake

- ▶ Neuropeptides in Energy Balance

---

## Food-Storing

### Definition

Several birds, but also mammals (e.g. squirrels) collect food (nuts, etc.) summertime and hide it in small “caches” at different places for later retrieval in winter.

- ▶ Evolution of the Brain: At the Reptile-Bird Transition

---

## Force

- ▶ Measurement Techniques

---

## Force Depression/Enhancement in Skeletal Muscles

WALTER HERZOG  
Professor, Faculty of Kinesiology, Calgary, Canada

### Synonyms

History dependence of force production; Residual force depression/enhancement; Steady-state force depression/enhancement

### Definition

Force depression (FD) is defined as the loss of steady-state ▶ **isometric** force, which occurs after shortening of an activated ▶ **muscle** or muscle fiber, when compared to the steady-state force obtained in a purely isometric contraction at the same muscle/fiber length (Fig. 1). The term “steady-state” here refers to the idea that any transient forces associated with the dynamic shortening of the muscle/fiber have subsided.

▶ **Force enhancement** (FE) is defined as the gain in steady-state isometric force that occurs following stretch of an activated muscle or muscle fiber, when compared to the steady-state force obtained in a purely isometric contraction at the same muscle/fiber length (Fig. 1).

### Characteristics

**Quantitative Description:** Force depression of skeletal muscle following shortening was described systematically for the first time more than half a century ago [1]. Since that time, FD has become a well-recognized and acknowledged property of skeletal muscle contraction, although there is great controversy as to the mechanisms producing FD. Interestingly, FD is not explained within the classical framework of the ▶ **sliding filament theory** [2] or the ▶ **cross-bridge theory** [3] of muscle contraction. However, the following relationships have been consistently observed: Force depression increases with increasing magnitudes of shortening (Fig. 2a), with increasing force during shortening (Fig. 2b), with increasing mechanical work during shortening, and with decreasing speed of shortening (Fig. 2c).

Furthermore, the amount of force depression for given shortening conditions depends on the length of the muscle, with peak FD observed near the plateau region of the ▶ **force-length relationship**. Force depression is long lasting (i.e. in excess of 30 s in cat soleus at physiological temperature), but can be abolished instantaneously by deactivation of the muscle for a period of time that is long enough for force to fall to zero (Fig. 2d). Furthermore, FD is associated with a parallel decrease in ▶ **fiber stiffness** [4] in the force depressed compared to the isometric reference state. Force depression occurs during electrically stimulated and voluntary contractions, and loss of force associated with FD can reach peak values of more than 50% [5].

**Force Enhancement:** Force enhancement (FE) of skeletal muscle following stretch was also first described in a systematic manner by Abbott and Aubert [1]. Like force depression, FE is a well recognized property of skeletal muscle contraction, is not explained within the framework of the classical sliding filament and cross-bridge theories, and the following relationships have been recognized and accepted in the scientific community: Force enhancement increases with increasing magnitudes of stretch (Fig. 3a) and increasing

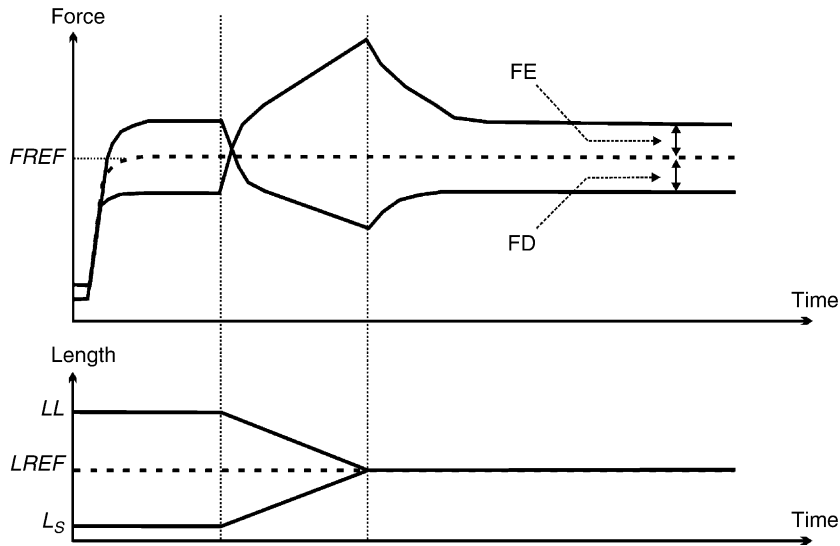

**Force Depression/Enhancement in Skeletal Muscles.** Figure 1 Schematic force-time and length-time histories of an activated muscle. When an activated muscle is shortened and then held isometrically, the force produced at the short length is smaller than the corresponding steady-state force obtained for a purely isometric contraction at that short length ( $F_{REF}$ ). This loss of force associated with active shortening is called force depression (FD). Similarly, when an activated muscle is stretched and then held isometrically, its force at the long length is greater than the corresponding steady-state force obtained for a purely isometric contraction at the long length ( $F_{REF}$ ). This gain in force associated with active muscle stretch is called force enhancement (FE).

muscle/fiber length, and is independent (or nearly so) of the speed of stretch. Since FE occurs at all muscle lengths, it is also seen on the plateau of the force-length relationship, where it may exceed the maximum isometric force (Fig. 3b) of the muscle/fiber by as much as 20%. Force enhancement at long muscle/fiber length is associated with a passive component that contributes part, but not all, of the force increase following muscle stretch (Fig. 3c). Force enhancement, like FD, is long lasting (>30 s in cat soleus at physiological temperature), but can be abolished instantaneously by deactivation of the muscle such that force drops to zero, except if part of the FE is contributed by the passive component [6]. The passive component of FE persists even after deactivation and complete loss of force. There is some controversy about whether FE is associated with an increase in muscle/fiber stiffness. Force enhancement, like FD, can reach magnitudes for specific stretch conditions of up to 50% above the isometric steady-state force obtained in purely isometric reference contractions.

### Higher Level Structures

Force depression and force enhancement are observed on the whole muscle level.

### Lower Level Components

Force depression and force enhancement are also observed in single fibers [4], and FE has also been verified in single myofibrils [7]. However, neither force depression nor force enhancement have ever been

observed in single actin-myosin interactions, therefore, it is not clear at present whether FD/FE are properties associated with the basic molecular mechanisms of muscle contraction, or if they occur at some higher structural level, such as the sarcomeres, only.

### Structural Regulation

It is not known how force depression and force enhancement are regulated. The following explanations are the most likely processes, based on the author's experience. They may turn out to be entirely wrong, and should be viewed as working hypotheses.

Force depression may be associated with a stress-induced inhibition of cross-bridges in the actin-myosin overlap zone that is newly formed during shortening. This hypothesis was first proposed by Maréchal and Plaghki [8]. It would account for the relationship of FD with the magnitude and speed of shortening, the force during shortening, and the loss of muscle stiffness in the depressed compared to the reference state. It would also fit with the observed relationship between FD and the mechanical work of the muscle during shortening, and would be consistent with the long lasting nature of FD and the fact that FD can be abolished by releasing the force on the muscle. However, direct testing of this hypothesis has proven difficult, and further work is required to gain direct insight into the mechanisms associated with force depression.

The most likely explanation for the mechanisms underlying force enhancement must include an active

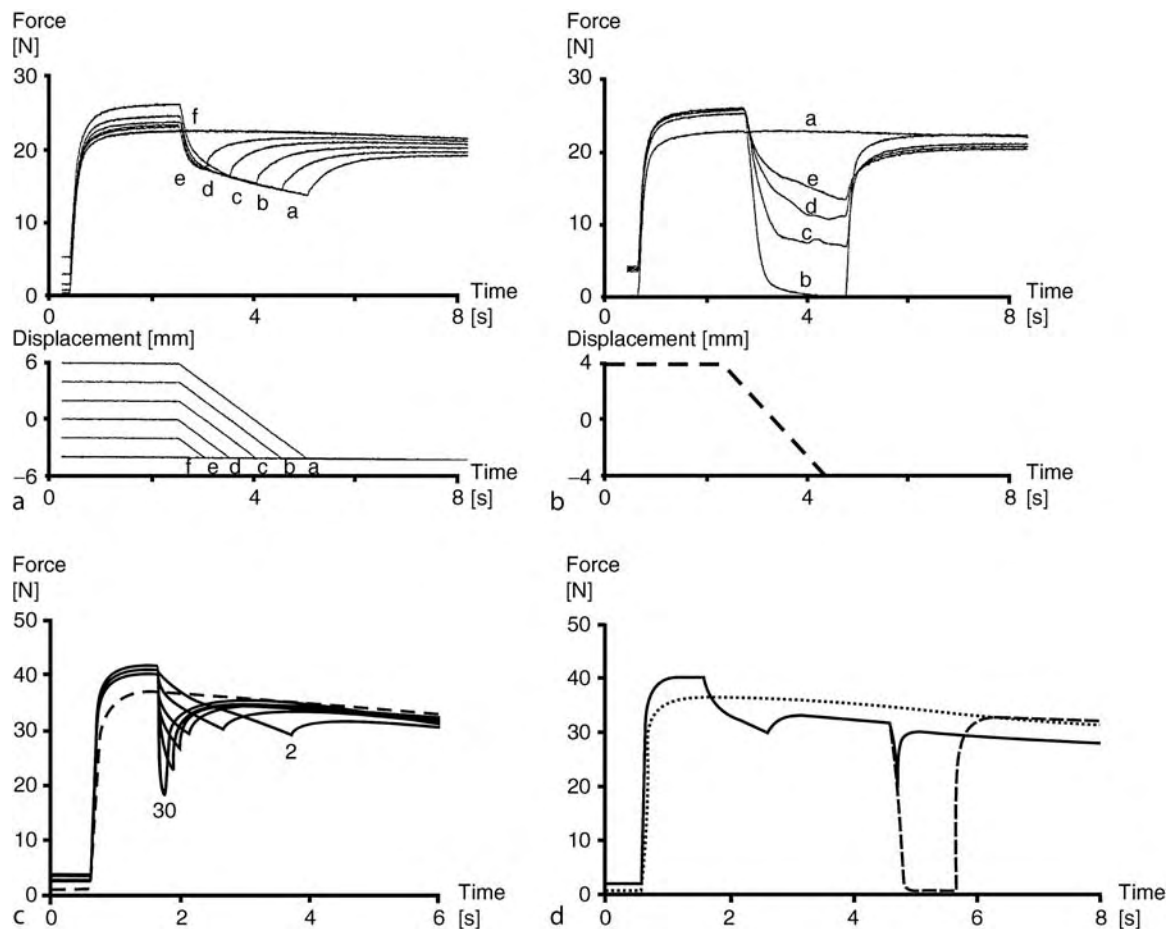

**Force Depression/Enhancement in Skeletal Muscles. Figure 2** Force-time and length time histories of isometric reference contractions and isometric-shortening-isometric test contractions that produce force depression. Force depression is known to increase with increasing magnitudes of muscle shortening (a), with increasing force during shortening (b), with decreasing speeds of shortening (note, the amount of shortening is constant; 30 represents the force-time trace for shortening at 30 mm/s, 2 the one for shortening at 2 mm/s (c), and force depression can be abolished by deactivating the force-depressed muscle just long enough for force to drop to zero (*dashed line*) (d).

and a passive component. At present, an explanation based on a stretch-induced decrease in the [rate of cross-bridge detachment](#) would account for many of the experimental observations associated with the active component of FE. This mechanism would account for the increase in stiffness observed in the force-enhanced compared to the isometric reference state [6], and might easily be fitted to the observation that FE increases with increasing magnitudes of stretch. It has also been observed quantitatively that the transient force decrease immediately following active muscle stretch and the force decay following deactivation are slower from the force-enhanced compared to the isometric reference state. However, the above proposal for FE is based on indirect and tentative arguments and must be thoroughly tested in the future.

The most popular mechanism for FE has been the sarcomere length non-uniformity theory [e.g. 9]. In

this theory, FE is associated with a stretch-induced instability of sarcomere lengths on the descending limb of the force-length relationship. However, this theory cannot be the sole explanation for FE, because it inherently does not allow for FE on the ascending limb of the force-length relationship (but this has been observed on numerous occasions [e.g. 1]. Furthermore, steady-state FE, according to this theory, cannot exceed the maximum isometric force observed at muscle/fiber [optimal length](#) (but again, this has been observed in whole muscle and single fiber preparations (e.g. Fig. 3b).

The passive component of force enhancement appears to be associated with a structural element that is in parallel with the cross-bridges, and that is elongated upon sarcomere or fiber stretch. The molecular spring [titin](#), which provides some of the physiological passive force in muscle, has been implicated to cause the observed passive FE [6]. Recently, it has been demonstrated that titin

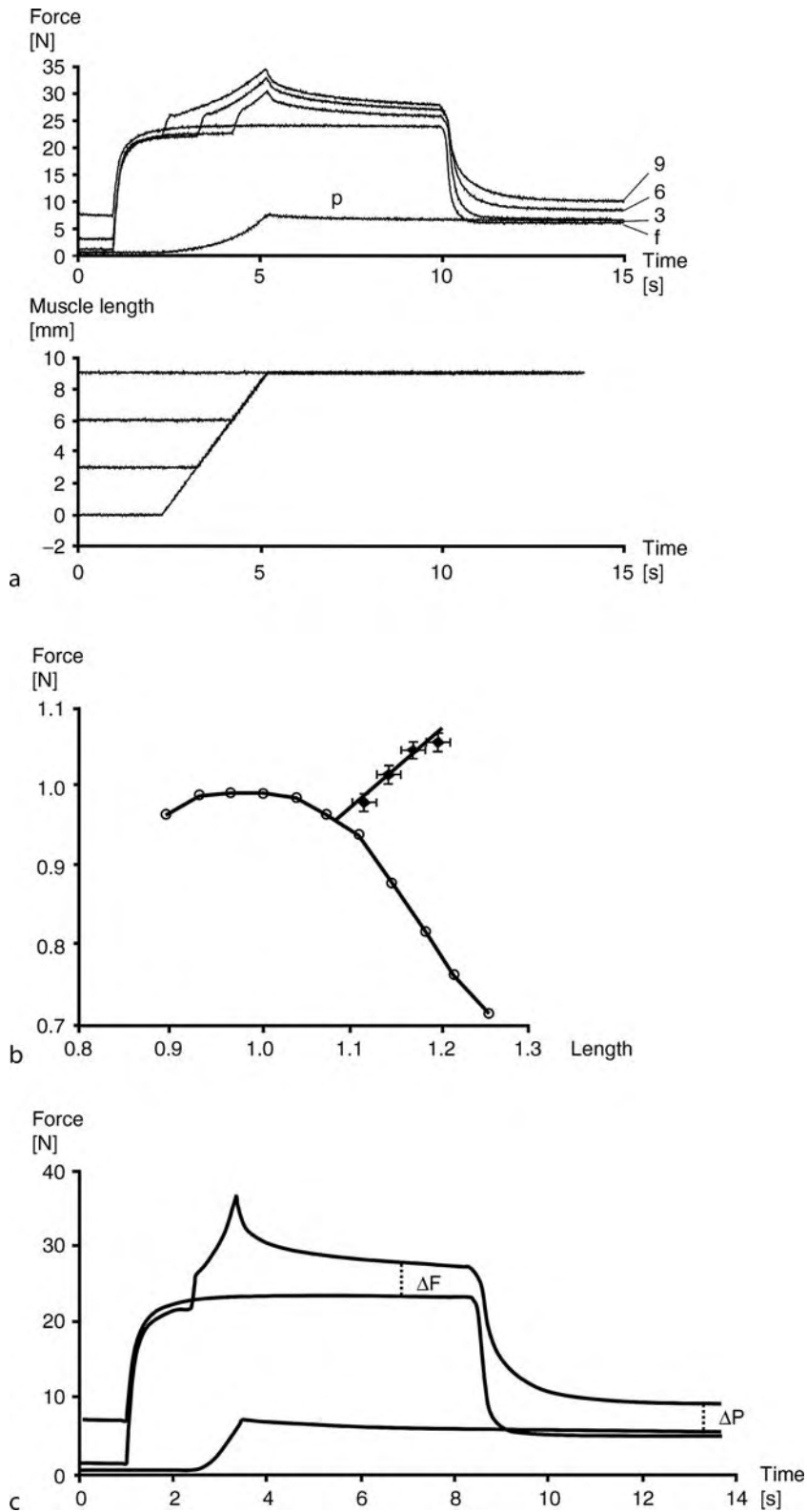

**Force Depression/Enhancement in Skeletal Muscles. Figure 3** Force-time and length-time histories of stretch contractions with increasing magnitudes of stretch (a). Force enhancement and passive force enhancement increase with increasing stretch magnitudes (f, isometric reference contraction; 3, 6, and 9, stretch contractions of 3, 6, and 9 mm magnitude; p, passive, 9 mm stretch).

changes its stiffness properties as a function of calcium concentration [10]; a property that would fit perfectly with the observed passive force enhancement, but direct proof of titin's involvement with the passive component of FE has not been found.

### Function

Force depression and force enhancement have been observed primarily in muscle/fiber preparations that were activated artificially through electrical stimulation. The fact that these properties also exist during voluntary contraction has only been verified recently [e.g. 5] for maximal voluntary contractions. Since muscles are not electrically stimulated or maximally activated during most normal everyday movements, it is not clear if FD and FE play a functional role in the control and regulation of normal movements. Unpublished pilot data from our group suggest that FD and FE occur to a similar relative degree during submaximal voluntary contractions in the human adductor pollicis muscle. If these results are confirmed, the functional relevance of FD and FE may be studied. At present, it appears that FD does not serve any functional purpose, as any loss of force associated with specific contractile conditions implies that a given force must be attained with an increase in activation, and thus presumably an increased effort and increased metabolic cost. Therefore, force depression might be a property that is based on a structural or functional insufficiency of the actin-myosin motor.

In contrast to force depression, force enhancement is associated with a gain in force. Therefore, a given force can be achieved and more easily maintained following stretch of an activated muscle than that achieved in a purely isometric contraction. Presumably, this reduces the required activation and decreases the metabolic cost associated with producing a given level of force following stretch.

The passive component of force enhancement appears to occur only at muscle/fiber lengths that are toward the end range of normal physiological use and beyond. Therefore, it appears that the passive FE is most effective when a muscle is stretched actively beyond its normal range of motion. Such contractile conditions have been associated with muscle injury, thus the passive component of FE may be viewed as an "emergency break" for accidental over stretching of muscles.

### References

1. Abbott BC, Aubert XM (1952) The force exerted by active striated muscle during and after change of length. *J Physiol*; 117:77–86
2. Huxley HE, Hansen J (1954) Changes in cross-striations of muscle during contraction and stretch and their structural implications. *Nature*; 173:973–976

3. Huxley AF (1957) Muscle structure and theories of contraction. *Prog Biophys Chem*; 7:255–318
4. Sugi H, Tsuchiya T (1988) Stiffness changes during enhancement and deficit of isometric force by slow length changes in frog skeletal muscle fibres. *J Physiol*; 407:215–229
5. Lee HD, Herzog W (2003) Force depression following muscle shortening of voluntarily activated and electrically stimulated human adductor pollicis. *J Physiol*; 551:993–1003
6. Herzog W, Leonard TR (2002) Force enhancement following stretching of skeletal muscle: a new mechanism. *J Exp Biol*; 205:1275–1283
7. Joumaa V, Leonard TR, Hertog W (2008) Residual force enhancement in myofibrils and sarcomeres. *Proc. R. Soc. B*. doi:10.1098/rsp6.2008.0412
8. Maréchal G, Plaghki L (1979) The deficit of the isometric tetanic tension redeveloped after a release of frog muscle at a constant velocity. *J Gen Physiol*; 73:453–467
9. Morgan DL (1990) New insights into the behavior of muscle during active lengthening. *Biophys J*; 57:209–221
10. Labeit D, Watanabe K, Witt C et al. (2003) Calcium-dependent molecular spring elements in the giant protein titin. *Proc Natl Acad Sci USA*; 100:13716–13721

## Force Potentiation in Skeletal Muscle

RENE VANDENBOOM

Faculty of Applied Health Sciences, Brock University, St. Catharines, ON, Canada

### Synonyms

Postactivation potentiation (PAP); Posttetanic potentiation (PTP)

### Definition

Vertebrate skeletal muscle functions as a biological motor, converting chemical energy to mechanical energy to generate force and do work that powers movement [1]. An important property of muscle mechanical function is that it is history-dependent and as such is sensitive to previous muscle activity. An important example of this history-dependence is "force potentiation," defined as the transient increase in ►isometric twitch force evoked by prior contractile activity (Fig. 1).

Experimentally, force potentiation is readily observed in ►fast-twitch skeletal muscles isolated from rodents [2–7] as well as in human skeletal muscle [8]. Although the physiological function of force potentiation is uncertain, it is hypothesized to be an important modulator of skeletal muscle locomotor function [9].

General model showing change in isometric twitch force evoked by electrical stimulation (+stimulation) of rodent fast-twitch skeletal muscle. Compared to

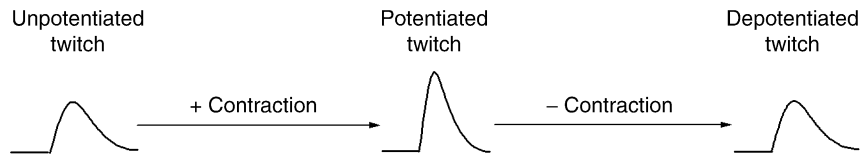

**Force Potentiation in Skeletal Muscle. Figure 1** General model for force potentiation. Example of how isometric twitch force is increased electrical stimulation (+stimulation) of rodent fast-twitch skeletal muscle. Compared to the unpotentiated twitch (left) the amplitude of the potentiated twitch (middle) is increased by ~50% and may exhibit a faster time course. In the absence of further activity (-stimulation) twitch force amplitude resumes pre-stimulation levels (“depotentiated” twitch) over the course of several minutes.

the unpotentiated twitch (left) the amplitude of the potentiated twitch (middle) is increased by  $\sim 75\%$ . In the absence of further activity ( $-$ stimulation) twitch force amplitude resumes pre-stimulation levels (“depotentiated” twitch) over the course of several minutes.

### Characteristics

Several different model- and stimulation-dependent classes of force potentiation have been described. Although the experimental setting under which these responses are evoked may differ, the basic response is essentially the same, i.e., an increase in isometric twitch force observed during or following muscle activity. As an example, posttetanic potentiation (PTP) refers to the increased twitch force evoked by high-frequency electrical stimulation of rodent fast-twitch skeletal muscle (in vitro or in situ). In contrast, *staircase* refers to the progressive increase in twitch force observed during low frequency stimulation of rodent fast-twitch or human skeletal muscle [7]. On the other hand, the increase in performance observed following voluntary contraction of human skeletal muscle in vivo is termed *postactivation potentiation* (PAP).

An important aspect of force potentiation is that it may occur coincident with reductions in high-frequency tetanic force [6]. Thus, because force potentiation process selectively enhances low-frequency forces, it does not represent a simple “scaling-up” of overall muscle force generating capability. The molecular mechanism for PTP in animal muscle appears to be an increased sensitivity of the contractile proteins to suboptimal levels of calcium-activation mediated by phosphorylation of the myosin regulatory light chains (R-LC) [7,10]. As recently pointed out by Zhi et al. (2005), the molecular mechanism for staircase potentiation of mouse fast-muscle may be more complex and may, in addition to phosphorylation of the myosin R-LC, involve contraction-induced changes in the level of calcium ion delivered to the contractile proteins [7]. Clearly, more work is needed to clarify the contribution of these respective mechanisms to staircase in animal skeletal muscle. Finally, although evidence supports a casual link between phosphorylation of myosin and both PTP and PAP of human skeletal muscle [8,9], the

influence exerted by altered calcium activation to these responses, as well as to staircase potentiation, is unclear.

Although force potentiation is an important feature of human skeletal muscle, this review will focus on data from animal studies that provide compelling evidence linking myosin R-LC phosphorylation to PTP of fast-twitch skeletal muscles from the mouse and rat hindlimb.

### Quantitative Description

#### General

The presence of force potentiation is usually assessed by comparing twitch responses obtained before (pre-) and after (post) muscle contractile activity. The magnitude of potentiation is calculated as the percent increase in isometric twitch force (i.e., post/pre) that is produced. Under optimal conditions, twitch force may be increased twofold; the precise characteristics of the potentiated twitch are however specific to the prevailing experimental conditions. For example, PTP is very temperature sensitive; the magnitude of potentiation of mouse extensor digitorum longus (EDL) muscle is inversely related to temperature in the range 15–35°C [3,4]. Moreover, biological factors such as fiber type also influences force potentiation; in animals, contraction-induced increases in twitch force are inversely proportional to muscle oxidative potential [4].

Posttetanic potentiation or PTP has been most extensively studied using fast twitch muscle from the mouse (in vitro) and rat (in situ). In general, studies using rat fast muscle (EDL or white gastrocnemius) show that isometric twitch force may be increased by 50–100% above pre-tetanic values [3,5]. Although saturable, the extent of force potentiation tends to increase with increasing frequency and/or durations of stimulation. For example, Manning and Stull (1982) used rat EDL to show that the extent of twitch potentiation induced by 1-s of stimulation was increased as frequency was increased from 10 Hz to 80 Hz [3]. Similarly, when stimulation frequency was held constant (200 Hz), twitch force potentiation increased as duration was increased from 50 ms to 2,000 ms [3]. Interestingly, the stimulation parameters required to saturate the force potentiation response may lie beyond

the time and frequency domains for muscle activation *in vivo*.

The extent of force potentiation observed in mouse muscle is generally less than that observed in rat muscle. For example, in the temperature range 25–35°C, the peak potentiation observed in mouse EDL muscle is only 30–35% above pre-stimulation values [4,6]. The greater twitch potentiation noted for rat vs. mouse muscle generally noted may be primarily due to differences in experimental conditions; studies using rat muscle are generally performed at warmer temperatures than are studies using mouse muscle. Interestingly, when studied at similar temperatures (20–25°C) the extent of twitch force potentiation reported for rat and mouse EDL muscle is similar [3,4]. For example, when measured 20 s after a brief **tetanus**, isometric twitch force of mouse EDL muscle maintained at 30°C was potentiated by 75% [7].

#### **Time Course of PTP in Rodent Muscle**

Under non-fatiguing conditions, the time-course of potentiation is such that twitch force peaks shortly after stimulation before decaying with an initial fast and a subsequent slow time course [3–5]. This characteristic time-course is influenced by temperature. For example, at 35°C, PTP is highest immediately following stimulation before declining steeply to pre-stimulation levels. At 25°C however, PTP tends to peak only after many seconds have elapsed following stimulation; thereafter, PTP slowly declines to pre-stimulation levels over a period of several minutes. Regardless of temperature, excessive contractile activity may also cause **fatigue**, a process that may complicate the time-course of PTP by delaying its appearance and/or diminishing its magnitude.

#### **Correlation of PTP with Myosin R-LC Phosphate Content in Rodent Hindlimb Muscle**

Several studies performed on mouse and rat skeletal muscle demonstrate that electrical stimulation of quiescent muscle induces large and rapid elevations in myosin R-LC phosphate content. For example, brief high-frequency or prolonged low-frequency stimulation of mouse EDL muscle *in vitro* elevates R-LC phosphate content from basal to near maximal levels (i.e., from ~0.15 to ~0.75 moles phosphate per mole R-LC [4,6–8]. Similar findings have been reported for rat muscle studied *in situ* [3,5]. The strong associations between stimulation-induced increases in myosin R-LC phosphorylation and the magnitude of twitch force potentiation observed coincident with this increase provided by these studies supports the notion that phosphorylation of the myosin R-LC is the molecular basis for PTP [3–5,7].

#### **Higher Level Structures**

Myosin is the major structural and contractile protein of muscle. Myosin is a large (~520 kD) molecule formed

by the dimerization of two heavy chain monomers, an assembly that produces an asymmetrical molecule with two “heads” linked to a single rod or “tail” [1]. As a molecular motor, myosin enzymatic (myosin ATPase) activity is coupled to structural changes within the head producing a molecular force that powers muscle contraction [1].

#### **Lower Level Components**

Covalently bound to each myosin head are two structures known as the myosin light chains (~20 kD). These subunits, known as the “essential” and “regulatory” light chains, appear to be important components for myosin motor function. Of these species, the regulatory light chain (R-LC) is phosphorylatable.

#### **Structural Regulation**

The addition of a negative charge to the myosin head via phosphorylation of the R-LC has been observed to alter myosin head configuration, an effect that may increase myosin head mobility relative to the thick filament [reviewed in 9].

#### **Lower Level Processes**

Sweeney et al. (1993) provide a comprehensive analysis of the processes regulating R-LC phosphorylation in vertebrate skeletal muscle [9]. Skeletal muscle contains a calcium – calmodulin dependent kinase enzyme termed skeletal muscle myosin light chain kinase (skMLCK). Although vertebrate skeletal muscle may also contain a smooth muscle MLCK isoform, it is the activity of the skMLCK isoform that appears to dominate myosin R-LC phosphorylation in skeletal muscle [7]. In this regard, the phosphate content of the R-LC is regulated via a signaling cascade wherein the intracellular calcium levels that govern muscle contraction also activates skMLCK to catalyze the transfer of a phosphate moiety from ATP to the R-LC. Dephosphorylation of the R-LC is accomplished via a phosphatase enzyme whose activity appears to be unregulated. At rest, phosphatase activity exceeds MLCK activity and R-LC phosphorylation is maintained at a low level. During muscle activity skMLCK activity increases to a point that favors phosphorylation of the R-LC. The magnitude of this increase is both stimulation frequency- and stimulation duration-dependent. Another order of regulation is achieved through a several-fold higher skMLCK content in fast-than **slow-twitch muscle fibers**, a difference that accounts for why R-LC phosphorylation is greater in fast-than in slow-muscle fibers [5].

#### **Process Regulation**

In a simple, two-compartment model for muscle force regulation, twitch force potentiation can be due



to either an increase in the calcium signal for contraction or to an increase in the sensitivity of the contractile proteins to the calcium signal for contraction. To date, most evidence supports the idea that force potentiation is due to R-LC phosphorylation-mediated increases in the sensitivity of the contractile proteins to calcium. For example, Persechini et al. (1985) used ►permeabilized rabbit psoas muscle fibers to show that phosphorylation of the R-LC increases isometric force in response to suboptimal, but not saturating, levels of calcium activation [10]. The mechanism by which phosphorylation of the myosin R-LC increases the sensitivity of the contractile proteins to subsaturating  $\text{Ca}^{2+}$  may involve alterations to myosin head configuration caused by the addition of a negatively charged phosphate moiety to the R-LC. For example, there is structural evidence to suggest that phosphorylation of the R-LC shifts the myosin head from the thick filament backbone [9]. This phosphorylation-induced offset of the myosin head from the thick filament is hypothesized to increase the mobility of the myosin head relative to the thin filament, an effect that may facilitate the rate constant describing the formation of force-generating states (i.e., *fapp*) particularly when the thin filament is suboptimally activated by calcium ion [9]; in contrast, myosin phosphorylation does not appear to alter the reverse rate constant, i.e., the transition of force-generating to non-force generating states (*gapp*). In intact muscle, this mechanism would be expected to enhance force during twitch and/or low frequency stimulation [8], conditions not expected to achieve full calcium-activation of the contractile proteins [9].

Although several studies have documented strong associations between R-LC phosphate content and PTP, the most compelling evidence that myosin phosphorylation mediates twitch force potentiation comes from experiments performed on mice in which the gene coding for skMLCK has been ablated [10]. Compared to muscles from wild-type mice, EDL and soleus muscles isolated from knockout mice (skMLCK<sup>-/-</sup>) expressed minimal skMLCK [7]. Thus, although tetanic stimulation (175 Hz for 2 s) of wild-type EDL elevated myosin R-LC phosphate content from basal levels to ~0.50 moles phosphate per mole R-LC, tetanic-stimulation of skMLCK<sup>-/-</sup> muscles did not elevate myosin R-LC phosphorylation above the very low, constituent level of myosin phosphorylation at rest. Moreover, although tetanic stimulation of wild-type EDL potentiated twitch force by ~75%, identical stimulation of skMLCK<sup>-/-</sup> EDL did not produce any PTP [7]. Although it is unclear as to why skMLCK<sup>-/-</sup> muscles from knockout mice displayed small basal levels of myosin phosphorylation (i.e. ~0.10 moles phosphate per mole of R-LC), the fact that stimulation of these muscles did not elevate myosin R-LC phosphorylation nor potentiate twitch force

provides evidence that these phenomena are functionally related in mouse EDL muscle (at 30°C). An interesting point in the data of Zhi et al. (2005) is that the ablation of skMLCK did not completely inhibit the staircase potentiation of EDL muscle [10]. For example, repetitive stimulation (10 Hz for 15 s) of wild-type EDL muscles potentiated twitch force by ~50% compared to the first twitch; this outcome was coincident with elevations in myosin R-LC phosphate content to ~0.50 moles phosphate per mole of R-LC [7]. On the other hand, although stimulation of skMLCK<sup>-/-</sup> EDL did not elevate myosin R-LC phosphorylation above baseline levels (see above), twitch force was potentiated by ~30% during the low-frequency train [7]. Thus, although these data strongly implicate a causal link between myosin phosphorylation and PTP, they also indicate that additional factors may contribute to staircase potentiation in mouse EDL muscle [7].

### Function

From a teleological perspective it is appealing to think that vertebrate striated muscle normally operates in a “potentiated state” in vivo. That is, repetitive or prolonged muscle activity may lead to sustained elevations in myosin R-LC phosphate content, a condition that may enhance muscle mechanical and metabolic properties compared to the fatigued but unphosphorylated state [6,8]. Moreover, although the isometric twitch is a poor surrogate for assaying physiological function of muscle, there is evidence to suggest that myosin phosphorylation may also enhance the dynamic properties of fast-twitch skeletal muscle. Although phosphorylation of the myosin R-LC does not enhance unloaded shortening velocity [4,10], it may augment loaded shortening velocity [2]. Thus, in addition to enhancing isometric force development, the potentiation process may augment ►isotonic muscle function. It is hypothesized that, by increasing the ability of cycling crossbridges to attain force-generating states on the thin filament, myosin phosphorylation may shift a given isotonic load toward the “faster” end of the ►force-velocity relation [2,9]. Although complicated by many different aspects of neural activation in vivo (e.g., high frequency activation of concentric and eccentric muscle forces) it seems reasonable to expect that activity-induced elevations in myosin R-LC phosphorylation may operate to enhance the dynamic properties of working fast-skeletal muscle in vivo. Finally, it should be mentioned that it is still unclear as to whether myosin phosphorylation mediated force potentiation operates to increase, decrease or does not change the economy of muscle contraction. This information is vital if we are to fully understand the teleological role of myosin phosphorylation and the ability of this molecular mechanism to modulate dynamic function of fast-twitch skeletal muscle in fatigued and un-fatigued states.

## References

1. Rayment I, Rypniewski WR, Schmidt-Base K, Smith M, Tomchick DR, Benning MM, Winkelman DD, Weseneberg G, Holden HM (1993) Three-dimensional structure of myosin subfragment-1: a molecular motor. *Science* 261(5117):50–58
2. Grange RW, Cory CR, Vandenboom R, Houston ME (1995) Myosin phosphorylation augments the force–displacement and force–velocity relationships of mouse fast muscle. *Am J Physiol* 269:C713–C724
3. Manning DR, Stull JT (1982) Myosin light chain phosphorylation–dephosphorylation in mammalian skeletal muscle. *Am J Physiol* 242:C234–C241
4. Moore RL, Palmer BM, Williams SL, Tanabe H, Grange RW, Houston ME (1990) Effect of temperature on myosin phosphorylation in mouse skeletal muscle. *Am J Physiol* 259:C432–C438
5. Moore RL, Stull JT (1984) Myosin light chain phosphorylation in fast and slow skeletal muscle in situ. *Am J Physiol* 247:C462–C471
6. Vandenboom R, Houston ME (1996) Phosphorylation of myosin and twitch potentiation in fatigued skeletal muscle. *Can J Physiol Pharmacol* 74:1315–1321
7. Zhi G, Ryder JW, Huang J, Ding P, Chen Y, Zhao Y, Kamm KE, Stull JT (2005) Myosin light chain kinase and myosin phosphorylation effect frequency-dependent potentiation of skeletal muscle contraction. *Proc Natl Acad Sci USA* 102(48):17519–17524
8. Houston ME, Grange RW (1990) Myosin phosphorylation, twitch potentiation, and fatigue in human skeletal muscle. *Can J Physiol Pharmacol* 68:908–913
9. Sweeney HL, Bowman BM, Stull JT (1993) Myosin light chain phosphorylation in vertebrate striated muscle: regulation and function. *Am J Physiol* 264:C1085–C1095
10. Persechini A, Cooke R, Stull JT (1985) The effect of myosin phosphorylation on the contractile properties of skinned rabbit skeletal muscle fibers. *J Biol Chem* 260(13):7951–7954

## Force-Frequency Relation of Skeletal Muscle

SAMUEL C. K. LEE<sup>1,2</sup>, DAVID W. RUSS<sup>3</sup>,  
STUART A. BINDER-MACLEOD<sup>2</sup>

<sup>1</sup>Research Department, Shriners Hospitals for Children, Philadelphia, PA, USA

<sup>2</sup>Department of Physical Therapy, University of Delaware, Newark, DE, USA

<sup>3</sup>School of Physical Therapy, Ohio University, Athens, OH, USA

### Synonyms

FFR

### Definition

The ►**force–frequency relation (FFR)** is the sigmoid relationship between a muscle’s activation frequency and isometric force output. The FFR is classically derived by plotting the peak force responses to trains of electrical pulses across a wide range of frequencies (see Fig. 1). At low stimulation frequencies (e.g., ≤5 pps) the FFR is flat, as no summation of force occurs in response to successive stimuli, resulting in a series of isolated twitches (Fig. 1b, region I). With increasing stimulation frequency, summation of force can be observed, resulting in a steep rise in the FFR (Fig. 1b, region II). At sufficiently high frequencies of stimulation, the responses to individual stimuli cannot be delineated and a smooth tetanic contraction is observed; and there is little further increase in peak force with increasing frequency (Fig. 1b, region III). Studies often quantify differences in the FFR by reporting the frequency needed to produce a set percentage of maximum force (e.g., the frequency required to produce 50% of maximum force).

### Characteristics

#### Quantitative Description

##### Force Production

During voluntary contractions, there are two basic mechanisms used by the CNS for modulating the force produced by a muscle: ►**recruitment** and ►**rate coding (frequency modulation)**. During electrical stimulation of skeletal muscle, force can be modulated by varying the intensity and frequency of the stimulation pulses, analogous to the processes of recruitment and rate coding. The FFR essentially describes the effect of rate coding.

##### Recruitment

The size principle describes a process for the orderly recruitment of motor units during voluntary contractions, with the smallest ►**motor units** recruited first and the larger motor units recruited with successively stronger contractions [1]. During direct electrical stimulation to the motor nerve, the recruitment order is reversed; the largest motor units are recruited first, and progressively smaller units are recruited with increasing stimulus amplitude. During neuromuscular electrical stimulation (NMES) with surface electrodes, however, recruitment appears to be more variable and less orderly than that observed during voluntary contractions or during direct nerve stimulation.

##### Rate Coding (Frequency Modulation)

The other mechanism used by the CNS for modulating muscle force is varying the discharge rate of those motor units that have been recruited. During voluntary contractions both recruitment and rate coding grade force, making it difficult to separate their effects on

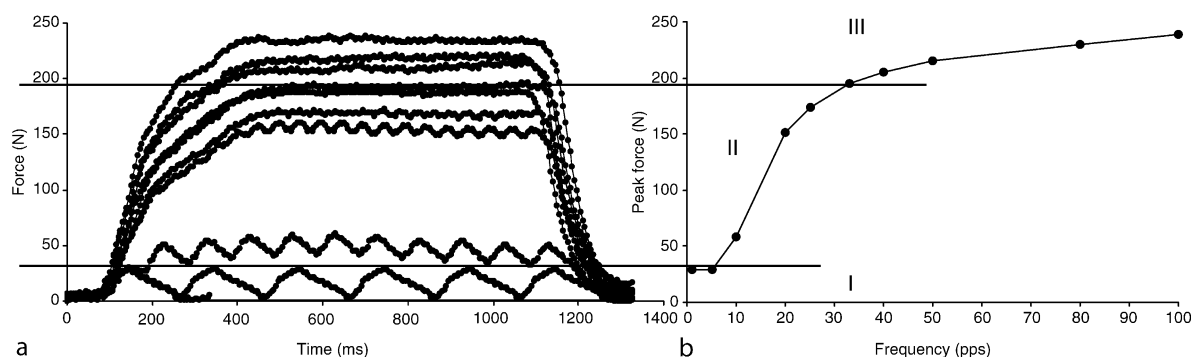

**Force-Frequency Relation of Skeletal Muscle. Figure 1** Raw force traces (a) and the corresponding force-frequency relationship (b) of the quadriceps femoris muscle in a young healthy individual. At low stimulation frequencies (e.g.,  $\leq 5$  pps) the FFR is flat, as no summation of force occurs in response to successive stimuli, resulting in a series of isolated twitches (b, region I). With increasing stimulation frequency, summation of force can be observed, resulting in a steep rise in the FFR (b, region II). At sufficiently high frequencies of stimulation, the responses to individual stimuli cannot be delineated and a smooth tetanic contraction is observed; and there is little further increase in peak force with increasing frequency (b, region III).

force production. Most studies have therefore relied on NMES to investigate the FFR. The classic, electrically elicited FFR, however, tends to overestimate the discharge rates observed during voluntary contractions. The asynchronous discharge of motor units during volitional contractions serves to smooth the contraction (at low forces and discharge rates) and produces greater forces at each mean motor unit activation frequency than are possible with synchronous activation of NMES. The FFR plotted during synchronous electrical stimulation has provided many important insights into the factors that affect this relation.

#### Factors Influencing the FFR

The contractile characteristics of a muscle affect its FFR. The rates of force development and relaxation, which are a function of the myosin heavy chain and sarcoplasmic endoplasmic reticulum calcium ATPase protein profiles of the fibers in the muscle, affect the frequency at which summation of force begins to occur (leftward boundary of region II in Fig. 1b) and the frequency needed to produce maximum tetanic force. The faster the contractile rates, the further to the right the FFR should lie.

Each muscle does not display a consistent FFR. The FFR observed in any given muscle is a function of the muscle's length and recent contractile activity. Thus, a single sigmoid curve cannot accurately portray the true FFR of any muscle.

#### Muscle Length

Changes in muscle length may affect the FFR by altering force transmission and force-generating capacity (also see muscle [force-length relation](#)). For

example, increasing muscle length increases passive tension, which in turn, reduces the amount of slack that the muscle must take up prior to transmitting force. This preferentially enhances the force measured at lower stimulation frequencies, thus shifting the FFR to the left. Conversely, the FFR would be shifted to the right in shortened muscles.

The sliding filament theory also predicts that variations in muscle length will affect muscular force generation by altering the degree of [myofilament](#) overlap. The maximum isometric tension that skeletal muscle can generate at different lengths has been well-studied. At any muscle length other than optimum, sub-maximal forces are generated by the muscle. Virtually all investigators have found maximum force at lengths that allowed maximum overlap of the thin and thick filaments, and nearly linear declines in force at longer and shorter lengths.

In addition to these mechanical effects of muscle length, it has been suggested that the  $\text{Ca}^{2+}$ -sensitivity of the myofilaments is influenced by muscle length [2], with sensitivity reduced at short muscle lengths. Such a reduction in  $\text{Ca}^{2+}$ -sensitivity would shift the FFR to the right. Thus, alterations in the FFR with changing muscle length may reflect both changes in force transmission and force generation.

#### Contractile History

Muscular contraction is associated with a number of phenomena that have been observed to influence the FFR. For example, contractile activity increases muscle temperature, which is associated with an increase in the contractile rate of the muscle. Such increases in contractile rate might be expected to shift the FFR to the right.

Both tetanic and sub-tetanic [3] stimulation, as well as voluntary contractile activity, produce muscle potentiation [4] resulting from a  $\text{Ca}^{2+}$ -activated myosin light chain phosphorylation, which increases the probability of actin–myosin interaction. Potentiation results as an increase in twitch and subtetanic force production, no effect on maximum tetanic tension, and a shift of the FFR to the left.

Another method of increasing the probability of actin–myosin interaction, and thus a leftward shift in the FFR, is to activate muscle using stimulation trains that elicit the ►catchlike property. The catchlike property of skeletal muscle is a tension enhancement produced when an initial brief high frequency burst of pulses (2–4 pulses) is used at the onset of subsequent subtetanic stimulation train [3]. Such tension enhancements at subtetanic stimulation frequencies by the catch-like property are attributed to increased calcium release by the ►sarcoplasmic reticulum caused by the initial high frequency burst at the onset of the stimulation train. Another mechanism attributed to force enhancements is that the catchlike property causes increased muscle stiffness and thus better transmission of the force generated by the existing crossbridges. As the catchlike property enhances force production of stimulation trains with lower mean frequencies, a leftward shift in the FFR is observed [3].

If contractile activity is maintained for a sufficient period of time, muscle fatigue will occur, and this can also influence the FFR. Bigland-Ritchie and associates [5] have shown, for the human adductor pollicis muscle, that following fatigue, the twitch contraction time decreased slightly and the half relaxation time markedly increased. Based on these findings and the fact that motor unit firing frequencies were shown to decrease

markedly during sustained, fatiguing, maximum voluntary contractions, Bigland-Ritchie and associates suggested that the FFR should shift to the left as a muscle begins to fatigue. This assertion assumed, however, that fatigue would affect force equally across all frequencies.

More recent work appears to disprove this assumption and has shown a shift in the FFR to the right during fatigue [6]. In several different human muscles, the FFR is shifted to the right when the muscle is fatigued by electrically or volitionally induced contractions. The shift in the FFR is the result of a greater attenuation of the twitch force than the tetanic force (i.e., a decrease in the twitch to tetanus ratio) [6]. This phenomenon is termed low-frequency fatigue, and occurs due to a reduction in  $\text{Ca}^{2+}$  released per stimulus. As a result of this impairment, force production is markedly impaired at low stimulation frequencies, whereas high-frequency stimulation (50 pps) produces sufficient  $\text{Ca}^{2+}$  release to permit full cross-bridge interaction to occur [7].

### Function

Rate coding is one of two primary ways that the CNS controls muscle force output. Similarly, during exogenous electrical activation of skeletal muscles, the timing of the presentation of successive pulses markedly affects the rate of force development, the amount of peak force produced, and the rate and amount of fatigue produced.

### Pathology

The effect of pathology on the FFR probably varies with the nature of the changes that accompany the specific condition. Increased age, for example, is believed to induce excitation–contraction “uncoupling” in skeletal

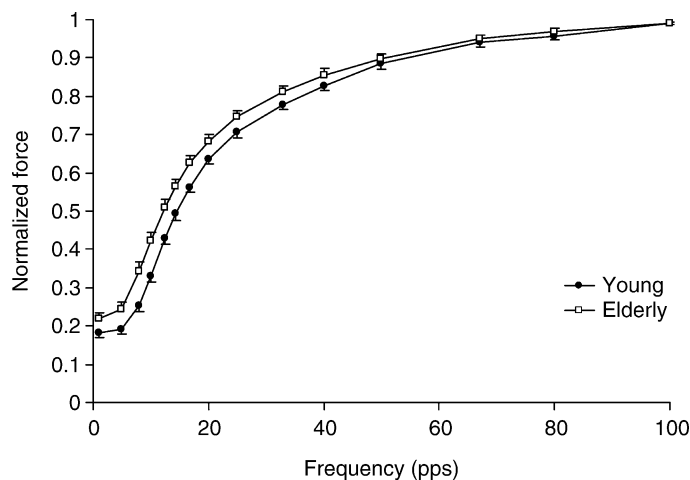

**Force-Frequency Relation of Skeletal Muscle. Figure 2** Normalized quadriceps femoris force-frequency curves from young (N = 20) and elderly (N = 20) individuals showing a leftward shift for elderly individuals. Error bars represent standard deviations.

muscle [8], a phenomenon that would be expected to shift the FFR to the right. However, aging is also associated with a reduction of Type II fiber area, which should induce a leftward shift. A number of investigators have, in fact, observed a leftward shift in the FFR in aged versus young muscle, suggesting that the shifts in myosin isoform composition have greater effect than diminished twitch forces observed in aged muscle. Other, more severe, pathologic conditions such as cerebral palsy and spinal cord injury have recently been shown to affect the FFR. In both conditions, a leftward shift in the FFR has been observed [9,10] (see Fig. 2). Although it is attractive to explain such shifts in the FFR by suspected changes in myosin heavy chain expression, the two conditions are associated with opposite shifts in fiber type, fast toward slow in cerebral palsy and slow toward fast in spinal cord injury, indicating that other factors must be at work. Interestingly, both conditions are associated with greater twitch and subtetanic force responses than uninvolved muscles, which are factors expected to shift the FFR to the left [9,10].

## References

1. Henneman E (1985) The size principal: a deterministic output emerges from a set of probabilistic connections. *J Exp Biol* 115:105–112
2. Roszek B, Baan GC, Huijing PA (1994) Decreasing stimulation frequency-dependent length-force characteristics of rat muscle. *J Appl Physiol* 77:2115–2124
3. Burke RB, Rudomin P, Zajac FE (1976) The effect of activation history on tension production by individual muscle units. *Brain Res* 109:515–529
4. Sweeney HL, Stull JT (1986) Phosphorylation of myosin in permeabilized mammalian cardiac and skeletal muscle cells. *Am J Physiol* 250:c657–c660
5. Bigland-Ritchie B, Johansson R, Lippold OC, Smith S, Woods JJ (1983) Changes in motoneuron firing rates during sustained maximal voluntary contractions. *J Physiol (Lond)* 340:335–346
6. Binder-Macleod SA, Lee SC, Fritz AD, Kucharski LJ (1998) New look at force-frequency relationship of human skeletal muscle: effects of fatigue. *J Neurophysiol* 79:1858–1868
7. Westerblad H, Bruton JD, Allen DG, Lannergren J (2000) Functional significance of  $Ca^{2+}$  in long-lasting fatigue of skeletal muscle. *Eur J Appl Physiol* 83:166–174
8. Delbono O, O'Rourke KS, Ettinger WH (1995) Excitation-calcium release uncoupling in aged single human skeletal muscle fibers. *J Membr Biol* 148:211–222
9. Gerrits HL, Hopman MTE, Sargeant AJ, Jones DA, de Haan A (2002) Effects of training on contractile properties of paralyzed quadriceps muscle. *Muscle Nerve* 25:559–567
10. Stackhouse SK, Binder-Macleod SA, Lee SCK (2005) Voluntary muscle activation, contractile, and fatigue properties in children with and without cerebral palsy. *Muscle Nerve* 31(5):594–601

## Force–Velocity Relationship of Skeletal Muscle

DAVID C. LIN

Programs in Bioengineering and Neuroscience,  
Washington State University, Pullman, WA, USA

### Definition

The force-velocity relationship describes how muscle force depends upon the velocity of movement or *vice versa*.

### Characteristics

#### Quantitative Description

The seminal experiments of A.V. Hill showed that the velocity of shortening in actively contracting skeletal muscle depended upon the force with which the muscle was loaded. Hill believed that the functional significance of these experiments was that an internal viscous resistance within the muscle had to be overcome in order for shortening to take place [1]. Although this theory proved to be incorrect, the fact that force and velocity are interrelated is important because quantifying force–velocity (F–V) characteristics is a crucial assessment of muscle contractile properties for modeling purposes, and for revealing the optimal mechanical conditions under which a specific muscle performs motor functions.

#### Measurement of the F–V Relationship

Ideally, measurement of the F–V relationship is the simultaneous measurement of steady-state force and steady-state velocity during steady-state activation. The term “steady-state” implies that a quantity does not change over time. However, due to the interaction of F–V property with other dynamic properties, it is virtually impossible to obtain steady-state conditions for both force and velocity. Hence, the experimental protocol used to measure the F–V properties can influence quantitative measurement of the F–V curve.

The most widely used method to measure F–V properties is the application of “isotonic” loads. In the isotonic experimental paradigm, the muscle is activated while being held at a constant length (i.e. isometric). Once the isometric force ( $F_o$ ) is constant, the force in the muscle is changed and set to a new constant level, the isotonic force. The change in force produces a change in length in the muscle. If the isotonic force is less than the isometric force, the muscle will shorten, and if the isotonic force is greater than the isometric force, the muscle will lengthen. The change in length usually contains a fast transient response immediately after the imposition of the isotonic load,

followed by a near constant slower velocity in the muscle (Fig. 1). However, the magnitude of velocity tends to decrease with time and usually does not reach a steady-state. Thus, most investigators choose an arbitrary time period, where initial transients have diminished and velocity is relatively constant, to measure the muscle velocity. It should be noted that the choice of the time period does influence the quantitative measurement of the F–V relationship. The experiment is repeated several times to obtain a series of discrete F–V data points.

The second method is the isovelocitv experimental paradigm. This experimental protocol is similar to the isotonic experiments except that muscle velocity is controlled and muscle force measured. Usually, the resulting force response is also not a true steady-state response, and force is measured in a specific time window or at a specific muscle length. The characterization of the F–V properties also requires a series of experimental trials to obtain a series of F–V data points. The third method is a “slack test.” In this method, the muscle is fully activated and then rapidly shortened by a specific distance, causing the muscle to become slack and muscle force to become zero. The muscle shortens in this unloaded condition until the slack is removed and force is redeveloped. Usually, the experiment is repeated several times with different distances of imposed slack, and the slope of the slack distance versus time to force redevelopment is equal to the

“unloaded shortening velocity” ( $V_0$ ). A shortcoming of the slack test method is that it only provides one data point for the F–V relationship.

A fourth method which has not been widely used to characterize the F–V relationship is to apply a “force ramp,” which is a linear change in force over time [2]. In this method, the force-controlled perturbation is applied and velocity measured from the resulting length change (Fig. 1). In this method, neither force nor velocity reaches a steady-state, thus the F–V measurement is under more dynamic conditions and can be more sensitive to other experimental parameters (e.g. the rate of force change). A major difference between this method and other methods is that only one experimental trial is needed to record the F–V property for shortening (another trial would be needed for lengthening), instead of a series of experimental trials. This is advantageous because exposing muscle to a series of activations with shortening or lengthening could change the state of the muscle due to fatigue and/or structural damage and lead to inconsistencies in the data collection.

In summary, several methods can be employed to measure the F–V relationship in constantly activated skeletal muscle. However, none of the methods truly measure a steady-state property, and all methods have a certain degree of arbitrariness which influences the quantitative measurement of the F–V relationship.

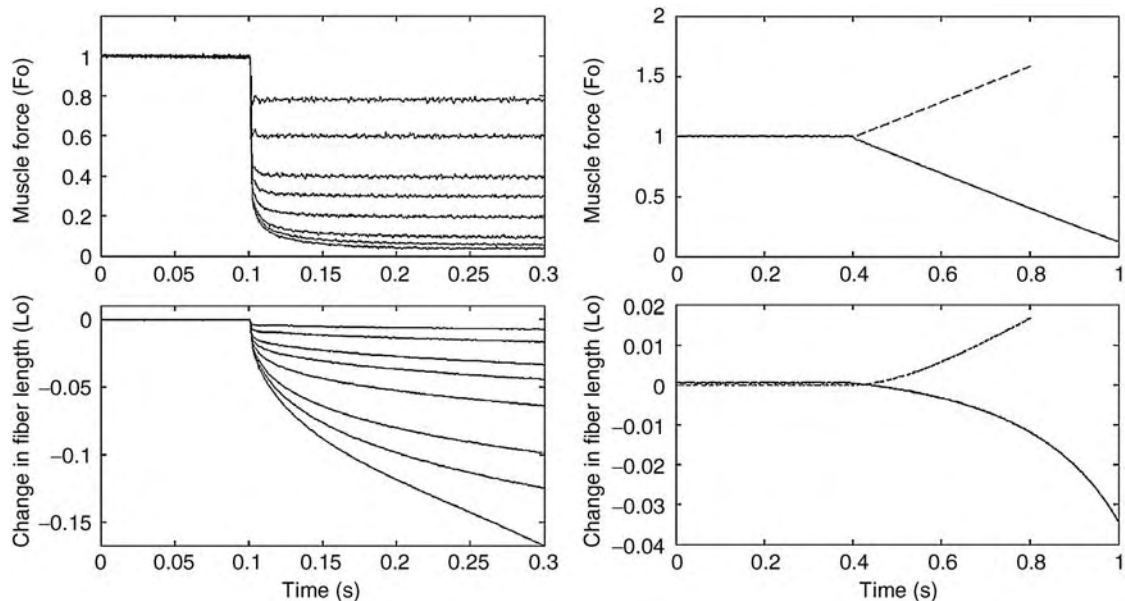

**Force–Velocity Relationship of Skeletal Muscle. Figure 1** Isotonic experimental trials (*right column*) for a chemically skinned rat *medial gastrocnemius* single fiber at 12°C are shown for eight different isotonic levels. Force ramp experimental trials (*left column*) for chemically skinned human *soleus* (type I) single fiber at 22°C are shown for shortening (*solid*) and lengthening (*dashed*) movements. Muscle force and length are normalized to their isometric values.

### Shortening F–V Relationship

The F–V relationship has been measured for shortening movements (i.e. force less than  $F_o$ ) in experimental preparations at all muscle structural levels (myofibril, single fiber, motor unit, and whole muscle) and in muscles from a broad spectrum of species. Most of the studies are performed with chemically skinned single fibers or whole muscles and in amphibian or mammalian muscle. Remarkably, plots of force versus velocity (or velocity versus force) for shortening movements obtained from almost all muscles by using any of the methods discussed previously have the same mathematical description, that of a hyperbolic equation [3]. The hyperbolic equation, often termed Hill's equation, is expressed as:

$$(F + a)(v + b) = (F_o + a)b \quad (1)$$

where  $F$  is the muscle force,  $v$  is the muscle velocity (shortening is defined as positive velocity), and  $a$  and  $b$  are parameters that vary from muscle to muscle (see Lower Level Components and Process Regulation). Examples of the shortening F–V relationship for slow and fast human muscle fibers are shown in Fig. 2.

One of the key values of the shortening F–V relationship is the velocity at zero force. From isotonic experiments, the values of  $a$  and  $b$  from Hill's equation are usually fitted to the data, and the velocity at zero force can be estimated from the equation (1). This estimate of velocity at zero force is called

“maximal shortening velocity” ( $V_{\max}$ ). Interestingly, measurements of  $V_{\max}$  and  $V_o$  are significantly different (10–20%) [4], although theoretically they should be similar. Moreover,  $V_{\max}$  estimates from the force ramp methods also show differences from isotonic measurements [2]. These discrepancies in the estimate of velocity at zero force also show that the quantitative measurement of the F–V relationship varies with the experimental method.

### Lengthening F–V Relationship

The F–V relationship in lengthening has not been recorded nearly as frequently as for shortening movements. A reason for this is that lengthening F–V data tend to be more variable than shortening data. This is partly due to the damage incurred during lengthening movements, which can result in structural irregularities, such as sarcomere non-uniformity [5]. In the few experimental studies, the F–V relationship has been characterized by a hyperbolic equation of the form:

$$(2F_o - F - a')v = (F_o - F)b' \quad (2)$$

where  $a'$  and  $b'$  are constants and  $v$  is negative to represent a lengthening velocity.

Due to the uncertainty and variability of the lengthening F–V data, other approximations have been used to characterize the F–V relationship. Namely, that as lengthening velocity increases, the force saturates between 1.4 and 1.8 times  $F_o$  with an exponential

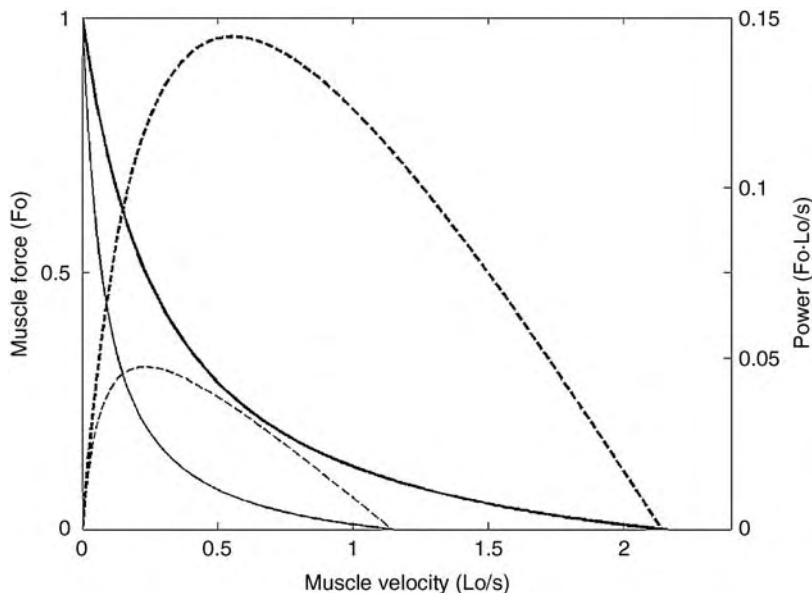

**Force–Velocity Relationship of Skeletal Muscle. Figure 2** The force–velocity (solid lines) and power–velocity (dashed lines) relationships for chemically skinned human single fibers at 20°C. Shown are the hyperbolic curves (equation (1) in text) based on data obtained in slow (type I) fibers (thin line) and fast (type IIa) fibers (thick line) by He et al. (2000 #305). Muscle force is normalized by isometric force ( $F_o$ ) and muscle length by optimal muscle length ( $L_o$ ).

type expression describing the relationship of velocity to force [6]. The ambiguity of how best to mathematically describe the lengthening F–V relationship reflects that lengthening movements are much more complex in nature than shortening movements.

### Factors that Influence the F–V Relationship

Generally, F–V data are normalized by  $F_o$  and the length of the muscle at which muscle generates the most isometric force (called “optimal muscle length,”  $L_o$ ), as shown in Fig. 2. However, there are several factors that can influence the shape of the F–V curve. First, the muscle length at which force and velocity are measured affects the F–V curve, especially in lengthening movements [6]. Second, the activation level affects the shape of the F–V both quantitatively and qualitatively. In shortening movements,  $V_{max}$  decreases as the activation level decreases [7]. In lengthening movements, force during lengthening velocities can be less than  $F_o$  for low levels of activation [8].

Besides these two external influences on the F–V relationship, there are important intrinsic factors. Portions of the myosin contractile protein (see Lower Level Components), namely the heavy chain and light chain portions of the myosin molecule, have different isoforms expressed, which can be grouped roughly into slow (type I) and fast (type II) isoforms. Due to differences in reaction rates between the myosin isoforms that bind with actin (see Lower Level Processes), the type of isoform is strongly correlated with the shape of F–V relationship. For instance,  $V_{max}$  of a single muscle fiber is almost wholly determined by the type of myosin heavy chain (MHC) and myosin light chain (MLC) found within a single fiber, and the difference in  $V_{max}$  between slow and fast fibers can be several fold (Fig. 2).

Moreover, certain factors, such as the pattern of neural activation and mechanical load, influence whether slow or fast isoforms are expressed. Thus, the F–V relationship is highly plastic to meet the needs of a motor function (see Process Regulation and Function).

### Lower Level Components

Several components within a muscle are responsible for force and movement generation. For a muscle with steady-state activation, implying that intracellular calcium level is constant, the main components responsible for the dynamic features of muscle contractions are the myosin and actin contractile proteins. The myosin molecule has two globular heads, each of which can be subdivided into two portions: the myosin heavy chain (MHC) portion is the top of the head and interacts with actin to form a ▶crossbridge (actomyosin); and a pair of myosin light chains (MLC), which are called the essential and regulatory light chains.

### Lower Level Processes

Muscle force and movement are generated by the cycle of ▶crossbridge attachment, myosin head rotation, and detachment via ATP hydrolysis. This cyclic process of ▶crossbridge attachment and detachment is responsible for the conversion of chemical energy (in ATP) to mechanical energy (work). An important aspect of the cycling behavior of ▶crossbridges is the rate of cycling: fast myosin isoforms cycle faster than slow isoforms. The faster cycling rate allows the muscle with fast isoforms to generate faster movements, which is reflected in the F–V relationship (e.g. a greater  $V_{max}$ ). In other words, the kinetics of the ▶crossbridge cycle, or the rate at which attachment and detachment of ▶crossbridges occurs, varies according to the contractile protein isoforms, especially those of the MHC and MLC.

### Process Regulation

One of the most important aspects of skeletal muscle is its ability to have widely divergent properties. Specifically, as discussed earlier, the F–V curves of different muscles can vary dramatically. This flexibility arises from the process of the contractile proteins constantly undergoing remodeling, and the expression of the isoform provides a direct link to meeting the functional demands placed on the muscle. A common example of this plasticity occurs in exercise. According to the mechanical demands of an exercise paradigm, such as endurance versus short-term high power training, the contractile protein isoforms expressed will be of a slow or fast type, and thus a muscle can switch from having predominately slow fibers to predominately fast fibers (or *vice versa*) [4]. Thus, the contractile process is regulated by the expression of contractile protein isoforms. By changing the percentage of slow and fast fibers within a muscle, the F–V curve can be adapted to meet the needed motor function (see Function).

### Function

The importance of the F–V relationship to motor function is that the F–V curve of a specific muscle is often “tuned” to match its predominant mechanical function. Roughly speaking, a muscle can serve two mechanical functions: maintaining posture, where the velocity of movements is relatively small; and generating movements, where the velocity of movements is relatively large. Power, which is the product of force multiplied by velocity, gives an indication of how much mechanical work can be produced in a given amount of time. Thus, for postural tasks, power output by the muscle should be optimized for slower velocities and for movements, power should be optimized for faster velocities.

The F–V curve can be easily transformed into the ▶power–velocity (P–V) curve by multiplying force



times velocity to yield **power** (Fig. 2). In shortening movements, the P–V curve has a velocity ( $V_{\text{opt}}$ ) where power output is at a maximum.  $V_{\text{opt}}$  is generally one-quarter to one-third of the value of  $V_{\text{max}}$ .  $V_{\text{opt}}$  for postural muscles is much smaller than that for muscles predominantly activated during fast movements. Muscles that serve both postural and fast movement functions tend to have intermediate values for  $V_{\text{opt}}$ . In terms of regulation of function, the plasticity of contractile protein isoforms, which in turn influences the F–V curve, gives a muscle the ability to adapt and match any changes in the mechanical demands of the muscle.

An excellent example of  $V_{\text{opt}}$  matching the mechanical demands of a specific muscle has been shown in frog muscles involved in jumping. Lutz and Rome [9] found that the primary muscle activated during the first 50 ms of the takeoff phase was the *semitendinosus* (a muscle between the hip and knee joints) and that it shortened at a nearly constant velocity of  $3.43 L_0/s$  ( $L_0$  is optimal fiber length). From the measured F–V curve,  $V_{\text{max}}$  of the frog *semitendinosus* was estimated to be  $10.35 L_0/s$  and  $V_{\text{opt}}$  to be  $3.44 L_0/s$ . Thus, the muscle shortened with a velocity equal to  $V_{\text{opt}}$  so as to optimize the **power** output to maximize the jump. Tuning  $V_{\text{opt}}$  is also of particular importance in cyclic movements, such as those which occur in locomotion. The main muscles used for sustained swimming in fish have been found to shorten at velocities near  $V_{\text{opt}}$  for those muscles [9].

## References

- Hill AV (1965) *Trails and trials in physiology*. Arnold, London
- Iwamoto H, Sugaya R, Sugi H (1990) Force–velocity relation of frog skeletal muscle fibres shortening under continuously changing load. *J Physiol (London)* 422:185–202
- Close RI (1972) Dynamic properties of mammalian skeletal muscles. *Physiol Rev* 52(1):129–197
- Fitts RH, Widrick JJ (1996) Muscle mechanics: adaptations with exercise-training. *Exerc Sport Sci Rev* 24:427–473
- Lin DC, Nichols TR (2003) Parameter estimation in a crossbridge muscle model. *ASME J Biomech Eng* 125 (1):132–140
- Brown IE, Scott SH, Loeb GE (1996) Mechanics of feline soleus: I. design and validation of a mathematical model. *J Muscle Res Cell Motil* 17(2):221–233
- Chow JW, Darling WG (1999) The maximum shortening velocity of muscle should be scaled with activation. *J Appl Physiol* 86(3):1025–1031
- Joyce GC, Rack PM, Westbury DR (1969) The mechanical properties of cat soleus muscle during controlled lengthening and shortening movements. *J Physiol (London)* 204 (2):461–474
- Rome LC (2002) The design of vertebrate muscular systems: comparative and integrative approaches. *Clin Orthop Relat Res* 403S:S59–S76

## Forced Desynchrony

### Definition

An experimental protocol designed to allow for the accurate assessment of human circadian rhythms. This protocol separates circadian (time dependent) and homeostatic (behavioral state dependent) contributions to sleep propensity and cognitive performance. Subjects are placed on a light-dark/rest-activity schedule that is much longer or shorter than 24 h, to which the endogenous circadian clock is unable to entrain, allowing it to free-run according to its own period. In this way, the effect of exogenous factors, such as sleep and activity, on variables of interest can be assessed at all circadian phases.

- ▶ Circadian Rhythm
- ▶ Internal Desynchrony

## Force-Length Relationship

### Definition

The force-length relationship describes the dependence of the steady-state isometric force of a muscle (or fiber, or sarcomere) as a function of muscle (fiber, sarcomere) length. It is characterized by a positive slope (i.e. force is getting greater as length increases) at short lengths (the so-called ascending limb of the force-length relationship), a zero slope (the so-called plateau region) at intermediate lengths, and a negative slope (i.e. force decreases with increasing lengths; descending limb of the force-length relationship) at long muscle lengths.

This property of muscle has been known since the mid nineteenth century, and has been described on the sarcomere level in a classic paper by A. Gordon, A. Huxley, and F. Julian in 1966. The force-length relationship is considered one of the basic properties of muscle.

- ▶ Force Depression/Enhancement in Skeletal Muscles
- ▶ Length-tension muscles

## Force-Sharing Problem

- ▶ Distribution Problem in Biomechanics

## Forebrain

### Definition

Rostral part of the brain composed by the telencephalon and the diencephalon. It lies rostral to the mesencephalon and contains the superior centers involved in the control of sensorimotor, autonomic and endocrine functions, in emotional behavior, as well as in cognitive functions such as learning and memory.

## Forensic Neuropsychiatry

JOACHIM WITZEL

Central State Forensic Psychiatric Hospital of Saxony-Anhalt, Schnöggersburger Weg 1, Uchtspringe, Stendal, Germany

### Synonyms

Neuropsychiatry; Neuroimaging; Biological psychiatry

### Definition

Neuroimaging in Forensic Psychiatry is concerned with the supply of additional information about the relationship between psychiatric abnormalities and legal violations and crimes. As we still face a considerable lack of available biological criteria, evaluation and therapy in forensic psychiatry are restricted to psychosocial and mental criteria of offenders' personalities. However, recent advances in neurosciences will allow a much closer approach to the neural correlates of personality, moral judgments, and decision-making. Thus, forensic neuropsychiatry increases our available techniques in judging mentally ill criminals by biopsychosocial and objective criteria. Determination of free and voluntary decision-making as well as brain-behavior relationships will be accomplished by neuroimaging techniques.

### Characteristics

#### History/Background

In the past years we have faced a tremendous development of neurobiological techniques in neuroimaging to assess neuronal correlates of psychological disorders which lead to dramatic changes in personality. These changes result in an altered attitude of probands towards their own way of living and to society in general as well. Now that we have just started to understand some aspects of these alterations of the brain and will be able to find out to some extent the reasons that contribute to

the development of psychopathologic symptoms, for example, sexually deviant behavior. While in the past this subject was approached merely by psychological means, investigations in the field of forensic neuropsychiatry now shed some light onto this important field of investigation.

In general forensic psychiatry is concerned with psychiatric abnormalities which result in legal violations and serious crimes. Due to the inavailability of specific biological criteria, evaluation and therapy in forensic psychiatry were so far limited to the psychosocial and mental criteria of offenders' personalities. However, the tremendous recent advances in neurosciences now allow a closer approach to the neural correlates of personality, moral judgments, and decision-making as well. It has therefore been proposed to discuss the introduction of biological criteria in the field of forensic psychiatry, and to establish rules to which extent such biological criteria will be a better and more reliable choice in judging mentally ill criminals, by also using available information based on specific biologically based assessment procedures which up until now could only be obtained by complicated technical means [1].

We are now entering a decade in which we will also use biopsychosocial and objective criteria, and we will finally be able to accomplish psychosocial and subjective criteria in forensic evaluation using neuroimaging techniques. Altogether these different methods might be helpful for each other to give a better result judging probands, when they are assessed and used correspondingly. The responsibility of having conducted a criminal act will no longer be defined by judging free and voluntary decision-making alone, but rather by brain-behavior relationships based on neuroimaging techniques.

Psychosocially-determined mental processes thus can be judged in a more appropriate way by estimating the degree of biopsychosocially-determined neural processes which had been involved in the complicated procedure which finally led to committing a serious crime. It might be concluded that the development of more detailed and differentiated biologically-based assessment methods in neuroimaging in the near future will contribute to a paradigm shift in forensic psychiatry, which will have profoundly essential implications for offenders, forensic psychologists and psychiatrists, the law and for society in general [1].

### Forensic Neuropsychiatry in Prisoners

According to biological investigations, we found a huge number of scientific articles dealing with the prevalence of mental illness to be found in prisoners. Indeed, these findings reported a considerably higher incidence of psychiatric illness in prisoners than was estimated in the past. The data indicated that it was increased tremendously compared to the findings

in the general population [2]. Our own results confirmed these findings: even in German prisons the prevalence of mental illness was obviously much higher than in the general population.

So we have to face the problem that there might be a relationship of delinquency on one hand and mental illness on the other. All prisoners who exhibited symptoms of serious mental illness at the time they committed crimes should have been psychiatrically investigated in the course of legal judgement.

Up until now we strongly referred to social aspects when judging probands who had committed a crime. In many cases they were sentenced to prison without a serious mental illness being documented at all. Of course, there is no doubt that suboptimal conditions in social life will contribute to the exhibition of a criminal way of living, but alas we are lacking the decisive link to find the reason for it. Investigations about e.g. the interference of social aspects in developing an antisocial career neglected to find out to what extent and in which way biological changes of the central nervous system might contribute to this development. So we will have to perform numerous investigations to understand better to what extent the behavior of probands could be influenced by neurobiological alterations.

### Neuroimaging in Forensic Psychiatry

Reflecting the highly complex structure of the human central nervous system, we should be aware that the finding to be expected will not be able to clarify all questions. In general, contradictory results will be found which have to be taken together like parts of a puzzle to give more detailed information about the impact of biological alterations of the brain in committing a crime. There will be no easy solution, and it will take hard work in the future to get more insight into this very important problem and to what extent mentally ill offenders should be exculpated due to the fact of biological changes.

Indeed, there are numerous scientists in the world who still deny a relationship between biological alterations of the brain and the changed behavior originating from this. They still propose that even striking psychical changes in a personality could be explained by neglecting biological aspects.

At present we are more and more able to give strong evidence that there is proof of a close relationship between biological changes and alteration of the personality itself. We faced during the past few years numerous investigations about differentiated psychiatric symptoms resulting in crimes and biological changes [3,4]. This may be judged as a first step towards a better understanding of highly complex aspects of delinquency and biological changes of the central nervous system. In accordance with the

development of very sensible techniques, we will be able to increase our knowledge in this field and to give answers which will be based more and more on scientific investigations – instead of proposals and opinions.

In the past years we have seen that sexual delinquency is able to cause considerable increased public concern as it is very often connected with sexual perversion. In general, the victims of such persons, mostly sexually perverted men, are children as well as women. In a modern world in which information is in easy reach of anybody now, we realize a considerably increased interest in the general population regarding sexual crimes, which is even bigger, when mentally ill probands are accused of having committed a serious crime. Alas, up until now it was not possible to find appropriate correlates for criminal behavior of such perpetrators. So we could not answer the question, why sexual deviances occur in a certain percentage of men and not in others and why treatment is so very difficult to perform successfully in some of them [3]. We just concluded, referring to specific environmental influences, that they might support conditions which made men act in a sexually deviant and criminal way.

Even lacking a sufficient number of investigations, we may dare to say, taking into account recent results in investigations on neuroscience, that there is a striking impact of neurobiological aspects on criminal behavior [1] – in contrast to the opinions we faced before without using the technical assistance of neuroimaging. For example, in a MRT-study on pedophilic men who had been sentenced to forensic psychiatry because of having committed serious paedophilic crimes, we got some more information about its biological sources. In detail it was shown that alterations which were described as a hypotrophy of the brain of the pedophilic perpetrators examined was significantly increased compared to a healthy control group. Namely the right amygdala and bilateral closely related structures were considerably affected [3].

It seems remarkable that these findings were paralleled by the results of a former investigation which demonstrated neurodevelopmental disturbances in a group of paedophilic perpetrators performed by Blanchard et al. in 2003. Obviously there are a lot of questions yet to be answered, but we have just started to learn that neuropsychiatric research will not only be helpful to explain biological changes of mentally altered probands. The recent findings documented by the help of modern neuroimaging are unavoidable as further investigations in this field will give additional answers which were not to be obtained up until now. So we found in paedophilic criminal probands that hypothesized regions relevant for the processing of erotic stimuli in healthy individuals showed reduced activation levels during visual erotic stimulation. These results are

now discussed to be the source of impaired recruitment of key structures that may contribute to an altered sexual interest of these patients towards adults [4].

In forensic psychiatry as well as in prisons we find numerous persons suffering from personal disorders or “psychopathy,” which was described by Hare in 1991. Those persons are not able to learn to deal with others in an empathic way, starting from a very young age [5]. They often exhibit very an extraordinarily aggressive behavior, which they use to achieve mostly illegal aims. They also usually react aggressively towards others, when they feel attacked.

These specific patterns of aggressive behavior are well known to be connected with structural changes of the central nervous system which have been detected in frontal and temporal areas of the brain. Obviously the brains of such persons are impaired to deal appropriately with emotional information as the function of frontal and temporal areas is decreased [5,6].

As we know that the risk of such persons to be involved in committing serious crimes is dramatically increased compared to the general population, the structural brain damages of persons diagnosed with “psychopathy” seem to be a very important source of such aberrant and illegal behavior. There can be no doubt that there is a close relationship between defects of the central nervous system and the increased ability to commit crimes in such probands [5,6].

Comparing probands sentenced to prison and those who were sent to forensic psychiatry we feel that there is obviously no striking difference between those groups regarding the mental illnesses found in them. With the help of technical methods of forensic neuropsychiatry which will allow us to delineate one group from another, we can conclude that in both groups there are similar structural changes to be seen. In fact, these results could be achieved under the presumption of installing subtle neuroimaging techniques which are well elaborated to give detailed information. Seemingly, there is a high percentage of structural brain alterations to be found in persons who committed serious crimes, as well in prisoners as in patients of forensic psychiatry. Further investigations on this most important subject are underway.

The more we will be able to increase the quality of information supplied by modern techniques of forensic neuropsychiatry, the more we will be able to detect biological alterations in mentally ill probands, no matter where they have been sentenced to, either prison or forensic psychiatry. So the widespread opinion about neuroimaging techniques applied and their inability to contribute to the assessment of mentally ill perpetrators cannot be agreed so far. In contrast, their impact on diagnostic and prognostic questions will increase, if modern and subtle techniques are used.

It is remarkable that in prisoners as well as in forensic psychiatric patients we find similar alterations of the central nervous system, although they had been judged in a different way at court regarding their responsibility in committing a crime. The detection and the assessment of the changes of brain, however, is a first step towards the support of the opinion that criminal conduct could be motivated in a very high percentage by neurobiological changes of the central nervous system. No matter where the treatment or detachment will take place later on, it will be necessary to be aware of the fact that e.g. a high percentage of sexually perverted persons having committed serious crimes, will be found to bear such biologically detectable alterations of the central nervous system [3,4]. It will be a question of time, when these finding will find a way into general assessment procedures as a golden standard which will be demanded by the courts prior to an accused person being sentenced to jail or a detention hospital [1].

As the way the legal systems deal with mentally ill criminals seems not to be closely related to recent neurobiological findings, we will face a paradigm shift in the treatment of a considerably large percentage of prisoners, which in many cases will not be delineated from forensic psychiatric probands anymore. This, however, will result in a dramatic change in the view of such probands. In the future, applying neuroimaging methods will make the process of being sentenced to a prison or detention hospital more understandable as it will refer to scientifically achieved standards of forensic neuropsychiatry.

So, we should take into consideration that neuropsychiatry will open a door to understanding the striking differences in probands referring e.g. to their ability and risk of criminal conduct.

In the past we were not able to explain these striking differences in an adequate way and even more, we were not able to treat such probands in an appropriate way. Now, at least, we can start to understand the mechanisms of altered behavior of mentally ill criminals. This will be the first step to developing cures for those who could not be healed by traditional methods in psychiatry up until now. In this way neuroimaging will broaden our knowledge about mental illness and the consequences arising from it. Accordingly, it represents the lacking link in psychiatry to make us understand why probands act in a way which is so very different compared to general standards of behavior. It will replace a merely moral judgement and will give us the tools to find explanations for it.

### **Ethical Issues in Forensic Neuropsychiatry**

Recent results in the neurosciences clearly point out that decision-making is not limited to a psychosocially-determined mental process; much more, it can be

referred to as a bio-psychosocially-determined neuro-psychological process. Thus, decision-making might not be as free and previously assumed voluntary as presupposed in forensic psychiatry at present. Numerous scientists have found decision-making not only to be modulated by cognitive functions, as emotional functions may not be neglected judging this complex process [7–10]. For example, the absence of emotions results in highly aberrant decision-making. This could be shown regarding cold-hearted murderers and extremely violent criminals.

At present, there is no doubt how important the crucial role of emotions in committing a serious crime is. Differential involvement of cognitive and emotional functions might imply different characterizations of decision-making. In this aspect cognitive functions like e.g. categorization, judgment, and distinction will allow the probands to make a choice and preferable alternatives. They will represent a subsequently free and voluntary selection of the most appropriate ones from which it is estimated by the individual that he will profit the best.

Another ethical problem concerns the informed consent. In general, informed consent is well known from psychiatric clinical investigation. However, in forensic psychiatry or any other detention hospital the situation is different for both the patients and the doctors. Even when the patients are prepared to take part in an investigation and give their informed consent, considerable doubt may remain whether this agreement is as voluntarily as it might seem. In fact, forensic patients in detention hospitals might assume that they will have to suffer from considerable disadvantages resulting e. g. in a much longer period of their stay in hospital or prison if they do not agree to participate and give informed consent. On the other hand, patients might expect their personal support of scientific investigations might have some positive impact upon their therapeutic evaluation and risk assessment. From this, their expectancy to be discharged sooner might arise.

So we will have to find ethical standards, which will allow us to perform neuroimaging studies in prisoners and patients of forensic psychiatry in an appropriate way as they are urgently needed to clarify the questions mentioned above. Whatever the decision of a prisoner or patient concerning the proposed investigations will be, it should never interfere with the therapy and the risk assessment of any proband. So prior to any scientific investigation in this field, we should pay attention to conditions and rules which will allow the protection of probands from any disadvantages.

These constraints can only be excluded, if we can assure an absolute separation between the staff performing investigations and those who will do daily forensic psychiatric treatment and risk assessment as

well. If not, the informed consent could be considered invalid.

This means that we face an urgent need to establish golden ethical standards in forensic neuropsychiatry in order to obtain valid informed consent in forensic patients and prisoners in performing neuroimaging investigations. Using them we will be assured that the voluntary and free decision of forensic patients as well as prisoners is really as free and voluntary as it should be to be the basis of scientific investigation in this very difficult field.

## References

1. Witzel J, Walter M, Bogerts B, Northoff G (2008) Neurophilosophical perspectives of Neuroimaging in Forensic Psychiatry – giving way to a paradigm shift? *Behav Sci Law*; 26:113–130
2. Fazel S, Danesh J (2002) Serious mental disorder in 23,000 prisoners: a systematic review of 62 surveys. *Lancet* 16:545–550
3. Schiltz K, Witzel JG, Northoff G, Zierhut K, Gubka U, Fellmann H, Kaufmann J, Tempelmann C, Wiebking C, Heinze H, Bogerts B (2007) Brain Pathology in Pedophilic Offenders: Evidence of Volume Reduction in the Right Amygdala and Related Diencephalic Structures. *Arch Gen Psychiatry* 64(6):737–746
4. Walter M, Witzel JG, Wiebking C, Gubka U, Rotte M, Schiltz K, BERPpohl F, Bogerts B, Heinze HJ, Northoff G (2007) Pedophilia is linked to reduced activation in hypothalamus and lateral prefrontal cortex during visual erotic stimulation. *Biol Psychiatry* 62(6):698–701
5. Blair RJ (2003) Neurobiological basis of psychopathy. *Br J Psychiatry* 182:5–7
6. Birbaumer N, Veit R, Lotze M, Erb M, Hermann C, Grodd W, Flor H (2005) Deficient fear conditioning in psychopathy: a functional magnetic resonance imaging study. *Arch Gen Psychiatry* 62(7):799–805
7. Bechara A (2004) The role of emotion in decision-making: evidence from neurological patients with orbitofrontal damage. *Brain Cogn* 55:30–40
8. Damasio A (2003) Mental self: the person within. *Nature* 423:227
9. Northoff G, Heinzel A, BERPpohl F, Niese R, Pfennig A, Pascual-Leone A, Schlaug G (2004) Reciprocal modulation and attenuation in the prefrontal cortex: an fMRI study on emotional-cognitive interaction. *Hum Brain Mapp* 21:202–212
10. Northoff G, BERPpohl F (2004) Cortical midline structures and the self. *Trends Cog Sci* 8:102–107

## Forensic Psychiatry

Psychiatric hospitals for the treatment of mentally ill criminals according to legal proceedings.

► Forensic Neuropsychiatry

## Form Perception

STEPHEN GROSSBERG

Department of Cognitive and Neural Systems, Center of Excellence for Learning in Education, Science and Technology, Boston University, Boston, MA, USA

### Synonyms

Object perception; Perceptual grouping; Surface perception; Figure-ground perception

### Definition

Form perception refers to our ability to visually perceive objects in the world in response to the patterns of light that they cast on our ►retinas.

### Characteristics

When an observer gazes steadily at a stationary object, form perception is facilitated by miniature ►eye movements, such as tremors, drifts, and microsaccades, that cause visually responsive cells to respond more vigorously to the object whenever the eyes move [1]. Motion of an observer relative to the object also refreshes cell responses. Even when cells respond vigorously, form perception represents a major challenge for the brain because our retinas have a large blind spot and retinal veins that impede light from reaching photodetectors (►Photoreceptors) (Fig. 1). How does the brain compensate for these holes in the visual world?

Boundary and surface processes facilitate this goal. Boundary processing includes ►perceptual grouping, ►boundary completion, and ►figure-ground separation. ►Surface processing includes compensation for variable illumination, also called “discounting the illuminant,” and surface filling-in (►Perceptual filling-in) using the surviving illuminant-discounted signals. These processes are carried out in different visual processing streams (►Visual processing streams in primates; ►Extrastriate visual cortex) within the visual cortex (Fig. 2). Both streams go through the ►Lateral Geniculate Nucleus (LGN), which transmits signals from the retina to the primary visual cortex (Brodmann’s area 17, striate cortex, area V1) (►Striate cortex functions). Two streams (in blue) compute boundaries and surfaces. The third stream is sensitive to visual motion. The boundary stream goes from retina through the LGN “parvo” stage (named for its “parvocellular” cell type; ►Geniculo-striate pathway) to the cortical stages V1 interblob, V2 interstripe, area V4, and on to inferotemporal cortex. The surface stream goes from retina through LGN parvo to V1 blob, V2 thin stripe, V4, and inferotemporal cortex (Striate cortex functions; Extrastriate visual cortex).

Why are there several cortical processing streams? Theoretical and experimental evidence suggests that they compute *complementary* properties [2], or properties akin to a lock fitting its key, or puzzle pieces fitting together. Each stream exhibits complementary strengths and weaknesses. Inter-stream interactions overcome these complementary deficiencies and generate percepts of conscious form.

What are these complementary interactions? Figures 3a and b illustrate three pairs of complementary properties using visual illusions (►Visual illusions). By viewing Fig. 3b, our brains complete a ►Kanizsa square boundary even though the image contains only four black pac-man figures on a white background. In this way, form boundaries are completed over the blind spot (Fig. 1). Thus many form percepts that appear to be “real” are “visual illusions.” What we call a visual illusion is often just an *unfamiliar* combination of boundaries and surfaces.

Visual boundaries and surfaces obey complementary computational rules in the following sense. In response to the images in Figs. 3a and b, boundaries form *inwardly* in an *oriented* manner between cooperating pairs of (almost) like-oriented and (almost) collinear inducers, such as the edges of the four pac man, or pie shaped, inducers.

### All Boundaries are Invisible

The square boundary in Fig. 3a can be recognized even though there is no visible brightness or color difference on either side of the boundary. It is perceptually invisible, or “amodal.” Figure 4a illustrates another invisible boundary that can be consciously recognized. FACADE theory [3] predicts that *all boundaries are invisible* within the interblob cortical stream (Fig. 2).

Why are all boundaries invisible? The vertical boundaries in Fig. 3a form between black and white inducers that possess opposite contrast polarity (black-to-gray or white-to-gray) with respect to the gray background. The same is true of the boundary around the gray square in Fig. 3c. To build a boundary around the entire square form, despite these contrast reversals, the boundary system pools, or adds, signals from pairs of ►simple cells that are sensitive to the same orientation and position, but to opposite contrast polarities. Pooling occurs at the ►complex cells in the V1 interblob area (►Visual subcortical and cortical receptive fields).

By pooling light/dark and dark/light contrasts at each position, boundaries become *insensitive* to contrast polarity, so that “all boundaries are invisible.” These pooled signals activate the *inward* and *oriented* boundary completion process that forms the illusory square in the V2 interstripe area [4]. Figure 3 summarizes these three properties of boundary completion.

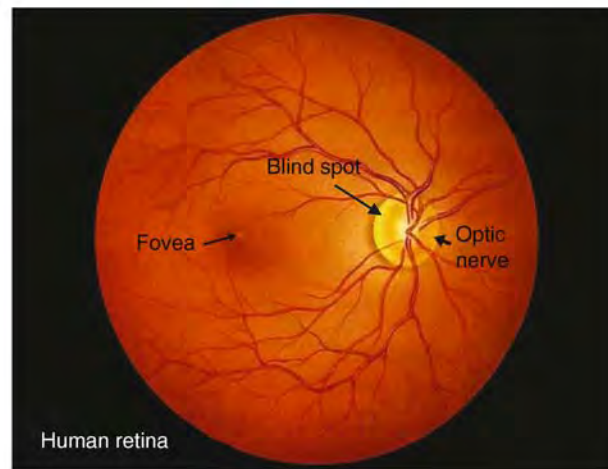
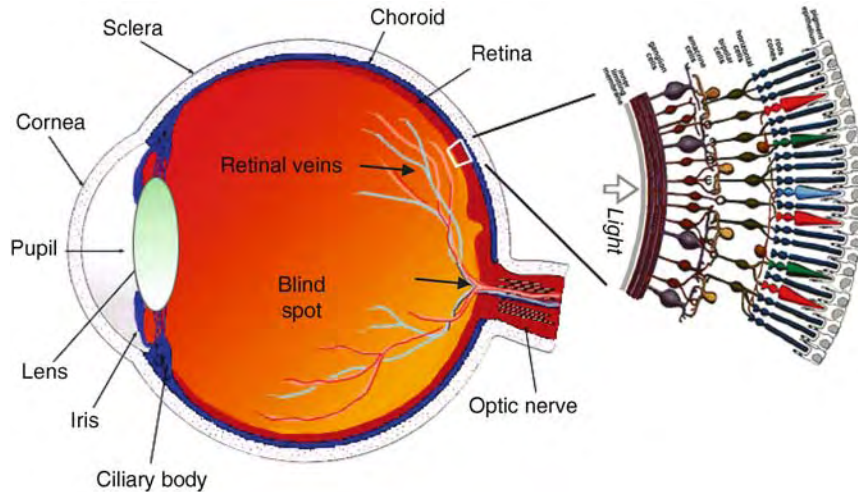

**Form Perception. Figure 1** A side view of an eye shows the blind spot and retinal veins. A top view of the photo-sensitive retina shows how big the blind spot and veins are relative to the fovea, which has the highest resolution for form vision.

Boundary completion helps to perceive continuous geometrical forms, discontinuous texture-defined forms, and to separate figures from their backgrounds (Fig. 5). Boundaries arise as coherent patterns of excitatory and inhibitory signals across cortical feedback circuits. Classical geometrical ideas such as points and lines are replaced by nonlinear neural networks that do on-line decision-making to select and complete the statistically most favored boundary groupings of a scene, while suppressing noise and incorrect groupings.

#### Only Some Surfaces Can Be Seen

If boundaries are invisible, then how do we see anything? An early stage of surface processing compensates for variable illumination, or *discounts*

*the illuminant*. Otherwise, illuminant variations could seriously distort all percepts. Discounting the illuminant attenuates color and brightness signals except near regions of sufficiently rapid surface change, such as edges or texture gradients. “Feature ▶*contours*” are selected at such positions and thus are relatively uncontaminated by illumination gradients.

Neural models have proposed how these feature contour signals trigger, at later processing stages, a filling-in process that completes surface representations [5]. Filling-in can allocate brightness and color to particular depths on a 3D surface via a process called *3D surface capture* (Fig. 6).

*Neon color spreading* [6] illustrates filling-in. In Fig. 3d, boundaries of the black circular segments cause small breaks, or *end gaps*, in the boundaries of the blue

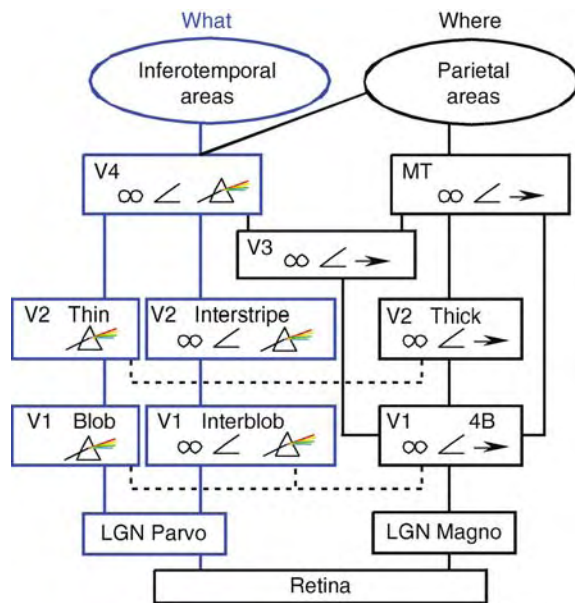

**Form Perception. Figure 2** Three processing streams in visual cortex. Boundaries are computed through the interblobs, and surfaces through the blobs, at multiple stages until area V4. Cortical cells have different selectivities to image properties. For example, rainbow = tuned and/or opponent wavelength selectivity (incidence at least 40%), angle symbol = orientation selectivity (incidence at least 20%), spectacles = binocular disparity selectivity and/or strong binocular interactions (area V2; incidence at least 20%), and right-pointing arrow = direction of motion selectivity (incidence at least 20%). (Adapted with permission from “Concurrent processing streams in monkey visual cortex,” by E.A. DeYoe and D.C. van Essen (1988) Trends Neurosci II:223. Copyright 1988 by Elsevier.)

circular segments. Blue color spreads through these gaps *outwardly* in an *unoriented* way until it hits a boundary or attenuates due to its spread. Filling-in can lead to visible percepts because it is *sensitive* to contrast polarity. These three properties of surface filling-in (outward, unoriented, sensitive to contrast polarity) are complementary to those of boundary completion (Fig. 3).

Another striking example of filling-in is the watercolor effect. In Fig. 7, the interior of the light blue regions is really white! Neon color spreading and the watercolor effect have both been explained using boundary completion and surface filling-in [7].

The mechanisms that fill in surface representations across the blind spot can also do so after discounting the illuminant. They also clarify how we see continuous blue surfaces, such as the sky, despite the fact that the spatial distribution of blue cones on the retina is very sparse [8].

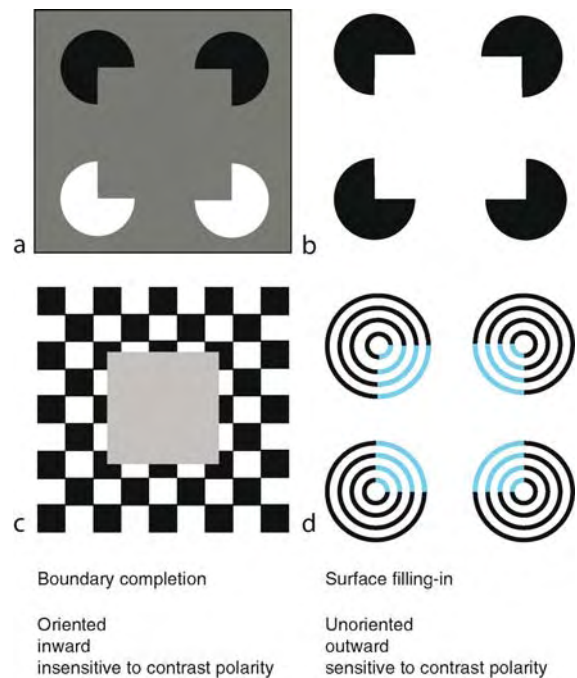

**Form Perception. Figure 3** (a) Opposite-contrast Kanizsa square shows that both opposite-contrast polarity and same-contrast polarity collinear edges can group together, and that both sorts of groupings are part of the same boundary completion process. Because two pac men are darker than the background gray, and the other two are lighter than the background gray, they induce lightening and darkening effects that cancel out within the Kanizsa square, thereby creating an invisible, or amodal, square percept that is recognized but not seen. (b) Same-contrast Kanizsa square is visible because all four black pac men induce brightness signals within the square that create a brighter square after surface filling-in. (c) Pooling of opposite contrast at every position along the square borders illustrates how the brain can build an object boundary around a textured background and thus why “all boundaries are invisible.” (d) Neon color spreading vividly illustrates the computationally complementary properties of boundary completion and surface filling-in that are summarized at the bottom of the figure.

### 3D Form Vision and Figure-Ground Separation

How do two eyes work together to generate percepts of 3D form, including percepts of occluding and occluded forms in depth (Fig. 5). Multiple problems need to be solved [3], including:

*3D Surface Capture and Filling-in.* How do multiple depth-selective boundary representations interact with multiple depth-selective surface filling-in domains to selectively *capture* brightness and color signals at prescribed depths (Fig. 6)?

*Binocular Fusion, Grouping, and daVinci Stereopsis.* How are the depth-selective boundaries formed that



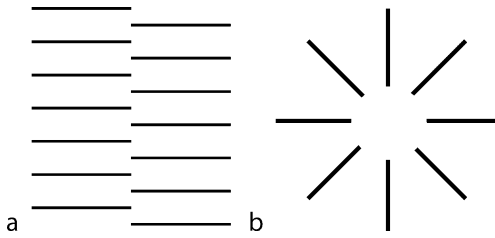

**Form Perception. Figure 4** (a) The vertical boundary that is induced by the offset horizontal grating is invisible, or amodal. It is an invisible percept, and thus cannot be seen, but nonetheless can be consciously recognized. (b) The circular disk in the ▶Ehrenstein illusion can be both seen and recognized because the circular boundary traps different levels of filled-in brightness inside and outside its contour.

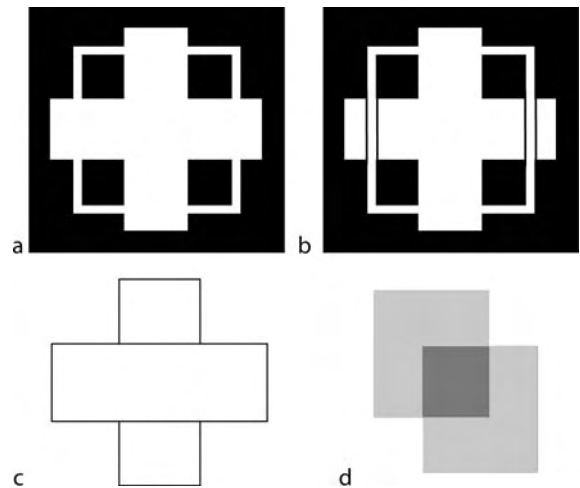

**Form Perception. Figure 6** (a) A Kanizsa stratification figure. The percept usually looks like a white cross in front of a partially occluded white square, but can switch to look like the square in front of a partially occluded cross. The white region that is shared by the square and the cross is “captured” by the surface form that appears to be in front. (b) Bayesian theorists claim that what we see is likelihood statistics. However, this figure causes the highly unlikely percept of a cross both in front of and behind the square. (c) This image of three abutting rectangles is perceived as a horizontal bar that partially occludes a vertical bar just behind it in depth. The occluded vertical surface is invisible [3]. (d) This juxtaposition of three figures generates a bistable percept of a transparent square in front of a background square. What determines when a surface appears opaque vs. transparent? Stable or bistable [3]?

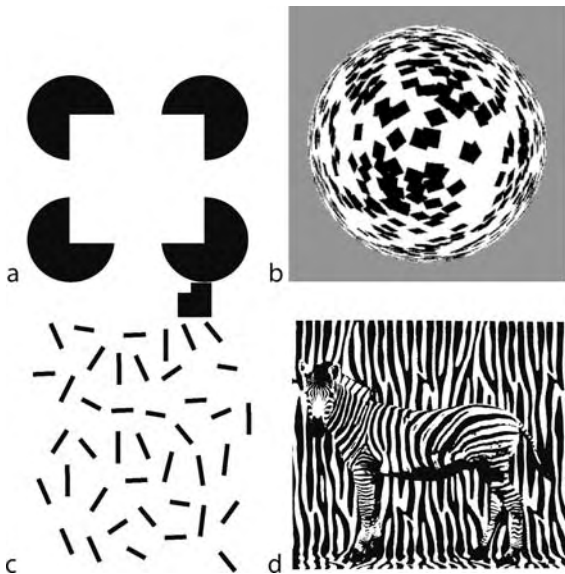

**Form Perception. Figure 5** Examples of perceptual grouping and boundary completion: (a) An illusory square emerges from the four pac men to be seen as the well-known Kanizsa square. (b) A discrete texture in a 2D picture can generate a percept of a continuous 3D surface by differentially activating a multiple-scale plexus of form-sensitive boundaries that is called a *boundary web*. (c) Collinear lines can pop-out from a field of randomly oriented lines by being linked by an emergent boundary. (d) An emergent boundary can separate the figure of the zebra from its background. T-junctions between the zebra and the background can help to push the background behind the zebra figure.

control surface capture? Our two eyes experience slightly different views of the world that lead to relative displacements, or disparities, on their retinas of observed scenes (Fig. 8; ▶Binocular vision). These

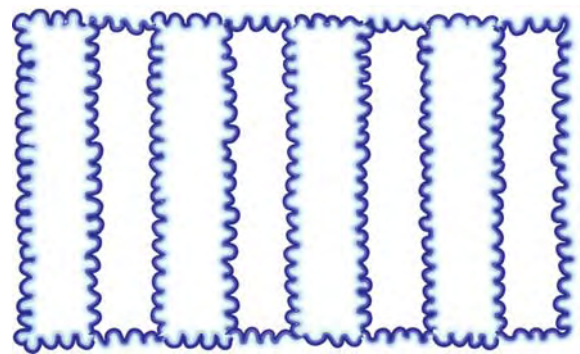

**Form Perception. Figure 7** An example of the watercolor illusion due to Baingio Pinna. The spatial juxtaposition of the more-contrastive thin blue curves abutting less-contrastive light blue curves enables the more contrastive boundaries to inhibit the less contrastive boundaries and thus release surface filling-in of the lighter blue color.

disparate retinal images are binocularly matched and fused at disparity-sensitive simple cells in area V1. Simple cell outputs combine at complex cells whose outputs to area V2 activate grouping cells that form depth-selective boundaries, which capture feature contour signals at the corresponding depth-selective surface filling-in domains (Fig. 9).

*Multiple Scales into Multiple Boundary Depths.* When a single eye views an object in depth, the same retinal image may be due to either a large object far away or to a small object nearby. How is this ambiguity overcome to activate the correct disparity-sensitive cells? The brain uses multiple receptive field sizes (Visual subcortical and cortical receptive fields), or

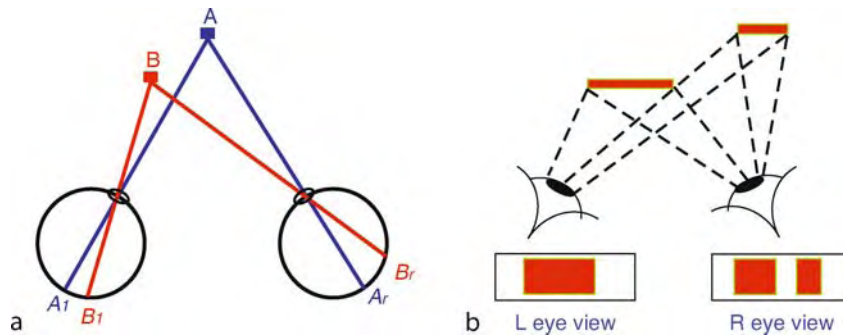

**Form Perception. Figure 8** (a) When the two eyes foveate an object such as A, an object such as B activates the two retinas at displaced positions  $B_l$  and  $B_r$ , leading to a binocular disparity that helps us see objects in depth. (b) Sometimes only one eye can see part of an object in depth when it is occluded by another object, thereby eliminating some disparity clues to depth. This sort of daVinci stereopsis is nonetheless solved by the brain [3].

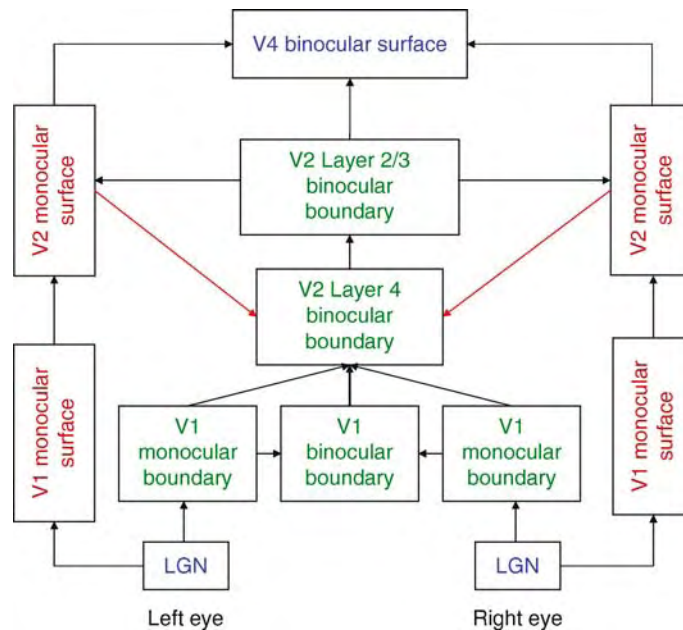

**Form Perception. Figure 9** Macro-circuit diagram of some processing stages whereby the boundary stream (green) and the surface stream (red) interact to form a visible percept of binocular form. Simple cells form the area V1 monocular boundaries. Both simple and complex cells form area V1 binocular boundaries. Area V2 layer 2/3 cells carry out long-range boundary completion, as in Fig. 5. Their signals contain filling-in within the area V2 monocular surfaces. The area V2 monocular surfaces combine to form area V4 binocular surfaces, constrained by boundary signals from area V2 layer 2/3. These binocular surfaces are predicted to give rise to visible percepts of surface form. see [3].

scales, that compute a “size-disparity correlation” between retinal size and binocular disparity (Binocular vision). Each scale can fuse multiple disparities, although larger scales can fuse a wider range of disparities [9]. Multiple boundary scales react differently to different regions of texture or shading, leading to a multiple-depth form-sensitive “boundary web” of small boundary compartments. Each depth’s boundary web captures different feature contours, whose filling-in can lead to a curved surface percept (Fig. 5b).

*Recognizing Objects vs. Seeing Their Unoccluded Parts.* In most scenes, some objects partially occlude others. How do we know which features belong to which objects? Figure 10 clarifies some issues [10]. In the lower left, gray B shapes can be recognized despite partial occlusion by the black snakelike occluder. This happens because the boundaries that are shared by the occluder and the gray shapes are assigned by the brain to the black occluder by a process of “▶border ownership,” leading to seeing the black occluder as closer. With the shared boundaries removed from the gray shapes, the B boundaries can be completed behind the positions of the black occluder, just like boundaries complete in response to Figs. 3 and 6. In the lower right, the occluder is removed and the B shapes are harder to recognize.

*From Boundary-Surface Complementarity to Consistency.* Given that boundary and surface computations are complementary, how do we see a single percept? How does *complementarity* become *consistency*? Consistency can be realized by feedback that occurs between the boundary and surface streams (Fig. 9).

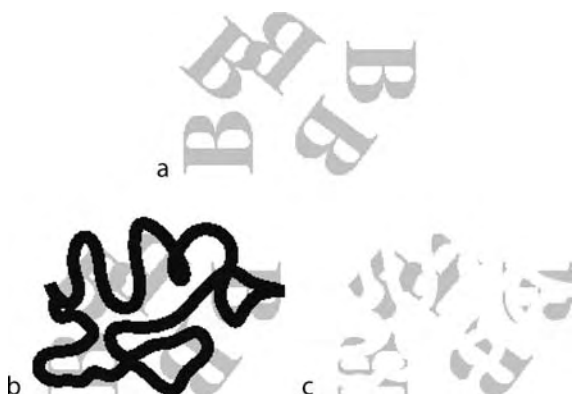

**Form Perception.** Figure 10 Both Albert Bregman and Gaetano Kanizsa discussed how an occluding form can “own” a shared boundary with an occluded form. Such border ownership influences how the occluded form may be recognized. The black occluder facilitates recognition of the partially occluded B shapes by owning the shared boundaries. This allows the remaining B boundaries to be completed at a farther depth, thereby facilitating their recognition there.

Remarkably, this feedback seems also to initiate the process of separating forms from each other during ▶figure-ground perception [3].

## References

1. Martinez-Conde S, Macknik SL, Hubel DH (2004) The role of fixational eye movements in visual perception. *Nat Rev Neurosci* 5:229–240
2. Grossberg S (2000) The complementary brain: unifying brain dynamics and modularity. *Trends Cognitive Sci* 4:233–246
3. Grossberg S (1994) 3D vision and figure-ground perception by visual cortex. *PerceptPsychophys* 55:48–120
4. von der Heydt R, Peterhans E, Baumgartner G (1984) Illusory contours and cortical neuron responses. *Science* 224:1260–1262
5. Pessoa L, De Weerd P (eds) *Filling-in: from perceptual completion to cortical reorganization*. New York: Oxford University Press
6. Redies C, Spillmann L (1981) The neon color effect in the Ehrenstein illusion. *Perception* 10:667–681
7. Pinna B, Grossberg S (2005) The watercolor illusion and neon color spreading: a unified analysis of new cases and neural mechanisms. *J Opt Soc Am A* 22:2207–2221
8. Boynton RM, Eskew RT Jr, Olson CX (1985) Blue cones contribute to border distinctness. *Vision Res* 25:1349–1352
9. Julesz B, Schumer RA (1981) Early visual perception. *Annu Rev Psychol* 32:1013–1022
10. Nakayama K, Shimojo S, Silverman GH (1989) Stereoscopic depth: its relation to image segmentation, grouping, and the recognition of occluded objects. *Perception* 18:55–68

## Formants

### Definition

Resonances of the vocal tract. Formants are specified by their center frequency. Denoted by integers that increase with relative frequency.

▶Speech Perception

## Formatio Reticularis

▶Reticular Formation

---

## Fornix

### Definition

Fiber bundles connecting the hippocampus with the hypothalamus and other regions. The hippocampal efferents form the alveus and then unite to form the crus of fornix. Some fibers cross via the commissure of the fornix to the contralateral side, but the majority form bundles with the fibers on the contralateral side, in turn forming the body of fornix, running beneath the corpus callosum, dividing frontally in the columns of fornix and passing to the hypothalamus.

► Diencephalon

---

## Forward Model

### Definition

A module which imitates the plant dynamics by mapping the effector activations into the plant outcomes.

► Neural Networks for Control

---

## Forward-propagation Learning

### Definition

Reinforcement-learning-based algorithm for training multilayer neural networks. Broadcasted reinforcement signals are sequentially applied from the input layer to the final layer.

► Neural Networks

---

## Fossa Sylvii

### Definition

The fossa (Latin for trench or ditch) Sylvii is (Sylvius was a seventeenth century French anatomist) a very

old term referring to the Sylvian fissure, now called the lateral fissure. It separates the temporal and frontal lobes.

---

## Fourier Transform

### Definition

The mathematical transformation of a time-domain waveform into a frequency-domain representation or vice versa. Any time-domain waveform can be Fourier transformed into a sum (integral) of sinusoidal time domain components, with each component defined by a magnitude, a frequency, and a starting phase term.

► Signals and Systems

---

## Fourth Ventricle

### Synonyms

► Ventriculus quartus

### Definition

It lies in the center of the rhombencephalon and stretches caudally into the central canal of the spinal cord. Via the apertures of the fourth ventricle, it releases CSF into the subarachnoid system. The latter is formed by the subarachnoid space and is subdivided into various cisterns. The CSF is reabsorbed by venous blood at the arachnoid granulations of the cranium and at the spinal roots.

► Meninges & Cisterns

---

## Fovea (Fovea Centralis)

### Definition

Region of  $\sim 1$  mm diameter in the temporal retina of haplorhine primates, located in the centre of the area centralis. Anatomically, the fovea is an indentation of the retina, where all cell layers, except the photoreceptor layer, are shifted aside to give light unscattered

access to the photoreceptors. The foveal pit (= foveola;  $\sim 300 \mu\text{m}$  diameter) contains only cones, no rods. The foveal cones are connected to the central-most bipolar and ganglion cells, positioned at the foveal rim. In primates, the fovea provides highest acuity and is used for the fixation of objects. Nonprimate mammals have no fovea, whereas a number of non-mammalian vertebrates (e.g. some fish, reptiles and birds) have foveae.

- ▶ Inherited Retinal Degenerations
- ▶ Photoreceptors
- ▶ Retinal Bipolar Cells
- ▶ Retinal Ganglion Cells
- ▶ Vision

## Foveal Magnification

### Definition

The primate retina shows variable resolution (unlike digital cameras) with the highest acuity at the center of the fovea and a continuous falloff of approximately 30-fold to the far periphery of the retina. The enhanced vision closer to the fovea is reflected in higher density of near-foveal neurons in retina and throughout the visual system.

- ▶ Fovea (Fovea Centralis)
- ▶ Visual Acuity, Hyperacuity

## Foveation

### Definition

The retina of primates is highly anisotropic, and the highest density of visual photoreceptors is found in a small, central area (fovea) which provides the best resolution and chromatic visual analysis in the central  $2^\circ$ – $3^\circ$  of the visual field. Thus foveation, which is the centering of the retinal image of an object of interest onto fovea, yields an updated visual analysis and localization of the newly-fixated point of interest.

Foveation is achieved by different types of eye (or gaze) movements to realign or maintain the point of interest onto the visual axes of the two eyes (saccadic, vergence and pursuit eye movements).

- ▶ Eye-Head Coordination
- ▶ Eye Movements Field

## Foveation Hypothesis

ADONIS MOSCHOVAKIS

Institute of Applied and Computational Mathematics, FO.R.T.H., and Department of Basic Sciences, Faculty of Medicine, University of Crete, Heraklion, Crete, Greece

### Definition

An early attempt [1] to explain how information flow through the superior colliculus (SC) leads to the generation of accurate (foveating) saccades towards visual targets.

### Description of the Theory

The “foveation hypothesis” (schematically illustrated in Fig. 1), takes advantage of the fact that the input to the SC is a retinal error signal (Re; the vector in red) represented in the superficial layers of the SC not in terms of firing rate, but in terms of the location of active cells (V) along the topographic representation of visual space in the SC (▶ SC – sensory maps). Due to the spatial distribution of their projections to the deeper tectal layers (▶ SC – interlayer neurons), the discharge of these superficial SC neurons in turn activates presaccadic neurons (M) that are located underneath the visual cells. As the motor map of the deeper SC is in register with the visual map of the superficial layers (▶ SC – tectal long lead burst neurons), the M cells engaged have movement fields such that the eyes are displaced by the vector in blue. As the latter is equal to the retinal error vector (in red), the eyes move accurately to the target which ends up being projected onto the fovea.

Acceptance of the “foveation hypothesis” in part depended on the existence of anatomical projections of the superficial to the deeper tectal layers. By the time supporting evidence had been documented (with the demonstration of the axonal trajectory and projections of L neurons considered in the entry devoted to SC – interlayer neurons), in particular in a higher mammal such as the monkey, a considerable number of psychophysical, and neurophysiological objections to the “foveation hypothesis” had been amassed [2]. An example of a relevant argument is illustrated in Fig. 2. While the subject fixates point O, targets A and B appear and their retinal error vectors (Fig. 2a) are represented in the superficial SC. Then the first saccade, to A, is executed as soon as both targets disappear (Fig. 2b). If the second saccade corresponded to vector OB (from the retinal error vector of target B initially represented in the SC), the eyes would end up in the wrong place (Fig. 2c). Instead, the eyes execute the

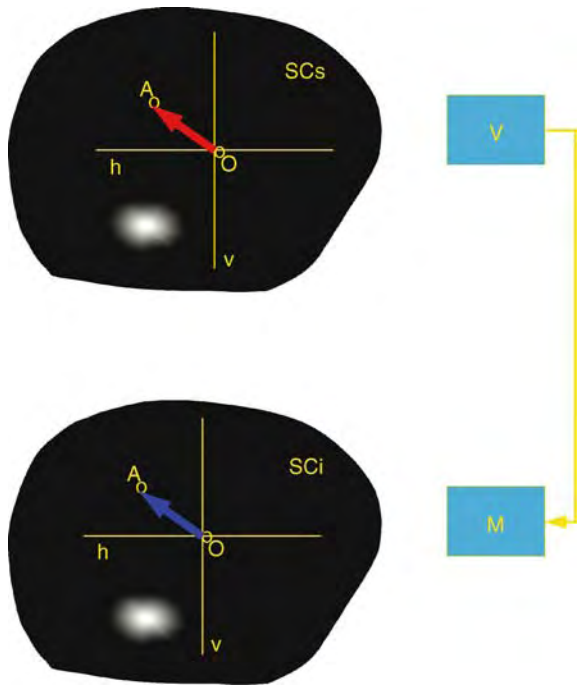

**Foveation Hypothesis. Figure 1** Information flow from the superficial (SCs) to the intermediate (SCi) SC layers according to the foveation hypothesis. Regions in black and gray demarcate the borders of the nucleus and of the activated areas as seen from above. Abbreviations: *h*, horizontal saccade size; *v*, vertical saccade size; *M*, movement cells (of the SCi); *V*, visual cells (of the SCs).

correct saccade (to B) thus falsifying the “foveation hypothesis.” Several experiments following this line of reasoning were described in the last quarter of the previous century (collectively called ▶double-step stimulation experiments). Probably the most dramatic of these was the demonstration that subjects are able to saccade to a target briefly flashed during the execution of a previous saccade [3]. As the target in this experiment was sometimes flashed onto the fovea, retinal error (Re) must equal zero and, therefore, the metrics of the foveating saccades cannot be computed from Re alone. Similarly, the foveation hypothesis cannot account for the ability of monkeys to compensate for the perturbations of orbital position that result from the electrical stimulation of the SC (this is equivalent to the presentation of target B only, in Fig. 2a, followed by an electrically evoked saccade OA), by executing target saccades to the approximate location of a visual target extinguished before the electrical stimulation [4].

To explain the performance of monkeys and humans in double-step stimulation experiments, one might think that the saccadic system is built in such a way that it represents targets (e.g. point B) as movement

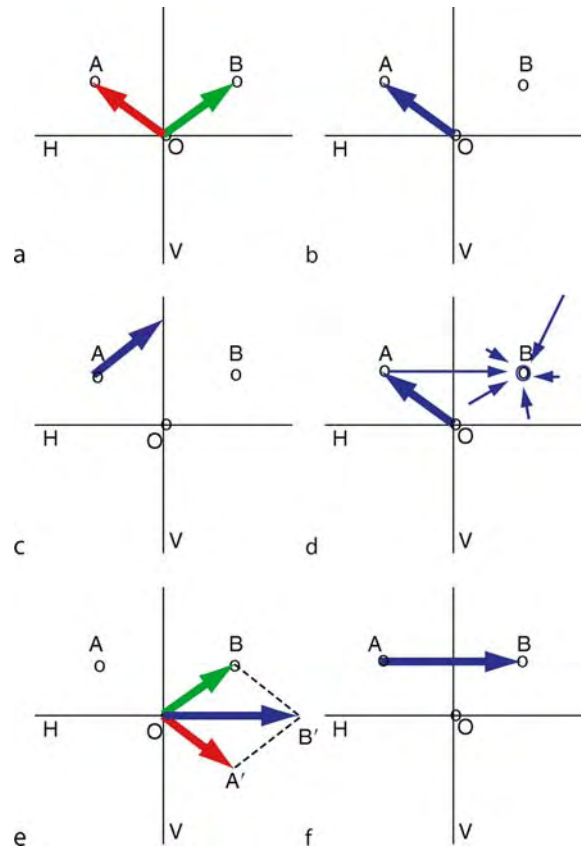

**Foveation Hypothesis. Figure 2** Sequence of saccades executed in response to two targets which appear simultaneously at the points A and B, and are extinguished before the first saccade. (a) Retinal error vectors immediately after target presentation. (b) Vector of eye displacement due to the first saccade executed. (c) Prediction of the “foveation” hypothesis regarding the eye displacement due to the second saccade executed (from point A). (d) Prediction of the “spatial” hypothesis regarding the eye displacement due to the second saccade executed (from any point, including A). (e) The vector of eye displacement due to the first saccade is subtracted (equivalent to adding its opposite, in stippled red) from the Re vector of target B (green) to obtain the vector of desired eye displacement for the second saccade to be executed from point A. (f) Prediction of the “vector subtraction” hypothesis regarding the eye displacement due to the second saccade executed (from point A).

goals (Fig. 2d), obliging the eyes to move to them from any initial position (including point A). An assumption of this form is implied in certain models that rely on non-retinotopic encoding of a target location, such as the “spatial hypothesis” illustrated in Fig. 3a. To see how it works, consider that a target (with a retinal error Re) is presented when the eyes are at position E<sub>1</sub>. The location of the target is first computed in head centered

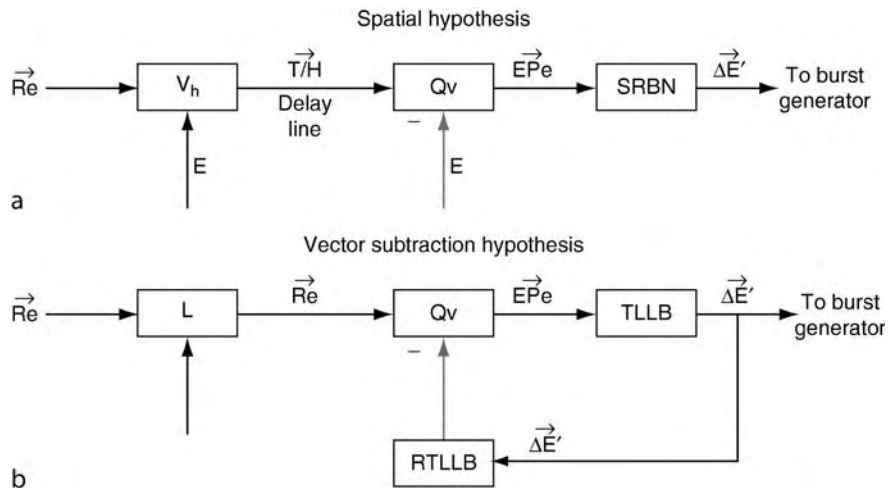

**Foveation Hypothesis. Figure 3** (a) “Spatial” hypothesis (adapted from ref. [5]). (b) “Vector subtraction” hypothesis (adapted from ref. [6]). Vector notation indicates place coding of relevant signals. Arrows indicate excitatory (solid) and inhibitory (stippled) connections. Abbreviations:  $\Delta E'$ , desired eye displacement;  $E$ , eye position;  $E P_e$ , eye position error;  $L$ , interlayer neuron of the SC;  $Q_v$ , quasivisual neuron;  $R_e$ , retinal error;  $R T L L B$ , reticulotectal long lead burst neuron;  $S R B N$ , saccade related burst neuron;  $T/H$ , target location with respect to the head;  $T L L B$ , tectal long lead burst neuron;  $T/R$ , target location with respect to the retina,  $V_h$ , visual cell encoding target location in head centered coordinates.

coordinates ( $T/H = R_e + E_1$ ). After a certain delay (i.e. just before saccade launching, indicated by the DELAY LINE), and while the eyes may have been deviated (naturally or electrically) to a new position ( $E_2$ ), the new eye position signal  $E_2$  is subtracted from  $T/H$ . The result of this subtraction (eye position error,  $E P_e = R_e + E_1 - E_2$ ) is carried by a particular class of tectal cells, the quasivisual neurons ( $Q_v$ ; see SC – quasivisual neurons), in such a way that different amounts of  $E P_e$  are coded by different populations of  $Q_v$  cells, arranged over the mediolateral and anteroposterior extent of the SC in an organized fashion. This signal is then relayed to presaccadic SC cells which generate the desired eye displacement command that leaves the SC [5]. This will produce an accurate saccade from point A to point B, because  $E P_e$  is equal to the sum of  $R_e$  and  $E_1 - E_2$  (in other words, equal to  $R_e$  corrected by the amount of eye displacement due to the first saccade,  $E_1 - E_2$ ).

It is possible to account for the whole evidential basis of the “spatial hypothesis” without adding and then subtracting the same signal (eye-position) to calculate target coordinates in a spatial and then again in an oculocentric frame of reference. Such a scheme is illustrated in Fig. 3b. As in the “foveation hypothesis,” the input to its SC units is  $R_e$ . As with the “spatial” hypothesis, instead of using this signal directly, its presaccadic SC units use the  $E P_e$  vector to compute the vector of desired eye displacement ( $\Delta E'$ ). However, in contrast to the “spatial” hypothesis, a neural replica of

$\Delta E'$  is fed back to the SC where it is vectorially subtracted (equivalent to adding its opposite; Fig. 2e, red) from the  $R_e$  signal (Fig. 2e, green) to obtain the  $E P_e$  signal (Fig. 2e, blue). When executed from point A, the saccade that corresponds to this  $E P_e$  vector sends the eyes correctly to point B (Fig. 2f). As it assumes the implementation of vector subtraction to compute the requisite eye displacement commands, this scheme is known as the “vector subtraction hypothesis” [6]. With straightforward extensions to take into account intervening joint angles, the same model can explain the accuracy of saccades to targets of other modalities such as auditory or somatosensory. For example, the location of auditory stimuli is coded in a head centered ( $T/H$ ) frame of reference (e.g. by inferior colliculus neurons [7]). Subtraction of a signal proportional to eye position from the signal specifying the location of the auditory target with respect to the head suffices to extract the  $E P_e$  of auditory targets (equivalent to remapping auditory fields in retinotopic coordinates). A neural network that could implement this process in the SC has been formulated [8], and there is experimental evidence consistent with eye position dependent shifts of the auditory receptive fields of SC neurons [7]. The same is true of the somatosensory receptive fields of SC neurons ([9]). After its extraction, the  $E P_e$  signal to auditory targets is handled in the “vector subtraction hypothesis” just like the  $E P_e$  signal to visual targets.

Since both the “spatial” and the “vector subtraction” hypotheses are consistent with it, psychophysical

evidence cannot be used to test their verisimilitude. Instead, to understand which of the two, if any, is implemented in the brain one should rely on neurophysiology. In principle, this should not be too difficult because the “vector subtraction” and the “spatial” hypotheses differ considerably in terms of the signals they manipulate. For example, a signal proportional to target location in head centered coordinates is important for the “spatial” but not for the “vector subtraction” hypothesis, which instead relies on an efference copy of intended saccadic eye displacement. Which of the two hypotheses is more consistent with known neuroanatomy and neurophysiology? Neurons encoding target location in head centered coordinates have been found in some cortical areas, but it is not known if their output is sent to the SC as required by the spatial hypothesis. In contrast, if a vector subtraction scheme is implemented in the brain, it should be possible to demonstrate the existence of neurons that carry a signal proportional to eye displacement, and (i) are located in a region of the brain where axons of tectal long lead burst neurons terminate, while (ii) their axonal terminations include the SC. The existence of such neurons has indeed been demonstrated (described in the entry [▶Reticulotectal long lead burst neurons – RTLLBs](#)). It is possible to connect the RTLLBs with the collicular machinery such that the resulting distributed network implements the “vector subtraction hypothesis,” as shown by Bozsis and Moschovakis [10] who presented a model of the SC consistent with known anatomy and physiology.

The advantages of the “vector subtraction” over the “foveation” hypothesis are evident only if the eyes move in the interval that elapses between target presentation and acquisition. It is unlikely that a neural system would have developed if its only function were to generate saccades in such artificial circumstances. Instead, it may have developed under the evolutionary pressure for a system that programs complicated sequences of saccades. Thus, the line of sight can serially visit important features of a complicated image without the need to reprocess visual information after each saccade. To see how implementations of the “vector subtraction” hypothesis would work in circumstances such as this, consider that several targets appear simultaneously, each of them represented by a mound of excitation in the SC. The model predicts that each time the eyes make a saccade to a target the mound that corresponds to it is destroyed, while those that correspond to all other targets are moved inside the SC, to new positions defining a new EPe signal. Saccades corresponding to these EPe signals are serially executed one after another (while the mounds of excitation that correspond to the remaining targets are appropriately re-positioned in the SC) until all targets are visited by the eyes.

## References

1. Schiller PH, Koerner F (1971) Discharge characteristics of single units in the superior colliculus of the alert rhesus monkey. *J Neurophysiol* 34:920
2. Sparks DL (1986) Translation of sensory signals into commands for control of saccadic eye movements: role of primate superior colliculus. *Physiol Rev* 66:118
3. Hallett PE, Lightstone AD (1976) Saccadic eye movements to flashed targets. *Vision Res* 16:107
4. Sparks DL, Mays LE (1983) Spatial localization of saccade targets. I. Compensation for stimulation-induced perturbations in eye position. *J Neurophysiol* 49:45
5. Sparks DL, Mays LE (1982) Role of the monkey superior colliculus in the spatial localization of saccade targets. In: Hein A, Jeannerod M (eds) *Spatially oriented behavior*, C.C. Springer, New York, pp 63
6. Moschovakis AK, Karabelas AB, Highstein SM (1988) Structure-function relationships in the primate superior colliculus. II. Morphological identity of presaccadic neurons. *J Neurophysiol* 60:263
7. Jay MF, Sparks DL (1987) Sensorimotor integration in the primate superior colliculus. II. Coordinates of auditory signals. *J Neurophysiol* 57:35
8. Groh JM, Sparks DL (1992) Two models for transforming auditory signals from head-centered to eye-centered coordinates. *Biol Cybern* 67:291
9. Groh JM, Sparks DL (1996) Saccades to somatosensory targets. III. Eye position dependent somatosensory activity in primate superior colliculus. *J Neurophysiol* 75:439
10. Bozsis A, Moschovakis AK (1998) Neural network simulations of the primate oculomotor system. III. A one-dimensional one-directional model of the superior colliculus. *Biol Cybern* 79:215

---

## Fractal

### Definition

Technically, a fragmented geometric shape that can be subdivided into parts, each of which is a reduced-size copy of the whole, a property called self-similarity.

▶ [Evolution and Brain-Body Allometry](#)

---

## Fractal Dimension

### Definition

A statistical quantity that gives an indication of how completely a fractal appears to fill space, as one zooms down to finer and finer scales.

▶ [Evolution and Brain-Body Allometry](#)



## Fractal Process

### Definition

The term “fractal process” denotes statistical self-similarity of a process in time (e.g. a neuronal spike train) leading to time-scale invariant, long-range correlations among events. In contrast to a random series of events, a fractal time series is characterized by long-term memory resulting from nonlinear interactions of processes occurring on different time scales; the product of a complex, deterministic system.

## Fractured Somatotopy

### Definition

Non-adjacent representation of adjacent parts of the body, as if an orderly somatotopic map had been fractured into many pieces and then reassembled in a new arrangement, for example with the index finger represented between the middle and ring fingers.

► [Motor Cortex – Hand Movements and Plasticity](#)

## Fragile X Syndrome

### Definition

A syndrome of X-linked mental retardation.

## Frames of Reference (FRs)

### Definition

Systems of coordinates in which muscles and neurons, including motoneurons, function or, at the level of the organism or its subsystems, action and perception are accomplished; FR parameters (origins, metrics, geometry, and the orientation of one FR in another FR) are defined by control variables, changes in which influence perception and action; are called actionproducing or physical in the  $\lambda$  model in order to distinguish

them from formal, mathematical FRs for which changing parameters modifies the description of the system’s behavior but not the behavior itself.

► [Equilibrium Point Control](#)

## Free Energy (of Helmholtz)

### Definition

The free energy density is defined as the internal energy density minus the product of the absolute temperature times the entropy density.

► [Mechanics](#)

## Free Nerve Endings

### Definition

Neural receptor elements without end-organ structures, located ubiquitously within and in the cutaneous covering of the body.

## Freedom of Will

ALFRED R. MELE

Department of Philosophy, Florida State University,  
Tallahassee, FL, USA

### Definitions

Freedom of will may be defined as the power to act freely. But what is it to act freely? Standard answers fall into two groups: compatibilist and incompatibilist. ► [Compatibilism](#) and ► [incompatibilism](#) are positions on the relationship between free action and ► [determinism](#). Determinism is the thesis that a complete statement of the laws of nature together with a complete description of the condition of the entire universe at any point in time logically entails a complete description of the condition of the entire universe at any other point in time. Compatibilism is the thesis that acting freely is

compatible with the truth of determinism. Paying due heed to what contemporary physics tells us, the overwhelming majority of compatibilists do not believe that determinism is true, but they do believe that even if it were true, we would be able to act freely. Their identifying themselves as compatibilists is explained by a lengthy tradition of framing the issue in these terms. (Incidentally, because very few contemporary philosophers believe that determinism is true, one rarely sees the once familiar expressions ►[soft determinism](#) and ►[hard determinism](#) in recent work on freedom of will. Soft determinism is the thesis that determinism is true and is compatible with free action. Hard determinism is the thesis that determinism is true and is incompatible with free action.) Incompatibilism is the thesis that acting freely is incompatible with the truth of determinism. In the incompatibilist group, most answers to the question what it is to act freely come from libertarians. ►[Libertarianism](#) is the conjunction of incompatibilism and the thesis that some people act freely. Some incompatibilists argue that no one acts freely [1]. They argue that even the falsity of determinism creates no place for free action.

### Description of the Theories

The compatibilist thesis typically sounds strange to nonspecialists. That is explained partly by the fact that when people first encounter the pair of expressions “free will” – or “freedom of will” – and “determinism” they tend to get the impression that the two ideas are defined in opposition to each other, that they are mutually exclusive by definition. This is one reason that it is useful to think of freedom of will as the power to act freely and to regard acting freely as the more basic notion – that is, as a notion in terms of which freedom of will is to be defined. Consider the following conversation in ordinary, non-technical English between two inner-city Chicago police officers who know a stingy man named Sam. Ann: “Sam gave \$20 to a street person today.” Bob: “Why? Did he hold a gun to Sam’s head?” Ann: “No, Sam gave him the money freely.” Surely, Ann and Bob do not need to have an opinion about whether determinism (as defined above) is true to have this conversation. If what Ann says is true – that is, if Sam freely gave the person \$20 – and freedom of will is the power to act freely, then Sam has freedom of will (or, at least, he had it at that time). Even if “free will” and “freedom of will” are typically opposed to “determinism” in ordinary speech, “he did it freely” seems not to be. And even if “he did it freely” were typically opposed to determinism in ordinary speech, that would settle nothing. After all, in ordinary speech, deductive reasoning seems to be defined as reasoning from the general to the particular, and that certainly would only jokingly be said to constitute an objection to a logician’s definition of deduction (according to which “Ann is here; Bob is here; therefore Ann and Bob are here” is a valid deductive argument).

Compatibilist theories of free action emphasize a distinction between ►[deterministic causation](#) and compulsion [2,3]. If determinism is true, then this author’s driving to work today, working on this article, eating dinner after work, and so on, were deterministically caused; and so were a certain compulsive hand-washer’s washing his hands dozens of times today, a certain delusional person’s spending the day trying to contact Martians with his ham radio, a certain crack addict’s smoking crack today while in the grip of an irresistible craving for the drug, and a certain person’s handing over the money in his pocket to gunmen who made it clear that they would kill him if he refused. But there is an apparent difference. This author is sane, suffers from no uncontrollable addictions, and received no death threats today. The basic compatibilist idea is that when mentally healthy people act intentionally in the absence of compulsion and coercion they act freely, and an action’s being deterministically caused does not suffice for its being compelled or coerced.

Many compatibilists have been concerned to accommodate the idea that, for example, if this author freely drove to work this morning, he could have done something other than drive to work this morning. They grant that, if determinism is true, then there is a sense in which people could never have done otherwise than they did: they could not have done otherwise in the sense that their doing otherwise is inconsistent with the combination of the past and the laws of nature. But, these compatibilists say, the fact that a person never could have done otherwise in that sense is irrelevant to free action. What is relevant is that people who act freely are exercising a rational capacity of such a kind that if their situation had been different in any one of a variety of important ways, they would have responded to the difference with a different suitable action [3]. For example, although this author drove to his office today, he would not have done so if someone had bet him \$1,000 that he would not stay away from his office all day. This truth is consistent with determinism. (Notice that if someone had made this bet with the author, the past would have been different from what it actually was.) And it reinforces the distinction between deterministic causation and compulsion. Offer a compulsive hand-washer \$1,000 not to wash his hands all day and see what happens.

Some compatibilists claim that what matters for freedom is the exercising of a rational capacity that is appropriately responsive to reasons even if it is agreed that an agent’s exercising a capacity of this kind is not sufficient for its being true that the agent “could have done otherwise.” Such compatibilists call themselves semicompatibilists (►[Semicompatibilism](#)) [4]. Unlike traditional compatibilists, they do not insist that acting freely entails that one could have done something

else; but like traditional compatibilists, they claim that determinism is compatible with free action.

Libertarian theories of free action divide into three kinds: noncausal, event-causal, and agent-causal. Most theories about what intentional actions are include a causal condition. Roughly speaking, according to these theories, all intentional actions are events that are caused in a certain distinctive range of ways – either deterministically or indeterministically. For example, it may be claimed that what it is to be an intentional action is to be an event that is suitably caused by motivational and representational states. Noncausal libertarian theories of free action reject this idea [5,6]. Like compatibilists, noncausal libertarians tend to maintain that when mentally healthy people act intentionally in the absence of compulsion and coercion they act freely, but they insist that the deterministic causation of an action is incompatible with the action's being freely performed and that uncaused events can be intentional actions.

Typical event-causal libertarian theories of free action assert that agents never act freely unless some of their actions are indeterministically caused by immediate antecedents that are events, broadly construed, in the agents [7]. Whereas the laws of nature that apply to deterministic causation are exceptionless, those that apply most directly to **▶indeterministic causation** are instead probabilistic. Typically, events like deciding to help a stranded motorist – as distinct from the physical actions involved in actually helping – are counted as mental actions. Suppose that Aida's decision to help a stranded motorist is indeterministically caused by, among other things, her thinking that she should help. Given that the causation is indeterministic, she might not have decided to help given exactly the same internal and external conditions. In this way, event-causal libertarians seek to secure the possibility of doing otherwise that they require for free action, or for fundamentally free action (free action that does not derive its freedom solely from earlier free actions the agent performed).

Agent-causal libertarian theories of free action assert that agents themselves – as opposed, for example, to agents' motivational and representational states – are causes of free actions. Think of causation as a relation between cause and effect. In ordinary event causation – for example, a lightning strike's causing a tree to crack – both the cause and the effect are events. These events are connected by the relation causation. In **▶agent causation**, an agent is connected by the relation causation to an action. Whereas most agent-causal libertarians prefer their agent causation straight [8], some mix it with event causation in a theory of the production of free actions [9].

Each of the theories of free action described above has its detractors. Some theorists view determinism as precluding a kind of flexibility that they take to

be required for free action and therefore reject all compatibilist views [7]. Even if they accept the compatibilist distinction between deterministic causation and compulsion, they contend that each of the two elements of the distinction precludes the required flexibility in its own way. Other theorists regard uncaused actions as impossible and therefore reject noncausal libertarianism [9,10]. Yet others maintain that although event-causal libertarianism introduces a chance of acting otherwise that is absent in deterministic universes (**▶indeterministic universe**), it does not give agents the sort of control over their actions that free action requires [1,8,9]. They argue, for example, that event-causal libertarianism has the undesirable result that it is just a matter of chance that an agent decides on a particular course of action at a given moment rather than deciding on an alternative course of action then [8]. And some theorists find it very unlikely that agent causation has a place in the natural order of our universe [1,7].

If a typical compatibilist theory of what it is to act freely is correct, then it is very likely that people often act freely [10]. After all, there are a great many mentally healthy people, and it is difficult to deny that they often act intentionally in the absence of compulsion and coercion. Also, of course, if freedom of will is simply the power to act freely, anyone who acts freely has that power. If any of the libertarian theories of what it is to act freely are correct, it may reasonably be doubted that anyone ever acts freely. If there are, in fact, no uncaused actions, then no theory that requires that free – or fundamentally free – actions be uncaused permits us to act freely. If the brain, in fact, does not work indeterministically in a way required by event-causal libertarianism, then if that theory of what it is to act freely is correct, no one acts freely. And if there is no agent causation in the real world, agent-causal libertarianism has the same upshot.

Often, theorists who disagree about what it is to act freely attempt to find support for their view in the closely related sphere of moral responsibility. A common claim about the power to act freely – that is, freedom of will – is that it is a necessary condition for being morally responsible for one's actions, where moral responsibility is understood as a necessary condition for such things as deserved punishment, deserved moral blame, and deserved moral praise or credit. The various theories of free action described here have readily recognizable counterparts in the sphere of moral responsibility.

## References

1. Pereboom D (2001) *Living without free will*. Cambridge University Press, Cambridge
2. Frankfurt H (1988) *The importance of what we care about*. Cambridge University Press, Cambridge

3. Smith M (2003) Rational capacities. In: Stroud S, Tappolet C (eds) Weakness of will and practical irrationality. Clarendon press: Oxford, pp 17–38
4. Fischer J (1994) The metaphysics of free will. Blackwell, Cambridge, MA
5. Ginet C (1990) On action. Cambridge University Press, Cambridge
6. McCann H (1998) The works of agency. Cornell University Press, Ithaca, NY
7. Kane R (1996) The significance of free will. Oxford University Press, New York
8. O'Connor T (2000) Persons and causes. Oxford University Press, New York
9. Clarke R (2003) Libertarian accounts of free will. Oxford University Press, Oxford
10. Mele A (2006) Free Will and Luck. Oxford University Press, New York

---

## Free Run

### Definition

The state of a rhythm or oscillator in the absence of time cues (zeitgebers) that can control their phase and period.

---

## Free-running Period

### Definition

Period length of the circadian oscillator in the absence of external timing cues (about 24 hrs). In mammals, normally determined under constant dim light or complete darkness conditions.

► Clock-Controlled Genes

---

## Free-running Rhythms

### Definition

Free running rhythms are rhythms with a period length (Greek symbol  $\tau$ ) which systematically deviates from the period length (Greek symbol  $T$ ) of synchronizing environmental cycles, like light-dark or temperature cycles.

---

## Freeze-fracture Technique

### Definition

This is a method for preparing tissue for viewing in an electron microscope. Tissue is frozen very quickly, e.g., with liquid nitrogen, and then broken. A replica of the surface of the break is created by coating it with metal vaporized in a vacuum. The tissue is dissolved leaving the metal replica which is viewed with an electron microscope.

---

## Frequency

### Definition

Measured in Hertz (Hz), a frequency of “n” Hz indicates that a periodic cycle has repeated itself “n” times per second.

---

## Frequency-band Lamina

### Definition

The main anatomical structure of the tonotopy in the central nucleus of the midbrain inferior colliculus. A frequency-band lamina is a sheet-like structure consisting of the main cells (disk-shaped neurons) in this nucleus. These cells together cover with their characteristic frequencies a narrow frequency range. The characteristic frequencies of the neurons of a frequency-band lamina depend on the position of the neurons in the lamina.

- Inferior Colliculus
- Tonotopic Organization (Maps)

---

## Frequency Domain

### Definition

A description of the signal as a sum of (a possibly infinite number of) sines in different frequencies and

phases. The actual description is the phase and amplitude of each sine.

► Signals and Systems

## Frequency-following Response (FFR)

### Definition

An auditory evoked response that involves phase locking to periodic signals. This phase-locked response has been recorded in a number of structures along the auditory pathway, with more central structures systematically following at lower maximal frequencies.

Measured from the scalp, it likely is a volume conducted response from rostral brainstem structures.

► Auditory Evoked Potentials

## Frequency Response

### Definition

The description of a system using a function, which specifies the change in amplitude and phase, which will be effected to a sine input at a given frequency.

► Signals and Systems

## Frequency Tuning

### Definition

Sensory cells and neurons of the auditory system respond like frequency filters, i.e. they respond only to a certain bandwidth of the total frequency range of hearing of a species. They are tuned to a certain frequency range. The frequency tuning curve of a neuron is the curve in a frequency-amplitude-plot following the minimum tone amplitude (threshold) for a neuron's response as a function to tone frequency.

► Tonotopic Organization (Maps)

## Friedreich's Ataxia

### Definition

Genetic disorder with combined degeneration, at the ► spinal cord level, of the ► corticospinal tracts and ► spinocerebellar tracts, and the ► dorsal columns. In adolescence, the disease usually starts with loss of ► proprioception, weakness of the legs and ► ataxia in walking. While ankle and knee ► tendon reflexes are lost, the ► Babinski sign may be present. Due to ► cerebellar involvement, ► tremor of arms and ► nystagmus may appear later.

## Frontal Cortex

► Prefrontal Cortex

## Frontal Cortex (Areas 6 + 8)

### Definition

Premotor cortex. It plays a decisive role in the initiation of movements and comprises the frontal eye field (area 8).

► Telencephalon

## Frontal Eye Fields

JEFFREY D. SCHALL

Center for Integrative and Cognitive Neuroscience, Vanderbilt Vision Research Center, Department of Psychology, Vanderbilt University, Nashville, TN, USA

### Definition

Frontal eye field (FEF) is the area in dorsolateral prefrontal cortex that signals the location of targets and controls the execution of goal-directed movements of the eyes.

## Characteristics

### Higher Level Structures

FEF influences *saccade* production through three pathways – a projection to the ipsilateral superior colliculus concentrated in the intermediate layers, a pathway through the basal ganglia via the ipsilateral striatum and subthalamic nucleus, and a projection to mesencephalic and pontine nuclei [1].

FEF is innervated by nuclei in the thalamus bordering the internal medullary lamina, mainly the lateral part of the mediodorsal nucleus and the medial part of the ventroanterior nucleus. The thalamic zones most heavily connected with FEF are themselves innervated by oculomotor afferents from the intermediate layer of the superior colliculus, the substantia nigra pars reticulata, and the dentate nucleus of the cerebellum.

FEF is connected with diverse cortical areas. Within the frontal lobe FEF is interconnected with SEF, with prefrontal areas 46 and 12, and weakly with anterior cingulate area 24 and postarcuate premotor cortex. FEF also receives abundant inputs from a multitude of visual cortical areas in both the dorsal and ventral streams [2]. In fact, FEF is unique in the extent of its connectivity with extrastriate visual cortex, and it should not be overlooked that FEF provides reciprocal connections to equally many extrastriate visual areas. Thus, FEF can influence the activation of neurons in extrastriate visual cortex.

The connectivity of FEF with visual areas caudal to the central sulcus is topographically organized. The more ventrolateral portion of FEF, which is responsible for generating shorter saccades, is interconnected with the perifoveal representation in retinotopically organized areas, from areas that represent central vision in infero-temporal cortex and from other areas having no retinotopic order. In contrast, mediodorsal FEF, which is responsible for generating longer saccades, is interconnected with the peripheral visual field representation of retinotopically organized areas, from areas that emphasize peripheral vision or are multimodal and from other areas that have no retinotopic order.

### Lower Level Components

In macaque monkeys, FEF occupies the rostral bank of the arcuate sulcus in Brodman's area 8 (Fig. 1). At a more refined level, the dorsal part of the rostral bank is designated area 8Ac and is distinguished from area 45 in the lower limb of the arcuate sulcus. The lip and convexity of the rostral bank of the arcuate sulcus is designated area 8Ar which borders rostrally with area 46. In humans, FEF is located in the rostral bank of the precentral sulcus at the caudal end of the middle frontal gyrus (Fig. 1). However, human FEF has been described as being in Brodman's area 6. The apparent difference between species seems to be more a difference of labels than of cortical architecture.

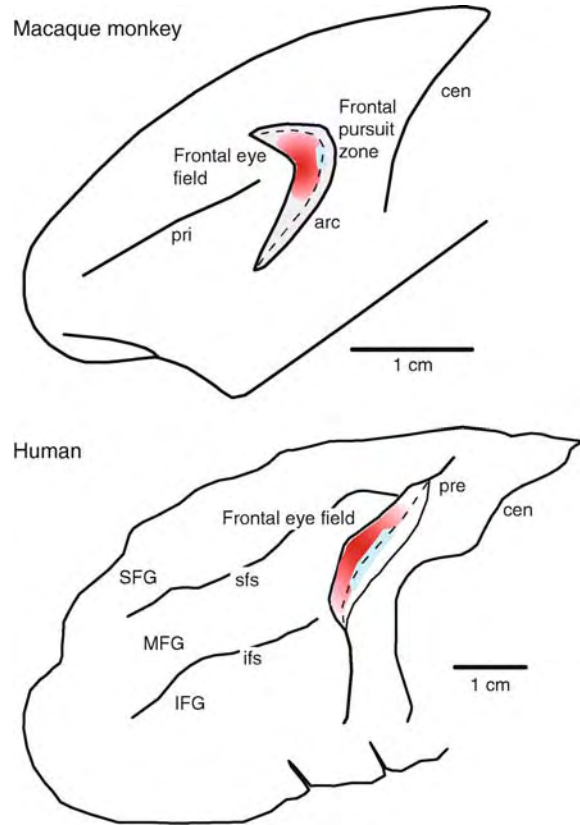

**Frontal Eye Fields. Figure 1** Stylized, lateral view of frontal cortex of macaque monkey (*top*) and human (*bottom*). The macaque arcuate sulcus is opened to expose the frontal eye field (red) on the rostral bank and the frontal pursuit zone (blue) on the fundus. The human precentral sulcus is opened to expose the frontal eye field (red) on the caudal end of the middle frontal gyrus with the pursuit zone (blue) in the fundus. Abbreviations: *arc*, arcuate sulcus; *cen*, central sulcus; *IFG*, inferior frontal gyrus; *ifs*, inferior frontal sulcus; *MFG*, middle frontal gyrus; *pre*, precentral sulcus; *pri*, principal sulcus; *SFG*, superior frontal gyrus; *sfs*, superior frontal sulcus.

### Higher Level Processes and Lower Level Processes

#### Role in Eye Movement Generation

The FEF has been regarded most commonly as part of the ocular motor system; the evidence for this is beyond dispute [1]. Most evidence has been obtained through invasive studies with nonhuman primates, but the human FEF has been located through brain imaging [3], transdural recording and stimulation [4], and transcranial magnetic stimulation [5]. FEF contributes to the generation of rapid saccadic gaze shifts as well as slow pursuit eye movements. The zone involved in pursuit is located at the fundus of the sulcus, separate from the area of frontal eye field that is involved in saccade production (Fig. 1).

Low intensity electrical stimulation of FEF in monkeys elicits saccadic eye movements, while stimulation of the ►frontal pursuit area elicits pursuit eye movements. Reversible inactivation of FEF prevents saccade production, complementing earlier observations that ablation of FEF causes an initially severe impairment in saccade production that recovers in some but not all respects over time. If the fundus of the arcuate sulcus is ablated, pursuit deficits occur.

The direct influence of FEF on saccade production seems to be mediated by neurons in FEF that are activated specifically before and during saccades [6,7]. Two kinds of neurons that control gaze have been distinguished. In general, *movement* neurons contribute to gaze shifting, and *fixation* neurons contribute to gaze holding. Neurons in FEF that generate movement-related or fixation-related activity are located in layer 5 and innervate the superior colliculus and parts of the neural circuit in the brainstem that generate saccades. Physiological recordings indicate that these neurons, in concert with a network including the superior colliculus, produce signals necessary to produce saccadic eye movements. Saccades are initiated when the activity of movement-related neurons reaches a threshold (Fig. 2). Variability in saccade latency can be accounted for by the time taken to reach this threshold. If an interrupting stimulus occurs, saccade preparation is canceled if, and only if, the activity of these neurons is reduced and prevented from reaching the threshold.

### Role in Target Selection

FEF contributes to selecting the target and shifting attention before gaze shifts, both saccadic and pursuit [8].

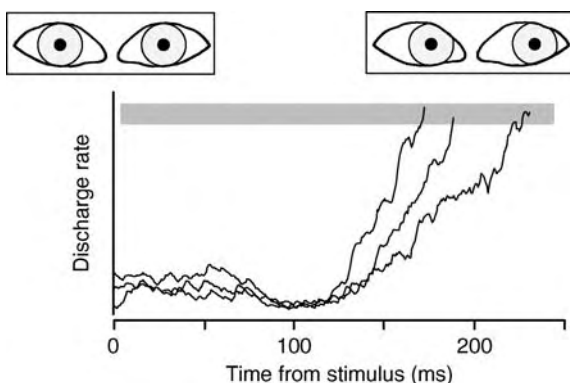

**Frontal Eye Fields. Figure 2** Saccades are produced when the activity of movement-related neurons in frontal eye field, as part of a network, reach a fixed threshold. Variability in the time of initiation of the saccade originates in the variable time taken for the activity to increase to the threshold.

It is also crucial to note that the neural signals occurring in FEF coincide with identical signals occurring in a network of interconnected structures including the superior colliculus and posterior parietal cortex. In macaque monkeys trained to shift gaze to the oddball target in visual search arrays, most visually responsive cells in FEF responded initially indiscriminately to the target or the distractor of the search array in their receptive field because neurons in FEF are not feature selective (Fig. 3). However, before gaze shifts, a selection process transpires by which most visually responsive cells in FEF signal the location of the target stimulus through suppression of the response to non-target stimuli, leaving only the response to the target. This selection process occurs if no saccade is made or if the saccade is directed to a non-target stimulus. The selection process is influenced by the similarity of the target and non-target stimuli, taking longer the more similar the stimuli. The selection process is also influenced by knowledge of target properties acquired over preceding trials or sessions. These properties of the target selection process observed in FEF indicate that it can be identified with the allocation of visual

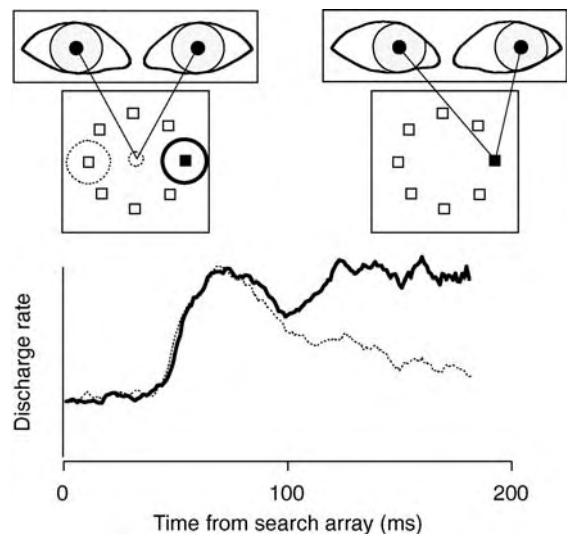

**Frontal Eye Fields. Figure 3** Targets for saccades are selected by the pattern of activity of visual neurons in frontal eye field, as part of a network. The activity of a visual neuron of a monkey shifting gaze to a single conspicuous stimulus. The response to the target (solid line), and the response to a distractor (dotted line), are superimposed for comparison. The stimulus array is shown at the top with superimposed receptive fields mapping onto the corresponding activation. After around 100 ms a selection process transpires that results in an accurate representation of the location of the target that can be used to guide the saccade.

spatial attention. The contribution of FEF and surrounding cortex to the allocation of spatial attention has been described in human studies using functional brain imaging [9] and transcranial magnetic stimulation [10]. All of these data can be organized under the framework that FEF is a salience map.

### Function

The FEF as part of a network samples the outcome of sensory processing to orient toward conspicuous and important elements in the environment.

### Pathology

Damage to the area of cortex including the FEF in humans results in deficits in controlling gaze in response to arbitrary cues while leaving visually guided eye movement control largely intact.

### References

1. Munoz DP, Schall JD (2003) Concurrent distributed control of saccades. In: Hall WC, Moschovakis AK (eds) *The oculomotor system: new approaches for studying sensorimotor integration*. CRC Press, Boca Raton, FL, pp 55–82
2. Schall JD, Morel A, King DJ, Bullier J (1995) Topography of visual cortical afferents to frontal eye field in macaque: functional convergence and segregation of processing streams. *J Neurosci* 15:4464–4487
3. Rosano C, Krisky CM, Welling JS, Eddy WF, Luna B, Thulborn KR, Sweeney JA (2002) Pursuit and saccadic eye movement subregions in human frontal eye field: a high-resolution fMRI investigation. *Cereb Cortex* 12:107–115
4. Blanke O, Seeck M (2003) Direction of saccadic and smooth eye movements induced by electrical stimulation of the human frontal eye field: effect of orbital position. *Exp Brain Res* 150:174–183
5. Nyffeler T, Bucher O, Pflugshaupt T, Von Wartburg R, Wurtz P, Hess CW, Muri RM (2004) Single-pulse transcranial magnetic stimulation over the frontal eye field can facilitate and inhibit saccade triggering. *Eur J Neurosci* 20:2240–2244
6. Bruce CJ, Goldberg ME (1985) Primate frontal eye fields. I. single neurons discharging before saccades. *J Neurophysiol* 53:603–635
7. Hanes DP, Schall JD (1996) Neural control of voluntary movement initiation. *Science* 274:427–430
8. Schall JD (2002) The neural selection and control of saccades by frontal eye field. *Philos Trans R Soc Lond B Biol Sci* 357:1073–1082
9. Shulman GL, McAvoy MP, Cowan MC, Astafiev SV, Tansy AP, d'Avossa G, Corbetta M (2003) Quantitative analysis of attention and detection signals during visual search. *J Neurophysiol* 90:3384–3397
10. Muggleton NG, Juan C-H, Cowey A, Walsh V (2003) Human frontal eye fields and visual search. *J Neurophysiol* 89:3340–3343

## Frontal Gyri

### Synonyms

► Gyri frontales

### Definition

The frontal gyri form three groups:

- Superior frontal gyrus
- Medial frontal gyrus
- Inferior frontal gyrus

Located in the gyri are also, inter alia, the premotor cortex and the motor speech center (Broca). The prefrontal cortex features additionally areas with pronounced associative functions.

► Telencephalon

## Frontal Lobe

### Synonyms

► Lobus front

### Definition

The frontal lobe extends from the frontal pole to the central sulcus.

► Telencephalon

## Frontal Pursuit Area

### Definition

A small region of the frontal lobe that contributes to the production of slow visual pursuit eye movements. In macaque monkeys it is located at the fundus of the arcuate sulcus. In humans it is located in the precentral sulcus. It contains neurons discharging in relation to pursuit and not saccadic eye movements. Its electrical stimulation elicits smooth, ipsiversive eye movements and its ablation results in pursuit deficits.

► Frontal Eye Fields



## Frontotemporal Dementia

### Definition

Uncommon but important degenerative disease accounting for up to 50% of dementia before age 60. While most cases are sporadic, some have a genetic basis (one mutation affecting the microtubule-associated protein (MAP) tau on chromosome 17, but there are others). Most often, frontotemporal degeneration is associated with ubiquitin inclusions. Frontotemporal dementia is characterized by personality alterations, often starting with disinterest and apathy, and behavioral changes such as disinhibition and perseverative, compulsive behavior, as well as corticobasal degeneration and ►[primary progressive aphasia](#), and occasionally semantic dementia (loss of the meaning of nouns and objects).

## FST

### Definition

Fundus of the superior temporal sulcus.

## FTNs

►[Cerebellum – Flocculus Target Neurons](#)

## Functional-anatomical System

GEORGE F. ALHEID

Northwestern University, Department of Physiology and Institute for Neuroscience, Chicago, IL, USA

### Synonyms

Systems physiology; Functional neuroanatomy; Correlative neuroanatomy; Comparative neurology

### Definition

Relative to neuroscience a “functional-anatomical system” encompasses the interconnected neuronal circuits and end organs serving identified or presumed core functions of animals including humans.

### Characteristics

Neuroscience research confronts the nervous system at a variety of levels ranging from the molecular biology and biophysics of the constituent neurons and glia to the overall physiological and structural organization of cellular networks serving the phenotypic behaviors of the organism. The latter include maintenance of internal and overt behaviors necessary for individual survival (respiration, food and water intake; cardiovascular/autonomic regulation e.g. [1]), and the persistence of individual species (e.g. social behaviors, including pair bonding, copulation, parenting, and territoriality, e.g. [2]). Functional-anatomical systems encompass most levels of organization included between molecular biology and organized overt behaviors. Functional anatomical systems are both modular and interactive. That is, functional specificity may be demonstrated for many regulatory and overt behavioral systems at least for broad portions of their underlying neural circuits. On the other hand, various classes of behaviors often interact, reinforcing or inhibiting one another. Prioritizing the activity for competing specific functional systems, however, do not invariably represent a static hierarchy; specific behaviors are expressed appropriate to the environmental context and according to varying levels of homeostatic demand.

One example of a modular functional-anatomical system is the neural circuitry controlling breathing (Fig. 1) along with its related central and peripheral sensors and the end organs in the lungs and the muscles of the respiratory pump.

Premotor neurons responsible for the regular and persistent (lifetime) oscillation between inspiration and expiration as well as for most adjustments in rate and amplitude of contraction on the “pump muscles” (diaphragm, intercostal, and abdominal muscles in mammals), are located entirely within the rhombencephalon. Following mid-collicular decerebrations, breathing persists practically unaltered from baseline rates and remains responsive to various homeostatic demands (e.g. hypoxia or ►[hypercapnea](#)) despite the absence of forebrain inputs. In the normal intact animal, however, breathing is a voluntary, albeit highly motivated behavior, which may be stopped and started at will.

The respiratory network is also interactive, in that a variety of behavioral systems may access and modify the activity of brainstem respiratory premotor and motor neurons for purposes other than gaseous (► $\text{PO}_2$ ,  $\text{PCO}_2$ ) homeostasis. These include modulation of expiratory and airway muscles during vocalizations, co-activation of inspiratory and expiratory muscles during vomiting, and modification of breathing in response to orientation and defense responses, and modification of breathing in response to strong emotional stimuli including painful stimuli. Breathing is also inhibited by a variety of behaviors for example

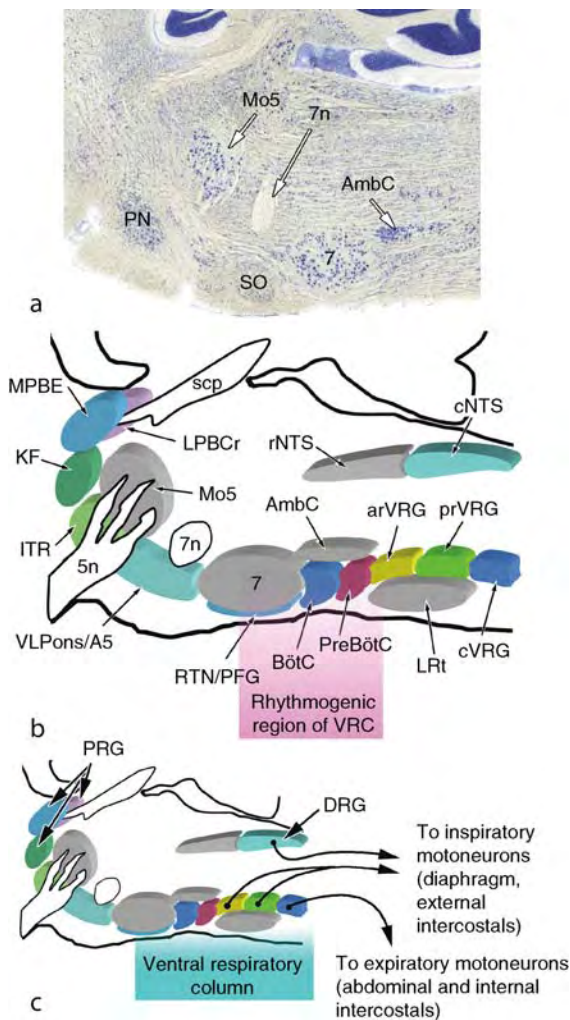

**Functional-anatomical System. Figure 1** Respiratory related compartments of the rhombencephalon of the rat. Adapted from Figure 1 in Alheid et al. (2004) [3] (with permission from Elsevier) (a) Nissl stained sagittal section through the lateral rhombencephalon of the rat brain at the level of the ventral respiratory column of the medulla. (b) Schematic of respiratory related compartments of the rhombencephalon. (c) Main brainstem respiratory outputs to spinal motoneurons activating the pump muscles for breathing. Generation of respiratory rhythm and pattern are controlled by a series of neuronal compartments found mainly in the lateral rhombencephalon (color coded regions in b). Respiratory neurons, whose firing pattern is more or less phase-locked to the respiratory cycle, are found in the dorsolateral pons in an area termed the pontine respiratory group (PRG), in the dorsal respiratory group, and most prominently in the ventral respiratory column of the medulla (VRC; blue bar in c), particularly by neurons within the ▶preBötzinger complex (preBötC) and likely within the parafacial respiratory group (PFG) located ventral to the facial nucleus. The PRG encompasses subsets of neurons in the medial and lateral parabrachial complex and in the ▶Kölliker-Fuse

during swallowing, and (in amphibious animals) as an element in the diving reflex. Interestingly, in the latter instance, breathing is suspended both before and during submergence implying involvement of anticipatory cognitive processes.

The known functions (e.g. for homeostasis or sensory processing) of many systems motivate the research aimed at understanding their neural basis. However, the precise functions of some anatomical systems are not initially clear. Investigations of such systems were undertaken because of the obvious coherence in their neural circuitry and/or their likely involvement in neurological disorders. For some of the latter, functional roles have been postulated only after much study and often remain a topic of debate.

Significant examples include the “cortico-striatopallido-system” (Fig. 2) and the “cerebellar systems.” In the past, these were characterized as parallel components of the so-called “▶extrapyramidal motor system.” The latter term, however, was merely one of exclusion from the presumed more direct motor activation effects of stimulation in primary motor cortex. Despite the initial lack of a functional focus, the physiology and neuroanatomy of the circuits centered on the striatum or cerebellum have been described in great detail. Both of these systems have profound effects on motor function, but with apparently limited direct interactions with one another except at the level of motor output. Moreover, evidence has been offered to suggest that each of these systems interacts with functions beyond the scope of direct motor control.

Cerebellar efferents interact relatively directly with motor cortex via cerebello-thalamo-cortical axons and

nucleus (KF), while the DRG is composed of respiratory related neurons in caudal portions of the nucleus of the solitary tract (cNTS). It is generally agreed that neurons in the rostral half of the VRC are responsible for the generation of the respiratory rhythm (pink bar in b), while neurons in the DRG (within caudal portions of the nucleus of the solitary tract; cNTS) and in the caudal half of the VRC (c) represent the most prominent source of premotor input to spinal motoneurons controlling the respiratory pump. Neurons in the ▶rostral ventral respiratory group (VRG) are mainly inspiratory premotor neurons, while neurons in the ▶caudal ventral respiratory group (cVRG) are mainly expiratory premotor neurons. The rVRG may be further subdivided, in that interneurons in the anterior part of the rostral ventral respiratory group (arVRG) also appear to contribute to respiratory rhythm generation [4], while stimulation of cells in the posterior portion of the VRG (pVRG) have little effect on respiratory frequency. Cranial motoneurons innervating airway muscles are also located within the VRC and are generally modulated by respiratory premotor neurons, as are motoneurons in the hypoglossal nucleus (not shown).

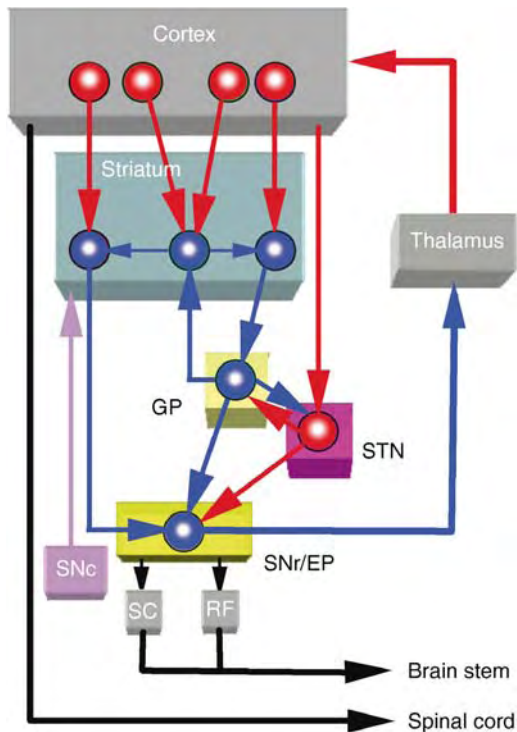

**Functional-anatomical System. Figure 2** Schematic of principal basal ganglia pathways. Redrawn from Figure 1 in Bolam et al. (2000) [5] (with permission from Blackwell publishing and the Author). In this simplified schematic excitatory connections are shown in red and inhibitory connections in blue. The dopaminergic input from the pars compacta is shown in purple since it may be potentially inhibitory or excitatory depending on the current activity of the targeted striatal neurons. The basal ganglia receive a broad pattern of input from cortical areas including cortical like regions in the lateral-basolateral complex of the amygdala. The rostral thalamus provides an ascending feedback loop to the cortex, but also afferent input from the ► [intralaminar thalamic nuclei](#) (not shown). Generally a *direct and indirect pathway* are described for basal ganglia circuits. In the first, the striatum sends an inhibitory projection directly to the entopeduncular nucleus (medial pallidal segment of primates) and or to the pars reticulata of substantia nigra, which are the principal output nuclei for basal ganglia. In the second, the striatum projects indirectly to the output nuclei via inhibitory projections to the globus pallidus (external pallidal segment of primates) which then send inhibitory projections to the substantia nigra and subthalamic nucleus. The subthalamic nucleus provides excitatory afferents to the output nuclei but also provides excitatory feedback to the globus pallidus. Note that the cortex may excite the subthalamic nucleus via two inhibitory steps or via a single step direct excitatory projection to the subthalamic nucleus. The dopaminergic neurons in the pars compacta, substantia nigra receive afferents from the basal ganglia and from the brainstem (not shown) and provide a massive input to the striatum that modulates

with the ventral horn of the spinal cord via cerebello-rubro-spinal axons to provide refinement of motor control (predictive, strength and timing of motoneuron activation). Human functional imaging data, however, also suggests that the cerebellum is also activated by a variety of non-motor behaviors, including during cognition and emotions. “Associative” regions of cortex also appear to be reciprocally linked to portions of the cerebellum and its output from the deep cerebellar nuclei. These interconnections are topographically distinct from those areas most closely connected with motor and premotor cortical areas. The cerebellum, when damaged, leads to clear disruption of movement (ataxia), however, pathological changes in the cerebellum have also been noted in the brains of schizophrenic patients.

The striatopallidal system when damaged, is the source of profound motor impairment in humans including hypokinesia, rigidity, and tremor consequent to the loss of neurons in the pars compacta of substantia nigra that provide the dopamine innervation of striatum (in Parkinson’s disease), or hyperkinesias following selective deterioration in subsets of striatal neurons (in Huntington’s chorea). Earlier theories postulated that the striatopallidal system was responsible for postural adjustments or alternatively, for the initiation of movements. More recent evidence, however, suggests that initial neural activity preceding movement occurs in cortical regions projecting to striatum and that the striatopallidal system may be responsible for the sequencing of motor activity subsequent to movement activation. In addition, the striatopallidal system is

information flow through this structure. In addition to output via the rostral thalamus, the substantia nigra, pars reticulata and entopeduncular nucleus send efferents to the brainstem and reticular formation that provide direct modulation of motor output. *5n* trigeminal nerve; *7* facial nucleus; *7n* facial nerve; *A5* A5 noradrenergic neuron in the ventrolateral pons; *AmbC* compact part of nucleus ambiguus; *arVRG* anterior rostral VRG; *BötC* Bötzing complex; *cVRG* caudal ventral respiratory group; *DRG* dorsal respiratory group; *EP* entopeduncular nucleus; *ITR* intertrigeminal nucleus; *KF* Kölliker-Fuse nucleus; *GP* globus pallidus; *LPBCr* lateral parabrachial complex, crescent subnucleus; *LRt* lateral reticular nucleus; *Mo5* motor nucleus of the trigeminal nerve; *MPBE* medial parabrachial complex external subnucleus; *PFG* parafacial respiratory group; *PN* basilar pontine nuclei; *preBötC* preBötzing complex; *PRG* pontine respiratory group; *prVRG* posterior rostral VRG; *RF* reticular formation; *RTN* retrotrapezoid nucleus; *SC* superior colliculus; *scp* superior cerebellar peduncle; *SNC* substantia nigra pars compacta; *SNr* substantia nigra pars reticulata; *STN* subthalamic nucleus; *VLPONS* ventrolateral pons.

postulated to function as a substrate for procedural learning (e.g. automatization of behaviors).

The striatopallidal system [5], on the other hand, receives input from nearly all cortical areas and has been implicated in a variety of behaviors that are not limited to motor activity or procedural sequences. Caudal striatal regions, for example, receive input from sensory regions of cortex and relay this input via globus pallidus to posterior (sensory) thalamus and to caudal brainstem. Absent from this “sensory striatal” circuit are the terminations in the subthalamic nucleus that characterizes portions of the striatopallidal system that serve motor and premotor cortices [6]. Increases in striatal dopamine release, and particularly increases in dopamine within “ventral striatum” (nucleus accumbens and olfactory tubercle), appear to be a general component of naturally rewarding stimuli [7], including the response to addictive drugs. Disturbances in the function of the striatopallidal system have also been implicated in the etiology of schizophrenia as well as in obsessive compulsive disorders and even disrupted memory [8].

The functions of some neuroanatomical systems remain elusive despite their intense scrutiny. One such region is the amygdala. This forebrain area is involved in a wide variety of behaviors such as the influences of learned emotional responses, including conditioned fear, on autonomic behaviors such as blood pressure and gastrointestinal motility. Reproductive behaviors such as copulation and parenting are mediated in part by subnuclei of the amygdala, including the extended amygdala, and neurons are observed that respond to familiarity in general, and to face recognition in particular. While studies often still refer to the amygdala as an anatomical entity, modern neuroanatomical, physiological, and psychopharmacological experiments relate sub groups of the numerous nuclei composing the amygdala to a variety of distinct functional anatomical systems. These include the modulation of reproductive and defensive behaviors by medial amygdaloid nuclei (e.g. [9]), and modulation of autonomic and neuroendocrine responses to emotional stimuli including stress, by the central amygdaloid complex. The cortical-like nuclei of the amygdala, including the lateral-basolateral complex, relay afferent input from the thalamus and cortex to medial and central amygdala and basal forebrain including the basal ganglia [10]. Prominent afferents from the main and accessory olfactory bulbs also provide direct afferents to medial amygdala and specific cortical amygdaloid nuclei.

### Functional Anatomical Systems are Genetically Determined

Functional anatomical systems are, to varying degrees, adaptive and modified by environmental demands during development, including the physical and social challenges confronting individual organisms. Nonetheless, all

functional anatomical systems are based on circuitry and structures defined by the genetic code. This is clear from the intraspecific homogeneity in the neural circuits and end organs serving particular functions, and the increasing discovery of related genes serving homologous functions across varieties of species spanning nearly entire phylogenetic orders. At one extreme this is represented by more or less hard wired systems resulting in stereotypic behaviors (fixed action patterns), with modest modifications by environmental interactions such as for the social and parental behaviors of birds, or for the development of synaptic refinement during critical developmental epochs for sensory and motor systems. At the other extreme is the life long modification of cognitive and verbal behaviors characterizing humans. The latter, of course, operate through genetically specified modules for the execution of overt behaviors such as vocalization, and through the genetically established neurological substrates of learning and memory.

All functional anatomical systems are composed of multiple modules each of which are specified by large arrays of interacting genes. Some of these specify basic developmental/neurochemical elements common to many different functional modules such as for cell metabolism, ion channels, neurotransmitter receptors, and differentiation of stem cells into neurons or glia. Other genes evince regional or system specific expression such as those controlling the development of rhombomeres in the brainstem, in specific amygdalar pathways related to reproductive or defensive behaviors [9], or genes specifically associated with the olfactory system. Since in the broadest sense, most functional anatomical systems are integrated across the entire neuroaxis, including the sensory and motor innervation of end organs, an important long term objective is identifying the various genetic determinants specifying the vertical integration of complex functional anatomical systems.

### References

1. Squire LR, Bloom FE, McConnell SK, Roberts JL, Spitzer NC, Zigmond MJ (eds) (2003) *Fundamental neuroscience*, 2nd edn. Elsevier-Academic Press, San Diego
2. Hammock EA, Young LJ (2006) Oxytocin, vasopressin and pair bonding: implications for autism. *Philos Trans R Soc Lond B Biol Sci* 361(1476):2187–2198
3. Alheid GF, Milsom WK, McCrimmon DR (2004) Pontine influences on breathing: an overview. *Respir Physiol Neurobiol* 143(2–3):105–114
4. Monnier A, Alheid GF, McCrimmon DR (2003) Defining ventral medullary respiratory compartments with a glutamate receptor agonist in the rat. *J Physiol* 548 (Pt 3):859–874
5. Bolam JP, Hanley JJ, Booth PA, Bevan MD (2000) Synaptic organisation of the basal ganglia. *J Anat* 196 (Pt 4):527–542

6. Shammah-Lagnado SJ, Alheid GF, Heimer L (1996) Efferent connections of the caudal part of the globus pallidus in the rat. *J Comp Neurol* 376(3):489–507
7. Kelley AE, Berridge KC (2002) The neuroscience of natural rewards: relevance to addictive drugs. *J Neurosci* 22(9):3306–3311
8. Benke T, Delazer M, Bartha L, Auer A (2003) Basal ganglia lesions and the theory of fronto-subcortical loops: neuropsychological findings in two patients with left caudate lesions. *Neurocase* 9(1):70–85
9. Choi GB, Dong HW, Murphy AJ, Valenzuela DM, Yancopoulos GD, Swanson LW, Anderson DJ (2005) Lhx6 delineates a pathway mediating innate reproductive behaviors from the amygdala to the hypothalamus. *Neuron* 46(4):647–660
10. Alheid GF (2003) Extended amygdala and basal forebrain. *Ann N Y Acad Sci* 985:185–205

## Functional and Neurochemical Organization of Vestibulo-Motor Pathways

H. STRAKA<sup>1</sup>, M. B. DUTIA<sup>2</sup>

<sup>1</sup>Laboratoire de Neurobiologie des Réseaux Sensorimoteurs, Université Paris 5, Paris, France

<sup>2</sup>Centre for Integrative Physiology, Edinburgh University, Edinburgh, Scotland

### Definition

Linear and angular head acceleration in three dimensions is detected and decomposed into individual acceleration vectors by the vestibular receptors located in the inner ears on both sides (the semicircular canal and macula organs) [8]. The three semicircular canals are oriented roughly perpendicularly to each other and sense angular head acceleration in their respective anatomical planes. Based on their mirror image like position on both sides of the head, the anterior vertical canal on one side and the posterior vertical canal on the other side as well as the horizontal semicircular canals on both sides form functional co-planar canal pairs respectively. The two macula organs detect static changes in the head position relative to gravity as well as linear acceleration of the head. In general, the utricle detects linear head acceleration in the horizontal plane and changes of the head with respect to gravity, whereas in mammals including humans the saccule detects vertical linear head acceleration. In non-mammalian species, vertical linear head acceleration is largely detected by the lagena, a third macula organ, whereas the saccule in these latter species is sensitive to bone-conducted sound or vibrations.

### Characteristics

#### Functional Organization of the Peripheral Vestibular Receptors

The functional organization of the sensory epithelium of semicircular canal and macular organs is very similar across different vertebrate species [4]. The sensory cells are embedded into the epithelium of the semicircular canal (cupula) and of the macula organs and consist, in mammals, of two different types called type I and type II hair cells. These differ in their cell morphology, in the synaptic structures of the afferent nerve fibers that innervate them and in the termination of efferent vestibular fibers. Particularly prominent are type I hair cells which are “bottle-shaped”, have calyx-like afferent terminals surrounding a large part of the cell body and originate from the thickest afferent nerve fibers. These hair cells are located mainly in the center of the semicircular canal cupula and the striola of the macula organs. In contrast, type II hair cells are cylindrical with multiple bouton-like afferent terminals. Based on the morphology of their synapse onto the hair cells, afferent fibers in mammals are subdivided into three classes, calyx fibers, bouton fibers and dimorphic fibers.

All present evidence suggests that glutamate is the putative neurotransmitter at the hair cell-afferent axon synapse in the mammalian as well as the non-mammalian inner ear [4,8]. Bath application of glutamate, aspartate or N-methyl-D-aspartate (NMDA) evokes a dose-dependent depolarization in semicircular canal afferent nerve fibers *in vitro* or an increase in the resting rate of afferent fibers. Postsynaptically, the amplitude of synaptic depolarizations is reduced by various glutamate receptor antagonists such as kynurenic acid or 2-amino-5-phosphono valeric acid (APV). A presynaptic effect of glutamate on hair cells, mediated by metabotropic receptors, might be related to an enhancement of signal discrimination. In a subpopulation of hair cells in toadfish and pigeon, GABA has been found to be colocalized with glutamate. Based on physiological evidence, a combined postsynaptic effect of both excitatory and inhibitory transmitters might be involved in shaping vestibular afferent responses.

#### Synaptic Transmission Between Vestibular Nerve Afferent Fibers and Second-Order Vestibular Neurons

Vestibular nerve afferent fibers from individual labyrinthine endorgans terminate in all major vestibular nuclei, the adjacent reticular formation and the cerebellum [3,6]. Although the termination of fibers from individual endorgans predominates in certain areas of the vestibular nuclei, there is neither a clear spatial segregation of signals from particular semicircular canals nor of signals from particular macula organs. However, at variance

with the general overlap of afferent fiber terminations, the ipsilateral convergence of afferent input at the single cell level of second-order vestibular neurons is rather specific and very similar in different species [8]. As a rule, signals from individual semicircular canals remain largely separate at the level of second-order vestibular neurons, whereas horizontal canal signals converge largely with signals from the horizontally oriented macula organ (utricle), and signals from the two vertical canals converge predominantly with those from the vertically oriented macula organ (sacculle in mammals, lagena in frogs).

All vestibular nerve afferent fibers mediate their signals to second-order neurons mainly by chemical transmission [4,8,10]. As it is the case for most excitatory synapses in the vertebrate central nervous system, glutamate is the putative transmitter of vestibular nerve afferent fibers. Postsynaptically different subtypes of glutamate receptors are activated in second-order vestibular neurons. The presence and the activation of multiple glutamate receptor subtypes as well as a number of additional, differentially distributed neuroactive substances in vestibular nerve afferent fibers such as glycine or substance P suggest that this chemical transmission is not however uniform. In fact, different response components might be mediated by different subsets of vestibular nerve afferent fibers that use different combinations of presynaptic neuroactive substances and postsynaptic receptors.

#### **The Putative Transmitter of Vestibular Nerve Afferent Fiber Is Glutamate**

Even though not all the criteria that are necessary to consider a substance as the neurotransmitter at a particular synapse are determined yet, glutamate meets a large number of these conditions in vestibular nerve afferent fibers [8]. Thus, it is very likely that this amino acid or a closely related analog is the excitatory transmitter between vestibular nerve afferent fibers and second-order vestibular neurons. Immunocytochemical studies have shown that glutamate is present in afferent fibers and ganglion cells in frog, mouse, rat and cat. However, the intensity of the glutamate immunoreactivity is not uniform across afferent fibers but decreases with increasing diameter of the ganglion cell. The role of glutamate as transmitter is supported by the presence in mouse vestibular ganglion cells of mitochondrial or cytosolic aspartate aminotransferase, an enzyme involved in the synthesis of glutamate and aspartate.

#### **Glycine and Substance P as Possible Cotransmitters**

In addition to the presence of glutamate in the ganglion cells of vestibular nerve afferent fibers a population of particularly large vestibular ganglion cells exhibits an intense glycine immunoreactivity. Thus, glycine and glutamate are colocalized in the largest ganglion cells,

their afferent nerve fibers and their terminal-like structures. The differential distribution of glycine in vestibular nerve afferent fibers is complemented by the presence and differential distribution of substance P in these fibers. Using antibodies against substance P, about 85% of the vestibular ganglion cells were immunopositive in guinea pig; these were significantly smaller in diameter than the unlabelled ganglion cells. The presence of substance P in particularly small ganglion cells, although they were fewer in number was corroborated in rabbit, cat and monkey. These data suggest that small vestibular nerve afferent fibers colocalize glutamate and substance P, whereas large vestibular nerve afferent fibers colocalize glutamate and glycine. If glycine and substance P were also released from vestibular nerve afferent fibers both substances might have a possible functional role as cotransmitter or neuromodulator of the synaptic transmission onto second-order vestibular neurons.

#### **Postsynaptic Glutamate Receptors in Second-Order Vestibular Neurons**

Electrophysiological and pharmacological studies in a variety of vertebrate species support the hypothesis that vestibular nerve afferent fibers use glutamate as the excitatory neurotransmitter to activate second-order vestibular neurons [8,10]. Electrical stimulation of vestibular nerve afferent fibers and recording of second-order vestibular neurons in fact activates different subtypes of postsynaptic glutamate receptors. These receptors subdivide into NMDA and non-NMDA or  $\alpha$ -amino-3-hydroxy-5-methyl-4-isoxalone (AMPA)/kainate receptors (Fig. 1).

The multitude of glutamate receptor subtypes opens the possibility that they might be activated by different subsets of vestibular nerve afferent fibers. Since vestibular nerve afferent fibers differ from each other in a number of interrelated physiological and pharmacological properties, different glutamate receptors might be activated and transmit different dynamic components of the sensory signals (Fig. 1).

Assuming that glycine is in fact localized in and released from thick vestibular nerve afferent fibers, it could theoretically activate the strychnine-sensitive inhibitory glycine receptor. However, all electrophysiological data preclude a possible role of glycine as an inhibitory transmitter at this synapse. Alternatively, glycine might bind to the glycine-binding site of the NMDA receptor on second-order vestibular neurons and act as a cotransmitter in conjunction with glutamate. The binding of glycine to the respective site of the NMDA receptor in addition to the binding of glutamate is a necessary requirement to activate this glutamate receptor subtype. Given the fact that glycine is only present in the thickest vestibular nerve afferent fibers, only the latter type of neurons but not thin

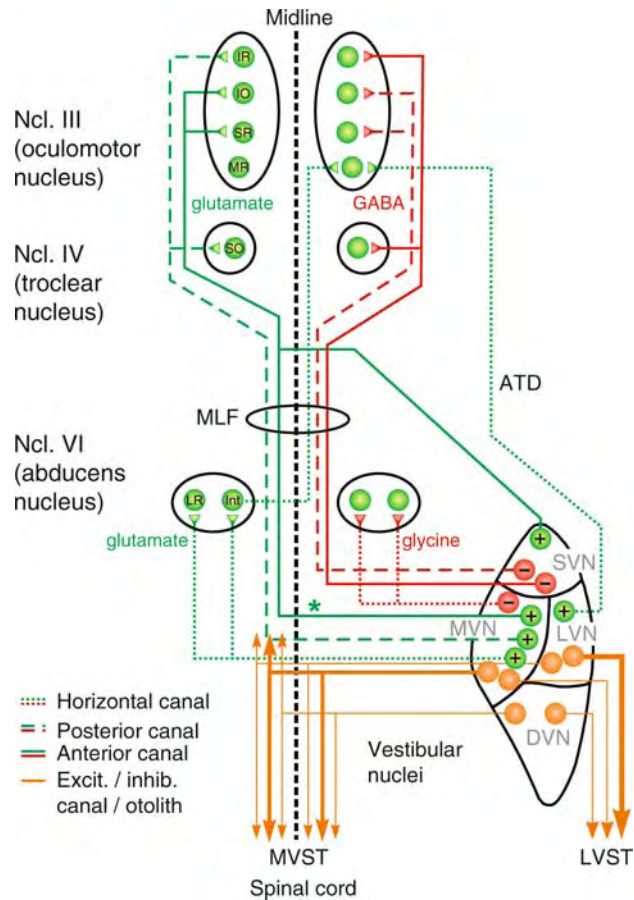

**Functional and Neurochemical Organization of Vestibulo-Motor Pathways. Figure 1** Summary of excitatory and inhibitory semicircular canal projections from the vestibular nuclei to individual subgroups of extraocular motoneurons and spinal targets. Signal pathways from particular semicircular canals are indicated by *solid* (anterior vertical canal), *dashed* (posterior vertical canal) and *dotted* (horizontal canal) lines. Projections in *green* (+) are excitatory, projections in *red* (–) are inhibitory, projections in *orange* are mixed or unknown. A MVN contribution of the excitatory pathway to contralateral IO and SR motoneurons (\*) is still open. *ATD*, ascending tract of Deiters; *DVN*, descending vestibular nucleus; *Int*, abducens internuclear neurons; *IO*, inferior oblique; *IR*, inferior rectus; *LR*, lateral rectus; *LVN*, lateral vestibular nucleus; *LVST*, lateral vestibulo-spinal tract; *MLF*, medial longitudinal fascicle; *MVN*, medial vestibular nucleus; *MVST*, medial vestibulo-spinal tract; *Ncl. III*, oculomotor nucleus; *Ncl. IV*, trochlear nucleus; *Ncl. VI*, abducens nucleus; *SO*, superior oblique; *SR* superior rectus; *SVN*, superior vestibular nucleus.

afferent fibers would activate NMDA receptors on second-order vestibular neurons.

### AMPA/Kainate Receptors

Subunits of the AMPA/kainate receptor are differentially distributed in almost all parts of the vestibular nuclei in gerbil, chinchilla and rat [6]. Bath application of glutamate, aspartate, kainate or quisqualate evokes pronounced depolarizations in frog, rat and guinea pig central vestibular neurons [10]. Part of these responses as well as vestibular nerve afferent-evoked monosynaptic EPSPs in central vestibular neurons are blocked by different glutamate receptor antagonists among which the relatively unspecific kynurenic acid is the most effective. More specific antagonists such as the AMPA/kainate

antagonists CNQX or DNQX reduce the monosynaptic responses in central vestibular nucleus neurons at very low concentrations. However, monosynaptic vestibular nerve afferent fiber-evoked responses were not blocked completely by these antagonists, but were only abolished by adding the NMDA antagonist D-(–)-2-amino-5-phosphonopivalic acid (D-APV) or 7-chloro-kynurenic acid. This indicates that the responses are mediated in part by AMPA/kainate receptors and in part by NMDA receptors.

### NMDA Receptors

The NMDA receptor subunit NMDAR1, the major subunit of this glutamate receptor subtype, is found in neurons in all four major vestibular nuclei, although

in differential densities [6,10]. Glutamate agonists like L-homocysteate or NMDA evoke pronounced depolarizations in frog, rat and guinea pig central vestibular neurons that can be reversibly blocked by the specific NMDA antagonist D-APV. Similarly, vestibular nerve afferent-evoked responses in second-order vestibular neurons are blocked by specific NMDA antagonists, indicating in fact an activation of these glutamate receptor subtypes during natural stimulation. Given the voltage-dependent  $Mg^{2+}$  block of these receptors, the discrepancies in the different studies concerning the respective magnitude of the NMDA responses relative to the total response are probably related to the level of  $Mg^{2+}$  in the Ringer solution used. Under these conditions, strong electrical stimuli applied to vestibular afferent nerve fibers are more likely to facilitate a release from the voltage-dependent  $Mg^{2+}$  block and to trigger an NMDA response.

#### Afferent Nerve Fibers with Different Dynamics Activate Different Glutamate Receptors

Selective electrical activation of thick and thin vestibular nerve afferent fibers in the isolated adult frog brain indicates that second-order vestibular neurons are activated by variable contributions of thick and thin vestibular nerve afferent fibers [8]. Thick vestibular nerve afferent fibers activate these neurons via NMDA as well as AMPA receptors, whereas thinner vestibular nerve afferent fibers activate predominantly non-NMDA receptors. The specific contribution of NMDA receptors to the afferent nerve-evoked excitatory response thus depends on the relative amount of convergence of thick and thin afferent fibers. The activation of NMDA receptors could be facilitated by glycine if the latter amino acid is coreleased together with glutamate from thick afferents and binds to the glycine-binding site of NMDA receptors. In fact, the binding of glycine to this site is a prerequisite for the NMDA receptor activation. Given the fact that the thickest vestibular nerve afferent fibers contain glycine and glutamate and assuming that both substances are released upon stimulation, the evoked responses are in fact facilitated by the colocalization and the possible corelease of the two amino acids. In fact, perfusion of specific agonists and antagonists of this glycine-binding site into the guinea pig vestibular nuclei indicated that vestibular responses can be modulated through this glycine-binding site [10].

#### Neuromodulatory Substances Acting on Second-Order Vestibular Neurons

Apart from vestibular nerve afferent inputs, most second-order vestibular neurons are endowed with a spectrum of neurotransmitter receptors of various subtypes that differ between vestibular neurons with different functional properties. Cholinergic, serotonergic, histaminergic,

dopaminergic and noradrenergic receptors are present as well as GABA<sub>A</sub>, GABA<sub>B</sub> and glycinergic receptors [2,9,10]. Of particular interest have been the actions of histamine and histaminergic agents on vestibular neurons, because of the mitigatory effects of histamine in vestibular dysfunction or during vestibular compensation. Current literature implicates pre-synaptic control of heterosynaptic neurotransmitter release by H3 histaminergic receptors as well as post-synaptic excitatory effects of H1 and H2 receptors in the actions of histamine [2]. Also of interest have been the effects of serotonin, which has either net excitatory effects through 5-HT2 receptors or inhibitory effects via 5-HT1A receptors or, in some cells, a biphasic action involving both subtypes. Opioids and neuroactive steroids also modulate neurotransmission in the vestibular nuclei [10].

#### Functional and Neurochemical Organization of the Vestibular Nuclei

Excitatory and inhibitory central vestibular neurons that relay particular semicircular canal signals are highly organized and project via distinct fiber tracts to individual populations of oculomotor, trochlear and abducens motoneurons (Fig. 1). The different functional subgroups develop ontogenetically from distinct hindbrain segments and are highly conserved among vertebrates [1,5].

The medial vestibular nucleus (MVN) is generally assumed to be the major vestibular relay nucleus for the VOR, particularly for horizontal canal and utricular signals [3,6]. It contains several functional subgroups that project to distinct pools of extraocular motoneurons and internuclear neurons mediating afferent inputs from semicircular canals to specific extraocular motoneurons (Fig. 1). These vestibular neurons thus form the central part of the classical three-neuronal vestibulo-ocular reflex pathway. Two subsets of MVN neurons are activated by afferent inputs from the horizontal canal and provide uncrossed, inhibitory projections and crossed, excitatory projections to lateral rectus (LR) motoneurons and abducens internuclear neurons respectively to generate the horizontal VOR (Fig. 1). Another subset of MVN neurons located in the magnocellular part of the caudal MVN are activated by posterior vertical canal inputs and excite contralateral inferior rectus (IR) and superior oblique (SO) motoneurons in the oculomotor and trochlear nucleus (Fig. 1). Whether neurons in the MVN contribute to an anterior vertical canal-activated excitatory pathway to contralateral inferior oblique (IO) and superior rectus (SR) motoneurons (\* in Fig. 1) still remains open.

Additional subgroups in the lateral (LVN) and superior (SVN) vestibular nuclei supplement the vestibulo-ocular projections from the MVN. A subgroup of neurons in the rostral LVN gives rise to the ascending



tract of Deiter's (ATD), which relays horizontal canal signals and excites ipsilateral medial rectus motoneurons (MR; Fig. 1). The SVN contains two inhibitory and one excitatory subgroup that mediate anterior and posterior vertical canal-related signals, respectively, and project to ipsi- (IR, SR, IO, SO) and contralateral (IO and SR) oculomotor/trochlear motoneurons controlling vertical and oblique eye muscles (Fig. 1).

Additional neuronal subgroups in the MVN, LVN and descending vestibular nucleus (DVN) project to spinal targets and transmit semicircular canal and macula signals for postural control (Fig. 1). Vestibular signals to the spinal cord are relayed by two major pathways, the uncrossed lateral vestibulo-spinal tract (LVST) that projects to all spinal levels and the bilateral medial vestibulo-spinal tract (MVST) that projects mainly to the cervical spinal cord. The LVST originates mainly from the LVN, the DVN and the magnocellular part of the MVN and the MVST largely from the MVN (Fig. 2). In different species a variable number of vestibular neurons have axon collaterals that project to both spinal and to extraocular motor nuclei, thus coupling the activation of motor targets for gaze and posture control. Both excitatory and inhibitory neuronal populations contribute to the different fiber tracts.

The pharmacological organization of the reciprocal inhibitory and excitatory canal connections is remarkably conserved among vertebrates [8,10]. All excitatory synapses in the VOR pathway use glutamate as a transmitter and activate NMDA as well as non-NMDA glutamate receptors. In contrast, inhibitory vestibulo-ocular connections use different transmitters for vertical/oblique as opposed to horizontal extraocular motoneurons, respectively. The vestibular inhibition of vertical and oblique extraocular motoneurons in the oculomotor and trochlear nucleus is mediated by GABA and an activation of postsynaptic GABA<sub>A</sub> receptors, whereas the vestibular inhibition of abducens motoneurons and internuclear neurons is mediated by glycine. This differential profile is most probably due to the different developmental origins of the different pools of inhibitory vestibulo-ocular neurons from particular hindbrain segments in which either GABAergic or glycinergic neurons predominate in the vestibular nuclear area [1].

### Control of Vestibular Neuron Activity by Inhibition

Sensory signal processing in second-order vestibular neurons is modified by several inhibitory side-loops that are hypothesized to control different response parameters such as gain (cerebellar loop), dynamics (uncrossed vestibular loop) and response sensitivity (commissural loop) [8]. The presence of these multiple control loops in different vertebrate species, suggests that these connections are a fundamental organizational property of vestibular signal processing.

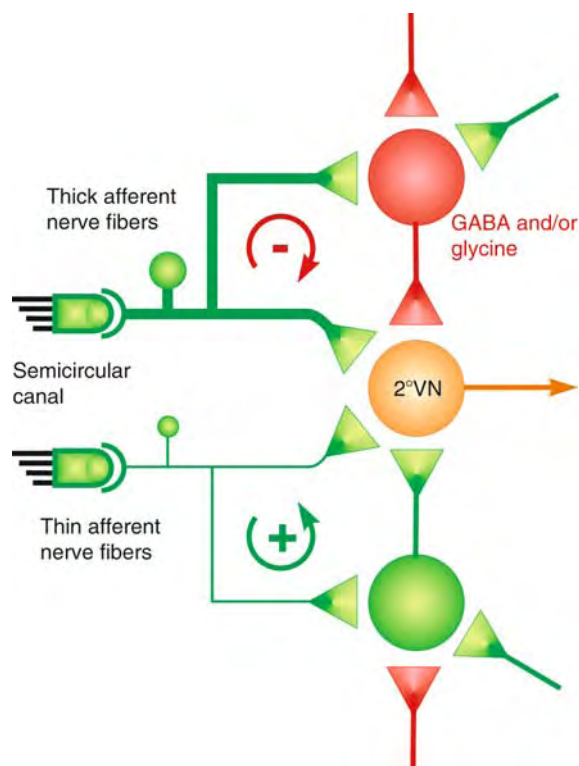

**Functional and Neurochemical Organization of Vestibulo-Motor Pathways.** Figure 2 Schematic diagram illustrating the interaction between the disynaptic inhibitory (red) and the disynaptic excitatory (green) feed-forward side-loop with the monosynaptic semicircular canal excitation in second-order vestibular neurons. The differential activation of the inhibitory (–) and excitatory (+) side-loop by afferent nerve fibers with different response dynamics (marked here as *thick* and *thin* fibers) and their graded control (additional excitatory and inhibitory synapses on these neurons) allows an adjustment and fine tuning of the response dynamics of second-order vestibular neurons.

### Uncrossed Vestibular Side-Loops

Monosynaptic EPSPs in second-order vestibular neurons evoked by electrical stimulation of vestibular nerve afferent fibers are superimposed by additional inhibitory and excitatory responses with a disynaptic onset (Fig. 2) [4,8].

Both response components are relayed by neurons located in the ipsilateral vestibular nuclei that are either local vestibular interneurons or projection neurons with local axon collaterals. The disynaptic IPSPs are mediated by GABA, by glycine or by a combination of GABA and glycine. In frog, both the disynaptic EPSPs as well as the IPSPs originate from the same semicircular canal that gives rise to the monosynaptic excitation (Fig. 2). More specifically, the vestibular

neurons mediating a disynaptic inhibition are activated predominantly by thicker vestibular nerve afferent fibers, whereas those mediating a disynaptic excitation are activated by vestibular nerve afferent fibers with intermediate or thin diameters (Fig. 2). This neuronal arrangement is highly suitable for a feed-forward control of the response dynamics of second-order vestibular projection neurons without changing their spatial response vector.

With this uncrossed vestibular side-loop, thick afferent nerve fiber-mediated responses of second-order vestibular neurons can be disfacilitated, thus allowing adjustment of the response dynamics in these neurons (Fig. 2). The inhibitory control is based on both cellular and network mechanisms. On a cellular level, the disynaptic IPSPs from thick vestibular nerve afferent fibers will restrict the monosynaptic, voltage-dependent activation of the NMDA receptors mediated by these fibers. On a network level, the disynaptic inhibition will reduce the phasic response components mediated by the thick vestibular nerve afferent fibers. This modifiable control loop involving excitatory and inhibitory neurotransmission within the vestibular nucleus seems to be a basic vertebrate design, appropriate for a graded control of tonic and phasic components and suitable for a continuous and adaptive fine-tuning of response dynamics.

### Commissural Vestibular Connections

Vestibular commissural fibers mediating semicircular canal and macular signals cross the brainstem and interconnect central vestibular neurons on both sides [3,6]. In the case of semicircular canal signals, brainstem vestibular commissural fibers relay a canal plane-specific inhibition that is supplemented to a variable degree by spatially unspecific, commissural excitatory connections [8]. The inhibitory canal-commissural pathway connects vestibular neurons related to co-planar semicircular canal pairs on both sides of the brainstem. This connectivity is present in all vertebrates and thus represents a phylogenetically conserved property of the vestibular network. The commissural inhibition is mediated either by an inhibitory neuron that crosses the brainstem (disynaptic) or by an inhibitory neuron on the contralateral side that is activated by an excitatory neuron that crosses the brainstem (trisynaptic) [3]. Whether the vestibular commissural inhibition is mediated by GABA as well as by glycine or only by GABA is still unclear. Functionally, the commissural inhibitory system increases the sensitivity of vestibular neurons for angular acceleration with respect to the activity of canal nerve afferent fibers by a factor of about two. During vestibular compensation vestibular commissural inhibition has been proposed to be modified by cellular mechanisms involving changes in the functional efficacy of GABA and glycine receptors, so as to re-balance the activity of vestibular neurons on the two sides of the brainstem [9].

### Cerebellar Inhibitory Loop

Purkinje cells exert a GABAergic inhibition onto second-order vestibular neurons. Depending on the somatotopic location of the Purkinje cells in the cerebellum, this inhibition is mediated onto vestibulo-spinal or onto vestibulo-ocular neurons and is thus involved in the control of gaze as well as posture. In mammals, the flocculus has been shown to be particularly important for the control of specific subsets of VOR neurons and is implicated in adaptive control of the gain of the VOR. Moreover, floccular target neurons in the vestibular nuclei form a distinct subpopulation of type B vestibular neurons and are thought to play an important role in VOR plasticity [7,9]. Neuroactive steroids, as well as histamine have been shown to modulate cerebellar inhibition of vestibular nucleus neurons.

### References

1. Baker R (1998) From genes to behavior in the vestibular system. *Otolaryngol Head Neck Surg* 119:263–275
2. Bergquist F, Dutia MB (2006) Central histaminergic modulation of vestibular function – a review. *Acta Physiologica Sinica* 58:293–304
3. Büttner U, Büttner-Ennever JA (2006) Present concepts of oculomotor organization. In: Büttner-Ennever JA (ed) *Neuroanatomy of the oculomotor system*. *Prog Brain Res*, vol 151. Elsevier, Amsterdam, pp 1–42
4. Goldberg JM (2000) Afferent diversity and the organization of central vestibular pathways. *Exp Brain Res* 130:277–297
5. Glover JC (2000) Neuroepithelial “compartments” and the specification of vestibular projections. *Prog Brain Res* 124:3–21
6. Highstein SM, Holstein GR (2006) The anatomy of the vestibular nuclei. In: Büttner-Ennever JA (ed) *Neuroanatomy of the oculomotor system*. *Prog Brain Res*, vol 151. Elsevier, Amsterdam, pp 157–203
7. Lisberger SG (1998) Physiologic basis for motor learning in the vestibulo-ocular reflex. *Otolaryngol Head Neck Surg* 119:43–48
8. Straka H, Dieringer N (2004) Basic organization principles of the VOR: lessons from frogs. *Prog Neurobiol* 73:259–309
9. Straka H, Vibert N, Vidal PP, Moore L, Dutia MB (2005) Intrinsic properties of vertebrate vestibular neurons: function, development and plasticity. *Prog Neurobiol* 76:349–392
10. Vidal PP, Vibert N, Serafin M, Babalian A, Mülhenthaler M, De Waele C (1999) Intrinsic physiological and pharmacological properties of central vestibular neurons. *Adv Otolaryngol* 55:26–81

---

## Functional Bowel Disorders

## Functional Ileus

### ►Bowel Disorders

## Functional Imaging

C. GIOVANNI GALIZIA

Universität Konstanz, Faculty of Biology, Konstanz, Germany

### Definition

A technique that records neural activity in many places in parallel, generally using light. Activity patterns can be visualized as images that reflect both anatomy in space and activity in time. Subtechniques include optical imaging (e.g. using intrinsic signals or voltage sensitive dyes), calcium imaging (using fluorescent dyes, ►**ratio-metric dyes**, measure of ►**deltaF/F**), and functional magnetic resonance tomography (fMRT), among others.

### Characteristics

#### Imaging Techniques

Brains consist of a high number of neurons that are interconnected and work as an ensemble. For example, the human brain has 10 billion neurons, and even the brain of a humble honeybee has 1 million neurons. Understanding their function requires recording from these neurons under physiologically controlled conditions. Single-cell electrophysiology gives information about neural activity in individual cells as a whole. Functional imaging techniques have been developed in order to record neural activity both in space and in time simultaneously. Space can include the analysis of activity along the branching pattern of a single neuron, or across large neuron populations. As a consequence, functional imaging has gained an important role in understanding the relationship between the morphology of neurons and their function, and in understanding combinatorial information processing in the brain.

In the following, I will review the major techniques that have been used in recent years, first from the point of view of the signal that is measured (intrinsic signals, dyes, reporter proteins), next from the point of view of the neurons measured (from single neurons to entire brains), including examples from the analysis of olfactory systems.

#### Optical Imaging: Intrinsic Signals

Neurons change their light properties when they are active, though the exact physics of this phenomenon

is as yet unknown. While these changes were used in the very early days of optical imaging, today intrinsic signals are used mostly for *in vivo* studies of mammalian brains. Here, the main signal derives from blood, which changes its color in its transition from the oxygenated to the deoxygenated state. Therefore, the brain is illuminated with a red light, and the reflectance is measured. While the skull has to be removed in order to gain optical access to the brain in most cases, in small mammals, notably rodents, successful measurements have been done through the thinned skull bone layer. The advantage of this technique is its independence from dyes, and therefore the brain is measured with very little interference. However, the signal is only an indirect measure of neural activity, since it consists of a blood oxygenation response, and therefore it is relatively slow and has a limited spatial resolution. Hence the strength of this technique to map spatial activity patterns.

#### Optical Imaging: Voltage Sensitive Dyes

Much faster measurements are possible with voltage sensitive dyes (VSD), and when only neurons are stained with these dyes, the signal is exquisitely neuronal. VSDs are generally fluorescent dyes, with a charged chromophore attached to a lipophilic moiety that integrates into the cell membrane. As the voltage across the membrane changes, the charged chromophore moves with respect to the membrane, and the fluorescent spectrum shifts. When using a ►**fluorescence** excitation and emission setting that hits the dye's maximum, a shift in fluorescent spectrum of the dye results in a fluorescence decrease. This decrease is proportional to the membrane's voltage change. VSDs are generally fast, which is their greatest advantage. In suitable preparations it is possible to resolve single spike events. However, changes in fluorescence are small, often resulting in a poor ►**signal to noise ratio**. Dyes can be applied by soaking the brain in it, or by selective staining (see below). Because optical access to the brain is necessary, these techniques are always invasive.

#### Optical Imaging: Calcium Signals

Most studies done with animals as opposed to humans have used calcium as an indicator for cellular activity. This has specific reasons: calcium is the ion that has the greatest concentration change when a neuron is active. Within cells, calcium concentration is in the range of 200 nM, while outside concentration can easily reach millimolar concentrations, giving a concentration difference of up to 10,000-fold. This enormous gradient is actively created by the cells with calcium pumps that keep intracellular concentration low, and is used for intracellular messaging: calcium plays an important role in many intracellular information cascades, ranging

from neurotransmitter release to second messenger cascades, including sensory transduction cascades. Most cells express voltage sensitive calcium channels, so that intracellular calcium concentration increases when the neuron depolarizes. However, although in most cases the correlation between calcium concentration and depolarization and/or spiking activity is very good, this relationship is not one-to-one, given that calcium fulfills many more tasks within the cell.

Calcium dyes are generally modified ► **calcium chelators** with a fluorescent chromophore attached to it. The calcium chelator has a predominance of negative charges that are compensated when the positive calcium ion is trapped in it. Thus, the fluorescence chromophore is modified, with a resulting change in fluorescence properties. In some dyes, such as *calcium green* or *fluo-4*, fluorescent intensity increases with increasing calcium concentration. In other dyes, such as *fura*, increase or decrease depend on the excitation wavelength. Specifically, in *fura* measurements, fluorescence with excitation light of 340 nm increases, and with excitation light of 380 nm it decreases (at approx. 360 nm there is an isosbestic point, i.e. a point where fluorescence is calcium-concentration independent).

#### Optical Imaging: Other Dyes

There are a variety of other dyes to monitor cell activity, including dyes for ions such as chloride and potassium, pH-sensitive dyes, or more sophisticated variants that monitor transmitter vesicle release. It is beyond the scope of this chapter to list them all.

#### Optical Imaging: Genetically Engineered Dyes

An area of fast and important growth is the development of genetically engineered reporter proteins. The basic concept is easy: a fluorescent protein is linked to another protein that is sensitive to the metabolic status of a cell in such a way that changes in metabolism result in fluorescent changes. Then, the gene for this artificial protein is inserted into an animal under the control of a cell-specific promoter creating a transgenic organism. As a result, a genetically defined population of cells will express the reporter gene, and measurements of these cells can be done with optical methods.

Take, as an example, the calcium sensitive G-CaMP. One component of this protein is a modified GFP-protein (GFP – green fluorescent protein – was the first of what is now a large family of proteins that are fluorescent. Several animals naturally express fluorescent proteins. GFP was isolated from the jellyfish *Aequorea victoria* that uses it together with a bioluminescent protein to produce light of controlled wavelength). The other component of G-CaMP is derived from the calcium-sensitive natural protein calmodulin. Thus, borrowing from natural proteins as if it were building blocks in a child's game, a new calcium-sensitive fluorescent

protein was created (of course, the technical details make the process much more complex). Finally, in order to use these proteins for functional imaging, their genes have to be inserted into the genome under the control of a promoter. It is the choice of the promoter that will lead to expression in neurons rather than in other cells, or even in genetically defined specific populations of neurons, e.g. only receptor cells, or only inhibitory cells – in fact, any cell populations for which a specific promoter is known. Alternative approaches include a random gene expression using a gene-gun, where gold particles are coated with the genetic material, shot into the tissue, taken up by some but not all cells, and then expressed, resulting in a situation where some but not all cells are labeled with the reporter protein.

Once the cells of interest have been labeled, recording follows the same procedures as for synthetic dyes. Being fluorescent dyes, it is necessary to gain optical access to these neurons (e.g. by removing the skull in the case of in-vivo measurements), then an excitation light is shone on the neurons, and the fluorescent light is measured using a light sensitive device, e.g. a photomultiplier or a CCD-Camera.

Just as calcium sensitive proteins have been created from calcium-sensitive cell constituents, proteins sensitive to other cell properties have been and/or are being developed. These include probes for membrane potential, for pH value, for synaptic transmission, and for second messengers such as cAMP. A further development is to create probes that interfere with cellular events: here we leave functional imaging, and enter the realm of targeted functional manipulation.

#### fMRT: BOLD Signal

An increasingly important technique in biomedical imaging measures the BOLD signal (Blood Oxygen Level Dependency) with fMRT (functional Magnetic Resonance Tomography). This is a technique that uses intrinsic signals (see above), but does not involve light. Rather, a strong magnetic field is applied as a pulse, and the magnetic relaxation is measured. The BOLD-signal is related to blood flow, and therefore also to neuronal activity. Just as for other intrinsic signals, this is an indirect measure of neuronal activity, and therefore intrinsically slow. Furthermore, the spatial resolution is limited by the strength of the magnetic fields used, and by the volume of blood affected by neural activity. Therefore, single cell analysis will never be possible with this technique. However, brain areas can be investigated. For example, in the olfactory system, the analysis of individual olfactory glomeruli is already possible. The greatest advantage of this technique is that the animals remain intact: no surgical manipulation is necessary, and no dye or contrast agent needs to be administered. As a consequence, fMRT gains increasing importance in studying brain activity in humans.

Most importantly, results from invasive experiments on animals can in many cases be verified for their relevance to the human system by using fMRT.

### Imaged Structures

Functional imaging studies play an important role in neuroscience research, because they allow measuring neuronal activity over time and space. However, the kind of results that can be obtained depend strongly on the technique used, and on the structures that are imaged. It is the combination of different staining techniques that is allowing scientist to study brain function just as putting together a jigsaw-puzzle.

### Single Neurons: Selective Loadings

The unit of brain activity is the individual neuron. After loading a single neuron with dye using a microelectrode (effectively a hollow glass tube with a microscopic tip that penetrates into the cell), functional imaging allows to analyze how the neuron itself is substructured into functional domains. A textbook neuron consists of an input branch (the dendrites) and an output site (the axon), joined by the cell body. Using functional imaging, these compartments can be characterized: their electrical and biochemical properties can be analyzed separately. For example, many cells have spines on their dendrites, small protuberances that are the sites of synaptic input. Imaging studies showed that each spine constitutes a compartment on its own, acting in concert with the rest of the cell, but independently to a great extent. In more complex neurons, where the input and the output regions are not separated so clearly, functional imaging is used to map input and output sites, and characterize their properties. For example, local neurons within the olfactory bulb create microcircuits mediating activity of neighboring mitral cell dendrites. Thus, these neurons do not really act as a unit, but themselves as a complex of many, interconnected units.

### Neuron Populations: Selective Staining

Neural processing occurs in neural networks of interconnected units and networks. By selectively staining particular populations of neurons it is possible to follow neural processing along its steps. For example, in the olfactory system odor coding can be followed from receptor neurons, to populations of local neurons in the first olfactory epithelium (the mammalian olfactory bulb, or the insect antennal lobe), to higher order brain centers, including the mammalian cortex. Such studies are only possible by selectively staining specific populations of neurons, because in any one brain area there are many neurons that contribute in different ways to processing in that area. Techniques for selective staining include filling many neurons by injecting a bolus of highly concentrated dye or dye crystals into a

brain region, with the result that many neurons in that region will pick up the dye. As a result, in other areas of the brain neurons will not be stained, unless they have a projection (e.g. an axon) into the treated area – with other words, here the staining is selective for those neurons that have specific connections to the injected area.

### Neuron Populations: Genetic Labeling

Many neurons that work in groups are not easy to label by dye injection. For example, in all brain regions there are local neurons that do not project to other areas. These neurons cannot be stained by dye injection without incurring into unspecific staining of other neuron populations. In many cases, however, it has been possible to find genetic promoters that are specific to local neurons, and to use these for expressing reporter genes in these neurons. The fruit fly *Drosophila melanogaster*, for example, is among the animals with the best genetic tractability. Here, it was possible to characterize at least three distinct populations of local neurons in the first olfactory processing area, the antennal lobe, and to show that they all have a distinct role in odor processing, and different functional properties.

As another example, many olfactory sensory cells express the same olfactory receptors, and consequently respond to the same odors. This is a property that derives from their genetic instruction, and has been used to create animals were only neurons expressing a particular receptor type express a reporter gene. Such preparations can be used to characterize the molecular response profiles of olfactory receptors, i.e. the entire description of the odors that bind to a particular receptor.

### Neuron Populations: Non-Selective Staining

Non-selective stainings are those that make no distinction of different cell types. One technique is to bath the brain tissue in dissolved dye, and to allow all neurons to incorporate the dye. These studies do not allow dissecting the cellular steps of neural processing. However, they allow investigating the spatial arrangement of information processing in the brain. For example, the olfactory system creates a functional map of activated glomeruli in the antennal lobe (insects) or the olfactory bulb (mammals). These maps can be directly measured using non-selective staining techniques. Such measurements have revealed the basic principles of olfactory coding: a combinatorial scheme, where each odor evokes activity not in one, but in many glomeruli, and the information about the odor resides not in any single glomerulus, but in its combinatorial arrangement. Thus, a single glomerulus will contribute to the code of very different odors, and the task of the brain is to extract the olfactory significance in each combinatorial pattern.

## Functional Magnetic Resonance Imaging (fMRI)

### Definition

Functional magnetic resonance imaging (fMRI) is used to monitor hemodynamic events related to changes in neuronal activation in the brain. This is accomplished by a sensitization to the effect from microscopic inhomogeneities in the magnetic field caused by the magnetic properties of hemoglobin.

- ▶ Magnetic Resonance Imaging

## Functional Muscle Synergies

- ▶ Postural Synergies

## Functional Neuroanatomy

- ▶ Functional-Anatomical System

## Functional Neuroimaging Methods

### Definition

Positron emission tomography (PET) and functional magnetic resonance imaging (fMRI) are two main functional imaging techniques used to study brain-behavior relationships. PET techniques involve intravenously injecting different short-lived radioactive agents and then imaging people in a specialized detector system to examine biochemical or physiological processes involved in cerebral blood flow and metabolism.

fMRI techniques produce images of brain activation by detecting the indirect effects of neural activity on local blood volume, flow, and oxygenation.

The most common fMRI technique involves blood oxygen dependent-level contrast, which detects endogenous changes in local concentrations of paramagnetic

deoxyhemoglobin associated with local increases/decreases in neural activity.

- ▶ Functional Magnetic Resonance Imaging (fMRI)
- ▶ Positron Emission Tomography (PET)

## Functional Role

### Definition

Specifies the relation between inputs, outputs, and internal roles of a system; it is used to characterize states, particularly mental states in the philosophy of mind.

- ▶ Emergence

## Functional Stretch Reflex

### Definition

Term referring to stretch evoked increases in EMG in the triceps surae muscles. These responses occur at latencies similar to those of volitional responses to an unexpected perturbation, so it is inappropriate to consider these responses to be long loop (long-latency) reflexes.

- ▶ Electric Fish
- ▶ Long Loop Reflexes

## Functionalism

### Definition

The view that the physical realization of a component is not its essence. Rather, what individuates a functional component of a special type is characterized in terms of its role in relating inputs to outputs and in terms of its relations to other (functional) components.

- ▶ Causality
- ▶ Mental Models
- ▶ Reductionism (Anti-Reductionism, Reductive Explanation)

## Fungiform Papillae

### Definition

(Papilla: small protuberance, Fungus: mushroom) These are small “mushroom shaped” structures of diameter up to 15 mm protruding slightly from the dorsal surface of the tongue. Fungiform papillae are disseminated between the filiform papillae all over the anterior two-third of the tongue with a higher density towards the tip. They can contain up to 20 taste buds (human) from which the pores emerge at the top however it is estimated that up to 60% of fungiform papillae lack taste buds. The average number of fungiform papillae on the tongue is around 200 for a density of taste buds at the tip of the tongue of about 150 taste buds/cm<sup>2</sup>.

► Taste

## Fusiform Cells

### Definition

Principal cell type in the dorsal cochlear nucleus.

► Cochlear Nucleus

## Fusiform Face Area

### Definition

► Face Processing in Different Brain Areas

## Fusimotor Neurons

### Definition

Small diameter motoneurons that innervate the intrafusal fibers of the muscle spindles. Firing of fusimotor

neurons causes the ends of the intrafusal fibers to contract. This stretches their central regions and stimulates the spindle afferent fibers.

► Proprioception: Roles of Muscle Receptors

## Fusimotor Reflexes

### Definition

Responses of fusimotor neurons to sensory inputs.

Fusimotor neurons control the background firing rate and stretch-sensitivity of muscle spindle afferents by activating intrafusal muscle fibers.

► Feedback Control of Movement

## Fusion Competence of Secretory Vesicles

► Neurotransmitter Release: Priming at Presynaptic Active Zones

## Fusion Pore

### Definition

The initial connection between the lumen of a vesicle and the extracellular space during the process of exocytosis.

► Non-synaptic Release

## F-Wave Method

### Definition

A method used to estimate the peripheral conduction time from spinal motoneurons to muscle(s). It is based

on electrical stimulation of the peripheral nerve with supra-maximal intensity and recording evoked muscle potentials. It is calculated as  $(F + M - 1)/2$ , where F is the shortest F-wave latency, M the onset of the direct muscle response and 1 ms allowed for neuron activation.

► [Transcranial Magnetic Stimulation](#)

---

## Fyn

### Definition

A non-receptor tyrosine cytoplasmic kinase that can transfer a phosphate group from ATP to tyrosine residues of target proteins.



## G Protein-activated Potassium Channels

### Definition

A family of inwardly-rectifying potassium channels that are activated by the  $\beta\gamma$  subunits of G proteins of the Gi/o family.

► Neuronal Potassium Channels

## G Protein-coupled Receptor

YUICHI HASHIMOTO, TATSUYA HAGA  
Institute for Biomolecular Science, Faculty of Science,  
Gakushuin University, Tokyo, Japan

### Synonyms

Metabotropic Receptor

### Definition

► G protein-coupled receptors (► GPCR) constitute the largest family of cell-surface receptors. GPCRs share a common architecture of seven membrane-spanning  $\alpha$ -helices and transduce the messages mediated by a diverse range of signaling molecules, including acetylcholine, adrenaline, dopamine, serotonin, glutamic acid,  $\gamma$  aminobutyric acid, proton,  $\text{Ca}^{2+}$ , adenosine, ATP, prostaglandins and other lipids, opioids and other peptides, and various proteins, as well as various kinds of odorants and taste substances, leading to alterations of cellular function. Targets for 30–60% of medicines and opsins (receptors for light) are also GPCRs. This superfamily of receptors contains approximately 900 members in the mammalian genome. Moreover, GPCRs are roughly estimated to account for 4 and 1% of the total genes in the genomes of *Caenorhabditis elegans* and *Drosophila melanogaster*, respectively, demonstrating that these receptors have been well conserved throughout evolution.

Upon binding of an extracellular ligand, GPCR is activated, and the activated receptor facilitates the release of GDP from heterotrimeric GTP-binding regulatory proteins (G proteins;  $G\alpha/G\beta\gamma$ ), resulting in the binding of GTP to  $G\alpha/G\beta\gamma$ , followed by its dissociation into GTP-bound  $G\alpha$  ( $G\alpha$ -GTP) and  $G\beta\gamma$ .  $G\alpha$ -GTP and  $G\beta\gamma$  then activate or inhibit several effector proteins such as adenylyl cyclases, phospholipase C $\beta$ s, phosphodiesterases, phosphoinositide 3-kinases, and ion channels, resulting in a variety of cellular responses. Upon GTP hydrolysis,  $G\alpha$ -GDP and  $G\beta\gamma$  reassociate into inactive G protein trimer, terminating activation of effector proteins.  $G\alpha$  itself has GTPase activity, which is stimulated by effectors themselves or specific GTPase-activating proteins referred to as regulators of G protein signaling (RGS) proteins. Thus, G proteins generally mediate GPCR signaling, although several reports have claimed recently that some GPCRs can mediate the signal by interacting with proteins other than G proteins, such as arrestin [1].

### Characteristics

#### Classification of GPCRs

The superfamily of GPCRs can be divided into several subfamilies based on sequence similarities. GPCRs in one subfamily do not share significant sequence similarity with those in another subfamily, although they all have a central core domain made up of seven transmembrane domains (TM1-TM7). TM1-TM7 are  $\alpha$  helices connected by three extracellular loops (e1-e3) and three intracellular loops (i1-i3). Aside from sequence variations, GPCRs differ in the length and function of their N-terminal extracellular domain, their C-terminal intracellular domain and their intracellular loops.

In one of the most frequently used classification, GPCRs are grouped into families A, B, C, D, E, and F [2]. Mammalian GPCRs are found only in family A, B and C.

#### Family A (Rhodopsin Family)

This family includes the most extensively studied GPCRs, such as rhodopsin, adrenergic receptors, and muscarinic acetylcholine receptors, and the majority of GPCRs identified to date. Small ligands like catecholamines bind in a cavity formed by seven TMs, while short peptides interact with the extracellular loops and

the N-terminal domain as well as with TMs. Receptors in the Family A are characterized by some highly conserved amino acids (Fig. 1a). For instance, an Asp in TM2 is essential for coupling to G proteins, and is known to form a hydrogen bond with the side chain of a

conserved Asn in TM1 and Ala in TM7 in rhodopsin. The Asp-Arg-Tyr (DRY), Glu-Arg-Tyr (ERY), or Glu-Arg-Tryp (ERW) sequences at the N-terminus of i2 are highly conserved and are directly involved in G protein activation. Furthermore, a disulphide bridge

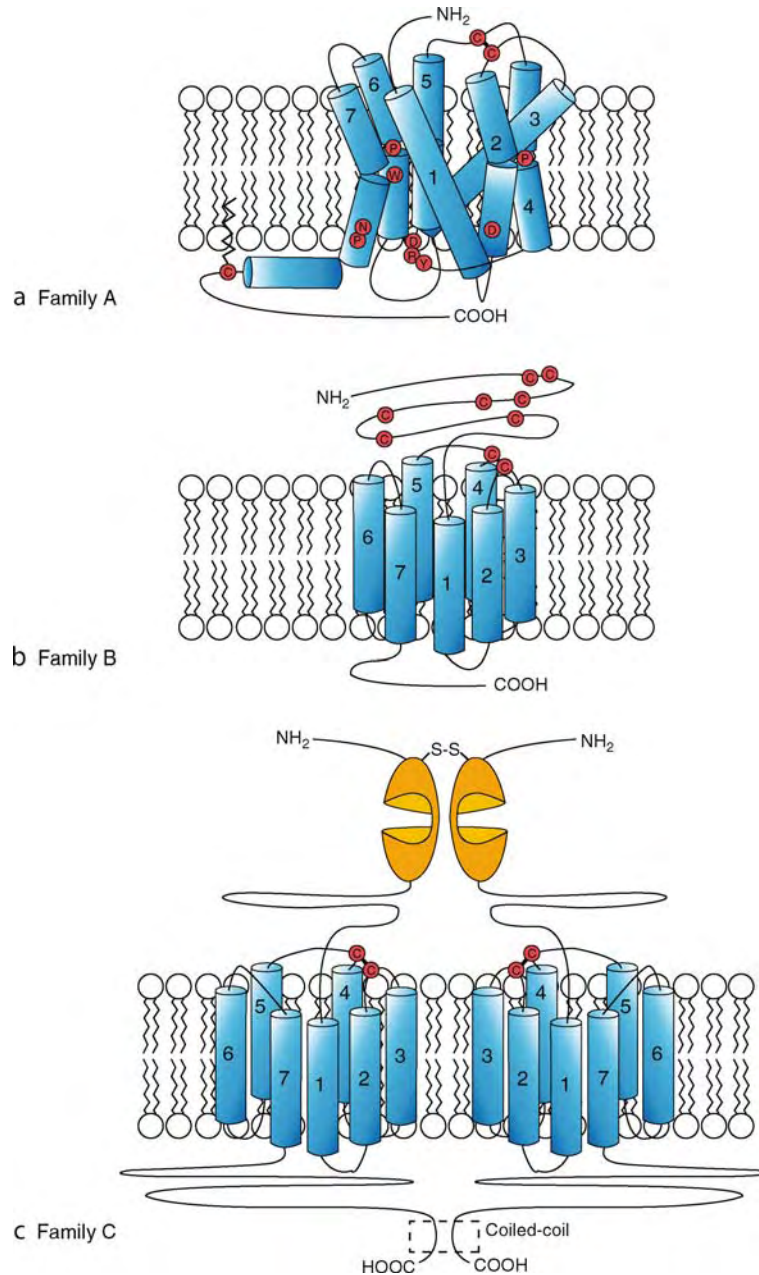

**G Protein-coupled Receptor. Figure 1** Structural models of G protein-coupled receptor (GPCR) families.

(a) Family A of GPCRs such as rhodopsin, muscarinic acetylcholine receptors, and adrenergic receptors. The GPCR structure is depicted according to the structure of rhodopsin. Cysteine and other residues common to family A GPCRs are shown with *red circle*. (b) Family B of GPCRs that are represented by secretin receptor. (c) Family C of GPCRs such as metabotropic glutamate receptors and GABA<sub>B</sub> receptor. As no structural information is available for TM regions of GPCRs in family B and C, 7 TMs are shown with *straight rods*. Coiled-coil structure is formed at the C-terminal tail in GABA<sub>B</sub> receptor (*enclosed in broken line*).

that connects e1 and e2 is conserved in most GPCRs in this family (Fig. 1a). Most of these receptors have the palmitoylated cysteine in the C-terminal tail, which serves as the membrane anchor (Fig. 1a).

### Family B (Secretin Receptor Family)

This family includes receptors for secretin, calcitonin, parathyroid hormone, glucagon, corticotropin-releasing factor, vasoactive intestinal peptide, and pituitary adenylyl cyclase-activating protein. The secretin receptor was the first one cloned among those in this family. The ligand-binding site of these receptors is mostly composed of extracellular domains, although TMs may be partly involved. GPCRs in this family are characterized by a relatively long N-terminus, which contains several cysteines that form a network of disulphide bridges (Fig. 1b). Conserved residues and motifs of the family B receptors are different from those of the family A receptors, and the palmitoylation site is missing in the former.

### Family C (Glutamate Receptor Family)

Family C contains at least eight metabotropic glutamate receptors (mGluRs), calcium-sensing receptors, and GABA<sub>B</sub> ( $\gamma$  aminobutyric acid, type B) receptors. These receptors are characterized by long N- and C-terminal tails (Fig. 1c). The ligand recognition domain in the mGluR is found in the N-terminus (Fig. 1c), which has been shown to form a disulphide-linked dimer by X-ray crystallographic analysis. The structure appears to resemble a “Venus fly trap,” which could open and close with the agonist bound inside. Receptors in this family do not have features common to those in family A and B receptors, except for two cysteine residues in e1 and e2 that are supposed to form a disulphide bridge (Fig. 1c). A unique feature of family C receptors is that i3 is short and highly conserved.

Family D represents the fungal pheromone A receptors.

Family E contains the cAMP (▶cAMP system) receptors of *Dictyostelium discoideum*.

Family F contains archaeobacterial opsins.

### Structure of GPCRs

In 2000, Okada et al. succeeded in crystallizing bovine rhodopsin, and reported its three-dimensional structure at the resolution of 2.8 Å [3]. This provided direct evidence that seven hydrophobic regions (20–25 amino acid residues each) form  $\alpha$  helices and transverse the membrane, and the N- and C-terminal tails are located in the outside and inside of cells, respectively. Although the mass of TM bundles for rhodopsin does not differ significantly from the mass of those for bacterial rhodopsin, the arrangement of seven helices is different. As expected from previous electron diffraction studies of rhodopsin, TM1, 4, 6, and 7 are bent at proline residues, although the bending is not apparent

in TM1 and is present at the extracellular end in TM4 (Fig. 1a). Proline residues are conserved in all members of family A GPCRs and are thought to be critical for their functions. TM5 is almost straight in spite of the presence of a proline residue in the middle, whereas TM2 is bent at the Gly-Gly doublet in the middle. TM4 and 7 are shorter than the other TMs. Moreover, the eighth  $\alpha$  helix was found to be present parallel to the membrane surface, between the end of TM7 and the palmitoylated cysteine residues in the C-terminal region (Fig. 1a). The highly conserved E-R-Y sequence at the N-terminus of i2 was found to be surrounded by hydrophobic residues from TM2, i2, TM5, and TM6. This region is likely to form a contact surface with G proteins. Retinal forms a Schiff base with Lys<sup>296</sup> of TM7 (retinal-CHO + NH<sub>3</sub><sup>+</sup>-Lys = retinal-CH = NH<sup>+</sup>-Lys). This protonated Schiff base interacts with the carboxyl anion of Glu<sup>113</sup> in TM3. A disulphide bridge between e1 and e2 was confirmed in rhodopsin and is supposed to be present in GPCRs of family A. The N-terminal domain of rhodopsin contains two anti-parallel  $\beta$  sheets that are located just below the e2, which also contains two anti-parallel  $\beta$  sheets. These four  $\beta$  sheets, as well as most of e2, appear to make an extracellular plug, which might serve to prevent the all-trans retinal from projecting out of the pocket during activation. It remains to be determined if such plugs are present in other GPCRs of family A. Recently, Okada et al. succeeded in improving the quality of rhodopsin crystals, and a higher resolution (2.2 Å) structure was reported. This revealed a complete structure of a cytoplasmic region of rhodopsin, which was missing in the previous structure.

The structure of rhodopsin is so far the one and only model for GPCRs. The determined structure, however, is that of rhodopsin in its inactive state, and this structure might not be an appropriate model for the active state of GPCRs and for the design of specific drugs. Several researchers have used this structure as a starting point to make a structural model for the active state of rhodopsin and other GPCRs in family A.

### Dimerization of GPCRs

For many years, GPCR and G protein were supposed to couple with one to one stoichiometry. The growing body of evidence, however, has suggested the dimerization or oligomerization of GPCRs. In the following, we refer to this as dimer for simplicity, although some might be tetramer or other oligomers.

The first convincing evidence came from studies on GABA<sub>B</sub> receptors. Heterodimerization of GABA<sub>B</sub> receptor subunits, GABA<sub>B</sub>R1 and GABA<sub>B</sub>R2, was demonstrated to be indispensable for cell surface expression and their functional coupling with G proteins. The GABA<sub>B</sub>R1 is retained in the endoplasmic reticulum through a C-terminal retention motif, and can be

translocated into the cell surface only after interaction with GABA<sub>B</sub>R2 through their C-terminal coiled-coil  $\alpha$  helical structures. It has been suggested that each subunit of the GABA<sub>B</sub>R1/R2 heterodimer share the respective role, the ligand binding activity by R1 and the G protein activation by R2. In addition, some taste receptors with the long N-terminus have been shown to form heterodimers with high affinity for amino acids and other substances. Furthermore, the tertiary structure of the extracellular domain of mGluR1a was determined by X-ray crystallography, demonstrating that they form a constitutive dimer. These results indicate that GPCRs in family C form the dimer.

Besides GPCRs in family C, a number of reports have indicated the functional significance of dimerization of GPCRs in family A. One of the striking examples is the change in pharmacological properties of  $\delta$ - and  $\kappa$ -opioid receptors. These receptors showed a high affinity for their respective selective ligands when expressed alone, but did have a very low affinity for them when expressed together. When a combination of two ligands was applied to cells that express both receptors, however, both receptors exhibited a high affinity for either of the ligands. This result indicates that the two receptors form a heterodimer that binds two ligands in a highly positive cooperative manner. Another example is chimeric receptors between the  $\alpha$ 2 adrenergic receptor ( $\alpha$ 2AR) and M<sub>3</sub> muscarinic receptor (M<sub>3</sub>), which are composed of the first five TMs of one receptor and the last two TMs of the other receptor. Neither chimera,  $\alpha$ 2(TM1–5)·M<sub>3</sub>(TM5,6) or M<sub>3</sub>(TM1–5)· $\alpha$ 2 (TM5,6), binds ligands nor activates G protein when expressed alone, but the binding activity for both  $\alpha$ 2AR and M<sub>3</sub> agonists and the G protein-activating activity are recovered when both chimeras are co-expressed. This result suggests that the two chimeras form the dimer, in which the ligand binding activity is retained complementarily by TM1–5 from one receptor and TM6,7 from the other. A number of other receptors have also been suggested to form heterodimers by analysis of ligand binding characteristics or of downstream signaling. In addition, other lines of evidence have suggested that dimerization is necessary for receptors to be translocated from the endoplasmic reticulum to the cell surface, and that an agonist for one receptor facilitates the internalization of the other receptor, or the agonist-induced internalization of one receptor is inhibited by coexpression of the other receptor (see review by Terrillon and Bouvier [4]). Some of these phenomena may be artifacts derived from high-level expression of receptors in the heterologous cell system. In fact, the  $\beta$ 2 adrenergic receptor is reported to form a heterodimer with  $\delta$ -opioid receptor only when expressed at a high level. On the other hand, some reports have shown that the synergistic binding or signaling between two types of receptors have been observed in native tissues as well as in the heterologous expression system.

Interestingly, rhodopsin has been reported to exist as homodimers in dark-adapted retinal membranes based on observation by atomic force microscopy [5]: it should be noted that critical comment was also made on the possibility for artificial segregation of rhodopsin from lipid layers during the sample preparation [6]. Recently, Baneres et al. [7] showed, by using reconstitution of solubilized receptors, G proteins and chemical cross-linking, that leukotriene B4 receptors form a dimer in the presence of leukotriene B4 and that the dimer interacts with one heterotrimeric G protein, forming a pentamer complex (B4 Receptor)<sub>2</sub>/Gi2 $\alpha$ /G $\beta$ 1 $\gamma$ 2. These results indicate that GPCRs may form homodimers as well as heterodimers, raising questions as to whether GPCRs are intrinsically dimers and if dimerization of GPCRs is prerequisite for their function. In this context, it is interesting to note that solubilized rhodopsin may exist either as a monomer or a dimer, depending on detergent concentrations, and that the monomeric rhodopsin appears to interact with and activate G protein [8]. If GPCRs can exist as either monomers or dimers on the cell surface, the question is raised as to what is the physiological function for GPCR to be a dimer in native tissues (see reviews Bouvie [4], Milligan [9]).

Some GPCRs have been reported to form dimers with other proteins. For example, calcitonin receptor-like receptor interacts with a protein called RAMP (receptor-activity-modifying protein) that has a single TM domain. The dopamine D5 receptor interacts with the C-terminal domain of GABA<sub>A</sub> ionotropic receptor, which is a member of the ligand-gated channels.

### Desensitization of GPCRs

Desensitization of GPCRs refers to a progressive attenuation of the effector activity and the loss of the physiological response, despite the continued presence of agonist stimulation. Two types of desensitization, homologous and heterologous, have been described. Both desensitizations are initiated by activation of GPCRs, but only agonist-bound GPCRs are desensitized in homologous desensitization, whilst any GPCRs may be desensitized in heterologous desensitization. Desensitization is generally thought to occur in three phases. The most rapid phase (seconds to minutes) involves uncoupling of the receptors from its G proteins, which is induced by agonist-stimulated GPCR phosphorylation (Fig. 2; [10]).

Sequestration/internalization is the second phase that commonly occurs with a slightly slower time course. In the third phase, internalized receptors can be recycled back to the cell surface (receptor recycling/resensitization) for further duty or targeted to lysosomes for degradation (down-regulation; Fig. 2). The extent to which each of these phases is responsible for desensitization depends on the types of receptors or cells expressing receptors.

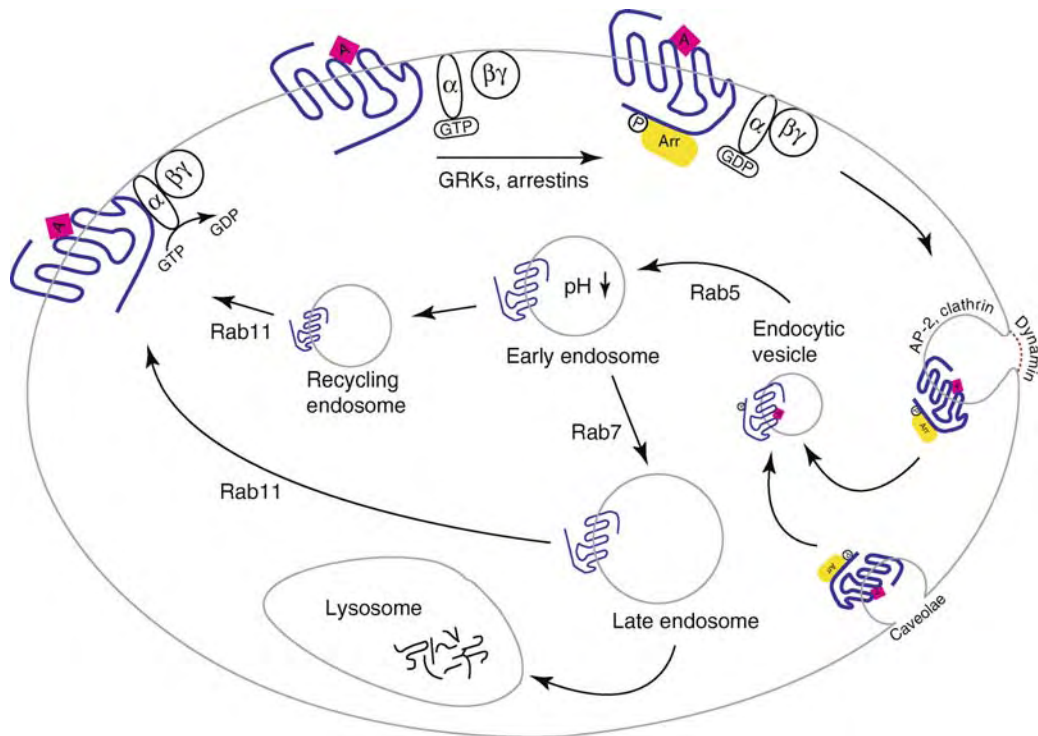

**G Protein-coupled Receptor. Figure 2** A model for internalization and recycling of GPCRs. Some GPCRs internalize in clathrin-mediated pathway that is dependent on phosphorylation of C-terminal tail or i3 by GRKs and the subsequent binding with arrestins, whereas some other GPCRs internalize in caveolae-mediated pathway. Some GPCRs can be recycled back to the cell surface for further obligation. A agonist; Arr arrestins; Rab small molecular weight GTP-binding protein.

In heterologous desensitization, second messenger-dependent kinases [protein kinase C (PKC) and protein kinase A (PKA)] are supposed to be involved. These kinases are activated by second messengers that are increased by the action of agonist-bound GPCR, but the substrates of these kinases may include not only the agonist-bound receptor, but also other receptors and other down-stream proteins.  $\beta_2$  Adrenergic receptors ( $\beta_2$ ARs) are good substrates for PKA, and their phosphorylation on the i3 leads to an uncoupling from Gs. The PKA-mediated phosphorylation can increase  $\beta_2$ AR coupling to  $G_i$  and promote MAP kinase cascade activation. It remains to be determined if this is a general mechanism applicable for other GPCRs. PKC-mediated heterologous desensitization has also been reported.

G protein-coupled receptor kinase (GRK)- and arrestin-mediated processes are involved in homologous desensitization of many GPCRs. GRKs can discriminate between inactive receptors and agonist-activated ones, partly because GRKs are activated by agonist-stimulated receptors including light-activated rhodopsin. Phosphorylation by GRKs occurs either in the C-terminal domain ( $\beta_2$ AR and rhodopsin) or i3 ( $\alpha_2$ AR and muscarinic  $M_2$ ). Phosphorylation does not

necessarily mean uncoupling. After GRK-mediated phosphorylation of rhodopsin and  $\beta_2$ AR, uncoupling occurs when arrestins bind to the phosphorylated receptors. The classical pathway for  $\beta_2$ AR endocytosis involves its targeting to clathrin-coated pits, although it can also be targeted to caveolae, as are some other GPCRs (Fig. 2). The targeting to clathrin-coated pits means the binding of arrestin-bound receptors with several proteins such as AP-2 (adapter protein 2) and Src as well as with clathrin. The clathrin-coated vesicle containing the receptor complex is pinched off from the plasma membrane by action of dynamin, and the receptor is transferred to other vesicles referred to as endosomes. Receptors in endosomes are recycled back to the cell surface or translocated to lysosomes (Fig. 2). Recently, ubiquitination has been suggested to be involved in the down-regulation of GPCRs [10]. Recycling of some GPCRs appears to require specific recycling-signal sequences at their C-terminal regions, but the molecular mechanisms remain to be elucidated.

## References

1. Lefkowitz RJ, Whalen EJ (2004)  $\beta$ -Arrestins: traffic cops of cell signaling. *Curr Opin Cell Biol* 16:162–168

2. Fredriksson R, Lagerstrom MC, Lundin LG, Schioth HB (2003) The G-protein-coupled receptors in the human genome form five main families. Phylogenetic analysis, paralogon groups, and fingerprints. *Mol Pharmacol* 63:1256–1272
3. Palczewski K, Kumasaka T, Hori T, Behnke CA, Motoshima H, Fox BA, Le Trong I, Teller DC, Okada T, Stenkamp RE, Yamamoto M, Miyano M (2000) Crystal structure of rhodopsin: a G protein-coupled receptor. *Science* 289:739–745
4. Terrillon S, Bouvier M (2004) Roles of G-protein-coupled receptor dimerization. *EMBO Rep* 5:30–34
5. Fotiadis D, Liang Y, Filipek S, Saperstein DA, Engel A, Palczewski K (2003) Atomic-force microscopy: rhodopsin dimers in native disc membranes. *Nature* 421:127–128
6. Chabre M, Cone R, Saibil H (2003) Biophysics: is rhodopsin dimeric in native retinal rods? *Nature* 426:30–31
7. Baneres JL, Martin A, Hullot P, Girard JP, Rossi JC, Parello J (2003) Structure-based analysis of GPCR function: conformational adaptation of both agonist and receptor upon leukotriene B<sub>4</sub> binding to recombinant BLT1. *J Mol Biol* 329:801–814
8. Jastrzebska B, Maeda T, Zhu L, Fotiadis D, Filipek S, Engel A, Stenkamp RE, Palczewski K (2004) Functional characterization of rhodopsin monomers and dimers in detergents. *J Biol Chem* 279:54663–54675
9. Milligan G (2004) G protein-coupled receptor dimerization: function and ligand pharmacology. *Mol Pharmacol* 66:1–7
10. Marchese A, Chen C, Kim YM, Benovic JL (2003) The ins and outs of G protein-coupled receptor trafficking. *Trends Biochem Sci* 28:369–376

## G Proteins (Guanine Nucleotide Binding Proteins)

### Definition

A family of proteins that act as the principal intermediaries in the regulation of second messenger pathways by G protein-coupled receptors. Each G protein is made up of three distinct subunits,  $\alpha$ ,  $\beta$  and  $\gamma$ .

Upon binding of a G protein-coupled receptor by its ligand, G proteins switch from an inactive state bound to guanosine diphosphate to an active state bound to guanosine triphosphate. This results in the separation of the  $\alpha$  subunit from the tightly bound  $\beta\gamma$  moiety and from the receptor. Both  $\alpha$  and  $\beta\gamma$  are then available to regulate second messenger pathways. Termination of the signal occurs by hydrolysis of the guanosine triphosphate to guanosine diphosphate.

- ▶ G Protein-Coupled Receptor (Metabotropic Receptor)
- ▶ G-Protein Coupled Receptors (GPCRs) in Sensory Neuron Function and Pain
- ▶ G-protein Coupled Receptors (GPCRs): Key Players in the Detection of Sensory and Cell-Cell Communication Messages

## GABA

### Definition

$\gamma$ -Aminobutyric acid (GABA) is the major inhibitory transmitter in the adult brain. GABA is recognized as being part of the amino acid family of classical neurotransmitters. GABA is formed from L-glutamic acid and the reaction is catalyzed by glutamic acid decarboxylase (GAD). After synaptic release the actions of GABA are terminated by active reuptake into glia and not into the presynaptic terminal.

## GABA<sub>A</sub> Receptor

### Definition

A ligand-gated ion channel (ionotropic receptor) located on sub-synaptic neuronal membranes, and also extra-synaptically. The major inhibitory neurotransmitter in the brain,  $\gamma$ -aminobutyric acid (GABA), opens the receptor ion channel to allow the influx of anions (chloride ions). This hyperpolarizes the neuronal membrane, thus reducing the ability of excitatory inputs to the neuron to generate an action potential.

- ▶ Chloride Channels and Transporters

## GABA Switch

- ▶ Chloride Homeostasis and Development

## Gadolinium Enhancing (GD<sup>+</sup>) Lesions

### Definition

In clinical studies, blood-brain barrier leakage, a marker of acute inflammation in the central nervous system (CNS), can be tracked by in vivo gadolinium enhancement on a T1-weighted magnetic resonance imaging (MRI) scan.

- ▶ Blood-brain Barrier

## Gain

### Definition

The amount of amplification (in decibels) added to the level of the input signal.

► Hearing Aids

## Gain Field

### Definition

► Gain Modulation

## Gain in Optokinetic System

### Definition

A measure of the performance of a system or behavior.

It is the ratio of the output of the system divided by the input to the system. For the optokinetic system, this is the angular velocity of the eye movements divided by the angular velocity of the optokinetic drum. If the optokinetic system produced eye velocity equal to the velocity of the drum, there would be no retinal slip, and the gain would be 1.0. But because some retinal slip is necessary to stimulate the optokinetic system, perfect tracking is not possible and the gain will always be less than one. Similarly, retinal slip in the opposite direction of the eye movements will force the optokinetic system to reduce the eye velocity, so gains greater than one are always short-lived.

► Retinal Slip

## Gain Modulation (Gain Field)

### Definition

Modulation of a neuronal activity evoked by visual stimulation or related to the associated motor response, as a function of the direction of the visual axis. In most instances, the gain field exhibits a linear relationship

between the neuronal discharge rate and eye position and has been assumed to result from a multiplicative (gain modulation) effect of eye position on the neuron's visual or motor sensitivity. The distribution over large neuronal populations of gain fields of visual responses has been thought to be the signature of a coordinate transformation from an initial retinal frame of reference to a head-centered frame of reference. Indeed, whereas the visual response of most neurons is retinotopically organized, the explicit encoding of visual target position in a head-centered frame of reference has been rarely found at the individual neuronal level. Thus, head-centered encoding of visual space is thought to derive from the combined activity of a large population of neurons with gain fields.

► Eye-Hand Coordination

## Gain Scheduling

### Definition

An approach to the control of non-linear systems, where different (often linear) controllers are used depending on some measure of the current system state.

► Nonlinear Control Systems

## Gain Sensitivity

### Definition

► Sensitivity of Sensory Receptors

► Sensory Systems

## Galanin

### Definition

A neuropeptide present in a population of cells in the preoptic area of the forebrain that plays an important role in regulation of sleep.

► Nocturnal/Diurnal

► Sleep-wake Cycle

## Galectin-1

### Definition

Galectin-1, which was the first  $\beta$ -galactoside-binding animal lectin to be discovered, has a molecular weight of 14.5 kDa. Galectin-1's 134 amino acid sequence includes six cysteine residues and is highly conserved evolutionarily, especially between humans and rats/mice. Galectin-1 is expressed in many tissues. The expression of galectin-1 in the nervous system changes as development progresses: it is localized in central nervous system (CNS) as well as peripheral nervous system (PNS) during development and becomes restricted to the PNS with maturation. The  $\beta$ -galactoside-binding activity of galectin-1 is evident only in the presence of a reducing agent, and this lectin (carbohydrate-binding) activity plays a role in cell adhesion, cell proliferation, and apoptosis in various cell types. The molecular structure of galectin-1 is changed by oxidization under non-reducing conditions, resulting in the loss of the lectin activity. This oxidized form of galectin-1 promotes axonal regeneration in the PNS.

► Schwann Cells in Nerve Regeneration

## GAL4/UAS Expression System

MARGARET J. SONNENFELD

Department of Cellular and Molecular Medicine,  
Faculty of Medicine, University of Ottawa, Ottawa,  
ON, Canada

### Synonyms

Bipartite GAL4/UAS expression system

### Definition

The GAL4/UAS system refers to the use of yeast proteins which interact to induce the expression of genes from any organism in a tissue and temporal-specific manner.

### Characteristics

#### The GAL4/UAS System

There are many tools available when using the fruitfly, *Drosophila melanogaster*, a model organism highly amenable to genetic analysis. One particular tool is the GAL4/UAS system that allows for the expression of genes from any organism in a tissue and temporal-specific manner. This has led to the identification of conserved genes involved in apoptosis [1], tyrosine kinase signaling [2] and neurodegenerative diseases.

GAL4 is a yeast protein that regulates genes induced by galactose. GAL4 binds to 17 basepair sites referred to as the Upstream Activating Sequences (UAS) in order to activate the *GAL10* and *GAL1* target genes. In 1993, Brand and Perrimon used the ability of GAL4 to activate transcription from the UAS element in *Drosophila* to show its use in tissue and temporal control over expression of any gene. As shown in Fig. 1, GAL4 can be placed under control of any promoter to generate the tissue specificity driving expression of the gene of interest.

There are two vectors which allow one to clone in the chosen promoter to direct GAL4 expression, which include pGATB and pGATN. Chosen regulatory elements are placed upstream of GAL4 in pGATB and pGATN and then the fusions are excised and placed in a ► P element transformation vector. Alternatively, there is a P transformation vector, pPT-GAL, in which regulatory sequences can be placed directly upstream of GAL4 (Fig. 1). These vectors contain P element inverted repeats at the ends, designated 5' P and 3' P, which allow for integration into the genome to make transgenic flies.

Many GAL4 fly lines are housed in the Bloomington stock centre which can be accessed at <http://flystocks.bio.indiana.edu/Browse/misc-browse/gal4.htm>. An additional GAL4 vector, called pGAWB, acts as an ► enhancer trap because it contains P transposase promoter sequences upstream of GAL4 (Fig. 1). P transposase is the enzyme required to allow P elements to hop. This means that the GAL4 vector can insert into random genomic sites and come under control of a particular promoter. GAL4 strains driving expression in almost every tissue exist and their expression patterns can be verified by activating a UAS-*lacZ* fusion and staining with an antibody to the *lacZ* product,  $\beta$ -Galactosidase ( $\beta$ -Gal).

The plasmid pUAST is used for GAL4-inducible expression of transgenes in flies (Fig. 1) [3,4]. pUAST is a vector containing P-element sequences, the basal promoter *heat shock protein 70* (*hsp70*), a multiple cloning site, the SV40 small t intron and a polyadenylation signal. The multiple cloning site contains a range of convenient restriction sites to allow for directional cloning of the gene of interest.

Transgenic flies carrying GAL4 and pUAST constructs are generated by injecting early syncytial *Drosophila* embryos with the DNA which will incorporate into the genome by P element-mediated transformation [5]. Fly strains carrying GAL4 and UAS are transcriptionally inactive until combined avoiding any potential lethal effects as shown in Fig. 2.

Once combined, the progeny express the UAS fusion protein in the pattern activated by the promoter fused to GAL4 (Fig. 2). Illustrated in Fig. 2 is the ectopic expression of the *Drosophila* UAS-DATR-X gene in a pair-rule pattern of seven stripes as driven by the *paired*-GAL4 driver.



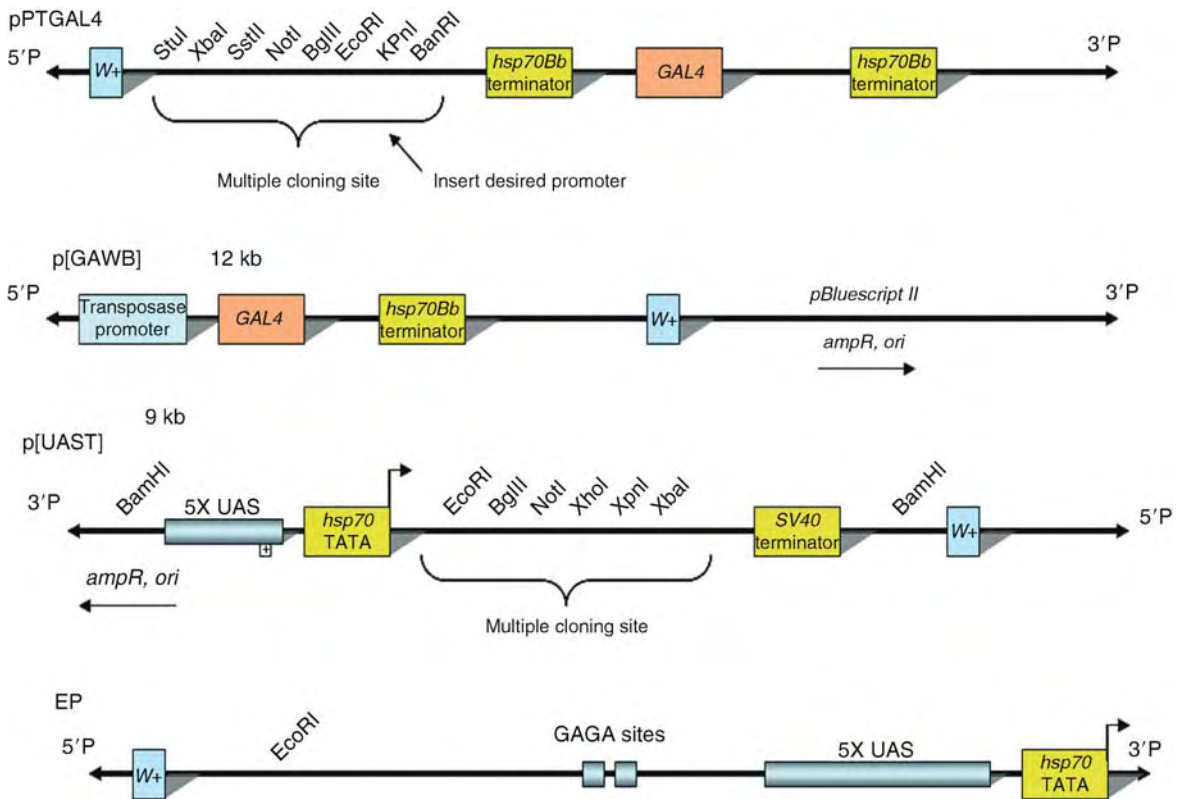

**GAL4/UAS Expression System. Figure 1** Illustrations of various GAL4/UAS vectors. The top diagram shows a variation of the GAL4 vector called pPTGAL4. The second diagram shows an example of a GAL4 vector called p[GAWB] which allows for inserting the desired promoter to drive expression. The third diagram shows the pUAST vector and its size. The last diagram shows a variation of the pUAST vector called the EP (enhancer/promoter) element. Adapted from Duffy, 2002.

## Variations of the GAL4/UAS system

### Enhancer-Promoter (EP)-transposable elements

The EP element contains five tandem repeats of UAS sites (5XUAS) next to a basal promoter (hsp70) which are adjacent to the 3' inverted repeat (3' P) (Fig. 1). In the presence of transposase enzyme, this element can be randomly hopped around the genome to allow for expression of any gene under control of GAL4. When the EP element is inserted proximal to a gene and in the same orientation it results in ectopic expression of the gene under control of GAL4. When the EP element is inserted in the opposite orientation the gene will be inactivated. This technique is limited by the insertion specificity of the P element. Overexpression or downregulation of the predicted downstream gene under the control of GAL4 can be confirmed by in situ hybridization. EP elements can be obtained from the *Drosophila* Szeged Stock Centre and from Exelixis. The EP insertion position and orientation can be determined using the online database of FlyBase. The Berkeley *Drosophila* Genome Project (BDGP) has used EP elements to create insertion mutations in genes found throughout

the genome. These insertions have been characterized and the adjacent gene identified.

### The Nova method

This stands for “novel overexpression activity” and was used to generate ▶dominant alleles of genes in the *Drosophila* epidermal growth factor receptor (EGFR) pathway [2]. A UAS transgene is exposed to mutagenesis and its expression is targeted using a GAL4 driver and then progeny are screened for novel visible phenotypes [2]. This technique resulted in new alleles that produce ▶RNA interference-like transcripts as well as other genetic rearrangements in the locus.

### Use of the GAL4/UAS System for Neurobiological Research

The analysis of disease mechanisms has traditionally been carried out using transgenic animal models such as the mouse. However, this system is costly and time consuming.

The creation of the GAL4/UAS system for targeted gene expression in *Drosophila* has opened the possibilities of investigating the role of genes from any organism

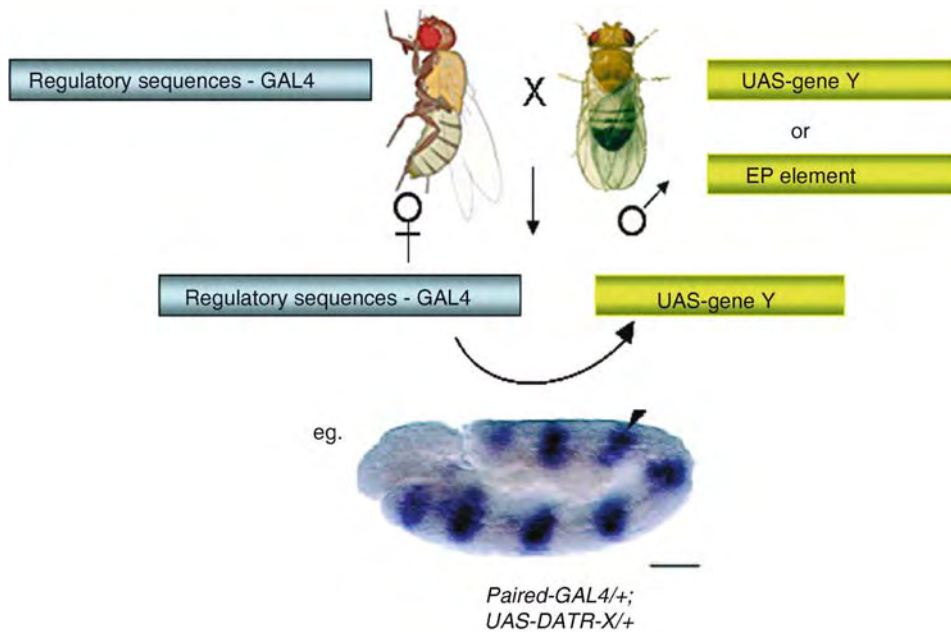

**GAL4/UAS Expression System. Figure 2** The bipartite GAL4/UAS system in *Drosophila*. Illustrated is the expression of the UAS-*DATR*X gene in a pair-rule pattern of stripes (arrowhead) driven by *paired*-GAL4.

with relevance to medical processes. Targeted mis-expression, using the GAL4/UAS system, of the products of human disease genes in flies has created models for trinucleotide repeat expansion disorders, Alzheimer's disease and Parkinson's disease.

#### Targeted RNA Interference (RNAi)

Homologs of human neurodegenerative disease genes are found in the *Drosophila* genome (<http://superfly.ucsd.edu/homophila/>). The function of these genes can be determined by creating mutations and studying the effects in flies. This genetic approach has been used to study ataxin-2 and parkin which are involved in spinocerebellar ataxia 2 and with autosomal recessive juvenile parkinsonism, respectively [6]. Generating endogenous point mutations in a gene can be time-consuming and therefore the use of RNA interference-mediated knock down of gene expression has become more popular. Since it uses the GAL4/UAS system, it has the distinct advantage that a mutation of the gene of interest can be targeted in time and space. RNA interference (RNAi) has been used to knock down the fly homolog of *huntingtin* and reveal its role in regulation of axonal transport and cell death [7]. In addition, targeted RNAi-induced knock down of the fly homolog of a human gene that causes X-linked mental retardation (*DATR*X) revealed a critical neuronal and glial role for this protein in axon guidance [8].

A vector exists that is designed to express double-stranded RNA as a **▶snapback hairpin** and is derived from the pUAST transformation plasmid [9]. This

plasmid is called pWIZ (*White Intron Zipper*). A fragment of the chosen gene is cloned into pWIZ to form an inverted repeat and the repeats are placed upstream and downstream of the intron of the *white* gene. The fragments are sequentially cloned in opposite directions using a number of restriction sites on either side of the intron. The optimal size of the fragment should be 500 and 1000 base pairs in length which causes stronger silencing than shorter fragments. A library of transgenic RNAi flies exists at VDRC (Vienna Drosophila).

#### Parkinson's Disease (PD)

Mutation as well as triplication of the  $\alpha$ -synuclein locus is associated with dominant parkinsonism. A *Drosophila* model using this gene has been developed to investigate its role in Parkinson's disease [6]. By expressing normal and mutant forms of  $\alpha$ -synuclein in *Drosophila*, the adult-onset loss of dopaminergic neurons in the brain, as found in human cases, was reproduced. Using this model, a role for the chaperone, heat shock protein 70 (Hsp70), in preventing dopaminergic neuron loss was shown by transgenic expression. This led to pharmacological tests altering chaperone levels to delay the progressive degeneration of dopaminergic neurons. Feeding flies geldanamycin, which upregulates chaperonins, protected against  $\alpha$ -synuclein-induced dopaminergic neuron loss.

The GAL4/UAS system was used to target *Drosophila* PINK1 (PTEN-Induced Kinase 1) (*DPINK1*) RNAi ubiquitously in flies to reveal that mitochondrial

pathology and muscle and dopaminergic neuron degeneration are associated with parkinsonism. This technology was also used to show that *DParkin* could rescue dopaminergic and muscle pathologies in *DPINK1* RNAi flies. Therefore, by using the power of *Drosophila* genetics and transgenic technology the evolutionary conservation of disease gene pathways can be revealed.

### Alzheimer's Disease (AD)

A pathological hallmark of AD is the hyperphosphorylation of tau protein which then forms insoluble aggregates. Fly models of tau toxicity have been developed using the GAL4/UAS system to determine how generation of  $\beta$ -amyloid peptides affects tau phosphorylation and aggregation. The entire human APP/secretase system, which processes the amyloid protein, has been recreated in the fly using the GAL4/UAS system [6]. Axonal transport and behavioral defects are observed when wild-type human tau is expressed in *Drosophila* motor axons.

Targeted expression of a tauopathy-associated mutant of human tau throughout the fly nervous system (using *elav*-GAL4) resulted in a rough eye, tau phosphorylation and neurodegeneration. A number of quick assays have been developed to determine the consequences of AD transgene expression in flies including longevity assays, locomotor assays, olfactory learning assays and rough eye phenotypes. Therapeutic agents that interfere with the generation of toxic aggregates of  $\beta$ -amyloid peptides can rescue AD flies. Therefore, the power and speed of the GAL4/UAS system and genetic screens (see below) in flies are being used to discover new therapeutic agents to treat AD.

### GAL4-UAS-based Genetic Screens

*Drosophila* geneticists have long used the adult eye, a system of 800 photoreceptor cells, as an ideal expression system to identify genes functioning in particular pathways in neural cells. Using a genetic modifier screen (Fig. 3), enhancers of *grim* (*grm*)-*reaper*

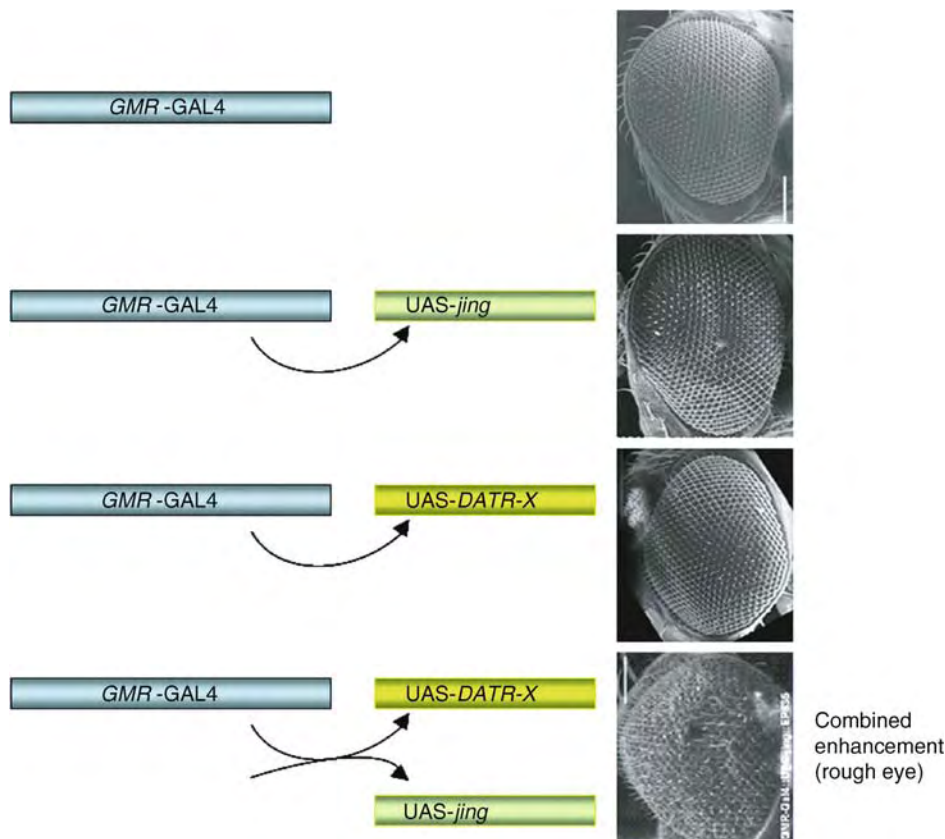

**GAL4/UAS Expression System. Figure 3** Screening for modifiers using the GAL4/UAS system. Shown is a screen for enhancers of misexpression of the transcription factor, *jing*, in the adult eye. Expression of UAS-*jing* under control of *GMR*-GAL4 has no effect on eye development when observed by scanning electron microscopy (SEM). Similar expression of the *Drosophila* homolog of human  $\alpha$ -thalassemia mental retardation on X (ATR-X) has no effect on eye development. Co-expression of UAS-*jing* and UAS-DATR-X under *GMR*-GAL4 control results in a rough eye phenotype signifying a disruption of ommatidial development.

(*rpr*)-induced cell death were identified including the F box/ubiquitin conjugase protein Morgue [1]. Using an eye-specific promoter called the glass multiple promoter (GMR) fused to Gal4, UAS-*grm/rpr* could be expressed in the larval photoreceptor cells. Flies carrying both elements were then combined with those containing EP elements upstream of 1200 different genes. Any enhancement of UAS-*grm/rpr*-induced cell death could be detected by a more severe disruption of eye morphology.

The modifier approach is also being used to identify genes involved in human disease [6]. Tau expression was targeted to the eye using the GMR-GAL4 driver causing a rough eye phenotype. Enhancers and suppressors of the Tau-induced rough eye phenotype were found by individually combining 2276 EP lines with the GMR-GAL4/ +;UAS-Tau/ + flies [10]. 16 enhancers and 8 suppressors were found that encode mediators of apoptosis, kinases and phosphatases which are known to phosphorylate or dephosphorylate Tau. Many of the kinases and phosphatases regulating Tau toxicity in flies have been implicated in Alzheimer's disease. This suggests that these proteins may act as key therapeutic targets in Alzheimer's disease and other related disorders.

## References

1. Wing JP, Schreder BA, Yokokura T, Wang Y, Andrews PS, Huseinovic N, Dong CK, Ogdahl JL, Schwartz LM, White K, Nambu JR (2002) *Drosophila* morgue is an F box/ubiquitin conjugase domain protein important for grim-reaper mediated apoptosis. *Nat Cell Biol* 4:451–456
2. Guichard A, Srinivasan S, Zimm G, Bier E (2002) A screen for dominant mutations applied to components in the *Drosophila* EGF-R pathway. *PNAS* 99:3752–3757
3. Brand AH, Perrimon N (1993) Targeted gene expression as a means of altering cell fates and generating dominant phenotypes. *Development* 118:301–415
4. Duffy JB (2002) GAL4 system in *Drosophila*: A fly geneticist's swiss army knife. *Genesis* 34:1–15
5. Rubin GM, Spradling AC (1982) Genetic transformation of *Drosophila* with transposable element vectors. *Science* 218:348–353
6. Bilen J, Bonini MM (2005) *Drosophila* as a model for human neurodegenerative disease. *Annu Rev Genet* 39:153–171
7. Gunawardena S, Her LS, Bruschi RG, Laymon RA, Niesman IR, Gordesky-Gold B et al. (2003) Disruption of axonal transport by loss of huntingtin or expression of pathogenic polyQ proteins in *Drosophila*. *Neuron* 40:25–40
8. Sun X, Morozova T, Sonnenfeld M (2006) Glial and Neuronal Functions of the *Drosophila* Homolog of the Human SWI/SNF Gene, *ATR-X* (*DATR-X*), and the *jing* Zinc Finger Gene Specify the Lateral Positioning of Longitudinal Glia and Axons. *Genetics* 173:1397–1415
9. Lee YS, Carthew RW (2003) Making a better RNAi vector for *Drosophila*: Use of inter spacers. *Methods* 30:322–329
10. Shulman JM, Feany MB (2003) Genetic modifiers of tauopathy in *Drosophila*. *Genetics* 165:1233–1242

## Galvanic Skin Response

### Definition

“Galvanic skin response” (GSR) proposed by Landis (1932) is now used to mean changes in electrical skin resistance (ESR). The electric resistance between two electrodes applied to the skin surface in humans may be recorded with a Wheatstone bridge circuit. To a large extent, the ESR is determined by the amount of sweat in the sweat ducts and its concentration of electrolytes.

The resistance of the corneal layer of the skin itself is high but may be reduced by infiltration of sweat.

### ► Sweat Gland Control

## Galvanic Stimulation of the Labyrinth

### Definition

Electrical stimulation of the labyrinth performed by using constant amplitude, long duration pulses of current or continuous currents applied through the mastoid bone(s). In bipolar stimulation, the negative (cathode) pole of the stimulator is connected to the mastoid bone of one side, while the positive (anode) pole is connected to the opposite mastoid, so that both electrodes may modify the activity of the vestibular nerve fibers, leading to an increase at the cathode and to a depression at the anode. In unipolar stimulation the anode is over the skin and does not affect the labyrinthine activity of the corresponding side.

### ► Peripheral Vestibular Apparatus

### ► Vestibulo-Spinal Reflexes

## Galvanic test

### ► Vestibular Tests: Myogenic Potentials Induced by Short Duration Galvanic Currents

## Galvanic Vestibular Balance Responses

► Galvanic Vestibulospinal Responses

## Galvanic Vestibulopostural Responses

► Galvanic Vestibulospinal Responses

## Galvanic Vestibulospinal Responses

F. HLAVACKA

Institute of Normal and Pathological Physiology,  
Bratislava, Slovakia

### Synonyms

Galvanic vestibulopostural responses; GVS; Galvanic vestibular balance responses

### Definition

Galvanic vestibulospinal responses refer to postural responses or muscle electromyographic responses elicited by direct current stimulation to the vestibular afferents.

### Description of the Theory

#### Method of the Galvanic Vestibular Stimulation

Galvanic vestibular stimulation (GVS) is a technique in which a low intensity current is transcutaneously delivered to the afferent nerve endings of the vestibular system through electrodes placed over the mastoid bones [1]. The applied current alters the firing rates of the peripheral vestibular afferents, causing a shift in a standing subject's vestibular perception and a corresponding postural sway. If the anodal electrode is placed on the mastoid, sustained positive currents decrease the firing rate of the vestibular nerve fibers, whereas sustained cathodal negative currents increase vestibular activity. GVS is well tolerated by subjects with current ranges up to 2 mA.

### Postural Responses to GVS

GVS causes an asymmetry of vestibular activity, resulting in postural sway with head, trunk and body

leaning toward the vestibular apparatus with the reduced level of afferent activity (i.e., toward the anodal current). GVS induces a postural response that depends on the position of the head and trunk with respect to the feet. If the subject is standing with the head facing forward, GVS with electrodes of different polarity placed over each mastoid (bipolar binaural stimulation) induces a lateral body tilt parallel to the ► **inter-labyrinthine line**. If the head or the trunk is turned to the side in the horizontal plane, the postural response will again be with direction parallel to the inter-labyrinth line, in this case sway is in the anteroposterior direction. Postural responses to GVS recorded by a force platform as the centre of pressure (CoP) or by kinematic sensors as the centre of body mass (CoM) are presented in Fig. 1. Sinusoidally varying bipolar binaural GVS with frequencies ranging from 0.01–1 Hz, the body tends to sway sinusoidally with the frequency of stimulating current.

Monoaural GVS activates one side of the vestibular apparatus and induces reproducible, stereotyped deviations of the centre of pressure (CoP) in both the anteroposterior and lateral plane [2]. With monopolar, binaural GVS, also called double monopolar GVS, electrodes of the same polarity are placed over both mastoids and indifferent electrodes are placed on the forehead. If anodal electrodes are placed on the mastoids, the stimulating current decreases the firing rates of the peripheral vestibular afferents on both sides. Cathodal electrodes placed on mastoids produces an increase of firing rate. This change in the firing rates of the vestibular afferents results in postural sway perpendicular to the inter-labyrinths line. A cathodal stimulation over both mastoids results in a larger sway in the forward direction than the backward sway induced by anodal stimulation over both mastoids.

Kinematic records of body segment responses to GVS showed that the head tilted more than the trunk and the trunk tilted more than the pelvis, resulting in a bending of the body towards the anodal ear. Trunk movement begins at a latency of 150–180 ms. The tilt of all three segments is reduced by increasing stance width. The results indicate that the response is organized to stabilize the body, rather than the head, in space.

When visual input about body sway is available, the whole body GVS sway responses are reduced or absent. Loss or alteration of somatosensory input leads to an increase in the GVS response. For example, stance on a compliant surface and somatosensory loss due to neuropathy results in larger GVS responses [3]. Thus, GVS responses include integration of vestibular, visual and somatosensory inputs for postural control.

GVS with a very small current (0.5 mA) before and during postural responses to platform translation alters automatic postural muscle activation and center of pressure responses and the final equilibrium position

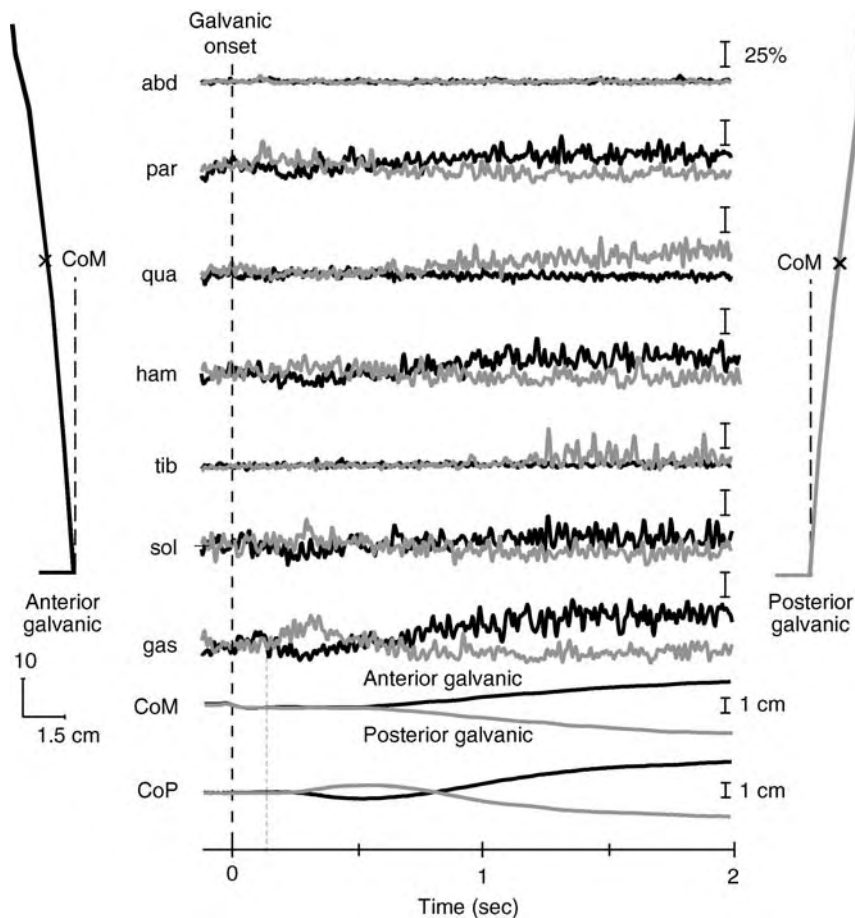

**Galvanic Vestibulospinal Responses. Figure 1** Comparison of anterior (black lines when anode is on forward ear) and posterior (gray lines when anode is on backward ear) galvanic stimulation during quiet stance with head turned to the right and eyes closed. Normalized EMGs, center of mass (CoM), center of pressure (CoP), and sagittal stick figures are group-averaged responses to 0.4 mA bipolar, galvanic stimulation. Sticks show difference from initial stance at 4 s following the onset of stimulation with x showing calculated CoM position. abd-rectus abdominis, par-paraspinals, qua-quadriceps, ham-hamstrings, tib-tibialis, sol-soleus, gas-gastrocnemius EMG responses. (From Horak, Hlavacka *Exp Brain Res* 2002).

[4,5]. The tonic vestibular asymmetry induced by bipolar galvanic current alters the sensory estimate of verticality to a new position. Subjects appear to alter the magnitude of their automatic postural response to realign their centre of mass (CoM) and CoP with a newly established equilibrium position.

#### Muscle Responses to GVS

After the onset of a GVS current, short and medium latency electromyographic responses can be observed in muscles of the upper limbs, the trunk and the lower limbs, which result in well organized body movement. In ankle muscles, the short latency muscle responses to GVS occur at 55–65 ms and the medium latency muscle responses occur at 105–120 ms [1,6]. The muscle responses to GVS are biphasic: a small, short latency component is followed by a larger, medium

latency component with opposite sign (see Fig. 1, Gas). Both responses increase with stimulus intensity, but the short latency response has a higher threshold [6]. The early response has a similar latency to muscle responses evoked by rapid postural perturbations. Cathodal and anodal stimulation produce opposite effects on short and medium latency responses in the soleus muscles.

Both short and medium latency responses are larger when the eyes are closed. When the support platform is unstable and in subjects with neuropathy, both muscle responses to GVS are larger. Galvanic vestibulospinal stimulation can alter medium latency automatic postural muscle response triggered 100 ms after surface translation [7].

Monopolar, monaural GVS can modify the amplitude of the ipsilateral soleus H-reflex and bipolar, binaural GVS significantly alters the onset of activation

and the initial firing frequency of gastrocnemius motor units. This suggests that in certain situations, it may be possible to use vestibular stimulation to examine the integrity of descending vestibulospinal pathways in human subjects.

The initial firing frequencies of motor units can be significantly altered by GVS. The changes in the initial firing frequencies and alterations in onset of motor unit activity with GVS suggest that vestibulospinal mechanisms can influence the force output of individual motoneurons.

### Interpretation of Motor Response to GVS

Galvanic vestibulospinal responses are elicited by modification of vestibular outputs from both canals and otoliths. Recent data indicates that the canal and otolith system exert their effects on balance through different pathways [8]. The GVS evoked canal signal indicates lateral head rotation while the otolith signal indicates lateral tilt or head acceleration. Galvanic vestibular stimulation induces a vestibular signal of head motion, which has reproducible effects on the human balance system. This virtual signal of head movement produced by GVS has an effect on the whole body postural control, evoking electromyographic responses and a highly organized balance response involving the entire body. The postural responses to GVS are highly sensitive to information coming from all other sensory sources.

### References

1. Fitzpatrick RC, Day BL (2004) Probing the human vestibular system with galvanic stimulation. *J Appl Physiol* 96:2301–2316
2. Cauquil AS, Martinez F, Ouaknine M, Tardy-Gervet MF (2000) Orientation of the body response to galvanic stimulation as a function of the inter-vestibular imbalance. *Exp Brain Res* 133:501–505
3. Horak FB, Hlavacka F (2001) Somatosensory loss increases vestibulospinal sensitivity. *J Neurophysiol* 86:575–585
4. Inglis T, Shupert CL, Hlavacka F, Horak FB (1995) Effect of galvanic vestibular stimulation on human postural responses during support surface translations. *J Neurophysiol* 73:896–901
5. Britton TC, Day BL, Brown P, Rothwell PD, Thomson PD, Marsden CD (1993) Postural electromyographic responses in the arm and leg following galvanic vestibular stimulation in man. *Exp Brain Res* 94:143–151
6. Fitzpatrick R, Burke D, Gandevia SC (1994) Task-dependent reflex responses and movement illusions evoked by galvanic vestibular stimulation in standing humans. *J Physiol* 478(2):363–372
7. Horak FB, Hlavacka F (2002) Vestibular stimulation affects medium latency postural muscle responses. *Exp Brain Res* 144:95–102
8. Cathers I, Day BL, Fitzpatrick RC (2005) Otolith and canal reflexes in human standing. *J Physiol* 563(1):229–234

## Game of Life

### Definition

Invented by mathematician Conway, is a two-dimensional cellular automaton, on which, based on a few mathematical rules, one can define complex structures and mechanisms, which exhibit interesting similarities to biological systems.

► Emergence

## Gamma Motoneuron

### Definition

A motoneuron, smaller than the alpha cells, that exclusively innervates specialized intrafusal muscle fibers within muscle spindle stretch receptors to control the sensitivity of the spindle.

► Motor Units

► Proprioception: Roles of Muscle Receptors

## Gamma Oscillation

### Definition

Gamma oscillation is a fast one with 40- to 100-Hz.

► Brain Rhythms

## Ganglia

### Definition

Ganglia are collections of neuron somata that aggregate during development, often in a segmental arrangement, and include autonomic ganglia and the primary afferent neurones in dorsal root ganglia and cranial nerve ganglia.

► Autonomic Ganglia

► Dorsal Root Ganglion (DRG)

## Ganglion

### Definition

A ganglion (Greek for knot) is a collection of nerve cell bodies, usually referring to such collections outside the CNS, e.g., collections of primary afferent neuron cell bodies located in the dorsal root ganglia or those associated with cranial nerve afferents. There is also a large group of neurons inside the CNS in the forebrain also referred with the same term, i.e., the basal ganglia (the caudate, putamen, and globus pallidus).

## Ganglion Cell Layer (GCL)

### Definition

The innermost cellular layer of the retina. It is comprised of the cell bodies of retinal ganglion cells and amacrine cells.

- ▶ Retinal Ganglion Cells
- ▶ Retinal Direction Selectivity and Starburst Amacrine Cells

## Ganglionic Eminences

### Definition

Regions of the basal forebrain (telencephalon) also known as sub-pallium that give rise to the striatum and basal ganglia. However, many interneurons that express GABA generated in the ganglionic eminences migrate tangentially to the neocortex/pallium.

## Ganglioside

### Definition

A glycolipid with one or more sialic acid residues. Glycocalix – to be defined elsewhere.

- ▶ Membrane Components

## GAP-43

### Definition

GAP-43 is a membrane-anchored neuronal growth associated protein (also known as neuromodulin or B50) expressed at high levels in actively motile growth cones and plastic presynaptic terminals. It has been implicated in the formation of novel neuronal connections, synaptic remodeling and in regeneration and sprouting after injury. GAP-43 is a substrate for calcium-dependent and phospholipid-dependent protein kinase C. In addition, it directly binds calmodulin, the  $\alpha$  subunits of Go and Gi proteins and PI(4,5)P<sub>2</sub>.

GAP-43 activity can also induce a transient rise in intracellular calcium that can affect cytoskeletal dynamics.

- ▶ Growth Cones

## Gap Junctions

### Definition

Gap junctions are clusters of channels that connect the interiors of adjoining cells and mediate the exchange of ions and small molecules between the coupled cells.

Gap junctions are formed by members of the connexin, innexin, and pannexin families, structurally related transmembrane proteins that assemble in sextamers to form a gap junction hemi-channel. Each of the adjoining cells contributes one hemi-channel to a complete gap junction channel.

- ▶ Electrical Synapses

## Gap-Saccade Paradigm

### Definition

The gap-saccade paradigm is an experimental eye movement task in which a central fixation point to which a subject is attending is extinguished before an eccentric target that is the goal for a saccade is turned on. The temporal period between the time of fixation offset and target onset is called the gap period.



The gap saccade paradigm produces saccades with short latencies.

► Saccade, Saccadic Eye Movement

## Garcia's Effect

► Aversive Taste Memory

## Gastric Mill

### Definition

In general muscular pouch for grinding food; specifically part of the digestive system of crabs.

## Gastrin-releasing Peptide (GRP)

### Definition

Contains 27 amino acids and is thought to be the mammalian equivalent of the anuran peptide bombesin.

In the periphery, GRP is released by fibers of the vagus nerve and stimulates cells of the stomach to release gastrin. GRP is also involved in the circadian system, playing a role in the signaling of light to the master circadian oscillator of the brain, in the suprachiasmatic nuclei (SCN). In the SCN, GRP is localized to the ventral retinorecipient zone, from where it communicates photic resetting signals to the rest of the nucleus.

After exposure to light, upregulation of the Per clock genes in the SCN is first apparent in ventrally located neurons, including GRP- or vasoactive intestinal peptide- (VIP)-containing cells, and later in the rest of the SCN. Within the SCN, GRP exerts its cellular actions through the BB2 receptor. In contrast to arginine vasopressin (AVP), it appears that neither VIP nor GRP is rhythmically expressed in the SCN under constant conditions, although in light/dark

cycles, GRP is elevated in the day and VIP is elevated at night.

- Circadian Cycle
- Clock Genes
- Gating
- Suprachiasmatic Nucleus (SCN)

## Gastrointestinal Disorders

► Bowel Disorders

## Gastrointestinal Function

► Ageing of Autonomic/Enteric Function

## Gastrointestinal Reflexes

### Definition

Gastrointestinal reflexes are those reflexes that are involved in regulating the functions of the esophagus, stomach, small intestine, large intestine, intestinal sphincters, pancreas and biliary system. Gastrointestinal reflexes can be divided into intrinsic reflexes, where all components of the reflex are in the gut wall, enteroenteric reflexes, in which a reflex arises in one part of the digestive system and affects a different region, and central reflexes, in which the reflex pathway passes through or originates in the central nervous system.

► Enteric Nervous System

## Gastrointestinal Tract

► Visceral Afferents

## Gating

HUGH PIGGINS<sup>1</sup>, RAE SILVER<sup>2</sup>

<sup>1</sup>Faculty of Life Sciences, University of Manchester, Manchester, UK

<sup>2</sup>Kaplan Professor of Natural and Physical Sciences, Departments of Psychology at Barnard College and Columbia University, and Department of Pathology and Cell Biology, Columbia Health Sciences Campus, Columbia University, New York, NY, USA

### Definition

Time-dependent sensitivity to environmental cues is determined by a process called gating, in which a predetermined set of conditions must be established to permit a second process to occur. Gated processes are those in which signals are selected only under specific conditions, acting as a control for further flow of information. In electrophysiological studies of the nervous system, the term gating generally refers to the opening or closing of ion channels.

### Characteristics

#### The SCN Circadian Clock Regulates Temporal Sensitivity to Internal and External Signals

The ▶suprachiasmatic nucleus (▶SCN) not only sustains daily rhythms in behavior and physiology so that the clock can be reset only at particular phases of the circadian cycle (▶circadian activity), it also “gates” its own response to environmental time cues. That is, the phasing of SCN pacemaker activity is tightly

regulated by photic input from the retina. Thus, light can reset behavioral and physiological rhythms only during the night (or ▶subjective night) time. During the ▶subjective day, light does not reset behavioral rhythms. On the other hand, resetting to light during the subjective night occurs very quickly (within 2 h, in mice) such that repeated exposure to light cannot cause further shifts within this temporal window [1–3]. Hence, the SCN controls if and how light can reset the clock (Fig. 1). In a parallel manner, stimuli such as exercise or social interactions that promote ▶arousal (so-called “non-photoc” cues) can only reset behavioral and physiological rhythms of nocturnal rodents during the subjective day [4]. During subjective night, non-photoc cues do not cause ▶phase shifts. Therefore, the SCN clock controls if and how it responds to time cues that promote arousal. This ▶gating by the SCN is the basis of a brain clock that is primarily sensitive to non-photoc stimuli during the day/subjective day, and photic stimuli during the night/subjective night.

#### Gating Occurs Within Clock Cells

Gating does not appear to be due alterations in the strength of either sensory signals that reach the SCN or of brain pathways terminating in the SCN, but rather to changes in the sensitivity of SCN clock cells to inputs. This has been best characterized for the phase-dependent resetting actions of light. SCN neurons show enhanced responsiveness to ▶glutamate (the major transmitter of the ▶retina’s input to the SCN) during the subjective night and this appears to be due in part to increases in the numbers or sensitivity (or both) of receptors for glutamate on clock cells. During

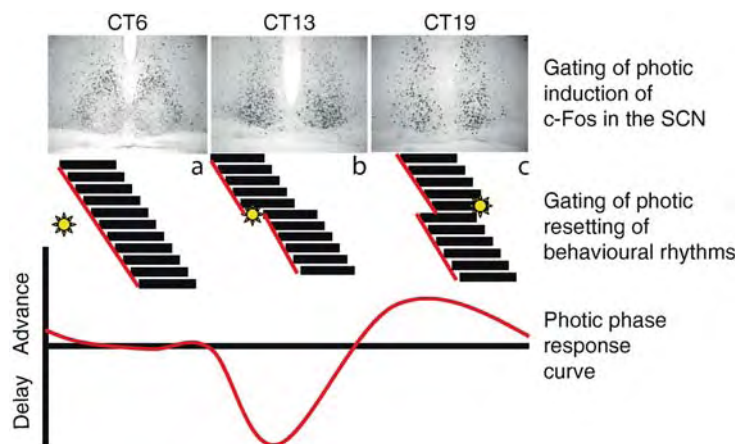

**Gating. Figure 1** The suprachiasmatic nuclei (SCN) circadian clock gates its response to light (photic) stimuli. a. In constant dark, at circadian time (CT) 6, a 15 min light pulse has no effect on the expression of c-Fos protein in the rodent SCN and has no overt effect on the onsets (fitted red lines) of the wheel-running activity rhythm to yield no measurable phase shift. b. One hour after the onset of activity (CT13), a 15 min light pulse slows the onsets of the behavioral rhythm to cause a phase delay in the SCN clock. c. Seven hours after activity onset (CT19), a 15 min light pulse, accelerates the onsets of wheel-running activity to give a phase advance in the SCN clock.

night, stimulation of these receptors augments cellular excitation and increases in calcium in clock cells. Such changes lead to activation of many intracellular signalling systems including the dexamethasone-induced ras protein 1 [2] and extracellular-signal regulated kinases I and II (ERKs) [1,3]. Indeed, retinal illumination evokes substantive increases in activated (phosphorylated) ERK only during subjective night – the phase of the circadian cycle at which light resets the SCN. Consistent with these findings, pre-treatment with pharmacological blockers of ERK activation abolishes light-driven increases in phosphoERK, and attenuates the size of the shifts to light. Interestingly, there is a rhythm in pERK expression in the central region of the SCN in mouse and hamster that is abolished through blinding or exposure to constant light.

The molecular targets of the light-driven pERK are likely to include increased transcription of immediate early genes such as *c-fos* (whose protein product, c-Fos can itself act as a transcription factor) as well as the transcription factors Elk-1 and cAMP-regulated binding protein (CREB). Response elements for Elk-1 and CREB are present in the promoter regions of the inhibitory elements of the molecular clock, namely the *Per1* and *Per2* genes [1,3,5], and hence activation of the ERK cascade can regulate the molecular clock through at least two pathways. Indeed, activation through phosphorylation of CREB and Elk-1 (pCREB and pElk-1 respectively) can only be induced by light or glutamate at the same phases that photic stimuli resets the SCN clock.

It is notable that in nocturnal rodent species light activates these mechanisms when spontaneous neuronal discharge activity, intracellular pERK, and *Per1/Per2* mRNA expression are at or near their respective nadirs [6]. This reduced night-time activity of SCN cells is thought to predispose this circadian clock to the excitatory actions of retinal input and hence the resetting actions of light.

The gating of non-photoc stimuli is much less well understood. Neural inputs associated with non-photoc resetting contain inhibitory neurochemicals such as ►neuropeptide Y, ►serotonin, and GABA, which in contrast to glutamate, suppress SCN neuronal activity [4,6]. In nocturnal species, non-photoc stimuli advance behavioral rhythms during the subjective day, when SCN neuronal activity is highest. In vivo neurophysiological recording has demonstrated that elevation of behavioral activities associated with non-photoc stimuli suppress SCN activity. This is mirrored in vitro as these neurochemicals can only ►phase advance SCN brain slices during the subjective day. Similarly, it is notable that *Per1* mRNA expression in the SCN reaches its zenith during the subjective day and that non-photoc stimuli and exogenously administered NPY suppress *Per1* mRNA in the SCN at this phase of the circadian

cycle. The intracellular mechanisms responsible for these actions are thought to involve the suppression of pERK and c-Fos.

### Gating is a Network Property of the SCN

At the tissue level, gating can not be explained by the behavior of a cell, but as a property of SCN circuitry. The mechanism whereby brief light pulses reset the mammalian circadian clock involves acute *Per* induction. The relationship between *Per* gene activity and behavioral phase shifts, can be seen in the effects of light-induced *Per1* and *Per2* expression in the mouse SCN [1,5]. In the (►vasoactive intestinal peptide) VIP-containing (►Vasoactive Intestinal Peptide (VIP)) region of the core SCN (►core and shell SCN), light-induced *Per1* expression occurs at all times of the subjective night, while *Per2* induction is seen only in early subjective night. In the remaining regions of the SCN (i.e., shell), a ►phase delaying light pulse produces no *Per1* but significant *Per2* expression, while a phase-advancing light pulse produces no *Per2* but substantial *Per1* induction. Moreover, following a light pulse during mid-subjective night, neither *Per1* nor *Per2* are induced in the shell (►SCN shell), and produces no behavioral phase shifts.

Gating to resetting stimuli arises through the interplay of influences arising within cells as well through cell-cell interactions [1,7]. For example, within clock cells, the molecular oscillator regulates receptor expression and the coupling of receptor activation to intracellular signalling cascades such that these cells are differentially responsive to photic and non-photoc inputs. It also is clear that intercellular communication is important for gating to photic inputs to be achieved across the SCN. For example, in transgenic mice lacking VPAC<sub>2</sub> receptor expression, photic stimuli activate the ERK cascade at any phase of the circadian cycle and hence at the tissue level, gating in the SCN has been lost [8]. The SCN of these mice show abnormally low levels of spontaneous cellular activity and clock gene expression and this dampening of clock activities predisposes the SCN to be photic driven. Therefore coordination of synaptic inputs, electrical activity, and clock gene expression is critical for appropriate integration and responses to exogenous time cues in the SCN [6,8].

### Gating as a General Property of Oscillators

The precise underpinnings of gating to photic and non-photoc stimuli encompasses a complex interplay of regulation of membrane-bound and intracellular signalling systems linking to transcriptional control of canonical clock genes. In turn the protein products of these clock genes modulate this temporal sensitivity to synaptic events. Ultimately, gating of

inputs must be translated into appropriate SCN output to regulate brain centers controlling behavioral and physiological states. Interestingly, neural circadian oscillators are also found outside of the SCN, and hence gating is a general property of a hierarchical circadian system; each brain sites gates its own response to SCN outputs to ensure appropriate temporal control of behavior and physiology.

Gating is also a property shared by ►oscillators in peripheral tissues, though the mechanisms underlying such gating are yet to be fully elucidated. For example, oscillators in the liver, heart, and kidney are differentially reset by injections of prostaglandin E<sub>2</sub> (PGE<sub>2</sub>). The molecular clocks in these peripheral tissues are phase-advanced by PGE<sub>2</sub> early in the day and in the middle to late night, and are phase-delayed by PGE<sub>2</sub> early in the night [10]. By contrast, PGE<sub>2</sub> has no consistent resetting action during the midday phase. In addition, ►peripheral oscillators are reset by periodic food availability [9] with velocity of resetting determined in part through actions of glucocorticoids [10]. Hence, regulation of phase and presumably gating in peripheral oscillators arise through complex interactions of metabolic and endocrine signals. Intriguingly, the finding that the molecular basis of oscillators in these extra-SCN clocks, appear to be different to that of the SCN [9], indicates that mechanisms for gating arise through different means in different oscillators.

#### ►Ion Channels from Development to Disease

## References

1. Antle MC, Silver R (2005) Orchestrating time: arrangements of the brain circadian clock. *Trends Neurosci* 28:145–151
2. Cheng HY, Obrietan K (2006) Dexras1: shaping the responsiveness of the circadian clock. *Sem. Cell Dev Biol* 25:80–91
3. Coogan AN, Piggins HD (2004) MAP kinases in the mammalian circadian system – key regulators of clock function. *J Neurochem* 90:769–775
4. Maywood ES, Mrosovsky N (2001) A molecular explanation of interactions between photic and non-photic circadian clock-resetting stimuli. *Gene Expr Pat* 1:27–31
5. Reppert SM, Weaver DR (2002) Coordination of circadian timing in mammals. *Nature* 418:935–941
6. Brown TM, Piggins HD (2007) Electrophysiology of the suprachiasmatic clock. *Prog Neurobiol* 82:229–255
7. Indic P, Schwartz WJ, Herzog ED, Foley NC, Antle MC (2007) Modeling the behavior of coupled cellular circadian oscillators in the suprachiasmatic nucleus. *J Biol Rhythms* 22:211–219
8. Vosko AM, Schroeder A, Loh DH, Colwell CS (2007) Vasoactive intestinal peptide and the mammalian circadian system. *Gen Comp Endocrinol* 152:165–175
9. Mendoza J (2007) Circadian clocks: setting time by food. *J Neuroendocrinol* 19:127–137
10. Stratmann M, Schibler U (2006) Properties, entrainment, and physiological functions of mammalian peripheral oscillators. *J Biol Rhythms* 21:494–506

---

## Gating Current

### ►Action Potential

---

## Gating (Ion Channel)

### Definition

Gating (of ion channels) is a property of many ion channels and refers to the active transition between open and closed states in response to specific signals, such as membrane potential changes (voltage-gating) or the presence of neurotransmitters (ligand-gating). In general, ion channels consist of multiple sub-units, which form a central ion-conduction pathway that can be opened, upon impact of the specific eliciting signal, by moving away transmembrane protein helices with a hydrophobic portion, thus allowing ion movement through the pathway. The way these helices are moved differs between different kinds of channels.

### ►Action Potential

---

## Gating (Signal)

### Definition

The process through which a signal passes when the gate is open, and fails to pass through when the gate is closed. The notion of gating alludes to the function served by a “gate” in ordinary English usage. Thus, gating is the process through which a signal passes when the gate is open, and fails to pass through when the gate is closed. The suprachiasmatic nucleus response to light is gated, in that a light pulse during the nocturnal animal's subjective night produces a change in gene expression in the nucleus along with a

resetting of rhythmic behavior, while a light pulse during the animal's day produces no response. This is true even when the organism is housed in complete darkness, and the physical conditions at the time of exposure to light is identical at both times points.

- ▶ Gating
- ▶ Suprachiasmatic Nucleus (SCN)

## Gaucher's Disease

### Definition

Rare, autosomal recessive defect in the degradation of ▶ sphingolipids, due to mutations in the lysosomal enzyme acid-β-glucosidase, which leads to accumulation of non-degradable glycosphingolipids in lysosomes of one or more organs (lysosomal storage disorder). The mild form of the disease (Gaucher type 1, GD1) is characterized by affection of visceral organs, with the brain being affected only sub-clinically. The early-onset neuronopathic type 2 (GD2; also with visceral signs: lung disease, hepatosplenomegaly, anemia) is additionally characterized by rapidly progressive ▶ brainstem degeneration, with ▶ opisthotonus, ▶ dysphagia, strabismus, breathing disturbances, with other symptoms occurring less frequently.

## Gaze

### Definition

As a verb it means to look at something attentively. As a noun it denotes the direction of the line of sight in space. In head free tasks, it is defined as the sum of eye position with respect to the head and the head position with respect to the body.

- ▶ Eye Movements Field

## Gaze Control

- ▶ Eye-Head Coordination

## Gaze Feedback Hypothesis

### Definition

Despite inefficient sensory feedback, the accuracy of saccadic eye movements is maintained against natural and experimentally-induced ocular trajectory perturbations.

Based on this observation, it has long been postulated that the saccadic pulse generator is controlled by an internal feedback loop keeping track of the instantaneous eye-to-target separation. By extension to the head-unrestrained condition, the gaze feedback hypothesis states that head movement information (efference copy and/or vestibular/proprioceptive signals) is added to the efference copy of the saccadic ocular command in the internal feedback loop to yield a feedback signal of current gaze displacement. This gaze feedback loop controls gaze accuracy independently of any head contribution by switching the saccadic pulse generator off as soon as gaze is on target. In turn the vestibuloocular reflex (VOR) gain, which is reduced during the saccade, automatically reaches pre-movement values as soon as the saccadic pulse generator stops discharging. Thus any residual head rotation is compensated by a vestibular-induced ocular counter-rotation.

- ▶ Efference Copy
- ▶ Eye-Head Coordination
- ▶ Saccade, Saccadic Eye Movement
- ▶ Vestibuloocular Reflexes (VOR)

## Gaze Motor Error (of a Neuron)

### Definition

Gaze motor error is a vector describing the direction and the amplitude of gaze shift required to move the line of sight from the current fixation point to a new target at another position. Saccade- or gaze-related neurons of the superior colliculus, including the tectoreticulospinal neurons, discharge maximally with movements of particular direction and amplitude. Each of them is characterized by its own optimal gaze motor error, i.e., the one for which its discharge is maximal. One can infer the location of the neuron on the motor map from its optimal gaze motor error.

- ▶ Gaze Shift
- ▶ Saccade, Saccadic Eye Movement
- ▶ SC – Motor Map
- ▶ SC-Tectoreticulospinal Neurons (TRSNs)
- ▶ Superior Colliculus (SC)

## Gaze Motor Error-Static

### Definition

A vector describing the direction and the amplitude of gaze shift required to move the line of sight from the current fixation point to a new target at a different position. It is encoded by neurons such as the saccade- or gaze-related neurons of the superior colliculus, including the tectoreticulospinal neurons, which discharge maximally with movements of particular direction and amplitude. Each of them is characterized by its own optimal gaze motor error, i.e., the one for which its discharge is maximal. One can infer the location of the neuron on the motor map from its optimal gaze motor error.

- ▶ Gaze Shift
- ▶ Saccade, Saccadic Eye Movement
- ▶ SC – Motor Map
- ▶ SC-Tectoreticulospinal neurons (TRSNs)
- ▶ Superior Colliculus (SC)

is the realignment of the line of sight so as to bring the image of a new object of interest to the central retina where receptor density and hence visual resolution are the highest. Rapid transfer of fixation from one object to another is achieved by eye saccades when the angular distance between the targets is small. When it is large, eye saccades are combined with head saccades. Gaze shifts to very eccentric targets usually require also rotation of the trunk and, eventually, movements of the limbs. In a larger sense, the term “gaze shifting” is also used to describe smooth gaze movements accompanying slowly moving targets, as well as vergence and divergence eye movements in animals endowed with stereoscopic vision. The above classes of gaze shifts are involved in active “looking” at objects of interest. Another class includes compensatory gaze shifts that serve to stabilize the images on the retina during externally induced disturbances.

- ▶ Eye-Head Coordination
- ▶ Saccade, Saccadic Eye Movement
- ▶ Smooth Pursuit Eye Movements

## Gaze Paretic Nystagmus

### Definition

Nystagmus that develops during eccentric gaze, usually due to problems with gaze-holding mechanisms.

- ▶ Central Vestibular Disorders

## Gaze Pursuit

### Definition

Continuous eye-head movements made to track a moving visual target.

- ▶ Position-Vestibular-Pause Neurons

## Gaze Shift

### Definition

Literally, the term gaze denotes attentive looking at something (see Gaze). In this narrow sense, a gaze shift

## Gaze-Velocity Neurons

### Definition

Neurons that appear to encode the angular velocity of gaze in space. The firing rate of these neurons is modulated during head-fixed smooth pursuit and during suppression of the vestibuloocular reflex (VOR) by fixating a target that rotates in conjunction with the head. In gaze-velocity neurons, these eye- and head-velocity sensitivities have the same preferred direction (e.g., excitation during rightward movement) and same magnitude. During the VOR in the dark, the eye and head move in opposite directions, so the respective modulations roughly cancel, and there is little net modulation. A gaze velocity signal can be generated by adding an appropriately weighted eye-velocity collicular discharge and a vestibular signal from the vestibular nuclei. It can also be created as a command from the smooth pursuit system to move the eyes. That is, the modulation during head-fixed smooth pursuit would be conveyed to the motoneurons to produce the eye movement. The modulation during suppression of the VOR would be conveyed to the motoneurons to exactly counteract the vestibular signal that arrives at the motoneurons via VOR pathways. During the VOR in the dark, the motoneurons are allowed to respond to their vestibular input and there is no command from

the smooth pursuit system (and no gaze-velocity modulation).

In reality, the VOR in humans and experienced animals is not ideal and the vestibular input to the motoneurons conveyed by VOR interneurons is partially nullified during suppression of the VOR. Therefore, the expected ratio of eye-velocity to head-velocity sensitivity for a smooth pursuit command signal would arguably be greater than 1.0. Correspondingly, true gaze-velocity neurons in most structure are a subpopulation of neurons having varying ratios of eye- and head-velocity sensitivities.

Gaze velocity neurons are found in the oculomotor vermis, the floccular lobe, the vestibular nuclei, the frontal eye fields, and pontine nuclei.

- ▶ Cerebellum - Role in Eye Movements
- ▶ Smooth Pursuit Eye Movements
- ▶ Vestibuloocular Reflexes (VOR)

## GDNF

### Definition

- ▶ Glia Cell Line-derived Neurotrophic Factor

## Gelasthic Seizures

### Definition

A minor seizure that manifests as a sudden, unprovoked outburst of emotion, usually laughter or crying.

- ▶ Neuroendocrinology of Psychiatric Disorders
- ▶ Neuroendocrinology of Tumors

## Gelineau Syndrome

- ▶ Narcolepsy

## Gender

### Definition

Social construct describing an individual's self-representation as male or female, which incorporates biological determinants as well as environmental influences such as experience, culture, and ethnicity.

The term gender refers to humans.

## Gender and Pain

- ▶ Gender/Sex Differences in Pain

## Gender/Sex Differences in Pain

RENÉ M. SHINAL<sup>1</sup>, ROGER B. FILLINGIM<sup>2</sup>

<sup>1</sup>Department of Community Dentistry and Behavioral Science, College of Dentistry, University of Florida, FL, USA

<sup>2</sup>Department of Community Dentistry and Behavioral Science, College of Dentistry, University of Florida and North Florida/South Georgia Veterans Health System, Gainesville, FL, USA

### Synonyms

Sex; Gender and pain; Sex differences in pain

### Definition

Despite substantial individual variability in pain responses, an expanding body of evidence indicates that males and females experience pain differently. ▶ Sex differences have been widely reported in the epidemiology of clinical pain, sensitivity to experimentally induced pain, endogenous pain modulation, and responses to analgesic compounds.

The terms sex and ▶ gender are often used interchangeably in research literature; however, their meanings contain important distinctions. To maintain consistency in this review, the term sex is used to classify organisms as male or female according

to genetic composition and consequent anatomic structures and functions [1]. The more inclusive term gender is a social construct describing an individual's self-representation as male or female, which incorporates biological determinants as well as environmental influences such as experience, culture, and ethnicity. As such, gender exclusively references human research, whereas the term sex can be used in reference to human or non-human animal research. This brief overview summarizes clinical and experimental evidence regarding the relationship of sex and gender to pain and analgesia.

## Characteristics

### Human Clinical Pain

Compared to men, women are more likely to acknowledge pain and seek medical care for numerous painful conditions such as migraine and tension-type headaches, fibromyalgia, autoimmune rheumatic disorders, temporomandibular disorder (TMD), and irritable bowel syndrome (IBS) [2]. In community populations, females describe poorer perceived health and well-being, experience a greater number of symptom recurrences, have more intense pain, and report a disproportionately larger number of pain symptoms for which they do not necessarily seek treatment [3]. These trends persist when confounding factors such as differences in prevalence rates of medical conditions, psychiatric disorders, and gynecologic pain, are statistically controlled.

Sex-specific patterns in pain incidence and prevalence vary between clinical conditions and change across the lifespan. Some discrete differences in pain reporting appear in pre-pubertal children and become more apparent during the reproductive years when gonadal hormone levels increase [2]. However, there are certain conditions that are more prevalent in men (e.g. cluster headache), or for which sex differences are negligible (e.g. toothache due to pulpitis) [2,4]. Sex differences have also been reported in the severity of acute clinical pain (e.g. postoperative pain), although negative findings also exist. Whereas the direction of differences is relatively consistent (i.e. women having a higher likelihood of reporting pain), the magnitude of sex differences varies greatly depending on the type of pain (e.g. acute, chronic), population (e.g. hospital, community-based), pain assay (e.g. thermal, pressure, ischemic, chemical irritant), anatomic location (e.g. cutaneous, visceral), pain dimension (e.g. sensory, cognitive, affective) and by the methodology used in a study [1,4].

### Experimental Laboratory Studies

#### Basal Pain (Nociceptive) Sensitivity

##### Non-Human Animal

Non-human animal studies (primarily rodents) yield mixed results concerning sex differences in nociceptive

responses. Female rodents tend to exhibit pronounced behavioral and physiological reactions and lower response thresholds for many, but not all, types of noxious stimuli [1,5]. The direction and magnitude of sex differences in nociception depend on many factors such as the genotype or strain of rodent, anatomic site of testing, age, estrus cycle phase, light exposure during testing, husbandry procedures, and assay type [5]. Importantly, rodent studies of sex differences in nociceptive sensitivity have relied almost exclusively on reflex measures, and the presence of sex differences in nociception has not been determined with operant assays.

Current data, while suggestive of sex differences in basal pain sensitivity, should be interpreted with discretion. Even under tightly controlled experimental conditions, the relative contributions of genetics and other factors can be difficult to distinguish. Several covariates have been found to interact with genotype in a sex-dependent fashion. For example, female estrus cycle is a predictor of baseline thermal nociceptive sensitivity for some, but not all, rodent strains. Divergent estrus cycle effects can mask sex differences when female rodents from hormone-sensitive strains are tested as a randomly mixed group (e.g. estrus and diestrus). Thus, when studies fail to note sex differences it is difficult to determine whether differences are indeed absent, or whether methodological issues (e.g. small sample sizes; choice of rodent strain) have prevented their detection. By using inbred rodent strains, as opposed to outbred strains commonly used in laboratories, specific phenotypes can be targeted for study. This method, in conjunction with transgenic and linkage mapping techniques, marks a promising step toward elucidating the mechanisms underlying specific sex dimorphic traits in laboratory animals [see also ► [Transgenic Animal](#); ► [Transgenic Techniques](#)].

##### Human

Laboratory studies with healthy humans of reproductive age suggest that females have lower pain thresholds and tolerances than males to a variety of noxious stimuli. These differences generally persist after adjusting for disparities in baseline sensory discriminative abilities (e.g. warmth detection threshold). As with rodent research, there is considerable variability in the magnitude of gender differences among humans. Effect sizes for pain threshold and tolerance range from moderate to large, and vary according to pain assay [1,4]. For example, males consistently exhibit substantially higher pressure pain thresholds and tolerances. Thermal, electrical pulses and ischemic pain assays yield comparatively less consistent outcomes. Men generally display higher pain thresholds and tolerances, and lower pain ratings than women during cold pressor stimulation. Intramuscular injections of algescic



substances such as hypertonic saline or glutamate solutions produce more intense, longer lasting, and more widespread pain in women compared to men. Women also tend to experience longer lasting and more intense post-exertion pain and discomfort, and longer recovery to baseline after certain tests of muscular strength and endurance (e.g. jaw muscle fatigue).

Although the exact mechanisms underlying sex differences in pain sensitivity are unclear, several biopsychosocial variables have been suggested, such as: (i) biological factors including genetic, anatomic (e.g. body composition), physiologic (e.g. cardiovascular and central nervous system differences), neurochemical, and hormonal contributions; (ii) developmental factors influencing the manifestation of pain in childhood and adolescence, and (iii) psychosocial factors such as social learning (e.g. culture/ethnicity, gender role identity), experience (e.g. pain history, abuse/trauma history), and psychological variables (e.g. mood, cognitions, coping strategies, expectations) (Fig. 1). It is unlikely that a single factor adequately explains the complex mechanisms driving gender differences in pain sensitivity. Rather, a multidimensional approach is more likely to be fruitful in gaining a comprehensive understanding of pain experiences.

### Clinical Relevance of Experimental Pain Responses

Temporal features of noxious stimuli can influence pain perception differently in males and females. ► **Temporal summation** refers to a perceived increase in pain created by rapid, identical pulses of noxious stimuli. This perceptual phenomenon presumably occurs when high frequency stimulation of C polymodal nociceptive afferents amplifies second-order neuronal activity in the spinal cord dorsal horn. This series of events has been shown to involve *N*-methyl-D-aspartate (NMDA) glutamate receptors [6]. [see also ► **NMDA Receptor**]

Temporal summation is thought to reflect central neural mechanisms similar to those responsible for the hyperalgesia and allodynia that accompany many forms of clinical pain. Healthy females often exhibit more robust temporal summation than males when given volleys of thermal, electrical, or mechanical stimulation [6]. Within chronic pain populations, robust temporal summation has been associated with greater severity of clinical symptoms and relatively ineffective responses to treatment. Such findings invite speculation that enhanced sensitivity to repetitive or sustained experimental stimuli reflects a predisposition for neuronal hypersensitivity, which may represent a risk factor for developing chronic pain conditions. At present, there is a need for prospective longitudinal studies to investigate further this possibility.

### Endogenous Analgesia (Antinociception)

In laboratory studies, endogenous analgesia can be produced by electrical or chemical stimulation of relevant anatomic sites (e.g. descending neural pathways), or by exposure to environmental stressors such as forced cold-water swims. Effects are assessed by measuring behavioral distress, biomarkers (e.g. plasma cortisol, endorphins in cerebrospinal fluid), and/or measuring neurochemicals extracted from postmortem tissue in laboratory animals. In humans, acupuncture and transcutaneous nerve stimulation (TENS) are examples of procedures used to control pain by stimulating endogenous analgesic mechanisms.

Endogenous pain modulation involves several distinct, but interrelated, systems that involve structures throughout the body [see ► **Descending Modulation of Nociception**]. In mammals, the opioid system relies heavily on mu, delta, and kappa receptor subtypes located in the central nervous system and peripheral tissue. Endogenous opioids (e.g. endomorphin,

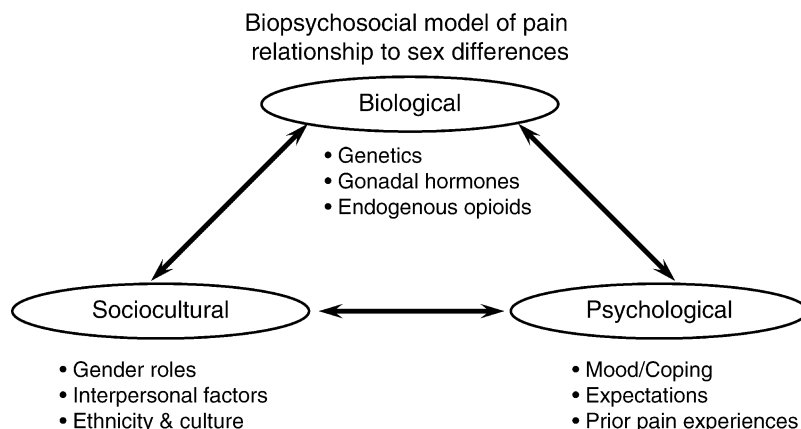

Gender/Sex Differences in Pain. Figure 1

endorphin, enkephalin, dynorphin) are released under a variety of naturally occurring conditions involving high arousal states such as physical exertion, sexual activity, or fear [7] [see also ►[Endorphins](#)]. Activation of opioid receptors generally inhibits downstream excitatory pathways. The result is temporary pain attenuation and a subjective sense of well being. Certain foods, such as carbohydrates and chocolate, can promote opioid release. Due to their relationship with other neurochemicals such as dopamine and serotonin, opioids have been associated with complex psychological states such as addiction, thrill-seeking behavior or extreme joy. Various chemicals such as ►[naloxone](#) can temporarily block opioid receptors [7]. Endogenous opioids play an important role in mediating some types of ►[Stress induced analgesia \(SIA\)](#).

### **Non-Human Animal**

In response to stressful events such as forced cold-water swims, stress-induced antinociception (SIA) involves both endogenous opioid and non-opioid (i.e. NMDA, naloxone-insensitive) systems. Given identical stressors, female rodents tend to display less opioid and non-opioid mediated SIA than males. It appears that antinociception displayed by females having intact ovaries is neurochemically different from that displayed by males and ovariectomized females. Selectively blocking relevant receptor sites and/or manipulating gonadal hormones can produce divergent effects on SIA in a sex-dependent fashion.

In addition to SIA, pregnancy-induced analgesia and analgesia produced by vaginocervical stimulation are hormonally-mediated endogenous processes unique to females. This suggests that quantitatively and qualitatively different neurochemical mechanisms might support endogenous pain modulation systems for males and females. As with nociceptive sensitivity, sex differences in endogenous antinociception also interact with the genotype of the rodent.

### **Human**

Relatively little human research has directly addressed sex differences in endogenous pain modulation. Higher resting blood pressure has been associated with lower pain sensitivity, and some evidence suggests that the modulation of pain by resting blood pressure may be more robust among men. In addition, brain-imaging studies have reported sex differences in the magnitude and direction of  $\mu$ -opioid receptor recruitment during exposure to a sustained painful stimulus [8]. After controlling for female gonadal hormone effects, men tend to demonstrate higher magnitudes of endogenous opioid release in brain regions involved in modulating sensory and affective aspects of pain (i.e. thalamus, nucleus accumbens, amygdala) [8]. It is important to note that opioid receptor availability, binding and/or

affinity are dynamic processes that also interact with other variables such as hormonal status, age, and genetics.

Counterirritation [i.e. ►[Diffuse noxious inhibitory controls \(DNIC\)](#)] refers to the process whereby one concurrently applied noxious stimulus inhibits the perception of a second painful stimulus. This phenomenon is thought to reflect descending inhibition of pain signals. DNIC is presumed to operate through activation of descending supraspinal inhibitory pathways initiated by release of endogenous opioids. Several studies have investigated sex differences in the efficacy of DNIC, with mixed results. For example, ischemic arm pain (the DNIC condition) seems to reduce the occurrence of a pain-initiated leg reflex (nociceptive flexion reflex or RIII reflex) equally in men and women. Other studies using variations on the DNIC model have shown that counterirritation is more effective for males. At present, it appears that any sex differences in DNIC are modest and highly variable depending upon the study design.

A variety of psychological factors (e.g. anxiety, anger, coping) are associated with pain responses, which represents another form of endogenous pain modulation. Considerable evidence suggests sex-dependence of some forms of psychological pain modulation. For example, anxiety has consistently been associated with pain responses more strongly among men than women. In addition, the association of anger with pain may differ across genders. Thus, while the precise neurobiological mechanisms underlying psychological pain modulation are not known, these findings provide further evidence of sex differences in the functioning of endogenous pain modulatory systems.

### **Exogenous Opioid Analgesia (Antinociception)**

#### **Non-Human Animal**

While multiple classes of analgesic drugs exist, research regarding sex differences in analgesic responses has focused primarily on opioids. Numerous studies have shown that male rats exhibit greater antinociception from a variety of opioid receptor (OR) agonists than females [1]. Compared to high-efficacy compounds such as morphine, larger sex differences have been observed with lower-efficacy opioids [1]. Indeed, under some experimental conditions, the same opioid can function as an agonist in males and an antagonist in females.

It is posited that gonadal hormone fluctuations, such as those occurring during the female estrus cycle, are partially responsible for sex differences in exogenous opioid responses, presumably by altering opioid receptor availability and/or binding affinity. For example, adult male rats depleted of hormones via gonadectomy (GDX) have shown unchanged or decreased  $\mu$ -opioid receptor-mediated antinociception

relative to their baseline, whereas female GDX rats tend to exhibit increased antinociception [1,7]. However, similar studies have failed to replicate these findings or have produced inconsistent results.

In contrast to the unpredictable effects observed with adult hormone changes, manipulation of fetal and neonate hormones typically alters responsiveness to opioids in adulthood. This indicates that early hormone exposure can produce durable effects on the developing central nervous system. As with nociception, sex differences in opioid responses change in accordance with the characteristics of the organism (e.g. genetics, hormonal status, age) in addition to the type of analgesic agent and procedures used to induce antinociception [1].

### Human

In contrast to rodent studies, human clinical and experimental pain models show a trend for women to derive superior analgesia from a variety of exogenous opioids compared to men; however, results vary substantially [9]. Clinical studies of patient controlled analgesia have noted that males consume higher doses of morphine compared to women. It is difficult to determine whether disparities in consumption reflect analgesia or other non-specific reasons such as differences in postoperative pain, previous pain experiences, concerns about addiction, or side effects. When differences are found in experimental pain models, they have generally been in the direction of women responding more favorably to  $\mu$ -opioid receptor agonists such as morphine, meperidine, and hydromorphone. Fairly consistent sex differences have been noted regarding side effects and subjective effects of opioids, with women experiencing more respiratory depression, attenuation of cardiac reactivity, feelings of heaviness, and feeling “spaced out,” particularly with  $\mu$ -opioid receptor agonists [9].

In clinically relevant pain models (e.g. extraction of third molars), women often derive better and longer-lasting analgesia from mixed agonist-antagonist opioids that are agonists at  $\kappa$ -opioid receptors (e.g. butorphanol, pentazocine, nalbuphine). Compared to women, men frequently require larger doses of  $\kappa$ -opioids (adjusted for body weight) to attain equivalent analgesia. It appears that the melanocortin-1 receptor gene (*MC1R*) influences responses to  $\kappa$ -opioids in a sex-dependent manner. Specifically, women with two variant *MC1R* alleles, responsible for the red hair and fair skin phenotype, report significantly better analgesia with  $\kappa$ -opioids. The *MC1R* genotype does not appear to be strongly associated with  $\kappa$ -opioid analgesia for men.

Although a portion of the sex differences observed in responses to analgesic compounds is due to variations in body composition, mounting evidence shows that pharmacodynamic differences exist in opioid receptor

binding, as well as in hormonal and other neurochemical influences [10]. Overall, the manifestation of gender differences likely depends on multiple factors including pharmacological characteristics of the opioid, dose administered, pain model employed, and timing of postdrug assessments. Moreover, data suggest that sex-by-genotype interactions may influence opioid responding. It is likely that advances in the field of ▶Pharmacogenomics will continue to reveal genetic contributions to sex differences in pain sensitivity and opioid responding.

### Summary

Substantial evidence demonstrates sex differences in responses to pain across multiple pain modalities in both human and non-human species. Specifically, females typically exhibit greater basal pain sensitivity than males, though the magnitude of these differences is variable. Moreover, women are at greater risk than men for many forms of clinical pain. Sex differences in opioid analgesic responses have also been reported, though these data are inconsistent across species, analgesic assays, and specific opioid tested. While sex hormones have been implicated, the nature and extent of their contribution remains undetermined. Findings of sex-dependent genetic associations with pain and analgesia indicate potentially important ▶qualitative sex differences in pain and analgesic circuitry. Additional research is needed to elucidate the multiple mechanisms underlying sex differences in pain and analgesia and to determine the implications for sex-dependent tailoring of clinical pain management.

### References

1. Craft RM (2003) Sex differences in opioid analgesia: from mouse to man. *Clin J Pain* 19:175–86
2. LeResche L (2000) Epidemiologic perspectives on sex differences in pain. In: Fillingim RB (ed) *Sex, gender, and pain*. IASP Press, Seattle, pp 233–249
3. Unruh AM (1996) Gender variations in clinical pain experience. *Pain* 65(2–3):123–167
4. Berkley KJ, Holdcroft A (1999) Sex and gender differences in pain. In: Wall PD, Melzack R (eds) *Textbook of pain*, 4th edn. Churchill-Livingstone, Edinburgh, pp 951–965
5. Mogil JS (2000) Interactions between sex and genotype in the mediation and modulation of nociception in rodents. In: Fillingim RB (ed) *Sex, gender, and pain*. IASP Press, Seattle, pp 25–40
6. Sarlani E, Grace EG, Reynolds MA, Greenspan JD (2004) Sex differences in temporal summation of pain and aftersensations following repetitive noxious mechanical stimulation. *Pain* 109(1–2):115–123
7. Bodnar RJ, Klein GE (2005) Endogenous opiates and behavior. *Peptides* 27(12):3391–3478

8. Zubieta JK, Smith YR, Bueller JA et al. (2002) mu-opioid receptor-mediated antinociceptive responses differ in men and women. *J Neurosci* 22(12):5100–5107
9. Fillingim RB, Gear RW (2004) Sex differences in opioid analgesia: clinical and experimental findings. *Eur J Pain* 8:413–425
10. Fillingim RB, Ness TJ (2000) Sex-related hormonal influences on pain and analgesic responses. *Neurosci Biobehav Rev* 24:485–501

---

## Gene Promoter

### Definition

A regulatory region of DNA located upstream of a gene, providing a control point for regulated gene transcription.

► [Neuroendocrinology of Psychiatric Disorders](#)

---

## Gene Therapy

### Definition

Therapeutic strategies for disease treatment involving the insertion of specific genetic material to alter the instruction set of a cell.

---

## Gene Therapy for Neurological Diseases

BAS BLITS, JOOST VERHAAGEN  
Netherlands Institute for Neurosciences, A research institute of the Royal Netherlands Academy of Arts and Sciences, Amsterdam, The Netherlands

### Synonyms

Brain; Central nervous system; Gene transfer; Transduction; Viral vector

### Definition

► [Gene therapy](#) can be defined as the use of therapeutic genetic material for the treatment of a disease.

## Characteristics

► [Viral vector](#)-mediated gene transfer in the nervous system is a promising strategy to treat certain neurological diseases including ► [neurodegenerative diseases](#) and enzyme deficiencies and in the future may turn out to be of value for the treatment of traumatic injuries of the spinal cord and brain tumors.

## Introduction

Gene therapy can be defined as the introduction of therapeutic genetic material into cells as a means to treat a disease. Recessive hereditary diseases caused by a defect in a single gene can in theory be treated by gene therapy. Gene therapeutic approaches can also be useful to express a therapeutic protein that is not able to pass the blood brain barrier in the brain or spinal cord. Moreover, in contrast to injection of a therapeutic protein itself, cellular delivery of a gene results in sustained and local expression of a therapeutic protein.

The gene of interest is usually delivered by a viral vector. Viruses have evolved into small genetic delivery systems, as they are able to enter a cell and deliver their RNA or DNA to the host. A viral vector is a genetically modified virus. For gene therapeutic purposes, an expression cassette harboring a promoter in front of a gene encoding a therapeutic protein usually replaces one or more genes in the viral genome. These modifications render a viral vector (in principle) non-pathogenic while the vector maintains its ability to deliver foreign genetic material to the cell nucleus ([Fig. 1](#)). We will first discuss the various vectors that are available to the gene therapist. Secondly, we will summarize the state of the art of gene therapy for neurological diseases (we refer to [[1](#)] for a comprehensive textbook on CNS gene therapy).

## Vectors for Gene Delivery to the Nervous System

Perhaps one of the most important decisions for gene therapy to be successful is the choice of the viral vector. Because each disease has its unique pathogenesis, each disease requires a vector with the appropriate properties. To make a well informed decision on which vector to use, one has to consider the location, cell type, quantity and duration of ► [transgene](#) expression required. During the last 20 years, gene therapy vectors have been created by modifying viruses and by developing non-viral gene delivery systems. Adeno-associated and lentiviral vectors have emerged as the most efficient vectors for gene transfer to the nervous system. Both in vivo as well as ex vivo gene delivery approaches have been developed ([Fig. 2](#)).

Using the in vivo approach, the viral vector is directly injected into the brain area of interest. The ex vivo approach entails genetic modification of cultured cells (preferable of the patient itself) prior to implantation into the area of interest. Following implantation in

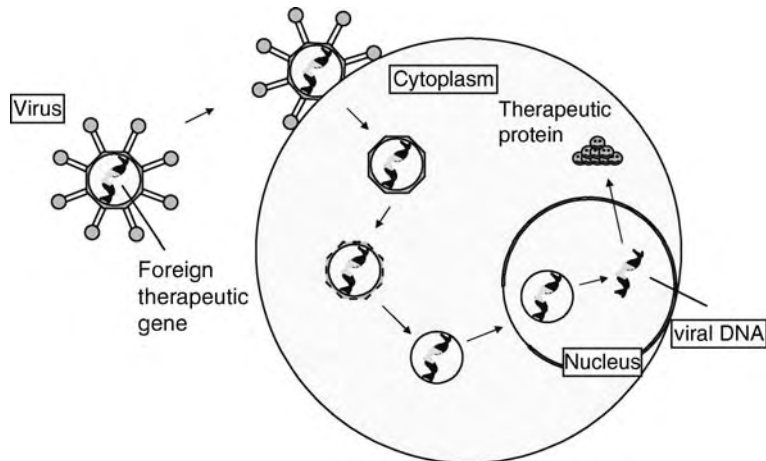

**Gene Therapy for Neurological Diseases. Figure 1** A viral vector as a carrier of a therapeutic gene. A virus is genetically modified in such a way that it is still able to infect a cell and deliver its genetic material into the nucleus of a cell. After uncoating of the virus and traveling to the nucleus, the genetic information is transcribed and translated into a possible therapeutic protein. The viral vector DNA can be kept episomal (for instance after transduction with an AdV) or can be inserted in the host cell genome (as is the case after transduction by an LV vector).

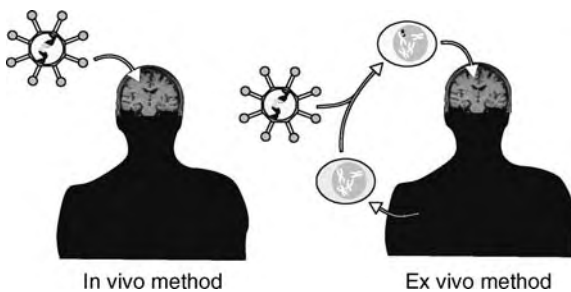

**Gene Therapy for Neurological Diseases. Figure 2** Principle of gene therapy in the brain. Gene therapy is possible through either direct in vivo injection of a viral vector or indirectly via an ex vivo approach in which cells of a patient are cultured, genetically modified by viral vectors and transplanted. Using the ex vivo approach, transduced cells serve as a local source of e.g. a growth factor. Using the direct in vivo approach, the viral vector is injected directly into the area of interest and transduces the neural tissue around the injection site.

the brain these cells serve as biological minipumps for e.g. neurotrophic factors.

### Non-viral Vectors

Because humans display (pre-existing) immunity to viruses, a single injection of a recombinant virus into CNS tissue may lead to an inflammatory reaction. In theory therefore, non-viral vectors would be ideal gene delivery vehicles due to their delivery of genetic material without the introduction of immunogenic viral proteins. Non-viral constructs that consists of a DNA

molecule, coated with a polymer and a humanized targeting antibody directed transgene expression in the CNS, which lasted for a few days. Thus, when transient gene expression is required, non-viral vectors may be considered. For most applications, however, long term therapeutic gene expression will be a prerequisite.

### Viral Vectors

Whereas non-viral vectors usually are relatively inefficient delivery systems and direct a short period of transgene expression, the use of most viral vectors results in extended periods of transgene expression. Viral vectors have been based on retrovirus (including lentivirus [LV]), herpes simplex virus (HSV), adenovirus (AdV) and adeno-associated virus (AAV). Extensive preclinical data in animal models has documented the advantages and disadvantages of each of these vector systems and has guided the way to the use of specific viral vectors in the clinical setting.

### Retroviral Vectors

The very first viral delivery system was a retroviral moloney murine leukemia vector (MMLV). The retroviridae comprise a family of RNA viruses, that upon infection of a cell, reverse transcribe their RNA into double stranded DNA, which is integrated into the host genome. Since MMLV only transduces dividing cells and most neural cells are post-mitotic, MMLV does not directly transduce nervous tissue. Retroviral vectors have successfully been applied to modify fibroblasts *ex vivo* prior to transplantation in the CNS [2]. In these studies transplanted genetically modified fibroblast served as biological minipumps that locally secreted the neurotrophic factor nerve growth factor

(NGF). These pioneering experiments have recently resulted in a clinical trial for Alzheimer's disease ([3], see below).

### **Herpes Simplex Viral Vectors**

Herpes simplex virus is a large double stranded DNA virus. HSV was chosen as a potentially interesting vector because it is a neurotropic virus, it maintains a life long state of latency in neurons, and is retrogradely transported along axons allowing peripheral delivery of the vector [4]. Two HSV vector systems exist: recombinant HSV vectors and defective or amplicon HSV vectors. In recombinant vectors deleting or replacing immediate early genes with an expression cassette encoding the gene of interest curtails the lytic cycle of the virus. The amplicon HSV vector is based on the observation that a plasmid containing a transgene and two small elements from the HSV genome (the origin of replication and a cleavage/packaging signal) can be amplified and packaged in the presence of a helper virus. It has been notoriously difficult to produce recombinant HSV vectors that are fully replication defective. The amplicon HSV vectors are contaminated with helper virus and the production of high titer helper free amplicon HSV stocks is extremely difficult. An immunoresponse to herpes virus proteins cuts short transgene expression to a few weeks. HSV vectors are being used in clinical trials for treatment of glioblastoma [5] and clinical trials for the treatment of chronic intractable pain are planned.

### **Adenoviral Vectors**

Adenovirus has a double stranded DNA genome of 36 kb, consisting of early (E) and late (L) genes. In first generation adenoviral vectors the E1 genes are substituted by a transgene. This renders the vector replication defective. To propagate the vector, E1 is supplied in trans by a cell line with the E1 gene. The adenoviral vector (AdV) genome remains ►**episomal** and transgene expression can be detected as early as 1 day post-injection in the rodent brain. AdV-mediated transgene expression declines rapidly after 2–3 weeks as a result of an immunological response against the transduced cells. Several strategies have been devised to overcome this problem, including the use of temperature sensitive AdV in combination with immune blockade and the generation of AdV completely devoid of all viral genes, so called “gutless” AdV. Although some successes have been reported, it remains very difficult to produce and purify “gutless” AdV in clinically relevant quantities and it is clear that advances in this area are still required before AdV can be applied in a clinical setting. Despite these problems, AdV have been important tools to show proof of concept in a variety of animal models of neurological disease.

### **Adeno-Associated Viral Vectors**

The adeno-associated virus (AAV) genome is only 4.7 kb in size and is encapsidated in a simple capsid composed of three viral proteins. AAV is only propagated as a lytic virus in the presence of e.g. adenovirus or HSV. Because the AAV genome is only 4.7 kb in size, a copy of the genome can be easily cloned in a plasmid, with the restriction that the size of the expression cassette should not exceed this limitation. The observation that the wild type AAV genome could be rescued from a plasmid and propagated following transfection into adenovirus infected cells led to the idea that AAV could be developed as a viral vector [6]. To date several plasmid and baculovirus based production systems are available that allow the generation of clinical grade AAV vectors. In addition to AAV2 at least 11 AAV serotypes have been developed into AAV vectors, all with different cellular tropism. Several AAV serotypes, including AAV1, 2 and 5 predominantly transduce neurons. AAV vectors direct transgene expression in rodents and primates for periods of years and so far no immunological response to AAV transduced cells in the brain has been noted. To date AAV vectors are regarded to be safe gene delivery agents and several gene therapy trials for neurological disease use AAV as vector (discussed below).

### **Lentiviral Vectors**

Lentivirus is a retrovirus that possesses accessory genes that allow these retroviruses to infect non-dividing cells, including neurons. Lentiviral vectors can be divided into two groups: (i) primate vectors, including human immunodeficiency virus [7] and simian immunodeficiency virus based vectors, and (ii) non-primate vectors, including equine infectious anemia virus (EIAV) and feline immunodeficiency virus (FIV) based vectors. EIAV displays a higher ►**neuronal tropism** compared to the other lentiviral vectors. ►**Pseudotyping** the capsid of the vector is an important strategy to generate tropism for specific cells. Whereas the commonly used VSV-G coat has a broad host range, pseudotyping EIAV with pseudorabies virus enhances the neuronal specificity and facilitates retrograde transport from nerve terminals in the muscle to spinal motor neurons. Since this vector integrates into the host genome this vector has become the most popular vector for ex vivo gene therapy of dividing cells like primary fibroblast or Schwann cells.

## **Gene Therapy for Neurological Diseases**

Gene therapy for neurological disease has advanced rapidly in two areas: neurological disorders resulting from enzyme deficiencies and neurodegenerative diseases. In the latter area phase I clinical trials that show

proof of concept have now been completed and phase II/III trials are ongoing (Fig. 3).

### Enzyme Deficiencies

Gene therapy for enzyme deficiencies primarily aims at correction of the compromised activity of the mutated enzyme by intervention with a vector encoding the wild type gene. In these diseases gene therapy has usually to be applied early in life to prevent neurological damage and global transgene expression throughout large areas of the cerebrum is required.

### GM-1 Gangliosidosis

GM1 gangliosidosis is caused by mutations in lysosomal acid beta-galactosidase. In lactase deficient mice, During and colleagues were able to introduce the gene into the gut of these mice using AAV-vectors. This resulted in complete correction of the enzymatic deficiency. AAV-mediated expression of acid beta-galactosidase into the brain of neonatal GM-1-gangliosidosis [ $\beta$ -gal ( $-/-$ )] mice resulted in almost complete **transduction** of the brain and in complete correction of the disease phenotype. For translation

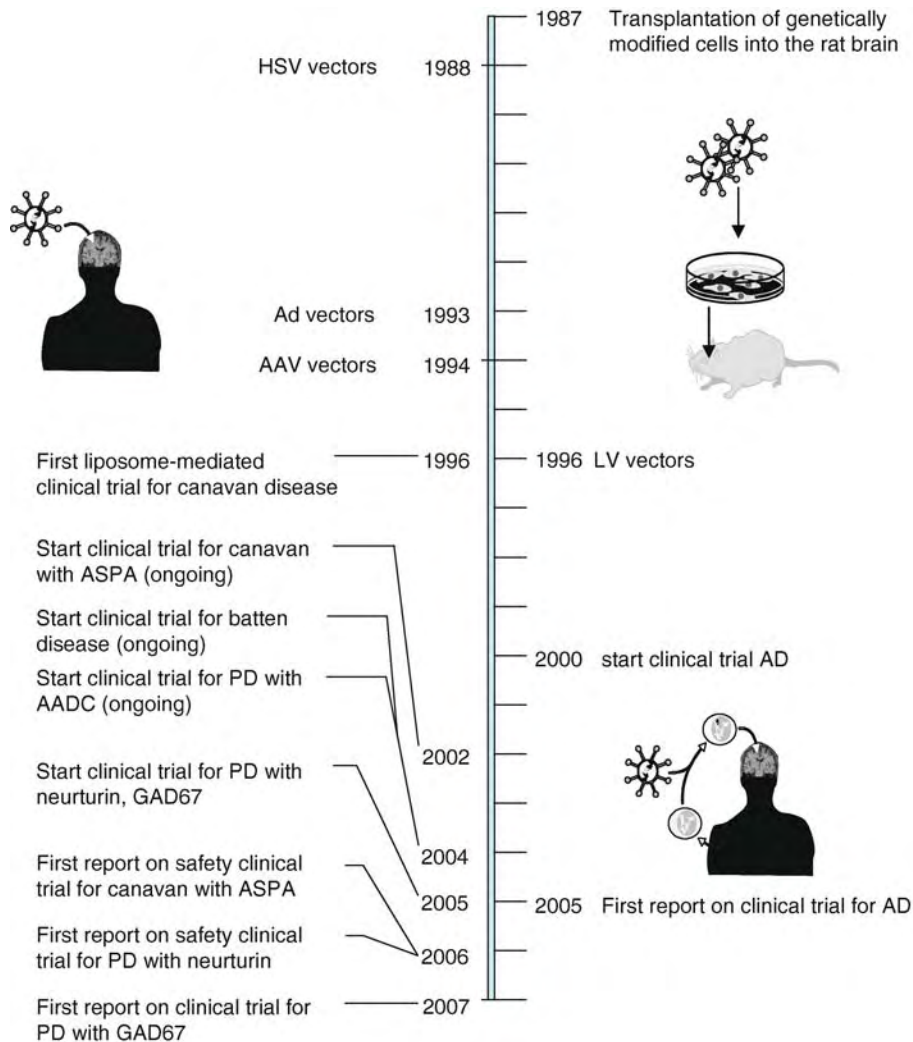

**Gene Therapy for Neurological Diseases. Figure 3** Highlights in gene therapy for neurological diseases. In 1987, a first report on grafting fibroblasts that had been genetically modified to secrete NGF into rat brain was published. In 2000, a clinical trial was initiated for the treatment of Alzheimer's disease using genetically modified cells to secrete NGF of the patient itself. In 2005 the results of a Phase I clinical trial using this treatment strategy were reported. Several vector systems have been developed during the eighties and nineties and were applied in the nervous system, including HSV (1988), Ad (1993), AAV (1994) and LV (1996). The use of AAV in various clinical settings is well underway and AAV gene therapy has been reported to be well-tolerated. For the treatment of Parkinson the results of a Phase I clinical trial recently have been reported [10].

of this gene therapeutic approach into a clinical trial, AAV vectors encoding lysosomal acid galactosidase are further evaluated in larger animal models of GM-1-gangliosidosis.

#### **Canavan Disease**

Canavan disease is autosomal-recessive leukodystrophy caused by mutations in the aspartoacylase (ASPA) gene. ASPA is enriched in oligodendrocytes and ASPA deficiency results in elevated levels of its substrate molecule, N-acetylaspartate (NAA). The disease is characterized by brain edema, demyelination, motor deficits and seizures. In a knockout mouse model, ASPA activity was normalized following intrathalamic injections of AAV-ASPA, and seizures were reduced but other important clinical parameters were unchanged. Thus, transfer of ASPA to neurons only partially corrects the disease and vectors with tropism for oligodendrocytes will be needed to fully correct the disease. The very first gene therapy trial was conducted to treat Canavan disease in 1996. The gene encoding ASPA was coated with liposomes and injected into the brain. Using this method, a transient expression pattern was achieved, with beneficial results that were linked to the expression pattern ([www.canavan.org](http://www.canavan.org)). Recently, in a phase I clinical trial, a total of 10 patients received six intracranial injections of the AAV vector each in an attempt to ameliorate this neurodegenerative disorder. This was a phase I feasibility study and functional improvements have not been reported. In three out of ten subjects, a low level of AAV-2 neutralizing antibody was detected. Long-term monitoring of subjects and expansion to phase II/III will be necessary to make definitive statements on the efficacy of gene therapy for this disease.

#### **Batten Disease**

Batten disease is a neuronal ceroid lipofuscinosis that arises from autosomal recessive mutations in the cyclin2 (CLN2) gene. Mutations in this gene result in early progressive widespread neurodegeneration and death. Pre-clinical efficacy studies with an AAV2-CLN2 were performed in rats and monkeys. A clinical study that started 2004 is ongoing. (<http://www.clinicaltrials.gov/ct/show/NCT00151216>).

#### **Neurodegenerative Diseases**

Gene therapy for neurodegenerative diseases involves the local delivery of genes encoding protective or restorative molecules with the primary aim to prevent neuronal loss, promote reestablishment of connections and stimulate or reset the function of the affected neurons.

#### **Amyotrophic Lateral Sclerosis**

Amyotrophic lateral sclerosis (ALS) is a progressive motoneuron disease. The cause of the disease is

unknown in most patients but dominant mutations in *SOD1*, the gene encoding Cu/Zn-superoxide dismutase, are responsible for the disease in about 5% of cases. The progressive loss of motoneurons was slowed down after viral vector-mediated retrograde delivery of IGF1 [8] or VEGF in a transgenic mouse model of ALS [9]. VEGF is an angiogenic factor and local overexpression of this factor may lead to neovascularization. Several hurdles need to be overcome to translate these results to the clinic. Control over the dose and timing of growth factor expression will be critical in future clinical trial. In ALS the degeneration of motoneurons is widespread. Delivery of the therapeutic gene throughout the ventral spinal motoneuron pool and motor cortex is a challenge for which no solution is as yet on the horizon.

#### **Alzheimer's Disease**

A key feature of AD is cholinergic neuron loss in the basal forebrain. Nerve growth factor (NGF) stimulates cholinergic function, improves memory and prevents cholinergic degeneration in animal models following injury, amyloid overexpression and during aging. A team led by Mark Tuszynski performed a successful phase I clinical trial of *ex vivo* NGF gene delivery in eight individuals with early signs of cognitive impairment [3]. Genetically modified autologous fibroblasts expressing NGF were transplanted in the forebrain. Patients were followed for 22 months and no adverse effects of the treatment were observed. Cognitive decline advanced at a diminished rate and serial PET scans showed significant increases in cortical 18-fluorodeoxyglucose uptake. A second NGF gene therapy trial for AD involves the delivery of AAV-NGF directly to the forebrain ([www.ceregene.com](http://www.ceregene.com)).

#### **Parkinson's Disease**

In Parkinson's disease (PD) dopaminergic neurons in the substantia nigra degenerate. This leads to changes in the circuitry of the basal ganglia, including the subthalamic nucleus (STN). At least two distinct gene therapy strategies are being pursued: (i) use of genes that can affect the activity of the remaining neuronal circuitry (e.g. glutamic acid decarboxylase [GAD]), and (ii) transfer of genes encoding neurotrophic factors involved in dopaminergic cell survival.

GAD synthesizes the inhibitory neurotransmitter (gamma)-aminobutyric acid. Dopaminergic cell loss results in disturbances in the circuitry of the basal ganglia; for instance excitatory neurons of the subthalamic nucleus become overactive. AAV-mediated expression of GAD in the STN resulted in silencing of this overactive circuitry in preclinical studies. Based on these results a phase I clinical trial to overexpress GAD in the STN of 12 patients has recently been completed [10]. Following unilateral injections of AAV-GAD into the STN no adverse events related to the gene



therapeutic approach were observed. A limited degree of functional improvement, especially on the side of the body contralateral to the surgery persisted in some patients up to 12 months.

Genzyme has initiated a phase I open label safety study of intrastriatal infusion of AAV encoding human aromatic L-amino acid decarboxylase (AAV-hAADC-2) in subjects with PD in 2004. AADC is an enzyme that converts L-dopa to dopamine, to restore therapeutic windows of orally administered L-dopa in advanced idiopathic PD. This trial is still ongoing ([www.genzyme.com](http://www.genzyme.com)).

Glial cell line-derived neurotrophic factor (GDNF) prevents degeneration of dopaminergic neurons. The neuroprotective effect of GDNF has been studied extensively in animal models for PD. Chronic infusions of GDNF in humans with PD had positive effects in two phase I studies. But the results were disappointing in a subsequent phase II trial and studies on GDNF were terminated. However, recently a phase I gene therapy trial for Neurturin, a naturally occurring member of the GDNF family of neurotrophic factors ([www.ceregene.com](http://www.ceregene.com)), reported a 36% reduction in Parkinson symptoms 12 months into the study. Neurturin is delivered to the brain by an AAV vector and a larger phase II clinical trial with more than 50 patients is underway.

### Prospects

Experimental direct viral vector-mediated gene transfer into the rodent nervous system using an HSV vector and the implantation of genetically modified fibroblast were both reported at the end of the eighties of the twentieth century. Since that time enormous progress has been made in the field of gene therapy for neurological diseases (Fig. 3). Gene therapy appears to be safe and well tolerated as suggested by ongoing clinical trials on the delivery of growth factor genes to the afflicted brains of PD and AD patients using AAV vectors. The efficacy in terms of therapeutic benefit for the patient now needs to be addressed in phase II and III clinical trials. These trials are either planned or ongoing. It will be fascinating to witness the progress of gene therapy for various other acquired or inherited disorders, including brain tumors, pain syndromes, spinal cord and peripheral nerve trauma and ophthalmic diseases.

### References

1. Kaplitt MG, During MJ (eds) (2006) Gene therapy in the central nervous system. From Bench to bedside, First edn. Academic Press, ISBN 0-12-397632-4
2. Gage FH, Wolf JA, Rosenberg MB, Xu L, Yi JK, Shults C, Friedmann T (1987) Grafting genetically modified cells to the brain: possibilities for the future. *Neuroscience* 23:795–807

3. Tuszynski MH, Thal L, Pay M, Salmon DP, UHS, Bakay R, Patel P, Blesch A, Vahlsing HL, Ho G, Tong G, Potkin SG, Fallon J, Hansen L, Mufson EJ, Kordower JH, Gall C, Conner J (2005) A phase I clinical trial of nerve growth factor gene therapy for Alzheimer disease. *Nat Med* 11 (5):551–555
4. Geller AI, Breakefield XO (1988) A defective HSV-1 vector expresses *Escherichia coli* beta-galactosidase in cultured peripheral neurons. *Science* 241:1667–1669
5. Mata M, Fink DJ (2007) Gene therapy for pain. *Anesthesiology* 106(6):1079–1080
6. Samulski RJ, Berns KI, Tan M, Muzyczka N (1982) Cloning of Adeno-associated virus into pBR322: rescue of intact virus from the recombinant plasmid in human cells. *Proc Natl Acad Sci USA* 973:2077–2081
7. Naldini L, Blomer U, Gage FH, Trono D, Verma IM (1996) Efficient transfer, integration, and sustained long-term expression of the transgene in adult rat brains injected with a lentiviral vector. *Proc Natl Acad Sci USA* 15:11382–11388
8. Kaspar BK, Llado J, Sherkat N, Rothstein JD, Gage FH (2003) Retrograde viral delivery of IGF-1 prolongs survival in a mouse ALS model. *Science* 301:839–842
9. Azzouz M, Ralph GS, Storkebaum E, Walmsley LE, Mitrophanous KA, Kingsman SM, Carmeliet P, Mazarakis ND (2004) VEGF delivery with retrogradely transported lentivector prolongs survival in a mouse ALS model. *Nature* 429:413–417
10. Kaplitt MG, Feigin A, Tang C, Fitzsimons HL, Mattis P, Lawlor PA, Bland RJ, Young D, Strybing K, Eidelberg D, During MJ (2007) Safety and tolerability of gene therapy with an adeno-associated virus (AAV) borne GAD gene for Parkinson's disease: an open label, phase I trial. *Lancet* 369:2097–2105

## Gene Therapy in the Central Nervous System: Chronic Pain

ERIN D. MILLIGAN<sup>1</sup>, STEVEN F. MAIER<sup>2</sup>,  
LINDA R. WATKINS<sup>2</sup>

<sup>1</sup>University of New Mexico, Albuquerque, NM, USA  
<sup>2</sup>University of Colorado at Boulder, Boulder, CO, USA

### Definition

The direct transfer of genes, DNA or RNA sequences directed to/into a specific population of central nervous system cells to correct ongoing pathology and/or disease conditions.

### Characteristics Background

Gene therapy for the expression of therapeutic proteins has been applied to clinical conditions that have no effective treatment. As of 2007, greater than 900 clinical trials, worldwide, were ongoing: <http://www>.

wiley.co.uk/genetherapy/clinical). The development of gene transfer techniques to the central nervous system (CNS) for therapeutic treatment of a variety of debilitating diseases has greatly diversified in the past dozen years and continues to increase with remarkable momentum. Multiple methods have been developed for gene transfer to the CNS: (i) “ex-vivo,” where cells are engineered with the therapeutic gene in culture followed by transplantation into the body, (ii) “remote,” where the transgene is delivered by either intramuscular or intraneural injection, (iii) “direct,” where the vector containing the transgene is injected directly into the brain or spinal cord with the latter two approaches leading to therapeutic gene expression by the recipient’s own cells [1], and lastly (iv) ribonucleic acid interference (RNAi) which is used to modulate or silence gene expression and is delivered to the CNS as naked RNA or via vectors [2]. The latter four approaches have been developed to a greater extent to treat neuropathic pain and will be discussed further. With regard to remote and direct vector delivery of genes to the CNS, several viral and non-viral vectors have been exploited for therapeutic gene transfer [1,3]. ▶ **Viral vector** therapeutic gene transfer includes the application of recombinant adenovirus (AdV), adeno-associated virus (AAV), herpes simplex virus (HSV), and lentivirus (LV), [1]. Non-viral vectors are fundamentally nucleotide-based therapies (RNA or DNA) in the form of oligonucleotides, plasmids, or ▶ **small interfering RNA (siRNA)** that are injected either unmodified, often referred to as naked or free, or after synthetic polymer treatment. In these approaches, the level of gene expression depends on the ▶ **promoter**, the design of the expression cassette containing the therapeutic gene, cell-type specific tropism when applying viral vectors, and in some cases, gene regulatory elements [1,4].

A major focus for viral and non-viral mediated gene delivery has been to develop vectors that do not activate the immune system so to maintain healthy, prolonged gene expression for chronic diseases [1]. Thus, an extensive overlap exists for gene therapy strategies to treat neurodegenerative diseases and neuropathic pain because these disorders are chronic, and prolonged treatment is required for successful clinical outcomes. Novel gene therapy development and application to treat neurodegenerative diseases such as Parkinson’s disease, Huntington’s disease, Alzheimer’s disease and amyotrophic lateral sclerosis (ALS) have laid the groundwork for subsequent utility to treat ▶ **chronic neuropathic pain**.

### **Gene Therapy for Neurodegenerative Diseases can be Applied to Neuropathic Pain** **Neurodegenerative Diseases**

Parkinson’s disease and Huntington’s disease are similar in that both involve alterations in basal ganglia function. However, Parkinson’s disease (55–65 years;

age of onset) is identified by a loss of dopaminergic neurons with concurrent loss of axonal projections within the basal ganglia [1,5], and leads to symptoms of motor abnormalities (i.e. rigidity, tremor) (see Chapter on ▶ **Drug Treatment for Motor Disorders**). Dopamine replacement is a standard therapy for treating Parkinson’s disease. In Huntington’s disease (40–50 years; age of onset), the basal ganglia activity is decreased leading to increasingly greater uncontrollable movements. A progressive and large loss of cholinergic and GABA-ergic neurons ultimately produces pronounced motor dysfunction. Therapeutic gene delivery for neurotransmitter replacement using transfected cells *in vitro* subsequently transplanted *in vivo*, and AAV and Lentiviral viral vectors have been explored in rodent and nonhuman primate models [1]. These approaches have been applied in several ongoing clinical trials. Often, gene therapy approaches are aimed only at neuroprotective effects rather than curative effects because the underlying cause of neuronal death has not been identified [5].

Several gene transfer strategies are being applied in the clinic and to animal models of Alzheimer’s disease (5% of people over age 65 are affected) and ALS. Alzheimer’s disease is identified by a decline in cognitive function, memory and intellectual skills. The neuropathological features of Alzheimer’s disease are senile plaques, neurofibrillary tangles and a high degree of neuronal loss in brain areas related to memory and cognition. This neuronal loss is likely the leading cause of cognitive dysfunction in Alzheimer’s disease [5]. A strong link exists between neuroinflammatory processes mediated by ▶ **microglia** and ▶ **astrocytes** and the formation of senile plaques and neurofibrillary tangles [5]. Results from clinical trials aimed at inhibiting inflammation suggest that anti-inflammatory drugs serve a neuroprotective role in disease progression rather than being therapeutic. However, in terms of gene therapy, several strategies are being developed that target enzymes responsible for producing Alzheimer’s-linked peptides, which are not yet known to play a role in inflammatory processes, including delivery of small ▶ **siRNA** (discussed further below) that are used to silence disease-causing gene expression [2].

In contrast, ALS is a progressive neurodegenerative disease of motor neurons in the spinal cord, brainstem and cerebral cortex culminating in death within 2–5 years of symptom onset [6]. Several mechanisms are suspected to lead motor neuron degeneration, and thus treatments aimed at motor neuron survival are potentially the best approach. As with several neuropathic pain conditions, activated glia (both astrocytes and microglia; discussed below) are believed to play critical roles in the progression of the ALS [6]. Gene therapy approaches are being applied to animal models of ALS, and several clinical studies are underway (Journal of Gene Medicine

clinical trial site: <http://www.wiley.co.uk/genetherapy/clinical>). As with Parkinson's, Huntington's, and Alzheimer's disease, novel gene therapeutic approaches for ALS are aimed at neuroprotective strategies. Further, these gene therapeutic approaches are now being applied to several models of neuropathic pain.

### Neuropathic Pain

Neuropathic pain is typically associated with either peripheral nerve or CNS damage caused by compression, transection, inflammation and/or altered metabolism [4]. When injured or inflamed tissue endures chronically, this leads to ongoing excitation in primary sensory neurons that communicate to pain transmission neurons in the dorsal horn of the spinal cord (see Chapter on ►Analgesics). Injured or inflamed tissue in the central nervous system can alter activity of spinal or brain neurons as well and, when this occurs in neurons relevant to the pain pathway, chronic pain ensues. Most often, treating such problems resolves pain. However, a number of chronic pain conditions exist where the underlying pathology cannot be treated or cannot be identified. The ongoing excitation leads to a sensitized, pain facilitatory state in the dorsal horn of the spinal cord (central sensitization) due to the ongoing activity of primary sensory neurons, their central nerve terminals and/or dorsal horn pain transmission neurons in the spinal cord [5]. Thus, chronic pathological pain no longer serves the adaptive, protective mechanism that normal pain serves for recuperation and wound healing. Estimates for the prevalence of chronic neuropathic pain in the USA and Europe have been as high as 7%, with most drugs leading to therapeutic efficacy in only ~50% of people [4]. Neuropathic pain, like ►allodynia, is pain associated non-painful stimuli. In rodent models, allodynia is often measured by changes from baseline values in hind paw responses to low threshold mechanical or thermal stimuli, referred to as mechanical or cold allodynia, respectively. Increased sensitivity to normally painful stimuli is often measured by changes from baseline hind paw responses to mechanical or thermal painful (noxious) stimuli, referred to as mechanical or thermal ►hyperalgesia, respectively. Thus, novel strategies using gene therapy to target specific nervous system regions relevant to pain transmission can be examined in a number of animal models of pathological pain. A variety of nerve injury and inflammatory manipulations that produce chronic allodynia and hyperalgesia in rodents have been used to explore gene therapeutic efficacy for the purpose of possible clinical utility. Indeed, the outcome of some of these studies in rodent models are leading to phase I/II clinical trials in patients with cancer pain [7]. Gene therapy strategies to examine pain control in rodents is relatively new, with 55% of pain-related gene therapy studies reported within the past 4 years. The first pain related report, published in 1990, used transplanted cells

in the subarachnoid space [4]. Since then, a range of gene therapy strategies has been explored using rodent models of neuropathic pain.

### Viral Vectors for Pain Control

Adenoviral vectors (AdV) have a wide cellular tropism and have been shown to transduce (gene transfer from vector to host cells) neurons and glial cells after direct injection into the CNS and to transduce sensory and motor neurons by axoplasmic transport after intramuscular injection [1]. The underlying mechanism for AdV retrograde gene transfer is poorly understood. Despite the possible clinical application of retrograde transport for gene delivery from the body to the CNS, the immunogenicity of AdV limits its therapeutic efficacy [1]. AdV leads to pronounced immune activation in the CNS that includes glial cell (astrocytes, oligodendrocytes and microglia) activation, increased expression of major histocompatibility complex (MHC) molecules that are critical for efficient antigen presentation, and proinflammatory cytokine expression [1]. Microglia are phagocytic, antigen-presenting cells that are part of the non-specific innate immune response (►Innate immunity), and are classically referred to as the macrophages of the CNS. Astrocytes have similar phagocytic properties, and upon activation, release many of the same immune signals that microglia release in addition to their role as modulators of synaptic transmission [8]. To circumvent the immunogenic properties of AdV, a number of new strategies are being explored that may be promising for future clinical application. For example, nonhuman AdV such as the recombinant, replication defective, canine AdV was reexamined in human blood cells with a canine AdV-immunological naïve background to assess immune responses [1]. This is an important consideration because >85% of individuals express high circulating antibodies to various serotypes of human AdV, which may lead to robust memory immune responses if given AdV for therapeutic purposes. That is, enhanced and rapid immune responses to previously encountered foreign invaders like human AdV. Thus, immunological responses to canine AdV were predicted to be substantially lower. The nonhuman canine AdV vector produced immune activation, as measured by increased MHC expression, in less than 50% of donors tested [1]. Although canine AdV vectors have not yet been exploited for neuropathic pain treatment, the lower immunogenicity and retrograde transport properties of canine AdV [1] may be useful for gene transfer to discrete regions of the CNS to control pain.

There are few studies examining AdV vectors for gene delivery to treat neuropathic pain. Gene therapy approaches have focused on decreasing the excitability of spinal cord pain transmission neurons, and more recently, has targeted activated spinal cord glia. Our previous

understanding of the creation and maintenance of neuropathic pain has been based primarily on studies focused on neuronal mechanisms of which currently mounting evidence suggests is too narrow. Evidence supports the idea that activated spinal cord glia contribute powerfully to the creation and maintenance of pain facilitation, at least in part, via release of proinflammatory ▶cytokines. This may be one reason that drugs only targeting neurons have not proven successful in treating chronic pain in many patients [8]. A number of pain syndromes with widely different etiologies (as discussed above) may involve a common underlying mechanism such as spinal cord glial activation. Glial proinflammatory cytokine involvement in pain facilitation may be alleviated by gene therapy that specifically targets the function of activated glia, rather than neurons. Virally directed, spinal release of the anti-inflammatory cytokines interleukin-10 (IL-10), interleukin-2 (IL-2), interleukin-1 receptor antagonist or soluble receptors for tumor necrosis factor- $\alpha$  could achieve this goal. Although AdV can infect a variety of dividing and non-dividing cell types, subarachnoid spinal delivery (▶intra-thecal; i.t.) of adenovirus primarily infects cells in the ▶meninges, both on the spinal and dural surfaces [1]. The meninges is comprised of three membranous layers that surround the spinal cord (dura matter, arachnoid matter, and pia matter). The subarachnoid space cerebrospinal fluid (CSF) [5]. Indeed, i.t. AdV delivery of proteins known to block the actions of proinflammatory cytokines with anti-inflammatory cytokines has proven to be effective by several gene therapeutic strategies. Thus, i.t. delivery of the anti-inflammatory cytokine genes, interleukin-10 (IL-10) or interleukin-2 (IL-2), reversed CCI-induced thermal hyperalgesia and mechanical allodynia from 2 to 4 weeks [4]. Several other studies using AdV delivery methods resulted in therapeutic outcomes in animal models of pain. Delivery of the pro-opiomelanocortin (POMC) gene that encodes beta-endorphin, which effectively blocked thermal hyperalgesia produced by a carrageenan injection into the hind paw, was the first demonstration that i.t. AdV could be a viable strategy for spinal delivery of therapeutic genes. Lastly, the intra-muscular AdV delivery of the neurotrophin-3 gene reduced pain thresholds in diabetic peripheral neuropathy [4,7].

Adeno-associated virus (AAV) is a single-stranded DNA virus that has been developed as a gene transfer vector with up to eleven distinct serotypes that influence cell and tissue specific tropism for gene expression [1]. For example, recombinant AAV serotype 2 has inherent tropism for neurons and glia, whereas recombinant AAV serotype 8 preferentially transduces cells in the liver. In addition, sequences of DNA that facilitate gene expression referred to as promoters, can be selected for more efficient transgene expression. For example, the widely used human cytomegalovirus immediate/early gene

promoter and ▶enhancer (CMV) to drive the expression of specific transgenes in the brain greatly improved gene expression. The AAV-based vectors lead to long-term gene expression in the brain. Up to eleven promoters have been utilized to drive cell-type specific gene expression mediated by recombinant AAV vectors [1]. Like AdV, only a few studies have applied recombinant AAV vectors for therapeutic gene delivery to pain relevant tissues [4,7]. AAV vector delivery encoding either brain-derived neurotrophic factor or IL-10, by direct spinal or intrathecal injection into the CSF, reversed hyperalgesia and allodynia that lasted from 2 to 8 weeks. Additionally, direct sciatic nerve injection or dorsal root ganglion (DRG) injection of AAV encoding the mu-opioid receptor enhanced morphine analgesia in an acute inflammatory pain model [4,7]. However, to date, AAV as a viable option for pain control is limited because of poor transduction properties, transient effects with a limited gene delivery capacity of a single gene, and can stimulate immune activation leading to viral clearance.

Retrovirus-based vectors, Lentivirus (LV) vectors, can lead to sustained gene expression in specific cell types by using promoter elements that are active only in the target cells. For example, promoter-generated transgene expression can be used to induce transgene expression only in neurons, and not in surrounding glia. Many LV vectors are derived from the human-immunodeficiency virus, exert minimal immunogenic responses, have a large capacity for DNA insertion into the host genome (up to ~10 kb), and are retrogradely transported after intra-muscular injection [1]. Recently, LV vectors encoding nuclear receptor-kB super repressor (sr/kBa) or glial cell-line derived neurotrophic factor (GDNF) reduced allodynia and hyperalgesia from 6 days to 3 weeks [4]. LV vectors preferentially infect glial cells in the dorsal horn of the spinal cord, a property that may be useful for targeting glial cell function involved in neuropathic pain. However, several drawbacks exist for utilizing LV vectors for pain control that include the risk of integration leading to oncogenesis. In addition, LV vector retrograde transport is not efficient, and high titers can be difficult to produce [4].

Recombinant herpes simplex virus (HSV) vectors have been utilized most frequently (~30%) for therapeutic gene delivery to control pain [4]. Some common features between HSV vectors and the naturally occurring “wild-type” parental virus for vector utility are that: (i) infection readily occurs in epithelial cells in the skin, followed by viral envelop glycoprotein interactions with high affinity receptors (herpesvirus entry mediator A, nectin-1 and nectin-2) expressed on sensory nerve terminals, (ii) retrograde axonal transport to sensory neurons in the DRG leads to therapeutic effects by 7 days, (iii) an establishment of a lifelong infection within neurons occurs while viral proteins remain undetectable, (iv) particles do not

integrate into the host genome and remain as intranuclear episomal chromatin structures, (v) large transgenes are a viable option, and (vi) low immunogenicity results; reinoculation leads to continued therapeutic efficacy for weeks [1,4]. Retrogradely transported HSV vectors after cutaneous inoculation have been utilized to elevate preproenkephalin, glutamic acid decarboxylase that enzymatically produces the inhibitory neurotransmitter, gamma-amino butyric acid, the anti-inflammatory cytokine IL-4 and glial cell-line derived neurotrophic. All of these factors expressed in the sensory neurons after HSV inoculation have proven therapeutic for neuropathic and inflammatory pain [4].

### Non-viral Vectors for Pain Control

Several non-viral approaches to deliver potentially therapeutic genes have been utilized primarily because of their low immunogenicity and ease of manufacturing [3,4,7]. However, such approaches have led to low levels of transgene expression. New approaches using synthetic polymers have been developed to optimize therapeutic efficacy for non-viral vectors. These strategies, each of which will be briefly discussed, include antisense oligonucleotides, siRNA, naked ►plasmid DNA, or plasmid DNA modified by ►liposomes or synthetic polymers, all of which have produced transient pain control lasting from days to as long as 4 weeks. Antisense oligonucleotide and siRNA are similar in that both are injected i.t. to inhibit the expression of proteins that are known to mediate neuropathic pain. However, the inhibitory effects are by different mechanisms. Antisense oligonucleotides are oligonucleotides that bind with specific, complementary messenger RNA sequences to the target gene. Gene activation is prevented once these complementary oligomers bind messenger RNA. However, oligonucleotides are quickly eliminated by degenerative nuclease enzymes, supporting the use of antisense oligonucleotides as diagnostic tools for the involvement of particular genes in neuropathic pain rather than as therapeutic treatments. Inhibition of gene expression by siRNA is achieved when this molecule is associated with a cytoplasmic multiprotein complex called, ribonucleic acid-induced silencing complex (RISC). In turn, RISC utilizes the siRNA antisense strand as a template to bind and selectively degrade messenger RNA after gene transcription has occurred [2]. Antisense oligonucleotides targeted against proteins implicated in spinal cord pain processing include cyclic AMP response element-binding (CREB), NaV1.8 (a tetrodotoxin resistant sodium channel), the N-methyl-D-aspartate (NMDA) receptor subunit R1, or the metabotropic glutamate receptor type 1, and lead to decreased allodynia and pain-related behavior in several experimental rodent pain models. Delivery of siRNA against the NMDA receptor subunit, 2B (NMDA-R2B), the transient receptor potential vanilloid receptor 1 (TRPV1), and against the ionotropic purinergic type 2X3

receptors decreased both allodynia and pain-related behaviors for up to 5 days [4,7].

Although plasmid DNA delivery to target cells is considered to be the least effective, strategies aimed at improving plasmid-based gene delivery are rapidly expanding [3] and show promise for future clinical applications. Plasmid DNA therapy relies on host transcription machinery for exogenous DNA expression. Several methods used to optimize gene delivery include engineering elements within the plasmid vector (exogenous DNA expression cassettes), electroporation (►In vivo electroporation), gene gun delivery or chemical modification by liposomes or synthetic polymers [4,7,9,10]. The plasmid-based gene delivery system is attractive because it tends to be less immunogenic, is easy to manufacture, and lacks the dangers associated with some viral vectors (i.e. insertional mutagenesis resulting in tumors). Successful attenuation or reversal of pathological pain was produced by i.t. plasmid DNA gene delivery that lasted up to 6 weeks [4,7,9,10]. In these studies, genes encoding either opioid peptides or anti-inflammatory cytokines were examined for neuropathic pain control. These studies are unique not only in applying plasmid-based vectors for intrathecal gene transfer, but also in some cases, the long duration of therapeutic efficacy for pain control [9,10], supporting a strong potential for clinical utility.

Spinal cord plasmid DNA gene transfer is typically limited to transient therapeutic expression either with naked or chemically modified plasmid DNA. A single i.t. IL-2 plasmid DNA injection reduced neuropathic pain for 3 days, prevented acute inflammatory-induced pain, and produced spinal cord mRNA and protein expression for 3 days. However, repeated-injection methods have produced improved plasmid DNA gene expression [9,10]. Indeed, repeated injections of plasmid DNA encoding the anti-inflammatory gene, IL-10, at inter-injection intervals of 2–3 days, leads to a reduction in hyperalgesia and allodynia lasting for up to 6 weeks [7]. One drawback using plasmid DNA vectors for i.t. gene delivery is the dose required to achieve prolonged pain control in rodent models because of inefficient uptake of plasmid DNA. The high dose may limit the potential clinical application of plasmid vectors because an estimated ~290 mg plasmid DNA may be required for a person of 81 kg (180 pounds) to control pathological pain. One possible solution has been the application of cationic agents such as ►polyethylenimine (PEI), liposomes, or synthetic polymers such as ►poly(lactic-co-glycolic) (PLGA) to sustain gene expression while decreasing the required dosages. Micro-encapsulation of plasmid DNA within PLGA does not significantly disrupt the functional integrity of plasmid DNA and produces a significant attenuation of allodynia at reduced doses (~100-fold decrease) in a rodent model of neuropathic pain [10].

Further development of methods to chemically modify plasmid DNA for improved gene delivery to control chronic pathological pain continues to rapidly expand. Overall, the number of clinical gene therapy trials to control chronic pain is expected to grow substantially.

## References

1. Kaplitt MG, During MJ (2006) Gene therapy in the central nervous system: from bench to bedside. Elsevier, San Diego, USA
2. Federici T, Boulis NM (2007) Ribonucleic acid interference for neurological disorders: candidate diseases, potential targets and current approaches. *Neurosurgery* 60(1):3–16
3. van Gaal EVB, Hennink WE, Crommelin DJA, Mastrobattista E (2006) Plasmid engineering for controlled and sustained gene expression for non-viral gene therapy. *Pharm Res* 23(6): doi 10.1007/s11095-006-0164-2
4. Goss JR, Goins WF, Glorioso JC (2007) Gene therapy applications for the treatment of neuropathic pain. *Expert Rev Neurother* 7(5):487–506
5. Kandel ER, Schwartz JH, Jessell TM (2000) Principles of neural science, 4th edn. McGraw-Hill, New York
6. Boillee S, Velde CV, Cleveland DW (2006) ALS: a disease of motor neurons and their non-neuronal neighbors. *Neuron* 52:39–59
7. Cope DK, Lariviere WR (2006) Gene therapy and chronic pain. *Scientific World Journal* 6:1066–1074
8. Watkins LR, Wieseler-Frank J, Hutchinson MK, Ledebauer A, Spataro L, Milligan ED, Sloane EM, Maier SF (2007) Neuroimmune interactions and pain: the role of immune and glial cells. In: Ader R (ed) *Psychoneuroimmunology*, vol 1, 4th edn. Elsevier, San Diego, USA, pp 393–414
9. Milligan ED, Sloane EM, Langer SJ, Hughes TS et al. (2006) Repeated intrathecal injections of plasmid DNA encoding interleukin-10 produce prolonged reversal of neuropathic pain. *Pain* 126:294–308
10. Milligan ED, Soderquist RG, Malone SM, Mahoney JH et al. (2007) Intrathecal polymer-based interleukin-10 gene delivery for neuropathic pain. *Neuron Glia Biol* 2:1–16

---

## Gene Transfer

- ▶ Gene Therapy for Neurological Diseases

---

## General Constrained Optimization

### Definition

A general constrained optimization problem is defined by an objective (cost) function, and the corresponding

equality and inequality constraint functions. The distribution problem in biomechanics is typically expressed as a general constrained optimization system.

- ▶ Distribution Problem in Biomechanics

---

## General Fascia

### Definition

Collagen fiber reinforced connective tissue sheet that envelopes the whole body below the subcutaneous fat tissue.

- ▶ Intramuscular myofascial force transmission
- ▶ Epimuscular Myofascial Force Transmission and Intermuscular Interaction

---

## Generality Problem

### Definition

This problem arises for reliabilist accounts of knowledge:

There seems to be no “fact of the matter” about how general the description has to be that is given of the method employed in acquiring a specific belief.

Therefore, there seems to be no “fact of the matter” about knowledge either.

- ▶ Knowledge

---

## Generalization

### Definition

Animal trained to respond to a particular stimulus shows responding not only to that stimulus but also to stimuli that differ from the original stimulus along the stimulus dimension. This spread of the effect of discrimination training is called generalization. The rate of responding has a peak at the trained stimulus and a slope called the generalization gradient.

- ▶ Discrimination

## Generalization of Learning

### Definition

The improvement of detection or discrimination achieved through training transfers to similar (classes of) stimuli.

► Sensory Plasticity and Perceptual Learning

## Generalization of Motor Skills

### Definition

Some learned motor skills are not effector specific and can be easily transferred between different parts of the motor system. Such motor skills are generalized.

► Motor Learning

## Generalized Epilepsy with Febrile Seizures Plus (GEFS+)

### Definition

GEFS+ is an autosomal dominant disorder that displays generalized epilepsy symptoms that can persist beyond early childhood age (6 years). Known causative genes are a GABA<sub>A</sub> receptor  $\gamma$  subunit gene, GABRG2,  $\alpha$  subunit genes of sodium channels, SCN1A and SCN2A and an associated  $\beta$  subunit of sodium channels, SCN1B.

► Ion Channels from Development to Disease  
► Sodium Channels

## Generator Current

### Definition

Denotes the receptor current in primary receptor systems, in which the receptor cell itself contains the encoder, which generates action potentials.

► Sensory Systems

## Generator Potential

### Definition

Denotes the receptor potential in primary receptor systems, in which the receptor cell itself contains the encoder, which generates action potentials.

► Sensory Systems

## Genetic Basis of Behavior

### Definition

Behavior in general has two components: an inherited or innate component and a component acquired by the animal in its individual life. The inherited component may have a variable contribution to a given behavior. There has been a long debate about the influence of inheritance on human behavior (nature versus nurture), but it is now accepted by most scientists that human behavior as well as animal behavior are influenced by both components.

## Genetic Defect

### Definition

Genes represent a code or set of instructions for cells to make proteins. The correct protein is made if the code in the gene is correct. However, the code in a gene can be modified or mutated (e.g. made defective) for several reasons. When this occurs the protein may not be formed at all, or only a portion of the protein may be formed. The result is a loss or incomplete function of the protein.

## Genetic Imprinting

### Definition

Genetic imprinting is a genetic mechanism whereby gene expression depends on parental origin. Certain

imprinted genes are expressed only from the allele inherited from the mother, whereas others are expressed only from the allele inherited from the father.

Epigenetic mechanisms control imprinting, with the two major ones being DNA methylation and histone modifications. The imprinting process is reversible in the next generation. Imprinting occurs in the early embryo either in the eggs or sperm of the ovaries and testes, respectively.

---

## Genetic Linkage

### Definition

Occurs when specific alleles are inherited jointly, because they are found close to each other on the same chromosome.

---

## Genetic Mapping

### Definition

Genetic mapping is used to help identify a gene underlying a mutant phenotype in an animal model or a disease in humans. The relative position on the chromosome of a mutant phenotype associated with a mutation of an unknown gene is determined by identifying the frequency at which the phenotype follows various genetic markers whose position on the chromosome is known.

---

## Genetic Marker

### Definition

An identifiable portion of the DNA whose inheritance can be followed.

---

## Genetic Modifier Screen

### Definition

Genetic modifier screen – when changing the gene dosage of a component of a particular genetic pathway

enhances or suppresses the existing phenotype of the mutated gene in question. A significant advantage of this method is the ability to identify genes without any prior knowledge of the genetic regulation of the phenotype.

► [GAL4/UAS](#)

---

## Genetic Screens (Use of Zebrafish Forward Genetic Screens to Uncover Novel Regulators of the Vertebrate Nervous System)

CURTIS R. FRENCH, ANDREW J. WASKIEWICZ  
Department of Biological Sciences, University of Alberta, Edmonton, AB, Canada

### Definition

The forward genetic screen aims to identify mutations that produce a certain ► [phenotype](#). A mutagen is used to cause random mutations in the germ line of the organism. Once mutants have been isolated, the mutated gene can be genetically mapped and molecularly identified.

### Characteristics

The ► [forward genetic](#) screen involves creating random mutations in the germ line of an organism, for example, the ► [zebrafish](#), which can be passed on to future generations. In a typical F2 screen, mutations are induced in one copy of a particular gene, thereby creating a fish that carries mosaic germ line mutations (parental generation). A mutagenized fish is then bred to a phenotypically normal “wild type” fish, creating F1 heterozygous progeny. F1 fish are then bred with siblings, to create clutches of fish in which half are wild type, and half are heterozygous for an induced mutation (F2 generation). Fish from the F2 generation are then crossed to siblings to create the F3 generation. Clutches derived from two F2 fish that are heterozygous for an induced recessive mutation will contain homozygous mutant fish in one quarter of the progeny, and can thus be screened for resulting phenotypes. Other variations of this screen have been adapted, such as the haploid screen, which negates the need for an F2 generation. In this case, the F1 generation female eggs are fertilized with UV-irradiated sperm that contain no functional genetic material. The now haploid egg can develop and the desired phenotype should be readily visible as there is no wild type version of the gene to mask the



phenotype created by the mutated copy. Although Laploid screens are labor saving, morphological development is not entirely normal, so they are more useful in studying early embryo patterning events. Genetic screens that have uncovered genes that regulate the development of the zebrafish nervous system are described below.

In contrast to forward genetic screens, scientists have often used ▶reverse genetics to implicate different genes in the development of the zebrafish nervous system, as well as other ▶model organisms. This system involves manipulating a candidate gene and observing the resulting phenotype. In zebrafish, this entails the creation of ▶morphants, where the function of one particular gene is inhibited. Creating a morphant involves injecting one-celled zebrafish embryos with ▶morpholino(s) oligonucleotides directed against a specific messenger RNA sequence, which results in the inability of that messenger RNA molecule to be translated into a functional protein.

## Introduction

Humans have used genetic methods – unknowingly at first – to shape their surrounding world. Systematic agriculture, including the selection of crops with desirable traits, dates to 9500 B.C. Similarly, domestication of dogs, sheep, goats, and cattle dates to 9000–7000 B.C. In each of these cases, humans practiced selective breeding to encourage or fix traits that they wished to be present in later generations. With the rediscovery of the work of Gregor Mendel (1822–1884), the pea, which coincidentally was one of the first crops to be cultivated, revealed the major rules of heredity. The combination of gene-based heredity with the advent of easily manipulated model systems such as the fruitfly *Drosophila melanogaster*, the nematode *Caenorhabditis elegans*, and the zebrafish, *Danio rerio*, have facilitated a novel scientific approach: the forward genetic screen. In the twentieth century, scientists turned their attention to the mysteries of the nervous system, with a goal of understanding the mechanisms that govern neural connectivity, learning, and memory.

Zebrafish are small, tropical, fresh water fish. Adult zebrafish are approximately 2 inches long, reach sexual maturity at 3 months, and are prolific breeders, generating 100–200 embryos per week. The pioneering work of George Streisinger (1927–1984) established that these traits make zebrafish an ideal model for vertebrate neural function and development, and harnessed these traits to conduct some of the earliest vertebrate genetic screens [1].

## Regulators of Neural Patterning and Neurogenesis Uncovered by Morphology-based Screens

Early zebrafish ▶saturation screens focused on alterations in morphology, and were successful in uncovering key molecules that pattern the nervous system. Defects in midbrain-hindbrain boundary, axial ▶mesoderm, and somite formation have revealed conserved signaling

casades that influence neural differentiation and regional patterning.

The *cyclops* (*cyc*) mutation was originally discovered as a zygotic lethal mutant that blocks floorplate formation and causes cyclopia [2]. A spontaneous enhancer of *cyc*, *squint* (*sqt*) was identified, and *cyc*; *sqt* double mutants entirely lack ▶endoderm and the majority of mesoderm. Three other mutants, *one-eyed-pinhead* (*oep*), *bonnie-and-clyde* (*bon*), and *schmalspur* (*sur*) have similar functions in regulating mesendodermal formation. Molecular cloning of the lesions in each of these mutants has demonstrated that these mutants define the Nodal signaling pathway in zebrafish. *Sqt* and *Cyc* are Nodal ligands; *Oep* is a Nodal co-receptor; and *Bon* and *Sur* are functionally overlapping Smad2 transcriptional cofactors. Nodal signaling is hypothesized to function largely in the ▶embryonic shield, leading to the specification of endoderm and axial mesoderm. The anterior-most axial mesoderm is known as the prechordal plate and underlies the ventral forebrain neuroectoderm. Signals emanating from the prechordal plate are necessary to specify both ventral and midline identity, so it is logical that Nodal pathway mutants lack forebrain midline identity and therefore are cyclopic.

## Midbrain-Hindbrain Boundary Mutants

Mutants were identified that lack the midbrain-hindbrain boundary (MHB), a key tissue not just because it separates midbrain and hindbrain, but also because it acts as a regional signaling center. These mutants include *acerebellar* (*ace*), *no isthmus* (*noi*) and *spiel ohne grenzen* (*spg*). Researchers have identified the genetic lesion causing each of these mutants: *ace* is caused by a mutation in *fibroblast growth factor 8* (*fgf8*); *noi* is caused by a mutation in the paired domain transcription factor *pax2a*; and *spg* is caused by a mutation in the POU domain transcription factor *pou2/oct4/pou5f1*. *Fgf8* and *Pax2a*, together with other key patterning genes, specify the identity of cells near the MHB and regulate the expression of the other MHB genes, while the *pou2/pou5f1* gene is required for proper initiation of *pax2a* expression. Neurons in each of the mutants are mis-specified. For example, the posterior commissure neuron is not properly specified in *noi* mutants.

## Somite Mutants Reveal Neurogenesis Defects

Somites are bilaterally paired units of paraxial mesoderm that form building blocks for muscle, dermis, and skeleton. In the vertebrate embryo, somites form in an ordered, stepwise fashion starting in the anterior trunk, proceeding to the tail. Researchers found mutants that affected all somites, and three mutants, *deadly seven* (*des*), *after eight* (*aei*), and *white tail/mindbomb* (*wit/mib*), that affected only posterior somites. Analysis of neuronal populations in these posterior somite mutants demonstrated that each also has a defect in neuron

number. The first born neuron (and also the largest neuron) in the zebrafish primary nervous system is the Mauthner (Mth) neuron. Two Mth neuron cell bodies are located in hindbrain segment rhombomere 4 (r4). In *mib* and *des* mutants, 8–10 Mth neurons are observed indicating a profound defect in the regulation of neuronal specification. Molecular cloning of each of these somite mutants demonstrated that they encode members of the Notch-Delta signaling pathway: *mib/wit* is caused by mutation in an E3 ubiquitin ligase that targets Delta; *aei* is zebrafish *deltaD*; and *des* is *notch1a*. The discovery of these zebrafish mutations allowed researchers to determine that Notch-Delta signaling is important for both cyclic gene expression in somites and for regulating the correct number of neurons.

### Zebrafish Marker Screens Identify Regulators of Neural Patterning, Migration, and Differentiation

Morphology screens were successful in identifying important regulators of neural patterning and differentiation, but the zebrafish nervous system is largely transparent and unobservable. A series of screens have directly targeted neural development, taking advantage of region specific gene expression, antibodies which recognize developing neurons, and transgenic green fluorescent protein (GFP) lines that label specific neurons.

The nervous system is divided along the anterior-posterior axis into a series of regional domains, including forebrain, midbrain, hindbrain, and spinal cord. Each of these regions is further subdivided as evidenced by subdomains of tissue-specific gene expression. Within the hindbrain, for example, the zinc finger transcription factor *krox20/egr2b* is expressed in segments rhombomere 3 (r3) and r5. Using whole-mount [▶in situ hybridization](#) as an assay, researchers identified four zebrafish mutants that perturb hindbrain patterning. These mutants, *valentino* (*val*), *lazarus* (*lzar*), *vhnf1/tcf2*, and *spg*, express lower levels of *krox20/egr2b* than wild type embryos. The *val* locus encodes a basic-leucine zipper transcription factor known as Mafb. *in situ* hybridization for *mafB* and cell transplantation demonstrate that it specifies segment r5 and r6 identity. The *vhnf1/tcf2* mutant encodes *variant hepatic nuclear factor 1* (*vhnf1*), is expressed in the caudal hindbrain, and mutants fail to initiate *mafB* expression. Two MHB mutants, *spiel-ohne-grenzen* (*spg*) and *acerebellar* (*ace*) have also been instrumental in understanding hindbrain patterning. The *spg* and *ace* mutants have helped define that hindbrain segment r4 is the site of a fibroblast growth factor signaling center, expressing both *fgf8* and *fgf3*. The combined activities of these two signaling molecules together with *lazarus* (*lzar*), a Pbx transcription factor, initiates *egr2b/krox20* expression in r3 and r5. Research on these key zebrafish hindbrain patterning mutants has formed the cornerstone of our understanding of vertebrate hindbrain patterning [3].

### Left-Right Asymmetry

The human nervous system has intrinsic left-right laterality. Psychologists and early neurobiologists were the first to discern brain handedness. Although it was originally believed that L-R asymmetry was a uniquely primate characteristic, there is considerable evidence that the fish, chick, and dog brains possess intrinsic L-R distinctions. Within zebrafish, the organization of the pineal and habenular nuclei display consistent polarity. For example, the parapineal, an accessory of the pineal, is located on the left side of the pineal gland in embryonic zebrafish. The *cyclops* gene is similarly expressed on the left side of embryo and blocking Nodal signaling leads to randomization of parapineal orientation. Researchers have now developed an extensive catalog of left- or right-specific genes, and genetic screens are underway to identify additional regulators of embryonic laterality.

### Myelination Screens

In contrast to invertebrate nervous systems, vertebrate nervous systems are myelinated, facilitating rapid transmission of electrical impulses over large distances. Oligodendrocytes in the central nervous system (CNS) and Schwann cells in the peripheral nervous system (PNS) form a membrane sheath that surrounds axons. In order to identify a genetic pathway for [▶myelination](#), researchers conducted genetic screens to detect defects in expression of *myelin basic protein*. Researchers found five loci that affect PNS-specific myelination, with two of these encoding *ErbB2* and *ErbB3*, the receptors for Neuregulin. Since it is known that Neuregulin's signaling to *ErbB* receptors is required for Schwann cell differentiation in mammals, the screen is certainly capable of identifying critical regulators of myelination. Three mutants were characterized that affected only CNS-specific myelination. One of these mutants is encoded by *monorail/foxa2*, a winged-helix transcription factor. Previous data has shown that *foxa2* is required for *sonic hedgehog* (*shh*) expression in the midline and *shh* is required for oligodendrocyte differentiation. Three additional mutants were identified that affected myelination in both CNS and PNS.

### Neural Migration Screens

During development, incredibly precise mechanisms control the exact positioning of each neuron. A small subpopulation of neurons differentiate in one position and subsequently migrate to their proper destination. These migrations, largely categorized as either radial or tangential, describing the direction of movement with respect to the axis of the tissue, are themselves carefully orchestrated events that are critical for neuronal function. In zebrafish, one of the most dramatic neuronal migrations, facial (nVII) branchiomotor neuron cell bodies moving from rhombomere 4 (r4) posteriorly to

r6 and r7, is easily observed in living embryos using the *isl1: GFP* (GFP driven under the control of the *isl1* promoter) transgenic zebrafish line. Genetic screens and analysis of existing mutants has demonstrated that two genetic pathways are essential for migration, Pbx-Hox to define neural identity and the non-canonical Wnt pathway to maintain integrity and polarity of neural tissues.

### Axon Pathfinding and Projection: Retinal Ganglion Cell Axons

The nervous system plays a highly specialized role in the development of vision. The neural retina must differentiate from surrounding tissue to include many different cell types that are required for functionality. In zebrafish, the neural retina begins to become distinct from surrounding tissues at the 14–15 h post fertilization (hpf), with the formation of the first neurons within the retina by 29–34 hpf. The earliest known postmitotic neurons, retinal ganglion cells (RGCs), are of great importance as they eventually extend their axons to connect with a visual processing center, which in zebrafish, is known as the optic tectum. This process is tightly regulated, as proper pathfinding toward the tectum, and mapping of axons onto the optic tectum is essential for normal vision. Genetic screens have revealed genes that are required for this precise mapping, as well as genes required for differentiation of these highly specialized neurons.

A highly informative screen conducted by the Friedrich Bonhoeffer lab in 1996 uncovered at least 114 mutations that affect the ability of retinal ganglion cells to properly project toward [4] and map onto optic tectum [5]. To visualize RGC axons, lipophilic fluorescent dyes, which dissolve and are transported along the length of axon membranes, were injected into the zebrafish retina. Nineteen distinct mutants displayed errors in axon projection toward the optic tectum. Another 44 distinct mutants displayed defects in the ordering of the topographic map on the tectum, or the formation of proper axon termination fields. Subsequent studies have identified genetic identities and molecular functions for many of these genes, greatly expanding our understanding of the molecular control of vision in vertebrate species.

In one such mutant, *belladonna* (*bel*), retinal ganglion cell axons project toward the ipsilateral tectal lobe as opposed to the normal contralateral tectal lobe. As a result, zebrafish homozygous for the *belladonna* mutation display a reverse optokinetic response (OKR) and oculomotor instabilities (spontaneous ocular movements) in the absence of stimulation. The *belladonna* mutation was mapped via positional cloning to a locus containing a Lim-homeodomain transcription factor (*lhx2*). Given that the RGC axons project toward the ipsilateral tectal lobe instead of crossing the midline of the forebrain and extending toward the contralateral

tectal lobe, the authors hypothesize that *Lhx2* is necessary for forebrain patterning to produce guidance cues directing axons across the midline, and toward the contralateral tectal lobe [6]. Consistent with this theory, diencephalic expression of the transcription factor *dlx2* is strongly reduced. Thus, *Lhx2* is required for proper patterning of the forebrain and potentially the production of guidance cues that allow for RGC axons to cross the midline.

Recently, a transgenic line of zebrafish was created in the lab of Herwig Baier that expresses Green Fluorescent Protein (GFP) under the control of the *brn3c* promoter/enhancer. This drives expression of GFP in a subset of retinal ganglion cells that map to the tectum and allows for large scale screening of RGC axon guidance defects in embryos without having to fix and inject lipophilic dyes into the retina. Thus, a GFP based screen would be less labor intensive, and allow the visualization of RGC axon defects multiple developmental stages as GFP can be viewed in live embryos. It is likely that more GFP transgenic zebrafish will be created in the years to come, with expression in different subsets of RGC axons, and greatly facilitate the identification of genes required for RGC **▶ axon pathfinding** and mapping.

### Neural Retina Differentiation

Differentiation of the neural retina is tightly regulated throughout development of the embryo, and perturbations in this process can lead to profound vision defects. To uncover genes required for the differentiation of different eye cell types, Jarema Malicki and colleagues (1996) conducted a genetic screen, paying particular attention to mutants that showed defects in eye morphology in live embryos and laminar structure in cross section. The zebrafish eye is an excellent tool for the study of eye laminar structure and is well characterized, highly organized, and cell types can be readily determined by their position and shape. Furthermore, molecular markers have been established to identify different cell types in the event that mutants display altered eye cell shapes or positions.

The screen by Maliciki et al. uncovered 49 mutations that affect the morphology and/or laminar structure of the eye [7]. These included mutants that fail to specify specific cell types, retardation of eye growth, retinal degeneration, and abnormal development of the eye anlage often leading to cyclopia. Further research has identified genetic loci for many of these mutants, and revealed valuable information as to how the mutated gene is required for proper eye development.

### Behavioral Screens: Vision

Genetic screens for mutants in eye morphology, as well as retinal ganglion cell pathfinding and mapping, have given great insight to the genes that govern these processes. However further studies are often required

to determine the extent of visual functionality in these zebrafish. An alternative approach by means of screening zebrafish behavior can uncover mutants with generalized visual system defects. Brockerhoff and colleagues utilized this approach to study the optokinetic response in mutagenized zebrafish, and uncovered 18 optokinetic-defective mutants [8]. This assay is relatively simple, and involves detecting eye movement in response to a moving drum displaying alternating black and white vertical stripes.

The majority of mutants uncovered using this assay have obvious morphological eye defects, indicating that aberrant retinal differentiation or organization is likely responsible for the visual system defect and would thus be readily identified in morphological screens. However, two mutants were found to have no obvious morphological defect, but lacked the wild-type optokinetic response. One mutant, *no optokinetic response (noa)* are able to move their eyes (in response to physical stimuli), but do not move their eyes in the direction of drum rotation. Electroretinography (ERG) analysis indicated that the defect is likely the result of impaired synaptic transmission between photoreceptor and bipolar cells, or in the bipolar cells themselves.

The sensitivity and robustness of the optokinetic assay has made it a powerful tool for genetic screens in zebrafish. Mutants have been uncovered that have been later found to represent defects at various stages of visual system development, such as *melanin deficiency (sandy)*, *lack of ganglion cells (lakritz)*, and *optic-nerve disorganization (grumpy and sleepy)* [9]. This approach has the advantage of detecting mutants with defects in any of the processes that govern the development of the neural retina as well as RGC pathfinding and mapping.

### Behavioral Screens: Locomotion and Chemical Preference

Behavioral screens in zebrafish have been utilized in recent years for a variety of purposes extending beyond the study of vision. Screens for locomotion behavior that have uncovered mutants with neural and neural/muscular defects. To this end, mutants with reduced locomotion, mechanosensory defective mutants, “spastic” mutants, circling mutants and motor circuit defective mutants have been identified [10]. In the realm of medical science, behavioral screens have been utilized to identify mutants with increased/decreased sensitivity to cocaine. In this assay, mutagenized fish are placed in a tank that is separated into two halves, but allows movement between halves. Cocaine is administered to one side, with wild-type fish showing a preference, or ►[chemotaxis](#) for that side over the other, reflecting cocaine’s rewarding effect. A preliminary screen uncovered three mutant families that do not display the normal preference for cocaine. Although these mutants have yet to be mapped, the genes

are promising targets for pharmaceuticals that may alleviate chemical addiction.

### The Future of Zebrafish Screens

Recent advances in transgenic technology have greatly simplified the production of transgenic lines, providing a plethora of new screening lines. Unfortunately, new mutants are becoming rare. One concern is the existence of 30% duplicate genes in zebrafish. These have been retained since the evolutionarily ancient teleost genome duplication. These gene pairs are likely to have partially overlapping function making the isolation of genetic mutants challenging. To circumvent this problem, researchers have begun large-scale efforts to create gene knockouts encompassing the entire genome. Two promising technologies are currently at the forefront: ►[Tilling](#) and ►[viral insertional mutagenesis](#). In the coming years, these two technologies will create 1,000’s of new zebrafish strains that will advance our understanding of the developing vertebrate nervous system.

### References

1. Streisinger G, Walker C, Dower N, Knauber D, Singer F (1981) Production of clones of homozygous diploid zebrafish (*Brachydanio rerio*). *Nature* 291:293–296
2. Hatta K, Kimmel CB, Ho RK, Walker C (1991) The cyclops mutation blocks specification of the floor plate of the zebrafish central nervous system. *Nature* 350:339–341
3. Moens CB, Prince VE (2002) Constructing the hindbrain: insights from the zebrafish. *Dev Dyn* 224:1–17
4. Karlstrom RO, Trowe T, Klostermann S, Baier H, Brand M, Crawford AD, Grunewald B, Haffter P, Hoffmann H, Meyer SU, Müller BK, Richter S, Van Eeden FJ, Nüsslein-Volhard C, Bonhoeffer F (1996) Zebrafish mutations affecting retinotectal axon pathfinding. *Development* 123:427–438
5. Trowe T, Klostermann S, Baier H, Granato M, Crawford AD, Grunewald B, Hoffmann H, Karlstrom RO, Meyer SU, Müller B, Richter S, Nüsslein-Volhard C, Bonhoeffer F (1996) Mutations disrupting the ordering and topographic mapping of axons in the retinotectal projection of the zebrafish, *Danio rerio*. *Development* 123:439–450
6. Seth A, Culverwell J, Walkowicz M, Toro S, Rick JM, Neuhaus SC, Varga ZM, Karlstrom RO (2006) *bella-donna*/*lhx2* is required for neural patterning and midline axon guidance in the zebrafish forebrain. *Development* 133:725–735
7. Malicki J, Neuhaus SC, Schier AF, Solnica-Krezel L, Stemple DL, Stainier DY, Abdelilah S, Zwartkruis F, Rangini Z, Driever W (1996) Mutations affecting development of the zebrafish retina. *Development* 123:263–273
8. Brockerhoff SE, Hurley JB, Janssen-Bienhold U, Neuhaus SC, Driever W, Dowling JE (1995) A behavioral screen for isolating zebrafish mutants with visual system defects. *Proc Natl Acad Sci USA* 92:10545–10549

9. Neuhauss SC, Biehlmaier O, Seeliger MW, Das T, Kohler K, Harris WA, Baier H (1999) Genetic disorders of vision revealed by a behavioral screen of 400 essential loci in zebrafish. *J Neurosci* 19:8603–8615
10. Granato M, Van Eeden FJ, Schach U, Trowe T, Brand M, Furutani-Seiki M, Haffter P, Hammerschmidt M, Heisenberg CP, Jiang YJ, Kane DA, Kelsh RN, Mullins MC, Odenthal J, Nusslein-Volhard C (1996) Genes controlling and mediating locomotion behavior of the zebrafish embryo and larva. *Development* 123:399–413

## Genetic Vaccination

►Neuroinflammation – DNA Vaccination Against Autoimmune Neuroinflammation

## Genetics

### Definition

Genetics is the study of the properties of single genes or groups of genes.

## Genetics and Molecular Biology of Protein Expression, Localization and Function

SARAH McFARLANE

Department of Cell Biology and Anatomy, Hotchkiss Brain Institute, Faculty of Medicine, University of Calgary, NW, Calgary, AB, Canada

For a neuron to function properly, it must first acquire during ►development a particular morphology, but one that can be subsequently altered in a plastic way in response to changes in the environment of the organism and/or of the neuron itself. In addition, appropriate sets of molecules have to be expressed and targeted to their correct subcellular compartments. An obvious example is that for any given neuron the proper

►neurotransmitter release machinery needs to be present at the ►synaptic nerve terminal at the end of the axon, and the ►neurotransmitter receptors must be expressed on the dendrites. In fact, the very establishment of the ►polarity of the developing neuron depends on the appropriate targeting of proteins, for example the ►par proteins and ►RhoGTPases. Notably, the identity and location of the particular proteins that are required is dynamic and changes both during the development of the neuron, and as it carries out its function in the adult. Two examples are illustrative. First, during development some neurons respond to the neurotransmitter ►gamma amino butyric acid (GABA) by depolarizing. As they mature, these neurons begin to express a different ►chloride co-transporter protein that allows GABA to hyperpolarize the membrane. This change in ►chloride homeostasis is critical for the establishment of GABA as one of the main inhibitory neurotransmitters in the adult brain, and involves a new gene being turned on and another off as development proceeds. The second example takes place in the adult, where changes in protein expression occur in response to alterations in neuronal function. The underlying mechanism in this case involves neural activity inducing the different component parts (►exons) of a gene to be mixed and matched by a process called ►alternative splicing, which changes the sequence or localization of the encoded protein. Here, neural activity regulates the distribution of two different splice variants of the ►N-methyl D-aspartate (NMDA) ►glutamate receptor in the ►postsynaptic membrane of cortical neurons [1]. The exon encoding the C2 domain of the receptor, which restricts ►NMDA receptors to the ►endoplasmic reticulum (ER), is used when neurons are electrically active, whereas the C2' exon, which targets receptors to the plasma membrane (►Cell membrane – components and functions), is employed when neurons are silent.

In summary, it is critical that a cell expresses the correct proteins at the right time and in the appropriate subcellular compartments, and there are multiple levels by which this requirement can be regulated. Here, I give an overview of the regulatory mechanisms in the nervous system that ensure that proteins are active in their correct time and place, providing illustrative examples. I also discuss some of the molecular and genetic tools available for their study in the embryonic, adult and diseased nervous systems.

### Regulation at the Level of Gene Transcription

The human ►genome has approximately 23,000 protein-coding genes (at last estimate, by sequence annotation; [ensembl.org/Homo\\_sapiens/index.html](http://ensembl.org/Homo_sapiens/index.html)). Only about 1.5% of the human genome, however, codes for proteins. The majority of the remaining sequence is in fact transcribed into ►non-coding RNA.

Notably, ►model organisms such as the fruitfly ►*Drosophila melanogaster* and worm ►*Caenorhabditis elegans*, have comparable numbers of genes in their genome as humans [2,3]. Thus, the complexity of humans, and, in particular, of their nervous system, cannot arise simply from a modest increase in the number of protein-coding genes present in their genome. Most of the differences between species in fact occur within non-protein coding regions, as is the case for the vast majority of the approximately 15 million changes at the DNA level between the genomes of humans and chimpanzees. Hence, it is not differences in the genes present in the two species that account for their differences. Rather the intricacy and size of the human nervous system likely comes about by the exquisite and careful turning on and off of protein-coding genes. ►Gene transcription is regulated by ►transcription or trans-acting factors, which either trans-activate or trans-repress the transcription of specific target genes. Ultimately, ►DNA transcription results in the production of a ►pre-mRNA that is processed into the final mature ►messenger RNA (►mRNA), which will be ►translated (►RNA translation) into protein by the cell.

Genes can be turned on and off as a result of signals extrinsic to the neuron. Indeed, a neuron's differentiation in the developing embryo, and its function in the adult, depends on it being able to respond to extrinsic signals that induce rapid, local changes and/or longer-term changes in gene expression. Thus, neuronal function depends on both the appropriate expression of molecules that are extrinsic to the cell (►cell non autonomous) (►cell autonomy), and ones that mediate the response to these molecules and are intrinsic to the cell (►cell autonomous, cell autonomy). Extrinsic signals come from both neighboring and distant cells. An example of the latter are secreted molecules called ►morphogens, which regulate the expression of sets of genes in a responding population of neuronal cells in a concentration-dependent manner.

Neurons require the appropriate receptors in order to respond to extrinsic signals. Much work has gone into identifying the signals and their receptors, as well as dissecting the regulatory pathways by which they impact gene transcription. Generally, extrinsic factors bind to receptors in the membrane, inducing ►signal transduction cascades that ultimately promote the activation of downstream transcriptional effectors, often via the translocation of these downstream effectors into the nucleus, where they can activate or repress gene transcription. Forward signaling involves a ►ligand binding to a receptor and activation of a signal transduction cascade in the receptor-expressing cell. In some instances, ►reverse signaling can occur whereby the molecule considered to be a "receptor" binds a "ligand" intimately associated with the plasma

membrane and causes activation of a signal in the ligand-expressing cell. Interestingly, proteins do not actually have to contain an intracellular domain to participate in reverse signaling: ephrinAs lack a cytoplasmic domain entirely, but by their localization to ►lipid rafts they control the recruitment of intracellular signaling proteins to the rafts. Reverse signaling plays a role in various developmental events, and, where reported, occurs local to that part of the cell so that a signal does not get sent to the nucleus.

Because a neuron's axon and dendrites are distant from the nucleus, mechanisms have evolved to transport the signals long distances within the cell. These include rapid events such as  $\text{Ca}^{2+}$  signals that arise either from  $\text{Ca}^{2+}$  entry through ►ligand-gated channels or ►voltage-gated ►channels (►Calcium channels) in the plasma membrane, or from the endoplasmic reticulum. Alternatively, slower signaling from distal parts of the cell to the nucleus can occur by transport of either proteins that are internalized into ►endosomes, or activated soluble molecules. In the latter case, the signals are likely transported in an active fashion, potentially facilitated by ►importin-mediated transport [4]. ►Retrograde transport of signals is important during development, and for ►synaptic plasticity and ►regeneration in the adult. For example, ►bone morphogenetic protein-dependent growth of the ►pre-synaptic element of the *Drosophila* ►neuromuscular junction requires activation of the ►Smad pathway. In this case, local signaling results in long-term, stable molecular and structural changes to the presynaptic element via Smad-dependent regulation of gene transcription in the nucleus.

Ultimately, activation of a multi-component transduction pathway results in translocation of a downstream factor or complex into the nucleus [4], where it influences the binding of a complex of interacting transcription factors and proteins to DNA at specific sequences known as ►transcription factor binding sites that are present in a gene's ►regulatory region including in ►promoter and/or ►enhancer elements. Ultimately DNA transcription is altered. Interestingly, recent evidence suggests that transmembrane proteins (Cell membrane – components and functions) classically thought of as molecules that transduce signals across the plasma membrane, such as the ►Notch receptor, ►receptor tyrosine kinases [5] and ► $\text{Ca}^{2+}$  channels, can be proteolytically cleaved to produce protein fragments that translocate to the nucleus to directly impact gene transcription.

The mammalian genome encodes for approximately 1,500 proteins with known DNA binding motifs [6]. Researchers are trying to understand how they regulate DNA transcription. Transcription factors generally do not bind DNA in isolation, but rather do so as complexes with other transcription factors and proteins.

Changing the proteins with which an individual transcription factor interacts can potentially alter the genes upon which it acts and/or its effectiveness at modifying gene expression. The individual components of these complexes are being elucidated by the use of ► **chromatin immunoprecipitation**. To identify the distinct DNA sequences to which they bind, ► **bioinformatic** approaches are commonly used. A researcher will look either for already established DNA binding ► **consensus sequences** in regions upstream of the coding regions of genes, or take advantage of species conservation to search these regions for short domains of nucleotide conservation between species. While such approaches can identify binding sites, they cannot be used in isolation, as many binding sequences are short, appear frequently in the genome, and are often not functional. Recently, a large-scale version of the chromatin immunoprecipitation assay was used at a genome-wide level to identify the entire set of direct targets of transcription factors [7]. Once identified, the functionality of regulatory elements is confirmed by careful deletion and mutational analyses of the identified regions. Gene regulatory sequences can be found downstream of the gene, within ► **intronic** (► **intron**) sequences, and as far as 1 Mb from the start of transcription. Thus, it can be difficult sometimes to identify all the on/off switches for a particular gene. The use of ► **bacterial artificial chromosomes**, which allow researchers to play with large DNA sequences that hopefully contain all of the regulatory sequences for a gene of interest, has helped get around this issue.

A careful ► **in situ hybridization** analysis of most of the transcription factors expressed in the mouse nervous system indicate that many have spatially and/or temporally restricted expression patterns, but rarely are transcription factors expressed exclusively in a specific cell type [6]. Thus, it is likely, and has been shown experimentally, that transcription factors act in combination to control cell type specification and/or differentiation, contributing to the acquisition of particular features of a neuron. Indeed, many transcription factor binding sites are clustered into ► **cis-regulatory modules** that can bind specific combinations of 2–10 transcription factors. Further, the expression of a single gene within a cell may require multiple transcription factors, which bind to sites in different cis-regulatory modules. The interaction between transcription factors has been particularly well studied in the developing nervous system. For instance, the identity of specific neurons in the vertebrate spinal cord and ► **Drosophila neuropeptidergic** neurons are each determined by a ► **combinatorial transcription factor code**, whereby the subset of transcription factors expressed by the neural progenitor dictates the type of neuron it becomes. The particular repertoire of transcription factors a neuron expresses is critical for its differentiation

during development, and is also likely to be important for its function in the adult [8,9], though considerably little is known of the function of transcription factors in the mature nervous system.

One way to generate complexity given a set number of genes is to diversify the mRNA transcripts that arise from DNA transcription. Diversification can arise by several means, both at the transcriptional and post-transcriptional levels (see below). One mechanism that may have widespread importance in the brain, given its prevalence, is the alternative usage of promoters, whereby different promoters are used to regulate transcription of a single gene. Indeed, over 50% of human genes may be subject to such regulation [10,11]. Usually different promoters are used in different tissues, and while the proteins generated from the alternate promoters are identical, their ► **5' untranslated regions (UTRs)** differ. mRNA transcript diversification also results from stochastic regulation of gene expression, whereby a transcription factor complex randomly activates transcription of one of several related genes [12]. The choice of which ► **olfactory receptor** to express is illustrative. A mouse olfactory neuron chooses from a subset of over 1,000 olfactory receptors based on its location in the ► **olfactory epithelium**, followed by stochastic expression of a single receptor and repression of the other choices. The stochastic selection of expression of a single olfactory receptor in a neuron may involve a ► **locus control region** upstream of each olfactory receptor gene cluster. Amazingly, this region can recruit a transcriptional activation complex to control gene expression ► **in cis**, and/or interact with the promoters of olfactory receptor genes located on different ► **chromosomes** to control their transcription ► **in trans**. Interestingly, in humans, whose dependence on olfaction is minimal, many of the olfactory receptor genes are likely ► **pseudogenes**.

Importantly, gene expression can be altered in a stable, sometimes inheritable fashion, by a host of ► **epigenetic** processes that impact the state of the ► **chromatin**, but do not alter the underlying DNA sequence [13]. Because of space constraints, DNA is packed in the nucleus as chromatin, which consists of DNA wrapped around four core ► **histones**. For the transcription complex to get access to and transcribe DNA, the chromatin complex around a gene has to relax and open up. Epigenetic mechanisms serve to provide cell specific contexts that modulate the success of transactivating factors at controlling DNA transcription. Current research in epigenetics is focused on elucidating how covalent and non-covalent modifications to DNA and histone proteins can influence gene expression, though we know little about how these changes are sometimes inherited through cell division. Modifications of the histone proteins, including ► **acetylation** (► **Histone acetylation**), ► **methylation**,

►phosphorylation, ►ubiquitination,► citrullination and ►sumoylation alter DNA-histone interactions and hence transcription [14,15]. The nature of these distinct histone modifications on any given gene defines its histone code. A special case of epigenetic control that regulates neural development and brain function is ►genetic imprinting, whereby only one allele (maternal or paternal) of a gene is expressed while the other is silenced. Epigenetic control can impact disease progression, as appears to be the case for human brain ►gliomas that are sensitive to the proliferative effects of transforming ►growth factor  $\beta$  (TGF $\beta$ ) signaling [16]: gliomas with an unmethylated promoter for the platelet-derived growth factor B (PDGF-B) (Growth factors) gene respond to TGF $\beta$ . In contrast, a PDGF-B promoter methylated on cytosine residues of ►CpG dinucleotides is not bound by the downstream TGF $\beta$  signaling transcriptional effectors, the regulatory Smads, and so the glioma fails to proliferate in response to TGF $\beta$ . Defects in epigenetic control can also themselves cause disease. For instance, the neurodevelopmental genetic disorder called ►Rett syndrome, characterized by mental retardation, is caused by mutations in the ►X-linked ►disease gene encoding for methyl-CpG binding protein 2, which binds methyl-CpG and attracts chromatin modification complexes [17].

Researchers use gene expression profiling technology such as ►SAGE and ►microarray analyses to assess the complement of genes that are expressed at any one time by either a tissue, a specific population of nervous system cells, or most incredibly at a single-cell level [18]. These types of analyses have to take into consideration several unique issues when applied to the nervous system (as discussed in [19]), but are being used successfully by researchers in an attempt to identify those genes that are important in a biological or disease process. Comparisons are made between at least two highly related samples that differ by some critical variable: time, treatment, cell type, disease, etc. From the list of genes that are differentially expressed between two samples, researchers can either identify specific genes they feel are worthwhile to study, or get an overview of the types of gene classes that are activated or inactivated in response to the variables discussed above.

### Regulation at the mRNA Level (Post-transcriptional Control)

Genes often have multiple exons, separated by ►introns. In many cases the mRNA transcript that is generated from DNA is ►alternatively spliced in the nucleus, so that certain exons are not present in the final mature mRNA [20]. Indeed, genome analyses estimate that 60–80% of human genes can undergo alternative splicing. This mixing and matching of exons generates different forms of the same protein from the same gene,

but with distinct features: unique protein ►isoforms can differ subtly or dramatically in function, in their levels of expression and in their cellular and subcellular localization. An extreme example of alternative splicing occurs with the ►Down's Syndrome Cell Adhesion Molecule (►DSCAM) in *Drosophila*, where splicing can generate over 38,000 different forms of the protein. Several different forms of alternative splicing can occur, which are not restricted to the use of alternate exons, but can include alternative 5' or 3' splice sites, retention of intron sequences and alternative ►polyadenylation sites. Alternative splicing can mediate differential subcellular targeting, for instance of ►ion channel isoforms to axons or soma/dendritic compartments. In other cases, alternative splicing produces isoforms with distinct functional properties. At a tissue level, alternative splicing can generate specific expression patterns of splice variants by the differential expression and function of ►splicing factors and ►RNA binding proteins [21]. Recently, such regulation was shown to be important even at late stages of cell differentiation within the nervous system; the RNA binding protein How and the splicing factor Crooked neck protein mediate ►alternative splicing and glial maturation. When alternative splicing fails it results in the generation of proteins with altered function, and expression characteristics, and can result in disease. For example, ►frontotemporal dementia with ►parkinsonism results from the aberrant splicing of the tau mRNA, resulting in protein isoforms that tend to aggregate [22].

Once transcribed and processed, mRNAs leave the nucleus, with the help of ►exportins, and are translated within the cytoplasm to make proteins. It had been thought that ►mRNA translation occurred only in the cell body and that proteins were then shipped off to different parts of the cell. While this is clearly the main route by which proteins are made and get to where they need to be, there is evidence for ►local or subcellular mRNA translation both at the tip of the developing axon (e.g.  $\beta$ -►actin), called the ►growth cone, and in dendrites in response to changes in the activity of synapses (e.g. ►CAMKII) [23,24]. Thus, ►local mRNA translation seems to be a sensible solution to the requirement for speed when responding to changes in the environment in regions of a neuron that are distant from the cell body.

The mechanisms that control the subcellular targeting of mRNA are starting to be elucidated [23,24]. mRNA targeting is controlled by sequences within the mRNAs themselves. These are recognized, likely in the nucleus, in a specific fashion by a relatively large number of trans-acting factors which form complexes that are referred to as localizing ribonucleoprotein particles (RNPs). RNPs are unable to translate in the absence of an initiating signal, a mechanism which ensures that once exported from the nucleus, translation



only occurs once the RNPs become localized. Localization of RNPs is not random and is dependent on the ►cytoskeleton. The mechanisms involved are multiple and include interactions with ►myosin motors and ►microfilaments, and microtubule motors such as ►dynein and ►kinesin [23].

Cells can also regulate mRNA levels independently of gene transcription by RNA silencing mechanisms that involve the ►micro RNA (►miRNA) pathway. miRNAs are ~22 nucleotide double-stranded RNAs that are transcribed from ►non-coding stretches of DNA that show imperfect base pairing (pairing over 6–8 nucleotides) with the 3' untranslated regions of specific transcripts. These interactions prevent the cell from translating mRNAs into protein either by inhibiting translation, or, in some cases, by destabilizing the mRNA [25]. There are hundreds of miRNAs in the nervous system, each of which can inhibit translation of multiple transcripts. In fact, it has been estimated that over a third of mRNAs are regulated by miRNAs. miRNAs are implicated in neural development and in synaptic plasticity in mature neurons. Interestingly, miRNAs may serve to control mRNA abundance and translation in distal regions of the cell, far from the global regulatory mechanisms of transcription available in the nucleus. In the case of localized mRNAs, it is not clear whether miRNA repression occurs during or after transport. miRNA can also control the other main mechanism of post-transcriptional regulation, alternative splicing [26]; knockdown of a key RNA binding protein causes a global switch in alternative splicing from a non-neuronal to a neuronal pattern.

### Regulation at the Protein Level

When mRNA translation occurs locally, protein products are available immediately at the site where they are needed. More often, however, proteins are synthesized within the soma and then have to be shipped off to the appropriate subcellular compartment. This is a particularly formidable task for neurons given their dendrites with complex morphologies and axons that extend for long distances from the cell body. Moreover, proteins often need to be there at the same time as essential interactors. To have some appreciation for the complexity of this last issue, recent ►proteomic experiments indicate that approximately 1,000 different proteins are present at the synapse [27]. In fact the glutamate neurotransmitter NMDA receptor complex and its associated signaling complex on its own has 185 different players: the NMDA receptor, scaffolding proteins and enzymes. Another example is the complex of proteins that is present at the migrating edge of cells and growth cones and interacts with the actin cytoskeleton, the ►integrin-dependent adhesion contacts. These structures are made up of 50 unique proteins that mediate cell adhesion to the extracellular matrix.

Many of the mechanisms involved in protein trafficking are fundamental to all eukaryotic cells and have been worked out in yeast, but neurons have also evolved unique mechanisms that serve their particular requirements as ►polarized structures [28]. A set of trafficking mechanisms exists for long-distance transport to the axon terminals and distal dendritic spines, whereupon local trafficking machinery takes over. These local mechanisms determine where and when proteins are inserted or removed from the membrane, and recycled or degraded. Further, they are often controlled by electrical activity (►Action potential). For instance, the local machinery makes alterations in the repertoire of proteins expressed in dendritic spines to accommodate changes in the inputs a cell receives.

Proteins first have to be sorted between the cytoplasm and the membrane. One mechanism involves a ►signal peptide at the N-terminus of proteins that are secreted or integrated in the membrane (transmembrane) that directs them into the endoplasmic reticulum (ER) after translation. The proteins are then transferred to the ►Golgi apparatus, eventually emerging on the cell surface through the trans-Golgi network. Targeting of proteins can be regulated by changes in the physiological state of the neuron. For instance, subcellular targeting of proteins can depend on neuronal activity. An example here involves RhoGTPases that are predominantly cytoplasmic when inactive, but in their active state are targeted to the membrane based on a C-terminal consensus sequence within the proteins themselves. Targeting can also depend, in proliferative neural precursors, on the stage of the cell cycle. For instance, ►prospero is a protein whose asymmetric localization in the dividing *Drosophila* neuroblast depends on the cell cycle.

Defects in the ability of proteins to move smoothly through the ER-Golgi network can result in neuronal disease. For instance, early familial onset ►Parkinson's disease can arise from mutations in ►alpha synuclein that interfere with normal ER-Golgi protein transport. A major job of the ER is to properly fold proteins. Defective folding often leads to proteins that aggregate, and aggregates accumulate and over the long term cause neuronal degeneration. The dire consequences of aggregation have meant that neurons protect against it through two distinct mechanisms. Protein ►chaperones assist protein folding, correct folding errors and hold back improperly folded proteins in the ER, whereas ubiquitination targets misfolded proteins for degradation by the ►proteasome.

Proteins next get sorted to somatic, axonal and/or dendritic compartments. The mechanisms that regulate this sorting share commonalities with those used in apical/basal targeting of proteins in epithelial cells. Here, and in neurons, different modes of targeting are possible and include directed targeting, transcytosis and selective retention [29]. In directed targeting,

post-Golgi carriers recognize sequences in proteins that they use to deliver proteins to specific subcellular domains. This appears to be especially true of targeting to axons. In transcytosis, proteins are integrated in a non-specific fashion into the plasma membrane and then translocated to the axonal nerve terminal by endocytic carriers. In selective retention, proteins are integrated in both axons and dendrites, and then removed selectively by endocytosis from one compartment and not the other [30]. Finally, a number of local targeting mechanisms exist to refine the localization of proteins within the complex organization of the ►postsynaptic density and the presynaptic element [28]. The issue of protein trafficking within the cell has been particularly well studied with respect to ►receptor trafficking at the postsynaptic element, which may underlie several forms of synaptic plasticity in the adult. What is particularly remarkable in neurons is their ability to maintain their unique polarity for the life time of the animal despite the continuous recycling of both membrane and proteins. At the same time, neurons retain the ability to rapidly modify shape in response to changes in neuronal activity, for example at the dendritic spine.

Protein function can be altered by a series of ►post-translational modifications. Some modifications occur in the endoplasmic reticulum (e.g. ►N-glycosylation, ►disulfide linkages) while others occur within the cytoplasm or at the lipid membrane (e.g. phosphorylation, dephosphorylation). Proteins can be activated or inactivated by phosphorylation of specific serine/threonine/tyrosine residues by ►protein ►kinases. The phosphorylation state of different residues imparts different properties to the protein and is often required to activate or silence protein function. For example, signaling often involves ligand-induced phosphorylation of the transmembrane receptor. Receptor activation then results in adaptor proteins being recruited to binding sites in the cytoplasmic tail, and activation of downstream signaling. A protein whose function is highly dependent on phosphorylation is CAMKII, where the kinase is activated by phosphorylation of one specific residue and inactivated by phosphorylation of another. Interestingly, CAMKII is turned on by phosphorylation in excitatory neurons when  $\text{Ca}^{2+}$  spikes are sufficiently frequent, allowing CAMKII to serve as a decoder of the temporal patterns of neural activity. Alternatively, protein activation (or de-activation) may require dephosphorylation by a ►protein phosphatase. Phosphatases remove phosphate groups and counter the function of protein kinases. Protein function thus depends on the balance between these two competing enzyme groups. Also, the function of proteins can be altered by the addition of groups, such as heparan sulfate and chondroitin sulfate ►glycosaminoglycan sugar side chains, and removal of important domains by proteolytic cleavage. Proteolysis will either inactivate a

protein by eliminating a domain critical for function, or activate a protein whose functional molecular sites are hidden when the protein, or a component of the complex it assembles with, is in a non-cleaved state. A group of enzymes that undertake such cleavage events in the developing, adult and diseased nervous systems are ►metalloproteinases. Ubiquitination can also be important in controlling normal biological processes within neurons, as it results in the regulated removal of key signaling elements. For instance, positive control of growth at nerve-muscle contacts by ►BMP signaling is negatively regulated by ubiquitination of a downstream Smad effector.

The end result of all of these levels of regulation is that proteins end up expressed at the right time and place, and in the right state, to carry out their assigned function. Figuring out which proteins are required in tissue- and cell-specific events has been helped by the use of proteomics where comparisons are made between the levels and presence of proteins in two or more related samples that differ in some key variable. Directly looking at protein levels gets around the problem that mRNA levels are not always representative of the protein levels expressed by a cell.

### Genetics and Molecular Biology as Tools to Study Neuronal Development and Function

As mentioned earlier, the human genome contains approximately 23,000 protein-coding genes. The task now is to figure out what all the individual genes are doing, and what medical conditions arise when their function is either lost or altered. The strongest approaches available to elucidate protein function *in vivo* involve generating animals mutant for a particular gene, and investigating the consequences either on the development of the nervous system or on its function in the adult. Mutant animals can be produced by two means. In a ►forward genetics approach, a ►genetic screen is designed where model organisms such as *Drosophila*, ►*C. elegans* and ►zebrafish are treated with a chemical DNA mutagen that produces random mutations in their germ lines. The kin of the mutagenized animals are then screened for an identifiable ►phenotype in a researcher-defined biological process. The gene that is mutated can then be ►genetically mapped and identified. In mouse, an alternative commonly used approach involves ►reverse genetics, whereby a molecule of interest is removed from (►knocked-out) or added to (►knocked-in) the genome, creating a ►transgenic animal.

One of the issues often encountered in mice with the production of ►germ-line transgenics is that many gene products function in the early development of both neural and non-neural tissues, often resulting in embryonic or early postnatal lethality, which precludes their investigation in later developmental events and in

functions in the adult nervous system. To get around this issue, researchers often use a ►**conditional transgenic**, where a gene is knocked out in a specific tissue or cell type, and at a specific time. In mice the ►**Cre/LoxP** system, a site-specific recombination based approach, has proven useful in this regard. Meanwhile the ►**GAL4/UAS** system, which is based on the use of tissue-specific promoters, is used in zebrafish and *Drosophila*. In *Drosophila*, conditional transgenesis has also been taken to the single cell level with the use of ►**Mosaic Analysis with a Repressible Cell Marker (MARCM)**, which has the added advantage of labeling those cells that are mutant.

A number of additional model organisms including chick, zebrafish and *Xenopus*, have proven extremely useful for understanding the molecular and cellular mechanisms underlying nervous system development. They develop rapidly, the embryos are readily accessible through most of their development, and one can have tight temporal and spatial control over gene manipulations without having to employ laborious germline transgenic approaches. In these organisms, as well as mouse, gain-of-function can be achieved by misexpression of the wildtype gene with tissue-specific, temporally regulated or ubiquitous promoters. Loss-of-function can be achieved by the use of an antisense ►**morpholino oligonucleotide** or ►**siRNA (small interfering RNA)** against an mRNA of interest to block translation, or a ►**dominant negative** mutant protein that interferes with the function of the endogenous wildtype protein.

As described above, a number of tools have been generated to identify genes and proteins important in normal or disease processes. In their simplest form, they involve looking for changes in the levels of expression of genes or proteins on a global scale within a tissue by the use of experimental approaches that include microarrays and SAGE for mRNA expression, and proteomics for proteins. Sophisticated bioinformatic tools have had to evolve to allow researchers to keep up with the large amount of data arising from high throughput DNA and protein sequencing, genome projects, and functional genomics and proteomics. Various computational tools are available that can be used to find and process this information.

### Genetics and Molecular Biology of Nervous System Disease

Of course, if any of processes described earlier go wrong, it ultimately results in the production of a non-functional protein, a protein that is mistargeted, or a protein whose levels and location are inappropriate. The functional consequences to the nervous system depend on the properties of the protein, the defect that occurs, and the extent of the redundancy of the molecules that control the biological events in which it takes part. In some cases, a single gene mutation (monogenic) can

underlie a nervous system disorder. Mutations can take many forms, which include duplications, single nucleotide substitutions, deletions, inversions, splicing mutations and chromosome translocations. Even ►**single nucleotide polymorphisms (SNPs)** that are non-pathogenic can cause weak effects on the protein that when combined with other SNPs can result in a ►**haplotype** that increases disease susceptibility. With the sequencing of the human genome, the identification of mutations and their association with disease states will be facilitated. Importantly, defects do not have to be in the protein-coding region of the gene. For instance, in ►**triple repeat diseases**, a tri-nucleotide gene sequence, commonly CAG (encodes for glutamine), is tandemly repeated multiple times either in the protein-coding or non-coding (►**non-coding DNA**) regions of a gene.

In humans, a gene underlying a monogenic disease can be identified by ►**positional cloning** [32]. Briefly, this involves collecting DNA from affected individuals and a control group, mapping the gene to a region of the chromosome and sequencing genes in that region to identify changes in their DNA sequence. The process is greatly facilitated if a family with the disease/disorder can be identified. Unfortunately, the etiology of human nervous system disorders is often complex, with multiple genes (possibly dozens) contributing to a disorder with a single set of characteristics [27]. Moreover, factors such as age, gender and environmental inputs can influence the onset and progression of the disease. In the future, the ability to access and process large volumes of data will facilitate the identification of the molecular and genetic mechanisms underlying human nervous system disorders.

Of course, while a disease arises as a result of a mutation in one or several genes, the functional consequences occur at the level of the proteins. Systematic global approaches are now being used to try and understand the molecular basis of nervous system disease. A top-down approach takes a disease and uses global genome screening tools such as SNP, cDNA and oligonucleotide based microarrays to identify proteins with altered expression levels. This has been used to effect with ►**multiple sclerosis**, a chronic neuroinflammatory disease [31]. Alternatively, a ►**proteomics** approach can identify the proteins involved in a biological event or in a functional protein complex, and then automated searching of web-based data bases (data and text mining) can be used to identify human genetic diseases associated with mutations in proteins of the complexes [27]. Such an approach has been taken with the NMDA receptor complex and its involvement in disorders relating to synaptic function (e.g. ►**autism**, ►**schizophrenia**, ►**bipolar disorder**).

Transfer of the information we obtain about the molecular and genetic basis of disease to the clinic will depend on the development of strategies to fix disabled

molecular pathways. These include pharmacological interventions and the reintroduction of missing or broken proteins back into the affected nervous tissues with ►**gene therapy**. Knowing something about how protein expression, targeting and activity is controlled will be key in ensuring that nervous system function can be restored.

## References

- Mu Y, Otsuka T, Horton AC, Scott DB, Ehlers MD (2003) Activity-dependent mRNA splicing controls ER export and synaptic delivery of NMDA receptors. *Neuron* 40:581–594
- Adams MD, Celniker SE, Holt RA, Evans CA, Gocayne JD, Amanatides PG, Scherer SE, Li PW, Hoskins RA, Galle RF, George RA, Lewis SE, Richards S, Ashburner M, Henderson SN, Sutton GG, Wortman JR, Yandell MD, Zhang Q, Chen LX, Brandon RC, Rogers YH, Blazej RG, Champe M, Pfeiffer BD, Wan KH, Doyle C, Baxter EG, Helt G, Nelson CR, Gabor GL, Abril JF, Agbayani A, An HJ, Andrews-Pfannkoch C, Baldwin D, Ballew RM, Basu A, Baxendale J, Bayraktaroglu L, Beasley EM, Beeson KY, Benos PV, Berman BP, Bhandari D, Bolshakov S, Borkova D, Botchan MR, Bouck J, Brokstein P, Brottier P, Burtis KC, Busam DA, Butler H, Cadieu E, Center A, Chandra I, Cherry JM, Cawley S, Dahlke C, Davenport LB, Davies P, de Pablos B, Delcher A, Deng Z, Mays AD, Dew I, Dietz SM, Dodson K, Doup LE, Downes M, Dugan-Rocha S, Dunkov BC, Dunn P, Durbin KJ, Evangelista CC, Ferraz C, Ferreira S, Fleischmann W, Fosler C, Gabrielian AE, Garg NS, Gelbart WM, Glasser K, Glodek A, Gong F, Gorrell JH, Gu Z, Guan P, Harris M, Harris NL, Harvey D, Heiman TJ, Hernandez JR, Houck J, Hostin D, Houston KA, Howland TJ, Wei MH, Ibegwam C et al. (2000) The genome sequence of *Drosophila melanogaster*. *Science* 287:2185–2195
- Antoshechkin I, Sternberg PW (2007) The versatile worm: genetic and genomic resources for *Caenorhabditis elegans* research. *Nat Rev Genet* 8:518–532
- Otis KO, Thompson KR, Martin KC (2006) Importin-mediated nuclear transport in neurons. *Curr Opin Neurobiol* 16:329–335
- Sardi SP, Murtie J, Koirala S, Patten BA, Corfas G (2006) Presenilin-dependent ErbB4 nuclear signaling regulates the timing of astrogenesis in the developing brain. *Cell* 127:185–197
- Gray PA, Fu H, Luo P, Zhao Q, Yu J, Ferrari A, Tenzen T, Yuk DI, Tsung EF, Cai Z, Alberta JA, Cheng LP, Liu Y, Stenman JM, Valerius MT, Billings N, Kim HA, Greenberg ME, McMahon AP, Rowitch DH, Stiles CD, Ma Q (2004) Mouse brain organization revealed through direct genome-scale TF expression analysis. *Science* 306:2255–2257
- Johnson DS, Mortazavi A, Myers RM, Wold B (2007) Genome-wide mapping of in vivo protein-DNA interactions. *Science* 316:1497–1502
- Cobos I, Long JE, Thwin MT, Rubenstein JL (2006) Cellular patterns of transcription factor expression in developing cortical interneurons. *Cereb Cortex* 16 Suppl 1:i82–i88
- Ghanem N, Yu M, Long J, Hatch G, Rubenstein JL, Ekker M (2007) Distinct cis-regulatory elements from the *Dlx1/Dlx2* locus mark different progenitor cell populations in the ganglionic eminences and different subtypes of adult cortical interneurons. *J Neurosci* 27:5012–5022
- Kimura K, Wakamatsu A, Suzuki Y, Ota T, Nishikawa T, Yamashita R, Yamamoto J, Sekine M, Tsuritani K, Wakaguri H, Ishii S, Sugiyama T, Saito K, Isono Y, Irie R, Kushida N, Yoneyama T, Otsuka R, Kanda K, Yokoi T, Kondo H, Wagatsuma M, Murakawa K, Ishida S, Ishibashi T, Takahashi-Fujii A, Tanase T, Nagai K, Kikuchi H, Nakai K, Isogai T, Sugano S (2006) Diversification of transcriptional modulation: large-scale identification and characterization of putative alternative promoters of human genes. *Genome Res* 16:55–65
- Kornblihtt AR (2005) Promoter usage and alternative splicing. *Curr Opin Cell Biol* 17:262–268
- Ma Q (2006) Transcriptional regulation of neuronal phenotype in mammals. *J Physiol* 575:379–387
- Goldberg AD, Allis CD, Bernstein E (2007) Epigenetics: a landscape takes shape. *Cell* 128:635–638
- Kouzarides T (2007) Chromatin modifications and their function. *Cell* 128:693–705
- Ooi L, Wood IC (2007) Chromatin crosstalk in development and disease: lessons from REST. *Nat Rev Genet* 8:544–554
- Bruna A, Darken RS, Rojo F, Ocana A, Penuelas S, Arias A, Paris R, Tortosa A, Mora J, Baselga J, Seoane J (2007) High TGFbeta-Smad activity confers poor prognosis in glioma patients and promotes cell proliferation depending on the methylation of the PDGF-B gene. *Cancer Cell* 11:147–160
- Francke U (2006) Mechanisms of disease: neurogenetics of MeCP2 deficiency. *Nat Clin Pract Neurol* 2:212–221
- Nelson SB, Hempel C, Sugino K (2006) Probing the transcriptome of neuronal cell types. *Curr Opin Neurobiol* 16:571–576
- Barlow C, Lockhart DJ (2002) DNA arrays and neurobiology – what’s new and what’s next? *Curr Opin Neurobiol* 12:554–561
- Lipscombe D (2005) Neuronal proteins custom designed by alternative splicing. *Curr Opin Neurobiol* 15:358–363
- Grabowski PJ (2007) RNA-binding proteins switch gears to drive alternative splicing in neurons. *Nat Struct Mol Biol* 14:577–579
- Dawson HN, Cantillana V, Chen L, Vitek MP (2007) The tau N279K exon 10 splicing mutation recapitulates frontotemporal dementia and parkinsonism linked to chromosome 17 tauopathy in a mouse model. *J Neurosci* 27:9155–9168
- Czaplinski K, Singer RH (2006) Pathways for mRNA localization in the cytoplasm. *Trends Biochem Sci* 31:687–693
- Sossin WS, DesGroseillers L (2006) Intracellular trafficking of RNA in neurons. *Traffic* 7:1581–1589
- Kosik KS (2006) The neuronal microRNA system. *Nat Rev Neurosci* 7:911–920
- Makeyev EV, Zhang J, Carrasco MA, Maniatis T (2007) The MicroRNA miR-124 promotes neuronal differentiation by triggering brain-specific alternative pre-mRNA splicing. *Mol Cell* 27:435–448

27. Grant SG, Marshall MC, Page KL, Cumiskey MA, Armstrong JD (2005) Synapse proteomics of multi-protein complexes: en route from genes to nervous system diseases. *Hum Mol Genet* 14 Spec No. 2: R225–R234
28. Kennedy MJ, Ehlers MD (2006) Organelles and trafficking machinery for postsynaptic plasticity. *Annu Rev Neurosci* 29:325–362
29. Lai HC, Jan LY (2006) The distribution and targeting of neuronal voltage-gated ion channels. *Nat Rev Neurosci* 7:548–562
30. Wisco D, Anderson ED, Chang MC, Norden C, Boiko T, Folsch H, Winckler B (2003) Uncovering multiple axonal targeting pathways in hippocampal neurons. *J Cell Biol* 162:1317–1328
31. Ibrahim SM, Gold R (2005) Genomics, proteomics, metabolomics: what is in a word for multiple sclerosis? *Curr Opin Neurol* 18:231–235
32. Wolff RK, Positional cloning: a review and perspective. *Drug Development Research* 41:129–139

## Geniculo-cortical Pathway

► Geniculo-Striate Pathway

## Geniculohypothalamic Tract (GHT)

### Definition

One of the three major projections afferent to the suprachiasmatic nucleus. The cells of origin are located in the intergeniculate leaflet (IGL) of the lateral geniculate complex.

- Intergeniculate Leaflet
- Suprachiasmatic Nucleus (SCN)

## Geniculo-Striate Pathway

DANIEL L. RATHBUN, W. MARTIN USREY  
Center for Neuroscience, University of California,  
Davis, CA, USA

### Synonyms

Geniculo-cortical pathway; Visual thalamo-cortical pathway

### Definition

The geniculo-striate pathway is the set of axonal connections that project from the ►lateral geniculate nucleus (LGN) of the ►thalamus to the ►primary visual cortex. It is the single-greatest source of thalamic input to visual cortex and serves to relay visual information from retina to cortex.

### Characteristics

With the exception of ►olfaction, all sensory information destined for the cerebral cortex is communicated by neurons in the thalamus. In the visual system, neurons in the lateral geniculate nucleus (LGN) of the thalamus are the major relay of retinal input to the primary visual cortex (also called V1, striate cortex and area 17). The pathway between the LGN and visual cortex, called the geniculo-striate pathway, was initially characterized by the Russian physician Constantin von Monakow well over 100 years ago [1]. Since that time, the geniculo-striate pathway has been the focus of intense research and serves as a model for understanding the relationship between thalamus and cortex.

### Retinal Inputs Establish LGN Responses

The majority of synapses made onto LGN neurons come not from the retina, but from non-retinal sources. Non-retinal sources of input include the brainstem (►parabrachial nucleus and the ►dorsal raphe nucleus), ►thalamic reticular nucleus, and visual cortex [2]. While non-retinal inputs adjust the responsiveness of LGN neurons, it is the retinal input that establishes the visual properties of LGN neurons. Indeed, the ►receptive fields and response properties of LGN neurons are remarkably similar to those of their retinal afferents in terms of size, sign (*on* vs. *off*), contrast sensitivity, and color specificity. This similarity is largely due to the specificity of retinogeniculate projections and the low levels of ►synaptic convergence between the retina and LGN [3]. Neurons in the LGN respond to visual stimuli located in the ►contralateral visual field. Although individual LGN neurons receive input from just one eye, separate populations of neurons receive input from the contralateral eye and ipsilateral eye.

Most neurons in the LGN (and retina) have receptive fields with a concentric and antagonistic, ►center/surround organization. Approximately one half of LGN neurons are excited by bright spots of light that are surrounded by dark annuli (*on-center/off-surround* receptive field). The remaining neurons have the inverse relationship (*off-center/on-surround* receptive field). For both types of neurons, responses are diminished if the stimulus sign that excites the center of the receptive field extends into the surround. In addition to the *on* versus *off* distinction of LGN neurons, LGN neurons can be further distinguished on the basis of anatomical and

physiological criteria. In so doing, it is clear that the pathway from retina to cortex is comprised of multiple, parallel pathways [4].

### The Geniculo-Striate Pathway: An Overview

The geniculo-striate pathway establishes a functional architecture in primary visual cortex. The most notable feature of this architecture is ►retinotopy, whereby visual space (and the surface of the retina) is mapped across the surface of the cortex. In most species, the functional architecture established by geniculo-striate inputs also includes ►ocular dominance columns and ►orientation columns (described below).

The geniculo-striate pathway is not homogeneous, but comprised of parallel pathways that convey distinct visual information to the cortex. Although the specific details of these parallel pathways differ between species, many aspects of the geniculo-striate pathway are shared (Fig. 1).

Most notable of the shared attributes is the division of projections that terminate in either the ►granular layer of cortex (layer 4; note: many axons targeting layer 4 also send a sparse collateral projection into layer 6) or the supragranular layers (layers 1–3) [2]. In all species, the pathway terminating in cortical layer 4 arises from neurons located in the principal layers of the LGN, whereas the pathway terminating in layers 1–3 arises from neurons located in the non-principal layers (sometimes called the W-cell layers, intercalated layers,

and/or koniocellular layers, depending on the species; described below). Compared to neurons in the non-principal layers, neurons in the principal layers generally have small receptive fields and produce short-latency, robust responses to visual stimulation. Furthermore, the axons of principal layer neurons and their synapses are significantly larger than those of neurons in the non-principal layers. Based on these properties, the pathway from the principal layers of the LGN to cortical layer 4 has been argued to function as a high-fidelity transmission line between the LGN and cortex, while the pathway from the non-principal layers to cortical layers 1–3 has been suggested to serve a more modulatory role (with the exception of primates, see below).

### The Geniculo-Striate Pathway: Rodents

In rodents, the geniculo-striate pathway follows the general plan (outlined above) with axons that terminate in either layer 4 or layers 1–3 (Fig. 1). Although the receptive fields of LGN neurons in the rodent are significantly larger than those of most other mammals, the distinction holds that neurons with projections to layer 4 have relatively smaller receptive fields and shorter response latencies than those with projections to layers 1–3. The geniculo-striate pathway in the ground squirrel appears to contain three classes of LGN neurons (described below for carnivores), however, more work is needed to be certain of this distinction in rats, mice and other rodents.

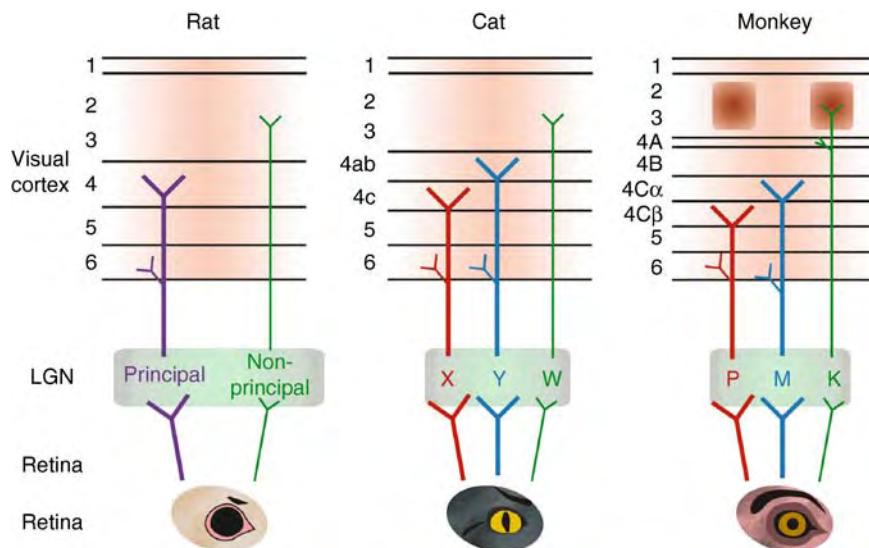

**Geniculo-Striate Pathway. Figure 1** Organization of the geniculo-striate pathway in three representative animals: rat, cat and monkey. In all mammals, including these examples, the majority of geniculo-striate axons terminate in cortical layer 4, a minority of axons terminate in cortical layers 1–3. In the cat, there are three parallel pathways to striate cortex – the X-cell pathway terminates in layer 4c, the Y-cell pathway terminates in layer 4ab, and the W-cell pathway terminates in layers 1–3. There are also three parallel pathways in the monkey – the parvocellular pathway (P) terminates in layer 4Cβ, the magnocellular pathway (M) terminates in layer 4Cα, and the koniocellular pathway (K) terminates in the layer 1–3 blobs.

Compared to carnivores and primates, the eyes of rodents are displaced further to the sides of the head. Consequently, the ►**binocular visual field**, is reduced in the rodent. The LGN therefore contains many more neurons with input from the contralateral eye than from the ipsilateral eye. The geniculo-striate pathway reflects this unequal distribution of retinal inputs, as the entire primary visual cortex responds to contralateral eye stimulation with a small portion also responding to ipsilateral eye stimulation. Restated, the geniculo-striate pathway in the rodent does not establish alternating ocular dominance columns similar to those in carnivores and primates (described below), but rather, establishes a single binocular field/column surrounded by a much larger monocular field/column.

### The Geniculo-Striate Pathway: Carnivores

The geniculo-striate pathway of the cat serves as a model for the carnivore pathway, as it has received the most attention and is arguably the best understood thalamo-cortical pathway in any species (Fig. 1). The cat LGN has two principal layers, A and A1, which receive input from the contralateral eye and ipsilateral eye, respectively, and project to cortical layer 4. Beneath the A layers are the C layers that contain cells with projections to cortical layers 1–3. Within the A layers, *on*- and *off*-center LGN cells are intermixed, as are X and Y cells. X and Y cells are members of two distinct parallel pathways that project to cortical layer 4. To summarize the major differences between X- and Y-cell pathways: (i) X cells receive input from ►**beta ganglion cells in the retina**, whereas Y cells receive input from ►**alpha ganglion cells**, (ii) X cells have smaller receptive fields than Y cells, (iii) X cells prefer stimuli that change or move at lower temporal frequencies (i.e., slower) than those preferred by Y cells, (iv) X cells display linear spatial summation, whereas Y cells display non-linear spatial summation, and (v) X cells have axons that are thinner and conduct action potentials somewhat more slowly than those of Y cells [reviewed in 4]. Although not emphasized here, the pathway from the C layers of the LGN to cortical layers 1–3 is largely comprised of the axons of W cells. LGN W cells have substantially larger receptive fields than those of X or Y cells and sluggish visual responses.

The projection patterns of X-, Y- and W-cells are distinct in the cat. Both X and Y cells project to layer 4; however, the axons of Y cells terminate in layer 4ab, while those of X cells terminate in layer 4c. The axons of W cells pass directly through layer 4 as they ascend to provide input to layers 1–3. In addition to showing laminar specificity in their projection patterns, LGN axons also display eye-specific projections. These eye-specific projections cluster to create alternating ocular dominance columns. Studies of the development of ocular dominance columns have provided crucial

insight into our understanding of the role of neuronal activity during development.

A remarkable transformation of receptive field structure occurs at the geniculo-striate synapse. In contrast to the concentric, center/surround receptive fields of LGN neurons, neurons in cortical layer 4 (immediately postsynaptic to LGN axons) have receptive fields with elongated and alternating on and off subregions. ►**Hubel and Wiesel** called these layer 4 neurons “►**simple cells**” and presented the first model for the construction of their receptive fields (Fig. 2) [5].

In their model, a row of LGN cells with receptive fields of the same sign (on or off center) provides convergent synaptic input to a common cortical cell (the simple cell). As a consequence of this arrangement of inputs, the simple cell has a receptive field with elongated on and off subregions. In addition, the simple cell is selective to the orientation of a bar or edge of light. Subsequent work has largely supported this model for the generation of simple cell receptive fields and ►**orientation selectivity** [6]. The geniculo-striate pathway establishes columns of cells that share a similar orientation preference. Across the surface of the cortex, these orientation columns display systematic shifts in preferred orientation.

### The Geniculo-Striate Pathway: Primates

The distinction of parallel pathways within the geniculo-striate projection is remarkably clear in primates (Fig. 1) [7,8]. The primate LGN contains ►**parvocellular**, ►**magnocellular** and ►**koniocellular** neurons that are segregated into distinct LGN laminae. As neurons that receive input from the contralateral or ipsilateral eye are also segregated, the primate LGN generally contains at least two parvocellular layers, two magnocellular layers and two koniocellular layers. For

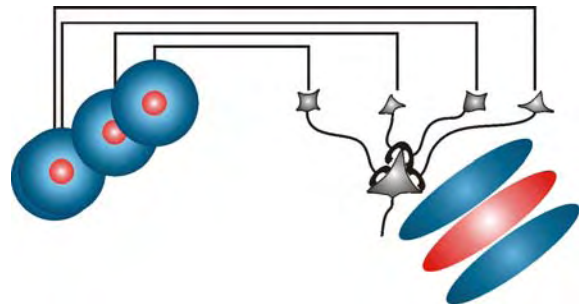

**Geniculo-Striate Pathway. Figure 2** The Hubel and Wiesel model for the emergence of the simple cell receptive field. In this model, multiple LGN neurons with collinear, same-sign (*on* vs. *off*) receptive fields provide convergent input onto a target cortical neuron. As a result of this organization of inputs, the target cell has a simple cell receptive field with elongated and adjacent *on* and *off* subregions. Adapted from [5].

example, the LGN of the macaque monkey has four dorsal parvocellular layers and two ventral magnocellular layers with koniocellular layers (also called intercalated layers) under and between each of the six layers.

Like the X, Y and W cells in the carnivore LGN, the parvocellular, magnocellular and koniocellular neurons in the primate LGN receive input from separate classes of retinal ganglion cells, give rise to axons that terminate in different divisions of visual cortex, and display distinct visual physiology. Parvocellular and magnocellular LGN neurons receive retinal input from ►midset and ►parasol ganglion cells, respectively. Less is known about the retinal input to koniocellular neurons; however, some are known to receive input from ganglion cells that convey ►S-cone (frequently called blue cone) information. The visual response properties of parvocellular and magnocellular neurons are well characterized. Compared to parvocellular neurons, magnocellular neurons have larger receptive fields, respond better to low contrast stimuli, are somewhat more sensitive to stimuli that are quickly moving or modulated at high temporal frequency, and respond with a shorter latency following the presentation of a visual stimulus. In addition, magnocellular neurons have little selectivity for color, while most parvocellular neurons are color-selective – particularly ►red/green opponent.

The axons of parvocellular and magnocellular neurons terminate in distinct subdivisions of cortical layer 4 – parvocellular axons terminate in layer 4C $\beta$  and magnocellular axons terminate in layer 4C $\alpha$  (Fig. 1). Koniocellular neurons have axons that terminate in cortical layers 1–3, however, only in patches of layers 1–3 called “blobs” that are rich in ►cytochrome oxidase. Accordingly, neurons in these recipient layers have visual responses in line with those of their LGN inputs. Finally, LGN axons carrying information from the contralateral and ipsilateral eye are remarkably segregated in their terminal fields in visual cortex. Consequently, alternating ocular dominance columns are robust in most primate species and individual blobs are eye specific.

### Spike Timing and Information Transmission in the Geniculo-Striate Pathway

With the advent of multielectrode recording techniques, it is now possible to examine the transfer of spikes between the LGN and visual cortex in vivo by recording from monosynaptically connected pairs of neurons. Results from such experiments show that the interaction time for geniculate spikes in driving a cortical response is quite brief – approximately 7 ms for spikes arriving from multiple presynaptic neurons and 15 ms for spikes arriving from the same presynaptic neuron [9]. These results are consistent with the view that, while geniculo-striate synapses experience synaptic

depression, depression is saturated under normal visual conditions, thereby allowing brief, temporal summation to occur in the generation of postsynaptic responses [10]. Accordingly, geniculo-striate synapses are particularly well suited to transmit information carried in LGN bursts, high firing rates and correlated activity.

## References

1. Monakow C von (1895) Experimentelle und pathologisch-anatomische Untersuchungen über die Haubenregion, den Sehhügel und die Regio subthalamica, nebst Beiträgen zur Kenntniss früh erworbener Gross- und Kleinhirndefekte. Arch Psychiatr Nervenkr 27:1–128, 386–478
2. Sherman SM, Guillery RW (2005) Exploring the thalamus and its role in cortical function, 2nd edn. MIT, Boston, MA
3. Usrey WM, Reppas JB, Reid RC (1999) Specificity and strength of retinogeniculate connections. J Neurophysiol 82:3527–3540
4. Stone J (1983) Parallel processing in the visual system. Plenum, New York
5. Hubel DH, Wiesel TN (1962) Receptive fields, binocular interaction and functional architecture in the cat's visual cortex. J Physiol 160:106–154
6. Reid RC, Alonso JM (1996) The processing and encoding of information in the visual cortex. Curr Opin Neurobiol 6:475–480
7. Merigan WH, Maunsell JH (1993) How parallel are the primate visual pathways? Annu Rev Neurosci 16:369–402
8. Hendry SHC, Reid RC (2000) The koniocellular pathway in primate vision. Annu Rev Neurosci 23:127–153
9. Usrey WM, Alonso J-M, Reid RC (2000) Synaptic interactions between thalamic inputs to simple cells in cat visual cortex. J Neurosci 20:5461–5467
10. Boudreau CE, Ferster D (2005) Short-term depression in thalamocortical synapses of cat primary visual cortex. J Neurosci 25:7179–7190

## Genome

### Definition

Genome is the complete DNA sequence, both protein coding and non-coding, contained in one set of chromosomes of an organism.

## Genomics

### Definition

Genomics is the study of the global properties of the DNA sequences, genomes, of related organisms.



## Genotype

### Definition

Genotype usually describes for an individual the exact DNA sequence for a specific allele.

## GENSAT Project

### Definition

The GENSAT (Gene Expression Nervous System Atlas) project is funded by the National Institute of Neurological Disorders and Stroke (NINDS) and aims to map the expression of all genes expressed in the mouse brain at various stages of development. This project is providing transgenic mice lines containing a BAC construct that expresses a marker gene under the promoters of the native genes and the information of expression patterns of the various genes in the brain.

► <http://www.ncbi.nlm.nih.gov/projects/gensat/>

## Geomagnetic Field

MICHAEL WINKLHOFFER  
Department für Geo- und Umweltwissenschaften –  
Sektion Geophysik, Ludwig-Maximilians-Universität  
Munich, Munich, Germany

### Synonyms

Earth's magnetic field; terrestrial magnetic field

### Characteristics

#### Origin

The magnetic field of the Earth,  $B$ , is a superposition of several magnetic fields generated by various internal and external sources. The primary and preponderant sources are convection currents in the metallic fluid outer core, called the geodynamo. The magnetic field due to the core, also referred to as the main field, varies slowly in time and smoothly over the Earth's surface, and therefore can be described by mathematical models such as the International Geomagnetic Reference field (►IGRF). The main field is spatially perturbed by

the inhomogeneous magnetization of the crust and temporally perturbed by electric current systems in the ►ionosphere and ►magnetosphere, which in turn are affected by solar activity. The time-varying ionospheric currents, on the other hand, induce telluric currents in the Earth, which in turn generate the so-called magnetotelluric fields. Another example of secondary magnetic fields are those produced by oceanic current systems flowing through the Earth's magnetic field. Just recently, due to ocean tidal flow, the secondary magnetic field has been identified in magnetic-field data measured aboard the CHAMP satellite [1].

### Magnetic Elements

The Earth's magnetic field is a (time-dependent) three-dimensional vector field. There are several triples of orthogonal components to completely describe the local magnetic field,  $B$ , at any given time and location in a geographically based coordinate system (Fig. 1).

These triples are, of course, equivalent to each other, and it is for practical and historical reasons that different sets are used interchangeably.

- 1)  $B = (X, Y, Z)$  –  $X$  (north),  $Y$  (east), and  $Z$  (downward). These are the Cartesian components of  $B$  as projected on the geographical coordinates. The magnetic

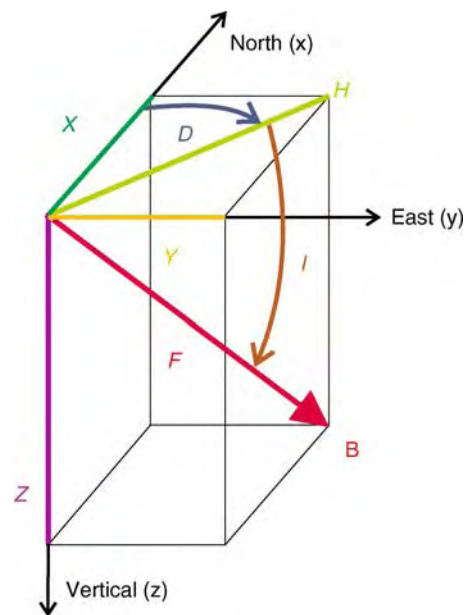

**Geomagnetic Field. Figure 1** The seven elements of the geomagnetic field  $B$ , declination  $D$ , inclination  $I$ , total intensity  $F$ , horizontal intensity  $H$ , vertical intensity  $Z$ , north component  $X$ , and east component  $Y$ . Only three independent elements such as  $(F, I, D)$  or  $(H, Z, D)$  are needed to give a complete vector specification of the local geomagnetic field.

elements  $X$ ,  $Y$ , and  $Z$  are quoted in units of intensity (magnetic induction, see below).

- 2)  $B = (H, Z, D) - H$  (horizontal),  $Z$  (downward), and  $D$  (declination). The horizontal intensity  $H$  is the projection of  $B$  on the local horizontal plane and points to magnetic north, which is the direction indicated by a magnetic compass. The declination is the horizontal angle between true north (along meridian) and magnetic north, reckoned positive eastward.
- 3)  $B = (F, I, D)$ , with  $F$  (total field intensity),  $I$  (inclination),  $D$  (declination). The magnetic inclination is the dip angle of the total field vector  $B$  with respect to the local horizontal plane. Positive (negative) values of  $I$  indicate that field lines are directed downward (upward). The point at which  $I = +90^\circ$  ( $I = -90^\circ$ ) is termed the north (south) magnetic, or dip, pole. It is this triple that is normally used in magnetobiology and [▶palaeomagnetism](#). It is also the most intuitive representation of a vector, which is characterized by a magnitude and direction in space.

### Units

In SI units, the magnitude of the geomagnetic field vector,  $F$ , and that of its components  $X$ ,  $Y$ ,  $Z$ ,  $H$ , is expressed in tesla (1 T), the unit of magnetic induction. In the Gaussian, or cgs, system, the unit of magnetic induction is the gauss, designated by G ( $\Gamma$ ), with  $10^4$  G = 1 T. Usually,  $F$  is quoted in units of nT ( $10^{-9}$  T) or, in the cgs system, in gamma ( $\gamma$ ), with  $1 \gamma = 10^{-5}$   $\Gamma = 1$  nT.

### Magnetic Charts Global Field Maps

Due to the complex nature of the geomagnetic field (see section “Origin”), it is impossible to produce an accurate geomagnetic map. The global maps presented here refer to the latest IGRF model (IGRF 9), and basically show the long-wavelength variations due to the main field. With the main field dominating the geomagnetic field, the IGRF model is a good approximation of the real field on a global scale: For the reference year 2000, it is accurate to within  $0.5^\circ$  for  $D$  and  $I$  and about 200 nT for the intensity elements, although some areas exist with local anomalies exceeding the error margin of the IGRF.

The most common display format for the distribution of magnetic elements over the Earth’s surface are isomagnetic charts. These charts are contour maps of equal values of a given magnetic element and are called isogonic, or isoclinic for declination, or inclination, respectively. Charts showing isolines of intensity of a field component ( $X$ ,  $Y$ ,  $Z$ ,  $H$ ,  $F$ ) are termed isodynamic. The lines of equal inclination (isoclinics) are also referred to as magnetic latitudes. The isoclinic defined

by  $I = 0^\circ$  is called magnetic (dip) equator, and winds about the globe at low geographic latitudes (Fig. 2). The inclination is downward (upward) throughout most of the Northern (Southern) hemisphere. In 2004, the IGRF north magnetic pole ( $I = 90^\circ$ ) was located at  $82^\circ$ N latitude and  $113^\circ$ W longitude, the IGRF south magnetic pole ( $I = -90^\circ$ ) was situated at  $64^\circ$ S,  $138^\circ$ E.

There are agonic ( $D = 0^\circ$ ) lines among the isolines for declination (Fig. 3). From Figs. 2 and 3 it can be seen that inclinations vary in a more regular manner over the globe than declination does. Especially at low latitudes, the isoclines form nearly parallel bands.

Here, changes in inclination can be used to determine relative changes in geographic latitude. The distribution of  $F$  is asymmetric (Fig. 4), with two pronounced large-scale magnetic anomalies, a deep global minimum over South Brazil (22,770 nT at  $26^\circ$ S,  $55^\circ$ W) and an intense maximum over Siberia (61,413 nT at  $61^\circ$  N,  $105^\circ$  E), which even exceeds the maximum (59,720 nT at  $60^\circ$  N,  $100^\circ$  W) associated with the magnetic north pole. The global maximum is located in the southern hemisphere (66,752 nT at  $60^\circ$ S,  $138^\circ$ E) near the south magnetic dip pole. Note that while the maxima in  $F$  are spatially associated with the dip poles, they do not coincide with them. The reason for this discrepancy is that the main field does not have a purely dipolar shape, or non-dipolar components. Nevertheless, the simplest model of a geocentric dipole, with its dipole axis inclined about  $10.7^\circ$  to the Earth’s spin axis, can account for some 90% of the spatial variations of the main field on the Earth’s surface. The theoretical poles of the geocentric inclined dipole are called geomagnetic poles. The north geomagnetic pole is near  $79^\circ$ N,  $70^\circ$  W, the south geomagnetic pole at the antipode, near  $79^\circ$ S,  $110^\circ$  E.

### Local Field Maps

While the main field varies relatively smoothly on a global scale (wavelengths greater than 3,000 km), the real geomagnetic field may change in a much more irregular fashion on a regional or local scale. Magnetic anomalies are due to magnetised rocks within the [▶Earth’s crust](#). The small-scale magnetic anomalies depicted in Fig. 5 are related to the local geology. The content of magnetic minerals in rocks varies from one rock type to the next, and so gives rise to variations in the natural magnetization across different rock units. Volcanic rocks contain a relatively large proportion of magnetic minerals, and therefore volcanic edifices such as cinder cones stick out on a magnetic anomaly map like a mountain in a topographic map. Many regions have their distinct magnetic fingerprint and so can provide animals with navigational information. A detailed map of the global crustal magnetic field (MF3) has recently been derived from data collected aboard the CHAMP satellite over three years [2].

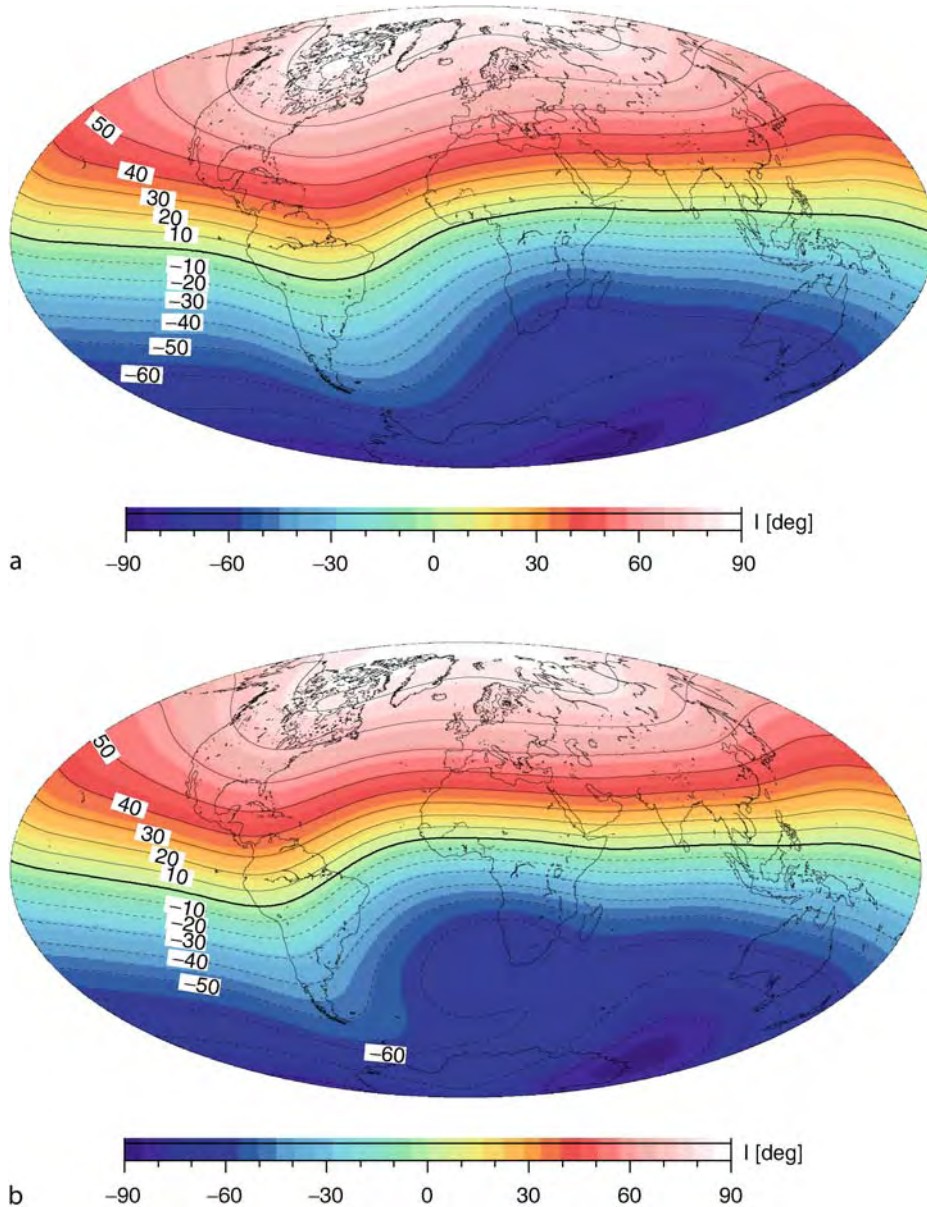

**Geomagnetic Field. Figure 2** Inclination according to International Geomagnetic Reference Field (IGRF 9) for the years 1900 (a) and 2004 (b) in isoclinic format, that is, contours are lines of equal inclination (magnetic dip latitudes). The thick black line demarcates the magnetic dip equator ( $I = 0^\circ$ ), where field lines are horizontal. Isoclinics for  $I > 0$  ( $I < 0$ ) are represented by *solid* (*dashed*) lines. Spacing between contours is  $10^\circ$ . The map is a cylindrical equidistant projection. All global charts are produced with GMT software, version 3.4.2 (<http://gmt.soest.hawaii.edu/>).

### Secular Variation

The magnetic elements change with time (compare charts for 1900 and 2004 in Figs. 2–4).

The largest changes are associated with the non-dipole part of the main field. In Fig. 3, one can see that the agonic line has moved westward across Eastern Europe and South America since 1900. There are also pronounced changes in the inclination over

the South Atlantic (Fig. 2). Bullard et al. [3] calculated a secular change in  $D$  of  $0.32^\circ/\text{yr}$ , and a westward drift of the non-dipole components of  $0.18^\circ/\text{yr}$  for the period 1907–1945. The observed westward drift may be explained as a consequence of the dynamo theory of the origin of the Earth's field, requiring the outer part of the core to rotate less rapidly than the inner part. Therefore, the core travels westward

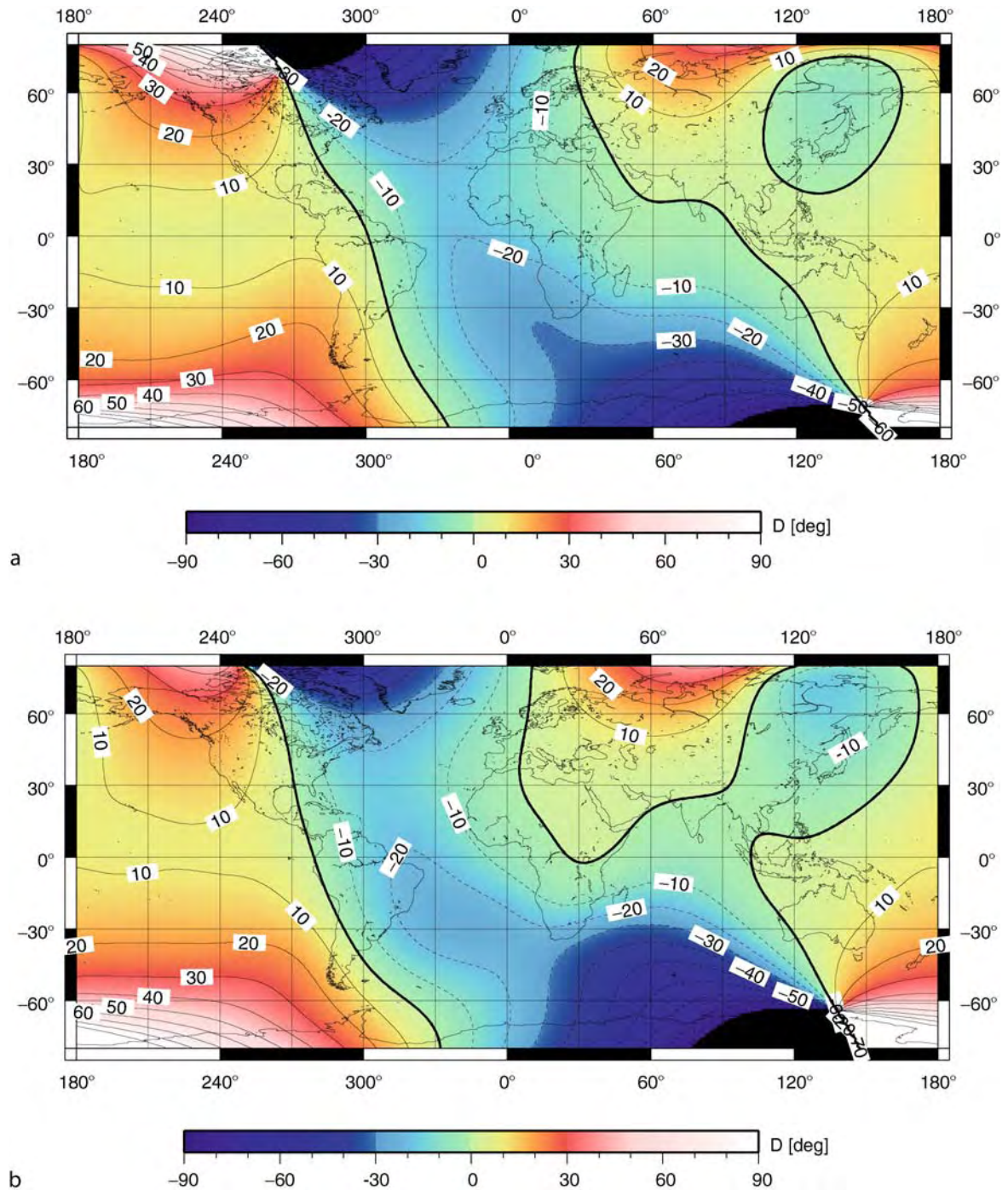

**Geomagnetic Field. Figure 3** Declination,  $D$  for the years 1900 (a) and 2004 (b) according to IGRF 9, in isogonic format. The thick contour wriggling around the globe is the agonic line ( $D = 0^\circ$ ). Isogonics for  $D > 0$  ( $D < 0$ ) are represented by *solid* (*dashed*) lines. Spacing between contours is  $10^\circ$ . Map projection: cylindrical equidistant with geographical grid underlain to emphasize local deviations of magnetic north from true north. Movies showing the evolution of the magnetic elements over the last four centuries are available under <http://geomag.usgs.gov/movies.html>.

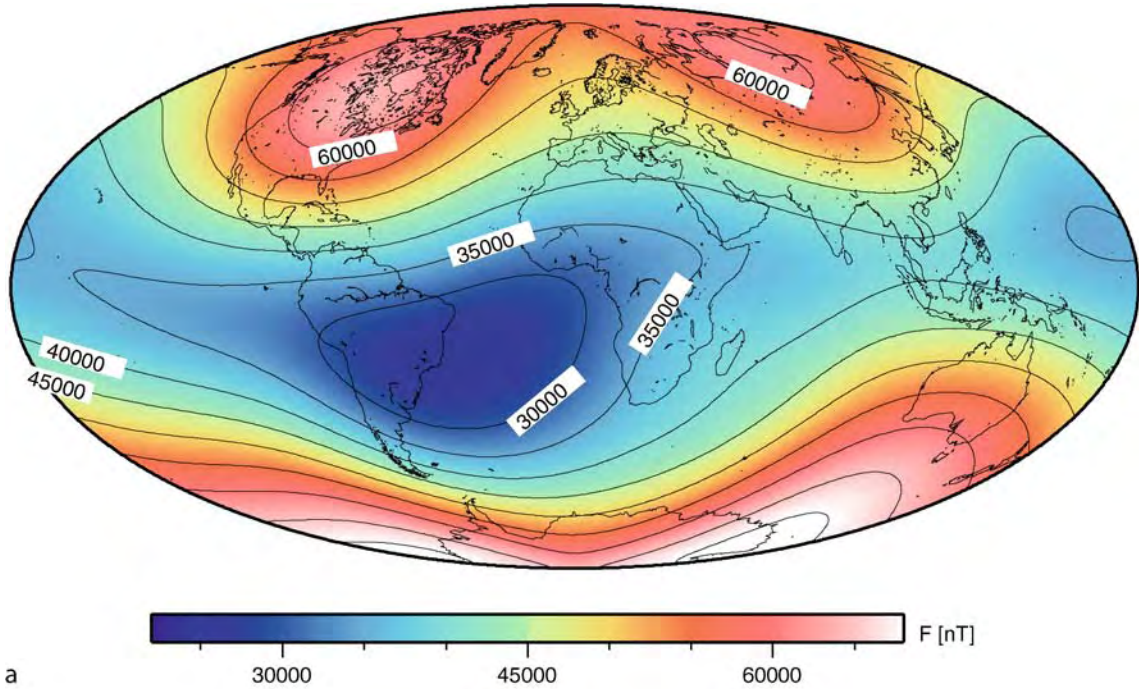

a

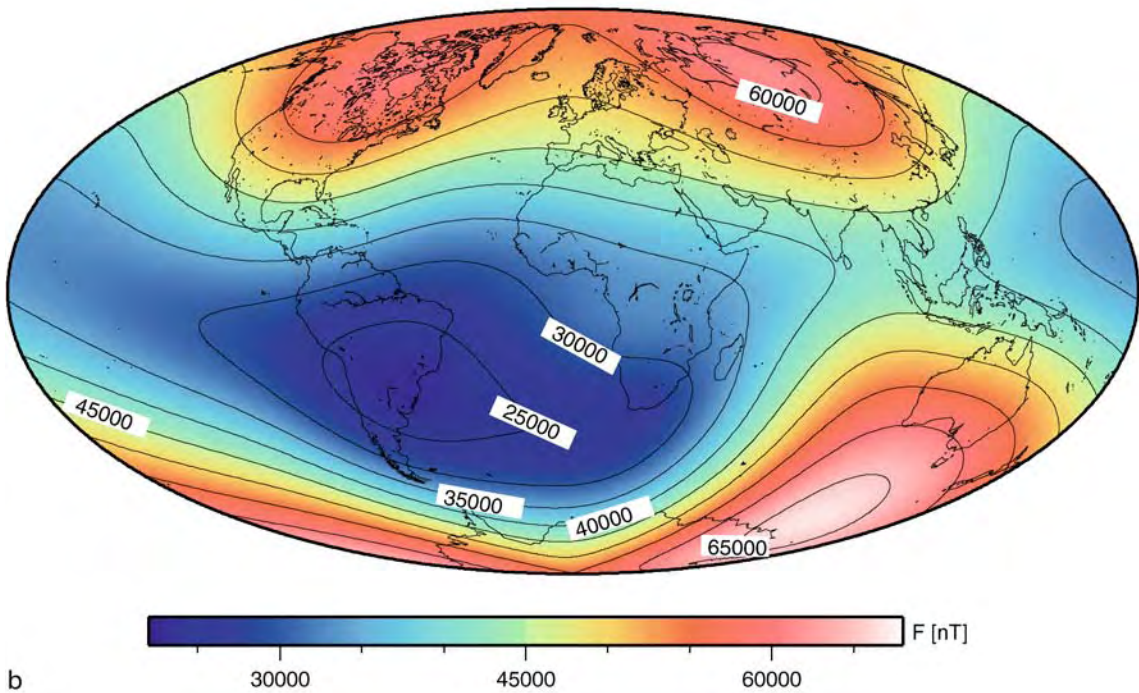

b

**Geomagnetic Field. Figure 4** Total field intensity,  $F$  for the years 1900 (a) and 2004 (b) according to IGRF 9, in isodynamic format and equal area projection.

relative to the mantle, carrying minor features of the field with it.

Magnetic charts showing lines of equal change are referred to as isoporic. Figure 6 shows the current

rate of change in  $F$ . At present,  $F$  is decreasing at the fastest rate in the North Atlantic offshore from South Carolina/USA, while it is increasing particularly rapidly over the Central Indian Ocean.

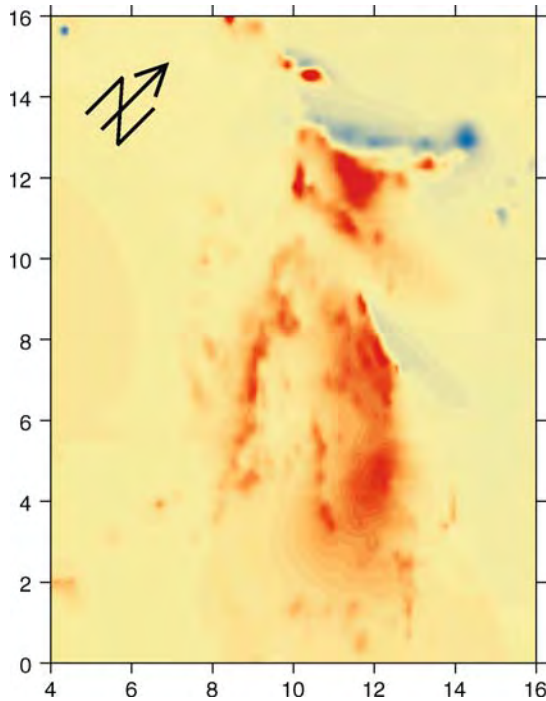

**Geomagnetic Field. Figure 5** Magnetic anomaly map, showing the deviation of the locally measured value of  $F$  from the value according to the IGRF for a  $12 \times 16 \text{ km}^2$  area around the site of the German continental deep-drilling programme in north-east Bavaria/Germany. The anomaly ranges from  $+100 \text{ nT}$  (red) to  $-100 \text{ nT}$  (blue). The map was obtained from an aeromagnetic survey flown at an altitude of  $50 \text{ m}$ . (Courtesy of Dr. J. Pohl).

### Polarity Reversals

The dipolar component of the magnetic field has been dwindling by 5% per century since the first analyses by Gauss in 1835, and if it were to continue diminishing at the same rate, it would disappear in about 2000 years' time [4]. Even though it is not possible to predict the behaviour of the main field for the distant future, the temporary disappearance of the dipole field would be no extraordinary event in the Earth's history. In the palaeomagnetic record obtained from sediment cores or lava sequences, periods of low magnetic field strengths have frequently been observed, often in relation to geomagnetic polarity reversals.

Polarity reversals are the most spectacular temporal variations in the geomagnetic field. However, while the polarity of the solar magnetic field changes regularly, at a frequency of 11 years, polarity reversals of the geomagnetic field are distributed randomly over geological time (Fig. 7).

Several hundreds of reversals are documented in the palaeomagnetic record. Over the last five million years, some twenty reversals have occurred, the last

one 780 kiloyears ago. Despite some recent progress in this field, it is still not clear how a polarity transition occurs in detail. Rather than simply being an instantaneous switch in polarity, a polarity transition appears to be a complicated process lasting at least a thousand years. From what has been observed in palaeomagnetic records and corroborated by numerical modelling [5], the onset of a polarity transition is marked by plummeting field intensities and erratic directional behaviour, which is interpreted in terms of an abating dipolar field. When the dipole builds up in the reverse direction and recovers its pre-transitional strength, the reversal is accomplished. Since the last reversal 780 kyrs ago, there seem to have been several reversal attempts, which obviously did not succeed. Such an aborted reversal attempt is often referred to as geomagnetic excursion, although geomagnetic excursions may also present periods of extraordinarily large secular variation. More high-resolution palaeomagnetic records worldwide are needed to resolve this question.

### Periodic and Transient Field Fluctuations of External Origin

In addition to the long-term ("secular") variation, there are also short-term fluctuations in the geomagnetic field from sources external to the Earth, transient or quasi-periodic in nature. Fig. 8 shows a magnetogram recorded on a "geomagnetically quiet" day compared to one recorded during a magnetic storm. Field variations on a "quiet" day have typical amplitudes of 20–30 nT. The quiet-day variation comprises a major diurnal variation (Sq – solar quiet) depending on solar time and a minor semidiurnal variation (L – lunar) depending on lunar time. Solar insolation is a function of daytime, latitude, and season, and therefore there are seasonal and latitudinal cycles superimposed to the diurnal variation. Nevertheless, because of their regular diurnal variations, the Sq variations may act as a zeitgeber to those animals whose magnetic sense is sensitive enough to detect changes of less than one per mille of the normal field intensity. The source of Sq variations are electric currents in the E-region of the dayside ionosphere, generated by moving charges in the main field like in a dynamo. The L variations represent tidal forces on the ionosphere also inducing dynamo currents. A magnetic storm, on the other hand, is a consequence of a solar burst, through which billions of tons of solar plasma are ejected into space and eventually hit the Earth's magnetosphere, causing large field disturbances that may last over several days. The magnetic field changes due to a magnetic storm that produces a different local field situation, and will therefore hamper navigation in animals that use local magnetic field anomalies as a map factor. Metaphorically speaking, these animals would be deceived by a magnetic fata morgana.

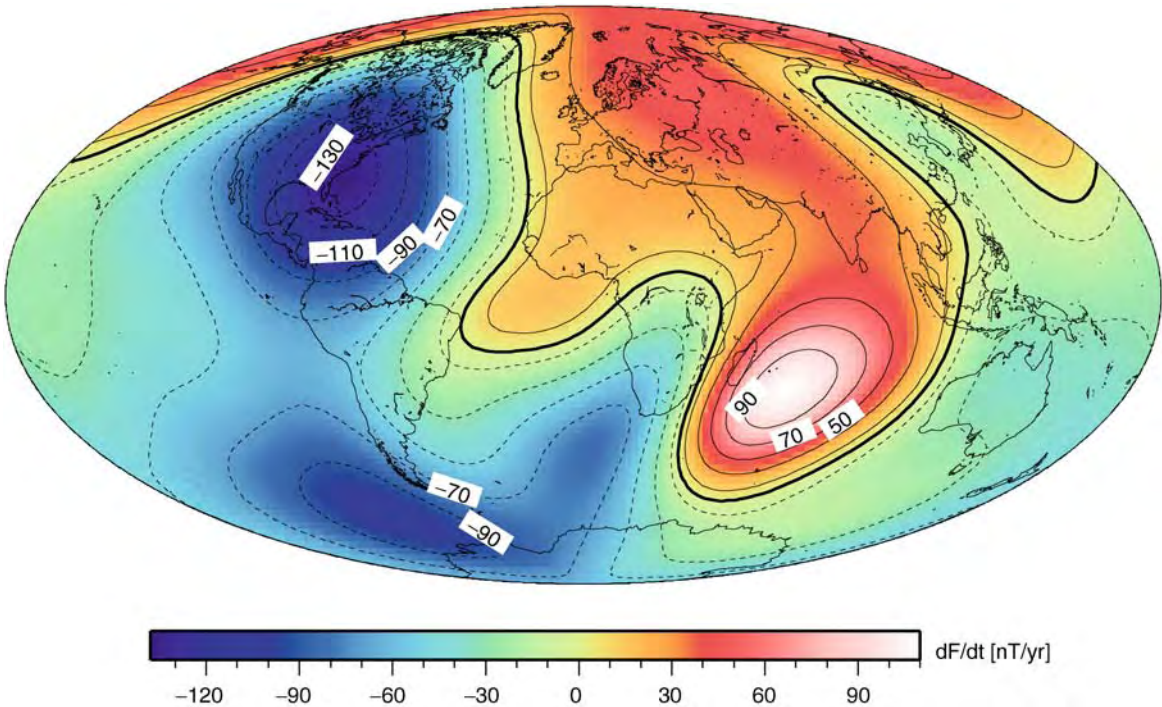

**Geomagnetic Field. Figure 6** Isopic chart for 2004 showing the rate of change in  $F$  in nT/yr, according to IGRF 9. Contours are lines of equal decay rate (*dashed*) or equal growth rate (*solid*). Spacing between contours is 20 nT/yr, the thick black line represents 0 nT/yr. Equal area projection.

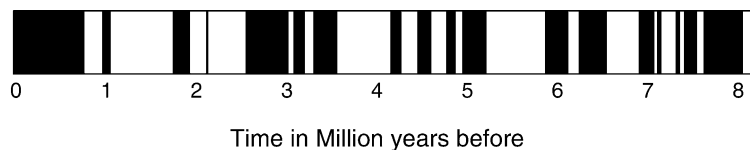

**Geomagnetic Field. Figure 7** Geomagnetic polarity time scale for the last seven million years. Normal (reversed) polarity intervals are black (white). Field reversals (transitions between two adjacent polarity intervals) have occurred irregularly in geological time.

## Theory

### Geomagnetic Bi-Coordinate System

The Earth's magnetic field contains considerable navigational information. The systematic variation of inclination with latitude over a global scale (Fig. 2) may provide an animal in its long travels with a reliable reference frame [6]. For precise navigation on the two-dimensional surface of the Earth, however, a pair of coordinates is required. The geographical coordinate system, with its regular grid of longitudes and latitudes, is unique in any point on the surface but cannot serve animals as a natural coordinate system because of its artificial nature. It has been postulated that two magnetic elements such as inclination and intensity [7,8] might form the basis of a natural bi-coordinate system; the pair inclination and declination may serve the same purpose, but celestial cues are needed to

determine geographic North. In any case, the isolines of the respective elements would represent the natural latitudes and longitudes in that model.

Figure 9 shows that such grids are far from regular on a global scale, and more importantly, are not unique: There are several locations with identical magnetic coordinate values. Likewise, magnetic latitudes and longitudes nearly coincide over large regions (parallel isomagnetics), which means that either coordinate is useless. Examples are the North Atlantic region (*I-Fmap*) or the Equatorial Pacific (*I-D map*). These limitations are aggravated by local magnetic anomalies, rendering the real magnetic bi-coordinate grid even more irregular, yielding umpteen ambiguities. Navigation based on a magnetic bi-coordinate system alone, therefore, does not appear to be viable. This has also been concluded from the analysis of satellite telemetry

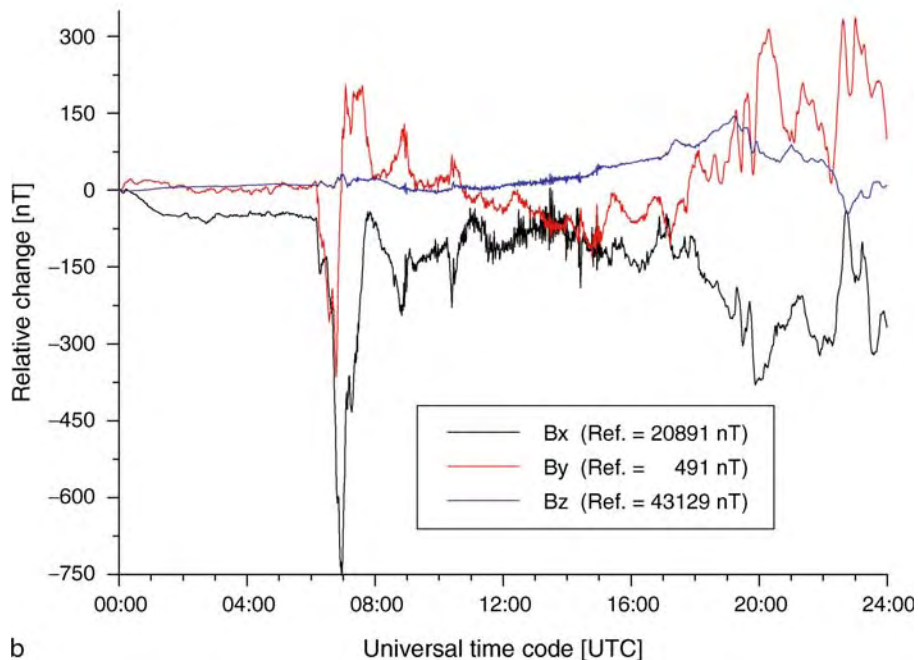
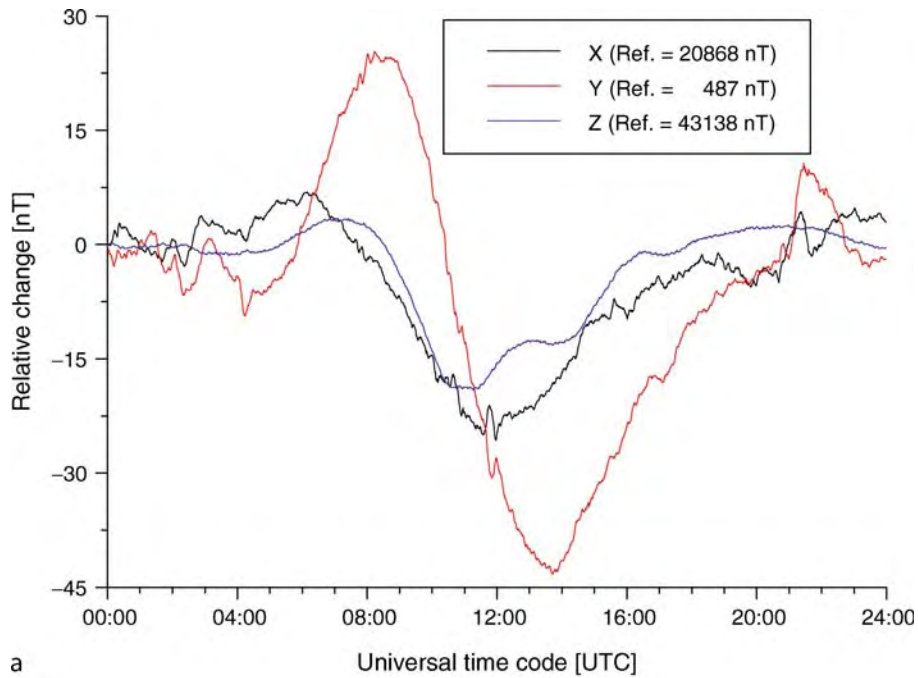

**Geomagnetic Field. Figure 8** Variations of the magnetic field elements X, Y, Z recorded over 24 h at the geophysical observatory near Munich, beginning at 0h UT on Sept 29, 2003 (*top*) and Oct 29, 2003 (*bottom*). To allow for a better comparison, the variations are plotted relative to the respective values at 0h UT. The upper magnetogram shows a diurnal field variation typical of a “magnetically quiet” day, while the lower one shows a stronger-than-average magnetic storm. Roughly one storm per year is larger than 250 nT at mid-latitudes of the Earth. Note that the scaling is largely different for the two magnetograms. Data available under <http://obsfur.geophysik.uni-muenchen.de/>.



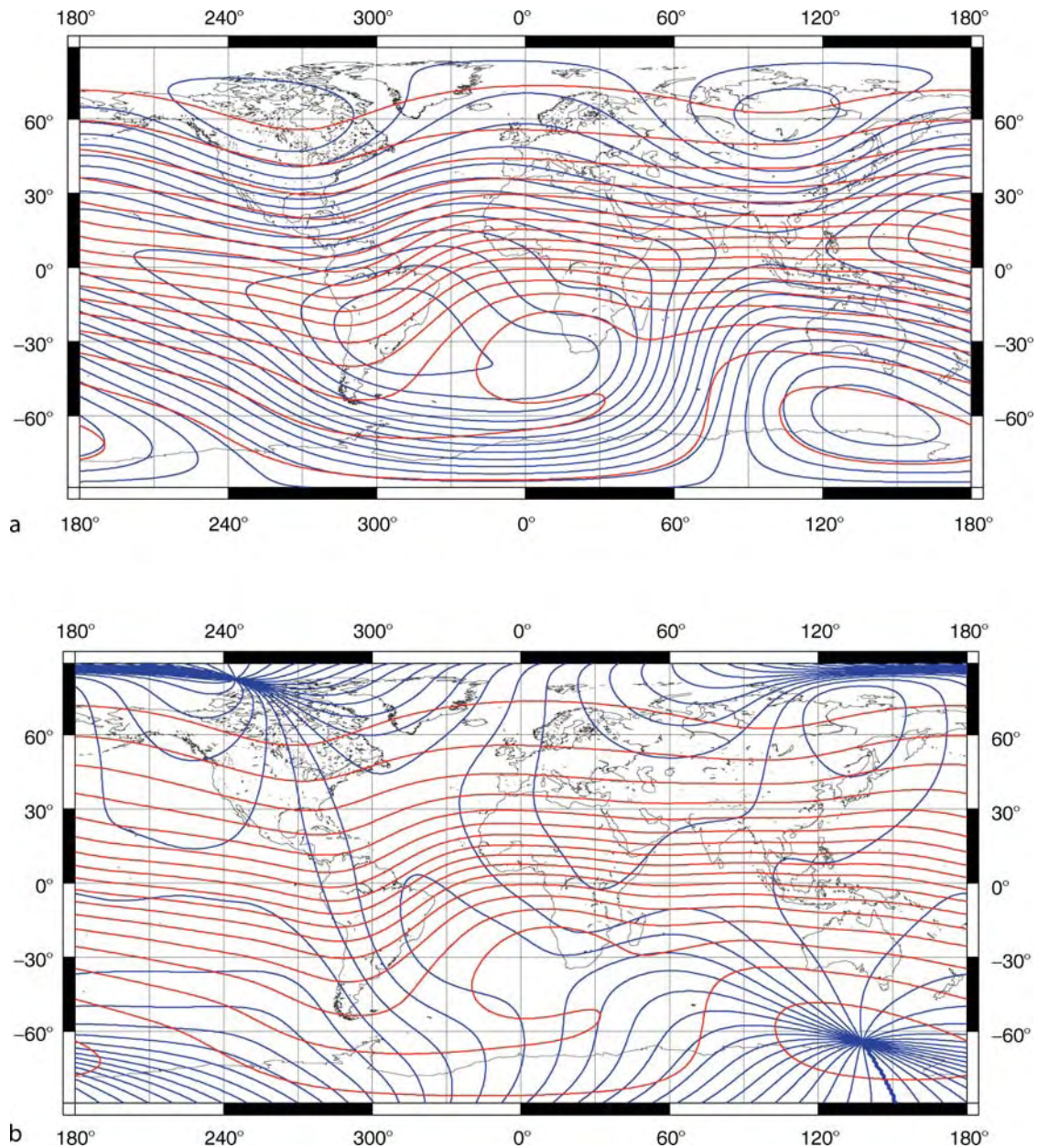

**Geomagnetic Field. Figure 9** Two possible bi-coordinate systems based on the isolines of two magnetic elements. (a) Isoclinics of  $I$  (red) and Isodynamics of  $F$  (blue), (b) Isoclinics of  $I$  (red) and Isogonics of  $D$  (blue). Contour spacing is  $10^\circ$  for  $D$ ,  $I$  and 2,500 nT for  $F$ . Reference year 2004, field model IGRF 9. Either natural bi-coordinate system is irregular as well as ambiguous and changes with time because of secular variation.

data on navigation behaviour in wandering albatrosses [9]. It is more likely that animals use distinct local and regional magnetic anomalies as magnetic map factors.

#### Possible Role of Magnetic Field on Evolution

The Earth's magnetic field guards the biosphere by shielding the Earth from highly energetic solar and cosmic radiation. The [solar wind](#) is both protective and detrimental: On the one hand, it helps shield the planetary

system from cosmic radiation. In times of high solar activity, the flux of cosmic protons with kinetic energy between 0.1 and 10 GeV is reduced by one order of magnitude [10]. High solar activity, on the other hand, results in more solar proton events, showers of highly energetic solar particles that cause partial destruction of the ozone layer, making the stratosphere temporarily more permeable to harmful UV radiation. Taken together, organisms may well be exposed to higher levels of UV

radiation during periods of low geomagnetic field intensity and high solar activity. In any case, organisms that use the geomagnetic field for orientation will be directly affected and have to retune their magnetic sense. During times of low geomagnetic-field intensity, the spatial field distribution on the Earth's surface may change completely from a dipole-dominated to a non-dipole dominated field geometry. Similarly, local magnetic anomalies, due to induced and remanent crustal magnetization, also become less pronounced or may change their fingerprint. Whether or not those changes turn out to be critical depends on the rate of change. The secular rate of decrease in dipole strength is roughly 50 nT/yr, obviously slow enough for organisms to adapt. In any case, an Earth with a weak magnetic field is more prone to suffer from perturbations by magnetic storms.

## References

1. Tyler RH, Maus S, Lühr H (2003) Satellite observation of magnetic fields due to ocean tidal flow. *Science* 199:239–241
2. <http://www.gfz-potsdam.de/pb2/pb23/SatMag/litmod3.html>
3. Bullard EC, Freedman C, Gellman H, Nixon J (1950) The westward drift of the Earth's magnetic field. *Philos Trans R Soc Lond A* 243(859):67–92
4. Merrill RT, McElhinny MW, McFadden PL (1998) The magnetic field of the Earth. Academic, San Diego
5. Coe RS, Hongre L, Glatzmeier GA (2000) An examination of simulated geomagnetic reversals from a palaeomagnetic perspective. *Philos Trans R Soc Lond* 358:1141–1170
6. Wiltschko W, Wiltschko R (1972) Magnetic compass of European robins. *Science* 176:62–64
7. Lohmann KJ, Lohmann CMF (1996) Detection of magnetic field intensity by sea turtles. *Nature* 380:59–61
8. Courtillot V, Hulot G, Alexandrescu M, le Mouél, Kirschvink JL (1997) Sensitivity and evolution of sea-turtle magnetoreception: observations, modelling and constraints from geomagnetic secular variation. *Terra Nova* 9:203–207
9. Akesson S, Luschi P, Papi F, Broderick AC, Godley BJ, Hays GC (2001) Oceanic long-distance navigation: do experienced migrants use the Earth's magnetic field? *J Navigation* 54:419–427
10. Meyer P, Ramaty R, Webber WR (1974) Cosmic rays – astronomy with energetic particles. *Phys Today* 27(10):23

---

## Geomagnetic Field

### Definition

The magnetic field of the Earth.

► [Magnetic Map](#)

---

## Geomagnetic Map

► [Magnetic Map](#)

---

## Geomagnetic Positioning System

► [Magnetic Map](#)

---

## Geometrical Illusions

### Definition

A subset of all visual illusions is the set that occur in simple geometrical line drawings, such as those in Fig. 3 and these are traditionally referred to as the geometrical illusions.

► [Visual Illusions](#)

---

## Geon Theory

### Definition

A theory of object recognition, introduced by Irving Biederman, that posits that objects and scenes are represented as arrangements of simple, viewpoint-invariant volumetric primitives (such as bricks, cylinders, wedges, and cones), labeled “geons.”

► [Mental Models](#)

---

## Germline

### Definition

The line of germ cells whose genetic material can be passed on to offspring.

## Gerontology

- ▶ Olfaction and Gustation Aging

## Gerstmann's Syndrome

### Definition

Quad of finger agnosia, dyscalculia, agraphia and right/left confusion, caused by damage in the parietal lobe in the dominant hemisphere.

- ▶ Stroke

## Gerstmann-Sträussler-Scheinker Syndrome (GSS)

### Definition

GSS belongs to a group of human *prion diseases* and presents with a range of symptoms from progressive ▶ cerebellar ataxia or ▶ spastic paraparesis (both usually associated with dementia), to isolated cognitive impairment resembling ▶ Alzheimer's disease.

- ▶ Alzheimer's Disease
- ▶ Cerebellar Disorders
- ▶ Spasticity

## Gestalt Psychology

WALTER H. EHRENSTEIN

Leibniz Research Center for Working Environment and Human Factors, University of Dortmund, Dortmund, Germany

### Synonyms

Gestalt theory

### Definition

*Gestalt psychology* emerged as an alternative to elementistic assumptions within the first two decades of the twentieth century. A then widely held view was that complex percepts were simply additive combinations of sensory elements tied together to larger complexes by mechanisms of associative learning. To Gestalt psychologists, notably Max Wertheimer (1880–1943), Kurt Koffka (1886–1941), and Wolfgang Köhler (1887–1967), structured entities, rather than “atomistic” elements, were the units of perception. According to them perception resulted from interactive processes within a “field” of dynamic “forces,” based on correspondingly configured (isomorphic) brain processes.

### Characteristics

#### Antecedents

*Gestalt*, a German word variously translated as figure, form, configuration, or shape has played an important role in discussions of perception ever since it was used by Ernst Mach, professor of physics at Prague, in his *Analysis of Sensations* (1886) [1]. Mach showed that two black-white figures can be recognized at first glance to share the same Gestalt in spite of the difference in each of their constituent elements (due to a reversal of contrast polarity). Conversely, he demonstrated the difficulty in recognizing the commonality between two physically identical forms: a square resting on one side is rather different in shape from the same square rotated by 45°, so that it stands on one corner and hence becomes a diamond (see also Fig. 2). Mach's observation inspired Christian von Ehrenfels, an Austrian philosopher, who in 1890 coined the term *Gestalt quality* to denote the difference between the perceptual whole and the mere sum of its constituent parts or elements (*superadditivity*). Ehrenfels further noted that a configuration may retain the same overall quality even if each of its parts is changed (*transposition*). A melody, played in several different keys so that each note is changed while the relations among them are retained, still appears as the same *tonal Gestalt* [2,3].

#### Experimental Grounding

Such general statements and qualitative observations by themselves would not have made a powerful scientific trend. “Far from being armchair philosophers, the early Gestaltists were as active in the laboratory as any student of human behavior” [1]. As an academic discipline, *Gestalt psychology* is usually traced to 1912 with the publication of Wertheimer's experimental studies on apparent visual motion [2,3]. Two orthogonal lines presented briefly in the proper sequence will show *phi motion* (pure motion without object displacement) or, at a slightly longer interval, appear as a single bar moving through a right angle (optimal motion). In both

cases, the observed motion is an emergent phenomenon that cannot be reduced to the piecemeal features of the two static line stimuli. Wertheimer carried out his work in the laboratory of Friedrich Schumann at the University of Frankfurt am Main, where his colleagues, Kurt Koffka and Wolfgang Köhler, participated as subjects. In sharing the striking observations they were also attracted by the new *Gestalt theory* [2] that originated with these experiments.

### The Berlin School

The Gestalt school was established in Berlin, where Köhler had been appointed to the chair of psychology in 1922, largely on the strength of his monograph on *physical Gestalten* (1920) that linked Gestalt phenomena more firmly to electromagnetic field processes. The neural correlates of perception were postulated to resemble structural properties of perceived Gestalten (*isomorphism*) at a stage, at which brain processes assume the quality of conscious experience (*psycho-physical level*) [3,4]. This was an early and systematic program to infer brain processes from percepts. It had been, again, anticipated by Mach who considered “illusory” percepts, such as brightness contrast, to rely on a fairly autonomous behavior of the sense organs, on the “dependence of retinal points on one another” (1868), rather than on errors in judgment.

The Berlin school was transplanted to the US with the rise of Nazism in Germany in 1933, when Wertheimer emigrated to join the New School for Social Research in New York City, followed by Köhler who left for Swarthmore College in 1935, whereas Koffka had already taken a position at Smith College in 1927. Of the Gestalt trio, Köhler adapted most successfully to life in the US; he was president of the American Psychological Association in 1959 [2].

### Principles of Perceptual Organization

The principles that determine why “things look as the do” (Koffka, 1935) and why, out of a multitude of possible solutions, only one percept typically materializes, have become known as the *laws of seeing* [5]. Using simple dot and line figures, Wertheimer (1923) first formulated a set of ► *Gestalt laws* with proximity, similarity, closure, and common fate as principal factors.

**Proximity.** Other factors being equal, the nearer stimuli are to one another, the more likely they are to be organized into unified percepts. An example is shown in Fig. 1, where the dots are easily organized into pairs of dots. Note that it is almost impossible to see the spaced dots as belonging together, i.e., to break up the units based on proximity.

**Similarity.** Objects that share common features (such as brightness, color, size, form, or orientation) tend to be grouped together. For example, filled and outline dots

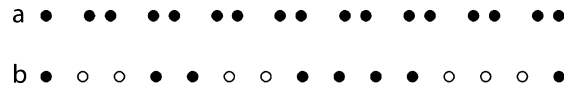

**Gestalt Psychology. Figure 1** Demonstration of proximity (a) and similarity (b) as Gestalt factors.



**Gestalt Psychology. Figure 2** Closure as Gestalt factor. The dots are seen to enclose a square or diamond rather than representing crosses (×) or (+).

are readily grouped together, even if they are evenly spaced (Fig. 1b).

**Closure.** Components that constitute a closed entity rather than an open one are more readily organized into a single percept. For example, the two arrangements of four dots in Fig. 2 appear as rectangle or diamond rather than as crosses (×) or (+), because the former are closed.

Closure also accounts for the tendency to complete otherwise incomplete, e.g., partly occluded, objects (modal and amodal completion). The configuration shown in Fig. 3 appears as a triangle behind a trapezoid (Petter’s rule). This perceptual option is favored over a complicated, 11-sided figure.

**Common Fate.** Stimuli moving simultaneously at the same rate and in the same direction are readily seen as a group, share a “common fate.” This factor can tie together objects that are quite distant and different and is essential in dynamic figure-ground segregation. Where grouping otherwise fails to occur in a stationary display, it is readily seen as soon as parts of the display move. A well-camouflaged animal will remain hidden only as long as it is standing still; it becomes visible (pops out) as soon as it moves.

These and other Gestalt factors were essentially considered as bottom-up mechanisms built into the visual system through evolution of the organism as it interacted with stimuli in a natural setting. As such they are not unique to humans, but are also effective in a variety of species (insects, fish, birds, mammals) [3]. Camouflage and concealment counteract the very Gestalt principles that establish figure-ground segregation and perceptual grouping. Particularly effective are blobs and textures that interrupt existing boundaries or create new contours and offset surfaces, by suggesting “wrong” perceptual entities [5].

**Prägnanz principle.** A key assumption of Gestalt psychology under which particular organizing factors

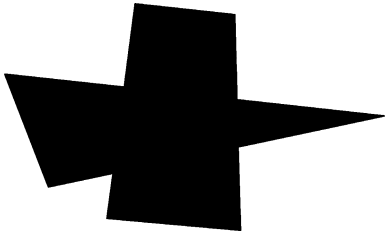

**Gestalt Psychology. Figure 3** A trapezoid overlapping a triangle is seen rather than a complex shape (with 11 sides).

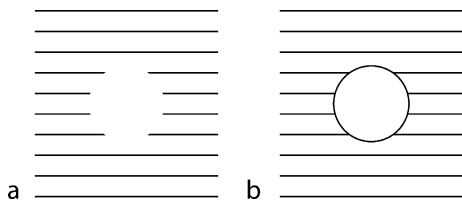

**Gestalt Psychology. Figure 4** The gap between the lines appears like a lemon-shaped surface (a), although the spacing allows for a perfect circle (b).

can be subsumed is the principle of *figural goodness* or *Prägnanz*. It denotes the tendency of the percept to become structured in the simplest, most regular and homogeneous way possible under the given stimulus conditions. This tendency was understood by Köhler (1920, 1940) as a self-organizing process, resulting from dynamic field forces inherent in the visual system and depending on global conditions of the system's equilibrium [3]. Thus, at a critically balanced energy distribution within brain fields, even a minor change of the stimulus or in the observer's state can precipitate a reorganization of the entire percept, causing a reversal of figure-ground segregation. Although the *Prägnanz* principle is supported by numerous examples [5], there are telling counterexamples. One (by Pinna, 1991), shown in Fig. 4, served Gaetano Kanizsa (1994) to illustrate "some real conceptual difficulties" of Gestalt theory [4]; it proves that a percept can indeed be *less* regular than afforded by its stimulus conditions (Fig. 4).

Even in cases that obey the *Prägnanz* principle, the question remains why we should see a stimulus pattern better than it is at the expense of veridicality. A possible answer is optimization in the interest of robust transmission of information. Straight lines, regular shapes are ubiquitous properties of objects in our daily environment. They are, however, rarely presented in their entirety. To make up for any stimulus occlusions or distortions, neural mechanisms may have evolved that strive to rectify crooked lines, fill in gaps, and complete surfaces, thereby restoring the stimulus to its original state [3,4].

### Gestalt Theory and Modern Neuroscience

It seems as if brain research has come to a stage comparable to that of the Gestaltists when they encountered the limitations of the elementalistic approach of psychophysics more than 80 years ago. Neural function is no longer understood as a mere addition of single-cell activities. Rather, neuronal responses have been shown to not only depend on the local stimulus that reaches the center of their **receptive fields**, but also on the presence of other stimuli in the surrounding parts of the **visual field** and the current state of the system. Gestalt terms that originally served to describe qualitative properties of figural grouping and segregation have meanwhile become essential concepts in grasping the significance of the spatiotemporal processing characteristics of the visual system [6–8]. The Gestaltists themselves tried to link perceptual organization to brain processes, notably Wolfgang Köhler who, inspired by the laws of thermodynamics, considered the brain as a homogeneous conductor of bioelectric forces [3]. However, the brain fields proposed as correlates of pattern perception and figural aftereffects (e.g., Köhler and Held, 1949), did more to hasten the demise of Gestalt theory than to promote it. Neurophysiologists in failing to establish firm evidence for such fields tended to dismiss Gestalt theory in general rather than Köhler's premature proposal in particular. The robust visual phenomena, however, continue to challenge neuroscientific accounts. Especially receptive (and corresponding perceptive) field organization [3,6–8] and synchronized coupling of neuronal activity within and across cortical areas [9,10] are increasingly favored as correlates of genuine Gestalt phenomena.

*Receptive field organization: A micro-Gestalt.* A basic notion made by Gestalt psychology (e.g., in studies of a homogeneous Ganzfeld by Metzger, 1930, and of figure-ground segregation by Ehrenstein, 1930) is the distinction between mere light sensation and structured perception. Without (suprathreshold) luminance differences Gestalt factors are ineffective. A figure will only emerge with an inhomogeneity that allows for segregation. The mechanism that encodes physical contrast is the *receptive field*. Receptive fields of retinal neurons are subdivided into a circular center and a concentric surround, either activated or inhibited by light falling into the center (*on-/off-center* neurons). Similar receptive fields are known to also code spectral or chromatic stimuli. A considerable degree of functional specialization exists at subsequent layers of visual processing with elongated receptive fields in **area V1** that respond to line orientation and direction of motion. Color and motion are further processed by specialized cells in **area V4** and **area V5**, respectively. There is also evidence of multi-purpose cells (Schiller, 1996), allowing for flexible, context-sensitive

interaction within distributed neural networks [4]. Thus, receptive fields – with their psychophysically established counterparts: ► *perceptive fields* – provide an organizing principle that allows for nonadditive, Gestalt-like integration of the initial stimulus input. Considering its various forms of center-surround antagonism and selective spatio-temporal sampling characteristics, receptive field organization has been proposed as a general neural correlate of Gestalt formation, regarded as a functional *micro-Gestalt* [3,4].

*Temporal binding.* Besides the striking correlations between the activity of highly specialized single neurons and Gestalt phenomena, temporal binding has been favored as a neural correlate of perceptual integration [9]. It consists of stimulus-dependent synchronized oscillations (within the range of 35–80 Hz) of even far-distant neurons. Especially the above mentioned Gestalt factor of *common fate* might be based on synchronized coupling of neuronal activity “tagged” by coherently moving stimuli. By this, objects can be tied together that may be widely distributed and rather different in form, size, or color. Temporal binding allows for flexible coupling of the spike activity of ever-new subsets of neurons within and even across cortical areas in response to global changes of the stimulus configuration; it has been found to be context-dependent and to reflect figural organization [9,10].

Gestalt phenomena, such as ► *motion integration* within and across apertures, ► *velocity transposition*, ► *kinetic depth*, ► *figure-ground segregation*, ► *subjective contours*, ► *hidden forms* and camouflage, or ► *ambiguous figures*, have become a major issue of current neuroscience [6–8,10]. They challenge neurophysiologists and computational modelers alike, especially in that they afford mechanisms that are not to be inferred from the physical stimulus alone.

## References

- Westheimer G (1999) Gestalt theory reconfigured: Max Wertheimer’s anticipation of recent developments in visual neuroscience. *Perception* 28:5–15
- King DB, Wertheimer M (2005) Max Wertheimer and Gestalt Theory. Transaction Publishers, New Brunswick, NJ
- Spillmann L, Ehrenstein WH (2004) Gestalt factors in the visual neurosciences. In: Chalupa L, Werner JS (eds) *The visual neurosciences*. MIT Press, Cambridge, MA, pp 1573–1589
- Ehrenstein WH, Spillmann L, Sarris V (2003) Gestalt issues in modern neurosciences. *Axiomathes* 13:433–458
- Metzger W (1936) *Gesetze des Sehens*. English edition: Metzger W (2006) *Laws of seeing* (trans: Spillmann L, Lehar S, Stromeyer M, Wertheimer M), MIT Press, Cambridge, MA
- Peterhans E, Heider B, Baumann R (2005) Neurons in monkey visual cortex detect lines defined by coherent motion of dots. *Eur J Neurosci* 21:1091–1100
- Qiu F, von der Heydt R (2005) Figure and ground in the visual cortex: V2 combines stereoscopic cues with Gestalt rules. *Neuron* 47:155–166
- Sasaki Y (2007) Processing local signals into global patterns. *Curr Opin Neurobiol* 17:132–139
- Engel AK, Singer W (2001) Temporal binding and the neural correlates of sensory awareness. *Trends Cogn Sci* 5:16–25
- Woelbern T, Eckhorn R, Frien A, Bauer R (2002) Perceptual grouping correlates with short synchronization in monkey prestriate cortex. *Neuroreport* 13:1881–1886

---

## Gestalt Theory

- Gestalt Psychology

---

## Gettier Problem

### Definition

The Gettier problem is the problem of finding an adequate and informative analysis of knowledge in view of the fact that there are examples that show that not just any justified true belief is knowledge.

- Knowledge

---

## GFAP

### Definition

Glial fibrillary acidic protein, the intermediate filament protein of mature astroglia.

---

## GFP-Exon Trap

### Definition

A genetic method in which GFP is inserted between two exons of a given gene leading to production of a GFP fusion protein.

- Alternative Splicing and Glial Maturation

## Giant Cell Arteriitis

### Definition

Chronic granulomatous vasculitis involving large vessels (e.g., arteriitis temporalis), mainly affects elderly people and presents with a variety of symptoms, including polymyalgia rheumatica, fever, weight loss, and anorexia. The involvement of cranial arteries (e.g., arteriitis temporalis) is often associated with severe ▶[headache](#) and scalp tenderness, may lead to ischemic optic neuropathy and blindness in 50% of the cases unless expediently treated with glucocorticoids. The etiology is still unknown, but evidence suggests a cellular ▶[autoimmunologic](#) reaction against a local antigen present in the arterial wall.

## Giant Depolarizing Potentials (GDP)

### Definition

▶[Ion Channel Development](#)

## Gilles de la Tourette's Syndrome

### Definition

▶[Tourette's Syndrome](#)

## Glabrous Skin

### Definition

The glabrous skin is the completely hairless skin areas, including the palmar surface of the hand and the plantar surface of the foot.

## Glia

### Definition

The glia (Greek for glue) or neuroglia are the non-neuronal supporting cells in the central nervous system, comprising the oligodendrocytes, astrocytes and microglia.

▶[Transplantation of Olfactory Ensheathing Cells](#)

## Glia Cells

### Definition

The term “glia” literally means “nerve glue” was assigned by Rudolph Virchow in 1859 referring to the “connective tissue” holding the neurons of the central nervous system together. Since its inception, the term glia has remained in use in its original form, though the functional attributes of glia cells have extended from mere structural and metabolic supporters of neurons to those of active participants in synaptic transmission.

## Glia Limitans

### Definition

At the surface of the brain and spinal cord are the layers of the meninges. The innermost layer is made up of three components, the layer of meningeal or leptomeningeal cells under which there is a layer of extracellular matrix, under which there is a layer of specialized astrocytic processes lying parallel to the meningeal surface. This inner layer of astrocytic process is the glia limitans. These three inner layers of the meninges have various functions, including the formation of a diffusion barrier between the cerebrospinal fluid and central nervous system (CNS) tissue (essential for the fine control of the composition of the extracellular fluid), the exclusion of inflammatory cells and probably mechanical protection. During development the processes of radial glia form a glia limitans; the structure plays an important part in cell migration.

▶[Cerebrospinal Fluid \(CSF\)](#)

▶[Neural Development](#)

## Glial and Neuronal Reactivity to Unconjugated Bilirubin

D. BRITES, A. FERNANDES, A. S. FALCÃO,  
M. A. BRITO, R F. M. SILVA

Centro de Patogénese Molecular - UMBE iMed.UL,  
Faculdade de Farmácia, University of Lisbon, Lisbon,  
Portugal

### Definition

In neonatal life there is an increased production of unconjugated ►**bilirubin** (UCB), due to a shorter life span of the erythrocytes, and a reduced hepatic clearance of UCB leading to its serum retention. In these conditions, elevated levels of UCB may become toxic to the central nervous system (CNS), thus causing ►**kernicterus** and other neurologic effects that are more severe in preterm than in term infants, even though the molecular mechanisms that trigger UCB neurotoxicity are still not completely clarified. Interestingly, UCB was shown to enhance the release of ►**glutamate** from nerve cells, an effect that may engender ►**excitotoxicity**. Recent studies also demonstrate that UCB stimulates ►**microglia**, ►**astrocytes**, and even ►**neurons** to produce ►**tumor necrosis factor (TNF)- $\alpha$** , ►**interleukin (IL)-1 $\beta$**  and IL-6. However, while microglia and astrocytes are the most active cells, neurons are much less responsive. Immunostimulation appears to be mediated through ►**TNF- $\alpha$  receptor 1 (TNFR1)**, the ►**mitogen-activated protein kinase (MAPK)** signalling pathways and the activation of the ►**nuclear factor kappa B (NF- $\kappa$ B)**. Identification of the potential points of therapeutic modulation are an important prelude for the development of new therapeutic strategies to prevent or reduce the emergence of neurodevelopmental disabilities following unconjugated hyperbilirubinemia.

### Characteristics

#### Nerve Cell Response to Bilirubin

A great body of evidence suggests that accumulation of extracellular glutamate is toxic to neurons and that astrocytes protect neurons by removing glutamate from the extracellular space. Several studies point out that brain damage by UCB requires the participation of glutamate toxicity. Incubation of astrocytes, neurons and microglia with 100  $\mu$ M UCB in the presence of 100  $\mu$ M human serum albumin (HSA) for 4 h at 37°C, to mimic a severe neonatal hyperbilirubinemia, leads to the release of glutamate to the extracellular space. Comparing the results obtained in neurons, astrocytes and microglia, the glial cells were most reactive to UCB. Levels of glutamate release by astrocytes were ~2-fold higher than those observed in neurons (Fig. 1A)

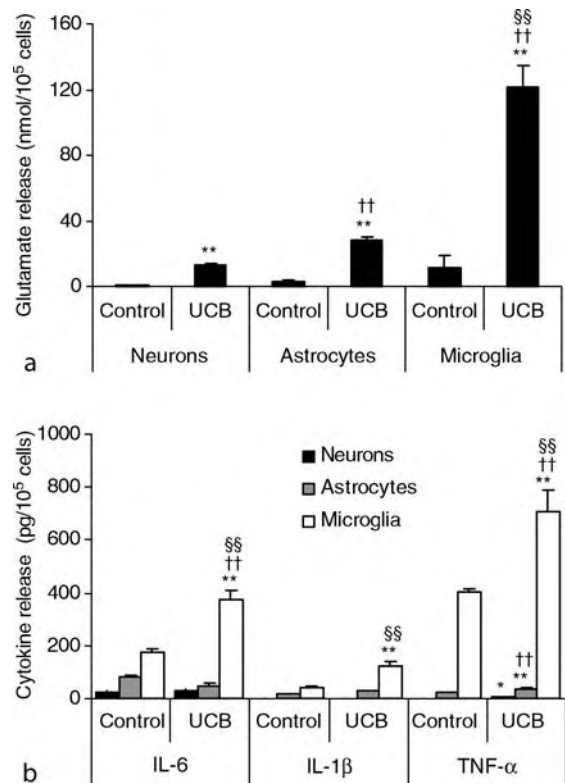

### Glial and Neuronal Reactivity to Unconjugated

**Bilirubin.** Figure 1 Microglia is the most reactive neural cell to unconjugated bilirubin (UCB). Rat cortical neurons, astrocytes and microglia were cultured for 8, 10 and 20 days *in vitro*, respectively, and incubated with either no addition (control) or 100  $\mu$ M purified UCB, in the presence of 100  $\mu$ M human serum albumin, at pH 7.4, for 4 h, at 37°C. The release of glutamate (a) and cytokines (b) to the incubation media was assessed by an enzymatic assay and ELISA, respectively. The highest release of glutamate and cytokines is observed in microglial cells, followed by astrocytes and finally by neurons, indicating that the first cell type is the most responsive to UCB stimulus. Values are means  $\pm$  SEM of at least three independent experiments. \* $P$  < 0.05 and \*\* $P$  < 0.01 Versus respective control; †† $P$  < 0.01 Versus neurons; §§ $P$  < 0.01 Versus astrocytes. Derived from data of Falcão et al. [1] and of Gordo et al. [2].

[1]. The release of glutamate by microglia was ~8- and ~4-fold over the values obtained for neurons and astrocytes, respectively [2]. Thus, microglia is the most susceptible neural cell to UCB-induced release of glutamate. It is worthwhile to point out that microglia have also shown an increased vulnerability to UCB-induced ►**cell death** by both ►**necrosis** and ►**apoptosis** (8% and 11%, respectively), as compared to neurons and astrocytes (5% and 4%, respectively, either for necrosis or apoptosis) [1,2].

The ►**inflammation** in the CNS, termed ►**neuroinflammation**, is a key component of host defence



responses to peripheral inflammation and CNS injury. Although this physiological response is considered necessary for the resolution of the injury, if present for long time periods it may contribute to the severity of the clinical picture and to secondary damage owing to an augmented inflammatory reaction, which will exacerbate the already altered homeostasis of the injured brain parenchyma [3]. Release of inflammatory mediators, as a consequence of neuroglial activation, initiate multiple signalling pathways that, although independent, may interact with each other and influence the magnitude and duration of the inflammatory response. ►Cytokines are multifunctional pleiotropic proteins that play crucial roles in cell-to-cell communication and cellular activation, being considered the major effectors of neuroinflammation. Although the number of cytokines released following a brain insult and the diversity of their actions may be overwhelming, there is a temporal pattern of cytokine induction that is usually reproduced in the development of neuroinflammation. First, injury induces a rapid mRNA upregulation of the proinflammatory mediators TNF- $\alpha$  and IL-1 $\beta$  which establishes a cytokine network. Both cytokines are known to trigger the secretion of IL-6 that is responsible for the reduction of TNF- $\alpha$  production.

Although the molecular pathogenesis of UCB-induced brain damage is not completely understood, several studies indicate that UCB-induced nerve cell injury is initiated at the level of membranes leading to neuronal excitotoxicity, mitochondrial energy failure or increased intracellular calcium concentration triggering apoptotic pathways and necrosis. Interestingly, we have also shown, for the first time, that UCB enhances the release of proinflammatory cytokines. In astrocytes incubated with UCB in the presence of HSA for 4 h at 37°C we have observed the release of TNF- $\alpha$  and IL-1 $\beta$  (Fig. 1B). In contrast, there was a depression in the secretion of IL-6 [4,5]. Comparative secretion of TNF- $\alpha$  by the three nerve cell types indicate that astrocytes produce ~4-fold more than 8 neurons and that microglia release ~24-fold more than astrocytes. Release of IL-1 $\beta$  was not detectable in neurons and again microglia was the main producer of this pro-inflammatory cytokine. Interestingly, the secretion of IL-6 that was suppressed by UCB in astrocytes was slightly increased in neurons and markedly enhanced in microglia [1,2]. Collectively, our data support the conclusion that microglia is the most responsive neural cell to UCB-induced release of cytokines. To note that for prolonged astroglial exposure to UCB there was an increase in the secretion of TNF- $\alpha$  and IL-1 $\beta$  with a maximum at 12 h and a sustained elevation at 24 h after UCB addition, as well as of IL-6 that showed the greatest production at 18 h. This later IL-6 secretion is probably due to the action of released TNF- $\alpha$  and IL-1 $\beta$  rather than to a direct effect of UCB. Since both TNF- $\alpha$  and IL-1 $\beta$  have shown to

induce the loss in astrocyte viability demonstrated either by LDH release or apoptosis [6] we may speculate that UCB-induced cytokine production, by mediating cell injury, can further contribute to exacerbate neurotoxicity.

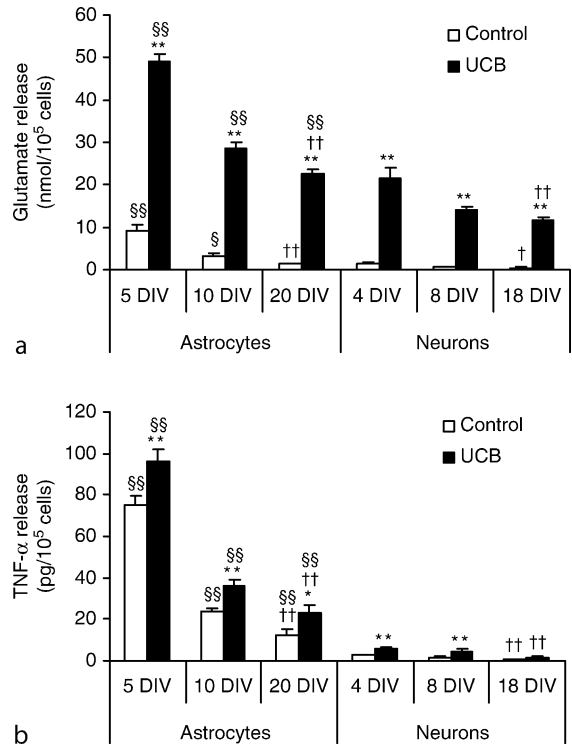

**Glial and Neuronal Reactivity to Unconjugated**

**Bilirubin. Figure 2** Reactivity of astrocytes and neurons to unconjugated bilirubin (UCB) is increased in undifferentiated cells. Rat cortical astrocytes and neurons, cultured for 5, 10 and 20 days *in vitro* (DIV) or 4, 8 and 18 DIV, respectively, were incubated with either no addition (control) or 100  $\mu$ M purified UCB, in the presence of 100  $\mu$ M human serum albumin, at pH 7.4, for 4 h, at 37°C. Release of glutamate (a) and TNF- $\alpha$  (b) to the incubation media was assessed by an enzymatic assay and ELISA, respectively. The highest release of glutamate and the pro-inflammatory cytokine TNF- $\alpha$  is observed in less differentiated cells, decreasing with the maturation state, indicating that immature nerve cells are more vulnerable to the effects of neonatal jaundice. In addition, responsiveness of astrocytes is higher than that of neurons, regardless the differentiation state. Values are means  $\pm$  SEM of at least three independent experiments. \* $P$  < 0.05 and \*\* $P$  < 0.01 Versus respective control; † $P$  < 0.05 and †† $P$  < 0.01 Versus 4 DIV neurons or 5 DIV astrocytes in the same experimental conditions; § $P$  < 0.05 and §§ $P$  < 0.01 Versus neurons in equivalent developmental stage and experimental condition. Derived from data of Falcão et al. [1].



### Less Differentiated Astrocytes and Neurons are More Reactive to Bilirubin than More Mature Cells

Prematurity has been considered to be a significant aggravating factor for UCB neurotoxicity, since preterm newborns have an increased susceptibility to UCB brain injury during moderate to severe neonatal jaundice. Thus, in one of our most recent studies we evaluated UCB-induced glutamate release in astrocytes and neurons cultured for different days, in order to relate the differentiation state with cell reactivity to UCB. Neurons and astrocytes at different stages of differentiation were incubated with UCB in the presence of HSA, for 4 h at 37°C. As shown in Fig. 2A, UCB markedly increased glutamate release, particularly in the immature cells. Comparing the results obtained in both cell types, glial cells were much more reactive to UCB, as demonstrated by the increased levels of glutamate release (~2-fold higher values than those observed in neurons,  $P < 0.01$ ) [1]. Cell-age dependent pattern of inflammatory response was also evaluated in the same conditions. Our studies showed that the release of TNF- $\alpha$  was greater in younger than in older cells, with astrocytes producing higher amounts than neurons (Fig. 2B) [1,2]. Interestingly, while the astroglial secretion of IL-1 $\beta$  reproduced that of TNF- $\alpha$ , neurons were unable to develop a similar response. In contrast, IL-6 secretion was inhibited by UCB in astrocytes at all cell-ages, while

the pattern of IL-6 release did not significantly change in neuronal cells exposed to UCB.

Having verified that UCB-induced production of TNF- $\alpha$  was enhanced in immature cells, particularly in astrocytes, we evaluated whether this higher responsiveness could be due to a developmentally regulated pattern of NF- $\kappa$ B activation. This transcription factor appears to modulate cell fate depending on the nature of the stimuli and the cell type involved [7]. NF- $\kappa$ B activation was investigated by following its translocation to the nucleus by immunocytochemistry (Fig. 3). When compared to neurons, astrocytes presented a much higher number of NF- $\kappa$ B positive nuclei, namely in the immature stage. In fact, after incubation with 50  $\mu$ M UCB in the presence of HSA, for 4 h at 37°C there was an increment of 2.4% NF- $\kappa$ B positive nuclei in neurons ( $P < 0.05$ ) and of 6.5% in astrocytes ( $P < 0.01$ ), which raised to 4.0% and 9.0%, respectively, when cells were incubated with 100  $\mu$ M UCB [1]. However, as cells grow old, this difference becomes less noticeable.

Altogether, these results provide a basis for the proneness of premature babies to UCB neurotoxicity.

### Inflammatory Signalling Pathways Involved in Astroglial Activation by Bilirubin

Production and release of cytokines depend on inducible gene expression mediated by activation of cell signaling.

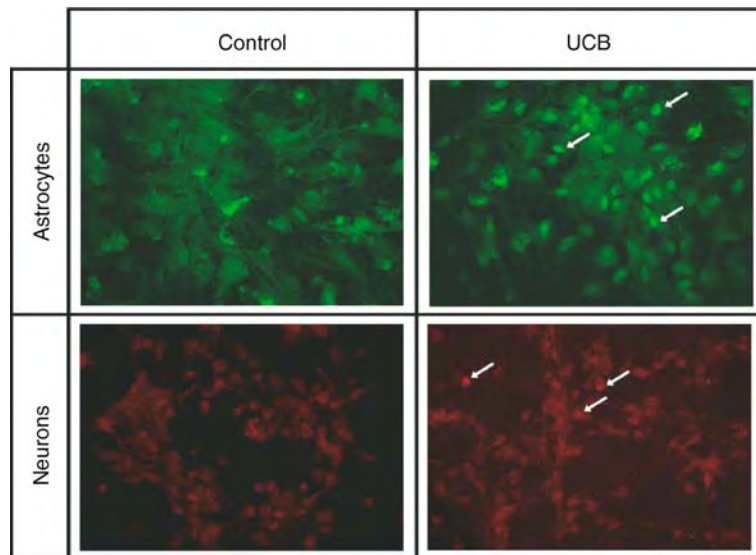

**Glial and Neuronal Reactivity to Unconjugated Bilirubin. Figure 3** NF- $\kappa$ B activation in neurons and astrocytes is induced by unconjugated bilirubin (UCB). Neurons and astrocytes were cultured for 8 and 10 days *in vitro*, respectively, and incubated with 50  $\mu$ M purified UCB, or no addition (control) in the presence of 100  $\mu$ M human serum albumin, at pH 7.4, for 4 h, at 37°C. Cells were immunostained with an antibody against p65 NF- $\kappa$ B subunit, followed by a species-specific fluorescent secondary antibody labeled with TRITC in neurons (red) or with FITC in astrocytes (green). Translocation of NF- $\kappa$ B is visualized by intense coloration of the nucleus, contrasting to cytoplasm localization. When compared to neurons, astrocytes presented a much higher number of NF- $\kappa$ B positive nuclei. Representative NF- $\kappa$ B positive nuclei are indicated by arrows. Original magnification: 516x.

Primary inflammatory stimulus may act through membrane receptors like TNFR1, which cause the activation of four major intracellular signaling pathways that are cascades of protein kinases, namely the three distinct MAPK pathways, p38, c-Jun-*N*-terminal kinases 1 and 2 (JNK1/2) and extracellular signal-regulated kinases 1 and 2 (ERK1/2), and the one leading to activation of NF-κB [8].

Incubation of astrocytes with UCB and HSA resulted in a rapid biphasic activation of TNFR1 during the 24 h observation period [6]. The early phase was detected

as early as 15 min ( $P < 0.01$ ), peaking at 1 h ( $>5$ -fold,  $P < 0.01$ ), followed by a sustained increment and a slight elevation at 12 h ( $>3.5$ ,  $P < 0.01$ ). While the early-phase activation may result from a direct interaction of UCB with the TNFR1, the secondary activation may be due to the action of IL-1β and IL-6 produced during astrocyte exposure to UCB. Downstream to UCB-induced expression of TNFR1 it was observed a rapid and transient activation of p38 at 30 min ( $\sim 3$ -fold,  $P < 0.01$ ) with a peak between 1 and 2 h ( $>4.5$ -fold,  $P < 0.01$ ), a later but more sustained activation of

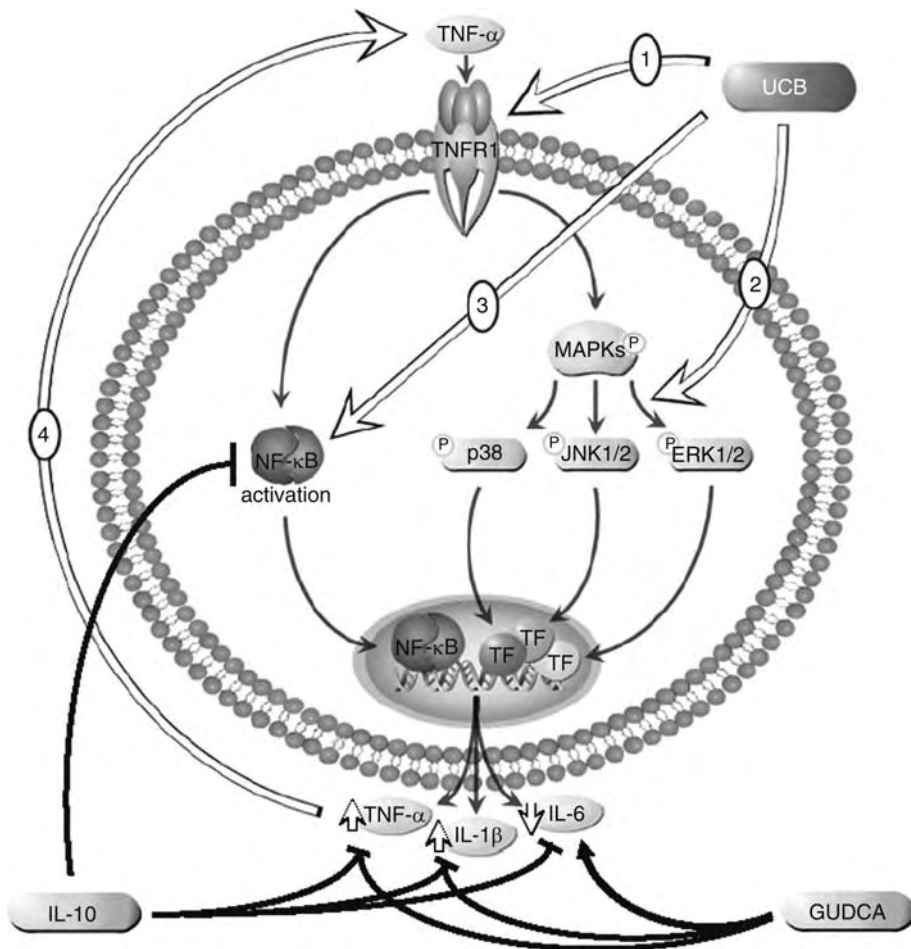

**Glial and Neuronal Reactivity to Unconjugated Bilirubin. Figure 4** Schematic representation of the signaling pathways involved in astrocyte reactivity to unconjugated bilirubin (UCB). UCB interaction with astrocytes for 4 h causes a rapid increase of the cell surface receptor TNFR1 protein levels (arrow 1), leading to phosphorylation of MAPKs and activation of transcription factors (TF) resulting in the secretion of cytokines TNF-α and IL-1β. TNFR1 signaling may also involve NF-κB activation and its consequent translocation into the nucleus where it promotes the up-regulation of cytokines. In addition, UCB may rapidly diffuse through the cell membrane directly inducing the activation of MAPKs (arrow 2) and NF-κB (arrow 3). The overall signal transduction pathway further occurs by the engagement of TNF-α with its specific receptor TNFR1 (arrow 4). Both IL-10 and glyoursodeoxycholic acid (GUDCA) reduce UCB-induced release of TNF-α and IL-1β to control values, while suppression of IL-6 release was only counteracted by GUDCA. Contrasting with GUDCA, IL-10 was also able to inhibit NF-κB nuclear translocation. Derived from data of Fernandes et al. [6].

JNK1/2 from 1 to 4 h (~3.5-fold,  $P < 0.01$ ) and a less pronounced ERK1/2 activation, with a peak at 2 h (~2.4-fold,  $P < 0.01$ ). Nuclear translocation of NF- $\kappa$ B occurred from 1 h onwards with a maximal localization in the nuclei of astrocytes of ~12% at 4 h [6]. As far as we know, only the report of Lin et al. [9] addressed this topic. These Authors have shown that UCB, in the absence of HSA, significantly induced the p38 MAPK phosphorylation at 1 h without involving JNK activation in rat cerebellar granule neurons. However, our data indicated that exposure of neurons to UCB leads to a slight production of cytokines, i.e. only 3.1 pg/10<sup>5</sup> cells of TNF- $\alpha$ , in contrast with 12.5 pg/10<sup>5</sup> cells produced by astrocytes in the same conditions [1], probably accounting to the activation of the three MAPKs in our astrocyte model (Fig. 4). Our demonstration that activation of MAPKs and NF- $\kappa$ B occurs between 1 and 4 h after UCB treatment and precedes marked up-regulation of cytokines reinforces the concept that UCB-induced astroglial cytokine production involves these pathways. Interestingly, only the inhibition of JNK1/2 and ERK1/2 pathways, but not of p38 cascade, abrogates UCB-stimulated NF- $\kappa$ B nuclear translocation, which indicates that activation of this transcription factor occurs downstream of JNK1/2 and ERK1/2 [10]. The dissection of the molecular mechanisms involved in UCB neurotoxicity may yield new targets upon which to focus drug discovery efforts aimed at reducing brain injury and disabilities.

### Promising Therapeutic Strategies Directed to Prevent Neuronal and Glial Reactivity to Unconjugated Bilirubin

Inflammation of the brain and its contribution to CNS injury is a relatively new area of research and clinical interest, but is now the focus of extensive investigation. Hence, therapeutic strategies have been designed to regulate cytokine bioactivity in the CNS diseases. We have done some studies with the anti-inflammatory cytokine IL-10 and the bile acid glycochenodeoxycholic acid (GUDCA). Experiments were performed in rat cortical astrocytes treated with UCB, GUDCA, IL-10, UCB plus GUDCA, UCB plus IL-10 or no addition, for 4 h at 37°C. Both IL-10 and GUDCA were able to reduce UCB-induced release of TNF- $\alpha$  and IL-1 $\beta$  to control values, while suppression of IL-6 release was only counteracted by GUDCA. Intriguingly, UCB-induced NF- $\kappa$ B nuclear translocation was inhibited in the presence of IL-10 but not of GUDCA (Fig. 4). In addition, neither GUDCA nor IL-10 has any effect on glutamate release, suggesting that this phenomenon occurs by a distinct mechanism independent of cytokine production (unpublished observations).

Collectively, our data suggest that IL-10 and GUDCA may prove to be interesting drugs for the

prevention of neurotoxicity associated with moderate to severe unconjugated hyperbilirubinemia.

### References

1. Falcão AS, Fernandes A, Brito MA, Silva RFM, Brites D (2006) Bilirubin-induced immunostimulant effects and toxicity vary with nerve cell type and maturation state. *Acta Neuropathol* 112:95–105
2. Gordo AC, Fernandes A, Falcão AS, Brito MA, Silva RFM, Brites D (2006) Unconjugated bilirubin activates and damages microglia. *J Neurosci Res* 84:194–201
3. Raivich G, Bohatschek M, Kloss CU, Werner A, Jones LL, Kreutzberg GW (1999) Neuroglial activation repertoire in the injured brain: graded response, molecular mechanisms and cues to physiological function. *Brain Res Brain Res Rev* 30:77–105
4. Fernandes A, Silva RFM, Falcão AS, Brito MA, Brites D (2004) Cytokine production, glutamate release and cell death in rat cultured astrocytes treated with unconjugated bilirubin and LPS. *J Neuroimmunol* 153:64–75
5. Falcão AS, Fernandes A, Brito MA, Silva RFM, Brites D (2005) Bilirubin-induced inflammatory response, glutamate release and cell death in rat cortical astrocytes are enhanced in younger cells. *Neurobiol Dis* 20:199–206
6. Fernandes A, Falcão AS, Silva RFM, Gordo C, Gama MJ, Brito MA, Brites D (2006) Inflammatory signaling pathways involved in astroglial activation by unconjugated bilirubin. *J Neurochem* 96:1667–1679
7. Kaltschmidt B, Kaltschmidt C, Hofmann TG, Hehner SP, Droge W, Schmitz M (2000) The pro- or anti-apoptotic function of NF- $\kappa$ B is determined by the nature of the apoptotic stimulus. *Eur J Biochem* 267:3828–3835
8. Saklatvala J, Dean J, Clark A (2003) Control of the expression of inflammatory response genes. *Biochem Soc Symp* 70:95–106
9. Lin S, Yan C, Wei X, Paul SM, Du Y (2003) p38 MAP kinase mediates bilirubin-induced neuronal death of cultured rat cerebellar granule neurons. *Neurosci Lett* 353:209–212
10. Fernandes A, Falcão AS, Silva RFM, Brito MA, Brites D (2007) MAPKs are key players in mediating cytokine release and cell death induced by unconjugated bilirubin in cultured rat cortical astrocytes. *Eur J Neurosci* 25:1058–1068

## Glial Cell Line-derived Neurotrophic Factor (GDNF)

### Definition

Glial cell line-derived growth factor is a glycosylated disulfide-bonded homodimer that is distantly related to the TGFbeta superfamily.

## Glial Cell Line–derived Neurotrophic Factor Receptors (GFR $\alpha$ 1–4)

### Definition

Glycosyl phosphatidylinositol (GPI)-linked proteins that bind members of the GDNF family of neurotrophic factors.

## Glial Development

► Gliogenesis

## Glial Neoplasm

► Gliomas

## Glial Reaction

### Definition

The reaction of mature central nervous tissue to lesions.

Astrocytes surround the site of the lesion, and demarcate it by their processes, while the expression of glial fibrillary acidic protein (GFAP), and some other substances is increased characteristically.

## Glial Reaction to Injury

► Glial Scar

## Glial Scar

JAMES W. FAWCETT

Cambridge University Centre for Brain Repair,  
Robinson Way, Cambridge, UK

### Synonyms

Reactive Gliosis; Gliosis; Astrocytosis; Glial Reaction to Injury

### Definition

The term glial scar describes the structure that develops at regions of CNS injury. Macroscopically, a region of pale tissue that looks similar to scar tissue in the skin or elsewhere in the body comes to surround the area of damage. However, the cellular and molecular composition of glial scar tissue is very different from that of scar tissue outside the CNS.

### Characteristics

In its mature form, the glial scar is predominantly an astrocytic structure [1]. Electron microscopic studies reveal many hypertrophic interweaving astrocytic processes, containing abundant intermediate filaments and joined frequently by junctional complexes, mediated by ► **connexins** that are upregulated after injury. There may be abundant ► **extracellular matrix**. The scar tissue develops over a period of weeks. The first event after mechanical or ischemic injury is an invasion from the blood stream of polymorphs. These cells usually remain close to damaged blood vessels, and disappear within 1–2 days unless there is continuing infection. Within 24 h monocytes enter from the blood stream, and are initially seen as large round cells with typical monocyte morphology. Over a period of approximately a week after injury these cells will usually disappear, many of them assuming the appearance and morphology of CNS ► **microglia**. CNS microglia become activated following injury, responding with proliferation, hypertrophy and upregulation of markers such as the complement receptor CD11b and secretion of numerous growth factors and ► **cytokines**. Also rapidly responsive to injury are the cells expressing the ► **chondroitin sulfate proteoglycan** NG2 that have been variously called ► **oligodendrocyte precursor cells** (OPCs), polydendrocytes and synantocytes. In the absence of an agreed name they will be called ► **NG2 + ve cells** in this article. Within 24 h of injury these cells upregulate NG2, hypertrophy and then start to proliferate so that by 3 days there are large numbers of these cells surrounding the injury [2]. Their numbers then start to decline, and by 1 month few are seen. Their fate is not determined, although it seems probable that many die, while others may participate in ► **remyelination** by

becoming ► **oligodendrocytes**. The reaction of ► **astrocytes** to damage is the particularly distinctive feature of the glial scar. These cells hypertrophy their processes, upregulate intermediate filament molecules GFAP, nestin and vimentin, and may also start to express MHC class II receptors. There is also an upregulation of extracellular matrix molecules, including ► **tenascin** and several chondroitin sulfate proteoglycan molecules (► **neurocan**, NG2, ► **versican**, brevican, ► **phosphacan**, aggrecan) [3]. The sulfation pattern of the glycosaminoglycan chains of these molecules changes after injury. The astrocytes upregulate CD44, a cell surface receptor that binds hyaluronan, a key component of the CNS extracellular matrix. Where there is physical injury to the ► **meningeal** layer of the CNS the fibroblast-like cells of the meningeal layer proliferate and migrate into the injury to cover the exposed CNS surface, leading to a re-formation of the ► **glia limitans**. This is the structure that surrounds the normal CNS consisting of a layer of ► **meningeal cells**, a thick layer of extracellular matrix to which are applied hypertrophic ► **astrocyte** processes [4]. At the interface between meningeal cells and astrocytes a collagen IV containing layer of matrix develops. Also in this lesion core region there are proliferating vascular ► **endothelial cells** and fibroblasts. Eventually the lesion core frequently also fills with ► **Schwann cells**. As the glial scar ages, the numbers of NG2 + ve cells and microglia decline, leading eventually to the predominantly astrocytic scar, usually bounded on one surface by a re-formed glia limitans. This is a stable structure that can persist for many months after the initial insult. However, if embryonic tissue is inserted into an injured region of the CNS it usually prevents the formation of a glia limitans around itself, and suppresses scar formation.

### Where Do Glial Scars Develop?

The process of reactive gliosis is initiated by many forms of CNS pathology. The picture described above is seen where there is mechanical or ischemic damage. However, initiation of gliosis does not require destruction of cells. A much-studied model is where gliosis is initiated by a ► **peripheral nerve injury**, causing activation of microglia and astrocytes around the motor neurons. A glial scar-like tissue is also found in the inflammatory demyelinating lesions of ► **multiple sclerosis**. Here, the inflammatory process causes invasion of blood-borne inflammatory cells with a large number of macrophages and lymphocytes. There is activation and proliferation of microglia and NG2 + ve cells, together with hypertrophy and proliferation of astrocytes. The appearance of this tissue varies as the lesion develops, the early inflammatory lesions generally having large numbers of activated microglia, macrophages, NG2 + ve cells and a loose astrocytosis [5]. In chronically demyelinated lesions there is little sign of inflammation, and there is a dense astrocytosis with astrocytic processes

closely surrounding axons. Some NG2 + ve cells persist, but in chronic lesions that do not successfully myelinate many of the remaining axons show signs of damage with deposition of transported proteins such as APP, and most of these axons will eventually die.

A reactive gliosis is seen around the plaques and tangles of ► **Alzheimer's disease**, which takes the form of ► **reactive astrocytes** strongly expressing GFAP, usually with hypertrophied and activated microglia. A gliosis is also associated with some other neurodegenerative diseases such as Huntington's disease, but not usually with Parkinson's disease.

### Function of the Glial Scar

The function of the glial scarring process has not been fully established. It is probable that, as in the rest of the body, the glial scar acts to seal off the CNS from infection. In addition the correct functioning of the CNS depends on very precise control of the extracellular ionic and biochemical environment, to a much greater degree of stability than is found in the rest of the body. Re-sealing the CNS from the general body environment by means of the glial scar will achieve this. Astrocytes in scar tissue play a key role in the formation of the ► **blood-brain barrier** through their interaction with endothelial cells. All forms of CNS damage lead to the death of cells, the debris from which has to be removed, which is achieved mainly by the cells of the macrophage lineage in glial scars. Much has recently been learned about the function of scar tissue through experiments in which reactive astrocytes are deleted in a transgenic mouse expressing the HSV-TK gene under a GFAP promoter. Following CNS damage and gangcyclovir treatment to kill reactive astrocytes, there is a failure to re-seal the blood brain barrier, increased and more widespread invasion of inflammatory cells and increased neuronal death [6]. The glial scar plays an important part in modulating repair processes in the CNS, discussed later in this article. The function of the glial scar reaction in neurodegeneration and in inflammatory lesions such as multiple sclerosis is less clear. In ► **demyelination**, activation of the NG2 + ve cells is probably an important precursor to remyelination, and inflammation has been shown to be essential for successful remyelination. The extensive cross-talk between the various glial cell types is probably part of this process. In Alzheimer's disease, the microglia in the glial scar tissue may be involved in converting amyloid into the fibrillar form, and may also be involved in ingestion of amyloid material as part of the continuing turnover of plaque protein. The ability of reactive astrocytes to express MHC class II molecules together with co-stimulatory molecules such as B7 and CD40 means that they may present antigen and be involved in T cell activation, and therefore be involved in promoting Th2 responses relevant to inflammatory diseases affecting the CNS (Fig. 1).

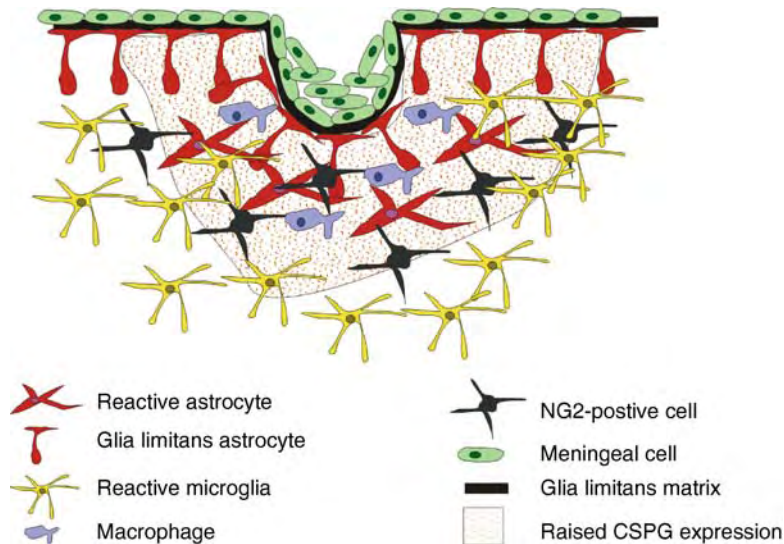

**Glial Scar. Figure 1** The diagram shows a glial scar as it would appear approximately 10 days after injury. The penetrating wound cavity has been lined with meningeal cells, re-creating the glia limitans. There is proliferation of NG2 + ve cells and microglia, with some invasion of macrophages from the bloodstream. The astrocytes become hypertrophic, with upregulation of GFAP. Chondroitin sulfate proteoglycans are upregulated around the injured region.

### Factors Involved in the Formation of the Glial Scar

The processes that initiate and control the glial scarring reaction are extremely complex and not fully understood. Any process that leads to inflammation within the CNS will initiate the reaction, and opening of the blood-brain barrier may also be an initiating event. Much of the investigative work on the control of the process has been carried out in the comparatively simple model in which the glial reaction around motor neurons is activated by a peripheral nerve lesion, and much of this work has focused on the facial nerve nucleus after facial nerve lesions. The glial reaction here must be initiated by the motor neurons whose axons have been damaged, but from that point on there is complex dialogue of cytokines and growth factors between neurons, microglia and astrocytes. One of the first cytokines to be upregulated within the damaged neurons is ▶**Interleukin 6** (▶**IL-6**), and IL-6 knockout animals show a very diminished glial response to axotomy. However, from the moment when microglia, neurons and astrocytes become activated a dialogue is initiated that involves multiple molecules, including ▶**TGF alpha** and beta, ▶**TNF alpha**, ▶**CNTF**, IL-1, ▶**Interferon Gamma** (▶**IFN gamma**) and many other molecules. Different aspects of the glial reaction are under different forms of control. Thus peripheral nerve section activates astrocytes and microglia but not NG2 + ve cells [7]. Formation of the glial scar may be modulated by the presence of embryonic CNS tissue. Embryonic transplants provoke little glial reaction, less upregulation of tenascin and ▶**chondroitin sulfate**

proteoglycans (CSPGs), and my partially dissolve an existing scar.

### Effects of the Glial scar on Repair Processes

Much of the interest in the glial scar centers on its effects on repair processes within the CNS. In particular ▶**axon regeneration** fails in the CNS, and the axons tips often appear to have stopped growing within glial scar tissue. Remyelination occurs within an environment of reactive gliosis which can affect the process in various ways.

### Axon Regeneration

There are many experiments that demonstrate that glial scar tissue is particularly inhibitory to axon regeneration. Thus axons from transplanted sensory neurons regenerate their axons readily in undamaged CNS white matter, but stop when they encounter a glial scar surrounding an injury, and inhibition of scarring with antimetabolic treatment permits some axon regeneration after injury. There are many molecules within the damaged CNS that inhibit axon regeneration. On oligodendrocytes, and therefore on the myelin debris found in scar tissue, are ▶**NogoA**, ▶**MAG** and ▶**OMgp** which inhibit axon regeneration via the Nogo receptor and other mechanisms [8]. The major inhibitory molecules within glial scar tissue, however are proteoglycans and particularly chondroitin sulfate proteoglycans (CSPGs) [9]. There is a general upregulation of CSPGs within reactive glial tissue, the molecules being produced by both astrocytes and

NG2 + ve cells. Neurocan, phosphacan, brevican are produced by astrocytes, NG2, phosphacan, neurocan, versican are produced by NG2 + ve cells, and aggrecan is produced by neurons and other cell types. All these CSPG molecules have been shown to be inhibitory to axon growth, although some axon types, particularly embryonic axons, can grow in their presence. The mechanism of inhibition is complex. However the glycosaminoglycan (GAG) chains of the CSPGs are a major source of the inhibition, and digestion of these by the bacterial enzyme ▶[chondroitinase](#) can remove inhibition to axon growth in tissue culture assays but more importantly treatment with the enzyme promotes axon regeneration *in vivo*. However the CSPG core proteins, particularly NG2 and neurocan, also have direct effects on axon growth independently of GAGs. Because removal of GAGs with chondroitinase reduces the inhibitory effects of CSPGs on axon growth, it has been injected into brain and spinal cord injuries, leading to increased axon regeneration and recovery of function [10]. A DNA enzyme which inhibits GAG synthesis has also been effective. An increase in intermediate filaments in astrocytes is always seen in the glial scar. Animals with a knockout of both GFAP and vimentin show less hypertrophy of astrocyte processes after injury and more extracellular space. There is increased regeneration of some axons after injury in these animals, and the mechanism may again involve a change in the extracellular matrix with increased expression of the growth-promoting molecules laminin and fibronectin. In the lesion cavity of the damaged CNS there is an accumulation of fibroblast-like cells which come from the ▶[meninges](#) or from meningeal-like cells which surround large blood vessels. This lesion core is usually an absolute barrier to axon regeneration [9,11]. Meningeal cells are highly inhibitory to axon growth through expression of the CSPGs NG2 and versican and the growth-inhibitory ▶[class 3 semaphorins](#), which bind to the CSPG GAG chains. At the interface between these cells and astrocytes a collagenous membrane is deposited. Disruption of the formation of this collagenous structure using an iron chelating agent, which removes the iron required by the collagen synthesis pathway, also promotes regeneration past CNS injuries. Finally, glial scar tissue usually contains myelin debris containing the inhibitory molecule NogoA. Blocking antibodies to NogoA produces robust axon regeneration with recovery of function.

### Remyelination

The role of gliosis in remyelination has been debated for many years and it is still not possible to provide a definitive description of its role. Where the CNS is demyelinated there is generally an astrocytosis. However the part played by astrocytes in remyelination is

complex. Remyelination after CNS damage can be by Schwann cells or by oligodendrocytes. It is clear that astrocytes exclude Schwann cells from the CNS, and Schwann cell myelination is therefore only seen in regions that contain a low density of astrocytes. Whether an astrocytosis inhibits or promotes oligodendrocyte remyelination is controversial [12]. Regions of persistent demyelination devoid of astrocytes can be created by injection of ethidium bromide followed by irradiation. Oligodendrocyte precursors transplanted into these lesions will form new myelin, and this can be enhanced if the cells are accompanied immature astrocytes. However co-transplantation of astrocytes aged in culture inhibits remyelination, so it is possible that the type of astrocytes found in chronic demyelinated lesions may be inhibitory. Highly upregulated on reactive astrocytes in demyelinated regions and other forms of glial scar is the hyaluronan receptor CD44. Overexpression of this molecule in rodents leads to accumulation of extracellular matrix and inhibition of remyelination. In order for remyelination to occur the NG2 + ve cells must proliferate, engage with axons and differentiate into oligodendrocytes. It appears that the presence of inflammation is essential to this process, with a reduction in remyelination after macrophage depletion. Oligodendrocyte precursors injected into the *taiep* mutant mouse, which loses its myelin after birth to be replaced by an astrocytosis, do not remyelinate unless inflammation is induced.

### References

1. Reier PJ, Houle JD (1988) The glial scar: its bearing on axonal elongation and transplantation approaches to CNS repair. *Adv Neurol* 47:87–138
2. Levine JM, Reynolds R, Fawcett JW (2001) The oligodendrocyte precursor cell in health and disease. *Trends Neurosci* 24:39–47
3. Carulli D, Laabs T, Geller HM, Fawcett JW (2005) Chondroitin sulfate proteoglycans in neural development and regeneration. *Curr Opin Neurobiol* 15:116–120
4. Krueger S, Sievers J, Hansen C, Sadler M, Berry M (1986) Three morphologically distinct types of interface develop between adult host and fetal brain transplants: implications for scar formation in the adult central nervous system. *J Comp Neurol* 249:103–116
5. Chang A, Nishiyama A, Peterson J, Prineas J, Trapp BD (2000) NG2-positive oligodendrocyte progenitor cells in adult human brain and multiple sclerosis lesions. *J Neurosci* 20:6404–6412
6. Sofroniew MV (2005) Reactive astrocytes in neural repair and protection. *Neuroscientist* 11:400–407
7. Raivich G, Bohatschek M, Kloss CU, Werner A, Jones LL, Kreutzberg GW (1999) Neuroglial activation repertoire in the injured brain: graded response, molecular mechanisms and cues to physiological function. *Brain Res Brain Res Rev* 30:77–105
8. Schwab ME (2004) Nogo and axon regeneration. *Curr Opin Neurobiol* 14:118–124



9. Silver J, Miller JH (2004) Regeneration beyond the glial scar. *Nat Rev Neurosci* 5:146–156
10. Rhodes KE, Fawcett JW (2004) Chondroitin sulphate proteoglycans: preventing plasticity or protecting the CNS? *J Anat* 204:33–48
11. Davies SJA, Goucher DR, Doller C, Silver J (1999) Robust regeneration of adult sensory axons in degenerating white matter of the adult rat spinal cord. *J Neurosci* 19:5810–5822
12. Blakemore WF, Gilson JM, Crang AJ (2003) The presence of astrocytes in areas of demyelination influences remyelination following transplantation of oligodendrocyte progenitors. *Exp Neurol* 184:955–963

## Gliogenesis

KAZUHIRO IKENAKA  
National Institute of Physiology Sciences,  
Division of Neurobiology and Bioinformatics,  
Myodaiyi, Okazaki, Japan

### Synonyms

Glial development

### Definition

“Gliogenesis” means the generation of glial cells from progenitor cells that generate neural cells (neural stem cells). It occurs during development of the central nervous system when neural progenitor cells switch to generating glial cells following the generation of neurons (neurogenesis).

### Characteristics

Glial cells in the central nervous system are composed of astrocytes, oligodendrocytes and microglia. The former two combined are called macroglia and are generated from neural progenitor cells lining the surface of ventricle during development. These immature pluripotent progenitor cells give rise to both neurons and macroglial cells. In the developing central nervous system, mature neurons appear first, followed by the appearance of mature astrocytes and then mature oligodendrocytes. Thus neurogenesis occurs earlier than gliogenesis.

### Neurogenesis and Gliogenesis

It is still under serious debate whether the cell that has generated neurons earlier generates glial cells later, or whether there are two populations of the neural progenitor cells from an early time point in development that generate the two lineages.

In the mammalian central nervous system during early development, cells that compose the neuroepithelium

send out processes extending across the entire thickness of the nervous system, which attach to both ventricular and pial surfaces. They are actively dividing and begin to produce neuroblasts, which migrate towards the pial surface along the processes. The original dividing cells (which are often called neuroepithelial cells) begin to express glial fibrillary acidic protein (GFAP), a marker for astrocytes in primates, thus they are named “radial glial cells.” Migration of newly generated neuroblasts is guided by the processes of radial glial cells.

There have been many models to explain this sequential generation of neurons and macroglia in the nervous system. To make the story simple all the models can be categorized into two groups, (i) cells that produced neurons earlier produce astrocytes later (Fig. 1a) [1] and (ii) neuronal progenitor cells and glial progenitor cells are different from an early time point in development (Fig. 1b) [2].

Both models agree that at a late stage of development radial glial cells generate or transform into astrocytes [3]. Therefore, the question is “Who produces the neuron?” Tritiated thymidine incorporation studies indicated that newly generated neurons undergo final cell division before migrating to the pial surface along the processes of radial glial cell. However, the cells undergoing mitosis in the ventricular zone did not seem to bear processes characteristic of radial glial cells. This would support the model in which neurons and glial cells are generated from two separate progenitor cell populations (neurons from the mitotic cells in the ventricular zone and glial cells, especially astrocytes, from the radial glial cells).

Recently, several studies demonstrated that radial glial cells do generate neurons (Fig. 1) [4,5]. Thus at least in some cases, radial glial cells serve as neural stem cells and produce both neurons and glia. However, further studies are needed to demonstrate whether this is a general phenomenon or not. Especially in the primate brain where radial glial cell processes extend long distances, it is very difficult for processes to extend or retract in preparing for the mitosis.

### Generation of Astrocytes and Oligodendrocytes

So far, generation of neurons and astrocytes has been discussed. How about oligodendrocytes? It had been believed that oligodendrocytes are generated after the generation of astrocytes in any region of the central nervous system. However, the study of Warf et al. (1991) [6] demonstrated that only the ventral half of the rat spinal cord could produce oligodendrocytes at embryonic day 14, suggesting that oligodendrocytes are generated in a restricted region of the spinal cord. This has proved to be true in all regions of the central nervous system. The generation of oligodendrocytes has been shown to require expression of the *olig2* gene, which is induced by sonic hedgehog. Since sonic hedgehog is produced

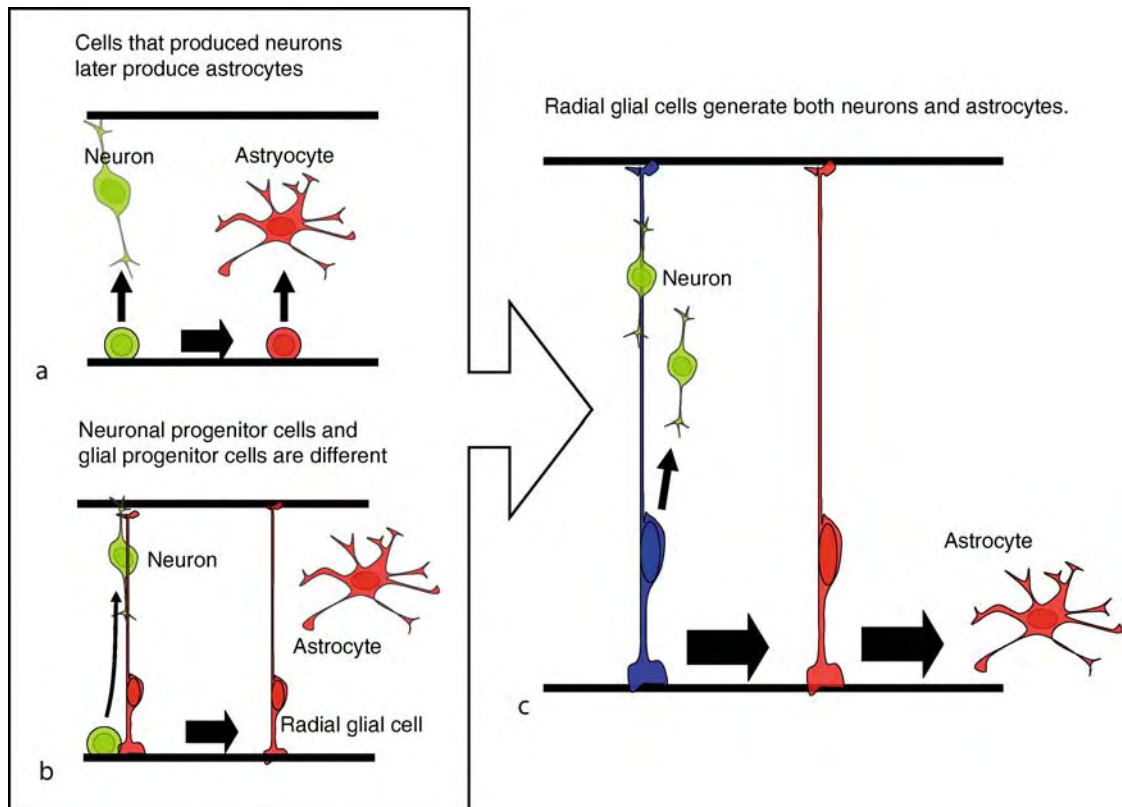

**Gliogenesis. Figure 1** Two models to explain sequential generation of neurons and astrocytes. A model is Fig. 1a illustrates that cells that produced neurons later produce astrocytes, whereas a model in Fig. 1b illustrates that cells that produced neurons and those producing astrocytes are different. More specifically it was suggested that radial glial cells are destined to produce astrocytes only 1(b). However, as shown in Fig. 1c, at least in some regions of the rodent central nervous system radial glial cells have been shown to produce neurons. It is not clear yet whether this is a general phenomenon or not.

in the most ventral portion of the spinal cord (floor plate), *olig2* expression is restricted to one of the ventral domains called the pMN domain. This domain is characterized by the production of motoneurons. The generation of oligodendrocytes is thus restricted to the pMN domain from where they migrate to the entire spinal cord.

However, recent studies demonstrated that at least a minor population of oligodendrocytes is generated from more dorsal regions of the spinal cord [7,8,9]. Although these regions do not express the *olig2* gene, cells migrated out from these oligodendrogenic regions begin to express *olig2* soon after they leave the ventricular zone. Moreover, lineage-tracing experiments revealed that *olig2*-expressing cells in the ventricular zone of the pMN domain become not only oligodendrocytes but also astrocytes [10]. Therefore, at present there is no evidence to indicate the presence of a glial progenitor that only gives rise to either astrocytes or oligodendrocytes. However, there are some regions

in the central nervous system that generate oligodendrocytes more abundantly than do other regions.

## References

1. Fujita S (1965) An autoradiographic study on the origin and fate of the sub-pial glioblast in the embryonic chick spinal cord. *J Comp Neurol* 124:51–60
2. Rakic P (1972) Mode of cell migration to the superficial layers of fetal monkey neocortex. *J Comp Neurol* 145:61–85
3. Schmechel DE, Rakic P (1979) A Golgi study of radial glial cells in developing monkey telencephalon: morphogenesis and transformation into astrocytes. *Anat Embryol (Berl)* 156:115–152
4. Miyata T, Kawaguchi A, Okano H, Ogawa M (2001) Asymmetric inheritance of radial glial fibers by cortical neurons. *Neuron* 31:727–741
5. Noctor SC, Flint AC, Weissman TA, Dammerman RS, Kriegstein AR (2001) Neurons derived from radial glial cells establish radial units in neocortex. *Nature* 409:714–720

6. Warf B, Fok-Seang J, Miller RH (1991) Evidence for the ventral origin of oligodendrocyte precursors in the rat spinal cord. *J Neurosci* 11:2477–2488
7. Cai J, Qi Y, Hu X, Tan M, Liu Z, Zhang J, Li Q, Sander M, Qiu M (2005) Generation of oligodendrocyte precursor cells from mouse dorsal spinal cord independent of *nkx6* regulation and *shh* signaling. *Neuron* 45:41–53
8. Fogarty M, Richardson WD, Kessaris N (2005) A subset of oligodendrocytes generated from radial glia in the dorsal spinal cord. *Development* 132:1951–1959
9. Vallstedt A, Klos JM, Ericson J (2005) Multiple dorsoventral origins of oligodendrocyte generation in the spinal cord and hindbrain. *Neuron* 45:55–67
10. Masahira N, Takebayashi H, Ono K, Watanabe K, Ding L, Furusho M, Ogawa Y, Nabeshima Y, Alvarez-Buylla A, Shimizu K, Ikenaka K (2006) Olig2-positive progenitors in the embryonic spinal cord give rise not only to motoneurons and oligodendrocytes, but also to a subset of astrocytes and ependymal cells. *Dev Biol* 293:358–369

## Gliomas

MACIEJ M. MRUGALA

Departments of Neurology and Neurosurgery,  
University of Washington Medical School, Fred  
Hutchinson Cancer Research Center, Seattle, WA, USA

### Synonyms

Brain cancer; Glial neoplasm; Glioma; brain tumor

### Definition

Gliomas are a group of primary brain tumors that arise from cells of neuroectodermal origin. In early embryonal development the neural plate and neural groove arise from neuroectoderm, a specialized portion of ectoderm. Mature elements of the central nervous system (CNS): neurons, astrocytes, oligodendrocytes, etc. arise from pluripotent primitive cells of neuroectoderm. Gliomas are neuroectodermal tumors that are named based on their cell type of origin; for example, ►astrocytomas show features of astrocytes.

### Characteristics

#### Classification

Primary brain tumors form a large and diverse group with at least 19 basic categories and many sub-categories. Astrocytomas account for approximately 80% of all malignant brain tumors. All gliomas, including astrocytomas, oligodendrogliomas, mixed oligoastrocytomas, and ►ependymomas are classified based on their histological and immunohistological features. Histologic pattern of recognition by light microscopic examination remains the standard tool used for classification of

gliomas and other brain tumors. Molecular genetic alterations that play an important role in the biology of glial neoplasms are being increasingly used for more precise diagnosis and subclassification [1]. There are several classification and grading systems for gliomas, specifically for astrocytomas. First historical attempts to classify this diverse group of neoplasms were undertaken in mid 1800s by a German pathologist Rudolf Virchow, who actually coined the name “glioma” and introduced it into the pathological literature. Older classification systems include the Kernohan grading system (1949), the Ringertz grading system (1950), St. Anne/Mayo system (1988), and the most commonly used today World Health Organization (WHO) grading system introduced in 1993. In contrast to most tumors of systemic organs (lung, breast, colon) brain tumors are not staged and the standard TNM (Tumor size, Node involvement, Metastases) system is not applicable. WHO classification divides gliomas into grades based on histopathologic features of anaplasia, such as nuclear pleomorphism, mitotic activity, microvascular proliferation and necrosis. WHO classification recognizes four distinct grades of astrocytoma (Table 1). Grades I and II represent slow growing tumors, while grades III and IV are aggressive, fast growing neoplasms. Each WHO grade is associated with different prognosis and dictates treatment choice [2]. Astrocytomas can additionally be divided into two distinct categories: diffuse or circumscribed (Table 2). The diffuse astrocytomas infiltrate brain parenchyma, making it very difficult for a surgeon to achieve gross total resection (Fig. 1). These tumors can undergo anaplastic progression over time. Circumscribed astrocytomas carry a better prognosis, since they can frequently be nearly totally resected.

Oligodendrogliomas differ from astrocytomas by their distinct histopathological appearance. Due to the tissue fixation artifact tumor cells have a distinct perinuclear halo giving the tissue so called “fried egg” appearance (Fig. 2). Oligodendrogliomas also frequently infiltrate

**Gliomas. Table 1** World Health Organization (WHO) Grading system for astrocytic tumors of the central nervous system

Grade I
• Pilocytic astrocytoma
• Subependymal giant cell astrocytoma
Grade II
• Low grade astrocytoma
Grade III
• Anaplastic astrocytoma
Grade IV
• Glioblastoma

**Gliomas. Table 2** Classification of astrocytomas (according to Fuller and Goodman, [1])

Diffuse astrocytomas
• Low-grade astrocytoma
• Anaplastic astrocytoma
• Glioblastoma
Circumscribed astrocytomas
• Pilocytic astrocytoma
• Pleomorphic xanthoastrocytoma
• Subependymal giant cell astrocytoma
• Desmoplastic cerebral astrocytoma of infancy



**Gliomas. Figure 1** Macroscopic preparation of human brain with infiltrating low-grade astrocytoma extending from the thalamus to the brainstem (from [www.neuropathologyweb.org](http://www.neuropathologyweb.org), with permission).

brain parenchyma. Specific molecular genetic alterations are associated with this tumor type and its progression to the anaplastic form. Loss of heterozygosity (LOH) for chromosome 1p and 19q frequently found in oligodendrogliomas is associated with better prognosis and response to alkylating chemotherapeutic agents.

Several primary brain and spinal cord tumors can exhibit ependymal differentiation. Ependyma is a layer of cells lining cerebro-spinal fluid (CSF) spaces (ventricles and their connections) within the CNS. While a large percentage of supratentorial (located above the *tentorium cerebelli*) ependymomas arise intraparenchymally without contact with CSF spaces, the majority of posterior fossa tumors are intraventricular. The histologic hallmark of ependymoma is a perivascular pseudorosette (Fig. 3). Seven different subtypes of ependymoma have been described, ranging from benign subependymoma to highly malignant ependymblastoma (Table 3).

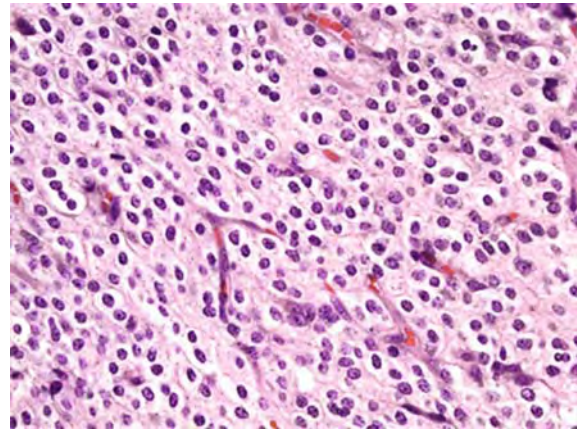

**Gliomas. Figure 2** Oligodendroglioma. Distinctive clearing of the cytoplasm around the nuclei – so called “fried egg” artifact. Hematoxylin and eosin staining (from [www.neuropathologyweb.org](http://www.neuropathologyweb.org), with permission).

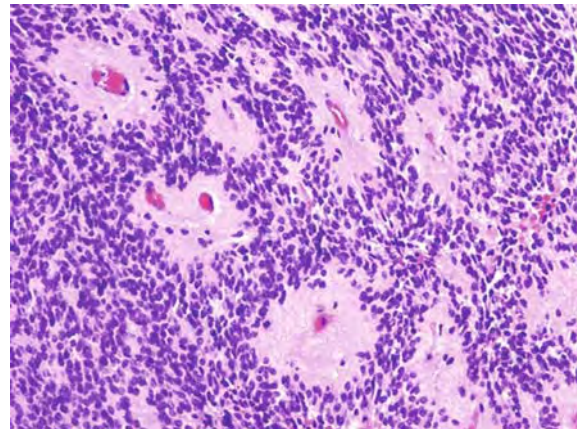

**Gliomas. Figure 3** Ependymoma with characteristic vascular pseudorosettes. Hematoxylin and eosin staining (from [www.neuropathologyweb.org](http://www.neuropathologyweb.org), with permission).

**Gliomas. Table 3** Ependymal neoplasms (according to Fuller and Goodman, [1])

Classic ependymoma
Papillary ependymoma
Clear cell ependymoma
Tancytic ependymoma
Myxopapillary ependymoma
Subependymoma
Ependymblastoma

Other less commonly encountered types of glial neoplasms include brain stem glioma and *Gliomatosis Cerebri*. Brain stem gliomas are histologically similar to astrocytomas but, as indicated by the name they are

located within the brainstem structures. *Gliomatosis cerebri* is a malignant glial neoplasm diffusely infiltrating large areas of the brain without forming an identifiable mass.

Tumors that exhibit neuronal differentiation are rare. Since mature neurons are incapable of division, it was postulated that these tumors may arise from neural stem cells. Of the six major types of the tumors with exclusive neuronal differentiation the majority are low grade (Table 4). Mixed glioneuronal tumors also occur. One example is ganglioglioma that is composed of a mixture of mature neuronal tumor cells and neoplastic astrocytes [2,3].

### Cell of Origin and Signaling Pathways

Gliomas have been previously thought to arise from de-differentiated mature brain cells in response to exogenous signals or genetic alterations. In the 1990s, when neurogenesis in the adult brain was recognized, the hypothesis that tumors may arise from neural stem cells (NSCs) was proposed. NSCs express nestin and glial fibrillary acidic protein (GFAP), two proteins that are also found in subpopulations of tumorigenic cells isolated from human gliomas. Nestin positive NSCs and isolated glioma cells also express the cell surface marker CD133. CD133 positive stem cells were found to have increased ability to self-renew, form tumor spheres in cultures and generate cellular phenotypes expressing both neuronal and glial markers. Both CD133 immunoreactive NSCs and their progenitors may be the targets for transformation, eventually leading to development of gliomas [3].

Several cellular signaling pathways have been identified in gliomas. Primary glioblastomas (WHO grade IV) frequently overexpress oncogenes such as epidermal growth factor receptor (EGFR) and platelet derived growth factor receptor (PDGFR). Mutations that frequently occur in glioma impact *p53*, *RBI*, and phosphatidylinositol 3-kinase (PI3-K) signaling pathways. In addition *PTEN* mutations and methylation are common in high grade astrocytomas and are

responsible for abnormally high levels of activity in the PI3-K pathway. mTOR (mammalian target of rapamycin) is a signal transduction mediator also linked with the PI3-K pathway. It regulates protein synthesis and cell growth and its inhibition may be beneficial in therapy of glioma. Alteration (epigenetic silencing through methylation) of the activity of certain DNA repair enzymes, such as O<sup>6</sup>-methylguanine-DNA methyltransferase (MGMT) was shown to be beneficial in patients with malignant gliomas (glioblastoma) treated with alkylating agents [3,4].

Figure 4 depicts critical molecular pathways important in gliomas and lists targeted molecular therapeutics being tested in clinical trials.

### Etiology

The etiology of brain tumors remains largely unknown. Carcinogenic risk factors for human gliomas have been studied extensively. Conclusive evidence exists only for a few known exposures. Therapeutic ionizing radiation is a strong risk factor for intracranial tumors, particularly meningiomas and gliomas. Even at very small doses, used in the past for treatment of ringworm infections of the scalp (*Tinea capitis*), the relative risk for developing brain tumor was shown to be high. Therapeutic radiation for acute lymphoblastic leukemia in children is also associated with high risk of developing glioma, and particularly glioblastoma WHO grade IV. The number of brain tumors among patients who received cranial radiation was reported to be 27 times greater than in the general population [5,6]. Survivors of Hiroshima and Nagasaki atomic bombings have been found to have an increased incidence of CNS tumors [7]. There was a dose-dependent relationship in this population that was particularly pronounced for schwannomas (tumors arising from Schwann cells). Exposure to low doses of diagnostic radiation [(dental X-rays, computer tomography scans (CT))] does not seem to play a significant role in glioma [5,8]. Occupational exposures (atomic energy, airline pilots and staff exposed to cosmic radiation) may have slightly increased risk for brain tumors, although more definite studies are needed. Electromagnetic field exposure has been suspected of influencing risk and progress of brain tumors, but no causal connection has been established. Cell phones that produce non-ionizing radiation of the same type as microwave ovens have not been conclusively shown to increase risk for glioma. One Swedish study found a significant risk of ▶acoustic neurinoma (odds ratio [OR] = 3.5) among analogue cellular telephone users. Anecdotal reports linking brain tumors to head trauma date back to the early 1900s when Dr. Harvey Cushing described several cases of presumed trauma related meningiomas. The evidence for gliomas is much less convincing. Experimental studies have suggested that physical trauma may be a co-carcinogen.

**Gliomas. Table 4** Neuronal tumors (according to Fuller and Goodman, [1])

Low grade
• Gangliocytoma
• Dysplastic gangliocytoma
• Central neurocytoma
• Paraganglioma of the filum terminale
High grade
• Ganglioneuroblastoma
• Cerebral neuroblastoma

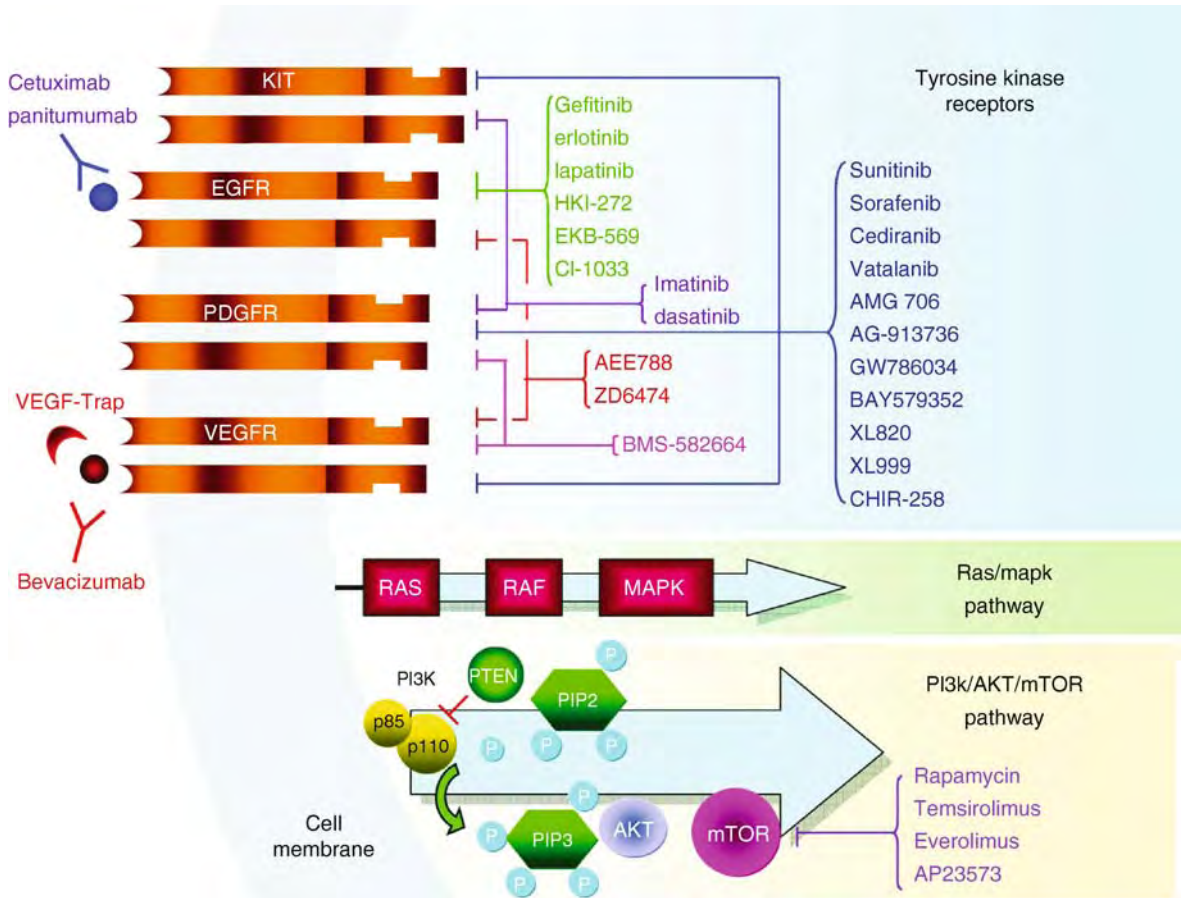

**Gliomas. Figure 4** Schematic representation of the molecular pathways important in glioma with associated targeted molecular therapeutics. From Omuro et al. (2007) *Mol Cancer Ther* 6(7):1909–1919 [4], with permission.

Several occupations (e.g. carpenters) that carry a risk for head trauma may have excess of brain tumors. Repetitive injuries are particularly risky. As many as three case-control studies showed increased risk for developing meningiomas in individuals with repetitive head injuries.

Studies examining dietary, habitual (smoking), and occupational risk factors have not provided solid evidence supporting increased risk for glioma [5,6].

A few rare genes and chromosomal abnormalities can greatly increase ones risk of developing brain tumor. For example CNS tumors are associated with Down syndrome and Neurofibromatosis among other disorders (Table 5).

**Epidemiology**

There are two different sources of data regarding the incidence of brain tumors in the US population. Surveillance, Epidemiology and End Results (SEER; <http://seer.cancer.gov/>) program, subsidized by the National Cancer Institute collects data on malignant brain tumors only [9]. Data from SEER include 13 state

**Gliomas. Table 5** Hereditary syndromes associated with brain tumors

Tumor type	Genetic syndrome
Glioma	NF-1 <sup>a</sup> , NF-2 <sup>b</sup> , Turcot syndrome, Tuberous sclerosis, Gardner syndrome, familial polyposis Li-Fraumeni syndrome
Medulloblastoma	Turcot syndrome, Gorlin syndrome
Meningioma	NF-2
Schwannoma	NF-2
Ependymoma	NF-2

<sup>a</sup>NF-1 – neurofibromatosis type 1

<sup>b</sup>NF-2 – neurofibromatosis type 2

registries and represent about 26% of the US population. A second source of data comes from the Central Brain Tumor Registry of the United States (CBTRUS; <http://www.cbtrus.org/>) [10]. This database includes both benign and malignant brain tumors corresponding

to grades I–IV on the WHO scale. Based on SEER data it is estimated that 20,500 men and women (11,170 men and 9,330 women) will be diagnosed with and 12,740 men and women will die of cancer of brain and other nervous system tumors in 2007. From 2000–2004, the median age at death for cancer of the brain and other nervous system tumors was 64 years of age. The annual incidence of malignant brain tumors for both genders and all races between 1992 and 2002 was estimated at 6.8 per 100,000 person-years. The incidence for primary benign tumors in the same time period was 4.2 per 100,000 person-years. Based on SEER database (1988–1992), the incidence rate of developing an astrocytic tumor is about 5.0 per 100,000 for white females and 8.0 for white males. Incidence rates for the same type of tumor for black population were 2.5 for females and 4.0 for males (Fig. 5).

Brain tumors account for only about 2% of cancers but the survival rates are very low. In fact, the 5-year survival rates for brain tumors are the sixth lowest among all types of cancer following pancreas, liver, esophagus, lung and stomach. Considering the two most malignant grades (WHO III and IV), the 5-year survival rates are 28.2% for grade III and only 2.9% for grade IV. Age-specific mortality rates, when analyzed for all races and both genders seem to show gradual increase with each decade of life until the age 55, after which there is a dramatic increase in the mortality rate from brain tumors. Despite the grim prognosis for survival, it has been shown recently that 5-year survival rates for all primary brain tumors have increased over the past 30 years from 22% to 32%.

Many studies have documented a rising incidence rate for brain tumors, especially in the industrialized countries. When we look at the trend from 1970s to

1990s, there was an estimated 18% increase in the incidence rate. Looking back into the 1950s and comparing the rates with the 1990s, an 80% increase can be seen (data available for white population only).

Since 1992 until now, the incidence rates seem to have stabilized, with only small yearly fluctuations. It is not completely clear what factors are predominantly responsible for the trends we observe, however, it is believed by some researchers that the increasing incidence rates observed before 1992 may have, at least in part, resulted from better ascertainment. This includes more complete ascertainment with improved diagnostic imaging technology computer tomography (CT) and magnetic resonance imaging (MRI), better access to health care and greater number of specialists in the field of neurology and neuro-oncology. Incidence rates for brain tumors were on the rise not only in the United States but also in other parts of the world. Similar factors are postulated to be responsible for this observation throughout the globe. The highest rates are noted in the well developed, industrialized countries like the United States, Canada, Australia and United Kingdom. Greater incidence rates are correlated with the availability of better detection systems in these countries. Intra-country variations in the incidence rates are also observed. For the United States, the highest rates were documented for Maine (8.5 per 100,000 person-years) while the lowest were for Hawaii (3.9 per 100,000 person-years). These variations, in contrast to international trends, do not seem to correlate with socioeconomic status. What is interesting, however, is the fact that most migrants adopt the brain cancer incidence rates of their host country. This suggests that environmental factors, at least to some degree are responsible for the development of brain tumors.

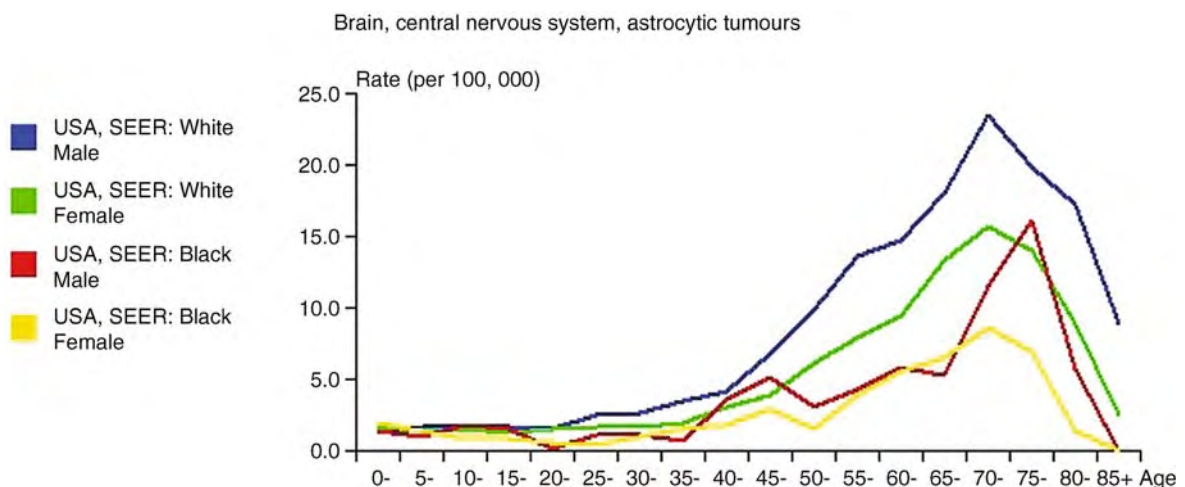

**Gliomas. Figure 5** Incidence of astrocytic brain tumors in the United States from SEER database (1988–1992) plotted by gender and ethnicity. Note the highest incidence in white males and the lowest in black females.

### Clinical Features and Diagnostic Approach

Gliomas may be found throughout the CNS. Depending on the size and location they may produce different symptoms. Patients can experience headaches, seizures, motor or sensory symptoms, visual deficits or coordination problems. Imaging studies such as CT and MRI are the primary diagnostic modalities used in the detection and characterization of gliomas (Fig. 6) – [see brain imaging section of the encyclopedia]. Final diagnosis is achieved by obtaining a tissue sample for histopathological testing through either biopsy or gross total resection of the lesion when possible. Molecular testing of the tissue samples is already being done and can provide prognosis and guide treatment choices for selected patients.

### Treatment

Surgical intervention is needed when a glioma is suspected for two reasons: to provide precise histopathological diagnosis and to achieve gross total resection when possible, since this may influence ultimate prognosis. Due to the heterogeneity of gliomas, successful future treatments will include multimodal therapies. Currently for low grade gliomas surgery and/or radiation are usually utilized, while for high grade tumors addition of chemotherapy is necessary. Only a few chemotherapeutic agents cross blood-brain barrier (BBB) – [see blood brain barrier section of the encyclopedia] which makes therapy of this disease challenging. Various delivery techniques

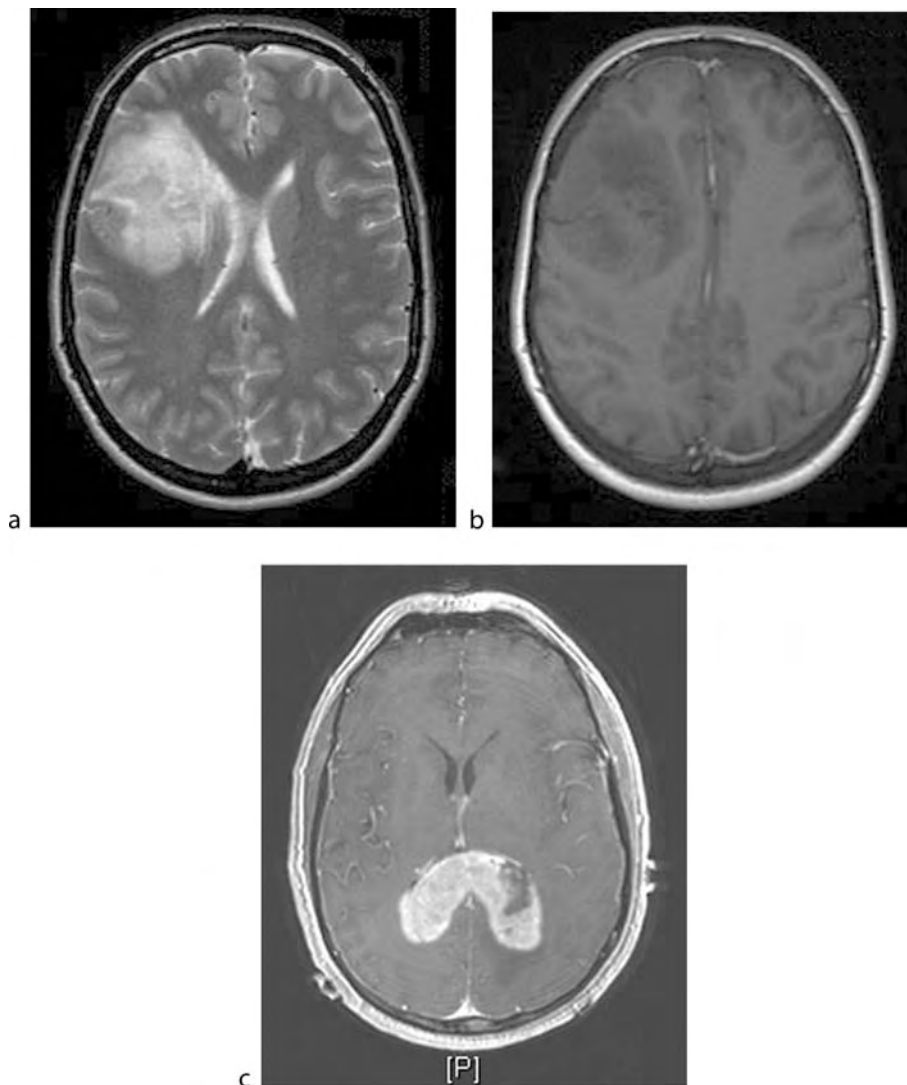

**Gliomas. Figure 6** Magnetic resonance imaging (MRI) of glial neoplasms. (a) Low grade glioma (oligodendroglioma) in the right frontal lobe – T2 MRI sequence; (b) T1 image from the same patient with administration of contrast, note lack of contrast enhancement frequently seen in low grade tumors. (c) High grade glioma (glioblastoma), T1 MRI sequence with administration of contrast, note contrast enhancement in the lesion spanning the *Corpus callosum*.



are being used including delivery of chemotherapy directly into the resection cavity (BCNU polymer wafers), intracranial catheters (convection enhanced delivery) and techniques focusing on disruption of the integrity of the BBB to allow for better penetration of chemotherapeutics into the tumor. Even with recent progress and identification of a subgroup of patients with high grade glioma (glioblastoma) who have better chances for response to therapy with the alkylating agent temozolomide, the prognosis remains poor with median survival around 14 months from the time of diagnosis. Further improvements in the drug delivery technologies are necessary. Recognition of the role of different molecular pathways in the biology and progression of gliomas already guides development and use of targeted molecular therapeutics.

## References

1. Fuller GN, Goodman JC (2001) Tumors. In: Fuller GN, Goodman JC (eds) Practical review of neuropathology. Lippincott Williams & Wilkins, Philadelphia, PA, pp 144–190
2. Kleihues P, Cavenee WK (eds) (2000) Pathology and genetics. Tumours of the nervous system. International Agency for Research on Cancer, Lyon, France
3. Presson AI, Fan Q, Phillips JJ, Weiss WA (2007) Glioma. In: Gilman S (ed) Neurobiology of disease. Elsevier Academic Press, Amsterdam, pp 433–444
4. Omuro AM, Faivre S, Raymond E (2007) Lessons learned in the development of targeted therapy for malignant gliomas. *Mol Cancer Ther* 6(7):1909–1919
5. Bondy M, El-Zein R, Wrensch M (2005) Epidemiology of brain cancer. In Schiff D, O'Neill BP (eds) Principles of neuro-oncology. McGraw-Hill, New York, pp 3–16
6. Batchelor TT, Dorfman MV, Hunter DJ (2005) Epidemiology of primary brain tumors. In: Black PM, Loeffler JS (eds) Cancer of the nervous system. Lippincott Williams & Wilkins, Philadelphia, PA, pp 1–13
7. Mabuchi KSM, Ron E et al. (1994) Cancer incidence in atomic bomb survivors. Part I: use of tumor registries in Hiroshima and Nagasaki for incidence studies. *Radiat Res* 137:S1–S16
8. Wrensch M et al. (2000) Are prior head injuries or diagnostic X-rays associated with glioma in adults? The effects of control selection bias. *Neuroepidemiology* 19(5):234–244
9. Surveillance, Epidemiology and End Results (SEER; <http://seer.cancer.gov/>) database, 2007
10. Central Brain Tumor Registry of the United States (CBTRUS; <http://www.cbtrus.org/>), 2007

## Gliososis

► Glial Scar

## Global Amnesia

### Definition

An early term used to refer to memory loss. This term is generally not used as much today as a result of a better understanding that there are several types of memory loss that can occur depending on which brain structures are affected. See transient global amnesia.

► Amnesia

## Global Aphasia

### Definition

Inability to comprehend language and to speak as well as read, write, repeat words or name objects. It results from large lesions of ► Broca's area, ► Wernicke's area and the ► arcuate fasciculus, thereby being associated also with right ► hemiplegia, right ► hemisensory defects and mostly, right ► homonymous hemianopsia.

► Broca's Area  
► Wernicke's Area

## Global Attention

### Definition

Global attention often refers to the alertness or wakefulness of an organism. Global attention is controlled by neurons in the reticular formation of the midbrain. Neurons in this region affect cortical activity by projecting to thalamic neurons, thereby gating neural activity that passes through the thalamus and regulating oscillatory activity in which the thalamus is involved.

Activity of the reticular formation is also accompanied with desynchronization of the cortical activity, such as recorded by the electroencephalogram. Nor-adrenaline is the most important neurotransmitter involved in global attention.

► Attention

## Global Image Motion

### Definition

Motion of the whole visual field, as for example caused by head or body motion.

- ▶ Retinal Direction Selectivity and Starburst Amacrine Cells
- ▶ Visual Field

## Global Linearization

### Definition

An approach to the design of nonlinear control systems, where the controlled system is first transformed into an equivalent linear system using variable transformations.

Also referred to as feedback linearization.

- ▶ Nonlinear Control Systems

## Global Minimum

### Definition

The global minimum defines the unique minimal solution of an optimization problem that is defined by the minimization of the objective (cost) function. It defines the minimal cost solution of many possible minima that can occur in a general constrained problem.

Minima that are not global are referred to as local minima, and they typically do not define the desired solution of an optimization problem.

- ▶ Distribution Problem in Biomechanics

## Globus Pallidus

### Definition

Part of the basal ganglia and a deep telencephalic nucleus that is a main recipient of massive outputs from the caudate nucleus and putamen.

Occupying the medial pointing apex of the lentiform nucleus, the globus pallidus is split by a thin layer of myelinated fibers (internal medullary lamina) into an external (lateral) segment that projects principally to the subthalamic nucleus and substantia nigra and an internal (medial) segment that projects to the brainstem reticular formation and via a relay in the thalamus, to motor staging areas of the cortex.

- ▶ Basal Ganglia

## Glomerular Contrast Enhancement

### Definition

The systematic spatial clustering of glomeruli responding to chemically related odorant stimuli may facilitate olfactory contrast enhancement by allowing local networks of inhibitory interneurons to narrow the range of mitral cell projection neurons responding to each of the similar odorants, which typically stimulate a large number of overlapping odorant receptors and sensory neurons.

- ▶ Contrast Enhancement
- ▶ Glomerular Map
- ▶ Olfactory Bulb

## Glomerular Filtration Rate (GFR)

### Definition

GFR is a renal parameter to estimate a clearance, which is the volume of fluid filtrated into the Bowman capsule per unit time.

- ▶ Blood Volume Regulation

## Glomerular Layer of the Olfactory Bulb

### Definition

The glomerular layer is the lamina of the olfactory bulb just internal to the olfactory nerve. It is comprised of

olfactory glomeruli and juxtglomerular neurons, which include periglomerular cells, so-called short axon cells, and external tufted cells.

- ▶ Glomerular Map
- ▶ Olfactory Bulb

## Glomerular Map

BRETT A. JOHNSON, MICHAEL LEON  
Department of Neurobiology and Behavior, University of California, Irvine, CA, USA

### Synonyms

Odotopic Representation; Chemotopic Representation; Glomerulus Map

### Definition

The orderly and species-stereotypical projection of ▶ olfactory sensory neurons from the ▶ olfactory epithelium into glomeruli of the main ▶ olfactory bulb produces a glomerular map wherein individual consistently located glomeruli can be related to individual ▶ odorant receptor genes. Because odorant receptors are differentially activated by a characteristic set of odorant ligands, different odorants activate characteristic spatial patterns of activity in the ▶ glomerular layer of the olfactory bulb (▶ odotopic representation). Because odorants that share particular aspects of chemical structure and/or overall molecular properties overlap in their stimulation of receptors and glomeruli, and because glomeruli responding to similar odorant chemicals tend to be located near one another in the bulb, the glomerular map can be described in terms of odorant chemistry (▶ chemotopic representation). Similarities in the spatial patterns of activation of glomeruli can be related to similarities in perceived ▶ odor.

### Characteristics

#### Olfactory Sensory Neuron Projections

Individual olfactory sensory neurons in the olfactory epithelium of the rodent nose appear to express only a single allele of a single odorant receptor gene, the protein product of which largely determines which odorant stimuli effectively activate each sensory neuron. Sensory neurons expressing the same odorant receptor generally are widely scattered within zones constrained in the dorsal-ventral axis but spanning the entire anterior-posterior axis of the nose (Fig. 1).

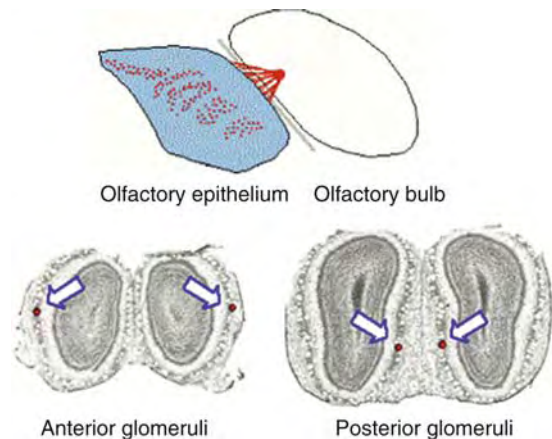

**Glomerular Map. Figure 1** Olfactory sensory neurons expressing the same odorant receptor gene are widely distributed across the anterior-posterior axis of the main olfactory epithelium in the nose (*red dots in top panel*), but converge in their projections to only a few (usually two) glomeruli in the main olfactory bulb. The projection is symmetrical between the left and the right bulbs and involves a more rostrally and dorsally located lateral glomerulus as well as a more caudally and ventrally located medial glomerulus.

However, the axons of sensory neurons expressing the same receptor converge tightly in their projection along the ▶ olfactory nerve through the cribriform plate of the skull and into the olfactory bulb, where they synapse with the dendrites of ▶ mitral cells and both inhibitory and excitatory ▶ interneurons in ball-shaped compartments of neuropil called ▶ olfactory glomeruli, located in a lamina of the bulb called the glomerular layer [1].

A typical rodent ▶ olfactory glomerulus receives projections only from sensory neurons expressing the same single receptor gene, and most receptor genes are associated with projections to only a few glomeruli. The most characteristic projection involves as few as two glomeruli for each odorant receptor, one of which is located on the lateral aspect and the other on the medial aspect of the bulb [2]. The sensory neurons projecting to glomeruli in the lateral bulbar aspect tend to be located in the lateral parts of the nose, whereas the sensory neurons projecting to medial glomeruli are located either medially along the nasal septum or in ventral nasal recesses. Dorsal and internal parts of the nose (also known as the central channel), which contain sensory neurons expressing class I receptors, project to dorsal parts of the olfactory bulb, whereas peripheral and ventral parts of the nose expressing class II receptors project ventrally [3]. The lateral member of a pair of homologous glomeruli is located more dorsal and anterior in the bulb than is the medial member of the pair (Fig. 1).

Glomeruli receiving projections from sensory neurons expressing a particular odorant receptor are located in similar positions in different individuals of a given species [2], although there is some variation (several glomerular diameters) even between the left and right bulbs of the same animal [3]. The positioning of glomeruli during development can be affected by genetically engineered deletions or substitutions of the odorant receptor gene/protein in the olfactory sensory neurons [3].

Principles of the projection pattern in the ►accessory olfactory bulb differ from that for the main bulb, because homologous sensory neurons in the ►vomeronasal organ project to multiple, less well-compartmentalized glomeruli in the accessory bulb. There also appear to be somewhat different patterns of organization in the olfactory systems of different animal species, although the principles of odotopic and, to some extent, chemotopic organization to be discussed below also have been described in fish and insects such as honeybees and *Drosophila* [4].

### Odotopic Representation

As is predicted from the anatomy of the epithelium-to-bulb projection, and from the fact that odorant stimuli are detected by the expressed odorant receptors, the inhalation of an odorant generates a pattern of differentially activated glomeruli in the rodent olfactory bulb. This pattern can be monitored by several methods, including uptake of metabolic labels such as  $^{14}\text{C}$ -labeled 2-deoxyglucose, electrophysiological recording, optical imaging, detection of activity-regulated ►immediate early gene products, and ►functional magnetic resonance imaging [4,5]. The pattern of activity is very similar between different individual animals of the same species and can be very different for different odorants (Fig. 2). The difference in patterns between odorants evoking the perception of distinct odors suggested the possibility that the spatial pattern might determine, or at least be related to, odor perception and discrimination (spatial coding of olfactory stimuli).

### Chemotopic Representation

Receptors anywhere in the body rarely are completely specific for a single ►ligand molecule. Rather, parts of an effective ligand typically can be modified without a complete loss of receptor activation, although changes in affinity and/or efficacy generally attend almost any modification. In contrast, other aspects of the same ligand molecule can be more critical for activation of the receptor, and modifications of these elements can cause complete loss of activation. Critical molecular features of a ligand typically either are involved in binding to chemical groups on the receptor molecule or are important for proper access of the ligand to the receptor's binding site. Receptors can be thought of as

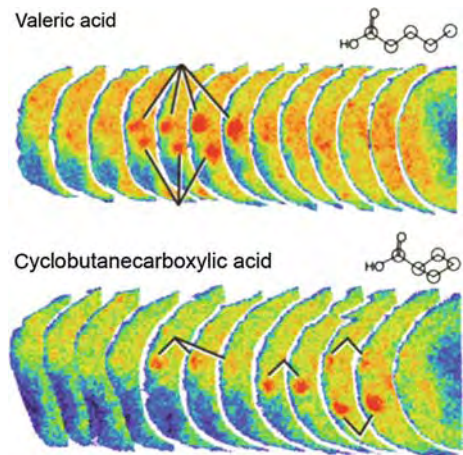

**Glomerular Map. Figure 2** The activation of distinct sets of glomeruli by different, but related, odorants is illustrated here using stacks of pseudocolor-enhanced images of 2-deoxyglucose uptake in coronal sections from one rat exposed to valeric acid and another rat exposed to cyclobutanecarboxylic acid. The posterior half of the lateral aspect of the olfactory bulb is shown, with warmer colors denoting greater uptake. There is partial overlap in the activation of certain clusters of glomeruli (*left*), but other activated clusters of glomeruli are spatially distinct.

detectors of these critical molecular features, and given the large number of distinct odorant chemicals that are emitted by objects and exposed to each receptor by airflow across the epithelium during inhalation, it is reasonable to think of olfactory receptors as detectors of these features rather than as detectors of specific odorant molecules.

By studying pure odorant chemicals that differ incrementally in structure, it has been possible to characterize some of the molecular features responsible for the activation of particular olfactory glomeruli, because related odorant chemicals often are found to overlap in their stimulation of glomeruli in particular regions of the bulb [4,6]. The overlap is typically only partial, with each related odorant optimally stimulating distinct glomeruli in the same general neighborhood. These clusters of similarly specific glomeruli, alternatively called “domains” or “modules,” also are evidenced by the increasing number of nearby glomeruli that tend to be activated upon increasing the concentration of flexible odorant ligands capable of assuming a variety of conformations.

The description of the locations of glomerular activity in terms of odorant chemistry has led to the concept of chemotopic organization in the olfactory system. Most ►olfactory glomerular modules can be characterized with respect to their responsiveness to odorant functional groups (e.g., carboxylate or hydroxyl groups), or elements of hydrocarbon structure (e.g., aromatic rings

or bicyclic structures), although at least one posterior module is responsive to highly water-soluble molecules independent of the particular functional groups or hydrocarbon structure of the odorants (Fig. 3) [4]. Response modules identified with respect to odorant chemistry are typically present as pairs in the lateral and medial aspects of the olfactory bulb, reflecting the paired medial and lateral projection of sensory neurons expressing homologous odorant receptor genes.

In several glomerular modules, the location of activity shifts progressively with increasing carbon number or molecular length along various homologous series of aliphatic odorant ligands (Fig. 3) [7]. Increasing carbon number tends to be associated with the activation of more ventral glomeruli in rats. This progression may be related to the tendency of more hydrophilic odorants (shorter chemicals in a homologous series) to be more strongly adsorbed in the nasal mucosa of the olfactory epithelium, and thereby more constrained to interact with receptors in the dorsal-projecting central channel through which odorized air first passes during inhalation [3]. More hydrophobic, longer odorants may not adsorb as strongly

and therefore may be freer to interact with receptors in more peripheral and ventral parts of the nose projecting more ventrally in the bulb.

Systematic chemotopic progressions of activity indicate that glomeruli with the most similar odorant specificity tend to be located nearer to one another within these modules. This type of anatomical organization may represent ►glomerular contrast enhancement, using local interneurons arrayed in a center-surround, ►lateral inhibition network to allow odorants that generally stimulate strongly overlapping sets of receptors to be represented by a smaller, more distinct, set of mitral cell projection neurons in the bulb [8]. In general, the spatial clustering of glomeruli with similar response profiles also would tend to facilitate contrast enhancement, and this may have been the selective pressure underlying chemotopic organization involving glomerular modules.

### Relationship to Olfactory Perception

When activity across the glomerular layer is normalized, it becomes easier to visualize similarities and

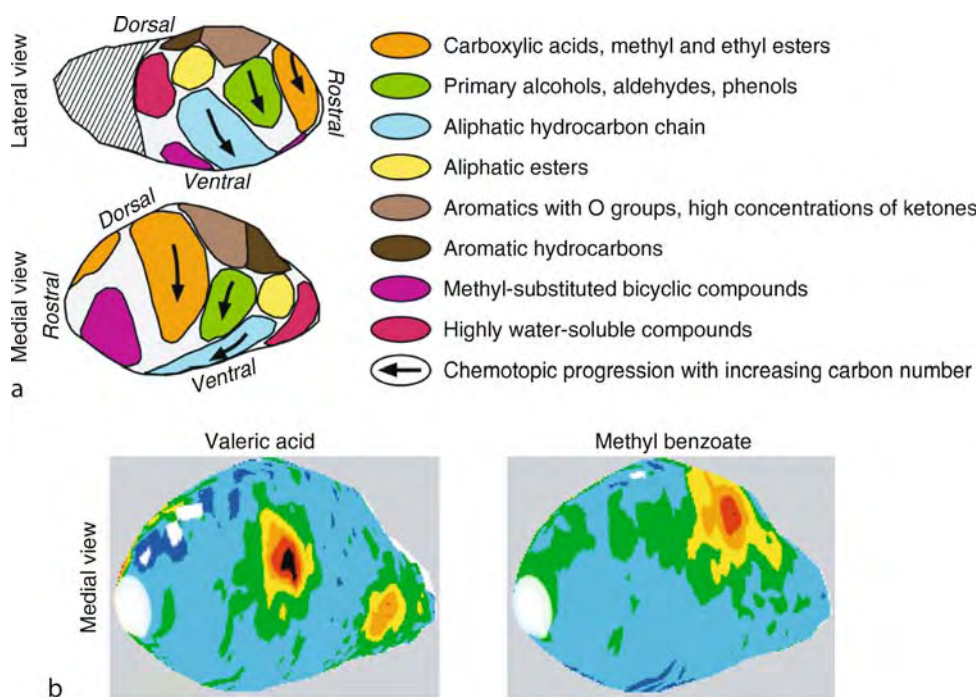

**Glomerular Map. Figure 3** Glomeruli that respond to odorants with similar structural features or overall molecular properties tend to be spatially clustered to form functional glomerular modules in the olfactory bulb. (a) Both the lateral and the medial views of a 3-dimensional model of the map of responses (2-deoxyglucose uptake) to identified molecular features across the entire glomerular layer of the rat bulb (<http://leonserver.bio.uci.edu>). In several modules, there is a systematic relationship between the location of the response and the molecular length within homologous series of aliphatic odorants possessing the same functional group(s). Arrows indicate the direction of these chemotopic progressions with respect to increasing odorant length. (b) Average 2-deoxyglucose uptake on the medial aspect of the glomerular layer in response to valeric acid (a carboxylic acid with an aliphatic hydrocarbon chain) and methyl benzoate (an aromatic odorant with an oxygenic functional group). Greater uptake is indicated by warmer colors.

differences in patterns of activity evoked by different odorants. Matrices containing z score-normalized values also can be compared quantitatively by correlation analysis to determine the degree of similarity between maps involving meaningful pairs of odorants. These calculations show both that more closely related odorant chemicals evoke more similar overall activity patterns and that the degree of pattern similarity is predictive of the degree of similarity in perceived odor [5,9]. Rodents are inherently accurate at discriminating the odors of even closely related odorants, especially with prior experience. Therefore, these analyses require the use of behavioral assays capable of showing odor generalization spontaneously, such as odorant cross-▶**habituation** in naïve animals, or odorant confusion tasks [5,9].

Normalization of representations by z scores also results in more similar activity patterns for different concentrations of the same odorant, which tend to be perceived as having similar odors. Computational modeling of the network of so-called short axon cells in the glomerular layer suggests the possibility that the bulb itself may normalize input to mitral cells in a manner similar to z scores, thus explaining the superior power of normalized activity patterns to predict perceived odor similarities [10].

## References

1. Buck LB (1996) Information coding in the vertebrate olfactory system. *Annu Rev Neurosci* 19:517–544
2. Mombaerts P (2006) Axonal wiring in the mouse olfactory system. *Annu Rev Cell Dev Biol* 22:713–737
3. Schoenfeld TA, Cleland TA (2005) The anatomical logic of smell. *Trends Neurosci* 28:620–627
4. Johnson BA, Leon M (2007) Chemotopic odorant coding in a mammalian olfactory system. *J Comp Neurol* 503:1–34
5. Xu F, Greer CA, Shepherd GM (2000) Odor maps in the olfactory bulb. *J Comp Neurol* 422:489–495
6. Mori K, Takahashi YK, Igarashi KM, Yamaguchi M (2006) Maps of odorant molecular features in the mammalian olfactory bulb. *Physiol Rev* 86:409–433
7. Johnson BA, Farahbod H, Xu Z, Saber S, Leon M (2004) Local and global chemotopic organization: general features of the glomerular representations of aliphatic odorants differing in carbon number. *J Comp Neurol* 480:234–249
8. Yokoi M, Mori K, Nakanishi S (1995) Refinement of odor molecule tuning by dendrodendritic synaptic inhibition in the olfactory bulb. *Proc Natl Acad Sci USA* 92:3371–3375
9. Youngentob SL, Johnson BA, Leon M, Sheehy PR, Kent PF (2006) Predicting odorant quality perceptions from multidimensional scaling of olfactory bulb glomerular activity patterns. *Behav Neurosci* 120:1337–1345
10. Cleland TA, Johnson BA, Leon M, Linster C (2007) Relational representation in the olfactory system. *Proc Natl Acad Sci USA* 104:1953–1958

## Glomerular Oscillations

### Definition

Glomerular oscillations are slow oscillations, coupled with breathing, which are evoked by olfactory stimulation and which represent the receptor neuron input to the olfactory bulb (OB).

▶ Temporal Coding

## Glomerulus

### Definition

Glomeruli are spherical conglomerate of neuropil (diameter of 50–100  $\mu$ ) that consists of the incoming axons of the olfactory sensory neurons and the dendrites of the main projection cells (mitral cells) in the olfactory bulb.

▶ Odorant Receptor

## Glomerulus Map

▶ Glomerular Map

## Glossopharyngeal Nerve

### Definition

The glossopharyngeal nerve is the IXth cranial nerve. The nerve root emerges from the lateral aspect of the medulla, just rostrally to rootlets of the vagus (Xth) nerve, with which the glossopharyngeal is closely related, both anatomically and functionally.

The glossopharyngeal nerve has two peripheral ganglia. The superior ganglion lies in the jugular foramen and contains the cell bodies of neurons that convey somatosensory information from retroauricular regions, terminating centrally in the spinal trigeminal

nucleus. The inferior or petrosal ganglion, which is extracranial, contains the soma of visceral afferent fibers that terminate centrally in the nucleus of the solitary tract. General visceral afferent fibres convey tactile, thermal and painful sensations from the mucosa of the posterior tongue, tonsils, pharynx and eustachian tube, while special visceral afferent fibers convey taste sensation from the posterior third of the tongue. The carotid sinus nerve, a branch of the glossopharyngeal, carries information from a baroreceptor in the bifurcation of the common carotid artery, the carotid sinus, relevant for the regulation of blood pressure.

The glossopharyngeal also carries efferent fibres.

Parasympathetic preganglionic fibers from the inferior salivatory nucleus will pass via the lesser petrosal nerve and synapse in the otic ganglion, which in turn innervates the parotid gland. Other efferent fibers, originating from the nucleus ambiguus, innervate parts of the pharyngeal musculature.

## Glucagon

### Definition

Glucagon is the hormone secreted by alpha cells of the islets of Langerhans in the pancreas. It responds to high blood glucose and acts to decrease blood glucose concentration.

## Glucocorticoid (GR) Receptor

### Definition

Nuclear receptor involved in steroid action and in mediating the stress response. The GR has a low affinity for glucocorticoids and is widely distributed in the body and brain.

►Hypothalamo-Pituitary-Adrenal Axis, Stress and Depression

## Glucocorticoids (GCs)

### Definition

Class of steroid hormones (including cortisol in primates and corticosterone in rodents) that are secreted

from the adrenal upon stress exposure. GCs exert a wide range of genomic and non-genomic actions throughout the brain and body with potent effects on e.g. energy metabolism, the immune system and cognition.

►Hypothalamo-Pituitary-Adrenal Axis, Stress and Depression

## Glutamate

### Definition

Glutamate (also referred to as glutamic acid) is one of the 20 amino acids which build up proteins. Glutamate is a key molecule in cellular metabolism and the main excitatory neurotransmitter of the central nervous system. Glutamate does not cross the blood-brain barrier and is synthesized from glucose via the Krebs cycle or by transamination of  $\alpha$ -ketoglutarate. Inactivation of glutamate is accomplished by reuptake into glial and neuronal cells. In glial cells glutamate is converted to glutamine. Glial cells release glutamine, which is then transported into neurons where it is converted back to glutamate by glutaminase. Glutamate activates ionotropic receptors and metabotropic receptors, which are thought to participate in cognitive functions like learning and memory. In excess, glutamate triggers excitotoxicity, causing neuronal and glial cell death.

## Glutamate Excitotoxicity

### Definition

Glutamate is the most common excitatory neurotransmitter in the central nervous system that activates postsynaptic neurons by change in membrane potential-depolarization.

Under conditions in which glutamate is released in excessive quantities or is not taken up by the glial cells, glutamate builds up at the junctions between neurons, the synapses. This excessive glutamate “overexcites” the postsynaptic neurons – glutamate excitotoxicity.

## Glutamate Receptor Channels

### Definition

Glutamate receptor channels are ligand gated channels that open in response to binding of the neurotransmitter glutamate. There are three types of glutamate receptors, which are distinguished by their sensitivity to glutamate analogs: N-methyl-D-aspartic acid (NMDA),  $\alpha$ -amino-3-hydroxy-5-methylisoxazole-4-propionic acid (AMPA) and kainate. Glutamate is the major excitatory neurotransmitter in the brain and mediates normal brain development and excitotoxic responses in disease. GluR subunits appear to be derived from an inverted KIR channel to which sequential bacterial gene modules have been appended to the amino terminus including a modulatory, periplasmic binding protein domain and a ligandbinding domain from G protein-coupled metabotropic receptors.

## Glutamate Receptors

### Definition

Receptors for the excitatory neurotransmitter glutamate. Glutamate receptors consist of ionotropic and metabotropic glutamate receptors.

- ▶ Memory, ▶ Molecular Mechanisms
- ▶ Associative Long-Term Potentiation (LTP)
- ▶ Long-Term Potentiation (LTP)
- ▶ Anti-DNA Antibodies against Microbial and Non-Nucleic Acid Self-Antigens

## Glutamate-Mediated Injury to White Matter: Mechanisms and Clinical Relevance

CARLOS MATUTE

Departamento de Neurociencias, Universidad del País Vasco, E-48940 Leioa, and Neurotek-UPV/EHU, Parque Tecnológico de Bizkaia, Zamudio, Spain

### Definition

▶ Glutamate excitotoxicity is caused by sustained activation of glutamate ▶ receptors. In recent years, it has been shown that glutamate can also be toxic to

white matter ▶ oligodendrocytes and to myelin by this mechanism. In particular, glutamate receptor-mediated injury to these cells is mediated by alpha-amino-3-hydroxy-5-methylisoxazole-4-propionic acid (AMPA), kainate and N-methyl-D-aspartate (NMDA) glutamate ▶ receptor types.

Alterations of glutamate homeostasis in white matter can determine glutamate injury to oligodendrocytes and myelin. Astrocytes are responsible for most glutamate uptake in synaptic and non-synaptic areas and consequently, are the major regulators of glutamate homeostasis. Activated microglia in turn may secrete cytokines and generate radical oxygen species, which impair glutamate uptake and reduce the expression of glutamate ▶ transporters. Finally, oligodendrocytes also contribute to glutamate homeostasis.

As a consequence, ionotropic glutamate receptors, the intermediaries of the signal cascades they activate, and glutamate transporters are potential targets for drug development to treat white matter damage in acute and chronic diseases.

### Characteristics

#### Function

Glutamate signaling is carried out by glutamate receptors and glutamate transporters [1,2]. Glial cells express most of these receptors and transporters [3,4]. In particular, cells of the oligodendrocyte lineage express functional AMPA, kainate, and NMDA receptors throughout a wide range of developmental stages and species, including humans. Moreover, oligodendrocytes also express receptors of all three groups of metabotropic glutamate receptors but their levels are developmentally regulated and are very low in mature cells of this lineage.

Glutamate uptake from the extracellular space by specific glutamate transporters is essential for the shaping of excitatory postsynaptic currents and for the prevention of excitotoxic death due to overstimulation of glutamate receptors. Glutamate transporter 1 (GLT-1; excitatory amino acid transporter 2 [EAAT2] in the modern nomenclature) exhibits the highest level of expression among all the glutamate transporters characterized so far and is responsible for most glutamate transport [2]. Glutamate transporters are expressed by astrocytes and oligodendrocytes. The main transporter expressed by oligodendrocytes is glutamate aspartate transporter (GLAST; EAAT1 in the modern nomenclature), but glutamate transporters EAAT2 and EAAT3 are also expressed by cells of the oligodendroglial lineage.

### Description of the Process

Numerous studies carried out over the last few years have shown that, in addition to neurons, glial cells can die by excitotoxicity. Oligodendroglia is the glial cell type most vulnerable to excitotoxicity. The first



evidence that oligodendrocytes are highly vulnerable to glutamate was obtained in primary cell cultures over ten years ago from today [5]. After a 24 h exposure to glutamate, oligodendroglial death was comparable to that described in neurons. However, oligodendroglial toxicity was not mediated by glutamate receptors, as in neurons, but rather by a transporter-related mechanism involving the inhibition of cysteine uptake, which results in glutathione (GSH) depletion and cellular vulnerability to toxic free radicals [5]. More recently, it was shown that prolonged activation of glutamate receptors is toxic to oligodendrocytes *in vitro* and *in vivo* (reviewed in [3]). This toxicity is directly related to  $Ca^{2+}$  influx subsequent to receptor activation, and it is greatly attenuated in the absence of  $Ca^{2+}$  in the culture medium.

Glutamate can also cause glial demise indirectly by inducing the release of toxic agents. In microglia, activation of AMPA and kainate receptors results in the release of tumor necrosis factor- $\alpha$  (TNF- $\alpha$ ), which can potentiate glutamate neurotoxicity and kill oligodendrocytes, destroy myelin and damage axons [6]. Moreover, inflammatory cytokines including TNF- $\alpha$

and interleukin (IL)-1 $\beta$ , which are commonly released by reactive microglia can impair glutamate uptake and trigger excitotoxic oligodendrocyte death. Indeed, inhibition of the expression and functioning of glutamate transporters in axonal tracts is sufficient to induce oligodendroglial loss and demyelination, which demonstrates that the integrity of oligodendrocytes and white matter depends on proper glutamate transporter function [3].

Activation of AMPA, kainate or NMDA receptors in oligodendrocytes leads to  $Ca^{2+}$  influx, an effect which is totally abolished by selective receptor antagonists or by removing this cation from the culture medium. The mechanisms triggered by NMDA receptor-mediated insults to oligodendrocytes have not been clarified yet [4]. However, the types of excitotoxic oligodendrocyte death induced by activation of AMPA and kainate receptors are known to depend on the intensity and duration of glutamate exposure. A central event to this process is the accumulation of  $Ca^{2+}$  within mitochondria, which leads to depolarization, increased production of oxygen free radicals (ROS), and release of proapoptotic factors that activate caspases (Fig. 1).

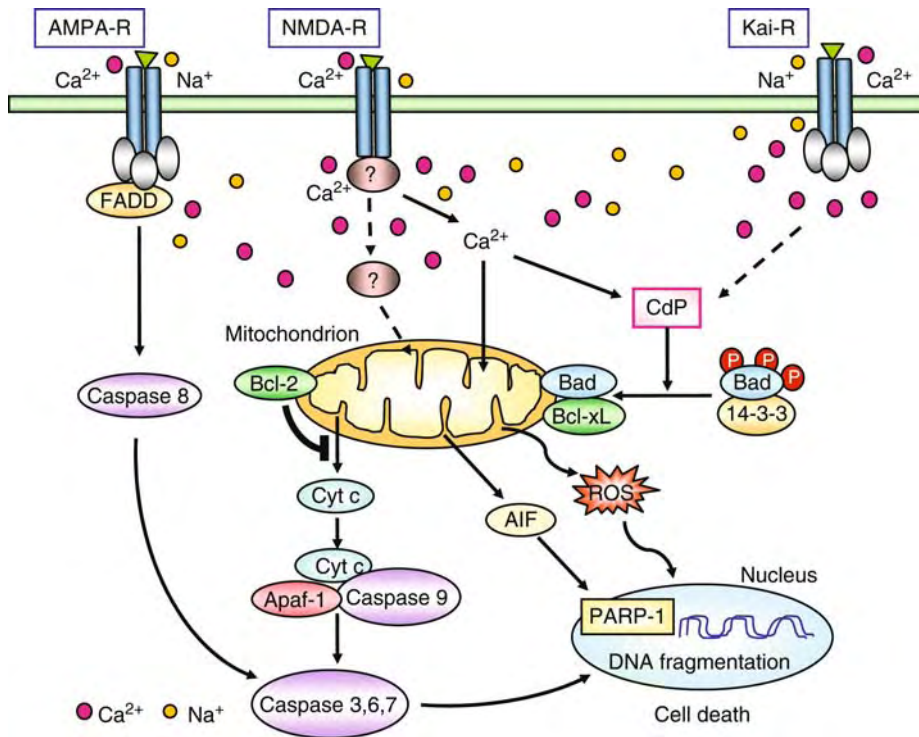

**Glutamate-Mediated Injury to White Matter: Mechanisms and Clinical Relevance. Figure 1** ▶ **Glutamate receptor-mediated oligodendrocyte toxicity.** Activation of receptors leads to  $Ca^{2+}$  overload, generates ROS, Cyt c and apoptotic protease activating factor 1 (Apaf-1) activates caspases and PARP-1 respectively. In addition,  $Ca^{2+}$  influx triggered by Kai-R stimulation but not by AMPA-R activates calcineurin (CdP) which dephosphorylates Bad and facilitates apoptosis. Finally, activation of NMDA receptors (NMDA-R) also initiates oligodendrocyte death which is entirely dependent on  $Ca^{2+}$  influx, however the molecular mechanisms activated by these receptors are not known yet. Modified from [3].

Glutamate at non-toxic concentrations (within the micromolar range) can also induce oligodendrocyte death by sensitizing these cells to complement attack [7]. Intriguingly, complement toxicity is induced by activation of kainate, but not of AMPA, NMDA or metabotropic glutamate receptors, and abolished by removing  $\text{Ca}^{2+}$  from the medium during glutamate priming. Oligodendrocyte death by complement required the formation of the membrane attack complex, which in turn increased membrane conductance, induced  $\text{Ca}^{2+}$  overload and mitochondrial depolarization as well as a rise in the level of ROS. Treatment with antioxidants and inhibition of poly (ADP-ribose) polymerase-1 (PARP), but not of caspases, protects oligodendrocytes against damage induced by complement. This novel mechanism of glutamate-induced toxicity to oligodendrocytes is also shared by neurons and may be relevant to glutamate injury in acute and chronic neurological disease with primary or secondary inflammation.

### Clinical Relevance

In humans, white matter constitutes about 50% of brain volume and consequently glutamate-induced oligodendrocyte death is highly relevant to the pathophysiology of CNS diseases. In addition, primary and/or secondary glutamate damage to oligodendroglia in grey matter may also contribute to the onset and progression of acute and chronic brain and spinal cord disorders. Thus, loss of oligodendrocytes and/or damage to white matter occurs in stroke, traumatic injury, neurodegenerative diseases, ►multiple sclerosis (MS) [3], as well as in psychiatric diseases [8]. The cases of stroke, periventricular leukomalacia (PVL) and MS are succinctly described below.

In humans, most cases of focal ischemia and occlusion of major cerebral arteries damage both grey and white matter. Energy deprivation causes neuronal death, axonal dysfunction and loss of oligodendrocytes, which are very sensitive to transient oxygen and glucose deprivation [9]. After 1h under these conditions, the viability of oligodendrocytes in mixed glial cultures is severely impaired, an effect which is attenuated by AMPA/kainate antagonists. In turn, immature oligodendrocytes are even more sensitive to ischemic injury than their mature counterparts. *In vivo* models of stroke and cardiac arrest such as permanent middle cerebral artery occlusion and brief transient global ischemia also induce rapid oligodendroglial death.

Periventricular leukomalacia (PVL), the main substrate for cerebral palsy, is characterized by diffuse injury of deep cerebral white matter, accompanied in its most severe form by focal necrosis. Injury to oligodendrocyte progenitors, caused in part by glutamate and the subsequent derailment of  $\text{Ca}^{2+}$  homeostasis, contributes to the pathogenesis of myelination disturbances in this illness. In addition to this mechanism, glutamate

induced depletion of glutathione and the subsequent oxidative stress in PVL also contributes to damage to oligodendrocytes, which are sensitive to oxidative stress in part because of their high lipid and iron content.

In MS, the immune system attacks the white matter of the brain and spinal cord, leading to disability and/or paralysis. Myelin and oligodendrocytes are lost due to the release of cytotoxic cytokines by immune cells, autoantibodies and toxic amounts of glutamate [3,10]. In turn, experimental autoimmune encephalomyelitis (EAE), an animal model which exhibits the clinical and pathological features of MS, is alleviated by AMPA and kainate receptor antagonists. Moreover, blockade of these receptors in combination with anti-inflammatory agents is effective even at an advanced stage of unremitting EAE, as assessed by increased oligodendrocyte survival and remyelination, and corresponding decreased paralysis, inflammation, CNS apoptosis and axonal damage.

Furthermore, glutamate levels are increased in acute MS lesions and in normal-appearing white matter in MS patients [10]. Potential cellular sources contributing to enhanced glutamate levels in CSF include activated microglia, which can release glutamate via the reversal of glutamate transporter function, a process which is potentiated under pathological conditions. In addition, oxidative stress may also contribute to the increase in glutamate concentrations in the extracellular space, since free radicals reduce the efficiency of glutamate transporters. Other factors which may contribute to perturbing glutamate homeostasis include altered activity of the glutamate producing enzyme glutaminase in activated macrophages/microglia in close proximity to dystrophic axons, and altered expression of the glutamate transporters EAAT-1 and EAAT-2 in oligodendrocytes as a consequence of enhanced exposure to the proinflammatory cytokine  $\text{TNF}\alpha$  [3]. Overall, these alterations likely lead to high extracellular glutamate levels and an increased risk of oligodendrocyte excitotoxicity in MS.

### Regulation of the Process

Oligodendrocytes display great vulnerability to over-activation of AMPA, kainate and NMDA receptors. The proper functioning of glutamate uptake is critical to prevent glutamate-induced damage to oligodendrocytes and drugs that regulate the function and expression of glutamate transporters have the potential to attenuate glutamate insults to glial cells. Likewise, positive regulators of the expression of glutamate transporters also have a protective potential. These include transforming growth factor (TGF)- $\alpha$  and epidermal growth factor (EGF), which by signaling through EGF receptors and activation of phosphoinositol-3-kinase (PI3K) and nuclear factor- $\kappa\text{B}$  (NF- $\kappa\text{B}$ ), a transcription factor, strongly enhance EAAT2 expression. In addition, clinically used  $\beta$ -lactam antibiotics are also potent activators of glutamate expression and thus hold great therapeutic potential.

Another set of molecular targets to prevent glutamate insults to oligodendrocytes lie downstream of glutamate receptors activation. For instance, tetracyclines, which attenuate mitochondrial damage subsequent to insults including excitotoxicity, protect oligodendrocytes and white matter, making these antibiotics promising candidates for the treatment of acute and chronic diseases with oligodendrocyte loss. On the other hand, drugs supporting the management of  $\text{Ca}^{2+}$  overload subsequent to glutamate receptors activation may improve oligodendrocyte viability.

In summary, knowledge about the mechanisms leading to glutamate receptor-mediated oligodendrocyte injury will facilitate new pharmacological strategies for the treatment of CNS disorders which cause white matter damage.

## References

1. Haddad JJ (2005) N-methyl-D-aspartate (NMDA) and the regulation of mitogen-activated protein kinase (MAPK) signaling pathways: a revolving neurochemical axis for therapeutic intervention? *Prog Neurobiol* 77(4):252–282
2. Danbolt NC (2001) Glutamate uptake. *Prog Neurobiol* 65:1–105
3. Matute C, Domercq M, Sánchez-Gómez MV (2006) Glutamate-mediated glial injury: mechanisms and clinical importance. *Glia* 53:212–224
4. Matute C (2006) Oligodendrocyte NMDA receptors: a novel therapeutic target. *Trends Mol Med* 12:289–292
5. Oka A, Belliveau MJ, Rosenberg PA, Volpe JJ (1993) Vulnerability of oligodendroglia to glutamate: pharmacology, mechanisms, and prevention. *J Neurosci* 13:1441–1453
6. Merrill JE, Benveniste EN (1996) Cytokines in inflammatory brain lesions: helpful and harmful. *Trends Neurosci* 19:331–338
7. Alberdi E, Sánchez-Gómez MV, Torre I, Domercq M, Pérez-Samartin A, Pérez-Cerdá F, Matute C (2006) Activation of kainate receptors sensitizes oligodendrocytes to complement attack. *J Neurosci* 26:3220–3228
8. Davis KL, Stewart DG, Friedman JI, Buchsbaum M, Harvey PD, Hof PR, Buxbaum J, Haroutunian V (2003) White matter changes in schizophrenia: evidence for myelin-related dysfunction. *Arch Gen Psychiatry* 60:443–456
9. Stys PK (2004) White matter injury mechanisms. *Curr Mol Med* 4:113–130
10. Srinivasan R, Sailasuta N, Hurd R, Nelson S, Pelletier D (2005) Evidence of elevated glutamate in multiple sclerosis using magnetic resonance spectroscopy at 3 T. *Brain* 128:1016–1025

## Glutamatergic Receptors

### Definition

Glutamic acid acts on two general classes of receptors (thus, glutamatergic receptors): metabotropic, which

are G-protein coupled, and ionotropic, which are ion channels. *N*-methyl-D-aspartate (NMDA) and non-NMDA (alpha-amino-3-hydroxy-5-methylisoxazole-4-propionic acid, AMPA) receptors are two of the most important ionotropic glutamatergic receptors.

## Glutamic Acid

### Definition

Glutamic acid is an amino acid that elicits neuronal excitatory effects. Glutamic acid is the major excitatory transmitter in the mammalian central nervous system.

## Glutamatergic Neurons

### Definition

Neurons that release glutamate as a neurotransmitter.

## Glycemia

### Definition

Glycemia refers to the concentration of glucose in blood.

## Glycine

### Definition

Glycine is an inhibitory transmitter in the adult brain and is also a modulator of *N*-methyl-D-aspartate (NMDA) receptors. Glycine is recognized as being part of the amino acid family of classical neurotransmitters.

Glycine appears to have an inhibitory effect in only certain areas of the brain, such as the spinal cord, medulla, and retina. Glycine activates GLY receptors leading to the influx of chloride into the postsynaptic cell leading to inhibition. More recently, glycine has been shown to bind to a site on NMDA channels, which increases the conductance of this channel.

## Glycogen

### Definition

A polysaccharide of glucose which serves as an energy store in liver, muscles, brain and other tissues.

Glycogen is formed from glucose to be stored in tissues under the influence of insulin and broken down to glucose to be used as fuel under the influence of glucagon, secreted respectively by the beta and alpha cells of the pancreas in response to different levels of glucose in the blood. In the liver, glycogen serves as a major store of readily available glucose for the whole body as well as the liver, where it can represent 8% of tissue weight. In muscle, it represents a smaller percentage of the tissue (~2%) but serves nonetheless as a critical, immediate reserve of glucose for the muscle cells themselves. In brain, glycogen represents a similarly small proportion of the tissue and is stored only in glial and not in neuronal cells. Brain glycogen levels change over the sleep-wake cycle. Just as fatigue in muscles occurs with depletion of glycogen, central fatigue also occurs following prolonged activity associated with decreases in glycogen during waking.

Just as rest allows replenishment of the glycogen stores in muscles, sleep allows replenishment of depleted glycogen stores in brain.

- ▶ Sleep-Wake Autonomic Regulation
- ▶ Sleep-Wake Mechanisms

## Glycogen Synthase Kinase 3b (GSK-3b)

### Definition

A serine/threonine protein kinase, one of many kinases that phosphorylate glycogen synthase. GSK-3 $\beta$  phosphorylates adenomatous polyposis coli (APC), preventing microtubule plus-end capping, thereby reducing stability and decreasing motility. In response to growth factor stimulation (TrkA activation) the activity of GSK-3 $\beta$  is inhibited by Akt phosphorylation, thus allowing microtubule plus-end capping by APC.

- ▶ Growth Factors
- ▶ Microtubule

## Glycogenolysis

### Definition

The breakdown of glycogen into glucose-1-phosphate by the action of the enzyme glycogen phosphorylase.

## Glycolic Acid, Lactic and $\epsilon$ -Caprolactone ( $\epsilon$ -Caproic Acids)

### Definition

These are naturally occurring hydroxyl acids. These are utilized for synthesizing biodegradable polymers: polyglycolic acid, polylactic acid and poly- $\epsilon$ -caprolactone in medicine. The degradation speed of poly  $\epsilon$ - caprolactone under physiologic conditions is slower than that of polyglycolic or polylactic acid.

- ▶ Transplantation o Artificial Materials for Nerve Regeneration

## Glycolipid

### Definition

A membrane lipid molecule with a short carbohydrate chain attached to a hydrophobic tail.

- ▶ Membrane Components

## Glycolysis

### Definition

The sequence of reactions that converts glucose to pyruvate.

## Glycoprotein

### Definition

A protein molecule with one or more oligosaccharide Chains.

- ▶ Membrane Components

## Glycosaminoglycans

### Definition

Glycosaminoglycans are long unbranched sugar side chains that are attached to the protein core of proteoglycans. The sugars are polysaccharides made up of a repeating disaccharide unit.

## Glycosylation

### Definition

Glycosylation is a post-translational modification by which sugars are added to proteins or lipids. Sugars can either be N-linked (to the amide nitrogen of asparagines side chains) or O-linked (to the hydroxy oxygen of serine and threonine side chains).

## Glycosylphosphatidyl Inositol (GPI)

### Definition

Glycosylphosphatidyl inositol (GPI) is a glycolipid that can be attached to the C-terminus of a protein, thus anchoring it to the plasma membrane. The phospholipid is attached in the endoplasmic reticulum as a posttranslational modification.

## GlyR

### Definition

Glycine receptor.

- ▶ Glycine

## Gnathostomata

### Definition

Craniates with jaws and paired fins.

- ▶ The Phylogeny and Evolution of Amniotes

## Gnathostomes

### Definition

Vertebrates with true jaws (chondrichthyans, actinopterygians, sarcopterygians).

- ▶ Evolution of the Brain: In Fishes
- ▶ Evolution of the Telencephalon: In Anamniotes

## GnRH Neurons

### Definition

(Synonym: LHRH neurons) A small subset of neurons in the anterior hypothalamus which secrete gonadotropin releasing hormone (GnRH). GnRH neurons form the final common pathway for central control of reproduction in vertebrates. GnRH triggers the release of gonadotropins (luteinizing hormone and follicle stimulating hormone) from gonadotrope cells in the anterior pituitary, which regulate puberty onset, gametogenesis, and estrus cycling.

- ▶ Gonadotropin Releasing Hormone (GnRH)

## Goal-Oriented Behavior

### Definition

Synonym of motivated behavior. Complex behavior elaborated by an animal to reach a specific goal which could be motivated by natural (food, sex, fear) or artificial (drug) stimuli.

## Goldman-Hodgkin-Katz Equation

### Definition

Goldman-Hodgkin-Katz equation is also called constant field equation.

- ▶ Membrane Potential: Basics
- ▶ Intracellular Recording

## Golgi Apparatus

### Definition

The Golgi apparatus is an endo-membranous organelle that is responsible for modifying and packaging proteins that are synthesized by the rough endoplasmic reticulum. The Golgi apparatus furthermore sorts proteins destined for lysosomes, the constitutive and regulated secretory pathway.

## Golgi Epithelial Cells

### Definition

Another name for Bergmann glia in the cerebellum (see above).

## Golgi Stain

### Definition

The Golgi stain is a method using silver nitrate to densely stain an entire single neuron including its dendrite and axon branches. Only a small subset of neurons are stained with the Golgi method, so the entire structure of those few neurons that are stained is visible for study. There is currently no explanation for why the Golgi method stains only a selected subset of neurons or of why those particular cells are stained. Camillo Golgi shared the Nobel Prize in Medicine with Santiago Ramón y Cajal in 1906.

## Golgi Tendon Organ

### Definition

A mechanoreceptor (with group Ib afferent fibers) located at the junction between the muscle fibers and tendon, which responds preferentially to the force and rate of change of force of the muscle fibers that attach to it directly.

## Golgi Type-I Neuron/Cell

### Definition

A type of pyramidal neuron identified with a long process that leaves the gray matter to travel in the white matter. It can be thought of as a projection neuron.

## Golgi Type-II Neuron/Cell

### Definition

The Golgi type-II neuron is a type of stellate neuron whose short axonal process remains in the gray matter. It can be thought of as an interneuron.

## Gonadotropin

### Definition

A protein hormone secreted by the pituitary gland that acts to stimulate the gonads.

- ▶ Hypothalamo-neurohypophysial System

## Gonadotropin Releasing Hormone (GnRH)

### Definition

Also known as luteinizing hormone-releasing hormone (LHRH) is a neuroendocrine decapeptide. There can be

up to three (GnRH1, GnRH2, GnRH3) distinct forms (at the amino acids level) found in vertebrates. The form found in the hypothalamus regulates reproductive function in vertebrates, the other forms are thought to neuromodulatory in function.

## Gourmand Syndrome

### Definition

Newly (1997) discovered rare eating disorder associated with lesions of the right frontal lobe. Patients develop a preference for fine eating.

► Neural Coding of Taste

## gp 41

### Definition

It is a viral (HIV) envelope protein found in association with gp120 protein, and is involved in the fusion of virus with the host cell. It is also said to activate host inflammatory responses including activation of the complement system.

► Central Nervous System Disease – Natural Neuroprotective Agents as Therapeutics

## gp130

### Definition

Cytokine signaling is mediated by a group of receptors that form signaling receptor complexes. gp130 is a highly promiscuous cytokine signaling receptor essential for various mammalian cell growth and homeostasis pathways. The receptors for the neurotrophic molecules LIF, IL-6 and CNTF all form receptor signaling complexes with gp130.

► Neurotrophic Factors in Nerve Regeneration

## G-protein Coupled Receptors (GPCRs): Key Players in the Detection of Sensory and Cell-Cell Communication Messages

JOËL BOCKAERT

Université de Montpellier, CNRS UMR5203, Montpellier, France; Inserm U661, Montpellier, France

### Synonyms

Seven transmembrane receptors; 7TM receptors; Heptahelical receptors

### Definition

The evolution and survival of complex multicellular organisms greatly depend upon the capacity of their cells to communicate with each other and with their environment. After the cloning of many genes and the availability of complete genome sequence data from human and many species, one of the surprises was to find that detections of sensory messages (such as light, odours, ► **pheromones**, gustative molecules) as well as cell-cell communication messages (such as hormones, neurotransmitters, growth and developmental factors) are assured by a few families of proteins. The most common one is the G-protein coupled receptor (► **GPCR**) family [1–4]. GPCRs are receptors that are made up of seven transmembrane integral proteins. They have two functions: one is to recognize sensory or cell-cell communication messages, the other is to transduce these messages into activation of other proteins associated, via lipids, to the internal surface of the cell: the G proteins. G proteins are heterotrimeric proteins. G proteins are heterotrimeric proteins composed of  $G\alpha$ ,  $G\beta$ ,  $G\gamma$  subunits.  $G\beta$  and  $G\gamma$  are always associated. In their inactive form,  $G\alpha$  binds GDP and forms a complex with  $G\beta\gamma$ . When a GPCR is activated by a sensory or a cell-cell communication message (also called first messengers) they catalyze the GDP/GTP exchange on the  $G\alpha$ .  $G\alpha$ -GTP is released from  $G\beta\gamma$  and both  $G\alpha$ -GTP and  $G\beta\gamma$  interact with specific effectors. Effectors can be enzymes such as the adenylyl cyclases and phospholipase C which produce intracellular messages (also called second messengers) such as adenosine 3'-5' cyclic-monophosphate (► **cAMP**) and inositol 1,4,5-trisphosphate (IP3), respectively. These second messengers modify cellular functions (division, secretion, movement, differentiation, etc.) via cascades of biochemical reactions. The cellular biochemical events following GPCR activation are called ► **signal transduction**. Effectors can also be ionic channels that modify the cellular potential, leading to the modulation

of action potentials in neurons, contraction in cardiac muscles, secretion, etc. There are 17 genes coding for  $G\alpha$ , 5 for  $G\beta$  and 14 for  $G\gamma$ , that are found in many, but by no means all possible combinations. Each GPCR can activate several G proteins and thus can induce a whole array of different cellular signaling events. In addition to interacting with G proteins, GPCRs also interact with many GPCR interacting proteins (GIPs) which modulate their targeting to a specific cell area, their trafficking to and from the membrane, the fine-tuning of their signaling, as well as their desensitization [2,4].

### Characteristics

Indeed, GPCRs constitute the most abundant family of genes in most animal genomes. In human, there are between 500 and 800 odorant GPCRs (ORs) and about 360 GPCRs for intercellular messages such as hormones, neurotransmitters, (these GPCRs are called endo-GPCRs). This represents about 3.3% of the total number of genes in the human [1,3].

These numbers and the main roles played by GPCRs in physiology explain why GPCRs are of interest for all domains of research, especially physiology, pharmacology and medical research. Another reason is the fact that among the 360 endo-GPCRs, more than 100 are still “orphan” GPCRs. “Orphan GPCRs” are GPCRs for which no endogenous ►ligands (hormone, neurotransmitter) are known. Although every year, few new endogenous ligands are discovered, many remain to be found. Many pharmaceutical and academic laboratories are interested because this is a way to discovering new physiological regulators and new drugs. Indeed, GPCRs represent the targets of more than 50% of the drugs currently on the market. To provide a few examples, morphine, anti-psychotics, some anti-hypertensive drugs, anti-histaminic, inhibitors of prolactin secretion, drugs for asthma, anti-migraine drugs and new anti-HIV drugs (anti-CCR5) all act on specific GPCRs.

The occurrence of GPCRs and G-protein signaling dates back to 1.2 billion years ago, which is well before plants, fungi and animals emerged from a common ancestor. The first glutamate-like GPCRs are found in the sponge (*Geodia cydonium*) and in slime mould (*Dictyostelium discoideum*). Fungi (*Saccharomyces cerevisiae*) express pheromone GPCRs. However, GPCRs had no evolutionary success in plants. In contrast, a remarkable expansion of GPCRs appeared in Bilateria species such as insects, nematodes, trematodes (500–800 million years ago) and of course in vertebrates (500 million years ago) [3].

### The Three-Dimensional Structure and the Different GPCR Classes

All GPCRs share a central core domain made up of seven transmembrane domains (TM-I to TM-VII) called heptahelical domains (HD) connected by three

extracellular (E-I to E-III) and three cytoplasmic (C-I to C-III) loops (Fig. 1).

The N-terminal domain is extracellular and the C-terminal domain is intracellular. The only crystal structure obtained is the crystal of inactivated rhodopsin (receptor of photons). GPCRs are dimeric structures (Fig. 1) most of them are homodimeric (two identical monomers), whereas some of them are heterodimeric (two different monomers). Among the latter, we can find a receptor for the major inhibitory receptor GABA (gamma aminobutyric acid), the GABA<sub>B</sub> receptors are formed from associating GB1 and GB2, the receptor for sweet molecules (sucrose, aspartame) composed of T1R2 and T1R3, the receptor for the Umani taste (glutamate taste typical of Asian food) composed of T1R1 and T1R3 (Fig. 2).

Based on the nature of their HD protein sequences, several GPCR classes can be defined (Fig. 2).

- **class 1:** contains the majority of GPCRs including those for odours in vertebrates (olfactory receptors: ORs), rhodopsin, receptors for small neurotransmitters (adrenaline, serotonin, dopamine, endocannabinoids, enkephalins, etc.) or large hormones (TSH = thyroid stimulating hormone, LH = luteinizing hormones, etc.).
- **class 2:** contains receptors for large hormones such as glucagon, secretin, calcitonin, etc.
- **class 3:** this is a particularly original class because of its structure (Fig. 1), the binding site for the ligand is in the extracellular domain within the two lobes of a Venus-fly trap like domain. It contains the receptors of glutamate (mGluRs), GABA<sub>B</sub>, sweet molecules (T1R2-T1R3), for Umami taste (T1R1-T1R3), some pheromone receptors (V2Rs) and a calcium receptor (Ca<sup>2+</sup>) [5].
- **class 4:** contains a family of pheromone receptors (VIR).
- **class 5:** contains receptors such as the frizzled receptors for regulators of embryonic development such as the **Wnt**.
- **class 6:** contains GPCRs for cAMP only found in the slime mould *Dictyostelium discoideum*.
- **class 7:** contains receptors for bitter taste (►T2Rs).
- **class 8:** contains receptors for odorants in *Drosophila*.

### Activation of GPCRs

Until recently, pharmacologists working on GPCRs used the traditional “receptor occupation theory.” The receptor was under an inactive conformation (R) and in the presence of an ►agonist ligand (A), the AR\* complex was formed which was active (R + A ↔ RA\*). GPCRs are now considered, similarly to receptor channels (for example nicotinic receptors), as ►allosteric proteins. They are in equilibrium between several conformations, some being inactive and some being



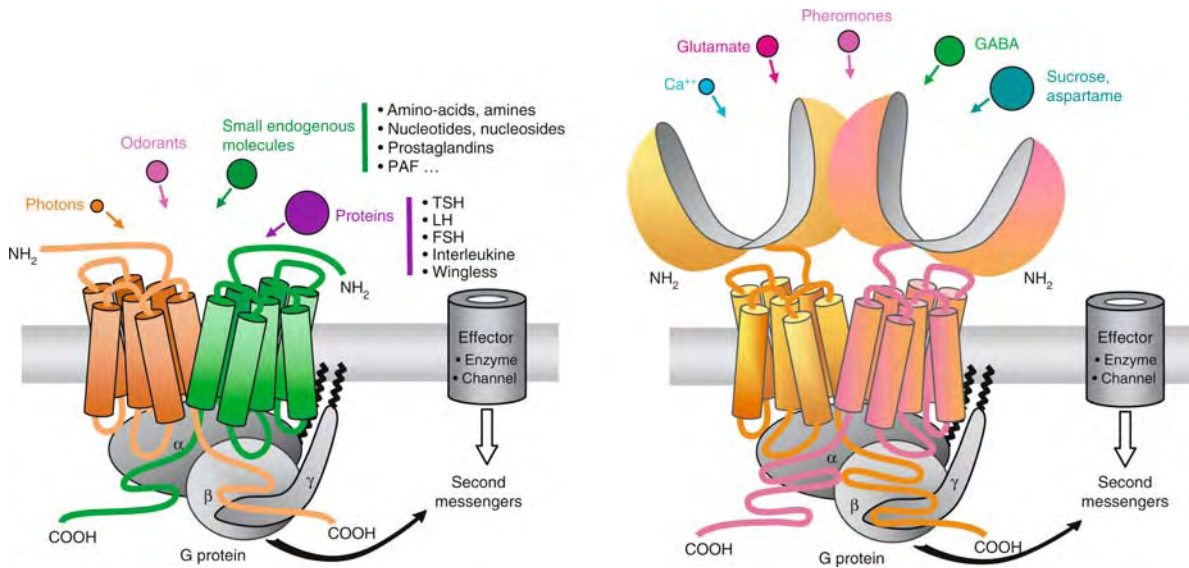

**G-protein Coupled Receptors (GPCRs): Key Players in the Detection of Sensory and Cell-Cell Communication Messages.** Figure 1 GPCRs are dimers that stimulate heterotrimeric G proteins (a) Class 1 GPCRs recognize a wide variety of ligands of different chemical nature, photons, odorants, small endogenous molecules (such as amino-acids), serotonin, adrenaline, prostaglandins, adenosine, ATP and hormonal or regulatory proteins (such as TSH, LH, interleukin). Depending on the size of the ligand, the binding site is within the transmembrane domain or more at the external surface of the receptor. (b) Class 3 GPCRs have a particular structure. The binding site of ligands is localized within the external N-terminal domain. It is formed of two lobes which enter the ligand. This two-lobe domain is called the Venus flytrap module (VFTM) because it resembles the two leaves from the *Dionea muscipula* which trap insects.

active. The different agonist ligands for a given GPCR (endogenous message molecules, natural active compounds, such as morphine or synthetic active drugs, such as medicinal drugs) select particular active conformations [6]. Some GPCRs may be under an active conformation without a ligand: the receptor is “constitutively” active. In these cases, it is possible to find ligands which reverse this activity: they are called ▶“inverse agonists”. There are two categories of “constitutive” GPCRs. The first one includes mutated GPCRs resulting often in pathologies (see GPCRs and human pathologies). The second one includes GPCRs which are physiologically “constitutive.” This is the case for the MC4R, a receptor for the anorectic hormone  $\alpha$ -MSH (melanocortin).  $\alpha$ -MSH further stimulates the receptor, resulting in reduced feeding, whereas the other physiological hormone, called agouti-related peptide which is an inverse agonist, is a potent anorectic regulator [7].

### An Example of GPCRs as Key Players in Physiology: GPCRs for Odours and Pheromones

Humans and animals have an extraordinary capacity of discriminating thousands of odorants [8]. This is assured by specific neurons from the nasal cavity, called the main olfactory epithelium (MOE). Each olfactory

neuron expresses only one of the 1000 ORs. However, each given OR can recognize different ORs, but with different affinities. Odorant recognition is a combinatorial coding strategy whereby a given odorant activates a particular constellation of receptors. When an odorant binds to an OR, a G protein called Gs, is activated which stimulates the adenylyl-cyclase of the olfactory neurons. Adenylyl cyclase synthesizes cAMP by interacting directly with a  $\text{Ca}^{2+}/\text{Na}^{+}$  channel (called the OCNC1 = olfactory-specific cyclic nucleotide gated channel), which depolarizes the neuron and generates the sensory signal.

Animals need specific strategies to recognize and attract mates and to identify the social status of conspecifics [9]. In many species, this involves the emission and recognition of message molecules, called pheromones. Pheromones control behaviors largely reproducible and genetically determined. In rodents, neurons expressing pheromone receptors are localized in a specific nasal cavity area called the vomeronasal organ (VNO) [9]. In the human and higher primates, the vomeronasal system is probably not functional. In rodent VNO, two types of GPCRs are expressed. The apical part expresses the V1R family, which constitutes the entire class 4 of GPCRs (Fig. 2), whereas the basal part expresses the V2R family of GPCRs. The V2Rs belong to

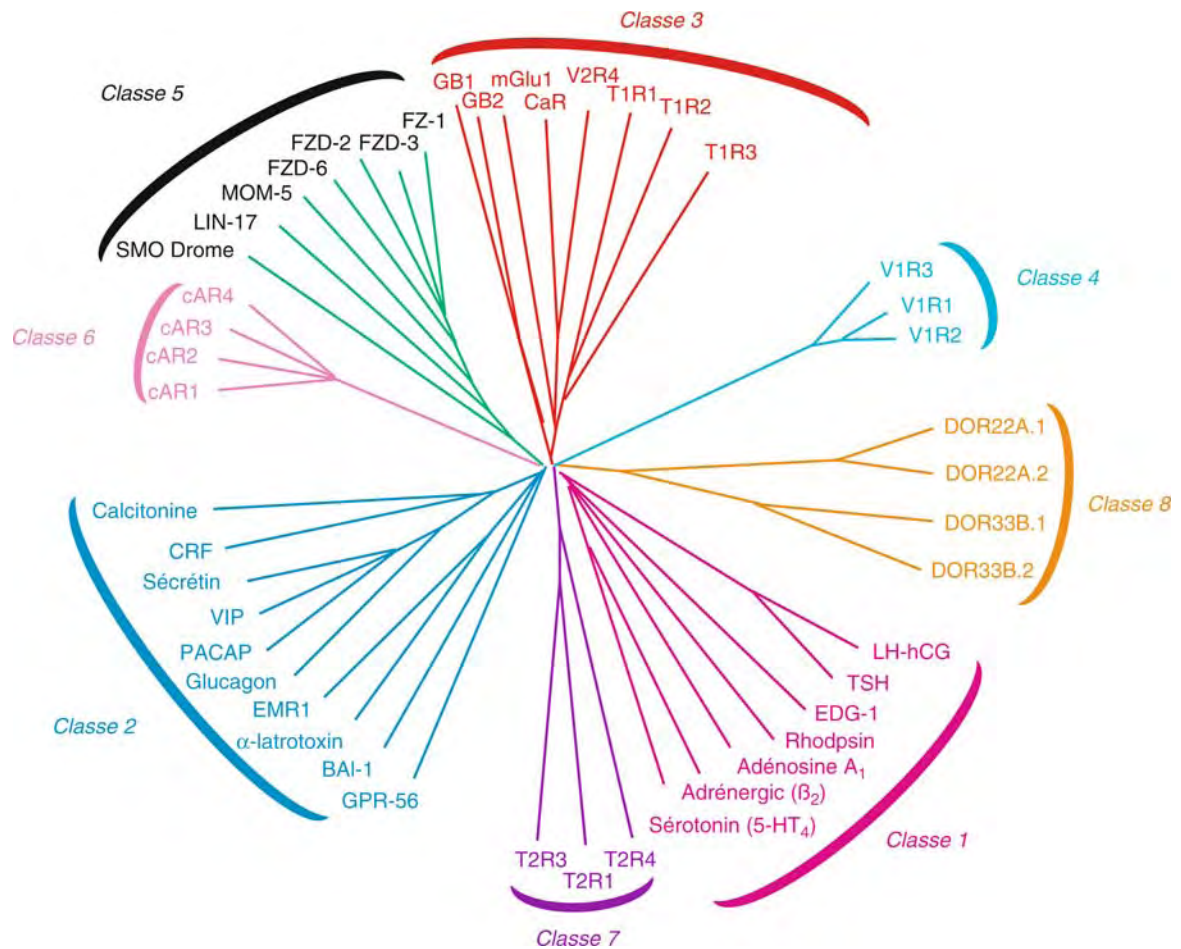

**G-protein Coupled Receptors (GPCRs): Key Players in the Detection of Sensory and Cell-Cell Communication Messages.** Figure 2 Phylogenetic-tree classifying the different GPCRs Protein sequences (excluding the N-terminal and the C-terminal domains) were multi-aligned and a tree was calculated using Clustal W. A bootstrap analysis was performed on the tree construction. The tree was drawn using Tree View. Eight classes of GPCRs were recognized (see text and 2).

class 3 GPCRs that are closely related to metabotropic glutamate receptors (Fig. 2). In order to be functional, V2Rs must be associated with the M10 and M1 families of the non-classical major histocompatibility complex (MHC) molecules and  $\beta$ 2-microglobulin. The mouse V1R and V2R gene families include about 150 functional genes each. V1R and V2R signaling involves activation of a G protein called Gq which stimulates a phospholipase C resulting in IP<sub>3</sub> and diacylglycerol (DAG), followed by the production of arachidonic acid. This second messenger activates a cation channel, called TRPC2 (transient receptor potential channel) and thus depolarizes the neurons [9].

The recent unexpected finding was that both receptors for olfaction (ORs) and receptors for recognition of pheromones are important for rodent sexual behavior and gender specific aggression [9]. ORs are essential

to trigger mating behavior, whereas GPCRs from the vomeronasal system (V1Rs, V2Rs) are essential to control the sex-specificity of reproductive behavior and male-male aggression. The possible implication of ORs of MOE, in addition to GPCRs of VNO, in pheromone-conditioned behavior may explain why, in human, some pheromonal types of responses have been observed in spite of a non-functional VNO system. This includes the synchronization of menstrual cycles in women living together, the effect of male androstadienone contained in sweat, in the alteration of women's mood and salivary cortisol levels [9].

#### GPCRs and Human Pathologies

The first pathology associated with GPCR dysfunction was *Retinitis pigmentosa* (RP) [10]. Indeed, one of the hereditary forms of RP was associated with the

3q21-qter locus which is the locus of rhodopsin. Two types of GPCR mutations may be responsible for pathologies [10]. The gain-of-function mutations, in which the receptor becomes constitutively active (see Activation of GPCRs), and the loss-of-function mutations. The loss-of-function mutations are largely hereditary. More than 150 mutant alleles have been identified in RP but also in nephrogenic diabetes insipidus (NDI) in which mutations affected the vasopressin V2 receptors. Among other pathologies associated with GPCR loss-of-function, one can quote: the Hirschsprung syndrome (mutation of the endothelin B receptor), ovarian dysplasia (mutation of the follitropin receptor) and many others. Among the most studied gain-of-function mutations are sporadic and hereditary toxic thyroid hyperplasia observed in the absence of auto-immunity Graves' disease, which is largely due to constitutively active TSH receptors. One can also quote the congenital night blindness (constitutively active rhodopsin) or the familial male precocious puberty (constitutively active LH receptors).

## References

1. Bockaert J, Pin JP (1999) Molecular tinkering of G protein-coupled receptors: an evolutionary success. *Embo J* 18(7):1723–1729
2. Bockaert J, Claeysen S, Becamel C, Pinloche S, Dumuis A (2002) G protein-coupled receptors: dominant players in cell-cell communication. *Int Rev Cytol* 212:63–132
3. Fredriksson R, Lagerstrom MC, Lundin LG, Schiöth HB (2003) The G-protein-coupled receptors in the human genome form five main families. Phylogenetic analysis, paralogue groups, and fingerprints. *Mol Pharmacol* 63:1256–1272
4. Lefkowitz RJ (2004) Historical review: a brief history and personal retrospective of seven-transmembrane receptors. *Trends Pharmacol Sci* 25(8):413–422
5. Pin JP, Kniazeff J, Goudet C, Bessis AS, Liu J, Galvez T, Acher F, Rondard P, Prezeau L (2004) The activation mechanism of class-C G-protein coupled receptors. *Biol Cell* 96:335–342
6. Urban JD, Clarke WP, von Zastrow M, Nichols DE, Kobilka B, Weinstein H, Javitch JA, Roth BL, Christopoulos A, Sexton PM, Miller KJ, Spedding M, Mailman RB (2007) Functional selectivity and classical concepts of quantitative pharmacology. *J Pharmacol Exp Ther* 320:1–13
7. Adan RA, Kas MJ (2003) Inverse agonism gains weight. *Trends Pharmacol Sci* 24(6):315–321
8. Julius D, Katz LC (2004) A nobel for smell cell 119(6):747–752
9. Dulac C, Wagner S (2006) Genetic analysis of brain circuits underlying pheromone signaling *Annu Rev Genet* 40:449–467
10. Schöneberg T, Schulz A, Biebermann H, Hermsdorf T, Rompler H, Sangkuhl K (2004) Mutant G-protein-coupled receptors as a cause of human diseases. *Pharmacol Ther* 104:173–206

## G-Protein Coupled Receptors in Sensory Neuron Function and Pain

DEREK C. MOLLIVER

Department of Medicine, University of Pittsburgh, Pittsburgh, PA, USA

### Synonyms

Metabotropic receptors; Pain and ligand-gated channels/receptors; GPCRs

### Definition

The function of membrane-bound receptors coupled to intracellular signaling pathways (GPCRs) in pain-sensing neurons.

### Characteristics

Quantitative information:

G protein-coupled receptors (GPCRs) have a canonical seven transmembrane domain structure and may act as homo-dimers or may bind with other GPCR family members to act as heterodimers. They couple to heterotrimeric G proteins through specialized intracellular domains.

Approximate molecular weights of G proteins:

G $\alpha$ : ~ 40,000

G $\beta$ : ~ 35,000

G $\gamma$ : ~ 8,000

Sensory neurons of the trigeminal and dorsal root ganglia (DRG) transduce mechanical, chemical and thermal stimuli to inform the organism of changes in bodily tissues and the external environment. Particularly important to the survival of the organism is the detection of potentially damaging (nociceptive) stimuli that lead to the sensation of pain. Pain-sensing neurons (nociceptors) innervate the entire body and interact intimately with their target tissues and with the immune system, responding to stimuli that threaten the well-being of the organism. Furthermore, nociceptors can increase their sensitivity to environmental stimuli in response to factors released by peripheral tissues or immune cells after injury. This nociceptor hypersensitivity leads to enhanced pain (**▶hyperalgesia**) (see **▶Hyperalgesia and Allodynia**), which may elicit survival-promoting responses such as escape behavior and protective guarding of the injured area. Activated nociceptors also play a role in maintaining the integrity of peripheral tissues by releasing neuropeptides that promote vasodilation, immune cell infiltration and wound healing. However, persistence of nociceptor hypersensitivity after the injury has healed may lead to the development of chronic pain. Therefore, the mechanisms underlying the functional plasticity of

nociceptors have received much attention as possible contributors to the development of pathological pain states caused by injury or disease.

A major mechanism regulating nociceptor sensitivity is the action of cell-surface receptors that interact with guanine nucleotide-binding proteins (▶G proteins) to control intracellular signaling systems in nociceptors. These G protein-coupled receptors (GPCRs) act through ▶second messenger pathways to (i) acutely modulate the function of other receptors, ion channels and enzymes, and (ii) induce lasting changes in neuronal functional properties by activating transcription. Many different GPCRs are co-expressed in nociceptive neurons, and the mechanisms that regulate both signaling specificity and signal integration within individual neurons represent areas of active investigation. While this essay focuses on the role of GPCRs in pain signaling, it should be noted that GPCRs are expressed by most or all somatosensory neurons, and their roles in the transmission of other sensory modalities, such as fine touch and proprioception, are poorly understood.

### Functional Organization of GPCRs

GPCRs make up the largest superfamily of proteins in eukaryotic cells, with more than 1,200 identified genes. At least 150 are orphan receptors (receptors with no known ligands). Roughly a third of drugs in clinical use target GPCRs, focusing on about 30 well-characterized receptors [1]. All GPCRs share a canonical structure similar to rhodopsin, the first GPCR whose structure was identified, with seven transmembrane domains linked by three intracellular and three extracellular loops.

G proteins are ▶heterotrimers: they include a  $G\alpha$  subunit that binds and hydrolyzes guanosine triphosphate (GTP) and a  $G\beta$  and  $G\gamma$  dimer that are tightly bound and do not dissociate under physiological conditions. In the inactive state, G protein heterotrimers are bound together and  $G\alpha$  is bound to GDP. Activation of a GPCR by its ligand causes the receptor to bind inactive G protein trimers and promote the binding of GTP to the  $G\alpha$  subunits. This causes  $G\alpha$  to dissociate from the GPCR and from the  $\beta\gamma$  dimer. The traditional model of GPCR function is that active  $G\alpha$  monomers then bind and activate a target effector molecule such as adenylate cyclase to initiate intracellular signaling. However, in many cases both  $G\alpha$  and  $G\beta\gamma$  are capable of regulating downstream effectors. G protein activation is terminated by hydrolysis of the GTP to GDP, which allows  $G\alpha$  to bind the  $\beta\gamma$  subunits and return to the inactive state.

Multiple genes exist for each of the G protein subunits that give rise to proteins with different functional properties [2]. At least 17  $\alpha$  subunits, 5  $\beta$  subunits and 13  $\gamma$  subunits have been identified. Selectivity of GPCR signaling is determined by the association of G proteins

with specific receptors, but the structural basis of this relationship has not been well characterized.  $G\alpha$  subunits are grouped into four families: ▶Gs (including Gs and Golf), ▶Gq (Gq, G11, G14, G15 and G16), ▶Gi/o ( $G_{i1}$ ,  $G_{i2}$  and  $G_{i3}$ , Go and Gz) and ▶G12 (G12 and G13) families.

The web of signaling pathways that can be activated by specific G proteins have been described in detail elsewhere [3]. Below are the principal effectors of each of the families of G proteins (Fig. 1).

Selectivity of these signaling pathways for neurons of specific functional modalities is restricted by the selective expression of the GPCRs, the G protein isoforms and their downstream effector molecules. For instance, Gq and G11 are ubiquitously expressed in DRG sensory neurons, whereas G14 is expressed in a restricted subset of neurons, and G15 and G16 are not expressed [4]. Gi/o proteins are the most widely expressed family of  $G\alpha$  subunits. Go is highly expressed in neurons as well as some non-neuronal tissues, whereas Gz is expressed in DRG primarily during development. Likewise, phospholipase C (PLC) isoforms PLC $\beta$ 1, 3 and 4, which are activated by Gq/11, show restricted expression in subsets of DRG neurons, whereas PLC $\beta$ 2 is not expressed in these cells. Protein kinase C (PKC) and calcium-calmodulin dependent protein kinase isoforms, which can be activated downstream of PLC, also show restricted patterns of expression.

### Mechanisms for Modulation of Nociceptor Function

Activation of GPCRs in primary sensory neurons in response to inflammation or traumatic injury results in a cascade of intracellular signaling events. These signals are integrated to modulate the function of other receptors and ion channels that determine nociceptor sensitivity to noxious stimuli. Activation of Gq-coupled receptors can be excitatory or inhibitory, but most examples of endogenously-expressed Gq-coupled receptors indicate that these receptors are pro-nociceptive. Well-characterized examples include receptors for inflammatory mediators released by peripheral tissues and immune cells in response to injury, such as bradykinin (B2), serotonin receptors, ATP (P2Y2), and protease-activated receptors (PAR2). Gq-evoked phospholipase C (PLC) activation and subsequent release of calcium from intracellular stores may promote neurotransmitter release at the presynaptic terminal, and can activate protein kinase C (PKC) in combination with diacylglycerol synthesized by PLC. Increased intracellular calcium may also lead to activation of gene expression, resulting in lasting changes in neuronal excitability.

GPCRs acutely alter neuronal excitability by modulating the function of both voltage-gated ion channels and channels that are specialized to gate currents in response to specific pro-nociceptive stimuli, such as extreme temperatures, acid and ATP. This represents a key

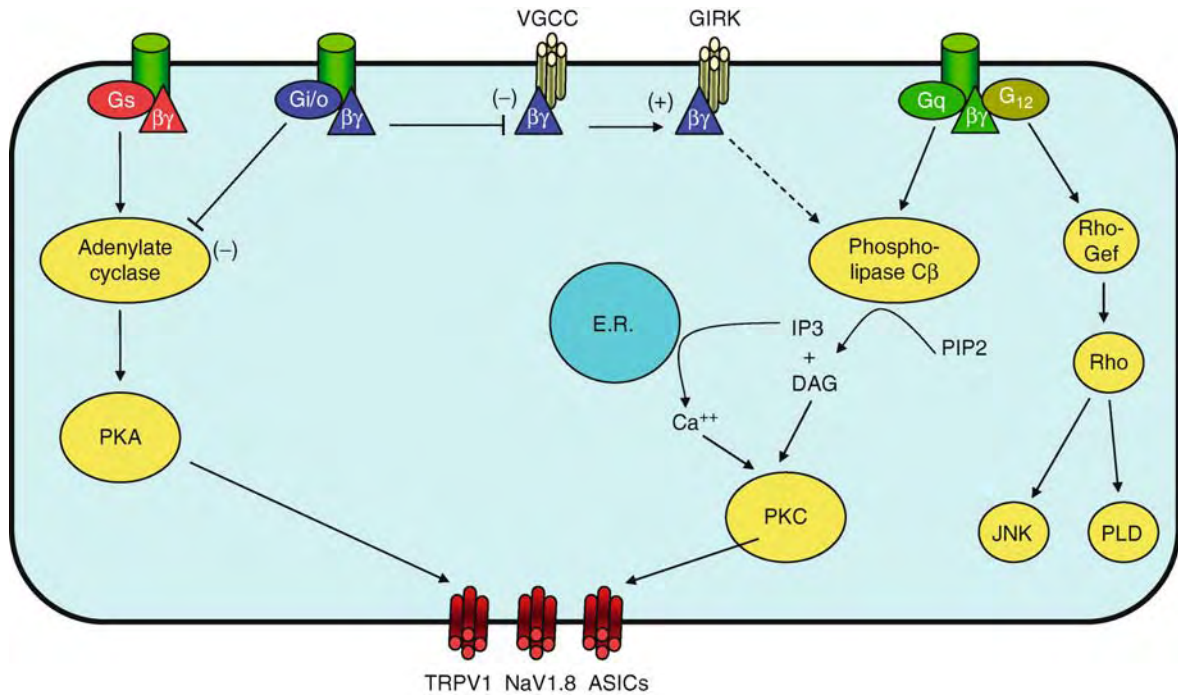

**G-Protein Coupled Receptors in Sensory Neuron Function and Pain. Figure 1** Diagram of the best-characterized intracellular signaling pathways activated by the different G protein family members in primary sensory neurons. G protein-coupled receptors regulate neuronal excitability by indirectly modulating the function of voltage-gated channels, such as voltage-gated calcium channels (VGCC) and G protein-gated inwardly-rectifying potassium channels (GIRK), and sodium channels like NaV1.8, as well as ligand-gated ion channels, such as the acid-sensing ion channels (ASICs) and TRPV1, a heat and proton sensor. Gq and G11 have highly similar pharmacological profiles and are thus often referred to as Gq/11. All three Gi gene products inhibit adenylate cyclase, whereas Go appears to act primarily through its  $\beta\gamma$  subunits. The dotted line represents the possible activation of phospholipase C by  $\beta\gamma$  subunits that has not been verified in sensory neurons. Abbreviations: *E.R.*, endoplasmic reticulum; *JNK*, c-jun N-terminal kinase; *PKA*, protein kinase A; *PKC*, protein kinase C. See text for references.

mechanism for the development of painful hypersensitivity in response to inflammation. For example, members of the *transient receptor potential* (TRP) family of ion channels are expressed in subsets of nociceptors and likely contribute to the detection of thermal stimuli of varying intensities [5]. Both Gq- and Gs-coupled receptors modulate nociceptor responsiveness by enhancing the function of TRPV1, a TRP family member that senses heat and acid (see Fig. 1). GPCRs implicated in this process to date include the prostaglandin and  $\beta$ -adrenergic Gs-coupled receptors, as well as the Gq-coupled bradykinin receptors, PAR-2, serotonin receptors, muscarinic acetylcholine receptors and P2Y2. Activation of Gq-coupled receptors results in a decrease in the temperature threshold of TRPV1 so that it may gate current at body temperature, potentially causing nociceptors to be activated under conditions that normally would not be painful. TRPV1 appears to be a critical integrator of signals produced by GPCRs in response to inflammatory injury, because mice lacking TRPV1 do not develop the painful heat hypersensitivity that normally

accompanies inflammation [5]. Modulation of TRPV1 occurs through phosphorylation-dependent mechanisms that have not been fully characterized, but require the activation of PKC epsilon (by Gq-dependent signaling) or PKA (by Gs signaling). Another TRP family member implicated in the response to noxious irritants, TRPA1, is similarly regulated by GPCRs. Other pro-nociceptive ligand-gated channels also show enhanced function in response to inflammation, including the ATP-gated ion channel P2X3 and the acid-sensing ion channel ASIC3.

Both Gs- and Gq-coupled receptors also increase nociceptor excitability by enhancing the function of voltage-gated channels, particularly **voltage-gated calcium channels** (VGCCs) and the **tetrodotoxin-resistant sodium channels** NaV1.8 and NaV1.9 (see Fig. 1) (see **Voltage-gated ion channels and pain**). PKC and PKA are key effectors for modulation of voltage-gated channels. In contrast, Gi/o-coupled receptors are generally antinociceptive, and mice lacking Go are hypersensitive to noxious stimuli [6]. Gi/o effects are mediated through the inhibition of

adenylate cyclase and thus PKA by the  $G\alpha$  subunit, as well as both the inhibition of VGCCs and the activation of  $\blacktriangleright$ G protein-activated potassium channels (GIRKs) by  $\beta\gamma$  subunits. These are the primary mechanisms of action of the opioid receptors ( $\mu$ ,  $\delta$ ,  $\kappa$ , and the opioid receptor-like (ORL1) receptor), which are the most widely-studied family of  $G_i$ -coupled GPCRs and the targets of opioid analgesics like morphine. Unfortunately, potentially severe side effects of these analgesics are mediated by opioid receptors expressed outside of the pain neuraxis, including suppression of respiration and peristalsis. Other  $G_i$ -coupled receptors acting in nociceptors include adrenergic receptors, adenosine A1 and A3 receptors, Group II metabotropic glutamate (mGluR) receptors, cannabinoid receptors and somatostatin receptors. In many cases,  $G_i$  receptors are expressed in the same neurons with  $G_q$ - and  $G_s$ -coupled receptors, suggesting the idea that opposing receptor subtypes act as a sort of “push-pull” mechanism to determine nociceptor sensitivity.

Attempts to link the expression of specific GPCRs to functionally-distinct subsets of sensory neurons have been only partly successful, in part because sensory neuron neurochemistry appears to be linked at least as closely to the type of target tissue as to the sensory modality conveyed by the neuron. However, a broad distinction has been observed between nociceptors that are labeled by the plant lectin IB4 and express the trophic factor receptor Ret and the ATP-gated ion channel P2X3, and a largely separate population of nociceptors that express pro-inflammatory neuropeptides and the trophic factor receptor TrkA. This distinction provides a framework for the analysis of signaling molecules with restricted expression in sensory neurons. Recently, the orphan GPCR MRGD was identified in IB4-positive neurons and was found to be exclusively expressed in neurons with unmyelinated axons innervating the epidermis, supporting earlier reports that most epidermal afferents are of the IB4-binding variety. Other GPCRs are also preferentially expressed in this population of neurons, including the histamine receptor H1, which is critical for the sensation of itch mediated by histamine (see  $\blacktriangleright$ Nociceptors and characteristics), the bradykinin receptor B1 and the nucleotide receptor P2Y1. Conversely, many GPCRs have been identified that are expressed preferentially in the TrkA- and neuropeptide-expressing population, including PAR2, the PGE2 receptor, the bradykinin receptor B2 and P2Y2. Opioid receptors are also more highly expressed in TrkA-positive neurons, providing an anatomical basis for the effectiveness of peripheral opioid analgesics in inflammatory pain.

### Regulation of GPCR Function

GPCR function is modulated by accessory proteins called regulators or activators of G protein signaling

(RGS or AGS, respectively), and GPCR kinases (GRKs), which terminate GPCR signaling by phosphorylating the receptor, targeting it for internalization and either destruction or recycling. Other regulatory proteins include the integrin family of cell adhesion receptors and scaffolding proteins, such as  $\beta$ -arrestins, *A kinase anchoring proteins* (AKAPs) and Homer, that bind together GPCRs with their downstream effectors [1]. RGS proteins regulate GPCR function by binding activated  $G\alpha$  subunits (primarily  $G_i$  and  $G_q$  family members) and increasing the rate of GTP hydrolysis, thereby decreasing signal duration, amplitude, or both [10]. They may also act as scaffolding molecules. At least 10 different RGS mRNAs are expressed in DRG. In particular, RGS3 and RGS4 are highly expressed in sensory neurons with unmyelinated axons likely to be nociceptors (i.e., C fibers), and their expression is down-regulated in response to nerve injury, resulting in enhanced GPCR signaling that could contribute to neuropathic pain [7]. Whereas RGS3 is ubiquitously expressed in nociceptors, RGS4 is selectively expressed in the IB4-binding subpopulation that provides the majority of cutaneous innervation.

GPCR-associated proteins are involved in targeting receptors to pre- or postsynaptic sites, to specific membrane domains, and in the assembly of signaling complexes. In addition, they may assist in membrane insertion and internalization of receptors. The best-characterized examples have been identified for the  $\beta$ -adrenergic and mGluR receptors, both of which are expressed in nociceptive neurons. In the extreme case, interacting proteins may be capable of activating receptors in the absence of ligand. Such is the case with the scaffolding protein Homer, which couples  $G_q$ -linked mGluRs to intracellular calcium release sites. Neuronal activity upregulates expression of a short isoform of Homer, Homer1a, that uncouples mGluRs and reduces glutamate-evoked calcium release from intracellular stores [8].

Another important form of GPCR regulation is receptor  $\blacktriangleright$ heterodimerization, which can alter receptor pharmacology and downstream signaling [9]. GPCRs that may heteromultimerize in sensory neurons include opioid and adrenergic receptors (between members of the same family and also between opioid and adrenergic receptors) and the  $G_q$ -coupled ATP/UTP receptor P2Y2 with  $G_i$ -coupled adenosine receptor A1. P2Y2 has been implicated in excitatory signaling in nociceptors. Coadministration of agonists to cells expressing both P2Y2 and A1 resulted in an inhibition of  $G_i$  signaling and enhanced  $G_q$  signaling. Dimerization between A1 and the  $G_q$ -coupled P2Y1, resulting in a unique pharmacological profile, has also been reported to occur in neurons.

In summary, GPCRs provide a powerful regulatory system that modulates nociceptor sensitivity in

response to changes in the state of peripheral tissues. Although receptors of different types are extensively co-expressed, their function is tightly regulated and is altered in injury and disease states. As a result, GPCRs are being aggressively targeted in the search for novel analgesics and techniques for therapeutic intervention in pathological pain syndromes.

## References

1. Hill SJ (2006) G-protein-coupled receptors: past, present and future. *Br J Pharmacol* 147:S27–S37
2. Offermanns S (2003) G-proteins as transducers in transmembrane signaling. *Prog Biophys Mol Biol* 83:101–130
3. Marinissen MJ, Gutkind JS (2001) G-protein-coupled receptors and signaling networks: emerging paradigms. *Trends Pharmacol Sci* 22:368–376
4. Han SK, Mancino V, Simon MI (2006) Phospholipase C beta 3 mediates the scratching response activated by the histamine H1 receptor on C-fiber nociceptive neurons. *Neuron* 52:691–703
5. Tominaga M, Caterina MJ (2004) Thermosensation and pain. *J Neurobiol* 61:3–12
6. Jiang M, Gold MS, Boulay G, Spicher K, Peyton M, Brabet P, Srinivasan Y, Rudolph U, Ellison G, Birnbaumer L (1998) Multiple neurological abnormalities in mice deficient in the G protein  $G_o$ . *Proc Natl Acad Sci USA* 95:3269–3274
7. Costigan M, Samad TA, Allchorne A, Lanoue C, Tate S, Woolf CJ (2003) High basal expression and injury-induced downregulation of two regulator of G-protein signaling transcripts, RGS3 and RGS4 in primary sensory neurons. *Mol Cell Neurosci* 24:106–116
8. Shiraishi-Yamaguchi Y, Furuichi T (2007) The homer family proteins. *Genome Biol* 8 206; Snider WD, McMahon SB (1998) Tackling pain at the source: new ideas about nociceptors. *Neuron* 20:629–632
9. Prinster SC, Hague C, Hall RA (2005) Heterodimerization of G protein-coupled receptors: specificity and functional significance. *Pharmacol Rev* 57:289–298
10. Ross EM, Wilkie TM (2000) GTPase-activating proteins for heterotrimeric G proteins: regulators of G protein signaling (RGS) and RGS-like proteins. *Ann Rev Biochem* 69:795–827

## Gracile Fasciculus

### Definition

The gracile fasciculus is a large bundle of axons running just medial to the cuneate fasciculus. Together the cuneate and gracile fasciculi form the dorsal columns in the dorsal medial part of the spinal cord. The dorsal columns are formed by the axons of neurons in the dorsal root ganglia just outside the spinal cord and carry

somatosensory information from the body to the caudal medulla. The gracile fasciculus carries information from the legs and the lower trunk.

## Gracile Nucleus

### Definition

The gracile (Latin for slender) nucleus is a slender nucleus located next to the midline in the caudal medulla. It receives tactile, proprioceptive and vibratory input from the leg and lower trunk by way of the gracile fasciculus. The cuneate nucleus is lateral to it (see above).

## Graded

### Definition

Continuous, not in a discrete manner. Graded responses mean that responses are analogue, but not digital, and increase or decrease without a gap.

## Graded Potential

### Definition

A local, non-regenerative, non-propagating change in membrane potential that varies in magnitude, in proportion to the intensity of a stimulus and resultant change of membrane current. The graded potential decreases exponentially with distance from its source, and therefore serves as a short distance signal in excitable tissue.

► Action Potential Propagation

## Gradient Descent

### Definition

Gradient descent is an optimization algorithm. For a system whose task is to approximate a given function,

its performance error is given in terms of the system's parameters. Gradient descent attempts to minimize this error by adjusting the parameter values incrementally.

The direction of adjustments (i.e., whether to increase or decrease a certain parameter's value) is determined by the gradient of the error function with respect to each parameter in turn. This can easily be visualized in the two-dimensional case (i.e., for a system with two parameters). The error can then be described as an error surface, and valleys in that surface represent local error minima. Any given parameter setting corresponds to one point on that surface. The gradient of the error indicates the direction of steepest descent, i.e., in which direction of each dimension the parameter setting has to be adjusted so as to reach a point closer to the nearest minimum. A problem with gradient descent is that they may get stuck in a local minimum and fail to reach the global minimum.

► Connectionism

---

## Grand Mal Seizures

### Definition

► Tonic-clonic Seizures

---

## Grandmother Neuron

### Definition

A concept for the description of the way of coding information in the nervous system. A grandmother neuron is a neuron that codes for very specific information (your grandmother only). Some evidence for specific coding comes from the finding of face neurons and hand neurons. The opposite, competitive concept is distributed or ensemble coding.

---

## Granular Cells

### Definition

Via the mossy fibers they receive afferent impulses from the pontine nuclei, spinal cord and myelencephalon.

► Cerebellum

---

## Granule Cell System

### Definition

Group of neurons that include the excitatory granule cells and the inhibitory Golgi, stellate and cartwheel neurons in the molecular layer of the dorsal cochlear nucleus.

► Cochlear Nucleus

---

## Grapheme

### Definition

The minimal contrastive unit in the writing system of a language (e.g., t vs. n).

► Lexical-Gustatory Synesthesia

---

## Grasping

### Definition

The act of closing the digits around an object so as to take hold of it.

---

## Graviception

### Definition

Graviception refers to the sensory processes that contribute to the generation of neural signals encoding the orientation of the gravity vector with respect to the organism. There are both kinematic and kinetic aspects to graviception. The kinematic aspect relates to the fact that access to an accurate neural representation of the direction of gravity provides information about the orientation and motion of the body with respect to earth vertical. The kinetic aspect is that gravity exerts a force on the body or parts of the body that would produce an acceleration if unopposed. Therefore, sensory systems that signal the presence of forces that oppose the acceleration due to gravity contribute to graviception.



Vestibular sensory signals are considered to be the primary contributor to graviception. However, the sensory signals from the two types of vestibular sensors (semicircular canals and otoliths) do not provide a direct measure of the orientation of the gravity vector. Rather, the signals from these two types of sensors must be appropriately combined by a sensory integration process to yield a reasonably accurate, although still imperfect, measure. From a more global perspective, information from virtually all sensory systems that encode signals that are correlated with changes in body orientation with respect to gravity can be considered to be contributors to graviception. But typically, sensory signals from systems such as vision and proprioception are not thought of as contributors to graviception. The integration of information from vision and proprioception with graviceptive information is considered to be another stage in the process of forming an overall sense of orientation.

- ▶ Peripheral Vestibular Apparatus
- ▶ Posture – Sensory Integration
- ▶ Sensory Systems
- ▶ Verticality Perception

## Graviceptors

### Definition

Graviceptors refer to the sensory receptors and sensory systems that contribute to providing a neural representation of the direction of gravity with respect to an organism and of motion of the organism with respect to the gravity vector. The vestibular system is a major contributor to graviception.

- ▶ Peripheral Vestibular Apparatus
- ▶ Posture – Sensory Integration

## Gravitational Potential Energy

### Definition

The energy associated with the vertical displacement of an object in a gravitational field ( $g$ ). Related to its height ( $h$ ) and mass ( $m$ ) by

- ▶ m.h.g.
- ▶ Energy/Energetics

## Gravito-inertial Acceleration (GIA)

### Definition

The vector sum of all linear accelerations and the equivalent acceleration of gravity.

## Gravity

### Definition

All masses generate an attractive force on other masses.

The pull of the Earth's mass on other masses is called gravity.

## Gravity Perception

- ▶ Verticality Perception

## Green Fluorescent Protein (GFP)

### Definition

A gene isolated from jellyfish that causes green fluorescence GFP, which has been engineered to attach to a gene or promoter of interest to show the expression pattern of that protein within a model organism or cell.

- ▶ *C. elegans* Neuroethology

## Greigite

### Definition

Ferrimagnetic thiospinel, chemically  $\text{Fe}_3\text{S}_4$ .

- ▶ Magnetic Bacteria

## Grey Matter

### Definition

The part of the brain consisting of nerve cell bodies, dendrites and synapses, together with glial cells. This region is responsible for processing information that is then transmitted to the neuronal axons.

## Grip – Precision Grip

### Definition

A grasp in which a typically delicate object is held between the tip of the thumb and the tip of the index finger, usually for purposes of fine manipulation.

► Motor Cortex – Hand Movements and Plasticity

## Grid Cells

### Definition

Neurons discharging selectively at multiple locations distributed in a regularly spaced hexagonal lattice (i.e., each node is surrounded by a hexagon of adjacent nodes).

► Neural Bases of Spatial Learning and Memory

## Ground Reaction Forces

### Definition

Forces arising at the area of contact between the body and environment. This usually involves the foot and ground; however, analogous reaction forces can occur at the hand if it is in contact with a stable object or surface.

► Postural Strategies

## Grief

### Definition

Grief constant emotional pain. The term is usually used in the context of mourning for a loved person. During grief there is less interest in the environment, decreased ability to love and decreased activity.

► Personality Disorder

## Group Fascicular Repair

### Definition

Adaptation of individual fascicular nerve bundles, using microsurgical techniques. The group fascicular repair technique requires an internal dissection of the nerve.

Individual large fascicles may be sutured individually.

► Regeneration: Clinical Aspects

## Grip – Power Grip

### Definition

A grasp in which an object is held tightly against the palm using the four fingers on one side and the thumb on the opposite side, enabling the subject to wield the object with considerable power, as in grasping a hammer.

► Motor Cortex – Hand Movements and Plasticity

## Growth Cones

KEVIN C. FLYNN, JAMES R. BAMBURG

Molecular, Cellular and Integrative Neurosciences Program, Department of Biochemistry and Molecular Biology, Colorado State University, Fort Collins, CO, USA

### Synonyms

Leading process; Axonal tip

## Definition

Growth cones are the specialized motile structure at the growing tips of developing and regenerating axons and dendrites. They are responsible for directed axon extension, dendritic growth and arborization, and consolidation of the motile tip into the cylindrical axon or dendrite. They were discovered over 100 years ago by Ramon y Cajal who wrote that the “cono de crecimiento” (growth cone) “may be regarded as a sort of battering ram, endowed with exquisite chemical sensitivity, with rapid amoeboid movements, and with certain impulsive force, thanks to which it is able to proceed forward and overcome obstacles met in its way, forcing cellular interstices until it arrives at its destination” [1].

Although they can assume diverse morphologies, growth cones of neurons cultured on flat substrata are generally hand shaped structures, with membranous ►lamellipodia (veils) in-between long finger-like extensions called ►filopodia (Fig. 1).

As extremely motile structures that can sense and respond to various types of ►guidance cues, growth cones can alter their shape and dynamics in response to their environment leading to directed growth (axon guidance). In addition, growth cones are sites where new material is incorporated into the plasma membrane. In fact, the majority of the cargo shipped during ►axonal transport is destined for the growth cone, providing the material necessary for the growing axon.

Growth cone motility and directional migration depend on the reorganization of the underlying ►actin and ►microtubule cytoskeleton and localized protein synthesis, which are spatially regulated in response to membrane receptors interacting with extracellular guidance cues [9,13]. Targeting therapies to growth

cones may thus be an approach to nerve regeneration (see below). In addition, other recent studies suggest that certain developmental disorders and genetic diseases may result from problems directly affecting the growth cone [11].

## Characteristics

### Quantitative Description

#### Size and Morphology

Most data on the morphological characteristics of growth cones are derived from studies performed on neurons cultured on glass. These *in vitro* studies have relevance *in vivo*, with many of the same structures identified in developing tissue. Among neurons commonly used in research, rat and chick dorsal root ganglion and spinal cord neurons, retinal ganglion neurons, and rat and mouse hippocampal neurons have smaller growth cones with average areas of about 50–200  $\mu\text{m}^2$ , whereas growth cones of bag cells of the sea slug *Aplysia* can reach sizes of 2,000  $\mu\text{m}^2$  in surface area. *In vivo*, *Xenopus* retinal ganglion neurons have growth cone areas averaging about 75  $\mu\text{m}^2$ .

The growth cone has two easily discernible domains, defined by the cytoskeleton and organelles contained therein [2,6]. The peripheral domain (P), which mainly consists of actin networks and filament bundles, is generally very thin, often 1  $\mu\text{m}$  or less. The central domain (C), on the other hand, is rich in ►microtubules and membranous organelles and can be up to several microns thick. The zone between these two domains is referred to as the transition zone (T).

#### Cytomechanics of Growth Cones

As a pulling engine, the growth cone elongates the axon via tension generated through adhesion to the substratum.

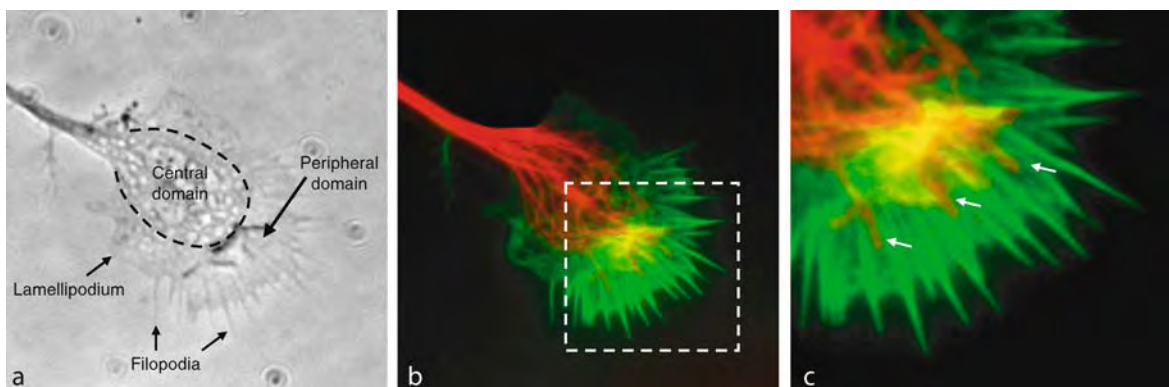

**Growth Cones. Figure 1** The neuronal growth cone. (a) Phase image of the axonal growth cone of a hippocampal neuron in culture. (b) Fluorescent image showing microtubules (immunostaining with Texas-Red secondary antibody) and actin filaments (stained in green with fluorescein-phalloidin). Microtubules are largely confined to the central domain of the growth cone, whereas actin filaments are localized to the peripheral domain. (c) Magnified view of *highlighted region* in (b). A few microtubules penetrate into the peripheral domain of the growth cone (*arrows*) where they associate with actin filament bundles.

There is a direct correlation between growth cone advance and neurite tension. In accordance with Newton's third law, growth cones also exert a rearward force, or traction, on the substrate in order to advance. A single filopodia of a chick sensory neurite can generate an estimated 50–90  $\mu$ dynes of force whereas the entire advancing growth cone can exert a force of 100–500  $\mu$ dynes. When this same force is applied exogenously, it is sufficient to induce neurite elongation. Conversely, the growth cones of CNS neurons, such as those from the chick forebrain and rat hippocampus, have a lower threshold, with 20–40  $\mu$ dynes of tension sufficient to initiate elongation. Once the threshold is reached, however, the growth cone advance for both forebrain and sensory neurons is directly proportional to applied tension; growth rates increase 1–3  $\mu$ m/h for each  $\mu$ dyne of applied tension [7].

The tension generated in the growth cone is presumably due to the contractile actions of myosin motor proteins on actin filaments. As mechanical force is applied to growth cones, the axon fills with polymerizing microtubules, which are necessary for axon elongation, suggesting that tension itself can signal to stimulate microtubule polymerization. In the absence of actin filaments in the P domain, neurites can still elongate due to microtubule assembly, but the advancing tips are unable to respond to guidance cues [2,14].

#### Rates of Growth

Growth rates *in vitro* and *in vivo* are highly variable, depending on the nature of the neuron, and the

substratum and local environment. *In vitro*, hippocampal neuronal axons have been reported to have an average growth rate of about 6  $\mu$ m/h with maximal growth rates averaging 20  $\mu$ m/h [12]. Chick sensory neurons have axonal growth rates that are highly dependent on the culture conditions and range from 6 to 100  $\mu$ m/h [13]. *In vivo*, growth cone advance at a maximal rate of 40  $\mu$ m/h has been reported in the transparent tail fin of frog tadpoles. Retinal ganglion cell axons in *Xenopus* embryos grow 60  $\mu$ m/h in the optic tract, but reduce to 16  $\mu$ m/h when they approach the target area in the optic tectum [6].

#### Lower Level Components

Filopodia probe the local environment and sense molecular cues that can lead to various growth cone responses such as turning (Figs. 1 and 2).

Lamellipodia veils make up much of the growth cone surface area, can provide mechanical tension and contribute to growth cone motility (Figs. 1 and 2).

► **Focal contacts** are localized throughout the surface of lamellipodia and filopodia in growth cones where they play an important role in axon growth and guidance.

#### Structural Regulation

The actin filament network of the peripheral domain of the growth cone largely determines the structure and dynamics of filopodia and lamellipodia (Fig. 2). Drugs that disrupt actin polymerization, such as cytochalasin and latrunculin A, disrupt growth cone

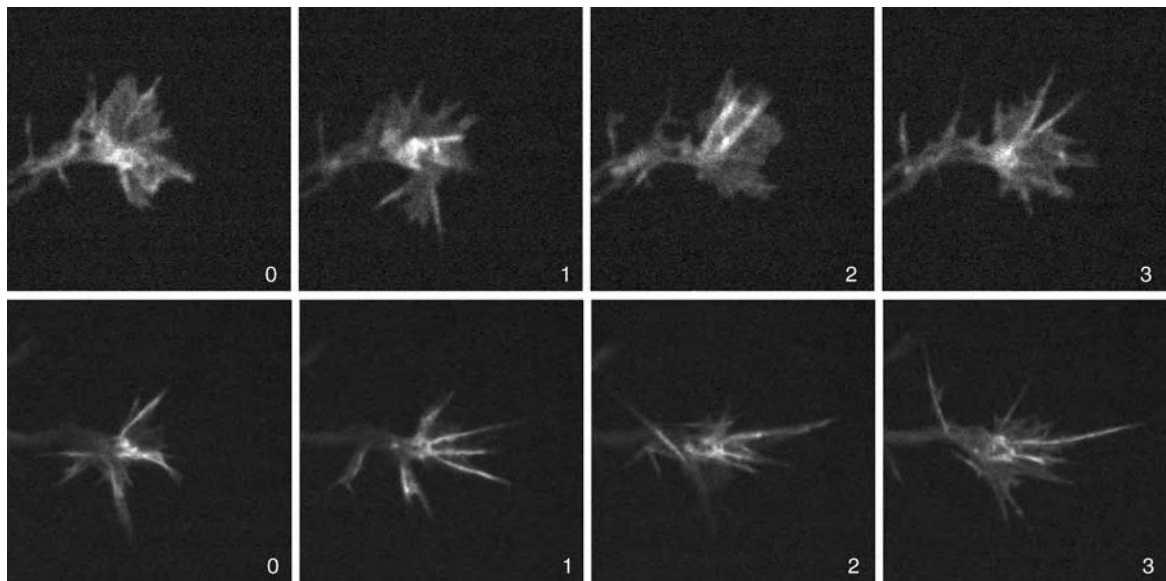

**Growth Cones. Figure 2** Actin dynamics in neuronal growth cones. Fluorescence micrographs of two growth cones of cultured embryonic day 18 rat hippocampal neurons expressing a  $\beta$ -actin-red fluorescent protein chimera. Images in each row are taken at 1-min intervals (numbers at *bottom right*). Growth cone in *top row* shows prominent lamellipodia, whereas the one in the *bottom row* shows more prominent filopodia.

structure, including the loss of filopodia and collapse of lamellipodia. Most actin filaments are oriented with their faster growing (barbed) ends pointing towards the outside of the growth cone. Filopodial growth occurs by polymerization of actin filaments with subunits adding at the tip of the ► **filopodium**, which pushes the membrane out. Lamellipodial protrusion occurs as the underlying meshwork of actin filaments are polymerized at the leading edge. When lamellipodia lose their attachment to the substratum, they form “ruffles” (loose lamellipodial membranes) which collapse backwards into the growth cone. Actin that assembles at the leading edge of the growth cone is under tension from myosin motors, resulting in a continuous retrograde flow of newly assembled filaments away from the leading edge to the transition zone where they disassemble. The amount of retrograde flow decreases with increasing rates of forward motility as the cytoskeleton is coupled to the substratum [2,14].

Microtubules are the main skeletal component of the central domain of the growth cone. They extend from the cell body in a discontinuous but overlapping manner down the length of the neurite into the growth cone and are oriented with their growing plus ends towards the P-domain. Microtubules also serve as the main transport for cellular material that gets incorporated at the growth cone, including vesicles needed for the expanding membrane and cytoskeletal proteins (see axonal transport). As dendrites mature, microtubules undergo a mixing of polarity, whereas in axons microtubules continually maintain a distal orientation of their plus ends. Microtubules in the proximal regions of the growing neurite become stabilized with associated proteins, however, those in the distal neurite and growth cone continue to undergo cycles of extension and retraction (dynamic instability). After entering growth cones, these dynamic microtubules splay out and occasionally penetrate into the actin-rich lamellipodia and filopodia of the P-domain where they play an important role in axon pathfinding (Fig. 1c arrows). The retrograde flow of actin often captures some of the microtubules that extend into the P-domain, causing them to buckle and break [2,14].

Focal contacts in the growth cone have to rapidly form and disassemble in order for migration to occur. In migrating cells, the speed of cell migration is the highest at intermediate levels of adhesiveness. This level of adhesiveness is determined by various parameters including ligand concentration, receptor density, ligand-receptor affinity, and the presence of intracellular signals. These factors ultimately affect the substrate-cell adhesion molecule (CAM)-actin interface. For example, CAM clustering and ligand binding increases the level of CAM-actin interactions. In addition, intracellular signaling mediated by tyrosine phosphorylation may enhance or weaken CAM-cytoskeletal

coupling [14]. Guidance cues can also affect assembly and disassembly of focal contacts in filopodia altering lamellipodial advance, which can determine growth cone guidance.

### Higher Level Processes

During embryonic development, growth cones navigate axons and dendrites to their appropriate targets and are involved in the formation of synapses necessary for correctly wiring the nervous system (see below under Functions). After injury to the nervous system, a nerve's capacity for regeneration depends on its ability to reform a functional growth cone (see below under Pathology).

### Lower Level Processes

Filopodial dynamics are critical to growth cone pathfinding. In addition, filopodia are important for neurite branching and determining the ultimate arborization and connectivity of the nervous system [16].

Lamellipodial veil expansion and shrinkage is also important in growth cone pathfinding. The lamellipodial cross-linked actin meshwork provides a framework for growth cone adhesion to the substrate and mechanical tension to aid subsequent growth cone movement. On a uniform substrate, growth cone turning may be correlated with lamellipodial size [16].

Membrane addition and the incorporation of cytoskeletal subunits also occur at growth cones and support the elongation of the growing process. Anterograde transport of membrane bound vesicles and cytoskeletal polymers, occurs along microtubules via kinesin motors [6].

Protein synthesis within the growth cone, particularly of actin and actin regulatory proteins, is critical to growth cone function. Decreased localized translation of  $\beta$ -actin mRNA in growth cones may contribute to smaller growth cones and decreased axon extension [4]. Several growth stimulatory factors enhance the transport of locally translated mRNAs from the cell body to the growth cone. Some guidance cues also require local protein synthesis to cause structural changes in growth cones [2].

### Process Regulation

The ► **Rho family of small guanosine triphosphatases** (Rho ► **GTPases**) are pivotal intracellular switches that transduce signals from many of the ► **guidance cue** receptors on the growth cone membrane to the actin and microtubule cytoskeleton [3]. The Rho GTPases Rac1 and Cdc42 regulate both filopodia and lamellipodia in growth cones through downstream actin effectors and are involved in axon growth and guidance [2,6,13].

Signal transduction pathways from extracellular guidance cues to cytoskeletal binding proteins are responsible for the regulation of filopodial and lamellipodial

extension and retraction. The “clutch” model proposes that filopodial protrusion occurs by actin assembly when actin filaments are fixed with respect to the substrate (the “clutch” is “engaged”) [14]. Retraction, conversely, occurs when myosin II exerts a contractile activity on actin filaments that have not anchored to the substratum via focal contacts (the “clutch” is “disengaged”), leading to retrograde flow of the actin. Filopodial dynamics are regulated by changes in actin assembly and myosin contractility mediated by the Rho family GTPases [4,6].

The initiation of filopodial and lamellipodial protrusions depends on actin polymerization and occurs through the actions of membrane bound proteins in the family of enabled/vasodilator stimulated phosphoprotein (Ena/VASP), which inhibit the capping of actin filament barbed ends and also their branching by the Arp2/3 complex [2]. In non-neuronal cells the Arp2/3 complex plays an important role in filament branching at the leading edge of expanding lamellipodia, but in neurons, the Arp2/3 complex plays important roles in the initiation of neurite outgrowth and in both lamellipodial and filopodial formation and dynamics. Proteins that enhance barbed end formation, actin recycling and polymerization, such as cofilin, actin depolymerizing factor (ADF), and profilin, contribute to filopodial and lamellipodial expansion. ADF/cofilin proteins play essential roles in filopodial extension and growth cone turning in response to guidance cues [4,16].

The growth-associated protein ►GAP-43 plays an essential role in growth cone motility during development. GAP-43 interacts with second messengers, particularly phosphatidylinositol(4,5)bis phosphate, and its ability to increase transient calcium concentrations suggests it functions to regulate actin dynamics affecting growth cone structure and motility [2].

### Function

Neuronal growth cones are responsible for the proper navigation of nerve fibers through the embryonic environment to their proper synaptic partners. This is a daunting task. In adult humans, there are trillions of neurons, each connecting with thousands of synaptic partners in an intricate network of neural circuits. Correctly wiring all this depends on the proper functioning of growth cones, which extend the axon along the correct pathway, choose the target region within which to terminate, and recognize specific cells on which to synapse. Growth cones must act as both guidance cue sensors and sites of signal transduction, leading to a range of dynamic behaviors such as increased growth rates, retraction, turning, stalling, branching and fasciculation.

Guidance cues fall into four main categories: diffusible attractants and repellents, and non-diffusible (or substrate-bound) attractants and repellents [15]. General

examples of cues in each category are presented in Fig. 3, but some molecules can be both attractive and repulsive cues, depending on when during development the neurons are exposed and on other conditions, particularly the intracellular concentration of second messengers such as cAMP, cGMP or calcium [13].

Guidance cues regulate the cytoskeleton leading to dynamic changes in growth cone structure and motility. ►Neurotrophins, such as BDNF, enhance formation and length of growth cone filopodia [6,14], which facilitates turning towards a gradient of BDNF [13]. Conversely, when a growth cone encounters a repellent cue, such as Semaphorin III, turning away from the cue results from localized F-actin depolymerization [6].

Growth cones navigate through complex environments to distances often more than a thousand times the diameter of the cell body. In some cases the navigation pathway is broken into segments by intermediate targets (“choice points” or “guidepost cells”), which present guidance information allowing growth cones to change course [15]. Growth cones *in vivo* generally assume one of two possible morphologies; a broad veil-like structure with multiple filopodia, or a bullet-shaped appearance with few filopodia. Generally, “►pioneer axons” that initially grow into an uncharted region of the embryo have the former appearance; this is consistent with the idea that the growth cones must make guidance decisions based on cues in the novel environment. Later axons will often fasciculate, using earlier pioneering axons as a track to grow along, and these growth cones have less filopodia [12]. Fasciculation may help simplify the development of complex nervous systems in which axons grow in successive waves [15].

Some guidance molecules appear to have unique gradients with a particular “address” that is recognized by specific axonal growth cones with a complementary gradient of receptors [12,15]. Growth cone pathfinding and target selection often result in topographic maps that are neural representations of the world. As growth cones approach their target and the target is selected, they undergo morphological changes and mature into presynaptic specializations known as ►terminal boutons. In the target region, growth cones slow and may arborize if multiple targets are to be innervated, as in the optic tectum, or may maintain a single dynamic growth cone, as during the innervation of muscle fibers [12]. When the growth cone contacts its target, its filopodia retract, and the membrane becomes closely associated with the target cell through adhesive contacts. Although some of the presynaptic neurotransmission machinery is present in growth cones before ►synaptogenesis, after target selection there is an accumulation of presynaptic vesicles. During muscle fiber innervation, the motor neuron growth cone induces the aggregation of acetylcholine receptors on the post-synaptic muscle cell. A rise in

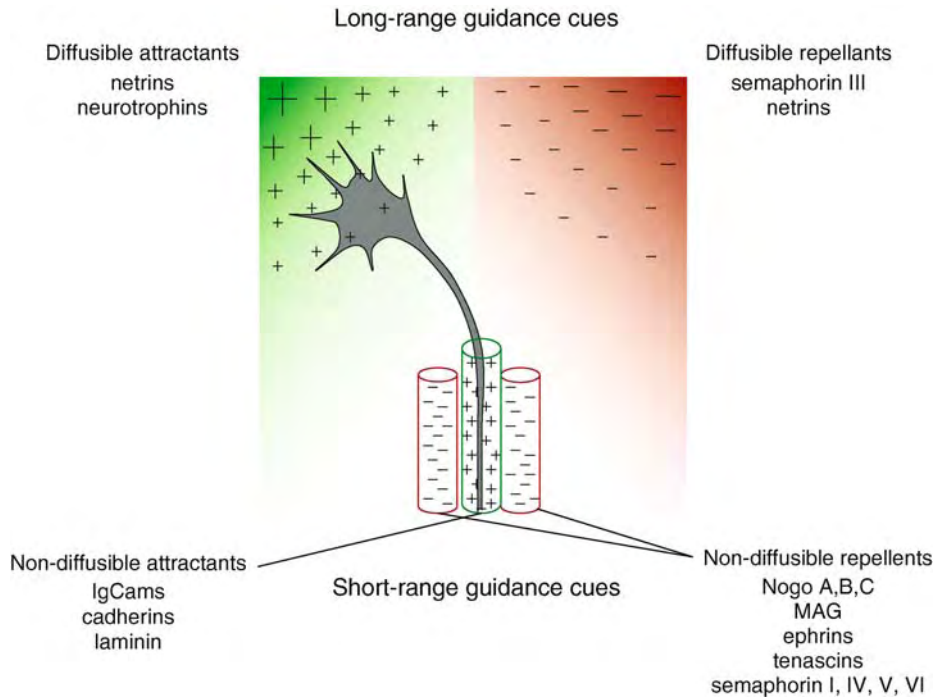

**Growth Cones. Figure 3** Schematic of growth cone guidance cues. There are four main types of guidance cues: diffusible (long-range) attractants and repellents, and substrate bound (short-range) attractants and repellents. Displayed are examples of each type. Diffusible guidance cues are secreted by cells in the embryo to either attract or repel growing axons, and thereby influence the particular trajectory the axon navigates. Netrin, a typical diffusible cue, attracts commissural axons to the ventral spinal cord, but netrin can also be a potent repellent. Semaphorins typically serve as repulsive guidance cues and can be secreted (Sema III) or substrate bound (Sema I, IV, V, VI). Other short-range guidance cues include components of the extracellular matrix, such as growth promoting laminin, and proteins expressed on the surface of cells, such as growth inhibiting Nogo, expressed on the myelin surface. The different guidance cues may be present simultaneously to influence pathfinding of developing axons and growth cones must be able to integrate the signals into one final behavioral outcome.

intracellular calcium and cAMP following target formation may be important to converting the growth cone into the specialized presynaptic terminals. Maturation of synapses often requires days to weeks, during which synapse-specific proteins are synthesized and incorporated into presynaptic and postsynaptic regions [12].

### Pathology

Problems in growth function have important implications for nervous system damage. Transecting nerve axons in the adult central nervous system (CNS) results in permanent impairment. Conversely, severing nerves of the peripheral nervous system (PNS) can be followed by regeneration and nearly full functional recovery. The difference is due to down-regulation of myelin components that are growth inhibitors in the PNS, thus allowing axon regeneration. Oligodendrocytes, which provide CNS myelin, express molecules such as Nogo and myelin associated glycoprotein (MAG), which inhibit axon re-growth following injury [20].

Following a lesion, transected axons can reform growth cones that appear functionally equivalent to those observed in development. Severed nerve fibers attempt re-growth, but are unable to penetrate the injury site. It is known that neurons from the adult CNS can extend axons *in vitro*. When severed CNS axons are given a PNS sheath, the axons are able to grow several centimeters [12]. Thus, it appears that the inhibitory molecules of CNS myelin are mainly responsible for the inability of a reformed CNS growth cone to regenerate a neurite. Targeting therapies to growth cones may facilitate CNS regeneration.

Abnormalities in growth cone pathfinding and target selection during development can lead to defects in nervous system function. There is little work directly linking developmental diseases with growth cone-specific defects, but some recent data implicates growth cone malfunction in certain pathologies. For example, growth cone irregularities may contribute to the pathology of spinal muscular atrophy (SMA), an autosomal recessive disease caused by deletion mutation in the

telomeric copy of the spinal neuron survival gene (SMN1). SMA is characterized by progressive muscular weakness due to specific degeneration of  $\alpha$  motor neurons. SMN may facilitate the transport and/or local synthesis of proteins, such as  $\beta$ -actin, that are critical in growth cone function. Motor neurons from the SMA mouse model have decreased axon elongation and smaller growth cones, presumably due to decreased  $\beta$ -actin levels [11]. Though not conclusive, this suggests that abnormal growth cone function should be considered in investigating developmental disorders.

### Therapy

Potential nerve regeneration therapies have targeted myelin-associated receptors or signal transduction pathways localized to growth cones. The Nogo antibody, IN-1, can be used to block the function of Nogo, which normally signals to prevent growth cone advance. Infusion of the IN-1 antibody into the CNS of a rat with spinal cord damage results in the long distance regeneration of only a few corticospinal axons, but these impart a significant functional recovery [5,8]. These studies demonstrate that adult mammalian CNS nerve regeneration is possible, if the inhibitory effects of myelin are blocked.

An alternative approach to regeneration has targeted intracellular signaling pathways in neurons. Modulating the neuronal signaling responses has shown success at overcoming the inhibitory properties of myelin. For example, it has been shown that manipulation of Rho GTPase signaling promotes regeneration *in vivo*. Other studies have demonstrated that elevation of cAMP levels allows growth cones to overcome the inhibitory effect of MAG and myelin [5]. Increasing neurotrophins with pumps or gene therapy techniques does not increase long-distance regeneration, but does promote local sprouting, re-innervation and remodeling in the CNS [8].

### ► Axonal Regeneration

### References

1. Bray D, Money NP, Harold FM, Bamberg J (1991) Responses in growth cones to changes in osmolarity of the surrounding medium. *J Cell Sci* 98:507–515
2. Dent EW, Gertler F (2003) Cytoskeletal dynamics and transport in growth cone motility and axon guidance. *Neuron* 40:209–227
3. Dotti C, Sullivan CA, Banker G (1988) The establishment of polarity by hippocampal neurons in culture. *J Neurosci* 8:1454–1468
4. Fass J, Gehler S, Sarmiere P, Letourneau P, Bamberg JR (2004) Regulating filopodial dynamics through actin-depolymerizing factor/cofilin. *Anat Sci Int* 79:173–183
5. Filbin MT (2003) Myelin-associated inhibitors of axonal regeneration in the adult mammalian CNS. *Nat Rev Neurosci* 4:1–11

6. Gallo G, Letourneau PC (2003) Regulation of growth cone actin filaments by guidance cues. *J Neurobiol* 58:92–102
7. Heidemann SR, Buxbaum RE (1994) Mechanical tension as a regulator of axonal development. *Neurotoxicology* 15:95–107
8. McKerracher L (2001) Spinal cord repair: strategies to promote axon regeneration. *Neurobiol Dis* 8:11–18
9. Piper M, Holt C (2004) RNA translation in axons. *Annu Rev Cell Dev Biol* 20:505–523
10. Ramón y Cajal S (1890) A quelle époque apparaissent les expansions des cellules nerveuses de la moelle épinière du poulet. *Anatomischer Anzeiger*. numéros 21 y 22
11. Rossoll W, Jablonka S, Andreassi C, Kröning A, Karle K, Monani UR, Sendtner M (2003) Smn, the spinal muscular atrophy-determining gene product, modulates axon growth and localization of  $\beta$ -actin mRNA in growth cones of motoneurons. *J Cell Biol* 163:801–812
12. Sanes DH, Reh TA, Harris WA (2000) Development of the nervous system. Academic Press, San Diego
13. Song H, Poo M (2001) The cell biology of neuronal navigation. *Nat Cell Biol* 3:81–88
14. Suter DM, Forscher P (2000) Substrate-cytoskeletal coupling as a mechanism for the regulation of growth cone motility and guidance. *J Neurobiol* 44:97–113
15. Tessier-Lavigne M, Goodman C (1996) The molecular biology of axon guidance. *Science* 274:1123–1133
16. Wen Z, Han L, Bamberg JR, Shim S, Ming G-I, Zheng JQ (2007) BMP molecules guide growth cones by a balancing act of LIM Kinase and slingshot phosphatase on ADF/cofilin. *J cell Biol* 178:107–119

---

## Growth Factors – Overview

HIDEFUMI FUKUMITSU, SHOEI FURUKAWA  
Laboratory of Molecular Biology, Gifu Pharmaceutical University, Gifu, Japan

### Definition

A group of proteins regulate the survival, differentiation and growth of various cell types, including neurons.

The precisely regulated generation and positioning of neuronal cells and the correct establishment of neuronal connections during development are essential for the proper function of the nervous system. Such a sophisticated nervous system is generated by a developmental program that involves early patterning, determination of the neural cell fate, axon–dendrite specification, target innervation, cell death, synaptogenesis and synaptic refinement and myelination. Many growth factors are crucial for this developmental program. There are essays specializing in each step of the developmental program in this Encyclopedia; in this essay about “growth factor” we have discussed the biochemical characteristics of each growth factor.



## Characteristics

### Description of the Structure/Process/Condition

#### **Epidermal Growth Factor (EGF) Family**

EGF is a 53 amino acid peptide, containing six spatially conserved cysteine residues (CX7 CX4–5 CX10–13 CXCX8 C) that form three intermolecular disulfide bonds. This consensus sequence is known as the EGF-like motif. The EGF family includes ►transforming growth factor- $\alpha$  (TGF- $\alpha$ ), amphiregulin (AR), heparin-binding EGF-like growth factor (HB-EGF),  $\beta$ -cellulin (BTC), epiregulin (EPR), epigen (EPI), neuregulin (Nrg)-1, neuregulin-2 (NTAK, DON-1), Nrg-3, Nrg-4, Nrg-5 and Nrg-6. All of the EGF-family proteins exist in a proform as type I transmembrane proteins consisting of an EGF motif flanked by an N-terminal extension and a C-terminal membrane-anchoring domain. Soluble ligands are produced through extracellular cleavage of the integral membrane precursor proteins, although there is no obvious homology in the predicted cleavage sites. Many studies have shown that metalloprotease activity is required for their release [1].

#### **Fibroblast Growth Factor (FGF)-Family**

FGF1–FGF23 have been identified in humans and mice. However, FGF19 is the human ortholog of mouse FGF15. In total, the human–mouse FGF family consists of 22 members (see essay on fibroblast growth factor in this Encyclopedia).

#### **Hedgehog (Hh)-Family**

The Hh-family includes Sonic hedgehog (Shh), Indian hedgehog (Ihh) and Desert hedgehog (Dhh) (see essay on Sonic hedgehog in this Encyclopedia). The Wnt and Hh families are found to be differentiation factors; therefore they are not classified as growth factors. However, we include these families in this essay, because they are very important for cell growth and differentiation of the developing nervous system.

#### **Hepatocyte Growth Factor/Scatter Factor (HGF/SF)**

HGF/SF is a multifunctional polypeptide, originally discovered in the late 1980s as a unique protein that promotes hepatocyte proliferation and liver regeneration. The amino acid sequence is highly homologous with plasminogen, a pro-enzyme of serine protease, involved in dissolving fibrin clots. Like plasminogen, inactive pro-HGF is synthesized and secreted as a single chain, then pro-HGF is cleaved between Arg and Val by serine proteases to convert it to the mature, physiologically active form. Thus, mature HGF consists of a light chain of 30 kD and a heavy chain of 60 kD linked by a disulphide bond. The heavy chain contains four kringle domains and a hairpin loop, which is almost the same as the heparin-binding domain. Therefore,

pro-HGF secreted from cells binds to extracellular matrix molecules until its conversion to mature HGF as described below.

A novel serine protease, HGF activator (HGFA), which has potent activity for cleavage of pro-HGF, has been purified from human sera. Other serum serine proteases such as blood coagulation factor XIIa, tissue type plasminogen activator and urokinase are also known to be capable of cleaving pro-HGF to form mature HGF. Compared with these serine proteases however, the proteolytic activity of HGFA for HGF is more powerful. HGFA is also synthesized and secreted as an inactive pro-form. The cleavage of pro-HGFA by a serine protease such as thrombin is essential for its activation [2].

#### **Insulin-Like Growth Factor (IGF)**

IGF I and II are growth-promoting peptides, members of a superfamily of related insulin-like hormones that includes insulin and relaxin in the vertebrates and bombyxin, locust insulin-related peptide and molluscan insulin-like peptide in invertebrates. However, insulin and IGFs are the most closely related in terms of primary sequence and biological activity. The IGFs are major growth factors whereas insulin predominantly regulates glucose uptake and cellular metabolism. They consist of A, B, C and D domains. Large parts of the sequences within the A and B domains are homologous to the  $\alpha$ - and  $\beta$ -chain of human proinsulin. This sequence homology is 43% for IGF-I and 41% for IGF-II. No sequence homology exists between the C domains of IGFs and the C peptide region of human proinsulin. The C domain of the IGFs is not removed during prohormone processing; thus the mature IGF peptides are single chain polypeptides. The gene encoding IGF-I is highly conserved, such that 57 of the 70 residues of the mature protein are identical among mammals, birds and amphibians [3].

#### **Platelet-Derived Growth Factor (PDGF)**

PDGF was purified to homogeneity in the late 1970s as a factor from platelets that promotes the proliferation of mesenchymal cells. Over the next 10–15 years, additional studies revealed that there are two PDGF genes (A and B) and three biologically active forms of the PDGF protein, AA, BB and AB. In the last five years two additional members of the PDGF family PDGF-CC and PDGF-DD were discovered. The PDGF C and D chains have a unique two-domain structure with an NH<sub>2</sub>-terminal CUB (compliment subcomponents C1r/C1s, Uegf and Bmp1) domain and a COOH-terminal PDGF/vascular endothelial growth factor domain. Whereas secreted PDGF AA, BB and AB can readily activate their cell surface receptors, it has been suggested that extracellular proteolytic removal of the CUB domain is required for the growth factor

domain of PDGF CC and DD dimers to preferentially activate  $\alpha\alpha$ -PDGFR and  $\beta\beta$ -PDGFR respectively [4].

#### **Neurotrophin (NT)-Family**

The NT-family includes nerve growth factor (NGF), brain-derived neurotrophic factor (BDNF), NT-3, NT-4/5, NT-6 and NT-7. NT-6 and -7 only exist in fish (see essay on neurotrophin in this Encyclopedia).

#### **Stem Cell Factor/Mast Cell Growth Factor/Kit-Ligand/Steel Factor (SCF/MGF/KL/SF)**

Stem cell factor (SCF) is produced in soluble and membrane bound forms, resulting from alternative splicing around the exon 6 of the gene. They differ in sequences amino-terminal of the transmembrane segment. Soluble form SCF is processed rapidly and efficiently by proteolytic cleavage to produce a secreted protein of 164 amino acids. In contrast, the membrane bound form lacks the major proteolytic cleavage site that is responsible for the generation of secreted protein and thus represents a more stable membrane form of the protein. Ultimately, in some cells membrane bound form-SCF is also processed to produce secreted protein, using a secondary cleavage site encoded by exon 7 sequences. This cleavage occurs at a slower rate [5].

#### **Transforming Growth Factor (TGF)- $\beta$ Superfamily**

The  $\blacktriangleright$ transforming growth factor- $\beta$  (TGF- $\beta$ ) superfamily consists of a large family of structurally related polypeptide growth factors. These can be phylogenetically divided into two main groups, the TGF- $\beta$ /activin and bone morphogenetic protein (BMP)/growth and differentiation factor (GDF) branches. These can be subdivided into several related sub-groups based on their sequence similarity and relationship to evolutionarily conserved molecules in primitive organisms (see essay on transforming growth factor in this Encyclopedia). Glial cell line-derived neurotrophic factor (GDNF) is classified in this family because of its structural similarity, but functions via tyrosine-kinase receptor c-Ret with GPI-linked alpha receptor (GFR- $\alpha$  1–4) or via GFR- $\alpha$  alone [6].

#### **Vascular Endothelial Growth Factor (VEGF) Family**

The VEGF family of molecules currently consists of six growth factors, including VEGF-A, VEGF-B, VEGF-C, VEGF-D, VEGF-E and placental growth factor. VEGF-A is currently the most well characterized member of the VEGF family and is composed of at least five isoforms due to alternative gene splicing. These vary in length from 121 to 206 amino acids (121, 145, 165, 189 and 206) and differ by the presence or absence of sequences located in exons 6 and 7. Exon 8 is common to all isoforms. Exons 6 and 7 have been shown to encode the ECM-binding domain of the protein. This domain is

able to bind heparin sulfate proteoglycans and other matrix proteins and is thought to be responsible for the sequestration of VEGF within the matrix. Thus the matrix constitutes a reservoir for the growth factor, which becomes liberated by matrix breakdown via extracellular enzymes such as heparinases and plasmin. Matrix metalloproteinases (MMPs) have also been implicated in the regulation of VEGF bioavailability from extracellular stores [7].

#### **Wnt-Family**

The Wnt-family includes wnt-1 to wnt-16. Wnt proteins have only recently been characterized. To some extent, early difficulties in isolating active Wnts are now explained by the finding that Wnt molecules are palmitoylated and therefore much more hydrophobic than predicted from the primary amino acid sequence. The palmitoylation on a cysteine residue was found by mutant analysis to be essential for function. Treating Wnt with the enzyme acyl protein thioesterase results in a form that is not hydrophobic and not active, strengthening the evidence that the palmitate is important for signaling. Because this cysteine is conserved in all known Wnt proteins, it is likely that all Wnts are palmitoylated. It remains an intriguing question as to how palmitoylated Wnt molecules are transported [8].

#### **Higher-Level Structure/Processes/Conditions Receptors and Signal Cascade**

##### **Receptor-Type Tyrosine Kinase Superfamily**

Receptors of many growth factors belong to receptor-type tyrosine kinases (RTKs), which are composed of an amino-terminal extracellular domain (ECD) that binds ligands, a single transmembrane domain (TMD) and an intercellular domain containing a tyrosine kinase catalytic unit. The superfamily of receptor-type tyrosine kinases includes c-kit (receptor of SCF), trk (high affinity receptor for the neurotrophin family) and the receptor for EGF, FGF, HGF, IGF, PDGF and VEGF. Signaling begins with ligand binding, which stabilizes receptor dimerization, thereby juxtaposing the tyrosine-kinase domains of the RTKs on the cytosolic face of the membrane. These kinase domains cross-activate each other by phosphorylation of critical residues within the catalytic domains and then further phosphorylate critical tyrosines outside the catalytic domain, which in turn function as docking sites for proteins containing SH2 or PTB domains. These latter proteins recognize primary sequence around the phosphorylation sites of receptors and act either as adaptors to recruit other proteins to the signaling complex or harbor catalytic domains capable of propagating the initial signal further. For example, the SH2-adaptor Grb2 recruits a component of the Ras signaling cascade (Fig. 1).

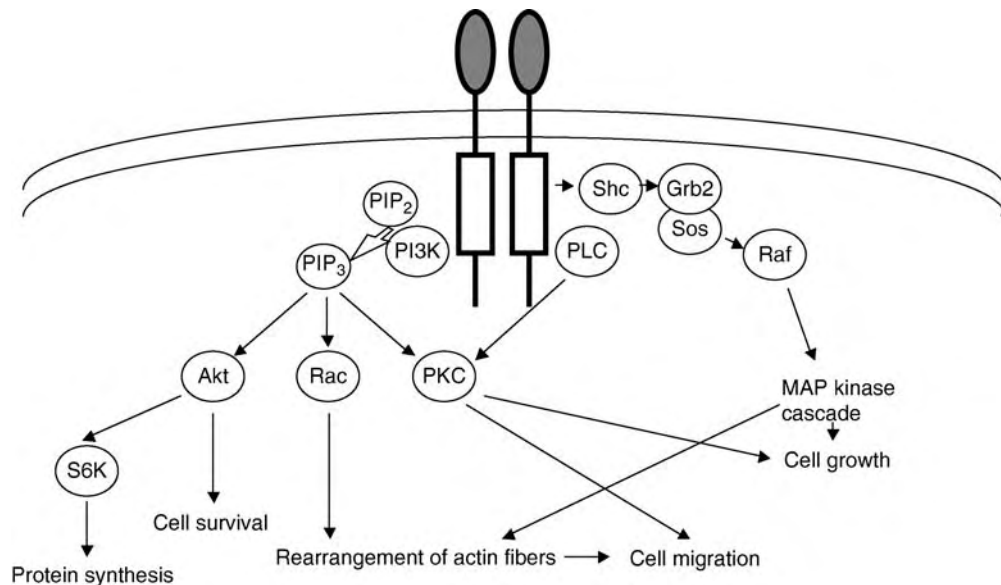

**Growth Factors – Overview. Figure 1** Signaling cascade activated by receptor-type tyrosine kinase. After growth factors bind to their specific receptors, the two receptors form a homodimer (dimerization) and tyrosine residues inside their receptors are phosphorylated (auto-phosphorylation). The phosphorylated tyrosine residues interact with and phosphorylate signaling molecules. The phosphorylated molecules sequentially activate down-stream signaling molecules. These pathways finally promote special sets of gene expression. To avoid excess signaling, the growth factor-receptor binding complex is then immediately taken into the cell body and degraded.

Another example is the SH2 domain-containing enzyme phospholipase  $C\gamma$ , which is recruited to the phosphorylated receptor to provide access to its phospholipid substrate in the plasma membrane. One of the hydrolysis products of phospholipase  $C\gamma$  activates protein kinase C. Eventually, a complex network of positive and negative regulators participates in the down-stream signaling, which precisely manipulates the transcription of a specific set of genes [9].

#### Receptor-Type Serine/Threonine Kinase Family

TGF- $\beta$  and BMP family members interact through extracellular domains of heteromeric complexes composed of type I and type II serine threonine kinase receptors (► [Transforming growth factor- \$\beta\$  receptor](#)). In general type II receptors are constitutive kinases responsible for ligand binding and for transphosphorylation of the type I receptor on a glycine-serine rich domain (GS domain). The phosphorylation of this domain activates the type I kinase which then phosphorylates downstream components of the ► [Smad signaling pathway](#) (members of the Smad family) (see essay on transforming growth factor in this Encyclopedia).

#### Wnt Receptor

Wnts receptors, Frizzleds (Fz), are serpentine receptors with seven transmembrane-spanning domains and a long N-terminal extension called a cysteine-rich

domain (CRD), closely related to G protein-coupled receptors. Wnt proteins bind directly to the Fz CRD. In *Drosophila* and in cultured cells, over-expression protein of the DFz2 receptor fails to activate Wnt signaling unless its cognate ligand, Wingless, is present, suggesting that Fz activates a down-stream signaling cascade in a ligand dependent manner (Fig. 2).

In addition to Wnt/Fz interactions, Wnt signaling also requires the presence of a single-pass transmembrane molecule of the LRP family, identified as the gene Arrow in *Drosophila* and as LRP5 or 6 in vertebrates. LRP5 consists of five conserved motifs that are characteristic of the LDL-receptor family: (i) LDL-receptor repeats required for ligand binding, (ii) four EGF-receptor-like cysteine-rich repeats with associated YWTD (Tyr-Trp-Thr-Asp) spacer domains, (iii) a putative signal peptide for protein export, (iv) a single membrane-spanning segment and (v) a cytoplasmic tail with NPXY (Asn-Pro-X-Tyr) motifs for receptor internalization. Extrapolating from LRP6, it is probable that the first and second EGF repeats and the associated YWTD domains participate in interactions with the Fz-Wnt complex, whereas the third and fourth EGF-YWTD domains bind to secreted antagonists, such as the Dickkopf (Dkk) family. The transport of LRP from the ER to the cell surface requires a specific accessory molecule called Boca in *Drosophila* and Mesd in mice; mutation of these genes produce phenotypes similar to

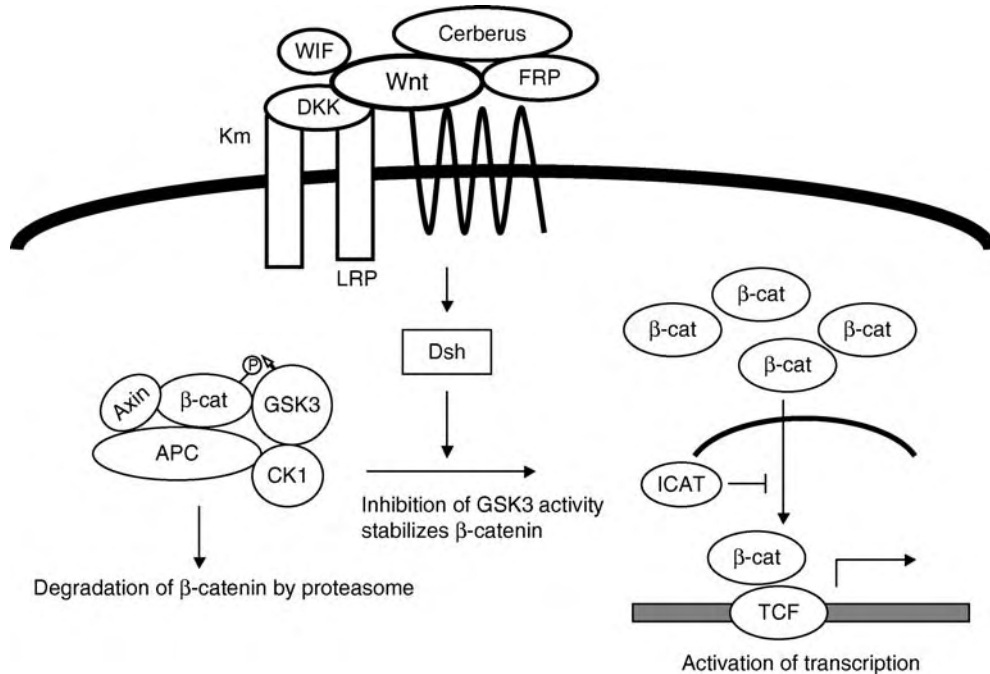

**Growth Factors – Overview. Figure 2** The canonical Wnt signaling pathway in cells not exposed to a Wnt signal (*left panel*),  $\beta$ -catenin is degraded through interactions with axin, APC and the protein kinase GSK-3. Wnt proteins bind to the Frizzled/LRP receptor complex at the cell surface (*right*). These receptors transduce a signal to Dishevelled (*Dsh*) and to axin, which may directly interact. As a consequence, the degradation of  $\beta$ -catenin is inhibited, and the protein accumulates in the cytoplasm and nucleus.  $\beta$ -catenin then interacts with TCF to control transcription.

loss of Arrow/LRP themselves. It has been proposed that Wnt molecules bind to LRP and Fz to form a receptor trimeric complex.

Receptor activation in turn somehow activates Dishevelled (*Dsh*), the most proximal cytosolic component known. The precise role of *Dsh* in pathway activation is still not clear, but it may be intricate because the pathway branches downstream of *Dsh*. In canonical Wnt signaling, *Dsh* is involved in turning off a protein complex dedicated to the degradation of  $\beta$ -catenin ( $\beta$ -cat, called Armadillo in *Drosophila*). Inactivation of the destruction complex allows  $\beta$ -cat to accumulate within responding cells and to enter the nucleus where it binds to Tcf, the transcriptional effector of the Wnt pathway. This complex recruits other proteins to drive transcriptional activation of Wnt target genes.

A hallmark of Wnt pathway activation is the elevation of cytoplasmic  $\beta$ -cat protein levels. In the absence of Wnt signaling,  $\beta$ -cat is phosphorylated by the serine/threonine kinase, casein kinase I $\alpha$  (CKI $\alpha$ ) and GSK-3. The interaction between these kinases and  $\beta$ -catenin is facilitated by the scaffolding proteins, axin and APC. Together, these proteins form  $\alpha$ -catenin “degradation complex,” which allows phosphorylated  $\beta$ -cat to be recognized by  $\beta$ -TrCP, targeted for ubiquitination and degraded by the proteasome. Activation

of Wnt signaling inhibits  $\beta$ -cat phosphorylation and hence its degradation. The elevation of  $\beta$ -cat levels leads to its nuclear accumulation and complex formation with LEF/TCF transcription factors.  $\beta$ -cat mutant forms that lack the phosphorylation sites required for its degradation are Wnt unresponsive and can activate Wnt target genes constitutively [10].

### Function

In the higher multi-cellular organisms, the cells respond to environmental stimuli like growth factors. Signaling through the receptors of the growth factors described above regulates a wide range of biological phenomena during the development of the nervous system. In most cases, the neural cells express certain sets of receptors for growth factors and the dynamic cross-talks of upstream and/or down stream signaling cascades, initiated by interaction between ligands and receptors, manipulate expression of special sets of genes or directly modify the cell structures and functions of neural cells. We have essays on each developmental step of the nervous system in this Encyclopedia.

### References

1. Massague J, Pandiella A (1993) Membrane-anchored growth factors. *Annu Rev Biochem* 62:515–541

2. Birchmeier C, Gheradi E (1998) Developmental role of HGF/SF and its receptor, the c-met tyrosine kinase. *Trends Cell Biol* 8:404–410
3. Lu C, Lan HN, Menon RK (2005) New members of the insulin family: regulators of metabolism, growth and now... reproduction. *Pediatr Res* 57:70R–73R
4. Funa K, Uramoto H (2003) Regulatory mechanisms for the expression and activity of platelet-derived growth factor receptor. *Acta Biochim Pol* 50:647–658
5. Sette C, Dolci S, Germina R, Rossi P (2000) The role of stem cell factor and of alternative products in the establishment, maintenance function of germ cells. *Int J Dev Biol* 44:599–608
6. Sariola H, Saarna M (2003) Novel functions and signaling pathways for GDNF. *J Cell Sci* 116:3855–3862
7. Shibuya M (2001) Structure and function of VEGF/VEGF-receptor system involved in angiogenesis. *Cell Struct Funct* 26:25–35
8. Logan CY, Nusse R (2004) The Wnt signaling pathway in development and disease. *Annu Rev Cell Dev Biol* 20:781–810
9. Bazley LA, Gullick WJ (2005) The epidermal growth factor receptor family. *Endocr Relat Cancer* 12:17–27
10. He X, Semenov M, Tamai K, Zeng X (2004) LDL receptor-related proteins 5 and 6 in Wnt/beta-catenin signaling: arrows point the way. *Development* 131:1663–1677

Growth factors are classified into families either on the basis of the specific receptor classes by which they mediate their effects or on the basis of conserved structural motifs that are shared amongst family members (Table 1).

Neurons are supported throughout life by the actions of a repertoire of growth factors and specific neuronal populations rely on specific growth factors for their maintenance and survival. For example, glial cell-line derived neurotrophic factor (GDNF) and brain-derived neurotrophic factor (BDNF) are major growth and survival factors for dopaminergic neurons in the substantia nigra, the neuronal population affected in Parkinson's disease. The growth factor families that have a major influence in the brain include:

*Neurotrophins:* The neurotrophins are the most well studied growth factor family [1]. Nerve growth factor (NGF) was the founding member in this family that also includes brain-derived neurotrophic factor (BDNF) and neurotrophins 3 and 4 (NT3, NT4). All neurotro-

## Growth Factors – Survival/Plasticity

DEBORAH YOUNG

Department of Molecular Medicine & Pathology,  
Department of Pharmacology & Clinical Pharmacology  
Faculty of Medical & Health Sciences, University of  
Auckland, Auckland, New Zealand

### Synonyms

Neurotrophic factors

### Definition

Growth factors are proteins that support the proliferation, migration, differentiation and survival of cells (neurons, glia) within the nervous system during early development and throughout adult life.

### Characteristics

Growth factors constitute a broad range of structurally diverse proteins that mediate a wide array of biological functions in the brain including neurogenesis, neuronal survival/▶apoptosis, neurite outgrowth and synaptic plasticity. These functions are mediated by binding of the growth factor to its cell surface receptor(s), which are in many cases, receptor tyrosine kinases, leading to the activation of intracellular cell signaling cascades.

**Growth Factors – Survival/Plasticity. Table 1** Growth factor and growth factor receptors

Growth factor family	Growth factor	Receptor
Neurotrophins	Nerve growth factor (NGF)	TrkA, TrkB, TrkC, p75 <sup>NTR</sup>
	Brain derived neurotrophic factor (BDNF)	
	Neurotrophin 3 (NT3)	
	Neurotrophin 4/Neurotrophin 5 (NT4/5)	
Insulin-like growth factors	IGF-1, IGF-2, insulin	IGF-1, IGF-2, insulin
Fibroblast growth factors (FGF)	Acidic FGF	FGF R1–5
	Basic FGF	
	FGF3–14	
	FGF16–23	
TGFβ	TGFβ1–3	TGFβ1/TβRII
	Activins/inhibins	
	Nodal	
	Bone morphogenetic proteins	
	Growth/differentiation factors	
Epidermal growth factor (EGF)	EGF	EGF receptor Erb B2–4
	Transforming growth factor alpha (TGF-α)	
	HB-EGF	
	Betacellulin	
	Amphiregulin	
	Neuregulin-1 and 3	

phins are synthesized as larger ~30–35 kDa precursors or proneurotrophins before the N-terminal prodomain, a peptide sequence that promotes folding of the protein and trafficking to secretory vesicles, is proteolytically cleaved prior to yield the secreted mature ~11–15 kDa neurotrophin. The mature neurotrophins mediate their biological effects by binding to two structurally distinct classes of receptors – the Trk family of receptor tyrosine kinases, to which NGF preferentially binds to the TrkA receptor, BDNF and NT3 to the TrkB receptor, NT3 to the TrkC receptor, – and the p75 neurotrophin receptor (p75<sup>NTR</sup>) to which all mature neurotrophins bind with equal affinity. More recent evidence has shown that both precursor forms of NGF and BDNF (proNGF and proBDNF) can also be secreted from cells and have functional activity [2].

**Insulin-like growth factors (IGFs):** The three members of this family, insulin, IGF-1 and IGF-II exert their effects by binding to two cell surface receptors, the IGF-1 (or type I) and IGF-II (or type 2) receptors [3]. The IGF-1 and IGF-II receptors bind IGF1 and IGF-II respectively with the highest affinities but also allow binding by other family members with lower affinity. However, the IGF-II receptor does not bind insulin. All IGFs can also interact with the insulin receptor but with much lower affinity. The IGF-1 receptor is a heteromeric protein harboring two identical  $\alpha$ -subunits containing a cysteine rich IGF-binding site and two transmembrane  $\beta$ -subunits that have tyrosine kinase activity. Activation of this receptor tyrosine kinase leads to phosphorylation of multiple cytoplasmic substrates such as the adaptor molecule insulin receptor substrate (IRS-1/4) proteins and the Shc proteins which bind to Grb2 and stimulate the activity of the Ras and mitogen activated protein (MAP) kinase pathway which involves Raf-1 and extracellular signal-related kinase (ERK)-1/2. Alternatively, IRS proteins can also activate the phosphatidylinositol-3 kinase (PI-3K) pathway via the adaptor protein p85.

**Epidermal growth factor (EGF) family:** members of this family share at least one common structural motif, the EGF domain that consists of six conserved cysteine residues that form three disulfide bonds. Like the neurotrophins, most members are synthesized as precursors before the mature peptide is released by proteolytic cleavage. The activity of EGF family members is mediated by the EGF receptor/ErbB receptor tyrosine kinases. The binding of the ligand to the EGF receptor leads to formation of heterodimers with one of three related proteins, ErbB2, ErbB3 and ErbB4 leading to downstream activation of MAP kinase and PI-3K pathways [4].

**Fibroblast growth factor (FGF) family:** The FGF family currently consists of 22 ligands and five cell surface receptor tyrosine kinases that are also expressed as several splice variants in humans [5]. All FGF ligands share a conserved 120 amino acid central heparin-binding

domain that is involved in the formation of stable FGF ligand-receptor interactions. FGF ligand binding induces dimerisation of the receptors and cross-phosphorylation of tyrosine residues leading to recruitment of intracellular second messengers including phospholipase C $\gamma$  and subsequent protein kinase C activation or Ras/Raf signaling and activation of the MAP kinase cascade. FGF1 (acidic fibroblast growth factor) and FGF2 (basic fibroblast growth factor) are the two prototypical members of this family. FGF1 is expressed predominantly in neurons and is primarily involved in promoting neuronal maturation and differentiation, whereas FGF2 is expressed in neurons and glial cells and is a potent mitogen that promotes proliferation of neural stem cells to either a neuronal or glial cell fate.

**Transforming growth factor beta (TGF- $\beta$ ) family:** this large superfamily comprises as many as 30 proteins in mammals and those with relevance to the central nervous system include the three TGF- $\beta$  isoforms (TGF- $\beta$ 1–3), activins and inhibins, nodal, bone morphogenetic proteins (BMP), growth/differentiation factors (GDFs) [6]. The most well-studied are the TGF- $\beta$  isoforms which act in a highly contextual manner depending on the cell type and environment. Thus these proteins may stimulate proliferation or induce differentiation, promote cell survival or induce apoptosis, initiate and or reduce inflammation. The three isoforms are synthesized as large precursors that are cleaved intracellularly by furin to release a C-terminal prodomain called the latency associated peptide (LAP) and the N-terminal active peptide. Each peptide forms homodimers and LAP non-covalently binds to the homodimer to keep it inactive before the complex is secreted and activated by a still poorly understood process. The actions of all three TGF- $\beta$  isoforms are mediated by a high-affinity receptor complex comprised of the TGF- $\beta$  type 1 (ALK5) and type 2 serine/threonine kinase (T $\beta$ RII) subunits. A third receptor called betaglycan, has no apparent intracellular signaling activity and regulates ligand availability to ALK5 and T $\beta$ RII. Binding of the ligand to the ALK5/T $\beta$ RII complex leads to phosphorylation of ALK5 and recruitment of receptor-regulated Smad (R-Smad) proteins, which translocate to the nucleus and, together with other transcription factors, regulate gene transcription. R-Smads 2 and 3 transmit signal for the TGF- $\beta$  and activin pathways while Smad 1, Smad 5 and Smad 8 do the same for the BMP pathway. TGF $\beta$ 1, 2 and 3 and their receptor are expressed at low levels within neurons, astrocytes, microglia in the normal CNS.

Glial-derived neurotrophic factor (GDNF) and related ligands neurturin, artemin and persephin are distant relatives of the TGF- $\beta$  family [7]. GDNF has attracted substantial attention as it is a potent survival factor for midbrain dopamine-containing neurons,

which degenerate in Parkinson's disease as well as spinal motoneurons which degenerate in amyotrophic lateral sclerosis. Members of the GDNF family signal through the RET receptor tyrosine kinase by binding to glycosyl phosphatidylinositol-anchored receptors termed GFR $\alpha$ 1 to 4, in collaboration with signaling receptor subunits such as the RET tyrosine kinase or the p140<sup>NCAM</sup> isoform of the neural cell adhesion molecule NCAM.

### Effects on Cell Survival/Apoptosis

Neuronal cell survival and death decisions need to be tightly regulated in order to maintain functional neuronal circuits. Neurons depend on the presence of optimal amounts of growth factors for their survival and their importance is highlighted in neurodegenerative diseases, where reduced growth factor signaling appears to be a major contributor to the degeneration of specific neuronal populations that depend on that growth factor for survival. Thus for example, impaired cortical production and supply of BDNF to the medium spiny neurons in the striatum is believed to contribute to the susceptibility of these cells to insult by toxic huntingtin protein fragments and excitotoxic and oxidative stressors in Huntington's disease. Similarly, age-related decreases in IGF1 and BDNF signaling in the hippocampus have been reported which might contribute to age-related cognitive impairment and BDNF signaling may be compromised early in the course of Alzheimer's disease [8]. As a consequence of these findings, a major therapeutic focus for many neurodegenerative diseases has centered on elevating growth factor levels or growth factor signaling to counter the degenerative effects of the disease. Numerous studies have shown that exogenous administration of recombinant growth factor protein or application of ► [gene therapy](#) technology rescues or promotes neuronal survival in animal models of epilepsy, stroke, Parkinson's, Alzheimer's or Huntington's disease as well as neuronal loss that accompanies aging (see Chapter on Gene Therapy). Similarly, behavioral interventions such as calorie restriction, environmental enrichment or voluntary exercise which induce growth factor expression also increase the resistance of the brain to traumatic or chemical insults. Growth factor expression (e.g. FGF, BDNF) can also be induced in response to brain injury or ischemia and may be a cellular defense mechanism in an attempt to rescue dying neurons.

One of the most recent findings is that members of the neurotrophin family can mediate cell survival or death decisions. The mature neurotrophins promote neuronal survival and differentiation through Trk receptor activation, whereas proneurotrophin-mediated interaction with the p75<sup>NTR</sup> and various binding partners including sortilin and Nogo initiates biological responses including apoptosis, myelination and neurite outgrowth. These observations coupled with findings that secreted proneurotrophins can also be cleaved

extracellularly by proteinases such as matrix metalloproteinase-7 and plasmin predict that neurotrophin action is tightly regulated by several mechanisms; the expression of distinct neurotrophin receptors that determine the responsiveness of the cell, the secretion and ratio of pro- versus mature neurotrophins and the expression of extracellular proteases that mediate conversion of proneurotrophins to mature forms [2].

Although growth factors may act on distinct receptors, the neuroprotective signal transduction pathways are often similar and involve the (PI3K)/Akt pathway which inhibits the apoptotic action of Forkhead and B-cell leukemia/lymphoma 2 (BCL-2)-associated death protein (BAD), the MAP kinase signaling pathway that promotes the activity or expression of anti-apoptotic BCL-2, and the transcription factor cyclic AMP responsive element binding (CREB).

### Effects on Brain Plasticity

The survival-promoting effects of many growth factors are also coupled to their effects on neural plasticity. At the synaptic level, growth factors can affect synaptic plasticity by promoting ► [long-term potentiation](#) (LTP) or ► [long-term depression](#) (LTD), cellular correlates of learning and memory. Of the neurotrophins, BDNF is the most well-studied for its role in regulating hippocampal LTP and more recently, proBDNF has been shown to facilitate LTD [1]. The impact of the strengthening or weakening of these synaptic connections can contribute to synaptic remodeling including stimulating axonal branching, dendritic growth and activity-dependent refinement of synapses. Therefore, neuroprotective strategies involving growth factors can have a dual effect by not only promoting neuronal survival but also recovery of function. For example, GDNF is neuroprotective of surviving dopamine neurons in animal models of Parkinson's disease but also promotes recovery from motor deficits by stimulating axonal sprouting and increasing dopamine production in the remaining surviving neurons. Similarly, bFGF is also effective in promoting neurite regeneration from injured axons by promoting sprouting at the proximal part of the injured axon that may lead to formation of new synapses and recovery of neural circuits.

Growth factors can also modulate brain plasticity at the cellular level, most notably by stimulating ► [neurogenesis](#) in the adult brain. Neurogenesis that occurs in the hippocampal brain region in adult life is an important mechanism that influences learning and memory and may enable organisms to adapt to environmental changes [9]. Voluntary exercise, exposure to enriched environments and calorie restriction all stimulate hippocampal neurogenesis and this process is thought to be mediated by the coordinated interaction between BDNF, VEGF, IGF1, FGF2 and EGF which induce the proliferation of neural precursors and support the differentiation and survival of

newborn neurons [10]. Hippocampal neurogenesis declines precipitously with ageing, primarily due to a reduction in neuronal precursor proliferation that consequently impacts on the number of mature neurons generated and this may be due to the reduced supply or composition of the growth factor cues (e.g. FGF2, IGF1 and VEGF) that drive hippocampal neurogenesis.

## References

1. Lu B, Pang PT, Woo NH (2005) The yin and yang of neurotrophin action. *Nat Rev Neurosci* 6:603–614
2. Hempstead BL (2006) Dissecting the diverse actions of pro- and mature neurotrophins. *Curr Alzheimer Res* 3:19–24
3. Laviola L, Naatalicchio A, Giorgino F (2007) The IGF-1 signaling pathway. *Curr Pharm Des* 13:663–669
4. Schlessinger J (2002) Ligand-induced, receptor-mediated dimerization and activation of the EGF receptor. *Cell* 110:669–672
5. Turner CA, Akil H, Watson SJ, Evans SJ (2006) The fibroblast growth factor system and mood disorders. *Biol Psychiatry* 59:1128–1135
6. Wyss-Coray T (2006) TGF- $\beta$  pathway as a potential target in neurodegeneration and Alzheimer's. *Curr Alzheimer Res* 3:191–195
7. Airaksinen MS, Saarma M (2002) The GDNF family: signalling biological functions and therapeutic value. *Nat Rev Neurosci* 3:383–394
8. Mattson MP, Magnus T (2006) Ageing and neuronal vulnerability. *Nat Rev Neurosci* 7:278–294
9. Kempermann G, Wiskott L, Gage FH (2004) Functional significance of adult neurogenesis. *Curr Opin Neurobiol* 14:186–191
10. Nithianantharajah J, Hannan AJ (2006) Enriched environments, experience-dependent plasticity and disorders of the nervous system. *Nat Rev Neurosci* 7:696–709

postnatal maturation. In adult systems, the role of growth factors changes and although they continue to provide ►**trophic** support, they also modulate afferent (sensory) properties. This is particularly true following tissue injury where changes in growth factor tissue content can have profound effects on sensory neuron gene expression and functional properties. This is best illustrated by the changes associated with inflammatory pain conditions where increased production of growth factors leads to sensitization of ►**primary sensory afferents**.

## Characteristics

### Growth Factors Affect Different Subpopulations of Sensory Afferents Through Receptor Tyrosine Kinase Signaling

Although several types of growth factors have survival and growth-promoting effects on sensory neurons, most studies of neurotrophic factors in relation to pain signaling have focused on members of two major families. The first of these is the neurotrophin family, which in mammals includes the founding member nerve growth factor (NGF), neurotrophin-3 (NT3), neurotrophin-4 (NT4) and brain-derived growth factor (BDNF). Neurotrophins are small (120 amino acids, 13 kDa) basic proteins that share approximately 50% amino acid homology between family members. They bind as homodimers to the external domain of transmembrane ►**receptor tyrosine kinase** proteins known as trks (tropomyosin related kinases). Binding of growth factor ligand stabilizes Trk receptor dimerization and allows subsequent auto- and trans- phosphorylation of tyrosine residues. Phosphotyrosines serve as binding sites for adaptor proteins, many of which contain src homology 2 (SH2) domains. Trk kinases signal through several cellular pathways that include PI3K, PLC and ras/MAPKs. Neurotrophins bind trk receptors in a preferential manner: NGF binds the receptor trkA, NT3 binds trkC and BDNF and NT4 bind trkB. How specificity of growth factor signaling through each receptor is attained is an area of significant interest. Some specificity may develop through interaction of trk receptors with the single pass transmembrane receptor p75, which can bind all neurotrophins.

Another growth factor family with importance in pain signaling is the glial cell line-derived neurotrophic factor (GDNF) family. The small (~13 kDa) proteins GDNF, neurturin, artemin and persephin comprise this family. These GDNF family ligand (GFL) proteins are classified as a subfamily of the transforming growth factor beta (TGF- $\beta$ ) superfamily of growth factors. GFLs bind as homodimers to activate the rearranged during transfection (Ret) receptor tyrosine kinase through binding of GPI-anchored co-receptor proteins known as growth factor receptor (GFR) alpha proteins. Preferential binding of GDNF ligands is found for each GFR, with GDNF binding GFR $\alpha$ 1, neurturin

## Growth Factors and Pain

KATHRYN M. ALBERS

Department of Medicine, University of Pittsburgh,  
Pittsburgh, PA, USA

### Synonyms

Pain and growth factors; Nociception and growth factors

### Definition

Primary sensory neurons that transmit painful mechanical, thermal or chemical stimuli are highly dependent on growth factors for their embryonic survival and



binding GFR $\alpha$ 2, artemin binding GFR $\alpha$ 3 and persephin binding GFR $\alpha$ 4.

### Growth Factors are Essential for Nociceptor Neuron Survival

Sensory afferents that transmit noxious heat, chemical, or mechanical stimuli can be divided into two major subtypes based on their growth factor requirements during embryonic development and postnatal maturation. This subdivision generally relates to whether the sensory neurons express trkA or Ret kinases and whether they are ►neuropeptide rich or neuropeptide poor. Peptide rich ►nociceptors express trkA, calcitonin gene related peptide (CGRP) or substance P (SP) and many require NGF for survival during development and have a relatively small cell body. The axons of these afferents are either thinly myelinated A $\delta$  fibers or unmyelinated C fibers. TrkA expressing, NGF-dependent neurons primarily terminate in the superficial lamina (I and II) of the spinal cord dorsal horn. Mice genetically engineered to lack a functional NGF or trkA gene lose ~70% of DRG neurons, lack CGRP-positive (peptidergic) neurons and have impaired response to sensory stimulation. Most exhibit postnatal lethality due to deficits in sensory and sympathetic systems. In humans, genetic analysis of subjects diagnosed with ►congenital insensitivity to pain with anhidrosis (CIPA) syndrome have an assortment of mutations that inhibit normal function of the trkA gene [1].

In addition to trkA neurons, the dorsal root ganglion (DRG) contains a subpopulation of sensory neurons responsive to BDNF that express trkB. Mice that lack functional trkB or BDNF genes exhibit loss of ~30% of DRG neurons and sensory deficits related to detection of mechanical stimuli. TrkB neurons are of both large and small diameter and in the wildtype ganglia comprise 10–30% of the DRG population. The DRG also contains NT3-responsive trkC expressing neurons (~20%). Many of these neurons have large-diameters, thickly myelinated axons and serve proprioceptive function. Mice lacking NT3 have up to 78% loss of DRG neurons. Although some trkB and trkC DRG neurons are likely to contribute to nociception, the major transmitters of pain stimuli are trkA neurons.

The peptide poor nociceptor neurons can be defined by their binding of the isolectin B4 (IB4) and lack of CGRP or SP. These neurons are primarily dependent on GDNF family members, most notably GDNF and neurturin. They tend to be small to medium in diameter and have central projections that primarily terminate in inner lamina 2 of the spinal cord dorsal horn. An interesting exception to this peptide-rich/IB4-positive dichotomy is that most (80%) of the sensory neurons responsive to artemin that express the GFR $\alpha$ 3 receptor also express CGRP peptide and trkA, and are therefore responsive to both NGF and the artemin GFL.

### Postnatal Role in Nociceptor Differentiation

NGF is required for the developmental survival of sensory neurons and for their postnatal differentiation [see ►Fitzgerald essay]. Modulation of NGF tissue content during the immediate postnatal period can have profound effects on primary afferent subtypes in the adult [2]. In studies of rats treated with an antiserum to NGF during a critical postnatal period (day 4–day11), electrophysiologic analysis of A $\delta$  afferent subtypes showed a complete depletion of the nociceptive A $\delta$  high threshold mechanoreceptor (HTMR) population. This depletion was accompanied by an increase in the proportion of the non-nociceptive low threshold mechanoreceptive (LTMRs) A $\delta$  population (D hairs). Anti-NGF treatment did not change the total number of DRG neurons, leading to the conclusion that NGF is required for postnatal development of HTMRs and that in its absence, HTMRs differentiate into LTMRs. In support of this possibility, overexpression of NGF in the skin of developing transgenic mice caused a sevenfold increase in the number of HTMRs and depletion of LTMRs. This result may, however, reflect both the survival and differentiation actions of NGF [2].

### Neurotrophin Growth Factors Sensitize Adult Nociceptors

Growth factor-induced sensitization of nociceptors is particularly associated with inflammatory pain conditions. Sensitization reflects increased neuron excitability, which alters normal sensory processing and elicits pain. Many chronic pain conditions in humans (e.g. arthritis, bladder cystitis, pancreatitis, etc.) are inflammatory in nature and can be linked to increased growth factor expression or trk receptor signaling. Studies have focused on the effect of NGF and trkA signaling in peripheral sensory afferents. NGF modulation of afferent sensitization and pain transmission occurs using indirect and direct mechanisms. Indirectly, growth factor and cytokine (e.g. TGF $\beta$ , PDGF, IL1 $\beta$ ) content increases in cells (mast cells, macrophages, immune cells) within inflamed tissues that in turn increase NGF expression. NGF binds and activates trkA receptors expressed on mast cells, keratinocytes, immune cells and sympathetic nerve terminals. This leads to synthesis of additional inflammatory mediators (e.g. TNF- $\alpha$  and interleukin-6). Preventing the increase in NGF during experimental inflammation using anti-NGF or trkA-IgG decoy proteins diminishes ►hyperalgesia associated with inflammation.

NGF directly modulates afferent activity via binding of trkA on sensory nerve terminals. TrkA activation stimulates SP and CGRP expression on transcriptional and translation levels. Peptide release following sensory afferent depolarization results in ►neurogenic inflammation [►see Vasko essay]. NGF signaling is also important for increased activity of ion channel

proteins involved in neural transmission in inflammatory conditions. Increased NGF enhances expression and activity of the transient receptor potential vanilloid 1 (TRPV1) receptor. Through trkA binding, NGF can potentiate TRPV1 activity by regulating phosphorylation of TRPV1 using mechanisms that include the serine/threonine kinases PKC and PKA, calcium/calmodulin-dependent kinase II and the tyrosine kinase c-src. TRPV1 activation is required for the development of thermal hyperalgesia associated with inflammation. NGF also increases activity of other channel proteins that affect afferent sensitivity that include acid sensing ion channel 3 (ASIC3), voltage-gated sodium channels and a receptor for bradykinin, an inflammatory mediator peptide that increases in inflamed tissue. Thus, NGF enhances the activity of neurons by sensitizing receptors (e.g. TRPV1, BK receptors), increasing their responses to thermal and chemical (capsaicin) stimuli, protons (ASIC3, TRPV1) and neuromodulator peptides (CGRP, SP and bradykinin).

NGF-mediated changes in channel, receptor and peptide expression are likely to contribute to the thermal and mechanical hyperalgesia that is induced in rodent and human subjects following NGF injection. In healthy humans, subcutaneous injection of recombinant NGF produces thermal hypersensitivity within 30 min and mechanical sensitivity within hours. Intravenous injection of NGF produces a mild to moderate muscle pain in a dose-dependent manner. Local injection of NGF had a greater effect, producing hyperalgesia at the injection site that at high doses persisted for several weeks. Thus, long-term changes in sensory processing occur in response to changes in growth factor signaling. These effects were more pronounced in women and may underlie, at least in part, sex-related differences in pain sensitivity [see ▶ [Shinal and Fillingim essay](#)].

Experimental manipulations in which anti-NGF strategies are used to reduce or prevent pain have been successful. Blockade of NGF/trkA signaling has been found effective, particularly in models of inflammation. In current human clinical trials, an anti-NGF compound is being tested on subjects as a means to prevent chronic osteoarthritis pain. NGF has also been used in clinical trials in attempt to reverse diabetic associated peripheral neuropathies that include numbness, loss of thermal sensation and abnormal tingling sensation [3]. Injection of NGF caused localized sensitivity, but no overall beneficial effect in sensory perception was recorded. However, topical NGF has successfully been used for treatment of degenerative corneal disease resulting from changes in trigeminal nerve innervation [4].

### Neurotrophins and Central Sensitization

The inflammation-associated sensitization of primary afferents by NGF can also impact spinal transmission

and lead to ▶ [central sensitization](#) [see ▶ [Sandkühler essay](#)]. In response to peripheral inflammation and increased NGF expression, nearly all trkA-expressing sensory neurons increase expression of the neurotrophin BDNF. Subsequent anterograde transport and activity-dependent release of BDNF from dense-core vesicles in terminals that project to the superficial dorsal horn leads to sensitization of spinal neurons (and generally to ascending pain pathways). Centrally released BDNF binds trkB receptors expressed on spinal interneuron and projection neuron populations. Binding activates trkB receptors, leading to subsequent phosphorylation and activation of several signaling pathways. Importantly, trkB activation stimulates activity of excitatory NMDA glutamate receptors. In this manner BDNF/trkB signaling acts to potentiate central glutaminergic transmission and increase nociceptive transmission. BDNF can also modulate central pain pathways by increasing descending pain facilitation at the level of the rostroventral medulla.

### GDNF-Family Ligands and Nociceptor Function

In addition to neurotrophin growth factors, members of the GDNF family may also have roles in sensory neuron pain signaling. Similar to neurotrophins, GFLs are important for development and postnatal differentiation of various sensory neuron subpopulations. GDNF and neurturin support development of Ret-expressing DRG neurons that are peptide poor and bind IB4. Artemin supports a subpopulation of Ret-positive neurons that express CGRP and SP peptides and the TRPV1 and TRPA1 channels. Artemin responsive neurons, although expressing Ret and its GFR $\alpha$ 3 co-receptor, also express trkA and are therefore responsive to NGF.

In comparison to NGF, the role of the GDNF-family ligands in afferent sensitization and pain signaling in the adult nervous system is much less understood at this time. In neuropathic pain, intrathecal application of GDNF reduced thermal and mechanical sensitivity associated with peripheral nerve injury [5]. Artemin injections also reduced behavioral hyperalgesia associated with nerve injury [6], although in another study, no effect on pain behavior was reported [7]. These different outcomes may relate to the animal model, dosage and/or delivery approaches used.

GDNF-family members appear to have a role in inflammatory pain signaling. In a rodent inflammatory pain model (Complete Freund's Adjuvant, CFA), anti-GDNF proteins decreased hyperalgesia associated with inflammation [8]. In humans, artemin and its receptor GFR $\alpha$ 3 were significantly over-expressed in chronic pancreatitis [9]. Expression was related to the degree of neural hypertrophy, pain severity and inflammatory infiltrate. In animal studies, footpad skin injected with the inflammatory compound CFA caused a tenfold rise in artemin mRNA [10]. In addition, injection of artemin (or

GDNF or neurturin) in footpad skin caused a transient (<24 h) increase in behavioral thermal sensitivity. Co-injection of artemin and NGF, which both increase in CFA inflamed tissue, led to prolonged heat hyperalgesia lasting up to 7 days. Thus, traumatic or chronic insults resulting in a combined increase in NGF and artemin may produce long-term effects on noxious thermal sensitivity.

In summary, growth factors in the neurotrophin and GDNF families have profound effects on the development, differentiation and functional properties of sensory afferents that transmit painful stimuli. Although their principal effect appears to be at the primary afferent level, accumulating evidence supports an important role at the spinal cord level as well.

## References

1. Indo Y (2002) Genetics of congenital insensitivity to pain with anhidrosis (CIPA) or hereditary sensory and autonomic neuropathy type IV. Clinical, biological and molecular aspects of mutations in TRKA(NTRK1) gene encoding the receptor tyrosine kinase for nerve growth factor. *Clin Auton Res* 12 Suppl 1:I20–I32
2. Mendell LM, Albers KM, Davis BM (1999) Neurotrophins, nociceptors, and pain. *Microsc Res Tech* 45:252–261
3. Apfel SC (2002) Nerve growth factor for the treatment of diabetic neuropathy: what went wrong, what went right, and what does the future hold? *Int Rev Neurobiol* 50:393–413
4. Lambiase A, Coassin M, Sposato V, Micera A, Sacchetti M, Bonini S, Aloe L (2007) NGF topical application in patients with corneal ulcer does not generate circulating NGF antibodies. *Pharmacol Res* 56:65–69
5. Boucher TJ, Okuse K, Bennett DL, Munson JB, Wood JN, McMahon SB (2000) Potent analgesic effects of GDNF in neuropathic pain states. *Science* 290:124–127
6. Gardell LR, Wang R, Ehrenfels C, Ossipov MH, Rossomando AJ, Miller S, Buckley C, Cai AK, Tse A, Foley SF, Gong B, Walus L, Carmillo P, Worley D, Huang C, Engber T, Pepinsky B, Cate RL, Vanderah TW, Lai J, Sah DW, Porreca F (2003) Multiple actions of systemic artemin in experimental neuropathy. *Nat Med* 9:1383–1389
7. Bolon B, Jing S, Asuncion F, Scully S, Pisegna M, Van GY, Hu Z, Yu YB, Min H, Wild K, Rosenfeld RD, Tarpley J, Carnahan J, Duryea D, Hill D, Kaufman S, Yan XQ, Juan T, Christensen K, McCabe J, Simonet WS (2004) The candidate neuroprotective agent artemin induces autonomic neural dysplasia without preventing peripheral nerve dysfunction. *Toxicol Pathol* 32:275–294
8. Fang M, Wang Y, He QH, Sun YX, Deng LB, Wang XM, Han JS (2003) Glial cell line-derived neurotrophic factor contributes to delayed inflammatory hyperalgesia in adjuvant rat pain model. *Neuroscience* 117:503–512
9. Ceyhan GO, Bergmann F, Kadihasanoglu M, Erkan M, Park W, Hinz U, Giese T, Muller MW, Buchler MW, Giese NA, Friess H (2007) The neurotrophic factor artemin influences the extent of neural damage and growth in chronic pancreatitis. *Gut* 56:534–544
10. Malin SA, Molliver DC, Koerber HR, Cornuet P, Frye R, Albers KM, Davis BM (2006) Glial cell line-derived neurotrophic factor family members sensitize nociceptors in vitro and produce thermal hyperalgesia in vivo. *J Neurosci* 26:8588–8599

## Growth Inhibitory Molecules in Nervous System Development and Regeneration

G

GERLINDE A. METZ, JAMSHID FARAJI  
Canadian Centre for Behavioural Neuroscience,  
Department of Neuroscience, University of Lethbridge,  
Lethbridge, AB, Canada

### Definition

Growth inhibitory and repulsive guidance molecules are major regulators of neural pattern formation and nervous system stability. Repulsive guidance molecules are expressed to direct growing axons or dendrites to appropriate targets during development. Neurite growth inhibitors are mainly found in central nervous system (CNS) myelin, where they are thought to support connective stability. After injury, however, neurite growth inhibitors may restrict regeneration and plasticity, thus impeding functional recovery.

### Characteristics

#### Mechanisms of Axo-Dendritic Guidance

During development of the nervous system, multiple molecular signals participate in the formation of neuronal networks. Once a cell has migrated from the site of origin to its final location, the goal is to establish connections with one or more appropriate target structures, including other neurons. These connections are established by sending out axons and dendrites, the neuron's processes for transmitting and receiving information, respectively. Axons and dendrites have the task to select correct targets, which can be far away from their location in the brain. Both, cell migration and the formation of complex connection patterns among a large number of neurons are accomplished by finely tuned interactions of a variety of guidance molecules. Among these molecules, repulsive guidance cues and growth inhibitors have raised particular interest because of their clinical relevance.

The Spanish histologist Santiago Ramón y Cajal was one of the first to hypothesize that chemical signals in the cell environment play a fundamental role in guidance of axons and dendrites to the appropriate target cells. It is now clear that it is the coordinated

action of chemoattractive and chemorepulsive signals that supply the directional information to pathfinding axons and dendrites. The final decision whether a signal has attractive or repulsive effects is made by the growth cone, the dynamic actin-supported apparatus at the tip of the extending neurite [1]. The growth cone interprets guidance signals that are present in the surrounding by translating the message into changes in intracellular levels of second messengers, such as cyclic nucleotides. A reduction in cyclic nucleotide levels in the growth cone, for instance, can switch an attractive response to a repulsive one [1,2]. In addition to the roles of repulsive signals, their receptors, and their intracellular signal transduction have recently been redefined as more complex than previously thought.

The responses to repulsive cues range from deviation in growth direction to the collapse and retraction of the growth cone. Cell repulsion requires rapid changes in actin filaments and microtubules while downregulating adhesion to other cells and to the extracellular matrix that surrounds these neurons. The repulsive molecules can be bound to the surface of cell membranes or to the extracellular matrix, operating by contact at short distances, or they can be soluble, thereby acting as long-distance cues via a ►chemical gradient. The directed growth of neurites to their targets over long distances suggests that the correct targets produce chemotactic signals that diffuse towards receptive neurons, thus generating gradients along which growth cones orient their direction of growth.

### Repulsive Molecules Guide Axons to Their Targets During Development

A number of molecules with repulsive action have been implicated in axo-dendritic guidance. The four most prominent candidates are the conserved families of ►semaphorins, ►netrins, ►slits and ►ephrins. Interestingly, many repulsive molecules, including semaphorins and netrins, can exert bifunctional effects depending on age and type of neuron. Thus, growth cones can respond differently to a specific guidance molecule at different stages during nervous system development. For example, semaphorins, a family of secreted and transmembrane proteins, can either promote or reduce neurite outgrowth. Semaphorins were originally identified as repulsive guidance signals [3], however, they can also function as chemoattractants with important roles in developmental and pathological processes. The attractive activity stimulates growth and orients neurites toward an increasing semaphorin concentration, while the repulsive activity orients neurites toward a decreasing semaphorin concentration. In the latter case, interaction with the two components of semaphorin receptors, plexin and neuropilin, regulates cytoskeletal changes that lead to detachment from the substratum and subsequent growth cone deflection or even repulsion. Thus, semaphorins

are able to antagonize axonal regeneration after injury, particularly in the CNS. Interestingly, in the peripheral nervous system (PNS) semaphorin mRNA levels become downregulated upon injury, which then provides a permissive environment for regeneration. In addition to limiting regenerative axon growth, semaphorins have been suggested to mediate ►apoptosis, a form of ►programmed cell death.

During development of the nervous system, apoptosis serves to optimize connections and pattern formation by elimination of surplus neurons. It is estimated that about half of the original cell population in the nervous system is eliminated by apoptosis. The classic view is that erroneous axons die as a result of a limited supply of neurotrophic substances, which are provided by the target cells upon formation of synaptic contacts. Thus, only neurons with synaptic connections to appropriate target cells survive. Recent findings, however, indicate that apoptosis not only occurs as a consequence of an unsuccessful competition for neurotrophic factors, but also in response to local high concentrations of repulsive guidance molecules. Excessive levels of molecules such as semaphorin3A might relay a cell death signal to neighboring neurons and determine their survival. Even in adulthood, the presence of high levels of repulsive molecules can expose susceptible neuron populations to unfavorable conditions and eventually cause cell death.

The observation that repulsive guidance molecules may act as neuronal death factors has also been made for proteins of the netrin family, which historically were the first chemotropic guidance molecules identified. Netrins determine neuronal survival by inducing cell death in regions of insufficient netrin-1 concentration. Netrins carry out their attractive and repulsive functions by interacting with two receptors, the deleted in colorectal cancer (DCC) and the uncoordinated-5 (UNC-5) receptors, respectively. Recently, DCC and UNC5H have been named dependence receptors because they promote neuronal survival, differentiation or migration in the presence of a ligand, and initiate or amplify apoptosis in the absence of ligand availability [4]. Indeed, DCC appears to directly interact with specific caspases, the key enzymes in the cascade of apoptosis. The conditional induction of apoptosis may represent a mechanism to determine neuronal fate during pathfinding and the elimination of neurons during development.

Aside from inducing apoptosis, the classic role of netrins during development is to act as bifunctional signals with attractive and repulsive consequences, depending on the type of neuron. Based on these functions, netrins play a vital role in embryonic midline development at various CNS levels in animals with bilateral symmetry. For example, netrin-1 is expressed in the floor plate, a structure of the neural tube

separating the left and right components of the basal plate to organize midline symmetry. The floor plate stimulates and directs outgrowth of commissural axons along a long-range gradient toward the ventral midline. At the same time, netrin-1 acts as a repellent to provide a barrier for specific axons that must not cross the midline. For fine-tuning the projection patterns of specific axon populations, netrin-1 cooperates with other guidance molecules, including slit proteins. Slit proteins are expressed by the floor plate at the brainstem level, where they delimit motoneuron trajectories, while their receptor roundabout (Robo) is expressed by dorsally projecting motoneurons. Thus, the slit-Robo system selectively prevents dorsally, but not ventrally projecting motoneurons from crossing the midline of the hindbrain. The graded presence of guidance molecules that directs growth cones might be driven by graded expression patterns of transcription factors, such as observed in the optic system.

In the optic system of lower vertebrates, axons of retinal ganglion cells encounter several choice points in their pathway. In one of them, the midline chiasm, retinal ganglion cell axons either cross or avoid the midline and project to the optic tectum in topographic order. The key molecule in directing these axons to form a topographic array is ephrin-B, a member of the membrane-bound ephrin family. B-type ephrins participate in patterning of retinal ganglion cells through attractive actions along a nasal-temporal gradient, which is complemented by repulsive actions of A-type ephrins for anterior-posterior topographic mapping. The effect of guidance molecules such as ephrins on a specific population of neurons, such as retinal ganglion cells, depends on the presence of the respective receptors. For example, B-type ephrins in the mouse chiasm exert repulsive actions on those retinal ganglion cells that express the receptor EphB1 but not on others. Thus, many guidance molecules of restricted expression patterns in the nervous system, including netrin-1 and ephrin-B, can assume multiple and changing functions in neurite guidance [5].

Some of the guidance cues described above are diffusible to form chemical gradients that may influence the trajectories of extending neurites far away from the source of secretion. It is estimated that growth cones can detect gradients that differ by as little as 1–2% across their diameter. In other cases, guidance cues are substrate- or membrane-bound and act on nearby axons. Repulsive substrate-bound molecules, such as extracellular matrix proteins and myelin-associated glycoproteins, can also lead to collapse of the growth cone upon contact. When they cause retraction of the growth cone, they are referred to as neurite growth inhibitors. Many of the growth inhibitory proteins appear as the CNS matures, hence their presence bears considerable clinical importance.

### Neurite Growth Inhibitors Limit Axonal Regeneration in the Adult CNS

When brain and spinal cord of higher vertebrates mature, axonal growth becomes increasingly restricted. This lack of spontaneous axonal growth limits ►regeneration and repair after acquired neurological injury. The failure of adult CNS regeneration is not due to an intrinsic lack of regenerative ability because axons are able to extend if a permissive environment is provided, such as a peripheral nerve explant [6]. This has led to the hypothesis that the local environment provided by the adult CNS determines the degree of spontaneous axonal growth. Aside from a low availability of neurotrophic factors in the mature CNS and injury-induced scar formation, the presence of growth inhibitors seems to be a major factor in limiting axonal extension. It is assumed that these inhibitory proteins provide connective stability in the mature CNS, however, the lack of axonal regeneration after injury represents a considerable clinical challenge.

The limited regrowth of the injured adult CNS in higher vertebrates, as opposed to the PNS or the immature CNS, is in part due to the appearance of inhibitory proteins associated with oligodendrocytes and myelin. Although the failure of the mature CNS to regenerate was already reviewed by Ramon y Cajal in 1928, it was not until the 1990s when the pioneering work of Martin Schwab and coworkers led to identification and isolation of inhibitory components of CNS myelin [7,8]. The finding of the inhibitory property of CNS myelin was supported by the observation that injured axons in young mammals fail to regenerate at an age when oligodendrocytes and myelin appear in white matter. Accordingly, if myelin formation and oligodendrocyte differentiation were prevented by x-irradiating the spinal cord in rats, severed corticospinal axons were able to regenerate at a much higher age.

Purification and biochemical characterization of the inhibitory constituent of rat CNS myelin revealed two active protein fractions with molecular weights of 35 and 250 kD. These very potent neurite growth inhibitors were called NI-35 and NI-250, respectively. *In vitro* assays showed that the application of ►NI-35/250 proteins to cultured neurons causes growth cone collapse and strongly inhibits neurite outgrowth. Experiments using an antibody directed against the inhibitory fraction of myelin, called IN-1, permitted axons to regenerate in the CNS environment. When injected into living animals with spinal cord injury, the IN-1 antibody treatment allowed long-distance growth of injured axons and compensatory sprouting of intact fibers. These structural changes were accompanied by improved functional recovery.

The antigen of IN-1, ►Nogo, was cloned and three distinct isoforms were identified, with Nogo-A being the predominant CNS isoform. Nogo-A likely

corresponds to NI-250, while Nogo-B may correspond to the NI-35 protein fraction. Nogo-C is the shortest splice variant of the full-length Nogo-A sequence. All three isoforms belong to the family of reticulon proteins. Nogo-A mediates its inhibitory activity via an amino-terminal domain and an extracellular 66 amino acid sequence (Nogo-66). Both Nogo-66 and the amino-terminus of Nogo-A have been shown to induce growth cone collapse and inhibit axonal extension. Accordingly, the application of an antagonist for the axonal Nogo-66 receptor (NgR, a multisubunit receptor complex [7,9]) was found to prevent the growth inhibitory effects of Nogo-A and promote sprouting of

severed axons, re-formation of synapses in target areas and enhanced functional recovery.

It is interesting to note that, besides Nogo-A, other neurite growth inhibitory myelin proteins might also bind to the NgR complex, including oligodendrocyte-myelin glycoprotein and myelin-associated glycoprotein. Myelin-associated glycoprotein, a transmembrane molecule and comparatively minor constituent of myelin, binds to the NgR complex with high affinity and prevents neurite outgrowth. Knockout mice deficient of myelin-associated glycoprotein display behavioral disturbances and anatomical findings confirmed its role in maintaining axon stability and regulating

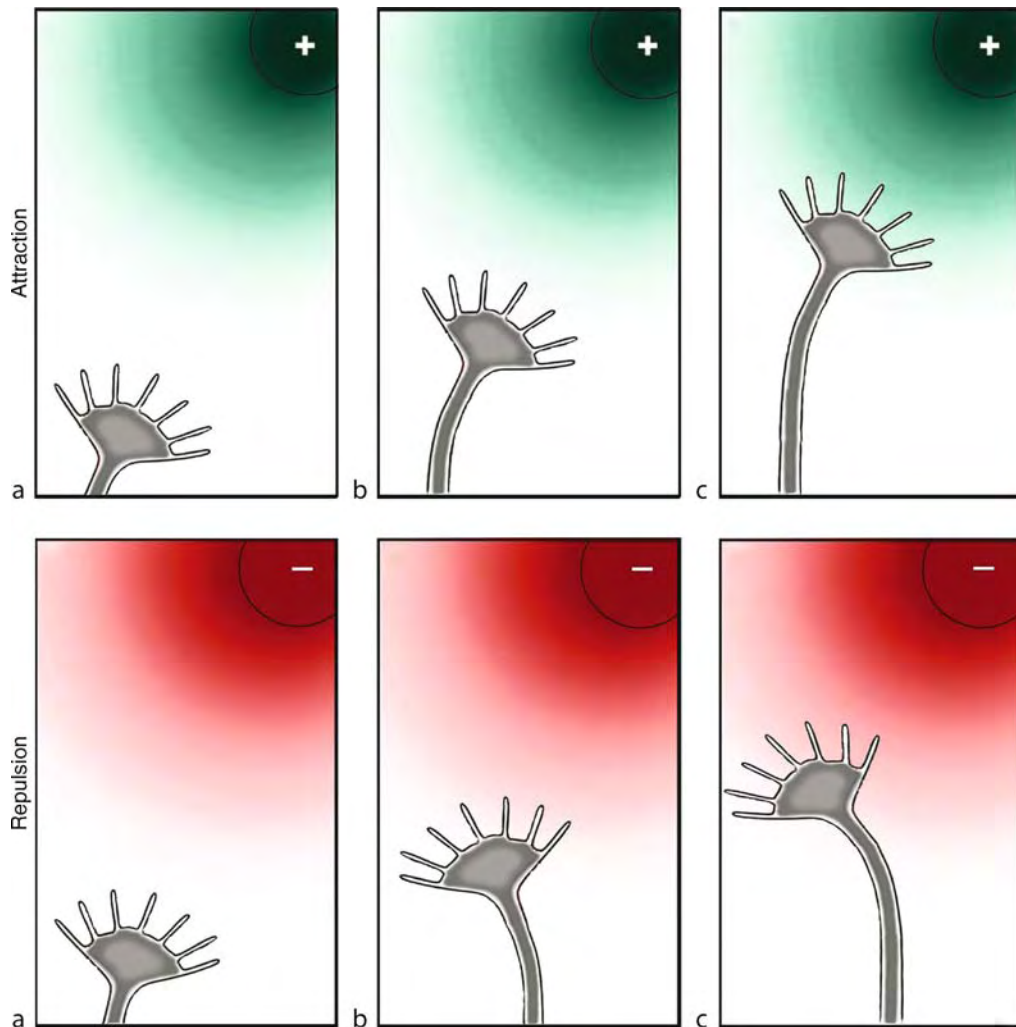

**Growth Inhibitory Molecules in Nervous System Development and Regeneration. Figure 1** Navigation of a growth cone responding to chemoattractive and chemorepulsive guidance cues. As the growth cone approaches a target emitting an attractive signal, it responds by turning and growing toward the target (upper panel, a–c). If the growth cone perceives a signal as repulsive, it will grow away from its source (lower panel, a–c).

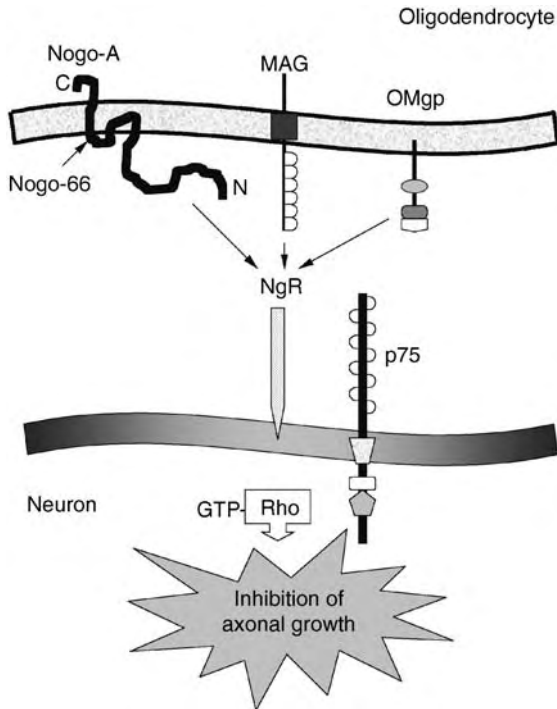

**Growth Inhibitory Molecules in Nervous System Development and Regeneration.** Figure 2 A number of major inhibitors of neurite growth, including the extracellular domain of Nogo-A (Nogo-66), myelin-associated glycoprotein, and oligodendrocyte-myelin glycoprotein are associated with CNS myelin. All three molecules interact with a multisubunit receptor complex comprising the Nogo receptor (NgR) and p75. The signal transduction cascade involves Rho GTPase, a member of the Rho family of small guanosine-5'-triphosphate (GTP) binding proteins. Rho is active in the GTP-bound state and involved in gene transcription, regulation of cytoskeletal structure, cell fate, and survival (adapted from [7]).

axonal outgrowth. Interestingly, myelin-associated glycoprotein is not only expressed by CNS oligodendrocytes but also by PNS Schwann cells. To explain that the PNS nevertheless provides a growth-permissive environment, it has been proposed that myelin-associated glycoprotein is cleared more rapidly after injury to peripheral nerves.

Aside from Nogo, oligodendrocyte-myelin glycoprotein, and myelin-associated glycoprotein, a fourth group of inhibitory proteins, chondroitin sulfate proteoglycans, can also be associated with myelin. Yet, these extracellular matrix components are mostly found in reactive astrocytes. Reactive astrocytes are responsible for the formation of a glial scar after CNS injury, which represents a major barrier to regenerating axons [10]. Because expression of chondroitin sulfate-carrying proteoglycans increases after CNS injury, recent studies have investigated the potential for destroying scar tissue

or preventing its formation in the first place for promoting axonal regeneration. On the other hand, chondroitin sulfate-carrying proteoglycans assume a role as axon guidance molecules during development. This again illustrates the multifarious roles of repulsive and growth inhibitory molecules in the developing and mature CNS.

### Therapy

The complex distribution of guidance molecules and the orchestrated balance between their repulsive and attractive actions on growing neurites allows the formation of highly complex neuronal circuits. The identification of guidance and inhibitory molecules is particularly exciting for the discovery of new therapeutic strategies to promote regeneration of axons after injury. Strategies that are currently explored include altering the response of growing axons to inhibitory molecules by abrogation of the inhibitory property of myelin or preventing glial scar formation by pharmacological means. Many neurite growth inhibitory molecules exert redundant actions thus providing a back-up plan for nervous system stability. Thus, it seems likely that a combinatorial approach directed against several growth inhibitory proteins and the simultaneous addition of growth-promoting signals might be most promising. These new therapeutic avenues will be essential for promoting axonal regeneration and functional recovery following CNS injury.

### References

- McFarlane S (2000) Attraction vs. repulsion: the growth cone decides. *Biochem Cell Biol* 78:563–568
- Song HJ, Ming GL, Poo MM (1997) camp-induced switching in turning direction of nerve growth cones. *Nature* 388:275–279
- Kolodkin AL, Matthes DJ, O'Connor TP, Patel NH, Admon A, Bentley D, Goodman CS (1992) Fasciclin IV: sequence, expression, and function during growth cone guidance in the grasshopper embryo. *Neuron* 9:831–845
- Mehlen P, Bredesen DE (2004) The dependence receptor hypothesis. *Apoptosis* 9:37–49
- Wilkinson DG (2001) Multiple roles of EPH receptors and ephrins in neural development. *Nat Rev Neurosci* 2:155–164
- David S, Aguayo AJ (1981) Axonal elongation into peripheral nervous system "bridges" after central nervous system injury in adult rats. *Science* 214:931–933
- Schwab ME (2004) Nogo and axon regeneration. *Curr Opin Neurobiol* 14:118–124
- Schwab ME, Caroni P (1988) Oligodendrocytes and CNS myelin are nonpermissive substrates for neurite growth and fibroblast spreading in vitro. *J Neurosci* 8:2381–2393
- Fournier AE, GrandPre T, Strittmatter SM (2001) Identification of a receptor mediating Nogo-66 inhibition of axonal regeneration. *Nature* 409:341–346
- Fawcett JW, Asher RA (1999) The glial scar and central nervous system repair. *Brain Res Bull* 49:377–391

## Growth-associated Protein

Protein, involved in regulating the processes required for outgrowth and/or elongation of the injured axon.

- ▶Neuronal Changes in Axonal Degeneration and Regeneration
- ▶Regeneration

## GTPases

### Definition

Members of a large diverse family of enzymes that bind and hydrolyze guanosine triphosphate (GTP), also known as guanosine-5'-triphosphate. GTPases play an crucial role in the signal transduction from the intracellular domain of many transmembrane receptors including neurotrophic receptors.

- ▶Neurotrophic Factors in Nerve Regeneration

## Guanylate Cyclase

### Definition

Guanylate cyclase is a lyase enzyme that converts guanosine triphosphate (GTP) to cyclic guanosine monophosphate (cGMP). There are both soluble and membrane bound forms of guanylate cyclase.

## Guidance Cue

### Definition

Guidance cue is any type of molecule that influences growth cone pathfinding. There are four main types of guidance cues: long-range attractants (diffusible attractants), long-range repellents (diffusible repellents), short-range attractants (substrate-bound attractants), and short-range repellents (substrate-bound repellents).

These cues can provide positional information for axon guidance. In the developing embryo, the various guidance cues act together to coordinate the pathfinding of growing neurites influencing the proper wiring of the mature nervous system.

- ▶Growth Cones

## Guillain-Barré Syndrome

### Definition

A type of idiopathic polyneuritis in which autoimmunity to peripheral nerve myelin leads to a condition characterized by chronic demyelination of the spinal cord and peripheral nerves.

## Gustation

ALBINO J. OLIVEIRA-MAIA<sup>1,2,3</sup>,  
SIDNEY A. SIMON<sup>3,4,5,6</sup>,  
MIGUEL A. L. NICOLELIS<sup>3,5,6,7,8</sup>

<sup>1</sup>Instituto de Biologia Molecular e Celular,  
Universidade do Porto, Porto, Portugal

<sup>2</sup>Faculdade de Medicina, Universidade do Porto,  
Porto, Portugal

<sup>3</sup>Department of Neurobiology, Duke University,  
Durham, NC, USA

<sup>4</sup>Department of Anesthesiology, Duke University,  
Durham, NC, USA

<sup>5</sup>Center of Neuroengineering, Duke University,  
Durham, NC, USA

<sup>6</sup>Department of Biomedical Engineering, Duke  
University, Durham, NC, USA

<sup>7</sup>Department of Psychology and Neurosciences,  
Duke University, Durham, NC, USA

<sup>8</sup>Edmond and Lily Safra International Institute of  
Neuroscience of Natal

### Synonyms

Both the Oxford English and the American Heritage dictionaries define gustation as “the act or faculty of tasting,” thus defining the concepts of gustation and taste as synonymic. However, as described in the following text, the term “gustation” has recently been used to define a broader concept [1] which includes, but is not limited to, taste



## Definition

Gustation is the multisensory process that allows for the selection of nutrients and rejection of irritating and/or toxic compounds. The process starts when a motivated animal searches and detects a desired food, usually using visual and/or olfactory cues. When consumption is initiated, flavor, the unitary sensory perception resulting from the taste, odor, texture and temperature of a substance that is placed in the mouth, will be a central contributor in the decision-making relative to ingestive behavior [2].

Feeding decisions are also impacted by the physiological context in which they are made and, thus, are not entirely stimulus-dependent. We know today that the central nervous system detects a multitude of peripheral neural and humoral signals reflecting several aspects of homeostatic balance, namely gastrointestinal status, current energy needs and availability, and energy stores. The regulation of energy homeostasis and maintenance of stable body weight depends on the integration of these signals with orosensory feedback, and the ability to respond adequately through the modulation of both energy expenditure and food intake [3].

The appearance and familiarity of a particular food, given the memory of the orosensory, olfactory and post-ingestive effects of previously encountered identical or similar substances, will influence the decision of ingestion [4]. Emotional, cognitive and social factors are also relevant. These observations underline that, when trying to understand food seeking and ingestion, one should consider not only sensory and homeostatic factors but also others such as motivation, learning and decision-making [5,6].

Data obtained by recording neural ensemble activity in awake animals has demonstrated not only that neural populations, distributed across several cortical and sub-cortical brain areas, can encode the multisensory properties of intra-oral stimuli, but also that this coding is modulated by physiological state [3]. Consequently, it has been proposed that gustatory processing must be considered in a multimodal perspective, combining the several sensory, homeostatic, affective and learning processes that occur in association with taste receptor activation. According to this view, gustation results from a distributed neural process by which information conveyed to the brain through specialized taste, oral somatosensory, olfactory and gastro-intestinal neural pathways is integrated with humoral signals, thus allowing the organism to feed in accordance with the maintenance of adequate energy homeostasis [1,7].

## Characteristics

### Peripheral Gustatory System

The peripheral gustatory system extracts multisensory information from foods placed in the mouth, and conveys this information through multiple neural

pathways to brainstem structures. Taste receptor cells (TRC's), are responsive to the type and quantity of chemicals dissolved in the saliva and allow for the detection of several primary taste qualities: salt, sweet, bitter, umami (savory taste of amino acids), and sour (acidic). Information about most relatively water-insoluble compounds, as well as food texture, weight and temperature, is primarily transduced by specialized somatosensory neurons with endings distributed throughout the oral epithelia [1]. When this system is impaired, symptoms such as ▶ageusia, ▶hypogeusia, ▶hypergeusia or ▶dysgeusia or ▶hyposmia are frequent. The subjective complaint of 'loss of taste' is commonly associated to hyposmia given perception of flavor.

### Taste Receptor Cells

In vertebrates, TRC's are found in specialized taste organs – the taste buds. Mammalian taste buds are onion-shaped cell clusters that are embedded at the surface of several intra-oral structures, mainly the palate and tongue, where they cluster in macroscopic structures named gustatory papillae. TRC's extend distally into the bud pore where they present microvillar processes to contact with sapid chemical stimuli in the mouth. Taste receptors are transmembrane structures found on these microvilli and are the basis for the chemosensory properties of TRC's since, upon detection of a specific stimulus, they will activate intracellular transduction cascades to initiate the process of gustatory neural signaling [8].

Proteins belonging to the G-protein-coupled receptor (GPCR) superfamily have been established as receptors for sweet tastants (T1R2/T1R3 receptors), amino acids (T1R1/T1R3 receptors) and bitter tastants (T2R receptors). The predominant downstream signalling pathways for these receptors require two common elements: TRPM5, a transient receptor potential ion channel that is activated by intracellular calcium, and phospholipase PLCβ2. There is also evidence implicating gustducin, a G-protein almost exclusively expressed in TRC's, in bitter taste transduction. Sour and salt (NaCl) taste qualities seem to rely on a different set of receptors and signaling pathways. Recently, cells expressing a member of the TRP ion channel family, the polycystic-kidney-disease-like ion channel PKD2L1, were shown to be necessary for sour taste transduction. While the molecular mechanisms for human peripheral salt taste transduction are more controversial, in rodents an amiloride-sensitive sodium channel, ENaC, accounts for part of the transduction of NaCl [8].

Taste receptors for sweet, bitter, umami and sour have been found to be present in largely segregated populations of cells. Additionally, perception of a particular taste quality, more than the property of

a specific tastant–taste receptor interaction, seems to reflect the selective activation of the TRC population expressing a particular taste receptor which is, in itself, sufficient to generate specific behavioral programs [8]. It therefore seems clear that, at the TRC level, sweet, bitter, umami and sour taste pathways are segregated (Fig. 1).

### Peripheral Gustatory Nerves

TRCs transmit information to the Central Nervous system (CNS) through primary sensory neurons that

terminate centrally in the nucleus of the solitary tract (NTS) of the medulla. Taste buds are innervated by primary sensory neurons from branches of the facial (VIIth), glossopharyngeal (IXth) and vagal (Xth) cranial nerves. The chorda tympani and greater superior petrosal branches of the facial nerve carry sensory axons of cells in the geniculate ganglion and innervate taste buds respectively in the anterior tongue and palate. Sensory axons of the **glossopharyngeal nerve**, with cell bodies in the petrosal ganglion, terminate in taste buds in the posterior tongue (lingual branch) and

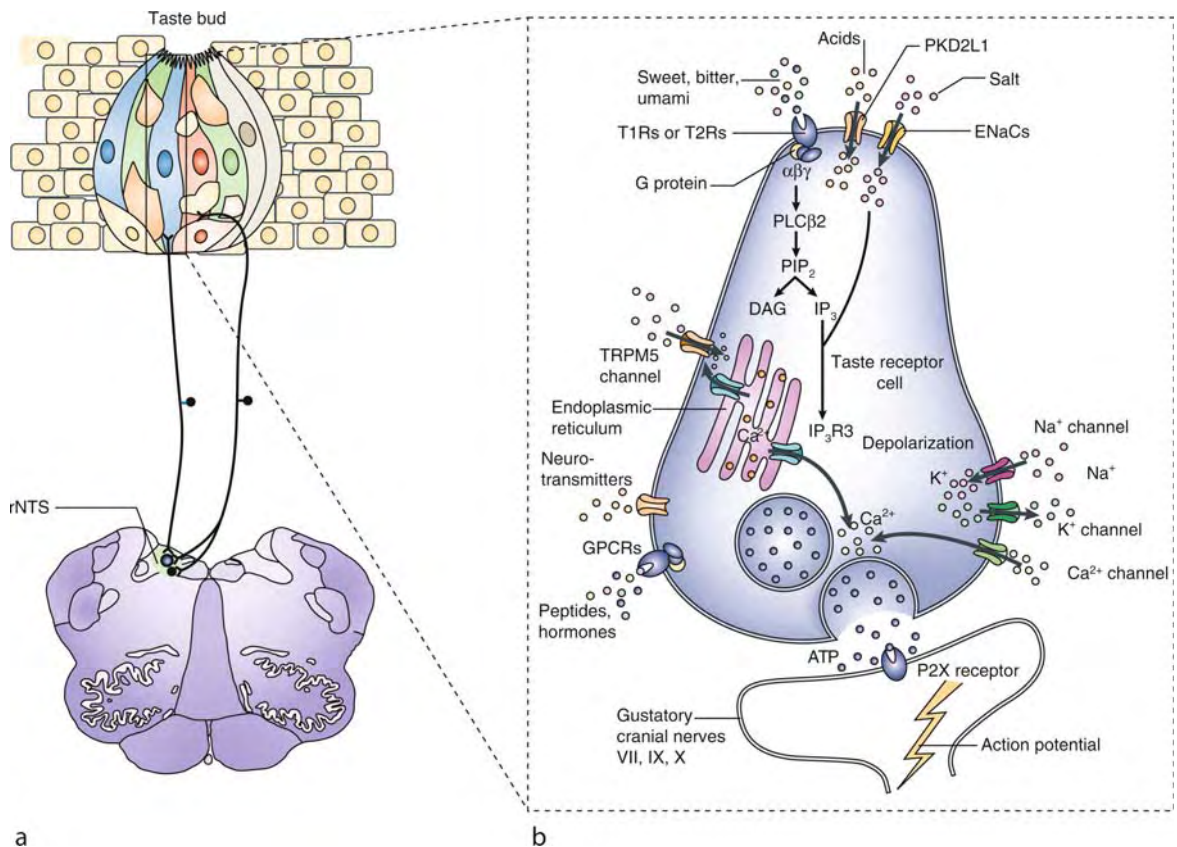

**Gustation. Figure 1** Illustration of a taste bud, taste receptor cell and associated neurons. (a) Depiction of a taste bud embedded in epithelial tissue. TRCs sample the intra-oral space through the taste pore, where they are connected by tight junctions that separate the membrane of each TRC into two distinct domains: the apical membrane, in direct contact with the external milieu, and the basolateral membrane, below the tight junctions and bathed by interstitial fluid. TRCs are color-coded according to “best-response” to a specific tastant quality. Primary gustatory neurons project ipsilaterally to the rNTS. (b) Diagram of a TRC and respective synapse with a primary gustatory neuron. The apical membrane of the cell contains receptors for tastants dissolved in the saliva. G-protein-coupled receptors (GPCRs) for sweet, bitter and umami tastant detection activate intracellular signal transduction cascades involving PLCβ2 (a phospholipase C) and TRPM5, a transient receptor potential ion channel on the basolateral membrane. Ion channels involved in salt (ENaCs) and, possibly, sour (PKD2L1) tastant detection are also shown in the apical cell membrane. Other GPCRs and ion channels, shown on the TRC basolateral membrane, are responsive to peptides, hormones and neurotransmitters that modulate responses to tastants. TRC activation culminates in the release of neurotransmitters, namely ATP, from intracellular vesicles to synapses with primary gustatory nerves, here shown with a post-synaptic purinergic P2X receptor. Note that taste receptors and signal transduction molecules described above are not necessarily expressed in the same TRC (see text for details) (adapted from Simon et al. *Nat Rev Neurosc*, 2006).

pharynx (pharyngeal branch). The nodose ganglion of the vagus nerve contains primary gustatory neurons with axons that integrate the pharyngeal, superior laryngeal and internal laryngeal branch of the vagus nerve to innervate taste buds in the epiglottis, larynx and oesophagus [1].

In addition to taste fibers, the vagal and glossopharyngeal nerves contain general sensory fibers from the oral and upper digestive mucosa, as does the trigeminal (Vth) cranial nerve, allowing for the transduction of information relating to the temperature and texture of ingested stimuli. The vagal nerve also carries visceral sensory nerve fibers from the gastrointestinal (GI) tract and abdominal viscera.

Some intra-oral somatosensory nerve endings have chemosensing properties, as exemplified by the responses of the thermo-sensitive TRPV1 and TRPM8 channels respectively to capsaicin (found in chilli peppers), producing a burning sensation, and menthol, producing a cooling sensation. Trigeminal fibers are also activated by high concentrations of the same chemical stimuli that define some primary tastants, such as NaCl, usually producing irritating sensations. On the other hand, physical variables may affect TRC taste transduction function, as evidenced by thermal modulation of sweet taste intensity. Thus it becomes clear that, even at the periphery, input to the gustatory system is inherently multisensory [1].

### Central Gustatory Neural Pathways

The central taste pathway has strong anatomical and functional connections with the viscerosensory system, which transmits information about the internal state of the organism, particularly at the NTS, where peripheral taste neurons synapse on second order ascending taste neurons. In rodents, second-order projections arising from the NTS ascend mostly ipsilaterally as a component of the central tegmental tract terminating in the parabrachial nuclei (PbN) of the pons. In turn, the PbN projects to the parvocellular subdivision of the ventral posterior medial nucleus of the thalamus (VPMpc), which then projects to the primary gustatory cortex (GC) in the insular cortex. In primates, there is a direct projection from the NTS to the thalamus, bypassing the PbN [9] (Fig. 2).

### Nucleus of the Solitary Tract

Chemosensory information, derived from all taste-responsive cranial nerves, converges on the rostral division of the NTS (rNTS). Trigeminal somatosensory inputs from oral branches of the fifth nerve also project to regions of NTS innervated by primary sensory taste neurons. A second subdivision of the nucleus, the caudal NTS (cNTS), is the main target of visceral (vagal and glossopharyngeal) afferent inputs. These

convey information from baroreceptors, chemoreceptors, osmoreceptors and nociceptors from thoracic and abdominal viscera, including the GI system.

Trigeminal stimulants with irritating effects can modulate taste responses in the rNTS, as does afferent vagal activity such as that produced by gastric distention. The rNTS is also a target of descending forebrain projections from the GC, prefrontal cortex, central nucleus of the amygdala (AMYce), lateral hypothalamus (LH), bed nucleus of the stria terminalis and substantia innominata. In fact, electrical stimulation of the GC has been shown to modulate processing and transmission of neuronal responses to tastants in the rNTS. The NTS thus offers the first opportunity for neural signals derived from the somatosensory and GI systems and other CNS centers to modulate incoming taste information [1].

Taste stimulation activates the afferent limb of a variety of somatic motor and visceromotor reflexes (appetitive or aversive) that accompany eating and drinking. The NTS has local medullary connections with a number of brainstem motor nuclei, either directly or through interneurons in the reticular formation, such that chronic decerebrate rats display both acceptance and rejection behaviors to oral stimulation with tastants. These projections to adjacent somatic and visceral premotor/motor areas are responsible for reflexes involved in chewing (motor nucleus of the trigeminal nerve), tongue movement (hypoglossal nucleus), salivation (superior and inferior salivatory nuclei), swallowing (nucleus ambiguus) and GI motility and secretion (dorsal motor nucleus of the vagal nerve) [9].

### Parabrachial Nuclei

The parabrachial complex is a collection of nuclei located in the dorsolateral aspect of the pons. The PbN is physically divided into medial and lateral subdivisions by fibers of the superior cerebellar peduncle. In rodents, ascending neural pathways from the rNTS include an obligatory synapse in the ipsilateral medial division of the PbN. Ascending visceral afferent projections arising from the cNTS terminate primarily in nuclei of the lateral subdivision [9].

Similarly to the rNTS, the PbN is a target of descending forebrain projections and taste-responsive neurons in this location have been shown to be modulated by electrical stimulation of forebrain sites. From the PbN, third order neurons project to several forebrain systems, forming two gustatory projection systems. The thalamocortical system, with synapse in the VPMpc nucleus of the thalamus, terminates in the GC. The ventral forebrain system includes PBN projections to several structures in the limbic forebrain, namely the LH, AMYce, bed nucleus of the stria terminalis and substantia innominata, thus establishing a subcortical loop between brainstem primary gustatory

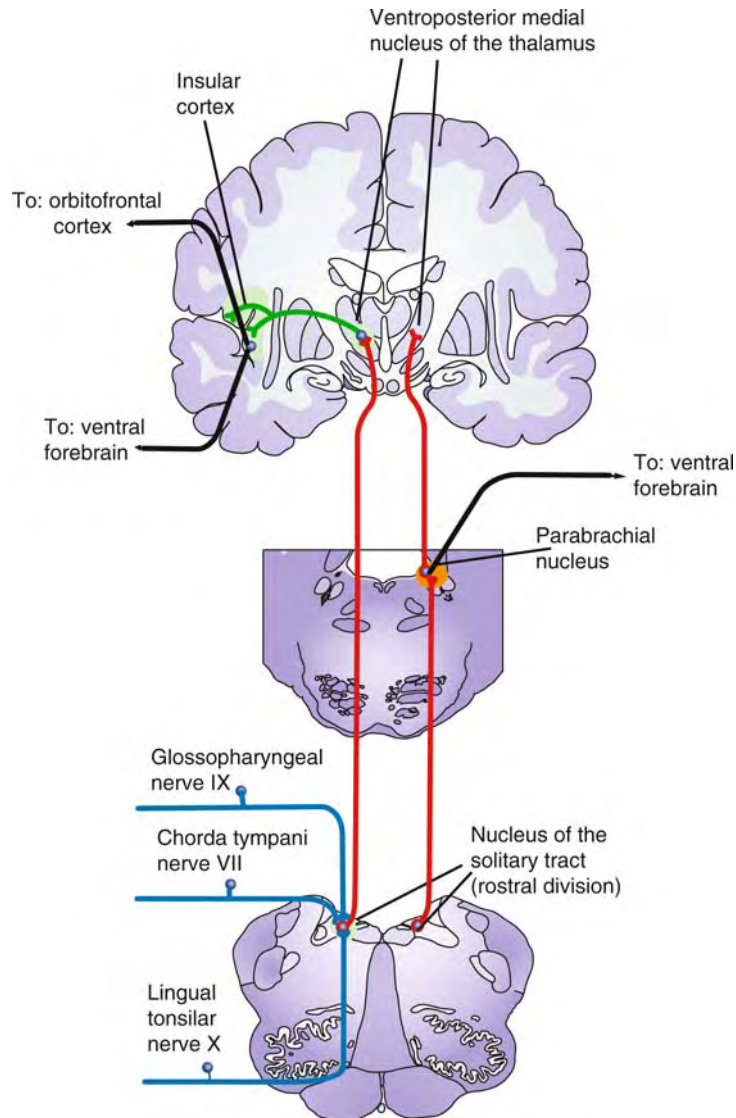

**Gustation. Figure 2** Anatomy of the principal central gustatory pathways. Taste-specific information is conveyed by cranial nerves VII, IX and X (blue lines) to the rNTS (rostral division of the nucleus tractus solitarius) in the medulla. In primates, fibers (red lines) from second-order taste neurons in the rNTS project ipsilaterally to the VPMpc (parvicellular part of the ventroposterior medial) nucleus of the thalamus. Shown in orange is the PbN (parabrachial nucleus) of the pons that, in rodents, is a relay for rNTS afferents and projects third-order fibers to the VPMpc. Thalamic efferents (green lines) project to the insula, defining the primary gustatory cortex (GC) which, in turn, projects (black lines) to the orbitofrontal cortex (OFC), sometimes defined as a secondary cortical taste area. Cortical gustatory regions also project to areas of the ventral forebrain, such as the amygdala, that in rodents, also receive ascending gustatory projections from the PbN, (adapted from Simon et al, Nat Rev Neurosc, 2006).

areas, namely the NTS and PbN, and motivational and reinforcement-related areas in the ventral forebrain, such as the mesolimbic dopaminergic system.

In primates, including humans, NTS projection fibers have not been shown to project to the PbN and synapse directly in the VPMpc. Thus, input to the PbN is essentially viscerosensory, the bulk of the projections from PbN are directed towards the ventral forebrain and

the VPMpc receives most of its gustatory input directly from the NTS [9].

#### **Parvicellular Ventroposterior Medial Nucleus of the Thalamus**

The VPMpc is the relay for orosensory information in the dorsal thalamus. Ascending gustatory projections to the thalamus are bilateral such that VPMpc neurons

will respond bilaterally to combinations of chemosensory and/or somatosensory oral stimulation.

### Gustatory Cortex

In macaques the primary GC, as defined by VPMpc thalamic efferent projections, corresponds to the frontal operculum and adjoining insula, extending rostrally to the caudolateral orbitofrontal cortex (OFC). In rodents, VPMpc projects to the agranular insular cortex, which is exposed on the lateral convexity of the brain just dorsal to the rhinal fissure. In addition, there are projections from the LH and AMY to the cortex that overlap the inputs from VPMpc.

The caudolateral OFC, sometimes defined as a secondary taste cortical area, receives converging projections from the GC and primary olfactory cortex, relevant for the perception of flavor, and is also connected to visual areas in the inferior temporal cortex [2,10] (Fig. 2).

Cortical chemoresponsive neurons (in the GC and OFC) have descending projections to subcortical structures in the ventral forebrain that also receive ascending projections from PbN and NTS. The insula (INS), where the GC is found, projects to the AMY, which in turn projects to the basal forebrain, LH, substantia nigra pars compacta (SNpc) and ventral tegmental area (VTA), the latter being the origin of the mesolimbic dopaminergic projection to the Nucleus Accumbens (NucAcb), a part of the ventral striatum. In turn, the OFC projects to the ventral striatum, LH and AMY, and these subcortical structures are also mostly interconnected. The described connections constitute part of a highly complex circuit that is proposed as the basis for the integration of multisensory gustatory input with factors relating to homeostatic and reward signaling, general arousal, directed motivation and neuronal effector mechanisms for motor, autonomic and endocrine responses [4–7].

### Gustatory Coding in the Central Nervous System

There are at least two opposing views regarding the neuronal representation of taste. The labeled-line model proposes that individual cells are tuned to respond to single taste modalities while in the across fiber models overlapping populations of cells and fibers are proposed to encode information relating to each taste quality. Some authors have also argued that temporal coding has a part to play in representing taste-specific information in both the NTS and cortex. While in the periphery the labeled-line model seems to reflect the coding scheme [8], it is nonetheless clear, from neural recordings in both rodents and monkeys, that NTS and GC taste neurons are preferentially broadly tuned, suggesting that the CNS codes for each taste quality via distributed population responses [1,7].

In addition to chemosensory-specific broadly tuned neurons, the GC contains neurons that integrate taste,

somatosensory and olfactory information. In the monkey, OFC neurons also exhibit multisensory responses, with cells responding to combinations of taste, olfactory, somatosensory and visual stimuli [10] while, in the rat, they have been shown to rapidly modulate their firing rate as a function of spontaneous licking clusters, as well as in response to tastants. Given the described broad tuning and multisensory responses of single neurons in multiple brain sites, the existence of a distributed central gustatory code is likely to reflect the coding scheme in these higher centers [1].

Modulation of gustatory responses in higher brain centers by the animal's physiological state is also well documented. Lower firing rates during satiety phases is suggested by functional neuroimaging findings of decreased activity levels in the LH, OFC, AMY and INS when satiation is compared to hunger or thirst. Electrophysiological investigations performed on alert monkeys are consistent with imaging studies and have revealed a large population of neurons in the OFC, AMY, and LH that respond to food when the animal is hungry but whose activity is greatly reduced when the animal becomes satiated. Recently, it has also been shown that satiety-modulated responses of individual neurons in the LH, OFC, AMY and GC differ across the feeding cycle, with increases and/or decreases in firing rate at each phase of the cycle (satiety or hunger). However, when single neuron responses are combined as a population, they translate with much greater accuracy the neuronal processes controlling feeding behavior across hunger-satiety cycles, with population firing rates correlating with a behavioral measure of the animal's motivation to feed [3]. The importance of considering a distributed gustatory code was thus demonstrated.

### Conclusions

The current obesity epidemic and the prevalence of eating disorders such as anorexia and bulimia nervosa have made the understanding of how the central nervous system regulates feeding behaviors a central theme in biomedical neuroscience research. The central gustatory system, viewed as a distributed brain circuit that integrates peripheral sensory information from multiple sensory modalities with neuroendocrine and gastrointestinal homeostasis-related signals, is thus a central concept in ingestive behavior research. A systems level approach, integrating neurophysiology from multiple brain areas in awake and freely-feeding animals with complimentary neurochemical and/or metabolic measurements, is essential to allow for further advances in this field, especially when this approach is used in conjunction with genetic or pharmacologic manipulations.

## Acknowledgements

This work was supported by NIH grant DC-01065 to S.A.S and M.A.L.N., grants from Philip Morris USA and Philip Morris International Inc to S.A.S., and a GABBA fellowship from FCT to A.J.O-M.

## References

1. Simon SA et al. (2006) The neural mechanisms of gustation: a distributed processing code. *Nat Rev Neurosci* 7(11):890–901
2. Small DM, Prescott J (2005) Odor/taste integration and the perception of flavor. *Exp Brain Res* 166(34):345–357
3. de Araujo IE et al. (2006) Neural ensemble coding of satiety States. *Neuron* 51(4):483–494
4. de Araujo IE, Oliveira-Maia AJ et al. (2008) Food reward in the absence of taste receptor signaling. *Neuron* 57(6):930–941
5. Balleine BW (2005) Neural bases of food-seeking: affect, arousal and reward in corticostriatolimbic circuits. *Physiol Behav* 86(5):717–730
6. Kelley AE et al. (2005) Corticostriatal-hypothalamic circuitry and food motivation: integration of energy, action and reward. *Physiol Behav* 86(5):773–795
7. Jones LM, Fontanini A, Katz DB (2006) Gustatory processing: a dynamic systems approach. *Curr Opin Neurobiol* 16(4):420–428
8. Chandrashekar J et al. (2006) The receptors and cells for mammalian taste. *Nature* 444(7117):288–294
9. Norgren R (1984) Central neural mechanisms of taste. In: Darien-Smith I (ed) *Handbook of Physiology – The Nervous System III. Sensory Processes 1*. American Physiological Society, Washington, DC. pp 1087–1128
10. Rolls ET, Baylis LL (1994) Gustatory, olfactory, and visual convergence within the primate orbitofrontal cortex. *J Neurosci* 14:5437–5452

## Gustatory Cortex

### Definition

The sensory cortex involved in processing taste information; its precise location in humans is uncertain, but likely is in the posterior insula and opercular regions near the central sulcus.

► [Olfaction and Gustation Aging](#)

## Gustatory Neural Coding

► [Neural Coding of Taste](#)

## Gustatory Neurons

### Definition

(vid. gustatory axons, gustatory nerves, taste axons) Neurons that specialize for the transduction of taste information. Peripheral taste neurons encompass the afferent taste fibers of the chorda tympani, glossopharyngeal nerve, vagal nerve and greater superficial petrosal nerve. Their central relays lie in the nucleus of the solitary tract.

► [Neural Coding of Taste](#)

## Gustatory Papillae

### Definition

Small round or cone-shaped projections on the surface of the tongue that contain taste buds and which function as a sensory organ; comprised of fungiform, foliate, and circumvallate papillae.

► [Olfaction and Gustation Aging](#)

► [Taste Bud](#)

► [Foliate Papillae](#)

► [Fungiform Papillae](#)

► [Circumvallate Papillae](#)

## Gustatory Receptor

### Definition

Gustatory receptors are chemoreceptors in lingual taste buds that signal in response to the different basic tastes.

Transmission within the gustatory system occurs via the facial, the glossopharyngeal and vagal (VII, IX and X) cranial nerves.

## Gustducin

WOLFGANG MEYERHOF

Department of Molecular Genetics, German Institute of Human Nutrition Potsdam-Rehbruecke, Nuthetal, Germany

### Synonyms

Alpha-gustducin;  $\alpha$ -Gustducin; Alpha subunit of gustducin

## Definition

The term gustducin is sometimes used to indicate the  $\alpha$  subunit of a heterotrimeric G protein. However, the polypeptide should be correctly referred to as  $\alpha$ -gustducin or to the  $\alpha$  subunit of gustducin, a regulatory heterotrimeric guanine nucleotide **▶(GTP) binding protein** (G protein).  $\alpha$ -Gustducin is defined by the nucleotide sequence of its gene (Official full name: guanine nucleotide binding protein,  $\alpha$  transducing 3 (gnat-3)), or mRNA (GenBank accession number, X65747) or by the amino acid sequence of the polypeptide (Swiss-Prot accession number, P29348).

## Characteristics

### Quarternary Structure of $\alpha$ -Gustducin

$\alpha$ -Gustducin forms together with the inhibitory G protein  $\alpha$  subunits, *Gaz*, and the **▶transducins**, one major family of G protein  $\alpha$  subunits. Other families are  $G_s$ ,  $G_o$ ,  $G_q$ , and  $G_{12}$ . It assembles with the  $\beta/\gamma$  dimer into a heterotrimeric G protein. As all other G protein  $\alpha$  subunits,  $\alpha$ -gustducin cycles between a GTP bound and a GDP bound form. Activation by receptors leads to GDP–GTP exchange. The GTP bound form can interact with cellular effector molecules. The GDP–GTP exchange also triggers the release of the  $\beta/\gamma$  dimer that can also engage in signaling functions. Intrinsic **▶GTPase** activity hydrolyzes GTP to GDP and terminates the activation cycle.  $\alpha$ -Gustducin displays a GTPase domain and a helical domain. The N-terminus and the GTPase domain contain the interaction sites for receptors, effectors, and the  $\beta/\gamma$  dimer while the helical domain may engage in modulating effector activity. Like other  $G_i$  protein  $\alpha$  subunits,  $\alpha$ -gustducin appears to be acylated close to the N-terminus by myristate and possibly by palmitate [1]. These modifications appear to be critical for membrane association of the polypeptide.

### Discovery and Expression of $\alpha$ -Gustducin

$\alpha$ -Gustducin has been discovered by an attempt to identify the G protein  $\alpha$  subunits involved in vertebrate **▶taste** transduction [2]. Degenerate oligonucleotides used as primers in polymerase chain reaction amplification protocols with rat taste tissue cDNA allowed the identification of an mRNA of about 1.7 kb encoding a novel G protein  $\alpha$  subunit of 354 amino acids, i.e.,  $\alpha$ -gustducin. The mRNA for  $\alpha$ -gustducin has been found specifically in taste tissue, i.e., in a subset of **▶taste receptor cells** in lingual epithelium but not in nonsensory lingual epithelium or various other tissues. **▶Taste receptor cell** specific  *$\alpha$ -gustducin* gene expression is apparently regulated by an 8.4 kb segment that contains a 1.4 kb minimal **▶promoter** and an upstream **▶enhancer** element [3].  $\alpha$ -Gustducin received its name from the close sequence homology to the visual G protein subunits, the **▶ $\alpha$ -transducins**, and its putative role in **▶gustation**.

Later on, more detailed studies detected expression of  $\alpha$ -gustducin in various tissues that are not involved in gustation, such as the **▶olfactory** and **▶vomeronasal** epithelium, intestine, colon, airways, and spermatozoa.

## The Functional Roles of $\alpha$ -Gustducin in Taste Transduction

Convincing evidence for a role of  $\alpha$ -gustducin in taste transduction comes from studies of gene-targeted mice. These animals showed impaired behavioral and electrophysiological responses to the bitter stimuli denatonium benzoate and quinine as well as to the sweet stimuli sucrose and SC45647, whereas their responses to the sour stimulus, HCl, and salty stimulus, NaCl, were not affected [4]. Moreover, transgenic expression of rat  *$\alpha$ -gustducin* driven by the 8.4 kb promoter fragment in gustducin null mice fully rescued the impaired responses to both bitter and **▶sweet taste** stimuli of these animals [3]. These results strongly suggest that  $\alpha$ -gustducin plays a crucial role in sweet taste and **▶bitter taste**, but not in salty taste (**▶Salt taste**) or **▶sour taste**. The role of  $\alpha$ -gustducin in bitter taste was also strongly supported by a combination of physiological recordings and immunohistochemistry, demonstrating that many but not all taste receptor cells containing  $\alpha$ -gustducin responded to bitter stimuli [5]. Further support comes from *in situ* hybridization and immunohistochemistry studies showing that  $\alpha$ -gustducin colocalizes with TAS2R bitter **▶taste receptors** or TAS1R sweet **▶taste receptor** subunits but not with candidate salty or sour taste receptors. Together these findings also firmly support the long held conjecture that sweet and bitter taste are elicited through activation of **▶G protein-coupled receptors** while salty and sour taste are thought to be elicited through activation of membrane **▶ion channels**. Later, two-bottle preference and brief-access taste tests as well as nerve recordings in wild-type and  *$\alpha$ -gustducin* knockout mice together with histochemical studies that colocalized  $\alpha$ -gustducin and the umami receptor subunit TAS1R1 in taste receptor cells indicated a role for  $\alpha$ -gustducin also in **▶umami taste**.

## Signal Transduction of Gustducin

Although above data clearly point to a critical role of  $\alpha$ -gustducin in taste, its signal transduction properties are less understood. The high homology of  $\alpha$ -gustducin to the  $\alpha$ -transducins of visual transduction suggested that both G proteins may be functionally similar or even equivalent. This assumption was reinforced by the notion that the sequence homology was particularly high in regions that mediate coupling to the receptor or effector molecules. In fact, recombinant  $\alpha$ -gustducin purified from insect cells closely resembled **▶ $\alpha$ -transducin** with respect to the interactions with the receptor, bovine **▶rhodopsin**, the effector, bovine retinal cyclic GMP

phosphodiesterase, and bovine brain and retinal G protein  $\beta/\gamma$ -dimers. Also, the rhodopsin-catalyzed GDP–GTP exchange rate and the intrinsic GTPase activity of both G proteins were very similar. This functional similarity is supported by the presence of  $\alpha$ -transducin in taste receptor cells and the finding that transgenic expression of  $\alpha$ -transducin under the  $\alpha$ -gustducin gene promoter in a  $\alpha$ -gustducin null background partially rescued the taste deficits of these animals [6]. On the basis of these structural and functional similarities, it has been proposed that  $\alpha$ -gustducin functions in taste transduction in analogy to  $\alpha$ -transducin that modulates phosphodiesterase activities in visual transduction. This assumption was supported by the identification of two types of phosphodiesterases in taste tissue and the demonstration that  $\alpha$ -gustducin couples to  $\blacktriangleright$ calmodulin-sensitive type I phosphodiesterases in vitro. In parallel, it has been demonstrated that several bitter compounds decreased cyclic nucleotide levels in taste tissue preparations, an effect that depended on the action of  $\alpha$ -gustducin. This pathway could alter the activity of cyclic nucleotide regulated kinases or gated ion channels. Although evidence has been obtained for the presence of cAMP,  $\blacktriangleright$ protein kinase A, and a  $\blacktriangleright$ cyclic nucleotide gated channel in taste tissue, the physiological importance of taste stimulus-decreased cyclic nucleotide levels has not been uncovered yet (Fig. 1).

Various other studies (reviewed in [7]) demonstrated that bitter substances stimulated the generation of  $\blacktriangleright$ inositol trisphosphate (IP<sub>3</sub>) fully consistent with the observations that  $\alpha$ -gustducin colocalizes with type III  $\blacktriangleright$ IP<sub>3</sub> receptor in taste cells and that a specific

phospholipase C (PLC) inhibitor blocked the response. Polymerase chain reaction amplification experiments of taste tissues with degenerate primers identified the  $\beta$ 2 isoform of PLC. Antibodies against PLC- $\beta$ 2 blocked the denatonium-stimulated rise in IP<sub>3</sub>. Finally, PLC- $\beta$ 2 gene-targeted mice lost or substantially impaired their responses to bitter, sweet, and umami stimuli, demonstrating the crucial role of this enzyme in taste transduction. The PLC- $\beta$ 2 isoform appears to be activated by the  $\beta/\gamma$  subunits of G<sub>i/o</sub>-type G proteins, i.e., G protein families to which also  $\alpha$ -gustducin belongs. PLC- $\beta$ 2 shows, however, little sensitivity for activation by G protein  $\alpha$  subunits. Differential screening of cDNA libraries from single taste receptor cells for the  $\beta/\gamma$  subunits that couple to  $\alpha$ -gustducin resulted in the isolation of G $\beta$ 1 and G $\beta$ 3 and of the novel G protein  $\gamma$  subunit,  $\gamma$ 13. Antibodies raised against these three G protein subunits blocked the response of mouse taste tissue preparations to the bitter substance denatonium benzoate. As the action of the anti- $\beta$ 3 antiserum appeared to be more robust than that of the anti- $\beta$ 1 antiserum, it has been suggested that the predominant gustducin composition in taste tissue may be  $\alpha$ -gustducin/G $\beta$ 3/G $\gamma$ 13 and that  $\alpha$ -gustducin couples taste receptors via  $\beta$ 1/ $\gamma$ 13 or  $\beta$ 3/ $\gamma$ 13 to PLC- $\beta$ 2 activation (Fig. 1). Recently, another member of the gustducin-initiated signal transduction cascade has been identified, i.e., the  $\blacktriangleright$ transient receptor potential channel TRPM5. TRPM5 appeared to be sensitive to several cellular components, but particularly to the rapid changes in the intracellular calcium concentration. The importance of TRPM5 was demonstrated by

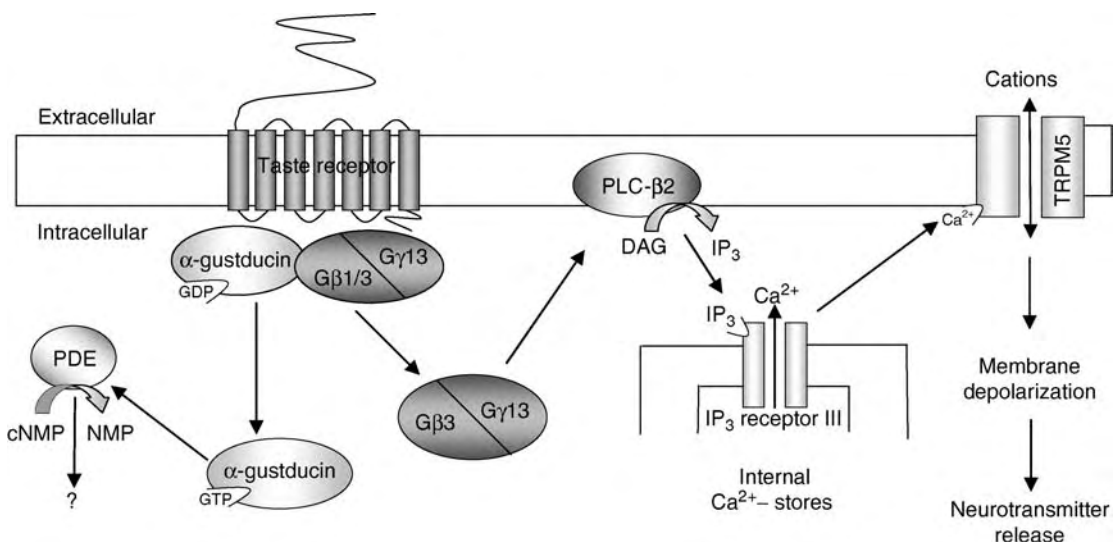

**Gustducin. Figure 1** Proposed role of  $\alpha$ -gustducin in taste transduction. For details, see text. cNMP, cyclic nucleoside monophosphate; NMP, nucleoside monophosphate; PDE, phosphodiesterase; DAG, diacyl glycerol; IP<sub>3</sub>, inositol trisphosphate.



gene targeting experiments in mice that showed loss of or largely diminished responses to bitter, sweet, and umami stimuli (Fig. 1).

### Coupling of $\alpha$ -Gustducin to Taste Receptors

Biochemical studies using competing blocking peptides and bovine taste membranes or solubilized fractions thereof found that various bitter substances coupled  $\alpha$ -gustducin to phosphodiesterases [8]. This action depended also on the presence of purified  $\beta/\gamma$  subunits. The data suggested that the unknown bitter taste receptors present in the membrane preparation are members of the superfamily of G protein-coupled receptors and physically interacted with the G protein  $\alpha$  subunit. Later on, direct activation of  $\alpha$ -gustducin has been monitored through an activation-dependent change in protease sensitivity. Following cloning of the bitter taste receptors, it has been demonstrated that stimulation of the receptor mTAS2R5 by its agonist cycloheximide led to  $\alpha$ -gustducin activation in an *in vitro* system reconstituted from insect cell membranes. In similar experiments also a number of human bitter taste receptors have been coupled to the G protein  $\alpha$  subunits of  $G_{i1}$ ,  $G_o$ , and  $\blacktriangleright$ transducin. This suggests that not only  $\alpha$ -gustducin but also other  $G_i$ -type subunits couple to bitter taste receptors. Characterization of the interaction of the receptor with  $\alpha$ -gustducin revealed that the carboxy-terminal 44 amino acids of the G protein  $\alpha$  subunit as well as the ultimate C-terminal region were of importance. In line with this finding, a chimeric G protein comprising of the N-terminal region of  $G_{\alpha 16}$  and the aforementioned 44 amino acids of  $\alpha$ -gustducin allowed the functional coupling of many bitter taste receptors to PLC in transfected cell lines [7]. In similar experiments, a G protein chimera containing five carboxy-terminal amino acid residues common to  $\alpha$ -gustducin, transducin-1 and -2, and  $G_{i\alpha 1}$  and  $G_{i\alpha 2}$  coupled the sweet taste receptor to PLC activity. Together, the findings suggest that  $\alpha$ -gustducin is intimately involved in taste transduction but that aspects of taste signaling rely on other G protein  $\alpha$  subunits.

### $\alpha$ -Gustducin in nontaste Tissues

In addition to its role in taste transduction, evidence is emerging that  $\alpha$ -gustducin fulfils additional functions [9,10].  $\alpha$ -Gustducin expression has been observed in the nasal and vomeronasal epithelium, in cells that resemble solitary  $\blacktriangleright$ chemosensory cells of nonmammalian vertebrates. These cells also express some bitter receptors, but apparently no sweet or umami receptor subunits. The findings suggest that, in analogy to its role in the warning function of bitter transduction,  $\alpha$ -gustducin, in the nasal respiratory epithelium, protects the animals from the aspiration of noxious substances. A similar role it may have in  $\blacktriangleright$ chemoreceptor-like laryngeal cells and cells of the airway epithelium.

Within the gastrointestinal tract,  $\alpha$ -gustducin has been detected in brush cells of the stomach, duodenum, and pancreas. Also other taste signaling molecules have been found in these tissues and intestinal cell lines, suggesting that information about the chemical content of the alimentary canal is being sampled and used to regulate gastrointestinal physiology. The clearest example currently available may be the role of  $\alpha$ -gustducin in sweet taste receptor-mediated glucose absorption through apical glucose transporter 2.

Other sites of  $\alpha$ -gustducin expression are the spermatozoa, suggesting a role for this polypeptide also in reproduction. Most likely, in the near future, researchers will detect  $\alpha$ -gustducin in more tissues and unravel the numerous aspects of its physiological importance.

### References

1. Hoon MA, Northup JK, Margolskee RF, Ryba NJ (1995) Functional expression of the taste specific G-protein, alpha-gustducin. *Biochem J* 309 (Pt 2):629–636
2. McLaughlin SK, McKinnon PJ, Margolskee RF (1992) Gustducin is a taste-cell-specific G protein closely related to the transducins. *Nature* 357:563–569
3. Wong GT, Ruiz-Avila L, Margolskee RF (1999) Directing gene expression to gustducin-positive taste receptor cells. *J Neurosci* 19:5802–5809
4. Wong GT, Gannon KS, Margolskee RF (1996) Transduction of bitter and sweet taste by gustducin. *Nature* 381:796–800
5. Caicedo A, Pereira E, Margolskee RF, Roper SD (2003) Role of the G-protein subunit alpha-gustducin in taste cell responses to bitter stimuli. *J Neurosci* 23:9947–9952
6. He W, Danilova V, Zou S, Hellekant G, Max M, Margolskee RF, Damak S (2002) Partial rescue of taste responses of alpha-gustducin null mice by transgenic expression of alpha-transducin. *Chem Senses* 27:719–727
7. Meyerhof W (2005) Elucidation of mammalian bitter taste. *Rev Physiol Biochem Pharmacol* 154:37–72
8. Margolskee RF (2002) Molecular mechanisms of bitter and sweet taste transduction. *J Biol Chem* 277:1–4
9. Hofer D, Puschel B, Drenckhahn D (1996) Taste receptor-like cells in the rat gut identified by expression of alpha-gustducin. *Proc Natl Acad Sci USA* 93:6631–6634
10. Rozengurt E (2006) Taste receptors in the gastrointestinal tract. I. Bitter taste receptors and alpha-gustducin in the mammalian gut. *Am J Physiol Gastrointest Liver Physiol* 291:G171–G177

## $\alpha$ -Gustducin

$\blacktriangleright$  Gustducin

## Gut Activities

### Definition

Gut activities are commonly subdivided into motility, digestion and absorption. The main gut function is to digest food materials and absorb nutrient substances into the bloodstream. Motility refers to gut movements, mixing gut contents and propelling the contents along the gut. Digestion and absorption can be more effectively performed by the proper assistance of these movements.

---

## GVS

► Galvanic Vestibulospinal Responses

---

## Gymnophiones

### Definition

Gymnophiones are one of three orders of living amphibians (order Gymnophiona). These amphibians may also be referred to as “apodans” or “caecilians.”

These are relatively rare (compared to the number of species in the other two groups, the anurans and urodeles) and very specialized organisms. Gymnophiones

lack limbs and limb girdles and tend to have shortened, compact skulls. These are adaptations for the lifestyles as burrowing fossorial creatures or organisms adapted for wet semiaquatic habitats. Less is known about this group of amphibians than any other.

► Evolution of the Brain: Amphibians

---

## Gyrification

### Definition

Gyrification refers to the formation of gyri (Greek for bent or curved) by folding the cortex in the cerebral hemispheres into convolutions.

---

## Gyrus Rectus

### Synonyms

► Straight rectus

### Definition

A long gyrus situated on the basal surface of the frontal lobe and running parallel to the olfactory tract and terminating, towards the brain, in the parolfactory sulcus.

► Telencephalon

---

## Habenula

### Definition

The habenula (from Greek = habenulare, small rein) consists of the medial and lateral habenular nuclei, which are situated in the dorsal diencephalon of all vertebrates. The habenular nuclei together with the habenular commissure and pineal gland are also referred to as epithalamus. The habenular nuclei convey limbic forebrain information (from posterior septum, pallidum, lateral hypothalamus) to regulatory midbrain nuclei (interpeduncular nucleus, raphé, ventral tegmental area, laterodorsal and pedunculo-pontine tegmental nuclei). The habenular nuclei are thought to be involved in stress, maternal behavior, reward, and learning.

---

## Habit

### Definition

Daily activities or routine acquired to adjust oneself to environment. It is maintained by repeated automatically for a long period of one's life.

- ▶ Long-Term Memory

---

## Habit Formation

- ▶ Learning and Motivation

---

## Habituation

### Definition

Habituation is a simple form of non associative memory, common to all sensory systems, which is

observed in animals, including humans. It consists of a progressive decrease in behavioral and physiological responses to a given stimulus, initially significant, which accompanies the repeated exposure to this stimulus in absence of occurrence of any biological reinforcing event. The decrease in the subject's response is clearly specific to the stimulus to which the animal was repeatedly exposed, since the same response remains releasable by an other sensory cue. Habituation allows filtering of weakly significant informative cues or predictable events and seems to involve higher-order processing, as opposed to receptor adaptation. Habituation can be distinguished from adaptation or fatigue by dishabituation (response is immediately recovered by a novel or noxious stimulus) or by examining the rate of recovery following different interstimulus intervals. It thus is a reversible process, the habituated stimulus keeping the possibility to become again significant, for instance by conditioning.

- ▶ Learning
- ▶ Sensory Plasticity and Perceptual Learning
- ▶ Learning and Motivation

---

## Habituation/Dishabituation Test

### Definition

In the habituation/dishabituation test, the investigation of a stimulus, such as an odor, decreases on repeated presentation of the stimulus as the response habituates.

If a different stimulus is then presented, and if it can be discriminated from the habituated stimulus, the amount of investigation it elicits will be increased, i.e. the response dishabituates. This is a sensitive test of the ability of an animal to discriminate two stimuli, which has the advantage that no prior training is required.

However, a disadvantage of the task is that the animal needs to be motivated to investigate the stimuli. For instance, male mice will readily investigate and discriminate urine from female mice in different

reproductive states in a habituation/dishabituation test, but not artificial odors or odorants that have no meaning to them.

► Memory – Odor

---

## Habituation of Taste Neophobia

### Definition

Non-associative learning that leads to increased consumption of familiar tastes that were not followed by aversive visceral consequences in previous presentations.

► Conditioned Taste Aversion

---

## Hair Cell Organ

► Electoreceptor Organs

---

## Hair Cells

### Definition

The mechano-electrical transducers of the auditory, vestibular and lateral-line systems of all vertebrate species.

► Cochlea

► Peripheral Vestibular Apparatus

---

## Hair Cells of Vestibular System

### Definition

Signal detecting sensory neurons in the cupula of the semicircular canals and the epithelium of the macula. These neurons are equipped with cilia on the apical surface that detect movements of the endolymph and

the otolith and are contacted on the basal surface by afferent fibers of the VIIIth cranial nerve. The displacement of the cilia in preferred and non-preferred directions provokes a graded depolarization and hyperpolarization of the cells respectively, and a concomitant change of transmitter release.

► Peripheral Vestibular Apparatus

---

## Hairy Skin

### Definition

Skin covering the major portion of the body excepting the palms of hands, soles of the feet, the lips and borders of the genital and anal regions.

---

## Half-center

### Definition

A neuron or group of neurons that forms one half of a half-center oscillator. A half-center oscillator consists of two neurons or groups of neurons that are connected by reciprocal inhibitory connections, so that when one half-center is active activity in the other half-center is suppressed. A half-center oscillator can produce patterns of alternating activity that switch between the two half-centers in response to a general tonic excitation of both half-centers.

► Central Pattern Generator

---

## Hallucinogens

DAVID E. NICHOLS

Department of Medicinal Chemistry and Molecular Pharmacology, Purdue University, West Lafayette, IN, USA

### Synonyms

Psychedelics; Psychotomimetics; Entheogens

## Definition

A precise definition of hallucinogens that would be universally accepted probably cannot be agreed upon. In the most general sense, hallucinogens produce an altered state of consciousness (ASC). They increase the intensity and lability of affective responses, and produce profound distortions of perceptual processes, including visual, auditory, somesthetic, and olfactory modalities. Marked alterations in mood, thought, and sensory perception also occur, including changes in the experience of time, space, and self that are rarely experienced otherwise except in dreams.

## Characteristics

Many different types of chemical classes are capable of producing altered states of consciousness. Although some of them occasionally have been referred to as hallucinogens, the focus in this essay is on those molecules whose primary mechanism of action is mediated by effects on serotonergic neuronal systems: the serotonergic hallucinogens.

Hallucinogens are comprised of a group of prototypical compounds that includes mescaline, psilocybin, and LSD (Fig. 1).

Mescaline and psilocybin occur in nature, and are representatives of the ►phenethylamine and ►tryptamine classes of hallucinogens, respectively. They have a long history of folkloric use. LSD is a semisynthetic material prepared from lysergic acid, which is obtained by the hydrolysis of ►ergot alkaloids produced by species of the ergot fungus, *claviceps*.

Documented human use of hallucinogens dates back more than two millennia, and archeological artifacts suggest a role for them that predates written records. The vast history of human experience with hallucinogens was derived from the ingestion of plant-derived materials. Traditionally, hallucinogens were employed in sacramental and ritual contexts appropriate to a particular culture. Within the past century, however, the chemical constituents of these plants have been identified and studied. Armed with that knowledge, modern organic chemistry has provided potent synthetic hallucinogens for research that have become widely available and often have been used in nontraditional ways.

## Altered States of Consciousness

Quantifying altered states of consciousness was problematic in the early years of hallucinogen research. Today, however, there are validated instruments for assessing various aspects of consciousness. For example, Dittrich developed a questionnaire that is now widely used to measure altered states of consciousness (ASCs) produced by hallucinogens. The common constellations of effects produced by hallucinogens measured with this instrument lie in three primary dimensions: (i) “oceanic boundlessness” (OB), referring to positively experienced ego dissolution; (ii) “anxious ego-dissolution” (AED), including thought disorder and loss of self-control; and (iii) “visionary restructuralization” (VR), referring to perceptual alterations and altered meaning of percepts. Recent brain imaging studies have demonstrated that the degree to which each of these key dimensions of ASCs

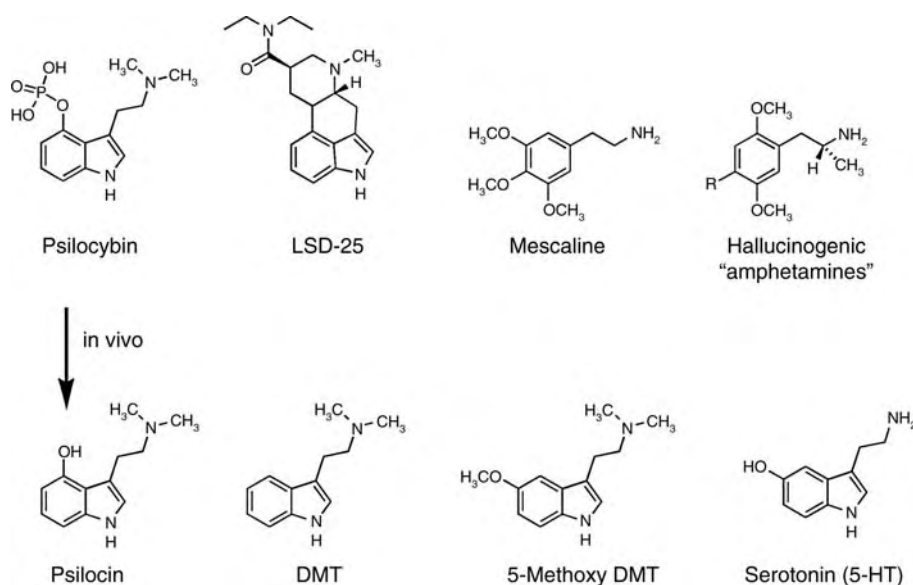

**Hallucinogens. Figure 1** The chemical structures of the serotonin agonist type hallucinogens. Mescaline served as the lead compound for hundreds of other substituted phenethylamines, including the so-called hallucinogenic amphetamines. The natural neurotransmitter serotonin is illustrated for comparison to the indole-based hallucinogens, which include various tryptamines, as well as LSD.

is manifested is correlated with functional alterations in prefrontal, temporal, and parietal cortical regions, as well as the thalamus and basal ganglia.

Hallucinogens also produce dose-dependent cognitive impairments, including deficits in attention, working memory, and associative learning, while leaving executive functions essentially intact. Serotonergic hallucinogens also impair high-level but not low-level motion perception and reduce binocular rivalry rate and rhythmicity in a manner that parallels subjective changes in consciousness.

In general, the intensity of alterations of consciousness produced by hallucinogens is dose-dependent. High doses and/or particular circumstances can, however, lead to the perception of a completely nonordinary reality, transporting the user to unknown realms and worlds of apparent physical substance and reality. Responses to hallucinogens can vary widely, however, depending on the individual and the circumstances of use. Mood changes can range from pleasure to bliss, and feelings of oneness with the universe, to extreme anxiety, fear, and paranoid ideation more typical of a psychotic state. See [1] for a recent review.

### Chemical Structures

The classical serotonergic hallucinogens are comprised of a basic amino group, separated by two carbon atoms from an aromatic system. This motif reflects the fact that tryptophan and tyrosine are the biosynthetic precursors for serotonin and the other monoamine neurotransmitters. The two major classes of serotonergic hallucinogens are the phenethylamines and the tryptamines. The tryptamines can further be divided into the simple tryptamines and the tetracyclic ergolines that include LSD and related lysergic acid amides (Fig. 1).

### Phenethylamines

The simplest phenethylamine hallucinogen is mescaline, which occurs naturally in the peyote cactus, *Lophophora williamsii*. It is the only naturally-occurring phenethylamine hallucinogen presently known. Although it has relatively low potency, mescaline has served as a molecular template for the chemical synthesis of hundreds of structural modifications. These substituted phenethylamines have been essential to understanding the structure-activity relationships of this class, as well as being instrumental in mapping the topography of the 5-HT<sub>2A</sub> receptor binding domain.

An early modification of the simple phenethylamines involved adding an alpha-methyl group to the side chain. These compounds are often referred to as "hallucinogenic amphetamines." They are more potent than the corresponding phenethylamine and generally have a longer duration of action. Most phenethylamines are much more potent than mescaline, with durations of action ranging from a few hours to 24 h or more.

### Tryptamines

The tryptamines bear close structural resemblance to the neurotransmitter serotonin. A number of these substances are found in nature, but a number of synthetic compounds also have been synthesized and tested. The simplest is *N,N*-dimethyltryptamine (DMT), which is found in a number of plant species, and also has been detected in human cerebrospinal fluid. It is not active orally due to degradation by monoamine oxidase (MAO) in the liver, and is usually smoked or injected, with brief but powerful effects lasting 15–30 min. Ayahuasca, or yagé, is an orally active preparation containing DMT that has been used by Indians of the Amazonian basin in Brazil. It is a decoction made from two plants, *banisteriopsis capii*, a source of beta-carboline alkaloids, and DMT-containing species such as *psychotria viridis*. The beta-carbolines include harmine, harmaline, and tetrahydroharmine, and are reversible MAO-A inhibitors. It is believed that ayahuasca has pharmacological activity because the harmala alkaloids inhibit the MAO in the liver that would normally deaminate DMT following oral ingestion.

Another naturally-occurring tryptamine, 5-methoxy-*N,N*-dimethyltryptamine (5-MeO-DMT), is found in *virola* species that grow in central and South America. The exudate from the inner bark surface of these trees is dried and finely ground to produce a powerful snuff called epená. The effects of 5-MeO-DMT are very short lasting, usually less than 30 min.

Psilocybin, a phosphorylated tryptamine, is produced by species of the *psilocybe* fungus ("magic mushrooms"). In contrast to DMT and 5-MeO-DMT, psilocybin is orally active, and has a 4–6 h action. Serum phosphatases remove the *O*-phosphate from psilocybin to reveal psilocin, the actual pharmacologically-active molecule [2].

### LSD and Other Ergolines

The tetracyclic ►ergoline *N,N*-diethyllysergamide (lysergic acid *N,N*-diethylamide; LSD; LSD-25) is the most potent of the known hallucinogens. A 0.10 mg oral dose of the tartrate salt produces effects lasting 8–10 h. LSD is semi-synthetic, prepared by the condensation of (+)-lysergic acid with diethylamine. Lysergic acid itself is obtained through basic hydrolysis of ergot alkaloids (e.g. ergotamine), which are obtained from any of a variety of *Claviceps* (ergot) species.

### Pharmacology in Animals

The early recognition that both LSD and serotonin were constructed with the same tryptamine scaffold led to hypotheses that LSD affected brain serotonin neurotransmission. Not surprisingly, studies in the 1950s clearly demonstrated that hallucinogens had profound effects on brain serotonin systems. After radioligand binding techniques were developed in the

1970s it was discovered that hallucinogens bound with high affinity to specific serotonin receptor subtypes and subsequently that all the chemical classes of hallucinogens activate serotonin 5-HT<sub>2A</sub> receptors, a G<sub>αq</sub>-coupled member of the G-protein-coupled receptor family.

### Serotonin Receptor Mechanisms

Early on it was found that LSD and tryptamine hallucinogens suppressed cell firing in the dorsal raphe nucleus, a group of midbrain cell bodies with extensive serotonergic projections to the forebrain. The correlation between raphe cell firing and general level of vigilance, and the cessation of firing during REM sleep, were intriguing phenomena that seemed consistent with raphe cells as targets for the hallucinogens. Nonetheless, some molecules that suppressed raphe firing were not hallucinogenic, and conversely, some hallucinogens did not directly suppress raphe cell firing.

Behavioral studies in animals ultimately revealed that blockade of the 5-HT<sub>2A</sub> receptor abolished the effects of hallucinogens. These receptors were found localized postsynaptically on cortical cells. Clinical studies recently have demonstrated that the selective 5-HT<sub>2A</sub> receptor antagonist ketanserin essentially abolished the psychopharmacological effects of psilocybin in human volunteers, the most compelling and conclusive proof of 5-HT<sub>2A</sub> receptor mediation of the effects of hallucinogens [3].

Nevertheless, experimental studies in animals indicate that LSD and other tryptamines may have subtle psychopharmacological properties that could be attributed to their agonist actions at other receptors. Although the phenethylamine hallucinogens appear to act solely or principally at serotonin 5-HT<sub>2A</sub> receptors, they also potentially activate 5-HT<sub>2C</sub> receptors, an effect with unknown consequences.

All of the tryptamines, including LSD, in addition to being agonists at 5-HT<sub>2A</sub> and 5-HT<sub>2C</sub> receptors, also are agonists at the 5-HT<sub>1A</sub> receptor subtype. Stimulation of somatodendritic serotonin 5-HT<sub>1A</sub> receptors attenuates raphe cell firing, with the consequence that tonic 5-HT activation at all levels of forebrain is reduced; it would be surprising if that effect had no psychopharmacological consequences.

From a pharmacology perspective LSD is unique among the hallucinogens. It is a nonspecific pharmacological agent, with potent agonist actions at a variety of other monoamine receptors, including the 5-HT<sub>4</sub>, 5-HT<sub>5</sub>, 5-HT<sub>6</sub>, and 5-HT<sub>7</sub> receptors, as well as the dopamine D<sub>2</sub>-like family of receptors. It has been speculated that the high potency of LSD, compared to other hallucinogens, results from some as yet unknown synergistic effect at one of these ancillary receptors. Nevertheless, sufficient data exist to make the argument that activation of the 5-HT<sub>2A</sub> receptor is a necessary, but perhaps not sufficient condition for producing hallucinogenic effects.

### Receptor Signaling

The 5-HT<sub>2A</sub> receptor is principally coupled to G<sub>αq</sub> proteins, stimulation of which leads to activation of PLC, and the production of ▶diacylglycerol (DAG) and inositol phosphates as second messengers. Nonetheless, a good correlation does not exist between behavioral effects in animal models and the ability to activate this signaling pathway. It has been suggested that a better correlation may exist between hallucinogenic potency and the production of arachidonic acid [4]. This signaling appears to arise through a complex pathway coupled to the 5-HT<sub>2A</sub> receptor by G<sub>α<sub>i/o</sub></sub> proteins [5]. In addition, at short times after receptor activation, the endocannabinoid ▶2-arachidinoylethanolamide (2-AG) is also produced, although there is no apparent relationship between 2-AG production and hallucinogenic activity.

Activation of 5-HT<sub>2A</sub> receptors by hallucinogens also leads to increased extracellular levels of glutamate, and enhances delayed glutamate release from thalamocortical terminals [6]. This glutamate spillover was found to be mediated by blockade of Kv1.2-containing K<sup>+</sup> channels [7]. One model proposed by these authors suggests that a retrograde messenger is produced that is capable of blocking these channels. Arachidonic acid, one of the second messengers produced by 5-HT<sub>2A</sub> receptor activation, blocks Kv1.2 in expression systems and at least one member of the high-voltage-activated Kv3 family.

The mechanistic picture that seems to be emerging is that postsynaptic activation of 5-HT<sub>2A</sub> receptors in cortical pyramidal cells leads to production of second messengers that cause membrane depolarization (which does not lead to cell firing), as well as the release of eicosanoids (e.g. arachidonic acid) that may serve as retrograde transmitters to enhance network activity in the prefrontal cortex through a phasic increase in glutamate spillover [8].

### Anatomical Locus of Action

After postsynaptic 5-HT<sub>2A</sub> receptors were identified as the likely primary target for hallucinogens, a search for these sites in the brain revealed that they were highly expressed on apical dendrites of cortical pyramidal cells, particularly in layer V of the cortex. High expression also was observed on interneurons that were presumably inhibitory GABAergic fibers. 5-HT<sub>2A</sub> receptor stimulation promotes cortical arousal and substantially increases the gain of layer 5 pyramidal neurons in rat PFC [9]. In addition, 5-HT<sub>2A</sub> receptors are expressed in areas of the thalamus and the reticular nucleus of the thalamus. Expression in all of these areas is consistent with a mechanism that involves disruption of sensory gating and corticothalamic circuits [1, 10].

PET imaging studies in humans using H<sub>2</sub>O-PET have shown increased blood flow in the frontomedial cortex extending into the anterior cingulate, dorsolateral,

insular, and temporal cortices (Fig. 2). Decreased blood flow was observed in areas important for gating or integrating cortical information processing such as bilateral thalamus, right globus pallidus, bilateral pons, and cerebrum. Psilocybin alters brain activation in such a way as to increase cognitive and affective processing in the context of reduced gating and reduced focus on external stimulus processing (unpublished data from F.X. Vollenweider). Interestingly, the discriminative stimulus produced by LSD in rats has been found to be localized within the anterior cingulate cortex.

### Gene Activation

A number of genes have been identified that are upregulated by LSD. Recently one group has proposed that upregulation of *Krox20* (*egr2*) may be a specific effect of hallucinogens, at least in the mouse. Interestingly, they also demonstrated that upregulation of this transcript results from activation of a *Gai/o* G protein, also implicated in the studies of arachidonic acid production by Kurrasch-Orbaugh et al. [4], cited earlier.

### Therapy

In the 1950s and early 1960s, LSD was hailed as a powerful new technology with the potential to revolutionize psychiatry. There were more than a thousand published clinical studies of over 40,000 subjects.

Unfortunately, these clinical studies were poorly designed, poorly controlled, and poorly analyzed, with inadequate post-treatment follow-up. In the absence of well designed studies, the only conclusion that can safely be drawn is that we do not presently know what medical value LSD or other hallucinogens might have.

There was, however, one well-documented use of hallucinogens as therapeutics in the treatment of dying cancer patients. Discovered somewhat serendipitously by Chicago internist Eric Kast, this work ended in several studies at the Baltimore State Hospital. When LSD was included in a program that included only a modest amount of counseling, some degree of benefit was produced in 60–70% of patients, measured as a reduced need for pain medication and improved mood.

### Conclusions

Serotonergic hallucinogens, the classical psychedelic compounds, have profound effects on human consciousness. These substances have been used ceremonially for many centuries in many cultures. Neurochemists and behavioral neuroscientists have identified agonist actions at specific subtypes of serotonin receptors, primarily the 5-HT<sub>2A</sub> receptors, as being the primary mechanism of action for the behavioral effects of psychedelics. More recent clinical studies of human volunteers have confirmed that the psychedelic effects of hallucinogens

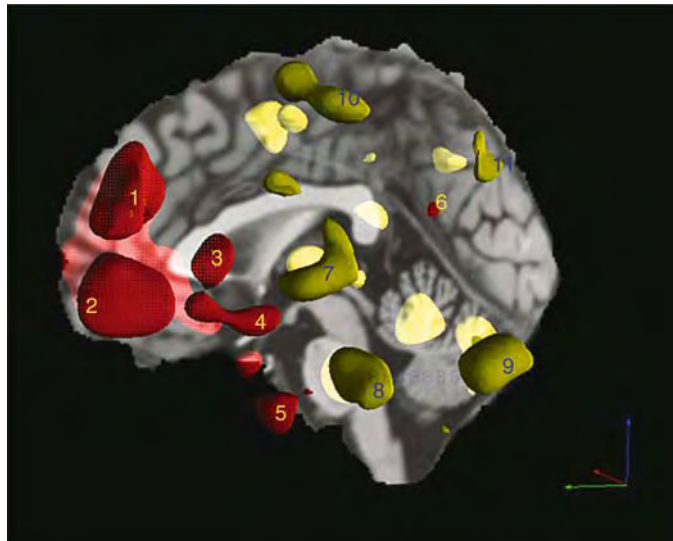

**Hallucinogens. Figure 2** An illustration of the effect of psilocybin on brain activity in healthy human volunteers as indexed by changes in cerebral blood flow (CBF) using H<sub>2</sub>O-PET. Red shows relative increases, and yellow indicates relative decreases in regional brain activity. Marked increases in activity are seen in areas important for cognitive and affective processes such as the frontomedial cortex extending into the anterior cingulate (1 and 2); the dorsolateral (3), insula (4), and temporal poles (5), and the left posterior cingulate (6). Decreased flow was observed in brain areas important for gating or integrating cortical information processing such as bilateral thalamus (7), right globus pallidus and bilateral pons (8), and in cerebellum (9). Psilocybin also reduced neuronal activity in components responsible for higher order visuo-spatial processing such as precuneus (11) and angular gyrus, as well as in supplementary eye fields of the pre-motor area (10) (unpublished data from F. X. Vollenweider).



such as psilocybin are largely attributable to the activation of 5-HT<sub>2A</sub> receptors. The study of serotonergic hallucinogens has been informative as to the neurobiological substrates of altered states of consciousness and likely mechanisms contributing to some psychiatric disorders such as schizophrenia. Further research in this area could lead to the identification of novel pharmacotherapeutics, potentially including therapeutic effects of the hallucinogens themselves in certain conditions.

## References

- Nichols DE (2004) Hallucinogens. *Pharmacol Ther* 101:131–181
- Presti D, Nichols D (2004) Biochemistry and neuropharmacology of psilocybin mushrooms. In: Metzner R (ed) *Teonanacatl: sacred mushroom of visions*. Four Trees, El Verano, CA, pp 89–108
- Vollenweider FX, Vollenweider-Scherpenhuyzen MF, Babler A, Vogel H, Hell D (1998) Psilocybin induces schizophrenia-like psychosis in humans via a serotonin-2 agonist action. *Neuroreport* 9:3897–3902
- Kurrasch-Orbaugh DM, Watts VJ, Barker EL, Nichols DE (2003) Serotonin 5-hydroxytryptamine 2A receptor-coupled phospholipase C and phospholipase A2 signaling pathways have different receptor reserves. *J Pharmacol Exp Ther* 304:229–237
- Kurrasch-Orbaugh DM, Parrish JC, Watts VJ, Nichols DE (2003) A complex signaling cascade links the serotonin 2A receptor to phospholipase A2 activation: the involvement of MAP kinases. *J Neurochem* 86:980–991
- Aghajanian GK, Marek GJ (1999) Serotonin, via 5-HT<sub>2A</sub> receptors, increases EPSCs in layer V pyramidal cells of prefrontal cortex by an asynchronous mode of glutamate release. *Brain Res* 825:161–171
- Lambe EK, Aghajanian GK (2001) The role of Kv1.2-containing potassium channels in serotonin-induced glutamate release from thalamocortical terminals in rat frontal cortex. *J Neurosci* 21:9955–9963
- Lambe EK, Aghajanian GK (2006) Hallucinogen-induced UP states in the brain slice of rat prefrontal cortex: role of glutamate spillover and NR2B-NMDA receptors. *Neuropsychopharmacology* 31:1682–1689
- Zhang ZW, Arsenault D (2005) Gain modulation by serotonin in pyramidal neurones of the rat prefrontal cortex. *J Physiol* 566:379–394
- Vollenweider FX, Geyer MA (2001) A systems model of altered consciousness: integrating natural and drug-induced psychoses. *Brain Res Bull* 56:495–507

## Haloperidol

### Definition

Drug with antipsychotic properties that is used in hyperactive or manic patients and in animal models of schizophrenia.

## Halteres

### Definition

Fast-moving (rotating) club-like righting organs of flies; working much like gyroscopes.

► Evolution of the Vestibular System

## Hamartoma

### Definition

A focal malformation that resembles a neoplasm in the tissue of its origin.

► Neuroendocrinology of Psychiatric Disorders

## Hand Path

### Definition

The set of positions of the hand that connects two points in space.

► Motor Control Models

## Hand Trajectory

### Definition

The 3D position as a function of time between two points in space.

► Motor Control Models

## Handedness

### Definition

The tendency to prefer using one hand and not the other for a particular task or set of similar tasks.

► [Motor Cortex – Hand Movements and Plasticity](#)

## Haploinsufficiency

### Definition

The condition when one functional copy of a gene (the other copy is non-functional) is not enough to prevent the manifestation of a mutant phenotype.

## Haplotype

### Definition

A combination of alleles along part of or the entire chromosome that are transmitted together. Haplotype can also refer to a set of single nucleotide polymorphisms along a single chromatid that tend to be inherited together. Haplotype information is used to identify the genes or genetic susceptibilities underlying certain disorders, and is available through the International HapMap Project.

## Haptics

LYNETTE A. JONES

Department of Mechanical Engineering, Massachusetts Institute of Technology, Cambridge, MA, USA

### Synonyms

Active touch; Stereognosis

### Definition

Haptics refers to the sensory inputs arising from receptors in skin, muscles, tendons, and joints that are

used to derive information about the properties of objects as they are manipulated. Haptic sensing therefore involves both the tactile and proprioceptive sensory modalities [1]. The tactile inputs come from slowly and rapidly adapting ► [cutaneous mechanoreceptors](#) in the palmar and dorsal skin of the hand that encode the surface features and shapes of objects as they are explored, whereas the proprioceptive inputs come from receptors in muscles, tendons and joints that respond to changes in muscle length and the forces generated by muscles. These proprioceptive signals provide the central nervous system with information about joint angles, the rate of joint movement and the forces generated on contact, all of which can assist in perceiving the properties of objects held in the hand. It is this active process of manual exploration in which there is a close interplay between finger movements and tactile perception that distinguishes haptics from tactile sensing. The latter term is often referred to as passive touch.

### Characteristics

#### Higher Level Structures

Sensory information from cutaneous receptors in the hand and from muscles that control finger movements is conveyed via afferent nerve fibers to the dorsal root ganglion neurons which lie on the dorsal root of a spinal nerve. In the spinal cord, the large diameter axons that mediate touch and proprioception diverge from the smaller diameter afferent fibers that subserve temperature and pain and they follow different pathways to the brain. Tactile and proprioceptive information is segregated anatomically and transmitted to the cerebral cortex via the central axons of dorsal root ganglion cells that enter the spinal cord. These axons ascend directly to the medulla in the dorsal column-medial lemniscal system. At higher spinal levels, the dorsal columns divide into the gracile fascicle that ascends medially and includes fibers from the ipsilateral sacral, lumbar and lower thoracic segments, and the cuneate fascicle that ascends laterally and contains fibers from the upper thoracic and cervical segments. Axons in these fascicles terminate in the gracile and cuneate nuclei in the medulla and from there cross to the other side of the brain stem and ascend to the ventral posterior lateral nucleus of the thalamus in a fiber bundle known as the medial lemniscus. The neurons in the thalamus that receive these inputs from the dorsal column medial lemniscal system send axons to the primary somatosensory cortex in the postcentral gyrus. Most of the thalamic input terminates in areas 3a and 3b and the cells in these areas project to areas 1 and 2. Sensory information from receptors in the skin is transmitted to areas 3b and 1, and proprioceptive information is received in areas 3a and 2. There are extensive interconnections between these four primary

sensory areas, and they send projections to the secondary somatosensory cortex on the superior bank of the lateral sulcus [2]. The four areas within the human somatosensory cortex each contain a full map of the body, with different types of information represented in each area. Parts of the body with high densities of sensory receptors, such as the finger tips and the thumb, have disproportionately larger areas of cortex devoted to processing their sensory signals.

The small diameter fibers from temperature and pain receptors in the skin terminate on second-order neurons in the dorsal horn of the spinal cord and the axons of these neurons cross the midline to form the anterolateral system. The axons involved in transmitting information about pain and temperature are segregated and are arranged somatotopically as they ascend the spinal cord. There are both direct and indirect connections from the anterolateral system to the thalamus via the reticular formation in the medulla and the pons [2]. From the thalamus, there are projections to the primary somatosensory cortex, the dorsal anterior insular cortex and the anterior cingulate gyrus.

### Higher Level Processes

Haptic sensing is focused on perceiving the physical properties of external objects rather than internal tactile sensations and as the hand is the primary organ through which the external world is explored tactually, the study of haptic perception primarily involves the hand. The distinction between haptic and tactile sensing, or active and passive touch, is based on the active component of the former, namely that the hand is voluntarily moved across a surface or an object with purposive movements to obtain specific information. For some properties, such as the perception of roughness of a surface or the detection of minute surface irregularities, it appears to matter little whether the hand moves over a stationary surface (haptic sensing) or the surface is moved across a stationary hand (tactile sensing), all that is important is that there is relative motion between the skin and the surface. For other properties, such as the perception of weight, hand movements greatly facilitate perception, as reflected in the increased sensitivity to changes in weight when an object is lifted as compared to when it rests on the passive hand [1]. In this context, peripheral proprioceptive feedback resulting from the active movement provides an additional source of information about the object. A further source of information about force comes from the cortically generated motor command transmitted to the muscles involved in supporting the weight. Internal correlates or copies of these commands, known as **corollary discharges**, are sent to a number of the sensory areas in the cortex and are involved in the perception of force [3].

Active movements affect the transmission of cutaneous signals through the dorsal column-medial lemniscal

pathway by diminishing or gating the sensory inputs. As a result, detection thresholds for cutaneous inputs increase and the perceived magnitude of vibrotactile stimuli is reduced during voluntary movements, although discrimination thresholds remain unchanged [4]. Given the superiority of haptic sensing over tactile sensing in many tasks, it seems paradoxical that movement modulates the transmission of self-generated tactile inputs to the primary somatosensory cortex. It has been proposed that as the rate and type of information acquired during haptic exploration is controlled by the individual, movement speed may be significantly diminished at critical times to minimize the influence of sensory gating. Any disadvantage associated with haptic sensing may then be counteracted by the individual's exploration strategy [4].

### Function

The ability to perceive the attributes of objects is essential to many domains of hand use, from using a tool to typing on a keyboard [1]. As the hand makes contact with an object an initial appraisal of its properties is required so that the grasping forces generated are appropriate for holding the object in a stable grasp. These prehensile forces are adapted to the weight of the object, the friction between the skin of the hand and the object being grasped and the object's shape and size, all of which may be sensed haptically [5]. Afferent information from cutaneous mechanoreceptors in the fingertips therefore plays a crucial role in regulating grasping forces as an object is manipulated. The mechanoreceptors also detect when an object begins to slip between the fingers so that there is an automatic increase (within 70 ms) in grip force that results in a more stable grasp. In the absence of tactile feedback from the fingers, due to peripheral or cortical lesions, the prehensile capacities of the hand are severely compromised.

When considering the dimensions along which an object may vary, a distinction is often made between material properties such as surface texture and thermal diffusivity, and geometric properties, such as shape and size [6]. Some properties such as weight are a function of both material and geometric features, with object density (a material attribute) and volume (a geometric attribute) being contributing factors. Material properties are generally processed more effectively and rapidly by the hand than geometric properties, which often require serial exploration of the object in order to acquire the relevant information. As most common objects vary along a number of different dimensions, people can identify small objects haptically very accurately and quickly (within 1–2 s) [7]. In contrast, it is considerably more difficult to recognize two-dimensional raised outline drawings of common objects haptically. These objects are typically raised

two-dimensional contours and so there is no change in three-dimensional shape and little variation in material properties to assist identification.

Analyses of the hand movements used by people as they manually explore an object indicate that the hand-movement patterns used vary for different properties. These movement patterns or exploratory procedures (EP) have been documented from analyses of hand movements as people manipulate objects to learn about a particular property [8]. A specific exploratory procedure is chosen depending on the property that the person is instructed to explore. For example, the hand is generally moved back and forth across a surface (lateral motion EP) if information about surface texture is of interest, whereas if the weight of the object is being judged, the hand lifts the object from its supporting surface (unsupported holding EP) as illustrated in figure 1 [9].

It has been noted that the exploratory procedure that people voluntarily use to find out about a specific property (i.e., hardness, texture, thermal properties) is the most precise way of learning about that attribute. Exploratory procedures do, however, vary in their execution time, relative precision and generality, that is, the total number of object properties that a single EP can extract. For example, a contour following EP that is used to determine the global or exact shape of an object also provides information about its thermal properties, surface texture, volume, hardness and weight, whereas a lateral motion EP provides cues only about texture, hardness and temperature [8].

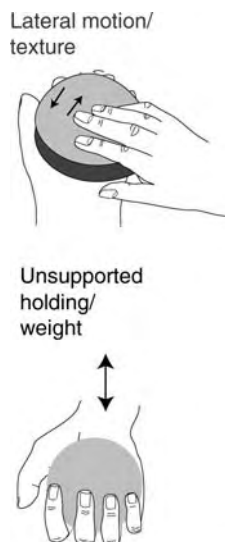

**Haptics. Figure 1** Two exploratory procedures (EPs) and the associated object properties. Adapted with permission from [9].

## Pathology

Deficits in haptic object recognition are frequently associated with elevated sensory thresholds on tactile sensory threshold tests such as ►two-point discrimination and pressure sensitivity. Many of these people have injuries to the peripheral nerves innervating the hand or lesions in the primary somatosensory cortex, and the damage to the peripheral or central nervous systems results in a loss of the basic sensory information required to identify an object haptically. Impairments in haptic object recognition can also occur in the absence of primary sensory loss. In these cases, which are usually associated with lesions in the posterior parietal lobe, sensory thresholds on the hand are normal or only mildly impaired, but there is a profound deficit in recognizing objects haptically. A number of terms are used to describe these impairments in haptic object recognition consequent to cortical damage, including astereognosis, ►tactile apraxia and ►tactile paralysis. The deficits appear to result from difficulties in tactile shape perception and inefficient manual exploration strategies. Analyses of the hand movements used by individuals with posterior parietal lobe lesions as they explore objects haptically indicate that there is a reduction in the frequency and regularity of finger movements as compared to normal healthy people, and that the exploration space used to find out about an object is more expansive than that used normally [10]. Lesions in the posterior parietal lobe therefore affect the capacity to make precise controlled finger movements and to plan these movements efficiently, both of which are essential to haptic object recognition.

## References

1. Jones LA, Lederman SJ (2006) Human hand function. Oxford University Press, New York
2. Gardner EP, Martin JM, Jessell TM (2000) The bodily senses. In: Kandel ER, Schwartz JH, Jessell TM (eds) Principles of neural science, 4th edn. McGraw-Hill, New York, pp 430–450
3. Gandevia SC (1996) Kinesthesia: roles for afferent signals and motor commands. In: Rowell LB, Shepherd JT (eds) Handbook of physiology, section 12: Exercise regulation and integration of multiple systems. Oxford University Press, New York, pp 128–172
4. Chapman CE (1994) Active versus passive touch: factors influencing the transmission of somatosensory signals to primary somatosensory cortex. *Can J Physiol Pharmacol* 72:558–570
5. Goodwin AW, Wheat HE (2004) Sensory signals in neural populations underlying tactile perception and manipulation. *Annu Rev Neurosci* 27:53–77
6. Klatzky RL, Lederman SJ (2003) Touch. In: Healy AF, Proctor RW (eds) Experimental psychology, vol 4: Handbook of psychology (Weiner IB, Editor-in-Chief). Wiley, New York, pp 147–176

7. Klatzky RL, Lederman SJ (2003) The haptic identification of everyday life objects. In: Hatwell Y, Streri A, Gentaz E (eds) *Touching for knowing: cognitive psychology of haptic manual perception*. John Benjamins, Amsterdam, pp 105–121
8. Lederman SJ, Klatzky RL (1987) Hand movements: a window into haptic object recognition. *Cognit Psychol* 19:342–368
9. Lederman SJ, Klatzky RL (1998) The hand as a perceptual system. In: Connolly KJ (ed) *The Psychobiology of the hand*. McKeith Press, London, pp 16–35
10. Binkofski F, Kunesch E, Classen J, Seitz RJ, Freund HJ (2001) Tactile apraxia: unimodal apractic disorder of tactile object recognition associated with parietal lobe lesions. *Brain* 124:132–144

---

## Hard Determinism

### Definition

The thesis that determinism is true and is incompatible with free action.

► Freedom of Will

---

## Hard Problem of Consciousness

### Definition

The problem of how it is possible to explain consciousness in terms of its neural (or some other) basis.

► Emergence

---

## Harmonics

### Definition

Frequencies at integer multiples of a fundamental frequency.

---

## HAROLD

### Definition

Hemispheric asymmetry reduction in older adults; states that, under similar circumstances, prefrontal activity during cognitive performances tends to be less lateralized in older adults than in younger adults.

► Hemispheric Asymmetry of Memory

---

## HCN Channels

### Definition

HCN channels are hyperpolarization-activated cyclic nucleotide-gated channels (Cyclic nucleotide-regulated cation channels). They are slowly activated by membrane hyperpolarization (termed Ih, If or Iq) and found in various excitable cells including neurons, cardiac pacemaker cells and photoreceptors.

► Action Potential

► Cyclic Nucleotide-regulated Cation Channels

---

## Head Coordinates

### Definition

The location of a target with respect to the head.

---

## Head Direction Cells

### Definition

Neurons discharging when the head is oriented in a particular direction in the horizontal plane (but not controlled by geomagnetic fields). Found in over 10 different brain areas including parts of Papez' circuit.

First discovered in the dorsal pre-subiculum by Ranck (1984). Found in rats, mice, chinchillas and monkeys.

► Neural Bases of Spatial Learning and Memory

## Head-down Bed Rest

### Definition

The most commonly used ground-based method to simulate long-term microgravity by eliminating gravitational input from the head to the leg (called +Gz), and inducing body fluid shift from the lower parts of the body toward the head by applying bed rest with 6° head down position.

► [Autonomic Function in Space](#)

## Head Movements

### Definition

A component of many different behavioral patterns, such as gaze shifting, an essential part of orienting behavior. They participate in both compensatory and active gaze shifts. Examples of the former are head movements induced by passive rotation of the body. They are controlled by the vestibulo-collic reflex and help to stabilize the line of sight in space.

During active, rapid gaze shifts, the contribution of the head strongly depends on functional properties of the oculomotor system. For example, primates with immobilized heads can move the eyes by up to 50° from a centered orbital position while cats can do it only up to 25°. Correspondingly, primates engage head movements in gaze shifts only if the angular distance between fixation point and the target is greater than 15–20°. In cats, this smallest gaze error is about 3–5°, and the association of eye and head movements (eye-head synergy) is more compulsory than in primates. In animals trained to make rapid eye-head gaze shifts for a reward, maximal head velocities attained during the largest movements are very high (e.g., 400–450°/s in humans, 250–300°/s in rhesus monkeys and 250–500°/s in cats). Because of their speed and because of a positive correlation of peak velocity with movement amplitude such movements are called “head saccades,” by analogy with saccadic eye movements. It should be noted that untrained animals often make non-saccadic head movements when their motivation to redirect the gaze to a new target is low. Head movements are also engaged in the tracking of objects moving at low velocity.

- [Eye-head Coordination](#)
- [Gaze Shift](#)
- [Saccade, Saccadic Eye Movement](#)
- [SC-Tectoreticulospinal neurons \(TRSNs\)](#)
- [Vestibulocollic Reflex](#)

## Head-Related Transfer Function (HRTF) in Audition

### Definition

Mathematical descriptions of the manner in which the ears, face, and head affect the amplitude and phase of sound waves at each ear. HRTFs are computed for each ear for a variety of locations in space, by inserting tiny microphones into the ear canals and moving a speaker emitting wide band signals. After removing the contributions of the microphones and speaker, the filtering effects of the head, face, and ear are left.

Arbitrary sound waves can then be filtered by HRTFs corresponding to a given location in space, and played back to the subject over headphones to generate a veridical perception of a sound coming from that location – the sound is said to have been presented in “virtual auditory space.”

► [Neuroethology of Sound Localization in Barn Owls](#)

## Headache

SYLVIA LUCAS

University of Washington Medical Center, Seattle, Washington

### Synonyms

Cephalalgia; Pain in the head

### Definition

Headache is a term indicative of an experience of pain or discomfort in the cranial regions of the head, but more broadly can include the face and facial structures, and the neck. It is one of the most common medical complaints of humans.

### Characteristics

In an attempt to classify headache into meaningful clinical entities, the International Headache Society (IHS) has organized headache disorders into operational diagnostic categories [1]. These specific definitions of headache types allow the clinician to determine a diagnosis for a patient with a headache complaint and subsequently provide the most effective treatment. The classification system has been particularly useful in the clinical and basic research setting in that it is more likely that the same headache type is studied.

Headaches are divided into two major categories: primary headache disorders (categories 1–4) in which the headaches themselves are the disease process and include ►tension-type headache, ►migraine, and ►cluster headache; and secondary headache disorders (categories 5–12) in which headache is likely to be a symptom based on an underlying structural, infectious or inflammatory etiology. The secondary headache disorders are extensive and may include headache caused by mass lesions, meningitis, subarachnoid hemorrhage, or vasculitis among many other possible entities (see below).

## The International Classification of Headache Disorders (Overview of Main Categories)

### The Primary Headaches

#### Migraine

Tension-type headache

Cluster headache and other ►trigeminal autonomic cephalalgias

Other primary headache

Adapted from the International Headache Consortium of 2004.

### The Secondary Headaches

Headache attributed to head and neck trauma

Headache attributed to cranial or cervical vascular disorder

Headache attributed to non-vascular intracranial disorder

Headache attributed to a substance or its withdrawal

Headache attributed to infection

Headache attributed to disturbance of homeostasis

Headache or facial pain attributed to disorder of cranium, neck, eyes, ears, nose, sinuses, teeth, mouth or other facial or cranial structure

Headache attributed to psychiatric disorder

Adapted from the Headache Classification Subcommittee of the International Headache Society, 2004

The clinical history is of the utmost importance in differentiating primary versus secondary headache. Perhaps the most useful data is the length of time the patient has had the headache. A long history of headache, particularly if episodic and occurring in other family members, is more indicative of a primary headache. A short history of headache with accelerating frequency may generate greater concern for a secondary headache and prompt diagnostic testing such as brain imaging. Other red flags might be change in character or development of a new type of headache especially if there are underlying medical conditions predisposing to secondary headache such as cancer, abnormal neurologic exam findings, prolonged ►aura, fever or stiff neck.

The primary headache syndromes are divided into episodic and chronic classifications based on headache frequency. Typically, episodic headache occurs less than 15 days/month and chronic headache is defined as being

present greater than 15 days/month for 4 or more hours per day.

Adapted from the International Headache Consortium of 2004.

## Common Primary Headache Syndromes

### Migraine

The most common primary headache disorder that brings a person to the attention of a physician is migraine, a common episodic disorder characterized by attacks of head pain, as well as accompanying autonomic, neurologic, and gastrointestinal features (see below).

### Diagnostic Criteria for Migraine Headache Without Aura

1. At least five attacks fulfilling criteria A through D
2. Headache lasts 4–72 h (untreated or successfully treated)
3. Headache has at least two of the four characteristics
  - (a) Unilateral location
  - (b) Throbbing, pulsating quality
  - (c) Moderate or severe intensity
  - (d) Physical activity increases pain (such as bending over or climbing stairs)
4. During headache attack, at least one of the following occurs:
  - (a) Nausea or vomiting
  - (b) Photophobia or phonophobia
5. Organic disorder is excluded

Adapted from the Headache Classification Subcommittee of the International Headache Society, 2004.

The word migraine is derived from the Latin term hemicrania and its derivatives: migranea, emigranea, megrane, megrim to describe a one-sided headache. Though only 60% of patients describe migraine pain as unilateral (40% describe bilateral or global pain), this is part of a syndrome in which pain may be throbbing, pounding or pulsatile, moderate to severe in intensity, and worsens with physical activity. Autonomic features such as nausea and vomiting and gastroparesis are frequently seen. Less often, diarrhea, nasal congestion, lacrimation, rhinorrhea or diarrhea may be symptoms. Photophobia and phonophobia are commonly experienced with migraine, and with the temporal development of the headache, many patients experience cutaneous allodynia, a hypersensitivity of the scalp, hair, face or teeth thought to be a manifestation of central sensitization.

Migraine is prevalent in ~12% of the population of industrialized countries [2] and has a 1-year prevalence of ~18% in women and 6% in men. Hormonal issues are thought to play a major role in the increased prevalence of migraine during women's reproductive years. The highest incidence in girls is around the age of menarche at 13–14 years, whereas in boys it is earlier at ~8–10 years old. Migraine is associated with menses in 60% of women

sufferers (menstrual-associated migraine) though it can occur at other times as well. Improvement during the latter two trimesters of pregnancy and resolution or dramatic decrease in frequency and intensity after menopause, suggest that the higher prevalence of migraine during reproductive years is an estrogen withdrawal phenomenon.

### **Migraine with Aura**

Approximately 12–18% of patients with migraine have aura, a focal, reversible neurologic deficit which develops over several minutes and lasts less than 60 min. Though aura typically happens before the head pain occurs, it may precede, accompany or rarely follow the headache. In many people, aura can occur without accompanying headache as a migraine equivalent. Migraine, migraine with aura, or migraine equivalents can occur as different headache syndromes in the same person.

Eighty percent of aura is visual, primarily scintillating scotoma often described as a small shimmering half-circle of light which may have rick-rack or triangular edges (fortification spectra) in either visual field. The aura typically develops by growing and moving across the visual field until resolution. Other visual auras have been described as tunnel vision, black spots or holes, colored spots or stars. Less frequent auras include paresthesias, numbness, weakness, aphasia, or hemiplegia. These symptoms can happen independently of one another, or can develop in series. In children a common migraine equivalent is cyclical vomiting. Confusion or other cognitive dysfunction may present as a migraine equivalent or as part of a migraine syndrome.

Aura is not to be confused with a migraine prodrome, in which 50% of people who develop migraine will be able to identify symptoms typically preceding their headache syndrome, such as food cravings, sleep disturbance, yawning, personality changes, or altered sensation over areas where pain develops.

### **Tension-Type Headache**

Episodic tension-type headache is perhaps the most prevalent of the primary headache disorders, with a 1-year prevalence ranging from 38–74% [3]. Though common, it is a mild to moderate headache by definition (see below).

### **Diagnostic Criteria for Tension-Type Headache**

1. At least ten previous headache episodes fulfilling criteria B to D
2. Headache lasting from 30 min to 7 days
3. At least two of the following pain characteristics:
  - (a) Pressing/tightening (nonpulsating quality)
  - (b) Mild or moderate severity
  - (c) Bilateral location
  - (d) No aggravation by walking stairs or similar routine physical activity

4. Both of the following:
  - (a) No nausea or vomiting
  - (b) Photophobia and phonophobia are absent or one but not the other is present
5. No evidence of organic disease

Adapted from the Headache Classification Subcommittee of the International Headache Society, 2004.

Therefore, most persons with this headache do not seek medical care and may choose to self-treat with simple analgesics. It is bilateral in location, squeezing, pressing or vice-like in character and nausea or vomiting is not part of this syndrome.

### **Cluster Headache**

Pain in this primary headache syndrome is thought to be the most severe of the primary headache syndromes. It is described as boring, burning, tearing, or “hot poker in the eye” excruciating pain. An attack of cluster headache has a rapid onset of 5–10 min to peak pain intensity and lasts from 15 min to 3 h, most typically 45–90 min. Cluster is strictly a unilateral, primarily quadrant headache which is retro-orbital or supra-orbital in location and may radiate into the temple. It is accompanied by autonomic features such as ipsilateral lacrimation, conjunctival injection, or nasal congestion and rarely accompanied by nausea, photophobia or phonophobia (see below).

1. At least five attacks fulfilling B-D
2. Severe unilateral, orbital, supraorbital and/or temporal pain lasting 15–180 min, untreated
3. Headache associated with at least one of the following signs, which have to be present on the pain side:
  - (a) Conjunctival injection and/or lacrimation
  - (b) Nasal congestion and/or rhinorrhea
  - (c) Forehead and facial sweating
  - (d) Miosis and/or ptosis
  - (e) Eyelid edema
  - (f) A sense of restlessness or agitation
4. Frequency of attacks: from 1 every other day to 8/day
5. No evidence of organic disease

Adapted from Headache Classification Subcommittee of the International Headache Society, 2004.

Commonly, attacks occur at least once every 24 h, but it is not unusual to have several attacks throughout the day. They may occur at the same time each day or night with nocturnal attacks most likely to happen 60–90 min after sleep onset. A cluster period may last several weeks, most often 6–12 weeks with many months, sometimes years between clusters. Interestingly, during a migraine patients prefer a dark, quiet room in which to rest or sleep. A cluster headache is a “pacing” headache during which restlessness, walking, rocking, even violent behavior is



seen [4]. The gender predilection in cluster is also different with a male: female ratio of 4:1.

### Treatment of Primary Headache Disorders

Effective headache treatment begins with the correct diagnosis, an evaluation of the impact of headaches on a person's daily life, and whether there are any modifiable behaviors or triggers. Migraineurs, for example, may be physiologically more susceptible to certain internal or external stimuli, which can increase the probability of developing migraine. These may include hormonal changes, dietary factors such as alcohol consumption, falls in barometric pressure, sensory stimuli such as bright, shimmering or fluorescent lights, stress, too little or too much sleep or strong smells such as perfume, cigarette smoke or diesel fumes. Avoidance of known triggers may be useful in some migraineurs.

One of the most predictable triggers of migraine in women is the menstrual period. Menstrual-associated migraine (MAM) occurs in 60% of women migraineurs ~2 days before to 3 days after onset of menses. Migraines during this time period appear to be longer in duration and may be more difficult to treat compared to migraines occurring at other times of the month. However, the predictability of the headaches may offer preventive treatment options.

Treatment of migraine is usually acute (abortive) though in patients with frequent headache preventive (prophylactic) therapy may be indicated as well. Acute treatment may be divided into specific and non-specific modalities based on current knowledge of migraine physiology. Migraine is associated with brainstem activation, which may generate or modulate the migraine process. Pain probably results from activation of meningeal and vascular nociceptors in the trigeminovascular complex. Trigeminal sensory afferent terminals contain inflammatory neuropeptides such as calcitonin gene-related peptide, substance P and neurokinins which are released during activation and cause the dilation and plasma extravasation. The neurogenic inflammation can be blocked by drugs that are 5-HT agonists [5].

Specific targeted therapies are based on inhibition of neurotransmitter release at receptors thought to play an important role in the development of the headache pain and its associated features [6,7]. The serotonin receptors 5-HT 1B and 5-HT 1D function as autoreceptors that control the release of 5-HT and other transmitters and are the molecular targets for the class of drugs known as the "triptans." Sumatriptan was the first available drug in this category. Sumatriptan and other marketed triptans (zolmitriptan, naratriptan, rizatriptan, almotriptan, frovatriptan and eletriptan) have relatively high efficacy with a tolerable side effect profile. The ergot alkaloids and derivatives such as dihydroergotamine (DHE) are also thought to exert their anti-migraine

activity at these receptors, though bind at other 5-HT, adrenergic, and dopaminergic receptors as well [8].

The putative mechanism of action of triptans and the ergot alkaloids is to block the release of proinflammatory neurotransmitters at the level of the trigeminal nerve terminal (5-HT 1D receptor) thus preventing neurogenic inflammation. However they also cause vasoconstriction of meningeal arterioles through a 5-HT 1B effect. In addition, they may also have a central effect in the brainstem through receptor binding in the trigeminal nucleus caudalis.

They are contraindicated in patients in whom vasoconstriction of coronary, peripheral or intracerebral arteries might lead to ischemic events.

Non-specific therapies consist of simple analgesics such as aspirin, acetaminophen or paracetamol, combination analgesics such as aspirin, acetaminophen and caffeine, opioids, or nonsteroidal anti-inflammatories. Other non-specific headache medications may contain butalbital or isometheptene [8].

Characteristics of the headache such as rate of pain evolution, intensity and severity of the headache, associated symptoms such as nausea or vomiting, and disability during the headache will determine whether specific or non-specific therapies will be effective, and which route of administration (i.e. oral versus injectable) is preferable.

### Other Headache Disorders

#### Chronic Daily Headache

►Chronic daily headache (CDH) is a headache syndrome in which headache occurs more than 4 h/day, more than 15 days/month. CDHs include transformed migraine, chronic tension-type headache, new daily persistent headache or hemicrania continua [9]. The most common CDH seen by headache specialists is Medication Overuse Headache (MOH) also known as rebound headache. This headache tends to be a constant, diffuse headache that is present upon awakening or shortly thereafter though more severe headache can be present. Typically MOH is caused by overuse of abortive medications used to treat headache and can present as headache with escalating frequency. The development from episodic headache to daily headache may take weeks or months. Any acute agents may cause MOH such as opiates, barbiturates, benzodiazepines, simple and combination analgesics, triptans and ergot derivatives. It is thought to be a withdrawal syndrome and may develop in persons who use the medication as little as two to three times a week on average. Treatment is to taper or stop the causative agent.

#### Idiopathic Stabbing Headache (Ice-Pick Headache)

This headache is characterized by stabs of sudden, sharp severe ice-pick-like pains located in the parietal, temple, or orbital regions of the head. The episodes

**Headache. Table 1** Clinical features of some of the short-lasting primary headaches

	Cluster	Paroxysmal hemicrania	SUNCT	Idiopathic stabbing headache	Trigeminal neuralgia
M:F ratio	4:1	1:1	5:1	F > M	F > M
Pain quality	Lancinating	Pulsating	Stabbing	Stabbing	Sudden stabbing
Pain intensity	Excruciating	Excruciating	Severe	Severe	Excruciating
Pain location	Orbital temporal	Orbital temporal	Orbital temporal	Head (any part)	V2-V3 (V1 rarely)
Attack duration	15–180 min	1–30 min	5–240 s	<1 s	<1 s to 2 min
Attack frequency	1–8/day	3–30/day	1/day to 30/h	Few to many/day	Few to many/day
Autonomic phenomena	Moderate	Moderate	Extensive	–	–

F, Female; M, Male, SUNCT, short-lasting neuralgiform headache attacks with conjunctival injection and tearing

usually last less than a second and can occur several times a day sometimes in clusters throughout the year. ▶ **Ice-pick headaches** usually occur in people who also have migraine, cluster or other trigeminal autonomic cephalalgias. If frequent, indomethacin can be used as preventive treatment.

### Occipital Neuralgia

This is a continuous dull aching, sometimes throbbing pain often superimposed by sharp stabbing pain in the distribution of the unilateral, sometimes bilateral greater occipital nerve. Occipital pain, which may radiate to the vertex, can often be reproduced by applying pressure over the occipital nerve. Causative factors may be trauma, compression or entrapment of the nerve or possibly excessive contraction or hypertonus of the cervical musculature. Definitive treatment is with local nerve blocks of the greater occipital nerve.

### Pseudotumor Cerebri (Idiopathic Intracranial Hypertension)

Idiopathic increased intracranial hypertension (ICH) is the most common presentation of ICH. More common in women than in men, it often occurs in young women in their 20's and is often associated with obesity. It may or may not be associated with papilledema on fundoscopic examination, but typically CSF examination to measure opening pressure is high (>200–250 mmH<sub>2</sub>O). This is a chronic headache with a quality similar to tension-type headache and may be unilateral, bilateral, occipital or frontal. It may be worse in the morning and there may be transient visual obscurations, tinnitus, diplopia or nausea. Hypotheses on the pathophysiology of ICH include increased CSF formation, decreased CSF absorption and increased venous pressure. Definitive treatment is usually weight loss, though lumboperitoneal or ventriculoperitoneal shunt placement or optic nerve fenestration may be used to prevent the visual loss or blindness that may be the outcome of untreated ICH.

### Trigeminal Autonomic Cephalalgias (TACs)

These are short-lasting headaches with unifying features of pain in the trigeminal nerve distribution (usually V1) and autonomic involvement of the cranial parasympathetic nervous system (for example, lacrimation, conjunctival injection, nasal congestion, rhinorrhea). The TACs include cluster, paroxysmal hemicrania, hemicrania continua and short-lasting unilateral neuralgiform headache with conjunctival injection (SUNCT). The hemicranias are indomethacin-responsive headaches, whereas cluster and SUNCT are not ([10]; Table 1).

### Trigeminal Neuralgia (Tic Douloureux)

Idiopathic trigeminal neuralgia (TN) typically presents in older patients with a slight preponderance in women. Secondary TN may be related to structural causes such as multiple sclerosis, aneurysm or arterial compression. TN is thought to be caused by irritation of the trigeminal nerve and presents as a lancinating, knife-like stabbing or electrical shock-like pain in the distribution of the trigeminal nerve. It is most commonly unilateral with episodes lasting seconds to 2 min several times a day. It can be provoked by chewing, talking, brushing the teeth or a breeze touching the face. An MRI of the base of the brain should be performed initially to rule out structural or compressive causes. ▶ **Tic douloureux** may be treated with antiepileptic drugs such as carbamazepine, baclofen or ablative procedures.

## References

1. Headache Classification Subcommittee of the International Headache Society (2004) The international classification of headache disorders, 2nd edn. Cephalgia 24 Suppl 1:9–160
2. Lipton RB, Stewart WF, Diamond S et al. (2001) Prevalence and burden of migraine in the United States: data from the American Migraine Study II. Headache 41:646–657

3. Rasmussen BK, Jensen R, Schroll M, Olesen J (1991) Epidemiology of headache in a general population—a prevalence study. *J Clin Epidemiol* 44:1147–1157
4. Dodick DW, Rozen TD, Goadsby PJ, Silberstein SD (2000) Cluster headache. *Cephalgia* 20:787–803
5. Silberstein SD (2000) Practice parameter: evidence-based guidelines for migraine headache. *Neurology* 55:754–762
6. Goadsby PJ, Lipton RB, Ferrari MD (2002) Migraine: current understanding and treatment. *N Engl J Med* 346:257–270
7. Silberstein SD, Lipton RB, Goadsby PJ (1998) The pathophysiology of primary headache. In: Silberstein SD, Goadsby PJ (eds) *Headache in clinical practice*. Isis Medical Media, Oxford, UK, pp 41–58
8. Lucas SM (2002) Initial abortive treatments for migraine headache. *Curr Treat Options Neurol* 4:343–350
9. Silberstein SD, Lipton RB (2001) Chronic daily headache, including transformed migraine, chronic tension-type headache and medication overuse. In: Silberstein SD, Lipton RB, Dalessio DJ (eds) *Wolff's headache and other head pain*. Oxford University Press, New York, pp 247–282
10. Goadsby PJ, Lipton RB (1997) A review of paroxysmal hemicranias, SUNCT syndrome and other short-lasting headaches with autonomic features including new cases. *Brain* 120:193–209

gravitational force from the head to the leg (+Gz). Puffy face occurs in this condition.

#### ► Autonomic Function in Space

## Hearing Aids

PAMELA SOUZA

Department of Speech and Hearing Sciences,  
University of Washington, Seattle, WA, USA

### Synonyms

Hearing instrument; Amplification

### Definition

A hearing aid is an electronic device worn in the ear to amplify sound. Within the hearing aid, a microphone converts acoustic energy to electrical energy. The signal is amplified, and a receiver converts the electrical signal back to acoustic energy. Power is provided by a small battery. Digital hearing aids combine electronic components with a computer chip. In a digital aid, the input electrical signal is sampled. Amplification and associated sound processing are then accomplished by manipulating the digital code before reconvertng to acoustic energy.

### Characteristics

#### Frequency Response

Amplification is applied differentially across ► **frequency**. This can be thought of as a mirror of the patient's ► **audiogram**, whereby frequencies where the listener has greater amounts of hearing loss are compensated for with greater amplification. Various aspects of the hearing aid response can be quantified, including the aided ► **output** and aided ► **gain**. A typical hearing aid response provides increasing gain at high frequencies with a peak at 3000 Hz to mimic the natural ► **resonance** of the open ear. Hearing aid gain is often expressed as gain measured at the maximum volume control position, with peak gain ranging from about 30 dB for an aid suitable for mild hearing loss to as much as 80 dB for power hearing aids. In practice, most listeners wear the aid at a lower volume setting, and will receive 5 to 15 dB less than maximum gain. The specific gain at each frequency is determined by applying one of several available target calculations to the listener's audiogram. The various calculations are designed to optimize speech intelligibility [1], audibility [2] or to normalize loudness [3].

## Heading (in Optic Flow)

### Definition

The direction of movement of an observer.

#### ► Optic Flow

## Headtilt

#### ► Vestibular Tests Ocular Tilt Reaction

## Headward Fluid Shift

### Definition

A condition of fluid shift in the human body from the lower parts of the body toward the head by a lack of

As **▶sensorineural hearing loss** introduces **▶recruitment** in addition to threshold elevation, the compensatory gain at each frequency is less than the amount of hearing loss at that frequency. An example is shown in (Fig. 1).

### Maximum Output

All hearing aids have a physical output limit based on the capacity of the receiver and battery. The maximum output is specified as the output level with an input of 90 dB SPL measured in a 2cc coupler. Maximum output can be as high as 130–140 dB SPL in some power hearing aids. Most hearing aids also incorporate an adjustable maximum output value set by the hearing aid fitter. The reduced limit maintains sound at levels below the listener’s discomfort level and prevents additional hearing damage from unintended high sound levels. Output limiting is accomplished either by peak clipping or by compression limiting; a technique whereby reduced gain is applied to input levels that would otherwise exceed the desired

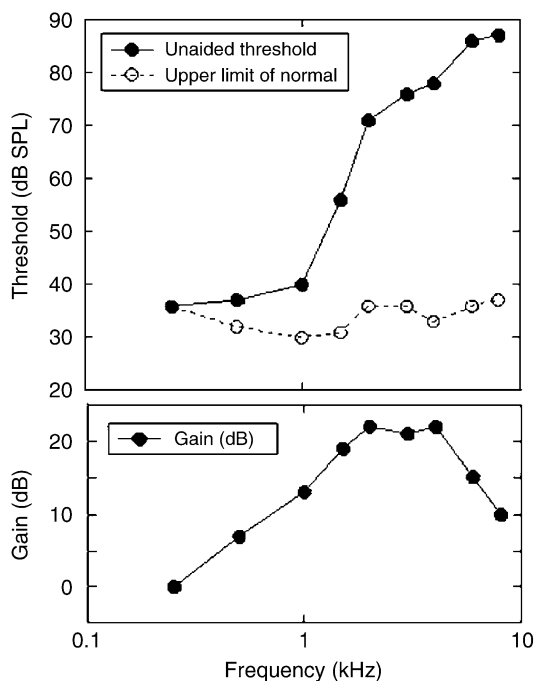

**Hearing Aids. Figure 1** Illustration of hearing aid gain. In the top panel, filled circles show a representative hearing loss, expressed as the dB SPL level that is just audible to the listener at each frequency. Normal hearing (open circles) is shown for comparison. The bottom panel shows the amount of gain required to compensate for threshold elevation. Note that the amount of gain at each frequency is not equal to the threshold elevation. For example, hearing threshold at 2 kHz is about 35 dB above the maximum criterion for normal sensitivity, but the prescribed gain is only 22 dB.

maximum output. Of the two methods, peak clipping results in significantly greater signal distortion.

### Lower Level Components

#### Case

The size and shape of the hearing aid depend on a number of factors, including the listener’s ear canal, age, communication needs, dexterity, and cosmetic preferences. In behind-the-ear aids, the electronic components are contained in a small plastic case that fits behind the outer ear and is coupled by means of plastic tubing to a custom-fit acrylic or silicone **▶ earmold**. With in-the-ear aids, all components are contained within a hard plastic shell that fits within the **▶ concha**. In-the-ear aids vary in size. The smallest hearing aids, completely-in-the-canal aids, are inserted deeply within the ear canal and are usually not visible to a casual observer. Fig. 2 shows some different styles of hearing aids. Each style has advantages and disadvantages.

The larger styles are more powerful and can offer more options, such as user controls. The smaller styles may be more convenient or cosmetically appealing for some users. Behind-the-ear aids are most appropriate for children, because the earmold can be changed frequently to accommodate their growing ears. Behind-the-ear aids with “open” earmolds reduce occlusion and improve sound quality and physical comfort, but are suitable only when the wearer has good low-frequency hearing. Disposable hearing aids contain an integrated battery and are designed for one-time use. However, disposable hearing aids fit only a limited range of hearing losses and ear canal sizes. Finally, a small percentage of individuals with **▶conductive hearing loss** may use bone conduction hearing aids, in which sound vibration is transmitted mechanically to the **▶ cochlea** via a small titanium screw surgically implanted in the **▶temporal** bone, or by a vibrating case held to the mastoid with a spring tension metal headband.

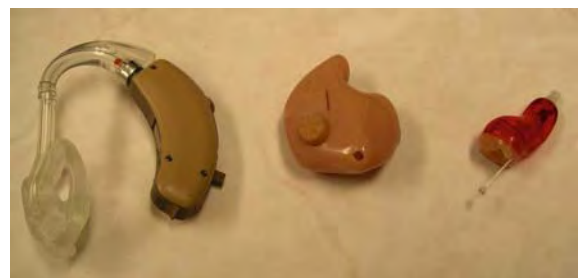

**Hearing Aids. Figure 2** Examples of different styles of hearing aids. From *left to right*: behind-the-ear hearing aid with earmold; in-the-ear aid, and; completely-in-the-canal aid.

### Venting

A ►vent that transverses the medial to distal portion of the aid or earmold may be used to allow airflow into the ear and prevent pressure discomfort. The vent also has an acoustic effect by allowing low frequency sounds to leak out of the ear, thus amplifying the high frequency sounds to a greater extent. The larger the vent, the more reduced the low-frequency amplification.

### User Controls

External volume adjustments may include a volume wheel, push button or remote control that allows the wearer to control volume level. The range of hearing aid gain available via the volume control is preset by the hearing aid fitter. Multimemory hearing aids either select automatically or allow the user to select among preset acoustic programs for different listening situations, using a button on the hearing aid or a remote control. These might include programs for listening to speech in quiet, speech in noise, telephone, or music, or programs that emphasize intelligibility or loudness comfort. The programs may vary in frequency response, volume adjustment, or microphone characteristics. For example, speech recognition is optimized with a rising frequency response that emphasizes high-frequency consonants, whereas a flatter frequency response that maintains the treble-bass relationship is more appropriate for music listening.

### Telecoil

With many hearing aids, placing an object such as a telephone receiver close to the microphone causes acoustic feedback. Changes in receiver position or connecting the receiver to a plastic or foam coupler may reduce the chance of feedback. Some digital hearing aids can numerically “cancel” the feedback by adding a signal of opposing phase or eliminate it by attenuating a narrow frequency region surrounding the feedback. Some hearing aids can be switched manually or automatically to an induction loop input that picks up electromagnetic energy from the telephone receiver. However, digital cellular phones emit distortion that may impair their use with telecoils. The extent of the problem depends on the amount of energy emitted by the cellular phone and how resistant a particular hearing aid is to that interference. In the United States, the Federal Communications Commission has implemented regulations that should improve this situation in a few years. In addition to telephone use, a telecoil can also be used to wear the hearing aid in combination with personal or group assistive listening systems.

### Function

Modern hearing aids do more than just amplify sound. Increasingly, they use sophisticated sound processing to manipulate various aspects of speech and noise signals.

### Linear and Nonlinear Gain

Linear hearing aids apply a constant gain, regardless of the input level. This is problematic because the high gain required to make low-intensity sounds audible may increase the level of high-intensity sounds to the point of discomfort. If the gain is reduced to make high-intensity sound comfortable, low-intensity sounds may be inaudible. Newer hearing aids use nonlinear gain called wide-►dynamic range compression. With this processing, the level of the input signal is continually monitored, and low-intensity sounds are automatically amplified more than high-intensity sounds. The goal is that all sounds received by the listener will be heard at comfortable levels. This scheme is also intended to compensate for the loss of the nonlinear cochlear amplifier provided by the outer hair cells in normal-hearing individuals. The speed with which gain is adjusted as the input level changes may range from a few ms to several seconds. In multichannel hearing aids, the gain adjustment is made separately in each of several overlapping frequency bands. Multichannel hearing aids can more easily accommodate differences in dynamic range across frequency.

### Noise Reduction

Difficulty hearing in background noise is the most common complaint of listeners with hearing loss. Hearing aids deal with this problem in several ways:

Digital noise reduction algorithms analyze the ►spectral and/or temporal pattern of the sound within each frequency band to determine whether the incoming signal is speech or noise. Sound categorized as noise is either attenuated or digitally cancelled by summing with an opposite phase signal. These systems are most effective when the noise is very different from the speech; for example, ventilation or road noise, which have little level variation. Digital noise reduction is less effective when the “noise” is another speaker, due to difficulty differentiating between similar varying signals.

Directional microphones can be used to reduce the level of extraneous sound sources. In an omnidirectional hearing aid, all sounds are amplified without respect to the direction of the sound source. Directional microphones amplify sounds from some directions more than others. The directional microphone can be comprised of a single directional microphone or a pair of electronically linked omnidirectional microphones. As the listener will usually turn to face the speaker, a common arrangement is a directional microphone by which sound from the front of the listener is amplified to a greater extent than sounds to the rear. More sophisticated directional microphones use adaptive processing in which directionality is combined with digital sampling. They attempt to determine whether sounds from various directions are speech or noise and orient the maximum amplification in the direction of the speech. Other

directions are attenuated to reduce surrounding background noise. Automatic hearing aids self-select between omnidirectional and directional responses. As directional microphones require a minimum distance between microphone ports, this feature is not available on smaller hearing aids, such as completely-in-the-canal aids.

### Therapy

Obtaining a hearing aid usually involves several visits. First, hearing is measured to evaluate whether the individual is a candidate for hearing aids. Generally, there is an inverse relationship between hearing sensitivity and the potential for significant hearing aid benefit, such that listeners with more hearing loss notice a greater improvement with the hearing aid. Exceptions include listeners with profound hearing loss, who have little ►residual hearing or for whom broadened ►auditory tuning restricts the ability to recognize amplified speech [4]; these individuals may be candidates for cochlear implants. If amplification is warranted, the listener's communication needs and preferences are determined. The listener's dynamic range may also be measured. A silicone impression is taken of the listener's ear(s). ►Binaural amplification is preferable when both ears are impaired, unless one ear cannot be fitted due to the type of pathology. Binaural aids improve speech recognition and localization over ►monaural amplification.

The timing of obtaining a hearing aid is also important. Young children, in particular, need early auditory input to facilitate development of auditory nerve fibers [5]. Adults with acquired hearing loss who have bilateral hearing loss but are fitted with only one hearing aid may also experience a loss of auditory function over a period of years. This phenomenon has been termed late onset auditory deprivation, and probably has more to do with the dominant contribution of the aided ear than with true deprivation of the unaided ear [6,7].

At the second visit, the hearing aid controls are adjusted. Most hearing aids are programmed using a standard hardware interface in combination with a software framework that is common across all hearing aid manufacturers. Each manufacturer provides programming cables and software modules for their products. The ►potentiometer controls on analog aids are adjusted with a small screwdriver. The hearing aid response is then measured to ensure that it will compensate adequately for the amount of hearing loss. This can be done in situ using a probe microphone, which is a small microphone coupled to a plastic tube. Alternatively, the hearing aid response can be measured in a 2cc coupler to mimic the ear canal volume medial to the tip of the hearing aid. A correction factor is then applied to the coupler values to obtain the

predicted in-ear response [8]. The coupler technique is often preferred when testing children because it requires less cooperation from the patient. At this visit, the listener also receives instruction in care, cleaning and effective use of the hearing aid. Like any electronic device, hearing aids are susceptible to moisture, heat, or impact and care should be taken to avoid these factors. Often a third visit is scheduled after a trial period to evaluate hearing aid performance and make any necessary adjustments. A series of standardized questionnaires are available to assess wearer satisfaction and benefit after the trial period.

### References

1. Dillon H (1999) NAL-NL1: A new prescriptive fitting procedure for non-linear hearing aids. *Hear J* 52(4):10–16
2. Cornelisse L, Seewald R, Jamieson D (1995) The input/output formula: A theoretical approach to the fitting of personal amplification devices. *J Acoust Soc Am* 97(3):1854–1864
3. Cox R (1995) Using loudness data for hearing aid selection: The IHAFF approach. *Hear J* 48(2):10, 39–44
4. Van Tasell DJ (1993) Hearing loss, speech and hearing aids. *J Speech Hear Res* 36(2):228–244
5. Gordon KA, Papsin BC, Harrison RV (2003) Activity-dependent developmental plasticity of the auditory brain stem in children who use cochlear implants. *Ear Hear* 24(6):485–500
6. Silman S, Gelfand S, Silverman C (1984) Late-onset auditory deprivation: Effects of monaural versus binaural hearing aids. *J Acoust Soc Am* 76(5):1357–1362
7. Gelfand S, Silman S, Ross L (1987) Long-term effects of monaural, binaural and no amplification in subjects with bilateral hearing loss. *Scand Audiol* 16(4):201–207
8. Munro KJ, Hatton N (2000) Customized acoustic transform functions and their accuracy at predicting real-ear hearing aid performance. *Ear Hear* 21(1):59–69

---

## Hearing in Birds

### ►Avian Auditory System

---

## Hearing Instrument

### ►Hearing Aids

## Hearing Loss (HL)

### Definition

The decibel level expressed relative to standardized audiometric threshold levels.

► Acoustics

## Heart Rate

### Definition

Heart rate is the number of contractions of the ventricles per unit of time, and is usually expressed as beats per minute. In clinical practice, the normal range of the resting heart rate in adults is regarded as between 60 and 100 beats per minute as measured by palpation of the pulse. However, the heart rate varies widely depending upon factors such as level of activity and psychological state. Additionally, even under constant conditions, the heart rate normally oscillates in concert with the respiratory rhythm.

## Heat Flux Vector

### Definition

The flux vector associated with the input or output of non-mechanical energy through the boundary.

► Mechanics

## Heaviside Function

### Definition

A function, which has a value of zero until a known time instant (usually zero) and a value of one from that point onward. Also known as a step function.

► Signals and Systems

## Heavy Exertion

► Stress Effects During Intense Training on Cellular Immunity, Hormones and Respiratory Infections

## Hebbian Learning

### Definition

A type of unsupervised learning algorithm stipulating that concurrent firing of pre- and post-synaptic neurons strengthens the synaptic connections between them.

► Neural Networks

## Hebbian Rule

### Definition

A rule proposed by Hebb that long-lasting enhancement of synaptic transmission, such as LTP, is induced only when both presynaptic and postsynaptic elements are activated. This requirement for synaptic potentiation is referred to as a Hebbian rule. The induction of LTP in the CA1 region of the hippocampus requires simultaneous high-frequency activation of the presynaptic terminal and depolarization of the postsynaptic pyramidal cell.

► Associative Long-Term Potentiation (LTP)  
 ► Long-Term Potentiation (LTP)  
 ► Memory, Molecular Mechanisms

## Hebephrenia

### Definition

Juvenile subtype of schizophrenia that usually begins during puberty. Prominent symptom is affective flattening. Hallucinations and delusions are less prevalent.

► Schizophrenia

## Hedonic Psychophysics

### Definition

Evaluation of both the magnitude of sensations and the unpleasantness or pleasantness of the feeling states that accompanies the sensations. Not all sensations are associated with such feeling states. The sensations associated with feeling states are usually involved in the regulation of bodily processes (homeostasis) such as temperature, hunger, thirst, and blood pH (urge to breathe).

## Helical Axis Decomposition

### Definition

Method for describing three-dimensional rotations and translations as a single rotation about an axis along with translation along that axis.

► Motion Analysis

## Helix-loop-helix Gene

### Definition

Helix-loop-helix (HLH) genes encode transcription factors important for cell fate determination. Many HLH genes include a basic domain (bHLH) important for DNA binding. bHLH transcription factors bind to CANNTG consensus binding sequences known as Eboxes.

NeuroD, neurogenin and MASH1 are wellknown members of the bHLH subclass. bHLH genes usually form heterodimers.

► Chromatin Immunoprecipitation and the Study of Gene Regulation in the Nervous System

## Hemagglutination

### Definition

Hemagglutination is a clumping of red blood cells usually present as 1% suspension which contain a red

blood cell attachment protein (hemagglutinin) on their surface. A large number of viruses hemagglutinate a wide variety of red blood cells each virus favoring certain cells from certain animals. Used as a quick, quantitative assay for certain viruses.

## Hemianopsias

### Definition

Losses of vision in halves of the visual field. Bitemporal hemianopsias result from selective lesions of the ► optic chiasm in which fibers from the nasal halves of the ► retina (representing the temporal halves of the visual field) cross to the contralateral side. Complete homonymous hemianopsias result from total destruction of one ► optic tract, such that, e.g., destruction of the right tract results in a left hemianopsia because fibers from the left nasal and right temporal halves of the retinas are destroyed. Incomplete homonymous hemianopsias result from partial lesions of the ► optic radiation or ► primary visual cortex.

- Optic Tract
- Primary Visual Cortex
- Retina
- Visual Field

## Hemiballism

### Definition

Ballismus is large amplitude and violent chorea. It is rare and usually occurs as hemiballismus after a lacunar infarct in the contralateral subthalamic nucleus. Hemiballismus tends to slow down into chorea over time and its treatment is similar to that of chorea. Hemiballismus can also occur iatrogenically after contralateral subthalamotomy or subthalamic nucleus deep brain stimulation surgery as part of the treatment for Parkinson disease.

- Chorea
- Parkinson Disease
- Subthalamic Nucleus (STN)



## Hemichorea

### Definition

►Chorea on one body side.

## Hemilabyrinthectomy

### Definition

Global extirpation of the labyrinth of one side, resulting in distinctive lesion symptoms.

## Hemiparesis

### Definition

►Paresis on one body side.

## Hemiplegia

### Definition

Paralysis (loss of muscle strength) in limbs and sometimes face on one body side, usually resulting from lesions to descending motor tracts, such that the site of lesion determines the distribution of paralysis.

## Hemisensory Defect

### Definition

Defect of sensory sensation on one side of the body.

## Hemispatial Neglect

### Definition

In its full-fledged form, hemispatial neglect typically results from damage of the right inferior ►parietal lobule (IPL; ►Brodmann areas 39 and 40). Patients deviate their head and eyes to the side of the lesion and frequently neglect objects in contralateral visual space, but occasionally the body half as well ('personal neglect'), entailing a lack of spontaneous movements of that half ('motor neglect'). Occasionally, neglect concerns only objects in far space ('extrapersonal neglect') or near objects ('peripersonal neglect'). However, neglect may also result from damage of the ►frontal eye field (FEF), inferior ►area 6, polysensory area of the ►superior temporal sulcus, ►cingulate gyrus and other, even sub-cortical structures. The symptoms, whose expression and combination depend on the precise extent of the damage, include attentional deficits, visual mislocalization and disorientation, topographical and spatial-memory deficits, ►constructional apraxia, and - possibly - alterations of temporal motor programming. Elementary visual and somatosensory functions may be preserved, but if compromised as well, the hemineglect may be so severe that patients do not recognize the opposite body side as their own. In less severe, more restricted cases, patients will not attend to objects in the opposite field of view, e.g. not draw opposite sides of objects.

►Frontal Eye Fields

►Visual Neuropsychology

## Hemispheric Asymmetry of Memory

LARS NYBERG<sup>1</sup>, REZA HABIB<sup>2,3</sup>

<sup>1</sup>Departments of Radiation Sciences (Radiology) and Integrative Medical Biology (Physiology), Umeå University, Umeå, Sweden

<sup>2</sup>Department of Psychology, Department of Computer Science, and School of Medicine, Southern Illinois University Carbondale, Carbondale, IL, USA

<sup>3</sup>Memorial Hospital of Carbondale, Southern Illinois Health Care, Carbondale, IL, USA

### Definition

Brain regions in the left and right cerebral hemispheres do not contribute equally to mental functions [1]. Here

we will be concerned with asymmetries of declarative long-term memory processes, in particular ►**episodic memory** processes [2]. Memory is a relatively recent addition to the list of functions that appear to differentially depend on right or left hemisphere regions. With the advent of ►**functional neuroimaging** techniques, it has become possible to separately examine how the brain is activated when new information is encoded into memory and how it is activated when that information is subsequently retrieved. Based on the results of early functional neuroimaging studies, episodic encoding and retrieval were found to be asymmetrically mediated by regions within the left and right frontal cortices [3]. This laid the foundation for the HERA (hemispheric encoding/retrieval asymmetry) model [4], which postulates that regions in the left prefrontal cortex are more active than right prefrontal regions during episodic memory encoding whereas regions in the right prefrontal cortex are more active than left prefrontal regions during retrieval from episodic memory.

It should be stressed that the model does not claim that right prefrontal regions are of no relevance

to encoding, and vice versa for the left prefrontal cortex and retrieval. Such a claim would clearly be inconsistent with the available evidence. Instead, the HERA model states that certain left prefrontal regions are differentially more engaged during encoding than retrieval compared to what is true for the homologous region in the right hemisphere. Conversely, relative to specific left prefrontal regions, certain right prefrontal regions are more activated during retrieval than encoding (Fig. 1).

Thus, the HERA model is concerned with the modulation of brain activity in select left and right prefrontal cortical regions by processing demands. This was made explicit in a recent definition of the HERA model [5]:

1. (Enc in left PFC – Ret in left PFC) > (Enc in right PFC – Ret in right PFC)
2. (Ret in right PFC – Enc in right PFC) > (Ret in left PFC – Enc in left PFC)

where Enc refers to encoding-related regional activity, Ret to retrieval-related regional activity, and PFC to the prefrontal cortex. Thus, according to this definition,

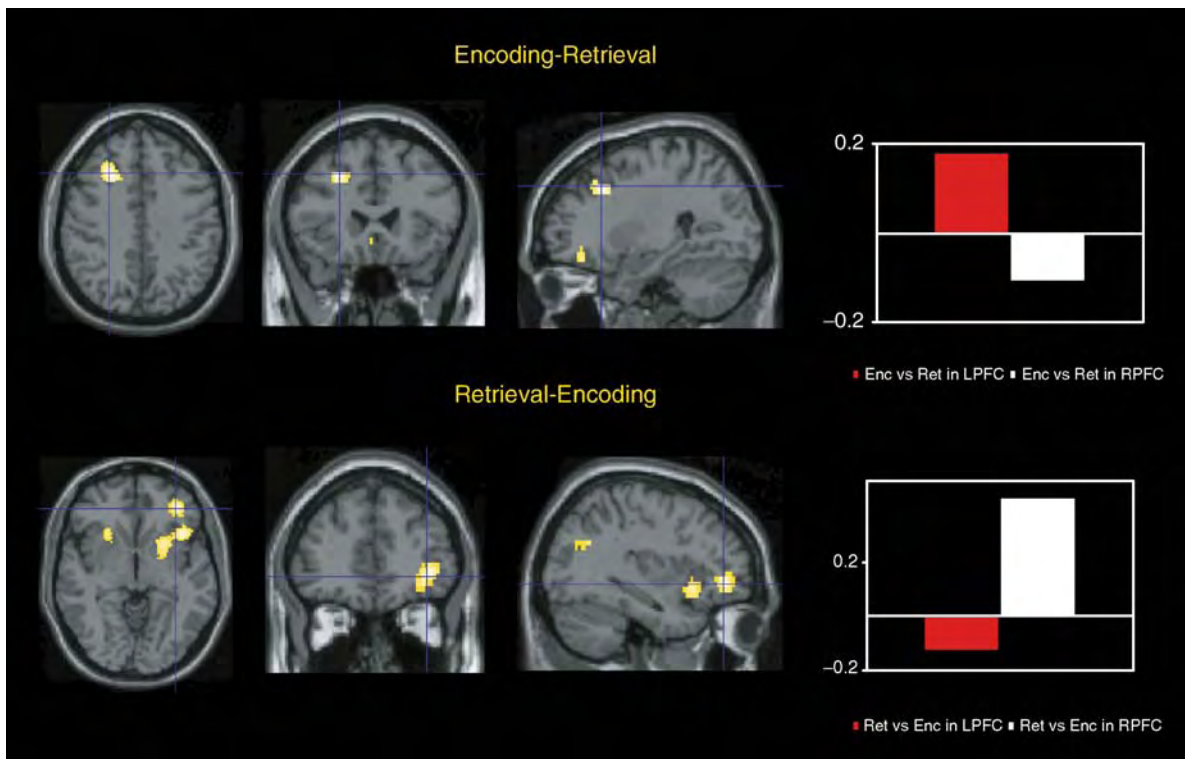

**Hemispheric Asymmetry of Memory. Figure 1** *Top*: Three different views of activity in the left prefrontal cortex during episodic memory encoding. The graph indicates that the difference between encoding and retrieval (Encoding – Retrieval) is greater in the left than in the right prefrontal cortex. *Bottom*: Three different views of activity in the right prefrontal cortex during episodic memory retrieval. The graph indicates that the difference between retrieval and encoding (Retrieval – Encoding) is greater in the right than in the left prefrontal cortex.

tests of the HERA model require that both encoding-related and retrieval-related brain activity be monitored in the left and right prefrontal cortex, with other variables held constant (e.g., mnemonic information such as verbal vs. pictorial). Although it is generally agreed that claims of asymmetric hemispheric contributions require such direct process-comparisons, to date, very few studies have adhered to this definition in tests of the HERA model.

## Characteristics

### Functional Basis for the Asymmetry

It has been proposed that the left and right hemispheres differ in terms of mnemonic functions [1]. The left hemisphere, since long associated with language processes, seems to be more specialized for semantic (elaborative) processes, whereas the right hemisphere maintains a veridical record of past events and is able in a recognition test to correctly classify presented test items as belonging to a previous study list. This view of hemispheric specialization can be related to assigned functional roles of the left and right prefrontal cortex during episodic encoding and retrieval, respectively.

Increased left prefrontal activity during episodic encoding has been related to elaborative, semantic processes. This may, for example, involve reflecting upon the meaning of presented information, relating it to what one already knows about a certain topic, or other higher-order meaning-based processes. It has been shown that instruction to focus on deeper, semantic aspects of verbal information during encoding is associated with increased left prefrontal cortex activity and higher subsequent retrieval [2]. This association between left prefrontal activity during encoding and elaborate semantic processes is in good agreement with the suggestion that the left hemisphere is specialized for interpreting events [1].

Right prefrontal activity during episodic retrieval has been linked to a specific neurocognitive set, termed episodic retrieval mode (►REMO [2]). This mental state is a necessary pre-condition for episodic retrieval. It can be triggered by a question (e.g., *What did you do last night?*) or an instruction (*Try to think back to the list I presented previously and say if these words were part of that list!*). These triggers have the effect that the person, for a limited period of time, enters REMO and thereby treats information (e.g., words in a word list) as clues for remembering past events (the previous presentation of these words). If a person is not in REMO, words or other similar clues have little chances of evoking past memories (unless very strongly associated with a past event). Thus, retrieval of episodic information seems to require processes mediated by right frontal regions, which is consistent with the theory that the right hemisphere can be linked to veridical retrieval of past events [1].

### Why did the Asymmetry Emerge?

The current thinking on the functional basis for asymmetry in memory, as described above, makes quite good sense, but it is far from settled. Even more unclear is the answer to the question of why the asymmetry emerged. Naturally, this is a general issue that goes beyond asymmetry in memory per se. One of several possibilities is that the asymmetry is a response to a competition for cortical space [1]. As more and more mental capacities were developed during the course of evolution, what was initially a bilateral function was successively turned into a lateralized function.

The cortical space hypothesis does not imply that the “dormant” region in the non-active hemisphere no longer has the capacity to perform the relevant computations – it simply states that it is possible to unilaterally perform the task with the more specialized hemisphere. By this view, a task that typically has an asymmetric functional basis can under certain circumstances start to recruit the normally less-active hemisphere. Support for this type of reorganization comes from findings of recruitment of *right* frontal cortex regions during performance of a semantic task by a patient with a left-sided frontal lesion [6], and findings of a bilateral activation pattern during the performance of normally asymmetric tasks after brain damage.

### Reduced Asymmetry in Memory

Asymmetry in memory may, thus, be conceived of as a sign of efficient processing in cognitive and neural terms. It is well established that several diseases and conditions are associated with impaired cognitive processing. Does this mean that the asymmetry in memory may be reduced or even eliminated in certain subject populations? The answer appears to be affirmative. One striking example of reduced asymmetry in memory comes from normal aging. Many elderly, even though not suffering from dementia or similar pathological conditions, show a reduction in cognitive performance [7]. Interestingly, functional imaging studies that have compared brain activity for younger and older adults indicate that elderly tend to display a more bilateral activation pattern whereas younger adults show a more asymmetric activation pattern [8]. This age-related reduction in asymmetry is captured by the ►HAROLD model [8].

The reductions in both cognitive performance and asymmetric activation patterns may be linked such that a more bilateral activation pattern can be seen as a compensatory response. There is some support for this notion. One example comes from a study that compared elderly with a declining or a stable level of memory performance over time [9]. These elderly were selected from a large database that comprises elderly that show the typical age-related decline in cognitive performance, as well as elderly that maintain a very high

level of cognitive performance in old age [7]. Of main interest was to see whether elderly with a declining level of cognitive performance would show a reduction in asymmetry. Such a result would link asymmetry reduction to a need for compensation. The groups of declining and stable elderly were studied with functional brain imaging while they performed a test of incidental episodic encoding. As expected, both groups were found to activate left prefrontal cortex. However, in addition, the declining group activated the corresponding right prefrontal region. This provided support for the hypothesis that reduced asymmetry in memory can be linked to a need for functional compensation. Further support for this hypothesis was provided from ►**structural imaging**, showing that the declining group had reductions of grey and white matter in select brain regions.

### Symmetry as well as Asymmetry in Memory

The focus of this essay has been on processes that operate during encoding or retrieval and tend to activate distinct and asymmetric brain regions. However, there are also several regions, in the left and right hemisphere, that are commonly activated during encoding and retrieval [10]. In other words, there are sites in the brain where “encoding meets retrieval.” This point should be stressed to avoid erroneous simplifications of the sort “encoding is located in the left hemisphere.”

### Other Asymmetries of Memory

While the focus of this essay has been on asymmetries between encoding and retrieval, the most studied and best known asymmetry of memory is between memory for verbal and non-verbal information. Neuropsychological studies of patients with lateral or medial temporal lobe damage has associated left-sided damage with disruptions of verbal memories (e.g., word-pair recall, story recall, verbal recognition), whereas right-sided damage has been associated with disruption of non-verbal memories (e.g., corsi blocks, face recognition, maze-learning). This kind of asymmetry has been observed in healthy adults using functional neuroimaging approaches, and functional neuroimaging has revealed an asymmetry between verbal and non-verbal memories in the frontal lobes, in regions close to those hypothesized by the HERA model to be differentially involved in encoding and retrieval (see [5]). Thus, it seems quite possible that there exists both material-based (e.g., verbal vs. non-verbal) and process-based (e.g., encoding vs. retrieval) asymmetries in the brain [5].

### Summary and Conclusion

Functional neuroimaging studies of declarative memory processes have provided strong support that certain encoding and retrieval processes engage different brain regions, notably in the prefrontal cortex. At least in part,

this difference in brain activity can be accounted for in terms of hemispheric asymmetry, such that encoding more strongly engages left frontal regions and retrieval right frontal regions. The association of encoding and elaborative processes with the left hemisphere is consistent with a role for this hemisphere in interpreting and structuring information, and the association of retrieval and retrieval mode with the right hemisphere is consistent with the idea that this hemisphere is specialized for veridical processing which would benefit, for example, episodic recognition memory [1].

### References

1. Gazzaniga MS (2000) Cerebral specialization and interhemispheric communication: does the corpus callosum enable the human condition? *Brain* 123:1293–1326
2. Tulving E (2002) Episodic memory: from mind to brain. *Annu Rev Psychol* 53:1–25
3. Tulving E et al. (1994) Hemispheric encoding/retrieval asymmetry in episodic memory: positron emission tomography findings. *Proc Natl Acad Sci USA* 91:2016–2020
4. Nyberg L, Cabeza R, Tulving E (1996) PET studies of encoding and retrieval: the HERA model. *Psychon Bull Rev* 3:135–148
5. Habib R, Nyberg L, Tulving E (2003) Hemispheric asymmetries of memory: the HERA model revisited. *Trends Cogn Sci* 7:241–245
6. Buckner RL et al. (1996) Preserved speech abilities and compensation following prefrontal damage. *Proc Natl Acad Sci USA* 93:1249–1253
7. Habib R, Nyberg L, Nilsson LG (2007) Cognitive and non-cognitive factors contributing to the longitudinal identification of successful older adults in the Betula study. *Aging Neuropsychol Cogn* 14(3):257–273
8. Cabeza R (2002) Hemispheric asymmetry reduction in older age: the HAROLD model. *Psychol Aging* 17:85–100
9. Persson J et al. (2006) Structure-function correlates of cognitive decline in aging. *Cereb Cortex* 16:907–915
10. Nyberg L (2002) Where encoding and retrieval meet in the brain. In: Squire LR, Schacter DL (eds) *Neuropsychology of memory*. Guilford, New York, pp 193–203

---

## Hepatocerebral Degeneration

### Definition

Hepatocerebral degeneration and the neurological syndrome it causes may occur in any case of acquired liver failure including alcoholic hepatitis, autoimmune hepatitis, viral hepatitis, and others. Since the ►**basal ganglia** are involved in the regulation of movement, people affected by this disorder may develop ►**tremors**,

twitching, involuntary movements and other neurologic symptoms.

► Basal Ganglia

## Heptahelical Receptors

► G-protein Coupled Receptors (GPCRs): Key Players in the Detection of Sensory and Cell-Cell Communication Messages

## Herbal Neuroprotectives

► Central Nervous System Disease – Natural Neuroprotective Agents as Therapeutics

## Herbicide

► Neuroinflammation: Modulating Pesticide-Induced Neurodegeneration

## Hereditary Neurological Disorders

► Neurogenetic Diseases

## Hering–Breuer Reflex

IKUO HOMMA  
Department of Physiology, Showa University School of Medicine, Tokyo, Japan

### Synonyms

Inspiratory inhibitory reflex

### Definition

Inspiration is inhibited by the vagal afferent.

### Characteristics

Research in the field of respiratory physiology has been carried out for several centuries. Numerous findings and terms have been designated as the name of the finder. One such named term, “Hering–Breuer reflex,” has been a steadfast term in the respiration control system. In 1868, two striking papers, written by Ewald Hering and Joseph Breuer, were introduced to the world. Although today the idea and the work do not seem surprising in our modern world, these works were extraordinary at that time in the mid-nineteenth century.

Ewald Hering (1834–1918) studied medicine at Leipzig University, Germany, and he worked in the basic research field. He was immensely interested in visual physiology and continued to study the subject throughout his life for his life work. In 1865, he became a professor at the University of Vienna. Joseph Breuer (1842–1925) studied medicine at the University of Vienna and worked as a clinician. During his clinical practice, he had the idea that breathing was accomplished under a self-regulatory mechanism. His clinical professor introduced him to E. Hering who had just joined the University of Vienna as a research professor. Interestingly, as the research work on breathing had been carried out by J. Breuer, many refer to their findings as the “Breuer–Hering reflex” rather than the “Hering–Breuer reflex.” E. Hering moved to a position in the Physiology Department of Prague University in 1869, and there he promoted the work of the respiratory control system. He encouraged his student, Henry Head (1861–1940), to investigate the neural control of breathing. Head’s paper (1889) prompted widespread interest in the Hering–Breuer reflex, and he proposed a term, “Head’s paradoxical reflex.” It may be said that the widespread recognition of the Hering–Breuer reflex is the result of the work by Head.

The living body is a conglomeration of many substances; it is differentiated into various systems to take change of numerous functions. Two factors are necessary for survival of the systems: integrity of the intrinsic systems and supply of extrinsic materials. Food (including water) and air are among the extrinsic materials. Every organ utilizes food and oxygen in its metabolic process. Man can survive for weeks without food and for days without water. However, man can not even survive for minutes without oxygen. There are three oxygen transport routes: the inlet of oxygen to the lung, oxygen transport in the blood, and oxygen transport in the cell. Air is transported to the lung from the outer environment by rhythmical expansion and shrinkage of the lungs. Such a simple system had not

come to scientists' attention until the mid-seventeenth century. Even William Harvey, who is well known for his circulation research, described that the lung is a pump for accelerating the blood flow between the pulmonary artery and vein. It was not until the time of Antoine Lavoisier in the mid-eighteenth century that the pumping of the lung was considered as a function for oxygen inhalation. It was later (early in the nineteenth century) brought out by Le Gallois and Pierre Flourens that the center for pumping is located in the medulla oblongata. However, the mechanism of the generation of respiratory rhythm, the pumping change from inspiration to expiration, and from expiration to inspiration remained unclarified. At this same period, Francois Maggendie elucidated the difference between afferent and efferent nerve fibers. It was also suggested that the center of the respiratory nervous system receives inputs from the vagus, trigeminal nerve, spinal nerve, and the higher center of volition, and it sends outputs to the respiratory muscles. The idea is seemingly modern; however, the idea was that normal inspiration is generated by CO<sub>2</sub>-activated vagal afferents. Inspiration diluted CO<sub>2</sub> in the lung, which in turn shut off the inspiration.

This simple conception of how rhythmic inspiratory and expiratory phases are produced had been entirely inadequate until the view based on the particular facts discovered by Hering and Breuer (1868) came into the world. They found that when an animal's trachea is clamped at the end of expiration and air is prevented from entering the lung, the animal gave a great inspiratory effort that was prolonged for a while. When clamping the trachea at the end of inspiration and interrupting the expulsion of air from the lung, rhythmic respiratory efforts that were alternated by inspiratory and expiratory efforts were interrupted for a while until the interruption was broken. These effects were completely abolished by the bilateral sectioning of the vagus nerve. After bilateral **vagotomy**, slow rhythmic respiratory efforts went on independently whether or not inflation or deflation of the lung was prevented. From these experiments, they recognized that the vagus nerve might carry two different types of afferents. Inflation of the lung stimulates one type of nerve ending of the vagus nerve to terminate inspiration and initiate expiration. On the other hand, deflation of the lung stimulates another type of afferent to terminate expiration and initiate inspiration. The former phenomenon was called the "Hering–Breuer inflation reflex" and the later, the "Hering–Breuer deflation reflex." As previously mentioned, the works of Hering and Breuer gained notoriety late in the century largely in part due to the work of Hering's student Henry Head. The latter phenomenon is also called the "Head paradoxical reflex."

How does the Hering–Breuer reflex correspond to the position of respiratory physiology today? We

now have the term "inspiratory off-switch mechanism," which was derived from the Hering–Breuer inflation reflex. In the twentieth century, with the progress of science and technology, we are able to record electrical activities of muscles and nerves, which could not be done in the nineteenth century. The activities recorded from the main inspiratory muscle, the **diaphragm**, or from the **phrenic nerve**, which innervates the diaphragm, show the same trajectories with and without lung inflation. This indicates that the Hering–Breuer inflation reflex, in other words, the inspiratory inhibitory reflex becomes available at the end of inspiration. Breuer described that the inspiratory effort increases when an animal's trachea is clamped to disturb lung inflation. The trajectories of inspiratory motor output with and without inflation did not differ, but they did differ according to whether or not the inspiratory off-switch occurred early. Receptors are necessary to induce reflexes. It is well known that the receptor operating in the Hering–Breuer inflation reflex is the pulmonary stretch receptor (PSR) and the activity is conducted in the vagus nerve. PSR is a mechanoreceptor that responds to mechanical stimulation. There are two types of mechanoreceptors distinguished by the difference in adaptation. One is the slowly adapting receptor and the other is the rapidly adapting receptor. PSR belongs to the former, the slowly adapting receptor, and it is not adaptable to stimulation. The appropriate stimulation for PSR is stretching, which is activated during inflation of the lung. The Hering–Breuer inflation reflex is just the reflex induced by the activation of PSR. However, inspiratory inhibition does not occur until the afferent activities from PSR increase and reach a certain level. Inspiratory inhibition suddenly occurs when the afferent activities reach the threshold. The abrupt inhibition is called "inspiratory off-switch." However, the inhibition is induced even after bilateral vagotomy. Tidal volume and inspiratory time increases after vagotomy. That is to say that the inspiratory off-switch occurs when the central inspiratory output reaches the threshold for inspiratory inhibition. The inspiratory off-switch is induced by a summation of activities of the central inspiratory output and vagal afferent activity. This research has been performed in animal experiments. In humans, the PSR is too weak to induce the reflex. The Hering–Breuer inspiratory inhibitory reflex does not occur until the lung inflation reaches 1.5-fold the eupneic tidal volume. In addition to PSR, there are other stretch receptors in skeletal muscles. The receptors are densely distributed in the intercostal muscles. The stretch receptor in intercostal muscles has been shown to induce the same kind of reflex as the Hering–Breuer inflation reflex.

You can find the term Hering–Breuer reflex in every textbook of physiology.

From the clinical viewpoint, the Hering–Breuer reflex is also important in that the reflex tends to prevent excessive distention of the lung during inspiration, which may cause injury to the alveoli, and prevents the collapse of the lung during expiration.

Hering and Breuer’s description of “self-regulation” of breathing remains as a general timeless hypothesis, and the term Hering–Breuer reflex will be carried on in the new millennium.

### Further Reading

1. Haldane JS, Priestley JG (1935) Respiration. Yale University Press, New Haven
2. Kellogg RH (1981) Historical perspectives. In: Horrbein TF (ed) Regulation of breathing. Marcel Dekker, New York, pp 3–66
3. Euler CV (1986) Brain stem mechanisms for generation and control of breathing pattern. In: Fishman AP, Cherniack NS, Widdicombe JG (eds) The respiratory system, Handbook of physiology. American Physiological Society, Bethesda, pp 1–68

## Hering’s “Law of Equal Innervation”

### Definition

It postulates that the eyes move in a conjugate fashion (i.e., simultaneously in the same direction and by roughly the same amount), because synergistic muscles of both eyes receive the same signal. It was formulated with two corollaries attached to it: (i) The principle of equal innervation is due to the existence of appropriate anatomical connections, and (ii) The appropriate anatomical connections are innate.

## Herpes Virus

### Definition

Herpes viruses are a family of large DNA-containing, enveloped viruses. Eight human herpes viruses are recognized and can be classified into three sub-families  $\alpha$ ,  $\beta$  and  $\gamma$  viruses based on their genomic organization, virus host range, and other biologic properties. Herpes viruses are transmitted through direct contact and

induce disease by destroying affected tissues. For example, both herpes simplex virus and varicella-zoster virus are  $\alpha$  herpes viruses and infect primarily epithelial cells, thus causing mucocutaneous infections. All herpes viruses induce latent infections after primary infection. Latent viruses are usually retained in certain types of cells, such as in sensory neurons for herpes simplex virus and varicella-zoster virus.

► Immune System and Pain

## Herpes Zoster

### Definition

Also known as “shingles,” herpes zoster is a reactivation of varicella zoster virus infection from a ganglion within the nervous system. Reactivation usually produces a skin rash that includes fluid-filled blisters.

Commonly affected sites of reactivation include the skin area (dermatome) innervated by the corresponding dorsal root ganglion of the spinal cord or area of the face innervated by the Trigeminal ganglion. Although reactivation can be painful, pain is more common after blisters have healed, and is called “post-herpetic neuralgia.” Diagnosis can be made presumptively from the dermatomal distribution of the rash, or confirmed by Tzanck smear or polymerase chain reaction (PCR) assay on scrapings of tissue from the base of a blister.

- Dorsal Root Ganglion (DRG)
- Neuropathic Pain
- Trigeminal Nerve

## Heteroassociative Memory

### Definition

A neural network that stores input–output pattern pairs to recall a stored output pattern by receiving a noisy or incomplete version of a stored input pattern paired with that output pattern. In each of the pairs, an input pattern should differ from an output pattern.

► Associative Memory

## Heterodimerization

### Definition

The binding of two different protein subunits, such as G protein-coupled receptors, to form a single functional unit. The pharmacological properties of the heteromeric receptor are generally different from a receptor composed of two identical subunits. Heterodimerization appears to be a mechanism for increasing the diversity of receptor pharmacology.

► G-Protein Coupled Receptors (GPCRs) in Sensory Neuron Function and Pain

## Heterologous Expression

### Definition

The process of expressing a foreign protein in cell line or type that does not usually make the target protein.

This is most often done to determine the functional consequences of introducing amino acid mutations into proteins or to assess the specific interactions among proteins. For example, heterologous expression has been extensively used to study the molecular mechanisms of ion channel function and modulation. Commonly used cells include immortalized mammalian cells derived from tumors, or amphibian oocytes (i.e. unfertilized eggs).

► Sodium Channels

## Heterologous Expression System

### Definition

Heterologous expression systems comprise prokaryotic organisms (e.g. *E. coli*) and eukaryotic cells (e.g. yeast, HEK293, *Xenopus* oocytes) that are used to functionally express foreign genes or cDNAs.

## Heteromodal

► Multimodal Integration

## Heterospecific

### Definition

► Conspecific

## Heterostasis

### Definition

Under varied condition of an organism, adaptation has to change the homeostatic state. Hans Selye named this changed state to be heterostasis.

► Homeostasis

## Heterosynaptic Depression

### Definition

When high-frequency stimulation is applied to one of the two independent pathways innervating the same postsynaptic cells, synaptic depression is sometimes induced in the other nontetanized pathway. This type of synaptic depression is called heterosynaptic depression.

► Associative Long-Term Potentiation (LTP)  
 ► Long-Term Potentiation (LTP)  
 ► Memory, Molecular Mechanisms

## Heterosynaptic Facilitation

### Definition

When high-frequency stimulation is applied to one of the two independent pathways innervating the same postsynaptic cells, synaptic facilitation is sometimes induced in the other nontetanized pathway. This type of synaptic facilitation is called heterosynaptic facilitation.

► Associative Long-Term Potentiation (LTP)  
 ► Long-Term Potentiation (LTP)  
 ► Memory, Molecular Mechanisms



## Heterosynaptic LTP

### Definition

When high-frequency stimulation is applied to one of the two independent pathways innervating the same postsynaptic cells, long-lasting synaptic facilitation is sometimes induced in the other nontetanized pathway. This type of long-lasting synaptic facilitation is called heterosynaptic LTP.

- ▶ Associative Long-Term Potentiation (LTP)
- ▶ Long-Term Potentiation (LTP)
- ▶ Memory, Molecular Mechanisms
- ▶ Synaptic Plasticity

## Heterotopia

### Definition

Displacement of an organ or cell group from its normal position.

- ▶ Endocrine Disorders of Development and Growth

## Hibernation

ARJEN M. STRIJKSTRA

Department of Chronobiology, University of Groningen, Groningen, The Netherlands

### Synonyms

Wintering (to hibernate = to winter)

### Definition

Hibernation: (a set of) adaptive behavior(s) which allow animals to survive winter by minimizing their exposure to harsh winter conditions.

### Characteristics

#### On the Word Hibernation

The word ▶ **hibernation** (Latin: “*Hibernare*”) refers to “behavior used in wintertime.” It indicates behaviors that animals use during their surface absence in winter. However, hibernation is often used for the long-lasting

inactive low body temperature (hypothermic) state, which euthermic hibernators (e.g., mammals and birds) have during hibernation. This seems incorrect since hibernation in euthermic animals almost always contains other vital behaviors, which require euthermic conditions at least. A better behavioral term for the inactive state is ▶ **torpor** (Latin: “*Torpere*,” being “stiff or numb”), which indicates inactive behavior with low reactivity.

### Why Hibernate?

Most animals cannot escape winter conditions (e.g., by migration) and thus have to endure them. Hibernating animals seclude themselves in a secure and shielded place (hibernaculum, e.g., a burrow, a den) for as long as possible, avoiding problems of outside exposure, e.g., predation risk, the high energy expenditure of activity in the cold, and the low energy yield of foraging. Hibernation thus increases survival by minimal exposure.

### Which Animals Hibernate?

Hibernation is widespread in the animal kingdom. Insects hibernate. Heterothermic vertebrates such as amphibians and reptiles also hibernate. Hibernation in heterothermic animals includes finding a suitable hibernaculum, minimization of activity, suppression of metabolism and coping with the ambient temperature conditions. In extreme cases, this may include being able to freeze solid and thaw after winter, e.g., in frogs. During the freezing process, frogs massively mobilize blood sugars, which are transported into cells to high concentrations. This minimizes cell damage by preventing growth of ice crystals during freezing. Other cryoprotective processes also have been described (e.g., preventing icicle nucleation, supercooling).

Euthermic animals, birds (e.g. Poorwills, Goatsuckers) as well as mammals (e.g. Bears, Ground squirrels, Syrian hamsters) [1], also hibernate. Many small mammals and birds do not completely refrain from surface activity in winter, but use short daily torpor bouts to cope with harsh winter conditions instead (e.g. Djungarian hamsters, Deermice, Willow Tits).

Strategies including reduced activity and torpor are not exclusive for winter conditions, but are also used to survive summer drought (estivation), to survive food shortage (e.g., fasting induced torpor) or may even be considered a part of normal euthermic life (e.g., Hummingbirds, Bats).

### Benefits of Hibernation

A primary benefit of hibernation is elongation of lifespan by avoiding winter conditions. However, since some hibernators already start hibernation in summer at high temperatures, there are probably additional benefits in avoidance of surface activity before winter. This may be related to avoiding summer drought or predation risk.

Additional benefits may be related to the positive effects on lifespan by torpor. The more time a euthermic hibernator spends in torpor, the longer it lives. Furthermore, euthermic hibernators generally live longer than non-hibernating euthermic species of similar size.

### Costs of Hibernation

Doing nothing comes at a cost. Hibernation prohibits reproduction. When not active above ground, animals will have problems to finding a mate. Additionally, hibernation physiology is incompatible with reproduction and gonads are regressed in deep hibernators. Furthermore, animals will not be able to forage while inactive. This means that animals have to prepare energy stores before hibernation, which takes time, effort and risk of surface activity, and in many cases major physiological adaptations.

Although one can not say that one species suffers more from hibernation than another, euthermic hibernators appear to face particularly dramatic changes [1]. Since euthermic animals have a high metabolic rate, the need for extreme energy stores and energy savings for hibernation appears essential. Additionally, euthermic animals have to cope with the loss of stable high body temperature.

Furthermore, doing nothing may have costs in itself: several tissues need to be used to be maintained. This is the case for body tissues, such as muscle, bone, and gut, although hibernators appear to deal with this very well. Disuse of the brain may however lead to behavioral consequences as well (“use it or lose it”).

### Mammalian Hibernation

Even within the mammalian hibernators a tremendous variety in hibernation and torpor patterns occurs. Hibernation behavior depends on life history characteristics and physiological limitations of the species, as well as on environmental conditions. Hibernation may thus differ between species, between populations, between sexes, between age classes, between individuals, and between years. However, it is possible to indicate general patterns of hibernation based on torpor timing.

### Patterns of Torpor

Three basic patterns in torpor timing occur in mammals: (i) continuous torpor, (ii) short torpor bouts on a daily basis, and (iii) long multi-day torpor bouts interspersed with short euthermic phases (i.e., arousal episodes, interbout arousals). These patterns can be mixed, but most torpor patterns fit the division into these three types.

### Continuous Hibernation

The classical view on hibernation – hibernation with continuous torpor – has been observed in few mammalian species. Bears are large animals with a low mass-specific metabolic rate (i.e., metabolic rate per

gram of body weight), large fat storage capabilities and high thermal capacity and insulation. This allows bears to hibernate continuously at a relatively high body temperature of  $>28^{\circ}\text{C}$ .

Fat-tailed lemurs can hibernate with long torpor bouts interspersed with euthermic phases, but also continuously. Their continuous hibernation is linked to regular torpid body temperatures of  $>30^{\circ}\text{C}$ , which occur by external heating during daytime: if these temperatures are not reached, long torpor bouts with euthermic phases occur [2]. This suggests that there may be a temperature limitation in the possibility to maintain a continuous natural torpid state.

### Daily Torpor

Many small species show short torpor bouts on a daily basis in winter, allowing them to forage on a daily basis. The daily torpor bouts are timed in the inactive phase of day and are governed by the internal biological daily (►circadian) timing system. Daily torpor is short ( $<12$  h per day) and has an apparent lower temperature limit of about  $15^{\circ}\text{C}$  in all species [3]. Daily short bouts of torpor may also be observed in early stages of deep hibernation.

### Deep Hibernation

Deep hibernation with long multi-day torpor bouts interspersed with euthermic phases represents the most extreme form of hibernation. Deep hibernators reduce their metabolic rate to a fraction (1–2%) of basal metabolic rate and allow body temperatures to drop close to  $0^{\circ}\text{C}$  [3], or even slightly below. Duration of torpor bouts varies between 1 and 2 days to  $>30$  days, and depends on species, body size and temperature. Larger hibernators usually have longer torpor bouts, higher torpor temperatures result in shorter torpor bouts. Below  $0^{\circ}\text{C}$ , torpor bout duration remains similar (or becomes much shorter).

### Obligate and Facultative Deep Hibernation

Obligate hibernators have an internal programmed drive to hibernate. These species (e.g., ground squirrels, European hamster) have an internal annual program governed by an elusive seasonal timing system, possibly mediated by a signal in the blood stream [4]. Ground squirrels will hibernate in an approximate 300-day (►circannual) cycle in the absence of any seasonal information. Obligate hibernators such as ground squirrels are the most extreme hibernators. In preparation for hibernation they become insulin insensitive and obese. Entering hibernation, they become anorexic, and hibernate for up to 7–9 months per year. They rely mainly on body fat reserves as energy supply. During hibernation they have a series of long torpor bouts of  $>10$  days in which sub-zero body temperatures may be reached.

Facultative hibernators are triggered to hibernate by ambient conditions: temperature and photoperiod (►**photoperiodism**). Syrian hamsters hibernate after a change of day length (photoperiod) from long days (>13 h light, “summer”) to short days (<10 h light, “winter”). This is governed by the internal daylength measurement system, using ►**melatonin**. Melatonin is a hormone produced by the ►**pineal** organ in the brain. Suppression of melatonin by light confines high melatonin levels to darkness. Melatonin presence thus indicates the length of darkness and thereby day length. A subsequent lowering of ambient temperature will trigger hibernation. Facultative hibernators are less extreme hibernators, having short torpor bouts and long euthermic phases. Furthermore, they may heavily rely on food stores as energy supply during hibernation.

### Torpor Physiology

Torpor starts with behavioral inactivity, followed by metabolic suppression, and subsequent hypothermia (►**natural hypothermia**). First, animals typically assume a sleep posture. Torpor is started from an inactive sleep-like state: electrical brain activity (electroencephalogram, EEG) suggests sleep, with regular alternations of the two sleep stages ►**rapid-eye-movement** (►**REM**) and ►**non-REM sleep** [5]. During this inactivating sleep, whole body oxygen consumption is reduced by 90% or more within the hour. This metabolic reduction leads to lower temperature of the body, cooling passively. Thus, animals reduce metabolism by fast active suppression, which is indicated by high ►**Q<sub>10</sub>** values. A Q<sub>10</sub> value is the change in rate of a process caused by a 10°C temperature change. For passive physiological processes Q<sub>10</sub> values range between 2 and 3, for regulated changes (such as in metabolic suppression entering torpor) Q<sub>10</sub> values may be >10.

The metabolic suppression is associated with reduced activity of rate limiting enzymes, reducing the entry of fuel substrates into the respiratory chain and the tri-cyclic-acid (Krebs) cycle. Blocking these pathways suppresses production of cellular energy (adenosinetriphosphate: ►**ATP**). In torpor, a suppressed ATP production does not lead to cell death. Somehow, energy production and consumption are balanced by a co-occurring reduction of cellular energy demanding processes. At temperatures below 18°C DNA read-off and protein production are negligible [6].

Although metabolism is minimal, this does not indicate deregulation. Thermoregulation is functional. Torpid mammals accurately regulate respiration, heart rate, cardiac output, blood pressure, oxygen delivery to tissues, even though blood/tissue pH (level of acidity) and CO<sub>2</sub> (carbon dioxide) clearance may be regulated differently. Torpid animals are reactive to external stimuli and will arouse from torpor spontaneously or by disturbances [1].

### Thermoregulation

Hypothermia during torpor is not an uncontrolled pathological situation which can only be reverted by external heating. Homeostatic (►**homeostasis**) thermoregulation is functional, although in torpor entry and steady state torpor, thermoregulation operates around different setpoints (►**rheostasis**). Bears regulate body temperature above 28°C in continuous torpor, daily torpor animals defend a body temperature of about 15°C, and deep hibernators defend a body temperature of about 0°C, even when ambient temperature is much lower.

Thermoregulation is vital to maintain in hypothermic torpor, because the animal has to rewarm eventually to resume euthermic life. Thermoregulatory function resides in the brain, in ►**hypothalamic** and ►**brainstem** nuclei and ►**hippocampus** [7]. Involvement of several ►**neurotransmitter** and ►**neuropeptide** systems (adenosinergic, cholinergic, noradrenergic, serotonergic, histaminergic and opioid [1,8]) in torpor and arousal regulation have been indicated.

### Arousal From Torpor

Rewarming starts with signals from the brain stem and hypothalamus. These lead to heat production by a specialized organ designed to generate heat: brown fat. The brown color is caused by the many blood vessels which transport the heat away from the tissue, and the densely packed mitochondria. Brown fat is located around the major arteries linking the heart to the brain.

Brown fat efficiently generates heat by uncoupling membrane pump action from its normal cellular energy (ATP) producing function using specialized uncoupling proteins. Heat is generated fast in the heart and brain region. When the brain is sufficiently warm, it can mobilize additional heat production by shivering. Depending on the starting temperature and size of the animal, the rewarming process may take about 30 min to several hours.

### Why Arouse Regularly From Deep Torpor?

During continuous torpor and daily torpor, (near) euthermic temperatures regularly occur. Deep hibernation apparently requires regular euthermia. The cost of the euthermic phases is extremely high compared to torpor, but the function appears difficult to find.

The basic idea is that torpor accumulates a problem of some kind. Several hypotheses have been forwarded ranging from the need to empty the bladder, restore blood fuels, and restore cell products (mRNA, proteins), to the need for brain maintenance and repair. Since the most vital regulatory functions (e.g., thermoregulation) reside in the brain, hypotheses related to maintenance of brain function are attractive.

### The Brain and Torpor Entry

During cooling, brain activity patterns change (Fig. 1). Electroencephalographic (EEG) power is reduced in steps: at 25°C, rapid-eye-movement (REM) sleep patterns disappear (preventing defining of sleep states) and EEG power starts to drop faster than passive at a  $Q_{10}$  of  $>3$ . At 15°C, EEG power drops massively, mediated by the cessation of thalamic neuronal firing. Below 10°C, the EEG suggests brain death. Only in deeper brain regions important for thermoregulation (e.g., hypothalamus, hippocampus) low electrical activity can still be measured. In general, torpor constitutes a phase of extreme brain inactivity, depending on temperature [5,7].

### The Brain After Torpor

During rewarming, effects on brain activity are reversed. Thalamic neurons start firing again around 15°C and cortical EEG returns to (approximately) normal above 25°C. However, subtle EEG differences

indicate carry-over effects of torpor in subsequent euthermia (►euthermia, ►normothermia). Initially, REM and NREM sleep-like firing patterns of thalamic neurons could be found simultaneously, which was never observed in any other sleep situation. Furthermore, ►slow-wave activity (SWA: power of the slow 1–4 Hz (delta) frequencies of the NREM sleep EEG, indicating the level of simultaneous hyperpolarization (relative inactivity) of cortical neurons, synchronously “burst-firing”) is high after torpor. This depends on duration of torpor (long torpor has high SWA increases) and the temperature during torpor (high torpor temperature has low SWA increases). This indicates that deep torpor affects functional neuronal connectivity in the brain [5].

### Torpor is Not Deep Sleep

Torpor induces high SWA, i.e., deep sleep. This indicates that torpor may resemble a kind of wakefulness, but certainly not a kind of sleep. Furthermore, after deep

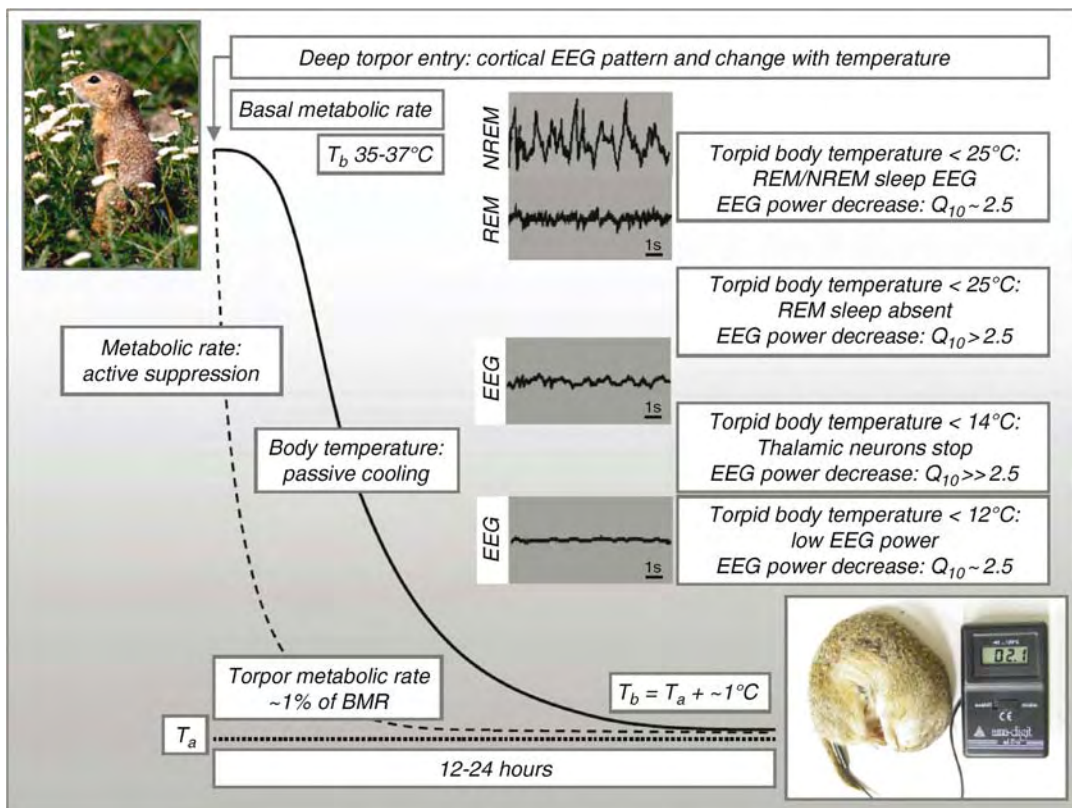

**Hibernation. Figure 1** Schematic representation of deep torpor entry from a euthermic body temperature ( $T_b$ ) to a deep torpor body temperature just over ambient temperature ( $T_a$ ) in a deep hibernator, the European ground squirrel (*Spermophilus citellus*). Active metabolic suppression (dotted line) from basal metabolic rates (lowest euthermic metabolic level) at euthermia is followed by a passive body temperature decrease (solid line). The 10 s EEG traces initially resemble NREM and REM sleep; REM sleep is lost below 25°C. At lower temperatures the EEG shows progressive changes in power with different rates, indicating regulated activity changes ( $Q_{10} > 2-3$ ) and passive changes ( $Q_{10} \sim 2-3$ ), ultimately resembling a flat line below  $\sim 10^\circ\text{C}$ .

torpor, the increased SWA is not attached to sleep regulation processes. Preventing SWA expression during euthermia by ►sleep deprivation or caffeine did not postpone the expression of SWA, which would be expected if the torpor induced SWA is similar to wakefulness induced SWA. In contrast to deep torpor, sleep deprivation did postpone SWA expression after daily torpor in Djungarian hamsters. Thus, the hypothesis that daily torpor may represent some kind of wakefulness can not be refuted yet.

### Torpor Affects Neuronal Status

The carry-over effects of torpor on subsequent euthermic EEGs suggest repercussions of inactivity. Indeed, neurons show marked cyclic reversible changes in neurons (i.e., reduced dendritic trees, synaptic contacts and neurotransmission capacity) over torpor and subsequent euthermia [5].

In torpor, the microtubule-associated protein “►tau” shows phosphorylation on locations indicative for the switch between physiological and pathological states of the neuroskeleton in aging and Alzheimer’s disease. Interestingly, this is rapidly reversed in euthermic phases. Although this phosphorylation is associated with decreased brain function in humans, in hibernation this may contribute neuroprotective action [9].

### Hibernation Affects Brain Function

Although many vital functions appear not affected by torpor, memory performance is. Ground squirrels forget spatial memory and operational conditioning due to low temperature torpor [10]. During hibernation, learning during euthermic phases may be enhanced. This indicates that the hibernating brain is plastic [9], although the functional reason for this is probably not related to learning.

Circadian function also is affected by hibernation. Ground squirrels have reduced amplitude in daily (circadian) body temperature and activity rhythms. This is reflected in the expression of a circadian output signal (arginine vasopressin) in neurons in the ►suprachiasmatic nucleus (►SCN), the neural substrate of the circadian clock.

### Medical Relevance

Considering the enormous physiological changes a mammalian hibernator goes through, torpor may be an important model system for medical problems related to cellular metabolism, for which hibernators may possess evolutionarily validated solutions.

Ground squirrels and marmots become insulin insensitive before hibernation, adding 50% of their body weight in fat in several weeks, mimicking obesity. When the animal starts hibernation, the obese state is changed to an anorexic state. Apparently, hibernators

possess cellular programs to battle obesity and metabolic syndrome.

Deep hibernators can maintain torpor for 10–20 days at near freezing temperatures without apparent damage to internal organs. This greatly contrasts the time window of less than 24 h for successful transplantation of cold-stored human organs. Hibernators are a model system for research on increasing this time window.

Acute problems of cardiac arrest and stroke are related to local circulatory arrest and reperfusion in the brain. The damage is caused by low cellular energy supply, which occurs rapidly in the brain. Mild hypothermia is beneficial for the neurological outcome of circulatory arrest patients. Hibernators combine hypothermia with metabolic suppression, which may further reduce neuronal damage [8].

Hibernators have phosphorylation of the microtubule-associated protein tau resembling that of Alzheimer’s disease (AD) and aging. Torpor leads to memory impairments and dampening of circadian rhythms, behavioral symptoms of AD and aging. Even if torpor does not lead to neurofibrillary tangles and cell death, torpor is a natural model system for tau phosphorylation and dephosphorylation [9].

### Suggested Reading

This brief overview of hibernation does not allow for full coverage and references for all behavioral and neurological issues. Besides some original papers, the reference list contains books and review papers that can be helpful as an entry into the hibernation literature.

### References

1. Lyman CP, Willis JS, Malan A, Wang LCH (1982) Hibernation and torpor in mammals and birds. Academic Press, New York
2. Dausmann KH, Glos J, Ganzhorn JU, Heldmaier G (2004) Hibernation in a tropical primate. *Nature* 429:825–826
3. Geiser F, Ruf T (1995) Hibernation versus daily torpor in mammals and birds: physiological variables and classification of torpor patterns. *Physiol Zool* 68:935–966
4. Kondo N, Sekijima T, Kondo J, Takamatsu N, Tohya K, Ohtsu T (2006) Circannual control of hibernation by HP complex in the brain. *Cell* 125:161–172
5. Strijkstra AM (2006) Good and bad in the hibernating brain. *J Brit Interplanet Soc* 59:119–123
6. Carey HV, Andrews MT, Martin SL (2004) Mammalian hibernation: cellular and molecular responses to depressed metabolism and low temperature. *Physiol Rev* 83:1153–1181
7. Heller HC (1979) Hibernation: neural aspects. *Ann Rev Physiol* 41:305–321
8. Drew KL, Buck L, Barnes BM, Christian SL, Rasley BT, Harris MB (2007) Central nervous system regulation of mammalian hibernation: implications for metabolic suppression and ischemia tolerance. *J Neurochem* 102:1713–1726

9. Arendt T, Stieler J, Strijkstra AM, Hut RA, Rüdiger J, Van der Zee EA, Harkany T, Holzer M, Härtig W (2003) Reversible PHF-like phosphorylation of tau is an adaptive process associated with neuronal plasticity in hibernating animals. *J Neurosci* 23:6972–6981
10. Millesi E, Prossinger H, Dittami JP, Fieder M (2001) Hibernation effects on memory in European ground squirrels (*Spermophilus citellus*). *J Biol Rhythms* 16:264–271

---

## Hidden Unit

### Definition

A model network neuron that may receive signals from input units, other hidden units, and/or send signals to other hidden units, output units.

► [Neural Networks](#)

---

## Hierarchy

### Definition

Neural networks usually contain more than one station. The organization of processing may be from one station to the next. Alternatively, processing may be distributed to many stations that handle information in parallel.

---

## HIF-1 and Neuroinflammation

THOMAS HELLWIG-BÜRCEL

Institute of Physiology, University of Lübeck, Lübeck, Germany

### Synonyms

HIF-1 $\alpha$ : ARNT Interacting Protein; Member of PAS Superfamily 1; Basic-Helix-Loop-Helix-PAS Protein MOP1; HIF-1 $\beta$ : Arylhydrocarbon Receptor Nuclear Translocator (ARNT)

### Definition

HIF-1, the ► [hypoxia-inducible factor-1](#), is a transcription factor which is activated under conditions when

cellular oxygen consumption exceeds the oxygen supply, or in other terms cellular hypoxia. HIF-1 activity leads to metabolic adaptation and cellular survival during situations in which oxygen is limited, typically found in inflamed tissues. A characteristic feature of inflamed tissue is the invasion of white blood cells producing different inflammatory mediators. Additionally to hypoxia, proinflammatory cytokines are potent activators of HIF-1 and some proteins involved in the inflammatory process are regulated by HIF-1 itself. Furthermore, HIF-1 seems to be necessary for hypoxia induced apoptosis. Therefore, HIF-1 activity plays an important role during maintenance and possibly termination of inflammation. At present HIF-1 inhibitors are in clinical trials as anti-cancer drugs, but HIF-1 inhibition should also be an attractive approach to fight rheumatoid arthritis or neuroinflammation.

### Characteristics

#### Quantitative Description

HIF-1 is a heterodimeric transcription factor consisting of an oxygen-labile  $\alpha$ -subunit and an oxygen-resistant  $\beta$ -subunit. The human  $\alpha$ -subunit is a single chain of 826 amino acids with a calculated molecular mass of approximately 92.5 kD, although the apparent molecular weight in Western blot experiments is somewhat higher in the range of 110 kD. The single copy gene is located on chromosome 14q21-q24. The  $\beta$ -subunit has been identified as the arylhydrocarbon receptor nuclear translocator, the dimerization partner of the dioxin-receptor. HIF-1 $\beta$ /ARNT consists of 789 amino acids, has a molecular mass of approximately 91 kD and is encoded on chromosome 1 in the region of 1q21.

Typical HIF-1 target genes are the genes encoding most of the glycolytic enzymes to enhance anaerobic glycolysis, the glucose transporter-1 and -4 to facilitate glucose uptake during oxygen deprivation, the vascular endothelial growth factor (VEGF) and the transforming growth factor- $\beta$ 3 (TGF- $\beta$ 3) to induce angiogenesis, the insulin-like growth factor-2 (IGF-2) and transforming growth factor- $\alpha$  (TGF- $\alpha$ ) to promote cell proliferation, heme oxygenase-1 (HOX-1) and NO-synthase-2 (NOS-2), both involved in regulating vascular tone, the ceruloplasmin, transferrin and the transferrin-receptor critical for iron metabolism, the carboanhydrase 9 for pH regulation and the well-known erythropoietin (EPO) increasing erythropoiesis and acting as a neuroprotectant [1]. Indeed, HIF-1 $\alpha$  and the active HIF-1 $\alpha$ / $\beta$  dimer were discovered in context with hypoxic EPO expression [2] and the EPO gene was the prototype of hypoxically regulated genes for years. More recently it became obvious that HIF-2, an isoform with a more restricted tissue distribution, is much more important for hypoxia dependent EPO expression than HIF-1, as well in the kidney as in hepatoma and neuroblastoma

cell lines and in cortical astrocytes. In any case, the number of validated target genes regulated by HIF transcription factors is increasing steadily.

### Description of the Structure/Process

In the presence of oxygen, the  $\alpha$ -subunit of HIF-1 is immediately hydroxylated by HIF-specific prolyl hydroxylase domain proteins (PHDs). PHDs are a family of HIF prolyl 4-hydroxylases, currently consisting of 3- or 4 members (PHD-1, -2, -3; and perhaps -4), hydroxylating specific proline residues (p402 and p564) in so-called oxygen dependent degradation domains of the HIF-1 $\alpha$  protein (N-terminal- and C-terminal oxygen dependent degradation domain, N-ODD and C-ODD) (Fig. 1).

The PHDs serve as cellular oxygen sensors, since their enzymatic activity depends on the availability of molecular oxygen. Hydroxylated HIF-1 $\alpha$  is recognized by the von-Hippel-Lindau protein, the substrate-recognition subunit of an E3 ubiquitin ligase complex. Subsequently, hydroxylated HIF-1 $\alpha$  is polyubiquitinated and thereby tagged for proteasomal degradation [3]. Thus, HIF-1 $\alpha$  remains undetectable under normoxic conditions, the averaged half-life is extremely short (minutes). In hypoxia PHD-activity is reduced due to limited amounts of oxygen and HIF-1 $\alpha$  becomes no longer hydroxylated. Although overall translation is clearly reduced under hypoxic conditions, HIF-1 $\alpha$  translation is apparently not affected. This might be due to the use of an internal ribosomal entry site (IRES)

within the HIF-1 $\alpha$  mRNA, rendering the translation to be cap-independent.

The hypoxically stabilized HIF-1 $\alpha$  subunit has then to be translocated into the nucleus. The nuclear destination is achieved by use of the C-terminal NLS (NLS-C) which is most probably of bipartite type and the classical  $\alpha/\beta$  importin system since most  $\alpha$ -importins bind HIF-1 $\alpha$  at the NLS-C domain. The NLS-N, in contrast, seems to be of minor importance for nuclear translocation. Within the nucleus, HIF-1 $\alpha$  dimerizes with HIF-1 $\beta$  *via* PAS-A and PAS-B domains and associates with additional transcriptional cofactors (e.g., CBP/p300) *via* transactivating domains (TAD-N and TAD-C). Within this complex, HIF-1 recognizes and binds to HIF-1-responsive elements (HREs) within promoter or enhancer regions of hypoxia regulated genes by use of the basic helix-loop-helix motifs (bHLH). The order of the described processes is not strictly as written, many processes happen simultaneously or the order is not clear. As a result, the formed protein-DNA complex directs the RNA-polymerase 2 to initiate transcription. Therefore, HIF-1 functions as a classical transcription factor, but it is of note that repressive effects have been reported too.

### Higher Level Structures/Processes/Conditions

Beside this main regulatory pathway, there exist some additional pathways to regulate the HIF-1 $\alpha$  protein amount. For instance, protein acetylation by ARD-1 has been reported to destabilize HIF-1 $\alpha$  *via* enhanced

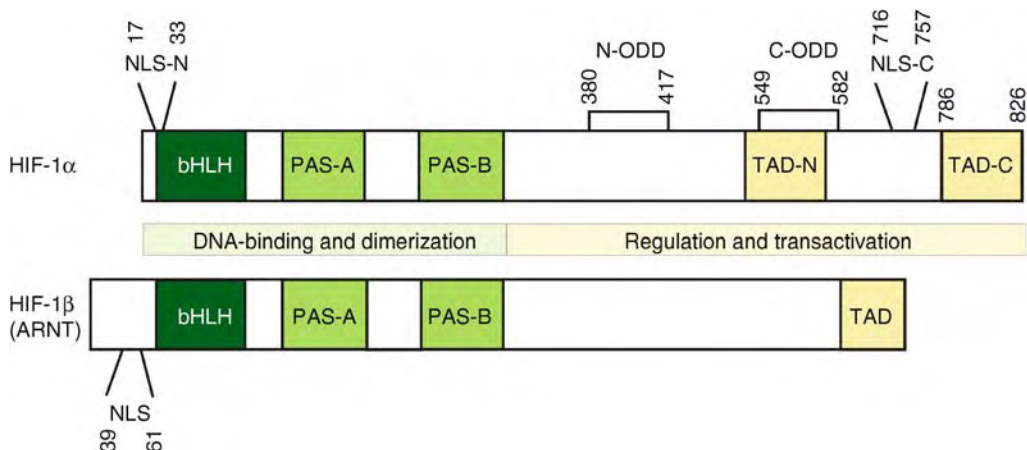

**HIF-1 and Neuroinflammation. Figure 1** Schematic drawing of HIF-1 $\alpha$  and HIF-1 $\beta$  proteins. Abbreviations are: N-ODD and C-ODD: Amino-terminal and carboxy-terminal oxygen dependent degradation domains; NLS-N and NLS-C: Amino-terminal and carboxy-terminal nuclear localization signals/sequences; PAS-A and PAS-B: Protein domains critical for dimerization, first identified in drosophila period protein, the arylhydrocarbon receptor and in the drosophila single-minded protein; TAD-N and TAD-C: Amino-terminal and carboxy-terminal transactivating domains; bHLH: Basic helix-loop-helix motif for DNA-binding. Figure adopted from Semenza GL, Agani F, Iyer N, Jiang B-H, Leung S, Wiener C and Yu A (1998) Hypoxia-Inducible Factor 1: From Molecular Biology to Cardiopulmonary Physiology. CHEST 114:40S-45S and extended.

interaction with pVHL and ubiquitination. The HIF-1 inhibitor YC-1 (3-(5'-hydroxymethyl-2'-furyl)-1-benzylindazole) reduces the amount of hypoxically induced nuclear HIF-1 $\alpha$  by a so far unknown mechanism. Nevertheless it has been shown that macrophage derived nitric oxide (NO) can lead to nitrosylation of cystein 533. This posttranslational modification within one ODD of HIF-1 $\alpha$  prevents its destruction. Despite the regulation *via* protein stability of the  $\alpha$ -subunit, HIF-1 activity can be regulated in many other different ways. One prominent and probably important possibility is the hydroxylation of asparagine 803 of the  $\alpha$ -subunit by an asparaginyl hydroxylase named factor inhibiting HIF-1 (FIH-1). This action prevents p300 and CBP to interact with HIF-1 $\alpha$  and, most likely, the transcriptional initiation complex cannot be established. In this context it is of note that HIF-1 $\alpha$  becomes nitrosylated in the presence of NO at cystein 800 (beside the above mentioned nitrosylation at cystein 533) which improves its interaction with p300 leading to increased transcriptional activity. Furthermore, HIF-1 $\alpha$  as well as HIF-1 $\beta$  are subject to lysine-sumoylation but the functional consequences are currently unclear due to contradictory reports.

### Regulation of the Structure/Process/Conditions

There are several interconnections between hypoxia, respectively HIF-1, and neuroinflammation. The systemic inflammatory response syndrome (SIRS) is characterized, besides other malfunctions, by large inflammatory changes in the brain causing fever, cardiovascular and neuroendocrine responses. At the sites of inflammation the cellular metabolism is changed, resulting in a disequilibrium of energy supply and demand. This situation is leading to inflammation-associated tissue hypoxia and local metabolic acidosis and thus stabilization and activation of HIF-1. As an early event the recruitment of inflammatory cells, particularly myeloid cells such as neutrophils and monocytes to the place of inflammation is observed. In animals with a conditional HIF-1 $\alpha$  knockout no such myeloid cell infiltration was found. A closer look at the HIF-1 $\alpha$  knockout myeloid cells revealed a decreased glycolytic rate and finally drastically reduced ATP levels within these cells. This in turn has negative effects on myeloid cell aggregation, motility, invasiveness and bacterial cell killing [4].

Bacterial infections and lipopolysaccharide (LPS) activate HIF-1 $\alpha$  under normoxia in many different cell types, including the above mentioned immune cells. Activated macrophages produce a large number of proinflammatory cytokines, including IL-1, IL-4, IL-6, IL-12 and TNF- $\alpha$  and knockout experiments revealed that the production is HIF-1 $\alpha$  dependent and that TLR-4 is necessary for LPS mediated activation of HIF-1 $\alpha$  (TLR-4 belongs to the pattern recognition receptor-family and is critical for the proinflammatory response) [5].

Considering that proinflammatory cytokines itself are potent inducers of HIF-1 $\alpha$ , the initial inflammatory response of the immune cells augments the overall HIF-1 activation in the inflamed tissue. Nevertheless, IL-1 is not solely expressed by immune cells. Astrocytes and microglia have been demonstrated to produce IL-1 $\beta$  under hypoxic conditions in a HIF-1-dependent manner. This is most likely the explanation, why peripheral, circulating leukocytes are attracted by the hypoxic brain. However, it has been shown that IL-1 and its type 1 receptor are necessary for progressive neurodegeneration upon a mild hypoxic/ischemic injury [6]. Focused on the immune cells, it has been reported that LPS increases the glucose uptake in neutrophils. A closer look revealed a HIF-1 and p38 dependent Glut-1 (glucose transporter-1) translocation from the interior to the cell surface to be the cause for the enhanced glucose uptake [7]. However, Glut-1 is a HIF-1 target; its expression is increased under hypoxia, which is of special importance, since the facilitated glucose shuttling across the blood-brain barrier (BBB) is achieved by this transporter. Considering VEGF as a HIF-1 target too, it becomes obvious that HIF-1 activation has dramatic effects on the BBB, since VEGF enhances the vascular permeability. Furthermore, VEGF is produced by virtually all cell types of the brain upon the onset of hypoxia or the stimulation with IL-1. But not only the effect on BBB function of VEGF is of importance, VEGF is the principal mediator of angiogenesis in normal and tumor tissues. Particularly malignant gliomas show strongly elevated HIF-1 $\alpha$  amounts and VEGF expression. The resulting tumors are highly vascularized. Recently it has been shown that HIF-1 $\alpha$  inhibition by either overexpression of a dominant-negative HIF-1 $\alpha$  isoform or by siRNA leads to decreased HIF-1 $\alpha$  and VEGF protein amounts in glioma cells and the tumor growth of identically transfected cells in an animal model was reduced [8]. Additionally, it could be proven that direct injection of HIF-1 $\alpha$ -siRNA into preexisting gliomas grown *in vivo* in mouse flanks reduced tumor volume by 50% compared to negative controls [9]. These works presented the proof of principle that HIF-1 $\alpha$  inhibition could be a successful intervention in glioma tumor therapy. Besides that, it might be a promising approach to test the anti-inflammatory effects of HIF-1 $\alpha$  inhibition in an animal model.

Another aspect, by which the interconnection of HIF-1 and neuroinflammation becomes evident, is neuroprotection by erythropoietin (EPO) [10]. EPO is, as mentioned above, a HIF-1 and HIF-2 target. The most prominent site of production is the adult kidney but astrocytes and neuronal cells have been shown to produce EPO too. The regulation is somewhat different in these tissues. In the kidney, EPO mRNA levels decline after long hypoxic conditions whereas EPO mRNA levels in the cerebrum remain high. This may reflect different functions of EPO. Kidney derived EPO should



elevate the number of red blood cells, whereas neuronal/astrocyte derived EPO acts neuroprotective. It is of note that HIF-1 $\alpha$  levels do not decline after prolonged hypoxic exposure of the brain and this may be the cause for maintained EPO production. Similar to the kidney, it has been shown that IL-1 $\beta$ , IL-6 and TNF- $\alpha$  reduce EPO expression in astrocytes. It should be noted that neuronal cells are also capable of producing EPO, but the effects of proinflammatory cytokines on these cells have not been investigated so far. In summary, the onset of hypoxia induces the expression of EPO thereby enhancing neuroprotection. This holds true as long as the hypoxic insult does not induce the production of proinflammatory cytokines. In this case the neuroprotection by endogenous produced EPO is lost.

## References

1. Hirota K, Semenza GL (2006) Regulation of angiogenesis by hypoxia-inducible factor 1. *Crit Rev Oncol Hematol* 59:15–26
2. Wang and Semenza GL (1993) General involvement of hypoxia-inducible factor 1 in transcriptional response to hypoxia. *Proc Natl Acad Sci USA* 90:4304–4308
3. Siddiq A, Aminova LR, Ratan RR (2007) Hypoxia inducible factor prolyl 4-hydroxylase enzymes: Center stage in the battle against hypoxia. *Metabolic compromise and oxidative stress. Neurochem Res* 32:931–946
4. Cramer T, Yamanishi Y, Clausen BE, Förster I, Pawlinski R, Mackman N, Haase VH, Jaenisch R, Corr M, Nizet V, Firestein GS, Gerber HP, Ferrara N, Johnson RS (2003) HIF-1 $\alpha$  is essential for myeloid cell-mediated inflammation. *Cell* 112:645–657
5. Peyssonnaud C, Cejudo-Martin P, Doedens A, Zinkernagel AS, Johnson RS, Nizet V (2007) Essential role of hypoxia inducible factor-1 $\alpha$  in development of lipopolysaccharide-induced sepsis. *J Immunol* 178 (12):7516–7519
6. Basu A, Lazovic J, Krady JK, Mauger DT, Rothstein RP, Smith MB, Levison SW (2005) Interleukin-1 and the interleukin-1 type 1 receptor are essential for the progressive neurodegeneration that ensues subsequent to a mild hypoxic/ischemic injury. *J Cereb Blood Flow Metab* 25:17–29
7. Schuster DP, Brody SL, Zhou Z, Bernstein M, Arch R, Link D, Mueckler M (2007) Regulation of lipopolysaccharide-induced increases in neutrophil glucose uptake. *Am J Physiol Lung Cell Mol Physiol* 292:L845–851
8. Jensen RL, Ragel BT, Whang K, Gillespie D (2006) Inhibition of hypoxia inducible factor-1 $\alpha$  (HIF-1 $\alpha$ ) decreases vascular endothelial growth factor (VEGF) secretion and tumor growth in malignant gliomas. *J Neurooncol* 78:233–247
9. Gillespie DL, Whang K, Ragel BT, Flynn JR, Kelly DA, Jensen RL (2007) Silencing of hypoxia inducible factor-1 $\alpha$  by RNA interference attenuates human glioma cell growth in vivo. *Clin Cancer Res* 13:2441–2448
10. Jelkmann W (2005) Effects of erythropoietin on brain function. *Current Pharm Biotechnol* 6:65–79

## HIF-1 $\beta$ : ARNT Interacting Protein

► HIF-1 and Neuroinflammation

## HIF-1 $\beta$ : Arylhydrocarbon Receptor Nuclear Translocator (ARNT)

► HIF-1 and Neuroinflammation

H

## “Higher” Sensory Cortices

### Definition

Those parts of the cerebral cortex to which the early sensory cortices send their output-signals.

## Higher Thalamic Sensory Processing

► Visual Role of the Pulvinar

## High-pass Filtering

### Definition

A filter that passes only those frequency components in the high end of the spectrum.

► Signals and Systems

## Hindbrain

### Definition

The region of the brain between the spinal cord and the midbrain. Comprised of the medulla oblongata and the pons. It contains the nuclei of many cranial nerves. Among its functions are control of the viscera, movements of the jaws and tongue, and a number of sensory systems.

► Evolution of the Spinal Cord

## Hindbrain Segments

### Definition

Vertebrate hindbrain development is characterized by segmental patterning at both cellular and genetic levels. During the ontogenesis the hindbrain neuroepithelium in all vertebrates is organized at the gross morphological level as a series of segments, the rhombomeres. Combinations of genes encoding transcriptional factors and cell signalling molecules are expressed in patterns corresponding to various inter- and intra-rhombomeric boundaries and are believed to define the identity of cells within each rhombomere.

► Functional and Neurochemical Organization of Vestibulo Pathways

## Hip Strategy

### Definition

A fixed support (feet in place) reaction to antero-posterior postural perturbation where the predominant stabilizing action involves active generation of hip torque. The “pure” hip strategy (i.e. where there is little or no ankle activation) can be learned under special conditions, but seldom (if ever) occurs during natural behavior.

► Postural Strategies

## Hippocampal Complex

### Definition

The hippocampal complex consists of the hippocampal formation (which comprises the hippocampus proper (cornu ammonis), the dentate gyrus, and the subiculum) and the adjacent parahippocampal gyrus (which includes the entorhinal, perirhinal, and parahippocampal cortices).

## Hippocampal Formation

MENNO P. WITTER<sup>1,2</sup>

<sup>1</sup>Kauli Institute for System Neuroscience, Centre for the Biology of Memory, Department of Neuroscience, Norwegian University of Science and Technology (NTNU), Trondheim, Norway

<sup>2</sup>Institute for Clinical and Experimental Neurosciences, Department of Anatomy & Neurosciences, VU University Medical Center, Amsterdam, The Netherlands

### Synonyms

Hippocampus; Hippocampal region; Ammons horn/Cornu Ammonis

### Definition

The hippocampal formation is a macroscopically defined cortical structure, present in the brain of all mammals. It derives its name from hippocampus (seahorse), which is easily appreciated in case of the human macroscopic structure – located in the inferior horn of the lateral ventricle of the medial temporal lobe – that resembles a seahorse (Fig. 1).

It belongs to the so-called allo (old) cortex and as such is part of the *cerebral cortex* and it is closely linked to a restricted number of cortical areas, which are collectively referred to as the *para-(next to)-hippocampal region*. The hippocampal formation is reciprocally connected with a wide variety of higher order *association cortices* representing all sensory domains as well as with number of *limbic* subcortical structures. Functionally it forms a key-component of the medial temporal lobe memory system, mediating conscious or *declarative memory*.

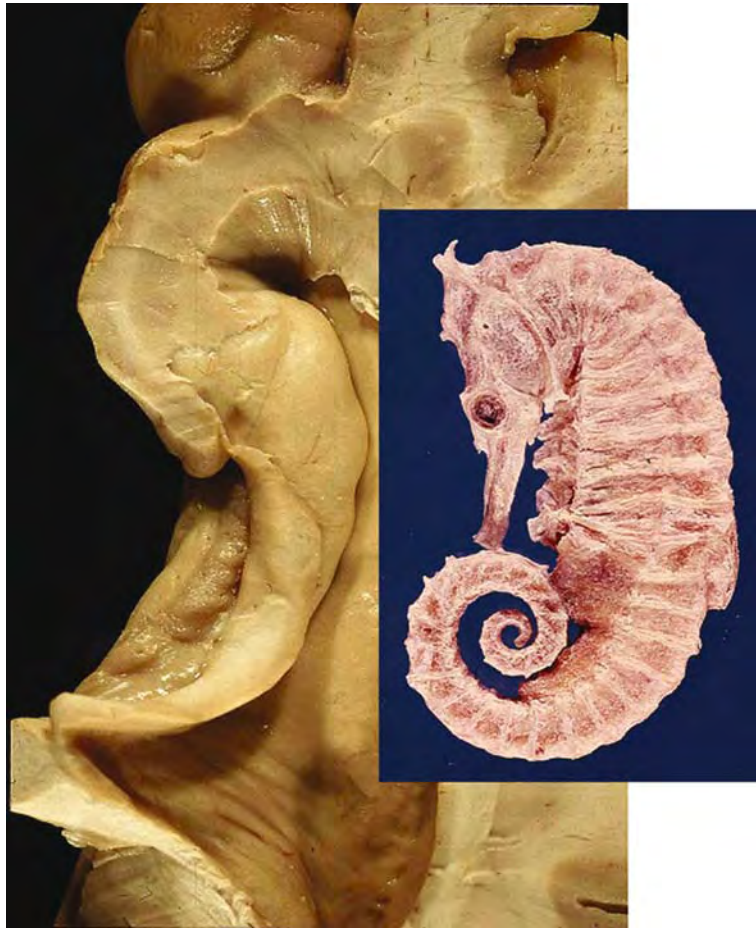

**Hippocampal Formation. Figure 1** Dissection of the right human temporal lobe, providing a view into the inferior horn of the lateral ventricle, showing the position and extent of the hippocampal formation (left). On the right a picture of the seahorse (*Hippocampus* sp.) is given, indicating the overall structural resemblance between the two structures.

## Characteristics

### Anatomical Organization

The precise orientation and curvature of the hippocampal formation and thus its overall position in the brain may vary between different species. In species with a clearly developed temporal lobe, the hippocampus is more ventrally and anteriorly (humans and monkeys) positioned, compared to the situation in for example the rat, where the hippocampus looks more like a c-shaped structure positioned in the caudal third of the hemisphere (Fig. 2).

However, this difference in position does not alter the major characteristics and the topological relations between the hippocampus and the parahippocampal structures. Nor does it influence the fact that the most anterior/ventral portion of the hippocampus has a close spatial relationship with the *amygdala*.

The wiring of the hippocampal formation, both intrinsically as well as extrinsically, is well-preserved in most species studied, such that a generalized description suffices. The hippocampus has two major pathways connecting it to the rest of the brain. The first pathway is mediated through reciprocal connections with the parahippocampal region, more in particular the *entorhinal area*, connecting the hippocampal formation with a wide variety of higher order association cortices representing all sensory domains. The second pathway, which mainly, but not exclusively, links the hippocampus to subcortical structures, makes use of the *fornix*.

The hippocampus consists of three major subdivisions, which can be easily recognized in all species (Fig. 3).

The first field, the *dentate gyrus*, is a c-shaped three-layered cortical structure which is characterized by a

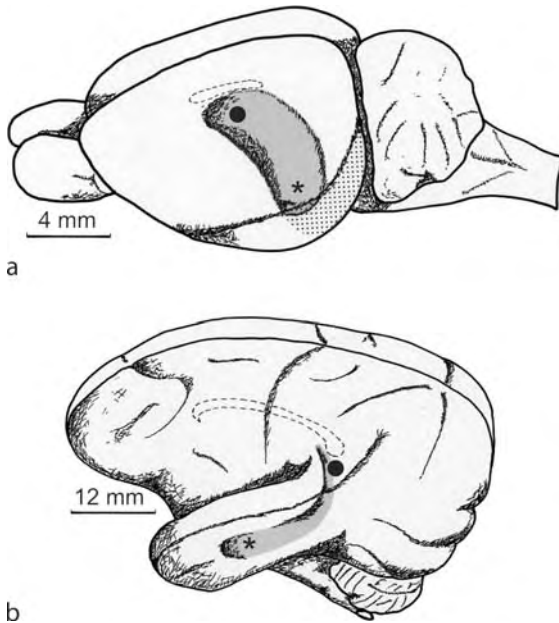

**Hippocampal Formation. Figure 2** Schematic representation of the position of the hippocampal formation in the hemisphere of the rat (a) and the monkey (b). As indicated the rodent hippocampus is positioned quite posterior in the brain such that the longitudinal feature is C-shaped, having its most dorsal pole as its most dorso-medial extension. The hippocampus in the primate, in contrast, is located in the medio-ventral part of the temporal lobe. Presumed homologous areas of the hippocampal formation, i.e. dorsal and posterior versus ventral and anterior are indicated with dot and star symbols respectively. (Reproduced and modified with permission from Witter et al. (1989) *Prog Neurobiol* 33:161–254).

densely packed cell layer, mainly consisting of granular cells, i.e. cells with a round soma, and a apical dendritic tuft and no or only sparse basal dendrites. Enclosed in this c-shaped cortical blade, is a polymorphic cell group generally referred to as the hilus of the dentate gyrus. The second subfield is the Ammon's Horn or Cornu Ammonis, generally abbreviated as CA-field. The CA-field is generally subdivided into CA1, CA2, and CA3. The third subdivision is the subiculum. Like the dentate gyrus, the Ammon's horn and the subiculum have an overall three-layered structure, comprising a superficially positioned fiber layer, a cell layer, mainly consisting of *pyramidal* cells with various soma-sizes, and a deep polymorph layer. The most deeply located white matter is called the alveus and the fibers that travel in the alveus are continuous with the *fornix*.

The original descriptions of hippocampal circuitry emphasized the so-called trisynaptic circuit comprising an exclusive unidirectional pathway from the entorhinal area to the distal dendrites of the granular cells in the

dentate gyrus, which in turn give rise to the mossy fiber pathway to the proximal part of the apical dendrites of CA3 pyramidal cells. These CA3 neurons finally convey their output by way of the Schaffer axon collaterals to the apical and basal dendrites of pyramidal cells in CA1. The notion of connectivity along the long axis as an integral feature of the hippocampal organization has been added. Finally, the subiculum has been added on a crucial position within this circuit.

A striking feature of the cortico-parahippocampal-hippocampal circuit is that the hippocampal formation does not have extensive direct connections with the cerebral cortex. This communication is largely mediated by way of the *parahippocampal region*. Of this region, the perirhinal cortex (peri = around the *rhinal sulcus*) and postrhinal cortex (post = behind the rhinal sulcus), maintain the highest number of cortico-cortical connections, including connections with all major sensory realms, such as visual, auditory, somatosensory, and gustatory cortices (note that the postrhinal cortex as described in rodents, cats, dogs, and guinea pig most likely is homologues to the *parahippocampal cortex* of primates). Also, massive connections exist with the other two major higher-order association domains, the parietal and prefrontal cortices, but connections with the motor cortex are less prevalent. The perirhinal and postrhinal/parahippocampal cortices, in turn, provide a major input to the superficial layers II and III of the entorhinal area, and these layers further receive inputs from olfactory structures, the amygdala, and from the remaining two components of the parahippocampal region, i.e. the *pre- and parasubiculum*. Neurons in entorhinal layers II and III, which are the recipients of this wide variety of inputs, give rise to the major cortical input to the hippocampus, the so-called *perforant pathway*. This name is derived from the traditional descriptions by Ramon y Cajal who noted that fibers from the entorhinal cortex perforate the underlying white matter and the cortical lamina of the subiculum, to gain access to the dentate gyrus molecular layer. In order to understand the potential functioning of the system, it is critical to point out that the perforant pathway projection harbors two different systems. Layer II cells distribute their axons to most, if not all of the dentate gyrus, as originally described, but also to CA3. It is now well established that cells in one particular subdivision of the entorhinal area, generally referred to as lateral entorhinal area distribute their axons exclusively to the most distal portions of the dendrites of dentate and CA3 cells. The other entorhinal subdivision, referred to as medial entorhinal area, sends its projection to the middle portions of the apical dendrites of cells in dentate and CA3. This laminar organization implies that a single dentate or CA3 neuron receives both pathways. The second pathway connecting entorhinal area to hippocampal formation originates from layer III cells and

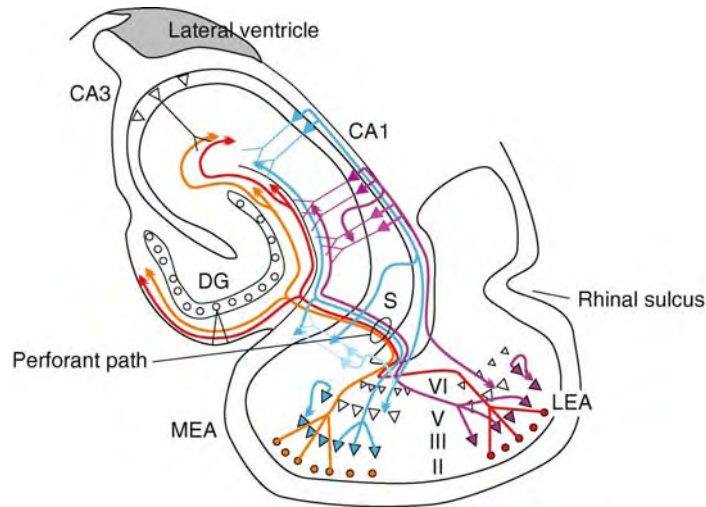

**Hippocampal Formation. Figure 3** Schematic representation of the intrinsic connectivity of the hippocampal formation and its main connectivity with the *entorhinal area*. The entorhinal area is subdivided into lateral (LEA) and medial subdivisions (MEA). Layer II projections from both subdivisions (red and yellow respectively) target different dendritic segments in DG and CA3. Layer III projections (purple and blue respectively) target different populations of neurons in CA1 and subiculum. Connections between CA1 and subiculum as well as projections from both back to LEA and MEA are in register, as are the connections between deep and superficial layers of both entorhinal subdivisions.

distributes to CA1 and the subiculum. In contrast to the laminar pattern as described for the lateral and medial layer II components, axons of layer III cells only target restricted groups of the available neurons in CA1 and the subiculum. The unidirectional projections from CA1 to the subiculum show a strikingly similar selective organization. This results in a pattern of connectivity such that neurons in CA1 and subiculum that share either inputs from the lateral entorhinal area or from the medial entorhinal area are interconnected (Fig. 3). Field CA1 and the subiculum constitute the major output structures of the hippocampal formation. This output is distributed by way of projections back to the deep layers of the entorhinal area and these projections are organized such that they reciprocate the input pathways from the superficial layers of the entorhinal area [1].

The *fornix* is a major fiber bundle that connects the hippocampus to the hypothalamus, in particular the ► **mammillary bodies**. The fornix carries fibers that originate from CA3, CA1, and subiculum, although parahippocampal cortices, in particular the pre- and parasubiculum and to a much lesser extent the entorhinal cortex contribute fibers. The CA3 fibers mainly distribute to the *septal area* and the contralateral hippocampal formation. Fibers from CA1 and subiculum en route to the *mammillary bodies*, issue collaterals to the *septal area*, the *ventral striatum*, and the *amygdala*. The fornix also carries the fibers from CA1 and subiculum targeting parts of the *prefrontal cortex*. The fornix is not a pure output pathway since projections from the septal area to the hippocampus and

in part to the entorhinal area travel by way of the *fornix* as well. These septal afferents provide the hippocampal formation with most of its *cholinergic* inputs. The fornix also forms one of the input routes for the noradrenergic, serotonergic, and dopaminergic innervation to reach the hippocampal formation. Aminergic fibers also enter the parahippocampal region through a ventral route, through the parahippocampal region. Additional innervation from midline *thalamic* structures as well as from the *anterior complex of the thalamus* travels in part by way of the fornix. Finally, the commissural connections between the left and right hippocampi also partially travel by way of the fornix [1].

### Functional Organization

Together, the overall cortical-hippocampal circuitry indicates the presence of functionally different, parallel circuits. One of the pathways carries inputs through the perirhinal cortex-lateral entorhinal area into and away from the hippocampus, whereas the second mediates transfer of information from and to the parahippocampal/postrhinal cortex-medial entorhinal area. These two pathways differ with respect to the types of information being transferred in that the first most likely deals with information about items (“what” information), whereas the second deals more with context (“where” information). In view of the anatomical organization outlined above it has thus been suggested that in the hippocampus these two pathways converge at the level of the dentate gyrus

and CA3, whereas they are kept more or less separate at the level of CA1 and the subiculum. This suggests that the hippocampal formation comprises two functionally different systems of which the dentate/CA3 system most likely mediates the rapid and efficient storage and recall of conjunctive (associated) information [2].

Structurally, the hippocampal formation looks apparently homogeneous along its long axis. However, the dorsal/posterior portion of the hippocampus receives its major cortical input from the more sensory-related or exteroceptive lateral and caudal portions of the entorhinal area, whereas the ventral/anterior hippocampus receives inputs from more ventromedial parts of the entorhinal cortex, which most likely convey information that reflects the interoceptive status of the individual. In addition, direct reciprocal connections with the amygdala are limited to the ventral/anterior and intermediate levels of the hippocampus and are absent for the dorsal/posterior portion of the hippocampal formation [1]. Behavioral data in support of this notion are the findings that in rats the dorsal hippocampus is critical for the initial learning and long-term memory of spatial information, whereas the ventral hippocampus appears not to be essential [3]. Recently, brain imaging studies have revealed that in humans also functional differences are present between anterior and posterior portions of the hippocampal formation; however the precise nature of these differences is still an issue of debate [2].

There is an overall emphasis on the role of the hippocampal formation in learning and memory processes and a related emphasis on the corticocortical connectivity. However, the hippocampal formation also communicates with a number of subcortical structures, including the ventral striatum and the amygdala. In the ventral striatum, interactions may take place between hippocampal, amygdaloid and prefrontal information, leading to the selection of appropriate behavioral strategies, for example in learning paradigms. The functional relevance of the reciprocal connections between the amygdala and hippocampus are likely an essential component of our motivational system providing the hippocampal formation with a marker for relevance to a particular memory episode and providing the amygdala with easy access to previously stored information. Finally, normal functioning of the hippocampal formation, and more generally its interactions with the cortex, depend strongly on a functional septal complex, and the cholinergic inputs that originate from it [4].

### Clinical Relevance

The hippocampal formation plays a critical role in mediating memory for relevant relationships among

conjunctions or associations unique to a particular episode [2]. Damage to the hippocampal formation is a hallmark of patients suffering from (early phase) Alzheimer's disease and patients suffering from *temporal lobe epilepsy*. In both groups of patients, damage is not confined to the hippocampal formation, but quite commonly includes additional damage in the *parahippocampal cortex* as well as diverse levels of cortical degeneration, depending on the state and severity of the disease. The resulting memory deficits seen in these patients are most likely the result of malfunction of the hippocampal-parahippocampal-cortical route. In contrast, short lasting ischemic accidents reportedly result in damage confined to the hippocampal formation, in particular to CA3 and CA1, resulting in an amnesic syndrome as well [5]. Perinatal asphyxia, a shortage of oxygen for a short period around birth results in damage of the hippocampal formation that has been suggested to be related to cognitive memory impairment and schizophrenia [6]. Hippocampal functions are strongly dependent on stress and in case of posttraumatic stress disorder both the volume and functional integrity of the hippocampal formation are diminished [7].

The *fornix* provides the hippocampus with another pathway, beside the cortical route, to communicate with a host of subcortical brain structures, including the mammillary bodies. The hippocampal-mammillary connection is part of the traditionally described *limbic or Papez* circuit, which includes the mammillothalamic tract connecting the mammillary bodies to the anterior complex of the thalamus, which in turn project to large portions of the limbic cortex, including anterior and posterior cingulate cortex, and pre- and parasubiculum. All these structures, in turn, provide input to the hippocampal formation, either directly, or indirectly by way of the entorhinal area. The role of the fornix-pathway in learning and memory is as yet poorly understood. Lesions of the fornix, although rare, have been described and result in impairment in recall, but not in recognition memory [8]. Lesions of the main target of the fornix, i.e. the mammillary complex in animals do not result in marked memory deficits. In Korsakoff's patients, which do show a marked anterograde as well as retrograde memory deficit, the mammillary bodies show a marked decrease in volume. However a comparable atrophy of the mammillary bodies is observed in cases of Wernicke's encephalopathy that do not present amnesic symptoms. The differentiating lesion between the two groups is the anterior complex of the thalamus [9]. Interestingly, there is now convincing evidence that in cases of ►diencephalic amnesia the critical lesion disconnects the mammillary bodies from the anterior nuclei [10].

## References

1. Witter MP, Amaral DG (2004) The hippocampal region. In: Paxinos G (ed) *The rat brain*, 3rd edn. Elsevier, San Diego, CA, US, London, UK, pp 637–703
2. Eichenbaum H, Yonelinas AR, Ranganath C (2007) The medial temporal lobe and recognition memory. *Annu Rev Neurosci* Apr 6; [Epub ahead of print]
3. Moser MB, Moser EI (1998) Functional differentiation in the hippocampus. *Hippocampus* 8:608–619
4. Hasselmo ME, Giocomo LM (2006) Cholinergic modulation of cortical function. *J Mol Neurosci* 30:133–135
5. Gold JJ, Squire LR (2006) The anatomy of amnesia: neurohistological analysis of three new cases. *Learn Mem* 13:699–710
6. Haan HM de, Wyatt JS, Roth S, Vargha-Khadem F, Gadian D, Mishkin M (2006) Brain and cognitive-behavioural development after asphyxia at term birth. *Dev Sci* 9:350–358
7. Shin LM, Rauch SL, Pitman RK (2006) Amygdala, medial prefrontal cortex, and hippocampal function in PTSD. *Ann N Y Acad Sci* 1071:67–79
8. Aggleton JP, McMackin D, Carpenter K, Hornak J, Kapur N, Halpin S, Wiles CM, Kamel H, Brennan P, Carton S, Gaffan D (2000) Differential cognitive effects of colloid cysts in the third ventricle that spare or compromise the fornix. *Brain* 123:800–815.
9. Harding A, Halliday G, Caine D, Kril J (2000) Degeneration of anterior thalamic nuclei differentiates alcoholics with amnesia. *Brain* 123:141–154
10. Van der Werf YD, Witter MP, Uylings HB, Jolles J (2000) Neuropsychology of infarctions in the thalamus: a review. *Neuropsychologia* 38:613–627

## Hippocampal Region

► Hippocampal Formation

## Hippocampus

### Definition

A part of the brain located in the medial temporal lobe with the shape of a seahorse that is involved in memory and neuroendocrine regulation.

► Neuroendocrinology of Psychiatric Disorders

## Hippocampus: Organization, Maturation, and Operation in Cognition and Pathological Conditions

YEHEZKEL BEN-ARI, ALFONSO REPRESA  
INMED, INSERM U29, Université de la Méditerranée,  
Campus de Luminy, Marseille, France

### Synonyms

Place cells; Sensory integration; Maps; Context; Synaptic plasticity; Rhythms

### Definition

The hippocampus is a primitive cortex that plays a central role in memory processes. It is endowed with a relatively simple organization that has served as a template for the determination of cellular and network mechanisms. The sequential maturation of hippocampal neurons and synapses has been extensively investigated and its principles confirmed in other brain structures. The hippocampus is amongst the most vulnerable brain structure to seizures and cerebrovascular infarcts, and studies on hippocampal insults provided most of our understanding on the mechanisms that underlie major neurological disorders.

### Characteristics

#### The Hippocampus has a Laminar Organization

The hippocampus is an important brain structure of the limbic system located in the temporal lobe. It is composed of three major fields ([Fig. 1a](#)) the dentate gyrus, the Ammon's horn with the CA1, 2, and 3 fields, and the subiculum. This simple cortex is composed of one main layer of glutamatergic granule cells and pyramidal neurons and a large variety of GABAergic interneurons distributed within the main cellular layer and the neuropile. The principal input of the hippocampal formation has its origin in the ► [entorhinal cortex](#) and targets mainly granule cells. Within the Ammon's horn, there is a tri-synaptic glutamatergic circuit that links dentate gyrus to CA3 (via mossy fibers), CA3 to CA1 (via Schaffer' collaterals), and CA1 to subiculum. The main output from the hippocampus originates in the subiculum and projects via the cingulum and fimbria fornix to other limbic areas (including the contralateral hippocampus and the entorhinal cortex). GABAergic interneurons compose a large variety of neuron classes located within the main cellular and neuropile layers ([Fig. 1b](#)), which differ by electrophysiological (intrinsic membrane properties and temporal firing patterns) and morphological (location, axonal distribution, peptides

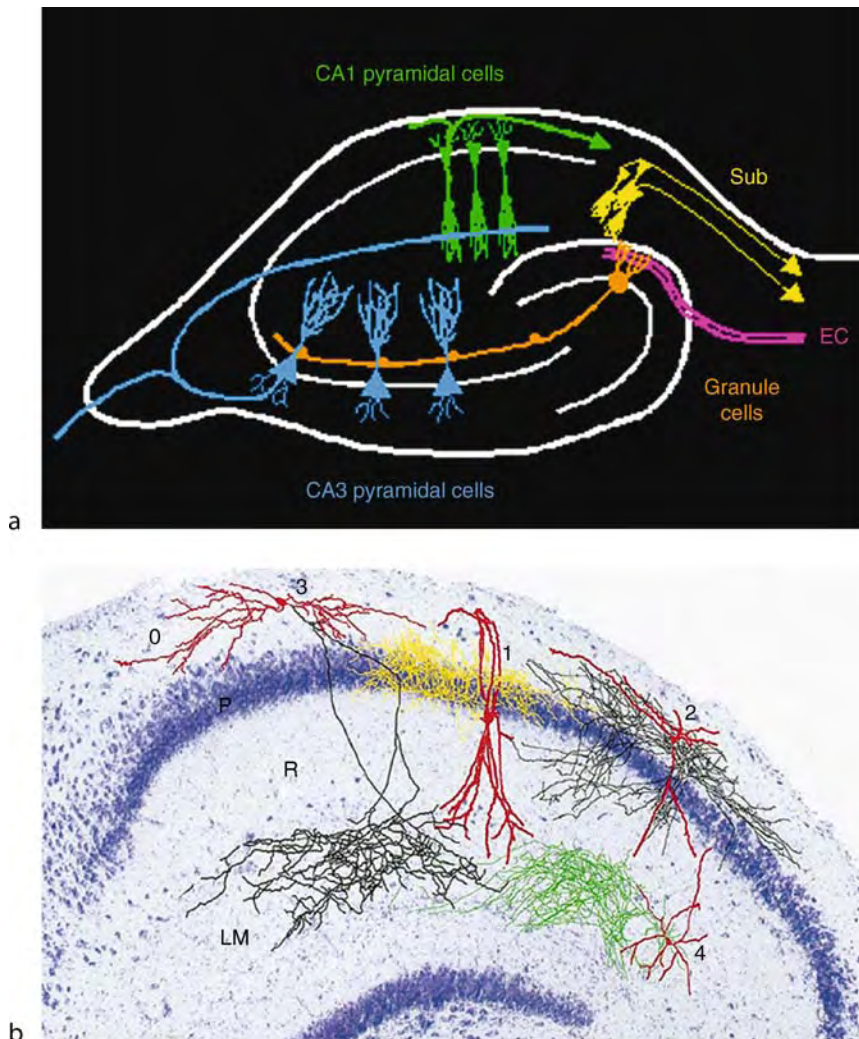

### Hippocampus: Organization, Maturation, and Operation in Cognition and Pathological Conditions.

**Figure 1** Hippocampal network and neuronal types. (a) Schematic representation of an hippocampal section depicting the different fields and the main excitatory network. Afferents from entorhinal cortex (EC) innervate mainly dentate granule cells. The axons of the later innervate CA3 pyramidal neurons, which in turn innervate CA1 pyramidal cells. Axons from CA1 pyramidal neurons innervate the subiculum (Sub), which constitutes the main output gateway of the hippocampal complex. (b) Photomontage depicting a CA1 field Nissl stained (blue) and biocytine reconstructed interneurons. Axonal trees (in different colors) allow the identification of different interneuron classes, some innervating depict the terminals the cell body of principal neurons (in yellow) and other targeting neuropile layers (in black or green).

that they express) features, and can schematically be segregated into three groups: (i) interneurons responsible for the feedback inhibition of principal cells, group represented mainly by basket cells and axo-axonic cells. They innervate the cell body and axonal initial segment of principal neurons, respectively, and are innervated by axon collaterals emerging from the later. (ii) interneurons responsible for the feed-forward inhibition of principal cells (e.g., bistratified neurons and O-LM (*oriens-lacunosum moleculare*) cells), which innervate the dendrites of principal neurons and are innervated by excitatory axons that also innervate the later.

(iii) interneurons innervating other interneurons, which compose a complex population of diverse cell types (e.g., back-projecting cells). Interneurons play a central and differential role in modulating the precise input–output transformation during the generation of behaviorally relevant network oscillations (see later).

### The Hippocampus is a Central Structure for Learning and Memory Processes

The hippocampus, with the entorhinal cortex, has an essential role in the formation of new memories (episodic or autobiographical memory) and participates with



the temporal lobe memory system in declarative memory. Damage to the hippocampus results in profound difficulties in forming new memories. Thus, in the classical “HM patient case” report [1], removal of medial temporal lobes, including entorhinal cortex and hippocampus led to severe anterograde amnesia. Though this type of lesions might also affect the access to memories prior to the damage (retrograde amnesia) relatively older memories were spared. These and other observations suggest that memory consolidation requires a transfer from the hippocampus to other brain areas. Other types of memories (e.g., procedural, semantic) do not require the contribution of the hippocampus.

Studies in experimental animals revealed the presence of “▶place cells,” in both the hippocampus and the entorhinal cortex [2], that fire when the animal is within a particular location. The majority of these neurons are sensitive to head direction and direction of travel.

In addition, interactions between olfactory cortices and the hippocampus support sensory discrimination functions (“▶odor cells”). The olfactory input accesses the hippocampal formation via a polysynaptic pathway mediated by the lateral and rostral entorhinal cortex.

Context-dependent cells that alter their firing pattern according to the animal’s past (retrospective) or expected future (prospective) have also been described. It was proposed that the entorhinal cortex contains a directionally oriented, topographically organized neural map of the spatial environment [2]. Recent studies in epileptic patients with deeply implanted electrodes have revealed place cells, thus reinforcing the suggestion that in human as in rats the hippocampus might act as a cognitive map involved in the representation of environmental plan, which plays an important role in spatial memory tasks.

Extensive investigations on cellular substrate of memory processes suggest that a brief period of enhanced stimulation generates a persistent increase of the synaptic response [3]. The mechanisms underlying this long-term potentiation (LTP) of synaptic efficacy are thought to include a NMDA-receptor-mediated post-synaptic rise of calcium that triggers a cascade of signals leading to a postsynaptic increase of the density of AMPA receptors. However, it is not yet clear whether the changes that underlie maintenance of LTP also underlie memory consolidation.

### The Hippocampus Generates Behaviorally Relevant Network Driven Oscillations

Synchronous firing of ensembles of neurons has been found in many regions of the brain. It is thought that a temporal organization of activity is required for neuronal integration, coincidence detection, and discrimination of information. Behaviorally relevant neuronal oscillations occur at different frequencies. In the hippocampus, three types of oscillations have been described [4]: (i) theta oscillations (4–10 Hz), which are linked to body

movements, memory tasks, and rapid-eye-movement sleep. They involve CA1 pyramidal neurons and mainly place cells during navigation. Interestingly, dendrite-innervating O-LM and bistratified cells discharge with highest provability at the trough of the pyramidal layer theta whereas the perisomatic interneurons (basket and axo-axonic) discharge on average at earlier phases of the theta cycle. (ii) sharp-wave-associated high-frequency ripples (120–200 Hz) of around 100-ms duration; they occur during slow-wave sleep and consummatory behaviors and concerned mainly pyramidal neurons. Basket cells and bistratified cells increase their frequencies of discharge during these ripple episodes while the firing of O-LM cells was suppressed. (iii) gamma oscillations (30–800 Hz) that occur at different brain states. They often coexist with theta oscillations.

### Basic Rules in the Maturation of the Hippocampus GABAergic Interneurons and Synapses Mature Before Glutamatergic Ones

Relying on BrdU dating techniques, several studies have identified several developmental gradients – earlier maturation of CA3 than CA1, late postnatal development of the fascia dentate, lateromedial gradient, etc. GABAergic interneurons divide and mature before principal neurons. Granule cells of the fascia dentate develop at later stages suggesting that the gate control of the Ammon’s horn is not operative until a relatively late stage. GABAergic synapses that impinge on other GABAergic neurons and on pyramidal glutamatergic neurons are also established first. Therefore, GABAergic currents will provide most of the activity at an early developmental stage. This gradient has been confirmed in various species including primates in utero [5,6].

### GABA Exerts Paracrine Actions on Neurons Prior to Synapse Formation

Immature neurons express functional receptors prior to the formation of synapses [5]. These receptors act as sensors of extracellular GABA as reflected by the large tonic currents generated by GABA receptor antagonists that also reduces significantly neuronal migration. This has important implications as GABA-acting drugs notably antiepileptic ones affect neuronal migration and constitute potential sources of heterotopic neuronal assemblies.

### GABA Excites Immature Neurons Because of a Higher $[Cl^-]_i$

GABA excites immature neurons consequently to a higher intracellular concentration of chloride ( $[Cl^-]_i$ ) that has been confirmed and extended to all brain structures and animal species investigated, suggesting that this feature has been preserved throughout evolution. GABA generates sodium action potentials, calcium currents and removes the voltage dependent  $Mg^{2+}$

blockade from NMDA channels at an early stage [6]. The developmental reduction of  $[Cl^-]_i$  and the excitatory to inhibitory shift is mediated by the delayed maturation of a chloride extruder. Early excitatory actions of GABA provide the source of calcium increase needed for neuronal growth and synapse formation while avoiding toxic actions of glutamate. An interesting illustration of this sequence is shown by the abrupt drop of  $[Cl^-]_i$  that occurs immediately before delivery (Fig. 2) [7]. This transient shift to inhibitory GABA is mediated by maternal hormone oxytocin released to start labor. This mechanism has a neuroprotective action as oxytocin augments the resistance of neurons to anoxic insults [7]. Therefore, the fetus is informed that delivery is to commence and protected from labor-associated insults by the hormone. This has important clinical implications notably in relation to preterm deliveries. GABA exerts also important trophic roles in neuronal and network construction [5]. Therefore, the regulation of  $[Cl^-]_i$  has a major impact on brain development.

#### The Immature Hippocampal Network Generates a Primitive Universal Pattern

Immature rodent hippocampal neurons generate until the 2nd week postnatal a pattern called giant depolarizing potentials (GDPs). This pattern is the first synapse-driven pattern in the hippocampus and consists of large polysynaptic events that provide most of the activity as long as a substantial proportion of GABAergic synapses are excitatory [6]. Similar patterns have been observed in a wide range of structures and animal species. GDPs are generated by depolarizing GABA that removes the voltage-dependent  $Mg^{2+}$  block from NMDA channels, thus generating large synaptic currents

that activate most neurons in the population [6]. GDPs are primitive events that are replaced by behaviorally relevant patterns. Prior to GDPs, nonsynapse-driven patterns have been described; their generation relies primarily on voltage-gated currents.

#### Pathology

##### Epilepsies

#### Excitatory GABA Plays a Central Role in Epileptogenesis of the Developing Brain

The incidence of seizures is highest at an early developmental stage in humans and in immature experimental animals. The excitatory actions of GABA contribute at early developmental stages to seizure generation as shown by the observation that GABA receptor antagonists can fail to trigger seizures and often aggravate them in immature neurons. Excitatory GABA also plays a central role in the consequences of seizures. Thus, in human epileptic slices removed during surgical interventions, GABA excites a substantial number of neurons because of a persistent increase of  $[Cl^-]_i$  [8]. A similar return to immature actions of GABA that has been reported after a variety of insults is due to downregulation of the main chloride cotransporter KCC2. In vitro, in a preparation that includes the two intact hippocampi, propagation of seizures from one hippocampus to the other transforms the latter to a permanent epileptogenic mirror focus. Activation of GABA and NMDA receptors is essential in that process, as antagonists of these receptors prevent this change. GABA excites neurons in the newly formed mirror focus, confirming the central role of  $[Cl^-]_i$  in epileptogenesis [5]. Thus, epileptogenesis recapitulates ontogenesis: clearly, alterations of  $[Cl^-]_i$  and GABA

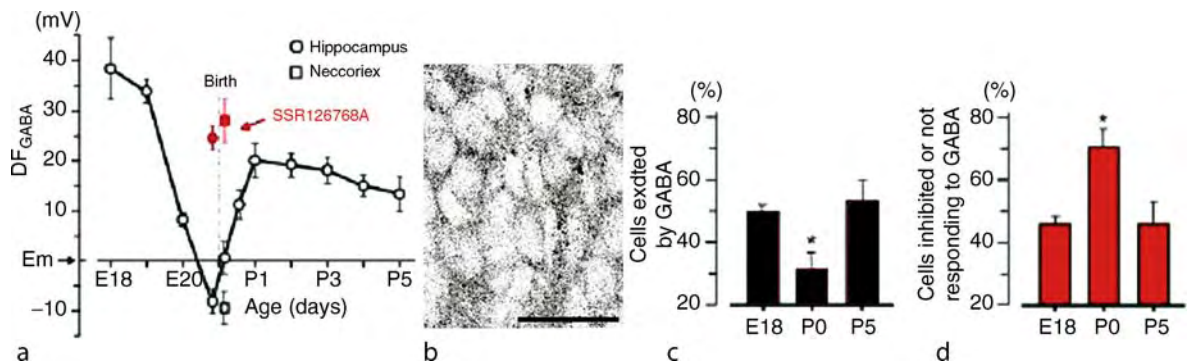

#### Hippocampus: Organization, Maturation, and Operation in Cognition and Pathological Conditions.

**Figure 2** Developmental changes on GABA actions and oxytocin. (a) Summary plot of the age dependence of GABA driving force ( $DF_{GABA}$ ) inferred from single  $GABA_A$  channels recordings.  $DF_{GABA}$  is strongly depolarizing in fetal and postnatal periods. However,  $DF_{GABA}$  negatively shifted during a brief near-term period (from E20 to P0) to a hyperpolarizing value. Red indicates pretreatment with oxytocin receptor antagonist SSR126768A, which abolishes this transient shift indicating that this parturition hormone mediates the effect. (b) Hippocampal neurons from a newborn rat immunolabeled with oxytocin receptor antibodies. (c, d) Histograms of the averaged fraction of cells excited (c) or inhibited or nonaffected (d) at different ages as recorded using bi-photon calcium imaging analysis. For more information, see [7].

actions are key elements in epilepsies and other neurological disorders.

### **The Hippocampus is a Key Player in Temporal Lobe Epilepsies**

The hippocampus is amongst the most susceptible brain structures to seizures and is affected in temporal lobe epilepsies (TLE), amongst the most frequent

drug-resistant type of epilepsies. Hippocampal sclerosis, the most common pathological substrate of TLE, is characterized by neuronal loss (both pyramidal neurons and GABAergic interneurons) and gliosis, axonal sprouting (mainly of mossy fibers; (Fig. 3), and granule cell dispersion. Studies using first the kainic acid model of TLE and then the pilocarpine model have provided most of present understanding as to how seizures

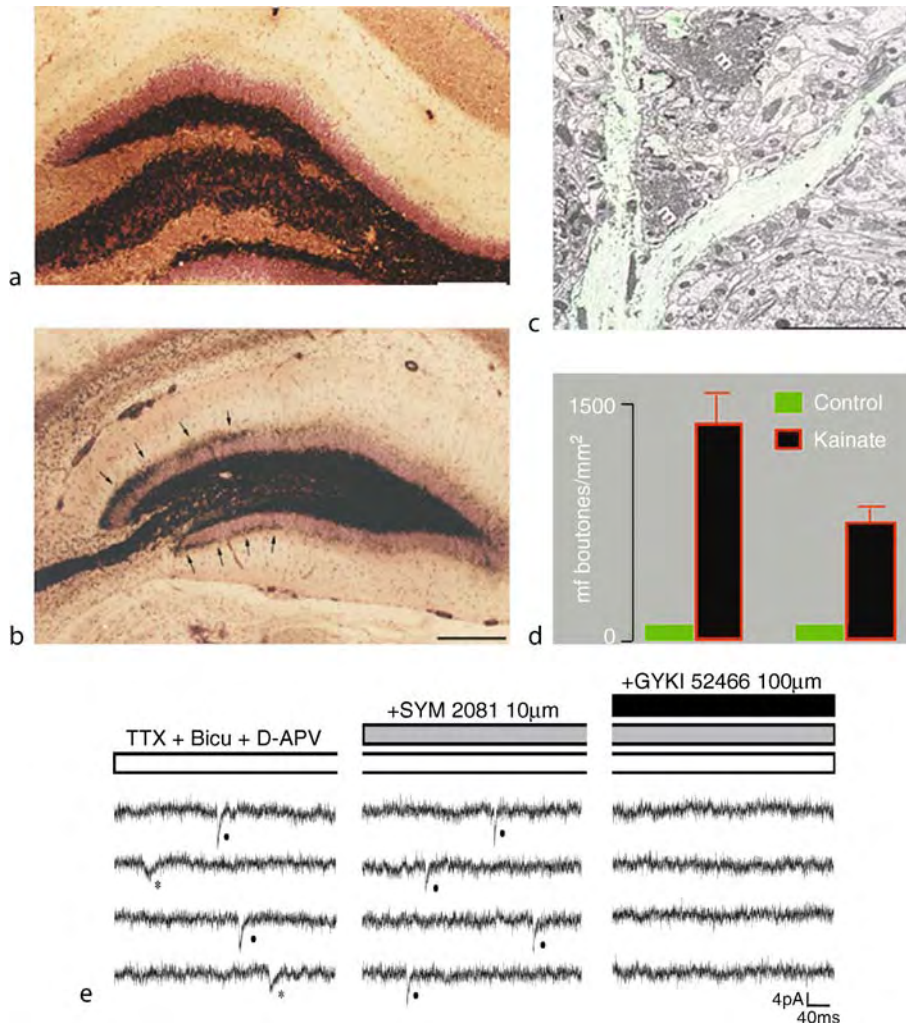

### **Hippocampus: Organization, Maturation, and Operation in Cognition and Pathological Conditions.**

**Figure 3** Sprouting and synaptogenesis of mossy fiber collaterals in experimental temporal lobe epilepsy. (a, b) TIM staining of hippocampal mossy fibers of control (a) and chronic epileptic (b) rats. Arrows depict the inner molecular layer invaded by mossy fiber terminals. (c) Electron microscopy micrograph from a chronic epileptic rat. Dendrites of a granule cell (overstained in green) are contacted by three giant mossy boutons (m). (d) Histograms depicting the mean density of mossy boutons in the inner molecular layer in control and chronic epileptic (30 days after kainate treatment) rats. (e) In epileptic rats, recurrent mossy fibers act through the activation of glutamate receptors of AMPA and kainate types. Miniature excitatory postsynaptic currents (mEPSC) were recorded in granule cells of chronic epileptic rats in the presence of 1 μM TTX, 10 μM bicuculline (Bicu), and 40 μM D-APV (to block voltage-gated fast sodium channels, GABA<sub>A</sub>, and NMDA receptors, respectively). Slow events (asterisk) are mediated by glutamate receptors of kainate type, because they are blocked by 10 μM SYM 2081. Fast events (filled circle) are mediated by AMPARs, because they are SYM 2081 resistant and abolished by 100 μM GYKI 52466. Bars = 500 μm (a, b), 100 μm and 10 μm (d) (for more information, see [9]).

produce neuronal cell loss and reactive sprouting. With the seizure-induced death of hilar mossy cells, mossy fiber axons redirect new collaterals to the inner molecular layer of the dentate gyrus and innervate granule cell dendrites, thus creating a hyperexcitable recurrent circuit that predisposes the hippocampus to paroxysmal firing. In addition, various GABA neurons – notably the O-LM interneurons – degenerate leading to a loss of inhibition on the apical dendrites of the principal cells. Therefore, a partial chronic destruction of the inhibitory drive – particularly that impinges on the dendrites of principal cells – plays an important role in TLE. In addition, newly formed aberrant mossy fiber synapses differ from control ones: thus, although control mossy fiber granule cells synapses operate by AMPA receptors only, newly formed mossy fiber synapses in the epileptic tissue are operated partly by kainate receptors [9] (Fig. 3). Therefore, the epileptic state is characterized not only by a synaptic reorganization but also by a change of the receptor type, thus conferring unique properties to the network. To sum up, the plasticity that is endowed in hippocampal synapses is also largely responsible for the major implication of this structure in epilepsies.

#### **Anoxo-Ischemic Insults**

In experimental animal models, brief episodes of global ischemia destroy selectively CA1 pyramidal neurons and various interneurons. Quite similar pathological insults have been reported following anoxic episodes in humans, suggesting that this region is also susceptible to interruption of oxygen and glucose. Underlying mechanisms include an excitotoxic release of glutamate that leads to cell death. However, although NMDA receptor antagonists reduce the damage in experimental animals, the mechanism and signaling cascade involved have not been elucidated.

#### **Alzheimer Disease**

It is widely accepted that the hippocampus as assessed by MRI volumetric analysis is atrophied early in Alzheimer disease patients and in patients with age-associated memory impairment [10]. Consequently, deficits on short-term and anterograde memory are the first clinical manifestations observed in patients with Alzheimer's disease that lose the estimation of time and place even in familiar locations and experience confusion. Hippocampus atrophy may also occur in other forms of dementia, like Lewy body dementia, frontotemporal lobe degeneration, and vascular dementia.

#### **References**

1. Deweer B, Pillon B, Pochon JB, Dubois B (2001) Is the HM story only a "remote memory"? Some facts about hippocampus and memory in humans. *Behav Brain Res* 127:209–224
2. Hafting T, Fyhn M, Molden S, Moser MB, Moser EI (2005) Microstructure of a spatial map in the entorhinal cortex. *Nature* 436:801–806
3. Lynch MA (2004) Long-term potentiation and memory. *Physiol Rev* 84:87–136
4. Somogyi P, Klausberger T (2005) Defined types of cortical interneurone structure space and spike timing in the hippocampus. *J Physiol* 562 (Part 1):9–26
5. Ben-Ari Y, Gaiarsa JL, Tyzio R, Khazipov R (2007) GABA: a pioneer transmitter that excites immature neurons and generates primitive oscillations. *Physiol Rev* 87(4):1215–1284
6. Ben-Ari Y, Khazipov R, Leinekugel X, Caillard O, Gaiarsa JL (1997) GABAA, NMDA and AMPA receptors: a developmentally regulated 'menage a trois.' *Trends Neurosci* 20(11):523–529
7. Tyzio R, Cossart R, Khalilov I, Minlebaev M, Hübner CA, Represa A, Ben-Ari Y, Khazipov R (2006) Maternal oxytocin prepares fetal neurons to delivery by triggering an inhibitory switch in GABA signaling. *Science* 314:1788–1792
8. Cohen I, Navarro V, Clemenceau S, Baulac M, Miles R (2002) On the origin of interictal activity in human temporal lobe epilepsy in vitro. *Science* 298:1418–1421
9. Epsztein J, Represa A, Jorquera I, Ben-Ari Y, Crépel V (2005) Recurrent mossy fibers establish aberrant kainate receptor operated synapses on granule cells from epileptic rats. *J Neurosci* 25:8229–8239
10. Jack CR, Petersen RC, Xu YC, O'Brien PC, Smith GE, Ivnik RJ, Boeve BF, Tangalos EG, Kokmen E (1997) Medial temporal atrophy on MRI in normal aging and very mild Alzheimer's disease. *Neurology* 49:786–794

---

## **Hirsutism**

### **Definition**

Excessive hair growth in women in locations where the occurrence of hair normally is minimal or absent.

### **► Neuroendocrinology of Psychiatric Disorders**

---

## **Histamine**

### **Definition**

A biogenic amine neurotransmitter involved in the ascending arousal system. Anti-histamines that cross the blood brain barrier produce drowsiness. Brain cells that produce histamine are referred to as histaminergic cells and these cells are primarily located in the hypothalamus. Histamine created outside of the brain also has influence on peripheral tissues.

## Histochemistry

### Definition

Histochemistry is the branch of histology that deals with the chemical components of cells and tissues.

## Histofluorescence Technique

### Definition

Histofluorescence techniques employ the use of fluorescing agents to identify specific molecules in cells.

## Histone Acetylation in the Developing Central Nervous System

PATRIZIA CASACCIA-BONNEFIL, SIMING SHEN  
Robert Wood Johnson Medical School UMDNJ,  
Piscataway, NJ, USA

### Synonyms

Post-translational modification of lysine groups on histone tails; Acetylation of nucleosomal histones; Histone code

### Definition

► **Histone** acetylation defines a post-translational modification of histone proteins, which are the major component of the basic unit of ► **chromatin** called the ► **nucleosome**. Histone modifications and the ► **methylation** of specific regions of DNA modulate transcription by modifying chromatin structure and thereby define a mechanism of regulation of gene expression called ► **epigenetics**.

Acetylation is the transfer of acetyl groups to the epsilon position of lysine residues in the tail of nucleosomal histones (Fig. 1). It is important to distinguish this modification from N-alpha-acetylation of eukaryotic structural proteins that occurs on alanine, serine, and methionine residues, and is catalyzed by N-acetyl-transferases.

Histone acetylation is catalyzed by a family of enzymes called histone acetyltransferases (HATs) and it is functionally correlated with transcriptionally competent chromatin. The removal of acetyl groups is catalyzed by a family of enzymes called histone deacetylases (HDACs or HDs) and is functionally correlated with transcriptionally inactive chromatin. Hence the ratio of HDAC to HAT activity determines the level of histone acetylation, one of the major epigenetic mechanisms regulating the inheritable pattern of gene expression on the progeny cells, without altering the DNA sequence. It is important to mention that although the core nucleosomal histone proteins H2A, H2B, H3 and H4 were originally identified as substrates for these regulatory enzymes, recent studies have reported an increasing number of non-histone cellular proteins that are also subject to acetylation of lysine residues [1].

### Characteristics

#### Histone Modifications

Reversible acetylation of selected lysine residues in the N-terminal tails of core histone proteins represents an efficient way to regulate gene expression [2]. In general, the removal of acetyl groups (i.e. histone deacetylation) mediated by HDACs keeps the positive charges on histone tails, promotes close contact of histone tails with negative charged DNA, and thereby prevents the accessibility of ► **transcription factors** and results in gene repression, characteristic of ► **heterochromatin** (Fig. 2). In contrast, the transfer of acetyl groups (i.e. histone acetylation) catalyzed by HATs neutralizes the positive charge on the N-terminal histone tails, loosens histone-DNA contacts and allows the access of

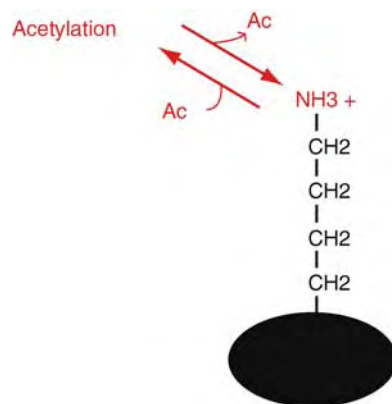

**Histone Acetylation in the Developing Central Nervous System. Figure 1** Acetylation and deacetylation of lysine residues. Histones are acetylated and deacetylated due to transfer or removal of acetyl groups on the epsilon position of lysine residues in the histone tails.

transcription factors and RNA polymerase II, thereby increasing transcriptional activity. This modification is associated with transcriptionally competent chromatin, which is structurally defined by a relaxed state (i.e. ►euchromatin) (Fig. 2).

Besides acetylation, the N-terminal tails of nucleosomal histones undergo several additional post-translational modifications that will not be extensively discussed in this chapter. They include methylation, phosphorylation, ►sumoylation, ►ubiquitination and ►citrullination. In addition, the same post-translational modification can either favor or repress gene expression, depending on the positional information. Methylation of lysine residues in the tail of histone H3, for instance, is associated with active transcription, if it occurs on lysine 4 and with repression, if it occurs on lysine 9 or 27. Therefore, the positional and combinatorial arrangement of distinct histone modifications on any given gene defines the “histone code,” which is

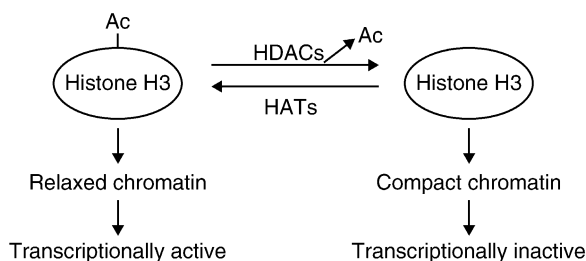

**Histone Acetylation in the Developing Central Nervous System. Figure 2** Post-translational modification of histones modifies the structural and functional state of chromatin. Schematic and simplified representation of the effects of acetylation and deacetylation of lysine residues of nucleosomal histones on chromatin.

essential in the induction of specific patterns of ►epigenetic inheritance.

### Enzymatic Activities Responsible for Histone Acetylation

The HAT family of mammalian histone acetyltransferases is composed of a growing number of family members, including GNAT, MYST and CBP/p300 families [3]. The GNAT (GCN-5-related-N-AcetylTransferases) family of HATs are characterized by sequence and functional similarity to the yeast gene Gcn5 and include members with a high degree of substrate specificity, including PCAF (Fig. 3). The MYST family (from the name of its founding members MOZ, Ybf2, Sas2 and Tip60) of acetyltransferases, shares with the GNAT family a region characterized by acetyl-CoA recognition and binding. One of the MYST members (i.e. MOZ) has been implicated in ►chromosomal translocations associated with oncogenic transformation.

P300 and CBP are structurally related and their homologues have been reported in a wide variety of multicellular organisms, including *Drosophila* and ►*C. elegans*, but not in yeast. These enzymes play a critical role in development especially of the nervous system, as shown by the phenotype of knockout mice.

### HAT Regulation of Gene Expression

Histone acetyltransferases like p300 and CBP have the ability to promote gene expression, by binding to specific transcription factors, as well as with basal components of the transcriptional machinery. Thus, HATs are part of co-activator complexes that render the chromatin accessible to transcription factors and to ATP-dependent chromatin remodeling complexes, thereby allowing efficient transcription by RNA pol II.

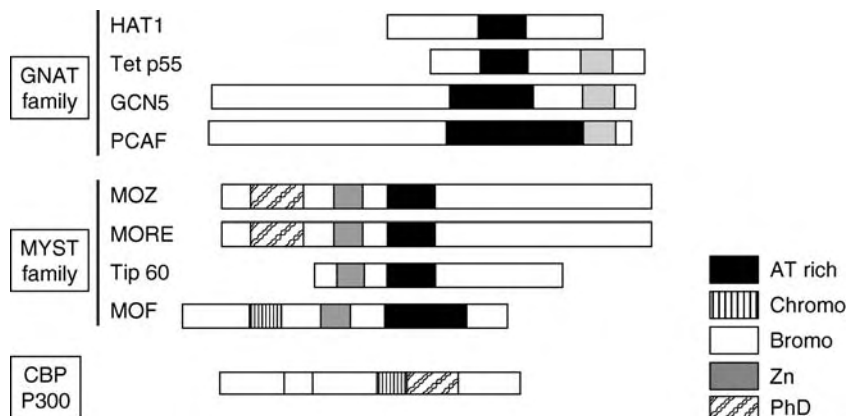

**Histone Acetylation in the Developing Central Nervous System. Figure 3** Histone acetyltransferases. Schematic representation and classification of distinct HAT family members. Note the structural similarities of the distinct domains that define each of the classes of HATs (adapted from [2]).

### Enzymatic Activities Responsible for Histone Deacetylation

HDACs are highly conserved enzymes from yeast to human [4,5]. Based on homology, mammalian HDACs can be broadly grouped into four major classes (Fig. 4). Class I is composed of small (377–488 amino acids) nuclear proteins, with a broad tissue expression pattern and includes the isoforms: HDAC-1, -2, -3 and -8. Class II is composed of cytosolic proteins of larger size (590–1215 a.a) with tissue-specific pattern of expression and includes: HDAC-4, -5, -6 -7, -9 and -10. Class III is composed of the NAD-dependent family of sirtuin proteins (SIRT1–7). These molecules are sensitive to the redox state of the cell and are inhibited by a different category of pharmacological inhibitors than the previous two classes. Class IV is composed of a single member, HDAC11, an isoform with the catalytic domain and conserved amino acid sequence of the active site of class I HDAC and the expression pattern limited to brain, heart, muscle and kidney, characteristic of class II HDACs.

### HDAC Regulation of Gene Expression

HDACs down-regulate gene expression by forming repressive complexes with transcription factors and co-repressors, thereby modifying chromatin structure and recruiting additional protein complexes involved in histone and DNA methylation. HDAC-complexed co-repressors include: Sin3, SMRT (Silencing Mediator of Retinoic and Thyroid hormone receptors), Groucho/TLE, N-CoR (Nuclear Co-Repressor), and Co-REST

(RE1 Silencing Transcription factors). These complexes are recruited to the ►promoter region of target genes by specific transcriptional inhibitors [6].

### Histone Acetylation in the Neuronal Lineage

Increasing evidence has shown that the level of histone acetylation has critical and varied functions during CNS development, such as cell fate specification and maturation. Neural stem cells (NSCs) are capable of self-renewal and have the ability to generate neurons, astrocytes and oligodendrocytes in an orderly manner. The plasticity of NSCs relies, at least in part, on the relatively relaxed chromatin structure of genes that are essential in maintaining the undifferentiated state (i.e. ►Sox2), as a result of histone acetylation. The progressive lineage restriction of these cells, requires a careful coordination with the exact timing of fate specification. An example of coordinated lineage progression modulated by chromatin modifications is the control of neurogenesis. In NSC cells and in multipotential progenitors, neuronal gene expression is prevented by the presence of repressive complexes containing the transcription factor REST, the co-repressor Co-REST and the histone deacetylases HDAC1 and 2 [7]. REST is a powerful repressor with the ability to recruit mSin3/HDAC1/2 complexes with its N-terminus and Co-REST/HDAC1/2 complexes with its C-terminus. The co-repressors, in turn, have the ability to recruit additional chromatin modifiers associated with gene silencing, thereby maintaining neuronal genes silent. This model explains why treatment of multipotential

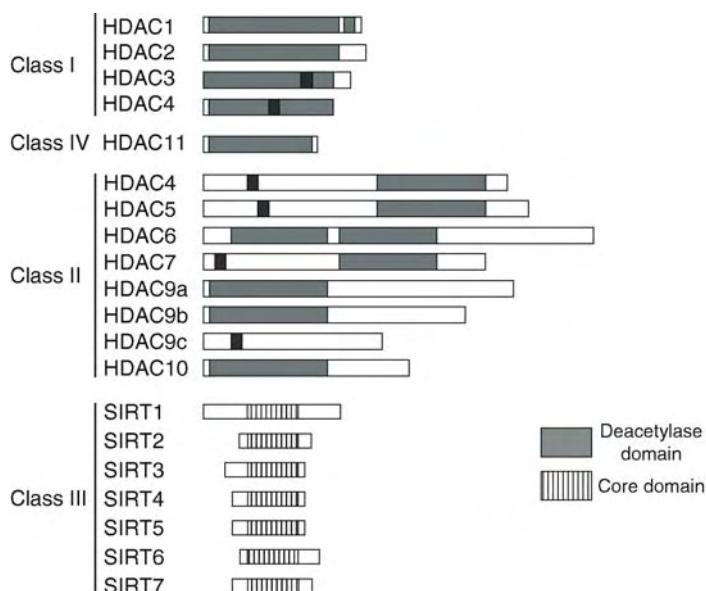

**Histone Acetylation in the Developing Central Nervous System. Figure 4** Histone deacetylases. Classification and sequence domains of the four classes of HDACs (adapted from [4,5]).

progenitors with HDAC inhibitors relieves REST-dependent repression and allows the expression of neuronal target genes [7].

During embryonic development, neuronal gene expression occurs when the inhibitory effect of REST is removed due to proteasomal degradation and transcriptional inactivation. By contrast, in adult neural stem cells REST-dependent neuronal gene expression has been linked to the conversion of ►REST from a repressor to an activator, due to a small double stranded non-coding RNA containing the REST specific RE1 sequence [7]. Regardless of the mechanism of REST inactivation, both embryonic and adult neural precursor share a similar mechanism of activation of neuronal gene expression that requires histone acetylation. Among the genes that promote neuronal differentiation and are regulated by histone acetylation, three basic helix-loop-helix (bHLH) transcription factors have been identified: ►NeuroD, ►Neurogenin (Ngn) and ►Mash1. This explains why treatment of embryonic or adult neural progenitors with HDAC inhibitors enhances neurogenesis at the expenses of gliogenesis and suggests that the neurogenic effect of HDAC inhibitors can be attributed, at least in part, to the direct activation of pro-neural transcription factors.

The REST-dependent modulation of neuronal gene expression in neural cells and multipotential progenitors, however, is very different from the one occurring in differentiated non-neuronal cells. In contrast to neural progenitors where silencing of REST target genes relies principally on histone deacetylation, in non-neuronal cells REST target genes are stably repressed by additional epigenetic modifications, including DNA methylation, tri-methylation of lysine 9 and stable chromatin condensation. This explains why treatment with HDAC inhibitors is not sufficient to induce REST-targeted gene expression in non-neuronal cells.

### Histone Acetylation in the Astrocytic Lineage

The differentiation of astrocytes from precursor cells has been defined by the expression of the intermediate filament protein glial fibrillary acidic protein (GFAP). Most of our current understanding of the epigenetic modulation of astrocytic differentiation is derived from studies on the regulation of the ►Gfap promoter. It was originally proposed that this gene was not expressed in undifferentiated embryonic precursors because of DNA methylation of the ►Gfap gene. Later studies confirmed these early findings and defined the presence of specific DNA methylation sites corresponding to binding regions for the transcription factor STAT in the ►Gfap promoter, as well as in the promoter of genes encoding signaling components of the ►JAK-STAT pathways. This was consistent with a vast literature supporting the astroglial potential of extracellular factors

enhancing the JAK-STAT signaling pathway, such as ►LIF and ►CNTF. It was later defined that ►Gfap promoter activation by STAT1/3 requires the recruitment of the histone acetyltransferases p300 and CBP [8]. Further, proneural transcription factors, such as neurogenin 1, prevented astroglialogenesis by inhibiting the formation of transcription factor/co-activator complexes. The importance of the HATs in astrocytic differentiation was further confirmed by the evidence that p300 is also recruited to the ►Gfap promoter by SMAD1, a downstream effector of the astroglial signal bone morphogenetic proteins (►BMPs). Therefore histone acetylation is clearly important for astrocytic differentiation because multiple astroglial signals regulate GFAP expression by recruiting the HATs (CBP/p300) to specific regions of the promoter.

### Histone Acetylation in the Oligodendrocytic Lineage

By analogy to the differentiation of neurons and astrocytes, it was proposed that histone acetylation could similarly regulate ►myelin gene expression during the differentiation of progenitors into myelin-forming cells. Transcriptional inhibitors, in complex with histone deacetylases and co-repressors, were identified on the promoter of myelin genes in oligodendrocyte progenitors. For instance, transcription factors Hes5 or Nrx2.2, in complex with the co-repressor Sin3A, were shown to recruit HDAC1 to the proximal region of the myelin basic protein (MBP) promoter. Similarly, the transcription factor Myt1, in complex with Sin3B, was shown to recruit HDAC1/2 to the proteolipid protein (PLP) promoter. This led to a model of myelin gene expression consequent to the displacement of the repressive complexes containing HDAC. The inference from this model was that treatment with HDAC inhibitors should promote myelin gene expression. In contrast to the prediction, the administration of HDAC inhibitors, such as trichostatin A (TSA) or valproic acid (VPA), prevented the differentiation of cultured progenitors into highly branched myelin gene expressing cells. Similar results were obtained *in vivo*, after systemic administration of HDAC inhibitors to neonatal rats and in ►hdac1 mutant zebrafish.

These surprising results revealed the need for alternative models that could explain the role of HDAC during oligodendrocyte progenitor differentiation. It is now well accepted that histone deacetylation is an essential event during a specific temporal window of progenitor differentiation. Global histone deacetylation occurs after cells have exited the cell cycle and is functionally related to decreased levels of inhibitors of morphological differentiation (i.e. stathmin) and of myelin gene expression (i.e. Id4) (Fig. 5). This model explains why pharmacological or genetic manipulations favoring histone acetylation prevent the differentiation of progenitors into myelin forming cells [9]. This arrested oligodendrocyte differentiation is



associated with the re-expression of markers of the undifferentiated state and is therefore suggestive of the reversal of oligodendrocyte progenitors to a multipotential state.

Together, these studies have suggested a model of oligodendrocyte differentiation as a multi-step process, characterized by the progressive epigenetic repression of inhibitory molecules, which is initially dependent on histone deacetylation. This model is also in agreement with early ultrastructural studies on the developing corpus callosum of neonatal rats reporting the progressive increase of chromatin compaction

in the nuclei of oligodendrocyte progenitors during differentiation.

In addition, this model predicts differences in the ability of oligodendrocyte lineage cells to be “reprogrammed” (Fig. 6). Progenitors are “reprogrammable” cells because the chromatin of genes affecting self-renewal is regulated by reversible HAT/HDAC-dependent post-translational histone modifications. Differentiated mature oligodendrocytes, in contrast, are not reprogrammable cells because the genes that are involved in the maintenance of the undifferentiated state are transcriptionally silent, due to more stable epigenetic modifications [10].

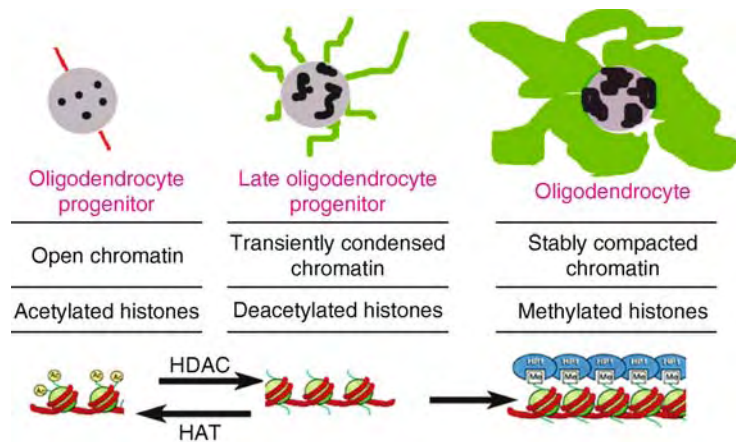

**Histone Acetylation in the Developing Central Nervous System. Figure 5** Model of progressive protein compaction during oligodendrocyte progenitor differentiation. Note that the HDAC dependent histone deacetylation in progenitors is the first and reversible step towards chromatin compaction, that is later followed by more permanent chromatin condensation, due to additional epigenetic modifications.

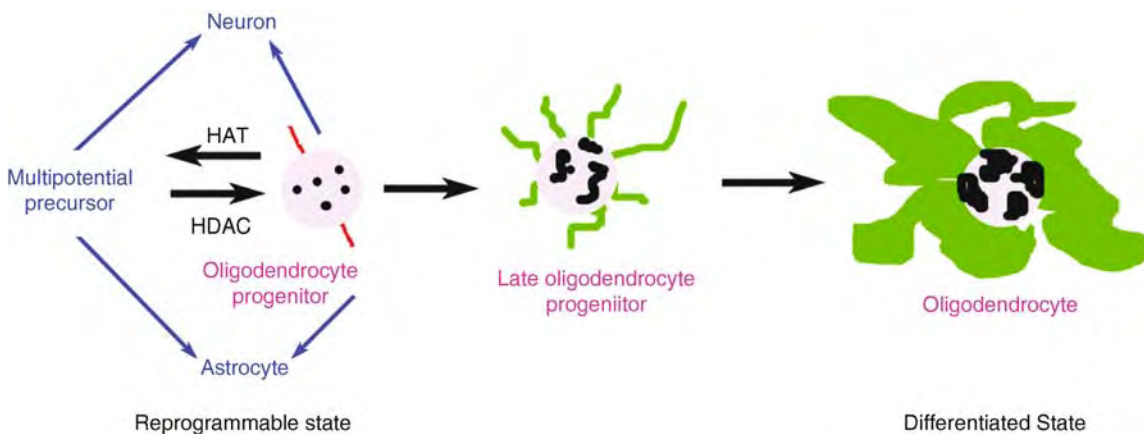

**Histone Acetylation in the Developing Central Nervous System. Figure 6** Two-step model of oligodendrocyte progenitor differentiation. Note that the transition between early and late progenitors is characterized by reversible modifications of nucleosomal histones, mediated by the activity of HAT and HDACs. This is a highly plastic and reprogrammable stage of development, which is later followed by a more stable chromatin compaction, characteristic of the differentiated state.

### Concluding Remarks

Epigenetics defines all the modifications of chromatin components that can affect gene expression. Transcriptionally active chromatin requires an open conformation that is dependent on the presence of acetyl groups on lysine residues in the tail of nucleosomal histones. When the acetyl groups are removed (by HDACs), chromatin is in a closed conformation and this renders the DNA inaccessible to specific transcription factors and results in transcriptional repression. These post-translational modifications of histones modulate the pattern of gene expression in distinct cell types, thereby modulating lineage specification and timing in the developing central nervous system.

### References

1. Yang XJ (2005) Multisite protein modification and intramolecular signaling. *Oncogene* 24:1653–1662
2. Kouzarides T (2007) Chromatin modifications and their function. *Cell* 128:693–705
3. Roth SY, Denu JM, Allis CD (2001) Histone acetyltransferases. *Annu Rev Biochem* 70:81–120
4. de Ruijter AJ, van Gennip AH, Caron HN, Kemp S, van Kuilenburg AB (2003) Histone deacetylases (HDACs): characterization of the classical HDAC family. *Biochem J* 370:737–749
5. Michan S, Sinclair D (2007) Sirtuins in mammals: insights into their biological function. *Biochem J* 404:1–13
6. Verdin E, Dequiedt F, Kasler HG (2003) Class II histone deacetylases: versatile regulators. *Trends Genet* 19:286–293
7. Ballas N, Mandel G (2005) The many faces of REST oversee epigenetic programming of neuronal genes. *Curr Opin Neurobiol* 15:500–506
8. Nakashima K, Yanagisawa M, Arakawa H, Kimura N, Hisatsune T, Kawabata M, Miyazono K, Taga T (1999) Synergistic signaling in fetal brain by STAT3-Smad1 complex bridged by p300. *Science* 284:479–482
9. He Y, Dupree J, Wang J, Sandoval J, Li J, Liu H, Shi Y, Nave KA, Casaccia-Bonnel P (2007) The transcription factor Yin Yang1 is essential for oligodendrocyte progenitor differentiation. *Neuron* (In press)
10. Kondo T (2006) Epigenetic alchemy for cell fate conversion. *Curr Opin Genet Dev* 16:502–507

## Histone Code

► [Histone Acetylation in the Developing Central Nervous System](#)

## Histones

### Definition

The main protein component of chromatin that act as spools around which DNA wraps.

## History-Dependent Properties of Skeletal Muscle

DAVID C. LIN

Programs in Bioengineering and Neuroscience,  
Washington State University, Pullman, WA, USA

### Definition

History-dependent muscle properties refer to the fact that muscle force not only depends entirely upon the instantaneous ►kinematic conditions, but also upon the occurrence of prior movements.

### Characteristics

#### Quantitative Description

A fundamental concept in the functional characterization of skeletal muscle contractile properties is that the force generated by the muscle depends upon the ►kinematics of the movement, namely the length and velocity of the muscle. Thus, muscle mechanical properties are generally defined by the way force varies with muscle length (i.e. the force–length relationship) and velocity (i.e. the force–velocity relationship). The measurement of mechanical properties is usually made by controlling the particular ►kinematic variable of interest and measuring the force produced by the muscle. Moreover, the measurement of mechanical properties is usually performed after imposition of a steady-state isometric condition (constant length and activation) for a relatively long duration. However, prior movement before the measurement of force under the controlled ►kinematic condition influences that measurement. This essay reviews how movement history influences the mechanical properties of muscle, the mechanisms by which this dependency occurs, and the functional importance of history-dependent muscle properties.

The observation that prior movements affect muscle properties has been shown under the simplest mechanical condition of an isometric contraction. If an isolated muscle is isometrically activated at a specific length, muscle force will reach a steady-state. If the same muscle

is again activated, but this time at a shorter length, and then stretched to the previous length, the steady-state force will be greater than the force that was measured during the first condition. This phenomenon has been called “permanent extra tension,” because the lengthening caused more isometric force to be generated at the same length [1]. Muscle shortening has the opposite effect; isometric force is decreased following a shortening if the muscle is activated before the movement. Furthermore, the lengthening and shortening effects cancel out if a shortening-lengthening movement takes place; however, a lengthening-shortening movement will produce a decrease in isometric force [2].

Another mechanical property of functional importance is stiffness, or how muscle force changes in response to a change in length (i.e.  $\Delta F/\Delta L$ ). The formal mechanical definition of stiffness assumes that the measurement of force and length should be with both force and length in a steady-state (►static) condition. This definition of stiffness would be equivalent to the slope of the well-known force-length relationship. However, the measurement of stiffness can be made under more dynamic conditions, or by measuring the changes in force and length during a movement. This measurement is useful for understanding the importance of mechanical properties related to motor function, especially in the maintenance of posture (see Function). Further, this measurement is useful for determining the number of attached myosin heads to actin binding sites (i.e. ►crossbridges; see Lower level components), which provides a basis for the experimental observations. This review will focus on the dynamic measurement of stiffness.

The measurement of stiffness during movement conditions has often been made by the imposition of a

constant velocity length change because any velocity dependent forces should not change during the movement. Early studies of this type showed that muscles exhibited a “short-range stiffness” behavior, where length changes less than  $\sim 1\%$  of the muscle length produced force changes that were in proportion to the length changes (Fig. 1) [3].

In other words, the muscle behaved as a linear, highly stiff spring for small length changes. When the muscle was lengthened beyond the short-range stiffness range, the muscle “yielded,” or the stiffness decreased considerably and quickly. The mechanism for yielding behavior is probably due to the disruption of muscle ►crossbridge interactions during the lengthening movement, resulting in fewer attached ►crossbridges, which provide stiffness (see Lower Level Processes). Furthermore, if a yielding stretch is imposed and followed by an isometric period, the stiffness is reduced during subsequent lengthening [4]. Prior shortening also reduces muscle stiffness expressed during subsequent stretches, and the reduction in stiffness depends upon the amount of shortening (Fig. 1) [5]. In summary, any prior movement, whether it be shortening or lengthening, significantly reduces muscle stiffness, and this will influence the reaction to disturbances to posture and the amount of force generated in cyclic movements (see Function).

The amount of muscle yield, or the dramatic reduction in stiffness following a large stretch, depends upon the prior movement history. As the amount of shortening increases prior to a large stretch, the yielding behavior is reduced until the response becomes linear spring-like (with a reduced stiffness) throughout the stretch (Fig. 1) [5]. The significance of this observation

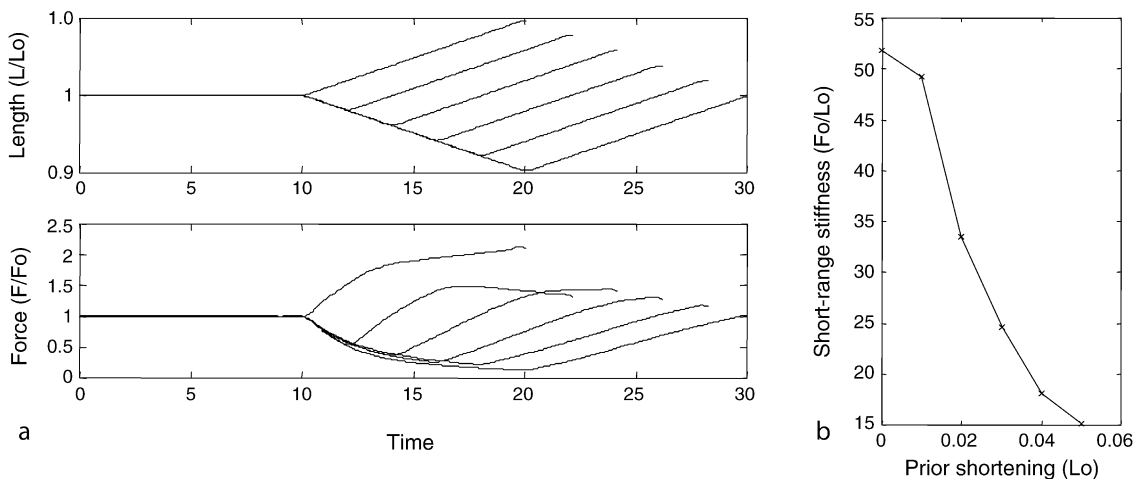

**History-Dependent Properties of Skeletal Muscle. Figure 1** The force response (a) and stiffness (b) measurements of chemically skinned cat soleus single muscle fibers at 22°C for six amounts of shortening prior to a lengthening. Muscle length and force are normalized by the initial length ( $L_0$ ) and force ( $F_0$ ). Short-range stiffness ( $\Delta F/\Delta L$ ) was measured over the first 25 ms (1.25% of  $L_0$ ) of lengthening for each case of prior shortening.

is that spinal reflexes arising from ►muscle spindles are affected by prior movement in a parallel fashion, and this influences the modulation of mechanical properties of muscle by reflex control (see Higher Level Processes and Function).

### Higher Level Structures

The mechanical properties of muscle interact with spinal reflexes to form a feedback system. The components of this feedback system are the sensory organs within the muscle, the distributed connections from the sensory organs to motoneurons innervating the muscle from which the sensory signal arises (and to motoneurons of other muscles as well), and muscle as a force-generating element. One of the best studied and strongest reflexes arises from ►muscle spindles, which are sensitive to changes in length. Specifically, the Ia reflex loop is a monosynaptic pathway in which muscle lengthening causes an increased ►spindle afferent firing rate, which in turn causes further excitation of the motoneurons innervating the same muscle. In terms of function, the Ia reflex is a key pathway involved with the maintenance of posture.

### Lower Level Components

The interaction of the contractile proteins myosin and actin to form ►crossbridges is responsible for the generation of force. In addition, the mechanical properties of an individual ►crossbridge are responsible for giving muscle its macroscopic mechanical properties. Specifically, muscle stiffness arises from the summed stiffness provided by all attached ►crossbridges. In fact, stiffness measured by the application of small stretches is often assumed to be proportional to the number of attached ►crossbridges.

### Higher Level Processes

An important higher level process which interacts with history-dependent mechanical properties of muscle involves the feedback provided through spinal reflexes. Namely, it has been shown that as muscle starts to yield during a lengthening movement, the Ia reflex compensates for the yield by recruiting additional motoneurons innervating the same muscle. The net effect is to preserve stiffness properties, so that the muscle with reflexive feedback is spring-like throughout the duration of a lengthening movement [6]. However, it is important to note that ►muscle spindle responses are also movement history-dependent, probably due to the properties of the ►intrafusal muscle fibers that surround the sensory region of the ►spindle [7]. Thus, both muscle and ►spindle properties are affected by prior movement in concert, and complementary effects are important to understanding their functional significance (see Function).

### Lower Level Processes

The formation and detachment of ►crossbridges is a cyclic process that is influenced by the mechanical conditions under which the muscle is exposed. In relation to movement history-dependent properties, prior shortening or lengthening is thought to promote ►crossbridge detachment (or inhibit crossbridge attachment), thereby decreasing the total stiffness of the muscle [8]. Thus, the interaction of movement with ►crossbridge kinetics is the mechanism by which movement history-dependent properties occur.

### Function

Movement history-dependent muscle properties have the potential to be influential both in reactions to postural disturbances and in voluntary movements, especially cyclic movements. During locomotion, specific muscles undergo cycles of shortening-lengthening movements while being active. In the cat gait cycle, the *triceps surae* muscle group is active while the muscles are shortening just prior to foot strike, and continue to be active while they are lengthening after foot strike. As the prior shortening prevents yielding during the subsequent lengthening, the muscle group behaves more spring-like [9], and this may assist in storing and returning potential energy during foot strike.

For reactions to postural disturbances, the mechanical properties of muscle combined with the spinal reflex response determine the initial response to maintain the desired posture. In early studies of muscle-reflex properties, it was demonstrated that the initial high stiffness state (short-range stiffness) was maintained throughout an imposed lengthening (see Higher Level Processes). The implication of this observation is that any change in muscle length following a postural disturbance would evoke a change in muscle force appropriate to resisting that change. However, the interaction of spring-like muscle-reflex properties and the mass of a limb segment could result in an oscillatory response and potential for instability. Further studies addressed this issue by using mass loads with the muscle-reflex system, and found that the magnitude of the stiffness properties decreased following the initial movement caused by a perturbation. The decrease in stiffness allowed any oscillations of the mass to be damped out more quickly than if the stiffness had remained at the initially high magnitude [10].

Movement history-dependent properties provide an explanation for the postural experiments with mass loads. Namely, the initial mechanical response to the perturbation was dominated by the high stiffness of the muscle-reflex system. This would allow the limb segment (i.e. mass load) to return quickly to its initial position, but with a large velocity comparable to a mass-spring oscillator. However, the initial movement of the limb decreases the stiffness of the muscle and

reduces the reflex response. Both of these effects would decrease the stiffness of the muscle-reflex system and enhance the dampening out of oscillations [10].

In summary, movement history-dependent effects of muscle properties have important functional consequences for both voluntary movements and postural maintenance. Namely, modulation of stiffness properties by prior movement enhances the ability of muscle alone and muscle with reflex action to interface with its primary mechanical load, the mass of the limbs.

## References

1. Julian FR, Morgan DL (1979) The effect on tension of non-uniform distribution of length changes applied to frog muscle fibres. *J Physiol* 293:365–378
2. Herzog W, Leonard TR (2000) The history dependence of force production in mammalian skeletal muscle following stretch-shortening and shortening-stretch cycles. *J Biomech* 33(5):531–542
3. Joyce GC, Rack PM, Westbury DR (1969) The mechanical properties of cat soleus muscle during controlled lengthening and shortening movements. *J Physiol (London)* 204(2):461–474
4. Lin DC, Rymer WZ (1993) Mechanical properties of cat soleus muscle elicited by sequential ramp stretches: implications for control of muscle. *J Neurophysiol* 70(3):997–1008
5. Nichols TR, Lin DC, Huyghues-Despointes CMJI (1999) The role of musculoskeletal mechanics in motor coordination. In: Binder MD (ed) *Peripheral and Spinal mechanisms in the neural control of movement*. Elsevier Science, Amsterdam, pp 369–378
6. Nichols TR, Houk JC (1976) Improvement in linearity and regulation of stiffness that results from actions of stretch reflex. *J Neurophysiol* 39(1):119–142
7. Haftel VK, Bichler EK, Nichols TR, Pinter MJ, Cope TC (2004) Movement reduces the dynamic response of muscle spindle afferents and motoneuron synaptic potentials in rat. *J Neurophysiol* 91:2164–2171
8. Campbell KS, Moss RL (2000) A thixotropic effect in contracting rabbit psoas muscle: prior movement reduces the initial tension response to stretch. *J Physiol (London)* 525(Pt 2):531–548
9. Huyghues-Despointes CMJI, Cope TC, Nichols TR (2003) Intrinsic properties and reflex compensation in reinnervated triceps surae muscles of the cat: effect of movement history. *J Neurophysiol* 90:1547–1555
10. Lin DC, Rymer WZ (2001) Damping actions of the neuromuscular system with inertial loads: human flexor pollicis longus muscle. *J Neurophysiol* 85(3):1059–1066

## Histrionic Personality Disorder

► Hysteria

## HIV-associated Dementia (HAD)

### Definition

In persons infected with human immunodeficiency virus (HIV), even at the early stage of the disease, HIV enters the brain. HIV along with its pathogenic proteins damages the neurons by activating pro-inflammatory mediators, or through their direct actions. This leads to the development of cognitive disability in those patients, and the condition is described as HAD. Other terms such as AIDS-dementia complex, HIV encephalopathy are also used to describe HIV-associated dementia.

► Central Nervous System Disease – Natural Neuroprotective Agents as Therapeutics

## HMBLs

► Burst Cells – Medium Lead – Horizontal

## Holism

### Definition

The idea that systems must be considered as organic wholes rather than analyzed in terms of the behavior of parts, including at least social systems, organisms, people, and sometimes cells.

► Reductionism (Anti-Reductionism, Reductive Explanation)

## Holonomic Constraint

### Definition

A geometric constraint of a mechanical system restricting just the positions (rather than the velocities) of the particles.

► Mechanics

## Homeobox

### Definition

Homeobox genes encode transcription factors with DNA binding homeodomains. Homeobox genes are required for patterning, regional specification and terminal differentiation. Homeobox transcription factors bind to TAAT/ATTA consensus binding sequences.

Many homeobox genes are members of genes families, such as the *Hox*, *Dlx*, and *Pax* genes.

► [Chromatin Immunoprecipitation and the Study of Gene Regulation in the Nervous System](#)

## Homeobox Gene

### Definition

A sequence of DNA conserved across species that is found within genes involved in the regulation of development. They generally encode transcription factors which typically switch on cascades of other genes.

► [Endocrine Disorders of Development and Growth](#)

## Homeodomain

### Definition

A homeodomain is the 60 amino acid DNA binding domain of homeobox transcription factors.

## Homeostasis

KIYOMI KOIZUMI

Department of Physiology and Pharmacology, State University of New York, Downstate Medical Center, Brooklyn, New York, USA

### Synonyms

Constant internal environment of an organism; Constant “milieu intérieur” in the biological system

### Definition

It is the mechanism(s) in the living organism for maintaining its internal environment at a constant level, or within narrow limits of the most adequate level, for its survival.

### Characteristics

#### History of the concept

In the human body and in the living organism most cells are surrounded by extracellular fluid, so that for living cells to function well and to survive, it is most important to maintain and control the internal environment.

In 1878, a French physiologist, Claude Bernard, introduced the idea of constant *milieu intérieur* (the internal environment) in the body, explaining the importance of the extracellular fluid in which an organism is bathed, separated from the internal environment [1]. He wrote, “It is the fixity of the internal environment that is the condition of free and independent life. All the vital mechanisms, however varied they may be, have only one object, that of preserving the constant conditions of life in the internal environment.” (Translation taken from [2].)

This concept was first termed as “homeostasis” by an eminent American Physiologist, Walter B. Cannon, and expanded in his famous book, *The Wisdom of the Body* [3], published in 1932. Cannon defined the word as “the coordinated physiological processes by which maintain most of the steady states in the organism.”

Homeostasis means that in the biological system the internal environment is maintained at a constant level or between narrow limits that are the most adequate levels for the living organism. Changes in the system do occur (e.g., changes in the outside temperature or invasion of toxic substance from infection), but the body eventually achieves “normal” conditions through various functional changes.

### Process Regulation

#### Processes to Achieve and Maintain Homeostasis

In normal and healthy conditions we can maintain fairly constant levels of many body variables, such as the body temperature, blood pressure, levels of respiratory gases, glucose and other chemicals in the blood, ion concentration in the extra-cellular fluid, etc. When changes of these parameters occur due to changes in the external and internal environment, multiple functions operate in the body in order to achieve a “constant” or “physiological” state. These multiple functions are termed “►homeostatic mechanisms,” or the homeostatic control system.

The mechanism for achieving a homeostatic state is through a ►feedback system. Each system is comprised of a sensor (or sensors) that must detect changes from a set point or reference point and the effector system.

A ►**set point** is the range of values to maintain physiological or “normal” condition in the system. When a sensor detects a change from a set point, error signals are sent to the brain or organs. These signals bring a series of reactions so that the system will be brought back to a set point level, as will be illustrated later.

The nervous system and the endocrine system play a major role in controlling and maintaining homeostasis. Some sensors are situated in the brain, such as in the hypothalamus, the pituitary gland. ►**Baroreceptors**, ►**chemoreceptors**, and volume receptors in the periphery as well as in the brain also act as sensors. In addition, the endocrine organs like the pancreas and the adrenal gland have sensors. The control system for bringing back the homeostatic state and maintaining it in most physiological conditions in the body is the negative feedback system. (The positive feedback system changes variables further by setting up a chain of responses, and does not operate for maintenance of homeostatic state. In physiological states, the positive feedback system operates only in certain specific cases, e.g., gonadal hormones causing ovulation.)

### Functions

There are many examples of homeostasis in the living system. In order for an organism to survive in a varied environment, a cell must receive oxygen and nutrients from the extracellular fluid, and move carbon dioxide and waste materials to the extracellular fluid to be carried away. In humans, the respiratory system brings oxygen into the body and removes carbon dioxide out of the body; the digestive system brings nutrients into the body, and excretes waste materials, the circulatory system carries oxygen and the nutrients to various organs including the brain, and takes away waste materials from the tissues; the renal system removes waste materials from the blood and reabsorbs certain ions to maintain the adequate levels of ions in the blood and tissue fluid, etc. Thus, the overall effect accomplished by many body functions is to maintain an environment adequate for all cells and organs to function.

### Specific Examples

#### Body Temperature

In warm-blooded animals and humans, body temperature is maintained around 37°C most of the time. When the body temperature is elevated, for instance during severe exercise, sensors in the brain called thermoreceptors, detect a change from its normal temperature and send error signals to the structures in the central nervous system that control the autonomic and somatic systems. This causes the autonomic nerves to cause sweating, dilation of the blood vessels in the skin and the body temperature drops. In the cold environment, sensors send the error signals to cause constriction of skin blood vessels, shivering, and erection of hairs in

hairy animals (goose bumps in humans). It is often stated that the autonomic nervous system plays an important role in achieving homeostasis, but, as seen in the above example, shivering involves the somatic system, i.e., the skeletal muscle contraction. The behavioral changes, such as putting more clothes on in the cold environment, etc., is also an important part of the homeostatic responses involving the whole body system. In cold-blooded animals, such as salamanders, the body temperature cannot be regulated as mammals, so that the regulation is accomplished solely by behavioral responses. During the cold night their body temperature drops, and in the morning these animals lie in the sun until the body temperature is raised so that they can move around. In long lasting changes, e.g., exposure to the hot or cold climate, the endocrine system, such as the adrenal medulla (for heat production) and the thyroid gland (against cold in animals) is also involved.

#### Blood Pressure

Changes in blood pressure are sensed by baroreceptors in the periphery, near the carotid artery in the neck and the arch of aorta near the heart. When the pressure is too high or too low, they send signals through their afferent nerves to the brain regions, mostly the medulla, to activate the autonomic nervous system response. This brings changes in blood vessels to dilate or constrict, and changes in heart rate and force of contraction, thus restoring the blood pressure to the normal range, 80–120 mmHg (which is called baroreceptor reflex). The response also involves release of epinephrine and norepinephrine from the adrenal glands.

#### Blood Sugar

In maintenance of blood sugar at adequate levels, at around 100 mg per 100 ml, specialized cells (beta cells) in the islets of Langerhans in the pancreas detect changes in the glucose level in the plasma. When the glucose level is elevated after a meal, secretion of ►**insulin** from beta cells increases while that of ►**glucagon**, produced by alpha cells in the pancreas, decreases so that the blood sugar level is returned to its normal level.

#### Hormones

In physiological conditions, the adequate level of various hormones is maintained. Sensors are located at various levels in the endocrine system, in the endocrine organs, the anterior pituitary gland and the hypothalamus. They detect changes in plasma levels of certain hormones, ions or metabolites. If the level is deviated grossly from the “normal” level of that particular hormone, error signals are sent to the appropriate regions in the brain. Depending on the particular situation

they act on the hypothalamus, altering secretion of ►releasing- or release-inhibiting hormones, or signals are delivered to the anterior pituitary gland, causing secretion of tropic hormones to increase or decrease, or directly act on peripheral endocrine glands to alter their hormone synthesis and release.

In many homeostatic controls both nervous and endocrine systems work together. For example, when there is a large amount of blood loss, baroreceptors and volume receptors situated in the periphery (vascular system and the heart) as well as in the brain send error signals to the central nervous system, and they increase blood pressure through the action of the autonomic nervous system and cause a release of epinephrine from the adrenal gland. At the same time, secretion of ►vasopressin (antidiuretic hormone, ADH) from the posterior pituitary gland is greatly increased so that water loss from the kidney is prevented by this hormone action. Release of renin from the kidney also occurs. Thus, through many mechanisms the blood pressure, blood volume and the body fluid are returned to their “normal” level.

### Pathology

#### Changes in Homeostasis: “Heterostasis”

Maintenance of the homeostatic state is important for the survival of an organism for the long run. However, in the biological system it does not mean that the “ideal” condition for an organism is maintained all the time. In many cases, adaptation has to change the homeostatic state. Such an idea was originated from Hans Selye in the early 70s [4].

After studying many stressful situations in the organism, Hans Selye proposed the state newly established by adaptation, called “►heterostasis.” This state is necessary for survival of an organism against potential dangers. According to Selye, heterostasis means “the new establishment of the new steady state by exogenous stimulation of adaptive mechanisms through development of and maintenance of unusual defensive tissue reaction.”

### References

1. Bernard C (1878–9) *Leçons sur les phénomènes de la vie communs aux animaux et aux végétaux*, vols 1 and 2, Librairie. J-B Balliere et Fils, Paris
2. Vander A, Sherman J, Luciano D (2001) *Human physiology*, 8th edn. McGraw-Hill, New York, p 6
3. Cannon WB (1932) *The wisdom of the body*. W. W. Norton, New York
4. Selye H (1975) Homeostasis and heterostasis. In: Brooks CMcC, Koizumi K, Pinkston JO (eds) *The life and contributions of Walter Bradford Cannon*. State University of New York, Downstate Medical Center, New York, pp 108–112

## Homeostatic Mechanism

### Definition

Homeostatic mechanisms are the multiple functions that operate in the organism in order to achieve and maintain homeostasis.

►Homeostasis

## Homeostatic Regulation

### Definition

The tendency of the nervous system (and all biological systems) for self-correction when the properties are altered in some way. For example, when the firing properties of a neuron or synapse are altered, over a period of time new proteins are synthesized that restore the neuron or synapse back towards their original properties.

## Homeostatic Regulation of Sleep Need

►Sleep Homeostasis

## Homeotic Genes/Hox Genes

### Definition

Evolutionary highly conserved genes, containing a homeobox. Hox genes are clustered along the chromosome in complexes, their relative location within the complex is reflected by the expression along the anterior–posterior body axis. Mutations in Hox genes lead to the alteration of segmental identity.



## Homogeneity

### Definition

The property of a uniform material body for which there exists a configuration in which the trivial translations between neighborhoods happen to be material isomorphisms.

►Mechanics

## Homogeneous Transformation

### Definition

Homogenous Transformation is a commonly used technique for simultaneously specifying translations and rotations between coordinate systems in three-dimensional motion analysis.

►Motion Analysis

## Homolog

### Definition

A gene that has the same origin and function in at least two species.

## Homologous

### Definition

Inherited from a common ancestor (with phyletic continuity), but not necessarily similar in function (e.g., the limbs of horses and sea lions, used for walking in one case, and swimming in the other case; another example are the wings of birds and bats which are both homologous and analogous, since they were both derived from forelimbs and are used for flying).

## Homologous Recombination

### Definition

Homologous recombination also known as DNA crossover, homologous recombination occurs in meiosis when homologous pairs of sister chromatids align.

Homologous recombination occurs between two homologous stretches of DNA and involves exchange of the DNA between sister chromatids. This naturally occurring process is taken advantage of by researchers when constructing a knockout transgenic animal, whereby one allele of a gene is replaced with an engineered DNA construct without affecting other loci in the genome. To perform homologous recombination in ES cells, the DNA sequence of the gene to be replaced needs to be known.

H

## Homologue

### Definition

Structures of the same evolutionary origin, which are not necessarily similar in function.

## Homology

### Definition

Structures are proposed to be homologous in different animals whenever it is thought that the same structures were present in their common ancestor, being not necessary a functional similarity.

►Evolution of the Amygdala: Tetrapods

## Homonymous Hemianopia

### Definition

Homonymous hemianopia is hemianopia which affects vision in both eyes in the same way. Hemianopia caused by damage to areas of the brain in which signals from

both eyes are combined (e.g. primary visual cortex) is homonymous, whereas damage to earlier monocular structures (e.g. the optic nerve) only affects vision in a single eye.

- ▶ Optic Nerve
- ▶ Primary Visual Cortex

---

## Homosynaptic Depression

### Definition

Reduction of transmitter release produced by prior activation of the same presynaptic terminals. Reflects a depletion of available neurotransmitter stores.

---

## Homosynaptic Long-term Potentiation (LTP)

### Definition

Homosynaptic LTP is that the enhancement in the amplitude of the excitatory postsynaptic potential (EPSP) is confined to the stimulated pathway and is thus input specific.

- ▶ Synaptic Plasticity

---

## Homotypic Fasciculation

### Definition

The fasciculation, or bundling, of neuronal processes with a common property. Commonly used to refer to the sorting of olfactory sensory neuron axons in the outer nerve layer of the olfactory bulb, where fibers from cells expressing the same olfactory receptor join into bundles for the first time.

- ▶ Olfactory Bulb
- ▶ Olfactory Nerve
- ▶ Olfactory Receptor

---

## Honey Bee

### Definition

Insect of the order hymenoptera that lives in colonies. The honey bee is a model system for learning and memory.

---

## Hopfield Model

- ▶ Associative Memory

---

## Hopocretin/Orexin

### Definition

See before.

- ▶ Neuroendocrinology of Tumors

---

## Horizontal Cells

### Definition

One of the lateral interneurons in the vertebrate retina, interacting with photoreceptors and bipolar cells in the outer plexiform layer (synaptic layer).

- ▶ Inherited Retinal Degenerations

---

## Horizontal Fissure (of Cerebellum)

### Synonyms

- ▶ Fissura horizontalis (cerebelli)

**Definition**

The horizontal fissure is a large cerebellar groove running transversely across the semilunar lobule. It separates the superior semilunar lobule from the inferior semilunar lobule.

- ▶ Cerebellum

## Horizontal-Gaze-Velocity Purkinje Cells

**Definition**

Purkinje cells found in the floccular lobe and in the oculomotor vermis that encode the velocity of horizontal gaze in their discharge

- ▶ Cerebellum – Role in Eye Movements
- ▶ Purkinje Cell, Neuron

## Horizontal Saccade Generator

**Definition**

- ▶ Brainstem Burst Generator
- ▶ Saccade, Saccadic Eye Movement

## Hormonal Secretion Regulated by the Autonomic Nerves

**Definition**

Both sympathetic and parasympathetic nerves regulate secretion of some hormones. Hormones secreted in response to stimulation by sympathetic nerves include catecholamines from the adrenal medulla, glucagon from the pancreas and renin from the kidney. Stimulation by sympathetic nerves inhibits insulin secretion from the pancreas. Hormones secreted in response to stimulation by parasympathetic nerves include gastrins from the stomach and insulin from the pancreas.

Secretion of these various hormones can be elicited by either direct stimulation of the central nervous system, or by visceral and somatic afferent stimulation whereby autonomic nerves serve as the efferent limbs of the respective reflex arcs.

- ▶ Autonomic regulation of endocrine system
- ▶ Parasympathetic Pathways
- ▶ Sympathetic Pathways

## Hormone

**Definition**

Molecule that is transported in the blood, reaches a specific target organ, where it binds to specific receptors and may influence metabolism, development, or behavior.

## Horner's Syndrome

**Definition**

Horner's syndrome is characterized by miosis (contracted pupil), anisocoria (difference in pupil sizes on both sides), ptosis (drooping eyelid) and enophthalmos (retraction of eye into its socket) and results from interruption of the oculo-sympathetic pathway, the clinical features being classified into central, preganglionic, and postganglionic types according to the anatomic location of the underlying pathologic process.

- ▶ Sympathetic Pathways

## Horseradish Peroxidase (HRP)

**Definition**

An enzyme used for tracing connections between different regions of the central nervous system, as well as the structure of cell bodies, dendrites and axons of single neurons. When delivered in small quantities to the extracellular space by iontophoresis or by pressure ejection, it is taken up by synaptic terminals and

transported retrogradely to cell bodies. Neurons projecting to the site of injection are made visible by applying a histochemical procedure based on the transfer of oxygen to a chromogene, a substance that changes color on oxidation.

#### ► Microiontophoresis and Micropressure Ejection

## Household Proteins

### Definition

Proteins synthesized inside the cell necessary for upheaval of the cellular functions, structure and integrity.

## HOW-Response Element

### Definition

An RNA nucleotide sequence to which the RNA binding protein HOW binds.

## Hox Gene-related Respiratory Control Disturbance

JEAN CHAMPAGNAT

UPR CNRS 2216 Neurobiologie Génétique et Intégrative, FRC CNRS Institut de Neurobiologie Alfred Fessard, Gif sur Yvette, France

### Synonyms

Breathing abnormalities after altered expression of genes orchestrating rhombomere formation

### Definition

Although an altered gene expression in the brain is a normal component of physiological adaptive responses, such as the acclimatization to altitude, most of our

knowledge on mechanisms that may link gene function and breathing patterns result from observations in transgenic mice, in which the respiratory behavior is studied after gene inactivation.

Transgenic models point to a major implication of ►developmental genes essential at all developmental steps from early specifications in the neural tube to the function of respiratory rhythm generators and controllers. During development, the assembly of neural circuits that encode animal behavior, results from several mechanisms contributing to generate distinct neuronal cell types in appropriate number and position. ►Regionalization of the neural tube controls proliferation and specifications of progenitors, until they exit from the cell cycle, at precise location according to antero-posterior and dorso-ventral axis of the neural tube. ►Neurogenesis refers to a variety of processes by which neuronal types differentiate, migrate and form nuclei to eventually produce neuronal populations and their synaptic interconnections. Once activity starts in primordial neurons, neuronal circuitry is refined in a use-dependent manner and the size of neuronal populations depends on the activity of ►neurotrophic factors interacting with apoptotic processes.

In all vertebrates, regionalization of the brainstem (rhombencephalon) along the antero-posterior axis, leads the partitioning of the neuroepithelium into a series of cellular compartments, called rhombomeres (r1-r8) [6]. ►Rhombomeres are polyclonal developmental compartments containing all types of progenitors that are required to produce the large variety of cellular elements forming neuronal circuits and reflex arches at a given level of the neural tube. Strong regulatory constraints couple ►Hox gene expression to the progression of hindbrain regionalization. Therefore, the chromosomal organization of ►Hox genes into four clusters is highly conserved in vertebrates. The formation of territories patterned by Hox genes is accompanied by a sequential activation of these genes from 3' to 5' in the clusters. As a result, early structures are given an anterior identity with 3'Hox genes (►anterior group Hox genes) as key determinants, while progressively later structures start expressing more 5' Hox genes and acquire a more posterior identity. The most 3' Hox genes, *Hoxa1* and *Hoxb1* are expressed up to the rhombomeric r3/r4 boundary and they are directly repressed in r3 by ►Krox20, a ►zinc-finger transcription factor also known as *Egr-2*. The *Krox20/Hox* signaling is required for the proper development of r3, r4 and of the boundary between r3 r4 [2,3,6].

### Characteristics

#### Structures

►Respiratory control refers to the activity of the hindbrain respiratory neuronal network generating and

modulating the breathing behavior. Peripheral sensory receptors such as chemoreceptors in the carotid body or stretch receptors in the lungs initiate the reflex control of this network. Within the hindbrain, central respiratory neuronal groups have been located with the help of electrophysiological studies on hindbrain preparations isolated *ex vivo*. The antero-posterior organization of the mature network conforms to the rhombomeric pattern of embryos [2,3] in register with location of branchio-motor nuclei (the vagal glossopharyngeal deriving from r6-r7, the facial from r4, the trigeminal from r2r3 [6]). Caudally, at the vagal glossopharyngeal level (called “post-otic” because it is caudal to the otic vesicle), the inspiratory rhythm is generated in the ►pre-Bötzinger complex (pre-BötC), and persists in coronal brainstem slices of newborn rodents, isolated *ex vivo* [4,9,10]. Stimulation of the rhythm by CO<sub>2</sub> results from the specific responsiveness of different structures, among which the ►retrotrapezoid nucleus [8]. At the facial (pre-otic) level, another rhythm generator, called the **para-facial respiratory group** (pFRG [6 and refs herein]), has been delineated by activity-dependent imaging. In the hindbrain isolated *ex vivo*, permanent rhythm generation requires a balanced interaction between the pFRG and the pre-BötC, which can be disrupted by potent pre-BötC depressants such as opioids [2,6]. At the trigeminal level, pontine controls of the rhythm include noradrenergic neurons of the A5 group exerting a depressant effect upon the more caudal respiratory groups. The most rostral hindbrain, close to the hindbrain/midbrain boundary contains the **pontine respiratory group** as well as several structures controlling breathing including cholinergic pediculo-pontine tegmental neurons [5,7].

## Processes

### Pontine Controls of Breathing

Regionalization of the hindbrain starts at E 7.5 in mice. Retinoic acid (RA) at this stage is known to affect the spread of *Hox* and *Gbx2* expression domains into the anterior hindbrain, followed by a retraction, leaving behind an abnormal gene expression pattern. RA treatment at E7.5 with low (subteratogenic) doses was found convenient in mice to further investigate the importance of this stage for the breathing behavior [5]. This induced pontine abnormalities associated with an hyperpnoeic episodic breathing, a clinical trait widely reported in pre-term neonates, in patients with Joubert syndrome, and in adults (Cheyne-Stokes respiration) with congestive heart failure and brainstem infarction. Respiratory and anatomical anomalies of treated mice resembled several traits reported in the Joubert syndrome, a genetically heterogeneous syndrome, with three known loci, on 9q34.3 (JBTS1), 11p11-q12 (CORS2/JBTS2, and JBTS3, on chromosome

6q23.2-q23.3. Defects might involve the pontine respiratory group [5,7] as well as the cholinergic control of breathing by the pediculo-pontine tegmentum. Impairment of this latter cholinergic control is known to induce an abnormal breathing pattern in adult mice, as seen by homozygous inactivation of the gene encoding the enzyme acetylcholinesterase. In these mice, although the pontine control [7] is altered and the breathing pattern significantly modified, rhythm generation appears normal and no abnormal apneas and lethality were seen in neonates.

### Parafacial Rhythm Generators: Induction Requires *Krox20* and *Hoxa1*

Investigation of the respiratory behavior of *Krox20*<sup>-/-</sup> and *Hoxa1*<sup>-/-</sup> mutants has established links between the transient rhombomere-related expression of these genes and deletions, neoformations and reconfiguration of the respiratory rhythm generator at the facial level [2,3,6]. Inactivation of *Krox20* and elimination of r4 in *Hoxa1* null mutants lead to neonatal apneas and death due to central respiratory deficits [2,3]. The *Hoxa1*<sup>-/-</sup> neonates show profound hypoplasia in the ventral pons including the facial branchiomotor nucleus (r4-derived) and of the underlying adjacent area where the pFRG is located. These mutants revealed the “anti-apneic” function of the pFRG at birth. In contrast to *Hoxa1* and *Krox20* null mice, homozygous *kreisler* mice lacking r5, show no life-threatening apneic respiratory patterns, but rather a hypoplasia of the ventral reticular formation causing an abnormal rostral positioning of the (vagal) ambiguous nucleus [3]. Therefore, r4 and r5 greatly differ with respect to their respiratory fates, and lethality in *Hoxa1* mutants involves the elimination of parafacial structures originating from r4 rather than from r5. *In vivo* and *in vitro* analysis show that the caudal medulla including the pre-BötC is not affected by the *Krox20*<sup>-/-</sup> and *Hoxa1*<sup>-/-</sup> mutations. These observations are important to understand neonatal apneic syndromes [2,4]. They give insights into the crucial role of *Krox20/Hoxa1* on early phenotypic choices that affect parafacial neuronal progeny [3], leaving the pre-BötC functionally active. Therefore, in both *Krox20*<sup>-/-</sup> and *Hoxa1*<sup>-/-</sup> mutants, administration of opioid antagonists to alleviate pre-BötC depression effectively improved survival at birth [2].

### Central Chemosensitivity in the Retro-Trapezoid Nucleus

In embryos and neonates, the paired-like ►homeobox transcription factor, Phox2b [8 and refs herein], provide the best documented case of matching gene expression with function in the autonomic reflex arc during development. Mutations of the human homolog PHOX2B have been identified in patients with congenital hypoventilation syndrome, CCHS, a rare

congenital syndrome which is characterized by a decreased sensitivity to hypercapnia and hypoxia, frequently associated with anomalies of the autonomic nervous system.

The majority of *Phox2b* dependent neuronal precursors, irrespective of their neurotransmitter phenotype, or of any aspect of their cellular phenotype or developmental history, are fated to partake in the medullary reflex circuits of the visceral nervous system. The homozygous inactivation of *Phox2b* affects glossopharyngeal and vagal afferents, the second order neurons of the nucleus tractus solitarius as well as vagal and glossopharyngeal motor nuclei. Recently, one of the central CO<sub>2</sub>-sensitive structure of the ventral medulla, the retro-trapezoid nucleus has been found to selectively express *Phox2b* thereby identifying a potential site of altered chemosensitivity in *Phox-2b* deficient animal models and human disease [8]. Interestingly, this *Phox2b*-expressing site appears anatomically and developmentally different from the *Krox20*-dependent pFRG oscillator, so that CO<sub>2</sub> chemosensitivity of the animal is preserved in *Krox20*<sup>-/-</sup> mutants. Altogether, these results suggest that breathing abnormalities in CCHS might result from abnormal chemosensitivity and are probably distinct from neonatal apneas and sudden infant death resulting from the impairment of the pFRG control [2,4,8].

#### Control of pre-Bötzinger Complex function

The pre-BötC neural network contains rhythmic neurons connected by glutamatergic synapses, some of them exhibiting pacemaker burst-generating properties [4,9,10]. Embryological experiments confirm that the post-otic territory (r6-r8, caudal to the otic vesicle) from which the pre-BötC develop, is endowed with a selective capacity to generate a respiratory-like rhythm [1]. In these experiments, pre-otic (r3r4), post-otic (r6r8) and spinal segments of the mouse neural tube were isolated and grafted into the same position in stage-matched chick hosts (heterospecific grafting, [1]). Three days later, cranial nerves exiting the graft and the host indicate that the rhythm is generated in post-otic segments, but not in more anterior (pre-otic) and more posterior (spinal) territories. These experiments suggest that a selective developmental program enforcing rhythm generation is already set at end segmental stages in post-otic segments [1]. In adults, the destruction of neurons expressing the NK1 receptor in the pre-BötC leading to ataxic respiration and sleep apneas supports the view that the pre-BötC plays a primary role in respiratory rhythmogenesis in adults [4].

Immunohistochemical, electrophysiological and calcium imaging studies on transverse slices of the brainstem showed that the pre-BötC is anatomically and functionally defined in the mouse embryo at E15 [9]. Recent results provide insights on the possible

mechanisms that turn on pre-BötC activity at this stage. Rhythm generation depends on glutamatergic transmission through AMPA/kainate receptors, as in older preparations [9,10]. Glutamate excitatory transmission is dependent on the release from glutamate-filled presynaptic vesicles loaded by three members of the solute carrier family, Slc17a6–8, that function as vesicular transporters (VGLUTs). VGLUT2 (Slc17a6) was found to be required for the function of the respiratory neuronal network [10]. While VGLUT1 is dispensable for life, *Vglut2* null mutant pups die immediately after birth due to complete loss of rhythm generation in the pre-BötC complex. Observations in embryos at the stage when the pre-BötC activity normally emerges shows that in these mutants respiratory rhythm is not turned on, although burst-generating mechanisms and non-glutamatergic transmission are available. The entire set of pre-BötC characteristics being differentiated at E15, functional VGLUT2 glutamatergic synapses underlying neuronal synchronization seems to constitute the rate limiting step for establishment of the pre-BötC as a rhythm generator [4,9,10].

## Conclusion

### The Dual Oscillator Hypothesis

There is emerging evidence that the pre-BötC and the pFRG are distinct and play a critical role in generating respiratory rhythm [2,4]. Ablation of the pre-BötC in adult rats resulted in a progressive, increasingly severe disruption of the respiratory pattern initially during sleep and then also during wakefulness. Therefore, sleep-disordered breathing and apneas may result from the loss of pre-BötC neurons in elderly humans and patients with neurodegenerative disease [4]. Studies in neonatal *Krox20*<sup>-/-</sup> and *Hoxa1*<sup>-/-</sup> rodents show that apneas can also be induced by disrupting the development of the pFRG. In an attempt to improve survival, administration of naloxone to block opioid receptors in the pre-BötC definitely suppressed the occurrence of apneas and all animals survived past 18h of age [2]. These observations revealed a post-natal stage of development after which the breathing rhythm loses post-natal irregularity in wild type and apneas are no more detrimental to survival after the elimination of the pFRG in mutants. Therefore, the novel hypothesis on a dual respiratory rhythm generation in restricted sites of the hindbrain [2,4], has important implications in respiratory pathology, with the pFRG playing a major role to prevent sudden infant death while the pre-BötC becomes prevalent with age to alleviate sleep apneas in adults. In summary, on the one hand, neonatal and mature respiratory rhythm generators are likely to play a vital anti-apneic role to control respiratory frequency [2,3,4,9,10]. On the other hand, mutations of the respiratory neuronal network outside these

rhythm generators, for example in the Pons, may cause significant respiratory abnormalities, although frequency and apneas are not dramatically affected [5,7].

## References

1. Borday C, Coutinho A, Germon I, Champagnat J, Fortin G (2006) Pre-/post-otic rhombomeric interactions control the emergence of a fetal-like respiratory rhythm in the mouse embryo. *J Neurobiol* 66:1285–1301
2. Chatonnet F, Domínguez del Toro E, Thoby-Brisson M, Champagnat J, Fortin G, Rijli FM, Thaeron-Antono C (2003) From hindbrain segmentation to breathing after birth: developmental patterning in rhombomeres 3 and 4. *Mol Neurobiol* 28:277–294
3. Coutinho AP, Borday C, Gilthorpe J, Jungbluth S, Champagnat J, Lumsden A, Fortin G (2004) Induction of a parafacial rhythm generator by rhombomere 3 in the chick embryo. *J Neurosci* 24:9383–9390
4. Feldman JL, Del Negro CA (2006) Looking for inspiration: new perspectives on respiratory rhythm. *Nat Rev Neurosci* 7:232–242
5. Guimarães L, Eduardo Domínguez-del-Toro E, Chatonnet F, Wrobel L, Cristina Pujades C, Monteiro LS, Champagnat J (2007) Exposure to retinoic acid at the onset of hindbrain segmentation induces episodic breathing in mice. *Eur J Neurosci*, 25:3526–3536
6. Lumsden A, Krumlauf R (1996) Patterning the vertebrate neuraxis. *Science* 274:1109–1115
7. Mc Crimmon DR, Milsom WK, Alheid GF (2004) The rhombencephalon and breathing: a view from the pons. *Resp Physiol Neurobiol* 143:103–337
8. Stormetta RL, Moreira TS, Takakura AC, Kanq BJ, Chang DA, West GH, Brunet JF, Mulkey DK, Bayliss DA, Guyenet PG (2006) Expression of *Phox2b* by brainstem neurons involved in chemosensory integration in the adult rat. *J Neurosci* 26:10305–10314
9. Thoby-Brisson M, Trinh JB, Champagnat J, Fortin G (2005) Emergence of the pre-Bötzinger respiratory rhythm generator in the mouse embryo. *J Neurosci* 25:4307–4318
10. Wallén-Mackenzie A, Gezelius H, Enjin A, Thoby-Brisson M, Nygard A, Fujiyama F, Fortin G, Kullander K (2006) Glutamatergic signaling mediated by VGLUT2 is required for respiratory rhythm generation but is dispensable for locomotor central pattern generation. *J Neurosci* 26:12294–12307

## Hox Genes

### Definition

Hox genes are genes that encode a class of DNA binding proteins that regulate DNA transcription, which contain an essentially invariant short sequence of nucleotides called the homeobox.

► Homeotic Genes/Hox Genes

## H-reflex (Hoffmann Reflex)

### Definition

An H-reflex (also called a “Hoffmann reflex”) is the earliest response of a muscle to stimulation of large afferent fibers in the muscle nerve. If the nerve stimulation also excites large efferent fibers, the H-reflex is typically preceded by an M wave (or M response), which reflects excitation of the muscle by these efferents. An H-reflex and the preceding M wave are usually detected and measured electromyographically.

An H-reflex is produced by an entirely spinal pathway consisting mainly of group Ia afferents from the muscle spindles, their excitatory synapses on the muscle’s motoneurons, and the motoneurons. Oligosynaptic (i.e., di- and tri-synaptic) excitatory and/or inhibitory inputs to the motoneurons from group I or II afferents may also contribute. Because it is largely monosynaptic, the latency of an H-reflex depends mainly on the lengths and conduction velocities of the afferent and efferent axons in the peripheral nerve. The H-reflex is often considered to be the electrical analog of the “tendon reflex,” since it involves the same afferents and spinal pathways and is elicited by direct stimulation of the nerve rather than by muscle stretch.

At the same time, it may differ from the tendon reflex in the contributions of different group I and large group II afferents, in the relative importance of monosynaptic and disynaptic inputs to the motoneurons, and in the synchrony of these inputs.

► Conditioned Reflexes

► Electromyography

► Tendon Reflex

## Human Circadian Timing System

MICHEL A. HOFMAN

Netherlands Institute for Neuroscience, Amsterdam, The Netherlands

### The Biological Clock in Mammals

Many organisms experience oscillations in biological processes within a period of around 24 h. These circadian rhythms (circa = around; dies = day) enable organisms to anticipate periodic changes in the environment and are consequently important adaptive

mechanisms. In mammals, these circadian cycles are regulated by an endogenous clock, the central component of which resides in the ►**suprachiasmatic nucleus** (SCN) of the hypothalamus [1]. The pacemaker of the SCN oscillates with a near 24-h period and is entrained to the daily light-dark cycle. Destruction of the SCN results in the complete absence of a regular sleep/wake rhythm. Consistent with its role in circadian timing, investigations in rodents and non-human primates furthermore suggest that the SCN is the locus of the brain's endogenous calendar, enabling organisms to anticipate seasonal environmental changes [3].

## Organization of the Human SCN

### Neural Organization

The human SCN is a distinct group of neurons in the basal part of the anterior hypothalamus, just dorsal to the optic chiasm on either side of the third ventricle. The bilateral SCN in humans is about 1 mm<sup>3</sup> in volume and contains close to 100,000 neurons in total [5,9]. Based on differences in morphology, afferent inputs and output projections, the SCN can be divided into a dorsomedial part or shell and a ventrolateral part or core (Fig. 1). The core receives primary and secondary visual afferents and predominantly contains neurons producing vasoactive intestinal polypeptide (VIP), gastrin-releasing peptide, neurotensin, neuropeptide-Y, substance-P and calbindin. The shell largely surrounds

the core and receives input mainly from nonphotic sources and is composed predominantly of neurons containing arginine-vasopressin (AVP). Many neurons in both regions of the SCN contain  $\gamma$ -aminobutyric acid (GABA). A similar topographic organization of SCN efferent projections was found, indicating that the nature of the signal conveyed to areas receiving core or shell projections varies as a function of the subdivision from which the innervation is derived.

### Molecular Organization

Circadian clocks arise from the expression and temporally regulated activity of specific genes and gene products. Individual SCN neurons express self-sustained circadian oscillations driven by autoregulatory transcription-translation feedback loops [1]. The period of this process is approximately 24 h, giving rise to the ►**circadian rhythm**. At least six genes have now been identified as putative components of the mammalian clock: *Per1*, *Per2*, *Cry1*, *Cry2*, *Clock* and *Bmal1*. Additional genes potentially involved in output pathways from and input pathways to the circadian clock have been identified. Oscillations of mRNA transcripts of these ►**clock genes** have been an important element of the study of biological clocks. These clock genes are expressed in a circadian manner, with peak values at different times. Expression profiles for a specific gene may also differ among subdivisions of the SCN. Similar

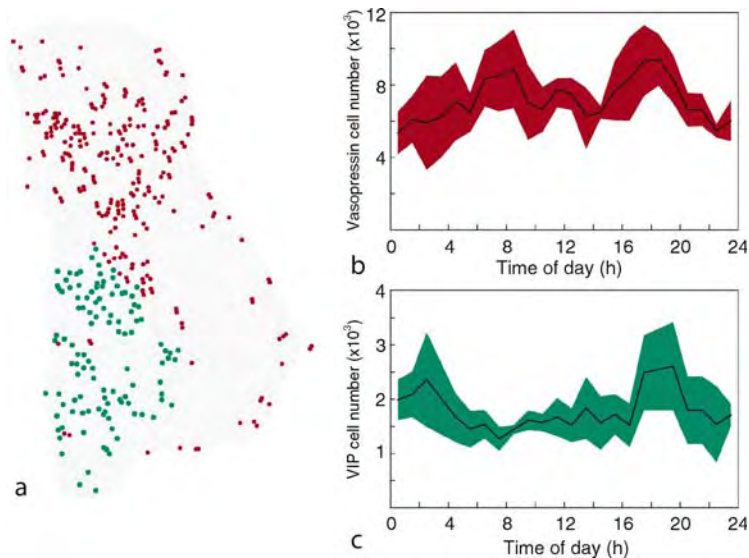

**Human Circadian Timing System. Figure 1** (a) Distribution of vasopressin (AVP) (red dots) and vasoactive intestinal polypeptide (VIP) (green dots) neurons in the human suprachiasmatic nucleus (SCN). Note that the populations of AVP and VIP neurons are located in the shell and core of the SCN, respectively. (b) Circadian cycle of the AVP-expressing neurons and (c) the VIP-expressing neurons in the human SCN. The original data sets were subjected to a simple scatterplot smoothing procedure and are represented by mean  $\pm$  SEM values. Note that both cycles have an asymmetrical, bimodal waveform and that the ►**neuropeptides** do not reach their peaks and troughs at exactly the same time of the 24-h light-dark cycle. Reproduced from [2], with permission.



phase differences that are observed at the molecular level exist at the level of electrical activity rhythms in the SCN.

### Functional Organization

Classically, the expression of circadian rhythms is thought to have three fundamental components: input pathways that transmit environmental cues to the circadian clock, the clock itself, which generates and coordinates the biological rhythm(s), and output pathways that transmit the clock's information regarding phase and periodicity to the rest of the brain and body [6,7]. The biological clock is synchronized to the environmental light-dark cycle by photic information from the retina to the SCN via the retino-hypothalamic tract (RHT) and via the intergeniculate leaflet of the lateral geniculate complex via the geniculohypothalamic tract (GHT). These afferent fibers predominantly terminate in the ventral part of the SCN, where they make synaptic contacts with VIP neurons. The VIP subdivision of the SCN is therefore thought to play a prominent role in the mediation of photic information to the circadian timing system.

In the past decade, several studies have been conducted to determine whether variations in light intensity and photoperiod affect the morphology and neuronal activity of the mammalian SCN, by studying brains obtained at autopsy [2,3,5]. The AVP- and VIP-expressing neurons in the human SCN, for example, were found to exhibit distinct circadian rhythms with an asymmetrical, bimodal waveform (Fig. 1). The AVP cycle has a peak in the early morning, a lower plateau during the day, a second peak in the late afternoon, and a decline beginning in the early evening, leading to a nadir around midnight. The VIP cycle shows a peak in the middle of the night, a lower plateau beginning in the late night lasting for about 12 h, and a second peak in the late afternoon, followed by a sharp decline in the early evening. The demonstration of two significantly different, but temporally linked, output profiles suggest that the SCN contains more than one oscillator.

### The SCN-Pineal Complex Circadian Timing

The ►pineal gland is a central structure in the circadian timing system and the major source of the hormone ►melatonin [8]. The pineal is innervated by a neural multi-synaptic pathway originating in the SCN (Fig. 2). Disruption of any portion of this pathway from the SCN to the pineal gland abolishes melatonin rhythmicity. In all species studied to date, there is a day/night variation in pineal melatonin production, with peak concentrations occurring during the dark phase [4]. The circadian clock and its output rhythms are synchronized to the 24 h light/dark cycle by ocular light which is transmitted from the retina primarily

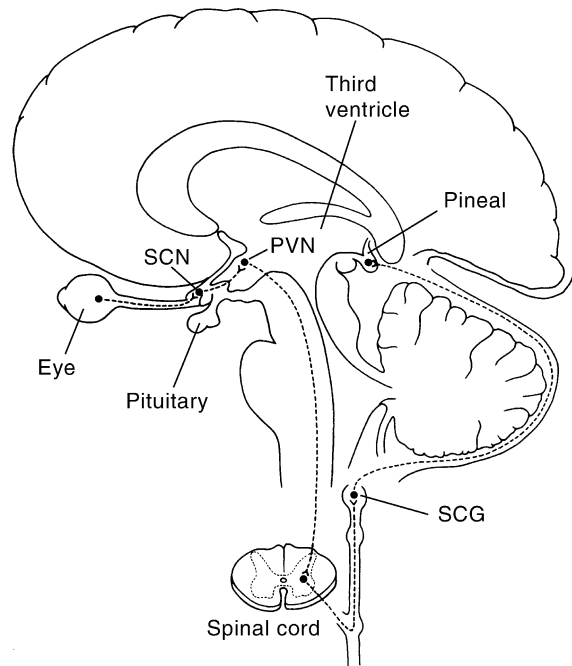

**Human Circadian Timing System. Figure 2** Diagram of the human brain (mid-sagittal section) showing the neural pathways of the circadian timing system by which photic information reaches the SCN and the pineal gland. SCN suprachiasmatic nucleus; PVN paraventricular nucleus; SCG superior cervical ganglion. Reproduced from [4], with permission.

via the retinohypothalamic tract (RHT) to the SCN. Although functions of this hormone in humans are mainly based on correlative observations, there is some evidence that melatonin stabilizes and strengthens coupling of circadian rhythms, especially of core temperature and sleep-wake rhythms [10].

### Seasonal Timing

In recent years it has also become clear that in mammals the SCN and the pineal gland are the principal neural structures involved in the regulation of annual cycles [3,4]. In fact, many of the functions that exhibit seasonal cycles in mammals, such as sexual behavior, energy metabolism, food intake, and hibernation, are regulated by this timing system in the brain. Photoperiodic information has been shown to be the strongest synchronizer of seasonal functions in most species. These findings strongly suggest that the endocrine activity of the mammalian pineal is under neural control, and receives a major input from the SCN. This means that in addition to its role as a circadian pacemaker, the SCN may also be involved in the seasonal timing of a number of physiological and behavioral processes by regulation of the photoperiod-dependent changes in melatonin secretion.

### Circadian Clock and Aging Suprachiasmatic Nucleus and Aging

With advancing age the circadian timing system is progressively disturbed, both in humans and other mammals, as is clearly demonstrated by a reduced amplitude and period length of circadian rhythms and an increased tendency towards internal desynchronization [5,10]. In humans, age-related changes have been described for hormonal rhythms, body core temperature, sleep-wakefulness, and several other behavioral cycles. A reduction in the amplitude of the circadian sleep-wake cycle was found in long-term registrations of activity patterns in young and elderly men, and even more so in patients with Alzheimer's disease (AD). It appears that aging not only affects the amplitude but also the frequency of circadian rhythms, particularly in dementia. The increase in time spent in both wakefulness during the night and daytime naps, a characteristic pattern in many elderly people, is a symptom of disruption of circadian sleep rhythms similar to the one found following experimental SCN lesions. In fact, disorders of the circadian timing system during aging may first be manifested as sleep-wake pathologies [10].

The many lines of evidence of age-related decrements in circadian time-keeping in human beings and the observed neuronal degeneration of the SCN in senescence and Alzheimer patients strongly suggest an organic deterioration of the circadian oscillator. The disruption of circadian rhythms and the increased incidence of disturbed sleep in humans during aging are paralleled by age-related alterations in the neural organization of the SCN, a decreased photic input to

the clock, and, in the SCN of demented patients, also with a dramatic decrease in peptide synthesis (Fig. 3).

The immunocytochemical data showing decreased activity of the SCN in Alzheimer's disease have been confirmed by *in situ* hybridization [9]. The total amount of AVP mRNA in the SCN of AD patients was three times lower than in age- and sex-matched controls. In addition, the AVP mRNA-expressing neurons in the SCN showed a marked day-night difference in controls under 80 years of age. The amount of AVP mRNA was more than three times higher during the day than at night, whereas no clear diurnal rhythm of AVP mRNA was observed in AD patients. These data support the idea that damage to the SCN is the underlying anatomical substrate for the clinically often-observed disturbances in circadian rhythmicity in Alzheimer's disease.

Immunocytochemical studies, furthermore, provide evidence that degenerative alterations in the human SCN occur at a later phase in life than the reported functional changes in circadian organization [5]. More frequent and prolonged awakenings and shorter sleep periods have already been found in 50- to 60-year-old subjects, whereas a reduction in SCN volume and number of AVP-expressing neurons are only present from the age of 80 years onwards. Thus, the observed loss of AVP-expressing neurons in the SCN of very old people may only be a relatively late correlate of functional changes in the biological clock appearing much earlier.

### Pineal Melatonin and Aging

Reduced melatonin concentrations during aging, especially nocturnal levels, have been reported in plasma,

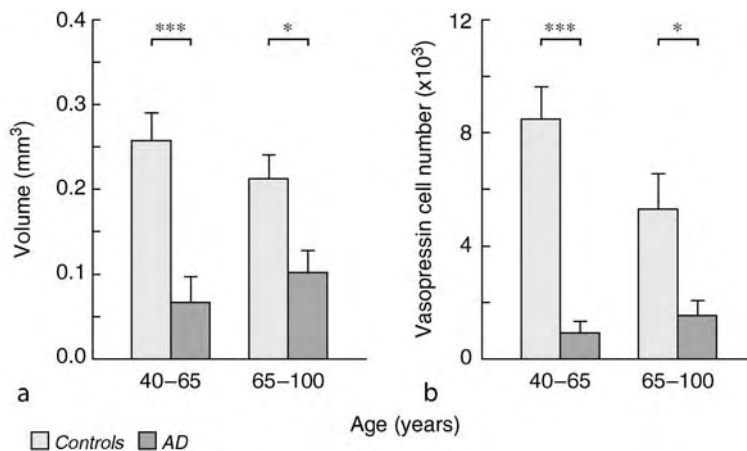

**Human Circadian Timing System. Figure 3** Effect of aging and Alzheimer's disease (AD) on the human suprachiasmatic nucleus (SCN). In Alzheimer patients, both presenile (<65 years of age) and senile (>65 years of age), the volume of the SCN (a) and the number of arginine vasopressin (AVP)-expressing neurons in the SCN (b) are significantly decreased compared to age-matched controls. Note that in presenile Alzheimer patients the number of AVP-expressing neurons is only 10% of that of controls of comparable age. Reproduced from [9], with permission.

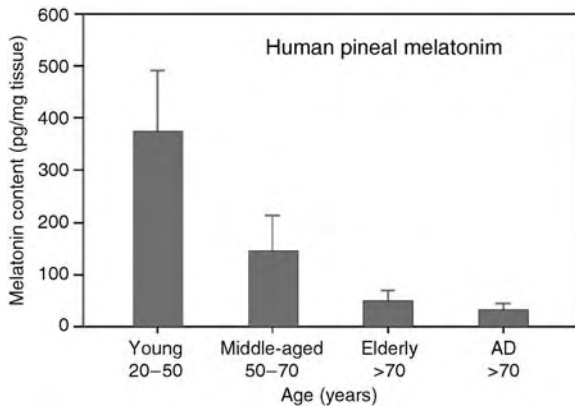

**Human Circadian Timing System. Figure 4** Effect of aging and Alzheimer's disease (AD) on the night-time melatonin level in the human pineal gland. Note the dramatic decline of the nocturnal melatonin production in middle-aged subjects compared to that of young subjects and the further decline after the age of 70 years.

cerebro-spinal fluid (CSF) and in urine [8,10]. Studies of the major urinary metabolite of melatonin, 6-sulfatoxymelatonin show that age related decrease in melatonin production occurs even as early as 20–30 years of age. A decline of the nocturnal serum melatonin peak was only significant at the age of 60 and further declined from 70 years of age onwards. Even within a fairly narrow age range (40–69 years) a significant effect of age was found on the daily excretion of urinary 6-sulfatoxymelatonin in 160 women.

Melatonin content in the human pineal has also been found to be reduced with age (Fig. 4). Besides the age-related decline of melatonin production, age-related changes in the timing of the melatonin rhythm have also been reported. Moreover, older subjects enter sleep and awake earlier relative to their nightly melatonin secretory episode, which indicates that aging is also associated with a change in the internal phase relationship between the sleep–wake cycle and the output of the circadian pacemaker. These findings suggest that degeneration of the SCN-pineal complex could well be the neural substrate for the disrupted circadian rhythms, which have been reported in elderly subjects, demented patients and in depression.

In patients who lack serum melatonin rhythms, clinical symptoms of delirium and sleep-wake disturbance were frequently but not always found. In AD patients with disturbed sleep-wake rhythms a higher degree of irregularities in melatonin secretion have been observed. The finding that the daily variations in pineal melatonin and 5-methoxytryptophol content disappeared in AD patients may be linked with the clinical

observations of sleep disorders and sundowning in these patients [10].

In conclusion, the age-related functional changes in circadian organization in humans may be associated with subtle degenerative alterations in the SCN and other parts of the clock, leading to disruptions of the circadian system. Recent studies suggest that this may happen relatively early in life, well before any dramatic neuronal atrophy of the biological clock becomes manifest.

## References

- Hastings MH, Herzog ED (2004) Clock genes, oscillators, and cellular networks in the suprachiasmatic nucleus. *J Biol Rhythms* 19:400–413
- Hofman MA (2003) Circadian oscillations of neuropeptide expression in the human biological clock. *J Comp Physiol A* 189:823–831
- Hofman MA (2004) The brain's calendar: neural mechanisms of seasonal timing. *Biol Rev* 79:61–77
- Hofman MA, Swaab DF (2002) A brain for all seasons: cellular and molecular mechanisms of photoperiodic plasticity. *Prog Brain Res* 132:255–280
- Hofman MA, Swaab DF (2006) Living by the clock: the circadian pacemaker in older people. *Ageing Res Rev* 5:33–51
- Kalsbeek A, Buijs RM (2002) Output pathways of the mammalian suprachiasmatic nucleus: coding circadian time by transmitter selection and specific targeting. *Cell Tissue Res* 309:109–118
- Saper CB, Lu J, Chou TC, Gooley J (2005) The hypothalamic integrator for circadian rhythms. *Trends Neurosci* 28:152–157
- Skene D, Swaab DF (2003) Melatonin rhythmicity: effect of age and Alzheimer's disease. *Exp Gerontol* 38:199–206
- Swaab DF (2004) The human hypothalamus: basic and clinical aspects. Part I: Nuclei of the human hypothalamus. In: Aminoff MJ, Boller F, Swaab DF (eds) *Handbook of clinical neurology*, vol 79. Elsevier, Amsterdam.
- Van Someren EJW (ed) (2000) Circadian rhythms and sleep in human aging. *Chronobiol Int* 17 (special issue):233–432

## Human Genome (Human Genome Project)

### Definition

This project was started in 1990 by a consortium of researchers, and was essentially complete in 2005. The aim of the project was to sequence the entire human genome and identify all the genes.

## Human Immunodeficiency Virus (HIV)

### Definition

The retrovirus, HIV, causes acquired immunodeficiency syndrome, or AIDS. HIV infects immunocompetent cells including CD4<sup>+</sup> T cells, macrophages, dendritic cells and glia. The primary consequences of HIV infection include acute renal failure, cardiomyopathy, dementia, encephalopathy, opportunistic infections and cancers.

- ▶ Acquired Immunodeficiency Syndrome (AIDS)

## Human Leukocyte Antigens (HLA – Human)

- ▶ Major Histocompatibility Complex

## Human Speech Recognition

- ▶ Speech Perception

## Human Speech Understanding

- ▶ Speech Perception

## Humoral Immunity

### Definition

Humoral Immunity denotes that aspect of immunity that is mediated by secreted antibodies, produced in the cells of the B lymphocyte lineage or plasma cells (B cells).

## Huntington's Disease (HD)

### Definition

Autosomal dominant, progressive neurodegenerative disorder caused by degeneration of cells in the brain, particularly in a specific pathway of the ▶ **striatum**, due to a mutant protein called huntingtin. Its main symptoms are ▶ **chorea** and ▶ **dystonia**, dis-coordination, later followed by ▶ **athetosis**, ▶ **dementia** and behavioral problems. Although the symptoms can become manifest at any time, their onset is often in middle age. The precise pathophysiological mechanisms are not yet well understood. In animal models, signs of Huntington's disease can be reproduced by excitotoxic cell death within the striatum induced by ibotenic and quinolinic acid, most successfully in association with ▶ **dopamine** agonists. The striatal ▶ **GABA/▶enkephalin** neurons giving rise to the 'indirect pathway' perish at an early stage. According to the traditional model of HD, this would result in increased activity of neurons in ▶ **globus pallidus externus (▶GPe)** and, hence, increased inhibition of the ▶ **subthalamic nucleus (▶STN)**, ▶ **globus pallidus internus (▶GPi)** and ▶ **substantia nigra pars reticularis (SNr)**, which would release the ▶ **thalamus** and subsequently the ▶ **cerebral cortex** from inhibition, giving rise to choreiform movement disorders similar to those often seen in ▶ **hemiballism**. Drug-induced dyskinesias may result from similar reductions of activity in STN and GPi. At later stages of HD, the striatal neurons containing GABA and ▶ **substance**.

▶ **P** may be affected as well, resulting in ▶ **rigidity** and ▶ **akinetic** symptoms. Huntington patients suffer from a number of psychic disorders, which need not go in parallel with the somatic symptoms. Disorders of affect, motivation and cognition are frequent, also hallucinations. The above model for hyperkinetic disorders has some problems. First, GPe lesions do not appear to reduce drug-induced dyskinesias. Second, if reduction in ▶ **basal ganglia** output alone were responsible, further reduction by lesions of the GPi/SNr should worsen the dyskinesias. However, ▶ **pallidotomy** ameliorates hemiballism, drug-induced dyskinesias and dystonia, and hyperkinetic disorders can be treated with ▶ **thalamotomy**. There must thus be explanations beyond the simple average-firing-rate model.

- ▶ Athetosis
- ▶ Basal Ganglia
- ▶ Chorea
- ▶ Dystonia
- ▶ GABA
- ▶ Hemiballism
- ▶ Rigidity
- ▶ Striatum
- ▶ Substance P

## Hybrid Architecture

### Definition

Architecture in robotics and artificial intelligence that combines subsymbolic connectionist and rule-based symbolic approaches.

- ▶ Emergence

## Hybrot

- ▶ Computer-Neural Hybrids

## Hydrencephalus

### Definition

Infant born without a forebrain, but still able to suckle, smile, cry, move eyes, arms and legs similar to normal newborns.

## Hydrocephalus

### Definition

“Waterhead” resulting from accumulation of ▶ [cerebrospinal fluid](#) in the cerebral ventricles (hydrocephalus internus) or at the brain’s surface below the subarachnoidal space (hydrocephalus externus). When the circulation or absorption of cerebrospinal fluid is blocked, or excessive fluid is produced, the volume of fluid in the brain becomes higher than normal. The accumulation of fluid puts pressure on the brain, forcing it against the skull and damaging or destroying the tissues. The symptoms vary depending on the cause of the obstruction, the person’s age when the problem develops, and the extent of brain tissue damage caused by the swelling.

- ▶ [Cerebrospinal Fluid \(CSF\)](#)

## Hydropathy

### Definition

The hydrophilicity or water solubility characteristics of a short sequence of amino acids within a protein. For membrane proteins, the variations in hydropathy in the amino acid sequence are used to predict those parts of the protein that will lie within the membrane bilayer itself (which is composed of oil-like hydrophobic domains) and those that will interact with the aqueous solutions on either side of the membrane bilayer. For example, a leucine or valine-rich sequence would tend to form transmembrane structures, whereas sequences enriched in charged residues (e.g. aspartate, glutamate, lysine, etc.) will tend to project into the aqueous solutions on either side of the membrane. Such predictions are made using computer programs that incorporate empirically determined hydropathy values (e.g. the Hopp and Woods, or Kyte and Doolittle indices).

- ▶ [Cell Membrane – Components and Functions](#)

## Hydroxyl Free Radicals

- ▶ [Neuroinflammation: Modulating Pesticide-Induced Neurodegeneration](#)

## Hyperaldosteronism

### Definition

Hyperaldosteronism is a disorder of primary sodium retention with subsequent extracellular fluid (ECF) volume expansion.

High plasma mineral corticoid activity can result from an adrenal tumor or hyperplasia, or from pharmacological therapy with synthetic mineral corticoids.

- ▶ [Blood Volume Regulation](#)

## Hyperalgesia and Allodynia

FERNANDO CERVERO

Anesthesia Research Unit (Faculty of Medicine),  
Faculty of Dentistry and McGill Centre for Research  
on Pain, McGill University, QC, Canada

### Synonyms

Pain hypersensitivity; Touch-evoked pain; Increased sensitivity to pain

### Definition

The following are the definitions proposed by the International Association for the Study of Pain (IASP):

- ▶ **Hyperalgesia:** An increased response to a stimulus which is normally painful.
- ▶ **Allodynia:** Pain due to a stimulus which does not normally provoke pain.

### Characteristics

#### The Dynamics of Pain Sensation: Pain and Hyperalgesia

Pain is a normal sensation that protects us from impending damage and helps us to heal once the damage is done. Like all other sensations pain has a sensory threshold and an encoding range (Fig. 1), but unlike most other sensations the stimuli that cause pain are not defined by the appropriate form of energy (mechanical, chemical, photic, thermal), but by their ability to cause pain. Stimuli that do not evoke pain are called innocuous and those that evoke pain are called noxious, regardless of their type of energy. Another unique property of pain is that the application of a prolonged and constant noxious stimulus does not lead to sensory adaptation – as is the case with all the other sensations – but, on the contrary, to sensory enhancement. Therefore, a prolonged noxious stimulus shifts the psychophysical curve of pain not towards the right – which would produce a higher threshold and reduced responses – but towards the left, thus resulting in a lowering of the pain threshold and the generation of enhanced pain sensitivity known as hyperalgesia (Fig. 1).

Under laboratory conditions it is possible to generate hyperalgesic sensations by the application of a stimulus of constant intensity that activates peripheral ▶ **nociceptors** [2]. In real life, hyperalgesia is a direct consequence of tissue injury and inflammation and the component of the normal sensory repertoire that demonstrates the dynamic nature of pain sensation. Hyperalgesic sensations can also appear in the absence of tissue injury or inflammation when there is a dysfunction of the peripheral or the central nervous system. In this case hyperalgesic sensations are abnormal and an expression of a pathological sensory process

known as ▶ **neuropathic pain** [▶ see **Neuropathic pain** essay and ▶ **Central pain**]. However, in all cases, normal or abnormal, the most significant sensory aspects of a hyperalgesic state are the enhancement of pain sensitivity and the lowering of the pain threshold.

### The Taxonomy of Hyperalgesia

There is some confusion as to the precise meaning of the word hyperalgesia and of its related terms. The expression hyperalgesia is often used to qualify all aspects of enhanced sensitivity to pain and therefore we talk about “hyperalgesic states,” meaning “pain hypersensitivity states,” in very general terms. However, the International Association for the Study of Pain (IASP) has restricted the meaning of the word hyperalgesia to an increased sensitivity to stimuli that are normally painful and has proposed the word “allodynia” to describe those pain sensations that are caused by stimuli that are normally not painful, such as the pain evoked by light touch of sunburned skin [3]. In this way, hyperalgesia defines augmented pain sensitivity and allodynia a change in the quality of the sensations evoked by normally non-painful stimuli (see Fig. 1). The key difference is whether the originating stimulus is normally painful (hyperalgesia) or normally non-painful (allodynia).

Before the IASP proposed this taxonomy and coined the new word allodynia, all forms of increased sensitivity to pain were known as hyperalgesia. From these earlier times comes a subdivision of hyperalgesia that not only has survived to our days, but has also

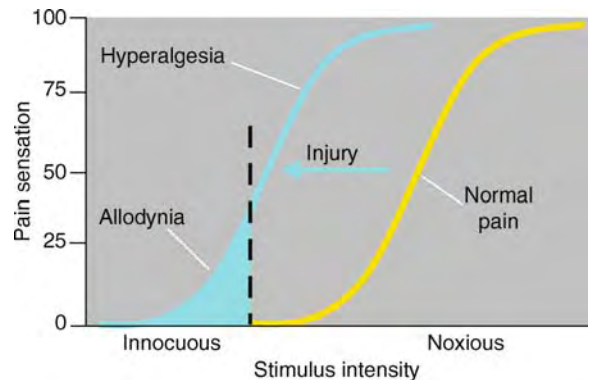

**Hyperalgesia and Allodynia.** Figure 1 Diagram that represents the changes in pain sensation induced by injury and the psychophysical definitions of hyperalgesia and allodynia. The normal relationship between stimulus intensity and pain sensation is represented by the yellow curve. The vertical dotted line indicates the normal pain threshold. Injury provokes a leftward shift in the curve as a consequence of which innocuous stimuli can evoke pain (allodynia) and stimuli that normally evoke pain produced increased pain sensations (hyperalgesia). From [1].

provided the contemporary basis for a mechanism-based distinction between different hyperalgesic states. Hardy and colleagues [4] carried out extensive psychophysical studies (psychophysics) in human volunteers and concluded that there were two kinds of hyperalgesia: primary and secondary. Primary hyperalgesia is an increased sensitivity to pain at the site of injury and secondary hyperalgesia is an increased sensitivity to pain at locations adjacent or even remote from the site of injury. For instance a burn to the hand will produce not only an enhanced pain sensitivity of the hand (primary hyperalgesia), but also increased tenderness and pain sensitivity of large portions of the forearm or even the arm (secondary hyperalgesia). When the primary lesion is in an internal organ, the area of secondary hyperalgesia may be remote, like the enhanced pain sensitivity of the left arm during cardiac ischemia. In these cases, secondary hyperalgesia is called referred hyperalgesia.

The distinction between primary and secondary hyperalgesia is not just based on location of the sensation. There is also an important mechanistic component to this division based on the facts that primary hyperalgesia is due to peripheral alterations of the sensory endings at the site of injury or inflammation and secondary hyperalgesia is the result of a change in the sensory processing by the central nervous system of afferent signals from an otherwise normal periphery.

### Mechanisms of Primary Hyperalgesia: Nociceptor Sensitization

It has been known for a long time that the functional properties of peripheral ▶nociceptors change following injury or inflammation of the territory that they innervate [5]. This property, known as ▶sensitization, results in nociceptors becoming more excitable to subsequent stimulation following a period of intense activation. Their threshold is lowered and their responses are enhanced, showing a characteristic leftward shift in their stimulus-response function that matches the leftward shift of behavioral hyperalgesia. In some cases, injury or inflammation can bring into action populations of nociceptors that were previously unresponsive (the so-called “silent” nociceptors). This is regarded as an extreme form of nociceptor sensitization.

Sensitization of nociceptors is believed to be the mechanism responsible for primary hyperalgesia (Fig. 2). The process of sensitization is not fully understood, but it involves the release of inflammatory mediators and tissue factors from the nociceptor terminals themselves or adjacent cells – such as mast cells – by the originating injury or inflammatory process. The consequence of nociceptor hyperexcitability at the injury site is a lowering of the pain threshold and an enhancement of pain responses evoked from the injured area, that is, primary hyperalgesia.

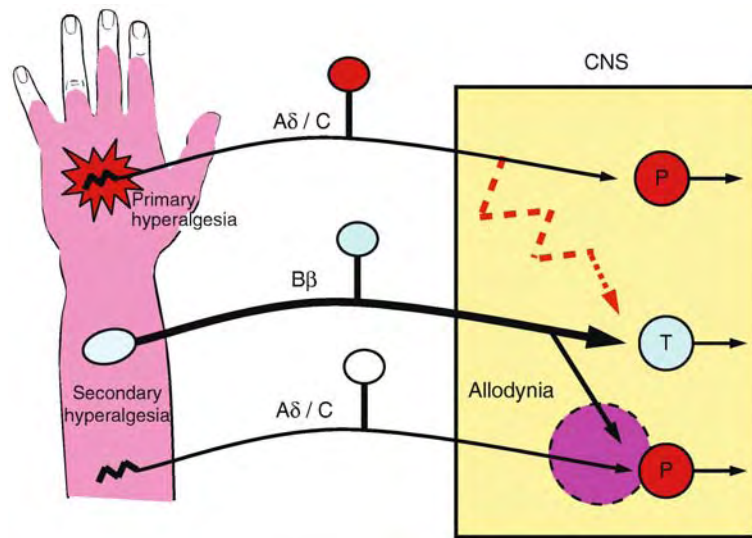

**Hyperalgesia and Allodynia. Figure 2** Diagram representing the basic neural organization of the peripheral and central mechanisms of primary and secondary hyperalgesia. The diagram shows the afferent input to the spinal cord ( $A\beta$ ,  $A\delta$  and C fibers) and their projection to spinal cord nociceptive (P) and tactile (T) neurons. Primary hyperalgesia (red star) is due to the sensitization of peripheral nociceptors by injury. Secondary hyperalgesia (pink area) is caused by a central alteration in the processing of the tactile and nociceptive inputs. This alteration is induced by the increased afferent barrage from sensitized nociceptors (indicated by the dotted-line red arrow).

### Mechanisms of Secondary Hyperalgesia: Central Sensitization

The fact that secondary hyperalgesia is felt in areas of the body distinct, or even remote, from the actual site of injury indicates that this form of hyperalgesia is more likely to be mediated by a central nervous system mechanism than by a peripheral alteration. We now know that the impulses generated in nociceptors at the site of injury or inflammation evoke central changes that in turn produce secondary hyperalgesia [7,8]. These changes are triggered by the impulses arriving from nociceptors at the injury site and maintained by the enhanced spontaneous activity of these nociceptors due to their sensitization (Fig. 2). This process has been

called “central sensitization” by analogy to the peripheral sensitization observed at the site of injury, and involves an increase in the excitability of second order neurons in the spinal cord and supraspinal nuclei and a switch in the sensory consequences of the activation of low threshold afferent fibers from touch to pain.

There is considerable evidence showing that intense or persistent activity in peripheral nociceptors leads to increases in responsiveness of dorsal horn neurons (see references in [1]). This enhancement of the excitability of spinal cord neurons matches the characteristic leftward shift of the pain curve observed in human and experimental animals in areas of secondary hyperalgesia (see Fig. 3) and it is conceivable that one

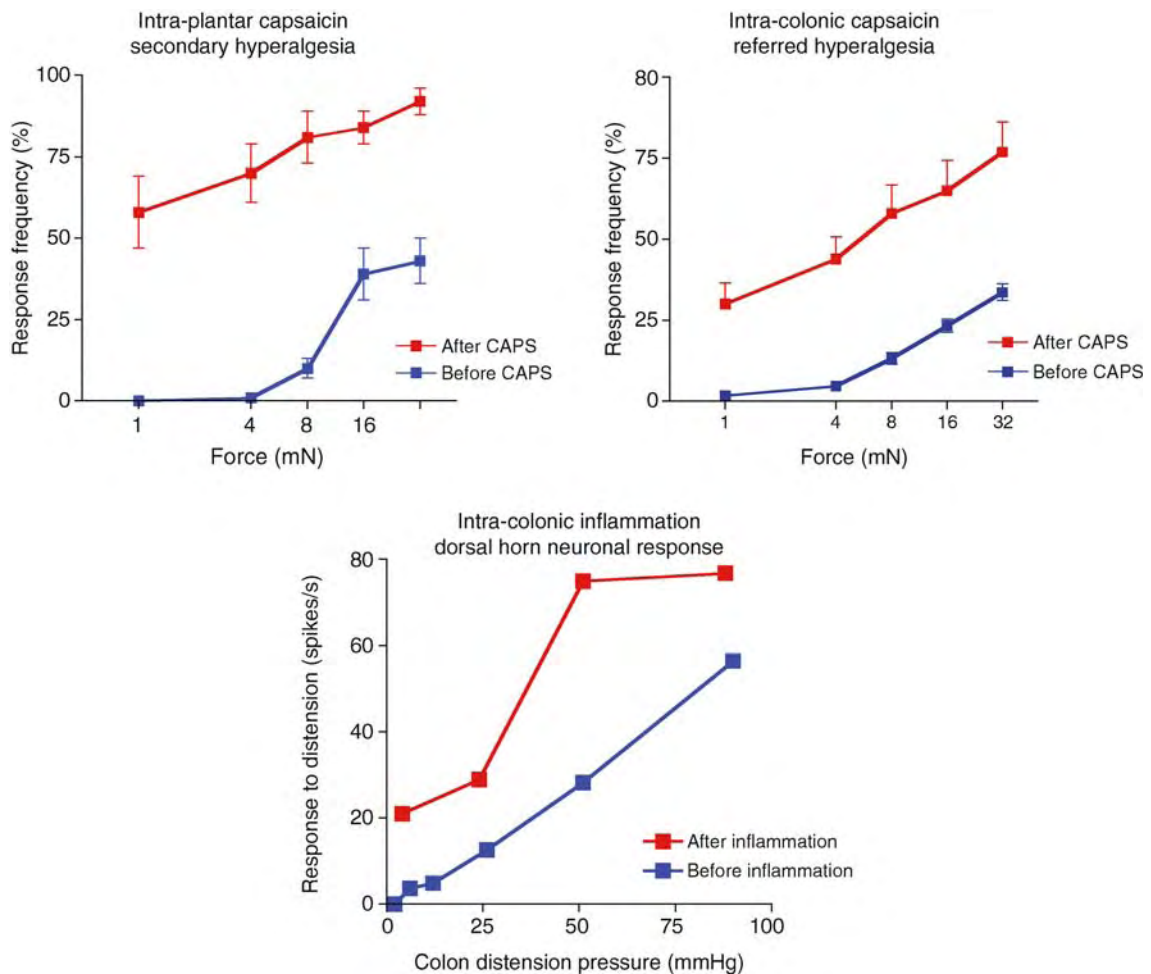

**Hyperalgesia and Allodynia. Figure 3** Three graphs with original data showing the characteristic leftward shifts that underlie hyperalgesic states. The two graphs at the top are from behavioral studies in awake mice in which the mechanical sensitivity of an area remote to the test site was tested before (blue curves) and after (red curves) the intradermal injection of capsaicin (left curve, test site adjacent to the paw) or the intracolonic installation of capsaicin (right graph, test site in the abdominal wall). The bottom graph is from an electrophysiological study in an anesthetized rat in which the responses of a dorsal horn neurone to colonic distension were recorded before (blue curve) and after (red curve) inflaming the colon by instillation of acetic acid. Data from the author's laboratory.



process leads to the other. Therefore, the idea of a central sensitization process has been widely accepted as a possible neural mechanism for the generation of hyperalgesic states.

Many molecular candidates have been put forward as mediators of central sensitization, including neurotransmitters such as glutamate and neuropeptides such as Substance P. However, there are also many aspects of this process that remain unknown, including the link between the increase in excitability observed in spinal cord neurons following a noxious stimulus and the specific sensory changes observed in secondary hyperalgesic states. Moreover, the precise meaning of “central sensitization” is not clear, as this expression has been used to qualify most forms of increased excitability in central neurons or of enhanced pain responsiveness in humans and experimental animals. The cellular processes that underlie these changes in excitability are due to alterations of synaptic excitability identical to those of ▶**Long term potentiation** ([9]; also see ▶**Synaptic long-term potentiation (LTP) in pain pathways**), which is also observed in other regions of the nervous system unrelated to pain processing. It is possible that “central sensitization” is an expression of synaptic plasticity in the central nervous system rather than a specifically pain-related phenomenon.

### Mechanisms of Allodynia: Touch-Evoked Pain

The characteristic features of secondary hyperalgesia include not only an increase in the magnitude of the pain sensations evoked from this zone, but also a change in the modality of the sensation evoked by ▶**low threshold mechanoreceptors** from touch to pain [2,7]. This process is known as touch-evoked pain or tactile allodynia. In areas of secondary hyperalgesia, touch-evoked pain is mediated by impulses in low-threshold mechanoreceptors connected to large myelinated afferent fibers. This shows that pain can be produced in normal individuals by the activation of low-threshold mechanoreceptors, albeit under the special circumstances of having sustained a previous injury. Touch-evoked pain can appear very shortly after the activation of nociceptors from the primary area and can also disappear very quickly if the activity of these nociceptors is reduced or blocked. The process is dynamic, reversible and not dependent on the formation of new anatomical connections between the tactile and the nociceptive systems.

Whereas the increased sensitivity to pain in areas of secondary hyperalgesia could be explained by an enhanced excitability of the nociceptive system (see Fig. 3), the switch from touch to pain in the central actions of low-threshold mechanoreceptors requires

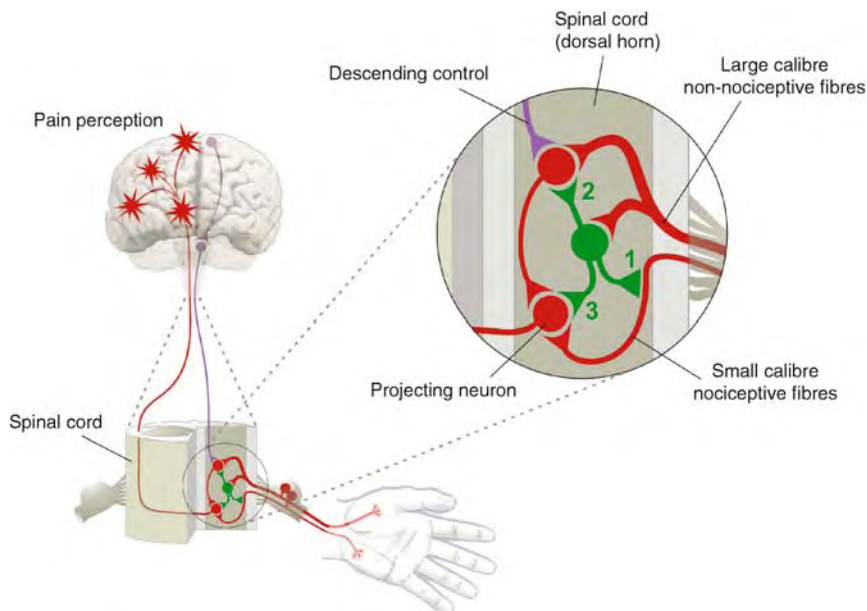

**Hyperalgesia and Allodynia. Figure 4** Spinal cord mechanisms that can cause hyperalgesia by facilitating low threshold input to nociceptive neurons. The enlarged diagram on the right illustrates three potential mechanisms by which input from large afferents may be conveyed to nociceptive neurons causing allodynia. (i) Exaggerated Primary Afferent Depolarization that can reach firing threshold and produce action potentials in the nociceptive afferent terminal evoked by impulses in the low threshold afferent; (ii) Disinhibition of polysynaptic pathways to nociceptive neurons that can unmask subliminal input to these neurons from low threshold afferents and (iii) Direct relay of low threshold input to nociceptive neurons via a reversal of the action of GABA/glycine such that low threshold afferents that would normally cause inhibition of the relay cell can now cause an excitation of this neuron. From [6].

alternative explanations. Several hypotheses have been put forward to address this remarkable switch and some are illustrated in Fig. 4. All of them are based on the reversal of the actions of the inhibitory neurotransmitters GABA and glycine such that they become excitatory and facilitate the low threshold input to nociceptive neurons [6].

One proposed mechanism is based on the ► **Primary afferent depolarization** of the terminals of nociceptive afferents induced by activity in low threshold sensory fibers. This is known to be mediated by a GABA-ergic current that is normally depolarizing because of the higher than normal concentration of chloride ions in primary afferent terminals. If these depolarizations were intense enough to evoke action potentials, this would provide an excitatory pathway for low threshold sensory fibers to activate nociceptive afferents and therefore the nociceptive pathway.

Another proposed mechanism is based on disinhibition of a polysynaptic pathway from low threshold afferents to nociceptive neurons. Under normal conditions these pathways are inhibited by local GABA-ergic interneurons, but release of this inhibition can unmask existing low threshold afferent input to the nociceptive system.

Finally, a mechanism has also been proposed based on the complete reversal of the actions of GABA or glycine on spinal cord neurons from inhibition to excitation [10]. This would be made possible by an increase in the intracellular concentration of chloride ions in these neurons produced by an inhibition of the co-transporter responsible for reducing internal chloride. Under these circumstances, GABA and glycine become excitatory by inducing cell depolarizations rather than hyperpolarizations and the normally inhibitory actions of low threshold afferents on nociceptive neurons become excitatory.

## References

1. Cervero F, Laird JM (1996) Mechanisms of touch-evoked pain (allodynia): a new model. *Pain* 68:13–23
2. Cervero F, Gilbert R, Hammond RGE, Tanner J (1993) Development of secondary hyperalgesia following non-painful thermal stimulation of the skin: a psychophysical study in man. *Pain* 54:181–189
3. Merskey H, Bogduk N (1994) Classification of chronic pain, IASP Press, Seattle, 222pp
4. Hardy JD, Wolff HG, Goodell H (1950) Experimental evidence on the nature of cutaneous hyperalgesia. *J Clin Invest* 29:115–140
5. Treede R-D, Meyer RA, Raja SN, Campbell JN (1992) Peripheral and central mechanisms of cutaneous hyperalgesia. *Prog Neurobiol* 38:397–421
6. Price TJ, Cervero F, de Koninck Y (2005) Role of Cation-chloride-cotransporters (CCC) in pain and hyperalgesia. *Curr Top Med Chem* 5:547–555

7. LaMotte RH, Shain CN, Simone DA, Tsai E-FP (1991) Neurogenic hyperalgesia: Psychophysical studies of underlying mechanisms. *J Neurophysiol* 66:190–211
8. Torebjörk HE, Lundberg LER, LaMotte RH (1992) Central changes in processing of mechanoreceptive input in capsaicin-induced secondary hyperalgesia in humans. *J Physiol (Lond)* 448:765–780
9. Sandkühler J (2007) Understanding LTP in pain pathways. *Molecular Pain* 3:9 <http://www.molecularpain.com/content/3/1/9>
10. Coull JA, Boudreau D, Bachand K, Prescott SA, Nault F, Sik A, De Koninck P, De Koninck Y (2003) Trans-synaptic shift in anion gradient in spinal lamina I neurons as a mechanism of neuropathic pain. *Nature* 424:938–942

---

## Hyperbaric Oxygen Treatment

### Definition

Treatment by 100% oxygen under increased pressure. Normal atmospheric pressure is defined as 1 atmosphere (1 ATA). Hyperbaric oxygen is supplied usually at a pressure of 2 ATA or more.

---

## Hypercoagulable State

### Definition

The propensity to develop blood clots due to an abnormality in the coagulation system.

The main tests for hypercoagulable states include prothrombin time and INR, partial thromboplastin time, thrombin time, fibrinogen levels, antiphospholipid antibody levels, protein C, protein S and antithrombin III, APC (activated protein C) resistance, factor V Leiden and prothrombin mutation. Other than persistent abnormalities of antiphospholipid antibodies, all these other problems are almost exclusively associated with an increased risk of venous, not arterial, thrombosis.

### ► Stroke

---

## Hyperelasticity

### Definition

A material model of an elastic body for which the elastic constitutive function for the stress tensor can be

obtained as the derivative of a single scalar function of the deformation gradient. This scalar function is sometimes called the strain-energy function or the stored energy function.

►Mechanics

## Hypergeusia

### Definition

Hypergeusia is used to describe the abnormal enhancement of the sense of taste, also referred to as gustatory hyperesthesia. Hypergeusia may occur in a generalized form or be specific to a single or limited number of tastants.

►Gustation

## Hyperkalemic Periodic Paralysis

### Definition

Autosomal dominant disease of early onset, resulting from a point mutation of the skeletal muscle ► $\text{Na}^+$  channel (Nav1.4) gene on chromosome 17 and characterized by periodic attacks of flaccid muscle weakness and areflexia (loss of tendon reflexes), and intermittent ►myotonia, although (despite its name) not necessarily associated with hyperkalemia during the attacks, while  $\text{K}^+$  administration may typically provoke attacks of muscle weakness. In some patients, muscle weakness is aggravated by cold and exercise.

►Tendon Reflex

## Hyperkinesia

### Definition

Abnormally increased motor activity, such as that seen drug-induced dyskinesia or the chorea seen in Huntington's disease. Hyperkinetic movement disorders include Huntington disease, tardive dyskinesia, essential tremor, restless limb syndrome,

neuroleptic-induced akathisia, myoclonus, and tic disorders (such as Tourette's syndrome).

- Essential Tremor
- Huntington's Disease
- Myoclonus
- Restless Legs Syndrome
- Tardive Dyskinesia
- Tourette's Syndrome

## Hyperlipidemia

### Definition

Defined as a low-density lipoprotein (LDL) cholesterol level of 160 mg/dl or higher and is associated with an increased risk of stroke. High levels of high-density lipoprotein (HDL) cholesterol reduce the risk of stroke.

►Stroke

## Hypermetria

### Definition

A type of dysmetria, characterized by overshooting an intended target during the trajectory movement of a limb towards that target, usually seen in cerebellar disorders.

## Hyperoxia

### Definition

Higher than normal oxygen levels.

## Hyperpolarization

### Definition

Hyperpolarization is the change in membrane potential to a more negative, less excitable potential.

- Action Potential
- Membrane Potential: Basics

## Hyperpolarization-activated Cyclic Nucleotide-gated Channels

- ▶ Cyclic Nucleotide-Regulated Cation Channels

## Hyperreflexia

### Definition

Enhancement of tendon reflexes above normal level.

- ▶ Tendon Reflex

## Hypersomnia

### Definition

An increased propensity to fall asleep or a subjective feeling of excessive sleepiness; this is a symptom of a variety of sleep disorders and other medical conditions.

- ▶ Sleep – Developmental Changes

## Hypertelorism

### Definition

Abnormally large distance between two organs such as the eyes.

- ▶ Endocrine Disorders of Development and Growth

## Hypertension

### Definition

Is defined as a blood pressure of 140/90 mmHg or higher for an extended period of time. It is the most important modifiable risk factor for stroke.

- ▶ Stroke

## Hyperthyroidism

### Definition

A clinical syndrome resulting from excess of thyroid hormone. Among its features are heat intolerance, restlessness, tachycardia, increased perspiration, weight loss and increased appetite.

- ▶ Hypothalamus-Pituitary-Thyroid Axis

## Hypertonia

### Definition

Increased muscle tone detected by the examiner during passive range of motion. Rigidity (seen in Parkinson disease) is one form of hypertonia and it should be differentiated from spasticity, paratonia, pain-related guarding of the joints in arthritic patients, or even a cogwheel phenomenon seen in essential tremor.

Spasticity is velocity-dependent (clasp-knife) hypertonia and is associated with upper motor neuron signs such as pathologic hyperreflexia, Babinski signs, and pyramidal distribution weakness. Paratonic hypertonia (paratonia), seen in dementia, is characterized by a resistance to passive movement that is proportional to the force applied by the examiner.

Joint pain in the setting of arthritis can lead to local muscle spasm and guarding and cause increased tone.

The cogwheel phenomenon is typically part of Parkinson disease, but may also be seen in severe essential tremor as a result of coarse tremor interrupting passive movement, especially if the patient fails to completely relax.

- ▶ Babinski Reflex
- ▶ Clasp-knife Phenomenon
- ▶ Essential Tremor
- ▶ Parkinson Disease
- ▶ Spasticity

## Hypertrophy

### Definition

Volume increase in a cell, due to increased protein synthesis and increased assembly of myofibrils in striated muscle cells.

- ▶ Sarcomere Structural Proteins

## Hypochondriasis

### Definition

Hypochondriasis objective groundless and constant worry about healthiness and life. The hypochondriac person is preoccupied with fears of having a serious disease, which persists despite medical reassurance to the contrary.

► Personality Disorder

## Hypocretin

### Definition

Hypocretins, also called orexins, are the common names given to a pair of highly excitatory neuropeptide hormones from the lateral hypothalamus.

## Hypocretin/Orexin

ANTOINE ADAMANTIDIS, LUIS DE LECEA  
Department of Psychiatry and Behavioral Sciences,  
Stanford University School of Medicine, Palo Alto,  
CA, USA

### Synonyms

Hypocretin-1, 2/Orexin-A, B

### Definition

The hypocretins (Hcrts) are neuroexcitatory peptides produced in approximately ~3200 neurons in the mouse brain (~6700 and 50,000–80,000 in the rat and human brain, respectively), restricted to the perifornical area of the lateral hypothalamus (LH) [1,2]. Hcrts were independently discovered in the late 1990s by two groups and thus have two names [1,2]. The name “hypocretin” is due to sequence similarities with various members of the incretin family and its hypothalamic localization [1]. The name “►orexin” comes from the orexigenic effect observed after intracerebroventricular administration the peptide in rat [2]. These two names designate the same peptide system and the terms are used interchangeably in the literature.

### Characteristics Peptide Structure

Hcrts are processed from the same 130 amino acids precursor. Hcrt-1 (33 residues; EPLPDCCRQKTCSCR-LYELLHGAGNHAAGILT-amide) and Hcrt-2 (28 residues; RPPGGLQGRLLQANGNHAAGILTM-amide) both contain an identical 13 amino-acid sequence in the C-terminal region, suggesting that the peptides have related structures and functions [1]. This region of Hcrt-2 contains a seven-amino-acid match with secretin. Hcrt-1 contains two intra-chain disulfide bonds. Human Hcrt-1 is identical to the rodent peptide, whereas human Hcrt-2 differs from rodent Hcrt-2 at two residues. The non-amidated forms of the peptides are not electrophysiologically active.

### Neuroanatomy of the Hcrt System

Hcrt neurons are multipolar or fusiform in shape, with 2–5 primary dendrites that are either smooth or sparsely invested with dendritic spines. Hcrt mRNA and Hcrt immunoreactivity are located in the perifornical area of the hypothalamus (►Perifornical area/lateral hypothalamus) [1]. In mammals, the projections of Hcrt-containing neurons are widely distributed within the central nervous system (CNS), including arousal centers of the CNS, cortex, hippocampus, amygdala, nucleus accumbens, and the hypothalamus itself. In addition to central expression in the lateral hypothalamus (LH), there are several reports of Hcrt and receptor expression in the periphery, including the enteric nervous system, pancreas, kidney, stomach and ileum. Hcrt expression has also been detected in the human retina, anterior pituitary, and adrenal gland.

The hypocretin peptides bind to two G-protein coupled receptors with differential affinities. Hypocretin receptor-1 (Hcrtr1, also referred to as OX1R), binds Hcrt-1 with high affinity and Hcrt-2 with 100–1,000-fold lower affinity. A related GPCR, Hypocretin receptor-2 (Hcrtr2/OX2R), shares 64% identity with Hcrtr1. These two receptors are highly conserved (95%) across species [2]. The mRNAs that encode the two hypocretin receptors, both are enriched in the brain but have different and complementary distributions [3]. The expression of Hcrt receptors is largely consistent with Hcrt axon innervation patterns and are found in the ►locus coeruleus (LC), amygdala, and ►brainstem noradrenergic groups. Hcrtr2 is predominantly expressed in regions such as the septum, hypothalamus, and much of the brainstem. The Hcrt receptors are also widely expressed in the periphery, especially in endocrine tissues including the pituitary, adrenal gland, testis, gastrointestinal tract, pancreas, and pineal gland.

Both Hcrt-1 and Hcrt-2 act through a family of GTP-binding proteins (Gq) that activate protein kinase C (PKC) and mobilization of intracellular calcium. Gq-activated signaling cascades result in phosphorylation

of  $\text{Ca}^{2+}$  channels, which can increase  $\text{Ca}^{2+}$  conductance and neuronal excitability. In some instances, *Hcrtr2* has been associated with activation of  $G_i$  and inhibition of adenylyl cyclase.

### Input and Output

The LH receives inputs from multiple, diverse neuron populations of the brain. Among those are the descending projections from the limbic forebrain, subsets of the hypothalamus itself (for example, arcuate nucleus, dorso-median hypothalamus, ►[paraventricular nuclei](#)), and subcortical and thalamic areas. Ascending projections come from the brainstem cholinergic nuclei, the reticular formation, the midbrain ►[raphe nuclei](#), and periaqueductal gray.

Hcrt neurons in the LH are highly interconnected with a network of glutamatergic, GABAergic, dopaminergic, and cholinergic neurons [3]. Several extracellular signaling molecules exert excitatory effects on Hcrt neurons, including ►[glutamate](#), ghrelin, glucagon-like peptide 1, CRF, ATP, noradrenaline and carbachol (acetylcholine agonist), cholecystokinin, neurotension, vasopressin, and oxytocin. A subpopulation of Hcrt cells were found to be excited by ACh. Other molecules, including GABA (through GABA<sub>A</sub>, b), glucose, ►[serotonin](#) (5-HT<sub>1a</sub>), noradrenaline (alpha 2), dopamine, NPY, leptin, acetylcholine (muscarinic receptor; 6% of the cells) and adenosine (A<sub>1</sub>) have been found to inhibit Hcrt neurons. Accordingly, proteins detected in Hcrt neurons include dynorphin, GABA<sub>A</sub> receptor epsilon subunit, 5-HT<sub>1a</sub> receptor,  $\mu$ -opioid receptor, pancreatic polypeptide Y4 receptor, adenosine A<sub>1,2</sub> receptor, leptin receptor, transcription factor STAT-3, and the neuronal pentraxin *Narp*, involved in clustering of ionotropic glutamate receptors.

### Functional Implications

The Hcrt system is a target of arousal ascending brainstem projections and descending forebrain structures, which in turn, projects back to these nuclei. Thus, they are in an ideal position to integrate peripheral inputs, such as metabolic and other homeostatic afferents, and modulate behavior outputs, such as arousal and ►[goal-oriented behaviors](#).

### Arousal

Concomitant discoveries of the link between ►[narcolepsy](#) and the Hcrt system established the role of Hcrts in arousal [3]. Continuous analysis of the behavior of mice with the Hcrt gene deleted (*Hcrt* knockout (KO) mice) revealed periods of ataxia, which were especially frequent during the dark/active period. EEG recordings showed that these episodes were not related to epilepsy, that the mice displayed abrupt behavioral arrests, reminiscent of cataplexy-like attacks, and that their

EEGs showed episodes of direct transition from wakefulness to ►[REM sleep](#), all hallmarks of narcolepsy. Similar observations were made in rats in which the hypocretin neurons of the lateral hypothalamus were inactivated by saporin targeting, although in this model, cataplexy was not observed.

Studies of mice deficient for hypocretin receptors support a role for the hypocretin system in arousal. *Hcrtr2* KO mice have a milder narcoleptic phenotype than the *Hcrt* KO animals, and double *Hcrtr1* and *Hcrtr2* mutant animals recapitulate the full *Hcrt* KO phenotype, suggesting that signaling through both receptors contributes to normal arousal, although the contribution of *Hcrtr2* appears greater than that of *Hcrtr1*. Dogs with deficient *Hcrtr2* displayed a similar phenotype.

Transgenic rats and mice depleted of Hcrt neurons (animals generated by expressing a mutant form of ataxin 3 in these cells) show a narcolepsy-like phenotype as well as reduced locomotor activity upon fasting [3], strongly suggesting that the Hcrt system is an important component of the brain circuit necessary to maintain arousal. Consistent with this hypothesis, data from recent studies demonstrate an increase of Hcrt neuron firing rate during robust locomotor activity during periods of wakefulness, as well as sleep-to-wake ►[transitions](#) during REM sleep [4,5]. Interestingly, Mochizuki and collaborators demonstrated that the behavioral state instability (e.g. fragmented wakefulness) of *Hcrt* KO animals is not a consequence of abnormal sleep homeostasis, poor circadian control, or defective fundamental arousal systems. Selective photostimulation of Channelrhodopsin-2-expressing Hcrt neurons using ►[optogenetic](#) tools *in vivo* increase the probability of sleep-to-wake transitions [6].

Altogether, these studies establish a causal link between the activation of the Hcrt system and the maintenance of arousal. Hcrt concentrations in the cerebral spinal fluid (CSF) are tightly regulated in healthy human whereas most of the patients with narcolepsy with cataplexy show neither Hcrt-producing neurons nor detectable Hcrt level [7,8]. Patients with other neurological diseases have normal Hcrt levels in the CSF. A single patient with a non-HLA-linked narcolepsy carries a mutation within the hypocretin gene itself. These findings leave no doubt as to the central role of the Hcrt system in narcolepsy and arousal. Because most cases are sporadic, mutations in the Hcrt gene or those for its receptors can account for no more than a small subset of human narcolepsies. The HLA association, loss of neurons with signs of gliosis, and age of disease onset are consistent with autoimmune destruction of the Hcrt neurons accounting for the majority of narcolepsy, although a non-immune-mediated degenerative process has not been ruled out. The cause of Hcrt neuron loss is an active area of narcolepsy research.

### Goal-Oriented Behaviors

Goal-oriented behaviors can be elicited by natural (food, thirst, sex) or artificial (drugs of abuse) clues. Onset of these behaviors requires an appropriate balance between sleep- and wake-promoting circuits of the brain, which set up an arousal threshold. Hcrt-producing neurons play a key role in setting up this threshold, and activate circuits involved in motivation for consummatory behaviors.

Intracerebroventricular administration of either Hcrt-1 or Hcrt-2 increases short-term food consumption in rats, sheep and goldfish. Furthermore, rats that have been deprived of food for 48 h show increased concentrations of hypocretin mRNA and peptides in the hypothalamus. The Hcrt system also influences and is influenced by primary energy homeostasis circuits. For example, Hcrt neurons are sensitive to glucose, leptin, triglyceride and carbon dioxide concentrations [3]. However, other findings suggest that the Hcrt are not critical players in food intake behavior, but rather play roles in increasing arousal and motivation levels that allow feeding to take place. Continuous administration of Hcrt-1 for 7 days in rats does not significantly alter daily food intake, body weight, blood glucose, total cholesterol, or free fatty acid levels, suggesting that many of Hcrt's effects may be limited to short-term, immediate stimulation of feeding behavior consequent to the increased duration of wakefulness. In addition, Hcrt KO mice show modest differences in food intake and Hcrt-ataxin 3 mice, which would be expected to be lean, show obesity and hypolocomotion phenotypes, an effect dependent on diet and genetic background. Also, during fasting, Hcrt-1 accumulation in the CSF does not exceed concentrations observed during the waking period. These data suggest that some of the food-uptake effects may result from heightened arousal during food craving and/or food intake as opposed to feeding pressure.

Infusion of Hcrt-1 in the brain ventricles elevates intra-cranial self stimulation (ICSS) thresholds indicating that the peptide decreases brain reward function in a similar way as stress [9]. Hcrt neurons, which express the  $\mu$ -opioid receptor, are highly responsive to morphine and their activation is linked to preferences for cues associated with drug and food reward and also naltrexone-precipitated withdrawal [10]. Interestingly, Hcrt neurons are strongly activated by copulatory behavior in male rats. Expression of Hcrt mRNA increases after precipitated withdrawal. Hcrt KO mice exhibit dramatically attenuated morphine withdrawal symptoms. Moreover, Hcrt reinstates extinguished drug-seeking behavior, an effect prevented by blockade of the Hcrt-1 systems. Accordingly, a Hcrt-1 receptor antagonist blocks footshock-induced reinstatement of previously extinguished cocaine-seeking behavior leading to the conclusion that the Hcrt system is an

important component of stress-mediated drug seeking behavior [9].

Finally, Hcrt neurons are activated in male mice hypothalamus during copulatory behavior and Hcrt-1 infusion in the medial preoptic area potentiates male sexual behavior in rats. Since Hcrt-1 downregulates the firing rate of downstream dopaminergic neurons in the ventral tegmental area, these data suggest that the Hcrt system may act in a steroid-sensitive manner to facilitate motivation toward natural rewards, such as food or sex, via activation of the mesolimbic dopaminergic system.

### Summary

Anatomical and electrophysiological data suggest that the Hcrt neuronal system integrates complex information about circadian, limbic and metabolic variables. This information is transmitted into a coherent behavioral output that excites arousal centers depending on the physiological demand. Together, the data gathered thus far indicate that the Hcrt peptides provide an alarm signal and stability to arousal centers.

### References

1. de Lecea L, Kilduff TS, Peyron C, Gao X, Foye PE, Danielson PE, Fukuhara C, Battenberg EL, Gautvik VT, Bartlett FS 2nd, Frankel WN, van den Pol AN, Bloom FE, Gautvik KM, Sutcliffe JG (1998) The hypocretins: hypothalamus-specific peptides with neuroexcitatory activity. *Proc Natl Acad Sci USA* 95:322
2. Sakurai T, Amemiya A, Ishii M, Matsuzaki I, Chemelli RM, Tanaka H, Williams SC, Richardson JA, Kozlowski GP, Wilson S, Arch JR, Buckingham RE, Haynes AC, Carr SA, Annan RS, McNulty DE, Liu WS, Terrett JA, Elshourbagy NA, Bergsma DJ, Yanagisawa M, (1998) Orexins and orexin receptors: a family of hypothalamic neuropeptides and G protein-coupled receptors that regulate feeding behavior. *Cell* 92:573
3. Sakurai T (2007) The neural circuit of orexin (hypocretin): maintaining sleep and wakefulness. *Nat Rev Neurosci* 8:171
4. Lee MG, Hassani OK, Jones BE (2005) Discharge of identified orexin/hypocretin neurons across the sleep-waking cycle. *J Neurosci* 25:6716
5. Mileykovskiy BY, Kiyashchenko LI, Siegel JM (2005) Behavioral correlates of activity in identified hypocretin/orexin neurons. *Neuron* 46:787
6. Adamantidis AR, Zhang F, Aravanis AM, Deisseroth K, de Lecea L (2007) Neural substrates of awakening probed with optogenetic control of hypocretin neurons. *Nature DOI* 10.1038/nature 06310:
7. Peyron C, Faraco J, Rogers W, Ripley B, Overeem S, Charnay Y, Nevsimalova S, Aldrich M, Reynolds D, Albin R, Li R, Hungs M, Pedrazzoli M, Padigaru M, Kucherlapati M, Fan J, Maki R, Lammers GJ, Bouras C, Kucherlapati R, Nishino S, Mignot E (2000) A mutation in a case of early onset narcolepsy and a generalized absence of hypocretin peptides in human narcoleptic brains. *Nat Med* 6:991

8. Thannickal TC, Moore RY, Nienhuis R, Ramanathan L, Gulyani S, Aldrich M, Cornford M, Siegel JM (2000) Reduced number of hypocretin neurons in human narcolepsy. *Neuron* 27:469
9. Boutrel B, Kenny PJ, Specio SE, Martin-Fardon R, Markou A, Koob GF, de Lecea L (2005) Role for hypocretin in mediating stress-induced reinstatement of cocaine-seeking behavior. *Proc Natl Acad Sci USA* 102:19168
10. Harris GC, Wimmer M, Aston-Jones G (2005) A role for lateral hypothalamic orexin neurons in reward seeking. *Nature* 437:556

---

## Hypogastric Nerve

### Definition

This nerve plus the lumbosacral sympathetic chain convey sympathetic fibers originating from both intermediolateral cell column and dorsal gray commissure for the thoracolumbar levels of the spinal cord (T12–L2).

- ▶ Neurophysiology of Sexual Spinal Reflexes
- ▶ Sympathetic Pathways

---

## Hypogeusia

### Definition

- ▶ Ageusia

---

## Hypoglossal Nerve (XII)

### Synonyms

N. hypoglossus (N.XII)

### Definition

Hypoglossal nerve (XII) is a purely somatomotor nerve and innervates the tongue muscles. It has important functions in speaking, drinking, eating and swallowing. Skull: hypoglossal canal.

- ▶ Nerves

---

## Hypokalemic Periodic Paralysis

### Definition

Autosomal dominant in 2/3 of cases (more males than females) and sporadic in 1/3, usually begins at early age (below 25) and is characterized by episodic attacks of weakness predominantly in proximal limb muscles (especially in the morning after night rest or after hard exercise and work), low serum K<sup>+</sup> concentration during attacks and elicibility of attacks by glucose and insulin administration. The pathophysiology is not well understood.

---

## Hypokinesia

### Definition

Associated with bradykinesia, it refers to abnormally reduced mobility such as that seen in Parkinson disease.

- ▶ Parkinson Disease

---

## Hypometabolism

### Definition

State of reduced metabolism, used by animals to reduce energy expenditure during phases of inactivity (torpor), e.g., in hibernation or daily torpor.

- ▶ Hibernation

---

## Hypometria

### Definition

A type of dysmetria, characterized by undershooting an intended target during the trajectory movement of a limb towards that target, usually seen in cerebellar disorders.

- ▶ Cerebellar Functions



## Hypomyelination

### Definition

Reduced levels of myelin detected in different mutants.

## Hyponatremia

### Definition

The electrolyte disturbance in humans when the sodium concentration in the plasma falls below 135 mmol/L.

► Neuroendocrinology of Psychiatric Disorders

## Hypophysis

### Synonyms

Pituitary gland

### Definition

The hypophysis consists of the hypothalamic neurohypophysis (posterior lobe of the hypophysis) and the adenohypophysis (anterior lobe of the hypophysis) arising on the pharyngeal roof (Rathke's pouch). The hypophysis is the "hormone center" of the body and has close connections with the hypothalamus. With its effector hormones and glandotropic hormones, it controls the autonomic processes and hormone glands of the body.

► Diencephalon

## Hypoplasia

### Definition

Incomplete development of organs or organ systems

► Endocrine Disorders of Development and Growth

## Hyporeflexia

### Definition

Reduction of reflexes.

## Hyposmia

### Definition

Hyposmia is a diminution in the sense of olfaction. The etiologies for hyposmia are much the same as those for anosmia (complete loss of the sense of smell).

Physical obstruction of the nasal cavities, due to inflammation (rhinitis), polyps and/or a deviated septum, may reduce olfactory acuity.

Olfactory dysfunction may also result from direct lesion of the olfactory system. Damage of the olfactory epithelium, for example due to a chemical burn or infection, may cause hyposmia or even anosmia. One of the most frequent causes of olfactory loss is head trauma, resulting in section of the olfactory nerves passing through the cribriform plate. Intracranial tumors have also been described to affect olfaction.

► Smell Disorders

## Hypothalamic Clock

### Definition

The primary circadian "clock" of the brain in mammals is located in the suprachiasmatic nucleus (SCN), a paired group of cells located on top of the optic chiasm that regulates e.g., sleep/wake rhythm.

► Neuroendocrinology of Psychiatric Disorders

## Hypothalamic Paraventricular Nucleus (PVN)

### Definition

The hypothalamic paraventricular nucleus is located in the vicinity of the third ventricle and is composed of

several functionally distinct subnuclei that affect both endocrine and autonomic responses. Specific sets of PVN neurons contain peptides involved in anterior and posterior pituitary regulation, and other neurons are involved in autonomic control.

## Hypothalamic-Pituitary Gland Axis

### Definition

The nervous part of the neuroendocrine system (hypothalamic-pituitary-adrenal axis), controlling reactions to stress and vital functions in regulating body homeostasis, immune reactivity and energy usage.

► Hypothalamo-Pituitary-Adrenal (HPA) Axis, Stress and Depression

## Hypothalamic-preoptic Area

### Definition

A region of the forebrain that includes both the hypothalamus and cells rostral to (in front of) the hypothalamus.

## Hypothalamo-neurohypophysial System

DICK F. SWAAB<sup>1</sup>, PAUL J. LUCASSEN<sup>2</sup>

<sup>1</sup>Netherlands Institute for Neuroscience, Amsterdam, The Netherlands

<sup>2</sup>Centre for Neuroscience, Swammerdam Institute of Life Sciences, University of Amsterdam, The Netherlands

### Definition

The hypothalamo-neurohypophysial system (HNS) consists of the *supraoptic* and *paraventricular* nuclei (SON and PVN) and their axons that run towards the neurohypophysis. There, vasopressin and oxytocin are

released into the blood circulation from where these neurohormones act on peripheral organs.

### Characteristics

The HNS represents the classic example of a neuroendocrine system, i.e. of hormone producing neurons. Vasopressin acts as an antidiuretic hormone on the kidney and regulates free water clearance by V2-type vasopressin receptors and the subsequent formation of aquaporin-2 water channels in the renal collecting duct. In women, oxytocin is involved in labor and lactation by its actions on the uterus and mammary gland respectively [1].

### Quantitative Description

Hypophysectomy causes an average loss of 80% of the large neurons from both the SON and PVN, showing that most large SON and PVN neurons project to the neurohypophysis. The SON is subdivided into three parts. The largest part, the *dorsolateral SON*, has a volume of 3 mm<sup>3</sup> and contains 53,000 neurons, 90% of which contain vasopressin and 10% oxytocin (Fig. 1).

The *dorsomedial* and *ventromedial SON* together contain another 23,000 neurons. The PVN has a volume of 6 mm<sup>3</sup> and consists of about 56,000 neurons of which some 25,000 contain oxytocin and 21,000 express vasopressin. Clusters of magnocellular neurosecretory neurons are further found in between the PVN and SON and are generally referred to as

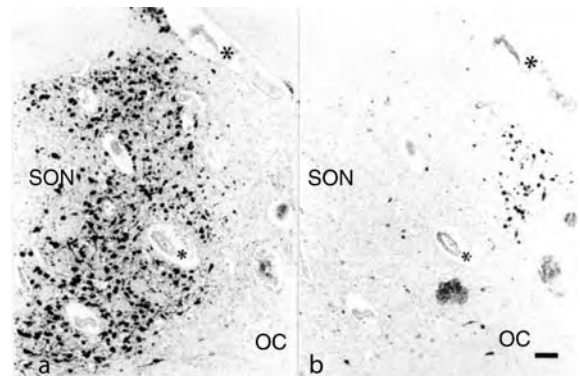

### Hypothalamo-neurohypophysial System.

**Figure 1** Consecutive sections of a 49-year-old female control stained for vasopressin and oxytocin. (a) dorsolateral supraoptic nucleus (SON) stained with an antiglycopeptide (Boris Y-2) against the vasopressin precursor and (b) oxytocin (O-1-V, purified). Note that the relatively small oxytocin cell population is clearly separated from the vasopressin cell population. Asterisk indicates a blood vessel that is present in both consecutive sections: OC = optic chiasm. Bar = 100 mm. (From Evans et al., 1996; Fig. 1, with permission.)

“accessory nuclei”. They contain more oxytocinergic than vasopressinergic neurons [1].

### Description of the Process (Fig. 2)

The nonapeptides vasopressin and oxytocin are synthesized in the hypothalamus as part of a large precursor that includes a neurophysin moiety for both peptides and a C-terminal glycoprotein for the vasopressin precursor only. The *oxytocin and vasopressin receptors* form a subfamily of G-protein coupled receptors. The vasopressin V1 receptor, formerly known as V1a, is expressed in the liver, blood vessels, smooth muscle cells and many other peripheral tissues. The V2 receptor is selectively expressed in the kidney and the brain of newborn rats, while the V3 receptor (formerly known as V1b) is more abundantly expressed in the majority of the anterior pituitary corticotropin cells, in multiple brain regions and in a number of peripheral tissues, including kidney, thymus, heart, lung, spleen, uterus and breast.

Vasopressin is released from the neurohypophysis during osmotic stimulation, hypotension or hypovolemia. The hypothalamus integrates signals from *osmoreceptors* that are probably located in the SON, from the organum vasculosum lamina terminalis, the subformal organ and from stretch or baro-receptors in the carotid sinus and aortic arch of the vascular tree. Aquaporin-4 expressing astrocytes in the SON, PVN and the subformal organ are also presumed to play a key role in osmoreception. In humans, 90% of the circulating vasopressin is bound to platelets. Men have higher vasopressin levels than women [2] and the posterior lobe of the pituitary is larger in boys than in girls. These sex differences are consistent with the higher metabolic activity in vasopressin neurons in the SON in young men as compared to women. In postmenopausal women activation of neurosecretory vasopressin neurons occurs.

During normal delivery, stretching of the lower birth canal triggers the neurohormonal “*Ferguson*” reflex, leading to rapid secretion of oxytocin by the pituitary gland, which results in strong expulsive uterine contractions. This would explain why, following epidurals, more arrests of the descent during the second stage of labor and more forceps deliveries are required. Indeed, oxytocin treatment during the second stage of labor with epidural analgesia reduces the need for forceps. Oxytocin is also involved in heart rate regulation by neuroendocrine and central mechanisms and oxytocin receptors are indeed present in all heart compartments and in the vasculature. In addition, oxytocin is synthesized in the heart and in large vessels like the aorta and vena cava. Finally, oxytocin induces contractions of smooth muscle cells both in men and women and may thus facilitate transport of eggs as well as sperm. During aging, the HNS is activated, especially in women [1,3,4].

### Higher Processes: Central Release (Fig. 3)

Vasopressin and oxytocin are not only released into the bloodstream, but also transported through nerve fibers from the PVN to other brain areas where they act as neurotransmitters or neuromodulators and influence central processes. The central vasopressinergic fibers are involved in blood pressure and temperature regulation, regulation of osmolality and corticosteroid secretion. As such, they may influence cognition, aggression, paternal behavior and social attachment.

Oxytocinergic central pathways are involved in reproduction, cognition, tolerance, adaptation and the regulation of cardiovascular and respiratory functions. Oxytocin neurons from the PVN innervating the brainstem nuclei are involved in blood pressure and heart rate regulation. Centrally released oxytocin would also give rise to sedation, e.g., during lactation. Oxytocin further induces a decline in cortisol, which may be essential for the formation of social bonds. Brain oxytocin modulates a range of social behaviors, from parental care to mate guarding, while it also has central effects on food intake as oxytocin neurons are considered putative satiety neurons for the control of eating behavior [1,5].

### Oxytocin, Vasopressin and Reproductive Behavior

Oxytocin and vasopressin are involved in affiliation, including pair bonding, parental care and territorial aggression in monogamous animals, maternal behavior and other aspects of reproductive behavior. In men, the oxytocin cells of the PVN are involved in penile erections. In addition, oxytocin may reduce *maternal aggression* in the period shortly after birth when lactating females are more aggressive anyway. In women, basal levels of oxytocin during lactation are associated with a desire to please, give and interact socially. Oxytocin released during labor and lactation may influence human maternal responsiveness and perhaps attachment. One minute after orgasm, oxytocin levels are increased in women. In men, oxytocin may also be involved in sexual arousal and ejaculation. In agreement with this, oxytocin levels are known to rise during sexual arousal and peak during orgasm in men [1].

### Vasopressin, Oxytocin and Osmotic Regulation in Pregnancy

Probably the most important factor contributing to the variation in plasma levels of vasopressin in pregnancy is the *in vivo* activity of cystyl aminopeptidase (CAP), an enzyme also called vasopressinase or oxytocinase. It degrades vasopressin or oxytocin very rapidly. Oxytocin plasma levels rise during delivery. The vasopressin levels in fetal cord blood are extremely high after delivery supporting the idea of an active role of the fetus in its own delivery [1].

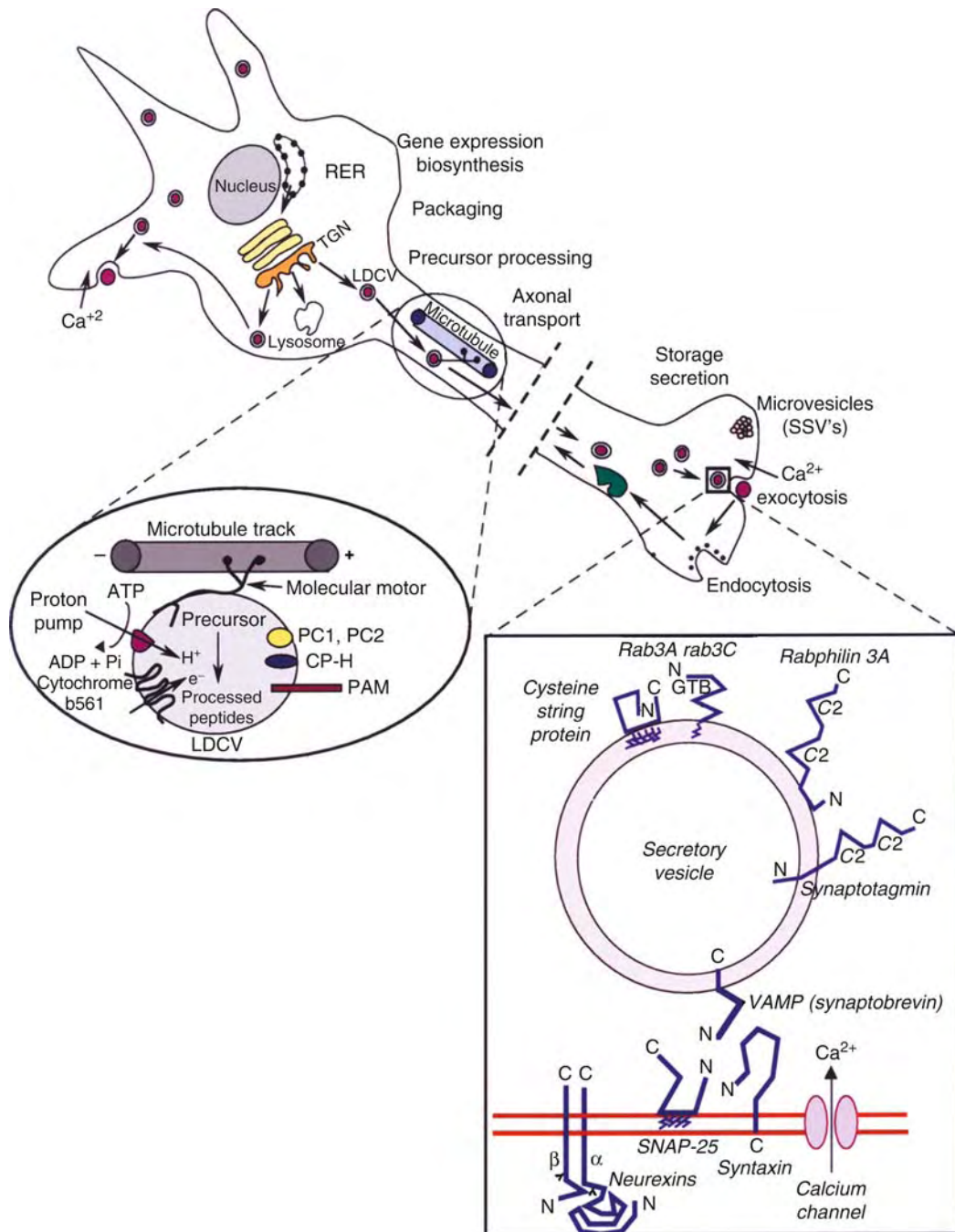

**Hypothalamo-neurohypophysial System. Figure 2** A neurosecretory cell shown schematically. Gene expression, protein biosynthesis, and packaging of the protein into large dense core vesicles (LDCVs) in the cell body, where the nucleus, rough endoplasmic reticulum (RER) and Golgi apparatus are located. Enzymatic processing of the precursor proteins into the biologically active peptides occurs primarily in the LDCVs (see *inset*), often during the process of anterograde axonal transport of the LDCVs to the nerve terminals on microtubule tracks in the axon. Upon their arrival at the nerve terminal, the LDCVs are usually stored in preparation for secretion. Conduction of a nerve impulse (action potential) down the axon and its arrival in the nerve terminal causes an influx of calcium ions through calcium channels. The increased calcium ion concentration then causes a cascade of molecular events (see *inset*) that leads to neurosecretion (exocytosis). Reuptake of the excess LDCV membrane after exocytosis is performed by endocytosis, but this membrane is not recycled locally and instead is retrogradely transported to the cell body for reuse or degradation in lysosomes. TGN trans-Golgi network; SSV small secretory vesicles; PC1 or PC2 prohormone convertase 1 or 2 respectively; CP-H carboxypeptidase H; PAM peptidylglycine  $\alpha$ -amidating monooxygenase. (From Burbach et al. 2001; Fig. 2, with permission.)

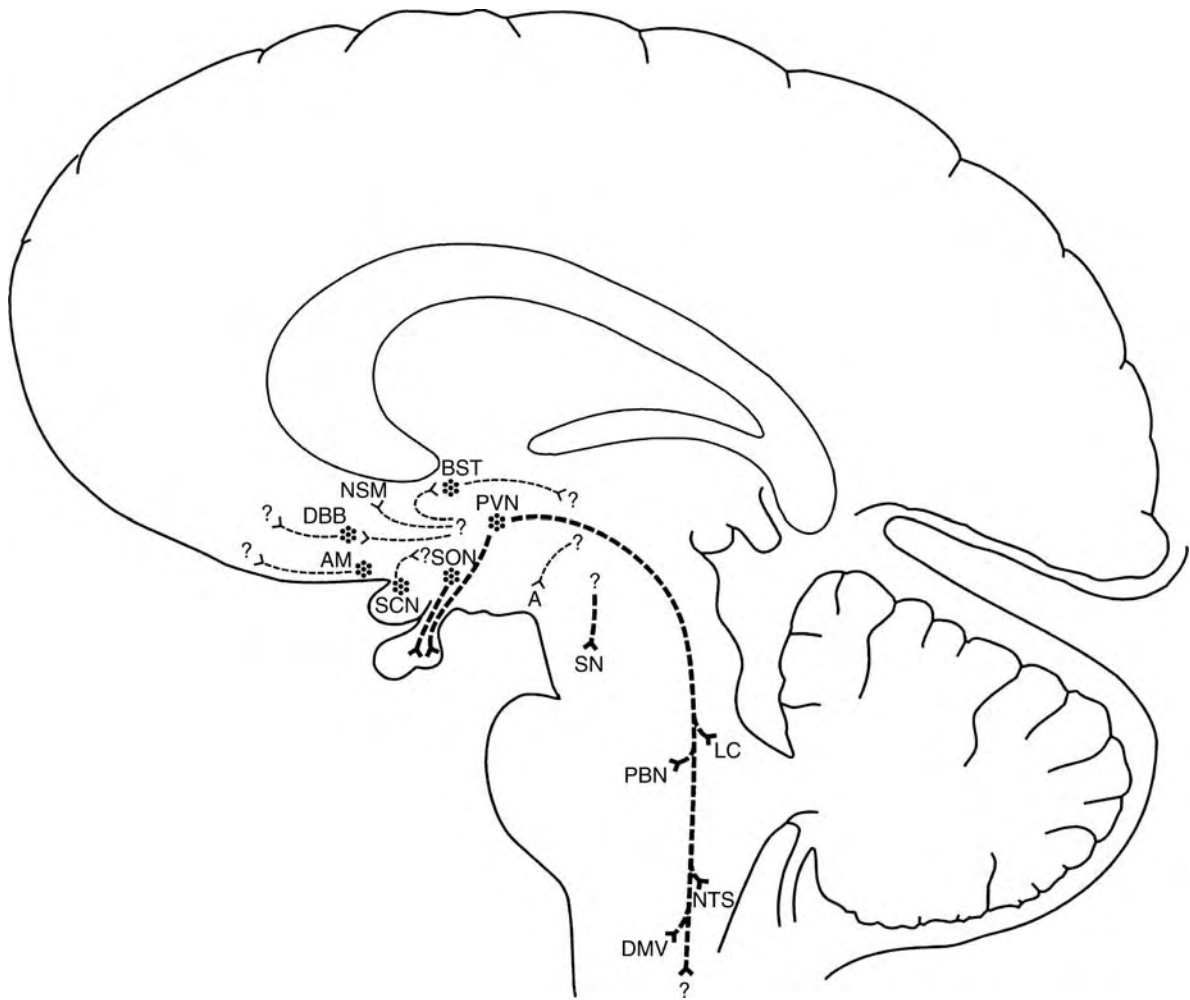

**Hypothalamo-neurohypophysial System. Figure 3** Vasopressin pathways in the human brain. Question marks indicate that at present no site of origin or termination is known. A: amygdala; AM: anteromedial subnucleus of the basal nucleus; BST: bed nucleus of the stria terminalis; DBB: diagonal band of Broca; DMV: dorsal motor nucleus of the nervus vagus; LC: locus coeruleus; NSM: nucleus septalis medialis; NTS: nucleus of the solitary tract; PBN: parabrachial nucleus; PVN: paraventricular nucleus; SCN: suprachiasmatic nucleus; SN: substantia nigra; SON: supraoptic nucleus. ([1], Fig 8.15 with permission).

### Vasopressin Secretion in Various Disorders

Activation of the HNS has been reported in depression [6,2]. Chronic alcohol consumption is toxic to hypothalamic SON and PVN neurons in a concentration and time dependent manner. Glucocorticoids have a suppressive effect on the expression of processed vasopressin, whereas the precursor of vasopressin itself is not decreased by these steroids, indicating a processing disturbance [7,8]. Consistent with this, in glucocorticoid deficient Addison patients, vasopressin levels are indeed increased. The vasopressin gene promoter further contains a glucocorticoid response element. In this way, glucocorticoids inhibit vasopressin promoter activity, which explains part of the nonosmotic increase in vasopressin secretion occurring with glucocorticoid

deficiency. In stroke patients, the increased vasopressin level is related to the size of the lesion. In pain and smoking, large rises in vasopressin levels, even up to several hundred-fold increases, have been reported. Surgery also increases vasopressin levels, which may at least in part relate to the stress of the operation [1].

### Vasopressin Administration in Various Disorders

DDAVP (1-desamino-8 D-arginine vasopressin = desmopressin) is used to treat central diabetes insipidus, while it has been also been used in children for prophylaxis of bleeding, e.g. in adenotonsillectomy and to stop bleeding in mild *hemophilia*, type I von Willebrand's disease, in hemophilia B and in patients with various functional defects of their platelets.

Vasopressin has been used for the treatment of refractory hypotension after cardiopulmonary bypass and may sometimes provide a dramatic improvement in hemodynamic conditions. For the same reason, vasopressin infusion at 0.01–0.04 U/min is often given and appears beneficial in patients with *septic shock* and *vasodilatory shock* as it increases urinary output while vascular resistance decreases [1].

In conclusion, the HNS and its main hormonal output form a dynamic and essential neuroendocrine system integrating various diverse central and peripheral homeostatic functions.

## References

1. Swaab DF (2003) The human hypothalamus. Basic and clinical Aspects, pt 1: Nuclei of the hypothalamus. In: Aminoff MJ, Boller F, Swaab DF (eds) Handbook of clinical neurology. Elsevier, Amsterdam
2. Van Londen L, Goekoop JG, Van Kempen GMJ, Frankhuijsen-Sierevogel AC, Wiegant VM, Van der Velde EA, De Wied D (1997) Plasma levels of arginine vasopressin elevated in patients with major depression. *Neuropsychopharmacol* 17:284–292
3. Ishunina TA, Swaab DF (2002) Neurohypophyseal peptides in aging and Alzheimer's disease. *Ageing Res Rev* 1:537–558
4. Lucassen PJ, Salehi A, Pool CW, Gonatas NK, Swaab DF (1994) Activation of vasopressin neurons in aging and in Alzheimer's Disease. *J Neuroendocrinol* 6:673–679
5. Insel TR (1997) A neurobiological basis of social attachment. *Am J Psychiatry* 154:726–735
6. Meynen G, Unmehopa UA, Heerikhuizen JJ, Hofman MA, Swaab DF, Hoogendijk WJ (2006) Increased arginine vasopressin mRNA expression in the human Hypothalamus in depression: a preliminary report. *Biol Psychiatry* 60:892–895
7. Erkut ZA, Pool CW, Swaab DF (1998) Glucocorticoids suppress corticotropin-releasing hormone and vasopressin expression in human hypothalamic neurons. *J Clin Endocrinol Metab* 83:2066–2073
8. Erkut ZA, Gabreëls BATF, Eikelenboom J, Van Leeuwen FW, Swaab DF (2002) Glucocorticoid treatment is associated with decreased expression of processed AVP but not of proAVP, neurophysin or oxytocin in the human hypothalamus: Are PC1 and PC2 involved? *Neuroendocrinol Lett* 23:33–44

## Hypothalamo-Pituitary-Adrenal (HPA) Axis

### Definition

Homeostatic feedback system involved in the coordination of the stress response and stress hormone release.

Includes hypothalamic brain centers, the pituitary and the adrenal glands.

- ▶ Hypothalamo-Pituitary-Adrenal Axis, Stress and Depression
- ▶ Neuroendocrinology of Psychiatric Disorders

## Hypothalamo-Pituitary-Adrenal Axis, Stress and Depression

PAUL J. LUCASSEN<sup>1</sup>, DICK F. SWAAB<sup>2</sup>

<sup>1</sup>SILS Centre for Neuroscience, University of Amsterdam, Amsterdam, The Netherlands

<sup>2</sup>Netherlands Institute for Neuroscience, Meibergdreef 33, Amsterdam, The Netherlands

### Definition

Stress systems are activated whenever a discrepancy occurs between an organism's expectations and the reality it encounters, particularly when it involves a threat to the organism's homeostasis.

### Characteristics

The hypothalamo-pituitary-adrenal (HPA) axis consists of several interconnected centers in the brain and body that together orchestrate the hormonal response to stress and that is aimed to restore homeostasis.

### Description of the Process

Stress-induced activation of the HPA system triggers the production of corticotropin-releasing hormone (CRH) in parvocellular neurons of the hypothalamic paraventricular nucleus (PVN). This in turn induces adrenocorticotrophic hormone (ACTH) release from the pituitary which causes glucocorticoid hormone (GC) release from the adrenal cortex into the blood. Glucocorticoids exert a wide range of biological effects on the brain and body. Their plasma levels are carefully kept within physiological limits through GC-mediated feedback inhibition at specific steroid receptors in the pituitary and PVN.

Stress represents an old and essential alarm system for any individual organism. Stress occurs whenever an organism encounters or anticipates a potential threat to its homeostasis, arising from outside or from within the organism. Such threats can derive from a lack of information, loss of control, unpredictability or uncertainty when faced with e.g. predator threat, but also when confronted with physical perturbations of its internal homeostasis, like food or water shortage, blood loss, injury or inflammation, or a serious disease. Also

psychosocial demands, or the social hierarchy within a given group can produce profound stress signals [1].

Whenever a stressor is perceived, various brain systems are activated that will coordinate a stress response by triggering various adaptive molecular, physiological and psychological processes aimed to restore homeostasis and thereby re-establish a functional steady-state. In mammals, the stress response is mediated by the limbic-hypothalamo-pituitary-adrenal (HPA) system, a classic neuroendocrine circuit in which limbic and hypothalamic brain structures integrate emotional, cognitive, neuroendocrine and autonomic inputs together determining magnitude and duration of the behavioral, neural and hormonal stress responses. Together with other neuro-hormonal components, stress-induced HPA axis activation (CRH) in paraventricular nucleus (PVN) (Fig. 1) and ACTH release from the pituitary which causes glucocorticoid (GC) release (cortisol in primates, corticosterone in rodents) from the adrenal cortex into the blood [1].

GCs exert a wide range of biological effects by influencing glucose, fat and mineral metabolism, cognition and the immune system. Their plasma levels are carefully kept within physiological limits through GC-mediated feedback inhibition at specific steroid receptors in the pituitary and PVN. Also the hippocampus, that contains high densities of glucocorticoid (GR) and mineralocorticoid (MR) receptors in rat, is sensitive to GC action. Upon GC binding to MR or GR, the activated steroid hormone receptor translocates from the cytoplasm to the nucleus, where gene transcription and electrophysiological properties of the cell can be altered [1]. Steroid action to target tissues is further influenced by

a.o., steroid converting enzymes and various co-activator/co-repressors. Amongst other brain areas, the hippocampus is thought to exert an (indirect) tonic inhibitory control on HPA system activity, and is important in emotional processing and in key aspects of learning and memory [1].

### HPA Changes, Stress and the Hippocampus

Even though the acute stress response itself is considered harmless, prolonged hyperactivity of the HPA system, as occurs after chronic stress, can result in maladaptation and alterations in HPA setpoint or feedback sensitivity. This can cause prolonged (over) exposure of the brain and body that may predispose to pathology and can affect hypothalamic and hippocampal function and hippocampal structure [1,2,3].

In rodents and man, GC excess is generally associated with deleterious functional changes in e.g. hippocampal excitability, longterm potentiation and learning. GCs can also affect structural hippocampal parameters, comprising initial, and still reversible atrophy of the CA3 dendritic tree as well as reversible remodeling of synaptic terminal structures. In later stages, the hippocampus as a whole shrinks, followed by an increased vulnerability to metabolic insults and even neuronal loss of CA3 neurons has been reported, that can extend into other hippocampal regions if severe stress persists [2,4,7].

Effects of chronic stress are assumed to be largely GR-mediated. However, chronic stress may also alter the function of the mineralocorticoid receptor (MR) that is implicated in tonic inhibitory control of the HPA axis and e.g. suppresses adrenalectomy-induced hippocampal apoptosis and modulates adult neurogenesis

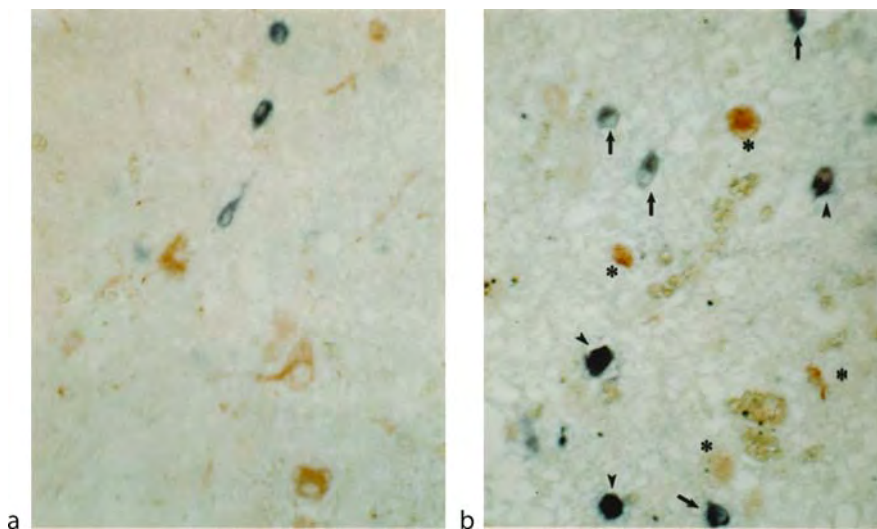

**Hypothalamo-Pituitary-Adrenal Axis, Stress and Depression. Figure 1** Immunocytochemical double staining for CRH (blue), vasopressin (red) and CRH/AVP co-expression (purple) in the PVN of a young (a) and old (b) subject indicates HPA axis activation. A similar activation is found in depression.

in the hippocampal dentate gyrus subregion [1,7,8]. In view of its proposed inhibitory role in HPA activity control, neuronal loss in the hippocampus as initially reported in stressed rodents and primates, was expected to disinhibit the HPA axis, that could cause a positive feedforward cascade of increasing glucocorticoid levels over time. This could be causally involved in an age-related accumulation of hippocampal damage in disorders like Alzheimer's disease and major depression, where reductions in hippocampal volume were found parallel to elevated basal GC plasma levels. Given other reports on correlations between hippocampal volume changes, cognitive impairment and HPA changes, the glucocorticoid cascade concept of stress and hippocampal damage was proposed, that has later been adapted [2,4,7,8].

Regarding the possibility of steroid-induced hippocampal damage, however, no neuropathology or major structural changes could be found in the hippocampus of depressed or synthetic steroid-treated subjects, consistent with observations on the recovery of hippocampal volume following treatment of the tumor in Cushing's disease e.g. [3,5,7]. However, cell death may have occurred earlier in time while also almost all patients studied received antidepressant therapy. From many antidepressant drugs, it is known they can influence adult neurogenesis and apoptosis and hence may preserve hippocampal structure [7,8].

### The HPA Axis and Major Depression

Numerous clinical and preclinical studies indicate that HPA axis hyperactivity is implicated in the pathogenesis of major depression. Although also the serotonin system and other factors are involved, HPA feedback abnormalities occur in many depressed patients often resembling a subset of the changes seen in chronically stressed animals [1,4,6,9]. Patients suffering from major depression frequently show psychomotor retardation, changed circadian activity patterns, appetite disturbances, weight changes and a loss of libido. HPA hyperactivity is reflected by the increased plasma ACTH and cortisol levels, elevated plasma and salivary cortisol and cortisone levels, increased urinary free cortisol excretion and increases in CRH and vasopressin co-expression in PVN neurons. Both patients with a major and bipolar depression show a much stronger CRH neuron activation than aged controls or Alzheimer's disease patients [4,9] (Figs. 1 and 2).

In addition to a hypothalamic hyperdrive, various other measures point to a primary role for the HPA-axis in depression [1,3,4,9]. First, a well-known side effect of glucocorticoid treatment is depression while atypical depression often occurs in Cushing patients, especially when their disease duration is long [1,5]. Moreover, decreased GR function, an enhanced adrenal response to ACTH as well as hypertrophy of the adrenal and

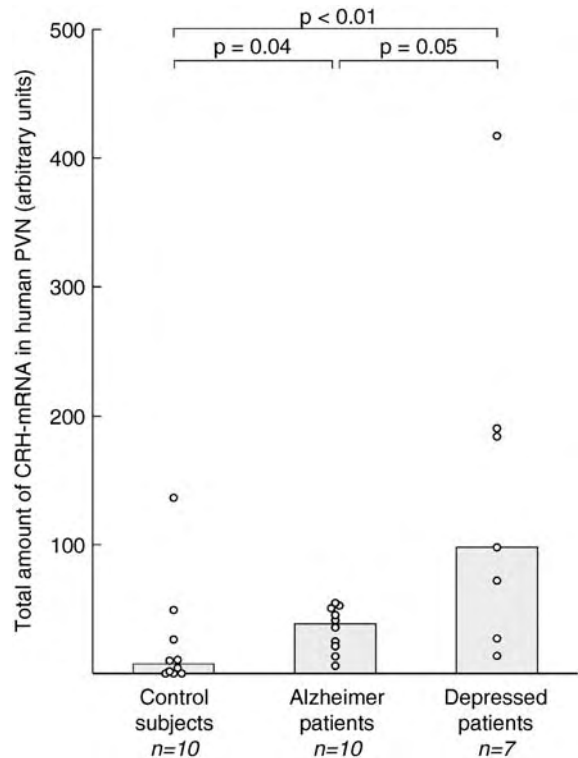

**Hypothalamo-Pituitary-Adrenal Axis, Stress and Depression. Figure 2** In situ hybridization revealed significant increases in CRH mRNA expression in the PVN of Alzheimer and depressed patients.

pituitary are common in depressed patients. In addition to significant reductions in hippocampal volume [3,7], many patients with depression are dexamethasone non-suppressor. The elevated cortisol response in the test also correlates with a higher risk for relapse than in individuals who had a depression but subsequently showed a normal cortisol response. Studies in high-risk probands of depressed patients have further shown that abnormalities in HPA axis function already exist prior to the onset of the clinical symptoms, suggesting that HPA abnormalities can in fact precipitate depressive episodes [1,10]. Hence, treatment aimed directly at interfering with the HPA axis may prove beneficial. Following (pharmaco)therapy, normalization of the HPA axis indeed decreases relapse probability, while studies in depressed patients treated with steroid synthesis blockers or GR-antagonist also support this concept [1].

It should be noted that not every depressed individual suffers from a hyperactive HPA axis and that considerable individual variability exists. Increased basal plasma cortisol levels are present in over 25% of the subjects with major depression, while on average more than 50% show non-suppression of cortisol to dexamethasone. Most depressed patients are not



hypercortisolemic when studied cross-sectionally; yet, clinically significant episodes of excessive exposure to glucocorticoids could have been present already. In addition, part of such differences may be attributed to methodological aspects like sampling over the circadian cycle, and whether or not patients had been admitted to psychiatric wards or were living at home when tested. Subjects with psychotic major depression even have higher cortisol levels than otherwise depressed subjects, which may contribute to the variability in cortisol levels.

An important argument for a hypothalamic hyperdrive as initial event is that symptoms resembling depression, e.g. a decreased food intake, decreased sexual activity, disturbed sleep and motor behavior and increased anxiety, can all be induced in experimental animals by intracerebroventricular injection of CRH. In addition, antidepressant drugs attenuate the synthesis and CSF concentrations of CRH. Lastly, a transgenic mouse model with an overproduction of CRH appeared to have increased anxiogenic and depressive like behavior, whereas a mouse with a genetic deletion of the CRH-1 receptor has indeed reduced anxiety-like behavior. An interesting new compound in depression research is urocortin, a CRH-related peptide that also exerts anxiogenic-like properties in experimental animals. The recent development of selective small molecule CRH1 receptor antagonists, blocking CRH effects, suggests these compounds could be effective in the treatment of mood and anxiety disorders. Taken together, hyperactivity of those CRH neurons that project into the brain, may be activated in depression [1,4].

An alternative possibility involves changes during early development lasting into adulthood. Although the set point of HPA-axis activity is programmed by genotype, it can be readjusted by early life stressors like bereavement, child abuse, and early maternal separation that also form risk factors for depression, anxiety disorder, or both [1].

Another hypothesis focuses on glucocorticoids as causative agents, secondary to a disturbed local corticosteroid signaling due to changes in GR level or sensitivity. Transgenic mice with a defective GR indeed show symptoms resembling those seen in depression. Although little is known about GR levels in human brain, glucocorticoid receptor antagonists could become promising candidates for additive treatment of stress related forms of depression [1].

## References

1. De Kloet ER, Joels M, Holsboer F (2005) Stress and the brain: from adaptation to disease. *Nat Rev Neurosci* 6:463–475
2. Sapolsky RM (1996) Stress, glucocorticoids, and damage to the nervous system: the current state of confusion. *Stress* 1:1–19

3. Neumeister A, Wood S, Bonne O et al. (2005) Reduced hippocampal volume in unmedicated, remitted patients with major depression versus control subjects. *Biol Psychiatry* 57:935–937
4. Swaab DF, Bao AM, Lucassen PJ (2005) The stress system in the human brain in depression and neurodegeneration. *Ageing Res Rev* 4:141–194
5. Bourdeau I, Bard C, Noel B et al. (2002) Loss of brain volume in endogenous Cushing's syndrome and its reversibility after correction of hypercortisolism. *J Clin Endocrinol Metab* 87:1949–1954
6. Lucassen PJ, Muller MB, Holsboer F et al. (2001) Hippocampal apoptosis in major depression is a minor event and absent from subareas at risk for glucocorticoid overexposure. *Am J Pathol* 158:453–468
7. Czeh B, Lucassen PJ (2007) What causes the hippocampal volume decrease in depression? Are Neurogenesis, glial changes and apoptosis indicated. *Eur Arch gen Psy & Clin Neurosci* 257(5):250–260
8. Fuchs E, Czeh B, Kole MH, Michaelis T, Lucassen PJ (2004) Alterations of neuroplasticity in depression: the hippocampus and beyond. *Eur Neuropsychopharmacol* 14(suppl 5):S481–S490
9. Plotsky PM, Owens MJ, Nemeroff CB (1998) Psychoneuroendocrinology of depression. *Hypothalamic-pituitary-adrenal axis*. *Psychiatr Clin North Am* 21:293–307
10. Ising M, Lauer CJ, Holsboer F, Modell S (2005) The Munich vulnerability study on affective disorders: premorbid neuroendocrine profile of affected high-risk probands. *J Psychiatr Res* 39:21–28

## Hypothalamo-pituitary-gonadal Axis

### Definition

Homeostatic feedback system involved in the coordination of sex hormone release. Includes hypothalamic centers, the pituitary and the gonads, i.e. the testis in males and the ovaries in females.

► Neuroendocrinology of Psychiatric Disorders

## Hypothalamus

QIAN GAO, TAMAS HORVATH

Section of Comparative Medicine, Department of Ob/Gyn & Reproductive Sciences and Neurobiology, Yale University School of Medicine, New Haven, CT, USA

### Definition

Hypothalamus is from the Greek ὑποθαλαμος, which means “under the thalamus.” As the name indicates, the

hypothalamus is located ventromedially in the brain, immediately beneath the thalamus. It is a small neuronal structure about the size of an almond comprising mostly grey matter and accounting for about 1/300 of total brain weight in humans. It forms part of the walls and floor of the third ventricle and is found in all mammalian brains.

## Characteristics

### Anatomy

The hypothalamus is divided in the rostrocaudal dimension into more or less arbitrarily designated anterior, middle (tuberal) and posterior regions. Each of these is further split into medial and lateral areas (Table 1). The region approximately between the optic chiasm and anterior commissure contains the preoptic area, which is generally regarded as the rostralmost part of the hypothalamus, and the anterior part of the hypothalamus proper. The mammillary bodies form the posterior end of the hypothalamus. Between the anterior and posterior hypothalamus, a tuberal part contains ventromedial, dorsomedial, lateral and dorsal territories. The hypothalamus extends downward to connect to the pituitary gland (also known as the *hypophysis*), a key endocrine organ controlled by the hypothalamus (Fig. 1).

The hypothalamus is composed of numerous nuclei (Table 1), each of which contains distinct neuron subpopulations and has distinct functions. Only a few examples will be given here. The anterior portion of the hypothalamus including the preoptic area is important in control of estrus cycle in females and fertility in both sexes. It also contains thermosensitive neurons important for regulation of ►[thyrotropin-releasing hormone](#) (TRH) secretion. At the base of the anterior hypothalamus, the suprachiasmatic nucleus is critical to maintaining the circadian rhythm, while at the dorsal-most extent of this region, the paraventricular nucleus is involved in feeding and metabolism. The ventromedial hypothalamus, together with the arcuate nucleus, a long cigar like structure localized to the very base of

the hypothalamus (Fig. 2), is known as a satiety center that inhibits food intake and increases energy expenditure upon accumulation of bodily energy stores. The lateral posterior hypothalamus is crucial in feeding and sleep-arousal behavior.

Some hypothalamic nuclei are sexually dimorphic with differences in gross neuroanatomy and function between males and females. Notable among these is the sexually dimorphic nucleus within the preoptic area, which presents only in males. The importance of these differences is not fully understood, but can be recognized by phenotypic differences between males and females. For instance, the secretion pattern of growth hormone is sexually dimorphic, and this contributes to the tendency in many species for adult males to be larger than females.

An effect of aging on the anatomy of the hypothalamus is an interesting, under studied phenomenon and its significance is not well understood. Nonetheless, it is observed that in female mice both the supraoptic nucleus (SON) and paraventricular nucleus (PVN) lose approximately one-third of insulin-like growth factor-1 receptor (IGF-1R) immunoreactive cells during normal aging. In contrast, senescent mice raised in a condition of caloric restriction (CR) lost more non-IGF-1R immunoreactive cells as compared to controls, but maintained similar counts of IGF-1R immunoreactive cells. Consequently, in comparison to normally aging mice senescent CR mice exhibited a higher percentage of IGF-1R immunoreactive cells along with an increased hypothalamic sensitivity to IGF-1 [1].

### Functions

The central function of the hypothalamus is to regulate bodily homeostasis. Thus, the hypothalamus contains neuronal circuits that control, e.g. long-term energy balance (fat stores), glucose utilization, water-salt balance, sleep-wake cycle, body temperature and blood pressure. Furthermore, the hypothalamus links the central nervous system to the endocrine system, autonomic nervous system and peripheral tissues.

**Hypothalamus. Table 1** Hypothalamic nuclei

Region	Medial area	Lateral area
Anterior	Medial preoptic nucleus	
	Supraoptic nucleus	Lateral preoptic nucleus
	Paraventricular nucleus	Lateral nucleus
	Anterior hypothalamic nucleus	Part of supraoptic nucleus
	Suprachiasmatic nucleus	
Tuberal	Dorsomedial nucleus	
	Ventromedial nucleus	Lateral nucleus
	Arcuate nucleus	Lateral tuberal nuclei
Posterior	Mammillary nuclei (part of mammillary bodies) Posterior nucleus	Lateral nucleus

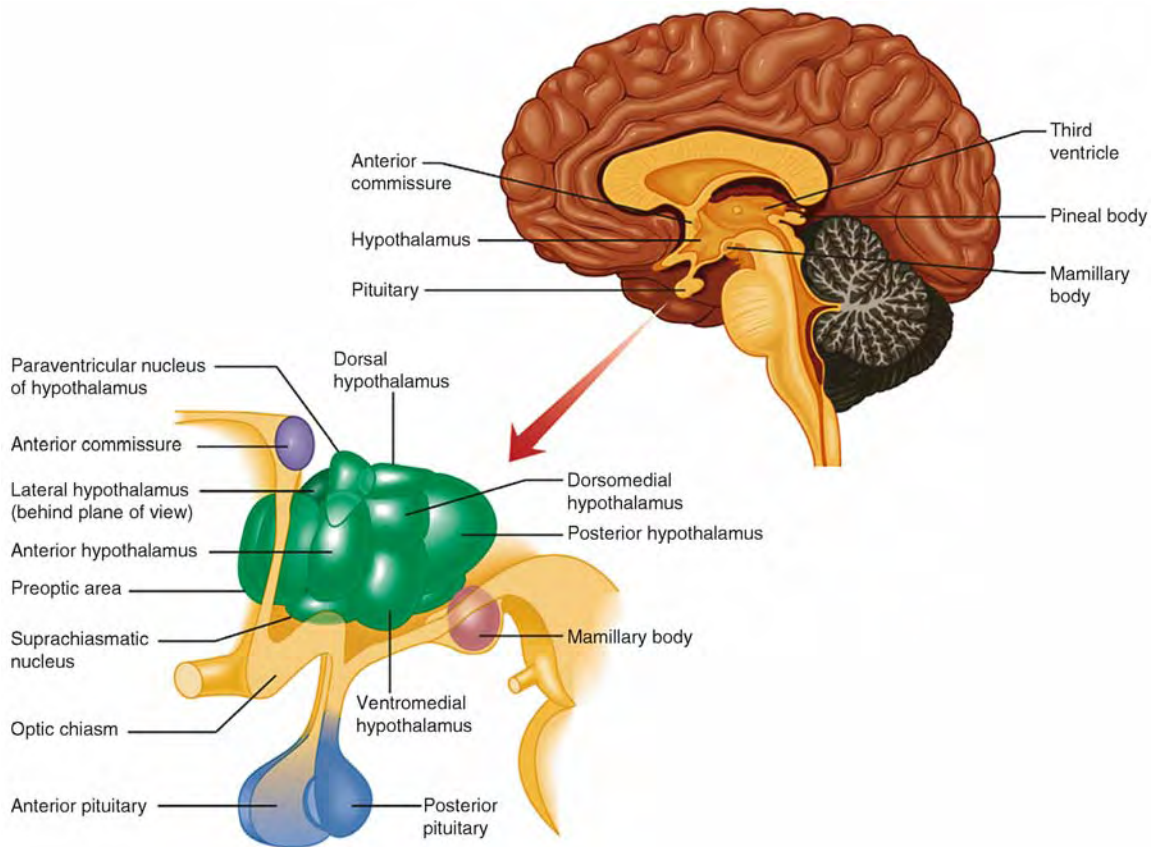

**Hypothalamus. Figure 1** Diagrammatic representations of the human hypothalamus in relation to the rest of the brain (*upper right*) and enlarged (*lower left*). A variety of landmarks and hypothalamic nuclei are labeled. Reproduced with permission from a drawing by Edward I. Pollak; [http://mywebpages.comcast.net/epollak/PSY255\\_pix/PSY255\\_pix.htm](http://mywebpages.comcast.net/epollak/PSY255_pix/PSY255_pix.htm).

The hypothalamus exerts these control functions by detecting peripheral cues, such as hormones, nutrients and salts and integrating them with various central and peripheral neuronal inputs, which also contain information about existing body conditions. In turn, the hypothalamus sends hormonal and neuronal outputs to the brain and peripheral tissues to adjust corresponding behavior and physiology. For example, hypothalamus regions implicated in the regulation of long-term energy homeostasis, the arcuate nucleus and ventromedial hypothalamus, by definition, need to “know” the amount of pre-existing body energy stores (fat) in order to determine the amount of energy intake and expenditure. This is accomplished by hypothalamic detection of the level of circulating adipohormone ►leptin, which is secreted by adipocytes (fat cells) in proportion to the total amount fat tissue.

The anatomical characteristics of the hypothalamus sustain such functions in the sense that neurons within the hypothalamus are, in part, anatomically placed in close proximity to fenestrated capillaries, giving them

access to various humoral signals that are unavailable to other regions of the brain. Thus, the subfornical organ (SFO), organum vasculosum of the lamina terminalis (OVLT), area postrema and the median eminence, so-called ►circumventricular organs, are in intimate contact with both blood and CSF and project widely within the hypothalamus and other brain sites. The neurohypophysis and the median eminence, on the other hand, are the sites of neurosecretion. All of these structures are densely vascularized.

The hypothalamus is also broadly connected with many parts of the CNS, including the reticular formation and autonomic effector sites in the brainstem, the limbic forebrain, including particularly the amygdala, septum and diagonal band of Broca, and the olfactory bulbs and cerebral cortex.

### Regulatory Inputs

#### Peripheral hormones and nutrients

Hypothalamic neurons are directly targeted by peripheral hormones and nutrients, including leptin, ►ghrelin,

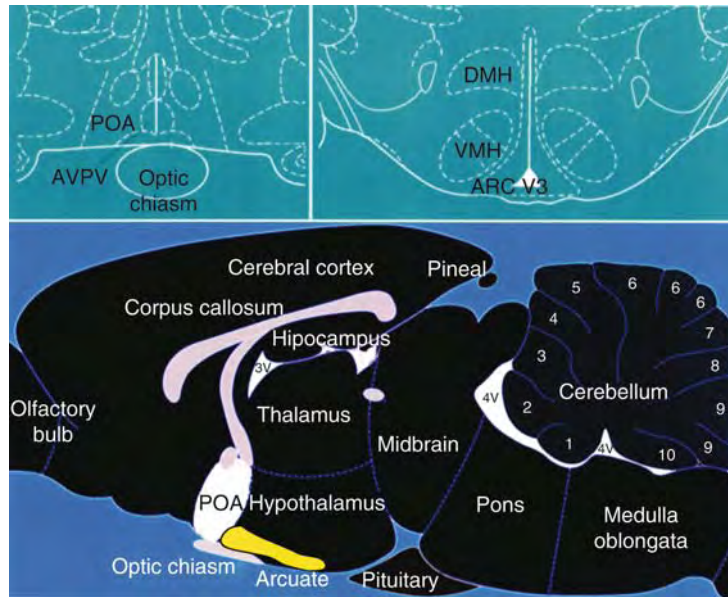

**Hypothalamus. Figure 2** Diagrams illustrating aspects of the rat hypothalamus in relation to the rest of the brain (*bottom*) and in a rostral (*upper left*) and more caudal (*upper right*) frontal section. The arcuate nucleus is shown in yellow. Abbreviations: *Arc* - arcuate nucleus; *AVPV* anteroventral periventricular nucleus; *DMH* dorsomedial hypothalamic nucleus; *POA* preoptic area; *Sp Co* spinal cord; *V3*, *3V* third ventricle; *VMH* ventromedial hypothalamic nucleus; *4V* fourth ventricle.

angiotensin, insulin, pituitary hormones, steroids (including gonadal steroids and corticosteroids), cytokines, glucose and long chain fatty acids.

### Neuronal projections

The hypothalamus is responsive to day length and photoperiod for generating circadian and seasonal rhythms, olfactory stimuli, including those elicited by pheromones, which arouse sexual behaviors, and somatic (autonomic) inputs arising from the heart, stomach, reproductive system relayed through the brainstem, via structures such as the ►nucleus of the solitary tract, locus coeruleus, and ventrolateral medulla. For example, ►oxytocin secretion occurs in response to suckling and vasopressin secretion in response to cardiovascular stimuli arising from chemoreceptors in the carotid sinus and aortic arch. The hypothalamus suppresses feeding in response to visceral signals elicited by gastric distension, which are conducted to the hypothalamus mainly via spinal pathways that relay in the brainstem.

### Regulatory Outputs

#### Hormones

Neurohormones produced in the hypothalamus, known as releasing hormones (Table 2), have the major function of stimulating the secretion of hormones by cells located in the adenohypophysis, or anterior pituitary gland (Table 3). Releasing hormones consist of simple amino acid chains (peptides) ranging in

size from only three amino acids (thyrotropin-releasing hormone) to 44 amino acids (►growth hormone-releasing hormone). Releasing hormones are secreted into the hypophysial-portal system in the median eminence of the hypothalamus from which they are carried in the blood stream to the adenohypophysis. Certain other hormones, such as oxytocin and vasopressin (►antidiuretic hormone) are released by the terminations of axons of neurons that project from the hypothalamus proper to a fenestrated capillary bed in the posterior pituitary (Table 3).

### Neuronal Projections

#### Projections to areas caudal to the hypothalamus

The hypothalamus sends descending signals through the medial forebrain bundle, mammillotegmental tract and dorsal longitudinal fasciculus (DLF). The descending fibers of the DLF originate in the hypothalamus, traverse the brain stem periaqueductal gray matter along the base of the fourth ventricle and continue into the spinal cord to synapse with preganglionic autonomic neurons.

#### Projections to areas rostral to the hypothalamus

These projections are carried by the medial forebrain bundle, mammillothalamic tract, fornix and stria terminalis, which contains fibers projecting from hypothalamus to the amygdala.

**Hypothalamus. Table 2** Hypothalamic hormones

Name	Other names	Abbreviations	Location	Function
Corticotropin-releasing hormone	Corticotropin-releasing factor, Corticoliberin	CRH, CRF	parvocellular neuroendocrine neurons in the paraventricular nucleus	with vasopressin, stimulates anterior pituitary to secrete ACTH
▶ Gonadotropin-releasing hormone	Luteinising-hormone releasing hormone	GnRH, LHRH	neuroendocrine neurons in the medial preoptic and arcuate nuclei	stimulates anterior pituitary to secrete LH and FSH
Growth hormone-releasing hormone	Growth-hormone-releasing factor, somatocrinin	GHRH, GHRF, GRF	arcuate nucleus neuroendocrine neurons	stimulates anterior pituitary to secrete growth hormone
Thyrotropin-releasing hormone	Thyrotropin-releasing factor, Thyroliberin, Protirelin	TRH, TRF	parvocellular neuroendocrine neurons in the paraventricular and anterior hypothalamic nuclei	stimulates anterior pituitary to secrete TSH
Somatostatin	Growth hormone-inhibiting hormone, Somatotropin release-inhibiting factor	SS, GHIH, SRIF	neuroendocrine neurons of the periventricular nucleus	inhibits secretion of growth hormone from the anterior pituitary
Vasopressin	Arginine vasopressin, Antidiuretic hormone, Argipressin	AVP, ADH	parvocellular neuroendocrine neurons in the [supraoptic nucleus supraoptic] and paraventricular nuclei	with Corticotropin-releasing hormone, stimulates anterior pituitary to secrete ACTH
Oxytocin			supraoptic nucleus	facilitates parturition (childbirth)

**Hypothalamus. Table 3** Pituitary hormones

	Hormone	Major target organ(s)	Major physiologic effects
Anterior Pituitary	▶ Growth hormone	Liver, adipose tissue	Promotes growth (indirectly), control of protein, lipid and carbohydrate metabolism
	▶ Thyroid-stimulating hormone	Thyroid gland	Stimulates secretion of thyroid hormones
	▶ Adrenocorticotrophic hormone	Adrenal gland (cortex)	Stimulates secretion of glucocorticoids
	▶ Prolactin	Mammary gland	Milk production
Posterior Pituitary	▶ Luteinizing hormone	Ovary and testis	Control of reproductive function
	▶ Follicle-stimulating hormone	Ovary and testis	Control of reproductive function
	▶ Antidiuretic hormone	Kidney	Conservation of body water
	▶ Oxytocin	Ovary and testis	Stimulates milk ejection and uterine contractions

### Pathology

Defects of the hypothalamus often result in severe dysfunction of homeostasis and various endocrine disorders. For example, patients with pituitary tumors (adenomas) that damage certain part of the hypothalamus, rapidly gain body weight (obesity) [2]. A hamartoma (a benign tumor) located in the hypothalamus may produce excessive amounts of GHRH, leading to acromegaly. Excessive secretion of ▶ corticotropin-releasing hormone

(CRH) leads to excessive stimulation of the adrenal cortex, resulting in Cushing's syndrome. On the other hand, reduced release of hypothalamic hormones could also result in corresponding defects. For example, a congenital deficiency of GnRH is associated with hypogonadism, in which the functional activity of the gonads is decreased and sexual development is inhibited. A deficiency of GHRH could cause abnormally small stature (dwarfism). Furthermore, because of the close

position of optic chiasm to the hypothalamus and pituitary gland, pressure from expanding tumors or inflammations in the hypothalamus or pituitary gland may cause severe visual defects or blindness.

## References

1. Yaghmaie F, Saeed O, Garan SA, Voelker MA, Gouw AM, Freitag W, Sternberg H, Timiras PS (2006) "Age-dependent loss of insulin-like growth factor-1 receptor immunoreactive cells in the supraoptic hypothalamus is reduced in calorically restricted mice." *Int J Dev Neurosci* 24(7):431–436
2. Mohr B (1840) Hypertrophie der Hypophysis cerebri und adurch bedingter Druck auf die Hirngrundfläche, ins besondere auf die Sehnerven, das Chiasma derselben und den linkseitigen Hirnschinkel. *Wschr des Heilk* 6:565–571

## Hypothalamus, Lateral

### Definition

the part of hypothalamus merging with no distinct boundaries with the preoptic region rostrally and the ventral tegmental area caudally and bounded medially by the mammillo-thalamic tract and fornix and laterally by the medial edge of the internal capsule. The medial forebrain bundle, which contains most of the afferent and efferent fibers connecting the lateral hypothalamus with other brain structures, is located eccentrically within the lateral hypothalamus throughout its rostro-caudal extent. Lateral hypothalamic tissue organization is reticular formation-like and projections extend from it rostrally into the forebrain and cortex, caudally far into the brainstem and medial-ward into the medial hypothalamus. The complex functional organization of the lateral hypothalamus is concerned with arousal, control of the autonomic and probably in coordination with the medial hypothalamus, the synthesis of defensive, ingestive and reproductive behaviors.

## Hypothalamus, Medial

### Definition

the part of the hypothalamus lying between the lateral and periventricular zones. Extending from the medial preoptic area rostrally to the mammillary region

caudally, the medial hypothalamus comprises a somewhat undifferentiated hypothalamic gray substance within which are found more obviously differentiated structures such as the ventromedial and dorsomedial hypothalamic nuclei. The medial hypothalamus is thought to play a role in the initiation of copulatory, aggressive and appetitive behaviors, probably in coordination with the lateral hypothalamus and to contribute to the coordination of neuroendocrine responses via its relations with the periventricular hypothalamic zone.

## Hypothalamus-Pituitary-Thyroid Axis

ERIC FLIERS

Dept of Endocrinology and Metabolism, Academic Medical Center, University of Amsterdam, Amsterdam, The Netherlands

### Synonyms

Thyroid axis

### Definition

The serum concentrations of the thyroid hormones thyroxin (T4) and the biologically active diiodothyronine (T3) are kept between narrow margins. This is accomplished by a negative feedback system consisting of (i) the thyroid gland, which synthesizes thyroid hormones and secretes T4 and T3 into the circulation and (ii) the anterior pituitary gland, which produces thyroid-stimulating hormone (TSH or thyrotropin), the secretion of which is inhibited by thyroid hormone. TSH stimulates the synthesis and release of thyroid hormone in the thyroid gland. The set point for serum concentrations of thyroid hormones is determined by thyrotropin-releasing hormone (TRH), produced in the paraventricular nucleus (PVN) of the [hypothalamus](#), which stimulates TSH release from the pituitary. The synthesis and release of TRH is inhibited by thyroid hormone. These components represent a classical example of a negative endocrine feedback system, generally referred to as the hypothalamus-pituitary-thyroid axis (HPT axis) or the thyroid axis.

### Characteristics

#### Description

TRH was the first hypothalamic hormone to be isolated and structurally characterized in the 1960s. This was followed by the immunocytochemical identification of

TRH neurons in the paraventricular nucleus (PVN) of the rat hypothalamus in the 1970s and 1980s and a key role for these neurons in the neuroendocrine regulation of thyroid hormone was gradually revealed. There appeared to be an inverse relationship between serum thyroid hormone levels and TRH mRNA expression in the PVN during experimentally induced hypo- and hyper-thyroidism [1] confirming a pivotal role for these neurons in this classical endocrine negative feedback loop. The rat PVN consists of magnocellular neurons containing, e.g. vasopressin and oxytocin in its lateral portions and of a parvocellular part in its more medial portions. TRH neurons in the medial and periventricular parvocellular subdivisions of the PVN project to the median eminence, which explains observations in experimental models of ►**hypothyroidism** showing increased TRH mRNA only in these subdivisions of the PVN (for review see [2]). These so-called hypophysiotropic TRH neurons project to the median eminence (ME) and terminate in its external zone, where TRH is released into the portal capillaries for transport to the anterior pituitary and regulation of TSH release. Hypophysiotropic TRH neurons in the PVN receive monosynaptic projections from leptin responsive neurons in the arcuate nucleus (ARC) containing either alpha-melanocyte stimulating hormone ( $\alpha$ -MSH) and cocaine and amphetamine regulated transcript (CART) or neuropeptide Y (NPY) and agouti-related protein (AGRP). These projections play a key role in the leptin mediated resetting of the thyroid axis during food deprivation, resulting in reduced TRH mRNA expression in the PVN, which contributes to lower serum concentrations of thyroid hormone in the fasting state [2].

In the 1990s TRH containing neurons and fibers were reported throughout the human hypothalamus, including some TRH neurons in the hypothalamic gray. The majority of TRH neurons reside in the dorsocaudal portion of the human PVN, with only a small number of magnocellular neurons expressing TRH. Both the suprachiasmatic nucleus (SCN), which is the circadian pacemaker of the brain acting as a biological clock and the sexually dimorphic nucleus (SDN) of the human hypothalamus contain a small number of bipolar TRH cells [3]. The exact efferent projections of hypothalamic TRH containing neurons in the human brain are unknown, but dense TRH fiber networks, e.g., in the tuberomammillary nucleus (TMN) and perifornical area suggest an important role for non-hypophysiotropic TRH neurons in the human brain as demonstrated earlier in the rat. The thyroid hormone receptor (TR) isoforms  $\alpha 1$ ,  $\alpha 2$ ,  $\beta 1$  and  $\beta 2$  are expressed by TRH cells in both the rat and the human PVN. Additional TR expression is present in the ARC of the rat and in the infundibular nucleus (IFN) of the human hypothalamus, which is the human homologue of the rat ARC [2,4].

Although the thyroid gland mainly secretes T4, most thyroid hormone actions are mediated via binding of the biologically active thyroid hormone T3 to its receptor. The biological activity of thyroid hormone in target cells is therefore determined in part by the intracellular concentration of T3, which depends on the activity of the iodothyronine deiodinases. In the brain, type 2 deiodinase (D2) is responsible for deiodination of T4 into T3, whereas type 3 deiodinase (D3) inactivates thyroid hormone by converting T3 into the biologically inactive diiodothyronine (T2) and T4 into reverse T3 (rT3). In the human hypothalamus, prominent D2 immunoreactivity is present in cells throughout the ependymal layer of the third ventricle, in glial cells within the IFN/ME region and in blood vessel walls. This distribution pattern of D2 immunostaining is in agreement with studies in rats, where electron microscopy studies have identified D2 immunoreactive cells as astrocytes, including ►**tanycytes** [2,4]. The distribution of hypothalamic D3 expression clearly differs from that of D2, showing intensely staining neurons in the human IFN and PVN. In contrast to D2, D3 is expressed exclusively in neurons showing a strong distribution overlap with TR, suggesting that D3 is expressed in T3-responsive neurons [5]. *MCT8* has recently been identified as a thyroid hormone transporter with a crucial role in thyroid hormone metabolism in the CNS, providing cells expressing deiodinases with thyroid hormone. The functional importance of *MCT8* became evident from observations in patients with severe psychomotor retardation who carry mutations or deletions in the *MCT8* gene [6]. Since TRH neurons in the human PVN express *MCT8* [5] and patients carrying *MCT8* mutations have unusual combinations of serum TSH, T3 and T4 [6], this protein is probably an important element in human HPT axis regulation.

The concept of thyroid hormone feedback at the level of the hypothalamus has traditionally focused on direct effects of thyroid hormone on TRH neurons. Taking into account more recent studies reporting hypothalamic D2, *MCT8* and TR expression, T4 may be taken up locally within the PVN from the circulation. Feedback following thyroid hormone uptake from the CSF represents an alternative possibility. In this model, thyroid hormone is taken up from the CSF in the third ventricle and transported by tanycytes to neurons in the arcuate nucleus that project to TRH cells in the PVN. Finally, thyroid hormone may have direct access from the circulation to the ARC or IFN in view of the absence of the blood-brain barrier in this part of the mediobasal hypothalamus. TR $\beta 2$  is predominantly expressed in rat ARC neurons that may be able to sense T3 produced by glial cells expressing D2. NPY, POMC and AGRP containing neurons from the ARC project to TRH neurons in the rat PVN. If indeed thyroid hormone

may act via the vascular compartment-IFN/ARC-PVN route remains hypothetical at this stage.

In the human anterior pituitary, folliculostellate (FS) cells show prominent D2 and *MCT8* immunoreactivity, while granular (hormone producing) cells express TR and D3 [7]. FS cells have long cytoplasmic processes and are able to modulate anterior pituitary hormone secretion by endocrine cells. Both TR $\alpha$ 2 and TR $\beta$ 2 co-localize with TSH. The overlap between TRs and D3 expression suggests that thyroid hormone action and degradation may occur in the same hormone secreting cells, while T4 conversion to T3 occurs in a subset of FS cells that may be stimulated by TSH via TSH-R binding. This fits very well with the ultra short feedback loop regulation of TSH as proposed earlier [8]. However, earlier studies in rat anterior pituitary have reported D2 expression in thyrotrophs. The apparent difference in D2 expressing cell types between human and rat anterior pituitary suggests an interspecies difference, although at this time fatal illness in the patients studied cannot be completely ruled out as a confounding factor for the anatomical distribution of D2 expression observed in human specimens.

### Function

During ►**hyperthyroidism**, elevated serum T4 and T3 concentrations exert negative feedback action at the level of the PVN and the anterior pituitary, leading to suppressed serum TSH, which may even become undetectable. During hypothyroidism, the reverse situation is present with lower serum T4 inducing elevated serum TSH. Thus, serum TSH is frequently used in the clinical setting to detect and monitor (even slight) changes in thyroid function. In some clinical situations, however, the thyroid set point regulation is clearly different and not consistent with negative feedback regulation. Highly prevalent examples are ►**critical illness** and ►**major depression**.

During critical illness, serum T3 levels decrease without giving rise to higher TSH levels, a phenomenon known as nonthyroidal illness (NTI) or the low T3 syndrome [9]. The magnitude of the drop in serum T3 within 24 h after the onset of a severe physical stress such as surgery or trauma reflects the severity of the stressor. The acute changes in the thyroid axis have been interpreted teleologically as an attempt to reduce energy expenditure. In patients treated in intensive care units (ICU) for prolonged periods, a dramatic decrease in TSH pulsatility occurs. Specifically, a loss of TSH pulse amplitude occurs in this setting in direct relation to low serum levels of thyroid hormone. Continuous iv administration of TRH, in particular when administered together with the GH secretagogue GHRP-2, to ICU patients with prolonged critical illness restores TSH pulsatility as well as physiological levels of thyroid hormones [10]. Whether this partial restoration of the

neuroendocrine features of critically ill patients is beneficial is unknown at present. The pathogenesis of NTI is incompletely understood but the paradoxically low TSH in the setting of decreased serum T3 points to a hypothalamic factor. In patients whose serum concentrations of TSH, T3 and T4 were assessed in a serum sample taken <24 h before in hospital death, a positive correlation was reported between total TRH mRNA hybridization signal in the PVN on the one hand and serum TSH and T3 on the other hand [11]. In addition, patients who die after severe illness have less than half the concentrations of tissue T3 in the hypothalamus and pituitary seen in patients who die acutely from trauma. The combination of low hypothalamic T3 and low TRH expression in the PVN implies a major change in hypothalamic thyroid feedback regulation during critical illness and suggests that the drop in thyroid hormone production in chronic severe illness has – at least in part – a hypothalamic origin [4].

Major depressive disorder has been associated with changes both in the HPT axis and the hypothalamic-pituitary-adrenal (HPA) axis. In the HPT axis a decrease in serum TSH, a blunted TSH response to TRH and an increase in serum free T4 (FT4) have been reported in inpatients by various authors as well as an increased prevalence of subclinical hypothyroidism and thyroid peroxidase (TPO) antibodies. Hypercortisolism in depression has been reported in many studies as reflected by elevated mean 24 h serum cortisol concentrations and increased 24 h urinary excretion of free cortisol. In view of the often blunted TSH response to TRH and the absent nocturnal TSH surge reported in depression, alterations in hypothalamic TRH expression may be involved in the pathogenesis of HPT axis changes in major depression. This was supported by one study comparing TRH mRNA expression in the PVN of patients with a long history of depression to age and sex matched controls by quantitative in situ hybridization, revealing a strong decrease in TRH mRNA expression in depression. That this decrease may be the result of hypercortisolism was supported by a subsequent study in glucocorticoid versus non-glucocorticoid treated patients showing decreased TRH mRNA expression in the glucocorticoid-treated group (for review see [4]).

### References

1. Segerson TP, Kauer J, Wolfe HC, Mobtaker H, Wu P, Jackson IM, Lechan RM (1987) Thyroid hormone regulates TRH biosynthesis in the paraventricular nucleus of the rat hypothalamus. *Science* 238:78–802
2. Lechan RM, Fekete C (2006) The TRH neuron: a hypothalamic integrator of energy metabolism. *Progr Brain Res* 153:209–235
3. Fliers E, Noppen NW, Wiersinga WM, Visser TJ, Swaab DF (1994) Distribution of thyrotropin-releasing hormone (TRH)-containing cells and fibers in the human hypothalamus. *J Comp Neurol* 350:311–323



4. Fliers E, Alkemade A, Wiersinga WM, Swaab DF (2006) Hypothalamic thyroid hormone feedback in health and disease. *Progr Brain Res* 153:189–207
5. Alkemade A, Friesema EC, Unmehopa UA, Fabrick BO, Kuiper GG, Leonard JL, Wiersinga WM, Swaab DF, Visser TJ, Fliers E (2005) Neuroanatomical pathways for thyroid hormone feedback in the human hypothalamus. *J Clin Endocrinol Metab* 90:4322–4334
6. Friesema EC, Grueters A, Biebermann H, Krude H, von Moers A, Reeser M, Barrett TG, Mancilla EE, Svensson J, Kester MH, Kuiper GG, Balkassmi S, Uitterlinden AG, Koehrlé J, Rodien P, Halestrap AP, Visser TJ (2004) Association between mutations in a thyroid hormone transporter and severe X-linked psychomotor retardation. *LANCET* 364:1435–1437
7. Alkemade A, Friesema EC, Kuiper GG, Wiersinga WM, Swaab DF, Visser TJ, Fliers E (2006) Novel neuroanatomical pathways for thyroid hormone action in the human anterior pituitary. *Eur J Endocrinol* 154:491–500
8. Prummel MF, Brokken LJ, Meduri G, Misrahi M, Bakker O, Wiersinga WM (2000) Expression of the thyroid-stimulating hormone receptor in the folliculostellate cells of the human anterior pituitary. *J Clin Endocrinol Metab* 85:4347–4353
9. Wiersinga WM (2005) Nonthyroidal illness. In: Braverman LE, Utiger RD (eds) *The thyroid*, 9th edn. Lippincott, Williams and Wilkins, Philadelphia, PA, pp 247–263
10. Van den Berghe G, de Zegher F, Baxter RC, Veldhuis JD, Wouters P, Schetz M, Verwaest C, Lauwers P, Bouillon R, Bowers CY (1998) Neuroendocrinology of prolonged critical illness: effects of exogenous thyrotropin-releasing hormone and its combination with growth hormone secretagogues. *J Clin Endocrinol Metab* 83:309–319
11. Fliers E, Guldenaar SE, Wiersinga WM, Swaab DF (1997) Decreased hypothalamic thyrotropin-releasing hormone gene expression in patients with nonthyroidal illness. *J Clin Endocrinol Metab* 82:4032–4036

## Hypothyroidism

### Definition

A clinical syndrome resulting from shortage of thyroid hormone, mostly as a consequence of thyroid gland failure. Among its features are depressed mood, decreased energy, weight gain, slowness and constipation.

► Hypothalamus-Pituitary-Thyroid Axis

## Hypotonia

### Definition

Abnormally reduced muscle tone seen in the acute phase of spinal cord injury, on in disorders of the

peripheral motor system, such as lower motor neuron disease, peripheral nerve disease, neuromuscular junction disorders, or myopathy.

## Hypoxemia

### Definition

A condition in which there is an inadequate supply of oxygen in the blood.

## Hypoxia

### Definition

Lower than normal oxygen levels.

## Hypoxia-inducible Factor-1 $\alpha$ (HIF-1 $\alpha$ )

### Definition

A transcription factor involved with hypoxia signaling and oxygen sensing. This transcription factor can be involved with neuroinflammation and a variety of other inflammatory disorders.

► HIF-1 and Neuroinflammation

## Hysteria

HEINZ BOEKER

University Hospital of Psychiatry Zurich, Hospital for Affective Disorders and General Psychiatry Zurich East, Zurich, Switzerland

### Synonyms

Hysterical neurosis; Histrionic personality disorder; Conversion disorder; Dissociation

## Definition

The concept of hysteria or conversion disorder, firmly anchored in psychoanalytic theory, postulates the emergence of physical symptoms as an unconscious attempt to resolve painful psychic conflicts. By adopting the role of a sick person unconsciously, the conflict remains and the symptoms are perpetuated.

## Characteristics

### History/Background

Descriptions of hysteria were included in ancient Greek medical texts. At that time, the disorder was thought to result from movement of the uterus from its normal position (hence the name of the condition). In the second century AD, Galen rejected the idea that the uterus had been displaced and suggested instead that the condition was caused by an undue retention of uterine secretions. Various forms of uterine pathology were generally thought to cause hysteria until the seventeenth century, when the English physician, Thomas Willis (1621–1675) suggested that hysteria was caused by a disorder of the brain. By the nineteenth century, the importance of predisposing constitutional and organic causes of this brain disorder was recognized, and it was accepted that strong emotion was the usual provoking cause.

Charcot, a French neurologist in the late nineteenth century, believed that hysteria was caused by a functional disorder of the brain which led to caused symptoms also rendering patients susceptible to hypnosis so that new symptoms could be detected by suggestion. Charcot's ideas were developed further by Pierre Janet, who proposed that the disorder in hysteria was a tendency to dissociate, that is to lose the normal integration between various parts of mental functioning, together with a restriction of personal awareness, so that the person became unaware of certain aspects of psychological functioning, which would otherwise be within his awareness [1]. Freud and his colleague Breuer studied patients with hysteria and reported their findings in a paper "On the psychical mechanisms of hysterical phenomena" [2]. In a subsequent monograph, *Studies in Hysteria* [3], Breuer and Freud suggested that hysteria was caused by emotionally charged ideas which had become lodged in the unconscious of the patient at some previous time, and which were excluded from conscious awareness by a process which the authors called repression. They summarized this idea in the phrase "hysterics suffer mainly from reminiscences" [2, p. 7]. Freud suggested that the repressed ideas were usually sexual.

After Janet, a wider view of the emotionally charged ideas that could cause hysteria was supported by findings from the First World War, when hysteria was observed as a response to the stressful experience of battle.

The terms "dissociation" and "désaggregation" ("disaggregation") were coined by Pierre Janet [4,5]. Janet viewed the mental life of the individual as an aggregate of mental elements, which he described as "psychological automatisms." Under normal circumstances, psychological automatisms are unified in nominal consciousness and are accessible to voluntary control. Under traumatic, stressful conditions, however, single automatisms may become split off – dissociated – from the rest of consciousness and exert their effects autonomously. Genetically transmitted temperamental traits as well as early experiences, together with the individual's present physical condition define the capacity of a person for the mental integration of new information in general, and of traumatic experiences in particular.

Janet's model of dissociation is essentially based on the idea of a constitutional pre-disposition to dissociation ("dégénération"). The individual's pre-morbid vulnerability to dissociative disorders thus plays a decisive role. A dissociation, which is to be understood as passive, by no means requires an intense external trauma for it to be released. Rather, reactivity to exaggerate emotions, inherent in the individual's personality, often exerts a traumatogenic effect and leads to the generation of a psychopathological disorder.

The original position of Freud and Breuer [3] is still very close to that of Janet. They too viewed traumatic exposure during a sensitive developmental phase and a pre-disposition to dissociative psychopathology as decisive. Like Janet, they also recognized the importance of autosuggestion, used as a defense against traumatic experiences, in the pathogenesis of dissociative syndromes, as well as the special role of hypnotic techniques in the treatment of this unique class of disorders.

A major shift of emphasis took place with the conception of the dissociative disorders. The predominant idea was initially that of external events leading to traumatic excitation beyond the individual's objective ability to cope and thus to a feeling of psychophysical helplessness. Later, Freud increasingly identified the strong influence of unconscious phantasies and the attribution of meaning to "traumatic situations." What was originally thought of as an external, traumatic situation came to be viewed as an intra-psychic situation of danger, for which the ego can prepare itself in advance with controlled amounts of signal anxiety, and to which it can react with specific defense mechanisms, such as repression. While developing these ideas, Freud in no way denied the existence and clinical relevance of real trauma. Yet this concept of repression and defense neurosis became the leading paradigm of dynamic psychiatry in the following years and consigned Janet's concept of dissociation to obscurity for many decades thereafter [7].

Kretschmer (1960) [6] proposed an interpretation of the observation of hysterical disorders in wartime. He suggested that the symptoms resulted from an innate biological mechanism counteracting highly stressful experiences. He believed that hysterical symptoms could develop in psychologically stable people as a result of this “reflex” mechanism, and could subside rapidly when the stress receded.

Hilgard [8], making use of the newly developed concepts of cognitive psychology, proposed a neo-dissociative theory that had many points of contact with the psychology of Janet. In his model of the “divided consciousness,” the psyche is viewed as an organized system of mental structures controlling perceptual, cognitive and behavioral processes in different areas. These mental sub-systems bear a certain resemblance to Janet’s psychological automatisms, but may also be thought of as comparable to the modules and cognitive units postulated in the cognitive theories of parallel information processing. According to Hilgard, the central executive system may become dysfunctional and cease to integrate and organize the individual control structures, resulting in a state of divided consciousness [9].

Two major problems with the concept of hysteria have detracted from its clinical value. The first is the difficulty in establishing the occurrence, relevance and timing of a “sufficient” psychological stressor. The second is how to distinguish “unconscious” motivation from feigning. Faced with these difficulties and the possibility of overlooking treatable neurological conditions, clinicians have opted for a diagnosis per exclusion, stating hysteria or conversion disorder only after detailed investigations have failed to find an alternative explanation for the symptoms [8].

### Classification

The two major systems of classification have adopted somewhat different ways of classifying the conditions formerly known as hysteria. In DSM-IV, two terms, conversion and dissociative disorder, are used. Conversion denotes cases in which physical symptoms are the principal manifestations of the disorder; whilst dissociative disorder denotes cases in which psychological symptoms are the principal manifestations. In ICD-10, both kinds of manifestation are called dissociative disorders (with the term conversion used as an alternative means of indicating the same meaning) (cf. Table 1).

In DSM-IV, conversion disorders (those with physical symptoms) are classified under the rubric “somatoform disorder” (a rubric for mental disorders with mainly physical symptoms), while dissociative disorders have a rubric of their own. In ICD-10, all these disorders are classified together under the rubric “dissociative disorder”.

**Hysteria. Table 1** Classification of dissociative or conversion disorders

ICD-10	DSM-IV
<b>F4 Dissociative (conversion disorders)</b>	<b>Dissociative disorders</b>
Dissociative amnesia	Dissociative amnesia
Dissociative fugue	Dissociative fugue
Dissociative stupor	
Other dissociative disorder	
Ganser’s syndrome	
Multiple personality disorder	Dissociative identity disorder (multiple personality disorder) Depersonalization disorder
Trance and possession disorder	Dissociative disorder not otherwise specified
Dissociative motor disorder	Conversion disorder (without further sub-divisions)
Dissociative convulsions	
Dissociative anesthesia	

In the modern psychiatric classification systems, the dominant characteristic of the diagnostic category of dissociative disorders is the partial or total loss of the integrative functions of consciousness, memory, personal identity and perception of the self and of the environment. These disorders were referred to in earlier diagnostic manuals as “hysterical neurosis of dissociative type”.

The term “histrionic personality disorder” can replace the term “hysterical personality disorder” (Histrion was an actor in ancient Rome). The historical forerunner of histrionic personality disorders was hysterical neurosis, which was always considered inconsistent and multifaceted, with conversion symptoms and dissociative phenomena at the forefront, and all descriptions have dwelled on the variety and diversity of the disorder. The term “hysteria” was abandoned as a category, not only because of discrimination and labeling problems, but also because it could not be shown that hysterical symptoms, as originally postulated, occurred primarily in Oedipus conflicts.

The main characteristics of histrionic personality disorder are a strong need for attention and recognition, suggestibility and a tendency towards affective instability and superficiality. Histrionic personalities have a sense of atmosphere, but also tend to dramatize and to manifest falseness and coquetry. They are largely unable to maintain a consistent pursuit of goals and value-orientation and are therefore inconstant, especially in relationships with other people and partners. Their typical thinking has been called “impressionistic”.

There is an increased tendency for identification and traits such as empathy, sensitivity and theatrical skills, which can be positive, but can also allow the individual to mimic a series of conditions. According to Nemiah [6], dissociation plays a central role where hysterical mechanisms of repression, denial and hyper-emotionality, identification and identity-shift can favor a “consciousness-impairing” effect.

The term “conversion” is derived from Freud’s hypothesis that the somatic symptoms are a symbolic solution to an unconscious conflict enabling a reduction of anxiety and the exclusion of the conflict from conscious awareness (a process called primary gain). Current theories stress the importance of social factors and regard conversion symptoms as a mal-adaptive variance of normal processes which, in some circumstances, are culturally accepted or even encouraged (e.g., possession states). *Belle indifférence*, an apparent lack of concern about the symptoms, was stressed in past accounts of the condition, but it is not an invariable feature.

In DSM-IV this category denotes symptoms or deficits involving voluntary motor or sensory functions.

Conversion disorder, as defined in DSM-IV, is much less common, with a reported prevalence of between 1% and 3% among patients referred to psychiatrists. However, short-lived conversion syndromes, such as difficulty in walking or sensory complaints, are seen regularly in emergency departments.

In DSM-IV, conversion disorder is sub-divided as follows:

- With motor symptoms or deficits (e.g., psychogenic paralysis, psychogenic disorder of gait, psychogenic tremor, psychogenic dysphonia and mutism and globus hystericus, a feeling of a lump in the throat)
- With sensory symptoms or deficits (e.g., dissociative anesthesia, paresthesia, hyperesthesia and pain, as well as deafness and blindness)
- With seizures and convulsions (the patient does not become unconscious, the pattern of movements does not show a regular and stereotype form of seizure, and there is no incontinence, cyanosis or injury and the tongue is not bitten; EEG findings are normal)

Assessment of conversion disorder depends on the patient’s history and an examination to ascertain the characteristic features, and on great caution in excluding neurological and other physical causes.

The cause of the condition is very variable. It is probable that most episodes are transient, but a minority have a chronic cause; recurrence is common.

### **Etiology and Pathogenesis**

There are, in essence, two conceptual approaches to the understanding of the causes of dissociative conditions:

- A complex mode of reaction to an external trauma

- Certain primary personality attributes that can predispose an individual to the occurrence of dissociation

### **Dissociation as a Reaction to Trauma**

Many patients with dissociative disorders report having experienced a severe psychological trauma, mostly during their early development. The most serious traumas described include sexual and physical abuse, emotional neglect and deprivation. It must be kept in mind, however, that most of the data published on this topic were gathered retrospectively and may thus give a distorted picture of the reality. The researchers and therapists favoring the explanation of a true post-traumatic reaction are opposed by those preferring that of a genetically pre-disposed personality [9].

A problem in many studies is the lack of distinction between different types of trauma, i.e., unexpected, single-event trauma versus continued or repeated exposure to trauma, or the presence or absence of protective compensation in a traumatized child. The relationship between trauma and dissociation indeed seems to be a close one, but it should not be thought of as linear or monocausal. The inter-relatedness of trauma, memory and dissociation should always be analyzed on multiple levels, reflecting the dilemma of “historical” versus “narrative truth” [10].

### **Trauma and the Neurobiology of Dissociation**

In the context of adjustment to a traumatic event, two basic modes of reaction may be distinguished. An individual typically reacts to an external threat with an alarm reaction consisting of an elevation of sympathetic tone in preparation for a basic fight- or flight-response pattern. This hyperarousal continuum is brought about mainly by the centrally driven peripheral secretion of epinephrine and norepinephrine, by the secretion of adrenal corticotrophic hormone (ACTH) and cortisol by the hypothalamic-pituitary-adrenal (HPA) axis, and by activation of the immune system.

On the other hand, a dissociative continuum is associated with a basic response pattern of surrender. It seems to be activated preferentially when an organized fight- or flight-response appears unlikely to succeed, or when this type of response is not yet fully developed, as in children. There is initially a stress-response with secretion of catecholamins and corticoids. However, in dissociation but not in hyperarousal, there is also a strong vagal activation. Moreover, the mesolimbic and mesocortical dopaminergic systems play an important role and, by way of the central reward systems, exert a primary influence on affect modulation. Collateral connections to the endogenous opioid system lead to a change in the perception of noxious stimuli and also to a distortion of the sense of time, place and reality.

Both response patterns can be combined, to varying relative extents, in basic adaptive styles.

A neurobiological inter-relationship of dissociation disorder and PTSD (post-traumatic stress disorder) is suggested by the fact that peri-traumatic dissociative symptoms have a high predictive value for the later development of PTSD.

### Hysterical Conversion and Brain Function

Hysterical conversion disorders represent “functional” or unexplained neurological deficits such as paralysis or somatosensory losses not explained by organic lesions in the nervous system, but arising in the context of “psychogenic” stress or emotional conflicts. Several recent studies have used functional brain imaging techniques (such as EEG, fMRI, PET or SPECT) in the attempt to identify specific neural correlates associated with hysterical conversion symptoms. Functional neuroimaging has revealed selective decreases in the activity of frontal and sub-cortical circuits involved in motor control during hysterical paralysis, decreases in somato-sensory cortexes during hysterical anesthesia, or decreases in visual cortex during hysterical blindness [11]. Such changes are usually not accompanied by any significant changes in elementary stages of sensory or motor processing, as measured by evoked potentials, although some changes in later stages of integration (such as P300 responses) have been reported. On the other hand, several neuroimaging results have shown increased activation in limbic regions, such as cingulate or orbito-frontal cortex during conversion symptoms, effecting different sensory or motor modalities. Taken together, these data generally do not support previous proposals that hysteria might involve an exclusion of sensory motor representations from awareness through attentional processes. Rather, they seem to point to a modulation of such representations by primary affective or stress-related factors, perhaps involving primitive reflexive mechanisms of protection and alertness that are partly independent of conscious control, and mediated by dynamic modulatory interactions between limbic and sensori-motor networks.

A better understanding of the neuropsychobiological basis of hysterical conversion disorder might therefore be obtained through future imaging studies comparing different conversion symptoms and employing functional connectivity analysis. This could also provide new insights into the brain mechanisms of self-awareness.

### A Contemporary Re-conceptualization of Hysteria

Yarom (1997) [12] presented a matrix of hysteria, which is a contemporary re-reading of Freud’s basic conceptualization. It integrated oedipal concepts (referring to unconscious conflicts in the triangular relationship between both parents and the child) with others borrowed from object-relation theories, self-psychology and the inter-subjective approach. In this way, the focus of the issues of gender and sexuality in hysteria has been

continued without the original roots being lost. The focus is on the content, whereas the structure may vary. Within the first axis of the matrix, Yarom proposes identifying the conflict of gender and sexual identity as the unconscious and conscious solutions adopted by a hysteric to the question “Am I a man or a woman?” Repression and conversion are incorporated to constitute the second and third axes of the matrix. Several defense mechanisms (repression, denial, dissociation and phantasy) are shown to be employed in the context of gender and sexuality, and along a continuum of personality structures. In this context, the turning to the body, the conversion, still acts as an effective language, to which therapists should listen.

### Psychotherapy

There is a consensus among experts that treatments should be planned and provided largely on an individual basis. Psychotherapeutic strategies are generally preferred to biological approaches. In view of the importance of severe trauma in the etiology and pathogenesis of both the simple and, in particular, complex dissociative disorders, emphasis should be placed on avoiding the danger of inducing further trauma through therapeutic measures. The treatment of a comorbid psychiatric disorder is geared towards the therapeutic standard for that particular disorder. Syndrome-oriented, mainly psychopharmacological treatment of this psychiatric comorbidity may become a priority when psychiatric emergencies arise or when access to the patient is blocked by the comorbidity, so that the selected form of psychotherapy can not be performed.

For acute dissociative and conversion disorders seen in general practice or hospital casualty departments, treatment by reassurance and suggestion is usually appropriate, together with immediate efforts to resolve any stressful circumstances that provoked the reaction. The general approach is to focus on the elimination of factors reinforcing the symptoms. It should be explained to the patient that he/she has a disability (as in remembering or moving arms and legs) not caused by physical disease but by psychological factors.

Patients with dissociative and conversion disorders often appear to respond well to psychodynamic psychotherapy or to psychoanalysis. Psychoanalysts working with hysteric patients find themselves in unconscious communication with the patient. The psychoanalyst may experience in his/her reveries that he/she is moved by particular mental contents narrated by the patient, and when the psychoanalyst echoes them, the patient usually responds by producing further material. This collaboration is of enormous importance in the outcome of such analysis, as the patient is a creatively contributing psychic partner to the psychoanalyst.

By interpreting transfer and counter-transfer processes, the therapeutic relationship is supposed to deal

not only with the Oedipus conflict, but also with desires for attention and care.

## References

1. Gelder M, Gath D, Mayou R, Cowen P (1996) Oxford textbook of psychiatry, 3rd edn. Oxford University Press, Oxford
2. Freud S (1893) On the psychical mechanisms of hysterical phenomena. In: Strachey J (ed) The standard edition of the complete psychological works, vol III. Hogart, London, pp 25–42
3. Breuer J, Freud S (1893–95) Studies on hysteria. In: Strachey J (ed) The standard edition of the complete psychological works, vol II. Hogart, London
4. Janet P (1894) État mentale des hystériques. Rueff, Paris
5. Janet P (1889) L'automatisme psychologique. Alcan, Paris
6. Kretschmer E (1960) Hysteria: reflex and instinct. Peter Owen, London
7. Nemiah JC (1998) Early concepts of trauma, dissociation and the unconscious: their history and current implications. In: Bremner JD, Marmar CR (eds) Trauma, memory and dissociation. American Psychiatric Press, Washington DC, pp 1–26
8. Hilgard ER (1986) Divided consciousness: the multiple controls in human thought and action. Wiley, New York
9. Kapfhammer HP (2001) Dissociative disorders and conversion disorders. In: Henn F, Sartorius N, Helmchen H, Lauter H (eds) Specific psychiatric disorders. Contemporary psychiatry, vol III. Springer, Berlin Heidelberg New York, pp 88–108
10. Bremner JD, Vermetten E, Southwick SM, Kryston JH, Charney DS (1989) Trauma, memory and dissociation: an integrative formulation. In: Bremner JD, Marmar CR (eds) Trauma, memory and dissociation. American Psychiatric Press, Washington DC, pp 365–402
11. Vuilleumier P (2005) Hysterical conversion and brain function. *Prog Brain Res* 150:309–329
12. Yalom N (1997) A matrix of hysteria. *Int J Psychoanal* 78:1119–1134

---

## Hysterical Amnesia

### Definition

Hysterical amnesia to forget something due to unconscious intrapsychical processes. Forgetting is just about

certain events or persons whereas other things are well remembered.

► Personality Disorder

---

## Hysterical Aphonia

### Definition

Hysterical aphonia lost of voice due to unconscious intrapsychical processes.

► Personality Disorder

---

## Hysterical Gait

### Definition

Bizarre gait seen with hysteria-conversion reaction. While walking the foot is usually dragged or pushed ahead, instead of lifted. Frequently the foot is held dorsiflexed and inverted.

► Personality Disorder

---

## Hysterical Neurosis

► Hysteria

---

## Hysterical Torticollis

### Definition

Torticollis, psychosomatic in aetiology.

► Personality Disorder

---

## Ia Inhibitory Interneuron

### Definition

Population of glycinergic spinal interneurons, which exert reciprocal inhibition between motoneurons of antagonistic muscles. The interneurons receive input from a number of different sensory modalities as well as descending motor tracts. One of the important sensory inputs is from muscle spindle group Ia afferents and elicitation of stretch reflexes is therefore coupled with reciprocal inhibition of the antagonist motoneurons.

However, it should be noted that the Ia afferent input is only one of many sensory inputs and that the naming of the interneurons is solely explained by the way they were originally discovered. A major descending input is from corticospinal tract fibers which branch to activate agonist motoneurons and Ia inhibitory interneurons projecting onto antagonist motoneurons in parallel.

This ensures that antagonist motoneurons are inhibited when agonist motoneurons are activated during voluntary movements. The Ia inhibitory interneurons are the only interneurons in the spinal cord to receive (recurrent) inhibition from Renshaw cells. This connection – and its supraspinal control – may help to ensure a larger flexibility in the activation of muscles working on a joint, and may for instance help to ensure co-activation of antagonistic muscles by decreasing reciprocal inhibition.

- ▶ Integration of Spinal Reflexes
- ▶ Muscle Spindle
- ▶ Renshaw Cell

---

## I $\kappa$ B- $\beta$

- ▶ Nf- $\kappa$ B – Potential Role in Adult Neural Stem Cells

---

## I $\kappa$ B- $\epsilon$

- ▶ Nf- $\kappa$ B – Potential Role in Adult Neural Stem Cells

---

## I $\kappa$ B- $\zeta$

- ▶ Nf- $\kappa$ B – Potential Role in Adult Neural Stem Cells

---

## ICC

### Definition

- ▶ Interstitial Cell of Cajal

---

## Ice-Pick Headache

### Definition

A recurrent severe, stabbing headache lasting less than one second occurring on any part of the head.

- ▶ Headache

---

## Ictal Phenomena

### Definition

Emotional changes occurring during seizures (icti) in ▶ chronic temporal epilepsy and consisting of transient

auditory and visual hallucinations, delusions, paranoia, feelings of unreality and depersonalization and of *déjà vu* (already seen), anger, fear, and sexual feelings.

---

## Identified Neuron

### Definition

A neuron that can be documented to occur as either a single copy or a small number of copies, and that can be characterized by repeated study in the same region of the nervous system in different individuals of the same species. Commonly, identified neurons are given a name that represents either their first identified function, anatomical location or some relatively unique feature.

---

## Identity

### Definition

Identity is either a relation that everything entertains with itself (sameness) or it is the characteristic properties of something that distinguish it unambiguously from other things. These different senses of identity are expressed in the questions “Is the evening star identical with the morning star?” and “What are the identity conditions of propositional attitudes?”.

► Information

---

## Ideomotor Apraxia

### Definition

► Apraxia

---

## Idiopathic

### Definition

Medical term to indicate that the etiology (i.e., cause) of a disease is unknown.

---

## Idiopathic Hypersomnia

### Definition

A condition of excessive sleepiness that is likely caused by abnormalities in the central nervous system arousal pathways. Unlike narcolepsy, another hypersomnia of central origin, little is known about the underlying mechanisms idiopathic hypersomnia. Sleep times are generally longer than in narcolepsy, and naps tend to be longer and less refreshing. Objective sleep propensity is high when measured on the multiple sleep latency test.

This is currently a diagnosis of exclusion when other causes of hypersomnia have been excluded.

► Sleep – Developmental Changes

---

## Idiopathic Inflammatory Demyelinating Diseases (IIDDs)

### Definition

IIDDs of the central nervous system are a heterogeneous group varying in their clinical course, regional distribution, and pathology, and containing ► acute disseminated encephalomyelitis, ► neuromyelitis optica, and classical ► multiple sclerosis, and characterized by several immunopathological patterns potentially implicating different inflammatory, ► demyelinating, and apoptotic mechanisms that suggest the involvement of diverse pathogenic effector mechanisms.

► Acute Disseminated Encephalomyelitis (ADEM)

► Multiple Sclerosis

► Neuromyelitis Optica (NMO or Devic’s Disease)

---

## Idiopathic Parkinsonism

► Parkinson Disease

---

## Idiopathic Parkinson’s disease

► Parkinson Disease



## Idiothetic Cues

### Definition

Synonym for self-motion cues. Typically contrasted with “allothetic cues.”

- ▶ Spatial Learning/Memory

## Idiothetic Information

### Definition

Stimuli provided by the body like vestibular, proprioceptive and motor command efferent copy inputs.

- ▶ Spatial Memory

## IEM

### Definition

Inherited erythromelalgia.

- ▶ Erythromelalgia

## IGRF

### Definition

The international geomagnetic reference field (IGRF) is a series of mathematical models describing the Earth’s main field and its secular variation. The IGRF is the product of a collaborative effort between magnetic field modelers, and the institutes involved in collecting and disseminating magnetic field data from satellites and from observatories and surveys around the world. See <http://www.ngdc.noaa.gov/LAGA/vmod/igrf.html>.

- ▶ Geomagnetic Field

## Iguanid (Type)

### Definition

Referring to the family Iguanidae, large-bodied South-American lizards.

- ▶ Evolution of the Brain: At the Reptile-Bird Transition

## ILD (Interaural Level Difference)

### Definition

The difference in the sound pressure level of the sound in the two ears.

- ▶ Acoustics
- ▶ Neuroethology of Sound Localization in Barn Owls

## Illusion

### Definition

A visual illusion occurs when there is a discrepancy between a physical stimulus and the perception of that stimulus, despite the normal functioning of the visual system. Generally, illusions are measured as follows:

An observer judges a test stimulus in isolation (called a pretest trial or baseline measure) and then judges it again, but this time with the addition of an inducing stimulus (called a test trial). The illusion, that is, the effect of the inducing stimulus on the test stimulus, is defined as the algebraic difference between the test and pretest judgments. Because on the test trial the test and inducing stimuli are presented together, an illusion is a simultaneous effect. For example, to measure the tilt illusion, an observer could be asked to make an isolated circular test grating look vertical or horizontal (pretest trial) and then do it again when the test grating is surrounded by an inducing grating tilted 15° clockwise of the test grating (test trial). This would make the vertical or horizontal test grating appear tilted slightly counterclockwise so the observer would have to set it slightly clockwise to now make it look vertical or horizontal again.

- ▶ Visual Illusions

## Illusory Contour

### Definition

A contour that is seen in the absence of any physical edge in the image. Also referred to as the subjective contour. The perceived shape of an illusory contour is induced by special alignment of local stimulus elements called inducers as their shapes and layout suggest an implicit object in front occluding other objects behind.

In the Kanizsa square, a square-shaped illusory contour is induced by four “pacman”-shaped inducers arranged appropriately such that their notches coincide with the apices of an implicit square.

- ▶ Perceptual Filling-In
- ▶ Visual Illusions

## Illusory Memory

### Definition

Memory for details or entire events that never occurred.

- ▶ Memory Distortion

## Image

### Definition

The projection of light onto a plane.

## Image-Mental

KLAUS SACHS-HOMBACH  
Otto-von-Guericke University Magdeburg,  
Magdeburg, Germany

### Synonyms

Imagery

### Definition

The term “mental image” in cognitive science denotes mental representations that represent information depictively. This can be understood in a stronger sense: that mental images actually are pictures; or in the weaker sense: that they function in the same way as pictures (are only picture-like). In both claims, mental (or internal) images are usually defined in analogy to external pictures by some kind of similarity relation, mostly by structure ▶ **isomorphism**. According to this relation, parts or properties of mental images represent parts or properties of objects, and the relations between the parts or properties of the mental images represent relations between parts or properties of the objects represented. This holds particularly for spatial relations.

The term “mental image” is regarded as an umbrella term. It is often used ambiguously to denote either ▶ **phenomenal images** (what one “sees with the mind’s eye”), certain functional states of the mind or the neurophysiological correlates of those states. Within the research on mental imagery in cognitive science, two theoretical viewpoints are in contest: ▶ **pictorialism** and ▶ **descriptivism** [1,2]. Pictorialists [3–6] defend a picture theory of mental images. They claim (i) that mental images consist of two components: the surface or phenomenal image and the underlying representations; (ii) that the underlying representational system contains at least two sorts of representations with distinct formats or data structures: propositional encodings related to language and picture-like encodings related to sensory input; and (iii) that mental images play an important causal role within information processing. Descriptivists [7,8] state (i) that the representational system contains only propositional representations with a unified language-like format; (ii) that mental images are reducible to ▶ **structural descriptions** that represent properties and spatial relations in an explicit manner; and (iii) that mental images (in the phenomenal sense) are therefore epiphenomenal.

### Description of the Theory

The concept of mental imagery has its roots in antiquity. It played an important role in the theorizing of the British Empiricists and has gained, after a decline in behaviorism, novel attention within cognitive science since 1960. Mental images were then postulated to explain more adequately some distinct behavioral features various experiments had pointed out. A highly influential set of experiments on mental imagery and mental rotation in the context of problem solving and information processing was conducted by Roger Shepard and Nancy Metzler [6]. In a variety of different settings, subjects were shown alphanumeric items, letters or pairs of figures depicting three-dimensional

geometric object in different forms. In the latter case, subjects were asked whether the figures are congruent or not. The outcome was that subjects needed the more time for deciding the more the figures were rotated: reaction time and degree of rotation are significantly correlated in linear proportion.

These findings seemed to support the plausible assumption that in order to solve the kind of task described, subjects imagine and then rotate one of the figures so as to superimpose it on the other in order to decide about congruency. If internal images are like external images, longer reaction times are to be expected since rotating external pictures takes time. If, in contrast, we assume that our cognitive system does not function the way but, e.g., by inspecting descriptions with lists of properties, we have difficulties to explain the differences in the reaction times observed. This interpretation is confirmed by another set of experiments on image scanning conducted by Stephen M. Kosslyn. These experiments showed a similar correlation between the actual distance of two points on a map and the time taken to scan internally from one point to another [4].

A famous early example of using the concept mental image in the context of psychology of memory is Allan Paivio's dual coding theory [9]. According to this theory, information can be stored in two independent but interconnected systems: verbally and pictorially. A particular item will be memorized more easily if it is decoded dually, i.e., in both systems. That is, e.g., more likely in the case of concrete concepts than in the case of abstract concepts.

The most influential work on mental imagery comes from Kosslyn. His early theory, orientated towards the cathode-ray tube metaphor (CRT-metaphor) (►Cathode-ray tube (CRT) metaphor), includes a computer model [4]. Within this model, images can be generated on a display from more abstract underlying representations. That is, the model contains a surface display, a memory system, and computational mechanisms to generate, maintain, inspect, and transform mental images on the display. The display is conceived of as a ►visual buffer that functions as short term memory. It is necessary both for inspecting visual information coming from visual perception and for retrieving it as constructed by mental imagery. It also accounts for typical restrictions like image resolution that can be observed in human imagery and in computational models as well [3]. The visual buffer depends on long term memory. In order to generate a mental image, information from visual perception has to be interpreted and encoded in long term memory, both propositionally and pictorially. Whereas propositional encoding describes the relevant properties and relations explicitly, pictorial encoding is thought of as a pixel matrix that preserves visual information particularly of spatial

relations in an implicit manner, not by explicit description. Generating a mental image therefore requires a top-down activation of both types of representations. Thus, mental images necessarily have propositional aspects as well. They include an interpretation although they can be regarded as ►analogue data structures.

Cognitivists like Zenon W. Pylyshyn [7,8] have criticized the pictorialist's view on mental imagery, focussing on the following questions: (i) In what sense can mental images be said to be picture-like; (ii) to what extent is mental imagery determined by the underlying propositional representations, and (iii) how is mental imagery linked to perception? Following these questions, three types of objections have been developed within cognitive science: (i) a conceptual, *a priori* critique of mental imagery, (ii) a methodologically orientated discussion on the architecture of cognitive science, and (iii) an empirical approach aiming mainly at the neurophysiological basis of mental imagery. *A priori* arguments were presented in the 1960s and 1970s prominently by Daniel C. Dennett and Jerry A. Fodor [1], the methodological discussion worked out by Pylyshyn took place mainly in the eighties [7], and the work on the neurophysiological questions summarized by Kosslyn [5] became increasingly prominent since 1990.

1. *A priori* arguments try to show that the concept of mental imagery is inconsistent and therefore useless in cognitive science. These arguments normally address a picture theory of mental imagery, which assumes that mental images are pictures in a literal sense. According to one of these arguments, put forward by Dennett, pictures are informative with respect to various details but mental images are not. The picture of a tiger reveals a determinate number of stripes but the corresponding mental image normally does not provide such information. According to Ned Block, that sort of argument is not successful because it commits the photographic fallacy [1]: descriptionists neglect that different types of pictures, e.g., photographs and sketches of stick figures, depict differently. Mental images do not have to be like photographs. Additionally, mental images do not have to share all properties with pictures. Even the strong view – that mental images are pictures in a literal sense – is only committed to the claim that mental images share some important properties with pictures, namely, that they are spatial.

Philosophers have developed a number of important arguments against the ►resemblance theory of pictures that are essential also for formulating a theory of mental images. Surprisingly, these arguments do not play any substantive role within the imagery debate. The most influential attack on the

resemblance theory has been undertaken by Nelson Goodman who claimed that resemblance is neither necessary nor sufficient for something to be a picture. The resemblance relation is symmetrical and reflexive while the depicting relation is not. Pictorialists, however, have an alternative: They can understand similarity in terms of structure isomorphism, a more sophisticated similarity criterion which may be combined with a causal theory that links perception with imagery.

2. Pylyshyn has put forward a different, methodological type of critique [7,8] that hinges mainly on the concept of ►cognitive penetrability. According to this line of reasoning, a mental process is cognitively penetrable if it depends on semantic interpretations and changes systematically when the interpretations vary. The concept of cognitive penetrability is meant to provide a criterion for distinguishing different levels of the cognitive architecture. Only those processes that depend on semantically interpreted representations like beliefs and desires are subject to cognitive rules whereas processes that are cognitively impenetrable belong to the neurophysiological level and are subject to neurobiological laws, only. Based on these considerations, Pylyshyn presents a dilemma: mental images are either defined by intrinsic properties of the underlying representational medium, as the pictorialists claim. In this case they are cognitively impenetrable and should not be considered as functional states that are to be explained within cognitive science. Or mental image including the process of generating, inspecting, or transforming them, are determined by tacit knowledge. Then they are cognitively penetrable and better thought of as ►structural descriptions. Pylyshyn does not deny that people experience imagistic representations. His claim is only that if these representations are subject to cognitive science they must be cognitively penetrable and, therefore, have a propositional character. Appealing to these representations as tacit knowledge in explaining the empirical evidence about imagery allows then for the possibility that an imitation of the use of external pictures is responsible for the observed effects of mental imagery.
3. Pictorialists are not committed to identifying a spatial medium (e.g. a mental canvass) for mental imagery but only to the weaker claim that mental images are picture-like. Accordingly, various attempts have been made to avoid the problems Pylyshyn's tacit-knowledge-argument poses by defining mental images functionally [2,10]. However, those pictorialists who take the analogy between internal and external images literally, as Kosslyn does, are forced to identify some physical properties of the representing medium that preserve at least the

spatial relations. These accounts claim that mental imagery and perception share the same neurophysiological basis. The decisive feature of mental imagery can then be seen in its perceptual equivalence [3]. Perceptual equivalence means that similar neural mechanisms in the visual system are activated no matter whether an object is imagined or actually perceived. Within this framework, the difference between imagery and perception can be explained with respect to different sources of activation. Whereas imagery entails top-down activation of the visual buffer caused by memory, perception relies on bottom-up activation caused by sensory input. This claim includes a correlation of imagery processes with neural processes that are usually activated in visual perception. These patterns are retinotopically mapped, i.e., correspond to the retinal image [5]. It is generally agreed in cognitive neuroscience that three levels of perceptual representations can be distinguished. Empirical findings suggest that imagery is not to be identified with low level representations that are associated with the primary visual cortex but rather with intermediate level representations that are associated with regions in the extrastriate cortex. At the intermediate level, mental images are organized in units similar to Marr's 2.5-D sketches, but since mental images can be reinterpreted under special circumstances, descriptive, high level representations must be involved as well [10].

## References

1. Block N (1981) (ed) Imagery. Cambridge, MA
2. Tye M (1991) The imagery debate. Cambridge, MA
3. Finke RA (1989) Principles of mental imagery. Cambridge, MA
4. Kosslyn S (1980) Image and mind. Cambridge, MA
5. Kosslyn SM (1994) Image and brain: The resolution of the imagery debate. Cambridge, MA
6. Shepard RN, Cooper LA (1982) Mental images and their transformations. Cambridge, MA
7. Pylyshyn ZW (1981) The imagery-debate: analogue media versus tacit knowledge. Psychol Rev 87:16–45
8. Pylyshyn Z (2002) Mental imagery: in search of a theory, Behav Brain Sci 25(2):157–238
9. Paivio A (1971) Imagery and verbal process. New York
10. Gottschling V (2003) Bilder im Geiste. Die Imagery-Debate, Paderborn

---

## Image Schemata

### Definition

A mental pattern that abstracts away from a special viewpoint and, therefore, provides structured

understanding of the internal image relations such as spatial and part/whole-relations.

► **Mental Models**

## Imagery

► **Image-Mental**

## Imitation

### Definition

A behavior whereby an individual observes and replicates another's [behavior].

► **Imitation Learning**

## Imitation Learning

AKICHIKA MIKAMI

Primate Research Institute, Kyoto University, Inuyama, Japan

### Synonyms

Learning by imitation

### Definition

► **Imitation** learning is learning by imitation in which an individual observes an arbitrary behavior of a demonstrator and replicates that behavior.

### Characteristics

#### Imitation in Humans and Animals

Imitation is the copying of a novel behavior. Arbitrary or unusual activity by the demonstrator leads to the emittance of similar, previously unemitted behavior by the observer. The target behavior should not already be part of the observer's repertoire. However, ruling out the prior existence of a behavior is usually difficult. Then, imitation can be defined as a relatively large increase in the probability of the demonstrated

response, relative to that of an appropriate group that controls for all of the already-noted non-imitative causes of such behavior.

Although the word "imitation" can often be used in a broader meaning including the mimicry, imprinting, discriminated following or observational conditioning, in a more conservative meaning, imitation has been considered as an advanced behavior and a cognitive process. According to this view, imitation includes understanding of the behavior of the demonstrator and ability to reproduce that behavior. Imitation itself is not necessary to cooperate with learning. However, its effect often remains in each individual for a long period of time and it can contribute to the acquisition of a new behavior. Imitation is an efficient way to learn something new. It allows us to pass the experience of one individual on to others and it works more efficiently than trial-and-error learning. Imitation is especially effective in learning motor skills, such as, performing athletic sports or playing musical instruments. Imitation is also effective in learning creative works such as painting or composing music. Thus, imitation can work as part of a learning process. Imitation learning is also a core topic of research in robotics. Imitation learning may be a powerful mechanism for reducing the complexity of search spaces for learning and offer an implicit means of training a machine.

Neonatal imitation has been reported in macaques, chimpanzees as well as in humans. Macaques imitate lip smacking and tongue protrusion from the first day of birth (Ferrari et al. 2006). This neonatal imitation disappeared within 7 days. They did not imitate hand gestures. Chimpanzees imitate tongue protrusion and other facial expressions within 2 months. Neonatal humans can also imitate various facial expressions from the first day of birth. It lasts for 2–3 months and then disappears. If true imitation can occur in newborns, it suggests that the mechanisms responsible for imitation are probably not cognitively based. Since the neonatal imitation starts very early in life and lasts for only a short period of time, it must be different from the true imitation of adulthood. At the same time, it must also be different to a simple reflex. Infants may have the ability to actively compare the visual information about the seen body movement with the proprioceptive feedback from their own movement in space. Neonatal imitation could be a sort of cross-modal matching.

Imitation of gestures in adult animals has been reported in chimpanzees, macaque monkeys, dolphins and a number of avian species. Chimpanzees can learn to respond correctly to the command "Do this" over some classes of behaviors. This was first demonstrated by Hayes and Hayes (1952) and was then replicated by Custance et al. (1995). More recently, Myowa-Yamakoshi and Matsuzawa [1] instructed the performance of 48 arbitrary actions consisting of different

bodily motor patterns and object directionality. Their chimpanzees could imitate 6% of them. For them, an object directed toward another external location was easier than a single object alone. Actions involving unfamiliar motor patterns were also more difficult for them to perform than those involving familiar motor patterns that were already present in the subject's repertoire. Thus, the chimpanzees could imitate, but could not imitate as well as humans. Macaque monkeys cannot imitate in natural conditions. However, imitation can be induced by joint attention. Kamashiro et al. [2] trained monkeys to follow the gaze or the pointing gesture of an experimenter. Then they showed the tongue-protrusion, manual actions such as nose-touching, hand-closing, cotton-separation, knob-touching or box-opening. Their monkeys could copy these actions from the experimenter. This result indicates that macaque monkeys have the potential ability to imitate.

### Neural Basis of Imitation

Brain areas involved in imitation have been explored in brain imaging studies. The observation of actions done by others activates a complex network including occipital, temporal, and parietal visual areas. Two cortical regions whose function is fundamentally or predominantly motor are also activated. Those two regions are the rostral part of the inferior parietal lobule (area PF and PFG) and the lower part of the precentral gyrus plus the posterior part of the inferior frontal gyrus (IFG). These regions probably form the core areas for imitation.

When two conditions, observation-only and observation-execution were tested, the fMRI activation was stronger during imitation trials than during the motor trials in four areas: the left pars opercularis of the IFG, the right anterior parietal region, the right parietal operculum, and the right superior temporal sulcus (STS) region (Iacononi et al. 1999, 2001). STS activation was highest when there was a matching between the action that was prepared and the action that was observed. Later experiments emphasized the importance of Broca's area when the action to be imitated had a specific goal (Grezes et al. 2003). In more complex imitation learning, musically naïve participants were scanned during observation of guitar chords played by a guitarist, pause after the observation and execution of the observed chords [3]. Event-related activation in observation-to-imitate condition was found in the inferior parietal lobule and the posterior part of the inferior frontal gyrus plus the adjacent premotor cortex. During pause, the middle frontal gyrus (area 46) plus structures, dorsal premotor cortex, superior parietal lobule, rostral mesial areas were activated. They suggested the contribution of the interaction between these areas.

The neuronal basis of imitation learning is unknown. However, ►mirror neurons found in the premotor

cortex (F5, Fig. 1) and in the inferior parietal cortex (PF/PFG, Fig. 1) are considered to be able to contribute to imitation. A mirror neuron is a neuron which fires both when an animal performs an action and when the animal observes the same action performed by another animal.

Thus, the neuron "mirrors" the behavior of another animal, as though the observer were itself performing the action [5] (Gallese et al. 1996, 2002, Fogassi et al. 1998). Fig. 2 shows an example of a mirror neuron. This neuron fired when the experimenter grasped a piece of food with his hand and when the subject grasped a piece of food. The neuron also fired when the subject grasped it in the dark, implying that the visual input is not necessary to activate this neuron.

To imitate someone's behavior, the observer needs to understand the act of the demonstrator. Since the mirror neurons are active during observation of the specific behavior, these neurons can contribute to the cognitive process of that behavior. Since these neurons are also active during the action of that behavior, they can bridge from the cognition of the behavior to the execution of that behavior. In general, a single neuron with multiple properties can contribute to integration of different kinds of information. In the case of a mirror neuron, two kinds of information, visual and motor, share the same single neuron. Thus, a neuron can integrate visual cognition of the motor act and the execution of that motor act. Although the true imitation is rare in macaque monkeys, the existence of mirror neurons in monkeys may indicate their potential ability to imitate. From these considerations, although there is no direct evidence that mirror neurons contribute to imitation,

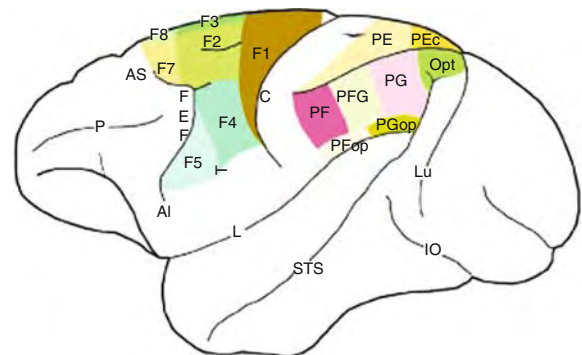

**Imitation Learning. Figure 1** Lateral view of the monkey brain. The shaded area shows the anatomical location of the rostral-ventral premotor cortex (F5) and the inferior parietal lobule (PF/PFG) where mirror neurons were recorded. AI, inferior arcuate sulcus; AS, superior arcuate sulcus; C, central sulcus; L, lateral fissure; Lu, lunate sulcus; P, principal sulcus; IO, inferior-occipital sulcus; STS, superior temporal sulcus (modified from Fig. 1 [4]).

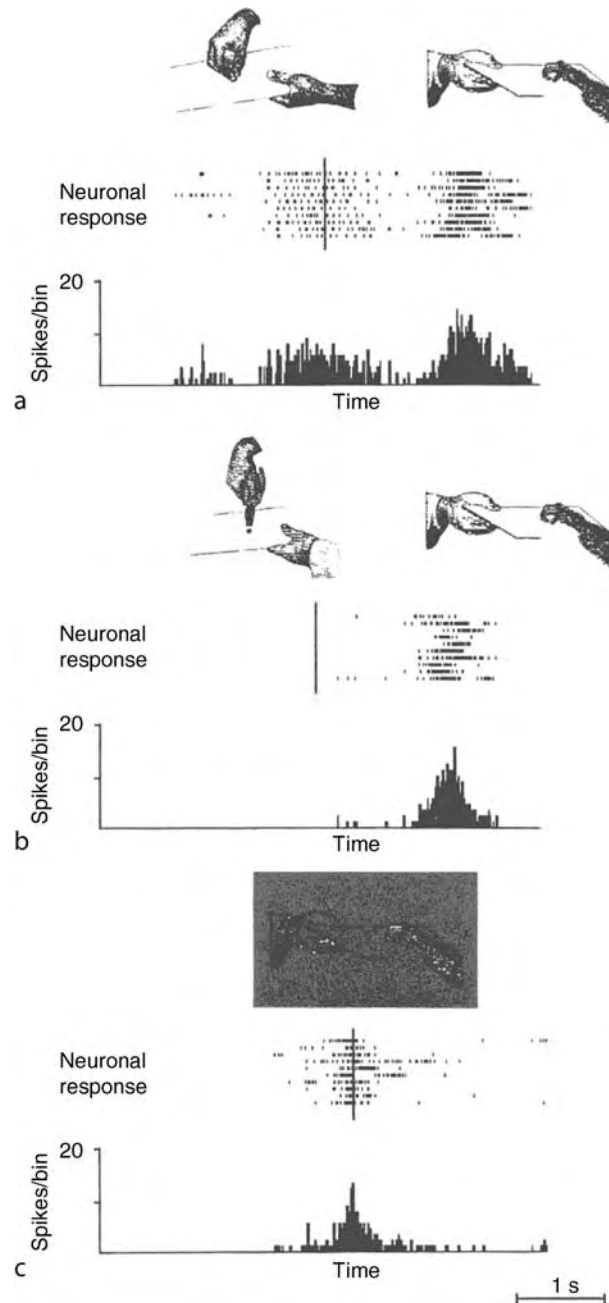

**Imitation Learning. Figure 2** Neuronal activities of a mirror neuron recorded in monkey F5. The behavioral situations are schematically represented in the upper part of each panel. In the lower part are shown a series of consecutive rasters and the peristimulus response histograms. a, the experimenter grasps a piece of food with his hand and moves it towards the monkey who, at the end of the trial, grasps it. The neuron discharges during grasping observation, ceases to fire when the food is moved and discharges again when the monkey grasps it. b, the experimenter grasps the food with a tool. Subsequent sequence of events as in a. The neuron response during action observation is absent. c, the monkey grasps food in the darkness. In a and b the rasters are aligned with the moment in which the food is grasped by the experimenter (vertical line across the rasters). In c the alignment is with the approximate beginning of the grasping movement (from Fig. 2 [1]).

mirror neurons can be candidate neurons to compose a neuronal circuit for imitation.

When the animal observed actions done by others, neurons in the superior temporal sulcus (STS) fired (Perrett et al., 1989, 1990). These neurons may also contribute to the generation of mirror neurons. Thus, the rostral portion of the ventral premotor cortex (F5), the inferior parietal lobule (PF/PFG) and STS can form a ► **mirror neuron system** in macaque monkeys. More recently, a brain-imaging study has revealed the activation in Area 45 and 46, in addition to F5, when monkeys were observing actions performed by others [6]. These areas may also be involved in imitation or ► **intention learning**.

There is no direct evidence for the existence of mirror neurons in humans. However, several brain areas activated during imitation are analogous to the areas where mirror neurons were recorded in monkeys. The brain areas activated during imitation in humans are often called the mirror neuron system. It has been suggested that mirror neurons might contribute to language acquisition. This idea is based on the fact that the area F5 of monkeys probably correspond to or overlaps with the Broca's area in humans. Imitation involves some degree of intentionality. The contribution of mirror neurons in ► **intentional attunement** has been also suggested. However, no plausible neural models have been put forward yet to describe how mirror neuron activity supports cognitive functions such as imitation learning, intention attunement or language acquisition. These topics are open for future research.

## References

1. Myowa-Yamakoshi M, Matsuzawa T (1999) Factors influencing imitation of manipulatory actions in chimpanzees (*Pan troglodytes*). *J Comp Psycho* 113:128–136
2. Kumashiro M, Ishibashi H, Uchiyama Y, Itakura S, Murata A, Iriki A (2003) Natural imitation induced by joint attention in Japanese monkeys. *Int J Psychophysiol* 50:81–99
3. Buccino G, Vogt S, Ritz A, Fink GR, Zilles K, Freund HJ, Rizzolatti G (2004) Neural circuits underlying imitation learning of hand actions: an event-related fMRI. *Neuron* 42:323–334
4. Rizzolatti G, Craighero L (2004) The mirror-neuron system. *Ann Rev Neurosci* 27:169–192
5. Rizzolatti G, Fadiga L, Gallese V, Fogassi L (1996) Premotor cortex and the recognition of motor actions. *Cog Brain Res* 3:131–141
6. Nelissen K, Luppino G, Vanduffel W, Rizzolatti G, Orban GA (2005) Observing others: multiple action representation in the frontal lobe. *Science* 310:332–336
7. Fogassi L, Ferrari PF, Gesierich B, Rozzi S, Chersi F, Rizzolatti G (2005) Parietal lobe: from action organization to intention understanding. *Science* 29:662–667
8. Oztop E, Kawato M, Arbib M (2006) Mirror neurons and imitation: a computationally guided review. *Neural Networks* 19:254–271
9. Buccino G, Binkofski F, Fink GR, Fadiga L, Fogassi L, Gallese V, Seitz RJ, Zilles K, Rizzolatti G, Freund HJ (2001) Action observation activates premotor and parietal areas in a somatotopic manner: an fMRI study. *Eur J Neurosci* 13:400–404
10. Gallese V (2006) Intentional attunement: A neurophysiological perspective on social cognition and its disruption in autism. *Brain Res* 1079:15–24

---

## Immediate Early Gene

### Definition

A gene whose expression can be triggered by specific kinds of inputs to cells and can, in turn, regulate expression of other genes. The genes that it regulates are not necessarily the same from one cell populations to another.

---

## Immune-based Therapy

### Definition

Treatment of acutely or chronically damaged tissue by harnessing an immune response, which facilitates the generation of a local response that supports cell survival and renewal and results in tissue regrowth.

---

## Immune Evasion

### Definition

Escape from immune surveillance.

#### ► Immune Surveillance

---

## Immune Surveillance

### Definition

Ability of the immune system to maintain vigilance for any deviation from homeostasis.



## Immune System

### Definition

A set of organs or parts in the body serving a particular function, namely defense of the internal environment against hostile exogenous agents (invading microorganisms) or endogenous factors (of physiological origin). It consists of two arms: “innate” immunity (natural killer cells, basophils, phagocytic cells including macrophages) that fights invading hostile agents without needing to specifically recognize them, and “adaptive” immunity (T and B lymphocytes), whose defensive activity requires specific recognition of the hostile agent.

## Immune System and Pain

LING CAO<sup>1</sup>, JOYCE A. DELEO<sup>2</sup>

<sup>1</sup>Department of Anesthesiology, Dartmouth-Hitchcock Medical Center, Lebanon, NH, USA

<sup>2</sup>Department of Pharmacology, Dartmouth-Hitchcock Medical Center, Lebanon, NH, USA

### Synonyms

Pain and immune system

### Definition

It has been gradually realized that although pain sensation, transmission and perception is mediated through a “wired” network of the nervous system; the immune system, the major host defense system in the body, is actively involved in every aspect of pain, including etiology, initiation and progression. Both traditional immune cells (circulating and tissue residing ►leukocytes) and nervous system resident glial cells (microglia, astrocytes and Schwann cells) are recognized as essential players in the pathophysiology of persistent pain states. In addition, it has become increasingly accepted that diseases of the immune system precipitate and enhance behavioral pain sensitivity (summarized in Fig. 1).

### Characteristics

#### Immunological Disorders Associated with Pain Symptoms

Immunological disorders are a significant cause of pathological pain. ►Autoimmune diseases are characterized by a dysregulation of an immune response that leads to the targeting of self components either in a

specific tissue/organ or systemically. Autoimmune diseases often lead to inflammation and pain, and are the leading causes of disability among the elderly in the United States.

Rheumatoid arthritis (RA) is a chronic destructive disease, featuring persistent inflammation in the synovium of peripheral joints in a symmetric distribution. The subsequent cartilage damage and bone loss in joints is the hallmark of the disease. Although the etiology is still unknown, abnormal immune responses targeting the joint are believed to be the significant players in the pathogenesis of RA. Infiltrating leukocytes, particularly activated CD4<sup>+</sup> T lymphocytes, CD8<sup>+</sup> T lymphocytes, B lymphocytes and ►macrophages are observed in the synovial membrane of the affected joints. Evidence indicates a key role of macrophage-produced proinflammatory cytokines such as tumor necrosis factor (TNF)- $\alpha$  and interleukin (IL)-1 $\beta$  in RA. These studies led to the concept and successful use of TNF- $\alpha$ -targeted treatments of RA in patients [1].

Multiple sclerosis (MS) is characterized as specific destruction of the CNS leading to demyelination and neurodegeneration. Pain is a common symptom in MS patients and moderate to severe pain may occur throughout the body. Due to the damage of pain processing systems in the CNS, it is often referred to as a central pain syndrome. The etiology of MS is still unknown, although a pathogenic mechanism of autoimmune responses targeting CNS myelin has been proposed and supported by animal models of MS and some clinical studies. Cytokines, including interferon (IFN)- $\gamma$ , TNF- $\alpha$ , IL-23 and IL-17, are positively associated with disease activity, while IFN- $\beta$  negatively modifies disease through its anti-inflammatory and/or immunosuppressive effects. Long-term IFN- $\beta$  administration has become the routine treatment for patients with relapsing remitting MS to reduce the frequency of relapses.

Diabetes mellitus (DM) is a metabolic disorder and one of its subtypes is caused by autoimmune responses targeting the insulin producing  $\beta$  cells of the pancreas. Diabetic neuropathies include polyneuropathy, mononeuropathy and polyradiculopathy, with symmetric polyneuropathy the most common form. Symmetric polyneuropathy often presents as a sensory disorder that starts in the extremities and spreads proximally. Neuropathy can be either acute or chronic and can be painful. In most cases, pain subsides eventually with the progression to anesthetic neuropathy.

Painful neuropathies associated with viral infectious diseases are most prevalent in human immunodeficiency virus (HIV) and reactive human ►herpes virus infections. HIV is a RNA retrovirus that specifically targets CD4<sup>+</sup> cells, resulting in a decrease in peripheral CD4<sup>+</sup> T lymphocytes, decreased immunity, and the development of the acquired immunodeficiency syndrome (AIDS). HIV-associated neuropathies include

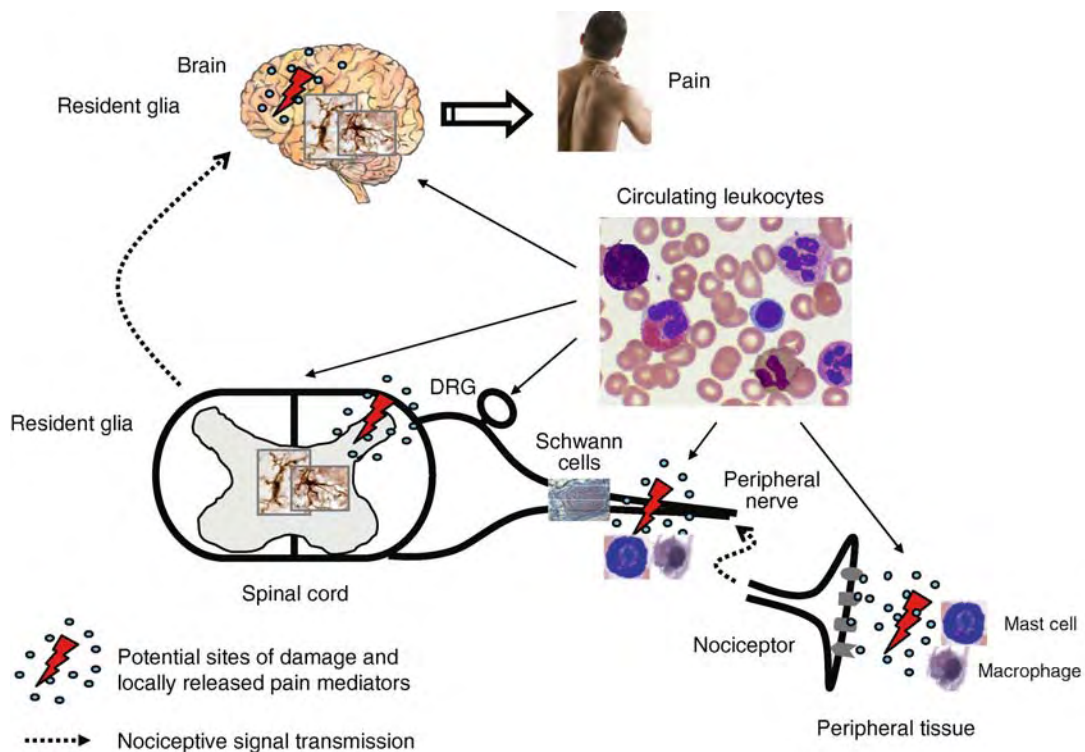

**Immune System and Pain. Figure 1** Overview of the immune system and pain processing. Pain is modulated via a neural/immune/glia network throughout the neuroaxis: nociceptors in the periphery, afferent nerves, sensory neurons in the DRG, and at the spinal cord and brain. Pain can be initiated by injury or disease localized at the peripheral tissue, nerve or in the CNS. Local resident immune cells (mast cells and macrophages surrounding the peripheral nerves or nerve terminals and glial cells in the nervous system), infiltrating leukocytes (both peripherally and centrally) and factors released by these cells can be actively involved in nociceptor activation, transmission to higher centers and perception.

HIV-associated distal symmetrical polyneuropathy (DSP), mononeuropathy and progressive polyradicularopathy. DSP is the most frequent neurological complication related to HIV infection and occurs in about one-third of patients with HIV infection. Similar to diabetic polyneuropathy, painful DSP is most prominent in the toes and soles of the feet in symmetrical distribution. DSP is often correlated with advanced stages of HIV infection, low CD4<sup>+</sup> T lymphocyte count and high plasma HIV loads. Anti-viral treatments, particularly dideoxynucleoside, have also been shown to be risk factors in DSP development.

Herpes simplex virus (HSV) and varicella-zoster virus (VZV) are human DNA herpes viruses that can be maintained in neurons after primary infection and cause recurrent infection upon reactivation. Both primary and recurrent HSV infections are related to painful mucosal and skin ulcerative lesions. Recurrent VZV infection, herpes zoster or shingles, involves localized skin lesions and severe pain along the distribution of affected nerves. A painful condition, known as postherpetic neuralgia, can last long after healing of the skin lesions. It is interesting to note that stress and immunosuppressants

can induce viral reactivation, however the underlying mechanisms are unknown.

#### Peripheral and CNS Immune Mechanisms of Pain

Immune cells involved in the pathophysiology of pain include leukocytes that act at peripheral or CNS sites such as the dorsal root ganglia (DRG), spinal cord and activated nervous system resident glia (i.e. Schwann cells, microglia and astrocytes). Immune factors released by these cells include but are not limited to cytokines (proinflammatory cytokines are particularly important in the development of pain) and chemokines.

#### Tissue Resident and Infiltrating Leukocytes

The tissue leukocytes involved are mainly ►mast cells and leukocytes that have long been known to mediate allergic reactions. Mast cells can be activated by damaged peripheral nerve and non-nerve tissue, and quickly release substances stored in their cytoplasmic granules. Several of these substances, including histamine, proteases and cytokines, can sensitize nociceptors and activate sensory afferent neurons, as well as recruit circulating leukocytes into the injured

site [2]. Circulating leukocytes can penetrate blood vessels and enter into the site of tissue damage upon injury or disease, becoming infiltrating leukocytes. The major types of infiltrating leukocytes are ►neutrophils, macrophages and T lymphocytes. All of these have been identified as present in peripheral nerve and DRG following nerve injury. Studies depleting a subtype of leukocytes, or using mutant rodents that lack a particular leukocyte subset or the ability to recruit leukocytes into injured sites, highlight the critical roles of infiltrating leukocytes in pain genesis [2]. Interestingly, infiltrating leukocytes with either macrophage or T lymphocyte morphology have also been detected in the spinal cord following peripheral nerve injury [3]. Infiltrating leukocytes can either act independently by releasing cytokines, chemokines and reactive oxygen species (such as nitric oxide) or function through an interaction with CNS resident cells (microglia and astrocytes) to enhance pain sensitivity.

Neutrophils and macrophages are cells involved in the non-specific, first-line defense of innate immunity (►innate immune responses), while T lymphocytes are cells within the ►adaptive immunity arm and are capable of specific recognition. Microglia have been shown to express increased content of the major histocompatibility complex class II (MHC class II). This molecule is involved in specific ►antigen presentation to T lymphocytes in ►adaptive immune responses, in a rodent nerve transection-induced neuropathic pain model. Also, MHC class II knockout mice exhibit decreased pain-like behavior post-nerve injury. These results led to the postulation that self antigens may be liberated after nerve injury and these antigens can specifically activate the adaptive immune responses mediated by T lymphocytes.

### **CNS Resident Immune and Glial Cells**

CNS immune cells include microglia which are bone marrow and monocyte derived and are the intrinsic macrophages in the CNS. As the first cellular defense in the CNS, microglia respond to a tissue disturbance by migrating towards the site of injury, proliferating to amplify their capacity to respond, phagocytosing any dead cells and debris, expressing certain activation surface molecules, and releasing soluble factors such as cytokines and chemokines. Activated microglia have been observed in multiple animal models of neuropathic pain as well as in animal models of MS. Mediators including ATP, bradykinin, substance P and prostaglandins have been shown to be able to activate microglia [2]. Minocycline, a microglial-inhibiting agent, is effective in both preventing [4] and reducing existing [5] pain-like behaviors in rodents after peripheral nerve transection and spinal cord injury, respectively. These studies indicate a role of microglia in both pain initiation and maintenance. Microglia have been shown *in vitro* to

release cytokines and chemokines and to interact with other effector cells via increased expression of some surface molecules such as MHC class II. Additionally, signaling through microglial receptors P2X4 and toll-like receptor 4 (TLR4) has been reported to be critical in the development of neuropathic pain and may be involved in the initial activation of microglia after nerve injury [6,7].

Astrocytes, derived neuro-ectodermally, play a role in maintaining CNS homeostasis and have been recognized to possess various immune features, including immune marker expression, antigen presentation, and production of cytokines and chemokines. Thus, astrocytes can be viewed as “immunocompetent cells.” Increased glial fibrillary acidic protein (GFAP) expression due to a hypertrophic response of astrocytes (thought to be sign of astrocytic activation) is reported in multiple animal models of pain. Non-specific glial modulators such as fluorocitrate are effective in preventing and reversing existing pain behaviors accompanied by decreased spinal GFAP expression in rodent models of pain. However, because specific glial inhibitors are not currently available, it is difficult to determine the role of distinct glia in pain etiology. It has been suggested that astrocytes may be more involved in the maintenance of neuropathic pain since GFAP and S100B (another protein expressed by astrocytes) demonstrate a delayed but sustained spinal expression after nerve injury. Non-immune functions of astrocytes, such as neurotransmitter regulation through glutamate transporter regulation, have also been implicated in pain processing [8]. Schwann cells which provide the myelin sheath for axons in the peripheral nervous system have also been reported to exhibit immune functions, including the production of algescic factors (such as TNF- $\alpha$  and IL-1 $\beta$ ). More recently, direct support of Schwann cell-producing TNF- $\alpha$  has been demonstrated in nerve injury-induced neuropathic pain [9].

### **Proinflammatory Cytokines**

IL-1 $\beta$ , TNF $\alpha$  and IL-6, produced by neutrophils, mast cells and macrophages, are critical mediators in acute and chronic inflammatory responses. They are also well-known algescic factors and can be detected at the site of injury of most painful disorders. Administration of these cytokines can produce pain-like behaviors, while neutralizing them can prevent or reduce these behaviors in animals. In addition to their role in active recruitment of circulating leukocytes, proinflammatory cytokines dose dependently affect the sensitivity of nociceptors in the periphery and interfere with pain processing in the CNS. Several mechanisms on how proinflammatory cytokines promote pain have been proposed: (i) Interaction with specific cytokine receptors expressed on nerve terminals and somata (such as receptors for IL-1 and TNF $\alpha$ ), which induces a cascade of signaling events within the neuron and increases their excitability to noxious stimuli; (ii) Mediating production

of other algescic factors (e.g. prostaglandin E<sub>2</sub> (PGE<sub>2</sub>) by IL-1β) that can act on their receptors on nerve terminals to further sensitize nociceptive responses; and (iii) Non-membrane receptor-mediated pathways have also been observed. For instance, IL-6/soluble IL-6 receptor complex has been shown to directly shift the activation threshold of nociceptors to noxious stimuli. A TNFα trimer can insert itself into the cell membrane and form a nonspecific cation channel, modifying sensory signal transduction. Other cytokines such as IFN-γ can contribute to the inflammatory responses and has also been implicated in T lymphocyte-mediated pain-like behaviors in rodents.

### Chemokines

Chemokines are chemotactic cytokines that are small secreted proteins which attract leukocytes into the site of tissue damage in a local inflammatory response. Strategies involving the use of chemokine receptor knockout mice and the administration of neutralizing antibodies confirm the involvement of chemokines in pain. Several chemokines, including monocyte chemoattractant protein-1 (MCP-1, CCL2), RANTES (regulated on activation, normal T cell expressed and secreted, CCL5) and fractalkine (CX3CL1), have been vigorously investigated for their roles in the pathophysiology of pain. Chemokines serve their functions in pain development, not only by recruiting leukocytes into the injury site, but also through several unique mechanisms [10]: (i) Sensory neurons in DRG express receptors for various chemokines, and ligation of these chemokine receptors can reduce DRG's threshold in responding to noxious stimuli resulting in hyperalgesia; (ii) The chemokine CCL3 can cross-sensitize the transient receptor potential vanilloid 1 (TRPV1) cation channel commonly expressed on nociceptive neurons and required for certain types of thermal hyperalgesia; and (iii) CNS-released fractalkine can bind to receptors expressed by microglia and enhance proinflammatory effects in the CNS.

In conclusion, peripheral and CNS immune responses are actively involved in every aspect of pain, including both acute and persistent pain as well as pain resulting from immunological disorders. Modulation can occur throughout the neuroaxis from peripheral nociceptors to sensory processing at all levels of the CNS. Targeting these specific immune responses and cell types may yield novel drug targets for the treatment of pathological pain conditions.

### References

1. Moreland LW (2004) Drugs that block tumour necrosis factor: experience in patients with rheumatoid arthritis. *Pharmacoeconomics* 22 (2 Suppl):39–53
2. Moalem G, Tracey DJ (2006) Immune and inflammatory mechanisms in neuropathic pain. *Brain Res Brain Res Rev* 51(2):240–264

3. Sweitzer SM, Hickey WF, Rutkowski MD, Pahl JL, DeLeo JA (2002) Focal peripheral nerve injury induces leukocyte trafficking into the central nervous system: potential relationship to neuropathic pain. *Pain* 100 (1–2):163–170
4. Raghavendra V, Tanga F, DeLeo JA (2003) Inhibition of microglial activation attenuates the development but not existing hypersensitivity in a rat model of neuropathy. *J Pharmacol Exp Ther* 306(2):624–630
5. Hains BC, Waxman SG (2006) Activated microglia contribute to the maintenance of chronic pain after spinal cord injury. *J Neurosci* 26(16):4308–4317
6. Tanga FY, Natile-McMenemy N, DeLeo JA (2005) The CNS role of Toll-like receptor 4 in innate neuroimmunity and painful neuropathy. *Proc Natl Acad Sci USA* 102(16):5856–5861
7. Tsuda M, Shigemoto-Mogami Y, Koizumi S, Mizokoshi A, Kohsaka S, Salter MW, Inoue K (2003) P2X4 receptors induced in spinal microglia gate tactile allodynia after nerve injury. *Nature* 424(6950):778–783
8. De Leo JA, Tawfik VL, LaCroix-Fralish ML (2006) The tetrapartite synapse: path to CNS sensitization and chronic pain. *Pain* 122(1–2):17–21
9. Campana WM, Li X, Shubayev VI, Angert M, Cai K, Myers RR (2006) Erythropoietin reduces Schwann cell TNF-alpha, Wallerian degeneration and pain-related behaviors after peripheral nerve injury. *Eur J Neurosci* 23(3):617–626
10. White FA, Bhangoo SK, Miller RJ (2005) Chemokines: integrators of pain and inflammation. *Nat Rev Drug Discov* 4(10):834–844

---

## Immunocytochemical Techniques

### Definition

This is a set of techniques for using antibodies to visualize the location and distribution of target molecules in cells or tissue. Typically these techniques consist of two steps. First, the cells or tissue are treated with a solution containing an antibody, called the primary, for the target molecule. These primary antibody molecules adhere specifically to the target molecule. Second, the cells or tissue are treated with a solution containing a fluorescent molecule, called the secondary, that adheres specifically to the antibody. Thus after both steps the target molecule is marked with a fluorescent molecule.

---

## Immunocytochemistry

### Definition

The techniques of using selective antibodies to visualize the distribution of a specific protein within cells.

## Immunoglobulin Superfamily Cell Adhesion Molecules

YOSHIHIRO YOSHIHARA  
RIKEN Brain Science Institute, Wako, Saitama, Japan

### Definition

Cell surface molecules that contain one to several ►immunoglobulin-like domains (Ig-like domains) in their extracellular region and that play roles in various cell-cell interaction events such as recognition, adhesion and signal transduction. Ig superfamily cell adhesion molecules (IgCAMs) comprise one of the largest gene families in the genome of various animal species.

### Characteristics Structures

The Ig-like domain is composed of 70–110 amino acid residues and has a globular structure containing two  $\beta$ -sheets, each of which consists of 3–5 anti-parallel  $\beta$ -strands. A hallmark of typical Ig-like domains is the presence of two conserved cysteine residues forming a disulfide bond that stabilizes the overall domain structure [1,2].

Most IgCAMs are type I integral membrane proteins composed of an N-terminal signal peptide, an extracellular region with Ig-like domains, a single transmembrane segment and a C-terminal cytoplasmic region. The extracellular regions of IgCAMs are the principal site of trans- and cis-interactions with molecules on the target cell membrane or on the same cell surface, respectively. The cytoplasmic regions play crucial roles in intracellular signal transduction and association with cytoskeletal proteins. Several IgCAMs lack the transmembrane/cytoplasmic regions and are attached to plasma membrane through another type of linkage structure, a glycosylphosphatidylinositol (GPI)-anchor. The GPI-anchoring structure may offer several advantageous properties to cell recognition/adhesion molecules, such as restricted localization in a specialized membrane compartment called a lipid raft, higher lateral mobility in plasma membrane compared with transmembrane proteins and GPI-specific phospholipase D-mediated release into the extracellular space, resulting in either turning off the switch for cell-cell interactions or producing soluble forms which might function as signal-transducing ligands or dominant-negative molecules.

Neural IgSF molecules can be classified into four groups based on their domain organization (Fig. 1). Group I includes molecules whose extracellular regions consist exclusively of Ig-like domains. The smallest molecules in the group I are P0 and Thy-1 that possess

only one Ig-like domain, while the largest one is ►telencephalin with nine tandemly arranged Ig-like domains. Group II includes molecules whose extracellular regions contain several Ig-like domains and fibronectin type III (FnIII) domains. Crystallographic studies revealed that the secondary structure of the FnIII domain is highly homologous to that of the Ig-like domain, having two opposing  $\beta$ -sheets with four and three antiparallel  $\beta$ -strands. Most of the IgCAMs belonging to group II are localized on axonal surfaces, as represented by L1, TAG-1, Robo and DCC. Group III consists of molecules that possess tyrosine kinase (TK) or tyrosine phosphatase (TP) domains in the cytoplasmic region. Hence the molecules belonging to group III are signal-transducing receptors for secretory ligands such as growth factors and neurotrophic factors. Group IV includes molecules whose extracellular regions contain Ig-like domains and other motifs such as a thrombospondin domain, a Sema domain, EGF-like repeats or a MAM domain.

### Functions

Neural IgCAMs play extremely diverse roles in various cell-cell interaction events in both the developing and mature brains. This review focuses on three important functions of IgCAMs, cell adhesion, axon guidance and dendritic development and synapse formation.

### Cell Adhesion

Many IgCAMs act as cell adhesion molecules. The mode of adhesion mediated by Ig-like domains is divalent and cation-independent, whereas other neural adhesion molecules such as cadherins and integrins require  $\text{Ca}^{2+}$  or  $\text{Mg}^{2+}$  for their adhesive functions. One of the representative structures in which IgCAMs play important roles as adhesion molecules can be seen at the sites of myelination of axons (Fig. 2a).

The compaction of myelin is mediated by P0, the smallest IgCAM as well as the most abundant structural protein of the peripheral myelin sheath of Schwann cells. A myelinated axon is compartmentalized into four segments, node, paranode, juxtaparanode and internode. Distinct sets of IgCAMs belonging to group II are involved in axon-myelin adhesion in these different segments, NrCAM and neurofascin-186 at the nodes, ►contactin and neurofascin-155 at the paranodes and TAG-1 at the juxtaparanodes. Perturbation of these IgCAM functions results in abnormal localization of ion channels and cytoplasmic adaptor molecules at the individual axon-myelin contact sites [3]. Other types of cell adhesion events mediated by IgCAMs in the nervous system include axon fasciculation and synapse stabilization.

### Axon Guidance

During development, newly generated neurons extend axons toward their target regions through a series of

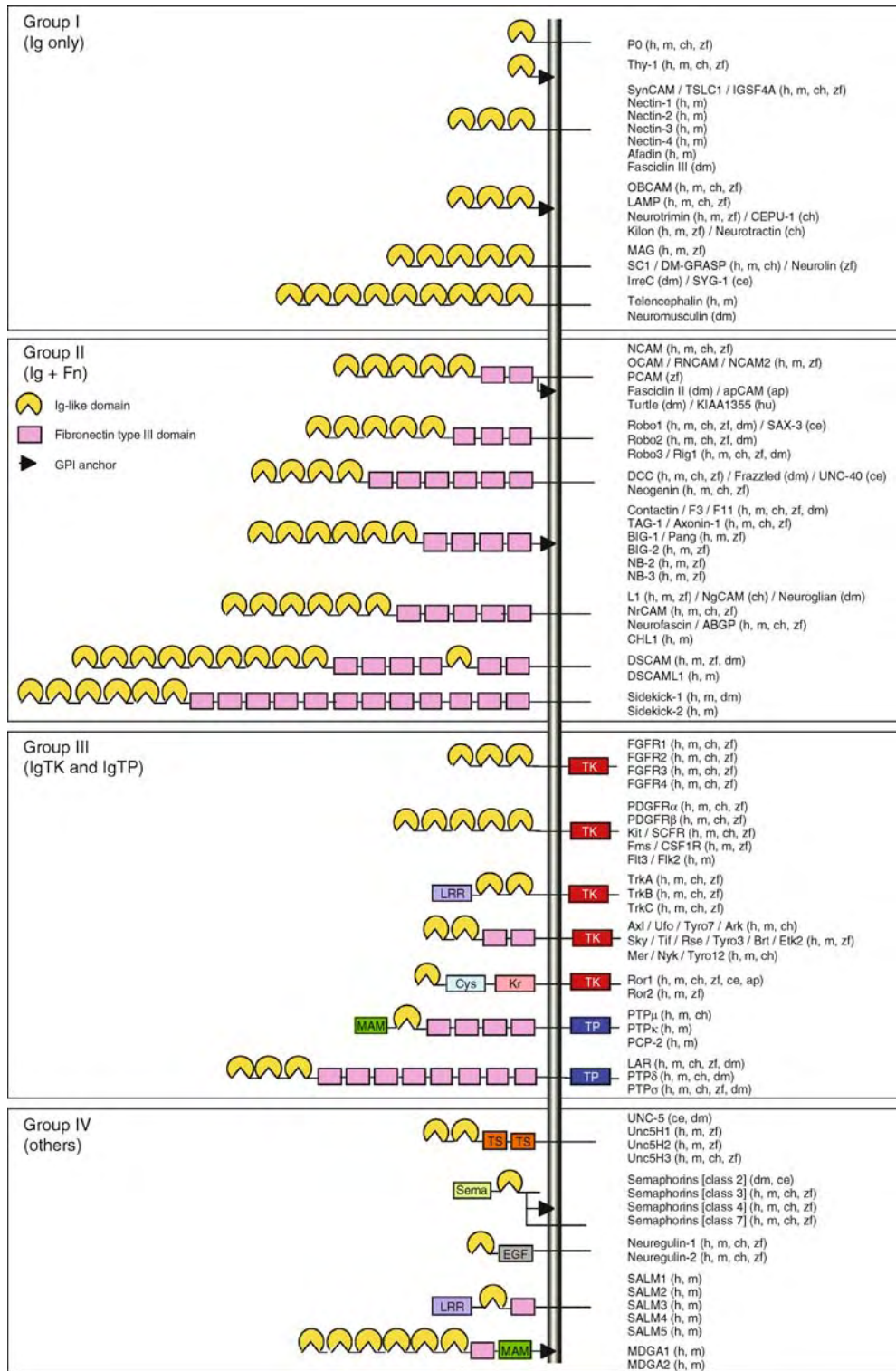

**Immunoglobulin Superfamily Cell Adhesion Molecules. Figure 1** Structures and classification of neural Ig superfamily molecules. Ig-like domain, yellow symbol; FnIII domain, pink rectangle; GPI anchor, arrowhead. Cys cysteine-rich domain; EGF epidermal growth factor-like repeat; LRR leucine-rich repeat; Kr Kringle domain; Cys meprin/A5/protein tyrosine phosphatase  $\mu$  domain; Sema semaphorin domain; TS thrombospondin domain; h human; m mouse; ch chick; zf zebrafish; dm Drosophila melanogaster; ce C. elegans; ap Aplysia.

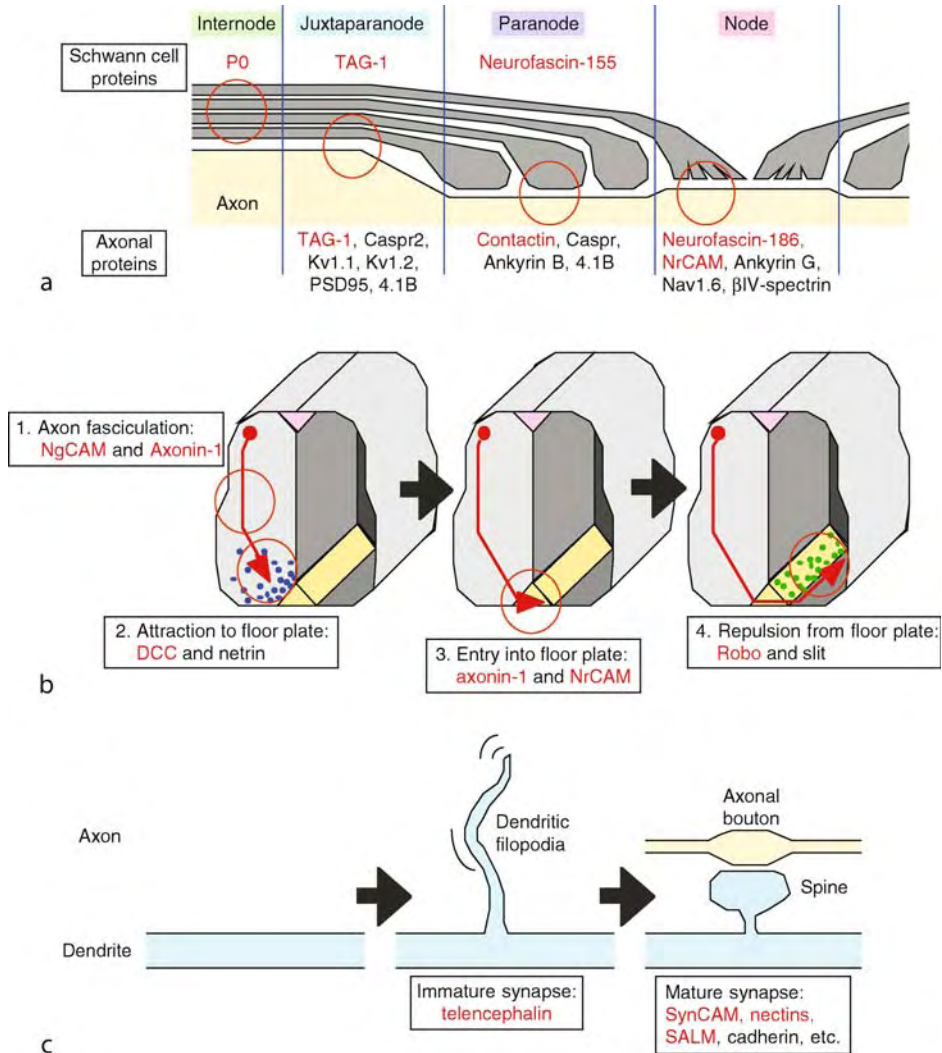

**Immunoglobulin Superfamily Cell Adhesion Molecules. Figure 2** Various functions of neural Ig superfamily molecules. (a) IgCAMs involved in myelin compaction and myelin-axon interactions. (b) IgCAMs involved in axon guidance of commissural neurons in the spinal cord. (c) IgCAMs involved in dendritic morphogenesis and synapse formation.

events called chemoattraction and chemorepulsion and make synaptic connections with appropriate partner cells. In recent decades, a number of secreted factors and receptors that promote axon elongation and/or that guide axonal growth cones to correct target regions have been identified. In particular, the commissural neurons in the spinal cord provided a good model for studies of molecular mechanisms of axon guidance (Fig. 2b) [4]. Several IgCAMs are expressed in developing chick commissural neurons, including axonin-1 (TAG-1), NgCAM (L1), DCC and Robo. The commissural neurons located in the dorsal spinal cord project axons toward the ventral midline structure, the floor plate. The fasciculation of commissural axons is mediated by the interaction between NgCAM and axonin-1.

The floor plate produces a chemoattractant, netrin-1, which acts on its receptor DCC expressed at the growth cones of commissural axons. The entry of commissural axons into the ventral midline structure is dependent on the interaction between axonin-1 on the axons and NrCAM on the floor plate. Once having crossed the midline, the commissural axons never recross the midline owing to a mechanism mediated by a chemorepellent, Slit, which is released from the floor plate and which acts on its receptor Robo on the growth cones of axons that have crossed. Thus, IgCAMs play different and important functions at multiple steps of commissural axon guidance. Other examples of IgCAM functions in axon guidance process have been reported for myelin-associated glycoprotein (MAG) as an

inhibitor of axon outgrowth acting on Nogo receptor [5], for Unc5H as a receptor on the trochlear motor axons for the chemorepellent netrin-1 [5], for Robo2 as an crucial molecule for olfactory axon guidance in zebrafish [7] and for TAG-1, DCC, Thy-1, OCAM, Robo and ▶L1 as differentially expressed markers of mitral cell axons in the developing lateral olfactory tract [8].

### Dendritic Development and Synapse Formation

Not only in axon guidance, but also in dendritic development, IgCAMs play several important roles. In particular, several IgCAMs have been identified that function in processes of dendritic filopodium formation, spine maturation and synaptogenesis (Fig. 2c). Telencephalin (TLCN; ICAM-5) is the sole neuronal member belonging to the ICAM subgroup of the Ig superfamily. It is expressed specifically by spiny neurons within the most rostral brain segment, the telencephalon. In the telencephalic neurons, TLCN is selectively localized to the somatodendritic compartment and not to axons. During development, TLCN is abundantly present on the ▶dendritic filopodia (precursors of spines), but is mostly excluded from mature spines. The over-expression of TLCN causes an increase in dendritic filopodia, while the loss of TLCN induces accelerated maturation of spiny synapses [9]. Therefore, TLCN regulates dendritic morphogenesis as a negative regulator of spine maturation. On the contrary, multiple IgCAMs function as positive regulators of synaptogenesis, including SynCAM, nectins and SALM2, together with cadherin family proteins [10]. The balance between positive and negative regulation of spine maturation by TLCN and SynCAM/nectins/SALM/cadherins respectively, may be important for the formation of appropriate synapses during the critical period of brain development.

### References

- Brümmendorf T, Rathjen F (1994) Protein profile: cell adhesion molecules 1: immunoglobulin superfamily. Academic Press, London
- Yoshihara Y, Oka S, Ikeda J, Mori K (1991) Immunoglobulin superfamily molecules in the nervous system. *Neurosci Res* 10:83–105
- Corfas G, Velardez MO, Ko CP, Ratne N, Peles E (2004) Mechanisms and roles of axon-Schwann cell interactions. *J Neurosci* 24:9250–9260
- Stoeckli ET, Landmesser LT (1998) Axon guidance at choice point. *Curr Opin Neurobiol* 8:73–79
- McKerracher L, Winton MJ (2002) Nogo on the go. *Neuron* 36:345–348
- Colomarinno SA, Tessier-Lavigne M (1997) The axonal chemoattractant netrin-1 is also a chemorepellent for trochlear motor axons. *Cell* 81:621–629
- Miyasaka N, Sato Y, Yeo SY, Hutson LD, Chien CB, Okamoto H, Yoshihara Y (2005) Robo2 is required for establishment of a precise glomerular map in the zebrafish olfactory system. *Development* 132:1283–1293
- Inaki K, Nishimura S, Nakashiba T, Itoharu S, Yoshihara Y (2004) Laminar organization of the developing lateral olfactory tract revealed by differential expression of cell recognition molecules. *J Comp Neurol* 479:243–256
- Matsuno H, Okabe S, Mishina M, Yanagida T, Mori K, Yoshihara Y (2006) Telencephalin slows spine maturation. *J Neurosci* 26:1776–1786
- Takai Y, Shimizu K, Ohtsuka T (2003) The roles of cadherins and nectins in interneuronal synapse formation. *Curr Opin Neurobiol* 13:520–526

---

## Immunogold Labeling

### Definition

This is a method for labeling target molecules in cells or tissue with gold molecules to make their location and distribution visible in electron microscopes.

---

## Immunohistochemistry

### Definition

It is a method allowing the detection of specific proteins in a tissue slice by using specific antibodies following several steps. First step consists of binding between a specific primary antibody and specific antigen. Second step requires a secondary antibody which binds to the previously formed antigen-antibody complex, this antibody is either enzyme- or fluorophore-conjugated.

Third step concerns the enzyme-conjugated antibody where the enzyme forms a colored deposit at the site of antigen-antibody binding in the presence of substrate and chromogen.

---

## Immunomodulation, Brain Areas Involved

DANUTA WRONA

Department of Animal Physiology, University of Gdansk, Gdansk, Poland

### Definition

Brain immunomodulation; Discrete brain area modulation of the immune response resulting in immunoenhancement or immunosuppression.



## Characteristics

### Bidirectional Neuroimmune Communications

Recent evidence has shown that there are bidirectional (Fig. 1) circuits between the central nervous system (CNS) and immune system [1]. The CNS can have far-reaching effects on the immune system after activating the hypothalamic-pituitary-adrenal (HPA) axis [2] and the sympathetic nervous system (SNS). Recent evidence has shown the importance of the acetylcholine-secreting neurons within the parasympathetic nervous system, which suppress acute inflammation and is termed the *inflammatory reflex* or *cholinergic anti-inflammatory pathway* [3]. The immune system, in turn, may communicate with the CNS through immune products, primarily cytokines leading to the direct activation of the CNS [2] or to the release of CNS-derived cytokines. Moreover, immune cells synthesize and secrete hormones, neurotransmitters and neuropeptides, similar to those released from the CNS, which react with the receptors in the common immune and central nervous systems. In addition, recent findings [4] indicate that the CNS responds to systemic bacterial infections with innate immune reactions without the pathogen's direct access to the brain.

### Brain Immunoregulation

In ►neuroimmunomodulation research, some investigators have taken a neuroanatomical approach, evaluating the role the CNS (brain) plays in modulation of immune reactivity. Studies utilizing ►brain lesions or ►brain stimulation suggest that specific regions of the brain may modulate immune activity (Fig. 1).

### The Hypothalamic Immunomodulation

It has been shown that the intact preoptic and anterior part of the hypothalamus (ah) and paraventricular nucleus of the hypothalamus (pvn) which represents an integral part of the neuro-endocrine circuit may be important for normal humoral and cell-mediated immune functions. Lesions of the ah usually evoked decreased immune function whereas stimulation of the ah increased it, which suggests the immunoenhancing effect of ah via endocrine and/or sympathetic activity systems. Moreover, pvn is proposed as an integrative center for immunomodulation.

### Emotion and Immunomodulation

Recently, it was shown that discrete brain areas related to emotionality influence the immune response. The positive or negative emotional state of the man or animal may influence immunological parameters via the limbic-hypothalamic circuits representing the neurophysiological background of emotionality. The structures of “the ►brain reward system” related to positive reinforcement such as the lateral hypothalamus

(lh) and ventral tegmental area (vta) have a beneficial effect on immune response, including antiviral and antitumor cytotoxic activity of natural killer cells (NKCC) and the behavioral outcome of lh/vta stimulation may influence the immunoenhancing effect of these structures. In parallel with stereotaxic methods, it was demonstrated that lh is closely related to an increase of NK cell activity induced by electroacupuncture, which when delivered through lh enhances or restores the splenic NKCC suppressed by anterior hypothalamic area lesions in rats.

On the other hand, it was suggested that immune suppression, including decreased NKCC obtained from the stimulation of the midbrain dorsal part of the periaqueductal gray matter (pag) or ventromedial hypothalamic nucleus (vmh), is due primarily to the ►stimulation-bound aversive effect of stimulating these structures. Interestingly, how such behaviorally opposite structures like LH and VMH influence the immune system are polarized: stimulation of LH increases immune response while stimulation of VMH decreases it.

### Limbic System and Immunomodulation

Parts of the limbic system related to emotions are differently involved in modulating the immune function. Lesions within the amygdaloid complex and hippocampus have generally enhanced several immune parameters while lesions of either the medial septum or bed nucleus of stria terminalis regions (bnst) inhibited T-lymphocyte proliferation, and decreased the number of peripheral blood leukocytes, and peripheral blood NKCC. The limbic effects on the immune system were mediated through the neuroendocrine axis. Moreover, it is known that both striatal and mesolimbic dopaminergic pathways are asymmetrically involved in neuroimmunomodulation.

### Neocortex and Immunomodulation

Brain asymmetry in neuro-immunomodulation also concerns the cerebral cortex influence on immune responses. These data yield interesting correlations with handedness and the increased incidence of early dyslexia, together with the development of autoimmune diseases in left-handed individuals. It has been shown [5] that there is a direct neocortical influence on the migration of mature T cells from the thymus mediated by the sympathetic nervous system and, therefore, proposed that a cortically derived neurothymic circuit regulates thymic production of mature CD4<sup>+</sup> and CD8<sup>+</sup> T cells. In addition, it seems that neocortical-dependent functions, such as attitudes, hopes and spiritual resources, may neutralize the effects of extreme stress thereby shaping the immunological mechanisms involved in the maintenance of health.

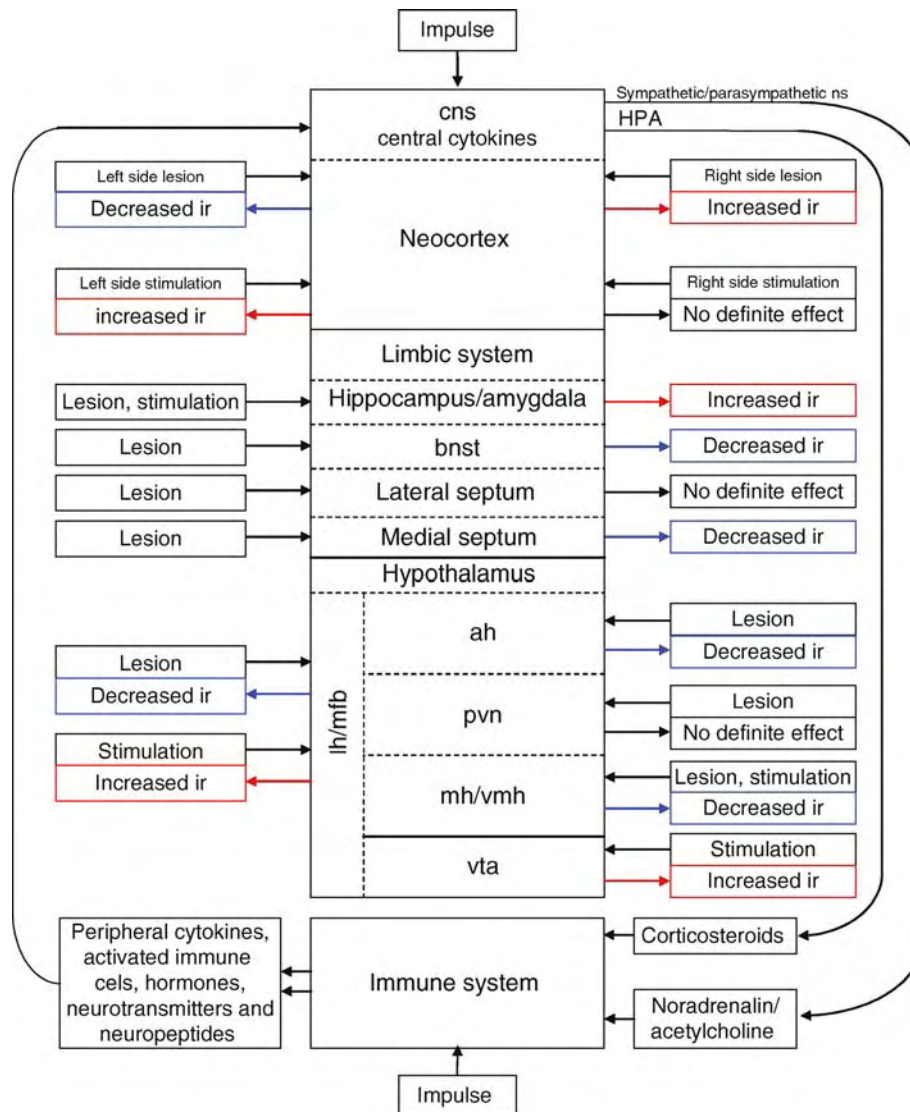

**Immunomodulation, Brain Areas Involved. Figure 1** The scheme of bidirectional communication between the central nervous and immune systems including the results of stereotaxic method used to study the location of brain areas involved in immunoregulation. Stimulation or lesion (ablation) of various regions of the brain can, depending upon the region, inhibit or enhance immune responses. Cytokines, neurotransmitters, neuropeptides represent the signaling molecules relaying chemical information and depending on the stimulus either neurons or immune cells can be the initial source. The chemical information in turn can be received by both neurons and leukocytes since they share receptor repertoires. Abbreviations: CNS, central nervous system; HPA, hypothalamic-pituitary-adrenal axis; IR, immune response; BNST, bed nucleus of stria terminalis; AH, anterior hypothalamus; PVN, paraventricular nucleus of the hypothalamus; MH/VMH, medial hypothalamus/ventromedial nucleus of the hypothalamus; LH/MFB, lateral hypothalamus/medial forebrain bundle; VTA, ventral tegmental area; red arrow and box, immunoenhancing effect of lesion or stimulation; blue arrow and box, immunosuppressive effect of lesion or stimulation; black arrow and box, no definite effect of lesion or stimulation.

### Blood-Brain-Barrier, Circumventricular Organs and Immunomodulation

Cytokines are the major mediators in bidirectional interactions. Circulating cytokines could enter the brain through areas with a poorly developed blood-brain-barrier (BBB) or can be actively transported. The

►circumventricular organs (CVOs) which are not homogenous, but consist of distinct regions, are a likely route through which signals from the periphery area are transmitted into the CNS by afferent and efferent nerves or the translocation of substances. The concept of afferent nerve transmission is well

documented for vagus, which provides another pathway for communication between the immune and nervous systems [6]. As the barrier pathways, the vagal input, and the CVOs are all represented in the area postrema, this small anatomical area could play a significant role in neuro-immune communication [7].

### Conclusions

The mutual functional relationship between the CNS and immune systems has been intensively studied with the perspective of immunity pharmaceutically through the modulation of selective brain functions in clinical practice. The “immunoreactive” brain areas include the hypothalamic nuclei, “brain reward system”, limbic structures, cortex, midbrain PAG, cerebellum, circum-ventricular organs and vagal complex. The brain structures related to positive reinforcement (“brain reward system”), positive attitudes and hopes (limbic structures and neocortex) have beneficial effects on immune response which may neutralize the effects of extreme stress and offer a new direction for therapy in immune disorders.

### References

1. Wrona D (2006) Neural-immune interactions: an integrative view of the bidirectional relationship between the brain and immune systems. *J Neuroimmunol* 172:38–58
2. Haddad JJ, Saade NE, Safieh-Garabedian B (2002) Cytokines and neuro-immune-endocrine interactions: a role for the hypothalamic-pituitary-adrenal revolving axis. *J Neuroimmunol* 133(1–2):1–19
3. Tracey KJ (2002) The inflammatory reflex. *Nature* 420:853–859
4. Rivest S (2003) Molecular insights on the cerebral innate immune system. *Brain Behav Immun* 17:13–19
5. Moshel YA, Durkin HG, Amassian VE (2005) Lateralized neocortical control of lymphocyte export from the thymus. I. Increased export after left cortical stimulation in behaviorally active rats, mediated by sympathetic pathways in the upper spinal cord. *J Neuroimmunol* 158:3–13
6. Marvel FA, Chen C, Badr N, Gaykema RPA, Goehler LE (2004) Reversible inactivation of the dorsal vagal complex blocks lipopolysaccharide-induced social withdrawal and c-Fos expression in central autonomic nuclei. *Brain Behav Immun* 18:123–134
7. Banks WA (2004) Neuroimmune networks and communication pathways: the importance of location. *Brain Behav Immun* 18:120–122

## Immunoregulation

### Definition

Regulation of immune-related functions.

## Impedance

### ► Muscular Stiffness

## Impedance Control

THEODORE E. MILNER

Department of Kinesiology and Physical Education,  
McGill University, Montreal, QC, Canada

### Definition

Impedance control is the ability of the central nervous system to modify the ►mechanical impedance of single joints independently of ►net torque or the mechanical impedance of multi-articulated body structures independently of the force which they produce [1]. Impedance control allows the central nervous system to vary the resistance to forces applied to the body, modulate energy exchange with the mechanical environment and stabilize the body.

### Description of the Theory

#### Muscle Impedance

The impedance of vertebrate limbs is fundamentally linked to the impedance of muscles. Although the ►inertia of a muscle is effectively an invariant property, its intrinsic stiffness and ►damping can be actively modified. Muscle stiffness arises from several sources, which include connective tissue (primarily collagen), structural proteins, contractile protein filaments and actomyosin ►crossbridges. Although the responses to imposed displacements are highly dependent on the characteristics of the displacements, they can be explained within the framework of crossbridge dynamics [2]. In general, an increase in muscle activation results in a relatively linear increase in muscle stiffness and damping for continuous, bi-directional stochastic displacements. This is also true for rapid step stretches that do not exceed short-range stiffness, i.e., that are not large enough to produce forcible crossbridge detachment. However, for larger amplitude stretches stiffness drops markedly. In addition, once the region of short-range stiffness has been exceeded, the muscle damping appears to dominate the impedance response until after the stretch stops. The final ►steady-state (static) stiffness is inversely related to stretch amplitude and is considerably lower than the ►dynamic stiffness during stretch. The switch from spring-like to damper-like mechanics appears to be less prominent in muscles of

mixed fiber type than pure slow twitch muscles, which may be related to faster crossbridge dynamics.

### Joint Impedance

The mechanical impedance of joints tends to depend less on the characteristics of imposed displacements than does muscle impedance. In particular, there is no switching from spring-like to damper-like mechanics during rapid step displacements, nor is there a marked difference between the dynamic stiffness and **steady-state stiffness**. This may be due in some measure to the contribution of **feedback loops**. Feedback loops originating from **muscle spindles** and **Golgi tendon organs** provide a mechanism for a delayed change in muscle activation, which can modulate muscle force in relation to changes in length or velocity. These changes in activation have been shown to create a more linear response to displacement, by replacing crossbridges that undergo forcible detachment when displacements exceed short-range stiffness [3]. Most estimates of joint impedance cannot distinguish between the contributions of intrinsic muscle properties and feedback loops.

Responses to both continuous, small amplitude stochastic displacements and rapid step displacements suggest that joint stiffness increases in a linear fashion with **muscle torque** [4], although ceiling effects may occur since **feedback gains** decline at high torques. However, joint stiffness is not an invariant function of displacement amplitude. It decreases in a linear fashion with joint displacement. This suggests that feedback loops do not completely compensate for forcible cross-bridge detachment on short time scales. However, when the imposed movement is relatively large, e.g., 30°, and the duration is in the order of seconds rather than tenths of seconds, the impedance can be adequately represented by a single stiffness value. If the joint has been stationary prior to the imposed displacement, there is an initial high stiffness region of about 1°, beyond which it drops to a lower value that is effectively constant even when the imposed movement is sinusoidal. Damping is also evident when the imposed movement is large, and although there is some evidence that it decreases as velocity increases, this has not been conclusively established. Like stiffness, damping varies with muscle torque [4], although it is proportional to the square root of torque such that the **damping ratio**,  $\zeta$ , remains constant (Fig. 1).

Whereas muscle torque is proportional to the **muscle moment arm**, joint stiffness and damping are proportional to the square of the **moment arm**. Consequently, a change in muscle force has a greater effect on joint stiffness and damping than on muscle torque. At the level of a single joint, it becomes possible to exert independent voluntary control over the impedance and net torque because of the ability to independently control **antagonist muscles**. A single pair of antagonist

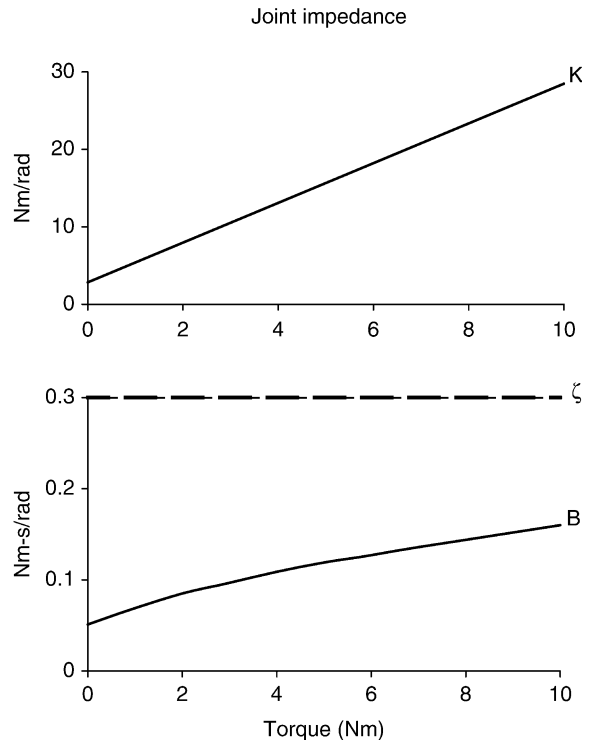

**Impedance Control. Figure 1** Typical relations between stiffness (K), damping (B) and torque. Stiffness increases linearly with torque, whereas **damping** increases as the square root of torque to keep the damping ratio ( $\zeta$ ) constant.

muscles can achieve a selected net torque by means of a range of activations. Consequently, for a selected net torque there is a range of possible impedances. The minimum impedance corresponds to exclusive activation of the muscle that produces the selected torque. However, the same net torque can be achieved by increasing its activation and coactivating its antagonist muscle. This will result in greater joint impedance since the impedances of the two muscles sum. Such coactivation is used to counteract destabilizing effects of environmental forces [5].

Co-contraction of a pair of antagonist muscles is the most primitive control of mechanical impedance. In general, more than two muscles act at a joint. This allows for more sophisticated control of impedance. Each activated muscle will contribute to the joint impedance as a function of its activation and the square of its moment arm. Since the impedances of all muscles acting at a joint sum, a desired combination of net torque and joint impedance can be achieved in a variety of ways. For example, if two **synergist muscles** have moment arms of different lengths, the same muscle torque can be achieved by activating either one muscle or the other or by activating both muscles. The highest impedance will be realized if only the muscle with the

longer moment arm is activated, whereas the lowest impedance will be realized if only the muscle with the shorter moment arm is activated. Any impedance between these two values can be realized with some combination of activation levels of both muscles. This allows independent control of muscle torque and impedance without the need to coactivate antagonist muscles. Coactivation of antagonist muscles allows impedance to be controlled over a larger range with an even greater selection of activation levels. Since a joint may have multiple degrees of freedom, a single muscle frequently produces torque about more than one axis of rotation. This presents even more versatility in the independent control of net torque and impedance.

### Feedback Modification of Impedance

The ability to control the feedback gain independently of muscle activation presents an additional means of controlling impedance independently of muscle torque. It appears that the gain of the fastest spinal feedback loop (monosynaptic stretch reflex) co-varies with the level of muscle activation, a property known as automatic gain compensation, which would act to reinforce changes in impedance achieved through voluntary control of muscle activation. There are situations, however, where the feedback response can be qualitatively transformed. An example of this is ball catching. There is a reversal of the feedback response in elbow muscles that shorten during impact of the ball. Rather than exhibiting an unloading response, which normally silences the shortening muscle, the feedback activity increases such that there is phasic coactivation of both the stretching and shortening muscles [6].

Longer latency feedback loops, which may involve supraspinal, as well as, spinal pathways appear to have a greater degree of independent gain control. In particular, the intention to resist a disturbance can lead to profoundly greater resistance than when the intention is to yield to the disturbance. Similarly, the gain of these feedback loops is greater when the objective is to control position as opposed to force.

It must be stressed that an increase in the feedback gain does not inevitably result in higher joint impedance. Due to sensory receptor dynamics, loop delays, low-pass filtering characteristics and various nonlinear properties of muscle, the contribution of feedback loops to joint impedance is highly dependent on the frequency content of the imposed motion. Since impedance due to feedback assists movement at certain frequencies it can reduce damping and stiffness, which has the potential to reduce dynamic stability if the feedback gain is sufficiently high [7].

### Impedance of Multi-Articulated Body Structures

In the case of multi-articulated limbs, impedance can be represented in terms of the resultant properties at the

end of the limb. Endpoint or **driving point impedance** is a function of the impedance of each joint, the joint angles and the limb segment lengths. The dependence of endpoint impedance on limb geometry provides another mechanism for control. It is possible to change the inertia, as well as the viscoelastic components of the impedance by simply changing the kinematic configuration of the limb without requiring any change in muscle activation [1]. This is a particularly effective way to change the endpoint impedance in postural tasks. In particular, redundant degrees of freedom may be exploited to vary the impedance at a particular endpoint location.

Endpoint and joint impedances are linked by the following transformations.

$$K_j = J^T K_e J + \frac{dJ^T}{d\theta} F$$

$$B_j = J^T B_e J$$

$$I_j = J^T I_e J$$

where  $J$  is the **Jacobian** matrix. Endpoint impedance is multi-dimensional;  $K_e$ ,  $B_e$  and  $I_e$  are the endpoint stiffness, damping and inertia matrices, respectively. The number of dimensions depends on the number of degrees of freedom of motion at the limb endpoint. In general, there would be six degrees of freedom—three translational and three rotational. However, constraints on how a limb can move may effectively reduce this number. The impedance of the three translational degrees of freedom is conveniently portrayed as an ellipsoid, where the orientation and shape are determined by the eigenvectors and eigenvalues of the impedance matrices (Fig. 2).

The distance from the center of the ellipsoid to any point on its surface represents the magnitude of the impedance along that translational direction. An important point is that the direction of the force response is generally not aligned with the direction of the perturbation, due to the way in which the **kinematics** of the limb transform torque into endpoint force. The two are aligned only along the principal axes of the ellipsoid. Due to this misalignment, the impedance will tend to change the direction of an imposed motion.

As implied by the equations above, endpoint stiffness and damping are linked kinematically to joint stiffness and damping, as well as through their mutual dependence on muscle activation. Endpoint stiffness and damping increase as a function of torques in such a way that the damping ratio remains relatively constant across muscle activation levels [8]. Significant differences in the shape and orientation of endpoint stiffness and damping ellipses do appear with increasing endpoint force in certain force directions (Fig. 3).

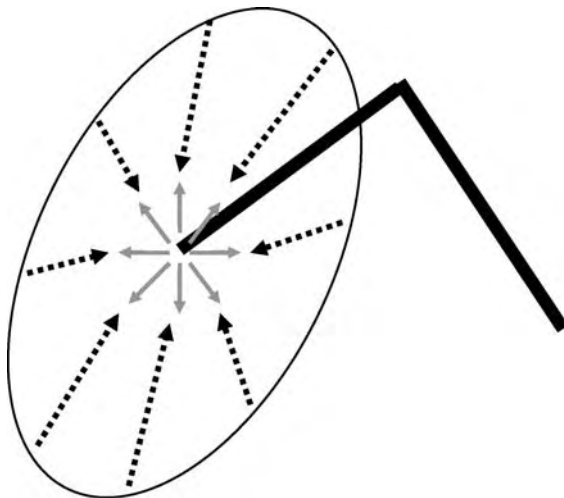

**Impedance Control. Figure 2** The endpoint impedance of a limb is usually depicted as an ellipsoid, shown here in a planar view. The forces (*dashed arrows*) are generally not aligned with the changes in acceleration, velocity or displacement (*solid arrows*) that they resist. The major and minor axes of the ellipse represent the directions of the eigenvectors corresponding to the maximum and minimum eigenvalues of the impedance matrix, respectively.

However, this can be attributed to the force dependent term in the transformation linking endpoint stiffness and joint stiffness, which is absent in the transformation linking endpoint damping and joint damping in the equations above.

**Locomotion**

The impedance of the leg is likely controlled in activities such as walking, running, hopping and jumping to regulate energy transfer, mechanical efficiency or dynamic stability. Muscle activity and leg kinematics are modified in a way that suggests that the leg impedance is adapted to the impedance of the support surface [9]. For example, there is greater coactivation of ankle flexor and extensor muscles prior to landing on a rigid surface than a compliant surface, as well as greater knee flexion. Progressively greater coactivation of ankle muscles is also observed when landing from increasing heights.

H-reflex studies of ankle muscles suggest that the feedback gain is modulated to reinforce intrinsic muscle impedance. In walking, running and hopping the gain is low during the time that the foot is in the air, but increases in parallel with muscle activation during the support phase. In landing from a jump and in walking

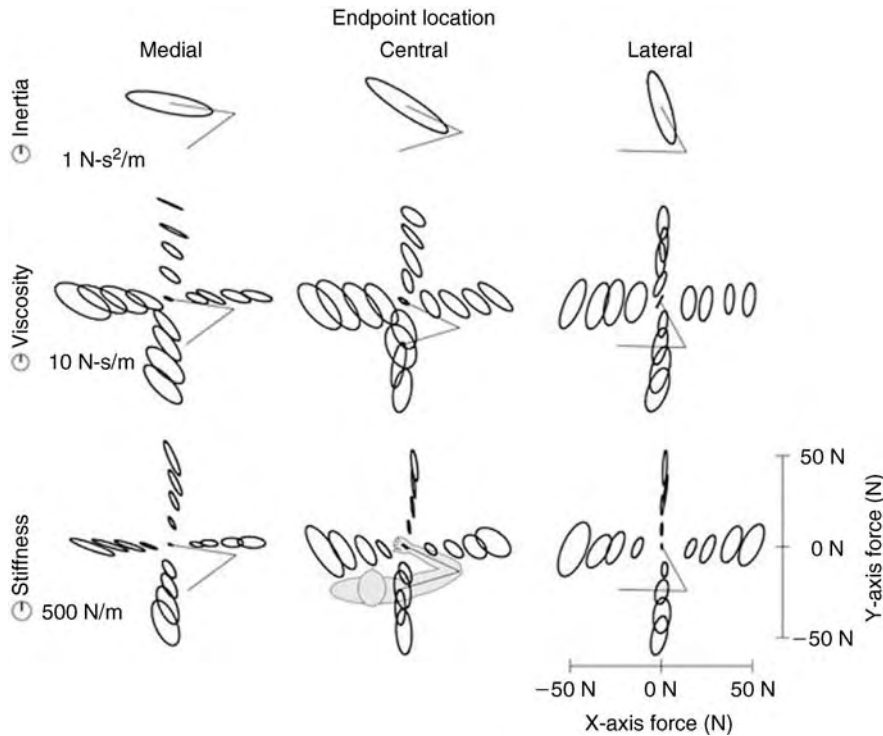

**Impedance Control. Figure 3** Inertial, viscosity (►damping) and stiffness ellipses for the arm for different hand force magnitudes and directions. The location of the center of each ellipse corresponds to the hand force being exerted during the impedance measurement.

on balance beam, ankle flexor and extensor muscles are coactivated during the support phase. Feedback gain is attenuated relative to activities where coactivation is not observed, viz. hopping and walking on a wide support surface, respectively. This suggests that feedback gain may be reduced when postural stability is critical and feedforward mechanisms, such as voluntary coactivation of antagonist muscles are used instead to increase joint impedance.

### Manipulation

The endpoint stiffness after adaptation to novel mechanical environments that engender a stable interaction with the hand during manipulation appears to vary directly with torque. However, when the interaction is unstable or unpredictable, or when surprised by an unfamiliar mechanical environment, subjects begin to coactivate **antagonistic muscles**. A uniform increase in the coactivation of all antagonistic muscles would result in an increase in the viscoelastic components of the endpoint impedance without altering the shape or orientation. This may be how the central nervous system deals with uncharacterized disturbances, although when subjects repeatedly experience the same disturbance and can adapt to it selective changes in shape and orientation may occur. When adapting to a lateral instability, subjects increased the stiffness in the direction of the instability without any significant change in stiffness along the movement direction [10] (Fig. 4).

### Constraints on Impedance Control

The impedance range corresponds to the difference between the minimum impedance, which occurs when only the agonist is used to produce the desired net torque and the maximum impedance, which occurs when the agonist is activated maximally and the antagonist produces whatever torque is needed to reduce the net torque to the desired value. In principle, when the desired net torque is small, the maximum impedance should be considerably greater than when either muscle is maximally activated on its own. However, the maximum impedance appears to be limited to what an individual muscle can produce (Fig. 5).

When antagonist muscles are coactivated, the maximum activation of each muscle is reduced, likely due to reciprocal inhibition. Since antagonists mutually inhibit each other, the effective torque that each can produce is reduced in proportion to its counterpart's activation.

Although the kinematics of multi-articulated body segments provide a means of varying impedance independently of muscle activation when changes in posture are possible, they can impose constraints when posture is fixed. In particular, as joints are extended towards the

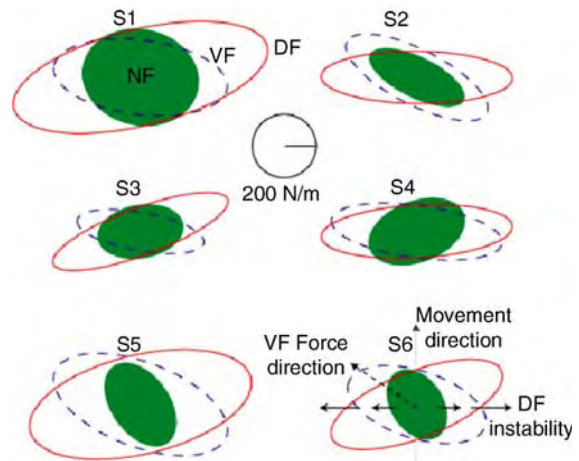

**Impedance Control. Figure 4** Endpoint stiffness ellipses of hand before (NF, filled green) and after adaptation to a velocity-dependent force field (VF, dashed blue), which produces a stable perturbation and a divergent force field (DF, solid red), which produces an unpredictable (unstable) perturbation. Movement direction and force field directions are indicated by arrows.

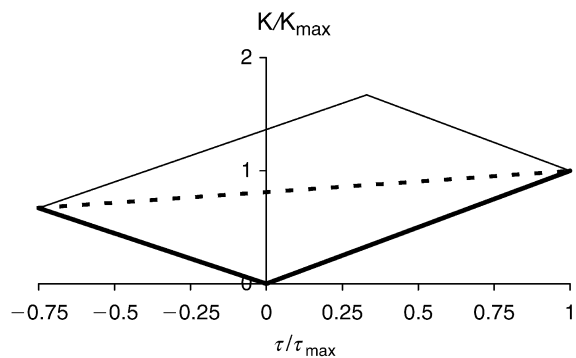

**Impedance Control. Figure 5** Theoretical region of joint stiffness that can be achieved by coactivation of antagonist muscles is bounded by solid lines. Values are expressed relative to the maximum stiffness ( $K_{max}$ ) and maximum torque ( $\tau_{max}$ ) that can be generated by the stronger muscle (positive torque). Practically, only values below the dashed line are possible.

extremes of their range of motion, the ellipsoids representing the viscoelastic components of impedance tend to become elongated and aligned with the extended body segments. No matter how selectively particular muscles can be activated, the ability to change the orientation of the ellipsoids or to increase impedance along the minor axes declines. Similarly, with large endpoint forces the kinematics also impose constraints

on impedance geometry due to the force-dependent term in the equation linking endpoint stiffness to joint stiffness.

## References

1. Hogan N (1985) The mechanics of multi-joint posture and movement control. *Biol Cybern* 52:315–331
2. Kirsch RF, Boskov D, Rymer WZ (1994) Muscle stiffness during transient and continuous movements of cat muscle: perturbation characteristics and physiological relevance. *IEEE Trans Biomed Eng* 41:758–770
3. Nichols TR, Houk JC (1976) The improvement in linearity and the regulation of stiffness that results from the actions of the stretch reflex. *Journal of Neurophysiology* 39:119–142
4. Hunter IW, Kearney R (1982) Dynamics of human ankle stiffness: variation with mean torque. *J Biomech* 15:747–752
5. Milner TE (2002) Adaptation to destabilizing dynamics by means of muscle co-contraction. *Exp Brain Res* 143:406–416
6. Lacquaniti F, Borghese NA, Carrozzo M (1991) Transient reversal of the stretch reflex in human arm muscles. *J Neurophysiol* 66:939–954
7. Rack PMH (1981) Limitations of somatosensory feedback in control of posture and movement. In: Brooks VB (ed) *Motor control. Handbook of physiology. Section 1. The nervous system, vol 2.* Williams and Wilkins, Bethesda, pp 229–256
8. Perreault EJ, Kirsch RF, Crago PE (2004) Multijoint dynamics and postural stability of the human arm. *Exp Brain Res* 157:507–517
9. Ferris DP, Liang K, Farley CT (1999) Runners adjust leg stiffness for their first step on a new running surface. *J Biomech* 32:787–794
10. Burdet E, Osu R, Franklin DW, Milner TE, Kawato M (2001) The central nervous system stabilizes unstable dynamics by learning optimal impedance. *Nature* 414: 446–449

## Impedance (Z) (Acoustic)

### Definition

Acoustic impedance of a medium is the mathematically complex ratio of the sound pressure on the surface of the medium to the flux (particle velocity multiplied by area) through the surface. It can be expressed in mechanical terms as the square root of the sum of the square of resistance (R) and reactance (X). Resistance is not dependent on sound frequency while reactance is. In terms of the complex ratio that defines impedance, resistance is the real component of impedance and reactance is the imaginary component.

► Acoustics

## Implicit Brain Functions

### Definition

Cognitive or perceptual processes not directly accessible to conscious awareness.

► Latent Learning

## Implicit Learning

### Definition

A type of learning resulting in enhanced performance through an unconscious learning process, such as learning a physical or sport skill. Conversely, explicit learning involves intentional remembrance of information at a certain conscious level, such as learning of historical events, phone numbers, etc.

► Latent Learning

## Implicit Memory

### Definition

Implicit memory refers to an unconscious form of memory that does not require any explicit recollection for specific episodes. Non-declarative memory corresponds to implicit memory. Semantic knowledge retrieved by indirect memory test as word completion or lexical decision is also included.

► Long-Term Memory

## Importin

### Definition

Importin is a molecule that transports molecules into the nucleus by binding to a nuclear localization signal within the molecule.



## Imprinting

HIDETO KABA

Department of Physiology, Kochi Medical School,  
Nankoku, Kochi, Japan

### Definition

The young of many precocial birds, such as ducks and chickens will follow and become socially bonded to the first moving object they encounter. Konrad Lorenz employed the term “imprinting” to describe the process by which the social bond was formed. He also postulated that imprinting had a constellation of features which distinguished it fundamentally from conventional forms of learning: (i) it takes place only during a brief critical period, (ii) it is irreversible, and (iii) it influences patterns of behavior that have not yet developed. The many years of research since Lorenz made these claims have demonstrated that the traditional view of imprinting is incorrect. Imprinting is neither limited to a brief critical period nor irreversible. Instead the recent findings lead to the conclusion that imprinting occurs in many species, including man, and that it can be redefined as the biologically relevant learning that occurs during a “▶sensitive period” coinciding with a particular developmental stage or physiological state [1].

The salient phenomena of the development of social preferences in birds have given rise to extrapolations to mammals and humans. The best characterized forms of imprinting in mammals, and those for which most is known at the synaptic and cellular levels, are the learning of male pheromonal signals by female mice during mating [2–4], the learning of newborn lamb odors after parturition in sheep [5,6], and the olfactory conditioning in neonatal animals such as rats and rabbits [1,7]. During a sensitive period of a few hours after mating, female mice form a memory to the urinary ▶pheromones of the male partner. This olfactory memory is vital for preventing pregnancy block that might otherwise be induced by the male’s pheromones. Pheromones from an unfamiliar male, for which no memory has been formed, activate a neuroendocrine reflex that results in pregnancy failure. Rats are altricial, and pups are confined to the nest environment with the main sensory input mediated by the olfactory and somatosensory modalities. Pups, however, must learn the odor of the mother to ensure nipple attachment and orientation to the mother. In fact, there is a developmentally determined sensitive period, during which olfactory learning is enhanced. Sheep are gregarious animals, and because they are seasonal breeders, hundreds of young may be born within a very short period. To restrict maternal investment to only her to

own offspring, the mother rapidly forms the ability to recognize her lamb immediately after parturition, and will show severe aggressive responses to strange young that attempt to suckle her.

### Characteristics

#### Higher Level Structures

Most mammalian species, with the exception of man and other higher primates, possess two major olfactory systems: the olfactory and vomeronasal systems (Fig. 1).

The sensory neurons for the olfactory system are located on the olfactory turbinates and septal wall of the nasal cavity; those for the vomeronasal system are located within the vomeronasal organ, which is a bilaterally-paired tubular structure lying on either side of the nasal septum. Whereas the olfactory sensory neurons send their axons, which are bundled to form the olfactory nerve, to the main olfactory bulb (MOB), the vomeronasal sensory neurons send axons, which together make up the vomeronasal nerve, to the accessory olfactory bulb (AOB), a structure that is spatially and histologically distinct from the MOB and is located at the caudal-dorsal end of the main bulbs. The MOB projects to the anterior cortical nucleus and posterolateral cortical amygdaloid nucleus, anterior olfactory nucleus, the olfactory tubercle, the tenia tecta, the piriform cortex, and the entorhinal cortex. In contrast to the diverse projections of the MOB, the projections of the AOB are much more limited. The principal neurons of the AOB send their axons primarily to the medial and posteromedial cortical nuclei of the ▶amygdala and send lesser projections to the nucleus of the accessory olfactory tract and the bed nucleus of the stria terminalis.

#### Lower Level Components

The main functions of the olfactory bulb, which has a relatively simple architecture, can be separated into two distinct levels: the level of input processing within the glomeruli and the level of output control in the external plexiform layer (Fig. 2).

Within the glomeruli, the olfactory and the vomeronasal nerve terminals form axodendritic synapses onto the dendritic tufts of both the mitral cells and the intrinsic periglomerular cells. Glutamate is a transmitter at the olfactory and vomeronasal nerve synapses on the mitral and periglomerular cell dendrites in the glomerulus. After the initial input to the mitral and periglomerular cells, further processing may take place within the glomerulus through the dendrodendritic microcircuits. The periglomerular cells are dopaminergic or GABAergic in both the MOB and AOB, but very few of the periglomerular cells in the AOB contain dopamine. At the second level of organization, the main type of microcircuit is the dendrodendritic reciprocal synapses between mitral cells and granule cell interneurons. The mitral cells, when activated by olfactory or

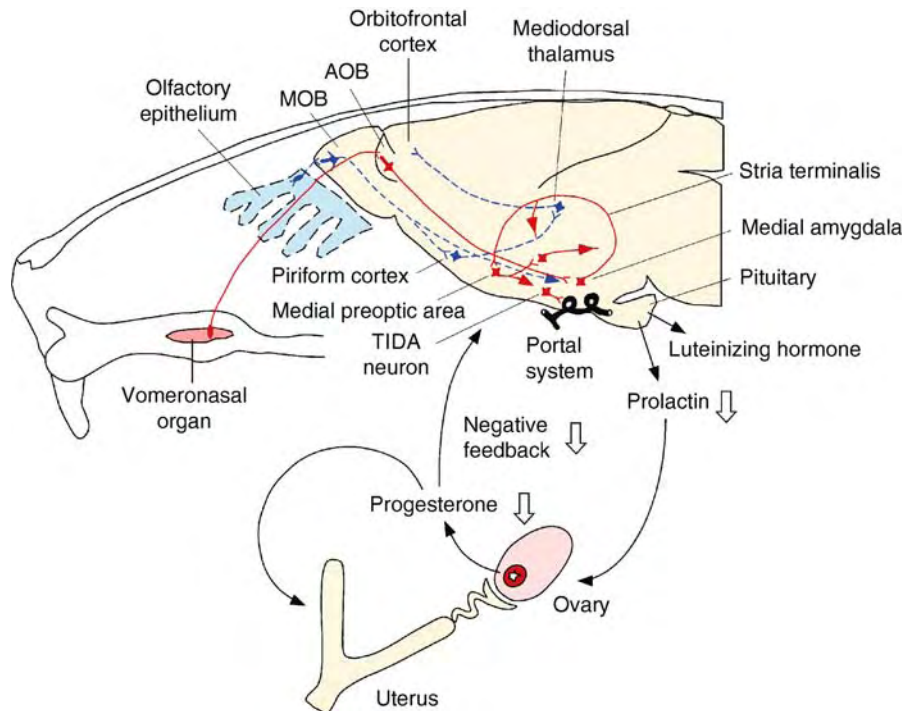

**Imprinting. Figure 1** The neural circuitry of olfactory and vomeronasal systems in mammals. Male chemosignals activate an excitatory pathway, via the AOB, medial amygdala and medial preoptic area, to tuberoinfundibular dopaminergic (TIDA) arcuate neurons. The excited TIDA neurons release dopamine into the hypophyseal portal circulation, which in turn inhibits prolactin secretion from the anterior pituitary. Without this luteotrophic support, progesterone secretion from the corpus luteum decreases. This causes implantation failure and releases the hypothalamo-pituitary axis from the negative feedback action of progesterone, resulting in a return to estrus. The medial amygdala receives input from both the vomeronasal and olfactory structures, and is a major site for the integration of chemosensory signals with other sensory cues and hormonal states. Part of the projections of the olfactory system are shown.

vomeronasal nerve inputs, depolarize the granule cells by means of glutamate released at the ►**dendrodendritic synapses** (Fig. 2). This depolarization in turn releases  $\gamma$ -aminobutyric acid (GABA) from the granule cells and hyperpolarizes the mitral cells.

The synaptic circuitry of the olfactory bulb has much in common with that of the retina. There are, however, significant differences between them. One of the striking differences is that the olfactory bulb, unlike the retina, receives the wealth of centrifugal projections from specific brain areas, including ascending cholinergic, noradrenergic and serotonergic systems. From this point of view, the olfactory bulb is more similar to higher cortical structures, which receive extensive “association” projections from other cortical areas. Hence, it is not surprising to learn that the olfactory bulb not only functions as a relay conveying information to its projection sites, but also serves as a structure which has the capacity for neural plasticity involved in learning and memory. This is true for all three specialized forms of olfactory imprinting. Although they involve very different behavioral contexts, they share several common

features, including a dependence on the association of the olfactory (conditioned) and somatosensory (unconditioned) signals in the olfactory bulb. In both pheromonal learning in mice and maternal recognition in sheep, vaginocervical stimulation arising from either mating or parturition triggers olfactory imprinting. Neonatal rabbits and rats can be classically conditioned to odors using tactile stimulation of the peri-oral region during suckling and one of a myriad of potential unconditioned stimuli such as milk, stroking and electric-shock, respectively. The somatosensory signals are conveyed by noradrenergic projections from the pontine nucleus ►**locus coeruleus** to the olfactory bulb. In each case, olfactory imprinting is prevented by noradrenergic lesions or the infusion of adrenergic receptor antagonists directly into the olfactory bulb. The neural changes underlying the pheromonal learning in mice occur in the AOB. Although the neural mechanisms of the maternal recognition in sheep and the neonatal olfactory learning in rats and rabbits are more distributed, they also involve changes occurring in the MOB.

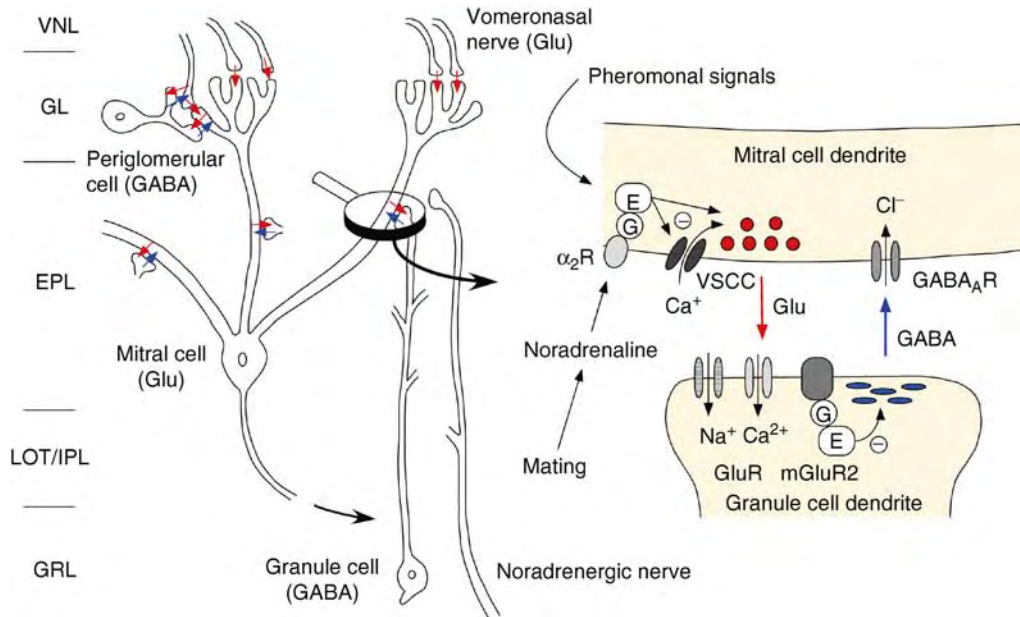

**Imprinting. Figure 2** Cellular hypothesis for olfactory imprinting in mice. Mating-induced releases of noradrenaline in the AOB facilitate the induction of *N*-methyl-*D*-aspartate (NMDA) receptor-dependent long-term potentiation (LTP) at the mitral to granule synapses by enforcing high-fidelity synaptic transmission. This ability of noradrenaline stems from a decrease in glutamate (Glu) release via the activation of presynaptic  $\alpha_2$ -adrenoceptors ( $\alpha_2R$ ). The activation of mGluR2, a metabotropic glutamate receptor, also leads to LTP, independently of NMDA receptors. Consequently, LTP results in a sequence of changes in the morphology of the reciprocal synapses and an increased release of GABA. Red and blue arrows show direction of glutamatergic and GABAergic transmission, respectively. The signaling pathways that inhibit transmitter release are marked by minus signs. E, intracellular effector; EPL, external plexiform layer; G, G protein; GABA<sub>A</sub>R, GABA<sub>A</sub> receptor; GL, glomerular layer; GluR, ionotropic glutamate receptor; GRL, granule cell layer; LOT/IPL, lateral olfactory tract/internal plexiform layer; VNL, vomeronasal nerve layer; VSCC, voltage-sensitive calcium channel.

### Structural Regulation

A notable feature of the olfactory and vomeronasal sensory neurons is that they are continuously replaced from ►stem cells in the epithelium throughout adult life. A second source of neural plasticity during adulthood occurs at the level of the olfactory bulb [8]. Adult-born cells arising from the ►subventricular zone of the telencephalon are incorporated as granule cells and periglomerular cells of the MOB and AOB. How is olfactory imprinting so far discussed related to ongoing neurogenesis in the mature system? The pheromonal memory in mice lasts for at least 30 days but fades by 50 days when recently mated females are exposed to an unfamiliar male to block their pregnancy. Accordingly, the memory could outlast the gestation period of 20 days and prevent the mate's pheromones from inducing oestrus, making a second pregnant less likely to occur. The likelihood of this sequence of events occurring in the wild is presumably rare; most females remain pregnant after mating. Notably, the endocrine environment during pregnancy curtails the duration of the memory, which may be related to an increased rate of turnover of vomeronasal sensory neurons. In a different

learning paradigm, the ability of a mother rodent to recognize and nurture her young is associated with an increase in newborn neurons that are integrated into olfactory bulb circuitry. Neurogenesis might therefore favor flexibility, stability, or both, in the adult brain.

When at 12 days of age rat pups are trained in a ►classical conditioning paradigm in which odor is paired with shock or stroking, they develop a conditioned aversion or preference for that odor, respectively, depending on the context. Paradoxically, however, at 9 days of age pups trained in the same paradigm demonstrate a subsequent odor preference regardless of whether the unconditioned stimulus is appetitive or aversive [9]. Thus, neonates have a sensitive period for rapid, robust odor learning characterized by increased ability to learn odor preferences and decreased ability to learn odor aversions. This sensitive period is supported by the hyper-functioning neonatal locus coeruleus and the hypo-functional amygdala. Pups' endogenous ►corticosterone, which is modulated by maternal stimulation, is important in sensitive-period termination and developmental emergence of olfactory fear conditioning that acts via the amygdala as a switch between fear and attraction.

In the mother's absence, odor-shock conditioning produces amygdala activation and learned odor aversions in preweanling (12–15 days old) rats. With maternal presence, this same conditioning yields an odor preference without amygdala activation [10]. These studies suggest that the neonatal brain is not an immature version of the adult brain but is uniquely designed to optimize attachment of the mother.

### High Level Processes

The neuroendocrine pathway by which male pheromones in mice exert their pregnancy block effect (►Bruce effect) has been characterized extensively and is shown in Fig 1.

### Lower Level Processes

There are several important anatomical differences between the AOB and the MOB that may reflect differences in the processing of chemosignals. The glomerular layer is less distinct in the AOB than in the MOB. In addition, periglomerular cells in the AOB are far fewer than in the MOB, implying that the glomeruli in the AOB are less involved in the input processing of chemosignals than those in the MOB. The most significant differences between the AOB and MOB are those of mitral cell morphology, which influence the sampling of glomerular signals and the function of inhibitory mechanisms [4]. A single mitral cell in the AOB projects several primary dendrites to several different glomeruli, whereas a single mitral cell in the MOB projects a primary dendrite to a single glomerulus. Mitral cells of the MOB have an extensive network of secondary dendrites that project radially, in the external plexiform layer, in a plane tangential to the mitral cell layer. In contrast, mitral cells of the AOB have poorly developed secondary dendrites; the dendrodendritic reciprocal synapses in the AOB are formed mainly on the primary dendrites rather than on the secondary dendrites. Although dendrodendritic reciprocal synapses in the AOB are capable of mediating both ►self-inhibition and ►lateral inhibition, the balance may be shifted toward self-inhibition. Thus, the inhibition mediated by the reciprocal synapses may be placed to disrupt the transmission of the pheromonal signal to the mitral cell soma.

### Process Regulation

A further feature common to all three forms of olfactory imprinting, in the mouse, sheep and neonatal rat and rabbit is their dependence on noradrenergic transmission that induces structural and functional changes at mitral/granule cell reciprocal synapses in the olfactory bulb. In the context of pheromonal learning in mice, the association of the mating male's chemosignals with increased levels of noradrenaline in the AOB results in potentiation of the mitral to granule cell synapses that receive input

from the mating male's chemosignals (Fig 2). During subsequent exposure to the mating male's chemosignals, the mitral cells with the potentiated synapses would be subject to enhanced feedback inhibition from the granule cells, which could selectively disrupt or modulate the transmission of the mating male's pregnancy-blocking signal at the level of the AOB. Urinary chemosignals from an unfamiliar male would activate a different subpopulation of mitral cells without potentiated synapses that would transmit the male chemosignals finally to the hypothalamus, resulting in pregnancy block. Indeed, *c-fos* expression, a marker of neuronal activity, is attenuated in the medial amygdala of mated females in response to the mating male's chemosignals.

Maternal recognition in sheep is associated with neural changes at mitral/granule cell reciprocal synapses in the MOB [5,6]. These changes involve both  $\beta$ -adrenergic receptors and a ►retrograde messenger action of nitric oxide that promote glutamate release from the mitral cells and a resultant upgrading of the mitral to granule cell synapses, with more GABA being released in response to the learned odors of the ewe's own lamb. Oxytocin release within the olfactory bulb during parturition may act to modulate noradrenaline release, facilitating maternal recognition. The increases in GABAergic transmission would represent a sharpening of the odor-induced pattern of activity, due to increases in lateral inhibition. In fact, a small proportion of the mitral cells respond preferentially to the learned odors of the ewe's own lamb, although mitral cells display almost no response to lamb odors before parturition.

In the context of neonatal learning in rats, the association of olfactory signals and somatosensory stimulation-induced releases of noradrenaline and serotonin in the MOB reduces habituation of mitral-cell odor responses during training, and elevates cAMP levels in mitral cells [7]. The elevated cAMP levels increase ►cAMP response element binding protein (CREB) phosphorylation and subsequent protein synthesis changes that lead to an odor-specific, long-term change in spatio-temporal output patterns of mitral cells, primarily expressed as an enhanced probability of inhibitory responses to the learned odor.

### Function

Humans, as Spinoza famously noted, are "a social animal," and hence, it is our social attachments that we live for. Contrary to the desirability of family ties, domestic violence often occurs. There has an alarming increase in child abuse and neglect throughout the world. Therefore, the establishment of an appropriate approach to child abuse and neglect should be a requirement in all nations. To understand social attachments in humans, we have found it valuable to learn from the detailed and precise observations of a wide range of animal species, since the requirements of

preserving the species may have led to the evolution of similar behavioral patterns in humans and other animals. This essay has focused on the neural basis of olfactory imprinting in three specialized contexts that occur during sensitive periods of enhanced neural plasticity and emphasized some of their common features. All three specialized forms of olfactory imprinting are associated with neural changes in the olfactory bulb at the first stage of sensory processing. These changes require the association of the olfactory and somatosensory signals in the olfactory bulb. They all depend on somatosensory stimulation-induced releases of noradrenaline that induce structural and functional changes at mitral/granule cell reciprocal synapses in the olfactory bulb, resulting in increases in inhibitory transmission. In the AOB, this would reflect the enhanced self-inhibition of mitral cells, which could selectively disrupt the transmission of the mating male's pregnancy-blocking signal at this level. In contrast, an extensive network of secondary dendrites of mitral cells in the MOB would result in a sharpening of the odor-induced pattern of activity, due to increases in lateral inhibition, leading to maternal recognition in sheep and neonatal learning in rats. Clearly, the studies described here show that inhibitory interneurons play a critical role in olfactory imprinting. Further work on how these neurons shape olfactory circuit function could be an excellent way to understand memory functions of interneurons in other systems.

#### ► Learning and Motivation

### References

- Hudson R (1993) Olfactory imprinting. *Curr Opin Neurobiol* 3:548–552
- Brennan P, Kaba H, Keverne EB (1990) Olfactory recognition: a simple memory system. *Science* 250:1223–1226
- Kaba H, Nakanishi S (1995) Synaptic mechanisms of olfactory recognition memory. *Rev Neurosci* 6:125–141
- Brennan PA, Keverne EB (1997) Neural mechanisms of mammalian olfactory learning. *Prog Neurobiol* 51:457–481
- Kendrick KM, Da Costa APC, Broad KD, Ohkura S, Guevara R, Lévy F, Keverne EB (1997) Neural control of maternal behaviour and olfactory recognition of offspring. *Brain Res Bull* 44:383–395
- Lévy F, Keller M, Poindron P (2004) Olfactory regulation of maternal behavior in mammals. *Horm Behav* 46:284–302
- Wilson DA, Best AR, Sullivan RM (2004) Plasticity in the olfactory system: lessons for the neurobiology of memory. *Neuroscientist* 10:513–524
- Lledo P-M, Alonso M, Grubb MS (2006) Adult neurogenesis and functional plasticity in neuronal circuits. *Nat Rev Neurosci* 7:179–193
- Sullivan RM, Landers M, Yeaman B, Wilson DA (2000) Good memories of bad events in infancy. *Nature* 407:38–39
- Moriceau S, Sullivan RM (2006) Maternal presence serves as a switch between learning fear and attraction in infancy. *Nat Neurosci* 9:1004–1006

## Impulse

#### ► Action Potential

## Impulse Propagation

### Definition

#### ► Action Potential Propagation

## Impulse Response

### Definition

The output of a system when a delta function is input into it. The impulse response is frequently used in order to classify a system, e.g. finite or infinite impulse response.

#### ► Delta Function

#### ► Signals and Systems

## In cis

### Definition

A factor is said to act in cis if it interacts with other proteins within the plasma membrane, cytoplasm or nucleus of the same cell.

## In trans

### Definition

A factor is said to act in trans if it interacts with proteins expressed on the plasma membrane of other cells, or if it binds to the regulatory sequence of a gene loci.

---

## In silico Biological Analysis

► Bioinformatics

---

## In situ Microscopy

► Neuron-Glia-Imaging

---

## In Vitro

### Definition

Refers to situations where experiments are performed on cells or tissue that is removed from a living organism. The principal advantage of using in vitro techniques is that the external medium can be tightly controlled. Another notable advantage is that more techniques can often be used since the tissue is more accessible. The main disadvantage is that some behaviors observed in vivo cannot be mimicked using in vitro preparations.

---

## In vitro Brain Preparations

► Brain Slices

---

## In Vivo

### Definition

Refers to situations where experiments are performed using living organisms. The principal advantage of using in vivo techniques is that the connectivity between cells within their normal extracellular environment is preserved. Indeed some experiments, especially those that measure behavior, can only be completed using in vivo approaches. The main disadvantage is that the external environment is more difficult to control compared to in vitro approaches.

---

## Inactivation

► Ion Channels from Development to Disease

---

## Inactivation Gate

### Definition

Inactivation of voltage-gated Na<sup>+</sup> or K<sup>+</sup> channels is thought to result from specific gates closing upon depolarization, one possible mechanism being a conformational change of the channel or a subunit different from the activation-related part, and another possible mechanism being plugging of an open channel from the inside by a tethered molecule.

► Action Potential

---

## Inactivation Gating

### Definition

Specialized molecular regions of the channel protein, which undergo conformational changes leading to inactivation (open-non conductive configuration). The inactivation gate can be controlled either by voltage or

$\text{Ca}^{2+}$  ions and leads the channel to an open-non conductive configuration which differs from the closed-non conductive configuration that the channel assumes at rest. A typical example of inactivation gating is the “ball-and-chain” model of voltage-gated  $\text{Na}^+$  channels.

- ▶ Calcium Channels – an Overview
- ▶ Sodium Channels

## Inattentive Blindness

### Definition

Is the inability of humans to recover any information from unattended sensory stimuli and is thought to be part of an important cognitive mechanism, namely that of focusing or “concentrating” on a task to be performed.

- ▶ Attention

## Incentive Motivation

### Definition

Motivation is a theoretical construct used to describe processes within the brain and mind that govern the selection and vigor of specific patterns of behavior required to achieve specific goals and objectives.

Incentive motivation emphasizes the capacity of environmental stimuli to attract and guide approach behavior toward events that have biological significance for the organism. Incentive stimuli such as odors or visual properties may have innate significance whereas other visual or auditory stimuli acquire their incentive properties through association with primary reward stimuli. A critical principle of incentive motivation implies that information external to the organism attracts it toward specific stimuli. This concept is in distinction to the ‘push’ attributed to internal drive states arising from physiological deprivation.

- ▶ Learning and Motivation

## Incentive Value

### Definition

The incentive value of an outcome controls goal-directed action selection for that outcome, such that the greater the incentive value, the more the animal will perform responses in order to obtain that outcome. The incentive value of an outcome can be modulated by extrinsic properties of the reward, such as the magnitude or quantity of reward delivered, as well as by intrinsic properties of the animal such as motivational state i.e. the degree of hunger or satiation, as well as through associative mechanisms by for example pairing that outcome with stimuli that elicit an aversive affective state such as illness.

- ▶ Value-based Learning

## Incidental Learning

- ▶ Latent Learning

## Incisional/Postoperative Pain

TIMOTHY J. BRENNAN

Departments of Anesthesia and Pharmacology,  
University of Iowa Carver College of Medicine,  
Iowa City, IA, USA

### Synonyms

Acute pain; Posttraumatic pain; Postsurgical pain

### Definition

Postoperative pain is pain occurring after a surgical procedure. In fact, nearly all surgeries cause some degree of discomfort, making incisional pain quite common. Yet, postoperative incisional pain remains a costly, poorly understood problem for patients. In the past, it was suggested that postoperative pain could be sufficiently treated by administration of adequate doses of parenteral opioids. We now know that this is not the case [1]. Thus, it is important to examine how incisions cause pain so that we can better appreciate the etiology

of postoperative pain and develop a mechanistic-based approach to its treatment.

In order to understand mechanisms of pain after surgery and investigate potential new therapies to alleviate postoperative pain in humans, models for human post-operative pain have been developed using incisions in experimental rodents (Table 1). Behaviors indicative of pain are present, yet these models have several unique properties compared to other animal models of persistent pain. Importantly, the pharmacology of the models is unique and the time course of pain behaviors has similar characteristics to pain assessments in postoperative patients [2].

## Characteristics

### Human Postoperative Pain Measurements

In clinical postoperative pain, a variety of measures are used for pain caused by surgery. For example, in patients undergoing thoracic and abdominal surgery, we typically obtain ►pain scores at rest, with ambulation and during cough. It is optimal if the measurement for pain is related to outcome for the surgical procedure (e.g. pain with coughing after thoracic surgery). After total knee replacement, pain measurements at rest and during flexion are typical, and range of motion can be used as a functional measure of improvement. Different measurements may be relevant to each type of surgery; for example, adequately controlled pain with ambulation after spine surgery may be a milestone for discharge from the hospital. A problem with some evoked pain measurements like pain during cough is difficulty in standardizing and measuring effort.

Other quantitative tests have been utilized to measure postoperative pain in patients. One of these tests is punctate mechanical ►hyperalgesia, usually mapped or quantified using a small punctate mechanical stimulus applied adjacent to the area of an incision. In many examples, a touch stimulus from a weak punctate stimulus elicits pain in the area near an incision. This hypersensitivity is termed ►primary hyperalgesia, and hyperalgesia outside the injured area, remote to the incision, is termed ►secondary hyperalgesia. Central nervous system sensitization causes pain in the

secondary (remote) zone because the primary afferent sensory fibers function normally outside the area of injury; therefore the central nervous system must contribute. ►Nociceptor sensitization at the incision causes primary hyperalgesia, although amplification in the central nervous system may contribute. Using a pressure algometer, a blunt mechanical device, evoked pain adjacent or distant to an incision can also be used to quantify postoperative pain [3].

### Description of Incisional Pain Models

A distinguishing feature of postoperative pain models is the performance of surgery using a sterile technique to reduce the incidence of confounding infection-driven inflammation. Many persistent pain models rely on inflammation to produce robust, reliable pain responses; importantly, inflammatory processes in postoperative/incisional pain are not fully understood.

Most experiments have been performed on adult rats [2]. General anesthesia is always utilized, usually induced with a volatile anesthetic like isoflurane mixed with air or oxygen in a sealed box. After induction, anesthesia is delivered via a nose cone. The area of the incision is prepared in a sterile manner with a sterile solution like 10% povidone-iodine solution or an acceptable alternative. A sterile drape surrounds the sterile area separating the sterilized and non-sterile regions. For example, in the plantar incision model, the hindpaw is placed through a hole in a sterile dressing (Fig. 1). A 1 cm longitudinal incision is made with a number 11 blade, through skin and fascia of the plantar aspect of the hindpaw, starting 0.5 cm from the proximal edge of the heel and extending toward the digits. After hemostasis with gentle pressure, the skin is apposed with two sterile sutures, which are removed under general anesthesia at a later time. Typically the wounds are well healed within 5–6 days. Infection and hematoma must be avoided as they will likely exacerbate any pain caused by the incision. In surgical models, there appears to be little evidence for severe discomfort because spontaneous pain behaviors like vocalization or persistent flinching have not been observed postoperatively.

### Pain-Related Behaviors in Incisional Models

Because pain is a subjective experience typically associated with tissue damage or threatened tissue damage, behaviors in animal models are carefully evaluated as a surrogate to pain reports generated in human studies. Therefore, these behaviors in animals are pain-related. For animal models of incisional pain or any pain model, noise or other disturbances will likely affect the responses in an unpredictable manner. Thus a quiet, enclosed area for testing pain-related behaviors is a necessity.

**Incisional/Postoperative Pain. Table 1** Rodent postoperative pain modes

Postoperative Pain Models
Plantar hindpaw incision
Hairy skin hindquarter incision
Paraspinal hairy skin incision
Ovariohysterectomy
Subcostal incision



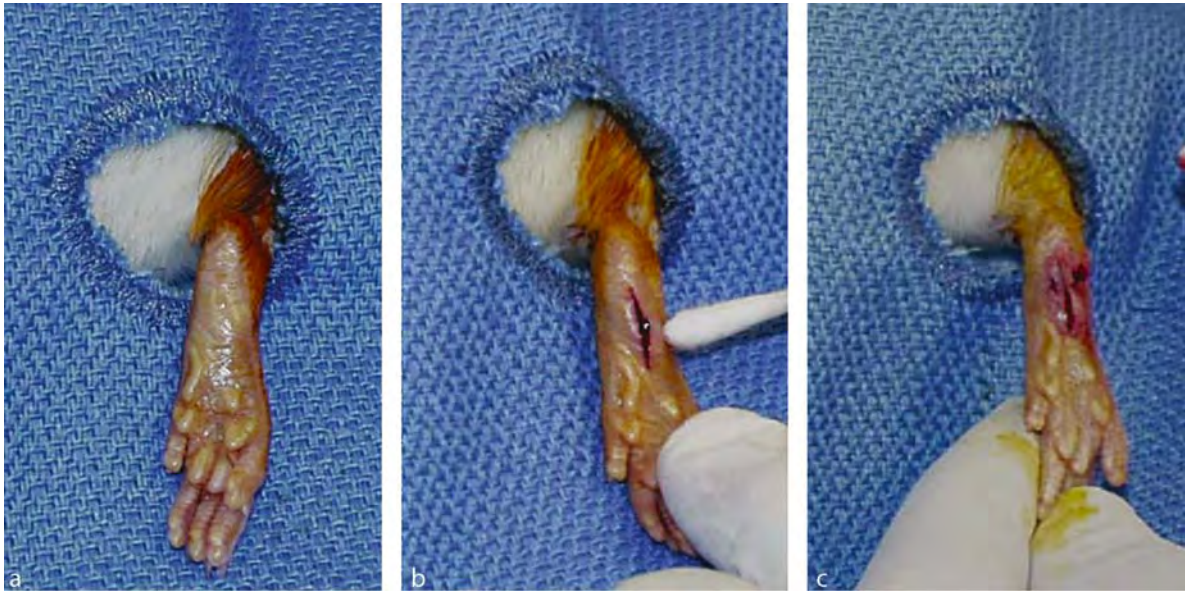

**Incisional/Postoperative Pain. Figure 1** Photographs of the different stages of the rat plantar incision. (a) A one cm longitudinal incision is made through the skin and fascia starting 0.5 cm from the proximal hindpaw and extending toward the distal paw. (b) The underlying flexor muscle is elevated and also incised longitudinally. (c) After hemostasis, the wound is opposed with the first of two nylon mattress sutures.

#### **A Plantar Incision Model for Postoperative Pain**

Many laboratories have studied the plantar incision model and the behavioral responses have been widely used in many studies. Several pain related behaviors in rats have been measured after plantar incision (Table 2).

As rats are placed undisturbed in the testing environment, we noted that they did not bear weight on the incised hindpaw for several days after plantar incision. A cumulative guarding score quantified this pain-related behavior based on hindpaw position and compared the score to the contralateral, unincised hindpaw. In general, after plantar incision, the pain score was increased through two days, gradually decreasing to where no guarding was appreciated at later times after the incision. This pain score is a result of the position chosen by the rat after the incision rather than a provoked response to a stimulus [2]. The cumulative pain score is relatively short-lived compared to other measurements and differences between these tests should be expected.

Pain in response to mechanical stimulation at the incision represents primary mechanical hyperalgesia, an exaggerated response caused by activation of sensitized primary afferent fibers. Withdrawal responses to mechanical stimulation are measured using calibrated, punctate monofilaments applied from underneath the cage through openings in the mesh floor to an area adjacent to the incision. Each filament is applied once starting with small force usually in the range of 10–15 milliNewtons (mN) and continued

**Incisional/Postoperative Pain. Table 2** Methods to measure pain-like responses in incisional pain modes. Modified from Ref. 5 with permission

Incisional Pain Models
Heat withdrawal latency
Primary mechanical withdrawal threshold
Secondary mechanical withdrawal threshold
Guarding
Weight bearing
General Activity
Conditioned responses
Primary mechanical allodynia
Secondary mechanical allodynia
Graded hyperalgesia
Graded allodynia

until a withdrawal response occurs or a strong force (500 mN, the cutoff value) is applied. The median withdrawal threshold in the incised hindpaw decreases from strong forces (approximately 500 mN) before incision to weak forces 10–60 mN through 3 days after incision. Withdrawal responses usually remain exaggerated for up to 5 or 6 days. Importantly, the reduced withdrawal threshold is sustained for a greater duration than the non-evoked guarding behavior.

A third stimulus used in the plantar incision model is hindpaw withdrawal to radiant heat applied directly to the incision [4]. Rats are placed individually on a glass floor covered with clear plastic cage and allowed to acclimate. Withdrawal latencies are assessed by applying a focused radiant heat source underneath the glass floor on the middle of the incision. The latency to evoke withdrawal is determined with a cut-off value for example, 20 s. Before plantar incision, the withdrawal latency to radiant heat is typically 10–12 s. The withdrawal latency to heat applied directly on the wound is usually decreased for 5–7 days after plantar incision. Other studies using the plantar incision pain model have also used a distant secondary mechanical withdrawal threshold, weight bearing and pressure pain threshold (Table 2) [5].

Mouse models of postoperative pain using plantar incision have also been described. The behaviors caused by plantar incision in the mouse roughly parallel those in the rat. However, guarding pain behaviors are not as evident in the mouse [6,7].

#### **Hairy Skin Incisions**

Most surgery is performed in hairy skin in humans. The innervations of hairy skin and glabrous skin are different. In the first hairy skin incision model, a 1-cm-long incision was made in the skin of the hindquarter. The withdrawal threshold to mechanical stimulation produced by calibrated monofilaments was measured. Withdrawal responses to punctate stimulation by von Frey hairs adjacent and distant to the incision were maximally decreased 30 min after the incision was performed. These exaggerated responses were sustained for at least 4 days [8].

A recent study by Duarte et al. examined several new tests for pain following a hairy skin incision on the paraspinal region of the rat (Table 2) [9]. First, the intensity of the response was measured, rather than an “all or none” response. Second, the responses were separated into allodynic-like and hyperalgesic-like responses based upon careful characterization of the stimuli. Finally, in this model, the regions of primary and secondary hypersensitivity are easily distinguished and these had distinctive time courses and unique responses to treatments. The model allows comparisons to a variety of tests; primary (the incised region) and secondary (remote to the incision) responses and the intensity of the responses can also be measured.

#### **Laparotomy Models for Postoperative Pain**

The initial postoperative models developed for incisional pain were laparotomy models like ovariohysterectomy. Mechanical nociceptive thresholds distant to the incision were measured using a paw pressure test and a reduced threshold was observed after laparotomy

(Table 2). In a new rat model, a subcostal incision that penetrated into the peritoneal cavity was performed. Exploratory locomotor activity, ambulation and rearing were decreased by laparotomy. Laparotomy also decreased conditioned operant responses and food-maintained behavior after surgery [5,10].

#### **Sensitization of Pain Pathways by Incisions**

The basis for pain-related behaviors is activation and sensitization of nociceptive pathways. Primary afferent nociceptors are an ideal target to better understand acute pain mechanisms and hyperalgesia. The characteristic features of experimentally-induced peripheral sensitization of primary afferent fibers are a lowering of response threshold, an increase in response magnitude to suprathreshold stimuli, enlarged receptive fields, or an increase in spontaneous activity. Evidence for these types of changes occurs after incisions; thus, the mechanisms that subserve incisional pain at the level of the primary afferent fiber are beginning to be understood.

Central nervous system dorsal horn neurons are also activated and sensitized by incisions. Results from recordings of dorsal horn neurons demonstrate that an incision causes activation of dorsal horn neurons. Dorsal horn neurons have increased background activity that is driven by activated primary afferent fiber and likely transmits evidence for non-evoked ongoing pain (e.g., guarding behaviors). Because the threshold of all dorsal neurons does not decrease to the range of the withdrawal responses in behavioral experiments, only certain dorsal horn neurons likely contribute to the reduced mechanical withdrawal threshold observed in behavioral experiments.

#### **Conclusion**

There are advantages of incision models of postoperative pain compared to clinical studies. First, some mechanistic studies that can not be performed in humans can be undertaken in experimental models. Second, clinical studies utilize a particular intervention to modify two variables: pain score(s) and opioid utilization. Studies examining novel pain treatments can result in a mixed effect: a reduction in opioid utilization with the same pain score(s), or a reduced pain score and the same opioid requirement. In models of incisional pain, a behavioral assessment of pain-related behavior usually can be made independent from rescue analgesic treatments. Of course, in animal models, in the event behaviors suggesting uncontrolled pain occur, analgesic treatments are always available.

#### **References**

1. Berde CB, Brennan TJ, Raja SN (2003) Opioids: more to learn, improvements to be made. *Anesthesiology* 98:1309–1312

2. Brennan TJ, Zahn PK, Pogatzki-Zahn EM (2005) Mechanisms of incisional pain. *Anesth Clin N Am*. Edited by Joshi GP, A. FL. Philadelphia, Saunders, pp 1–20
3. Meyer RA, Rainkamp M, Campbell JN, Raja SN (2006) In: McMahon SB, Koltzenburg M (eds) *Peripheral mechanisms of cutaneous nociception*, Textbook of pain, 5th edn. Elsevier, Philadelphia, PA, pp 3–34
4. Zahn PK, Brennan TJ (1999) Primary and secondary hyperalgesia in a rat model for human postoperative pain. *Anesthesiology* 90:863–872
5. Brennan TJ (2005) Incisional sensitivity and pain measurements – Dissecting mechanisms for postoperative pain. *Anesthesiology* 103:3–4
6. Pogatzki EM, Raja SN (2003) A mouse model of incisional pain. *Anesthesiology* 99:1023–1027
7. Banik RK, Woo YC, Park SS, Brennan TJ (2006) Strain and sex influence on pain sensitivity after plantar incision in the mouse. *Anesthesiology* 105:1246–1253
8. Kawamata M, Koshizaki M, Shimada SG, Narimatsu E, Kozuka Y, Takahashi T, Namiki A, Collins JG (2005) Changes in response properties and receptive fields of spinal dorsal horn neurons in rats after surgical incision in hairy skin. *Anesthesiology* 102:141–151
9. Duarte AM, Pospisilova E, Reilly E, Mujenda F, Hamaya Y, Strichartz GR (2005) Reduction of postincisional allodynia by subcutaneous bupivacaine: findings with a new model in the hairy skin of the rat. *Anesthesiology* 103:113–125
10. Martin TJ, Kahn WR, Eisenach JC (2005) Abdominal surgery decreases food-reinforced operant responding in rats: relevance of incisional pain. *Anesthesiology* 103:629–637

justification is defeasible, i.e. undeterminable by further evidence.

► Knowledge

## Indeterministic Causation

### Definition

Causation other than deterministic causation.

► Freedom of Will

## Indeterministic Universe

### Definition

A universe of which determinism is false.

► Freedom of Will

## Incompatibilism

### Definition

The thesis that acting freely is incompatible with the truth of determinism.

► Freedom of Will

## Individual Recognition

### Definition

Some animals are able to recognize individuals. This is especially important for animals living in a pack like wolves or animals living in hierarchical structures.

## Indefeasibility Theories

### Definition

These theories claim that knowledge is (more or less) nothing but indefeasibly (sometimes also called “Defeasibility Theories”) justified true belief. There are several different attempts to specify when a

## Individuation of Finger Movement

### Definition

The extent to which a given digit can be moved voluntarily without motion of other digits.

► Motor Cortex – Hand Movements and Plasticity

## Indoleamine 2,3-dioxygenase or Indoleamine-pyrrole 2,3-dioxygenase (IDO or INDO EC 1.13.11.42)

### Definition

Indoleamine 2,3-dioxygenase or Indoleamine-pyrrole 2,3-dioxygenase (IDO or INDO EC 1.13.11.42) is an immuno-modulatory enzyme secreted by some alternatively activated macrophages and other immuno-regulatory cells (also used as an immune subversion strategy by many tumors or viruses). This enzyme catalyzes the degradation of the essential amino acid L-tryptophan to N-formylkynurenine. IDO is the first and rate-limiting enzyme of tryptophan catabolism through the kynurenine pathway, thus causing depletion of tryptophan, which can cause halted growth of microbes as well as T cells.

► Neurodegenerative Diseases: Tryptophan Metabolism

## Induced Activity (Novel Wheel)

### Definition

Induced activity, either by confining an animal to a running wheel or by presentation of a novel running wheel, is a non-photoc stimulus that can have substantial effects on the circadian clock. Induced activity can produce phase shifts as large as those produced by light, depending on the time of day of confinement to the novel wheel and the rodent species. The phase-response curve of novelty-induced wheel running is different from that of light, with exposure during the day resulting in phase advance, while exposure during the subjective night produces phase delays. It is not known what aspect of induced activity cause phase shift. The amount of activity induced is a good predictor of the magnitude of the phase shift with greater activity tending to produce greater phase shifts. Photoc and non-photoc responses can interact to alter the magnitude of a phase shift.

► Clock  
► Masking (Positive/Negative)

## Inducible Nitric-Oxide Synthase (iNOS)

### Definition

The inducible isoform of nitric-oxide synthase (NOS) is also known as NOS2. The iNOS enzyme catalyzes the NADPH-dependent oxidation of L-arginine to nitric oxide and citrulline. In most cell types iNOS levels are either very low or undetectable. However, stimulation of these cells with cytokines, growth factors or traumatic insult leads to increased transcription of the iNOS gene with subsequent production of high concentrations of NO.

## Inertia

### Definition

The proportionality constant for a linear dynamical system that relates the force (or torque) produced in response to an imposed acceleration.

► Impedance Control

## Infant-directed Speech

### Definition

Speech directed to infants and young children (“motherese,” “baby talk”) differs from speech directed to adults in speed (slow pacing), in phonology (exaggerated intonation and stress), as well as in syntax and semantics (short, simplified sentences). Not only parents, but all adults simplify their speech when talking to infants, and young children do, too.

Motherese is helpful in enhancing infants’ interest in speech, in helping infants make phonological distinctions, and in helping them segment utterances at the boundaries between clauses.

► Cognitive Development

## Infant Psychology

### Definition

The scientific study of cognitive, emotional, and motor development in human infants (i.e. in the first two years

of life). It addresses the infants' psychological functioning at birth, the development of these functions, the role of the environment in development, as well as the infants' developing ability to engage in social interaction with caretakers.

► Cognitive Development

## Infarction

### Definition

Tissue death because of loss of vascular supply to involved tissue.

## Infectious Encephalomyelitis

### Definition

Inflammation involving both the brain and the spinal cord due to infection by micro-organisms.

## Infectious Meningitis

### Definition

Inflammation of the meninges due to infection by micro-organisms.

## Inference

► Argument

## Inferior Cerebellar Peduncle

### Synonyms

Pedunculus cerebellaris inf.; Inferior cerebellar

### Definition

peduncle Afferents: olivocerebellar tract (from olive), posterior spinocerebellar tract (from spinal cord, trunk) vestibulocochlear tract (directly and via vestibular nuclei), cuneocerebellar tract (from cuneate nucleus, neck), trigemino-cerebellar tract (face). Efferents to vestibular nuclei: cerebellovestibular tract (directly from cerebral cortex), uncinata fasciculus (from fastigial nucleus).

► Cerebellum

## Inferior Colliculus

DOUGLAS L. OLIVER

University of Connecticut Health Center, Department of Neuroscience, Farmington, CT, USA

### Synonyms

Posterior colliculus; Corpora quadrigemina

### Definition

The ►inferior colliculus (IC) is the main component of the ►central auditory system located in the ►midbrain (►mesencephalon). The dorsal portion of the midbrain, the ►tectum, contains four protrusions, the ►corpora quadrigemina. The two caudal protuberances are the IC, while the anterior protuberances are the ►superior colliculi. In the human, the IC is often called the ►posterior colliculus. The IC receives inputs from virtually all parts of the central auditory system. The main output is to the ►medial geniculate body in the thalamus, but other smaller outputs to the superior olive and cochlear nucleus are found.

### Characteristics

#### Higher Level Components

The IC is subdivided into a ►central nucleus and a cortex that covers the dorsal, caudal, and lateral surfaces [1]. The IC is dorsal to the midbrain ►tegmentum, medial to the ►central gray, and caudal to the ►intercollicular tegmentum (►intercollicular area) that separates the IC and the superior colliculus. The ►brachium of the IC and its nucleus contain the main output fibers of the IC that ascend to the thalamus.

The central nucleus, the main part of the IC, is defined by the presence of ►fibro-dendritic laminae. These are narrow layers (<200 µm thick) formed by the principal neuron type and the axons of the major inputs from the lower brainstem auditory system. The

principal neurons are flat, ▶disc-shaped cells with dendritic fields only 50–70 μm thick, while the other dimensions of the dendritic field range from 300–1,000 μm [2]. To form the laminae, the flat surfaces of the dendritic fields parallel each other. About 80% of the neurons in central nucleus are disc-shaped. Depending on the species, the non-disc-shaped neurons have dendrites that are unoriented or perpendicular to the laminae (▶stellate neurons), or ‘less-flat’ neurons with dendrites oriented parallel to the laminae. Axons of central nucleus cells often have local collaterals that terminate within central nucleus, but a specific cell type has not been identified as an interneuron. Local axons of disc-shaped neurons are confined to the neuron’s own lamina. The axons in the fibro-dendritic laminae form layers approximately 200 μm thick in parallel to the dendritic fields of the disc-shaped cells. Laminar axons in the central nucleus originate from the ▶dorsal and ▶ventral cochlear nucleus, ▶medial and ▶lateral superior olivary nuclei, the ▶dorsal and ▶ventral nuclei of the lateral lemniscus, and the contralateral IC. The fibro-dendritic laminae create the anatomical substrate for ▶tonotopic organization in the central nucleus.

The ▶dorsal cortex is usually regarded as a separate anatomical and functional area in the IC and is similar to the thin, less well-studied, caudal cortex. Dorsal cortex is dorsomedial to the central nucleus in most species, usually thicker in the rostral part of the IC. Unlike the central nucleus, the dorsal cortex has poorly defined layers parallel to the surface of the IC, and is composed of stellate and oriented neurons. A comparison of the superficial dorsal cortex (also called pericentral in the older literature) and deeper dorsal cortex (previously called dorsomedial nucleus of central nucleus) shows that the neurons in the deeper portions tend to be larger, although the size changes are gradual. The deepest parts of dorsal cortex receive inputs from the primary auditory neocortex (A1), cochlear nucleus, and contralateral IC. This is the main region in IC where both ascending and descending inputs may interact. More superficial layers of dorsal cortex receive inputs exclusively from the non-primary, belt regions of auditory neocortex, and they lack the inputs from the lower brainstem.

The ▶lateral cortex, identified by many different names, may integrate auditory activity with that in other sensory systems. Lateral cortex is part of a larger, heterogeneous region called the external nucleus in the older literature, which included all of the areas rostral and lateral to central nucleus (see intercollicular tegmentum). The deep part of the lateral cortex receives inputs from the lower brainstem auditory structure and from the somatosensory system (spinal cord, dorsal column nuclei, and trigeminal system), and is part of an extralemiscal auditory pathway that may modulate auditory processing in the context of somatosensory activity. The superficial

lateral cortex and the nucleus of brachium of the IC are regions that receive their main inputs from the central nucleus of IC. In the barn owl, this region of lateral cortex contains a map of space [3]. This information is transmitted to the superior colliculus that controls ▶gaze, i.e. the movement of the head and eyes towards a visual target.

### Lower Level Components

*Neurons in the IC* are defined by morphology, neurotransmitter synthesis, axonal target, and responses to sound. The disc-shaped cell in central nucleus of IC does not represent a single cell type, but should be viewed as the common structural mode in the IC required for laminar organization. Both disc-shaped and stellate neurons project to the medial geniculate body, the main target of the IC. Specific cell types involved in projections to the superior olive, cochlear nucleus, and contralateral IC have not been identified.

The IC has both excitatory and inhibitory output neurons. Most IC neurons are likely to use glutamate as a neurotransmitter, since only 20% of the IC neurons synthesize GABA and none synthesizes glycine. There is no evidence of cholinergic or monoaminergic neurons in IC. However, 20–40% (depending on species) of the IC neurons that project to the medial geniculate body are GABAergic [4]. Parallel excitation and inhibition of the thalamus by the IC may be an important mode of action by the auditory system not evident in other sensory systems.

The *intrinsic membrane properties* can define IC neurons [5]. Firing patterns of IC neurons differ due to the presence of specific potassium currents in different cell types. About half the IC neurons respond to hyperpolarization with a Ca<sup>++</sup>-sensitive rebound depolarization; and they respond to depolarization with regular firing, transient responses (rapid adaptation) or slow adaptation. Different Ca<sup>++</sup>-activated potassium conductances cause the adaptation. Non-rebound neurons in IC include regular firing, pause-build, and onset firing patterns. Pause-build cells have an A-type potassium conductance, and onset cells have a high-threshold delayed rectifier conductance. The use of a GAD67-GFP knock-in mouse has allowed the initial investigation of the intrinsic properties in GABAergic IC neurons, and suggests that the non-rebound regular firing and pause-build cells are GABAergic [6]. Further work is required to clarify the neurotransmitters, morphology, and axonal targets of IC neurons with different membrane properties.

*Organization of inputs to the IC into synaptic domains.* The fibrodendritic laminae of the central nucleus appear to be further divided into two or more functional zones called synaptic domains [1]. While one frequency-band laminae contains axons with a similar range of best frequencies, the function in each zone may depend on the source of the axons from the auditory

brainstem. This creates synaptic domains that partition a lamina into dorsal-ventral parts or rostral-caudal parts. Some inputs, such as those from the dorsal cochlear nucleus, terminate over an entire lamina. Others from the lateral superior olive terminate ventrally in the high-frequency IC, and inputs from the medial superior olive terminate only in the low-frequency IC in the caudal half of the lamina. Since the olivary inputs are binaural, it suggests that there is a segregation of different types of monaural and binaural processing.

*The IC has both excitatory and inhibitory inputs that ascend from the lower auditory brainstem. Major excitatory, likely glutamatergic, inputs for monaural processing come from the cochlear nucleus; and the main excitatory input for binaural processing comes from medial superior olive. On the other hand, binaural inputs to the IC from the lateral superior olive contain at least three populations of neurons: glycinergic neurons that make inhibitory synapses in the ipsilateral IC and two sets of glutamatergic neurons that synapse in either the contralateral or ipsilateral IC. Thus, the action of this nucleus on the IC depends on which input from the lateral superior olive is in the domain. Another mixed excitatory-inhibitory input is that of the commissure from the opposite IC. About 25% of the commissural neurons that project to the opposite IC are GABAergic. Some IC inputs are exclusively inhibitory. The dorsal nucleus of the lateral lemniscus is a binaural nucleus, whose GABA-containing neurons project to the IC, and the inputs from the ventral nucleus of the lateral lemniscus (ventral complex of nuclei) come from neurons that co-localize both glycine and GABA.*

### Structural Regulation

Most of the molecular mechanisms that control the development of the IC remain to be determined. Since the final structure of the fibro-dendritic lamina is not complete until after the onset of hearing, activity-dependent processes may play an important role in regulation of the structure of the IC.

### Higher Level Processes

The fibro-dendritic laminae provide a structural basis for ► **tonotopic organization** in IC. In the IC of the cat, each layer is a ► **frequency-band lamina** that represents a step of roughly one-quarter of an octave in the ► **best frequency** of the neurons, the frequency where the response of the neuron is maximal in amplitude and minimal in threshold [7]. This range could differ in other species.

Neurons in the IC respond to the frequency and intensity of sound and exhibit ► **tuning curves** of different shape. “V-type” tuning curves are similar to those seen in the auditory nerve, where the neurons respond to a broader frequency range as sound intensity increases from the minimum intensity required to define the best

frequency. Other IC neurons have inhibitory areas in their tuning curves that modify the shape. “I-type” tuning curves have inhibitory side bands that prevent the spread of responses over a larger range as the sound intensity increases. Neurons with “O-type” tuning curves respond only to low intensity stimuli and are inhibited as the sound intensity increases.

Many neurons in the IC are part of the binaural system, due to inputs from the superior olivary complex, and they respond to ► **interaural time differences** (ITD) and ► **interaural level differences** (ILD). IC neurons have ITD curves that are narrower than those found in the superior olivary complex, and, thus, may respond to smaller locations in space along the azimuth.

IC neurons also respond to amplitude modulation, frequency modulation, the duration of the stimulus, and to novel stimuli [8]. Many of these responses to complex stimuli are monaural.

The IC is also involved in the control of the cochlea. Neurons in the central nucleus project to the periolivary regions of the superior olivary complex and control the responses of the medial ► **olivocochlear system**. The ventrolateral region of lateral cortex is implicated in the control of the lateral ► **olivocochlear system** [9].

### Lower Level Processes

Excitatory ► **synaptic transmission** in the IC most commonly uses glutamate as the neurotransmitter. All IC neurons appear to have receptors for AMPA and NMDA. Inhibitory synapses are found on all IC neurons and employ GABA-A or glycine receptors. Some IC neurons may also have receptors for nicotine (acetylcholine), serotonin, noradrenaline, or enkephalin.

### Process Regulation

Responses in the IC may be modified by pathology in the lower parts of the auditory system, especially in young animals. Some inputs from the cochlear nucleus on the side opposite an ablated cochlea in a young animal may expand their projection to the ipsilateral IC. Changes in the responses of the IC neurons in an adult animal may be influenced and controlled by inputs from the neocortex. Electrical stimulation of the cortex can modify the tuning of IC neurons [10].

### Function

The IC, as a part of the auditory pathway, is involved in hearing, auditory processing, and the efferent control of the cochlea.

### Pathology

Lesions of the IC may impair hearing and sound localization. In some species, loud sound will evoke ► **audiogenic seizures** that begin in the IC.

## References

1. Oliver DL (2005) Neuronal organization in the inferior colliculus. Chapter 2. In: Winer JA, Schreiner CE (eds) *The Inferior Colliculus*, Springer, Berlin Heidelberg New York, pp 69–114
2. Malmierca MS, Blackstad TW, Osen KK, Karagulle T, Molowny RL (1993) The central nucleus of the inferior colliculus in rat: a Golgi and computer reconstruction study of neuronal and laminar structure. *J Comp Neurol* 333:1–27
3. Knudsen EI, Konishi M (1978) A neural map of auditory space in the owl. *Science* 200:795–797
4. Peruzzi D, Bartlett E, Smith PH, Oliver DL (1997) A monosynaptic GABAergic input from the inferior colliculus to the medial geniculate body in rat. *J Neurosci* 17:3766–3777
5. Sivaramakrishnan S, Oliver DL (2001) Distinct K currents result in physiologically distinct cell types in the inferior colliculus of the rat. *J Neurosci* 21:2861–2877
6. Ono M, Yanagawa Y, Koyano K (2005) GABAergic neurons in inferior colliculus of the GAD67-GFP knock-in mouse: Electrophysiological and morphological properties. *Neurosci Res* 51:475–492
7. Schreiner CE, Langner G (1997) Laminar fine structure of frequency organization in auditory midbrain. *Nature* 388:383–386
8. Covey E, Casseday JH (1999) Timing in the auditory system of the bat. *Annu Rev Physiol* 61:457–476
9. Groff JA, Liberman MC (2003) Modulation of cochlear afferent response by the lateral olivocochlear system: activation via electrical stimulation of the inferior colliculus. *J Neurophysiol* 90:3178–3200
10. Suga N, Ma X (2003) Multiparametric corticofugal modulation and plasticity in the auditory system. *Nat Rev Neurosci* 4:783–794

## Inferior Frontal Gyrus

### Synonyms

Gyrus front. inf.

### Definition

The inferior frontal gyrus comprises the following:

- Inferior frontal gyrus, orbital part
- Inferior frontal gyrus, triangular part
- Inferior frontal gyrus, opercular part

In the areas of the frontal gyrus close to the precentral gyrus is situated the premotor cortex, which plays an important role in planning effector voluntary movements and has close interaction with the cerebellum, thalamic nuclei and basal ganglia.

In the inferior frontal gyrus, opercular part, lies the motor speech center (Broca). Here speech is planned but not executed. Damage to the inferior frontal gyrus

causes motor aphasia. Comprehension of spoken and written language is preserved, with mistakes occurring only on generating one's own language, whose severity correlates with the extent of damage and can range from impaired word-finding ability through agrammatism to complete loss of language.

► Telencephalon

## Inferior Oblique Muscle

### Definition

Inferior oblique is one of the six eye muscles.

► Eye Orbital Mechanics

## Inferior Olivary Nucleus

### Definition

A neuronal group in the medulla that is associated with the cerebellum. It is present in all vertebrates and is well developed in species with a large cerebellum. It is the source of the climbing fiber input to the cerebellar cortex. It receives input from many regions of the brain including the spinal cord, various cranial nerve nuclei, the motor system, and the cerebral cortex.

► Cerebellar Functions

► Evolution of the Cerebellum

## Inferior Olive

### Synonyms

Oliva inf

### Definition

A large nucleus directly beside the pyramid, on the lower margin of the pons. Part of the motor system. Afferents come from the red nucleus and, as collaterals, from the pyramidal tract, from the precentral gyrus (motor cortex). Efferents course as the olivocerebellar



tract to the contralateral cerebellum, thus participating in the feedback loops between cerebellum and cortex regulating movement coordination.

► Myelencephalon

## Inferior Parietal Lobule

### Synonyms

Lobulus parietalis inf.

### Definition

In the direction of the occipital pole, the inferior and superior lobules unite at the postcentral gyrus. Analogous to the secondary motor cortex there is also a secondary sensory cortex for the somatosensory control; this is believed to stretch across both lobules and to be responsible for analysis, recognition and assessment of tactile information.

While dysfunctions of this area do not undermine tactile perception, they do subvert the accompanying recognition, judgmental and associative processes. The ensuing condition is called tactile agnosia.

► Telencephalon

## Inferior Rectus

### Definition

Inferior rectus is one of the six eye muscles.

► Eye Orbital Mechanics

## Inferior Temporal Cortex

### Definition

This area is the underside of the temporal lobe comprised mainly of portions of the inferior temporal, fusiform (occipitotemporal) and parahippocampal gyri. This area contains many visual neurons thought to be involved in identifying specific objects.

## Inferior Temporal Gyrus

### Synonyms

Gyrus temporalis inf

### Definition

The inferior temporal gyrus lies on the lower edge of the parietal lobe, passing on the basal side to the occipitotemporal sulcus.

► Telencephalon

## Inferior Temporal Visual Cortex

► Face Processing in Different Brain Areas

## Inferior Vestibular Nucleus

### Synonyms

Nucl. vestibularis inf.

► Vestibular Nuclei (Medial, ► Superior, ► Inferior)  
► Pons

## Inflammation

### Definition

Inflammation is the first response of the immune system to infection or irritation and may be referred to as the innate cascade. Inflammation is characterized by the following quintet: redness (rubor), heat (calor), swelling (tumor), pain (dolor) and dysfunction of the organs involved (functio laesa).

► Neuronal Cell Death and Inflammation

## Inflammatory Cascade

### Definition

A sequence of cellular events following injury to the central nervous system. The sequence of events leads to cells being killed or damaged.

## Inflammatory Pain

MICHAEL R. VASKO

Department of Pharmacology and Toxicology, Indiana University School of Medicine, Indianapolis, IN, USA

### Definition

Inflammatory pain is the perception of and affective response to noxious stimuli that occur during an inflammatory or immune response.

### Characteristics

The inflammatory response represents a series of well orchestrated physiological processes that occur after injury or infection in an attempt to combat and resolve the pathology. It is characterized by five classic symptoms: redness (*rubor*), heat (*calor*), swelling (*tumor*), pain or hypersensitivity (*dolor*), and loss of function (*functio laesa*). Under normal conditions, ►inflammation is an important protective mechanism essential for wound healing. Despite this, acute inflammation produces overt pain through the direct activation of sensory neurons that conduct the pain signal (Fig. 1).

More frequently, inflammation results in a reduced threshold for activation of sensory neurons (principally nociceptors) and/or an increase in the firing of these neurons in response to a given stimulus (Fig. 1). This phenomenon is termed peripheral sensitization and causes an increase in sensitivity to noxious stimuli (hyperalgesia) or the perception of non-noxious stimuli as painful (allodynia) [see ►Hyperalgesia and Allodynia].

Of greater clinical concern, however, is chronic inflammatory pain which occurs in diseases like rheumatoid arthritis (an autoimmune disorder; see ►Immune System and Pain) and osteoarthritis. Chronic inflammatory pain can result from a sustained inflammatory or immune response and from changes in the expression of proteins that contribute to altered excitability of sensory neurons (Fig. 1). It is important to note that inflammation-induced increases in the firing of sensory neurons also may result in an augmentation of the

synaptic response that occurs in the dorsal horn of the spinal cord over time. This increase in synaptic activity is termed central sensitization and results in an increased responsiveness of dorsal horn nociceptive neurons to peripheral stimuli. Central sensitization is considered a major component of non-inflammatory chronic pain syndromes known as neuropathic pain syndromes ([1]; see also ►Neuropathic Pain). Although inflammatory and neuropathic pain may share some common mechanisms, they are generally thought of as separate entities both in terms of etiology and treatment.

Although a number of different cell types release inflammatory mediators that contribute to the inflammatory response, it is the activation of a subset of the small diameter sensory neurons (i.e., those associated with thinly myelinated A- $\delta$  fibers or unmyelinated C-fibers) that conduct noxious information from the periphery to the dorsal horn of the spinal cord. These specialized sensory neurons (nociceptors) have slow conduction velocities and are usually activated by high threshold thermal and/or mechanical stimuli or by chemical stimuli. Subsets of small diameter sensory neurons also conduct non-noxious thermal sensation or itch from the periphery to the dorsal horn of the spinal cord [see ►Nociceptors and Characteristics]. Although sensory neurons innervate cutaneous, muscle, joint and visceral tissues throughout the body, the cell bodies of these neurons are localized in the dorsal root ganglia (from the neck down), in the trigeminal ganglia for sensory neurons innervating the head and neck, and in the nodose ganglion for sensory neurons innervating much of the viscera. Sensory neurons innervating tissues have a single axon traversing from peripheral tissues to the dorsal horn of the spinal cord [see ►Visceral Pain re. Visceral Innervation]. These neurons also are called primary afferent neurons because their major function is to convey sensory information from the periphery directly to the spinal cord. However, these small diameter sensory neurons also release transmitters from their nerve endings in the periphery and thus subservise an efferent function (see below). Nociceptive sensory neurons form synaptic connections on nociceptive specific or wide dynamic range dorsal horn neurons in laminae I, II, and V of the spinal cord, which then conduct the nociceptive signal to supraspinal sites including brain stem nuclei, thalamus, hypothalamus, etc. [see ►Ascending Nociceptive Pathways].

### Activation of Nociceptive Sensory Neurons

Direct activation of sensory neurons occurs when thermal, mechanical, or chemical stimulation causes sufficient  $\square$  depolarization to result in the firing of an action potential (see Fig. 1). Stimuli that directly activate nociceptors include temperatures in excess of 42°C or below 17°C [2], high pressure mechanical stimuli,

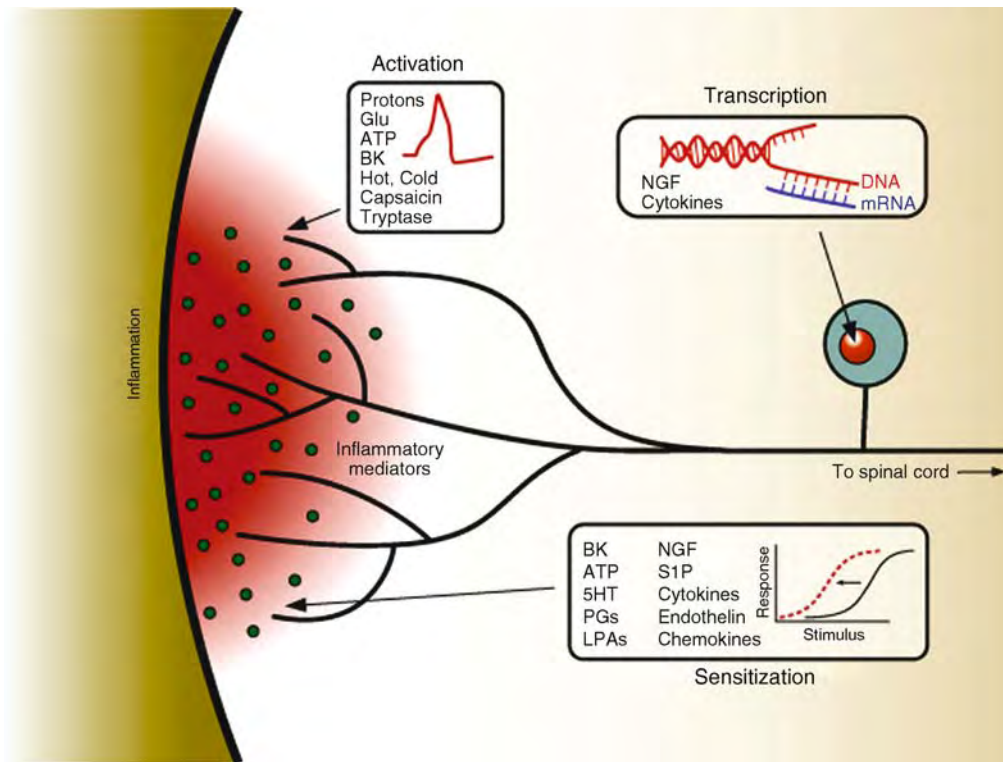

**Inflammatory Pain. Figure 1** Mechanisms for the initiation and maintenance of **inflammatory pain**. Inflammatory pain is initiated by activation of nociceptive sensory neurons by hot or cold thermal stimulation, by mechanical stimulation, or by inflammatory mediators as indicated. Depolarization of sensory nerve endings in the periphery generate action potentials that travel to the spinal cord, thus conveying the noxious information. Inflammatory mediators can also reduce the threshold of activation of nociceptive sensory neurons, thereby producing **peripheral sensitization** (see text). Maintaining sensitization occurs with a sustained inflammatory response and with an increase in transcription, resulting in enhanced expression of proteins that regulate the excitability of sensory neurons. (Abbreviations: *Glu*, glutamate; *ATP*, adenosine triphosphate; *Bk*, bradykinin; *5Ht*, 5-hydroxytryptamine; *PGs*, prostaglandins; *LPAs*, lysophosphatidic acids; *NGF*, nerve growth factor; *S1P*, sphingosine 1-phosphate).

and an increase in the concentration of protons. In addition, a number of putative inflammatory mediators including (but not limited to) ATP, bradykinin, proteinases, and endovanilloids are released during inflammation and directly activate sensory neurons. The depolarizing effects of heat, protons and endovanilloids on a subset of nociceptive sensory neurons are mimicked by exogenous administration of capsaicin, the active ingredient in hot peppers. Depolarization of sensory nerve endings by inflammatory mediators results from activation of distinct receptors which increase their permeability to cations and thus generate inward currents. Prominent receptors include transient receptor potential (TRP) channels such as TRPV1 (activated by capsaicin, heat, protons) and TRPA1 (activated by cold). Additional receptors include acid sensing ion channels activated by protons, P2X channel receptors activated by ATP, proteinase-activated receptors activated by trypsin or tryptase, nicotinic acetylcholine receptors, glutamate receptors, and bradykinin receptors. Once nociceptors are depolarized, action

potentials travel from the periphery to the dorsal spinal cord. In sensory nerve terminals in the spinal cord, the incoming action potentials depolarize their central nerve terminals, causing release of neurotransmitters such as glutamate, **substance P (SP)** and **calcitonin gene-related peptide (CGRP)**. Once released, these transmitters activate receptors on dorsal horn neurons which depolarize these cells. Thus, in the conduction of pain information from the site of injury or inflammation, sensory neurons transduce mechanical, thermal, or chemical energies into electrical signals which are then converted, by release of transmitters, to a chemical signaling process in the spinal cord.

Small diameter sensory neurons also release neurotransmitters from their peripheral endings and this release contributes to the inflammatory response. For example, the release of SP from peripheral sensory endings contributes to plasma extravasation in part by degranulating mast cells, whereas CGRP release results in a direct action on the vasculature and local vasodilation [3]. This neural component of the

inflammatory response is termed neurogenic inflammation. The release can be the result of local depolarization of nerve endings accompanied by an influx of extracellular calcium. It has long been proposed that depolarization of one branch of a sensory neuron not only results in conduction of action potentials toward the spinal cord, but also action potential invasion of nerve terminal branches that travel antidromically (i.e., from a more proximal to distal site) and thus depolarize and release transmitter(s) from other peripheral branches of the same sensory neuron [4]. This “▶axonal reflex” is postulated to account for the classic flare that is observed in cutaneous regions near the site of local injection of histamine or other inflammatory mediators ([5]; see also ▶Nociceptors and Characteristics).

Another proposed mechanism for producing neurogenic inflammation is through ▶dorsal root reflexes, which are action potentials that travel from the spinal cord to the periphery after depolarization of central endings of ▶sensory neurons [6]. Indeed, it has long been appreciated that high threshold stimulation of dorsal roots of sensory neurons results in peripheral vasodilation [7]. Furthermore, electrophysiological evidence shows that sensory nerve endings in the spinal cord and dorsal roots can be depolarized by gamma aminobutyric acid; a phenomenon known as primary afferent depolarization. Although dorsal root reflexes are observed under experimental conditions, their relative importance in generating neurogenic inflammation *in situ* remains a point of debate.

### Peripheral Sensitization

Although injury results in direct firing of small diameter sensory neurons, it is peripheral sensitization that appears the most important mechanism for generating and maintaining ▶hypersensitivity during inflammation. The increased sensitivity of small diameter sensory neurons reduces their threshold of firing and augments transmitter release from both their peripheral and central terminals. The clinical consequences of peripheral sensitization are neurogenic inflammation, hyperalgesia and/or allodynia. For example, under normal conditions, a temperature below 40°C is perceived as warm (non-noxious) rather than hot (noxious). However, if an individual has a cut or burn that causes an inflammatory response, the 40°C stimulus is perceived as hot and painful. In a similar manner, non-noxious or mildly noxious mechanical stimuli also may be perceived as noxious.

A number of inflammatory mediators do not produce overt pain, but rather cause peripheral sensitization (see Fig. 1). These agents act by binding to receptors on sensory neurons which in turn activate signal transduction cascades that cause posttranslational modifications of ion channels and/or other proteins that increase excitability of sensory neurons [8]. The classic

inflammatory mediators that produce peripheral sensitization are the prostaglandins, PGE<sub>2</sub> and PGI<sub>2</sub>. These compounds are synthesized and released in response to acute injury and/or after chronic inflammation by the actions of cyclooxygenases on arachidonic acid. Indeed, the major mechanism to explain the analgesic actions of aspirin and other nonsteroidal anti-inflammatory drugs is inhibition of cyclooxygenases, which prevents prostaglandin synthesis [9]. There are a number of additional compounds synthesized and released during inflammation that contribute to peripheral sensitization. These include cytokines and chemokines, nerve growth factor and other trophic factors, lysophosphatidic acids, sphingosine 1-phosphate, 5-hydroxytryptamine, and endothelin-1 (see Fig. 1). Furthermore, agents that directly depolarize sensory neurons such as ATP and bradykinin also alter the sensitivity of these neurons to other stimuli. Their direct versus sensitizing actions depend on their concentration and on the relative expression of different receptors on sensory neurons. For example, ATP induces inward currents in sensory neurons by binding to P2X receptors (ligand-gated ion channels), but this nucleotide also binds to P2Y receptors (G-protein coupled receptors; GPCRs) and alters the sensitivity of nociceptive sensory neurons.

Based on the accumulated evidence, peripheral sensitization is mediated largely by posttranslational modifications of surface receptors and ion channels which alter the excitability of sensory neurons. Inflammatory mediators drive these alterations by activation of various signal transduction cascades. For example, pro-inflammatory prostaglandins bind to specific GPCRs that are linked to an increase in cAMP production with activation of protein kinase A and exchange factors activated by cAMP (Epacs). Bradykinin and ATP binding to their GPCRs increase the activity of phospholipase C $\beta$ , which liberates inositol trisphosphate (IP3) that releases calcium from intracellular stores and diacylglycerols (DAGs) that activate protein kinase C (PKC). Protein kinase A and PKCs, in turn, phosphorylate voltage-gated and ligand-gated ion channels that enhance excitability of sensory neurons [10]. Chemokines, lysophosphatidic acids and sphingosine 1-phosphate also bind to GPCRs expressed on sensory neurons, although the signaling pathways and effects for these inflammatory mediators are yet to be determined. Other inflammatory mediators, such as nerve growth factor (NGF) and cytokines, cause peripheral sensitization by binding to tyrosine kinase receptors or TNF-like receptors, thereby activating a number of downstream signaling pathways involved with posttranslational modification of proteins in sensory neurons. Effectors activated by NGF and cytokine receptors include phospholipase C $\gamma$ , PI3 kinases, and small G-proteins such as ras. The activation of PLC $\gamma$  liberates IP3 and DAGs, while PI3 kinases activate

another protein kinase, AKT, and small G-proteins activate MAP kinases (p38, ERKs, JNKs).

Peripheral sensitization is maintained during chronic inflammation by two major factors: a maintenance of inflammatory and/or immune response over time, and the ability of inflammatory mediators to increase gene expression of neurotransmitters, receptors, or channel proteins that increase the excitability of nociceptive sensory neurons (Fig. 1). Both cytokines and NGF bind to their respective receptors and activate various transcription factors. In addition, inflammatory mediators that increase cAMP levels in sensory neurons also may increase gene expression by activation of the transcription factor CREB (cAMP response element binding protein). Cytokines contribute to maintaining hypersensitivity by increasing the expression of an inducible form of cyclooxygenase (COX2) in various tissues with a concomitant increase in prostaglandin production. Both inflammation and exogenous administration of NGF increase the expression of SP and CGRP in sensory neurons, and this increase can augment release of these peptides in the periphery and the spinal cord. Recent evidence also suggests that inflammation increases expression of ligand-gated and voltage-gated ion channels in sensory neurons. Whether these alterations in gene expression only affect the sensitivity of small diameter nociceptive sensory neurons or recruit large diameter touch and proprioceptive sensory fibers to conduct noxious information is yet to be determined.

► **Voltage-gated Sodium Channels: Multiple Roles in the Pathophysiology of Pain**

## References

- Campbell JN, Meyer RA (2006) Mechanisms of neuropathic pain. *Neuron* 52:77–92
- Patapoutain A, Peier AM, Story GM, Viswanath V (2003) Thermotropic channels and beyond: mechanisms of temperature sensation. *Nat Rev Neurosci* 4:529–539
- Holzer P (1988) Local effector functions of capsaicin-sensitive sensory nerve endings: involvement of tachykinins, calcitonin gene-related peptide and other neuropeptides. *Neuroscience* 24:739–768
- Bruce N (1913) Vaso-dilator axon-reflexes. *J Exp Physiol* 6:48–58
- Langley JN (1923) Antidromic action. Part 1. *J Physiol* 57:428–446
- Willis WD Jr (1999) Dorsal root potentials and dorsal root reflexes: a double-edged sword. *Exp Brain Res* 124:395–421
- Bayliss WM (1901) On the origin from the spinal cord of the vaso-dilator fibres of the hind-limb, and on the nature of these fibres. *J Physiology* 26:173–209
- Richardson JD, Vasko MR (2002) Cellular Mechanisms of Neurogenic Inflammation. *J Pharmacol Exp Ther* 302:839–845
- Vane JR (1971) Inhibition of prostaglandin synthesis as a mechanism of action for aspirin-like drugs. *Nat New Biol* 231:232–235
- Bhave G, Gereau (2004) Posttranslational mechanisms of peripheral sensitization. *J Neurobiol* 61:88–106

## Influence of Ca<sup>2+</sup> Homeostasis on Neurosecretion

AMY TSE, ANDY K. LEE,  
VALERIE YEUNG-YAM-WAH, FREDERICK W. TSE  
Department of Pharmacology, Centre for Neuroscience,  
University of Alberta, Edmonton, AB, Canada

### Synonyms

Ca<sup>2+</sup> clearance; Exocytosis

### Definition

Ca<sup>2+</sup> homeostasis refers to the ability of cells to regulate the cytosolic concentration of Ca<sup>2+</sup>; neurosecretion refers to the secretion of hormone and neurotransmitters from neurons and neuroendocrine cells.

### Characteristics

#### Multiple Mechanisms Determine the Time Course of the Cytosolic Ca<sup>2+</sup> Clearance

In most neurons and neuroendocrine cells, agonist stimulation frequently elicits a rise in cytosolic Ca<sup>2+</sup> concentration ([Ca<sup>2+</sup>]<sub>i</sub>). The amplitude and duration of the agonist-induced Ca<sup>2+</sup> signals in turn regulate exocytosis of hormone or neurotransmitter containing granules. The shape of the Ca<sup>2+</sup> signal is regulated by multiple mechanisms. The rising phase of the agonist-induced Ca<sup>2+</sup> signal is mainly determined by the amount of Ca<sup>2+</sup> entry via voltage-gated Ca<sup>2+</sup> channels (VGCCs) or Ca<sup>2+</sup> release from endoplasmic reticulum (ER) stores (e.g. the inositol trisphosphate (IP<sub>3</sub>) stores and the ryanodine-sensitive Ca<sup>2+</sup> stores). Following Ca<sup>2+</sup> release from ER stores, the activation of capacitance or non-capacitance entry of extracellular Ca<sup>2+</sup> is important for the refilling of the ER stores. The decay phase of the Ca<sup>2+</sup> signal is regulated by endogenous Ca<sup>2+</sup> buffers and four Ca<sup>2+</sup> clearance mechanisms: mitochondria, plasma membrane ►Na<sup>+</sup>-Ca<sup>2+</sup> exchanger (NCX), plasma membrane Ca<sup>2+</sup>-ATPase (PMCA) and ►sarco-endoplasmic reticulum Ca<sup>2+</sup>-ATPase (SERCA) pumps (Fig. 1).

The influence of VGCCs and intracellular Ca<sup>2+</sup> release in shaping the Ca<sup>2+</sup> signal and triggering of exocytosis has been well documented in many cell types. Recently, there is increasing evidence that endogenous Ca<sup>2+</sup> buffers and Ca<sup>2+</sup> clearance mechanisms

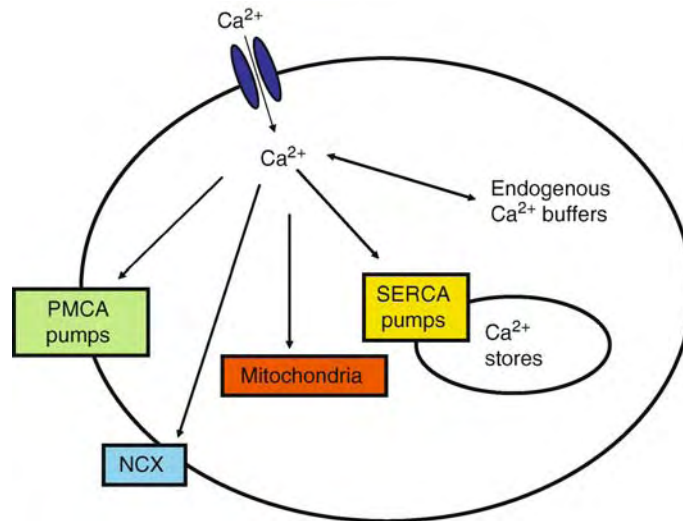

**Influence of  $\text{Ca}^{2+}$  Homeostasis on Neurosecretion. Figure 1** Multiple  $\text{Ca}^{2+}$  clearance mechanisms. When extracellular  $\text{Ca}^{2+}$  enters the cell (e.g. via VGCCs), some  $\text{Ca}^{2+}$  are rapidly bound by endogenous  $\text{Ca}^{2+}$  buffers and some are taken up by mitochondria or pumped into the intracellular  $\text{Ca}^{2+}$  stores via SERCA pumps. The removal of  $\text{Ca}^{2+}$  from the cytosol to the extracellular space by PMCA pumps and NCX on the plasma membrane further lowers the cytosolic  $\text{Ca}^{2+}$  concentration.

can influence the shape of the  $\text{Ca}^{2+}$  signal and thus affect exocytosis. Different cell types appear to utilize various combinations of  $\text{Ca}^{2+}$  buffers and  $\text{Ca}^{2+}$  clearance mechanisms to regulate their  $\text{Ca}^{2+}$  signals. In this chapter, we shall discuss the relative contribution of these mechanisms to the  $\text{Ca}^{2+}$  dynamics and secretion in neurons, neuroendocrine and endocrine cells.

### Endogenous $\text{Ca}^{2+}$ Buffers

When extracellular  $\text{Ca}^{2+}$  enters the cell (e.g. via VGCCs), only a very small fraction ( $\sim 1\text{--}5\%$ ) ends up as free  $\text{Ca}^{2+}$ . A large fraction of the  $\text{Ca}^{2+}$  is rapidly and reversibly bound to endogenous  $\text{Ca}^{2+}$  buffers. Multiple types of  $\text{Ca}^{2+}$  buffers are present in neurons and neuroendocrine cells. In general, they can be classified as mobile or immobile  $\text{Ca}^{2+}$  buffers. Immobile endogenous  $\text{Ca}^{2+}$  buffers refer to buffers which do not wash out of the cytoplasm during whole-cell patch clamp recording (via diffusion into the recording electrode). The very slow mobility of these  $\text{Ca}^{2+}$  buffers suggests that they either have a large molecular mass or that they are anchored to some proteins (thus preventing diffusion). The immobile  $\text{Ca}^{2+}$  buffers have low  $\text{Ca}^{2+}$  binding affinities (several  $\mu\text{M}$ ) and their molecular identity remains unclear. Because of their overall properties, the immobile  $\text{Ca}^{2+}$  buffers are postulated to be important in maintaining the  $\text{Ca}^{2+}$  microdomains near the VGCCs. In contrast, the mobile  $\text{Ca}^{2+}$  buffers are diffusible and they may contribute to the acceleration in the collapse of the  $\text{Ca}^{2+}$  microdomains following the closure of VGCCs. Examples of mobile endogenous  $\text{Ca}^{2+}$  buffers include the

cytosolic proteins calbindin D-28k and parvalbumin. The  $\text{Ca}^{2+}$  affinity of these mobile buffers is in the nM to  $\mu\text{M}$  range, similar to the well known exogenous  $\text{Ca}^{2+}$  buffers, EGTA and BAPTA. Calbindin D-28k has fast  $\text{Ca}^{2+}$  binding kinetics and it reduces the amplitude of the depolarization-triggered  $\text{Ca}^{2+}$  signal as well as slows the decay of the  $\text{Ca}^{2+}$  transient. In contrast, the slower  $\text{Ca}^{2+}$  binding buffer, parvalbumin does not affect the amplitude of the  $\text{Ca}^{2+}$  signal but accelerates the decay of the  $\text{Ca}^{2+}$  transient.

The literature shows that the mobile  $\text{Ca}^{2+}$  buffers play important roles in the modulation of short-term facilitation of transmitter release in synapses. Short-term synaptic plasticity is typically estimated by paired-pulse facilitation. This procedure involves the delivery of a pair of presynaptic action potentials within a short time ( $< 1$  s) interval. An increase in the amplitude of the second postsynaptic potential when compared with the first postsynaptic potential reflects facilitation. As the time interval between the two presynaptic action potential increases, there is a gradual reduction in facilitation (referred as the decay in facilitation). Multiple mechanisms have been proposed to underlie paired-pulse facilitation, including the “residual  $\text{Ca}^{2+}$  accumulation” model and the “partial  $\text{Ca}^{2+}$  buffer saturation” model [1]. According to the “residual  $\text{Ca}^{2+}$  accumulation” model, the decaying  $\text{Ca}^{2+}$  signal (residual  $\text{Ca}^{2+}$ ) from the first presynaptic action potential adds to the amplitude of the  $\text{Ca}^{2+}$  signal triggered during the second one, thus increasing transmitter release and results in a larger amplitude in the second postsynaptic potential. The “residual  $\text{Ca}^{2+}$  accumulation” model also

suggests that a slow Ca<sup>2+</sup> buffer such as EGTA can reduce residual Ca<sup>2+</sup> and blocks paired-pulse facilitation. In contrast, the “partial Ca<sup>2+</sup> buffer saturation” model proposes that Ca<sup>2+</sup> entry after the first presynaptic action potential causes a progressive and local saturation of the fast endogenous Ca<sup>2+</sup> buffers at the release site, resulting in a larger local [Ca<sup>2+</sup>]<sub>i</sub> rise during the second presynaptic action potential and thus more transmitter release. According to the “partial Ca<sup>2+</sup> buffer saturation” model, the fast Ca<sup>2+</sup> buffers can effectively compete with the Ca<sup>2+</sup> sensor (e.g. synaptotagmin) for binding to Ca<sup>2+</sup>. The fast Ca<sup>2+</sup> binding kinetics of calbindin D-28k makes it a suitable candidate for this model. Consistent with this notion, paired-pulse facilitation in some synapses, including the hippocampal and cortical synapses have been shown to be dependent on calbindin D-28k [2]. Although the slow Ca<sup>2+</sup>-binding kinetics of parvalbumin does not fit the profile of the fast Ca<sup>2+</sup> buffer in the “partial Ca<sup>2+</sup> buffer saturation” model, a recent study in the Calyx of Held synapse [3] has shown that parvalbumin which accelerates the decay of the Ca<sup>2+</sup> transient, does not affect the amplitude of the paired-pulse facilitation but accelerates the decay of the facilitation (see above). This finding suggests that parvalbumin may be important in limiting residual Ca<sup>2+</sup> accumulation between a pair of presynaptic action potentials. Thus, both fast and slow mobile Ca<sup>2+</sup> buffers may modulate short-term facilitation in synapses. Since the expression of the various Ca<sup>2+</sup> buffers in synapses changes with development and the dominant Ca<sup>2+</sup> buffer is different among the various types of synapses, an important challenge in future research is to understand how the various immobile and mobile endogenous Ca<sup>2+</sup> buffers interplay to shape the Ca<sup>2+</sup> signal and influence synaptic transmission in different synapses.

### Mitochondria

Mitochondria are the major supplier of cellular ATP. It is well known that ATP is essential for the increased metabolic demand during the different processes of secretion including exocytosis, endocytosis and granule mobilization. The metabolic role of mitochondria in neurotransmitter release will not be addressed here. Instead, this section will discuss the influence of mitochondria in the shaping of the Ca<sup>2+</sup> signals which in turn regulates secretion. Ca<sup>2+</sup> uptake into the mitochondria is regulated by the ►mitochondrial uniporter and is driven by the large (150–200 mV) inside-negative mitochondrial membrane potential. Because of the low Ca<sup>2+</sup>-affinity of the uniporter (K<sub>d</sub> > 10 μM at physiological Mg<sup>2+</sup> concentration), it has been long believed that mitochondrial Ca<sup>2+</sup> uptake occurs only in conditions of cellular Ca<sup>2+</sup> overload. However, it is now clear that in many cell types, mitochondria are in close apposition to VGCCs and/or ER stores such that the

generation of Ca<sup>2+</sup> microdomains during the opening of VGCCs or Ca<sup>2+</sup> release from ER stores triggers mitochondrial Ca<sup>2+</sup> uptake. When [Ca<sup>2+</sup>]<sub>i</sub> decays, Ca<sup>2+</sup> in the mitochondria is extruded into the cytoplasm via the actions of the mitochondrial Na<sup>+</sup> Ca<sup>2+</sup> exchanger and possibly via the opening of the mitochondrial permeability transition pore. Inhibition of mitochondrial Ca<sup>2+</sup> uptake causes an increase in the amplitude of the Ca<sup>2+</sup> signal and/or a slowing in the decay of the Ca<sup>2+</sup> transient in some neurons and neuroendocrine cells. In some neuroendocrine cells, such as ►chromaffin cells and pituitary cells, mitochondrial inhibition results in enhancement of secretion. For example, the dominant mechanism for cytosolic Ca<sup>2+</sup> clearance in pituitary ►corticotropes is the mitochondrial Ca<sup>2+</sup> uptake [4]. As shown in Fig. 2a, application of cyanide (a mitochondrial inhibitor) dramatically slowed the decay of depolarization-triggered Ca<sup>2+</sup> transient in corticotropes.

Figure 2b shows that in corticotropes, the increase in the duration of Ca<sup>2+</sup> transient during mitochondrial inhibition in turn caused an increase in the amount of exocytosis (measured with ►capacitance measurement). While these findings suggest that mitochondria may play a role in limiting excessive secretion in neuroendocrine cells, the influence of mitochondria in transmitter release from nerve terminals is more complex. For example, in motor nerve terminals, inhibition of mitochondrial Ca<sup>2+</sup> uptake causes a reduction in phasic release (i.e. release triggered by a train of action potentials in high frequency) [5]. Thus, in nerve terminals, mitochondrial Ca<sup>2+</sup> uptake may be important for maintaining neurotransmission during high frequency stimulation.

### Plasma Membrane Na<sup>+</sup>-Ca<sup>2+</sup> Exchanger

Two families of Na<sup>+</sup>-Ca<sup>2+</sup> exchanger (NCX) proteins have been described in mammalian tissues: the cardiac type NCX and the K<sup>+</sup>-dependent NCX (NCKX). Both NCX families are expressed in the brain. In the forward mode (i.e. extrusion of Ca<sup>2+</sup> from the cell), NCX exchanges one Ca<sup>2+</sup> for three Na<sup>+</sup>. In contrast, the stoichiometry of NCKX is one Ca<sup>2+</sup> and one K<sup>+</sup> to four Na<sup>+</sup>. Thus, Ca<sup>2+</sup> clearance by NCX depends on the Na<sup>+</sup> gradient (low intracellular [Na<sup>+</sup>]) but NCKX depends on both the Na<sup>+</sup> and K<sup>+</sup> gradients (high intracellular [K<sup>+</sup>]). Small axon terminals have high surface-to-volume ratio. This property may render the axon terminals more vulnerable to accumulation of Na<sup>+</sup> (thus high intracellular [Na<sup>+</sup>]) during bursts of action potentials. Under this condition, the reduction in Na<sup>+</sup> gradient may be less favorable for the forward mode of NCX. However, because of its dependence on K<sup>+</sup> gradient, NCKX can still extrude Ca<sup>2+</sup> efficiently even when intracellular [Na<sup>+</sup>] is high. NCKX is a major Ca<sup>2+</sup> clearance mechanism in the axon terminals of rat neurohypophysis but has little contribution to Ca<sup>2+</sup> clearance in the somata of the supraoptic magnocellular

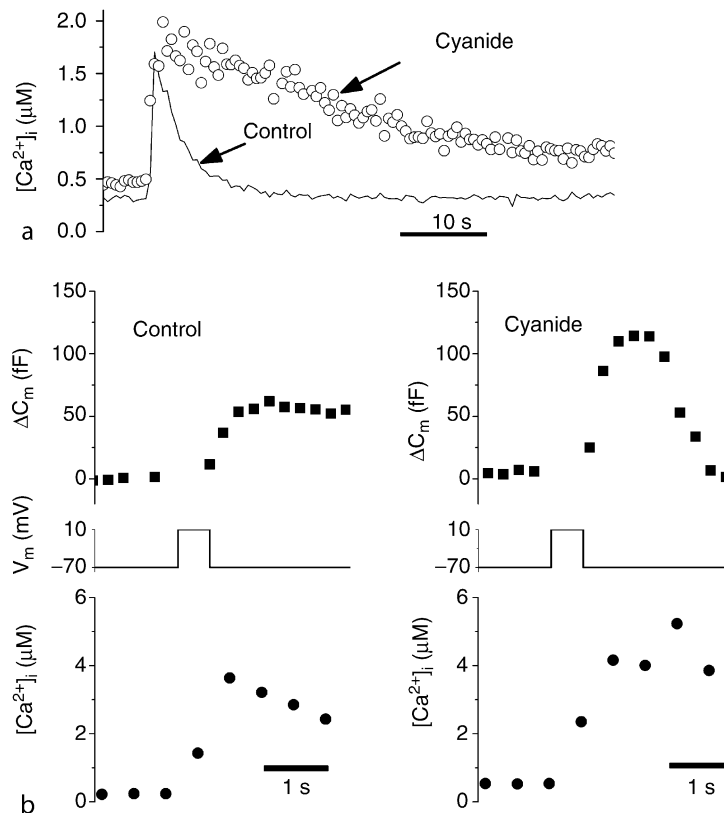

**Influence of  $\text{Ca}^{2+}$  Homeostasis on Neurosecretion. Figure 2** Mitochondrial inhibition slows the decay of the  $\text{Ca}^{2+}$  signal and enhances exocytosis in rat pituitary corticotropes. (a) Superimposed depolarization-triggered  $\text{Ca}^{2+}$  signal before and after mitochondrial inhibition by cyanide (5 mM). The cell was whole-cell voltage clamped at  $-70$  mV. The pipette solution contained 5 mM ATP.  $[\text{Ca}^{2+}]_i$  was monitored with indo-1 fluorometry. Note that the decay of the  $\text{Ca}^{2+}$  signal slowed dramatically in the presence of cyanide. (b) Simultaneous measurement of exocytosis (reflected as increase in membrane capacitance;  $\Delta C_m$ ) and  $[\text{Ca}^{2+}]_i$  from a corticotropes before and in the presence of cyanide. Following mitochondrial inhibition, the same voltage step triggered a more sustained  $[\text{Ca}^{2+}]_i$  elevation and the amount of exocytosis was increased by  $\sim 2$ -fold.

neurons which project their axons to the neurohypophysis [6]. While inhibition of NCX and/or NCKX have been shown to slow the decay of the  $\text{Ca}^{2+}$  signal in some nerve terminals, their influence on neurotransmitter release from nerve terminals is not clear. However, NCX as well as NCKX knock-out mice exhibit changes in synaptic plasticity in the hippocampus (for example, see [7]). Thus, the neurotransmission in some synapses may be strongly dependent on the  $\text{Ca}^{2+}$  clearance mechanism of NCKX and/or NCX.

### Plasma Membrane $\text{Ca}^{2+}$ -ATPase

The plasma membrane  $\text{Ca}^{2+}$ -ATPase (PMCA) removes cytosolic  $\text{Ca}^{2+}$ . This process is dependent on ATP hydrolysis and in exchange extracellular protons are transported into the cell. PMCA binds  $\text{Ca}^{2+}$  with a high affinity (0.2–0.6  $\mu\text{M}$ ) and thus have an important role in the regulation of the resting  $[\text{Ca}^{2+}]_i$  in many cells. However, the capacity of PMCA to extrude  $\text{Ca}^{2+}$  from

the cell may be limited by its slow turnover rate (i.e. the amount of  $\text{Ca}^{2+}$  transported per carrier per unit time). Thus, NCX which has a lower  $\text{Ca}^{2+}$  affinity but higher turnover rate than PMCA is suggested to be more important in cytosolic  $\text{Ca}^{2+}$  clearance during a substantial  $[\text{Ca}^{2+}]_i$  rise. Nevertheless, because of the proximity of PMCA to VGCCs as well as the high surface-to-volume ratio in small nerve terminals, PMCA may be an effective  $\text{Ca}^{2+}$  extrusion mechanism in some nerve terminals. Consistent with this, inhibition of PMCA in the peripheral sensory nerve terminals slows the decay of the  $\text{Ca}^{2+}$  transient by approximately twofold but inhibition of NCX in the same preparation has little influence on  $\text{Ca}^{2+}$  homeostasis [8]. A direct demonstration of the effect of inhibition of PMCA on transmitter release is lacking. However, mice with targeted or spontaneous mutation in certain PMCA isoforms have balance and hearing defects that may involve changes in neurotransmission [9].



### Sarco-Endoplasmic Reticulum Ca<sup>2+</sup>-ATPase

The uptake of cytosolic Ca<sup>2+</sup> into the ER stores by sarco-endoplasmic reticulum Ca<sup>2+</sup>-ATPase (SERCA) pump is important for the replenishment of Ca<sup>2+</sup> in the ER stores. Inhibition of SERCA pumps leads to depletion of ER stores and is associated with ER stress and apoptosis. In many neurons, SERCA pump is also an important Ca<sup>2+</sup> clearance mechanism. For example, in the somata of supraoptic magnocellular neurons, inhibition of SERCA pumps slows the decay of the depolarization-triggered Ca<sup>2+</sup> transient by ~50% [6].

A major function of supraoptic magnocellular neurons is the secretion of vasopressin and oxytocin in their terminals (neurohypophyses). However, the dominant Ca<sup>2+</sup> clearance mechanism in the neurohypophyses is NCKX [6]. Thus, it is unclear whether the activities of SERCA pump have any influence on hormone secretion from the supraoptic magnocellular neurons. Nevertheless, in endocrine cells such as pancreatic  $\beta$  cells, where SERCA pump is the dominant Ca<sup>2+</sup> clearance mechanism, inhibition of SERCA pump can dramatically affect exocytosis [10]. Figure 3a shows

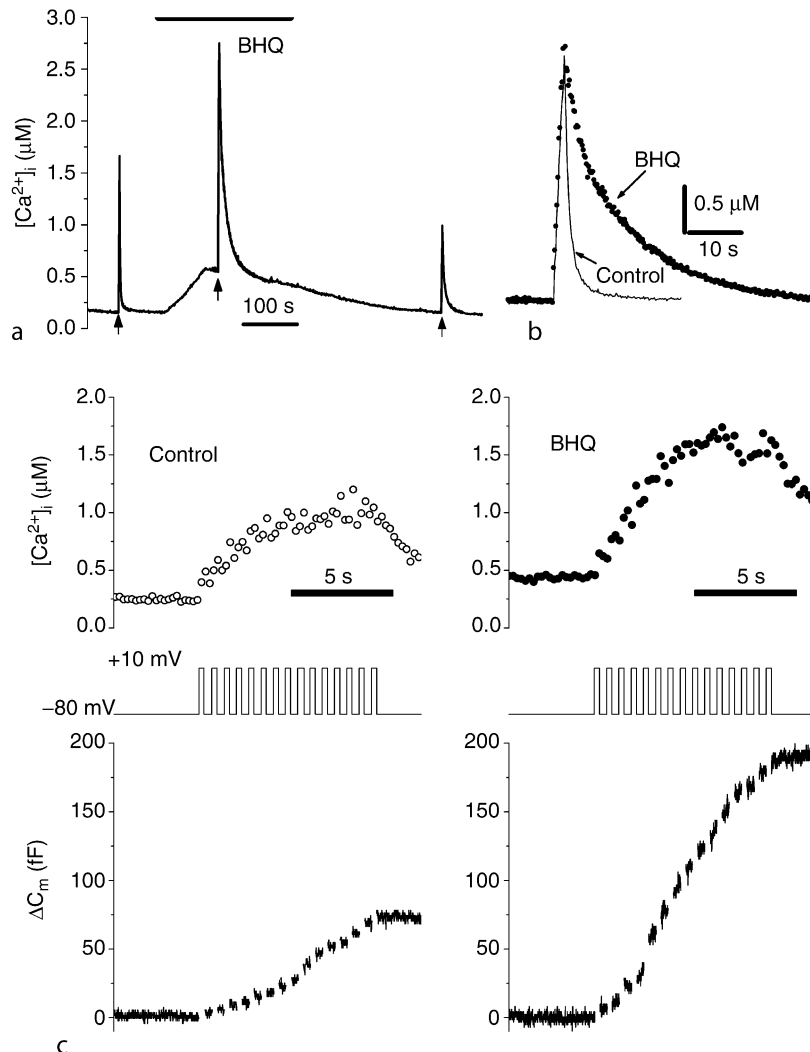

**Influence of Ca<sup>2+</sup> Homeostasis on Neurosecretion. Figure 3** Inhibition of SERCA pumps increases the amplitude of the depolarization-triggered Ca<sup>2+</sup> signal and enhances exocytosis in rat pancreatic  $\beta$  cells. (a) Inhibition of SERCA pump by BHQ elevated the basal  $[Ca^{2+}]_i$  and increased the amplitude of the depolarization-triggered Ca<sup>2+</sup> signal. The cell was whole-cell voltage clamped at -80 mV. The arrows indicated the delivery of a train of depolarizing voltage steps. (b) Dramatic slowing of the decay of the Ca<sup>2+</sup> transient in the presence of BHQ. Superimposed Ca<sup>2+</sup> signals before and after SERCA pump inhibition. The amplitude of the Ca<sup>2+</sup> signals in control was scaled to match that in BHQ. Same cell as in (a). (c) Simultaneous measurement of exocytosis ( $\Delta C_m$ ) and  $[Ca^{2+}]_i$  from a  $\beta$  cell before and during BHQ. Following SERCA pump inhibition, the same train of depolarizing voltage steps triggered a larger  $[Ca^{2+}]_i$  elevation and this was accompanied by ~3-fold increase in the amount of exocytosis.

that inhibition of the SERCA pump by 2,5-di-(*t*-butyl)-1,4-hydroquinone (BHQ) caused an increase in the amplitude of the depolarization-triggered  $\text{Ca}^{2+}$  signal as well as a dramatic slowing in the decay of the  $\text{Ca}^{2+}$  transient (Fig. 3b). Simultaneous measurement of  $[\text{Ca}^{2+}]_i$  and exocytosis shows that the increase in the amplitude of depolarization-triggered  $\text{Ca}^{2+}$  transient during SERCA pump inhibition was accompanied by an increase in the amount of exocytosis (Fig. 3c).

### Conclusion

Following the opening of VGCCs, the  $\text{Ca}^{2+}$  entering the cytosol can be rapidly taken up by the fast endogenous  $\text{Ca}^{2+}$  buffers, the mitochondria, as well as the SERCA pumps. Thus, these three mechanisms are important in limiting the amplitude of the  $\text{Ca}^{2+}$  signal. On the other hand, the slow endogenous  $\text{Ca}^{2+}$  buffers, the mitochondria, the SERCA pump, the plasma membrane NCX, as well as PMCA pump, contribute to the acceleration in the decay of  $\text{Ca}^{2+}$  signal, thus limiting the duration of the  $\text{Ca}^{2+}$  signal. The relative contribution of individual  $\text{Ca}^{2+}$  clearance mechanism varies not only with different cell types but also with different cellular compartments (e.g. soma versus axon terminals). These complexities may reflect the adaptations of individual cell types or cellular compartments to meet their specific demands. For example, because of the high-surface-to-volume ratio in the small axon terminals, NCX and PMCA which are on the plasma membrane can extrude  $\text{Ca}^{2+}$  efficiently. On the other hand, for neuronal somata and neuroendocrine cells with a low surface-to-volume ratio, the large  $\text{Ca}^{2+}$ -handling capacity of the mitochondria and SERCA pumps may be more efficient in lowering cytosolic  $[\text{Ca}^{2+}]_i$ .

Since the  $\text{Ca}^{2+}$  sensor in the triggering of exocytosis may operate in a co-operative fashion, a small increase in the amplitude of the  $\text{Ca}^{2+}$  signal can dramatically enhance secretion. On the other hand, a slowing in the decay of the  $\text{Ca}^{2+}$  signal can also influence secretion. In many neuroendocrine and endocrine cells, the secretory granules are not in close proximity to the VGCCs and exocytosis can continue to occur briefly after the closure of the VGCCs (see for example, in Fig. 2b, exocytosis in corticotropes continued to occur for ~500 ms after the termination of the voltage step). Therefore, a slowing in the decay of the  $\text{Ca}^{2+}$  signal can dramatically increase exocytosis in these cells. On the other hand, in synapses, synaptic vesicles are tightly coupled to VGCCs and exocytosis terminates with the closure of VGCCs (collapse of  $\text{Ca}^{2+}$  microdomains). Therefore, in synapses, a slowing in the decay of the  $\text{Ca}^{2+}$  transient may have little immediate effect on exocytosis. However, a slowing in the decay of  $\text{Ca}^{2+}$  transient may enhance short-term facilitation in synapses (for example as described in the “residual  $\text{Ca}^{2+}$  accumulation” model) and a modest elevation of  $[\text{Ca}^{2+}]_i$  is known to increase the

rate of mobilization of granules to the readily releasable pool. Thus, changes in the duration of the  $\text{Ca}^{2+}$  transient can affect synaptic plasticity. Since the activities of many of the  $\text{Ca}^{2+}$  clearance mechanisms can be regulated by kinases and intracellular messengers (e.g. modulation of SERCA pump by protein kinase C), such modulations may allow individual cell type to fine tune its  $\text{Ca}^{2+}$  signals to meet its specific secretory demand.

### References

1. Burnashev N, Rozov A (2005) Presynaptic  $\text{Ca}^{2+}$  dynamics,  $\text{Ca}^{2+}$  buffers and synaptic efficacy. *Cell Calcium* 37:489–495
2. Blatow M, Caputi A, Burnashev N, Monyer H, Rozov A (2003)  $\text{Ca}^{2+}$  buffer saturation underlies paired pulse facilitation in calbindin-D28k-containing terminals. *Neuron* 38:79–88
3. Muller M, Felmy F, Schwaller B, Schneggenburger R (2003) Parvalbumin is a mobile presynaptic  $\text{Ca}^{2+}$  buffer in the calyx of held that accelerates the decay of  $\text{Ca}^{2+}$  and short-term facilitation. *J Neurosci* 27:2261–2271
4. Lee AK, Tse A (2005) Dominant role of mitochondria in calcium homeostasis of single rat pituitary corticotropes. *Endocrinology* 146:4985–4993
5. David G, Barrett EF (2003) Mitochondrial  $\text{Ca}^{2+}$  uptake prevents desynchronization of quantal release and minimizes depletion during repetitive stimulation of mouse motor nerve terminals. *J Physiol* 548:425–438
6. Kim MH, Lee SH, Park KH, Ho WK, Lee SH (2003) Distribution of  $\text{K}^+$ -dependent  $\text{Na}^+/\text{Ca}^{2+}$  exchangers in the rat supraoptic magnocellular neuron is polarized to axon terminals. *J Neurosci* 23:11673–11680
7. Li XF, Kiedrowski L, Tremblay F, Fernandez FR, Perizzolo M, Winkfein RJ, Turner RW, Bains JS, Rancourt DE, Lytton J (2006) Importance of  $\text{K}^+$ -dependent  $\text{Na}^+/\text{Ca}^{2+}$ -exchanger 2, NCKX2, in motor learning and memory. *J Biol Chem* 281:6273–6282
8. Gover TD, Moreira TH, Kao JP, Weinreich D (2007) Calcium regulation in individual peripheral sensory nerve terminals of the rat. *J Physiol* 578:481–490
9. Shull GE, Okunade G, Liu LH, Kozel P, Periasamy M, Lorenz JN, Prasad V (2003) Physiological functions of plasma membrane and intracellular  $\text{Ca}^{2+}$  pumps revealed by analysis of null mutants. *Ann N Y Acad Sci* 986:453–460
10. Hughes E, Lee AK, Tse A (2006) Dominant role of sarcoendoplasmic reticulum  $\text{Ca}^{2+}$ -ATPase pump in  $\text{Ca}^{2+}$  homeostasis and exocytosis in rat pancreatic beta-cells. *Endocrinology* 147:1396–1407

### Information

JÜRGEN SCHRÖDER  
University of Karlsruhe, Heidelberg, Germany

### Synonyms

True proposition; Information content

## Definition

In everyday life “information” means either the act of giving someone some knowledge that he or she did not have yet or the content of this knowledge. Information in the latter sense can be produced, lost, destroyed, concealed, changed, distorted, picked up, sold, exploited etc. During the time of scholastic philosophy “informatio” meant the formation of matter such that, after this process, it had a certain form [1,2]. In this sense, a wooden block is informed when a statue is made out of it. The notion of giving form to something can also be applied to the mind, and informing the mind can be understood as impregnating it with various forms [3].

The relationship between information as a form-giving act or process,<sup>1</sup> and information as an act that conveys *knowledge* of something is such that the latter is a subset of the former. Every act of a person that conveys knowledge of something to another person is at the same time an act that forms the mind of the second person in a certain way. But not every such formation does also convey knowledge.

For the concept of information considered so far the notion of content is absolutely central. Information is either the content of some knowledge or the act of conveying this knowledge (which implies conveying the content). In the case of verbal information (i.e. verbal transmission of knowledge) this content is mostly propositional since propositions are the contents of sentences and sentences make up the bulk of vehicles or transmission items in verbal communication.

## Description of the Theory Information and Information Theory

There is a theory about the transmission of signals that deals with questions concerning the efficiency of signal transmission from a source to a destination. This theory is known as “information theory [4].” Information theory is not directly concerned with information as true propositions. It is not interested in the question what and how many true propositions are conveyed by a signal. Nevertheless it does ask how much information is conveyed by a signal. But it doesn’t count information in terms of the number of propositions. Rather it measures the amount of information transmitted from a source to a destination in terms of the number of different types of messages at the source and the probability of their occurrence at the source. The leading idea is that information is something that reduces uncertainty and that the amount of information should be greater the greater the initial uncertainty. Suppose that two children of two different classes get a prize for the best essay in English. One

class has fifteen students, the other twenty five. The event that Nancy of the class with fifteen students gets a prize produces less information than the event that John of the class with twenty five students gets a prize because in the latter case more possibilities (viz. 24) are excluded (more uncertainty is reduced) than in the former case (14). On the one hand we have the production of information and a measure of this information that takes into account the respective space of possibilities and the various probabilities of these, on the other hand we have the transmission of information through a channel (air, cable, etc.) and a measure of the information that arrives at the destination point. The amount of information that is produced at a source can decrease during the transmission process because of various adverse conditions which are called “noise.”

In the diagram the “message” can be any event that reduces a space of possibilities to one. The transmitter is a device for coding the event into a signal. This signal is propagated through a channel where it may be affected by “noise.” The received signal is the one that arrives at the receiver *after* having been exposed to noise. The receiver decodes the signal into a comprehensible message (although not necessarily into the same kind of event that produced the information at the source). The amount of information that is generated at a source depends on the size of the space of possibilities. Without such a space the amount of information associated with an event cannot be determined.

In principle there are various ways to express the amount of information numerically, but Shannon and Weaver, the originators of information theory, adopted the convention to express it as the logarithm to the base 2. So if the space of possibilities is 64 (e. g. the position of the king on a chessboard) the information associated with the event (e.g. king on c3) is 6,  $2^6$  being 64.

However, Shannon and Weaver were not interested in the amount of information associated with particular events, but rather in the average amount of information of events occurring at a certain source. If the probabilities of various types of events are not equal, the information associated with an event of a certain type is given by  $\log 1/p(s_i)$  where  $p(s_i)$  is the probability of events of type  $i$ . The average amount of information of events occurring at a certain source is then a weighted sum of the amount of information associated with the various types of events:  $\sum p(s_i) \log 1/p(s_i)$ . This is the average amount of information generated at the source (the classroom, the chessboard, etc.). In order to calculate the amount of information that arrives at the receiver the impact of the noise has to be subtracted. From the point of view of information theory it doesn’t matter whether the events at the source are linguistic or non-linguistic events nor does it matter whether these events are representations of something like pictures and sentences or not. What matters for the application of

<sup>1</sup> “Process” is here understood as referring to series of events that are not initiated by agents, i.e. entities with a self.

information theory is what the various probabilities of the event types are and what size the space of possibilities is.

According to Fred Dretske there is, however, a certain connection between information theory and information in the sense of “true proposition [5].” A plausible principle concerning information in the latter sense is that if an event  $A$  carries the information that  $B$  (that an individual  $s$  has the property  $F$ ), and  $B$  carries the information that  $C$  (that an individual  $t$  has the property  $G$ ), then  $A$  carries the information that  $C$ . For example, if a doorbell rings only if its button is depressed and if the button is depressed only if some person depresses it then the ringing of the doorbell will not only carry the information that the button of the doorbell ( $s$ ) is depressed ( $F$ ), but also the information that someone ( $t$ ) depressed it ( $G$ ).

This principle, which Dretske called the Xerox principle, places a certain constraint on the transmission of information if what is being transmitted is information in the sense of true propositions: The *amount* of information carried by a signal (i.e. information in the information theoretic sense) must be the same as the amount of information generated at the source. A communication chain (Fig. 1) in which a signal  $A$  carries the information that  $B$  and  $B$  carries the information that  $C$  can be such that in the transmission process from  $C$  to  $B$  a little amount of information is lost and also in the transmission from  $B$  to  $A$ . By adding more links to this chain the more distant links may carry amounts of information that are close to zero. In this case these links would carry no information about  $C$ , contrary to the Xerox principle. If information in the sense of true propositions is to be transmitted and if the Xerox principle is to be satisfied then the amount of information in the information theoretic sense generated at the source has to be the same as the amount of information carried by the signal. Thus, for the transmission of information in the sense of true propositions the *whole* amount of information in the information theoretic sense is necessary.

### Information and Semantics

One can exploit the notion of information content of a signal for a theory of the *semantic* content of mental representations. The first step of this enterprise is to

define the notion of informational content. According to Dretske’s definition, a signal  $r$  carries the information that  $s$  is  $F$  if and only if the conditional probability of  $s$ ’s being  $F$ , given  $r$ , is 1, i.e.  $p(F(s)/r) = 1$ . This definition captures the sense of information as being a true proposition since a signal cannot carry the information that  $s$  is  $F$  without it being the case that  $s$  is  $F$ . Only such information are carried by a signal for which there is a *lawful connection* between properties. This connection may be nomological as in the case of heat and expansion or it may be logical as in the case of being a square and being a rectangle. A signal that carries the information that  $s$  is  $F$  carries every other information that is logically or nomologically connected with  $s$ ’s being  $F$ .

The fact that something, a signal, a physical occurrence of some sort, carries as information all the propositions that are nomologically and logically connected to a certain proposition  $p$  distinguishes informational content from semantic content. When we consider thoughts as signals and look at their contents then they have single propositions as contents (they may be complex but they can still be counted as *one* complex proposition) and not many. The thought that a certain liquid is water does not also contain the proposition that this liquid is  $H_2O$ . A theory of semantic content that wants to have informational content as an essential ingredient must therefore embody a further element that selects one out of the many propositions which constitute the informational content.

Dretske himself opted for a teleological element [6]. What selects a certain proposition as the semantic content of a signal is the function of the signal. Hearts, for example, have various properties. Among them are the following three: They pump blood, they make a thumping noise and they exert a gravitational force on other bodies. The function of hearts, however, is only to pump blood. In this way informational semantics accounts for the fact that meanings of representations can be specific, that not every proposition being part of the informational content of a signal belongs to the meaning of that signal. A problem for informational semantics arises out of the fact that representations have their meanings, e.g.  $\langle$ a horse far away $\rangle$ , even if the corresponding proposition isn’t true. In short, there are misrepresentations, representations of states

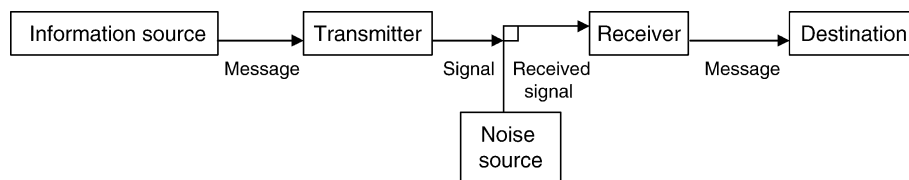

**Information.** Figure 1 General structure of a communication system.

of affairs that do not obtain. The animal seen from afar that looks like a horse may in fact be a cow. Since informational semantics requires that the conditional probability of  $s$ 's being  $F$ , given the occurrence of the signal  $r$ , is 1,  $s$  must be  $F$  if  $r$  occurs, i.e. the proposition that  $s$  is  $F$  must be true and misrepresentation seems therefore to be impossible.

Dretske tries to solve this problem in the following way. The basic idea is that once a state of an organism has adopted *the function* (e.g. during the evolution) to carry information about certain states of the world, it can keep this function even if this state has stopped to carry information about the world. According to this account, misrepresentation occurs only in cases where once there was an informational relation between a state of an organism and a state of the world, where the state of the organism has adopted the function to carry information about certain states of the world and where, for one reason or other, the informational relation has been broken.

This explanation of misrepresentation makes it clear that the conditional probability of  $s$ 's being  $F$  given that the signal  $r$  occurred has to be relativized to a certain habitat, to the absence of genetic or developmental accidents and to an orderly state of the representing mechanism in question. Otherwise this conditional probability will just never equal 1 and nothing would stand in an informational relationship to anything else.

However, there seem to be cases of misrepresentation that occur when the relevant organs are in good shape, when there is no genetic accident and when the organism is in its natural habitat. A case in point is misperception of something under less than optimal conditions (of sight, hearing, etc.). Although one might deal with such cases along the lines already presented, a deeper problem reveals itself if one asks whether it was ever the case for any kind of organism and any kind of detection mechanism that the conditional probability of some  $s$ 's being  $F$ , given the occurrence of signal  $r$  was 1. If this seems questionable, the informational ingredient in a semantic theory that combines informational and teleological aspects turns out to be questionable as well.

### Information and the Empirical Content of Scientific Theories

The idea of information in the context of probability theory has been used by Karl Popper in order to distinguish scientific theories according to their epistemic value, i.e. according to how much they tell us about reality [7]. Popper's basic idea was that a theory is the better the more it forbids and the easier it can be refuted by empirical evidence. A theory that forbids nothing, i.e. that is compatible with *every* possible evidence does tell us nothing about reality and is cognitively useless.

Popper thought that Marxism and psychoanalysis were such theories or theoretical programs. The empirical content of a theory  $T_1$  is higher than the empirical content of a theory  $T_2$  if  $T_1$  excludes more observation sentences than  $T_2$ . For example, the sentence that all trajectories of heavenly bodies are circles excludes more possibilities than the sentence that all trajectories of planets are ellipses because the latter sentence is compatible with the state of affairs that heavenly bodies move in squares or straight lines or that planets move in ellipses that are not circles (a circle being a limiting case of an ellipse, viz. an ellipse where the two foci collapse into one). Since the sentence that all heavenly bodies move in a circular fashion excludes more possibilities than the sentence that all planets move in an elliptical way it is said to have greater empirical content. The greater the empirical content of a theory the more it tells us about reality where this "more" is not to be understood as "more propositions" but as "more information," information in exactly the sense of information theory. According to information theory more information is generated at a source by an event if the space of possibilities that is reduced by the event is greater. A theory contains zero information if it doesn't rule out anything, if it is compatible with every way the world may turn out to be. It may seem that a theory which can explain everything in its domain and which is refuted by nothing is intellectually superior to a theory which is unable to explain everything in its domain and which would be refuted by many possible observations. But in fact, the price that has to be paid for the irrefutability of a theory is its empirical emptiness, its missing contact with reality.

### References

1. Champeaux W (1885) quoted in Prantl C Geschichte der Logik im Abendland, Leipzig
2. Schütz L (1895) Thomas-Lexikon. Paderborn
3. Descartes R (1904) Œuvres, Adam Ch, Tannery P. (eds) Paris
4. Shannon CE, Weaver W (1949) The mathematical theory of communication. Urbana
5. Dretske F (1981) Knowledge and the flow of information. Oxford
6. Dretske F (1988) Explaining behavior. Cambridge, Mass
7. Popper K (1960) The logic of scientific discovery. London

## Information Content

## Information Theory

YOAV TOCK<sup>1</sup>, YOSSEF STEINBERG<sup>2</sup>

<sup>1</sup>IBM Haifa Research Laboratory, University Campus, Haifa, Israel

<sup>2</sup>Electrical Engineering Department, Technion, Haifa, Israel

### Synonyms

A mathematical theory of communication; Shannon theory

### Definition

Information theory is above all a branch of communication theory. According to Claude Shannon [1]: “The fundamental problem of communication is that of reproducing at one point either exactly or approximately a message selected at another point.” These two points may be separated in time and/or in space. Information theory addresses this problem and tells us what the ultimate rate of communication is over a noisy channel. Information theory also tells us what the ultimate data compression rate is. In general, information theory is concerned with stating what can and cannot be done in various communication settings. The theory also suggests schemes to achieve those limits and analyses the performance of those schemes. The insight and principles embodied in the theory form the foundation for virtually all modern communication systems.

The enormous influence of information theory on manmade communication systems has inspired many neuroscientists to try to harness the theory to the investigation of neural communication processes (possibly the first such attempt, [2], came only four years after Shannon’s publication). In this context, sensory neural systems are probably the most popular subject of information theoretic analysis (see the comprehensive study of [3]), along with synaptic transmission (e.g. [4]) and intracellular communication (e.g. [5]).

However, the meaning of the Shannon information rate in the context of sensory systems research (and neuroscience in general) is sometimes misinterpreted. This is in sharp contrast to the situation in information theory, where the information rate has a very accurate operational meaning. We therefore pay special attention in this essay to the clarification of this issue. The two most important results of information theory, the **source coding** theorem and the **channel coding** theorem, will be presented. (Both are due to the pioneering work of Shannon, [1].) We formulate an operational interpretation for the information rate measured in a sensory system, an interpretation that places the information rate in the context of

stimulus discrimination experiments. In addition, other information theoretic viewpoints are presented and briefly discussed.

## Characteristics

### Introduction

Most information theoretic studies of sensory systems concentrate on estimation of the **mutual information rate** between the input and output of a sensory system. (See, for example, several different estimation methods: [3,5–8].) What does the mutual information rate actually mean? One type of interpretation is the following.

Consider two random variables,  $X$  and  $Y$ , which are the input and output of a system, respectively. The **entropy rate**,  $H_x$ , is interpreted as the uncertainty with respect to  $X$ . The **conditional entropy rate**,  $H_{x|y}$ , is interpreted as the uncertainty that remains about  $X$ , after having observed  $Y$ . Thus, the mutual information rate,  $H_x - H_{x|y}$ , is interpreted as the reduction of uncertainty about the input  $X$ , after having observed the output ( $Y$ ). This “subjective” interpretation does not really tell us what can, or cannot be done with the signals (or channels) at hand.

In contrast, information theory goes beyond the subjective interpretations and offers operative interpretations. **Entropy** and mutual information are related to well defined communication problems, and are used to place limits on what can or cannot be done with them.

When the logarithm in the definition of mutual information is in base 2, the units of mutual information are bits. Suppose that in an experiment, a neurophysiologist estimates the mutual information rate between two signals, and arrives at an estimate  $R$ . What is the meaning of  $R$  bits per second measured between the input and output of a neural sensory system? Surely, we can use the subjective interpretation. However, we would like to associate an operational meaning to the results of such an experiment. For that purpose, let us briefly review the definition of mutual information and its relation to channel capacity. We will describe some of the classical information theoretic interpretations and then describe the operational meaning we associate with such an experiment.

### Source Coding and Compression

Let us consider the two random variables  $X, Y$  with joint probability distribution

$$p(x, y) = \Pr\{X = x, Y = y\}, x \in \mathbf{X}, y \in \mathbf{Y} \quad (1)$$

where  $\mathbf{X}$  and  $\mathbf{Y}$  are finite sets, called the alphabets of the random variables  $X$  and  $Y$ . Let the marginal probability distributions be  $p(x)$  and  $p(y)$ , respectively. The “randomness” or “uncertainty” in a single random

variable (say  $X$ ) is usually taken as the entropy of  $X$ , denoted  $H(X)$ , and defined by

$$H(X) = - \sum_{x \in \mathbf{X}} p(x) \log p(x). \quad (2)$$

(All logarithms are to base 2.) Let  $X^n = (X_1, X_2, \dots, X_n)$  be a random vector, the components of which are generated by  $n$  independent drawings of the random variable  $X$ . The entropy,  $H(X)$ , is related to compression via the following well-known result [1,9].

**Theorem 1 (The source coding theorem, direct part)**

For any  $R > H(X)$ , any  $\delta > 0$ , and  $n \geq n(R, \delta)$  sufficiently large, there exists a pair of mappings,

$$f_E : \mathbf{X}^n \rightarrow \{0, 1\}^N \text{ and}$$

$$f_D : \{0, 1\}^N \rightarrow \mathbf{X}^n$$

where  $N = \lceil nR \rceil$ , such that

$$\Pr\{f_D \circ f_E(X^n) \neq X^n\} < \delta.$$

The mappings  $f_E$  and  $f_D$  are called encoder and decoder, respectively. The essence of Theorem 1 is that it is possible to encode (compress) the random sequence  $X_1, X_2, \dots$  into a binary sequence with  $H(X)$  bits per symbol. This is the operative interpretation of the entropy of a random variable. We illustrate that with an example.

**Example 1**

Nine cars participate in a car race. Suppose the odds of winning the race for each of the cars are  $(\frac{1}{2}, \frac{1}{4}, \frac{1}{8}, \frac{1}{16}, \frac{1}{32}, \frac{1}{128}, \frac{1}{128}, \frac{1}{128}, \frac{1}{128})$ . The entropy of the car race can be calculated:

$$H(X) = -\frac{1}{2} \log \frac{1}{2} - \frac{1}{4} \log \frac{1}{4} - \frac{1}{8} \log \frac{1}{8} - \frac{1}{16} \log \frac{1}{16} - \frac{1}{32} \log \frac{1}{32} - \frac{1}{128} \log \frac{1}{128} - \frac{1}{128} \log \frac{1}{128} - \frac{1}{128} \log \frac{1}{128} - \frac{1}{128} \log \frac{1}{128} = 2\text{bit}$$

Assume we would like to communicate the result of the race to a distant location. One option would be to send the index number of each car. That description would use 4 bits for any of the cars ( $0_D = 0000_B$ , while  $8_D = 1000_B$ ;  $D$  for decimal,  $B$  for binary). However, a better alternative would be to assign shorter descriptions for more probable cars, and longer descriptions for less probable cars. For example, let us use the following bit strings to represent each of the nine cars: (0,10,110,1110,11110,1111100,1111101,1111110,1111111). The average description length in this case is 2 bits, as opposed to 4 bits in the previous case. According to the theorem, it is impossible to find an encoding scheme with a better average description length. The reason this scheme achieves the limit is that the win probabilities are negative powers of 2, i.e.  $2^{-K}$ . In other cases, a more elaborate scheme would have to be used in order to achieve the limit. In particular,

one would have to communicate results of many independent car races (many independent drawings of the random variable  $X$ ), in order to approach an average description length of 2 bits per result of one car race.

The mutual information between variables  $X$  and  $Y$  is defined as:

$$\begin{aligned} I(X; Y) &= I(Y; X) \\ &= \sum_{x \in \mathbf{X}, y \in \mathbf{Y}} p(x, y) \log \frac{p(x, y)}{p(x)p(y)} \\ &= H(X) - H(X|Y) \end{aligned} \quad (3)$$

where

$$H(X|Y) = - \sum_{x \in \mathbf{X}, y \in \mathbf{Y}} p(x, y) \log p(x|y). \quad (4)$$

is the conditional entropy of  $X$  given  $Y$ . Thus, following (3), the subjective interpretation of mutual information is “the reduction of uncertainty of  $X$  due to the knowledge of  $Y$ ” [1].

The mutual information between two random variables also has a compression-related operational interpretation. Suppose, for example, it is required to compress the random sequence  $X_n$ . Theorem 1 tells us that we can do this with  $H(X)$  bits per symbol. However, if the communicating parties both know the sequence  $Y_n$ , we can use it to enhance the compression of  $X_n$ . In fact, a simple extension to Theorem 1 tells us that we can do this with  $H(X|Y)$  bits per symbol. Thus, following (3), mutual information can be interpreted as the reduction in the encoding length of  $X_n$ , when we can also use  $Y_n$ .

Although the subjective interpretation of mutual information (reduction of uncertainty) sounds promising at first, it is clear that the operational interpretations presented so far (compression) do not agree with the problem of sensory information transmission. First, the sensory system is not about compression of sequences. It certainly does not use the input sequence in order to facilitate the compression of the output sequence, or vice versa. Second, note that these operational interpretations require the knowledge of both  $X$  and  $Y$ . In contrast, the central nervous system (CNS) receives only spike trains, coming from the output of a sensory system. With knowledge of the output of the sensory system alone, the CNS must extract information on, or make decisions with respect to, the unknown state of the world outside the sensory system.

**Channel Coding and Channel Capacity**

Transmission of information, rather than compression, seems more related to sensory information transmission. Therefore, we show here the essentials of the channel coding theorem.

A discrete memoryless channel is characterized by the channel transition probability matrix

$$p(y|x) = \Pr\{Y = y|X = x\}. \quad (5)$$

The channel is memoryless if

$$p(y_1^n|x_1^n) = \prod_{i=1}^n p(y_i|x_i) \quad (6)$$

The probability distribution of the input,  $p(x)$ , induces a certain mutual information,  $I(X;Y)$ , across the channel. The channel “information” capacity is the maximal mutual information, maximized over all admissible input distributions.

**Definition 1: Channel information capacity**

$$C_{\text{inf}} = \max_{p(x) \in \mathbf{P}} I(X;Y) \quad (7)$$

where  $\mathbf{P}$  is the set of admissible input distributions.

The input distribution that achieves the maximum in (7), denoted  $p^*(x)$ , is called the capacity achieving distribution. Note that the definition of channel information capacity, in itself, is just a maximization problem over the set of “single letter” input distributions – it does not refer to the communication problem over the actual channel. In contrast, the operational definition of capacity, cited below, is given in terms of an actual communication problem [1,10].

**Definition 2: A code**

An  $(M, n)$  code for the channel  $(\mathbf{X}, p(y|x), \mathbf{Y})$  consists of the following:

- An index set  $I_M = \{1, 2, \dots, M\}$ .
- An encoding function  $f: \{1, 2, \dots, M\} \rightarrow \mathcal{X}^n$  yielding codewords  $X^n(1), X^n(2), \dots, X^n(M)$ . The set of codewords is called the codebook.
- A deterministic decoding function  $g: \mathcal{Y}^n \rightarrow I_M$  that assigns a guess to every received vector.

**Definition 3: Probability of error**

The maximal probability of error for an  $(M, n)$  code is defined as:

$$\lambda^{(n)} = \max_{i \in I_M} \Pr\{g(Y^n) \neq i | X^n = f(i)\}.$$

**Definition 4: The rate**

The rate  $R$  of an  $(M, n)$  code is  $R = \frac{\log_2 M}{n}$  bits per transmission.

**Definition 5: Achievable rate**

A rate  $R$  is said to be achievable if there exists a sequence of  $(\lceil 2^{nR} \rceil, n)$  codes for which  $\lambda^{(n)} \rightarrow 0$  as  $n \rightarrow \infty$ .

**Definition 6: Channel “operational” capacity**

Operational channel capacity  $C_{\text{op}}$  is the supremum of all achievable rates.

It is important to understand that the message that goes across the channel is the index  $i$ , chosen out of the index set  $I_M$  (see Fig. 1a). Each index is associated with a codeword  $X^n(i)$ . If the codewords are chosen appropriately, the received output block  $Y^n$  can be used to find the message index  $i$  with arbitrarily low probability of error. A good choice of codewords means that they are “widely spaced” (see Fig. 1b). The wide (or “appropriate”) spacing of codewords means that the noise in the channel rarely throws the transmitted codeword too far off, in a manner that would result in a decoding error. On the other hand, a bad codebook may result from an inappropriate selection of codewords, or the selection of too many codewords (see Fig. 1c).

The two definitions – operational-capacity ( $C_{\text{op}}$ ) and information-capacity ( $C_{\text{inf}}$ ), are distinct. From the definitions alone, it is not at all clear that they are related. It is Shannon’s channel coding theorem that unites them and gives an operational interpretation to the channel information capacity. Basically, it tells us that channel information capacity is the maximum rate, in bits per channel use, in which information can be sent with an arbitrarily small probability of error. In other words

$$C_{\text{op}} = C_{\text{inf}}. \quad (8)$$

The formal statement follows [10].

**Theorem 2: (The channel coding theorem)**

For any discrete memoryless channels, the following hold:

- (I) All rates below the “information” capacity  $C_{\text{inf}}$  are achievable. Specifically, for every  $\varepsilon > 0$ , rate  $R < C_{\text{inf}}$ , and sufficiently large  $n$ , there exists a  $(\lceil 2^{nR} \rceil, n)$  code with maximum probability of error  $\lambda^{(n)} < \varepsilon$ .
- (II) Conversely, any sequence of  $(\lceil 2^{nR} \rceil, n)$  codes with  $\lambda^{(n)} \rightarrow 0$  must have  $R \leq C_{\text{inf}}$ .

The appropriate spacing of codewords incurs a limit on the number of codewords  $M$ , that is, the rate of the code. The theorem tells us that if we increase the dimensionality of the input space (i.e. increase  $n$ , the block length) the rate  $R$  can approach  $C$  with an arbitrarily small probability of error. Since for the current channel model, the operational and informational capacity are the same, it has become customary to use one term, Capacity( $C$ ), to denote both.

**Example 2**

Suppose we have an alphabet of 16 symbols (say 0123456789ABCDEF). We assign each symbol a binary number, from  $0000_B = 0_D$  up to  $1111_B = 15_D$  (see Fig. 2a). We attempt to use those 16 binary codewords to communicate with a distant site over a noisy binary channel. Alas, the channel flips a bit every once in a (rare) while (Fig. 2b). The (4,7) Hamming code shown in Fig. 2a can help us. Every 4-bit source word is assigned a



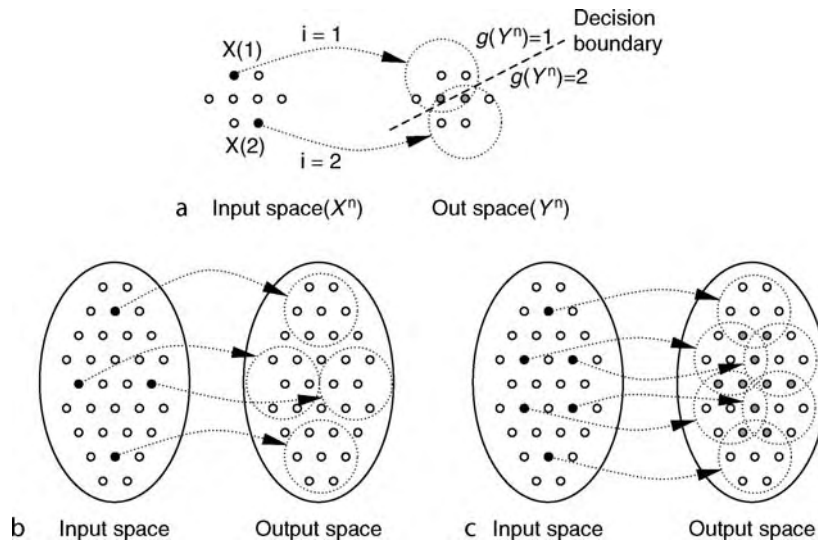

**Information Theory. Figure 1** Example of codeword selection and expurgation. (a) An  $(M = 2, n = 3)$  code. Two codewords (black filled circles) are selected from the eight possible words in the input space (thus  $n = \log_2 8 = 3$ ). Due to channel noise, after a codeword is sent over the channel, any one of the output words that are within the dotted circle can be received. Decoding is based on the decision boundary. If the received word is above (below) the boundary,  $i = 1'$  ( $i = 2'$ ) is detected. Reception of the gray filled output words may cause decoding errors. The rate of this code is  $R = \log_2 2/3 = 1/3$ . The maximal probability of error is  $\lambda^{(3)}$ , which can be calculated if the noise characteristics are known. (b) An  $(M = 4, n = 5)$  code. A good spacing between the codewords results in a low probability of error. (c) An  $(M = 6, n = 5)$  code. A bad spacing between the codewords, or the selection of too many codewords, may result in a relatively high probability of error.

	<i>Source word</i>	<i>Code word</i>		<i>Message:</i>	C	0	F	F	E	E
	0	0000			1100	0000	1111	1111	1110	1110
	1	0001		<i>Noise</i>	x		x			x
	2	0010								
	3	0011		<i>Received:</i>	1110	0000	1110	1111	1110	1100
	4	0100	b		D	0	D	F	E	C
	5	0101								
	6	0110								
	7	0111								
	8	1000								
	9	1001								
	A	1010		<i>Message:</i>	C	0	F	F	E	E
	B	1011			1100011	0000000	1111111	1111111	1110100	1110100
	C	1100		<i>Noise</i>	x	x		x		x
	D	1101								
	E	1110		<i>Received:</i>	1101011	0000100	1111111	1011111	1110100	0110100
a	F	1111	c	<i>Decoded:</i>	C	0	F	F	E	E

**Information Theory. Figure 2** The (4,7) Hamming code, and example of a simple error correction code. (a) Every 4-bit source word is assigned a 7-bit codeword. (b) Without coding errors are received. (c) The (4,7) Hamming code can recover from, at most, a single bit flip in every 7 bit codeword.

7-bit codeword. Since the channel flips the occasional bit, the output of the channel might be any of the 128 7-bit strings. Every 7-bit output string is decoded to be the codeword closest to it in Hamming distance, which is just the number of different bits between binary words. Note that every pair of the 7 bit codewords is different in at least 3 bits. Thus, this code can recover from a single bit flip in every codeword, as shown in Fig. 2c.

It is important to realize that since most physical system satisfy  $I(X;Y) < H(X)$ , the number of blocks (words) that are allowed into the channel in order to accomplish reliable communication is only a small subset of the space of input blocks (this process is sometimes called “expurgation,” and is reflected in the number of black circles versus the total number of circles in Fig. 1).

$$M = \lceil 2^{nR} \rceil \leq 2^{nC} < 2^{nH^*(X)} \leq |X|^n \quad (9)$$

where  $H^*(X)$  is the entropy of the capacity achieving input distribution  $p^*(x)$ , and  $X \in \{0, 1\}$ . Here  $|X|$  denotes the size of  $\mathbf{X}$ , the alphabet at the channel input. The relation  $\lceil 2^{nR} \rceil < 2^{nH^*(X)}$  is of particular interest, because it implies that the number of codewords must be exponentially smaller than the number of typical sequences according to  $p^*(x)$  in the input space [1] (note that  $R$  and  $H^*(X)$  are fixed as  $n$  grows).

Although  $p^*(x)$  achieves the maximum in (7), using  $n$ -blocks that originate from the distribution

$$p^*(X^n) = \prod_{i=1}^n p^*(x_i) \quad (10)$$

as the input to the channel will not allow us to decode messages with an arbitrarily low probability of error, unless they are expurgated appropriately, resulting in a codebook exponentially smaller than the typical set of  $X^n$ .

It is important to emphasize that, as easily seen from Theorem 2, the role of  $p^*(x)$  is only in determining the number  $C_{op}$ , the operational capacity. A common misinterpretation of the terms “information” and “mutual information” is the following: if an information source  $p(x)$  is presented at the channel input, inducing the mutual information  $I(X;Y)$  between the channel input and output, then, by observing the channel output  $Y$  one can “extract”  $I(X;Y)$  information bits on  $X$  from  $Y$ . Note, however, that such a claim is not well defined, since it is not clear what the term “extract” in this context means. If it is meant that portions of the input vectors  $X^n$  can be fully decoded from the output  $Y^n$ , then such an interpretation is not true, and does not follow at all from any of the results in information theory. In fact, if we just imply a distribution  $p(x)$  at the input, without any expurgation or operation on it, we will not be able to extract information on  $X$  from  $Y$  with a small probability of error. This can be clarified by the following example.

**Example 3**

Consider the binary symmetric channel (see Fig. 3)

$$p(y|x) = \begin{cases} p & x \neq y \\ 1-p & x = y \end{cases}, x, y \in \{0, 1\} \quad (11)$$

Assume that  $0 < p < \frac{1}{2}$ . The capacity of this channel is

$$C = 1 - h(p)$$

where

$$h(p) = -p \log p - (1-p) \log(1-p)$$

is the binary entropy. The input distribution that achieves capacity is uniform  $p^*(x) = [\frac{1}{2}, \frac{1}{2}]$ . Thus, if  $p^*$  is the input distribution to the channel, the

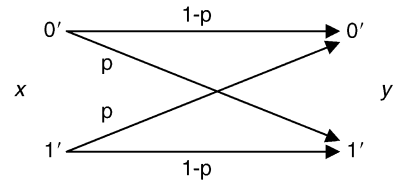

**Information Theory. Figure 3** The binary symmetric channel. The transmitted bit is  $x$ , the received bit is  $y$ . The probability of bit error is  $p$ .

mutual information between the input and the output would be  $I(X;Y) = C = 1-h(p^*)$ . (Note that for  $0 < p < \frac{1}{2}$ ,  $0 < h(p) < 1$ ). According to the channel coding theorem, in order to convey information with rate  $R < C$ , one must use no more than  $2^{nR}$  blocks of size  $n$ . However, with  $p^*(X^n)$  as input distribution, for each  $n$ , there exist  $2^n$  possible input blocks  $X^n$ , all equally probable, and typical according to  $p^*(X^n)$ . It is as if the codebook has included all the ( $2^n$ ) probable sequences emitted from the source  $p^*(X^n)$  (i.e. no expurgation), with rate  $R' = 1 > C$ . As evident from the converse to the channel coding theorem, this means that the average probability of error is bounded away from zero. In fact, it can be shown that as  $n \rightarrow \infty$ , the average probability of error converges to one.

The channel coding theorem implies that control over the input distribution of the channel is essential in order to establish reliable coded communication. Control over the input distribution manifests itself as the codebook, a collection of carefully chosen blocks, which are the only blocks allowed into the channel.

**Interpretation to the Neural Channel**

Let us now consider a sensory neural channel. In a typical experiment (see for example [3]), the sensory system is stimulated, and the information rate between the input and the output of the system is estimated. The input stimulus is a waveform  $s(t)$  that is generated according to some predefined probability distribution  $P\{s(t)\}$ . The estimated information rate between the input and output of the sensory system is denoted  $\hat{R}$ . Let us ignore, for the sake of argument, the properties of the estimator and assume that the estimator is perfect. The first conclusion we can draw from Theorem 2 (channel coding) is the following<sup>1</sup>.

<sup>1</sup>Theorem 2 dealt with discrete channels, whereas now we deal with waveform channels. An extension to waveform channels exists, although the expressions are more complicated [3]. Nevertheless, the implications and interpretations with respect to waveform channels are essentially the same. Note that the duration of the waveform,  $T$  replaces the block length,  $n$ . Thus, the codebook consists of  $M = \lceil 2^{TR} \rceil$  waveforms, instead of  $M = \lceil 2^{nR} \rceil$ . The rate is given in bits per second instead of bits per transmission.

The fact that the estimated information rate across the channel is  $\hat{R}$  bits per second, does not mean that the same amount of “information” can actually be extracted from the output. This can only be done with proper expurgation of the input, or, in other words, proper design of the “encoding function”  $f$  of the system input.

The situation in the experiment (and in the behaving animal) is very similar to the situation described in Example 3 above. In both cases, the entire input space is allowed into the channel. This does not allow reliable communication. Although the mutual information rate is  $\hat{R}$ , actual reliable communication does not necessarily take place.

A possible interpretation, which does follow from Shannon’s results, and is consistent with the classical meaning of the mutual information function, is the following (see Fig. 4). One can choose a set of  $M = [2^{RT}]$  waveforms, each waveform with duration  $T$ . Every  $T$  seconds one out of  $M$  waveforms is presented as input to the channel. Every  $T$  seconds the observer of the neural channel output must decide which of the  $M$  waveforms was presented. Theorem 2 (channel coding) tells us that if the waveforms are chosen wisely, and for  $T$  long enough, an arbitrarily small decoding error can be achieved. Note that the theorem does not tell us explicitly how to choose the waveforms (how to encode).

This interpretation allows us to put the information rate estimation experiment in the context of stimulus discrimination experiments. Those are experiments in which a discrete set of stimuli is presented to a sensory system. The researcher tries to discriminate between the different stimuli based on observation of the neural output alone. The information rate estimation experiment basically tells us what would be the ultimate result of such an experiment. The advantage is that we are free from the need to design the codebook (i.e. choose the waveform set) and the decoder (i.e. find the decision rules). This is a big advantage, because the design of the optimal encoder and decoder can be very complicated. Moreover, a sub-optimal choice can have a huge impact on the results.

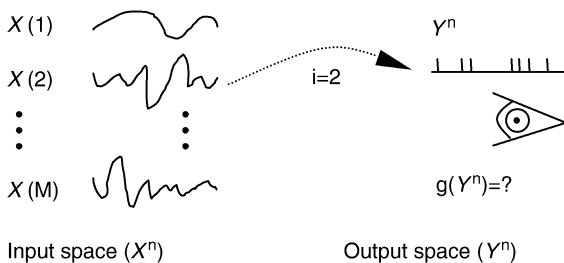

**Information Theory. Figure 4** A neural waveform channel. Every  $T$  seconds the observer of the output spike train(s) tries to determine which one of the  $M$  input waveforms was presented at the input.

**Remark 1**

Note that we did not address the problem of finding the capacity achieving input distribution. In some information rate estimation experiments, the input distributions were chosen using heuristic arguments based on the physiology of the system [3]. It is important to emphasize that for a given input distribution, the induced mutual information rate over the channel is an achievable (operative) information rate.

**Remark 2**

In the terms of information theory, the estimated mutual information rate  $\hat{R}$  places a lower bound to channel capacity. It is a lower bound because the input distribution used in the estimation procedure,  $P\{s(t)\}$ , is not necessarily the capacity achieving distribution.

**Conclusions**

We presented the two fundamental results of information theory: the source coding theorem (compression) and the channel coding theorem (error-free communication over a noisy channel). We related those theoretic results to neuroscientific concepts and provided an interpretation to the mutual information rate in the context of the neural channel.

The subjective interpretation portrays the mutual information rate between the input and the output of a system as “reduction in uncertainty of the input, after having observed the output.” We claimed that this interpretation does not give us an operational meaning. We presented the operational meaning of the mutual information rate, as it emerges from the channel coding theorem. Let us recapitulate.

Assume that a mutual information rate  $\hat{R}$  is measured between the input and output of a sensory system. Then, one can choose a set of  $M = [2^{RT}]$  waveforms, each with duration  $T$ . Every  $T$  seconds one of these waveforms is presented as input to the channel. The channel coding theorem tells us that if the waveforms are chosen wisely, and for  $T$  long enough, the observer of the output can decide which of the  $M$  waveforms was presented with an arbitrarily small decoding error. Thus, measuring the mutual information rate  $\hat{R}$  gives us the ultimate result of a stimuli discrimination experiment, yet without the need to actually build the codebook (choose the waveforms) or find the decoding function (decide which waveform was transmitted).

**References**

1. Shannon CE (1948) A mathematical theory of communication. Bell Syst Tech J 27:379–423, 623–656
2. MacKay D, McKulloch WS (1952) The limiting information capacity of a neuronal link. Bull Math Biophys 14:127–135

3. Rieke F, Warland D, de Ruyter van Stevenink R, Bialek W (1997) *Spikes: exploring the neural code*. MIT Press, Cambridge, MA
4. de Ruyter van Steveninck RR, Laughlin SB (1996) The rate of information transfer at graded-potential synapses. *Nature* 379:642–645
5. London M, Schreibman A, Häusser M, Larku m ME, Segev I (2002) The information efficacy of a synapse. *Nat Neurosci* 5:332–340
6. Strong SP, Koberle R, de Ruyter van Steveninck RR, Bialek W (1998) Entropy and information in neural spike trains. *Phys Rev Lett* 80:197–200
7. Tock Y (2004) Information theoretic analysis of the muscle spindle system, PhD thesis. Technion – Israel Institute of Technology, Haifa, Israel
8. Tock Y, Inbar GF, Steinberg Y, Ljubisavljevic M, Thunberg J, Windhorst U, Johansson H (2005) Estimation of muscle spindle information rate by pattern matching and the effect of the gamma system activity on parallel spindles. *Biol Cybern*:92:316–332
9. Gallager RG (1968) *Information theory and reliable communication*. Wiley, New York
10. Cover TM, Thomas JA (1990) *Elements of information theory*, Wiley, New York

---

## Information Processing

### Definition

In nervous systems the translation of information received by a cell into information transmitted to another cell, usually measured as yes-no electrical events (e.g. action potentials) recorded from cells.

► Evolution and Brain-Body Allometry

---

## Infradian Rhythms

### Definition

Rhythms with a period longer than 24 h. Formally, this category comprises circannual rhythms (period length about 1 year), circalunar rhythms (period length about 29 days) and some of the circatidal rhythms (e.g., those with a period length of 24.8 h). Usually, the term infradian is reserved for those endogenous biological rhythms which have no counterpart in the natural environment and are characterized by allometric relationships. Examples are estrus cycles and population cycles.

► Circannual Rhythms

---

## Infundibular Nucleus

### Synonyms

Nucl. arcuatus; Arcuate nucleus

### Definition

This nucleus, also called arcuate nucleus, lies in the intermediate group of the medial zone of the hypothalamus in the tuber cinereum, directly at the attachment of the infundibulum. It contains neurons producing release and release-inhibiting factors, which regulate hormone secretion in the anterior lobe of the hypophysis. The axons of these neurons course in the tubero-infundibular tract to the median eminence, where they anchor at blood vessels.

► Diencephalon

---

## Infundibulum

### Definition

The infundibulum is the neurohypophyseal part of the hypophyseal stalk. It emerges from the tuber cinereum and, in its upper segment, it surrounds an evagination of the third ventricle, the infundibular recess. In the infundibulum run primarily the axons of the supraoptic nucleus and paraventricular nucleus, which release their hormones ADH and oxytocin into the blood.

► Diencephalon

---

## Inherited Retinal Conditions or Inherited Retinal Diseases

### Definition

Describes a family of retinal diseases that are associated with genetic mutations. They typically affect individuals at different ages, although most affect vision at an early age. These conditions may be predominantly affecting central vision, e.g., juvenile macular degeneration, or the family of conditions described as “Retinitis Pigmentosa” that originally impair peripheral vision.

► Inherited Retinal Degenerations

## Inherited Retinal Degenerations

ERICA L. FLETCHER<sup>1</sup>, MONICA L. ACOSTA<sup>2</sup>,  
MICHAEL KALLONIATIS<sup>1,2</sup>

<sup>1</sup>Department of Anatomy and Cell Biology, The University of Melbourne, Parkville, VI, Australia

<sup>2</sup>Department of Optometry and Vision Science, University of Auckland, Auckland, New Zealand

### Definition

The ►vertebrate retina is susceptible to a number of inherited retinal conditions (►Inherited retinal conditions or inherited retinal diseases) that lead to vision loss. Although relatively few people inherit these devastating diseases (1:4000), they have been the target of considerable research effort. This is largely because many of the events that occur in retinal degeneration are also features of more common retinal conditions such as ►Age-related macular degeneration (AMD); treatments developed that prevent or slow retinal degeneration are likely to have broad application in the management of retinal disease. In addition, the mechanisms that lead to photoreceptor (►Photoreceptors) death are common to neuronal death in other regions of the Central Nervous System (CNS). The retina is an easily accessible part of the CNS and therefore much can be gained about the function of neurons in general by examining specific aspects of retinal function. The purpose of this chapter is to provide an overview of the research that has led to our understanding of retinal degeneration and outline key research results that have provided useful insights to develop treatment options for this family of ocular conditions.

### Characteristics

#### Structure of the Normal Retina

The mammalian retina is a complex array of neurons and glia that converts light energy into electrical impulses to begin the visual process (►Phototransduction). The light-sensitive cells of the retina are the photoreceptors, which subsequently interact with post-receptor cells leading to the encoding of the spatio-temporal-colour information of our visual space. The two types of photoreceptors operate over different light levels: rod photoreceptors at low or ►scotopic light levels whereas the cone photoreceptors operate over a large ►photopic range extending from twilight to very high light levels. There are two major pathways in the retina: the through-pathway involves *photoreceptors*→*bipolar cells*→*ganglion cells* (►Retinal bipolar cells, ►Retinal ganglion cells), although the rod pathway in the mammalian retina incorporates a unique amacrine cell (AII), as part of the through-circuit [1]. Ganglion cells are the output cells of the retina sending

their axons to the central visual pathway. The lateral elements of the retina (►retinal horizontal cells and ►amacrine cells) play critical roles in the encoding of visual information through lateral interactions (►Lateral interactions in the retina; ►Retinal direction selectivity: role of starburst amacrine cells) with the elements of the through pathway (Fig. 1).

The retina is a laminated structure of alternating synaptic and neuronal layers (Figs. 1 and 2). The most distal layer, comprising the outer segments of photoreceptors, sits amongst the microvilli of the ►Retinal pigment epithelium (RPE). Rhodopsin is the visual pigment located in rod photoreceptor outer segments, while the cone photoreceptors have different cone photopigments (►Photopigments). Both rod and cone photopigments are composed of a protein (►opsin) and a ►chromophore (a vitamin-A derivative called 11-cis retinal). The different spectral sensitivity of mammalian photoreceptors is derived from different opsins with all photoreceptors sharing the same chromophore. There is an intricate relationship between photoreceptors and the underlying RPE. Vitamin A and other retinoids are transported from the blood stream across the RPE cells to the photoreceptor outer segment. In addition, the RPE cells actively phagocytose the end tips of the photoreceptor outer segment as part of the outer segment

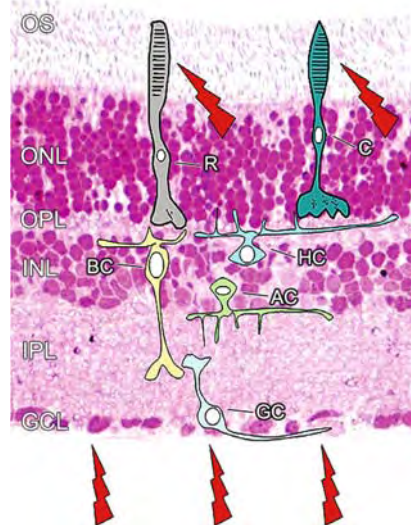

**Inherited Retinal Degenerations. Figure 1** Basic fuchsin stained cross section of the rat retina with schematics of the different cell types. Light (red "lightning rods") must traverse the whole retina before reaching the photoreceptor outer segment. Abbreviations: R, rod photoreceptor; C, cone photoreceptor; BC, bipolar cell; HC, horizontal cell; AC, amacrine cell; GC, ganglion cell; OS, outer segments of photoreceptors; ONL, outer nuclear layer; OPL, outer plexiform layer; INL, inner nuclear layer; IPL, inner plexiform layer; GCL, ganglion cell layer.

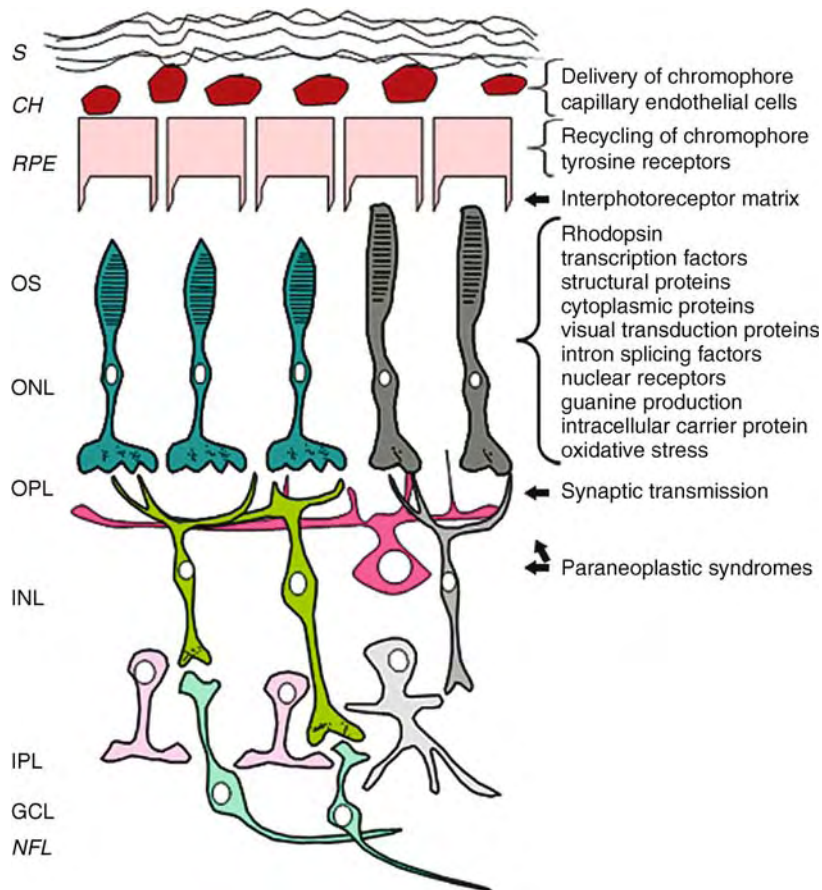

**Inherited Retinal Degenerations. Figure 2** Schematic of the different retinal cells and the retinal layers and location of defects leading to inherited retinal degeneration. Also included are paraneoplastic syndromes as antibodies destroy either rod bipolar cells (►[melanoma-associated retinopathy](#)), or photoreceptors and some bipolar cells (►[cancer-associated retinopathy](#)). Abbreviations: S, sclera; CH, choriocapillaris; RPE, retinal pigment epithelial cells; NFL, nerve fiber layer; other abbreviations as in Fig. 1.

renewal process. These important photoreceptor-RPE functions are crucial for maintaining vision, and defects in these interactions result in many forms of retinal degeneration.

The more proximal layers of the retina, the inner nuclear layer and ganglion cell layer, contain the somata of the second and third order neurons, bipolar, horizontal, amacrine and ganglion cells. The photopigment captures light leading to a cascade of events where the electrical potential is altered, causing changes in ►[neurotransmitter](#) release at the photoreceptor terminal. Horizontal cells are the first to provide lateral interaction modifying the signal that is transmitted by bipolar cells. Bipolar cells transmit the signal from photoreceptors to the inner retina where further interactions occurs with amacrine cells. Complex interactions at the two synaptic layers, outer plexiform and ►[inner plexiform layers](#), are crucial to transmit and shape the signal originally encoded by photoreceptors. The ►[outer plexiform layer](#) contains the synapses

between photoreceptors and bipolar and horizontal cells. The inner plexiform layer contains synapses between bipolar and ganglion and amacrine cells (Fig. 1).

### The Retina and Inherited Diseases: General Principles

The retina is susceptible to a wide range of ocular diseases that may be inherited, acquired or associated with external insult such as excessive light levels. Retinal cell death can involve all retinal layers with some diseases affecting specific cell classes. Figure 2 outlines the different anomalies causing inherited forms of retinal degeneration. Inherited retinal diseases and the dry form of AMD are characterized primarily by photoreceptor loss, whereas ►[glaucoma](#) preferentially affects retinal ganglion cells. In addition, the retina has a very high metabolic demand receiving blood supply from both an inner and outer retinal source. Consequently, any systemic condition affecting circulation impacts on retinal function. Acute disruption of

the blood supply leads to major retinal anomalies and includes cell death secondary to ischemia (lack of both oxygen and metabolites), hypoxia (low oxygen availability) or hypoglycemia (low glucose availability).

A prevailing concept is that diseases targeting a specific cell class leave the remaining neurons structurally intact and retinal circuitry unaltered. This view has been challenged recently with results showing ►**anatomical remodeling** of the whole retina secondary to photoreceptor loss [2], and more importantly, remodeling involving retinal circuitry (►**neurochemical remodeling**), reflected by changes in neurotransmitter receptor expression or receptor function likely affecting the retina secondary to any “insult” (for examples see [3–5]). Remodeling is of major clinical and scientific significance, especially for developing strategies that restore rudimentary vision to those with permanent vision loss. For example, the use of stem cells to replace damaged cells or electronic implants designed to provide rudimentary vision, have not met *clinical expectations* [6]. These approaches have not met clinical expectations because not only do anatomical changes in the damaged retina impair the accessibility to the remaining neurons of implanted cells or devices, but even if access to remaining neurons is gained, altered retinal circuitry means that the signal will be modified. This altered circuitry may render the signal “jumbled” and the transmitted signal will not be able to be decoded, or worse, the neurons may not be able to send a signal: the collision circuit theory of Marc and co-workers [3]. Although relatively new in the retina, the concept of neuronal remodeling (circuitry alterations) is a large active area of research in the ►**somatosensory** domain: i.e., the ►**phantom limb** syndrome. Patients who have had limbs amputated

experience sensations, including pain, which has now been found to be due to alterations in cortical circuitry. The *basic science* questions relate to understanding how retinal neurotransmitter modification leads to altered receptor expression and functionality. The retina provides a perfect model to study, firstly, the basic mechanisms of both normal receptor expression and function and, secondly, the molecules that determine the alterations that cause major circuit alterations. Clearly, a better understanding of basic science questions will provide appropriate strategies to be employed to significantly improve the clinical outcome of patients with degenerative diseases.

### Retinitis Pigmentosa

►**Retinitis pigmentosa** (RP) refers to a family of hereditary diseases, affecting around 1:4000 people worldwide, that causes gradual photoreceptor loss and eventually blindness [7]. RP can be inherited with virtually any inheritance pattern including autosomal dominant, autosomal recessive, or X-linked mutations extending from the delivery/recycling of the chromophore to photoreceptor proteins, ►**synaptic transmission** and are the secondary to neoplastic syndromes (Fig. 2). Although most of the inheritance patterns follow Mendelian genetics, many RP sufferers have no family history of the disease.

The ocular fundus appearance in more advanced cases displays the typical bone spicule appearance (Fig. 3), which was originally mistaken to reflect an inflammatory response of the retina—hence the name “retinitis”. We now know that cell death is through the process of ►**apoptosis** or programmed cell death and the condition is not due to an inflammation of the retina. Typically, patients with RP experience difficulties with ►**night blindness** during their teenage years, with

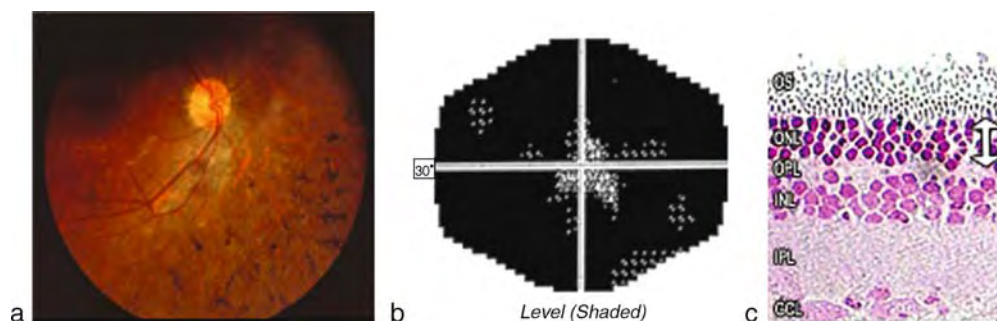

**Inherited Retinal Degenerations. Figure 3** Ocular fundus photograph from a patient with RP showing the characteristic “bone spicule” pigment on the retina (panel a). The patient has extremely restricted visual fields with only some functional vision available in the central  $\sim 5^\circ$ . Most of the central visual field is dysfunctional (denoted by the black encoding from the visual field plot: panel b). Basic fuchsin stained retinal section from a mature rat model of RP (the P23H transgenic rat (►**P23H rat**) that has a human rhodopsin mutation: panel c). Note the markedly reduced number of photoreceptor layers in the outer nuclear layer: compare with Fig. 1. Abbreviations as in Fig. 1. We are grateful to Associate Professor Ian Gutteridge for providing to us the ocular fundus photograph and visual field of the patient with RP.

gradual loss of the peripheral visual field (Fig. 3), so that by the age of 40 many patients are legally blind, because of severely constricted visual fields. Considerable variation exists in the age at which symptoms are first recognized. Despite this variation in disease presentation, it is well recognized that the disease is caused by gradual death of rod photoreceptors. Later in the course of the disease, cone photoreceptors also die (Fig. 3).

Retinitis pigmentosa can also be associated with other sensory loss with approximately 20–30% of patients also having non-ocular changes leading to the identification of at least 30 syndromes [7]. ►Usher's syndrome is the largest, with patients experience both vision and hearing loss. Retinitis pigmentosa is caused by genetic mutations in proteins important for rod function such as rhodopsin, phosphodiesterase, photoreceptor structural proteins, or RPE proteins. Indeed, mutations in more than 150 different genes have been causally linked with RP. The majority of genetic mutations are in the rod photopigment, rhodopsin (see <http://www.sph.uth.tmc.edu/Retnet/disease.htm>, for continued updates on mutations leading to inherited retinal degenerations).

#### Death of Photoreceptors is not Entirely Explained by Genetic Mutations

Although retinal degenerations are caused by genetic mutations, it is now recognized that other events take place that exacerbate photoreceptor loss. For example, in animals that have been created by combining the genetic encoding of a normal with an abnormal animal, regions of retina will express normal photoreceptors, whilst other regions will express photoreceptors that carry a mutation. When photoreceptor death was examined it was noted that it was not restricted to regions that contained only mutant photoreceptors. Rather, photoreceptors died in regions that had “normal” photoreceptors indicating that the mutation alone was not the only trigger for photoreceptor death. Also, a perplexing observation is the death of cone photoreceptors during retinal degeneration where the primary mutation is in rod photoreceptors. This highlights again that the mutation alone is not the only cause of photoreceptor death and other “intrinsic” factors cause cell death. External factors such as light exposure are known to accelerate photoreceptor death in both normal and animal models of RP. The light exposure does not necessarily imply extreme light levels but may involve routine clinical procedures such as clinical photography [8]. The relationship between light exposure and photoreceptor viability is complex. We know from our own work that neurochemical and metabolic changes occur within two hours of light exposure, and molecular biology studies have shown patterns of DNA-fragmentation peaks at different times

post-light exposure, consistent with likely attempts of the retina trying to repair itself.

#### Aetiology of Photoreceptor Death

Despite the large number of mutations and variety of proteins that these mutations affect, it is well known that photoreceptor death occurs via common pathways involving programmed cell death or apoptosis [9]. What is not clear is the factors that lead to the activation of these common apoptotic pathways. Considerable work has been undertaken with animal models of RP. The rd/rd mouse (rd/rd or rd1 mouse) carries a natural mutation in the beta subunit of phosphodiesterase, a rod-specific enzyme important in the phototransduction cascade (Phototransduction). These animals experience rod photoreceptor death from postnatal day 12, and are blind by 3–4 weeks of age. As a consequence of the mutation, the levels of ►cGMP rise within rod photoreceptors with anatomical changes present in photoreceptors of rd/rd mice well before they undergo apoptosis. Using a cation probe, ►agmatine (►AGB), photoreceptors destined to degenerate display higher labeling density compared to control tissue in two different models of RP: the rd/rd mouse and the Royal College of Surgeons rat (►RCS rat). The elevated agmatine labeling may reflect early photoreceptor dysfunction (Fig. 4). *What would be the consequences of early and sustained dysfunction in rd/rd photoreceptors?* One possible answer to this question is the increased energy requirements of abnormal photoreceptors. The energy requirements of photoreceptors are the highest of any cell within the body, because of energy-dependent ion pumps (►Ion transport) present in the inner segment of photoreceptors. Moreover, the light level imposes different energy requirements on photoreceptors; in the light, photoreceptors are hyperpolarized and have lower energy demands, whilst in the dark, photoreceptors are depolarized and have greater energy demands. We have shown that the level of the key metabolic enzyme, ►lactate dehydrogenase, was elevated prior and during the degenerative phase in rd/rd mice, suggesting that metabolic activity is higher in rd/rd mouse retinae prior to their degeneration (Fig. 4). These findings are in agreement with other studies that show that genes important for regulating metabolism are upregulated in several animal models of retinal degeneration prior to degeneration [9]. It is possible that the elevated energy demand of mutant photoreceptors cannot be sustained, leading to their demise.

There are other important changes that have been observed in degenerating photoreceptors that may also contribute to their death. It is well recognized that elevated intracellular  $\text{Ca}^{2+}$  plays a key role in the early stages of photoreceptor death, perhaps stimulating the intracellular signaling pathways that lead to apoptosis. In rd/rd mice, the level of intracellular  $\text{Ca}^{2+}$  within



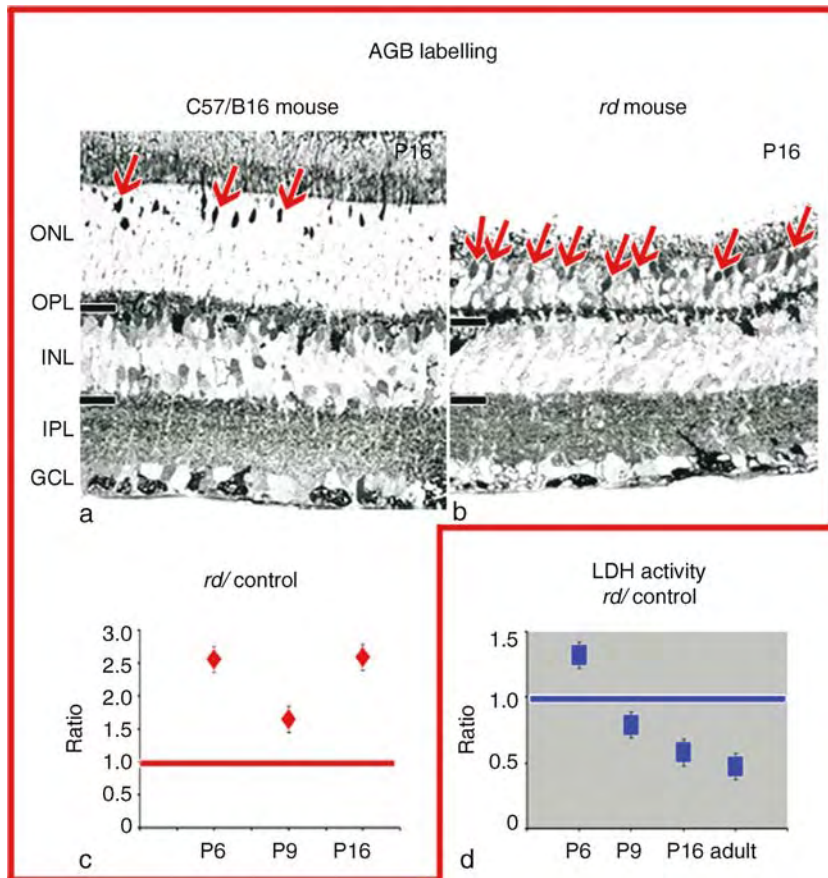

**Inherited Retinal Degenerations. Figure 4** Agmatine (AGB) photoreceptor labeling in control (a) and *rd/rd* mice with the phosphodiesterase mutation (panel b). The number of agmatine labeled photoreceptors (red arrows) per unit area is significantly increased in the *rd/rd* retina compared to the control (panel c depicts the ratio). The lactate dehydrogenase activity is significantly elevated before photoreceptor degeneration at post-natal day (P6) in the *rd/rd* mouse retina (panel d depicts the *rd/control* lactate dehydrogenase activity). The marked reduction after photoreceptor degeneration (P9 and older) is likely an epiphenomenon due to decreased metabolic demand due to the loss of photoreceptors. Data modified after Acosta and co-workers: *Molecular Vision* 11: 717–728.

photoreceptors increases approximately 190% compared to control photoreceptors, and genes that are known to be important in regulating intracellular  $\text{Ca}^{2+}$  (e.g., [▶calbindin](#), [▶vinsin-like 1](#) and [▶sparc](#)) are elevated during the early phase of retinal degeneration [9]. One possible reason for the increase in intracellular  $\text{Ca}^{2+}$  is influx of  $\text{Ca}^{2+}$  through voltage dependent  $\text{Ca}^{2+}$  channels ([▶Calcium channels – an overview](#)). Sustained increases in intracellular  $\text{Ca}^{2+}$  could be induced by activation of neurotransmitter receptors present on photoreceptor terminals. Receptors to the neurotransmitters [▶glutamate](#) and [▶ATP](#) have been described on photoreceptors; however, their detailed role in causing elevated  $\text{Ca}^{2+}$  within photoreceptors is not well understood. Glutamate levels and expression of glutamate transporters are elevated within the retina at a stage during the rod degeneration phase. However,

further work is necessary to define the role of abnormal neurotransmission in photoreceptor death.

The mechanism of cone death is not well understood. Cone photoreceptor death follows that of rod photoreceptors suggesting that cones depend in some way on the presence of rods for their survival. One possible explanation is cone death via [▶oxidative stress](#). The vasculature of the choroid does not autoregulate, meaning that blood flow in this vascular bed is not tightly tuned to the energy needs of the overlying retina. As the rods die, the oxygen level within the photoreceptor layer increases, possibly causing oxidative stress [10]. Other studies have shown altered byproducts of lipid peroxidation and the beneficial effects of antioxidants. Several reports indicate that cone survival may depend on the release of a cone-survival factor from rods. A third possible explanation of cone death is that rods or

perhaps microglial cells release a toxic substance that is detrimental to cone photoreceptors. Further work is needed, however, to fully define this possibility.

### Neuronal Remodeling During Retinal Degeneration

A central tenet in neuroscience is the plasticity of the brain, especially in infants and following loss of input. Similarly, de-afferentation of photoreceptors during retinal degeneration is associated with wide-spread remodeling of second- and third-order retinal neurons. Gaining a better understanding of the processes that occur during remodeling is significant for at least two reasons. First, for treatments, which involve implantation of stem cells, photoreceptors, or retinal prostheses to be successful, adequate control of the remodeling needs to be taken into consideration. Secondly, although the examples provided imply that remodeling is a negative outcome, this may be far from the truth. Indeed, if the cellular processes that lead to remodeling could be controlled in some way, this may be beneficial for long-term treatment.

Four stages of retinal remodeling have been described in a vast number of animal models of retinal remodeling

[2]. During the phase of rod loss, there is active loss of bipolar cell dendrites, and reshaping of second-order bipolar cells. In addition, in transgenic animals that either lack rods or cones, rod bipolar cell dendrites reconnect with cones, and the dendrites of cone bipolar cells reconnect with rods. These results suggest that remodeling is an active process; de-afferented second-order neurons attempt to maintain functional contacts where possible. Following the loss of both rods and cones, a larger scale remodeling takes place. In particular, glial cells form a scar in the outer nuclear layer. In addition, there is widespread migration of neurons into “neuro-mas” and the establishment of aberrant synapses throughout the inner plexiform layer [2] (Fig. 5). In animal models of RP, there appears to be a down-regulation and aberrant expression of glutamate receptors with the continual preservation of receptors on OFF cone bipolar cells [3]. In end-stage of the disease ON and OFF cone bipolar cells lose glutamate receptor expression [3,4]. The characteristics of such neurochemical changes need to be fully understood before external intervention strategies can yield fruitful outcomes.

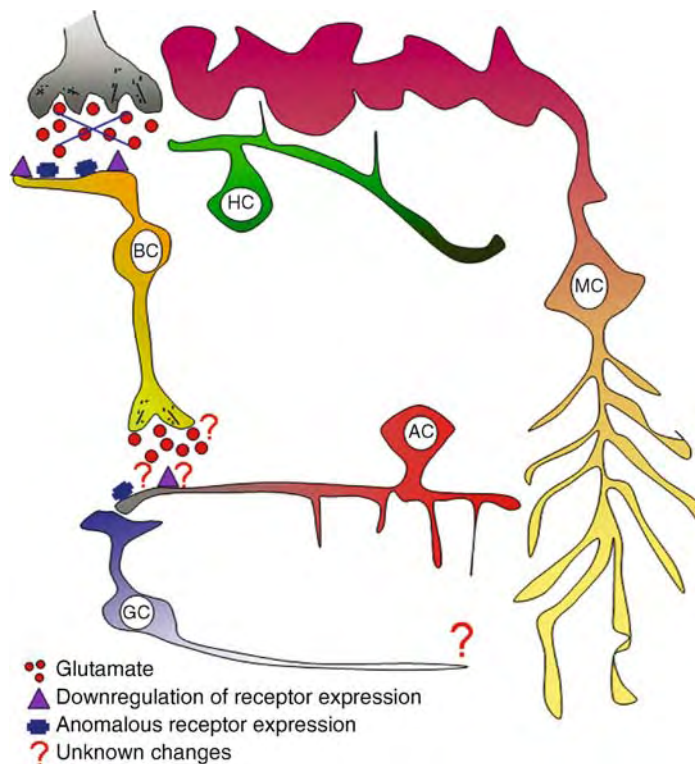

**Inherited Retinal Degenerations. Figure 5** Schematic of anatomical and neurochemical remodeling in the degenerating retina. Müller cells (MC) proliferate and enclose the whole retina. Abnormal glutamate release, down-regulation of glutamate receptors and anomalous glutamate receptors are shown in the outer plexiform layer (photoreceptor-bipolar cell interactions). Within the inner retina, unknown changes are present in neurotransmitter release, and yet unknown receptor properties likely leading to neurochemical remodeling within the inner plexiform layer. Other abbreviations as in Figs. 1 and 2.

### Possible Treatment Strategies

Currently there are no standard treatments that are effective in preventing or slowing photoreceptor death. Large multi-centre clinical trials have evaluated the potentials for high dose vitamin A, combined vitamin A and E as well as anti-oxidants to slow photoreceptor loss in patients. Most studies demonstrate small if any improvements in slowing the rate of progression [6,7]. Over the last few years, several animal studies have shown promising results. Gene therapy and stem cell therapy have all been shown to be beneficial in the treatment of retinal degeneration in animal models. A remarkable improvement in vision was obtained in dogs that carry a gene that causes ▶[Leber's congenital amaurosis](#), a rare bilateral retinal degeneration affecting infants. This is one example where clinical expectations have been met. Stem cells have received interest as possible treatments of a wide number of CNS diseases. Injection of haemopoietic stem cells or neural precursor cells, rather than stem cells lead to visual improvement in rodent models of retinal degeneration.

### Conclusions

Inherited retinal degenerations represent a devastating family of diseases that are characterized by gradual photoreceptor death and blindness. Although they are caused by genetic mutations in proteins important for rod function, many other factors contribute to the death of rods as well as cones. A great deal is known now about how photoreceptors die in these conditions, setting the stage for the development of treatment strategies. However, a greater understanding of how photoreceptor function normally, factors important in their death, and when and how the retina undergoes retinal neurochemical remodeling, has broad applicability to other retinal diseases and neurodegenerative disorders of the CNS.

### References

1. Wässle H (2004) Parallel processing in the mammalian retina. *Nat Rev Neurosci* 5:747–757
2. Marc RE, Jones BW, Watt CB, Strettoi E (2003) Neural remodeling in retinal degeneration. *Prog Retin Eye Res* 22:607–655
3. Marc RE, Jones BW, Anderson JR, Kinard K, Marshak DW, Wilson JH, Wensel T, Lucas RJ (2007) Neural reprogramming in retinal degeneration. *Invest Ophthalmol Vis Sci* 48:3364–3371
4. Strettoi E, Pignatelli V (2000) Modifications of retinal neurons in a mouse model of retinitis pigmentosa. *Proc Natl Acad Sci USA* 97:11020–11025
5. Sun D, Bui BV, Vingrys AJ, Kalloniatis AJ (2007) Alterations in photoreceptor-bipolar cell signaling following ischemia/reperfusion in the rat retina. *J Comp Neurol* 505:131–146

6. Kalloniatis M, Fletcher EL (2004) Retinitis pigmentosa: understanding the clinical presentation, mechanisms and treatment options. *Clin Exp Optom* 87:65–80
7. Hartong DT, Berson EL, Dryja TP (2006) Retinitis pigmentosa. *Lancet* 368:1795–1809
8. Cideciyan AV, Jacobson SG, Aleman TS, Gu D, Pearce-Kelling SE, Sumaroka A, Acland GM, Aguirre GD (2005) In vivo dynamics of retinal injury and repair in the rhodopsin mutant dog model of human retinitis pigmentosa. *Proc Natl Acad Sci USA* 102:5233–5238
9. Röhler B, Blanco R, Marc RE, Lloyd MB, Bok D, Schneeweis DM, Reichardt LF (2004) Functionally intact glutamate-mediated signaling in bipolar cells of the TRKB knockout mouse retina. *Vis Neurosci* 21:703–713
10. Yu DY, Cringle S, Valter K, Walsh N, Lee D, Stone J (2004) Photoreceptor death, trophic factor expression, retinal oxygen status, and photoreceptor function in the P23H rat. *Invest Ophthalmol Vis Sci* 45:2013–2019

## Inhibition

### Definition

The change that moves the membrane potential of neurons away from the threshold for action potentials.

▶ [Action Potential](#)

▶ [Membrane Potential: Basics](#)

## Inhibitory Burst Neurons (IBNs)

### Definition

In the horizontal system for controlling rapid eye movements, IBNs are medium-lead burst neurons that make monosynaptic inhibitory connections with contralateral abducens motoneurons and interneurons, with contralateral prepositus nucleus neurons, and with contralateral excitatory burst neurons. Their somata are located in the medial portion of the medullary reticular formation just below and behind the abducens nucleus.

IBNs with vertical preferred direction are in the rostral interstitial nucleus of the medial longitudinal fasciculus (riMLF) in the midbrain reticular formation near the oculomotor nucleus.

▶ [Brainstem Burst Generator](#)

▶ [Burst Cells – Medium Lead - Horizontal](#)

▶ [Burster-Driving Neurons](#)

▶ [Saccade, Saccadic Eye Movement](#)

## Inhibitory Learning

### Definition

Learning that tends to reduce responses to a stimulus.

► Learning and Extinction

## Inhibitory Mechanisms in Developing Nociceptive System

### Definition

A broad description for the peripheral and central processing that leads to inhibition of nociceptive responses or pain perception. Although the growth of descending inhibitory projections to the dorsal horn is well-advanced comparatively early in development, physiological maturity occurs some time later, possibly due to insufficient levels of serotonin or other neurochemicals or delayed maturation of dorsal horn interneurons. This functional immaturity appears to be one of the reasons for much lower reflex thresholds in the infant as compared to the older child and adult.

► Descending Modulation of Nociception

► Pain in Children

## Inhibitory Molecules in Regeneration

SAMUEL DAVID, ELIZABETH FRY  
Center for Research in Neuroscience, McGill  
University Health Center, Montreal, Canada

### Definition

Damaged nerve fibers (axons) in the brain and spinal cord that comprise the central nervous system (CNS) fail to regrow. This lack of axonal regeneration in the CNS results in permanent paralysis, sensory loss, and loss of bowel and bladder function that is seen after spinal cord injury. Seminal work published in 1981 by David and Aguayo [1] showed that neurons in the adult mammalian CNS have the ability to regenerate their axons for long distances if they are provided with an appropriate glial (non-neuronal) environment. Many

factors in the non-neuronal environment can influence the regeneration of damaged axons. These include the absence of sufficient amounts of positive factors such as growth factors or neurotrophins (link to *neurotrophins and regeneration* – Matt Ramer), and the presence of negative factors such as axon growth inhibitory molecules. In this essay we present the structural and functional characteristics of a number of axon growth inhibitory molecules, which are currently thought to play a crucial role in the failure of axon regeneration in the CNS.

### Characteristics

Several inhibitors of axon growth have been identified, which are associated with either ► [myelin](#) or the glial scar [2]. Myelin, the insulating membranes that wrap around axons is produced by ► [oligodendrocytes](#) a type of glial cell, while the glial scar is produced mainly by another glial cell type, the ► [astrocyte](#). Myelin contains three well-characterized inhibitors – Nogo-A (MW = 250 kDa), myelin-associated glycoprotein (MAG; MW = 100 kDa), and oligodendrocyte-myelin glycoprotein (OMgp; MW = 110 kDa). Recent studies also suggest that two other molecules in myelin produced by oligodendrocytes, Sema4D and ephrin-B3, also have axon growth inhibitory activity. The inhibitors in the glial scar are ► [chondroitin sulfate proteoglycans \(CSPGs\)](#) (MWs = ranging from 145 to 500 kDa for different CSPGs). Nogo-A and OMgp are minor components of myelin, while MAG comprises about 1% of all myelin proteins. In this review, we will focus on four well-characterized inhibitors.

### Description of Structure

*Nogo-A*. This is a glycoprotein that belongs to the reticulon family of proteins, which in general are associated with the endoplasmic reticulum. However, there is evidence that a proportion of Nogo-A produced by oligodendrocytes is localized to the cell surface and in myelin membranes where it can contact damaged axons and prevent their growth. Nogo-A has two transmembrane domains that result in the formation of a 66-amino acid extracellular loop. Two inhibitory domains have been identified in Nogo-A: the 66-amino acid loop (Nogo-66) and a domain near the N-terminal region (amino-Nogo). Nogo-A may have different topologies within the membrane in terms of the orientation of the N-terminal region, with evidence for both the Nogo-66 and the N-terminal regions being located extracellularly.

*MAG*. This is a glycoprotein that belongs to the immunoglobulin (Ig)-superfamily of proteins. It has five Ig-like domains that are located extracellularly, one transmembrane domain and a short cytoplasmic tail. The extracellular portion of the molecule containing the five Ig-domains is thought to form a hairpin-shaped

bend. MAG has an abundance of sugar residues making it a highly glycosylated protein. It also binds sialic acid and its Ig-like domains have homologies to members of the SIGLEC family (sialic acid binding Ig-like lectins). The axon growth inhibitory domain(s) in MAG have not been fully identified.

**OMgp.** This is also a glycoprotein that is attached to the cell or myelin membrane via a lipid anchor (glycosylphosphatidylinositol [GPI]). It therefore has no intracellular domain. It is largely localized to the paranodal loops of myelin. A major inhibitory domain of OMgp is a region that contains leucine-rich repeats.

**CSPGs.** Unlike the three inhibitors associated with myelin described above, which are membrane-bound proteins, CSPGs belong to a large, diverse class of extracellular matrix (ECM) molecules. ECM molecules are secreted by cells and deposited in a matrix around cells. There are many families of ECM molecules. CSPGs belong to the proteoglycan family, which are molecules that have a protein core to which is attached long sulfated sugar (glycosaminoglycan; GAG) chains. A number of CSPGs are expressed in the CNS that include brevican, aggrecan, NG2, phosphacan and neurocan [3]. Their inhibitory activities largely reside in their GAG chains.

### Higher Level Structures

These axon growth inhibitors exert their effects at the ►growth cone, a specialized structure at the growing tip of axons. Growth cones are highly motile and possess finger-like extensions called filopodia that constantly move and sense the chemical environment. When they

encounter attractive chemical cues such as growth factors or adhesion molecules they respond by forward growth. On the other hand when they encounter repulsive cues such as axon growth inhibitory molecules, the filopodia retract and the entire growth cone, which has an expanded structure (lamellipodia), collapses, thereby arresting its forward growth [4]. For example, this effect of MAG was demonstrated *in vitro* by confronting growth cones of hippocampal neurons with polystyrene beads coated with MAG [5]. Within a few minutes after the growth cones contact the MAG coated beads, the filopodia retract and the growth cones collapse (Fig. 1).

Similar effects have been observed with the other inhibitors using different *in vitro* assays. Filopodial retraction and growth cone collapse is mediated via receptors on the surface of growth cones that bind the axon growth inhibitors. Interestingly, the receptor that was first identified as a receptor for Nogo-66 (NgR; MW = 85 kDa) was subsequently found to also serve as a receptor for MAG and OMgp. NgR is a GPI-anchored protein that partners with the transmembrane proteins p75<sup>NTR</sup> or TROY and the Nogo-binding protein LINGO-1 to form a receptor complex. When NgR binds to one of its ligands in myelin the receptor complex triggers the activation of an intracellular signaling molecule RhoA, which causes changes in the cytoskeletal components of the growth cone that results in collapse [4] (Fig. 2).

Although CSPGs do not bind to NgR, their effects are also mediated via the activation of RhoA, a member of the Rho GTPase family. Activation of other members

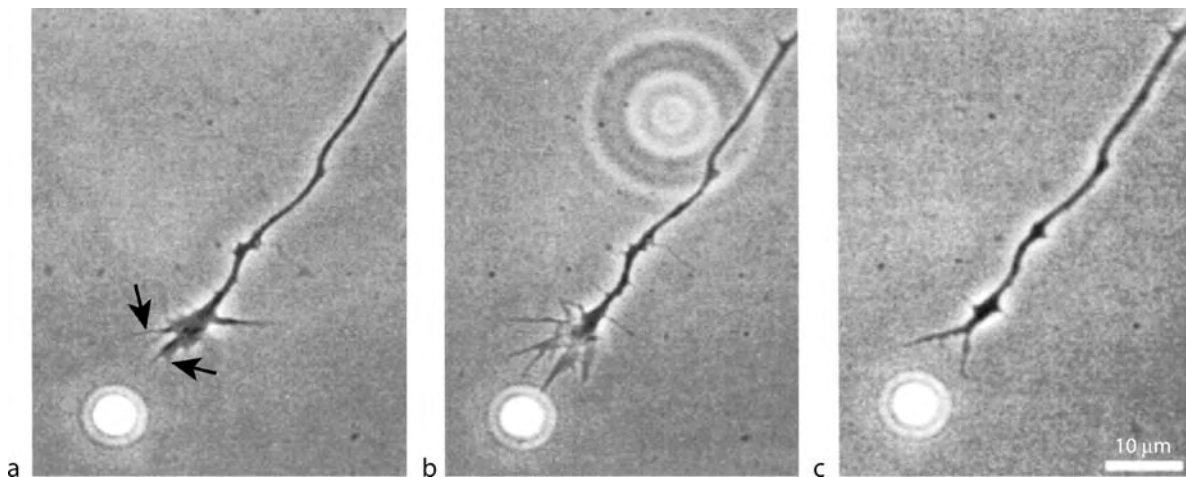

**Inhibitory Molecules in Regeneration. Figure 1** Time-lapse video microscope images showing a hippocampal axonal growth cone growing toward a polystyrene bead coated with MAG. (a) Shows the growth cone prior to contacting the MAG-coated bead. Note the numerous finger-like extensions called filopodia (arrows). (b) Shows the growth cone contacting the bead with a few filopodia. (c) Shows that approximately 17 min after first contacting the MAG-coated bead most of the filopodia have retracted, the body of the growth cone called the lamellipodia has collapsed, and the entire growth cone has retracted from the bead. (Reproduced with permission from Li [5] *J Neurosci Res* 46:404–414.)

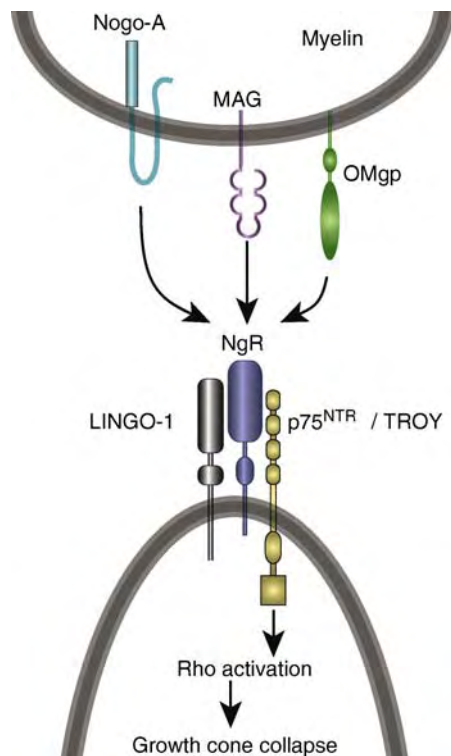

### Inhibitory Molecules in Regeneration.

**Figure 2** Schematic diagram showing the three inhibitory molecules in myelin, Nogo-A, MAG and OMgp. The diagram illustrates that these inhibitory molecules bind to NgR, which partners with either p75<sup>NTR</sup> or TROY and LINGO-1. This receptor complex activates RhoA, which triggers changes in the growth cone cytoskeleton leading to growth cone collapse and repulsion.

of this family, namely Rac or Cdc42 leads to forward motility of the growth cone and axonal growth. Therefore extracellular cues can signal axon growth or inhibition by signaling these intracellular pathways. If such repulsive mechanisms are activated selectively on one side of the growth cone, it can cause the growth cone to turn, and thus serve as a mechanism to steer axons to their appropriate targets.

### Regulation of the Structure

During development, myelin appears after axons have grown to their targets. Therefore, Nogo-A, MAG and OMgp are not present when the nervous system is getting wired-up to appropriate targets. However, some axon fiber tracts in the CNS grow and become myelinated earlier than other fiber pathways. It has been suggested that inhibitory molecules in pathways that become myelinated earlier, play a role in corraling the later growing axons and thus help in the development of anatomically distinct pathways [6]. The inhibitors associated with myelin are present in the adult

CNS and are thought to play a role in preventing unwanted sprouting in the uninjured nervous system. After CNS injury, damaged axons are likely to first encounter the inhibitors in myelin at the site of injury where myelin is damaged. Even if some of the axons are able to navigate past the site of the lesion, they are then likely to encounter inhibitors on the surface of oligodendrocytes and the outer wraps of the undamaged myelin sheaths. There are some reports that dorsal root ganglion neurons, which are part of the peripheral nervous system, are able to grow axons for long distances when transplanted into the adult CNS. It is not clear at present whether this is due to the unique properties of these neurons. In general, however, embryonic CNS neurons are unable to growth axons for long distances when transplanted into the adult CNS. CSPGs on the other hand are not expressed at substantial levels in the normal white matter fiber pathways. Their expression is markedly increased at the site of CNS injury, whereas CSPGs are induced only after injury, it seems reasonable to assume that the inhibitors in myelin are the ones that are first encountered by damaged axons. Nevertheless, there is clear evidence that CSPGs contribute importantly to the failure of axon growth after CNS injuries [3].

### Function

The *in vivo* role of the axon growth inhibitors in myelin was first demonstrated in experiments in which the IN-1 antibody that neutralizes Nogo-A was infused into the injured (dorsal hemisection lesion) adult rat spinal cord [7]. Although only a small number of damaged axons regenerated, this work provided the first clear evidence that blocking such molecules can promote long distance axon regeneration. Subsequently, the IN-1 antibody was tested extensively to assess regeneration in various parts of the injured CNS. Our group immunized adult mice with recombinant Nogo-66 and MAG, and showed that this type of vaccine approach generated antibodies in these animals that neutralized these inhibitors and promoted axon regeneration after dorsal hemisection lesion in adult mice [8]. A peptide that blocks the interaction of Nogo-66 with its receptor was also shown to promote axon regeneration after spinal injury. Work from our laboratory indicates that myelin contains other inhibitory activities in addition to the three already identified, namely Nogo-A, MAG and OMgp [5]. In other work, we immunized mice with myelin using an immunization procedure that prevents autoimmune myelin disease but at the same time generates antibodies against myelin proteins [9]. We showed that the anti-myelin antibodies were able to neutralize the inhibitory activity of myelin, enter the spinal cord, and stimulate extensive growth of injured axons *in vivo*. Although this treatment approach cannot

be directly translated to use in humans because of the potential danger of producing autoimmune disease, it nevertheless provided a valuable proof-of-principle evidence of the importance of the inhibitors in myelin for the failure of axon regeneration after spinal cord injury. Vaccine strategies that are directed at the three inhibitors or their active domains, or the use of small blocking peptides are being developed for therapeutic use. Since Nogo-66, MAG and OMgp bind to the same receptor, NgR, treatments directed at blocking this receptor is another valuable therapeutic goal. Despite these exciting possibilities, recent work from several laboratories on mice which lack either Nogo-A or NgR have provided conflicting results. Whether the differences in the results obtained by the different laboratories are due to technical differences associated with the lesioning and neuronal labeling techniques, or to compensatory changes in the expression of genes sub-serving similar functions or other reasons is not yet resolved.

Interestingly, treatment with the IN-1 antibody that blocks Nogo-A also stimulates sprouting of uninjured fiber tracts, which then reinnervate denervated targets [2]. This sprouting of uninjured fiber tracts may contribute to the functional recovery detected in these experiments. Although the sprouting of uninjured axons may be an effective way to recover lost function, there is also the danger that inappropriate sprouting may cause abnormal motor or functional consequences. It is possible that appropriate rehabilitation techniques may help to refine and strengthen correct neural connections and eliminate incorrect ones.

Several studies have shown that CSPGs inhibit neurite or nerve fiber growth *in vitro*. CSPGs are thought to serve as barriers to axon growth in different parts of the developing CNS [10]. In addition, *in vivo* lesioning and transplantation studies in the adult CNS have shown that damaged or growing axons appear to stop at the boundary of CSPG rich areas adjacent to the lesion [3,10]. Degradation of the GAG chains of CSPGs with the enzyme chondroitinase ABC neutralizes its inhibitory activity. A number of recent studies using spinal cord lesioning models, including some that were combined with cell transplantation have shown that treatment of the injured spinal cord in rodents with chondroitinase ABC promotes axon regeneration and functional recovery [3]. CSPGs expressed in the normal gray matter are organized into perineuronal nets that may inhibit plasticity. Treatment of injured spinal cord with chondroitinase ABC may therefore affect not only the growth of injured fibers but may also promote plasticity of uninjured fibers which may contribute to the recovery of function. Various modes of delivery of this enzyme to sites of CNS injury are currently being tested to assess their therapeutic usefulness.

The neutralization of the myelin associated axon growth inhibitors with antibodies or peptides; and neutralization of CSPGs in the glial scar with enzyme treatments; or the blocking of their intracellular signaling molecules, namely RhoA or its downstream targets such as Rho-associated kinase, have exciting therapeutic potential for the treatment of spinal cord injuries, as well as other CNS disorders such as stroke and multiple sclerosis in which axon damage occurs.

## References

1. David S, Aguayo AJ (1981) Axonal elongation into peripheral nervous system "bridges" after central nervous system injury in adult rats. *Science* 214:931–933
2. David S, Lacroix S (2003) Molecular approaches to spinal cord repair. *Annu Rev Neurosci* 26:411–440
3. Carulli D, Laabs T, Geller HM, Fawcett JW (2005) Chondroitin sulfate proteoglycans in neural development and regeneration. *Curr Opin Neurobiol* 15:116–120
4. McKerracher L, David S (2004) Easing the brakes on spinal cord repair. *Nat Med* 10:1052–1053
5. Li M, Shibata A, Li C, Braun PE, McKerracher L, Roder J, Kater SB, David S (1996) Myelin-associated glycoprotein inhibits neurite/axon growth and causes growth cone collapse. *J Neurosci Res* 46:404–414
6. Schwab ME, Schnell L (1991) Channeling of developing rat corticospinal tract axons by myelin-associated neurite growth inhibitors. *J Neurosci* 11:709–721
7. Schwab ME (2002) Repairing the injured spinal cord. *Science* 295:1029–1031
8. Sicotte M, Tsatas O, Jeong SY, Cai CQ, He Z, David S (2003) Immunization with myelin or recombinant Nogo-66/MAG in alum promotes axon regeneration and sprouting after corticospinal tract lesions in the spinal cord. *Mol Cell Neurosci* 23:251–263
9. Huang DW, McKerracher L, Braun PE, David S (1999) A therapeutic vaccine approach to stimulate axon regeneration in the adult mammalian spinal cord. *Neuron* 24:639–647
10. Silver J, Miller JH (2004) Regeneration beyond the glial scar. *Nat Rev Neurosci* 5:146–156

## Inhibitory Postsynaptic Potential (IPSP)

### Definition

An inhibitory postsynaptic potential (IPSP) usually results from presynaptic activation and hyperpolarizes the membrane potential due to a temporal increase in postsynaptic membrane permeability for  $K^+$  ions and/or  $Cl^-$  ions, thereby bringing the membrane potential closer to the equilibrium potential of these ions.

► Membrane Potential: Basics

► Synaptic Transmission: Model Systems

## Inhibitory Synapse

### Definition

The synapse exhibits the feature that presynaptic stimulation decreases the excitability of a postsynaptic cell. At inhibitory synapses, transmitter binds to the postsynaptic receptors, allows anions to enter the cell, and drives the membrane potential away from threshold, maintaining a membrane potential that is negative relative to the threshold value.

▶ Synaptic Transmission: Model Systems

## Initial Segment

### Definition

Slim initial region of an axon where it originates from the cell body or a proximal dendrite; often site of action potential initiation.

▶ Action Potential

## Injury

▶ Transplantation of Olfactory Ensheathing Cells

## Innate

### Definition

Developing through a process of biological maturation, rather than by learning.

▶ Theory Theory (Simulation Theory, Theory of Mind)

## Innate Immune Responses

### Definition

Innate immune responses are non-specific host defense responses to tissue damage, infection and cancer. Innate immune responses are mediated through (i) anatomic barriers, such as skin and mucous membranes, providing physical barriers to most micro-organisms; (ii) physiologic barriers, such as high body temperature and acidic environment in the stomach; (iii) endocytic and phagocytic barriers which involve ingesting extracellular macromolecules and particulate materials; and (iv) inflammatory responses featuring increases in capillary permeability, influx of leukocytes and locally released cytokines, chemokines and other mediators.

The major leukocyte types involved in innate immunity are monocytes/macrophages, neutrophils, mast cells and natural killer cells.

- ▶ Chemokines
- ▶ Cellular and Humoral Immunity
- ▶ Cytokines

## Innate Immunity

### Definition

First line of defense against infection, in which phagocytic cells use primitive non-specific recognition systems to kill pathogens. Innate immune molecules can also recognize toxic cell debris such as apoptotic cells and mis-folded proteins and this function may represent the most ancestral role of the innate immune system.

▶ Innate Immune Responses

## Innate Knowledge

### Definition

Innate knowledge is knowledge that is not acquired by sense experience but is possessed (at least in a dispositional sense) from birth. Some think that the basic principles of language (natural logic) are known in this way.

▶ Knowledge



## Inner Ear

### Definition

Sensory organ containing multiple receptors subserving vestibular and acoustic sensitivity. Innervated by the octaval or eighth cranial nerve.

► Evolution of Mechanosensory and Electrosensory Lateral Line Systems

## Inner Ear Disorder

► Disorders of the Vestibular Periphery

## Inner Hair Cells

### Definition

The hair cells of the mammalian cochlea which stimulate most of the auditory-nerve afferent neurons.

► Cochlea

## Inner Nuclear Layer (INL)

### Definition

Layer in the retina, containing the somata of horizontal, bipolar, Müller and amacrine cells.

► Horizontal Cells  
 ► Inherited Retinal Degenerations  
 ► Retinal Bipolar Cells  
 ► Retinal Direction Selectivity and Starburst Amacrine Cells

## Inner Plexiform Layer (IPL)

### Definition

Synaptic layer in the inner (proximal) retina where ganglion cell dendrites receive synaptic input from

bipolar cells and amacrine cells. Dendrites of different ganglion cell types stratify at different levels of the IPL and contact different types of presynaptic neurons.

► Inherited Retinal Degenerations  
 ► Retinal Bipolar Cells  
 ► Retinal Direction Selectivity and Starburst Amacrine Cells  
 ► Retinal Ganglion Cells

## Innervation

### Definition

The distribution of nerve fibers to a body region or organ.

## Innervation Ratio

### Definition

The number of individual muscle fibers in a given motor unit.

► Motor Units

## Inotropic

### Definition

Inotropic refers to that which influences the contractility of muscular tissue, and is defined as a positive or negative inotropic effect if the force increases or decreases, respectively.

## Input Unit

### Definition

A model network neuron that receives external signals such as sensory signals, signals from other networks,

etc. The stimulation of input units may change activities of hidden units to which they are connected.

► Neural Networks

---

## Insomnia

### Definition

The complaint of repeated difficulty falling asleep, staying asleep or obtaining sufficient sleep despite adequate sleep opportunity. The sleep complaints are accompanied by a complaint about associated daytime dysfunction.

► Sleep-Wake Cycle

---

## Inspiration

► Nasal Passageways

---

## Inspiratory Drive Latency

### Definition

The interval of time during which summing excitatory synaptic inputs depolarize respiratory neurons prior to the onset of the inspiratory motor discharge in cranial (e.g., XII) or spinal (e.g., phrenic) nerve motor output.

► PreBötzingner Complex Inspiratory Neurons and Rhythm Generation

---

## Inspiratory Inhibitory Reflex

► Hering–Breuer Reflex

---

## Inspiratory Off-switching (IOS)

### Definition

The inspiratory off-switching (IOS) is the transition process of respiratory cycle from inspiration to expiration.

---

## Instinct

### Definition

An innately determined behavior that is specific to a certain species, and appears in the same form in all members of the species.

► Neural Correlates of Imprinting

---

## Instinctive (Innate) Behavior

### Definition

Behavior driven by inheritance.

---

## Instrumental Conditioning

### Definition

► Operant Conditioning (Instrumental Learning)  
 ► Operant Conditioning

---

## Instrumental (Operant) Conditioning

► Learning and Motivation

## Insula

### Definition

The insula (Latin for island) is region of cerebral cortex made up of several short and long gyri that are covered over by opercular parts of the frontal and temporal lobes, deep in the floor of the lateral fissure. The insula receives pain as well as other somatosensory input from viscera.

## Insular Cortex

### Definition

The insular cortex is an area of the cerebral cortex located within the lateral (Sylvian) sulcus. The insula is the site of cortical representation of taste, visceral, pain, and temperature sensations. It receives inputs from the ventromedial portion of the thalamus and is connected with the orbitofrontal cortex, amygdala, hypothalamus, and brainstem autonomic nuclei.

## Insulin

### Definition

Insulin is a hormone produced by beta cells in the islets of Langerhans of the pancreas. It is secreted into the blood in response to an increase in blood glucose and amino acid levels. The hormone promotes glucose utilization and storage, uptake of amino acid, and lipid synthesis, and it inhibits lipolysis and gluconeogenesis, thus decreasing blood glucose level.

## Integral Proteins

### Definition

Protein molecules that completely traverse the cell membrane, such as ion channels and ion pumps.

► Membrane Components

## Integrate-and-Fire Neuron

### Definition

A simple single-neuron model that captures the phenomenon of generation of action potentials observed in real neurons.

► Neural Networks

## Integration of Spinal Reflexes

MICHAEL J. GREY, JENS BO NIELSEN  
Department of Exercise and Sport Science &  
Department of Neuroscience and Pharmacology,  
The Panum Institute, Copenhagen, Denmark

### Definition

In general, the neural control of complex bodily functions involves the coordination of numerous responses to sensory input, ranging from the simplest automatic responses called reflexes, to the most complex responses involving the higher centers of the nervous system. This coordination or melding of sensorimotor mechanisms was originally described in the mid-nineteenth century by Ivan Sechenov as a sequential process whereby voluntary activity comprised chains of simple reflexes. Since then, many other neurophysiologists, most notably Charles Sherrington, John Eccles and Anders Lundberg, have used the word “Integration” to describe the central nervous process of modulating and combining sensorimotor mechanisms of varying complexity according to internal and external circumstances.

### Characteristics

#### Introduction

A century ago Charles Sherrington suggested that complex movements could be performed by the integration of a chain of “simple reflexes”. Through a series of careful experiments in the early 1900s, Sherrington and his co-workers combined anatomical, physiological, and behavioral evidence to develop a comprehensive theory of reflex action that forms the basis for our current understanding of reflex physiology. This work was continued by John Eccles and his co-workers who, following the introduction of intracellular recording from single neurones in the spinal cord, successfully disclosed the underlying pathways for a number of reflex mechanisms during the 1950s and early 1960s (see [1] for a recent review). Subsequent work by Anders Lundberg

and his co-workers focused on the convergence of interneurons in identified reflex pathways from many different sources, including different classes of sensory afferents and descending fibers from various supraspinal centers [1]. The concept of integration of spinal reflexes in the execution of voluntary movement emerged from this work (Fig. 1). This concept has now been amply documented in human and animal experiments conducted within the last 20 years (see [2] for a recent review). To mention just one example, the Ia reciprocal inhibitory interneurons are facilitated by descending motor tracts (probably most importantly by the corticospinal tract) as much as 50 ms before the onset of the contraction in the target muscle (e.g., [3]; Fig. 2). In this way, the excitability of the motoneurons of antagonistic muscles is reduced even before the contraction has started. This mechanism helps to focus the descending excitatory command to the agonists and to reduce the risk of eliciting the stretch reflex activity that would otherwise be produced when the antagonistic muscles are stretched at the onset of movement. The facilitation of the Ia inhibitory interneurons is tightly linked to the activation of the agonist

motoneurons and is in all likelihood conveyed by collaterals from the descending motor tracts that are responsible for activation of the agonist motoneurons (e.g., [4]). However, Ia inhibition may also be reduced in situations where co-activation of the agonist-antagonist muscles is advantageous. For example, this is the case during balancing tasks where co-activation of antagonistic ankle muscles ensures high stiffness of the ankle joint [4]. Co-activation requires that Ia inhibition is reduced, and this is effected by descending commands. The descending tracts probably do not exert direct inhibition on the interneurons themselves; it is more likely that they facilitate the activity of other interneurons, which in turn inhibit the Ia inhibitory interneurons. It is most likely that this occurs through Renshaw cells which mediate the recurrent inhibition from spinal motor collaterals. The main basic understanding that emerges from findings such as these is that reflex mechanisms are not fixed; instead, they are substantially modulated in order to help the brain to achieve optimal muscle activation in any given motor task.

#### Voluntary Movement Versus Spinal Reflex

Further support for the concept that integration of sensory feedback with descending motor commands is a fundamental principle in motor control may be found from investigations of the organization of the corticospinal tract. The corticospinal tract is the primary conveyor of descending commands for voluntary movement in humans. It projects directly onto all spinal motoneurons in most primates, and this is especially true in humans (e.g., [5]). However, as in the cat, the majority of the tract projects onto spinal *interneurons* in primates, and this is very likely also the case in humans (e.g., [2,5]). Therefore, to a large extent, the corticospinal tract exerts its effect on muscle activity by modulating the flow of information through spinal neural circuitries. The integration of sensory feedback with descending motor commands in spinal circuitries should therefore be considered as part and parcel of voluntary movements. We contend that it does not make sense to regard spinal reflexes and voluntary movements as two separate entities, as is done, in many contemporary textbooks. The prevailing evidence strongly suggests that the emphasis should instead be on how spinal neuronal circuitries are used by the descending motor commands to facilitate optimal activation of the muscles.

There are still many unresolved issues in this regard. For example, there is evidence to suggest that the direct corticomotoneuronal pathway may, to some extent, have replaced spinal control mechanisms through evolution, especially in the control of hand and finger muscles [6]. In both primates and humans, hand and finger motoneurons receive a greater number of direct projections from the corticomotoneuronal tract than do motoneurons of other muscles [5]. Does this mean

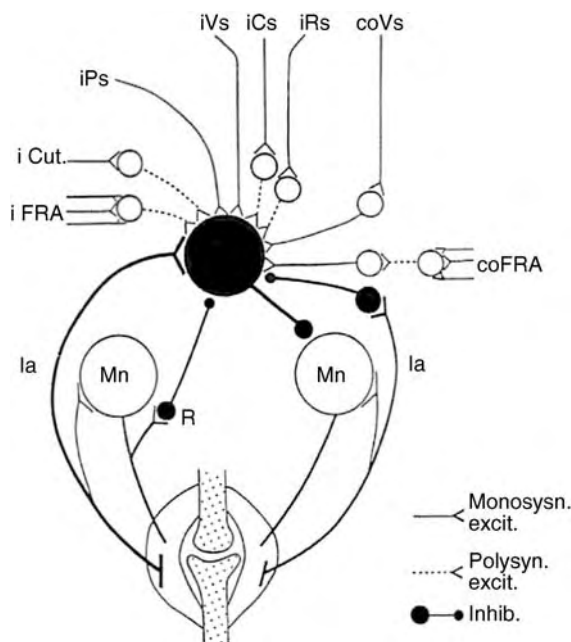

**Integration of Spinal Reflexes. Figure 1** Integration of descending motor tracts and sensory afferent fibers on common Ia inhibitory interneurons in the spinal cord. *Ia* Ia afferents, *Mn* motoneurons, *FRA* flexor reflex afferents, *Cut* cutaneous afferents, *Ps* propriospinal, *Vs* vestibulospinal, *Cs* corticospinal, *Rs* rubrospinal. The prefixes *i-* and *co-* designate that the input originates from the *ipsi-* or *contra-*lateral limb in the case of sensory inputs and the *ipsi-* or *contra-*lateral side of the brain in the case of descending motor tracts. This figure is adapted from Hultborn (1972) *Acta Physiol Scand Suppl* 375:1–42 with permission.

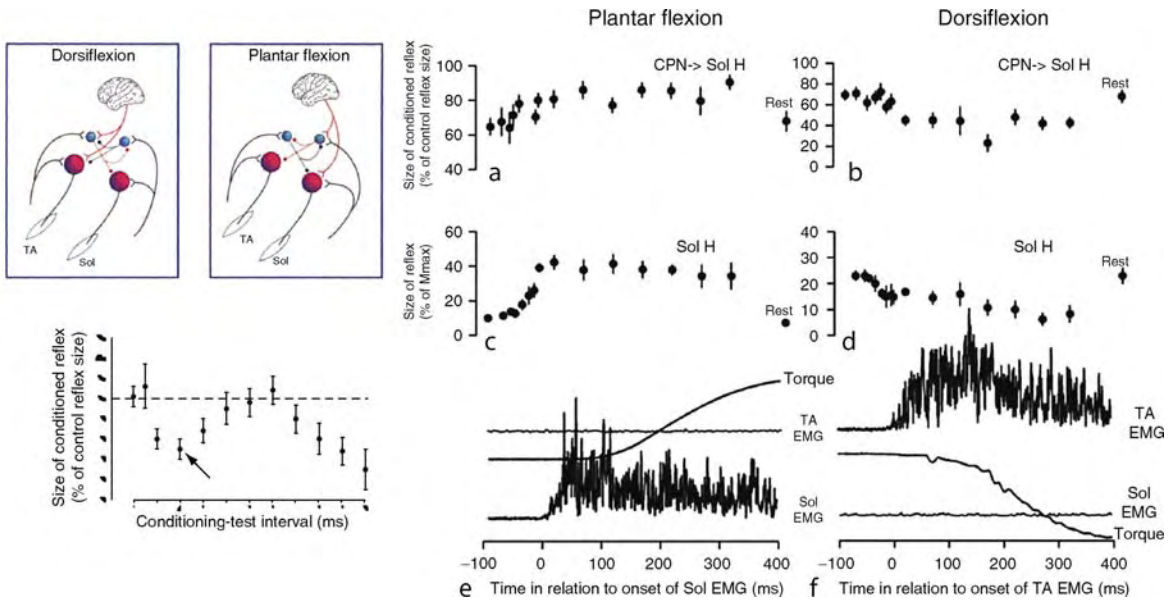

**Integration of Spinal Reflexes. Figure 2** Regulation of reciprocal inhibition in human subjects. Reciprocal inhibition between antagonistic ankle muscles may be investigated in human subjects by measuring the inhibition of the soleus H-reflex evoked that follows a conditioning stimulation of the common peroneal nerve. The time course of this inhibition is shown in the lower left corner of the figure. The horizontal dashed line in the figure designates the size of the control H-reflex without a conditioning stimulation, and the arrow indicates the conditioning-test interval at which a depression of the H-reflex is evoked. This depression is evoked by the activation of Ia inhibitory interneurons from the afferents in the common peroneal nerve. Prior to the onset of a plantar flexion the inhibition is reduced (a), whereas the inhibition is increased prior to the onset of a dorsiflexion (b). These changes in inhibition reflect the descending control of transmission in the reciprocal inhibitory pathway (diagram in upper left corner of figure). The changes in the unconditioned (control) H-reflex (c and d) reflect changes in motoneuronal excitability, and this is partly explained by this central modulation of reciprocal inhibition. This figure is adapted from Nielsen (1998) *Dan Med Bull* 45:423–435 with permission.

there are fewer corticospinal connections to the interneurons involved in the control of these muscles? Could it be that spinal reflex pathways play little or no role in the control of hand and finger muscles as the available data suggest [5]? Which control mechanisms would have changed through this evolutionary process from the spinal to the cortical level? Is activity in the “evolutionarily new” direct corticomotoneuronal system coordinated with activity in the “evolutionarily old” indirect corticospinal system via spinal interneurons, or has it replaced the older system so that the control of spinal interneurons in humans is primarily conveyed by collaterals from the corticomotoneuronal system? We do not have firm answers to these and many other similar questions; yet they are fundamental to our understanding of human motor control, and they are within reach of experimental inquiry.

### Reflex Versus Sensory Feedback

The manner by which reflex circuitries contribute to movements depends not only on how the supraspinal structures modulate transmission in the sensory pathways, but also on whether or not the sensory activity is

within the range of the normal sensory feedback that is expected when a motor program is executed. By normal sensory feedback, we mean the normal *expected* changes in the afferent feedback signal that are generated by changes in muscle length, tendon tension, joint movement, skin stretching, etc. This feedback is different from that which is evoked by a sudden *unexpected* external perturbation that is imposed either at rest or during the execution of the movement. The feedback produced in response to such a perturbation might be considered an *error signal* that requires a change in the central motor command. The stretch reflex is an afferent burst that is elicited by a rapidly imposed joint perturbation, and it may represent an error signal that is interpreted by the nervous system differently than the afferent feedback that is associated with an unperturbed self-generated movement. Based on this reasoning, a stretch reflex response may be used experimentally to investigate corrective responses, but it may not be used to derive information about the typical afferent feedback that contributes to normal motor control. The temporal nature of the afferent burst likely helps the central nervous system to differentiate between normal afferent

feedback and a stretch reflex response that elicits a corrective action (e.g., [7]).

A better way to investigate the role of afferent feedback during motor control tasks may be to remove the feedback by rapidly unloading the muscle-tendon unit. Rather than imposing a perturbation that stretches the muscle-tendon unit and enhances the feedback, a rapid unloading reduces the afferent feedback from proprioceptors and results in a transient reduction of electromyographic activity. This technique has been used during walking in the leg [8,9]. We refer to this as the “unload response” in order to avoid confusion between the corrective reflex response that is evoked by a stretch of the muscle-tendon unit and the reduction of afferent feedback that contributes to a normal movement. It might be argued that the unload response simply reflects a reciprocal inhibition of the unloaded muscle due to the stretch of the antagonist. However, the unload response is not affected by an anesthetic block of antagonist muscle, thus demonstrating that it does indeed result from the removal of afferent feedback [9]. These results were extended by demonstrating that the unload response is not affected by the anesthetic block of cutaneous nerves that supply the foot and ankle [8]. The unload response, therefore, represents the removal of proprioceptive feedback to the spinal cord.

The importance of making the distinction between the stretch reflex response and the unload response may be illustrated with the example of walking. It is well known that the major contributor to the stretch reflex response is the muscle spindle receptor via the group Ia pathway. Dorsiflexion perturbations applied to the ankle produce a stretch reflex response in the soleus muscle (e.g., [10]), and this response has been used to conclude that spindle afferents contribute to the background locomotor activity. More recently, however, we have demonstrated that the plantar flexion evoked unload response in the soleus muscle is delayed with respect to the stretch reflex response [8], and it appears that it is the feedback from Golgi tendon organ receptors via the group Ib pathway that makes the more important contribution to the locomotor activity, at least during the late stance phase of the step cycle.

### Concluding Remarks

Despite a rich tradition of more than 100 years of research, the integration of spinal reflex circuitries and descending motor commands still has many challenging puzzles to solve. As we have pointed out, there is still no consensus about the mechanism by which the most well-studied and meticulously characterized pathway, the monosynaptic stretch reflex, contributes to the activation of muscles during a fundamental motor behavior such as walking, if it makes a meaningful contribution at all. Solving this and a plethora of similar questions related to more complex spinal neuronal networks will keep

researchers active for many years to come and hopefully continue to attract young research talents. This is a requirement for our future ambition of translating the basic understanding of the integrative properties of movement control into useful therapeutic strategies in the rehabilitation of neurological disorders such as stroke, spinal cord injury, and cerebral palsy.

### References

1. Hultborn H (2006) Spinal reflexes, mechanisms and concepts: from Eccles to Lundberg and beyond. *Prog Neurobiol* 78:215–232
2. Pierrot-Deseilligny E, Burke DC (2005) The circuitry of the human spinal cord: its role in motor control and movement disorders. Cambridge University Press, Cambridge
3. Crone C, Nielsen J (1989) Spinal mechanisms in man contributing to reciprocal inhibition during voluntary dorsiflexion of the foot. *J Physiol* 416:255–272
4. Nielsen J, Crone C, Hultborn H (1993) H-reflexes are smaller in dancers from The Royal Danish Ballet than in well-trained athletes. *Eur J Appl Physiol Occup Physiol* 66:116–121
5. Porter R, Lemon RN (1993) Corticospinal function and voluntary movement. Oxford University Press, Oxford
6. Lemon RN, Kirkwood PA, Maier MA, Nakajima K, Nathan P (2004) Direct and indirect pathways for corticospinal control of upper limb motoneurons in the primate. *Prog Brain Res* 143:263–279
7. Morita H, Petersen N, Christensen LO, Sinkjaer T, Nielsen J (1998) Sensitivity of H-reflexes and stretch reflexes to presynaptic inhibition in humans. *J Neurophysiol* 80:610–620
8. Grey MJ, Mazzaro N, Nielsen JB, Sinkjaer T (2004) Ankle extensor proprioceptors contribute to the enhancement of the soleus EMG during the stance phase of human walking. *Can J Physiol Pharmacol* 82:610–616
9. Sinkjaer T, Andersen JB, Ladouceur M, Christensen LO, Nielsen JB (2000) Major role for sensory feedback in soleus EMG activity in the stance phase of walking in man. *J Physiol* 523:817–827
10. Sinkjaer T, Andersen JB, Larsen B (1996) Soleus stretch reflex modulation during gait in humans. *J Neurophysiol* 76:1112–1120

## Integrin-dependent Adhesion Contacts

STEPHANIE WOO<sup>1</sup>, TIMOTHY GOMEZ<sup>2</sup>

<sup>1</sup>Department of Biochemistry, Biophysics, University of California-San Francisco, San Francisco, CA, USA

<sup>2</sup>Department of Anatomy, University of Wisconsin School of Public Health, Madison, WI, USA

### Synonyms

Focal adhesions; Focal contacts; Focal complexes; Point contacts

## Definition

Integrin-dependent adhesion contacts are macromolecular structures that mediate cell adhesion to the ►extracellular matrix (ECM). Cell adhesion sites consist of clustered integrin receptors bound to a plaque of adhesion proteins that ultimately link to the ►actin cytoskeleton. Over 50 unique proteins have been identified within cellular adhesions, making adhesion sites incredibly complex structures. Adding to this complexity is the dynamic assembly, growth, stabilization and disassembly of adhesions that occurs during cell migration and cellular morphogenesis. This process involves continuous modulation of inter-molecular interactions among adhesion proteins (e.g., by ►phosphorylation/►dephosphorylation), which alters cell-substratum binding. Importantly, adhesion-associated proteins often participate in multiple cellular functions. Thus, integrin-dependent adhesion contacts function to both physically link the extracellular matrix to the internal cytoskeleton of the cell, as well as act as sites of localized cell signaling.

## Characteristics

Integrins are ►integral membrane receptors that function as  $\alpha/\beta$  heterodimers to bind ECM ligands such as laminin, fibronectin, vitronectin, and collagen. In humans, there are 18 alpha and 8 beta integrins that combine to form at least 24 distinct receptors [1]. Because the cytoplasmic tails of integrin receptors are relatively short, they rely on interaction with a large number of adhesion-associated adaptor proteins to link to the actin cytoskeleton. An expanding number of proteins have been identified that localize to adhesion contacts. Although it is impractical to list all integrin-associated proteins here, some of more common adhesion related proteins are identified in Table 1, and detailed discussions can be found elsewhere [2].

An important area of current study is focused on how adhesion contacts are formed and regulated during cell

migration. Adhesion to the ECM is especially important for this process as it provides traction for motile cells. Cell migration begins with the extension of ►membrane protrusions driven by actin polymerization at the leading edge. These nascent protrusions are stabilized by the formation of small, punctate adhesion sites known as focal complexes. Most focal complexes are relatively labile, but some can stabilize and mature into focal adhesions (also termed focal contacts), larger structures that are elongated in appearance. Focal adhesions are coupled to contractile ►actin stress fibers, which provide the traction forces that can pull the cell forward. Finally, focal adhesions must be disassembled in the cell rear to allow the cell to continue moving forward.

►Neuronal growth cones at the tips of elongating axons, as well as many rapidly migrating cells, generally do not contain large focal adhesions, but instead form smaller and more transient structures known as point contacts ([3,4], Fig. 1).

Similar to the adhesion dynamics of non-neuronal cells, point contacts also initially form as small puncta that mature into elongated structures associated with actin bundles. However, even mature point contacts are on average five times smaller than non-neuronal cell focal adhesions and exhibit much shorter lifetimes. The dynamic assembly/disassembly of adhesion sites is thought to facilitate rapid cell migration.

## Regulation by Rho GTPases

Members of the ►Rho family of small GTPases regulate the assembly and organization of the actin cytoskeleton in many ways. In addition, recent evidence suggests that RhoA and Rac1 regulate the formation and stabilization of adhesion sites [5,6]. Rac1 activity is required to initiate focal complex and point contact formation, but the exact mechanism remains unknown. Integrin engagement increases the interaction between Rac1 and its effector, p21-activated kinase (►PAK). As PAK is known to activate several actin regulatory molecules, actin reorganization downstream of PAK at adhesion sites may be a necessary step in adhesion site formation.

While Rac1 is required for focal complex formation, RhoA activity promotes the maturation of focal complexes into focal adhesions and is similarly required for the maturation and elongation of neuronal point contacts. RhoA-induced adhesion maturation primarily involves activation of ►myosin contraction by the RhoA effector, Rho Kinase (►ROCK). Interestingly, studies in which external force was applied to cells with a glass micropipette showed that mechanical tension alone is sufficient to induce growth of focal adhesions. Although it is unclear how tension or contraction can induce adhesion maturation, one possibility is that

**Integrin-dependent Adhesion Contacts. Table 1**

Protein	Function	Binding partners
Talin	Scaffolding	Integrin, actin
Paxillin	Scaffolding	FAK
Vinculin	Scaffolding	Actin
FAK	Signaling	Src, Paxillin, p130 Cas
Src	Signaling	Src
Integrin-linked Kinase	Signaling	Integrin
p130 Cas	Scaffolding	FAK

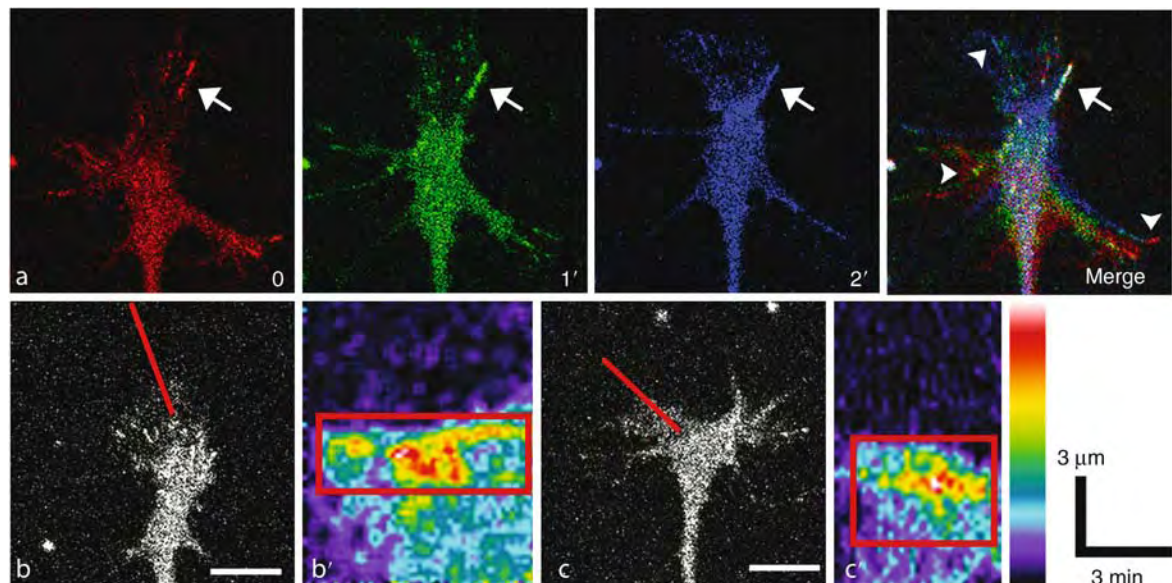

**Integrin-dependent Adhesion Contacts. Figure 1** Live point contact dynamics in neuronal growth cones. Green fluorescent protein (GFP) fused to the adhesion protein paxillin (paxillin-GFP) was expressed in *Xenopus* spinal neuron growth cones as a live marker for neuronal point contacts. Paxillin-GFP is organized into discrete puncta and “streak-like” structures that dynamically assemble, grow, and disassemble during growth cone advance on laminin. (a) Pseudocoloring three time points separated by one min red, green and blue help identify stable regions that display as white in the merged image. Large, stable point contacts appear white in the merge (arrow) while more transient contacts appear as separate colors (arrowheads). (b–c) Kymographs (►Kymography) through individual point contacts (b' and c') assembled from the lines indicated in the frames to the left show the dynamic assembly of individual point contacts. Pseudocolor scale indicates bright fluorescence as hot colors. Point contacts tend to elongate proximally, as and fluorescence intensity increases rearward during elongation (red boxes). In contrast, point contact disassembly occurs rapidly and with no directional bias. White scale bars, 5 μm. Black scale bars refer to the kymographs.

mechanical deformation of adhesion proteins may reveal new binding sites for additional proteins, leading to growth and/or maintenance of an adhesion site.

Interestingly, Rac1 and RhoA appear to have antagonistic roles during adhesion site dynamics. For example, expression of activated Rac1 in cultured fibroblasts results in an overabundance of focal complexes at the leading edge coupled with a loss of focal adhesions, whereas expression of activated RhoA had the opposite effect, since existing focal adhesions grow in size and focal complexes fail to form. These observations led to a model in which dynamic assembly and maturation of adhesions sites during cell migration is regulated by spatially and temporally restricted domains of active Rac1 and RhoA. Adhesion contacts initially form at the leading edge where active Rac1 is concentrated. As the cell continues migrating, these contacts transition into an area of elevated RhoA activity, which promotes their maturation. These domains of Rac1 and RhoA activity likely remain distinct through mutual antagonism.

However, this model may not hold true for all cell types. For example, in leukocytes, activation of RhoA

is associated with a decrease in cell adhesion, whereas Rac1 is activated during adhesion and cell spreading. Moreover, using a ►fluorescent biosensor for RhoA, active RhoA appears concentrated at the leading edge of new protrusions. This suggests that mechanisms regulating cell adhesion, including the role of Rho GTPases, may vary according to cell type.

### Regulation by Tyrosine Kinase Signaling

Integrin-mediated adhesion sites are highly enriched in tyrosine-phosphorylated proteins [2]. In addition, many adhesion proteins contain ►Src-homology 2 (SH2) domains, which facilitate binding to phosphorylated tyrosine residues. Induction of cell adhesion is associated with an increase in tyrosine phosphorylation, suggesting that adhesion site assembly may be triggered by a cascade of phosphorylation events, followed by recruitment of SH2 domain-containing proteins. Two of the best-characterized adhesion-associated tyrosine kinases are focal adhesion kinase (►FAK) and Src.

Focal adhesion formation is associated with an increase in phosphorylated FAK [2,6]. Furthermore, studies in neuronal growth cones have shown that loss



of FAK results in loss of adhesive point contacts [4]. These studies suggest that FAK promotes adhesion assembly, perhaps by initiating a phosphorylation cascade that signals for additional protein recruitment. However, the role of FAK in regulating adhesion dynamics may be more complex. Rather than inhibiting focal adhesion formation, cells deficient in FAK and Src exhibit enlarged focal adhesions that are slow to disassemble [6]. Thus, although the presence of FAK/Src within nascent adhesion sites suggest they may be involved in assembly, the activity of these proteins also appears to be required for focal adhesion turnover.

How do Src and FAK promote adhesion turnover? Live imaging of ►fluorescent protein components of adhesion sites suggest that adhesions elongate by sequentially incorporating new proteins rearward (opposite to the direction of forward translocation), whereas turnover occurs by rapid dissolution with no apparent directional bias (Fig. 1). This suggests that structural linkages either among adhesion proteins or between adhesion components and the actin cytoskeleton can be rapidly broken down. Breaking those links may be promoted by FAK/Src activity. For example, FAK has been shown to phosphorylate the actin cross-linking protein  $\alpha$ -actinin, which reduces its ability to bind to and crosslink actin into bundles. This may lead to weakened connections between actin stress fibers and focal adhesion components. Another possibility involves the protease ►calpain, which is indirectly regulated by FAK/Src activity. Many adhesion proteins are targets of calpain-mediated proteolysis, and cleavage of focal adhesion components contributes to adhesion site disassembly. FAK/Src signaling may also promote focal adhesion turnover through inactivation of RhoA, which as discussed earlier promotes adhesion stabilization. Src has been shown to phosphorylate and activate p190RhoGAP, a negative regulator of RhoA. *fak*<sup>-/-</sup> cells have elevated RhoA activity in addition to over-stabilized focal adhesions, suggesting that FAK normally acts to inhibit RhoA. However, this is complicated by the ability of FAK to bind the RhoA exchange factor p190RhoGEF, and in some studies, FAK has been linked to increased rather than decreased RhoA signaling. In fact, both Src and FAK contain multiple protein-protein interaction domains that allow them to participate in a variety of signaling pathways. Therefore, the role of FAK/Src signaling in adhesion site dynamics is complex and likely to vary under different conditions and among different cell types.

### Integrin-dependent Adhesion During Nervous System Development

Integrin receptors and associated adhesion proteins are important for several aspects of nervous system development. Given the importance of adhesion to cell

migration, it is not surprising that integrin-dependent signaling is implicated in neuronal migration and axon extension. However, integrins have also been demonstrated to play roles in other processes including neuronal differentiation and synaptogenesis.

*Neuronal differentiation.* Integrin receptors activate signaling pathways common to growth factor receptors, and have been shown to regulate neuronal proliferation, survival, and cell fate determination [7]. During development of the mammalian cortex and chick neural tube, neural progenitors express high levels of  $\beta$ 1-integrin, which decreases with the onset of differentiation. Concurrently, expression of laminin-1, a  $\beta$ 1-integrin ligand, also decreases within the surrounding ECM. These findings suggest that changes in ECM composition and integrin subunit expression may function as a developmental switch during neuronal differentiation. This switch may be regulated by ►microRNAs (miRNAs) – short, single-stranded RNAs that negatively regulate gene expression by blocking translation of target messenger RNAs. The most abundant miRNA in developing neural tissue, mir-124, is upregulated during neuronal differentiation and targets both  $\beta$ 1-integrin and the laminin  $\gamma$ 1 chain. Also, introduction of mir-124 into nonneuronal cells alters gene expression to a more neuronal-like profile. Integrin-ECM interactions have also been implicated in the maintenance of ►neural stem cells [7]. Reducing levels of  $\beta$ 1 integrin resulted in the loss of stem cell markers and ultimately led to altered differentiation or cell death. Therefore, integrins and the ECM may play a role in defining stem cell niches. FAK activity has also been linked to the regulation of gene expression and protein translation, suggesting that these processes may be initiated at sites of adhesion [6].

*Axon guidance.* ECM proteins such as laminin and fibronectin promote axon outgrowth and can guide developing axons if proteins are presented discontinuously. Studies performed both *in vitro* and *in vivo* demonstrate that growth cones often alter their direction of outgrowth at sites where ECM composition changes [3]. In addition, soluble ►axon guidance cues can modulate growth cone adhesion and thereby influence growth cone migration. Soluble guidance cues modulate adhesion by influencing the activation state of integrin receptors or by altering the activity of adhesion-associated signaling proteins [8]. For example, the repulsive guidance cue Semaphorin 3A has been shown to activate Rac1 and protein kinase C, leading to inhibition of point contact formation and stabilization, which reduces adhesion. In *Drosophila*, genetic studies have shown that the repulsive cue Slit interacts with talin, integrin-linked kinase, and integrins themselves. Also, several guidance cues have been shown to signal through the kinases Src and FAK, including Netrin-1 and both A- and B-type Ephrins. FAK has also

been demonstrated to be required for axon guidance decisions in vivo [3].

*Neuronal migration.* Integrin receptors are required for migration of cortical neurons into appropriate layers of the cerebral cortex [9]. For example, disruption of  $\beta 1$ -integrin reduces overall cortical migration whereas mutations in  $\alpha 6$ -integrin result in neurons “overmigrating” and invading superficial layers. In addition, the  $\alpha 3\beta 1$  integrin has been shown to be a receptor for Reelin, an ECM protein that is critical for cortical development. However,  $\alpha 3\beta 1$  does not seem to directly regulate neuronal migration, but rather is required for the formation of the marginal zone basement membrane. This in turn regulates Reelin distribution as well as organization of the radial glia upon which cortical neurons migrate.

*Synaptogenesis.* Integrin-mediated adhesion also plays an important role in synapse formation and plasticity [9,10]. Conditional ablation of FAK in mouse Purkinje neurons resulted in increased axon branching and an increase in the number of axon terminals and synapses. This suggests that FAK is a negative regulator of branching and synaptogenesis. Interestingly, as FAK is known to promote adhesion contact disassembly, this further suggests that loss of adhesion may be a necessary step in pruning excess synapses. Integrin-dependent signaling may also be important for synaptic plasticity. In hippocampal slice studies, application of peptide inhibitors against integrin receptors blocked maintenance of ► [long-term potentiation \(LTP\)](#), and integrin mutations have been identified in a *Drosophila* mutagenesis screen for defects in learning and memory.

## References

1. Hynes RO (2002) Integrins: bidirectional, allosteric signaling machines. *Cell* 110:673–687
2. Geiger B, Bershadsky A, Pankov R, Yamada KM (2001) Transmembrane crosstalk between the extracellular matrix–cytoskeleton crosstalk. *Nat Rev Mol Cell Biol* 2:793–805
3. Robles E, Gomez TM (2006) Focal adhesion kinase signaling at sites of integrin-mediated adhesion controls axon pathfinding. *Nat Neurosci* 9:1274–1283
4. Woo S, Gomez TM (2006) Rac1 and RhoA promote neurite outgrowth through formation and stabilization of growth cone point contacts. *J Neurosci* 26:1418–1428
5. Geiger B, Bershadsky A (2001) Assembly and mechanosensory function of focal contacts. *Curr Opin Cell Biol* 13:584–592
6. Mitra SK, Hanson DA, Schlaepfer DD (2005) Focal adhesion kinase: in command and control of cell motility. *Nat Rev Mol Cell Biol* 6:56–68
7. Campos LS (2005) Beta1 integrins and neural stem cells: making sense of the extracellular environment. *Bioessays* 27:698–707
8. Huber AB, Kolodkin AL, Ginty DD, Cloutier JF (2003) Signaling at the growth cone: ligand-receptor complexes and the control of axon growth and guidance. *Annu Rev Neurosci* 26:509–563
9. Milner R, Campbell IL (2002) The integrin family of cell adhesion molecules has multiple functions within the CNS. *J Neurosci Res* 69:286–291
10. Rico B, Beggs HE, Schahin-Reed D, Kimes N, Schmidt A, Reichardt LF (2004) Control of axonal branching and synapse formation by focal adhesion kinase. *Nat Neurosci* 7:1059–1069

---

## Intellectual Development

### ► Cognitive Development

---

## Intelligent Behavior

### ► Cognitive Elements in Animal Behavior

---

## Intensity

### ► Sleep Homeostasis

---

## Intention

### Definition

The specific purpose or the aimed goal of an agent in performing an action.

### ► Imitation Learning

## Intention Tremor

### Definition

A type of action tremor, usually seen in essential tremor. Intention (or trajectory) tremor is best brought out by finger-nose-finger test.

► Essential Tremor

## Intentional Attunement

### Definition

Mental attunement based on the understanding of intention of others.

► Imitation Learning

## Intentional Explanation

### Definition

An explanation is intentional if it refers to an intentional state (e.g., a belief or desire). Typically we use intentional explanations in order to explain someone's actions. For example, we explain Mary's entering the supermarket by mentioning her desire to buy some milk.

► Representation (Mental)

## Intentional Realism

### Definition

The view that intentional mental states are real in that they (i) are governed by folk psychological laws, (ii) have semantic contents, and (iii) are causally efficacious.

► Representation (Mental)

## Intentionality

### Definition

Intentional states are characterized as being about things; examples are beliefs and desires, plans and wishes. Different orders of intentionality are distinguished (zero-order, first-order, etc.).

► Theory Theory (Simulation Theory, Theory of Mind)

## Intentionality – Naturalization of

DANIEL KELLY<sup>1</sup>, KELBY MASON<sup>2</sup>,  
DENNIS WHITCOMB<sup>3</sup>

<sup>1</sup>Department of Philosophy, Purdue University,  
West Lafayette, IN, USA

<sup>2</sup>Department of Philosophy, Rutgers, The State  
University of New Jersey, New Brunswick, NJ, USA

<sup>3</sup>Department of Philosophy, Western Washington  
University, Bellingham, Washington, USA

### Definition

Some mental states are about things. For instance, the belief that the cat is white is about the cat. States that are about things are *intentional*, that is, they have *content*. The precise nature of intentional states is a matter of dispute. What makes some states, but not others, intentional? Of those states that are intentional, what makes them about what they are about as opposed to something else, i.e. what gives them their *specific* content?

### Description of the Theory

To naturalize intentionality is to give these questions scientifically legitimate answers. Philosophers consider this project important because they want to know where intentional states fit within our rich scientific picture of the world, which is rooted in other areas of scientific enquiry such as biology and physics. Many think that, if intentional states do not fit in this picture, then in some sense they do not really exist.

To understand the debates about intentionality, three distinctions are important. The first is between *narrow* and *wide* theories of content. Narrow theories explain the content of intentional states via conditions that are internal to the mind; wide theories do not. For example, some theories say that part of what makes the belief that the cat is white about *the cat* is the fact that it is caused

by the cat. Since the causal relation between the cat and the belief extends beyond the boundaries of the mind, these theories are wide. Narrow theories deny the relevance of any such mind-external conditions.

Our second distinction is between two persistent problems. Attempts to naturalize intentionality are often unable to account for mismatches between the way the world is and the way intentional states represent it to be. This is the *problem of error*. They are also often unable to capture the fine differences between related but distinct contents. This is the *problem of fine-grainedness*.

Our third distinction is between mental states and sentences of natural language. Both of these can be intentional, or about things. We are concerned mainly with the former, but it is worth noting that the project of naturalizing intentionality can cover both mental states and natural language. Terminologically, the issues are usually described in terms of *meaning* and *semantics* in discussions about language, *content* and *representation* in discussions about mental states.

One earlier project which overlapped with the naturalization of intentionality was the *causal theory of reference*. After Russell and Frege, the dominant theory of names in the early twentieth century was that they were abbreviations of much longer descriptions, e.g. “Napoleon” meant “the French emperor who did such-and-such...”. Against this, Kripke and Putnam [1,2] claimed that the meaning of proper names and category names is set by causal and historical connections between the names (“Napoleon,” “water”) and what they refer to (Napoleon, water). This emphasis on causal relations gave encouragement to other philosophers that a general causal/scientific account could be given for language, mental states and any other intentional states. More fully developed and explicitly naturalistic theories of intentionality followed; they can be split into three major types.

The causal theory of reference had the most direct influence on *informational/causal* theories of intentionality, which elaborate the causal relations necessary for content in general. Informational theories, closely associated with Dretske [3], analyze the content of a state in terms of the information it carries: a particular mental state is about hammers, for instance, because it carries information about hammers. *Information* is then defined non-intentionally, the basic idea being that  $x$  carries information about  $y$  just in case there is some reliable generalization that, whenever  $x$  obtains, so does  $y$  (other things being equal). Smoke carries information about fire; tree-rings carry information about the tree’s age; hammer-thoughts carry information about hammers.

This theory has trouble with the problem of error. Suppose that most people reliably thought “there’s a frog” whenever they saw a toad, as well as a frog. The thought would carry the information that a frog

or toad is present, but that would not be its content; thinking frog thoughts when only toads were about would be a mistake.

Fodor’s [4] causal theory aims to solve the problem of error by restricting the causal relations that are relevant to content. Even if in general people have frog-thoughts in the presence of toads, that is irrelevant to the content of the thoughts, because this generalization *asymmetrically depends* on the generalization that people have frog-thoughts when they see frogs. It is not clear, however, whether the notion of asymmetric dependence can itself be specified naturalistically.

Teleosemantic theories like Millikan’s [5] place informational accounts in an evolutionary context. According to such theories, the content of a state is given by its *biological function*: frog-thoughts have their content because their biological function is to carry information about frogs. Biological function is then defined in terms of natural selection: just as the heart was selected to pump blood, frog-thoughts were selected to carry information about frogs.

Teleosemantic theories readily handle the problem of error. Even if everyone now made mistakes with their frog-thoughts, and even if our ancestors did too, the thoughts would still be about frogs and not toads provided they were selected to carry information about frogs specifically. Where such theories might have trouble is in individuating finely-grained contents. For instance, suppose that in our evolutionary history we only came into contact with one species of frog. Then what makes our frog-thoughts about frogs in general, rather than about that particular species? It is not clear that teleosemantic theories can answer such concerns.

Another family of attempts to naturalize intentionality falls under the heading of *conceptual role semantics* (CRS). According to this sort of theory, advanced by e.g. Field [6], the content of a given mental state is determined by that state’s conceptual role. Both wide and narrow versions of CRS have been advocated. Narrow versions take the conceptual role of a given mental state to be determined by its patterns of interaction with other mental states. Wide versions take the conceptual role of a mental state to be determined by its patterns of interaction with other mental states *as well as* features of the external world. For instance, part of the conceptual role of the belief that the cat is white, and thus part of what makes that belief about the cat, may be the fact that that belief tends to come to mind when one is looking at the cat. Since the cat is part of the external world, versions of CRS that subscribe to such views are wide rather than narrow.

There are many problems with CRS. The most important of these is that no one has yet been able to adequately explain how to pick out a specific pattern of interaction that is the conceptual role for the belief that the cat is white, as opposed to a similar but distinct

pattern of interaction that is the conceptual role for the belief that the cat is hungry, etc. Without such an explanation CRS has almost no resources for specifying content, and thus faces a particularly acute form of the problem of fine-grainedness.

In addition to the objections raised to each of these particular approaches to the naturalization problem, some philosophers have viewed the entire project as problematic. Such philosophers have been influenced by Quine's sophisticated arguments concerned with language [7], which supported two related doctrines: the *indeterminacy of translation* and the *inscrutability of reference*. Each of these questioned whether there is any fact of the matter about certain facts about meaning, such as what the correct translation of an utterance is, or what a particular term refers to. The totality of physical facts fail to fix the relevant semantic facts, Quine argued, and concluded from this that meaning facts have no place in a naturalistic worldview, and so semantic and intentional terms deserve no role in a serious science.

When behaviorism, which self-consciously refused to deal in intentional and other mentalistic terminology, was replaced by cognitivism as the dominant paradigm in psychology, the shift raised problems for Quine's conclusions. Psychology began producing robust theories that were couched in intentional terms, and which were therefore committed, at least on the face of it, to the existence of intentional states. For many philosophers, this only made the need to naturalize intentionality more urgent, and their subsequent efforts to produce an adequate account have led to the various theories described above.

Still, the project itself has continued to have its discontents, who take the proliferation of approaches, together with the outstanding lack of success (or even consensus), as indirect evidence for their own skeptical position. More specifically, Stich and Laurence [8] suggest that a fundamental confusion is generated by ambiguity in the notion of naturalization itself. They claim that although fear of *intentional irrealism* – the doctrine that no intentional properties exist whatsoever – has motivated the project of naturalization, the connection between irrealism and naturalization is much less clear than most naturalizers tacitly assume. Once they have surveyed all of the currently available accounts of “naturalization,” Stich and Laurence argue that, however it is construed, failure of the naturalization project does not lead to such an unacceptable irrealism.

This issue of what naturalization amounts to emerges less explicitly in many other discussions as well, where “naturalize” is used to mean something like “legitimize.” For some, the pressing question is whether a science *should* be committed to contentful states and intentional properties, as contemporary cognitive science is widely held to be. The answer lies in whether

or not those intentional properties can be naturalized, and thus legitimized, according to some further, more stringent criterion. Others hold that if a successful natural science is committed to the existence of intentional properties, then this fact *suffices* to naturalize those properties. The search for some further method of legitimization is thus taken to be misconceived.

Other concerns about the viability of naturalizing intentional properties stem from an alleged relation between intentional and normative properties. Most notably, Kripke [9], under the influence of Wittgenstein, starts by considering the activity of rule following, and generates arguments that intentional properties are *essentially* normative. He suggests that since normative properties cannot be naturalized, neither can the intentional properties that essentially contain them.

In sum, the only thing beyond controversy is that, despite much work and debate, none of these issues have been definitely settled yet. Loewer [10] sees a pattern in the failures of the particular approaches, however. He notes that the accounts that successfully deal with the problems of error and fine-grainedness smuggle in and rely, tacitly or otherwise, on non-natural notions, while the accounts that employ only natural notions are unable to give satisfactory answers to the problems of error and fine-grainedness. It is possible that giving a fully adequate account that both solves the problems of error and fine-grainedness *and* uses only naturalistic notions is too complicated, given our formidable but limited cognitive resources. Perhaps, that is, we are *cognitively closed* with respect to the issue. Though some have endorsed this position in other areas of philosophy as well, urging that time and resources would be better spent addressing more tractable problems, it strikes others as defeatist, and methodologically unhelpful. For them, the project of naturalizing intentionality continues.

## References

1. Kripke S (1972) Naming and necessity. Harvard University Press, Cambridge, MA
2. Putnam H (1975) The meaning of “meaning”. In: Gunderson K (ed) Language, mind and knowledge. University of Minnesota Press, Minneapolis, MN, pp 131–193
3. Dretske F (1981) Knowledge and the flow of information. Clarendon Press, Oxford
4. Fodor JA (1990) A theory of content and other essays. MIT Press, Cambridge, MA
5. Millikan R (1984) Language, thought, and other biological categories. MIT Press, Cambridge, MA
6. Field H (2001) Truth and the absence of fact. Clarendon Press, Oxford
7. Quine WVO (1960) Word and object. MIT Press, Cambridge, MA

8. Stich SP, Laurence S (1994) Intentionality and naturalism. In: French PA, Uehling TE Jr (eds) *Midwest studies in philosophy*, vol. 19, Naturalism, University of Notre Dame Press, pp 159–182
9. Kripke S (1982) Wittgenstein on rules and private language. Harvard University Press, Cambridge, MA
10. Loewer B (1997) A guide to naturalizing semantics. In: Hale B, Wright C (eds) *A companion to the philosophy of language*. Blackwell, Oxford, pp 108–126

---

## Interaction Torques

### Definition

According to Newton's law, velocity of an object does not change in an inertial frame of reference if there is no force acting on the object. However, objects experience a force in an accelerating frame of reference, even when there is no physical force acting on the object. This is what happens in the forearm, when the upper arm rotates at the shoulder. The rotation of the elbow on a sphere implies a centripetal acceleration, which is experienced as a force acting on the forearm. The force on a one limb due to linear or centripetal accelerations of another (usually more proximal) limb is called interaction force. The corresponding joint torque is called interaction torque.

► Motor Control Models

---

## Interactionism, Mind-Body Interactions

### Definition

Mental events are distinct from physical events, and they interact with physical events: mental events cause physical events, and physical events cause mental events.

► Causality

---

## Interaural Level Difference (ILD)

### Definition

The difference in sound pressure level (SPL) for an acoustic stimulus arriving at the two ears located on opposite sides of the body is due to the acoustic shadowing effect

of the head and external ears and is one of the major cues for localizing sounds in the horizontal plane.

► Acoustics  
 ► Superior Olivary Nuclei

---

## Interaural Time Difference (ITD)

### Definition

The difference in time of arrival for an acoustic stimulus arriving at the two ears located on opposite sides of the body is one of the major cues for localizing sounds in the horizontal plane.

► Superior Olivary Nuclei

---

## Interdental Papillae

### Definition

The peaked gingival (gum tissue) between the teeth.

► Tactile Sensation in Oral Region

---

## Interference in Memory

### Definition

The presence of competing information in memory that renders the original memory inaccessible.

► Memory Distortion

---

## Interference Pattern

### Definition

Superposition of action potential trains from multiple nerve or muscle fibers in a multi-unit recording during maintained activity.

► Action Potential  
 ► Extracellular Recording

## Interfering RNA

### Definition

Short double-stranded RNA molecules involved in the RNA interference (RNAi) pathway can interfere with specific gene expression.

## Interferon Gamma

### Definition

Interferon gamma (IFN-gamma), also known as type II interferon or immune interferon, is a cytokine produced primarily by T cells and natural killer cells, and may also be produced by central nervous system (CNS) glia. It has widespread effects on all forms of CNS glia.

►Cytokines

## Interferon (IFN)

### Definition

Denotes a class of natural proteins produced by the cells of the immune system in response to challenges by foreign antigens. Interferons belong to the large class of glycoproteins known as cytokines.

►Cytokines

►Central Nervous System Inflammation: Cytokines and JAK/STAT/SOCS Signal Transduction

## Intergeniculate Leaflet

LAWRENCE P. MORIN

Department of Psychiatry, Stony Brook University Medical Center, Stony Brook, NY, USA

### Synonyms

Pregeniculate nucleus (primates); magnocellular division of the ventral lateral geniculate nucleus (cat)

### Definition

The intergeniculate leaflet is a nucleus in the lateral thalamic complex bordered dorsally along most of its length by the dorsal lateral geniculate nucleus and ventrally by the ventral lateral geniculate nucleus. The lateral border is the optic tract and medial border, the super thalamic radiation. Toward the caudal end, the intergeniculate leaflet is bordered medially by the medial geniculate nucleus and lateral part of the zona incerta and ventrally it is bordered by the lateral terminal and subgeniculate nuclei.

### Characteristics

#### Development

The intergeniculate leaflet (IGL) is part of the thalamic lateral geniculate complex. It is homologous with the pregeniculate nucleus of primates and the ventrolateral geniculate nucleus, magnocellular division, of the cat. Developmentally, the IGL arises from the reticular neuroepithelial lobule in which are situated radial glial cells with their endfeet located in the lateral thalamic, primordial IGL [1]. ►Neuropeptide Y (NPY) cells differentiate medially and migrate to the IGL along the path of radial glial processes. As this is completed, the radial glial cells facilitating IGL development detach their cell bodies from the germinal zone of the reticular thalamic neuroepithelium and they are translocated to the IGL, there transforming into reactive astrocytes (found throughout the IGL). This process begins about embryonic day 15 in the hamster. At this time, the NPY cells in the IGL re-orient and send axons ventrally, with the NPY terminal plexus in the ►suprachiasmatic nucleus (►SCN) developing from postnatal day 3–10. In the adult, the IGL is situated ventral to the dorsal lateral geniculate nucleus, and dorsal and generally medial to the ventral lateral geniculate nucleus. For most of its length, it is a fairly thin lamination (Fig. 1b, c), but has an unexpectedly large volume because of its length (approximately 2 mm in the hamster).

#### Retinal Input

The IGL is densely retinorecipient with retinal axons penetrating and arborizing by embryonic day 15.5. The large majority of retinal innervation arrives from the contralateral eye. Both ipsi- and contralateral ►retinas innervate the IGL with substantially overlapping terminal distributions and no evidence of terminal density variation that is relative to the eye of origin [2]. The IGL receives much of its retinal input from ►intrinsically photoreceptive retinal ganglion cells (►ipRGCs), although a significant portion arises from one or more additional classes of ganglion cells. Some of the ipRGCs bifurcate and project to both the SCN and IGL [3].

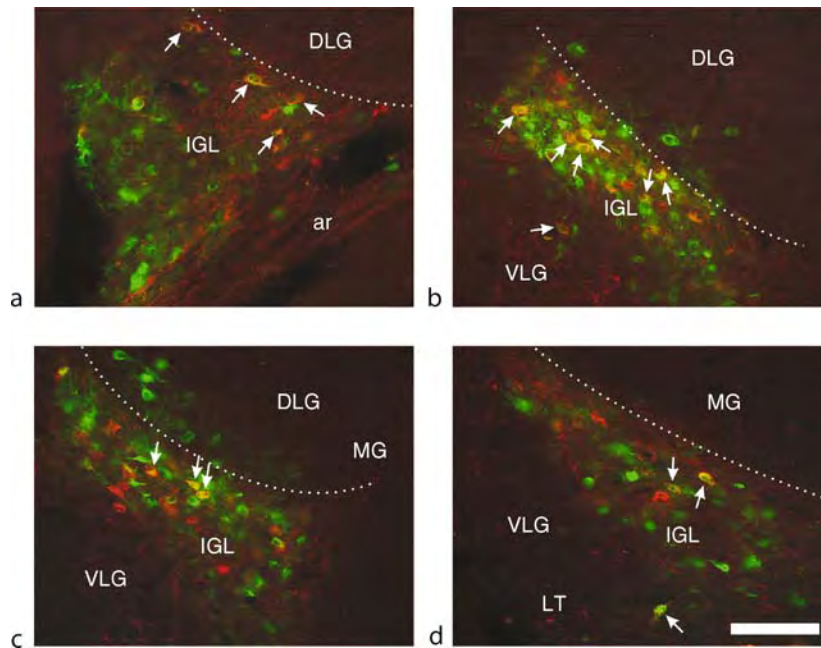

**Intergeniculate Leaflet. Figure 1** (a–d) Coronal sections through four rostral to caudal levels of the hamster IGL showing cells projecting directly or indirectly to the SCN (green), cells projecting from the contralateral IGL to the ipsilateral IGL and directly or indirectly to the SCN (yellow; arrows). The dotted line indicates the border with the DLG. Cells identified as green or yellow contain retrogradely transported transneuronal virus tracer injected into the SCN; those labeled with red or yellow contain retrogradely transported cholera toxin  $\beta$ -subunit injected into the IGL contralateral to the images shown. Such SCN injections of virus label very few cells in the pretectum despite the fact that many cells in this region project robustly to the IGL.

### Function as part of the Circadian Rhythm System

The only known function of the IGL is its involvement in circadian rhythm regulation. It was the first brain location distal to the circadian clock in the SCN that was identified as being part of the circadian rhythm system [4]. The anatomical connections of the IGL are widespread and complex, offering evidence that the IGL contributes to the regulation of non-rhythm-related activities (see below).

The IGL makes distinct contributions to both photic and **non-photoc** control of circadian **rhythmicity** [5]. **Photic** – Animals with IGL lesions fail to show the expected lengthening of the circadian **period** that normally occurs in constant light and have slower re-**entrainment** to a shifted light/dark **photoperiod**. Lesions of the IGL also disrupt the ability of animals to show normal photon integration. Although light information is received by IGL neurons and passed on to the SCN via the **geniculohypothalamic tract (GHT)**, there does not appear to be a direct connection between retinal terminals in the IGL and cells projecting to the SCN [6,7]. Therefore, because of the many IGL-afferent connections with other retinorecipient nuclei, it is not possible to exclude the possibility that the

important photic information arrives via one of the other nuclei. **Non-photoc** – The IGL mediates the actions of several *non-photoc* stimuli that modify circadian rhythm phase. For example, the benzodiazepine drug, triazolam, or locomotor activity in a novel wheel can elicit shifts in circadian rhythm phase the temporal and magnitude properties of which are described by an NPY-type **phase response curve** [5]. The target in the brain, at which triazolam acts to initiate the sequence of events that elicits a phase shift, is not known. With respect to activity in a novel wheel, it is not known what aspect of this behavior constitutes the actual stimulus that elicits non-photoc **phase shifts**. Because the most robust such shifts occur following activity in a novel wheel during the rest portion of the animal's day, it has been thought that sleep deprivation might cause the phase shifts. However, it is now clear that sleep deprivation can occur without associated shifts in circadian rhythm phase.

The IGL is easily identified as the only place in the lateral geniculate region containing NPY cells. Many, but not all, of these cells project to the SCN and provide a dense terminal plexus throughout nearly the entire nucleus (it is less dense dorsomedially and dorsally).



In addition, hamster IGL neurons contain neurotensin co-localized in a subset of the NPY cells. Other IGL neurons also contain enkephalin or GABA which co-localize with each other and with NPY to varying degrees. All cell types project to the SCN via the GHT with similar terminal distributions [5].

NPY release from the GHT appears to be critical for the regulation of certain non-photically-induced phase shifts (e.g. by triazolam or activity in a novel wheel). IGL lesions destroy the GHT, eliminating the NPY terminals in the SCN. Stimulation (electrical or chemoexcitatory) of the IGL elicits phase shifts of the NPY-type. Elimination of endogenous NPY from the SCN also eliminates the ability of animals to show non-photically induced phase shifts [5,8].

The enkephalinergic component of the GHT may also contribute to circadian rhythm regulation. Opioid receptors are present in the SCN and activation of delta opioid receptors with an enkephalin agonist can induce NPY-type phase shifts. In addition, enkephalinergic delta opioid agonists attenuate magnitude of light-induced phase shifts [5].

The route by which non-photically induced stimulus information arrives at the IGL and is transmitted to the SCN is uncertain. Activity in a novel wheel induces FOS protein in IGL neurons containing NPY. However, these particular cells apparently are not among those contributing to the GHT. Similar results are found when light is the stimulus. Despite the fact that light-induced FOS seldom occurs in neurons giving rise to the GHT, those IGL neurons that do express FOS protein appear to be more sensitive than SCN neurons with respect to the FOS-inducing effects of light [6,7].

The neural substrates mediating phase shifts induced by triazolam treatment or activity in a novel wheel are different. Lesions of the deep **▶superior colliculus/olivary pretectal nucleus** eliminate the triazolam-induced PRC, but have no effect on shifts in response to novel wheel activity. The same is true for lesions that specifically destroy serotonergic neurons in the median (but not the dorsal) **▶raphe** nucleus. Thus, although several non-photically induced stimuli exert their ultimate effects upon the SCN through the “final common path” of the IGL and GHT, they appear to have different anatomical substrates afferent to the IGL [9].

### **Extensive Connectivity with Sleep, Visuomotor and Vestibular Systems**

One of the many regions afferent to the IGL is the dorsal raphe nucleus which provides both serotonergic and non-serotonergic input. The median raphe does not project to this region. Hence, it has been thought that the midbrain serotonergic system may exert both direct and indirect effects on the circadian clock. The former can occur via the median raphe projection to the SCN and

the latter via the dorsal raphe projection to the IGL with final input to the SCN through the GHT. The dorsal raphe and its projection to the IGL may mediate novel-wheel activity-induced phase shifts, although the data are not entirely clear on this issue [5].

In the context of the role of the deep superior colliculus and **▶pretectum** with respect to circadian rhythm regulation, it is important to note that lesions of this general area can also prevent **▶dark-induced REM** sleep that occurs in certain rat strains.

The anatomical connectivity of the IGL is extraordinarily extensive and, as a consequence, complicated [10]. In addition to the multiple cell types contributing to SCN innervation via the GHT, some of the cell types (but not the same cells) project to midbrain **▶pretectal nuclei** and to the contralateral IGL. All pretectal nuclei plus the adjacent superior colliculus are also retinorecipient and form part of the **▶subcortical visual shell** consisting of 12 contiguous retinorecipient nuclei extending from the ventral lateral geniculate nucleus, ventrally, to the medial pretectal nucleus and superior colliculus dorsally and medially. Of the 12 nuclei, only those that are involved in classical vision processes (dorsal lateral geniculate and lateral posterior thalamic nucleus) do not receive IGL input.

The IGL connects with more than 100 brain regions with a pattern based on three general principles of organization: (i) extensiveness; (ii) bilaterality; and (iii) reciprocity of innervation between the IGL and its targets [10]. These characteristics, in conjunction with the known functions of specific targets, imply other functions of the IGL. For example, the IGL receives input from hypocretin/orexin neurons, as well as projecting to nearly all the targets of such neurons. Thus, the IGL projects to nearly all brain regions known to contribute to sleep regulation (e.g., dorsal raphe, ventrolateral preoptic area, lateral dorsal tegmentum, **▶locus coeruleus**) and most of these regions reciprocally innervate the IGL. The same is true for the regions involved in **▶visuomotor** function, including the medial vestibular nucleus (Fig. 2). The pattern of IGL anatomical connectivity strongly suggests that the IGL is involved in the regulation of rapid eye movements during sleep. This is further supported by the presence of two distinct classes of IGL cell, as defined by their connectivity. One set projects, directly or indirectly, to the SCN, while the other does not. Instead, the latter project to midbrain nuclei and more caudal structures.

### **Non-Circadian Rhythm Studies**

The available electrophysiological data support the idea that one IGL activity concerns visuomotor function in the monkey. Other studies in the rat have described a slow oscillation (about 20 Hz in a burst over 70 s) with a period of about 106 s. Lesions of the dorsal raphe

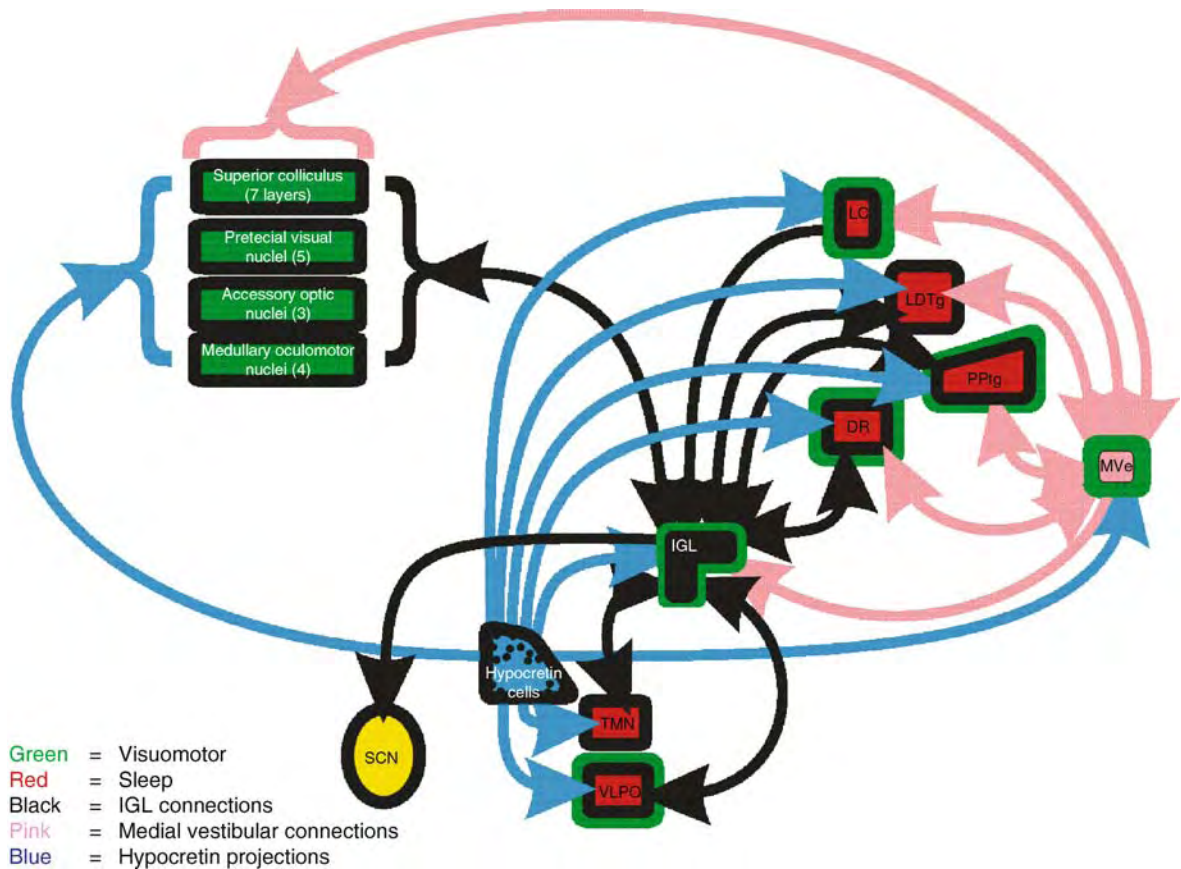

**Intergeniculate Leaflet. Figure 2** Connectivity (black) relationship between the IGL and a variety of brain regions involved in the regulation of visuomotor (green), sleep (red) and equilibrium (pink) functions, will emphasis on the relationship to projections of the hypocretin system (blue).

nucleus increase IGL cell discharge frequency by about 100%. The rhythmicity either originates outside the IGL or is dependent upon afferent activity for its expression. Whether the slow oscillatory bursting activity is related to circadian rhythm regulation, visuomotor activity or something else remains to be established [5].

## References

1. Botchkina GI, Morin LP (1995) Specialized neuronal and glial contributions to development of the hamster lateral geniculate complex and circadian visual system. *J Neurosci* 15:190–201
2. Muscat L, Huberman AD, Jordan CL, Morin LP (2003) Crossed and uncrossed retinal projections to the hamster circadian system. *J Comp Neurol* 466:513–524
3. Morin LP, Blanchard JH, Provencio I (2003) Retinal ganglion cell projections to the hamster suprachiasmatic nucleus, intergeniculate leaflet and visual midbrain: bifurcation and melanopsin immunoreactivity. *J Comp Neurol* 465:401–416
4. Johnson RF, Smale L, Moore RY, Morin LP (1988) Lateral geniculate lesions block circadian phase shift responses to a benzodiazepine. *Proc Natl Acad Sci USA* 85:5301–5304
5. Morin LP, Allen CN (2006) The circadian visual system, 2005. *Brain Res Rev* 51:1–60
6. Muscat L, Morin LP (2006) Intergeniculate leaflet: contributions to photic and non-photoc responsiveness of the hamster circadian system. *Neuroscience* 140:305–320
7. Thankachan S, Rusak B (2005) Juxtacellular recording/labeling analysis of physiological and anatomical characteristics of rat intergeniculate leaflet (IGL) neurons. *J Neurosci* 25:99195–99204
8. Biello SM, Janik D, Mrosovsky N (1994) Neuropeptide Y and behaviorally induced phase shifts. *Neuroscience* 62:273–279
9. Morin LP (1999) Serotonin and the regulation of mammalian circadian rhythmicity. *Ann Med* 31:12–33
10. Morin LP, Blanchard JH (2005) Descending projections of the hamster intergeniculate leaflet: relationship to the sleep/arousal and visuomotor systems. *J Comp Neurol* 487:204–216

## Interictal Phenomena

### Definition

Personality and emotional changes becoming apparent during periods between seizures (inter icti) in ► **chronic temporal epilepsy** and consisting of a decline in sexual interest often paralleled by increasing social aggressiveness, the patients often being extremely emotional, religious, moralistic and devoid of humor.

## Inter-Labyrinthine Line

### Definition

A line drawn through the right and left vestibular labyrinths.

- Galvanic Vestibulospinal Responses (Theory)

## Interleukin-2 (IL-2)

### Definition

Interleukin 2 (IL-2) was initially identified as a T cell growth factor and is produced by many cell types. It has widespread effects on the cells of the immune system, on microglia/macrophages, on oligodendrocytes and on astrocytes.

## Interleukin-6 (IL-6)

### Definition

IL-6 is a pleiotropic cytokine that is involved in the regulation of numerous physiological cellular processes (e.g., proliferation, differentiation and apoptosis) and in immune responses. The IL-6 receptor consists of two distinct subunits (IL-6Ra) and two signaling subunits (gp130). The gp130 subunit is also required for the signaling of other members of the IL-6 family such as IL-11, LIF, OsM, CNTF. IL-6 signaling is associated with JAK1, JAK2 and TYK2 that phosphorylate upon activation STAT3, STAT1 and the protein phosphatase

SHP-2. The JAK/STAT pathway and the SHP-2 pathway have counter regulatory functions.

- Central Nervous System Inflammation: Cytokines and JAK/STAT/SOCS Signal Transduction
- Cytokines

## Interleukin-12 (IL-12)

### Definition

Interleukin 12 (IL-12) is a key pro-inflammatory cytokine in the regulation of immune responses. It is secreted mainly by macrophages, dendritic cells, and granulocytes after stimulation and exerts its effects mainly on T and B lymphocytes and natural killer (NK) cells predominantly through the activation of STAT4.

IL-12 induces the differentiation of CD4-positive Th cells from a Th0 (naïve) to a Th1 (activated) phenotype that is characterized by up-regulation of numerous pro-inflammatory cytokines, including several chemokines and interferon (IFN)- $\gamma$ .

- Chemokines
- Cytokines
- Central Nervous System Inflammation: Cytokines and JAK/STAT/SOCS Signal Transduction

## Interleukin-6 Receptor (IL-6R)

### Definition

Following IL-6 binding the IL-6 receptor forms a complex with gp130, a highly promiscuous cytokine signaling co-receptor essential for various mammalian cell growth and homeostasis pathways. Ligand binding results in signaling through the JAK/STAT and MAPK pathways.

## Intermediate Layer of the Superior Colliculus

### Definition

The superior colliculus is a region in the dorsal part of the midbrain that controls saccadic eye movement and

other orienting movements. Its intermediate layer contains neurons that project to the brainstem and the spinal cord and that exhibit a burst of spikes before saccade.

- ▶ Saccade, Saccadic Eye Movement
- ▶ SC – Saccade Related Burst Neurons

---

## Intermediate Substance

### Synonyms

Subst. intermedia

### Definition

The gray matter of the spinal cord between posterior horn and anterior horn. Here the afferents of the touch receptors synapse, as do the visceromotor afferents.

Afferents from the joints terminate here in rather ventromedial sections.

- ▶ Medulla Spinalis

---

## Intermediolateral Nucleus

### Synonyms

Nucl. intermediolat

### Definition

Also called intermediolateral substance. Part of the lateral horn in the thoracic cord with sympathetic neurons for vasomotor activities.

- ▶ Medulla Spinalis

---

## Intermittent Hypoxia

### Definition

Exposure to repeated brief periods of lower than normal oxygen levels. These exposures are normally seconds to

minutes in duration, separated by similar periods of normal oxygen levels. The most common clinical manifestation of intermittent hypoxia is sleep apnea, a condition in which patients intermittently stop breathing during sleep due to instability in respiratory control, or collapse/obstruction of the upper airways.

- ▶ Neural Respiratory Control during Acute Hypoxia
- ▶ Obstructive Sleep Apnea
- ▶ Respiratory Network Responses to Hypoxia

---

## Intermodal

- ▶ Multimodal Integration

---

## Intermuscular Myofascial Force Transmission

### Definition

The specific case of epimuscular myofascial force transmission, in which force is transmitted directly between the two connective tissue stromata of adjacent muscles.

- ▶ Intramuscular Myofascial Force Transmission

---

## Intermuscular Septum

### Definition

Collagen fiber reinforced connective tissue sheet that separates two antagonistic muscle groups. The septum is usually connected via the periosteum to bone and to the general fascia. If not connected to the periosteum of a bone, it is connected to the interosseal membrane.

- ▶ Epimuscular Myofascial Force Transmission and Intermuscular Interaction
- ▶ Intramuscular Myofascial Force Transmission

## Internal Capsule

### Synonyms

Capsula interna

### Definition

Virtually all ascending and descending cortical pathways pass through the internal capsule. The capsule is v-shaped in horizontal sections and is composed of three regions:

- Anterior limb of internal capsule
- Genu of internal capsule
- Posterior limb of internal capsule. Depending on the position vis-a-vis the lentiform nucleus, two other portions can also be distinguished in the posterior limb:
- Retrolenticular part of internal capsule
- Sublenticular part of internal capsule

► Telencephalon

## Internal Desynchronization

### Definition

One of the definitions of a circadian rhythm is that the rhythm persists under conditions devoid of external time cues, although the rhythms period can slightly deviate from 24 h. Under these conditions, regular rhythms of body temperature and sleep-wake alternations are observed and in most cases, the rhythms of the various variables are phase locked. In some cases, the period of the sleep-wake cycle can spontaneously lengthen and therefore dissociate or desynchronize from the rhythms of other physiological variables such as body temperature that maintain their original period length. This phenomenon is referred to as internal desynchronization and does not occur in real life, except in certain blind individuals.

- Circadian Rhythm
- Internal Desynchrony
- Sleep Homeostasis
- Sleep-wake Autonomic Regulation
- Sleep-wake Cycle

## Internal Desynchrony

RALPH MISTLBERGER

Department of Psychology, Simon Fraser University, Burnaby, BC, Canada

### Synonyms

Spontaneous internal desynchrony; Transient internal desynchrony

### Definition

Loss of synchrony between two or more circadian rhythms within an organism.

### Characteristics

#### Overview of Circadian Systems

Circadian (~24 h) rhythms of biochemistry, physiology, and behavior are ubiquitous in living organisms. In the presence of an appropriate environmental stimulus (e.g., a 24 h light-dark or feeding cycle), these rhythms exhibit stable ►phase relations relative to local time and to each other. In the absence of such “entraining” stimuli (“zeitgebers”, G. time giver), circadian rhythms ►free-run (persist) with a species-typic circadian ►period (denoted by the Greek letter “ $\tau$ ”), indicating control by one or more endogenous, self-sustaining circadian ►oscillators. Under steady-state conditions, phase relations among circadian rhythms are typically stable, suggesting that all circadian rhythms may be controlled by a single master oscillator (pacemaker) with multiple “hands.” However, experiments employing ►zeitgeber shifts, multiple conflicting zeitgebers, or prolonged exposure to environments without zeitgebers (►constant conditions), and more recent experiments mapping circadian ►clock gene expression in multiple tissues, have revealed a more complex underlying circadian structure, with one or more ►circadian pacemakers specialized for entrainment to photic or nonphotic zeitgebers, and for coordinating “secondary” ►oscillator or ►slave oscillators that drive rhythms in local tissue functions. Components of this multioscillator system may exhibit stable coupling at one or more phase relations, and can become uncoupled, creating internal desynchrony. This essay will illustrate principles of internal desynchrony by reference to the mammalian circadian system. The order of subtopics reflects an approximate historical chronology of research.

#### Spontaneous Internal Desynchronization: Humans

Like other species, humans maintained in constant conditions, or with self-control of environmental light but no knowledge of clock time, exhibit ►free-running

circadian rhythms with  $\tau$  in the 24–25 h range. Under these conditions, the sleep-wake cycle initially assumes a delayed phase relative to the body temperature cycle, such that sleep-onset falls closer to the circadian body temperature minimum (which normally occurs near the end of the sleep period, in people entrained to a ►light:dark (LD) cycle). In the early foundational studies conducted in Andechs, Germany [1], most subjects exhibited an average  $\tau$  of  $\sim 25$  h, but this is now known to be an artifact of increased light exposure late in the ►subjective day, due to the delayed bedtime relative to the body temperature cycle (light late in the subjective day slows the circadian pacemaker; see ►phase-response curve to light) [2]. When light-exposure is controlled using special procedures (see ►forced desynchrony, below),  $\tau$  is closer to 24.2 h. If temporal isolation is maintained for a month or more, most

individuals exhibit an apparent spontaneous uncoupling of the sleep-wake and body temperature cycles, with other rhythms remaining synchronized to one or the other of these cycles (Fig. 1a; [1]).

During this so-called ►spontaneous internal desynchronization, the body temperature cycle may shorten slightly (e.g. from 25 h to 24.5 h in the original studies) while the ►sleep-wake cycle dramatically lengthens, with some cycles in the 30–50 h range (e.g. 30 h of wake alternating with 10 h or more of sleep). These long sleep-wake cycles occur sporadically among cycles closer to normal length, resulting in an average periodicity of 30 h or more.

Remarkably, during spontaneous internal desynchrony, subjects do not recognize lengthening of the sleep-wake cycle, and appear to experience an elapsed time of only  $\sim 24$  h over the course of a 30–50 h day as

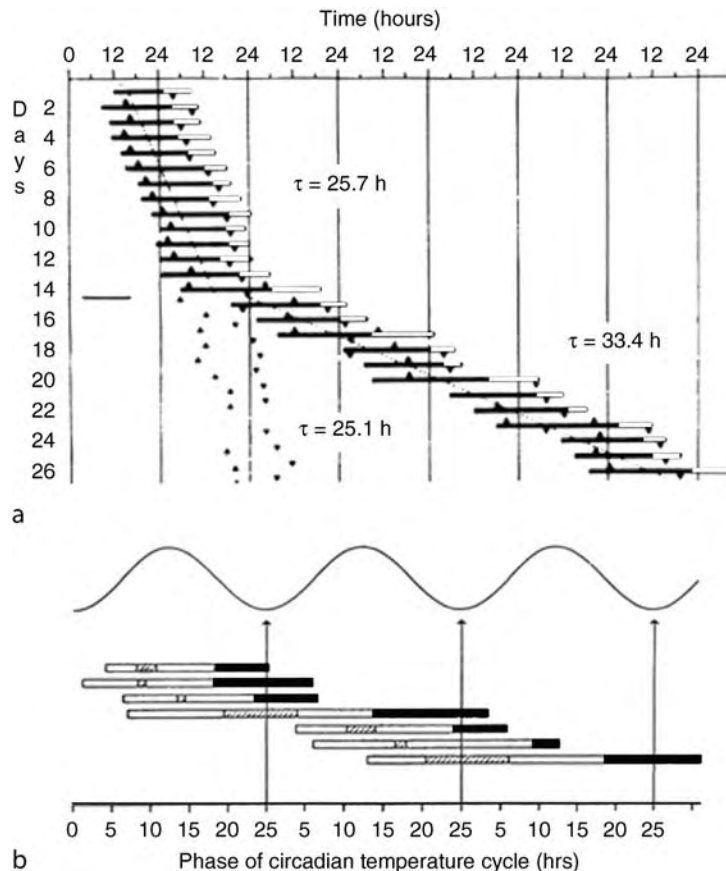

**Internal Desynchrony. Figure 1** (a) Circadian rhythm of sleep-wake and body temperature in a human subject in temporal isolation for a month. Each bar represents one sleep-wake cycle, with wake time opaque. The daily peaks and troughs of body temperature are marked by triangles and arrowheads, respectively. During the first 2 weeks of this record, the subject exhibits internal synchrony of sleep-wake and temperature, both expressing a circadian period of 25.7 h. During the second two weeks, the sleep-wake cycle lengthened to an average of 33.4 h, while the temperature cycle shortened slightly (modified from 1). (b) Replotting of a similar record, with naps (striped sections) included. This reanalysis revealed that subjects usually were asleep during the trough of the body temperature cycle, although they sometimes identified this a nap, despite the length of some of these episodes (up to 8-h). Internal desynchrony disappears when the nap sleep is included (modified from [3]).

defined by the sleep-wake cycle. Estimates of short temporal intervals in the seconds to minutes range are normal, but estimates in the hourly range are proportional to the duration of the sleep-wake cycle. The passage of time is therefore underestimated. This may contribute to preservation of the normal internal structure of daily activities, such that individuals continue to eat only three meals per “day”, despite unusually long inter-meal intervals [1].

The observation that different sets of rhythms can become uncoupled and free-run with different “circadian” periods suggests that there may be two circadian pacemakers, a so-called “strong” oscillator reflected in core body temperature, with a stable endogenous periodicity typically just below 25 h, and a “weak” oscillator reflected in the sleep-wake cycle, with a labile periodicity in the 25 to 50 h range. When internally coupled, the two pacemakers assume a compromise periodicity of  $\sim 25$  h, thereby defining their relative coupling strengths.

This two-pacemaker model has been challenged by several observations. In the Andech studies, subjects were often instructed to refrain from napping, but to identify sleep episodes as naps or primary sleep episodes as they occurred. Naps that did occur were subsequently omitted from analyses. When naps were reincorporated, sleep episodes were found to occur at most or all body temperature minimums, thereby eliminating apparent desynchrony between sleep-wake and temperature rhythms (Fig. 1b; [3]). While not all of the data sets could be clearly explained in this way, the instructions not to nap, combined with altered perception of time and volitional control of bedtime, may have caused some subjects to delay sleep onset excessively, creating occasional long sleep-wake cycles. A critical role for instructions, time perception and volition can also explain the lack of evidence for apparent spontaneous internal desynchronization in truly blind humans that free run despite exposure to daily social cues.

### Spontaneous and Forced Desynchrony, Animal Models

If there are two pacemakers driving different sets of circadian rhythms, it should be possible to identify similar phenomenology and neural correlates in animal models. Long-term continuous recordings of sleep-wake and brain temperature in rats free-running in constant dim light have yielded no evidence for spontaneous desynchrony in that species [4]. Similar results have been obtained in other species. Complete ablation of the **►suprachiasmatic nucleus** (**►SCN**), now established as the master circadian pacemaker critical for the generation light-entrainable circadian rhythms, eliminates free-running rhythms of both sleep-wake and temperature in rodents and squirrel monkeys. Reports of persisting temperature rhythms following SCN-ablation are now

believed to reflect masking (direct) effects of LD cycles or incomplete SCN lesions [5].

In human research, **►forced desynchrony** is an experimental protocol used to dissociate circadian and homeostatic (time awake) contributions to sleep propensity and waking functions [2]. The protocol involves measuring these variables in subjects forced to maintain sleep-wake and light exposure schedules that are either too long (e.g. 28 h) or too short (e.g. 22 h) to entrain circadian rhythms, which consequently free-run. The effects of circadian phase and time awake can then be isolated by averaging the data, over at least one full beat cycle, at the period of the circadian temperature rhythm and at the period of the sleep-wake, respectively. In this protocol, the 22 h or 28 h sleep-wake rhythm is forced, and not the expression of a true rhythm, thus forced desynchrony and spontaneous internal desynchrony are conceptually distinct. A forced desynchrony protocol, employing a 22 h LD cycle, has been reported to induce desynchrony of slow wave sleep and core body temperature in the rat. Under this schedule, rats exhibit locomotor activity rhythms of both 22 h and  $> 24$  h (free-running). Slow wave sleep also exhibits both components, while body temperature is reported to exhibit primarily a  $> 24$  h free-running component. It remains possible that, as in the human forced desynchrony model, the 22-h rhythm is imposed by the environmental condition, and is not a true endogenous rhythm; this will need to be considered in evaluating neural and molecular correlates.

### Splitting, Damping and Threading

Although free-running circadian rhythms can persist almost indefinitely in the absence of environmental zeitgebers, constant bright light or dark can induce rhythm damping and dissociations that reveal structural features of the circadian system [6]. In nocturnal rodents, constant bright light can induce splitting (**►split rhythms**), whereby the circadian rest-activity (**►rest-activity cycle**) rhythm divides into two components, one of which transiently slows while the other accelerates, until stable coupling is achieved in antiphase, creating the appearance of a 12 h free-running rhythm (Fig. 2a).

This new temporal organization is rapidly reversed in constant dark or LD. During splitting, circadian rhythms of activity, core temperature, and endocrine rhythms remain internally synchronized, i.e. all rhythms appear to split in unison. Splitting has been formally modeled as the output of separate circadian oscillators with two stable coupling modes  $180^\circ$  apart [7]. When entrained to normal LD cycles, the two oscillators are coupled within a range of phases determined by the length of the day, with one oscillator driving evening activity (and possibly light sensitivity), and the other driving morning activity (and light sensitivity). The phase relation between these

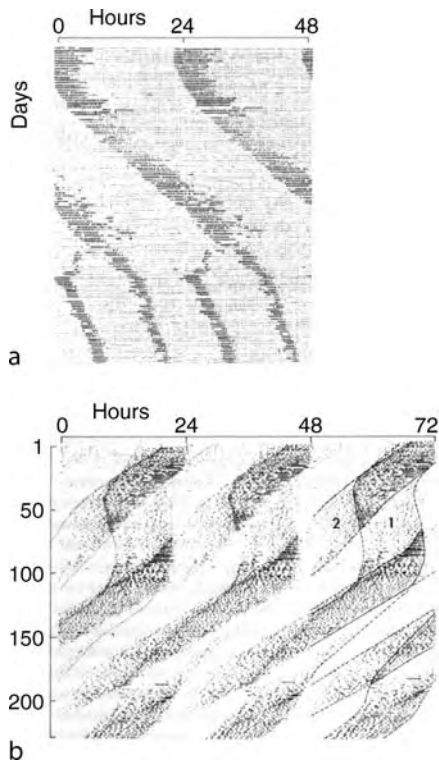

**Internal Desynchrony. Figure 2** Wheel running rhythms of a Syrian hamster in constant light (a) and a tree shrew in constant dark (b). In panel A, each line represents 48 consecutive hours, and consecutive days are also aligned vertically, creating a double-plot. Heavy lines indicate wheel running activity. The activity rhythm free-runs in the absence of a light-dark cycle. The period of the rhythm lengthens from near 24-h to over 25 h, until the daily active period (alpha) “splits” into two components, one with a shorter period, and one with a longer period. The two components recouple in antiphase. In panel B, the data are triple plotted, to illustrate the presence of two circadian activity components free-running with different periodicities. The two components appear to interact, as indicated by regular modulations of periodicity depending on the mutual phase relation. This type of interaction is known as relative coordination. Modified from [7] and Meijer JH, Daan S, Overkamp GJ, Hermann PM (1990) The two-oscillator circadian system of tree shrews (*Tupaia belangeri*) and its response to light and dark pulses. *J Biol Rhythms* 5:1–16.

so-called Evening and Morning oscillators can thereby code for daylength, and serve as a calendar for annual rhythmicity. Exposure to constant light is thought to alter the circadian period of Evening and Morning oscillators differentially, driving them out of synchrony.

Splitting is readily induced in the Syrian hamster, a photoperiodic species. In this species, split components usually recouple in antiphase. Splitting can also be readily induced in the prosimian tree shrew, but in this

▶diurnal (day active) species, continuous dark is the necessary condition, and the split components tend not to resynchronize, but instead may exhibit distinct but clearly interacting free-running circadian components indefinitely (Fig. 2b). In non-photoperiodic species of mice and rats, splitting is less common (but see Fig. 3i). Instead, constant bright light is associated with gradual damping and loss of rhythmicity (Fig. 3e). In rats, the process of rhythm damping has been described as “threading,” suggestive of a population of circadian oscillators gradually uncoupling [4].

Synchrony of behavioral and physiological rhythms during splitting suggests that structural correlates of this state are to be found in the master pacemaker common to these rhythms, the SCN. The SCN is a bilateral structure comprised of ~16,000 neurons. A large percentage of these neurons are circadian oscillators (“clock cells”; Fig. 3a–d). Splitting may represent loss of coupling between left and right SCN, with sustained coupling among clock cells on each side. During splitting, the left and right SCN do oscillate in antiphase (Fig. 3i–l). Unilateral lesions of the SCN have been reported to eliminate one activity component in split animals, although splitting may also be lost by control lesions in other brain structures. Within each SCN, core-shell, ventrolateral-dorsomedial and other anatomical subregions have been defined based on neuronal phenotypes, responses to zeitgebers and patterns of afferent input. These subregions may also uncouple in split hamsters [8], which may account for cases of splitting observed in hamsters with unilateral SCN ablations. *In vitro*, SCN slices cut on the horizontal plane can also exhibit splitting of ipsilateral subregions. Although SCN subregions are evident in rats and mice, splitting may be less common in those species because of stronger intra- or inter-SCN coupling. Alternatively, the mechanism for synchrony among clock cells in each SCN may be weaker, and the population may thus be more likely to lose synchrony altogether (e.g. Fig. 3e–h) rather than to split into independently oscillating subunits.

### Desynchrony Induced by Conflicting Zeitgebers

Circadian oscillations are a property of individual cells, and are believed to emerge from daily cycles of expression of so-called clock genes and/or posttranslational modification of their protein products. Circadian rhythms of clock gene expression are characteristic of neurons in the SCN circadian pacemaker, and these cycles can be reset and entrained by light. Clock genes also exhibit circadian expression in many brain regions outside of the SCN, and in most if not all peripheral organs and tissues. For these extra-SCN and peripheral clock cells, food availability appears to be the primary zeitgeber, and entrainment to LD cycles may be secondary to the daily rhythm of food intake [9]. In



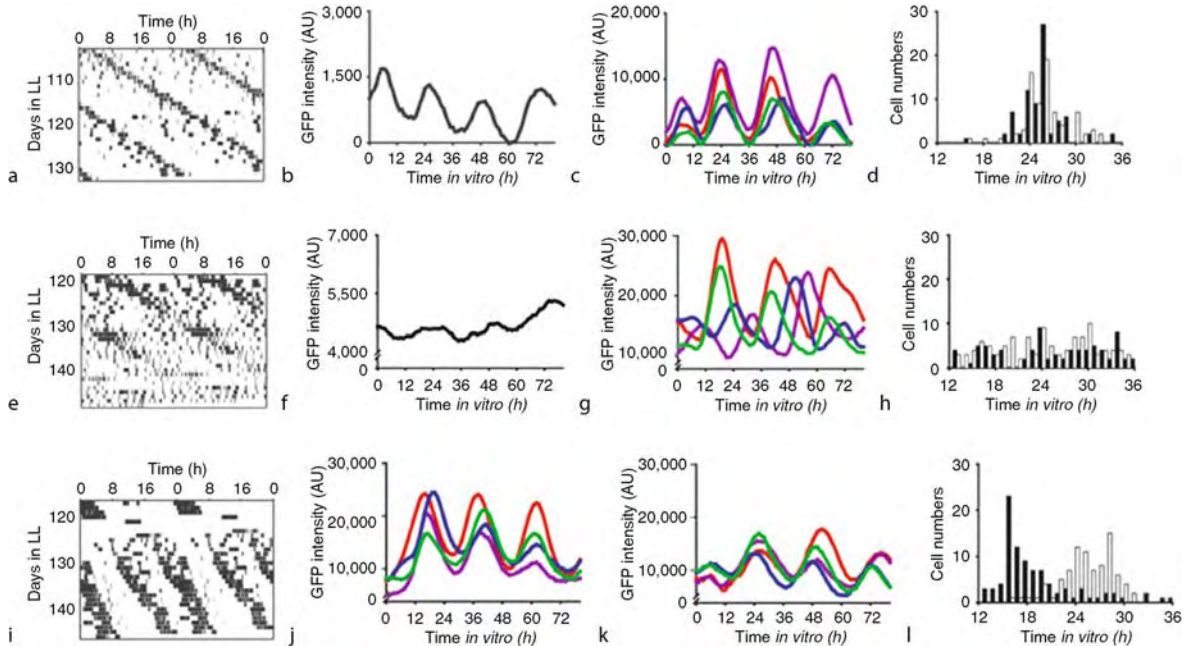

**Internal Desynchrony. Figure 3** Circadian rhythms of wheel running (a, e, i) and of green-fluorescent protein bioluminescence reporting *per1* clock gene expression in SCN explants (b, f) from *per1:GFP* transgenic mice maintained in constant light for over 140 days. Behavioral rhythms and neuronal bioluminescence rhythms are highly correlated. Mice that expressed normal free-running activity rhythms exhibited robust circadian oscillations of *per1* expression at both the whole explant (b) and single neuron (c, each waveform represents a single neuron) levels. The time of peak expression in single neurons is tightly clustered in the population (d), indicating a high degree of synchrony among these oscillating cells. Mice in which the circadian behavioral rhythm damped out exhibited little circadian oscillation of *per1* at the whole explant level (f), but sustained oscillations at the single neuron (g) level that lack population synchrony (h). Mice with split behavioral rhythms exhibited robust oscillations at the single neuron level that were in synchronous within the left (j) and right (k) SCN, but in antiphase between SCN (l). Ohta J, Yamazaki S, McMahan DG (2005) Constant light desynchronizes mammalian clock neurons. *Nat Neurosci* 8:267–269.

nocturnal rodents, if food is restricted to the middle of the day, circadian oscillations in peripheral organs shift to remain aligned with mealtime. A ► [food-anticipatory activity](#) rhythm also emerges, resulting in both daytime and nighttime bouts of activity [6]. By contrast, rhythms of clock gene expression and neuronal activity in the SCN, and of pineal melatonin secretion (critical for measuring daylength in seasonal breeders), remain synchronized to the LD cycle. Thus, although the SCN normally has a dominant role in maintaining internal synchrony, the mammalian circadian system appears designed to support entrainment to conflicting zeitgebers, due in part to indirect (behaviorally mediated) coupling between the SCN pacemaker and peripheral oscillators. For these peripheral oscillators, coordination of tissue functions and metabolism with mealtime is presumably of primary importance. Conflicting zeitgebers can induce internal desynchrony, but the outcome can be construed as adaptive. Both photoperiodic time measurement, mediated by the SCN and the pineal gland, and synchrony of metabolic rhythms with daily cycles of food intake, are preserved.

### Desynchrony Induced by Shifts of Zeitgebers

While animals in natural environments may experience shifts in the best time of day to forage (e.g. due to seasonal variations in food sources), they do not normally experience abrupt, large temporal shifts of sunrise and sunset. Humans, by virtue of jet travel, do experience such events. To reestablish synchrony with local time, phase advance shifts are required for easterly flights less than 12 h, and phase delay shifts for westerly flights. The empirically-based rule of thumb is that it takes about 1 day per time zone to accomplish such shifts, although delays for westerly travel are achieved more quickly in most people. During the process of re-entrainment, humans may exhibit ► [transient internal desynchrony](#), characterized by abnormal phase relations among different circadian rhythms. Some rhythms appear to shift more rapidly than others, although whether this is due to differential rates of resetting of different circadian oscillators, or to ► [masking](#) (direct) effects of altered light exposure, mealtimes and other factors, is unclear. At the level of the SCN pacemaker, different subregions of the SCN appear to shift at

different rates, and to the extent that outputs from these subregions to SCN targets are not fully redundant, this can be expected to contribute to differential resetting rates of other brain regions and organs [10]. Unlike entrainment to food, there is nothing adaptive about desynchrony induced by shifts of the solar day, a decidedly unnatural phenomenon. Transient desynchrony is likely the primary cause of ►jet-lag, and associated symptoms of fatigue, insomnia and gastrointestinal malaise. Similar disruptions of circadian timing are implicated in ►shiftwork malaise, and may underlie some of the adverse health consequences of working rotating shifts (e.g. increased risk of cardiovascular and gastrointestinal disease, and some types of cancer). These considerations underscore the importance of internal synchrony within the circadian system for optimal functioning of physiological processes.

## References

1. Aschoff J (1984) Circadian timing. *Ann N Y Acad Sci* 423:442–468
2. Czeisler CA, Buxton OM, Khalsa SB (2005) The human circadian timekeeping system and sleep-wake regulation. In: Kryger MH, Roth T, Dement WC (eds) *Principles and practice of sleep medicine*, 4th edn. WB Saunders & Co, Philadelphia, PA, pp 375–394
3. Zulley J, Campbell SS (1985) Napping behavior during “spontaneous internal desynchronization”: sleep remains in synchrony with body temperature. *Hum Neurobiol* 4:123–126
4. Eastman C, Rechtschaffen A (1983) Circadian temperature and wake rhythms of rats exposed to prolonged continuous illumination. *Physiol Behav* 31:417–427
5. Kittrell EMW (1991) The suprachiasmatic nucleus and temperature rhythms. In: Klein DC, Moore RY, Reppert SM (eds) *Suprachiasmatic nucleus: The mind’s clock*. Oxford University Press, New York, pp 233–245
6. Mistlberger RE, Rusak B (2005) Circadian rhythms in mammals: formal properties and environmental influences. In: Kryger MH, Roth T, Dement WC (eds) *Principles and practice of sleep medicine*, 4th edn. WB Saunders & Co, Philadelphia, PA, pp 321–334
7. Pittendrigh CS, Daan SA (1976) functional analysis of circadian pacemakers in nocturnal rodents. V. Pacemaker structure: a clock for all seasons. *J Comp Physiol* 106:333–355
8. Yan L, Foley NC, Bobula J, Kriegsfeld LJ, Silver R (2005) Two antiphase oscillations occur in each suprachiasmatic nucleus of behaviorally split hamsters. *J Neurosci* 25:9017–9026
9. Schibler U, Ripperger J, Brown SA (2003) Peripheral circadian oscillators in mammals: time and food. *J Biol Rhythms* 18:250–260
10. Nagano M, Adachi A, Nakahama K, Nakamura T, Tamada M, Meyer-Bernstein E, Sehgal A, Shigeyoshi Y (2003) An abrupt shift in the day/night cycle causes desynchrony in the mammalian circadian center. *J Neurosci* 23:6141–61451

## Internal Energy

### Definition

A quantity postulated by the first law of thermodynamics (namely the law of balance of energy). For a continuous body, it is given by the integral over the body of the internal energy density, assumed to be a function of state of the system (that is a quantity specified via a constitutive law).

►Mechanics

## Internal Forces

### Definition

Internal forces in a mechanical system are forces that occur within the system; that means they always have an equal but opposite equivalent internally, and so, do not contribute to the system’s movement. For the distribution problem in biomechanics defined for a joint, the internal forces are typically considered the muscle, ligament and bony contact forces.

►Distribution Problem in Biomechanics

## Internal Forward Model

### Definition

A neuronal predictive mechanism that estimates a current state of body or external environments by integrating current sensory signals reporting past body states and efference copies of motor signals. This computation is called forward because a current state is calculated in a causal manner, essentially by solving body equations of motion. Forward models have several computational advantages: estimation of a current state, prediction of movement outcomes, and computation of a movement error needed for motor learning.

►Efference Copy

►Motor Learning

►Theories on Motor Learning

## Internal Interval Timer

### Definition

A biological time-keeping mechanism that operates by effectively counting time elapsed from a given event, such as a change in lighting conditions.

► Seasonality

## Internal Inverse Model

### Definition

A neuronal control mechanism that maps a desired effector (i.e., limb or eye) state to motor control signals that are needed to realize that desired state. This computation is called inverse because inverse models compute necessary control signals by substituting a desired effector state into equations of motion, in a way opposite to that of internal forward models. Motor commands produced by inverse models are referred to as feedforward control signals, in contrast to feedback control. Inverse models have a theoretical advantage such that fast and smooth feedforward control becomes possible without using sluggish and awkward feedback control.

► Theories on Motor Learning

## Internal Medullary Lamina of the Thalamus

### Synonyms

Lamina medullaris med

### Definition

This internal medullary layer subdivides the thalamus into three large thalamic nuclear groups:

- Medial thalamic nucleus
- Ventral thalamic nucleus and
- Lateral thalamic nucleus

► Diencephalon

## Internal Models

PAUL CISEK

Groupe de recherche Sur le système nerveux central,  
Department of Physiology, University of Montreal,  
Montreal, QC, Canada

### Definition

The term ► **internal model** refers to the general notion that the central nervous system contains knowledge about properties of the body and of the external world. For example, when you get ready to pick up a box that you believe to be heavy, you prepare your posture for generating a large lift force long before you begin lifting. If the box turns out to be empty, it will move unexpectedly fast. One can say that your internal estimate of the ► **dynamics** of the object was inaccurate, or that you had the wrong internal model of its properties. As you used an incorrect internal model of the box to guide your actions, you generated unnecessarily large forces in trying to pick it up.

### Description of the Theory

Within the context of computational motor control, several specific kinds of internal models have been proposed and have found use both in theoretical discussions and interpretations of experimental results. These fall into two general categories: ► **forward models** and ► **inverse models**. Forward models are used to predict the consequences of a given action, such as predicting the motion of a ball after you strike it with a tennis racquet. They are called “forward” models because they capture the causal properties of the world in the forward direction, from causes to effects. Given some specific motor command (swing the racquet), you get a specific consequence (the ball travels in a new direction). With practice, you become better and better at predicting the consequences of your actions and this is one aspect of learning a skill.

Inverse models capture information in the opposite direction, by inferring causes given specific desired effects. For example, if you know which way you want the tennis ball to travel, what is the right way to hit it? An inverse model is thought to aid in this process. Given a particular desired outcome, an inverse model computes the required motor commands that can produce it.

Both forward and inverse models can be used to solve a variety of problems, and their roles are largely determined by their placement within a control system. Two examples are shown in Fig. 1.

In Fig. 1a, a forward model is used to predict the trajectory which results from a given motor command, and to thus provide the information that a feedback controller needs to generate a desired trajectory. This

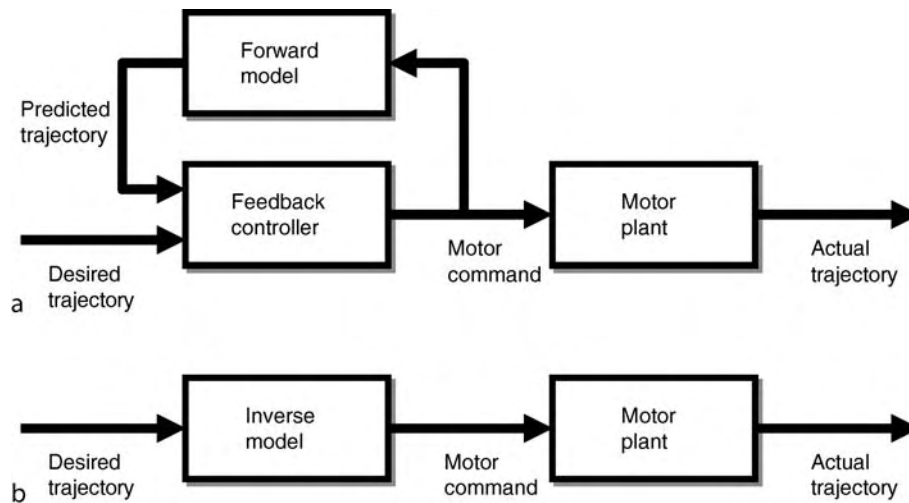

**Internal Models. Figure 1** Examples of the two most basic types of internal models and their placement within a control system. (a) A forward model can be used within a feedback control system to provide a prediction of the trajectory that results from a particular motor command being sent to a particular motor plant. This can be used to compensate for plant properties without waiting for actual feedback about the resulting movement to return from the periphery. Thus, a forward model can be used to implement zero-lag feedback control. (b) If an inverse model of the plant has been learned, then it can be used to generate the required motor command to produce a given desired trajectory. Thus, an inverse model can be used to implement accurate feed-forward control.

is extremely useful because sensory feedback about movement is always significantly delayed, and these delays can cause a feedback circuit to fall into large oscillations. A prediction of feedback by a forward model essentially provides the circuit with zero-lag feedback, avoiding oscillations due to delays. In Fig. 1b, an inverse model is used to compute the command in a feed-forward manner. (Note that there is a potential confusion that can be caused by this terminology, since a “forward model” is often used within a “feedback” control scheme, while an “inverse model” is used for “feed-forward” control.) The concepts of forward and inverse models are similar to classic ideas on cybernetic control systems and theories of cerebellar deficits [2,8], which have been formalized into more recent theories of neural circuits underlying motor control [3]. These concepts are described briefly below (for an authoritative review, see Kawato [4]).

A forward model can predict the consequences of a particular motor command at various levels of detail, including (i) the sensory feedback that will result from the command (proprioceptive signals from stretch receptors, visual motion on the retina, etc.); (ii) the particular joint rotations that will be produced, or the ►intrinsic kinematics; (iii) the movement of the end effector through external space, or the ►extrinsic kinematics (e.g., the motion of the head of a tennis racquet); (iv) the effect of the action on task-relevant variables (e.g., the trajectory of the ball after it is hit); (v) and even higher-order knowledge about goals and task outcomes (e.g., winning the point). When the forward model is used to predict

external events, it is sometimes referred to as an “output predictor,” and when it predicts internal variables such as future joint configurations, it is referred to as a “state estimator.” Again, the role that a forward model plays is determined by its placement in the control system. One particularly interesting role proposed for a forward model is to act as a “distal teacher” that trains the inverse model [3]. This is valuable because in general, learning an inverse model is harder than learning a forward model, but it can be made simpler and done off-line if a forward model is already present.

Inverse models also come in a variety of forms. One example of an inverse model is the sensorimotor transformation that converts a desired movement vector defined in extrinsic space into a vector of desired joint rotations. This can be called an ►inverse kinematic transformation from an ►extrinsic kinematic coordinate system to an ►intrinsic kinematic one. A second sensorimotor transformation may then convert that vector of desired joint rotations into a pattern of desired muscle torques. This would be called an ►inverse dynamics transformation from ►intrinsic kinematics to ►intrinsic dynamics. Any time that a representation of a desired outcome is used to compute the required control signals to accomplish that outcome, we can say that an internal inverse model is being used.

By these broad definitions, forward and inverse models are almost certainly used by the nervous system to control movement. The ability to move one’s hand to a target defined by visual information requires that the visual information is used to compute control signals,

and ultimately, those control signals have to respect the features of the skeletomuscular system that produces the movement. Thus, an inverse model has to exist, at least implicitly (see below). There is some debate on whether control signals have to take into account the dynamics of the act (see ► [equilibrium point hypothesis](#)) [7], but they certainly have to be tailored to the geometry of the arm and the placement of individual muscles.

One must be careful when using these concepts for interpreting data to be clear about whether an internal model is *explicit* or *implicit*. Any control system whose input–output properties mimic attributes of the kinematics or dynamics of the body or the external world, and which can adapt to changes in those attributes, can be said to contain an internal model that is implicit within the parameters of the control system. However, while the concept of internal models captures the computational aspects of what the nervous system is doing, it does not necessarily have to correspond to a specific neural structure that *explicitly* performs that given operation. In other words, even if there is no specialized module within the brain to perform an input–output mapping that corresponds to inverse kinematics, the system as a whole may still implicitly solve the inverse kinematic problem. For example, it is possible that the computation of a required intrinsic dynamics command from a desired extrinsic kinematics command is done in a single step, which encompasses both the inverse extrinsic-to-intrinsic kinematics transformation and the inverse intrinsic dynamics transformation. This distinction between a computational description of what a neural system does implicitly and a putative physical neural module that explicitly performs that computation is important, because a great deal of evidence exists for the former but does not necessarily imply the existence of the latter.

Nevertheless, many studies aimed at elucidating the use of internal models in motor control have shown the value of these concepts. First, there have been numerous psychophysical experiments lending support to the use of internal models in motor control, and some of these will be briefly reviewed here. One influential study examined how human subjects adapt to changes in the force environment while performing simple point-to-point reaching movements with a planar manipulandum [9]. Shadmehr and Mussa-Ivaldi [6] showed that if the manipulandum was programmed to exert perturbing forces on the arm, each subject first exhibited curved trajectories and endpoint errors. With practice in the force-field, the trajectories straightened and accuracy was restored. However, when the forces were removed and the subject was once again moving in normal unperturbed conditions, trajectories were curved once again, in a direction opposite to the original effect of the perturbation. These “aftereffects” can be taken as evidence that the nervous system learned something

specific about the force environment with which it was faced, and did not simply increase stiffness to become more resistant to perturbations in general. It is not known whether this specific adaptation occurs through changes in an inverse model that converts desired hand movement to required joint torques, or through changes in a forward model that predicts the imposed perturbation so that the controller can preemptively correct it. However, Shadmehr and Mussa-Ivaldi showed that the pattern of transfer of this kind of learning implies that it occurs in ► [intrinsic](#) and not ► [extrinsic](#) coordinates.

Psychophysical studies have also provided strong evidence for the use of forward models in motor control. For example, Flanagan and Wing [1] showed that when human subjects hold an object in their hand while they move their arm around in various ways, their grip force is scaled perfectly to compensate for any slippage which might occur. Importantly, this compensation occurs with *zero lag*, that is, it does not rely on sensory feedback from the fingers reporting actual slip. Instead, it must make use of a prediction of what slippage would occur given the current arm movement that is being performed. In other words, these results provide evidence for a forward model that functions as an “output predictor,” which predicts how a given movement of the arm will produce slippage in the hand, allowing anticipatory grip compensation.

Internal models may capture many different aspects of motor control, and a question of recent interest concerns how the nervous system decomposes the problem of learning internal models. There are several possibilities. For instance, it is possible that learning of internal models that deal with kinematics is separate from learning of internal models that deal with dynamics. Evidence in support of this kind of separation has been provided by studies showing interference (i.e., a reduction in the speed of learning) when subjects try to learn two different kinematic transformations at the same time, or when they try to adapt to two different changes in dynamics at the same time [5]. However, there was no interference when subjects were adapting to a kinematic transformation at the same time as a change in dynamics. This suggests that the learning of kinematics is separate from learning of dynamics. However, another possibility is that learning of internal models is separated on the basis of the dependent variables involved. That is, learning the relationship between the required motor command and a variable such as position may be separate from learning the relationship between the command and a variable such as velocity. Tong et al. [10] provide evidence that this may be the case, showing that a position-dependent force field can be learned alongside a velocity-dependent force field.

In addition to psychophysical studies of internal models, efforts have been aimed at finding the neural structures that implement these putative computational

operations. One classic and prominent theory suggests that the cerebellum's role in motor control is equivalent to a forward model [2]. This proposal is supported by the kinds of deficits that accompany cerebellar damage and by the results of temporary cerebellar inactivation on the control signals sent from primary motor cortex to the spinal cord. More recent studies have examined how neural activity in primary motor cortex changes during adaptation to the kinds of force-fields that have been used in psychophysical studies of internal models [6]. While a straightforward mapping of neural structures to modules such as those sketched in Fig. 1 has not been established (nor indeed should one necessarily be expected), these studies do confirm that motor commands are indeed tailored to the specifics of particular kinematic and dynamic environments in a manner that is well captured by the concepts of internal models.

## References

1. Flanagan JR, Wing AM (1997) The role of internal models in motion planning and control: evidence from grip force adjustments during movements of hand-held loads. *J Neurosci* 17:1519–1528
2. Ito M (1984) *The cerebellum and neural control*. Raven, New York
3. Jordan MI, Rumelhart DE (1992) Forward models: supervised learning with a distal teacher. *Cogn Sci* 16:307–354
4. Kawato M (1999) Internal models for motor control and trajectory planning. *Curr Opin Neurobiol* 9:718–727
5. Krakauer JW, Ghilardi MF, Ghez C (1999) Independent learning of internal models for kinematic and dynamic control of reaching. *Nat Neurosci* 2:1026–1031
6. Shadmehr R, Mussa-Ivaldi FA (1994) Adaptive representation of dynamics during learning of a motor task. *J Neurosci* 14:3208–3224
7. Ostry DJ, Feldman AG (2003) A critical evaluation of the force control hypothesis in motor control. *Exp Brain Res* 153:275–288
8. Rosenblueth A, Wiener N, Bigelow J (1943) Behavior, purpose and teleology. *Philos Sci* 10:18–24
9. Li CS, Padoa-Schioppa C, Bizzi E (2001) Neuronal correlates of motor performance and motor learning in the primary motor cortex of monkeys adapting to an external force field. *Neuron* 30:593–607
10. Tong C, Wolpert DM, Flanagan JR (2002) Kinematics and dynamics are not represented independently in motor working memory: evidence from an interference study. *J Neurosci* 22:1108–1113

---

## Internal Representation

### Definition

The central representation of information critical for the performance of motor and non-motor tasks.

Information related to the performance of movements may include properties and location of the target, extrapersonal space, features of the musculoskeletal system and/or body image (body schema), and elements of the motor sequence.

### ► Cerebellar Functions

---

## Internalist/Externalist Theories of Knowledge

### Definition

The distinction is drawn in a number of different ways. According to one common usage, internalist theories of knowledge claim, while externalist theories of knowledge deny, that some cognitively accessible form of justification is an essential condition for knowledge.

### ► Knowledge

---

## Internal model Hypothesis

### Definition

A hypothesis that the brain has neural mechanisms (internal models) that mimic input–output relationship of body or external objects such as hand-held tools or visual targets. Internal models are usually classified into two categories of prediction and control; an internal forward model that computes a current body state from delayed sensory signals and efference motor copies, and an internal inverse model that maps a desired body state onto needed motor control signals. This hypothesis has been tested and then supported successfully by various electrophysiological, psychophysical, and human imaging studies.

### ► Efference Copy

### ► Theories on Motor Learning

---

## Interneuron

### Definition

The interneuron is a neuron situated between two other neurons. A good example is the interneurons in the

intermediate part of the spinal cord gray matter. These neurons are involved in spinal reflexes and are located between a sensory neuron in the dorsal horn and a motoneuron in the ventral horn. In general sense interneurons are considered to be any neuron whose axons and dendrites are confined within an area near the cell body, such as the Golgi Type II neuron mentioned above.

## Internode

### Definition

Internode denotes the myelinated region of an axon between two nodes of Ranvier.

► Node of Ranvier

## Internuclear Neurons in Extraocular Motor Nuclei

### Definition

Groups of cells resident largely within or near an extraocular motor nucleus, and projecting to extraocular motoneurons innervating a synergist of the muscle controlled by that motor nucleus. The best studied are the abducens internuclear neurons.

► Extraocular Motor Neurons

## Internuclear Ophthalmoplegia

### Definition

Patients affected by this syndrome have disconjugate eye movements upon lateral gaze. Namely, with a left-sided syndrome the left eye does not cross the midline when attempting to look to the right.

► Extraocular Motor Neurons

## Interocular Rivalry

► Binocular Rivalry

## Interosseal Membrane

### Definition

Collagen fiber reinforced connective tissue sheet that connects two adjacent bones in a segment of the limb (e.g. tibia-fibula).

► Intramuscular myofascial force transmission

## Interpositus Nucleus (Emboliform Nucleus + Globose Nucleus)

### Synonyms

Nucl. Interpositus (Nucl emboliformis + globosus); Interpositus nucleus (emboliform nucleus + globose nucleus)

### Definition

Emboliform nucleus as well as globose nucleus receive their afferences from the Purkinje's corpuscles of the cerebellar hemisphere, intermediate pars. Therefore they are also summed up as interpositus nucleus. They are also called "intermediary nuclei."

► Cerebellum

## Intersaccadic Interval

### Definition

The period of time between two saccades.

► Saccade, Saccadic Eye Movement

## Intersegmental Coordination

RONALD L. CALABRESE

Department of Biology, Emory University, Atlanta, GA, USA

### Definition

Wave-like behaviors such as undulatory swimming and ventilatory and locomotory movements of multiple appendages that depend on accurate progressive timing of muscular contractions in neighboring ►segments and appendages are said to show intersegmental coordination [1,2]. Even terrestrial locomotion of limbed animals such as vertebrates and insects can be thought to show intersegmental coordination, or interlimb coordination as the case may be. However, as there is often considerable flexibility in the coordination in such limbed terrestrial locomotion – expressed as changes of gait – the complexity is greater, and the focus here will be on wave-like movements where the coordination is more rigidly fixed [1]. Numerous studies have shown that the isolated nervous system is capable of producing rhythmic motor output in the absence of sensory feedback, which is similar to that required for specific behaviors in the intact animal [3]. The neuronal networks that produce this activity are called ►Central Pattern Generators (CPGs) and for wavelike behaviors, this output shows proper intersegmental coordination. For example, in the lamprey forward swimming is accomplished by means of side-to-side undulations that travel from anterior to posterior along the length of the body [4]. The isolated spinal cord will produce a ►motor pattern with the correct side to side alternation and intersegmental coordination of motor neuron bursts in response to stimulation with ►NMDA receptor agonists [4]. In the lamprey, as in other animals, the CPG that produces such wave-like motor patterns is distributed longitudinally along the neural axis [3]. This type of neural network consists of a chain of coupled segmental oscillators, local neural networks that are capable of independently generating rhythmic output [2]. The appropriate coordination between these segmental oscillators arises as an emergent property of the segmental oscillators and the coupling between them. Although this distributed organization is found in many different animals, there are large differences in terms of the properties of the segmental oscillators, the strength and symmetry of coupling, and the importance of sensory feedback. Here we focus on some of the similarities and differences in mechanisms that underlie intersegmental coordination in the swimming CPGs of two animals – one vertebrate and one invertebrate: the lamprey and the leech [5].

### Characteristics

#### Quantitative Description

The parameters most commonly used to describe the intersegmental coordination for wave-like behaviors are period and phase [2]. The period is the time for one complete cycle of the behavior. Phase is the percent of the period that describes the delay between activity (e.g., motor neuron activity) in one segment and activity in the next caudal segment. In some cases, this percent is multiplied by  $360^\circ$  and expressed as degrees. Phase can be measured with respect to a designated reference segment (absolute phase or phase) or it can be expressed as a difference between adjacent segments (phase difference). Phase differences (and indeed absolute phase) thus vary between  $-50$  ( $-180^\circ$ ) and  $50\%$  ( $180^\circ$ ). When the phase difference is  $0\%$  ( $0^\circ$ ), it means that activity in adjacent segments is simultaneous, whereas if the phase is  $50\%$  ( $180^\circ$ ) then activity in the next caudal segments is delayed by half the period; the activity is said to be antiphasic. Negative phase differences correspond to activity in the next caudal segment leading rather than lagging temporally. For many wave-like behaviors – but not for all – stability and efficiency of motion demand that there is a constant phase difference between segments, regardless of the period of the motion [2]. The delay in activity between segments must scale exactly with changes in period for such phase constancy to be maintained. The neuronal mechanisms that thus control intersegmental coordination must be able to produce intersegmental delays that scale with period.

Our understanding of the mechanisms, at the cellular, network, and abstract levels, for intersegmental coordination of wave-like behaviors has been greatly aided by quantitative modeling work, because the dynamic nature of the underlying oscillatory networks makes comprehension based on static circuit diagrams impossible. The use of models with different levels of detail has proven to be a particularly successful approach. Abstract models provide a general indication of the important features of a system [6], while models that are more detailed allow for a direct comparison with the biological system [1,7–10].

#### Higher Level Structures

While there is a rich literature that suggests that higher level input can influence CPGs for wave-like behaviors, the mechanisms of intersegmental coordination appear to be local to the spinal cord in the case of vertebrates, or to the ventral nerve cord in the case of invertebrates. In addition, the brain may be removed without causing disruption of normal coordination in both isolated nervous system preparations and in more intact preparations [2,4].



### Lower Level Components

Motor neurons – segmentally arranged – represent the final output of CPGs and as such, they are the focus of attention in assessing intersegmental coordination. In most cases, the neuronal networks comprising CPGs are presynaptic to these motor neurons. Progress in studying the cellular mechanisms of intersegmental coordination are most advanced in invertebrates, simply because the relatively small number of neurons composing the ventral nerve cord compared to a vertebrate spinal cord has made cellular definition of the segmental oscillators and the coordinating interneurons that link them, i.e., the CPGs, more tractable. While these networks are beginning to be worked out in several vertebrates, only in lampreys [4,9] and *Xenopus* frog tadpoles [8] has this analysis progressed sufficiently to begin defining the mechanisms of intersegmental coordination. While it is clear that CPGs possess the necessary neuronal circuitry to generate the general dimensions of intersegmental phase differences for wave-like behaviors, there is mounting evidence that feedback from peripheral sensory neurons – particularly stretch receptors – play a crucial role in sharpening intersegmental phase differences, adjusting them to environmental realities [2,4,5].

### Higher Level Processes

The leech and the lamprey both swim in an undulatory fashion, with the body forming approximately one full wave at any given time during swimming. To maintain this mode of swimming as an animal changes its swim cycle period, the phase between the muscle contractions in different segments must remain constant [2,4,5].

### Lamprey Swimming

In the lamprey, which swim by side-to-side undulation, forward swimming results from a traveling wave of one body length that begins at the anterior end of the animal. The lamprey has about 100 body segments; therefore, the phase difference between body segments is about 1% in the intact animal. An identical phase difference occurs in the isolated spinal cord when rhythmic activity is induced with the NMDA receptor agonists [4]. Although it is not possible to identify individual interneurons as in the leech swim network, two classes of interneurons, excitatory (E) and inhibitory (C), appear to be essential for burst generation [4]. The E interneurons synapse ipsilaterally with other E interneurons and with C interneurons. The mutual excitation between E interneurons appears to support the generation of bursts in hemisegments. The C interneurons project contralaterally and inhibit other C interneurons as well as E interneurons. These interneurons are responsible for producing alternating activity between the right and left sides of the spinal cord, which is necessary for side-to-side undulatory swimming.

Reciprocal inhibition is not, however, the primary factor that terminates bursts, but rather the activation of two types of  $\text{Ca}^{2+}$ -dependent  $\text{K}^+$  channels (KCa) i.e., on the intrinsic membrane properties of the neurons.

Important early theoretical work [6] indicated that appropriate phase lags for lamprey swimming might be generated by two mechanisms: asymmetries in the coupling between segmental oscillators and differences in inherent segmental periods. Evidence for coupling asymmetries comes from a variety of experiments. Movements imposed on the isolated spinal cord can entrain the activity of the entire swim network by activating intra-spinal stretch receptors, which provide sensory feedback to the interneurons [4]. Movement applied to the caudal end of the spinal cord can entrain the system to a greater range of frequencies than movements applied to the rostral end. Additionally, split-bath experiments, in which the rostral and caudal halves of the spinal cord were bathed in pools with different concentrations of NMDA receptor agonist, demonstrated that the rostral spinal cord dominates the frequency of the coupled network. Physiological and computer modeling results suggest that longitudinal coupling is due primarily to ipsilateral excitatory coupling that is stronger in the descending direction than in the ascending direction [4,10].

There is also evidence of anatomical coupling asymmetries. For example, whereas the E interneurons project symmetrically over a few segments both rostrally and caudally, the C interneurons project 14–20 segments caudally but have only short rostral projections [4]. Evidence for, or against, the existence of a gradient of segmental oscillator frequency is more limited than for asymmetric coupling. Pharmacologically induced frequency gradients can alter and even reverse the normal rostrocaudal phase lags in the isolated spinal cord [4]. Although such experiments cannot demonstrate that such a gradient exists naturally, they show that, at least in principle, a gradient could produce the appropriate phase lags. Presumably, in the intact system a gradient of oscillator frequencies could be produced by a corresponding gradient of descending synaptic drive, as has been found in the swim network of *Xenopus* embryos [8]. In contrast to these results, surgically isolated sections of the spinal cord do not vary in frequency in a systematic way [4]. One problem with such studies, however, is that the rhythm is induced pharmacologically rather than by normal descending spinal pathways. To address this problem, a study was conducted in which fictive swimming was induced by pharmacological microstimulation of the brain. By blocking local rhythmic activity in either the rostral or the caudal half of the spinal cord with a low  $\text{Ca}^{2+}$  saline, it was possible to measure the activity of independent sections of the spinal cord [2,4]. This study revealed faster

oscillations in the rostral spinal cord than in the caudal spinal cord. The extent of longitudinal coupling between segmental oscillators in the lamprey is doubtless another important factor for determining phase lags. Functional coupling that determines phase appears to extend over a much more limited range than the full projection range of 30–50 segmental reported for some interneurons. In one study, the lamprey spinal cord was placed in a chamber with partitions allowing the rostral, middle, and caudal sections to be bathed in different solutions [2,4]. Local synaptic activity was blocked in the middle section with a solution containing low- $\text{Ca}^{2+}$  and high- $\text{Mg}^{2+}$  without affecting spike conduction in axons spanning the middle compartment. The results indicated that although the maximal functional length of propriospinal coupling is 16–20 segments, phase was controlled by short-range coupling that spans only 4–6 segments.

It has been proposed that the interneurons that comprise a segmental oscillator act not only to generate the local rhythm but also project to, and influence, rhythm generation in other segments. The feasibility of this idea, which has been termed “synaptic spread,” has been demonstrated in modeling studies in which the synaptic contacts made locally by an interneuron are also made with similar targets in neighboring segments but with lower synaptic strengths [4,10]. Models incorporating cellular and synaptic properties of the swim network can replicate many of the observed properties of the swimming animal such as a reversal of phase lag necessary for backward swimming.

### Leech Swimming

In the leech, which swims by dorsoventral undulations, forward swimming results from a traveling wave of one body length that begins at the anterior end of the animal. There are 18 body segments that are actively used for swimming. Thus, the phase lag between consecutive body segments is about  $20^\circ$  in the swimming animal [5]. Intersegmental phase lags that are nearly independent of cycle period are also observed in isolated chains of the leech nerve cord consisting of as few as two ganglia. However, in contrast to the intact animal, the phase lag per segment within a long chain of ganglia *in vitro* is only about  $8^\circ$ . A segmental oscillator of the leech swim CPG consists of a bilaterally symmetric network of oscillator interneurons within a single ganglion that drive segmental motor neurons. Oscillations originate within a single ganglion from the local circuit formed by these oscillator interneurons, which are connected almost exclusively by inhibitory synapses. Strong electrical and chemical coupling across the midline within the segmental oscillator ensures side to side synchrony in the activity. This activity pattern is appropriate since the leech swims by dorsoventral undulations, which require

synchronous activation of muscles on the left and right sides of the body.

The segmental oscillators are coupled by ascending and descending projections of the oscillator interneurons, which synapse directly with oscillator interneurons in other ganglia. In principle, the generation of phase lags appropriate for swimming can be explained by a system consisting of a chain of coupled oscillators in which the anterior oscillators have shorter inherent periods than the posterior oscillators. When a system such as this is coupled, all segmental oscillators of the network share the same period, but the faster oscillators will lead in phase. In the case of the leech swimming, this explanation is not sufficient to explain swimming because experiments show that the segmental oscillators with the shortest cycle period lie at the midpoint of the ventral nerve cord. Experimental and modeling work has provided evidence that forward swimming most likely arises from asymmetries in the coupling between the segmental oscillators [7].

Intersegmental coupling, which is approximately equal in functional strength, spans six segments in both directions [5]. At the level of specific interconnections, however, there are many asymmetries. The oscillator interneurons are active at three different phases of a swim cycle separated by  $120^\circ$ . The interneurons in the  $0^\circ$  phase group all project their axons in the descending direction, whereas the interneurons of the  $120^\circ$  and  $240^\circ$  groups only project in the ascending direction [5]. In addition, the sole excitatory interneuron projects in the descending direction, whereas inhibitory interneurons project in both directions. Finally, the synaptic targets are asymmetric; ascending and descending projection neurons project to targets with different activity phases. A computer model that incorporates these asymmetries but not any inherent period differences produced a  $8\text{--}10^\circ$  phase lag, similar to that seen in long chains of isolated nerve cords as well as phase constancy with changing cycle period [7]. Although the model replicated activity in the isolated nerve cord, the  $8^\circ$  phase lag between segments is too small to produce a traveling wave of one wavelength along the body.

### Lower Level Processes

Sensory feedback is known to affect both the strength and timing of output from CPGs. To test the idea that sensory feedback from **stretch receptors** embedded in the body wall and mechanical coupling between muscles in neighboring segments may contribute to the phase lag observed in the intact animal, and thus account for the discrepancy between the isolated nerve cord and intact leech, these mechanisms were added to the computer model [5]. The resulting computer model produced a phase lag of  $17^\circ$  per segment, which is similar to the value in the intact leech ( $20^\circ$ ), suggesting that sensory feedback and mechanical coupling are indeed important for appropriate coordination.

At first glance, sensory feedback appears to be less important for swimming in the lamprey than in the leech, since the motor output of the isolated spinal cord closely resembles the pattern of the intact animal in lamprey [4]. Indeed, experiments in which the nervous system was transected have shown that mechanical coupling and sensory feedback are more important for intersegmental coordination in the leech than in the lamprey. To assess the contribution of sensory feedback in the lamprey, a model was created that included the swim network, muscle activation, body mechanics, counteracting water forces, and sensory feedback [4,9]. In this model, stretch receptors had very little effect on swimming movements in still water. However, when the virtual lamprey swam in a cross current, a model incorporating stretch receptors performed much better than a model lacking them. In the latter, transversely flowing water forced the head to one side, eventually resulting in a complete change of direction. In the model with stretch receptors, the sensory feedback counteracted the perturbing effects of the current and allowed the simulated lamprey to swim straight. Therefore, although sensory feedback does not contribute strongly to phase lag as in the leech, in the lamprey it is necessary to counteract environmental perturbations.

### Function

This entry has focused on intersegmental coordination in two well-studied preparations. Discovering how motor patterns are coordinated in these model systems may help us to understand how coordination is accomplished in more complicated networks such as those responsible for terrestrial limbed locomotion [1]. At the most fundamental level of rhythm generation there are clear similarities between the systems we have discussed. For example, in the lamprey and leech swim CPGs, reciprocal inhibition and intrinsic membrane properties of the neurons both contribute to rhythm generation. However, at the greater network level, the differences are perhaps more striking than the similarities. For example, although the swimming behaviors of leech and lamprey are very similar, the two underlying neural circuits are very different in terms of their architecture and the role of sensory feedback. Perhaps a high degree of peripheral feedback is necessary in an animal such as the leech, which has a hydrostatic skeleton. In the future, researchers will need to do a better job identifying network mechanisms that transcend structural differences in circuit architecture but lead to similar function. To do so will necessitate more modeling work.

### Therapy

The loss of intersegmental or interlimb coordination resulting from spinal cord injury is severely debilitating. Thus, understanding the detailed cellular-level

mechanisms for intersegmental coordination will be pivotal to understanding how to circumvent or replace their loss after injury or disease.

### References

1. Bem T, Cabelguen JM, Ekeberg Ö, Grillner S (2003) From swimming to walking: a single basic network for two different behaviors. *Biol Cybern* 88:79–90
2. Hill AA, Masino MA, Calabrese RL (2003) Intersegmental coordination of rhythmic motor patterns. *J Neurophysiol* 90:531–538
3. Marder E, Calabrese RL (1996) Principles of rhythmic motor pattern generation. *Physiol Rev* 76:687–717
4. Grillner S, Deliagina T, Ekeberg Ö, El Manira A, Hill RH, Lansner A, Orlovsky GN, Wallén P (1995) Neural networks that co-ordinate locomotion and body orientation in lamprey. *Trends Neurosci* 18:270–279
5. Friesen WO, Cang J (2001) Sensory and central mechanisms control intersegmental coordination. *Curr Opin Neurobiol* 11:678–683
6. Kopell N, Ermentrout GB (1988) Coupled oscillators and the design of central pattern generators. *Math Biosci* 90:87–109
7. Cang J, Friesen WO (2002) Model for intersegmental coordination of leech swimming: central and sensory mechanisms. *J Neurophysiol* 87:2760–2769
8. Tunstall MJ, Roberts A, Soffe SR (2002) Modelling intersegmental coordination of neuronal oscillators: synaptic mechanisms for uni-directional coupling during swimming in *Xenopus* tadpoles. *J Comput Neurosci* 13:143–158
9. Wadden T, Hellgren-Kotaleski J, Lansner A, Grillner S (1997) Intersegmental co-ordination in the lamprey—simulations using a continuous network model. *Biol Cybern* 76:1–9
10. Williams TL (1992) Phase coupling by synaptic spread in chains of coupled neuronal oscillators. *Science* 258:662–665

## Intersegmental Forces and Moments

### Definition

The intersegmental forces and moments represent the vector sum of all the internal forces and moments crossing a joint. The intersegmental forces and moments, therefore, have the same mechanical effect on the system as the vector sum of all the internal forces.

However, in contrast to the internal forces, the intersegmental forces and moments are not related to a specific joint structure.

► **Distribution Problem in Biomechanics**

## Interstimulus Interval

### Definition

The silent interval between two individual or bursts of stimuli.

Afferents: insula, subiculum, amygdaloid body, hypothalamus, myelencephalon. Efferents: amygdaloid body, hypothalamus, thalamus, brainstem.

Function: regulation of cardiovascular and respiratory components as well as of male sexual behavior.

► Diencephalon

## Interstitial Cells of Cajal (ICC)

### Definition

The interstitial cells of Cajal lie at the surface between varicose nerve fibers and gut smooth muscle cells. ICCs are distributed in regions with pacemaker activity in the gut and are electrically coupled to smooth muscle cells via gap junctions. ICCs act as pacemaker cells, producing slow waves to which smooth muscle cells respond.

► Bowel Disorders

## Intervertebral Disc

### Definition

The fibro-cartilaginous structure that binds together two adjacent bones of the vertebral column; composed of an outer circumferential fibrocartilaginous annulus fibrosus and an inner gelatinous core, the nucleus pulposus.

► Joints

## Interstitial Nucleus of Cajal

### Definition

Cluster of cells located in the rostral portion of the midbrain, ventrolaterally to the periaqueductal gray.

These neurons project to the motor nuclei of the extraocular muscles and to the whole extent of the spinal cord and control both eye and body (particularly neck) movements.

## Intestinal Disorders

► Bowel Disorders

## Intestinal Motility Disorders

► Bowel Disorders

## Interstitial Nucleus of the Stria Terminalis

### Definition

The stria terminalis, most important amygdaloid efferent, divides into three bundles at the anterior commissure. One bundle, the postcommissural stria terminalis, terminates here.

## Intestinofugal Neurons

### Definition

Intestinofugal neurons are neurons with cell bodies in the gut wall and axons that project to and make connections with neurons in prevertebral ganglia. These are afferent neurons serving reflexes between gut regions.

► Enteric Nervous System

## Intorsion

### Definition

One of the principal directions of an eye movement. The term designates the direction of a torsional eye movement, i.e., a rotation of the eye ball about the optic axis. During intorsion the upper limit of the eye ball rotates towards the nose, i.e., nasal-ward (a movement in the opposite direction is called “extorsion,” i.e., rotation away from the nose: temporal-ward).

► Vestibulo-Oculomotor Connections

## Intorsion in Eye Movement

### Definition

One of the principal directions of an eye movement.

The term designates the direction of a torsional eye movement, i.e., a rotation of the eye ball about the optic axis. During intorsion the upper limit of the eye ball rotates towards the nose, i.e., nasal-ward (a movement in the opposite direction is called “extorsion”, i.e., rotation away from the nose: temporal-ward). in the opposite direction is called “extorsion”, i.e., rotation away from the nose: temporal-ward).

## Intracellular

### Definition

Literally means inside the cell. In all cells, a cell membrane exists which separates the intracellular and extracellular compartments. Partly due to the presence of transporters and ion channels within the cell membrane, the intracellular concentrations of many ions is different compared to the extracellular environment.

► Membrane Potential: Basics

## Intracellular Labeling

### Definition

When applied in non-anesthetized animals, this is the only presently available method to study morphology of

single neurons together with their activity patterns, in the search for correlations between structure and function. The best results have been obtained with the use of horseradish peroxidase (HRP) as the labeling substance. In brief, micropipettes containing HRP are inserted in the cell body or in the axon.

Electrophysiological parameters, such as resting membrane potential and spike amplitude, are used to ascertain the intracellular position of the pipette. Cell activity during behavioral tests is then recorded, HRP is injected by iontophoresis and neurons are visualized thereafter in tissue sections undergoing a specific histochemical treatment. Three-dimensional images of the dendritic trees, axon trajectories, collaterals and terminals of the neuron are obtained by matching labeled segments of the neuron in series of a large number of consecutive histological sections.

► Horseradish Peroxidase (HRP)

## Intracellular Recording

PETER M. LALLEY

Department of Physiology, The University of Wisconsin School of Medicine and Public Health, Madison, WI, USA

### Synonyms

Transmembrane recording

### Definition

The recording of a potential difference (voltage) or current generated by movement of ions across a cell membrane with a glass capillary electrode containing an electrolyte solution.

### Purpose

Current flow across a cell membrane and the resulting development of a transmembrane potential difference determine whether the cell is active, resting or in a suppressed or inhibited state. Intracellular recording provides information about the direction, magnitude and duration of membrane current flow and voltage changes. It can also be used to estimate a cell's size, its functional architecture and how the cell communicates with other cells.

### Principles

Intracellular recording of membrane current and voltage is based on the principle that when aqueous channels

that permeate a cell's enclosing membrane are open, they allow the passage of ions across the membrane under the influence of ion concentration and voltage differences between the inside and outside of the cell. The flow of ionic current across the cell membrane and the resultant development of transmembrane potential are picked up by electrodes positioned inside and outside the cell and passed to amplifiers and recorders.

### Advantages and Disadvantages

Intracellular recording allows measurement of neural events with a high degree of temporal and spatial precision. In many cases, sampling of many ▶neurons in a single experiment is possible with minimal damage to nervous tissue. Events that go undetected by extracellular recording can be measured, such as resting membrane potential, postsynaptic potentials and postsynaptic currents, neuron ▶input resistance, whole cell capacitance and other passive membrane properties. Ions that move across the cell membrane to initiate postsynaptic potentials can be identified from their ▶reversal potentials and from the effect of altering their transmembrane concentration gradients. Single channel currents and conductances are measurable with ▶patch clamp techniques. The influence of intracellular signaling pathways on membrane potentials and currents can be assessed by intracellular injections of protein kinase activators and inhibitors. Neurons can be labeled intracellularly for subsequent localization, analysis of their morphological properties and synaptic connections with other neurons, or for the presence of releasable neurotransmitters or neuromodulators.

A disadvantage of intracellular recording, relative to other electrophysiological methods, is the need for extraordinary stability in order to obtain high quality recording.

### Membrane Resting Potential and Synaptic Potentials

Measurements of membrane potential were first made by inserting a glass capillary tube filled with electrolyte solution longitudinally into a squid giant axon (0.1–1.0 mm diameter). The potential difference at rest and during the active state evoked by an electric shock was picked up between the internal capillary electrode and a wire in the external electrolyte bath solution, amplified by vacuum tube amplifiers and displayed on a cathode ray ▶oscilloscope (Cathode ray oscilloscope). The experiments elucidated the ionic mechanisms responsible for the resting membrane potential and the generation of the nerve ▶action potential [1,2].

Recording membrane potential intracellularly from intact cells with ultra-microelectrodes was introduced by Ling and Gerard [3] and first used to measure the resting membrane potential of frog skeletal muscle fibers. Glass capillary tubing was flame heated and

pulled to yield a needle-like profile with a fine tip, and then filled with KCl solution. A chlorided silver wire inserted into the pipette solution and connected to the grid of an electron tube amplifier made it possible to record a resting membrane potential of  $-90$  mV when the microelectrode was inserted into a muscle fiber.

Modern microelectrode and computer technologies permit precise measurement of a variety of bioelectrical signals, such as ▶postsynaptic potentials (PSPs) that determine the neuron's ▶excitability state. ▶PSPs are often evoked *in vivo* or *in situ* by stimulating afferent nerve fibers with electric shocks. When sharp micro-pipettes are used for recording membrane potential, they are filled with an aqueous potassium salt solution such as 3 M KCl, 2 M K-citrate or 2 M K-methylsulfate.

Eccles and colleagues provided a detailed description of stimulus-evoked PSPs in spinal cord experiments [4]. They demonstrated that electric shocks applied to hind limb afferent nerves evoke either ▶inhibitory postsynaptic potentials (IPSPs) that transiently hyperpolarize motoneuron membrane potential and reduce the probability of action potentials, or ▶excitatory postsynaptic potentials (EPSPs) that briefly depolarize and increase the likelihood of action potentials (Fig. 1). The magnitude of the PSP is proportional to the number of hind limb afferent nerve fibers that are depolarized to threshold by the electric shock, which is reflected in the size of the ▶afferent volley recorded from a dorsal root. Simultaneous application of constant negative (hyperpolarizing) or positive (depolarizing) current through the microelectrode and across the cell membrane produces a steady shift of membrane potential that allows the PSP reversal potential, the value of the membrane potential at which the waveform of the PSP reverses direction, to be measured. IPSPs of spinal motoneurons in the adult cat reverse at about  $-80$  mV (Fig. 1b, right column), indicating that the IPSP is caused by membrane diffusion of ions with a negative ▶equilibrium potential, such as chloride or a combination of chloride and potassium ions. ▶EPSPs reverse at about  $+5$  mV, indicating that the depolarizing current is carried by combination of ions with positive ( $\text{Na}^+$ ,  $\text{Ca}^{2+}$ ) and negative ( $\text{K}^+$ ) equilibrium potentials.

### Input Resistance

The degree to which membrane ion channels open and close during synaptic perturbations can be determined by measuring neuron input resistance. Current pulses of constant intensity and negative polarity are applied through the recording microelectrode. By knowing the current intensity and measuring the peak of the evoked ▶electrotonic potential, one obtains the membrane resistance change from Ohm's law. A limitation of the method is that it may not detect membrane permeability changes that occur in remote regions of the dendrites.

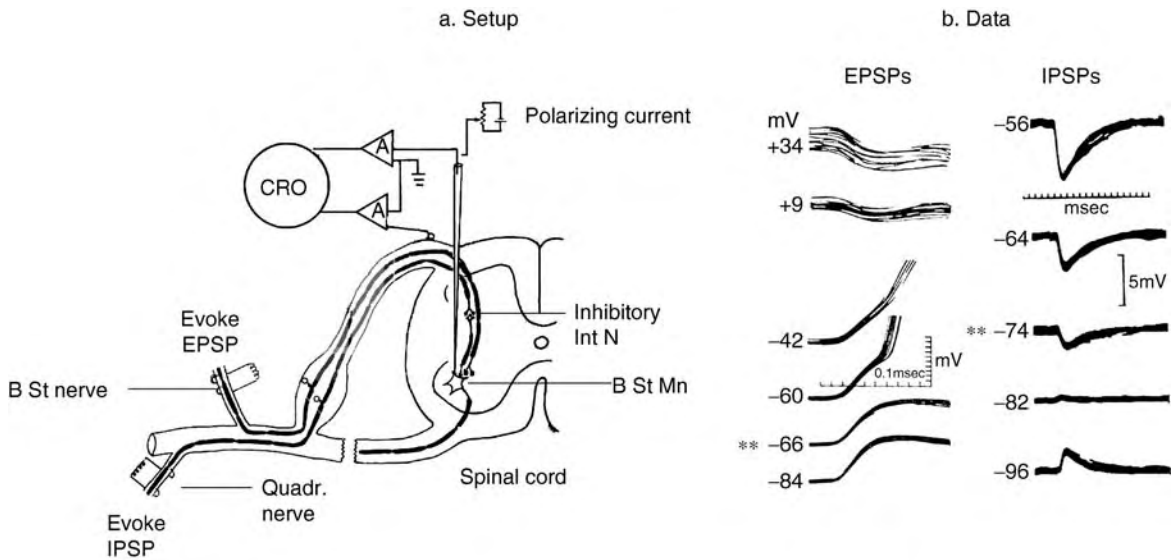

**Intracellular Recording. Figure 1** Recording electric shock-evoked postsynaptic potentials (PSPs) from spinal cord motoneurons in vivo. (a) Setup for sharp capillary microelectrode recording of PSPs from a spinal cord motoneuron innervating the hind limb biceps semitendinosus (B St) muscle. Single electrical shocks delivered to nerve trunks innervating hind limb muscles evoke different types of synaptic potentials. Monosynaptic excitatory postsynaptic potentials (EPSPs) and action potentials are evoked when biceps semitendinosus (B St) afferent nerve fibers are stimulated. Disynaptic inhibitory postsynaptic potentials (IPSPs) are evoked by stimulating Quadriceps (Quadr.) afferent nerve fibers at sufficient intensities to activate inhibitory interneurons (Int). An extracellular amplifier (A) records the afferent action potential volley picked up from the dorsal roots with a monopolar electrode referenced to earth. Intracellular activity of the B ST motoneuron is recorded with an intracellular preamplifier (see Fig. 2) and registered on an oscilloscope (CRO) as superimposed traces (this figure, (b)). A dc current source is connected through the preamplifier to bring membrane potential to different steady levels. (b) Data from an in vivo intracellular recording experiment in the pentobarbital anesthetized cat. Records in the left column are EPSPs obtained from a B St motoneuron with a resting potential of  $-66$  mV and brought to different levels of MP by dc polarizing currents. Subthreshold EPSPs marked by \*\* were recorded without current application. Records in the right column are IPSPs from another B St motoneuron, resting potential  $-74$  mV. The IPSPs recorded without polarizing current are identified by \*\*. The level of membrane potential where the stimulus-evoked PSP deflections were turned over (reversed) by polarizing currents reveals the approximate equilibrium potential: EPSPs,  $-3$  mV; IPSPs,  $-82$  mV. (a) was modified with permission from the original in Willis WD, Grossman RG (1973) *Medical neurobiology*. CV Mosby, St. Louis, p 97, Figs. 4–17. (b) was obtained with permission from Eccles JC (1964) *The physiology of synapses*. Springer-Verlag, NY, p 49, Fig. 17B and p 156, Fig. 60A.

### Passive Membrane Properties

Membrane potential measurements are also used to derive passive electrophysiological properties that reflect their functional architecture of neurons, such as ►electrotonic length and total ►cell capacitance [5]. Electrotonic length ( $L$ ) determines how ►synaptic potentials distribute between the soma and dendrites as a function of dendritic length and degree of branching. It is a useful measurement to analyze, for example, the effectiveness of a synaptic connection as a function of its distance from the action potential-generating regions of the input neuron. Total cell capacitance ( $C$ ) is determined by the cell surface charging area, and in combination with membrane resistance ( $R$ ) determines the temporal relationship between current flow and the resulting potential change. The product of  $R \times C$  determines the time course of the

synaptic potential. Larger values of  $RC$  cause synaptic potentials to build up and decay to baseline more slowly, and to temporally summate consecutive potentials more effectively toward or away from action potential threshold.

### Amplifiers and Recording Techniques

#### Recording in Balanced Bridge Mode

Intracellular recording at present makes use of (i) solid state, fast responding amplifiers capable of picking up membrane potential and passing current through the same micropipette, (ii) an electrical stimulus source and (iii) recording devices with wide ►frequency bandwidths. Increasingly, all three components are computer-controlled. Figure 2 is a circuit diagram of a ►preamplifier designed for ►balanced bridge mode recording.

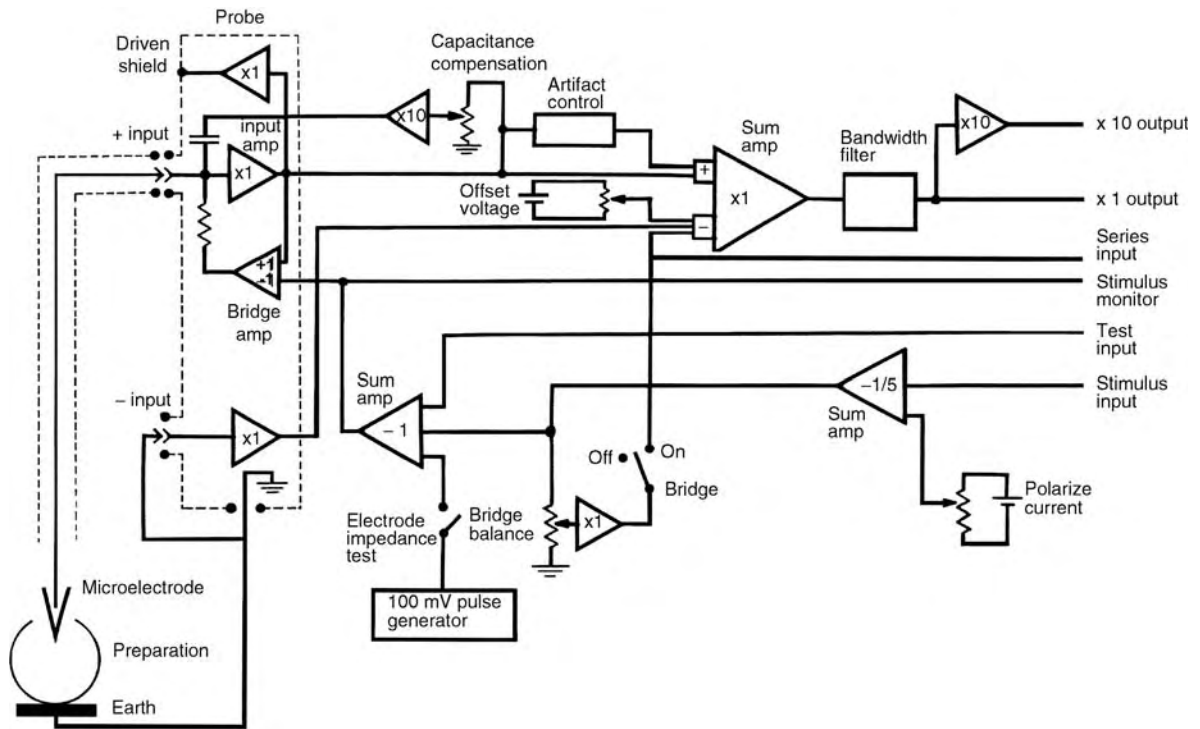

**Intracellular Recording. Figure 2** Block Diagram of a preamplifier for intracellular recording of membrane potential in balanced bridge mode. Circuit diagram illustrates components of a contemporary intracellular preamplifier. See text for a description of circuit components and why they are used (diagram adapted and used with permission from the Model 8500 Intracellular Preamp-Clamp Operating Manual, Preamplifier Block Diagram. Dagan Corporation, Minneapolis, MN, USA, p 8).

The preamplifier is equipped with the basic components needed to record membrane potential properties. An offset control cancels potentials due to series resistances that develop between the reference (earth) silver/silver chloride electrode and the input stage of the amplifier. The **bridge circuit** eliminates potentials developed across the microelectrode resistance, enabling accurate recording of membrane potential. An artifact control reduces fast transients at the beginning and end of intracellular current pulses. Capacitance neutralization minimizes stray capacitance sources at the input so that high frequency components of membrane potential signals are recorded faithfully. A high frequency cutoff control allows recording of membrane potential between DC and 10–300 kHz, although the high frequency cutoff is normally set at 10 kHz. An internal source provides steady positive or negative polarizing current to shift membrane potential. An impedance test circuit is used to measure microelectrode resistance in the tissue outside the cell or in the bathing medium. Amplifier outputs with gains of 1× and 10× are used to lead off signals to computers, oscilloscopes, strip chart and tape recorders.

### **Discontinuous Current Clamp Mode**

Another approach to recording membrane bioelectrical behavior is the discontinuous single electrode current clamp (dSECC) method. A preamplifier with sample-and-hold and switching circuits enables the microelectrode function to cycle at high frequency, typically in the range of 10–40 Hz, between passing current and picking up membrane potential (see Fig. 4, Setup). The arrangement allows the recording of membrane potential independently of the voltage change across the microelectrode resistance. Membrane input resistance during passage of current pulses can also be selectively measured (Fig. 4, right upper panel). A potential shortcoming of dSECC recording is that the signal-to-noise ratio may be reduced somewhat in smaller neurons with high input resistance due to electrical interference produced by switching between current application and recording.

### **Voltage Clamp Mode**

Measurements of the direction, magnitude and time course of ionic current flow across the nerve cell membrane provide information that can be used to identify ions, conductance mechanisms and temporal changes in cell excitability. **Voltage clamp** amplifiers with



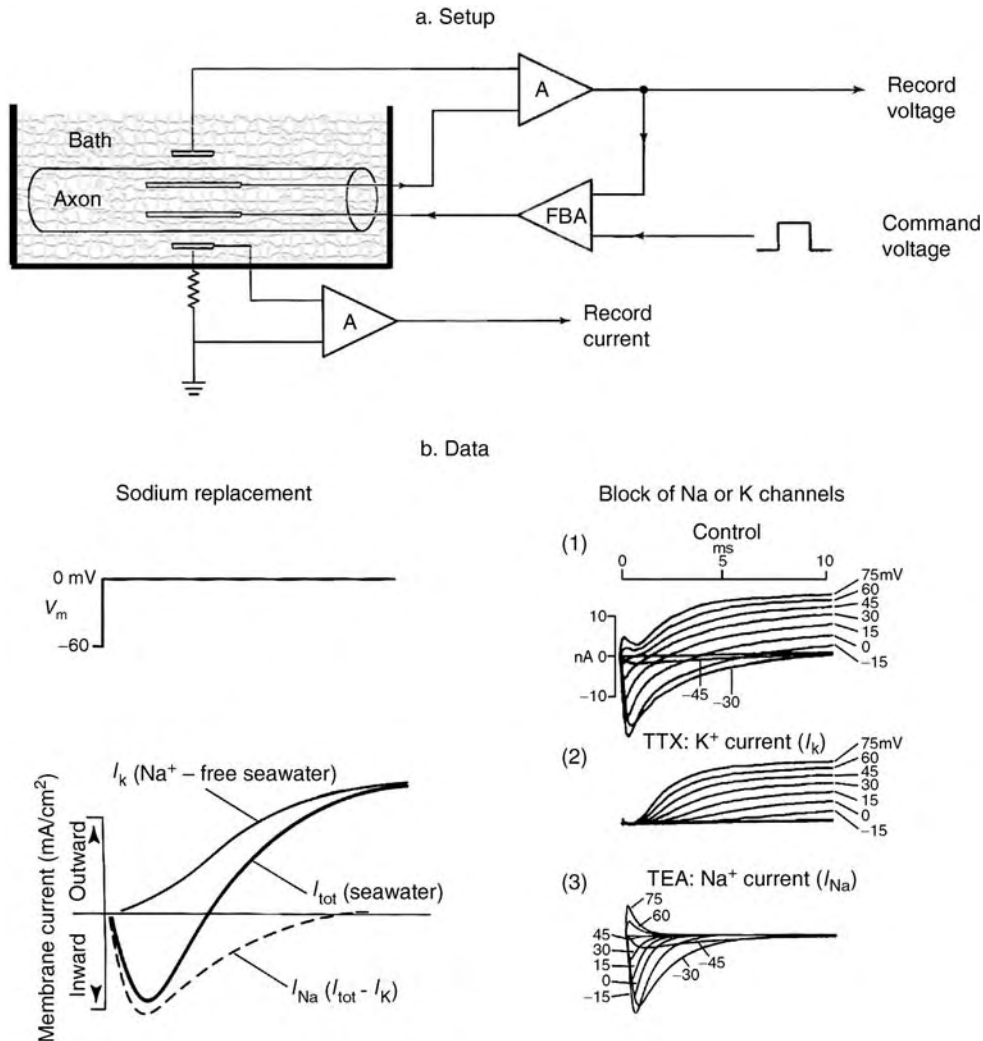

**Intracellular Recording. Figure 3** Voltage and space clamp recording from an isolated squid giant axon. (a) Experimental setup. A large diameter axon (0.1–1 mm) is bathed in conducting seawater. Two wire electrodes have been inserted into the axon, one to record membrane potential and the other to pass current across the membrane. The amplifiers (A) record membrane potential (voltage) and current. The output of the voltage amplifier is also passed to the feedback amplifier (FBA) that, in addition, receives a **command voltage** to change membrane potential. Differences between the membrane potential and the command voltage are amplified by the FBA and passed to the current electrode, which generates a current that crosses the membrane to the pickup electrode in the bath solution. The amplifier records the transmembrane current when the membrane potential is brought to and held at a selected level by the command voltage. (b) Left. Effects of replacing sodium on depolarization-evoked currents. In normal seawater a voltage step from resting membrane potential (–60 mV) to 0 mV that would trigger an action potential under unclamped conditions evokes an initial inward current (shown as a downward deflection through the baseline on the oscilloscope trace  $I_{tot}$  in the lower panel), followed by an outward current (upward deflection). Replacement of sodium with an equi-osmolar concentration of membrane-impermeable choline eliminates the inward current and reveals the time course and magnitude of the outward current, which turns out to be a potassium ion current ( $I_K$ ,  $Na^+$  – free seawater). Subtraction of this trace from the  $I_{tot}$  trace reveals the magnitude and time course of the potassium current. (b) right. Isolation of the sodium and potassium currents responsible for the action potential with selective ion channel blockers. Panel (1) illustrates a family of superimposed current traces produced by stepping membrane potential to different levels from –60 mV in normal seawater. Panel (2) shows outward potassium current traces that remain after sodium channels have been selectively blocked by adding tetrodotoxin (TTX) to the bath. Panel (3) shows sodium currents after blockade of potassium channels with tetraethylammonium. (a) is modified with permission from Aidley DJ (1998) *The physiology of excitable cells*, 4th edn. Cambridge University Press, p 11, Fig. 2.3. Panels in (b) are modified and reproduced with permission from Kandel ER (ed) *Handbook of physiology*, Sect. 1, vol 1. American Physiological Society, Bethesda MD, pp 99–136.

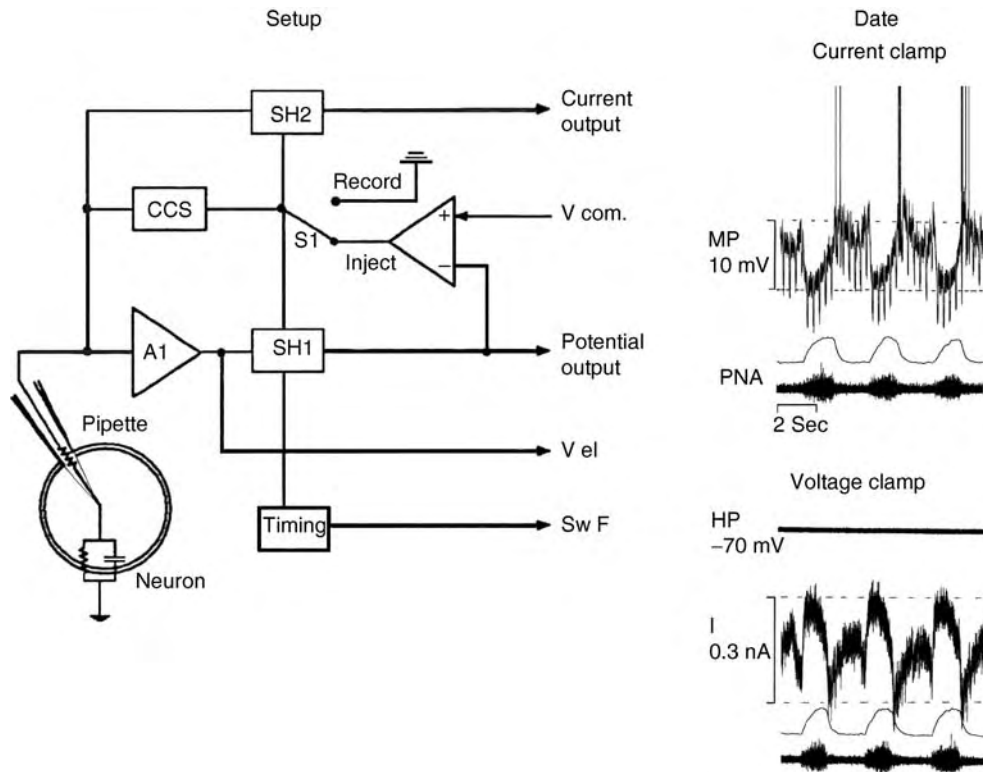

**Intracellular Recording. Figure 4** Discontinuous single microelectrode current and voltage clamping. Left (Setup), circuit block diagram of the 05LX Single electrode current and voltage clamp system, version 1.2, npi Instruments for the Life Science, Tamm, Germany, copied with permission from the npi Operating Instructions and System Description, Fig. 2a. Right (Data), in vivo intracellular current clamp (upper) and voltage clamp (lower) records obtained from a postinspiratory neuron in the ventral medullary respiratory group of a pentobarbital anesthetized cat. Tracings recorded in current clamp mode are, from top to bottom, membrane potential (MP), integrated spike frequency (middle trace) and electroneurogram (bottom) of phrenic nerve action potential (PNA) discharges. In voltage clamp mode, traces are membrane voltage held steady at  $-70$  mV, membrane current ( $I$ ), integrated PNA frequency and PNA electroneurogram. Neuron membrane potential and membrane current oscillate with a respiratory rhythm along with PNA. In current clamp mode, neuron action potentials discharge with the cessation of PNA during the postinspiratory phase. Brief, regularly occurring downward deflections are constant current pulses used to follow changes of input resistance as MP oscillates. In voltage clamp mode, periodic bursts of inward current occur during the activated (postinspiratory) phase, and outward waves occur during the inhibitory (inspiratory) phase of the respiratory cycle (Lalley PM, unpublished data).

fast-responding **feedback circuits** permit membrane potential to be “clamped” at various selected levels while current is measured. The first voltage clamp recording was accomplished by threading two chlorided silver wire electrodes longitudinally within a giant axon of the squid and connecting them to feed-forward and **feedback amplifiers** (Fig. 3a). Measurements by Cole and associates (see [1]) and by Hodgkin et al. [6], linked sodium and potassium currents to the generation of the nerve action potential (Fig. 3b).

Two-microelectrode **voltage clamping** was later developed for recording membrane currents from nerve cell bodies, followed by voltage-clamp technology for recording with a single microelectrode. The single pipette technique, referred to as discontinuous single electrode

voltage clamping (dSEVC), enables measurement of membrane currents with high temporal resolution in small as well as large neurons, and minimizes damage to nerve cells [7,8].

The dSEVC operating system (Fig. 4, setup) includes a command voltage source (**Command voltage (potential) source**), buffer (**Buffer amplifier**) and feedback amplifiers, **sample-and-hold circuits** and a switching circuit that alternates at high frequency between current-injecting and voltage-recording modes. A feedback circuit compares the cell membrane potential ( $E_M$ ), sampled at a time when the voltage change across the microelectrode resistance has decayed to zero, with the **command potential** ( $E_C$ ), and injects current to compensate for the difference ( $|E_M - E_C|$ ). The injected

current is equivalent to the spontaneous or evoked intrinsic membrane current.

Potential limitations of dSEVC include (i) the limitation imposed on the method by cell size and geometry. In large cells with extensive dendritic arborizations, it is sometimes difficult to adequately voltage clamp regions of the cell where the clamping voltage doesn't reach unless large currents than can damage the cell membrane are applied. (ii) The high resistance and capacitance of fine-tipped micropipettes may result in incomplete decay of the electrode potential between switching from current injection to recording in some amplifiers, resulting in incorrect values of holding potential and current. (iii) The

relative complexity of dSEVC recording and procedures increases the possibility of errors resulting from improper circuit adjustments. The last two factors depend on circuit design, and have been largely eliminated in the circuit illustrated in Fig. 4 and in some other recent dSEVC circuits [9].

#### Voltage Clamp-Controlled Current Clamp Recording

A very recent and useful supplement to single microelectrode voltage clamping, called voltage clamp-controlled current clamp recording, involves the addition of ►low-pass filters with selectable time constants to control the response time of the voltage clamp amplifier's

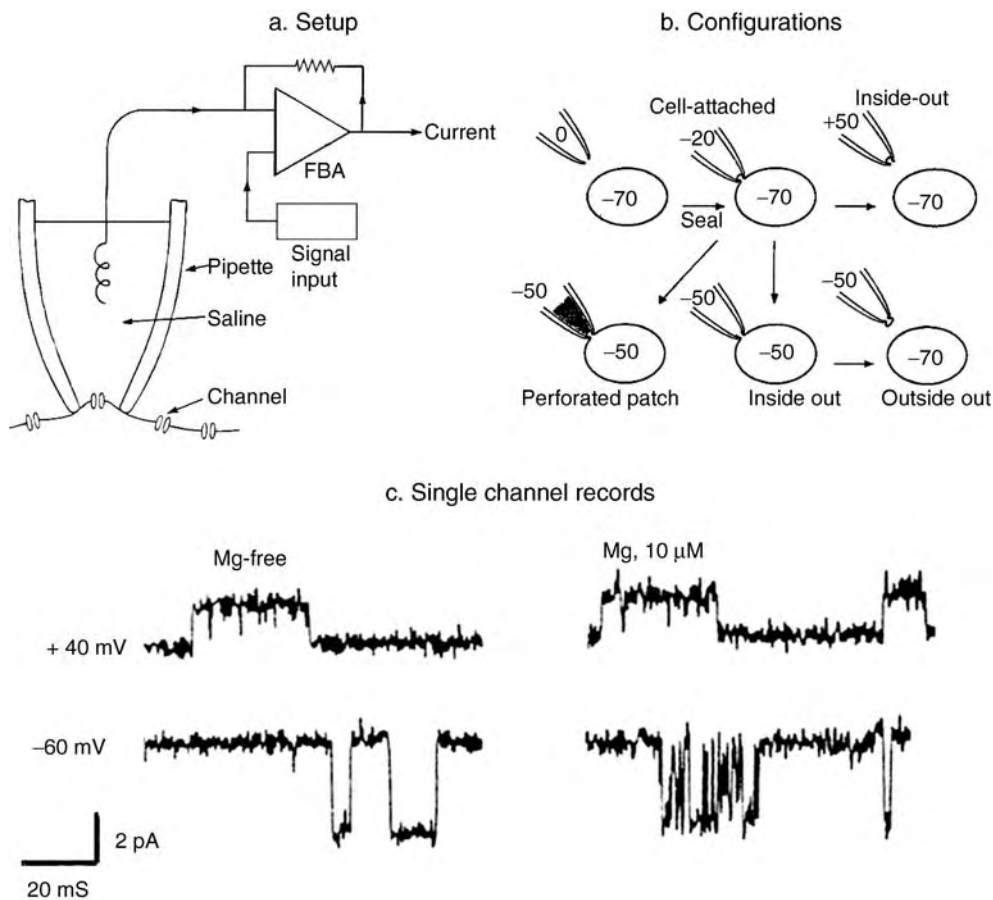

**Intracellular Recording. Figure 5** Patch Clamp recording and results. (a) Recording setup. A patch clamp filled with a recording solution that mimics the internal ionic environment of the cell (see text) is attached to the cell membrane by application of slight suction. The feedback amplifier holds the membrane potential steady while the current is measured. (b) Different patch clamp recording configurations. Mild suction allows recording of single channels in the cell-attached configuration. Breaking the patch with a pulse of suction or voltage, or adding nystatin or amphotericin to the pipette solution obtains whole cell recording. Withdrawal of the cell in the cell-attached configuration produces an inside-out patch, whereas withdrawal in the whole cell configuration produces an outside-out patch. Isolated inside out or outside out patch of membrane can then be submerged in bathing media containing drugs that alter ion channel activity. (c) Single channel currents evoked by the excitatory neurotransmitter glutamate in embryonic mouse brain cells. The experiment tests the effect of magnesium ions. Single channel currents are inward at  $-60$  mV and outward at  $+40$  mV (figure adapted with permission from Aidley DJ (1998) *The physiology of excitable cells*, 4th edn, Cambridge University Press, p 12. Figs. 2.4 and 2.5 and p 151, Fig. 8.24).

feedback circuit [9,10]. This modification allows slow oscillations of membrane potential to be selectively suppressed without influence on faster responses. In neurons that oscillate due to network interactions or ►pacemaker properties, for example brainstem respiratory neurons, it may be desirable to suppress such slow waves and hold membrane potential at different steady levels while recording and measuring PSPs or input resistance.

### Patch Clamp Recording of Single or Small Aggregates of Channel Currents

A major leap forward in intracellular recording technology came with the development of the patch-clamp method by Neher and Sakmann [10], which allows recordings to be obtained from single or small numbers of membrane channels from whole cells or from excised membrane patches *in vitro*. A heat-polished glass pipette containing an electrolyte solution and other chemicals to maintain cell integrity is brought into contact with the cell membrane and secured to it by suction, forming a seal with a high electrical resistance. Currents in the patch of membrane under the pipette orifice are detected with a minimum of background noise. Alternatively, the membrane can be ruptured by further controlled suction, sealing the membrane against the pipette's polished opening, so that whole cell currents are recorded. Either way, a patch clamp circuit is utilized that further reduces extraneous noise and improves frequency response (Fig. 5). Recording is quite stable because of suction-mediated attachment.

A disadvantage of conventional whole cell-attached ►patch clamp recording is that the cell is dialyzed with the solution inside the recording electrode, diluting nutrients and other components of the intracellular fluid that may cause rundown of responsiveness.

A variant of this technique, the “perforated patch” technique (Fig. 5b), uses chemicals such as nystatin or amphotericin to permeabilize the membrane, i.e. produce small membrane openings for current flow without suction and avoids dialyzing the cytoplasm.

A third approach is to withdraw the electrode from the cell during applied suction, removing the patch from the rest of the cell. Membrane properties can be investigated pharmacologically by measuring currents in the excised patch during immersion in bathing solutions containing neurochemicals.

## References

1. Cole KS (1968) Membranes, ions and impulses. University of California Press, Berkeley, CA, 569 pp
2. Hodgkin AL, Huxley AF (1939) Action potentials recorded from inside a nerve fibre. *Nature (Lond)* 144:710–722
3. Ling G, Gerard RW (1949) The normal membrane potential of frog sartorius fibers. *J Cell Comp Physiol* 34:383–396

4. Eccles JC (1964) Chapters III–VII, X, XI. In: Eccles JC (ed) *The physiology of synapses*. Springer-Verlag, NY, 316 pp
5. Lallely PM, Moschovakis AK, Windhorst U (1999). Electrical activity of individual neurons in situ: Extra- and intracellular recording. In: Windhorst U, Johansson H (eds) *Modern techniques in neuroscience research*. Springer, Heidelberg, pp 127–172
6. Hodgkin AL, Huxley AF, Katz B (1952) The effect of sodium ions on the electrical activity of the giant axon of the squid. *J Physiol (Lond)* 108:37–77
7. Finkel AS, Redman SJ (1983) The synaptic current evoked in cat spinal motoneurons by impulses in single group 1a axons. *J Physiol (Lond)* 342:615–632
8. Richter DW, Pierrefiche O, Lallely PM, Polder HR (1996) Voltage-clamp analysis of neurons within deep layers of the brain. *J Neurosci Methods* 67:121–123
9. Sutor B, Grimm C, Polder HR (2003) Voltage-clamp-controlled current-clamp recordings from neurons: an electrophysiological technique enabling the detection of fast potential changes at preset holding potentials. *Pflugers Arch Eur J Physiol* 446:133–141
10. Neher E, Sakmann B (1976) Single-channel currents recorded from membrane of denervated frog muscle cells. *Nature (Lond)* 260:799–802

## Intracellular Staining

### Definition

This is a set of techniques in which a solution containing a marker molecule is driven into a single neuron via a pipette whose tip passes through the cells membrane and is in the cytoplasm. If the marker molecule is charged it can be driven into the interior of the cell by iontophoresis, i.e., applying current to the solution in the pipette. The marker solution can also be driven into the cell by applying air pressure to the back of the pipette.

## Intra cortical Facilitation (ICF)

### Definition

Phenomenon of increased cortical excitability evoked by conditioning stimuli and assessed by test stimuli in a conditioning-test paradigm.

► Transcranial Magnetic Stimulation

## Intra cortical Inhibition (ICI)

### Definition

Phenomenon of increased cortical inhibition evoked by conditioning stimuli and assessed by test stimuli in a conditioning-test paradigm.

- ▶ Transcranial Magnetic Stimulation

## Intracortical Microstimulation (ICMS)

### Definition

ICMS consists of repetitively applied electrical pulses delivered by a microelectrode. Currents are usually very low (6–12  $\mu$ A) and very short (200  $\mu$ s) but applied at high frequencies (about 300 Hz). The resulting temporally synchronized neuronal discharges are highly effective for the induction of re-organizational processes. ICMS has been successfully used to study rapid, i.e. plastic changes inducible within a few hours, in adult motor, somatosensory and auditory cortex and thalamus, which were fully reversible. The region of tissue that is stimulated by direct activation during ICMS is very small (50 to 100  $\mu$ m).

- ▶ Somatosensory Reorganization

## Intrafusal Muscle Fibers

### Definition

- ▶ Muscle Spindle

## Intralaminar Nuclei

### Definition

A set of dorsal thalamic nuclei in mammals that lie between fiber laminae formed by the axons of other dorsal thalamic nuclear groups. They have diverse inputs and projections.

- ▶ Evolution, of the Dorsal Thalamus

## Intralaminar Thalamic Nuclei

### Synonyms

Nuclei intralaminares thalami; Intralaminar nuclei of thalamus

### Definition

The Intralaminar nuclei lie in the internal medullary lamina of the thalamus and are characterized by their double projections, with one going to the cerebral cortex and one to the corpus striatum. A distinction is made between

- Rostral group: lateral central nucleus, paracentral nucleus, medial central nucleus
- Caudal group: centromedian nucleus, parafascicular nucleus

Afferents from the globus pallidus, cerebellum, spino/trigeminothalamic tract.

- ▶ Diencephalon

## Intramural Ganglia

### Definition

Intramural ganglia are autonomic ganglia that lie within the walls of organs, such as the lungs, bladder, pancreas and intestine.

## Intramuscular Myofascial Force Transmission

PETER A. HUIJING

Research Instituut

Faculteit Bewegingswetenschappen, Vrije Universiteit, Amsterdam, The Netherlands

### Synonyms

Lateral force transmission [1]; Myofascial force transmission [2,3]

### Definition

**Myofascial Force Transmission and the Endomysial Stroma**

Force transmission from or onto a muscle fiber as force is transmitted between a passive or active muscle fiber and

the collagen fibers embedded within its extracellular matrix. Exclusively, if those target collagen fibers are not a part of the aligned collagen fibers of the micro-tendon of the muscle fiber, we call such transfer of force ▶ **myofascial force transmission**. The fibrous connective tissue structure context within which each muscle fiber operates that fits this limitation is the ▶ **endomysium**. Myofascial force transmission may occur along the perimeter of the muscle fiber along its whole length.

As force transmission has to take place on a path that is almost perpendicular to the line of pull of sarcomere forces it cannot be tensile in nature. Instead, force transmission is mediated by ▶ **shearing** of the sarcolemma – ▶ **basal lamina** – endomysium complex (Fig. 1).

The shearing ▶ **stiffness** of this complex is dependent on the relative position of the sarcolemma and nearby endomysium.

Note that this endomysial ▶ **stroma** also constitutes the surroundings for capillaries and nerve branches to reach the muscle fiber. In fact, capillaries and nerve branches are embedded within the endomysial stroma and protected by its collagen fibers that bear most of the force.

## Characteristics

### Quantitative Description

The endomysial walls form “tunnels” for each muscle fiber to operate within. They create a 60–100 μ diameter honeycomb-like structure (Fig. 2).

### Higher Level Structures

#### Relevant Connective Tissue Structures

The type of honeycomb-like structure repeats itself at higher levels of organization and size:

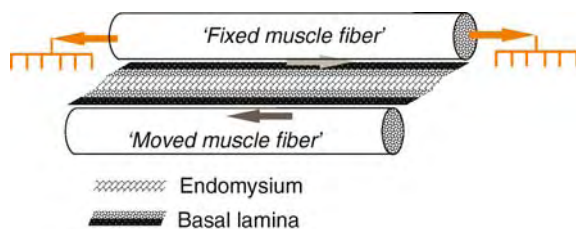

### Intramuscular Myofascial Force Transmission.

**Figure 1** Schematic representation of two muscle fibers and their sheared extracellular matrix. If one muscle fiber is fixed and a neighboring muscle fiber is moved, the interface between the muscle fibers consisting of the basal lamina (shown as two layers) and the endomysium is sheared. As a consequence of the shearing deformation, elastic structures within the interface are lengthened and a shear force is exerted (light grey arrow). If the size of this shear matches the force that causes the movement or shortening of the other muscle fiber, the movement will stop due to myofascial force transmission.

- ▶ **Perimysium** or fascicle ▶ **fascia** (also called perimysium internum).

Each muscular fascicle (i.e. bundle of muscle fibers) also operates within a connective tissue tunnel: the wall of this tunnel is formed by the perimysium. Its wall consists of a crossed-ply arrangement of collagen fibers that reorient on changing muscle sarcomere length [4]. The mean collagen fiber direction, relative to the longitudinal direction of the muscle fibers, ranged from  $\sim 80^\circ$  at sarcomere length = 1.1 μ to  $\sim 20^\circ$  at 3.9 μ. The perimysium is composed of several layers of 100–200 μ-thick sheets surrounding and attaching to the honeycomb structure of the fascicular endomysial stroma. The perimysial tunnels of neighboring fascicles are interconnected and form a network that can be sheared as the relative position of fascicles is changed. Note that the major intramuscular blood vessels and nerves are embedded and attached by collagen fibers to this structure [5] and are protected by the collagen fibers reinforcements of the perimysium that bear most of the local force. Note that muscular receptors (e.g. muscle spindles and the pressure sensitive Pacinian receptors) also operate within this mechanical context.

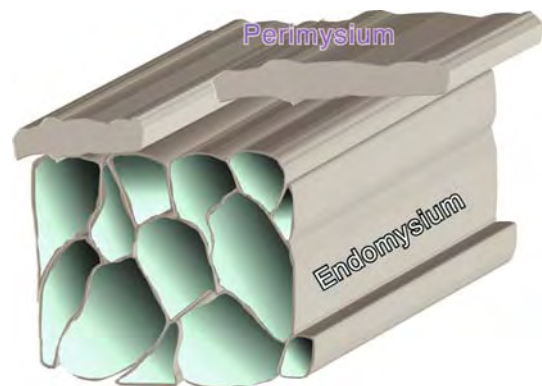

### Intramuscular Myofascial Force Transmission.

**Figure 2** Schematic representation of a small section of the endomysial stroma of a muscle fascicle. This image represents a part of a muscle with the muscle fibers removed. A set of “tunnels” remain, each of which was the domain of a muscle fiber. At the periphery of a fascicle, the endomysial stroma is continuous, with the epimysial fascia investing the whole fascicle. At higher levels of organization (not shown), this type of structure repeats itself until the collection of all fascicles form the muscle stroma, which is invested by the epimysial fascia. The walls of this structure are predominantly made up of type I collagen fibers running in many directions. The directions of collagen fibers within the endomysium are muscle fiber length dependent.

2. The ►**epimysium** or muscle fascia (also called perimysium externum).

This structure is composed of two distinct layers of connective tissue sheets.

1. The inner layer consists of collagen fibers lying in a regular wavy pattern parallel to the axis of the muscle fiber.
2. The outer layer of epimysium is composed of several sheets of wavy collagen fibers that run transversely to the longitudinal axis of the muscle fiber. In a region of the epimysium, there is a thick wall of about 1 mm thickness, where collagen fiber bundles of 200–300  $\mu$  in diameter run longitudinally parallel to the axis of muscle fiber.

### Lower Level Components

Force is generated within the sarcomeres of the muscle fiber by its contractile proteins. Serial arrangements of sarcomeres are called myofibrils; the area attached at the myotendinous junction, but are also embedded within the intracellular non-contractile proteins of the cytoskeleton, which forms the connections between parallel myofibrils and a layer of molecules just below the sarcolemma (muscle fiber cell membrane).

The most peripheral layer of the cytoskeleton is connected by molecules that cross the sarcolemma and are attached to the molecules of basal lamina, which constitutes the part of the extracellular matrix that separates muscular and connective tissues. Non-fibril forming collagen type IV is a major constituent of the basal lamina. The network formed by these basal lamina collagen molecules is on its periphery, connected to the wall of the endomysial tunnel. Such connections are most likely made via proteoglycans [6].

### Higher Level Processes

As some force is transmitted between a muscle fiber and its endomysium, there are a number of paths potentially available for further transmission

1. Intramuscular paths [2,7]
  - a. Along the endomysium to the tendon [1] (i.e. ►**intramuscular myofascial force transmission**). The endomysium is continuous with a similar structure (endotenon) that surrounds the longitudinal collagen fibers of the muscle fiber's micro-tendon. A collection of such micro-tendons forms the tendon or aponeurosis (tendon plate) of the muscle.
  - b. Onto the cytoskeleton within a neighboring muscle fiber. This process of inter-fiber force transmission has been argued to be active [8] for so called ►**non-spanning muscle fibers** [9] i.e. muscle fibers that do not extend from proximal to distal tendon plate of muscle, but end with tapered ends within the belly of the muscle.

- c. As the endomysial tunnels of neighboring muscle fibers are connected, force can be transmitted, again by shearing along the connective tissue network that is a part of a fascicle (bundle of muscle fibers), across fascicles until the limits of the muscle are reached.

2. Epimuscular paths [10] (see accompanying essay of this encyclopedia):
  - a. Extramuscular path [7,3]
  - b. Intermuscular path [7,3]

A major difference between these two types of paths is that intramuscular effects will yield equal forces exerted origin and insertion of a muscle, whereas for epimuscular force transmission these forces should be different.

### Process Regulation

Within the muscle, a number of serial paths for myofascial and ►**myotendinous force transmission** are available. Most force will be borne by the stiffest connections.

### Function

In a classical view, active or passive force generated with sarcomeres is transmitted exclusively from sarcomere to sarcomere in arranged series until the end of the muscle fiber is reached, where the interface between a muscle fiber (muscle fiber) and its tendon is located (myotendinous junction). At this junction, force will be transmitted onto the tendon collagen fibers running almost exclusively in longitudinal direction, and from there to the bones.

Myofascial force transmission constitutes an additional mechanism of force transmission from the muscle: Force is transmitted from or onto the endomysial-perimysial-epimysial stroma, which acts as an integrator for forces exerted within the muscle. Furthermore, the intramuscular stroma, as an integrator of force as well as the location of neural receptors (muscle spindles, tendon organs, Pacinian corpuscles), provides global information to the central nervous system of the muscle's condition rather than information about very localized processes within the muscle.

In this essay, we have so far described force transmission more or less as a transmission of force out of muscle fibers onto the extracellular context. It should be realized that this is actually a bi-directional process: If the sarcomere can exert a force via the cytoskeleton onto the extracellular stroma, in principle, it should also be possible for the extracellular stroma to exert forces on the cytoskeleton (transduction). Such processes may play an important role in the adaptation of muscle fibers (regulation of hypertrophy or atrophy, or changes in number of serial sarcomeres). This would mean that mechanical stimuli on the cytoskeleton could play an important role in processes of muscular adaptation.

### Pathology

If one of the series molecules connecting the muscle fiber cytoskeleton to the endomysium is deficient, and myofascial force transmission may be absent or very limited, the sometimes very serious pathology of muscular dystrophy is present. The way this pathology and its effects are related exactly to myofascial force transmission is presently not fully understood.

### References

1. Street SF (1983) Lateral transmission of tension in frog myofibres: a myofibrillar network and transverse cytoskeletal connections are possible transmitters. *J of Cell Physiol* 114:346–364
2. Huijing PA, Baan GC, Rebel G (1998) Non myotendinous force transmission in rat extensor digitorum longus muscle. *J Exp Biol* 201:682–691
3. Huijing PA, Baan GC (2001) Extramuscular myofascial force transmission within the rat anterior tibial compartment: proximo-distal differences in muscle force. *Acta Physiologica Scandinavica* 173:1–15
4. Purslow PP (1989) Strain-induced reorientation of an intramuscular connective tissue network: implications for passive muscle elasticity. *J Biomech* 22:21–31
5. Jarvinen TA, Jozsa L, Kannus P, Jarvinen TL, Jarvinen M (2002) Organization and distribution of intramuscular connective tissue in normal and immobilized skeletal muscles. An immunohistochemical, polarization and scanning electron microscopic study. *J Muscle Res Cell Motil* 23:245–254
6. Nishimura T, Hattori A, Takahashi K (1996) Arrangement and identification of proteoglycans in basement membrane and intramuscular connective tissue of bovine semitendinosus muscle. *Acta Anatomica* 155:257–265
7. Huijing PA (1999) Muscle as a collagen fiber reinforced composite material: force transmission in muscle and whole limbs. *J Biomech* 32:329–345
8. Trotter JA (1990) Interfiber tension transmission in series-fibered muscles of the cat hindlimb. *J Morphol* 206:351–361
9. Hijikata T, Ishikawa H (1999) Functional morphology of serially linked skeletal muscle fibers. *Acta Anatomica* 159:99–107
10. Huijing PA (2003) Muscular force transmission necessitates a multilevel integrative approach to the analysis of function of skeletal muscle. *Exerc Sport Sci Rev* 31:167–175

---

## Intraparietal Sulcus

### Synonyms

Sulcus intraparietalis

### Definition

Sulcus between the superior parietal lobule and the inferior parietal lobule.

► [Telencephalon](#)

---

## Intravenous Self-administration

### Definition

Knowledge about the neurobiological processes related to drug-addiction is essential for the control and treatment of this disorder and this in turn requires valid animal models of addictive behavior. Humans who use drugs to excess often use needles to self-administer these compounds intravenously. Animals, including rats and primates, prepared with indwelling intravenous catheters which can in turn be connected to a remotely operated syringe attached to an infusion pumps, readily acquire a response such a lever-press to self-administer the same range of drugs used by humans to induce euphoria and subsequently maintain a habit of drug abuse. Animals eventually extinguish voluntary responding for intravenous self-administration when saline is substituted for an active drug. Importantly, drug-seeking behavior is reinstated after a period of abstinence following presentation of a single “priming” dose of the drug, a cue or environment associated with drug-reward, and also exposure to an acute stressor, thus proving a model of relapse. Availability of drugreward during long-duration test sessions (>6 h) leads to increased consumption of the drug and the development of habitual patterns of behavior.

► [Learning and Motivation](#)

---

## Intrinsic Bursting

### Definition

Bursts of action potentials caused by intrinsic conductances.

---

## Intrinsic Excitability

### Definition

Intrinsic excitability refers to the canonical patterns of action potentials that can be produced in a neuron by



injection of a current pulse, independent of the activation of synaptic inputs. Intrinsic excitability depends on the genetic expression of specific types of ion channels in the neuron, as well as their placement in the cell membrane.

► Action Potential

## Intrinsic Primary Afferent Neurons

### Definition

Neurons of the enteric nervous system that are detectors of the states of the digestive organs, including detection of chemical entities within the lumen of the intestine, and the tension in the gut wall. Intrinsic primary afferent neurons are the first neurons of intrinsic neural reflex circuits of the intestine.

► Enteric Nervous System

## Intrinsic Properties of Auditory Neurons

PAUL B. MANIS

Otolaryngology/Head and Neck Surgery and Cell and Molecular Physiology, University of North Carolina at Chapel Hill, NC, USA

### Synonyms

Electrical Excitability; Membrane Properties; Channel Expression

### Definition

The ►intrinsic properties of neurons refer to the electrical excitability of the cell independent of ►synaptic inputs. All neurons use electrical signals and changes in their electrical properties in order to receive, process, and pass on information. The processing of electrical information is conducted by specialized proteins in the cell membrane called ►ion channels. Ion channels control how specific ions, such as sodium, potassium, calcium or chloride, pass into and out of the cell. Different classes of neurons express selected sets of ion channels. The particular pattern

of channel expression gives each cell type a unique electrical signature that can be described as the ►intrinsic electrical response [1]. Ion channels shape the responses of the cells to synaptic inputs, by determining the patterns of ►action potential firing, and help provide important feedback to synapses about when cells are excited (or not). Ion channels are often subject to modulation by a variety of mechanisms that make the ►intrinsic excitability adjustable over a limited range. In any given cell, the role of intrinsic conductances in tuning neuronal firing patterns to natural stimuli or internal neural events depends on several factors: the relative strengths of synaptic and ion channel conductances, the shape of the dendritic tree, as well as the temporal patterns of synaptic excitation and inhibition that a cell receives.

### Characteristics

Auditory stimuli, particularly those with minute time differences, present a challenge to neuronal processing in the brain. Consider that the detection of the location of a sound source can require timing sensitivity in the order of tens of microseconds ( $\mu\text{s}$ , one one-millionth of a second), whereas the action potentials that signal information from one neuron to the next have widths of about 1 millisecond (ms, one one-thousandth of a second). Sounds used in communication, such as vowel sounds of speech, are also encoded in part by the timing of action potentials, with variability in the order of 100  $\mu\text{s}$ . Timing information in the auditory system is conveyed by a phenomenon called ►phase locking, meaning that action potentials occur during a particular part of the stimulus waveform. Neurons in the auditory nerve and in the nuclei of the auditory brainstem transmit and process information within these time scales. Many auditory neurons are thus specialized to operate on time scales that are much shorter than those encountered in most other areas of the brain, and this ability depends in part in the ►intrinsic electrical properties of the neurons.

In the brainstem auditory system, neurons exhibit four fundamental intrinsic electrical signatures, suggesting that specific patterns of ion channel expression are needed for computation in this system. Each intrinsic electrical signature is characterized by the action potential discharge patterns that are produced when a cell is depolarized by a current pulse from an intracellular electrode. Two of these patterns were first recognized by Oertel [2] in her groundbreaking studies of ►cochlear nucleus (CN) neurons in the brain slice, and a third pattern was identified by Manis [3] in another set of CN neurons in the brain slice. A fourth pattern appears in only a few types of CN neurons, and was identified by Zhang and Oertel [4] and Manis et al. [5]. Additional variations on the first three electrical signatures are seen

in neurons in other parts of the brainstem auditory system, including the superior olivary complex and inferior colliculus. Furthermore, each firing pattern has been seen in cells from homologous cell groups in a variety of mammalian species, as well as in cells with homologous connections and function in birds, attesting to an evolutionarily conserved role for specific combinations of ion channels in auditory information processing.

The first electrical signature is defined by the production of an evenly spaced train of action potentials. The spacing of action potentials in time becomes shorter as the cell is more strongly stimulated by current or synaptic input; therefore the firing rate reports the average strength of the synaptic inputs. The firing rate does not change during sustained constant stimulation, and is not sensitive to the membrane voltage of the cell before stimulation. Cells with this firing pattern are thought to convey information about sound intensity by their average firing rate. These neurons often have narrow action potentials, and can fire quite rapidly at frequencies up to 400 Hz. The cells with this signature often receive convergent input from many weak synapses. *In vivo*, these cells also fire very evenly spaced trains of action potentials to natural acoustic stimuli. Neurons of this type have membrane time constants of 7–10 ms, which is short by the standards of most neurons. Voltage-clamp studies have been used to characterize the ion channels found in these cells. Aside from the sodium channels whose activation creates the action potentials, these cells express a high-threshold delayed rectifier (very likely the Kv3.1 potassium channel), a hyperpolarization activated cation (Na and K permeable) conductance, and possibly a persistent sodium current. In computational models, the combination of the Na, K, and Ih currents is sufficient to recapitulate most of the responses of these cells found *in vitro* and to simulate natural patterns of synaptic activity recorded *in vivo*. Cells with this firing pattern and channel complement are found in the cochlear nuclei, as well as in other brainstem and midbrain auditory nuclei. The properties of these neurons are similar to those of fast-spiking cortical inhibitory interneurons, although most of these auditory cells are excitatory.

The second electrical signature is characterized by the ability to elicit only one or two action potentials at the onset of a current pulse. The action potentials can be very precisely timed to the onset of the pulse and are followed by a brief hyperpolarization, after which the membrane potential stays close to the resting potential. This pattern was first described by Oertel [2], and is found in specific subsets of cochlear nucleus neurons called bushy cells and octopus cells, as well as in other brainstem and midbrain auditory neurons. In many of these neurons, the action potentials at the cell body are quite small. In response to acoustic stimuli, neurons

showing this intrinsic firing pattern either respond only at the onset of tones, or may respond with action potentials that occur at times similar to their inputs. Some of these neurons with these intrinsic properties can improve (sharpen) the temporal precision of firing of their inputs. Voltage clamp studies have shown that this firing pattern is founded on a very strong potassium conductance that is active at the resting potential, and which is activated by depolarization [6]. This conductance shows variation in strength and speed among different cell populations, but is most likely composed of membrane proteins containing both Kv1.1 and Kv1.2 potassium channels. These cells also express other potassium and mixed ion conductances, similar to the cells described above. The important role of this conductance in auditory processing will be discussed below.

The third intrinsic pattern is similar to the first one described above, in that the cells can fire regular trains of action potentials. However, the latency of the first action potential, or the duration of the interval between the first and second spike, is uniquely sensitive to the membrane potential prior to an excitation. These cells can show three different intrinsic firing signatures that are sensitive to the history of their synaptic inputs. In one, the first spike latency can be very long (from tens of milliseconds to about 300 ms). In the other pattern, first spike latency is short, but the time between the next two spikes is longer. After the first or second action potential, the firing pattern is regular. These patterns occur when the membrane potential is below the cell's resting potential for at least 10 ms before a strong depolarization. When the neuron is depolarized without prior hyperpolarization, a third pattern of regular discharge with short first spike latency, similar to the first (regular) pattern described above, can be elicited. Whether the cell fires with a long latency spike or a long first interspike interval is a function of both the strength of the depolarization and the prior membrane potential. When studied *in vivo*, cells with these intrinsic properties often show similar firing patterns, and some cells can show all three patterns depending on the auditory stimulus. Voltage clamp analysis of the membrane conductances in these cells has revealed a strong transient (inactivating) potassium conductance that is not present or is much weaker in other cell types. The transient conductance is both necessary and sufficient for the long first spike latency or first interspike interval, and imparts a sensitivity of the neurons' activity pattern to prior inhibition. This pattern, which was first seen in neurons of the dorsal cochlear nucleus, has also been reported in other neurons of the cochlear nucleus, as well as other midbrain and brainstem auditory nuclei. This pattern is thought to convey information about the history of activity using spike timing across a population of cells [7].

The fourth electrical signature is found in cells that can fire brief bursts of action potentials at high frequencies. Such bursting cells are found in the dorsal cochlear nucleus, where they have been identified as cartwheel cells, as well as in a few other midbrain auditory nuclei. The bursting pattern is supported by a combination of calcium and sodium conductances in the dendrites of the cells. There are no published voltage clamp studies on these cells. Cells with bursting properties also respond to sound with bursting patterns *in vivo*. Bursts are likely to have multiple functions. First, because they are associated with the opening of calcium channels, cells often have high intracellular calcium levels during the bursts. Such increased calcium can initiate changes in the strength of synapses onto the cells, and can also activate or modulate other ion channels. As such, the bursts may play a role in initiating synaptic plasticity. In addition, when action potential bursts reach the synaptic terminals of these cells, they cause increased transmitter release through repetitive activation of the synapses. In some systems, the bursts are thought to signal events of special significance to the cells.

Thus, neurons in the brainstem auditory system can be classified according to their intrinsic excitability. There are four main patterns of excitability, and each pattern appears to be present in specific types of cells that play different roles in auditory information processing. Cells with onset responses to current pulses are often involved in pathways that analyze timing information. Those with regular firing patterns are often involved in pathways that report intensity or slowly varying timing information. Neurons with variable first spike latencies are found in pathways that process complex patterns of synaptic input, and may signal temporal aspects of their synaptic input through spike times. Cells with complex spiking patterns may be involved in plastic circuits where activity-driven calcium entry is important. In addition, since each morphological class of neurons is associated with a particular intrinsic behavior, the developmental events that specify cell morphology and connections may also help specify the expression and localization of ion channels in the cell.

### The Functional Contribution of Intrinsic Patterns to Information Processing

The functional specialization of auditory neurons for rapid temporal processing is largely expressed by neurons that show the second intrinsic motif: single action potentials elicited by excitation, and the presence of low-voltage activating potassium conductances. These two features allow the cells to fire precisely timed action potentials. This has been demonstrated through modeling studies, and is supported by experimental analyses in brain slices and with knockout mice. The

low-voltage activated potassium channels are active at the resting membrane potential, and consequently provide the main control of the cell input resistance and time constant at rest. These channels can be rapidly activated by depolarization, hence shape the voltage trajectory of synaptic potentials, and even provide intrinsic feed-forward inhibition. These channels are useful in neurons that need to detect the temporal coincidence of afferent inputs on a short time scale, since the voltage effects of synaptic conductance changes last less than a millisecond when these channels are present. This specialization is found in few other types of neurons in the brain.

### References

1. Zhang S, Oertel D (1993) Cartwheel and superficial stellate cells of the dorsal cochlear nucleus of mice: intracellular recordings in slices. *J Neurophysiol* 69:1384–1397
2. Kanold PO, Manis PB (2005) Encoding the timing of inhibitory inputs. *J Neurophysiol* 93:2887–2897
3. Manis PB (1990) Membrane properties and discharge characteristics of guinea pig dorsal cochlear nucleus neurons studied *in vitro*. *J Neurosci* 10:2338–2351
4. Oertel D (1983) Synaptic responses and electrical properties of cells in brain slices of the mouse anteroventral cochlear nucleus. *J Neurosci* 3:2043–2053
5. Manis PB, Spirou GA, Wright DD, Paydar S, Ryugo DK (1994) Physiology and morphology of complex spiking neurons in the guinea pig dorsal cochlear nucleus. *J Comp Neurol* 348:261–276
6. Llinas RR (1988) The intrinsic electrophysiological properties of mammalian neurons: insights into central nervous system function. *Science* 242:1654–1664
7. Manis PB, Marx SO (1991) Outward currents in isolated ventral cochlear nucleus neurons. *J Neurosci* 11:2865–2880

## Intrinsic Properties of Neurons

### Definition

These are voltage dependent properties intrinsic to a neuron which modify the response properties of a cell.

In other words, a similar level of synaptic transmission can produce differing effects in two different cells depending on the individual conductances expressed in the target cell. These intrinsic properties are not fixed and can usually be altered by neuromodulators.

Changes in response properties of groups of cells can have a profound effect on network dynamics.

### ► Neurotransmitters and Pattern Generation

## Intrinsically Photosensitive Retinal Ganglion Cells (ipRGCs)

### Definition

A small subset of retinal ganglion cells that are inherently light-sensitive because they contain the photopigment melanopsin. These cells are critical for many non-visual responses to light such as the pupillary light reflex and circadian photoentrainment.

- ▶ Melanopsin
- ▶ Photopigments
- ▶ Pupillary Light Reflex
- ▶ Retinal Ganglion Cells

## Intron

### Definition

Intervening, often non-coding DNA sequences between coding DNA sequences known as exons.

- ▶ Chromatin Immunoprecipitation and the Study of Gene Regulation in the Nervous System
- ▶ Exon

## Introspection

### Definition

Attending to one's own thoughts and experiences, to find what one thinks and feels.

- ▶ Theory Theory (Simulation Theory, Theory of Mind)

## Invaginating Synapse

### Definition

Specialization at the synaptic terminal of photoreceptors.

Presynaptic ribbons are apposed to the invaginating processes of horizontal and ON bipolar cells.

- ▶ Horizontal Cells
- ▶ Photoreceptors
- ▶ Retinal Bipolar Cells
- ▶ Retinal Ribbon Synapses

## Inverse Agonist

### Definition

An inverse agonist is an agent which binds to the same receptor binding-site as an agonist for that receptor but exerts the opposite pharmacological effect. An inverse agonist can reverse the constitutive activity of a receptor. This constitutive activity can be a physiological or a pathological (mutation) situation.

## Inverse Dynamics Approach

### Definition

The inverse dynamics approach is based on Newton's second law of motion, and is used in biomechanics to calculate the resultant intersegmental forces and moments from the known kinematics and inertial properties of the system.

- ▶ Distribution Problem in Biomechanics
- ▶ Measurement Techniques
- ▶ Motion Analysis

## Inverse Effectiveness

### Definition

The principle that signals from different sensory modalities presented simultaneously will be integrated in inverse proportion to their effectiveness when presented in isolation. Effectiveness is measured, for example, by counting the number of neural impulses generated by a given neuron in response to a visual

stimulus alone, a tactile stimulus alone, and a visual and tactile stimulus in combination.

► **Multimodal Integration**

## Inverse Model

### Definition

A module which maps the desired plant outcomes to the required effector activations; inversely to the mapping from effector activations to actual outcomes, performed by the plant.

► **Neural Networks for Control**

## Inverse Square Law in Acoustics

### Definition

Sound intensity decreases by a ratio of the square of the distance from the source to the point of measurement.

► **Acoustics**

## Invertebrate Ears and Hearing

PAUL A. FAURE<sup>1</sup>, ANDREW C. MASON<sup>2</sup>,  
JAYNE E. YACK<sup>3</sup>

<sup>1</sup>Department of Psychology, Neuroscience & Behavior,  
McMaster University, Hamilton, ON, Canada

<sup>2</sup>Integrative Behavior and Neuroscience Group,  
Department of Biological Sciences, University of  
Toronto at Scarborough, Scarborough, ON, Canada

<sup>3</sup>Department of Biology, Carleton University, Ottawa,  
ON, Canada

### Synonyms

Acoustic Sensillum; Auditory Sensillum

### Definition

A cuticular sense organ (sensillum) containing a specialized ► **mechanoreceptor** for transducing the

particle velocity or pressure component of sound energy into electrochemical nerve impulses that are transmitted to the central nervous system (CNS) and which are used to mediate acoustically evoked behavior (e.g., detection and localization of mates, predators, prey or hosts).

### Characteristics

Among invertebrates, a sense of hearing has been described only in arthropods. Except for a few species of Crustacea, members of the Insecta are the only invertebrates known to both produce and receive airborne sounds, and to use airborne acoustic signaling to mediate behavior. Some insect auditory organs, such as Trichoid Sensilla (Fig. 1a) or Johnston's Organs (Fig. 1b) are sensitive to the particle velocity component of sound, sometimes called near-field sounds. Particle displacement receivers are inherently directional because particle displacement occurs parallel to the direction of sound propagation and therefore the magnitude of the sensory response varies with the orientation of the receiver in the sound field. ► **Tympanal Organs** (Fig. 1d) detect sound pressure via the movement of a tympanal membrane (eardrum) that becomes deformed by fluctuations in the far-field pressure component of sound. Pressure detector receivers are used to obtain directional information by comparing responses from receptors that are separated in space and time. Sound localization is thus achieved using ► **interaural level difference (ILD)** and ► **interaural time difference (ITD)** cues. The detection of substrate-borne vibrations is widespread in invertebrates, has many parallels with airborne sound reception, and has been widely studied in insects, spiders and other arthropods. Little is known of insect vibration receptor organs, but the best known is the Subgenual Organ (Fig. 1c).

This essay will first discuss the ► **chordotonal organ** – the main type of acoustic sensillum innervating insect ears. We will then review the different types of acoustic receptors, with a concentration on tympanal organs but also including particle displacement and substrate vibration receptors.

### Chordotonal Organs

Insect auditory sensilla are derived from more generalized mechanosensory structures consisting of sensory cells, accessory cells, and cuticular structures [4]. The sensory cell is usually a ► **bipolar neuron** with a dendrite that becomes modified in its outer (distal) segment to contain a cilium constructed of microtubules – the ciliary dendrite that connects to the external cuticle. Accessory cells envelop and provide mechanical and nutritive support to the sensory neuron. Cuticular structures couple the point of mechanical stimulation, either directly or indirectly, to the sensory ciliary dendrite and aid in mechanoelectrical transduction.

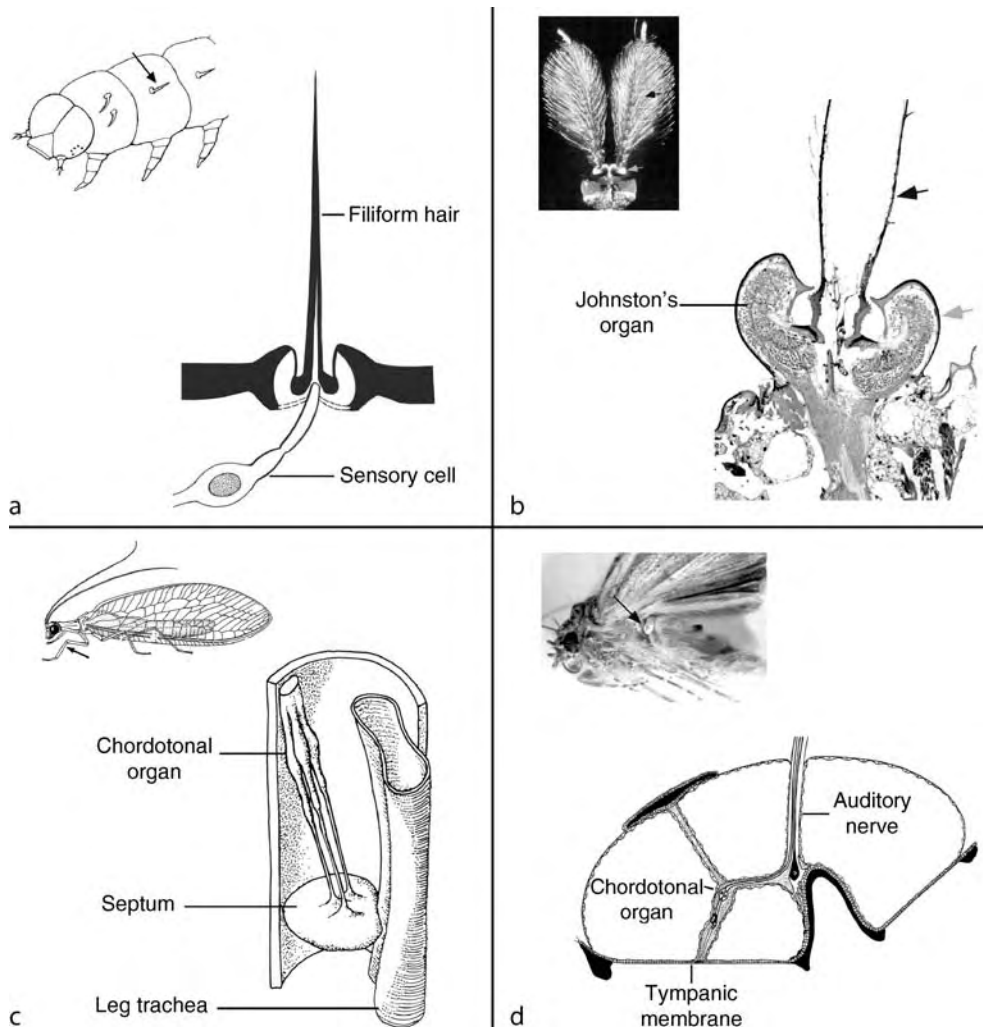

**Invertebrate Ears and Hearing. Figure 1** Insects possess a diverse array of acoustic sensilla that detect a broad range of sounds and vibrations. (a) Trichoid Sensilla. Some caterpillars use long hairs (*arrow*) to detect near-field acoustic signals produced by flying parasitoid wasps. A bipolar sensory cell responds to deflections of the hair shaft. [Caterpillar and sensillum redrawn with permission from Markl H, Tautz J (1975) The sensitivity of hair receptors in caterpillars of *Barathra barassicae* L. (Lepidoptera, Noctuidae) to particle movement in a sound field. *J Comp Physiol* 99:79–87, and [4], respectively.] (b) Johnston's Organ. Other insects, including many flies, detect near-field sounds of conspecifics with their antennae. Flight sounds cause the antennal flagellum (*black arrow*) to vibrate, stimulating chordotonal organs in the Johnston's organ located at the base of the antenna (*gray arrow*). A cross section of the antennal base shows that the Johnston's organ is comprised of thousands of scolopidia. [Photograph courtesy of D. Huber. Micrograph adapted from Göpfert MC, Robert D (2001) Active auditory mechanics in mosquitoes. *Proc R Soc Lond B* 268:333–339.] (c) Subgenual Organ. Many insects communicate using solid borne vibrations. The best-studied receptor of seismic signals in insects is the subgenual organ, illustrated here from the leg of a green lacewing (*arrow*). The chordotonal organ connects via attachment cells to a septum, and vibrations of the leg hemolymph result in stretching and stimulation of the constituent scolopidia. [Lacewing drawing courtesy C. Henry. Subgenual organ schematic redrawn with permission from Devetak D, Pabst MA (1994) Structure of the subgenual organ in the green lacewing, *Chrysoperla carnea*. *Tiss Cell* 26:249–257.] (d) Tympanal Organ. In noctuid moths, the ears are located on the posterior metathorax (*arrow*). Schematic drawing of the moth ear illustrates how the simple chordotonal organ, with only two sensory neurons, attaches to the tympanic membrane. [Redrawn with permission from Treat AE, Roeder KD (1959) A nervous element of unknown function in the tympanal organs of moths. *J Insect Physiol* 3:262–270.]

The most common auditory sensillum is the chordotonal organ (Fig. 2). Chordotonal organs are proprioceptive stretch receptors in crustaceans and insects [1,3]. Individual mechanosensory units within chordotonal organs are called scolopidia. Scolopidia consist of a linear chain of four cell types. (i) One or more bipolar neurons, each with a dendrite containing a modified  $9 \times 2 + 0$  cilium. At present, the function of the cilium is unknown; however, it may act to mechanically support the dendrite and/or it may aid in the transfer of vibrational energy to the stimulus transduction region of the sensory neuron. (ii) A scolopale cell that forms a lumen around the dendritic cilium, and inserts distally into the extracellular scolopale cap (Fig. 2).

Within the cytoplasm of the scolopale cell, adjacent to the lumen, are the scolopale rods, which are bands of electron dense material composed of longitudinally oriented microtubules surrounded by actin filaments. The scolopale rods likely support and limit lateral movements of the dendritic cilium, thus providing a

mechanism for restricting sensillum responses to specific locations or axes of mechanical stimulation. Scolopale cells are also thought to selectively transport ions into the space surrounding the dendrite, thus establishing an electrical potential difference between the lumen and the dendritic cytoplasm, which serves as the ionic basis for action potential generation during stimulus transduction. (iii) Attachment cells connect the scolopale cell to the external cuticle (or provide an internal anchor point for inverted scolopidia). In addition to providing mechanical support, they are likely important for transferring mechanical energy to the spike generation region of the neuron. (iv) Glial (accessory) cells envelop and provide nutritive and mechanical support to the sensory soma. Despite tremendous diversity in their form and function, all insect ears that respond to the pressure component of sound are innervated with chordotonal organs that have Type 1, monodynal, mononeuronic scolopidia (for definitions, see [1,9].

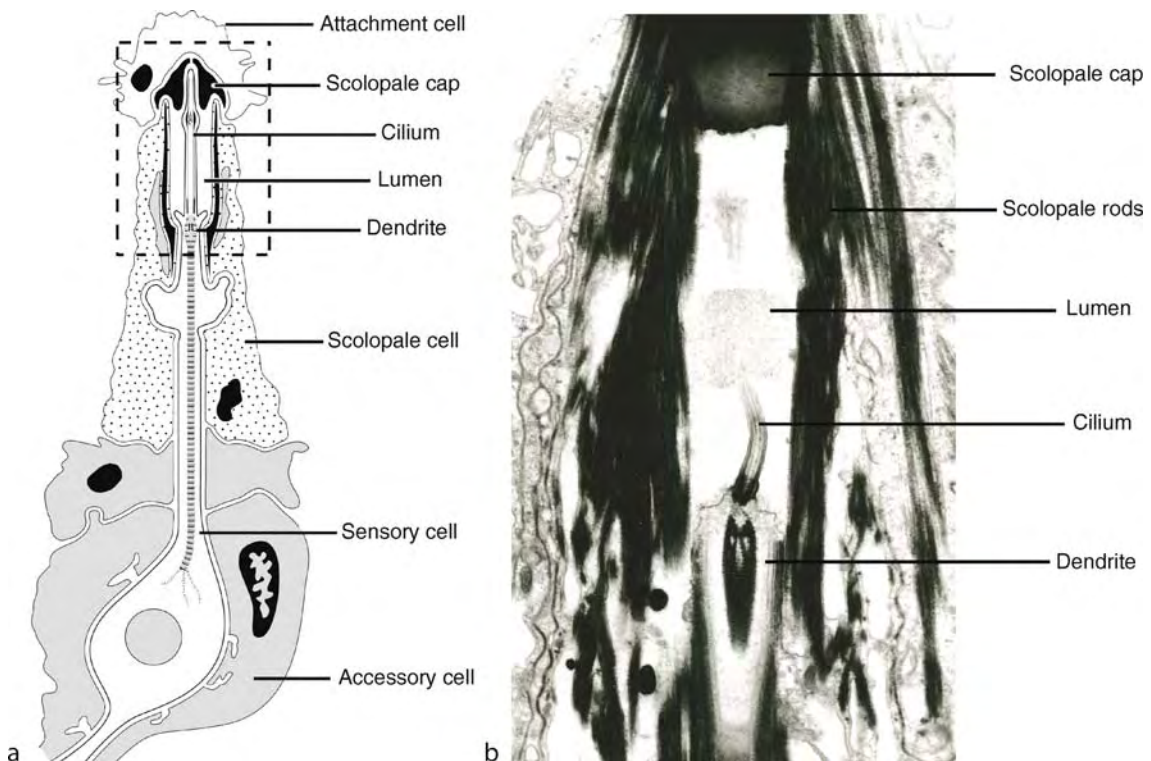

**Invertebrate Ears and Hearing. Figure 2** Chordotonal Organ ultrastructure. Chordotonal organs are comprised of individual sensory units called scolopidia. (a). Diagrammatic representation of a monodynal, mononeuronic scolopidium illustrating the main cell types: attachment cell, scolopale cell, sensory cell, and accessory cell. [Drawing by M. Nelson modified with permission from Gray EG (1960) The fine structure of the insect ear. *Phil Trans R Soc Lond B* 243:75–94.] (b). Electron micrograph of a single scolopidium showing the principle components of the scolopale and sensory cell. The micrograph is at the location of the dashed box in panel A [Adapted from Yack JE, Roots BI (1992) The metathoracic wing-hinge chordotonal organ of an atympanate moth, *Actias luna* (Lepidoptera, Saturniidae): a light- and electron-microscopic study. *Cell Tissue Res* 267:455–471.]

### Acoustic Receptive Organs

Four main types of acoustic receptive organs have been described for insects: Trichoid Sensilla, Johnston's Organ, Subgenual Organs, and Tympanal Organs [8,9].

1. *Trichoid (filiform) sensilla* (Fig. 1a) are hair-like cuticular projections specialized for the detection of near-field, low frequency sounds at close distances. The hair rests loosely in an epithelial socket and is innervated at its base by one or more sensory afferents that are bathed in a receptor lymph of special ionic composition. The neurons become depolarized in response to lever-like deflections of the hair shaft. Some caterpillars use trichoid sensilla to detect faint air currents caused by the wing beats of hymenopteran predators and parasitoids. Filiform hairs on the cerci of many insects, such as crickets and cockroaches, are used to detect air particle oscillations that are generated by predatory strikes and/or the wing movements of singing conspecifics.
2. *Johnston's organs* (Fig. 1b) are chordotonal sensory organs associated with the second antennal segment of insects. In some groups, including Diptera and Hymenoptera, the Johnston's organ is known to function in the detection of airborne sound [3]. The flagellar portion of the antenna oscillates in response to low frequency (near-field) sounds. The vibrations are then transmitted to mechanosensory scolopidia located at the base (pediculus) of the antenna. Many species of Diptera (e.g., mosquito) and Hymenoptera (e.g., honeybee) use the Johnston's organ to detect air currents produced by the wing beats of flying conspecifics, usually members of the opposite sex. The Johnston's organ is thought to be a diagnostic character for insects.
3. *Subgenual organs* (Fig. 1c) are chordotonal sensory organs located on the legs (proximal tibia) of most insects [1]. Substrate vibrations are thought to provide an adequate stimulus by setting into motion the fluid (hemolymph) within the leg, which in turn vibrates a septum to which the scolopidia are attached. Because subgenual organs are exquisitely sensitive to small-amplitude vibrations, they can effectively operate over long distances. Many terrestrial insects communicate with substrate vibrations, and the subgenual organ is thought to be the main vibrational receptor in adult insects. At present, little is known about how larval insects detect vibrations despite the widespread use of this modality by juvenile insects in a variety of taxa.
4. *Tympanal organs* (Figs. 1d, 3 and 4) are specialized for detecting the pressure (far-field) component of sound at relatively long distances and over a broad range of frequencies and amplitudes. Although anatomically and functionally diverse across taxa, insect tympanal organs are composed of three units:

a tympanal membrane, a tracheal air space, and a chordotonal sensory organ. The tympanal membrane is a thinned region of cuticle that vibrates in response to changes in pressure between the external and internal sides of the membrane; the membrane vibrates most efficiently when the acoustic impedance of the sound medium is similar (matched) on the front and back sides. Insects obtain this impedance matching by modifying their internal, tubular tracheal (breathing) system to create an air space directly behind the membrane. The chordotonal organ is attached, either directly or indirectly, to the internal surface of the tympanal membrane. Oscillations of the membrane stretch the scolopidia. Longitudinal deformations of the sensory dendrite are thought to open membrane channels, resulting in a change of ion conductance, current flow, a change in receptor potential and the consequent generation of an action potential. The threshold of displacement for receptor activation can be as small as 1–10 nm [2]. Exact details of the spike generation mechanism are still unclear.

Most insects that detect acoustic far-field sounds have a pair of tympanal membranes, and a few species have multiple paired membranes. Across taxa, the most common placement for the pair is on either side of the thorax or abdomen. This is typically the widest body region and is best suited for generating maximal interaural level difference (ILD) and interaural time difference (ITD) cues for sound localization [6,10]. ILD cues are generated by sound diffraction, which varies as a function of frequency (wavelength) relative to the size of the diffracting body. ITD cues vary with distance (arrival time or phase) between the two ears. Many insects show excellent directional hearing while flying or walking. Peripheral (tympanal organ) mechanisms of signal reception can be highly selective for sound direction.

Insect auditory afferents share many physiological characteristics with vertebrate receptors. For example, variation in the number, rate and timing of action potentials is the basis of information coding by the CNS [5]. Most auditory afferents fire tonically or phasitically with an intensity-dependent change in spike rate and latency, and show spike adaptation to prolonged or repeated stimulus presentations. Receptor populations also vary in their absolute sensitivity to sound amplitude (range fractionation). In most cases where receptors are tuned to different frequencies, there is clear anatomical variation in scolopidia size and/or the mechanics of attachment to the point of stimulation, although the possibility that receptors with variable tuning also differ in their intrinsic cellular properties has not been eliminated. While both receptors and interneurons show a high degree of temporal pattern copying to the amplitude envelope of the stimulus, owing to the



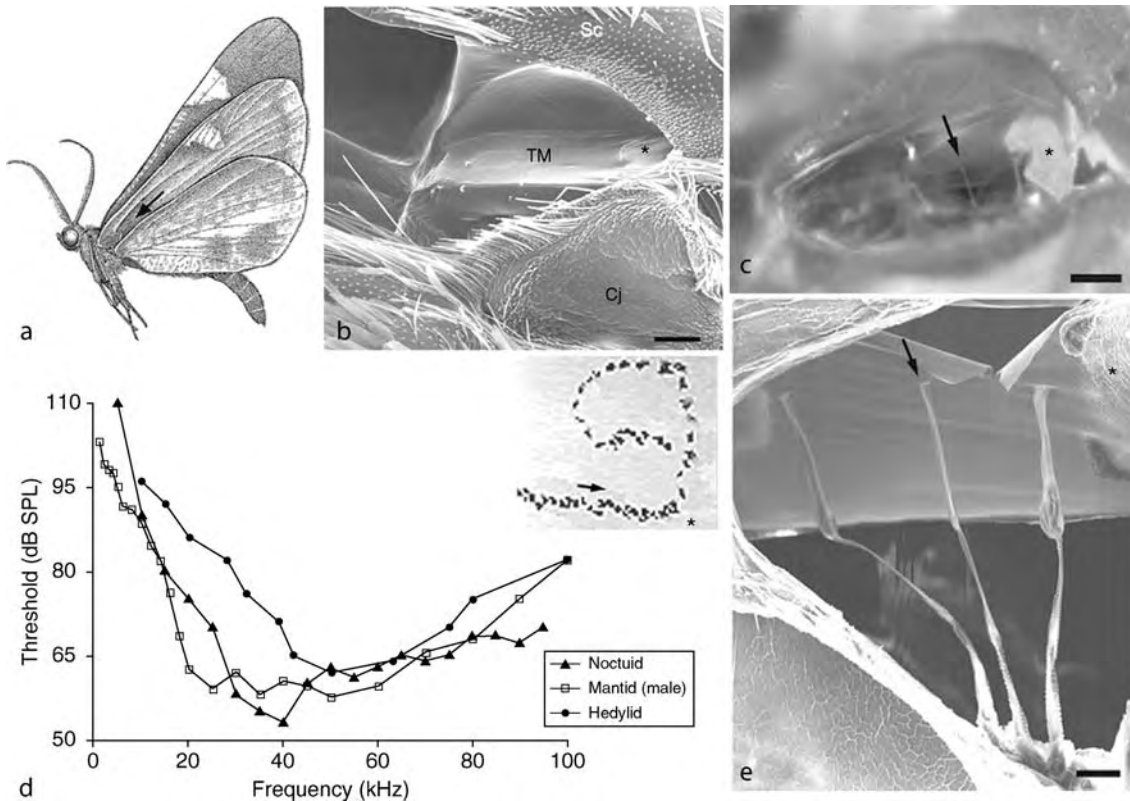

**Invertebrate Ears and Hearing. Figure 3** Tympal ears used to detect the ultrasonic echolocation calls of predatory bats have evolved independently in several insect orders. (a). This nocturnal butterfly, belonging to the superfamily Hedyloidea, possesses a tympal ear at the base of its forewing (*arrow*). (b). Scanning electron micrograph of the tympal cavity, where the tympanal membrane (TM) resides. Modifications of the subcostal wing vein form a protective covering for the delicate tympanum and a canal that directs sound toward the ear. Also shown is the conjunctivum (Cj), also known as the countertympanal membrane. An asterisk marks a thickened region of the tympanal membrane. Scale bar: 100  $\mu\text{m}$ . (c). Light micrograph of Hedylid ear. The *arrow* points to the middle of three chordotonal organs that attach to the inner surface of the transparent tympanal membrane. An asterisk marks the membrane thickening as shown in B and E. Scale bar: 100  $\mu\text{m}$ . (d). Audiograms derived from extracellular recordings of auditory afferents in three groups of insects whose ears function primarily for bat detection: noctuid moth (*closed triangle*), praying mantis (*open square*), and hedylid butterfly (*closed circle*). *Inset*: consecutive video frames (33 ms interval) illustrating the evasive flight maneuver of a hedylid butterfly in response to stimulation with bat-like ultrasound. The direction of flight prior to stimulus onset (*asterisk*) is shown with a *black arrow*. (e). Scanning electron micrograph of the three hedylid chordotonal organs viewed from inside the tympal chamber. The middle chordotonal organ is marked with an *arrow*. An asterisk marks the membrane thickening as shown in B and C. Scale bar: 20  $\mu\text{m}$ . [(a–c), *inset* of (d), and (e) adapted from: Yack JE, Kalko EK, Surlykke A (2007) Neuroethology of ultrasonic hearing in nocturnal butterflies (Hedyloidea). *J Comp Physiol A* 193:577–590. Frequency tuning curves of (d) from Fullard JH, Yack JE (1993) The evolutionary biology of insect hearing. *TREE* 8: 248–252, and Yager DD (1996) Nymphal development of the auditory system in the praying mantis *Hierodula membranacea* Burmeister (Dictyoptera, Mantidae). *J Comp Neurol* 364:199–210.]

relatively high frequencies at which many species hear, insect auditory neurons typically do not phase lock to the fine waveform structure of the stimulus.

As in vertebrates, auditory behavior arises from serial and parallel central processing mechanisms [5]. Auditory afferents project to the ipsilateral auditory **neuropile** in the CNS where they synapse with interneurons (both intra- and interganglionic) that integrate with motoneurons. Central auditory neurons receive both excitatory

(EPSP) and inhibitory post-synaptic potentials (IPSP) that vary in their strength, duration and latency. In some species a corollary discharge (efference copy) is used for processing self-generated sounds [7]. Central auditory neurons have responses that are tuned to stimulus frequency, amplitude, direction, or timing. Spectral tuning curves of interneurons are sharpened by frequency-dependent lateral inhibition. Extraction of directional information is achieved by integrating receptor spikes

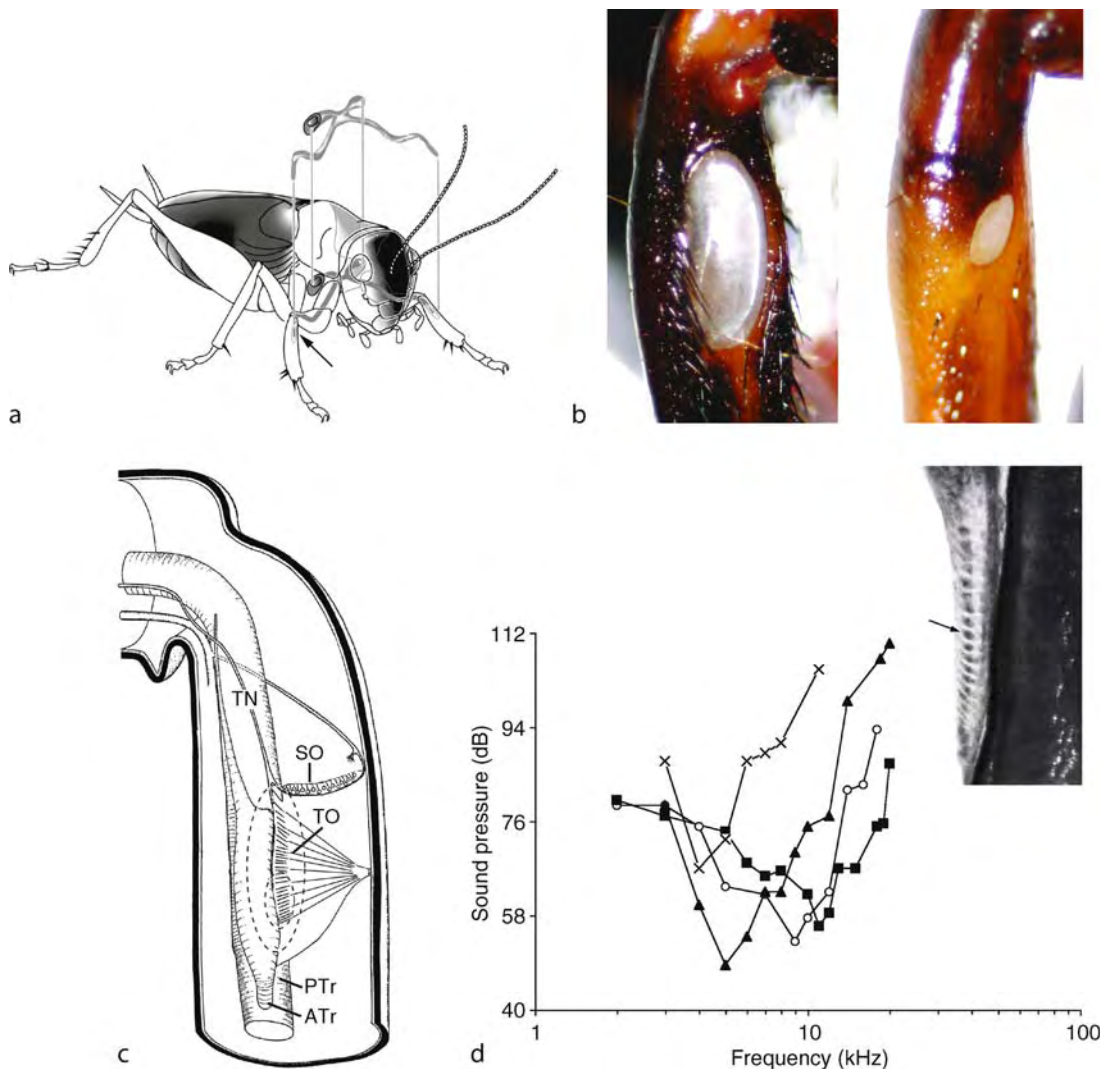

**Invertebrate Ears and Hearing. Figure 4** Many insects use tympanal hearing organs for localizing and communicating with conspecifics. (a) Crickets use a pressure-difference receiver mechanism to localize sounds with wavelengths larger than the spatial separation of their ears, which are located on the proximal tibia of the forelegs (arrow). An H-shaped tracheal system (illustrated as floating above the cricket's body) internally connects sound inputs from both tympanal ears and from the acoustic spiracles located on opposite sides of the thorax. (b) Light micrographs of the large posterior (left) and small anterior (right) tympanal membranes. [(a–b) reproduced from: Yack J, Hoy R (2003) Hearing. In: Resh VH, Cardé RT (eds) *Encyclopedia of insects*. Academic Press, New York, pp. 498–505.] (c) Schematic internal view of the proximal tibia of a cricket, showing the tympanal nerve (TN), subgenual organ (SO), tympanal organ (TO) and the posterior and anterior trachea (PTr, ATr) that back their respective tympanal membranes. The approximate locations of the anterior (small dashed oval) and posterior (large dashed oval) tympanal membranes are shown. [Redrawn from Michel K (1974) Das Tympanalorgan von *Gryllus bimaculatus* Degeer (Saltatoria, Gryllidae). *Z Morph Tiere* 77:285–315.] (d) Threshold tuning curves of four primary auditory neurons showing a range of characteristic frequencies. The inset shows the linear, tonotopic arrangement of the tympanal organ scolopidia. A black arrow points to the cell body of an individual sensory cell. [Data extracted from Oldfield BP, Kleindienst HU, Huber F (1986) Physiology and tonotopic organization of auditory receptors in the cricket *Gryllus bimaculatus* DeGeer. *J Comp Physiol A* 159:457–464.]

binaurally and is enhanced by reciprocal contralateral inhibition. A similar mechanism of mutual inhibition for contrast enhancement can also be used to extract stimulus amplitude or temporal pattern information.

#### Diversity of Insect Ears

Tympanal hearing organs have arisen repeatedly in insects. To date, the count stands at 20 independent evolutions. Depending on the taxa, insect ears can be

found all over the external body surface, including the thorax, abdomen, wings, legs, and mouthparts. The organs may be highly visible or cryptically located, and in some cases have become internalized. It is now commonly believed that the present diversity of insect auditory organs is a result of their evolving from pre-existing chordotonal sensilla that primarily served a proprioceptive or low-frequency vibratory detection function at that body location. The evolution of tympanal membranes, through a progressive thinning of appropriate regions of the exoskeleton, increased the organ's sensitivity to stimulus amplitude and frequency. The ubiquity of such mechanosensors near the exoskeleton surface provides many potential locations for the evolution of ears.

The number of scolopidia, and thus sensory neurons per hearing organ, varies widely across taxa, ranging from 1–4 in moths, 2 in water boatman, 3–8 in beetles, 5–20 in lacewings, 20–75 in crickets and katydids, 60–100 in locusts, 100+ in flies, 600–2,000 in cicadas, and 2,000+ in some primitive grasshoppers. No clear relationship exists between the number of sensory afferents and the sensitivity of the tympanal organ to stimulus amplitude, frequency or phase (timing). Ears tend to be simplest in those groups that use hearing primarily for predator detection, and more complex in those groups that use sound for intraspecific communication.

Many of the simplest tympanal organs are the broadband pressure detecting ears found in moths and butterflies (Lepidoptera), lacewings (Neuroptera), beetles (Coleoptera) and mantids (Dictyoptera). Hearing in these groups has evolved primarily in the context of predator detection. More specifically, their ears function mainly to detect the ultrasonic echolocation signals of aerial insectivorous bats, and hearing in many species has been shown to mediate evasive flight maneuvers (Fig. 3).

Lepidopteran ears are often found on the thorax or abdomen, although a few species have evolved ears on their wings and mouthparts. The ears of lacewings are located in the radial vein at the base of each forewing. In beetles, ears have recently been described on both the abdomen and on the prothorax just behind the neck region. The ears of mantids are hidden within a groove along the ventral midline between the metathoracic legs. In many mantids, hearing is sexually dimorphic because the females are flightless and therefore are not subject to predation by aerial insectivorous bats; male mantids fly and thus their ears are better developed anatomically and have a higher sensitivity. A minority of lepidopterans use sound production and hearing for intraspecific communication. There is no behavioral or physiological evidence for frequency discrimination or well-developed directional hearing in these insect groups.

In two groups of Hemiptera the sense of hearing primarily serves intraspecific communication. In both groups the ears are normally sharply tuned to the sounds

of calling conspecifics. With only two sensory cells, the mesothoracic ears of water boatman (Heteroptera) may appear to be simple, but are functionally complex. Each tympanal membrane connects to a clubbed cuticular process that alters the membrane resonance frequency and imposes a left–right hearing asymmetry. The membrane can vibrate effectively underwater because it contacts an air bubble that becomes trapped by the waxy integument when the bug submerges; the bubble oscillates in response to the stridulatory calls of conspecifics. During a dive, the volume of air depletes due to respiration, and this increases its resonance frequency. The ears of terrestrial cicadas (Homoptera) are also structurally complex. The tympanal membranes are located ventrally in a recess on the second abdominal segment; the chordotonal organ is contained in a rigid capsule connected to the membrane. Depending on the species, the organs may have thousands of scolopidia. The sense of hearing is often sexually dimorphic (commonly more sensitive in males). Male cicadas emit very loud songs to attract females from far distances. To avoid self-deafening while singing, the males fold (relax) their tympanal membranes and this dampens the dynamic range of their auditory sensitivity by >20 dB.

Invertebrate hearing is probably best understood in the Orthoptera, where hearing serves the functions of mate attraction, courtship display, territorial spacing, aggression, prey detection, and defense from predators and parasitoids. Within this group there is ample behavioral and physiological evidence for frequency discrimination and directional hearing [6]. Locusts (Caelifera) possess a tympanal ear on either side of the first abdominal segment, and the modes of vibration of the tympanum systematically vary with sound frequency. Frequency discrimination is achieved by having four groups of scolopidia attached to the membrane at different positions that correspond to locations of vibrational maxima at different frequencies. Crickets and katydids (Ensifera) have a pair of tympanal membranes (anterior and posterior) on the proximal tibia of each foreleg (Fig. 4a, b), although the anterior membrane is not sensitive in crickets. A tracheal chamber apposed to the interior tympanal surface forms an air space behind each membrane, thus providing impedance matching (Fig. 4c). The tracheal chamber is continuous with a complex system of acoustic tracheae that influence hearing sensitivity, frequency tuning and directionality (Fig. 4a). As in vertebrates, frequency discrimination is achieved by having receptors that are tuned to different frequencies (tonotopy). The chordotonal organ consists of a linear array of scolopidia that attach indirectly to the tympanal membrane. Although the mechanism of receptor tuning is unresolved, a mechanical basis is likely because scolopidia gradually taper in size within the organ; proximal cells are tuned to lower frequencies whereas distal cells are tuned

to higher frequencies (Fig. 4c, d). In katydids, the peripheral tonotopy is maintained with the CNS by the differential projection of receptors to interneurons within the auditory neuropile.

Some parasitoid flies (Diptera) have evolved tympanal hearing organs on the thorax just behind the head. Hearing is also sexually dimorphic in this group – poorly developed in males, whereas females use their ears to localize the songs of acoustic Orthoptera or Homoptera, and then deposit larvae on the host. Directional hearing in some female Diptera is among the most accurate in the animal kingdom. Although each ear has a single chordotonal organ connected to the inner surface of the tympanal membrane via an apodeme, the two membranes share a common tracheal air space and are also mechanically coupled. This has resulted in a completely novel and remarkably accurate sense of directional hearing [5].

## References

1. Field LH, Matheson T (1998) Chordotonal organs of insects. *Adv Insect Physiol* 27:1–228
2. French AS (1992) Mechanotransduction. *Annu Rev Physiol* 54:135–152
3. Hallberg E, Hansson BS (1999) Arthropod sensilla: morphology and phylogenetic considerations. *Microsc Res Tech* 47:428–439
4. Keil TA (1997) Functional morphology of insect mechanoreceptors. *Microsc Res Tech* 39:506–531
5. Mason AC, Faure PA (2004) The physiology of insect auditory afferents. *Microsc Res Tech* 63:338–350
6. Michelsen A (1998) Biophysics of sound localization in insects. In: Hoy RR, Fay RR, Popper AN (eds) *Comparative hearing: insects*. Springer handbook of auditory research, vol. 10. Springer, Berlin, Heidelberg, New York, pp 18–62
7. Poulet JFA, Hedwig B (2003) A corollary discharge mechanism modulates central auditory processing in singing crickets. *J Neurophysiol* 89:1528–1540
8. Römer H, Tautz J (1992) Invertebrate auditory receptors. In: Ito F (ed) *Comparative aspects of mechanoreceptor systems*. Advances in comparative and environmental physiology, vol. 10. Springer-Verlag, Berlin, Heidelberg, New York, pp 185–212
9. Yack JE (2004) The structure and function of auditory chordotonal organs in insects. *Microsc Res Tech* 63:315–337
10. Yager DD (1999) Structure, development, and evolution of insect auditory systems. *Microsc Res Tech* 47:380–400

## Invertebrates

- Evolution of the Vestibular System

## Inverted Pendulum

### Definition

A biomechanical model of the body, where the center of mass of the body is situated at the upper end of a rigid link that pivots about a joint at the base (i.e. the ankle).

In a multi-link inverted pendulum, the different segments of the body (e.g. foot, shank, thigh, trunk, etc.) are represented by separate links (each with its own mass and rotational inertia) that are interconnected at the joints (ankle, knee, hip, etc.).

- Center of Mass (CoM)
- Postural Strategies

## Involuntary Memory

Unconscious spontaneous memory.

- The Proust Effect

## Inwardly Rectifying K<sup>+</sup> Channel Family

### Definition

There are seven subfamilies of the inwardly rectifying potassium (Kir) channel family (Kir1.0, Kir2.0, Kir3.0, Kir4.0, Kir5.0, Kir6.0, Kir7.0) with two transmembrane domains, M1 and M2, linked by a pore loop (the H5 region) which is critical for K<sup>+</sup> ion selectivity. The asparagine residue in M2 is critical for the rectification property.

- Neuronal Potassium Channels

## Ion Channel

### Definition

Ion channels are transmembrane proteins that have gated pores for the selective passage of ions across cell

membranes. Ion channels can be classified into those with and without a re-entrant pore-loop. Voltage-gated channels ( $K^+$ ,  $Ca^{2+}$ ,  $Na^+$ ) and glutamate metabotropic receptors all bear an extracellular, re-entrant loop, that provides a highly selective aqueous pore for particular ions. All pore-loop channels are structural derivatives of inward rectifying potassium ( $K^+$ ) channels. Other ion channels outside this class do not have an obvious evolutionary relationship. These include the Cys-loop receptor channels (AChR, GABA, GlyR, 5HT), connexins, M2, chloride channels, intracellular calcium release channels (IP3, RYR) and CFTR. Ion channels can also be classified as voltage-gating or ligand-gating.

Ion channel pore opening are usually controlled by gating mechanisms responding to voltage-changes, allosteric coupling of ligands to binding domains, as well as pH, stretch and temperature. Functional ion channels often require accessory subunits.

## Ion Channel Conductance

### Definition

Ion channel conductance is a measure of the ion flux through an ion channel at a particular voltage. Conductances are measured in the units of Siemens (S) and the scale of individual channel conductances are in the pico-Siemens range. Ion channel conductance is a dependent on the ion channel permeability and the concentration of permeant ion.

## Ion Channel Development

MARTHA M. BOSMA

Department of Biology, University of Washington,  
Seattle, WA, USA

### Definition

Ion channel development encompasses the expression of ion channels, including transcriptional regulation, processing, localization and modulation, and the incorporation of those ion channels into the membrane excitability parameters regulating neuronal circuits and networks.

This entry will concentrate on membrane properties due to the expression of ion channels in immature

excitable cells, how those properties can modify the expression of both the immature and mature ion channels in an activity-dependent manner, and the changes that are effected in ion channel expression as consequences of maturation and ion channel development.

### Characteristics

During the development of circuits in the nervous system, patterns of immature physiological properties are often created which are distinct from those in the mature animal. The function of immature behavior is crucial for the formation of the nervous system, while mature expression of ion channels is required to function within a developed nervous system. In many cases, however, it has been shown that the unique immature pattern is required for the appropriate mature circuit formation. A prototypical example of this interaction between immature and mature systems is found in the ►retina, in which waves of spontaneous activity (SA; not initiated by sensory input) that propagate across retinal domains are required to direct synaptic formation at the synapses of the ►retinal ganglion cells in the ►lateral geniculate nucleus (LGN) or ►tectum. Disruption of these waves, or manipulation of the extent or frequency of the waves, alters the mapping of the retina in ►retinotopic positions within the more central structures. This spontaneous activity is expressed for a limited time period, which differs between species, but in almost every case spontaneous activity ceases at the time of eye opening. In the mature retina, spontaneous activity is not present, and the output of retinal ganglion cells is determined by visual input. SA has been shown to occur in many brain regions, and can regulate diverse developmental events, including neurogenesis, migration, pathfinding and synaptic connectivity [1].

We will consider the modulation and development of three very general categories of ion channels, which determine spontaneous activity using one or two examples within each category: ►voltage-gated ion channels, ligand-(transmitter-) gated ion channels, and ►resting channels. In addition, discrete neuronal populations within brain regions, pacemaker or driver regions that initiate SA, will also be explored. It must be emphasized that although the topics are being addressed in a reductionist fashion, it is more than likely that a combination of several events from each ion channel category will actually create SA in any one neuronal population. References to examples from the older literature can be found in [1,2].

### Voltage-gated Ion Channels

#### Inner Hair Cells

►Inner hair cells (IHC) of the ►cochlea are non-neuronal sensory cells whose SA and synaptic output onto postsynaptic brainstem targets is required for the

survival of those targets. SA in IHC is recorded between approximately embryonic (E)18 (almost birth) to postnatal (P)12 (close to onset of hearing) in mouse, generated by the increased expression of  $\text{Ca}^{2+}$  and  $\text{Na}^+$  channels (►Calcium channels – an overview; Sodium channels), which are down-regulated at the onset of hearing, terminating SA ( $\text{Na}^+$  channels are down-regulated completely). The SA is also terminated by the appearance of a  $\text{Ca}^{2+}$ -stimulated  $\text{K}^+$  current (►Neuronal potassium channels). The expression of this latter current is itself regulated by the SA, which precedes its appearance. Thus, SA, presumably functioning to drive specific genetic programs and to ensure survival of downstream brainstem nuclei, is self-terminating. This cessation of SA occurs at the same point in time when conventional sensory-driven use of the IHC cells begins. Thus, the immature state is quite different (spontaneous ►action potential generation) than the mature, non-action potential-driven transduction of sensory input, and this difference is caused by coordinated developmental up- and down-regulation of voltage-gated channels.

#### Ascidian Muscle

In developing ascidian muscle, SA occurs during a 6-h window of time just after exit from the cell cycle. This activity is triggered by the temporary disappearance of an ►inwardly rectifying  $\text{K}^+$  current ( $I_{\text{IR}}$ ), which represents the resting conductance of these cells (see III, Resting Conductances, below). Activity is terminated by the reappearance of this resting current and by the appearance of an outward ►delayed rectifier  $\text{K}^+$  current that activates much faster than the one present earlier in development. This latter event shortens the duration of the action potential, which would be expected to reduce  $\text{Ca}^{2+}$  entry. This would be problematic for muscle cells that depend on  $\text{Ca}^{2+}$  entry for contraction. To solve this problem, a large increase in  $\text{Ca}^{2+}$  current density occurs at the same time as the rapidly activating delayed  $\text{K}^+$  current appears. As in other cells, some of the developmental changes in ion channels in ascidian muscle – in this case the appearance of a rapidly activating outward  $\text{K}^+$  current – depend on the SA that they help to terminate.

#### Xenopus Neurons

In *Xenopus* spinal neurons, the action potential shortens by 2–10 folds over a time period of 1–2 days, due primarily to an increase in current density and activation kinetics of a delayed rectifier  $\text{K}^+$  current. The long-duration immature action potential, which admits more  $\text{Ca}^{2+}$  than the mature event, is required for the increase in  $\text{K}^+$  current, as artificially shortening it by mis-expressing a related  $\text{K}^+$  current during the immature time period alters the normal developmental changes.

#### Ligand-gated Channels

In the examples given above, isolated cells, or cells in relatively small populations, are examined for individual SA events. In the present examples, large populations of developing neurons are undergoing SA, and often synchronized with other neurons around them. Thus, an additional component of SA is synchronization within a large population of developing networks.

#### Hippocampus

SA in the ►hippocampus is recorded around birth and into the first postnatal week. Waves of spontaneous activity, known as ►Giant Depolarizing Potentials (GDP), occur within the entire neuronal population. Each GDP consists of bursts of action potentials associated with large synaptic depolarizations, and is based upon both GABAergic and glutamatergic components. Ligand binding to ►GABA<sub>A</sub> receptors at this developmental stage activates a conductance that is excitatory, as the reversal potential for  $\text{Cl}^-$  ( $E_{\text{Cl}}$ ) is positive to threshold in many developing neurons. This paradoxical response is caused by the slow developmental appearance of  $\text{Cl}^-$  pumps (e.g. KCC2) that are not yet expressed; thus intracellular  $\text{Cl}^-$  is high, and  $E_{\text{Cl}}$  is set at a relatively depolarized potential (►Chloride channels and transporters; ►Ion transport). With the expression of KCC2 over developmental time,  $E_{\text{Cl}}$  gradually shifts more negative, and the depolarizing “drive” that allows other inputs to bring cells to threshold is absent. Thus, SA termination is caused by decreased reversal potential for  $\text{Cl}^-$ . GDP activation in the hippocampus also includes a component of ►glutamate receptor activation, including ►NMDA receptors and ►AMPA receptors.

#### Cortex

In the cerebral cortex, widespread spontaneous activity occurs during the 3–4 days around birth. Although this activity, unlike that in hippocampus, does not require GABA<sub>A</sub> excitation, it does require that GABA<sub>A</sub> action not be inhibitory, and thus that  $E_{\text{Cl}}$  be above threshold. Two events terminate cortical spontaneous activity: the emergence of strong GABA<sub>A</sub> inhibition (as  $E_{\text{Cl}}$  shifts to more negative potentials), and a decline in the participation of NMDA receptors in spontaneous bursts. Both of these events occur in the first postnatal week, and both are triggered by the spontaneous activity itself. Thus, as in other preparations, spontaneous activity is at least in part self-terminating [3,4].

#### Resting Conductances

Developmentally regulated conductances that open at or near rest, or that provide a tonic inward current, would be crucial in the ability to both support SA, and to be modulated by developmental events that might then alter SA in that cell. Among others, classes of ion

channels that are known to regulate resting conductance developmentally are the  $K^+$  inward rectifier ( $I_{IR}$ ), an inwardly rectifying ▶non-specific cation channel ( $I_H$ ), and ▶gap junction channels.  $I_{IR}$  and  $I_H$  are particularly appropriate to be involved in changes in excitability, as they are both activated near the ▶resting membrane potential (▶Membrane potential – basics), and set the resting conductance of the membrane [5]. With excitation, both channels close, increasing the resistance of the neuron and allowing depolarizing inputs to be amplified. In addition,  $I_H$  is excitatory when the cell is hyperpolarized, as it allows  $Na^+$  entry.

In mammalian muscle cells, which express  $I_{IR}$  in the adult, innervation upregulates expression of  $I_{IR}$  due to stabilization of the mRNA caused by increases in  $[Ca^{2+}]_i$  generated by the activity of innervation, while denervation downregulates its expression. In ascidian muscle,  $I_{IR}$  disappearance allows a window of SA that then triggers the re-appearance of both  $I_{IR}$  and a voltage-gated IK to terminate the SA (also see section I above, Voltage-gated ion channels). In the hippocampus, the ability of hilar neurons to generate spontaneous activity (see also section IV below, Pacemakers) is dependent on the presence of  $I_H$  in specific populations of neurons.

In gap junctional communication, ion channels called ▶connexins pass both electrical signals and small molecules between cells in contact with each other, and are present in many developing neurons. In many cases, gap junctions disappear upon maturity. The role of gap junctions in development of SA is observed in the neocortex and hippocampus. In the cortex [6], discrete compartments of developing cells are coupled, and only some of those become uncoupled over postnatal time. In the hippocampus, the ▶hilus acts as a pacemaker (see also section IV below, Pacemakers) and the neuronal elements within that pacemaker are electrically coupled. Gap junctions can act as a resting conductance that can be modulated with developmental events, changing the resistance of the cells and the effectiveness of inputs. In mammalian ▶motor neurons, reduced gap junctional coupling by use of specific connexin knock-out transgenic animals [7] leads to a reduction in correlation of firing, and to premature synapse elimination. This suggests both an electrical and developmental role for gap junction communication during development.

### Pacemakers

In examples where large groups of neurons are able to participate in SA that is synchronized, the mechanism(s) initiating the SA have not been clear. In some cases, such as the spinal cord, network properties in which each neuron is an independent excitatory unit, able to modify neighbors which then in turn feed back onto itself, direct the rate and interval of SA events. This model requires mutual excitation between neurons,

as well as post-activity depression, which is involved in directing the interval between events. However, in several systems, a discrete region of the tissue acts as a driver or pacemaker, and leads the tissue in SA participation.

### Hindbrain

An example of discrete pacemaker-driven SA is found in the hindbrain during early embryonic development in both mouse and chick. The hindbrain becomes the ▶pons, ▶medulla, and ▶cerebellum, and is initially divided into distinct regions called rhombomeres, a fate-patterning system unique to the hindbrain. Each rhombomere encloses a group of progenitor cells and their resultant neurons that have a particular fate because of their initial position; at about E11.5 in the mouse embryo the rhombomere boundaries disappear. SA in individual labeled motor neurons derived from different rhombomeres, as measured by  $[Ca^{2+}]_i$  recording, develops from very long (duration of minutes) events to shorter more frequent events between days E9.5–E11.0. Abruptly at E11.5, SA events between motor neurons, indeed between neurons encompassing the entire hindbrain, become highly synchronized, and remain synchronized until E13.5. Examination of the anatomical arrangement of SA revealed that midline neurons of the developing ▶serotonergic raphe nuclei, found in former rhombomere 2, initiate all of the activity of the hindbrain, and propagate events in the rostral-caudal dimension along the midline, and to the lateral regions away from the midline. Separation of the raphe from lateral tissue obliterates SA in the lateral tissue, while maintaining it in the pacemaker raphe [8,9]. Thus, a small group of neurons within the tissue of the hindbrain are acting as a pacemaker. Although a distinct pacemaker region is now identified, it is clear that this only pushes the question of initiation of SA back one step: what causes the neurons within the pacemaker region to initiate activity?

Recent experiments using ▶patch-clamp techniques have shown that serotonergic neurons in the initiation region are more highly coupled to one another than neurons in other regions. Neurobiotin (a marker that crosses through gap junction channels) in the pipette shows that anatomical coupling occurs within the initiation region at higher ratios than in other areas. In addition, application of low concentrations of  $Ba^{2+}$ , which blocks resting  $K^+$  channels (most likely  $I_{IR}$ ), has a larger effect on lateral neurons than on midline neurons, suggesting that midline (driver) neurons do not express a resting  $K^+$  conductance that would tend to suppress their excitability.

### Hippocampus

In the hippocampus, evidence of an initiation region in the hilus is supported by separation experiments where

the hilus maintains activity, timing experiments showing that hilar events precede ►CA3 events, evidence for gap junctional coupling between hilar neurons, and possible pacemaker current expression in hilar neurons. However, there is other evidence, obtained in tissue slices with different orientations, that the ►septum may initiate activity within the hippocampus. Other experiments point to the ability of any isolated hippocampal region to initiate activity as evidence of network properties driving SA in the hippocampus.

### Conclusions

The expression of patterns of ion channels in immature excitable cells can determine whether they undergo SA. That SA can alter the developmental expression of both the original and the newly transcribed or synthesized channels that terminate SA, and pattern excitability as a mature cell. The ability to undergo SA may be present in individual cells, entire neuronal networks, or discrete pacemaker regions, but in each case may be part of a program to modify ion channel expression, and transform immature to mature physiological behavior.

### References

1. Moody WJ, Bosma MM (2005) Ion channel development, spontaneous activity, and activity-dependent development in nerve and muscle cells. *Phys Rev* 85:883–941
2. Spitzer NC (2006) Electrical activity in early neuronal development. *Nature* 444:707–712
3. McCabe AK, Chisholm SL, Picken-Bahrey HL, Moody WJ (2006) The self-regulating nature of spontaneous synchronized activity in developing mouse cortical neurones. *J Physiol* 577:155–167
4. McCabe AK, Easton CR, Lischalk J, Moody WJ (2007) Burst properties and participation of glutamate and GABA receptors in the generation and developmental timing of spontaneous synchronized activity in developing mouse cortex. *Dev Neurobiol* 67:1574–1588
5. Rocha N, Rolf A, Strauss U (2006)  $I_h$  is maturing: implications for neuronal development. *Neurodegener Dis* 3:27–31
6. Sutor B, Hagerty T (2005) Involvement of gap junctions in the development of the neocortex. *Biochim Biophys Acta* 1719:59–68
7. Personius KE, Chang Q, Mentis GZ, O'Donovan MJ, Balice-Gordon RJ (2007) Reduced gap junctional coupling leads to uncorrelated motor neuron firing and precocious neuromuscular synapse elimination. *PNAS* 104:11808–11813
8. Hunt PN, McCabe AK, Bosma MM (2005) Midline serotonergic neurons contribute to widespread synchronized activity in embryonic mouse hindbrain. *J Physiol* 566:807–819
9. Hunt PN, McCabe AK, Gust J, Bosma MM (2006) Spatial restriction of spontaneous activity towards the rostral primary initiating zone during development of the embryonic mouse hindbrain. *J Neurobiol* 66:1225–1238

## Ion Channel Modulation

### Definition

The process by which intracellular signaling cascades dynamically change the function of ion channels. For example, the phosphorylation of amino acid residues (e.g. tyrosine, serine) by protein kinases (e.g. PKA, PKC) has been shown to change the voltage gating behavior of certain ion channels. Modulation is thought to be an important part of the molecular basis for learning and memory in the nervous system.

### ►Sodium Channels

## Ion Channels from Development to Disease

PHUC H. PHAM, ADRIANO SENATORE,  
J. DAVID SPAFFORD  
Department of Biology, University of Waterloo,  
Waterloo, ON, Canada

### Synonyms

Voltage-gated ion channels; Ligand-gated receptors; Pore-loop; Multimerization; Gating; Activation; Inactivation; Deactivation; Depolarization; Hyperpolarization; Selectivity

### Definition

►Ion channels serve as gate keepers to ion movement across cell membranes and mediate functions such as the excitation of nerve and muscle, control of hormone secretion, establishment and maintenance of ionic balance, sensory responses, cell proliferation and programmed cell death, and the capacity to learn and lay down memories [1]. Some 340 human genes encode ion channels and at least sixty ion channels have been linked to disease states [2]. Ion channelopathies, as they are termed, generally fall into either gain or loss of function phenotypes. The former is like a dam where control of the flood gates has been lost, as is the case with ion flow through voltage-gated sodium (Na) channels without inactivation gates to curb excitatory activity [3]. This clinically manifests as a hyper-active or seizure phenotype. In the opposite case, the flood gates never open, resulting in hypo-active or paralysis phenotypes caused by a decrease or loss of  $\text{Na}^+$  flux [3]. The loss of function can be caused by impaired



membrane trafficking and expression of channels or weakened responsiveness of channels to voltage-changes [3]. The following text will provide a cursory review of the diverse subunit features of ion channel types and describe the typical ways that mutations can lead to altered channel activity.

## Characteristics

### Subunit Assembly and Selectivity

All ion channel genes encode pore-forming subunits that integrate into the lipid bilayer and contribute to aqueous-lined membrane pores. ► **Pore-loop channels** are modular derivatives of a minimal  $K_{IR}$  structure composed of a re-entrant loop separating two single transmembrane segments (see Fig. 1); this design likely originated from a primordial ancestor structurally similar to the bacterial K (potassium) channel KcsA [4]. Crystallographic studies suggest that KcsA bears wide vestibules surrounding either side of a short and narrow selectivity filter [4]. The KcsA selectivity filter serves as more than a size delimiting barrier such as the sieve of an hourglass since  $K^+$  ions but not smaller monovalent cations such as  $Na^+$  ions permeate (by a 100–1,000-fold difference in permeability). As hydrated K ions pass through the channel, they must shed their water molecules to pass single file, in a rapid and intimate process along carbonyl oxygens of an invariant “GYG” backbone sequence lining the channel pore [4]. Other ions such as  $Na^+$  do not possess a keylock fit, and thus are left stranded outside the gate with their hydration shells intact [4]. Voltage-gated calcium (Ca) channels exhibit similar selectivity against  $Na^+$  ions (>1,000:1), but their strategy does not appear to involve backbone residues. Rather, an inner ring of four glutamate side chains face the pore to form a  $Ca^{2+}$  attracting, chelator-like filter [5]. Na channels possess one positive and one neutral side chain replacing two of the four glutamate residues of Ca channels resulting in an asymmetrical pore filter that is less discriminatory against rival cations (permeability of one  $Ca^{2+}$  for every ten  $Na^+$  ions) [1].

Ion channels outside of the pore-loop class do not possess the highly discriminatory re-entrant pore loop and are more diverse in structure. The ► **chloride (Cl<sup>-</sup>) channels**, for example, lack the hydration vestibules of the pore loop K, Ca and Na channels, and instead possess long and narrow pores which serve as molecular sieves to discriminate anions of different sizes [6]. Cl<sup>-</sup> channels will equally pass many monovalent anions of similar size (e.g. Br<sup>-</sup>, I<sup>-</sup>, NO<sub>3</sub><sup>-</sup>), but the only relevant anions the Cl<sup>-</sup> channel will encounter in biological terms, will be larger in size such as PO<sub>4</sub><sup>2-</sup> and SO<sub>4</sub><sup>2-</sup> [6]. Cl<sup>-</sup> channels, like the chloride-selective receptor channels of the Cys-loop family (GABA and GlyR) (see ► **Cys-loop receptors**) attract

anions and repulse cations by strategic positioning of rings of positively-charged residues within the pore [7]. In opposite fashion, the non-pore-loop cation selective channels such as the acetylcholine (AChR) or 5-HT receptors of the Cys-loop family, have electro-attracting negative charges which prevent anion permeation [7].

### Subunit Assembly and Selectivity in Disease

Subunit assembly is a significant factor which may attenuate or enhance the effectiveness of ion channel mutations. While Na and Ca channel genes form monomers, K channels form homo-tetramers (all four subunits are created from the same gene) [2]. Additional functional diversity is created upon heterotetramerization (multiple gene isoforms or different alleles of the same gene contribute subunits to form one channel). For example, individuals harboring one wild type and one mutated allele for a K channel gene may produce functionally compromised homo-tetramers comprised entirely of the mutated subunits, or phenotypic effects may be masked by hetero-tetramers or homo-tetramers of the wild type subunits [2]. It is also possible for mutant subunits within a hetero-tetrameric channel to have dominant-negative effects (mutation in one of four subunits prevents channel function completely), to have no effect (only one working wild type subunit is required for function), or to bear a dosage-dependent effect (mutation in one of four subunits alters channel function up to 25% of maximum).

Neonatal diabetes is a disease where the severity of the phenotype is related to the relative influence of the mutation on  $K_{ATP}$  channel function [8]. Normally, ATP is bound to  $K_{ATP}$  channels preventing their ion conductances which serves to repolarize the membrane potential and inhibit insulin secretion in pancreatic beta cells [8]. Therefore, mutations that reduce or eliminate ATP sensitivity of the  $K_{ATP}$  channel cause neonatal diabetes [8]. Each channel subunit bears an ATP binding site, and the activity of only one subunit is enough to close the  $K_{ATP}$  channel [8]. It would be rare for all  $K_{ATP}$  channel subunits in a heteromultimer to bear a mutant and thus the disease phenotype affecting ATP binding is less severe. The more severe neonatal diabetes with extra-pancreatic effects is in those mutants that affect the opening of  $K_{ATP}$  channel gates directly downstream of ATP binding [8]. These dominant-negative mutations bear consequences to channel gating even if only one of four subunits bears the mutation.

Similar to the K channels, multimerization of (Multimerization (of Ion Channels)) receptor-operated channel subunits creates diversity and determines the severity of subunit mutation. Such channels include the heteropentameric ligand-gated Cys-loop channel family (ACh, GABA, Glycine), the hetero-tetrameric

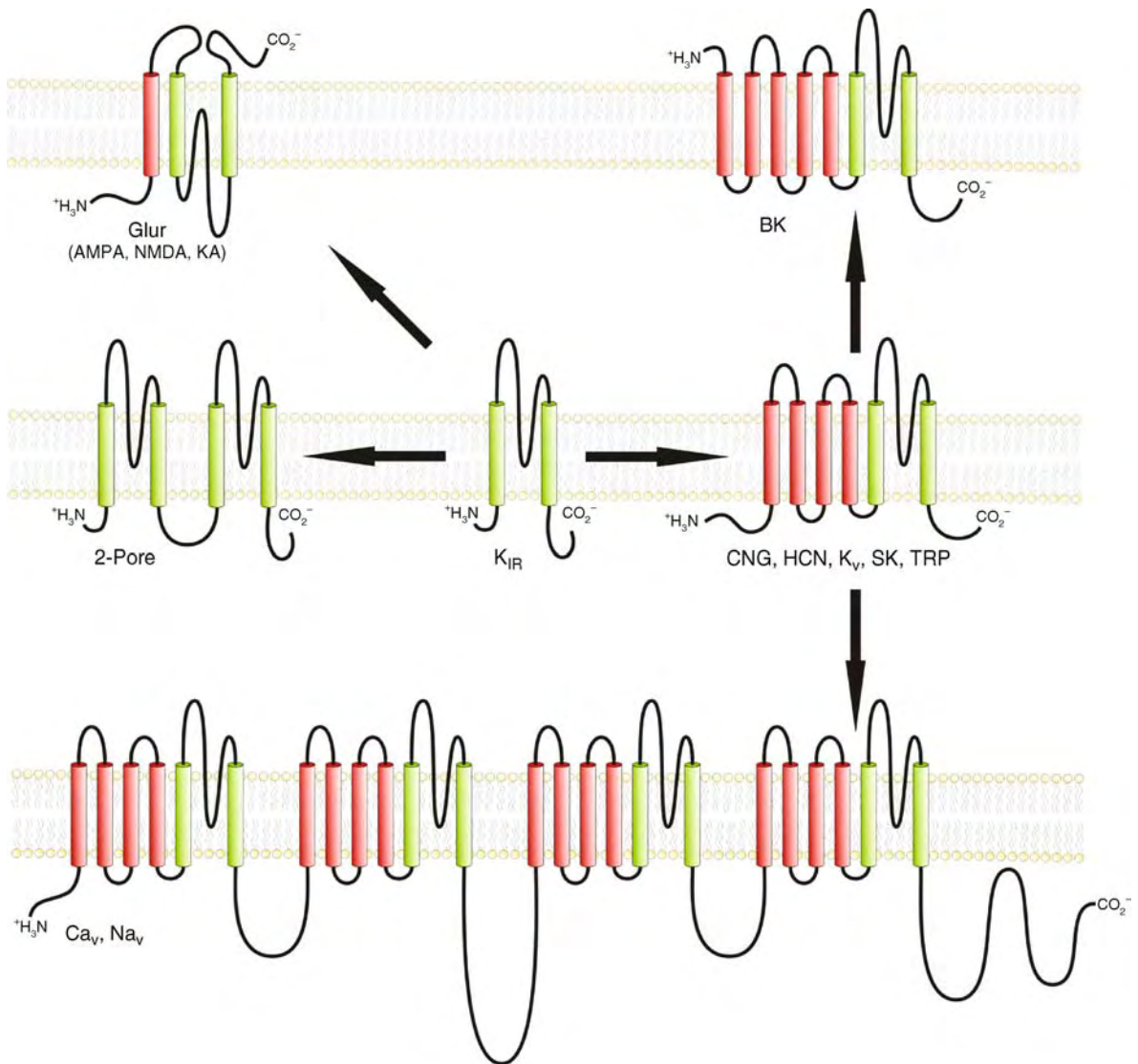

**Ion Channels from Development to Disease. Figure 1** Pore-loop channels are modular derivatives of the minimal  $K_{IR}$  structure composed of a re-entrant loop separating two single transmembrane segments. Addition of three transmembrane segments and a fourth harboring positively-charged, voltage-sensing residues to the N-terminus of  $K_{IR}$  converts it into a voltage-gated K channel. One round of duplication of  $K_{IR}$  produces a tandem pore K channel. Two rounds of duplication of a voltage-gated K channel results in an overall structure that resembles voltage-gated Ca and Na channels. Other add-ons provide binding capacity such as ATP (KATP channels), calmodulin (Ca channels),  $Ca^{2+}$  (BK channels) or cyclic nucleotides (cyclic nucleotide-gated (CNG) channels). Ligand-gated receptor channels such as glutamate receptors (GluR) are similarly composed of modular units. GluR subunits appear to be derived from an inverted  $K_{IR}$  channel to which sequential bacterial gene modules have been appended to the amino terminus including a modulatory, periplasmic binding protein domain and a ligand-binding domain from G protein coupled metabotropic receptors.

GluR receptors, and the cyclic nucleotide-gated and  $K_{ATP}$  channels [2]. AchR are comprised of distinct subunits resulting in several configurations: homopentameric  $\alpha_7$  or heteropentameric  $\alpha_2$  and  $\beta_4$  channel complexes in neurons, and  $\alpha$ ,  $\alpha$ ,  $\beta$ ,  $\epsilon/\gamma$  and  $\delta$  channel complexes at the neuromuscular junction [7]. AchR subunit mutations are the most common cause

of congenital myasthenic syndrome (CMS). In this severe motor endplate disease, the deficit is in expression of the  $\epsilon$ -subunit, which is compensated by the up-regulation of a fetal  $\gamma$  isoform [7]. Likely, the absence of a replacement isoform for the  $\beta$  and  $\delta$  subunits proves lethal in individuals with loss of function mutations in either gene [7].

Another source of mutational phenotype in ►**ligand-gated channels** is in the high affinity ligand binding sites. Opening of a receptor-operated channel gate requires large conformational changes, since the gate can be considerably distant from the ligand-binding site [7]. Most often ligand-binding sites span the interface between adjacent subunits, facilitating large-scale structural movements [7]. For most ligand-gated channels, the switch for channel gating is ligand dependent, and requires the cooperativity of multiple ligands bound at once to induce channel opening (e.g. 2 for AchR) [7]. There is also rapid channel closure if multiple occupancy is lost. Ligand-gated channels are thus highly susceptible to mutations that alter ligand affinity and function. Mutations in different participating subunits of the AchR heteropentamer (either  $\alpha$ ,  $\delta$  or  $\epsilon$ ) can lead to CMS, either from a gain of function phenotype (increasing AchR binding and occupancy time) or loss of function phenotype (reduced AchR binding and occupancy time) [7]. Interestingly, glutamate is the ubiquitous excitatory transmitter in the central nervous system and yet there are no human diseases associated with GluR subunits [9].

### Channel Gating

Besides ligand occupancy, ion channels gate in response to changes in voltage, pH, stretch and temperature [1]. The classical mechanism is the voltage-gate of K, Ca, Na channels requires dipole-conferring, charged residues within the fourth segment of each domain which rotate outwards in response to membrane ►**depolarization** [1]. S4 movements are modeled to spread open the pore at the C-terminal end of the S6 segments [1]. After a few ms of opening, most of these channels stop conducting current even in the presence of stimulus and enter an inactivated state, where channels are refractory to opening until the membrane potential has reset to a negative or hyperpolarizing potential [1]. Rapid forms of inactivation involve a tethered N-terminal plug which occludes the pore of *Shaker*-type K channels, or a hinged lid bridging the III-IV linker of Na channels [1]. A slower form of inactivation involves noose-tightening of residues surrounding the outer mouth of voltage-gated channel pores [1]. After opening, ►**voltage-gated channels** (►**Excitable cells**) can bypass the inactivation state altogether and rapidly transition from an open to a closed state (known as ►**deactivation**) [1].

Gating of CIC channels is different and illustrates that movement of as few as one amino acid (instead of the more dramatic structural changes in voltage-gated channels) is all that can be required for some forms of gating [6]. Other channels lack voltage-gating completely, such as the inward-rectifying and two-pore K channels, which are constitutively open at

negative voltages, and likely contribute to the resting potential [2].

### Channel Gating in Disease

Opening of K, Ca and Na channels is dependent on voltage changes, with opening probability increasing 10-fold for  $\sim 10$  mV of depolarization [1]. Disease states can result from slight changes in the kinetics or voltage-dependence of gating. Slowing or inhibiting inactivation of Na channels causes persistence of the Na current; a similar phenotype is observed if channel activation is shifted to more hyperpolarizing potentials causing channels to open more readily [3]. Since Na channels are responsible for the upstroke of the ►**action potential**, the net result of such mutations is hyperexcitability and enhanced firing, which manifests as epilepsy (►**Generalized epilepsy with febrile seizures plus (GEFS+)**) in the brain or persistent contraction and stiffness in skeletal muscle (myotonia), or a pathological broadened ventricular action potential of the heart (LQT syndrome) [3]. Furthermore, patients with hyperkalemic periodic paralysis bear a persistent Na current (1–2% of total current) as a result of a Na<sup>+</sup> channel mutation which sustains skeletal muscle fiber depolarization [3]. Patients suffer from intermittent bouts of muscle paralysis from Na channels undergoing inactivation from prolonged openings. K channels repolarize the membrane, functioning counter to Na channel activity and extinguish membrane excitability. As expected, loss of function mutations of K channels result in a similar hyperexcitable phenotype as gain of function mutations in Na channel, such as epilepsy, muscle disorders or LQT syndrome [2].

### Roles of Supportive Proteins

Most ion channels have accessory subunits and are also components of larger supportive protein complexes which regulate the membrane localization, expression levels, and gating of channel subunits [2]. Mutations in these supportive proteins can be equivalent to loss of expression and sometimes altered gating of their associated ion channels. The following outlines some examples of this phenomenon: mutation of the protein rapsyn, which normally functions to cluster AchR subunits, can cause CMS; mutation of SUR1, a protein necessary for K<sub>ATP</sub> channel function, is associated with congenital hyperinsulinemia; mutation of the  $\beta_1$  subunit of the SCN1A/SCN1B Na channels causes a similar form of epilepsy as mutation of the channels themselves (known as GEFS+); finally, the etiology of LQT syndrome in the heart can be caused by mutation of Na, Ca or K ion channels, but also can be caused by MiRP1 or MinK, which are accessory subunits for hERG and KCNQ1 channels, respectively or ankyrin-B, an ion channel anchoring protein [2,3,5,7–9].

### Role of Cell Background

Expected consequences of altered ion channel function can be anticipated readily from *in vitro* studies, but the expression patterns of a mutated gene will influence how it manifests into a phenotype. For example, specific L-type Ca channel types are dedicated specialists of a particular tissue, such as  $Ca_v1.1$  which is a key element in excitation-contraction coupling in skeletal muscle, and  $Ca_v1.4$  which is essential for transducing visual stimuli in the retina [5]. Their loss of function causes predictable localized deficits, such as a muscle disorder (hypokalemic periodic paralysis) or retinal disease (incomplete X-linked congenital stationary night blindness, type 2), respectively [5]. In comparison,  $Ca_v1.2$  has a widespread distribution, and accordingly the mutations of  $Ca_v1.2$  channels in ►**Timothy's syndrome** cause a more complex, less predictable phenotype affecting the brain (autism spectrum disorder), heart (LQT syndrome and arrhythmias) and metabolism (hypoglycemia) [5].

Mutation phenotypes can appear counter-intuitive without guidance from the cellular context. As discussed earlier, gain of function mutations in  $Na_v1.1$  channels lead to hyper-excitability and inherited epilepsy (GEFS+) [3]. Interestingly, loss of function mutations of  $Na_v1.1$  channels can also cause epilepsy (►**Severe myoclonic epilepsy of infancy (SMEI)**) [3]. In excitatory neurons, loss of function of  $Na_v1.1$  channels leads to a compensatory upregulation of other Na channel isoforms which reduces the severity of the mutation in these neurons [3]. Inhibitory GABAergic neurons, which depend on  $Na_v1.1$  for 75% of their action potential upstroke, do not undergo compensatory upregulation and shut down when the Na channel is lost leaving no restraint on excitation of their target neurons [3].

The neurological disorder erythromelalgia illustrates how an observed phenotype for an ion channel mutation depends on cell background [10]. A leucine to histidine mutation at position 858 in the  $Na_v1.7$  channel peptide leads to hyper-excitability in nociceptive sensory cells in the dorsal root ganglion (DRG) manifesting as a severe burning-type pain in response to mild stimuli such as heat [10]. Paradoxically, the same  $Na_v1.7$  mutation causes hypo-excitability in sympathetic ganglion neurons, leading to a loss of sympathetic vasoconstriction of peripheral blood vessels and redness of the extremities [10]. The  $Na_v1.7$  mutation shifts the channels' voltage-dependence of activation in a hyperpolarizing direction and also causes a slowing of inactivation (transition from open to a closed state), both of which result in an increased willingness of  $Na_v1.7$  mutant channels to open and stay open longer at rest [10]. Consequently, a rise in ►**resting membrane potential** of 5 mV leads to hypo-excitability due to inactivation of Na channels which could contribute to the action potential upstroke in sympathetic ganglion

neurons [10].  $Na_v1.7$  mutation causes a similar rise in resting membrane potential in nociceptive DRG neurons, yet (as mentioned above) the resulting phenotype is opposite as that of sympathetic ganglion neurons [10]. The difference is in the expression of another sodium channel ( $Na_v1.8$ ) expressed in nociceptive DRG neurons, but not sympathetic ganglion neurons.  $Na_v1.8$  decloak from the cell background in nociceptive DRG neurons as the membrane potential rises in response to the  $Na_v1.7$  mutation [10].  $Na_v1.8$  has a higher threshold voltage-dependence of inactivation than other resident Na channels translating into an active  $Na_v1.8$  that assumes command of action potential electrogenesis leading to the hyper-excitability circuits observed for this mutation [10].

### Summary

Ion channels are essential players in most of life's processes. Most are bacterial homologs or close derivatives of prokaryotic ancestors and have adapted to play specialized roles in different tissues including neurons, skeletal muscle and heart. High resolution structures and biophysical studies have given us insights into the inner workings of these sophisticated molecular machines, especially their highly selective pores which permit ion flow near the limits of diffusion and intricate gating systems. Ion channels are often one of many cogwheels in complex signaling networks. Because of their interdependence in cellular processes, often the manifestation of an ion channel related disease depends on the cellular context in which these mutations are found.

### References

1. Cannon SC (2007) Physiologic principles underlying ion channelopathies. *Neurotherapeutics* 4(2):174–183
2. Ashcroft FM (2006) From molecule to malady. *Nature* 440(7083):440–447
3. Meisler MH, Kearney JA, Sprunger LK, MacDonald BT, Buchner DA, Escayg A (2002) Mutations of voltage-gated sodium channels in movement disorders and epilepsy. *Novartis Found Symp* 241:72–81
4. Doyle DA, Morais CJ, Pfuetzner RA, Kuo A, Gulbis JM, Cohen SL, Chait BT, MacKinnon R (1998) The structure of the potassium channel: molecular basis of K<sup>+</sup> conduction and selectivity. *Science* 280(5360):69–77
5. Bidaud I, Mezghrani A, Swayne LA, Monteil A, Lory P (2006) Voltage-gated calcium channels in genetic diseases. *Biochim Biophys Acta* 1763(11):1169–1174
6. Miller C (2006) CIC chloride channels viewed through a transporter lens. *Nature* 440(7083):484–489
7. Sine SM, Engel AG (2006) Recent advances in Cys-loop receptor structure and function. *Nature* 440(7083):448–455
8. Nichols CG (2006) KATP channels as molecular sensors of cellular metabolism. *Nature* 440(7083):470–476

9. Mayer ML (2006) Glutamate receptors at atomic resolution. *Nature* 440(7083):456–462
10. Rush AM, Dib-Hajj SD, Liu S, Cummins TR, Black J A, Waxman SG (2006) A single sodium channel mutation produces hyper- or hypoexcitability in different types of neurons. *Proc Natl Acad Sci USA* 103(21):8245–8250

## Ion Current

► Ion Transport

## Ion Flux/Flow

► Ion Transport

## Ion Pump

### Definition

Ion Pump is a transmembrane protein that moves ions across a plasma membrane against their electrochemical gradient, using normally ATP as the source of energy.

► Ion Transport

## Ion Transport

CLAUDIO RIVERA

Institute of Biotechnology, University of Helsinki, Helsinki, Finland

### Synonyms

Ion current; Ion flux/flow

### Definition

The movement of ions across biological membranes. The transport of ion species can be passive (facilitated) or active. Facilitated transport is mainly mediated through

ion channels whereas active transport can be either conveyed by primary active (ion pumps) transporters and secondary active (ion cotransporters and exchangers) transporters.

### Characteristics

Ion transport through cell membranes and organelles is fundamental for many of the basic neuronal functions (► [Cell membrane – components and functions](#)). Ion pumps build gradients across the membrane, which are then used as an energy source by ion channels and other transport proteins to pump nutrients into cells, generate ► [action potentials](#), regulate ► [synaptic transmission](#), regulate cell volume, and secrete electrolytes across epithelial layers into the ► [cerebrospinal fluid](#).

### Passive Versus Active Transport

*Fick's first law* states that movement of molecules by diffusion is always spontaneous, down a gradient of free energy or chemical potential until equilibrium is reached. The spontaneous downhill movement of ion species is termed passive diffusion. At equilibrium, no further net movements of ions can occur without the application of a ► [driving force](#).

The driving force for diffusion of ions can be calculated from the difference in ► [electrochemical potential](#) between inside and outside the cell.

As the electrochemical potential is defined:

$$\tilde{\mu}_j = \tilde{\mu}_j^* + RT \ln C_j + z_j F E \quad (1)$$

where  $\tilde{\mu}_j$  is the electrochemical potential of a given ion species  $j$  in joules per mole ( $\text{J mol}^{-1}$ ). The first part of the equation is composed of  $\tilde{\mu}_j^*$  that is the electrochemical potential under standard conditions. The next part is the concentration component where  $R$  is the universal gas constant,  $T$  is the absolute temperature, and  $C_j$  is the concentration (activity) of  $j$ . The last part of the equation is the electrical term where  $z$  is the electrostatic charge of the ion (+1 for monovalent cations, -1 for monovalent anions, +2 for divalent *et cetera*),  $F$  is Faraday's constant, and  $E$  is the overall electric potential of the solution (with respect to the ground).

The driving force is then:

$$\Delta \tilde{\mu}_j = \tilde{\mu}_j^i - \tilde{\mu}_j^o \quad (2)$$

Substituting the appropriate terms from (1) into (2) gives

$$\Delta \tilde{\mu}_j = \left( RT \ln [j]^i + z_j F E^i \right) - \left( RT \ln [j]^o + z_j F E^o \right) \quad (3)$$

In general, during passive transport ions always move from the side of a permeable membrane with higher electrochemical potential downhill to the side with lower potential. Net Movement of ions against the

electrochemical potential is indicative of active transport (see Fig. 1).

### Ion Channels Dissipate Energy generated by Ion Pumps

Unlike small, neutral solutes (e.g., O<sub>2</sub>, CO<sub>2</sub> or N<sub>2</sub>) and uncharged polar molecules (e.g., urea, ethanol, and small organic acids), ions are practically impermeable for artificial lipid bilayers. The permeability coefficients of major monovalent ion species, Na<sup>+</sup>, K<sup>+</sup> and Cl<sup>-</sup>, are in the range of 10<sup>-15</sup> and 10<sup>-10</sup> cm s<sup>-1</sup>, approximately 8–10 orders of magnitude smaller than the permeability coefficients of small non-polar solutes. The reason for this is that in the aqueous environment, ions strongly polarize the surrounding water so that dipoles of water molecules tend to align themselves with the electric field created by the ion. As the ion moves into the membrane, strong, favorable water-ion interactions are broken at a considerable free energy expense. The permeability of biological membranes for ions is significantly larger. This difference is made by the composition of specialized proteins in biological membranes that convey ion transport.

Ion channels are transmembrane proteins that function as selective pores, through which ions can diffuse across the membrane [1]. Thus, the major function of ion channels is to facilitate, usually for only

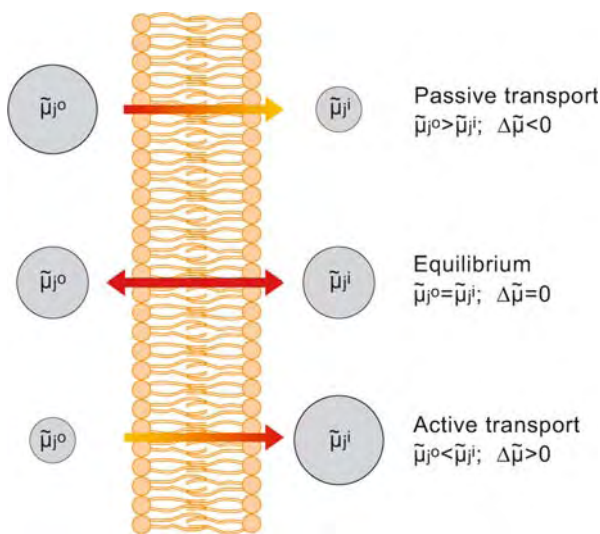

**Ion Transport. Figure 1** Relationship between the electrochemical potential  $\bar{\mu}_j$ , and the transport of ions across the plasma membrane. The net flux of ion species  $j$  from outside to inside depends on the relative magnitude of the electrochemical potential on both sides of the plasma membrane (represented by the size of the circles around  $j$ ). Movement down a gradient is spontaneous and is called passive transport. Movement against the gradient requires energy and is called active transport.

very short durations, the movement of ions down the electrochemical gradients previously established across either the plasma membrane or the membranes of intracellular organelles. The size of the pore and the nature and density of fixed charges lining the walls of the pore determines the ion specificity. This is achieved without strong interaction with the ion allowing the characteristically very rapid diffusion through ion channels which is in the range of 10<sup>8</sup> ions per second through each channel protein. On the contrary, the kinetics of transport proteins is much slower and typically requires several milliseconds per ion. This is because the significantly stronger ion-transporter interaction causes a conformational change that leads to the release of the ion on the opposite side of the membrane.

### Primary Active Transport Stores Energy in Ion Gradients

Active transport across biological membranes must couple the energetically uphill translocation of ion species with another energy releasing event so that the overall free-energy change is negative.

Active transport processes can be divided into primary active and secondary active or flux-coupled transport. Primary active transport is linked directly to a source of energy other than  $\Delta\bar{\mu}_j$ , such as ATP hydrolysis.

The most important primary active transport systems are ion pumps (ion transporting ATPases or pump ATPases). The pump ATPases are classified into four groups.

Coupling factor ATPases (F-ATPases) are also called H<sup>+</sup>-ATPases (H<sup>+</sup>-transporting ATPases). In mitochondria, the “powerhouses” of the cell, the F-ATPase works in the backward direction, synthesizing ATP from ADP and phosphate as protons move down a concentration gradient. Cytoplasmic vesicles, such as lysosomes, endosomes and secretory granules, are acidified by the V-type (vacuolar) H<sup>+</sup>-ATPase in their membranes [2]. Acidification by this V-ATPase is important for the activity of lysosomal enzymes that have acidic pH optima, and for the accumulation of drugs and neurotransmitters in secretory granules.

P-ATPases form phosphorylated intermediates that drive ion translocation: the “P” refers to phosphorylation. These transporters have an active-site aspartate residue that is reversibly phosphorylated by ATP during the transport process. The P-type Na<sup>+</sup>/K<sup>+</sup>-ATPase in various tissues and the Ca<sup>2+</sup>-ATPase in the sarcoplasmic reticulum have important roles in maintaining cellular ion gradients. Na<sup>+</sup>/K<sup>+</sup>-ATPases [3] also create an electrochemical gradient of Na<sup>+</sup> and K<sup>+</sup> that produces the driving force for the function of many important secondary active transport systems (see below). The discharge of this electrochemical gradient is also fundamental to the process of action potential generation.

The ATP-binding cassette (ABC) transporters comprise the fourth active transporter family. “ABC” is the abbreviation for “ATP-binding cassette”, referring to an ATP-binding region in the transporter. The members of this subfamily of transporters exert a variety of functions: P-glycoprotein (where ~“P” stands for permeability) and the MRP (multidrug resistance-associated protein) are thought to have a physiological role in excretion of toxic metabolites and xenobiotics; this is believed to contribute to resistance of cancer cells to chemotherapy. The TAP transporters, a class of ABC transporters associated with ▶antigen presentation, are required for initiating the ▶immune response against foreign proteins; they mediate antigen peptide transport from the cytosol into endoplasmic reticulum. CFTR (▶cystic fibrosis transmembrane conductance regulator) is an ATP-gated chloride ( $\text{Cl}^-$ ) channel (▶Chloride channels and transporters). Mutations in the gene encoding this protein lead to cystic fibrosis.

Ion pumps can be further divided into electrogenic and electroneutral depending on whether they produce a net movement of charges across the membrane. A prototypical example of an electrogenic transporter is the  $\text{Na}^+/\text{K}^+$ -ATPase. This ▶ion pump moves three  $\text{Na}^+$  ions out for every two  $\text{K}^+$  ion in, resulting in a net outward movement of one positive charge (Fig. 2). In contrast, electroneutral transporters as the name implies do not move a net charge. In the case of the  $\text{H}^+/\text{K}^+$ -ATPase one  $\text{H}^+$  is moved out of the cell for every  $\text{K}^+$  in, yielding no net movement of charges across the membrane.

### Secondary Active Transporters

Secondary active transport systems use the energy stored in the electrochemical gradient of certain ions (such as  $\text{K}^+$  and  $\text{Na}^+$ ) accumulated by primary active transporters to drive the energetically unfavorable transport of other ion species. Secondary active ion transporters can be divided in ▶cotransporters and exchangers (Fig. 3). Below are some examples of secondary transport systems important for normal brain function.

### Neuronal pH Homeostasis

There is a reciprocal relationship between electrical activity and pH. Increased electrical activity can produce rapid changes in pH, and vice versa fluctuations in pH affect neurotransmission and firing properties of neurons [4]. The regulation of intracellular pH in neurons and glia is in principle similar to that in other cells and is exerted mainly by  $\text{Na}^+/\text{H}^+$  exchange,  $\text{Na}^+$ -driven  $\text{Cl}^-/\text{HCO}_3^-$  exchange,  $\text{Na}^+/\text{HCO}_3^-$  cotransport, and  $\text{Cl}^-/\text{HCO}_3^-$  exchange. Molecular identification of isoforms of the transporters involved has revealed heterogeneity among brain regions and cell types. Whereas one of the isoforms of the  $\text{Cl}^-/\text{HCO}_3^-$  ▶exchanger AE3 and the  $\text{Na}^+$ -driven  $\text{Cl}^-/\text{HCO}_3^-$  exchanger NDCBE1 are widely expressed in the brain, the five known isoforms of  $\text{Na}^+/\text{H}^+$  exchanger (NHE1–5) show distinct preferences for diverse brain regions. Differences in the repertoire of transporter isoforms involved in pH regulation between various cell types and brain regions suggest that the exact mechanism for pH regulation may vary.

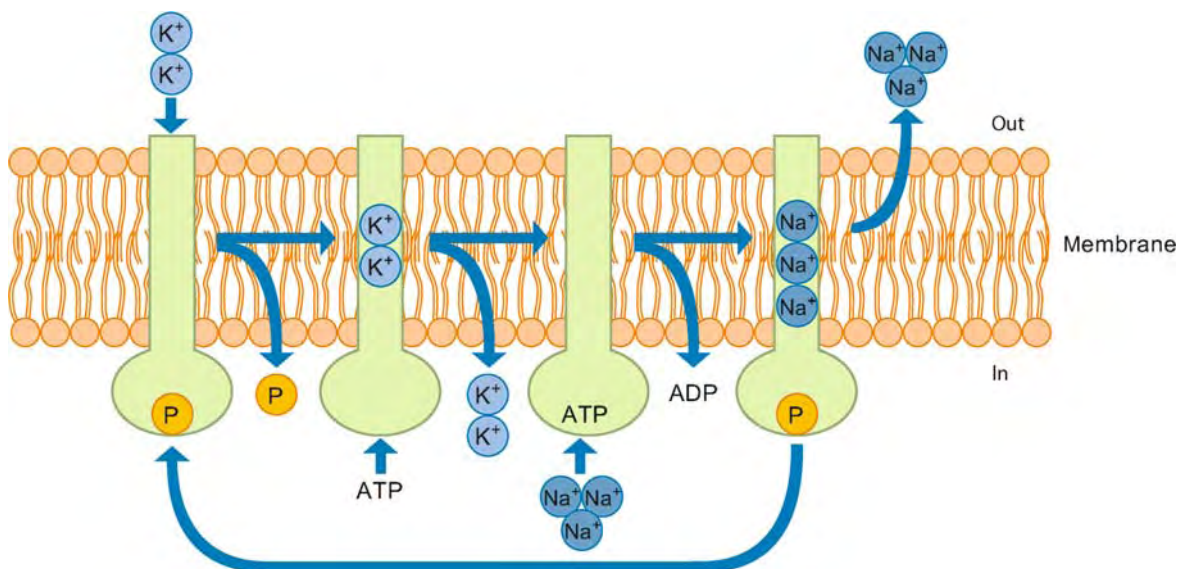

**Ion Transport. Figure 2** Model for electrogenic ATP-dependent  $\text{Na}^+/\text{K}^+$  transport.  $\text{Na}^+$  and  $\text{K}^+$  are transported against their electrochemical gradients. The energy required for this process is provided by the hydrolysis of ATP which phosphorylates the pump. The flux of the ions is asymmetrical with two  $\text{K}^+$  ions transported for every three  $\text{Na}^+$  ions. This produces a net current across the membrane.

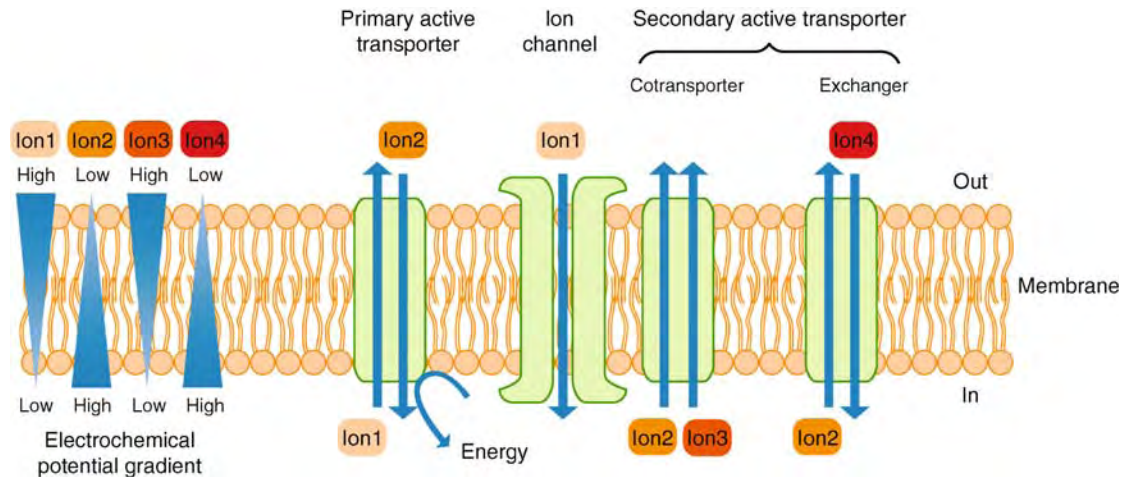

**Ion Transport. Figure 3** The interaction between primary, passive and secondary transport systems. Primary active transport drives the transport of ion species (ion 1 and 2) against their electrochemical gradient using another energy source than the electrochemical gradient, e.g., the energy released upon hydrolysis of ATP. Ion channels allow the passive transport of ion species (ion 1) downhill their electrochemical gradient. There are two major types of secondary transport systems: cotransporters drive the transport of different ion species in the same direction using the downhill transport of one ion (ion 2) to fuel the uphill transport of the other (ion 3). Exchangers promote the transport of ion species in opposite directions using the electrochemical gradient of one ion (ion 2) to drive the other (ion 4).

### Low $[Ca^{2+}]_i$ Is Maintained by $Ca^{2+}$ -ATPase and $Na^+/Ca^{2+}$ Exchanger

The maintenance of low  $[Ca^{2+}]_i$  is crucial for  $Ca^{2+}$  dependent intracellular signaling which relies on transient changes in cytosolic  $Ca^{2+}$  [5]. Two systems are responsible for the export of  $Ca^{2+}$  from cells [6]: a high-affinity, low-capacity  $Ca^{2+}$ -ATPase, and a lower-affinity, but much larger-capacity  $Na^+/Ca^{2+}$ -exchanger. The ATPase (commonly called the  $Ca^{2+}$  pump) is the fine-tuner of  $[Ca^{2+}]_i$ , as it functions well even if the concentration of  $[Ca^{2+}]_i$  drops below the  $\mu M$  level. It is a large enzyme, with ten transmembrane domains and a C-terminal cytosolic tail that contains regulatory sites, including a  $\blacktriangleright$ calmodulin-binding domain. The plasmalemmal  $Ca^{2+}$ -pump is different from the sarcoendoplasmic reticulum  $Ca^{2+}$ -ATPase (SERCA) pump whose main function is to accumulate  $Ca^{2+}$  in the endoplasmic reticulum [7].  $Ca^{2+}$  calmodulin regulates the plasmalemmal pump but not the SERCA pump, allowing for rapid activation when cytoplasmic  $Ca^{2+}$  rises.

Mammalian  $Na^+/Ca^{2+}$  exchangers are members of three branches of a much larger family of transport proteins, the  $Ca^{2+}$ /cation antiporter (CaCA) superfamily which comprises the  $Na^+/Ca^{2+}$  exchanger (NCX1–3),  $Na^+/Ca^{2+}$ - $K^+$  exchanger (NCKX1–5) and the  $Ca^{2+}$ /cation exchanger (CCX). Although the main function of  $Na^+/Ca^{2+}$  exchangers is to extrude  $Ca^{2+}$  from the cytoplasm, they are reversible and may allow  $Ca^{2+}$  entry under special conditions of subcellular localization and compartmentalized ion gradients. NCX3 and 5 are expressed mainly in

the brain and skeletal muscle. NCKX1 is expressed in retinal rod  $\blacktriangleright$ photoreceptors, NCKX2 is expressed in cone photoreceptors and in neurons throughout the brain, NCKX3 and NCKX4 are abundant in the brain, but have a broader tissue distribution, and NCKX5 is expressed in skin, retinal epithelium and brain.

### Decrease in $[Cl^-]_i$ Sets the Hyperpolarization Shift in GABA<sub>A</sub>-Mediated Responses During Development

During development the  $\blacktriangleright$ reversal potential for  $\blacktriangleright$ GABA<sub>A</sub>-mediated responses ( $E_{GABA_A}$ ) experiences a shift to more hyperpolarized values. This change produces a qualitative change in GABA<sub>A</sub>-mediated responses from depolarizing to  $\blacktriangleright$ hyperpolarizing in neurons where  $E_{GABA_A}$  becomes more negative than the resting membrane potential. GABA<sub>A</sub> receptors are  $Cl^-$ -permeable channels implying that the direction of the net ion flux through this channel is governed by the electrochemical gradient of  $Cl^-$ . Thus, during development there is a gradual decrease in  $[Cl^-]_i$  that underlies the maturation of GABA<sub>A</sub>-mediated responses [8].

The  $\blacktriangleright$ homeostasis of  $[Cl^-]_i$  is mainly maintained by members of the cation-chloride cotransporter family. This family is comprised of nine gene products of which seven are known to function as transporters. These are:  $Na^+-K^+-Cl^-$ -cotransporters NKCC1 and 2,  $Na^+-Cl^-$ -cotransporter NCC and the  $K^+-Cl^-$ -cotransporters KCC1–4. Out of these only KCC2 is specifically expressed in neurons whereas NCC and NKCC2 are expressed predominantly in the kidneys. All other family members are expressed also in the brain as well as other tissues. The high  $[Cl^-]_i$  in



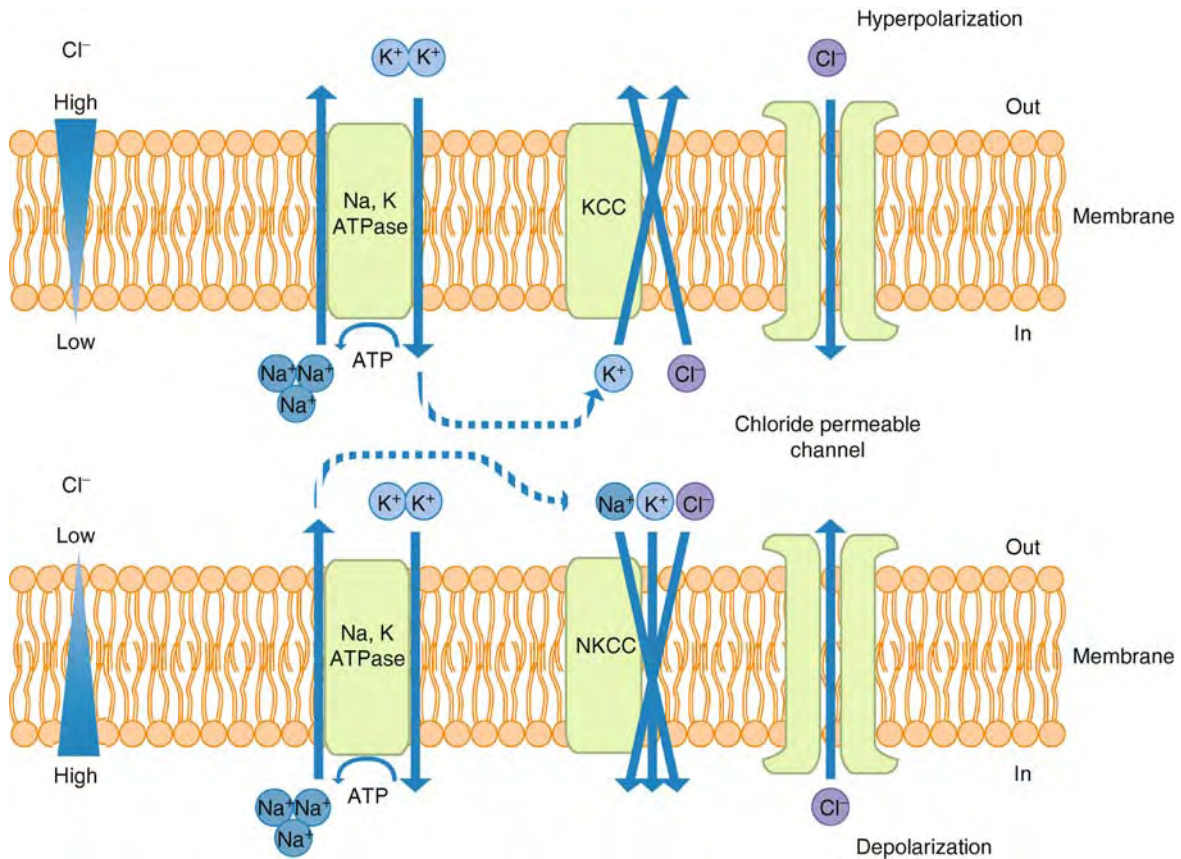

**Ion Transport. Figure 4** Ionic mechanism for the developmental change in GABA<sub>A</sub>-mediated responses. The transport of Cl<sup>-</sup> by secondary active transporters is driven by the concentration gradients of cations. In immature neurons the uptake of Cl<sup>-</sup> by NKCC1 (*bottom*) is driven mainly by the energy stored in the Na<sup>+</sup> gradient generated by the Na<sup>+</sup>/K<sup>+</sup>-ATPase. The resulting outward Cl<sup>-</sup> electrochemical gradient permits depolarizing Cl<sup>-</sup> currents through the anion-permeable  $\blacktriangleright$ GABA<sub>A</sub> receptor. As neurons mature, K<sup>+</sup> Cl<sup>-</sup>-cotransport becomes predominant due to the upregulation of KCC2. The K<sup>+</sup> gradient maintained by the Na<sup>+</sup>/K<sup>+</sup>-ATPase fuels the extrusion of Cl<sup>-</sup> by KCC2, which results in an inwardly directed electrochemical gradient for Cl<sup>-</sup> that generates hyperpolarizing currents across anion-permeable channels (*top*).

developing neurons is mainly maintained by NKCC1 that uses the electrochemical gradient of Na<sup>+</sup> (built up by the Na<sup>+</sup>/K<sup>+</sup>-ATPase) to drive Cl<sup>-</sup> uptake (Fig. 4).

While NKCC1 expression decreases during development, the expression of the Cl<sup>-</sup> extruder KCC2 increases. KCC2 employs the K<sup>+</sup> gradient that is also generated by the Na<sup>+</sup>/K<sup>+</sup>-ATPase to extrude Cl<sup>-</sup> from neurons rendering lower [Cl<sup>-</sup>]<sub>i</sub> values that results in more hyperpolarized values of E<sub>GABA<sub>A</sub></sub> [9].

### Ion Channels in Transporters

The traditional model of ion transport where large conformational changes in the protein accompany ion translocation (alternating access model) has been recently challenged [10]. Several results provide evidence for the existence of channels in transporters and vice versa ion channels that display transport activity. The marine toxin palytoxin presumably binds to the Na<sup>+</sup>/K<sup>+</sup>-ATPase

forming an ion channel that is permeable for Na<sup>+</sup> and K<sup>+</sup>. Several ion transporters show channel-akin properties, exhibiting brief electrical events that are comparable to discreet ion channel events. The glutamate transporters EAATs are confirmed to include an ion channel permeable for Cl<sup>-</sup>, the DA transporter DAT-1 shows  $\blacktriangleright$ single-channel currents that are specific for Cl<sup>-</sup>. Conversely, there are examples where proteins believed to be ion channels have turned out to be transporters, e.g., the CLC-ec1 that was predicted by homology to be a Cl<sup>-</sup> channel was shown to be a Cl<sup>-</sup>/H<sup>+</sup> exchanger.

### References

1. Hille B (2001) Ion channels of excitable membranes, 3rd edn. Sinauer Associates, Sunderland, MA
2. Forgacs M (2007) Vacuolar ATPases: rotary proton pumps in physiology and pathophysiology. *Nat Rev Mol Cell Biol* 8:917–929

3. Kaplan JH (2002) Biochemistry of Na, K-ATPase. *Annu Rev Biochem* 71:511–535
4. Kaila K, Ransom B (1998) pH and brain function. Wiley-Liss, New York
5. Augustine GJ, Santamaria F, Tanaka K (2003) Local calcium signaling in neurons. *Neuron* 40:331–346
6. Guerini D, Coletto L, Carafoli E (2005) Exporting calcium from cells. *Cell Calcium* 38:281–289
7. Møller JV, Nissen P, Sørensen TL, le Maire M (2005) Transport mechanism of the sarcoplasmic reticulum  $\text{Ca}^{2+}$  ATPase pump. *Curr Opin Struct Biol* 15:387–393
8. Payne JA, Rivera C, Voipio J, Kaila K (2003) Cation-chloride co-transporters in neuronal communication, development and trauma. *Trends Neurosci* 26:199–206
9. Rivera C, Voipio J, Payne JA, Ruusuvuori E, Lahtinen H, Lamsa K, Pirvola U, Saarma M, Kaila K (1999) The  $\text{K}^{+}/\text{Cl}^{-}$  co-transporter KCC2 renders GABA hyperpolarizing during neuronal maturation. *Nature* 397:251–255
10. Transporters as Channels Louis J (2007) DeFelice1 and Tapasree Goswami2. *Annu Rev Physiol* 69:87–112

## Ionosphere

### Definition

The Ionized region of the upper atmosphere, starting at roughly 60 km in altitude. Ionization of gas particles is largely caused by the Sun's ultraviolet light, with wavelengths  $< 100$  nm (EUV). In the lower layers of the ionosphere, the percentage of ionized gas particles is so minute that their motion is coupled to the neutral gas rather than being affected by the geomagnetic field. The electric conductivity of the ionized gas is due to free electrons, the motion of which is controlled by the magnetic field, giving rise to the observed dynamo effect. Animation: [http://www.windows.ucar.edu/spaceweather/sun\\_earth9.html](http://www.windows.ucar.edu/spaceweather/sun_earth9.html).

► Geomagnetic Field

## Ionotropic

### Definition

An influence on ion channel activity mediated directly by the binding of a neurotransmitter to a receptor channel complex. Transmitter binding to its receptor opens the associated channel by changing its conformation for the duration of binding. This is a relatively short-latency, short-duration event.

## Ionotropic Receptor

KENJI SAKIMURA

Department of Cellular Neurobiology, Brain Research Institute, Niigata University, Niigata, Japan

### Synonyms

Ligand-gated ion channel; Receptor channel

### Definition

Ionotropic receptors are membrane-spanning protein complexes that direct the coupling of the neurotransmitter receptor to the ion channel. They contain two functional domains: an extracellular site that binds neurotransmitters and a membrane-spanning domain that forms an ion channel. The neurotransmitter binding to the ionotropic receptor leads to a conformational change that is passed along to the closely associated ion channel, and as a result the channel properties are altered. This important feature of ionotropic receptors means that the modulation of ion channel properties varies with the length of time that the transmitter occupies the receptor. Therefore they mediate rapid-onset and rapidly reversible synaptic transmission, generally in millisecond orders. In contrast, the activation of metabotropic receptors produces much slower responses, ranging from hundreds of milliseconds to minutes or even longer. Ionotropic receptors that are cloned and characterized are shown in Table 1. The nicotinic acetylcholine receptor (nAChR), glutamate receptor channels, one of the serotonin receptors ( $5\text{-HT}_3$ ) and certain purinergic receptors ( $\text{P2}_x$ ) are permeable cations and contribute to postsynaptic excitation. The  $\gamma$ -aminobutyric acid A ( $\text{GABA}_A$ ) receptors and the glycine receptors are permeable anions ( $\text{Cl}^{-}$ ) and mediate inhibitory functions. Ionotropic glutamate receptors are divided into three classes and originally named after reasonably selective agonists; *N*-methyl-D-aspartate (NMDA),  $\alpha$ -amino-3-hydroxy-5-methyl-4-isoxazole propionic acid (AMPA), and kainate (KA).

In a broad sense of the definition, some kinds of channels which are activated by intracellular second messengers (such as  $\text{Ca}^{2+}$  or the cyclic nucleotides, cAMP and cGMP) are also classified as ionotropic receptors (ligand gated-channels).

### Characteristics

#### Structures

Ionotropic receptors are classified into three groups according to their structures. Comparison of the amino acid sequences of cloned ionotropic receptors shows that they are similar in their structure but different in their ancestral genes. One group comprises the nACh

**Ionotropic Receptor. Table 1** Ionotropic receptor subtypes and functions

Neurotransmitter	Receptor type	Permeable ion	Cloned subunit
Acetylcholin (ACh)	nACh	Na <sup>+</sup> , K <sup>+</sup> , Ca <sup>2+</sup>	$\alpha 1$ - $\alpha 10$ , $\beta 1$ - $\beta 4$ , $\gamma$ , $\delta$ , $\epsilon$
Glutamate (Glu)	AMPA Kinate NMDA	Na <sup>+</sup> , K <sup>+</sup> , (Ca <sup>2+</sup> ) Na <sup>+</sup> , K <sup>+</sup> Na <sup>+</sup> , K <sup>+</sup> , Ca <sup>2+</sup>	GluR1-4 ( $\alpha 1$ -4, A-D) GluR5-7 ( $\beta 1$ -3), KA1,2 (GluR $\gamma$ 1,2) NR1 (GluR $\zeta$ 1), NR2A-D (GluR $\epsilon$ 1-4), NR3A, B
GABA	GABA <sub>A</sub> GABA <sub>C</sub>	Cl <sup>-</sup> Cl <sup>-</sup>	$\alpha 1$ -6, $\beta 1$ -4, $\gamma 1$ -4, $\delta$ , $\epsilon$ , $\pi$ p1-3
Glycine (Gly)	Gly	Cl <sup>-</sup>	$\alpha 1$ -4, $\beta$
Serotonin	5-HT <sub>3</sub>	Non-selective cation	5-HT <sub>3</sub>
Purines (ATP)	P2 <sub>x</sub>	Non-selective cation	P2 <sub>x1-7</sub> (P2 <sub>x7</sub> /P2 <sub>z</sub> )

receptors, the GABA<sub>A</sub> receptors, the glycine receptors, and the 5-HT<sub>3</sub> receptor. The other group includes all types of glutamate receptor channels. Purinergic receptors (P2<sub>x</sub>) belong to an independent group. The nACh receptor was the first to be characterized as a neurotransmitter receptor [1]. It was purified from the electric organ of a *torpedo*, accumulating huge amounts of nicotinic receptors (1000 fold higher than skeletal muscle). This receptor is composed of five subunits (Fig. 1) and has a native molecular mass of approximately 290 kDa. The subunits are named  $\alpha$ ,  $\beta$ ,  $\gamma$ ,  $\delta$ , and each receptor complex contains two copies of the  $\alpha$  subunit, each of which is bound to one molecule of ACh. Each subunit consists of four transmembrane-spanning domains referred to as TM1-TM4, with both the N- and C-termini being in the extracellular space. Five such subunits assemble to form a complex structure containing 20 transmembrane domains that surround a central pore. The membrane-spanning domains that line the pore are composed of the five TM2 regions. Transmitter binding induces rapid conformational changes that are translated into an increase in the diameter of the pore, permitting influx. The muscle nACh receptor is composed of five subunits:  $\alpha_2\beta\gamma\delta$  (embryonic) or  $\alpha_2\beta\epsilon\delta$  (adult), and its molecular mass is approximately 280 kDa. Neuronal nACh receptors consist of only two types of subunits,  $\alpha$  and  $\beta$ , that combine to produce the functional receptor. At least nine different  $\alpha$ s have been identified as subtypes ( $\alpha 1$  belongs to the muscle  $\alpha$  subunit), and some are species specific (e.g.  $\alpha 9$  is found only in rats). Four different  $\beta$  subtypes have been isolated ( $\beta 1$  belongs to the muscle  $\beta$  subunit), but neuronal  $\beta$  subunits are not closely related to the muscle  $\beta 1$  subunit and thus are sometimes referred to as non- $\alpha$  subunits.

The GABA<sub>A</sub> receptor is a heteropentameric glycoprotein of about 275 kDa composed of combinations of at least 19 different subunits. The subunits have 50–60 kDa molecular weight and have 20–30% sequence similarity between classes and about 70% similarity within a class (Table 1). In addition, splice variants exist in several

subunits. The glycine receptor is a macromolecular complex of about 250 kDa composed of a combination of two homologous subunits,  $\alpha$  and  $\beta$ . There is an approximately 50% amino acid sequence similarity between the  $\alpha$  and  $\beta$  subunits, and they have a comparatively high homology to GABA<sub>A</sub> receptor subunits [2]. Usually a 93 kDa polypeptide named gephyrin is copurified with the glycine receptor.

Since the cloning of the first glutamate receptor GluR1 in 1989, 18 mammalian genes that encode structurally related proteins have been identified. They are currently classified into seven functional subfamilies according to their structural homologies [3]. Glutamate receptors are derived from a different ancestral gene and are structurally distinct from other ionotropic receptors. They adopt a different architecture from that previously described for the nAChR group. The TM2 domain of glutamate receptors constructs a pore forming loops instead of traversing the membrane. Furthermore, functional glutamate receptors are composed of four subunits. Thus, it appears that glutamate receptors are rather highly divergent from the nAChR group (Fig. 1). In fact, their structure conforms more closely to the family of K channels in that both appear tetrameric and both have a unique P segment (pore-forming domain that produces the selectivity filter). AMPA receptors are composed of four subunits that are termed GluR1–GluR4 (GluR $\alpha 1$ –GluR $\alpha 4$ , GluRA–GluRD) [3]. Each glutamate subunit consists of approximately 900 amino acids. The native form of AMPA receptor molecular mass is approximately 600 kDa. Thus, the size of the AMPA receptor is almost twice that of nACh receptor because of the large extracellular segment. Recently some members of voltage dependent calcium channel  $\gamma$  subunit family have been described as essential auxiliary subunits of native AMPA receptors [4]. They are  $\gamma 2$  (stargazin),  $\gamma 3$ ,  $\gamma 4$ ,  $\gamma 7$  and  $\gamma 8$  subunits and termed as TARPs (transmembrane AMPA receptor regulatory protein). KA receptors consist of two subunit subfamilies, GluR5–GluR7 (GluR $\beta 1$ –GluR $\beta 3$ ) and KA1, KA2

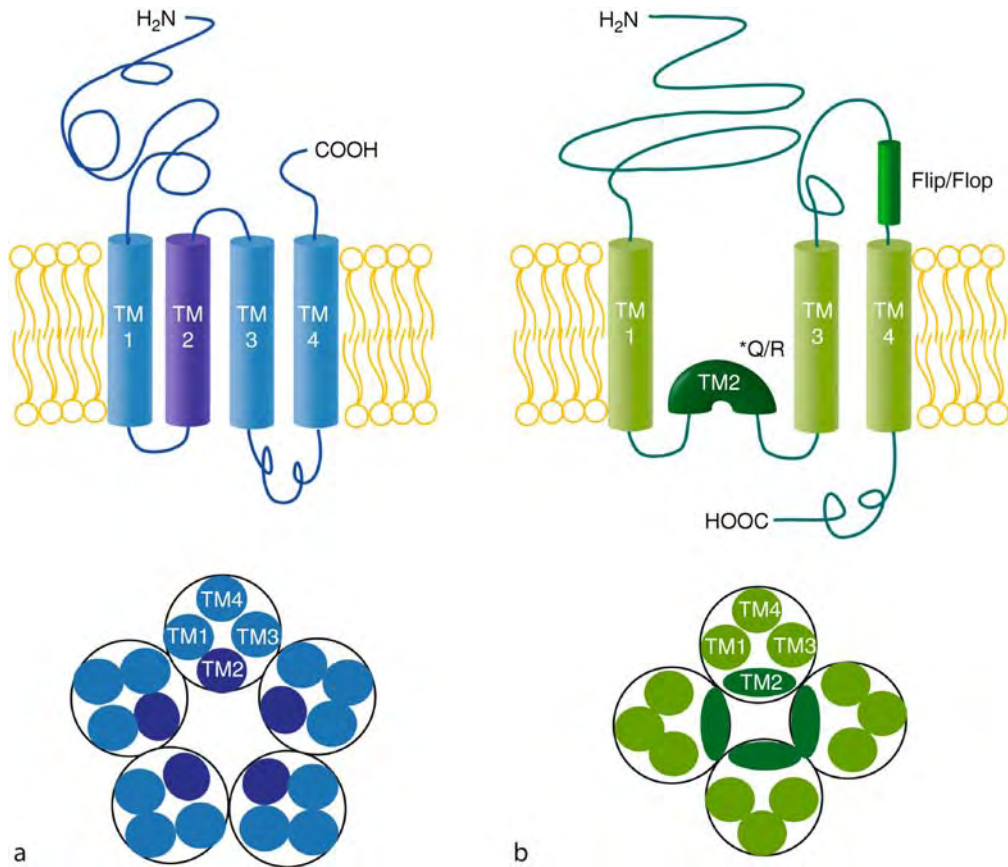

**Ionotropic Receptor. Figure 1** Schematic structure of ionotropic receptors. (a) *Upper*, diagram highlighting the orientation of the membrane-spanning of one subunit of nACh receptor. The amino acid and carboxy termini extend in the extracellular space. Lower, top view of all five subunits highlighting the relative positions of their membrane-spanning segments, TM1–4, and the position of TM2 that lines the channel pore. (b) *Upper*, schematic structure of AMPA type glutamate receptor subunit GluR2 (GluR $\alpha$ 2 or GluRB). Ionotropic glutamate receptors have four membrane-spanning segments. Unlike nACh receptor, however, only three of them traverse the lipid bilayer. TM2 forms a pore forming loops and re-exits into the cytoplasm. The large amino acid terminal region extends into the extracellular space, while the carboxy terminus extends into the cytoplasm. Two extracellular segments associate with each other to form the binding site for transmitter. There are two domains termed *flip* and *flop* between the TM3 and TM4, which are produced by alternative splicing. RNA editing of Q/R site that is critical for Ca<sup>2+</sup> permeability, is present in the TM2 segment. Lower, glutamate receptors are composed of four subunits and the loop forming TM2 lining channel pore.

(GluR $\gamma$ 1, GluR $\gamma$ 2). NMDA receptors consist of combination of the glutamate-binding NR2 (GluR $\epsilon$ ) subunit and glycine-binding NR1 (GluR $\zeta$ ) is essential NMDA receptor *in vivo* [5]. There are four NR2A-NR2D (GluR $\epsilon$ 1–GluR $\epsilon$ 4) and one NR1 (GluR $\zeta$ 1) genes. Two NR3 subunits, which may carry the regulatory function are also reported. Two homologous subunits, GluR $\delta$ 1 and  $\delta$ 2, remain unassigned to any particular receptor.

P2<sub>x</sub> receptors are membrane ion channels that open in response to the binding of extracellular ATP [6]. Seven P2<sub>x</sub> receptor subunits have been shown to share less than 50% identity and range in length from 379 to 595 amino acids. P2<sub>x</sub> receptor subunits share a similar structural topology consisting of two transmembrane

domains connected by a large extracellular loop, containing the putative ATP binding site and intracellular N and C termini of various lengths.

### Function

The main function of ionotropic receptors is to convert extracellular chemical signals (neurotransmitters) into electrical information. These receptors are essential for synaptic transmission and other forms of cell-cell signalling phenomena. In the neuromuscular synapse, the binding of ACh to postsynaptic nACh receptors opens ion channels which are permeable to cations and generate excitatory postsynaptic responses. Functional characterizations of the neuronal nACh receptors

are carried out using exogenous expression systems. When certain pairs or triplets of cDNAs encoding neuronal  $\alpha$  and  $\beta$  subunits are cotransfected into cells or their corresponding mRNAs are injected into oocytes, characteristic Ach-gated channel function can be achieved. The  $\alpha 4\beta 2$  subunit combination is major in the CNS, however its deficiency causes only limited changes. Four permutations of  $\alpha 4$ ,  $\alpha 5$ ,  $\alpha 6$ ,  $\beta 2$  and  $\beta 3$  subunits are found in the striatum, and they mediate dopamine release. Several noticeable properties of the neuronal nACh receptors are their presynaptic localizations and regulation of several neurotransmitter releases. Continued exposure of nACh receptors to the agonist leads to desensitization of the receptors ([► Receptor regulation, Desensitization](#)). This diminution of the response is attributed to the presence of multiple conformational states of receptor-ligand complex.

Ionotropic glutamate receptors mediate major excitatory neurotransmission in the mammalian brain and spinal cord. They also play the leading role in brain functions such as development, learning and memory, and in brain disease. The KA and AMPA receptors are closely related, whereas the NMDA receptors are both functionally and structurally distinct from the KA and AMPA receptors. The KA and AMPA receptors activate cation channels that usually allow sodium and potassium ions to flow. Near a neuron's resting potential, the driving force for  $K^+$  is low and that for  $Na^+$  is high, so activation of these channels leads to depolarization as a result of an inward sodium current. AMPA receptors are responsible for the majority of fast excitatory signals in the CNS (mediating, e.g., sensory information and motor commands). AMPA receptors that contain the GluR2 subunit are much less permeable to  $Ca^{2+}$  than those assembled without GluR2. This important feature of AMPA receptors is determined by a single amino acid within the TM2 of the GluR2. A glutamine (Q) resides in this position in GluR1, GluR3 and GluR4, but an arginine (R) is present in GluR2; this site has thus been named the "Q/R" site. The genomic DNA sequence of GluR2 has a glutamine codon in the Q/R position, but its mature mRNA has an arginine codon in this site. A novel RNA editing ([► Receptor Regulation, Editing](#)) on the GluR2 mRNA is one cause of this phenomenon. In addition, the function of AMPA receptors is regulated by splicing ([► Receptor regulation, Splicing](#)). "Flip" and "flop" versions of the splice isoforms GluR1–GluR4 have been reported [7]. The flip and flop splice variants give rise to receptors that differ in desensitization rate and in their regional distribution in the brain. NMDA receptors have properties that distinguish them from other ionotropic receptors. One important feature of NMDA receptors is that they are more permeable to  $Ca^{2+}$  than  $Na^+$  (in contrast to AMPA receptors). This makes possible

many postsynaptic effects of glutamate binding in addition to depolarization, because  $Ca^{2+}$  can trigger a number of intracellular processes. Another feature of NMDA receptors is that they are blocked by extracellular  $Mg^{2+}$  in a voltage-dependent manner. The binding of glutamate to the receptor opens it only if the membrane is already depolarized, for example, by the opening of AMPA receptors in the vicinity. Furthermore, NMDA receptors require two kinds of agonists to be activated: one is glutamate and the other is glycine. Thus regulation of their channels is more complex than that of other glutamate receptors. These properties are the basis for dynamic brain functions such as development, synaptic plasticity, learning, and memory, and are one of the causes of neuronal damage. NMDA receptors work only with the combination of NR1 and NR2 *in vivo*. Four NR2 subunits are major functional determinants of NMDA receptors [8]. Each of the four has a distinct expression profile during development and in areas of the mature brain.

Synaptic inhibitory transmission in the mammalian brain is mediated mainly by GABA receptors [9]. Among them, GABA<sub>A</sub> receptor is the most widespread ionotropic receptor. The subunits composing the GABA<sub>A</sub> receptor have sequence homology with the nACh receptor subunit family, and their general structures appear to be quite similar. Five different types of subunit subfamilies associated with GABA<sub>A</sub> receptors are named  $\alpha$ ,  $\beta$ ,  $\gamma$ ,  $\delta$ , and  $\epsilon$ . An additional subunit subfamily  $\rho$  is predominantly expressed in the retina, but the other subunits are widely distributed in the brain. Many subunits that belong to the subfamilies have been reported, for example, six  $\alpha$ , four  $\beta$ , four  $\gamma$ , and two  $\rho$ . Like neuronal nACh receptors, these subunits mix in a heterogeneous fashion to produce complex GABA<sub>A</sub> receptors, which have been characterized by pharmacological and electrophysiological analyses. The expression of subunit mRNAs in oocytes indicated that the  $\alpha$  subunit is essential for producing a functional receptor channel. The GABA<sub>A</sub> receptor's ion channel is selective for anion ( $Cl^-$ ), and this important property is caused by positively charged amino acids that form a ring near the end of the ion channel. When GABA binds to the receptor,  $Cl^-$  flows into the cell, producing hyperpolarization by causing the membrane potential to recede from the threshold for firing an action potential. Glycine receptors greatly resemble the GABA<sub>A</sub> receptors both structurally and functionally, and work as major inhibitory receptors in the spinal cord. They also work in the entire brain particularly in the brainstem. These receptors appear to be pentameric, and are most likely composed of three  $\alpha$  and two  $\beta$  subunits. Three molecules of glycine must bind to the  $\alpha$  subunits in order to open the anion channel.

The ionotropic serotonin receptor 5-HT<sub>3</sub> is unique among serotonin receptors, and is a close relative of the

nACh receptor [10]. The 5-HT<sub>3</sub> receptor is a homomeric complex composed of five copies of the same subunit, and has a structure most analogous to the  $\alpha 7$  subunits of neuronal nACh receptors (which also form a homo-oligomeric complex). This receptor also resembles nACh receptors in that it is permeable to Na<sup>+</sup> and K<sup>+</sup> and is rapidly desensitized.

### Pathology

Some kinds of naturally occurring poisonous molecules and synthetic drugs can influence the nACh receptor functions and produce involuntary muscle contractions or muscle paralysis. Myasthenia gravis is an autoimmune disease that targets nACh receptors. Thus, normal nACh receptors are decreased at the neuromuscular junction and muscle weakness occurs. The symptoms improve following treatment with acetylcholinesterase inhibitors, which degrade acetylcholine at the neuromuscular junction.

Excitotoxicity refers to the ability of glutamate and related compounds to destroy neurons by prolonging their receptor activation. Ionotropic glutamate receptors are several candidates for mediating cell damage after abnormal excitatory activation. When nervous tissue receives insufficient oxygen (ischemia), as in severely reduced blood pressure, stroke, cerebral bleeding, etc., the extracellular glutamate concentration rises steeply and all kinds of glutamate receptors are presumably activated. Abnormal intense excitation may also occur during epileptic seizures. Of the glutamate receptors, NMDA receptors are especially important because they can produce a rapid increase of the intracellular Ca<sup>2+</sup> concentration that is crucial for cell death.

### Therapy

The GABA<sub>A</sub> receptor is the major molecular target for the action of many drugs used in brain treatment. Benzodiazepine is a well known drug and is used for the treatment of anxiety disorders such as panic disorder, agoraphobia, and other phobias. This drug binds to a site on the GABA<sub>A</sub> receptor and acts to make GABA much more effective in opening the chloride channel and producing inhibition. The site on the receptor that binds Benzodiazepine is thought to be used by a naturally-occurring brain chemical, and modulates channel functions, although the endogenous molecule has not yet been identified. The anxiolytic effects of alcohol are explained in that ethanol is also bound to another site on the GABA<sub>A</sub> receptor and stimulates GABA actions. Barbiturates are another type of drug commonly used therapeutically for anesthesia and control of epilepsy. They allosterically increase the binding of GABA to their binding sites at pharmacological concentrations, resulting in an increase of chloride flux. The 5-HT<sub>3</sub> receptor is clinically significant because antagonists of 5-HT<sub>3</sub> receptors have

important applications as antiemetics, anxiolytics and antipsychotics.

### References

1. Unwin N (1993) Neurotransmitter action: opening of ligand-gated ion channels. *Cell* 7 (Suppl):31–41
2. Betz H, Laube B (2006) Glycine receptors: recent insights into their structural organization and functional diversity. *J Neurochem* 97:1600–1610
3. Hollmann M, Heinemann S (1994) Cloned glutamate receptors. *Annu Rev Neurosci* 17:31–108
4. Mori H, Mishina M (1995) Structure and function of the NMDA receptor channel. *Neuropharmacology* 34:1219–1237
5. Nicoll RA, Tomita S, Brecht DS (2006) Auxiliary subunits assist AMPA-type glutamate receptors. *Science* 311:1253–1256
6. Valera S, Hussy N, Evans RJ, Adami N, North RA, Surprenant A, Buell G (1994) A new class of ligand-gated ion channel defined by P2x receptor for extracellular ATP [see comments]. *Nature* 371:516–519
7. Sommer B, Keinänen K, Verdoorn TA, Wisden W, Burnashev N, Herb A, Kohler M, Takagi T, Sakmann B, Seeburg PH (1990) Flip and flop: a cell-specific functional switch in glutamate-operated channels of the CNS. *Science* 249:1580–1585
8. Sakimura K, Kutsuwada T, Ito I, Manabe T, Takayama C, Kushiya E, Yagi T, Aizawa S, Inoue Y, Sugiyama H, Mishina M (1995) Reduced hippocampal LTP and spatial learning in mice lacking NMDA receptor  $\epsilon 1$  subunit. *Nature* 373:151–155
9. Seighart W (1992) GABA<sub>A</sub> receptors: ligand-gated Cl<sup>-</sup> ion channels modulated by multiple drug-binding sites. *Trends Pharmacol Sci* 13:446–450
10. Maricq AV, Peterson AS, Brake AJ, Myers RM, Julius D (1991) Primary structure and functional expression of the 5HT<sub>3</sub> receptor, a serotonin-gated ion channel. *Science* 254:432–437

## Ionophoretic Application

### ► Microiontophoresis and Micropressure Ejection

## IOS

### Definition

#### ► Inspiratory Off-switching (IOS)

## Ipsilateral

### Definition

Located on the same side of the body (antonym: contralateral).

## Ipsiversive

### Definition

Directed toward the ipsilateral side.

## IPSP

### Definition

► Inhibitory Postsynaptic Potential (IPSP)

## Iris

### Definition

Part of the eye. Used for fast and precise adaptation (bright-dark adaptation).

► Eye

## Irritant Receptors

► Respiratory Reflexes

## Ischemia/Ischemic

### Definition

Decrease in the blood supply to a bodily organ, tissue or part caused by constriction or obstruction of the blood vessels.

## Ischemic Stroke

CLAIRE CREUTZFELDT, DAVID TIRSCHWELL  
Harborview Neurology - Comprehensive Stroke Center  
University of Washington School of Medicine, Seattle, WA, USA

### Synonyms

Cerebrovascular disease; Cerebrovascular accident; CVA; Thrombotic stroke; Brain attack

### Definition

The sudden onset of focal neurological deficits due to a blockage of arterial blood flow and injury to a certain area of the brain, with symptoms lasting longer than 24 h.

### Characteristics

#### Epidemiology

Stroke is the second leading cause of lost disability-adjusted life years in high-income countries and of death worldwide, after ischemic heart disease; in 2001, an estimated 5.4 million people died from stroke worldwide [1]. In Western societies, approximately 80% of strokes are ischemic, and the remaining 20% are caused by hemorrhages. In the USA, there are approximately 500,000 ischemic strokes each year. One-month case fatality rate for ischemic stroke ranges from 8–20%, with the main predictors of early functional outcome being initial stroke severity, level of consciousness, size of infarct and type of neurologic deficit.

#### Etiology

Etiologic classification of ischemic stroke is based on clinical features and ancillary diagnostic test results. The TOAST classification differentiates between five subtypes: (i) large-artery atherosclerosis, (ii) ► **cardioembolism**, (iii) small-vessel occlusion, (iv) stroke of other known etiology, and (v) stroke of unknown etiology [2]. Anatomically, infarcts located in the ► **cortex** are

distinguished from ▶**subcortical infarcts**. Age, gender and genetic predisposition are important non-modifiable risk factors. The main modifiable risk factors are arterial ▶**hypertension**, ▶**atrial fibrillation**, carotid artery stenosis, cigarette smoking, ▶**hyperlipidemia**, ▶**diabetes mellitus**, and a previous stroke or transient ischemic attack (▶**TIA**). Less common causes for ischemic stroke are ▶**arterial dissection**, inflammatory disorders of the arteries (vasculitis) and genetic disorders such as ▶**CADASIL**. Knowledge of these risk factors is important for preventing a stroke in the first place and to avoid recurrence of one.

### Pathophysiology

Ischemic stroke is caused by an interruption in the blood supply, resulting in depletion of oxygen and glucose in the affected area. Brain tissue that no longer receives its blood supply can die within a few hours unless something is done to stop the damage. Three different mechanisms have been proposed that cause this interruption of blood supply: embolic infarcts, watershed infarcts and lacunar infarcts. Many times, however, we will find a mixed picture.

- *Embolic infarcts* are caused by dislodgement of an embolus (blood clot) from a proximal source, mostly the heart or a large to medium-sized artery, which then travels distally in the cerebral circulation, lodges at some point depending on size of thrombus vs. size of artery, thus impeding blood flow distal to this thrombus. ▶**Cardiac emboli** can result from cardiac rhythm abnormalities (in particular atrial fibrillation), from changes in the wall of the heart in the setting of coronary artery disease or cardiomyopathy, or from diseased heart valves. ▶**Paradoxical emboli** are clots that originate in the venous system (for example deep vein thrombosis) and reach the arterial system through a ▶**right (venous) to left (arterial) shunt**. *Arterial emboli* originate from atherosclerotic plaques in any of the arteries from the aortic arch up to the brain (most commonly the internal carotid artery) Fig. 1. Embolic infarcts are also called territorial infarcts as they involve the area (territory) of the brain that is supplied by one artery and result in a typical combination of symptoms. For example, a middle cerebral artery (MCA) territory infarct in the dominant hemisphere commonly causes language impairment and contralateral hemiparesis (see below, vascular syndromes).
- *Watershed (Hypoperfusion)-infarcts* involve the distal fields of two non-anastomosing arterial territories where perfusion pressure is lowest. They occur in the setting of hemodynamic compromise, which can be either local (tight narrowing of an artery), systemic (low blood pressure) or a combination of the two. This phenomenon is often referred to as the “last meadow” comparing it to an irrigation system where the last meadow receives the least amount of water.
- *Lacunar infarcts* are small infarcts (2–20 mm in diameter) in the subcortical white matter, basal ganglia or pons, that are presumed to result from the occlusion of a single small penetrating branch of the large cerebral arteries [3]. Occlusion of a penetrating branch can be caused by microatheroma, microemboli or hypoperfusion. Even though the size of a lacunar infarct is small, the deficits can at times be severe (▶**lacunar syndrome**).

### Signs and Symptoms

The symptoms of stroke depend on the type of stroke and the area of the brain affected. They are usually unilateral, occurring on the side of the body opposite to the affected side of the brain, i.e., “contralateral” (“ipsilateral” is when the same side of the body is affected). As is implied in the word *stroke*, symptoms typically develop suddenly and rapidly.

Common symptoms include weakness or numbness; confusion, trouble speaking or understanding; loss of vision in all or part of the visual field; loss of balance or coordination, trouble walking or dizziness. Less typical features are headache, impairment of consciousness, seizure at the onset or bilateral findings.

If symptoms are maximal at onset, the cause is more likely to be an embolic stroke. In watershed infarcts, symptoms tend to be more episodic, fluctuating or progressive [4]. Lacunar infarcts can be asymptomatic, their onset is often not as sudden as with embolic infarcts, and they may be identified by a typical combination of symptoms that constitute a “▶**lacunar syndrome**.” The term *vascular syndrome* refers to the association of certain neurological symptoms with impairment of one arterial territory. Even though the structures involved will differ from person to person, knowledge of the typical syndromes will help the clinician with localization and further management (see Table 1).

The *anterior circulation* includes the part of the brain that is supplied by the internal carotid arteries (ICAs), which give rise to anterior choroidal (AChA), anterior cerebral (ACAs), anterior communicating (AComm), middle cerebral (MCAs) and posterior communicating arteries (PComms).

The *posterior circulation* is made up of the vertebral arteries (VAs), which give off the posterior inferior cerebellar arteries (PICAs) before they join at the pontomedullary junction to form the basilar artery (BA), which gives rise to the anterior inferior cerebellar (AICAs), superior cerebellar (SCAs) and posterior cerebral arteries (PCA). In 20–25% of people, one of the PCAs is mainly supplied from the anterior circulation, and in 5–10% both PCAs are so supplied.

Occlusion of the basilar artery is particularly threatening because it supplies most of the brainstem, and it is



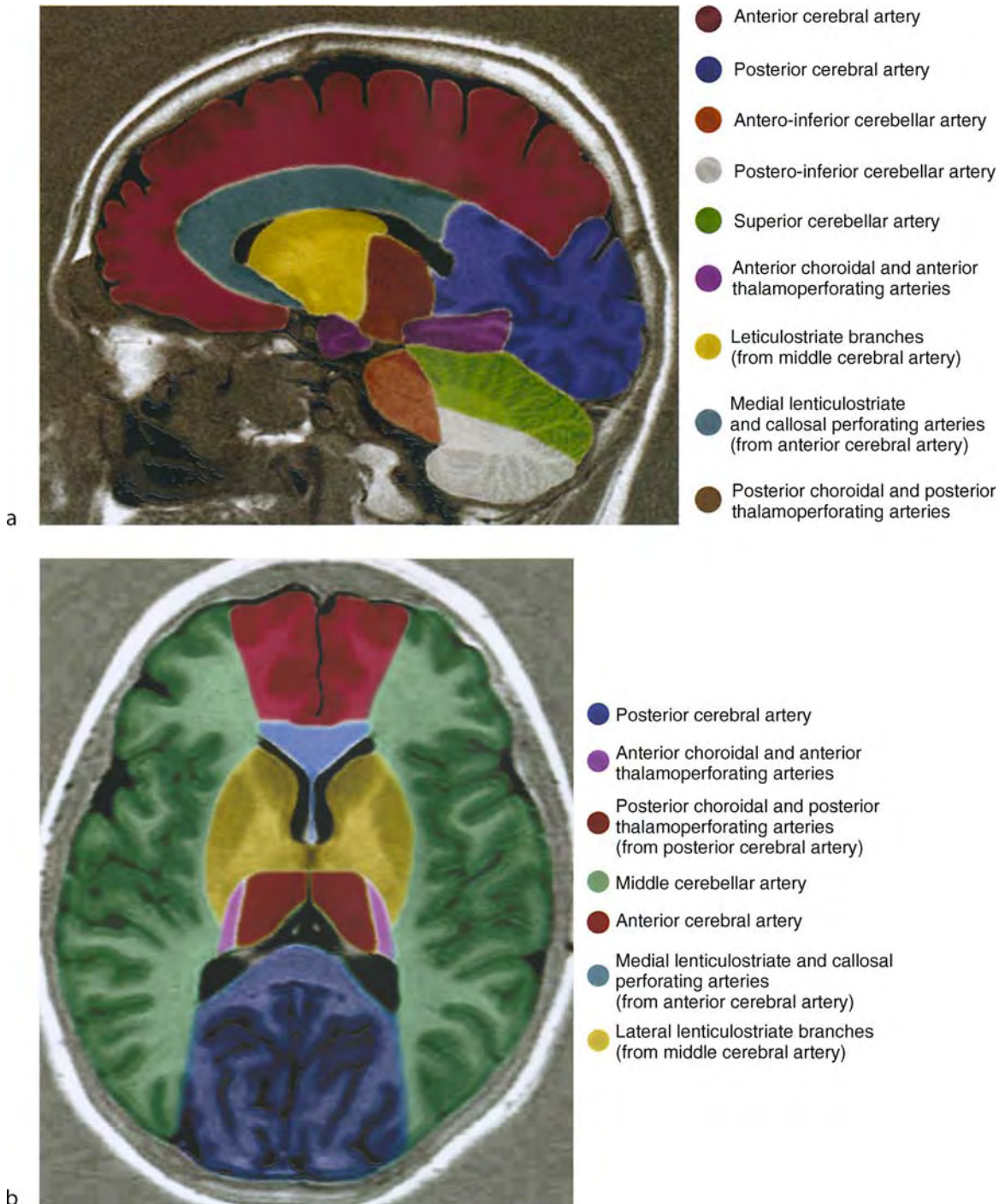

**Ischemic Stroke. Figure 1** Vascular supply Arterial Territories of the Brain. Gallucci M, Capoccia S, Catalucci A (eds) (2007) Radiographic atlas of skull and brain anatomy. Springer, New York, p 322, 334 (with permission).

unpaired. Symptoms can be bilateral, and often times, the patient is comatose because of involvement of the reticular activating system, the collection of neurons and fibers in the brainstem that are responsible for arousal.

The most important manifestation of all brainstem infarcts are “crossed” signs, with cranial nerve deficits

seen on the side contralateral to sensory or motor deficits in the body.

#### Differential Diagnosis

See [Table 2](#).

**Ischemic Stroke. Table 1** Vascular Syndromes

Deficits					
Anterior circulation	Motor	Sensory	Visual	Speech & Language	Other
ICA	Contralateral arm/leg weakness	Contralateral arm/leg numbness	Ipsi lateral eye (▶ amaurosis fugax)	See MCA	See MCA
AChA	Contralateral arm/leg weakness	Contralateral arm/leg numbness	Contralateral ▶ homonymous hemianopia	–	–
ACA	Contralateral arm < leg weakness	Contralateral arm < leg numbness	–	–	–
MCA	Contralateral arm/leg weakness	Contralateral arm/leg numbness	Contralateral ▶ homonymous hemianopia Eyes are often deviated to side of the infarct	▶ Aphasias are typically caused by involvement of the ▶ cortex in the dominant (left in 95% of people) hemisphere: with the frontal branches affected, an expressive aphasia is seen; with temporal branches a receptive aphasia; parietal branches can cause a conduction aphasia and may cause ▶ Gerstmann's syndrome.	▶ Hemispatial neglect and ▶ Anosognosia are seen with involvement of cortical branches in the non-dominant hemisphere.
Posterior circulation	Motor	Sensory	Visual	Speech & Language	Other
PICA (see also ▶ Wallenberg syndrome)	Ipsilateral ataxia	Contralateral arm/leg numbness	–	Slurred speech, hoarseness	ipsilateral facial numbness, and Horner's syndrome; contralateral arm/leg numbness, trouble swallowing
SCA	Ipsilateral ataxia	Contralateral loss of pain and temperature	–	Slurred speech	Nausea, vomiting, vertigo
AICA	Ipsilateral ataxia	–	▶ Nystagmus	–	Horner's syndrome Nausea, vomiting, vertigo Ipsilateral deafness, tinnitus
PCA	–	–	Contralateral ▶ homonymous hemianopia	Involvement of the ▶ cortex in the dominant (left in 95% of people) hemisphere, can cause ▶ aphasia	Involvement of deeper branches can affect the ▶ thalamus and cause contralateral sensory changes. Imbalance, confusion, headache

**Diagnosis**

See Algorithm for Acute stroke evaluation (Fig. 2).

Deficits are identified by a careful ▶ neurological examination, and the severity assessed using one

of the standardized stroke scales, i.e., the National Institute of Health Stroke Scale ([http://www.ninds.nih.gov/doctors/NIH\\_Stroke\\_Scale\\_Booklet.pdf](http://www.ninds.nih.gov/doctors/NIH_Stroke_Scale_Booklet.pdf)). A shortened version of the NIHSS, appropriate for

**Ischemic Stroke. Table 2** Differential Diagnosis of Acute Stroke Presentation

• TIA	• CNS Infection
• Ischemic Stroke	• Tumor (with sz)
• Intracerebral Hemorrhage	• Peripheral nerve lesions
• Subdural Hematoma (small)	• Metabolic abnormalities
• Focal seizure	• Hyper/hypoglycemia
• Post-ictal Todd's paralysis	• Anamnestic deficit
• Syncope/Presyncope	• Esp. infected elderly
• Complicated migraine	• Toxic States
• Transient confusion in the elderly and/or demented	• Hypertensive Encephalopathy
• Vertigo of peripheral origin	• Conversion disorder

placement in the medical record, is seen in the NIH stroke scale which can be viewed from the link [http://www.ninds.nih.gov/doctors/NIH\\_Stroke\\_Scale.pdf](http://www.ninds.nih.gov/doctors/NIH_Stroke_Scale.pdf).

- ▶ **Laboratory workup** should include basic metabolic panel with glucose, complete blood count, markers of cardiac ▶ **ischemia** and coagulation parameters. In the appropriate setting, ▶ **hypercoagulable** workup and vasculitis testing may be indicated, as well as hepatic function tests, toxicology screen, blood alcohol level, pregnancy test and arterial blood gas.
- ▶ **Imaging**: Even though an ischemic stroke may not be visible on CT within the first 6–12h after onset of symptoms, non-contrast head CT remains the most commonly used initial imaging modality: it is more widely available, faster and less expensive than MRI and immediately rules out the presence of a hemorrhage which would preclude the administration of intravenous ▶ **thrombolysis** (the only approved treatment for acute ischemic stroke). MRI is more sensitive for detection of acute ischemic stroke and is better at identifying acute, small cortical, small deep, and posterior fossa infarcts, and at distinguishing acute from chronic stroke [5]. CT- or MR-Angiography are helpful noninvasive methods to identify any cervical or intracranial stenoses and can detect aneurysms in 95% of the cases [6]. Venous sinus thrombosis can usually be detected on MRI, but if there is clinical suspicion for it, CT- or MR-Venogram should be obtained.
- ▶ **Ancillary tests**:
- EKG followed by cardiac monitoring for at least 24 h after the event, to identify arrhythmias, acute or previous myocardial infarction.
- Echocardiogram is an ultrasound study of the heart that can look for any source of cardioembolism, for example wall motion or valvular abnormalities. “Bubble studies” can identify a right to left ▶ **cardiac shunt** as a cause of paradoxical embolism.
- Ultrasound of the arteries in the neck and brain (carotid ultrasound, transcranial ultrasound) evaluates

the presence and degree of vessel narrowing and may identify emboli traveling through that vessel.

- Catheter based cerebral angiography most directly visualizes the arteries and veins in the cerebral circulation, and remains the gold standard for vascular imaging, but with the increasing quality of CT and MR angiography, this more invasive and risk laden technique is seldom necessary.

### Acute Management (See Algorithm, Fig. 2.)

An ischemic stroke is a medical emergency – “time is brain”. Patients treated in hospitals with a dedicated Stroke Team or Stroke Unit and a specialized care program for stroke patients are more likely to recover and less likely to die. Thus, if a stroke is suspected, emergency medical services should be activated immediately [5].

The goals of therapy are to restore blood flow to the ischemic area and to limit any further injury (neuroprotection). In an attempt to restore blood flow in the acute setting (less than three hours after onset of the event), ▶ **intravenous thrombolysis** is the standard of care if the patient meets the strict inclusion and exclusion criteria [5]. If the patient presents for medical care later than three hours, intraarterial thrombolysis or mechanical thrombectomy may be considered.

*Blood pressure* should be monitored carefully. If it is too high, brain edema, hemorrhagic transformation and damage of other organs may be exacerbated. If blood pressure is too low, perfusion to the rim of ischemic, but salvagable brain tissue surrounding the center of the stroke ▶ **(the ischemic penumbra)** is impaired and could enlarge the stroke. Unless the systolic pressure is >220 mmHg or the diastolic pressure is >120, blood pressure lowering medications should be withheld [5].

Other therapies are aimed at limiting further injury and salvaging brain tissue at risk (ischemic penumbra). Aspirin (ASA) should be started within 24–48 h after onset of stroke. The indications for the use of other antiplatelet agents (clopidogrel, dipyridamole) in the acute ischemic stroke setting are not clear. Anticoagulant therapy is not routinely recommended in

## Acute stroke evaluation and treatment

(Based on algorithm created for the UW Medicine Comprehensive Stroke Center at Harborview Medical Center, Seattle, Washington, all rights reserved)

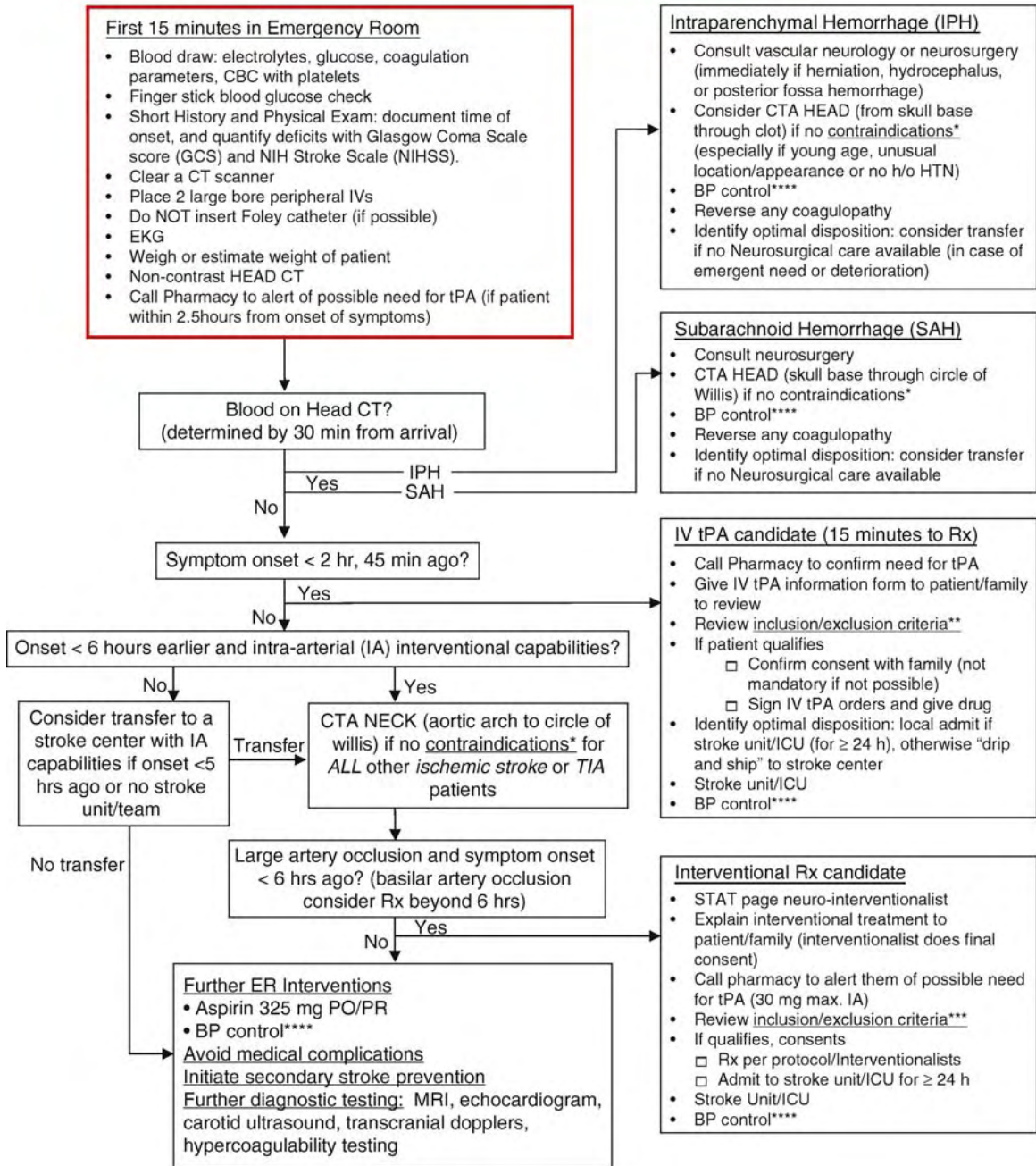

**Ischemic Stroke. Figure 2** Acute Stroke Algorithm.

the acute setting, but may still be considered in special circumstances (e.g., arterial dissection, thrombus seen on Echocardiogram). Neuroprotective agents such as glutamate antagonists or free radical scavengers have not been shown to be effective to date.

Finally, emphasis should be made on preventing further medical complications such as infection, hyperthermia, hyperglycemia, malnutrition, dehydration or thromboembolic events (deep vein thrombosis and pulmonary embolism).

## Secondary Stroke Prevention

Survivors of a TIA or stroke are at increased risk of another ischemic – cardiac or cerebral – event: almost a third of all strokes are recurrent attacks [7]. Thus, careful attention needs to be paid to all vascular risk factors [8]. The ways to reduce the risk of a recurrent stroke are very similar to those that can prevent a stroke in the first place. In addition to the prevention measures described in the general section on stroke, two additional procedures are sometimes important for the prevention of ischemic stroke.

- Carotid stenosis: If diagnostic workup reveals significant (>70%) carotid stenosis in a patient with a recent ischemic stroke or TIA in the vascular territory supplied by the stenosed carotid, surgical intervention (►carotid endarterectomy) is indicated. ►Carotid angioplasty and stenting can be considered in patients who are at high risk from a standard carotid endarterectomy procedure, or in the research setting. There is no role for anticoagulation in carotid stenosis.
- ►PFO: The optimal secondary prevention strategy (i.e., antiplatelet agents vs. anticoagulant therapy vs. PFO closure) is still uncertain, and current recommendations are based on insufficient evidence [9].

## Prognosis

Prognosis depends on the patient's age, type of stroke and how severe the symptoms are at the onset. Within one month of an ischemic stroke, approximately 20% of victims die, and many of survivors have some long-term disability.

## Stroke Rehabilitation

Early stroke rehabilitation services are very effective in reducing long-term disability and improving quality of life as well as reducing overall health care costs [10]. Rehabilitation doctors, Speech and Language therapists, Physical and Occupational therapists should be involved early on in the care of a stroke patient.

## References

1. Lopez AD et al. (2006) Global and regional burden of disease and risk factors, 2001: systematic analysis of population health data. *Lancet* 367(9524):1747–1757
2. Adams HP Jr et al. (1993) Classification of subtype of acute ischemic stroke. Definitions for use in a multicenter clinical trial. TOAST. Trial of org 10172 in acute stroke treatment. *Stroke* 24(1):35–41
3. Fisher CM (1982) Lacunar strokes and infarcts: a review. *Neurology* 32(8):871–876
4. Momjian-Mayor I, Baron JC (2005) The pathophysiology of watershed infarction in internal carotid artery disease: review of cerebral perfusion studies. *Stroke* 36(3):567–577

5. Adams HP Jr et al. (2007) Guidelines for the early management of adults with ischemic stroke: a guideline from the American Heart Association/American Stroke Association Stroke Council, Clinical Cardiology Council, Cardiovascular Radiology and Intervention Council, and the Atherosclerotic Peripheral Vascular Disease and Quality of Care Outcomes in Research Interdisciplinary Working Groups: the American Academy of Neurology affirms the value of this guideline as an educational tool for neurologists. *Stroke* 38(5):1655–1711
6. van Gijn J, Kerr RS, Rinkel GJ (2007) Subarachnoid haemorrhage. *Lancet* 369(9558):306–318
7. Rosamond W et al. (2007) Heart disease and stroke statistics – 2007 update: a report from the American Heart Association Statistics Committee and Stroke Statistics Subcommittee. *Circulation*, 115(5):e69–e171
8. Sacco RL et al. (2006) Guidelines for prevention of stroke in patients with ischemic stroke or transient ischemic attack: a statement for healthcare professionals from the American Heart Association/American Stroke Association Council on Stroke: co-sponsored by the Council on Cardiovascular Radiology and Intervention: the American Academy of Neurology affirms the value of this guideline. *Circulation*, 113(10):e409–e449
9. Messe SR et al. (2004) Practice parameter: recurrent stroke with patent foramen ovale and atrial septal aneurysm: report of the quality standards subcommittee of the American academy of neurology. *Neurology* 62(7):1042–1050
10. Walker MF (2007) Stroke rehabilitation: evidence-based or evidence-tinged? *J Rehabil Med* 39(3):193–197

## Isochoric Motion

### Definition

A motion that preserves the volume of every part of a material body. Incompressible materials are characterized by the fact that the only possible motions are isochoric.

### ►Mechanics

## Isocortex

### Definition

Isocortex (also called neocortex) refers to the six-layered cerebral cortex, which in humans makes up the bulk of cortex. It is opposed to allocortex with different structure (the Greek “allos” means other).

### ►Neocortex

## Isodendritic Core

- ▶ Reticular Formation

## Isoforms

### Definition

Distinct types of proteins that result from alternative splicing of a pre-mRNA encoded by a single gene.

- ▶ Alternative Splicing and Glial Maturation

## Isofrequency Stripe in Auditory Cortex

### Definition

A band of neurons with very similar characteristic frequencies in the primary auditory cortex or any other auditory cortical field with a well defined tonotopy.

- ▶ Tonotopic Organization (Maps)

## Isografting

Synonym: isotransplantation

Transplantation of tissues and organ pieces between monozygotic twins, or from one animal to another of the same strain.

## Isolated Nervous Tissues

- ▶ Brain Slices

## Isometric

### Definition

The force response when a skeletal muscle or muscle fiber is stimulated to contract with muscle length held fixed. As a result, force is generated but the muscle does not undergo external shortening. Although the absence of shortening allows the muscle to generate maximal force, isometric activations produce neither work nor power.

- ▶ Force Depression/Enhancement in Skeletal Muscles
- ▶ Force Potentiation in Skeletal Muscle

## Isometric Contraction

### Definition

A period of muscle activity during which the length of the muscle fibers does not change.

- ▶ Energy/Energetics

## Isomorphism

### Definition

An *isomorphism*, defined relative to some specified structural relations, is a one-to-one correspondence between two sets of objects  $A$  and  $B$  that preserves those structural relations. Thus, whenever  $a_1$  is related to  $a_2$  in  $A$ , then the isomorphism corresponds these to  $b_1$  and  $b_2$ , respectively, which are related in the same way in  $B$ .

The notion of isomorphism is thus dependent on the particular structural relations being considered, and a correspondence that is an isomorphism with respect to say, order, may not be an isomorphism with respect to, say, distance.

- ▶ Physicalism

## Isotherm

### Definition

A region of constant temperature within a thermal gradient.

---

## Isotonic

### Definition

The force response when a skeletal muscle or muscle fiber is stimulated to contract with unfixed muscle length. Muscle shortening occurs when generated force exceeds that needed to move the external load.

Although muscle shortening reduces force compared to the isometric condition, isotonic activations produce mechanical work and power. The ability of a muscle to shorten against a load is described by the force–velocity relation.

► Force Potentiation in Skeletal Muscle

---

## Isotropic Definition

Isotropic means having the same properties (e.g. elasticity or viscosity) in all directions.

---

## ITD

### Definition

► Interaural Time Difference (ITD)

## Jacksonian Motor Seizures

### Definition

▶ Partial seizures (or focal seizures) characterized by focal motor symptoms indicating the location of brain lesions. Focal (Jacksonian) motor seizures may result from localized lesions (injury or tumor) to the contralateral ▶ primary motor cortex (M1) and may start as local rapid (clonic) contractions, often at a finger, great toe or mouth corner, and then spreading over the body with loss of consciousness (Jacksonian march).

- ▶ Motor Cortex – Hand Movements and Plasticity
- ▶ Motor Cortex – Output Properties and Organization
- ▶ Primary Motor Cortex (M1)

## Jacksonian Sensory Seizures

### Definition

Epileptic attack with abnormal sensory experiences. Numbness and ▶ paresthesias may first be felt at a restricted spot of the body surface and thence spread over the ipsilateral body surface.

- ▶ Paresthesia

## Jacobian ( $\partial x / \partial \Theta$ )

### Definition

The mathematical relation that represents the amount of displacement of the endpoint position vector,  $x$ , for a differential displacement of the joints,  $d\Theta$ .

- ▶ Impedance Control

## JAK

### Definition

- ▶ Janus Kinases (JAKs)

## Jamming Avoidance Response (JAR)

### Definition

A behavior found in wave-type electric fish, in which two individuals with similar electric organ discharge (EOD) frequencies shift their frequencies away from each other, to reduce jamming of their active electrolocation systems and to improve discrimination of conspecific EOD waveforms.

- ▶ Conspecific
- ▶ Electric Communication and Electrolocation
- ▶ Electric Fish
- ▶ Electric Organ Discharge
- ▶ Electrorceptor Organs

## Janus Kinases (JAKs)

### Definition

Members of a family of intracellular tyrosine kinases that are involved in the JAK-STAT pathway. JAK participates in the signaling cascade of cytokines by associating with one of the intracellular domains of a cytokine receptors as a result of ligand binding. JAKs phosphorylate STATs, which then dissociate from the receptors and regulate gene expression.

- ▶ Cytokines



## Jerk

### Definition

Rate of change of acceleration (i.e. jerk is to acceleration what acceleration is to speed), or the third derivative of position with respect to time.

- ▶ Arm Trajectory Formation

## Jet Lag

### Definition

Jet lag occurs after traveling by plane across time zones. Sleep can be more or less forced into the appropriate time at destination, but it takes about a day for every time zone crossed for the other circadian rhythms to completely adjust. Rate of adjustment can be increased two- or threefold by scheduling low-dose melatonin before and after travel and by scheduling sunlight exposure after travel, depending on the phase response curves for light and melatonin. It is also important to avoid sunlight at certain times after travel across more than six time zones.

- ▶ Circadian Rhythm
- ▶ Circadian Sleep Phase Syndromes
- ▶ Melatonin

## Joint Equipollence Equations

### Definition

The joint equipollence equations relate the intersegmental forces and moments to the corresponding forces and moments produced by all internal forces about a joint. The equipollence equations state that the vector sum of all internal forces and moments about a joint is equal to the intersegmental forces and moments calculated using the inverse dynamics approach.

- ▶ Distribution Problem in Biomechanics
- ▶ Intersegmental Forces and Moments
- ▶ Inverse Dynamics Approach

## Joint Pain

HANS-GEORG SCHAIBLE

Institute of Physiology, Friedrich-Schiller-University of Jena, Jena, Germany

### Synonyms

Articular pain

### Definition

Pain in a healthy joint is elicited by the impact of tissue-damaging stimuli on the joint such as hitting and twisting. These stimuli activate high-threshold nociceptors in the joint nerve and nociceptive neurons in the central nervous system that receive nociceptive joint input. Clinically relevant pain in the joint is evoked by injury, inflammatory and degenerative joint disease. Major neuronal mechanisms of clinically relevant pain include sensitization of nociceptive joint afferents and the development of central hyperexcitability.

### Characteristics

#### Pain Sensation in the Joint

The major sensation from deep tissue such as joint and muscle is pain. Although sensory information from deep tissue continuously controls the activity of the motor system and supports the sense of movement and position, we are not aware of these processes. Pain influences the motor control system and usually forces the patient to restrict movements.

Joint pain is often dull and aching, and poorly localized, and is thus different from precisely localized cutaneous pain. In the normal joint, acute and short-lasting pain is elicited by hitting or twisting the joint. However, clinically relevant joint pain is different and usually appears as ▶ **hyperalgesia** or persistent pain at rest. In the hyperalgesic state, noxious stimuli cause more pain than normal, and pain is elicited by mechanical stimuli whose intensity does not normally elicit pain, such as movements in the working range and gentle pressure (palpation) [1,2].

In order to study conscious pain sensations arising from articular tissue, experimental invasive sensory testing has been carried out in humans. Pain in the normal joint can be elicited when noxious mechanical and chemical stimuli are directly applied to the fibrous structures such as ligaments and fibrous capsule. No pain is elicited by stimulation of cartilage, and stimulation of normal synovial tissue rarely evokes pain. Stimulation of fibrous structures with innocuous mechanical stimuli can evoke pressure sensations [3].

### Causes of Clinically Relevant Joint Pain

Joints are a major site of injury (e.g., sport injuries), acute and chronic inflammatory processes (e.g., gout and rheumatoid arthritis) and degenerative disease (e.g., osteoarthritis, OA, which is characterized by severe cartilage degradation and osteophyte formation). During chronic joint inflammation, such as in rheumatoid arthritis, the synovial tissue and the articular and periarticular soft tissues are initially the most important sites of inflammation, but with time the joint undergoes structural changes such as cartilage degradation, pannus formation and bone deformation. Presumably all of these changes contribute to pain, and mechanical as well as inflammatory factors may activate the nociceptive system.

OA pain shows similarities and differences to inflammatory pain. It is usually worsened by exercise and relieved at rest. Some patients suffer from night pain [4]. The site and nature of OA pain are discussed here because the cartilage is not innervated and the correlation between radiological signs (narrow joint space and osteophytes) and joint pain is poor [4,5]. MRI reveals more abnormalities, such as synovial hypertrophy, synovial effusions, and subchondral bone marrow edema lesions (which may increase intraosseal pressure), in painful OA joints than in non-painful OA joints [5]. Thus, inflammatory mechanisms may be predominant in early OA, but capsular fibrosis and muscle contracture around the joint may contribute to late OA pain. Obesity and psychological factors also may influence OA pain [4].

### Peripheral and Central Processing of Noxious Stimuli Applied to the Joint

*Joint innervation.* Joints are supplied by branches descending from main nerve trunks or their muscular, cutaneous and periosteal branches. Joint nerves contain thick myelinated A $\beta$  (group II), thinly myelinated A $\delta$  (group III) and a high proportion (~80%) of unmyelinated C (group IV) fibers. The latter are either sensory afferent or sympathetic efferent (each ~50%). A $\beta$  fibers terminate as corpuscular endings of the Ruffini-, Golgi- and Pacini-type in fibrous capsule, articular ligaments, menisci and adjacent periosteum. Articular A $\delta$  and C fibers terminate as free nerve endings in the fibrous capsule, adipose tissue, ligaments, menisci, the periosteum, and in the synovial layer. The cartilage is not innervated [1,2].

A large proportion of articular sensory neurons are peptidergic, containing substance P, CGRP, and somatostatin, but neurokinin A, galanin, enkephalins and neuropeptide Y have also been found. Neuropeptides influence the inflammatory process in the periphery and modify spinal processing of joint input. They may also affect joint afferents themselves [2].

*Response properties of joint afferents.* In single fiber recordings, joint afferents have been classified according to their mechanosensitivity. More than 50% of the A $\delta$  fibers and most C fibers with a detectable receptive field are able to encode noxious mechanical stimuli applied to the joint. They are either weakly activated by innocuous stimuli (light to moderate pressure and movements within the joint's normal working range) and strongly activated by noxious stimuli (high intensity pressure that causes pain when applied to humans, and movements against the resistance of the tissue beyond the limit of the joint's normal working range), or they are exclusively activated by noxious stimuli. Fibers activated by noxious mechanical stimuli are thought to be the nociceptors that cause pain upon forceful twisting of the normal joint [1,2].

Some A $\delta$  fibers and a significant proportion of C fibers do not respond to any mechanical stimulus applied to the normal joint. These "initially mechanoinensitive" or "silent nociceptors" are only activated during inflammation [1,2]. In contrast, most A $\beta$  fibers and about half of the A $\delta$  fibers are low threshold units and are strongly activated by innocuous mechanical stimuli. Their message might be used to control movements and to prevent unphysiological movements. Although these units may maximally discharge during noxious stimuli, their overall discharge pattern does not discriminate between innocuous and noxious stimuli [1,2].

Most A $\delta$  and C fibers are chemosensitive (e.g. respond to inflammatory mediators such as prostaglandins, bradykinin and others). Chemosensitivity plays a major role in the excitation and sensitization of neurons during inflammation (see below).

*Spinal cord neurons with joint input.* Neurons with joint input are located in the superficial and deep dorsal horn. Their distribution matches the spinal termination of joint afferents which project to the superficial and, in particular A $\beta$  and A $\delta$  fibers, to the deep dorsal horn [1,2]. These neurons are either exclusively driven by input from deep tissue (typically from the joint and adjacent muscles), or they exhibit convergent inputs from skin, joint and adjacent muscles. Most neurons with deep input only are high-threshold and require noxious pressure onto joint and/or muscle and noxious movements to be activated, like articular nociceptors. Most neurons with convergent inputs from deep tissue and skin are wide dynamic range neurons which respond to innocuous and noxious pressure applied to deep tissue in a graded fashion. They may be activated by movements in the working range, but show much greater responses to painful movements. Often deep tissue receptive fields are located more rostral than cutaneous receptive fields [1,2].

Neurons with joint input project to different supraspinal sites (e.g. cerebellum, spinocervical nucleus,

thalamus, reticular formation) that subserve the generation of the conscious response and adaptations to pain, or they project to intraspinal (segmental) interneurons and motoneurons [1,2]. Noxious stimulation of joint afferents, acute chemical stimulation and inflammation of the knee can evoke nociceptive withdrawal reflexes and enhance spinal motor reflexes. However, during joint inflammation some  $\gamma$ -motoneurons develop progressive inhibition rather than facilitation, showing modification of the reflex pattern. Articular dysfunction and ligamentous strain can elicit muscle spasms [2].

Most spinal cord neurons with joint and muscle input are tonically inhibited by descending inhibitory systems that modulate spinal cord activity. These neurons are also inhibited by DNIC, diffuse noxious inhibitory control mechanisms [2].

*Supraspinal neurons with input from the joint.* The thalamus and cortex contain nociceptive neurons that are activated by nociceptive input from the joint. Most of these neurons have convergent inputs from skin and deep tissue. In the thalamus, such neurons are located in the ventrobasal complex, in the posterior complex and in the medial nucleus. Similarly, the somatosensory cortex contains a large proportion of neurons that respond to noxious stimulation, and a small proportion of these neurons is driven by deep input [2].

### Peripheral and Central Sensitization During Joint Inflammation

*Sensitization of joint afferents.* An important mechanism for the heightened pain sensitivity during inflammation is increased mechanosensitivity of joint afferent fibers. During development of inflammation in the joint, some low threshold A $\beta$  fibers show transiently increased responses to joint movements. Importantly, the majority of A $\delta$  and C fibers show persistent increased mechanosensitivity. Many low threshold A $\delta$  and C fibers show increased responses to innocuous and noxious movements. Most strikingly, a large proportion of high threshold afferents is sensitized and begin to respond to innocuous movements; they may also develop ongoing discharges in the resting position. Mechanical sensitization is also an important neuronal basis for persistent hyperalgesia during chronic arthritis [1,2].

Furthermore, initially mechanoinensitive (silent) nociceptors are sensitized. While these fibers are unresponsive to mechanical stimuli applied to the normal joint, they can develop mechanosensitivity within 1–4 h after onset of inflammation, after which they respond to movements of the joint and a receptive field upon mechanical stimulation of the inflamed tissue. Thus inflammation “recruits” further nociceptive sensory neurons for signaling of noxious events [1,2].

*Development of ▶spinal hyperexcitability.* In the course of joint inflammation, spinal cord neurons with joint input develop a state of hyperexcitability. Spinal

cord neurons with high threshold show a decrease of their excitation threshold such that they are activated by innocuous stimuli applied to the inflamed tissue. Both high threshold and wide dynamic range neurons show a marked increase in response to noxious stimulation of the inflamed tissue. These mechanisms contribute to ▶primary hyperalgesia at the inflamed joint. With a similar time course, the neurons also give enhanced responses to mechanical stimuli applied to adjacent and even remote healthy tissue, and the total receptive field may expand. Thus the sensitivity of the spinal cord neuron is increased so that previous subthreshold inputs are now sufficient to excite the neuron. Central sensitization can persist during chronic unilateral arthritis and chronic polyarthritis [1,2].

The changes in the spinal cord are likely to account for deep referred pain and ▶secondary hyperalgesia that are induced in humans by noxious stimulation of deep tissue. Numerous pathological conditions such as inflammation and OA seem to be associated with central sensitization. When a noxious stimulus (e.g., intramuscular injection of 6% NaCl), is applied to a muscle, the area in which pain is felt is larger during pathological conditions such as OA [6], suggesting a state of central sensitization.

Sensitized nociceptive afferents from inflamed tissue play a key role in initial sensitization. Obviously, these afferents not only evoke enhanced synaptic activation of spinal cord neurons to stimulation of inflamed tissue, but they also trigger the processes that increase sensitivity of spinal cord neurons. Interestingly, stimulation of primary afferents from deep tissue (muscle and joint) evokes more prolonged facilitation of nociceptive flexor reflexes than stimulation of cutaneous afferents, and capsaicin injection into deep tissue elicits more prolonged hyperalgesia than injection of capsaicin into the skin, suggesting that deep input is particularly able to induce long-term changes in the nociceptive system [2].

Tonic descending inhibition as well as DNIC are increased during acute inflammation, but may be normalized in the chronic stage of inflammation. Interestingly, inhibition is mainly observed on neurons with input from the inflamed region (thus attenuating primary hyperalgesia), but processing in neurons with input from neighboring tissues may instead be enhanced, thus facilitating secondary hyperalgesia [2].

*Enhanced activity at the thalamocortical level.* In polyarthritic rats, many neurons in the ventrobasal complex respond to movements and gentle pressure onto inflamed joints and often show long-lasting afterdischarges whereas only few neurons respond to these stimuli in normal rats. Furthermore, neurons in the nucleus centralis lateralis acquire input from the inflamed joint that is not apparent in normal animals. Similarly, neurons in superficial cortical layers that do

not respond to joint stimulation in normal rats start to respond to joint stimulation in polyarthritic rats [2]. These findings indicate substantial neural plasticity at the thalamocortical level that may contribute to inflammatory deep tissue pain. It is unknown whether these alterations mirror the altered spinal processing or whether additional elements of neural plasticity are generated in the thalamus and/or cortex.

### Molecular Mechanisms of Peripheral Sensitization

Sensitization (►Peripheral sensitization) results from the effect of inflammatory mediators that bind to receptors in the membrane of sensory nerve endings, and from changes in the intrinsic properties of the neurons. Dorsal root ganglion (DRG) or trigeminal neurons from inflamed tissue maintain enhanced excitability even when the neurons are removed from the ganglion and acutely dissociated several days after inflammation of the joint [7].

Effects of inflammatory mediators on joint afferents have been summarized in detail elsewhere [2]. These mediators affect A $\delta$  and/or C fibers, not A $\beta$  fibers, they have an effect only in subpopulations of the units, they may affect high as well as low threshold A $\delta$  and C fibers, and they render some silent nociceptors mechanosensitive.

Injection of bradykinin into the joint artery causes an immediate short-lasting activation (<1 min) of joint afferents and a sensitization to subsequent mechanical stimuli that lasts minutes (even when bradykinin did not excite the neuron). Both PGE<sub>2</sub> and PGI<sub>2</sub> cause ongoing discharges and/or sensitization to mechanical stimulation of the joint and sensitize joint afferents to the effects of bradykinin. PGE<sub>2</sub> and bradykinin together can cause a greater mechanical sensitization than bradykinin or PGE<sub>2</sub> alone. Conversely, NSAIDs such as aspirin and indomethacin, which block prostaglandin synthesis, reduce spontaneous discharges from acutely and chronically inflamed joints and attenuate responses to mechanical stimulation. Serotonin also sensitizes joint afferents to mechanical stimuli [1,2]. Cytokines such as TNF $\alpha$ , interleukin1- $\beta$  and interleukin-6 (IL-6) are of particular importance to the progression of arthritis. They play an important role in neuropathic pain, but IL-6 also induces a long-lasting sensitization of C fibers of the joint to mechanical stimulation [8].

ATP, adenosine, capsaicin and anandamide excite proportions of joint afferents (the latter suggesting the presence of the TRPV1 receptor). Substance P and VIP (vasoactive intestinal polypeptide) increases, whereas somatostatin and endomorphin reduces mechanosensitivity in numerous afferents; galanin, neuropeptide Y, and nociceptin sensitize some neurons and reduce responses of other neurons. Whether the different patterns of peptide effects (excitation or inhibition) are dependent on the functional state of the neuron is not known.

Receptor expression in DRG neurons can change in the course of arthritis (e.g. downregulation of mu-opioid receptors or biphasic regulation of somatostatin receptors [9]). Disease processes are dynamic and, therefore, it is likely that different cells and molecules are important at different times in chronic inflammatory or degenerative processes [4]. Hence the molecular mechanisms of nociception may change over time.

### Molecular Mechanisms of Spinal Sensitization

During development of inflammation in the joint, the intraspinal release of glutamate and neuropeptides is enhanced [2]. In the normal joint, only noxious compression of the joint enhances the intraspinal release of substance P, neurokinin A and CGRP above baseline. In the inflamed joint, these excitatory peptides are released intraspinally even by innocuous joint compression [2]. In addition, the intraspinal milieu is altered by (enhanced) release of other mediators (e.g. PGE<sub>2</sub>) [2].

Both AMPA/kainate (non NMDA) and NMDA receptors are involved in the generation and maintenance of inflammation-induced spinal hyperexcitability. Antagonists at both receptor types can reduce responses of spinal neurons to mechanical stimulation even in a chronic model of inflammation [2]. The excitatory neuropeptides (see above) facilitate the responses of spinal neurons to mechanical stimulation of the joint and further the development of inflammation-evoked hyperexcitability [2]. Topical application of PGE<sub>2</sub> to the spinal cord surface facilitates the responses of spinal neurons to mechanical stimulation of the joint, as also produced by knee joint inflammation, and topical application of the COX inhibitor indomethacin to the spinal cord before inflammation attenuates the development of hyperexcitability, showing that spinal prostaglandins are involved in the generation of inflammation-evoked spinal hyperexcitability [10].

### References

1. Schaible H-G, Grubb BD (1993) Afferent and spinal mechanisms of joint pain. *Pain* 55:5–54
2. Schaible H-G (2006) Basic mechanisms of deep somatic pain. In: McMahon SB, Koltzenburg M (eds) *Wall and Melzack's textbook of pain*, 5th edn. Elsevier, Amsterdam, pp 621–633
3. Kellgren JH, Samuel EP (1950) The sensitivity and innervation of the articular capsule. *J Bone Joint Surg* 32B:84–91
4. Scott DL (2006) Osteoarthritis and rheumatoid arthritis. In: McMahon SB, Koltzenburg M (eds) *Wall and Melzack's textbook of pain*, 5th edn. Elsevier, Amsterdam pp 653–667
5. Felson DT (2005) The sources of pain in knee osteoarthritis. *Curr Opin Rheumatol* 17:624–628

6. Bajaj P, Graven-Nielsen T, Arendt-Nielsen L (2001) Osteoarthritis and its association with muscle hyperalgesia: an experimental controlled study. *Pain* 93:107–114
7. Flake NM, Gold MS (2005) Inflammation alters sodium currents and excitability of temporomandibular joint afferents. *Neurosci Lett* 384:294–299
8. Brenn D, Richter F, Schaible H-G (2007) Sensitization of unmyelinated sensory fibres of the joint nerve for mechanical stimuli by interleukin-6 in the rat. An inflammatory mechanism of joint pain. *Arthritis Rheum* 56:351–359
9. McDougall J (2006) Arthritis and pain: neurogenic origin of joint pain. *Arthritis Res Ther* 8:220–229
10. Vasquez E, Bär K-J, Ebersberger A, Klein B, Vanegas H, Schaible H-G (2001) Spinal prostaglandins are involved in the development but not the maintenance of inflammation-induced spinal hyperexcitability. *J Neurosci* 21:9001–9008

## Joint Position Sense

### Definition

The ability to detect the position of joints of the body. It is tested clinically as part of assessments of proprioception.

#### ► Position Sense

## Joint Sense

#### ► Proprioception Role of Joint Receptors

## Joints

JOHN ROBERT MATYAS

Faculty of Veterinary Medicine, University of Calgary, Calgary, AB, Canada

### Definition

The union of two or more rigid elements of the skeleton. Commonly referring to an articulation of the skeleton where two or more adjacent bones meet and move

relative to one another. Also refers to articulations of the exoskeletal elements of invertebrates – especially arthropods and bivalves. In vertebrates, each joint is an independent organ system that is variously composed of bones, ► **cartilages**, articular cartilages, intra-articular ► **fibrocartilages** (e.g. disc, meniscus, labrum), joint capsule, ligaments, tendons, retinaculae, fat pads, and ► **synovium** (Fig. 1).

### Characteristics

Joints can be classified into two types based on macroscopic inspection: diarthroses have a cleft that separates the skeletal elements; in synarthroses, solid tissue connects the skeletal elements. This macroscopic classification is extended by microscopic inspection. Diarthroses are all termed “synovial” joints, whereas synarthroses are subclassified based on histomorphology into “cartilaginous” and “fibrous” joints.

Synovial joints are characterized by hyaline articular cartilages, which form a thin veneer on the ends of the bones, and contain a small volume of synovial fluid in the so-called joint cavity. Synovial joints are enveloped by a joint capsule, which consists of a tough outer layer that helps stabilize the joint, and a delicate inner synovial layer, which produces synovial fluid. Synovial joints typically allow substantial movement (e.g. the knee and hip); a few synovial joints such as the sacroiliac joint have relatively little motion between

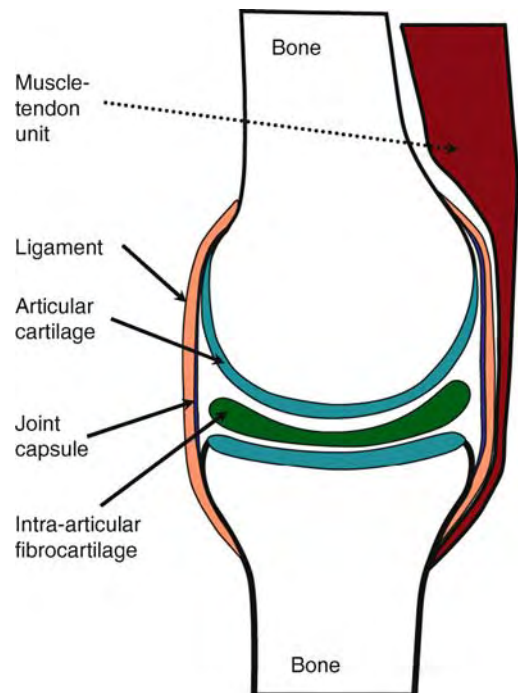

**Joints. Figure 1** Joints may be classified based on their histomorphology, shape, or the quantity and quality of joint movement.

the bony segments, as its joint capsule is highly reinforced with many stout ligaments. Embryonic movement caused by muscle contraction is necessary for the normal development of synovial joint tissues, as well as for the formation of the joint “cavity.” Normally the joint cavity contains a small volume of synovial fluid, which is viscous and is enriched with special molecules (notably hyaluronan and the glycoprotein known variously as lubricin, superficial zone protein, and megakaryocyte stimulating factor [1]) that have very low coefficients of friction.

Cartilaginous joints lack joint cavities characteristic of synovial joints, and their apposing bone surfaces are joined by cartilaginous or fibrocartilaginous elements. Compared to most synovial joints, cartilaginous joints allow relatively little movement. The pubic symphysis and the **▶intervertebral disc** are typical examples of cartilaginous joints. During long bone growth, the growth plate cartilage separates two parts of the growing bone, and is said to form a cartilaginous joint known as a synchondrosis. Fibrous joints also lack joint cavities, and the apposing bone surfaces are joined by a fibrous rather than cartilaginous connective tissue. Compared to synovial and cartilaginous joints, fibrous joints typically allow even less motion among the skeletal elements. In humans, there are three types of fibrous joints: **▶suture**, syndesmosis and gomphosis. Suture is found between the flat bones of the skull, syndesmoses refer to the tibiofibular and radioulnar interosseous membranes, and gomphoses refers to the union of the teeth and the jaw bones, which are connected in the tooth socket by the specialized periodontal ligament.

Joints can also be classified based on shape (Table 1). As shape is a primary determinant of joint motion, it is possible to define the primary motions allowed by the number of rotational axes (uniaxial, biaxial, triaxial). Gliding joints may not have any rotational axes and their motion can be called multiaxial.

Joints serve two functions in opposition: motion and stability. The geometry of the bones and cartilages largely determines the mobility of a joint; the degree of internal and external support offered by the geometry of the ligaments and intra-articular cartilages largely determines joint stability. The bones, cartilages, capsule, and ligaments confer “static” stability to the joint; the tendons, by virtue of their attachment to skeletal muscle, confer “dynamic” support to the joint and can influence joint stability depending on the state of neuromuscular tone. The static constraints of joints define the normal range of joint motion; when this normal range is exceeded, one or more of the static constraints of the joint sustains a so-called hyperextension or hyperflexion injury. When the stabilizing structures fail to keep the bones in their normal position, the joint is said to be either fully or partially dislocated (subluxed). Dislocation or

subluxation is a pathological state of the joint, typically associated with excessive laxity (e.g. Ehlers Danlos, a family of genetic diseases of collagen and other extracellular matrix proteins) or trauma.

Joints can also be classified functionally [2,3], based on the relative quantity of movement taking place at an articulation (Table 2). Similarly, the quality of movement between the opposing elements of a joint can be categorized (Table 3). Common movements of freely moving joints have special denominations (Table 4).

With the possible exceptions of synovium and bone, the physiology of the various connective tissue organs in joints is typically absent from textbooks. As the main function of the joint is to transmit loads from bone to bone, the functional anatomy of joints historically has been described in textbooks of biomechanics (the study of mechanical and material behavior of biological organs) and kinesiology (the study of bodily movement). Until recently, joint connective tissue organs have challenged physiologists, in part because many of the traditional physiological methods (e.g. measurements



**Joints. Table 1** Joints categorized by shape

Shape category	Primary motion	Example
Ball-and-socket	Triaxial	Hip, shoulder
Hinge (ginglymus)	Uniaxial	Ankle, elbow
Saddle (sellar)	Biaxial	Thumb
Ellipsoid (condyloid)	Biaxial	Knee
Plane (gliding)	Multiaxial	Sternoclavicular joint
Pivot	Uniaxial	Atlantoaxial joint

**Joints. Table 2** Joints categorized by amount of movement

Relative movement	Functional category	Morphological classifications
Minimal movement	Synarthroses	Fibrous joints (sutures, gomphoses)
		Cartilaginous joints (growth plates)
Modest movement	Amphiarthroses	Fibrous joint (interosseous ligaments)
		Cartilaginous joint (symphysis, intervertebral disc)
Free movement	Diarthroses	Synovial joints

**Joints. Table 3** Joints categorized by type of movement

Joint movement	Description of movement
Gliding	Surfaces sliding against one another
Angulation	Movement of a bone at an angle relative to a point of contact (rolling/sliding)
Rotation	Rotation (spin) about an axis with respect to a point of contact
Circumduction	Complex circular motion of a bone with respect to its contact surface that may include gliding, angular movement, and rotation

**Joints. Table 4** Joints movements action

Movement	Definition	Example
Adduction, Abduction,	Toward, away from the midline	Arm, fingers
Flexion, Extension	Reduces, increases angle of joint	Elbow, knee
Plantarflexion, dorsiflexion	Foot aimed down, up	Ankle
Protraction, retraction	Outward, inward	Jaw
Elevation, depression	Up, down	Jaw, Shoulders
Inversion, eversion	Medial, Lateral rotation	Foot
Pronation, Supination	Medial, lateral rotation	Forearm, Foot
Circumduction	Complex movement arc	Shoulder, thumb
Opposition	Moving thumb to fingers	Thumb
Lateral flexion	Movement from the midline	Spine

of blood flow, gas exchange, electrolyte flux, and electrophysiology) are relatively insensitive when applied to tissues that contain relatively few cells, vessels, and nerves. Nonetheless, joint physiology, particularly the physiology of joint pain, is a rapidly emerging and important area of study.

Unlike articular cartilage, which lacks both vessels and nerves, the synovium and the bones are rich in small diameter blood vessels as well as nerves, which make them common sites of joint inflammation that is known as ►**arthritis**, a disease that is often associated with joint pain known as ►**arthralgia**. The collection of antigen-antibody complexes in the small vessels of the synovium can induce the release of bioactive factors from reactive leukocytes and cause arthralgia, either acutely (e.g. the common cold) or chronically (e.g. systemic inflammatory diseases). Inflamed synovial joints typically contain large volumes of dilute synovial fluid and can contain numerous leukocytes. In certain autoimmune diseases characterized by chronic systemic inflammation (e.g. rheumatoid arthritis), the inflamed synovium forms a so-called “pannus,” a membranous structure filled with inflammatory cells that can secrete various enzymes and factors that are locally destructive. Some metabolic diseases promote the formation of crystals (e.g. sodium urate, calcium pyrophosphate, calcium oxalate, homogentisic acid) in joint tissues,

which typically induces a destructive inflammatory response. Synovial joints are normally sterile, but they can frequently be seeded with infectious organisms, a condition known as septic arthritis, which can cause considerable destruction of joint tissues. Possibly, due to their hypovascularity, neoplastic diseases of joints are exceedingly rare, though some bone tumors may cause joints to fail when the weakened bony support beneath the articular cartilages collapses.

The destruction of joint tissues, whether by injury or inflammation, leads to abnormal joint function, which is known as ►**arthropathy**. The progressive destruction of joint tissues ultimately leads to joint failure when the joint can no longer function properly. Joint failure can be initiated by insufficiencies in the cartilages, ligaments, bones, and intra-articular fibrocartilages. The loss of the articular cartilage is a hallmark pathological feature of osteoarthritis, a so-called degenerative joint disease. Osteoarthritis is the most prevalent joint disease; it most commonly involves the mobile weight-bearing joints (hip, knee, shoulder) as well as the fingers, but occurs only rarely in the ankle. The etiology of osteoarthritis is unknown and its course is both insidious and progressive. As the articular cartilage contains no nerves, the underlying disease process may precede significantly the onset of symptoms. Treatments and therapies for osteoarthritis

are directed at managing the symptoms of the disease, primarily to reduce pain and inflammation.

Depending on the size and location, failed joints may be replaced by artificial joints (endoprotheses), either totally or partially. Total joint replacement (total joint ►arthroplasty) involves the complete surgical replacement of the articulating surfaces of the joints and usually their bony support with artificial materials, typically with composites of metal and plastic. Partial joint replacements (hemiarthroplasties) are surgeries in which one side of a joint or one surface of a joint is replaced. Interpositional arthroplasty is reconstructive surgery that reshapes part of a joint and adds an artificial ►prosthesis (e.g. a plastic or metal disc) between the bones forming a joint. Regardless of material, artificial joints do not have the regenerative abilities of biological tissues and repeated loading of these inanimate materials eventually leads to material fatigue and failure. Hence, after receiving a joint replacement, younger active patients may be faced with a revision or replacement arthroplasty. There is currently considerable interest and research in bioprosthesis, which are biological replacement materials developed by ►tissue engineering, for use in arthroplasty.

## References

1. Jay GD, Tantravahi U, Britt DE, Barrach HJ, Cha CJ (2001) Homology of lubricin and superficial zone protein (SZP): products of megakaryocyte stimulating factor (MSF) gene expression by human synovial fibroblasts and articular chondrocytes localized to chromosome 1q25. *J Orthop Res* 19:677–687
2. Martini FH (2001) Articulations. In: Martini FH (ed) *Fundamentals of anatomy and physiology*, 5th edn. Prentice Hall, Upper Saddle River, NJ, USA, pp 245–269
3. Williams et al. (1995) Arthrology. In: *Gray's anatomy*, 38th British edn. Churchill Livingstone Edinburgh, pp 484–510

## J1/Tenascin

### Definition

Also called tenascin-R and is one member of the tenascin family.

## Jun

### Definition

A family of proteins involved in the formation of transcriptionally active complexes. Members of the Jun family (c-Jun, JunB and JunD) can dimerize with each other as well as members of the Fos protein family to form these active complexes. In some neuronal populations axon injury increases the expression of c-Jun and the active transcription factor AP-1.

## Junctin

### Definition

A 20-kDa transmembrane protein located in the junctional sarcoplasmic reticulum (terminal cisternae) that forms a supramolecular complex with casepuestrin, triadin and RyRI, the sarcoplasmic reticulum  $Ca^{2+}$  release channel in skeletal muscle, which functions to anchor casepuestrin and thereby increase  $Ca^{2+}$  buffering close to sites of SR  $Ca^{2+}$  release.

►Excitation-Contraction Coupling

## Jurassic

### Definition

The period between 170 and 130 million years ago.

## Just-Noticeable Difference

### Definition

►Sensory Systems



---

## Kölliker-Fuse Nucleus

### Synonyms

Nucl Subparabrachialis (Kölliker-Fuse); Subparabrachial nucleus (Kölliker-Fuse)

### Definition

The nucleus belongs to the parabrachial area and partially corresponds to the functionally defined pneumotactic center. The nucleus receives afferents from the caudal part of the solitary nucleus and the ventrolateral superficial reticular area.

Efferents ascend to the preoptic area and to the central amygdaloid nucleus. The most important efferents go to the lower myelencephalon and the spinal cord.

► Diencephalon

---

## K<sup>+</sup>-aggravated Myotonia

### Definition

► Non-dystrophic Myotonias

---

## K<sup>+</sup> Channels

### Definition

► Neuronal Potassium Channels

---

## K<sub>ATP</sub> Channels

### Definition

► Neuronal Potassium Channels

---

## Kainate Receptors

### Definition

One of the subtypes of ionotropic glutamate receptors that are activated pharmacologically by kainate.

- Glutamate Receptor Channels
- Memory, ► Molecular Mechanisms
- Associative Long-Term Potentiation (LTP)
- Long-Term Potentiation (LTP)

---

## Kalman Filter

### Definition

The Kalman Filter is a process whose inputs are noisy incomplete measurements of a linear stochastic system and whose outputs are optimal estimates of all system variables.

- Modeling of Human Postural Control
- Neural Networks for Control

## Kanizsa Square

### Definition

- ▶ Form Perception
- ▶ Perceptual Filling-in
- ▶ Visual Illusions

## KCC2

### Definition

A neuron-specific K-Cl cotransporter that induces a developmental shift to render GABAergic transmission from depolarizing to hyperpolarizing.

- ▶ Development of the Respiratory Network

## K-complex

### Definition

A high amplitude ( $>100 \mu\text{V}$ ), slow potential ( $\sim 0.5 \text{ s}$ ) recorded on the electroencephalogram (EEG) from the cerebral cortex. It was originally observed following auditory stimulation (K for knock) in drowsy individuals. More recently, a similarly shaped wave was recognized in the slow EEG oscillations during sleep, particularly Stage 2 slow wave sleep in humans. In this case, the K-complex is often followed by a sleep spindle (spindle shaped bursts of waves at 12–14 Hz), recurring several times a minute and also evocable by sensory stimulation.

- ▶ Alpha Rhythm
- ▶ Beta Rhythm
- ▶ Brain Rhythms
- ▶ Delta Waves/Rhythm
- ▶ EEG in Sleep States
- ▶ Electroencephalography
- ▶ Sleep States
- ▶ Sleep-Wake Mechanisms
- ▶ Slow wave sleep
- ▶ Theta Rhythm

## Kernicterus

### Definition

Kernicterus is the pathological term to indicate the deposition of unconjugated bilirubin with a characteristic pattern in the brain causing degenerative lesions.

Brainstem regions typically affected in kernicterus include the basal ganglia, especially the globus pallidus and subthalamic nucleus, metabolic sector of the hippocampus, oculomotor nuclei and ventral cochlear nuclei. Other susceptible areas are the cerebellum, especially Purkinje cells. Abnormalities of the auditory brainstem nuclei are associated with deafness, hearing loss, and a new entity known as auditory neuropathy. The term bilirubin encephalopathy is used to denote the clinical condition associated with elevated bilirubin.

- ▶ Encephalopathy (or Acute Organic Brain Syndrome)
- ▶ Glial and Neuronal Reactivity to Unconjugated Bilirubin

## Key Stimulus

### Definition

Stimulus that elicits a certain behavior just as a key fits into a lock. The red belly of a stickleback male elicits fighting behavior in other males (see also Sign Stimulus).

## KH Domain

### Definition

An RNA binding motif identified first in the hnRNPK (heterogeneous nuclear ribonucleoprotein K).

- ▶ Alternative Splicing and Glial Maturation

## Kidney

- ▶ Visceral Afferents

## Kinase

### Definition

An enzyme that regulates a phosphorylation–dephosphorylation reaction.

## Kinds, Natural

### Definition

A natural kind is a class of (relevantly) similar things; membership in that class is determined by the presence of a presumed underlying common nature. Natural kind terms like “oak,” “water” or “tiger” refer to classes of things with theoretically interesting essences which may be unknown to us or about which we may be mistaken. Scientific essentialism holds that the essences of kinds – what it is for something to be an oak, water or a tiger – are not stipulated by definition, but discovered by means of empirical investigation. That for something to be water is for it to be  $H_2O$ , for instance, was the empirical discovery of the essence of the thing people use to call “water” (but did not change the meaning of the term “water”). If this is correct, reality is populated by mind-independent natural kinds of things, which are characterized as such by the fundamental, intrinsic causal powers which they possess, although there are lively debates in biology and philosophy about precisely what factors determine a kind’s essence.

► Epiphenomenalism

## Kinematics of Deformation

MARCELO EPSTEIN

SCHULICH SCHOOL OF ENGINEERING  
University of Calgary, Calgary, AB,  
Canada

### Definition

The part of ► mechanics that deals with the geometric description of motion and ► deformation.

### Description of the Theory

Leaving aside the rigorous definition of a ► material body and of classical space-time as ► differentiable manifolds, the notion of a ► configuration, that is a manifestation of the body in space, is accepted as a primitive concept. Two configurations are related by a *deformation*, namely a mapping between the positions of the material particles (making up the body) in the first (or *reference*) configuration and their counterparts in the second (or *spatial*) configuration. The reference configuration is assumed to be fixed, while the spatial configuration evolves in time. Adopting (for simplicity, Cartesian) coordinate systems  $X^I$  and  $x^i$ , respectively in the reference and spatial configurations, a deformation is represented by three smooth invertible functions of the form  $x^i = x^i(X^I, X^2, X^3)$ , with  $i = 1, 2, 3$ . A *motion* is a one-parameter family of deformations  $x^i = x^i(X^I, X^2, X^3; t)$ , the parameter  $t$  representing time. The ► *deformation gradient* at a point  $\mathbf{X}$  and at time  $t$  is the two-point tensor  $\mathbf{F}$  whose matrix representation in the coordinate systems used is:

$$F_i^I = \frac{\partial x^i}{\partial X^I}, \quad (1)$$

where the partial derivatives are calculated at the point in question and at the given time.

To interpret its physical meaning, let  $dx^i$  be the components of a small spatial segment made up of the material particles comprising the segment with components  $dX^I$  in the reference configuration. By the chain rule of differentiation:

$$dx^i = F_i^I dX^I. \quad (2)$$

In this formula and henceforth, ► Einstein’s summation convention for diagonally repeated indices is used. The matrix  $\mathbf{F}$  contains thus all the information regarding the first-order approximation of the deformation in the neighborhood of the point. For obvious reasons, it is convenient to split this information into that part that corresponds to a mere rigid-body motion of the neighborhood and the part corresponding to an actual change of size and shape. According to the ► polar decomposition theorem of algebra, every non-singular

## Kinematics

### Definition

As regards biomechanics, kinematics refers to the description of the orientation and motion of objects (position, velocity, acceleration) using words, diagrams, numbers, graphs, and equations, without considering the forces that act on these objects.

matrix  $\mathbf{F}$  is uniquely decomposable into the product of an orthogonal matrix  $\mathbf{R}$  and a symmetric positive-definite matrix  $\mathbf{U}$ , as follows:  $\mathbf{F} = \mathbf{R}\mathbf{U}$ . The orthogonal matrix  $\mathbf{R}$  represents a rigid rotation (possibly followed by a reflection), while the matrix  $\mathbf{U}$ , when expressed in an orthogonal eigenbasis, can be reduced to a diagonal form, clearly showing that it represents stretches in three mutually perpendicular (principal) directions. Each of the principal stretches is the ratio between the new and the original length of an infinitesimal length element along the corresponding principal direction. The tensor  $\mathbf{C} = \mathbf{U}^2$  is called the *right Cauchy-Green tensor*. The tensor  $\mathbf{E} = (\mathbf{C} - \mathbf{I})/2$  ( $\mathbf{I}$  being the identity) is known as the *Lagrangian strain tensor*. It vanishes if, and only if, the deformation of the neighborhood is rigid. There exists an alternative (left) polar decomposition of the form  $\mathbf{F} = \mathbf{V}\mathbf{R}$ , where  $\mathbf{V} = \mathbf{R}\mathbf{U}\mathbf{R}^T$  is symmetric and positive-definite. It differs from the previous one by the order in which the effects of stretching and rotation are applied. The square  $\mathbf{B} = \mathbf{V}^2$  is called the *left Cauchy-Green tensor*. Let  $J$  denote the determinant of  $\mathbf{F}$ . Since the rotation tensor  $\mathbf{R}$  has a unit determinant, it follows from the polar decomposition theorem that  $J = \det(\mathbf{U}) = \det(\mathbf{V})$ . But the determinant of  $\mathbf{U}$  is the product of the three principal stretches and therefore represents the ratio between the spatial and the referential volume elements occupied by the same material particles. Denoting the referential and spatial volume elements respectively by  $d\omega$  and  $d\Omega$ ,

$$d\omega = J d\Omega. \tag{3}$$

A motion with a point-wise constant  $J$  (as time goes on) is called *isochoric* or *volume preserving*. Let  $\mathbf{N}$  and  $\mathbf{n}$  denote the unit exterior normals to elements of area  $dA$  and  $da$  in the reference and spatial configurations, respectively, comprising the same material particles. It can be shown that they are related by:

$$da \mathbf{n} = J \mathbf{F}^{-T} dA \mathbf{N}. \tag{4}$$

Equations 2, 3 and 4 clearly display the geometrical significance of the deformation gradient in relating linear, area and volume dimensions of corresponding first-order material neighborhoods in the reference and spatial configurations.

The *velocity*  $\mathbf{v}$  of a particle  $\mathbf{X}$  at time  $t$  is given in spatial components as:

$$v^i = \frac{\partial x^i}{\partial t}, \tag{5}$$

where the partial derivatives are calculated at  $\mathbf{X}$  and  $t$ . Any field  $\psi$  of interest (for example, temperature), can be given in its *spatial* (or *Eulerian*) or in its *referential* (or *Lagrangian*, or *material*) description. In the spatial description the field is specified as a function of the spatial coordinates  $x^i$  and time,  $\psi = \psi(x^i, t)$ , while the referential description makes use of the referential

coordinates  $X^I$  and time,  $\psi = \psi_o(X^I, t)$ . The two descriptions are related by the motion, namely,

$$\psi = \psi(x^i, t) = \psi(x^i(X^I, t), t) = \psi_o(X^I, t). \tag{6}$$

The partial time-derivative of the function  $\psi_o(X^I, t)$  represents the rate of change of  $\psi$  at a specific particle, while the partial time-derivative of the spatial description  $\psi(x^i, t)$  represents the rate of change of  $\psi$  as seen by an observer fixed in space. Thus, for instance, in steady-state conditions of flow of a liquid through a tapered pipe, the spatial observer would report a zero rate of speed, while in fact the particles themselves are accelerating. To recover the particle-wise rate of change from the spatial description the chain rule of differentiation is applied to the previous equation to obtain:

$$\frac{D\psi}{Dt} = \dot{\psi} = \frac{\partial \psi_o}{\partial t} = \frac{\partial \psi}{\partial t} + \frac{\partial \psi}{\partial x^i} v^i, \tag{7}$$

where two alternative notations have been used to denote this *material time-derivative*. An interesting application is the calculation of the *acceleration*  $\mathbf{a}$  when the velocity field is given in the Eulerian description, as is often the case in fluid mechanics:

$$a^i = \frac{Dv^i}{Dt} = \frac{\partial v^i}{\partial t} + \frac{\partial v^i}{\partial x^j} v^j. \tag{8}$$

It is important to note that in the Lagrangian description (namely, when the velocity field is given as  $v^i = v^i(X^I, t)$ ), the acceleration is simply the partial time-derivative. The extra term needed in the Eulerian description is sometimes called the *convective term*. It consists of the contraction of the spatial gradient of the velocity with the velocity itself.

A hidden dependence on the choice of reference configuration affects the expression of physical quantities, particularly in the Lagrangian description. Let  $\mathbf{F}_0$  and  $\mathbf{F}_1$  represent the deformation gradients of the same spatial configuration with respect to two different reference configurations, with coordinates  $X^I$  and  $Y^I$  respectively and let  $\mathbf{H}$  denote the deformation gradient of the second with respect to the first, namely:

$$H^I_j = \frac{\partial Y^I}{\partial X^j}. \tag{9}$$

Clearly, by the chain rule,  $\mathbf{F}_0 = \mathbf{F}_1 \mathbf{H}$ . Taking the material time-derivative yields  $\dot{\mathbf{F}}_0 = \dot{\mathbf{F}}_1 \mathbf{H}$ , since  $\mathbf{H}$  is independent of time. The product  $\mathbf{L} = \dot{\mathbf{F}}_0 \mathbf{F}_0^{-1} = \dot{\mathbf{F}}_1 \mathbf{F}_1^{-1}$  is, therefore, independent of reference configuration. To find its physical meaning, consider the material time-derivative of the polar decomposition, namely:

$$\dot{\mathbf{F}} = \dot{\mathbf{R}}\mathbf{U} + \mathbf{R}\dot{\mathbf{U}}, \tag{10}$$

whence:

$$\mathbf{L} = \dot{\mathbf{F}}\mathbf{F}^{-1} = \dot{\mathbf{R}}\mathbf{U}\mathbf{F}^{-1} + \mathbf{R}\dot{\mathbf{U}}\mathbf{F}^{-1}. \tag{11}$$

Since, as shown, this expression is independent of the reference configuration, the present configuration may be adopted as reference, whereby  $\mathbf{F}_t = \mathbf{R}_t = \mathbf{U}_t = \mathbf{I}$ , where the subscript  $t$  is a reminder of the peculiar choice of reference configuration. It may be concluded that:

$$\mathbf{L} = \dot{\mathbf{F}}_t = \dot{\mathbf{R}}_t + \dot{\mathbf{U}}_t. \quad (12)$$

It follows from the first equality in (12), by the commutativity of mixed partial derivatives, that  $\mathbf{L}$  is the *spatial velocity gradient*, so that Eq. 8 can be rewritten as:

$$a^i = \frac{\partial v^i}{\partial t} + L_j^i v^j. \quad (13)$$

Moreover, the tensors  $\mathbf{D} = \dot{\mathbf{U}}_t$  and  $\mathbf{W} = \dot{\mathbf{R}}_t$  are, respectively, the symmetric and skew-symmetric parts of  $\mathbf{L}$  and, according with Eq.10, can be interpreted as the “infinitesimal” versions of  $\mathbf{U}$  and  $\mathbf{R}$  in the polar decomposition theorem. They are known, respectively as the *stretching* (or *rate of deformation*) and the *spin* (or *vorticity*) tensors. Their component versions are:

$$D_{ij} = \frac{(v_{i,j} + v_{j,i})}{2}, \quad W_{ij} = \frac{(v_{i,j} - v_{j,i})}{2}, \quad (14)$$

where commas denote partial derivatives.

The content of an extensive physical quantity within a spatial volume  $\omega$  may be given in terms of the integral of a density  $\psi$ . As time goes on, this content will in general change. If the rate of change of this content is calculated following the material particles, the volume  $\omega$  will itself be a function of time, so that this is another instance of a material time-derivative. According with *Reynolds' transport theorem*:

$$\frac{D}{Dt} \int_{\omega} \psi d\omega = \int_{\omega} \left( \frac{D\psi}{Dt} + \psi \operatorname{div}(\mathbf{v}) \right) d\omega, \quad (15)$$

where *div* stands for the spatial divergence. Note that  $\operatorname{div}(\mathbf{v}) = \operatorname{trace}(\mathbf{L})$ . Invoking the *divergence theorem* of vector calculus, this equation can also be written as:

$$\frac{D}{Dt} \int_{\omega} \psi d\omega = \int_{\omega} \frac{\partial \psi}{\partial t} d\omega + \int_{\partial \omega} \psi \mathbf{v} \cdot \mathbf{n} da. \quad (16)$$

Just as in classical mechanics, the motion of a body presents itself differently to different observers. From the technical point of view, the physical space is a *Cartesian affine space*, which is roughly something that becomes a vector space once an origin is chosen. This vector space is endowed with a special inner (“dot”) product (consistent with the theorem of Pythagoras), which is assumed to have an intrinsic physical meaning. A *frame* consists of the choice of an origin and of a right-handed orthonormal basis (three unit and mutually perpendicular vectors). The coordinates of one and the

same point present themselves in two different frames, therefore, in ways that are not completely arbitrarily related, precisely because of this orthonormality. In other words, both frames must agree on the measurement of distances, and this is possible if, and only if, the coordinates  $x^i$  and  $x^{*i}$  in the two frames are related by the formula:

$$x^{*i} = c^i + Q_j^i x^j. \quad (17)$$

Here,  $Q_j^i$  are the entries of an orthogonal matrix, thus guaranteeing the preservation of the dot product, while  $c^i$  are the components (in the “starred” frame) of the vector that joins the two origins. Notice that a change of frame does not affect the reference configuration, only the spatial one. In fact, the reference configuration can be seen, in principle, as just a coordinate chart of the body manifold, without any connotation of “presence” in physical space.

As far as time is concerned, in the non-relativistic setting two observers may disagree only to the extent that their time measurements are related by  $t^* = t + a$ ,  $a$  being a real constant. Returning now to the complete space-time notion of observer, it is established that two physical observers can differ only by a time-dependent change of frame, so that the motions recorded by two observers must be related by:

$$x^{*i} = c^i(t) + Q_j^i(t) x^j. \quad (18)$$

Two observers are said to be *inertially related* if  $\ddot{c}^i(t) = \dot{Q}_j^i(t) \equiv 0$ , where a superimposed dot indicates differentiation with respect to time. These formulas correspond to the statement that the origins of the frames recede from each other at a constant velocity, while the relative orientation of the bases remains constant (no “relative angular velocity”). The equivalence relation of being inertially related splits all possible observers into equivalence classes, of which Isaac Newton affirms that one, and just one, is to be preferred to all others for the formulation of the laws of mechanics.

## References

1. Truesdell C, Toupin R (1960) The classical field theories. In: Flügge S (ed) *Handbuch der Physik*, vol III (part 1). Springer, Berlin
2. Truesdell C, Noll W (1965) The non-linear field theories of mechanics. In: Flügge S (ed) *Handbuch der Physik*, vol III (part 3). Springer, Berlin and New York
3. Eringen AC (ed) (1971) *Continuum physics*, vols I–IV. Academic, New York
4. Fung YC (1981) *Biomechanics*. Springer, New York
5. Gurtin M (1982) *An introduction to continuum mechanics*. Academic, New York
6. Chadwick P (1999) *Continuum mechanics: concise theory and problems*, 2nd edn. Dover, New York

## Kinesin

### Definition

A class of motor proteins in cells that move proteins along microtubules, usually from the cell body to the distal parts of the cell (i.e. in the direction of the plus end of microtubules). This form of transport is known as anterograde transport.

- ▶ Microtubules

## Kinesthesia

### Definition

Kinesthesia comes from the Greek word for motion. Strictly speaking, kinesthesia refers to the sense of movement of the limbs and body. The term is often, confusingly, taken to englobe the senses of movement and position, as well as the sense of effort.

- ▶ Movement Sense
- ▶ Proprioception and Orthopedics
- ▶ Proprioception Effect of Aging
- ▶ Proprioception Effect of Gravity
- ▶ Proprioception Role of Joint Receptors
- ▶ Proprioception Roles of Muscle Receptors

## Kinetic Energy

### Definition

In classical mechanics (of particles) the kinetic energy of a particle is given by one-half of the product of the mass of the particle times the square of its speed (the speed being the magnitude of the velocity vector). In continuum mechanics, the kinetic energy density is obtained in a similar manner using the mass density instead of the mass. The total kinetic energy is then obtained as the integral of the kinetic energy density over the body.

- ▶ Energy/Energetics
- ▶ Mechanics

## Kinetics

### Definition

As regards biomechanics, kinetics refers to the effects of forces acting on an object and how forces cause motion of an object.

## Kinetosis

### Definition

- ▶ Motion Sickness
- ▶ Anti-Motion Sickness Drugs

## Kinocilium

### Definition

A true cilium that is longer than the adjacent stereocilia and contains the transduction channels of the hair cell.

- ▶ Cochlea
- ▶ Hair Cells

## Kirchhoff's Conservation Laws

### Definition

Kirchhoff's current law states that, at any instant of time, the sum of the instantaneous values of all the electrical currents flowing towards a point (node) is equal to the sum of the instantaneous values of all the electrical currents flowing away from the point.

Kirchhoff's voltage law states that, at any instant of time, the algebraic sum of the voltage rises is equal to the algebraic sum of the voltage drops, both being taken in the same direction around the closed loop.

## Klenow Fragment

### Definition

DNA polymerase I from *E. coli* is commonly used in many applications of molecular biology. This holoenzyme not only has DNA polymerase activity but it also has 5'→3' and 3'→5' exonuclease activity. However, 5'→3' exonuclease activity is undesirable in some applications. When DNA polymerase I is exposed to the protease subtilisin the molecule is cleaved into two fragments. The smaller fragment retains the 5'→3' exonuclease activity. The larger fragment, the Klenow fragment, retains the DNA polymerase and 3'→5' exonuclease activity.

► Serial Analysis of Gene Expression

## Klippel-Feil Syndrome

### Definition

Klippel-Feil syndrome results from an unusual connectivity of ► [corticospinal neurons](#) that bifurcate to make connections to ► [motoneurons](#) on both sides resulting in bilateral voluntary movements.

► Corticospinal Neurons

## Klüver-Bucy Syndrome

### Definition

A behavioral syndrome first produced in 1937 when Heinrich Klüver and Paul Bucy removed large portions of the temporal lobes in monkeys. Monkeys with these ablations exhibited a profound loss of fear, as well as hypersexuality, hyperactivity and inappropriate mouthing of inedible objects. In general, it appeared that these amygdalotomized monkeys were unable to recognize the emotional or behavioral significance of visual stimuli. Subsequent studies suggested that most of these behavioral abnormalities were due to the removal of the amygdala in the ablations.

► Amygdala

## Knockout

### Definition

A transgenic knockout is an animal that has been engineered so that the protein encoded for by a gene is eliminated. In this way the function of the gene can be studied by comparing a biological process in the knockout and wildtype organism.

## Knollenorgan

### Definition

A specific type of tuberous electroreceptor in mormyrids, which responds with phase-locked action potentials to positive voltage transients.

- Electric Communication and Electrolocation
- Electroreceptor Organs
- Temporal Coding in Electroreception

## Knowledge

GERHARD ERNST

Seminar für Philosophie, Logik und  
Wissenschaftstheorie, Ludwig-Maximilians-  
Universität München, München, Germany

### Definitions

One of the main concerns of epistemology is to answer the question of what, by its very nature, knowledge is. In order to elucidate the nature of (personal propositional) knowledge an analysis of the sentence “(Subject) S knows (the proposition) that p” in terms of (individually) necessary and (jointly) sufficient conditions for this sentence to be true (► [Conceptual analysis](#)) has been sought.

### Description of the Theory

#### The Standard Analysis of Knowledge

A necessary condition hardly ever disputed for the sentence “S knows that p” to be true is that it is the case that p. A second necessary condition widely accepted is that S believes that p. Some philosophers, however, question this condition. They either claim that not

belief, but acceptance, conviction or psychological certainty is needed or they deny that any belief-like attitude is a necessary condition for knowledge (► [Personal Knowledge](#)). The following example – the “fortuneteller example” – shows that these two conditions, taken together, are not sufficient. A fortuneteller told Mary that she would win the lottery, she believed what he said and, as it turned out, she in fact won the lottery. Certainly it could not be said that she knew that she would win the lottery, although she had a true belief. So a third condition is needed in order to complete the analysis of knowledge. There is much disagreement about what this third condition should be. Given the fortuneteller example, a natural proposal is that S has to be justified in believing that p. Mary is not justified in believing that she will win the lottery because she acquired her true belief in an irresponsible manner. And this seems to be the reason why knowledge would not be ascribed to her. The tripartite definition of knowledge arrived at – knowledge as justified true belief (JTB analysis) – goes back at least to Plato. It is sometimes called the “standard analysis” of ► [propositional knowledge](#).

### The Gettier Problem

There are, however, counterexamples. Here is Goldman’s “barn example.” Henry, on a drive out in the country, sees a barn. He thereby justifiably acquires the true belief that there is a barn. What he doesn’t know though, is that (for whatever reasons) there are hundreds of barn facades (fake barns) placed in the vicinity in such a way that, had Henry seen them, he would have taken them to be real barns too. It was by mere luck that he encountered the only real barn within miles. Surely, we would not say that Henry’s justified true belief is knowledge. So, the three conditions considered so far are not sufficient. The ► [Gettier problem](#) [1] is the problem of finding an analysis of knowledge that avoids such counterexamples.

Two main strategies should be distinguished. Many philosophers hold that the JTB analysis has to be supplemented by a fourth condition. Since they claim that a cognitively accessible form of justification, i.e. justification “internal” to the cognitive perspective of S, is an essential condition for knowledge, the resulting definitions are sometimes called ► [internalist theories of knowledge](#). Other philosophers try to find an alternative to the JTB analysis. According to them it is mainly “external” factors that distinguish knowledge from true belief (► [Externalist theories of knowledge](#)). (Note that the internalist/externalist distinction is drawn in several different ways in the literature.)

### Internalist Accounts of Knowledge

Internalists disagree about how exactly to avoid Gettier style examples. The following fourth condition seems to do the trick: S’s grounds establish the truth of S’s

belief that p. (Henry’s ground – i.e. seeing something which looks like a barn – does not establish that there is a barn.) Avoiding redundancy the following analysis results:

S knows that p if and only if S justifiably came to believe that p on grounds that establish the truth of p [2].

Unfortunately the price that has to be paid for adequacy is indeterminateness. Because the crucial question is: when do S’s grounds establish the truth of p?

► [Indefeasibility theories](#) (e.g. Lehrer, Pollock) try to answer this question along the following lines. Henry’s justification would be adequate if it would not be “defeated” by the fact that there are fake barns in the vicinity. This point can be generalized. S’s grounds establish the truth of what S believes just in case S’s justification is indefeasible. But what has to be the case for the justification to be indefeasible? Obviously, it is not enough that it does not rest on any false lemma because Henry’s justification does not rest on any such lemma. It has also been proposed that S’s justification must not be undermined by further information. But this seems to be demanding too much as Keith Lehrer’s “Grabit example” shows. John sees Tom Grabit taking a book, hiding it under his jacket and leaving the library. He justifiably arrives at the (true) belief that Grabit stole a book. It could be said that he knows that Grabit stole the book. But now let us assume that – unbeknown to John – Grabit’s father, who has been driven mad by Grabit’s thieving ways, tells everyone who cares to listen that his son has got a twin brother who really is the one to blame for all the thefts. Certainly, we still would say that John knows that Grabit stole the book. Nevertheless, if he were given the information that Grabit’s father believes in a twin brother, but not the information that the father is demented, his justification would be defeated. Therefore it cannot be necessary for knowledge that S’s justification is not undermined by *any* kind of further information – some defeaters are misleading and therefore irrelevant. The main problem for indefeasibility theories is how to distinguish relevant from irrelevant defeaters. There is no universally accepted answer to that question.

### Externalist Accounts of Knowledge

According to ► [Externalist theories](#) the reason why we do not ascribe knowledge to Mary in the fortuneteller example is not that she is not justified in her belief, but that this belief somehow came about in the wrong way from an external point of view. ► [Causal theories of knowledge](#) for example, claim that the reason why she did not know that she would win the lottery is simply that the fact that she wins the lottery was not the cause of her belief (and there was no common cause for that fact and her belief either). These theories get into trouble when confronted with the barn example because



Henry's belief that there is a barn seems to be caused by the fact that there is barn. Subjunctive (or counterfactual) accounts of knowledge try to deal with the example by pointing to the fact that Henry would have believed that there is a barn even if there had not been one (but a fake barn instead). The method he used to acquire his belief was not reliable (►[Reliabilism](#)) (e.g. Goldman). It has also been said that Henry does not have conclusive reasons (Dretske); his true belief does not track the truth (Nozick). It would not be true in a nearby possible world. Nevertheless, eventually externalists are confronted with a rather similar problem as internalists. Because in the Grabit example John does know that Grabit stole the book, even though he would have had the very same belief if Grabit's father had not been demented and a twin brother of Tom Grabit had really stolen the book. The possible world in which this alternative obtained seems to be too "remote." Therefore the alternative is irrelevant. But how can we distinguish between relevant and irrelevant alternatives? Again there is no universally accepted answer to this question.

Virtually the same problem occurs for all philosophers who claim that knowledge is true belief arrived at in a reliable manner. For, what is the relevant method by which a belief is acquired? How general must its description be (►[Generality problem](#))? Does Henry (in the barn example) acquire his true belief by just looking or by looking where there is no fake barn? The latter, surely, is a reliable method for finding out where there are barns (even in an environment with many fake barns) while the former (in the example) is not. Why is it that we want to say that Henry used the more general method? Reliabilists are hard put to it to answer that question.

►[Virtue epistemology](#) (e.g. Plantinga, Sosa, Zagzebski) is another variety of reliabilism. The basic idea is that S's true belief has to be the result of S's intellectual virtue in order to count as knowledge. There are various attempts to elucidate what "being the result of an intellectual virtue" exactly amounts to.

According to some philosophers (e.g. Quine, Goldman, Kornblith) we have to look to the natural sciences in order to learn more about what knowledge is (►[Naturalized epistemology](#)). Others suggest that there is no general answer to the question which defeaters/alternatives/methods are relevant. What is relevant in one context might not be relevant in another. ►[Contextualist theories of knowledge](#) (e.g. Cohen, DeRose, Williams) (in the narrow sense of the term) claim that the context of the person ascribing knowledge has to be taken into account when the question whether or not S knows that p is evaluated. There is no ascriber independent "fact of the matter" about knowledge. Whether these theories are convincing is one of the focal issues in current epistemological research.

## Objects of Knowledge

Following Gilbert Ryle a distinction is often made between knowing that (propositional knowledge) and knowing how. But, as it stands, this distinction is unfortunate. Knowing how to start the record player for example, is nothing but knowing that this or that is the right button to press. Some cases of knowing how seem to be mere abilities. Knowing how to ride a bicycle seems to consist merely in being able to ride it. But one has to be careful here because you can be able to do something without knowing how to do it and vice versa. Chicken sexers are able to distinguish male from female chickens but they don't usually know how (i.e. by which method) they distinguish them. (Most of them think that they can see the difference while in fact they smell it.) A team coach on the other hand, may very well know how to play soccer without being able to do it. A worthwhile distinction can be drawn between cases in which what we know can be (easily) communicated and cases in which it cannot (at least not fully and satisfactorily). Knowing how high the Eiffel Tower is belongs to the first class of cases, whereas knowing how to play the piano belongs to the second; knowing what Peter said belongs to the first, knowing what pictures of Picasso look like belongs to the second and so on. The first class has been characterized as symbolic, conceptual or propositional knowledge (since what is known is captured in our concepts and can be expressed using symbols and propositions) while the latter is referred to as pictorial (in cases where what is known is what something looks like), ►[non-conceptual knowledge](#) or non-propositional knowledge (since concepts don't suffice to capture what is known in these cases and propositions are not apt to express the knowledge – it is implicit knowledge, shown rather than communicated).

It must be kept in mind that these distinctions concern the objects of knowledge. But a difference in what is known must not be confused with a difference in what it is to know something. Some philosophers claim that there is a contrast between knowing things (►[Knowledge by acquaintance](#)), for example knowing Peter, and knowing about things (►[Knowledge by description](#)). But whether these are really two fundamentally different ways of knowing is contentious.

## References

1. Gettier EL (1963) Is justified true belief knowledge? *Analysis* 23:121–123
2. Fogelin RJ (1994) *Pyrrhonian reflections on knowledge and justification*. Oxford University Press, New York
3. Lehres K (2000) *Theory of Knowledge*. Westview Press, Boulders
4. Ernst G (2007) *Einführung in die Erkenntnistheorie*. Wissenschaftliche Buchgesellschaft, Doststadt

5. Blaauw M, Pritchard D (2005) *Epistemology A-Z*. Edinburgh University Press, Edinburgh
6. Greco J, Sosa E (1999) *The Blackwell guide to epistemology*. Blackwell, Oxford
7. Steup M, Sosa E (2005) *Contemporary Debate in Epistemology*. Blackwell, Oxford
8. Sosa E, Kim J (2000) *Epistemology: an anthology*. Blackwell, Oxford
9. White A (1982) *The nature of knowledge*. Rowman and Littlefield, Totowa, NJ
10. Williams M (2001) *Problems of knowledge*. Oxford University Press, Oxford

## Knowledge Argument

FRANK HOFMANN

Philosophisches Seminar, Universität Tübingen,  
Tübingen, Germany

### Definition

The knowledge argument was originally presented and clarified by the Australian philosopher Frank Jackson in two papers [1,2]. It is, and was intended as, an argument against ► **physicalism**. In this connection, “physicalism” is the thesis that all knowledge is physical knowledge. The knowledge argument is concerned with features of experiences that are commonly called “phenomenal” or “experiential features,” or simply “► **qualia**.” To explain these qualia has become one of the most central questions in contemporary philosophy of mind and the other sciences of the mind. So the knowledge argument belongs to the same family of anti-physicalist arguments as Saul Kripke’s modal argument, Thomas Nagel’s “what it is like to be” argument, Joseph Levine’s explanatory gap argument, and David Chalmers’s Zombie argument. It is fair to say that the knowledge argument presents some of the most challenging and instructive considerations to the physicalist. In the meantime, a “standard response” to the knowledge argument has evolved and become widely accepted, though by no means universally. It has been developed by Paul Churchland [3], Brian Loar [4], and others. The standard response tries to solve the problem by invoking a distinction between facts and ways of knowing facts (or “modes of presentation” of facts, as they are also called), and it attempts to rescue ► **physicalism** by insisting that all facts are physical facts, whereas there may very well be many different ways of knowing these facts; there is no gap between the physical world and some nonphysical world, there are only different ways of knowing one and the same

physical world, by means of different ► **concepts** (different “modes of presentation”).

### Description of the Theory

In the following, Jackson’s argument will be stated first, and the relevant notions and background explained. Then, some misunderstandings will be cleared away. After that, two responses will be discussed, the ability hypothesis and the “standard response.” Further, and open, questions will be mentioned at the end.

The argument consists of two premises and a thought experiment. The thought experiment is supposed to provide evidence for one of the premises; the other premise is simply a supposition of the thought experiment.

Here is the thought experiment. Imagine Mary, a brilliant scientist, who has acquired all physical knowledge, but has never had any experience of red herself. This is so because she has been living in a black and white room all her life, and had to investigate the world by means of a black and white television monitor. Nevertheless, Mary has managed to learn all the lessons of physics, chemistry, biology, and so on. Taking “physical” in a wide sense here, which includes chemistry, biology, and all other “physical sciences,” and making the idealization that physics in this sense has been completed, we can say that Mary has complete physical knowledge of the world. Note that Mary’s physical knowledge includes all physical knowledge about what goes on in human beings when they see ripe tomatoes and use terms like “red,” “green,” and so on. She knows what goes on in their nervous systems, and she knows all the intrinsic physical properties of the brain states and their functional roles and relations to their environment, including everything physical about their history. (It seems possible that Mary could, in principle, have arrived at such a complete physical knowledge, since all such knowledge can be taught by means of black and white television, at least in principle.) Thus, the first premise of the argument is the following supposition:

1. Before her release Mary has complete physical knowledge of the world (including, of course, complete physical knowledge of the workings of nervous systems).

Now that Mary has been released from her black and white room and sees a ripe tomato for the first time. It seems quite plausible to say that she will learn something new about experiences on this occasion. She will come to know something about the visual experience that people undergo when they see things. She comes to know what it is like to see something red. Mary did not have this knowledge about experiences before her release. So her knowledge about experiences was not complete before her release.

2. Before her release Mary did not know everything about other people's experiences.  
Therefore,
3. Physicalism is false: There are truths which are not included in the complete physical story.

Sometimes, Jackson states the conclusion in terms of facts: There are facts which are not physical facts. Presumably, this amounts to the same defeat of physicalism.

Clearly, the argument could be run for various other mental states, such as hearing, tasting, bodily sensations and so on. Nothing hangs on the sense modality; all that matters is that we are dealing with states that have specific experiential features (qualia).

The argument can be described as an inference from (the incompleteness of) a certain kind of knowledge to (the incompleteness of) certain facts: because physical knowledge is incomplete there are nonphysical facts. Conceived of in this way, the argument may appear dubious, and Frank Jackson himself has become skeptical about the soundness of the argument in the meantime (cf. [5], p. 43f., fn. 21).

Three possible misunderstandings should be avoided. The first is to see the problem as a problem of mapping language onto experience. This is not the real problem, however, since it is irrelevant whether Mary knows which predicate applies to an experience. Even if Mary had been able to say truly before her release "The experiences of these people are red experiences," she would not have known what she now knows by uttering the same sentence. For, before her release she would not have known what she was talking about when speaking of "red experiences." At least, her knowledge about what she was talking about would not have been complete.

The second possible misunderstanding is to think that the problem is trivial since the answer simply is that for knowing all the experiential features of an experience it is necessary and sufficient to have the experience. It may be correct that one must have had an experience in order to know all the experiential features of it, and that everybody who has had the experience knows these features, but it would be highly problematic to claim that knowing an experiential feature simply consists in nothing else but having the experience. To know what it is like to have a headache is not simply to have one. For, first, one can know a quale even if one does not currently have it. Second, and more importantly, even if one has a headache, that in itself is not enough for knowing its experiential features. Here, the gap may seem very small, indeed, vanishingly small. But still there is a gap, since having an experience is not in itself yet a piece of knowledge. Rather, having the experience is something like an enabling condition for knowing its experiential features.

It provides one with the kind of "access" to the experience which enables one to know its experiential features. But it is not identical with having this knowledge.

A third possible misunderstanding is to think that what Mary learns on her release is simply the fact that she undergoes a visual experience of seeing something red. It is obvious that Mary learns something when she is let out, namely that she is now having a red experience, but that is not the objection against physicalism. The objection to physicalism is that Mary's conception of the phenomenal states of other people has been so impoverished before she was let out that she did not know everything about the experiences of others (even though she was supposed to have complete physical knowledge).

One ingenious response to the knowledge argument has been worked out, independently from one another, by Laurence Nemirow [6] and David Lewis [7]. They hypothesize that knowing the qualia of an experience is an ability rather than a piece of propositional knowledge. It is the ability to remember, recognize and imagine (states with) these qualia. A problem with this response, however, is that these abilities do not appear to be necessary for knowing the experiential features. For, on the occasion of her first encounter with a red experience, a person can plausibly be said to know what it is like to have the experience, even though she may forget all of this a moment later. Having the experience may not leave any of the traces that amount to the Lewis–Nemirow abilities. At least, it does not seem necessary for knowing qualia that the subject is in possession of these abilities, even though the two may frequently come together.

Another response to the argument has become popular in the meantime, the "standard response," as I would like to call it. Most prominently, it goes back to ideas of Paul Churchland [3] and Brian Loar [4]. According to this view, we have to distinguish between what there is – the facts, what belongs to our ontology – and our epistemic access to what there is. As physicalists we can hold that there are only physical facts; no fact escapes the physical sciences. At the same time, we may concede that there are nonphysical ways of knowing physical facts. Physical ways of knowing facts are the ways that one can learn from physics books and lessons. If one knows a (physical) fact in a physical way, one represents it by means of physical concepts. In the philosopher's jargon, one employs a physical "mode of presentation." If one knows that a certain brain state exhibits a 40 Hz oscillation of a certain kind, this fact is given to one in a physical mode. But there are other ways of knowing facts. Most importantly, introspection provides one with a different access to one's own mental life. In introspection, one comes to know that what one is currently undergoing is a red experience. This fact is not given to one in a physical mode of presentation, but rather in a more direct, introspective mode of presentation. One

employs a “►phenomenal concept,” as many say. The normal subject who has had red experiences is in possession of a special concept, the phenomenal concept ►red experience. Having a red experience, or red experiences, somehow “triggers” the acquisition of this concept. The special functional role that connects the concept to one’s own experiences in a direct way is part of its mode of presentation. This is why one comes to know immediately (without having to make observations of one’s behavior and to draw inferences) that one is having a red experience whenever one has it and asks oneself what experience one is currently undergoing. Having the phenomenal concept normally enables one to imagine and conceive of the experience, and to remember and recognize it. But it is a representation of its own, not just the sum of these abilities. As a conceptual representation, the concept red experience has its own characteristic mode of presentation.

The standard response prompts new questions. As much depends on the details of one’s theory of concepts and modes of presentation, it is desirable to develop a full theory of ►phenomenal concepts and to integrate it into a theory of concepts in general. One question here is whether phenomenal concepts have certain “copies” or exemplars of experiential states associated with them (as, for example David Papineau [8] claims). Does imagining a pain involve having a pain-like mental “image”? Other questions concern the relation between phenomenal concepts and experiences. What exactly is the “direct” connection between phenomenal concepts and experiences? How do phenomenal concepts refer to experiences? Are they somehow indexical? These and other related questions are the topic of much contemporary debate. In the end, it depends on answers to questions like these whether the knowledge argument can be rejected on solid grounds.

## References

1. Jackson F (1982) Epiphenomenal qualia. *Philos Q* 32:127–136
2. Jackson F (1986) What Mary didn’t know. *J Philos* 83:291–295
3. Churchland Paul M (1985) Reduction, qualia, and the direct introspection of brain states. *J Philos* 82:8–28
4. Loar B (1997) Phenomenal states. In: Block N et al. (eds) *The nature of consciousness*. MIT, Cambridge, pp 597–616
5. Jackson F (1998) *From metaphysics to ethics*. Clarendon, Oxford
6. Nemirov L (1980) Review: mortal questions by Thomas Nagel. *Philos Rev* 89:473–477
7. Lewis D (1990) What experience teaches. In: Lycan W (ed) *Mind and cognition*. Blackwell, Oxford, pp 499–519
8. Papineau D (2002) *Thinking about consciousness*. Clarendon, Oxford

## Knowledge by Acquaintance/ Knowledge by Description

### Definition

These expressions usually mark a distinction between knowing things (for example knowing Peter) and knowing about things (for example knowing that Peter is tall).

► Knowledge

## Koniocellular Cells

### Definition

Very small primate lateral geniculate nucleus (LGN) cells that are located anatomically below each parvocellular and magnocellular LGN layers. These cells have been proposed to be part of a separate K pathway from retina to visual cortex whose function(s) are still being discovered. Some K cells are part of a yellow/blue color pathway.

► Geniculo-striate Pathway

► Lateral Geniculate Nucleus (LGN) – Koniocellular Neuron

► Evolution of the Visual System: Mammals – Color Vision and the Function of Parallel Visual Pathways in Primates

## Korsakoff’s Syndrome

### Definition

Some impoverishment of intellect, changes of personality (usually euphoria or apathy), disorientation, confabulations and memory impairment due to neurodegeneration following alcohol abuse.

► Neuroendocrinology of Tumors

## Kuru

### Definition

Kuru belongs to a group of human ►transmissible spongiform encephalopathies or ►prion diseases. It affects Fore tribes in New-Guinea, but has now almost disappeared since the cessation of ritualistic endocannibalism. It has a long incubation period and presents clinically as a progressive ►cerebellar ataxia associated with ►tremors and late ►dementia. The central nervous system shows spongiform changes and neuronal loss, with amyloid (kuru) plaques in approximately 75% of cases. Another human prion disease is ►Creutzfeldt-Jacob disease.

- Creutzfeldt-Jacob Disease
- Prion (Proteinaceous Infectious Particle)
- Transmissible Spongiform Encephalopathies (TSEs)

## Kynurenine

### Definition

An amino acid that is a product of the metabolism of L-tryptophan and the substrate for the metabolism of kynurenic acid.

- Neurodegenerative Diseases: Tryptophan Metabolism

---

## L1

### Definition

The L1 glycoprotein is a 200 kDa cell surface molecule, and is a member of the immunoglobulin superfamily (IgSF). The protein is involved in many processes involving cell-cell interactions, including cell migration, neurite fasciculation and elongation, myelination, and growth cone morphology. L1 is expressed in axon tracts of the developing and adult nervous system and is also found on non-neural cells.

- ▶ Growth Cones
- ▶ Myelin
- ▶ Schwann Cells in Nerve Regeneration

---

## Labeled Lines in Olfaction

### Definition

In sensory physiology, refers to the dedication of a set of neurons to the detection, transmission and processing of a particular type of stimulus. This can include specialized receptors and specialized central brain structure. A typical example in the field of olfaction is the pheromone-detection system of moths. Female sexual pheromone is a blend of a few chemical components detected on the male moth antenna by olfactory sensory neurons, each dedicated to the detection of one of these components. Sensory information then projects to the brain via a specialized subsystem. Thus, in the antennal lobe, the primary olfactory center of moths, the processing of the female sex pheromone components is carried out by a macroglomerular complex, made of a few specialized glomeruli. This term, referring to a neural sensory pathway that is necessary and sufficient for coding stimulus quality, is often presented in opposition to “across-fiber pattern,” which refers to a system in which

stimulus quality is coded by multiple neurons in a combinatorial way.

- ▶ Olfactory Plasticity

---

## Labeled-Line Code (also: Dedicated-Line Code)

### Definition

Hypothesis stating that neural information is essentially coded in the activities of specialized neurons with distinct sensitivities, such as modalities and submodalities, place etc.

- ▶ Sensory Systems

---

## Labyrinth

- ▶ Evolution of the Vestibular System

---

## Labyrinth (Vestibular Labyrinth)

### Definition

Vestibular labyrinth consists of two functional components: (i) the otolith organs (the utricle and the saccule), which are sensitive to gravity and linear acceleration, and (ii) the three semicircular canals, which detect angular acceleration in the three perpendicular planes during rotating movement of the head.

- ▶ Peripheral Vestibular Apparatus
- ▶ Saccule
- ▶ Semicircular Canals
- ▶ Utriculus

## Labyrinthectomy

### Definition

Ablation of the membranous labyrinth of the inner ear. In the context of vestibular compensation, either the entire labyrinth may be destroyed or only the vestibular portion of the labyrinth may be removed, leaving the cochlea intact (though the extent to which cochlear function is retained, may vary). As an alternative to surgical labyrinthectomy, ototoxic drugs may be injected into the middle ear, to achieve a “chemical labyrinthectomy” where the labyrinth remains anatomically intact but the hair cell sensory receptors are destroyed.

- ▶ Vestibular Compensation and Plasticity

## Labyrinthine Receptors

### Definition

Ciliated cells located within a specific region of the membranous labyrinth, a closed structure consisting of ducts formed by an epithelium and containing a fluid (endolymph). The membranous labyrinth is contained within cavities of the mastoid bone filled by another fluid of different composition (perilymph). The cilia of the receptors protrude towards the endolymph and one of them (kinocilium) is longer than the remaining ones (stereocilia). The receptors are excited (depolarized) when the kinocilium is bent towards the stereocilia and inhibited (hyperpolarized) by displacements in the opposite direction. Ciliary movements are induced by linear or angular accelerations imposed on the head. According to their anatomical location, labyrinthine receptors can be distinguished as macular or ampullar receptors.

- ▶ Peripheral Vestibular Apparatus

## Lacertid (Type)

### Definition

Referring to the family Lacertidae, small lizards worldwide.

- ▶ Evolution of the Brain: At the Reptile-Bird Transition

## Lactate Dehydrogenase (LDH)

### Definition

A metabolic enzyme that interconverts lactate and pyruvate.

## Lacunar Syndrome

### Definition

Lacunar infarcts are small infarcts (2–20mm in diameter) in the subcortical white matter, basal ganglia or pons, that are presumed to result from the occlusion of a single small penetrating branch of the large cerebral arteries.

- ▶ Basal Ganglia
- ▶ Stroke

## Lagrangian Density

### Definition

The difference between the kinetic and the potential energy of a system. In analytical mechanics, it is postulated that the integral over time of this quantity attains a stationary value when the system follows its actual trajectory.

- ▶ Mechanics

## Lagrangian Description

### Definition

A formulation of the equations of continuum mechanics in terms of fields whose independent variables are the referential (or material) coordinates and time. Also called the referential (or material) description.

- ▶ Mechanics

## Lambert-Eaton Myasthenic Syndrome

MASAHARU TAKAMORI

Neurological Center, Kanazawa-Nishi Hospital and  
Kanazawa University, Kanazawa, Ishikawa, Japan

### Definition

►Lambert-Eaton myasthenic syndrome (LEMS) is a disease of neuromuscular transmission, in which antibodies directed against the P/Q-type ►voltage-gated calcium channels (in most cases) and ►synaptotagmin (in some cases) present on the presynaptic nerve terminal play a crucial role in causing a deficient quantal release of acetylcholine, resulting in skeletal muscle weakness and autonomic dysfunction (Fig. 1).

This syndrome is often associated with cancers, particularly ►small-cell lung carcinoma (SCLC), and is

thought to result from a disturbance remote from the site of the tumor (termed “paraneoplastic syndrome”). The motor nerve terminal and carcinoma cell may share a common antigen, suggesting an immunological cross-reactivity between the two, which provides a neurological disorder.

### Characteristics

#### Remote Effect of Cancer

The voltage-gated calcium channel (VGCC) is expressed in SCLC, as demonstrated by the SCLC cells being capable of generating calcium spikes and LEMS IgG exerting an inhibitory action on the depolarization-induced calcium flux into SCLC cell line. Anti-VGCC antibodies that recognize the SCLC may react with a homologous target in the motor nerve terminal, resulting in a presynaptic defect of neuromuscular transmission [1]. The same is postulated for the presynaptic impairment caused by anti-synaptotagmin

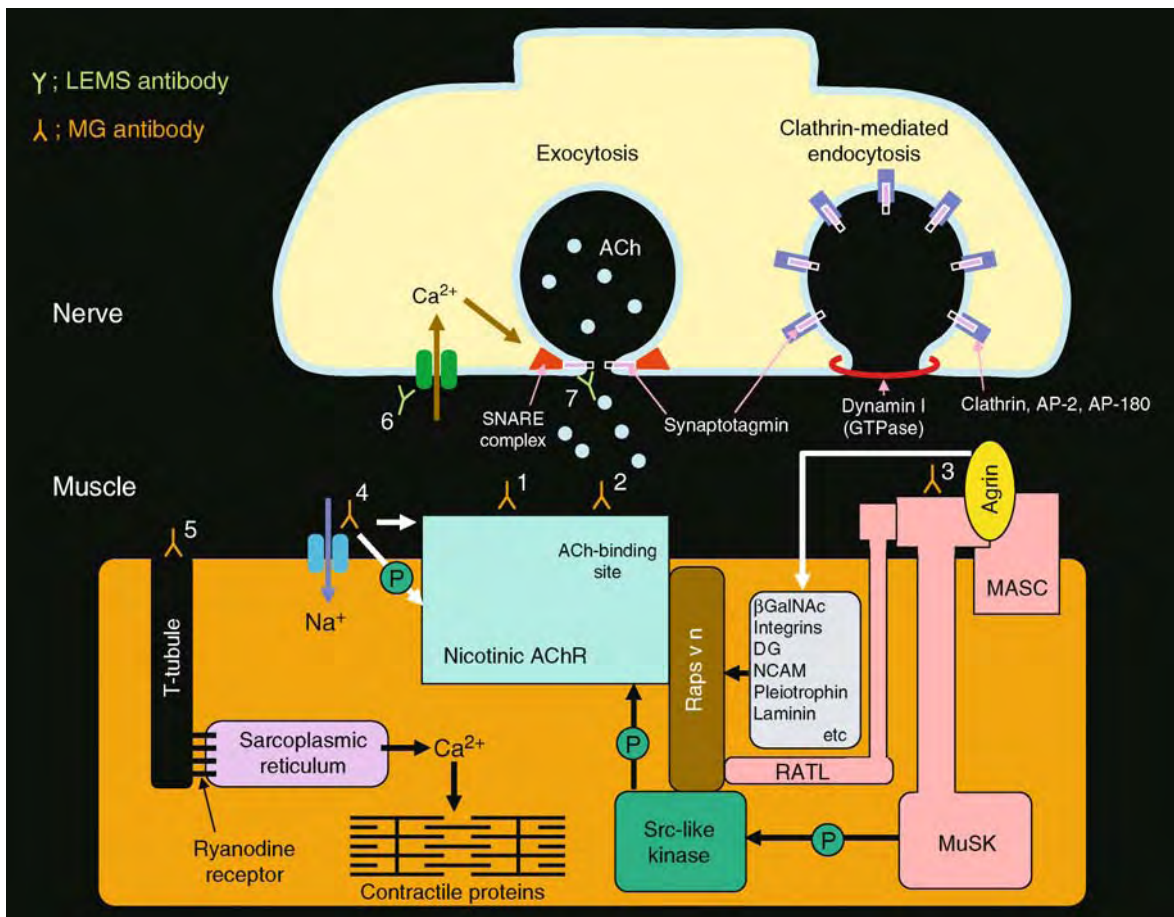

**Lambert-Eaton Myasthenic Syndrome. Figure 1** Schematic representation of neuromuscular synapse. The Lambert-Eaton myasthenic syndrome (LEMS) is caused by antibodies to P/Q-type voltage-gated calcium channel (antibody-6), and, in a proportion of patients, to synaptotagmin (antibody-7). Antibodies numbered 1–5 are referred to the section of Myasthenia gravis (MG).



antibodies because synaptotagmin is also expressed in SCLC [2].

The etiology of LEMS developed in patients without SCLC (approximately 40%) is unclear, but they tend to be associated with immunological disorders. The high frequency of HLA-B8 in non-cancer LEMS suggests the distinct genetic predisposition and immunological routes to the similar clinical presentation of LEMS with or without SCLC [3].

### Type of Calcium Channels Involved in LEMS

Among various neuronal VGCCs, the P/Q-type VGCC, found predominantly at the neuromuscular junction and also in SCLC [2], is highly recognized by LEMS antibodies [1] (Fig. 1, antibody-6). LEMS IgGs bind to the surface of the P/Q-type VGCC cell line and cause a significant reduction in whole-cell calcium currents [4]. The LEMS antibodies, directed against not only P/Q-type but also other types, downregulate the P/Q-type VGCC function and upregulate the other types of VGCC functions [4]. This finding suggests a plasticity to compensate neurons for defective presynaptic function in LEMS.

In addition, the anti-P/Q-type VGCC antibodies are detected in some SCLC, with cerebellar ataxia in both the presence and absence of concomitant LEMS [5]. The postmortem cerebellar tissue from ataxic patients showed a reduction of P/Q-type VGCC [6]. The autonomic dysfunction that occurs in approximately 80% of LEMS patients is also caused by the anti-P/Q-type VGCC antibodies [7].

The search for epitopes in the molecular structure of P/Q-type VGCC, by use of synthetic peptides and recombinant protein, indicates the extracellular S5-S6 linker regions in 3 of 4 domains as immunodominant sites [1]. These regions can be immunogenic in the induction of the animal model of LEMS [1].

### Synaptotagmin as Pathogenic Antigen in LEMS

Synaptotagmin I functions in highly organized stimulation-secretion coupling at the synapse as one of calcium sensors [8]. It is enriched in synaptic vesicles and participates in calcium-dependent synchronous release of neurotransmitters, and also shares a key property with many ▶clathrin accessory proteins in the clathrin-mediated endocytosis to recycle synaptic vesicles [8] (Fig. 1). In this functionally VGCC-associated presynaptic protein, the segment that exposes extracellularly during exocytosis can be antigenic in the detection of LEMS antibodies, and immunogenic in the induction of the LEMS animal model [1].

### Clinical Features, Diagnosis and Treatments

The disease begins in mid to late life, and presents with proximal skeletal muscle weakness and fatigue, a reduction or absence of tendon reflexes and autonomic

dysfunctions (dry mouth, sexual impotence, constipation, postural hypotension, impaired sweating and dilated pupils responsive poorly to light). Weakened muscle strength and decreased tendon reflexes may improve by having the patient briefly contract the corresponding muscle. The oropharyngeal and extraocular muscles may be affected, but not so marked to the degree seen in myasthenia gravis. Some patients present with respiratory failure [9].

LEMS patients with underlying SCLC may have other ▶paraneoplastic syndromes such as sensorimotor neuropathy, cerebellar ataxia and inappropriate secretion of antidiuretic hormone [9]. LEMS is a warning to latent cancer as reported by that in most patients, the cancer is discovered within the first 2 years after the onset of LEMS and virtually all patients within 4 years [9]. Reportedly, some LEMS patients have lymphoproliferative malignancies, or cancer of breast, stomach, colon, prostate, bladder, kidney or gallbladder [9].

Anti-cholinesterase drugs are not so effective (diagnostic) as in the case with myasthenia gravis. The diagnosis can be confirmed by characteristic findings on electromyographic studies: the muscle action potential amplitude is small with single nerve stimulation but markedly increased during 20–50 Hz repetitive nerve stimulation (Fig. 2).

The anti-P/Q-type VGCC antibodies are positive in 80–90% of LEMS patients by the immunoprecipitation assay using omega-conotoxin MVIIC-labeled VGCC (extract from cerebellar tissue) (Fig. 1, antibody-6). The anti-synaptotagmin I antibodies can be detected in some of LEMS patients by immunoblotting assay using a recombinant protein (Fig. 1, antibody-7). The anti-acetylcholine receptor antibodies, specific for diagnosis of myasthenia gravis, are found in some LEMS patients, but this may be considered as epiphenomenon.

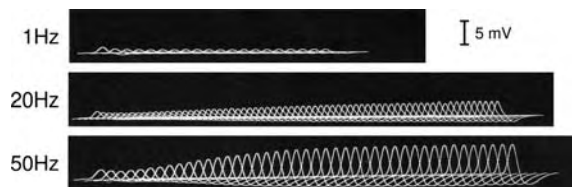

### Lambert-Eaton Myasthenic Syndrome.

**Figure 2** Muscle action potentials evoked by repetitive nerve stimulation at rates of 1, 20 and 50 Hz. The initial response is small in size. With rapid rates of stimulation (such as 20 and 50 Hz), the successive responses show a progressive increment in amplitude. These phenomena are provided by the increased membrane depolarization, which compensates the acetylcholine quantal release for the defect by impaired calcium entry into the nerve terminal due to the antibodies to P/Q-type voltage-gated calcium channel.

Prior to the internal treatment, the attention should first be focused on an extensive search for malignancies by including radiographs and computer tomography scans (CT) of the chest, and bronchoscopy. This search is indispensable to smokers and patients with less than 2 years' history of LEMS. Even if no tumor is detected, the search for occult malignancy should be repeated periodically. The treatment aimed at cancer therapy takes precedence over any immunosuppressive treatments.

As the symptomatic management, the drug to improve neuromuscular transmission by facilitating the release of acetylcholine (► **3,4-diaminopyridine**) is advocated rather than anti-cholinesterase drugs. When weakness is severe, plasmapheresis or high-dose intravenous immunoglobulin may be used. Immunosuppressants (corticosteroids, azathioprine and cyclosporine A) can be added in an attempt to produce more sustained improvement [9]. However, the attention should be focused on the fact that SCLC patients with LEMS have an increased survival rate, compared with those without LEMS, suggesting that the immunosuppression limits the immunological suppression of tumor growth and metastasis [10]. The immunotherapy is justified in the LEMS patients who do not have cancer, decided after careful and repeated search, and have evidence for a coexisting autoimmune disease.

## References

1. Takamori M (2004) Lambert-Eaton myasthenic syndrome as an autoimmune calcium channelopathy. *Biochem Biophys Res Commun* 322:1347–1351
2. Benatar M, Blaes F, Johnston I, Wilson K, Vincent A, Beeson D, Lang B (2001) Presynaptic neuronal antigens expressed by a small cell lung carcinoma cell line. *J Neuroimmunol* 113:153–162
3. Wirtz PW, Willcox N, Roep BO, Lang B, Wintzen AR, Newsom-Davis J, Verschuuren JJ (2003) HLA-B8 in patients with the Lambert-Eaton myasthenic syndrome reduces likelihood of associated small cell lung carcinoma. *Ann NY Acad Sci* 998:200–201
4. Lang B, Pinto A, Giovannini F, Newsom-Davis J, Vincent A (2003) Pathogenic autoantibodies in the Lambert-Eaton myasthenic syndrome. *Ann NY Acad Sci* 998:187–195
5. Graus F, Lang B, Pozo-Rosich P, Saiz A, Casamitjana R, Vincent A (2002) P/Q-type calcium channel antibodies in paraneoplastic cerebellar degeneration with lung cancer. *Neurology* 59:764–766
6. Fukuda T, Motomura M, Nakao Y, Shiraishi H, Yoshimura T, Iwanaga K, Tsujihata M, Eguchi K (2003) Reduction of P/Q-type calcium channels in the postmortem cerebellum of paraneoplastic cerebellar degeneration with Lambert-Eaton myasthenic syndrome. *Ann Neurol* 53:21–28
7. Watermann SA, Lang B, Newsom-Davis J (1997) Effect of Lambert-Eaton myasthenic syndrome antibodies on autonomic neurons in the mouse. *Ann Neurol* 42:147–156
8. Murthy VN, De Camilli P (2003) Cell biology of the presynaptic terminals. *Ann Rev Neurosci* 26:701–728
9. Sanders DB (1995) Lambert-Eaton myasthenic syndrome: clinical diagnosis, immune-mediated mechanism, and update on therapies. *Ann Neurol* 37(S1):S63–S73
10. Maddison P, Newsom-Davis J, Mills KR, Souhami RL (1999) Favourable prognosis in Lambert-Eaton myasthenic syndrome and small-cell lung carcinoma. *LANCET* 353:117–118

## Lamellipodium

### Definition

Lamellipodium is a broad membrane expansion on the leading edge of migrating cells and neuronal growth cones. It is filled with a cross-linked actin filament meshwork that provides a two dimensional framework for focal contacts and can generate mechanical tension to direct the cellular movement. A lamellipodia that occurs in between two filopodia is known as a veil, and whether it expands or contracts depends on flanking filopodial stability. When lamellipodia lose their adhesion with the substratum they form ruffles that fold back away from the leading edge.

### ► Growth Cones

## Lamina Splendens

### Definition

The most superficial layer of articular cartilage with a thickness of about 2 µm and randomly aligned collagen fibers.

### ► Articular Cartilage

## Laminin

### Definition

A significant element of the basal laminae of epithelial cells where it serves to anchor these cells to the underlying basal laminae. It is able to interact with a range of molecules including type IV collagen, heparin

and integrins and is important for the migration of some cell types and promotes outgrowth from neurons in culture. Laminin is a molecule classically described as “cross-shaped,” composed of three polypeptide chains: two  $\alpha$ -chains and one  $\beta$ -chain. There are at least 15 variant forms of laminin known.

► Axonal Pathfinding and Network Assembly

## Laminin-Alpha2

### Definition

One type of laminin and is related to myelination.

► Myelin

## Lamor Frequency

### Definition

The Lamor frequency is the specific frequency at which specific atomic nucleus positioned in a magnetic field absorb energy from an electromagnetic pulse. The Lamor frequency is linearly proportional to the magnetic field strength. For example, the Lamor frequency for hydrogen in a magnetic field strength of 1.5 Tesla is approximately 63.87 MHz.

► Magnetic Resonance Imaging (MRI)

## Landmark

### Definition

A landmark is a stable environmental cue that guides navigation. Landmarks plays a role in either beacon or map-based navigation. Landmarks are inferential cues in that landmarks, while not the goal location themselves, have stable spatial relations to a goal location.

► Spatial Learning/Memory

## Language of Thought

KLAUS SACHS-HOMBACH

Otto-von-Guericke University Magdeburg,  
Magdeburg, Germany

### Definition

The language of thought hypothesis – originally worked out by Jerry A. Fodor [1,2] and supported, e.g., by Zenon W. Pylyshyn [3] – is a highly influential approach in the philosophy of mind and particularly in cognitive science. It provides a basic framework for the computational model of the mind. According to this model, two levels of the ►cognitive architecture can be distinguished: the level of physical ►symbol processing and the level of ►mental representations. Theories referring to the former were developed in computer science, particularly in Artificial Intelligence, most famously by Herbert A. Simon and Alan Newell. They describe computational processes as formal operations on so called “physical symbols” [4]. Theories referring to the latter consider mental representations as intentional states that stand for something and have a representational, semantically interpreted content. Both kinds of theories are combined in the computational model of the mind as hierarchical levels of information processing. Since the basic level is the level of formal operations performed on syntactical properties only, semantic properties must, in order to be causally relevant, rely on corresponding syntactical properties. Thus, cognitive activities depend in general on syntactically individuated symbols that require an internal code, namely a language of thought. This language is conceived of as a propositionally structured medium. The language of thought is sometimes (e.g. by G. Harman or H. Field, cf. [5]) regarded as an internalized spoken language of a thinker. Normally however, it is taken to be more abstract than natural languages, only language-like and also called “Mentalese.”

Fodor has combined the language of thought hypothesis with a number of controversial claims: (i) The language of thought is innate, (ii) it is fundamental, i.e. not derived from something else, and (iii) the assumed internal symbols are not just theoretical but real entities, physically implemented in the brain [2].

The language of thought hypothesis has been confronted with various critical replies both from the philosophy of mind and from cognitive science. Opposing views from philosophy question the existence or the explanatory value of a language of thought and of mental representations in general. Cognitive scientists normally accept the representational theory but postulate different representational formats, e.g., a propositional and a pictorial format (►pictorialism).

A different, also highly influential critique within cognitive science directed against both the representational theory and the physical ►**symbol processing theory** was launched by the connectionists who consider cognitive processes mainly as sub-symbolic processes that can be performed by ►**neural networks** without involving internal symbols or mental representations.

### Description of the Theory

The philosophical background of the language of thought hypothesis is ►**functionalism** that replaced behaviourism in the second half of the twentieth century as the predominant view in the philosophy of mind and in cognitive psychology. The main assumptions of functionalism are that mental states can be individuated by their functional or causal role within the cognitive system. The functional role, in turn, is defined as a relation between sensory inputs, behavioral outputs and other mental states. According to Ned Block, functionalism can thus be seen as a sophisticated theory of mind that is closely related to behaviourism [5]. Compared to behaviourism, functionalism proposes a stronger criterion for something to be a mental system, namely that it has beliefs and desires in addition to the relevant input-output relations. At the same time, however, functionalism weakens this criterion insofar as the characterization of functional states abstracts from the physical realization. This opens the possibility of ascribing mental states also to computers; likewise it justifies the functionalist claim according to which computing machines may serve as an empirical example of how mental states can be realized within a cognitive architecture.

Since the computational theory of mind is mainly interested in how mental states function within a network of formal rules, it is not intended to be a biological theory. Although the internal code – i.e. the language of thought – is usually assumed to be implemented in a neural network, functional analysis is not reducible to neurophysiology, but provides an independent level of description. To explain the behavior of cognitive systems therefore requires referring to semantically interpreted representations. Although being non-committal about different realizations of cognitive states, the computational model of the mind, particular in Fodor's version, nevertheless demands an answer to the question of how to relate the different levels of the cognitive architecture. Possible solutions can be distinguished depending on how the relation between (i) syntactically performed operations in different kinds of hardware and (ii) semantically interpreted representations is conceived of. According to Fodor's version of the language of thought hypothesis, the cognitive architecture is hierarchically organized so that complex cognitive abilities are split up into smaller, less complex abilities

and less intelligent components and processes. Those components are then split up again into still smaller and less intelligent components until the level of ►**primitive processors** is reached at a purely mechanical level.

Having in mind the philosophical background described above, it becomes clear why Fodor postulates a language of thought as an internal propositional code. It permits him to account for the basic assumptions of folk psychology within the framework of the computational model of the mind. According to folk psychological explanations, our behaviour is determined by intentional states like beliefs and desires. We therefore normally account for performing a certain action by referring to ►**propositional attitudes** that include a semantically evaluable content and therefore presuppose also conditions of truth or satisfaction. In our ordinary understanding, propositional attitudes are the basic units of the mind. The language of thought hypothesis comes into play by assuming (i) that cognitive states are relations between an organism and its internal representations – between an attitude and a propositional content – and (ii) that representations are causally relevant due to their formal or syntactic features. This requires, of course, that the internal code must preserve various features of the propositional attitudes like the conditions of truth or satisfaction, systematicity, and productivity. Since thoughts and sentences are alike in many respects, the language of thought is described as a propositional, language-like medium.

The language of thought hypothesis emphasizes the functional role of propositional attitudes for adequately explaining behaviour. A functional analysis of mental states is therefore taken to be an irreducible task of cognitive science [1,3]. This has been criticized for different reasons. The language of thought hypothesis has sometimes been understood as purely syntactical. But if propositional attitudes are only causally relevant in virtue of their syntactical properties, semantic content of ►**mental representation** becomes superfluous. According to Stephen Stich, this would lead to an eliminativist position with respect to propositional attitudes in particular and folk psychology in general [6]. A more cautious conclusion has been drawn by Daniel Dennett. He states, contrary to Fodor, that mental representations cannot be regarded as real entities. He is therefore sceptical about the causal influence of the semantically interpreted content of propositional attitudes. According to his instrumentalist view however, the ascription of intentional states is a useful device for the explanation of the behaviour of humans and even of computing machines [7].

A quite different philosophical critique results from taking the semantic aspect of mental representations as fundamental. This is done, e.g., by John R. Searle who objects that the computational model of the mind is

not able to account for intentionality as the basic property of mental states [8]. He supports his claim by denying (i) that the brain is a syntactic engine and (ii) that a purely syntactic engine is able to produce semantic content. Searle's reason for the first claim is that brains, unlike computers, are biological systems with quite specific mechanisms for information processing. Although we might be able to describe a system computationally, it does not necessarily have to be a computational system. The second claim is illustrated by Searle's highly controversial Chinese Room argument. According to this argument, a purely syntactical machine may display exactly the verbal behaviour of a person who does understand a language, even if the machine evidently has no verbal understanding whatsoever.

An influential critique of the language of thought hypothesis within cognitive science comes from ► **pictorialists** [5]. Stephen M. Kosslyn, the most prominent proponent of the pictorialist view, concedes that there may be a propositionally structured medium for representing and processing information; still he claims that visual information has to be encoded in a picture-like format as well. Whereas propositionally organized representations describe relevant properties and relations explicitly in a language of thought, the pictorial encodings are thought of as a pixel matrix that preserves visual information particularly of spatial relations implicitly, not by explicit description. The encodings are said to be analogue, i.e., they represent information by isomorphism.

A more radical critique of the language of thought hypothesis stems from ► **connectionism** that is nowadays acknowledged as the most promising competitor to the computational model of the mind. An influential version of the connectionist view is the parallel distributed processing approach (PDP) that was developed by David Rumelhart, James McClelland and colleagues [9]. While the classical symbol processing account orientates itself towards Artificial Intelligence, the connectionist view draws on research in neurophysiology. The main assumption of connectionism is that information processing does not require symbol structures but can be carried out by neural networks. One of the main objections against the computer model of the mind (► **computer theory of the mind**) is that it does not account for the specific neural "implementation" of human cognition. Instead of describing cognitive processes as manipulating single representations, connectionists postulate patterns of activity that are distributed over groups of units and that process information by adjusting the connection strengths between neurons. Fodor and Pylyshyn have objected that this approach cannot account for the systematicity and productivity of natural languages. Those features require a compositional syntax and semantics. The connectionist view therefore does not provide an alternative to the

computational model of the mind but only a different realization of it [10].

## References

1. Fodor J (1975) *The language of thought*. New York
2. Fodor J (1980) *Representations: philosophical essays on the foundations of cognitive science*. Cambridge, MA
3. Pylyshyn ZW (1984) *Computation and cognition: towards a foundation for cognitive science*. Cambridge, MA
4. Haugeland J (1981) *Mind design: philosophy, psychology, artificial intelligence*. Cambridge, MA
5. Block J (1982) *Readings in the philosophy of psychology*, vols 1 and 2. Cambridge, MA
6. Stich S (1984) *From folk psychology to cognitive science: the case against belief*. Cambridge, MA
7. Dennett DC (1987) *The intentional stance*. Cambridge, MA
8. Searle JR (1984) *Minds, brains and science*. Cambridge, MA
9. Rumelhart DE, McClelland JL, the PDP Research Group (1986) *Parallel distributed processing. Explorations in the microstructure of cognition*, vol 1: Foundations, vol 2: Psychological and biological models. Cambridge, MA
10. Fodor J, Pylyshyn ZW (1988) *Connectionism and cognitive architecture: a critical analysis*. *Cognition* 28:3–71

---

## Large Deformation, Large Strain

### Definition

Most soft tissues undergo deformations and strains that are well beyond the range where the relationships between strain and displacement gradients and between stress and strain are linear. This is certainly the case for arterial wall deformation and heart wall deformation. It means that the analysis of such materials needs to be based on "finite deformation elasticity" and not on the classical linear elasticity used in most engineering problems.

### ► Cardiovascular Mechanics

---

## Large-fiber Sensory Neuropathy

JONATHAN COLE

University of Southampton Clinical Neurological Sciences, Poole Hospital, Dorset, UK

### Synonyms

Acute sensory neuronopathy; Acute and chronic ataxic neuropathy

## Definition

A condition giving rise to degeneration of large myelinated sensory (afferent) nerve cells. When the primary lesion involves peripheral axonal degeneration or loss, this may be called an axonopathy (or commonly a neuropathy), where the primary damage is to the cell body of the neuron in the dorsal root ganglia, then this may be called a neuronopathy.

## Characteristics

### Quantitative Description

Large myelinated sensory nerve fibers arise from receptors of cutaneous touch and movement and position sense in the skin and muscles and tendons, and travel to the central nervous system in nerve trunks. These have been divided between A alpha for afferents underpinning movement and position sense and A beta for cutaneous light touch. Their cell bodies are in the dorsal root ganglia. They synapse either in the ipsilateral dorsal horn before ascending in that dorsal column or pass through the spinal cord to synapse in the dorsal column nuclei and other rostral structures.

Their size is 7–15  $\mu$ , with conduction velocities in humans between 35 and 70 m/s and they comprise ~40% of the axons in a peripheral sensory nerve.

### Function

Cutaneous touch, muscle and position sensation or proprioception. However much of the afferent activity within this system is not presented to consciousness and enables motor control by providing the brain with continuous information about the position and state of the moving parts.

Though loss of touch sensation may be easy to imagine, the effects of loss of proprioception are quite difficult to understand and are best appreciated by analysis of those few people with large fiber neuropathy.

### Pathology

Pure large fiber neuropathy is rare, being predominant in less than 5% of large series of neuropathies. It is, however, seen selectively in very rare conditions in which large fibers or their cell bodies are specifically targeted by disease. These fall into two broad areas. A specific concentration of a toxic agent and/or selective vulnerability to that agent (or its lack) may be the cause of large fiber neuronopathy/neuropathy in cisplatin and vitamin B6 neuropathies, in Friedreich's ataxia and in vitamin E deficiency [1]. In other diseases of the large sensory nerve an immune reaction appears to target the large fiber cell bodies in the dorsal root ganglia. This appears to be the case in carcinomatous sensory

neuropathy, IgM neuropathy, Sjogren's syndrome and acute sensory neuronopathy.

Onset can be insidious and progressive, as in some carcinomatous and Sjogren's syndrome related neuropathy, or can be acute and severe, with all large sensory nerve cells being destroyed in days, as in some acute sensory neuronopathy syndromes. In most large fiber axonopathies, sensory loss predominates, but in some neuronopathy syndromes ataxia is the main and presenting symptom, suggesting a selective loss of proprioceptive afferents.

### Selective Toxicity of Large Sensory Nerve Fibers

Vitamin B6 in large doses is neurotoxic to large sensory fibers or their cell bodies. This is reversible if the doses are stopped in time. In these severe toxicities other symptoms of central and peripheral nervous system affects are also seen, with autonomic disturbances, lethargy and respiratory depression [2].

Neuropathy associated with cisplatin therapy, then mainly used in gynecological cancers, was reported soon after the drug was employed. Though some early patients presented with parasthesiae and sensory loss in a classical glove and sticking distribution later, as the syndrome became more recognized, it has been realized to be primarily a neuronopathy rather than a dying back axonopathy. Post-mortem studies have shown necrosis of the large fiber cell bodies in the dorsal root ganglia as well as loss of peripheral axons. In a sample of 21 patients post mortem, Gregg et al. [3] found that tissue platinum levels were highest in the dorsal root ganglia and lowest in tissue protected by the blood-brain barrier. They suggested a linear relationship between platinum levels and cumulative dose and that cisplatin was retained indefinitely in a neurotoxic form. If the development of neuronopathy with cisplatin therapy is dependent on dose and exposure duration, then this must limit its usefulness, at least in those for whom survival times are long. More recently though it has suggested that limited prolonged use may be possible.

In inherited spinocerebellar atrophies, of which Friedreich's ataxia (FA) is the most common, the ataxia is associated with peripheral loss of large sensory fibers over and above any cerebellar cause. It is an autosomal recessive disease, which, in addition to degeneration in the central and peripheral nervous system, is also associated with cardiomyopathy, skeletal abnormalities and increased risk of diabetes; it is progressive and remorseless. Friedreich's ataxia is caused by expansion of a GAA triplet located within the first intron of the frataxin gene on chromosome 9q13. Frataxin is a mitochondrial protein that plays a role in iron homeostasis, with deficiency resulting in

mitochondrial iron accumulation, defects in specific mitochondrial enzymes and free-radical mediated cell death [4]. Though the precise pathological mechanism is unknown its dependence on a defect in oxidation allows potential treatment with anti-oxidants.

### Immune Mediated Neuronopathy

Autoimmune neuropathies are a subset of the sensory/ataxic neuropathies. These often present with ataxia, rather than cutaneous sensory loss. Their causes include sensory variants of the Guillain-Barre syndrome, sensory neuronopathy syndromes, subsets of immunoglobulin M paraproteinaemic neuropathy, paraneoplastic neuropathy and the neuropathy associated with Sjogren's syndrome. The targets for autoantibodies are varied, but include gangliosides, myelin associated glycoprotein, Hu antigen and extractable nuclear antigens [5]. The major site of pathology in autoimmune ataxic neuropathies is the dorsal root ganglion, but dorsal roots and peripheral nerve myelin and axons may also be affected. The discovery of the autoimmune origin of some of these neuropathies has led to trials of immune suppressant therapy, though with mixed results as yet.

IgM associated sensory neuropathy is a predominantly axonopathy which presents with ataxia but also with distal large and small fiber symptoms. It is associated with serum IgM binding GalNAc-GD1a and GM2 gangliosides and causes, unusually for these diseases, a demyelinating neuropathy. It is slowly progressive over years and may be treated with IVIg [6].

Paraneoplastic sensory neuropathy occurs almost always in smokers with small cell carcinoma of the lung, though at time of presentation of the neuropathy, no tumor is evident in ~50%. The presentation can involve pain, suggesting small fiber involvement and includes motor nerve involvement too in up to 50% in some samples [7]. About 80% are positive for anti-Hu antibodies [8]. It can also be associated with other nervous system dysfunction including LEMS, cerebellar ataxia and autonomic problems. Tumor resection sometimes improves the neuropathy, though median survival is poor, with ~20% surviving 3 years.

Large fiber sensory neuropathy is a rare but well-known neurological problem seen with Sjogren's syndrome. The majority presented with numbness and paresthesia. Most follow a rather indolent but progressive course, despite treatment with steroids, cyclophosphamide or intravenous immunoglobulins [9].

The acute sensory neuronopathy syndrome was first described in 1980 in three adults who, after an infection, (and antibiotics), rapidly and irreversibly developed sensory loss and ataxia [10]. They were followed for 5 years without evidence of coexistent neoplasia or

immunological disease. Subsequently more patients with this condition have been described in clinical series. In parallel, detailed neurophysiological and neurophenomenological work has been done on these subjects to elicit the role of proprioception in motor control [see Large-Fiber Sensory Neuropathy: Effect on Proprioception].

Large fiber sensory neuropathy is therefore a rare subset of peripheral neuropathy/neuronopathy, but important to diagnose since its causes are limited and depending on the cause its prognosis is broadly understood, with treatments possible. Where not treatable, it becomes even more important to explain the symptoms of loss of proprioception to the patient and their family and to ameliorate its effects as best one can.

### References

1. Koenig M (2003) Rare forms of autosomal recessive neurodegenerative ataxia. *Semin Pediatr Neurol* 10:183–192
2. Schaumburg HH, Kaplan J, Windebank A, Vick N, Rasmus S, Pleasure Brown MJ (1983) Sensory neuropathy from pyridoxine abuse. A new megavitamin syndrome. *N Engl J Med* 309:445–448
3. Gregg RW, Molepo JM, Monpetit VJ, Mikael NZ, Redmond D, Gadia M, Stewart DJ (1992) Cisplatin neurotoxicity: the relationship between dosage, time, and platinum concentration in neurologic tissues, and morphologic evidence of toxicity. *J Clin Oncol* 10:795–803
4. Alper G, Narayanan V (2003) Friedreich's ataxia. *Pediatr Neurol* 28:335–341
5. O'Leary CP, Willison HJ (1997) Autoimmune ataxic neuropathies (sensory ganglionopathies). *Curr Opin Neurol* 10:366–370
6. Comi G, Roveri L, Swan A et al. for the Inflammatory Neuropathy Cause and Treatment Group (2002) A randomised controlled trial of intravenous immunoglobulin in IgM paraprotein associated demyelinating neuropathy. *J Neurol* 249:1370–1377
7. Camdessanche JP, Antoine JC, Honnorat J, Vial C, Petiot P, Convers P, Michel D (2002) Paraneoplastic peripheral neuropathy associated with anti-Hu antibodies. A clinical and electrophysiological study of 20 patients. *Brain* 125:166–175
8. Lucchinetti CF, Kimmel DW, Lennon VA (1998) Paraneoplastic and oncologic profiles of patients seropositive for type I antineuronal nuclear autoantibodies. *Neurology* 50:652–657
9. Font J, Ramos-Casals M, de la Red G, Pou A, Casanova A, Garcia-Carrasco M, Cervera R, Molina JA, Valls J, Bove A, Ingelmo M, Graus F (2003) Pure sensory neuropathy in primary Sjogren's syndrome. Longterm prospective followup and review of the literature. *J Rheumatol* 30:1552–1557
10. Sterman AB, Schaumburg HH, Asbury AK (1980) The acute sensory neuronopathy syndrome; a distinct clinical entity. *Ann Neurol* 7:354–358

## Large-fiber Sensory Neuropathy: Effect On Proprioception

JONATHAN COLE

University of Southampton, Clinical Neurological Sciences, Poole Hospital, Dorset, UK

### Definition

A condition giving rise to degeneration of large myelinated sensory (afferent) nerve cells. When the primary lesion involves peripheral axonal degeneration or loss this may be called an axonopathy (or commonly a neuropathy), where the primary damage is to the cell body of the neuron in the dorsal root ganglia then this may be called a neuronopathy.

### Characteristics

#### Function

Large fiber sensory neuropathy deprives the patient of both cutaneous touch sensation and sense of movement and position, i.e. proprioception, in the body and limbs.

Proprioception means, in its simplest definition, knowledge of self but is usually considered to be knowledge of the body's position and movement (see Proprioception, Kinesthesia). One can logically talk of peripherally originating proprioception, the senses of movement and position sense, but also of visual proprioception, knowledge of these from visual inspection. Much of the afferent information arising from muscle spindle and Golgi tendon organs and from low-threshold large cutaneous afferents, which signal movement and position in the face and to an extent in the hand, is not perceived and therefore seems to lie outside the sense of proprioception. This essay follows the convention of using proprioception to mean peripherally originating senses of movement and position sense. Then, since the large myelinated sensory nerve fibers convey all information concerning movement and position sense and cutaneous touch, the effect of a complete loss of these fibers is to abolish peripheral signals underlying proprioception.

Proprioception was first described by Bell in the 1830s though named later by Sherrington. Bell considered it the sixth sense, but it is so basic within us that it has not really been considered in these terms. Though Purdon Martin wrote in 1967 of a man who had had a penetrating knife wound in the neck, severing his dorsal columns, who was "de-afferented" for proprioception and touch and who was shown standing [1], it effect to make one longer sentence was not until the 1970s and beyond that the full effects of proprioceptive loss were understood.

One of the first detailed descriptions was of a man who had a loss of distal proprioception in the limbs, though clinically he had a large and small fiber pan-sensory axonal dying back neuropathy [2]. This man was able to do a range of pre-programmed finger movements and could produce three different levels of force at the thumb pad once learnt. But he could not maintain a constant motor output after a few seconds without vision. Despite success in many laboratory tests, he was practically useless in daily life, being unable to fasten shirt buttons or to hold a cup.

In 1980 [3] the acute sensory neuronopathy syndrome was defined as an acute and severe loss of large sensory fibers as a result of a cross-immune reaction to a foreign antigen (see section on large fiber sensory neuropathy). Subjects with similar conditions have also been studied in more detail physiologically and phenomenologically. Sacks (1985) [4] wrote of a subject, "Christina" who had lost predominantly proprioception as "The Disembodied Lady." She felt disembodied by her inability to control movement and still felt this after she had re-learnt some movements. Other studies, mainly of two important subjects GL and IW, have taken place over many years. The subjects' complete losses of proprioception and cutaneous low threshold touch allowed the role of these to be assessed. The responses of these two has also allowed an understanding of the extents and limits of motor learning without peripheral feedback.

The case of GL was elaborated by Forget and Lamarre [5] and subsequently in innumerable studies (see <http://deafferented.apinc.org>). It is now over 20 years since she lost all large afferent sensory nerve function from the lower face (the third division of the trigeminal cranial nerve) down, so she has no touch or movement/position sense in her lower mouth and face, neck and body. Small fiber function and motor nerve function are normal. A second subject extensively studied, IW, has a lower level (round C3), so he has cervical afferents but none below the collar line. This difference between the upper levels of sensory loss may well be crucial. GL has to chew her food very carefully, but more importantly for movement, she has no automatic control of head position, whereas IW has both of these intact.

Any consideration of the effect of proprioception based on the effects of its loss must also consider the time of study after the acute loss and the time of life at which it happened. GL and IW were in their late teens and early twenties when they suffered their neuronopathy. They had learnt most motor skills and their rehabilitation was helped by their youthful sense of purpose. In contrast, subject CF was 60 when it occurred and has found recovery of functional movement far more difficult.

Without proprioception all subjects find that controlled movement is impossible and require full nursing



care for several weeks after the loss. Initially the effects of the neuropathy are devastating. But both GL and IW discovered that movement was possible, using visual feedback to replace peripheral originating proprioception and cognitive control of all movement. It was as if they had effectively been deprived of subconscious motor schema and were using their conscious body image in a novel way to control movement. Both learnt to dress and feed themselves over months [6]. GL, with her additional loss affecting neck proprioception decided to live in a wheelchair; IW younger and without family responsibilities, spent 17 months in rehabilitation re-learning movement. After 1 year, he managed to stand and a few months later could walk. He has lived independently for years and worked as a civil servant and more recently in disability access management. In addition to locomotion and instrumental movements, writing, dressing etc, both re-learned to gesture consciously, so that they appear emotionally and linguistically embodied, like others.

Research on these subjects has encompassed a large number of areas. With eyes open the ability to distinguish the weight of an object was similar to controls, with the deafferented subjects making a certain movement force and seeing whether the lifted weight moved faster/further than the last. With eyes shut, the liminal difference for the percept was about 100%, though still present, This might reflect a peripheral originating percept (in remaining small afferents) or be read from, say, associated head movement using vestibular afferents. These subjects tend to use an amplitude model in moving single joints between two places, rather than a moving end point one [7].

In a reaching task, with vision of the target but with manipulation of the seen position of the moving hand, GL was able to move to a target accurately despite the reach direction being altered and despite her being unaware of the alteration [8]. This study offered evidence that motor efference processes, in themselves, are insufficient for conscious experience of our own actions. More recently Olausson et al. [9] were able to show the existence of a novel class of sensory afferents, called C-touch, which may underlie the affective aspect of light touch, in GL (and subsequently in IW). Functional imaging studies of a number of subjects with varying pan-sensory neuropathies and with clinical loss of peripheral proprioception have shown that in order to move, these subjects activate premotor and cerebellar areas more than controls without visual or proprioceptive input [10].

Subject IW appears to move using a complex combination of pre-visualization and forward planning, with visual supervision. By the latter it is suggested that he does not use vision for strict real time on-line feedback, but rather to correct errors in a higher order way. Some automaticity of movement may have also

returned, since it is difficult to conceive that he could walk if concentrating on all aspects of that movement at all times. He himself agrees, saying that walking now takes round 50% of his attention at the least, whereas originally it was 100%. Similarly his gestures seem automatic and since they do not require accuracy in place, but in time and in shape, these may be the most automatic of movements in this group.

Though the subjects studied over many years have learnt to move with degrees of smoothness and control unexpected from the earlier studies, there are still movements that are beyond them. Their reaction times for simple movements are normal but coordinated sequential fast movements are impossible; IW can neither run nor walk fast. Fine dextrous finger movements are difficult and of course active touch without vision impossible – they cannot take keys or coins from their pockets. Simultaneous accurate movements are also difficult. Lastly, their movements remain under conscious attention and so are very vulnerable. This is not always apparent, such is the skill these subjects have developed. But IW, for instance, retires to bed if he has a head cold or flu and can never afford even gentle intoxication. He cannot cope with the attentional demands of movement if not clear in the head.

These subjects are very rare but have allowed a new understanding of the ability to coordinate movement without proprioception, substituting vision feedback and cognitive control for automatic motor programs. Thus far these subjects have been adults when deprived of movement and position feedback. One imagines that a young child, so deprived, before skilled motor programs had developed, would be more incapacitated.

## References

1. Purdon Martin J (1967) *The basal ganglia and posture*. London, Pitman
2. Rothwell JC, Traub MM, Day BL, Obeso JA, Thomas PK, Marsden CD (1982) Manual motor performance in a deafferented man. *Brain* 105:515–542
3. Sterman AB, Schaumburg HH, Asbury AK (1980) The acute sensory neuronopathy syndrome; a distinct clinical entity. *Ann Neurol* 7:354–358
4. Sacks O (1985) The disembodied lady. In: *The man who mistook his wife for a hat*, Chapter 3. Duckworth, London
5. Forget R, Lamarre Y (1987) Rapid elbow flexion in the absence of proprioceptive and cutaneous feedback. *Hum Neurobiol* 6:27–37
6. Cole J (1991) *Pride and a daily marathon*. Duckworth, London
7. Nougier V, Bard C, Fleury M, Teasdale N, Cole J, Forget Y, Paillard J, Lamarre Y (1996) Control of single joint movements in deafferented subjects: evidence for amplitude coding rather than position control. *Exp Brain Res* 109:473–482

8. Fourneret P, Paillard J, Lamarre Y, Cole J, Jeannerod M (2002) Lack of conscious knowledge about one's own actions in a haptically deafferented patient. *Neuroreport* 13:541–547
9. Olausson H, Lamarre Y, Backlund H, Morin C, Wallin BG, Starck G, Ekholm S, Strigo I, Worsley K, Vallbo AB, Bushnell MC (2002) Unmyelinated tactile afferents signal touch and project to insular cortex. *Nat Neurosci* 5:900–904
10. Weeks RA, Gerloff C, Dalakas M, Hallett M (1999) PET study of visually and non-visually guided finger movements in patients with severe pan-sensory neuropathies and healthy controls. *Exp Brain Res* 128:291–302

## Larva

### Definition

Young stage in the life of animals that undergo metamorphosis. Anatomically distinct stage between the embryo and the adult, with the larva changing into the adult.

► Evolution and Phylogeny: Chordates

## Laryngeal Apnea

► Laryngeal Chemoreflexes

## Laryngeal Chemoreflexes

JAMES C. LEITER, DONALD BARTLETT, JR.  
Department of Physiology, Dartmouth Medical School,  
Lebanon, NH, USA

### Synonyms

Laryngeal apnea

### Definition

The laryngeal chemoreflex (LCR) is a complex behavioral response elicited following stimulation of laryngeal receptors by liquids and consists, to variable degrees, of apnea, respiratory inhibition, coughing, swallowing,

arousal, bradycardia and redistribution of blood flow to vital organs. It is one of a family of airway protective reflexes such as the dive response and the cough reflex.

### Characteristics

#### Stimulus

The laryngeal receptors mediating the LCR are stimulated by hypo-osmolar solutions with a low chloride concentration. The reflex response varies inversely with the chloride concentration in the solution; as the chloride concentration rises, the reflex response diminishes [1]. Water alone is, therefore, an effective stimulus, whereas saline is relatively ineffective. Solutions containing anions with larger hydrated volumes than chloride (e.g.,  $F^-$ , acetate,  $SO_4^-$ , etc) also elicit the LCR, as do solutions with elevated potassium concentrations. Fluids with a low pH stimulate the LCR regardless of the chloride concentration in the fluid. Thus, gastric liquids with a low pH are potent stimuli of the LCR when gastro-esophageal reflux occurs.

The afferent receptors for the LCR are located in and around the larynx. The receptors are particularly dense on the epiglottis, interarytenoid space and aryepiglottic folds, but extend into the body of the larynx below the glottis. The water receptors are slowly adapting, so receptor activity persists until the offending solution is removed. The afferent information from the receptors is conducted to the central nervous system in fibers in the superior laryngeal nerve (SLN), and for that reason, cutting the SLN completely abrogates the reflex response to laryngeal stimulation of water receptors. The nerves within the SLN terminate in interstitial and medial subnuclei of the nucleus of the solitary tract (NTS).

#### Response

The LCR occurs often in neonates and infants and consists of apnea, laryngeal closure, coughing, swallowing and a period of variable respiratory inhibition (Fig. 1).

The reflex response may include cardiovascular responses such as bradycardia, mild hypertension and peripheral vasoconstriction and a redistribution of blood flow to sustain oxygen delivery to vital organs such as the brain and heart. The elements of the response fall into two categories: airway clearance and a set of defensive reflex responses that limit inspiration of the liquid stimulus into the lungs and preserve oxygen delivery to vital organs. Thus, coughing and swallowing remove the offending stimulus and clear the airway, but apnea, laryngeal closure and the cardiovascular elements of the reflex response seem designed to limit further damage and preserve vital functions. The cessation of breathing causes carbon dioxide levels to rise within the body and oxygen levels fall as the period of respiratory inhibition

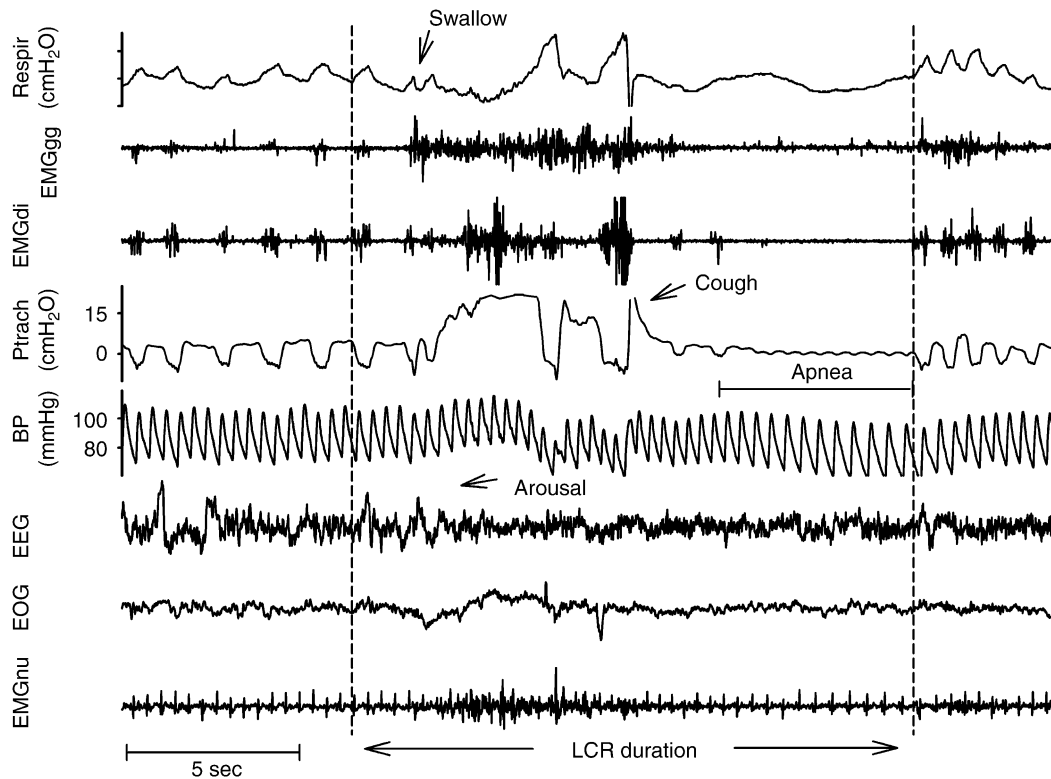

**Laryngeal Chemoreflexes. Figure 1** An example of the LCR from a neonatal piglet at 9 days of age during NREM sleep after muscimol dialysis in the brainstem. Water (0.05 ml) was introduced into the larynx at the *left vertical dashed line*. Note the occurrence of swallowing, coughing after arousal, apnea and respiratory disruption, and note that when swallowing occurs, respiratory activity of the diaphragm ceases so that the multiple events of the LCR are well coordinated. Respir, respiratory trace from the plethysmograph; EMGgg, genioglossus (tongue) electromyogram; EMGdi, diaphragm electromyogram; Ptrach, tracheal airway pressure; BP, blood pressure; EEG, electroencephalogram; EOG, electro-oculogram; EMGnu, nuchal electromyogram. Figure adapted from [2], used with permission of the American Physiological Society.

persists. These stimuli, hypercapnia and hypoxia, may be important in terminating the respiratory inhibition elicited by laryngeal stimulation. When the LCR occurs during sleep, arousal, whether directly from the laryngeal stimulation or as a consequence of hypercapnia and hypoxia that develop during the period of apnea, is an important part of the process limiting the duration of the LCR and clearing the airway. Coughing does not seem to occur during sleep, and airway clearance is, therefore, deficient until arousal from sleep occurs.

The manifestations of the LCR vary depending on the intensity of the stimulus. When the volume of fluid is small and not acidic, the reflex response in newborn animals and humans may consist of brief apnea, swallowing and mild respiratory disruption. Coughing emerges as a more prominent part of the LCR, and apnea and bradycardia become less common as neonates mature. As the stimulus intensity increases, the duration of the apnea, coughing, swallowing and

respiratory disruption increases and bradycardia, hypertension and redistribution of blood flow may develop. In anesthetized animals, it is possible with large volume stimuli to elicit a LCR with apnea of sufficient duration to lead to an asphyxial death in the animal unless resuscitation efforts are begun. The hierarchical pattern of responses, in which mild stimuli elicit swallowing and coughing, but apnea, bradycardia and redistribution of blood flow occur only as the stimulus intensity increases, suggests that the airway restorative aspects of the LCR are the first line of defense, but to the extent they are ineffective, those aspects of the reflex aimed at conserving vital organ function emerge.

### Central Integration

After the afferent impulses in the SLN terminate in the NTS, interneurons process and distribute sensory information from the larynx throughout the brainstem and activate the wide variety of behaviors that constitute

the LCR. Electrical stimulation of the SLN, which mimics many aspects of the LCR, or stimulation the laryngeal mucosa with water inhibits phrenic motor neuron activity and inhibits inspiratory and expiratory neurons in the ►ventral respiratory group and depolarizes post-inspiratory neurons. Stimulation of the SLN seems to prolong expiratory time by preventing inhibition of post-inspiratory neurons in the ventral respiratory group; the depolarized state of the post-inspiratory neurons has been labeled “post-inspiratory apneusis”; [3], and the transition between the depolarized “apneustic” state in post-inspiratory neurons early in expiration and their hyperpolarized state during late expiration seems to require the activity of chloride-dependent inhibitory post-synaptic potentials. Reflex prolongation of the post-inspiratory period after SLN stimulation is associated with the suppression or absence of inhibitory post-synaptic potentials that usually hyperpolarize post-inspiratory neurons in the ventral respiratory group, terminate the effect of SLN stimulation and thus prepare the way for the final phase of expiration and the next inspiration. The inspiratory and expiratory inhibition is mediated by GABAergic mechanisms, and bicuculline administration attenuates the duration of apnea and respiratory inhibition associated with SLN stimulation. Thus, ventral medullary sites seem to mediate the respiratory effects of SLN stimulation on the LCR.

Laryngeal motor neurons are excited during SLN stimulation, and this is consistent with the activation of laryngeal muscles that close the glottis during the LCR. Swallowing is generated by a central pattern generator in the NTS and distributed to the large variety of motor neurons involved in swallowing by another group of neurons within the ventral medulla in or near the nucleus ambiguus [4]. Similarly, a central pattern generator for coughing seems to be activated during laryngeal stimulation. Many of the individual activities use a common set of premotor neurons, and the activity of one behavior often precludes the others. Thus, swallowing inhibits coughing and respiratory activity (see Fig. 1). Although it is clear that one activity prevents the others, the neurophysiological mechanisms whereby this reciprocal inhibition among multiple behavioral central pattern generators is achieved have not been established.

### Interactions

The duration of the LCR is modified by a variety of factors, and in general, there is an inverse relationship between the duration of the LCR and respiratory drive in unanesthetized animals. Hypercapnia generally shortens the duration of the LCR [5]. On the other hand, focal dialysis of muscimol, a GABA<sub>A</sub> receptor agonist, in the rostroventral lateral medulla decreases the ventilatory response to CO<sub>2</sub> in piglets and also

prolongs the LCR [6]. Moreover, stimulation of muscle afferents, which enhances ventilation, also shortens the LCR in lambs. Hyperoxia, on the other hand, prolongs the LCR in awake and sleeping piglets.

The effect of hypoxia on the LCR is less consistent. In different studies, hypoxia has been shown to prolong or shorten the LCR in anesthetized piglets and enhances apnea duration and bradycardia associated with the reflex, but hypoxia also shortened apnea duration in the same species in a related study. Hypoxia reduces the duration of apnea after stimulation of the SLN in decerebrate piglets. Often hypoxia prolongs the LCR in anesthetized animals, but shortens the LCR in studies of unanesthetized animals. However, hypoxia prolongs the apnea associated with laryngeal infusion of water in unanesthetized infants.

The duration of the LCR also increases during sleep. The LCR is generally longest during REM sleep, of intermediate duration during NREM sleep and shortest during wakefulness in neonatal piglets and lambs. Minute ventilation and the ventilatory response to CO<sub>2</sub> are also least in REM sleep, intermediate in NREM sleep and greatest during wakefulness, and, some of the prolongation of the LCR may be due to a state-dependent reduction in ventilatory drive. It is an attractively simple hypothesis to suggest that the duration of the LCR is inversely related to the level of respiratory drive (and some data support this concept), but the control of the LCR is more complicated than this simple hypothesis suggests, especially when one considers the effects of hypoxia.

The body temperature also alters the duration of the LCR, and this is not associated with any clear change in respiratory drive. Haraguchi et al. [7] first noticed that elevating the body temperature of puppies approximately 2°C reduced the threshold of SLN stimulation necessary to activate the thyroarytenoid muscles, which contribute to the glottic closure typical of the LCR. The thermal reduction in threshold was most apparent in young animals and was absent in adult dogs. Elevating the body temperature of decerebrate neonatal piglets by 2°C also prolongs the LCR quite significantly. The activity of water receptors in the larynx is not altered in the temperature range of 38–42°C, and focal heating of the NTS, while body temperature remains constant, is sufficient to elicit the thermal prolongation of the LCR. Therefore, the thermal prolongation of the LCR is centrally mediated within or very near to the NTS. Moreover, the prolongation seems to depend on GABAergic processes since focal administration of gabazine, a GABA<sub>A</sub> antagonist, in or near the NTS completely reverses the thermal prolongation of the LCR without affecting other aspects of respiration in decerebrate piglets [8]. Similar prolongation of the LCR is apparent in newborn rats, although the thermal prolongation wanes by

postnatal day 21 even though the apnea associated with the LCR persists at that age.

Finally, upper respiratory tract infections, particularly respiratory syncytial virus, increase the sensitivity of the LCR so that respiratory inhibition is greater in the setting of upper airway infection for any level of stimulation of the LCR. The sensitization is centrally mediated by uptake of cytokines from sensory neurons in the laryngeal mucosa.

### Developmental Features

The manifestations of the LCR change as animals mature [2]. Swallowing, cough, apnea, bradycardia and redistribution of blood flow frequently occur in neonatal animals when the LCR is elicited, but cough and swallowing become the sole manifestations of the LCR in older animals and adults – respiratory inhibition and cardiovascular manifestations of the LCR, which tend to conserve the function of vital organs, are absent in adults. The rate at which apnea, respiratory inhibition and bradycardia cease to be part of the LCR varies among species. In premature lambs delivered two weeks early, apnea and bradycardia are present at postnatal day 7, but absent when the LCR is stimulated at postnatal day 14. Lambs, which are a precocial species, have little or no apnea and bradycardia at postnatal days 4–6 following a normal gestation period. Apnea is also absent at one month of age in neonatal piglets when the larynx is stimulated even though apnea is common in younger animals. In more altricial species such as cats, apnea is present at postnatal ages 5 and 14 days, and swallowing becomes a major manifestation of the LCR by one month of age, but the adult pattern of frequent swallowing does not emerge until two months of age. In puppies, apnea is prominent during the first 10 days of postnatal life, but is not an important component of the response after one month of age. In anesthetized rat pups, apnea remains a prominent part of the LCR at least through postnatal day 21. It is interesting to note that the thermal prolongation of the LCR described above disappears as animals mature before the apnea is lost as a manifestation of the LCR. This suggests that the neurophysiological processes controlling the thermal prolongation of the LCR and the respiratory inhibitory parts of the LCR are controlled by different mechanisms in the brainstem. This separation of processes is also supported by what limited neuroanatomical information exists: thermal prolongation of the LCR seems to be controlled in or near the NTS, whereas the apneic and bradycardic manifestations of the LCR seem to be controlled by structures in the ventral respiratory area and ventral medulla.

Many investigators feel that the LCR contributes to the ► **Sudden Infant Death Syndrome (SIDS)** [9]. SIDS may begin with apnea related to the LCR. Moreover, a variety of risk factors for SIDS are associated in

experimental animals with prolongation of the LCR. Gastro-esophageal reflux and upper respiratory tract infections have been associated with some SIDS deaths: gastric fluid is a potent stimulus of the LCR, and some respiratory tract infections enhance the sensitivity of the LCR. In addition, infants who died of SIDS are thought to lack a variety of neurotransmitter receptors in the brainstem, and when decreased neuronal activity within these brainstem areas is induced in neonatal piglets by dialyzing muscimol into the rostroventral lateral medulla, the LCR is prolonged. Moreover, SIDS usually occurs during sleep, and the LCR is longest in REM sleep and longer in NREM sleep than during wakefulness in neonatal piglets and lambs. Hyperthermia is a risk factor for SIDS in humans, and hyperthermia in neonatal piglets prolongs the LCR. Finally, apnea and bradycardia wane as manifestations of the LCR as animals mature, and the risk of SIDS also diminishes in human infants as they mature, although the actual relationship between the transformation of the LCR to an adult pattern in humans and the decline in the risk of SIDS has not been studied in detail.

### Summary

The LCR is a behavioral response to laryngeal stimulation that contains many elements, which both clear the airway and protect and preserve respiratory and cardiovascular function. The protective elements of the reflex are dominant in neonatal animals and may represent a holdover from fetal life, when the adaptive alternatives to hypoxic stress are limited. The airway clearance mechanisms tend to dominate the adult response. The persistence of respiratory inhibition and cardiovascular responses to laryngeal stimulation may contribute to the risk of SIDS [9], and interventions that shorten the LCR or reduce its apneic and respiratory inhibiting elements may, in the future, be shown to reduce the risk of SIDS.

### Acknowledgement

This work was supported by grants 36379 and 042707 from the National Institute of Child Health and Human Development and by a grant from the Flight Attendant Medical Research Institute.

### References

1. Boggs DF, Bartlett D Jr (1982) Chemical specificity of a laryngeal apneic reflex in puppies. *J Appl Physiol* 53:455–462
2. Lee JC, Stoll BJ, Downing SE (1977) Properties of the laryngeal chemoreflex in neonatal piglets. *Am J Physiol* 233:R30–R36
3. Remmers JE, Richter DW, Ballantyne D, Bainton CR, Klein JP (1986) Reflex prolongation of stage I of expiration. *Pflügers Arch* 407:190–198

4. Jean A (2001) Brain stem control of swallowing: neuronal network and cellular mechanisms. *Physiol Rev* 81:929–969
5. Lawson EE (1982) Recovery from central apnea: effect of stimulus duration and end-tidal CO<sub>2</sub> partial pressure. *J Appl Physiol* 53:105–109
6. van der Velde L, Curran A, Filiano JJ, Darnall RA, Bartlett D Jr, Leiter JC (2003) Prolongation of the laryngeal chemoreflex after inhibition of the rostroventral medulla in piglets: A role in SIDS? *J Appl Physiol* 94:1883–1895
7. Haraguchi S, Fung RQ, Sasaki R (1983) Effect of hyperthermia on the laryngeal closure reflex. Implications in the sudden infant death syndrome. *Ann Otol Rhinol Laryngol* 92:24–28
8. Xia L, Damon T, Niblock MM, Bartlett D Jr, Leiter JC (2007) Unilateral microdialysis of gabazine in the dorsal medulla reverses thermal prolongation of the laryngeal chemoreflex in decerebrate piglets. *J Appl Physiol* 103:1864–1872.
9. Leiter JC, Böhm I (2007) Mechanisms of pathogenesis in the sudden infant death syndrome (SIDS). *Respir Physiol Neurobiol*:Jun 8; [Epub ahead of print] PMID: 17644048

## Laser Trap

### Definition

Laser traps or optical traps are instruments that use a focused laser beam to capture small (micron sized or smaller) particles. In biomechanics, laser traps are typically used to measure the mechanical properties of isolated molecules. Micron-sized beads that can be captured with the laser trap are attached to the ends of molecules. Each end of the molecule can be controlled, and so the molecule can be extended and the force associated with the extension can be calculated by the distance that the bead moves out of the centre of the laser trap and the specific stiffness of the trap.

► [Molecular and Cellular Biomechanics](#)

## Latch Neurons

CHARLES SCUDDER  
Portland, OR, USA

### Definition

Latch neurons are a component of the ► [saccadic burst generator](#) and are hypothesized to inhibit the

► [omnipause neurons \(OPNs\)](#) for the duration of the saccade. Inhibition of the OPNs is necessary to permit the high-frequency bursts of ► [medium-lead burst neurons](#) (► [Burst cells – short lead](#)) that provide the powerful excitation and inhibition of agonist and antagonist motoneurons, respectively. As originally formulated, they form interneurons in a loop of reciprocal inhibitory connections between OPNs and ► [excitatory burst neurons \(EBNs\)](#). This positive feedback loop “latches” the OPNs in an inhibited state and the EBNs in an excited state, until this state is reversed when the saccade reaches its target.

### Characteristics

#### Description and Function

The partial diagram of the saccadic burst generator illustrated in [Fig. 1](#) shows one idea of how latch neurons

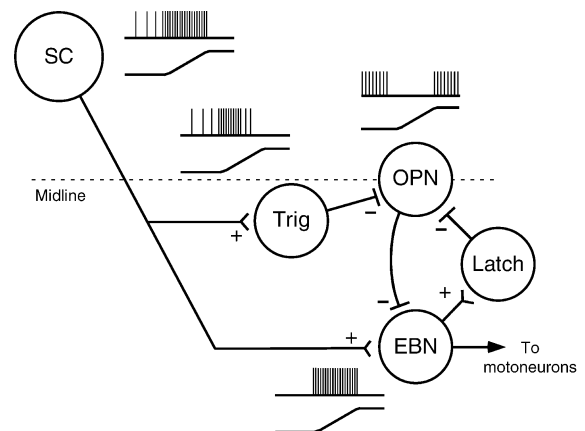

**Latch Neurons. Figure 1** Schematic diagram of a portion of the brainstem saccadic burst generator showing the proposed function of the latch neurons. Schematized spike discharges are illustrated next to each neuron type. The latch neurons (Latch), the omnipause neurons (OPN), and the excitatory burst neurons (EBN) are connected in a positive feedback loop consisting of two inhibitory connections (–) and one excitatory connection (+). The positive feedback makes the circuit bistable such that the OPNs are “latched” off (no discharge) when the EBNs are discharging, or the EBNs are latched off when the OPNs are discharging. The OPNs are thought to have some excitatory input that causes them to tonically discharge when there is no inhibitory input. When the superior colliculus (SC) begins to discharge just before a saccade, the trigger neurons (Trig) are excited and the tonic discharge of the OPNs is inhibited. This allows the EBNs to respond to their input from the SC and to maintain inhibition of the OPNs via the latch neurons. The OPNs cannot resume firing until the excitatory input to the EBNs has been removed.

might operate. Central to the diagram are the OPNs, which are tonically active during fixations and must be inhibited before the medium-lead EBNs can discharge. This is brought about first by the ►trigger neurons, which receive early excitation from higher-level inputs such as the ►superior colliculus. Once the OPNs are inhibited, the EBNs can begin to fire. In the illustrated schema, the latch neurons receive all their excitation from EBNs, and therefore have discharges that are nearly identical to those of EBNs except for a slight delay. The firing of the latch neurons accelerates the inhibition of the OPNs, and the regenerative inhibitory loop produces a sudden onset of EBN firing and a sudden cessation of OPN firing. Towards the end of the saccade, the EBN firing rate declines as its excitatory input declines. When the firing rate of the latch neurons decline sufficiently, the OPNs begin to fire, the EBNs are inhibited, and the regenerative inhibitory loop produces a rapid onset of OPN firing and a rapid offset of EBN firing.

As originally formulated by Robinson [1], the trigger neurons discharged briefly, and the job of maintaining the inhibition of the OPNs fell to the latch neurons. Moreover, the tight coupling between EBNs and latch neurons insured that the OPNs would not begin firing again (to terminate the saccade) until EBN firing had dropped to a critical level. This allowed the “motor error” input that was hypothesized to comprise the functional input signal to the EBNs, to control the amplitude and durations of the saccade, so that the saccade landed on target (see ►Local feedback and ►brainstem burst generator).

### Higher Level Structures

As a discrete population of neurons that perform the function of latch neurons has not been identified physiologically, the exact inputs to latch neurons are not known. Current proposals expand on Robinson’s idea that the input comes from EBNs, while preserving the two functions of latch neurons that Robinson considered.

As outlined above, one function is to form part of a positive feedback loop that causes a rapid change in the firing rates of OPNs and EBNs. However, many ►long-lead burst neurons (LLBNs) (►Burst cells – long lead (LLBNs)) have an abrupt-onset high-frequency component to their burst in addition to their low-frequency early discharge [2,3]. Hence, inhibitory input to OPNs from these LLBNs might produce a rapid cessation of OPN firing, and it may not be necessary to have such a powerful positive feedback loop to produce the rapid cessation. The LLBNs, which could include the ►saccade-related burst neurons (SRBNs) in the superior colliculus and ►ponto-pontine LLBNs, might be expected to use the latch neurons as the inhibitory interneuron.

The second function is to maintain OPNs in a “latched” off state until the saccade reaches its target (amplitude control function). However, in many modern models of the saccadic burst generator, the control of saccade amplitude is accomplished by local feedback loops that do not exclusively pass through the EBNs [cf.4,5]. As these feedback loops have a need to control the duration of the pause in OPNs, the output of such feedback circuits might also impinge on the latch neurons. Input from the cerebellum is a likely possibility [6] (see also ►Cerebellum – role in eye movements).

In summary, the latch neurons could serve as less specialized interneurons that mediate the inhibition of

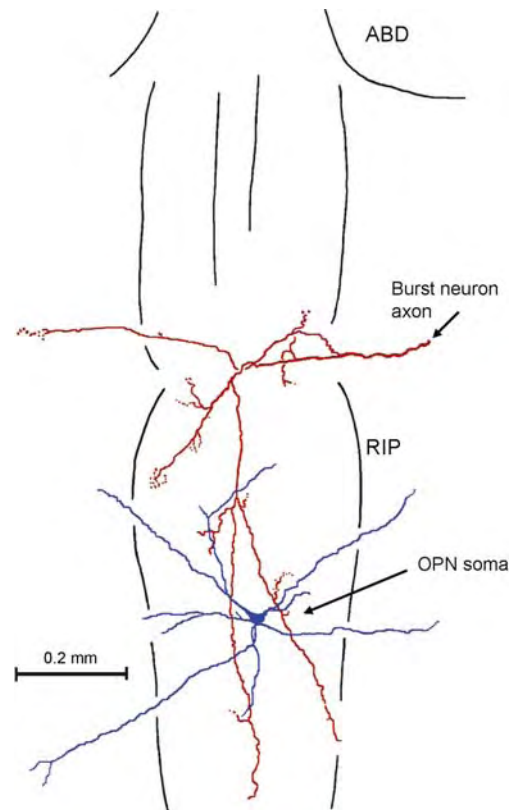

**Latch Neurons. Figure 2** Reconstruction of intra-axonally labeled neurons in the region of raphe interpositus (RIP), the locus of omnipause neurons (OPNs). The arborization and synaptic terminals of a physiologically identified saccadic burst neuron are illustrated in red. The soma and dendrites of physiologically identified OPN from a different experiment are illustrated in blue. The burst neuron is well positioned to synapse on the OPNs in the RIP and could possibly be a latch neuron. ABD = abducens nucleus. Data were obtained by R. McCrea, A. Strassman, and C. Evinger and were first illustrated in Moschovakis et al. [9].

OPNs. For instance, the functions of the trigger and Latch neurons could be somewhat merged.

### Evidence for Latch Neurons

There is both physiological and anatomical evidence for the existence of latch neurons. By recording intracellular potentials from OPNs in alert cats making saccades, Yoshida et al. [7] found that OPNs were subject to two phases of inhibition. An early phase which preceded EBN firing, and a later one in which the depth of inhibition mirrored saccadic eye velocity. As the EBN firing rate is correlated with eye velocity [8], EBNs are a likely source of input to the interneurons that inhibit OPNs. By definition, these neurons would be Latch neurons. The early phase of OPN inhibition is presumably provided by LLBNs.

Anatomical evidence consists of data from intra-axonal staining of physiologically identified saccade-related neurons in alert monkeys. Fig. 2 shows the soma and dendrites of an OPN and the axonal arborization in the ▶*raphe interpositus* (RIP) of a burst neuron, whose soma was found ventral and medial to the abducens nucleus. The axonal arborization is clearly well situated to provide synaptic input to the OPNs in RIP.

### References

1. Robinson DA (1975) Oculomotor control signals. In: Lennerstrand G, Bach-y-Rita P (eds) Basic mechanisms of ocular motility and their clinical implications. Pergamon, Oxford, pp 337–374
2. Keller EL (1974) Participation of medial pontine reticular formation in eye movement generation in monkey. *J Neurophysiol* 37:316–332
3. Luschei ES, Fuchs AF (1972) Activity of brainstem neurons during eye movements of alert monkeys. *J Neurophysiol* 35:445–461
4. Quaia C, Lefevre P, Optican LM (1999) Model of the control of saccades by superior colliculus and cerebellum. *J Neurophysiol* 82:999–1018
5. Scudder CA, Kaneko CRS, Fuchs AF (2002) The brainstem burst generator for saccadic eye movements: a modern synthesis. *Exp Brain Res* 142:439–462
6. Scudder CA, McGee DM (2003) Adaptive modification of saccade size produces correlated changes in the discharges of fastigial nucleus neurons. *J Neurophysiol* 90:1011–1026
7. Yoshida K, Iwamoto Y, Chimoto S, Shimazu H (1999) Saccade-related inhibitory input to pontine omnipause neurons: an intracellular study in alert cats. *J Neurophysiol* 82:1198–1208
8. van Gisbergen JAM, Robinson DA, Gielen S (1981) A quantitative analysis of generation of saccadic eye movements by burst neurons. *J Neurophysiol* 45:417–442
9. Moschovakis AK, Scudder CA, Highstein SM (1996) The microscopic anatomy and physiology of the mammalian saccadic system. *Prog Neurobiol* 50:133–254

## Late Selection

### Definition

A model, first proposed for attention, assuming that unattended signals are nevertheless processed on early cerebro-cortical levels and eliminated only on higher cortical levels of processing.

- ▶ Attention
- ▶ Sensory Plasticity and Perceptual Learning

## Latency of Response

### Definition

In event-related potentials, the timing of the response is referenced to the time of the stimulus-evoking event (light flash, noise burst, etc.). Latency is the elapsed time between stimulus and response.

- ▶ Event-Related Potentials

## Latent Inhibition

A CS which has been repeatedly presented in the absence of the US requires more pairings with the US to establish the conditioning. Such lowered conditioning performance, called latent inhibition, may be derived from the diminution of novelty and the development of safe learning to the CS or a failure of retrieval even if the association of the pre-exposed CS to the US proceeds normally.

- ▶ Conditioned Taste Aversion
- ▶ Learning and Extinction

## Latent Learning

RYOTA KANAI, DAW-AN WU  
Division of Biology, California Institute of  
Technology, Pasadena, CA, USA

### Synonyms

Incidental learning; Unreinforced learning; Implicit learning



## Definition

Latent learning is an acquisition of neutral information in the absence of external reinforcement or punishment. In latent learning, the acquisition of information does not lead to an immediate change in behavior until the subject is given an incentive to demonstrate the knowledge.

## Characteristics

### A Brief Introduction

Learning is typically defined operationally as a process whereby pre-existing behavioral patterns undergo long-term modification. However, there are many cases in which the impact of a learning process may not immediately express itself, instead remaining latent. For example, one may learn how to perform a task by observing someone else, but this acquired knowledge may not become behaviorally expressed until performance of that task becomes necessary some time in the future. The study of latent learning helps to bridge behaviorist, operational definitions of learning with the more traditional introspective definitions involving the internalization of concepts.

### The Classical Animal Study

In one of Tolman's most famous experiments [1], a number of rats were allowed to explore in a maze for several days. One group was rewarded with food at the goal box and another group did not receive any reinforcer. After the 11th day, both groups were given food in the goal box. As soon as the unrewarded rats were given food, they began to perform as well as the rats that had been trained with the reward, and much better than a third group of rats that had not been familiarized with the environment at all. This indicated that, although the rats performing unreinforced exploration did not exhibit alterations in their behavior, there were unseen internal changes that could become expressed as a behavioral alteration once incentive was provided. Because this form of learning is not externally observable until the reinforcer was introduced to the maze, it is termed latent learning.

Latent learning processes can be separated into three phases: pre-exposure, training and the test [2]. In the pre-exposure phase, rats are allowed to explore a maze, but no reinforcer (e.g., food) is available in the maze. In the training, the rats are trained to learn association between food and a location in the maze, but they are confined to one location. In the expression phase, the rats are again allowed to freely explore the maze without a reinforcer. Because this experimental design isolates the learning of spatial layout from the association of reward with a location, changes in the rats' way-finding performance during the test phase should reflect latent learning processes occurring

during pre-exposure phase. If the rats spend more time at the location associated with the reinforcer in the test phase, it is inferred that they have learned about the spatial relationship between the locations during the pre-exposure phase.

Latent learning contrasts with conditioning (reinforcement) learning in which animals learn the association between a reinforcer and a location as they explore the environment. The presence of latent learning indicates that reinforcement is not a requirement for learning.

Furthermore, the existence of latent learning is often taken as evidence that animals acquire "cognitive map" of the environment, rather than simply associating a fixed series of behavioral steps with food reward. This internal perceptual representation of external environmental features and landmarks allows animals to generalize their behavioral strategies. They can more readily utilize short cuts to the food, and can compensate for changes in their initial placement in the maze. As such, latent learning paradigms are an extension of reinforcement learning paradigms, allowing animal investigators operating within the behaviorist framework to address issues such as internalized concepts.

### Latent Inhibition

Latent inhibition is an effect which runs in opposition to latent learning [3]. In latent inhibition, exposure to a stimulus without consequence disrupts subsequent associative learning regarding that stimulus and a reinforcer. However, latent inhibition is induced by a slightly different experimental conditions. One difference is attributed to the active involvement of the animals in the exploration. Latent inhibition occurs when animals are exposed to the environment in a passive fashion, whereas latent learning occurs as a consequence of active exploration. The amount of exposure is another factor which might determine whether pre-exposure leads to inhibition or facilitation of subsequent learning.

### Incidental Learning in Humans

While the term "latent learning" is commonly used in the context of animal behavior, the acquisition of information or skills in humans without intention to learn is more commonly referred to as *incidental learning* or *implicit learning*.

One popular method to study implicit learning in humans is *artificial grammar learning* [4]. Artificial grammar learning typically involves pre-exposure of subjects to letter strings generated from an artificial grammar structure. After the exposure phase, subjects are tested with a new set of letters strings and asked to judge whether the strings follow the same rules or not. Usually, subjects can discriminate grammatical from nongrammatical strings above the chance level. However,

they usually do not have a conscious knowledge of the nature of the artificial grammar.

*Serial reaction time* experiment is another example of implicit learning [5]. In a serial reaction time experiment, subjects are asked to press a corresponding button to each location on a screen. The order of the stimulus sequence is structured. Subjects can perform the task without becoming aware of the sequence structure. However, subjects typically respond faster when the sequence structure is consistent over many trials than when it is switched to another. The fastening of the response speed indicates that people learn the task-irrelevant structure despite the fact that in many cases, they are not consciously aware of the presence of such a structure in the sequence.

*Contextual cueing* is yet another form of implicit learning [6]. In contextual cueing, subjects perform a visual search task for target objects among distractors (e.g. the letter “T” among “L”s) and report the orientation of the target letter. The target appears on every trial and surrounded by distractors that form a context for the target. The spatial arrangements of the target and distractors are fixed, and the target appears at a consistent location for each configuration. Thus, the global context of the overall arrangement of distractors predicts where the target should be. As subjects perform the task, they learn to direct their attention to the target location more quickly in the repeated patterns compared with trials with a new randomly generated configuration. As in other types of implicit learning, subjects usually do not have explicit memory about the repeated patterns.

Perceptual learning refers to improvements in sensory processing over training and occurs in the absence of apparent reinforcement [7,8]. Usually, the improvement in performance is highly specific to the stimulus and in the case of vision spatial location. These observations suggest that perceptual learning occurs at an early sensory processing stage. While perceptual learning occurs without conscious effort and even exposure to subthreshold stimuli is sufficient for learning [9], whether attention and internal reinforcement signals play a role in perceptual learning is a matter of debate [10].

## References

1. Tolman EC, Honzik CH (1930) “Insight” in Rats. *Publ Psychol* 4:215–232
2. Chai SC, White NM (2004) Effects of fimbria-fornix, hippocampus, and amygdala lesions on discrimination between proximal locations. *Behav Neurosci* 118:770–784
3. Lubow RE (1989) *Latent inhibition and conditioned attention theory*. Cambridge University Press, New York

4. Reber AS (1967) Implicit learning of artificial grammars. *J Verbal Learn Verbal Behav* 5:855–863
5. Nissen MJ, Bullermer P (1987) Attentional requirements of learning: evidence from performance measures. *Cognit Psychol* 19:1–32
6. Chun MM, Jiang Y (1998) Contextual cueing: implicit learning and memory of visual context guides spatial attention. *Cognit Psychol* 36:28–71
7. Karni A, Sagi D (1991) Where practice makes perfect in texture discrimination: evidence for primary visual cortex plasticity. *Proc Natl Acad Sci USA* 88:4966–4970
8. Shiu LP, Pashler H (1992) Improvement in line orientation discrimination is retinally local but dependent on cognitive set. *Percept Psychophys* 52:582–588
9. Watanabe T, Nanez JE, Sasaki Y (2001) Perceptual learning without perception. *Nature* 413:844–848
10. Seitz AR, Dinse HR (2007) A common framework for perceptual learning. *Curr Opin Neurobiol* 17:1–6

## Lateral Column

### Synonyms

Funiculus lat.; Lateral funiculus

### Definition

The white matter between the ventral root and dorsal root gives rise to the lateral column, containing:

1. Anterolateral column with
  - Anterolateral fasciculus
  - Parts of the anterior spinocerebellar tract.
  - Osterolateral column with
2. Posterior spinocerebellar tract
  - Parts of the anterior spinocerebellar tract
  - Lateral pyramidal tract

► [Medulla Spinalis](#)

## Lateral Cortex

### Definition

The subdivision of the inferior colliculus lateral to the central nucleus involved in transmitting signals from the auditory system to the visual-motor systems for eye and head movement.

► [Inferior Colliculus](#)

## Lateral Corticospinal Tract

### Synonyms

Tractus corticospinalis lat

- ▶ Lateral Pyramidal Tract
- ▶ Pathways

## Lateral Force Transmission

- ▶ Intramuscular Myofascial Force Transmission

## Lateral Gaze

### Definition

Looking to the right or to the left in the horizontal plane. Gaze is defined as a combined eye-head movement, i.e., eye-in-space, but is also used loosely to designate an eye movement per se. This function is subserved by the ill-defined term “horizontal gaze center” which involves both abducens nuclei, i.e., abducens (lateral) rectus motoneurons and abducens internuclear neurons for conjugacy, the horizontal saccade generation network of the paramedian pontine reticular formation (PPRF) for directed movements, and the horizontal gaze holding network to maintain an eye movement on target (nucleus prepositus hypoglossi and adjacent medial vestibular nucleus, the so-called horizontal neuronal integrator).

- ▶ Paramedian Pontine Reticular Formation (PPRF)
- ▶ Neural Integrator
- ▶ Saccade, Saccadic Eye Movement

## Lateral Geniculate Nucleus (LGN)

### Definition

The lateral geniculate (Latin for knee-like) nucleus is a laminated nucleus of the thalamus in which many of the

retinal ganglion cell axons in the optic tract terminate. The axons of many lateral geniculate cell neurons terminate in the primary visual cortex, V1.

- ▶ Geniculo-striate Pathway
- ▶ Lateral Geniculate Nucleus (LGN) – Magnocellular Neuron
- ▶ Lateral Geniculate Nucleus (LGN) – Parvocellular Neuron
- ▶ Lateral Geniculate Nucleus (LGN) – Koniocellular Neuron
- ▶ Retinal Ganglion Cells
- ▶ Thalamus
- ▶ Evolution of the Visual System: Mammals – Color Vision and the Function of Parallel Visual Pathways in Primates

## Lateral Hypothalamic Area

### Definition

The lateral hypothalamic area is the area coupled to the central regulation of hunger and thirst.

## Lateral Intraparietal Area

CAROL L. COLBY

Department of Neuroscience Center for Neural Basis Cognition, University of Pittsburgh, Pittsburgh, PA, USA

### Synonyms

LIP

### Definition

The Lateral Intraparietal Area (area LIP) is a region of cortex in monkeys located in the lateral bank of the intraparietal sulcus. It was originally defined on the basis of its axonal projections to the frontal eye field. Physiologically, it is defined on the basis of its unique constellation of single neuron response properties.

### Characteristics

#### Higher Order Structure

Area LIP is part of the parietal association cortex. It is a subdivision of Brodmann’s area 7.

### Parts of This Structure

Area LIP has been described as containing a dorsal (LIPd) and a ventral (LIPv) subdivision. These subdivisions differ in their myeloarchitecture and in their anatomical connections [1].

### Functions of This Structure

In awake, behaving monkeys, LIP neurons exhibit several different kinds of task-related activity [2]. First, LIP neurons, like neurons elsewhere in striate and extrastriate visual cortex, respond to the onset of a visual stimulus in the neuron's receptive field. Second, these visual responses are enhanced when the monkey attends to the stimulus: the amplitude of the visual response is increased when the stimulus or stimulus location becomes the focus of attention. This enhancement occurs no matter how the monkey will subsequently respond to the stimulus. Regardless of whether the task requires a hand movement, or an eye movement, or requires that the monkey refrain from moving toward the stimulus, the visual response of an LIP neuron becomes larger when the stimulus is made behaviorally relevant. This means that the same physical stimulus arriving at the retina can evoke very different responses in cortex as a result of spatial attention. Area LIP contributes critically to the guidance of spatial attention. When neurons in LIP are inactivated, monkeys are impaired at allocating their attention to objects in the contralateral visual field [3]. A third significant feature of LIP neuron activity is the sustained responses observed when the monkey must remember the location at which the stimulus appeared. In this task, a stimulus is flashed only briefly but the neuron continues to fire for several seconds after the stimulus is gone, as though it were holding a memory trace of the target location. A particularly intriguing question in understanding spatial representation concerns the fate of this memory-related activity in area LIP following an eye movement, as will be described below. A fourth kind of activation commonly observed in LIP neurons is specifically related to performance of a saccade – a rapid eye movement – toward the receptive field. LIP neurons fire just before the monkey initiates a saccade, which will move the fovea onto a target presented in the receptive field. This saccade-related activity reflects the fact that area LIP is closely interconnected with structures that contribute to the planning and execution of eye movements. Indeed, saccades can be evoked by injecting small amounts of current into area LIP [4,5]. These microstimulation effects are likely mediated by pathways linking area LIP to the frontal eye fields and superior colliculus [6].

LIP neurons have overlapping sensory and motor fields, just like neurons in the superior colliculus. In a task in which the animal has to make a perceptual decision, the activity of LIP neurons reflects both the impending eye movement and the sensory information

that was used to choose that particular response [7]. Finally, LIP neuron activity can be modulated by the position of the eye in the orbit [8]. For instance, the visual response of a given cell may become larger when the monkey is looking toward the left part of the screen than when it is looking toward the right. This property is striking because it suggests that neurons in area LIP may contribute to spatial representations that go beyond a simple replication of the retinal map. These higher-order representations appear to be essential for guiding accurate spatial behavior. When neurons in area LIP are temporarily silenced, monkeys perform less accurately on an eye movement task that relies on non-retinotopic information. In sum, individual LIP neurons have retinal receptive fields and carry visual, memory, and saccade-related signals that can be modulated by attention and by eye position. Activity in area LIP cannot be characterized as a simple visual or motor signal. Rather, the level of activation in a given LIP neuron reflects the degree to which attention has been allocated to a location within the receptive field [9].

### Higher Order Function

Every time we move our eyes, each object in our surroundings activates a new set of retinal neurons. Despite this constantly changing input, we experience a stable visual world. How is this possible? More than a century ago, Helmholtz proposed that the reason the world appears to stay still when we move our eyes is that the “effort of will” involved in making a saccade simultaneously adjusts our perception to take that specific eye movement into account. He suggested that when a motor command to move the eyes is issued, a copy of that command, or corollary discharge, is sent to brain areas responsible for generating our internal image of the world. This image is then updated so as to be aligned with the new visual information that will arrive in cortex after the eye movement. A simple experiment demonstrates that Helmholtz's account must be essentially true. When the retina is displaced by pressing on the eye, the world does seem to move, presumably because there is no corollary discharge. Without that internal knowledge of the intended eye movement, there is no way to update the spatial representation of the world around us.

Single neuron recording experiments indicate that neurons in area LIP contribute to this updating of the internal image [10]. The experiment illustrated in Fig. 1 shows that the memory trace of a stimulus is updated when the eyes move. The activity of a single LIP neuron was recorded under three different conditions. In the first set of trials, the monkey looked at a fixed point on the screen while a stimulus was presented in the receptive field (panel A). The visual response shown in this left panel is typical of that observed in neurons

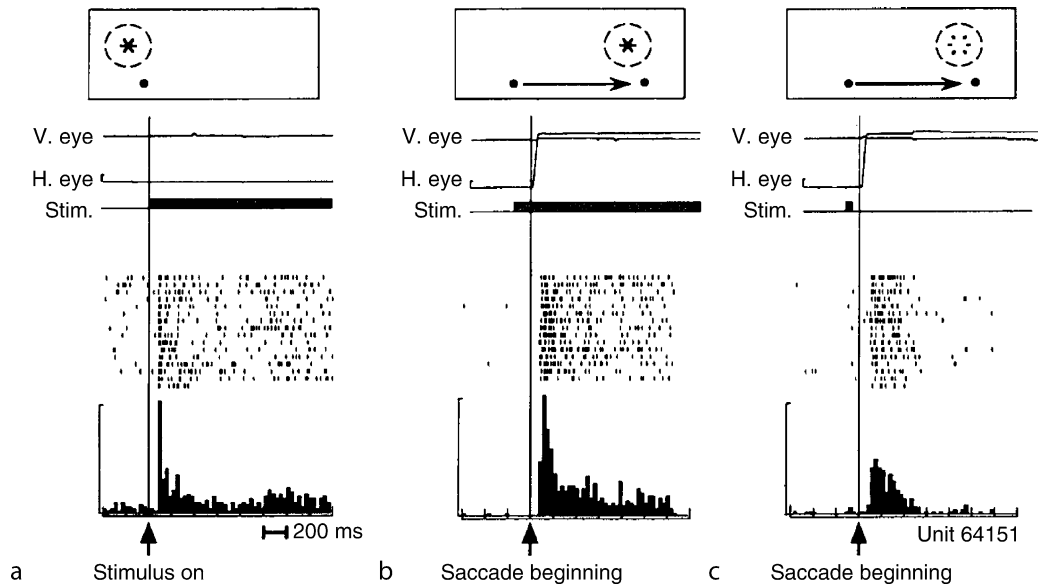

**Lateral Intraparietal Area. Figure 1** Responses of a single LIP neuron in three tasks. (a) Fixation task. In the cartoon at the top, the dot is the fixation point, the dashed circle shows the location of the receptive field, and the asterisk represents the visual stimulus. The time lines just below the cartoon show that the vertical and horizontal eye position remained steady throughout the trial, demonstrating that the monkey maintained fixation. The stimulus time line shows that the stimulus appeared 400 ms after the beginning of the trial and continued for the entire trial. The raster display shows the electrical activity of a single LIP neuron in 16 successive trials. In these rasters, each dot indicates the time at which an action potential occurred, and each horizontal line of dots represents activity in a single trial. The rasters show that in each trial there was a brief initial burst of action potentials shortly after the stimulus appeared, followed by continuing neural activity at a lower rate. The histogram at the bottom of the panel shows the average firing rate as a function of time. (b) Saccade task. At the beginning of the trial, the monkey looked at the fixation point on the left, and the rest of the screen was blank. Then, simultaneously, a new fixation point appeared on the right and a visual stimulus appeared above it. The monkey made a saccade from the old fixation point to the new one, indicated by the arrow. The eye movement was straight to the right, so only the horizontal eye position trace shows a change. At the end of this saccade, the receptive field had been moved to the screen location containing the visual stimulus. The rasters and histogram in this panel are aligned on the time that the saccade began. (c) Remapping task. While the monkey fixates, a stimulus flashes for 50 ms at a location outside the receptive field. The neuron is activated when an eye movement brings the receptive field onto the previously stimulated location.

in many visual areas: the neuron fired when a stimulus appeared in the neuron's receptive field. In the second set of trials (panel B), a visual response occurred when the monkey made an eye movement that brought a stimulus into the receptive field. In each trial, the neuron began to respond after the receptive field had landed on the stimulus. This result is just what would be expected for neurons in any visual area with retinotopic receptive fields.

The surprising finding is shown in panel C. In this third set of trials, the monkey made a saccade that would bring a stimulus into the receptive field, just as in the second set of trials. The only difference was the duration of the stimulus, which lasted for a mere 50 ms instead of staying on for the entire trial. As can be seen on the stimulus time line, the stimulus actually disappeared before the saccade began. This means that the stimulus was never physically present in the receptive field. Nevertheless, the neuron fired as though there

were a stimulus in its receptive field. This result shows that LIP neurons respond to the memory trace of a previous stimulus. Moreover, the representation of the memory trace is updated at the time of a saccade. The general idea of how a memory trace can be updated is as follows. At the beginning of the trial, while the monkey is looking at the initial fixation point, the onset of the stimulus activates those neurons whose receptive fields encompass the stimulated location. Some of these neurons will continue to respond after stimulus offset, encoding a memory of the location at which the stimulus occurred. When the monkey moves its eyes toward the new fixation point, a copy of the eye movement command is sent to parietal cortex. This corollary discharge causes the active LIP neurons to transmit their activity to the new set of neurons whose receptive fields will encompass the stimulated screen location after the saccade. By this means, LIP neurons encode the spatially updated memory trace of a previous stimulus.

The significance of this discovery lies in what it demonstrates about spatial representation in area LIP. It indicates that the internal image is dynamic rather than static. Tonic, memory-related activity in area LIP not only allows neurons to encode a salient spatial location after the stimulus is gone, but also allows for dynamic remapping of visual information in conjunction with eye movements. This updating of the internal visual image has specific consequences for spatial representation in LIP. Instead of spatial information being encoded in purely retinotopic coordinates, tied to the specific neurons initially activated by the stimulus, the information is encoded in eye-centered coordinates. This is a subtle distinction, but a very important one in generating accurate spatial behavior. Maintaining visual information in eye-centered coordinates tells the monkey not just where the stimulus was on the retina when it first appeared, but where it will be on the retina following an intervening eye movement. As a consequence of this remapping, the monkey always has accurate information with which to program an eye movement toward a current or a remembered target. The creation of such a spatially accurate representation in LIP suggests that LIP contributes to solving the problem of spatial constancy, and allows us to construct and maintain a stable image of the world.

## References

- Lewis JW, Van Essen DC (2000) Cortico-cortical connections of visual, sensorimotor, and multimodal processing areas in the parietal lobe of the macaque monkey. *J Comp Neurol* 428:112–137
- Colby CL, Duhamel J-R, Goldberg ME (1996) Visual, presaccadic and cognitive activation of single neurons in monkey lateral intraparietal area. *J Neurophysiol* 76:2841–2852
- Wardak C, Olivier E, Duhamel JR (2004) A deficit in covert attention after parietal cortex inactivation in the monkey. *Neuron* 42:501–508
- Shibutani H, Sakata H, Hyvarinen J (1984) Saccade and blinking evoked by microstimulation of the posterior parietal association cortex of the monkey. *Exp Brain Res* 55:1–8
- Mushiake H, Fujii N, Tanji J (1999) Microstimulation of the lateral wall of the intraparietal sulcus compared with the frontal eye field during oculomotor tasks. *J Neurophysiol* 81:1443–1448
- Ferraina S, Pare M, Wurtz RH (2002) Comparison of cortico-cortical and cortico-collicular signals for the generation of saccadic eye movements. *J Neurophysiol* 87:845–858
- Shadlen MN, Newsome WT (2001) Neural basis of a perceptual decision in the parietal cortex (area LIP) of the rhesus monkey. *J Neurophysiol* 86:1916–1936
- Andersen RA, Bracewell RM, Barash S, Gnadt JW, Fogassi L (1990) Eye position effects on visual, memory, and saccade-related activity in areas LIP and 7a of macaque. *J Neurosci* 10:1176–1196
- Colby CL, Goldberg ME (1999) Space and attention in parietal cortex. *Annu Rev Neurosci* 22:319–349
- Duhamel J-R, Colby CL, Goldberg ME (1992) The updating of the representation of visual space in parietal cortex by intended eye movements. *Science* 255:90–92

## Lateral Lemniscal Nuclei

- Nuclei of the Lateral Lemniscus

## Lateral Lemniscus

### Definition

Axonal tract (and associated nuclei) carrying sensory information from the hindbrain to midbrain centers. In mammals, this is predominantly an acoustic pathway, but it primitively includes all octavolateralis modalities.

- Evolution of Mechanosensory and Electrosensory Lateral Line Systems
- Nuclei of the Lateral Lemniscus

## Lateral Line

### Definition

A sensory system present in many aquatic vertebrates of mechano-receptive (water current) or electro-receptive nature (electric fields).

- Electrorceptor Organs
- Evolution of Mechanosensory and Electrosensory Lateral Line Systems

## Lateral Line Organ

- Electrorceptor Organs

## Lateral Medullary Syndrome

### Definition

▶ Wallenberg's Syndrome

bounded medially by the medial preoptic area and laterally by the sublenticular region.

- ▶ Basal Forebrain
- ▶ Hypothalamus
- ▶ Ventral Striatopallidum

## Lateral Nucleus of the Trapezoid Body

### Definition

One of the nuclei in the superior olivary nuclei with cell bodies within the trapezoid body.

- ▶ Superior Olivary Nuclei
- ▶ Trapezoid body

## Lateral Pyramidal Tract

### Definition

In the pyramidal decussation 70–90% of the fibers cross to the contralateral side forming the lateral pyramidal tract, descending in the lateral column of the spinal cord. The tract features a somatotopic arrangement (the lateralmost fibers pass to the lowest, the medialmost to the highest spinal segment). Its fibers terminate in the motoneurons (or interneurons of the motoneurons) of the distal extremity (forearm, hand) and play a major role in fine motor control.

## Lateral Occipitotemporal Gyrus

### Synonyms

Gyrus occipitotemporalis lat

### Definition

On the underside of the hemisphere, two well-developed gyri spread across the occipital lobe and temporal lobe. They are called:

- Lateral occipitotemporal gyrus: runs parallel to the hippocampal gyrus, which lies on the other side of the collateral sulcus. This marks a transition zone between the allocortex and cerebral cortex.
- Medial occipitotemporal gyrus: area 17, the striate cortex, is situated in the occipital portion, directly on the calcarine sulcus.

- ▶ Telencephalon

## Lateral Rectus

### Definition

Extraocular muscle for abduction of the eye.

- ▶ Eye Orbital Mechanics

## Lateral Reticular Formation

### Definition

This small-celled region of the reticular formation is limited to the pons and medulla. It has six different sections:

- Ventrolateral superficial reticular area
- Parvocellular reticular area
- Lateral pontine area
- Noradrenergic cell groups A1–A7
- Adrenergic cell groups (C1, C2)
- Cholinergic cell group (Ch1–Ch6).

These areas are involved in brainstem reflexes, cardiovascular, respiratory and gastrointestinal regulation and pain suppression.

## Lateral Preoptic Area

### Definition

The part of the subcortical basal forebrain located between the ventral pallidum and anterolateral hypo-thalamus,

## Lateral Septum

### Definition

Lateral part of the septum, an area in the medial wall of the cerebral hemispheres, contains cholinergic cells in many species.

- ▶ Evolution of Subpallial Cholinergic Cell Groups

## Lateral Sulcus

### Synonyms

Sulcus lat.; Lateral sulcus = Sylvian fissure

### Definition

Large and deep lateral sulcus, caudally contiguous with the temporal lobes and supporting the insula at its deep level.

The lateral sulcus has two important lateral branches: the posterior branch around which the supramarginal gyrus lies, as well as the ascending branch and anterior branch, around which the inferior frontal gyrus is grouped. The primary and secondary auditory cortices are grouped at the lateral sulcus.

- ▶ Telencephalon

## Lateral Superior Olive

### Definition

One of the primary nuclei in the superior olivary nuclei located most laterally and important for encoding interaural level disparities.

- ▶ Superior Olivary Nuclei

## Lateral Vestibular Nucleus (Deiters)

### Synonyms

Nucl. vestibularis lat. (Deiters)

### Definition

Cluster of neurons located in the rostro-lateral portion of the complex of the vestibular nuclei. It contains giant cells of large diameter characterized by a high conduction speed. The lateral vestibular nucleus provides for close coupling of vestibular nuclei with the cerebellum and can be viewed as being an outpost cerebellar nucleus. The large cells have afferents from Purkinje cells of the vermis cerebelli, posterior spinocerebellar tract as well as the auditory tract. Efferents go to the motoneurons of the spinal cord, eye muscle nuclei, red nucleus and the sensory cells in the labyrinth.

- ▶ Pons
- ▶ Vestibular Nuclei
- ▶ Vestibulo-Spinal Reflexes

## Lateral Vestibulospinal Tract

### Synonyms

Tractus vestibulospinal lat

### Definition

Bundle of axons arising from the lateral vestibular nucleus (with a minor component from the descending vestibular nucleus) traveling through the ipsilateral ventro-lateral funiculus of the spinal cord, up to its lumbosacral segments. At these levels, its position in the ventral funiculus is displaced medially.

- ▶ Lateral Vestibular Nucleus
- ▶ Vestibulo-Spinal Reflexes

## Lattice Spacing

### Definition

Lattice spacing is defined as the distance between myosin and actin filaments. According to isovolumetricity considerations, the lattice spacing decreases (increases) with increasing (decreasing) sarcomere lengths.

- ▶ Sliding Filament Theory



## Law, Lawfulness

### Definition

The terms law and lawfulness are used in various contexts: we find, for example, laws of thought, laws of nature, or laws in legal practice. They all have in common that something – an action, an event, a transition, etc. – is constrained by what the laws demand. For example, the logical law of excluded middle tells you that for any statement  $S$  you cannot truly assert “ $S$  and not  $S$ .” A legal law threatens you with penalties in case your actions fail to comply with what it demands, and a law of nature governs the natural course of events.

- ▶ Meaning
- ▶ Necessity, Nomological

## Law, Natural

### Definition

Our universe is said to be governed by laws of nature, like Newton’s law of gravitation. The empirical sciences seek to discover those laws. They figure in explanations and predictions and are often supposed to underpin causal relations: that the earth’s gravitational field causes a stone to fall down is explained and can be predicted by reference to Newton’s law. Mostly, law statements are general, exceptionless, and conditional sentences that do not contain reference to particular space-time regions or individuals: “when- and wherever  $C$  happens (or is the case) then  $E$  will also happen (or be the case) – or, for probabilistic laws,  $E$  has a certain objective chance to happen (or be the case).”

- ▶ Meaning
- ▶ Necessity, Nomological

## Leading Process

- ▶ Growth Cones

## Leak Conductance

### Definition

Ion permeability at resting membrane potential, allowing a constant flow of current through the cell membrane due to channels that remain open at resting membrane potential

- ▶ Membrane Components
- ▶ Membrane Potential - Basics

## Leakage Potassium Current ( $I_{K-Leak}$ )

### Definition

A catch-all classification for  $K^+$  selective channels that influence input resistance and baseline membrane potential.

## Leaky Integrate-and-Fire Models

### Definition

Leaky integrate and fire models represent a specific type of connectionist networks (artificial neural networks) which incorporate real-time dynamics. Unit activation is computed according to a differential equation relating the change in activation level of a specific unit to its net incoming activation and any loss of signal that naturally occurs over time.

- ▶ Connectionism

## Leaky Integration in Oculomotor Control

### Definition

Several oculomotor functions require neural activity be integrated in the mathematical sense, an operation

which can be viewed as an accumulation, or counting, of incoming action potentials and which is thought to be achieved by positive feedback loops (“reverberating circuits”). For perfect integration feedback gain would have to be unity, but for reasons of stability it is generally less; as a result, the integrator gradually loses the accumulated activity much like a leaky vessel loses the stored liquid.

- *Glissades*. These are slow onward or backward drifts occurring in the aftermath of saccades when the saccadic innervation pulse does not bring the eye exactly to where its integral, the saccadic innervation step, thereafter will hold the eye.
- *Donders’ law*. The statement that the amount of eye torsion about its line of sight, measured relative to a space fixed reference, is uniquely specified by the eye’s horizontal and vertical deviation from its primary position, regardless of which path led the eye to this position. Thus, to the extent that this law is valid, the eye’s rotational degrees of freedom are effectively reduced from 3 to 2; without a mechanism implementing this law, a horizontal eye rotation followed by an elevation would lead to a different torsion relative to space as when the same position of the line of sight is reached by first elevating the eye and then rotating it about its vertical axis.

- ▶ Degrees of Freedom
- ▶ Oculomotor Control
- ▶ Saccade, Saccadic Eye Movement

## Learned Helplessness

### Definition

Learned helplessness is a term applied to a task in which animals are initially trained to fear a neutral stimulus (CS) in a classical fear conditioning procedure, and are later tested for performance in a bidirectional shuttle box. The uncontrollable, inescapable shocks delivered in the classical fear conditioning training are said to impair learning of active avoidance, or escape responses. The functional explanation for learned helplessness is still of considerable debate. While initially classified as a model of depression, it is now regarded as a more accurate model of anxiety. Learned helplessness is sensitive to both anti-depressants and anxiolytics.

- ▶ Aversive Learning

## Learned Taste Aversion

- ▶ Aversive Taste Memory

## Learned Toxiphobia

- ▶ Aversive Taste Memory

## Learning

SHINTARO FUNAHASHI  
Kokoro Research Center, Kyoto University,  
Kyoto, Japan

### Definition

The acquisition of new information or knowledge or the process to acquire knowledge or skill by systematic study or by trial and error.

### Characteristics

Learning can be defined as the process to acquire knowledge by systematic study or by trial and error. Two types of learning are known in psychological studies; ▶ *associative learning* and ▶ *non-associative learning*. The associative learning is the learning of associations between events. In associative learning, a subject learns the relationship between two different stimuli or between the stimulus and the subject’s behavior. *Classical conditioning*, *operant* (or instrumental) *conditioning*, and *category learning* (▶ *Category Learning/Memory*) are typical examples of the associative learning. On the other hand, non-associative learning can be defined as a change in the behavioral response that occurs over time in response to a single type of stimulus. Non-associative learning would be the simplest form of learning. ▶ *Habituation* and ▶ *sensitization* are typical examples of non-associative learning.

### Classical Conditioning

One of the typical examples of associative learning is *classical conditioning*. In classical conditioning, a subject learns about the relationship between two stimuli. In a typical case of classical conditioning,

originally neutral stimulus (conditioned stimulus, CS) eventually produces a certain behavioral response (conditioned response, CR) by repetitive presentation of both the CS and a stimulus that produces the CR reflexively (unconditioned stimulus, US). For example, an application of rather strong stimulus (e.g. touch or electric shock) to any body part (e.g. siphon, tail, or mantle) elicits a quick withdrawal of the gill in *Aplysia* [1]. This phenomenon is known as the gill withdrawal reflex. When a mild touch to the siphon (CS), which is weak enough to produce the gill withdrawal reflex, is presented together with a stronger electric shock to the tail (US), the gill withdrawal reflex is elicited. If these two stimuli (CS-US pair) are presented repeatedly for several 10s trials, only a mild touch to the siphon (CS) eventually elicits the gill withdrawal reflex (CR). This is a typical example of classical conditioning. Once classical conditioning is established, it is maintained for several days. However, if these two stimuli (CS-US pair) are presented in an unpaired or random manner, a mild touch to the siphon could not elicit the gill withdrawal reflex. Based on these observations, two important rules have been known in classical conditioning; *temporal contiguity* and *contingency*. In order to establish classical conditioning, CS must precede US by some critical interval (usually several seconds). This rule is called *temporal contiguity*. In addition, to establish classical conditioning, CS must predict the occurrence of US. This rule is called *contingency*. Once classical conditioning is established, a mild touch to the siphon (CS) elicits the gill withdrawal reflex (CR). However, if only CS is applied repeatedly, the strength of CR gradually becomes weak and eventually the effect of classical conditioning is vanished. This phenomenon is called *extinction*. Thus, classical conditioning provides the simplest example of the rules for associating two events.

### Operant Conditioning

In *operant conditioning*, a subject learns about the relationship between a stimulus and the subject's behavior. An animal not only reacts to stimuli but also behaves in a way to produce changes in the environment. For example, when a dog is left alone in a room, it behaves in a variety of ways, such as walking around, jumping up on the sofa, sniffing, picking up a stick or a ball, playing a ball, and so on. When the dog plays a ball, whether or not the dog continues to play a ball depends on its outcomes. In this situation, a dog is not responding to a particular external stimulus. It is thought that a dog is operating on the environment.

In the typical case of operant conditioning, a subject is placed in an experimental box named the *operant box*, which usually has a small lever and a food well. When the subject is placed in the operant box at the first

time, the subject knows nothing about the meaning of the lever. The subject spontaneously walks around inside the box and occasionally touches the lever. If a food pellet is delivered when the subject accidentally presses the lever, the probability to press the lever by the subject gradually increases. If the subject recognizes that the food pellet is delivered whenever the subject presses the lever, the probability to press the lever dramatically increases. Eventually, the subject repeatedly presses the lever to get the food. Since the food has the value as a reward and reinforces the lever press behavior, the probability of the lever press behavior dramatically increases. Thus, the subject learns the relationship between the lever press behavior and the food delivery as an outcome in the operant box. This is operant conditioning.

If a particular behavior is followed by a *reinforcer*, the probability of the occurrence of that behavior either increases or decreases. If the probability increases, the reinforcer is called a *positive reinforcer* or a reward. If the probability decreases, the reinforcer is called a *negative reinforcer* or punishment.

Operant conditioning is widely used in psychological studies as well as neurophysiological studies [1,2]. For example, a delayed matching-to-sample task and a delayed non-matching-to-sample task are used for studying functions of episodic memory [1]. A delayed-response task, a delayed alternation, a delayed object alternation, and a conditional task using position, color, or object are frequently used for studying functions of the prefrontal cortex in animals [2].

### Category Learning

*Category learning* (or *categorization*) refers to the process of assigning an object to a concept. A *concept* is the set of properties that we associate with a particular class. For example, the concept of “elephant” includes the properties of having a big body, a long nose, four legs, and so on. When we categorize an animal as an elephant, we consider this animal as if this animal has many of the properties associated with the concept of “elephant,” including properties that we have not directly perceived. To categorize an object appropriately, we need to have the *prototype* of the concept, which is one set of properties that describe the best examples of the concept. The prototype of the concept can also be established by learning [3].

We categorize whenever we recognize an object, whenever we encounter a problem, and so on. We always use concepts to categorize something in our world. When we categorize something, we usually apply a rule. For example, if she is the female parent of his parent, she is his grandmother. There have been many studies of rule-based categorization with well-defined concepts. They show that the more properties are present in the rule, the

slower and more prone to error the categorization process becomes, since in the rule-based categorization, the properties may be processed one at a time. In other cases, we often rely on similarity between an object and the prototype to categorize, when we categorize an object using fuzzy concepts, in which we do not know enough properties.

### Non-Associative Learning

Another type of learning is *non-associative learning*. When a stimulus (e.g. a loud noise) is presented repeatedly over time, the magnitude of the behavioral response to that stimulus (e.g. an orienting response to the noise) progressively decreases and eventually the response no longer occurs even though the stimulus is still present. This phenomenon is called *habituation*. On the other hand, if a harmful stimulus, for example, is unexpectedly applied to an animal, sensitivity to a variety of stimuli increases and behavioral responses not only to this harmful stimulus but also to other stimuli increase. This phenomenon is called *sensitization*. In both cases, learned changes in behavior would persist for hours to days in some cases.

### Habituation

There are several types of non-associative learning. *Habituation* is one of non-associative learning leading to decreased behavioral responses to a certain stimulus when it appears repeatedly and is innocuous. Habituation can be observed in our daily life. For example, a loud screech sound would startle us when we hear it first time. However, if this screech sound occurs repeatedly during a short period of time, the magnitude of our startle response to each sound progressively decreases. This is a typical example of habituation.

Neural mechanisms of habituation have been examined using *Aplysia* by Kandel and his group [1]. When a mild touch is applied to the siphon of *Aplysia*, *Aplysia* produces a gill withdrawal reflex and immediately hides away the gill within the mantle shelf. However, if a mild touch is repeatedly applied to the siphon, the amount of the gill withdrawal reflex gradually decreases. Eventually, a mild touch to the siphon elicits no reflex at all. The process of the gradual decrease of the reflex by repeated application of a mechanical stimulus to the siphon can be called habituation. Kandel and his group [1] showed that habituation observed in the gill withdrawal reflex in *Aplysia* is caused by a decrement of the synaptic transmission between sensory neurons innervating in the siphon and motor neurons controlling muscle contraction of the gill. This can be seen as a progressive decrease of the magnitude of EPSP (excitatory post-synaptic potential) observed in motor neurons by repetitive stimulation of the siphon. Since a

decrease in the number of synaptic vesicles at release sites within the active zones was observed in the terminal of sensory neurons, it is suggested that some factor affects  $Ca^{2+}$  channels to decrease  $Ca^{2+}$  influx to the pre-synaptic terminals, although what factor suppresses the opening of  $Ca^{2+}$  channels is not yet known.

### Sensitization

*Sensitization* is another type of non-associative learning that results an increase in responses in general or responses once habituated (► *dishabituation*). Sensitization typically occurs when noxious or fearful stimuli are presented to an animal. Animals usually learn about the properties of a harmful or threatening stimulus by sensitization. If the animal encounters a threatening or harmful stimulus, it quickly responds more vigorously to a variety of stimuli, even harmless neutral stimuli. Sensitization is somehow similar to the phenomenon of arousal, because both sensitization and arousal increase the sensitivity to stimuli.

As is seen in habituation, repeated touch to the siphon eventually elicits no gill withdrawal reflex in *Aplysia*. However, after the response is habituated, an electric shock applied once to the tail immediately restores the gill withdrawal reflex which is caused by a touch to the siphon [1,4]. Similarly, a mouse startles when it first exposes to a loud noise. When that noise is repeated, the mouse will habituate to the noise and no longer exhibit startle responses. However, by applying a single sensitizing shock to the leg, the startle response to the noise can be quickly restored [3]. The quick restoration of a habituated response by applying a sensitizing stimulus is called *dishabituation*.

Neural mechanisms related to sensitization have been examined extensively using *Aplysia* by Kandel and his group [1,4,5]. As is seen in habituation, repeated touch to the siphon eventually produces no gill withdrawal reflex in *Aplysia*. However, after the gill withdrawal reflex is habituated, if rather strong electric shock is applied once to the tail, this electric shock will not only restore the reflex itself but also increase responsiveness to a variety of stimuli. Kandel and his group [1] showed following mechanisms of sensitization in *Aplysia*. The electric shock to the tail produces strong excitatory response in sensory neurons innervating in the tail. This excitatory response of sensory neurons produces excitatory responses in modulatory interneurons, which make synapses on the pre-synaptic terminals of siphon's sensory neurons attaching on the gill's motor neurons. Therefore, modulatory interneurons modulate synaptic transmission from siphon's sensory neurons to gill's motor neurons. Modulatory interneurons use serotonin as a neurotransmitter. When modulatory interneurons are excited by applying an electric shock at the tail, these interneurons release

serotonin from their pre-synaptic terminals. Released serotonin interacts with the serotonin receptor in the pre-synaptic terminal of siphon's sensory neuron. As the serotonin receptor is classified as a metabotropic receptor, a molecule named cyclic-AMP (cAMP) is used as a second messenger to modulate ion channels. The binding serotonin to serotonin receptor activates an enzyme named adenylyl cyclase through the activation of G-protein and synthesizes cAMP from ATP. cAMP then activates cAMP-dependent protein kinase (PKA). PKA closes down  $K^+$  channels by phosphorylating these channels, causing a broadening of the action potentials. The broadening of the action potential increases the influx of  $Ca^{2+}$  through  $Ca^{2+}$  channels and consequently increases transmitter release from the pre-synaptic terminal of siphon's sensory neuron to gill's motor neuron. This increase of transmitter release restores the gill withdrawal reflex from habituation. Although this is a specific case observed in *Aplysia*, similar mechanisms would be observed in other animals in sensitization [1].

## References

1. Squire LR, Kandel ER (1999) Memory: From Mind to Molecules. W.H. Freeman and Company, New York
2. Fuster JM (1997) The prefrontal cortex: anatomy, physiology, and neuropsychology of the frontal lobe. 3rd edn. Lippincott-Raven, Philadelphia, PA
3. Smith EE, Nolen-Hoeksema S, Fredrickson BL, Loftus GR, Bem DJ, Maren S (eds.) (2003) Atkinson & Hilgard's Introduction to Psychology. Wedsworth/Thomson Learning, Belmont, CA
4. Bristol AS, Marinesco S, Carew TJ (2004) Neural circuit of tail-elicited siphon withdrawal in *Aplysia*. II. Role of gated inhibition in differential lateralization of sensitization and dishabituation. *J Neurophysiol* 91:678–692
5. Bristol AS, Sutton MA, Carew TJ (2004) Neural circuit of tail-elicited siphon withdrawal in *Aplysia*. I. Differential lateralization of sensitization and dishabituation. *J Neurophysiol* 91:666–677

## Learning Algorithm

### Definition

A systematic procedure describing how to adjust synaptic connections between neurons so the underlying network performs a specific input-output transformation task.

► Neural Networks

## Learning and Extinction

DEVIN MUELLER, GREGORY J. QUIRK  
Department of Psychiatry, University of Puerto Rico  
School of Medicine, San Juan, Puerto Rico

### Definition

Extinction is the decline in the frequency or intensity of a conditioned response following the withdrawal of reinforcement. In ►Pavlovian conditioning, the conditioned response declines when the conditioned stimulus (CS) is no longer followed by the unconditioned stimulus (US). The term extinction can be used to describe a procedure, a result, or a process. Extinction refers to (i) the procedure in which the CS is repeatedly presented in the absence of the US (►extinction training), (ii) the decrease in conditioned responding to the CS that is observed under these conditions (►response extinction), and (iii) the associative or cellular processes responsible for this decrease in responding (►extinction memory).

### Characteristics

From the behavioral point of view, extinction represents a reversal of the original conditioning phase of learning and, like conditioning, is characterized by an “S” shaped learning curve. There are two possible mechanisms by which extinction could occur: (i) elimination of the original conditioning memory, or: (ii) the acquisition of a new memory, but of an inhibitory nature. Predominant evidence from behavioral and neurobiological studies supports the second alternative. Following extinction training, the CS has two different associations with the US: the original excitatory association and the new inhibitory association. Which of these associations will be recalled depends on the situation in which the CS is encountered. Return of the conditioned response after extinction is observed under several conditions: (i) following the passage of time (►spontaneous recovery), (ii) following a change in context (►renewal) or (iii) following the presentation of the US or other stressor after extinction training (►reinstatement). The re-emergence of the conditioned response after extinction constitutes the *prima facie* evidence that extinction does not eliminate the original conditioned association but, as originally observed by the Russian physiologist Pavlov, is a form of ►inhibitory learning.

Like other types of learning, extinction occurs in three phases: acquisition, consolidation, and recall (Fig. 1). Acquisition of extinction is the initial learning that occurs as conditioned responses decline within the training session. This is followed by a consolidation

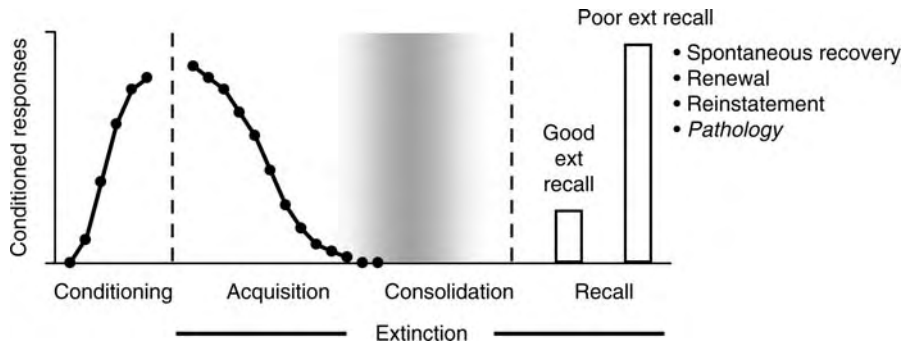

**Learning and Extinction. Figure 1** Schematic representation of the three phases of extinction. Acquisition is characterized by a decrease in conditioned responses to the presentation of a CS without the US. Consolidation is a time-dependent process during which a long-term extinction representation is formed. Recall of extinction is a test at a later time, in which the CS is presented alone. Good recall is characterized by low levels of conditioned responses, whereas poor recall is characterized by high levels of conditioned responses. Poor recall of extinction is observed during renewal, reinstatement, spontaneous recovery, or in pathological conditions in which extinction fails.

phase, lasting one to three hours, in which physiological and molecular processes strengthen ►[extinction learning](#). Subsequent to this, presentation of the extinguished CS triggers recall of extinction, as evidenced by low levels of conditioned responding. Failure to recall extinction is characterized by high levels of conditioned responding to the CS, reflecting expression of the original conditioning memory.

Extinction learning is one of several closely related forms of interference paradigms. In conditioned inhibition, the US that normally follows a CS (“A”) is omitted when the CS is presented in conjunction with a new stimulus “X.” Thus, “A” is followed by the US, but the compound “AX” is not. Under these conditions, the “X” stimulus acquires an inhibitory association with the US and becomes a conditioned inhibitor. In ►[latent inhibition](#), the CS is repeatedly presented without any consequences prior to pairing it with a US, resulting in slowed rates of conditioning.

### Neurobiology

Much of what we know concerning the neural circuitry underlying extinction comes from studies of fear conditioning, in which animals or humans are exposed to a CS (e.g., a tone) that co-terminates with an aversive US (e.g., a shock). A quarter century of research on the neurobiology of fear conditioning has laid the groundwork for examining the neurobiology of extinction. ►[Fear extinction](#) is dependent upon a network of brain regions that includes the amygdala, the medial prefrontal cortex (mPFC), and the hippocampus (Fig. 2).

It is well established that fear conditioning is acquired, consolidated and expressed by the amygdala [1]. Tone-induced neural activity in the lateral amygdala is potentiated following the pairing of a tone CS with a

shock US. During extinction, however, the responses of many of these cells return to pre-training levels. Because expression of fear is dependent on amygdala, expression of extinction is thought to be reflected in decreased amygdala output. Acquisition and expression of extinction requires *N*-methyl-D-aspartate (NMDA) receptor activity in the amygdala, activation of downstream signaling molecules such as mitogen-activated protein (MAP) kinase and phosphatidylinositol 3-kinase (PI-3 kinase), and the  $\gamma$ -aminobutyric acid (GABA) receptor clustering protein gephyrin [2]. Extinction is associated with an increase in surface expression of GABA receptors in the amygdala, and expression of extinction is thought to involve GABAergic inhibitory interneurons within the amygdala, particularly the intercalated neurons which directly inhibit amygdala output neurons [3]. Thus, the amygdala is necessary for the acquisition and expression of extinction.

Despite the behavioral evidence that extinction is not erasure of fear memory, recent findings suggest that extinction may reverse conditioning-induced plasticity within the amygdala [2]. Extinction increases phosphatase activity in the amygdala, reversing conditioning-induced increases in phosphorylated Akt and CREB. This results in a depotentiation of synapses and weakening of the original conditioning memory. There is even evidence that extinction can erase conditioning entirely, if done within an hour of conditioning, at a time when fear memory has not been fully consolidated. Thus, extinction could weaken conditioning memory in the amygdala, even though this memory remains intact elsewhere.

In contrast to the amygdala, the mPFC is responsible for consolidating and recalling extinction learning. Inhibition of protein synthesis in the infralimbic (IL)

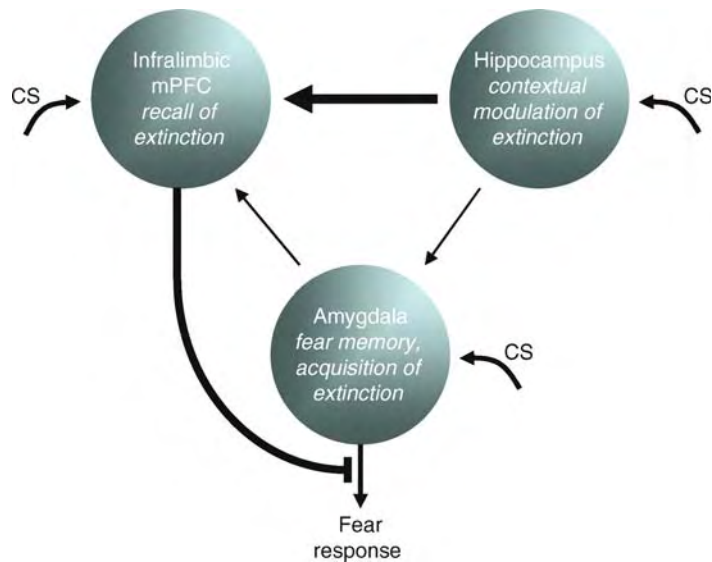

**Learning and Extinction. Figure 2** Neural circuitry of fear extinction. The amygdala stores both conditioning and extinction memories. CS information is processed by the amygdala, hippocampus, and mPFC. The mPFC integrates CS information with contextual information from the hippocampus in order to determine extinction recall. In the extinction context, mPFC inhibits amygdala output via projections from the infralimbic cortex (IL). Outside the extinction context, amygdala output is not inhibited.

mPFC leaves acquisition of extinction intact, but impairs recall of extinction the following day [4]. Post-training infusion of a MAP kinase inhibitor or an NMDA receptor antagonist into IL impairs consolidation of extinction, and blockade of NMDA receptors reduces extinction-induced bursting of IL neurons [4,5]. Finally, during recall of extinction, IL neurons exhibit potentiated responses to the CS [4], which activate inhibitory networks within the amygdala. In support of this, stimulation of IL decreases conditioned fear and inhibits amygdala output [4]. Thus, expression of amygdala-based fear memories is subject to cortical control following extinction.

The hippocampus provides for contextual modulation of the consolidation and expression of extinction to a CS. Temporary inactivation of the hippocampus prior to extinction does not prevent extinction learning, but results in impaired extinction recall [6]. In addition, inactivation prior to a retention test prevents renewal. Lesions of hippocampus also interfere with context-specific reinstatement effects [6]. For extinction of contextual fear conditioning and inhibitory avoidance, the hippocampus is itself a site of extinction plasticity. These forms of extinction require activation of NMDA receptors, MAP kinase, and protein synthesis in the hippocampus. The hippocampus and IL are interconnected and may work together to gate the expression of extinction under a variety of circumstances.

Relative to fear extinction, there are few studies on the neurobiology of appetitive extinction. The available

evidence, however, suggests that the amygdala, mPFC, and hippocampus perform similar roles in appetitive extinction as in fear extinction [6,7]. Lesions of the amygdala attenuate acquisition of extinction of drug-seeking behavior, whereas inactivation of IL increases reinstatement of drug-seeking behavior, consistent with a failure to recall extinction. IL is thought to inhibit drug seeking through interactions with the nucleus accumbens, the site of expression of drug-seeking behaviors [7]. Inactivation of the hippocampus prevents context-dependent reinstatement of drug seeking, suggesting that the hippocampus may be important for contextual modulation of appetitive extinction. Thus, the amygdala, mPFC, and hippocampus may constitute a general extinction network.

Functional neuroimaging is revealing homology between rats and humans in the learning and expression of extinction. The amygdala, hippocampus, and the ventral mPFC are all activated at various stages of extinction learning and recall [8,9]. For hippocampus and ventral mPFC, the degree of activation is correlated with the degree of extinction recall. Thus, the neural mechanisms of extinction appear to be conserved across species.

### Clinical Relevance

Perhaps more than any other field in learning and memory, extinction is directly applicable to the treatment of various clinical disorders, which arise when conditioned responses are pathologically over-expressed. In the

appetitive domain, over-expression of conditioned responses can lead to addiction, whereas in the aversive domain, over-expression of conditioned fear responses can lead to ►[anxiety disorders](#) and phobias. Extinction-based exposure therapies are used to treat anxiety disorders, and are beginning to be used for addiction. Extinction deficits are observed in patients with ►[post-traumatic stress disorder](#) (PTSD) [9]. Thus pharmacological treatments that enhance extinction offer promise for PTSD and other anxiety disorders. Cognitive enhancers such as the NMDA partial agonist D-cycloserine (DCS), which facilitate fear extinction in rats, augment the therapeutic response to exposure therapy for phobias [10]. With respect to addiction, extinction of drug-seeking behavior in rats is also facilitated by DCS, suggesting that DCS may improve the therapeutic outcome of extinction-based treatments for addiction. Neuroimaging has revealed a general decrease in basal metabolic activity in mPFC in addicted individuals, suggesting a lack of cortical inhibition. Thus, pharmacologically enhancing metabolic activity in mPFC may improve extinction recall in addicts and reduce the probability of relapse.

## References

1. Rodrigues SM, Schafe GE, LeDoux JE (2004) Molecular mechanisms underlying emotional learning and memory in the lateral amygdala. *Neuron* 44:75–91
2. Quirk GJ, Mueller D (2008) Neural mechanisms of extinction learning and retrieval. *Neuropsychopharmacology*, 33:56–72
3. Pare D, Quirk GJ, LeDoux JE (2004) New vistas on amygdala networks in conditioned fear. *J Neurophysiol* 92:1–9
4. Quirk GJ, Garcia R, Gonzalez-Lima F (2006) Prefrontal mechanisms in extinction of conditioned fear. *Biol Psychiatry* 60:337–343
5. Burgos-Robles A, Vidal-Gonzalez I, Santini E, Quirk GJ (2007) Consolidation of fear extinction requires NMDA receptor-dependent bursting in the ventromedial prefrontal cortex. *Neuron* 53:871–880
6. Bouton ME, Westbrook RF, Corcoran KA, Maren S (2006) Contextual and temporal modulation of extinction: Behavioral and biological mechanisms. *Biol Psychiatry* 60:352–360
7. Kalivas PW, Peters J, Knackstedt L (2006) Animal models and brain circuits in drug addiction. *Mol Interv* 6:339–344
8. Milad MR, Wright CI, Orr SP, Pitman RK, Quirk GJ, Rauch SL (2007) Recall of fear extinction in humans activates the ventromedial prefrontal cortex and hippocampus in concert. *Biol Psychiatry* 62:446–454
9. Rauch SL, Shin LM, Phelps EA (2006) Neurocircuitry models of posttraumatic stress disorder and extinction: Human neuroimaging research—past, present, and future. *Biol Psychiatry* 60:376–382
10. Davis M, Ressler K, Rothbaum BO, Richardson R (2006) Effects of D-cycloserine on extinction: Translation from preclinical to clinical work. *Biol Psychiatry* 60:369–375

## Learning and Memory

TAKETOSHI ONO

Molecular and Integrative Emotional Neuroscience,  
Graduate School of Medicine, University of Toyama,  
Sugitani, Toyama, Japan

### Introduction

Learning refers to processes of acquiring or encoding information and developing the capability to carry out new behaviors. Learning continues throughout our lives, we learn to deal appropriately with other individuals, to adapt properly with complex systems in our societies, and learn to acquire experiences. Therefore, learning influences almost all aspects of our social behavior. Studies of learning have emphasized a relation between changes of behavior as a result of an individual's experiences.

Memory sometimes refers to an engram (i.e., memory trace) that is acquired by learning, and is formed and processed through encoding, storage, and retrieval of information. Encoding refers to the initial acquisition of information, storage is the retention of encoded information over time, and retrieval refers to the processes involved in using stored information. A breakdown in one of these stages can intervene in a successful recall of information.

The concepts of ►[learning](#) and ►[memory](#) are closely related, and the terms often describe roughly the same processes. In a thread of consequential relation, learning is the process of acquiring new information, while memory refers to the persistence of learning in a state that can be recalled at a later time, so memory is the usual consequence of learning. Nowadays, the term ►[learning/memory](#) process is used as a means of incorporating all aspects of acquisition, storage, and retrieval. Naturally, learning and memory are features seen in all creatures, and they are pivotal to the survival of humans and all living organisms. The psychology of learning and memory is broad, and though these two processes are intermingled, this synopsis will discuss them in parts.

### Learning

There are many types of learning including simple and complex ones. Simple forms of learning consist of habituation and sensitization [1]. Habituation refers to a process that an individual becomes accustomed with a stimulus after repeated presentation of it. An example of habituation is the orienting response, in which a new sight or a loud sound can firstly attract an individual's attention. If the stimulus is presented repeatedly but with no consequences, the orienting response will abate. Sensitization is another simple type of learning, and refers to the increase in response to stimuli of an



individual after an exposure to an intense stimulus. With habituation individuals learn about the properties of a benign stimulus, allowing individuals to ignore repetitive and insignificant stimuli. With sensitization an individual learns about the properties of harmful or threatening stimuli, which is helpful for survival, especially in the wild nature. Habituation and sensitization refer to learning of the stimulus itself.

There are complex forms of learning [1,2]. People or animals learn to associate two stimuli occurring in sequence in ►classical conditioning, or learn to form an association between a behavior and its reward or punishment consequences in ►operant conditioning (►instrumental conditioning), or learn by observation, etc. The following parts concern principles of these complex forms.

### Classical Conditioning

In classical conditioning, organisms learn to form an association between two stimuli occurring in sequence, and in which a natural response transfers from one stimulus to another. Classical conditioning was discovered serendipitously by Russian physiologist Ivan P. Pavlov in the early 1900s, when he was conducting experiments on digestion. He gave a dog food and monitored the amount of saliva secreted while the dog ate the meal. After the dog performed this procedure a few times, then Pavlov found that the dog would begin salivating before getting any food. This basic type of learning is now known as classical conditioning or ►Pavlovian conditioning. The conditioning process generally has the same general procedure and components including unconditioned and conditioned stimuli, conditioned and unconditioned responses. The relationship between conditioned and unconditioned stimuli occurs and their influence on the consequences of learning are concerned in the ►theory on classical conditioning. Pavlov and his colleagues determined the main processes in classical conditioning, which include acquisition, ►extinction, generalization, and ►discrimination.

The acquisition phase is the initial step for conditioning an animal, for instance, to train the dog to salivate at the sound of the bell. The sequential and temporal order of unconditioned and conditioned stimuli can affect the forming of conditioning. The conditioned stimulus should come prior to the unconditioned stimulus and can easily produce a conditioned response, and more difficultly in producing a response if this order is inverted.

Extinction is used to describe the decline in the conditioned response by repeatedly presenting the conditioned stimulus in the absence of the unconditioned stimulus (extinction training), which then consequently induces a response extinction and extinction

memory. The conditioned salivation response will gradually abate if the experimenter rings the bell repeatedly giving no food.

Generalization refers to a process in which an animal has been conditioned to a particular stimulus, it may also respond to a similar stimulus without training of this new stimulus.

Discrimination refers to a process in which an individual learns to respond differently in the presence of distinct stimuli.

This classical conditioning is suggested to account for some changes in human social behaviors, such as phobia, a phenomenon of excessive fearing of specific objects or circumstances. Classical conditioning is also used to deal with certain behaviors.

### Operant Conditioning

Operant conditioning, is also called instrumental conditioning [1,2], and refers to a process involving changes of behaviors by reward or punishment. In operant conditioning the subjects must perform or operate certain behaviors in order to get a reward or punishment. Research in operant conditioning was pioneered by American psychologists Edward L. Thorndike and B.F. Skinner.

Edward L. Thorndike conducted research on operant conditioning at the end of nineteenth century using several species of animals such as chicken, dogs, and cats [1]. He placed an animal in a so-called puzzle box, and if the animal responded correctly, the door would open and the animal would get out and have some food placed outside the box. The first time the animal took a long time to make the correct response and making the door open to receive rewards. As he put the same animal in the box repeatedly, the animal would respond in a correct manner more quickly. Based on these experiments, Thorndike proposed a principle that was called the law of effect, which states that behaviors that are followed by pleasant or unpleasant consequences will be strengthened or weakened, and will be more or less likely to occur in the future, respectively. His law coincides with what is now called operant conditioning.

B.F. Skinner, a famous psychologist, from the beginning of 1930s discovered important principles of operant conditioning, a type of learning involving reward and punishment, using rats and pigeon [1]. He trained the animal in chambers, which are now known as Skinner boxes. In such a box, the animal could get food by making responses, such as pressing a lever or pecking at a hole. A device attached to the box recorded the animal's responses, and he could observe the influence of food delivery on an animal's behavior. From his discoveries, he argued that the rewards and punishments could also manipulate human behaviors. There are several principles of operant conditioning

including reinforcement, punishment, shaping, extinction, discrimination, and generalization.

In operant conditioning, positive reinforcement strengthens behaviors with a following pleasant stimulus, and negative reinforcement strengthens a behavior by removing a following unpleasant stimulus. Reinforcers can control the behavior of humans and other living organisms [1,2]. Appetitive reinforcers, such as food or water, typically increase the probability of responses on which they are contingent. Reinforcement schedules are rules that specify the timing and frequency of reinforcers. There are several types of reinforcement schedules, such as continuous reinforcement, fixed-ratio schedule, variable-ratio schedule, etc.

Punishment or ▶**aversive** reinforcers weaken behavior, reducing the chances that the behavior will occur again, which is ▶**aversive learning**. There are positive and negative punishments. Positive punishment refers to reducing a behavior by delivering an unpleasant stimulus if the behavior occurs, and negative punishment refers to reducing a behavior by removing a pleasant stimulus if the behavior occurs.

Shaping method refers to a process of training animals or people to learn behaviors that they have never performed before, by reinforcing the behavior the learner can perform from easy steps to more difficult ones. This method is often used to train animals to perform some specific behaviors.

Extinction in operant conditioning is the elimination of a trained behavior by extinguishing the reinforcer for that behavior. The lever pressing for food or drink in rats can be eliminated if such a reward is not delivered anymore.

In general, individuals perform a learned behavior in one circumstance and in other similar circumstances, for example we learn to apply the greeting “congratulations” to several happy circumstances of other people, such as when a person is promoted or when another one has good news on business.

Discrimination is learning when a behavior will be and will not be reinforced with reward in different circumstances, such as not to say “congratulations” to a person in an uncomfortable situation since it may not produce a good result at all.

### Observational Learning

Though classical and operant conditionings are important, living organisms can learn a great deal through observing others, which is observational learning/memory or ▶**imitation learning**. Learning by observation refers to a process including observation of the behavior of others and imitating their behavior. People learn languages as a means of communication, and learn to develop social behaviors, skills, and personality by observing others and gaining experience. Many other

species can also learn by observing other members of their societies.

Albert Bandura, a Canadian-American psychologist, in the early 1960s conducted experiments on how observational learning influences the behavior of children [1]. In one experiment, he showed preschool children a movie of an adult showing aggressive behavior to a doll, and then found that the children witnessed the movie mimicked that aggressive behavior. Bandura’s theory, also called social learning theory, mentions that there are some components in observational learning, including attention, retention, reproduction and ▶**motivation**. The learner at first needs to pay attention the behavior of others; secondly the learner must have retention of that observed information; thirdly the learner should mimic to reproduce the same behavior, and finally the learner should also have the desire or motivation to mimic the observed behaviors. Though neuronal substrates for imitation learning are still unspecified, the mirror neuron systems found in the monkey cortices are considered as a contribution to imitation. In human society, observational learning has a wide influence on people’s social behaviors and interaction, especially through education and media.

### Other Forms of Learning

Learning and comprehending language are essentially important for people since they use language as a means to communicate with other people. It is one of the most complex types of learning, and all children learn this skill in the first few years of their lives. Since 1950s American linguist Noam Chomsky proposed that humans have an innate ability to deal with word meanings and other grammatical rules. Later on scientific evidence shows that there are regions in the human brain as domains for language. Since people communicate using their language, so they can learn tremendous information by listening and by reading also. For humans, language is a specific signaling system, yet it can play roles as rewards or punishments in specific circumstances. Using language, people can develop a concept of objects in their environment, and more extraordinarily, they can have the abstract concepts. Other species also have their specific vocalization as a means to interact with their society’s members.

There are other forms of learning/memory such as ▶**perceptual learning**, habit learning, and ▶**sensorimotor learning**. ▶**Perceptual learning** refers to sensitivity enhancements in perception such as auditory, visual sensation, as a result of training. Sensorimotor learning, a type of procedural learning, refers to a process of learning to do physical movements in a coordinated manner. Motor skills, once mastered, can be performed unconsciously, such as riding a bicycle or playing a musical instrument.

More specialized terms have been developed concerning particular aspects of learning, such as ►latent learning, ►metalearning/metacognition, ►value-based learning, and ►spatial learning, etc. In latent learning, learning would occur without reinforcement, which is contradicted with reinforcement learning. Metalearning refers to the self-regulatory process of cognitive processes while engaging in the task. Value-based learning refers to a process of learning to obtain rewards and avoid punishments available in the environment, which encompasses principal components of both classical and operant conditionings.

A ►learning curve [3] is applied as a tool to analyze learning processes, in which correct and error performance of tasks through a time course of training are measured.

Mathematical and computational sciences have used simulated ►neural networks to decipher more computational traits of learning and memory. Principles of learning applied to artificial neural networks as in ►competitive learning, ►associative learning/memory, and ►connectionism studies are helpful in elucidating learning functions, contributing to the development of intelligent machines and brain machine interface.

### Factors Affect Learning

Learning is complex, and learning ability is different among species. For example, a monkey may take several months to master a task that a child can learn simply within a few minutes. Within a species, some factors such as age, experience, and mental conditions can affect learning ability.

Learning in animals and people occurs at all ages, but it is not similar at all ages. For example, at infant age, children quickly learn a new language, but learning a new language to some extent is harder for aged people. Many residents in Quebec, a province of Canada, are bilingual native speakers as they speak fluently both English and French languages, since they are exposed to both languages naturally from their infant age. Prior exposed experience is helpful to learn new ones that have some similar aspects. Matured people master the logical and abstract thinking more easily, as they experienced many abstract ideas previously, as the adult more easily understands a concept of “passion” or “tolerance” than adolescence. Various developmental disorders can intervene in the learning ability and influence one’s behaviors. Children with attention-deficit hyperactivity disorder (ADHD) or autism have difficulty in learning and developing their social behaviors. In adults, aged-related and degenerative diseases, such as Alzheimer’s disease (AD), can severely impair the learning/memory ability. Consolidation of learning/memory is enhanced with ►sleep, and it has been shown beneficial for some types of learning.

Learning is also individually different and somewhat influenced by motivation and ►emotion. In one class pupils may have different achievements of study, though they share the same schooling conditions, since they are different in their level of intelligence. There are people who have specific ability and skills to learn some subjects, such as are talented at music or mathematics but may not be excellent at the others. Therefore, encouraging the specific learning ability of people, motivating and taking care of people having learning problems should be publicly considered.

### Memory

Memory, as mentioned, is formed and processed through initial acquisition, retention, and retrieval of information in the brain. Memory is essential for the existence of all animals, it allows people access to the past, to form experience, and therefore to learn many skills. Memory has been a fascinating issue to many physiologists, thinkers and philosophers. Consider a life as a thread of events and facts that are recorded by one’s memory, we may then recall the proclamation of Rene Descartes “I think therefore I am”. There are several types, processes, and interesting phenomena in memory.

### General Division of Memory

Memory generally is divided into three main categories: sensory memory, short-term or working memory, and ►long-term memory [4]. Each of these categories is further divided.

#### Sensory Memory

Sensory memory refers to the initial recording of information in sensory systems. The brief encoding of visual or acoustic information is called iconic memory or echoic memory, respectively. Analogously, sensory memory is encoded in other sensory modalities. Our sensory systems often receive a large amount of information; they work unconsciously and retain sensory memory for a brief period of seconds or less, and only a handful of information that captures attention can be registered into ►short-term memory.

#### Short-Term Memory

William James in 1890 used the term primary memory to refer to the process of the information that forms the focus of attention and occupies the stream of thought.

The term short-term memory refers to the ability to hold information in mind over a brief period of time. The term working memory was created by Baddely and Hitch, and since 1974 has provided a broader concept of short-term memory, referring to a workspace or memory buffer that stores and allows access to use the stored information. Repetition of information can help to hold information in memory, but if something

interferes with the information holding process then we can quickly lose or forget information from the working memory. Hermann Ebbinghaus, a German philosopher, developed a measure for forgetting, and found that forgetting is rapid immediately after a study period but the rate of forgetting slows over time. Working memory can hold a limited number of information at one time. As estimated by American psychologist George Miller, generally the limited number that can be stored in the working memory is seven items. The working memory is also thought as having correlation with intelligence.

### **Long-Term Memory**

The term long-term memory is used to refer to a brain system that can store a great deal of information on a long-lasting basis. This terminology may describe the storage of all traces from something learned just minutes before and memories of a long period ago. There seems to be infinite storage capacity of long-term memory. For example, people can recall events that occurred a few decades ago, and can also retain a vast amount of information of various types throughout their lives. There are some views on how information engages in long-term memory. The classical view supposes that firstly information enters the short-term memory, and then may be processed somehow and transferred to long-term memory. Another view supposes that information may be processed separately and entered simultaneously into short-term and long-term memories. Long-term memory is further divided into two categories as declarative and non-declarative memories with main domains: ►**episodic memory**, semantic memory, and procedural memory.

### **Divisions of Long-Term Memory**

Long-term memory is divided by some ways with specific terms serving as synonyms.

#### **Declarative Memory and Non-Declarative Memory**

Declarative memory refers to memory that can be consciously recalled and described verbally, and non-declarative memory is memory that can be unconsciously recalled and only expressed through behaviors.

#### **Declarative Memory**

Episodic memory refers to memories of specific episodes in one's life. Episodic memories are linked with a specific time and place, it is a memory to answer "when" and "where" questions. Episodic memory stores the autobiographical details of our lives. We would rely on episodic memory to recall the events, such as memory of a nice trip to a beautiful resort (where) with friends last year (when). Since individuals can consciously recall events, facts and then can linguistically declare them, episodic memory is assigned

as a type of declarative memory or explicit memory. In human society, declarative memory is largely associated with spoken information, which is referred to as ►**verbal memory**.

Semantic memory refers to general knowledge of the world and all of the facts we know. Knowing that Paris has the Eiffel tower or Japan has Mount Fuji is a kind of semantic memory. Whereas episodic memory is closely related to time and place, semantic memory is not related to the particular time and place of learning the fact. We do not need to remember when and where we learned that Mount Fuji is in Japan. Semantic memory is also assigned as a type of declarative memory, yet semantic and episodic memories may have a different neural basis for their capacities.

#### **Non-Declarative Memory**

Non-declarative memory refers to memory that does not require conscious effort to recall. Non-declarative memory includes procedural memory, priming, simple classical conditioning such as eye blink response, and others such as perceptual, ►**emotional**, and habit learning/memory. Mainly procedural memory is mentioned here.

Procedural memory refers to the procedures and skills that an individual possesses. Playing a musical instrument, riding a bicycle, writing skills are examples of procedural memory. In contrast to episodic and semantic memories, procedural memory is expressed through performance and typically does not recall consciously; therefore it is called non-declarative memory. Practice plays an important and direct role in procedural memory; for example, a pianist can still improve his skills and performance through repetitive rehearsals over time.

Long-term memory is divided into two categories, and there are activities that require a pure memory component. Yet human activities also require blended involvements of these components. For example, people learn to play sports firstly need to receive instructions given in words or witness images (declarative components), and once they master these skills perfectly (procedural component), they can describe more precisely the skills. Thus, declarative memory and procedural memory may have certain mutual effects on each other.

#### **Explicit Memory and Implicit Memory**

In other words, memory is classified into implicit and explicit memories. The psychologist William McDougall distinguished these terms in 1924.

#### **Explicit Memory**

Explicit memory refers to the process of conscious retrieval of facts and past events. Explicit memory is consistent with declarative memory. Recall about a trip

to Mount Fuji last summer requires explicit memory. For testing explicit memory, there are tests for recall and ► **recognition** components. Showing a list of words, subjects would then be asked to write down as many words as they could, this is an example of a recall test. This type of test requires explicitly recalled information from memory. Showing a list of items and then asking subjects to classify which they have seen before and which are newly added items, this is an example of a ► **recognition memory** test.

### **Implicit Memory**

Implicit memory refers to using stored information without any effort to retrieve it. Implicit memory is consistent with non-declarative memory. In daily living, people capture and store experiences, and can then use them unconsciously. Very often we hear and see others, some time later we may say out the word we heard or imitate the other's behavior without realizing it. The automatic retrieval of information resulting from prior exposure is called priming effect. Subjects in experiments study a list of words (for example, friend, tower), they are then shown a list of fragmented words (fr\_\_nd, t\_w\_r) and are required to complete these fragmented words with the first word that come to their mind. Since previous exposure to the word "friend" and "tower," the subjects are primed to complete the fragmented words with what they have seen in the first list. Priming effect often occurs in daily life.

### **Consequences of Memory**

Encoding and storage are essential processes to attain and retain information. Encoding or perception refers to the process of perceiving information and conveying it into the memory system. Encoding is the first process, it convert information from one form to another. Proper analogue signals from the outside world enter sensory systems. The receiving parts of sensory modalities convert the received analogue signals to bioelectrical signals and then send them to the brain to be interpreted in forms that we can perceive. Individuals receive a vast amount of information, and much of it is encoded unconsciously. Prior experience is helpful for recording new information; repetitive rehearsal of information, changing information into images or a meaningful set can efficiently help the encoding ability and routine to store in memory.

Retrieval allows using stored information, and this process is crucial for accessing memories. There are several retrieval phenomena, which people may have experienced sometime [4,5].

Concerning consequences of memory, there are some interesting phenomena that one may have experienced at some moment, such as the following.

*Flashbulb memory.* Many American people remember well where and when they heard the exceptional

news such as the event that occurred with the twin trade towers in New York in 2001, since it created a flashbulb memory for them. This specific type of memory is associated with important emotional events in one's life, such as our marriage, or the birthday of our own babies.

*Déjà Vu.* French originated word *déjà vu*, with its meaning as "seen before," is the hallucination of having been somewhere before, or experienced the current situation before, even though it has never experienced. *Déjà vu* is supposed that aspects of the current situation act as cues for retrieval that unconsciously evoke an earlier experience, resulting in a sense of familiarity.

*Jamais Vu.* Also a French originated word, *jamais vu*, with meaning as "never seen," is the feeling when people feel they are experiencing circumstances for the first time, even though they know they have experienced it before. *Jamais vu* is explained that even though the similarity of the current and past circumstances, the cues of the current situation do not match the encoded trace of the past circumstance.

*Tip-of-the-tongue state.* The *tip-of-the-tongue state* refers to the situation in which a person tries to retrieve a familiar name, word, or fact, but finds it impossible to do so. The correct retrieval may come after sometime of trying to recall some other relatively close items. This phenomenon is explained as memory of other items that may prevent the retrieval of the correct item, or another possible explanation is that only a part of the information is insufficient to the retrieval of the correct item.

Memory is sometimes recalled differently from what actually occurred, as memory may undergo typical transformation over time, including omissions, deletions, reconstruction, and distortions. ► **Memory distortion** can occur as information is transformed serially through a number of people (social factor), or can also occur by our own recollection of memory. In memory processing sleep plays a certain role, especially in the consolidation process of learning and memory across animal species.

### **Forgetting**

A reverse side of memory is forgetting, which is defined as the decay and loss of information as time passes. Hermann Ebbinghaus in his memory experiments had used lists of nonsense syllables consisting of three letters with a vowel in between two consonants such as QAP or PIH. He learned a list until he could recall the list without error, and knew how long and the number of trials he took to master the list, then he tested his memory of the list over intervals from 20 min to 31 days. He found that rapid forgetting occurs at first and then the rate of forgetting was consistent as more time passes. His forgetting curve demonstrated the decay of stored information in long-term memory. It is thought

that forgetting occurs because of interference from other information over time. Forgetting is troublesome in some aspects, but it is a natural process and useful to wash out outdated unnecessary information.

## Neural Substrates of Memory

### *The Search for the Engram*

The biological basis of learning and memory is one of the most intriguing topics in cognitive science, with exciting questions such as where is the storage of memory. Psychologists in the early and mid of 1900s engaged in the “search for the engram” [4]. The term engram (i.e., memory trace) is used to refer to the changes in the nervous system that have occurred as a result of experience, or in the other word, it refers to specific loci of memory. American psychologist Karl Lashley surgically removed various parts of the brains of rats after they were well trained to solve a maze. He found that the rats still retained the ability to solve the maze. Now a modern concept of distributed memory across the brain is widely accepted.

### *Brain Regions Involved in Memory*

Many brain regions are involved in encoding, storing, and retrieval of different information in different memory-related processes, and they seem partially to work in interaction. However, there are brain regions that are involved specifically in processing and storing of specific memory. The case of the patient H.M. demonstrates the significance of the hippocampal formation in episodic memory. In 1953, 27-year-old H.M. underwent brain surgery as a final solution to treat his intractable epileptic seizures. The surgeons removed bilaterally his medial temporal lobes including the hippocampus, amygdala, and surrounding cortices. The surgery successfully controlled his seizures, yet it unexpectedly led H.M. to cope with a new syndrome that he was unable to perform basic activities as a normal people. He could not remember anything that happened to him after the surgery; he had amnesia. His memory of events before the surgery was almost intact, but he could not remember new people or new events even only for few minutes. Brenda Milner and her associates investigated his case for nearly 40 years but she needed to introduce herself every time meeting him. Researchers concluded that the hippocampal formation plays a critical role in episodic memory, a memory type that links events with a specific place and time.

In 1937 Papez proposed a circuit called the emotional circuit, but that circuit was lately regarded as a memory circuit, and some components of his proposed circuit are now classified as parts of emotional circuits. In fact, memory and emotional circuits are interconnected and have mutual interaction [4–6], for example, in a flashbulb memory, the emotional factor

strongly influences the memory. Other brain regions, such as the cerebellum, striatum, brainstem, amygdala, and other sensory and motor systems are importantly involved in non-declarative learning/memory [4–8]. Further evidence for the importance of these regions and other brain areas has been provided by advanced brain imaging techniques. Studying verbal memory suggests that the left hemisphere processes verbal information and the right hemisphere processes visuo-spatial information. Numerous studies also found that the left and right cerebral hemispheres do not contribute equally in some mental functions, suggesting a phenomenon of **hemispheric asymmetry** of memory and the split brain.

### *Synaptic Mechanisms for Declarative Memory*

It is interesting to look at how neurons and their synapses contribute to learning/memory. Donald O. Hebb, a Canadian psychologist, in 1949 proposed a way that learning might take place at the level of synapses [9]. Suppose that there are two neurons A and B that are interconnected but have a weak synaptic relation. If on some occasions A neuron fires and the impulses from A reach B, then a functional link between the two cells is formed. Consequently, when A fires then the possibility for B also firing is increased. The strengthened connection between two cells in this way is now called Hebbian synapse. Hebb’s hypothesis was interesting but was unproved about how learning might take place for many years [10]. In 1973, from a series of studies of hippocampal synaptic function carried out by Tim Bliss and Terje Lømo showed a phenomenon that the magnitude of the synaptic response could be increased by applying a brief period of electrical stimulation (tetanus) at a very high rate (100 Hz) [11], which is now so called long-term potentiation (LTP). Following researches on LTP has identified this is the mechanism making Hebbian plasticity possible. LTP has interesting properties. LTP can occur within each of three principal pathways through which information flows in the hippocampus: the perforant pathway, the mossy fiber pathway, and the Schaffer collateral pathway. It is rapidly induced, and once induced it is stable for hours or days or longer (if the tetanus is repeated). LTP has features of the memory process itself. It can be formed quickly at appropriate synapses and it lasts for a long time. In 1971 John O’Keefe and John Dostrovsky made the extraordinary discovery that the hippocampal pyramidal cells, the very cells that exhibit LTP, have a specific firing location in an environment [12]. These cells are called “place cells,” and they are thought as an internal representation—a cognitive map-of its spatial environment. Place-related activity was also found by Ono et al. in the monkey’s hippocampus [13]. Research showed that defects in LTP interfere with the stability of the

spatial map over time. This unstable map in turn reveals itself in behavior as an unstable ►[spatial memory](#). Given together, the findings of place cells, grid cells, and head direction cells support ►[neural bases of spatial learning and memory](#).

Another phenomenon of ►[synaptic plasticity](#) was found by Masao Ito in 1982 [7], which is called long-term depression (LTD), it was firstly found in the cerebellum, an important structure in ►[theories on motor learning](#), but lately was also found in other neural pathways [14]. LTD would be induced by applying a low-frequency stimulation (1–4 Hz) to a certain neural pathway. LTP and LTD have been attractive candidates for mnemonic function.

Research on memory has also focused on biochemical and genetic aspects of learning and memory, as numerous studies investigated the role of neurotransmitter systems on learning and memory [4,6]. A number of proteins, substances, and receptors, such as a protein called N-methyl-D-aspartate (NMDA) and its receptors, and dopamine and its receptors have been determined as having an important role in learning and memory, and their molecular mechanisms.

## Impairment of Memory

### Amnesia

►[Amnesia](#) [5] refers to impairment or loss of memory. It is classified into functional amnesia, organic amnesia, and infantile amnesia. Amnesia caused by brain damage is called organic amnesia, whereas one caused by psychological trauma is called functional amnesia. The H.M. case described above is an example of organic amnesia. Inability to remember new information is referred to as anterograde amnesia, whereas unable to remember events of the past is referred to as retrograde amnesia.

Childhood or infantile amnesia refers to the phenomenon that people can recall only a little about the first few years of their lives.

### Dementia

►[Dementia](#) is a progressive neurodegenerative disease causing intellectual impairment observed in elderly people (senile dementia) [5]. There are many kinds of memory, and each kind has a different fate in patients with the most common form of dementia, Alzheimer's disease (AD). The distinct forms of memory are differently compromised dependent on the neuroanatomic distribution of disease in AD. This disease strikes younger people in a form known as presenile dementia.

## Methods for Improving Memory

►[Memory improvement](#) refers to the enhancement of cognitive functions such as attention, learning and memory in healthy subjects as well as subjects with cognitive deficits.

Some healthy individuals have a striking ability in their memories. D.C. Shereshevskii has been mentioned as a typical example of a man having a remarkable memory [5]. He could learn a blackboard full of materials and could recall them after years. Shereshevskii used a method called mental imagery by creating rich images to represent information.

There are some typical techniques for improving memory, which have been used for a long time. Techniques for memory involve encoding and storing information in a way that are easy to recall, and using hints or cues to recall information.

An old mnemonic method is the method of loci (loci means "locations"). According to this method, subjects generate vivid images between locations and items to be memorized, and then put each item into a location where it can be seen in the mind.

Pegword method refers to a way that people learn words to serve as cues, and those cues can trigger a memory when needed. Making the pegwords rhyme as in a poem to remember items more easily is an example of this method.

In cognitive deficit persons, there are substances which would help to enhance memory, such as NMDA receptor antagonists, radial scavengers [4,5]. Various agents are currently being investigated or used as cognitive enhancers or anti-dementia agents, including acetylcholine esterase inhibitors. Neuroprotective agents that can prevent neurons from neurotoxic substances may also help improve memory. Proper physical exercise and training in a rich environment could also help to enhance memory.

There are more methods for improving different kinds of memories and some of them maybe used automatically by us sometimes but we may not recognize them. For example, we may have tried to learn a book by skimming through it, address questions to self-test what we have read, and read carefully, etc. However, we do not recognize that this is also a mnemonic method. For enhancing procedural memory, practicing regularly is effective.

Learning and memory are interesting and important for living organisms. Continuously learning throughout life could help greatly in improving memory.

## References

1. Mazur JE (2002) Learning and behavior, 5th edn. Prentice-Hall, New Jersey
2. Mackintosh NJ (1983) Conditioning and associative learning. Oxford University Press, New York
3. Gallistel CR, Fairhurst S, Balsam P (2004) The learning curve: implications of a quantitative analysis. Proc Natl Acad Sci USA 101:13124–13131
4. Squire LR (1987) Memory and the brain. Oxford University Press, New York

5. Squire LR, Kandel ER (1999) *Memory from mind to molecules*. Scientific American Library, New York
6. Tran AH, Tamura R, Uwano T, Kobayashi T, Katsuki M, Ono T (2005) Dopamine D1 receptors involved in locomotor activity and accumbens neural responses to prediction of reward associated with place. *Proc Natl Acad Sci USA* 102:2117–2122
7. Ito M, Sakurai M, Tongroach P (1982) Climbing fiber induced depression of both mossy fiber responsiveness and glutamate sensitivity of cerebellar Purkinje cells. *J Physiol* 324:113–134
8. Uwano T, Nishijo H, Ono T, Tamura R (1995) Neuronal responsiveness to various sensory stimuli, and associative learning in the rat amygdala. *Neuroscience* 68:339–361
9. Hebb DO (1949) *The organization of behavior*. Wiley, New York
10. Ledoux J (1996) *The emotional brain: the mysterious underpinnings of emotional life*. Simon & Schuster, New York.
11. Bliss TVP, Lomo T (1973) Long-lasting potentiation of synaptic transmission in the dentate area of the anaesthetized rabbit following stimulation of the perforant path. *J Physiol* 232:331–356
12. O’Keefe J, Dostrovsky J (1971) The hippocampus as a spatial map. Preliminary evidence from unit activity in the freely-moving rat. *Brain Res* 34:171–175
13. Ono T, Nakamura K, Nishijo H, Eifuku S (1993) Monkey Hippocampal neurons related to spatial and nonspatial functions. *J Neurophysiol* 70:1516–1529

several distinct categories, including Non-associative (habituation, sensitization, imprinting, play) and Associative-learning which encompasses Operant and Classical conditioning. With respect to Associative learning, Classical conditioning refers to the capacity of stimuli with no intrinsic significance (a conditioned stimulus) to gain the ability to elicit an adaptive reflex when associate closely in time with a second class of stimuli (an unconditioned stimulus) that can trigger a more robust reflexive response in aid of survival or protection of the organism. Operant-conditioning underlies the capacity of an organism to “operate” on the environment in a manner whereby its actions can achieve a specific outcome or reward. The increased occurrence of motor responses which enable access to a reward constitutes reinforcement of those specific components of behavior. The capacity of the brain, and hence the mind, to store newly learned responses and associated information within its synaptic structure and chemistry, which in turn can be used to guide future thought and action is referred to as Memory.

A second psychological process underlies the biology of adaptation and survival and is referred to as ►**motivation**; a theoretical construct invoked by experimental psychologists as a motive force behind the selection, initiation, vigor and persistence of behavior in humans and in many other species. Behavioral neuroscientists have been guided in their search for neural substrates of motivation by two different theoretical perspectives namely Drive-reduction theory and ►**Incentive motivation**. The former idea postulates that homeostatic imbalance within specific regulatory systems such as those responsible for energy, fluid or thermoregulation, gave rise to specify ‘drive’ states. Reduction of a specific ‘drive’ state by consumption of food or water reduces motivation to seek these stimuli and also provides reinforcement which increases the probability that action patterns that brought the organism into contact with these natural reward stimuli will be repeated (Thorndike’s Law of Effect).

In contrast to Drive-reduction theory as an internal motive force pushing the organism into action, Incentive motivation emphasizes the control over behavior exerted by stimuli external to the organism. The attractant properties of biologically- significant stimuli may be characterized as exerting a ‘pull’ on the organism that helps an organism to locate, move toward (or away) from the stimulus and in the case of positive incentive stimuli, eventually gain access to objects which are often essential for life. As reliable predictors of objects of desire, incentive stimuli become powerful attractors of orientation and approach behaviors which are the hallmarks of motivation. The subjective psychological state triggered by salient incentive stimuli is characterized as ‘wanting’ by Berridge and Robinson [1] in distinction to “liking” used to convey

## Learning and Motivation

ANTHONY G. PHILLIPS

Department of Psychiatry, University of British Columbia, Vancouver, BC, Canada

### Synonyms

Learning: Classical (Pavlovian) conditioning; Instrumental (Operant) conditioning; Response acquisition; Habit formation; Memory; Habituation; Sensitization; Imprinting; Play

Motivation: Drive reduction; Emotional arousal; Incentive motivation; Reward; Reinforcement; Outcome-expectancy

### Definition

Successful engagement with a specific ecological niche is essential for survival of all species on earth and for those with the capacity to move on land, within sea or air, the development of patterns of behavior which ensure the necessities for life is often based on trial and error, which constitute different forms of learning. Formal theories of learning recognize



an attraction to the hedonic properties of many reward stimuli.

The relationship between learning, memory and motivation is considered further under the heading Characteristics, with an emphasis on the role of the neurotransmitter ►dopamine in incentive motivation and its relation to memory. A brief discussion of aberrant behaviors that constitute ►addiction is provided in the context of the Incentive motivation theory of addiction.

## Characteristics

### An Ecological Perspective on Motivation

Ecological theories of animal behavior provide a functional behavioral perspective on motivation by emphasizing the distinction between preparatory and consummatory behaviors. Preparatory behaviors also referred to as appetitive or approach behaviors such as foraging and hoarding represent flexible patterns of activity designed to locate and bring the organism into contact with goal objects such as food or water. As such, these aspects of motivated behavior can be sustained over extended periods a fact that must be considered when seeking a biological basis for incentive motivation. Following contact with a reward stimulus, this pattern of behavior is terminated and is usually replaced by a separate class of consummatory behaviors such as chewing, swallowing and licking in the case of feeding, which have precise response topographies that facilitate ingestion of food. It is noteworthy that different patterns of preparatory behavior may lead to identical consummatory responses. With respect to the concept of incentive motivation, preparatory behaviors can be readily triggered by presentation of a conditioned incentive stimulus paired with the delivery of food.

### Dopamine and Incentive Motivation

The modern era of research into the synaptic mechanisms of motivation can be traced to the classical studies of Ungerstedt from the early 1970's in which severe aphagia and adipsia were induced by stereotaxic injections of the neurotoxin 6-hydroxydopamine into afferent projections of the mesocorticolimbic dopamine system. These findings were amongst the first to link the neurotransmitter dopamine to motivation. Further evidence linking brain dopamine function to motivational processes came from studies on the neurochemical bases of ►brain-stimulation reward. Converging evidence from neurotoxic lesions, neuropharmacological studies with selective dopamine agonists and antagonists, and in vivo measurement of dopamine efflux, all confirmed that dopamine plays a critical role in brain-stimulation reward. Brain dialysis studies also confirmed significant increases in DA efflux during food or fluid consumption and sexual behavior. Collectively these data gave rise to the dopamine theory of reward and motivation.

Shultz and colleagues [2] postulate that dopamine activity serves as an error detection signal which facilitates temporal difference learning. Specifically, dopamine neurons in the ventral mesencephalon of the rhesus monkey show increased rates of firing when the value of a received reward stimulus exceeds the predicted value. Importantly, a significant decrease in the firing rate of these dopamine neurons also reflects situations in which the magnitude of reward is less than predicted, including those when reward is omitted all together. McClure and colleagues [3] in developing their computational model of incentive salience note that the functional correlate of increased dopaminergic activity is to predict the occurrence of future reward and to ensure that appropriate actions are selected and initiated to maximize the opportunity to obtain the reward.

### Motivation and Memory

Motivated behavior is rarely seen as a random search strategy for locating the essentials for life. Indeed, preparatory behaviors are optimized by prior experience which enables many organisms to associate specific features of the environment including spatial locations with the objects they are seeking. The neural substrates of efficient foraging behavior have been studied extensively using radial-arm maze procedures pioneered by Olton. The hippocampus, the medial prefrontal cortex and the nucleus accumbens form interconnected neural circuits responsible for spatial cognition and memory. Activation of dopamine D<sub>1</sub> receptors in the prefrontal cortex is required for accurate foraging behavior guided by memory about the probable location of food. Neurochemical experiments confirm that dopamine in the medial prefrontal cortex is released in a phasic manner during recall thus ensuring an appropriate level of dopamine D<sub>1</sub> receptor activation essential for the retrieval of trial-unique information by memory processes which, in turn, can guide response selection during delayed response tasks. Computational models based on the effect of dopamine on a variety of biophysical measurements from pyramidal neurons within the frontal cortex suggest that tonic D<sub>1</sub> activity contributes to stability of memory engrams in the medial prefrontal cortex, by increasing signal to noise ratios of background activity at the expense of evoked activity. Encoding and maintenance of salient new inputs is linked to phasic activity at D<sub>2</sub> receptors. Accordingly, there appears to be an important relationship between dopamine as a neurochemical substrate of incentive motivation, and its ability to modulate memory function in corticolimbic regions of the brain [4].

### Incentive Motivation and Addiction

The uncontrollable urge to seek mind-altering substances and other forms of highly arousing activity such as gambling and risky sexual behavior can be

attributed to aberrant motivational states and together they constitute different aspects of ► **Addiction**. Addiction is also maintained by compelling memories of previous behavioral episodes in which specific sensory events and environmental contexts figure prominently and may trigger relapse to addictive behavior when encountered in the future. Accordingly, addiction has also been attributed to the modification of synaptic plasticity mechanisms in neural circuits responsible for reward and incentive motivation, of which the mesocorticolimbic dopamine pathways to the nucleus accumbens and prefrontal cortex play a prominent role [5].

Long-lasting changes in neural circuits connecting the prefrontal cortex to the nucleus accumbens can be induced by intermittent exposure to many drugs of abuse including psychostimulants (amphetamines and cocaine) and opiates. The consequence of this pattern of drug exposure is enhanced motor activity to subsequent administration of the same or other drugs and this defines the phenomenon of behavioral sensitization. Robinson and Berridge [6] first proposed that drug-induced sensitization of the mesocorticolimbic dopamine pathways, and the ensuing distortion of incentive motivation, could explain the powerful control over behavior and thought processes (extreme ‘wanting’) that is often exerted by addictive stimuli. Here it is important to note that the hedonic property of drugs (‘liking’) is not enhanced by repeated ► **intravenous self-administration** in humans or experimental animals.

An alternate hypothesis proposed by Kalivas and Volkow [7] acknowledges the primary role of the mesocorticolimbic pathways in initiation of drug-seeking behavior, but emphasizes the role of drug-induced pathophysiology of synaptic plasticity within glutamateric projections from the prefrontal cortex to nucleus accumbens. As a consequence, the capacity of the cortex to ascertain the consequences of specific actions (executive control) is diminished, along with decreased value of natural rewards and increased control over behavior by drug-associated stimuli; the net effect of which is compulsive behavior that typifies the thoughts and actions of addicts.

## References

1. Berridge KC (2007) The debate over dopamine’s role in reward: the case for incentive salience. *Psychopharmacology* 191:391–431
2. Schultz W (2007) Multiple dopamine functions at different time courses. *Annu Rev Neurosci* 30:259–288
3. McClure SM, Daw ND, Montague PR (2003) A computational substrate for incentive salience. *Trends Neurosci* 26:423–428
4. Phillips AG (2003) Mesocorticolimbic dopamine: a neurochemical link between motivation and memory. *Int Congr Ser* 1250:509–526

5. Kauer JA, Malenka RC (2007) Synaptic plasticity and addiction. *Nat Rev Neurosci* 8(11):844–858
6. Robinson TE, Berridge KC (1993) The neural basis of drug-craving: an incentive-sensitization theory of addiction. *Brain Res Rev* 18:247–291
7. Kalivas PW, Volkow ND (2005) The neural basis of addiction: a pathology of motivation and choice. *Am J Psychiatry* 162(8):1403–1413

## Learning by Imitation

### ► Imitation Learning

## Learning: Classical (Pavlovian) Conditioning

### ► Learning and Motivation

## Learning Curve

YUKA SASAKI<sup>1,2,3</sup>, TAKEO WATANABE<sup>4</sup>

<sup>1</sup>Athinoula A. Martinos Center for Biomedical Imaging, Charlestown, MA, USA

<sup>2</sup>Harvard Medical School, Boston, MA, USA

<sup>3</sup>Exploratory Research for Advanced Technology, Shimajo Implicit Brain Function Project

<sup>4</sup>Boston University, Boston, MA, USA

### Definition

Learning curve is a performance change as a function of a time course or a trial number of training.

### Characteristics

► **Learning curves** are shown in a wide range of different research fields from education to robotics. The shape of a learning curve depends on both independent and dependent variables, subjects, and contexts.

Traditionally, encoding and retention in memory and learning have been thought to occur in clearly different stages of the time course. ► **Supervised learning** and

non-supervised learning (►[unsupervised learning](#)) algorithms that are described in the glossary have been developed mostly to describe the mechanisms of encoding of learning and memory [10]. However, recently a growing body of neurobiological evidence has shown that after encoding, rather than mere process of passively retaining learning and memory, progressive stabilization occurs. This process and the phase during which such stabilization occurs are called consolidation. In this section, we concentrate on learning curves in relation to consolidation. The time scale of learning depends on the consolidation process [1]. Beyond the consolidation period, resistance to external interfering noise becomes stronger. There are two types of learning consolidation: fast and slow.

The fast consolidation process is often called synaptic or molecular consolidation, which takes place within a time window of a few minutes to hours after encoding. The underlying mechanisms are studied at the molecular level including protein synthesis. By contrast, the long consolidation process is often called system consolidation, which appears to take place in much longer time scale, ranging from months to years. The time scale depends on the type of memory as described below.

Memory is often categorized into declarative and non-declarative memory. Declarative memory includes episodic memory and semantic memory. Non-declarative memory includes skill or habits. The dichotomy originally came from studies of patients with hippocampal damage or amnesia. While amnesic patients demonstrate the ability to carry out skill or procedural learning [2], they have difficulties in encoding new memories, suggesting that non-declarative memories and learning are independent of the hippocampal formation.

It is assumed that declarative memory is formed through the system consolidation via the hippocampal formation [3]. Interestingly, the time scale involved in the consolidation of skill learning seems closer to that of cellular consolidation. Several reports have shown that consolidation of visual or motor skill learning takes place within hours of the initial encoding. Non-declarative memory is thus presumed to form through the molecular consolidation in the relevant cortex, according to the time scale of the consolidation process.

The most dominant hypothesis in declarative memory formation postulates a two-stage model [4], in which memory initially depends on the hippocampus, and with the passage of time, depends on the neocortex. In procedure learning including perceptual learning, the time course of learning over days seems to take place further in two phases; a rapid learning phase and a slow learning phase. Right after the starting of practice, the degree of improvements seems larger. In contrast, after the few sessions of practice, the degree

of improvements becomes smaller. This seemingly logistic learning curve in function of number of ►[training](#) session appears to take place in both vision and auditory [5]. However, interestingly, performance in visual learning has been shown to degenerate, not to improve, if repeated within a few hours in a day without intervening naps [6].

Moreover, recent evidence suggests that sleep is beneficial for both declarative and non-declarative memory including perceptual and skill learning [7–9]. Evidence suggests that the benefit of sleep on learning consolidation would originate in an internal biochemical process in the brain. However, a mechanism concerning how sleep improves system level consolidation is not yet fully understood.

## References

1. Doya K (1999) What are the computations of the cerebellum, the basal ganglia and the cerebral cortex? *Neural Netw* 12:961–974
2. Dudai Y (2002) *Memory from A to Z: keywords, concepts and beyond*. Oxford University Press, Oxford
3. Milner B, Corkin S, Teiber HL (1968) Further analysis of the hippocampal amnesic syndrome: 14 years follow-up study of H.M. *Neuropsychologia* 6:215–234
4. Hasselmo ME (1999) Neuromodulation: acetylcholine and memory consolidation. *Trends Cogn Sci* 3:351–359
5. Alvarez P, Squire LR (1994) Memory consolidation and the medial temporal lobe: a simple network model. *Proc Natl Acad Sci USA* 91:7041–7045
6. Hawkey DJ, Amitay S, Moore DR (2004) Early and rapid perceptual learning. *Nat Neurosci* 7:1055–1056
7. Mednick S, Nakayama K, Stickgold R (2003) Sleep-dependent learning: a nap is as good as a night. *Nat Neurosci* 6:697–698
8. Walker MP, Stickgold R (2006) Sleep, memory, and plasticity. *Annu Rev Psychol* 57:139–166
9. Born J, Rasch B, Gais S (2006) Sleep to remember. *Neuroscientist* 12:410–424
10. Tononi G, Cirelli C (2003) Sleep and synaptic homeostasis: a hypothesis. *Brain Res Bull* 62:143–150

---

## Learning Plasticity (Learning-induced Plasticity)

### Definition

Neuronal plasticity due to learning (to be distinguished from compensatory and developmental plasticity).

► [Neuroethological Aspects of Learning](#)

## Learning Rule

### Definition

A rule that specifies how synaptic strengths in a network change given training data.

► Neural Networks for Control

## Learning Set

### Definition

Learning set is training in which animal is repeatedly trained on new simultaneous discriminations. Performance in later discriminations improves over successive training. The improvement suggests that animals learn how to learn in the learning set training.

► Discrimination

## Leber's Congenital Amaurosis

### Definition

A rare bilateral retinal degeneration affecting infants

► Inherited Retinal Degenerations

## Left-Right Coordination

HIROSHI NISHIMARU

Neuroscience Research Institute, National Institute of Advanced Industrial Science and Technology (AIST) Tsukuba Center, Higashi, Tsukuba, Ibaraki, Japan

### Definition

The coordinated activation of muscles on the left and right side of the body during rhythmic movements in vertebrates [1–10].

Locomotion in most animals is characterized by its rhythmic activity. Muscles involved in this activity need to contract and relax rhythmically, in a coordinated manner, to generate efficient movements. For example, in aquatic vertebrates such as fish or amphibian tadpoles, a

wave of alternating contraction of the muscles in each body segment results in a sinusoidal movement during swimming. In limbed terrestrial animals, such as mammals living on land, corresponding muscles of the legs on the two sides contract, alternating while the animal walks. Various patterns of left-right coordination can be observed during different types of locomotion in these animals depending on their speed of movement. For example, during a high speed such as galloping, the activity in corresponding muscles on either side of the body becomes synchronous, i.e., simultaneous flexion and extension on the two sides.

### Characteristics

#### Quantitative Description

The basic patterns of such rhythmic movements are generated by a neuronal network called the central pattern generator (CPG) [2]. The CPG for locomotion is located in the spinal cord, since such coordinated rhythmic motor activity can still be evoked after the removal of higher brain structures. The CPG is capable of producing rhythmic activity in motor neurons that innervate the muscles, without rhythmic inputs from higher brain structures or sensory input. During the coordinated locomotor activity, the CPG activates motor neurons on the left and right side of the spinal cord in a sequential manner.

#### Higher Level Structure

The basic left-right coordinated rhythmic motor patterns for locomotion are generated by CPG located in the spinal cord. There are other examples of left-right coordinated rhythmic motor activities generated in other parts of the central nervous system, such as breathing that is produced by CPGs located in the brainstem [8].

#### Lower Level Components

Commissural interneurons (CINs) are essential for left-right coordination [1]. These CINs project their axons across the midline to convey information to the other side of the spinal cord. CINs are known to be active during locomotion [1], and the coordinated left-right pattern is disrupted if the axons of these neurons are severed at the midline of the ventral commissure of the cord [4]. Left-right coordination is regulated by CINs that function from the onset of the rhythmic activity in embryonic life (fish and tadpoles [9]), rodents [6]). In mammalian experimental models such as cat and rodent spinal cords, these CINs are located in the ventro-medial region of the spinal cord [1], where other CPG neurons are also localized [4]. These CINs exert either inhibitory or excitatory actions to their target CPG neurons on the other side of the cord, connecting the synergistic motor activity between the left and right side. Moreover, it has been shown

that some of the CINs can directly inhibit motor neurons on the contralateral side [1].

### Higher Level Processes

Local left-right coordinated activity in each part of the body is organized in a way so that patterned body movements are generated. For example, a local circuit coordinates alternating left-right rhythmic activity in each spinal segment in the lamprey. This circuit is connected to other circuits in neighboring segments during swimming to produce sinusoidal body movements along the body of the fish [2,3]. In quadrupeds, left-right coordination of forelimbs and hindlimbs are also coordinated during locomotion. CINs also receive direct inputs from the brainstem locomotor regions, presumably so that they can be activated directly when locomotion starts.

### Lower Level Processes

It has been shown in many experimental models of vertebrate locomotion, that one side of the spinal cord that is split in the midline contains a network capable of generating locomotor-like coordinated activity in the flexor and extensor muscles on the same side [3,4,7]. This has led to the assumption that there are two independent rhythm and pattern generating networks on the left and right side of the spinal cord, which are connected by crossed excitatory and inhibitory pathways. Latter pathways are crucial for the left-right coordination in vertebrates. In particular, mutual inhibitory connections between the two sides of the spinal cord are thought to be responsible for generating alternating patterns between the two sides, since blocking the neurotransmission mediated by inhibitory amino acids, like glycine and GABA, disrupts the alternating pattern between the two sides. Reciprocal inhibitory coupling mediated by glycine has been shown to be crucial for producing alternating muscle activity patterns during swimming in lamprey [2] and amphibian tadpole [9]. Similar observations have been made in the spinal cord of rodents [7]. The synchronous left-right activity seen during hopping or galloping is mediated via crossing excitatory CINs. Mice with a targeted deletion of the axon guidance molecule EphA4 show a rabbit-like gait instead of an alternating gait seen in wild type mice [5]. In the spinal cord of these mice, the axon of some of the excitatory neurons that normally project only ipsilaterally crosses the midline. This characteristic synchronous left-right rhythm is generated by the spinal CPG in these animals, leading to the assumption that the imbalance between inhibition and excitation in the left-right coupling is causing this abnormal gait.

Interestingly, it has been shown that from the time of onset of the coordinated rhythmic motor activity in rodent embryos, left-right pattern of the rhythm is

synchronous [6]. Unlike in mature animals, the synchronous pattern in embryos is likely to be due to excitatory effects of the inhibitory neurotransmitters GABA and glycine. Such excitatory effects of these inhibitory neurotransmitters during the early fetal period are likely to be caused by the high intracellular concentration of Cl ions in spinal neurons. Thus, generation of the reciprocal left-right pattern coincides with the emergence of inhibitory actions of the two amino acids in the spinal cord [7].

### Process Regulation

Left-right coordination during locomotion is modulated by descending inputs from higher brain structures. Inputs from diencephalic and mesencephalic locomotor centers in the brainstem can initiate locomotion and control its speed. For example, electrical stimulation of the mesencephalic region in cats can initiate locomotion, and its speed can be increased if the intensity of the stimulation is increased resulting in the change of gait i.e., walking (left-right alternating) to galloping (left-right synchronous) [10]. Neurons in the mesencephalic locomotor centers and reticulospinal neurons in these animals have direct inputs to CINs [1,3], indicating that these descending inputs have a strong influence on the left-right coordination during locomotion.

### Function

Left-right coordination is essential for the organism to move its body. Especially during patterned rhythmic body movements such as locomotion, a precise timing of contraction and relaxation in every muscle involved is crucial.

### Therapy

Left-right coordinated rhythmic motor activity is one of most common and essential behaviors in most vertebrates. Understanding their neuronal mechanisms can be utilized to develop ways of treatment and rehabilitation methods for patients suffering from spinal cord injury.

### References

1. Butt SJ, Le Bret JM, Kiehn O (2002) Organization of left-right coordination in the mammalian locomotor network. *Brain Res Brain Res Rev.* 40:107-117
2. Grillner S (1985) Neurobiological bases of rhythmic motor acts in vertebrates. *Science* 228:143-149
3. Grillner S (2003) The motor infrastructure: from ion channels to neuronal networks. *Nat Rev Neurosci* 4:573-586
4. Kiehn O, Kjaerulff O (1998) Distribution of central pattern generators for rhythmic motor outputs in the spinal cord of limbed vertebrates. *Ann NY Acad Sci* 860:110-129

5. Kullander K, Butt SJ, Le Bret JM, Lundfald L, Restrepo CE, Rydstrom A, Klein R, Kiehn O (2003) Role of EphA4 and EphrinB3 in local neuronal circuits that control walking. *Science* 299:1889–1892
6. Nakayama K, Nishimaru H, Kudo N (2002) Basis of changes in left–right coordination of rhythmic motor activity during development in the rat spinal cord. *J Neurosci* 22:10388–10398
7. Nishimaru H, Kudo N (2000) Formation of the central pattern generator for locomotion in the rat and mouse. *Brain Res Bull* 53:661–669
8. Reikling JC, Feldman JL (1998) PreBotzinger complex and pacemaker neurons: hypothesized site and kernel for respiratory rhythm generation. *Annu Rev Physiol* 60:385–405
9. Roberts A (2000) Early functional organization of spinal neurons in developing lower vertebrates. *Brain Res Bull* 53:585–589
10. Shik ML, Orlovsky GN (1976) Neurophysiology of locomotor automatism. *Physiol Rev* 56:465–501

---

## Lemniscus

### Definition

Lemniscus conducts protopathic and epicritic sensibility from the spinal cord and brainstem to the appropriate synaptic centers in the thalamus (medial lemniscus). The lateral lemniscus is part of the auditory tract.

- ▶ Medial Lemniscus
- ▶ Lateral Lemniscus
- ▶ Pathways

---

## Length-Force

- ▶ Length-Tension

---

## Length-Tension

THOMAS G. SANDERCOCK  
 Department of Physiology, Northwestern University,  
 Feinberg School of Medicine, Chicago, IL, USA

### Synonyms

Length-Force; L-T; Stress-strain

### Definition

The length-tension property of a whole muscle (or muscle fiber or sarcomere) is the relationship between muscle length and the force the muscle can produce at that length.

### Characteristics

#### Quantitative description

##### Introduction

During a voluntary contraction a person has no sense that their muscles have an optimal length for producing force. The complexity of the muscle architecture, skeleton, and neural control masks this functional property. However, early experiments in excised frog muscle showed force was dependant on muscle length. Since these early observations, this important property has been extensively studied. The molecular basis is now quite well understood, but the functional implications during normal movement still remain in question.

#### Total, Active and Passive Components of the Length-Tension Curve

The length-tension curve has an active and passive component that results from different structures within the muscle. [Fig. 1a](#) shows a classic length-tension curve taken from cat soleus muscle.

The passive curve generally assumes an exponential shape. Force is zero at short lengths but increases rapidly when the muscle is stretched beyond resting length. The active portion has a hyperbolic shape. The length producing peak tetanic force is referred to as  $L_0$ . The rising portion of the curve (lengths less than  $L_0$ ) is commonly referred to as the ascending limb, and the falling curve (length above  $L_0$ ) the descending limb. [Fig. 1b](#) shows some of the raw data used to construct the length-tension curve. The data points are experimentally obtained by making static measurements at various lengths. This is important because different results are obtained depending on muscle length and activation history (see below). Different muscles show considerable variation in the passive length-tension properties. As a result, the total length-tension curve sometimes shows a dip at lengths longer than  $L_0$ , and sometimes monotonically increases with length (see [Fig. 1c](#)).

#### Active Component During Tetanic Stimulation

A seminal paper by Gordon et al. [1] showed the sliding filament theory can account for the active length tension curve in a frog sarcomere. Assuming each cross-bridge can produce the same force irrespective of its position, and the cross-bridges and their binding sites are spaced uniformly, then parts of the length tension curve are expected to exhibit a linear force-length relationship ([Fig. 2](#)).

At long lengths, the number of possible cross-bridge attachments follows this relationship. At the plateau

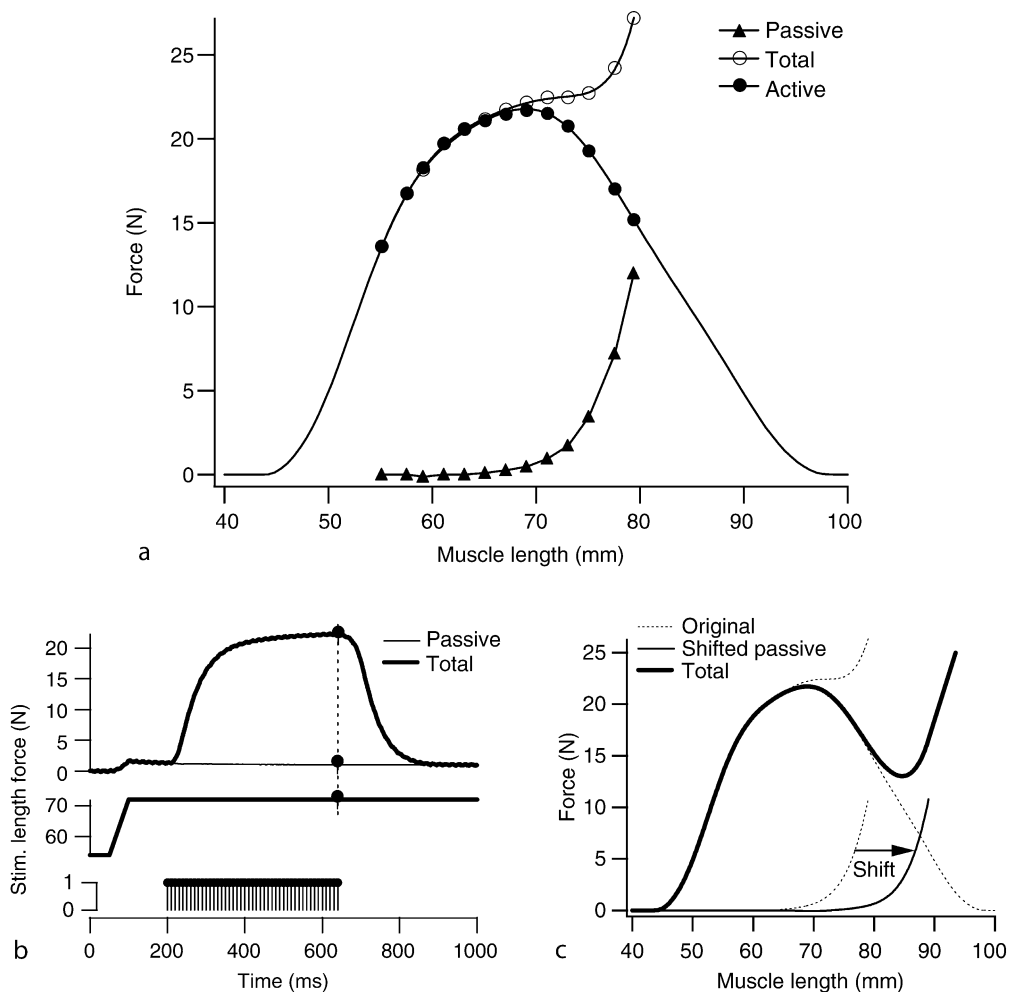

**Length-Tension. Figure 1** Length-tension curve measured from cat soleus. (a) Data points plotted and fit with curves. (b) Waveforms showing the procedures to measure the force at a single test length. The muscle is moved from slack length to the test length at time 50–100 ms. The muscle was stimulated at 100 Hz from 200 to 650 ms. The resulting total force is shown in the top trace. The identical movement is repeated without stimulating the muscle to measure passive tension. The difference between the two provides the measure of active tension. (c) Theoretical length-tension relationship obtained with a different passive length-tension relationship (unpublished data Sandercock and Heckman).

region, the number of attachments remains constant with length. The underlying mechanism is less clear at shorter sarcomere lengths. Region C-D may follow the same slope because the overlap of the thin filaments may block possible binding sites. At very short lengths, folding of the filaments may cause the steeper slope.

Actin filament lengths vary across species leading to different sarcomere length-tension relationships. Human muscle has a longer actin filament leading to a broader length-tension relationship.

#### Normalized Whole Muscle Versus Sarcomere Length-Tension: Scaling Length-Tension

The active whole muscle length-tension curve can be related to that of a single sarcomere. Two sarcomeres in

series should have a length-tension curve twice as wide (length axis) as compared to a single sarcomere. Two sarcomeres in parallel should produce twice as much force as a single sarcomere. Thus, assuming all sarcomeres are identical and lengthen synchronously, normalizing the whole muscle length axis by the number of sarcomeres in series, and the force axis by the number of sarcomeres in parallel (PSCA), should produce the sarcomere length-tension relationship. The series elasticity of the tendon and aponeurosis will broaden the whole muscle length-tension properties. The heterogeneity of individual sarcomere lengths will further broaden the length-tension curve for the whole muscle. Other factors altering the relationship include the angle of pennation, different fiber types, and

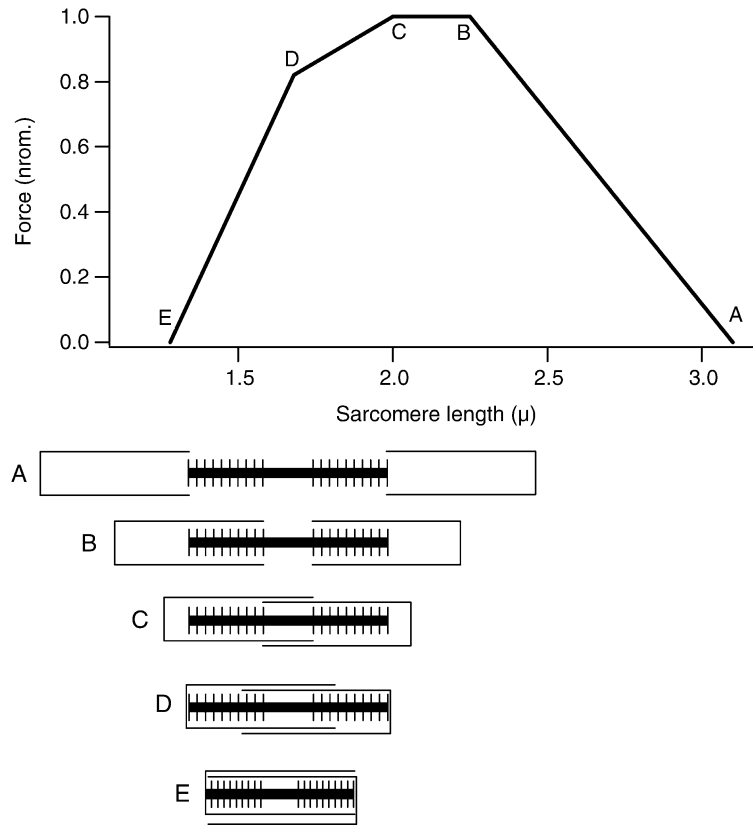

**Length-Tension. Figure 2** Theoretical determination of the active length-tension relationship. See text for details (modified from Gordon et al. [1]).

differences in fascicle length for different fiber types. In spite of these complications, the normalized length-tension curves from muscles in the cat hindlimb have approximately the same shape. The theoretical length-tension relationship of Fig. 2 fits whole cat soleus data if it is assumed there is a distribution of sarcomere lengths or fiber lengths (solid line Fig. 1a).

#### Determinants of Passive Length-Tension Properties

When the muscle is inactive (no action potentials), the length-tension properties depend on the structural proteins within the muscle fibers as well the extracellular connective tissue structure linking the fibers. In individual fibers, the large protein titin plays a significant role in keeping the thick and thin filaments from pulling apart, particularly at longer lengths. Titin appears to have an ideal structure to act as a spring. Other proteins may also play a role. In whole muscle the properties depend on those of the constituent fibers, as well as connective tissue links between fibers. The aponeurosis and tendon also play a significant role since they are in series with the muscle fibers. The details of force transmission within a muscle have yet to be understood in detail, so the passive length-tension properties have not been linked to specific structures.

The exponential shape shown in Fig. 1 is common to both individual fibers and whole muscles, but the zero point and the steepness of the rise vary considerably. For example, in the wallaby the gastrocnemius has few muscle fibers, and the passive tissue plays the major physiological role. In some disease states the passive properties of the muscle change such that passive force predominates and hinders movement.

#### Active Component During Sub-Maximal Activation

During submaximal contractions, the length-tension curve is shifted to the right (see Fig. 3). The cause of this shift not fully understood. During tetanic contractions the length-tension curve depends primarily on filament overlap. Enough  $\text{Ca}^{2+}$  is released to fully activate the troponin binding site. However, during sub-maximal contractions  $\text{Ca}^{2+}$  dynamics play a significant role. Muscle length does not appear to effect  $\text{Ca}^{2+}$  release, but rather, the sensitivity to  $\text{Ca}^{2+}$  becomes length dependant [3].

As muscle is rarely fully activated during normal use, the shifted length tension curve is a more realistic measure of the contractile properties during voluntary contractions, and thus very important for motor control. The importance of this shift was demonstrated by Rack



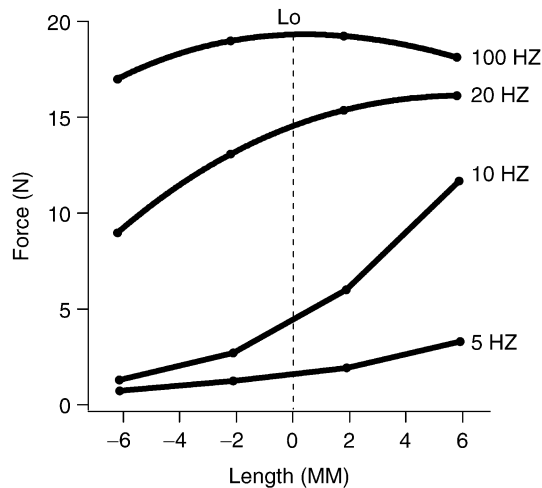

**Length-Tension. Figure 3** Static length-tension properties measured during different stimulation frequencies in cat soleus (modified from Sandercock and Heckman [2]).

and Westbury [4] in cat soleus. They used a distributed low frequency stimulation to simulate natural activation and showed this produced a dramatically different length-tension curve. Sandercock and Heckman showed similar results during normal recruitment and rate coding in cat soleus [2].

### Changes in Length of an Active Muscle-Movement along the Length-Tension Curve

Length-tension properties depend strongly on the way they are measured. The classic curve shown in Fig. 1a is a static property. Passive muscle is moved to a test length and then activated. The muscle is allowed to relax and the next point is measured. Different results are obtained if an active muscle is moved through different lengths. Figure 4 shows results when active cat soleus muscle slowly moved and compared to the static length-tension curve. Force-velocity properties can't explain all the difference, since this cat soleus has a maximum velocity of shortening greater than 160 mm/s and the movement is very slow.

The underlying physiological reasons for the difference are not fully understood. Persistent tension excess or tension deficit are similar phenomena and it was initially believed that sarcomere inhomogeneities were responsible [5]. It was proposed that during a prolonged contraction, or with movement, the strong sarcomeres shortened at the expense of the weak ones, each sarcomere moving along its respective length tension curve until all produced the same force. Recent work in frog fibers, where every sarcomere length was measured, showed no substantial increase in the inhomogeneity with movement, suggesting inhomogeneities are not the cause.

### Use of the Length-Tension Curve in Mathematical Muscle Models

Simple muscle models, particularly those using some version of Hill's model, often incorporate a tetanic length tension curve in the model. For motor control studies this is probably worse than using no length tension curve at all. As muscles are rarely, if ever, activated at rates approaching tetanic stimulation frequencies, the length-tension curve will be right shifted. Furthermore, active stretch or shortening alters the relationship (see above).

### Operating Point on the Length-Tension Curve

Surprisingly, the length at which sarcomeres operate during normal movements is not well known. This is a result of the difficulty in measuring muscle force, tendon strain, and/or sarcomere length during voluntary movements. To make efficient use of a muscle, the operating point must be near  $Lo$ . Some have argued that the muscle will become unstable if operated at lengths beyond  $Lo$  because the strong sarcomeres will shorten at the expense of the weak ones [6]. This may be why runners, whose muscles tend to operate on a stretch-shortening cycle, may operate on the ascending limb of the length-tension curve, and bicyclists, whose muscles operate on a shortening-stretch cycle, may operate on the descending limb of the length-tension curve [7]. However, a detailed review of the available literature, examining vertebrate muscles in different animals, concluded the operating range of most muscles is quite narrow covering  $94\% \pm 13\%$  of  $Lo$  [8].

Muscle may be able to add or subtract sarcomeres to maintain the ideal operating range. Williams and Goldspink showed that muscles immobilized for several weeks, at a sarcomere length far from optimal, added or subtracted sarcomeres to restore the optimal sarcomere length for the new muscle position [9]. However, Friden et al. found the opposite – muscle immobilized at a long length had fewer sarcomeres [10]. The ability of muscles to regulate the number of sarcomeres may vary with the species, muscle, and exact conditions of use.

### Higher Level Structures

► See Muscle Modelling.

### Lower Level Components

Myofilament, myofibril, muscle fiber, sarcomere, cross-bridge.

### Structural Regulation

Sarcomeres may be added to or subtracted from a muscle to alter the length-tension characteristics. The extent to which this occurs in adult animals has not been determined [9].

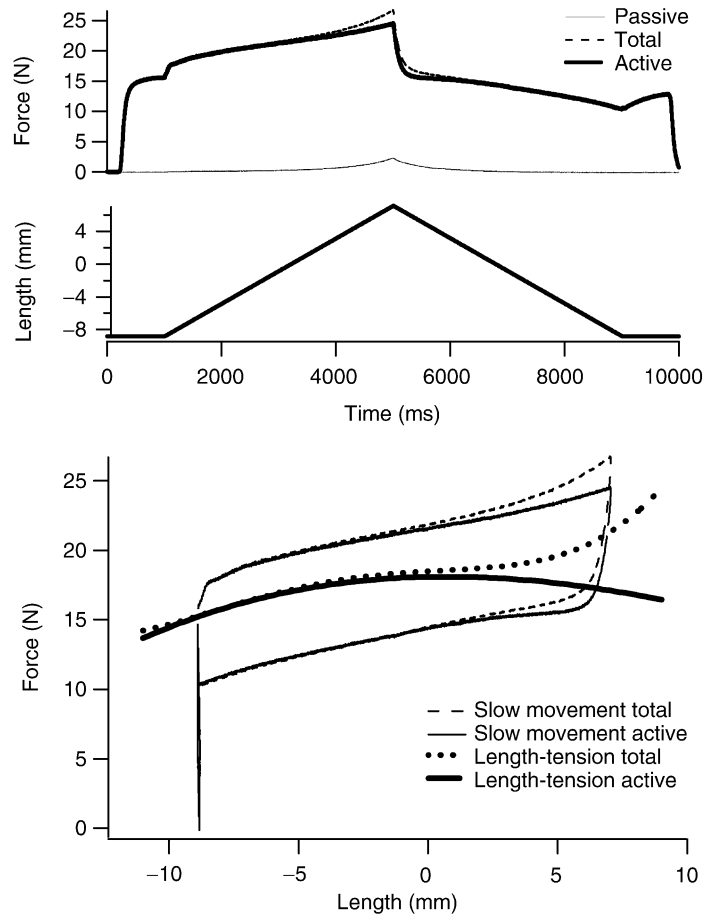

**Length-Tension. Figure 4** Effects of movement on the relationship between force and length, measured in cat soleus. Plot A depicts muscle force during whole muscle stimulation at 100 Hz. The muscle was slowly stretched from 9 mm shorter than  $L_0$  to 7 mm longer than  $L_0$ . At  $t = 5$  s the direction was changed and the muscle shortened to the starting length (plot B). Plot C depicts the same data re-plotted as force versus length and plotted along with the standard length-tension properties. The length-tension curve was measured from the same muscle (*heavy lines*) using standard procedures (see Fig. 1). The stretch-shortening speed was only 4 mm/s (maximum velocity of shortening approximately 160 mm/s) so the force velocity properties of the muscle can't account for most of the extra force. Note that on the descending portion of the length-tension curve force increases during stretch of the active muscle in spite of the decrease in the length-tension curve. Similar results are seen regardless of the starting point for activation and slow stretch (unpublished data Sandercock and Heckman).

#### Higher Level Processes

The length-tension relationship is mapped to an angle-moment relationship via joint and skeletal anatomy.

#### Lower Level Processes

Cross-bridge, excitation-contraction coupling.

#### Process Regulation

Muscle activation must account for the change in force with length.

#### Function

The length-tension property results from the structure of the muscle. The animal's skeletal anatomy and/or neural control must make use of, or correct for, this property.

#### Pathology

Most muscle or connective tissue diseases will secondarily alter the length-tension relationship.

#### Therapy

Tendon transfer and tenodesis are used to restore functionality and alleviate excess passive tension. The procedures are only partially successful. A better understanding of sarcomerogenesis may be helpful.

#### References

1. Gordon AM, Huxley AF, Julian FJ (1966) The variation in isometric tension with sarcomere length in vertebrate muscle fibres. *J Physiol* 184:170–192

2. Sandercock TG, Heckman CJ (2001) Whole muscle length-tension properties vary with recruitment and rate modulation in areflexive cat soleus. *J Neurophysiol* 85:1033–1038
3. Balnave CD, Allen DG (1995) Intracellular calcium and force in single mouse muscle fibres following repeated contractions with stretch. *J Physiol* 488:25–36
4. Rack PMH, Westbury DR (1969) The effects of length and stimulus rate on tension in the isometric cat soleus muscle. *J Physiol Lond* 204:443–460
5. Morgan DL (1990) New insights into the behavior of muscle during active lengthening [see comments]. *Biophys J* 57:209–221
6. Morgan DL, Brockett CL, Gregory JE, Proske U (2002) The role of the length-tension curve in the control of movement. *Adv Exp Med Biol* 508:489–494
7. Rassier DE, MacIntosh BR, Herzog W (1999) Length dependence of active force production in skeletal muscle. *J Appl Physiol* 86(5):1445–1457 [Review] [89 refs]
8. Burkholder TJ, Lieber RL (2001) Sarcomere length operating range of vertebrate muscles during movement. *J Exp Biol* 204:1529–1536
9. Williams P, Goldspink G (1978) Changes in sarcomere length and physiological properties in immobilized muscle. *J Anat* 127:459–468
10. Friden J, Ponten E, Lieber RL (2000) Effect of muscle tension during tendon transfer on sarcomerogenesis in a rabbit model. *J Hand Surg* 1:138–143

---

## Lens Evolution

- ▶ Evolution of Eyes

---

## Lenticular Fasciculus

### Synonyms

Fasciculus lenticularis

### Definition

Fiber tract of the subthalamus. The lenticular fasciculus and ansa lenticularis together form the pallidothalamic projection, the biggest efferent of the globus pallidus. The fibers terminate in the ventral lateral thalamic nucleus, which in turn projects to parts of premotor cortex (area 6) and of the supplementary motor area. They arrive at the thalamic nuclei via the thalamic fasciculus.

- ▶ Diencephalon

---

## Lepidosauria

### Definition

Diapsid reptile clade incorporating lizards, snakes, amphisbaenians (worm lizards) and tuatara (*Sphenodon* and its fossil relatives)

- ▶ The Phylogeny and Evolution of Amniotes

---

## Leptin

### Definition

A hormone from fat tissue which plays a key role in the regulation of appetite, energy expenditure and metabolism.

- ▶ Neuroendocrinology of Eating Disorders
- ▶ Neuroendocrinology of Psychiatric Disorders

---

## Leptomeningeal Cell

### Definition

Also known as meningeal cells or meningeal fibroblasts these cells lie on the glia limitans (q.v.), forming the inner meningeal layer. The glia limitans results from an interaction with between leptomeningal cells and the underlying astrocytes. After CNS injury meningeal cells proliferate and invade the lesion. Together with endothelial cells and inflammatory cells they form most of the lesion core that is particularly prominent in spinal cord injuries, and which is a barrier to axon regeneration. The leptomeningeal cells express members of the semaphorin 3 family.

- ▶ Glial Scar

---

## Leukemia Inhibitory Factor (LIF)

### Definition

A cytokine involved in cell growth, cell differentiation, embryogenesis, inflammation and neuronal development. LIF was initially named because of its ability

to induce the terminal differentiation of leukaemic cells. LIF binds the LIF receptor (LIFR- $\alpha$ ) and forms a heterodimer with the gp-130 signal transducing subunit leading to the activation of the JAK/STAT (Janus kinase/signal transducer and activator of transcription) and MAPK (mitogen activated protein kinase) pathways.

- ▶ Cytokines
- ▶ Janus Kinases (JAKs)

## Leukocytes

### Definition

Generally referred to as white blood cells, these cells develop from bone marrow stem cells, a process called hematopoiesis. Circulating leukocytes include lymphocytes (including T lymphocytes that can be further classified based on their functions into CD4<sup>+</sup> and CD8<sup>+</sup> T lymphocytes, B lymphocytes and natural killer cells); monocytes; and granulocytes (including neutrophils, eosinophils and basophils). Circulating leukocytes constantly circulate in the blood and lymphoid organs (where lymphocytes mature and adaptive immune responses are initiated). Under disease conditions, circulating leukocytes can cross blood vessels and enter into local injured tissue driven by local released factors (a process called extravasation). Tissue leukocytes include macrophages and mast cells. Additionally, resident tissue or circulating dendritic cells are specialized leukocytes that are the most effective professional antigen-presenting cells.

## Leukoencephalitis

### Definition

Inflammation of the white matter of the brain.

## Lewy Bodies

### Definition

Characteristic intracellular proteinaceous inclusions that are formed in the brains of individuals with

Parkinson disease. They contain high levels of the protein  $\alpha$ -synuclein.

- ▶ Parkinson Disease
- ▶ Alpha-Synuclein: From Neurological Disorders to Molecular Pathways

## Lexical-Gustatory Synesthesia

JULIA SIMNER

School of Philosophy, Psychology and Language Sciences, University of Edinburgh, Edinburgh, UK

### Synonyms

Word-taste synesthesia

### Definition

Lexical-gustatory synesthesia is a sub-variant of the familial condition known as ▶ **synesthesia**, which is characterized by a merging of sensory and/or cognitive functions. In lexical-gustatory synesthesia, words trigger accompanying food sensations, and these are experienced as either veridical perceptions of flavor (e.g., the word *jail* tastes of bacon in the mouth) or as an overwhelming and automatic cognitive association between the inducing word and the food type (e.g., the word *jail* evokes the notion of bacon).

### Characteristics

#### Quantitative Description

Synesthesia is a multi-variant condition in which everyday activities (e.g., reading, listening to music) give rise to extraordinary experiences (e.g., colors, tastes). Each variant is characterized by the pairing of a particular type of synesthetic “inducer” (i.e., triggering stimulus) with a particular type of experience (or synesthetic “concurrent”) and in the lexical-gustatory variant these are words and flavors respectively. Hence for lexical-gustatory ▶ **synesthetes**, hearing words, saying words, reading words, or even thinking about words, gives rise to associated food experiences [1–3]. For synesthete JIW, for example, the word *this* tastes of bread soaked in tomato soup, while the name *Philip* tastes of unripe oranges [1]. As in other variants of synesthesia, the condition is characterized by the consistency of inducer-concurrent pairings, which tend to remain constant across the synesthete’s life-time. Hence, synesthetes typically score between 90% and 100% in retests of their word-food associations across many months or even years, and they significantly outperform controls subjects, even if these latter are tested over considerably

shorter intervals [1–3]. The condition is rare, even within the sphere of synesthesia, and although 11 cases have now been reported in the contemporary literature [1–4] along with four from historical sources (see [1,2]) no cases emerged in the population recruited for the most extensive prevalence study based on random sampling [5], and this suggests that the prevalence of lexical-gustatory synesthesia is less than 0.2% of the population (and may be considerably lower). As in other studies of synesthesia, the lexical-gustatory variant can be investigated by examining the nature of the concurrent experience, the nature of the inducing stimulus, and the processes by which these become associated, and we follow this structure in the essay below.

### Description of the Structure/Process/Conditions

Lexical-gustatory synesthetes can be divided into two groups according to the nature of their concurrent (flavor) experiences. For “projector synesthetes,” these flavors are tasted as veridical perceptual experiences, with the same reported phenomenology as for flavors generated by food substances in the mouth (with the exception of having a substance to roll on the tongue). Synesthete MM [3], for example, reports that her mouth is flooded with the taste of baked cornbread when she encounters the name *John*. Some concurrent flavors are particularly strong and can persist for some time, often until the taste is overridden by another. For this reason, projector lexical-gustatory synesthetes can come to regard their synesthesia as a source of irritation, which makes it hard for them to read books, or concentrate in conversation. For “associator synesthetes,” however, the food concurrent represents a cognitive association, which automatically enters into consciousness when the inducing word is encountered. Synesthete PS, for example, has the overwhelming notion of orange jelly when he hears the word *shoulder*. In all cases, food experiences are complex sensations (rather than generic tastes of bitter/sweet, etc.) and are highly specific and rich in detail, such that the synesthetes go to some trouble to describe them [1]. For synesthetes JG for example, the name *Adrian* tastes of lettuce coated with Caesar salad dressing, and for CS, *part* tastes of chicken noodle soup [2]. Associations can incorporate temperature and texture as well as flavor, so for synesthetes JIW for example, the word *jail* generates the experience of cold, hard bacon [1], while *tambourine* is very crumbly biscuit. For all reported projector synesthetes, concurrent tastes have a subjective location in the mouth and tongue area, while some synesthetes additionally report olfactory experiences. Researchers have been reticent to draw strong conclusions from this, however, (see [2]) given that taste and smell are difficult to separate subjectively, and there is a natural tendency to misattribute olfaction to taste sensations in the mouth (e.g., the rated intensity of taste sensations in the

mouth is increased for all people in the presence of olfactory cues; [6]). In at least one case (an Italian speaker), however, the same word was reported to trigger different food experiences in the gustatory versus olfactory domains (e.g., *Alessandro* tasted of fried potatoes but gave the smell of burnt wool). Taken at face value, this historical report (for description, see [2]) would suggest that concurrents may indeed extend across both taste and smell.

Careful analyses of synesthetic concurrents reveal that certain flavors tend to dominate (e.g., sweets and chocolate) while others are often conspicuous in their absence (e.g., alcohol). The synesthetic flavor concurrents of synesthetes JIW are shown in Fig. 1 (data adapted from [1]), and this type of non-random response space can distinguish between synesthetes and controls.

The nature of the flavor concurrent in lexical-gustatory synesthesia is known to be shaped by dietary experience: the frequency of synesthetic flavors is related to the frequency with which the corresponding food is consumed in the synesthete’s diet, such that commonly eaten foods are significantly more likely to occur as synesthetic concurrents [1]. Notably, however, synesthetic tastes are statistically more likely to reflect the diet eaten during childhood compared to adulthood. For instance, JIW is currently a heavy coffee drinker, but did not drink coffee as a child. Coffee rarely appears as a synesthetic concurrent, and when it does, it typically arises as coffee flavored chocolates [1]. Indeed, foods consumed during JIW’s childhood are 10 times more likely to occur as synesthetic concurrents, compared to those consumed only in later life. This over-representation of childhood foods suggests that synesthetic associations are set during early development, and indeed, lexical-gustatory synesthetes report that their experiences date back for as long as they can remember (e.g., [2]). Figure 1 shows that a small number of synesthetic flavors represent non-food substances, and these include both bodily and

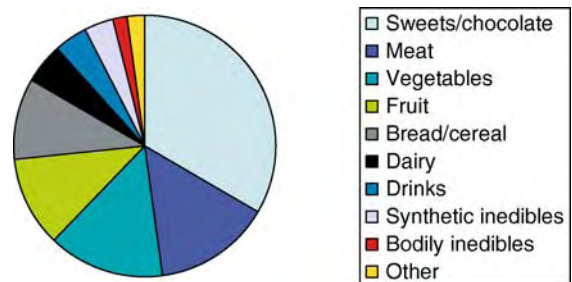

**Lexical-Gustatory Synesthesia.** Figure 1 Summary of synesthetic flavor associations of synesthete JIW, elicited by 1,195 target words (data adapted from [2]).

non-bodily inedibles (e.g., earwax and plastics respectively). It is possible that such tastes may yet have been experienced during early exploratory eating behavior.

Descriptions of the inducers have remained remarkably similar across centuries and across continents (see [2]). Flavours are triggered by words, although there is a clear phonological component, in that similar sounding words tend to taste alike (e.g., for JIW, the words *message*, *college* and *village* all taste of sausage). Indeed, each synesthetic flavor can be traced to a particular ►**phoneme** (or phonemes), whose presence in a word endows a significant likelihood of generating that particular concurrent. For example, words containing /k/ (e.g., *York*) tend to taste of egg for JIW, and such relationships are largely independent of orthographic properties, since, for example, the egg concurrent arises whether the phoneme /k/ is spelt with a *c* (e.g., *accept*), *k* (e.g., *York*), *ck* (e.g., *chuck*) or *x* (e.g., *fax*) [1]. Some phoneme “triggers” have been shown to derive from food names (e.g., /l/, /n/ and /s/ trigger JIW’s taste of mince) while others have less obvious roots (e.g., /f/ is associated with the flavor sherbet). Interesting, the synesthesia is sensitivity to fine-grained phonological constructs of which the synesthetes has no conscious awareness [1]. For example, different flavors can be associated to different ►**allophones** (i.e., acoustic/articulatory variants) of the same phoneme. Hence, JIW tastes both fingernails and potato from the phoneme /l/, although the former is associated, specifically, to the “dark” allophone (which has a secondary articulation in which the back of the tongue is raised towards the velum, as in *deal*) while the latter flavor is associated to the “clear” (unvelarized) allophone (as in *like*). JIW’s synesthesia also responds to further distinctions within these allophones: the taste of Rice Krispies<sup>®</sup> is associated with a “syllabic” dark /l/ (i.e., one that fills the peak of an unstressed syllable, as in *bottle*) while the taste of fingernails is associated to the “non-syllabic” dark /l/ (as in *deal*) [1].

Although phonology may be important during development to determine the pairings of particular words with particular flavors, gustatory pathways may in fact target structures encoding word meanings (“lemmas”), at least in the adult brain [3]. There are several strands of evidence for this: first, associations between phonemes and flavors are not entirely productive, as might be expected if processing a phoneme were enough to trigger flavor (e.g., for JIW /g/ significantly associates with yogurt, but some /g/ words are tasteless). The presence of lexical gaps suggests that gustatory pathways target words, and can do so selectively. Other word-level influences, too, suggest that flavors are tied to lexical rather than phonological units (e.g., flavors are stronger from high- versus low-frequency words [2] and some associations are dictated by word-meaning; e.g., the word *blue* tastes inky) [1].

Third, synesthetic experiences are significantly weaker from non-words [2], which have no lemmas. Finally, synesthetic flavors can be triggered even when phonological information is temporarily inaccessible, as in “tip-of-tongue” states. Tip-of-tongue is the familiar experience in which a word is known but temporarily cannot be recalled from memory. This arises when the word’s lemma, but not its phonemes, has been retrieved. When synesthetes are in tip-of-tongue states (which can be induced by showing pictures of uncommon objects such as gazebos, metronomes, platypuses, etc.) they begin to taste the word before they can say it [3]. One woman, for example, tasted Dutch chocolate while struggling to retrieve the word *phonograph*, and this is precisely her synesthetic flavor for that particular word. This phenomenon suggests that it is word meaning – not sound or spelling – that elicits the flavor sensation and this fact, together with the findings above, suggests that gustatory pathways may target lexical-semantic centers.

By examining the particular pairings of inducer and concurrent across different synesthetic variants, researchers have begun to understand the ways in which these might come to be associated in the synesthetic brain. The exact cause of synesthesia is unknown, although a genetic component is strongly implicated (e.g., [7]), and all contemporary theories emphasize changes in patterns of neural communication. Some accounts suggest that genetic inheritance may cause a greater retention of early anatomical connections (through a failure in ►**apoptosis**), while others propose a lack of inhibition in ►**feedback** pathways (see [8] for review). In both cases the outcome is assumed to be the same: an atypical, functional cross-talk between brain regions encoding the inducer and concurrent modalities. Hubbard and colleagues (e.g., [8]) have proposed a theory of short-range cortico-cortical connectivity, based on the observation that common pairings tend to arise from adjacent brain regions (e.g., ►**grapheme-color** synesthesia may reflect left fusiform adjacency between the visual word-form area, and the color-selective region hV4). Their adjacency account extends to lexical-gustatory synesthesia since they point out that regions implicated in language processing are local to cortical taste areas, distributed along ►**insular cortex** and opercular cortex. Their candidate regions include the frontal operculum extending into ►**Broca’s** area, which may play a role in both speech perception and production, and the superior temporal gyrus and anterior ►**temporal lobe**, which have been implicated in lexical-semantic processing [9,10]. Indeed, ►**fMRI** data from a single projector synesthete demonstrates activation of Brodmann’s area 43 when listening to words but not tones (while controls showed no such activity) and this is consistent with these proposals (Parslow et al., unpublished; see [1]). Such imaging data not only provides a clue to the neurological roots of the condition, but is strong evidence that the experiences of (projector)

lexical-gustatory synesthetes are, to some extent, perceptual in character.

In summary, lexical-gustatory synesthesia is a condition of unique interest to neuroscientists, psychologists, philosophers and linguistics alike. Its blending of linguistic constructs with perceptual flavor experiences has forced a redefinition of synesthesia beyond a purely perceptual viewpoint, as well as informing more general theories about the interplay between perceptual and non-perceptual systems. The gustatory and olfactory “reality” of the tastes, textures, temperatures and odors experienced by lexical-gustatory synesthetes allows us to see, in a very direct way, that perceptual sensations are the result of internal neurological processes, rather than external stimuli from the outside world, and shows that our perceptual inner worlds can be idiosyncratically constructed in the most surprising ways.

## References

1. Ward J, Simner J (2003) Lexical-gustatory synaesthesia: linguistic and conceptual factors. *Cognition* 89:237–261
2. Ward J, Simner J, Auyeung V (2005) A comparison of lexical-gustatory and grapheme-colour synaesthesia. *Cogn Neuropsychol* 22:28–41
3. Simner J, Ward J (2006) Synaesthesia: the taste of words on the tip of the tongue. *Nature* 444:438
4. Cytowic RE (1989) *Synaesthesia: a union of the senses*. Springer, New York
5. Simner J, Mulvenna C, Sagiv N, Tsakanikos E, Witherby SA, Fraser C, Scott K, Ward J (2006) Synaesthesia: the prevalence of atypical cross-modal experiences. *Perception* 35:1024–1033
6. Murphy C, Cain WS, Bartoshuk LM (1977) Mutual action of taste and olfaction. *Sens Processes* 1:204–211
7. Ward J, Simner J (2005) Is synaesthesia an X-linked dominant trait with lethality in males? *Perception* 34:611–623
8. Hubbard EM, Simner J, Ward J (2007). Anatomically constrained cross-activation: a grand unified theory of synesthesia. Manuscript under review
9. Scott SK, Johnsrude IS (2003) The neuroanatomical organization of speech perception. *Trends Neurosci* 26:100–107
10. Mummery CJ, Patterson K, Price CJ, Ashburner J, Frackowiak RSJ, Hodges JR (2000) A voxel-based morphometry study of semantic dementia: relationship between temporal lobe atrophy and semantic memory. *Ann Neurol* 47:36–45

## Lhermitte's Symptom

### Definition

Lhermitte's symptom is an electrical sensation caused by neck flexion, which may radiate from the neck down

the spine and/or into the arms and legs indicating a myelopathy. This may occur from an multiple sclerosis (MS) lesion in the cervical spine though is not specific to MS and can occur from spondylosis or other disorders of the cervical spine.

- ▶ [Multiple Sclerosis](#)
- ▶ [Myelopathy](#)

## Libertarianism

### Definition

The conjunction of incompatibilism and the thesis that some people act freely.

- ▶ [Freedom of Will](#)

## Ligaments

CY FRANK

Department of Surgery, University of Calgary, Calgary, AB, Canada

### Definition

As defined in several excellent reviews on this topic [1–3], ligaments are anatomically discrete bands of dense connective tissue that attach bones across joints (Fig. 1).

### Characteristics

#### Gross Anatomy

Each joint has several ligaments that connect to specific locations to serve their individual mechanical roles in resisting tensile forces while keeping the joint surfaces appropriately juxtaposed. The ligaments of each joint work together to guide its ▶ [kinematic](#) movements during normal joint motion, and they resist abnormal displacements of those bones when abnormal forces act on the joint. The ligaments are thus said to be the “passive stabilizers” of each joint. An additional function of ligaments is their ability to serve a sensory and ▶ [proprioceptive/Proprioception](#) role through the presence of ▶ [mechanoreceptors](#). These sensory receptors respond to mechanical pressure or distortion, feeding back information to the central nervous system that

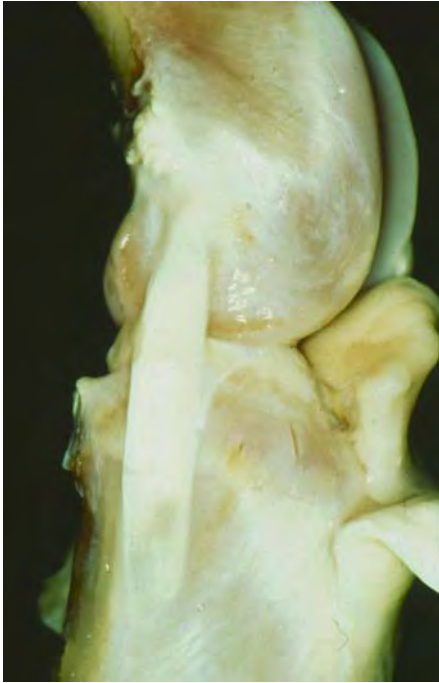

**Ligaments. Figure 1** Gross appearance of the New Zealand White rabbit medial collateral ligament.

relays information to the muscles, potentially affecting the resultant muscular function.

There is no standardized anatomic or biological nomenclature for ligaments. They are named according to a variety of descriptive characteristics: their relationships to a joint (e.g. collateral or “capsular”) or to each other (e.g. cruciate), by the bones that they connect (e.g. acromioclavicular), or by their gross anatomic shape (e.g. deltoid). There are several hundred ligaments in the body thus having a variety of names.

### Histology and Biochemistry

Microscopically, it can be seen that ligaments contain both blood vessels and nerves. They are supplied superficially by small penetrating arterioles that are more abundant at their surfaces and near their insertions into bone, but which do not penetrate bone. Their ▶**innervation** is a combination of ▶**nociceptive** and proprioceptive nerve endings, again more abundant near their insertions into bone but not penetrating the bone.

Histologically and immunohistochemically, ligament substance is known to be made up of relatively densely packed parallel fibred material (collagen fibers) with a few interspersed cells. These ligament fibroblasts, although relatively few in number compared to other connective tissues, are nevertheless metabolically active and participate in the turnover of ligament ▶**matrix** that occurs anywhere from months to years. For many

years, it was assumed that ligament fibroblasts existed in isolation of one another, but we now know that their long cytoplasmic projections communicate via gap junctions, and this allows ligament fibroblasts to maintain continuous contact with relatively few cells spread throughout a large volume of tissue [4]. The collagen fibers of the matrix are made up of many so-called collagen fibrils. The fibrils are, in turn, made up of helically organized collagen microfibrils, and those, in turn, of helical collagen molecules. These molecules are cross-linked to each other at the molecular level, making this substance very stiff and strong (the strongest tensile resisting protein in the body). At higher levels of organization, the helix has an unusual “crimped” appearance when viewed with polarized light indicating some sort of multi-micron “kinking” of these fibrils along their long axes. As discussed below, this crimp is thought to be a key feature in facilitating low load tensile displacements along the long axis of ligament collagen fibers.

Although six genetically distinct types of collagen have been isolated from ligament, the major types of collagen present in ligament subunits are mainly collagen type I and quantitatively minor amounts of collagen types III and V. The spaces in between these fibrils contain tiny bead like filaments of type VI collagen, which serve as cross connections between the larger type I fibrils, binding to their surfaces at particular locations occupied by small ▶**proteoglycan** molecules (e.g. decorin, lumican, fibromodulin and biglycan). A large proteoglycan, thought to be versican, is also present in normal ligaments. These proteoglycans contribute to water binding capability and likely help control water distribution within the matrix. Ligament matrix is about 65% water by weight, with the other 35% dry weight composed mainly of collagen (with small amounts of several subtypes of proteoglycans, elastin, fibronectin and several other glycoproteins).

Ligament substance is not homogeneous. The surface of ligaments is covered with a very thin epiligament layer that is more cellular, more metabolically active and more vascular than the underlying substance. Ligament insertions into bone are also heterogeneous and unique [5]. Direct ligament insertions consist of ligament substance transitioning into small zones of fibrocartilage and calcifying fibrocartilage leading into bone. Within the bone are so-called Sharpey’s fibers that are, in fact, ligament collagen fibers that are encased in bone mineral.

### Structural Properties

Ligaments behave as non-linear ▶**viscoelastic** materials that are ▶**anisotropic**. When loaded in tension along their longitudinal axis (their normal functional axis in vivo), they exhibit increasing stiffness with increasing displacement up to displacements that cause damage to



their matrix. At that point, yield of some fibers occurs prior to progressive, sudden catastrophic failure. As compared with other tissues in the body, ligaments are considered relatively stiff and relatively non-compliant, but due to their unique fibrillar architecture and internal organization, they allow some modest (millimeter) amounts of displacement at very low loads prior to this increasing stiffness.

### Material and Viscoelastic Properties

Ligaments are viscoelastic. Under low loads and slowly applied tensile loads, ligaments are dominated by their viscous behaviors, which allows them to load-relax (decrease their tensile load when held at a fixed length) and to creep (increase their length when pulled in tension under a constant load) a few percent of their overall length [6]. This results in some subtle “adjustments” of length and loads within each structure as joints are cyclically loaded or elongated during function. Ligaments are also somewhat strain-rate sensitive (being a few percent stronger and stiffer at higher rates of loading). Their loading behaviors are thus said to be “load-history dependent.”

At higher loads, ligaments become more elastically dominated, with higher stiffness and less viscous behavior. Their tensile strength is normally in the 80–100 MPa range. Under high load conditions, ligaments fail in tension either partially (a “sprain”) or completely, with fibril disruption and subsequent joint laxity. Not every sprain results in symptoms, as ►**neuromuscular** control systems and/or conscious decisions to avoid the stresses that would render the damaged joint “unstable,” may prevent it from being symptomatic [7].

### Ligament Healing

Ligaments heal with “scar tissue,” which is a unique connective tissue that forms in adults. The scar, which is generally larger than the original injured structure, is produced by a combination of fibroblasts, recruited macrophages and other inflammatory cells that produce a scar matrix, which starts very disorganized but remodels and matures over months to years (Fig. 2).

The collagen fibrils in the scar are remodeled, and “aligned” fibrils (aligned with the load axis of the structure) make up the main replacement tissue over many years. This can make a ligament scar almost as strong structurally as a normal ligament, but its material strength remains quite a bit weaker than normal (only reaching 30–50% of normal ligament material strength and stiffness even after months to years of healing). Some ligaments have particularly poor healing potentials – e.g. the anterior cruciate ligament in the knee. There is somewhat variable scar production, remodeling and



**Ligaments. Figure 2** Gross appearance of the healing New Zealand White rabbit medial collateral ligament (6 weeks post injury). Note the central portion with scar tissue is more translucent than the uninjured ligament in Fig. 1.

maturation under different loading and environmental conditions, making ligament healing variable between structures and between individuals.

Ligament scars are made up of many elements similar to normal ligaments but in different proportions. There is more Type III and V collagen and less Type I collagen in scars. There are also fewer collagen ►**cross-links** and abnormally large proteoglycans present in the scar. These alterations are implicated in the production of abnormally small collagen fibrils, which remain small for months to years during the healing and scar maturation process (Fig. 3).

Scars are generally more cellular than normal ligaments, and the elaborate cellular organization of normal ligaments with cell projections and ►**gap junctions** is altered. In some scars, it is replaced by areas devoid of cells and cytoplasmic projections, possibly leading to ineffective cellular communication. The small collagen fibrils, along with the abnormal collagen and proteoglycan types, abnormal collagen cross-linking, altered cellular communication and on-going presence of structural “flaws” in the scars (i.e. “holes” in the matrix: blood vessels, fat cells, inflammatory cells, loose or disorganized collagen) represent their “weak spots,” and explain why ligament scars are permanently inferior to

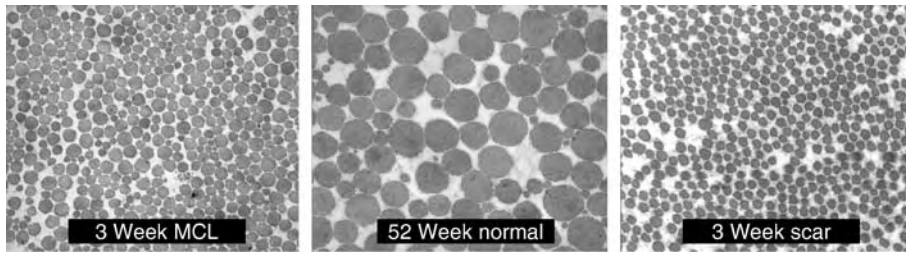

**Ligaments. Figure 3** Typical transverse transmission electron micrographs of collagen fibrils in developing 3 week, 52 week skeletally mature and healing (3 weeks post injury) New Zealand White rabbit medial collateral ligaments. Note the bimodal distribution of large and small diameter fibrils in the mature ligament as opposed to the small unimodal distribution in developing and healing ligaments.

normal ligaments [8–10]. These processes and their potential enhancement are currently receiving considerable research attention.

## References

- Shrive NG, Thornton GM, Hart DA, Frank CB (2002) Ligament mechanics: structural behaviour and material properties of normal and healing ligaments (Chapter 7). In: Padowitz RA, O'Connor JJ, Akeson WH (eds) Daniel's knee injuries: ligament and cartilage structure, function, injury and repair, 2nd edn. Lippincott Williams and Wilkins, Baltimore, USA, pp 97–112
- Frank CB, Shrive NG, Lo IKY, Hart DA (2007) Form and function of tendon and ligament. In: Buckwalter JA, Einhorn TA, Simon SR (eds) Orthopaedic basic science: biology and biomechanics of the musculoskeletal system. AAOS, Rosemont, Illinois, USA, pp 191–222
- Lo IKY, Thornton G, Miniaci A, Frank CB, Rattner JB, Bray RC (2003) Structure and function of diarthroidal joints. In: McGinty JB (ed) Operative arthroscopy, 3rd edn. Lippincott Williams and Wilkins, Philadelphia, PA, USA, pp 41–126
- Benjamin M, Ralphs JR (2000) The cell and developmental biology of tendons and ligaments. *Int Rev Cytol* 196:85–130
- Dienst M, Burks RT, Greis PE (2002) Anatomy and biomechanics of the anterior cruciate ligament. *Orthop Clin North Am* 33:605–620
- Thornton GM, Frank CB, Shrive NG (2002) Ligament creep recruits fibres at low stresses and can lead to modulus-reducing fibre damage at higher creep stresses: a study in a rabbit medial collateral ligament model. *J Orthop Res* 20:967–974
- Solomonow M (2004) Ligaments: a source of work-related musculoskeletal disorders. *J Electromyogr Kinesiol* 14:49–60
- Plaas AHK, Wong-Palms S, Koob T, Hernandez D, Marchuk L, Frank CB (2000) Proteoglycan metabolism during repair of the ruptured medial collateral ligament in skeletally mature rabbits. *Arch Biochem Biophys* 374:35–41
- Shrive NG, Chimich D, Marchuk L, Wilson J, Brant R, Frank C (1995) Soft tissue “flaws” are associated with the material properties of the healing rabbit medial collateral ligament. *J Orthop Res* 13:923–929
- Woo SL, Niyibizi C, Matyas J, Kavalkovich K, Weaver-Green C, Fox RJ (1997) Medial collateral knee ligament healing. Combined medial collateral and anterior cruciate ligament injuries studied in rabbits. *Acta Orthop Scand* 68:142–148

## Ligand

### Definition

A molecule that binds specifically to a receptor site.

## Ligand-gated Channels

### Definition

Ligand-gated channels bear extracellular ligand binding sites which allosterically modulate the opening or closing of the channel in response to the binding of neurotransmitter. Binding of ligand often occurs at the interface between subunits composing the receptor channels. Most ligand-gated channels bear multiple ligand binding sites and there is positive cooperativity of ligand binding for channel opening. Ligand-gated channels include the Cys-loop receptor channels [acetylcholine receptor (AChR),  $\gamma$ -amino-butyric acid (GABA), glycine receptor (GlyR), serotonin (5HT)] and metabotropic glutamate receptors [glutamate (Glu),  $\alpha$ -amino-3-hydroxy-5-methylisoxazole-4-propionic acid (AMPA), kainate (KA)] as well as those that respond to ATP ( $K_{ATP}$  channels),  $Ca^{2+}$  (BK channels) or cyclic nucleotides (cyclic nucleotide-gated (CNG) channels).

► BK Channels

► Cyclic Nucleotide-Regulated Cation Channels

## Ligand-gated Ion Channel

### Definition

- ▶ Ligand-gated Channels
- ▶ Ionotropic Receptor

## Light-Dark Cycle

### Definition

Alternation of a light (or photo) phase, and a dark (or scot) phase. Although denotations may differ, usually abbreviated as for instance LD 16:8, in case of a light phase of 16 h and a dark phase of 8 h.

- ▶ Circannual Rhythms

## Light Pulse

### Definition

Brief presentation of light used in circadian biology to test the effects of acute light exposure on the circadian clock, and on the rhythms it controls.

- ▶ Circadian Rhythm
- ▶ Clock

## Limb-girdle Muscular Dystrophy (LGMD)

### Definition

Group of muscular dystrophies characterized by different patterns of inheritance, age of disease onset and extent of limb weakness. While, as compared to ▶ [Duchenne and Becker muscular dystrophies](#), muscular dystrophin is normal, the genes giving rise to sarcoglycans are abnormal due to mutations of the related gene. Since sarcoglycans appear to be necessary for normal functioning of dystrophin, the clinical LGMD syndromes may look similar to Duchenne and Becker dystrophies.

- ▶ Becker Muscular Dystrophy
- ▶ Duchenne Muscular Dystrophy

## Limb Kinetic Apraxia

### Definition

One of the types of apraxia designated by Liepmann (1910), caused by damage to the central region, namely the precentral motor cortices or the postcentral sensory cortex. It is characterized by the clumsiness of the hand without accompanied by paralysis nor sensory loss.

- ▶ Somatosensory Cortex I

## Limbic

### Definition

A descriptor, extracted from the term limbic system, used in reference to aspects of neural circuitry and function that are otherwise not regarded as subject to proper mechanistic consideration. Thus, reward, motivation and emotional expression and the neural circuits thought to subservise them are frequently referred to as limbic functions and limbic connections, respectively.

- ▶ Limbic Lobe
- ▶ Limbic System

## Limbic Lobe

### Definition

A term suggested by Pierre Paul Broca in 1878 (le grand lobe limbique) to describe a collection of cortical and subcortical structures forming a ring at the medial border of the cerebral hemispheres of all mammals. Broca's term included prepyriform cortex (primary olfactory cortex), diagonal band, medial prefrontal cortical areas, the cingulate gyrus, retrosplenial gyrus, the hippocampus, and parahippocampal gyrus (including the subiculum). Based on changes in emotional behavior correlated with brain pathology, Papez (1937) subsequently included the limbic lobe (particularly hippocampus and cingulate gyrus) in his cortical theory of emotions while adding anterior thalamic and hypothalamic nuclei as areas providing afferents directly or indirectly to the cingulate cortex. MacLean (1949) subsequently expanded on Papez's theory, including the amygdala within the system serving the sensory and expressive (motor) aspects of emotion.

MacLean later suggested the term “limbic system” as a term with neutral connotations for the structures within his expanded Papez’s circuit. The limbic system and its core cortical structures have since remained a focus of research on the neural basis of emotional experience, and in pathology is thought to be etiological in the most severe mental illnesses which afflict mankind. Over the years since Broca’s initial description, the Definition of the limbic lobe has been often modified.

Most recently, Heimer and van Hoesen (2006) have reviewed the history of the limbic lobe and suggested modifications limiting this designation to cortical structures and eliminating areas such as the diagonal band and olfactory tubercle. The latter arguably are better analyzed as part of largely parallel subcortical relays in the hippocampal-septal system, and ventral striatopallidal systems, respectively. In addition, Heimer and van Hoesen suggest that only the lateralbasolateral part of the amygdala be retained within the limbic lobe since this is cortical in nature and that the subcortical centromedial amygdala should not be included. They also urge the inclusion of bordering transitional areas such as the insular, temporal pole and perirhinal cortices. This modern view of the limbic lobe would thus not represent a closed circuit as has sometimes been envisioned for the interconnections characterizing the limbic lobe, but as interacting points of entry into cortical-subcortical circuits that both process extrinsic and intrinsic sensory information relevant to evoking emotions, and provide efferents modulating adaptive autonomic and somatic emotional expression via the emotional motor systems in the basal forebrain, hypothalamus and brainstem.

#### ► Extended Amygdala

## Limbic System

DANIEL S. ZAHM<sup>1</sup>, LENNART HEIMER<sup>2</sup>

<sup>1</sup>Department of Pharmacological and Physiological Science, Saint Louis University School of Medicine, MO, USA

<sup>2</sup>Departments of Neurological Surgery and Neuroscience, University of Virginia School of Medicine, Charlottesville, VA, USA

The limbic system constitutes an indeterminate number of extensively interconnected brain structures located near the core of the brain and is said to be responsible

for the genesis of ►emotions and emotional responses. The importance of emotional functions to the social fabric of animal societies and human cultures and to the mental health of individuals has fueled a near insatiable interest in the limbic system. Indeed, the limbic system is invoked at every educational level worldwide to explain the full spectrum of emotional behaviors, from the fearful to the affiliative, and the concept is securely embedded in the scientific and popular literature. However, what components comprise a limbic system and how they interact as a system to produce emotional functions have yet to be determined; i.e., a generally accepted theoretical framework addressing limbic system structure and function remains to be described. This lack of rigor in the conceptualization of the limbic system has caused opponents of the concept to advocate that it be abandoned [1,2]. In contrast, proponents argue that the limbic system, despite its limitations, has proven to be a durable and valuable conceptual framework that has survived over the course of many years and should be retained until suitably replaced [3]. Rudolf Nieuwenhuys, a prominent scholar of brain organization and proponent of the limbic system concept, has captured the gist of the discourse on the limbic system, commenting that “...the validity of the term and the concept behind it has been endlessly debated in the literature” [4].

Consistent with persistent conceptual snags that make it difficult to define the limbic system, the intellectual underpinnings of the concept have evolved in fits and starts over a period of nearly 130 years. The most frequently cited antecedent to the limbic system is “le grande lobe limbique,” the great ►limbic lobe, which ►Paul Pierre Broca described on the basis of extensive comparative anatomical observations [5]. Broca, like ►Thomas Willis [6] and a few others (see [7,8]), noticed that the callosal gyrus (►cingulate gyrus) and hippocampal gyrus (►parahippocampal gyrus) form a border (limbus) or circular cortical field around the corpus callosum and ►thalamus. Primary olfactory input appears to enter the parahippocampal gyrus and, to a lesser extent, the cingulate gyrus, begging the impression that olfaction must dominate the limbic lobe. Broca associated these olfactory influences with emotional coloration reflecting the “brute within” and thus thought his great lobe should be involved with the drives and emotions that underlie behavior.

In 1937, ►James Papez [9], although not directly referring to Broca, extended Broca’s seminal conceptualization by drawing attention to a series of neural connections forming a circuit (the ►Papez circuit) in part involving Broca’s great limbic lobe. Papez proposed that the cingulate gyrus projects via the cingulum to the parahippocampal gyrus, including the ►entorhinal area, which densely innervates the hippocampus (see ►hippocampal formation), which in turn projects massively via the ►fornix to the

► **hypothalamus**, including the ► **mammillary body**, associated with emotional expression. The mammillary body projects by way of the ► **mammillothalamic tract** to the anterior thalamic nucleus (see **thalamus**), which in turn innervates the cingulate gyrus, which would be important for emotional experience. Papez de-emphasized the olfactory influences on these structures and proposed that the relationships described above “constitute an harmonious mechanism which may elaborate the functions of central emotion as well as participate in emotional processes.” Approximately coinciding with the emergence of Papez’s functional-neuroanatomical construct, Klüver and Bucy [10,11] reported that bilateral lesions of the medial temporal lobe in monkeys, involving predominantly the ► **amygdala**, produce strikingly reduced fear and anger responses in combination with hyperorality and hypersexuality. These seminal findings were thought to confirm Papez’s theory, at least in part, but also expanded appreciation of the role of the medial temporal lobe in emotional functions.

► **Paul MacLean** [12,13] expanded on the ideas of Broca and Papez. He argued, for example, that the hippocampus receives multisensory information via the ► **association cortex** and brainstem, noting that stimulation of the ► **vagus nerve** elicits robust hippocampal responses. Furthermore, the “► **Klüver-Bucy syndrome**” suggested that the amygdala is intimately associated with emotional behavior. MacLean went on to suggest that the amygdala, hippocampus and a number of other subcortical structures (e.g., the ► **septal area**, anterior thalamic nucleus and ► **habenula**) with relations to Broca’s limbic lobe contribute to a system dedicated to emotional behavior. In attempting to provide a name for this system, MacLean first suggested “visceral brain” [12], using the term in the sense of strong, inward feeling, but he was soon confronted with complaints from physiologists, who define the term “visceral” more literally. MacLean subsequently reverted to Broca’s original term, “limbic” [13], thinking that this term might be used in a more mechanistic and neutral, rather than connotative, sense. Ironically, this intent has been so perverted by subsequent developments that “limbic” currently seems to connote all things neural having anything to do with emotion.

With these modifications, the “limbic system” was soon subjected to additional liberal bouts of conceptual retooling. ► **Walle Nauta** conceived of a “limbic-midbrain axis” (see ► **limbic midbrain area of Nauta**) involving additional ► **basal forebrain**, mesencephalic (in the rostral brainstem) and rhombencephalic (in the caudal brainstem) “limbic” structures, such as the ► **preoptic region**, ► **periaqueductal gray** and dorsal raphe nucleus (see ► **serotonergic system**), which he showed to be intimately related by connections to each other and other “limbic” structures [14,15]. Also, with a

view to its connections with the preoptic region, lateral hypothalamus and dopaminergic ► **ventral tegmental area** (see ► **dopaminergic system**), Nauta advocated for a “limbic” characterization of the ► **nucleus accumbens**, which Mogenson subsequently popularized as the “limbic-motor interface” [16]. Kelley et al. [17] noted that afferents from the amygdala, hippocampus, ► **prefrontal cortex**, ventral tegmental area and raphe nucleus converge not only in the accumbens, but also in medial and ventrolateral parts of the caudate-putamen (see ► **basal ganglia**; ► **striatopallidum**), giving rise to further extensions of the limbic system into a so-called “limbic” striatum and the (midline-intralaminar) thalamic (see **thalamus**) and (medial prefrontal and rhinal sulcal) cortical (see **prefrontal cortex**) areas that innervate it.

Nieuwenhuys’s thorough review [4] of the limbic system concept culminated with a description of modern neuroanatomical, neurochemical and functional features, on the basis of which he defines the “limbic” system. Among these features, he included: (i) numerous discrete sites which, upon stimulation, elicit integrated behavioral and/or autonomic responses; (ii) many thin, varicose unmyelinated axons interconnecting with other limbic structures; (iii) presence of ► **tancycyte-like** neurons or ► **circumventricular organ-like** structures mediating analysis of cerebrospinal fluid and/or blood composition and conduction of the information into the local neuropil; (iv) presence of foci containing steroid-containing neurons; and (v) presence of an extraordinary diversity of classical and, particularly, neuropeptidergic neurotransmitter/modulators (see ► **neuropeptide**; ► **synapse**). As it turns out, these chemical-neuroanatomical features correspond precisely to those used earlier by Nieuwenhuys and colleagues in a description of the “core of the neuraxis,” a construct aligned along or projecting into the main, predominantly unmyelinated, fiber tracts of the forebrain and brainstem, e.g., the periventricular, medial forebrain and dorsal longitudinal bundles [18]. Use of the same criteria to define the core of the neuraxis and the limbic system had the primary effect of expanding the limbic system further into the caudal brainstem, bringing into the “limbic” fold such structures as the pedunclopontine and laterodorsal tegmental nuclei (see ► **mesopontine tegmentum**), ► **parabrachial nucleus**, ► **nucleus of the solitary tract** and ► **dorsal vagal complex**. In contrast to the expansion of the limbic system advocated by Nauta and Mogenson, however, Nieuwenhuys excludes the limbic striatum and associated cortical and thalamic structures from his conceptualization of the limbic system, which he refers to as the “greater limbic system.” It is interesting to note that nothing of Broca’s limbic lobe is included in Nieuwenhuys’s definition of the limbic system.

A strength of Nieuwenhuys’s model of limbic system is that it defines “limbic” in terms of the general neurochemical-cytoarchitectural composition of the

included neural tissue, thus implying the kinds of neural mechanisms that might underlie “limbic” function. His limbic core is replete with diverse networks of largely unmyelinated neuropeptidergic and, to a lesser extent, neurosteroidergic fibers engaged in perhaps near equivalent amounts of synaptic, parasympaptic and paracrine neurotransmission and neuromodulation (see synapse). Neuropeptide transmitter/modulators bind largely to G protein-coupled receptors (see ▶synapse) that give rise to synaptic potentials and intracellular signaling cascades of slow onset and long duration. Furthermore, numerous and diverse physiological stimuli are known to alter the genomic expression of forebrain and brainstem neuropeptides. Thus, the prominent neuronal response in Nieuwenhuys’s multi-peptidergic corridor develops gradually, lasts relatively long and involves genomic regulation of neuromodulator levels, a combination of processes that fits with the gradual transitions that typically separate different emotional responses and states.

Despite its strengths, the “greater limbic system” of Nieuwenhuys is nonetheless subject to perhaps the most venerable criticism of limbic system hypotheses in that it lacks consideration as to how the cognate components of the system interact to carry out designated functions. This oft-mentioned deficiency of limbic system theories has led Joe LeDoux and like-minded neuroscientists, such as Thomas Insel and Antonio Damasio, into a more reductionistic approach aimed at identifying the neural circuitry and mechanisms committed to the execution of discrete emotions, such as fear [19], affiliative behaviors [20] or perceived emotional feelings [21]. The success of this approach is evident in the broad variety of published studies describing quite specific interventions involving, e.g., lesions, drug infusions, or gene deletions that target specific, typically “limbic,” circuitry to modulate particular emotional behaviors. These kinds of experiments support a hypothesis that integrated emotional responses require the interactions of functionally specified subcircuits acting primarily, but not exclusively, within neural territories that are, or have been, regarded as part of the limbic system.

In order to facilitate the development of a more comprehensive mechanistic understanding of the genesis of emotions and their impact on behavior, neuroscientists were also concerned with the relationships of so-called “limbic” subcircuits with the rest of the brain. In this regard, and, from an unanticipated direction, a conceptual breakthrough occurred when it was shown in experimental neuroanatomical studies that the olfactory tubercle, despite its laminar morphology, is not a cortex [22,23], as previously portrayed in the neuroanatomical literature. The massive projection of the piriform (olfactory) cortex to the superficial layers of the tubercle is unaccompanied by a reciprocal projection from the tubercle back to the cortex (required if the tubercle is cortex). Rather, neurons in the superficial layer of the

tubercle that receive robust cortical input project massively into the overlying subcommissural region where their axon terminations form a dense feltwork of inputs to aspiny neurons identical to those in the overlying globus pallidus (see basal ganglia; ▶striatopallidum). This was the beginning of the idea of a ventral striatopallidal system (see ▶striatopallidum; ▶ventral). This connectivity and the medium sized, densely spiny morphology of superficial tubercle neurons argue that the tubercle is a striatal structure projecting to a pallidal target, which turns out to be a rostroventral extension of the globus pallidus and, accordingly, was called ventral pallidum (see ▶striatopallidum; ▶ventral). The nucleus accumbens, which Nauta and colleagues had designated as a limbic system structure due to massive input from the hippocampal ▶subiculum and basolateral amygdala, was also shown to comprise largely medium spiny neurons and project to the ventral pallidum.

The upshot of these findings is that the entire cortical mantle is subserved by basal ganglia-like mechanisms, which now could be extended to involve so-called “limbic” structures. It is generally agreed that basal ganglia functions are critical to any kind of adaptive behavior, although precisely what a basal ganglia-like mechanism is remains elusive, even to this day. Nonetheless, these observations served notice that “limbic” mechanisms are unlikely to be fundamentally different from other neural mechanisms in the forebrain, and they dispelled the misconception of a limbic system-basal ganglia dichotomy, as reflected in expressions like “limbic versus basal ganglia” or “limbic versus extrapyramidal,” which pervades twentieth century neuroscience literature. Subsequent tract-tracing studies showed that ventral pallidum projects to the mediodorsal thalamus rather than the ventral anterior/ventral lateral “motor” nuclei of the thalamus [24]. Since the mediodorsal thalamus is related to the prefrontal cortex rather than the motor and supplementary motor cortex, this discovery provided the first indication of segregated ▶cortico-subcortical reentrant circuits through the basal ganglia to motor cortex and prefrontal cortex, respectively. The further elaboration of the notion of parallel cortico-subcortical reentrant circuits through the basal ganglia and thalamus [25] has been widely acclaimed, and the concept of parallel cortico-subcortical reentrant circuits through the ventral striatopallidal system has all but replaced the limbic system as a strategic approach to the study of neuropsychiatric disorders [26].

It was subsequently determined on the basis of strong evidence that will not be discussed in detail here (instead see [27,28], that the central nucleus of the amygdala (see amygdala; ▶extended amygdala), bed nucleus of stria terminalis (see extended amygdala) and septum, all structures regarded as “limbic” by MacLean

and others that followed him, also exhibit neuroanatomical relationships consistent with designation as modified striatopallidum. Lateral septum (see septal area) gets cortical inputs predominantly from hippocampus supplemented by fewer from the prefrontal cortex and the cortical-like basolateral amygdala. The central amygdala-bed nucleus of stria terminalis complex, the so-called extended amygdala [29], receives its most prominent input from the basolateral amygdala and a lesser complement from the prefrontal cortex and hippocampus. In contrast, the nucleus accumbens receives more or less equivalently strong inputs from the prefrontal cortex, basolateral amygdala and hippocampus. Outputs from each of these structures descend in robust, fairly separate, albeit overlapping, trajectories through the forebrain and brainstem largely within the confines of Nieuwenhuys's greater limbic system, with some reaching all the way to its caudal pole. These pathways converge at various sites in the basal forebrain and brainstem, suggesting that outputs of the striatopallidal-like "►functional-anatomical systems" compete and cooperate [30] to influence motor function, via modulation of the activity of brainstem somatomotor (see ►motor system) and visceromotor (see ►autonomic nervous system) effectors and, via modulation of direct and trans-thalamic reentrant pathways, cognitive function in the frontal cortex [31]. The potential impact of these segregated, occasionally convergent descending systems on brainstem and spinal motor effectors and ascending cortical neuromodulatory projections (see ►ascending neuromodulatory projection systems) converges conceptually with functional implications proposed by Holstege [32,33] in his description of the "►emotional motor system."

Alheid and Heimer [27] and, more recently, Heimer and van Hoesen [34] have emphasized that the massive cortical inputs to the major forebrain striatopallidal-like functional-anatomical systems, including ventral striatopallidum, extended amygdala, and septal-preoptic system, originate largely in Broca's great limbic lobe, which, however, they define slightly differently than did Broca. First, their expanded conceptualization includes the hippocampus, a bona fide cortical structure, which, as discussed above, has been more or less uniformly included in the limbic system since the time of Papez and MacLean. Second, Heimer and van Hoesen include the cortical-like amygdaloid basolateral complex and cortical amygdaloid nucleus in the concept of the limbic lobe. This is based on connectivity and neurochemistry/cytoarchitecture, in accord with numerous earlier neuroanatomical analyses. Thus, the laterobasal-cortical amygdala receives and reciprocates cortical association connections and the neuronal morphology and transmitter/modulators of its principal and interneuronal cell types faithfully emulate those of cortex. From a conceptual point of

view, Heimer and Van Hoesen's [34] modifications, formalized as the "greater limbic lobe," serve to reinvigorate Broca's original and functionally relevant anatomical concept of a ring-like, cortically based limbic lobe, which, over the course of many years, had been subjected to gradual, inexorable de-emphasis in favor of the limbic "system." In other words, with this expanded version of Broca's limbic lobe, the term "limbic" regains its literal meaning.

Outputs from the greater limbic lobe terminate profusely and almost entirely within structures that form the head ganglia of the "greater limbic system" of Nieuwenhuys [4] and outputs from those structures descend through the forebrain and brainstem to innervate structures almost entirely within that construct. In contrast to earlier iterations of the limbic system, however, considerable knowledge has been acquired regarding the specificity of these pathways with regard to their trajectories and many of the structures they innervate. This knowledge, however, is embryonic and much remains to be discovered. How are the descending pathways related anatomically and functionally to somatomotor and visceromotor centers and to direct and trans-thalamic reentrant pathways? How do the descending influences integrate with ascending sensory influences conveyed by the vagus nerve and collaterals of spinothalamic projections (see ►anterolateral sensory system)? How does interoceptive information arising in the circumventricular organs and preoptic nucleus and conveyed via the hypothalamus integrate within the system? How does Nieuwenhuys's greater limbic system inter-relate with other functional-anatomical constructs occupying the brainstem and forebrain, such as the ►reticular formation, its ►ascending reticular activating system and the HPA (hypothalamic-pituitary-adrenal), i.e., stress, axis (see ►stress response)? To summarize, current knowledge and discoveries anticipated to occur in the foreseeable future seem consistent with the continuing development of more mechanistic, systems-oriented approaches to the problems of understanding the neural substrates of emotions. Indeed, the time may soon arrive when it will be generally agreed upon that reliance on a "limbic system" has outlived its usefulness. Until then, terms like "limbic system structures" and "limbic activation" will continue to inhabit the neurophysiological, behavioral and neuropsychiatric lexicons, as will the ambiguities and questions attached to them.

*In Memoriam* – Lennart Heimer passed away March 12, 2007.

## References

1. Brodal A (1981) Neurological anatomy in relation to clinical medicine, Oxford University Press, New York

2. LeDoux JE (1991) Emotion and the brain. *J NIH Res* 3:48–51
3. Cory GA Jr, Gardner R Jr (2002) The evolutionary neuroethology of Paul MacLean: convergences and frontiers. Praeger, Westport CT
4. Nieuwenhuys R (1996) The greater limbic system, the emotional motor system and the brain. *Prog Brain Res* 107:551–580
5. Broca P (1878) Anatomie comparée des circonvolutions cérébrales. Le grand lobe limbique et la cissure limbique dans la série des mammifères. *Rev Anthropol* 1:385–498
6. Willis T (1664) *Cerebri anatomie: cui accessit nervorum descriptio et usus*. J. Flesher, London
7. Finger S (1994) *Origins of neuroscience: a history of explorations into brain function*. Oxford University Press, New York
8. Schiller F (1979) Paul Broca: founder of French anthropology, explorer of the brain. University of California Press, Berkeley
9. Papez J (1937) A proposed mechanism of emotion. *Arch Neurol and Psychiat* 38:725–743
10. Klüver H, Bucy PC (1937) “Psychic blindness” and other symptoms following bilateral temporal lobectomy in rhesus monkeys. *Am J Physiol* 119:352–353
11. Klüver H, Bucy PC (1938) An analysis of certain effects of bilateral temporal lobectomy in the rhesus monkey, with special reference to psychic blindness. *Arch Neurol Psychiat* 42:979–1000
12. MacLean PD (1949) Psychosomatic disease and the “visceral brain.” Recent developments bearing on the Papez theory of emotion. *Psychosom Med* 11:338–353
13. MacLean PD (1952) Some psychiatric implications of physiological studies on fronto-temporal portions of the limbic system (visceral brain). *Electroencephalog Clin Neurophysiol* 4:407–418
14. Nauta WJH (1958) Hippocampal projections and related neural pathways to the midbrain in the cat. *Brain* 81:319–340
15. Nauta WJH (1973) Connections of the frontal lobe with the limbic system. In: Laitinen LV, Livingston KE (eds) *Surgical approaches in psychiatry*. Medical and Technical Publishing, Lancaster, pp 303–314
16. Mogenson GJ, Jones DL, Yim YL (1980) From motivation to action: functional interface between the limbic system and the motor system. *Prog Neurobiol* 14:69–97
17. Kelley AE, Domesick VB, Nauta WJH (1982) The amygdalo-striatal projection in the rat – an anatomical study by anterograde and retrograde tracing methods. *Neuroscience* 7:615–630
18. Nieuwenhuys R, Veening JG, Van Domburg P (1989) Core and paracores: some new chemoarchitectural entities in the mammalian neuraxis. *Acta Morphol Neerl–Scand* 26:131–163
19. LeDoux JE, Iwata J, Cicchetti P, Reis DJ (1988) Different projections of the central amygdaloid nucleus mediate autonomic and behavioral correlates of conditioned fear. *J Neurosci* 8:2517–2529
20. Pitkow LJ, Sharer CA, Ren X, Insel TR, Terwilliger EF, Young LJ (2001) Facilitation of affiliation and pair-bond formation by vasopressin receptor gene transfer into the ventral forebrain of a monogamous vole. *J Neurosci* 21:7392–7396
21. Damasio AR, Grabowski TJ, Bechara A, Damasio H, Ponto LL, Parvizi J, Hichwa RD (2000) Subcortical and cortical brain activity during the feeling of self-generated emotions. *Nat Neurosci* 3:1049–1056
22. Heimer L (1972) The olfactory connections of the diencephalon in the rat. An experimental light- and electron-microscopic study with special emphasis on the problem of terminal degeneration. *Brain Behav Evol* 6:484–523
23. Heimer L, Wilson RD (1975) The subcortical projections of allocortex: Similarities in the neural associations of the hippocampus, the piriform cortex and the neocortex. In: Santini M (ed) *Golgi Centennial Symposium Proceedings*. Raven, New York, pp 173–193
24. Young WS, Alheid GF, Heimer L (1984) The ventral pallidal projections to the mediodorsal thalamus: a study with fluorescent retrograde tracers and immunohisto-fluorescence. *J Neurosci* 1626–1638
25. Alexander GE, DeLong MR, Strick PL (1986) Parallel organization of functionally segregated circuits linking basal ganglia and cortex. *Annu Rev Neurosci* 9:357–381
26. Lichten DG, Cummings JL (2001) *Frontal-subcortical circuits in Psychiatric and Neurological Disorders*. Guilford, New York
27. Alheid GF, Heimer L (1988) New perspectives in basal forebrain organization of special relevance for neuropsychiatric disorders: the striatopallidal, amygdaloid and corticopetal components of substantia innominata. *Neuroscience* 27:1–39
28. Swanson LW (2000) Cerebral hemisphere regulation of motivated behavior. *Brain Res* 886:113–164
29. de Olmos JS, Heimer L (1999) The concepts of the ventral striatopallidal system and extended amygdala. *Ann NY Acad Sci* 877:1–32
30. Zahm DS (2006) The evolving theory of basal fore-brain “functional-anatomical macrosystems.” *Neurosci Biobehav Rev* 30:148–172
31. Alheid GF, Heimer L (1996) Theories of basal forebrain organization and the “emotional motor system.” In: Holstege G, Bandler R, Saper CB (eds) *The emotional motor system*. *Prog Brain Res* 107:461–484
32. Holstege G (1989) Descending motor pathways and the spinal motor system: Limbic and non-limbic components. *Prog Brain Res* 87:307–421
33. Holstege G (1992) The emotional motor system. *Eur J Morphol* 30:67–79
34. Heimer L, Van Hoesen GW (2006) The limbic lobe and its output channels: implications for emotional functions and adaptive behavior. *Neurosci Biobehav Rev* 30:126–147

## Limbic–Motor Interface

### Definition

A hypothetical construct, where limbic information was thought to be able to gain control of the mechanisms of motor control – an interface between “desire” and



action. The nucleus accumbens was once thought of as fulfilling this role, but it is more likely that this concept is better understood in a more distributed manner. For a brief discussion, see Winn P, Brown VJ, Inglis WL (1997) On the relationship between the striatum and the pedunculopontine nuclei. *Crit Rev Neurobiol* 11:241–261.

► Mesopontine Tegmentum

---

## Limits to Entrainment

### Definition

A range of periods (cycle duration) of a time cue (zeitgeber) that can entrain a self-sustaining oscillator.

► Zeitgeber

---

## Linear Damper

### Definition

A rheological element whereby the force is proportional to the speed. Also called a linear dashpot.

► Mechanics

---

## Linear Momentum

### Definition

In classical (particle) mechanics, the linear momentum is the vector obtained as the product of the mass of the particle times its velocity. In continuum mechanics, the linear momentum density at a point in space is obtained as the product of the mass density at that point multiplied by its velocity vector. The total linear momentum of the body is then obtained as the integral over the body of the linear momentum density.

► Mechanics

---

## Linear Spring

### Definition

A rheological element whereby the force is proportional to the elongation.

► Mechanics

---

## Linear Summation Hypothesis

### Definition

Shifting gaze toward a target involves the combined activation of both the saccadic system and the cephalic motor system. Thus, the eyes are potentially submitted to two simultaneous but opposite commands: a saccadic drive to shift gaze toward the target and a vestibuloocular reflex (VOR) slow phase drive elicited by the concurrent head rotation. The linear additivity hypothesis postulates that these two antagonistic ocular commands linearly add during the whole duration of gaze shift such that any physical contribution of the head to the gaze shift is in effect cancelled by the VOR. Thus, in this scheme, there is no need for the saccadic system to take the head movement into account to program and execute an accurate gaze shift. In contrast, the non additivity hypothesis, which is now largely accepted, states that the VOR is momentarily inhibited during the gaze shift, and therefore that a VOR-independent mechanism must take the head contribution into account to ensure gaze shift accuracy.

- Gaze Shift
- Saccade, Saccadic Eye Movement
- Vestibuloocular Reflexes (VOR)

---

## Linear System

### Definition

A system is linear if the output generated when a weighted sum of two input variables is equal to the weighted sum of the outputs generated when each variable is passed separately through the system.

► Signals and Systems

## Linearization

### Definition

The process of simplifying a non-linear system so that it can be described using linear equations. Linearization can be performed using several techniques, the most common of which is the Taylor series expansion.

► Signals and Systems

## LIP

► Lateral Intraparietal Area

## Lipid Raft

### Definition

A microdomain of the plasma membrane enriched in sphingolipids and cholesterol. Certain signaling proteins are enriched in these domains.

## Lipopolysaccharide (LPS)

### Definition

Lipopolysaccharide (LPS) is a component of the cell wall of gram-negative bacteria. It has been used experimentally to stimulate production of endogenous IL-1 and other cytokines,  $\beta$ -APP and complement proteins.

► Cytokines  
► Neuroinflammation – LPS-Induced Acute Neuroinflammation

## Liprin- $\alpha$

### Definition

An active zone-enriched scaffolding proteins that participates in functional multi-protein complexes,

including direct or indirect interactions with CASK, ELKS, RIMs, and KIF1A (a motor protein), among others.

► Synaptic Proteins and Regulated Exocytosis

## Lissauer's Tract

### Definition

Fiber tract in the dorsolateral quadrant of the spinal cord that contains the central projecting axons of unmyelinated and thinly myelinated sensory fibers.

► Nociceptors: Adequate Stimulus

## Listing's Law

### Definition

Listing's law applies to voluntary, not reflex eye movements, and specifies that at each gaze direction, the eye is positioned as though that gaze direction had been reached from a specific primary gaze position by a single rotation around an axis in a head-fixed plane orthogonal to this primary position. This plane of axes is called Listing's plane. With Listing's law, primary gaze determines 3D eye position for all gaze directions.

► Oculomotor Control  
► Vestibulo-Oculomotor Connections

## LLR

► Long Loop Reflexes

## Load Compensation

### Definition

Change in active force in response to a change in loading of a body segment or muscle.

► Feedback Control of Movement

---

## Loadstone, lodestone

► Magnetite

---

## Lobectomy

### Definition

Removal of a particular lobe of the brain, i.e. frontal lobectomy, temporal lobectomy. This surgical procedure is done to remove the diseased part of the brain harboring a tumor or an epileptic focus. It can also be performed if a certain lobe was damaged by trauma or stroke.

---

## Lobster

### Definition

Animal of the class Crustacea; a model system for studying small neural networks (see also gastric mill).

---

## Local Autonomic Ganglia

### Definition

For many autonomically innervated organs, ganglia lie very close to the organs that they supply. These are local ganglia, and include ganglia close to the salivary glands, ganglia close to the airways, the cardiac ganglia, ganglia adjacent to the urinary bladder and uterus, and ganglia behind the globe of the eye (ciliary ganglia).

► Autonomic Ganglia

---

## Local Cues

### Definition

The cues in the immediate vicinity of an animal, such as textures and odors on the floor or an object adjacent to

the animal. Distinct from “distal cues”, one typically moves amongst and around local cues.

► Spatial Learning/Memory

---

## Local Feedback

### Definition

A proposed mechanism that monitors the output of the saccadic burst generator and shuts down the burst when an internally maintained estimate of the position of the eyes reaches an internally maintained estimate of the position of the intended saccade target.

► Brainstem Burst Generator  
► Saccade, Saccadic Eye Movement

---

## Local Field Potential

### Definition

The local field potential is an electrophysiological signal recorded with an extracellular microelectrode. The overall recorded potential is the summation of electrical changes produced by synaptic activity of all the neurons present around the tip of the electrode. It reflects the global activity of a large neuronal population.

► Extracellular Recording

---

## Local Global Interaction

► Contextual Influences in Visual Processing

---

## Local Image Motion

### Definition

Motion of a visual object relative to the background.

## Local Immune Response

### Definition

Supportive reaction by the immune system, induced and expressed at the site of an acute or chronic lesion. Its components include microglia, blood-borne monocytes (innate immune cells), and T and B cells (adaptive immune cells).

▶ Autologous Macrophages for Central Nervous System Repair

## Local Navigation

### Definition

Map-based navigation. Typically contrasted with “taxon” or route-based navigation.

▶ Spatial Learning/Memory

## Local Protein Synthesis

▶ mRNA Targeting: Growth Cone Guidance

## Local Translation

▶ mRNA Targeting: Growth Cone Guidance

## Locked-in Syndrome

### Definition

Locked-in syndrome denotes a state, in which the patient is ▶quadriplegic, incapable of facial movements and speech, but conscious and able to communicate by

eye and eyelid movements. The syndrome results from bilateral lesions of the ventral ▶pons, most often due to occlusion of the basilar artery, which leads to damage to the ▶corticobulbar tracts and ▶corticospinal tracts.

▶ Corticospinal Tract  
▶ Quadriplegia

## Locomotion

### Definition

Motor behavior allowing an animal to move from one point to another. This motor behavior requires the activation of several hundreds of muscles in vertebrates.

## Locomotor Areas

▶ Locomotor Regions in the Midbrain (MLR) and Diencephalon (DLR)

## Locomotor Centers

▶ Locomotor Regions in the Midbrain (MLR) and Diencephalon (DLR)

## Locomotor Reflexes

### KEIR PEARSON

Department of Physiology, University of Alberta, Edmonton, AB, Canada

### Synonyms

Afferent regulation of locomotion; Sensory control of locomotion

### Definition

Locomotor ▶reflexes are involuntary modifications of locomotor movements produced by sensory signals from receptors in the limbs and body.

## Characteristics

Animals have the capacity to move with ease in a variable environment. This ability depends on using information from sensory receptors for three purposes: (i) to plan appropriate movements, (ii) to control ongoing **▶motor commands** according to the mechanical state of the body, and (iii) to respond quickly to unexpected changes in the environment. The rapid, automatic modifications of motor commands in response to changes in the state of the body and to features in the environment are known as *locomotor reflexes*. Over the past 20 years an enormous amount has been discovered about the organization and function of locomotor reflexes in a wide variety of animals, ranging from insects to humans. This has allowed the identification of some common features of locomotor reflexes [1].

## Locomotor Reflexes Originating from Muscle Proprioceptors

The muscles of the limbs and body of mammals are richly supplied with sensory receptors that detect mechanical events in the muscles, such as muscle length, the rate of lengthening and shortening of the muscle (velocity), and muscle force. Signals arising from these receptors, known as *muscle ▶proprioceptors*, strongly influence the motor commands for walking. The two primary functions of muscle proprioceptors during walking are (i) to control the timing of the phase transitions from stance to swing and from swing to stance, and (ii) to regulate the ongoing activity in muscles during a single phase.

Two **▶reflex** pathways are known to have a role in controlling the stance-to-swing transition. The first is an inhibitory pathway from the force-sensitive afferents, **▶Golgi tendon organs**, in ankle extensor muscles onto the system generating bursts of activity in flexor **▶motoneurons** producing the swing phase, and the second is a pathway from length-sensitive afferents, **▶muscle spindles**, in flexor muscles acting at the hip onto the same flexor burst generating system [2]. These pathways are appropriate for controlling the stance-to-swing transition because the excitatory signal from the muscles spindles increases and the inhibitory signal from the Golgi tendon organs decreases during the latter half of stance, thus acting synergistically to promote the initiation of burst activity in flexor motoneurons, i.e. the initiation of the swing phase. Similar pathways are considered to play a role in controlling the stance-to-swing transition in walking humans, because leg unloading and hip extension have been shown to promote the stance-to-swing transition in walking human infants. The other major phase transition, the transition from swing to stance, may also be regulated by feedback from muscle proprioceptors. Imposed flexion of the hip in decerebrate walking cats initiates the swing-to-stance transition

and the hip angle at which this transition occurs remains relatively constant when normal animals are walking in a variety of conditions.

The second major function of muscle proprioceptors during locomotion is to regulate the magnitude of motor commands to muscles. At all times during the locomotor cycle there is an enormous amount of sensory feedback from muscle proprioceptors, and some of this feedback is used to establish an appropriate level of activity in the motoneurons according to the mechanical demands. The most detailed analysis of this phenomenon is positive force feedback (**▶Positive feedback**) from the Golgi tendon organs in ankle extensor muscles onto the motoneurons innervating these muscles in walking cats and humans [3]. The positive force feedback increases the stiffness of the muscles and provides a mechanism for automatically increasing and decreasing the magnitude of muscle contractions when cat walk up and down slopes, for example, or in bouncing gaits such as galloping.

There are also indications that feedback from the length sensitive muscle proprioceptors, the muscle spindles, contributes to the regulation of ongoing activity in the soleus muscle of walking humans [4]. This contribution likely comes from the secondary endings of the muscle spindles. Surprisingly, there is very little direct evidence in either humans or cats that feedback from the primary endings of the muscle spindles has a significant role in controlling ongoing activity in leg extensor muscles during the stance phase. In fact, recordings from afferents from primary endings of extensor muscles in walking cats has revealed they have relatively modest activity during stance and that the temporal pattern is not strongly correlated with the pattern of muscle activation [3].

The extent to which feedback from muscle proprioceptors regulates activity in flexor muscles during the swing phase of locomotion in cats and humans is unknown. Nevertheless, there are powerful afferent pathways from flexor muscles onto flexor motoneurons that are enabled during the swing phase [5]. Thus it would be surprising if flexor activity in walking animals was not influenced to some extent by feedback from muscle proprioceptors.

## Locomotor Reflexes Originating from Cutaneous Receptors

Sensory receptors in the skin sensitive to touch and pressure are known to have two functions in walking mammals. The most obvious is to initiate reflexes to compensate for unexpected changes in the environment. The second is to regulate the magnitude of motor activity to control the ongoing biomechanical properties of the system, such as the location of the centre of pressure on the sole of the foot. The latter has been clearly demonstrated in the walking system of humans

in which reducing feedback from ►cutaneous receptors in the soles of the feet by cooling alters the pattern of pressure changes in the feet and the activity in variety of leg muscles. Reducing feedback from the paws of the hind legs in cats also produce changes in the mechanics and muscle activity, especially when animals are walking up and down slopes and over complex terrains that require visual signals to adjust stepping movements, such as walking across the rung of a ladder [6]. In the latter situation the animals fail to place their paws correctly on the rungs. Cutaneous sensory signals from the paws are also necessary for correct paw placement in cats with mid-thoracic spinal cord transections (spinal cats) when they walk on a treadmill belt.

The fact that robust rhythmic stepping can occur in cats and humans in the absence of cutaneous signals from the paws and feet, respectively, indicates that cutaneous signals do not have a major role in the generation of the basic motor pattern for walking. Rather their influence is to regulate this basic pattern.

Currently very little is known about the neuronal pathways underlying the regulatory influence of cutaneous signals during walking. ►Spinal reflex pathways must be the main substrate for the regulating motor commands in spinal cats, and are likely important in controlling some aspects of motor activity in intact cats and humans when walking on flat surfaces. For more complex terrains, however, long-loop reflexes via supraspinal regions are almost certainly involved to allow the integration of perceptual information from cutaneous receptors into the forebrain systems involved in the planning and execution of leg movements.

The roles of cutaneous reflexes in compensating for unexpected events in the environment have been extensively investigated in the walking system of mammals [7]. Unexpected contact of an object with the dorsum of foot in humans or the paw in cats initiates a reflex response that first extends the leg to clear the object and then flexes the leg to rapidly lift it over the object. This is known as the ►*stumbling-corrective reaction*. The motor pattern underlying the stumbling-corrective reaction is complex, and in cats it involves the activation of some extensor muscles followed by activation of flexor muscles. The neuronal pathways underlying the stumbling corrective reaction have not been fully defined but the response appears to depend primarily on transmission of cutaneous signals via spinal reflex pathways. Cutaneous reflexes also play an important role in initiating compensatory movements in response to unexpected shifts in the terrain and thereby assist in the maintenance of balance.

### Locomotor Reflexes Originating from the Vestibular Apparatus

Surprisingly little is known about the functional characteristics of reflex pathways from the ►vestibular apparatus

to the pattern generating networks for locomotion in the spinal cord of mammals. By contrast, considerable insight has been gained from studies of swimming in the lamprey [8]. Signals from the vestibular system of the lamprey form part of closed-loop negative feedback systems to assist in maintaining body orientation with respect to gravity during swimming. In mammalian walking systems vestibular signals may also have a similar function since damage to the vestibular system can cause marked ataxia and loss of balance.

Although the vestibular system is not necessary for the generation of the basic motor pattern for walking in mammals, phasic signals from the vestibular system can influence the pattern generating networks on a cycle-by-cycle basis. Furthermore, these reflex responses are highly phase- and task-dependent, being largest at the time of heel contact and absent during other rhythmic behaviors such as cycling. Thus reflexes from the vestibular system have the potential to immediately modify locomotor networks in response to movements of the head. Reflex responses in leg muscles evoked by galvanic vestibular stimulation are appropriate for stabilizing body movements around the roll axis [9].

Electrophysiological studies in walking cats have also provided some insight into the function of vestibular signals in regulating stepping. In intact animals, the activity of ►vestibulospinal neurons is rhythmically modulated in a manner that has suggested that they regulate the overall activity of extensor muscles in all four legs and thereby have a role in the control of balance. On the other hand, ►reticulospinal neurons receiving input from the vestibular system have rhythmic patterns of activity suggesting they have a more restricted role in regulating the activity in specific groups of flexor and extensor muscles [10].

### Summary

Locomotor reflexes play an essential role in the patterning of motor activity for walking. These reflexes have three major functions: (i) to regulate the timing of motor commands according to the mechanical state of the limbs and body, (ii) to control the magnitude of ongoing muscle activity, and (iii) to initiate corrective responses when the limbs or body are unexpectedly perturbed by events in the environment.

### References

1. Pearson KG (1993) Common principles of motor control in vertebrates and invertebrates. *Ann Rev Neurosci* 16:265–297
2. Pearson KG (2008) Role of sensory feedback in the control of stance duration in walking cats. *Brain Res Rev* 57(1):222–227

3. Donelan JM, Pearson KG (2004) Contribution of sensory feedback to ongoing ankle extensor activity during the stance phase of walking. *Can J Physiol Pharmacol* 82:589–598
4. Mazzaro N, Grey MJ, Sinkjaer T (2005) Contribution of afferent feedback to the soleus muscle activity during human locomotion. *J Neurophysiol* 93:167–177
5. McCrea DA (2001) Spinal circuitry of sensorimotor control of locomotion. *J Physiol (Lond)* 533:41–50
6. Bouyer LJD, Rossignol S (2003) Contribution of cutaneous inputs from the hindpaw to the control of locomotion. I. Intact cats. *J Neurophysiol* 90:3625–3639
7. Zehr EP, Stein RB (1999) What functions do reflexes serve during human locomotion. *Prog Neurobiol* 58:185–205
8. Zelenin PV, Orlovsky GN, Deliagina T (2007) Sensory-motor transformation by individual command neurons. *J Neurosci* 27:1024–1032
9. Iles JF, Baderin R, Tanner R, Simon A (2007) Human standing and walking: comparison of the effects of stimulation of the vestibular system. *Exp Brain Res* 178:151–166
10. Matsuyama K, Drew T (2000) Vestibulospinal and reticulospinal activity during locomotion in the intact cat. I. Walking on a level surface. *J Neurophysiol* 84:2237–2256

known themselves to be capable of initiating locomotor activity. Therefore, a locomotor region should be defined as a neuronal area specifically devoted to the initiation of locomotion in a controllable fashion. One such center is a circumscribed region at the border between the midbrain and the hindbrain, first identified in cats by a group of neuroscientists in Moscow [1]. This area was named the *Mesencephalic Locomotor Region* (MLR). Interestingly, the MLR was identified in all vertebrate species examined. It elicits walking and running in quadrupeds, flying in birds, and swimming in fish. Because of its strategic location between higher brain structures and hindbrain neurons directly projecting to the spinal CPGs for locomotion, the MLR is believed to play a key role in goal-directed locomotion. Another locomotor region has been identified in the diencephalon. This diencephalic locomotor region (DLR) also projects to descending projection neurons of the hindbrain to activate locomotion. Both of these locomotor regions have been identified physiologically and their exact anatomical location is still the subject of debate.

## Characteristics

### Upstream Events

The MLR is controlled in large part by forebrain structures (Fig. 1).

The projections to the MLR were examined more extensively in mammals and it was proposed that the MLR is divided in three specific areas generating locomotion in different motivational contexts: exploration, defense, and food seeking (for review see [2]). The forebrain inputs to these three specific areas also differ as they originate from the basal ganglia, and two different parts of the hypothalamus: the lateral and medial hypothalamus. It was proposed that the part of the MLR involved in exploratory locomotion receives inputs from the basal ganglia. The activation of the nucleus accumbens, a part of the basal ganglia, elicits locomotion that is abolished by inactivation of the MLR. Projections from the nucleus accumbens to the ventral pallidum also in the basal ganglia, and then to the MLR are important components of this neural circuitry involved in controlling locomotion. It appears therefore that neurons located in the pallidum would be tonically active at rest, keeping the MLR under tonic inhibition using GABA as a neurotransmitter (for review see [3]). Activation of the MLR by the nucleus accumbens would thus result from disinhibition. Consistent with this view is the finding that injections of GABA<sub>A</sub> antagonists in the MLR induce locomotion. The hypothalamic projections to the MLR are involved in locomotion in two specific behavioral contexts. The medial hypothalamus projects to the MLR via the periaqueductal grey in the ►brainstem and this pathway is proposed to be involved in locomotion generated for

## Locomotor Regions in the Midbrain (MLR) and Diencephalon (DLR)

RÉJEAN DUBUC

Département de Kinanthropologie, Université du Québec à Montréal, Montréal, QC, Canada  
 Département de Physiologie, Université de Montréal, Montréal, QC, Canada

### Synonyms

Locomotor centers; Locomotor areas

### Definition

►Locomotion is a stereotyped rhythmical motor activity allowing an animal to move from one point to another. In vertebrates, locomotion is generated by specific networks of neurons in the spinal cord referred to as ►central pattern generators (CPGs). The initiation and control of locomotion both rely on supraspinal structures. A large number of studies carried out in different animal species have shown that stimulation of specific supraspinal regions elicits locomotor activity. However, not all these regions appear to be specifically devoted to the control of locomotion, nor does their stimulation elicit locomotion in a controllable fashion in all cases. Some of these areas relay sensory inputs

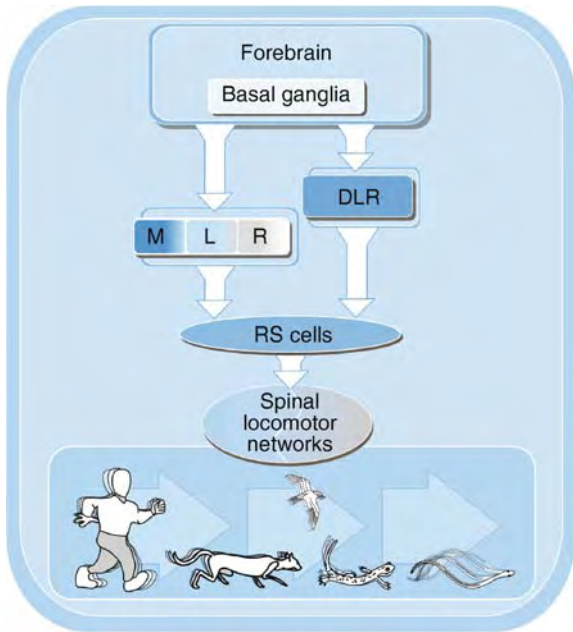

**Locomotor Regions in the Midbrain (MLR) and Diencephalon (DLR).** Figure 1 Schematic representation of locomotor regions in the CNS. Two specific locomotor regions have been identified, one at the transition between the pons and mesencephalon (Mesencephalic Locomotor Region: MLR) and the other in the diencephalon (Diencephalic Locomotor Region: DLR). Both regions receive inputs from forebrain regions and, in turn, project directly to ►reticulospinal cells. Stimulation of these two locomotor regions elicits swimming in fish, flying in birds, as well as walking and running in tetrapods.

defensive purposes. In addition, the medial hypothalamus projects directly to the hindbrain reticular formation. The projection from the lateral hypothalamus was proposed to be involved in initiating locomotion for food seeking and there is also a direct lateral hypothalamic projection to the reticular formation [4] (for review see [2]). The inputs to the DLR have received less attention. Anatomical studies in fish revealed that several forebrain areas project to the DLR. These projections originate from the olfactory bulbs, different pallial regions thought to be the ancestral precursors of the cerebral cortex, the striatum, and the hypothalamus. Projections from the contralateral side were also seen originating from the ventral and dorsal thalami.

#### Downstream Events

The MLR of mammals does not project directly to the spinal cord. The information is relayed by reticulospinal cells in the medial reticular formation of the hindbrain. Neural networks within the spinal cord collectively known as CPGs are responsible for generating the basic locomotor synergy in all vertebrate species and these

spinal networks are turned on by reticulospinal cells in turn activated by the MLR. Therefore, reticulospinal cells play a role as command neurons for locomotion. They also receive peripheral inputs. Such a general organization has been demonstrated in all vertebrate species where the role of reticulospinal neurons has been examined. Numerous anatomical and physiological studies have confirmed this. The details of the connections between the MLR and the reticular formation (types of connections, neurotransmitters, and postsynaptic receptors) are still not established in higher vertebrates. However in lampreys where the general connectivity between the MLR and reticulospinal cells is remarkably similar, this has been recently detailed because of the greater accessibility of the *in vitro* preparation of the lamprey brainstem [5]. There are two neurotransmitter systems involved: cholinergic (nicotinic receptor subtypes) and glutamatergic excitatory projections from the MLR to reticulospinal cells [6]. One interesting feature of this connection between the MLR and reticulospinal cells is a regional variation in the strength of the connectivity. The MLR excitatory inputs are largest in reticulospinal cells located in the rostral half of the hindbrain. The strength of the inputs decreases as the reticulospinal cells are located further caudally in the hindbrain. The recruitment of reticulospinal cells with increasing strength of MLR stimulation also displays a specific pattern. The reticulospinal cells that are located in the rostral hindbrain are recruited at the lowest stimulation intensities, whereas those located more caudally require larger stimulation strengths [7]. Therefore, it is believed that rostrally located reticulospinal cells would be recruited to initiate slow locomotion and as more intense locomotion is required, caudal reticulospinal cells would then be recruited. The DLR also projects directly to reticulospinal cells in lampreys. The inputs are glutamatergic [8]. No other neurotransmitter systems have been identified in the connections between the DLR and reticulospinal cells. Interestingly, the excitatory synaptic responses can be potentiated with high-frequency stimulation of the pathway. Such potentiation will likely be important to produce sustained activation of reticulospinal cells to maintain locomotor activity.

#### Involved Structures

Both the MLR and the DLR have been identified physiologically in different vertebrate species. However, the exact anatomical structures comprising these two locomotor regions have been subject of controversy and are still not firmly identified. The MLR was originally identified in cats in the early 1960s. It was then established that the cuneiform nucleus located at the mesopontine border was the main element forming the MLR. Another nucleus containing cholinergic neurons,



the pedunculopontine nucleus, was later proposed to also be part of MLR. In rats for instance, the group of Garcia-Rill showed a close relationship between the location of cholinergic neurons and specific sites from which controllable locomotion could be elicited in response to their stimulation [9]. The link between the MLR and cholinergic neurons is still a subject of debate in mammals. A group of cholinergic neurons more caudally located in the laterodorsal tegmental nucleus was also proposed as being part of the MLR. In lampreys there is a link between the location of cholinergic neurons and sites from which controllable swimming is elicited. Stimulation within the lamprey pedunculopontine area was initially shown to elicit locomotion. As additional experiments were carried out examining the MLR of lampreys, it became clear that locomotion could be elicited more readily by stimulating further caudally in the laterodorsal tegmental nucleus. Interestingly, the same area was also very efficient in eliciting stepping movements as well as swimming in salamanders [10]. Another common feature observed in all vertebrate species into which the MLR has been identified is the projection to the medial reticular formation in the hindbrain. At present, it is safe to assume that the MLR comprises more than one anatomical nucleus and that different parts of the MLR elicit locomotion in different behavioral contexts. The DLR has received less attention in different animal species. The first studies indicating that it was possible to initiate locomotion from the diencephalon suggested a subthalamic area. It was later shown that the zona incerta was the effective site for the initiation of locomotion in the subthalamic area. Therefore in addition to regulating several behavioral functions (arousal, attention and posture), the zona incerta plays an important role in the initiation of locomotion. In mammals, neurons of the zona incerta project down to the caudal end of the hindbrain. In lampreys, the DLR is located in the ventral thalamus, a region that could be homologous to the zona incerta of mammals [8].

### Methods to Measure the Events

Locomotor regions have been identified physiologically. Locomotion was measured in behaving animals and it consisted of stepping movements in tetrapods, walking or flying in birds, and swimming in fish. The first demonstration of the presence of such a locomotor region in the CNS was made in cats in the early 1960s. The animals were decerebrated by removing most of the forebrain tissue above the mesencephalon. The animals were suspended over a treadmill belt and an electrode was inserted at the mesopontine border. Upon stimulation at low intensities, slow walking involving the four limbs was elicited. As the stimulation strength was increased, the animal exhibited faster

walking movements until galloping was elicited. This stunning demonstration indicated that specific regions of the CNS are devoted to controlling stereotyped locomotor movements. Later on, it was shown that a similar rhythmical activity was elicited in response to stimulation of the same region in paralyzed animals. In this case, the recordings were made directly over the hindlimb peripheral motor nerves. Because neurotransmission was blocked between the nerve endings and the muscles and no actual movements were produced, the rhythmic activity recorded from the nerves was referred to as “fictive locomotion.” In all animal species tested to date, it is also possible to record fictive locomotion in response to MLR stimulation. Interestingly, stimulation of the MLR in salamanders known to display two different modes of locomotion (walking or swimming), induces stepping movements of the limbs at low intensity of stimulation and swimming at higher stimulation strengths [10]. Again, the intensity of the locomotor output is proportional to the stimulation strength.

Chemical stimulation can also be used as a substitute for electrical stimulation to activate locomotor regions in the CNS. For instance, chemicals mimicking the action of some excitatory neurotransmitters are injected locally within specific regions of the CNS to selectively activate neurons in the vicinity. A micropipette is inserted into the locomotor region and small quantities of drugs are injected. Such experiments were originally done in cats and allowed the researchers to confirm that cell bodies of neurons located in the stimulated areas were the elements activated by the stimulation. Chemicals blocking inhibitory transmission have also been injected in the MLR and found to elicit locomotion indicating that neurons within the injected area are likely to be subjected to a tonic inhibitory control.

### References

1. Shik ML, Severin FV, Orlovsky GN (1966) Control of walking and running by means of electrical stimulation of the midbrain. *Biofizika* 11:659–666
2. Jordan LM (1998) Initiation of locomotion in mammals. *Ann NY Acad Sci* 860:83–93
3. Grillner S, Georopoulos AP, Jordan LM (1997) Selection and initiation of motor behavior. In: Stein PSG, Grillner S, Selverston AI, Stuart DG (eds) *Neurons, networks, and motor behavior*. A Bradford Book, The MIT Press, Cambridge, pp 3–19
4. Sinnamon HM (1993) Preoptic and hypothalamic neurons and the initiation of locomotion in the anesthetized rat. *Prog Neurobiol* 41:323–344
5. Sirota MG, Viana Di Prisco G, Dubuc R (2000) Stimulation of the mesencephalic locomotor region elicits controlled swimming in semi-intact lampreys. *Eur J Neurosci* 12:4081–4092

6. Le Ray D, Brocard F, Bourcier-Lucas C, Auclair F, Lafaille P, Dubuc R (2003) Nicotinic activation of reticulospinal cells involved in the control of swimming in lampreys. *Eur J Neurosci* 17:137–148
7. Brocard F, Dubuc R (2003) Differential contribution of reticulospinal cells to the control of locomotion induced by the mesencephalic locomotor region. *J Neurophysiol* 90:1714–1727
8. El Manira A, Pombal MA, Grillner S (1997) Diencephalic projection to reticulospinal neurons involved in the initiation of locomotion in adult lampreys *Lampetra fluviatilis*. *J Comp Neurol* 389:603–616
9. Garcia-Rill E (1986) The basal ganglia and the locomotor regions. *Brain Res* 396:47–63
10. Cabelguen JM, Bourcier-Lucas C, Dubuc R (2003) Bimodal locomotion elicited by electrical stimulation of the midbrain in the salamander *Notophthalmus viridescens*. *J Neurosci* 23:2434–2439

## Locomotor Rehabilitation

### ► Locomotor Training

## Locomotor Training

SERGE ROSSIGNOL  
 Centre de recherche en sciences neurologiques,  
 Department of Physiology, Pavillon  
 Paul-G.-Desmarais, Université de Montréal,  
 Montreal, QC, Canada

### Synonyms

Locomotor rehabilitation

### Definition

After a spinal cord injury in animals and humans, locomotion may be more or less impaired depending on the extent of the lesion (complete or partial). Intrinsic mechanisms of the nervous system leads to a certain degree of functional recovery below the lesion with re-expression of locomotion. However, systematic locomotor training supplemented by pharmacological stimulation can improve such functional recovery.

### Characteristics

#### Quantitative Description

Most mammalian species can recover hindlimb locomotion on a treadmill after a complete section at the

thoracic level [1]. For example, kittens spinalized early after birth can, after some days, express locomotor movements of the hindlimbs when the feet are placed in contact with a moving treadmill at increasing speeds. Since these animals have not learned to walk before spinalization, it can be concluded that the recovery of the locomotor pattern results from the expression of a genetically-determined sensory-motor circuit in the spinal cord called ► **Central Pattern Generator, or CPG**. Adult cats can also regain locomotion of the hindlimbs when trained with the feet positioned on the surface of a moving treadmill belt, while the forelimbs stand on a platform. With active daily training for 2–3 weeks on a treadmill, adult cats walk with their hindlimbs and make plantar foot contacts that allow them to support the weight of the hindquarters. Kinematic analyses and EMG recordings (Fig. 1) show that step cycles are generally shorter after spinalization (compare Fig. 1a and 1d). There is also quite often a foot drag at the onset of the swing phase (compare mtp joint in Fig. 1b and e).

However, the time course of activation and coupling between muscles are largely preserved (compare Fig. 1c and f). For instance, the sharp increase in the burst of ankle extensors and the gradual onset of the knee extensors are preserved. The EMG pattern is often more “spiky” after spinalization, and the relative timing between flexor muscles of different joints may be perturbed (see differences in LSt-LSrt coupling and RSt-rSrt coupling). Rats spinalized as neonates or weanlings, recover the ability to walk spontaneously when becoming adult. However, adult rats spinalized as adults do not spontaneously recover any significant locomotion. This is in contrast to adult mice that recover hindlimb locomotion about two weeks after a complete spinal section at T8 [2]. Following a complete spinal lesion in humans, involuntary rhythmic activity of the lower limbs has been described in clinically complete spinal patients, suggesting that humans, like all other vertebrate, have a spinal CPG that participates in the control of locomotion.

Incomplete spinal cord lesions lead to less severe loss of locomotor function than complete spinalization. For example, voluntary quadrupedal locomotion can be regained after extensive lesions of the medial and medio-lateral (Fig. 2) pathways (see Fig. 2d–f and [3]).

The severity of the deficits varies with time after the lesion and on its size. With large lesions, sparing only part of the dorsal columns and part of one dorsolateral column, cats dragged their hindquarters over ground for 3–6 weeks as do complete spinal cats. However, all cats eventually regained quadrupedal locomotion. The forelimbs and hindlimbs could even walk at slightly different mean frequencies leading to occasional stumbling. Whereas normally cats use their hindlimbs to propulse the body, after such lesions the

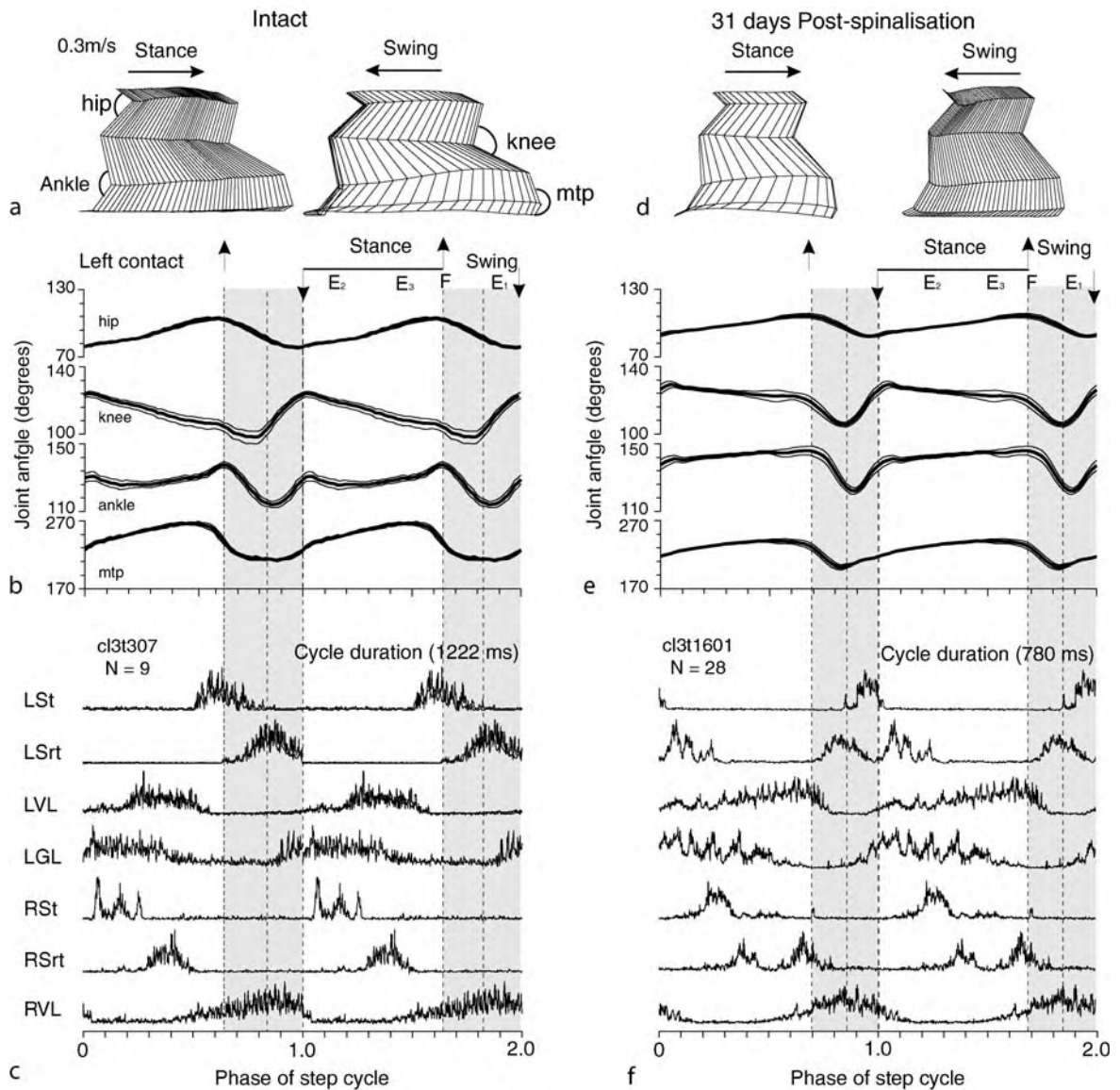

**Locomotor Training. Figure 1** Comparison of hindlimb locomotion at 0.3 m/s in the same cat before and 31 days after spinalization at T13. (a) and (d). Stick figures reconstructed from video sequences of one-step cycle before and after spinalization. The swing and the stance phases, with arrows pointing in the direction of motion of the leg, are illustrated separately. The orientation of joint angle measurements is given. Note that to prevent overlap of the stick figures, each figure is displaced by an amount equal to the displacement of the foot on the horizontal axis and, therefore, the horizontal calibration seen in (d) is twice that of the vertical. (b) and (e). Angular excursion of the four joints averaged from nine steps in the intact state (c.d. = cycle duration with a mean of 1,222 ms) and from 28 steps in the spinal state 9 c.d. = 780 ms). Flexion always corresponds to a downward deflection of the angular traces. Mtp, metatarsophalangeal joint. The vertical dotted lines separate various epochs: F for flexion and E1 for first extension phase constitute the swing while E2 and E3, the second and third extension phases, constitute the stance phase of the step cycle according to Philippson, 1905. Note that the transition between E2 and E3 is not always obvious, and the two sub-phases have been merged together in these examples. (c) and (f). Average of rectified EMG traces of the corresponding cycles. *L* left hindlimb; *R* right hindlimb. Muscles are Semitendinosus *St* a knee flexor and hip extensor; Sartorius, anterior head *Srt* a hip flexor and knee extensor; Vastus Lateralis *VL*, a knee extensor; Gastrocnemius Lateralis *GL*, an ankle extensor. The step cycle is normalized to one and the display is repeated twice for clarity of illustration at turning points of the step cycle. The average is synchronized on foot contact, which starts at the onset of E2 on the left side.

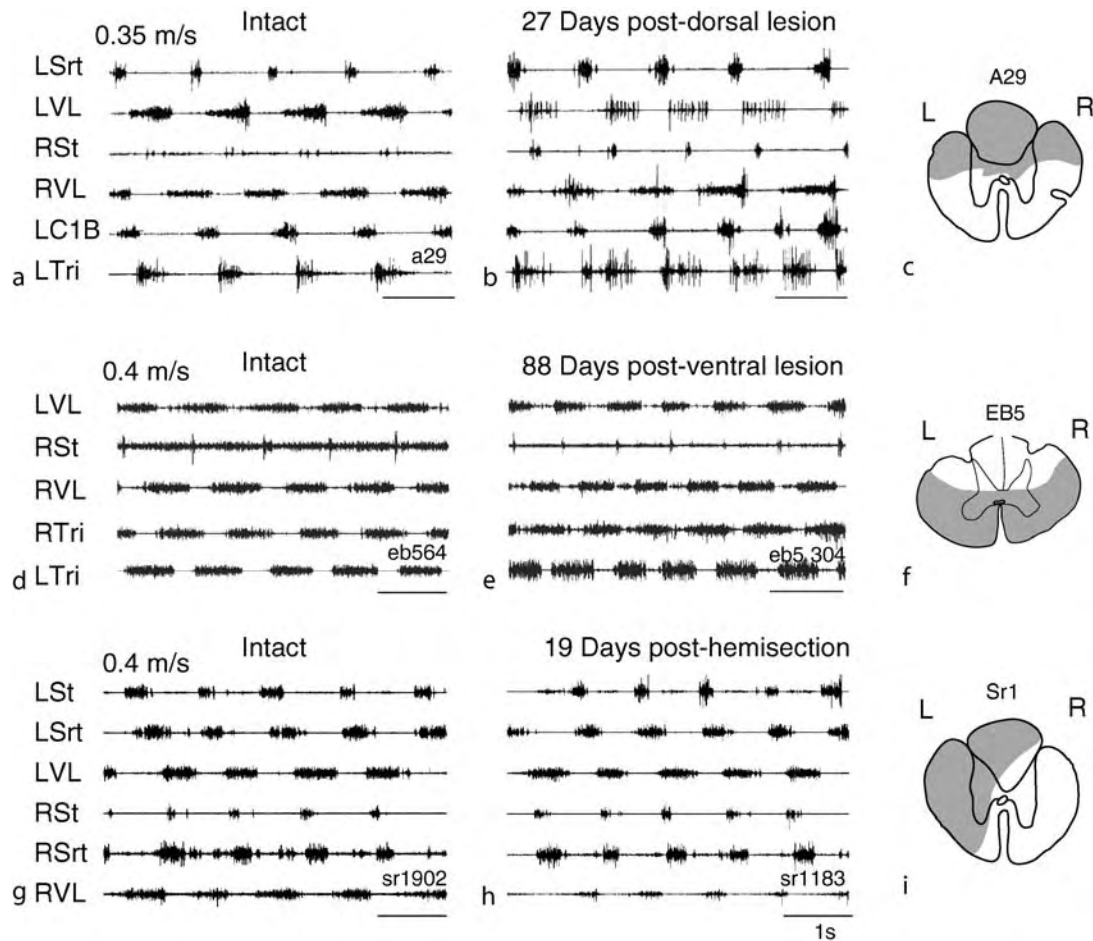

**Locomotor Training. Figure 2** Recovery of locomotion after partial spinal lesions at T13. (a–c): Bilateral dorsal hemisection. (a) raw EMG records in the intact condition; (b) raw EMG records 27 days post-lesion; (c) outline of the spinal lesion from histological sections showing the area of greatest damage. Cleido-brachialis (CIB, a shoulder and elbow flexor) and Triceps brachialis (Tri, an elbow extensor). (d–e): Bilateral ventral and ventrolateral lesion. (d), (e) and (f) correspond to (a), (b) and (c). See [3]. (g–i): Over hemisection. The section includes most of the hemi-cord and impinges on the dorsal column on the other side. (g), (h) and (i) correspond to (a), (b) and (c).

forelimbs became propulsive. Cats with large lesions of the dorsolateral pathways can also walk over ground (Fig. 2a–c). Such lesions induce a short period of impaired voluntary quadrupedal locomotion lasting for 3–10 days, during which the animals adopted a crouched posture and the step cycle length that was prolonged at the end of stance. In contrast to cats with ventrolateral lesions, these cats could not correct properly for obstacles placed on the treadmill. Finally, after hemisection (see Fig. 2g–i), cats can also regain quadrupedal locomotion. Both after complete and incomplete spinal lesions, the functional locomotor rehabilitation can be improved dramatically by systematic treadmill training alone or in combination with appropriate pharmacological stimulation (see therapy below).

### Higher Level Structures

Four systems control normal (Fig. 3) locomotion (see Fig. 3, left).

These systems are: (i) the CPG (Grillner, ERN), (ii) the afferent control of the CPG (Hultborn ERN), (iii) the descending controls of the CPG acting through fast pathways (Corticospinal CS; Rubrospinal RuS; Reticulospinal RS; Vestibulospinal VS) (Dubuc, ERN), and (iv) the neurochemically-defined pathways (NA, 5-HT). Plastic changes in one or several of these control structures are responsible for functional locomotor rehabilitation (see below).

### Lower Level Components

The locomotor recovery on a treadmill is largely dependent on afferent regulation of the spinal CPG

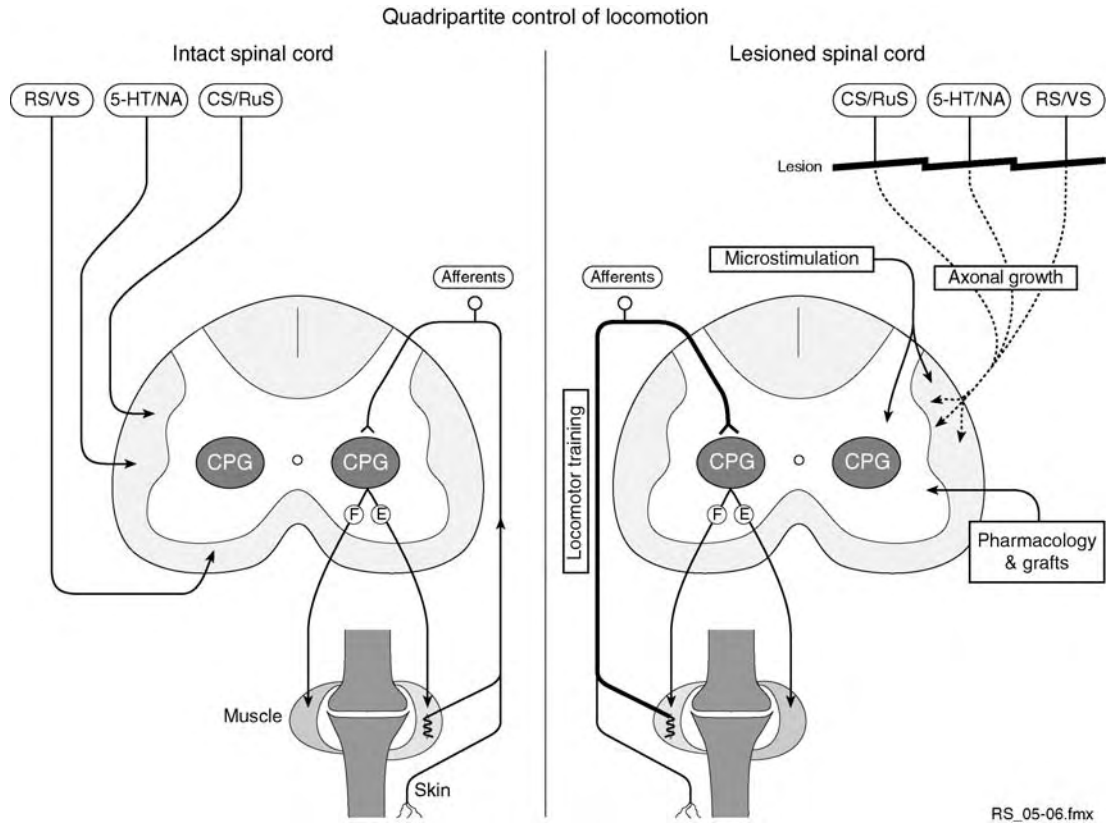

**Locomotor Training. Figure 3** The quadrupartite locomotor control and rehabilitation after spinal cord injury. The left panel illustrates the spinal cord, including a CPG on which afferent inputs originating from muscles and skin as well as descending pathways eventually converge. These pathways include fast pathways of the lateral system (CS cortico spinal pathway; RuS Rubrospinal pathway) and the medial system (RS reticulospinal pathways; VS vestibulospinal pathways), as well as slow neurochemically-defined pathways such as noradrenergic pathway (originating from the locus coeruleus) and serotonergic pathway (originating from the raphe). The right panel shows how different locomotor therapies may be used to “replace” missing pathways or strengthen existing pathways. Thus, ► [locomotor training](#) can, by an enhanced activation of sensory afferents, improve the locomotor performance. Injections of drugs (NA, 5-HT systems) or neurotransmitters provided by intraspinal grafts may trigger or modulate the activity of the CPG. Electrical microstimulation of spinal structures (motoneuron pools or pathways) may also provide start-stop signals normally provided by descending pathways. These could eventually complement other approaches destined to promote axonal growth through the damaged cord.

(see [Fig. 3](#), left) and by activity in descending fibers that have been spared in cases of partial spinal lesions.

Proprioceptive afferent inputs are implicated in modulating the frequency of stepping, the duration of EMG bursts as well as their duration so that locomotion can be achieved in various conditions. These fibers have access to the locomotor CPG. Cutaneous inputs, on the other hand, are responsible for the correct positioning of the foot [4] and for adequate phase-dependent responses to stimuli during walking. The effects are mediated through spinal neuronal circuits. Locomotor training will activate many types of sensory afferents that will influence the recovery of locomotion. Although it would be important to know which

afferents play a critical role, our knowledge is still quite limited. However, experiments in cats with peripheral nerve lesions strongly suggest that both proprioceptive and cutaneous afferents are involved. It can thus be concluded that the role of sensory inputs is probably enhanced during locomotor rehabilitation, and that removing this sensory information prevents a proper rehabilitation. Studies in humans evaluating the importance of cutaneous inputs in the recovery of locomotion would be informative.

#### Higher Level Processes

Much like most other neuronal circuits in the brain, there is increasing evidence that spinal circuitry

including the CPG can be subject to plastic changes. This suggests that locomotor recovery in spinalized animals is due to plastic changes in the spinal network and interactions with peripheral inputs. This further suggests that the spinal cord can be “changed” by the long-term sensory-motor experience so that that specific training will lead to the improvement of the specific task being trained (for example walking vs. standing [5]).

### Lower Level Processes

After spinalization, receptor density changes below the level of the lesion. For instance, fifteen and thirty days following spinalization, binding densities for  $\alpha_1$ -,  $\alpha_2$ -noradrenergic and serotonin<sub>1A</sub> (5-HT<sub>1A</sub>) receptors significantly increased in lumbar segments. For longer survival times, binding densities returned to near control values. The pronounced up-regulation of various monoaminergic receptors, observed in the lumbar region in the first month after spinal transection, represents a clear neurochemical plastic change and suggests that these receptors might be important during the period when cats normally recover locomotion of the hindlimbs [6]. There is no data on the effect of ►locomotor training on the regulation of these receptors. However, concentrations of glutamic acid decarboxylase 67 (GAD<sub>67</sub>), the rate limiting enzyme in GABA synthesis, also increase after spinalization, suggesting an increase in GABA inhibition that could partly account for the reduced muscle activity. Locomotor training decreases the levels of GAD<sub>67</sub> and might constitute a biochemical marker for the beneficial effect of training [7]. Changes have also been observed in glycinergic pathways since strychnine can re-instate locomotion in poor walkers or cats trained only to stand.

Little actual electrophysiological work has been performed on the spinal circuitry to evaluate the effects of locomotor training. In spinalized cats trained to walk several changes in reflex responses have been observed [8]. All together, these changes will tend to decrease spasticity, which is pronounced after spinalization and prevents locomotion. Moreover, those changes tend to improve the potency of afferent related feedback to extensor muscles, which will improve weight-bearing capability.

Extensive work on the musculoskeletal changes after spinal transection in cats have shown that the force generated by extensor muscles were smaller after spinalization even during treadmill walking. However, weight-bearing training markedly improved the EMG amplitude in these muscles that could even reach the level attained in normal cats. Intensive training also reduces the amount of muscle atrophy and conversion of slow fibers to fast fibers that are observed after

spinalization. Of great interest is that locomotor training maintains the mechanical and metabolic properties of some extensor muscles much closer to normal than training to stand, probably because of the specific demand required during stepping.

### Process Regulation

The preceding sections have established that a quadripartite system controls locomotion (CPG, afferent control and supraspinal controls), and therefore locomotion recovery after spinal section must depend on modifications of the interactions between the components of this quadripartite system. After complete spinal section, changes within the spinal cord (physiological and neurochemical) and sensory-motor interactions are changed. After partial lesions, compensatory mechanisms from intact systems can also compensate, to a certain extent, the deficits resulting from the lesion of specific pathways. These changes most probably involve molecular and biochemical changes, which eventually lead to the changes in synapses strength/formation. The exact nature of these processes is at the moment unknown.

### Function

The function of the recovery is to establish normal locomotion after complete or incomplete spinal lesions. The indication that the spinal cord can be modified by training suggests that locomotor training can induce long-lasting changes in the quadripartite locomotor control system, which may have an important functional outcome. For instance, humans trained to walk on a treadmill may, in some cases, become functional walkers i.e. perform safely some daily life locomotor tasks. Furthermore, locomotor training may have significant beneficial effects on cardiovascular functions as well as improve bone density.

### Pathology

The principles for locomotor recovery following spinal lesions outlined also apply to locomotor impairments following neurodegenerative diseases, like multiple sclerosis or stroke that may affect any part of the quadripartite control system of locomotion. Rehabilitative procedures should be evaluated within this framework.

### Therapy

Locomotor training procedures on a treadmill with partial body weight support has been initiated in humans [9]. Training can increase the weight bearing of the individuals, accompanied by an increase in activity of antigravity muscles and a reduction in unwarranted activity of flexor muscles. There is also an increase in endurance, speed and step length. These benefits are seen

not only after partial lesions but also after complete spinal sections, but whereas these benefits persist after training in partially lesioned patients, they disappear in completely spinal patients. As is the case for animals, it appears that sensory stimulation (i.e. loading of the ankle) is an important part of the training effect. Robots have been used to “teach” spinal rats to walk on a treadmill, but a similar approach has not yet been tested in humans.

Application of precursors or agonists of noradrenalin (cat) or serotonin (rodents) can initiate locomotion after an acute spinalization. There has therefore been a great interest in finding drugs that modulate the characteristics of the CPG also after chronic spinalization. There is intensive research in this area that might provide a potent adjuvant during locomotor training. Grafting of embryonic serotonergic raphe cells to a site below the spinal lesion in rats has also been used as a means to increase the excitability of the CPG [10] This treatment can induce a remarkable recovery of hindlimb locomotion. Further work has also suggested that chronic exposition of the spinal cord to serotonergic agonists significantly improved the spontaneous expression of locomotion, suggesting that the chronic activation of 5-HT receptors may preserve membrane characteristics of motoneurons or interneurons necessary for the operation of the spinal pattern generator.

Locomotion can also be evoked in spinal cats through electrical microstimulation of the spinal cord. Different approaches are being pursued i.e. combination of electrical stimuli of different motoneuronal pools or specific segmental activation to induce synergistically the locomotor pattern from restricted areas of the cord. Various attempts are being made to use epidural stimulation of the cord or intraspinal stimulation to improve the recovery of locomotor function. Instead of stimulating the cord directly, electrical stimulation of muscles or nerves has been used to improve the recovery of locomotion in humans. Such stimulation can increase the walking speed by 45%, even in patients who have had a spinal injury for many years.

## References

1. Rossignol S, Bélanger M, Chau C, Giroux N, Brustein E, Bouyer L, Grenier C-A, Drew T, Barbeau H, Reader T (2000) The spinal cat. pp 57–87
2. Leblond H, L'Espérance M, Orsal D, Rossignol S (2003) Treadmill locomotion in the intact and spinal mouse. *J Neurosci* 23:11411–11419
3. Rossignol S, Drew T, Brustein E, Jiang W (1999) Locomotor performance and adaptation after partial or complete spinal cord lesions in the cat. *Prog Brain Res* 123:349–365
4. Bouyer L, Rossignol S (2003) Contribution of cutaneous inputs from the hindpaw to the control of locomotion:2. Spinal cats. *J Neurophysiol* 90:3640–3653

5. Edgerton VR, de Leon RD, Tillakaratne N, Recktenwald MR, Hodgson JA, Roy RR (1997) Use-dependent plasticity in spinal stepping and standing. *Adv Neurol* 72:233–247
6. Giroux N, Rossignol S, Reader TA (1999) Autoradiographic study of  $\alpha_1$ -,  $\alpha_2$ - Noradrenergic and Serotonin  $1_A$  receptors in the spinal cord of normal and chronically transected cats. *J Comp Neurol* 406: 402–414
7. Tillakaratne NJ, de Leon RD, Hoang TX, Roy RR, Edgerton VR, Tobin AJ (2002) Use-dependent modulation of inhibitory capacity in the feline lumbar spinal cord. *J Neurosci* 22:3130–3143
8. Côté M-P, Poulin I, Gossard J-P (2003) Plasticity in load pathways after complete locomotor recovery in spinal cats. *Soc Neurosci Abstr* 29
9. Barbeau H, Rossignol S (1994) Enhancement of locomotor recovery following spinal cord injury. *Curr Opin Neurol* 7:517–524
10. Ribotta MG, Provencher J, Feraboli-Lohnherr D, Rossignol S, Privat A, Orsal D (2000) Activation of locomotion in adult chronic spinal rats is achieved by transplantation of embryonic raphe cells reinnervating a precise lumbar level. *J Neurosci* 20:5144–5152

## Locus Coeruleus

### Definition

A small nucleus in the rostral pons of animals and humans, in which it was first seen as a blue (coeruleus) site, due to its pigmentation in man. The pigment, melanin, develops from the catecholamine synthetic pathway, as the neurons of this nucleus synthesize noradrenaline (NA) in all mammals. The LC neurons project in a highly diffuse manner through the brain and spinal cord where they release NA in the vicinity of target neurons. Given their use of NA as a neurotransmitter and their diffuse projections, the LC neurons and nucleus resemble a peripheral sympathetic ganglion located within and providing innervation to the central nervous system. As in the periphery, NA is also released from terminals in a nonsynaptic manner in the brain and affects both neurons and glia in the vicinity to support activity. The LC neurons discharge during waking and arousal and cease firing during sleep. By the action of NA upon target cells, they stimulate both cortical activation and behavioral arousal with motor activity and muscle tone. They also by direct projections onto the sympathetic preganglionic neurons in the spinal cord excite the peripheral sympathetic system to support motor activity by appropriate physiological adjustments.

- ▶ Melanins
- ▶ Noradrenaline (NA)
- ▶ Sympathetic Pathways

## Locust

### Definition

Insect of the order Orthoptera; has been a model system for studying flight and motor behavior.

## LOD (Logarithm of Odds) Score

### Definition

A statistical test often used in human and animal populations to determine if two markers or Mendelian traits are inherited in a linked fashion. Linkage is suggested by a LOD score greater than 3.0.

## Logic

RALF BUSSE

Institut für Philosophie, Universität Regensburg,  
Regensburg, Germany

### Definition

►**Logic** is the systematic inquiry into the validity of inferences or arguments. However, the totality of logical relations between elements of a system of representation, in particular a language, is also called *the logic* of that system. The core of modern logic is elementary logic, the part of deductive logic which comprises ►**propositional logic** and (extensional) first-order predicate logic. The standard view of logic is called classical logic. Prominent non-classical alternatives are many-valued, intuitionistic, relevance, and ►**non-monotonic logic**. There is no consensus as to whether extensions of elementary logic such as second-order predicate logic, modal logic, so-called ►**philosophical logics**, or inductive logic fully deserve the name “logic”.

### Characteristics

We shall focus on classical elementary logic in its usual ►**model-theoretic** treatment and shall be brief on alternatives and extensions. (See [1] for all topics mentioned.)

### Deductive Inference: Propositional Logic as a Paradigm

The central topic of deductive logic is the (deductive) *logical validity of inferences*. While psychology can

*describe* the actual way of human reasoning, the bearing of logic on inference is ►**normative**: it tells us what inference patterns we *ought* to follow. The usual view is that we ought to follow a certain pattern because the elements of an inference of that form stand in certain objective relations to each other which render the inference logically valid.

In modern logic inferences are identified with finite sequences of sentences  $\varphi_1, \dots, \varphi_n, \psi$  in an artificial language, where the  $\varphi_i$  are the ►**premises** and  $\psi$  is the ►**conclusion**. In a language **PL** for propositional logic sentence letters like  $p, q, r, \dots$  roughly play the role of simple natural-language sentences like “Grass is green”. The symbol  $\rightarrow$  is read as “if – then”,  $\neg$  as “not” or “it is not the case that”. Thus, the inference

$$\begin{array}{l} p \rightarrow q \\ \neg p \\ \hline \therefore \neg q \end{array}$$

is read as “If  $p$  then  $q$ , not  $p$ , therefore not  $q$ ”. (Quotation marks are dropped in ►**references** to expressions of artificial languages.) An inference is (deductively) *logically valid* if and only if (iff) it is excluded for logical reasons that all its premises are true but its conclusion is false. This is equivalent to saying that the conclusion  $\varphi$  *follows logically from*, or is *logically implied* or *entailed* by, or is a *logical consequence* of the set of premises  $\Gamma$ . It is a topic of ►**philosophy of logic** what this exclusion for logical reasons consists in. The usual model-theoretic way of doing logic rests on three semantic principles (due to G. Frege and A. Tarski): (i) The central semantic properties are the truth and falsity of complete sentences. (ii) The semantic properties of any complex expression are determined by the semantic properties of its constituent expressions and their syntactic arrangement (principle of ►**compositionality**). (iii) A semantic theory (►**Theory – Theoretical Expression**) of a well-defined language takes the form of a recursive definition of truth conditions of its sentences (relative to an assignment of meanings to the ►**descriptive vocabulary** of the language).

The ►**syntactical description** of a language **PL** for propositional logic introduces the vocabulary and grammar of **PL**. The descriptive vocabulary consists of sentence letters  $p, q, r$  etc. The ►**logical vocabulary**, i.e. the class of ►**logical constants**, consists of ►**truth-functional** sentential connectives, in particular of the negation sign  $\neg$  and the conditional connective  $\rightarrow$ . The *grammar* is captured by a recursive definition of the notion of a sentence. An expression is a sentence of **PL** iff it can be obtained by possibly repeated application of the following rules: (i) every sentence letter  $\sigma$  is a sentence. (ii) If  $\varphi$  is a sentence, so is  $\neg\varphi$  (the *negation* of  $\varphi$ ). (iii) If  $\varphi$  and  $\psi$  are sentences, so is  $(\varphi \rightarrow \psi)$  (the material *conditional* with the antecedent  $\varphi$  and the consequent  $\psi$ ).



The **semantic description** of **PL** starts with the notion of a possible assignment of meanings to the descriptive vocabulary of **PL**. A *valuation*  $\mathbf{V}(\sigma)$  is a function that assigns to any sentence letter  $\sigma$  one of the two truth-values truth (T) and falsity (F). The second part of semantics is the recursive definition of *truth conditions* relative to valuations  $\mathbf{V}$ : (i) A sentence letter  $\sigma$  is *true under a valuation*  $\mathbf{V}$  iff the value of  $\mathbf{V}$  for  $\sigma$  is T; otherwise it is false. (ii) A negation  $\neg\phi$  is true (false) under a valuation  $\mathbf{V}$  iff  $\phi$  is false (true) under  $\mathbf{V}$ . (iii) A conditional  $(\phi \rightarrow \psi)$  is true under a valuation  $\mathbf{V}$  iff  $\phi$  is false under  $\mathbf{V}$  or  $\psi$  is true under  $\mathbf{V}$  or both (i.e., iff it is not the case that  $\phi$  is true and  $\psi$  is false under  $\mathbf{V}$ ), and false otherwise. Usually further connectives are added: **Conjunctions**  $(\phi \wedge \psi)$ , read as “ $\phi$  and  $\psi$ ”, are true iff both conjuncts are true. **Disjunctions**  $(\phi \vee \psi)$ , read as “ $\phi$  or  $\psi$ ”, are true iff at least one of the disjuncts is true. **Biconditionals**  $(\phi \leftrightarrow \psi)$ , read as “ $\phi$  if and only if  $\psi$ ”, are true iff either both  $\phi$  and  $\psi$  are true or both are false. The connectives are truth-functional because the truth-value of compounds is determined by (is a function of) the truth-values of the constituents.

The meanings of the descriptive vocabulary vary with different valuations. By contrast, the meanings of logical constants such as  $\neg$  and  $\rightarrow$  are fixed once and for all by clauses like (ii) and (iii). **Logical** properties and relations are semantic features of sentences that are already determined by the meanings of the logical constants, independently of any particular valuation. A sentence  $\phi$  is *logically true (false)* iff it is true (false) under any valuation  $\mathbf{V}$ .  $\phi$  and  $\psi$  are *logically equivalent* iff they have the same truth-value under any  $\mathbf{V}$ . A set of sentences  $\Gamma$  is *consistent* iff there is a valuation  $\mathbf{V}$  under which all sentences in  $\Gamma$  are true. Such a valuation is called a **model** of  $\Gamma$ ; hence the name “model-theoretic approach”.  $\phi$  *follows logically from*  $\Gamma$ , in symbols  $\Gamma \models \phi$ , iff there is no valuation  $\mathbf{V}$  such that  $\phi$  is false under  $\mathbf{V}$  while all sentences in  $\Gamma$  are true under  $\mathbf{V}$ , i.e. iff  $\Gamma \cup \{\neg\phi\}$  has no model. An inference is *logically valid* iff its conclusion follows from the set of premises. The inference from  $p \rightarrow q$  and  $\neg p$  to  $\neg q$  turns out invalid: any valuation  $\mathbf{V}$  such that  $\mathbf{V}(p) = F$  and  $\mathbf{V}(q) = T$  is a counterexample to its supposed validity, for both premises are true under  $\mathbf{V}$  while the conclusion is false under  $\mathbf{V}$ . Contrariwise, validity of an inference can be proved by showing that the assumption that there is such a counterexample leads to contradiction.

In general, logical properties and relations are semantic properties and relations that can be defined by universal (“all”) or existential (“there is”) quantification over assignments of meanings to the descriptive vocabulary of a language without reference to particular assignments. An alternative to this model-theoretic approach is an **inferentialistic** understanding of logic which accepts the consequence relation (or specific cases of it) as primitive. This seems to have been

Aristotle’s idea of deductive logic in his **Prior Analytics** [2].

Typically the logic of a language is supplemented with a formal procedure, a **calculus** (or **deductive system**)  $\mathbf{C}$ , within which sentences can be *derived* from given premises. A **calculus of natural deduction** for the logic of a language consists of a finite set of rules for moving from given sentences to further sentences according to purely syntactic criteria. (An **axiomatic calculus** specifies axioms and few rules.) E.g., **modus ponens** allows one to move from any two sentences  $\phi$  and  $(\phi \rightarrow \psi)$  to  $\psi$ . A sequence of sentences is a **derivation** of  $\phi$  in calculus  $\mathbf{C}$  from a set of sentences  $\Gamma$  just in case it leads to  $\phi$  from a finite number of elements of  $\Gamma$  by a finite number of applications of the rules of  $\mathbf{C}$ .  $\phi$  is *derivable* from  $\Gamma$  in  $\mathbf{C}$  ( $\Gamma \vdash_{\mathbf{C}} \phi$ ) iff there is such a derivation.  $\phi$  is a **theorem** of  $\mathbf{C}$  ( $\vdash_{\mathbf{C}} \phi$ ) iff  $\phi$  is derivable from the empty set. A calculus  $\mathbf{C}$  is **sound** (or **correct**) iff for any  $\Gamma$  and  $\phi$ , if  $\Gamma \vdash_{\mathbf{C}} \phi$  then  $\Gamma \models \phi$ .  $\mathbf{C}$  is *complete* iff for any  $\Gamma$  and  $\phi$ , if  $\Gamma \models \phi$  then  $\Gamma \vdash_{\mathbf{C}} \phi$ . There are calculi for propositional logic that are both sound and complete. Propositional logic is also *decidable*: there are **decidability procedures**, such as the truth-table technique, that for any  $\Gamma$  and  $\phi$  determine in a finite number of steps whether  $\Gamma \models \phi$  or not.

*Many-valued* alternatives to classical logic reject the classical semantic **principle of bivalence**, which states that all meaningful sentences are either true or false. According to three-valued logic, sentences may have a third value of indeterminateness (I) instead. **Intuitionistic logic** rests on an understanding of truth as provability or verifiability. Intuitionistic calculi are weaker than their classical pendants. Neither the principle  $(\neg\neg p \rightarrow p)$ , which corresponds to the rule of **Double Negation Elimination**, nor the **Law of Excluded Middle**  $(p \vee \neg p)$  are intuitionistic theorems. **Relevance logic** seeks to exclude classically valid inferences that seem irrelevant, such as the inference from  $\{p, \neg p\}$  to  $q$ . Non-monotonic logic deals with inferences that are valid by default but are defeasible, so that  $\phi$  may be a consequence of  $\Gamma$  but not of all supersets of  $\Gamma$  [3].

### First-Order Predicate Logic

The sentences of **PL** are ultimately composed of unstructured sentence letters. A language **L1** for first-order predicate logic forms its simplest sentences from sub-sentential expressions. **Individual constants** like  $a, b, c$  roughly play the role of ordinary proper names that designate particular **things**, persons, or (like “ $\pi$ ”) numbers. Monadic **predicate letters** like  $F^1$  and  $G^1$  can be compared to simple ordinary predicates such as “is red” or “is a dog”. Dyadic (in general:  $n$ -place) predicate letters like  $R^2$  (in general:  $R^n$ ) are comparable to ordinary relational predicates such as “is larger than” or “is a child of”.  $F^1 a$  and  $R^2 ab$  are **atomic sentences**

that, given an appropriate interpretation, can mean that Fido is a dog and that Ann is a child of Bob. Atomic sentences form truth-functional compounds such as  $(F^1a \rightarrow G^1a)$ . In addition, there are ►individual variables  $x, y, z, \dots$  that can take the positions of individual constants. Variables do not stand for particular things, but “range over” a fixed ►domain of individuals. Hence expressions like  $F^1x, R^2xy$  or  $(F^1x \rightarrow G^1x)$  have no truth conditions and are not sentences, but mere *formulas*. Prefixed with ►universal quantifiers or ►existential quantifiers like  $\forall x$  and  $\exists x$  that bind the otherwise free variables in such formulas they yield quantified sentences. The ►universal quantification  $\forall x F^1x$  can mean that everything we are talking about is a dog, the ►existential quantification  $\exists x F^1x$  that at least one of the things we are talking about is a dog. “Every dog is brown” is construed as “For every  $x$ : if  $x$  is a dog,  $x$  is brown” and translated as  $\forall x(F^1x \rightarrow G^1x)$ . “Some dogs are brown” is translated as  $\exists x(F^1x \wedge G^1x)$ , “Everybody is a child of someone” as  $\forall x \exists y R^2xy$ .

Truth conditions are stated relative to ►interpretations. An interpretation  $\mathbf{I}$  is a pair  $\langle \mathbf{D}, \mathbf{I} \rangle$  of a non-empty set of individuals  $\mathbf{D}$ , called the domain of  $\mathbf{I}$ , and an ►interpretation function  $\mathbf{I}$  (we use the same symbol for the interpretation and the interpretation function).  $\mathbf{I}$  assigns to every individual constant an element of  $\mathbf{D}$ , to every monadic predicate letter a subset of  $\mathbf{D}$ , and to every dyadic (in general:  $n$ -place) predicate letter a dyadic relation, i.e. a set of ordered pairs  $\langle u, v \rangle$  (in general: of  $n$ -tuples) of elements of  $\mathbf{D}$ . A monadic atomic sentence such as  $F^1a$  is true under an interpretation  $\mathbf{I}$  iff  $\mathbf{I}(a)$  is a member of  $\mathbf{I}(F^1)$ , e.g. iff Fido is a member of the set of dogs. The dyadic atomic sentence  $R^2ab$  is true under an interpretation  $\mathbf{I}$  iff the pair  $\langle \mathbf{I}(a), \mathbf{I}(b) \rangle$  is a member of the relation  $\mathbf{I}(R^2)$ . Truth-functional compounds have truth conditions in accordance with propositional logic. E.g.,  $(F^1a \rightarrow G^1a)$  is true under  $\mathbf{I}$  iff  $F^1a$  is not true under  $\mathbf{I}$  or  $G^1a$  is true under  $\mathbf{I}$ .

The truth conditions of quantifications like  $\forall x F^1x$  or  $\exists x F^1x$  cannot be reduced to those of a mere formula like  $F^1x$ , as it has no truth conditions. But replace in  $F^1x$  the variable  $x$  by an arbitrary individual constant that does not already occur in the quantification under consideration, e.g. by  $a$ . The truth conditions of  $\forall x F^1x$  and  $\exists x F^1x$  under an interpretation  $\mathbf{I}$  can then be explained in terms of truth conditions of the sentence  $F^1a$  under interpretations closely related to  $\mathbf{I}$  [4]. An  $a$ -►variant of  $\mathbf{I}$  is an interpretation that is exactly like  $\mathbf{I}$  except for the fact that it may assign to the constant  $a$  a different member of the domain  $\mathbf{D}$  than  $\mathbf{I}$  does.  $\forall x F^1x$  is true under  $\mathbf{I}$  iff  $F^1a$  is true under every  $a$ -variant of  $\mathbf{I}$ .  $\exists x F^1x$  is true under  $\mathbf{I}$  iff  $F^1a$  is true under at least one  $a$ -variant of  $\mathbf{I}$ . Modern logic systematically yields truth conditions for arbitrarily complex quantifications. E.g.,  $\forall x \exists y R^2xy$  is true under  $\mathbf{I}$  iff  $\exists y R^2ay$  is true under any

$a$ -variant  $\mathbf{I}'$  of  $\mathbf{I}$ ; which is the case iff  $R^2ab$  is true under at least one  $b$ -variant  $\mathbf{I}''$  of any  $a$ -variant  $\mathbf{I}'$  of  $\mathbf{I}$ . If we read  $R^2$  as “is a child of”,  $\forall x \exists y R^2xy$  is true iff, no matter which person is assigned to  $a$ , there will always be an assignment to  $b$  such that the person assigned to  $a$  is a child of the person assigned to  $b$ ; in short, iff everybody is a child of someone.

A sentence of **L1** is *logically true* (false) just in case it is true (false) under every interpretation (rather than valuation). For example,  $(\forall x F^1x \leftrightarrow \neg \exists x \neg F^1x)$  and  $(\exists x F^1x \leftrightarrow \neg \forall x \neg F^1x)$  are logical truths. Similarly, logical equivalence, consistency, logical consequence, and logical validity are defined in analogy to the notions of propositional logic. A *model* of a set of sentences  $\Gamma$  is an interpretation under which all sentences in  $\Gamma$  are true.

A calculus for predicate logic is an extension of a calculus for propositional logic. Here are typical applications of the two natural deduction rules for universal quantifications: (i) From the premise  $\forall x(F^1x \rightarrow G^1x)$  one may move by ►universal specialization to  $(F^1a \rightarrow G^1a)$ . Given  $F^1a$  as a further premise, modus ponens yields  $G^1a$ . (ii)  $(F^1a \vee \neg F^1a)$  is a theorem of propositional logic. Since its derivation does not draw on any premise that involves  $a$ , one may move by ►universal generalization to the theorem  $\forall x(F^1x \vee \neg F^1x)$ . There are complementary rules of existential specialization and generalization.

The standard calculi for first-order predicate logic are sound and complete:  $\varphi$  can be derived from  $\Gamma$  iff  $\varphi$  is a logical consequence of  $\Gamma$ . But predicate logic is *undecidable*: there is no procedure that for any input  $\varphi$  and  $\Gamma$  stops after a finite number of steps to give output “YES” if and only if  $\varphi$  is a consequence of  $\Gamma$ .

## Second-Order Predicate Logic

Elementary predicate logic is called ►first-order logic, because it only allows for variables in the places of *individual* constants. However, translating “Ann and Bob have something in common” as  $\exists X^1(X^1a \wedge X^1b)$  requires quantification into predicate positions and hence a language **L2** for ►second-order logic. The price is *incompleteness*: there is no correct calculus **C** such that for any  $\Gamma$  and  $\varphi$  of **L2**, if  $\Gamma \models \varphi$  then  $\Gamma \vdash_{\mathbf{C}} \varphi$ . Many philosophers think that predicate variables like  $X^1$  would have to range over sets, that second-order logic is therefore ontologically committal and not part of logic proper. All results mentioned concerning completeness, undecidability and incompleteness go back to K. Gödel, A. Church and A. Turing.

## Modal Logic and Philosophical Logics

The semantics considered so far have been *extensional*. For example, sentence letters are assigned truth-values, but no intensional contents such as the proposition that grass is green. A model-theoretic approach to the logic of modal operators like “It is possible that...” ( $\diamond$ ) and

“It is necessary that...” ( $\Box$ ) requires an *intensional* semantics. Sentences like  $\Diamond p$ ,  $\Diamond \Box \neg p$ ,  $\Box(p \rightarrow q)$  or  $(\Box p \rightarrow \Box q)$  for modal propositional logic are obtained by adding a clause to the syntax of **PL**: If  $\varphi$  is a sentence, so are  $\Diamond \varphi$  and  $\Box \varphi$ . The semantics rests on a structure  $\mathbf{S} = \langle \mathbf{W}, \mathbf{R} \rangle$  that consists of a set  $\mathbf{W}$  of entities  $w$  called **possible worlds** and an **accessibility relation**  $\mathbf{R}$  between those worlds. A valuation  $\mathbf{V}(\sigma, w)$  now assigns truth-values to sentence letters  $\sigma$  relative to worlds in  $\mathbf{W}$ .  $\mathbf{V}$  thereby determines for any letter  $\sigma$  a function from possible worlds in  $\mathbf{W}$  to the truth values T and F. Intuitively, this intension of  $\sigma$  is the proposition expressed by  $\sigma$  because it tells us what a possible world scenario has to be like in order to render  $\sigma$  true.

As seen from our world, it is possible (necessary) that  $p$  just in case  $p$  is true at (or in) at least one (at every) possible world that is accessible from actuality. In general,  $\Diamond \varphi$  is true under  $\mathbf{V}$  at world  $w$  iff there is a world  $w'$  that is accessible from  $w$  such that  $\varphi$  is true under  $\mathbf{V}$  at  $w'$ .  $\Box \varphi$  is true under  $\mathbf{V}$  at world  $w$  iff for every world  $w'$  that is accessible from  $w$   $\varphi$  is true under  $\mathbf{V}$  at  $w'$ .  $\Diamond \varphi$  is equivalent to  $\neg \Box \neg \varphi$ , and  $\Box \varphi$  to  $\neg \Diamond \neg \varphi$ . Logical truth of  $\varphi$  is its truth at any world  $w$  of any structure  $\mathbf{S}$  under any valuation  $\mathbf{V}$ . The other logical notions are defined accordingly. The sound and complete standard calculi K, T, B, S4 and S5 for modal propositional logic correspond to different formal restrictions on the accessibility relation  $\mathbf{R}$  such as reflexivity, symmetry or transitivity.

Adding  $\Diamond$  and  $\Box$  to predicate logic yields **quantified modal logic**. Quantifiers and modal operators can interact in two different ways:  $\Diamond \exists x(F^1x \wedge \neg F^1x)$  is a **de dicto** modal statement to the effect that it might have been the case that something is both F and non-F, which is logically false.  $\exists x(F^1x \wedge \Diamond \neg F^1x)$  is a **de re** modal statement to the effect that there is something F that might have been non-F, which may well be true. The nature of possible worlds and de re modalities is a serious philosophical problem.

Philosophical logics such as **tense logic**, **epistemic logic** or **deontic logic** use the techniques of modal semantics to formulate theories for philosophically important concepts. E.g., “ $s$  believes/knows that  $p$ ” is construed as meaning that  $p$  holds in all possible worlds that are compatible with what  $s$  believes/knows.

### Non-Deductive Reasoning and “Inductive Logic”

Not every intuitively “good” inference *guarantees* the truth of the conclusion given the truth of the premises. The fact that the polls are 58:42 in favor of the president 3 days before the election strongly *supports* the conclusion that the president will win, but cannot guarantee its truth. Theories of non-deductive rationality seek to specify this kind of support. Typically they apply the main theorem of classical probability theory: for a scientific hypothesis  $h$  and

experimental evidence  $e$  Bayes’ theorem  $P(h|e) = P(h) \cdot P(e|h) / P(e)$  says that the probability of  $h$ ’s being true given  $e$  equals the unconditional **prior probability** of  $h$  times the *likelihood* of  $e$  given  $h$  divided by the unconditional probability of  $e$ . Carnap’s idea of inductive logic was that the prior probability of a hypothesis was determined by its logical structure, so that the degree of support of  $h$  by  $e$  was a completely objective affair. Today most philosophers believe that we must accept a subjective input (**Subjectivity**). A family of theories of non-deductive rationality has emerged, some members of which are probability logic, confirmation theory, decision theory, and the theory of **belief revision**.

## References

- Goble L (2001) (ed) The Blackwell guide to philosophical logic. Blackwell, Oxford
- Kneale H, Kneale M (1984) The development of logic. Clarendon Press, Oxford
- Priest G (2001) An introduction to non-classical logic. Cambridge University Press, Cambridge
- Mates B (1972) Elementary logic, 2nd edn. Blackwell, Oxford

## Long Latency Reflex

### ▶ Long Loop Reflexes

## Long Loop Reflexes

VAUGHAN G. MACEFIELD

School of Medicine, University of Western Sydney, Sydney, NSW, Australia; Prince of Wales Medical Research Institute, Sydney, NSW, Australia

### Synonyms

Transcortical reflex; Long latency reflex; LLR; M2; E2

### Definition

Long loop reflexes are automatic motor responses to somatosensory stimuli that are believed to operate via the cerebral cortex, hence the term **transcortical reflexes**. By definition, long loop reflexes occur at latencies too long to be mediated by segmental circuits

within the spinal cord yet too short to be mediated volitionally. For muscles in the hand, the fastest (spinal) reflexes (►[Segmental reflexes](#)) to muscle stretch occur at latencies  $\sim 35$  ms; long loop reflexes occur at latencies  $\sim 60$  ms, whereas volitional responses occur at  $\sim 140$  ms. However, automatic motor responses of comparable latencies can also be generated by tactile (cutaneous) stimuli that do not involve muscle stretch, so the term “long loop reflex” should not be restricted to those generated by muscle stretch. The term “►[functional stretch reflex](#)” was introduced to describe the long-latency responses recorded in calf muscles following a sudden disturbance of the ankle joint, but given that these occur at volitional latencies this term should not be used synonymously with the long-latency response.

### Characteristics Muscle Reflexes

The first demonstration of a long latency reflex in humans came from studies by Hammond in 1954, who showed that forceful extension of the elbow causes a short-latency increase in EMG followed by a long-latency increase; later responses, which could be influenced by instructions to the subject (e.g. to pull hard or to let go on detecting the movement), occurred at volitional latencies. The first quantitative studies, performed by Marsden, Merton and Morton [1], examined the stretch reflex in flexor pollicis longus (FPL): brisk extension of the interphalangeal joint of the thumb causes a small short-latency response (SLR; M1) but a much larger long-latency response (LLR; M2); studies in patients with lesions of ascending sensory pathways in the spinal cord, or lesions in the sensorimotor cortex or capsular pathways, demonstrated that M2, but not M1, was abolished, thereby cementing the idea that M2 was truly a long-loop reflex [2]. Nevertheless, various counter arguments were presented, including fractionated discharge in the firing of ►[muscle spindle primary endings](#) or slow transmission of stretch-evoked activity in ►[muscle spindle secondary endings](#): there is no doubt that the dynamically sensitive primary endings (►[Ia afferents](#)) are responsible for the early spinal reflex (M1), but it was postulated that the slower-conducting secondary muscle spindle afferents (►[Group II afferents](#)) could be responsible for the long-latency response - in other words, M2 was simply a spinal reflex generated by slower-conducting sensory inputs. An elegant experiment performed by Matthews, the proponent of the latter hypothesis, resulted in the hypothesis being by his own work: slowing nerve conduction by cooling the arm resulted in proportional delays in the M1 and M2 components (not the hypothesized greater slowing of M2), i.e. the two components were generated by the same class of muscle afferent [3]. The relative

magnitudes of the M1 and M2 components to stretch of upper limb muscles vary according to the muscle: M1 is larger than M2 in biceps, but the reverse is true in FPL and first dorsal interosseous (FDI). Stretch of FDI causes a small short-latency response at  $37 \pm 2$  ms and a larger long-latency response and  $59 \pm 1$  ms [4].

### Cutaneous Reflexes

Electrical stimulation of the digital nerves of the index finger (which activates cutaneous and joint afferents), evokes in most subjects a short-latency ( $35 \pm 1$  ms) excitatory response (termed E1), subsequent inhibitory response (I1), and in all subjects a large long-latency response (E2;  $58 \pm 1$  ms) in the first dorsal interosseous muscle (FDI) [5]. Natural stimulation of cutaneous afferents also evokes short- and long-latency excitatory responses. Unpredictable pulling forces applied to an object held between the index finger and thumb evoke reactive increases in grip force that serve to prevent escape of the object from the grasp. In most studies only a long-latency component is produced, but if the stimulus is brisk enough a smaller short-latency component can also be generated: the short- and long-latency responses to fast pulling loads (64 N/s) occur at  $35 \pm 1$  ms and  $59 \pm 2$  ms, respectively [6], latencies comparable to those produced by stretch of FDI [4]. [Figure 1](#) shows records from one subject instructed to restrain a manipulandum using only his index finger and to prevent its escape: in one set of trials the manipulandum was covered with slippery material (rayon; thin lines) and in the other was attached to the subject's finger with double-sided tape (thick lines). Short- and long-latency responses, as well as responses at volitional latencies, occurred even when the manipulandum could not escape, indicating that it is the shear forces developed between the skin and the grasped object – rather than slips *per se* – that trigger these responses. It is known that tactile afferents bear sole responsibility for triggering the short- and long-latency responses to these types of stimuli (see ►[Cutaneous mechanoreceptors, functional behavior](#)).

### Higher Level Structures

While short-latency EMG responses can only be mediated by spinal pathways, it is believed that long loop reflexes can be mediated by pathways involving the cerebral cortex. Much of this comes from latency considerations: given that the average onset latency of the long-latency EMG response in muscles of the hand is  $\sim 60$  ms, and it takes  $\sim 20$  ms for a sensory volley to reach the sensorimotor cortex from a finger muscle and a similar delay for a cortico-motoneuronal volley to reach the muscle, some 20 ms is available for cortical processing of the afferent volley and generation of an appropriate response. There is considerable evidence in the monkey for rapid transmission of Ia afferent

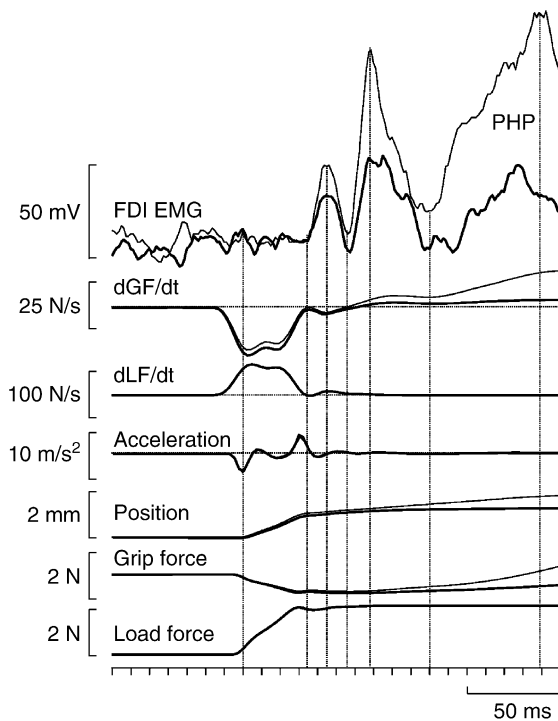

**Long Loop Reflexes. Figure 1** Averaged records from one subject during application of 2-N pulling loads (64 N/s) to the pad of the index finger. Traces shown with thin lines were obtained in which the contact surface of the manipulandum was rayon (128 trials); traces shown with thick lines were obtained when the finger pad was stuck to the manipulandum with double-sided tape (128 trials), which prevented slips from occurring. Vertical lines refer to the rayon condition and indicate the following temporal events: stimulus onset, onset and peak of short latency response, onset and peak of long latency response, onset and peak of volitional responses (Reproduced from [6]).

activity and modulation of the discharge of corticospinal motoneurons by muscle stretch. In addition to the studies of neurological lesions in patients referred to above [2], transcranial magnetic stimulation (TMS) provided further evidence for cortical involvement in the long-latency stretch reflex in humans: when brief stimuli were delivered to the motor cortex at a time coinciding with the long-latency response (but not the short-latency response) there was facilitation of the EMG that was greater than that produced by transcranial electrical stimulation (TES); based on the differential sites of action of TMS and TES this was interpreted as an increase in excitability of the motor cortex during the long-latency stretch reflex [7]. Interestingly, this same approach failed to demonstrate that long-latency responses to tactile stimulation were associated with an increase in motor cortex excitability (in the majority of subjects), suggesting that – unlike

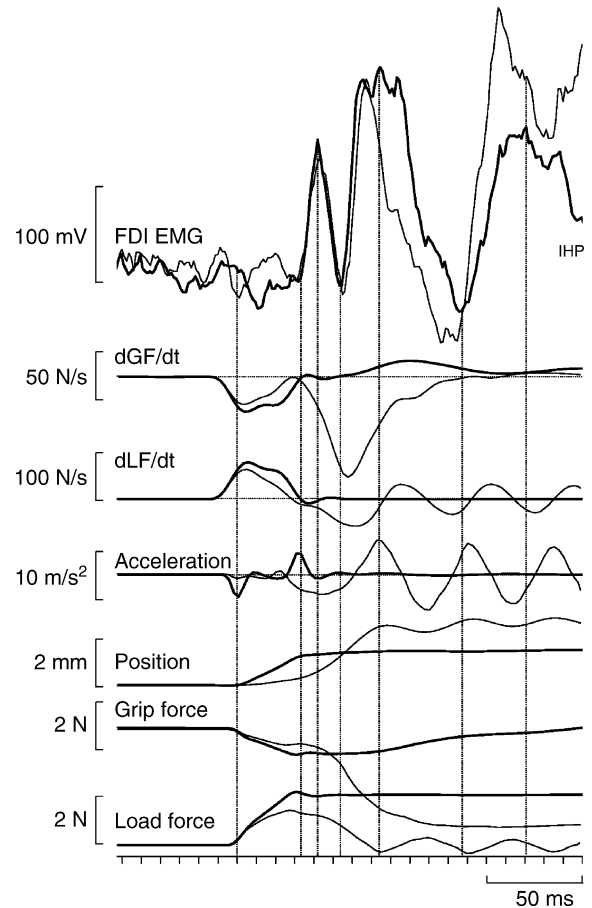

**Long Loop Reflexes. Figure 2** Averaged records from one subject during application of 2-N pulling loads (64 N/s) to the pad of the index finger. The contact surface of the manipulandum was sandpaper. Traces shown with thick lines were obtained for trials ( $n = 128$ ) in which overt slips did not occur, and trials with slips ( $n = 30$ ) are represented by the traces with thin lines. For the latter the display gains of the acceleration and position records have been reduced to 50 m/s<sup>2</sup> and 20 mm, respectively, for clarity. Vertical lines refer to the non-slip condition and indicate temporal events as in Fig. 1 (Reproduced from [6]).

the long-latency responses to muscle stretch – these cutaneomotor reflexes are not mediated by a transcortical mechanism [4]. Nevertheless, neurological studies in patients do support the concept that – like the long-latency responses to muscle stretch – those to cutaneous stimulation do require integrity of the dorsal columns of the spinal cord, the sensorimotor cortex, and descending corticomotoneuronal pathways [8].

### Function

Given that long latency stretch reflexes, at least those acting on the hand, contribute to positional servo-assistance, it is generally accepted that these responses

are functionally significant. Indeed, they can be so effective that volitional responses may be absent: sensorimotor control is thereby delegated to an automatic mode of operation, one that requires no conscious oversight. This is particularly the case for the long-latency tactile reflexes, in which purposeful control of grip force – subserved by cutaneous afferents – can be achieved without volitional intervention. **Figure 2** illustrates the responses to unexpected pulling loads that, in some trials, resulted in overt slips and escape of the manipulandum: it can be seen that the long-latency increases in EMG did contribute to the maintenance of an adequate grip force. Indeed, the short-latency responses are probably of negligible importance.

### Pathology

As noted above, long-latency – but not short-latency – responses are absent in patients with dorsal column lesions, or lesions within the sensorimotor cortex [2,8]. Mirror movements, in which a command to move one hand causes movements in the contralateral hand, are characteristic features of people with Klippel-Feil syndrome, in whom corticospinal projections are branched and innervate both sides of the body: stretch of FDI in a patient with this syndrome generated short- and long-latency responses on the ipsilateral side, but also a long-latency response on the contralateral side, lending support to the transcortical nature of this long loop reflex [9]. However, studies of cutaneous reflexes in patients with X-linked Kallmann's syndrome do not support a transcortical mechanism [10], a conclusion reached elsewhere [5].

### References

- Marsden CD, Merton PA, Morton HB (1972) Servo action in human voluntary movement. *Nature* 238:140–143
- Marsden CD, Merton PA, Morton HB, Adam J (1977) The effect of posterior column lesions on servo responses from the human long thumb flexor. *Brain* 100:185–200; The effect of lesions of the sensorimotor cortex and the capsular pathways on servo responses from the human long thumb flexor. *Brain* 100:503–526
- Matthews PBC (1989) Long-latency stretch reflexes of two intrinsic muscles of the human hand analysed by cooling the arm. *J Physiol* 419:519–538
- Macefield VG, Rothwell JC, Day BL (1996) The contribution of transcortical pathways to long-latency stretch and tactile reflexes in human hand muscles. *Exp Brain Res* 108:147–154
- Evans AL, Harrison LM, Stephens JA (1989) Task-dependent changes in cutaneous reflexes recorded from various muscles controlling finger movement in man. *J Physiol* 418:1–12
- Macefield VG, Johansson RS (2003) Loads applied tangential to a fingertip during an object restraint task can trigger short-latency as well as long-latency EMG responses in hand muscles. *Exp Brain Res* 152:143–149
- Day BL, Riescher H, Struppler A, Rothwell JC, Marsden CD (1991) Changes in the response to magnetic and electrical stimulation of the motor cortex following muscle stretch in man. *J Physiol* 433:41–57
- Jenner JR, Stephens JA (1982) Cutaneous reflex responses and their central nervous pathways studied in man. *J Physiol* 333:405–419
- Matthews PBC, Farmer SF, Ingram DA (1990) On the localization of the stretch reflex of intrinsic hand muscles in a patient with mirror movements. *J Physiol* 428:561–577
- Harrison LM, Mayston MJ, Johansson RS (2000) Reactive control of precision grip does not depend on fast transcortical reflex pathways in X-linked Kallmann subjects. *J Physiol* 527:641–652

## Longitudinal Fissure of Cerebrum

### Synonyms

Fissura longitudinalis cerebri; Longitudinal cerebral fissure

### Definition

Inter-hemisphere fissure.

It separates the two hemispheres from each other. Deep in the fissure is located the corpus callosum. Encountered here are the large fiber bundles exchanging information across the two hemispheres.

Tumor or hemorrhage in the longitudinal fissure of cerebrum generally triggers symptoms in both body halves. Accordingly, flaccid paralysis of both legs can be induced by a pathological event at the level of area 4. A tumor at the level of area 4 can cause complete blindness.

► Telencephalon

## Long-Lead Burst Neurons (LLBNs)

### Definition

On the basis of the time interval between the beginning of the burst and the onset of the saccade (latency), burst neurons can be subdivided into long-lead and medium-lead burst neurons. LLBNs have a longer latency than that of MLBNs and usually have an irregular prelude of activity that begins more than 100 ms before the saccade.

► Burster-Driving Neurons

► Saccade, Saccadic Eye Movement

## Long-Term Depression (LTD)

### Definition

Prolonged low-frequency activation of synapses sometimes causes a long-lasting decrease of synaptic efficacy referred to as long-term depression at central synapses in some brain regions such as the hippocampus and cerebral cortex.

- ▶ Memory, ▶ Molecular Mechanisms
- ▶ Associative Long-Term Potentiation (LTP)
- ▶ Long-Term Potentiation (LTP)

## Long-term Facilitation

- ▶ Long-Term Potentiation

## Long-Term Memory

HIROTAKA TANABE

Department of Neuropsychiatry, Neuroscience, Ehime Graduate School of Medicine, Shitsukawa, Japan

### Synonyms

Long-term memory storage; Recent and remote memory; Declarative and nondeclarative memory

### Definition

Long-term memory refers to information derived from one's lifelong experience, or system to store information occurred in the past.

### Characteristics

#### Neuropsychology of Human Memory

##### Amnesia

Amnesia (isolated memory disorder) refers to a specific clinical condition in which there is impairment in the ability to learn new information despite normal attention and intact cognitive function such as perception, language and intelligence. Clinical studies of amnesics revealed that memory consisted of dissociable systems that accomplish different forms of learning and

that are mediated by distinct neural networks. Namely, memory is not a single entity but entails a number of different aspects of mental faculty. Here, recent classifications of memory widely used along with neural substrates for individual memory systems and amnesia following cerebrovascular diseases and degenerative disease will be surveyed.

### Time Aspect of Memory

The stages of memory processing are generally divided into encoding, storage and retrieval. With respect to the time span, clinicians have divided memory into the following three stages. *Immediate memory* that is usually evaluated by serial repetition as typified by the digit span verbally or by the block-tapping test non-verbally, has a time course measured in seconds. This corresponds to *short-term memory* used in the domain of psychology. Immediate memory is preserved in amnesic patients and its impairment suggests attention disorders as in confusional state or major cognitive deficits as in dementia. Working memory, that is another meaning of the short-term memory concept, refers to a system comprised of an executive component that guides goal-directed behaviors and short-term memory stores [1]. This memory is linked to the dorsolateral prefrontal cortex. *Recent memory* is evaluated by tests of the ability to learn new information (e.g., The Logical Memory subtest of Wechsler memory scale-revised [2]). *Remote memory* is assessed by tests of the ability to retrieve old, already learned information. Recent and remote memory is tested by free recall as well as recognition techniques. Thus, recent and remote memory refers to retention over longer periods of time and together encompasses the total of our remembered experiences. Recent and remote memory corresponds to long-term memory used in the domain of psychology. Recent memory loss is a main characteristic of amnesic patients.

There is another important distinction of memory about the time aspect. Anterograde amnesia refers to the inability to retain information encountered subsequent to the onset of amnesia, while retrograde amnesia refers to the inability to retrieve information learned prior to the onset of amnesia. Amnesic patients with vascular etiology usually exhibit a temporally limited retrograde amnesia with intact memory for very remote events in addition to anterograde amnesia.

### Kinds of Long-Term Memory

Most widely accepted classification in neuropsychology is dichotomy of declarative and nondeclarative memory (Fig. 1). Each memory has subordinate systems where distinctive learning and memory abilities are operated according to demanding situations. ▶ **Declarative memory** is mainly affected with brain lesions including

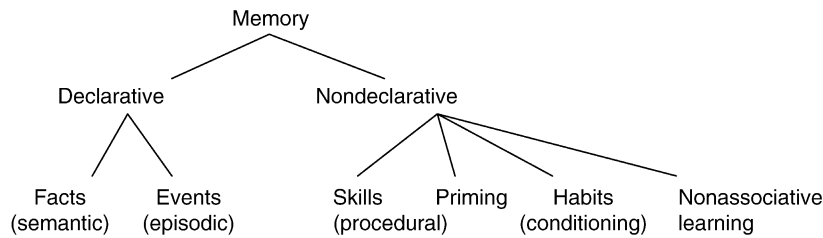

**Long-Term Memory. Figure 1** Components of long-term memory proposed by Squire and Zola-Morgan [3].

hippocampus and related structures causing amnesia while ►nondeclarative memory is spared.

Declarative memory is subdivided into episodic and semantic memory. These two subsystems are originally defined by Tulving [4]. Episodic memory refers to the system involved in recollecting past events in an individual's life. This system stores the cumulated experiences or episodes of one's life, an individual ►autobiographical memory, in which an event can be associated with a context. Hence episodic memory can be located in time and place. On the other hand, it doesn't need such contextual information to access more generalized knowledge as ►semantic memory. The most representative component of semantic memory is our knowledge of the meaning of words.

The distinction between declarative and ►procedural memory is based on the view that procedural learning represents the acquisition of skills, "learning how," while declarative learning involves the acquisition of facts, "learning what" [3]. ►Priming effects are mainly assessed using perceptual priming tasks such as word stem completion, in which words (e.g., motel) are presented and later cued by three-letter word stems (e.g., mot), and conceptual priming tasks such as word association techniques, in which words (e.g., patient) are presented and later asked to free associate to related words (e.g., hospital). According to learning theory, acquisition of ►habits is a result from conditioning. In classical conditioning a previously neutral stimulus such as a bell can cause unconditioned reflex as salivation if it is regularly paired with presentation of unconditioned stimulus as meat powder. In instrumental conditioning voluntary behavior is apt to maintain or reinforced if it leads to a reward.

In the domain of experimental psychology, distinction of explicit and ►implicit memory has also often been used. According to Schacter [5], this distinction depends on consciousness when retrieving information demanded by the memory task. Squire considers that declarative memory corresponds to ►explicit memory, while nondeclarative memory corresponds to implicit memory [3].

In amnesic patients, declarative memory is impaired, but nondeclarative memory is spared. Declarative memory, in particular episodic memory, depends on the integrity of brain structures and connections in the medial temporal lobe and the diencephalon. Amnesic patients can at least access to semantic memory, whereas they have great difficulty adding new knowledge to semantic memory. In recent years, selective semantic memory loss has been reported in patients with focal temporal lobe atrophy, in whom there are also little or no priming effects for words. Thus, lateral aspects of the temporal lobes are regarded as major importance for semantic memory [6].

Skill acquisition typically preserved in amnesic patients is impaired in patients with pathology in the basal ganglia such as Parkinson's disease and Huntington's disease. Recent studies revealed that basal ganglia and cerebellum plays a crucial role in the acquisition of procedural memory [1]. Thus, explicit and implicit memory is subserved by independent neural systems.

### Vascular Amnesic Syndromes

The medial temporal lobe and the diencephalon receive their blood supply from penetrating branches of the posterior cerebral artery. Bilateral damage to these structures causes persisting profound amnesia. Left hemispheric lesions principally affect memory for verbal material, while right hemispheric lesions memory for nonverbal material such as faces and spatial information.

### Medial Temporal Amnesia

Recent studies in humans and monkeys provide convergent evidence that the hippocampus and related structures such as the entorhinal and perirhinal cortices and the parahippocampal gyrus are responsible for the formation of new declarative memories [3]. Lesions confined to the medial temporal lobe structures produce pure amnesia, that is selective amnesia without other deficits such as loss of insight, confabulation and personality change. When the hippocampal formation is selectively damaged, amnesia is not so severe.



Additional damage to the above-mentioned surrounding cortical regions makes amnesia more severe [3].

### **Diencephalic Amnesia**

Diencephalic forms of amnesia arise following vascular accidents in the territories of the tuberothalamic or paramedian arteries. The lesion involves midline structures such as the mammillary bodies, the anterior nuclear group of the thalamus, the dorsomedial thalamic nucleus and two related fiber tracts (the mammillothalamic tract connecting the mammillary bodies with the anterior thalamic nuclei and the ventral amygdalofugal pathway connecting the amygdala with dorsomedial nucleus). Amnesic patients with diencephalic damage are often emotionally flat, apathetic, and without insight about their deficit. Confabulation is also frequently noted. These additional cognitive and personality disorders may be related to frontal lobe dysfunction presumably produced by damage to major link in a thalamo-frontal network [1]. Some authors suggest that diencephalic structures principally contribute to the acquisition of new information and are less involved in retrieval of previously learned knowledge [7]. However, it remains unclear that damage to diencephalic structures produces retrograde amnesia.

### **Basal Forebrain Amnesia**

Other than medial temporal and diencephalic structures, damage to basal forebrain may produce amnesia. The basal forebrain is thought to contribute to memory function by providing cholinergic innervation to the hippocampus. It is known that rupture of the anterior communicating artery causes amnesic syndromes with or without a change in personality, but the lesion usually encroaches not only basal forebrain but also adjacent structures such as striatum and ventral frontal cortex. Thus, it is controversial whether a focal basal forebrain lesion produces amnesia or not. Irle et al. suggested that discrete damage to the basal forebrain or striatum did not produce amnesia and combined lesions involving both the basal forebrain and striatum or ventral frontal cortex cause memory deficits [8]. The characteristic of this amnesia as well as the “cholinergic hypothesis” for the pathogenesis remains to be elucidated, even though Tranel and Damasio proposed the possibility that the basal forebrain contributes to the binding together of different modal components of a particular memory [7].

### **Related Syndrome**

#### **Transient Global Amnesia (TGA)**

TGA is a well-recognized clinical entity characterized as follows [9]. Patients suffer sudden anterograde and retrograde memory loss without other neurological signs or symptoms. They retain personal identity and are able to carry on normal activities. However, they are unable to acquire any new information, namely they

show complete anterograde amnesia. In addition, their inner world go back into a certain point of the past due to retrograde amnesia, while the outer world including their appearances are on the real time. As a result, various things incomprehensible to them develop in their immediate environment and situation. For example, one patient was astonished at a scar from a burn on her hand she had gotten 5 months before and asked her husband about the scar. Like this, the patients ask questions such as “What day is today?” and “Why am I here?” to try to grasp things incomprehensible to them or orient themselves into that particular situation. However, they cannot simultaneously retain answers due to the complete anterograde amnesia, so that they repeat the same questions despite repeated explanations. The retrograde memory loss, extending back for days, months or even years before the attack, gradually or quickly shrinks as the patients recover. No or only a brief period of permanent retrograde amnesia persists, but memory for events during the acute phase is permanently impaired. The amnesic episodes generally last several hours. Thus, the amnesic features of TGA closely resemble those of medial temporal amnesia. Actually, transient hypoperfusion limited to the medial temporal lobes has been demonstrated in SPECT images during the amnesic attack [10], although the pathogenesis remains unclear.

### **Memory Impairment of Primary Degenerative Dementia**

Memory deficits in the early stage of primary degenerative dementia were investigated in the light of the classification of memory systems from the standpoint of anatomo-clinical correlation. The results indicated the following.

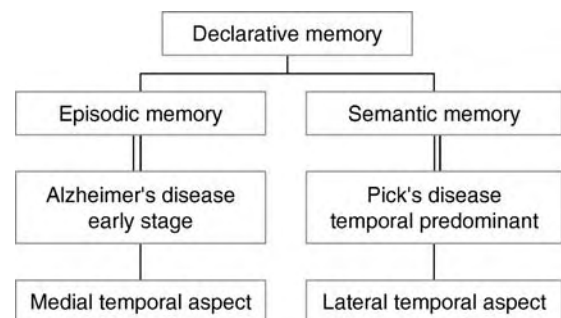

**Long-Term Memory. Figure 2** Neural basis of declarative memory suggested by distinctive symptomatology of each cortical dementia. Alzheimer's disease typically causes episodic memory deficit associated with damage of medial temporal lobe involving the hippocampal area. While semantic memory is selectively affected with semantic dementia associated with lateral temporal lobe atrophy.

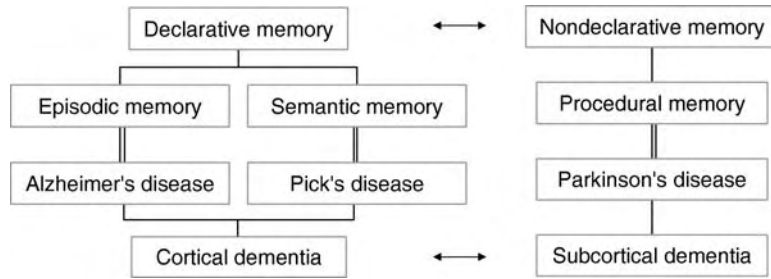

**Long-Term Memory. Figure 3** Relationship between memory systems and dementia. Declarative memory impairments caused by cortical dementia. Procedural memory (nondeclarative memory) impairment often occurs with subcortical dementia. *Double line* shows most closely and representatively affected memory system with each disease.

### Cortical Dementia

Declarative memory is affected in the context of preserved procedural memory, which is a kind of nondeclarative memory.

#### 1. Alzheimer's disease

Episodic memory is selectively involved without semantic memory loss. Nondeclarative memory is preserved. In atypical cases, progressive loss of episodic memory could remain the single most salient feature for some years.

#### 2. Pick's disease

In cases of lobar atrophy with temporal predominant type (semantic dementia), semantic memory is selectively affected without episodic memory loss. Involvement of the left temporal lobe results in semantic memory loss for words, while that of the right temporal lobe in semantic memory loss for faces. Neuroimaging studies on early cases of these diseases demonstrated that medial temporal lobe involving the hippocampal area is responsible for episodic memory loss, while lateral temporal lobe for semantic memory loss (Fig. 2).

### Subcortical Dementia

Procedural memory, a kind of nondeclarative memory, is affected in the context of preserved declarative memory. Involvement of subcortical nuclei such as caudate, putamen and substantia nigra is considered to be responsible for procedural memory loss. Hence, it is thought that striato-nigral systems are neuroanatomically important for procedural memory, while limbic systems including the hippocampal area for episodic memory. Furthermore, neurochemical findings obtained from diseases belonging to subcortical dementia such as Parkinson's disease, Huntington's disease and Progressive Supranuclear Palsy as well as Alzheimer's disease suggest the following; procedural memory is mainly subserved by noncholinergic systems such as dopaminergic systems and serotonergic systems, while episodic memory by the cholinergic system.

Thus, the distinct neuroanatomic and chemical substrates for the two memory systems may exist (Fig. 3).

### References

- Gabrieli JDE (1993) Disorders of memory in humans. *Curr Opin Neurol Neurosurg* 6:93–97
- Wechsler D (1987) Wechsler memory scale-revised. Psychological Corporation, New York
- Squire LR, Zola-Morgan S (1988) Memory: brain systems and behavior. *Trends Neurosci* 11:170–175
- Tulving E (1972) Episodic and semantic memory. In: Tulving E, Donaldson W (eds) *Organization of memory*. Academic, New York, pp 381–403
- Schacter DL (1992) Implicit memory. In: Squire LR (ed) *Encyclopedia of learning and memory*. Macmillan, New York
- Tanabe H, Nakagawa Y, Ikeda M, Hashimoto M, Yamada N, Kazui H, Nishikawa T, Okuda J (1996) Selective loss of semantic memory for words. In: Ishikawa K, McGaugh JL, Sakata H (eds) *Brain processes and memory*. Elsevier Science, Amsterdam, pp 141–152
- Tranel D, Damasio AR (1995) Neurobiological foundations of human memory. In: Baddeley AD, Wilson BA, Watts FN (eds) *Handbook of memory disorders*. Wiley, New York, pp 27–50
- Irle E, Kunert HJ, Hampl J, Kunze S (1992) Memory disturbance following anterior communicating artery rupture. *Ann Neurol* 31:473–480
- Tanabe H (1995) Memory deficit and awareness. In: Nakajima T, Ono T (eds) *Emotion, memory and behavior – study of human and nonhuman primates*. Japan Scientific Societies Press, Tokyo, pp 117–124
- Kazui H, Tanabe H, Ikeda M, Nakagawa Y, Shiraishi J, Hashikawa K (1995) Memory and cerebral blood flow in cases of transient global amnesia during and after the attack. *Behav Neurol* 8:93–101

## Long-Term Memory Storage

### ► Long-Term Memory

## Long-Term Potentiation (LTP)

TOSHIYA MANABE

Division of Neuronal Network, Department of Basic Medical Sciences, Institute of Medical Science, University of Tokyo, Tokyo

### Synonyms

Long-term synaptic potentiation; Long-term facilitation; LTP

### Definition

Long-lasting increase in the efficacy of synaptic transmission induced by special activation patterns of the synapse.

### Characteristics

#### Quantitative Description

LTP is an activity-dependent synaptic modification, usually induced by high-frequency activation (e.g., 100 Hz for 1 s) or theta burst stimulation of afferent fibers, for instance, in the hippocampus [1]. The magnitude of LTP at excitatory synapses in the CA1

region of hippocampal slices is typically 140–180% of baseline synaptic responses (Fig. 1) and the potentiation lasts for more than an hour. LTP recorded in the living animal sometimes lasts more than a day [2].

#### Higher Level Structures

LTP can be observed in both excitatory and inhibitory synapses formed between neurons. LTP is most dramatically induced in the hippocampus; however, it is also observed in other brain regions, such as the cerebral cortex, amygdala, cerebellum, spinal cord and so on.

#### Lower Level Components

LTP is a form of plasticity in synaptic transmission. It is evaluated by measuring the change in parameters recorded with electrophysiological methods, such as postsynaptic potentials, postsynaptic currents and population spikes.

#### Higher Level Processes

LTP in the hippocampus is regarded as a cellular basis for certain kinds of learning and memory. Pharmacological interruption of LTP induction often results in impairment of memory, for instance the memory

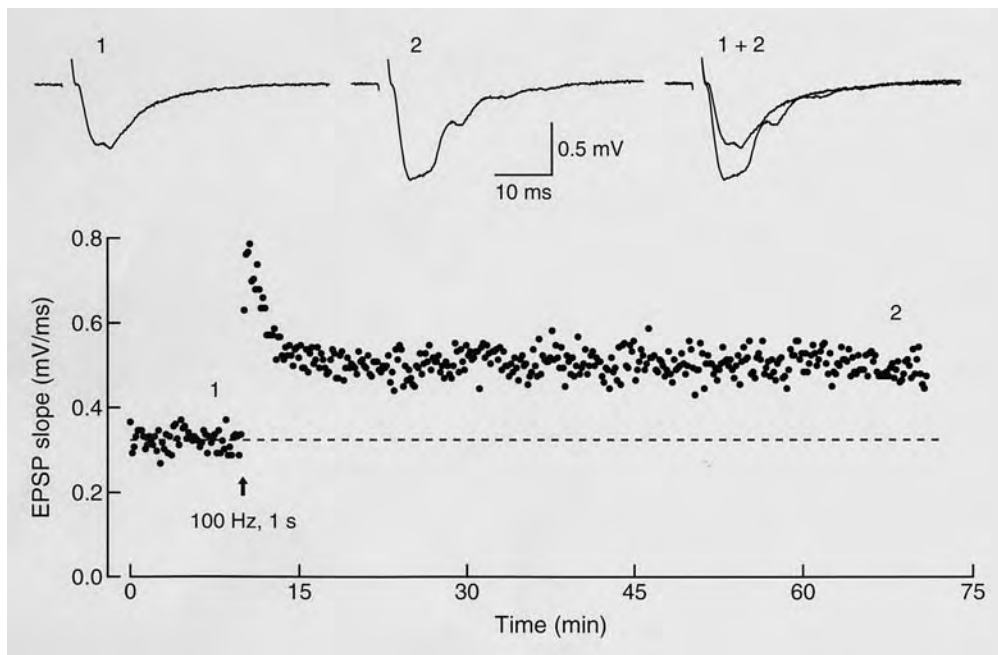

**Long-Term Potentiation (LTP).** **Figure 1** An example of LTP in the CA1 region of the hippocampus. Excitatory postsynaptic potentials (EPSPs) were recorded with field potential recording techniques, and initial maximal slope values were measured and plotted. Baseline EPSPs were evoked at 0.1 Hz by stimulating Schaffer collaterals in the stratum radiatum. High-frequency stimulation (100 Hz, 1 s) was applied at time 0, and then EPSPs were again recorded at 0.1 Hz. Representative EPSP traces recorded at the times indicated by the numbers in the graph are shown on the *upper panel*.

concerning the space [3]. Furthermore, gene manipulations that affect LTP induction or expression in the hippocampus cause memory impairment [4].

### Lower Level Processes

The commonest types of LTP at the excitatory synapse can be divided into two classes [5]. One is NMDA receptor dependent, and the other, NMDA receptor independent.

#### NMDA Receptor-Dependent LTP

This type of LTP is induced and expressed postsynaptically. High-frequency activity of synapses activates postsynaptic NMDA receptors in addition to AMPA receptors, which causes an increase in intracellular  $\text{Ca}^{2+}$  concentrations by the influx of  $\text{Ca}^{2+}$  through the NMDA receptor channel. Increased  $\text{Ca}^{2+}$  then activates a series of biochemical processes that are  $\text{Ca}^{2+}$  dependent, including calcium/calmodulin-dependent protein kinase II, which give rise to the insertion of active AMPA receptors to the postsynaptic membrane or the increase in the channel conductance of AMPA receptors preexisting on the postsynaptic membrane. This type of LTP is observed at Schaffer collateral-CA1 synapses or at perforant path-dentate gyrus synapses in the hippocampus.

#### NMDA Receptor-Independent LTP

This type of LTP is induced and expressed presynaptically. High-frequency activity of the presynaptic terminal strongly activates presynaptic  $\text{Ca}^{2+}$  channels, which causes an increase in  $\text{Ca}^{2+}$  concentrations at the presynaptic terminal. The increased  $\text{Ca}^{2+}$  then activates  $\text{Ca}^{2+}$ -dependent adenylate cyclase, which results in an increase in cAMP at the terminal. The resulting activation of protein kinase A is believed to be involved in the long-lasting enhancement of glutamate release from the presynaptic terminal. This type of LTP is observed at mossy fiber-CA3 synapses in the hippocampus or at parallel fiber-Purkinje cell synapses in the cerebellum.

### Process Regulation

#### Frequency

The induction of LTP is regulated by a variety of factors. The frequency of synaptic activation is one of the most critical factors: in the standard *in vitro* conditions, LTP is induced when the activation frequency is higher than 10 Hz, while long-term depression (LTD) is induced when the activation frequency is less than 5 Hz.

#### $\text{Ca}^{2+}$ Concentrations

It is generally believed that bidirectional regulation of synaptic efficacy is dependent on the level of postsynaptic  $\text{Ca}^{2+}$  concentrations: a moderate increase in postsynaptic  $\text{Ca}^{2+}$  concentrations preferentially

activates protein phosphatases, resulting in LTD, and a large increase in postsynaptic  $\text{Ca}^{2+}$  concentrations activates protein kinases, giving rise to LTP.

#### Metaplasticity

Metaplasticity is a type of synaptic plasticity that is induced by some patterns of synaptic activation, which do not necessarily cause the change in normal synaptic transmission, and affects subsequently occurring synaptic plasticity such as LTP or LTD [6]. Modification of NMDA receptors may play a critical role in metaplasticity, as well as other molecules such as metabotropic glutamate receptors or other G-protein-coupled receptors that might also be involved in metaplasticity.

#### Biochemical Processes

LTP lasting a few hours is mediated by modification of preexisting proteins such as  $\text{Ca}^{2+}$ /calmodulin-dependent protein kinases, tyrosine kinases, protein kinase C and so on, while a longer-lasting type of LTP is believed to involve synthesis of new proteins through gene expression [1]. Thus, LTP can be modified by the regulation of these biochemical processes.

#### Function

When the hippocampus is damaged, certain kinds of learning and memory are severely impaired in experimental animals and humans. The hippocampus is a center of declarative memory and can store neural information for some duration. In 1973, Bliss and Lømo [2] published a comprehensive paper concerning long-lasting modification of excitatory synaptic transmission in the hippocampus of living rabbits. The reported phenomenon is now called LTP. Since the hippocampus plays a critical role in declarative memory, LTP, which is easily and dramatically induced in the hippocampus, was already regarded at that time as a cellular model of memory formation. When NMDA receptors are inhibited in the rat by D-AP5, an NMDA receptor antagonist, and thus LTP induction is blocked, the rat shows severe impairment in spatial learning [3]. In mutant mice lacking NR2A (GluRε1), a subunit of NMDA receptors, LTP is considerably reduced and spatial learning is severely impaired [7]. On the other hand, in mice overexpressing the NR2B (GluRε2) subunit, LTP as well as learning ability is enhanced [8]. Quite a number of papers have appeared reporting the relationship between LTP and learning ability, and it is likely that LTP is involved in memory formation in some way, although there still lacks definitive, direct evidence supporting the conclusion.

#### Pathology

There are papers that report the impairment of LTP in aged mice and rats, Alzheimer's disease model mice and many kinds of mutant mice lacking functional molecules localized in the synapse [1].

## References

1. Lynch MA (2004) Long-term potentiation and memory. *Physiol Rev* 84:87–136
2. Bliss TVP, Lomo T (1973) Long-lasting potentiation of synaptic transmission in the dentate area of the anaesthetized rabbit following stimulation of the perforant path. *J Physiol* 232:331–356
3. Morris RGM, Anderson E, Lynch GS, Baudry M (1986) Selective impairment of learning and blockade of long-term potentiation by an *N*-methyl-D-aspartate receptor antagonist, AP5. *Nature* 319:774–776
4. Crawley JN, Paylor R (1997) A proposed test battery and constellations of specific behavioral paradigms to investigate the behavioral phenotypes of transgenic and knockout mice. *Horm Behav* 31:197–211
5. Nicoll RA, Malenka RC (1995) Contrasting properties of two forms of long-term potentiation in the hippocampus. *Nature* 377:115–118
6. Abraham WC, Bear MF (1996) Metaplasticity: the plasticity of synaptic plasticity. *Trends Neurosci* 19:126–130
7. Sakimura K, Kutsuwada T, Ito I, Manabe T, Takayama C, Kushiya E, Yagi T, Aizawa S, Inoue Y, Sugiyama H, Mishina M (1995) Reduced hippocampal LTP and spatial learning in mice lacking NMDA receptor  $\epsilon 1$  subunit. *Nature* 373:151–155
8. Tang YP, Shimizu E, Dubé GR, Rampon C, Kerchner GA, Zhuo M, Liu G, Tsien JZ (1999) Genetic enhancement of learning and memory in mice. *Nature* 401:63–69

## Long-Term Potentiation, Gene Expression

### Definition

LTP lasting a couple of hours requires modification of preexisting proteins at the synapse, but LTP lasting more than a few hours is believed to be mediated by intracellular biochemical processes that involve gene expression in the nucleus of the postsynaptic cell.

- ▶ Memory, ▶ Molecular Mechanisms
- ▶ Associative Long-Term Potentiation (LTP)
- ▶ Long-Term Potentiation (LTP)

## Lordosis

### Definition

Lordosis is a term used to describe arching of the back to facilitate vaginal penetration, and is mostly seen in quadrupedal animals.

- ▶ Sexual Reflexes

## Lou Gehrig's Disease

### Definition

- ▶ Amyotrophic lateral sclerosis

## Loudness

### Definition

This refers to values along a listener's judgmental dimension and quantifies the perceived "magnitude" of a sound.

- ▶ Psychoacoustics

## Low Back/Spine Pain

NIKOLAI BOGDUK

University of Newcastle, Newcastle Bone and Joint Institute, Royal Newcastle Centre, Newcastle, NSW, Australia

### Synonyms

Backache; Lumbago; Lumbar spinal pain

### Definition

There is no universally accepted definition of low back pain. The term encompasses any combination of what the International Association for the Study of Pain (IASP) defines as lumbar spinal pain and sacral spinal pain [1]. Essentially this means pain perceived anywhere in a region bounded superiorly by first lumbar vertebra, inferiorly by the caudal end of the sacrum, and laterally by the lateral margins of the back muscles or the sacrum.

This definition is based on where the patient perceives their pain. It does not presuppose or imply that the source of pain lies in this region. Often it does, but sometimes the source can be from structures beyond the immediate vicinity of the lumbar spine.

### Characteristics

#### Sources

The possible sources of low back pain can be local or remote. The local sources are any of the components of

the lumbar spine that receive an innervation. Remote sources are vessels and viscera that are not part of the lumbar spine, but which share a similar segmental nerve supply with the lumbar or sacral spine.

The lumbar spine and sacral region are innervated by the dorsal rami, ventral rami, and sinuvertebral nerves of the L1–L5 spinal nerves and the upper two or three sacral spinal nerves [2]. These nerves innervate the muscles and fascia of the lumbar spine, the dura mater at lumbar and sacral levels, the ligaments of the lumbar spine and sacroiliac joint, the lumbar zygapophysial joints and intervertebral discs, and the sacroiliac joint. Any of these structures can, potentially, be a source of low back pain [2].

Remote sources include the abdominal aorta, the bladder and uterus, the uterine tubes, and the ovary. Viscera of the posterior abdominal wall may appear to be a source of back pain, but it is not evident if the pain arises from the organ itself or as a result of irritation of the anterior structures of the lumbar spine.

Experimental studies in normal volunteers and in patients with back pain have shown that back pain can be evoked, or reproduced, by noxious stimulation of the posterior back muscles, the interspinous ligaments, the lumbar zygapophysial joints, the lumbar intervertebral discs, and the sacroiliac joint [2,3].

### Referred Pain

Referred pain is pain perceived in the territory of a nerve other than the nerve that innervates the source of pain [1,3]. Typically the other nerve is another branch of the same spinal nerve that innervates the source.

Pain stemming from lumbar or sacral spinal structures can be referred to the gluteal region or groin, into the thigh, and even into the leg as far as the foot. Such distributions have been shown for pain stemming from the lumbar interspinous ligaments, the lumbar zygapophysial joints, the lower lumbar intervertebral discs, and the sacroiliac joint [3]. The patterns of distribution tend to be segmental, in so far as pain from higher spinal segments tends to be referred more proximally in the lower limb or lower limb girdle. However, there is considerable overlap between patterns from different segments, and considerable variation between individuals, which prevents patterns being diagnostic of the segmental source of pain.

Referred pain is perceived deeply, and is dull and aching in quality, or like an expanding internal pressure. It is distributed over relatively broad areas. These features distinguish referred pain from radicular pain, which is lancinating or shooting in quality and travels into the lower limb along narrow bands [3].

### Associated Features

Low back pain can be associated with reflex activity in muscles. In experimental studies, this activity develops

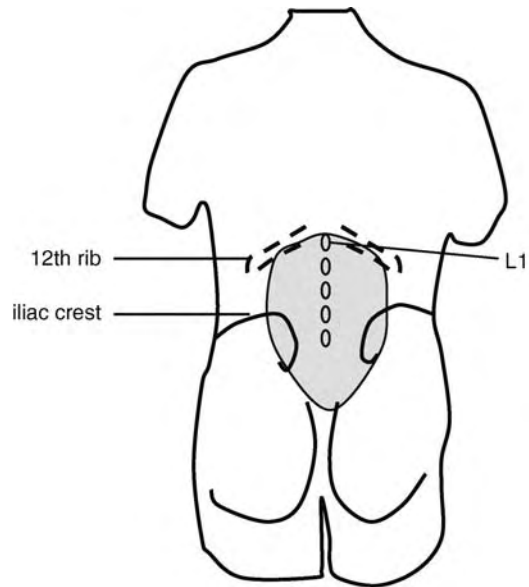

**Low Back/Spine Pain. Figure 1** Low back pain is pain perceived anywhere in the region shaded.

soon after the onset of pain, and typically lasts for as long as the pain is perceived. As a rule, it occurs in muscles with a segmental innervation similar to that of the source of pain. The muscles may be in the back (e.g., multifidus) or in the lower limb (e.g., gluteal muscles) or hamstrings [4] (Figs. 1 and 2).

### Causes

Although any innervated structure of the lumbar spine and sacrum can potentially be a source of back pain, evidence is limited as to what the actual sources and causes of pain are, either generally in populations or specifically in individual patients. At one time or another, during the last 100 years, virtually every structure of the lumbar spine has been invoked as the source of pain, and various conjectures have been raised as to its cause.

The International Association for the Study of Pain lists some 96 entities that could be causes of back pain [1]. However, the problem that has impeded progress in this field is the lack of reliable and valid diagnostic tests. Whereas various authorities have proposed various entities, they have not produced diagnostic tests that diagnose that entity and distinguish it from other possible causes of pain. Consequently, although the IASP provides diagnostic criteria for many entities, these criteria cannot be satisfied for lack of reliable and validated diagnostic tests.

Tumors and infections are accepted causes of low back pain, but they are rare. They account for fewer than 1% of cases of acute low back pain, and probably fewer than 5% of cases of chronic low back pain [3].

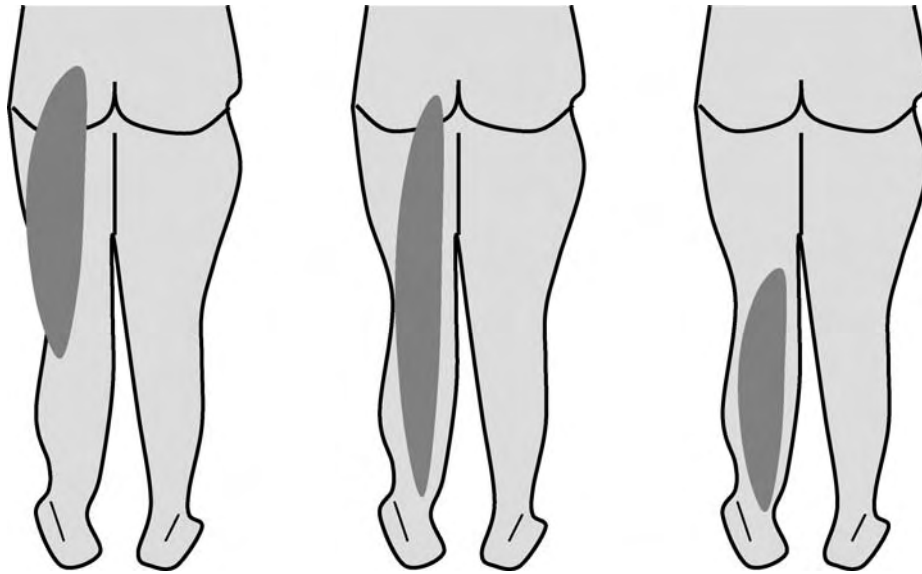

**Low Back/Spine Pain. Figure 2** Patterns of referred pain evoked by noxious stimulation of the lumbar zygapophysial joints, lumbar intervertebral discs, or the sacroiliac joint.

Likewise, fractures are rare causes of back pain, other than in patients who are at high risk of having sustained a fracture. Those risk factors are age, severe trauma, osteoporosis, and long-term use of corticosteroids [3].

Many practitioners believe that disorders of muscles can cause back pain. These have been described as trigger points, spasm, imbalance, and insufficiency. However, no reliable and valid test allows these conditions to be unequivocally diagnosed.

Some practitioners believe that ligament sprain can be a cause of low back pain, but there is only limited evidence for this contention. Injecting the affected ligament with local anaesthetic purportedly relieves this pain, but no controlled studies have demonstrated this. Therefore, a non-specific or placebo-effect has not been excluded.

Purportedly, pain from the dura mater can be diagnosed by a variety of so-called stretch tests, but no studies have shown that the pain that is aggravated by stretch tests specifically arises from the dura mater. No studies have provided evidence that back pain can arise from the fascia of the back.

For chronic low back pain, the strongest evidence to date incriminates the joints of the lumbar spine and sacrum as the most common sources of pain [3]. Equivalent data for acute low back pain are not available because the tests required to diagnose joint pain are not indicated, and have not been applied, in patients with acute pain.

Pain from the lumbar zygapophysial joints can be diagnosed using controlled blocks of the nerves that innervate these joints (medial branch blocks) [5].

Controlled blocks reduce the likelihood of a false-positive response. The prevalence of lumbar zygapophysial joint pain appears to differ with age. In younger, injured workers, zygapophysial joint pain accounts for fewer than 10% of cases [6]. In elderly patients, the prevalence may be as high as 40%. Still elusive, however, is the actual cause of lumbar zygapophysial joint pain. It is tempting to attribute the pain to osteoarthritis, but radiological studies have found that back pain is not significantly more common in patients with radiographic osteoarthritis.

In some 20% of patients with chronic low back pain, the source can be traced to the sacroiliac joint, using controlled diagnostic blocks [5]. The cause remains elusive, but is presumed to be some sort of injury to the joint, or excessive strain in its supporting ligaments.

Pain from the intervertebral discs is the most extensively studied basis for chronic low back pain. Discogenic pain can be diagnosed using disc stimulation. It accounts for some 40% of cases. The pathology is internal disruption of the disc [2,3]. Under repeated compression loading, fatigue failure of a vertebral endplate occurs in the form of a fracture. This precipitates a degradation of the nuclear matrix, and radial fissures develop into the outer anulus fibrosus. The capacity of the nucleus to bear compression loads becomes irregular and reduced, and greater than normal loads are borne by the posterior anulus. The presence of radial fissures, reduced nuclear stress, and increased anulus stress are each strongly associated with reproduction of pain when the affected disc is stimulated.

## Diagnosis

Serious causes of back pain can be suspected from key aspects of the history, such as a history of cancer, weight loss, cardiovascular risk factors, and risk factors for infection. They can be confirmed by magnetic resonance imaging [3].

Common causes of back pain defy diagnosis by history, physical examination, or imaging. The one exception is discogenic pain. Using McKenzie techniques, centralization of pain is reasonably predictive of an internal disc disruption being the cause of pain [7]. As well, some 30% of patients may exhibit, on magnetic resonance imaging, a high-intensity zone in the annulus fibrosus. This sign is strongly predictive of the affected disc being the source of pain [3].

For precision diagnosis of low back pain, invasive tests are required. Diagnostic blocks can be used to diagnose pain from synovial joints, and disc stimulation can be used to diagnose discogenic pain [5]. For these tests to be valid, they must be rigorously controlled. Diagnostic blocks must be performed in a single-blind, but preferably double-blind manner. Disc stimulation must be controlled for pressure of injection, and discs at adjacent segments must be shown to be asymptomatic [5].

## Treatment

Systematic and other reviews have shown that most of what has been used to treat back pain either lacks sufficient evidence of efficacy or is no more effective than sham therapy or no treatment [3,8,9].

For acute low back pain, the best evidence supports explanation, reassurance, and resuming activity as the mainstay of treatment. Passive treatments are not effective and should be avoided [3,8].

For chronic low back pain, the evidence is very limited. Intensive exercises, either alone or in the context of a multidisciplinary rehabilitation program are the mainstay of conservative management [9]. However, although they may reduce pain and improve function, they do not eliminate low back pain. Drug therapy does not eliminate back pain. Ironically, the most powerful agent shown to produce complete relief of back pain are injections of normal saline [10].

Zygapophysial joint pain can be treated by percutaneous radiofrequency neurotomy [3,9]. Discogenic pain can be treated by fusion, disc arthroplasty, or various intradiscal therapies. However, compelling evidence of efficacy is still lacking for these invasive interventions.

## References

1. Merskey H, Bogduk N (eds) (1994) Classification of chronic pain. Descriptions of chronic pain syndromes and definitions of pain terms, 2nd edn. IASP Press, Seattle

2. Bogduk N (2005) Clinical anatomy of the lumbar spine and sacrum, 4th edn. Elsevier, Edinburgh
3. Bogduk N, McGuirk B (2002) Medical management of acute and chronic low back pain. Elsevier, Amsterdam
4. Bogduk N (1980) Lumbar dorsal ramus syndrome. *Med J Aust* 2:537–541
5. Bogduk N (ed) (2004) Practice guidelines for spinal diagnostic and treatment procedures. International Spine Intervention Society, San Francisco
6. Bogduk N (2005) A narrative review of intra-articular corticosteroid injections for low back pain. *Pain Med* 6:287–296
7. Laslett M, Oberg B, Aprill CN, McDonald B (2005) Centralization as a predictor of provocation discography results in chronic low back pain, and the influence of disability and distress on diagnostic power. *Spine J* 5:370–380
8. Nachemson A, Jonsson E (eds) (2000) Neck and back pain: the scientific evidence of causes, diagnosis, and treatment. Lippincott, Williams & Wilkins, Philadelphia
9. Bogduk N (2004) Management of chronic low back pain. *Med J Aust* 180:79–83
10. Bogduk N (2004) Pharmacological alternatives for the alleviation of back pain. *Expert Opin Pharmacother* 5:2091–2098

## Low-back Pain: Lumbago

►Neural-Immune Interactions: Implications for Pain Management in Patient with Low-Back Pain and Sciatica

## Lower Motor Neuron Disease

### Definition

Lower motor neuron disease results from block or destruction of ►motoneurons in ►brainstem or ►spinal cord or of their axons in nerve roots or peripheral nerves, and may lead to paresis or paralysis of the innervated muscles depending on the site of lesion.

## Low-frequency Fatigue

### Definition

A type of fatigue that is prominent at low action potential (stimulation) frequencies (10–20 Hz) that



occurs when metabolites have recovered and in the presence of normal action potentials and that can take days to recover. Low-frequency fatigue is thought to be due primarily to impaired excitation-contraction coupling and reduced sarcoplasmic reticulum  $\text{Ca}^{2+}$  release.

► [Excitation-Contraction Coupling](#)

---

## Low-Pass Filtering

### Definition

A filter that passes only those frequency components in the low end of the spectrum.

► [Signals and Systems](#)

---

## Low-Pass Filtering by Electrical Synapses

### Definition

A low-pass frequency filter is an electrical circuit (or biological equivalent thereof) containing resistive elements in series with reactive elements that progressively attenuates the transmission of high-frequency signals. Electrical synapses act as low-pass filters with passband attenuation as a consequence of the (resistive) electrical pathway provided by gap junction channels standing in series with the parallel electrical capacitance and resistance of the postsynaptic cell membrane.

► [Electrical Synapses](#)

---

## Low-threshold C Fiber Mechanoreceptors

► [Tactile C Fibers](#)

---

## Low-threshold Cutaneous Mechanoreceptors

► [Cutaneous Mechanoreceptors, Functional Behavior](#)

---

## Low-Threshold Mechanoreceptor

### Definition

A primary somatosensory neuron that detects and encodes information about innocuous mechanical deformation of its receptive field. These receptors are stimulated by very subtle degrees of mechanical deformation and contrast to high-threshold mechanoreceptors, which include receptors that detect and encode information about noxious mechanical deformation and damage of the tissues (i.e., nociceptors).

► [Nociceptors and Characteristics](#)  
 ► [Sensory Systems](#)

---

## Low-threshold Spikes

### Definition

Membrane depolarizations generated by T-type  $\text{Ca}^{2+}$  channels, which originate at low negative voltages and are favored by preceding membrane hyperpolarizations. Low-threshold spikes (LTS) drive neurons to the threshold of action potential generation and trigger all-or-none burst firings sustained by  $\text{Na}^+$  channels. LTS are usually recorded in isolated neurons from a variety of brain nuclei, such as inferior olive, thalamic relay, hippocampus, subthalamic nucleus and thalamus.

► [ActionPotential](#)  
 ► [Calcium Channels – an Overview](#)  
 ► [Sodium Channels](#)

---

## LTD

Long-term depression is the persistent weakening of synaptic strength that results from either persistent weak synaptic stimulation (as in the hippocampus) or

strong synaptic stimulation (as in the cerebellar Purkinje cells).

---

## LTP

Long term potentiation is the persistent increase in synaptic strength following high-frequency stimulation of a chemical synapse.

- ▶ Long-Term Potentiation
- ▶ Associative Long-Term Potentiation
- ▶ Synaptic Long-Term Potentiation in Pain Pathways

---

## Lucifer Yellow

### Definition

Lucifer yellow is a bioluminescent technique that oxidizes luciferin to a compound that emits a yellow light.

---

## Lumbago

- ▶ Low Back/Spine Pain

---

## Lumbar Spinal Pain

- ▶ Low Back/Spine Pain

---

## Lumbar Spine

### Definition

that region of the body formed by the five lumbar vertebrae of the vertebral column and their adnexae,

being the joints and ligaments between them, the muscles that cover them, and the nerves and blood vessels that supply them.

- ▶ Low Back/Spine Pain

---

## Lungs

- ▶ Visceral Afferents

---

## Luteinizing Hormone Releasing Hormone

### Definition

Synthesized and released by the hypothalamus which is responsible for the release of FSH and LH from the anterior pituitary. FSH and LH are two hormones that in concert regulate reproductive function.

- ▶ Neuroendocrinology of Psychiatric Disorders

---

## LVOR (Linear VOR)

- ▶ Vestibulo-Ocular Reflex

---

## Lyapunov Design

### Definition

A general approach to the design of nonlinear control systems, which starts with a candidate Lyapunov function and chooses feedback control to obtain desired properties for this function that guarantee stability and related properties.

- ▶ Nonlinear Control Systems

## Lyapunov Function

### Definition

An energy-like function that is used to establish stability properties of state-space systems, via Lyapunov's direct method.

- ▶ Nonlinear Control Systems

---

## Lyapunov Stability

### Definition

In system theory, the basic notion of stability in the state space, that deals with the asymptotic convergence to equilibrium of trajectories that start off an equilibrium point.

- ▶ Nonlinear Control Systems

## Lysosomal Storage Disease

### Definition

Any of a wide range of disorders resulting from the abnormal accumulation of undigested macromolecules in the lysosome, the usual intracellular site where these molecules are hydrolyzed. Many, but not all, lysosomal storage diseases result from defects in enzymes that degrade macromolecules, including  $\beta$ -glucosidase (Gaucher's Disease), hexoseaminidase (e.g. Tay-Sachs Disease), and others.

- ▶ Gaucher's Disease
- ▶ Metachromatic Leukodystrophy (MLD)
- ▶ Tay-Sachs Disease

---

## M2

- ▶ Long Loop Reflexes

---

## Machinery of the Neuronal Secretory Pathway

- ▶ Synaptic Proteins and Regulated Exocytosis

---

## Mackintosh Model

### Definition

Developed to account for attentional phenomena (latent inhibition, perceptual learning), this model of classical conditioning views variations in the effectiveness of CS-US pairings in terms of variations in CS processing. The model asserts that attention to a CS is modifiable and it specifies rules for how CS processing is influenced by experience. Attention to a CS will decrease if it is a poor predictor of the US and increase if it is the best predictor of the US.

- ▶ Theory on Classical Conditioning

---

## Macrophages

### Definition

Macrophages are derived from circulating monocytes and differentiate into tissue macrophages (including

microglia in the central nervous system (CNS) during development). Normally, macrophages are at a resting state. Upon infection, tissue injury or other disturbance in the tissue, macrophages can be activated and become more effective in eliminating damaged tissue, infected cells or tumor cells. Activated macrophages are characterized by increased phagocytosis, increased secretion of inflammatory mediators and cytotoxic substances, and increased ability to activate the adaptive immune response. Macrophage functions can be further enhanced or inhibited by certain cytokines.

---

## Macula Organs

### Definition

Epithelia of sensory cells covered by an otolithic structure (utricle, saccule, lagena) arranged in different spatial positions, forming an integral part of the peripheral vestibular sensory apparatus in the inner ear of all vertebrates. The detection of static and dynamic changes of the position of the otolith by the sensory cells makes this organ sensitive to linear head acceleration and constant changes of head position relative to gravity.

- ▶ Functional and Neurochemical Organization of Vestibulo Pathways

---

## Maculae

### Definition

Specific areas located in two regions (the sacculus and the utriculus) of the membranous labyrinth where labyrinthine (macular) receptors are located.

- ▶ Peripheral Vestibular Apparatus
- ▶ Vestibulo-Spinal Reflexes

## Macular Receptors

### Definition

Labyrinthine receptors located within the maculae of the utricle and saccule whose cilia are embedded in a gelatinous structure (the otolith membrane). The membrane contains crystals of calcium carbonate whose density is three times higher than that of endolymph. Linear accelerations imposed on the head or changes in head position with respect to the vertical axis displace the membrane and stimulate the receptors.

► [Peripheral Vestibular Apparatus](#)

## Magnetic and Electric Senses

WOLFGANG WILTSCHKO<sup>1</sup>, BERND KRAMER<sup>2</sup>

<sup>1</sup>Universität Frankfurt, Zoologisches Institut  
Biologie–Campus der Universität, Frankfurt am Main,  
Germany

<sup>2</sup>Institut für Zoologie, Animal Behaviour and  
Behavioural Physiology Research Group, Universität  
Regensburg, Regensburg, Germany

### Synonyms

Magnetoreception; Magnetoperception; Magnetosensitivity; Magnetic orientation; Magnetotaxis; Magnetoneavigation; Electroreception; Electric sensitivity; Electric orientation; Electrolocation; Electrocommunication

### Definition

Many animals use magnetic or ► [electric fields](#) to obtain information about their environment. Although the senses for both types of fields are discussed here in one chapter, the role of these physical features in animal behavior is fundamentally different. The magnetic field used is the ► [geomagnetic field](#); it provides a reliable source of information utilized by the animals in numerous ways for orientation in space and possibly time. The electric information used by animals, on the other hand, is normally not provided by the ► [physical environment](#), but comes from other animals or is produced by the user of the information for ► [active electrolocation](#). The ► [electroreceptor organs](#) of marine elasmobranch fish, termed ► [ampullae of Lorenzini](#), might additionally act as magnetoreceptors. At the same time, while the ecophysiology of magnetic and electric senses is generally known, at least in the most prominent animal groups studied, our

knowledge about the neurobiological base differs greatly. The neurobiology of the electrical sense is comparatively well understood, and a prominent example of neurobiology, whereas our knowledge on the neurobiology of the magnetic senses is still rather limited; here, most of our knowledge comes from behavioral experiments.

### Magnetic Senses

For animals that are able to perceive magnetic parameters, the geomagnetic field provides an omnipresent source of navigational information. Its field lines exit the earth at the southern magnetic pole, run around the globe and reenter at the northern magnetic pole. This vector quality provides directional information to be used as a ► [magnetic compass](#), whereas total ► [intensity](#) and/or ► [inclination](#), showing a gradient from the poles to the equator, can provide positional information on a large-scale ► [magnetic “map”](#) to be used for navigation. The latter two magnetic parameters may also serve as “► [sign posts](#)” or triggers, marking specific locations or regions where they elicit specific responses. In a similar sense, even magnetic anomalies could serve to characterize a specific location. Furthermore, the daily variation of the geomagnetic field – in the temperate zones a decrease of magnetic intensity from sunrise to noon, followed by a corresponding increase – have been discussed as potential *Zeitgebers* for the circadian clock. In summary, in order to make optimal use of the wealth of information offered by the geomagnetic field, animals need sensors for magnetic direction as well as sensors for magnetic intensity or intensity changes.

The use of the magnetic field for locating directions is rather widespread among animals. The associated behavior can be classified either as alignment responses or as a magnetic compass orientation. Alignment responses are characterized by an axial preference of the prominent magnetic directions, with the dances of honeybees on a horizontal comb being a classic example: without view of the sky, the largest activity is found along the magnetic N–S and the E–W axes ([Fig. 1](#)).

When, however, the magnetic field is used for compass orientation the animals can prefer any arbitrary direction with respect to the direction of the magnetic field. The behavioral context of the animal determines the specific angle relative to magnetic north. The selected course, or “set direction,” of the compass can be of different origin: it can be innate, imprinted or learned.

The best studied examples for magnetic compass orientation is that of birds ([Fig. 2](#)).

It is a so-called “► [inclination compass](#),” as the birds do not use the polarity of the magnetic field, but the inclination of the magnetic field lines in space to derive directions. This type of compass response does not distinguish between magnetic North and South, but between “poleward,” where the axis of the field lines forms the acute, and “equatorward,” where it forms the

obtuse angle with gravity. At the same time, the avian magnetic compass functions only in a narrow **▶intensity window**; this functional window is finely tuned to the ambient magnetic intensity where the birds live. These findings from behavioral experiments imply specific

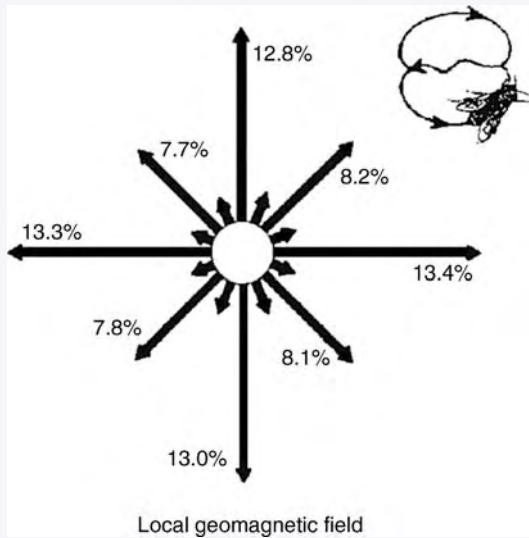

**Magnetic and Electric Senses. Figure 1** Dancing directions of bees on a horizontal comb in the absence of directing visual stimuli under diffuse light in the natural geomagnetic field. 24,601 individual dances were recorded; the arrows are proportional to the percentage of dances in the various directions. For the main classes the percentage is given numerically. The results clearly demonstrate a spontaneous preference of the main-direction N, E, S, W and a still remarkable preference of the intermediate direction NE. SE, SW, NW (after [37]).

characteristics of the receptors mediating magnetic compass orientation in birds. Various other animals are also able to perceive the direction of the magnetic field and use it as a magnetic compass. Two types of compass **▶mechanisms** have been described: marine turtles and amphibians have an inclination compass like birds, but mole rats, some fish and all invertebrates studied so far use a **▶polarity compass** that is based on the polarity of the magnetic field lines, similar to our technical compass. This suggests the existence of at least two different receptor mechanisms among vertebrates [1].

Birds use their magnetic compass for homing and for migration. Avian navigation is usually described as a two-step process: the direction to the goal is first determined as a compass course (= set direction); then, this course is located with a compass and converted into a heading for flight. Orientation within the home range and homing means that the compass course varies according to the position of the animal relative to home; it is determined by a navigation process or remembered from previous visits. For migration, the migratory direction as fixed set direction is innate; the respective course is genetically encoded and passed on from one generation to the next. Here, the geomagnetic field serves as external reference system and, together with celestial rotation, ensures that this genetic information is converted into the species-specific migratory direction [2]. In birds, the magnetic compass is also involved in establishing the directional relationship between sun azimuth and the circadian clock for the sun compass and in calibrating a stellar compass for nocturnal migrants. The biological significance of the avian magnetic compass lies in its role as a basic component of a complex navigational system (see [1]).

In non-avian species, magnetic compass orientation also provides a directional reference in various

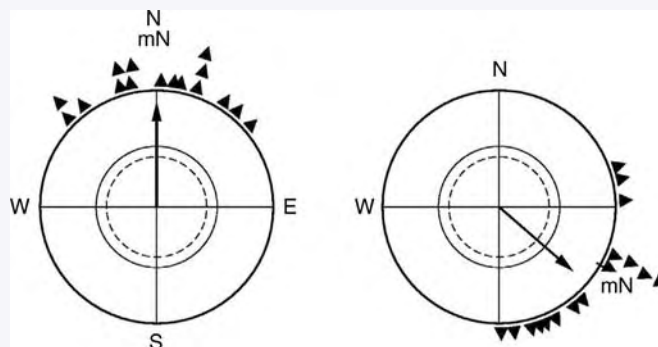

**Magnetic and Electric Senses. Figure 2** Orientation behavior of 16 European Robins in spring, tested in the natural geomagnetic field (*left*) and in an experimental magnetic field with the horizontal component shifted to the SE (*right*). mN, magnetic North. The triangles at the periphery of the circle mark the headings of the individual birds. The arrows represent the mean vectors calculated from the 16 headings. The length of the vector is proportional to the radius of the circle. The two inner circles are the 5% (dashed) and the 1% significance levels of the Rayleigh test (after [35]).

behavioral situations. It is used by salmon fry that prefer innate directions to find their way in complex lake-river systems [3] and by hatchlings of sea turtles that use an imprinted magnetic course to head away from the shore to the open sea. Another famous example is the well-studied “y-axis”-orientation that is typical for animals living at the border of land and water, e.g., salamanders, beach hoppers and isopods: here, the animals move along a magnetic axis perpendicular to the shoreline toward water or land, depending on their physiological needs (Fig. 3; [4]).

In birds as well as in other vertebrate species, the magnetic compass may be used in a navigational strategy called “path integration,” based on directional information obtained during the outward journey. Recording the net direction of the displacement could be based on endogenous (idiothetic) cues alone, or on external (allothetic) factors. In very young pigeons, wood mice, box turtles and young alligators, the geomagnetic field was shown to provide the external reference for path integration (see [1]). Blind mole rats of the genus *Spalax* were shown to use idiothetic factors alone over short distances, but to turn to the magnetic field as external reference on more extended excursions [5].

A special case of directional orientation with the help of the magnetic field is found in ►magnetic bacteria. While all animals detect the direction of the magnetic field with specialized receptors and act according to this information, magnetic bacteria contain chains of tiny crystals of magnetic material. By the force of the geomagnetic field lines, they are passively rotated and aligned along the field lines by magnetic crystals; they

then propel themselves along the field lines down into the mud (see [6]). Their orientation is thus fundamentally different from that of animals.

The geomagnetic field is not only used as a source of directional information. An increasing body of evidence suggests that non-directional features of the geomagnetic field are also utilized by animals. Because of the gradients running from the poles to the equator, magnetic intensity and/or inclination can serve as components in a potentially world-wide ►navigational map. The use of magnetic “map”-factors has been discussed for birds since the nineteenth century and is indicated by some findings with homing pigeons, other birds, marine turtles and alligators; Fig. 4 gives a recent example of navigation based on magnetic factors in an invertebrate for the first time.

Navigational “maps” are typical for territorial animals; their biological function is to ensure that the animals find back to their home territory after extended excursions or displacements. Such “maps” are established by experience, involving learning and memory. In these learning processes, the magnetic compass might be involved as reference system, allowing animals to record the regional directions in which navigational factors show a maximum change.

Aside from their role as components of the navigational “map,” magnetic intensity and inclination or a combination of both may serve as “sign posts” or triggers to elicit specific preprogrammed responses in certain areas characterized by these magnetic features. A famous example is the responses observed in young sea-turtles from Florida that spend their first year of life

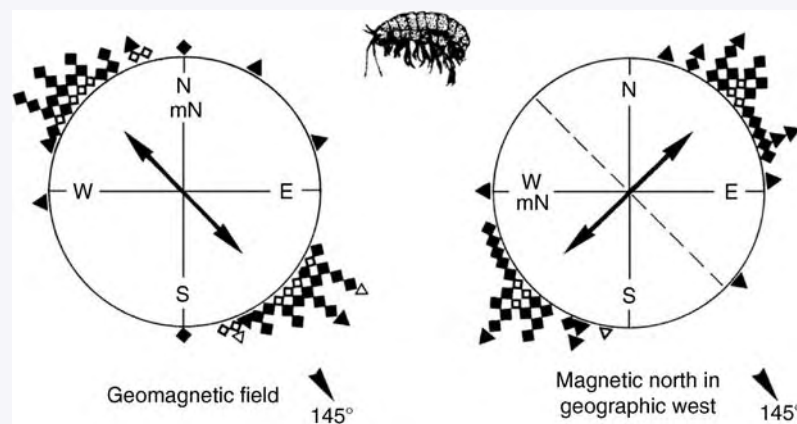

**Magnetic and Electric Senses. Figure 3** Orientation of the equatorial sandhopper *Talorchestia martensii* in the laboratory in a centrally lit arena. Test in the local geomagnetic field (*left*); test with magnetic North shifted 90° counterclockwise to geographic west (*right*). The theoretical escape direction to the sea of 145° is marked by the arrowhead outside the circle; the symbols at the periphery indicate the mean headings of individual sandhoppers: triangles unimodal behavior; diamonds axially bimodal behavior, with both ends of the axis indicated; solid symbols samples significant according to Rayleigh test; open symbols non-significant samples. The double-headed arrows represent the mean axes, the dashed diameter in the right diagram marks the axis of the respective controls (after [4]).

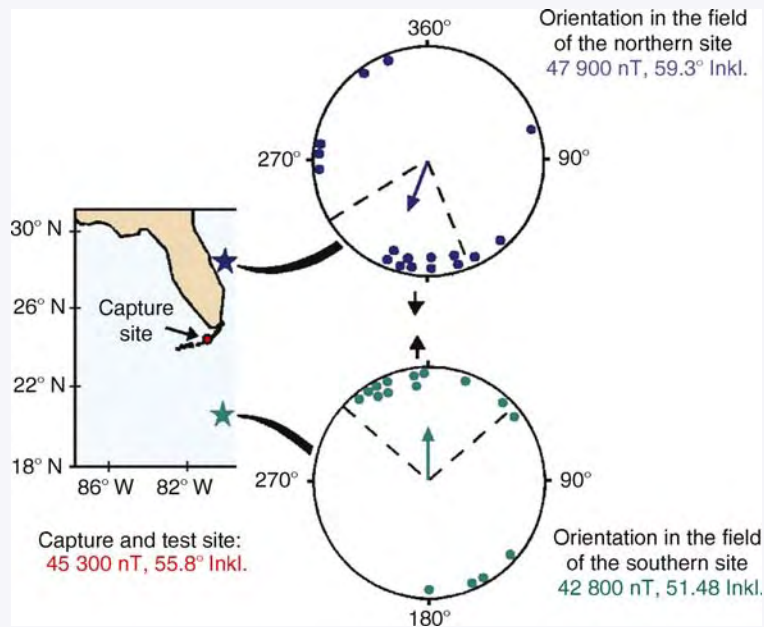

**Magnetic and Electric Senses. Figure 4** True navigation by magnetic parameters indicated in spiny lobsters. The lobsters were tested near their capture site in magnetic fields replicating the ones of two distant geographic locations (*marked with asterisks*). In the circular diagrams, the small arrows outside of the circle indicate the home directions from the simulated sites. Dots at the periphery of the circle mark the headings of single lobsters; the arrow represents the mean vector proportional to the radius of the circle, with the dashed radii indicating the 95% confidence interval of the mean direction (after [19]).

in the Atlantic gyre. When freshly hatched turtles were exposed in the laboratory to magnetic fields simulating those at the edge of the gyre, they altered their headings and chose directions that would have brought them toward the center of the gyre, thus helping them stay within suitable waters (see ▶“Entry” Magnetic maps). Similar preprogrammed responses have also been described for migratory birds that change direction or respond physiologically by increasing their fat load when encountering specific magnetic conditions.

A further role of the magnetic field in orienting animal movements has been discussed for the extended migrations of whales between their polar feeding grounds and the temperate regions where they spend the winter; following magnetic contours was suggested as navigational strategy (see [1]).

Organisms like magnetic bacteria need no perception mechanism at all, as they are passively aligned by the force of the geomagnetic field. In contrast, animals that actively respond to magnetic parameters need to obtain information about the direction or the intensity of the geomagnetic field. By what kind of mechanism they detect these features is not yet entirely clear, however. Experiments with birds suggest that magnetic compass orientation requires a stable direction of the magnetic field, but would tolerate changes in intensity and inclination to a certain degree. For the magnetic

components of the navigational “map,” on the other hand, detecting minute changes in intensity is crucial, whereas the direction of the field appears not to be important. Considering the physical aspects of magnetoreception, three mechanisms have been suggested: induction, ▶magnetite-based mechanisms and ▶radical-pair processes.

Electric current induction through the Faraday Effect as primary process for magnetoreception is an option only for marine fish. It has been discussed for elasmobranch fish, because the ampullae of Lorenzini, the electroreceptor ▶organs of sharks and rays (see below), are highly sensitive to electric fields. With a threshold of as low as 5 nV/cm, these receptor organs are, at least theoretically, sensitive enough to distinguish the voltage induced by the normal swimming speed when moving in different directions and thus provide the information required for magnetic compass orientation (see [1]).

▶Magnetite is a specific form of  $\text{Fe}_3\text{O}_4$ , with its magnetic features depending on particle size. Small crystals of less than 40 nm are superparamagnetic (SPM), which means that they do not have a stable magnetic moment; their magnetic moment fluctuates due to thermal instability, but can be stabilized by static ambient magnetic fields like the geomagnetic field. Particles of an intermediate size of 40–120 nm form



so-called single domains (SD) and have a stable magnetic momentum; theoretically, they could align themselves along the magnetic field lines like minute compass needles. Larger particles above 120 nm become multi-domain and have no pronounced net magnetic moment, because the moments of the various domains largely cancel each other.

Considerations on ►magnetite-based magnetoreception usually favored single domains, and several models have been suggested how single domains could mediate magnetic information. E.g., attached to hair cells or specialized membranes, they would be able to transduce the magnetic torque to mechanical torque and thus act as a compass. By magnetic remanence measurements, single domain particles were indicated in the tissues of numerous animals (see [7]). In vertebrates, magnetite was found in the nasal and orbital region, a region which is innervated by the ophthalmic branch of the *nervus trigeminus*, from which electrophysiological responses to magnetic stimulation involving changes in intensity were recorded. Structures that may be candidates for a ►magnetite-based magnetoreceptor based on single domains have been described for fish (e.g. [8]). In the upper beak of homing pigeons a structure has been identified which contains clusters of superparamagnetic magnetite; it may serve as modified pressure receptor measuring magnetic intensity [9].

The radical-pair hypothesis postulates magnetoreception by specialized photopigments. By photon absorption, molecules are raised to the excited singlet state, where some of them undergo a transition into the excited triplet state. The probability to reach the triplet state, and with it, the triplet yield, depends on the alignment of the photopigments with respect to the magnetic field lines. In the spherical or hemispherical structure, the triplet yield would form a specific pattern that was centrally symmetric to the axis of the field lines, thus forming a ►chemical compass. By comparing the triplet yield in the various spatial directions, animals could obtain information on the direction of the magnetic field [10]. Because of their biochemical properties, cryptochromes are discussed as possible candidates for the photopigments underlying these processes. The radical-pair model is indirectly supported by behavioral findings indicating that the magnetic compass of salamanders and birds is ►light-dependent: short-wavelength monochromatic light allows normal orientation, whereas the use of long-wavelength light abolishes orientation behavior [11]. The recent observation that the magnetic compass of birds can be disrupted by high-frequency magnetic fields points directly to a radical-pair process underlying magnetoreception [12].

In salamanders, the receptors mediating compass information appear to be situated in the pineal, the ancestral “third eye” of vertebrates [13]. In birds, too,

magneto-sensitive cells have been found in the pineal; however, in two species of passerine birds, magnetoreception was shown to occur almost exclusively in the right eye [14]. Since the optic nerves of birds cross over almost completely, this means that magnetic information is processed predominantly in the left hemisphere of the brain. The tectofugal part of the visual system shows a marked anatomical lateralization, with the relevant pathways in the left hemisphere more pronounced than in the right [15] which might also be associated with processing magnetic compass information. Electrophysiological recordings from the *tectum opticum* and the nucleus of the basal optic root (nBOR), a nucleus belonging to the tectofugal system, revealed units that were stimulated by changing the direction of the ambient magnetic field [16].

Altogether, the available findings on magnetoreception suggest a variety of mechanisms based on different principles. It seems plausible to assume that the magnetic compass and the magnetic part of the “map” require different types of magnetoreceptors, because they utilize different physical features of the magnetic field. This asks for different primary processes and different ways of neuronal processing. So far, evidence from birds suggests that a ►radical-pair mechanism in the right eye provides compass information, whereas magnetite-based receptors associated with the trigeminal system provides intensity information for the “map.” A radical-pair mechanism is also discussed for the compass of salamanders, but what kind of mechanisms other animals might use is not yet known.

## Electric Senses

In contrast to the geomagnetic field, the electric field of the earth is highly variable. Its variability is caused by differences in the activity of thunderstorms and related phenomena, and the ►field intensity depends on many factors like air humidity, temperature and conductivity of the surface. The polarity of the electric field is directed vertically downward. In view of this, it is hard to see how the electric field could provide information that is useful to animals. Yet a number of animals were found to be electroreceptive. Only in the past 50 years, peculiar structures (sensory pores) in the skin of some aquatic vertebrates that had been known for a long time were identified as electroreceptor organs (see entry “Electroreceptor organ”). Such electroreceptor organs are found in all groups of lower aquatic vertebrates and in certain amphibians, while they are lacking in most of the modern fish (such as the Teleostei within the Neopterygii). In two, possibly three, not closely related lineages of Teleostei, they obviously reevolved independently, namely in the ►Mormyriiformes from the Osteoglossomorph branch and the ►Siluriformes (catfish) and ►Gymnotiformes from the Neognath branch. Because of the insulating properties of air,

electroreceptor organs are generally lacking in terrestrial vertebrates such as reptiles, birds and mammals, the only exceptions being the ►*Monotremata*, the ►*Echidna* and the ►*Platypus*, where electroreceptor organs have been recently described (see entry “►*Electroreception and Electrolocation in the platypus and the echidna*”).

Electroreceptor organs are voltmeters; the receptor cells are modified hair cells and are part of the ►*octavo-lateral sensory system* that is responsible for hearing and the sense of equilibrium. Electroreceptor organs are contacted by sensory nerves only.

There are several types of electroreceptive organs. ►*Ampullary electroreceptor organs* are extremely sensitive to weak gradients of the electric field. The ampullae of Lorenzini of the marine elasmobranch fish have thresholds of about 5 nV/cm, the analogous “►*ampullary*” receptor organs of freshwater teleosts may reach 1–5  $\mu$ V/cm maximum sensitivity. Reflecting their different origin, the structure of ampullary electroreceptor cells differs in the various groups: in non-teleosts, they bear a kinocilium, sometimes in addition to microvilli, whereas in electroreceptive teleosts, the secondarily evolved electroreceptor cells have only microvilli, but no kinocilium (Fig. 5).

The ampullary organs as a whole, as well as their teleost analogs, consist of a layer of receptor cells lining an ampulla which is embedded in the skin and connects

to the outside by a canal. In marine fish, this canal is long, in fresh-water fish, it is short. The adequate stimulus is the voltage difference between the inside of the skin and the surface of the fish. The lumen of the ampulla and of the canal connecting to the surface is filled with a highly conductive jelly so that the electric potential at the luminal surface of the receptor cells is almost identical with that on the outside of the skin. Because of the relatively high conductivity of the skin of marine fish, their ampullary canals must be longer than those of freshwater fish to achieve similar sensitivity. Also, whereas the ampullary organs of the ancestral forms of vertebrates are stimulated by negative voltages on the outer skin, those of teleosts are stimulated by positive voltages.

Animals with ampullary organs make use of their high sensitivity to detect minute changes in the ambient electric field, thereby locating prey by detecting the normal electric activity of living organisms, like prey buried in sand or active at night. The detection of electric fields that are produced by other organisms rather than the animal itself is called ►*passive electrolocation*. Orientation responses along local electric fields, even magnetoreception based on the voltage induced by moving in various directions with respect to the geomagnetic field have been described (see above).

Most ►*Electrogenic fishes* are not only sensitive to ambient electric fields, but also generate their own

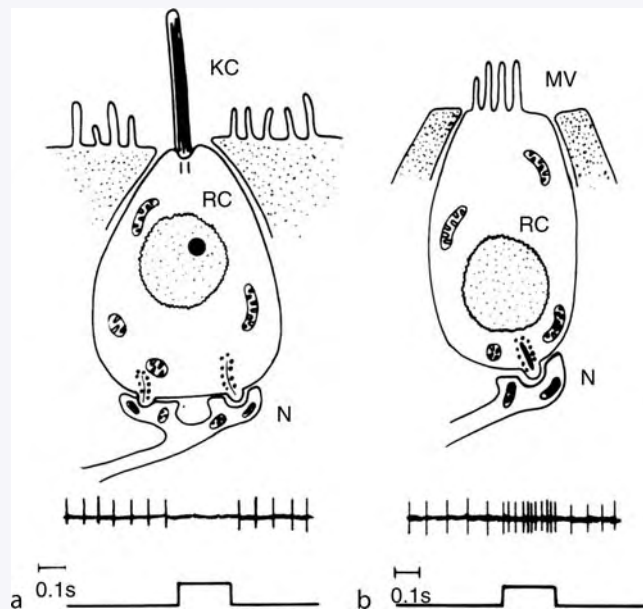

**Magnetic and Electric Senses. Figure 5** Ampullary electroreceptor cells (*RC*) of nonteleosts (a) bear an apical kinocilium (*KC*), sometimes in addition to microvilli (*MV*), whereas electroreceptive teleosts (b) have only microvilli and no kinocilium. The spontaneously active, afferent nerve fibers (*N*) increase their firing rate when the electrical stimulus (in this case a square-wave pulse of 200 ms) is positive outside the ampulla in teleosts, while in nonteleosts a negative stimulus is required for a similar response (from [36] modified).

electric fields by specialized ▶**electric organs** (see entry “Electric fish”). Any living tissue generates ▶**electric fields of low intensity** by maintaining the ionic balance of its cells, and by field potentials from nerve and muscle activity; these fields’ strength ranges from 0.5 mV to several mV (as measured between the body and a distant electrode). Electrogenic fish, however, possess electric organs consisting of orderly arranged, closely packed groups of modified muscle cells (nerve endings in one taxon). These fishes can discharge their electric organs in a controlled way; thereby producing electric fields ranging from a few mV up to 500 V. Electrogenic fish are found among both cartilaginous and bony fishes; prominent examples for species producing strong electric fields are the electric rays (genus *Torpedo*) and the electric eel (*Electrophorus electricus*).

The rhythmic discharge of electric organs (▶**EOD**) generates species-characteristic electric signals that are highly stereotyped (see entry “▶**Electric organ discharge**”). Among the teleosts, both gymnotiform and mormyrid fish have a second type of electrosensitive receptor organ besides the ampullary organs, namely ▶**tuberous electroreceptor organs**. These receptor organs are specifically tuned to the frequency spectrum (15–20,000 Hz, depending on the species) generated by the discharge of their own electric organ.

The ▶**tuberous** electroreceptor organs occur in two types: one acts as ▶**time marker unit** of high sensitivity and short and constant latency, whereas the other type acts as ▶**amplitude coder** that is relatively insensitive in absolute terms, but encodes minute changes in the

intensity of the fishes’ own electric organ discharges. Like ampullary receptor organs, ▶**tuberous receptor organs** are located in the skin and form part of the ▶**lateral line system** whose afferences project to the ▶**electrosensory lobe of the lateral line (ELL)**. With these tuberous electroreceptor organs, the fish detects impedance inhomogeneities in its environment by recording the associated modulations of their electric organ discharges in amplitude and phase. Thus, these fishes are capable of active electrolocation. Probably the predominant function of producing and perceiving electric fields is ▶**electrocommunication**. With their electric organs, fishes produce signals either of the pulse- or the wave type that can be perceived and decoded by their neighbors (see entry “Electrocommunication and Electrolocation”).

The tuberous electroreceptor organs of the African Mormyridae are the ▶**knollenorgane** and the ▶**mormyromasts** (Fig. 6).

Knollenorgane fire one action-potential per EOD pulse. As the mormyrid fish brain blanks the reafferences from self-generated electric organ discharges, only the pulses from other fish gain access to the higher centers of the brain. Knollenorgane thus serve electrocommunication. The second type of tuberous electroreceptor organ, the mormyromasts, has a higher threshold and therefore responds primarily to the fish’s own EODs (those of other fish being centrally blanked); they appear to be primarily responsible for active electrolocation. Mormyromasts comprise two kinds of electroreceptor cell that are innervated separately. Mormyromasts are capable of coding for both resistive

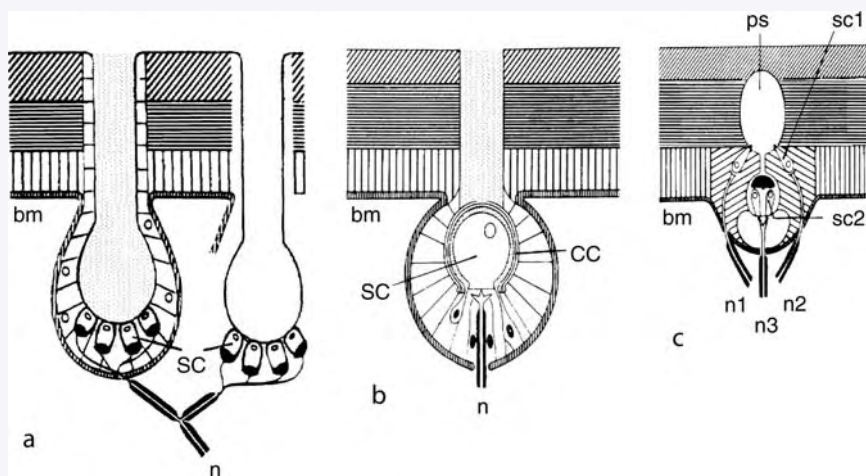

**Magnetic and Electric Senses. Figure 6** Schematic electroreceptor organs in freshwater teleosts, located in invaginations (or ampullae) of the epidermis. (a) Small pit organ, the teleost equivalent of the ampullary electroreceptor organ of similar structure that is common to all classes of lower aquatic vertebrates (but lacking in neopterygians, including teleosts). (b) Knollenorgan, one kind of tuberous electroreceptor organ present in mormyrid fish. (c) Mormyromast, the other kind of tuberous electroreceptor organ in mormyrid fish [33].

and capacitive loads associated with nearby objects, and fish can discriminate between live and dead material by their difference in capacitive impedance.

The central-nervous processing of information from the various types of electric organ takes place in different structures of the brain; e.g., the input from mormyromasts and knollenorgane, involving active electrolocation and ►communication, are processed separately. In gymnotiform fishes, many of which generate discharges of the wave type, electrosensory reafferences are encoding time (phase) and amplitude (of the wave discharge envelope) by different receptor organs whose afferences are processed separately by different parts of the brain, analogous to the hearing system of other vertebrates. This separate neuronal processing of phase- and amplitude information is thought by one theory (theory I) to be important for the so-called “►jamming avoidance response” (JAR) that was mainly studied in the gymnotiform wave fish *Eigenmannia virescens*. A fish will tend to shift its own discharge frequency away from a stimulus too close in frequency such that the two signals beat against each other faster, in an attempt to restore its active electrolocation performance (according to theory I; see entry ►Temporal coding in electroreception). By contrast, theory II stresses that the jamming avoidance behavior has long been shown to be sexually dimorphic and to differ between juveniles and adults, and envisions its sensory mechanism and functional adaptation to be radically different (for aspects of theory II, see also entry ►Electric communication and electrolocation). For example, incompatible with theory I is the observation that the JAR threshold is identical to stimulus detection threshold, that is, it is defined by the more sensitive ►T receptor organs. Consequently, phase (timing) information (that is coded for by the ►T receptor organs) has been found to be both necessary and sufficient for evoking and guiding the JAR, and information on amplitude modulation of the beat envelope from the rather insensitive P receptor organs is not available in the threshold range and well above (as would be required by theory I, but not theory II; P receptor organs or probability coders report the amplitude modulation of the EOD by a stimulus of similar frequency only at sufficiently strong modulation depth, that is, sufficiently strong stimulus/EOD intensity ratios). Furthermore, the JAR may be evoked by a stimulus of exactly the fish’s own frequency (that is, the frequency difference equals 0 Hz), even when maintained dynamically constant by a frequency clamp; an observation theory I cannot explain but which does not present a problem for theory II. According to theory II, by purely temporal analysis of beat features, the zero-crossings times of the individual oscillations within a beat wave that are reported by T receptor organs, the fish extracts (i) the strength of the stimulus signal

harmonic closest to its own fundamental discharge frequency (only that stimulus harmonic is driving the JAR), (ii) the frequency difference and its sign, (iii) the waveform of the stimulus signal. The JAR is thought by theory I to support active electrolocation in the presence of “jamming” conspecifics in the near field (the reach of active electrolocation is limited to a few cm). Theory II, however, has demonstrated that the JAR supports electrocommunication and the detection of EOD waveforms generated by neighbors from a much greater distance (far field sensitivity). This discussion exemplifies the dual nature of the electric system that is adapted for both functions.

## References

1. Wiltschko R, Wiltschko W (1995) Magnetic orientation in animals. Springer, Berlin Heidelberg New York
2. Weindler P, Wiltschko R, Wiltschko W (1996) Magnetic information affects the stellar orientation of young bird migrants. *Nature* 383:158–160
3. Quinn TP (1982) Intra-specific difference in Sockeye Salmon fry compass orientation mechanisms. In: Brannon EL, Salo EO (eds) Proceedings of the Salmon and Trout Migratory Behavior Symposium, University of Washington, Seattle, pp 79–85
4. Pardi L, Ugolini A, Faqi AS, Scapini F, Ercolini A (1988) Zonal recovering in equatorial sandhoppers: interaction between magnetic and solar orientation. In: Chelazzi G, Vannini M (eds) Behavioral adaptation to intertidal life. Proceedings of the NATO Science, Plenum, New York London, pp 79–92
5. Kimchi T, Etienne AS, Terkel T (2004) A subterranean mammal uses the magnetic compass for path integration. *Proc Nat Acad Sci USA* 101:1105–1109
6. Mann S, Sparks NHC, Board RG (1990) Magnetotactic bacteria: microbiology, biomineralization, palaeomagnetism and biotechnology. *Adv Microb Physiol* 31:125–181
7. Kirschvink JL, Jones DS, MacFadden BJ (1985) Magnetite biomineralization and magnetoreception in organisms. Plenum, New York
8. Walker MM, Diebel CE, Haugh CV, Pankhurst PM, Montgomery JC, Green CR (1997) Structure and function of the vertebrate magnetic sense. *Nature* 390:371–376
9. Fleissner G, Holtkamp-Rötzler E, Hanzlik M, Winklhofer M, Fleissner G, Petersen N, Wiltschko W (2003) Ultrastructural analysis of a putative magnetoreceptor in the beak of homing pigeons. *J Comp Neurol* 458:350–360
10. Ritz T, Adem S, Schulten K (2000) A model for vision-based magnetoreception in birds. *Biophys J* 78:707–718
11. Wiltschko W, Wiltschko R (2002) Magnetic compass orientation in birds and its physiological basis. *Naturwissenschaften* 89:445–452
12. Ritz T, Thalau P, Phillips J, Wiltschko R, Wiltschko W (2004) Avian magnetic compass: resonance effects indicate a radical pair mechanism. *Nature* 429:177–180
13. Deutschlander, ME, Borland SC, Phillips JB (1999) Extraocular magnetic compass in newts. *Nature* 400:324–325

14. Wiltschko W, Munro U, Wiltschko R, Kirschvink J (2002) Magnetite-based magnetoreception in birds: the effect of a biasing field and a pulse on migratory behavior. *J Exp Biol* 205:3031–3037
15. Güntürkin O (1997) Morphological asymmetries of the tectum opticum in the pigeon. *Exp Brain Res* 116:561–566
16. Semm P, Nohr D, Demaine C, Wiltschko W (1984) Neural basis of the magnetic compass: interaction of visual, magnetic and vestibular inputs in the pigeon's brain. *J Comp Physiol* 155:283–288
17. Markowski B, Baier B, Kramer B (2007) Differentiation in electrical pulse waveforms in a pair of sibling dwarf stonebushers, *Pollimyrus castelnaui* and *P. marianne*: possible mechanisms and functions (Mormyridae, Teleostei). *Behaviour* 145:115–135
18. Bennett MVL (1971) Electroreception. In: Hoar WS, Randall DJ (eds) *Fish physiology*, vol V. Academic, London New York, pp 493–574
19. Boles LC, Lohmann KJ (2003) True navigation and magnetic map in spiny lobsters. *Nature* 421:60–63
20. Bullock TH, Hopkins CD, Popper AN, Fay RR (eds) (2005) *Electroreception*. Springer, Berlin Heidelberg New York
21. Heiligenberg W (1991) *Neural nets in electric fish*. MIT, Cambridge, Mass.
22. Hopkins CD (1999) Signal evolution in electric communication. In: Hauser MD, Konishi M (eds) *Design of animal communication*. MIT, Cambridge, Mass., pp 461–491
23. Kramer B (1990) *Electrocommunication in teleost fishes: behavior and experiments*. Springer, Berlin Heidelberg New York
24. Kramer B (1996) *Electroreception and communication in fishes*. Gustav Fischer Verlag, Stuttgart, Jena, Lübeck, Ulm
25. Kramer B (1999) Waveform discrimination, phase sensitivity and jamming avoidance in a wave-type electric fish. *J Exp Biol* 202:1387–1398
26. Ladich F, Collin SP, Moller P, Kapoor BG (eds) (2006) *Communication in fishes*. Science, Enfield, New Hampshire, USA
27. Lissmann HW (1958) On the function and evolution of electric organs in fish. *J Exp Biol* 35:156–191
28. Meek J, Grant K, Bell C (1999) Structural organization of the mormyrid electrosensory lateral line lobe. *J Exp Biol* 202:1291–1300
29. Moller P (1995) *Electric fishes: History and behavior*. Chapman & Hall, London
30. Peters RC (1993) *Orientation in catfish and dogfish. Orientation and navigation*. The Royal Institute of Navigation, Oxford, pp 33–43
31. Scheich H (1977) Neural basis of communication in the high frequency electric fish, *Eigenmannia virescens* (jamming avoidance response). I. Open loop experiments and the time domain concept of signal analysis. II. Jammed electroreceptor neurons in the lateral line nerve. III. Central integration in the sensory pathway and control of the pacemaker. *J Comp Physiol A* 113:181–255
32. Stoddard PK, Zakon HH, Markham M, McAnelly L (2006) Regulation and modulation of electric waveforms in gymnotiform electric fish. *J Comp Physiol A* 192:613–624
33. Szabo T (1974) Anatomy of the specialized lateral line organs of electroreception. In: Fessard A (ed) *Handbook of sensory physiology*, vol III/3. Springer, Berlin Heidelberg New York, pp 13–58
34. von der Emde G, Schwarz S (2001) How the electric fish brain controls the production and analysis of electric signals during active electrolocation. *Zoology* 103:112–124
35. Wiltschko W, Wiltschko R (1999) The effect of yellow and blue light on magnetic orientation in European robins, *Erithacus rubecula*. *J Comp Physiol A* 184:295–299
36. Bullock TH, Heiligenberg W (eds) (1986) *Electroreception*. John Wiley, New York
37. Martin H, Lindauer M (1977) der Einfluß des Erdmagnetfeldes auf die Schwereorientierung der Honigbiene (*Apis mellifica*). *J Comp Physiol* 122:145–187

## Magnetic Bacteria

MICHAEL WINKLHOFER

Department für Geo- und Umweltwissenschaften –  
Sektion Geophysik, Ludwig-Maximilians-Universität  
Munich, Munich, Germany

### Synonyms

Magnetotactic bacteria

### Definition

Magnetic bacteria are a morphologically and phylogenetically diverse group of motile Gram-negative prokaryotes. Their common feature is intra-cellular ►ferrimagnetic crystals, made of ►magnetite ( $\text{Fe}_3\text{O}_4$ ) or ►greigite ( $\text{Fe}_3\text{S}_4$ ), called magnetosomes. Rather than being ingested from food, magnetosomes are synthesized within the cell and are most often arranged in a single chain or two chains, apparently fixed within the cell (Fig. 1).

A chain of magnetosomes carries a permanent ►magnetic moment and thus acts as an internal compass needle, rotating the cell into alignment with the geomagnetic field axis. Due to this magnetic torque, magnetic bacteria are constrained to move along magnetic field lines when swimming. They are actively motile rather than being pulled or pushed by the magnetic field. Magnetic bacteria can move both parallel and antiparallel to the magnetic field, corresponding to downward (north seeking) and upward (south seeking) motions in the ►geomagnetic field, which has inclined lines of forces except at the magnetic equator, where field lines are horizontal. Their magnetically enforced one-dimensional locomotion, makes magnetic bacteria highly



**Magnetic Bacteria. Figure 1** Wildtype magnetic vibroid bacterium. The cell contains a linear chain of magnetite crystals, so-called magnetosomes. The chain length is 2  $\mu\text{m}$ , the average length of the magnetosomes is 120 nm. Note that the magnetite crystals at the ends of the chain are smaller than average and therefore may represent nascent crystals. Courtesy of M. Hanzlik.

efficient at migrating to suitable chemical conditions in a vertically stratified water column or sediment, and so gives magnetic bacteria an advantage over their nonmagnetic counterparts that pursue purely chemotactic strategies such as run-and-tumble. The behaviour of magnetic bacteria is often referred to as **▶magnetotaxis**, which is misleading by implying motion as a *reflex* action to a magnetic field, and ignoring the fact that magnetic orientation in magnetic bacteria is a passive process. Stimuli to which magnetic bacteria react instead are high or low concentrations of free oxygen. It is therefore more appropriate to speak of magnetically assisted **▶aerotaxis**.

### Characteristics

Magnetic bacteria, discovered by Salvatore Bellini in the late 1950s, are widespread in both marine and freshwater habitats (see [1] for a review), and have even been identified in soils. They usually occur at zones where the gradients of oxygen or sulphide concentration are steepest, be it in the topmost few centimetres of lake sediments or deep-sea sediments, or be it at the oxic-anoxic-transition-zone (OATZ) within a chemically

stratified water column as encountered in poorly ventilated marine environments.

### Behaviour

The behaviour of magnetic bacteria from sedimentary habitats has not been accessible to *in situ* observations, and has had to be inferred from *in vitro* experiments under the light microscope. The easiest way to study magnetic bacteria is to place a wet sediment sample on a microscope slide and apply a horizontal magnetic field. Magnetic bacteria then swim out of the sediment and eventually collect at the edge of the sample. The swimming speed varies from one species to another, with magnetic coccoid cells (Fig. 2) being the fastest swimmers (around 100  $\mu\text{m}/\text{s}$ ). In samples taken from the northern hemisphere, the predominant swimming direction is towards the magnetic North Pole, in samples from the southern hemisphere, movement is towards the magnetic South Pole.

At the geomagnetic equator, where the magnetic field is horizontal, equal numbers of both polarities exist. Despite the hemispherical bias, a small percentage of magnetic bacteria can always be found that swim opposite to the prevailing direction.

The swimming behaviour observed under the light microscope was extrapolated to the natural environment, such that magnetic bacteria tend to swim downward along the downward- and upward-inclined geomagnetic field lines in the northern and southern hemisphere, respectively. This way, displaced magnetic bacteria (by bioturbation, wave action, etc.) are guided back into the sediment by persistently swimming downward until they reach their preferential position in the sediment. Such a unidirectional motility is usually referred to as magnetotaxis.

Other tactic responses may, however, override magnetotaxis. In particular, the notion of magnetotaxis needs to be revised when considering magnetic bacteria from aquatic habitats where the OATZ occurs within the water column. The vertical position of the OATZ in the water column may change seasonally, and magnetic bacteria have to migrate accordingly. To maintain position at the OATZ, magnetic bacteria must be capable of reversing their swimming direction once they have reached the border of their preferred chemical zone. Experimental evidence exists that bi-directional motility is coupled with an oxygen gradient: Spormann and Wolfe [2] observed the formation of a distinct band of actively motile cells (magnetic **▶spirillum**), with individual cells swimming back and forth within the band, parallel and antiparallel to the magnetic field  $B$ . It therefore depends on the oxygen concentration  $[\text{O}_2]$  if cells swim parallel or antiparallel to  $B$ . The observed band was arc-shaped, roughly 60 mm across (cell length  $\sim 2$  mm), and formed at a distance of  $\sim 100$  mm from an air bubble trapped under the cover slide. The edge of the band nearer to the

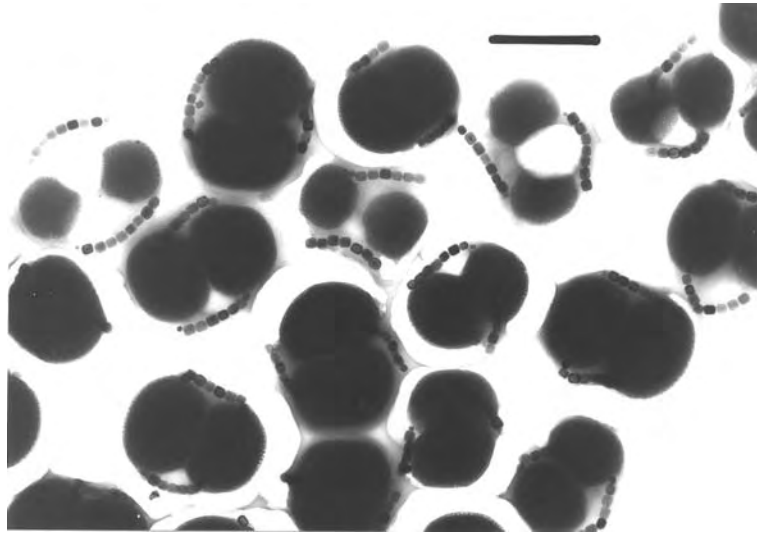

**Magnetic Bacteria. Figure 2** Cells of a wildtype magnetic **coccus**, the most abundant type of magnetic bacterium. A cell usually contains two linear chains of magnetosomes, lying at opposite sides within the cell. Cells have typical diameters of 1.5  $\mu\text{m}$ . The average magnetosome dimensions are 100 nm by 80 nm. The dark globules are inclusions rich in phosphorous and sulphur. Courtesy of M. Hanzlik.

air bubble was more sharply demarcated than the far edge, implying that the tolerance of all cells reach an upper limit for tolerance of oxygen but individually varying lower limits. The role of the magnetic field here is to assist active aerotaxis. This behaviour, therefore, was later referred to as magnetically assisted aerotaxis, or briefly, **magneto-aerotaxis** [3].

A similar experiment by Frankel and co-workers [3] resulted in a further distinction between axial and polar aerotaxis and is summarized in Fig. 3.

In their standard essay, a magnetic field  $B$  is directed along a capillary tube, into which oxygen diffuses from the open ends, thereby building up an oxygen-concentration  $[\text{O}_2]$  gradient from the centre of the tube towards each end. While magnetic spirilla form aerotactic bands at both ends (axial magneto-aerotaxis), magnetic cocci from the northern hemisphere form only one band, located at that end of the tube where the  $[\text{O}_2]$  gradient is opposite to  $B$  (polar magneto-aerotaxis). While the band of spirilla remain intact after reversal of  $B$ , the band of cocci disperses. The reversed-field condition appears to impair their sensing mechanism for aerotaxis, which under normal field conditions triggers reversal in swimming direction.

### Behaviour and Ecology

The large majority of naturally occurring magnetic bacteria display polar magnetotaxis, with the advantage being that an oxygen gradient is not necessary for efficient orientation in the **anoxic** zone, thereby enabling a rapid return of the cell over large distances to

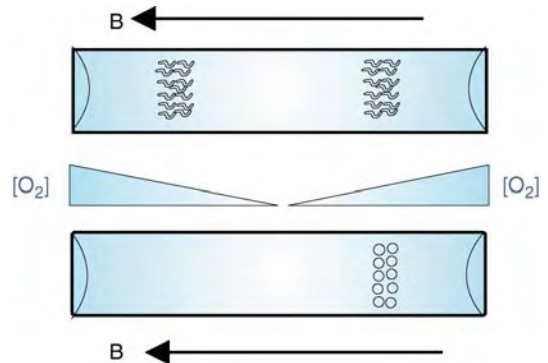

**Magnetic Bacteria. Figure 3** Axial (*top*) and polar (*bottom*) magneto-aerotaxis. *Top*: Formation of aerotactic bands by spirilla is symmetrical and maps the two microoxic zones in the tube. *Bottom*: Band formation by cocci occurs only in that microoxic zone where the magnetic field direction is opposite to the oxygen-concentration  $[\text{O}_2]$  gradient (after ref. [3]).

the preferred **microoxic** conditions, without wasting energy by constant movement along gradients [4]. On the other hand, if greater than optimal oxygen concentrations are encountered, the cells - then in an "oxidized state" - will display the typical down-seeking response. Reversing the swimming direction can be accomplished by switching the rotational sense of the flagella. That the sense of flagellar rotation can be

regulated by an oxygen sensory system has been observed in other aerotactic bacteria.

By analogy with sulphide-oxidizing bacteria, it was suggested that magnetic bacteria perform excursions to the anoxic zones of their habitat in order to accumulate reduced sulphur compounds as an electron donor [4]. The bacteria, then in a “reduced state,” would again reverse their swimming direction and move up to the microoxic zone where oxygen is available to them as an electron acceptor. In fact, many magnetic bacteria contain inclusions of sulphide (Fig. 2).

### Magnetosomes

The grain-size and crystal habits of magnetosomes as well as their arrangement within the cell may vary remarkably among the different morphological types of bacteria. Cells from a given strain, however, show little variation in crystal size, habit, and arrangement of chains. This implies that biomineralization of magnetosomes is genetically controlled. The biochemical details of magnetosome synthesis, however, remain elusive. It has been suggested that their biomineralization occurs in membrane vesicles [5], because magnetosomes in many species are enveloped by a bilayer membrane consisting of phospholipids and proteins, at least several of which appear to be unique to this membrane [6]. A vesicle would not only provide chemically stable conditions for magnetosome growth, but could also explain why magnetosomes do not grow above a certain maximum size. On the other hand, the hook-shaped magnetosomes of *Magnetobacterium bavaricum* (Inset in Fig. 4) do not appear to be surrounded by a membrane, and it is possible that magnetite crystals start growing from some template. From growth experiments monitored with Moessbauer spectroscopy [5], it was recently concluded that magnetite precipitates directly in empty magnetosome vesicles. This is in contrast to greigite-producing magnetic bacteria, in which a series of non-magnetic phases of approximately FeS composition has been identified as crystalline precursors to ferrimagnetic greigite [7].

### Evolutionary Aspects

Interestingly, magnetite and greigite are the strongest ferrimagnetics of all the naturally occurring iron oxides and iron sulphides, respectively, and it is only these two phases that have consistently been identified in magnetic bacteria. Magnetotaxis obviously gives magnetic bacteria an edge over their nonmagnetic counterparts. If it were only for iron metabolism, there would be no need for the cells to sequester excess iron in a ferromagnetic form.

Not only are magnetosomes made of strong ferrimagnetics, they also appear to be magnetically

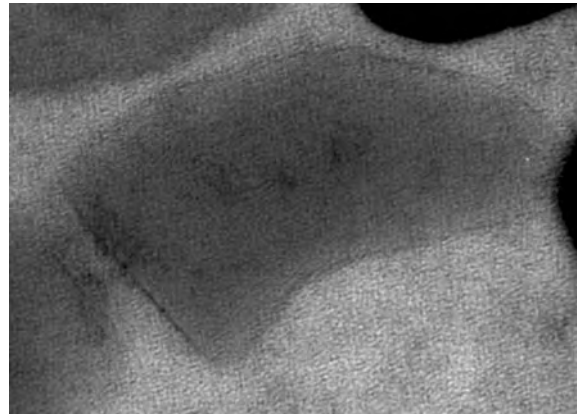

**Magnetic Bacteria. Figure 4** *Magnetobacterium bavaricum*. A cell may contain up to a thousand magnetite crystals, which are arranged in several rope-shaped bundles of chains. Inset: The hook-shaped magnetosomes are characteristic of this unusual type of magnetic bacterium. The average magnetosome dimensions are 100 nm by 40 nm. A dark layer at the crystal base may represent a template from which the magnetite crystal may have nucleated. Courtesy of M. Hanzlik.

optimised for the purpose of magnetotaxis: they are magnetic single domains (SD), that is, the magnetization within each magnetosome is uniform and so the magnetic moment of the particle assumes the maximum value attainable. Thus, the available magnetic material is used in the most efficient way.

Magnetic bacteria achieve this magnetic optimisation by limiting the grain size of magnetosomes to values below  $\sim 150$  nm, while it usually ranges between 40 nm and 120 nm. Above  $\sim 150$  nm, non-uniform magnetization structures develop in magnetite crystals, resulting in lower magnetic moments. This means that magnetic material would be “wasted” by growing magnetosomes much larger than  $\sim 150$  nm. If on the other hand the grain size were below some 30 nm, the particles would be in a **superparamagnetic** (SP) state and could not carry a stable magnetic moment because of thermal fluctuations constantly buffeting the magnetization, leading to frequent spontaneous magnetization reversals within the particle. A magnetosome chain grows as new magnetosomes are synthesized at either end (see Fig. 1). A newly forming magnetosome has to go through the SP stage (provided that it has already transformed into a ferrimagnetic from the non-magnetic precursory phase), but grows in the magnetic stray field produced by the adjacent, mature magnetosome. As it grows further and eventually crosses the SP-SD threshold size (roughly 30 nm), its magnetization becomes locked in, and so has the same magnetic polarity as the mature magnetosome. By growing



this way, a magnetosome chain will always consist of individual magnetic dipoles pointing in the same direction. That the particles in a chain are all polarized in the same direction has been directly imaged by means of transmission electron holography [8]. In addition to the optimal grain-size range for magnetosomes, there is also a theoretical optimum for the number of magnetosomes per cell: Between 10 and 20 magnetosomes, with a typical grain size of 50 nm, are sufficient to constitute a permanent magnetic dipole strong enough to keep the cells aligned with the comparatively weak geomagnetic field. With the exception of the unusual *M. bavaricum*, which contains up to a thousand magnetosomes per cell (Fig. 4), this optimum is achieved in most types of magnetic bacteria. It is therefore fair to say that magnetic bacteria have evolved their peculiar traits under the influence of the Earth's magnetic field, which prompts the question of how magnetic bacteria adapt to periods of low geomagnetic field strength. In periods of reduced field strength, magnetic bacteria that produce more magnetosomes or grow larger magnetosomes than normal have an advantage. At present, such a scenario is to some extent realized in Rio de Janeiro, Brazil, where the field strength is anomalously low (0.25 G): The magnetosomes in one morphological type of bacterium had average dimensions of 120 nm in length and 110 nm in width, a volume nearly ten times greater than average [9]. Other bacteria from the same region, however, had rather averagely sized magnetosomes in usual numbers per cell. The field strength is obviously not low enough to cause a selection of magnetic bacteria with stronger magnetic moments. If, on the other hand, sediment samples that initially contained magnetic bacteria are kept in a zero magnetic field, the population of magnetic bacteria appears to decline rapidly, but it is not known whether magnetic bacteria become extinct or just stop producing magnetosomes, or whether non-magnetic mutants take over. Similar experiments with Northern-hemisphere sediments incubated in *reversed-field* conditions yielded an initial decrease in the population density of magnetic bacteria. With increasing duration of the experiment, South-seeking bacteria emerged in greater numbers and eventually supplanted North-seeking bacteria [10]. Thus, in the case of a geomagnetic field polarity reversal, the few cells in a natural population that have wrong polarity, (such as due to a malfunction in cell division) can take over and guarantee the survival of the species. That applies to polarily magnetoaerotactic bacteria, whereas "two-way swimmers" (axial magnetoaerotaxis) should remain unaffected. However, detailed paleomagnetic records and numerical geodynamo simulations strongly suggest that there is more to a geomagnetic polarity transition than a mere polarity flip. The global change in polarity is often foreshadowed by large directional variations and a period

of decreasing field strength down to values of 10% of present-day values or even less, which may last thousands of years. The fossil magnetosome record in sediments analysed thus far is too scarce to clearly monitor adaptation of magnetic bacteria or evolutionary changes. Research is further complicated by the fact that bacterial magnetite, because of the small particle size, is prone to dissolve under increasingly reducing pore-water conditions with increasing burial.

## References

1. Bazylinski DA, Frankel RB (2004) Magnetosome formation in prokaryotes. *Nat Rev Microbiol* 2:217–230
2. Spormann AM (1987) Unusual swimming behaviour of a magnetotactic bacterium. *FEMS Microbiol Ecol* 45:37–45
3. Frankel RB, Bazylinski DA, Johnson MS, Taylor BL (1997) Magneto-aerotaxis in marine coccid bacteria. *Biophys J* 73:994–1000
4. Spring S, Bazylinski DA (2000) Magnetotactic bacteria. In: Dworkin M et al. (eds) *The prokaryotes: an evolving electronic database for the microbiological community*, 3rd edn. (release 3.4). Springer, Berlin Heidelberg New York, [www.prokaryotes.com], (released 10. Sep. 2001)
5. Faivre D, Böttger LH, Matzanke BF, Schüler D (2007) *Angew Chem Int Edn* 46:8495–8499
6. Jogler C, Schüler D (2007) Genetic Analysis of Magnetosome Biomineralization. In: Schüler D, Magnetoception and Magnetosomes in Bacteria, 133–161, Springer, Berlin
7. Pósfai M, Buseck PR, Bazylinski DA, Frankel RB (1998) Reaction sequence of iron sulfide minerals in bacteria and their use as biomarkers. *Science* 280:880–883
8. Dunin-Borkowski RE, McCartney MR, Frankel RB, Bazylinski DA, Pósfai M, Buseck PR (1998) Magnetic microstructure of magnetotactic bacteria by electron holography. *Science* 282:1868–1870
9. Farina M, Kacharo B, Lins U, Broderick R, de Barros HL (1994) The observation of large magnetite (Fe<sub>3</sub>O<sub>4</sub>) crystals from magnetotactic bacteria by electron and atomic force microscopy. *J Microsc* 173:1–8
10. Blakemore RP (1982) Magnetotactic bacteria. *Annu Rev Microbiol* 36:217–238

## Magnetic Compass

### Definition

An animal with a magnetic compass has an ability to maintain a heading relative to the Earth's magnetic field (such as a course toward the north or the south).

► [Magnetic Map](#)

## Magnetic Displacement Experiments

### Definition

Experiments in which animals are subjected to the magnetic fields that exist in distant geographic areas, with a view toward determining if the animals possess a magnetic map.

► [Magnetic Map](#)

## Magnetic Field Inclination

### Definition

The angle formed between the field lines and the surface of the Earth, also known as dip angle.

► [Magnetic Map](#)

## Magnetic Map

KENNETH J. LOHMANN,  
CATHERINE M. F. LOHMANN  
Department of Biology, University of North Carolina,  
Chapel Hill, NC, USA

### Synonyms

Geomagnetic map; Geomagnetic positioning system; Magnetic positioning system; Magnetic position-finding

### Definition

A convenient, shorthand term used to indicate that an animal has the ability to derive positional (as opposed to directional) information from the Earth's magnetic field. The term is now increasingly used in a broad and metaphorical way.

### Characteristics

The Earth's magnetic field provides animals with two potential types of information. The simplest of these is directional or compass information, which enables an animal to maintain a consistent heading in a particular direction such as north or south. Magnetic compasses are phylogenetically widespread and exist in several

invertebrate groups, as well as in all major groups of vertebrate animals.

Alone, a compass is often insufficient to guide an animal to a specific destination or to steer it reliably along a long and complex migratory route. For example, a sea turtle migrating through the ocean towards a distant target can be swept off course by currents, and a migratory bird's heading can be altered by wind. Navigation can therefore be enhanced by an ability to determine geographic position along a desired pathway of travel or relative to a destination. For today's humans, this need is usually met through a global positioning system (GPS), which provides users with their geographic position and can also continuously compute the direction to a goal. For some migratory animals, positional information inherent in the Earth's magnetic field provides a similar, although considerably less precise, way of assessing geographic location. Animals that can derive positional information from the Earth's field (as opposed to directional information) are often said to have a ► [magnetic map](#).

It is important to recognize that the term magnetic map is now increasingly used in a broad and metaphorical way [1,2]. The term does not imply that an animal necessarily has a detailed mental representation in its head equivalent to a human roadmap or high-resolution topographic map. Instead, the information in a magnetic map may be minimal and very general [1]. For example, it might simply tell the animal that it is approximately north or south of the area where it lives (possibly without encoding distance), or that the animal has arrived at a point in a migratory route where it should orient westward. Moreover, information from a magnetic map is often used in combination with other sensory information.

### Positional Information in the Earth's Magnetic Field

Several geomagnetic elements vary in a predictable way across the surface of the globe and might hypothetically be used in position-finding [3]. For example, at each location on the earth, the magnetic field lines intersect the earth's field at a specific angle of inclination (Fig. 1).

At the magnetic equator, the field lines are essentially parallel to the Earth's surface and the inclination angle is said to be 0°. The field lines become progressively steeper, however, as one moves toward the magnetic poles; at the poles themselves, the field lines are perpendicular to the Earth's surface. Thus, inclination angle varies predictably with latitude, and an animal able to detect this field element may be able to determine if it is north or south of a particular area.

In addition to inclination angle, at least three other magnetic field elements might hypothetically be used in assessing position. These include: (i) the intensity (strength) of the total field; (ii) the intensity of the horizontal field; (iii) the intensity of the vertical field.

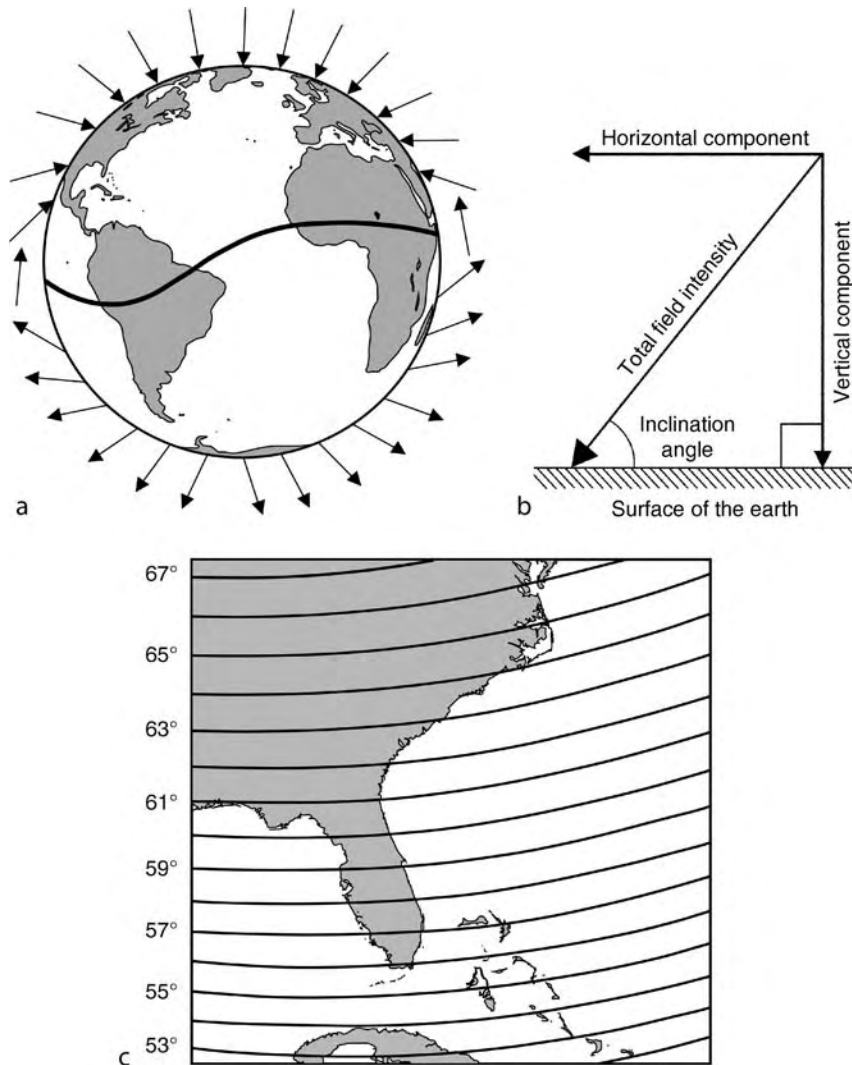

**Magnetic Map. Figure 1** (a) Diagrammatic representation of the Earth's magnetic field illustrating how field lines (represented by *arrows*) intersect the Earth's surface, and how inclination angle (the angle formed between the field lines and the Earth) varies with latitude. At the magnetic equator (the curving line across the Earth), field lines are parallel to the Earth's surface and the inclination angle is  $0^\circ$ . The field lines become progressively steeper as one travels north toward the magnetic pole, where the field lines are directed straight down into the Earth and the inclination angle is  $90^\circ$ . (b) Diagram illustrating four elements of **geomagnetic field** vectors that might, in principle, provide animals with positional information. The field present at each location on Earth can be described in terms of a total field intensity and an inclination angle. The total intensity of the field can be resolved into two vector components: the horizontal field intensity and the vertical field intensity. (Whether animals are able to resolve the total field into vector components, however, is not known.) (c) Map of **magnetic field inclination** along the southeastern coast of the United States. The isolines represent isoclinics (lines of equal magnetic field inclination). In this part of the world the isoclinics trend east-west, while the coastline is aligned approximately north to south. As a result, each area of coastline along the eastern seaboard is marked by a unique inclination angle. A similar pattern exists for the isolines of total intensity. A sea turtle navigating along the east coast to a particular feeding or nesting area might thus hypothetically do so by detecting a single magnetic element such as inclination or intensity [1].

For animals that can perceive the direction of true geographic north (for example, by perceiving the area of the northern hemisphere night sky that does not rotate), additional magnetic parameters such as

declination (the difference between true north and magnetic north) might also potentially be used.

The pattern of variation in magnetic field elements differs greatly in different geographic areas and may

thus influence what an animal can do with magnetic positional information in a given situation [1,4]. In some areas, the four magnetic elements listed above vary in similar directions over the surface of the earth. In others, such as the Indian Ocean, the gradients of inclination and intensity are oriented almost perpendicularly, so that each location is marked by a unique magnetic field. Thus, in some areas, an animal might be able to determine its position in only one dimension (for example, whether it is north or south of a goal). In others, bicoordinate magnetic navigation using two elements of the Earth's field might be possible. The matter is further complicated in some areas by the existence of magnetic anomalies arising from geological formations. Whether an animal can use a magnetic map to help solve a given navigational task, and the capabilities and limitations of such a system, may thus be influenced by a complex set of variables that differ among geographic settings.

### Experimental Evidence for Magnetic Maps

The idea that animals derive positional information from the Earth's magnetic field was first proposed more than a century ago, but until recently, the concept remained controversial. Several early studies provided indirect correlative evidence consistent with the idea of magnetic maps. For instance, homing pigeons released in areas with slight magnetic anomalies appeared to have difficulty establishing a homeward course, and pigeon orientation was more dispersed on days when solar storms disrupted the Earth's field slightly – enough to potentially interfere with a magnetic map but not enough to affect a [magnetic compass](#) [3]. These findings generated much discussion, but it was not until researchers began exposing navigating animals to the actual magnetic fields found at different geographic locations that more definitive evidence began to emerge. These “[magnetic displacement experiments](#)” provide a powerful tool for investigating magnetic maps because they do not involve physically displacing animals to new areas where numerous cues and factors may vary. Instead, animals can be tested under carefully controlled laboratory conditions in which only the magnetic field is altered.

Among animals that home to specific areas, the most compelling evidence for magnetic maps has come from studies with spiny lobsters [5], juvenile sea turtles [6], and newts [7]. Spiny lobsters inhabit dens in coral reefs and forage out from them at night, often returning to the same den before sunrise. These lobsters are capable of “true navigation,” meaning that they can determine the direction to a capture site even if displaced to locations where they have never been. In one experiment [5], lobsters captured in their dens were taken to a nearby arena surrounded by a magnetic coil system that could be used to generate magnetic fields replicating those

found in distant geographic locations. Lobsters exposed to a field that exists approximately 400 km north of the testing site oriented southward, whereas those exposed to a field that exists approximately 400 km south of the testing site oriented northward (Fig. 2).

In effect, the lobsters were apparently tricked into thinking that they were at distant locations when they encountered the magnetic fields that exist at those sites. These results provide strong evidence that lobsters have a magnetic positioning system that enables them, at a minimum, to determine if they are north or south of their goal.

Similar results have been obtained with juvenile green sea turtles [6]. After several years in the open ocean, these young turtles return to the southeastern

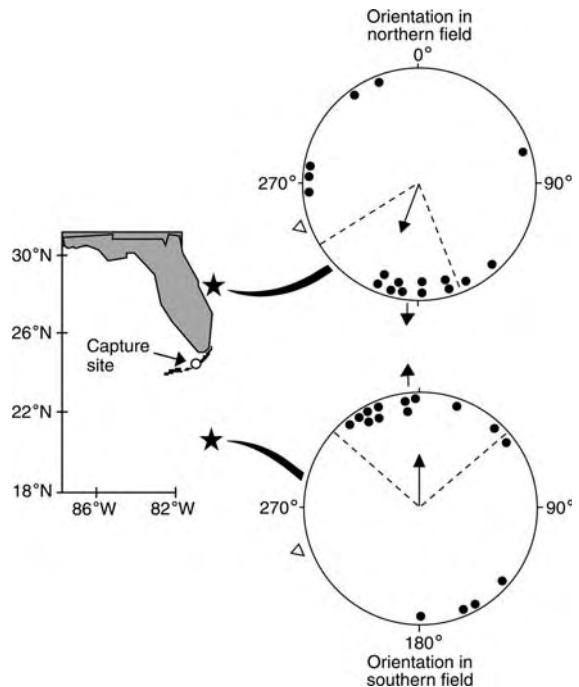

**Magnetic Map. Figure 2** Evidence for a magnetic map in spiny lobsters (*Panulirus argus*). Lobsters from the middle Florida Keys were subjected to magnetic fields that exist in locations north or south of the location where they were captured. Lobsters subjected to the field from the northern site oriented approximately southward, whereas those exposed to the field from the southern site crawled approximately north. The *open triangle* outside each orientation diagram indicates the actual direction to the capture site from the test site. In each case, lobsters responded as if they had been displaced to the locations marked by the stars rather than orienting in the direction that was actually toward the capture site. The *arrow* in the center of each circle represents the mean angle of the group. *Dashed lines* represent the 95% confidence interval for the mean angle. Figure is modified from [5].

coast of the United States to take up residence in feeding grounds. Turtles are known to return to these locations after experimental displacements and long seasonal migrations. In a recent experiment, turtles captured in their feeding grounds were tethered in an arena and exposed to magnetic fields that exist at locations north or south of their home areas. As with the lobsters, turtles exposed to a field that exists north of the capture site oriented southward, whereas those exposed to a field south of the capture site oriented northward. Thus, juvenile turtles evidently possess a magnetic map which permits an assessment of position relative to specific geographic destinations.

Sea turtles and spiny lobsters migrate over considerable distances, but a magnetic map may also exist in a kind of salamander that moves only over distances of about 1–3 km. Red-spotted newts exposed to an inclination angle found far north of their home area oriented southward, whereas those exposed to an inclination angle found south of their home area walked northward [7]. Although the fields used in these experiments did not precisely match those that exist in nature, these initial results are consistent with the hypothesis that newts, like lobsters and sea turtles, also have some type of magnetic map.

### Magnetic Maps and Migratory Pathways

Positional information in the Earth's magnetic field is also used by some animals during long-distance migrations that do not involve well-defined endpoints such as a particular home site. For example, young loggerhead sea turtles (*Caretta caretta*) from Florida, U.S.A., do not live in coastal feeding areas as older turtles do. Instead, they undertake a circular migration around a large region of the Atlantic Ocean. Newly hatched loggerheads, when exposed to magnetic fields replicating those found in three widely separated oceanic regions, responded by swimming in directions that would, in each case, facilitate movement along the migratory pathway [8]. Thus, young sea turtles appear to inherit responses that enable them, in effect, to exploit regional magnetic fields as navigational markers; such fields elicit changes in swimming direction at crucial geographic boundaries.

A similar use of magnetic positional information occurs in the pied flycatcher *Ficedula hypoleuca*, a migratory bird. Captive flycatchers exposed to a sequence of magnetic fields matching those they normally encounter while migrating shifted orientation in the same direction and at the same time as conspecifics during the natural migration [9]. Such shifts in orientation did not occur in birds maintained in the ambient field at the migration start point, or in birds maintained in a field replicating that at the migratory endpoint. Thus, for the pied flycatcher, the results suggest a complex interaction between an

endogenous time program and magnetic parameters, in which the birds must apparently experience sequentially the fields of specific locations at the appropriate times in order to orient appropriately at each point in the migration.

In at least one species of bird, regional magnetic fields appear to act as a behavioral trigger of a different kind. The thrush nightingale *Luscinia luscinia* migrates south across the Saharan desert, a vast region over which food is seldom available. Birds held in Sweden but exposed to a sequence of regional fields along the migratory route, the last from a location just north of the desert, gained significantly more weight than control birds held under identical conditions but in the local Swedish field [10]. Thus, the results imply that a regional field just north of the Sahara, or perhaps a sequence of fields normally encountered during the migration, triggers changes in behavior and physiology that result in the birds accumulating fat needed for their trans-desert flight.

Given the phylogenetic distance between lobsters and the three vertebrate groups known to exploit positional information in the Earth's field, it appears likely that magnetic position-finding has evolved at least twice. Moreover, natural selection has apparently sculpted this ability for multiple uses in different animals, depending upon whether the animal needs to move along a migratory route, navigate to a specific home area, or store fat in preparation for a particularly difficult segment of a migration. The recent nature of these findings suggests that additional investigation will be fruitful, and that researchers have only begun to uncover the ways in which animals exploit magnetic maps.

### References

1. Lohmann KJ, Lohmann CMF (2006) Sea turtles, lobsters, and oceanic magnetic maps. *Mar Freshw Behav Physiol* 39:49–64
2. Mouritsen H (2001) Navigation in birds and other animals. *Image Vis Comput* 19:713–731
3. Wiltschko R, Wiltschko W (1995) *Magnetic orientation in animals*. Springer, Berlin
4. Lohmann KJ, Hester JT, Lohmann CMF (1999) Long-distance navigation in sea turtles. *Ethol Ecol Evol* 11:1–23
5. Boles LC, Lohmann KJ (2003) True navigation and magnetic maps in spiny lobsters. *Nature* 421:60–63
6. Lohmann KJ, Lohmann CMF, Ehrhart LM, Bagley DA, Swing T (2004) Geomagnetic map used in sea-turtle navigation. *Nature* 428:909–910
7. Fischer JH, Freake MJ, Borland SC, Phillips JB (2001) Evidence for the use of magnetic map information by an amphibian. *Anim Behav* 62:1–10
8. Lohmann KJ, Cain SD, Dodge SA, Lohmann CMF (2001) Regional magnetic fields as navigational markers for sea turtles. *Science* 294:364–366

9. Beck W, Wiltschko W (1988) Magnetic factors control the migratory direction of pied flycatchers (*Ficedula hypoleuca* Pallas). In: Ouellet H (ed) Acta XIX Congressus Internationalis Ornithologica, University of Ottawa Press, Ottawa, Canada, pp 1955–1962
10. Fransson T, Jakobsson S, Johansson P, Kullberg C, Lind J, Vallin A (2001) Magnetic cues trigger extensive refuelling. *Nature* 414:35–36

## Magnetic Moment

### Definition

A measure of the torque exerted on a magnet when placed in a magnetic field.

- ▶ Magnetic Bacteria

## Magnetic Orientation

- ▶ Magnetic and Electric Senses

## Magnetic Position-finding

- ▶ Magnetic Map

## Magnetic Positioning System

- ▶ Magnetic Map

## Magnetic Remanence

### Definition

Magnetism in the absence of an external magnetic field.

- ▶ Magnetite

## Magnetic Resonance Imaging

PETER FRANSSON

MR Research Center, Cognitive Neurophysiology, Department of Clinical Neuroscience, Karolinska Institute, Stockholm, Sweden

### Definition

Magnetic Resonance Imaging (▶MRI) is an imaging method that is based on the principles and properties of water. It uses a combination of magnetic fields and radiofrequency electromagnetic pulses to produce images that show how water, or more precisely hydrogen, is distributed in the human body.

### Purpose

The medical usage of MRI is to locate and diagnose pathological changes in the human body. Recent advances in MRI technology have opened up the possibility of investigating physiological processes. Pertinent examples are measurements of macroscopic flow (MR angiography), in-vivo MR spectroscopy (MRS), perfusion, diffusion of water [▶Diffusion weighted magnetic resonance imaging (DW-MRI)] and changes in cerebral hemodynamics related to changes in neuronal activity [▶Functional magnetic resonance imaging (fMRI)].

### Principles

Magnetic Resonance Imaging (MRI) is founded on the same principles as ▶Nuclear Magnetic Resonance (NMR), a technique that has been primarily used by chemists to study the three-dimensional structures of chemical compounds since the beginning of the 1950s [1,2]. It should be noted that the NMR phenomena occurs in different atom types, but since virtually all medical imaging is based on the magnetic properties of hydrogen atoms in the human body, this essay will only discuss hydrogen-based MRI.

The hydrogen nucleus consists of a single charged particle. In addition, the proton in the hydrogen nucleus possesses a nuclear magnetic spin, i.e. it spins around its own axis. Together, these properties of the proton entail that each proton behaves like a small magnet, much like a microscopic compass needle with a south and north pole. If protons are positioned in an external magnetic field, the protons will be aligned to the magnetic field, and start to precess around the external field with a precession frequency (▶Lamor frequency) that is governed by the strength of the applied magnetic field. A field-strength of 1.5 Tesla, typical for clinical MR scanners, would imply a proton resonance frequency of approximately 63.87 MHz. In the presence of a magnetic field, the ensemble of protons split up into

two different energy levels, where the population of protons in the lower energy level is aligned parallel to the external magnetic field, whereas the population of protons in the high energy level is aligned anti-parallel to the external magnetic field. Subsequently, if a radiofrequency (RF) pulse is applied with a frequency that exactly matches the Larmor frequency of the precessing protons, a subpopulation of protons can be brought to jump from the low to the high energy level. This can be thought of as a process of energy absorption. The uptake of electromagnetic energy from the RF pulse is often called excitation, and it is said that the protons are at “resonance”. After RF-excitation, the energy equilibrium between the two energy states is altered and the protons will again strive to reach an equilibrium state. A return to the equilibrium state is accomplished by an emission of energy in the form of a new radiofrequency pulse. This process, in which the protons jump back from the high to the low energy level, is termed relaxation in the MR literature. The emitted energy from the excited protons is subsequently detected as an induced current in a receiver coil, and this current is the basis for the MR signal.

The deciding factor for MR-image contrast between tissue types is the chemical environment for each excited proton. Immediately after RF-excitation, two relaxation processes start simultaneously. First, a net loss of magnetization, i.e. energy dissipation from the protons, is accomplished by a transportation of the extra energy to the surrounding tissue or “lattice” through spin-lattice relaxation (►T1-relaxation). Second, protons will feel the microscopic field from neighboring protons, which

in turn causes an exchange of energy between protons. The exchange of energy between neighboring protons is called spin-spin relaxation or ►T2-relaxation. Protons residing in different tissue types have different T1 and T2-relaxation properties. For example, in white brain matter hydrogen is primarily found in the triglyceride chains of fat molecules due to the presence of myelin sheaths. The presence of fat will reduce the T1 and T2-relaxation times in white compared to grey brain matter. The local value of the T1 and T2-relaxation constants are, together with the local concentration of protons (proton density), the major factors that contribute to soft tissue contrast in MR images. The effect of different T1 and T2 relaxation times for the tissue types found in the human brain is shown in Fig. 1.

In order to spatially resolve the MR signal from the object being imaged, magnetic gradients are introduced during the image acquisition process [3]. Applying a magnetic gradient in an arbitrary direction in space implies that the magnetic field strength will vary spatially along the chosen direction. Since the proton precession frequency is proportional to the magnetic field strength, the proton precession (Larmor) frequency will increase or decrease depending on which direction we move along in the magnetic gradient. By applying linear gradients along all three dimensions in space during image acquisition, a spatial encoding is effectively enforced by the fact that the proton precession frequency is now uniquely dependent on its location in space. Hence, the raw data collected during the MRI acquisition takes the form of a sample of its discrete Fourier transform. The final step in the

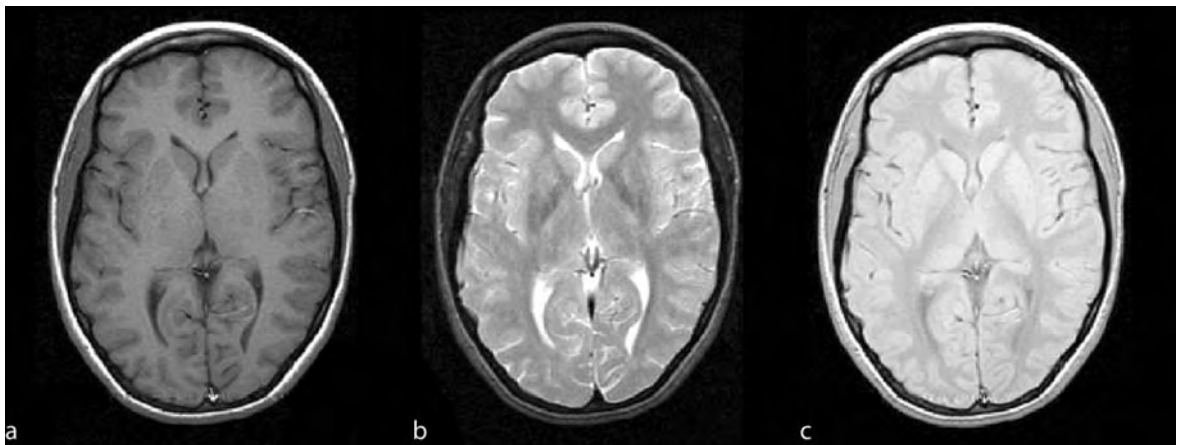

**Magnetic Resonance Imaging. Figure 1** Images demonstrating the basic image contrast mechanisms available in MRI. Fig. 1a shows a T1-weighted, axial section of human brain where the MR signal is primarily governed by the local T1-relaxation times of the hydrogen atoms that reside in each voxel. Similarly, Fig. 1b shows the typical contrast achieved in a T2-weighted MR image, for the same section as in Fig. 1a, where the MR signal is dependent on the local T2-relaxation time of hydrogen. Note that the image contrast between gray and white brain matter is reversed for the T2-weighted image compared to the T1-weighted image. A proton-density-weighted image where the MR image signal intensity is proportional to the absolute concentration of hydrogen atoms in each voxel is shown in Fig. 1c.

MR image acquisition process is to translate the recorded frequencies to spatial information, and this is performed by reconstructing the images by using the two-dimensional Fourier transform. Virtually any image orientation is possible with MRI by employing pertinent linear combinations of magnetic gradients in the x, y and z-direction. The feasibility to set arbitrary slice orientation profiles is shown in Fig. 2, where a T1-weighted image of the human brain is shown in an axial, coronal and sagittal orientation.

The workhorse in MR imaging is the so called spin-echo sequence [4], which by using two RF-pulses produces superior image contrast and spatial resolution with excellent diagnostic quality. However, conventional spin echo images typically take minutes to acquire. Consequently, throughout the history of Magnetic Resonance Imaging, numerous approaches have been developed to achieve increases in image acquisition speed. The rationale for this work has primarily been to relieve patient discomfort in the MR scanner by reducing scan time. More recently, a second motive for faster image acquisition has been the possibility of monitoring parameters such as perfusion, flow and diffusion. Methodological advances in image acquisition techniques in the mid-eighties such as the FLASH (Fast Low Angle Shot) gradient echo [5] and the RARE (Rapid Acquisition with Relaxation Enhancement) spin echo technique [6] decreased the scan time ten-fold. Ultra-rapid image acquisition schemes such as ►EPI (Echo-Planar Imaging), which allows single image acquisition in a tenth of a second, were conceived in 1977 [7] but it was not possible to make it available on a commercial scale until rather recently due to high demands on magnetic gradient hardware.

## Advantages and Disadvantages

During the last decades, MRI has expanded its usability to include the ability to examine and record physiological parameters in the brain. Two examples are given below:

### Functional MRI

MRI has recently become an important research tool in the field of cognitive neuroscience. In 1990, Seiji Ogawa and colleagues discovered the MR contrast mechanism that is commonly referred to as BOLD fMRI [8]. ►BOLD (Blood Oxygenation Level Dependent) imaging takes advantage of the fact that hemoglobin, which contains four iron ions, has different magnetic properties depending on whether it has an oxygen molecule attached to it or not. If oxygen is attached to an hemoglobin molecule, it is called oxy-hemoglobin and is slightly diamagnetically similar to the rest of the human body, and thus does not interact with an externally applied magnetic field. However, if the hemoglobin molecule has released its oxygen to the surrounding tissue, it is paramagnetic and called deoxy-hemoglobin. Consequently, a deoxy-hemoglobin molecule in the presence of a magnetic field will cause a local, microscopic inhomogeneity of the magnetic field. This inhomogeneity leads to a change in resonance frequency of the hydrogen atoms in the immediate vicinity of the deoxy-hemoglobin molecule. The deoxy-hemoglobin induced local change in resonance frequency will in turn lead to a reduction in the local MR signal intensity. However, since the increase in cerebral blood flow upon an increase in neuronal activity is much larger than the increase in oxygen consumption, the net result is an MR signal increase due to a wash-out of paramagnetic deoxy-hemoglobin. By employing fast

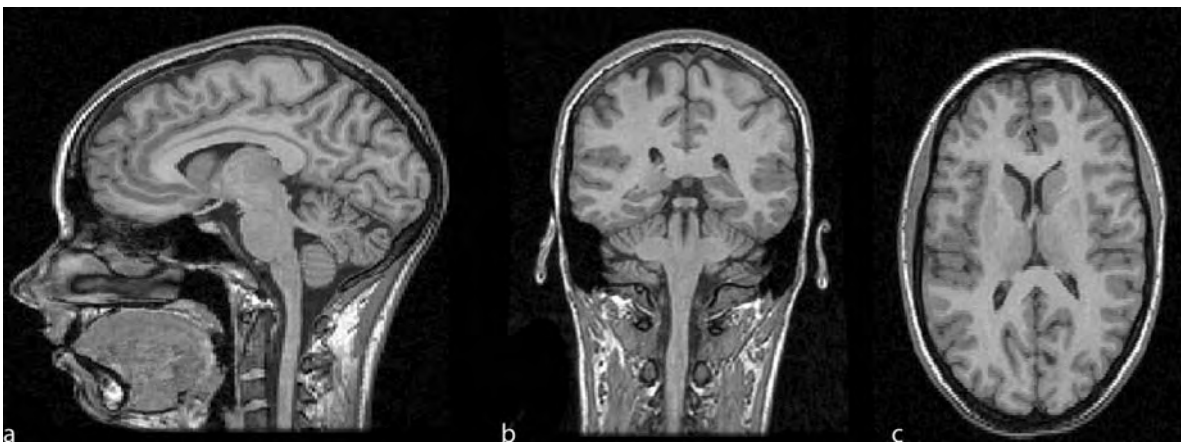

**Magnetic Resonance Imaging. Figure 2** High-resolution, T1-weighted MR images of a human brain in (a) sagittal, (b) coronal, and (c) axial slice orientations. An arbitrary spatial image orientation is possible in MRI through pertinent choices of linear combinations of magnetic gradients applied in the x, y and z-direction during image acquisition.



MR acquisition schemes such as echo-planar imaging [7], the whole brain can be scanned in 2–3 s with BOLD sensitivity. Thus, fMRI is usually performed by repeated echo-planar image acquisitions, which provide the possibility of detecting changes in hemodynamic activity that follow changes in external stimuli and/or cognitive processing. Examples of functional Magnetic Resonance Imaging for stimulation of the visual and motor systems in the human brain are given in Fig. 3.

### Diffusion Weighted Imaging and Diffusion Tensor Imaging

Another rather recent addition to the family of MRI techniques aimed at investigation of human physiology is diffusion-weighted MRI (DW-MRI) [9]. Image contrast in DW-MRI is based on differences in diffusivity of water molecules in the human body (random translational movement of molecules based on Brownian motion). For example, diffusional movement of water is relatively more restricted by cellular membranes in gray and white brain matter compared to cerebrospinal fluid. MR imaging sequences can be made sensitive to differences in diffusional movement by including additional magnetic gradients that encode for movement along an arbitrarily chosen spatial direction. Thus, the mechanism behind DW-MRI is that the MR signal from stationary hydrogen atoms is not affected by the additional gradients, whereas the MR signal from hydrogen atoms moving along the direction of the applied diffusion encoding gradient will

be reduced. Moreover, the signal reduction for moving hydrogen is proportional to the speed of movement. If no preferred direction exists for diffusion of water, e.g. in cerebrospinal fluid, diffusion is said to be isotropic. That is, the size of diffusional movement is similar in all directions. However, water diffusion can also be anisotropic. This is the case for water in white matter tracts, where the movement of water is much less restricted along a line parallel to the fiber bundles compared to an orthogonal direction. A complete characterization of the spatial distributions of diffusional movement in each image voxel can be obtained by measuring the so-called **diffusion tensor (DT-MRI)**. Diffusion tensor calculations require at least seven (six different directions and one image acquisition measurement without any diffusion gradients) separate MR image acquisitions. An average value of diffusion anisotropy based on diffusion tensor calculations is usually displayed using a scalar value such as the fractional anisotropy (FA) index, which shows the magnitude of the diffusion tensor that can be attributed to anisotropic diffusion (Fig. 4a). The spatial direction of the diffusion tensor can be indicated by using a color-coding scheme as depicted in Fig. 4b, where, for example, the color red indicates fibers running in the left-right direction (genu and splenium part of the corpus callosum).

### Limitations

Since the MRI technique is based on the usage of strong magnetic fields, caution must be exercised when bringing

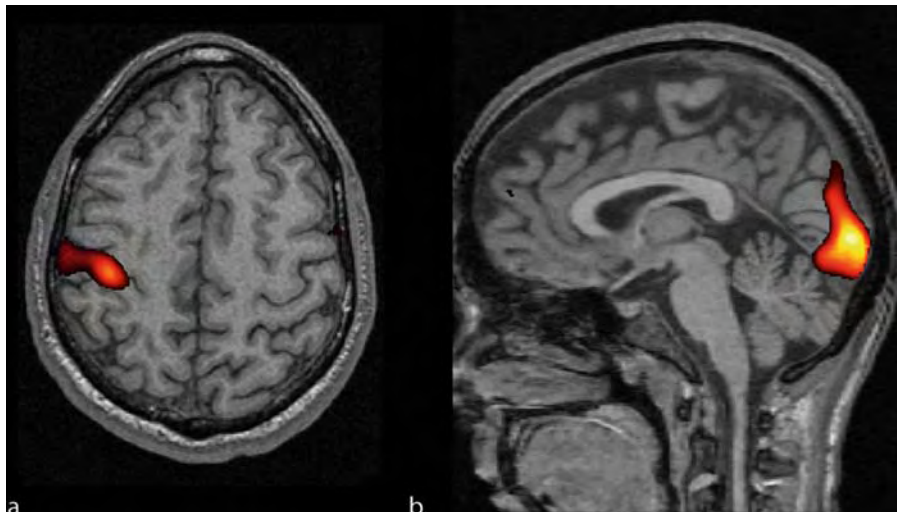

**Magnetic Resonance Imaging. Figure 3** Color-coded statistical parametrical maps superimposed on anatomical T1-weighted MR images showing significant functional activation of the motor cortex (a) and the primary visual cortex (b) using the functional Magnetic Resonance Imaging (fMRI) technique. fMRI was used to record changes in neuronal activity as observed by local changes in blood oxygenation (Blood Oxygenation Level Dependent, BOLD) for either right hand finger-thumb opposition versus rest (a) or presentation of a visual, flickering checkerboard versus darkness (b).

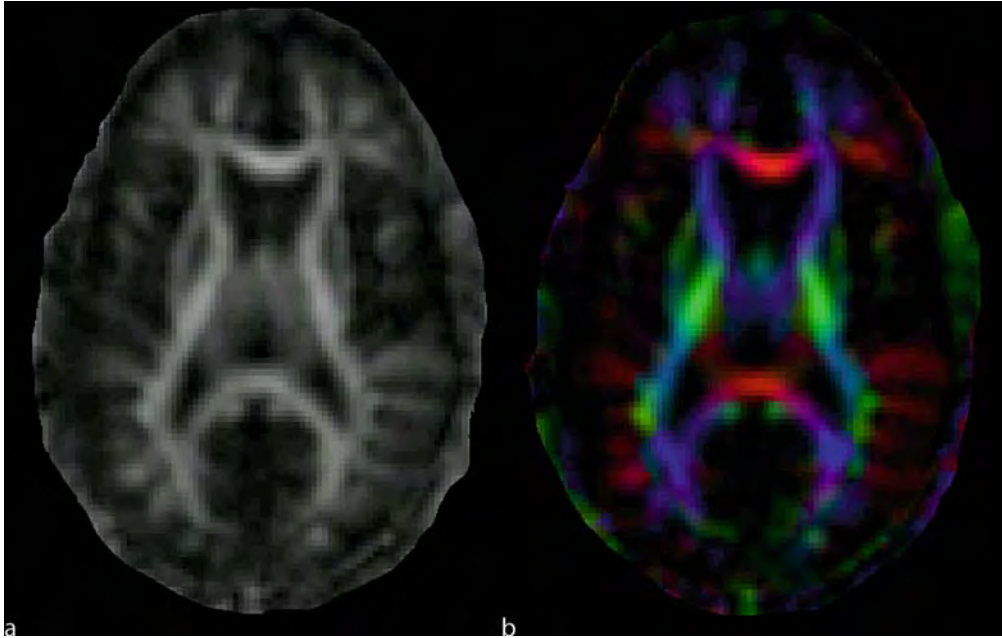

**Magnetic Resonance Imaging. Figure 4** Water diffusion anisotropy in an axial section of the human brain measured with Diffusion Tensor Magnetic Resonance Imaging (DT-MRI). The mean degree of anisotropy is shown as an FA-map (Fractional Anisotropy) in Fig. 4a, where the white matter fiber tracts show a high degree of diffusional anisotropy due to the parallel arrangement of fiber bundles in white brain matter. The spatial orientation of the diffusion tensor for the same section is shown in Fig. 4b, where color represents the preferred direction of diffusion of water molecules, predominantly in white fiber tracts (red: left-right, blue: anterior-posterior, and green: inferior-superior). Courtesy of Zoltan Nagy.

metal objects into the MR scanner room. All ferromagnetic objects will experience both a translational force and a twisting force (torque) in the presence of the magnetic field created by the MR scanner. Moreover, the magnetic field may compromise the function of cardiac pace-makers. In addition, non-ferromagnetic metal objects will produce inhomogeneities in the vicinity of the magnetic field causing in-plane signal displacement and signal drop-out. These image artefacts are called susceptibility-induced image artifacts, and are also present in air-tissue interfaces, e.g. near the ear canals and the nasal cavities. This is a particular problem for functional MRI that is sensitive to macroscopic (tissue-air interfaces) as well as microscopic (deoxy-hemoglobin) magnetic field inhomogeneities.

## References

1. Bloch F, Hanson WW, Packard ME (1946) Nuclear Induction. *Phys Rev* 69:127
2. Purcell EM, Torrey HC, Pound RV (1946) Resonance absorption by nuclear magnetic moments in solid. *Phys Rev* 69:37
3. Lauterbur PC (1973) Image formations by induced local interactions: examples employing nuclear magnetic resonance imaging. *Nature* 243:190–191
4. Hahn EL (1950) Spin Echos. *Phys Rev* 20(4):580
5. Hennig J, Nauerth A, Friedburg H (1986) RARE imaging: a fast imaging method for clinical MR. *Mag Reson Med* 3:823–833
6. Haase A, Frahm J, Matthaei D, Hänicke W, Merboldt KD (1986) FLASH imaging. Rapid NMR imaging using low flip-angle pulses. *J Magn Reson* 67:258–266
7. Mansfield P (1977) Multi-planar image formation using NMR spin echoes. *J Phys C* 10:L55–L58
8. Ogawa S, Lee TM, Kay AR, Tank DW (1990) Brain magnetic resonance imaging with contrast dependent on blood oxygenation. *Proc Natl Acad Sci USA* 87:9868–9872
9. Le Bihan D, Breton E, Lallemand D, Grenier P, Cabanis EA, Laval-Jeantet M (1986) MR imaging of intravoxel incoherent motion: application to diffusion and perfusion in neurological disorders. *Radiology* 161:401–407

## Magnetic Resonance Spectroscopy (MRS)

### Definition

It produces spectra that reflect levels of metabolites and thus provides information on tissue properties.

## Magnetic Stimulation

### ► Transcranial Magnetic Stimulation

## Magnetite

MICHAEL WINKLHOFER

Department für Geo- und Umweltwissenschaften –  
Sektion Geophysik, Ludwig-Maximilians-Universität,  
Munich, Germany

### Synonyms

Iron ferrite, mixed-valence iron oxide; Loadstone, lodestone

### Definition

Magnetite is a ferrimagnetic mineral with chemical formula  $\text{Fe}_3\text{O}_4$ .

### Characteristics

#### Occurrence

Magnetite (empirical formula  $\text{Fe}_3\text{O}_4$ ) is the oldest magnetic mineral known to man. Being the most abundant magnetic mineral in terrestrial rocks of igneous and metamorphic origin, magnetite has helped paleomagnetists to reconstruct the ancient geomagnetic field from rocks, and with it, the past positions of the continents on the globe. As an ore, magnetite is economically valuable, containing 72 wt% of iron. In sediments, magnetite may be of detrital (inorganic) or biogenic origin. Magnetic bacteria, algae, and some higher organisms such as molluscs have been shown to synthesize magnetite of high chemical purity, although the biochemical pathways of biogenic magnetite formation remain to be elucidated. Magnetite may form the basis of a magnetic-field receptor in homing pigeons and migratory animals. Magnetite is also technically important in electrochemical applications (electrodes, catalysts) and magnetic storage media. Owing to its half-metallic character and high ►Curie temperature, magnetite is currently being considered for spintronic applications.

#### Crystal Structure and Ferrimagnetism

The mixed-valence iron oxide magnetite (structural formula  $\text{FeO} \cdot \text{Fe}_2\text{O}_3$ ) crystallizes in the inverse ►spinel structure, i.e.,  $(8 \text{ Fe}^{3+})^{[4]}[8 \text{ Fe}^{2+} + 8 \text{ Fe}^{3+}]^{[6]} 32 \text{ O}^{2-}$ , with () and [] denoting tetrahedrally and octahedrally coordinated sites (A and B sites), respectively (Fig. 1).

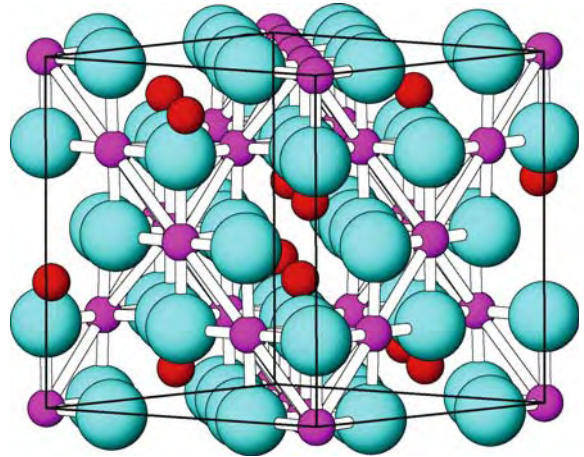

**Magnetite. Figure 1** Lattice structure of magnetite. Green: Oxygen anions; red: tetrahedral sites; pink: octahedral sites (courtesy of Dr. R. Pentcheva). The cube defines the system of the crystallographical  $\langle 100 \rangle$  axes.

The unit cell (edge length 8.396 Å) is a cubic-close packed lattice of 32 oxygen anions (8 formula units), which are slightly distorted toward the octahedral interstices to accommodate a third of the iron cations on tetrahedral interstices. The 16 B sites per unit cell (p.u.c.) are occupied by an equal number of randomly distributed  $\text{Fe}^{2+}$  and  $\text{Fe}^{3+}$  cations, and the remaining 8  $\text{Fe}^{3+}$  cations p.u.c. are on A sites. The A-site moments are aligned anti-parallel to the B-site moments, neutralizing the magnetic spin moment of the  $\text{Fe}^{3+}$  cations in the B-sites. The net magnetic spin moment is therefore carried by the  $\text{Fe}^{2+}$ , resulting in a net magnetic spin moment of exactly  $4 \mu_B$  (►Bohr magneton) per formula unit  $\text{Fe}_3\text{O}_4$ . A small contribution from the orbital moments results in a total magnetic moment of  $4.07 \mu_B$  per formula unit  $\text{Fe}_3\text{O}_4$  (value extrapolated to 0 K). This ferrimagnetic structure of magnetite was first suggested by Néel [1] and later confirmed by neutron scattering experiments.

The ►ferrimagnetism of magnetite breaks down at a critical temperature of  $T_C = 580^\circ\text{C}$  (Curie temperature), above which magnetite is paramagnetic. At  $T_V = 125 \text{ K}$ , magnetite undergoes a first-order phase transition, the so-called ►Verwey transition, below which the  $\text{Fe}^{2+}$  and  $\text{Fe}^{3+}$  cations on octahedral sites order, and so reduce the symmetry of the lattice from cubic to monoclinic. On warming through  $T_V$ , the electrical conductivity of magnetite increases by two orders of magnitude. The black color of magnetite, as well as its moderate electrical conductivity above  $T_V$ , is due to electron hopping between the  $\text{Fe}^{2+}$  and  $\text{Fe}^{3+}$  cations in the octahedral sites, that is, the cations exchange their valence between the +II (ferrous) and +III (ferric) oxidation states. The temperature of the Verwey

transition decreases with increasing oxidation parameter  $\delta$  in  $\text{Fe}_{3(1-\delta)}\text{O}_4$ . The fully oxidized form of magnetite with  $\delta = 1/9$ , called maghemite (formula unit  $\text{Fe}_2\text{O}_3$ ), does not undergo a Verwey transition, but is an electrical insulator and roughly 10% less magnetic than stoichiometrically pure magnetite. The unit cell of maghemite has a defect spinel structure and can formally be written as  $(8 \text{Fe}^{3+})^{[4]}[40/3 \text{Fe}^{3+} + 8/3 \text{ } ]^{[6]} 32\text{O}^{2-}$ , where stands for a lattice vacancy. If ordered on a tetragonal superlattice, the vacancies in the maghemite lattice give rise to additional reflexes in X-ray diffraction (XRD), by which maghemite can be distinguished from stoichiometrically pure magnetite. However, not all maghemite crystals show vacancy ordering, and the unit-cell parameter reported in the literature ranges from 8.330 Å to 8.340 Å, reflecting differences in how the samples were synthesized or in the precursory minerals (magnetite or iron-oxyhydroxides,  $\text{FeOOH}$ ) from which maghemite is naturally formed.

From the above, it is clear that discrimination between magnetite and maghemite may not always be straightforward by means of diffraction methods. The situation is even more complicated when it comes to identifying tiny amounts of magnetic material in tissue [2]. The amount of material in tissue is not sufficient for XRD (let alone spectroscopical techniques such as Moessbauer spectroscopy) and electron diffraction, as the only remaining crystallographical identification technique is not accurate enough to resolve the small differences in lattice spacing between magnetite and maghemite. Here, magnetometric measurements can be used to further constrain the nature of the magnetic material (see below).

### Domain State

Magnetic properties of magnetite crystals such as ►magnetic remanence and coercive force are largely controlled by domain state, which in turn depends upon grain size and shape. Figure 2 shows a magnetic phase diagram for submicron-sized single crystals of magnetite as a function of grain size and axial ratio, calculated with a micromagnetic model [3,4]. Magnetite cubes with an edge length smaller than 68 nm are magnetic single domains (SD) and so have a nearly uniform magnetization structure (Fig. 3a). Departures from the uniform magnetization structure near the corners and edges of the cubes become larger with increasing grain size (Fig. 3a,b). As the grain size increases above 68 nm, however, SD magnetization states become energetically less favorable, but can still exist up to a threshold edge length of 140 nm (Fig. 2), where they finally give way to non-uniform magnetization structures such as magnetic vortices (Fig. 3c).

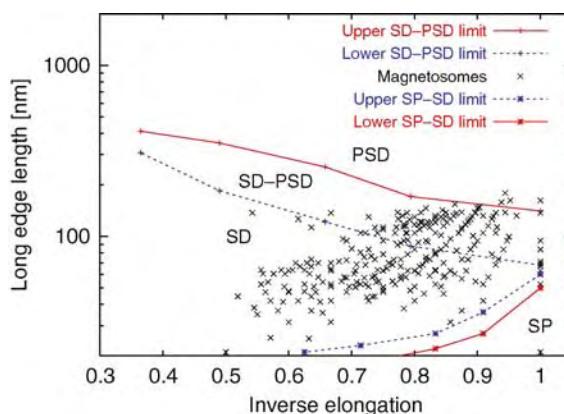

**Magnetite. Figure 2** Phase diagram for magnetic domain state in submicron-sized rectangular crystals of magnetite as a function of axial ratio (width/length) and long edge length calculated for room temperature (according to [3,4]). The upper two lines demarcate the stability of single domain (SD) magnetization states against pseudo-single-domain (PSD) states [3], the lower two lines against superparamagnetic behavior [4]. The crosses represent data from edge-length measurements on magnetite particles (magnetosomes) in magnetic bacteria [5]. With a few exceptions, magnetosomes fall into the stable SD field or in the field where SD states coexist with vortex states (SD–PSD field).

In a magnetic vortex, the magnetization structure is curling, thereby efficiently reducing the stray field outside the particle, however, at the expense of such magnetic moment. Particles containing such magnetic swirls are also referred to as pseudo-single-domain (PSD) particles. Magnetite crystals with grain sizes larger than 1  $\mu\text{m}$  host several uniformly magnetized, lamellar domains (multi-domain, or “MD” particles) with adjacent domains in the interior having opposite polarity (see Fig. 3d).

While single-domain particles carry the maximum magnetic moment per particle volume (►saturation magnetization), the specific magnetic moment of a vortex decreases rapidly with grain size [3], and is nearly zero in MD particles. For the purpose of magnetotaxis, in magnetic bacteria it is therefore most efficient to have SD particles. This can be achieved by limiting the particle size to 140 nm and by increasing the particle elongation. It therefore comes as no surprise that magnetite crystals in magnetic bacteria, so-called magnetosomes, usually have grain sizes below 140 nm and are elongated [5]. It is true that vortex states are energetically more favorable in magnetite cubes with an edge length greater than 68 nm, but one has to bear in mind that the magnetization in growing magnetosomes already occupies a SD state, as the particle size exceeds the threshold of 68 nm.

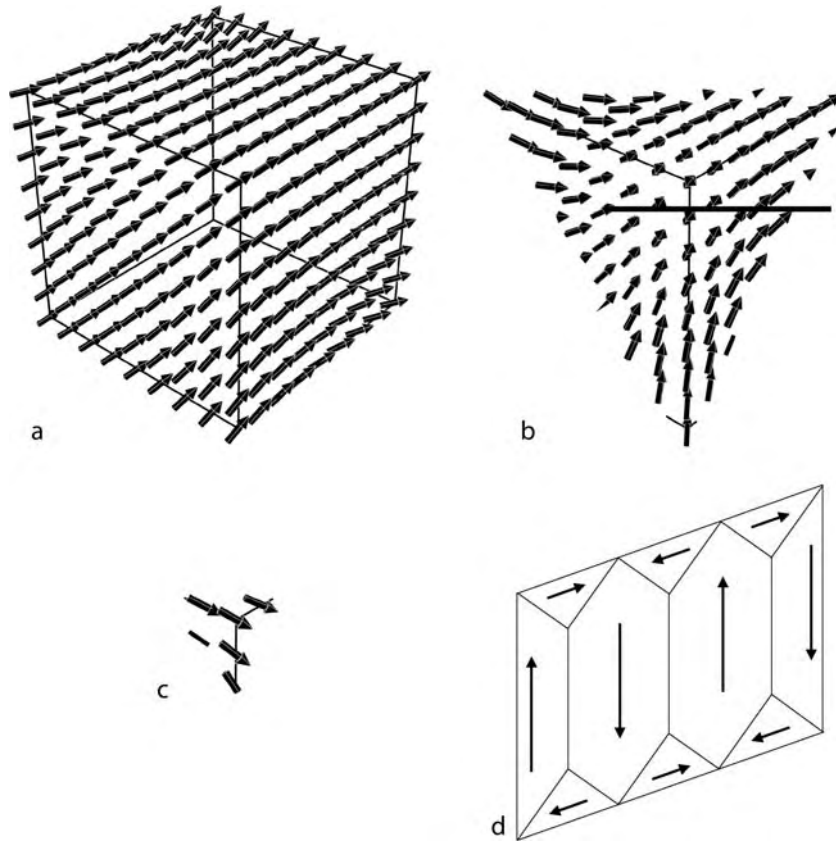

**Magnetite. Figure 3** Domain state in submicron-sized cubes of magnetite as defined by the magnetization structure: (a) single-domain (SD) state with nearly uniform magnetization; (b) SD “flower” state; (c) pseudo-single-domain (PSD) state containing a spin-curling structure (vortex). For comparison (d) shows a cross section (viewing plane 110) through a multi-domain (MD) magnetite (grain size  $>1 \mu\text{m}$ ), which contains lamellar magnetic domains and so-called closure domains near the surface to minimize magnetic pole density on the surface.

There are energy barriers preventing the (metastable) SD state from collapsing into a vortex, up to a critical size of 140 nm. That the magnetization in magnetosomes from the SD–PSD field is SD has convincingly been demonstrated by transmission electron holography [6]. Likewise, it is necessary to emphasize that the magnetic phase diagrams were calculated for isolated crystals in zero external field. Magnetosomes are usually arranged in chains, and so strongly magnetically interact. The interactions are such that the SD state will be stabilized.

### Superparamagnetism

If, on the other hand, the edge-length becomes less than some 50 nm, magnetite cubes cannot retain a temporally stable SD magnetization at room temperature because the magnetization structure is constantly buffeted by thermal fluctuations, leading to frequent spontaneous magnetization reversals in the particle. Such behavior is called Néel superparamagnetism. In a magnetic field, an assemblage of SP particles carries a magnetization, which will decay logarithmically with

time after the magnetic field is switched off. Although **superparamagnetism** does not represent a true domain state but rather describes a thermal relaxation phenomenon, it is sensible to include it into the magnetic phase diagram, defining the lower end of SD stability (Fig. 2).

It is important to note that Néel superparamagnetism refers to the stability of magnetic remanence with respect to the coordinate system of the particle. If the particles are not embedded (as in a solid rock matrix), but dispersed in a fluid, then the magnetic remanence of an assemblage of particles will decay through Brownian motion in the fluid. Magnetically stable SD particles, which are able to rotate freely in a viscous medium, are therefore subject to the Brownian type of superparamagnetism. Using magnetic relaxometry, one can distinguish Néel and Brownian relaxation by their different relaxation time characteristics.

### Magnetic Measurements as a Diagnostic Tool

Thermomagnetic curves allowing for Curie-point determination are a widely used tool in rock magnetism for identifying different magnetic crystals with different

Curie temperatures. Due to the high Curie temperature of magnetite, this rock magnetic technique is not suitable in biomagnetism for detecting magnetite in tissue.

The electronic and structural changes at the Verwey transition are also accompanied by abrupt changes in magnetic properties, which can be used to identify magnetite by measuring magnetic properties at low temperatures (►ZFC–FC measurements). Figure 4a shows a conspicuous discontinuity in magnetic remanence associated with the Verwey transition. This is, however, not the case with magnetite particles smaller than some 30 nm (Fig. 4b).

With decreasing grain size, not only thermal fluctuations, but also surface effects become important and affect the (magnetic) Verwey transition, first by lowering the temperature of the Verwey transition, and eventually by suppressing it altogether. Magnetic relaxation may also obscure the Verwey transition in SP particles. Nevertheless, low-temperature magnetic measurements are an excellent tool to identify and characterize SP particles. With decreasing temperature, thermal fluctuations diminish and SP particles are able to retain a magnetic remanence. The temperature at which SP particles become stable SD particles is called the blocking temperature. On heating above the blocking temperature, the magnetic remanence acquired at temperatures below the blocking temperature becomes unblocked and relaxes (linear-logarithmic decay). The spectrum of blocking temperatures contains useful information on the SP particle-size

spectrum (magnetic granulometry). Interpretation of low-temperature measurements may not be straightforward when additional phases are present that become magnetic at low temperatures (such as the iron-storage proteins ferritin or hemosiderin).

## Theory

### Magnetoreception Based on SD Magnetite

Following the example of magnetic bacteria, it was postulated that chains of SD magnetite particles might form an efficient basis for magnetoreception in animals [7]. A chain of magnetite particles would produce a torque in the geomagnetic field, which via mechanosensitive structures such as Pacinian corpuscles, hair cells, etc., could be transduced into a nerve signal. Despite the conceptual beauty of the model, a chain of magnetite particles has never been identified directly in animal tissue. It is true that SD crystals of magnetite have been extracted from brain tissue of bone fish, but the crucial questions have remained unanswered thus far, namely: (i) do the magnetite crystals have a physiological function and is it related to the magnetic sense? (ii) how had the magnetite crystals been arranged in situ before the tissue was dissolved and a magnetic extract made? (iii) what is the nature of the connection in the nervous system? In a more timely approach to unearth the elusive magnetic sense, iron-rich magnetic particles, probably SD magnetite, were detected by in-situ measurements on magnetically active nerve cells in the nose of trout [8]. Surprisingly, the particles detected were not arranged in a chain, but appeared to

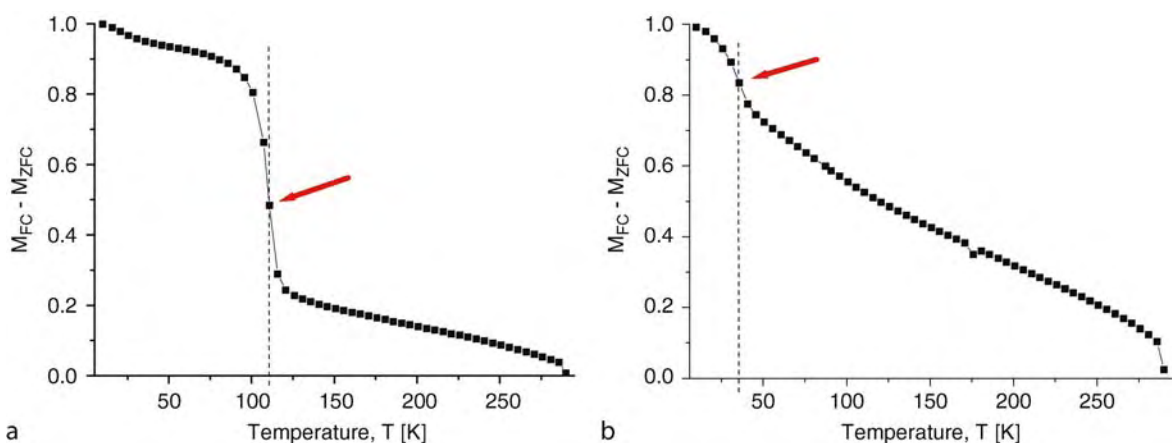

**Magnetite. Figure 4** Low-temperature magnetic measurements on synthetic magnetite samples, (a) median grain-size 60 nm (interacting SD particles), and (b) median grain-size 20 nm (interacting SP particles). A magnetic remanence was acquired during ZFC–FC cycling in a field of 1 mT. The SD sample is characterized by a pronounced discontinuity at 110 K (arrow) associated with the Verwey transition. The SP sample on the other hand shows no apparent discontinuity, except for the change in curvature at 35 K (arrow). When it comes to identifying magnetic material in tissue, magnetization curves similar to the one on the left will make the case for magnetite, while curves resembling the one on the right can only be taken as evidence of very-fine grained material, however, not necessarily of magnetite (Winklhofer and Maher, unpublished data).

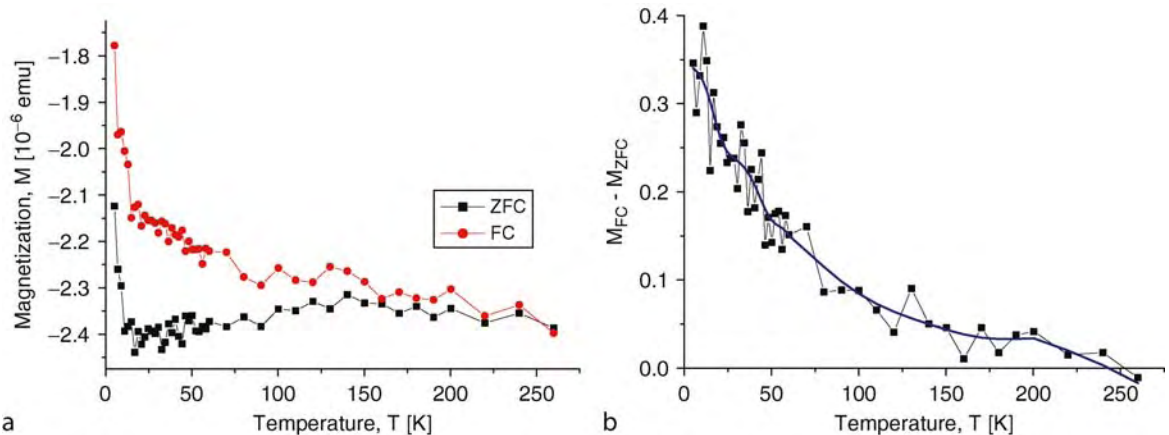

**Magnetite. Figure 5** Low-temperature magnetic measurements indicating the presence of SP crystals in the upper beak skin of homing pigeon [2]. (a) ZFC–FC cycling in a field of 5 mT. The mean concentration of magnetic material in the tissue is so little that the signal is dominated by the diamagnetic background and the variations in the signal are just above the noise level. (b) The resulting remanence curve (inset), obtained by subtracting the ZFC curve from the FC curve (raw data: squares; smoothed data: blue line), shows that most of the magnetic remanence is blocked well below 100 K. This is consistent with SP particles smaller than 10 nm grain size.

form an irregular cluster in the cell body of the neuron. Yet, the magnetic inclusions are a first structural candidate for the postulated magnetoreceptor in trout.

#### Magnetoreception Based on SP Magnetite

Using an approach combining bulk magnetic measurements (Fig. 5), histological staining techniques and electron microscopy, it was possible to identify a putative magnetoreceptor in the beak skin of homing pigeons [2,9], namely clusters of SP crystals of magnetite (or maghemite) located in free nerve endings of the ophthalmic branch of the N. trigeminus.

Free nerve endings in the skin are sensitive to mechanical stimulation and so can convert, in principle, magnetic-field induced deformation into a nervous signal. There are several ways of producing mechanical deformation by SP clusters interacting with the magnetic field, as has been demonstrated theoretically and experimentally using droplets of magnetic fluids as a model system [10]. A single cluster of SP particles will assume a shape that depends upon the magnetic field direction and intensity (Fig. 6a).

The micrographs in [9,10] show that the clusters do not occur singly, but form coherent groups of some 20 clusters. The clusters will therefore be magnetically interacting [10], which opens new ways of producing mechanical deformation. If embodied in an elastic matrix (such as the cytoskeleton), adjacent clusters will attract or repel, depending on the relative orientation of the magnetic field axis to the (imaginary) axis connecting the clusters (Fig. 6b). This way, stress is produced on the cytoskeleton and can be measured using cellular mechanotransducers. If contained in a viscous medium, the clusters self-organize

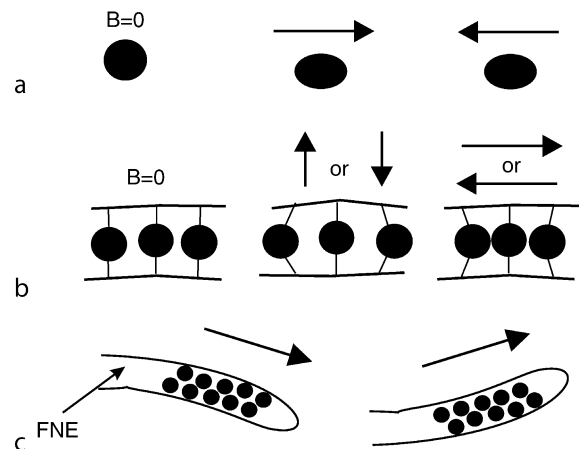

**Magnetite. Figure 6** Possible ways of transforming a magnetic field into mechanical deformation based on SP clusters. (a) Single cluster in zero field ( $B = 0$ ) and in an applied magnetic field. (b) Magnetically interacting SP clusters in an elastic matrix coupled to the membrane of the dendrite; the matrix is under dilatation (compression) if  $B$  is perpendicular (parallel) to the axis joining the clusters. (c) Magnetically interacting SP clusters in a viscous medium within a free nerve ending (FNE), which behave as a single mechanic unit. The magnetic field exerts a torque on the double chain of clusters, and by aligning the chain into the magnetic field, the FNE will be bent. Note that all the mechanisms are independent of the polarity of the magnetic field.

into a chain-like arrangement parallel to the magnetic field. Due to the shape anisotropy of the arrangement, a magnetic torque is produced when the relative orientation between the chain and field axis changes. The

torque tries to realign the chain into the magnetic field axis and bends the free nerve ending (see Fig. 6c). In conclusion, there are several possibilities for transducing the magnetic field based on SP clusters. The theoretical predictions have been successfully confirmed by experiments on model systems, and it is about time to start in-situ experiments in order to find out which mechanism is realized.

## References

1. Néel L (1948) Propriétés magnétiques des ferrites: ferrimagnétisme et antiferromagnétisme. *Ann Phys (Paris)* 3:137–198
2. Hanzlik M, Heunemann C, Holtkamp-Rötzler E, Winklhofer M, Petersen N, Fleissner G (2000) Superparamagnetic magnetite in the upper beak tissue of homing pigeons. *Biometals* 13:325–331
3. Fabian K, Kirchner A, William W, Heider F, Leibl T, Hubert A (1996) Three-dimensional micromagnetic calculations for magnetite using FFT. *Geophys J Int* 124:89–104
4. Winklhofer M, Fabian K, Heider F (1997) Magnetic blocking temperatures of magnetite calculated with a three-dimensional micromagnetic model. *J Geophys Res* B102:22695–22709
5. Petersen N, Weiss DG, Vali H (1989) Magnetic bacteria in lake sediments. In: Lowes et al. (ed) *Geomagnetism and Palaeomagnetism*. Kluwer, Dordrecht, pp 231–241
6. McCartney MR, Lins U, Farina M, Buseck PR, Frankel RB (2001) Magnetic microstructure of bacterial magnetite by electron holography. *Eur J Mineral* 13:685–689
7. Yorke ED (1979) A possible magnetic transducer in birds. *J Theor Biol* 77:101–105
8. Diebel CE, Proksch R, Green CR, Neilson P, Walker MM (2000) Magnetite defines a vertebrate magnetoreceptor. *Nature* 406:299–302
9. Fleissner G, Holtkamp-Rötzler E, Hanzlik M, Winklhofer M, Fleissner G, Petersen N, Wiltshko W (2003) Ultrastructural analysis of a putative magnetoreceptor in the beak of homing pigeons. *J Comp Neurol* 458:350–360
10. Davila AF, Fleissner G, Winklhofer M, Petersen N (2003) A new model for a magnetoreceptor in homing pigeons based on interacting clusters of SP magnetite. *Phys Chem Earth* 28(16–19):647–652

## Magnetization Transfer Imaging (MTI)

### Definition

Is an MRI technique based on the selective saturation of protons bound to macromolecules such as myelin. In damaged brain tissue, for example, the increased concentration of protons in free water leads to a quantifiable reduction of MT saturation effects.

## Magneto-aerotaxis

### Definition

Aerotaxis guided by a magnetic field.

► [Magnetic Bacteria](#)

## Magnetoencephalography

ANDREAS A. IOANNIDES<sup>1,2</sup>

<sup>1</sup>Laboratory for Human Brain Dynamics, Brain Science Institute, RIKEN, Saitama, Japan

<sup>2</sup>Laboratory for Human Brain Dynamics, Aesthetic Analysis of Ideas: Scientific Cultural services Ltd, Nicosia, Cyprus

### Synonyms

Magnetoencephalography; MEG

### Definition

Magnetoencephalography (MEG) encompasses a family of non-contact, non-invasive techniques for detecting the magnetic field generated by the electrical activity of the brain, for analyzing this MEG signal and for using the results to study brain function.

### Purpose

The overall purpose of MEG is to extract estimates of the spatiotemporal patterns of electrical activity in the brain from the measured magnetic field outside the head. The electrical activity in the brain is a manifestation of collective neuronal activity and to a large extent it is the currency of brain function. The estimates of brain activity derived from MEG can therefore be used to study mechanisms and processes that support normal brain function in humans and help us understand why, when and how they fail.

### Principles

#### Basic Physical Principles

Brain function is expressed through electrical activity within and between *neurons*. The same neuronal generators responsible for the generation of the MEG signal are also responsible for changes in the electrical potential on the scalp that can also be measured non-invasively as the ► [Electroencephalogram \(EEG\)](#) by attaching electrodes to the scalp. The well-understood laws of electromagnetism define how electric currents in the brain generate EEG and MEG signals.



The determination of the EEG and MEG signal from the knowledge of the sources, the electrical properties of their biological environment and the configuration of the measuring devices is known as the forward problem. The estimation of generator strength, location and timecourse from the EEG and MEG signal and the knowledge of electrical properties of their biological environment and the configuration of the measuring devices is known as the inverse problem. The laws of electromagnetism define what can be asked of the data and how the forward and inverse problems should be tackled, in particular what *a priori* assumptions can be made about the generators. The basic elements of the hardware used for the detection of the MEG signal will first be described. The forward problem and then the inverse problem will then be considered, describing in each case the theoretical framework established by the laws of electromagnetism and its implications for useful MEG (and sometimes EEG) applications.

### Recording and Strength of MEG Signal

As will be described later the MEG signal is generated by the collective activity of a large number of neurons. Nevertheless, the strength of the MEG signal is extremely weak compared to typical terrestrial magnetic fields. The earth's magnetic field is about a billion times as strong, while the usual urban environment at frequency ranges that overlap the ones of interest in MEG is still many orders of magnitude higher than the strongest MEG signal from a normal human brain. A pre-requisite for useful MEG measurements is therefore the availability of sensors that can detect the weak magnetic fields generated by the brain. Also required are methods that can exclude the large ambient fields and tools that can separate out the signal of interest from any remaining interfering signals from the environment and other signals generated by the body of the subject that are often considerably stronger than the signal of interest.

The basic MEG measurement relies on the detection of the electrical current in a small loop of wire, typically about one centimeter across, induced by the change in the magnetic field component perpendicular to the loop surface. Measurement of the induced current determines the value of the change in the magnetic field. Usually a set of coils is used arranged as a ►gradiometer to emphasize nearby signals from the brain at the expense of distant sources. The detection of the minute magnetic field changes outside the head generated by electrical currents in the brain is measured by coupling the coil or gradiometer to an extremely sensitive "superconducting quantum interference devices" (►SQUID). ►SQUIDS as the name implies rely for their exquisite sensitivity on ►superconductivity and together with their sensing coils must be kept at extremely low temperatures, just a few degrees above absolute zero.

To achieve this, sensing coils and SQUIDS are kept in a thermos-like container, the ►dewar, which under normal operating conditions is filled with liquid helium. In modern systems the bottom of the dewar is shaped into a helmet with well over one hundred, nowadays a few hundred sensing coils evenly distributed on its inner surface. Just a few millimeters away, on the other side of the insulating layer, at normal room temperature a subject can safely place his/her head inside the helmet. Each sensing coil samples the local magnetic field and the full set of sensing coils can be "scanned" a few thousand times a second. Each scan delivers an independent measurement of the instantaneous magnetic field just outside the head.

The second requirement, separating the signal of interest from the larger ambient background and other interfering signals is achieved by a combination of passive shielding, use of gradiometer design either in hardware for the sensing coils coupled to the SQUIDS or in software using additional reference channels. Other signal processing techniques, e.g. Independent Component Analysis (ICA) coupled to the use of information from auxiliary channels like the ►electro-oculogram (EOG) and electrocardiogram (ECG) can effectively eliminate biological and other artifacts. The combination of the exquisite SQUID sensitivity with these hardware and software methods allows the measurement of the magnetic field generated by the brain with little contamination.

In a modern MEG hardware typically a few hundred sensing coils, each coupled to its own SQUID, are housed at the bottom of the helmet-shaped dewar distributed so that they capture evenly the magnetic field just outside the head. The magnetic field for just one "timeslice" can be mapped by recording the signal from each sensor independently from, and for all practical purposes simultaneously with, the signal of each other sensor. In one second a few thousand such timeslices can be recorded so that successive timeslices provide a movie of the instantaneous change in the magnetic field just outside the head. Since, as we will shortly describe, the speed of propagation from the generators to the sensors is the speed of light, the MEG signal change corresponds to the instantaneous change of the electrical current density in the brain generated by neuronal activity. The peaks of the signal generated by the brain are about two orders of magnitude higher than the device noise level, so the map of the magnetic field not only has exquisite time resolution (a fraction of a millisecond) but is also a very clean map of the topography of the magnetic field just outside the head.

### The Forward Problem

It is useful to separate the full current density into two terms. In general we are interested in the first term,

known as impressed currents because they describe the active currents generated by energy-demanding neuronal activity. The remaining currents make up the second term; they describe the passive flow of currents that flows as a result of the impressed currents in the biological medium. Impressed currents of an individual neuron cannot be directly detectable by either MEG or EEG because they are too weak. Even under the most favorable conditions, a detectable signal can only be generated by the collective activity of many tens, possibly many hundreds of neurons spread over at least  $1 \text{ mm}^2$  of cortex. At this spatial scale the appropriate terms that best separate the full current density into active and passive elements are referred to as primary current density and volume current or return current respectively. The primary current density depends on both intracellular currents and the local extracellular currents. The intracellular currents are closely related to the local impressed currents. Since these ionic flows are along axons and dendrites the net contribution from a single neuron is a sum of vectors each pointing along the long axis of the corresponding active dendrite or axon. The overall primary current density generated by intracellular currents is the vector sum of contributions from active neurons, which is therefore strongly dependent on the overall arrangement of neurons. The extracellular currents flow along the local conductivity gradients is determined mainly by cell membranes. For each focal neuronal activity, the local arrangement of cells determines the combined effect of both intracellular and extracellular currents and therefore shapes the resulting primary current density. The source space is a convenient label for the region of space where the primary current density can be non-zero, and it includes the entire brain. Primary currents can be thought of as the generators of the volume or return currents, i.e., the large-scale passive electrical current flowing in the “volume conductor,” in the brain at large and bounded by the highly resistive skull. These large-scale passive electrical currents do not contribute to the magnetic field, except where they “twist” at boundaries with sharp changes in conductivity, especially the skull. In the special case that only concentric spherical boundaries of changes in conductivity are present, the magnetic field generated outside a conductor is given by an analytical expression [1]. Furthermore, the laws of electromagnetism and spherical symmetry define explicitly which generators can produce an external magnetic field and which are magnetically silent, i.e. they do not produce an external magnetic field no matter how strong they are. Specifically, radial components of the current density are magnetically ▶[silent sources](#). The non-zero contribution of tangential components of the current density can be written analytically in a form that depends on the center of the conducting sphere(s) and it does not depend on either the conductivities of the

different compartments or the radii of the concentric shell(s), as long as the magnetic field is computed outside the conductor (last spherical shell). Finally the magnetic field in the *radial* direction depends only on the primary currents. The skull is smooth and nearly spherical so the convenient and relatively simple spherical model can provide an excellent estimate for the second term, except around openings like the eye sockets or parts of the skull that deviate substantially from the spherical model.

In contrast to the MEG forward problem the EEG forward problem poses real difficulties in practice. The computation of EEG signal is more complicated because it depends closely on details of the conductivity profile. The differences in the forward problem for MEG and EEG signals have two main consequences. First, the relationship between neuronal activity is easier to model for MEG. On the one hand the skull is transparent to magnetic fields and highly resistive to electrical currents (that must cross it to produce the scalp EEG) and on the other the effect of the conducting medium can be approximated by simple models for accurate computations of the magnetic field but have to be described in detail for the computation of the surface potential. Second, the EEG is influenced strongly by both radial and tangential electric currents while MEG is only sensitive to tangential sources.

The laws of electromagnetism endow both EEG and MEG signals with a direct relationship with the neuronal sources. Specifically, the electric and magnetic fields propagate from the (neuronal source) generator site with the speed of light. Since the sensors are just some centimeters away, for all practical purposes the effect is immediate: a change in the source electrical activity in the brain produces an immediate change in the MEG and EEG signal. This is in sharp contrast with other neuroimaging methods like ▶[positron emission tomography \(PET\)](#) and ▶[functional magnetic resonance imaging \(fMRI\)](#) that rely on changes in blood flow or content (e.g. radioactive labeling or oxygenation) and therefore produce indirect correlates of neuronal activity with delays that are at best a good fraction of a second in the case of fMRI and minutes in the case of PET.

Finally, the forward problem is linear as a direct consequence of the linearity of the laws of electromagnetism. In other words the electric and magnetic field generated by any combination of instantaneous current elements is simply the sum of individual contributions from each element. In the case of continuous primary current density, the instantaneous electric and magnetic field can be computed by integrating the contributions from each small volume element in the source space. In the case of a spherical model the source space for MEG includes only regions where neurons and possibly white matter exists, any intervening regions and boundaries

are not part of the source space as long as they do not generate primary currents.

### Inverse Problem

In contrast to the forward problem, the inverse problem has no unique solution, a mathematical fact that was already demonstrated over 150 years ago [2]. Simply stated, it is impossible to reconstruct uniquely the electrical current density inside the head from MEG and/or EEG measurements. Even if we knew exactly the electrical potential on the surface of the head and the magnetic field everywhere outside the head we would still be unable to determine the currents inside the head. In practice, non-uniqueness is much less of a problem than would appear from the dry mathematical statements. By definition silent sources cannot be recovered and noise and sparse sensor coverage further limit what can be reliably extracted about the non-silent part of the current density vector. Nevertheless what is often required of the data is to provide reliable estimates about which areas of the brain were preferentially activated by some stimuli or tasks and when. This limited objective is often satisfied with estimates of the timecourse of the non-silent part of the source configuration. The key question in practice is how accurately and reliably one can recover the non-silent part of the primary current density.

A unique solution of the biomagnetic inverse problem can be obtained by introducing constraints for the form of the generators. Two types of constraints are particularly popular [3]. The first assumes that the generators are one or more point-like sources, or current dipoles. ▶**Dipole source localization** solutions are often interpreted as representatives for their neighborhood and are referred to as equivalent current dipoles (ECD). The second family of popular source localization methods assumes that the continuous current density can be written as a linear sum of (weighted) functions, each defining the sensitivity profile, or lead fields, of the sensors. These methods, known as ▶**minimum norm** or weighted minimum norm solutions, are popular because they lead to a linear system of equations which allows standard pseudoinverse techniques to define the inverse operator that can then be applied directly to the data. Theoretical scrutiny of the mathematical foundation of the inverse problem shows that neither current dipoles nor linear solutions are adequate. Minimum norm is not appropriate for tomographic localization for a rather subtle reason; although the forward problem is linear the optimal algorithm for tackling the inverse problem cannot be linear [4]. The laws of electromagnetism provide no justification for expressing the full primary current density vector as a weighted sum of lead fields, only the direction of the primary current density can be so represented and this leads inevitably to a non-linear relationship between the

measurements and the distribution of generators. This conclusion was reached first on the basis of simulation studies leading to the standard form of ▶**magnetic field tomography** (MFT) [5]. In the last 10 years accurate MFT reconstructions have been demonstrated with many applications and extended to single timeslices of ▶**single trial data** [6,7].

### Neural Mechanisms

A detectable MEG signal requires concerted action from many neurons numbering at a minimum many tens probably many hundreds. These neurons must be arranged in a similar way in space and they must be activated in near synchrony. The very presence of a good size MEG and EEG signal is evidence for dual organization of neurons: a spatial organization in the way they are grouped together in space and large scale synchrony in the way their activity is organized in time. It is generally believed that relatively slow changes in electrical activity associated with ▶**post-synaptic potentials (PSP)** at the ▶**apical dendrites** of large ▶**pyramidal neurons** are the main contributors to the MEG signal. Large pyramidal neurons are prime candidate generators of MEG signals because their elongated shape is ideal for producing strong primary currents. Furthermore they are arranged in parallel in the cortex so the net impressed current from nearby large pyramidal neurons will tend to sum up constructively. It is very likely that a large part of the MEG signal is indeed due to slow PSPs in the apical dendrites of pyramidal neurons, especially at frequencies well below 100 Hz. For this standard mechanism, typical estimates require about a million *synapses* to be simultaneously active to produce a measurable MEG signal [3]. MEG activity at frequencies well above 100 Hz is likely to be produced by synchronous ▶**action potentials** [7].

### Advantages and Disadvantages

#### Advantages

MEG is a completely non-invasive method. With appropriate analysis methods it can provide simultaneously accurate localization of different brain regions and exceptional temporal resolution. The MEG signal depends weakly on the conductivity changes in the brain and simple models can provide accurate estimates of the magnetic field generated by a source in the brain. The insensitivity to radial sources adds to the discriminability of MEG, especially for sources in sulci.

#### Disadvantages

The need for shielding and use of liquid helium makes MEG an expensive technology both in terms of the cost of hardware and the operating costs. Another disadvantage of MEG is the need for the subject to stay

motionless while data are collected. MEG is insensitive to radial currents so generators close to the center of the head (e.g. ►[thalamus](#)) and at the crest of gyri are close to silent sources. The patterns of activity identified with MEG are not very meaningful on their own because they lack anatomical context. The background anatomy must be provided by other methods, usually ►[MRI](#) and the process of combining the background anatomy and the functional information requires considerable effort to ensure accurate coregistration between the two modalities for each subject and experiment.

►[Magnetoencephalography](#)

## References

1. Sarvas J (1987) Basic mathematical and electromagnetic concepts of the biomagnetic inverse problem. *Phys Med Biol* 32:11–22
2. von Helmholtz H (1853) Ueber einige Gesetze der Vertheilung elektrischer Ströme in körperlichen Leitern, mit Anwendung auf die thierisch-elektrischen Versuche. *Ann Phys Chem* 89:211–233, 353–377
3. Hamalainen M, Hari R, Ilmoniemi RJ, Knuutila J, Lounasmaa OV (1993) Magnetoencephalography – theory, instrumentation, and applications to noninvasive studies of the working human brain. *Rev Mod Phys* 65:413–497
4. Taylor JG, Ioannides AA, Muller-Gartner HW (1999) Mathematical analysis of lead field expansions. *IEEE Trans Med Imaging* 18:151–163
5. Ioannides AA, Bolton JPR, Clarke CJS (1990) Continuous probabilistic solutions to the biomagnetic inverse problem. *Inverse Probl* 6:523–542
6. Ioannides AA (2001) Real time human brain function: observations and inferences from single trial analysis of magnetoencephalographic signals. *Clin EEG* 32:98–111
7. Ioannides AA, Fenwick PBC, Liu LC (2005) Widely distributed magnetoencephalography spikes related to the planning and execution of human saccades. *J Neurosci* 25(35):7950–7967

## Magnetonavigation

►[Magnetic and Electric Senses](#)

## Magnetopause

### Definition

The outer boundary of the magnetosphere, which is teardrop shaped and highly variable in altitude, because

of variations in solar wind speed. Roughly  $10 R_E$  (Earth radii) on the dayside,  $\sim 1000 R_E$  on the night side.

►[Geomagnetic Field](#)

## Magnetoperception

►[Magnetic and Electric Senses](#)

## Magnetoreception

### Definition

The ability to detect magnetic fields.

►[Magnetic Map](#)

►[Magnetic and Electric Senses](#)

## Magnetosensitivity

►[Magnetic and Electric Senses](#)

## Magnetosphere

### Definition

The uppermost part of the atmosphere, which is fully ionized and where all charges are controlled by the geomagnetic field.

►[Geomagnetic Field](#)

## Magnetotactic Bacteria

►[Magnetic Bacteria](#)

## Magnetotaxis

### Definition

Unidirectional motility along magnetic lines of force.

- ▶ Magnetic Bacteria
- ▶ Magnetic and Electric Senses

## Magnification Factor

### Definition

The cortical magnification factor describes how much cortical area is related to a certain area on the receptor sheet. The magnification factor depends on the receptor density of the corresponding body surface, which is also related to the behavioural relevance of the respective sensory inputs and on the divergence of the afferent projections arising from the subcortical relay structures (spinal cord, brain stem, thalamus).

- ▶ Somatosensory Reorganization

## Magnitude (Amplitude) Spectrum in Acoustics

### Definition

A description of the relationship between magnitude (pressure or sound intensity) and frequency of the sinusoidal components of a complex sound wave.

- ▶ Acoustics

## Magnocellular Cells

### Definition

Large cells located in two layers of the lateral geniculate nucleus (LGN) of primates that have been proposed to be part of a pathway (the M pathway) from the retina to visual cortex concerned with visual motion.

- ▶ Geniculo-striate Pathway
- ▶ Lateral Geniculate Nucleus (LGN) – Magnocellular Neuron

- ▶ Retinal Ganglion Cells
- ▶ Visual Motion Processing
- ▶ Evolution of the Visual System: Mammals – Color Vision and the Function of Parallel Visual Pathways in Primates

## Magnocellular Division of the Ventral Lateral Geniculate Nucleus (Cat)

- ▶ Intergeniculate Leaflet

## Magnocellular Pathway

### Definition

The magnocellular visual pathway takes its input from retinal ganglion cells with large cell bodies. The pathway proceeds through layers 1 and 2 of the lateral geniculate nucleus (LGN) to layer 4c $\alpha$  of primary visual cortex.

- ▶ Geniculo-striate Pathway
- ▶ Lateral Geniculate Nucleus (LGN) – Magnocellular Neuron
- ▶ Retinal Ganglion Cells
- ▶ Striate Cortex Functions
- ▶ Visual Motion Processing

## Main Olfactory Bulb

### Definition

- ▶ Olfactory Bulb

## Main Olfactory System

### Definition

Specialized in the detection of odorants. Signals generated by olfactory sensory neurons in the olfactory

epithelium are transmitted to the main olfactory bulb, and then relayed through the primary olfactory cortex to higher cortical areas involved in conscious perception as well as limbic areas that control basic drives and emotions.

► Odor

## Maintenance of Wakefulness Test

### Definition

Standardized test of the ability of subjects to stay awake while in a sleep-conducive environment, e.g. a darkened room.

► Sleep-Wake Cycle

## Major Depression

### Definition

A psychiatric diagnosis indicating a state of depressed mood diagnosed according to DSM IV criteria.

► Major Depressive Disorder

## Major Depressive Disorder

HEINZ BOEKE

University Hospital of Psychiatry Zurich, Hospital for Affective Disorders and General Psychiatry Zurich East, Zurich, Switzerland

### Synonyms

Major depression; Endogenous depression; Unipolar depression; Melancholia

### Definition

Major depression is the most severe category of depression and is marked by a combination of symptoms that occur together and last for at least two weeks without significant improvement.

Symptoms from at least five of the following categories must be present for a major depression, although even a few of the symptom clusters are indicators of a depression, but perhaps not a major depression:

- Persistent depressed, sad, anxious, or empty mood
- Feeling worthless, helpless, or experiencing excessive or inappropriate guilt
- Hopeless about the future, excessive pessimistic feelings
- Loss of interest and pleasure in usual activities
- Decreased energy and chronic fatigue
- Loss of memory, difficulty making decisions or concentrating
- Irritability or restlessness or agitation
- Sleep disturbances, either difficulty sleeping, or sleeping too much
- Loss of appetite and interest in food, or overeating, with weight gain
- Recurring thoughts of death, or suicidal thoughts or actions

### Characteristics

#### History/Background

Descriptions of what is today known as depression or mood disorders appear in many ancient documents. About 400 BC Hippocrates used the terms mania and melancholia to describe mental disturbances. Around 30 AD, in his work “De re medicina” the Roman physician Celsus described melancholia (from the Greek “melan” meaning “black” and “chole” meaning “bile”) as a depression caused by black bile.

In 1899, the German psychiatrist Emil Kraepelin, building on the ideas and theories of earlier French and German psychiatrists, described manic-depressive psychosis; according to Kraepelin, a dementing or deteriorating course in manic-depressive psychosis differentiated it from dementia praecox (as schizophrenia was then called). Kraepelin also described a depression that later came to be known as involuntional melancholia as a form of depression beginning in late adulthood.

Epidemiological studies have shown that depressive disorders are more common and have a less favorable course than previously assumed. Concepts of diagnosis have also changed over time. The entity of endogenous depression, part of Kraepelin’s systematic, triadic nosology (1913), was abandoned in favor of depressive episodes, as defined in ICD-10 (WHO 1992), and major depression as defined in DSM-IV (APA 1994). These became the new major diagnostic categories for depressive disorders. The heterogeneity of the depressive syndrome has resulted in a continuous demand for new attempts at classification. When the current DSM-IV and ICD-10 systems for the classification of depressive disorders are considered from the

controversial historical perspective, it becomes clear that the distinction between unipolar and bipolar disorders has prevailed and that classification on the sub-syndrome level has been taken up again, albeit in a somewhat modified form. The main change occurring in the transition from ICD-9 to ICD-10 was the abandonment of the distinction between endogenous and neurotic forms of depression: this distinction was considered to be too etiologically oriented, and could not be adequately validated on an empirical basis.

### Diagnostic Considerations

There is no general agreement about the best method of classifying depressive disorders. Three broad approaches have been made: first to base classification on etiology, second on symptoms and third on the course of the disorder.

Both ICD-10 and DSM-IV classify depressive episodes on the basis of severity and whether or not ▶psychotic features are present. It is also possible to specify whether a depressive episode has ▶melancholic (DSM-IV) or ▶somatic (ICD-10) ▶features. In DSM-IV, an episode of major depression with the appropriate clinical symptomatology can be specified as ▶atypical depression. In ICD-10 atypical depression is classified separately under “other depressive episodes.” Both ICD-10 and DSM-IV allow the diagnosis of ▶recurrent brief depression. Nowadays it is argued that the phenomenologically-based concept of “major depression” has led to sterility in depression research and clinical practice, and that there is a need for a paradigm shift in modeling and classifying the depressive disorders [1].

### Epidemiology

Major depressive disorder is a common disorder, with a lifetime prevalence of about 15% and perhaps as high as 25% for women. The incidence of major depressive disorder is 10% in primary care patients and 15% in medical inpatients.

An almost universal observation, independent of country or culture, is that major depressive disorder is twice as prevalent in women than in men. Possible reasons for this are hormonal differences, the effects of childbirth, different psychosocial stressors for women than for men and behavioral models of learned helplessness.

The gender differences have been found in community samples and can thus not be accounted for by the fact that women are more likely to seek help than men. Race, education, income and marital status do not influence prevalence rates for major depressive disorder. Recent epidemiological data clearly indicate that the age of onset of major depressive disorder has decreased in recent years (the “birth cohort” effect) in many Western cultures [2].

The lifetime psychiatric co-morbidity rate for major depressive disorder can be as high as 43% [3], i.e., up to 43% of patients with major depressive disorder have a history of one or more non-mood psychiatric disorders. The one-month point prevalence for concurrent in contrast to lifetime psychiatric co-morbidity is 8%.

There is strong empirical evidence suggesting that psychosocial events or stressors may play a significant role in precipitating the first or second episode of major depressive disorder, but this becomes less important for the onset of subsequent episodes [4]. This means that for the recurrent forms of major depressive disorder, new episodes are less likely to involve a specific precipitant as the disorder becomes more firmly established.

### Course and Outcome

Periods of significantly increased risk for the onset of the illness include late adolescence and early adulthood, with a progressively increasing incidence up to the age of 45. The age of 30 is usually considered the typical age of onset, although more recent investigations have implied that the average age of onset is considerably earlier [5]. Contrary to the traditional clinical conception that the highest rates for depression are found in older persons, more recent studies have found the highest rates in younger age-groups [6]. More and more young patients are developing depression at an increasingly earlier age. It seems likely that the increased risk of depression in younger people is environmentally mediated, but the factors involved are unknown [7].

Major depression is 2.5 times more common in separated people living alone [5].

People who have been unemployed for at least 6 months of the 5 years preceding diagnosis are three times more likely to develop an episode of major depression.

Critical life events with respect to inter-personal relationships, particularly the death of a close friend or relative, and physical illness combined with poor social resources (e.g., inadequate social support) and personal resources (e.g., dysfunctional coping behavior) are found primarily in depressive cases [8]. An earlier onset of illness, a slower rather than an acute onset, the presence of dysthymia, the presence of chronic physical illness and above all the presence of a chronic anxiety disorder all significantly increase the risk of chronic depression.

The duration of the episodes varies, but several prospective studies have shown that affective disorders remit completely much more often than anxiety disorders (ratio: 32–46%).

The remission rate (defined as five years without relapse) is 42% for unipolar depressive illnesses.

For those who experience a first depressive episode, the risk of recurrence is 80–90%. About 50% of patients with major depressive disorder become chronic cases:

more than 20–30% do not respond to antidepressant medication, with up to 60% of primary care patients remaining depressed after 12 months and 20% of clinic patients remaining depressed for over two years despite pharmacological treatment. Further, one third of those initially responding to medication relapse within one year, with up to 75% relapsing within five years. Chronic depression leads to psychosocial deficits, which place a tremendous burden on both patients and society. It is not only associated with various somatic illnesses, but also entails massive economic costs. According to the WHO, it is predicted that depression will become the major burden on mental health services by the year 2020.

The risk of suicide has been estimated at 15% and is thus considerably higher than in the normal population. Co-morbid depressive episodes last significantly longer than non-co-morbid depression and have a considerably higher rate of relapse.

## **Etiology**

### **Genetic Causes**

Most family studies have shown that parents, siblings and children of severely depressed patients have a morbid risk of about 20% for mood disorders, as compared with about 7% for the relatives of controls. The concordance rates for manic depressive disorder were 69% for monozygotic twins reared together, 67% for monozygotic twins reared apart, and 13% for dizygotic twins.

### **Neurodevelopment Factors**

It has been proposed that stress-induced changes in the hippocampus may be central to the development of depression in genetically vulnerable individuals. New evidence implicates the pre-frontal cortex (PFC) in addition to the hippocampus as a site of neuropathology in depression. The PFC may be involved in stress-mediated neurotoxicity as stress alters PFC functions and glucocorticoid receptors, the PFC is directly interconnected with the hippocampus, and metabolic alterations can be seen in the PFC in depressed patients. Post-mortem studies in major depression provide preliminary evidence for specific neuronal and gliohistopathology in mood disorders. Three patterns of morphometric cellular changes are noted: cell loss (subgenual PFC), cell atrophy (dorsolateral PFC and orbitofrontal cortex) and increased numbers of cells (hypothalamus, dorsal raphe nucleus, cf. [9]).

### **Neurotrophic Factors**

Several neurotrophic factors (such as nerve growth factor, NGF, brain-derived neurotrophic factor, BDNF, and glyo-derived neurotrophic factor, GDNF), as well as cytokines and insulin-like growth factor-1 (IGF-1)

increase cell survival. The cAMP response element-binding protein (CREB) is a critical integrator of neuroplasticity that is responsive in a brain region-specific manner to a variety of environmental and pharmacological stimuli, including widely prescribed antidepressant medications. CREB is an ubiquitous key-element of intracellular signal transduction cascades that may contribute to symptoms of depression. The increase in CREB-phosphorylation might be a molecular state marker for the response to antidepressant treatment.

There is emerging evidence – primarily from post-mortem studies – supporting the role of abnormalities in neurotrophic signaling pathways in depression. Recent studies suggest that stress-induced atrophy and loss of hippocampal neurons may contribute to the pathophysiology of depression. At the cellular level, evidence has emerged indicating neuronal atrophy and cell loss in response to stress and in depression. At the molecular level, it has been suggested that these cellular deficiencies, mostly detected in the hippocampus, result from decreased expression of BDNF associated with elevation of glucocorticoids.

### **Serotonergic Markers**

Imipramine binding to blood platelets is generally decreased in depression, as indicated by decreased maximal binding capacity. Similarly, 5-HT-uptake in blood platelets is decreased. These findings correspond to a decreased maximal binding capacity of imipramine to brain tissue. Imipramine binding to platelets is a robust biological marker for depression.

### **5-HT-Receptors**

Due to the efficacy of serotonergically acting drugs in major depression, some 5-HT-receptors have been extensively studied in major depression. Almost all the studies point to a decreased or unchanged expression of the 5-HT-1A-receptor. A trend towards decreased 5-HT-1A-receptor expression appears to be a robust finding in major depression.

### **Biochemical Markers**

Several studies have investigated lipids as biological markers for depression. Hypocholesterolemia has been associated with depression, suicide and affective disorders. Low or lowered cholesterol may be associated with increases of suicides and accidents. Cholesterol levels have been identified as a blood marker for depression and anxiety in a normal population in a primary care setting. A hypertriglyceridemia-driven metabolite cause of depression has also been demonstrated in controlled clinical trials, showing that triglyceride lowering alleviates the symptoms of depression. Recent evidence has suggested an important role for lipids in the etiology and treatment of depression. There is empirical evidence for the hypothesis that unipolar



depression may be associated with abnormalities in lipid-associated signaling systems.

#### **Vitamins: Folic Acid**

Several cross-sectional studies have focused on the low blood folate levels in depression patients. In a large Finnish study, depressed patients in the general population with energy-adjusted folate intake below the median had a higher risk of being given the discharge diagnosis of depression during the follow-up period than those with a folate intake above the median. A low dietary intake of folate may be a risk factor for severe depression.

#### **Vitamins B<sub>6</sub> and B<sub>12</sub>**

A group of Danish investigators have suggested that a low level of vitamin B<sub>6</sub> is associated with symptoms of depression. A low plasma level of the vitamin B<sub>6</sub> derivate, pyridoxal phosphate (POP), was significantly associated with the depression score. Higher vitamin B<sub>12</sub> levels were significantly associated with better outcome. Vitamin B<sub>12</sub> level may thus be positively associated with the probability of recovery from major depression.

#### **G-proteins**

Abnormal signal transduction pathways have been implicated in the pathogenesis of major depression. G-proteins are key elements of these pathways in the regulation of cellular responses by transmission of signals from receptors to effector proteins. Several studies have reported altered levels and activities of G-protein subunits in depressive patients.

Although it is well established that depression is a major risk factor for the development of coronary artery disease and that cerebro-vascular disease can be a major contributing factor for the development of depression, the information interplay between the central nervous system and cardio-vascular disease is still limited. In an investigation of the G-protein beta-3-subunit C825T polymorphism and the angiotensin-1 converting enzyme (ACE) ID polymorphism, analysis of both genes showed that the combined actions of ACE and C825T genotypes accumulate in carriers of the ACE-D allele and C825T-TT homozygotes with IC/DD-TT carriers showing a more than fivefold increase in risk for major depression. Thus, the study reports that the same allelic combination of two genes that have been shown to increase the risk for myocardial infarction increase the vulnerability for depressive disorder. This finding strengthens the evidence for the involvement of G-protein-couple signal transduction in the pathogenesis of affective disorders.

#### **Hypothalamic Pituitary-Adrenal Axis**

The HPA axis stimulating properties of higher ACE and consecutively higher angiotensin and lower

substance peak concentrations may be crucial factors for the HPA system hyperactivity during major depressive episodes.

The corticotropin-releasing hormone binding protein gene is likely to be involved in the genetic vulnerability for major depression.

#### **Neural Imaging Markers**

Positron emission tomography (PET) imaging studies have revealed multiple abnormalities in regional cerebral blood flow (CBF) and glucose metabolism in limbic structures and the prefrontal cortex (PFC) in mood disorders. In unmedicated subjects with major depression, regional CBF and metabolism are consistently increased in the amygdala, orbital cortex and medial thalamus, and decreased in the dorsomedial/dorsal anterolateral PFC and anterior cingulate cortex ventral to the genu of the corpus callosum (subgenual PFC), compared with healthy controls [10]. These abnormalities implicate limbic-thalamic-cortical and limbic-cortico-striato-pallidal-thalamic circuits involving the amygdala, orbital and medial PFC, and anatomically related parts of the striatum and thalamus in the pathophysiology of major depression. These circuits have also been implicated more generally in emotional behavior by the results of electrophysiological, lesion analysis and brain-mapping studies in humans and experimental animals. Structural imaging studies have demonstrated reduced greymatter volumes in areas of the orbital and medial PFC, ventral striatum and hippocampus, and enlargement of the third ventricle. It is not known whether these deficits constitute developmental abnormalities that may confer vulnerability to abnormal mood episodes, compensatory changes to other pathogenic processes, or the sequelae of recurrent affective episodes per se [9]. Taken together with other pre-clinical data regarding these structures' specific roles in emotional processing, the neuro-imaging and neuropathological abnormalities in major depression suggest that the illness is associated with the activation of regions that putatively mediate emotional and stress responses, whereas areas that appear to inhibit emotional expression (such as posterior orbital cortex) contain histological abnormalities that may interfere with the modulation of emotional or stress responses.

#### **Cognitive Deficits in Major Depression**

There is growing evidence that several cognitive domains are significantly impaired in patients with major depression, including attention, memory and executive functioning. Patients with major depression manifest significant impairment in their ability to maintain attention in tasks requiring strenuous mental operations, i.e., tasks requiring selective and sustained attention or implying a large resource-allocation capacity.

Patients with major depression also have widespread executive dysfunction, including working memory, set-shifting and inhibition processes, even during the euthymic state.

It has been suggested that cognitive deficits in major depression may depend on age, severity of illness and psychotic or melancholic features. Cognitive deficits in depression may be associated with both trait and state factors and raise questions regarding the long-term cognitive functioning in patients with major depression. These deficits may be explained by structural or functional changes associated with the severity of illness, ageing effects or a possible cumulative pathologic effect of depression on brain structure and function across recurrent episodes of illness [9].

In summary, none of the biological and neuropsychological markers (see Fig. 1) have been shown to be sufficiently specific to allow inclusion in diagnostic manuals of major depression.

### Sleep Abnormalities

Problems sleeping – initial and terminal insomnia, multiple awakenings, hypersomnia – are common and classic symptoms of depression. The sleep electroencephalograms (EEGs) of many depressed persons show

abnormalities. Common abnormalities are delayed sleep onset, shortened rapid eye movement (REM) latency (the time between falling asleep and the first REM period), a longer first REM period and abnormal delta sleep.

### Circadian Rhythms

The abnormalities in sleep architecture in depression and the transient clinical improvement associated with sleep deprivation have led to theories that depression reflects the abnormal regulation of circadian rhythms. Experimental studies with animals indicate that many of the standard antidepressant treatments are effective in changing the setting of internal biological clocks (endogenous zeitgebers).

### Psychosocial Factors

#### Life Events and Environmental Stress

Stressful life events precede more often first rather than subsequent episodes of major depression. According to Post [4], the stress accompanying the first episode results in long-lasting changes in the brain's biology. These long-lasting changes may alter the functional states of various neurotransmitter and intra-neuronal signaling systems, and may even include the loss of neurons and an excessive reduction in synaptic

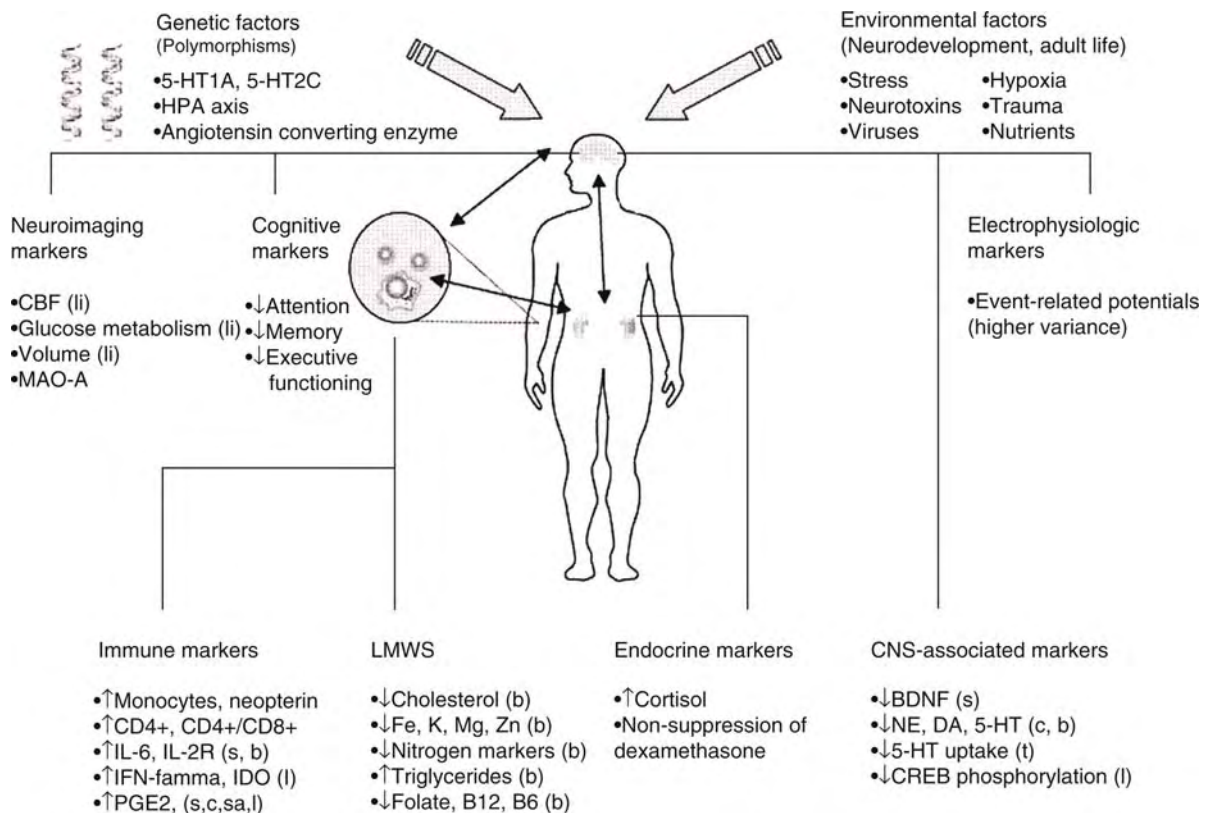

**Major Depressive Disorder. Figure 1** Biological markers of depression.

contacts. This greatly increases the risk of subsequent episodes of a mood disorder, even without an external stressor.

The most compelling data indicate that the life event most often associated with the development of depression is losing a parent before the age of 11. The environmental stressor most often associated with the onset of an episode of depression is the loss of a spouse. Another risk factor is unemployment: persons out of work are three times more likely to report symptoms of an episode of major depression than those working.

### **Personality Factors**

All humans, regardless of their personality pattern, can and do become depressed under appropriate circumstances. Persons with certain personality disorders – obsessive-compulsive, histrionic and borderline – may be at greater risk for depression than persons with antisocial or paranoid personality disorder. The latter can use projection and other externalizing defense mechanisms to protect themselves from their inner rage. Patients with dysthymic and cyclothymic disorder are at risk of developing major depression or bipolar I disorder later.

Stressors experienced by the patient as reflecting more negatively on his/her self-esteem are more likely to result in depression. What may seem to be a relatively mild stressor to outsiders may be devastating for the patient because of particular idiosyncratic meanings attached to the event.

### **Pharmacotherapy**

Since the introduction of the first tricyclic antidepressant, imipramine, in 1957, many new types of antidepressants have been developed. The classes of substances currently available differ little in their antidepressant effect; there is no convincing evidence that one particular class of antidepressant is more effective or has a more rapid onset of effect than the others. The newer antidepressants of the 1980s and 1990s generally have less serious side effects than the “classic” substance groups of the tricyclic agents and the irreversible monoamine oxidase (MAO) inhibitors. Approximately 30–40% of both in- and out-patients fail to respond adequately to an initial 4–6 week treatment with an antidepressant. As many as 10–15% of patients fail to improve sufficiently, even after several different treatment attempts. 12–15% of depressive patients are not yet asymptomatic two years after onset of the illness. The lack of success of antidepressant therapy is often due not to the illness itself, but to sub-optimal treatment. If resistance to therapy remains intractable despite attempts at treatment optimization, the use of augmentative or combination therapy should be considered. Among augmentative therapies, the addition of lithium to traditional antidepressants, has

been found useful. Combination therapy with various antidepressants has been tried with varying success, as has so-called pindolol augmentation, a combination of the beta-blocker pindolol with a serotonin-reuptake inhibitor (SSRI). The combination of a neuroleptic with an antidepressant has proven useful in the treatment of depression with psychotic features.

### **Psychotherapy**

The majority of patients with an episode of major depressive disorder respond to the first or second attempted treatment. In patients with mild or moderately severe episodes, treatment with antidepressant drugs and brief psychotherapies are adequate and equally effective. In those with severe episodes, antidepressant medication alone or a combination of medication and psychotherapy is recommended. The treatment of chronic depression and in particular of patients failing to respond to adequate drug treatment (approximately 20%) is more problematic. In addition, these patients have marked impairment in psychosocial functioning, incomplete remission even after two years and very high rates of use of healthcare resources. Furthermore, even if there is a partial remission, there remains a high risk of relapse (up to 80%).

Many studies indicate that a combination of psychotherapy (cognitive behavioral psychotherapy, psychodynamic psychotherapy, interpersonal psychotherapy) and pharmacotherapy is the most effective treatment for major depressive disorder. Some data suggest another view: either pharmacotherapy or psychotherapy alone is effective, at least in patients with mild major depressive episodes.

Three types of short-term psychotherapy (cognitive therapy, interpersonal therapy and psychodynamic psychotherapy) have been studied to determine their efficacy in the treatment of major depressive disorder.

### **References**

1. Parker G (2005) Beyond major depression. *Psychol Med* 35(4):467–474
2. Rush AJ, Golden WE, Walton Hall G et al. (1993) Detection and diagnosis. Depression in primary care, vol 1. US Department of Health and Human Services, Rockville, MD
3. Sargeant JK, Bruce ML, Florio LP, Weissman MM (1990) Factors associated with 1-year outcome of major depression in the community. *Arch Gen Psychiatry* 47:519–526
4. Post RM (1992) Transduction of psychosocial stress into neurobiology of recurrent affective disorder. *Am J Psychiatry* 149:999–1010
5. Kessler RC, McGonagle KA, Zhao S et al. (1994) Lifetime and 12-month prevalence of DSM-III-R psychiatric disorders in the United States. *Arch Gen Psychiatry* 51:8–19

6. Wittchen H-U (2001) Epidemiology of affective disorders. In: Henn F, Sartorius N, Helmchen H, Lauter H (eds) *Specific psychiatric disorders. Contemporary psychiatry*, vol 3. Springer, Berlin Heidelberg New York, pp 231–241
7. Klerman GL, Weissman MM (1989) Increasing rates of depression. *JAMA* 261:2229–2235
8. Angst J, Dobler-Mikola A (1985) The Zurich study. VI A continuum from depression to anxiety disorders? *Eur Arch Psychiatry Neurol Sci* 235:179–186
9. Mössner R, Mikova O, Koutsilieri E, Saoud M, Ehli A-C, Müller N, Fallgatter J, Riderer P (2007) Consensus paper of the WFSBP Task Force on biological markers: biological markers in depression. *World J Biol Psychiatry* 8(3):141–174
10. Drevets WC (2001) Neuroimaging and neuropathological studies of depression: implications for the cognitive-emotional features of mood disorders. *Curr Opin Neurobiol* 11:240–249

## Major Histocompatibility Complex

ERNESTO SALCEDO, DIEGO RESTREPO  
University of Colorado at Denver and Health Sciences  
Center, Aurora, CO, USA

### Synonyms

Human leukocyte antigens (HLA – human); H-2 (mouse)

### Definition

A locus of highly polymorphic genes found on the short arm of human chromosome 6 and mouse chromosome 17 that encode proteins involved in the adaptive immune response (see Fig. 1), and certain aspects of brain function.

### Characteristics

#### MHC Proteins

Genes in the MHC encode for proteins involved in the adaptive immune response. MHC proteins fall into two classes: I or II. Class I molecules (MHCI) consist of an MHC-encoded  $\alpha$  heavy chain, and a smaller, non-MHC-encoded  $\beta$  chain ( $\beta 2$  microglobulin). Class II molecules (MHCII) are comprised of two MHC-encoded, non-covalently associated polypeptide chains,  $\alpha$  and  $\beta$  (Fig. 1b). Both classes of MHC bind proteosomally degraded peptides (MHC peptides) in a binding cleft that is presented on the surface of the presenting cell. The entire MHC-peptide complex is then recognized by T cells as “self” or “non-self.” The complex is considered “self” if the bound MHC peptide is a degraded product of an endogenous protein. If, however, the bound MHC peptide originated from

an exogenous source, such as protein from bacteria, viruses, or from cells in a tissue graft, then the complex is recognized as “non-self” and the cell presenting the MHC complex is marked for destruction. MHCI molecules have been shown to be present on virtually all nucleated cells, whereas MHCII molecules expression is typically limited to a small subset of immune response cells such as B lymphocytes and macrophages [1].

### MHC Polymorphism

The unique collection of MHC alleles possessed by a given individual is known as the MHC haplotype (Fig. 1a). The MHC displays a high degree of polymorphism; alleles differ greatly from individual to individual within a species. The high degree of allelic variation in MHC is thought to be crucial to defeat attempts by foreign organisms to avoid detection by the immune system. In fact, all of the polymorphic residues found in encoded MHC proteins line the interior of the peptide binding cleft and directly interact with the anchor amino acid residues in the bound peptide (Fig. 1c) [1].

### Detection of MHC Haplotype by Smell

Mice and – to some extent – humans are able to detect differences in MHC haplotype between individuals [2]. In mice the detection of MHC identity by smell has been postulated to play a key role in social interactions involving individual recognition, such as mate selection and offspring recognition [3–5]. Indeed, mating preferences dependent on MHC type differences in seminatural populations of mice have been shown to be sufficient to account for much of the MHC genetic diversity [4].

Mice are able to discriminate among individuals with different MHC haplotypes through detection of differences in urine volatiles (these urine volatiles are often termed “odortypes”). The different odortypes elicit distinct maps of activity in the glomerular layer of the olfactory bulb that allow the mice to discriminate between MHC haplotypes [2–3]. In addition to volatiles, released MHC peptides can themselves also be detected by the main and accessory olfactory systems and appear to be involved in detection of MHC haplotype [2]. Intriguingly, MHCI molecules are expressed in the vomeronasal organ of mice and appear to directly interact with chemical receptors classically associated with the detection of pheromones [6].

### MHCI and Neuronal Plasticity

The unexpected discovery of activity-dependent MHCI expression in the developing visual system disproved the long held tenet that neurons in an uninjured brain were immune-privileged [7]. Subsequently, other well characterized members of the adaptive immune response have been shown to be expressed throughout

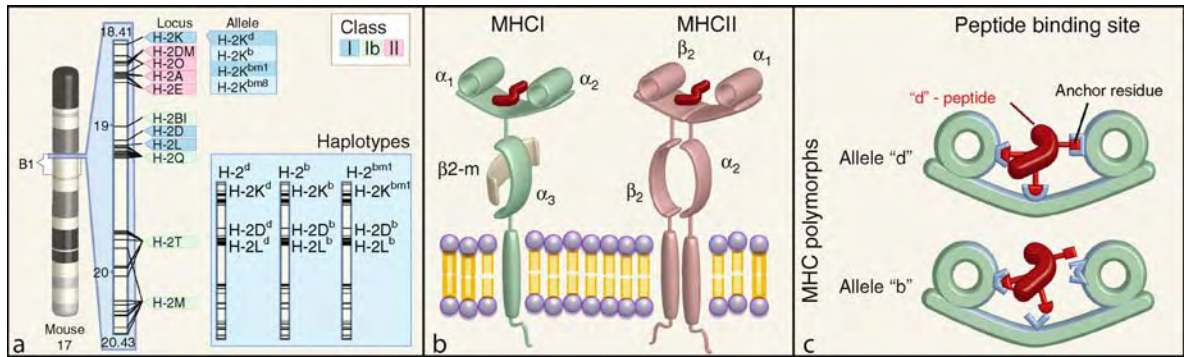

**Major Histocompatibility Complex. Figure 1** The major histocompatibility complex (MHC) is a multigene cluster found on chromosome 17 in mice. (a) Schematic representation of mouse chromosome 17 including the location and composition of the MHC gene cluster (also named the H-2 region in mice). The banding pattern of the chromosome is shown on the far left. To the right of the chromosomal representation is a partial list of MHC genes. Loci for Class I (blue and green) and Class II genes (pink) are clustered in the MHC located in the 17 B1 band between 18.41 and 20.43 cm. Each gene (locus) is identified by the prefix “H-2” followed by a capital letter (e.g. H-2K). Different alleles for each of these loci are denoted by a lower case superscript (e.g. H-2K<sup>b</sup>). Listed in the two dark blue panels to the right of the H-2K locus are a selection of H-2K alleles. Haplotypes inset. Examples of three MHC I allele sets for three different mouse haplotypes: H-2<sup>d</sup>, H-2<sup>b</sup>, and H-2<sup>bm1</sup>. (b) Renditions of an MHC class I (MHCI) and a class II (MHCII) transmembrane molecule. In MHCI, two homologous segments ( $\alpha_1$  and  $\alpha_2$ ) form the peptide-binding region, which consists of two parallel strands of  $\alpha$ -helix supported by an eight-stranded  $\beta$ -pleated sheet. The non-MHC encoded  $\beta_2$ -microglobulin ( $\beta_2$ -m) chain is required for proper presentation of the molecule on the cell surface. In MHCII, the peptide binding region is formed by the interaction between the  $\alpha_1$  and  $\beta_1$  subdomains of the two non-covalently associated MHC-encoded polypeptide chains. Polymorphic variation for a particular MHC locus is restricted almost entirely to amino-terminal domains that line the base of the binding cleft or are directed inward from the walls of the  $\alpha$ -helices (indicated by blue shading) [1]. Contained within the binding site is an MHC peptide (red). (c) Example of the specificity of an MHC peptide to a particular MHC polymorph. “d”-peptide: a hypothetical MHC peptide that, due to its anchor amino acid residues, can only bind a hypothetical MHCI molecule encoded by a “d,” but not a “b” allele. This specificity illustrates how MHC peptides, based solely on the configuration of their anchor residues and regardless of their primary amino acid sequence, can provide information on MHC haplotype.

the central nervous system during development and into adulthood. These molecules include the MHCI subunit,  $\beta_2$ -microglobulin; the peptide loading enzyme transporter associated with antigen presentation (TAP); critical subunits of the T cell receptor, such as TCR $\beta$  or CD3 $\zeta$ ; and the Paired-immunoglobulin-like receptor, another MHCI receptor [7–8].

While the components of adaptive immunity are expressed in neuronal cells, the collective function of these molecules appears to have changed. Loss of MHCI or CD3 $\zeta$  disrupts the activity-dependent structural reorganization of axons in the lateral geniculate nucleus and the hippocampus [7]. After lesion of the sciatic nerve, fewer neurons are able to regenerate axons in a deficient MHC background [9]. An in vitro examination of cultured hippocampal neurons revealed that MHCI sublocalizes to the soma and dendrites. Moreover, cultured neurons deficient in MHCI had changes indicative of a defect in homeostatic synaptic plasticity. Thus, MHCI molecules appear to function as components of a mechanism that regulates synaptic morphology and physiological function [10].

## References

- Janeway CA, Travers P, Walport M, Schlomchik M (2001) Immunobiology. Garland, New York
- Restrepo D, Lin W, Salcedo E, Yamazaki K, Beauchamp G (2006) Odortypes and MHC peptides: complementary chemosignals of MHC haplotype? Trends Neurosci 29:604–609
- Boehm T, Zufall F (2006) MHC peptides and the sensory evaluation of genotype. Trends Neurosci 29:100–107
- Penn D, Potts W (1998) How do major histocompatibility complex genes influence odor and mating preferences? Adv Immunol 69:411–436
- Jacob S, McClintock MK, Zelano B, Ober C (2002) Paternally inherited HLA alleles are associated with women’s choice of male odor. Nat Genet 30:175–179
- Olson R, Dulac C, Bjorkman PJ (2006) MHC homologs in the nervous system – they haven’t lost their groove. Curr Opin Neurobiol 16:351–357
- Boulanger LM, Shatz CJ (2006) Immune signalling in neural development, synaptic plasticity and disease Nat Rev Neurosci. 5:521–531
- Syken J, Grandpre T, Kanold PO, Shatz CJ (2006) PirB restricts ocular-dominance plasticity in visual cortex. Science 313:1795–1800

9. Oliveira AL et al. (2004) A role for MHC class I molecules in synaptic plasticity and regeneration of neurons after axotomy. *Proc Natl Acad Sci USA* 101:17843–17848
10. Goddard CA, Butts DA, Shatz CJ (2007) Regulation of CNS synapses by neuronal MHC class I. *Proc Natl Acad Sci USA* 104:6828–6833

## Major Tranquilizer

- ▶ Antipsychotic Durgs

## Male Hypogonadism

### Definition

A clinical syndrome due to reduced levels of testosterone. Clinical hallmarks include absence or regression of secondary sex characteristics, reduced fertility (oligospermia, azoospermia), anemia, muscle wasting, reduced bone mass (and bone mineral density), and/or abdominal adiposity. This syndrome has a multifactorial etiology that includes genetic conditions, anatomic abnormalities, infection, tumor, and injury.

## Malignant Hyperthermia (MH)

### Definition

A pharmacogenetic disease of skeletal muscle with autosomal dominant inheritance that is manifested in humans as an acute hyperthermic reaction, arising from uncontrolled skeletal muscle  $\text{Ca}^{2+}$  release and contraction, and usually triggered by potent inhalational anesthetics.

- ▶ Excitation-Contraction Coupling

## Mammalian Respiratory Rhythm Generators

- ▶ Respiratory Network Analysis, Isolated Respiratory Center Functions

## Mammillary Body

### Synonyms

Corpus mamillare

### Definition

The mammillary nuclei are located in the medial zone of the hypothalamus. Major afferents arrive via the fornix of hippocampus, while efferents pass largely via the mammillothalamic fasciculus, Vicq d'Azyr bundle to the anterior thalamic nucleus or via the dorsal longitudinal fasciculus (Schütz) to the visceral centers in the brainstem and spinal cord. Component of the Papez neuronal circuit. Involved in affective actions and learned processes.

Damage to the mammillary body, e.g. in the case of alcoholic encephalopathy, results in affective impairments and marked loss of perceptivity.

- ▶ Diencephalon

## Mammillary Nuclei

### Synonyms

- ▶ Nuclei mamillares; ▶ Nuclei of mammillary body

### Definition

A distinction is made between the following nuclei of the mammillary body:

- Mammillary body, medial nucleus
- Intermediate mammillary nucleus
- Mammillary body, lateral nucleus
- Posterior nucleus

The medial nuclear region is especially pronounced in humans and connected via the thalamus with the prefrontal cortex. Selective dysfunction of the mammillary body, medial nucleus results in Korsakoff syndrome (amnetic syndrome with anterograde and retrograde impaired memory, and diminished drive).

- ▶ Diencephalon

## Mania

- ▶ Bipolar Affective Disorder

---

## Manic-depressive Illness (MDI)

- ▶ Bipolar Affective Disorder

---

## MAP

### Definition

Microtubule-associated Protein.

- ▶ Microtubule

---

## Map Refinement

### Definition

The process by which the initial crude topographic map of a sensory surface to structures in the central nervous system, is refined later in development.

---

## MAPK

### Definition

- ▶ Mitogen Activated Protein Kinase

---

## Mapping Study

### Definition

An experimental procedure in which electrodes are placed into the cortex of a living brain to record the electrical activity of neurons in response to various stimuli.

- ▶ Evolution of Association Pallial Areas: Parietal Association Areas in Mammals

---

## Maps

### Definition

Neurons may be arranged so that they represent the outside world in a systematic, topographic manner. Those arrangements are called neural maps. The most famous maps may be the representation of the body surface in the somatosensory cortex.

---

## Marburg's Variant

### Definition

This is a fulminant, widespread demyelinating disease without remissions which is fatal within 1–2 years. Lesions in Marburg's multiple sclerosis (MS) are more destructive than those usually seen in MS with widespread myelin destruction, severe axonal loss, edema, massive macrophage infiltration and extensive necrosis. Lesions on magnetic resonance images (MRI) increase in size and become confluent reflecting large areas of demyelination.

- ▶ Multiple Sclerosis

---

## MARCM

- ▶ Mosaic Analysis with a Repressible Cell Marker

---

## Masking of Sounds

### Definition

This refers to the increase in the level of a "target" sound (measured in dB) that is required to overcome effects produced by a second sound.

- ▶ Psychoacoustics

## Masking (Positive/Negative)

ELAINE WADDINGTON LAMONT<sup>1</sup>, SHIMON AMIR<sup>2</sup>

<sup>1</sup>Institute of Neuroscience, Carleton University, Life Sciences Building, Ottawa, ON, Canada; Department of Psychiatry, McGill University, Montréal, QC, Canada

<sup>2</sup>Center for Studies in Behavioral Neurobiology, Department of Psychology, Concordia University, Montreal, QC, Canada

### Synonyms

Disguising

### Definition

The attenuation (negative) or enhancement (positive) of a measure of the circadian master clock by an exogenous stimulus or factor.

### Characteristics

Masking is a term applied to a number of phenomena in circadian research, whereby some clock-controlled variable of interest is obscured, but not necessarily altered, by an exogenous factor. Masking can be superimposed on ►entrained or ►free-running rhythms, and can be identified by the sudden change in behavioral state that occurs with its onset or offset. Often the effectiveness of the masking stimulus is dependent on the circadian phase of the variable of interest. Masking can limit the interpretation of experimental results, which has necessitated the adoption of particular experimental protocols in order to reveal the endogenous circadian rhythm of the variable of interest. Two areas where masking has had a significant impact on experimental methodology are masking of locomotor activity by light in rodents and the masking of the core body temperature (CBT) rhythm by posture and sleep in humans.

### Photic Masking of Locomotor Activity

Photic masking is caused by the direct enhancement or inhibition of locomotor activity by light, and is mediated by the visual system, as it is abolished by orbital enucleation [1], but not by lesions of the master circadian clock, the ►suprachiasmatic nucleus (►SCN) [2]. Devising means of reducing masking effects has led to the development of special methodologies including the use of constant darkness, constant light, and skeleton photoperiods. In ►diurnal species like canaries, light produces positive masking, inducing or increasing locomotor activity, while darkness inhibits activity [3]. In ►nocturnal species, the effect of light is inhibitory, particularly when exposure occurs during the active phase, while darkness results in a release

from inhibition or “unmasking” [4]. Positive masking by light has been observed in nocturnal rodents at very low light levels, inviting speculation that the utility of low light levels for successful foraging, compared to total darkness, can result in increased locomotion [1].

Interestingly, in rodents, positive and negative masking appear to be mediated by different aspects of the visual system. Negative masking is independent of the image-forming visual pathway, as suppression of locomotor activity was observed in mutant mice that have nearly total degeneration of both rods and cones [1]. In fact, negative masking appears to be mediated by melanopsin-expressing ►retinal ganglion cells, as melanopsin knock-out mice show an impaired masking response to light, compared to wild-type mice. Negative masking of activity occurs in melanopsin knock-outs during the first part of a 3 h light pulse, but activity gradually increases to darkness levels, despite the continued presence of light. In contrast, wild-type animals show negative masking throughout the three hour light pulse [5]. This suggests that melanopsin-expressing retinal ganglion cells are necessary for the maintenance of photic inhibition of locomotor behavior, but not for the initiation of masking. Interestingly, positive masking requires the classical ►photoreceptors. Positive masking is intact in wild-type mice and in melanopsin knock-out mice [5], but is absent in rodless mice [1].

### Masking of Circadian Core Body Temperature

Masking is a confounding variable in human circadian rhythms research because of the enormous difficulty of eliminating or even effectively modeling the effects of exogenous variables on the circadian core body temperature (CBT) rhythm. CBT is frequently used as a marker of the phase and amplitude of the circadian clock in humans because it is more readily measured in a continuous manner than circadian rhythms of ►melatonin or cortisol secretion, which must be sampled frequently via plasma, saliva, or urine. CBT is directly controlled by the SCN master clock, and easily measured with a rectal probe, but is influenced by a large number of exogenous variables including the ►light/dark cycle, sleep, activity, social interaction, posture, ambient temperature, and humidity [6]. Three methods have been used to control masking effects in humans: the ►constant routine (CR) procedure, the ►forced desynchrony procedure, and ►mathematical purification. The “gold standard” of these is the CR, which holds masking effects constant in order to reveal the CBT rhythm. After maintaining a regular sleep-wake schedule for several days to weeks, subjects enter a temperature, light, and humidity controlled laboratory where they remain awake in a semirecumbent posture throughout the 30–72 h assessment. Movements are kept to a minimum and meals are replaced by isocaloric



snacks at regular intervals. Using this technique, Czeisler and colleagues have been able to accurately determine the human phase response curve to light [7]. A major limitation of the CR is that effects of fatigue and sleep deprivation are not controlled. In contrast, a forced desynchrony protocol allows for the measurement of masking effects of sleep by placing subjects on a sleep-wake schedule either much longer, or much shorter than 24 h, to which the master **▶circadian pacemaker** is unable to entrain. In this way, the intrinsic circadian period of CBT is revealed and the effect of sleep can be observed at all circadian phases [8,9]. While both of these techniques are very powerful, they are limited by the necessity of being carried out in a laboratory over extended periods of days to weeks. In contrast, mathematical purification, which removes masking effects mathematically, can be performed on any data set, whether obtained in the laboratory under rigorous conditions, or in the field. Unfortunately, although purification is very powerful, it is limited by the availability of the data used to describe masking effects. For example, physical activity raises core body temperature. Therefore, to subtract the effect of activity from the endogenous CBT rhythm, the effect of that activity on temperature must be known. While some work has been done to measure the effects of posture and activity on temperature, normative values for a particular population of interest may not be available [6]. Also problematic is that many purification methods assume that exogenous factors affecting CBT are independent of each other and of the phase of CBT. If this assumption is violated, a purification model that was simply additive could potentially obscure changes in phase. Using a 90 min day protocol, Moul and colleagues [10] demonstrated that the masking effects of sleep and posture on CBT are not consistent across the day, but in fact also show circadian rhythms. The greatest rate of temperature decrease occurred several hours before the CBT minimum, while the subject was lying in bed awake, and gradually decreased after sleep onset. While a model for purification of CBT could certainly incorporate this type of data, rigorous testing and comparison with accepted laboratory based protocols like the CR will be necessary to determine the reliability and validity of any purification method, particularly when used with clinical populations, where observations about the phase relationships between CBT and masking variables may differ from that observed in normal subjects.

## References

1. Mrosovsky N, Foster RG, Salmon PA (1999) Thresholds for masking responses to light in three strains of retinally degenerate mice. *J Comp Physiol A* 184:423–428
2. Redlin U, Mrosovsky N (1999) Masking by light in hamsters with SCN lesions. *J Comp Physiol A* 184:439–448

3. Aschoff J, von Goetz C (1989) Masking of circadian activity rhythms in canaries by light and dark. *J Biol Rhythms* 4:29–38
4. Aschoff J, von Goetz C (1988) Masking of circadian activity rhythms in hamsters by darkness. *J Comp Physiol A* 162:559–562
5. Mrosovsky N, Hattar S (2003) Impaired masking responses to light in melanopsin-knockout mice. *Chronobiol Int* 20:989–999
6. Hanneman SK (2001) Measuring circadian temperature rhythm. *Biol Res Nurs* 2:236–248
7. Czeisler CA, Allan JS, Strogatz SH, Ronda JM, Sanchez R, Rios CD, Freitag WO, Richardson GS, Kronauer RE (1986) Bright light resets the human circadian pacemaker independent of the timing of the sleep-wake cycle. *Science* 233:667–671
8. Czeisler CA, Duffy JF, Shanahan TL, Brown EN, Mitchell JF, Rimmer DW, Ronda JM, Silva EJ, Allan JS, Emens JS, Dijk DJ, Kronauer RE (1999) Stability, precision, and near-24-hour period of the human circadian pacemaker. *Science* 284:2177–2181
9. Dijk DJ, Czeisler CA (1995) Contribution of the circadian pacemaker and the sleep homeostat to sleep propensity, sleep structure, electroencephalographic slow waves, and sleep spindle activity in humans. *J Neurosci* 15:3526–3538
10. Moul DE, Ombao H, Monk TH, Chen Q, Buysse DJ (2002) Masking effects of posture and sleep onset on core body temperature have distinct circadian rhythms: results from a 90-min/day protocol. *J Biol Rhythms* 17:447–462

---

## Mast Cell

### Definition

Mast cells are a type of resident tissue leukocyte, widely distributed in a variety of tissues/organs. Mast cells have large numbers of cytoplasmic granules containing histamine, bradykinin, prostaglandins, and etc., which can be released upon mast cell activation (a process called degranulation). Many of these substances released have effects such as vasodilation and smooth muscle contraction. In an activated state, mast cells can also secrete certain types of cytokines that shape further adaptive immune responses.

---

## Master-Slave Oscillators

### Definition

Master oscillators are those that set the phase and period of circadian rhythms by driving effectors for multiple

rhythmic processes, or by coordinating slave (secondary) oscillators that drive effectors. Slave oscillators drive local rhythms, and do not coordinate the phase of oscillators elsewhere.

#### ► Internal Desynchrony

## Mastication

JAMES P. LUND<sup>1</sup>, ARLETTE KOLTA<sup>2</sup>

<sup>1</sup>Faculty of Dentistry, McGill University, Montréal, QC, Canada

<sup>2</sup>Faculté de Médecine Dentaire, Université de Montréal, Succursale Centre-ville, Montréal, QC, Canada

### Synonyms

Chewing; rhythmic jaw movements

### Definitions

The initial stage of digestion in which pieces of food are mechanically broken down and mixed with saliva by the rhythmical action of the teeth.

### Characteristics

#### Quantitative Description

Humans and most other mammals except carnivores grind or chop food between their upper and lower teeth prior to swallowing. The incisor teeth are used to bite off pieces of food that are then transported back in a series of simple movements (Fig. 1a) by the tongue and facial muscles to the premolar and molar teeth, where reduction of the food takes place (Fig. 1b) during a series of repetitive movements of the mandible, at about 1.5 Hz in adult humans. The general form of each movement cycle depends on the type of food being eaten: brittle foods tend to be chopped, while tough foods are chewed with wider lateral strokes. As the size of the particles declines with successive cycles, the amplitude and velocity of the opening and closing movements of the jaw fall, and forces applied between the teeth drop. The tongue forms the food and intermixed saliva into a bolus during a pause in the opening phase of the cycles preceding swallowing (Fig. 1c).

#### Higher Level Structures

The essential circuits controlling mastication are located in the ►hindbrain, and the basic rhythmical alternation of jaw opening and closing movements can be produced by a hindbrain Central Pattern Generator (CPG) in the absence of sensory feedback [1–3]. However, when scientists began to use repetitive electrical pulses to

stimulate the brain in the nineteenth century, they found that mastication was represented in the cerebral cortex of primitive mammals and in more evolved species, including humans [3,4]. In lower species, the various patterns of natural mastication are represented at distinct sites in an orderly fashion. In primates, the cortical masticatory area is found at the lateral end of the ►precentral gyrus, but it does overlap with the more medial representation of individual jaw, tongue and facial muscles in the primary motor cortex, and also extends into the adjacent sensory cortex in the ►postcentral gyrus [5]. Neurons in both the cortical masticatory and adjacent motor cortex receive inputs from orofacial sensory receptors, and lesions or cold block of both regions disrupt ingestion, mastication and swallowing.

#### Lower Level Structures

The essential parts of the masticatory CPG lie between the rostral poles of the Vth (trigeminal) and VIIth (facial) cranial motor nuclei. There are two CPGs, one for each side, that are connected by axons that cross the midline. Each CPG is made up of many neurons. There are a large number in the lateral ►reticular formation (RF) that surrounds the Vth motor nucleus (Motor V), in the adjacent spinal trigeminal nucleus (Spinal V) and in the dorsal cap of the Vth main sensory nucleus (Main V), which change their pattern of firing during ►fictive mastication (Fig. 2).

Many of these neurons control V motoneurons directly [2]. Some fire tonically, but most of them fire rhythmical bursts of action potentials that coincide with either the jaw closing or jaw opening phases of the “fictive” masticatory cycle [6,7]. Most of the neurons receive inputs from oral mechanoreceptors or ►muscle spindles, and from the motor cortex [7]. The CPG also includes the central axons of muscles spindle afferents, which appear to transmit messages from their terminals in Spinal V and lateral RF backwards to their other terminals in Motor V [2]. The motor neurons in turn control the activity of four groups of muscles: one to open the jaws- the digastric, and three closers- the temporalis, masseter and pterygoid groups, and four groups of teeth (Incisors, Canines, Premolars, and Molars). The jaw closing groups are complex, multi-component muscle systems that are capable of moving the mandible in all three planes. All are innervated by the trigeminal nerve, except for a portion of the digastric muscle that is innervated by the facial nerve. The jaw closing groups are very powerful and also fatigue resistant. Mastication requires coordinated actions of the tongue and facial muscles. Saliva is mixed with the food during mastication, and salivary enzymes begin the first stage of chemical digestion. However, the main function of saliva is to provide lubrication during mastication and swallowing. Activation of ►periodontal pressoreceptors causes reflex salivation.

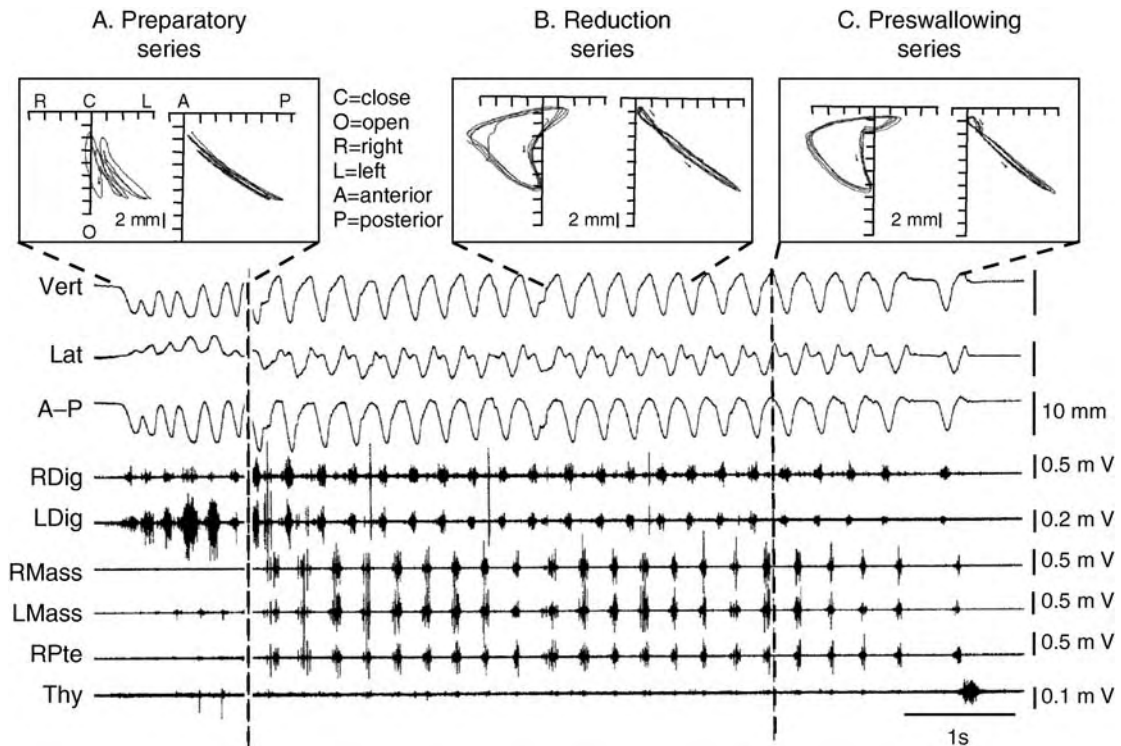

**Mastication. Figure 1** Records of movements of the lower incisor teeth of an awake rabbit and of jaw muscle electromyographic (EMG) activity during the mastication of a pellet of rabbit chow. The sequence of movements is divided into Preparatory, Reduction and Preswallowing series of cycles. The Preparatory cycles have only two phases, Opening and Closing; the Reduction series has a Slow Closing phase in which the food is ground up, and during the Preswallowing phase, the jaw pauses during opening to allow the bolus to be formed. Vert, Lat and A-P- movement of the teeth in the vertical, lateral and anterior-posterior directions. RDig, LDig- right and left digastric EMGs. RMass, LMass- right and left masseter EMGs. RPte- right medial pterygoid EMG. Thy- thyrohyoid muscle EMG (swallowing marker). In A, B and C, the output of two pairs of axes is combined to show movement of the teeth viewed from the front (left) and from the left side (right). Data from Schwartz G et al. (1989) *Journal of Neurophysiology* 62:273–287.

The medial RF at the level of Motor V also seems to be implicated in the control of mastication [3,8], but we do not know yet if it is an essential part of the CPG. This region does not project directly to V motoneurons, but it is reciprocally connected with the lateral subgroups [9]. It gets direct inputs from the motor cortex, but not from sensory afferents [8]. Many neurons in the dorsal half of the medial RF fire in either the jaw opening or the jaw closing phases, while most ventral neurons fire tonically. These tonic neurons appear to inhibit the lateral subgroups during mastication, while the phasic dorsal neurons have mixed effects [8].

#### Higher Level Processing

The primary motor cortex has a primary role in coordinating the ingestion and the transport phase of mastication, while the masticatory cortex is more important in food reduction, preswallowing and swallowing [4, 5].

The corticobulbar pathways from these regions of the cortex innervate all of the brainstem masticatory cell groups bilaterally (Fig. 2), and the firing pattern of many brainstem neurons is modified by the short-latency inputs from the cortex during fictive mastication [4,5,7,8].

#### Lower Level Processing

The motoneurons of the jaw closing muscles occupy the anterior and dorsal portions of Motor V, while the jaw opening motoneurons are confined to the ventral and caudal parts. During fictive mastication, the CPG causes jaw opening motoneurons to fire in very high frequency (up to 250 Hz) bursts, which are superimposed on slow rhythmical depolarizing potentials that return to resting levels during the jaw closing phase [3]. The slow rhythmical oscillations are mediated by excitatory amino acids. The jaw closing motoneurons are only weakly depolarized by similar slow potentials during the closing phase of fictive

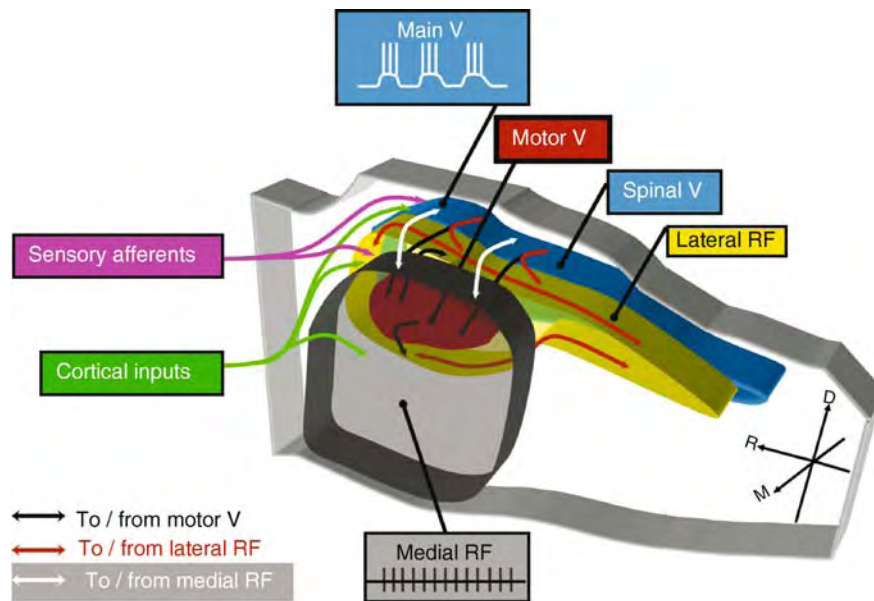

**Mastication. Figure 2** A model of the hindbrain CPG for mastication and associated structures. The figure shows the right side of the brain viewed from the midline and slightly from behind. The Main sensory (blue-Main V) and Spinal trigeminal nuclei (blue- Spinal V) and adjacent lateral reticular formation (yellow-lateral RF) receive direct inputs from sensory afferents and from the sensori-motor cortex that are capable of activating the CPG. The three regions are reciprocally connected, and all project directly to Motor V. Some neurons in Main V have the intrinsic ability to generate slow depolarizing potentials and bursts of spikes (Inset). The medial RF has direct inputs from the cortex, but not from sensory receptors. It is reciprocally connected with the lateral nuclei, but not with Motor V. Neurons in the middle of the nucleus can fire tonically even when isolated from other neurons. R-rostral, M-medial, D-dorsal.

mastication: however, they are much more active during jaw closing in real mastication, because of excitatory feedback from sensory receptors (see below). This feedback is cut off by strong glycinergic inhibition of the motoneurons during jaw opening [3]. Trigeminal motoneurons receive a dense serotonergic innervation, and express several receptor subtypes. Serotonin has little effect on the activity of quiescent neurons, but it plays an important role by modulating firing generated by other transmitters. It also modifies the masticatory rhythm [2,3].

The CPG can be turned on by tonic stimulation of sensory receptors in the mouth and muscles [1], and during mastication, several groups of afferents provide feedback to motoneurons, the CPG and to higher centers (Fig. 2). The pattern of firing that emerges from the motoneurons is the result of these interactions. The effects of three groups of afferents (muscle spindles, periodontal pressoreceptors and nociceptors) have been well described.

There are no, or very few, muscle spindles in jaw opening muscles, but jaw closing muscles contain many. These provide monosynaptic excitatory glutamatergic feedback to jaw closing motoneurons, and

to many interneurons in the trigeminal sensory nuclei and lateral RF [2,6,7]. During the jaw opening phase of mastication, these receptors are stretched, and they fire at high frequency [10]. This activity facilitates the CPG, but the monosynaptic excitation of the jaw closing motoneurons is prevented by hyperpolarization (see above). Many spindle afferents continue to fire as the jaw closing muscles shorten because the **fusimotor neurons** are driven strongly by the CPG. This muscle spindle input lengthens the jaw closing motoneuron bursts and greatly increases firing frequency [1,10].

Periodontal pressoreceptors are located in the ligament surrounding the roots of the teeth. They signal the direction and intensity of loads generated during mastication. Tapping on the teeth causes a bi-synaptic inhibition of the jaw closing muscles that is abolished by the glycine antagonist, strychnine, but heavy pressure on the teeth does not cause inhibition during mastication. Instead, these receptors cause the jaw closing phase to lengthen, and jaw closing motoneurons to fire at higher frequency. It appears that the CPG shuts the inhibitory pathway, and opens an excitatory one during mastication [1,10].

The CPG also modulates inputs from other oral mechanoreceptors and particularly from nociceptors (pain afferents). When nociceptors are stimulated during chewing (e.g., by biting the tongue), they strongly inhibit the jaw closing muscles [1].

### Process Regulation

Tonic stimulation of inputs to the CPG coming from sensory receptors, from the cortex and other forebrain and midbrain structures is converted into rhythmical mastication by the CPG [1–3]. It is not known how this happens, but there is evidence that special properties of the network and of individual neurons may be involved. For example, when the pattern of mastication changes, say from grinding on the left teeth to grinding on the right, about half of the active lateral RF and Spinal V neurons change their rhythmical firing pattern, while the others stop participating in the CPG [7]. This suggests that the CPG uses at least two methods to generate different patterns of mastication: addition and subtraction of its constituent neurons, and changes in firing frequency of active elements. There are extensive interconnections, both excitatory and inhibitory, between all of the lateral subgroups of the CPG [9] that must be important in this reorganization, and perhaps also in generating the rhythm. However, some CPG neurons seem capable of generating self-sustained membrane oscillations either spontaneously, or in response to tonic inputs, and this can lead to regular bursts of firing at about the masticatory frequency [6,9]. Most of these are in the dorsal cap of Main sensory V, which is the only region of the nucleus that seems to be part of the CPG [6]. Most of the interactions within these circuits involve amino-acid neurotransmitters. Excitatory synapses seem to release glutamate, while inhibitory inputs are either glycinergic or ►GABAergic [2,9].

### Function

The function of mastication is the mechanical breakdown of food to prepare it for digestion.

### Pathology

Disorders of mastication are not a frequent symptom of neurological disease, although strokes that cause lesions of the cortical masticatory area are associated with difficulty in initiating mastication and swallowing [5]. Abnormal orofacial movements, which sometimes resemble purposeless mastication, are a symptom of tardive ►dyskinesia, which is associated with damage to the striatum caused by long-term treatment with neuroleptic drugs.

Chronic pain of the jaw muscles and joints slows mastication and reduces chewing forces, and loss of salivary tissue (autoimmune disease, radiation) makes it hard to chew and swallow. Many millions of people

throughout the world are handicapped because the ability to masticate falls as teeth are lost.

### Therapy

There is no effective treatment for tardive dyskinesia. Lost teeth can be replaced by prostheses.

### References

1. Lund J (1991) Mastication and its control by the brainstem. *Crit Rev Oral Biol Med* 8:718–724
2. Lund JP, Kolta A, Westberg KG, Scott G (1998) Brainstem mechanisms underlying feeding behaviours. *Curr Opin Neurobiol* 8:718–714
3. Nakamura Y, Katakura N (1995) Generation of masticatory rhythm in the brainstem. *Neurosci Res* 23:1–19
4. Lund J, Enomoto S (1988) The generation of mastication by the central nervous system. In: Cohen AH, Rossignol S, Grillner S (eds) *Neural control of rhythmic movements in vertebrates*. Wiley, New York, pp 41–71
5. Narita N, Yamamura K, Yao D, Martin RE, Masuda Y, Sessle BJ (2002) Effects on mastication of reversible bilateral inactivation of the lateral precentral gyrus in the monkey (*Macaca fascicularis*). *Arch Oral Biol* 47:673–688
6. Tsuboi A, Kolta A, Chen CC, Lund JP (2003) Neurons of the trigeminal Main sensory nucleus participate in the generation of rhythmic motor patterns. *Eur J Neurosci* 17:229–238
7. Westberg KG, Clavelou P, Sandstrom G, Lund JP (1998) Evidence that trigeminal interneurons form subpopulations to produce different forms of mastication. *J Neurosci* 18:6466–6479
8. Scott G, Westberg KG, Vrentos N, Kolta A, Lund JP (2003) Effect of lidocaine and NMDA injections into the medial pontobulbar reticular formation on mastication evoked by cortical stimulation in anaesthetized rabbits. *Eur J Neurosci* 17:2156–2162
9. Bourque MJ, Kolta A (2001) Properties and interconnections of trigeminal interneurons of the lateral pontine reticular formation in the rat. *J Neurophysiol* 86:2583–2596
10. Hikedada O, Morimoto T, Kato T, Masuda Y, Inoue T, Takada K (1999) Behavior of jaw muscle spindle afferents during cortically induced rhythmic jaw movements in the anesthetized rabbit. *J Neurophysiol* 82:2633–2640

## Matching to Sample

### Definition

Matching to sample discrimination (MTS) is a kind of conditional discrimination. In MTS training, a sample stimulus is given first, then two or more different choice stimuli are given to animal. One of the choice stimuli is the same as the sample stimulus and the animal has to choose that stimulus to get reward.

### ►Discrimination

## Material Body

### Definition

A continuous collection of material particles. Technically, such a collection is known as a material “continuum” or, more precisely, a differentiable manifold.

► Mechanics

## Material Evolution

### Definition

A concept used in theories of growth and remodeling, whereby certain phenomena (such as motion of dislocations, addition of matter or rearrangement thereof) take place in the material body, in addition to its deformation in space. An evolution law prescribes the time-evolution of the material isomorphisms of a body.

► Mechanics

## Material Frame Indifference

### Definition

A constitutive principle according to which the constitutive functionals are independent of the observer, whether it be inertial or not.

► Mechanics

## Material Isomorphism

### Definition

A map between the neighborhoods of two points bringing the material responses into exact coincidence. Also called a material transplant.

► Mechanics

## Material Symmetry

### Definition

A material isomorphism of a point with itself.

► Mechanics

## Material Time-Derivative

### Definition

The derivative of a field with respect to time while following a specific particle. In the Lagrangian description, the material time-derivative coincides with the partial derivative of the field with respect to time. In the Eulerian description an additional term needs to be added to take into consideration the fact that the particle is moving in space.

► Mechanics

## Materialism (Dialectical, Eliminative, Emergentist)

JÜRGEN SCHRÖDER

University of Karlsruhe, Heidelberg, Germany

### Synonyms

Materialist monism

### Definition

Materialism is a metaphysical doctrine opposed to idealism according to which everything that exists is material, i.e. there are only material but no spiritual substances. Angels, gods, incorporeal souls and spirits are denied. Secondly, materialism is a methodological attitude that is critical of tradition and authority. According to this attitude, explanations of mental phenomena should be given without reference to occult powers whose existence cannot be independently (from the facts to be explained) ascertained.

### Description of the Theory

#### Dialectical Materialism

Dialectical materialism is a doctrine that originated in the nineteenth century in the works of Marx and especially

Engels [1,2,3]. Both authors approved of Hegel's dialectical method but rejected his idealism. They held that matter is primary and that mind and consciousness are dependent on matter. Marx's materialism was empiricist in the sense that all real knowledge is based on sense experience, it was realist in that he believed in a mind-independent material world. Furthermore he rejected supernaturalism (the doctrine that some events like, for example, the plague are to be explained by the intervention of God or the Devil) and mind-body dualism.

The dialectical aspect of dialectical materialism was especially emphasized by Engels who understood dialectical materialism as superseding mechanical materialism as it was defended e.g. by Vogt, Büchner, or Moleschott. At the core of mechanical materialism is the idea that every phenomenon of nature, including life and mind, can be reduced to arrangements of the simple constituents of matter and explained by the laws of mechanics. As opposed to this sort of reductive materialism, dialectical materialism holds that there is real novelty in the development of the world and human history, e.g. new substances result from chemical combinations, life as a novel phenomenon results from the combination of a complex of chemical processes and minds result from the complex functioning of brains. Mechanical materialism turned out to be false because electromagnetic phenomena cannot be explained by the laws of mechanics. The underlying idea, however, that every phenomenon can be ultimately reduced to physical arrangements and physical laws has survived until today in the doctrine of physicalism.

Engels claimed that there were three fundamental dialectical laws of nature [3]: (i) The sudden change of qualities of phenomena when certain quantities in them reach a certain threshold, (ii) the law of the interpenetration of opposites, (iii) The law of the negation of the negation. Examples of the first law are the change from liquid to solid state when water is cooled down, the transformation of mechanical motion into heat, and the occurrence of a social revolution after the oppression of the people reaches a certain threshold. The interpenetration of opposites is an idea that Hegel used in order to explain how change and development are possible. For example, the movement of a body in space, Hegel thought, is only possible if the body is at one and the same instant at a certain place and at another place. For if it were at each instant at only one place then there would be only a series of stationary states but no movement. According to Engels (and Hegel) the opposites (the different places) have to interpenetrate one another if movement is to be possible.

The law of the negation of the negation is a law that applies especially to those changes in nature that give rise to novel phenomena and to progress in some sense. Examples of this law are the process in which a plant

produces seeds giving rise to further plants, the process in which the early materialism of the Greeks was superseded by idealism which was superseded in turn by dialectical materialism, and the development of geological formations.

Of these three laws the second and the third seem to be unacceptable for different reasons. The second law amounts to the idea that there are contradictions in nature and to the idea that two sentences that contradict each other can both be true. From a contradiction, however, any sentence whatsoever can be logically derived and that means that the idea of truth, the idea that truth is a property only of *some* descriptive sentences and not of all, is abandoned. The third law suffers from a different defect. A law that is applicable to virtually everything and that accordingly cannot be refuted by any possible observation is cognitively useless. It is uninformative and its explanatory power is zero.

### Eliminative Materialism

Eliminative materialism shares the rejection of supernatural entities like gods and angels with dialectical materialism. It also rejects the existence of soul substances in addition to physical substances. Whereas dialectical materialism with its three laws and its emphasis on novelty and progress is a positive doctrine (although a poor one), eliminative materialism is a negative doctrine. It says that certain things are not what we take them to be. Furthermore, the scope of eliminative materialism is much narrower than the scope of dialectical materialism. Eliminative materialism is a thesis about a certain part of the mental, viz. the propositional attitudes and qualia. The thesis about propositional attitudes says that since they are posits of a folk theory, viz. folk psychology, and since every folk theory in the past was wrong, folk psychology will also be wrong. Besides, Churchland argues that folk psychology does not explain certain things (e.g. why we need sleep), that it has been in a state of stagnation for more than 2,000 years and that it is not reducible to the neurosciences (which is bad for folk psychology because the ontology of the latter is beyond any doubt) [4]. But – and this is the decisive move – if the theory (folk psychology) gets the properties of its posits quite wrong then the terms that are used in folk psychology like “belief,” “fear,” “hope,” “desire” etc. do not refer. They do not designate any part of reality. They are empty. And their being empty means that propositional attitudes don't exist.

The corresponding thesis about qualia, viz. that they don't exist, is similarly argued for. Qualia, i.e. sensory qualities like tickles or color qualities, are supposed to have certain properties as e.g. that one cannot be wrong about one's own sensations. But there is nothing that has this property. So qualia *in the traditional sense* don't exist [5]. This line of attack on qualia is, however, easily rebutted by admitting that qualia *in this sense*

don't exist and by insisting that states with a characteristic feel and a subjective character do exist.

The basic strategy of eliminativists is, first, to say that propositional attitudes are posits of a theory with which we explain behavior and then to argue that this theory is quite probably false. The final step concludes from the alleged falsity of the theory to the emptiness of the terms of the theory and thereby to the non-existence of the entities those terms were supposed to refer to. This strategy can be criticized at every step.

First, as an alternative to the idea that we predict and explain the behavior of others by applying a theory (folk psychology) some theorists have urged that we run a simulation of the other's mental processes within ourselves, i.e. we take the information about the other person's situation in terms of her goals and beliefs and then ask ourselves what *we* would do in a similar situation [6]. In order to exclude the possibility that this simulation is done with an underlying theory of behavior, the proponents of the simulation approach point out that human behavior is very sensitive to slight changes in situations and that an incorporation of all the possible details of a situation into either the theory or the computational process of deriving conclusions would be just too complex a task.

Second, contrary to Paul Churchland's claim that our folk psychology (if we accept that we use a theory in the prediction of everyday behavior) is probably false, other theorists have insisted that it is a highly successful and deep theory without parallel in its domain (i.e. everyday behavior) [7].

Third, even if one takes folk psychology to be a false theory, it is far from clear what consequences its falsity has. A theory can be false in many ways. It may be that one peripheral claim of the theory is false or that many are. Or it may be that a central postulate has to be given up. The theory of electrons from 1900 ascribed trajectories to electrons, but the theory from 1934 rejected trajectories. Both theories, however, were about the same entities, viz. electrons. The term "electron" did not lose its reference by the fact that the theory from 1900 was found to be false. On the other hand, the theory of combustion before Lavoisier postulated a substance called "phlogiston" that was thought to be released in a combustion process. Oxygen, however, was thought to be absorbed by the burning material. In this case, the phlogiston theory of combustion was not only false, but the term "phlogiston" was said to refer to nothing. In order to adjudicate the plausibility of eliminative materialism it would be necessary to argue that folk psychology gets things so fundamentally wrong that the propositional attitudes will share the fate of phlogiston.

One way to argue for this conclusion takes its cue from cognitive science. There are certain models of cognitive processes like memory and inference according to which the information that is needed for various tasks is

distributed over a network of nodes (connectionist models). In these networks there are just no entities to which the two characteristic properties of propositional attitudes, viz. a certain content and a certain causal role, can be ascribed. If connectionism with distributed representations turns out to be the best paradigm in cognitive science then this may be a decisive reason against the existence of propositional attitudes *thus* conceived (as distinct entities with a particular content and a particular causal role) [8].

On the other hand, propositional attitudes needn't be conceived in this way. They needn't be states with distinct causal roles, but may be rather like parallelograms of forces, i.e. devices that we use in order to make predictions but that do not themselves belong to the furniture of the world [9]. However, this move, viz. an instrumentalist conception of propositional attitudes, amounts to abandoning the reality of the attitudes altogether if one adopts a causal criterion of reality, i.e. that being real requires being causally efficacious.

A common objection to eliminative materialism urges that the eliminative materialist makes an assertion when expressing the thesis that there are no propositional attitudes. According to common sense assertions express beliefs. The eliminativist thus falls victim of the contradiction that he or she believes that there are no beliefs. Against this Patricia Churchland pointed out that we need a successor concept for the concept of belief [10]. Once we dispose of such a concept we can say that an assertion expresses a type of cognitive state T which is not a belief. Thus the contradiction would disappear. However, the problem with this answer is that nobody has any idea what such a successor concept would be like. So this answer does not seem to amount to much more than handwaiving.

### Emergentist Materialism

Emergentist materialism in the broad sense is the doctrine that although there are only material substances there are various types of such substances with properties that cannot be reduced to properties of their parts together with composition laws describing the interaction of the parts [11]. According to a weaker sense of "emergentist materialism" any materialism that acknowledges properties of wholes which are not properties of their parts is emergentist [12]. In the early 1920s, before the advent of quantum mechanics and quantum chemistry, C.D. Broad believed that certain properties of chemical compounds, in particular their chemical behavior, could not be predicted in principle from knowledge about the properties of the atoms and knowledge about how the atoms interact in a molecule. "In principle" meant that empirical regularities like "whenever atoms of type x, y, z etc. combine in proportion P, then the resulting compound will show behavior B in circumstances C" were disallowed for the



prediction. These regularities were also called “ultimate laws” because they were not reducible to or explainable by other facts. The British emergentists like Samuel Alexander and Convy Lloyd Morgan thought that predictions of chemical, biological, psychological or sociological properties could be made on the basis of such empirical laws but they also thought that these laws were brute facts that cannot be further explained. According to the British emergentists a property of a whole was emergent if and only if (i) it was not also a property of its parts and (ii) it was not deducible from the properties of the parts and general composition laws. If a property of a whole was only deducible from the properties of the parts and an ultimate law connecting these properties with the property of the whole then it was said to be emergent. The important point about composition laws was that they be general. In the case of chemistry this meant that they should be valid for all chemical compounds and not only for a certain kind of compound.

A *prima facie* strength of emergentist materialism was that it allowed to account for the major distinctions in our common sense picture of the world: the distinction between the living and non-living, and the distinction between organisms with a mind and organisms without a mind. Life and mind were considered to be major emergent properties.

A problem with emergentism thus construed is whether emergence is a property of reality itself or whether it is rather a property of our knowledge of reality. Certain properties that were considered to be emergent in the past such as the chemical properties of chemical compounds or the property of life with its more specific properties of growth, reproduction, metabolism etc. have turned out to be non-emergent according to Broad’s criterion of non-deducibility. This fact supports the hypothesis that emergence has to do with our knowledge rather than with reality itself [13].

As far as the mind and the brain are concerned, emergentist materialism claims that among all properties of all things there is a certain class, viz. the qualities of sensations, which is not deducible from physical properties and furthermore that these qualities will remain undeducible and therefore emergent forever [14,15]. The more specific idea is that it will appear forever contingent that the special character of, for example, a visual sensation is connected with a particular brain process. It is claimed that we cannot give any reason why a visual sensation should be correlated with brain process A and another visual sensation with a brain process B instead of the reverse.

There is, however, an ambiguity as to the concept of qualia involved in this claim. The quality of an sensation can be described relationally by comparing it to other qualities of the same domain. Colors, for example, can be arranged in a circle such that any color

that is on the opposite side of the circle is maximally dissimilar to a given color with respect to the other colors. All the relational properties of a sensory quality constitute its relational profile. It seems plausible that a state with a certain relational profile cannot be realized just by any brain state but only by such brain states that have enough structure in order to guarantee the relational profile of the respective sensory quality. Qualitative states with different relational profiles should accordingly be correlated with brain states that have different structures. If we identify a sensory quality with a certain relational profile there probably are explanations of sensory qualities that remove the impression of contingency that constitutes the so-called explanatory gap [16].

On the other hand, qualia may be taken non-relationally. One may conceive of a quale as a structureless property that has a certain intrinsic character. Even then qualia would not be completely without relations. But the only relations would be relations of difference without any specifications of greater or smaller difference. The emergentist claim would then be that with respect to these intrinsic, non-relational qualities any correlation with some brain process or other would be arbitrary, i.e. there would be no reason why the intrinsic quality of red should be correlated with brain process A instead of B.

According to this line of reasoning the only really emergent properties would be the intrinsic qualities of experience. But the underlying idea may also be used to show that any real property whatsoever is emergent relative to more fundamental properties. For, imagine any property, e.g. the property of being magnetic or the property of having some mass *m*. In order to characterize this property, you may specify a certain relational profile. You may say what the causal role of this property is and you may say how it differs from other properties in its domain. But you may also assume that this property has a certain intrinsic character over and above its relational profile. You may even assume that this intrinsic character is the bearer of the relational profile. In contrast with the case of qualia you don’t know what this intrinsic character is like, you only think of it indirectly via its role of being the bearer of the relational profile. All the same, if you take any set of supposedly more fundamental properties and any composition rules there will be no reason why it is correlated with intrinsic character A instead of intrinsic character B. So the reason for the appearance of contingency of qualia relative to the brain states they are correlated with is their intrinsic character and not their being mental. Accordingly, every real property, i.e. every property with a distinct causal role is emergent relative to some set of more fundamental properties as it appears equally contingent that its intrinsic character is correlated with that set of more fundamental properties.

But if every real property is emergent then the concept of emergence does no useful work anymore, e.g. to demarcate the major layers of reality.

## References

1. Marx K (1845) Die heilige familie. Frankfurt
2. Engels F (1878) Herrn eugen dührings umwälzung der wissenschaft. Leipzig
3. Engels F (1985) Dialektik der nature. Berlin
4. Churchland PM (1981) Eliminative materialism and the propositional attitudes. *J Phil* 78:67–90
5. Dennett D (1988) Quining qualia. In: Marcel A, Bisiach E (eds) *Consciousness in comtemporary science*. New York, pp 42–77
6. Gordon RM (1986) Folk psychology as simulation. *Mind Lang* 1:158–171
7. Fodor J (1987) *Psychosemantics*. Cambridge, Mass
8. Ramsey W, Stich S, Garon J (1990) Connectionism, eliminativism and the future of folk psychology. *Philos Perspect* 4:499–533
9. Dennett D (1981) Three kinds of intentional psychology. In: Healy R (ed) *Reduction, time, and reality*. Cambridge, pp 37–61
10. Churchland PS (1986) *Neurophilosophy*. Cambridge, Mass
11. Broad CD (1925) *The mind and its place in nature*. London
12. Bunge M (1980) *The mind–body problem*. Oxford
13. Schröder J (1998) Emergence: non-deducibility or downwards causation? *Philos Q* 48:433–452
14. DuBois-Reymond E (1872) Über die grenzen des naturerkennens. In: Strich F (ed) *Deutsche akademiereden*, München, 1924
15. Levine J (1983) Materialism and qualia: the explanatory gap. *Pacific Philos Q* 64:354–361
16. Hardin CL (1988) *Colour for philosophers*. Indianapolis

## Materialist Monism

- ▶ Materialism (Dialectical, Eliminative, Emergentist)

## Maternal Transcript

### Definition

Transcribed mRNA that is provided to the embryo directly by the mother.

- ▶ Alternative Splicing and Glial Maturation

## Mathematical Model

### Definition

A mathematical model is a mathematical tool (expression) representing the behavior of a physical system. Differential or difference equations are commonly used as models. Some mathematical models result from laws of physics. Others are obtained by experimenting on the system.

- ▶ Adaptive Control

## Mathematical Purification in Circadian Rhythm

### Definition

A procedure for mathematically removing the influence of exogenous factors on rhythmic circadian variables of interest. The correction is generally based on normative data measuring the size of the effect of the exogenous factor on the variable of interest, and applied according to currently theory on the timing of that influence. For this reason, the accuracy of mathematical purification is limited by the quality of the experimentally derived data used to develop the purification formula.

- ▶ Masking (Positive/Negative)

## Mathematical System in Biomechanics

### Definition

A defined set of mathematical equations.

- ▶ Distribution Problem in Biomechanics

## Mathematical Theory of Communication

- ▶ Information Theory

## Matrix

### Definition

Body of the ligament that consists of water, collagen, proteoglycans, fibronectin, elastin, actin and other glycoproteins. In a ligament, the majority of the matrix is composed of collagen.

- ▶ Articular Cartilage
- ▶ Ligaments

## Matrix Metalloproteinases

### Definition

The family of enzymes contributing to both normal and pathological remodeling of the extracellular matrix and playing a key role in the migration of normal and malignant cells through the body. Matrix metalloproteinases are the members of a family of at least 15 Zn-dependent endopeptidases that function extracellularly. Their catalytic domains have a similar structure but the topology of the active site clefts differs, accounting for some of the differences in substrate specificities.

## Maturation of Cells – Differentiation of Cells

- ▶ Nervous, Immune and Hemopoietic Systems: Functional Asymmetry

## Mauthner Cell

### Definition

Giant interneurons, arranged in a pair on either side of the brainstem, that mediate directed escape turns (Cstart escape) in fish and larval amphibians. Mauthner cells respond to acoustic, vibrational and various other sensory signals and initiate muscle contractions along

the flank of the animal, resulting in a C-shaped bend of the body (see C-start escape).

- ▶ Auditory-Motor Interactions
- ▶ Startle Response

## Mayer Waves

### Definition

Blood pressure oscillations of low frequency (0.1 Hz in humans and cats, 0.4 Hz in rats). These waves are slower than the respiratory rate and are not synchronous with each breath but affect the ventilatory pattern.

- ▶ Pontine Control of Respiration

## Maze Learning

### Definition

A maze is a spatial puzzle. Mazes are typically two-dimensional and involve a player, termed a “traveler”, who attempts to move from a start location to a goal. A labyrinth is a particular type of maze with tortuous, walled alleyways and a single route from start to goal. Mazes have long been used as tests of learning, memory and intelligence. Common animal mazes include the T maze, the plus maze, Hebb-Williams mazes, the sunburst maze, the radial-arm maze, the water maze and the Barnes maze. Three important chapters in animal psychology involve mazes. Beginning in the 1920s Karl Lashley trained rats in labyrinths to explore their general learning capabilities. He found that no particular part of rat neocortex was necessary or sufficient to support maze learning and memory, and, from this observation, derived the principle of equipotentiality (also known as mass action). In the 1940s and 1950s two contentious groups (the behaviorists and the cognitivists) used a broad array of mazes to test whether rats learn about space by means of response learning or map learning. Finally, in recent years the radial-arm maze, the Barnes maze and the water maze have been used extensively to assess the role of the hippocampus in spatial learning and memory.

- ▶ Spatial Learning/Memory

## M-channels

### Definition

M-channels (M for muscarine) are non-inactivating, voltage-sensitive  $K^+$  channels that exist in many types of neuron in the central nervous system and in peripheral sympathetic neurons, and generate the only sustained current in the range of action potential initiation. In the absence of acetylcholine, M-channels open at resting membrane potential and dampen neuronal excitability. Acetylcholine inhibits M-channel activity by activation of the muscarinic  $M_1$  receptors. The M-current can be modulated by various receptor types, either by suppression or enhancement. There are two main ways of modulation: receptor-mediated modulation and the control of current amplitude by intracellular  $Ca^{2+}$ .

- ▶ Acetylcholine
- ▶ Action Potential
- ▶ Muscarinic Receptors
- ▶ Neuronal Potassium Channels

## Meaning (Verification Theory)

MARKUS SCHRENK DPHIL

Research Fellow, Department Philosophy, University of Nottingham, University Park, Nottingham, UK

### Synonyms

Verificationist theory of meaning; Verification principle; Verification criterion; Verificationism

### Definition

The verification theory of meaning aims to characterize what it is for a sentence to be meaningful and also what kind of abstract object the ▶**meaning** of a sentence is. A brief outline is given by Rudolf Carnap, one of the theory's most prominent defenders:

If we knew what it would be for a given sentence to be found true then we would know what its meaning is. [...] thus the meaning of a sentence is in a certain sense identical with the way we determine its truth or falsehood; and a sentence has meaning only if such a determination is possible. [1: 420]

In short, the verification theory of meaning claims that the meaning of a sentence is the method of its verification.

### Description of the Theory

Verificationism can only be fully appreciated in the larger context of the philosophical credo it emerged from, namely twentieth Century ▶**logical empiricism** (also known as ▶**logical positivism**) [2].

An empiricist subscribes at least to the following doctrine: intuition or pure reasoning, can reveal what the world is like. All *factual* ▶**knowledge** has its sole source in sense experience. For example, if you want to understand how the human brain works, there is no other way to knowledge than via observation, especially via empirical experiments.

This *epistemic* doctrine (see ▶**epistemology**) about the nature and source of factual knowledge had already been put forward by the ▶**classical empiricists** in the seventeenth and eighteenth Centuries. The novelty of twentieth Century logical empiricism is a shift in focus from this doctrine about knowledge to a doctrine about (scientific) language. More exactly, the logical empiricists tried to underpin the validity of the doctrine about factual knowledge with a doctrine about sentence ▶**meaning**. This is where the verification theory of meaning has its place.

Suppose we stipulate that the meaning of a ▶**statement** (a sentence, a ▶**proposition**) is given by the observations we have to make to find out if it is true. Or stronger, that a sentence has to be discarded as meaningless unless one can offer a description of what fact or state of affairs has to be observable so that this sentence can be said to be true or false. That is precisely what the verification theory of meaning demands: “The meaning of a proposition is the method of its verification.” [3: 148]

Suppose furthermore, that all factual knowledge is expressed in meaningful sentences. Then, together with the verification theory of meaning, we arrive back at the epistemic doctrine from above: factual knowledge has its justification in observation. Thus, verificationism is the linguistic counterpart of the empiricists' doctrine about knowledge.

Both logical empiricism and the verification theory of meaning are, however, outdated theories. This is not because the general idea behind them – that empirical knowledge depends on sense experience – has been given up by philosophers. Rather, verificationism in its strongest form faced a few unsolvable technical difficulties. A closer look at the verification theory of meaning, as well as exemplary applications of the theory will unveil some of these problems.

### Verificationism and the Hierarchy of Language

*Historical Background.* The verificationist theory of meaning has a by-product: logical empiricists perceive language to be hierarchically structured. Observational terms are at the basis of that structure, and all other terms further down the hierarchy are translatable into

terms of this basis. ►Logic and ►conceptual analysis is the central tool to arrive at such translations of non-observational terms to observational terms. What does this mean?

Take a sentence like “This apple is red.” The verification theory of meaning claims that it is meaningful if and only if we can describe which state of affairs has to be observable so that the sentence can be said to be true. In this case, the task seems to be rather easy: “This apple is red” is, indeed, a meaningful sentence – it is true just if the apple in front of us is really red, i.e. precisely if, under normal light conditions, it appears red to us, and false if not.

However, not every sentence contains terms that refer to directly observable features of easily observable objects. For those sentences it is difficult to see how the verificationist criterion can be met. For example, what kind of observation verifies sentences like “This fluid has a temperature of 100°C” or, worse, “The electron’s mass is  $m_e = 9.11 \times 10^{-31} \text{kg}$ ”?

For these sentences to meet the verificationist criterion of meaning, an intermediate step seems unavoidable: scientific terms which do not refer themselves to directly observable features of the world have to be analyzed or reduced to descriptive terms that do so (See ►operationalism). Those sentences that contain non-observational terms can, with the help of these analyses, be translated into sentences that are observational. Only then can the verification criterion of meaning be applied.

The following example illustrates what we mean: “object O has temperature T” can be analyzed into the phrase “if a Mercury thermometer is placed into or nearby object O the mercury will rise (or fall) to mark T.” With the help of this analysis we can translate “This fluid has a temperature of 100°C” into “if a mercury thermometer is placed into this fluid the mercury will rise (or fall) to mark 100.” The latter sentence clearly indicates which possible observation would verify it. Hence, according to verificationism, the sentence has meaning.

The actual translation of all terms (or sentences) to observational terms (or sentences) is, of course, a utopian dream. In any case, the general possibility of such a reduction would suffice to support the empiricists’ credo. Attempts to prove the general possibility have indeed been given [4].

*Verificationism and Metaphysics.* It is easy to see how both the conceptual analysis of terms and the verificationist doctrine about sentence meaning could be used as a tool to criticize or even ridicule metaphysical philosophy. Indeed, to try to show that metaphysics does not make any sense at all was part of the empiricists’ programme. Terms like *god*, *nothingness*, or *meaning of life* are so the empiricists not suitable for analysis into observational terms and are,

hence, not apt to figure in meaningful, verifiable sentences and philosophical research in general. They can, at best, be used to express a general attitude towards life, a *Lebensgefühl*, but they have no factual content [5].

*Verificationism and Behaviorism.* There is a close relation between verificationism and behaviorism (see ►behaviorism, ►logical). The aforementioned idea of a reduction of all scientific terms and sentences to observable terms and sentences means, too, that psychological terms, i.e., terms concerning the human ►mind, have to be translatable into observational language. This is precisely what behaviorism asks for: attributions of mental states to people (like “Agnes is happy”) must be translated into statements about people’s observable behavior or, at least, their dispositions to behave.

Take the sentence “Alfons desires a good bottle of wine.” Such an ascription of a mental state to a person can only be admitted into scientific language if we can, according to the verificationist theory of meaning, describe the way we determine its truth or falsehood in observable terms. Hence, in order to give the meaning of that sentence we would have to say something along the following lines: “Alfons desires a good bottle of wine” is true if and only if (i) Alfons reaches for a bottle of wine when he sees one standing on the table, (ii) Alfons utters the words “Yes, please!” when someone offers him a glass of Riesling, (iii) Alfons seeks a wine shop when he has got the money and time, etc. This list amounts to a catalogue of observable stimulus and response connections (see ►testability). It thereby offers testing conditions and so gives the meaning of the initial sentence. In this way, statements about mental states are generally thought to be reduced to sentences about behavior (or dispositions to behave).

### Problems with Behaviorism and Verificationism

There are, however, severe problems for behaviorism and consequently for verificationism. For a start, note that the list given above seems to be endless. Wine lovers do various other things additional to those listed above. Yet, when can we stop and be sure to have reached the full meaning of the sentence which is to be analyzed? Is it not rather doubtful that there is a comprehensive catalogue of stimulus-response entries?

Furthermore, some wine lovers might not always be disposed to do the things listed: they might have interfering wishes, other preferences or they might obey certain prohibitions. Alfons could be a wine lover but he might not touch any alcohol for religious reasons. Hence, some sort of proviso will have to be added to the stimulus conditions: if Alfons sees a bottle of wine *and* no other wish or desire or prohibition or promise etc. prevents him from pouring himself a glass then he will do so. However, the verificationist is still not off

the hook, since the word *preventing*, which occurs in the proviso clause, is again an unobservable mental ►predicate (we were not talking about Alfons being observably chained to the chair but about other desires preventing him). In trying to reduce a statement about one mental state to observational language we had to use the non-observational mental terms, and it is questionable whether we can ever escape. (Kind of this vicious regress is already a danger for the analysis of non-mental non-observational terms).

### Verificationism and Physics: Further Problems

Aside from the realm of the mental, verificationism has difficulties with statements from the very ►science which should cause the least problems, namely physics. Consider a law hypothesis like “All masses attract each other.” Which kind of observation would conclusively establish this sentence’s truth and hence it’s meaning? No doubt, this difficulty relates back to the traditional problems of ►induction of how to conclude from some observed events to all of them (including unobserved ones). In the guise of a puzzle about meaning, the problem of induction is, however, aggravated: not only is it difficult to define what would provide conclusive evidence for “All masses attract each other”, for verificationism, the lack of such a characterization would mean that law hypotheses do not form meaningful sentences. Hence, they should be dropped from scientific language. And yet, this is unacceptable for general and universal hypotheses are, arguably, central to any scientific enterprise. Note that similar problems arise from sentences about past events for which observations are also in principle impossible.

There have been attempts to reformulate verificationism in weaker forms to avoid these consequences: observations should only be *somehow relevant* to the determination of the truth or falsehood of sentences [6,7: 18–19]. However, instead of going further into detail of those reformulations (which have anyway been unsuccessful in the end) it is worth turning to problems on a more abstract level. The first concerns the status of the verificationist doctrine itself. The second challenges tacit presuppositions of verificationism which turned out to be untenable.

### Verificationism Applied to Itself

Ironically, the verificationist doctrine itself falls short of its own high demands. Take the statement: “Sentences have meaning only in so far as they are empirically verifiable.” Are there possible observations which could prove the truth of this very sentence? It seems not. But then the doctrine itself lacks meaning, i.e. it is a statement like metaphysical claims without any sensible content. The logical empiricists’ response to this charge was

to claim that the verification criterion is prescriptive rather than descriptive in character. It is meant to be a recommendation to scientists of what is best to be counted as proper scientific language; it is not meant to be a factual statement. Note inside that verification is a similar answer have offered for other indispensable non-factual claims, like mathematical or logical statements, or sentences which state conceptual truths. (See ►necessity; ►necessity, conceptual).

### Verificationism and Meaning Holism

Still more problematic for verificationism is a thesis called *meaning ►holism*. Take again the sentence “if a mercury thermometer is placed into this fluid the mercury will rise (or fall) to mark 100.” which is supposed to give the meaning of “The fluid is 100° C”. Suppose your observation speaks against its truth. You place a thermometer into the fluid, Yet, the mercury does move only a little but not to 100. Unsurprisingly, it is possible to make, adjustments at various other points in our belief-system such that we could, in principle, nonetheless affirm to the sentence that the fluid is 100: we could, for example, doubt that the pressure is appropriate for the measurement and the pressure remains constant; we could suppose that the thermometer is broken; we could claim that thermometer’s scale has been wrongly calibrated, etc.

The upshot of this ►thought experiment is that the verificationists’ assumption that isolated sentences alone face the tribunal of observational evidence is not justified. It is always a whole bunch of interrelated sentences – a whole belief system – which is tested by observation. This is a thesis which came to be known as meaning ►holism and was argued for by W. V. O. Quine [8]. Single sentences are too small a unit to be verifiable by experience. Instead “the unit of empirical significance is the whole of science.” [8: 42]. But if this is so, the verification theory of meaning which is defined for single sentences is false from the outset.

### Verificationism Rejected

The *prima facie* attractive verificationist doctrine proves to be untenable for various reasons: (i) It turned out to be difficult if not impossible to apply the verificationist theory of meaning in a concrete case: this has been shown in the example from behaviorism. Endless lists and regresses threaten the success of an analysis. (ii) It was necessary to rewrite the verificationist doctrine several times, as underlined by the example of law statements which would otherwise have to be discarded as being nonsense. (iii) The self-application of the doctrine reveals its own non-empirical status; and finally, (iv), the hidden presupposition that sentences are the units of observational verification had to be dropped, and so verificationism as a whole.

### The Remnants of Verificationism

It should be mentioned that some verificationist ideas still live on and are indeed worth pursuing. For philosophical theories of sentence meaning it is essential to hold on to the strong link between truth and meaning: some philosophers claim that giving the truth conditions of a sentence (not the *verification conditions* for its truth, though) is giving the meaning of that sentence [9]. The philosopher Michael Dummett even revived a verificationism which is, in some respects, akin to the logical empiricist's doctrine. As a result, Dummett had to adopt anti-realist positions (compare ►*realism*) when it comes, for example, to statements about laws of nature (►*Law, Natural*; ►*Law, Lawfulness*) or the past: he claims that statements whose truth cannot decisively be verified are neither true nor false [10].

### References

1. Carnap R (1936) Testability and meaning I. *Philos Sci* 3:419–471
2. Ayer AJ (ed) (1959) *Logical positivism*. Free Press, New York
3. Schlick M (1936) Meaning and verification. *Philos Rev* 45:339–369
4. Carnap R (1928) *Der logische Aufbau der Welt*. Weltkreis, Berlin (repr. Meiner, Hamburg 1998)
5. Carnap R (1932b) Überwindung der Metaphysik durch logische Analyse der Sprache, *Erkenntnis* 2:219–41 (English translation in [2])
6. Hempel CG (1950) Problems and changes in the empiricist criterion of meaning. *Revue internationale de philosophie* 4:41–63 (appears slightly modified as Empiricist criteria of cognitive significance: problems and changes. In: Hempel CG (ed) (1965) *Aspects of scientific explanation*. Collier-Macmillan, London; Free Press, New York)
7. Ayer AJ (1936) *Language, truth and logic*. Victor Gollancz, London (repr. Penguin, London 2001)
8. Quine WVO (1951) Two dogmas of empiricism. *Philos Rev* 60. (repr. in Quine, WVO (1953) *From a logical point of view: nine logico-philosophical essays*. Harvard University Press, Cambridge, MA
9. Davidson D (1984) Truth and meaning. In: Davidson D (ed) *Inquiries into truth and interpretation*. Clarendon Press, Oxford, pp 17–36
10. Dummett MAE (1993) *The seas of language*. Clarendon Press, Oxford

## Measurement Techniques (Biomechanics)

WALTER HERZOG

Professor, Faculty of Kinesiology, University of Calgary, Canada

### Synonyms

Optical techniques; Force; Acceleration; Sonomicrometry; Strain

### Definition

►*Optical methods* in biomechanical analyses include high-speed film and video. In the past decade, various motion analysis systems that track passive or active markers have become the preferred mode to capture human and animal movements.

“►*Force*” cannot be defined by itself. However, the effects of forces can be described. Most importantly, force is described by Newton's second law, which states that, for a particle system, the resultant force acting on a system is proportional to the acceleration of that system. Therefore, forces manifest themselves by accelerating but also by deforming systems.

►*Acceleration* is the second time derivative of displacement, or the first time derivative of velocity. Acceleration is an instantaneous vector quantity.

►*Sonomicrometry* is a technique that uses ultrasound transmission from one piezoelectric crystal to another to measure distances and strains. The principle of sonomicrometry rests on the idea that ultrasound pulses travel in a straight line and constant speed through a medium. Therefore, by measuring the time it takes the ultrasound signal to go from one crystal (transmitter) to another (receiver), the distance between the crystals can be calculated.

►*Engineering strain* is defined as the change in length of a material from its original reference length divided by the original reference length; that is:

$$(L - L_0/L_0)$$

Where:  $L_0$  is the original reference length, and  $L$  is the current length of the material.

### Purpose

Optical methods in biomechanics are used to quantify the movements of the system of interest. These movements may be on the whole system level, for example human walking, or may be on the microscopic level and include cell motility and division, or the movements of a ►*molecular motor* protein (e.g. kinesin) on its motor track (microtubule). From movements, forces can often be calculated through the

## Measure of Equilibrium

►*Vestibular Tests Static and Dynamic Posturography*

so-called ► **inverse dynamics approach** [1], when direct ► **force measurements** are difficult or impossible.

Force measurements in biomechanics represent a basic tool to quantify the mechanics of a biological system. Forces in human locomotion provide insight into the loading of the musculoskeletal system and the workings and control of muscles. Forces obtained in micro scale systems may provide an understanding of basic life functions, such as cell division, muscle contraction, and ► **ATP synthesis**.

Acceleration measurements are often performed in situations where force measurements cannot be made. Accelerations of a system are proportional to the ► **resultant external forces** acting on the system, and therefore represent a valuable piece of information of the ► **kinematics** and ► **kinetics** of the target system.

Sonomicrometry has become an accepted tool for measuring deformations of soft tissues *in vivo*. For example, sonomicrometry is frequently used to measure deformations of the heart on a beat-by-beat basis, or to measure the strains in muscle fibers in freely moving animals.

► **Strain measurements** in biomechanics are fundamental to define the constitutive properties of hard and soft tissues. The ultimate strain defines the strain at which a material fails, while stress-strain measurements provide ► **Young's modulus**, a basic material property.

## Principles

Early optical methods for movement analysis in biomechanics include single shot photography, chronophotography, and stroboscopy. Photography has the distinct disadvantage that only a single picture of a movement is available, or in the case of multiple exposures, several photographs may be available, but typically with a poor time resolution.

Chronophotography uses a conventional photographic camera with a rotating disc shutter placed in front of the film. The shutter can be rotated typically at very high frequencies and the film is exposed every time the opening of the shutter is in front of the film. Thus, a movement is captured on a still photograph. The limitations of chronophotography include that the movement of interest must be in a given direction, so that exposures do not start to overlap in time, that the movement is relatively fast compared to the shutter speed, and that movements are best captured in an artificial environment where the background makes a very good contrast with the system of interest.

Stroboscopy is also based on multiple exposures of a still film. However, the exposures are obtained through pulsed flashes in an otherwise dark room, thus the system of interest is exposed each time the flash comes on, and is invisible when the flash is off. Stroboscopy, in principle, allows for very high frequencies of data collection. However, in practice, the same limitations as

for the chronophotography apply. In addition, stroboscopy can only be performed in a laboratory setting and for movements that can be performed easily in partial darkness.

In the 1970s and 1980s, most biomechanical analyses of movements were performed with high-speed cameras. These cameras typically used 16mm film and were intermittent pin registered or rotating prism cameras. The intermittent pin registered cameras use a mechanical device to advance and then hold the film with pins that grab the holes on the side of the perforated film. When the film is held still, one frame is behind the lens and shutter and will be exposed during that time. This process is repeated frame by frame for a maximal time resolution of about 2 ms (i.e. 500 exposures per second).

In the rotating prism camera, light is focused through the lens onto a rotating prism that directs the light onto the continuously moving film. These cameras can reach time resolutions of about 0.1 ms (i.e. 10,000 frames/s).

Today, most movement analyses with optical methods are based on automated video systems that capture passive or active markers, and track them in three-dimensional space through multiple camera systems, and through software that is based on direct linear transformation [2]. These systems are commercially available (hardware and software), and typically operate at set frequencies, with a maximal time resolution of about 200 frames per second. Tracking of the markers is performed automatically, and the tester merely needs to interfere with manual corrections of the marker tracking system when markers start to overlap and cannot be identified uniquely by the tracking software, or when markers are not simultaneously observed by at least two cameras (for three-dimensional analyses).

In the past few years, high-speed digital cameras have also become available. These cameras allow data collection at rates of several kHz (i.e. several thousand frames per second), but because of memory limitations, can typically only operate for a few seconds at the highest sampling frequencies. The advantages of digital video cameras include that the movements can be directly viewed and displayed on a computer, and that the system can be configured such that very fast events may be captured after they have occurred. For example, a digital camera may be set to collect data continuously, but not store the data. Once the event of interest has occurred, data storage may be triggered to include events that occurred several seconds prior to the triggering of data storage, so that the event of interest is included.

The principles of force measurements are virtually unlimited. They range from mechanical springs, to piezoelectric sensors, to ► **optical trapping** and atomic



force microscopy. Here, three examples of force measurement principles are given. The first is the ►force platform that is based on piezoelectric force sensors; the second is a strain gauge based ►tendon force transducer for muscle force measurements in freely moving animals and humans; and the third is an optical trapping method using lasers to measure the pico Newton forces in ►molecular motors and springs.

Force platforms have been used in biomechanical research for over a century and have been continuously refined for force and time resolution. Commercial platforms come in a variety of sizes and shapes, and they typically contain force sensors in four corners of a rectangular plate (Fig. 1, top panel, labels 1–4).

With this setup of sensors, it is possible to measure the three-dimensional forces and moments in an orthogonal reference system ( $x, y, z$ , Fig. 1), as well as the point

of application of the force ( $P$ , Fig. 1, lower panel). Force platforms are typically based on piezoelectric or strain gauge sensors. The piezoelectric effect was discovered in the 1880s by the Curie brothers. Piezoelectric materials are based on non-conducting crystals that generate an electrical charge when strained. Quartz and ceramic materials have piezoelectric properties. For biomechanical applications, quartz crystals are typically cut into discs, and when subjected to forces they produce an electric charge that is proportional to the applied load. Piezoelectric sensors have the advantage that they can be used over a large range of forces. However, they have the disadvantage that the charge “leaks,” and thus they are not well suited for long-term static force measurements.

Strain gauge based tendon force transducers have been used for many years to measure the muscle forces

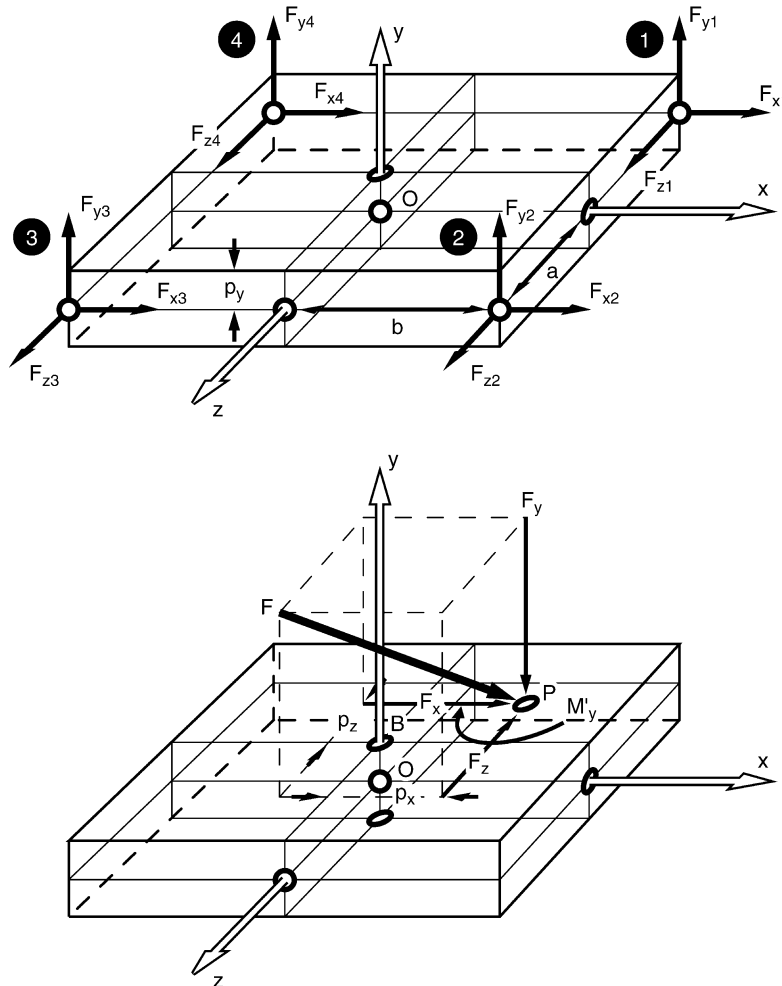

**Measurement Techniques (Biomechanics).** Figure 1 Force platform with reference frame ( $x, y, z$ ) and force sensors at each of the four corners (top drawing). Resultant force ( $F$ ) applied to the force platform with the corresponding point of application ( $P$ ), and force components ( $F_x, F_y, F_z$ ) (bottom drawing).

in freely moving animals. Walmsley et al. [3] measured the forces in the cat medial gastrocnemius and soleus, and Herzog and Leonard [4] measured these same forces, plus the plantaris and tibialis anterior forces, for a variety of locomotor conditions. The tendon force transducers used in these experiments are of different shape and size depending on the tendon geometry. However, the principle of these tendon force measurements remains the same. A transducer element is either fixed externally (Fig. 2) or internally (Fig. 3) to the tendon.

Upon force production by the muscle, the transducer element is deformed, this deformation is measured with appropriately placed strain gauges, and the strain gauge output is then calibrated against known forces that are applied to the tendon in a terminal experiment. Measurements of this kind have been instrumental in identifying the forces acting on musculoskeletal structures, such as joints, (e.g. [5]) and in determining strategies of movement control (e.g. [3]).

Optical trapping was developed in the early 1970s by Arthur Ashkin. Optical trapping and the manipulation of small neutral particles is based on the forces of radiation pressure. These forces allow for trapping of a particle of the size of several nm to several  $\mu\text{m}$  in diameter at the centre of focus of a laser beam.

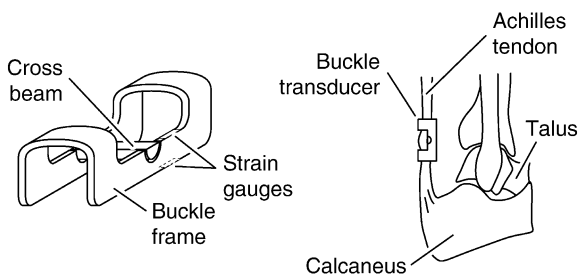

### Measurement Techniques (Biomechanics).

**Figure 2** Schematic illustration of a buckle transducer (*left*) and a possible arrangement on an Achilles tendon (*right*). (From [6], with permission.)

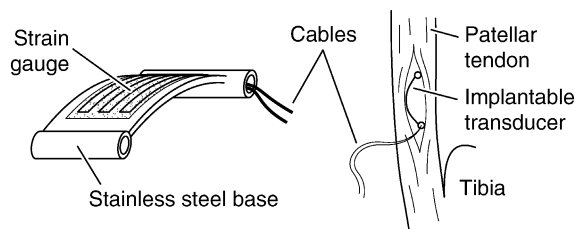

### Measurement Techniques (Biomechanics).

**Figure 3** Schematic illustration of an implantable force transducer (*left*) and a possible arrangement in a patellar tendon (*right*). (From [7], with permission.)

Optical trapping has been used in atomic physics, but its use in biological applications is of primary interest here. Due to the virtually perfect control that can be exerted with optical traps, they have been used for a variety of biological applications: the unfolding and refolding of proteins and nucleic acids, testing of the strength of ligand to receptor bonding, and the study of a variety of molecular motor functions, and the corresponding forces and basic displacement steps.

Optical traps are perfectly suited to measure forces up to about 200 pN with sub-pico Newton resolution. When combined with adequate displacement sensors, nano metre steps of molecular motors can be detected (e.g. [8]). These techniques have resulted in great advances in our understanding of the basic forces and displacements produced by elementary cycles of a variety of molecular motors. For example, for the myosin II-actin motor associated with muscle contraction, single motor protein interactions are thought to produce forces in the 2–10 pN range, with single step sizes of 3–12 nm and the unbinding force of myosin II from actin in the absence of ATP has been measured as  $9.2 \pm 4.4$  pN.

Accelerations in biomechanics are often determined using high-speed film or video for measuring displacements as a function of time, and then calculating acceleration through the second time derivative of the displacement data. However, this approach is not very accurate for situations where displacements are small and accelerations are high, and taking time derivatives of “noisy” displacement-time data using numerical approaches always introduces errors that are hard to quantify. Therefore, a number of sensors have been used for specific applications in biomechanics to measure accelerations directly rather than determining them numerically through displacement data.

Accelerometers work on the principle that a small inertial mass segment is moved within a sensor, that this movement is captured electronically and is converted, through appropriate calibration, into the corresponding acceleration. Often, accelerometers are built around a seismic mass element as shown in Fig. 4.

The cantilever is fixed to the base element, and the seismic mass is attached to the base through a weakened part in the beam design to allow for deformation of the element as the sensor is accelerated. The deformation is measured through strain gauge elements, as shown in Fig. 4 or piezoresistive elements.

Another principle underlying acceleration measurements is based on a mass element that is positioned between two coils that are attached to the accelerometer base (Fig. 5).

The mass is magnetically coupled between the coils, and when the mass is displaced by acceleration, the magnetic coupling is changed and the corresponding change in the inductive current is measured as a change

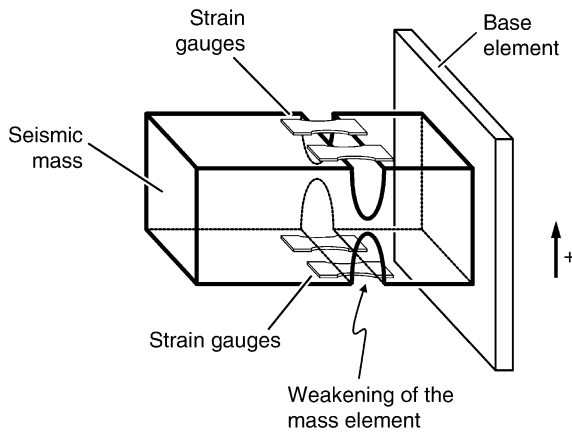

#### Measurement Techniques (Biomechanics).

**Figure 4** Illustration of a piezoresistive accelerometer. (From Instruction Manual for Endevco Piezoresistive Accelerometers, 1978, with permission.)

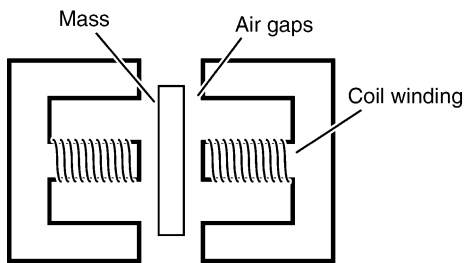

#### Measurement Techniques (Biomechanics).

**Figure 5** Schematic illustration of the construction of an inductive accelerometer.

in electrical output that can be related to the acceleration of the transducer. Accelerometers can be custom built for applications that require specific frequency and amplitude responses. Proper acceleration measurements are extremely difficult to perform and interpret because it is typically not trivial to attach the sensors rigidly to the target segment and to place them at the point of interest.

Sonomicrometry is a method based on ultrasound transmission between piezoelectric (ceramic) crystals for measurement of length and strain in tissues. For recording, a minimum of two crystal markers are attached to the target sites (for example, on arteries [10] or muscle fibers [11]). One of the crystals emits a short ultrasound pulse while the second crystal receives the pulse. From the known time between transmission and reception of the pulse, and the known speed of ultrasound transmission, the distance between the two markers can be measured continuously. Sonomicrometry can be used with at least 32 crystals, each acting simultaneously as a transmitter and a receiver for all the

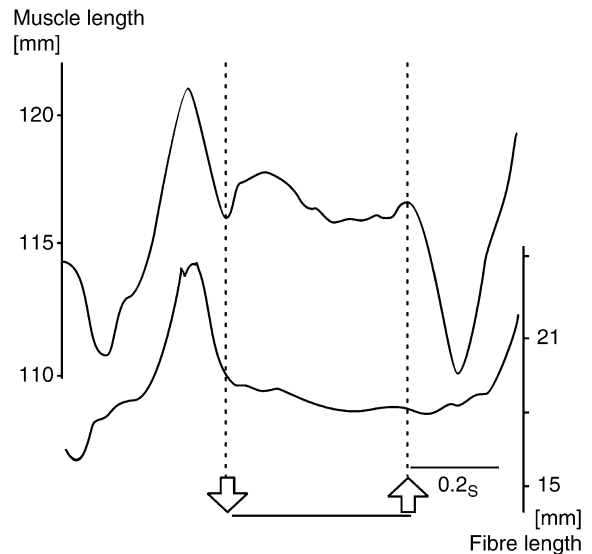

#### Measurement Techniques (Biomechanics).

**Figure 6** Muscle length (*top trace*) and fiber length trace (*bottom trace*) from the medial gastrocnemius during one-step cycle. The “down” arrow indicates first paw contact, the “up” arrow indicates paw aft at the end of the stance phase. Note how immediately after first paw contact, muscle length increases while fiber length decreases, thereby illustrating the dissociation of muscle and fiber length for specific contractile conditions. (Adapted from [9], with permission.)

other crystal markers. Depending on the number of recording crystals, sonomicrometry signals can be measured with a time resolution of better than 1 ms (>1 kHz) and a spatial resolution of 12  $\mu\text{m}$ .

Sonomicrometry has been used extensively to measure the behavior of single muscle fibers (cells) in cardiac and skeletal muscles. With this technique, it was first demonstrated that fiber length changes were not necessarily in concert with the corresponding length changes of the entire muscle (Fig. 6), a result that had great implications for the mechanics of whole muscle contraction, as well as the control of muscles through the [muscle spindles](#) [9]. Recently, measurements of the strains in vertebral arteries during high speed, low amplitude spinal manipulation of the neck have been instrumental in providing practice guidelines for these types of medical treatments [10].

Strain measurements are fundamental in biomechanics research. They are used to derive constitutive laws for biological tissues, to determine failure properties of materials, to determine stress distributions indirectly, to analyze interface compatibility between artificial and biological materials, and many other applications. Strain on hard tissues, where deformations are less than about 1% of specimen length, can be measured

readily and cheaply with today's technology. However, strain measurements on soft (hyperelastic) materials are much more difficult to measure, as strain transducers are typically hard to fix "rigidly" on soft specimens and might add to the force required to stretch the test specimen.

Strain gauges measure engineering strain ( $\epsilon$ ), which is defined as the change in length divided by the original length. There are a variety of possibilities of strain measurement and many of these have been used in biomechanical applications. These include electrical resistance strain gauges, extensometers, optical methods, Hall effect transducers, and many more. Strain gauges are used more often in biomechanics than any other strain-measuring device and they will be discussed briefly below.

Electrical resistance strain gauges rely on the general principle that the resistance of an electric conductor is a function of its dimensions and resistivity, or:

$$R = sL/A$$

Where  $R$  is the electrical resistance,  $s$  is the resistivity,  $L$  is the length and  $A$  the cross-sectional area of the conductor. When a conductor is stretched,  $L$  increases and  $A$  decreases, and the change in resistance ( $\Delta R$ ) can be captured with the appropriate circuitry and related to the corresponding change in length of the conductor ( $\Delta L$ ):

$$R/R_0 = G_f(L/L_0)$$

Where  $R_0$  is the electrical resistance of the unstrained material,  $G_f$  is the gauge factor, and  $L_0$  is the length of the unstrained material. Strain gauge signals are captured with a conditioning amplifier in a  $1/4$ ,  $1/2$ , or a full bridge configuration. In the  $1/4$ -bridge configuration, only one gauge will be active during testing (e.g.  $R_1$  in Fig. 7). Two of the remaining gauges ( $R_3$  and  $R_4$ ) would be precision resistors of equal value inside the amplifier, while  $R_2$  would be a dummy gauge.

In the unstrained condition,  $R_2$  is adjusted to have the same resistance as the active gauge,  $R_1$ , and the circuit is balanced with a zero output. If  $R_1$  experiences strain,  $R_1$  changes by  $\Delta R$  and the output,  $V_{out}$  is non-zero and depends directly on  $\Delta R$ . If  $R_1$  and  $R_2$  are active, we have a half-bridge configuration, which is particularly useful when one of the gauges is compressed while the other is stretched, as for example when they are attached to opposite sides of a deflecting beam. When all four gauges are active (Fig. 7), we have a full bridge configuration that maximizes the voltage output of the sensor.

There are two basic types of strain gauges: foil gauges and semiconductor gauges. Foil gauges consist of a thin layer of a metal conductor arranged in an array of connected parallel lines. These gauges are the most

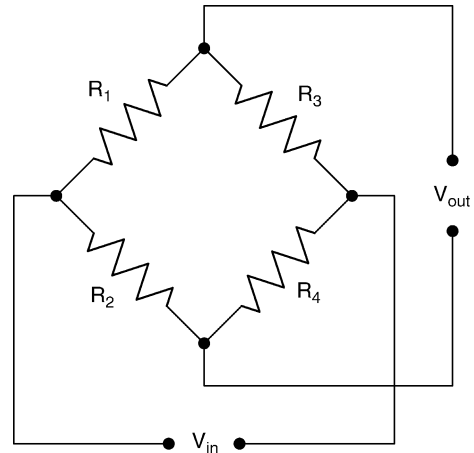

### Measurement Techniques (Biomechanics).

**Figure 7** Typical arrangement of four strain gauges with resistances  $R_1$ ,  $R_2$ ,  $R_3$ , and  $R_4$ , respectively, for strain measurements in biomechanics. Depending on the number of active cross-bridges, signals are captured with a conditioning amplifier in a  $1/4$ ,  $1/2$  or a full bridge configuration (see text for details).

commonly used sensors in biomechanical applications. Semiconductor strain gauges are wafers of semiconductor doped to the form of a strain gauge. They have a higher gauge factor than the foil gauges, and thus, have a higher voltage output for a given strain and excitation voltage than the foil gauges. Semiconductor strain gauges can measure strains with a resolution of  $\sim 1$  microstrain.

### References

1. Andrews JG (1974) Biomechanical analysis of human motion. *Kinesiol* 4:32–42
2. Abdel-Aziz YI, Karara HM (1971) Direct linear transformation from comparator coordinates into object space coordinates. *Proceedings of ASP/UI Symposium on close-range photogrammetry*. Am Soc Photogrammetry, Falls Church, VA, 1–18
3. Walmsley B, Hodgson JA, Burke RE (1978) Forces produced by medial gastrocnemius and soleus muscles during locomotion in freely moving cats. *J Neurophysiol* 41:1203–1215
4. Herzog W, Leonard TR (1991) Validation of optimization models that estimate the forces exerted by synergistic muscles. *J Biomech* 24S:31–39
5. Hasler EM, Herzog W, Leonard TR et al. (1998) In-vivo knee joint loading and kinematics before and after ACL transection in an animal model. *J Biomech* 31:253–262
6. Salmons S (1969) The 8th annual international conference on medical and biological engineering: meeting report. *Biomed Engr* 4:467–474
7. Xu WS, Butler DL, Stouffer DC, Grood ES, Glos DL (1992) Theoretical analysis of an implantable force transducer for tendon and ligament structures. *J Biomech Eng* 114:170–177

8. Finer JT, Simmons RM, Spudich JA (1994) Single myosin molecule mechanics: piconewton forces and nanometre steps. *Nature* 368:113–119
9. Hoffer JA, Caputi AA, Pose IE, Griffiths RI (1989) Roles of muscle activity and load on the relationship between muscle spindle length and whole muscle length in the freely walking cat. In: Allum JHH, Hulliger M (eds) *Progress in brain research*. Elsevier Science, B.V. Amsterdam, pp 75–85
10. Symons B, Leonard TR, Herzog W (2002) Internal forces sustained by the vertebral artery during spinal manipulative therapy. *J Manipulative Physiol Ther* 25:504–510
11. Griffiths RI (1987) Ultrasound transit times gives direct measurement of muscle fiber length in vivo. *J Neurosci Methods* 21:159–165

## Measurement Techniques (Electromyography)

VINZENZ VON TSCHARNER

Human Performance Laboratory, University of Calgary,  
AB, Canada

### Synonyms

Wavelet analysis; Time/frequency analysis; Windowed Fourier analysis

### Definitions

*Electromyogram (EMG)*: EMG is the electrical signal in volts recorded by electrodes from a contracting muscle.

*Wavelets*: Wavelets are short oscillations that have a zero (0) integral, are defined in a limited time window and have a band limited power spectrum. Usually one has a “mother” wavelet and scales and shifts (translates) this wavelet appropriately to obtain a set of wavelets that cover the frequency and time range of the signal of interest.

*Tiling*: Subdivision of the time-frequency plane into time-frequency boxes covered by the scaled and shifted wavelets.

*Wavelet transform*: The mathematical method for obtaining the wavelet transformed EMG is a convolution of the EMG with different wavelets.

*Scalograms*: The intensity that is extracted from the signal by the wavelet transform is displayed in a scalogram as a function of time (abscissa) and scale (ordinate). Scalograms do not show the phase aspects of the wavelet transform (Fig. 1).

The intensity may be displayed in different ways, for example, as a gray scale, where intensity is represented in different shades of gray, black representing the

highest intensity and white the lowest one. If colors are available, it is preferable to use color-coding to represent the intensities (e.g. rainbow colors). It has also become common practice to display constant intensities as contour lines similar to contour lines on geographical maps.

The time intervals on the abscissa are given by the tiling or by constant time increments in a time continuous wavelet transform.

The scale (ordinate) is used to represent the differently scaled wavelets. Frequently, the scale is represented by the actual scaling factor, but an index representing the different wavelets can also be used. If wavelets can be characterized by a center frequency, then the center frequencies can be displayed on the ordinate and thus the ordinate represents a measure of frequency in Hz. These scalograms are also called intensity patterns [1].

*Wavelet domain*: The wavelet domain contains the intensity of the EMG that is extracted by one wavelet and displayed over time (wavelet domains are represented as horizontal lines in an intensity pattern).

*Intensity spectrum*: The Wavelet transform decomposes the power of the EMG signal for each time point (small time window) into a limited set of frequency bands (Fig. 2). The intensity spectrum (wavelet spectrum) is the equivalent of a power spectrum for the Fourier transform. The intensities along a vertical line in an intensity pattern represent the wavelet spectra.

*Total intensity*: The sum of the intensities of the intensity spectrum is called the total intensity, and is assigned to the specific time point at which the intensity spectrum was measured. The total intensities represent a summation of the intensities across all

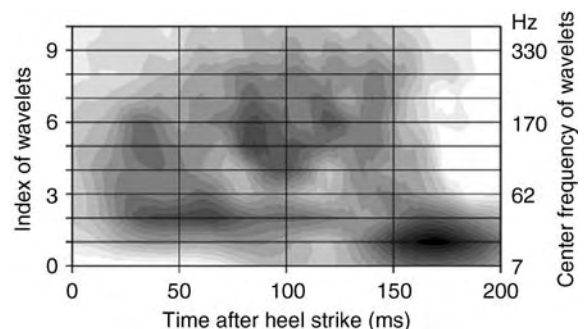

### Measurement Techniques (Electromyography).

**Figure 1** Scalogram (average over five trials) of EMGs of the gastrocnemius medialis for a person running at 4 m/s. The signal rises from lower frequencies at 50 ms to higher frequencies at 125 ms, and the high frequency components end at 150 ms. The drop in frequency seen after 150 ms leads to a muscular event that lasts about 50 ms and is typically seen when wearing shoes.

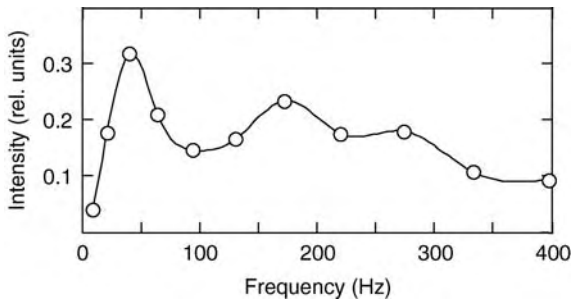

### Measurement Techniques (Electromyography).

**Figure 2** Wavelet spectrum extracted from Fig. 1. The dots represent the intensities extracted by the wavelets 70 ms after heel strike. The dots are located at their respective center frequencies. The solid line represents an interpolation between the dots.

wavelet domains and form a one-dimensional time series. The square root of total intensities of this time series contains the same information as the root mean squared EMG signal [1].

*Heisenberg's uncertainty principle:* This principle states that the time resolution  $\Delta t$  and the frequency resolution  $\Delta f$  cannot simultaneously be infinitesimally small. The product  $\Delta t \cdot \Delta f$  is constant and equals about 1. To exemplify this principle one can think of a sinusoidal signal of finite duration. If the duration is much shorter than the period of the sinusoidal wave one cannot accurately determine its frequency. On the other hand, if the signal duration is very long, and thus the time when the signal occurs is not known, then one can accurately measure its frequency.

*Frequency resolution:* Frequency is a property of a signal. If signals with distinctly different frequencies are superimposed, the difference can only be resolved if it is larger than the frequency resolution. The frequency resolution is a property of the wavelet and relates to the bandwidth of the wavelet. Scaling wavelets to make them shorter increases their frequency resolution.

*Time resolution:* Each wavelet has a frequency resolution,  $\Delta f$ , and, according to Heisenberg's uncertainty relationship, a corresponding time resolution,  $\Delta t$ . The time resolution is different for each wavelet domain and represents the shortest time separating two events that are located in the same wavelet domain. Time resolution relates to the finite width in time of the wavelet.

*Discrete versus continuous wavelet transforms:* Wavelet transforms require a discrete base set of wavelets to fully represent the information contained in an EMG signal. A discrete wavelet transform uses the smallest number of discretely scaled and discretely translated wavelets to transform the signal without losing information about the original signal. Thus, discrete wavelet transforms require the smallest computational

effort retaining the information for reconstructing the original signal. If we focus on the scaling and thus on the spectral aspect first we find that the spacing between the differently scaled wavelets can be so large that the resolution is too broad for projects that aim at a very fine frequency resolution. This handicap can be overcome by using a continuous wavelet transform in which the wavelets are scaled using very small, almost continuous changes of the scaling factors. The continuous wavelet transform is best used for getting a smooth wavelet spectrum, which allows for finding the maximum of the spectrum very accurately.

If two independent EMG signals are recorded, Heisenberg's uncertainty principle does not apply and one can resolve very small spectral differences; for example, differences in the position of the mean of the spectrum that are smaller than the frequency resolution. However, if one analyzes spectra that were recorded within a time interval in the order of the time resolution, then Heisenberg's uncertainty relationship becomes the limiting factor and one cannot have infinitely fine spectral resolution. In this case it does not make sense to use the continuous wavelet transform. Thus, when recording and analyzing movement related patterns of EMG intensities, the continuous wavelet transform is not appropriate.

The discrete wavelet transform is also discrete in time. The time intervals are given by the appropriate tiling. Thus, if one desires to see a smooth continuous development of the wavelet transformed signal in time, one will use almost continuously shifted (translated) wavelets to obtain a time continuous wavelet transform. A time continuous wavelet transform should be used if one is interested in observing the exact timing of muscular activities during a movement. If two EMG signals were separately recorded, for example, for two different external conditions, then the timing difference of muscular events can be measured with an accuracy that exceeds the time resolution imposed by Heisenberg's uncertainty relationship. However, if two muscular events occur in the same EMG recording then Heisenberg's uncertainty applies.

The decision of how "continuous" the wavelet transform should be depends on the desired frequency or time resolution. Unfortunately, one cannot have both simultaneously with great accuracy.

### Characteristics Purpose

The purpose of wavelet analysis of EMG signals is to decompose EMG signals into their frequency components in such a way that temporal aspects of the signal are conserved and resolved [1–3]. For practical cases of analyzing EMG signals, the purpose translates into decomposing the signal in such a way that conclusions about muscle physiological aspects can be drawn. Four

specific purposes relating to physiological aspects are mentioned below.

1. Muscles contain different fiber types that have type specific motor unit action potentials and conduction velocities. Short motor unit action potentials and fast conduction velocities generate high frequency contributions, and broad action potentials and slow conduction velocities generate low frequency contributions to an EMG. Decomposition of an EMG signal into the frequency bands covered by the wavelets provides information about the interplay of muscle fibers generating high or low frequency components in the EMG [4].
2. Muscles are typically only activated during parts of cyclic movements. Decomposition using wavelet analysis can resolve time-dependent muscle activities. Therefore, the time resolution can be selected such that it corresponds to physiological response times for activation and relaxation.
3. Assessment and evaluation of fatigue is a major field of muscle research. Evaluations are typically limited to steady-state recordings of EMG lasting at least 250 ms. Decomposition using wavelet analysis allows detection of the continuous decrease in frequency content that occurs with fatigue. Wavelet analysis is particularly useful when analyzing muscle fatigue for dynamic conditions such as isokinetic contractions [5].
4. Decomposition of EMG through wavelet analysis yields EMG intensity patterns representing the activity of one or multiple muscles at the same time. These patterns can be used as input to pattern recognition methods, which can reveal small differences in muscle activities governing a given movement. For example, male and female runners generate different EMG intensity patterns [6].

### Principles

An EMG signal is a recording of the potential generated by ionic fluxes in muscle fibers at the position of the electrode with reference to some other potential (reference potential). These potentials depend on tissue properties between the electrodes and the muscle fibers, and the recorded voltages depend on electrode configuration. The frequency of the EMG depends on the inter electrode distance and on the shape of the electrodes. Proper electrode placement is the key to obtaining high quality signals. The recorded EMG is a signal of the fiber action potentials as measured by “remote” electrodes. However, independent of the distortion of EMG signals as a result of electrode placement, any EMG contains information about the underlying physiological processes and structures.

The theory of wavelet analysis has greatly evolved in the last decade and has been well described by Mallat [7]. Various biomedical applications have emerged using this technology [8]. For time/frequency analyses of EMG signals, an appropriate set of base functions, or wavelets are required. Commercial software packages (MathCad™ or MatLab™) provide wavelets algorithms. There are commercial software packages that use a specific set of wavelets (Biomechanigg Research Inc.) designed for the analysis of EMGs. There are many different types of wavelets, and the selection of the wavelets depends on the purpose of the analysis. If one is mainly interested in frequency aspects, it is an advantage to select wavelets of a damped sinusoidal shape (Morley or Cauchy wavelets). For data compression, one might prefer Daubechies wavelets. The result of the transform depends on the wavelet selection, and there is no consensus as to which wavelets would be the most appropriate for a given situation. Selection is often guided by what is available in software packages, rather than by functionality. Once the wavelets have been selected, the wavelet transform is a straightforward mathematical operation of convolving the measured signal with the wavelets (Convolution, see Karniel in this Encyclopedic Reference). The magnitude of the wavelet-transformed signal (square root of the sum of the squared real and imaginary part) is called the intensity. Phase aspects are not used for the analysis of EMG signals.

### Advantages and Disadvantages

The main advantage of the wavelet transformed EMG signal is that physiological processes that change the frequency content of the EMG signal become visible simultaneously in the time and frequency domain. Thus, the classical separation of time- and frequency-domain can be overcome. Wavelet analysis is also an improvement over windowed Fourier transform because the time/frequency compromise is optimized.

Since researchers have used many different types of wavelets, it is difficult to compare results across studies. Nevertheless, wavelet analysis combined with pattern recognition algorithms will probably become the method of choice of EMG signals.

### References

1. von Tscharner V (2000) Intensity analysis in time-frequency space of surface myoelectric signals by wavelets of specified resolution. *J Electromyogr Kinesiol* 10:433–445
2. Constable R, Thornhill RJ (1993) Using the discrete wavelet transform for time-frequency analysis of the surface EMG signal. *Biomed Sci Instrum* 29:121–127
3. Karlsson S (1999) Enhancement of spectral analysis of myoelectric signals during static contractions using wavelet methods. *IEEE Trans Biomed Eng* 46(6):670–684

4. Wakeling JM, Kaya M, Temple GK, Johnston IA, Herzog W (2002) Determining patterns of motor recruitment during locomotion. *J Exp Biol* 205(3):359–369
5. Karlsson JS, Oestlund N, Larsson B, Gredle B (2003) An estimation of the influence of force decrease on the mean power spectral frequency shift of the EMG during repetitive maximum dynamic knee extensions. *J Electromyogr Kinesiol* 13:461–468
6. von Tscharnar V, Goepfert B (2003) Gender dependent EMGs of runners resolved by time/frequency and principal pattern analysis. *J Electromyogr Kinesiol* 13:253–272
7. Mallat SA (1999) Wavelet tour of signal processing, 2nd edn. Academic Press, San Diego
8. Aldroubi A, Unser M (1996) Wavelets in medicine and biology. CRC Press, Boca Raton, New York, London, Tokyo

## Measurement Techniques (Pressure)

ANDREA L. CLARK

Faculty of Kinesiology and Medicine, KNB 304,  
University of Calgary, Calgary, AB, Canada

### Synonyms

Stress

### Definitions

► *Stress/Pressure*: The force per unit area exerted on a material.

► *Diarthrodial Joint*: A joint encased in a ligamentous capsule including an articular cavity.

► *Spatial/Temporal Resolution*: A property of a measurement system that defines its ability to resolve measurements taken at two adjacent points in space or time. The closer the adjacent space or time points, the better the resolution is said to be.

### Characteristics

#### Introduction

Pressure measurement techniques are currently utilized in several major biomechanical fields. For example, pressure sensitive mats and plates are used to measure the pressure distribution between different parts of the body (e.g. the foot or finger) and external surfaces (e.g. the floor, a shoe or a keyboard) [1]. Direct measurement of the contact pressure at articular interfaces within diarthrodial joints of the body (such as the femoral head and acetabulum in the hip joint) continues to remain a challenge in orthopedic biomechanics. Research in this particular field has enabled us to better understand the structure-function relationships of ► *articular cartilage* and other joint tissues in providing joint motion and the

pathomechanical processes involved in joint diseases such as ► *osteoarthritis*. The main focus of this essay will be to give an overview of this latter area of application.

### Measurement Methods

#### Pressure Sensitive Films

Fuji prescale pressure-sensitive film (Fuji Photo Film Co. Ltd, Tokyo, Japan) is the most extensively used technique to measure contact pressures in diarthrodial joints. The film comes in grades, with each grade covering a different pressure range between 0.2 and 130 MPa (Table 1).

Except for the high-grade film, Fuji film consists of an A- and C-sheet [2]. The A-sheet contains randomly arranged fluid filled bubbles 2–25 µm in diameter. When pressure is applied, the bubbles burst, releasing their fluid content. The second C-sheet contains an active layer that reacts to the fluid to produce a red stain (Fig. 1) [2].

Since different sized bubbles break at different pressures, the amount of fluid released and thus the color density of the stain is dependent upon the pressure acting across that area (Fig. 1). The A- and C-sheets of the film are generally sandwiched between polyethylene layers to protect them from humidity. The film including the sealing materials is ~250 µm thick [2]. Thicker packets of film have been made by stacking films of different grades on top of one another [3]. This technique increases the sensitive range of the Fuji film packet. A much thinner Fuji film, 25–50 µm thick, has recently been introduced, though it has not yet been thoroughly assessed for biomechanical applications [4].

A second pressure sensitive film was developed and applied in the biomechanics field around the same time as Fuji film was first introduced. This sensor consisted of four layers with a total thickness of 285 µm [5]. A layer of fast-drying enamel paint sprayed onto an acetate film acted as a plastic material in this sensor. A nylon screen woven out of monofilament threads with 12 threads per millimetre lay on top of the paint layer with a mylar film on top of that to protect the

**Measurement Techniques (Pressure).** Table 1 Grades of Fuji film and their pressure ranges [2]

Film grade	Pressure range (MPa)
Ultra-super-low	0.2–0.5
Super-low	0.5–2.5
Low	2.5–10
Medium	10–50
High	50–130



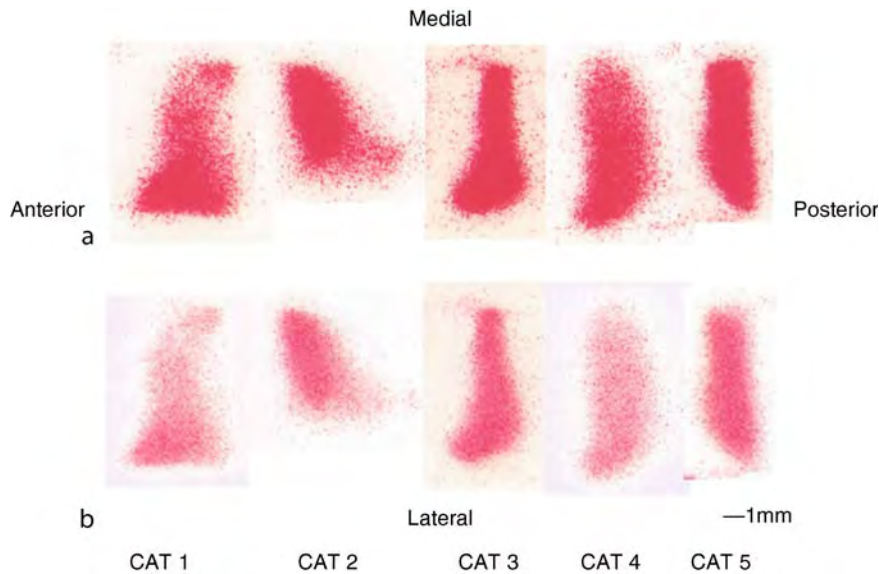

**Measurement Techniques (Pressure).** **Figure 1** Typical Fuji film stains from the patellofemoral joints of five cats under 300N of applied force on: (a) low- and (b) medium-grade film. Increasing pressures are associated with increasing stain darkness. Reprinted from the *Journal of Biomechanics*, 35:1, Clark AL, Herzog W and Leonard TR, contact area and pressure distribution in the feline patellofemoral joint under physiologically meaningful loading conditions, Pages 53–60, Copyright (2002), with permission from Elsevier.

sensor from moisture [5]. Pressure applied to the film pressed the threads of the nylon screen into the plastic paint material leaving a series of permanent micro-indentations. The depth of these micro-indentations were then evaluated and related to the magnitude of the applied pressure with ►calibration [5].

Most recently Iscan, an electric film for measuring pressure in joints, has been developed. The Iscan sensor (Tekscan Inc, South Boston, MA, USA) is 200  $\mu\text{m}$  thick, has a sensing area of 56  $\text{mm}^2$ , and can take measurements at up to 125 Hz [4]. Each sensor consists of two polyester sheets bonded together with a layer of semi-conductive ink between them. The polyester sheets have electrical conductors evenly distributed across them producing a sensing element at each point where the conductors on both sheets cross each other. As pressure is applied to the sensor, the semi-conductive ink is compressed, altering the resistance between the two polyester sheets [4]. This change in resistance is then related to the applied pressure by a calibration routine.

#### **Discrete Pressure Transducers**

In addition to pressure sensitive films, a second major approach to measuring contact pressure in diarthrodial joints has been to place a number of small discrete ►transducers over the articulating surfaces. In the majority of cases, piezoelectric materials have been used to make transducers that are recessed into the

superficial layer of the articular cartilage. In one series of studies, 24-flat-bottomed cylindrical wells,  $\sim 3.5$  mm in diameter, were drilled into the articular surfaces of cadaver femoral condyles and femoral heads [6]. Miniature piezoresistive transducers 400  $\mu\text{m}$  thick were then secured into the wells using cyanoacrylate adhesive. The depth of each well was adjusted so that the face of the transducer was palpably flush with the articulating surface. Two lead wires from each transducer passed across the cartilage surface to a signal-processing unit [6]. The transducers were made of a tightly packed granular piezoresistive material, contained and loaded in parallel through a silastic annular spacer. Transducer resistance changes due to the applied surface pressure were detected by output changes to a simple electronic circuit [6].

In a more recent study, a piezoelectric film replaced the piezoresistive material as the sensing element of these transducers [7]. Piezo film develops an electrical charge proportional to the mechanical stress or strain applied to it. The piezo film was sandwiched between two stainless steel electrodes and sealed in a water resistant capsule. Six of these transducers, 3 mm in diameter and  $\sim 300$   $\mu\text{m}$  thick, were embedded into the articular surface of cadaver patellae [7]. Wells were drilled into the cartilage as described above; however, an extra 1mm diameter hole was drilled in each well through the subchondral bone to allow the wires to pass through to the other side of the patella [7].

In contrast to these piezoelectric transducers, pressure pipes (1.5 mm in diameter) inserted into holes drilled through the articular cartilage and subchondral bone have also been used as discrete pressure transducers [8]. Physiological saline was utilized as a pressure medium within the pipes and the pipe pressure was measured using a transistor pressure transducer and pressure gauges. This set up was used to measure instantaneous contact pressures between cadaver femoral condyle and tibial articular surfaces [8].

### **Instrumented Prosthesis**

Among the earliest attempts to measure contact pressures in diarthrodial joints was an instrumented femoral hip ►prosthesis [9]. A number of small pressure transducers were introduced in the hollow sphere at the end of the prosthesis to be positioned in the hip joint in contact with the cartilage in the socket. A hole (4 mm diameter) was machined into the inside of the hollow hemisphere leaving a thin diaphragm 445 µm thick. This diaphragm was deflected slightly (0.28 µm/MPa) by the contact pressure with the acetabular cartilage [9]. The displacement of the centre of the diaphragm was detected and measured by a strain-gauged, silicon crystal cantilever beam transducer. Fourteen pressure transducers were evenly distributed across the sphere of the prosthesis. Each transducer was switched on serially and the output sent to a remote data collection station using a radio transmitter and receiver [9]. The transducers were sampled at 253 Hz and the electronics were powered using an induction arrangement involving a pair of magnetically coupled concentric coils. The primary coil circled the upper thigh and was coupled with a smaller secondary coil located on the tip of the stem of the prosthesis inside the femur. The prosthesis was therefore completely self-contained and used no batteries [9].

### **Advantages and Disadvantages**

#### **Disruption of Joint Contact Mechanics**

Introducing a pressure sensitive film between two contacting surfaces alters the very pressure distribution that is being measured. This error is primarily caused by the stiffness and thickness of the film. The softer and thinner the film is, the smaller the errors will be. The magnitude of this problem has been evaluated for Fuji film using a theoretical approach [10]. The pressure distribution in the feline patellofemoral joint was calculated for given loading conditions with and without the pressure sensitive film. The film, including sealing materials, was defined as 250 µm thick with a stiffness of about 200 times the stiffness of the articular cartilage. The results of this case indicated that introducing the Fuji film into the joint caused an underestimation of the true pressure distribution by about 10% [10]. Along similar lines, pressures recorded by an instrumented

prosthesis are likely to be quite different from those in a natural joint due to the metal on cartilage as opposed to the cartilage on cartilage interface [9].

With discrete pressure transducers, the cylindrical defects made in the articular cartilage and the different elastic moduli of the transducer relative to the surrounding cartilage may alter the local load transmission processes and therefore the pressures being measured [7]. Slight differences in the amount of cement used at the base of each transducer and differences in the congruity match at the cartilage surface may also influence local pressures [7]. While drilling holes through the bone to allow leads to pass out of the joint will keep the leads from disrupting joint contact, it may also cause greater disruption to the fluid flow within the cartilage and between the cartilage and bone in the vicinity of the defect.

When an instrumented prosthesis is implanted, roughly half of the cartilage in the joint is lost [9]. This will almost certainly affect the distribution and quantity of ►synovial fluid between the joint surfaces [9]. The significance of any variation in pressure distribution caused by this redistribution of synovial fluid is currently unknown.

#### **Spatial Resolution of Pressure Measurements**

One of the major advantages of pressure sensitive films is that they can record the pressure distribution over the entire contact area within a given joint. In contrast, discrete transducers only record local pressure values from certain points in the joint from which the corresponding whole contact stress patterns must then be reconstructed [6]. In particular, the reported peak local stress values reflect the highest single transducer reading, which may not coincide with the most highly stressed point on the contact surface. Increasing the number of transducers in a joint would improve the spatial resolution of this method, although would also lead to more severe disruption of joint mechanics as discussed above.

#### **Temporal Resolution of Pressure Measurements**

The viscoelastic deformational characteristics of articular cartilage suggest that static measurements may not be ideal for estimating the transient pressure distribution that occurs in diarthrodial joints in vivo. One of the major advantages of the pressure measurement techniques that utilize electronics, the pressure pipes or the instrumented prosthesis is that they have the potential to record virtually continuous pressures during joint loading. For example, an Iscan sensor can record measurements at 125 Hz [4] and an instrumented prosthesis at 253 Hz [9]. Pressure films similar to the Iscan, however, have demonstrated drift; a significant time-dependent response to load which may lead to large errors during measurements of dynamic activities

[4]. Fuji film and the film introduced by Ahmed do not allow such time resolution of pressure measurements [5,10,2]. Both of these films record maximal pressures. Therefore, either of these films inside a joint will record the local peak pressures occurring during a loading period rather than any actual pressure distribution or the time history of the pressure distribution.

#### **Other Potential Sources of Artifact**

The complex and often multidimensional curvature in many diarthrodial joints is a potential cause of artifacts in pressure measurements. Studies using Fuji film have described artifacts as the film has crinkled while negotiating the curvatures in a joint [10,2]. While not wrinkling, the accuracy of the Iscan sensor may be affected by joint curvature, though it is not clear by how much [4]. Clearly, discrete pressure transducers are not affected as significantly by the curvature of a joint.

The majority of the pressure transducers outlined above are sensitive to things other than pressure. These include temperature, humidity, electromagnetic interference and crosstalk. It is important, therefore, that these variables are either eliminated (e.g. by sealing transducers in water resistant coating), minimized (e.g. by limiting the number of connecting wires routed through a joint) and/or held constant throughout loading and calibration routines.

#### **Adaptability of Technique for In-Vivo Measurements**

Ultimately, in trying to understand the in vivo structure-function relationships of joints it is most desirable to conduct experiments that resemble the in vivo situation as closely as possible. Use of the instrumented prosthesis, for example, has enabled pressure measurements to be made in humans during a wide range of daily activities such as riding a bike and using a bedpan. The Iscan sensor has also been inserted into the medial compartment of knees during routine arthroscopic examination. It was used to measure the effects of braces on patient knee loading during normal stance.

#### **References**

1. Nigg BM (1999) Pressure distribution. In: Nigg BM, Herzog W (eds) *Biomechanics of the musculo-skeletal system*, John Wiley & Sons Ltd., Chichester, UK, pp 281–287
2. Liggins AB (1997) The practical application of Fuji prescale pressure-sensitive film. In: Orr JF and Shelton JC (eds) *Optical measurement methods in biomechanics*. Chapman & Hall, London, pp 173–189
3. Atkinson PJ, Newberry WN, Atkinson TS, Haut RC (1998) A method to increase the sensitive range of pressure sensitive film. *J Biomech* 31:855–859

4. Wilson DR, Apreleva MV, Eichler MJ, Harrold FR (2003) Accuracy and repeatability of a pressure measurement system in the patellofemoral joint. *J Biomech* 36:1909–1915
5. Ahmed AM (1983) A pressure distribution transducer for in-vitro static measurements in synovial joints. *J Biomech Eng* 105:309–314
6. Brown TD, Shaw DT (1984) In vitro contact stress distribution on the femoral condyles. *J Orthop Res* 2:190–199
7. Manouel M, Pearlman HS, Belakhlef A, Brown TD (1992) A miniature piezoelectric polymer transducer for in vitro measurement of the dynamic contact stress distribution. *J Biomech* 25(6):627–635
8. Inaba H, Arai M (1989) A method for measuring contact pressures instantaneously in articular joints. *J Biomech* 22(11):1293–1296
9. Carlson CE (1971) A proposed method for measuring pressures in the human hip joint. *Exp Mech* 11:499–506
10. Wu JZ, Herzog W, Epstein M (1998) Effects of inserting a pressensor film into articular joints on the actual contact mechanics. *J Biomech Eng* 120:655–659

---

## **Mechanical Impedance**

### **Definition**

A dynamic operator that specifies the forces that a mechanical system generates in response to imposed motions. It is normally represented as the transfer function relating the velocity of the system (input) to the force (output). Inertia, damping and stiffness can be identified from the phase relation between output force and imposed velocity. Admittance is the inverse of impedance: an operator specifying a motion in response to imposed forces. Muscle-environment interaction is fundamentally two-way; since the muscle is coupled to the skeleton, which tends to impose motions, muscle is usually best regarded as providing impedance. In the context of vertebrate motion, mechanical impedance determines how the forces applied to a body segment will be transformed into motion.

#### **► Impedance Control**

---

## **Mechanical Obstruction (or Ileus)**

#### **► Bowel Disorders**

## Mechanically Skinned Fiber

### Definition

An isolated single muscle fiber preparation that involves physically peeling or rolling back the sarcolemma (plasma membrane) leaving the other structures relatively unaltered. Upon skinning, the transverse-tubular system seals off which makes it possible to study the normal excitation-contraction coupling process in these fibers (i.e. depolarization-induced  $\text{Ca}^{2+}$  release).

► [Excitation-Contraction Coupling](#)

## Mechanics

MARCELO EPSTEIN

Schulich School of Engineering, University of Calgary, Calgary, AB, Canada

### Definition

The science that studies the motion of material bodies and its relation with the forces acting on them.

### Description of the Theory

As the science of motion and ► [deformation](#) of ► [material bodies](#), ► [mechanics](#) plays an essential part in the study of those aspects of biological systems that underlie the functioning of living tissues and organs regardless of the fact that they are alive. In biomechanics therefore, mechanics and physiology are complementary disciplines. The barriers between these two main components of biomechanics are not however sharply defined. A chemical reaction involving long, geometrically complex molecules may require a mechanical description of the relative motion of the molecules, while a proper understanding of the macroscopic deformation of an organ may need the incorporation of chemical reactions in the continuum model. In broad terms, mechanics can be divided into two main branches, classical mechanics of particles and rigid bodies and continuum mechanics of deformable media. Both are of relevance to biomechanics. For instance, the description of many physical activities and sports, such as diving or running, can be undertaken fairly faithfully by ignoring the deformability of the tissues involved and considering the human or animal body as an assembly of rigid members joined together by means of ideal hinges and articulations. Models developed under such assumptions fall

within the realm of classical rigid body mechanics. The description of the functioning of the heart, on the other hand, is a typical example in which the methods of continuum mechanics are called for. Intermediate between these two realms lies the domain of the so-called rheological models, which represent an attempt at describing deformable systems as if they were made of a discrete array of a small number of idealized deformable elements (such as ► [springs](#) and ► [dampers](#)).

### References

1. Goldstein H (1950) *Classical mechanics*. Addison-Wesley, Cambridge
2. Truesdell C, Toupin R (1960) *The classical field theories*. In: Flügge S (ed) *Handbuch der Physik*, vol III/1. Springer, Berlin
3. Fung YC (1981) *Biomechanics*. Springer, New York
4. Nigg B, Herzog W (eds) (1994) *Biomechanics of the musculo-skeletal system*. Wiley, New York
5. Epstein M, Herzog W (1998) *Theoretical models of skeletal muscle*. Wiley, Chichester

## Mechanoelectric Transduction

► [Mechanosensory Transduction](#)

## Mechanoreceptor Mechanism

► [Mechanosensory Transduction](#)

## Mechanoreceptors

### Definition

A class of sensory receptors whose adequate stimulus is a physical change in the position of a body part or surface, including the various mechanoreceptors in the skin, the auditory and vestibular hair cells of the inner ear, and the stretch receptors in skeletal muscle. The mechanical deformation causes an electrical change within the receptor cell (i.e., the generator or receptor potential), and eventually an action potential in the nerve fiber(s) connected to the receptor organ.

► [Sensory Systems](#)

## Mechanosensation

### Definition

The sensation of a mechanical event (e.g., contact, deformation, stretch or displacement) involving a somatic tissue, such as the skin, oral mucosa, muscle or joint.

## Mechanosense

► Evolution of the Mechanosensory and Electrosensory Lateral Line Systems

## Mechanosensory Transduction

HISASHI OGAWA

Department of Neurology, Kumamoto Kinoh Hospital, Kumamoto, Japan

Department of Sensory and Cognitive Physiology, Faculty of Medical and Pharmaceutical Sciences, Kumamoto University, Honjo, Kumamoto, Japan

### Synonyms

Mechanoelectric transduction; Mechanoreceptor mechanism; Mechanosensitive ion channels; Mechanically-gated ion channels

### Definition

Low mechanical energy is received at cutaneous mechanoreceptors and converted into electrical energy in the form of receptor potential. Mechanoreceptors work as sensory transducers to transform mechanical energy to electrical energy. Receptor potential is then converted into a series of impulses at a spike generating site, the first Ranvier node of sensory nerve fibers innervating. Different structures of mechanoreceptors may be suitable to receive different forms of mechanical energy. Comments are also made on the mechanical filter of lamella of corpuscles, the possible functional role of Merkel cells in the Merkel cell-►neurite complex, which yield receptor potentials in response to mechanical stimulator mechanosensitive ion channels.

### Characteristics

#### Quantitative Description

Receptor potentials in response to mechanical stimulation were first discovered at Pacinian corpuscles

isolated from the mesentery in cats [1]. Receptor potentials to mechanical stimulation were also recorded from the muscle spindle of frog [2] and from stretch receptors of muscles in crayfish. Receptor potentials are generated locally at the non-myelinated nerve terminals (or at the dendrites of muscle stretch receptor cells), and ►graded depending on the strength of mechanical stimulus. Receptor potentials from the Pacinian corpuscle are rapidly adapting or ►phasic in time course, generated at the onset and offset of mechanical pulses applied (Fig. 1c), whereas those from muscle spindles and stretch receptors are tonic, lasting during the application of muscle stretch.

Thus, it is believed that receptor potentials are phasic in rapidly adapting mechanoreceptors, such as lamellated corpuscles or Meissner corpuscles, but they are tonic in slowly adapting mechanoreceptors, such as Merkel cell-neurite complexes or Ruffini endings, although receptor potentials have not been recorded from most of the cutaneous mechanoreceptors. The size of receptor potentials are dependent on the sodium concentration in the solution bathing the isolated Pacinian corpuscles. Therefore, mechanical forces increase ►membrane conductance, probably by gating the ionic channels permeable sodium ions [3] which have not yet been identified. ►Tetrodotoxin and local anesthetics affect receptor potentials, however, the effects of amiloride which affect Deg/ENaC, mechanosensitive ion channels in *C. elegans* (see below), have not been investigated.

Receptor potentials increase in a graded manner in response to the increased strength of mechanical pulses. The magnitude of the receptor potential is proportional to the strength of mechanical stimulation [1] (Fig. 2).

Receptor potentials spread electrotonically [►Electrotonus, electrotonic (ally)] to the spike generation site, the first Ranvier node, and are recorded as generator potentials. Generator potentials are now converted into spikes when they exceed the threshold for the firing spike. As far as generator potentials exceed the firing threshold, spikes are generated successively, although adaptation at the spike generation sites is different with different mechanoreceptors. The number of spikes generated in a unit time is proportional to the receptor potential height as well as to the mechanical stimulus applied.

Further study of the mechanosensory transduction mechanism may exceed the limit of electrophysiological technique, and may proceed with collaboration of both electrophysiology and molecular biology (see mechanosensitive ion channel).

#### Lamellate Structure Works as a Mechanical Filter

Lamellated corpuscles work as a mechanical filter and transmit a transient change of mechanical forces applied to the unmyelinated nerve terminal in the central core [3]. Application of short mechanical pulses to the

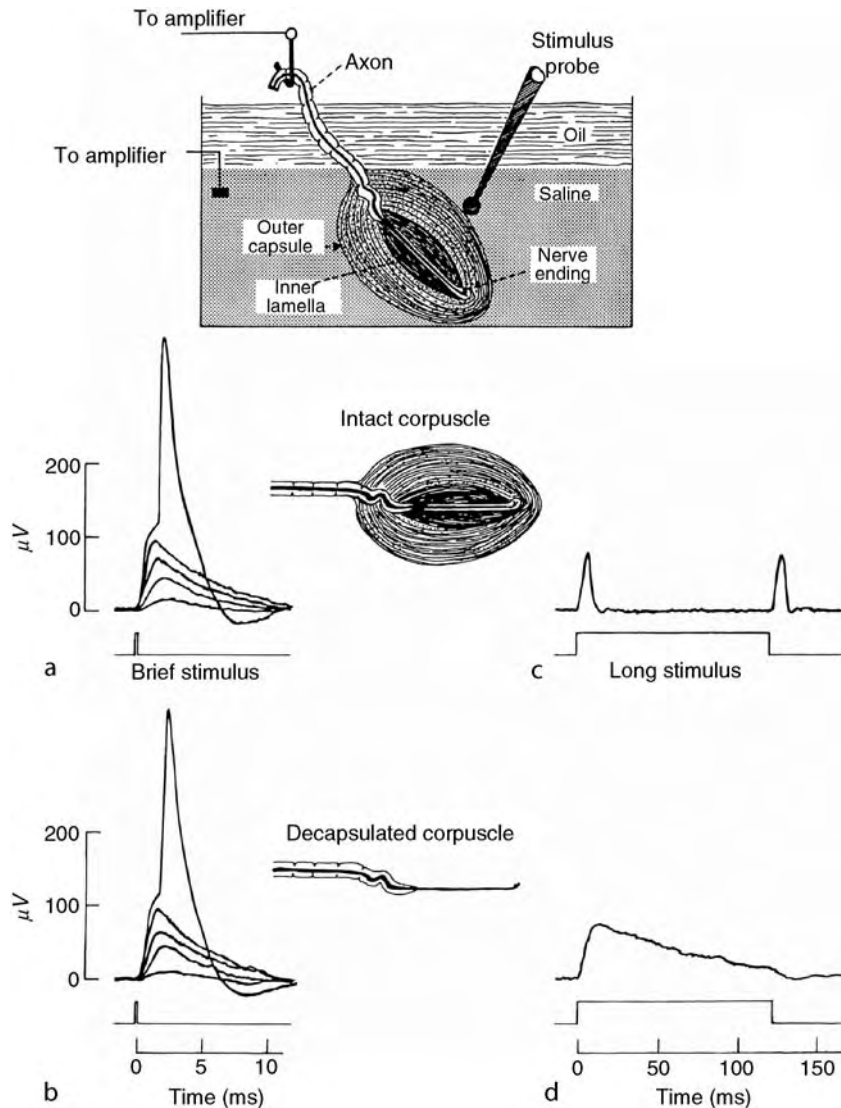

**Mechanosensory Transduction. Figure 1** Responses of intact and decapsulated Pacinian corpuscles (PC) to brief and prolonged mechanical stimulation. The upper part of the figure illustrates the gross morphology of an intact PC and the method to stimulate and record from it. A, B; Responses to evoked by graded brief mechanical stimuli at both intact and decapsulated Pacinian corpuscles (A, B). The strongest stimulus evoked a response that exceeded threshold for generation an action potential. C. An intact PC produced a phasic receptor potential at the onset and offset of a prolonged stimulus. D. A decapsulated PC produced a sustained receptor potential. (Reproduced and modified from PB Detwiler 'Sensory transduction', In: HD Patton et al. (eds) *Textbook of Physiology*, 21<sup>st</sup> Edition, vol. 1, Excitable Cells and Neurophysiology, WB Saunders Company, Philadelphia 1986, pp 98–129, Fig. 5–9).

outer lamella in the Pacinian corpuscle generates both transient and static phases of mechanical displacement at the outer part of the lamella. But the static phase of the displacement is rapidly decreased as the displacement is transmitted further down to the inner core, and finally only the transient phase of displacement is transmitted to the non-myelinated nerve terminal. Such a mechanical filter action has theoretically also been analyzed. Resection of the outer lamella from the

Pacinian corpuscle changes the adaptation of receptor potentials from phasic to tonic form; now, receptor potentials last during the period of mechanical stimulation (Fig. 1b). Thus, the lamella works as a mechanical filter to pass only the high frequency component of mechanical forces to the nerve terminals.

Generation of the RP at offset as well as at onset of mechanical compression is explained by the oval form of nerve terminals [3]. The unmyelinated nerve terminal

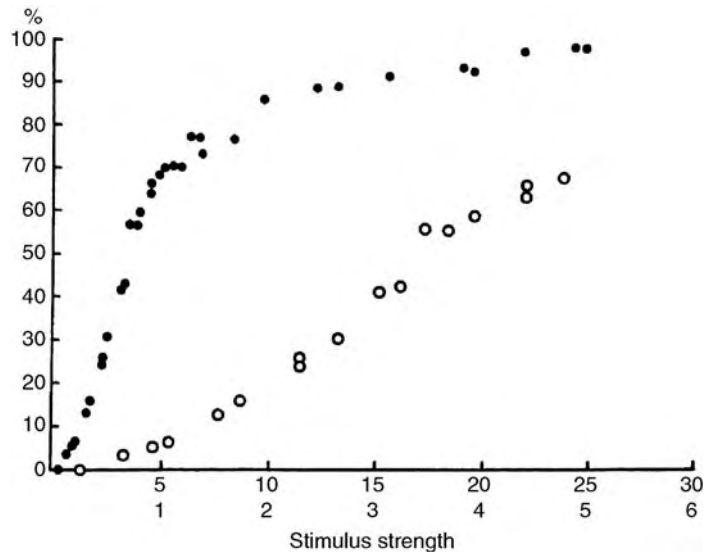

**Mechanosensory Transduction. Figure 2** Relationship between the stimulus strength applied to crystal or an electromechanical transducer (in voltage) and receptor potential relative to the maximum amplitude (%) in a PaC. Filled circles, relationship in the range of 0~30 volts; open circles, in the range of 0~6 volts. (Reproduced and modified from JAB Gray and M Sato (1952) 'Properties of the Receptor Potential in Pacinian Corpuscles', *J. Physiol.* 122:610–636, Fig. 8).

is oval in shape, and the longer transverse axis is aligned with the cleft of the inner lamella. The application of mechanical displacement to the shorter axis depolarizes the nerve terminal but the stimulation of the longer axis hyperpolarizes it. Application of mechanical forces displaces the lamella at the onset to increase the pressure inside the lamella, depolarizing the nerve terminal at the shorter axis. When mechanical distortion is over, the lamella return to the original sphere and the pressure inside the lamella is decreased as a whole, which depolarizes the nerve terminal at the longer axis.

This mechanical filter hypothesis is applicable to all lamellated corpuscles, since all sensory units innervating lamellated corpuscles are rapidly adapting to generate both on and off discharges in response to mechanical pulses.

#### **Functional Role of Merkel Cells at Merkel Cell-Neurite Complexes**

Since F Merkel (1875) discovered Tastzellen (Merkel cells) in various vertebrates, it has been known that they are located at the position of the skin to readily receive mechanical deformation or force to the skin from the outside; under the touch dome in hairy skin or under the papillary ridges in glabrous skin. However, there is long-lasting controversy over the issue of whether Merkel cells are receptor cells, merely accessory cells to transmit mechanical forces to the associated nerve terminals or to induce their innervation of the skin

during development [4]. Among affirmative evidence for the mechanotransduction hypothesis, included are phototoxic or chemical destruction of Merkel cells to abolish the tonic phase of discharges, chemical or gaseous manipulation of the circulating blood supply or bathing solutions for Merkel cells in situ or in vitro to modify the discharge patterns, and tonic discharges to anodal DC stimulation [4–6]. Among the negative evidence against the hypothesis, however, the failure by phototoxic destruction of Merkel cells to abolish discharges in response to short mechanical stimulations, the capability of Merkel cell-►neurite complex afferents to follow high frequent sinusoidal stimulation, possibly denying the function of synapse between Merkel cells and nerve terminals, and the survival of slowly adapting afferent discharges of irregular form (a specific feature of mechanoreceptor afferents innervating Merkel cell-neurite complexes) in spite of almost all loss of Merkel cells in mice lacking some neurotrophin [4,7]. To compromise the two parties, two-mechanotransduction site hypotheses have been submitted [4] (Fig. 3); Merkel cells are receptor sites for both phasic and tonic transduction and nerve terminals those for phasic transduction.

#### **Mechanosensitive Ion Channels**

Application of mechanical forces to mechanoreceptors open mechanosensitive ion channels which is reflected as an increase in membrane conductance, to generate receptor potentials. By using techniques

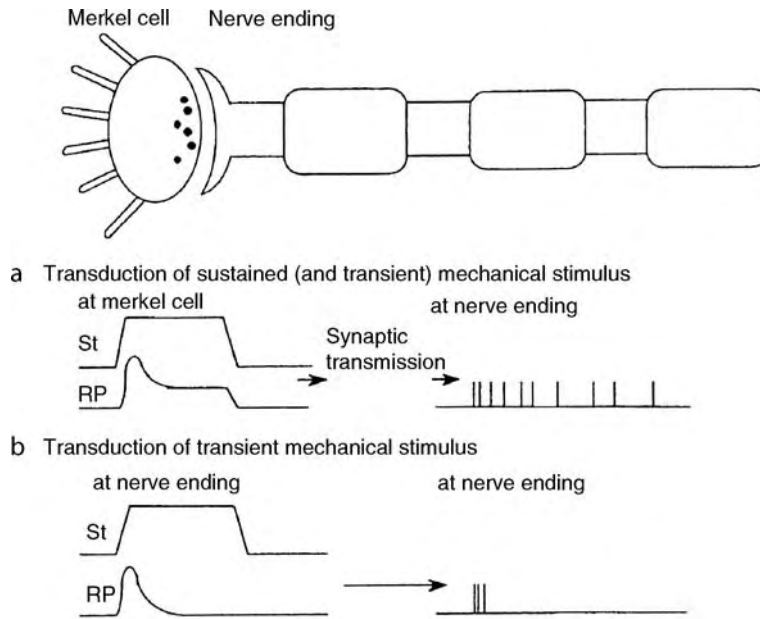

**Mechanosensory Transduction. Figure 3** Schematic illustration of two site-hypothesis in mechanosensory transduction in Merkel cell-neurite complex. Each of the two receptor sites, Merkel cells and nerve ending, transforms different forms of mechanical forces (static + phasic and phasic only). *GP*, generator potential at the spike generation site; *MC*, Merkel cell; *NE*, nerve ending; *RP*, receptor potential; *ST*, stimulation. (Reproduced from H Ogawa (1996) "The Merkel Cell as a Possible Mechanoreceptor Cell", *Progress in Neurobiology*, 49:317–334. Elsevier Science Ltd, Fig. 15).

of both electrophysiology and molecular biology, mechanosensitive ion channels have been extensively studied in nematode (*Caenorhabditis elegans*) and arthropod (*Drosophila*), and some correspondence in mammals has also been studied. However, ion channels gated by low mechanical stimulation have not yet been identified in mammals.

In both *C. elegans* and *Drosophila*, ion channels of two gene families, degenerin/epithelial Na channel (Deg/ENaC) and transient receptor potential (TRP) superfamily, are proposed as the candidates for mechanosensitive ion channels to mechanically gate in a short latency. Corresponding genes in are also found.

*Deg/ENaC superfamily* [8] have two transmembrane domains with a large extracellular loop for receiving physical stimuli from outside and the N and C terminals facing intracellular space. Among the superfamily, MEC-4 complexes have been identified as a mechanotransduction in *C. elegans*; the assembly is composed of Deg/ENaC subunits MEC-4 and MEC-10 and the accessory subunits MEC-2 and MEC-6. The MEC-4 complex is thought to associate with the extracellular matrix. ▶Null mutation in MEC-4, MEC-2 and MEC-6 abolish mechanotransduction in body touch neurons. Since mammalian correspondence,  $\beta$ -ENaC and  $\gamma$ -ENaC, localize at lanceolate nerve endings in the vibrissae, Merkel cells and lamellated corpuscles in the food pad of

the rat, they are assumed to act as a mechanotransduction channel. However, the function remains to be studied because of failure in their mutation study.

Three members of the acid-sensing ion channels (ASICs), a related subfamily of Deg/ENaC, are tested for a possible mechanotransduction channel. Na current through the channel is blocked by amiloride and facilitated by an acid lower than pH 5 and Zn. Knockout of respective genes in mice has been carried out to elucidate their involvement. Knockout of ASIC1 did not affect cutaneous touch, but did affect visceral mechanical afferents. Since both ASIC 2 and ASIC 3 are expressed at various mechanoreceptor afferent terminals, such as Meissner's corpuscles, Merkel cell-neurite complex, and hair follicles, several research groups knocked out ASIC 2 and 3 to see the influence on cutaneous mechanoreception. One group found that knockout of either ASIC 2 or ASIC 3 reduced in ▶firing rates of rapidly adapting afferents in hairy skin but not in other types of mechanoreceptor afferents. Other groups, however, did not find any disruption of mechanoreceptor afferent activities by knockout of ASIC2 and/or ASIC3.

*TRP family* [8,9] is comprised of seven families. They are generally nonselective cation channels, having a molecular architecture similar to that of voltage-gated ion channels: subunits have six transmembrane domains with



a putative pore region, and are arranged to form a tetrameric channel. Almost all TRP families are expressed at ciliated structures, such as hair cells in the inner ear, and the vanilloid receptor TRP subfamily (TRPVs) is probably involved in mechanotransduction in vertebrates. TRPV4 are expressed at cutaneous nerve terminals, including Meissner corpuscle, Merkel-cell neurite complex, and Ruffini endings, but not in hair follicle palisade, however, its knockout did not impair mechanotransduction in low threshold mechanoreceptors but did in high threshold pressure receptors or mechanical nociceptors. TRPV4 is also activated by osmotic stimuli which cause cell to swell to regulate osmotic pressure in the brain. Since TRPV4 are usually activated by a second messenger in response to chemicals or temperature, a real mechanosensor is suggested in an upstream element even if it is involved in mechanosensory transduction. Isolated Merkel cells increased intracellular Ca in response to hyposmotic stimuli [10] and Merkel cells have lots of cytoplasmic processes probably corresponding to cilia of hair cells (see Mechanoreceptor, Anatomy in this Encyclopedia). However, it is not known whether TRP is involved in mechanotransduction of Merkel cells.

In spite of efforts, no mechanosensitive ion channels have so far been identified for low threshold cutaneous mechanoreceptors. Attempts to record mechanically-gated ionic currents from dorsal root ganglion (DRG) cells with genes of possible candidates for mechanosensitive ion channels have resulted in vain, probably because mechanosensors are not expressed at the membrane of DRG cells but at the nerve terminals.

## References

1. Gray JAB, Sato M (1953) Properties of the receptor potential in pacinian corpuscles. *J Physiol* 122:610
2. Katz B (1950) Depolarization of sensory terminals and the initiation of impulses in the muscle spindle. *J Physiol* 111:261–282
3. Hunt CC (1974) The Pacinian corpuscle. In: Hubbard JI (ed) *The peripheral nervous system*. Plenum Press, New York, pp 405–420
4. Ogawa H (1994) The Merkel cell as a possible mechanoreceptor cell. *Prog Neurobiol* 49:317–334
5. Senok SS, Halata Z, Baumann KI (1996) Chloroquine specifically impairs Merkel cell mechanoreceptor function in isolated rat sinus hairs. *Neurosci Lett* 24:167–170
6. Fagan M, Cehusac PMB (2001) Evidence for glutamate receptor mediated transmission at mechanoreceptors in the skin. *NeuroReport* 12:341–347
7. Kinkelin I, Stucky CL, Koltzenburg M (1999) Postnatal loss of Merkel cells, but not of slowly adapting mechanoreceptors in mice lacking the neurotrophin receptor p75. *Eur J Neurosci* 11:3963–3969
8. Lumpkin EA, Bautista DM (2005) Feeling the pressure in mammalian somatosensation. *Curr Opin Neurobiol* 15:382–388
9. Lin S-Y, Corey DP (2005) TRP channels in mechanosensation. *Curr Opin Neurobiol* 15:350–357
10. Tazaki M, Suzuki T (1998) Calcium inflow of hamster Merkel cells in response to hyposmotic stimulation indicates a stretch-activated ion channel. *Neurosci Lett* 243:69–72

---

## Mechanotransduction

### Definition

The sensing of mechanical stimuli by specialized mechanoreceptor cells, which transduce the stimuli into membrane potential changes (receptor potentials).

► Sensory Systems

---

## Medial Diencephalic Disorder

### Definition

Frequently referred to as ‘diencephalic amnesia’, medial diencephalic disorder is a type of amnesic disorder linked to lesions in the medial diencephalic region of the brain. The specific structures and connections in this region that must be damaged to cause memory impairment continue to be investigated. Two structures most frequently implicated include the medio-dorsal thalamic nucleus and mammillary nuclei. The presentation of diencephalic amnesia is similar to medial temporal lobe amnesia, with the usual occurrence of both anterograde and temporally graded retrograde amnesia.

► Amnesia

---

## Medial Eminence

### Synonyms

► *Eminentia medialis*; ► Medial eminence

### Definition

Protrusion created by underlying cranial nerve nuclei and pathways.

► Pons

## Medial Geniculate Body

ADRIAN REES

Auditory Group, Institute of Neuroscience, Newcastle University, Newcastle upon Tyne, UK

### Synonyms

Auditory thalamus; Medial Geniculate Nuclei

### Definition

The medial geniculate body is the thalamic processing centre of the auditory pathway. It receives projections from several nuclei in the auditory brainstem and midbrain (predominantly the inferior colliculus), the auditory cortex, and the thalamic reticular nucleus (TRN). The projections of the MGB include regions of the auditory cortex, the TRN, and the lateral nucleus of the amygdala. The MGB comprises several sub-nuclei, each of which has distinct structural and functional properties. As well as being important for sound recognition and localization, it also plays a role in the emotional responses to sounds and auditory attention.

### Characteristics

#### Introduction

The innervation of the MGB provides compelling evidence that sound perception depends on more than the upward sweep of sensory information from cochlea to cortex. Although the MGB receives ascending inputs chiefly, but not exclusively, from auditory centers in the brainstem, these are greatly outweighed by the descending inputs it receives from cortical sources. Indeed, the thalamic and cortical centers are so closely interconnected they are often referred to conjointly as the thalamo-cortical loop. Although we know little about the function of these connections, it seems likely they enable prior experience and stimulus history to influence sensory inflow to the cortex. But as well as projecting to the cortex, the MGB also targets the limbic system, a region of the brain involved in controlling emotions, and other subcortical targets such as the auditory sector of the thalamic reticular nucleus (TRN). Thus, the MGB not only has an essential role in auditory perception, but also contributes to learning, memory and attention in the auditory domain.

Our knowledge of the MGB is based on anatomical studies in a variety of mammals from rodents to humans, and physiological studies principally in cat, rat, guinea pig and primate. Species differences exist, but for the sake of clarity the emphasis here will be on the common features.

### Location and Subdivisions

The paired MGBs are the most caudal thalamic nuclei, and are visible as rounded eminences on the lateral edges of the diencephalon at its junction with the mesencephalon. Caudal to each MGB is the superior colliculus, while dorsally and laterally is the lateral geniculate body: the principal visual nucleus of the thalamus.

The MGB is not a single uniform structure, but consists of three divisions, or nuclei: ventral (MGv), dorsal (MGd) and medial (MGm). Within these divisions further subdivisions have been recognized by their distinct cytoarchitecture, connections, and functional properties [1]. In contrast to some structures in the auditory brainstem, the two MGBs are not directly interconnected.

MGv, the largest of the three divisions, is overlain by the flatter dorsal division (MGd), while the narrow MGm lies medial to them. Of the three divisions MGv appears to be primarily sensory. It receives the major ascending (lemniscal) input from the ►inferior colliculus in the auditory midbrain, and sends outputs to the frequency mapped (tonotopic) subdivisions of the auditory cortex on the ipsilateral side, which in turn project back to MGv. MGd receives its inputs primarily from the dorsal cortex of the inferior colliculus and projects predominantly to nontonotopic, or extra-lemniscal, auditory fields and to the limbic system. MGm is characterized by polymodal inputs, and outputs that project to both tonotopic and non-tonotopic regions of auditory cortex. It also targets non-cortical structures including the lateral ►amygdala in the limbic system, and is involved in emotional responses to sound and auditory learning. The TRN comprises a shell of GABAergic neurons enveloping the thalamus laterally and rostrally; the auditory sector being most caudal part of the nucleus. It receives collateral inputs from excitatory thalamo-cortical and cortico-thalamic synapses, while delivering inhibitory feedback to the MGB via GABA<sub>A</sub> and GABA<sub>B</sub> fibers. Thus, under the influence of these feed forward and feedback connections, TRN modulates information flow from thalamus to cortex. The connections of the MGB are summarized in Fig. 1.

#### Ventral Nucleus (MGv)

The major ascending input to MGv is from the midbrain, chiefly the central nucleus of the inferior colliculus on the ipsilateral side. Although this projection is predominantly excitatory, there is also a significant GABAergic, inhibitory projection, at least in rat and cat. As with other nuclei in the lemniscal division of the auditory pathway, the incoming fibers are arranged systematically within MGv according to their ►best frequency (BF), so giving rise to a topographic representation of sound frequency (a ►tonotopic map) that reflects the spatial analysis of frequency on the basilar membrane in the cochlea.

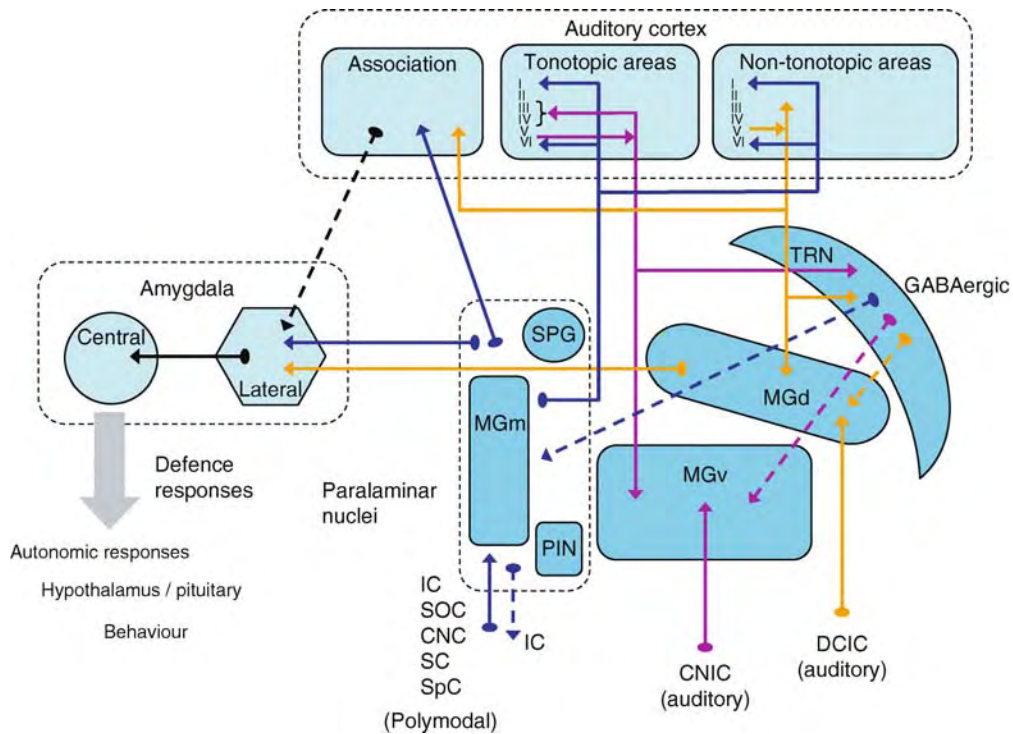

**Medial Geniculate Body. Figure 1** Connections to and from the medial geniculate body. *Double-headed arrows* indicate bi-directional connections. *Arrows in the area enclosed by the dashed line* labeled “paralaminary nuclei” represent connections of all nuclei in this group. Key: CNC, cochlear nucleus complex; CNIC, central nucleus of the inferior colliculus; DCIC, dorsal cortex of the inferior colliculus; IC, inferior colliculus; MGv, MGd, MGm, ventral, dorsal and medial nuclei of MGB, respectively; PIN, Posterior intralaminar nucleus; TRN, thalamic reticular nucleus; SC, superior colliculus; SOC, superior olivary complex; SpC, spinal cord; SPG, supragenulate nucleus.

The neural substrate underlying this organization is an arrangement of large principal neurons whose flattened, tufted dendrites align with the incoming fibers. In the lateral part of MGv in cat, the species investigated most intensively, the cells and fibers are arranged in curved sheets or laminae orientated approximately dorsal to ventral and rostral to caudal. Neurons responding best to low-frequency sounds are encountered in the most lateral laminae and those with high frequency BFs occur medially. The sequence changes in the neighboring pars ovoidea; a region named for the laminae’s distinctive concentric arrangement. The tonotopic mapping reflects this structure with neurons tuned to low frequency in the centre [2]. The tonotopy continues into the lateral part of the Posterior Group of the thalamus, a nucleus that abuts the MGv on its lateral, rostral and medial borders. The similarity of the auditory representation in the posterior group to that in MGv has led to its inclusion as a lemniscal component of the auditory pathway [2]. The tonotopic organization of MGv is reportedly less precise in lightly, or unanesthetized animals.

Other parameters of sounds are distributed across the two dimensional surface of each frequency lamina in MGv. Specific regions of the laminae represent

different binaural interactions, e.g., bands of neurons that are excited by sound at either ear are separated by neurons that are excited by sound presented to the contralateral ear and inhibited by sound in the ipsilateral ear.

In cat and primate, MGv has an abundance of small inhibitory (GABAergic) interneurons distributed amongst the lamina-forming principal cells. These neurons form complex nests of connections with the principal cells called glomeruli. In marked contrast, GABAergic neurons are virtually absent in the rat, indicating differences of function across species [1].

In general, neurons in MGv are selective, or tuned, for sound frequency, with the majority showing the same or sharper tuning compared to that of auditory nerve fibers. A variety of different firing patterns to tonal stimuli have also been described including onset (the majority), tonic and off responses [3]. These patterns may reflect the distinct response properties of different units, but they may also be influenced by different functional states of the thalamus. Cells in the MGB, like many in the other thalamic nuclei, are capable of switching between two different modes of firing, “tonic” and “burst,” depending on the state of a voltage-sensitive calcium conductance.

Bursts occur when this ion channel is activated by hyperpolarization of the neuron's membrane potential, presumably as consequence of the abundant inhibition derived from intrinsic and extrinsic sources in the MGB. Suggestions for the possible functional relevance of bursting include enhancing sensitivity to weak stimuli, and more effective driving of cortical target neurons. In MGv there is a greater tendency for bursts to fire when the stimulus is near the neuron's best frequency, thus perhaps generating a more robust representation of such sounds.

A caveat to any discussion about the functional role of these different modes of firing is the influence of the animal's conscious state. Membrane potential hyperpolarization appears to be prominent under anesthesia and slow-wave sleep, whereas MGB neurons are more depolarized in awake animals. Recordings in unanesthetized preparations are thus essential to reveal the true physiological response patterns of MGB neurons.

Outputs of MGv project to the tonotopic areas of the auditory cortex; these include A1 and AAF in cat, and the equivalent areas in primates identified as the "core" areas (AI and R, the area rostral to AI). These projections terminate predominantly in layers III–IV; the main input layers of the cortex. The ventral nucleus receives a heavy projection from the same areas of cortex particularly from cells in layer VI, but these patterns of connections are complex, and not simply reciprocal to the sources of input [4]. Collaterals of thalamo-cortical fibers from the MGv terminate in TRN which sends projections back to MGv and the other subdivisions.

We still know little about the functional role of the cortico-thalamic projection, although several studies have demonstrated changes in the tuning and firing rates of thalamic neurons following manipulation of the cortical activity [5]. It seems likely that cortico-thalamic projections mediate the feed-forward as well as feedback of cortical information to the MGB.

### Dorsal Nucleus (MGd)

The dorsal nucleus of the MGB has been subdivided into as many as five heterogeneous subdivisions. Like the ventral nucleus, the inputs to MGd originate from excitatory and inhibitory (GABAergic) neurons in the inferior colliculus, but in this case mainly from the dorsal cortex and the nearby lateral tegmental area rather than the central nucleus.

Generally, MGd neurons are not particularly selective for sound frequency and have broad or complex tuning curves; consequently there is little evidence of tonotopic organization in this nucleus, except in the deep dorsal division where neurons with more sharply tuned frequency responses have been recorded [3].

A particular property of MGd neurons is that many fail to respond to simple acoustic stimuli, and their responses habituate to repeated presentation of the same

stimulus. Some authors have also reported the preference of MGd neurons for sounds that are spectrally and temporally complex, particularly animal calls and vocalizations [3].

The outputs of MGd are predominantly to the auditory cortex, but they are distributed more diffusely than those of MGv and directed mainly to the non-tonotopic, non-primary areas. For example, in cat there is a particularly strong input to the second auditory area AII, and in primates the strongest projections are to the belt regions surrounding the primary core areas of auditory cortex. The fibers' terminals are more widely distributed within the cortical layers with endings in all six layers [4]. Projections from MGd also go to the insular cortex and to the lateral nucleus of the amygdala indicating that it contributes to emotional responses to sound. MGd receives reciprocal projections from the auditory cortex, particularly from layer V cells, from the perirhinal cortex, the caudate and the putamen. As is the case with MGv, collaterals of MGd output fibers project to the TRN which, in turn, sends projections back to MGd.

### Medial Nucleus (MGm)

The medial nucleus of the MGB lies within the paralamina group of nuclei found medial to the rest of the MGB. The group includes MGm, the suprageniculate nucleus (SPG; included in MGd in some classifications) and the posterior intralaminar nucleus (PIN). Functionally, these nuclei have many features in common and may be parts of the same entity [6].

MGm is a multimodal nucleus; in addition to its auditory input it also receives connections from other sensory pathways including the visual (superior colliculus), vestibular (vestibular nuclei) and ▶**somatosensory** (spinal cord) systems. Its auditory afferents originate chiefly from the extra-lemniscal external cortex of the inferior colliculus, but it also receives axons from the central nucleus of the inferior colliculus, and auditory centers peripheral to the midbrain including the superior olivary complex and the cochlear nucleus.

Consistent with the input it receives from lemniscal as well as extra-lemniscal divisions of the IC, some neurons in MGm have properties rather like those in MGv, namely relatively sharp tuning and short response latencies. But in general the frequency tuning of MGm neurons is broad, and some have distinctive multi-peaked tuning curves. Tonotopic organization is similarly relatively weak in MGm, although more apparent in the rostral part of the nucleus [3]. Responses are often more labile than those in the MGv, and, like neurons in MGd, often show habituation to repeated stimulus presentation. An important functional difference between neurons in MGm and those in other subdivisions of MGB is the reduced or absent expression of the calcium conductance responsible for the burst mode of firing [6].

A subset of MGm neurons are amongst the largest found in the MGB. An asymmetry in the size and number of these magnocellular neurons has been reported in the brains of dyslexic subjects at post mortem [7]. Compared with controls there was a deficit in the number and size of the neurons in the left MGm. Some assert this finding supports a general magnocellular theory of ►[dyslexia](#). This posits that dyslexia results from a general deficit in magnocellular neurons leading to impaired processing of rapidly changing visual and auditory signals in the thalamus. However, while auditory deficits in processing dynamic stimuli have been reported in dyslexics, they are not always most pronounced for sounds with the most rapid fluctuations of frequency or amplitude. Furthermore, MGm does not appear to be homologous in input or function to the magnocellular layers in the visual thalamus.

The outputs of MGm project widely in the auditory cortex and target both primary, (tonotopic) and secondary (nontotopic) areas. In contrast to the cortical projections of the other subdivisions, axons from MGm terminate primarily in the most superficial and deepest cortical layers (I and VI). Such a distribution is consistent with evidence that inputs to the cortex from MGm and other paralamina nuclei contribute to cortical mechanisms mediating the formation of auditory memories, perceptual binding and aspects of attention. Electrical stimulation of the PIN enhances 40 Hz ►[gamma oscillations](#) in the cortex in rat, whereas they are attenuated by stimulation of MGv and MGd. These oscillations are hypothesized to reflect the binding of the different sensory representations of an object into a single percept [8]. Similarly, stimulation of TRN also increases cortical gamma oscillations suggesting that the paralamina group and TRN are part of the same circuit.

Another important role of MGm is its contribution to the circuit mediating ►[fear conditioning](#) to acoustic stimuli. In this behavioral paradigm studied in rat, a neutral conditioned stimulus, e.g., a tone, is paired with a fear inducing unconditioned stimulus (mild foot-shock). After several such pairings, and consequent to the neural plasticity they induce, presentation of the conditioned stimulus alone is sufficient to elicit the fear response. The MGm and other paralamina nuclei send direct projections to the lateral nucleus of the amygdala in the limbic system, the centre responsible for activating the behavioral and autonomic changes associated with fear responses [9]. The importance of such mechanisms for survival may explain the existence of a direct, and therefore fast, connection between the cochlear nucleus, (the first nucleus of the auditory pathway) and the MGm. An fMRI study in human has reported a correlation between activity in the amygdala and thalamus during conditioning.

There is no dispute that MGm is a source of auditory input to the fear conditioning circuit, but there is

disagreement about where the conditioned and unconditioned stimuli become associated. The combined auditory and somatosensory input to MGm could provide a necessary substrate for such an interaction. Receptive field plasticity has been reported for MGm neurons in the form of an enhanced response and selectivity for the frequency of the conditioned stimulus [10]. These changes are persistent and occur with appetitive as well as fear conditioning. Others argue that the association between the conditioned and unconditioned stimulus first occurs in the lateral amygdala, and changes in MGm reflect feedback from the amygdala – although the necessary feedback connection has not been described. Alternatively, plasticity could of course occur at both sites, and differences in the properties of the plasticity observed in the two nuclei are consistent with this possibility.

Information from the MGB also reaches the amygdala via a second (albeit slower) indirect projection from both the dorsal and medial nuclei via the cortex. Other projections of MGm include the basal ganglia and feedback connections to the inferior colliculus.

## References

1. Winer JA (1992) The functional architecture of the medial geniculate body and primary auditory cortex. In: Webster DB, Popper AN, Fay RR (eds) *The mammalian auditory pathway: neuroanatomy*. Springer, New York, pp 222–409
2. Imig TJ, Morel A (1988) Organization of the cat's auditory thalamus. In: Edelman GM, Gall WE, Cowan WM (eds) *Auditory function: neurobiological bases of hearing*. Wiley, New York, pp 457–485
3. de Ribaupierre F (1997) Acoustical information processing in the auditory thalamus and cerebral cortex. In: Ehret G, Romand R (eds) *The central auditory system*. Oxford University Press, New York, pp 317–397
4. Winer JA, Miller LM, Lee CC, Schreiner CE (2005) Auditory thalamocortical transformation: structure and function. *Trends Neurosci* 28:255–263
5. Yu Y-Q, Xiong Y, Chan Y-S, He J (2004) In vivo intracellular responses of the medial geniculate neurones to acoustic stimuli in anaesthetized guinea pigs. *J Physiol* 560:191–205
6. Smith PH, Bartlett EL, Kowalkowski A (2006) Unique combination of anatomy and physiology in cells of the rat paralamina thalamic nuclei adjacent to the medial geniculate body. *J Comp Neurol* 496:314–334
7. Galaburda A, Menard M, Rosen G (1994) Evidence for aberrant auditory anatomy in developmental dyslexia. *Proc Natl Acad Sci USA* 91:8010–8013
8. Barth DS, MacDonald KD (1996) Thalamic modulation of high-frequency oscillating potentials in auditory cortex. *Nature* 383:78–81
9. Doron NN, LeDoux JE (2000) Cells in the posterior thalamus project to both amygdala and temporal cortex: A quantitative retrograde double-labeling study in the rat. *J Comp Neurol* 425:257–274

10. Edeline JM, Weinberger NM (1992) Associative retuning in the thalamic source of input to the amygdala and auditory-cortex – receptive-field plasticity in the medial division of the medial geniculate-body. *Behav Neurosci* 106:81–105

## Medial Lemniscus

### Synonyms

Lemniscus med.

### Definition

The medial lemniscus arises from the union of the spinothalamic tract (anterior column of the spinal cord, protopathic sensibility), the bulbothalamic tract (gracile nucleus and cuneate nucleus, epicritic sensibility), the trigeminal lemniscus (face) and afferents of the solitary nucleus (gustatory sensibility). Hence it is also called the somatosensory tract. The fibers terminate in the corresponding thalamic nuclei,

which in turn project to the somatosensory cortex.

- ▶ Pathways
- ▶ Somatosensory Projections to the Central Nervous System

## Medial Longitudinal Fasciculus

### Synonyms

Fasciculus longitudinalis med.

### Definition

A nerve fiber bundle running rostrally to caudally in the brainstem, a little laterally to the midline and below the oculomotor complex (rostrally) and the surface of the fourth ventricle caudally. The riMLF (rostral interstitial nucleus of the MLF) is the rostralmost of the nuclei and is reticulated by the interspersed fibers of the MLF. It borders caudally with a second interstitial nucleus of the MLF, the interstitial nucleus of Cajal from which it is separated by the dorsal to ventral running fibers of the tractus retroflexus. Also, dorsally and medially it is demarcated by the thalamo-subthalamic paramedian artery. The medial longitudinal fasciculus is composed of two fiber components:

- Vestibular component: conducts efferents of the vestibular nuclei to the nuclei for controlling eye and cervical muscles, thus coordinating organ of equilibrium with eye and head movements
- Internuclear component: it coordinates motor cranial nerve nuclei and provides for synchronous eye movement and coordination of pharyngeal muscles while speaking and swallowing

The following tracts course here:

- Interstitiospinal tract
- Reticulospinal tract
- Tectospinal tract
- Lateral vestibulospinal tract
- Medial vestibulospinal tract

- ▶ Interstitial Nucleus of Cajal
- ▶ Pathways

## Medial Nucleus of the Trapezoid Body

### Definition

One of the primary nuclei in the superior olivary nuclei located within the fibers of the trapezoid body.

- ▶ Superior Olivary Nuclei
- ▶ Trapezoid Body

## Medial Octavolateralis Nucleus (MON)

### Definition

Primary hindbrain recipient zone for mechanosensory neuromast afferents.

- ▶ Evolution of Mechanosensory and Electrosensory Lateral Line Systems

## Medial Pallium

- ▶ Evolution of the Hippocampus

## Medial Preoptic Nucleus

### Synonyms

POML; Nucl. preopticus med.

### Definition

Lies in the preoptic area, involved in thermoregulation, hypovolemic thirst, male sexual behavior, brood care, modulation of gonadotropin secretion. Larger afferents from the amygdala, subiculum, interstitial nucleus of the stria terminalis, lateral septal nucleus, insula. Efferents to the diagonal band, septum, substantia innominata, interstitial nucleus, amygdaloid body, brainstem. Has numerous cells with receptors for gonadal steroids. Disruption of this nucleus induces ongoing hypothermia, while stimulation results in hyperthermia.

The menstruation cycle is also interrupted in the event of dysfunctioning of this area.

► Diencephalon

## Medial Rectus Muscle

### Definition

Medial rectus is one of the six eye muscles.

► Eye Orbital Mechanics

## Medial Reticular Formation

### Definition

The magnocellular, medial region of the RF stretches across the entire brainstem and enables the following sections to be distinguished:

- Gigantocellular reticular nucleus
- Caudal pontine reticular nucleus
- Oral pontine reticular nucleus

Belonging here are also the mesencephalic nuclei: cuneiform nucleus, subcuneiform nucleus and central medulla oblongata nucleus. This region of the RF is involved in motor and sensory tasks.

► Pons

## Medial Septum

### Definition

Medial part of the septum, an area in the medial wall of the cerebral hemispheres, contains cholinergic cells in many species.

► Evolution of Subpallial Cholinergic Cell Groups

## Medial Superior Olive

### Definition

One of the primary nuclei in the superior olivary nuclei located most medially and important for encoding interaural time disparities.

► Interaural Time Difference (ITD)

► Superior Olivary Nuclei

## Medial Superior Temporal Area (Area MST)

### Definition

An area in the superior temporal sulcus of the rhesus monkey that contains neurons with selectivity for large-field optic flow. Area MST receives its main input from the middle temporal area.

► Optic Flow

## Medial Temporal Lobe Amnesia

### Definition

Amnesia that results from damage to one or several medial temporal lobe structures crucial for memory; such as, the hippocampal region and the adjacent perirhinal, entorhinal, and parahippocampal cortices.

The severity of amnesia observed depends on the locus and extent of medial temporal lobe damage. A typical presentation might include anterograde amnesia with temporally graded retrograde amnesia. Generally,

memories for remote events are spared in medial temporal lobe amnesia.

- ▶ Amnesia
- ▶ Anterograde Amnesia

## Medial Vestibular Nucleus

### Definition

Cluster of cells located within the medial region of the complex of the vestibular nuclei. It projects to the spinal cord, the cerebellum and the motor nuclei of the extraocular muscles.

- ▶ Vestibular Nuclei
- ▶ Vestibulo-ocular Reflexes
- ▶ Vestibulo-Spinal Reflexes

## Medial Vestibulospinal Tract

### Synonyms

Tractus vestibulospinalis med

### Definition

The efferents going from the medial vestibular nucleus and inferior vestibular nucleus in the direction of the spinal cord form the medial vestibulospinal tract which passes in the medial longitudinal fasciculus of the spinal cord into the cervical and upper thoracic cord, ending here on the motoneurons, innervating the cervical musculature and the upper extremities. The motor fibers of the lateral vestibular nucleus runs in the lateral vestibulospinal tract.

- ▶ Medulla spinalis

## Mediterranean Diet

### Definition

Traditional diet of the inhabitants of the countries around the Mediterranean Sea comprises of fresh fruits and vegetables. Their diet is popular all over the world,

after the research linked their better health with their traditional and cultural diet.

- ▶ Central Nervous System Disease – Natural Neuro-protective Agents as Therapeutics

## Medium Spiny Neuron

### Definition

A type of central nervous neuron comprising more than 95% of the neurons in basal ganglia input structures, such as the caudate nucleus, putamen, nucleus accumbens and striatal districts in the olfactory tubercle. The cell body has a diameter in a range between 15 and 18  $\mu\text{m}$  and gives rise to three to five primary dendrites that are aspiny proximally, but densely spiny beginning at about the first branch point.

The dendrites are extensively branched, producing approximately spherical dendritic fields with diameters of 200–300  $\mu\text{m}$ . Medium spiny neurons utilize  $\gamma$ -amino butyric acid (GABA) as an inhibitory neurotransmitter and may co-express a number of peptide neuromodulators, such as enkephalin, substance P, dynorphin and neurotensin. They express dopamine and glutamate receptors and their activities are robustly modulated by dopaminergic projections arising in the midbrain and glutamatergic projections from a variety of sources, including the cortex and intralaminar thalamic nuclei.

The axons of medium spiny neurons give rise to dense terminations characteristic of the striatopallidal and striatonigral projections. Medium spiny neurons are also found in certain other of the deep telencephalic nuclei, such as the central and medial nuclei of the amygdala, bed nucleus of stria terminalis and lateral septum.

- ▶ Basal Ganglia
- ▶ Ventral Striatopallidum

## Medium-Lead Burst Neurons in Eye Movement (MLBNs)

### Definition

Neurons that exhibit a burst of spikes beginning no more than 15 ms before the onset of saccades in a preferred direction, but are silent or nearly silent during



fixation or slow eye movements. These include excitatory and inhibitory burst neurons.

- ▶ Brainstem Burst Generator
- ▶ Saccade, Saccadic Eye Movement

## Medulla Oblongata

### Definition

The medulla (Latin for marrow) is the caudal most part of the brainstem. Its rostral border is immediately caudal to the caudal edge of the pontine nuclei and its caudal border is marked by the top of the spinal cord just caudal to the pyramidal decussation and the cuneate and gracile nuclei.

- ▶ Evolution of the Hindbrain
- ▶ Myelencephalon

## Medulla Spinalis

- ▶ Spinal Cord

## Medullary Raphe Nuclei and Respiratory Control

GEORGE RICHERSON

Department of Neurology, School of Medicine, Yale University, New Haven, CT, USA

### Definition

Effect of medullary serotonin (5-HT) neurons on motor output from the brainstem respiratory network.

In the accompanying essay of this Encyclopedia, we discuss the effects of medullary 5-HT neurons on the control of breathing. By releasing 5-HT, substance P (SP) and thyrotropin releasing hormone (TRH), they are thought to modulate respiratory output in a sleep state dependent manner, are required for ▶[hypoxia](#) induced plasticity, and contribute to the stimulation of respiratory output by high CO<sub>2</sub> and/or low pH.

## Characteristics

### Anatomy

There is a caudal group of 5-HT neurons found in four locations in the caudal pons and medulla: the raphé pallidus, raphé obscurus, raphé magnus and parapyramidal region (▶[caudal raphé](#)). Using tract tracing methods combined with immunohistochemistry for 5-HT or tryptophan hydroxylase (TPH), caudal 5-HT neurons have been found to project widely to nuclei containing respiratory neurons, including the nucleus ambiguus, nucleus tractus solitarius (NTS), hypoglossal motor nucleus and phrenic motor nucleus [1]. A variety of 5-HT receptor subtypes have been identified within these respiratory nuclei, including 5-HT<sub>1a</sub>, 5-HT<sub>1b</sub>, and 5-HT<sub>4a</sub> [1].

### Effect of 5-HT on Breathing in vivo

5-HT has a variety of modulatory effects on respiratory output and respiratory neurons *in vivo* [1]. Early experiments showed that blockade of 5-HT synthesis induced an increase in ventilation, suggesting that 5-HT inhibits breathing. Later it was found that stimulation of neurons within the medullary raphé nuclei causes release of 5-HT into the NTS and phrenic motor nucleus, and this could either stimulate or inhibit breathing depending upon where the electrode is placed. In contrast, selective agonists for 5-HT<sub>1a</sub>, 5-HT<sub>2a/1c</sub> and 5-HT<sub>4a</sub> receptors stimulate ventilation (Fig. 1) [1,2]. The precise role of 5-HT and serotonergic neurons remains unclear, because it has been difficult to determine how endogenous release of 5-HT influences breathing *in vivo* under physiological conditions. This has been particularly problematic due to confounding effects of arousal state, separation of the effects of different receptor subtypes, and the interaction with other neuromodulatory inputs (e.g., norepinephrine, acetylcholine, histamine, SP and TRH). However, the consensus is that 5-HT has a primarily excitatory effect on respiratory motor output under most conditions.

### Co-localized Neuropeptides

Many 5-HT neurons in the medulla are also immunoreactive for neuropeptides, including SP and TRH. These neuropeptides are co-released by 5-HT neurons, and there are receptors for them on respiratory neurons. For example, neurokinin 1 (NK1) receptors for SP are localized in high concentration within the pre-Bötzinger Complex (pre-BötC) [3]. When administered *in vivo*, SP and TRH both have effects on breathing that are often stronger than 5-HT itself, and are uniformly stimulatory [1]. For example, studies in a variety of species have shown that TRH reverses respiratory depression induced by anesthetics. The relative importance of TRH in mediating the respiratory effects of 5-HT neurons has been difficult to determine, because there are not good antagonists of TRH receptors, but

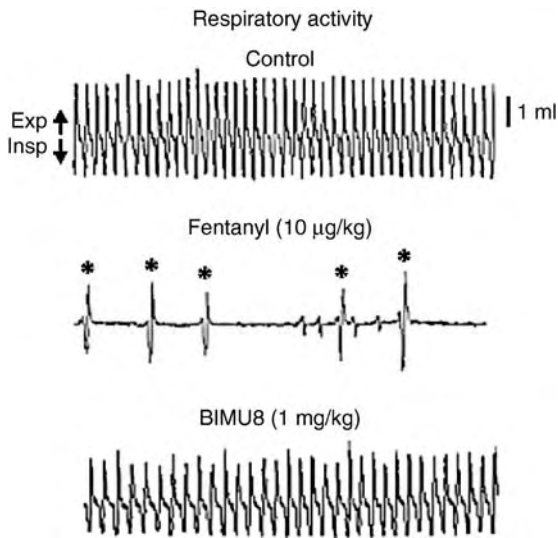

**Medullary Raphe Nuclei and Respiratory Control.** **Figure 1** 5-HT<sub>4a</sub> receptor activation stimulates breathing *in vivo*. Data is from a rat *in vivo*. Each trace is a recording of lung ventilation. Under control conditions there is regular breathing. Fentanyl leads to severe apnea that required ventilatory support to prevent the animal from dying. Breathing was restored with the 5-HT<sub>4a</sub> receptor agonist BIMU8. (From Manzke et al, *Science*, 301:226, 2003).

there is some evidence that TRH and SP are released primarily as the firing rate of 5-HT neurons increases to higher levels.

### Effects of 5-HT, SP and TRH on Respiratory Neurons *in vitro*

Compared with *in vivo* experiments, *in vitro* work has more consistently shown that 5-HT, and 5-HT neurons, stimulate the respiratory network. For example, spontaneous respiratory output generated by the pre-BötC in brain slices is stimulated via 5-HT<sub>2a</sub> (Fig. 2) and NK1 receptors [4,5]. In slices, 5-HT induces ectopic bursting activity in non-pacemaker neurons of the pre-BötC, and TRH induces bursting pacemaker activity in neurons within the respiratory portion of the NTS [1]. 5-HT, SP and TRH also have excitatory effects in the *in vitro* brainstem spinal cord preparation and perfused brain preparations. It is not clear why there are different results from *in vitro* preparations compared to *in vivo*, but it may be related to the more reduced nature of these preparations in which there is less influence of inputs from the periphery and other brain regions.

### CO<sub>2</sub>/pH Chemoreception by 5-HT Neurons

5-HT neurons are normally tonically active *in vivo*, with greater activity during wakefulness and less during sleep, but are relatively unresponsive to most other

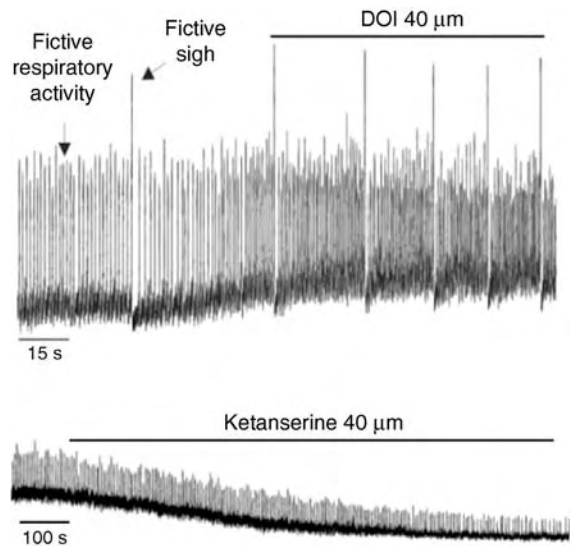

**Medullary Raphe Nuclei and Respiratory Control.** **Figure 2** 5-HT<sub>2a</sub> receptor activation stimulates respiratory activity *in vitro*. Shown is activity recorded from the pre-Bötzing Complex in a brain slice from the rostral rat medulla. Fictive respiratory activity is recorded as regular bursts of action potentials (shown here as an “integrated” recording). Application of the 5-HT<sub>2a</sub> agonist DOI increases the frequency of respiratory output (top trace). Application of the 5-HT<sub>2a</sub> antagonist ketanserin abolishes respiratory output (bottom trace), due to blockade of the effect of endogenously released 5-HT. (From Pena & Ramirez, *J Neurosci*, 22:11055, 2002.)

perturbations and afferent inputs *in vivo*. Two exceptions are that they increase their firing rate *in vivo* in response to inhalation of CO<sub>2</sub> and during repetitive motor activities. This has been shown using extracellular recordings from medullary raphe neurons in behaving cats [6], as well as *c-fos* staining in rats. Interestingly, the response of these neurons to CO<sub>2</sub> is depressed during sleep, in tandem with a decrease in the ▶hypercapnic ventilatory response.

5-HT neurons are intrinsically chemosensitive to CO<sub>2</sub>. After chemical or physical isolation from other neurons in brain slices and in cell culture, they respond to ▶hypercapnia with an increase in firing rate (Fig. 3) [1]. This response is indirectly due to the decrease in pH induced by increased PCO<sub>2</sub>. Based on these and other data, serotonin neurons are thought to be ▶central respiratory chemoreceptors (CCRs), i.e., sensors of blood CO<sub>2</sub> that stimulate respiratory output in response to hypercapnic acidosis. This response lowers PCO<sub>2</sub>, thus maintaining pH homeostasis.

5-HT neurons in rats have anatomy that suggests they are specialized to detect changes in blood PCO<sub>2</sub>. Many 5-HT neurons are located in the midline medulla, which is highly perfused by large arteries, and they have

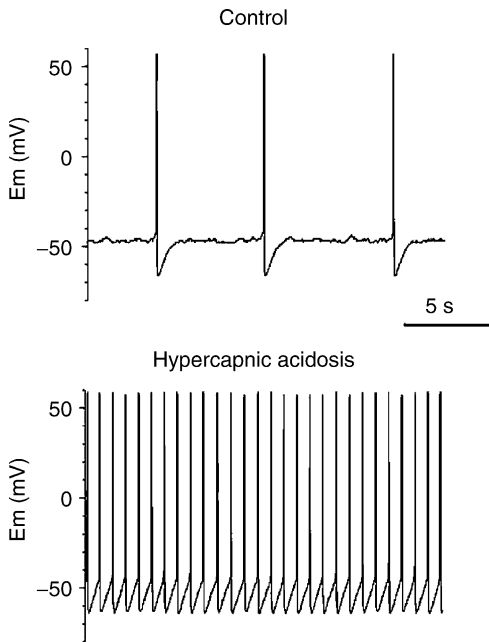

**Medullary Raphe Nuclei and Respiratory Control.**  
**Figure 3** 5-HT neurons are intrinsically sensitive to acidosis. Shown is the membrane potential of a 5-HT neuron from the medullary raphé grown in cell culture. A decrease in pH from 7.4 to 7.2 induces an increase in firing rate. (From Wang et al, *J Physiol*, 540:951, 2002.)

dendrites and cell bodies that are closely apposed to these arteries (Fig. 4). The  $PCO_2$  of arterial blood is inversely proportional to gas exchange in the lungs. This location would avoid confounding effects of changes in local brain metabolism or cerebral blood flow that would influence the  $PCO_2$  near venous blood or brain capillaries, and would thus allow a relatively greater selectivity for monitoring lung ventilation.

5-HT neurons play a role in the increased ventilation induced by hypercapnic acidosis. In slices of the medulla, focal application of acidic solution into the raphé nuclei leads to an increase in frequency of respiratory rhythm generated by the pre-BötC. In rats and goats *in vivo*, focal acidosis in the medullary raphé leads to an increase in ventilation [3]. Specific lesions of 5-HT neurons with the neurotoxin 5,7-dihydroxytryptamine, or genetic deletion of 5-HT neurons, leads to blunting of the hypercapnic ventilatory response *in vivo*. The relative importance of 5-HT neurons in central respiratory chemoreception *in vivo*, compared to other putative chemoreceptors in the brain, has not been determined. However, some data suggest that as much as 50% of the central chemoreceptor response is dependent upon 5-HT in mice. Current work is aimed at defining the relative importance of each of the candidates for central chemoreceptors, and whether this

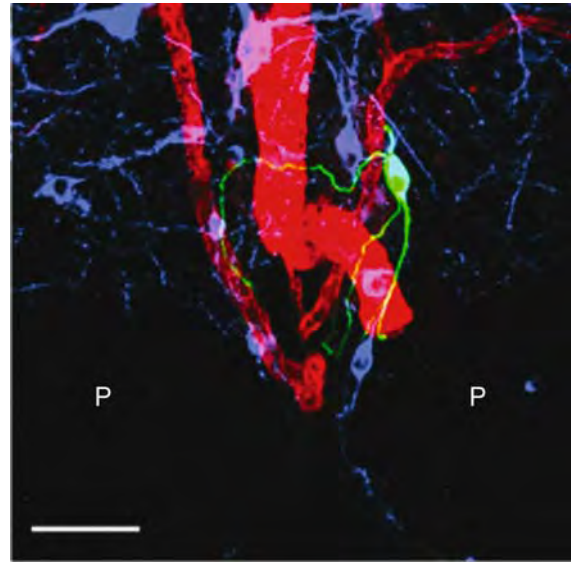

**Medullary Raphe Nuclei and Respiratory Control.**  
**Figure 4** Serotonin neurons are closely associated with large midline arteries in the medullary raphé and ventrolateral medulla. Shown is a brain slice after recording from a neuron that was stimulated by acidosis. The neuron was identified by filling with biocytin (green). Immunohistochemistry for tryptophan hydroxylase (blue) revealed that it was serotonergic. This neuron had dendrites that were closely associated with large penetrating arteries stained with an antibody for  $\alpha$ -smooth muscle actin (red). P – pyramidal tract. Bar – 50  $\mu$ m. (From Bradley et al, *Nature Neurosci*, 5: 401, 2002.)

varies under different conditions, such as sleep or disease states.

### 5-HT and Plasticity of Respiratory Output

Respiratory output is generally considered to be hard-wired, but it has recently been shown to undergo considerable plasticity [3]. For example, after three episodes of mild hypoxia of 5 minutes each, ventilation slowly increases over the next hour despite withdrawal of the hypoxic stimulus. This “long term facilitation” of respiratory motor output is due to strengthening of the synaptic drive to respiratory motor neurons from the medullary respiratory centers, and requires protein synthesis. It has recently been found that this LTF is blocked by 5-HT antagonists [3]. Elucidation of the serotonergic mechanisms involved in LTF may provide new avenues for treatments to strengthen respiratory drive in patients with respiratory weakness, such as that due to incomplete spinal cord injury.

### 5-HT Neurons and Breathing in Disease

5-HT neurons of the midbrain (dorsal and median raphé) are central to many psychiatric diseases. Those

within the medulla are now known to be involved in the pathophysiology of diseases in which there are breathing abnormalities.

► **Sudden infant death syndrome (SIDS)** is defined as the “sudden death of an infant under one year of age, that remains unexplained after a complete clinical review, autopsy, and death scene investigation.” SIDS is a heterogeneous disorder, including a small subset due to genetic cardiac defects. However, a large percentage of SIDS cases are believed to occur when a developmental defect in the brainstem of otherwise normal infants makes them vulnerable to an exogenous stressor such as obstruction of the airway, a mild infection, or variations in ambient temperature. The stressor can then lead to a decrease in ventilation, hypoxia and hypercapnia, and ultimately death.

Recent neuropathological studies of infants that died of SIDS have found abnormalities in serotonin receptors, the serotonin transporter and the number and morphology of serotonin neurons in the medulla [7]. Genetic studies have also linked SIDS to polymorphisms in the promoter for the serotonin transporter. It is now believed that a large percentage (> 50%) of SIDS cases are due to a developmental defect in 5-HT neurons. This defect can be genetically influenced or induced by environmental factors such as cigarette smoking.

Animal experiments have provided insight into mechanisms by which a defect in the 5-HT system could lead to vulnerability to an exogenous stressor. Selective deletion of 5-HT neurons by genetic methods or neurotoxins in rodents leads to blunted CO<sub>2</sub> chemoreception and impaired thermoregulation in adults. There is also irregular breathing and an increase in mortality in neonatal mice [8]. These abnormalities in mice are reminiscent of defects proposed to exist in SIDS cases. Although the pathological changes in these mouse models are not the same as those in human SIDS, current research is aimed at determining whether the physiological changes are similar, if a test can be developed to identify infants at highest risk, and if preventive treatments are possible.

► **Sleep apnea** occurs in 4% of adult males in the US, and is most commonly due to obstruction of the upper airway from withdrawal of muscle tone during sleep, particularly during REM. Many patients are apneic more than 15 times per hour, each time becoming hypoxia. This can lead to a variety of consequences including daytime sleepiness, difficulty concentrating, hypertension, right sided heart failure and stroke.

One of the factors that contributes to airway obstruction during sleep is the withdrawal of 5-HT input onto motor neurons that innervate upper airway muscles. Hypoglossal neurons, which have been studied the most intensively, are depolarized *in vitro* by 5-HT, SP and TRH, each of which inhibit leak K<sup>+</sup> channels. During sleep, the firing rate of 5-HT neurons decreases, with

almost complete cessation during REM. The decrease in excitatory neuromodulation of motor neurons is thought to play an important role in the decrease in upper airway tone during sleep.

► **Multi-System Atrophy (MSA)** is a neurodegenerative disorder that involves degeneration of dopamine and autonomic neurons in the brain. Patients have symptoms similar to Parkinson’s disease, but also have autonomic dysfunction. It has recently been found that there is also degeneration of 5-HT neurons in some of these patients [9]. This may explain why sleep apnea can be an early manifestation of MSA, because of impairment of central respiratory chemoreception and/or greater reduction in 5-HT tone during sleep.

► **Panic attacks** are discrete periods of fear or discomfort in which there is rapid development of symptoms such as a feeling of air hunger, choking and/or palpitations. They often include hyperventilation. These episodes can occur spontaneously or can be induced by situational triggers. They can also be induced by breathing CO<sub>2</sub>. Selective serotonin reuptake blockers are highly effective for treatment. A widely held theory is that panic attacks are an inappropriate triggering of a reflex that can be activated in normal people by hypercapnia, and which is designed to restore normal blood CO<sub>2</sub> levels. This “false suffocation alarm” has been proposed to be due to a defect in 5-HT neurons [10].

## References

1. Richerson GB (2004) Serotonin neurons as CO<sub>2</sub> sensors that maintain pH homeostasis. *Nat Rev Neurosci* 5:449–461
2. Manzke T, Guenther U, Pomimaskin EG, Haller M, Dutschmann M, Schwarzacher S, Richter DW (2003) 5-HT<sub>4</sub> receptors avert opioid-induced breathing depression without loss of analgesia. *Science* 301:226–229
3. Feldman JL, Mitchell GS, Nattie EE (2003) Breathing: rhythmicity, plasticity, chemosensitivity. *Ann Rev Neurosci* 26:239–266
4. Pena F, Ramirez JM (2002) Endogenous activation of serotonin-2A receptors is required for respiratory rhythm generation *in vitro*. *J Neurosci* 22:11055–11064
5. Pena F, Ramirez JM (2004) Substance P-mediated modulation of pacemaker properties in the mammalian respiratory network. *J Neurosci* 24:7549–7556
6. Veasey SC, Fornal CA, Metzler CW, Jacobs BL (1995) Response of serotonergic caudal raphe neurons in relation to specific motor activities in freely moving cats. *J Neurosci* 15:5346–5359
7. Paterson DS, Trachtenberg FL, Thompson EG, Belliveau RA, Beggs AH, Darnall R, Chadwick AE, Krous HF, Kinney HC (2006) Multiple serotonergic brainstem abnormalities in sudden infant death syndrome. *JAMA* 296:2124–2132
8. Erickson JT, Shafer G, Rossetti MD, Wilson CG, Deneris ES (2007) Arrest of 5HT neuron differentiation delays respiratory maturation and impairs neonatal homeostatic responses to environmental challenges. *Resp Physiol Neurobiol* (in press)

9. Benarroch EE (2007) Brainstem respiratory chemosensitivity: new insights and clinical implications. *Neurology* 68:2140–2143
10. Klein DF (1993) False suffocation alarms, spontaneous panics, and related conditions. An integrative hypothesis. *Archiv Gen Psych* 50:306–317

---

## MEG

► [Magnetoencephalography](#)

---

## Meissner Corpuscle

### Definition

Cutaneous mechanoreceptor located in the dermis just below the epidermis, only in glabrous skin.

- [Cutaneous Mechanoreceptors, Anatomical Characteristics](#)
- [Cutaneous Mechanoreceptors, Functional Behavior](#)

---

## Meissner Corpuscle Regeneration

CHIZUKA IDE

Department of Anatomy and Neurobiology, Kyoto University Graduate School of Medicine, Yoshidakonoe-cho, Sakyo-ku, Kyoto, Japan; Department of Occupational Therapy, Aino University Faculty of Nursing and Rehabilitation, Ibaragi City, Osaka, Japan

### Synonyms

Meissner's corpuscle; Wagner's corpuscle; Corpusculum tactus; Tactile lamellar corpuscle; Digital lamellated corpuscle

### Definition

A rapidly-adapting mechanoreceptor for touch sensation, situated at the top of the dermal papillae of the

skin. The corpuscle consists of thin sheets of lamellar cells densely piled around axon terminals.

### Characteristics

#### Structure

The corpuscle is oval in shape, with a long axis of ca. 100–300  $\mu\text{m}$ . The corpuscle is usually situated with the apical end pointing towards the base of the epithelium of the dermal papillae. Generally, one or sometimes two to three nerve fibers innervate the corpuscle, ending as enlarged terminals after branching within. The axon terminals are characterized by containing numerous mitochondria and clear vesicles, and are sandwiched by thin lamellar cell processes (ca. 0.5  $\mu\text{m}$  in width) in the basal-apical direction of the corpuscle [1]. Lamellar cells are specialized Schwann cells, extending thin sheet-like cytoplasmic processes with characteristically numerous caveolae on the cell surface membrane [2]. Lamellar cell processes are interposed with neighboring ones by narrow connective tissue spaces, being covered by basal laminae at the connective tissue surface. Lamellar cells secrete the enzyme cholinesterase into the interlamellar spaces [3], and have TGF-beta immunoreactivity [4]. The corpuscle lacks the perineurial sheath.

#### Regeneration

When an innervating nerve is cut, its axon terminals disappear, and concomitantly the surrounding lamellar cells become atrophic. The atrophic corpuscle then persists for an extended time. When regenerating axons enter the atrophic corpuscle, the lamellar cells retain their original "active" form. Some trophic factors available from axons are needed for lamellar cells to maintain their active form [5]. Meissner corpuscles are reinnervated by host axons in the allograft skin [6], or ectopically grafted digital skin [7]. Meissner corpuscles can regenerate in an acellular environment. When the skin is freeze-treated with liquid nitrogen, all cellular components including lamellar cells are killed and only connective tissues including basal laminae constituting the corpuscle remain in their original condition. Reinnervating axons first enter such an acellular environment, followed by Schwann cells. The Schwann cells then gradually develop into lamellar cells with a small number of thin cytoplasmic processes (Fig. 1). Innervating axons are enlarged at their ends as in the original Meissner corpuscle. Although the patterns of lamellar cells are incomplete compared to the original normal corpuscle, the overall structures are those of normal Meissner corpuscles, and thus can be called an atypical Meissner corpuscle [8]. The extracellular matrix of the Meissner corpuscle has the ability to develop new Meissner corpuscles after re-innervation. A new corpuscle can never develop in an acellular site other than that of the original corpuscle. Similarly, there is no evidence of Meissner corpuscle

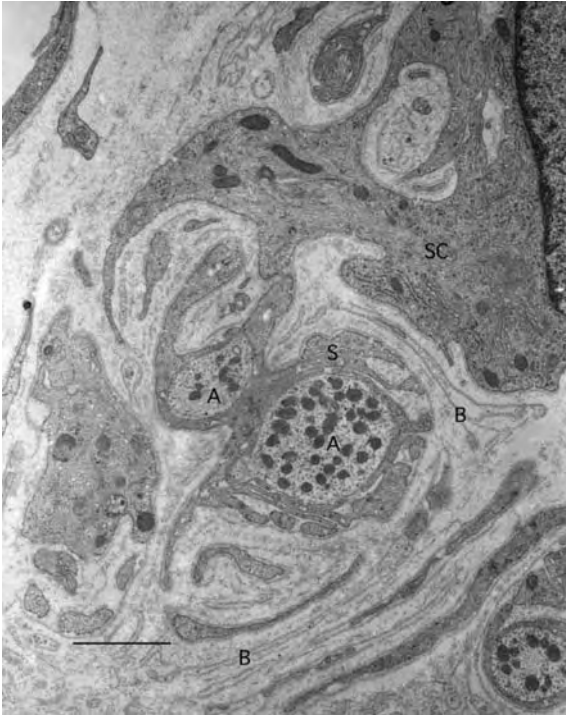

**Meissner Corpuscle Regeneration. Figure 1** The rat toe skin was freeze-treated to kill the cellular components of tactile digital corpuscles in the toe pad. The extracellular matrix of the corpuscle remained in loco after the cellular components had been removed. About 1 week after treatment, regenerating axons (A) accompanied by immature Schwann cells (SC) entered the acellular matrix of the corpuscle. It is noted that immature Schwann cells with regenerating axons begin to develop into digital corpuscles by extending cellular processes (S) through the basal lamina scaffolds (B), mimicking the formation processes during digital corpuscle development. Axons end in axon terminals associated with layers of Schwann cell lamellae. Thus, the new digital corpuscle, although atypical in cellular organization, can be formed in the acellular matrix of the old corpuscle. Scale bar: 2  $\mu$ m.

regeneration de novo in nerve fascicular repair [9]. There is no tactile lamellar corpuscle regeneration when developing corpuscles are denervated before postnatal day 5 in the rat [10].

## References

1. Ide C (1976) The fine structure of the digital corpuscle of the mouse toe pad, with special reference to nerve fibers. *Am J Anat* 147:329–356
2. Ide C (1977) Development of Meissner corpuscle of mouse toe pad. *Anat Rec* 88:49–68
3. Ide C (1982) Histochemical study of lamellar cell development of Meissner corpuscles. *Arch Histol Jpn* 45:83–97

4. Stark B, Carlstedt T, Risling M (2001) Distribution of TGF-beta, the TGF-beta type I receptor and the R-II receptor in peripheral nerves and mechanoreceptors; observations on changes after traumatic injury. *Brain Res* 913:47–56
5. Ide C (1982) Regeneration of mouse digital corpuscles. *Am J Anat* 163:73–85
6. Samulack DD, Munger BL, Dykes RW, Daniel RK (1986) Neuroanatomical evidence of reinnervation in primate allografted (transplanted) skin during cyclosporine immunosuppression. *Neurosci Lett* 72:1–6
7. Uno H, Montagna W (1982) Reinnervation of hair follicle end organs and Meissner corpuscles in skin grafts of Macaques. *J Invest Dermatol* 78:210–214
8. Ide C (1986) Basal lamina and Meissner corpuscle regeneration. *Brain Res* 384:311–322
9. Dellon AL (1976) Reinnervation of denervated Meissner corpuscles: a sequential histologic study in the monkey following fascicular nerve repair. *J Hand Surg* 1:98–109
10. Zelena J, Jirmanova I, Nitatori T, Ide C (1990) Effacement and regeneration of tactile lamellar corpuscles of rat after postnatal nerve crush. *Neuroscience* 39:513–522

## Mel

► Melatonin

## Mel1a

► Melatonin Receptors

## Melancholia

► Major Depressive Disorder

## Melancholic Features

### Definition

These involve the inability to find pleasure in positive things combined with physical agitation, insomnia or

decreased appetite. Roughly 10% of people with depression suffer from melancholic depression.

► Major Depressive Disorder

## Melanin and Neuromelanin in the Nervous System

WILLIAM H. TOLLESON

Division of Biochemical Toxicology,  
National Center for Toxicological Research,  
US Food and Drug Administration, Jefferson,  
AR, USA

### Synonyms

Neuromelanin; Melanin; Eumelanin; Pheomelanin

### Definition

► **Melanins** are naturally occurring polymeric pigments produced from L-tyrosine and L-cysteine by catecholaminergic neurons and ► **melanocytes**. Melanin subcategories occurring in humans include ► **neuromelanin**, ► **eumelanin** and ► **pheomelanin**.

## Characteristics

### Quantitative Description

In humans, melanin pigments are distributed among anatomic sites harboring melanocytic cells or dopaminergic and noradrenergic neurons. Melanocytes residing in hair follicles and the interfollicular epidermis produce eumelanin and pheomelanin pigments that are responsible for natural individual variations in external pigmentation. Other major populations of melanocytes are present in the: (i) uveal tract in the posterior portion of the eye, (ii) stria vascularis within the scala media of the cochlea, and (iii) meninges covering the brain [1].

Neuromelanin is produced by dopamine- and norepinephrine-synthesizing neurons, but not those producing epinephrine. It is generally believed that ► **catecholamine** neurotransmitters are the major biochemical precursors of human neuromelanin, although definitive chemical analysis of neuromelanin has been impeded by its low abundance. Elucidating the chemical structure and origin of neuromelanin is a matter of active research.

Dopaminergic neurons of the substantia nigra lack neuromelanin at birth; it is detectable as intracellular granules within the substantia nigra pars compacta by 3 years of age and becomes increasingly abundant throughout life [2]. The substantia nigra pars compacta of normal brains (mean age 61 years) contain approximately 1 mg of neuromelanin, or about 2.5  $\mu\text{g}$  neuromelanin per mg wet tissue (Fig. 1).

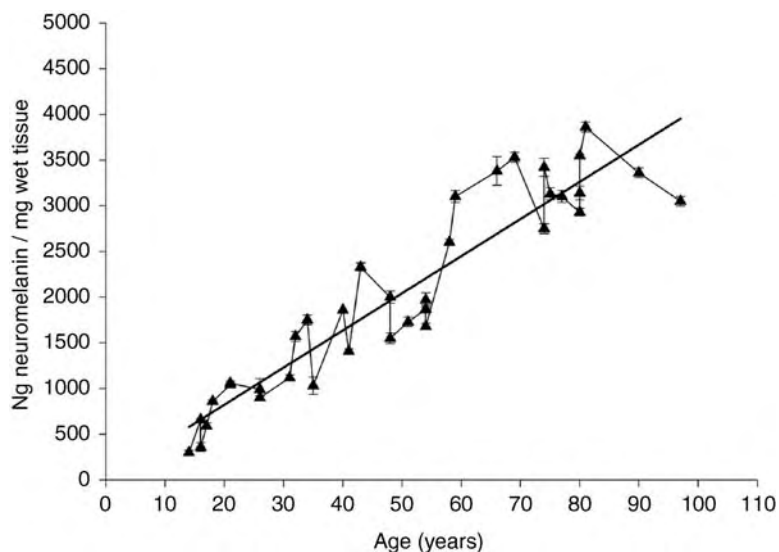

**Melanin and Neuromelanin in the Nervous System. Figure 1** Neuromelanin content within the substantia nigra increases steadily throughout life. Regression analysis of the relationship between neuromelanin content in the substantia nigra (ng/mg tissue) and age of normal male and female subjects, ages 14–97 years. (By permission, Zecca et al. [2]; copyright (2004) National Academy of Sciences, USA.) Similar concentrations of neuromelanin accumulate within the locus coeruleus.

The major population of noradrenergic neurons located in the locus coeruleus of the brain stem also contains neuromelanin granules. Although greater inter-individual variation is apparent, neuromelanin levels in the locus coeruleus also increase with age and are comparable to the amounts found in the substantia nigra of the same individuals ( $\sim 2.5$   $\mu\text{g}/\text{mg}$  wet tissue at 61 years) [2].

### Higher Level Structures

#### *Pigmented Dopaminergic Neurons of the Substantia Nigra Pars Compacta*

The largest nuclear mass of the mesencephalon is the substantia nigra (Fig. 2), divided into two sections by the interpeduncular fossa and interpeduncular nucleus [3]. The substantia nigra extends caudally from the rostral mesencephalon to the pons. The substantia nigra can be subdivided into its dorsal neuromelanin pigmented portion, designated the substantia nigra pars compacta, and the ventral substantia nigra pars reticularis. The substantia nigra pars compacta includes closely packed, pyramidal or polymorphic neurons containing neuromelanin. The substantia nigra pars reticularis, also called the stratum intermedium, containing polymorphic GABAergic neurons, is positioned

ventrally to the substantia nigra pars compacta and dorsally to the crus cerebri. Cells of the substantia nigra pars reticulum lack neuromelanin but contain abundant iron, which imparts a reddish color to this region. Dopaminergic axons from the substantia nigra pars compacta project anteriorly to the striatum, constituting the nigrostriatal neural pathway that regulates muscle control. A minor number of pigmented dopaminergic neurons innervate the nucleus accumbens and cerebrum. These neurons originate from the ventral tegmentum area, which is ventral to the red nucleus, medial to the substantia nigra and dorsal to the interpeduncular nucleus.

#### *Pigmented Noradrenergic Neurons of the Locus Coeruleus*

Noradrenergic neurons are aggregated in the locus coeruleus (Fig. 2) [3,4]. The tightly packed, pigmented, polygonal cells of the locus coeruleus communicate with diverse regions of the CNS. The locus coeruleus receives inputs from the hypothalamus, amygdala, cingulate gyrus, raphe nuclei, and cerebellum. Efferent fibers from the locus coeruleus innervate the spinal cord, cerebellum, hypothalamus, amygdala, cerebral cortex, and the basal telencephalon.

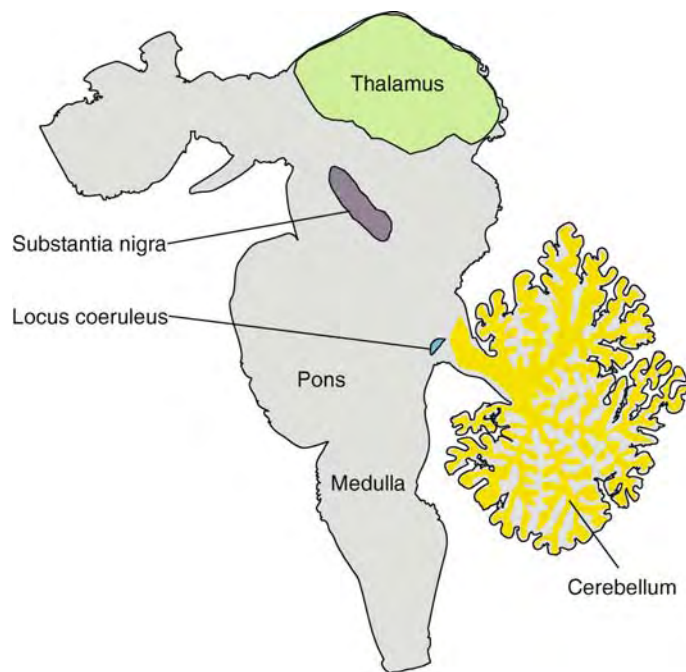

**Melanin and Neuromelanin in the Nervous System. Figure 2** Primary neuromelanin-containing regions of the human brain. The majority of neuromelanin-containing dopaminergic neurons are found in the substantia nigra located in the mesencephalon. Another major cluster of neuromelanin-containing cells are found within the locus coeruleus in the anterior pons adjacent to the superior cerebellar peduncle. Dopaminergic axons from the substantia nigra pars compacta, ventral tegmentum area, and arcuate nucleus of the mediobasal hypothalamus project to the striatum, nucleus accumbens, cerebrum, and the hypothalamic median eminence. Noradrenergic neurons innervate the spinal cord, cerebellum, hypothalamus, amygdala, cerebral cortex, and the basal telencephalon.



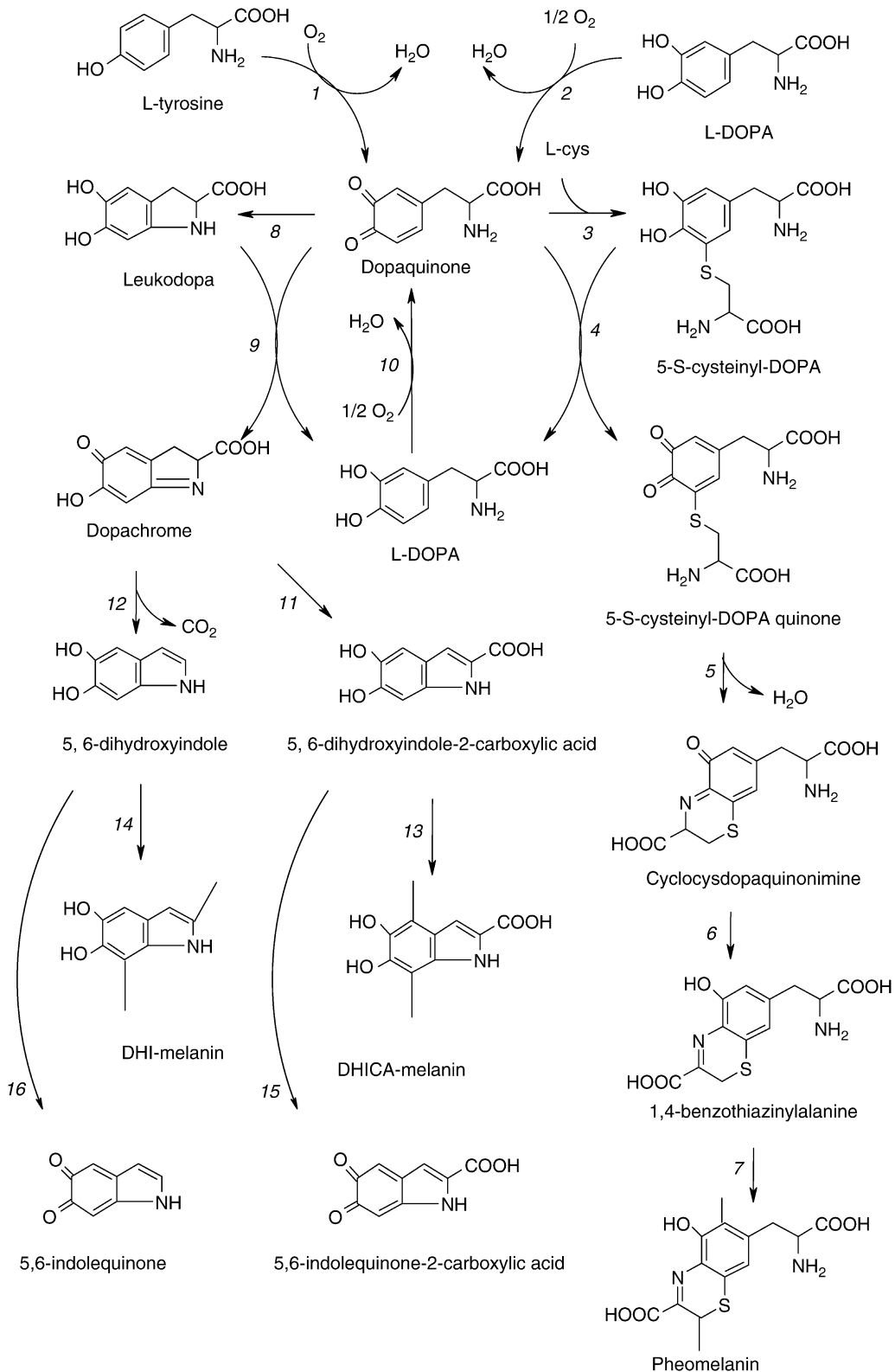

**Melanin and Neuromelanin in the Nervous System. Figure 3** Synthesis of eumelanins and pheomelanins. Tyrosinase (EC 1.14.18.1), a copper-containing monooxygenase, catalyzes the first steps of melanogenesis (reactions 1, 2, and 10) – the formation of dopaquinone by hydroxylation and oxidation of L-tyrosine. Dopaquinone is a key intermediate essential for synthesis of both pheomelanins and eumelanins. Pheomelanin synthesis is initiated

### Dopamine Neural Pathways

Four dopamine neural pathways exist: (i) nigrostriatal, (ii) mesocortical, (iii) mesolimbic, and (iv) tuberoinfundibular. The nigrostriatal is the largest of the four dopamine pathways and it connects the substantia nigra pars compacta and striatum to facilitate muscle control. The mesocortical pathway regulates emotional responses and connects the ventral tegmentum area of the midbrain to the cerebrum. The mesolimbic pathway connects the ventral tegmentum area to the nucleus accumbens, the reward/desire center of the brain. The tuberoinfundibular pathway connects the arcuate nucleus of the mediobasal hypothalamus to the hypothalamic median eminence, and regulates the release of prolactin. Neuromelanin granules have been detected within dopaminergic neurons in each of the four pathways, but are the most abundant and consistently evident in the substantia nigra pars compacta of the nigrostriatal pathway.

### Melanocytes Associated with the Nervous System

Three major populations of extracutaneous melanocytes provide accessory functions for the nervous system [1]. A large number of highly pigmented melanocytes can be found within the posterior choroid and ciliary body of the uveal tract, separated from the neural retina by the retinal pigment epithelium and Bruch's membrane. Melanin of the pigment epithelium and uveal tract prevents photodynamic damage in the very highly perfused choriocapillaris of the uveal tract and improves visual acuity by absorbing stray light. Specialized melanocytes, termed intermediate cells, are found in the stria vascularis of the scala media in the inner ear. These cells play a critical role in maintenance of the endocochlear potential, essential for hearing, by regulating potassium transport into the endolymph. Scattered melanocytes can be found throughout the meninges but are most apparent within the ventrolateral leptomeninges overlying the pons and medulla. Melanin produced by these melanocyte populations is believed to scavenge toxic

materials, including organic and inorganic cations and reactive oxygen species, providing a defense/protective function.

### Lower Level Components

#### Synthesis of Melanin, Pheomelanin, and Neuromelanin

Eumelanin and pheomelanin biosynthesis from L-tyrosine and L-cysteine sequestered within melanosomes, the specialized cytoplasmic organelles related to lysosomes and unique to melanocytes, is well understood (see Fig. 3) [1]. The levels of these two amino acids within melanosomes, along with intramelanosomal pH and the relative expression of melanin-producing enzymes, influence the forms of melanin ultimately produced. By contrast, less is known concerning neuromelanin synthesis (see Fig. 4). Within melanosomes, tyrosine is converted to L-DOPA by tyrosinase followed by oxidation to dopaquinone (Fig. 3, reactions 1, 2). Dopaquinone may react spontaneously with L-cysteine in the first committed step towards pheomelanogenesis (Fig. 3, reaction 3) or experience intramolecular cyclization to form leukodopa, which leads to the eumelanogenesis pathway (Fig. 3, reaction 8). The cytoplasmic enzyme tyrosine hydroxylase catalyzes formation of L-DOPA from L-tyrosine in neurons (Fig. 4, reaction 1) followed by decarboxylation to form dopamine in a reaction catalyzed by aromatic amino acid decarboxylase (Fig. 4, reaction 2). Dopamine is readily oxidized to the neuromelanin precursor dopamine quinone within dopaminergic neurons (Fig. 4, reaction 3). In noradrenergic neurons, dopamine is converted to norepinephrine by dopamine  $\beta$ -hydroxylase, which is also subject to oxidation to its analogous quinone, noradrenoquinone, believed to be another neuromelanin precursor.

#### Melanosome Structure

The processes of melanin synthesis and melanosome assembly (divided into Stages I–IV) are coordinated in human melanocytes. Mature human Stage IV **eumelanosomes** are membrane-enclosed ellipsoidal

---

when L-cysteine reacts spontaneously with dopaquinone to form 5-S-cysteinyl DOPA (reaction 3). Excess dopaquinone or other oxidants convert 5-S-cysteinyl-DOPA to 5-S-cysteinyl-dopaquinone nonenzymatically (reaction 4). Elimination of water from 5-cysteinyl-dopaquinone yields cyclocysdopaquinonimine (reaction 5), which isomerizes spontaneously to form 1,4-benzothiazinylalanine (reaction 6). Polymerization of 1,4-benzothiazinylalanine monomers yields pheomelanin (reaction 7). Synthesis of eumelanins begin with the spontaneous cyclization of dopaquinone to produce leukodopa (cyclodopa; reaction 8) followed by its oxidation to form dopachrome via a recycling reaction that regenerates L-DOPA from excess dopaquinone (reactions 9, 10). Dopachrome tautomerase (tyrosinase-related protein-2, TRP-2, EC 5.3.3.12) converts dopachrome to 5,6-dihydroxyindole-2-carboxylic acid (reaction 11). Spontaneous decarboxylation of dopachrome may occur at a reduced rate in the absence of TRP2 enzyme activity to yield 5,6-dihydroxyindole (reaction 12). Polymerization of 5,6-dihydroxyindole-2-carboxylic acid (reaction 13) yields a lighter colored pigment than does polymerization of 5,6-dihydroxyindole (reaction 14). Tyrosinase (in humans) or tyrosinase-related protein 1 (TRP-1, catalase B) catalyze oxidation of 5,6-dihydroxyindole-2-carboxylic acid or 5,6-dihydroxyindole to their respective o-quinones (reactions 15 and 16, respectively), which polymerize spontaneously to form eumelanins.

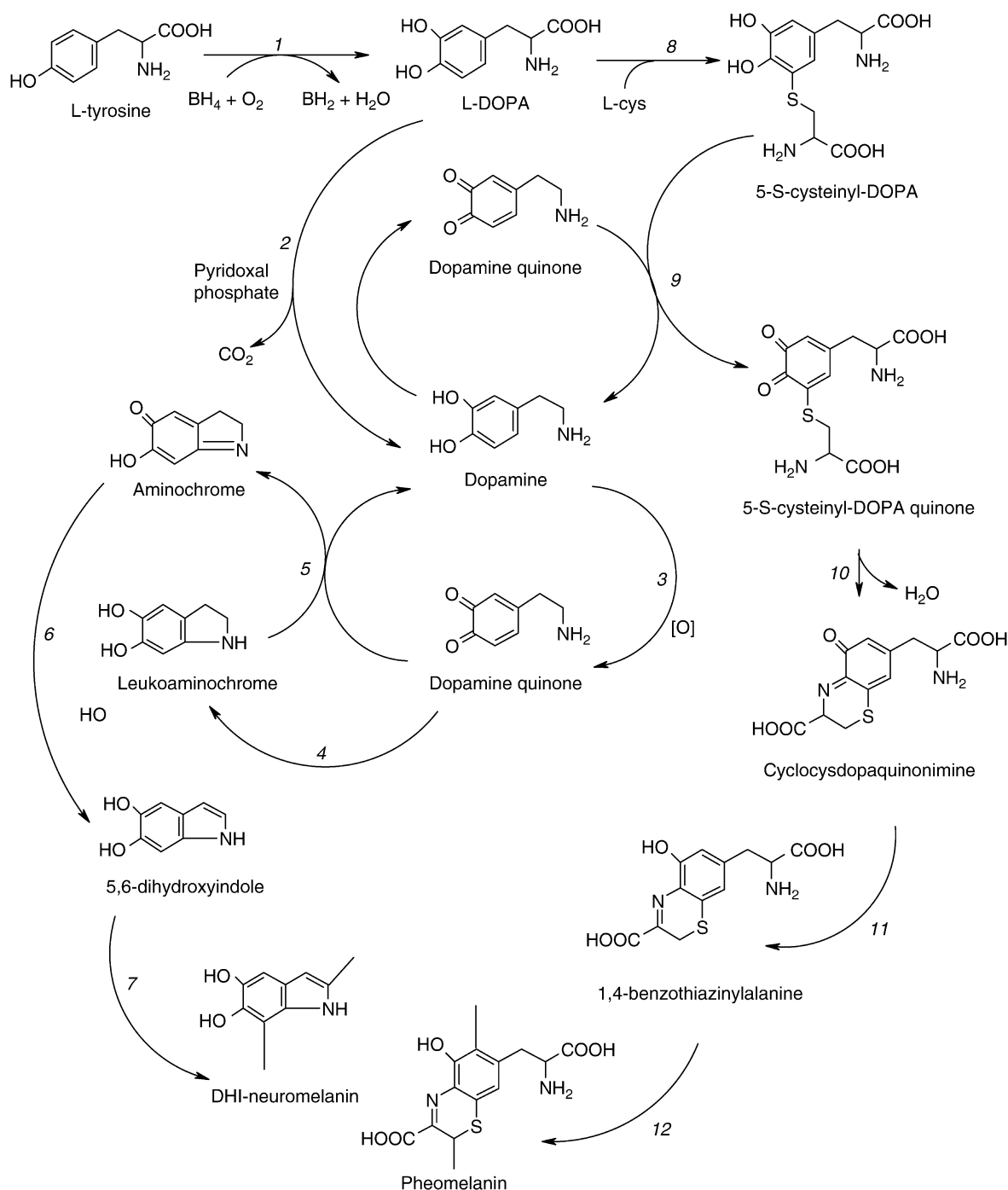

**Melanin and Neuromelanin in the Nervous System. Figure 4** Neuromelanin synthesis. Neuromelanin synthesis begins with hydroxylation of L-tyrosine to produce L-DOPA (reaction 1), catalyzed in catecholaminergic neurons by tyrosine hydroxylase (EC 1.14.16.2), a nonheme Fe-containing monooxygenase that utilizes tetrahydrobiopterin (BH<sub>4</sub>) as a cofactor. Aromatic amino acid decarboxylase (EC 4.1.1.28) utilizes pyridoxal phosphate as a coenzyme to produce dopamine via L-DOPA decarboxylation (reaction 2). Dopamine is easily oxidized nonenzymatically at physiological pH to generate dopamine o-quinone (reaction 3). Cyclization of dopamine o-quinone (reaction 4) to form leukoaminochrome occurs more slowly at physiological pH than in acidic conditions. Leukoaminochrome can be oxidized to aminochrome by dopamine o-quinone (reaction 5). Aminochrome rearranges to generate 5,6-dihydroxyindole (reaction 6) that polymerizes to form neuromelanin (reaction 7). Tyrosine hydroxylase also possesses an L-DOPA: L-cysteine conjugating activity that generates 5-S-cysteinyl-DOPA (reaction 8). Excess dopa (amine) quinone converts 5-S-cysteinyl-DOPA to its o-quinone (reaction 9), which can form pheomelanin by the

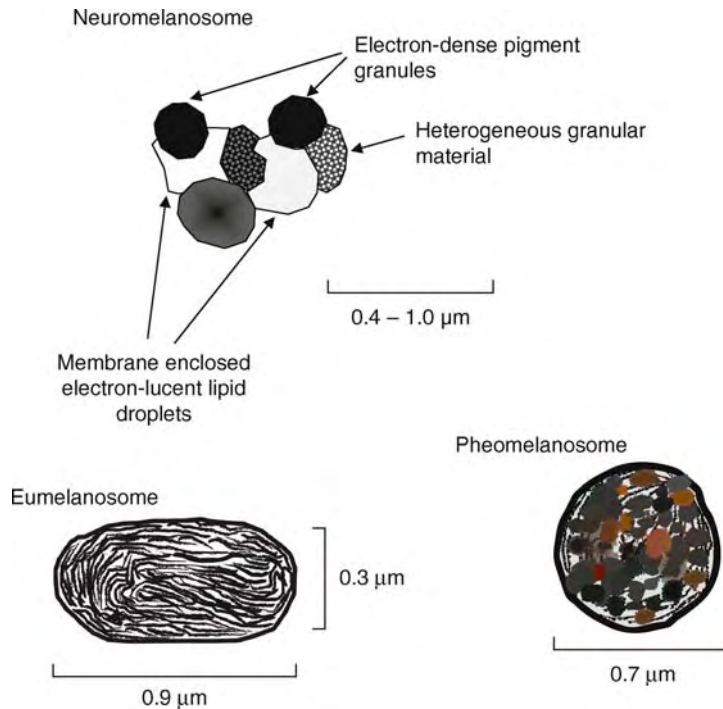

**Melanin and Neuromelanin in the Nervous System. Figure 5** Melanosome structure. Mature Neuromelanosomes found within catecholaminergic neurons may exhibit a distinct lipid bilayer enclosing aggregates of electron dense pigment granules associated with electron lucent lipid and heterogeneous granular material. Eumelanosomes and pheomelanosomes are found within melanocytes – or may be taken up by adjacent cells. A eumelanosome (Stage III) and a pheomelanosome (Stage IV) are depicted here. Stage II–III melanosomes exhibit a striated proteinaceous network that imparts a characteristic “fingerprint” appearance that is often obscured by pigment deposits in Stage IV melanosomes.

structures  $0.3 \mu\text{m} \times 0.9 \mu\text{m}$  that contain eumelanin pigment deposited in, or on, a fibrillar proteinaceous network that may be partially visible or completely obscured by pigment. Human Stage IV [▶pheomelanosomes](#) are spherical membrane-bound organelles  $0.7 \mu\text{m}$  in diameter that contain pheomelanin pigment (Fig. 5).

Melanosome development begins with budding of spherical Stage I melanosomes from the endoplasmic reticulum. Stage I melanosomes (premelanosomes) accumulate their major melanosomal scaffolding protein, Pmel17, which is organized to form the characteristic “fingerprint” network pattern via proteolytic processing. Stage II eumelanosomes begin to adopt their typical ellipsoidal shape and acquire tyrosinase via

endosome sorting vesicles. Pigment synthesis begins in Stage III melanosomes and Stage IV melanosomes are fully pigmented.

#### **Neuromelanosome Structure**

Mature [▶neuromelanosomes](#) examined by electron microscopy vary in size from  $0.5 \mu\text{m}$  to  $2.5 \mu\text{m}$  and appear as aggregates of electron dense pigment granules combined with electron lucent lipid bodies and heterogeneous granular material [5]. A lipid bilayer can sometimes be detected. Proteomic analysis of purified human neuromelanosomes identified 72 proteins and over half were characteristic of lysosomes (29), endosomes or sorting vesicles (9), or endoplasmic reticulum (4), supporting the hypothesis that these

same mechanism as in melanocytes (Fig. 3, reactions 5–7 and Fig. 4, reactions 10–12). Neuromelanogenesis in noradrenergic neurons begins similarly with 3-hydroxylation of L-tyrosine via tyrosine hydroxylase to form L-DOPA, followed by decarboxylation catalyzed by aromatic amino acid decarboxylase to produce dopamine. Norepinephrine is formed from dopamine via dopamine  $\beta$ -hydroxylase (EC 1.14.17.1), a Cu-containing oxidoreductase that utilizes ascorbate and molecular oxygen as cosubstrates. In a process analogous to that described for incorporation of dopamine into neuromelanin, norepinephrine is oxidized to noradrenochrome, which then cyclizes and rearranges to generate noradrenochrome. Tautomerization converts noradrenochrome to 3,4,6-trihydroxyindole, a neuromelanin monomer.

structures are derived from a lysosomal-endosomal lineage [6].

### Process Regulation

Melanin synthesis by melanocytes is stimulated by  $\alpha$ -melanocyte stimulating hormone, stem cell factor, endothelins, histamine, eicosanoids, estrogen, and vitamin D [7]. Neuromelanin synthesis is driven by cytoplasmic dopamine or norepinephrine levels that exceed their capacity for removal. In addition to consumption to form neuromelanin, the other principal mechanisms for cytoplasmic clearance of neurotransmitters include: (i) vesicular monoamine transporter (VMAT2)-dependent packaging into secretory vesicles, (ii) conversion to DOPAC by monoamine oxidase, and (iii) methylation via catechol *O*-methyltransferase.

### Function

Excessive cytoplasmic catecholamine levels generate dangerous quinone and semiquinone species [1,2,5,8,9]. Polymerization of reactive intermediates to form neuromelanin provides an effective cellular defense mechanism.

Hydrogen peroxide can be converted to much more reactive and dangerous hydroxyl radicals via the ►Fenton reaction. Melanins bind copious amounts of metal ions via abundant hydroxyl and amine functional groups which block these metal ions from participating in hydroxyl radical formation [1,8]. Chemical analysis of eu- and pheomelanosomes isolated from human hair reveal that metal ions represent 4.0% and 1.6% of the total mass, respectively [10]. Similar metal ion binding properties have been determined for neuromelanin [8]. The toxicity of a variety of chemicals and drugs, such as paraquat, chlorpromazine, haloperidol, amphetamine, and imipramine, can be modulated through sequestration by melanins [1,8].

Melanins are characterized as sinks for reactive oxygen species and diffusible alkoxy (RO $\cdot$ ) and peroxy (ROO $\cdot$ ) radicals. Electron spin resonance spectroscopy shows that melanins (including neuromelanins) exist as stable free radicals; a typical free radical content is one radical per 2,000 polymer unit [2,9]. The uniquely stable combination of quinone, hydroquinone, and radical groups present in melanin allows it to participate as electron donor or acceptor in one- and two-electron transfer reactions. Thus, melanins contribute to cellular antioxidant defenses by consuming a spectrum of toxic oxidizing agents.

### FDA Disclaimer

No official support or endorsement of this article by the Food and Drug Administration is intended or should be inferred. The views presented in this article do not necessarily reflect those of the Food and Drug Administration.

## References

1. Tolleson WH (2005) Human melanocyte biology, toxicology, and pathology. *J Environ Sci Health C Environ Carcinog Ecotoxicol Rev* 23:105–161
2. Zecca L, Stroppolo A, Gatti A, Tampellini D, Toscani M, Gallorini M, Giaveri G, Arosio P, Santambrogio P, Fariello RG, Karatekin E, Kleinman MH, Turro N, Hornykiewicz O, Zucca FA (2004) The role of iron and copper molecules in the neuronal vulnerability of locus coeruleus and substantia nigra during aging. *Proc Natl Acad Sci USA* 101:9843–9848
3. Truex RC, Carpenter MB (1969) Human neuroanatomy, 6th edn. Williams and Wilkins, Baltimore, MD
4. DeArmond SJ, Fusco MM, Dewey MM (1989) Structure of the human brain, 3rd edn. Oxford University Press, Oxford
5. Fedorow H, Tribl F, Halliday G, Gerlach M, Riederer P, Double KL (2005) Neuromelanin in human dopamine neurons: comparison with peripheral melanins and relevance to Parkinson's disease. *Prog Neurobiol* 75:109–124
6. Tribl F, Gerlach M, Marcus K, Asan E, Tatschner T, Arzberger T, Meyer HE, Bringmann G, Riederer P (2005) "Subcellular proteomics" of neuromelanin granules isolated from the human brain. *Mol Cell Proteomics* 4:945–957
7. Slominski A, Tobin DJ, Shibahara S, Wortsman J (2004) Melanin pigmentation in mammalian skin and its hormonal regulation. *Physiol Rev* 84:1155–1228
8. Zecca L, Zucca FA, Wilms H, Sulzer D (2003) Neuromelanin of the substantia nigra: a neuronal black hole with protective and toxic characteristics. *Trends Neurosci* 26:578–580
9. Borovansky J (1996) Free radical activity of melanins and related substances: biochemical and pathobiochemical aspects. *Sb Lek* 97:49–70
10. Liu Y, Hong L, Wakamatsu K, Ito S, Adhyaru B, Cheng CY, Bowers CR, Simon JD (2005) Comparison of structural and chemical properties of black and red human hair melanosomes. *Photochem Photobiol* 81:135–144

## Melanocyte

### Definition

Melanocyte is a cell located in the bottom layer of the skin's epidermis and in the middle layer of the eye, the uvea. Through a process called melanogenesis, these cells produce melanin, a pigment in the skin, eyes, and hair. There are both basal and activated levels of melanogenesis; lighter-skinned people generally have low basal levels of melanogenesis, and exposure to ultraviolet (UV) radiation generally causes increased melanogenesis (see MSH).

►Melanin and Neuromelanin in the Nervous System

## Melanoma-associated Retinopathy

### Definition

► Inherited Retinal Degenerations

## Melanopsin

IGNACIO PROVENCIO

Department of Biology, University of Virginia,  
Charlottesville, VA, USA

### Synonyms

Opn4; OPN4

### Definition

The opsin-based ► **photopigment** that confers photosensitivity upon ► **intrinsically photosensitive retinal ganglion cells (ipRGCs)**. In non-mammalian vertebrates, it is also present in other photoreceptive cells such as melanophores and pinealocytes.

### Characteristics

#### Discovery

Melanopsin was originally identified in the dermal melanophores of the African clawed frog *Xenopus laevis*. Melanophores darken in response to light and this photosensitivity is maintained in culture. Darkening is dependent upon the presence of retinoids, thereby suggesting that an opsin-based photopigment initiates this response. The search for such a photopigment in these cells eventually led to the discovery of melanopsin which was achieved through low-stringency screening of a melanophore cDNA library using probes based on the nucleotide sequences of the known opsin-based photopigments of *Xenopus*. Overexpression of melanopsin in these cells causes hyperphotosensitivity indicating a prominent role for this photopigment in darkening [1].

Melanopsin's deduced amino acid sequence shows highest homology to members of the opsin superfamily of G protein-coupled receptors. A lysine residue is present in the predicted seventh transmembrane domain, a hallmark of all opsins and a required site for retinoid chromophore attachment. Melanopsin possesses an unusually long intracellular carboxy-terminus tail containing many putative phosphorylation sites. Despite being identified in a vertebrate, melanopsin shares greater sequence homology to the rhabdomeric opsins that are typically found in invertebrate ► **photoreceptors** rather than the ciliary opsins of vertebrate ► **rods** and ► **cones** [2].

In addition to amphibians, melanopsin homologs have been characterized in cephalochordates, fish, reptiles, birds, and mammals. Non-mammalian vertebrates possess at least two melanopsin genes designated "x" and "m." The "x" genes are orthologs of the original gene identified in *Xenopus*, and the "m" genes are orthologs of the original homolog identified in mouse. The "x" melanopsin gene was lost in mammals prior to the eutherian/metatherian split [3].

### Localization

Like all opsin-based photopigments, mature melanopsin resides in the plasma membrane. However, unlike ciliary or rhabdomeric photoreceptors, the cells that contain melanopsin do not possess a photopigment-dense organelle specialized for light capture such as the outer segments of rods and cones or the rhabdomeres of invertebrate photoreceptors. Rather, melanopsin is found throughout the plasma membrane of most of the cell including the membranes of the cell soma, dendrites, and proximal axon [1].

In mammals, melanopsin is only expressed in a small subset of ► **retinal ganglion cells** that are intrinsically photosensitive (ipRGCs) [4]. At least three morphologically distinct subclasses of ipRGCs exist. The first subclass has dendrites that reside within the OFF sublamina of the inner plexiform layer (IPL) of the ► **retina**. The second subclass has dendrites that stratify within the ON sublamina of the IPL. The third subclass ramifies dendrites in the ON and OFF sublaminae of the IPL [5]. The primary central projections of these cells are to the ► **suprachiasmatic nucleus (SCN)**, ► **intergeniculate leaflet**, ► **olivary pretectal nucleus**, and lateral habenula. Other areas of the forebrain and midbrain receive less prominent projections [6].

In non-mammalian vertebrates, melanopsin is expressed in a range of cell types previously believed to be photoreceptive. For example, in *Xenopus* a high level of melanopsin is expressed in iridial myocytes, suggesting that melanopsin is likely to be responsible for the photosensitivity observed in the isolated amphibian iris. Non-mammalian vertebrates also exhibit melanopsin expression in the pineal gland and areas of the brain believed to harbor encephalic photoreceptors. In lower vertebrates and birds, inner retinal cells, in addition to a small number of retinal ganglion cells, also express melanopsin. The pattern of retinal expression varies across the classes of vertebrates, with birds demonstrating the most expansive pattern of retinal melanopsin expression. Finally, melanopsin has been identified in amphioxus (*Branchiostoma* spp.), the closest living relative to modern-day vertebrates. In these animals, melanopsin is found in the rhabdomeric Joseph and Hesse photoreceptor cells but not the frontal eye that contains ciliary photoreceptors [1].

### Spectral Sensitivity

The pupillary light reflex and ►**entrainment** of behavioral ►**circadian rhythms** to the ambient ►**light:dark cycle** are both examples of light-regulated physiology that does not require the construction of images. Accordingly, they can be considered non-visual responses to light. Previous action spectra studies on such responses in mice lacking functional rods and cones revealed a sensitivity in the blue wavelengths that peaked around 480 nm. At the time of these studies, the photoreceptor cells and their respective photopigments responsible for this blue sensitivity were not known. It is now firmly established that melanopsin-expressing ipRGCs mediate these non-visual photoresponses in blind mice. Consistent with this is the finding that the peak spectral sensitivity of light-induced membrane depolarization in ipRGCs is 484 nm. This value correlates well with photoresponses measured in *Xenopus* oocytes and HEK293 cells heterologously expressing mouse melanopsin. The peak sensitivities observed in these systems were 480 and 479 nm, respectively. Heterologously expressed amphioxus melanopsin absorbs maximally at 485 nm and behaves as a bistable photopigment much like Rh1 opsin of *Drosophila* [1,3,4,6–8].

### Signal Transduction

Metazoan opsin-based photopigments can be classified as rhabdomic (r-opsins) or ciliary (c-opsins) according to the photoreceptor type in which they reside. Typically, ciliary photoreceptors electrically hyperpolarize their cell membrane in response to illumination while rhabdomic photoreceptors depolarize the membrane. The characteristic that correlates most closely with the rhabdomic/ciliary classification scheme of opsins is the second messenger system that these photopigments initiate; r-opsins activate a  $G_q\alpha$ -mediated transduction cascade while c-opsins activate a  $G_t\alpha$ -mediated pathway. As mentioned, melanopsin, at the amino acid level, shows greater sequence homology to r-opsins than c-opsins [2]. Additionally, all melanopsin-bearing cells studied to date depolarize in response to light. These features strongly suggest that melanopsin initiates a  $G_q\alpha$ -based cascade [4].

Studies in cultured amphibian melanophores have shown that inhibitors of phospholipase C (PLC) and protein kinase C (PKC) block photoresponses. Furthermore, chelation of intracellular calcium renders melanophores photically insensitive. Moreover, a small cohort of proteins is phosphorylated in a PKC-dependent manner after melanophores are exposed to light. Taken together, these data also suggest that a  $G_q\alpha$ -based transduction cascade is initiated by melanopsin [1]. Several studies employing heterologous expression in cells not typically photoreceptive have concluded that melanopsin likely signals through a rhabdomic  $G_q\alpha$ -mediated pathway [6]. The details of such a transduction mechanism remain unknown. For example, the terminal

effector of this cascade that directly results in membrane depolarization is yet to be elucidated. Because of the similarities between melanopsin-based signaling and the canonical insect ►**phototransduction** cascade, it has been proposed that the melanopsin-initiated cascade is likely to regulate the gating of an ion channel in the *transient receptor potential* channel superfamily [4]. The kinases potentially involved in regulating or modulating the terminal effector also remain to be determined. Interestingly, PKC $\zeta$  colocalizes with melanopsin in ipRGCs, and mice null for PKC $\zeta$  are behavioral phenocopies of mice null for melanopsin [3,7].

### Function

In mammals, non-visual responses to light persist in the absence of rod and cone photoreceptors. Surgical removal of the eyes, however, abolishes these responses. These findings suggested the presence of an ocular non-rod, non-cone class of photoreceptor. The identification of melanopsin and the subsequent discovery of the ipRGCs that express this photopigment provided an explanation for the paradox that mammals lacking visual photoreceptors continue to respond to light. Mice null for melanopsin show some attenuated non-visual responses to light. Interestingly, they retain residual photoresponses that are mediated by rods and/or cones. Consequently, mice null for melanopsin and lacking rods and cones display no responses to light; they behave as animals do when bilaterally enucleated [1,3,7,9].

Among the non-visual photoresponses shown to be at least partially dependent upon melanopsin-based signaling are the photoentrainment of circadian locomotor rhythms, the acute photic regulation of pineal melatonin synthesis, the acute light-induced suppression of nocturnal activity, and the pupillary light reflex. The central targets of ipRGCs also provide insight into other potential forms of non-visual photophysiology that may be influenced by this newly discovered photosensory system. For example, a projection to the ventrolateral preoptic area suggests a role in the photic regulation of sleep. Likewise, a minor projection to the supraoptic nucleus of the hypothalamus implicates ipRGCs in the light-mediated regulation of neuroendocrine output. The previously described sparse retinal inputs to the lateral hypothalamus now appear to be derived almost exclusively from ipRGCs, suggesting that information from these cells may converge with olfactory inputs to regulate the reproductive axis. Other targets too numerous to detail here indicate a broad role for the melanopsin-expressing ipRGCs in the photic regulation of physiology [10].

Several human responses to light are maximally sensitive to blue wavelengths, consistent with the involvement of melanopsin. Acute photosuppression of serum melatonin, photic control of alertness and vigilance, light regulation of sleep architecture, and light mediated changes in heart rate all show maximal

sensitivity in the blue wavelengths thereby implicating the melanopsin-based photoreceptive system. In addition, some humans, despite being cognitively blind, continue to suppress serum melatonin levels in response to illumination. Taken together, these responses should give pause to clinicians who recommend enucleation of blind patients to minimize ocular complications such as recurrent infections. Although these patients may not be capable of forming images (vision), their eyes may still be serving them to regulate the multiple emerging examples of physiology regulated by light via the melanopsin-based ipRGC photoreceptors.

## References

1. Provencio I (2007) Melanopsin Cells. 1.20:423–431 In: Basbaum AI, Bushnell M, Smith D, Beauchamp G, Firestein S, Dallos P, Oertel D, Masland R, Albright T, Kaas J, Gardner E (eds) *The Senses: A Comprehensive Reference*. Elsevier, Amsterdam, 4640 pp
2. Arendt D (2003) Evolution of eyes and photoreceptor cell types. *Int J Dev Biol* 47:563–571
3. Hankins MW, Peirson SN, Foster RG (2007) Melanopsin: an exciting photopigment. *Trends Neurosci* 31:27–36
4. Berson DM (2007) Phototransduction in ganglion-cell photoreceptors. *Pflügers Arch* 454:849–855
5. Viney TJ, Balint K, Hillier D, Siegert S, Boldogkoi Z, Enquist LW, Meister M, Cepko CL, Roska B (2007) Local retinal circuits of melanopsin-containing ganglion cells identified by transsynaptic viral tracing. *Curr Biol* 17:981–988
6. Fu Y, Liao HW, Do MT, Yau KW (2005) Non-image-forming ocular photoreception in vertebrates. *Curr Opin Neurobiol* 15:415–422
7. Peirson S, Foster RG (2006) Melanopsin: another way of signaling light. *Neuron* 49:331–339
8. Van Gelder RN (2005) Nonvisual ocular photoreception in the mammal. *Meth Enzymol* 393:746–755
9. Foster RG, Hankins MW (2007) Circadian vision. *Curr Biol* 17:R746–R751
10. Hattar S, Kumar M, Park A, Tong P, Tung J, Yau KW, Berson DM (2006) Central projections of melanopsin-expressing retinal ganglion cells in the mouse. *J Comp Neurol* 497:326–349

## Melatonin

JOSEPHINE ARENDT

Centre for Chronobiology, Faculty of Health and Medical Sciences, University of Surrey, Guildford, Surrey, UK

### Synonyms

N-acetyl-5-methoxytryptamine; mel (abbreviation); MT (abbreviation); Pineal hormone; Darkness hormone

### Definition

An indolic hormone derived from the amino-acid tryptophan, via the tryptophan metabolite serotonin (5-hydroxytryptamine).

### Characteristics

#### Synthesis

The primary site of melatonin synthesis is the ►**pineal gland** (*epiphysis cerebri*), a small, unpaired central structure, essentially an appendage of the brain. In humans the pineal weighs around 100–150 mg. Melatonin is synthesized within pinealocytes – cell types derived from ►**photoreceptors** – via the pathway shown in Fig. 1. In virtually all species studied to date, whether ►**nocturnal or diurnal**, melatonin is synthesised and secreted during the dark phase of the day. Melatonin production is clearly a highly evolutionarily conserved phenomenon. In most circumstances the rate-limiting enzyme is serotonin-*N*-acetyltransferase (arylalkylamine *N*-acetyltransferase [AA-NAT] commonly abbreviated as NAT). Control in mammals is via sympathetic innervation from the superior cervical ganglia terminating in adrenergic receptors within the pineal gland. The rhythm of production is endogenous in that, like other circadian rhythms, it is generated in the ►**suprachiasmatic nucleus (SCN)**, the major central rhythm-generating system in mammals (the pineal itself is a self-sustaining “clock” in some, if not all, lower vertebrates) [1]. Other sites of synthesis exist, notably the ►**retina**, however pinealectomy abolishes the rhythm of circulating melatonin in mammals. Within the rodent retina a self-sustaining “clock” maintains rhythmic production of melatonin *in vitro* as it does in some lower vertebrates [2]. Whether this pattern is true in humans remains to be seen.

Melatonin synthesis is both entrained and suppressed by light of suitable intensity and spectral composition such that the duration of night time secretion reflects the length of the night [3]. The most effective wavelengths for melatonin suppression and ►**phase shifting** lie in the 460–480 nm area [4]. Rapid decline in activity with light treatment at night appears to depend on proteasomal proteolysis of NAT following dephosphorylation and removal of a protective 14–3–3 protein [5].

### Metabolism

Melatonin is metabolized primarily within the liver by 6-hydroxylation, followed by sulphate and/or glucuronide conjugation. 6-sulphatoxymelatonin (aMT6s) is the principle metabolite in humans, accounting for 50–80% of melatonin produced. A number of minor metabolites are also formed through ring splitting, cyclization of the side chain, or demethylation. In humans and rodents, exogenous oral or intravenous melatonin has a short metabolic half-life (20–60 min, depending on the author and species), with a large



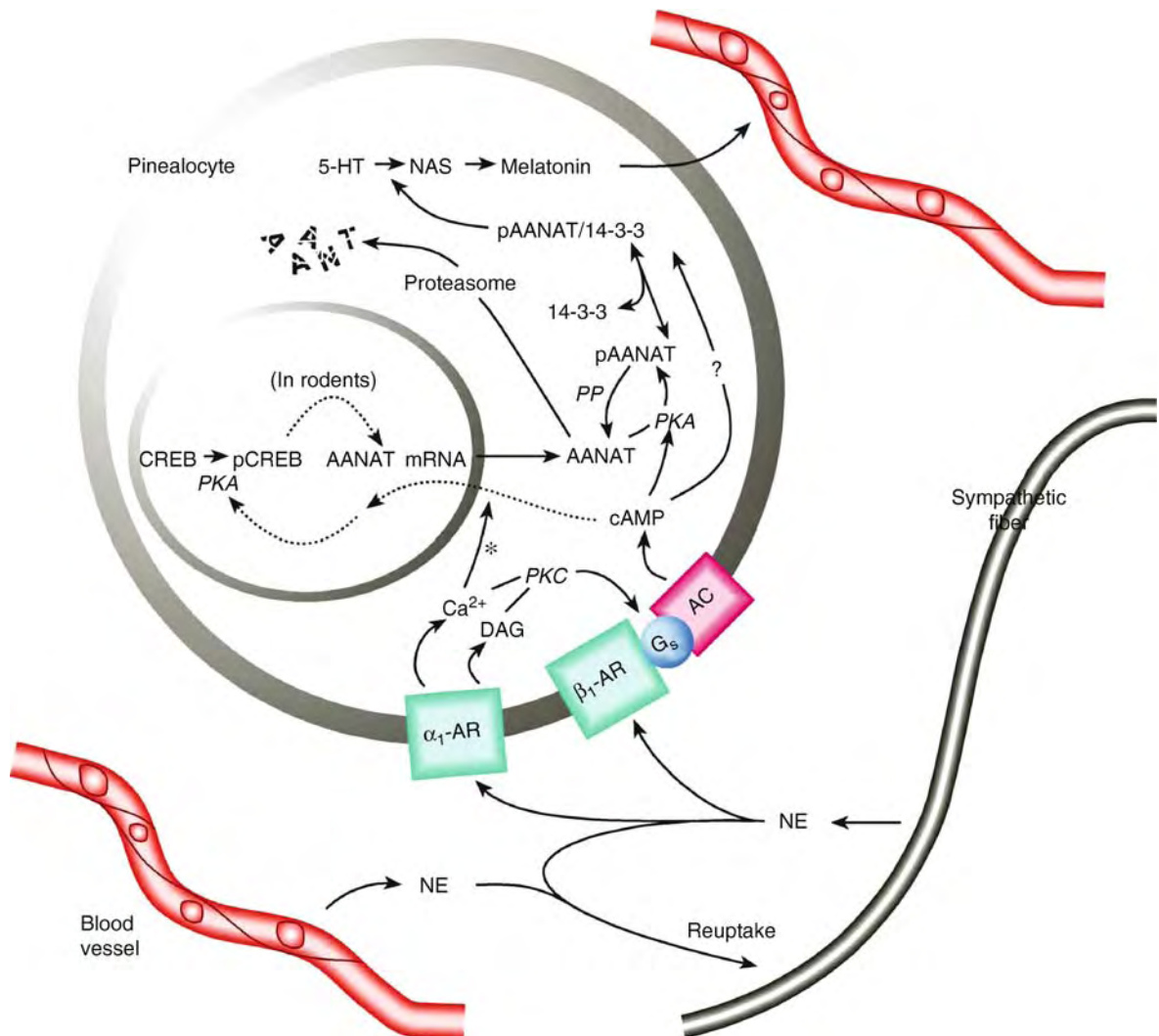

**Melatonin.** Figure 1 Diagram of the sympathetic control of melatonin synthesis in the rodent pineal gland. *5HT*, 5-hydroxytryptamine; *NAS*, N-acetyl serotonin; *AANAT*, serotonin-N-acetyltransferase; *NE*, noradrenalin (norepinephrine); *cAMP*, cyclic adenosine monophosphate; *AC*, adenylate cyclase; *pKA*, protein kinase A; *pKC*, protein kinase C; *DAG*, diacylglycerol; *AR*, adrenergic receptor; *CREB*, cAMP-responsive element-binding protein; *pCREB*, phosphorylated cAMP-responsive element-binding protein; *pAANAT/14-3-3*, phosphorylated serotonin-N-acetyltransferase/14-3-3 protein complex; *pAANAT*, phosphorylated serotonin N-acetyl transferase. From Ganguly, S., Coon, S.L. & Klein D.C. Control of melatonin synthesis in the mammalian pineal gland: the critical role of serotonin acetylation. *Cell Tissue Res*, 2002, 309:127–137.

hepatic first-pass effect and a biphasic elimination pattern. In ruminants, longer half-lives are seen after oral administration [3].

#### A Photoneuroendocrine Transducer

When seasonal functions are primarily timed by day length, species are referred to as being photoperiodic. Moreover photoperiod is often critical for the timing of pubertal development. In photoperiodic mammals and marsupials, an intact innervated pineal gland is essential for the perception of photoperiodic change. The critical signal is the changing duration of melatonin secretion in

response to daylength. Long-duration melatonin is equivalent to short days, and short-duration melatonin is equivalent to long days. Interpretation of the signal, as with day length, depends on the physiology (for example, long- or short-day breeder) of the species in question [6]. The mechanism of action of melatonin with regard to seasonal variation in reproductive competence and the timing of puberty in animals is thought to involve an influence of melatonin on steroid feedback mechanisms in the brain, together with a direct influence on the pituitary gland via melatonin receptors. There is recent evidence that melatonin

acts directly on peripheral **clock genes** to convey information about photoperiod. Melatonin treatment has been commercialised for the purpose of changing the time of the breeding season (and other seasonal functions) in domestic species such as sheep and goats. In appropriate experimental conditions humans show a duration change in response to daylength changes, like animals [4].

### A Hand of the Clock

The secretion of melatonin from the pineal is probably the most direct peripheral link to the central circadian clock. In healthy individuals, the timing, amplitude, and even the details of the profile can be highly reproducible from day to day and from week to week, rather like a hormonal fingerprint even without strictly controlled sampling conditions. The very large interindividual variations have been ascribed to the size of the pineal gland rather than to variations in enzymic activity. No consistent gender differences have been found and a small number of apparently normal individuals have no detectable melatonin in plasma at all times of day. Diurnal preference (morningness) and short **free-running** circadian **period** are associated with earlier

melatonin phase. There are seasonal variations in human melatonin (and aMT6s), with an earlier phase in summer and, according to some reports, increased levels and duration of secretion in winter in high latitudes. Plasma melatonin declines during development and with age [4].

For clinical assessments of possible circadian abnormality, the use of melatonin “onset” – the start of the evening rise – in plasma or saliva has been used as a phase marker of the internal clock, as it avoids overnight sampling [4]. There is some evidence that two **oscillators** usually known as M and E (for **morning/evening oscillators**) are concerned with the generation of the melatonin rhythm. The rise is theoretically associated with E, and the fall with M [4]. Differential effects on the rise and fall, and even on the details of the overnight profile, may well be clinically important (Fig. 2). There is extensive evidence for good correlations in both timing and amplitude between the rhythms of plasma and saliva melatonin and the urinary metabolite aMT6s.

A variety of observations in disease states indicate that the amplitude and sometimes the timing of the rhythm may be modified. It is hard to draw any general

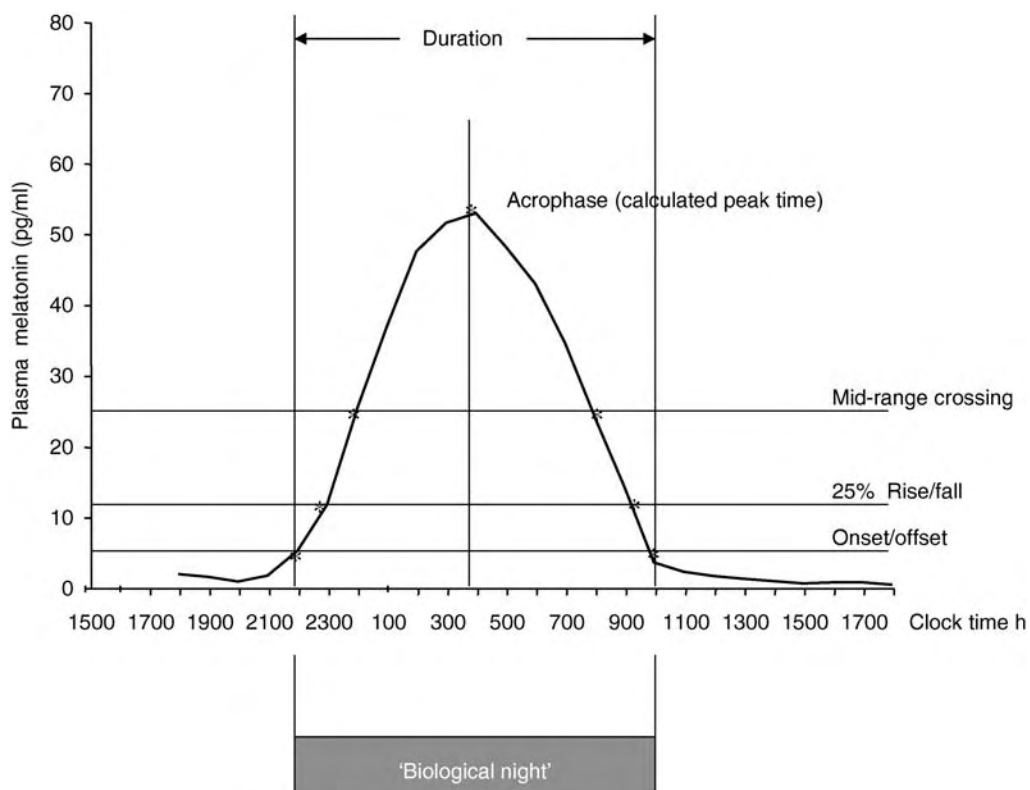

**Melatonin. Figure 2** Diagram of the markers used to characterize melatonin and aMT6s (6-sulphatoxymelatonin) rhythms. Area under the curve or total 24-h excretion (aMT6s) is used to assess total secretion. At present, there is no standard definition of onset-offset (and hence duration). Redrawn from: Arendt, J. & Skene, D. J. Melatonin as a chronobiotic. *Sleep Med Rev*, 2005, 9:25–39.

conclusions, and it is rare for such clinical studies to control for all known masking factors.

The timing and duration of melatonin secretion are its critical features with regard to physiological functions. The relevance of small changes in melatonin amplitude remains obscure, particularly in view of the enormous individual variation between normal healthy subjects.

### Role of Melatonin in the Circadian System

In some lower vertebrates and birds melatonin has a major role in the organisation of circadian rhythms. In mammals this role is hierarchically less important and until quite recently, opinion was that the pineal did not have an important role in the mammalian circadian system. Some strains of (healthy, prolific) laboratory mice have virtually no detectable melatonin. Pinealectomised rats show no obvious circadian abnormalities unless 'challenged'. However, in rats, pinealectomy increases the rate of re-**entrainment** to forced phase shifts of the light-dark cycle, and pinealectomy of hamsters in constant light leads to major disruption of the circadian system [3]. In rodents, maternal melatonin can influence the circadian timing of the foetus [7]. In humans it is likely that the phase shifting effects of light do not depend on melatonin suppression, but that the presence of endogenous or exogenous melatonin can in some circumstances modulate the effects of light on the circadian system. Melatonin has received much attention as a 'sleep hormone'. However it is quite possible to sleep out of phase with melatonin (although sleep is somewhat compromised). Essentially the presence of melatonin secretion appropriately timed, at night, reinforces physiological events that occur at night, for example sleep and the decline in core body temperature. Most evidence for a circadian role of melatonin derives from timed administration.

### Effects of Exogenous Melatonin on Sleep and Circadian Rhythms

Aaron Lerner discovered melatonin. He was the first person to show, 40 years ago, that melatonin had sleep-inducing effects. Now it is clear that low (0.1–10 mg) doses of melatonin during the "biological day," that is, when endogenous melatonin levels are low, can induce transient sleepiness or sleep, and lower core body temperature, in suitably controlled circumstances (posture is important; the greatest effects are seen with recumbent subjects in very dim light). These effects are opposite to the acute effects of bright light given at night. A substantial body of literature has described effects on sleep and sleep structure comparable to but not identical with benzodiazepines [8]. There is little evidence to suggest that it has important effects in normal sleepers if given at habitual bedtime.

Melatonin can shift the timing of SCN activity in vitro: clear evidence that it affects the central circadian clock [9]. In the dose range 0.05–10 mg melatonin is able to shift circadian timing to both later and earlier times when administration is appropriately timed. **Phase advances** (and possibly **phase delays**) are dose-dependent using a single dose in the range 0.05 to 5 mg. As for light, appropriate timing of treatment to delay or advance the circadian system can in principle be predicted from a **phase-response curve** (PRC) in subjects whose body clock phase is known [10]. The reported PRCs to melatonin are essentially the reverse of that to light. In controlled experiments melatonin can shift all circadian rhythms observed to date. It is possible to differentiate the acute sleep-inducing and circadian phase shifting effects and in these circumstances it is evident that melatonin changes the timing and distribution of sleep but not total sleep time in healthy subjects (Fig. 3). In subjects whose sleep is suboptimal due to misalignment of circadian rhythms the ability of melatonin to optimise circadian phase relative to sleep and to induce sleep during biological day mean that it has therapeutic properties in circadian rhythm sleep disorder.

The phase shifting properties of melatonin mean that in principle it can entrain free running rhythms. This property was initially demonstrated in rats. However it was only 15–20 years later that full entrainment was shown in humans. There is no doubt that timed melatonin administration (0.5–5 mg at 24-h intervals, usually at desired bedtime) can entrain (or synchronize) the free-running circadian rhythms of most blind subjects, with a consequent improvement in sleep and daytime alertness (even without entrainment, sleep is improved). Interestingly, if entrainment does not occur, shortening of circadian period is seen in the blind. It is possible that one action of melatonin is to shorten period, to the extent that entrainment is possible by other time cues if present [10].

### Treatment of Circadian Rhythm Sleep Disorders

Melatonin has been employed to treat various circadian rhythm disorders, including **delayed sleep phase syndrome (DSPS)**, free run (non-24 h sleep wake cycles, common in blind people with no light perception at all), and desynchrony due to **jet lag** and **shift work**. Most success has been obtained in DSPS and in blind free-run [10]. Various factors may influence the ability of melatonin to entrain and or phase shift both blind and sighted humans including dose, formulation, individual pharmacokinetics, free-running period, receptor sensitivity, and behavior. In sighted subjects, unknown circadian phase, unpredictable light exposure, and self-selected sleep times are probably the reason for some inconsistency in the clinical trials of melatonin in shift work and jet lag.

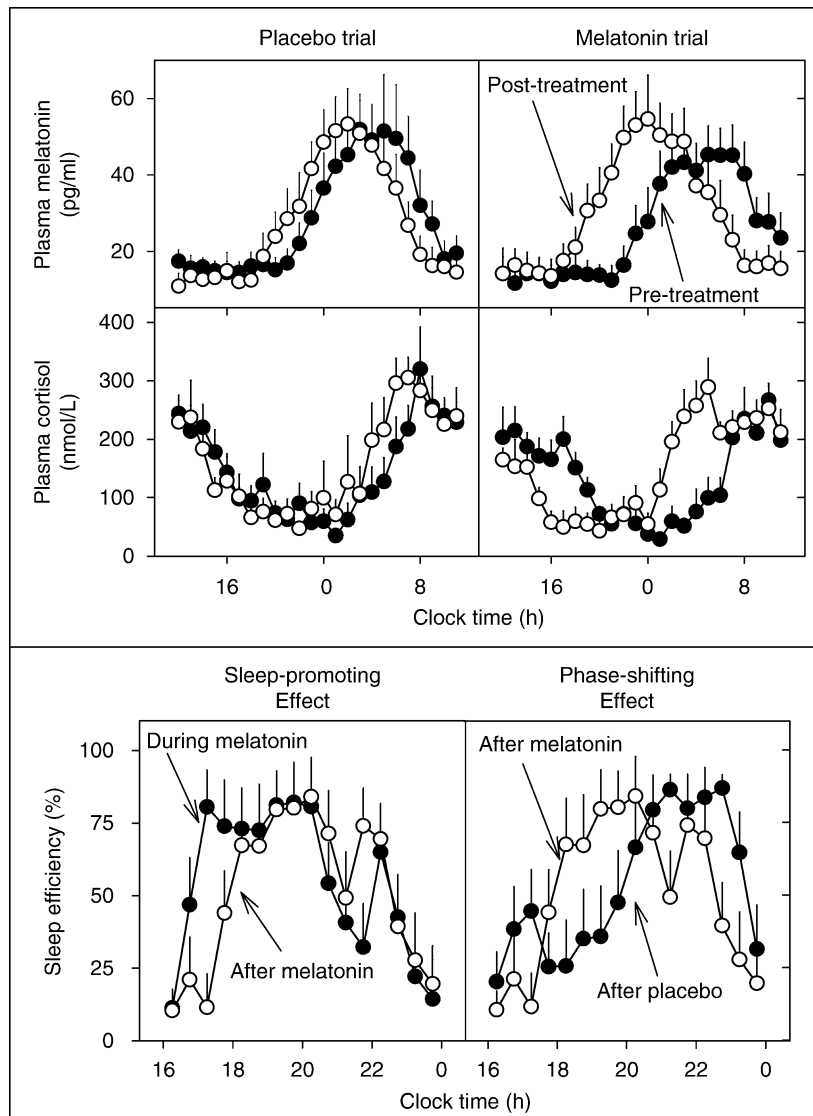

**Melatonin. Figure 3** The direct and circadian effects of melatonin. (a) Melatonin administration (at 16h) phase-advances endogenous melatonin and cortisol rhythms in healthy volunteers ( $n = 8$ ) exposed to a phase-advanced, extended sleep opportunity (16.00 h, daily for 8 days). Data are mean  $\pm$  SEM for placebo trial (left) and melatonin (right), pre-treatment (closed circles) and post-treatment (open circles). Melatonin reinforced the phases advances seen with placebo ( $P < 0.05$ ). Redrawn from Rajaratnam, S. W., Dijk, D. J., Middleton, B., Stone, B. M. & Arendt, J. Artificially prolonged melatonin profile phase-shifts human circadian rhythms without altering the duration of endogenous melatonin secretion, daytime sleepiness, mood or the 24h production of reproductive hormones. *J Clin Endocrinol Metab*, 2003, 88:4303–9. (b) Sleep-promoting and phase-shifting effects of melatonin. Sleep efficiency (% per hour, mean  $\pm$  SEM, polysomnography) from the study in Fig. 3a. The direct, sleep-promoting effect of melatonin (left panel) is seen by comparison of the last day of melatonin treatment (closed circles) and the first post-treatment day, open circles). Increased sleep efficiency is observed for the first 2 to 3 h during melatonin treatment (grey shaded). The phase-shifting effect of melatonin on sleep (right panel) is seen when comparing data (melatonin, closed circles, placebo open circles) from the first post-treatment day. A shift in the distribution of sleep can be observed after melatonin treatment. Redrawn with permission from Rajaratnam, SM.W., Middleton, B., Stone, B.M., Arendt, J. & Dijk, D-J. Melatonin advances the circadian timing of EEG sleep and directly facilitates sleep without altering its duration in extended sleep opportunities. *J Physiol*, 2004, 561:339–351.

## Melatonin and Cancer

This subject is included here since there is evidence that pinealectomy, photoperiod per se and forced phase shifts of the light dark cycle can influence growth of tumors. In vivo, it has also been reported that melatonin may increase or decrease tumor growth, depending on ►**photoperiod**, in hamsters. It has been proposed that light at night during night shift work suppresses melatonin and that this loss of melatonin “activity” is responsible for the possible increased cancer risk. However, to attribute any detrimental effects directly to loss of melatonin is overspeculative. Light at night has numerous other effects. The mere fact of frequent disruption of all circadian rhythms, not just melatonin, is effectively a physiological insult [4].

## Summary

The rhythm of melatonin production provides information on daylength for the organisation of biological rhythms. It appears to be the only solidly established humoral method of signaling time of day and time of year to other physiological systems. The rhythm in plasma or saliva provides the best available measure of the timing of the internal circadian clock. Melatonin is not only a “hand of the clock”; endogenous melatonin acts to reinforce the functioning of the mammalian circadian system. Most is known in humans about its relationship to sleep and the decline in core body temperature and ►**alertness** at night. Melatonin clearly has the ability to induce sleepiness and lower core body temperature during “biological day” and to change the timing of human rhythms when treatment is appropriately timed. It can entrain free-running rhythms and maintain entrainment in most blind and some sighted people. Used therapeutically it has proved a successful treatment for circadian rhythm disorder, particularly the non-24-h sleep wake disorder of the blind. Numerous other clinical applications are under investigation. In normal subjects endogenous melatonin and light may act in concert to help maintain synchrony with the 24 h day. Threads of evidence indicate an involvement in timing mechanisms throughout life. For therapeutic purposes a combination of timed melatonin and exposure to bright light promises much for the future.

## References

1. Klein DC, Coon SL, Roseboom PH, Weller JL, Bernard M, Gastel JA, Zatz M, Iuvone PM, Rodriguez IR, Begay V, Falcon J, Cahill GM, Cassone VM, Baler R (1997) The melatonin rhythm-generating enzyme: molecular regulation of serotonin N-acetyltransferase in the pineal gland. *Recent Prog Horm Res* 52:307–357; discussion 357–358
2. Iuvone PM, Tosini G, Pozdeyev N, Haque R, Klein DC, Chaurasia SS (2005) Circadian clocks, clock networks, arylalkylamine N-acetyltransferase, and melatonin in the retina. *Prog Retin Eye Res* 24:433–456

3. Arendt J (1995) Melatonin and the mammalian pineal gland, Chapman Hall, London
4. Arendt J (2005) Melatonin: characteristics, concerns, and prospects. *J Biol Rhythms* 20:291–303
5. Klein DC (2007) Arylalkylamine N-acetyltransferase: “the Timezyme”. *J Biol Chem* 282:4233–4237
6. Goldman BD (2001) Mammalian photoperiodic system: formal properties and neuroendocrine mechanisms of photoperiodic time measurement. *J Biol Rhythms* 16:283–301
7. Goldman BD (2003) Pattern of melatonin secretion mediates transfer of photoperiod information from mother to fetus in mammals. *Sci STKE:PE29*
8. Brzezinski A, Vangel MG, Wurtman RJ, Norrie G, Zhdanova I, Ben-Shushan A, Ford I (2005) Effects of exogenous melatonin on sleep: a meta-analysis. *Sleep Med Rev* 9:41–50
9. Gillette MU, Tischkau SA (1999) Suprachiasmatic nucleus: the brain’s circadian clock. *Recent Prog Horm Res* 54:33–58; discussion 58–59
10. Arendt J, Skene DJ (2005) Melatonin as a chronobiotic. *Sleep Med Rev* 9:25–39

## Melatonin Receptors

JOSEPHINE ARENDT

Centre for Chronobiology, Faculty of Health and Medical Sciences, University of Surrey, Guildford, Surrey, UK

## Synonyms

MT1, Mel1a, MTNR1A; MT2, Mel1b, MTNR1B

## Definition

A seven transmembrane domain, G protein-coupled receptor (GPCR) which binds melatonin.

## Characteristics

### Melatonin Binding Sites

Melatonin G protein-coupled membrane receptors are considered to mediate the effects of this hormone on numerous physiological systems and notably its influence on seasonal and circadian rhythms. The development of 2-<sup>125</sup>I-iodomelatonin as a high-specific activity ligand permitted the identification of high-affinity, saturable, specific, and reversible ►**melatonin** binding to cell membranes in the central nervous system, initially in the central circadian clock, the ►**suprachiasmatic nucleus** (►**SCN**), and the *pars tuberalis* (PT) of the pituitary, [1–4] and subsequently in many brain and other areas, including cells of the immune system, a number of cancer cell lines, the gonads, the kidney, and the cardiovascular system. The SCN shows clear binding in human postmortem tissue [3]. Species

variation of melatonin-binding sites in the brain is apparent. The most consistent (but not universal) binding site between mammalian species is the *pars tuberalis*, primarily implicated in transduction of the effects of ►photoperiod, via melatonin, on seasonal variations in prolactin secretion in ruminants [5].

A functional melatonin receptor exists in rabbit and chicken ►retina (inhibition of calcium-dependent dopamine release) and is localized in dopamine-containing amacrine cells in the inner plexiform, in the outer and inner segments in mice, and possibly in the pigmented layer in some mammals [4].

The interaction of melatonin with nuclear receptors (RZR/ROR alpha and RZR beta) and intracellular proteins, such as calmodulin or tubulin-associated proteins has also been reported. The transcription factor RZR/ROR alpha may mediate a direct gene regulatory action of the hormone. It has been hypothesized that while the effects of melatonin on circadian and seasonal rhythms appear to use the membrane receptors, peripheral effects of melatonin (such as immunomodulatory effects) may largely be mediated by RZR/ROR alpha [6].

### Melatonin Receptor Pharmacology

Melatonin-induced pigment aggregation in amphibian melanophores provided an early model for investigation of melatonin receptor pharmacology. It is a pertussis toxin-sensitive system and melatonin inhibits forskolin-activated cAMP formation. Inhibition of cAMP production may be a general feature of melatonin receptors. Intensive investigation of the properties of the *pars tuberalis*-binding site has revealed that physiologic doses of melatonin inhibit forskolin-activated cAMP production *in vitro* in a time- and dose-related manner [2]. Guanosine triphosphate analogues, which interfere with the regeneration of G<sub>1</sub>-coupled receptors, decrease the affinity and sometimes the capacity of <sup>125</sup>I-melatonin binding in reptiles, birds, and mammals.

Melatonin receptors have been cloned, and three subtypes were initially named Mel-1a, Mel-1b, and Mel-1c [3]. The Mel 1a receptor gene has been mapped to human chromosome 4q35.1. Its primary expression is in the *pars tuberalis* of the pituitary and the SCN. Mel 1b has been mapped to chromosome 11q21–22 and its main expression is in the retina and the brain. Mel 1c is not found in mammals. Two cloned mammalian receptors (Mel 1a, Mel 1b) have now been renamed MT1 and MT2 [4]. They are a new family of G protein coupled receptors (GPCRs), have high affinity (K<sub>d</sub> 20–175 picomolar) and inhibit forskolin-stimulated cyclic AMP formation. The so-called MT3 receptor is an enzyme, quinone reductase, concerned with detoxification mechanisms. This may be at least a partial explanation for some of the free-radical scavenging/antioxidant properties of high dose melatonin (not to be considered here).

The two cloned receptors, MT1 and MT2, are of particular importance with regard to rhythm physiology and pharmacology. Using gene knockout technology in mice and pharmacological manipulations, initially the MT1 receptor, most studied in the SCN and the *pars tuberalis* of the pituitary, and the MT2 receptor (also found in the SCN) were thought to have different functions, with ►phase shifting rhythms attributed to MT2 and suppression of SCN activity (countering the “wake” signal of the SCN) attributed to MT1. However more recently it appears that there is redundancy between these two receptors [7]. They can also form heterodimers which differ in properties from the monomeric forms [8].

MT1 has important actions within the *pars tuberalis* controlling seasonal prolactin variations in ruminants [5]. The hypothalamic receptor(s) concerned with seasonal and circadian variations in gonadotrophins has not been unequivocally identified, however melatonin regulation of reproductive functions in sheep is mediated by action in the premammillary hypothalamus [9].

Genetic polymorphism has been identified within melatonin membrane receptors, and further investigation of these polymorphisms in relation to photoperiodism, human disease, sensitivity to melatonin, and so on, is ongoing.

Probably the most interesting development in the effects of melatonin concerns its influence on peripheral gene expression in the *pars tuberalis* [5]. In rodent *pars tuberalis* cells, rhythmic expression of the ►clock gene *per1* appears to be dependent on sensitization of adenosine A2b receptors, which in turn depend on melatonin activation of MT1 receptors [10]. Clearly it is possible that the melatonin signal is a widespread humoral mechanism related to biological timing, acting through modification of peripheral clock gene expression. The effects of melatonin on peripheral, as well as central, clock gene expression are likely to be a rich field of enquiry.

### Melatonin Analogues

In view of the properties of melatonin (see section “Melatonin”) there has been much effort directed to the synthesis and evaluation of indolic and non-indolic analogues specific for either or both of the MT1 and MT2 receptors. Both agonists and antagonists with varying specificity have been described. Human trials of sleep promoting, circadian phase-shifting and anti-depressant effects are ongoing. Most information is available for three agonists (agomelatine/valdoxan/S20098, *N*-[2-(7-methoxynaphthalen-1-yl)ethyl]acetamide, ramelteon TAK-375 rozerem (*S*)-*N*-[2-(1,6,7,8-tetrahydro-2*H*-indeno-[5,4-*b*]furan-8-yl)ethyl]propionamide and VEC-162 (1*R*-*trans*)-*N*-[[2-(2,3-dihydro-4-benzofuranyl) cyclopropyl] methyl] propanamide). All appear to be selective for the MT1 and MT2 receptors with little

affinity for other receptors. Agomelatine in addition has 5-HT<sub>2c</sub> antagonist activity and in view of this the emphasis of clinical work has shifted to its anxiolytic and anti-depressant activity. It effectively targets both depressive disorders, in particular major depressive disease, and circadian rhythm sleep disorders. Ramelteon has received marketing authorization for insomnia. VEC-162 shows promise with respect to its ability to phase shift the circadian system and to regulate sleep [11].

Development of melatonin agonists and antagonists, with varying affinities to MT1 and MT2, and possibly to other, yet to be reported, melatonin receptors, may elucidate the mechanisms of melatonin action, and further enhance the therapeutic potential of “melatonergic” drugs.

## References

1. Vanecek J, Watanabe K (1999) Mechanisms of melatonin action in the pituitary and SCN. *Adv Exp Med Biol* 460:191–198
2. Morgan PJ, Williams LM (1989) Central melatonin receptors: implications for a mode of action. *Experientia* 45:955–965
3. Reppert SM (1997) Melatonin receptors: molecular biology of a new family of G protein-coupled receptors. *J Biol Rhythms* 12:528–531
4. Dubocovich ML, Rivera-Bermudez MA, Gerdin MJ, Masana MI (2003) Molecular pharmacology, regulation and function of mammalian melatonin receptors. *Front Biosci* 8:d1093–d108
5. Hazlerigg DG, Morgan PJ, Messenger S (2001) Decoding photoperiodic time and melatonin in mammals: what can we learn from the pars tuberalis? *J Biol Rhythms* 16:326–335
6. Carlberg C (2000) Gene regulation by melatonin. *Ann N Y Acad Sci* 917:387–396
7. Jin X, Von Gall C, Pieschl RL, Gribkoff VK, Stehle JH, Reppert SM, Weaver DR (2003) Targeted disruption of the mouse Mel(1b) melatonin receptor. *Mol Cell Biol* 23:1054–1060
8. Ayoub MA, Levoe A, Delagrangre P, Jockers R (2004) Preferential formation of MT1/MT2 melatonin receptor heterodimers with distinct ligand interaction properties compared with MT2 homodimers. *Mol Pharmacol* 66:312–321
9. Malpoux B, Tricoire H, Mailliet F, Daveau A, Migaud M, Skinner DC, Pelletier J, Chemineau P (2002) Melatonin and seasonal reproduction: understanding the neuroendocrine mechanisms using the sheep as a model. *Reprod Suppl* 59:167–179
10. Von Gall C, Garabette ML, Kell CA, Frenzel S, Dehghani F, Schumm-Draeger PM, Weaver DR, Korf HW, Hastings MH, Stehle JH (2002) Rhythmic gene expression in pituitary depends on heterologous sensitization by the neurohormone melatonin. *Nat Neurosci* 5:234–238
11. Arendt J, Rajaratnam SW (2008) Melatonin and its agonists for treatment of sleep and circadian rhythm disorders – an update. *Brit J Psychiat* (in press)

## Membrane Biophysics

P. M. LALLEY<sup>1</sup>, U. WINDHORST<sup>2</sup>

<sup>1</sup>Department of Physiology,  
The University of Wisconsin School of Medicine,  
Medical Science center, Madison,  
Wisconsin, USA

<sup>2</sup>Göttingen, Germany

### Synonyms

Membrane physico-chemical relationships

### Definition

Application of the laws and methods of physics to the study of cell membrane properties and functions.

### Introduction

At a cellular level, information transmission and processing must occur within the cell, between its different parts, and with the extracellular environment at the cell surface. Internal membranes that delineate compartments, and the surface cell membrane (► **plasmalemma** or ► **sarcolemma**) play prominent roles in organizing cellular life. They serve to preserve the semi-autonomy of the cell, with two competing aspects: cell ► **homeostasis** (maintenance and preservation of a fairly constant internal milieu) by incapsulation on the one hand, and exchange with the environment through a continual flux of matter, energy and information on the other. Membranes provide and organize means to subserve both aspects. In particular, information transmission must be securely put on a molecular basis. The cell membrane should thus provide the following:

- Mobility of cell wall constituents
- Selective permeability for compounds, implying a reconnaissance function
- Asymmetry between internal and external sides
- Electrical insulator function because the cell membrane must also separate ions and, hence, electric charges (see below)

The information exchange process has two aspects: acquisition and delivery of information. Acquisition involves reception of signals related to many different facets of the environment. Delivery implies executive acts, be they motor, excretory or the like. In single-celled organisms (protozoa) such as *Paramecia*, the same cell carries out both processes and for the most part they take place at cell surface membranes. In highly developed metazoa, cells have specialized functions, certain groups being “receivers” and others “executors” of information, but most in fact are both. Executors include muscle, glandular and other cells because motor

acts and glandular functions transmit information to the environment or other cells.

In the following sections, we will be primarily concerned with information transmission in metazoa. To receive information, metazoa have developed specialized “▶receptor cells” (or often, for brevity, ▶receptors). As is intuitively clear, metazoa need to collect information about many different aspects of their internal and external environments (▶Sensory systems).

Information is an abstract entity that needs to be encoded in a signal to be transmitted and processed. Signals in turn are generated by some material substrate or carrier that may engage one or the other mechanism to produce a signal. This chapter will deal with the following questions:

- What are the signals used by the nervous system to encode information?
- What are the structures carrying them?
- How are the signals generated, by what mechanisms?
- How are the signals transmitted over some distance?
- How is information encoded and decoded again?
- How can information be quantified?

The first problem to be solved by evolving cellular organisms is to find a suitable signal and a carrier. The signal should be:

- Easily implemented with biological structures at hand: molecules and their aggregates
- Reproduced into what can be called a resting state
- Able to propagate over long distances
- Fast (within the scope of biological “time”)
- Energy-efficient
- Versatile
- Modifiable

In processing information, protozoa and multi-celled organisms have the same interest. It is therefore intuitively appealing to think that the basic structures and mechanisms involved in information transfer have evolved early on and been preserved fairly well throughout evolution. The signal and its supporting physical structure should then be common to most animals. Communication of a unicellular organism and of an individual cell within a metazoon must occur at their cell surfaces, hence signals must be generated, propagated and processed at cell membranes.

*Historical Notes.* The study of cell physiology was launched in the seventeenth century with the use of microscopes by M. Malpighi (1627–1694) and A. von Leeuwenhoek (1632–1723). Neurophysiology took off in the eighteenth century after electricity had become amenable to experimentation (Leyden flask). Seminal experiments were performed by A. Galvani (1737–1798) who noted that frog muscles contracted whenever

a contact was made with a Leyden flask. He demonstrated that no external source was needed if different metals were used in the frog experiments: contractions also occurred when the brass wire in contact with the spinal cord touched the iron support on which the frog was lying. He concluded that electricity was an intrinsic property of the muscle. Galvani’s interpretations were criticized by A. Volta (1745–1827) because he was able to produce electrical batteries from different metals and salt solutions. Volta was correct in saying that Galvani had used external electrical stimulation. Nonetheless, Galvani’s idea of the existence of intrinsic electricity turned out to be right in the end. Further important contributions came from, among others, J. Müller (1801–1858), T. Schwann (1810–1882), C. Matteucci (1811–1868), E. du Bois-Reymond (1818–1896), H. von Helmholtz (1821–1894), A. Fick (1829–1901), L. A. Ranvier (1835–1922), W. Kühne (1835–1900), L. Hermann (1838–1914), J. Bernstein (1839–1917), J. von Kries (1853–1928) [1]. In the twentieth century, the field exploded, and a number of achievements were rewarded with the Noble Prize (NP) for Medicine or Physiology, among the prize winners being: E. D. Adrian (1889–1977; NP 1932), J. Erlanger (1874–1965; NP 1944), H. S. Gasser (1888–1963; NP 1944), J. C. Eccles (1903–1997; NP 1963), A. H. Hodgkin (1914–1998; NP 1963), A. F. Huxley (\*1917; NP 1963); B. Katz (1911–2003; NP 1970), E. Neher (\*1944; NP 1991), B. Sakmann (\*1942; NP 1991).

## Nerve Cell Membrane Membrane Structure

The nerve cell membrane (▶Cell membrane – components and functions) is a microscopically thin membrane that separates the cell cytoplasm and intracellular organelles from the extracellular milieu. Its chemical composition and structural features allow free passage of most lipids, and selective passage of ions, sugars and amino acids. The membrane, in addition, contains the molecular machinery for cell-to-cell chemical and electrical communication (below) and immune responsiveness (▶Neuroimmunology).

## Anatomy and Chemical Makeup of the Nerve Cell Membrane

The unit membrane of the nerve cell is, on average, about 50 nm thick and comprised of various types of phospholipids, proteins and carbohydrates. Proteins, being the largest molecules, make up the greatest membrane mass but the smaller phospholipids are the largest in number and carbohydrate molecules are the fewest. The molecules making up the membrane proper, or attached to it, are mobile, interactive and in many cases functionally interdependent. They are replaced by intracellular biosynthesis, and turned over by a process called membrane trafficking.



### Membrane Phospholipids

Membrane lipids are arranged in a bilayer with the glycerol phosphates facing the extracellular and intracellular fluids, and the fatty acid chains arranged in rows side by side in the membrane. Phospholipid molecules have a high degree of lateral mobility in the bilayer, which facilitates movement of small non-polar molecules across the cell membrane. Fluidity of cell membrane phospholipids also facilitates ►transport processes and enzyme activities. Less frequently, phospholipid molecules will “flip-flop,” i.e., migrate from a monolayer on one side to that on the other.

Functions of membrane phospholipids include:

- Insulation and barrier properties
- Intracellular signaling
- Electrical properties

The extremely thin, expansive lipid bilayer of the nerve cell membrane has a ►membrane capacitance on the order of  $1 \mu\text{F}/\text{cm}^2$  that produces a charge of about  $8 \times 10^{-9}$  coulombs/ $\text{cm}^2$  at a resting membrane potential (below; ►Membrane potential – basics) of  $-80$  mV, or approximately  $5 \times 10^{11}$  monovalent ions/ $\text{cm}^2$ .

*Cholesterol.* The nerve cell membrane contains large amounts of ►cholesterol, which enhances the permeability-barrier property of the lipid bilayer. This renders the lipid bilayer less permeable to small water-soluble molecules.

*Glycolipids.* These lipids contain carbohydrate groups and are found only on the extracellular side of the cell membrane. ►Glycolipids are believed to be involved in cell-cell interactions. Five to ten percent of the total lipid mass consists of a particular type of glycolipid called a ►ganglioside. Gangliosides are thought to alter the electrical field across the cell membrane, as well as the concentration of  $\text{Ca}^{2+}$  ions along the external surface of the cell membrane. They may also be involved in cell-cell recognition at the extracellular matrix that promotes cell aggregation.

### Membrane Proteins

The membrane contains a large group of membrane proteins, not all of which have been identified. ►Integral proteins completely traverse the cell membrane, whereas ►peripheral proteins are anchored to either the cytoplasmic or extracellular side. Membrane proteins exhibit function-dependent polarity. Cell membrane proteins are also stored in membranous cisterns in dendrites and axons, where they play important roles in ►synaptic plasticity and ►axon growth.

The locations of different types of proteins in the cell membrane serve as general predictors of how they function in the nerve cell.

Integral membrane proteins serve as:

- ►Ion pumps (below), moving ions against a concentration gradient, using energy derived from adenosine triphosphate (ATP)
- ►Ion channels (below), allowing flow of ions and water across the cell membrane down an electrochemical gradient
- ►Transporters of sugars and amino acids
- Cell-cell recognition sites

Peripheral proteins function as:

- Receptors for ►neurotransmitters, ►neuromodulators, ►hormones and other chemical messengers that trigger membrane ion permeability changes
- Enzymes that catalyze intracellular signal cascades
- Immunoreactive elements (Neuroimmunology)
- Membrane structural support proteins
- Mediators of neurite outgrowth and axon bundling
- Intermediaries in membrane trafficking

### Membrane Potential

Membrane potential denotes the electrical potential difference (►voltage,  $V$ ) across the cell membrane of all living cells, which is produced by an unequal net distribution of positive and negative charges on either side of the cell membrane. The potential in the intracellular milieu is normally negative with respect to the extracellular milieu, reference set to zero (Membrane potential – basics).

Resting membrane potentials can be measured in all living cells. They vary in magnitude, but are negative inside vs. outside. It is assumed, on well-established physico-chemical grounds, that they originate from concentration differences across the cell membrane of ions that carry electric charges. Generally, the concentrations of  $\text{Na}^+$  and  $\text{Cl}^-$  are high extracellularly and low intracellularly, thus establishing a strong inward concentration gradient across the cell membrane. The situation is opposite for  $\text{K}^+$ . Another ion that is unequally distributed is  $\text{Ca}^{2+}$ , with a high extracellular and a normally very low intracellular concentration.

### Membrane Potential and Ion Concentration Gradients

In 1902, Julius Bernstein [2] hypothesized that the resting membrane potential,  $V$ , is a diffusion potential determined exclusively by  $\text{K}^+$ . According to the ►Nernst equation,  $V$  should then be the  $\text{K}^+$  equilibrium potential,  $E_K$ :

$$V = E_K = \frac{R \cdot T}{F} \times \ln \frac{[\text{K}^+]_o}{[\text{K}^+]_i}$$

where  $[\text{K}^+]_o$  is the external and  $[\text{K}^+]_i$  the internal  $\text{K}^+$  concentration.

However, later measurements showed that Bernstein's hypothesis could not fully account for the real

situation because, in addition to  $K^+$ , other ions can permeate the membrane even under resting conditions, giving rise to deviations of the membrane potential from  $E_K$ . A most important ion is  $Na^+$ , whose equilibrium potential is opposite in sign to that of  $K^+$ . In most cells, the resting membrane potential is much closer to  $E_K$  than to  $E_{Na}$ , however, because under resting conditions the membrane permeability for  $K^+$  is much larger than that for  $Na^+$ . Also,  $Ca^{2+}$  with its positive charge and inwardly directed concentration gradient has, like  $Na^+$ , a positive equilibrium potential. Chloride with its negative charge and inwardly directed concentration gradient has a negative equilibrium potential (Membrane potential – basics).

### Ion Pumps

As outlined above, even under steady-state or resting conditions, membrane channels, including some  $K^+$  and  $Na^+$  channels, stay open and generate a “▶leak conductance” [3]. In effect, what results is a leaky RC circuit, with a specific membrane resistance of about  $1,000 \Omega cm^2$  [4]. The RC circuit properties have functional consequences. In the resting state, the net movement of  $K^+$  ions down its concentration gradient through leak channels will leave behind impermeant cytoplasmic organic anions that accumulate on the inner side of the cell membrane and an accumulation of cations on the extracellular side [5], which accounts for the potential difference ( $V$ ) of about  $-80$  mV across the cell membrane (Membrane potential – basics).

Because the membrane is permeable to several ions that flow passively down electrochemical gradients, unrestricted ion flow would eventually abolish concentration differences between the inside and outside of the cell and, in consequence, the equilibrium and membrane potentials. In order to prevent this, the cell invests much energy in so-called ion pumps that transport the leaking ions back to where they come from, against their respective gradients (▶Ion transport). Such pumps need

- Metabolic energy, ultimately supplied by adenosine triphosphate (ATP)
- Regulation mechanisms, including the sensitivity for particular ions and their concentrations (e.g., inside for  $Na^+$ )

The action of the  $Na^+$  pump that expels  $Na^+$  from a cell was first demonstrated by Hodgkin and Keynes [6], who showed that the metabolic poison dinitrophenol (DNP), which deprives energy sources for the  $Na^+/K^+$  pump, depresses cellular extrusion of  $Na^+$ . Since then, other laboratories have demonstrated the active role of ion pumps that maintain steady state membrane potential by regulating intracellular  $Na^+$ ,  $Cl^-$ ,  $K^+$  and  $Ca^{2+}$  concentration.

### Spread of Local Potentials

Local potential changes (▶receptor potential, ▶synaptic potential) originating anywhere on the cell surface must ultimately be conveyed to other regions of the cell or, more generally, the nervous system, where a response to the stimulus begins to be formulated. However, passive electrical properties, resistive and capacitive, reduce the size and alter the shape of the receptor potential as it moves transversely through the cell's soma and fibrous, cable-like processes (▶Cable theory). Passive cable properties that affect the receptor potential are also present in dendrites and axons of nerve cells, and thin elongated muscle fibers such as frog sartorius muscle [5]. In the latter preparation, a rectangular current pulse depolarizes membrane potential with a near-exponential time course, declines in amplitude with distance along the fiber and changes shape due to temporal filtering. The pulse-evoked response is an approximate simulation of the receptor potential, and attributable to the cable properties of an ▶equivalent electrical circuit that consists of a membrane ▶capacitor ( $C_m$ ) and a resistor ( $R_m$ ) arranged in parallel. In the RC circuit of a biological membrane,  $C_m$  is a leaky capacitor that allows ionic charge to accumulate and dissipate through  $R_m$ . The time-related change of voltage during discharging of an RC circuit is described by the relationship:

$$V(t) = V_0[\exp(-t/\tau)] \quad (1)$$

Where  $V_0$  is the membrane potential at the cessation of applied current,  $V(t)$  is the membrane potential at a corresponding time after termination of the applied current, and  $\tau$  is the time constant, where  $\tau = R_m C_m$ . In neurons, time constants  $\tau$  are of the order of 0.5–5 ms [7].

Current flowing from the receptor region through the longitudinal resistances of the cytoplasm and extracellular fluid form current circuit loops. Current gets progressively smaller with distance. A constant fraction per unit length is diverted through ion leak channels, and falls off exponentially with distance from the region where the stimulus has originated:

$$\Delta V(d) = \Delta V_0 \cdot \exp(-d/\lambda), \quad (2)$$

where the length (space) constant  $\lambda$  is  $\sqrt{(R_m/R_i)}$ , defining the distance at which the original voltage change drops to a fraction of  $1/e \approx 0.37$ .

The principles illustrated in these simple reduced preparations provide only a relatively primitive explanation for some of the basic properties of sensory transduction. Nonetheless, two important conclusions are evident:

- The passive or ▶electrotonic spread of local membrane potential changes (receptor and synaptic potentials) across a cell membrane is no means for transmitting information over long distances.

- A process of ►**encoding**, is necessary to transform the receptor potential from a wave form to a discharge of ►**action potentials** that reach sites of sensory integration, and that reflects the magnitude and duration of the waveform and thus the applied stimulus.

## Action Potential

The action potential is the active electrical response of an excitable cell membrane to a stimulus, reflected in a fairly stereotyped change in membrane potential from a resting value (negative inside) to a depolarized (positive inside) value and back (Action potential). The durations of action potentials range from a few milliseconds in neurons to hundreds of milliseconds in cardiac and smooth muscle cells. The underlying mechanisms include time- and voltage-dependent changes in ion conductances.

### Ion Currents Underlying the Squid-Axon Action Potential

Early, simple experiments by a number of investigators led Bernstein [2] to propose that the action potential represented a sudden transition from a selective  $K^+$  permeability at rest to a generalized, i.e. non-selective increase of membrane ion permeability. On this basis, one would predict a value of 0 mV at the peak of an action potential. However, Bernard Katz's measurements with conventional ►**intracellular recording** in the 1940's (reviewed in [4,8]) showed that membrane potential at the peak of a shock-evoked action potential was on the order of +50 mV. From Nernstian considerations, this implicates a cation species such as  $Na^+$ , which Katz proved by showing that the amplitude of the action potential changed by about 58 mV for a 10-fold change of extracellular  $Na^+$  concentration. But the peak depolarization was rapidly followed by repolarization and ►**hyperpolarization** that momentarily exceeded the resting value, indicating that a secondary, selective ion permeability change had occurred. It was previously shown that in frog muscle fibers, resting membrane potential changed in approximate conformation with the Nernst equation when external  $K^+$  concentration was varied. Moreover, Keynes [9] was able to measure shock-evoked efflux of radioactive  $K^+$  from Sepia giant axons.

The superposition of various time-varying currents was difficult to disentangle using the more conventional methods of the time. The invention of the ►**voltage-clamp** technique (Action potential; Intracellular recording), a by-product of advances in electronics pioneered by K. S. Cole in 1949 [10] and used by A. F. Hodgkin and A. L. Huxley in the 1950's [11], made it possible to separate and analyze voltage- and time-dependent properties of the action potential (Action potential). The giant axon of the squid turned out to be a favorable structure because its size (diameter 0.5–1 mm) and

robustness allowed it to be removed from the animal, placed in a bath and subjected to varying extracellular compositions. Its size allowed insertion of relatively bulky longitudinal electrodes, and because of membrane durability it was possible to squeeze out the intracellular content and replace it with solutions of varying composition (Intracellular recording).

The squid-axon experiments showed that the action potential is brought about by voltage-dependent opening of  $Na^+$ ,  $Ca^{2+}$  and  $K^+$  channels. The action potential is initially depolarizing due to opening of  $Na^+$  (►**Sodium channels**) and/or  $Ca^{2+}$  channels (►**Calcium channels – an overview**), and subsequently repolarizing due to delayed opening of  $K^+$  channels (►**Neuronal potassium channels**).

*$Na^+$  Inactivation.* The fall of the action potential from its peak is promoted not only by  $K^+$ -channel opening, but also by inactivation of the  $Na^+$  conductance, which has a slower time course than activation. The  $Na^+$  system recovers from inactivation with an approximately exponential time course and a time constant on the order of 5 ms, with the time constant depending on the holding potential imposed experimentally [2]. The period of reduced  $Na^+$  channel reactivity characterizes the ►**refractory period**. The impact of membrane depolarization on both activation and inactivation of  $Na^+$  conductance has profound functional consequences. The sequence of  $Na^+$  activation and inactivation (i) limits action potential rate (below); (ii) controls the direction of ►**action potential propagation** (Action potential propagation); (iii) leads to accommodation; (iv) has clinical implications (Action potential).

*Single-Channel Currents.* In 1976, Neher and Sakmann [12] introduced the breakthrough ►**patch-clamp** technique, through which it became possible to voltage-clamp small patches of cell membrane and record ►**single-channel currents** (Intracellular recording).

### Action Potentials in Central Neurons

The squid axon is a simple system devoted to conducting action potentials along the axon (Action potential propagation). Individual central neurons, however, typically express several subtypes of voltage-dependent ► **$Na^+$  channels**, voltage-dependent  $Ca^{2+}$  channels (Calcium channels – an overview), voltage-dependent  $K^+$  channels (Neuronal ►**potassium channels**),  $Ca^{2+}$ -activated  $K^+$  channels (Neuronal potassium channels), ►**hyperpolarization-activated**, ►**non-selective cation channels** (►**HCN channels**), and more. The different combinations of channels enable diverse action potential amplitudes, shapes and firing patterns [13].

*Sodium ( $Na^+$ ) Currents.* In central neurons, the rising phase of the action potential is generated by very fast activation and inactivation of ►**voltage-dependent  $Na^+$  channels** [13] (Action potential propagation).

*Calcium ( $Ca^{2+}$ ) Currents.* Inward  $Ca^{2+}$  currents (Calcium channels – an overview) contribute little to

the action potential upstroke, but initiate intracellular signaling pathways, influence action-potential shape and firing patterns, and – at presynaptic terminals the amount of neurotransmitter released [13] (Action potential propagation).

**Potassium ( $K^+$ ) Currents.** Central neurons express a wide range of ▶Voltage-gated (or –dependent)  $K^+$  channels (Kv; Neuronal potassium channels), only a fraction of which activate appreciably during the action potential. Significant contributions to action potential repolarization are commonly made by Kv3 family and Kv4 family channels mediating the ▶A-type  $K^+$  current ( $I_A$ ). Large-conductance  $Ca^{2+}$ -activated  $K^+$  channels (▶BK channels) promote membrane repolarization. Small-conductance  $Ca^{2+}$ -activated  $K^+$  channels (SK channels) contribute to the following ▶afterhyperpolarization [13] (Action potential propagation; Neuronal potassium channels). Furthermore, ▶ $Na^+$ -activated  $K^+$  channels (K(Na) channels) may modulate action-potential shape, and contribute to slow afterhyperpolarization after repetitive firing [14] (Action potential).

**Afterdepolarization.** In many neurons, the fast phase of action potential repolarization is followed by a delayed depolarization, whose origins may be passive and/or active, i.e., mediated by an electrotonic mechanism or amplified and supported by active  $Na^+$ ,  $Ca^{2+}$  and ▶non-selective cation currents (Action potential propagation).

**Afterhyperpolarization (AHP).** Afterhyperpolarizations in mammalian central neurons may be complex, often showing different phases and being due to different  $K^+$  currents. BK-channel-mediated afterhyperpolarizations are usually brief, while SK-channel-mediated ones can last up to seconds [13] (Action potential propagation). ▶ $Na^+$ -activated  $K^+$  channels (K(Na) channels) may contribute to slow afterhyperpolarization after repetitive firing [14] (Action potential).

**Repetitive Firing.** Many central neurons discharge over a wide range of rates and with various patterns, to which many factors may contribute, including various  $Na^+$ ,  $K^+$ ,  $Ca^{2+}$  and HCN channel currents. Many central neurons fire spontaneously and fairly regularly, and are called “▶pacemakers” [13] (Action potential propagation).

**Fast-Spiking Neurons.** Neurons capable of firing at high rates for prolonged periods often possess voltage-gated  $K^+$  channels or special “resurgent”  $Na^+$  current, which activates transiently upon repolarization after inactivation due to strong depolarization and is sensitive to ▶tetrodotoxin (TTX) [13] (Action potential propagation).

## Action Potential Propagation

### Propagation along Muscle and Nerve Fibers

The action potential propagates over long distances. Propagation along a nerve or muscle fiber occurs

automatically as a consequence of the axonal cable structure (Cable theory; Action potential propagation).

In a muscle or nerve fiber, the ring of membrane that is just being depolarized during the action potential’s rise experiences a strong influx of positive charges ( $Na^+$ ) that distribute internally in both forward and backward directions. The local currents reaching out in the action potential’s propagation direction unload the capacitor of the advanced membrane regions and depolarize them. This depolarization increases the  $Na^+$  conductance and elicits the inward  $Na^+$  current in the adjacent membrane segment until threshold is reached for action potential generation at this site. Since charging or discharging of a capacitor takes some time, expressed in the time constant, the substantial depolarization-induced ionic ( $Na^+$ ) currents are delayed.

In a muscle fiber or an unmyelinated axon, action potentials propagate in feed-forward fashion, regenerating progressively with passage in small increments of membrane. In myelinated nerve fibers, the conduction mechanism is different. The ▶myelin sheath is a good insulator. When a ▶node of Ranvier between internodes (stretches of myelin sheath) is depolarized during an action potential, local circuit currents depolarize the next one ahead, without discharging the internodal region. The excitation thus leaps from node to node, a process called ▶saltatory conduction. This type of conduction confers several advantages: (i) economy of space; (ii) economy of energy expenditure; (iii) high safety factor for conduction (Action potential propagation).

Myelination has notable disadvantages, namely limits to ▶regeneration after injury and involvement in various neurological diseases. Functional recovery following injury differs dramatically in the peripheral and the central nervous system (Regeneration).

Demyelination disorders are numerous and are exemplified by the ▶Guillain-Barré syndrome and ▶Multiple sclerosis.

### Back-propagation of Action Potentials

In many neurons, action potentials originate close to the axon’s juncture with the cell soma (the initial segment), from where they travel down the efferent axon, but may also “back-propagate” into the dendritic tree (Action potential propagation). These back-propagating action potentials are supported by active, tetrodotoxin-sensitive, voltage-dependent  $Na^+$  channels and possibly ▶ $Ca^{2+}$  channels. The extent of this decremental back-propagation varies widely between different types of central neurons, different specimens of the same sort, and possibly different dendritic branches of individual cells. Back-propagation depends on cell morphology and densities of dendritic ion channels, as well as adaptive influences provided by excitatory and inhibitory inputs and neuromodulators. Back-propagating action potentials have been implicated in

short-term and long-term changes in ►synaptic efficacy involving increases in  $\text{Ca}^{2+}$  influx [15] (Action potential propagation).

### More Ion Channels and their Functions

A wide range of channels affect additional cellular functions in addition to control of excitability.

#### Cyclic Nucleotide-regulated Cation Channels

►Cyclic nucleotide-regulated cation channels are activated by intracellular binding of cyclic AMP (cAMP) or cyclic GMP (cGMP) to a cyclic nucleotide-binding domain (CNBD) in the channel protein, thereby translating intracellular changes in signaling molecules to changes in membrane potential. Two families of channels, both exhibiting a high sequence similarity to voltage-gated  $\text{K}^+$  (Kv) channels (Neuronal potassium channels) and regulated by cyclic nucleotides, have been identified, the *cyclic nucleotide-gated (CNG) channels* and the *hyperpolarization-activated ►cyclic nucleotide-gated channels (HCN) channels*. CNG channels require the obligatory binding of a cyclic nucleotide in order to be activated. In contrast, HCN channels are activated by membrane hyperpolarization and modulated by cyclic nucleotides [16]. Cyclic nucleotides enhance HCN channel activity by affecting the voltage-dependence of channel activation.

#### Hyperpolarization-activated Cyclic Nucleotide-regulated Channels

The HCN1–4 channel gene family encodes HCN channels. They are slowly activated by membrane hyperpolarization and by intracellular cAMP or cGMP, and give rise to depolarizing inward ionic currents termed *I<sub>h</sub>*, *I<sub>f</sub>* (“f” for “funny”) or *I<sub>q</sub>*. They were first discovered in cardiac pacemaker cells, but are widely distributed in various excitable cells including CNS neurons, retinal ►photoreceptors and ►taste buds. HCN channels are structurally similar to voltage-gated  $\text{K}^+$  (Kv) channels (Neuronal potassium channels), but much ( $>$  or  $=$  25 times) less selective than Kv channels [17]. They are involved in a range of functions, including the setting of resting membrane potential (Membrane potential – basics), ►input conductance and ►length constants, dendritic integration, cardiac and neuronal pacemaker activity, and the regulation of presynaptic release of neurotransmitter [18]. Deficits in the HCN1 gene impair motor learning but enhance spatial learning and memory. Deletion of HCN2 plays a role in ►absence epilepsy, ►ataxia and sinus node dysfunction [19].

#### Non-selective Cation Channels

Non-selective cation channels are macromolecular pores in the cell membrane that form an aqueous

pathway. In distinction to selective ion channels, non-selective cation channels enable cations such as  $\text{Na}^+$ ,  $\text{K}^+$  or  $\text{Ca}^{2+}$  to flow rapidly, as determined by their electrochemical driving force, at roughly equal rates ( $>10^7$  cations per channel pore and per second). One of them is the ►nicotinic acetylcholine receptor (►nAChR); others include the ►ionotropic glutamate receptors, ►capsaicin receptors, cyclic nucleotide-gated (CNG) cation channels, and ►TRP channels.

#### Transient Receptor Potential (TRP) Channels

Non-selective cation channels of the *transient receptor potential* (TRP) superfamily (TRP channels) display a great variety of activation mechanisms and sensitivities and are thus involved in multifarious functions. TRP proteins are assigned to distinct subfamilies based on sequence similarities to *Drosophila* TRP or structural and functional features. The ion-permeating pores mostly allow the permeation of monovalent and divalent cations through all channels and of  $\text{Ca}^{2+}$  ions through all but two channels [20]. TRP channels make significant contributions to ►olfaction, taste, ►hearing, ►vision, ►thermosensation, ►touch, ►osmosensation, and ►nociception [21]. As to thermosensation, at least six different TRP channels cover the spectrum of relevant temperatures for our body. As mechanosensors, TRP channels are involved in functions ranging from *Drosophila* hearing to nematode touch to mouse mechanical pain [22]). Other TRP channels are essential for the  $\text{Ca}^{2+}$  and  $\text{Mg}^{2+}$  homeostasis in our body.

#### Anion Channels

Chloride channels (►Chloride channels and transporters) are membrane proteins that allow for the passive flow of anions across biological membranes. As  $\text{Cl}^-$  is the most abundant anion under physiological conditions, these channels are often called “ $\text{Cl}^-$  channels” instead of “anion channels”, although other anions (such as iodide or nitrate) may permeate more easily. In mammals, the CLC gene family encodes nine different  $\text{Cl}^-$  channels in the plasma membrane or intracellular organelles such as vesicles. These diverse channels are involved in the control of membrane potential in muscle and nerve cells, in the regulation of cell volume, in the acidification and ionic homeostasis of endosomes and synaptic vesicles, in the transepithelial transport of salt and water, and in the degradation of bone by osteoclasts. Mutations of human CLC channels cause diseases such as myotonia, neurodegeneration and possibly epilepsy, cystic fibrosis, Bartter syndrome (renal salt loss) with or without deafness, Dent’s disease (kidney stones and proteinuria), osteopetrosis. The CLC from *Escherichia coli* functions as a  $\text{Cl}^-/\text{H}^+$  exchanger [23]. Some  $\text{Cl}^-$  channels are activated by intracellular  $\text{Ca}^{2+}$  ( $\text{Ca}^{2+}$ -activated  $\text{Cl}^-$ -channels) [24].

## Ion Channel Development

The distribution patterns and properties of ligand- and voltage-gated ion channels in developing nerve and muscle cells differ profoundly from those of mature cells (► [Ion channel development](#)). At early developmental stages, these specific patterns determine the timing and waveform of spontaneous electrical activity, which is required for the normal maturation of excitability and synaptic connections and for  $\text{Ca}^{2+}$  influx triggering activity-dependent developmental programs [25].

## Channelopathies

Rapid advances in genetics, molecular biology and neurophysiology have enabled unraveling and characterization of the molecular bases of a number of neurological and other diseases, among which ► [channelopathies](#) comprise a class of diseases caused by ion channel dysfunctions. They can be due to autoimmune and paraneoplastic [26] processes and drug, toxic or genetic mechanisms that affect all kinds of channels:  $\text{Ca}^{2+}$ ,  $\text{Cl}^-$ ,  $\text{K}^+$ ,  $\text{Na}^+$ , HCN, TRP channels etc. Mutations in genes encoding ion channel proteins that alter channel function are common mechanisms underlying channelopathies. Examples are plentiful (see [Calcium channels](#) – an overview; ► [Calcium channelopathies](#); ► [Epilepsy](#) [27]; ► [Episodic ataxia](#) [28]; ► [Familial periodic paralyses](#) and ► [Non-dystrophic myotonias](#) [29]; ► [Migraine](#); ► [Neuromyelitis optica](#); Non-dystrophic myotonias). Channelopathies may also affect internal cell membranes, e.g., of the mitochondria [30].

## Prospects

There has been a rapid progression of new concepts related to membrane structure and function, so much so that we seem to have merely touched the surface in our understanding of cell membranes. As we go forward with new techniques that provide more accurate spatial and temporal resolution of membrane dynamics, it seems likely that molecular conformational changes involving channel proteins and lipids will be visualized with optical methods and other techniques as they occur. Gene-gene interactions and the impact of environmental perturbations may also be fruitfully investigated, leading to treatments directed at channelopathies, synaptic dysfunction and correction of myelin disorders.

## References

- Greger R, Windhorst U (1996) Physiology past and future. In: Greger R, Windhorst U (eds) *Comprehensive human physiology. From cellular mechanisms to integration*. Springer, Berlin Heidelberg New York, pp 1–17
- Bernstein J (1902) Untersuchungen zur thermodynamik der bioelektrischen Ströme. *Pflügers Arch ges Physiol* 92:521–562
- Snutch TP, Monteil A (2007) The sodium “leak” has finally been plugged. *Neuron* 54:505–507
- Aidley DJ (1998) *The physiology of excitable membranes*, Chapter 3, 4th edn. Cambridge University Press, UK
- Woodbury JW (1965) In: Ruch TR, Paton HD, Woodbury JW, Towe (eds) *AL Neurophysiology*, Chapter 1, 2nd edn. WB Saunders, Philadelphia.
- Hodgkin AL, Keynes RD (1955) Active transport of cations in giant axons from Sepia and Loligo. *J Physiol (Lond)* 128:28–60
- Kuffler SW, Nicholls JG (1976) *From neuron to brain*. Sinauer Associates, Sunderland (Mass)
- Katz B (1966) *Nerve, Muscle and Synapse*. McGraw-Hill, New York
- Keynes RD (1951) The ionic movements during nervous activity. *J Physiol (Lond)* 114:119–150
- Cole KS (1949) Dynamic electrical characteristics of the squid axon membrane. *Arch Sci Physiol* 3:253–258
- Hodgkin AL, Huxley AF (1952) A quantitative description of membrane current and its application to conduction and excitation in nerve. *J Physiol (Lond)* 117:500–544
- Neher E, Sakmann B (1976) Single-channel currents recorded from membrane of denervated frog muscle cells. *Nature (Lond)* 260:799–802
- Bean BP (2007) The action potential in mammalian central neurons. *Nat Rev Neurosci* 8:451–465
- Bhattacharjee A, Kaczmarek LK (2005) For  $\text{K}^+$  channels,  $\text{Na}^+$  is the new  $\text{Ca}^{2+}$ . *Trends Neurosci* 28:422–428
- Waters J, Schaefer A, Sakmann B (2005) Backpropagating action potentials in neurones: measurement, mechanisms and potential functions. *Prog Biophys Mol Biol* 87:145–170
- Craven KB, Zagotta WN (2006) CNG and HCN channels: two peas, one pod. *Annu Rev Physiol* 68:375–401
- Siu CW, Lieu DK, Li RA (2006) HCN-encoded pacemaker channels: from physiology and biophysics to bioengineering. *J Membr Biol* 214:115–122
- Robinson RB, Siegelbaum SA (2003) Hyperpolarization-activated cation currents: from molecules to physiological function. *Annu Rev Physiol* 65:543–480
- Hermann S, Stieber J, Ludwig A (2007) Pathophysiology of HCN channels. *Pflügers Arch* 454:517–522
- Nilius B, Owsianik G, Voets T, Peters JA (2007) Transient receptor potential cation channels in disease. *Physiol Rev* 87:165–217
- Venkatachalam K, Montell C (2007) TRP channels. *Annu Rev Biochem* 76:387–417
- Christensen AP, Corey DP (2007) TRP channels in mechanosensation: direct or indirect activation? *Nat Rev Neurosci* 8:510–521
- Jentsch TJ, Poët M, Fuhrmann JC, Zdebek AA (2005) Physiological functions of CLC Cl<sup>-</sup> channels gleaned from human genetic disease and mouse models. *Annu Rev Physiol* 67:779–807
- Hartzell C, Putzier I, Arreola J (2005) Calcium-activated chloride channels. *Annu Rev Physiol* 67:719–758
- Moody WJ, Bosma MM (2005) Ion channel development, spontaneous activity, and activity-dependent development in nerve and muscle cells. *Physiol Rev* 85:883–941

26. Vernino S (2007) Autoimmune and paraneoplastic channelopathies. *Neurotherapeutics* 4:305–314
27. Heron SE, Scheffer IE, Berkovic SF, Dibbens LM, Mulley JC (2007) Channelopathies in idiopathic epilepsy. *Neurotherapeutics* 4:295–304
28. Rajakulendran S, Schorge S, Kullmann DM, Hanna MG (2007) Episodic ataxia type 1: a neuronal potassium channelopathy. *Neurotherapeutics* 4:258–266
29. Ryan AM, Matthews E, Hanna MG (2007) Skeletal-muscle channelopathies: periodic paralysis and nondystrophic myotonias. *Curr Opin Neurol* 20:558–563
30. Pi Y, Goldenthal MJ, Marín-García J (2007) Mitochondrial channelopathies in aging. *J Mol Med* 85:937–951

## Membrane Capacitance

### Definition

The membrane capacitance is the stored charge of ions across the cell membrane. The cell membrane serves as an insulator of the membrane potential generated by the disequilibrium of ionic charge on either side of the membrane. The membrane capacitance (C) is a function of the stored charge divided by the potential difference across the membrane. As a result, any potential difference change generates a capacitance transient. Membrane capacitance is directly proportional to surface area, so biophysicists often use membrane capacitance as a measure of the changes to membrane surface area.

- ▶ Action Potential
- ▶ Cable Theory
- ▶ Membrane Potential: Basics

## Membrane Conductance

### Definition

Easiness of passing ion or electricity across membrane. When membrane is activated, membrane conductance increases probably because certain ionic channels are open.

- ▶ Action Potential
- ▶ Action Potential Propagation
- ▶ Cable Theory
- ▶ Membrane Potential: Basics

## Membrane-delimited Modulatory Mechanism

### Definition

Molecular events confined to the membrane surface and triggered by the activation of a G-protein coupled receptor (GPCR). The activated G-protein subunit diffuses along the membrane and activates (or inhibits) surrounding ion channels or metabotropic receptors.

- ▶ Calcium Channels – an Overview
- ▶ G-protein Coupled Receptors (GPCRs): Key Players in the Detection of Sensory and Cell-Cell Communication Messages

## Membrane-patch Excision

### Definition

Mechanical manipulation of the cell using glass micropipettes that leads to the extraction of a narrow region of cell membrane. The excision can lead to an isolated membrane patch in which the side of the membrane is preserved (outside-out) or inverted (inside-out).

- ▶ Intracellular Recording

## Membrane Potential: Basics

UWE WINDHORST<sup>1</sup>, PETER M. LALLEY<sup>2</sup>

<sup>1</sup>Göttingen, Germany

<sup>2</sup>Department of Physiology, The University of Wisconsin School of Medicine, Medical Science center, Madison, Wisconsin, USA

### Synonyms

Transmembrane voltage

### Definition

The electrical potential difference (▶ voltage) across the cell membrane (▶ plasmalemma or ▶ sarcolemma) of all living cells that is produced by an unequal net distribution of positive and negative charges on either

side of the cell membrane. The potential in the intracellular milieu is normally negative with respect to the extracellular milieu, reference set to zero.

### Characteristics

Even phylogenetically ancient unicellular organisms such as *Paramecium* need to exchange matter and information with their environment. In multicellular organisms, the exchange must be organized across different cellular and body parts. Information is an abstract entity that needs to be encoded in a signal to be generated, transmitted and processed. Signals in turn are generated by mechanisms bound to some material substrate or carrier. The basic structure for information exchange is the cell membrane, and the signals required are generated by physico-chemical mechanisms. Here, we describe a fundamental type of signal: the membrane potential. To understand how it is generated, it is instructive to start from two basic principles.

### Ion Concentrations Differ in the Internal and External Solutions of Cells

The first principle is that the concentrations of some basic sorts of ions, which characteristically are abundant on the earth's surface, are different in the internal and external milieus of cells. Table 1 lists concentrations of some pertinent ions in the frog muscle fiber and in the giant axon of the squid.

The respective ion concentrations are higher in the squid axon than in the frog muscle fiber, because the squid lives in seawater with higher ion concentrations. For both types of cells, the concentrations of  $\text{Na}^+$  and  $\text{Cl}^-$  are high extracellularly and low intracellularly, thus establishing a strong inward **concentration gradient** across the cell membrane. The situation is opposite for  $\text{K}^+$ . Another ion that is unequally distributed is  $\text{Ca}^{2+}$ , with a high extracellular and a normally very low intracellular free concentration.

**Membrane Potential: Basics. Table 1** Extra vs. intracellular concentrations of several types of ion in mM/l (Data from [1])

Ion	Extra	Intra	Ratio extra/intra
(A) Frog muscle fiber			
$\text{K}^+$	2.5	140	0.018
Organic anions	40	86	0.465
$\text{Na}^+$	120	10	12
$\text{Cl}^-$	77.5	1.5	51.667
(B) Giant axon of squid			
$\text{K}^+$	10	400	0.025
Organic anions		360	
$\text{Na}^+$	460	50	9.2
$\text{Cl}^-$	540	40–100	5.4–13.5

### Cells Exhibit a Resting Membrane Potential

This second principle is apparent from the experimental measurement illustrated in Fig. 1a. A long skeletal muscle fiber is isolated and put in a medium representing the extracellular milieu. Two sets of electrodes measure the electrical potential differences and apply electrical stimuli. To do the former, a large electrode (so-called indifferent, or reference electrode) is placed in the extracellular milieu, and another movable electrode with a very fine tip is also situated initially in the extracellular fluid. Both electrodes are connected to an amplifier that leads the potential difference to a voltmeter (**Intracellular recording**). As long as the movable electrode remains in the homogeneous extracellular milieu, there is no potential difference (Fig. 1b, left), but once the fine electrode penetrates the membrane and enters the interior, a potential difference of about  $-90$  mV is measured (Fig. 1b, right). This steady-state voltage is called the **resting membrane potential**. A value of roughly  $0.1$  V across a membrane  $50\text{--}100$  Å thick corresponds to an electrical field strength of  $1\text{--}2 \times 10^5$  V  $\text{cm}^{-1}$  [2].

Resting membrane potentials can be measured in all living cells. They vary in magnitude, but are negative inside vs. outside. It is assumed, on well-established physico-chemical grounds, that they originate from concentration differences across the cell membrane of ions that carry electric charges.

### Relation Between Ion Concentration Gradients and Membrane Potential

In order to understand this relation, consider some fundamental phenomena in aqueous salt solutions.

#### Diffusion

Imagine a container made up of two compartments separated by a thin membrane. Both compartments contain a solution of two types of electrically uncharged molecules, one of relatively high molecular weight and the other small. The concentrations are low in the left compartment ( $c_2$ ) and high in the right compartment ( $c_1 = 10.c_2$ ). If a step-like change in concentration occurs right at the membrane and the membrane is removed, diffusion occurs because of the statistical thermal movement of the particles. The diffusion process follows the following physico-chemical rules:

1. Net flux of both particles proceeds from higher (right) to lower (left) concentrations because, on the average, there are more particles on the right moving leftward than particles on the left moving rightward.
2. Concentration gradients, initially step-like, flatten with progressing diffusion until equilibrium (homogeneous particle concentration) is reached.



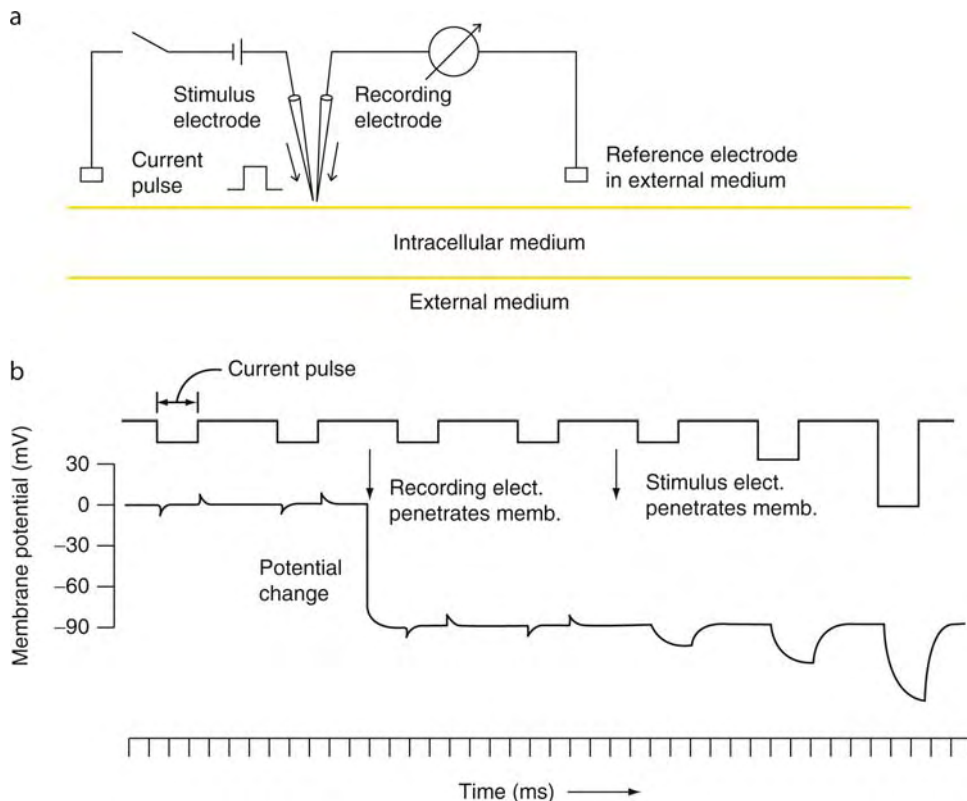

**Membrane Potential: Basics. Figure 1** (a–b) Recording from, and stimulation of, an isolated skeletal muscle fiber (yellow lines). (a): Two microelectrodes (micro-pipettes filled with an electrolyte solution) are connected to a battery (left) or voltmeter (right), and are referenced to large indifferent electrodes in the external medium. (b): As long as the recording electrode tip remains in the external medium, it measures a zero potential difference relative to the large indifferent electrode (left lower trace). When the recording electrode tip enters the internal medium of the muscle fiber (first vertical arrow), the potential difference jumps to a negative value of ca.  $-90$  mV, corresponding to the so-called resting membrane potential. As long as the stimulus electrode tip remains in the external medium, rectangular current pulses passed through it (upper trace) elicit only small smoothed voltage changes picked up by the recording electrode whether extra- or intracellular (left upper trace). When the stimulus electrode tip enters the muscle fiber (second vertical arrow), the recording electrode measures deviations from the resting potential corresponding to low-pass filtered versions of the current pulses (Adapted from [7]).

- Velocity of diffusion depends quantitatively on:
  - Concentration gradient at any time and site: the shallower the gradient, the slower the diffusion.
  - Velocity is faster for the small than the large particles because the former meet less friction in solution than do the latter, therefore the diffusion fronts of both particles will separate over time (this difference being eliminated in equilibrium). The higher the temperature, the faster are the particles' motions, thus diffusion is faster.

### Diffusion Potential

The above model considers uncharged particles. What happens when we are dealing with ions? Assume, for example, that the small particles are potassium ions ( $K^+$ ) and the large particles are organic anions ( $A^-$ ) such as isethionate, glutamate, aspartate and organic

phosphates with a net negative charge. Initially, when the membrane is still in place, there are equal numbers of oppositely charged particles in each compartment, providing electro-neutrality.

After removal of the membrane, diffusion will again set in from right to left, with the small (positive) particles tending to rush away from the large (negative) particles, as long as there is a concentration gradient. However, the two types of particle are not moving independently of each other because positive and negative charges attract each other. There is thus a competition between opposing forces. The concentration gradient tends to separate small from large particles, while the ensuing charge separation tends to re-unite particles in the opposite direction. These two forces create an **electrochemical equilibrium**. (In case the two opposite forces are not of equal magnitude, they create an **electrochemical gradient**).

The two particle types will therefore separate only partially, building up a potential difference between their diffusion fronts; specifically, a ► **diffusion potential**. It is a vector force, with a direction and a magnitude. The direction is from left (positive) to right (negative), because  $K^+$  ions rush away leftward from the anions.

The diffusion potential has the following characteristics:

1. ► **Equilibrium potential**. It is an equilibrium potential because it equalizes the chemical force originating in the concentration gradient and acting in opposite direction.
2. Dependence on concentration gradient. The equilibrium potential's magnitude naturally depends on the concentration gradients, it thus disappears when diffusion stops (in thermodynamic equilibrium).
3. Dependence on the difference of ion mobilities. The equilibrium potential's magnitude depends on the difference of ion mobilities in watery solution,  $u_+$  and  $u_-$ . If there is no mobility difference, as is the case with  $K^+$  and  $Cl^-$ , there is no diffusion potential.

Quantitatively, the last two dependencies are formalized as follows. The magnitude of the diffusion potential,  $E_D$ , depends on the concentration gradient as expressed in the ratio  $c_1/c_2$ , and on the difference of ion mobilities,  $u_+ - u_-$ , according to the formula [2]:

$$E_D = \frac{R \cdot T}{z \cdot F} \times \frac{u_+ - u_-}{u_+ + u_-} \times \ln(c_1/c_2), \quad (1)$$

where  $R$  is the general gas constant ( $1.987 \text{ cal K}^{-1} \text{ mol}^{-1} = 8.315 \text{ J K}^{-1} \text{ mol}^{-1}$ ),  $T$  the absolute temperature in Kelvin (K),  $z$  the number of elementary electric charges per molecule (e.g.,  $z = 1$  for  $K^+$ ), and  $F$  the Faraday constant ( $9.648 \times 10^4 \text{ C mol}^{-1}$ ).

In the special case where one ion, say the large anion, cannot diffuse at all, i.e., that its mobility is zero and  $u_- = 0$ , (1) simplifies to:

$$E_D = \frac{R \cdot T}{z \cdot F} \times \ln(c_1/c_2) \quad (2)$$

This is the famous *Nernst equation* (named after Walther Nernst, Nobel Prize in Chemistry 1920), which describes the situation of a single sort of ion in free solution. (For a derivation from thermodynamic principles see, e.g., [2,3]. Could it describe a real situation?

### Semi-Permeable Membranes

In the container model (above), the two compartments are initially separated by a membrane that cannot be passed by either sort of ion. Now assume that the membrane contains pores, through which only the small  $K^+$  ions, but not the large anions can pass. The  $K^+$  ions will then diffuse through the pores from right to left, but separate from the anions left behind only as much as the

evolving diffusion potential allows them to do. This diffusion potential is the equilibrium potential for  $K^+$ ,  $E_K$ . This is a physical situation described by the Nernst equation (2).

The membrane described above is semi-permeable, which has important consequences:

1. The concentration differences are maintained because the large anions cannot diffuse through the membrane and thus, through the diffusion potential, also prevent the small permeable ions from equalizing their concentrations.
2. The diffusion potential is maintained because the concentration differences stay the same.

Semi-permeability can be generated by several mechanisms: Pores (more often called channels) with different diameters let ions pass or not pass, according to their (hydratized) diameters. Electric charges within in the channels prevent the passage of ions of the same charge.

### Bernstein's Hypothesis

In 1902, Julius Bernstein [4] proposed that the resting membrane potential,  $V$  (Fig. 1b), is a diffusion potential that is determined exclusively by  $K^+$ . According to the Nernst equation,  $V$  should then be equal to the  $K^+$  equilibrium potential,  $E_K$ :

$$V = E_K = \frac{R \cdot T}{F} \times \ln \frac{[K^+]_o}{[K^+]_i}, \quad (3)$$

where  $[K^+]_o$  is the external and  $[K^+]_i$  the internal  $K^+$  concentration.

Bernstein was not able to test his hypothesis experimentally because the required techniques including ► **intracellular recording** and the related electronics were not yet available. A more recent test [5] is shown in Fig. 2. It was conducted at the frog muscle fiber at a temperature of  $T = 20^\circ \text{C} = 293 \text{ K}$ . Inserting values for  $R$  and  $F$ , and with  $\ln a = 2.3 \log_{10} a$ , (3) becomes

$$V = E_K = 58 \log_{10} [K_o/K_i] \text{ (in mV)}. \quad (4)$$

While the internal  $K^+$  concentration  $[K^+]_i$  remains constant at about  $140 \text{ mM l}^{-1}$ , the external  $K^+$  concentration  $[K^+]_o$  can easily be changed, and the resultant theoretical dependence of  $V$  on  $[K^+]_o$  according to (4) is depicted in Fig. 2 as the solid straight line. The values actually measured experimentally are given as dots. Note that, since the external  $K^+$  concentrations are lower than the internal concentrations, the resultant membrane potentials are negative. At high external  $K^+$  concentrations, the measured resting membrane potentials are fairly well fitted by the solid line, in agreement with Bernstein's hypothesis, but the measurements deviate from the prediction to more positive values at low  $K^+$  concentrations.

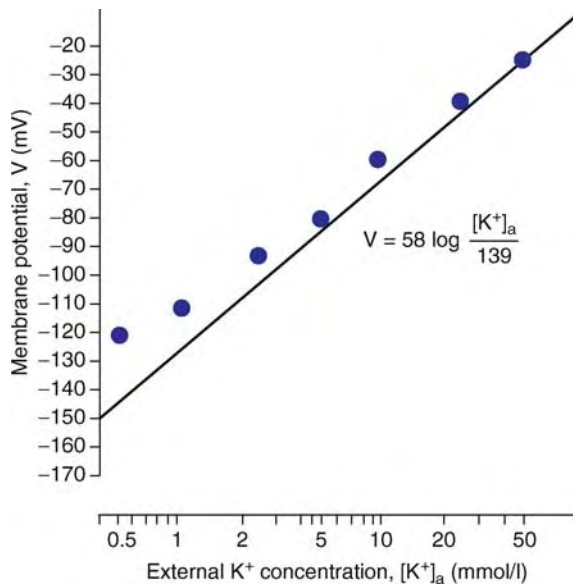

**Membrane Potential: Basics. Figure 2** Dependence of resting membrane potential on extracellular K<sup>+</sup> concentration. Frog sartorius muscle fiber. The resting membrane potential is plotted on the ordinate (in linear coordinates) as a function of extracellular K<sup>+</sup> concentration in logarithmic units on the abscissa. The *straight solid line* shows the theoretical relation according to the Nernst equation, assuming that only K<sup>+</sup> passes through the membrane; the *blue dots* are experimental measurements (Adapted from [5]).

### Resting Membrane Potential: Weighted Average of Equilibrium Potentials

The discrepancies between theory and measurement in Fig. 2 suggest that Bernstein's hypothesis cannot fully account for the real situation, and invite an inquiry into the underlying reasons. The starting point of course is to question the central assumption in the hypothesis, which is that K<sup>+</sup> is the only ion able to diffuse through the membrane.

What happens if – in addition to K<sup>+</sup> ions – other ions can diffuse through the membrane as well? First consider another major cation, namely Na<sup>+</sup>. The resulting situation can be captured by two limiting cases:

1. Limiting case 1: Membrane permeable solely to K<sup>+</sup> ions  $\Rightarrow V = E_K$ , as assumed by Bernstein: This makes the cell interior negative with respect to the outside, according to the Nernst equation; in nerve cells  $E_K$  is around -70 mV, in muscle cells around -90 mV.
2. Limiting case 2: Membrane permeable solely to Na<sup>+</sup> ions  $\Rightarrow V = E_{Na}$ ; this makes the cell interior positive with respect to the exterior because Na<sup>+</sup> ions would tend to diffuse inward and thus impose their positive charge onto the inside:  $E_{Na}$  is around +50 mV.

If, however, the membrane is permeable to both K<sup>+</sup> and Na<sup>+</sup> ions, membrane potential  $V$  must lie somewhere between  $E_K$  and  $E_{Na}$ , which as extreme cases constitute the limits for  $V$ :  $E_K < V < E_{Na}$ . This could account for the positive deviation of the experimentally measured  $V$  values (circles) from the theoretical  $E_K$ s (straight line) in Fig. 2.

If the membrane is permeable to both K<sup>+</sup> and Na<sup>+</sup> ions, no cation is at its equilibrium. This has important consequences, as illustrated in Fig. 3. The left column (a–b) explains the situation for K<sup>+</sup> ions and the right column (c–d) for Na<sup>+</sup> ions.

Figure 3a depicts limiting case 1, where  $V = E_K$ . K<sup>+</sup> is at its equilibrium, and there is thus no net K<sup>+</sup> flow through the membrane. In Fig. 3b,  $E_K < V$ , implying that the electrical potential does not compensate for the K<sup>+</sup> concentration gradient. Hence, K<sup>+</sup> ions flow out of the cell, following the surplus electrochemical gradient directed outward.

Figure 3c depicts limiting case 2, where  $V = E_{Na}$ . Na<sup>+</sup> is at its equilibrium, and there is thus no net Na<sup>+</sup> flow through the membrane. In Fig. 3d,  $V < E_{Na}$ , implying that the electrical potential does not compensate for the Na<sup>+</sup> concentration gradient. Hence, Na<sup>+</sup> ions flow into the cell, following the electrochemical gradient directed inward.

In general, therefore, when  $E_K < V < E_{Na}$ , there will be net ion currents flowing through the membrane, outward K<sup>+</sup> and inward Na<sup>+</sup> currents.

These qualitative points can be formulated quantitatively. According to ▶Ohm's law, the amount of current  $I$  carried by each ion through the membrane is proportional to the electric ▶conductance  $g$  (in units of  $\Omega^{-1} \text{ cm}^{-2}$ ) of each ion and the ▶driving potential, which is the difference between the actual membrane potential  $V$  and the equilibrium potential for each ion, as follows:

$$I_{Na} = g_{Na}(V - E_{Na}), \quad (5a)$$

$$I_K = g_K(V - E_K). \quad (5b)$$

Whenever the membrane potential  $V$  remains constant during steady state, no net current flows through the membrane. Hence, the two currents  $I_{Na}$  and  $I_K$  must cancel each other:

$$I_{Na} = -I_K \text{ or } I_{Na} + I_K = 0$$

$$g_{Na}(V - E_{Na}) + g_K(V - E_K) = 0$$

Solving for  $V$  yields

$$V = \frac{g_{Na} E_{Na} + g_K E_K}{g_{Na} + g_K} \quad (6)$$

In the extreme,

1. Limiting case 1: for  $g_{Na} = 0 \Rightarrow V = E_K$

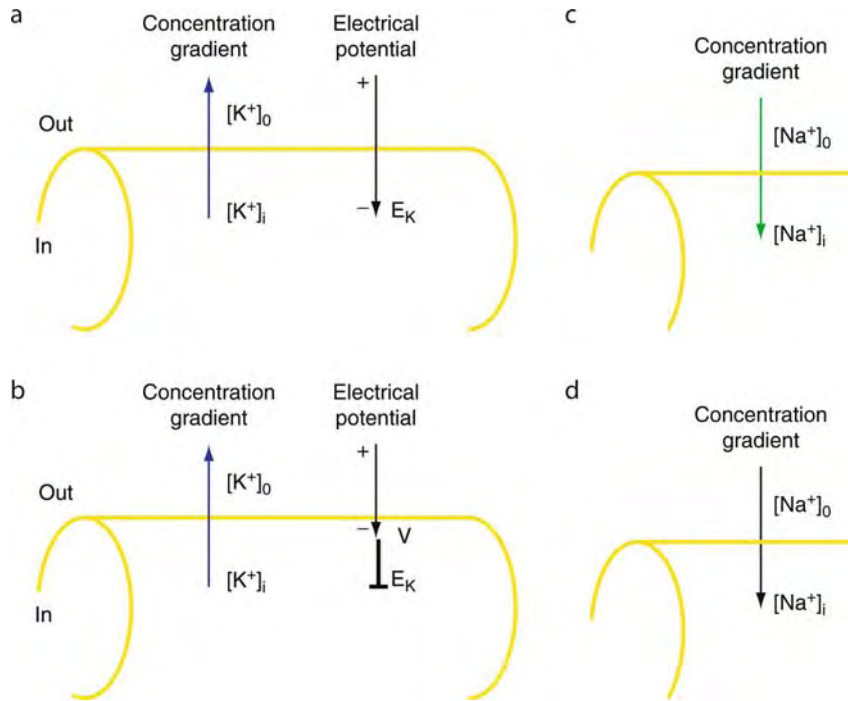

**Membrane Potential: Basics. Figure 3** (a–d) Origin of passive net  $K^+$  and  $Na^+$  ion flows across the cell membrane. The left column (a–b) explains the situation for  $K^+$  ions and the right column (c–d) for  $Na^+$  ions. (a): Situation at  $V = E_K$ : There is no net  $K^+$  flow because the outward concentration gradient (*left blue arrow headed upward*) is balanced by the inward electrical potential (*right arrow headed downward*) corresponding to the  $K^+$  equilibrium potential,  $E_K$ . (b): Situation for  $E_K < V$ :  $K^+$  ions flow out of the cell, following the surplus electrochemical gradient directed outward. (c): Situation at  $V = E_{Na}$ . There is no net  $Na^+$  flow because the inward concentration gradient for  $Na^+$  (*left green arrow headed downward*) is balanced by the outward electrical potential difference (*right arrow headed upward*). (d): Situation for  $V < E_{Na}$ .  $Na^+$  ions flow into the cell, following the huge electrochemical gradient directed inward (Adapted from [6]).

## 2. Limiting case 2: for $g_K = 0 \Rightarrow V = E_{Na}$

In this  $Na^+K^+$  system (with conductances for all other ions being zero), the two equilibrium potentials determine the limits, within which the membrane potential  $V$  can move.

### Other Ions

Equation 6 can be extended to other sets of ions, e.g., by including additional conductances, such as, e.g., for  $Ca^{2+}$  and  $Cl^-$ .  $Ca^{2+}$  with its positive charge and inwardly directed concentration gradient has, like  $Na^+$ , a positive equilibrium potential. Chloride with its negative charge and inwardly directed concentration gradient has a negative equilibrium potential. Including  $Cl^-$  with  $Na^+$  and  $K^+$  in (6) would yield:

$$V = \frac{g_{Na} E_{Na} + g_K E_K + g_{Cl} E_{Cl}}{g_{Na} + g_K + g_{Cl}} \quad (7)$$

### Constant Field Equation

The formulations in (6) and (7) use electrical variables, i.e., conductances and potentials, which are related to

chemical variables, albeit not in a simple way. The equilibrium potentials are related to concentration gradients via the Nernst equation, and the conductances to permeabilities (in units of cm/s) of the membrane to certain ions [2].

These relationships are expressed in the ►Goldman-Hodgkin-Katz equation (Alan Hodgkin and Bernard Katz, Nobel Prizes in Physiology or Medicine 1963 and 1970, respectively) or ►constant field equation, which has the form of a generalized Nernst equation (generalized to several permeant ions) (see, e.g., refs. [2,3,7,8]):

$$V = \frac{R \cdot T}{F} \times \ln \frac{P_K [K^+]_o + P_{Na} [Na^+]_o + P_{Cl} [Cl^-]_i}{P_K [K^+]_i + P_{Na} [Na^+]_i + P_{Cl} [Cl^-]_o}, \quad (8)$$

where  $P_K$  is the membrane permeability for  $K^+$  etc. Note that, in the strict sense, the common habit of using the terms conductance and permeability as synonyms is not correct [2].

### Conductances as Weighting Factors

Equations (6) and (7) reveal the role of the different ion conductances as weighting factors: Increasing any one

of them drags the membrane potential  $V$  closer to the equilibrium potential of the respective ion, and vice versa.  $V$  is thus an average of the relevant equilibrium potentials weighted by the conductances.

In most cells, the resting membrane potential is much closer to  $E_K$  than to  $E_{Na}$  because under resting conditions  $g_K$  is much larger than  $g_{Na}$  (by a factor of 10–75 in different cells, the latter value applying to frog muscle fibers; see ref. [2]).

### Ion Pumps

Because the membrane is permeable to several ions that flow passively down electrochemical gradients, unrestricted ion flow would eventually abolish concentration differences between the inside and outside of the cell and, in consequence, the equilibrium and membrane potentials. In order to prevent this, the cell invests much energy in so-called **ion pumps** that transport the leaking ions back to where they come from, against their respective gradients (**Ion Transport**). Such pumps need:

1. Metabolic energy, ultimately supplied by adenosine triphosphate (ATP).
2. Regulation mechanisms, including the sensitivity for particular ions and their concentrations (e.g., inside for  $Na^+$ ).

The action of the  $Na^+$  pump that expels  $Na^+$  from a cell was first demonstrated by Hodgkin and Keynes [9], who showed that the metabolic poison dinitrophenol (DNP), which deprives energy sources for the  $Na^+/K^+$  pump, depresses cellular extrusion of  $Na^+$ . Since then, other laboratories have demonstrated the active role of ion pumps that maintain steady state membrane potential by regulating intracellular  $Na^+$ ,  $Cl^-$ ,  $K^+$  and  $Ca^{2+}$  concentrations [10].

### Sub threshold Membrane Potential Transients are Shaped by cable Properties

Membrane potential changes in response to transmembrane current flow are low-pass filtered as illustrated in Fig. 1, (right side). As long as the stimulus electrode tip remains in the external medium, rectangular current pulses passed through it (upper trace) elicit only small smoothed voltage changes picked up by the recording electrode whether extra- or intracellular (left upper trace). When the stimulus electrode tip enters the axon (second vertical arrow), the recording electrode measures deviations from the resting potential corresponding to low-pass filtered versions of the current pulses. The low-pass filtering is due to cable properties of the nerve or muscle fiber (**Cable Theory**).

### References

1. Sargent PB (1992) Electrical signaling. In: Hall ZW (ed) An introduction to molecular neurobiology. Sinauer Associates, Sunderland (Mass), pp 33–80

2. Katz B (1966) Nerve, muscle and synapse. McGraw-Hill, New York
3. DeVoe RD, Maloney PC (1981) Principles of cell homeostasis. In: Mountcastle (ed) Medical physiology. Mostby, St Louis, pp 3–45
4. Bernstein J (1902) Untersuchungen zur Thermodynamik der bioelektrischen Ströme. Pflügers Arch ges Physiol 92:521–562
5. Adrian RH (1956) The effect of internal and external potassium concentration on the membrane potential of frog muscle. J Physiol (Lond) 133:631–658
6. Kuffler SW, Nicholls JG (1976) From neuron to brain. Sinauer Associates, Sunderland (Mass)
7. Hille B (1992) Ionic channels of excitable membranes, 2nd edn. Sinauer Associates, Sunderland (Mass)
8. Keener J, Sneyd J (1998) Mathematical physiology. Springer, Berlin Heidelberg New York
9. Hodgkin AL, Keynes RD (1955) Active transport of cations in giant axons from Sepia and Loligo. J Physiol (Lond) 128:28–60
10. DiPolo R, Beauge L (2006) Sodium/calcium exchanger: influence of metabolic regulation on ion carrier interactions. Physiol Rev 86:155–203

---

## Membrane Properties

- ▶ Intrinsic Properties of Auditory Neurons

---

## Membrane Resistance

### Definition

The membrane resistance is a measure of the impediment to the transmembrane flow of ions. The membrane resistance is infinite in the absence of ionic channels and transporters in the membrane. The membrane resistance decreases as the number of ion channels and transporters increase in the membrane, which permit the transmembrane flux of ions under the driving force of electrochemical gradients.

- ▶ Action Potential
- ▶ Action Potential Propagation
- ▶ Cable Theory
- ▶ Membrane Potential: Basics

---

## Memory

- ▶ Learning and Motivation

## Memory, Long-term

### Definition

► Long-term Memory

## Memory, Molecular Mechanisms

TOSHIYA MANABE

Division of Neuronal Network, Department of Basic Medical Sciences, Institute of Medical Science, University of Tokyo, Tokyo, Japan

### Definition

Formation of certain kinds of memory (declarative memory) requires functional activation of the hippocampus. Synaptic plasticity of excitatory synaptic transmission, represented by long-term potentiation (LTP), has been regarded as a cellular and molecular model of learning and memory. LTP in the hippocampal CA1 region is induced by the activation of the ►NMDA receptor, which is one type of the ►ionotropic glutamate receptors, and is expressed by the enhancement of basal synaptic transmission mediated by the ►AMPA receptor, which is another type of the ionotropic glutamate receptors. NMDA receptor activation regulates intracellular biochemical processes, resulting in long-lasting modification of synaptic transmission, which has been thought to be a molecular mechanism of memory.

### Characteristics

#### Hippocampal LTP

Fast excitatory synaptic transmission in the central nervous system is mediated mainly by the two ionotropic glutamate receptors, the AMPA receptor and NMDA receptor [1]. Basal synaptic transmission in the pyramidal cell at a membrane potential around the resting membrane potential is mostly mediated by AMPA receptors. When the neurotransmitter glutamate is released from the presynaptic terminal and binds to the AMPA receptor, the receptor channel opens regardless of the membrane potential and permeates monovalent cations. Because the ionic concentration of  $\text{Na}^+$  is higher outside the cell, the ionic concentration of  $\text{K}^+$  is higher inside the cell, and the membrane potential of the cell is negative at rest, mainly  $\text{Na}^+$  ions enter the cell through AMPA receptors, resulting in the depolarization of the cell.

On the other hand, NMDA receptors fail to open at a membrane potential around the resting membrane

potential even if glutamate binds to the receptor, because external  $\text{Mg}^{2+}$  ions block the ionic channel of the receptor ( $\text{Mg}^{2+}$  block). However, when the synapse is repetitively activated at high frequencies and the postsynaptic cell sufficiently depolarizes, the  $\text{Mg}^{2+}$  block is released and  $\text{Ca}^{2+}$  ions as well as  $\text{Na}^+$  ions enter the postsynaptic cell through the NMDA receptor channel [1]. Thus, the NMDA receptor functions as a coincidence detector for presynaptic and postsynaptic activities.

The increased intracellular  $\text{Ca}^{2+}$  then activates  $\text{Ca}^{2+}$ -dependent biochemical processes such as the calcium/calmodulin-dependent protein kinase II (CaMKII) and protein kinase C cascades, which further promotes the process of LTP expression. The final expression mechanism for LTP is thought to involve an insertion of active intracellular AMPA receptors into the synaptic site and/or a long-lasting increase in the conductance of AMPA receptor channels [2].

### LTP and Memory

LTP has been thought to be involved in memory formation. In Morris water maze task, in which the ability of spatial memory in rats and mice can be assessed, the blockade of LTP by intraventricular injection of an NMDA receptor antagonist impairs the spatial learning in the rat [3]. It has also been reported that the genetic deletion of the NR2A subunit of NMDA receptors in the mouse causes the reduction of hippocampal LTP and the impairment of learning abilities in Morris water maze task [4]. Furthermore, overexpression of the NR2B subunit has been reported to enhance learning and memory in the mouse [5]. Thus, the NMDA receptor, which is essential for LTP induction, plays a pivotal role in memory formation.

There are many reports showing the involvement of various intracellular signaling molecules downstream of NMDA receptor activation in learning and memory. The first papers in which LTP of knockout mice is examined suggest that CaMKII is essential for LTP induction in the hippocampal CA1 region [6] and that spatial memory of the mutant mice is severely impaired [7]. So far, many intracellular signaling molecules, such as protein kinase C, mitogen-activated protein kinase and protein kinase A, have been shown to be involved in both LTP and memory formation.

### References

- Ozawa S, Kamiya H, Tsuzuki K (1998) Glutamate receptors in the mammalian central nervous system. *Prog Neurobiol* 54:581–618
- Lynch MA (2004) Long-term potentiation and memory. *Physiol Rev* 84:87–136
- Morris RGM, Anderson E, Lynch GS, Baudry M (1986) Selective impairment of learning and blockade of long-term potentiation by an N-methyl-D-aspartate receptor antagonist, AP5. *Nature* 319:774–776

4. Sakimura K, Kutsuwada T, Ito I, Manabe T, Takayama C, Kushiya E, Yagi T, Aizawa S, Inoue Y, Sugiyama H, Mishina M (1995) Reduced hippocampal LTP and spatial learning in mice lacking NMDA receptor  $\epsilon 1$  subunit. *Nature* 373:151–155
5. Tang YP, Shimizu E, Dubé GR, Rampon C, Kerchner GA, Zhuo M, Liu G, Tsien JZ (1999) Genetic enhancement of learning and memory in mice. *Nature* 401:63–69
6. Silva AJ, Stevens CF, Tonegawa S, Wang Y (1992) Deficient hippocampal long-term potentiation in  $\alpha$ -calcium-calmodulin kinase II mutant mice. *Science* 257:201–206
7. Silva AJ, Paylor R, Wehner JM, Tonegawa S (1992) Impaired spatial learning in  $\alpha$ -calcium-calmodulin kinase II mutant mice. *Science* 257:206–211

---

## Memory, Short-term

### Definition

► Short-term Memory

---

## Memory: Eidetic, Photographic

### Definition

The ability to store perceived events. Eidetic memory refers to motor programs that help to orient in familiar environments even when no sensory input is present (people may find light switches in familiar dark rooms). If the storage results in a representation of space similar as in a photograph, the term photographic memory is used.

---

## Memory and Dementia

MURRAY GROSSMAN

Department of Neurology, University of Pennsylvania School of Medicine, Philadelphia, PA, USA

### Definition

Memory is the acquisition and mental representation of information. ► **Dementia** is a progressive neurodegenerative disease that compromises neurologic functioning in individuals who have attained adult levels of intact cognition. There are many kinds of memory, and

each of these has a different fate in patients with the most common form of dementia, ► **Alzheimer's disease** (AD). The distinct ways in which these different forms of memory are compromised depends in large part on the neuroanatomic distribution of disease in AD.

### Characteristics

► **Episodic memory** is the ability to learn a new event consciously and then to recall this specific event purposefully and at will [1]. This form of memory depends on the hippocampus and intimately related structures in the medial temporal lobe. The earliest evidence of histopathologic disease in AD is the accumulation of neuritic plaques composed of amyloid and neurofibrillary tangles consisting of paired helical filaments of tau in the hippocampus, and the earliest clinical feature of AD thus is impaired episodic memory. Indeed, a prodromal Alzheimer's condition known as amnesic Mild Cognitive Impairment (aMCI) is defined clinically as an isolated deficit of episodic memory.

Impaired episodic memory is commonly demonstrated by a list-learning task. On this task, a supraspan list of words (a list of 10–15 words that is longer than can be repeated in one try) is presented for learning, and as many words as possible are repeated by the patient. This sequence of list presentation and repetition is repeated for several learning trials. Subsequently, a brief period filled with another task is administered to prevent rehearsal of the words, then the list is recalled. Although we do not fully understand how the hippocampus and medial temporal structures accomplish this task, one important theory proposes that a to-be-remembered event is bound to its context or other associated attributes of the event. On a list-learning task, this is the specific list of words bound to its recent presentation as part of the memory test. Healthy adults typically demonstrate learning by repeating a longer list on each successive learning trial. Moreover, despite the filled period that prevents rehearsing the list, healthy adults can recall most of the stimulus words. In AD, by comparison, there is impaired learning and impaired recall. AD patients may repeat only three or four words during a learning trial, and they do not show learning by repeating more words on subsequent trials. Moreover, AD patients typically recall no words following the brief delay. Patients with aMCI and mild AD may be able to recognize some of the words in a multiple-choice format. A similar pattern of findings is evident regardless of the stimulus modality (e.g. aural or visual) or material (e.g. words or geometric designs). Imaging studies directly relate this episodic memory deficit to hippocampal atrophy or reduced hippocampal metabolism in AD through correlation studies, while functional imaging that monitors brain activity during episodic memory shows reduced hippocampal activation in AD patients compared to healthy adults [2].

► **Remote Memory** is the long-term representation of information that was learned months to years earlier [3]. This may include factual knowledge or personal autobiographical knowledge. It often seems that remote memory is relatively preserved in AD, since these patients frequently enjoy reminiscing about events that occurred in their early years. However, careful examination demonstrates that remote memory also may be impaired in AD [4]. These are at least two possible explanations for this deficit. One account, paralleling the mechanism for episodic memory mediated by the hippocampus, suggests that impaired remote memory involves difficulty retrieving facts bound to a specific, remote period of time. However, functional neuroimaging studies of healthy adults suggest that the hippocampus may not be activated to retrieve information from remote memory. An alternate possibility is that the neural representation of remote memories is degraded as the disease in AD spreads from the hippocampus to other cortical areas in the temporal lobe and the frontal lobe.

► **Semantic Memory** is the representation of the meaning of words, objects, actions, thoughts, and the like [5]. Semantic memory is also impaired in up to 50% of patients with AD. Like episodic memory and remote memory, one theory of semantic memory difficulty in AD is that hippocampal disease interferes with this form of memory. This may be because the hippocampus is necessary for binding features into a meaningful category of knowledge, or the hippocampus mediates retrieving semantic information from its long-term cortical representation. However, these accounts would not explain the dissociation between episodic memory difficulties present in virtually all patients with AD, and the semantic memory deficit that is present only in a subset of these patients. An alternate possibility is related to the frequent correlation of impaired semantic memory with cortical atrophy in the posterolateral temporal and dorsolateral frontal lobe. It is unlikely that temporal and frontal regions are the neural repository for all semantic knowledge. Instead, the semantic memory deficit associated with temporal and frontal disease may be related to a categorization process that assembles information that is widely represented throughout the cortex into a meaningful concept. Consistent with this possibility, the temporal and frontal regions consist of multimodal association cortex, where there is a connectivity pattern involving reciprocal projections with all unimodal association cortices. Functional neuroimaging studies of semantic categorization in healthy adults show activation of these areas, and this activation is reduced in AD [6].

► **Working Memory** is a form of short-term memory that may supplement many of the other forms of memory described above [7]. For example, retrieval from episodic, remote or semantic memory may benefit from working memory that maintains the to-be-remembered

target in an active mental state during searches and decision-making components of these forms of memory. Working memory also may contribute to other processes such as understanding a long and grammatically complex sentence, or weighing all relevant facts during mental reasoning tasks. Much evidence indicates that working memory is impaired in AD. This appears to be related to disease in prefrontal cortex and inferior parietal cortex, according to correlation studies of cortical atrophy in AD.

► **Implicit Memory** is another form of memory for acquiring new information [8]. Unlike the kinds of memory described above, implicit memory occurs without conscious awareness. This may take the form of a habit that is acquired through repeated performance of a particular activity, or repeated exposure to a category of similar materials that subsequently biases an individual towards accepting similar appearing materials as members of the same category. Implicit memory appears to be relatively preserved in AD [9]. Thus, patients with AD are able to learn a new habit and a new perceptual category such as a dot array when presented implicitly. Recent work also suggests that AD patients can learn a meaningful category when presented implicitly. Functional neuroimaging studies in healthy adults suggest that implicit memory tasks involve the caudate as well as other cortical association regions. Functional neuroimaging studies of patients with AD during implicit memory challenges show some activation of caudate and cortical association regions. The hippocampus is not activated in AD, and this may account for the minor deficit in implicit memory tasks in AD relative to age-matched controls.

Memory difficulty in non-Alzheimer's forms of dementia is also well documented [10]. In semantic dementia, for example, there is profound impairment of semantic memory. In this condition, comprehension of words, objects, actions and abstract concepts is significantly compromised. This is related to their temporal lobe disease. In frontotemporal dementia presenting with a disorder of social comportment and personality, working memory is regularly compromised. This appears to be due to their prefrontal disease. In Parkinson's dementia, habit learning is impaired due to disease affecting the caudate.

Multiple forms of memory difficulty are evident in AD. While we typically think of an episodic memory deficit as the *sine qua non* of AD, difficulty with remote memory, semantic memory, and working memory also are regularly compromised in AD. More surprisingly, it appears that some forms of memory are relatively preserved in patients with AD, including habit learning and implicit memory.

### Acknowledgement

This work was supported in part by NIH (AG15116, AG17586; NS44266; NS53488) and the Dana Foundation.



## References

1. Eichenbaum H (2004) Hippocampus: cognitive processes and neural representations that underlie declarative memory. *Neuron* 44:109–120
2. Golby A et al. (2005) Memory encoding in Alzheimer's disease: an fMRI study of explicit and implicit memory. *Brain* 128:773–787
3. Nadel L, Samsonovich A, Ryan L, Moscovitch M (2000) Multiple trace theory of human memory: computational, neuroimaging, and neuropsychological results. *Hippocampus* 10:352–368
4. Fama R et al. (2001) Remote memory for public figures in Alzheimer's disease: relationships to regional cortical and limbic brain volumes. *J Int Neuropsychol Soc* 7:384–390
5. Koenig P, Grossman M (2007) Neural basis of semantic memory. Cambridge University Press, Cambridge, UK
6. Grossman M et al. (2003) Neural basis for semantic memory difficulty in Alzheimer's disease: an fMRI study. *Brain* 126:292–311
7. Baddeley AD, Sala Della S (1996) Working memory and executive control. *Philos Trans R Soc Lond B Biol Sci* 351:1397–1403
8. Squire LR, Knowlton BJ (1995) Learning about categories in the absence of memory. *Proc Natl Acad Sci USA* 92:12470–12474
9. Fleischman DA et al. (2005) Implicit memory and Alzheimer's disease neuropathology. *Brain* 128:2006–2015
10. Libon DJ et al. (2007) Patterns of neuropsychological impairment in frontotemporal dementia. *Neurology* 68:369–375

---

## Memory and Sleep

SHIGENOBU SHIBATA

Division of Physiology and Pharmacology, School of Science and Engineering, Waseda University, Tokyo, Japan

### Definition

Memory and sleep refer to the role of sleep in memory processing

### Characteristics

A large number of studies offer substantial evidence supporting the role of sleep in what is becoming known as sleep-dependent memory processing [1]. Many reports, ranging from studies on cellular and molecular processes in animals to behavioral studies in humans, have provided a wealth of converging evidence that sleep-dependent mechanisms of neural plasticity lead to the consolidation of learning and memory across a range of animal species. There are a number of stages of

memory consolidation, and each stage uses distinct brain processes to perform separate functions. When combined with multiple memory systems such as procedural or declarative memory and the different stages of sleep such as ►REM or ►NREM sleep, one is faced with a truly staggering number of possible ways that ►sleep cycle might affect memory consolidation. Recent findings show that sleep deprivation can impair learning and memory for both motor procedural and declarative memory systems. It is only by asking whether a specific stage of sleep affects a particular aspect of memory processing for a given type of memory that one can begin to ask scientifically answerable questions concerning sleep-dependent memory processing. There remain numerous important and unanswered questions regarding sleep-dependent memory consolidation. While procedural learning, both perceptual and motor, is clearly enhanced by post-training sleep, the forms of declarative memory that are similarly affected are uncertain. Contribution of sleep to the processes of memory stabilization, enhancement, reconsolidation, integration, translocation, and active erasure require further elucidation. The actual processes within sleep that effect consolidation are almost completely unknown; however, many papers allow us to draw conclusions. Both REM and NREM sleep seem necessary for learning and memory: thus, for efficient consolidation of both (declarative) knowledge and (procedural) skills, the biggest risk can come from sleep loss or fragmentation.

### Different Sleep Stages: REM and NREM Sleep

Sleep can be defined as a state of immobility and greatly reduced responsiveness distinguishable from coma or anesthesia by its rapid reversibility. An additional defining characteristic of sleep is that when it is prevented, the body tries to recover the lost amount, termed “rebound.” Sleep is the state of natural rest observed in humans and throughout the animal kingdom in all mammals and birds, and in many reptiles, amphibians, and fish. Two types of sleep have been defined based on the measurement of eye movement during slumber: rapid eye movement (REM) and non-rapid eye movement (NREM). Each type has a distinct set of associated physiological, neurological, and psychological features.

In NREM sleep, the body is active and the brain inactive, and there is relatively little dreaming. NREM is comprised of four stages according to the “The American Academy of Sleep Medicine (AASM)”; stages 1 and 2 are considered the light sleep stages, and 3 and 4 the deep sleep stages, differentiated solely by electroencephalography (EEG). NREM accounts for 75–80% of total sleep time in normal human adults.

Sleep-activated neurons, which have been discovered in the preoptic and basal forebrain regions [2], are maximally active during NREM sleep. When

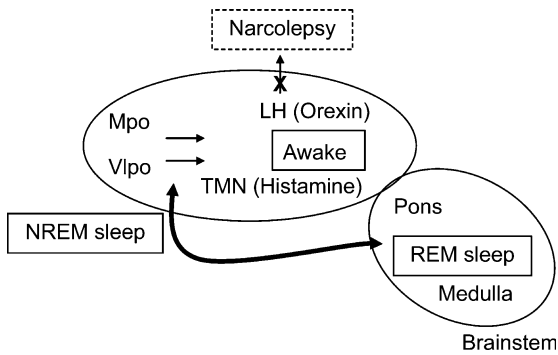

**Memory and Sleep. Figure 1** Schema of sleep-regulating neuronal populations. Mpo, median preoptic area; Vlpo, ventrolateral preoptic area; LH, lateral hypothalamus; PH, posterior hypothalamus; NREM sleep, non-rapid eye movement sleep; REM sleep, rapid eye movement sleep.

stimulated, these cells will induce the NREM state. In contrast, damage to these regions greatly reduces sleep. The neurons in these brain regions give inhibitory projections to aminergic, cholinergic, and orexinergic neurons in the forebrain and brainstem. GABAergic inhibitory projections from preoptic regions might be important in inhibiting orexin neurons, which are thought to be involved in sleep regulation, during sleep (Fig. 1).

In humans, the duration of REM sleep episodes progressively increases throughout the sleep period and is maximal just prior to the expected time of awakening. For example, the initial REM sleep period may last only 5–10 min, whereas the last REM period before awakening may last for more than 25 min. REM amounts are maximal near the nadir of the brain and the core body temperature cycles. REM sleep phenomena can be generated by the isolated brainstem region, in particular the pons and adjacent midbrain [2]. Although an animal in REM sleep is behaviorally asleep, brain metabolic and neuronal activity are high, respiration and heart rate are variable, rapid eye movement and twitches of the extremities occur, and males frequently develop erections. Several theories have suggested that REM state, and its associated ▶periodic brain activation, plays a role in localized recuperative processes and in emotional regulation during sleep. The brain areas where REM sleep neural activity is higher than wakefulness consist of the anterior cingulate cortex, the amygdala and the limbic-paralimbic regions, and the associated visual areas [3].

Each sleep cycle (NREM sleep + REM sleep) lasts about 90 min. Most people repeat this cycle four times a night, for a total of approximately 6–8 h of sleep. REM sleep time elongates with each repeating cycle, and a comfortable wake-up is best just after the end of a REM sleep period. The alternation between NREM and

REM sleep is the outcome of a balanced action based on the cyclic function of the brainstem and forebrain structures.

### Sleep and the Different Memory Systems: Declarative and Non-Declarative Procedural Memory

Human memory has been subjected to several different classification schemes, the most popular being based on the distinction between declarative and non-declarative (procedural) memory. Non-declarative memory includes procedural memory (“knowing how”) learning of actions, habits, and skills, as well as implicit learning. This type of memory system appears to be less dependent on medial temporal lobe structures. Declarative memory is comprised of the consciously accessible memories of fact-based information. Current neural models of declarative memory formation emphasize the critical importance of structures in the medial temporal lobe, including the hippocampus, a structure that is thought to form a temporally ordered retrieval code for neocortically-stored information.

The evidence for sleep-dependent consolidation of declarative memories is less consistent. Many earlier experiments investigated the effects of classic tests of declarative memory (verbal learning tasks) on REM sleep changes following training. More recently, verbal (recall of paired-associated word lists) and non-verbal declarative memory were investigated through a subject’s ability to recall spatial locations in memory rotation tasks, and findings showed improved recall spanning the early sleep interval, rather than late sleep interval, and the corresponding intervals of wakefulness. While the results were taken to mean that in addition to REM sleep, NREM also exerted a selective facilitation of declarative memory consolidation in humans, they may actually just reflect the nature of the word pairs used: unrelated word pairs such as dog-leaf for earlier and related pairs such as dog-bone for later. Other findings on declarative memory suggest that following initial practice of a numeric sequence problem-solving task, a night of sleep can trigger insight into a hidden rule(?) and thus improve performance strategy the following morning.

In contrast to the declarative memory system, there have been robust and consistent findings that across a wide variety of functional domains, including visual, auditory and motor systems, procedural memory relies on sleep. The results from many reports seem to support the hypothesis of sequential processing of memories during sleep stages, suggesting that memory formation is promoted by NREM and then consolidated by REM sleep. Accordingly, the amount of sleep-dependent improvement on a perceptual learning task is linearly correlated with the amount of NREM during the first quarter of the night and with the amount of REM sleep in the last quarter.

The beneficial effect of sleep on procedural memory has also been investigated through motor skill learning tasks. A night of sleep can trigger significant performance improvements in speed and accuracy on a sequential finger-tapping task, while equivalent periods of awake time provide no significant benefit. These sleep-dependent benefits appear to be specific to both the motor sequence learned and the hand used to perform the task. Furthermore, overnight learning gains seem to correlate with the amount of stage 2 NREM sleep. A complex procedural motor adaptation task requiring hand–eye coordination was introduced. The extent of the local parietal lobe increase in slow-wave activity in the first 90 min of sleep strongly correlated with subsequent performance enhancement (learning) observed the next day, showing a close relationship between local EEG activity and subsequent regional slow-wave activity homeostasis.

It has been shown that periods of awake time following training on a synthetic speech recognition task result in a degradation of task performance, while a subsequent night of sleep can restore performance to post-training levels. Hence, it appears that there is a process of sleep-dependent consolidation capable of reestablishing previously learned complex auditory skill memories. Faced with such consistent and reproducible findings on sleep-dependent visual, auditory, and motor skill learning, it seems difficult to refute the claim that sleep is necessary for the consolidation of human procedural skills, the restoring of previously decayed memory traces, and the triggering of additional learning.

On the whole, recent findings have generally been interpreted as supportive of the notion that early night NREM and late night REM play a fundamental role in the consolidation of procedural memories in humans, while NREM-rich sleep seems to have facilitating effects for declarative memories.

Studies with monoamine oxidase inhibitors and other REM suppressing antidepressants have proven that REM sleep plays no role in memory consolidation, and thus the argument arose that such REM suppressants could be taken for years with no deleterious effects on memory. However, there are some arguments for the reemergence of REM sleep with chronic drug treatment and REM rebound with drug withdrawal.

### Sleep-Dependent Brain Plasticity

Memory formation depends on brain plasticity—lasting structural and/or functional neuronal changes in response to stimuli from an individual's experiences. If sleep is to be considered a critical mediator of memory consolidation, then evidence of sleep-dependent plasticity would greatly strengthen this claim. Indeed, there is now a wealth of data describing sleep-dependent brain plasticity at a variety of different levels thanks to neuron-imaging studies, electrophysiological studies,

and cellular molecular studies in both animals and humans, complementing evidence of sleep-dependent changes in behavior. Findings of sleep-dependent plasticity in the visual cortex of the rat suggest that REM sleep, in conjunction with visual stimuli, modulates the initial course of visual cortex maturation. At the molecular level, administration of protein synthesis inhibitors to rats during REM sleep windows, a time thought to be critical to consolidation, prevents behavioral improvement following the sleep period. Thus, learning and memory are dependent on processes of brain plasticity, the same processes that must also mediate sleep-dependent learning and memory consolidation. Many examples of such plasticity during sleep have now been reported, several of which were specifically induced by experiences that took place during awake time.

### Sleep and Academic Performance

As sleep has a relevant role in facilitating learning and memory processes, and since sleep deprivation and/or fragmentation usually impair these functions, the effect of sleep patterns and schedules on academic performance is an area of interest. In terms of an indirect link between sleep and academic performance, it was shown that students with more regular sleep-wake patterns (shorter sleep latency, fewer night awakenings, later school rise times, earlier rise times on weekends) reported a higher grade point average, whereas students with lower grades reported increased daytime sleepiness, also as a consequence of less sleep at night [4].

### Orexins, Narcolepsy and Memory

Endogenous ►orexin, also referred to as hypocretin, may be involved in multiple functions including arousal, the sleep-wake cycle, sleep disorders, and learning and memory. Orexin is the common name given to a pair of highly excitatory neuropeptide hormones. The two related peptides (orexin A and B), are produced by cleavage of a single precursor protein. Although these peptides are produced by a very small population of cells in the lateral hypothalamus [5], they send projections throughout almost the entire brain. The orexin system was initially suggested to be involved in the stimulation of food intake, and later in sleep regulation because of dysfunctional orexin and its association with the sleep disorder ►narcolepsy. Orexin neurons strongly excite various brain nuclei with roles in wakefulness and the dopamine, norepinephrine, histamine, and acetylcholine systems.

Orexin A enhances normal long-term potentials (LTP) in medial perforant path – dentate granule cell synapse in the hippocampus. Given the well-documented involvement of monoaminergic and cholinergic neurotransmitter systems over a wide range of memory processes,

memory impairments might accompany the sleep symptoms seen in narcolepsy.

The main characteristic of narcolepsy is an overwhelming excessive daytime sleepiness, even after an adequate night of sleep. A person with narcolepsy is likely to become drowsy or fall asleep, often at inappropriate times and places. Daytime naps can occur several times a day. Drowsiness may persist for prolonged periods of time, and nighttime sleep may be fragmented by frequent awakening.

In narcolepsy, the order and length of NREM and REM sleep periods are disturbed, with REM sleep occurring at sleep onset instead of after a period of NREM sleep. Thus, narcolepsy is a disorder in which REM sleep appears at an abnormal time. When narcolepsy patients were compared to matched control subjects on a range of tasks that measured attention, memory and executive control, impairments were only observed during the attention and executive function tasks, which involved higher demands on inhibition or task management abilities. The relatively routine memory and attention tasks yielded intact performances in the narcolepsy patients. Thus, the overall pattern of results indicates an executive control deficit that occurs with narcolepsy that might be related to a reduction of available cognitive processing resources because of the need for continuous allocation of resources toward monitoring and maintaining vigilance.

## References

1. Stickgold R, Walker MP (2007) Sleep-dependent memory consolidation and reconsolidation. *Sleep Med* 8:331–343
2. Siegel (2005) Clues to the functions of mammalian sleep. *Nature* 437:1264–1271
3. Halasz P, Terzano M, Parrino L, Bodizs R (2004) The nature of arousal in sleep. *J Sleep Res* 13:1–23
4. Curcio G, Ferrara M, De Gennaro (2006) Sleep loss, learning capacity and academic performance. *Sleep Med* 10:323–337
5. Ohno K, Sakurai T (2008) Orexin neuronal circuitry: role in the regulation of sleep and wakefulness. *Front Neuroendocrinol* 29(1):70–87

## Memory Capacity

### Definition

Maximum ratio between the number of patterns stored in an associative memory network and the number of units of that network, above which the stored patterns are not stable states of the network.

- ▶ Associative Memory
- ▶ Neural Networks

## Memory Consolidation

### Definition

The time-dependent process of fixation of new memory traces into stable long-term memory.

- ▶ Emotional Learning/Memory

## Memory Distortion

DANIEL M. BERNSTEIN<sup>1</sup>, ELIZABETH F. LOFTUS<sup>2</sup>

<sup>1</sup>Department of Psychology, Kwantlen University College, Surrey, BC, Canada

<sup>2</sup>Departments of Psychology and Social Behavior, Criminology, Law and Society, Cognitive Sciences, University of California, Irvine, Irvine, CA, USA

### Synonyms

False memory; Memory illusions

### Definition

Memory distortion refers to a memory report that differs from what actually occurred.

### Characteristics

Memory's fate is determined by factors present at encoding (when the memory is first recorded), storage (how and where the memory is represented in the brain), and retrieval (when the memory is reported). The level of attention paid to the original event, the time that passes after the original encoding, the match between encoding and retrieval contexts, and the presence of competing and interfering information in memory are but a few of the factors that determine memory accuracy. Memory records experiences. The recording includes sensory information like sight, sound and touch, as well as emotions, thoughts, and feelings about the experience. These details are stored in a distributed fashion throughout the brain, making it difficult if not impossible to localize any particular memory trace in the brain [1].

The British psychologist, Sir Fredrick Bartlett [2] demonstrated the constructive nature of memory. Bartlett examined the fate of memory, and concluded that memory undergoes typical transformation over time including omissions, deletions and distortions. In one of Bartlett's most famous experiments, British subjects read a Native American folktale called the War of the Ghosts in which a battle occurs between two warring tribes. Using a

method called serial reproduction (akin to the child game called “telephone”), one subject would recall the story in as much detail as possible. Another subject would read the first subject’s account of the story and then try to recall it, followed by additional subjects reading the account of their immediate predecessor and trying to recall it. This method revealed that memory for the original story undergoes massive distortion after very few repetitions.

### Memory Distortion Techniques

Many techniques have been shown to distort memory. A partial list of techniques includes misinformation, outcome information, semantic relatedness, suggestion, imagination, and more subtle manipulations such as subliminal repetition and unscrambling. Each of these techniques reveals the inherent fallibility of memory.

In the early 1970s, researchers began to explore the effects of misleading post-event information on memory for events. In one study, subjects viewed a simulated vehicle-pedestrian accident. Some subjects watched as a car approached an intersection and stopped at a stop sign. The car then turned right and hit a pedestrian who was crossing the street. After viewing the accident, some subjects were asked a question that suggested it was a yield sign. Later subjects had to report on the sign they had actually seen, and many subjects who received the misinformation incorrectly recalled seeing the opposite sign. In related work, researchers showed how the wording of a question during an eyewitness interview affects memory for what was seen. For example, subjects who viewed an accident on film and were asked, “About how fast were the cars going when they smashed into each other?” reported greater speed than did subjects who were asked, “About how fast were the cars going when they hit each other?” Additionally, those who were asked the “smashed” question were more likely to report having seen broken glass than subjects who were asked the “hit” question, even though no broken glass had appeared. Thus, simple word choices can distort memory for details of an event [3].

In a related paradigm involving post-event information, subjects predicted the outcome of an event that had not yet occurred. After finding out the true outcome, they were asked to remember what they originally predicted. For example, prior to Nixon’s 1972 visit to China and the Soviet Union, subjects were asked to provide probability estimates for various outcomes: President Nixon will meet Chairman Mao; President Nixon will declare the trip a success. Even when told to ignore the true outcome, most subjects adjusted their original estimates to concur with the actual outcome, thereby claiming that they “knew it all along.” This hindsight bias has been demonstrated using a variety of materials and sensory modalities, including verbal, visual, and even gustatory judgments [4]. Like the misinformation effect, hindsight bias is a form of memory

distortion that is influenced by outcome information that conflicts directly with one’s original memory.

Other techniques show how easy it is to distort memory for details of prior experience. For example, consider the following set of words: bed, rest, awake, tired, dream, wake, night, blanket, pillow. Most people who hear or read a similar list will mistakenly recall hearing or seeing the word, “sleep” in the original list. The fact that the words in the list are all semantically related to the critical word, “sleep” causes the vast majority of people to misremember [5]. Semantic relatedness also underlies another common form of memory distortion called **conjunction errors**. These errors occur when people fuse together in memory aspects of an event or experience. For example, subjects who read the words, blackboard and jailbird often mistakenly remember having read the conjunction word, blackbird. Again, these examples demonstrate how easy it is to distort people’s memory for details of a prior experience [6].

But is it possible to distort memory in a larger way, namely by making people believe that they experienced a whole event in the past that never occurred? The answer is, “yes.” Simply by suggesting to adults that they had experienced a particular event in their childhood, like being lost in a shopping mall for an extended period of time or being hospitalized overnight for an ear infection, investigators have created **false memories** for whole events in their subjects’ minds. In such studies, researchers often use a form of strong suggestion where they might tell a subject that a family member reported the event in question or that the subject’s dreams suggest that she had a particular unpleasant experience as a child. For instance, researchers might tell the subject that “most” people under the age of five have been attacked by a dog. The purpose of such suggestive techniques is to increase the plausibility of the false event. Researchers might also ask their subjects to imagine the false event in detail: “Even if you do not recall the event, just try to imagine what it was like. Where were you when the event occurred? Who were you with? What were you doing? How did it make you feel?” Imagination serves to imbue the false memory with sensory details, and often leads people to adopt the false memory as part of their autobiography [3].

In contrast to the more obvious forms of suggestion that distort memory for the past, memory can be distorted by more subtle means. Consider the phenomenon called unconscious plagiarism, in which a person inadvertently claims ownership of an idea that belongs to someone else. There are numerous examples of unconscious plagiarism, including cases of accusations against high-profile individuals like the writer, Helen Keller and the singer, George Harrison. Unconscious plagiarism relates to priming in that the information or idea, once heard or read from another source, may return to one’s memory

later without the person realizing that the information was encountered before. Another related form of memory distortion, called unconscious transference, occurs when an eyewitness to a crime adamantly declares that a certain person was the “one” who committed the crime simply because this certain person looks familiar. For example, the memory researcher, Donald Thomson, was accused of rape after appearing on live television in Australia. The victim in this case was raped while watching the television program featuring Dr. Thomson. Thus, the fact that the victim had seen Thomson’s face before, albeit in another context that was linked to the rape, was enough to lead her to believe that Thomson was the rapist.

Given the variety of memory distortions that have been observed and created in laboratory experiments, what is the evidence that memory distortion also happens in the real world? Unfortunately, all-too-meaningful therapists, seeking to help a client, may encourage their client to plumb the depths of memory for clues that might help explain the client’s problems. Although potentially therapeutic, this tactic sometimes backfires: Therapists have been known to implant false memories in their clients, often using many of the techniques that we have discussed here, like suggestion and imagination. These implanted false memories have resulted in innocent people being sent to prison, and have caused lasting and irrevocable damage to family unity and trust. Related to this issue of false memory, is the issue of repressed memory. ▶ **Repressed memory** refers to the hypothesized notion that the mind banishes traumatic experiences from conscious awareness due to the memory’s threatening nature. This memory, once repressed, may return to consciousness at some later point in a person’s life. The resulting memories are thought to be accurate in detail, and the processes involved different from ordinary forgetting and remembering. Although there is clear experimental evidence that false memories exist, there is at present no direct experimental evidence for repressed memories.

By now, it should be clear that memory is malleable. Given the variety of techniques that can and have been used to distort memory, one might ask how these techniques work.

### Proposed Mechanisms

Several theories have been proposed to explain the formation of false memories and memory distortion. We focus here on three of these theories. According to the *Source Monitoring Framework*, people routinely monitor their memory for accuracy. ▶ **True memories** tend to elicit more sensory and contextual detail, for example, “It was a rainy afternoon when I saw the accident. I remember that my jacket was drenched and my shoes squished when I walked. The car turned at the intersection and hit the pedestrian in the crosswalk.” False memories, however, can also contain sensory detail.

This makes it particularly difficult to distinguish between true and false memories. The *Source Monitoring Framework* argues that techniques such as imagination serve to create memory traces that sometimes can be distinguished from actual experiences stored in memory. The problem is that over time it becomes harder to monitor the origin of information coming from different sources like imagination, perception and action, resulting in source monitoring errors and false memories [7].

Another theory, related to source monitoring, involves what is called *Familiarity Misattribution*. According to this theory, techniques like suggestion, imagination, repetition and unscrambling serve to increase the fluency with which a person processes an event or experience. By fluency, we mean that the experience is processed more quickly. Consider imagination and repetition. Both techniques serve to prime an individual to process an event or experience more quickly. After imagining an event in detail, the event will be processed more quickly and fluently when the person subsequently thinks about it. In this way, the event seems to “spring” to mind. Similarly, repetition speeds subsequent processing. For example, if I present the word “window” to you, and then sometime later ask if you ever broke a window as a child, you will process the word “window” more quickly the second time you see it. This means that you will read and understand the word “window” faster than if you had not seen that word presented earlier. Just like with imagination, we tend to interpret the enhanced processing fluency as familiarity. So, the event, “broke a window” might now feel somehow familiar to you. If you fail to realize that the event feels familiar because you saw the word, “window” earlier, then you may mistakenly claim that you broke a window as a child [8].

One final theory that we discuss, called *Fuzzy-trace theory*, divides memory into two types of traces. Verbatim traces store sensory information, while gist traces store semantic information. Verbatim-based memory relates to detailed recollection of past experience, while gist-based memory relates to familiarity for past experiences [9]. Both types of memory traces can produce true and false memory; however, true memory is more often associated with verbatim traces, while false memory is more often associated with gist traces. Returning to our memory-distortion techniques, the suggestion that one was lost in the mall as a child leads to many different associations with malls. The person receiving this suggestion might begin to think about different, actual experiences that she did have in malls as a child. She might even think about how she would feel if she were lost in the mall. These associations, thoughts, and emotions would be stored as gist-based memory traces. When later asked about the event in question “were you ever lost in the mall as a child,” the event will likely feel familiar. If our imaginary subject fails to realize the source of this familiarity – that

last week the experimenter told her that she had been lost in the mall as a child – she will mistakenly come to believe that the event actually occurred.

Thus, source monitoring, familiarity misattribution and fuzzy trace theory all posit that people routinely monitor their memory for accuracy. Failure to distinguish among potential sources (e.g., I imagined the broken glass, I saw the broken glass, I only heard the broken glass) can result in memory distortion.

### Memory Distortion and Brain

Much work over the past decade has focused on the neural regions supporting true and false memory. In search of a neural signature of true and false memories, researchers have employed a variety of neuropsychological, neuroimaging, and electrophysiological techniques. These include lesion studies, Positron Emission Tomography (PET), functional Magnetic Resonance Imaging (fMRI), electroencephalogram (EEG), event-related potentials (ERPs), and more recently transcranial stimulation, and near-infrared spectroscopy. A consensus is beginning to emerge that true and false memories activate different brain regions, leading some investigators to claim that they have located a neural signature of false memories. Specifically, the medial temporal lobe has been implicated in false recognition, while the prefrontal cortex has been implicated in memory monitoring errors [7,10]. Despite these advances, some studies have also found that true and false memories activate similar brain regions, including prefrontal cortex, parietal cortex and medial temporal lobe. There is at present growing excitement in the field of cognitive neuroscience. As this field advances, it should soon be possible to distinguish true from false memories reliably and consistently by observing brain activation. Someday it may even be possible to determine the veridicality of one's memory for an individual event simply by looking at the person's overall pattern of brain activity.

### References

1. Thompson RF, Madigan SA (2005) Memory: the key to consciousness. Joseph Henry, Washington DC
2. Bartlett FC (1932) Remembering: a study in experimental and social psychology. Macmillan, New York
3. Loftus EF (2003) Make-believe memories. *Am Psychol* 58:864–873
4. Blank H, Musch J, Pohl RF (2007) Hindsight bias: on being wise after the event. *Soc Cogn* 25:1–9
5. Roediger HL, McDermott KB (1995) Creating false memories: remembering words that were not presented in lists. *J Exp Psychol Learn Mem Cogn* 21:803–814
6. Jones TC, Bartlett JC, Wade KA (2006) Nonverbal conjunction errors in recognition memory: support for familiarity but not for feature bundling. *J Mem Lang* 55:138–155

7. Johnson MK (2006) Memory and reality. *Am Psychol* 61:760–771
8. Bernstein DM, Whittlesea BWA, Loftus EF (2002) Increasing confidence in remote autobiographical memory and general knowledge: extensions of the revelation effect. *Mem Cognit* 30:432–438
9. Brainerd CJ, Reyna VF (2005) The science of false memory. Oxford University Press, New York
10. Schacter DL, Slotnick SD (2004) The cognitive neuroscience of memory distortion. *Neuron* 44:149–160

---

## Memory Dysfunction

- ▶ Amnesia

---

## Memory-guided Saccade Task

### Definition

A task in which a target is briefly presented at the same time that the subject continues to look at a fixation point. The subject is not allowed to make a saccade to the target until after the fixation point is extinguished, usually 0.5–3 s after the target disappears. Thus the subject must make a saccade to the remembered location of the target.

- ▶ Saccade, Saccadic Eye Movement

---

## Memory-guided Saccades

### Definition

A type of saccadic eye movement that is directed to a remembered target. The target position is indicated while the subject is fixating at the center and then the subject is required to make a saccade to the remembered position.

- ▶ Saccade, Saccadic Eye Movement

---

## Memory Illusions

- ▶ Memory Distortion

## Memory Impairment

► Amnesia

## Memory Improvement

KIYOFUMI YAMADA<sup>1</sup>, TOSHITAKA NABESHIMA<sup>2</sup>

<sup>1</sup>Laboratory of Neuropsychopharmacology, Graduate School of Natural Science and Technology, Kanazawa University, Kanazawa, Japan

<sup>2</sup>Department of Chemical Pharmacology, Graduate School of Pharmaceutical Sciences, Meijo University, Nagoya, Japan

### Synonyms

Cognition enhancement

### Definition

Memory improvement refers to the enhancement of cognitive functions such as attention, learning and memory without affecting other physiologic functions in subjects with cognitive deficits as well as in healthy subjects.

### Characteristics

#### Conditions

Learning is the acquisition of new information or knowledge. Memory is the retention of learned information. Certain diseases and injuries to the brain cause a serious impairment of learning and memory, the condition known as amnesia. Amnesia following brain trauma has two different forms; ► [anterograde amnesia](#) and ► [retrograde amnesia](#). Transient global amnesia is an inability to form new memories (anterograde amnesia), which lasts less than 24 h, and is not associated with other focal neurological signs or symptoms. This type of amnesia can be induced by brief cerebral ischemia, in which the blood supply to the brain is temporarily reduced, or concussion to the head from trauma such as a car accident. There is also retrograde amnesia for recent events before the attack. ► [Anxiolytic agents](#) such as benzodiazepines, muscarinic acetylcholine (ACh) receptor antagonists such as scopolamine, and N-methyl-D-aspartate (NMDA) receptor antagonists are known to induce memory impairment in humans and experimental animals. Some neuropsychiatric diseases, including Alzheimer's disease, mild cognitive impairment, vascular dementia, and schizophrenia, are accompanied by memory impairment or loss.

### Alzheimer's Disease

Alzheimer's disease is the most common cause of senile dementia, which is characterized by the presence of numerous senile plaques, neurofibrillary tangles accompanied by neuronal loss. The cholinergic neurons that project from the medial septal nuclei and basal nucleus of Meynert to the hippocampus and cerebral cortex, respectively, play an important role in learning and memory. Degeneration of the basal forebrain cholinergic neurons is correlated with cognitive deficits in Alzheimer's disease. The so-called "cholinergic hypothesis" proposed in the early 1980s essentially states that a loss of cholinergic function in the central nervous system contributes significantly to the cognitive deficits associated with aging and Alzheimer's disease [1]. Based on the hypothesis, agents that can enhance cholinergic function have been developed to improve memory deficits in Alzheimer's disease. An alternative hypothesis regarding the mechanism of Alzheimer's disease is that excessive activation of glutamate receptors may be responsible for the neuronal loss observed in those with the disease. Although it is unlikely that glutamate-mediated excitotoxicity is the primary etiopathological factor in Alzheimer's disease, it may partly contribute to the neurodegeneration. Supporting this idea, memantine, an uncompetitive NMDA receptor antagonist with moderate affinity, has been approved in Europe and USA for the treatment of moderate to severe Alzheimer's disease. In addition, various ► [neuroprotective agents](#) with diverse mechanisms of action have been proposed for treating Alzheimer's disease [2]. The dominant hypothesis regarding the etiology and pathogenesis of Alzheimer's disease is the "amyloid cascade hypothesis": Amyloid  $\beta$  produced by the amyloidogenic processing of amyloid  $\beta$  precursor protein triggers a neurotoxic cascade, thereby causing neurodegeneration and Alzheimer's disease [3]. According to the amyloid cascade hypothesis, there are several possible molecular targets for treating Alzheimer's disease [2].

### Mild Cognitive Impairment (MCI)

Mild cognitive impairment is regarded as a transition phase between healthy cognitive ageing and dementia. Accordingly, clinical studies of elderly individuals with memory impairment reveal a rapid rate of conversion to Alzheimer's disease, reaching as high as 15% per year. Recognition that MCI may represent a transition phase between normal cognitive decline by ageing and dementia will provide a possible early diagnosis and potential treatment with the aim of delaying the onset or preventing dementia [4].

### Vascular Dementia and Stroke

Vascular dementia, the second most common form of dementia, is a term currently used to define any



type of dementia resulting from cerebral blood vessel disease. The classification of vascular dementia is based on the following main diagnostic points: cognitive deficits, a history of stroke and/or focal vascular neurological deficits, neuroimaging showing neurovascular focal or diffuse lesions, and a temporal association between stroke and the onset of dementia. Among the risk factors for vascular dementia, hypertension has a major role. An elevated blood pressure measured in midlife increases the risk of dementia or accelerates age-related cognitive decline. Clinical studies have demonstrated that donepezil, an acetylcholinesterase (AChE) inhibitor, has significant effects on the cognitive deficits of vascular dementia [5]. In stroke victims, the ischemic vascular bed is composed of a core area where cerebral blood flow (CBF) is severely decreased and a more distal penumbra with less severely affected CBF. The penumbra is the focus of new therapeutic targets because it may be salvaged with restored circulation, and prevention of cell death may be possible with neuroprotective agents. Several compounds such as NMDA receptor antagonists, calcium channel blockers, radical scavengers, and antioxidants have shown neuroprotective effects in animal models, but have failed to be effective in human clinical trials [6].

### Schizophrenia

Schizophrenia is a chronic mental disorder characterized by psychosis (e.g., hallucinations and delusions), flattened emotions, and impaired cognitive function. There are no drugs that can effectively treat the cognitive dysfunction in patients with schizophrenia. The areas of impaired function are verbal learning and memory, working memory, visual learning and memory, speed of processing, reasoning and problem solving, attention and vigilance, and social learning [7]. The “NMDA receptor hypofunction hypothesis” has been proposed for schizophrenia because NMDA receptor antagonists such as phencyclidine and ketamine induce a schizophrenia-like spectrum of symptoms in healthy subjects and exacerbate symptoms in patients with schizophrenia. Hypofunctioning of NMDA receptors contributes to the pathophysiology of schizophrenia, especially those symptoms associated with the endophenotype such as cognitive impairment and negative symptoms [8]. According to the hypothesis, agents that enhance NMDA receptor function may ameliorate the cognitive impairment and negative symptoms in patients with schizophrenia. Because an excessive activation of NMDA receptors could lead to excitotoxicity and neuronal degeneration, an indirect enhancement of NMDA receptor function with agonists acting at the glycine modulatory site on NMDA receptors would be required for the treatment of schizophrenia [8]. Ampakines that bind to a site on the AMPA receptor and stabilize the receptor in its channel-open state following the binding of glutamate are also

promising candidates for agents to treat cognitive dysfunction [9]. Furthermore, there are possible molecular targets for treating cognition in schizophrenia such as dopamine D<sub>1</sub> receptors, serotonin 5-HT<sub>1A</sub>, 5-HT<sub>2A</sub>, and 5-HT<sub>6</sub> receptors, muscarinic and nicotinic ACh receptors, and GABA receptors [7].

### Cognitive Enhancers

Various agents with different chemical structures and diverse mechanisms of action are currently being investigated as a ►cognitive enhancer or ►anti-amnesic agent to improve cognitive functions such as learning and memory. They include AChE inhibitors, and muscarinic and nicotinic ACh receptor agonists. Alternatively, agents that directly or indirectly activate the glycine modulatory site on the NMDA receptor complex, ampakines, and ►sigma-1 receptor ligands may provide memory improvement in those with cognitive disorders. Furthermore, neuroprotective agents that can protect neurons from various neurotoxic substances including glutamate, amyloid  $\beta$ , and free radicals may afford memory improvement in cases where cognitive deficits are associated with neurodegenerative diseases, such as Alzheimer’s disease and cerebral ischemia.

### AChE Inhibitors

The cholinergic system in the cerebral cortex and hippocampus plays an important role in learning and memory. Degeneration of the basal forebrain cholinergic neurons is correlated with cognitive deficits in Alzheimer’s disease. Therefore, enhancement of cholinergic function would lead to an improvement of memory deficits in those with Alzheimer’s disease. One of the pharmacologic strategies used to enhance cholinergic function is to inhibit the decomposition of ACh into choline and acetic acid, which is catalyzed by AChE. Four AChE inhibitors (tacrine, donepezil, rivastigmine and galantamine) have been approved so far for the treatment of Alzheimer’s disease [2].

### Muscarinic ACh Receptor Agonists

The direct activation of muscarinic ACh receptors is supposed to improve cognitive deficits in Alzheimer’s disease as well as other neuropsychiatric diseases. Muscarinic M1 receptors are predominantly present in the frontal cortex and hippocampus, while M2 and M3 receptors predominate peripherally where they mediate effects on cardiovascular, respiratory, and secretory systems. Accordingly, specific M1 receptor agonists are supposed to ameliorate cognition impairment with few peripheral side effects associated with the stimulation of M2 and M3 receptors. However, no muscarinic M1 receptor agonists have been approved so far because of their side effects [2,7].

### Nicotinic ACh Receptor Agonists

The activation of nicotinic ACh receptors with selective agonists may have some beneficial effects on the cognitive deficits in patients with Alzheimer's disease and/or schizophrenia. Nicotinic ACh receptors are ligand-gated cation channels, the neuronal subtypes of which ( $\alpha 7$  and  $\alpha 4\beta 2$ ) are highly permeable to  $\text{Ca}^{2+}$ . Thus, nicotinic ACh receptors modulate neurotransmitter release and synaptic plasticity, and thereby improve cognition. Moreover, accumulated evidence demonstrates that nicotine and subtype selective nicotinic ACh receptor agonists have neuroprotective effects in the brain. For instance, nicotine provides neuroprotective effects against glutamate and amyloid  $\beta$  toxicity via  $\alpha 7$  nicotinic ACh receptors. Galantamine, a weak AChE inhibitor, allosterically modulates nicotinic ACh receptors and improves Alzheimer's disease [2,7].

### Ampakines

Ampakines bind to a site on the AMPA-type glutamate receptor, and stabilize the receptor in its channel-open state following the binding of the neurotransmitter glutamate, with no agonistic or antagonistic effects. Thus, ampakines prolong current flow through AMPA receptors and enhance synaptic responses. Ampakines accelerate learning, reduce age-related memory impairments, and suppress symptoms in models of schizophrenia, attention-deficit hyperactivity disorder, and depression [9].

### Glycine Modulatory Site Agonists

NMDA receptors play an important role in the synaptic plasticity associated with learning and memory. The activation of NMDA receptors requires the binding of L-glutamate to the NR2 subunit and a co-agonist (D-serine or glycine) at the glycine modulatory site on the NR1 subunit. D-serine is abundant in the forebrain and the expression is correlated with that of NMDA receptors. The glycine modulatory site is not saturated so that the activation could potentially modulate responses of the NMDA receptors. According to the NMDA receptor hypofunction hypothesis, enhancement of NMDA receptor function with agonists at the glycine modulatory site could have benefits in the treatment of schizophrenia. The results of clinical trials are encouraging with D-serine having a beneficial effect on the positive, negative, and cognitive domains of schizophrenia [8].

### Sigma-1 Receptor Ligands

Sigma receptors are widely distributed in the mammalian brain, and recognize a diverse array of compounds, including opiates, antipsychotics, antidepressants, phenylindole-related compounds, and neurosteroids. Two sigma receptor subtypes have been identified, and the sigma-1 receptors have been cloned. Sigma-1 receptors

regulate NMDA receptor function and the release of neurotransmitters such as ACh and dopamine. Accordingly, selective sigma-1 receptor ligands have been suggested to represent a new class of therapeutic agents for neuropsychiatric disorders [10].

### References

1. Coyle JT, Price DL, Delong MR (1983) Alzheimer's disease; a disorder of central cholinergic innervation. *Science* 219:1184–1190
2. Yamada K, Nabeshima T (2002) Animal models of Alzheimer's disease and evaluation of anti-dementia drugs. *Pharmacol Ther* 88:93–113
3. Hardy JA, Higgins GA (1992) Alzheimer's disease: the amyloid cascade hypothesis. *Science* 256:184–185
4. DeCarli C (2003) Mild cognitive impairment: prevalence, prognosis, aetiology, and treatment. *Lancet Neurol* 2:15–21
5. Chui H, Stoog I (2006) Advances in vascular cognitive impairment 2005. *Stroke* 37:323–325
6. Weinberger JM (2006) Evolving therapeutic approaches to treating acute ischemic stroke. *J Neurol Sci* 249:101–109
7. Tamminga CA (2006) The neurobiology of cognition in schizophrenia. *J Clin Psychiatry* 67:9–13
8. Coyle JT (2006) Glutamate and schizophrenia: beyond the dopamine hypothesis. *Cell Mol Neurobiol* 26:365–384
9. Lynch G, Gall CM (2006) Ampakines and the three-fold path to cognitive enhancement. *Trends Neurosci* 29:554–562
10. Hayashi T, Su TP (2004) Sigma-1 receptor ligands: potential in the treatment of neuropsychiatric disorders. *CNS Drugs* 18:269–284

## Memory Loss

► Amnesia

## Memory Retrieval

### Definition

A cognitive process in which information is accessed from memory.

► Emotional Learning/Memory

## Menière's Disease

### Definition

Disorder of the labyrinth characterized by episodes of vertigo, fluctuating hearing loss, tinnitus and fullness in the ear. The disorder typically begins in one ear but can in some patients progress to involve both ears.

- ▶ Disorders of the Vestibular Periphery
- ▶ Labyrinth (Vestibular Labyrinth)
- ▶ Tinnitus
- ▶ Vertigo

## Meningeal Cell

### Definition

- ▶ Leptomeningeal Cell

## Meninges and Cisterns

- ▶ Dura Mater Of Brain
- ▶ Falx Cerebri
- ▶ Fourth Ventricle
- ▶ Pia Mater
- ▶ Third Ventricle
- ▶ Ventricular System

## Meningism

### Definition

A syndrome of headache and neck stiffness with flexion indicative of meningeal irritation. This syndrome may be found with viral or bacterial meningitis or subarachnoid hemorrhage.

- ▶ Headache

## Meningitis

### Definition

An inflammation of the membranes (dura mater, arachnoid mater and pia mater) covering the brain and spinal cord due to infectious, immune-related or paraneoplastic (associated with cancer) causes, injury or medication. Infectious causes of meningitis include bacteria, viruses, fungi, parasites and protozoa. Symptoms typically begin with non-specific flu-like symptoms: fever, headache, eye pain, back pain, malaise, myalgias and sometimes a rash, then proceed to stiffness and pain of the neck (meningismus), change in mental status or coma, and at times weakness, cranial nerve dysfunction, or seizures. Diagnosis is confirmed by demonstration of increased number of white blood cells in the cerebrospinal fluid (pleocytosis) or contrast enhancement of the meninges on computerized tomography or magnetic resonance imaging.

## Meningoencephalitis

### Definition

Inflammation of the brain and meninges. Also called cerebromeningitis, encephalomeningitis, and meningocerebritis.

## Meningoencephalomyelitis

### Definition

Inflammation of the meninges, brain, and spinal cord.

## Meningovascular Syphilis

### Definition

Meningovascular syphilis manifest itself ca. 2 years after the primary infection and presents with cerebrovascular accidents, cranial nerve palsies, and often convulsions.

## Mental Causation

### Definition

“*Mental causation*” is a term for the causal interaction between mental and physical phenomena. Although it applies to physical-to-mental causation and mental-to-mental causation no less than to mental-to-physical causation, it is customarily reserved for instances of mental-to-physical causation, as when a sharp pain makes one wince, fear makes the heart beat faster, remembering an embarrassing situation makes one blush, and Fred’s desire for beer and his belief that there is beer in the fridge cause him to go to the fridge.

► Epiphenomenalism

## Mental Development

### Definition

Cognitive development. Changes with age in human ontogeny in mental processes and abilities, that is, the development of higher mental processes such as problem solving, reasoning, conceptualizing, classifying, and planning, as well as more basic processes such as perception and language.

► Cognitive Development

## Mental Models

VERENA GOTTSCHLING  
Department for Philosophy, York University,  
Toronto, ON, Canada

### Definitions

Kenneth Craik was the first to introduce the term “mental model.” He contends that humans translate external events into internal mental models and that ► *reasoning* takes place by manipulating these models. Then, either the resulting symbols are in turn translated into actions, or recognition of a correspondence between these symbols and an external event occurs. Hence, for Craik a mental model is mainly a simulation

of the world; this simulation also has a structure similar to that of the simulated process.

Subsequently, various mental model accounts have been introduced. Apart from their labels, these accounts have little in common other than the fact that internal representations are involved. Indeed, the term “mental model” is sometimes used as a synonym for “► *mental representation*.”

In our days, the term “mental model” is used mainly to refer to Philip Johnson-Laird’s mental models account. According to Johnson-Laird, a mental model is a special kind of mental representation – either long-term or short-term knowledge – whose structure is isomorphic to the structure of the situation it represents, and in which no free variables are found.

### Characteristics

#### Description of the Theory

Mental models are thought to be the result of several cognitive processes, and they are assumed to play a role in central cognitive processes like comprehension, reasoning, and discourse. [1] They are internally generated models of situations, scenes, or objects and can play a role in very different situations. But besides this, it turns out to be surprisingly difficult to determine precisely what mental models are. As we will see, mental models can be short-term or long-term representations, conscious or unconscious representations, and they can be voluntarily or spontaneously generated. We can distinguish mental models in discourse, in perception, and in reasoning processes. I will consider them in turn. A further tricky issue is to determine the role mental models play in another cognitive capacity, namely visual imagination and mental imagery.

#### Mental Models in Discourse

Mental models are considered to be representations that can be constructed during verbal discourse. Descriptions of complex situations lead us to construct a mental model of the situation and read out information that is only implicitly contained in the description. For example, by using a mental model in working memory we envisage the setting of a verbal description. Consider: “Watson enters the kitchen from the right door, at the opposite end Holmes was kneeling beside the crying victim, whereby the glistening sunshine from the window nearby threw light on the scene, even if the rest of the kitchen was relatively dark.” This assertion establishes a relation between several entities, Holmes, Watson, and other elements of the scene, the door, and the window. We can infer that the victim is at the left side of the kitchen on the basis of a mental model we construct. This mental model is isomorphic to the situation described, and contains at least three mental tokens, corresponding to Watson, the unnamed victim, and Holmes. Furthermore, these tokens are interrelated

in a way that corresponds to the spatial relation between them. According to Johnson-Laird, these discourse models make explicit the structure of situations as we perceive or imagine them.

### Mental Models in Perception

Mental models are also supposed to play a role in perception, especially in vision. Vision is characterized as a multi-stage process. It is accomplished in three separable and successive processing states often referred to as low-level, intermediate-level and high-level vision.<sup>1</sup> Cognitive neuropsychologists distinguish successive states in vision roughly corresponding to David Marr's levels, together with three different levels of perceptual representations mentioned before [2].

Johnson-Laird's mental models have often been identified with high-level representations, that is, with viewpoint independent, three-dimensional models of the spatial relations between objects. Correspondingly, the most appropriate candidates for their neural correlates seem to be regions in the inferior-temporal cortex (IT) in the ventral system.

In contrast to high-level representations, the experienced percept, a viewpoint-dependent representation is typically identified either with low-level or intermediate representations. These representations are not object-centered, but strongly bound to knowledge about visual appearances – information that resides in the 3D representation described above. Therefore, images and percepts are restricted to a particular point of view; they are instances of categories stored in the conceptual system and generated from knowledge contained in 3D models.

Ray Jackendoff [3] proposes a related but different view. He sees the conceptualized world as divided between the “cognitive structure,” which is approximately propositional, and the “spatial structure,” which is geometric, but is nonetheless not restricted to a particular point of view, and more abstract than experienced images and percepts. In the cognitive structure, knowledge, like category memberships and properties, is encoded. The spatial structure<sup>2</sup>, by contrast, is identified with Marr's 3D sketch and Johnson-Laird's mental models. Here, knowledge about visual appearance is encoded; these representations are 3D representations, which are roughly understood as images of prototypic instances of categories. Thus, they are imagistic, but no longer strictly visual. Additionally, they are abstract and support visual object categorization and identification. They are image-schemas, abstract structures from which a variety of different images can be generated and to which a variety of percepts and images can be compared.

<sup>1</sup> They can be roughly identified with David Marr's three levels, the primary sketch, the 2.5D-sketch, and the 3D-sketch.

<sup>2</sup> Jackendoff's spatial structure makes use of Marr's 3D sketch and understands Biederman's geons as an extension.

These representations are conceptual, they specify the configuration of the object's parts relative to one another, and encode possible shape variations of objects. But for Jackendoff, this structure is, to some degree, modality-independent<sup>3</sup>. Thus, elements in the spatial structure including mental models are not perceptual representations, but part of central cognition. The spatial structure is concerned with judgments and inferences having to do with shapes and locations and necessary for visual object categorization and identification. This structure includes all parts of the object, including hidden parts. It is not a simple three-dimensional object but a complex hierarchy of representations, which encode how objects can be regarded as assemblages of parts.

### Mental Models and Visual Images

Other authors do not distinguish between theories of visual imagery and mental model theories. They identify mental models and visual mental images. Pictorialist theories of visual imagery understand images as mental representations that function in the way pictures do, whereas the most important relations to be discussed are spatial relations. During the last years, participants in this debate moved away from an emphasis of pictorial representation and more towards perceptual representations. [4] The mental spatial representations they focus on are identical with perceptual representations, and are also thought to play an important role in reasoning and learning. But as in the case of identification with perceptual representations, the relation between mental models and visual images is controversial. Their possible relations can be summarized as follows:

1. Images and mental models are assumed to be different terms for the same entities.
2. Images are a subclass of mental models, very rich mental models within perception. “Mental models” is the more general term, though [5] mental models can take many forms and serve many purposes. A model can be a “physical” model and consist of elements corresponding only to perceptible entities, in which case it may be realized as an image, either perceptual or imaginary. Alternatively it can contain elements corresponding to abstract notions; in this case it would be a “conceptual” model.
3. According to Johnson-Laird's “triple-code” hypothesis [6], mental models are a different and more abstract format of mental representations than images. Images differ from mental models and need distinct processes, although they often function like models. But both sorts of representations are more closely related than the third kind of mental representations, namely propositional representations. Both mental

<sup>3</sup> In contrast to Marr, who saw it as a part of vision, as the “perceptual front end.”

models and visual images can be used in reasoning processes, but under some circumstances visual imagery can in fact impede reasoning [1,7]. There is a structural isomorphism between the represented situation and the representations in both cases. Both mental models and visual images are isomorphic, but differ with respect to the relations and properties that make up this structural isomorphism. In contrast to images, mental models are pure spatial representations. In mental models, visual characteristics like color, texture, and form can be neglected. Mental models are not restricted to a specific modality, they can contain symbols, and there may be only a minimal degree of analogical structure. Even tokens representing abstract concepts like negation, which are hard to visualize, are accredited. However, mental models can also be used to generate visual images. These images are assumed to be necessarily restricted to two dimensions, are conscious, and contain visual information.

All three views understand mental models as representations in working memory, in contrast to theories described above, which identify them only with the structures used to generate these representations. The situation is even worse: Imagery theorists describe the relation between visual images and mental models differently. The focus in the imagery debate lies in spatial relations as well. With regard to other typically “pictorial” properties the theories are more or less silent; it is not always assumed that images can only be two dimensional. It is controversial how strongly they are bound to concepts, as well as whether they have to be pictorial in a literal sense [4,8,9], and whether they are to be identified with patterns of activation in the visual system, and if so, which level this is. Sometimes image properties (such as color and texture) are assumed to be represented elsewhere in a more abstract format, and are connected by pointers to specific parts of the depictive representation. The main proponent of pictorialism, Steven Kosslyn, is sympathetic to these hybrid accounts. A related claim is that images are symbolic representations, but nonetheless modality-specific; they consist of a subset of neural activity associated with the corresponding visual perception. [10] Thus, images are basically representations using a spatial layout. In addition, images are not to be identified with the experience of having them. The imagery debate is rather about the format of the mental representations that come along with this experience. In other words, it seems we run into a similar problem than the one we already encountered: The term “image” is used in the same broad sense as “mental model.”

### Reasoning in Mental Models

Mental model theory as a model-theoretical method is an alternative view to formal rule theories. Formal rule

theories posit that deduction depends on formal rules of inference. In contrast, the main idea in the mental model theory of deduction uses the idea that instead of rules we use a special kind of mental representation in reasoning. We construct a model, or a set of models, based on such things as relevant background knowledge, meaning of the premises, and perceptual information. We then formulate a conclusion by describing a relation in the models that was not explicitly asserted in the premises. Finally, we check whether there are alternative models that comply with the premises but are incompatible with the conclusion. The conclusion is valid and necessary if the conclusion holds in all models of the premises. In cases of connectives like “if,” “and,” and “or” we construct a set of models in which each model represents a different possibility. The complete set of mental models describes exactly the cases where the compositional statement is true. Deductions that depend on quantifiers like “all” or “some” call for the construction of models containing sets of tokens, in which each token represents an individual. Again, we generate as many mental models as possible and check whether the conclusion is true. If we fail to find a mental model in which the conclusion is false, the composed statement is taken to be true. The underlying idea in mental model theory is again that the model or set of models represents the relation between the elements by isomorphism. Drawing the inference, then, is reading out the information that is implicitly contained.

An important advantage of mental model theory is that it covers not only deductive reasoning, but also probabilistic and **modal logic**. In probabilistic and modal cases, we need to adjust the description above: We do not talk about true or false statements, but about possible or impossible circumstances, propositions that might be true or false etc. A conclusion is impossible if it holds in no mental model; possible if it holds in at least one mental model; probable if it holds in most mental models; and necessary if it is valid in all mental models.

Furthermore, mental model theory gives us explanations for several systematically invalid conclusions people typically draw, i.e. they explain performance errors reasoners frequently make. These conclusions tend to correspond to just a single model instead of all possible models. Reasoners seem to fail to realize what is common in those multiple models. Mental model theory even predicts that reasoners will commit certain systematic fallacies. In the case of complex models, they construct models that are too simple and neglect some aspects. Content effects are to be expected as well. Logically untrained reasoners do not use formal rules, but rather, rely on their ability to understand the premises. Their models mirror their understanding of the situation, along with their background knowledge. The conclusions they draw are true with respect to their

models. Other systematic invalid conclusions are illusory inferences in probabilistic reasoning. Naïve individuals assume that each constructed model is equally probable, and wrongly infer the probability of an event from the proportion of models in which this event occurs.

For all these reasons, mental model theory in deduction can be seen as a strong alternative to formal rule reasoning.

### **Mental Models and Central Cognition: Meta-Reasoning, Mindreading, and Theories of Concepts**

In addition to reasoning associated with logical conclusions, mental models are assumed to play an important role in other central cognitive capacities such as meta-reasoning, i.e. reasoning about what other individuals have reasoned. Mental models are also thought to play a role in mindreading, our ability to understand and predict the mental states of our conspecifics. More precisely, they are assumed to play a role in developing central concepts for mindreading: In order to attribute mental states or to reason about other people's reasoning, I need to understand how a situation is represented from the perspective of other subjects. It is assumed that we use mental models during these processes.

In addition, the value of mental models for theories of concepts has recently been discussed. According to exemplar theories, concepts are stored instances of individual categories; they are perceptually derived mental representations. These stored representations can be activated in working memory to represent a category. Prototype theories and proxytype theories are related versions, which see concepts either as generated from perceptually derived individual representations (prototypes) or sets of prototypes (proxytypes). Again, mental models are frequently mentioned as paradigm examples for these representations. Since concepts play a role in almost all cognitive processes, these accounts would assign mental models a central role in cognition in general.

Let us take stock. According to the majority of mental model accounts, these representations are short-term representations. They are generated during reasoning processes, during discourse or in mental imagery, or as the result of visual perception. Sometimes the concept "mental model" is used for long-term representations as well, for example if mental models are identified with the underlying information used to generate short-term representations. Even if the term "mental model" is used for representations stored in long-term memory, these representations are assumed to have a similar structure to the representations used in working memory. Examples are accounts that treat mental models as schemas or stored prototypes of

spatial representation, or accounts of concepts holding that they are long-term memory networks of perceptual representations. These accounts do justice to Johnson-Laird's central idea that mental models may be a central structure of cognition: "It is now plausible to suppose that mental models play a central and unifying role in representing objects, states of affairs, sequences of events, the way the world is, and the social and psychological actions of daily life." [5, p. 397]

### **Problems With Mental Models**

#### ***Mental Models: A Variety of Connected Concepts***

The most pressing problem in the debate is that the notion of a mental model is unclear and that proponents do not use the same characterization of "mental model." In other words, the central term is used both vaguely and ambiguously. Moreover, the term "mental model" is often used as an umbrella term covering all sorts of spatial representations. Researchers in Artificial Intelligence, linguistics, and psychology often seem to use mental models in this broad sense as well. Mental models are spatial representations of any kind. Moreover, authors who use the term in a stricter sense use it either for long-term representations or short-term representations. Different authors also explicitly use different characterizations. Unfortunately, these characterizations are probably incompatible. The term is used not only in different ways, but also in mutually exclusive ways.

#### ***Ockham's Razor***

The postulation of a special format of mental representations characterized by structural isomorphism is frequently accused of being unnecessary. The reason is that alternative explanations exist which postulate symbolic representations only. According to Ockham's Razor, entities must not be multiplied beyond necessity. As a result, the postulation of mental model is not warranted, or so the argument goes.

A standard reply is that the legitimacy of a postulated entity does not only depend on Ockham's Razor. More factors play a role, and Ockham's Razor is only warranted if the alternative explanations and predictions are comparable. Other criteria, such as physiological evidence, optimality, plausibility, and efficiency, give us additional constraints, and they help us to decide between theories that posit different kinds of representations. Consequently, advocates of mental models could argue, for example, by presenting empirical evidence for spatial representations in high-level vision and intermediate-level vision. They can also argue that mental models explain performance errors in reasoning, and systematic invalid conclusions people typically draw, in a more plausible way than rule-based reasoning theories.

### Confusing Levels of Explanation? Properties of the Underlying Representations

Related to the former two issues, another group of objections is frequently mentioned: We witness a confusion of levels in mental model theory. Mental models are supposed to be high-level representations, representations at the “representational level” (Marr). At this level we postulate *representations of different formats and algorithms*. We deal with representations of the input and output as well as an algorithm, which transforms one into the other. Another level of analysis is the implementation or *hardware level*, dealing with the physical realization of these algorithms and representations. According to the theory we outlined, mental models are representations which play an important role for explanatory projects at the representational level. It seems hasty to simply identify them with neural representations in the brain, representations postulated as elements within a different explanatory project. A related objection states that we should not identify these representations with the experiences we have during events of reasoning. For it is not clear that the experience during, for example, mental imagery, helps us to learn something about the properties of the representations used in these processes. This takes us to the classical interface problem: how do explanations at different levels (in the different disciplines) relate to one another? This is a question about the connection between the different explanatory projects and of the theoretical postulates at different levels. In other words, what does a successful inter-theoretical reduction look like? What are the requirements a theory has to fulfill in order to give an explanation for phenomena at a higher level? Unfortunately, the term “explanatory level” is not clear, nor do unambiguous criteria exist for distinguishing particular levels, or for specifying the notion of an explanatory (or analytical) level. It is clear though that the personal level and sub-personal levels of analysis should be distinguished. The former level of explanation deals with the explanation and prediction of behavior of the thinking and acting person, whereas lower levels of analysis explain the mind at sub-personal levels. If consciously experienced images (personal level) are identified with mental models (sub-personal level), or even specific retinotopic areas in the brain (a lower sub-personal level), it is tempting to suspect that we witness a confusion of levels. Another question is how the theoretical postulates in different accounts are related. Far from uncontroversial though, according to the classical view, the structure of “higher levels” of a system should not be assumed to be isomorphic, or even similar, to the structure of “lower levels” of a system. The same holds for the explanatory projects at these levels. Since the term “mental model” is used for structures at different levels, it invites confusion, to put it moderately.

But to say that the concept of mental models is an umbrella concept, and that some of the characterizations are even incompatible, does not imply that it is out of the question to develop a consistent explanatory account. Rather, a refinement and improvement of this concept is required.

### References

1. Held C, Knauff M, Vosgerau G (ed) (2006) Mental models and the mind. Amsterdam
2. Marr D (1982) Vision. New York
3. Jackendoff R (2002) Foundations of language. Oxford
4. Kosslyn SM (1994) Image and brain: the resolution of the imagery debate. Cambridge, MA
5. Johnson-Laird PN (1983) Mental models. Cambridge, MA
6. Johnson-Laird PN (1996) Images, models, and propositional representations. In: de Vega M, Intons-Peterson MJ, Johnson-Laird PN, Denis M, Marshar M (eds) Models of visuospatial cognition. New York, pp 90–127
7. Knauff M, Johnson-Laird PN (2002) Visual imagery can impede reasoning. *Mem Cogn* 30:363–371
8. Gottschling V (2003) Bilder im Geiste. Die Imagery-Debatte. Paderborn
9. Tye M (1991) The imagery debate. Cambridge, MA
10. Barsalou L (1999) Perceptual symbol systems *Behav Brain Sci* 22(4):577–660

## Mental Representation

### Definition

A theoretical construct of cognitive science. It is a basic concept of the Computational Theory of Mind, according to which cognitive states and processes are constituted by the occurrence, transformation and storage (in the mind/brain) of information-bearing structures (representations) of one kind or another. More broadly construed, a mental representation is a mental object with semantic properties, which need not be understood only in computational terms, but as a vehicle that refers to or denotes something, or as the relation between a thing and the object or state of affairs that it stands for.

► [Mental Models](#)

## Mental Rotation

### Definition

A particular type of mental image transformation abilities. The ability to mentally rotate representations



of two-dimensional or three-dimensional objects is conceived to be analogous to a physical rotation. Research showed that reaction times are linearly proportional to the difference in angle between two items when participants decide whether they are the same or not (i.e. a mirror image).

► Action Representation

---

## Mental States (States of Mind)

### Definition

The perceptions, beliefs, desires, hopes, fears and intentions of an individual.

► Theory Theory (Simulation Theory, Theory of Mind)

---

## Mentalizing, Mind-Reading

### Definition

The ability to attribute mental states to oneself and others in order to predict and explain thoughts, feelings and behavior.

► Theory Theory (Simulation Theory, Theory of Mind)

---

## Merkel Cell-Neurite Complex Regeneration

TAMIKO TACHIBANA<sup>1</sup>, CHIZUKA IDE<sup>2,3</sup>

<sup>1</sup>Department of Oral Anatomy, Iwate Medical University School of Dentistry, Uchimarui, Morioka, Japan

<sup>2</sup>Department of Anatomy and Neurobiology, Kyoto University Graduate School of Medicine, Yoshidakonoe-cho, Sakyo-ku, Kyoto, Japan

<sup>3</sup>Department of Occupational Therapy, Aino University, Faculty of Nursing and Rehabilitation, Shigashiohta, Ibaragi, Osaka, Japan

### Synonyms

Merkel's corpuscle

### Definition

The Merkel cell-neurite complex is a slowly adapting type I mechanoreceptor that recognizes punctate pressure stimuli applied to the surface of the skin or oral mucosa.

The corpuscle is composed of a specific epithelial cell, the Merkel cell, discovered by F. S. Merkel in 1875, and an afferent axon terminal.

### Characteristics

#### Structure and Distribution

Merkel cell-neurite complexes are usually localized in the basal layer of the epithelium of the skin and oral mucosa. They are mainly distributed in areas of high touch sensitivity, including the digital pads, the vermilion border of the lip, ► touch domes of hairy skin, hair follicles, ► sinus hair, ► Eimer's organ and the epithelia of masticating oral mucosa [1].

Merkel cells are less electron-dense with scanty tonofilaments than epidermal cells, extending spur-like projections (1–2 µm long and ca. 0.2 µm wide) into the intercellular spaces between neighboring epithelial cells. An axon terminal containing numerous mitochondria and clear vesicles attaches to the Merkel cell like a disc at the basal surface, i.e., the side towards the basal lamina. Merkel cells contain many dense-cored granules of ca. 100 nm in diameter, which deviate in the cytoplasm towards the associated axon terminal. These granules contain bioactive substances such as neuropeptides, ATP, serotonin and glutamate [1]. Although the function of Merkel cells is still unclear, it has been proposed that Merkel cells serve as mechanoreceptors by the exocytotic release of neurotransmitters or neuro-modulators from granules [1,2].

### Regeneration

Following transection of the nerve innervating Merkel cell-neurite complexes, most Merkel cells (60–80%) disappear, while some survive without any contact with axons for an extended period [3,4]. Regenerating axons, after penetrating the basal lamina, make contact with those surviving Merkel cells. Although the number of Merkel cells decreases immediately after denervation, the original population of Merkel's corpuscles can be retained following re-innervation [4]. There are usually nerve-free Merkel cells in varying proportions in normal skin and oral mucosa. Approximately 4% of the total Merkel cells have no contact with axon terminals in the adult rabbit labial mucosa, in which the population of Merkel cells is estimated to be ca. 1,000 per 1 mm<sup>2</sup> [5]. A touch dome in the adult rat contains between 80–100 Merkel cells, of which only 50% or fewer are innervated [6]. It is considered that Merkel cells are targets of regenerating axons [6].

Merkel cells can newly differentiate in the epithelium of labial mucosa during wound healing in adult rabbits. These Merkel cells make contact with the regenerating

axons, and finally develop into structurally normal Merkel cell-neurite complexes [5].

It appears that Merkel cells probably develop from epithelial cells bordering the wound. On the other hand, a recent study has reported that Merkel cells are derived from the neural crest [7]. Interestingly, Merkel cells do not develop in the absence of neurotrophin-3 [8].

## References

1. Tachibana T (1995) The Merkel cell: recent findings and unresolved problems. *Arch Histol Cytol* 58:379–396
2. Halata Z, Grim M, Bauman KI (2003) Friedrich Sigmund Merkel and his “Merkel cell”, morphology, development, and physiology: review and new results. *Anat Rec* 271:225–239
3. Tachibana T, Sakakura Y, Ishizeki K, Iida S, Nawa T (1983) An experimental study of the influence of sensory nerve fibers on Merkel cell differentiation in the labial mucosa of the rabbits. *Arch Histol Jpn* 46:469–477
4. Nurse CA, Macintyre L, Diamond J (1984) Reinnervation of the rat touch dome restores the Merkel cell population reduced after denervation. *Neuroscience* 13:563–571
5. Tachibana T, Ishizeki K (1981) Merkel cell development in the wound healing in the labial mucosa of adult rabbits. *Arch Histol Jpn* 44:151–165
6. Mills LR, Nurse CA, Diamond J (1989) The neural dependency of Merkel cell development in the rat: the touch domes and foot pads contrasted. *Dev Biol* 136:61–74
7. Szeder V, Grim M, Halata Z, Sieber-Blum M (2003) Neural crest origin of mammalian Merkel cells. *Dev Biol* 253:258–263
8. Halata Z, Kucera J, Kucera T, Grim M (2005) Apoptosis of Merkel cells in neurotrophin-3 null mice. *Anat Embryol (Berl)* 209:335–340

## Merkel’s Corpuscle

►Merkel Cell-Neurite Complex Regeneration

## Merosin (Laminin-2)

### Definition

One type of laminin and is closely related to axonal regeneration.

- Laminin
- Regeneration
- Regeneration of Optic Nerve

## Mesencephalic

### Definition

Related to the midbrain (mesencephalon).

## Mesencephalic Locomotor Area

### Definition

Mesencephalic nuclear region that can coordinate simple step movements. Corresponds to the pedunculo-pontine tegmental nucleus, pars compacta.

►Mesencephalon

## Mesencephalic Reticular Formation (MRF)

### Definition

A neuronal structure located in the core of the brain stem whose caudal boundary is the crossing of the superior cerebellar peduncle (brachium conjunctivum) and extends rostrally to the thalamic reticular nucleus. It is reciprocally interconnected with the superior colliculus. Original function was defined as part of the reticular activating system (RAS). Clear evidence now that there are subgroups of cells that participate in the control of saccadic and vergence eye movements. The MRF has two major subdivisions. The posterior commissure in the sub-human primate serves to separate the MRF into rostral and caudal regions. The cells of the rostral portion of the MRF are associated with the control of vertical eye movements, while neurons in the caudal region also termed the central MRF (cMRF) are more closely associated with the control of horizontal eye movements.

►The Central Mesencephalic Reticular Formation – Role in Eye Movements

## Mesencephalon

### Definition

Midbrain. The most rostral portion of the brainstem. Three parts:

1. The cerebral peduncles contain large fiber bundles from the cerebrum.
2. The tegmentum area contains substantia nigra, red nucleus, cranial nerve nuclei and parts of the reticular formation.
3. The tectum is formed from the quadrigeminal plate (inferior and superior colliculi). Tasks: eye movement, fine motor control, sensory-motor coupling, effector movement, synaptic center.

## Mesenchymal Stem Cell

### Definition

Mesenchymal stem cells are derived from various tissues including bone marrow, skin, adipose tissue, synovium, periosteum, skeletal muscle, placenta and thymus. They proliferate *in vitro*, and have the pluripotent capacity of differentiating into a broad range of cells such as osteocytes, chondrocytes, tenocytes, adipocytes, and smooth and cardiac muscle cells. Mesenchymal stem cells express CD 13, CD 29, CD 44, CD 90, CD 105, and HLA-ABC.

► Transplantation of Bone Marrow Stromal Cells for Spinal Cord Regeneration

## Mesentery

### Definition

Mesentery is a thin transparent membrane containing neurovascular bundles supplying blood and innervation to the viscera. In certain areas, the membranes form an omentum with a similar structure, but without such well defined attachments to viscera.

## Mesopallium, Nidopallium, Entopallium

### Definition

Three major nuclear components of the pallium of birds (see Reiner et al., 2004, *J Comp Neurol* 473:377–414).

► Evolution of the Wulst

## Mesopontine Tegmentum

PHILIP WINN

School of Psychology, University of St Andrews, Fife, UK

### Definition

The mesopontine tegmentum sits between the midbrain (also called the *mesencephalon* and therefore *meso*) and the anterior pons (and therefore *pontine*). The term *tegmentum* is a generic one that translates directly from Latin as “a cover”. The mesopontine tegmentum is therefore the upper area at the junction of pons and midbrain; it is a region of brain rather than a clearly delineated structure. It sits above the underlying pontine tissue (principally the pontine nuclei and the nuclei of the pontine reticular formation) and the fibers of the superior cerebellar peduncle, which marks an approximate border between the mesopontine tegmentum and these nuclei. Laterally, both the pontine nuclei and mesopontine tegmentum are bordered by the fibers of the lemniscal system. Medial to the mesopontine tegmentum is the central gray and in the dorsal part of the area is the inferior colliculus, though this is a structure better understood in conjunction with the superior colliculus in the midbrain proper. In comparative terms, the mesopontine tegmentum differs little across vertebrate species, suggesting that whatever its functions are, they evolved early and have been preserved. What differentiates the region across species most clearly is the density of the fiber systems that cross the area rather than its structural or morphological identity.

Within the mesopontine tegmentum are two small nuclei with uncertain functions, the microcellular tegmental nucleus and the deep mesencephalic nucleus. These are identifiable by the aggregation of neurons of similar morphology, separable from the surrounding structures. In addition there is the cuneiform nucleus and three nuclei – the parabigeminal nucleus, the laterodorsal tegmental nucleus (LDTg) and the pedunculo-pontine tegmental nucleus (PPTg PPT or PPN). The pedunculo-pontine tegmental nucleus can also be referred to as the pedunculo-pontine nucleus, the tegmental pedunculo-pontine nucleus (TPP) or the nucleus tegmenti pedunculo-pontinus (NTPP). Pedunculo-pontine tegmental nucleus (PPTg) is preferred, being used by the major stereotaxic atlases. These nuclei, all of which contain large, deeply pigmented neurons whose principal neurotransmitter is acetylcholine, are undoubtedly the most prominent in the mesopontine tegmentum and are thought to be part of the ascending reticular activating system (ARAS), an organized network of neurons in the hind- and mid-brain that regulate neural

functions throughout the entire CNS. However, while the cholinergic neurons of the PPTg and LDTg fulfill the criteria for inclusion in this system, it is important to recognize that different elements of the ARAS have different functions. Using this one generalized term to describe a number of structures collectively carries the danger that one obscures the specific functions of each one.

### Characteristics Neurodevelopment

The neurodevelopmental literature refers to a structure not recognized in the adult brain, called the isthmus. It sits between the midbrain and hindbrain – the area that in the adult brain includes the mesopontine tegmentum. This primordial tissue contains what is known as the “isthmic organizer”, responsible for the proper development of midbrain and hindbrain tissue from the tectum to the cerebellum. The critical molecule involved in this, as demonstrated by a range of transplantation techniques, appears to be *Fgf8*, though a variety of other transcription factors are also involved [1].

The developmental history of the large cholinergic neurons that are the most prominent cells of the mesopontine tegmentum has been specifically studied. In rats, similar histories have been described for both PPTg and LDTg cholinergic neurons. The final adult number and morphology are achieved by postnatal day 21, but their development is not linear. The numbers of what will become cholinergic neurons (identifiable by morphology, location and the use of antibodies for choline acetyltransferase [ChAT] and the vesicular acetylcholine transporter [VAcHT]) *declines* over postnatal days 1–3 but *increases* progressively thereafter, with ChAT and VAcHT activity developing during postnatal days 7–14. Neuronal size is relatively large during this time, with later shrinkage to the adult form. This developmental time course appears to parallel changes in sleep, from the juvenile active sleep (which does not involve muscle atonia) through to the adult rapid eye movement (or paradoxical) sleep, in which muscle atonia is a prominent feature [2].

### Principal Structures

The cuneiform nuclei – so called because of their wedge (cuneiform) shape – receive inputs from the superior colliculus and send projections to the medulla and spinal cord. They function as relay stations for collicular motor output and have been suggested to be involved in rapid “fight or flight” activities. For example, local chemical manipulation of the cuneiform nuclei produces behavioral freezing or darting movements. The cuneiform nuclei are also part of the mesencephalic locomotor region (MLR), a region defined functionally rather than anatomically. In pre-collicular – post-mamillary transected animals, electrical stimulation of the MLR elicits

co-ordinated walking. This is a robust and reliable effect, but one whose significance can be misinterpreted. In otherwise intact animals, bilateral ► **excitotoxic lesions** of the cuneiform do not impair locomotion and similar lesions of the PPTg (similarly suggested to be in the MLR) also leave locomotion intact. The MLR’s existence should not be taken as showing that the primary function of this part of the brain is locomotor control. Rather, it might better be taken to demonstrate that in the absence of descending inhibitory control from the forebrain, these low level systems are capable of generating organized responses.

The pedunculopontine tegmental, laterodorsal tegmental and parabigeminal nuclei are nuclei that each contain a population of cholinergic neurons, designated (using the classification of Marek Marsel-Mesulam) Ch5, Ch6 and Ch8 respectively. The Ch8 neurons of the parabigeminal nuclei sit in an isolated cluster and innervate principally the geniculate nuclei of the thalamus. Ch5 and Ch6 however are closely coupled, forming a continuous chain of cholinergic neurons – called the caudal cholinergic column when first identified – that stretches (in rodents) from the caudal pole of the substantia nigra back as far as the locus coeruleus. These cholinergic neurons are thought in addition to contain a variety of other neurotransmitters (including neuropeptides and neuroactive amino acids) and neuromodulators (including nitric oxide – nitric oxide synthase is present in virtually all mesopontine cholinergic neurons). Receptors for a very wide variety of signaling molecules are present on these neurons, including those for acetylcholine; there appears to be strong intercommunication between PPTg and LDTg. Both also contain populations of non-cholinergic neurons, identified by morphology, electrophysiology and the absence of cholinergic markers. Precisely which neurotransmitters characterize these neurons is not clear, though recent evidence from immunohistochemical and *in situ* hybridization studies strongly suggests that many of them contain GABA.

### Mesopontine Connections with the Limbic System, Basal Ganglia, Sensory and Motor Systems

The mesopontine tegmentum is a point of convergence for a variety of information. Visual, auditory and somatosensory data are all processed through here and some of this processing is very fast, PPTg neurons for example fire in response to auditory signals with a mean latency of only ~8 ms. Complementing this sensory input, several structures in the mesopontine tegmentum have output to sites of motor control in (for example) the pontine and medullary reticular formation, the trigeminal complex and spinal cord. As well as these sensory inputs and motor outputs, there is substantial descending (mostly inhibitory) control from the forebrain, with convergence of information from both basal ganglia and limbic system. Indeed, the description

“►limbic-motor interface” which was applied to the nucleus accumbens in the forebrain might better be used in relation to the mesopontine tegmentum. All of this connectivity is well illustrated by considering in particular the most closely studied mesopontine structures, the PPTg and LDTg.

### The Pedunculopontine and Laterodorsal Tegmental Nuclei

The cholinergic neurons of the PPTg and LDTg project widely through the brain. These neurons are both heavily collateralized and, in many instances, have ascending and descending connections. They innervate the thalamus *en masse*, as well as midbrain dopamine (DA)-containing neurons (which they excite) and elements of the basal ganglia, the colliculi, hypothalamic and basal forebrain sites of non-specific cortical input and multiple motor structures in the brainstem and spinal cord. As well as these cholinergic neurons, both PPTg and LDTg contain non-cholinergic neurons that project widely, though not to quite the same extent as the cholinergic neurons. What controls the activity of these neurons appears to be two types of information: (i) basic sensory information from midbrain and brainstem visual, auditory and somatosensory systems and (ii) descending control from limbic structures (such as the amygdala, extended amygdala and hypothalamus) and from various parts of the basal ganglia (including the prefrontal and motor cortex). These various connections can be made sense of if brain systems are considered to be organized hierarchically in a form of layered architecture. The PPTg and LDTg receive primary sensory data and can generate output aimed at motor systems – this represents a simple system aimed at producing rapid responses to imperative signals. In addition to this, it can activate systems at a higher level, aiding more detailed processing. However, descending forebrain output, nearly all of which is GABA-mediated inhibition, allows for modification of both the ascending signals from PPTg and the rapid motor response generation to be effectively regulated by neural systems at higher levels of the architecture [3]. Note that this organization is consistent with the effects described above in relation to the MLR; loss of descending inhibition does not impair the ability of the PPTg to organize locomotion.

At the single unit level, the characteristic firing patterns of individual neurons in the PPTg and LDTg have been used to discriminate putative cholinergic and non-cholinergic neurons (see [4] for a brief review). More globally, mesopontine cholinergic neurons have been known for many years to be involved in regulating the electrical activity of the thalamus and through this, the cerebral cortex. Cholinergic activity in the thalamus has a complex action on the thalamic reticular nucleus

and thalamic relay nuclei, with the outcome that increased cholinergic activity is associated with effective corticothalamic transmission, while decreased cholinergic activity inhibits traffic. These two states are differentiated in ►behavioral state control processes – increased cholinergic activity is associated with the waking state and REM sleep, while decreased activity is associated with slow wave (or paradoxical) sleep [5].

The traditional view has been very much that structures at this level of the brain are associated with basic mechanisms of behavioral state control and the regulation of locomotion. However, recent studies have revealed that more complex processing is represented here as well. There is no doubt that PPTg and LDTg neurons are differentially active at different stages of the sleep wake cycle, and as such play a role in behavioral state control. However, bilateral excitotoxic lesions of the PPTg do not prevent rats from exhibiting normal patterns of sleep and wakefulness, indicating that while the PPTg is important in the sleep wake cycle, it is not critical; it is not some form of master switch for sleep. As noted above, the PPTg is a part of the brain described previously as part of the MLR. Likewise, bilateral excitotoxic lesions do not impair locomotion, indicating that the essential function of this area is not just the production of movement. Indeed, a variety of studies from many labs worldwide have shown that bilateral excitotoxic lesions of the entire PPTg do not impair locomotion, feeding, drinking, grooming or any other basic activity; in their home cages, such lesioned rats are indistinguishable from controls. However, when challenged in a variety of tests involving more complex processes relating to ►reward and reinforcement, attention, learning and memory, lesioned rats are strikingly impaired [4]. In a recent attempt to aggregate these various deficits into a theoretical framework, Alderson and Winn [6] argued that the essential deficit present in PPTg lesioned rats is an inability to properly associate actions and outcomes. It is a significant move away from considering tissue at this level of the neuraxis as being only involved in automatic regulatory processes, one that moves toward a different account of the relationships between processes such as learning and memory and widely distributed brain systems.

One final point of interest is that the PPTg has been linked to neurodegenerative brainstem disorders such as Parkinson’s disease and progressive supranuclear palsy [4]. In this context it is important to note that outflow from the basal ganglia to a focused part of the PPTg (termed the midbrain extrapyramidal region by David Rye and his colleagues) is disturbed in Parkinsonism. Very recently, several groups have shown that deep brain stimulation in the region of the PPTg can provide relief from some of the motor symptoms of this disorder. What the longer-term consequences of

this are – and whether there are any non-motor effects – remains unclear, but this is nevertheless an exciting new therapeutic development.

New ideas about the role of this part of the brain in both neurological disorders and more complex psychological processing than had previously been expected suggest that it might be exposed to more detailed study in the near future.

## References

1. Nakamura H, Katahira T, Matsunaga E, Sato T (2005) Isthmus organizer for midbrain and hindbrain development. *Brain Res Rev* 49:120–126
2. Ninomiya Y, Kayama Y, Koyama Y (2005) Postnatal development of cholinergic neurons in the mesopontine tegmentum revealed by histochemistry. *Int J Dev Neurosci* 23:711–721
3. Prescott TJ, Redgrave P, Gurney K (1999) Layered control architectures in robots and vertebrates. *J Adaptive Behav* 7:99–127
4. Winn P (2006) How best to consider the structure and function of the pedunculopontine tegmental nucleus: evidence from animal studies. *J Neurolog Sci* 248:234–250
5. Steriade M (2006) Grouping of brain rhythms in corticothalamic systems. *Neuroscience* 137:1087–1106
6. Alderson HL, Winn P (2005) The pedunculopontine and reinforcement. In: Bolam JP, Ingham CA, Magill PJ (eds) *The basal ganglia VIII*. Springer, Berlin Heidelberg New York, pp 523–532

## Messenger RNA (mRNA)

### Definition

Messenger RNA (mRNA) is the mature RNA, processed from the single stranded pre-mRNA transcribed from DNA, which is translated into protein.

## Metabolic Coupling

### Definition

The term metabolic coupling refers to the ability of many gap junctions to coordinate the metabolic and/or signaling state of multiple cells through the exchange of small intracellular messenger molecules and metabolites.

- ▶ Electrical Synapses
- ▶ Gap Junctions

## Metabolic Encephalopathy

### Definition

One form of encephalopathy.

- ▶ Encephalopathy (or Acute Organic Brain Syndrome)

## Metabotropic

### Definition

An influence on ion channel activity mediated indirectly by the binding of a neurotransmitter or hormone to its receptor. Commonly, receptor binding activates one or more second messenger systems within the target cell, which ultimately causes relatively long-lasting changes in the activity of voltage-dependent ion channels. This is a relatively long-latency, long-lasting event.

## Metabotropic Glutamate Receptors (mGluRs)

### Definition

G-protein-coupled receptors activated by glutamate made up of three groups: I, II, and III. Group I mGluRs trigger phospholipase C (PLC) hydrolysis of phosphatidyl inositol (4,5)-bisphosphate (PIP<sub>2</sub>), whereas groups II and III trigger adenylyl cyclase synthesis of cyclic adenosine monophosphate (cAMP).

- ▶ G-protein Coupled Receptors (GPCRs): Key Players in the Detection of Sensory and Cell-Cell Communication Messages

## Metabotropic Receptors

### Definition

Neurotransmitter receptors that activate or inhibit intracellular biochemical processes when the neurotransmitter

binds to the receptor. They are membrane protein with a seven-transmembrane domain.

- ▶G-Protein Coupled Receptors in Sensory Neuron Function and Pain
- ▶Memory, ▶Molecular Mechanisms
- ▶Associative Long-Term Potentiation (LTP)
- ▶Long-Term Potentiation (LTP)

## Metachromatic Leukodystrophy (MLD)

### Definition

Rare, autosomal recessive, lysosomal storage disorder characterized by severe and progressive ▶**demyelination**. It is caused by a deficiency of the lysosomal enzyme arylsulfatase A (ARSA), which leads to the accumulation of galactosylceramide-3-O-sulfate (sulfatide) in the central and peripheral nervous systems. In the late-infantile form (50% of the patients), which manifests in the second year of life and for which no efficient therapy exists, death occurs within a few years. There are also juvenile forms (onset between 4 and 12 years) and adult forms (onset after 12 years). Allogeneic hematopoietic cell transplantation may ameliorate the condition of selected patients with juvenile or adult forms.

- ▶Lysosomal Storage Disease

## Metacognition

SHUNICHI MARUNO, KAZUO KATO  
Department of Psychology, Kyushu University,  
Fukuoka, Japan

### Synonyms

Metalearning

### Definition

Metacognition is, in a narrow sense, defined as cognition about and emotion for one's own cognitive states and processes, but in a broader sense, the self-regulatory process of cognitive processes while

engaging in the task, or even more simply cognition and cognition (which is based upon the view underlying those definitions that "humans are reflective thinking agents who are actively monitoring, regulating, and reflecting upon their own cognitive processes while engaging, in order to achieve certain set goals").

### Characteristics

In the accompanying essay, we shall discuss (i) components, (ii) characteristics of research, and (iii) new directions.

### Two Components of Metacognition

The first component includes declarative, procedural, and conditional (if-then) knowledge and strategies, and beliefs on human cognitive processes and states (e.g., ▶**self-appraisal**). It could be called as a set of beliefs or as naïve theories of human cognitive functioning.

The second component constitutes the online control process that monitors and guides underlying cognitive processes, or the dynamic executive system (e.g., ▶**self-management**) that actively guides the processes generating cognitions. It consists of the four functions: (i) to know what the problem is, (ii) to plan and activate strategies appropriate for engaging in and solving the problem, (iii) to predict and direct performance, and (iv) to monitor and regulate ongoing cognitive activities [1,2]. Those functions are closely intertwined and are recurrently deployed until achieving set goals satisfactorily.

### Five Research Areas: What Aspects of Metacognition have been Focused upon?

Metacognition has been investigated in various areas of psychology (developmental, educational, cognitive, social, brain/neuroscience, etc.). What functions and mechanisms of metacognition researchers believe is essential to elucidate and unveil and probably what methodology to employ, however, depends upon what theoretical approach they would take [3]. For example, cognitive psychologists analyze accuracy and bases of metacognitive judgments in memory and learning – where ▶**prospective monitoring** and ▶**retrospective monitoring** is involved (e.g., feeling of knowing (FOK), judgments of task difficulty and ease of learning (EOL), and judgments of learning (JOL)), and regulatory mechanisms of the cognitive processes that occur based upon those judgments. Educational psychologists investigate the role of metacognition as a tool for self-regulated learning of reading, writing, mathematics, and problem-solving in academic contexts (i.e., in what way metacognition is related with age, motivation, IQ, and academic achievement, and how

it can be cultivated so as to facilitate instruction and learning) [4,5]. Developmental psychologists study ontogeny of metacognition in a variety of areas, by examining individual- and group-differences in metacognitive knowledge, ability, strategies, etc. Brain scientists and cognitive neuropsychologists determine, with elders and patients suffering from brain function disorders, the area(s) that control(s) metacognition, and how those different areas interact.

Finally, the solution to the endlessly debated question of whether metacognition is conscious/explicit versus unconscious/implicit depends upon what metatheory researchers hold. We believe that “metacognition operates implicitly as long as problem-solving proceeds smoothly, but once problems emerge, it begins to function explicitly and solves them; the beneficial functions of metacognition, therefore, come into play whenever trouble-shooting is necessitated.”

### New Directions in Metacognition Research

Figure 1 shows differentially increasing trends (the number of papers) in the five research areas from 1981 to 2005.

The following characteristics can be pointed out: (i) in the 1980s, most research focused on memory, comprehension, and problem-solving with normal children and adults; (ii) in the late 1980s, social metacognition research began to increase; (iii) in 1992, brain/neuroscience research began (the journal of “Consciousness and Cognition” started), and (iv) research with the populations suffering from psychiatric and brain function disorders increased, corresponding closely to the increment of brain/neuroscience research. In addition to those general trends, the following changes are particularly noteworthy.

### Metacognition in Social Contexts

A review on the previous research led to the realizations: (i) although online, or moment-to-moment, monitoring, control, and emotional reactions have been well investigated, implicit theories underlying society and culture were not paid much attention, and (ii) most research has put too much emphasis on metacognitive judgments within the individual, and, therefore, failed to put into perspective the role of metacognition on others and situations [4]. On the basis of those realizations,

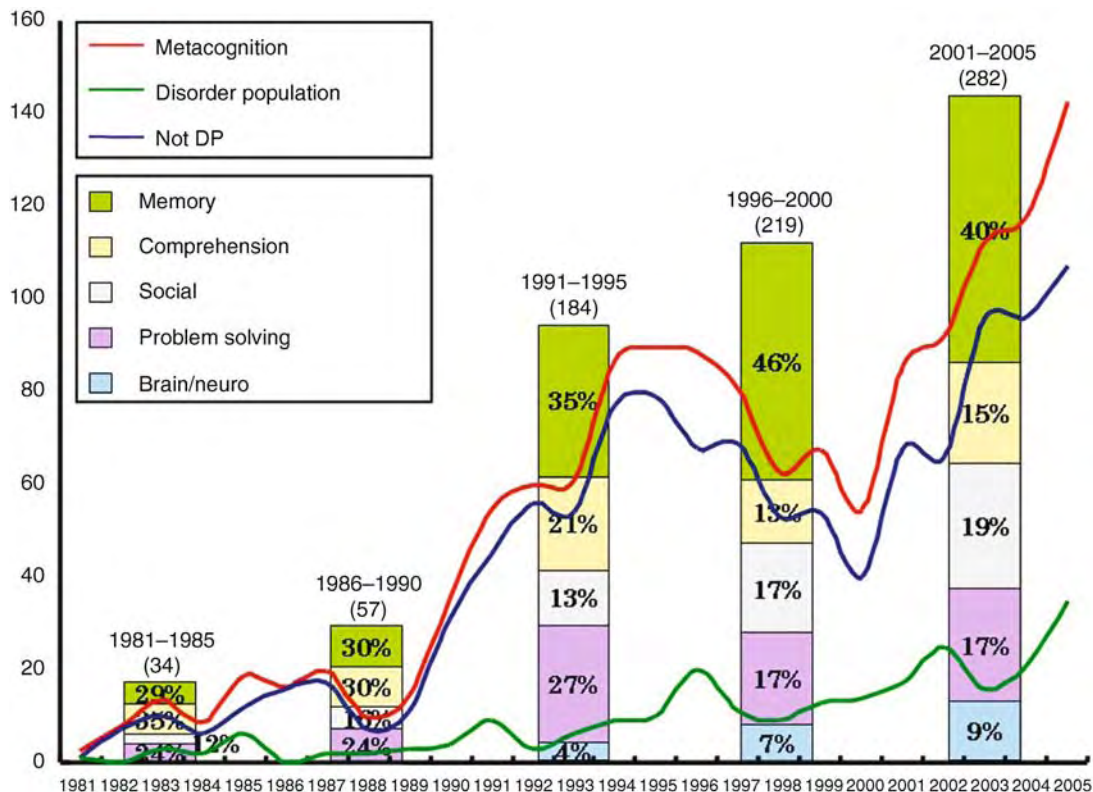

**Metacognition. Figure 1** Trends in the five areas of metacognition research from 1981 to 2005. (a) 1358 articles in peer-reviewed journals were retrieved, by searching PsycInfo database with the keyword “metacognition.” (b) Five bar graphs indicate the percentages for the total number of articles published during 5 years in the five areas. (c) Line graphs delineate the increasing trend of research in each area from 1981 to 2005.



social cognition researchers recently began to address the importance of metacognitive perspectives and accordingly to investigate theories of mind, stereotypes, naïve psychology, and even further critical thinking in discussion situations as well as decision-making processes. Especially, the processes in which creative thinking is generated through discussions with others deserve special attention because they require situational monitoring of grasping the situation and social metacognitive abilities of flexibly collaborating with others.

### **Expertise and Metacognition**

Metacognition facilitates the progress in expertise. Expertise can be categorized into routine and adaptive expertise [6]. Routine experts carry out a predetermined (or routinized) sequence of procedures accurately and quickly. Adaptive experts, on the other hand, not only carry out such procedures (or strategies) effectively, but because they deeply understand the utility and limitations of those procedures, they can also flexibly and appropriately adjust and modify them so as better to cope with incessantly changing demands of the situation. To become an adaptive expert, therefore, it is not sufficient just to be able to apply previously acquired declarative and procedural knowledge to the task, but one needs to expand expertise constantly, to attempt self-improvement, and to gain many experiences of reflective practice with conditional knowledge and strategies.

To facilitate the acquisition of adaptive expertise in students' learning, metacognitive tool (e.g., computers – which allow to externalize tacit thinking processes and monitor metacognitive strategies) and teachers' adaptive metacognition (e.g., knowledge of how to create social environments to support reflective discourse) are drawing attention from researchers [6,7].

### **Frontal Lobe Dysfunction and Metacognition**

In the last decade, researchers have attempted to identify the brain regions that control metacognitive functions, especially the executive function involving monitoring and control, using neuroimaging techniques (e.g., positron emission tomography (PET), functional magnetic resonance imaging (fMRI), and magnetoencephalography (MEG)), by examining higher-level mental activities in the brain [8,9].

Patients who are in the pathological states involving the frontal lobes (e.g., traumatic brain injury, frontal strokes, dementia, schizophrenia, attention deficit disorder, Alzheimer's disease, Korsakoff's syndrome) suffer from disorders in cognitive monitoring (e.g., error detection, [▶source monitoring](#) in memory retrieval) and cognitive control (conflict resolution, error correction, inhibitory control, emotional regulation). They also suffer from disorders not only in executive functions but also in self-appraisal. However, they do not

show disorders in implicit memory (e.g., routinized procedural knowledge), because it requires no active and conscious metacognitive monitoring functions.

The regions that control the error monitoring system are located in the medial areas of the frontal lobe. The fact that the task requiring cognitive and emotional controls activates its mid-frontal areas suggests that a common neuroanatomy underlying those executive controls might exist. For the time being, however, it is still unknown whether this neuroanatomy is a set of independent modules or an integrated cognitive-emotional system that is located in the midfrontal areas.

### **Social Neuroscience and Metacognition**

To live a social life, human beings need to figure out what the other person thinks, wants, and intends to do, and, at the same time, to make appropriate judgments on what actions should be taken accordingly.

Amodio and Frith [10] conducted meta-analyses on neuroscientific findings to determine in what regions of the brain are located the following functions of social cognition: (i) mentalizing, or theory of mind (TOM) (e.g., self-reflection, person perception, making inference about the other's thought and intent), (ii) outcome monitoring linked to the reward system (reward and punishment), and (iii) action monitoring. The analyses revealed that these functions are located in the medial prefrontal cortex (MPFC).

## **References**

1. Chambres P, Izaute M, Marescaux PJ (2002) *Metacognition: Process, function and use*. Kluwer Academic, Norwell, MA
2. Paris SG, Paris AH (2001) Classroom applications of research on self-regulated learning. *Educ Psychol* 36:89–101
3. Kuhn D (2000) Metacognitive development. *Curr Dir Psychol Sci* 9:178–181
4. Hacker DJ, Dunlosky J, Graesser AC (1998) *Metacognition in educational theory and practice*. LEA, New Jersey
5. Perfect T, Schwartz B (2002) *Applied metacognition*. Cambridge University Press, Cambridge, MA
6. Lin X, Schwart DL, Hatano G (2005) Toward teachers' adaptive metacognition. *Educ Psychol* 40:245–255
7. Azeved R (2005) Using hypermedia as metacognitive tool for enhancing student learning?: The role of self-regulated learning. *Educ Psychol* 40:199–210
8. Fernandez-Duque D, Baird JA, Posner MI (2000) Executive attention and metacognitive regulation. *Conscious Cogn* 9:288–307
9. Pannu JK, Kaszniak AW (2005) Metamemory experiments in neurological population: a review. *Neuropsychol Rev* 15:105–130
10. Amodio DM, Frith CD (2006) Meeting of minds: The medial frontal cortex and social cognition. *Nat Rev* 7:268–277

## Metalearning

- ▶ Metacognition

## Metalloproteinases

### Definition

Metalloproteinases are a family of proteolytic enzymes, known as the metzincin superfamily, that depend on Zn as a co-factor for endopeptidase activity. Several different subfamilies exist, including matrix metalloproteinases (MMPs), A disintegrin and metalloproteinases (ADAMs) and astacins. They can proteolytically degrade extracellular matrix proteins as well as a number of bioactive molecules (e.g. cell surface receptors). In the nervous system, metalloproteinases are implicated in cancer biology and other pathologies, and more recently during development. Secreted, transmembrane and membrane associated forms exist.

## Metamorphosis

### Definition

A radical change in body form and lifestyle between larval and adult stages of an organism

- ▶ The Phylogeny and Evolution of Amniotes

## Metarepresentation

### Definition

A representation of a representation, e.g. a thought about a thought or a belief about a belief.

- ▶ Theory Theory (Simulation Theory, Theory of Mind)

## Metencephalon

### Definition

Pons and cerebellum.

- ▶ General CNS

## Method of Adjustment

### Definition

A psychophysical procedure in which an observer adjusts stimulus intensity: Increasing intensity until s/he just perceives (ascending trials), or decreasing a clearly perceptible intensity until s/he just fails to perceive the stimulus (descending trials).

- ▶ Psychophysics

## Method of Constant Stimuli

### Definition

A psychophysical procedure in which each of a fixed set of stimuli (ranging near the threshold) is presented repeatedly in random order; the stimulus value yielding a detection response in 50 percent of the time is taken as the threshold.

- ▶ Psychophysics

## Method of Limits

### Definition

A psychophysical procedure in which stimulus intensity is varied independently of the observer (by the experimenter or computer program) until the observer

just perceives (ascending trials), or just fails to perceive the stimulus (descending trials).

► [Psychophysics](#)

---

## Methylphenidate

### Definition

Methylphenidate is a stimulant drug that inhibits the noradrenaline and dopamine transporters. The drug is used in the treatment of patients with attention deficit hyperactivity disorder (ADHD).

► [Attentional Disorder](#)  
 ► [Stimulants](#)

---

## 1-Methyl-4-phenyl-1,2,3,6-tetrahydropyridine (MTPT)

### Definition

MTPT is a meperidine derivative that is used for experimental studies in a non-human primate model of

► [Parkinson disease.](#)

► [Parkinson Disease](#)

---

## Metric, Metric Space

### Definition

A coordinate system for measuring arbitrary spaces. Measurements and judgments about the similarity or relatedness of objects require an explicitly or implicitly defined metric by which to compare them. For example, a blue ball on the ground and another blue ball on the roof are similar if the metric is color or some quantification of shape, but are relatively dissimilar in terms of spatial location. Scale is of course a critical factor in such judgments – on a continental scale, for example, the two balls are in nearly identical locations.

Objects can be located as points or regions within metric spaces according to their properties; e.g. with a color metric, our ball would be located at a point in the blue spectrum. The distance between two objects in the relevant metric space is a measure of their similarity; e.g. blue is more similar to green than it is to red.

---

## Meynert Cells

### Definition

Meynert (nineteenth century Austrian psychiatrist) cells make up the nucleus basalis neurons in the basal part of the forebrain. They are cholinergic and project widely to the cerebral cortex. The term Meynert cell is also an old term for large pyramidal cells found in occipital cortex near the calcarine fissure. Meynert also gave the first description of “association neurons.”

---

## Microaerobic

### Definition

Living, active, or occurring only in the presence of low concentrations of oxygen.

---

## Microampullary Organ

► [Electroreceptor Organs](#)

---

## Microarray, DNA Chip

### Definition

A technology that allows simultaneous measurement of the expression levels for up to tens of thousands of genes (genome-wide expression profiling) in various cells and tissues and under different conditions.

## Microarray Analysis of Molecular-Genetic Controls over Development of Neuronal Subtypes

NORIYUKI KISHI<sup>1</sup>, U. SHIVRAJ SOHUR<sup>1</sup>,  
BRADLEY J. MOLYNEAUX<sup>1</sup>, PAOLA ARLOTTA<sup>2</sup>,  
JEFFREY D. MACKLIS<sup>1</sup>

<sup>1</sup>MGH-HMS Center for Nervous System Repair, Departments of Neurosurgery and Neurology, and Program in Neuroscience, Harvard Medical School; Nayef Al-Rodhan Laboratories, Massachusetts General Hospital; Department of Stem Cell and Regenerative Biology, and Harvard Stem Cell Institute, Harvard University, Boston, MA, USA

<sup>2</sup>Center for Regenerative Medicine, Department of Neurosurgery, Massachusetts General Hospital, Harvard Medical School, Boston, MA, USA

### Synonyms

Characterization of neuronal subtypes by microarrays; Microarray analysis using pure neuronal subpopulations;

Identification of neuronal subtype-specific genes by microarrays

### Definition

Emergence of microarray technology is now enabling molecular-genetic analysis of developmental controls for neuronal subpopulations in the cellularly heterogeneous brain.

### Characteristics

#### Cellular Heterogeneity in the CNS

The central nervous system (CNS) is composed of three major cell-types: neurons, astroglia, and oligodendroglia (Fig. 1), and these cell types are differentiated from neural progenitors/precursors/"stem cells," which have self-renewal capacity and multipotency (diverse populations of neural precursors are often termed "neural stem cells," though many types of data indicate that these are quite heterogeneous by region and developmental stage) [1]. Neurogenesis is a very involved process: unlike other tissues, there are hundreds of intermixed neuronal subtypes in the mammalian brain [2–4]. The mechanisms by which such a rich neuronal diversity is produced in the CNS are poorly

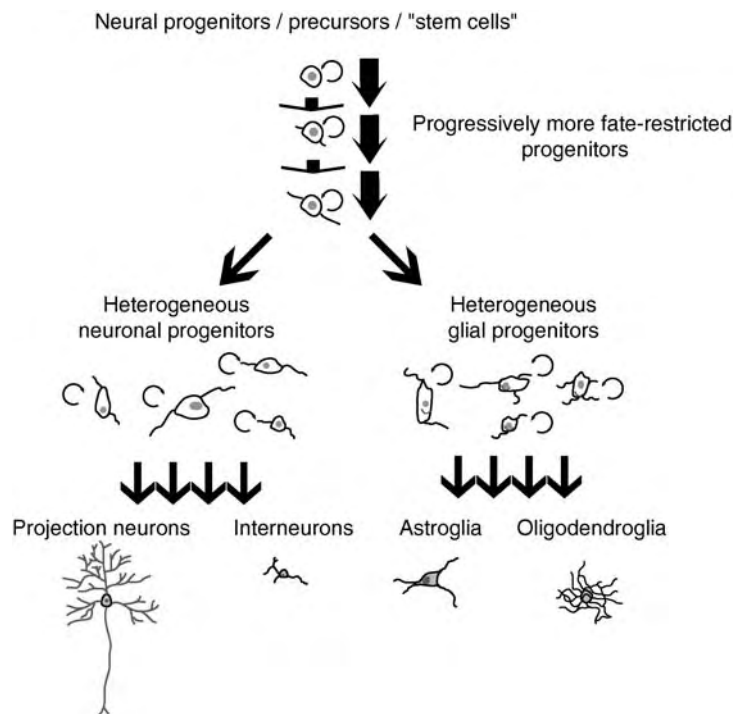

### Microarray Analysis of Molecular-Genetic Controls over Development of Neuronal Subtypes.

**Figure 1** Diversity of neural lineage. There is progressive differentiation of early neural progenitors/precursors/"stem cells," by which they become more fate-restricted by regional type, neuron subtype, and neuronal-glia lineage. Subsequently, neural progenitors include heterogeneous neuronal and glial progenitors. Heterogeneous neuronal progenitors produce related groups of distinct mature neuronal subtypes. Morphologically and functionally, neurons are subdivided into two major classes, excitatory projection neurons that send axons long distances, and inhibitory and local interneurons.

understood. During the development of the CNS, neuronal progenitors undergo precise stepwise differentiation to ultimately produce the complex variety of neuronal subtypes that populate the mature brain. Morphologically, neurons are divided into two broad categories: (i) projection neurons, which extend axons to distant target areas, and (ii) interneurons, which make local connections. Projection neurons and interneurons are further subclassified by location, neurotransmitter production or sensitivity, electrophysiological characteristics, and axonal connectivity and neuronal circuits within which they send projections. Gene expression analysis in the brain is generally complicated by the coexistence of many different cell types, resulting in high background noise and the masking of small differences in cell type-specific gene expression.

The relative lack of approaches for efficient isolation of pure neuronal populations, and the difficulties involved with analysis of minute amounts of mRNA, have previously hampered progress toward understanding the molecular development of neuronal subtypes. However, the rapid emergence of microarray technologies, as well as development of approaches for isolation of neuronal subtypes have provided for a synergistic advance in the field. ►DNA microarrays (also known as gene chips or gene arrays) are a collection of DNA spots representing individual genes, arranged on a chip, and used for monitoring expression levels of thousands of genes simultaneously, thus allowing comparison of thousands of genes between different populations.

In this essay, we review three recent approaches using microarray analysis to investigate the molecular developmental controls and/or identity of specific brain neuronal subtypes.

### **Molecular Controls over Development of Corticospinal Motor Neurons (CSMN) and Other Forebrain Neuronal Populations**

Our laboratory has begun to uncover molecular controls over the development of corticospinal motor neurons (CSMN; upper motor neurons; residents of layer V of the cerebral cortex) and other forebrain projection neurons (Fig. 2). CSMN degeneration is a key component of motor neuron degenerative diseases, including amyotrophic lateral sclerosis (ALS), and CSMN injury contributes critically to the loss of motor function in spinal cord injury. The anatomical and morphological development of CSMN have been extensively characterized, but the genetic mechanisms that control their development were previously unknown. Importantly, understanding the molecular controls over CSMN circuitry development might enable future strategies for therapeutic repair or modulation in disease.

To uncover the gene regulation programs of mouse CSMN development and other forebrain projection

neurons, our lab has developed and established approaches using comparative microarray analysis of stage-specific gene expression by CSMN purified by ►fluorescence-activated cell sorting (FACS) [5]. Like other forebrain projection neurons, there are no specific markers for CSMN that could be utilized to isolate them. However, CSMN extend axons to the spinal cord, so they can be retrogradely labeled by injecting an appropriate retrograde label in the spinal cord. We developed an approach to retrogradely label CSMN with fluorescent latex microspheres; dissociate labeled cortex; and isolate the labeled CSMN by FACS. In addition to CSMN, we also purified two distinct cortical projection neuron subtypes, callosal projection neurons (CPN) and corticocortical projection neurons (CTPN) (Fig. 2). CPN are interhemispheric callosal projection neurons, a subset of which share lamina V location with CSMN, offering insight into genes that are involved in cell type specification rather than lamina specification by comparing between CSMN and CPN. CTPN are subcerebral layer V projection neurons extending axons to the tectum instead of the spinal cord, likely sharing some overlapping early developmental gene regulation programs with CSMN. Comparison between CSMN and CTPN can allow the identification of genes unique to CSMN among other highly related layer V subcerebral projection neurons. Using these FACS-purified pure cell populations at multiple developmental stages, we performed microarray analyses, and identified genes specifically expressed in CSMN as well as genes that are expressed in other projection neurons, but not in CSMN. We classified those genes into one of six groups based on expression profiles suggestive of specific role in distinct aspects of CSMN development: (i) genes that are expressed at higher levels in CSMN at all stages of development and might be important for the establishment and maintenance of CSMN identity; (ii) genes that are highly expressed in CSMN early in development and may be important for early CSMN specification; (iii and iv) genes that exhibit increasing levels of expression as CSMN develop and might control intermediate (iii) or later aspects (iv) of CSMN differentiation; (v) genes that are expressed at higher levels in CSMN compared to the highly related population of CTPN and are representative of the small class of genes that differentiate CSMN from other subcerebral projection neurons of layer V; (vi) genes that are negative markers of CSMN but that are expressed in CPN or CTPN.

Thus, we identified a number of CSMN-specific genes, including *COUP-TF1 interacting protein 2* (*Ctip2*, also known as *Bcl11b*). *Ctip2* had very recently been identified by Kominami and colleagues to have a critical role in the immune system, controlling T cell subtype specification and survival in the developing thymus, but had not been investigated in the CNS. *Ctip2* is expressed at high levels in layer V of cortex, and

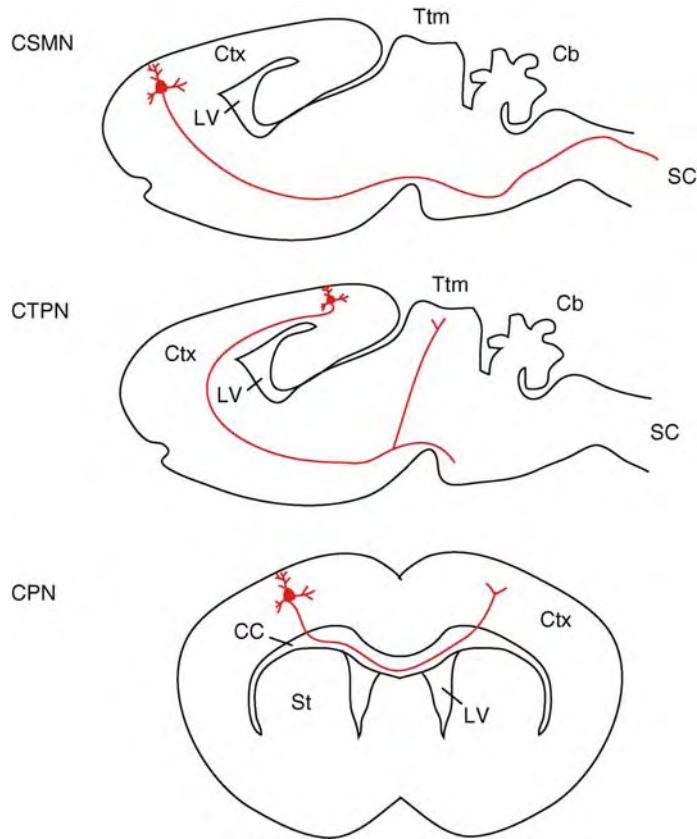

### Microarray Analysis of Molecular-Genetic Controls over Development of Neuronal Subtypes.

**Figure 2** Subtypes of cortical projection neurons. Arlotta et al. analyzed three distinct populations of cortical projection neurons [5]. CSMN (corticospinal projection neurons) are located in the sensorimotor area of the neocortex and maintain primary projections to the spinal cord. CTPN (corticotectal projection neurons) are located in the visual area of the neocortex and maintain primary projections to the superior colliculus of the tectum. CPN (callosal projection neurons) are primarily located in layers II/III, V and VI, and extend their axons across the corpus callosum to the contralateral hemisphere. Cb; cerebellum, CC; corpus callosum, Ctx: neocortex, LV: lateral ventricle, SC: spinal cord, St: Striatum, Ttm: tectum. (Adapted from Molyneaux, Arlotta et al. *Nat Rev Neurosci*, 2007 [2].)

expressed both in CSMN and CTPN, but not in CPN, indicating that *Ctip2* is expressed at high levels in subcerebral projection neurons which extend axons to outside of the cortex. In *Ctip2* mutant mice, CSMN axons exhibit defects in fasciculation, outgrowth, and pathfinding, resulting in failure of CSMN to connect to the spinal cord [5]. Interestingly, Arlotta, Molyneaux and others in our lab have recently identified that *Ctip2* in the *Gsh2* developmental domain plays a totally different and critical role in the proper differentiation of striatal medium spiny neurons and the patch-matrix cytoarchitectural organization of the striatum.

Another CSMN-specific gene, *Forebrain embryonic zinc finger-like (Fez1)*, recently renamed *Fezf2* [6], is also expressed in CSMN and CTPN, like *Ctip2*. However, unlike *Ctip2*, *Fez1* is expressed in ventricular zone and subventricular zone progenitors of subcerebral neurons, in addition to subcerebral neurons themselves.

*Fez1* is centrally involved in the birth and specification of CSMN. Importantly, in *Fez1* mutant mice, the entire population of both CSMN and CTPN is never born in the cortex. In addition, both anterograde and retrograde labels confirm the total absence of the corticospinal tract in *Fez1* mutant mice, indicating that no other neurons compensate to form such circuitry. Gain-of-function analysis using *in vivo* electroporation showed that overexpression of *Fez1* in cells that give rise to superficial layer neurons results in an accessory layer of *Ctip2*-expressing subcerebral neurons that send axons toward the spinal cord, further reinforcing that *Fez1* plays a critical role in the specification of subcerebral projection neurons.

As a third example of critical regulators of the development of CSMN and other corticofugal neurons, Lai, Jabaudon and others in our lab recently identified *Sox5* as regulating the sequential generation

of cortical projection neuron diversity [7]. It represses the onset of differentiation of CSMN, thereby allowing generation of the other corticofugal neuron types. *Ctip2*, *Fezl*, *Sox5*, and a larger program of molecular-genetic controls over CSMN differentiation all were identified by the original microarray analysis.

### Molecular Analysis of Excitatory and Inhibitory Neurons in the Adult Forebrain

Nelson and colleagues used microarray analysis to propose a molecular taxonomy of major neuronal classes in the adult forebrain [8]. They identified various neuronal subtypes by retrograde labeling with a fluorescent tracer, or using fluorescently labeled neurons from transgenic mice. In these transgenic mice, specific neuronal subtypes are visualized with green/yellow fluorescent protein (GFP and YFP, respectively) driven by the promoters *Thy1*, *Gad1*, and *Gad2*. *Thy1* is an immunoglobulin superfamily member that is expressed by excitatory projection neurons in many parts of the nervous system, as well as by several nonneuronal cell types, including thymocytes. *Gad1/2* are glutamic acid decarboxylase 1 or 2, and are expressed in distinct subpopulations of inhibitory GABAergic interneurons. Using these transgenic mice, they defined 12 neuronal populations characterized by neurotransmitters and electrophysiological properties, and analyzed gene expression profiles by microarray. Based on similarity of the gene expression, they classified these 12 populations, showing that this molecular taxonomy largely parallels the traditional classification criteria (e.g. GABAergic neurons vs. glutamatergic pyramidal neurons, neocortex vs. hippocampus vs. amygdala).

### Molecular Analysis of Striatal Projection Neuron Subtypes

Yang and colleagues analyzed differential gene expression between striatal projection neuron subtypes using FACS-purified cell populations from [►GENSAT project \(Gene Expression Nervous System Atlas\)](#) BAC transgenic mice [9,10]. In the striatum, 95% of the neurons are projection neurons called medium spiny neurons (MSNs), and these neurons are subdivided into two morphologically indistinguishable neuronal subtypes: striatonigral MSNs and striatopallidal MSNs. Current understanding suggests that these two projection neuron pathways provide balanced but antagonistic influences on the basal ganglia output and behavior. It is thought that their functional imbalance is involved in movement disorders, such as Parkinson's and Huntington diseases, and psychiatric disorders including schizophrenia and depression.

Using FACS, Yang and colleagues isolated striatonigral MSNs and striatopallidal MSNs for microarray studies from mice containing cell type-specific regulatory elements that express enhanced green fluorescent

protein (EGFP) specifically in MSN subtypes. Their analysis identified a new set of differentially expressed genes in addition to known MSN subtype-specific genes, such as *Penk1* and *Drd2*. They identified the transcription factors *Zfp521* and *Ebfl* as new striatonigral MSN-specific genes, which functionally interact with each other. Importantly, they showed that the number of striatonigral MSNs and their axonal projections to the substantia nigra are affected in *Ebfl* mutant mice, whereas striatopallidal MSNs are preserved, demonstrating that these striatonigral MSN-specific genes play a critical role in the development of striatonigral MSNs.

### Molecular Analysis of Neuronal Subtypes in the Future

Although developmental, precursor, and stem cell biology may enable future therapeutic approaches to some diseases of the nervous system, including neurodegenerative diseases, little is known about individual molecular and genetic characteristics of individual neuronal subtypes. Understanding regarding molecular controls over development of specific neuronal subtypes is still in its infancy. Recent microarray technologies have enabled analysis of broad gene expression profiles using smaller amounts of RNA (nanogram levels). New markers and control genes now enable dissection of neuronal diversity more and more deeply. Additionally, availability of genetic labeling using fluorescent proteins under neuronal subtype specific promoters has dramatically increased. These approaches will promote understanding of the molecular development and molecular anatomy, and functional analysis of individual neuronal subtypes, and reveal gene regulation underlying precise development and potentially regeneration of specific neuronal subtypes.

### Acknowledgments

This work was partially supported by grants from the National Institutes of Health (NS45523, NS49553, NS41590), the Harvard Stem Cell Institute, the Spastic Paraplegia Foundation, the ALS Association, and the International Rett Syndrome Foundation to J.D.M.. P.A. was partially supported by a Claflin Distinguished Scholar Award, the Harvard Stem Cell Institute, the Spastic Paraplegia Foundation, and a grant from the ALS Association. B.J.M. was supported by the Harvard M.S.T.P. and the United Sydney Association. U.S.S. was partially supported by fellowships from the CP Repair Research Fund, and the Edward R. and Anne G. Lefler Center. N.K. was supported by a fellowship from the Japan Society for the Promotion of Science.

### References

1. Gage FH (2000) Mammalian neural stem cells. *Science* 287:1433–1438

2. Molyneaux BJ, Arlotta P, Menezes JR, Macklis JD (2007) Neuronal subtype specification in the cerebral cortex. *Nat Rev Neurosci* 8:427–437
3. Rallu M, Corbin JG, Fishell G (2002) Parsing the prosencephalon. *Nat Rev Neurosci* 3:943–951
4. Sohur US, Emsley JG, Mitchell BD, Macklis JD (2006) Adult neurogenesis and cellular brain repair with neural progenitors, precursors and stem cells. *Philos Trans R Soc Lond B Biol Sci* 361:1477–1497
5. Arlotta P, Molyneaux BJ, Chen J, Inoue J, Kominami R, Macklis JD (2005) Neuronal subtype-specific genes that control corticospinal motor neuron development *in vivo*. *Neuron* 45:207–221
6. Molyneaux BJ, Arlotta P, Hirata T, Hibi M, Macklis JD (2005) Fezl is required for the birth and specification of corticospinal motor neurons. *Neuron* 47:817–831
7. Lai T, Jabaudon D, Molyneaux BJ, Azim E, Arlotta P, Menezes JR, Macklis JD (2008) SOX5 controls the sequential generation of distinct corticofugal neuron subtypes. *Neuron* 57:232–247
8. Sugino K, Hempel CM, Miller MN, Hattox AM, Shapiro P, Wu C, Huang ZJ, Nelson SB (2006) Molecular taxonomy of major neuronal classes in the adult mouse forebrain. *Nat Neurosci* 9:99–107
9. Gong S, Zheng C, Doughty ML, Losos K, Didkovsky N, Schambra UB, Nowak NJ, Joyner A, Leblanc G, Hatten ME, Heintz N (2003) A gene expression atlas of the central nervous system based on bacterial artificial chromosomes. *Nature* 425:917–925
10. Lobo MK, Karsten SL, Gray M, Geschwind DH, Yang XW (2006) FACS-array profiling of striatal projection neuron subtypes in juvenile and adult mouse brains. *Nat Neurosci* 9:443–452

## Microarrays

### Definition

Microarrays consist of thousands of cDNAs printed on a glass slide. Alternatively, the GeneChip® arrays (Affymetrix, Santa Clara, CA, USA) consist of quartz chips on which up to 500,000 oligonucleotide probes can exist on an area of 1.28 cm<sup>2</sup>. Both are used to bind labelled cDNA derived from tissues or cells of interest. Differences in the intensity of binding between cDNA samples can be used to assess differences in RNA expression levels between experimental samples. This technology can pinpoint differences between normal and diseased tissues, identify genes crucial to certain disease processes, and generate gene expression profiles unique to individual tissue samples. Such “fingerprints” are proving useful in assignment of identity to samples and revealing relationships between them.

► Bioinformatics

## Microcephaly

### Definition

Developmental brain disorder characterized by a small-sized brain and skull, often associated with mental retardation.

► Endocrine Disorders of Development and Growth

## Microcircuits

Patterns of interaction between nerve cells which process information such as the odor patterns.

► The Proust Effect

## Microdialysis

### Definition

A technique for measuring extracellular concentrations of substances (e.g. neurotransmitters) in tissues, usually *in vivo*, by means of a small probe equipped with a semi-permeable membrane. Substances may also be introduced into the extracellular space through the membrane.

## Micro-electrode Array (MEA)

### Definition

Device for *in-vivo* or *in-vitro* multi-site, long-term recordings of the electrical activity of neuronal populations. MEAs may be passive (arrays of metal or silicon electrodes), or active (electrodes and amplifiers are integrated in the same chip). Since their introduction in the early 80's due to advancements in micro-fabrication technologies, these devices have enabled the experimental investigation of the collective dynamics and computational properties of large populations of neurons.

► Extracellular Recording



## Microelectrophoresis

► Microiontophoresis and Micropressure Ejection

## Microfilament

### Definition

A thin (approximately 7 nm in diameter) cytoskeletal filament composed of a linear polymer of actin subunits.

## Microglia

### Definition

(Greek mikros, small; glia, glue) Small supporting cells of the central nervous system (CNS), serving as brain-resident phagocytes and antigen-presenting cells. They normally exist in a resting state, but a trigger (injury, illness) can activate them to support injured tissue. If their activation is not properly regulated, it can have devastating side effects, including neurotoxicity.

► [Microglia: Functions in Immune Mechanisms in the Central Nervous System](#)

## Microglia: Functions in Immune Mechanisms in the Central Nervous System

AKIO SUZUMURA

Department of Neuroimmunology, Research Institute of Environmental Medicine, Nagoya University, Nagoya, Japan

### Definition

Immune mechanisms are implicated in various pathological conditions in the central nervous system (CNS). Microglia are resident immune cells functioning as

either antigen presenting cells or effector cells that destroy myelin or neurons. In contrast, they also produce a variety of neurotrophins to support neuronal survival. Microglia-derived cytokines induce proliferation of astrocytes, also suggesting their possible role in gliosis formation.

### Characteristics

#### Quantitative Description

Since ► [microglia](#) first appear in the early postnatal period in the brain parenchyma, they may play a role in the development of neural cells and/or neuronal network. Another important role of microglia is the function as immune cells in the CNS. Microglia provide a first line defense in either infection or injury of the brain. They express ► [CD14](#) and a variety of ► [toll-like receptors \(TLR\)](#). Microglia express TLR1,2,3,4,6, which are upregulated in inflammatory lesions in the CNS. Microglia recognize lipopolysaccharide (LPS) or peptidoglycan on the bacterial membrane non-specifically via these receptors to produce ► [cytokines](#), such as IL-1 $\beta$ , IL-6, TNF $\alpha$ , and other inflammatory mediators like nitric oxide (NO) or reactive oxygen species (ROS). Microglia are also activated through complement receptors and Fc receptors. This classical innate immunity had been considered to be only a defense mechanism in the CNS. The brain had long been considered as an immunological privileged site where specific immune responses do not occur. However, studies in the last three decades have clearly disclosed that this is no more the case. In acquired immunity, microglia play a critical role, either as antigen presenting cells (APC), or effector cells. Microglia, as other neural cells, do not usually express class II ► [major histocompatibility complex \(MHC\) antigen](#) that is essential for antigen presentation to T cells. However, in some pathological conditions, microglia are induced to express class II MHC antigens. Although astrocytes and endothelial cells can be class II MHC antigen-positive, the functional APC that express all other co-stimulatory molecules are microglia.

Microglia also function as effector cells in inflammation, demyelination, and gliosis via production of various inflammatory mediators. In addition, the recent studies have shown the involvement of immune and/or inflammatory mechanisms in neurodegenerative disorders such as Alzheimer's disease (AD), Parkinson's disease (PD) and Huntington disease (HD). Activated microglia are accumulated in or around degenerating neurons in these diseases, and have been shown to play a principal role in neuronal degeneration and regeneration.

### Microglia as Antigen Presenting Cells

The immune response is initiated when protein antigen is presented to T cells by APC. The APC process

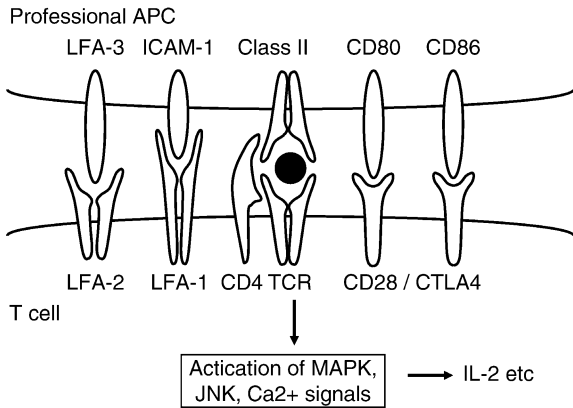

**Microglia: Functions in Immune Mechanisms in the Central Nervous System. Figure 1** Molecules and signals in antigen presentation. Antigens (*black circle*) processed and expressed on class II MHC antigens by professional antigen presenting cells (APC) are recognized by T cell receptors (TCR), which activates MAP kinase (MAPK), JNK and Ca<sup>2+</sup>-NFAT system. These signal cascades activate transcriptional regulation region to produce T cell activating factors including interleukin-2 (IL-2).

antigen, either foreign or self, by internalizing and digesting it into peptide fragments. The processed peptide fragments are then expressed on the surface of APC as a form of MHC-peptide complex. When the MHC-peptide complex interacts with T cell receptors (TCR), subsequent T cell activation occurs (Fig. 1). Class II MHC molecules present antigen to CD4-positive T cells, while class I MHC molecules present antigen to CD8-positive T cells. Binding of the MHC-peptide complex to the TCR is critical, but not sufficient, for activation of T cells. There should be several co-stimulatory molecules that interact with the ligands on T cells for sufficient activation. These co-stimulatory molecules include B7.1 (CD80), B7.2 (CD86), leukocyte function associated molecule-3 (LFA-3), intercellular adhesion molecule-1 (ICAM-1), ICAM-2 and ICAM-3. They bind to ligands on T cells to form ligand pairs such as B7.1-CD28/CTLA4, B7.2-CD28/CTLA4, LFA-3-CD2, ICAM-1, 2 or 3-LFA-1. Interaction of T cells and APC occurs in a MHC-restricted manner. The T cells recognize a foreign antigen only when the antigen forms a complex with self MHC molecules on APC. Therefore, the cells expressing class II MHC and co-stimulatory molecules constitutively are considered to be professional APC. Those include macrophages, B cells, dendritic cells, and Langerhans cells. Non-professional APC differs from the professional APC by expressing little or no MHC class II molecules constitutively, and by not having a complete set of co-stimulatory molecules. The candidates for the non-professional APC in the CNS are

microglia, astrocytes and endothelial cells. They do not usually express class II MHC antigen constitutively. These cells, however, are induced to express class II MHC molecules with certain inflammatory cytokines, especially IFN $\gamma$  [1], and also express some of the co-stimulatory molecules [2]. There are evidences that endothelial cells, astrocytes, and pericytes can process and present protein antigens to primed CD4-positive T cells in vitro, but the specific role of these cells as APC in vivo is still unclear. At least, astrocytes do not usually express class II MHC antigens in vivo, even in the presence of inflammatory cells. Since microglia have very similar characteristics to macrophages and are induced to express class II MHC antigens as discussed above, microglia are the most possible candidates for APC in the CNS. Microglia express co-stimulatory molecules, such as B7, ICAM, LFA3, but only some in astrocytes. It has been shown that human microglia, but not astrocytes, express both B7-1 and B7-2, suggesting that microglia is a much more suitable candidate for local APC in the CNS. In fact, microglia when stimulated with IFN $\gamma$  can present antigen to antigen-specific T cells in vitro. Microglia have been shown to function as APC in pathological conditions in vivo [3]. In bone marrow chimera of experimental autoimmune encephalomyelitis (EAE)-susceptible and resistant animals, EAE lesions developed only when the perivascular microglia were replaced with an EAE-susceptible strain, suggesting that antigen presentation by perivascular microglia is critical for the development of EAE lesions.

Professional APC such as dendritic cells or macrophages produce IL-12 and IL-18. IL-12 and IL-18 are key cytokines in the development of autoimmune processes, regulating differentiation of naïve T cells into T helper 1 (Th1). To exert its activity, IL-12 needs to form a heterodimer of p35 and p40; homodimer of p40 suppresses the functional heterodimer. Immature IL-18 is cleaved by caspase-1 to become functionally mature IL-18 that induces differentiation of Th1 and cytotoxic activity of NK and T cells. Microglia produce a functional heterodimer of IL-12 upon stimulation. LPS-stimulated microglia have bioactivity of IL-18 to induce INF $\gamma$  production by T cells in synergism with IL-12. This suggested that microglia also express caspase-1.

Another IL-12 family cytokine, IL-23, is a heterodimer of IL-12 p40 and p19. It has been shown recently that p35 knockout mice that cannot produce IL-12 develop EAE, while p40 knockout mice that cannot produce IL-12 and IL-23 do not, suggesting that IL-23, but not IL-12, is a critical cytokine for the Th-1 development [4]. IL-27 is also an IL-12 family member, and plays a role in the early stage of Th-1 development. Both IL-23 and IL-27 are produced by microglia upon activation [5]. Since all Th-1 inducing cytokines are produced by microglia in the CNS, while IL-4 that induces Th-2 response is not

produced, a Th-1 response occurs much more easily in the CNS than a Th-2 response.

The most potent stimulus to induce MHC class II antigen on neural cells is IFN $\gamma$ . IFN $\gamma$  has been considered to be produced exclusively by lymphoid cells, such as T cells or NK cells. However, microglia can produce IFN $\gamma$  upon stimulation with IL-12 and/or IL-18 [6]. Thus, induction of MHC antigen expression on neural cells may occur without immune cell infiltration in the CNS.

### Immune Mechanisms in Neurodegenerative Disorders

Recent evidence suggests the presence of immune and/or inflammatory mechanisms in neurodegenerative disorders [7]. In AD, PD and HD, there is no obvious accumulation of activated immune cells. Nevertheless, potent inflammatory molecules such as cytokines, chemokines, free radicals and complement are detected in the cerebrospinal fluid and CNS lesions. Amyloid- $\beta$  (A $\beta$ ) or tau protein reportedly activates microglia to produce neurotoxic substances to kill neurons. Visualizing microglial activation in vivo using positron emission tomography (PET) with activated microglial marker, PK11195, clearly demonstrated accumulation of activated microglia in the early stage of AD and HD. Therefore, microglia may play a critical role in neurodegeneration and prevention of the active inflammation may suppress disease process. A non steroidal anti-inflammatory drug (NSAID) was used for this purpose to prevent the progression of AD, and gave favorable results.

In contrast, microglia can also produce neurotrophic factors, such as nerve growth factor (NGF), brain derived neurotrophic factor (BDNF), glial cell line-derived neurotrophic factor (GDNF) and neurotrophin-3, 4 (NT-3,4), suggesting neuroprotective functions of microglia. Taken altogether, immune and inflammatory mechanisms may be involved in neurodegeneration, where microglia play a critical role on both neuronal degeneration and regeneration. The mechanisms of how microglia exert the opposite effects on neurons are currently unknown. There may be distinct subpopulations of microglia, toxic versus protective. Alternatively, some specific ligand-receptor complex may decide the functions of microglia.

### Microglia as Effector Cells in Inflammation and Neuronal Degeneration

Microglia produce a variety of cytokines, such as IL-1, IL-5, IL-6, IL-8, IL-10, IL-12 family, TNF $\alpha$ , and M-CSF, in response to LPS and/or IFN $\gamma$ . These stimuli also induce chemokines, nitric oxide (NO), superoxide (O $_2^-$ ) and glutamate. TNF $\alpha$ , NO, O $_2^-$  have been shown to destroy myelin and neuronal cells to induce demyelination and neuronal degeneration. Recently, it has been shown that the most neurotoxic factor from activated

microglia is glutamate, which disturbs the mitochondrial respiratory chain to cause energy depletion in neurons [8]. TNF $\alpha$  was a candidate for neurotoxic factor from activated microglia. However, in our experimental conditions, TNF $\alpha$  did not kill neurons. Although TNF $\alpha$  by itself is not a potent neurotoxic factor, it induces glutamate production in microglia via upregulation of glutaminase. Interestingly, thus produced glutamate is released through the hemichannel of gap junctions but not through glutamate transporters [9]. Thus, microglia can act as effector cells in either inflammatory demyelination and neuronal degeneration. In addition, since IL-1 $\beta$ , TNF $\alpha$  and IFN $\gamma$  induce proliferation of astrocytes in vitro, these microglia-derived cytokines may contribute to the formation of gliosis, a scar formation in the CNS (Fig. 2).

Recently, a great deal of attention has been focused on the relation between activated microglia through adenosine 5'-triphosphate (ATP) receptors and neuropathic pain [10]. Neuropathic pain is often a consequence of nerve injury through surgery, bone compression, diabetes, or infection. There is abundant evidence that extracellular ATP and microglia have an important role in neuropathic pain. The expression of the P2X4 receptor, a subtype of ATP receptors, is enhanced in spinal microglia after peripheral nerve injury model, and blocking pharmacologically and suppressing molecularly P2X4 receptors produces a reduction of the neuropathic pain. Several cytokines such as IL-1 $\beta$ , IL-6, and TNF $\alpha$  in the dorsal horn are increased after nerve lesion and have been implicated in contributing to nerve-injury pain, presumably by altering synaptic transmission in the CNS, including the spinal cord. Nerve injury also leads to persistent activation of p38 mitogen-activated protein kinase (MAPK) in microglia. An inhibitor of this enzyme reverses mechanical allodynia following spinal nerve ligation. ATP is able to activate MAPK, leading to the release of bioactive substances, including cytokines, from microglia. Thus, diffusible factors released from activated microglia by the stimulation of purinergic receptors may have an important role in the development of neuropathic pain.

### Suppression of Microglial Functions as Therapeutic Strategy

Inhibitory cytokines such as TGF $\beta$  and IL-10 suppress the IFN $\gamma$ -induced class II MHC antigen expression and LPS-induced cytokine production by microglia. Therefore, suppression of microglial functions by TGF $\beta$  or IL-10 may result in suppression of the disease process. As expected, these inhibitory cytokines successfully suppressed the development of EAE. The cAMP-elevating agents, either phosphodiesterase inhibitor or adenylate cyclase activator, suppress TNF $\alpha$  and NO production by microglia. These drugs have also effectively suppressed the development of EAE and clinical relapse of multiple sclerosis (MS). Analysis of

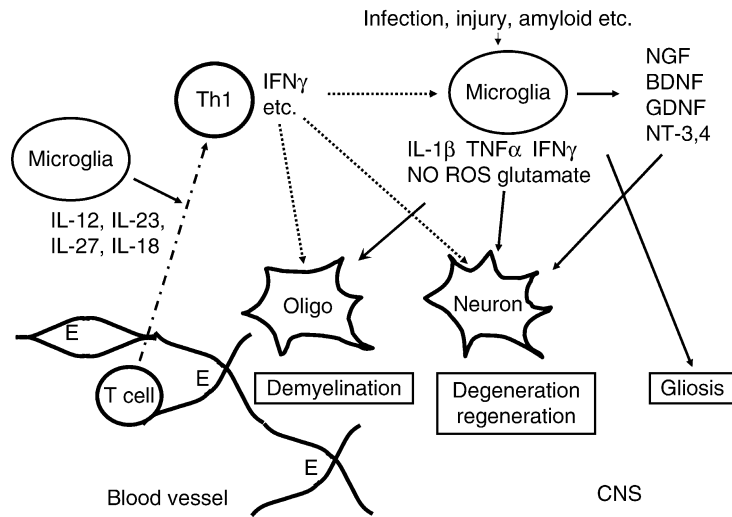

**Microglia: Functions in Immune Mechanisms in the Central Nervous System. Figure 2** Functions of microglia in immune and inflammatory mechanisms in the CNS. Microglia produce a variety of neuroprotective and neurotoxic factors. These factors play a role on the development of demyelination, neuronal degeneration, regeneration, and gliosis. Infiltrating T cells, especially Th1 cells, activate microglia to function as effector cells in neuroinflammation. Arrows indicate functions of soluble factors from microglia, and dotted lines indicate functions of Th1-derived factors. E: endothelial cells, oligo: oligodendrocytes, other abbreviations are indicated in the text.

the cytokine profile in CD4-positive T cells during the treatment of MS shows that phosphodiesterase inhibitors induce a Th1 to Th2 shift. Since phosphodiesterase inhibitors upregulate IL-10 and down-regulate IL-12 production by microglia, this mechanism may be involved in the Th1 to Th2 shift to suppress MS relapse.

HMG Co-A reductase inhibitors (statins) may also be useful to suppress EAE via suppressing microglial activation, cytokine production and induction of MHC antigen. Statins are now the candidates for the treatment of MS, ischemic brain disease and neuronal degeneration.

As discussed above, neurotoxic glutamate is released from microglia via gap junctions. In addition, microglia produce glutamate by glutaminase using extracellular glutamine as a substrate. Thus, inhibitors for gap junction or glutaminase may be able to suppress glutamate from activating microglia without affecting physiological glutamate. These drugs are another candidate for the treatment of neurodegenerative disorders.

## References

1. Suzumura A, Mezitis SGE, Gonatus N, Silberberg DH (1987) MHC antigen expression on bulk isolated macrophage-microglia from newborn mouse brain: induction of Ia antigen expression by gamma-interferon. *J Neuroimmunol* 15:263–278
2. De Simone R, Giampaolo A, Giometto B, Gallo P, Levi G, Peschle C, Aloisi F (1995) The costimulatory molecule B7 is expressed in human microglia in culture and multiple sclerosis acute lesions. *J Neuropathol Exp Neurol* 54:175–187
3. Hickey WF, Kimura H (1988) Perivascular microglial cells of the CNS are bone marrow-derived and present antigen in vivo. *Science* 239:290–292
4. Gran B, Zhang GX, Yu S, Li J, Chen XH, Ventura ES, Kamoun M, Rostami A (2002) IL-12p35-deficient mice are susceptible to experimental autoimmune encephalomyelitis: evidence for redundancy in the IL-12 system in the induction of central nervous system autoimmune demyelination. *J Immunol* 169:7104–7110
5. Sonobe Y, Yawata I, Kawanokuchi J, Takeuchi H, Mizuno T, Suzumura A (2005) Production of IL-27 and other IL-12 family cytokines by microglia and their subpopulations. *Brain Res* 1040(1–2):202–207
6. Kawanokuchi J, Mizuno T, Takeuchi H, Kato H, Wang J, Mitsuma N, Suzumura A (2006) Production of interferon- $\gamma$  by microglia. *Mult Scler* 12:558–564
7. Zipp F, Aktas O (2006) The brain as a target of inflammation: common pathway link inflammatory and neurodegenerative diseases. *Trends in Neurosci* 29(9):518–527
8. Takeuchi H, Mizuno T, Zhang G, Wang J, Kawanokuchi J, Kuno R, Suzumura A (2005) Neuritic beading induced by activated microglia is an early feature of neuronal dysfunction toward neuronal death by inhibition of mitochondrial respiration and axonal transport. *J Biol Chem* 280:10444–10454
9. Takeuchi H, Jin S, Wang J, Zhang G, Kawanokuchi J, Kuno R, Sonobe Y, Mizuno T, Suzumura A (2006) Tumor necrosis factor- $\alpha$  induces neurotoxicity via glutamate release from hemichannels of activated microglia in an autocrine manner. *J Biol Chem* 281:21362–21368
10. Inoue K (2002) Microglial activation by purines and pyrimidines. *Glia* 40(2):156–163

## Microglial Cell

### Definition

The microglial cell is the smallest of the neuroglial cells. It is of mesodermal origin and some can act as phagocytes absorbing and digesting up neuronal waste products and debris.

## Microglial Signaling Regulation by Neuropeptides

KYOUNGHO SUK

Department of Pharmacology, School of Medicine, Kyungpook National University, Daegu, Korea

### Definition

Neuropeptides are short-chain peptides found in brain tissue, with some functioning as neurotransmitters and others functioning as hormones. Recent studies indicated that neuropeptides may directly or indirectly regulate glial functions in the central nervous system (CNS). Described here are the effects of neuropeptides pituitary adenylate cyclase-activating polypeptide (PACAP) and corticotropin-releasing hormone (CRH) on inflammatory activation of microglia and intracellular signal transduction pathways associated with the microglial activation. As microglia are believed to function as the resident immune defense system of the brain and to participate in neuroinflammation in response to intrinsic or extrinsic stimuli, the neuropeptides may modulate immune and inflammatory responses in the CNS by influencing microglial signaling.

### Characteristics

#### Description of the Structure/Process/Conditions

##### *Microglia and Neuroinflammation*

The central nervous system (CNS) consists of neuron and neuroglia. Neuroglia were once merely thought of as a structural support for neurons in the CNS. Increasing evidence now indicates that neuroglial cells actively participate in brain functions by nurturing neurons and facilitating neuronal activity. Four different types of neuroglial cells – oligodendrocytes, ependymal cells, astrocytes, and ►microglia – fulfill distinct tasks. Oligodendrocytes are the myelin-forming cells of the CNS and they ensure rapid signal conduction in the white matter. Ependymal cells constitute the lining of cerebral ventricles. Astrocytes provide guiding

structures during development and they represent important elements for controlling the composition of the extracellular space mediating signals between the brain endothelium and the neuronal membrane. Microglial cells are immunocompetent cells in the brain and their functional role is best defined as the first responsive elements during pathologic events in the CNS [1]. Microglial cells are ubiquitously distributed in the CNS and comprise of up to 20% of the total glial cell population in the brain [2]. Microglial cells function in a manner similar to monocytes/macrophages in the periphery. Microglia, as the CNS resident phagocytes, migrate to the area of injured nervous tissue, and they engulf and destroy microbes and cellular debris. In response to brain injury or infection, microglia are mobilized to secrete various soluble immune mediators such as cytokines and chemokines, and they function as immunocompetent cells expressing MHC class I and II molecules. Activated microglia also secrete neurotoxic inflammatory cytokines and mediators such as tumor necrosis factor (TNF) $\alpha$  and nitric oxide (NO), which may initiate or amplify the neuroinflammatory responses [3,4] (Fig. 1). The activation of microglial cells may initially be aimed at protecting neurons. Activation of microglial cells and inflammatory products derived from them, however, have also been implicated in neuronal destruction commonly observed in various neurodegenerative diseases [4] (Fig. 1). Recent studies indicated that brain inflammation is closely associated with the pathogenesis of neurodegenerative diseases. Compared with inflammation in peripheral tissue, inflammation in the brain appears to follow distinct pathways and time courses. The major immune cells that respond to and produce inflammatory stimuli in the brain are microglia. The inflammatory responses in microglia are coordinately regulated by the production of cytokines, chemokines, proteases, and reactive oxygen or nitrogen species. These molecules function in a synergistic and/or antagonistic manner, eventually leading to neurodegeneration via inflammatory cascades. The activation of microglia is regulated by signals from neurons and astrocytes as well as various systemic signals.

##### *Intracellular Signal Transductions of Microglial Activation*

Microglia exert both positive and negative effects on the nervous system. As the first line of defense, microglia protect neurons against toxic insults, while the chronic and excessive activation of microglia may play direct or indirect roles in various neuropathologies [5]. The signals that activate microglia or that are produced by activated microglia could be neutralized in order to suppress the negative effects of microglia. Alternatively, intracellular signal transduction pathways that are involved in microglial activation could be interrupted to block microglial activation. Many endogenous and

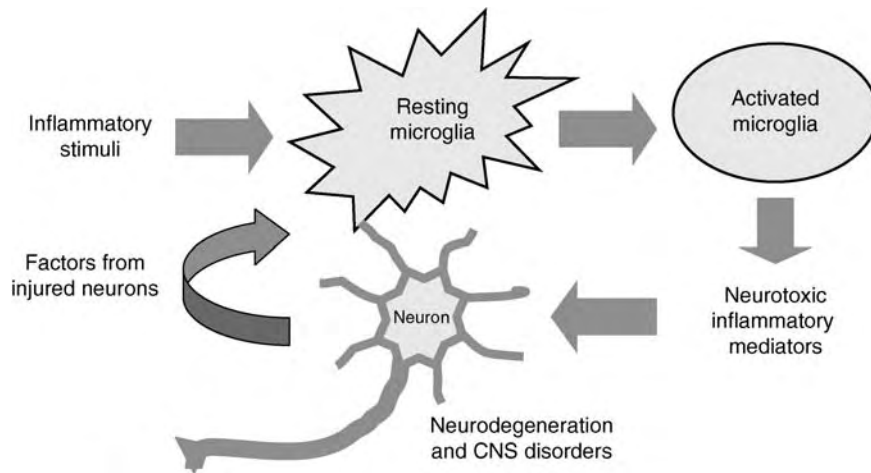

**Microglial Signaling Regulation by Neuropeptides. Figure 1** A role of microglial activation in neurodegeneration. Resting microglia (ramified type) can be activated by inflammatory stimuli such as LPS, IFN $\gamma$ , and hypoxia. Activated microglia (amoeboid type) produce a variety of inflammatory mediators including nitric oxide, TNF $\alpha$ , and IL-1 $\beta$ , which in turn cause neuronal injury and neurodegeneration (and possibly other CNS disorders). Damaged neurons also act as a stimulus that induces neuroinflammation. This constitutes a vicious cycle by which the process of inflammation-mediated neurodegeneration is perpetuated.

exogenous agents have been demonstrated to influence the microglial signal transduction. Signal transduction pathways that have been shown to be associated with microglial activation include NF- $\kappa$ B, MAPKs, STAT/IRFs, and TLRs.

NF- $\kappa$ B constitutes a canonical pathway of microglial activation in neuroinflammation. NF- $\kappa$ B regulates a wide variety of inflammatory gene expressions in microglia, and its signaling pathways are well characterized. Upon the stimulation of microglia with a wide variety of inflammatory mediators, I $\kappa$ B kinase (IKK) is activated to phosphorylate I $\kappa$ B. Phosphorylated I $\kappa$ B triggers its degradation through the ubiquitin system, where the target molecule is masked by a chain of ubiquitins for degradation by the 26S proteasome. The free NF- $\kappa$ B can then translocate to the nucleus and activate the transcription of numerous inflammatory genes. NF- $\kappa$ B has been shown to mediate the transcriptional activation of CD40, inducible nitric oxide synthase (iNOS), cyclooxygenase (COX)-2, chemokines, TNF $\alpha$ , interleukin (IL)-1 and other cytokines upon the stimulation of microglia with lipopolysaccharide (LPS; endotoxin), transglutaminase 2, S100B, thrombin, gangliosides, plasminogen, advanced glycation endproducts (AGEs), and neuromelanin. NF- $\kappa$ B also plays an important role in a number of neuropathology occurring in neurodegenerative processes and neuronal cell death [6, 7]. NF- $\kappa$ B activation can prevent the death of neurons by inducing the production of anti-apoptotic proteins. Molecular pathways upstream and downstream of NF- $\kappa$ B in neurons are being elucidated and may provide novel targets for therapeutic intervention in

various neurological disorders. MAPK pathways have been implicated in the inflammatory activation of glial cells. MAPKs consist of three subgroups: ►p38 MAPK, extracellular signal regulated kinase (ERK), and c-Jun N-terminal kinase/stress-activated protein kinase (JNK/SAPK). These kinases are activated by the phosphorylation of both tyrosine and threonine residues that is catalyzed by specific upstream MAPK kinase (MAPKK). Activated MAPKs phosphorylate their specific substrates on serine and/or threonine residues, thus ultimately leading to the activation of specific subsets of transcription factors. While ERKs are stimulated mainly by growth factors and tumor promoters, p38 MAPK and JNK/SAPK are activated by inflammatory stimuli and environmental stresses such as osmotic shock. In the CNS, ERKs and p38 MAPK have been shown to regulate the iNOS and TNF $\alpha$  gene expression in endotoxin-stimulated primary glial cultures. In addition, MAPKs play a crucial role in regulating the neurochemistry of N-methyl-D-aspartate receptors, their physiologic and biochemical/biophysical properties, and their potential role in pathophysiology [8]. JAK/STAT1 and IRF-1 constitute the main component of IFN $\gamma$  signaling in microglia. IFN $\gamma$  phosphorylates STAT1 through JAK and subsequently the IRF-1 expression is induced. As a transcription factor, these two gene products regulate the expression of numerous IFN $\gamma$ -inducible genes, thereby playing a critical role in the cellular response to IFN $\gamma$ . The specific inhibition of JAK by AG490 attenuated the IFN $\gamma$ -induced NO production in microglia as well as in mixed glial cultures, thus demonstrating the critical role of JAK in IFN $\gamma$  signaling in the glia. In contrast to the downstream

signaling events of microglial activation that have been partly elucidated, little is known about the early signaling events proximal to the plasma membrane. Toll-like receptors (TLRs) play a critical role in early innate immunity to invading pathogens by sensing microorganisms. TLRs are evolutionary conserved homologues of the *Drosophila* Toll gene, which recognize structural motifs that are only expressed on microbial pathogens called pathogen-associated molecular patterns (PAMPs). PAMPs include bacterial DNA, flagellin, and their cell wall components such as LPS, peptidoglycan, and lipopeptides. The stimulation of TLRs by these PAMPs initiates a signaling cascade that involves a number of Toll/IL-1 receptor (TIR) domain-containing adaptor proteins (MyD88, TIRAP/Mal, TRIF, TRAM), protein kinases (IRAK-1, IRAK-M, MAPK), and other signaling intermediates (TRAF6, Tollip). The TLR-initiated signaling pathways ultimately lead to the activation of NF- $\kappa$ B, PKR, STAT1, and IRFs. Some of these signaling pathways are involved in the microglial activation.

### Regulation of the Structure/Process/Conditions

#### Regulation of Microglial Signal Transductions by Neuropeptides

► **Neuropeptides** are short-chain peptides found in brain tissue, with some functioning as neurotransmitters and others functioning as hormones. Recent studies indicated that neuropeptides may directly or indirectly regulate glial functions in the CNS. Among many neuropeptides, this essay focused on the effects of PACAP and CRH on inflammatory activation of microglia and intracellular signal transduction pathways associated with microglial activation.

#### Effect of PACAP

Pituitary adenylate cyclase-activating polypeptide (PACAP) is a neuropeptide that was first identified as an activator of adenylate cyclase in rat anterior pituitary cells. PACAP is widely distributed in the brain and peripheral organs, notably in the endocrine pancreas, gonads, and respiratory and urogenital tracts. Consistent with its widespread distribution, PACAP exerts multiple actions in the CNS and periphery through three distinct receptor subtypes – PAC1, VPAC1, and VPAC2. In the CNS, PACAP is thought to act as a neurotrophic factor during development, whereas the neuropeptide seems to function as a neuroprotector against various insults in the adult brain [9]. PACAP also elicits a broad spectrum of biological effects on natural and acquired immunity [10]. PACAP has been shown to inhibit cytokine production and the proliferation of T cell, and to inhibit several macrophage functions, including phagocytosis, respiratory burst, chemotaxis, and cytokine production. It has also

been shown that PACAP inhibits inflammatory activation of microglia through VPAC1 receptor. PACAP inhibited production of chemokines and CD40 expression from LPS-stimulated microglia. However, little information is available regarding the effect of PACAP on microglial signal transduction pathways. In one report, PACAP inhibited the JNK signaling pathway in endotoxin-activated microglia. PACAP inhibited TNF $\alpha$  production from rat microglia following spinal cord injury via a cAMP-dependent pathway. PACAP has also been reported to inhibit LPS-stimulated production of inflammatory mediators by inhibiting NF- $\kappa$ B activation. Moreover, PACAP inhibition of NF- $\kappa$ B-controlled gene expression was mediated via inhibition of CBP-NF- $\kappa$ B interaction. A recent study systematically evaluated the effect of PACAP on signal transduction of microglia initiated by various inflammatory stimuli, in an attempt to better understand how the neuropeptide PACAP influences CNS inflammation [11] (Fig. 2). In that study, the BV-2 mouse microglia cell line was utilized as a model system to determine the effect of PACAP on microglial signal transduction. The BV-2 cell line was originally established by oncogenic viral transformation of primary microglial cells derived from mouse brain. The cell line is known to exhibit morphological and functional properties that are similar to freshly isolated microglia, and has been widely used for the investigation of microglial activation. It has been shown that PACAP suppresses the inflammatory activation of BV-2 microglia via specific inhibition of LPS-induced p38 MAPK pathway (Fig. 2): (i) pretreatment of BV-2 cells with PACAP resulted in a significant decrease in LPS- or IFN $\gamma$ -induced NO production as well as iNOS and IL-1 $\beta$  mRNA levels; (ii) the inhibitory effect of PACAP appeared to be mediated through an increase in intracellular cAMP; (iii) PACAP inhibition of LPS-induced NO production was accompanied by inhibition of p38 MAPK activation, but not ERK, JNK, or NF- $\kappa$ B; and (iv) IFN $\gamma$ -induced STAT-1 activation or IRF-1 induction was not significantly influenced by PACAP [11].

As it has previously been shown that hypoxia induces inflammatory activation of cultured microglia and their inducible nitric oxide synthase induction via the p38 MAPK pathway [12], it was hypothesized that the neuropeptide may inhibit the hypoxic activation of microglia, and this may provide a neuroprotection against inflammation-induced neuronal injury. When this possibility was tested using cultured microglia and PC12 cells, it was found that PACAP attenuates inflammatory activation of microglia under hypoxic condition, and protects co-cultured PC12 cells from microglial neurotoxicity [13]. In addition, the neuropeptide reduced the hypoxia-induced activation of p38

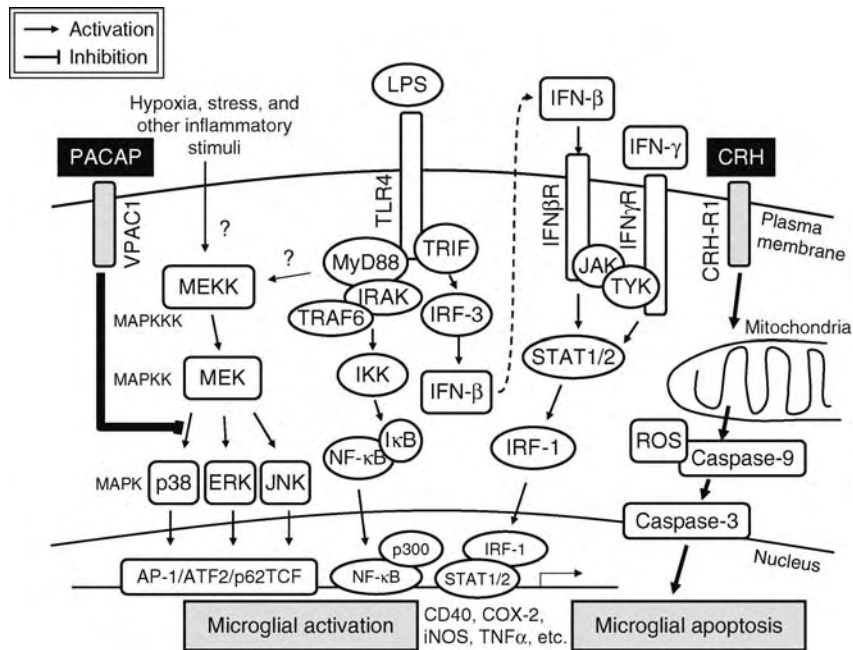

**Microglial Signaling Regulation by Neuropeptides. Figure 2** Schematic diagram of microglial signal transduction following exposure to LPS, IFN $\gamma$ , and other inflammatory or stress signals: the action sites of PACAP and CRH. After treatment of microglia with LPS, TLR4 signaling is initiated with the ensuing NF- $\kappa$ B activation and IFN $\beta$  production, which feeds back to evoke the secondary signaling. IFN $\gamma$  induces STAT1 activation followed by IRF-1 induction. Hypoxia and stress signals initiate three subgroups of MAPK pathways. NF- $\kappa$ B, STAT/IRF, and MAPKs commonly induce the transcription of a wide variety of inflammatory genes. PACAP specifically inhibits p38 MAPK, while CRH induces apoptosis of microglia via mitochondrial pathway (ROS production and caspase-9 activation with subsequent caspase-3 activation).

MAPK, indicating that the p38 MAPK is also a molecular target of the PACAP action in microglia under the hypoxic condition. The neuroprotective effects of PACAP in animal models of cerebral hypoxia/ischemia may be partly due to its direct actions on brain microglia and neurotoxic inflammation.

#### Effect of CRH

Corticotropin-releasing hormone (CRH) plays a pivotal role in stress responses as a key mediator of hypothalamic-pituitary-adrenocortical system [14]. CRH is released from the hypothalamus, and then carried to the pituitary gland, where it causes secretion of the adrenocorticotropic hormone (ACTH) that triggers cortisol secretion from the adrenal glands. The peptide hormone has also been implicated in the regulation of neuronal cell survival, exerting either neurotoxic or neuroprotective effects. Peripheral secretion of CRH is involved in the modulation of peripheral immune responses by acting at specific receptors on multiple populations of immune cells to produce a wide range of effects. Earlier works support a proinflammatory role of CRH: it induced activation of monocytes/macrophages, T cells, and mast cells. In the CNS, primary microglia

cultures, microglial cell lines, and microglia in vivo have been shown to be a direct target of CRH action. Microglia express CRH receptor 1 (CRH-R1), and the ligation of this receptor by CRH induced TNF $\alpha$  release in cultured rat microglia, IL-18 and  $\beta$ -endorphin production in microglial cells, and cAMP accumulation in mouse microglia, respectively.

Proapoptotic activity of CRH has previously been reported in the PC12 rat pheochromocytoma cell line with neuronal characteristics, where CRH induced Fas ligand expression and  $\blacktriangleright$ apoptosis. CRH also increased the apoptosis of activated T cells through Fas ligand induction, suggesting a role for CRH in immunotolerance. Based on these proapoptotic activities of CRH, the effects of the neuropeptide on the survival or death of purified microglia have been investigated [15]. While vasoactive intestinal peptide, substance P, cholecystokinin, or neuropeptide Y did not affect microglial cell viability, CRH induced a classical apoptosis of mouse microglia in culture as evidenced by nuclear condensation and fragmentation, TUNEL staining, and cleavage of caspase-3 and poly (ADP-ribose) polymerase (PARP) protein (Fig. 2). CRH, however, did not influence nitric



oxide production or inflammatory gene expression including cytokines and chemokines, indicating that CRH did not affect the inflammatory activation of microglia. The CRH-induced microglial apoptosis appeared to involve a mitochondrial pathway and reactive oxygen species (Fig. 2). Taken together, these results indicate that the stress neuropeptide CRH may regulate neuroinflammation by inducing the apoptosis of microglia, the major cellular source of inflammatory mediators in the CNS.

## Function

### *Regulation of Microglial Signaling by PACAP*

PACAP has been proposed as a deactivator of innate immune responses. In the CNS, PACAP suppressed neuroinflammation by inhibiting inflammatory activation of microglia. Therefore, PACAP may act as a neuroprotector by inhibiting microglial activation under the conditions where inflammatory responses associated with microglial activation play an important pathogenic role in neuronal injury. In fact, the neuroprotective effect of PACAP has been well documented in a variety of experimental models in vivo as well as in vitro. PACAP has been reported to reduce brain damage after global and focal ischemia in vivo. Also, PACAP has been found to prevent neuronal cell death under various neurotoxic conditions in vitro: PACAP protected cerebellar granule neurons against oxidative stress- or ethanol-induced apoptosis; it reduced LPS-induced neurotoxicity in mixed cortical neuron/glia cultures; and it attenuated  $\beta$ -amyloid-induced toxicity in PC12 cells. Although some of these previous works have shown that PACAP may act on neurons directly to exert its neurotrophic or neuroprotective activities, it has also been suggested that inhibition of pathological activation of microglia may be another way that PACAP exerts its neuroprotective effects in vivo. The findings that PACAP specifically inhibits p38 MAPK activation thereby resulting in down-regulation of inflammatory activation of microglia enhance our understanding of the mechanistic basis of the neuroprotective action of PACAP. The cellular target of PACAP action in the CNS may be either microglia or neurons, and the molecular target of PACAP in microglia appears to be p38 MAPK.

During cerebral ischemia, hypoxia may not only impose the damage on neurons directly, but also promote neuronal injury indirectly via microglial activation. The neuroprotective PACAP also inhibited microglial activation under hypoxic conditions, thereby suggesting that PACAP may directly act on microglia to exert its neuroprotective effects against hypoxia/ischemia. In addition, using a co-culture of microglia and PC12 cells, it has been shown that PACAP is protective against microglial neurotoxicity. In the co-culture system, it was demonstrated that: (i) hypoxia could stimulate microglia to secrete neurotoxic molecules, which actually

mediated PC12 cell death; and (ii) PACAP acted on microglia to block their activation under hypoxic condition, mitigating PC12 cell death [13]. The results corroborated the hypothesis that the PACAP inhibition of hypoxic activation of microglia is neuroprotective.

### *Induction of Microglial Apoptosis by CRH*

Activated microglia are believed to contribute to neuronal damages in neurodegenerative diseases or stroke through the excess release of proinflammatory and/or cytotoxic factors [4]. An apoptotic elimination of activated microglia has recently been suggested as one way of regulating the microglial activation in vitro as well as in vivo [15]. It has recently been reported that a stress neuropeptide CRH induces apoptosis of microglia, and reactive oxygen species (ROS) generation and mitochondrial pathways are involved in the CRH-induced microglial apoptosis. As microglia play a central role in inflammatory responses in the CNS, the current results indicate an important link between the stress response and the neuroinflammation, and may have a relevance to CNS pathologies under stress conditions. An abnormal production of CRH under stress conditions may deregulate the self-regulatory microglial apoptosis, thereby contributing to CNS diseases.

CRH may exert dual effects on microglia depending on their proliferative state. CRH seems to enhance proliferation of serum-starved microglia to some extent, while it may induce apoptosis of normally growing microglia (at the inflammatory sites in vivo). The CRH-induced proliferation was also observed in astrocytes cultured under serum-free conditions, while CRH inhibited proliferation of mouse melanoma cells that were actively progressing through the cell cycle. CRH did not affect the viability, proliferation, or apoptosis in astrocyte cultures that were maintained with 5% serum. Astrocytes have previously been reported to express CRH receptor. These results suggest that CRH exerts differential effects on cell proliferation or viability depending on the conditions under which the cells reside.

CRH mediates immunological, autonomic, and behavioral responses to stress. In the CNS, CRH has been shown to act on glia to exert either neurotoxic or neuroprotective effects depending on the experimental systems employed. In addition, the neuropeptide induced apoptosis of microglia, a cellular population that plays a pivotal role in neuroinflammation. As neuroinflammation is closely associated with neuronal injury and neurodegenerative diseases, the CRH induction of microglial apoptosis suggests an existence of the interconnection among stress responses, neuroinflammation, and CNS disorders. However, further study is required to precisely understand the in vivo relevance of the CRH-induced microglial apoptosis, and to determine the molecular mechanisms underlying the CRH-induced microglial apoptosis.

## Acknowledgements

The author's laboratory was supported by the Korea Research Foundation Grant funded by the Korean Government (MOEHRD, Basic Research Promotion Fund) (KRF-2006-005-J04202; KRF-2006-311-E00045) and by the Brain Korea 21 Project in 2006–2007. This work was also supported by the Neurobiology Research Program from the Korea Ministry of Science and Technology. Studies on the microglial signal transduction were supported by grant No. R01-2006-000-10314-0 from the Basic Research Program of the Korea Science & Engineering Foundation.

## References

- Streit WJ, Conde JR, Fendrick SE, Flanary BE, Mariani CL (2005) Role of microglia in the central nervous system's immune response. *Neurol Res* 27:685–691
- Gehrmann J, Matsumoto Y, Kreutzberg GW (1995) Microglia: intrinsic immunoeffector cell of the brain. *Brain Res Brain Res Rev* 20:269–287
- Minghetti L, Levi G (1998) Microglia as effector cells in brain damage and repair: focus on prostanoids and nitric oxide. *Prog Neurobiol* 54:99–125
- Gonzalez-Scarano F, Baltuch G (1999) Microglia as mediators of inflammatory and degenerative diseases. *Annu Rev Neurosci* 22:219–240
- van Rossum D, Hanisch UK (2004) Microglia. *Metab Brain Dis* 19:393–411
- Lezoualc'h F, Behl C (1998) Transcription factor NF- $\kappa$ B: friend or foe of neurons? *Mol Psychiatry* 3:15–20
- Mattson MP, Meffert MK (2006) Roles for NF- $\kappa$ B in nerve cell survival, plasticity, and disease. *Cell Death Differ* 13:852–860
- Haddad JJ (2005) N-methyl-D-aspartate (NMDA) and the regulation of mitogen-activated protein kinase (MAPK) signaling pathways: a revolving neurochemical axis for therapeutic intervention? *Prog Neurobiol* 77:252–282
- Vaudry D, Gonzalez BJ, Basille M, Yon L, Fournier A, Vaudry H (2000) Pituitary adenylate cyclase-activating polypeptide and its receptors: from structure to functions. *Pharmacol Rev* 52:269–324
- Delgado M, Abad C, Martinez C, Juarranz MG, Leceta J, Ganea D, Gomariz RP (2003) PACAP in immunity and inflammation. *Ann N Y Acad Sci* 992:141–157
- Lee H, Suk K (2004) Selective modulation of microglial signal transduction by PACAP. *Neuroreport* 15:1469–1474
- Park SY, Lee H, Hur J, Kim SY, Kim H, Park JH, Cha S, Kang SS, Cho GJ, Choi WS, Suk K (2002) Hypoxia induces nitric oxide production in mouse microglia via p38 mitogen-activated protein kinase pathway. *Brain Res Mol Brain Res* 107:9–16
- Suk K, Park JH, Lee WH (2004) Neuropeptide PACAP inhibits hypoxic activation of brain microglia: a protective mechanism against microglial neurotoxicity in ischemia. *Brain Res* 1026:151–156
- Charmandari E, Tsigos C, Chrousos G (2005) Endocrinology of the stress response. *Annu Rev Physiol* 67:259–284
- Jones LL, Banati RB, Graeber MB, Bonfanti L, Raivich G, Kreutzberg GW (1997) Population control of microglia: does apoptosis play a role? *J Neurocytol* 26:755–770

## Microgliosis

### Definition

Aggregation of microglia in the brain in response to hypoxia/ischemia or infection. Microglial activation involves increased recruitment of cells through mitosis of resident microglia and probably also from bone marrow derived precursors that infiltrate the central nervous system (CNS). Microglia phagocytose debris occurring as a result of injury, programmed cell death and possibly axonal and dendritic remodelling. Prolonged microglial activation in inflammation can release toxic substances including cytokines and cause cell death.

► Cytokines

## Micrographia

### Definition

Small handwriting, usually a sign of bradykinesia in Parkinson disease. Micrographia is best brought out by asking the patient to write continuously in cursive letters without resting or taking the pen off the paper.

► Parkinson Disease

## Microgravity

### Definition

A condition of cancelled terrestrial gravitational force (weightlessness) during orbital flight in space.

► Autonomic Function in Space

## Microiontophoresis and Micropressure Ejection

PETER M. LALLEY

Department of Physiology, The University of Wisconsin School of Medicine and Public Health, Medical Sciences Center, Madison, WI, USA

### Synonyms

Microelectrophoresis; Iontophoretic application; Pressure micro-ejection

### Definition

Microelectrophoresis: Ejection of charged molecules from a capillary microelectrode close to or within a nerve or muscle cell by electrical current.

Micro-pressure ejection: Ejection by pressure of a small liquid volume containing a chemical or drug from a micropipette in the vicinity of a cell or group of cells.

### Purpose

► **Microiontophoresis** and Micro-pressure Ejection are used to apply drugs or chemicals to nerve cells. The ejected agents bind to cell membrane binding sites (► **receptors**) or cross the cell membrane, altering the cell's excitability. The methods are also used to mark the location of cells in a region of the central nervous system.

### Principles

#### Microiontophoresis

Microiontophoresis involves the ejection of charged drugs or chemicals from a conductive electrolyte solution in a glass capillary micropipette into the extracellular milieu of cells or into a cell's cytoplasm. Direct current (d.c.), either negative or positive and ranging from nanoamperes to microamperes ( $10^9$ – $10^6$  amperes), is passed from a "current pump" through a fine silver wire to a micropipette solution containing positively- or negatively-charged molecules to be ejected. To eject the substance, current of a polarity identical to its charge is applied. Between ejections, applying current of opposite polarity retains the substance. Thus, for example, acetylcholine (ACh<sup>+</sup>) would be ejected with positive current and retained by negative current.

Extracellular microiontophoresis is commonly used to test several substances on a neuron by ejecting them sequentially or simultaneously from a ► **multibarrel microelectrode assembly** (Fig. 1). Several ► **neurotransmitters** or analogs that bind to cell receptors and alter action potential discharges as well as substances

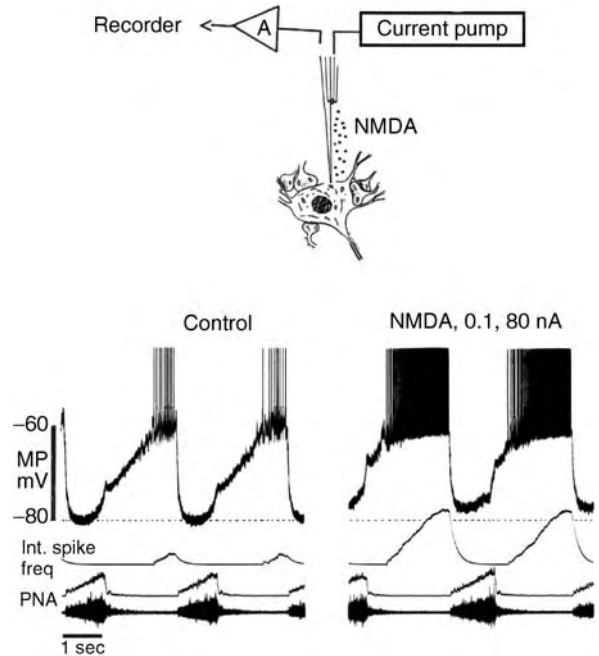

#### Microiontophoresis and Micropressure Ejection.

**Figure 1** Intracellular recording of responses evoked from a respiratory neuron during extracellular application of an excitatory neurotransmitter analog. Upper panel: Recording and microiontophoresis arrangement. The sharp tip of the recording micropipette penetrates the cell membrane and records membrane potential changes evoked during extracellular iontophoresis of *N*-methyl-D-aspartate (NMDA), an amino acid that binds to a subtype of receptor for the excitatory neurotransmitter glutamate. Iontophoresis of NMDA is accomplished by applying negative d.c. current from a current pump connected to a silver wire inserted in a pipette containing 0.1 M Sodium NMDA, a negatively charged compound. Lower panels: Responses to NMDA recorded intracellularly from a respiratory neuron in an anesthetized cat. Traces, top to bottom in each panel, are: Membrane potential (MP), the time integral of neuron action potential frequency, the time integral of action potential frequency recorded from the phrenic nerve and the electroencephalogram of phrenic nerve activity (PNA) (Lalley and Bischoff, unpublished data).

that block the neurotransmitter's receptor sites can be tested on the same cell. After testing, a dye can be ejected to mark the location of the cell.

Present day microiontophoresis units typically consist of 6–7 constant current pumps, or channels. Each pump provides a separate, independent source of ejecting or retaining current that is passed through a silver wire to a current-conducting electrolyte solution, typically 165 mM NaCl solution containing the charged chemical. The current pump incorporates a high voltage

► **field effect transistor (FET)** amplifier with plus or minus outputs in the nanoampere range (typically, up to  $\pm 200 \times 10^9$  amperes). Some units may have pumps capable of generating microampere currents for dye ejection. Channel output is measured and recorded by a ► **galvanometer** and can be operated manually, programmed for automatic sequential operation or controlled externally, e.g. by computer. A summing, or neutralizing channel applies a current that is the sum of all applied currents but of opposite polarity to a separate barrel of the array. The neutralizing current balances out ejecting and retaining currents that might otherwise pass through the extracellular fluid to alter excitability by direct electrical field effects on the cell membrane.

Intracellular microiontophoresis of a chemical allows nerve cells to be labeled for subsequent histological identification, or it can be used to study the actions of a substance that alters excitability through actions on intracellular signaling proteins. The ejecting current is most often delivered while recording with a conventional capillary microelectrode, or with ► **theta glass capillary tubing** (► **theta tubing**). On one side of the ► **theta glass** septum is the electrolyte and a fine Ag/AgCl wire connected to an amplifier to record bioelectric signals, and on the other side is the solution of molecules to be ejected and a silver wire connected to the current pump.

Extracellular microiontophoresis can be combined with intracellular recording to more thoroughly analyze effects of ejected substances on membrane potential (Fig. 1). A single glass capillary micropipette for intracellular recording is either glued side by side to a multibarrel microiontophoresis assembly, or a recording micropipette is inserted into the enlarged central orifice of a customized multibarrel array. In either case the tip of the recording pipette projects beyond the multibarrel tips, usually by 40–50  $\mu\text{M}$ .

## Advantages and Disadvantages

### Advantages and Disadvantages of Microiontophoresis

Microiontophoresis has three principal advantages over other methods of drug and chemical delivery. (i) Diffusion barriers and breakdown by enzymes that impede access to neurons by parenteral administration can be avoided. (ii) Effects of neurotransmitters, their congeners, second messengers and receptor blockers can be analyzed on a single cell. (iii) Many cells can be tested in an experiment.

There are two major disadvantages. (i) Neuronal responses can be evoked with the applied electric current and interpreted as drug or chemical effects, however there are well-established control procedures [1] that minimize the potential for such current artifacts. (ii) The concentration of the ejected substance at

the site of action is unknown, however there are procedures to determine relative potencies of test substances [2,3].

### Micro-Pressure Ejection

Pressure ejection is used to deliver uncharged or poorly charged substances to the vicinity of neurons. The technique is useful for in vivo and in vitro studies. In the in vitro slice preparation, separate recording and pressure-ejection pipettes are positioned close to the target neuron. In the in vivo preparation, ► **micropressure ejection** has been used in two general ways:

1. Single micropipettes with relatively large tips (10  $\mu\text{m}$  or greater) have been used to inject nanoliter volumes for the purpose of altering the excitability of groups of neurons in a small area.
2. Volumes less than 1nl of neuroactive drugs and neuromodulators have been applied to single neurons from ► **multibarrel assemblies** during extracellular or intracellular recording [4].

Volumes of neuroactive substances are ejected from micropipettes connected by soft catheter tubing and high-pressure tubing to a source of compressed gas, usually nitrogen. A switch- or ► **TTL pulse**-controlled ► **solonoid valve** is used to deliver pulses of known pressure and duration.

The general procedure is to microscopically measure with a reticule the length (L) of fluid ejected under pressure from a pipette of known internal radius (r). Volume (V) can then be calculated from  $V = \pi r^2 L$ . From the known concentration of the pipette solution, the amount of substance ejected can be calculated. The volume ejected is linearly proportional to either the applied pressure with ejection duration held constant, or to ejection duration when pressure is constant [4].

Micropipettes with tip resistances between 1.0 and 1.4 M $\Omega$  resistance will usually eject uniform volumes for a given pressure and duration over long test periods. Pipettes with finer tips tend to plug in brain or spinal cord tissue, whereas larger tips (resistance less than 1.0 M $\Omega$ ) produce variable results, and larger volumes are ejected that are more likely to produce volume-related response artifacts [4,5].

### Advantages and Disadvantages of Micro-Pressure Ejection

Pressure ejection has several advantages. (i) Uncharged drugs and chemicals that can be made soluble in an aqueous medium can be tested on neurons. (ii) As with microiontophoresis, diffusion barriers and enzymatic degradation outside the central nervous system are circumvented. (iii) There is no possibility for current artifacts, as with iontophoretic drug delivery. (iv) The essential equipment is relatively inexpensive.

Disadvantages include (i) Potential effects on neurons related to pH when substances are made soluble by pH values <5.5 and >8. (ii) Solution volume can produce injury discharges and changes of membrane potential, and can move nerve cells away from the recording and drug delivery assembly. (iii) Solvents other than water, such as ethanol or dimethylsulfoxide, can also alter neuron behavior. (iv) Solutions of high osmolarity can affect neuron responses through redistribution of cytoplasmic and extracellular water.

## References

1. Lalley P (2004) Dopamine<sub>1</sub> receptor agonists reverse opioid respiratory network depression, increase CO<sub>2</sub> reactivity. *Resp Physiol Neurobiol* 139:247–262
2. Curtis DR (1964) Microelectrophoresis. In: Nastuk WL (ed) *Physical techniques in biological research*, vol 5. *Electrophysiological methods, Part A*, Academic Press, New York, pp 144–190
3. Hill RG, Simmonds MA (1973) A method for comparing the potencies of  $\gamma$ -aminobutyric acid antagonists on single neurones using micro-iontophoretic techniques. *Br J Pharmacol* 48:1–11
4. Palmer MR, Fossum LH, Gerhardt GA (1986) Micro pressure-ejection techniques for mammalian neuropharmacological investigations. In: Geller HM (ed) *Electrophysiological techniques in pharmacology*. Alan R. Liss, New York, pp 169–187
5. Sakai M, Swartz BE, Woody CD (1979) Controlled micro-release of pharmacological agents: measurements of volumes ejected in vitro through fine-tipped glass micro-electrodes by pressure. *Neuropharmacology* 18: 209–213

## Microneurography

### Definition

Technique developed by Karl-Erik Habarth and Åke Vallbo in Upsalla, Sweden, in which an insulated tungsten microelectrode is inserted percutaneously into an accessible peripheral (or cranial) nerve to record electrical signals from nerve fibers (axons) in awake human subjects. The technique is used to record from groups of axons or, usually, single type-identified axons such as muscle spindles, tendon organs and tactile afferents. Microneurography also allows one to record from single unmyelinated axons, such as afferent C fibers or sympathetic axons. The technique has contributed significantly to our understanding of sensorimotor control, pain and cardiovascular control.

- ▶ Cutaneous Mechanoreceptors, Functional Behavior
- ▶ Muscle Spindle
- ▶ Tendon Organs

## Microoxic

### Definition

Conditions characterized by low concentrations of oxygen.

## microRNA

- ▶ miRNAs in Neurobiology

## Microsaccades

### Definition

A saccade which ranges from about 0.01°–0.3° in amplitude and is unconsciously generated at a rate of 1–2 Hz during fixation but is suppressed during tasks requiring fine visual discrimination. The functional role of micro-saccades is unclear as yet; to some degree they appear to correct for fixation errors from slow eye drifts, and they may contribute to avoid fading of the visual scene (which occurs if its image is stabilized on the retina), although other involuntary micro-movements of the eyes could serve the same purpose.

- ▶ Saccade, Saccadic Eye Movement

## Microsatellite Markers

### Definition

Highly polymorphic di-, tri- or tetranucleotide repeat sequences which are scattered over the genome. Mapped microsatellites are used in linkage analysis to locate disease genes. Furthermore, their highly polymorphic nature makes them useful for forensic analysis and paternity testing, for example.

- ▶ Bioinformatics

## Microstimulation

### Definition

Low intensity (less than about 100  $\mu\text{A}$ ) electrical activation of a region of the brain through a microelectrode.

## Microtubule

### Definition

Microtubules form a major part of the cell's cytoskeleton and are found in most eukaryotic cells. Structurally, microtubules are hollow cylinders that are  $\sim 24$  nm in diameter with a wall thickness of about 5 nm and with 13 protofilaments that consist of the dimeric protein  $\alpha$ - and  $\beta$ -tubulin. Microtubules exhibit a structural and functional polarity with a minus (–) end and a plus (+) end. Microtubule-organizing centers nucleate the assembly of microtubules from their –end. In a process known as dynamic instability, microtubule plus ends undergo alternating phases of growth and shrinkage. Microtubules associate with a wide range of proteins (e.g., microtubule-associated proteins (MAPs) which contribute to the dynamism of the microtubule networks, and motor proteins involved with transport such as kinesin). Microtubules are involved in a number of cellular processes such as cell elongation, migration and maintenance of cell shape. Microtubules also serve as tracks for the movement of molecular cargo in cells; in neurons this is particularly important where material needs to be transported down the length of the axon (axonal transport).

- ▶ Cytoskeleton
- ▶ Kinesin
- ▶ Microtubule-associated Proteins (MAPs)

## Microtubule-associated Proteins (MAPs)

### Definition

Proteins that interact with microtubules of the cytoskeleton. Neurotrophin binding and activation of the mitogen-activated protein kinase (MAPK) pathway

results in MAP phosphorylation, leading to increased stabilization of microtubule structure.

- ▶ Cytoskeleton
- ▶ Mitogen Activated Protein Kinase (MAPK)
- ▶ Microtubule

## Microvilli

### Definition

Small processes found on the receptive surface of sensory cells, such as taste cells, olfactory cells, or Merkel cells.

## Micturition, Neurogenic Control

WILLIAM C. DE GROAT

Department of Pharmacology, University of Pittsburgh Medical School, Pittsburgh, PA, USA

### Synonyms

Neural control of voiding; Neural control of the lower urinary tract; Urination

### Definition

#### Micturition

Storage and periodic elimination of urine are dependent on a complex neural control system that coordinates the activity of two functional units in the lower urinary tract: (i) a reservoir (the urinary bladder) and (ii) an outlet (consisting of the bladder neck, urethra, and striated muscles of the ▶ pelvic floor) [1–3]. During urine storage the bladder outlet is closed and the bladder is quiescent, thereby maintaining a low intravesical pressure over a wide range of bladder volumes. A low intravesical pressure is essential to allow urine flow from the kidney into the bladder. During micturition (▶ Bladder control (neural)), outlet resistance is reduced as a consequence of relaxation of the pelvic floor and periurethral striated muscles in conjunction with mechanical shortening of the urethra and opening of the bladder neck. These changes are followed in a few seconds by a bladder contraction and a rise in intravesical pressure, which is maintained until the bladder is empty. This reciprocal relationship between bladder and outlet is controlled by neural pathways

(►Urogenital reflex) that are organized in the brain and lumbosacral spinal cord.

### Characteristics

During urine storage intravesical pressure is usually below 10 cm H<sub>2</sub>O and maximal pressure in the urethral outlet is high (70–100 cm H<sub>2</sub>O) [1]. Cystometric studies in normal healthy women revealed that the first sensation of bladder filling and the first desire to void occur on average at mean bladder volumes of 160 and 320 ml, respectively. Voiding occurs at intravesical pressures ranging between 50 and 70 cm H<sub>2</sub>O and normal maximal urine flow rates range between 20 and 30 ml/min. Healthy women normally void 5–7 times per day at a mean volume of 300 ml.

### Peripheral Nervous System

The lower urinary tract is innervated by three sets of nerves arising at the lumbosacral level of the spinal cord [1–3]. Like other visceral organs, the bladder and urethra receive an innervation from both divisions of the autonomic nervous system. Parasympathetic preganglionic pathways, which arise from neurons in the intermediolateral region of the sacral spinal cord (S<sub>2</sub>–S<sub>4</sub>) travel in the ►pelvic nerve and provide an excitatory

input to parasympathetic ganglion cells located in the pelvic plexus and in the wall of the organs. These cells in turn innervate the bladder and urethral smooth muscle. Sympathetic preganglionic pathways to the lower urinary tract which arise in the lumbar spinal segments (L<sub>1</sub>–L<sub>4</sub>) provide excitatory input to ganglion cells in the sympathetic chain ganglia as well as prevertebral ganglion cells in the hypogastric and pelvic plexus that in turn innervate bladder and urethral smooth muscle [3]. Periurethral striated muscles, which form the external urethral sphincter, and pelvic floor striated muscles are innervated by sacral motoneurons (S<sub>2</sub>–S<sub>3</sub>) that send axons into the ►pudendal nerves and levator ani nerves, respectively.

Afferent activity arising in the bladder is conveyed to the central nervous system via both sets of autonomic nerves [2,3]. The most important afferents for initiating micturition are those, which arise from neurons in the lumbosacral dorsal root ganglia and travel in the pelvic nerve to the sacral spinal cord. These afferents consist of small myelinated (A- $\delta$ ) and unmyelinated (C) fibers (Fig. 1), which convey impulses from tension receptors and nociceptors in the bladder wall. Afferent activity arising in the urethra passes through the pelvic, hypogastric and pudendal nerves.

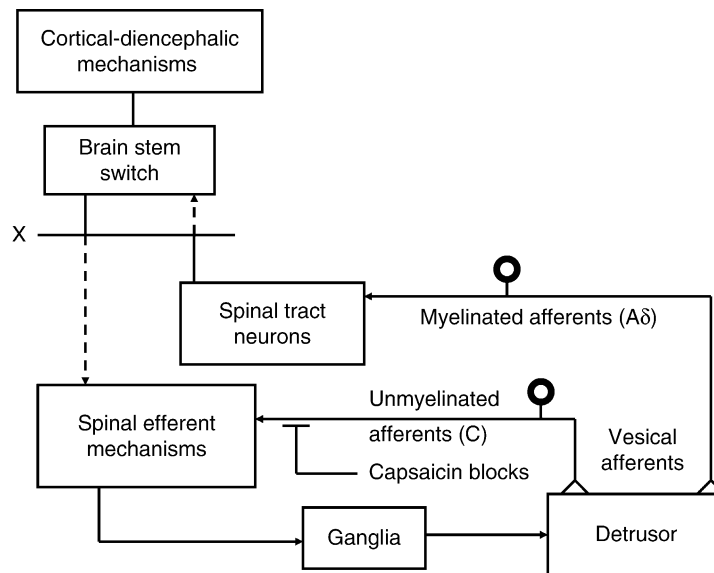

**Micturition, Neurogenic Control. Figure 1** Diagram showing the organization of the parasympathetic excitatory reflex pathway to the detrusor muscle. Scheme is based on electrophysiologic studies in cats. In animals with an intact spinal cord, micturition is initiated by a supraspinal reflex pathway passing through a center in the brain stem. The pathway is triggered by myelinated afferents (A  $\delta$  fibers) that are connected to the tension receptors in the bladder wall. Injury to the spinal cord (indicated by X) above the sacral segments interrupts the connections between the brain and spinal autonomic centers and initially blocks micturition. However, over a period of several weeks following cord injury, a spinal reflex mechanism emerges, which is triggered by unmyelinated vesical afferents (C-fibers); the A-fiber afferent inputs are ineffective. The C-fiber reflex pathway is usually weak or undetectable in animals with an intact nervous system. Capsaicin (20–30 mg, subcutaneously) blocks the C-fiber reflex in chronic spinal cats, but does not block micturition reflexes in intact cats. Intravesical capsaicin also suppresses detrusor hyper-reflexia in patients with neurogenic bladder dysfunction.

## Central Nervous System

The central neural control of micturition depends on reflex pathways in the spinal cord and brain stem as well as circuitry in the forebrain that mediate the voluntary control of micturition [3,4]. Anatomical tracing and electrophysiological studies in animals have revealed that spinal reflex pathways are primarily polysynaptic and consist of at least three elements. Afferent neurons from the bladder and urethra send projections into Lissauer's tract from which collaterals extend laterally and medially around the surface of the dorsal horn into the region of the autonomic nuclei and the dorsal commissure. Afferent fibers terminate on interneurons. Interneurons in turn make synaptic connections with preganglionic neurons that send their axons into the periphery via the ventral roots. A similar circuitry controls the motoneurons innervating the urethral sphincter.

Electrophysiological and tracing studies in animals [2,3,5] and brain imaging experiments in humans [4,6] have been identified various populations of neurons at sites in the brain stem (periaqueductal grey, ► **pontine micturition center (Barrington's nucleus)**, medullary raphe nucleus, locus ceruleus, A5 noradrenergic nucleus) and in the forebrain (paraventricular nucleus, medial preoptic nucleus, cingulate gyrus, prefrontal cortex, basal ganglia) that have a role in the regulation of micturition.

## Lower Level Components

The parasympathetic postganglionic innervation of the bladder is distributed throughout the base and dome of the bladder and each smooth muscle cell receives a neural input [2,3]. However the sympathetic innervation is concentrated in the base of the bladder and in the urethra. Afferent nerves are also heavily concentrated in the bladder base. A- $\delta$  afferent nerves are located in the smooth muscle layers; whereas C-fiber afferents (► **C-fiber afferent nerves**) are distributed within and below the epithelial layer (the urothelium) [1,3,7].

## Peripheral Nervous System

Parasympathetic nerves excite bladder smooth muscle via the release of acetylcholine and a noncholinergic transmitter (adenosine triphosphate, ATP). Acetylcholine acts on ► **muscarinic receptors** ( $M_2$  and  $M_3$ ); whereas ATP acts on P2X ► **purinergic receptors** [8–10]. Parasympathetic nerves also inhibit urethral smooth muscle via the release of nitric oxide. Sympathetic postganglionic nerves which release norepinephrine provide an excitatory input to the smooth muscle of the bladder neck and urethra and an inhibitory input to smooth muscle of the bladder dome. The excitatory effects of adrenergic nerves in the bladder and urethra are mediated by  $\alpha_1$ -adrenergic receptors, whereas the inhibitory effects in the bladder dome are mediated by  $\beta_3$  adrenergic receptors [8,10]. Sympathetic nerves also inhibit transmission in bladder parasympathetic ganglia.

A- $\delta$  afferents respond to bladder distension and normally trigger the sensation of bladder fullness and initiate voiding [3]. C-fiber afferents are activated by bladder irritation or infection and can induce bladder hyperactivity. C-fiber afferents synthesize and release various transmitters including substance P, calcitonin-gene-related peptide, and ► **glutamic acid** and express multiple receptors, e.g., purinergic (P2X<sub>2/3</sub>), neurokinin and capsaicin receptors (TRPV1) [3,9]. Although afferent nerves can respond directly to bladder distension or to chemicals present in the urine, it is also likely that they are affected indirectly by chemical transmitters released from the urothelial cells which line the bladder lumen and which receive an afferent innervation. Recent studies have revealed that urothelial cells release ATP and nitric oxide in response to stretch or chemical stimulation. Urothelial cells express ► **TRPV1 receptors** [7] as well as receptors for various transmitters including, muscarinic, nicotinic, adrenergic, purinergic and serotonergic receptors [1,3]. It has been proposed that ATP and nitric oxide released by urothelial cells act on afferent nerves adjacent to and within the urothelium to influence afferent nerve firing. Thus urothelial cells exhibit "neuronal-like" properties and seem to play a role in sensory mechanisms in the bladder [7].

## Central Nervous System

Electrophysiological studies in animals indicate that the micturition reflex is mediated by a spinobulbospinal (SBS) reflex pathway that passes through a coordinating center (the pontine micturition center, PMC) in the rostral brain stem (Fig. 1). This pathway is activated by A- $\delta$  bladder afferents and is in turn subject to modulating influences from higher centers in the cerebral cortex and diencephalon, which are essential for the voluntary control of micturition. Axonal tracing studies in cats indicate that the ascending limb of the SBS micturition pathway consists of projections of spinal tract neurons in the sacral spinal cord to neurons in the periaqueductal gray that in turn send inputs to neurons in the PMC [4]. Projections from the PMC back to the sacral parasympathetic nucleus in the spinal cord complete the reflex circuit [3,4].

Pharmacological experiments in animals have revealed that glutamic acid is the principal excitatory transmitter in the spinal and supraspinal components of the micturition reflex pathway [2,3]. The effects of glutamic acid are mediated by NMDA and non-NMDA ► **glutamatergic receptors**. Other excitatory transmitters (substance P, dopamine, nitric oxide, vasoactive intestinal polypeptide, pituitary adenylate cyclase activating peptide and norepinephrine) appear to act by modulating glutamatergic transmission. Transmitters that are involved in inhibition of the micturition reflex include: gamma aminobutyric acid, glycine, opioid peptides, serotonin and dopamine [2,3].



## Function

Micturition is a visceral function that is under voluntary control. Storage and elimination of urine requires the coordinated activity of a number of smooth and striated muscles and is dependent upon the integrative properties of neural pathways at various levels of the neuraxis ranging from the cerebral cortex to the lumbosacral spinal cord and the peripheral autonomic ganglia. The central reflex mechanisms controlling lower urinary tract function seem to be organized as simple on-off switching circuits which maintain a reciprocal relationship between the bladder and urethral outlet. During urine storage a low level of activity in the sacral afferent pathways initiates reflex firing in the sympathetic and somatic efferent pathways to the urethral outlet, thereby contributing to the maintenance of urinary continence. At the same time, parasympathetic efferent pathways to the bladder are quiescent. The storage reflexes are organized in the lumbosacral spinal cord. During micturition a high level of sacral afferent activity from tension receptors in the bladder wall reverses the pattern of efferent outflow, resulting in firing in the parasympathetic excitatory pathways to the bladder and inhibition of the sympathetic and somatic inputs to the outlet. These reflexes occur in their simplest form in infants where micturition is purely an involuntary act. In adults the basic reflexes are integrated into a more complex voluntary control of micturition.

## Pathology

Damage to forebrain structures due to injury, tumors, cerebrovascular disease or neurological disorders such as Parkinson's disease or multiple sclerosis usually leads to an enhancement of micturition reflexes and symptoms of urinary urgency, frequency and incontinence; indicating that forebrain mechanisms mediate a predominant inhibitory control [2-4]. In these conditions the bladder usually exhibits involuntary contractions during storage leading to activation of mechano-sensitive afferent nerves and irritative sensations; however bladder-sphincter coordination is usually maintained. Similar symptoms (the overactive bladder syndrome) can also occur by unknown mechanisms in the absence of overt neural dysfunction particularly in the elderly population.

Damage to the bulbospinal pathways in patients with spinal cord injuries leads initially to urinary retention and complete loss of bladder function due to interruption of the supraspinal micturition reflex pathway. In most paraplegic patients, bladder reflexes slowly recover as a result of a reorganization of synaptic connections in the spinal cord and the emergence of sacral reflex mechanisms that initiate involuntary bladder contractions [3,5]. However, micturition in these patients is usually compromised due to a lack of coordination between

bladder and sphincter activity (a condition termed detrusor-sphincter dyssynergia). This condition is characterized by simultaneous contractions of the bladder and the striated urethral sphincter causing incomplete emptying and urinary retention.

Experimental studies in animals and humans indicate that the emergence of involuntary voiding reflexes following spinal cord injury is due in part to plasticity in bladder afferent pathways and the unmasking of reflexes triggered by capsaicin-sensitive, C-fiber bladder afferent neurons (Fig. 1) [2,3,5]. C-fiber afferents have also been implicated in the bladder hyperactivity associated with other neurological disorders such as multiple sclerosis.

Damage to peripheral neural pathways to the lower urinary tract or to the lumbosacral spinal cord (i.e. a lower motoneuron lesion) causes a loss of bladder sensations as well as loss of voluntary and reflex voiding. Injury to muscles or the motor nerves of the urethral sphincter and pelvic floor can often occur during pregnancy and/or childbirth. This results in decreased urethral closure mechanisms and involuntary loss of urine (stress urinary incontinence) during increases in abdominal pressure that are associated with straining, sneezing or coughing.

## Therapy

Urinary frequency, urgency and urgency incontinence occurring in the absence of a neurological disorder (the overactive bladder syndrome) or as a result of central nervous system lesions are usually treated with antimuscarinic agents that reduce involuntary bladder contractions [1,3,10]. These drugs increase bladder capacity and reduce urgency sensations as well as incontinent episodes. However these agents are not effective against stress urinary incontinence which is caused by reduced urethral outlet resistance. A new drug (duloxetine) that blocks serotonin and norepinephrine reuptake mechanisms in the central nervous system and that enhances reflex activation of the urethral sphincter is effective in the treatment of stress urinary incontinence. Botulinum toxin is injected into the external urethral sphincter to suppress detrusor-sphincter-dyssynergia or injected into the wall of the urinary bladder to treat neurogenic or idiopathic overactive bladder conditions. Intravesical administration of capsaicin or resiniferatoxin, neurotoxins that desensitize C-fiber afferents, is also used to treat neurogenic bladder hyperactivity and incontinence [3,10].

## References

1. Chancellor MB, Yoshimura N (2002) Physiology and pharmacology of the bladder and urethra. In: Walsh PC, Retik AB, Vaughn ED, Wein AJ (eds) Campbell's urology. W.B. Saunders, Philadelphia, pp 831-886

2. de Groat WC, Booth AM, Yoshimura N (1993) Neurophysiology of micturition and its modification in animal models of human disease. In: Maggi CA (ed) *The autonomic nervous system, vol 3: nervous control of the urogenital system*. Harwood Academic Publishers, London, pp 227–289
3. Morrison J, Steers WD, Brading A, Blok B, Fry C, de Groat WC, Kakizaki H, Levin R, Thor K (2002) Neurophysiology and neuropharmacology. In: Abrams P, Cardozo L, Khoury S, Wein A (eds) *Incontinence*. Health Publication Ltd, Paris, pp 83–164
4. Blok BFM (2002) Brain control of the lower urinary tract. *Scand J Urol Nephrol Suppl* 36 210:11–15
5. de Groat WC, Araki I, Vizzard MA, Yoshiyama M, Yoshimura N, Sugaya K, Tai C, Roppolo JR (1998) Developmental and injury induced plasticity in the micturition reflex pathway. *Behav Brain Res* 92:127–140
6. Athwal BS, Berkley KJ, Hussain I, Brennan A, Craggs M, Sakakibara R, Frackowiak RSJ, Fowler CJ (2001) Brain responses to changes in bladder volume and urge to void in healthy men. *Brain* 124:369–377
7. Birder LA, Nakamura Y, Kiss S, Nealen ML, Barrick S, Kanai AJ, Wang E, Ruiz G, de Groat WC, Apodaca G, Watkins S, Caterina MJ (2002) Altered urinary bladder function in mice lacking the vanilloid receptor TRPV1. *Nat Neurosci* 5:856–860
8. Andersson KE, Arner A (2004) Urinary bladder contraction and relaxation: physiology and pathophysiology. *Physiol Rev* 84:935–986
9. Burnstock G (2001) Purinergic signaling in the lower urinary tract. In: Abbracchio MP, Williams M (eds) *Handbook of experimental pharmacology*. Springer Verlag, Berlin, pp 423–515
10. de Groat WC, Yoshimura N (2001) Pharmacology of the lower urinary tract. *Ann Rev Pharmacol Toxicol* 41:691–721

## Midbrain

### Definition

Also known as the mesencephalon. The region of the brain between the hindbrain and the diencephalon. Its dorsal region is the tectum and its ventral region is the tegementum. Among its functions are aspects of vision and the control of eye movements and reflexes.

► Evolution of the Spinal Cord

## Middle Cerebellar Peduncle

### Synonyms

Pedunculus cerebellaris med

### Definition

Composed exclusively of afferent fibers which all come from the pontine nuclei, and account for the majority of cerebellar afferents and are designated collectively as the pontocerebellar tract. The fibers decussate before entering the peduncle of the contralateral side, giving off collaterals to the dentate nucleus and projecting to the cerebral cortex of the cerebellar hemispheres.

► Cerebellum

## Midline and Intralaminar Thalamic Nuclei

### Definition

A group of nuclei extending from the rostral to caudal pole of the thalamus in the midline and embedded within the internal medullary lamina. Midline nuclei include the parataenial, paraventricular, intermediodorsal, reuniens and rhomboid. Intralaminar nuclei are the central medial, paracentral, central lateral, parafascicular and subparafascicular. These nuclei are extensively connected to brainstem and diencephalic structures associated with the reticular formation, such as the pedunculopontine and laterodorsal tegmental nuclei and the lateral hypothalamus and also receive inputs from brainstem viscerosensitive nuclei such as the nucleus of the tractus solitarius and parabrachial complex. Collectively, they project to the entire cerebral cortex and most of the deep telencephalic nuclei and are thought to be involved in processes associated with arousal and awareness.

► Thalamus

## Migraine

### Definition

A moderate to severe primary headache disorder which is usually unilateral with a pulsating quality, accompanied by nausea and/or vomiting, photophobia and phonophobia.

► Headache

## Migrating Motor Complex

### Definition

During fasting, several hours after the previous meal, the stomach and the small intestine exhibit a distinct pattern of behaviour characterized with bursts of intense activity, electrically and mechanically, with long silent intervals of 75–90 min in humans. This pattern is termed the migrating motor complex (MMC) or migrating myoelectric complex. Other terms used by different investigators are the intestinal housekeeper, the interdigestive migrating electric complex, and the interdigestive migrating motor complex.

## Miller Fisher's Syndrome

### Definition

A clinical syndrome consisting of ophthalmoplegia, areflexia and ataxia without significant limb weakness.

## Mind Body Problem

### Definition

The question of how mental states, such as beliefs and desires, are related to physical, actual brain states.

► [Mental Models](#)

## Mineralocorticoid Receptor (MR)

### Definition

Nuclear receptor with a 10 fold higher affinity than the GR for glucocorticoids and a high affinity for aldosterone. It is involved in mineral metabolism and is more restricted in its distribution than the GR, and e. g. found selectively in the hippocampus and the kidney.

► [Hypothalamo-Pituitary-Adrenal Axis](#), ► [Stress and Depression](#)

## Minimum Convex Polygon

### Definition

A minimum polygon with no obtuse internal angles, drawn to enclose the points in a data-set.

► [Evolution and Brain-Body Allometry](#)

## Minimum-jerk Model

### Definition

This model makes the assumption that movement trajectories are smooth, i.e. that the square of jerk, which is the third derivative of position (or equivalently, jerk is the first derivative of acceleration), integrated over movement time, is minimal.

► [Motor Control Models](#)

## Minimum Torque-change Model

### Definition

This model makes the assumption that movements from one position to another with a particular movement time, are made under the constraint that the integral over movement time of the square of changes in torque is minimal.

► [Motor Control Models](#)

## Mint

### Definition

Together with CASK and Velis, a component of a conserved heterotrimeric synaptic scaffolding protein complex; also known to interact with Munc18. Also known as the X11 protein family.

► [Synaptic Proteins and Regulated Exocytosis](#)

## Miosis

### Definition

Pupillary constriction, particularly when the pupil is strongly constricted to approach its minimum diameter.

► Neural Regulation of the Pupil

## miRNA Profiling

### Definition

Refers to an in depth analysis of the miRNAs present in a biological sample, for example from a particular cell type or a developmental stage. A variety of experimental assays are now available for miRNA profiling (e.g. microarray technology, Real-Time PCR, deep sequencing, bead-based flow cytometry).

► miRNAs in Neurobiology

## miRNAs in Neurobiology

F. GREGORY WULCZYN

Center for Anatomy, Institute for Cell and Neurobiology, Charité University Hospital, Berlin, Germany

### Synonyms

microRNA

### Definition

miRNA are ~21–22 nucleotide single-stranded RNAs that are encoded in the genome. The transcription units lie either in mRNA-poor genomic regions, or frequently within the introns of protein-encoding genes. In either case, they are generally transcribed by the same RNA polymerase as mRNAs, RNA polymerase II, and carry the standard features of a protein-encoding mRNA (5' cap and a polyadenosine tail). The transcribed product undergoes nuclear and cytoplasmic processing events to generate the ~21–22 nucleotide single-stranded miRNA. The single-stranded miRNA is incorporated into a regulatory multi-protein complex, the

miRNA-specific RNA induced silencing complex (miRISC), which scans mRNAs for short stretches of sequence complementarity to the miRNA. Although exceptions to the rule have recently been identified, in most cases recognition of the mRNA by the miRISC leads to a decrease in the translation of the mRNA. While a great deal remains to be learned about the miRNA/mRNA interaction, it is well established that miRNAs represent a widespread and fundamental level of control over the protein repertoires of individual cells.

### Characteristics

#### Putting miRNAs in Context

Most people are familiar with the allegory of the butterfly in Mexico beating its wings, and how the initial motion is successively amplified, and initiates a chain of events that ends in a typhoon sweeping ashore on a distant continent. The discovery of the first miRNA in 1993 is akin to the butterfly, and presently the winds in the scientific world are gathering. Indeed, in a recent review of progress in genomic biology in the scientific journal *Nature*, the discovery of miRNA was placed alongside the elucidation of the DNA double helix structure by Watson and Crick as one of the seminal discoveries. These analogies may, of course, prove overblown, and the purpose of this review is to summarize recent advances in our knowledge of miRNAs as they relate to nervous system development and function. But we will also attempt to provide some ideas about where this very new and promising field may be heading.

One of the reasons that miRNA are generating so much interest is because they are an unexpected challenge to one of the underpinnings of molecular genetics, the formulation of the one gene – one protein hypothesis by Beadle and Tatum in 1941. miRNA share many of the features of a conventional regulatory gene: they are encoded in the genome, are transcribed (most frequently) by the same RNA polymerase as mRNAs, RNA polymerase II, and often carry the standard features of a protein-encoding mRNA (5' cap and a polyadenosine tail). Like mRNA for protein-coding genes, the primary miRNA transcript is first subjected to nuclear processing events that ready the transcript for export to the cytoplasm. However, the nuclear and cytoplasmic processing pathways for miRNA and mRNA differ, as will be discussed later. For miRNAs, the end result is an ~21–22 nucleotide single-stranded RNA. To date, the sole known function of miRNAs is to influence the efficiency of protein-encoding mRNA utilization. As such, miRNAs represent an additional level of control over the protein repertoire of individual cells that was essentially unrecognized until the year 2000. Indications are that the influence of miRNAs, in particular during development, is pervasive, as efforts to elucidate their myriad functions intensify.

Scientific reviews of the discovery of miRNAs can be found in [1], of miRNA biology in [2] and current knowledge of miRNA in neurobiology in [3–5]. There are many excellent reviews discussing miRNA, and more are published almost weekly, but these should give an overview and links to the entire miRNA literature.

### miRNA Biogenesis

Because one of the approaches to study the significance of miRNAs for neural development and function is to interfere with the pathway in which miRNAs are generated and then utilized, it is useful to briefly describe miRNA biogenesis. An overview of the pathway is also provided in Figure 1. miRNA genes can be transcribed either as independent transcription units from mRNA-poor genomic regions, or as part of mRNA transcripts with the mRNA positioned in an

intron. One consistent feature shared by miRNA genes is that sequences immediately surrounding the mature miRNA form stable ▶stem-loop structures of approximately ~60–70 nucleotides. In most cases, this structure serves as a recognition element for a nuclear processing complex comprised, at a minimum, of the ▶ribonuclease (RNase) Drosha and its partner the DGCR8 (DiGeorge Candidate Region 8) protein (Some intronic miRNAs have recently been shown to bypass Drosha cleavage). Drosha cleavage releases the hairpin from surrounding sequences, generating the so-called miRNA precursor. The miRNA precursor is actively transported to the cytoplasm, where it is recognized by a second protein complex centered on the ribonuclease Dicer. The Dicer complex orients itself on the precursor stem and cleaves off a 21–22 nucleotide duplex RNA. What happens next is not understood in detail, but the

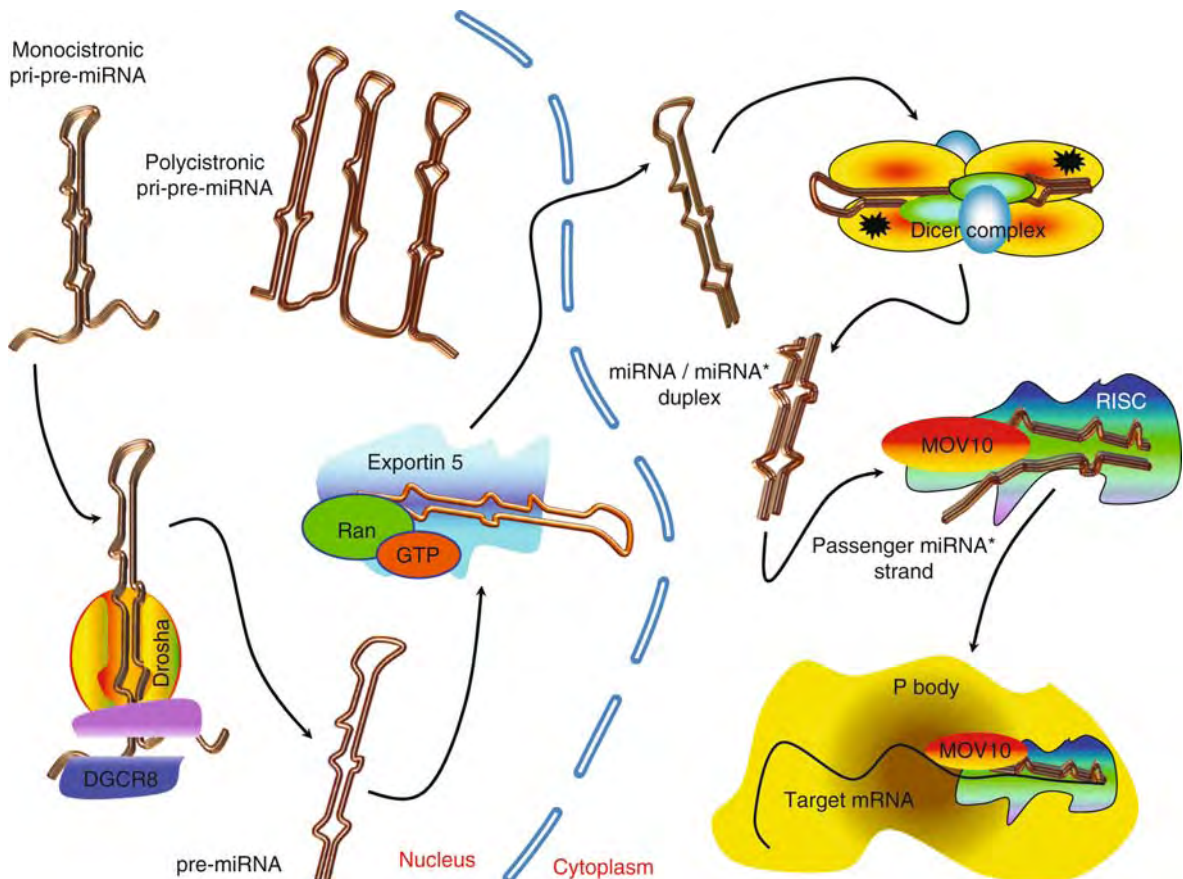

**miRNAs in Neurobiology. Figure 1** Overview of the miRNA pathway. Starting at the upper left, primary miRNA transcripts (either mono- or polycistronic) are seen. Pri-miRNA are engaged by the Microprocessor, a protein complex containing DGCR8 and Drosha. Drosha cleavage releases the miRNA precursor (Pre-miRNA). Exportin 5 mediates the energy dependent export of the pre-miRNA to the cytoplasm. Cytoplasmic processing is performed by the Dicer ribonuclease, accompanied initially by an Argonaute protein and TARBP2. Cleavage of the pre-miRNA yields a 22nt duplex RNA. One strand becomes integrated within a third protein complex, the miRISC, which mediates regulatory interactions between the miRNA and its target mRNAs. miRNAs, the miRISC as well as translationally suppressed mRNAs accumulate in P-bodies, cytoplasmic centers of RNA storage and metabolism.

duplex is subsequently unwound, with one strand destined for incorporation into a regulatory multi-protein complex we will refer to as the miRISC (for miRNA-specific RNA induced silencing complex). The miRNA-primed miRISC is a regulatory machine that scans mRNAs for short stretches of sequence complementarity to the miRNA. In almost all studies performed so far, recognition of an appropriate miRNA interaction site in an mRNA, referred to as a target mRNA, results in suppression of the target mRNA. Very recently, the group of Joan Steitz at Yale University found that under certain conditions (cell cycle arrest), the outcome may be reversed: that miRNA binding may activate translation. It is not yet clear how widespread miRNA-mediated activation may be, but this is a very exciting new insight.

At the moment, there is considerable controversy regarding the precise mechanism miRNA use to inhibit translation, and different targets may in fact interact with the miRISC in different ways. In general, however, the miRNA-miRISC-mRNA interaction appears to suppress the entry of the targeted mRNA into the translational cycle, leading to an inhibition of protein synthesis. Frequently, but not always, mRNA targeting also results in the destruction of the mRNA due to enhanced degradation.

Although the field is progressing rapidly, the genetic and biochemical analysis of the miRNA pathway is in its infancy. Mutational phenotypes of a number of genes in the pathway have been reported, whether in humans, mice or invertebrate model systems. In general, loss of Droscha, DGCR8, Dicer, or the Argonaute proteins of the miRISC is incompatible with embryonic development; in most cases nervous system development is also severely disrupted. From these results, it seems clear that the miRNA pathway plays a fundamental role in the developmental regulation of gene expression in the nervous system.

### Neural miRNA Genes

By intervening between the transcription and translation steps of mRNA utilization, miRNAs act to sculpt the raw information of the transcriptional output of the cell into temporal and tissue specific patterns of protein expression. This raises the inevitable question: “Who regulates the regulators.” There is not yet a firm count of the number of miRNA genes, over 400 have been experimentally verified in mammalian genomes, with some estimates of the total number exceeding one thousand. Expression analysis of miRNAs initially relied on Northern blotting of individual sequences, this has now been supplanted by high-throughput sequencing of cloned miRNA libraries, miRNA-specific RT-PCR, chip-based miRNA microarrays, and ▶**deep sequencing**. At the cellular level, the introduction of high affinity locked-nucleotide probes has allowed

traditional in situ hybridization methods to be modified for detection of miRNAs (please refer to [2] for a description and references for these important innovations). The CNS has a particularly rich repertoire of miRNAs, with over 30% of the known miRNAs expressed in the brain. An increasing body of work applying these new methods is now providing a detailed look at miRNA expression patterns. One fundamental issue that was addressed early on is whether miRNA expression is specific for individual cells and tissues. As more and more miRNAs were discovered and characterized, it was shown that many miRNAs are expressed nearly ubiquitously with little preference for particular organs or tissues, but others show various degrees of tissue specificity. In a study headed by Todd Golub at the Broad Institute, tissue specificity was found to be characteristic enough to allow the tissue of origin of tumor samples to be predicted based on ▶**miRNA profiling**. A recently published large scale compendium of miRNA expression patterns (headed by Thomas Tuschl at The Rockefeller University), however, identified less than a dozen miRNAs with strong overrepresentation in the human and mouse nervous systems. Within the brain, large scale efforts to define expression patterns in zebrafish, chicken, mouse and in primates have revealed regional as well as temporal specificity in expression patterns (again, refer to [2] for links to specific papers). These efforts provide an invaluable starting point for the investigation of the roles of individual miRNAs in both the development of the nervous system, and in the function of neural cell types in the brain.

### miRNA Functions in the CNS

#### *The Sensory Nervous System of *Caenorhabditis Elegans* Leads the Way*

As discussed above, the complexity of neural miRNA populations appears to reflect the cellular and architectural complexity of the nervous system. Approximately 30% of the known miRNA genes are expressed in the CNS, however, their precise roles and functions remain for the most part enigmatic. In this section we will highlight groundbreaking studies that have revealed the involvement of miRNAs in developmental processes such as neuronal specification, and then turn to evidence for miRNAs as mediators of mature brain functions such as synaptic plasticity and memory.

Probably the most thoroughly characterized example of miRNA involvement in cell specification relates to the establishment of asymmetry in the nematode *Caenorhabditis elegans* as elaborated in a series of papers from Oliver Hobert’s group at the Columbia University Medical Center. These studies evoke the classical molecular genetic investigations by Jacob and Monod of another binary fate choice, the decision between lysis and lysogeny by the bacteriophage  $\lambda$ . In

both cases, transcriptional and post-transcriptional regulatory mechanisms intertwine to stabilize genetic networks that discriminate between alternative cell states. In the gustatory system of *Caenorhabditis elegans*, two taste receptor neurons termed “ASE left” (ASEL) and “ASE right” (ASER) express distinct sets of ►chemoreceptors, an arrangement that allows the nematode to orient itself in relation to a source of food. The establishment of left/right asymmetry in gene expression from symmetric ►progenitors involves mutually exclusive ►feedback loops driven by miRNAs working in concert with ►transcription factors.

In ASEL cells, the transcription factor *die-1* and the miRNA *lxy-6* are expressed and together promote ASEL genes while suppressing ASER genes. Similarly, in ASER cells the transcription factor and miRNA pair *cog-1* and *miR-273* activate ASER specific genes and antagonize *die-1* and *lxy-6*. Although the initial trigger has not yet been defined, the results so far demonstrate how miRNAs can play integral roles in the establishment, reinforcement and maintenance of cell-specific ►gene expression patterns and therefore represent a model for the possible contribution of miRNAs to the myriad ►cell fate decisions required to construct the vertebrate brain. Whether or not miRNAs are also involved in the ►left/right asymmetry typical for the human brain is not yet clear, but very recently a study by Choi, Giraldez, and Schier implicated the zebrafish miRNA *mir-430* in left/right asymmetry, and the group of Tamas Dalmay at the University of East Anglia demonstrated strong asymmetry in the expression of mouse *mir-500*.

#### ***mir-124* – a Significant Actor in Neuronal Cell Identity**

Turning to studies of the vertebrate nervous system, *mir-124* has attracted a great deal of interest as a paradigm for tissue specific miRNAs. By sequencing small RNA libraries prepared from various mouse tissues, Thomas Tuschl’s group, then at the Max-Planck-Institute in Martinsried, had originally discovered a remarkable property of miRNA expression. Whereas many miRNA were expressed across many tissues, others were highly restricted to individual tissues or organs. *mir-124* is a striking example of this principle, with expression restricted to neurons, where it accounts for over 25% of the total miRNA population. Very recently, Tom Maniatis’ group at Harvard University found that *mir-124* promotes neuronal specification by regulating mRNA splicing factors. The end consequence is to allow a greater degree of flexibility in neuronal splicing. Although it is not yet clear what the relative advantage of greater diversity in splicing products for neurons compared to other somatic cell types might be, the conservation of *mir-124* across animal phyla suggests that neurons may have acquired this property early in the evolution of the nervous system.

#### ***miRNAs and Synaptic Plasticity and Learning***

So far, we have discussed examples of miRNAs that act at early stages in the establishment of neuronal identity. Michael Greenberg’s laboratory, also at Harvard University, has shown that miRNAs influence neuronal connectivity. They were able to demonstrate that one neuronal miRNA, *mir-134*, is present in ►dendritic spines, structures that form the receiving end of synaptic communication between neurons. It is known that translational regulation is important in reinforcing connectivity at active synapses. *mir-134* was shown to target a mRNA, *limK1*, that encodes a kinase involved in determining the size of dendritic spines. Interestingly, both the levels of *mir-134* and its efficiency as a translational inhibitor were affected by synaptic activity. In their model, *mir-134* acts as a local inhibitor of dendritic maturation; at least in part by regulating *limK1*. Importantly, the inhibitory effect of *mir-134*, and by extension other synaptic miRNAs, was relieved after neuronal stimulation by brain derived neurotrophic factor (►BDNF). Because BDNF is released at active synapses, the result conforms to expectations for positive regulators of ►synaptic plasticity.

Taking advantage of the genetic power of *Drosophila melanogaster*, another group at Harvard University headed by Sam Kunes was able to go one step further and link the miRNA pathway to ►memory formation. The beauty of this study lies in their ability to monitor local translation at specific synapses as they respond to a learning task. Specifically, they examined the role of miRNA-mediated regulation of a key synaptic translation product: ►Calcium/Calmodulin-dependent Kinase II (CaMKII). Synapses participating in memory formation increase their synthesis of CaMKII. Flies carrying mutations that inactivate the miRISC express much higher levels of CaMKII, implying a regulatory network similar to that described above for *LimK1* and *mir-134*. The Kunes group showed that increased synaptic activity resulted in the elimination of miRNA pathway proteins by protein degradation, suggesting a general role for the pathway in dampening responses in quiescent neurons.

#### ***The miRNA Pathway and the Maintenance of the Cerebellum***

In the near future, transgenic approaches can be expected to rapidly advance our understanding of miRNA functions in the brain. As a recent example, Paul Greengard’s group at the Rockefeller University examined the effects of eliminating the Dicer protein in a single cell type within the ►cerebellum, the ►Purkinje neurons. Although the analysis was complicated by the gradual and uneven loss of the Purkinje miRNA population, the affected mice did not display an overt phenotype or detectable changes in the electrophysiological properties of the affected cells for several weeks. Thereafter, profound ►neurodegeneration set

in, beginning with the Purkinje cells and then spreading to the entire cerebellum. Although more work remains to be done, these results underscore a requirement of miRNAs for cellular viability. In contrast, they do not provide evidence for miRNA involvement in short term synaptic activity, at least in Purkinje neurons.

### The miRNA Pathway and Neurological Disease

Several protein components of the miRNA biogenesis pathway discussed in the previous sections are critical not only for CNS development but also are associated with neurological diseases. We will discuss some of the initial discoveries, including miRNA involvement in mental retardation syndromes, neurodegeneration, Tourette's Syndrome and cancer (Fig 1).

#### miRNAs and Mental Retardation

The ▶Fragile X Mental Retardation Protein (FMRP) is silenced in patients with Fragile X Syndrome, an inherited form of mental retardation. The gene responsible for Fragile X Syndrome, FMR1, is situated on the X chromosome and consequently contributes to the higher incidence of mental retardation observed in males. As a likely correlate of cognitive impairment, affected individuals also demonstrate altered dendritic spines, focusing attention on alterations of neuronal ▶connectivity in the disease state. FMRP is an evolutionarily conserved protein that contains several RNA binding domains that mediate interactions with mRNAs. mRNA binding by FMRP leads to a suppression of protein translation. FMRP can be detected in synapses where it regulates local protein synthesis and thereby plays an important role in synaptic plasticity and dendritic development. The initial link to the miRNA pathway was forged by the groups of Scott Hammond at the Cold Spring Harbor Laboratory and Haruhiko Siomi at the University of Tokushima, who showed that the *Drosophila melanogaster* FMRP homolog, dFMR1, co-purified with miRNA pathway proteins. Stephen Warren's group at the Emory University School of Medicine extended these findings to the human protein, then returned to the *Drosophila melanogaster* system to show that dFMR1 acts together with the miRNA pathway protein dAgo1 in the regulation of synaptic plasticity. These studies provided the first demonstration that the miRNA pathway contributes to normal neuronal function, in addition to advancing our understanding of the Fragile X disease state.

#### miRNAs and Neurodegeneration

The miRNA pathway has also been implicated in the pathogenesis of a complex of neurodegenerative diseases characterized by ▶expansion of the trinucleotide CAG (poly-glutamine, or poly-Q, expansion). Using a genetic model designed in *Drosophila melanogaster*, a group

headed by Nancy Bonini at the University of Pennsylvania designed a genetic test which showed that disruption of the miRNA biogenesis pathway exacerbated neurodegeneration induced in the fly retina by poly-Q proteins. The authors then extended the results to a human cell-based system, supporting the potential relevance for human disease. How miRNA's contribute to the observed neuroprotection remains to be determined.

#### miRNA Dysregulation and Tourette's Syndrome

The Fragile X Mental Retardation and the Poly-Q Expansion Syndromes summarized above may reflect the consequences of widespread disruption of miRNA biogenesis or translational regulation. In the case of ▶Tourette's Syndrome, a mutation that disrupts a single miRNA-mRNA interaction is linked to a neurological disorder. A team of scientists centered at the Yale University School of Medicine and headed by Matthew State identified ▶*Slit and Trk-like 1* (SLITRK1) as the first candidate gene for Tourette's Syndrome, a prevalent neuropsychiatric disorder characterized by so-called ▶tics. The term tic refers to repetitive, stereotyped and irresistible movements or vocalizations with considerable individual variability, ranging from sneezing or blinking to outbursts of profanity or complex series of movements. In two independent cases, point mutations were identified in the 3'UTR of the SLITRK1 gene. Remarkably, the mutations were shown to lie in a binding site for the miRNA *mir-189*, and had the affect of increasing the affinity of the miRNA for the mRNA, thus enhancing inhibition of SLITRK1. SLITRK1 is one of a family of transmembrane proteins with similarities to both the SLIT family of ▶axon guidance factors and, with the exception of SLITRK1, ▶neurotrophin receptors. So far, the SLITRK's have not been well-characterized functionally, but the State group was able to support the initial characterization of SLITRK1, by Aruga and Mikoshiba at the Riken Brain Science Institute, as a protein involved in dendritic ▶outgrowth and morphology. Although the work to date depends primarily on correlation, it represents a breakthrough as the first example in which mutations in a miRNA binding site were shown to be causative for a human disease.

#### miRNAs and Cancer

One of the most active current directions in miRNA research relates to their role in cellular growth control and apoptosis. A thorough discussion of this rapidly expanding field is beyond the scope of this review. In general terms, miRNAs have been implicated in the control of stem cell differentiation in a variety of contexts, and in the regulation of a number of well-studied genes and pathways commonly affected in human cancers (for example *bcl-2*, *c-myc*, *N-ras*, *p27* and *p53*). Given the likelihood that cancer stem cells are



the catalysts for each of the main forms of brain tumors (►medulloblastoma, ►glioblastoma and ►ependymoma), interest in the contribution of miRNA misregulation is high. In the case of glioblastoma, a number of investigators have catalogued characteristic changes in miRNA profiles, and begun to relate those changes to potential oncogenic target genes. miRNAs are attractive targets for pharmaceutical interventions, as they can at least in principle be specifically blocked or mimicked by small molecules, such as chemically modified antisense inhibitors.

### Conclusions and Outlook

It is impossible to introduce all of the interesting findings from dozens of new miRNA articles that appear each month. In this short overview, we have instead focused on a few of the groundbreaking discoveries that have illuminated the whole field. Going forward, it seems likely that miRNA research will be increasingly integrated into traditional research programs as outlined above (oncogenesis, ►cell specification, cortical development, learning and memory, etc). Continuing refinement in target mRNA predictions are facilitating the identification of gene networks under miRNA control, which can then be studied with a variety of new tools for manipulating miRNA expression. Genetic analysis will dissect the functions of miRNA pathway proteins and individual miRNAs at an increasingly fine scale, despite the challenge imposed by the considerable redundancy of miRNA genes. The pace of discovery in the field over the past 5 years has been bracing, we hope we have been able to communicate a sense of that excitement.

### References

1. Ruvkun G, Wightman B, Ha I (2004) The 20 years it took to recognize the importance of tiny RNAs. *Cell* 116:S93–6
2. Bushati N, Cohen SM (2007) microRNA Functions. *Annu Rev Cell Dev Biol* 23:175–205
3. Klein ME, Impy S, Goodman RH (2005) Role reversal: the regulation of neuronal gene expression by microRNAs. *Curr Opin Neurobiol* 15:507–513
4. Kosik KS, Krichevsky AM (2005) The elegance of the MicroRNAs: a neuronal perspective. *Neuron* 47:779–782
5. Cao X, Yeo G, Muotri AR, Kuwabara T, Gage FH (2006) Noncoding RNAs in the mammalian central nervous system. *Annu Rev Neurosci* 29:77–103

---

## Mirror Neuron

### Definition

A particular class of neurons, originally discovered in the ventral premotor cortex of macaque monkeys (area

F5) and then observed in the inferior parietal lobule (PF/PFG), which code goal-related motor acts like grasping. They become activated both when the subject performs a particular action, e.g. a precision grip, and when the subject observes another individual performing a similar goal-related action. There is evidence for a similar system in the human brain.

- Action Representation
- Visual Space Representation for Reaching

---

## Mismatch Negativity (MMN)

### Definition

A sound-evoked event-related potential. A response to an acoustical change in two sounds. It is evoked by an occasional subtle stimulus change in a long train of repetitive stimuli. The difference may be in frequency, intensity, complexity, etc. A difference in the evoked response between the two stimulus types indicates that a detection of the difference has taken place.

- Auditory Evoked Potentials

---

## Missense Mutation

### Definition

A nucleotide substitution that causes the replacement of one amino acid by another in the polypeptide typically leading to a change in the function of the protein.

---

## Mitochondrial Disease

### Definition

Mitochondrial disease refers to a group of medical disorders in which the primary metabolic defect affects the respiratory train/electron transfer system producing ATP in the intracellular organelles called mitochondria.

Genetic disorders of mitochondrial dysfunction can be inherited as either single gene mendelian or primary mitochondrial traits. This is because the mitochondrial respiratory train enzymes are encoded by both nuclear and mitochondria DNA. The clinical syndromes often

include seizures, cognitive deficits, visual loss, hearing loss, myopathy and peripheral neuropathy.

► Seizures

## Mitochondrial Myopathies

### Definition

Consequences of ►mitochondrial diseases resulting from defects in the mitochondrial respiratory chain (in particular defects in nuclear DNA and mutations in tRNA genes of mitochondrial DNA), which compromise energy production. This may cause myalgia, cramps, exercise intolerance, recurrent ►myoglobinuria, or weakness, particularly in extraocular muscles leading to ptosis (drooping of eyelids) and progressive external ►ophthalmoplegia.

## Mitochondrial Uniporter

### Definition

A channel on the inner membrane of the mitochondria that transports cytosolic  $\text{Ca}^{2+}$  into the mitochondrial matrix.

►Influence of  $\text{Ca}^{2+}$  Homeostasis on Neurosecretion

## Mitogen-activated Protein Kinase (MAPK)

### Definition

MAPK cascades are signaling molecules that serve as important mediators of signal transduction from the cell surface to the nucleus.

## Mitral Cell

### Definition

Mitral cells are large glutamatergic neurons found in the olfactory bulb, which along with tufted cells, receive

input from olfactory sensory neurons and project to central olfactory areas of the brain, including the anterior olfactory nucleus and piriform cortex. The primary dendrite of a mammalian mitral cell projects to a single olfactory glomerulus and thus receives information from olfactory sensory neurons expressing a single type of olfactory receptor. The extensive lateral dendrites of mitral cells mediate inhibitory interactions (via granule cell interneurons) with neighboring mitral cells that generates a bulb-wide spatio-temporal pattern of mitral cell activity in response to odor stimulation.

► Glomerular Map  
► Olfactory Bulb  
► Olfactory Pathways

## Mixture Theory

### Definition

The branch of continuum mechanics that deals with the equations governing the motion of mixtures, that is, of material bodies each of whose spatial positions is occupied simultaneously by particles of two or more different materials.

► Mechanics

## MLF

### Definition

► Medial Longitudinal Fasciculus

## MMC

### Definition

► Migrating Motor Complex

## M-modes

► Postural Synergies

## Mnestic Block Syndrome

### Definition

A type of memory disorder characterized by a sudden onset of severe retrograde amnesia, usually without significant anterograde amnesia. It typically includes memory loss for personal identity and autobiographical memories, as well as a period of wandering. It is usually precipitated by severe psychological stress (e.g., marital discord, financial collapse). Episodes generally resolve over a short period of time, lasting from a few hours to a few days.

► Amnesia

## Modafinil

### Definition

Modafinil is a stimulant drug that is used clinically for the treatment of excessive sleepiness (narcolepsy). The mechanism of action of the drug is unknown.

► Narcolepsy  
► Stimulants

## Modal Logic

### Definition

Modal logic studies reasoning that involve the use of the expressions “necessarily” and “possibly.” However, the term “modal logic” “it is obligatory that” and “it is permitted that.”

► Mental Models

## Modality

### Definition

Modalities refer to large classes of senses and the related sensory receptors, e.g. visual, auditory, olfactory,

gustatory and tactile (the five classic senses) (Sensory Systems).

► Sensory Systems

## Modality-specific

### Definition

From a single sensory modality (i.e., unimodal). Used in two forms: (a) to categorize a neuron based on the stimuli to which it can respond (e.g., a neuron responsive only to light would be a modality-specific neuron), and (b) to categorize a particular neuronal response regardless of the type of neuron from which it is evoked (e.g., a response to light, even in a multisensory neuron, is a modality-specific response).

► Multimodal Integration

## Model-based View

### Definition

Characterization of a system in terms of a model. Data are referenced to the parameters and predictions of the model.

## Model Estimator

### Definition

A model estimator is a tool used to generate a mathematical model for a physical system. Typically, it consists of an assumed family of mathematical models and an algorithm. The algorithm uses available data (commonly, actions on the system – inputs, and measurements – outputs) to choose the “best” fit to the physical system.

► Adaptive Control

## Model Presynaptic Release Sites

► Synaptic Transmission: Model Systems

## Modeling of Human Postural Control

JOHN JEKA<sup>1</sup>, TIM KIEMEL<sup>2</sup>

<sup>1</sup>Department of Kinesiology, Neuroscience and Cognitive Science Program, Bioengineering Graduate Program, University of Maryland, MD, USA

<sup>2</sup>Department of Kinesiology, University of Maryland, MD, USA

### Synonyms

Modeling; control theory

### Definition

Mathematical models represent the interaction of control processes with underlying physiological sub-systems to develop testable predictions of behavior associated with stable, flexible upright stance control.

### Description of the Theory

Human upright stance is inherently unstable. The small, continuous displacements referred to as “sway” reflect a complex control process that counteracts the torque due to gravity, which continually accelerates the body away from vertical equilibrium. The end result of this control process is corrective joint torques that maintain the body upright. There is considerable controversy about how the nervous system generates these corrective torques. Here we illustrate the issues by starting with the simplest possible model, a single-joint negative feedback model, and progress to the current state of more complex models.

### The Control Theory Perspective

The predominant perspective for modeling postural control is based on principles of ►control theory [1]. In its most fundamental form, upright stance control has three elements a plant, sensory systems and a neural controller (see Fig. 1).

The plant is the mapping from motor commands to movement of the body and depends on musculotendon properties and the mechanics of the body. Sensory systems detect the body’s position and movement and send related sensory signals to the neural controller. The neural controller then maps these incoming sensory signals into motor commands. Control theory addresses the question of how to design a controller based on the properties of the plant and sensory systems that is capable of producing the desired behavior of the plant, in this case maintenance of stable upright stance. The control theory perspective for postural control will be illustrated with simple plant and sensory models and a suitable neural controller.

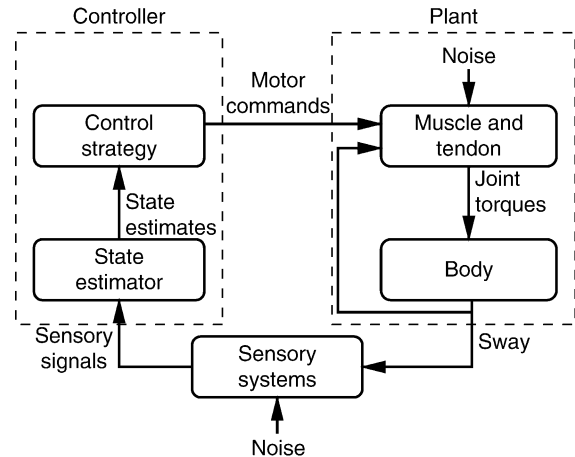

**Modeling of Human Postural Control. Figure 1** A schematic representation of the postural control system from a control theory perspective.

### A Simple Plant Model

The body during “quiet stance” is often modeled as a single-joint inverted pendulum with the body bending only at the ankles and movement restricted to the sagittal plane [2,3]. “Quiet” means upright stance that is undisturbed externally by for example, a moving support surface. The motivation for the single-joint approximation is not only to simplify the control problem, but is also based on empirical results demonstrating that modulation of muscle activity during quiet stance is seen mostly for muscles of the lower legs, soleus and gastrocnemius. Since angular deviations of the body from vertical during quiet stance are small, the body model can be further simplified by linearizing its dynamics around vertical. In addition to simplifying body dynamics, musculotendon properties are often trivialized by assuming that the motor command is directly mapped into ankle torque. These simplifications result in the plant model

$$J\ddot{\theta}(t) = mgh\theta(t) + u(t) + \sigma\xi(t), \quad (1)$$

where  $t$  is time,  $\theta(t)$  is the angular deviation of the body from vertical,  $\ddot{\theta}(t)$  is the body’s angular acceleration,  $u(t)$  (the motor command) is the net forward ankle-muscle torque specified by the neural controller and  $\xi(t)$  is a white noise. The noise in the model is meant to account for the fact that the actual torque produced by ankle muscle will not be exactly equal to the torque specified by the motor command. The model parameters are:  $J$ , the body’s moment of inertia around the ankle joint;  $m$ , the mass of the body;  $h$ , the height of the body’s center of mass above the ankle joint ( $J$ ,  $m$  and  $h$  do not include the mass of the feet);  $g$ , the acceleration due to gravity; and  $\sigma$ , the noise level.

Although the plant model (1) is highly simplified, it contains essential features of the control problem the nervous system must solve. Most importantly, the plant is unstable. If the control signal  $u$  is zero (or constant), the body will quickly deviate from vertical due to continual disturbances, both internal (e.g., physiological tremor) and external (e.g., uneven support surface, moving visual environment, etc.). Engineered devices, such as cars and robots, solve the stability problem by having a wide base of support and/or concentrating the bulk of their weight lower down. However, the human body has evolved with more than just upright stability as a constraint, with most of its mass concentrated higher up in the trunk, making it inherently unstable and prone to falls. Thus, the evolutionary development of bipedal stance, which freed the hands from locomotion and is considered the fundamental distinction between humans and our closest relatives, requires a sophisticated feedback control process to detect deviations from vertical and generate motor commands for a corrective torque to keep the body upright.

### A Simple Sensory Measurement Model

There are two common approaches to modeling sensory feedback. In models that focus on sensory integration, sensory signals are often assumed to be noisy versions of plant variables such as the body's position and velocity, because biological sensors are inherently noisy. Models that focus on biomechanics often assume that the neural controller has access to the true values of all relevant plant variables. For simplicity, the second approach is illustrated. If the plant is assumed to be a single-joint inverted pendulum, as in (1) it is completely described by two variables, the angular position and velocity of the body. Therefore, we assume that the neural controller has access to these two sensory signals:

$$z_1(t) = \theta(t), \quad z_2(t) = \dot{\theta}(t). \quad (2)$$

Although the sensory model is not usually explicitly presented when it is this simple, here it paves the way for the discussion of more complicated sensory models below.

### A Simple Neural Controller

It is well known from control theory that stabilization of an inverted pendulum requires that the control signal (corrective ankle torque) depends on both body position and velocity:

$$u(t) = -K_P\theta(t) - K_D\dot{\theta}(t). \quad (3)$$

This is an example of proportional-derivative (PD) control, where  $K_P$  and  $K_D$  are the proportional and derivative gains, which are assumed to be positive. Because of the negative signs, (2) describes *negative*

feedback control. For example, if the body's position is forward and is moving forward, ankle torque will act to accelerate the body in the backward direction. If the body's position is forward but already moving backward toward vertical, the direction of the correcting ankle torque depends on the relative size of the proportional and derivative feedback gains.

### A Simple Posture Model

Combining the plant model (1), the sensory measurement model (2) and the controller model (3) results in the postural control model

$$J\ddot{\theta}(t) = (mgh - K_P)\theta(t) - K_D\dot{\theta}(t) + \sigma\xi(t). \quad (4)$$

There are two criteria for this model to stabilize the upright orientation of the body. First, the proportional gain  $K_P$  must be greater than  $mgh$ , so that ankle torque produced by muscles is greater than the torque produced by gravity. Such position feedback by itself turns the inverted pendulum of the uncontrolled body into a controlled system that is mathematically equivalent to a frictionless non-inverted pendulum. Thus, position feedback turns an unstable system, which actively moves away from equilibrium, into a neutrally stable system whose oscillations neither grow nor decay. For example, a large perturbation would lead to a large oscillation that never decays. Adding velocity feedback is like adding friction to the pendulum. Any movement is counteracted by a torque in the opposite direction leading to a damped oscillation. Because of noise in the model, the damped oscillation does not decay completely to zero. Instead the body's orientation fluctuates around vertical, providing a simple model of sway during quiet stance.

### Current Models

Although model (4) provides insight into some of the essential features of postural control, such as the use of feedback control to stabilize upright stance, it is too simple to address other important features. Current research focuses on developing sophisticated models that explicitly represent features of the plant, feedback and control that allow for more complex behavior. For example, there is a long history of studying and modeling multi-joint postural control. When the support surface is translated backwards under standing subjects and they are instructed not to step, two patterns (or their combination) emerge. For small disturbances, the segments remain aligned in an ankle strategy, rotating predominantly around the ankle joint. Larger disturbances produce a hip strategy, a counter-rotation of the trunk relative to the legs [4]. A plant model with at least two joints, ankle and hip, are necessary to model the hip strategy.

Plant models may also include musculotendon dynamics so that muscle torques are no longer an instantaneous function of the motor commands (Fig. 1).

Musculotendon dynamics have been modeled using Hill type models, (e.g., [5]), or more simply as a time delay between the motor command and the generation of muscle torque. Time delays have also been added to sensory models. The inclusion of time delays in plant and sensory models are of interest because they tend to increase postural sway and can destabilize upright stance (e.g., [3]). Sensory integration models may also include dynamics specific to each sensory modality. For example, the vestibular dynamics is modeled as a low pass filter of the head's acceleration. At low frequencies, the vestibular signal that the neural controller receives is proportional to acceleration, whereas at higher frequencies it is proportional to velocity. Explicit modeling of sensory subsystems allows testing of model predictions that may help to identify important aspects of postural control in neurologically impaired populations such as individuals with loss of vestibular function [6,7]. Moreover, an open question is how to model ►adaptive control processes (e.g., sensory reweighting) that enable stability as environmental conditions change [6,7,8].

### Optimal Control Models

When considering specific features of the plant and sensory systems, the great challenge is to determine whether the neural control strategy takes these features into account. One approach to this question is

to study ►optimal control models. Such models contain neural controllers that are optimally designed for the specific features of the plant and sensory systems included in the model, such as multi-joint, musculotendon and sensory dynamics. For example, the human nervous system has well known time delays associated with processing sensory information and generation of muscle force. Do time delays influence the appropriate type of controller to stabilize posture? Adding a time delay to the plant and the sensory systems (same delay for all modalities) and using the same PD control strategy, the posture model (4) becomes

$$J\ddot{\theta}(t) = mgh\theta(t) - K_P\theta(t - \tau) - K_D\dot{\theta}(t - \tau) + \sigma\xi(t), \quad (5)$$

where  $\tau$  is the sum of the plant delay and the sensory delay. For larger values of  $\tau$  more torque from ankle muscles is necessary to stabilize upright stance (solid line in Fig. 2).

The question is how much of this additional muscle activity is necessary. An optimal control model provides this answer (dashed line in Fig. 2). For time delays of about 100 ms or less, the PD control model is near optimal. However, for longer time delays, a control strategy other than PD control offers a substantial advantage. This result does not, by itself,

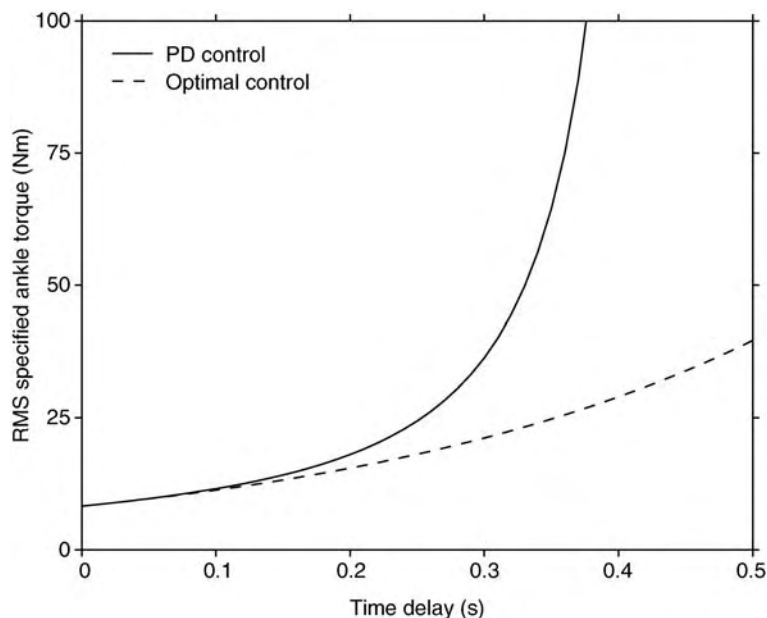

**Modeling of Human Postural Control. Figure 2** The root mean square ankle torque specified by the neural controller as a function of time delay. For the PD control model (5), the proportional and derivative gains are adjusted to minimize ankle torque for each time delay. The optimal control model minimizes ankle torque across all possible controllers. The plant is characterized by the parameter  $mgh/J = 9.83 \text{ s}^{-2}$ .

answer the question of which control strategy the nervous system uses, but it does provide insight into the challenge to postural control caused by time delays and how the nervous system *might* address this challenge.

As this example illustrates, optimal control theory provides a systematic method to generate a hypothesis about the control strategy the nervous system might use account for any (linear) feature of the plant or sensory systems. Determining the optimal control strategy requires three things, a model of the plant, a measurement model describing how sensory signals are related to plant variables, and a performance index. Models as in (1 and 2) above are examples of plant and measurement models respectively. Both plant and measurement models may contain noise terms. Also, there is no requirement that there be one measurement for every plant variable. An optimal control model uses an optimal state estimator, called a ►[Kalman filter](#), to estimate the values of all plant variables, even those that are not directly measured (Fig. 1). The performance index is a quadratic function that describes the relative importance of minimizing the individual plant variables and control signals. Minimizing plant variables would include for example minimizing the deviations from vertical of body segments. Minimizing control signals involves minimizing the amount of motor neuron activity, which is related to the metabolic cost of muscle activity.

Optimal control models have addressed a variety of issues in postural control. For example, an optimal control model has been used to investigate how the performance index affects multi-joint coordination [9]. Appropriate choices of the performance index result in coordination patterns such as the ankle and hip strategies. Optimal control, or more specifically optimal state estimation, has also been used to investigate issues related to multi-sensory integration [2,10]. Incorporating a state estimator, such as a Kalman filter, into a model provides a potential solution to how non-comparable sensory signals such as position, velocity and acceleration signals can be fused to generate state estimates. For example, a Kalman filter in a posture model can estimate position and velocity based only on velocity signals.

Models with state estimation may also provide insight into underlying sources of sway variability. State estimation adds additional variables (there is one estimate for every plant variable) to a posture model and can therefore add dynamical components with additional time scales that increase sway variance. For example, it has been hypothesized that the slow dynamics observed in postural sway, which account for most of sway variance, are due to errors in state estimation [2]. This suggests that swaying is not due to errors of motor execution but because motor commands are based on inaccurate – estimates of self-motion.

## Summary

Human postural control has historically been modeled within a control theory framework using simple approximations of the plant (single-joint inverted pendulum) and the controller (proportional-derivative). While these classical engineering models have been useful to investigate fundamental problems of upright stance control such as its inherent instability, current models use techniques such as optimal control to generate testable hypotheses about neural control schemes based upon specific features of the postural control system. The focus is now to investigate properties of multi-joint, musculo-tendon and sensory dynamics to promote a more biologically motivated understanding of human postural control.

## References

1. Levine W (1999) Control system fundamentals. CRC, Boca Raton
2. Kiemel T, Oie K, Jeka J (2002) Multisensory fusion and the stochastic structure of postural sway. *Biol Cybern* 87:262–277
3. Peterka R (2000) Postural control model interpretation of stabilogram diffusion analysis. *Biol Cybern* 82(4): 335–343
4. Kiemel T, Oie K, Jeka J (2002) Multisensory fusion and the stochastic structure of postural sway. *Biol Cybern* 87:262–277
5. Menelgaldo LL, Fleury AT, Weber HI (2003) Biomechanical modeling and optimal control of human posture. *J Biomech* 36:1701–1712
6. Maurer C, Mergner T, Peterka RJ (2006) Multi-sensory control of human upright stance. *Exp Brain Res* 171(2):231–250
7. van der Kooij H, Jacobs R, Koopman B, van der Helm F (2001) An adaptive model of sensory integration in a dynamic environment applied to human stance control. *Biol Cybern* 84:103–115
8. Carver S, Kiemel T, van der Kooij H, Jeka JJ (2005) Comparing internal models of the dynamics of the visual environment. *Biol Cybern* 92:147–163
9. Kuo (1995) An optimal control model for analyzing human postural balance. *IEEE Trans Biomed Eng* 42:87–101
10. Kuo (2005) An optimal state estimation model of sensory integration in human postural balance. *J Neural Eng* 2: S235–S249

---

## Models of Respiration

► [Anatomy and Function in the Respiratory Network](#)

## Modulation of Memory Storage

### Definition

A process of either strengthening or weakening of memory consolidation, typically induced by drug or hormone treatments, during a critical time-window shortly after the learning experience.

► Emotional Learning/Memory

## Modulatory Inputs

► Modulatory Projection Neurons

## Modulatory Projection Neurons

MICHAEL P. NUSBAUM

Department of Neuroscience, University of Pennsylvania School of Medicine, Philadelphia, PA, USA

### Synonyms

Projection neurons; modulatory inputs; command neurons

### Definition

Broadly defined, projection neurons are neurons whose axons extend from the neuronal cell body within the central nervous system (CNS) to one or more distant regions of the CNS. ► **Modulatory projection neurons** are the subclass of these neurons which have modulatory (generally synonymous with ► **metabotropic**) actions on their target neurons usually in addition to having classical (i.e., ► **ionotropic**) actions. Such neurons are likely to be essential to neuronal integration for all sensory, associative and motor systems, but to date they are most extensively studied and understood at the cellular-level in terms of their regulation of rhythmically active motor circuits. To more readily obtain a cellular-level understanding of their function, studies of modulatory projection neurons on these motor circuits are generally performed in the isolated CNS. The value of using the isolated CNS is enhanced by the fact that the projection neurons can be stimulated in a manner that mimics their in vivo activity. Moreover,

their motor circuit targets continue to generate neuronal activity patterns that are similar to those that they generate in vivo [1–6].

### Characteristics

Rhythmically active motor circuits, often called central pattern generators (CPGs), are small populations of CNS neurons that generate rhythmic neuronal output in response to non-rhythmic input, even in the isolated CNS. This type of circuit construct underlies all studied rhythmic motor behaviors, including various forms of locomotion, respiration, chewing and scratching [2–3,5]. CPGs are ► **multifunctional** circuits, each of which generates multiple neuronal activity patterns. These different activity patterns can be variations on a common pattern or else be quite distinct from one another [3–5,7].

The ability of CPGs to be multifunctional largely results from the presence of metabotropic (modulatory) receptors on the membranes of the individual circuit neurons [2–3,5,8]. Activation of this type of receptor elicits long-lasting biochemical cascades in the target neurons, which lead to changes in the intrinsic electrophysiological and synaptic properties of these neurons. Changes in these properties lead to changes in the related circuit activity.

In all systems studied, each different ► **neuromodulator** applied to the region of an isolated CNS that contains a CPG elicits a distinct activity pattern from that circuit [3,5]. Using applied neuromodulators to document the functional flexibility of CPG circuits led to the original paradigm shift in our understanding that neuronal circuits are in fact functionally flexible constructs. The ability of a tonically present neuromodulator to evoke a reproducible and stable change in the rhythmic output of a neuronal circuit results from the fact that these substances alter neuronal excitability by acting primarily on ► **voltage-sensitive ion channels** [8]. As their descriptor suggests, this class of ion channels is not open at all membrane potentials so that, despite changing the excitability of a neuron, the opening and closing of these channels can still be regulated by sufficiently strong synaptic inputs between the circuit neurons [3,5,8].

Modulatory projection neurons are a major source of metabotropic influence to CPG circuits [2–5,7]. These neurons typically reside in higher centers, from which they project to the region of the CNS where the relevant CPG is located. For example, the vertebrate locomotor CPG network in the spinal cord receives considerable input from projection neurons whose somata are located in the brainstem [2,5]. Similarly, CPGs in invertebrate ganglia are generally influenced by projection neurons that originate in higher-order ganglia [1,3–4,6–7].



In many small motor systems, individual projection neurons are physiologically and often neurochemically identified [4–5,7,9]. Consequently, these ►identified neurons are studied repeatedly in different preparations, allowing for the acquisition of considerable information about their function. The ability to work with identified neurons is facilitating the development of basic concepts regarding how these neurons are incorporated into larger network constructs [1,4,6–7].

Experimental activation of single projection neurons is sufficient for activating an entire CPG in small motor systems [4–7]. A comparable situation appears to occur for single populations of projection neurons in larger motor systems [2,9]. In the intact animal, however, sets of distinct projection neurons are more likely to be coactivated to drive a particular motor output [2,10]. Discerning the rules by which such populations are coactivated by natural stimuli, and determining their consequences for motor activity, is an active area of research.

### Quantitative Description

The parameters most commonly used to assess the state of a modulatory projection neuron are its pattern and intensity of activity. Thus far, data from different projection neurons indicate that some are silent unless activated, while others are spontaneously active [1–2, 4–7,9]. The latter subset is readily separated both by whether their spontaneous activity is tonic or rhythmic, and whether that activity is sufficiently strong to influence the target circuit(s). Each of these conditions has been documented to occur for different identified projection neurons including, in some cases, different projection neurons in the same system. Additionally, some projection neurons impose their own rhythmic activity pattern onto the target circuit, while others exhibit the rhythmic pattern generated by the target circuit as a result of synaptic feedback from that circuit [1,6–7]. The intensity of projection neuron activity is commonly described either by its instantaneous firing frequency or its mean intraburst firing frequency.

The consequences of projection neuron activity are determined by characterizing the ►motor pattern generated by the target CPG circuit(s). The standard set of criteria used for this purpose include determining changes in: (i) speed (cycle frequency) of the resulting motor pattern; (ii) the activity level (burst duration, number of spikes and intraburst spike frequency) of each circuit neuron; (iii) the relative timing of activity (phase) of each circuit neuron; (iv) the duration of these changes; and (v) the interactions between separate CPGs [1,3,5–6,9].

### Higher Level Structures

Modulatory projection neurons that influence the same neuronal network are often clustered into the

same region of the CNS (e.g., brainstem, higher-order invertebrate ganglion). These projection neurons are not completely independent, parallel pathways whose actions only converge at the level of their shared targets. Instead, these neurons also interact to either facilitate or prevent their coactivation [2,4,7]. However, the extent to which there are well defined circuits among such populations of projection neurons remains to be determined. Further, although stimulation of an individual modulatory projection neuron is often sufficient to elicit or modulate an entire motor pattern, it appears likely that subsets of these neurons are normally coactivated by particular sensory or higher-order inputs [1–2,10].

### Lower Level Components

The influence of modulatory projection neurons can reach every level of a motor system. These neurons commonly synapse directly with CPG neurons and thereby activate, terminate or alter circuit output [2–5, 8–9]. These synapses often include both ionotropic and metabotropic components, so there are generally both short-term and long-term actions. As indicated above, there are also synapses between different projection neurons. In parallel, projection neurons also directly influence the same motor neurons whose activity is driven by the CPG, thereby modifying the motor neuron response to CPG activity. Finally, some projection neurons also project to the periphery, where they regulate transmitter release from motor neuron terminals at their neuromuscular junctions as well as directly altering muscle fiber properties [3,5,8].

### Structural Regulation

Focused sensory stimuli clearly activate modulatory projection neurons and thereby influence CPG activity [1–2,5,9]. Furthermore, any such focal sensory pathway stimulation appears to target subsets of the population of projection neurons relevant to any particular motor act [1,10]. However, the general organizing principles underlying this level of operation are yet to be determined. Thus far, the data set is small, but distinct sensory inputs are as likely to elicit distinct motor programs from the same CPG because they activate different or the same subset of modulatory projection neurons [1,10].

There is also feedback regulation from the target CPG(s) to the projection neurons. This often results in the projection neuron exhibiting a rhythmic activity pattern that is time-locked to that of the CPG [2,5–6]. The function of this feedback regulation remains obscure in most systems, although some recent work has documented a role for this feedback in enabling one CPG to regulate the activity of a distinct but related CPG circuit [6].

This general schema for sensorimotor organization implies a hierarchical organization for motor control. However, as we learn more about the cellular-level details at each level of organization, the lines between them have begun to blur. For example, some projection neurons also satisfy the criterion to be CPG members and some CPG members, when directly activated, can turn on the entire CPG [1,3–6].

### Higher Level Processes

The basic organizational features represented by the population of modulatory projection neurons that influence different CPGs seem comparable, but there are few data sets available for comparison. It is clear that such populations include subsets that use different sets of co-transmitters [2–3]. Furthermore, selective activation of some individual projection neurons is sufficient to orchestrate complete activation or termination of a CPG in small motor systems in invertebrates and non-mammalian vertebrates [2,4–5,9]. However, it appears likely that behaviorally-relevant activation of projection neurons in all motor systems involves the coactivation of subpopulations of these neurons [1–2,10]. The current issues being addressed that relate to this organization include determining: (i) how any single population of distinct but functionally related projection neurons are influenced by distinct sensory and higher-order inputs, and (ii) the extent to which inter-projection neuron interactions sculpt the influence of these neurons on their CPG targets. It is also important to expand to additional systems an understanding of the function of rhythmic CPG feedback onto these projection neurons.

### Lower Level Processes

Many of the concepts now known to be relevant to modulatory projection neurons were first established by studies in which neuromodulators were bath-applied to the isolated nervous system, as a model system for how modulatory neurons influence CPG activity [2–5,7–8]. Included among these now well-established concepts is that: (i) Neuromodulation alters CPG output, quantitatively and sometimes qualitatively, by changing the cellular and synaptic properties of the circuit neurons. (ii) Modulation works at multiple levels, often also altering the properties of pre-CPG interneurons and post-CPG targets, such as motor neurons and muscles. (iii) These modulatory consequences result from both convergence and divergence of modulator action. For example, different neuromodulators can evoke different motor patterns from the same CPG and yet have convergent actions on the same second messenger system(s) and/or ion channel(s). In such situations, the different motor patterns result at least partly from different CPG neurons having

overlapping but distinct sets of receptors for the different modulators. There are also examples whereby a single modulator influences a CPG by altering the activity of a set of different ion channels, but the subset that it influences is distinct in each CPG neuron. (iv) Not all CPG neurons need be direct targets of any single modulator. (v) To completely understand modulation of a circuit, it is equally important to identify which CPG neurons are not targets and are targets of a modulator, because the synaptic actions of non-targets often alter the activity of the target neurons.

Studies using direct, intracellular recording and manipulation of individual projection neurons have revealed that, like bath-applying different modulators, stimulating different projection neurons elicits distinct outputs from the same CPG [3–5,7]. In addition to confirming the results of bath-applying neuromodulators, stimulating single projection neurons has revealed additional degrees of freedom available to these systems. For example, (i) many projection neurons contain co-transmitters, but each target neuron in a CPG does not necessarily contain receptors for all of the co-transmitters released by any single projection neuron; (ii) different projection neurons with the same co-transmitter complement can elicit different outputs from the same CPG; (iii) consistent with the belief that projection neurons provide no timing cues to the CPG, some projection neurons modulate CPG output by providing a non-rhythmic input to their target CPG; and (iv) the ability of a projection neuron to activate/modulate a CPG output cannot always be mimicked by bath application of its co-transmitters. This last point may be due to the difficulty in mimicking the temporal nature of the ionotropic actions of the projection neuron with either focal or bath application, or because of local regulation of transmitter release (see below).

### Process Regulation

There is both biochemical and synaptic regulation of the actions of projection neurons. Regarding biochemical regulation, despite the general belief that neurally-released peptides freely diffuse, many of them are locally inactivated by extracellular peptidase activity [7]. Such focal regulation of released neuropeptide can enable different projection neurons to elicit distinct CPG outputs despite releasing the same peptide.

At the so-called lower levels, synaptic regulation of projection neuron activity originates from both sensory feedback and CPG feedback [1–7]. Various sensory systems either trigger, terminate or modify projection neuron actions onto CPGs. Triggering and terminating tends to occur at the level of the projection neuron dendrites/soma, thereby influencing the ability of the neuron to generate action potentials. In contrast, the modifying actions of a sensory input can occur either at that same location or via axo-axonic synapses,

thereby having focal actions on specific transmitter release sites of the affected neuron.

The activity of some projection neurons is time-locked to that of their target CPG [5–6]. This rhythmic projection neuron activity is generally a consequence of synaptic feedback from the CPG activated by that projection neuron. The feedback can either globally or focally affect projection neuron activity, depending on the site of the synapse [4–7]. In most such cases, the function of this rhythmic projection neuron feedback is not known. In one recently documented example, its function is to enable one CPG to regulate the activity of a behaviorally related CPG [6].

### Function

Modulatory projection neurons integrate inputs from sensory and higher-order centers and, when activated, provide persistent drive to one or more rhythmically active motor circuits (CPGs). Different subsets of these projection neurons share the ability to activate a particular CPG, but their distinct actions enable them to generate different neuronal output patterns from that circuit. These distinct actions lead to the generation of particular coordinated rhythmic movements, such as walking, running or swimming from the spinal locomotor CPG. The collective influence of modulatory projection neurons appears to be necessary to enable CPGs to express their full potential. Their complete elimination may prevent the expression of any natural versions of the behaviors generated by that CPG.

### Therapy

The loss of input from modulatory projection neurons, such as might occur for the vertebrate locomotor CPG after spinal cord injury, either eliminates or severely limits the ability to activate that CPG [2–3,6]. Thus, understanding the detailed cellular-level influences of these neurons on their CPG targets will be pivotal to understanding how to circumvent or replace their loss after injury or disease.

### References

1. Beenhakker MP, Kirby MS, Nusbaum MP (2007) Mechanosensory gating of proprioceptor input to modulatory projection neurons. *J Neurosci* 27:14308–14316
2. Grillner S (2003) The motor infrastructure: from ion channels to neuronal networks. *Nat Rev Neurosci* 4:573–586
3. Marder E, Bucher D, Schulz DJ, Taylor AL (2005) Invertebrate central pattern generation moves along. *Curr Biol* 15:R685–R699
4. Nusbaum MP, Blitz DM, Swensen AM, Wood D, Marder E (2001) The roles of co-transmission in neural network modulation. *Trends Neurosci* 24:146–154
5. Stein PSG, Grillner S, Selverston AI, Stuart DG (eds) (1997) *Neurons, networks and motor behavior*. MIT, Cambridge, MA

6. Wood DE, Manor Y, Nadim F, Nusbaum MP (2004) Intercircuit control via rhythmic regulation of projection neuron activity. *J Neurosci* 24:7455–7463
7. Nusbaum MP (2002) Regulating peptidergic modulation of rhythmically active neural circuits. *Brain Behav Evol* 60:378–387
8. Harris-Warrick RM (2002) Voltage-sensitive ion channels in rhythmic motor systems. *Curr Opin Neurobiol* 12:646–651
9. Perrins R, Walford A, Roberts A (2002) Sensory activation and role of inhibitory reticulospinal neurons that stop swimming in hatchling frog tadpoles. *J Neurosci* 22:4229–4240
10. Kristan WB, Shaw BK (1997) Population coding and behavioral choice. *Curr Opin Neurobiol* 7:826–831

## Module

### Definition

In neuroscience, “module” refers to a functional component of the brain, describable in terms of neurological structures, e.g. cells, columns, layers. In cognitive science, module refers to a specialized mental device that operates on specific types of information (domain-specificity), provides predetermined outputs for predetermined inputs (mandatory operation), has no access to information in mental systems except its own subsystems or dedicated input devices (informational encapsulation), delivers output restricted to relatively simple concepts (shallow output) and is subject to characteristic patterns of breakdown. The operations of a mental module are also fast and inaccessible to attention processes or consciousness.

► Theory Theory (Simulation Theory; Theory of Mind)

## Module in Central Pattern Generator

### Definition

A population of neurons within a central pattern generator (CPG) that acts in concert. Neurons in the module are active during a specific phase of a behavior and are quiet during other phases of the behavior. The unit-burst-generator and the half-center are examples of modules.

- Half-center
- Scratching

## Molecular and Cellular Biomechanics

WALTER HERZOG

Professor, Faculty of Kinesiology, University of Calgary, Canada

### Definition

Molecular and cellular biomechanics is the branch of biomechanics that deals with single molecules, molecular interactions, or cells as the system of interest. It deals with the effects that the mechanical environment has on gene expression, mRNA and protein production in cells, and transport and assembly of proteins in extracellular matrices, and further deals with the mechanical properties of isolated molecules or the interaction of proteins, specifically those that make up ►molecular motors that produce essential functions in living systems.

### Characteristics

Molecular and cellular biomechanics is a relatively new branch of biomechanics. It was made possible by technological developments and by the interest of scientists to understand phenomena of tissue growth and adaptation, transport phenomena involving molecular motors, and material properties of isolated molecules, to name just a few of the emerging fields of research. Here, selected approaches are highlighted to provide insight into the field of molecular and cellular biomechanics, and to give specific examples of applications.

The first example will deal with the mechanisms of muscle contraction involving the molecular motor composed of ►myosin II and ►actin; the second example will deal with the giant molecular spring ►titin, which plays an important role in passive force production in skeletal and cardiac muscle.

### Myosin-Actin Interactions and the Molecular Mechanisms of Contraction

In order to deal with molecular interactions, it is important to have a detailed structural description of the proteins that are considered. In the case of myosin II, Rayment et al. [1] described the portion of that molecule that is referred to as the subfragment 1, S1. This part of the molecule contains the actin and nucleotide binding sites, as well as the regulatory and essential light chains (Fig. 1).

The structure of the S1 was determined by x-ray diffraction in a two-step procedure: first, the positions of the metal binding sites were determined using x-ray data sets with a 4.5 Å resolution, and then these data were filled in with Synchrotron radiation results to produce a 2.8 Å resolution. In a companion study, Rayment et al.

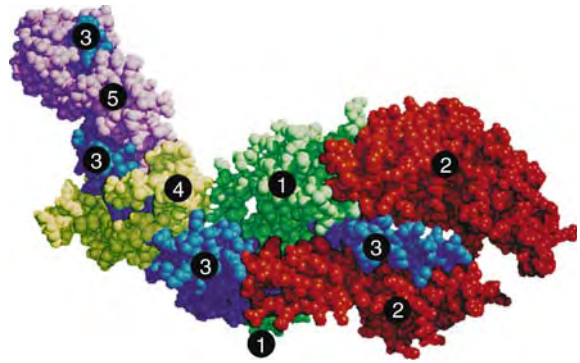

**Molecular and Cellular Biomechanics. Figure 1** Space-filling representation of all atoms in the myosin subfragment 1 model. Segments labeled 1, 2, and 3 represent parts of the heavy chains, while those labeled 4 and 5 show the essential and regulatory light chains, respectively. The proposed actin binding site is located at the lower right-hand corner (2). The active nucleotide site is on the opposite side from the proposed actin binding surface; segment 1 (Reprinted with permission from Rayment et al. [1]. Copyright 1993 American Association for the Advancement of Science).

[2] revealed the structure of the actin binding site, and they speculated on the interaction of S1 with the actin attachment site that produces muscle contraction.

Starting from the rigor confirmation, Rayment et al. [2] suggested that the narrow cleft that splits the 50 kD segments of the myosin heavy chain into two domains is closed (Fig. 2a and e, horizontal gap, perpendicular to the actin filament axis).

The addition of ATP and initial ATP binding to myosin at the active site causes an opening of the narrow cleft between the upper and lower domains of the 50 kD segment. This in turn disrupts the strong binding between actin and myosin but still allows for a weak attachment (Fig. 2b). The final ATP binding to myosin causes a closure of the nucleotide binding pocket and a corresponding configurational change of the myosin molecule. ATP is now hydrolyzed (Fig. 2c). Rebinding of myosin to actin can occur, presumably in multiple steps. The gap between the upper and lower domain closes in this process to produce strong binding, and phosphate, P, is released. This event starts the so-called power stroke, the myosin molecule reverses its conformational change induced by ATP binding, and the active site pocket is reopened, establishing the ►rigor configuration (Fig. 2e). The cross-bridge cycle can then start all over again.

The studies by Rayment et al. [1,2] suggested the possible mechanism of contraction from a structural point of view. However, the actual movement produced by actin myosin interactions, the corresponding forces, and the relationship of the mechanical events with

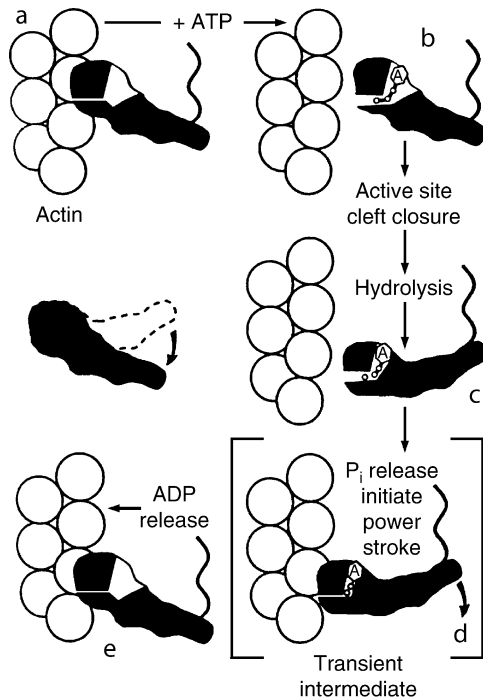

**Molecular and Cellular Biomechanics. Figure 2** Proposed molecular mechanism of contraction. (a) Rigor conformation. The narrow cleft that splits the 50-kD segments of the myosin heavy-chain sequence into two domains is closed (horizontal gap, perpendicular to the actin filament axis). (b) Addition of ATP, and initial binding of ATP to the active site, causes an opening of the narrow cleft and disrupts the strong binding between actin and myosin, but still allows for weak binding. The actin and myosin dissociate. (c) The final binding of ATP to myosin causes a closure of the nucleotide binding pocket and a corresponding configurational change of the myosin molecule. ATP is now hydrolyzed. (d) Myosin can now reattach to actin, presumably in multiple steps. The narrow cleft closes to produce strong binding. Phosphate,  $P_i$ , is released, and the power stroke starts. (e) During the power stroke, the myosin molecule reverses its conformation change induced by ATP binding, and the active site pocket is reopened, establishing the rigor conformation. The cross-bridge cycle can now start all over again (Reprinted with permission from Rayment et al. [2]. Copyright 1993 American Association for the Advancement of Science).

the corresponding biochemical steps cannot be determined using x-ray diffraction. In 1994, Finer et al. [3] showed the first results of forces produced by the interaction of a single cross-bridge with an actin filament using a double beam **laser trap** approach.

### Single Myosin Mechanics

Finer et al. [3] attached silica beads to a microscope cover slip. The cover slip was coated with skeletal

muscle heavy meromyosin (HMM) at a low density to allow for single attachments of cross-bridges to actin. Polystyrene beads coated with N-ethylmaleimide (NEM)-treated HMM were attached to actin filaments. An actin filament with two beads attached near its end was then caught and suspended in two optical traps (Fig. 3).

The image of one of the beads was projected to a photodiode detector for position detection. The actin filament was then pulled taut (with a force of about 2 pN) and was lowered to the silica bead with the HMM. Now, a single HMM molecule could interact and attach to the actin filament. When a cross-bridge head attached to the actin, a rapid transient movement of the silica bead along the axis of actin was observed. Consistent displacement traces were observed by keeping the stiffness of the optical traps high enough to decrease the noise caused by **Brownian motion** (i.e. about 0.02 pN/nm per trap), but small enough that a myosin molecule could produce a full displacement. The average size found for single myosin cross-bridge steps was about  $11 \pm 2.4$  nm, independent of the ATP concentration ( $1\mu\text{M}$ – $2\text{mM}$  ATP) and independent of the total trap stiffness (0.014–0.08 pN/nm).

In order to measure the forces produced by single HMM molecules, the stiffness of the optical trap was increased to 6 pN/nm. Movements of the bead from the centre of the optical trap were proportional to the force applied on the actin filament. For the force measurements, movements of the bead were prevented by a feedback position system, which moved the optical trap (when force was applied to the bead) by the exact amount required to keep the bead stationary. Therefore, the displacement of the trap became a measure of the applied force. The magnitude of forces measured by single HMM interactions with actin were 1–7 pN, and they averaged  $3.4 \pm 1.2$  pN. The force magnitudes were not affected by ATP concentration.

One of the limitations of the study by Finer et al. [3] was that it could not be determined with confidence whether a given mechanical event was produced by one or more HMM molecules or by one or both heads of the HMM molecule. Molloy et al. [4] addressed this issue using two optical traps in essentially the same way as Finer et al. [3], and measured the interactions of HMM molecules (two-headed cross-bridges) and myosin subfragment 1 (S1, single-headed cross-bridges) with actin. Molloy et al. [4] found that the average working strokes of S1 and HMM were comparable (about 4 nm) and were much smaller than those found by Finer et al. [3] for HMM (about 11 nm). Also, the average force values for both S1 and HMM interactions with actin were low (about 1.7 pN) compared to those measured by Finer et al. [3].

Muscle contraction with the myosin II-actin motor is just one example that could have been chosen to present

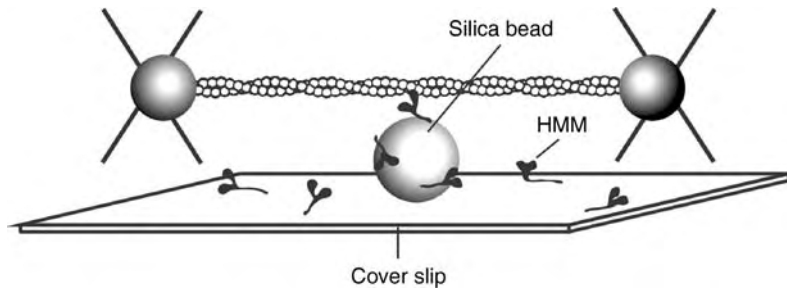

**Molecular and Cellular Biomechanics. Figure 3** Schematic illustration of single heavy meromyosin, HMM, interaction with an actin filament. The silica bead on the cover slip is coated with skeletal muscle heavy meromyosin (HMM). Coated polystyrene beads are attached to the ends of actin. The actin filament with its two beads is caught and suspended in two optical traps. The suspended actin filament is then lowered to the silica bead, and single HMM interactions with the actin filament are now possible (Reprinted by permission from *Nature*, Finer et al. [3]. Copyright 1994 Macmillan Magazines Ltd).

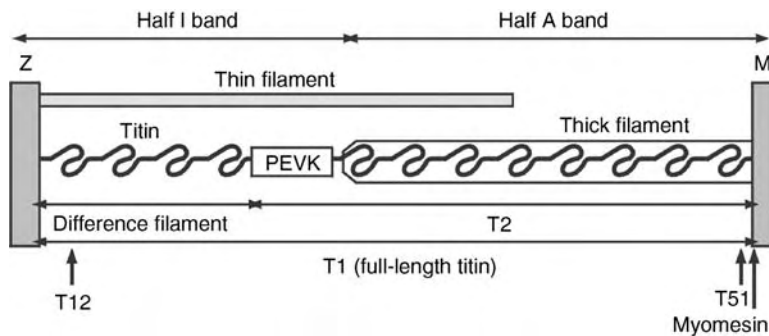

**Molecular and Cellular Biomechanics. Figure 4** Schematic illustration of titin and its association with other structures within a half-sarcomere. Titin spans from the Z-line to the M-band. It consists of about 300 immunoglobulin and fibronectin type III repeats and a proline (P), glutamate (E), valine (V), and lysine (K)-rich (PEVK) domain (Reproduced from Kellermayer et al. [8], with the permission of the American Association for the Advancement of Science).

some of the measuring techniques and approaches in molecular biomechanics. Excellent reviews describing the function of molecular motors are available (e.g. [5–7]).

### Molecular Springs

Here, we would like to discuss the function and action of titin, a molecular spring that is particularly important in skeletal and cardiac muscle where it is thought to provide a big portion of the passive forces, and to play an important role in providing longitudinal stability of the myosin filament in sarcomeres. Titin, sometimes referred to as connectin, is a giant filamentous polypeptide, consisting primarily of about 300 immunoglobulin (Ig) and related fibronectin type III (FNIII) repeats, and a unique proline (P), glutamate (E), valine (V), and lysine (K)-rich (PEVK) domain. Titin spans each half-sarcomere and is anchored to the Z-line and the thick filament reaching all the way to the M-band (Fig. 4). Titin is thought to play a basic role

in maintaining sarcomere structural integrity and producing passive force when muscle sarcomeres are stretched. Titin is also believed to provide a molecular scaffold for thick filament formation.

It has been argued that titin stabilizes the thick filament in the centre of the sarcomere when, upon contraction, small asymmetries in pulling forces are produced on the two halves of the thick filament. Furthermore, titin is assumed to produce passive force in muscles. Such passive forces might help stabilize what has been labelled the unstable [9], or softening, behavior of active muscle force on the descending limb of the force-length relationship. Finally, once a sarcomere is stretched beyond thick and thin filament overlap, cross-bridge attachments become impossible, and the forces required to re-establish myofilament overlap are thought to come primarily from the passive elastic forces of the highly stretched titin.

Despite the apparent importance of titin, the way it accomplishes its functional role has not been fully

resolved. If titin really provides most of the passive force in a stretched muscle, it should have several distinct characteristics: first, for centring the thick filament upon contraction, it should provide a low-level stiffness. The stiffness needs to be low because the asymmetries in active force acting on the thick filaments would presumably not be large, and the muscle (sarcomere) should still be stretchable without much resistance within its normal physiological range. Second, at some point titin should become stiff at a very fast rate in order to prevent large stretches of muscle against external forces that might cause injury. Finally, titin must accomplish its passive force at different lengths in different muscles, as the passive forces measured in different muscles occur at distinctly different sarcomere lengths. For example, in cardiac muscle, passive force is known to be high at about optimal sarcomere length, whereas in many skeletal muscles, passive force is negligible at optimal sarcomere length.

Rief et al. [10] used atomic force microscopy to study the mechanical properties of titin. Single titin molecules were stretched, and molecular elongation and the corresponding forces were recorded simultaneously. Rief et al. [10] found force-extension curves for titin that showed a sawtooth-type pattern (Fig. 5) that was typically preceded by a “smooth” increase in force of variable length. The periodicity of the force peaks was in the range of 25–28 nm, i.e. close to the expected full length of an Ig domain, and the force peaks varied from about 150–300 pN.

In order to test whether the peaks of the sawtooth pattern indeed reflect an unraveling of the Ig domains, two model recombinant titin fragments were constructed, consisting of either four (Ig4) or eight (Ig8)

Ig segments in the I-band region (the flexible region) of titin. All traces obtained with these Ig segments showed a strict 25 nm periodicity. Furthermore, the force peaks were found to increase from the first to the last (Fig. 6), but stiffness was found to decrease from one force peak to the next (Fig. 6). Finally, when these Ig segments were released to one-half of their fully stretched length (but not to their resting length) and then pulled again, the sawtooth force-extension curve was not apparent. The sawtooth pattern was only fully recovered after complete relaxation of the titin to its resting length.

Based on their results, Rief et al. [10] concluded that each sawtooth pattern corresponded to an unfolding of one Ig domain: the force on the ascending part reflecting the molecular forces that must be overcome to produce the unfolding, the force decrease following the peak reflecting the fact that the molecular spring was now “abruptly” elongated by about 25 nm. The increasing peak forces with each subsequent sawtooth pattern were assumed to reflect increasingly stronger molecular bonds of the folded Ig domains; therefore, the “weakest” domain was unfolded first, followed by increasingly “stronger” Ig domains. The relative “smooth” increase in force preceding the sawtooth patterns was associated with a different molecular mechanism, possibly an elongation of the PEVK region, although this assumption was not rigorously tested. Finally, it took a full shortening of titin before a sawtooth pattern force-extension curve could be observed after the molecule had been stretched. Partial shortening did not produce partial sawtooth patterns, therefore it appears that a refolding of the Ig domains only occurs at or near titin’s “resting” length or, in terms of force, at very low titin forces.

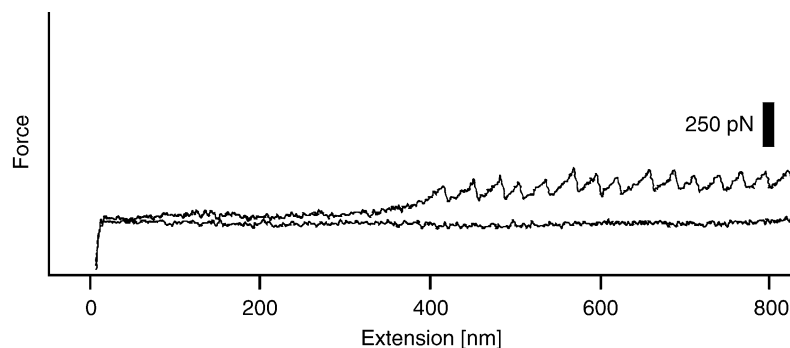

**Molecular and Cellular Biomechanics. Figure 5** Force-extension curve of a single titin molecule obtained using atomic force microscopy. The force-extension curve shows a sawtooth-type pattern that is preceded by a smooth increase in force. The periodicity for the force peaks is about 25–28 nm, and the force peak magnitudes were in the range of 150–300 pN. The smooth increase in force preceding the sawtooth pattern was associated with an elongation of the PEVK region. The sawtooth pattern was associated with an unfolding of the Ig domains (Reproduced from Rief et al. [10], with the permission of the American Association for the Advancement of Science).

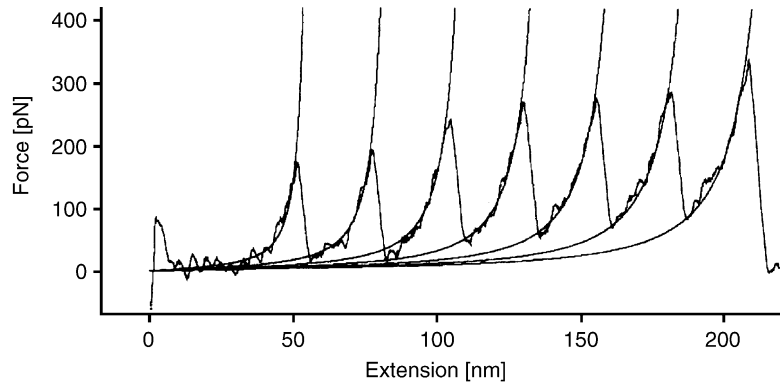

**Molecular and Cellular Biomechanics. Figure 6** Force-extension curve of a recombinant titin fragment consisting of eight Ig segments. The curve shows a strict 25 nm periodicity. Force peaks increase from the first to the last sawtooth pattern, but the stiffness decreases. The force and stiffness on the ascending part of the sawtooth pattern likely reflect the molecular forces that must be overcome to produce unfolding of one Ig domain. The force decrease following the peak, reflects the sudden 25 nm elongation of the molecule once the molecular unfolding forces have been overcome (Reproduced from Rief et al. [10], with the permission of the American Association for the Advancement of Science).

Here we described the molecular motor myosin II-actin and the molecular spring titin as two examples of biomechanical investigation on the molecular level. Many other examples could have been advanced. However, these two covered some of the new technologies that are available today for performing mechanical experiments on the micro-scale level. We neglected a great number of studies relating to cell biomechanics. Many of these deal with the mechanical loading and the corresponding biological responses of cells, and tissue engineering. Regarding these issues, we would like to recommend the book by Mow et al. [11] for people with an interest in musculoskeletal tissues, and the book by Fung [12] for additional discussions on the cardiovascular system.

## References

1. Rayment I, Rypniewski WR, Schmidt-Bäse K et al. (1993) Three-dimensional structure of myosin subfragment-1: a molecular motor. *Science* 261:50–58
2. Rayment I, Holden HM, Whittaker M et al. (1993) Structure of the actin-myosin complex and its implications for muscle contraction. *Science* 261:58–65
3. Finer JT, Simmons RM, Spudich JA (1994) Single myosin molecule mechanics: piconewton forces and nanometre steps. *Nature* 368:113–119
4. Molloy JE, Burns JE, Kendrick-Jones J et al. (1995) Movement and force produced by a single myosin head. *Nature* 378:209–212
5. Ait-Haddou R, Herzog W (2002) Brownian ratchet models of molecular motors. *Cell Biochem Biophys*; 38: 191–213
6. Astumian RD, Bier M (1996) Mechanochemical coupling of the motion of molecular motors to ATP hydrolysis. *Biophys J* 70:637–653
7. Julicher F (1999) Force and motion generation of molecular motors: a generic description. In: Muller SC, Parisi J, Zimmermann W (eds) *Transport and structure in biophysical and clinical phenomena*. Springer Berlin Heidelberg, New York, pp 1–27
8. Kellermayer MSZ, Smith SB, Granzier HLM, Bustamante C (1997) Folding-unfolding transitions in single titin molecules characterized with laser tweezers. *Science* 276:1112–1116
9. Hill AV (1953) The mechanics of active muscle. *Proc R Soc Lond* 141:104–117
10. Rief M, Gautel M, Oesterhelt F et al. (1997) Reversible unfolding of individual titin immunoglobulin domains by AFM. *Science* 276:1109–1112
11. Mow VC, Guilak F, Tran-Son-Tray R, Hochmuth RM (1994) *Cell Mechanics and Cellular Engineering*. Springer: Berlin Heidelberg New York
12. Fung YC (1993) *Biomechanics: mechanical properties of living tissue*, 2nd ed. Springer, Berlin Heidelberg New York

## Molecular Cues

Signals in the extracellular environment that instruct the axon which way to grow during pathfinding.

## Molecular Features in Odors

### Definition

Based on the assessment of odor similarity in relation to the molecular structure, two different but overlapping



categories of odorant molecular characteristics have been identified. One category is a polar functional group that contains an oxygen, or a nitrogen, or a sulfur atom. The other category is the molecular profile that is formed mainly by the overall molecular shape. Polar functional groups and molecular profiles strongly influence the perceived odor quality.

► Odor Maps

## Molecular Motors

### Definition

Molecular motors are engines made up of individual molecules. There are a series of well-studied molecular motors that perform life essential functions in the human body. For example, the myosin II-actin motor is responsible for muscle contraction, kinesin and dynein transport organelles or vesicles from one location of a cell along polar and periodic tracks (actin and microtubules), and membrane bound motor proteins transport ions against chemical concentration gradients.

- Actin
- Dynein
- Kinesin
- Microtubule
- Molecular and Cellular Biomechanics
- Myosin
- Sarcomere Structural Proteins

## Molecular Pharmacology

► New Developments in G Protein-Coupled Receptor Theory

## Monaural

### Definition

Sound presented to one ear.

► Hearing Aids

## Monoaminergic Cell Groups

### Definition

These are cell groups that use monoamines as neurotransmitters. The monoamines include the catecholamines (dopamine, norepinephrine, and epinephrine) and the indoleamine serotonin (5-hydroxytryptamine). The catecholamines are derivatives of the amino acid tyrosine. Serotonin is a derivative of the amino acid tryptophan. The major cell groups that use dopamine are the substantia nigra and the ventral tegmental area in the midbrain. A major cell group that uses norepinephrine is the locus ceruleus (Latin for blue spot) in the dorsal pons. There are few if any epinephrine neurons in the brain. Epinephrine is secreted into the blood by the adrenal gland near the kidney. The major cell groups that use serotonin are the raphe (Greek for ridge or seam – refers to nuclei near the midline) nuclei which scattered from the caudal pons to the medulla.

## Monoamines

### Definition

Brain monoamine synaptic transmitters consist of an aromatic ring and amino group attached by a two carbon chain (-CH<sub>2</sub>-CH<sub>2</sub>-). Monoamines are further classified as catecholamines or indolamines depending on the specific essential aromatic amino acid, phenylalanine or tryptophan respectively, from which they are derived. Dopamine and norepinephrine (noradrenaline) are derived from L-tyrosine first by the action of the enzyme tyrosine hydroxylase to form L-Dopa which is subsequently decarboxylated by aromatic amino acid decarboxylase to form dopamine. Norepinephrine is synthesized following the  $\beta$ -oxidation of dopamine by dopamine beta hydroxylase, with the co-factor ascorbate serving as an electron donor. Epinephrine is synthesized from norepinephrine in a restricted group of neurons in the brain-stem by phenylethanolamine N-methyltransferase. Serotonin is synthesized from Ltryptophan in two enzymatic steps involving tryptophan hydroxylase and aromatic amino acid decarboxylase. The discovery by Falk and Hilarp of histochemical fluorescence enabled the visualization of catecholamines and serotonin within specific nuclei and efferent neural pathways, which could then be lesioned by specific neurotoxins. Preclinical experiments employing this lesion technique helped to identify the function of specific brain monoamines in

many aspects of behavior ranging from motor control to emotional and cognitive processes. Monoamine transmitters influence post-synaptic neurons via specific receptor sub-types and synaptic levels are determined mainly by the action of selective uptake mechanisms. These sites have served as targets for the development of highly effective drugs for the treatment of neuropsychiatric disorders, including the SSRI's (serotonin-selective reuptake inhibitors) and neuroleptic drugs for the treatment of schizophrenia.

- ▶ Antipsychotic Drugs
- ▶ Schizophrenia

## Monochromatopsia

### Definition

- ▶ Color Blindness

## Monocular Deprivation

### Definition

A condition in which normal visual experience is prevented for varying periods to one eye by a natural or artificial condition.

- ▶ Binocular Vision

## Mononeuropathy

### Definition

Damage or destruction of an isolated nerve or nerve group. It is a type of ▶ [peripheral neuropathy](#) (damage to nerves outside the brain and spinal cord). Mononeuropathy is most often caused by damage to a local area resulting from injury or trauma, although occasionally systemic disorders may cause isolated nerve damage (as with mononeuritis multiplex).

- ▶ Peripheral Neuropathies

## Monophyletic

### Definition

A set of taxa derived from a single common ancestor.

- ▶ Evolution, and the Concept of Homology

## Monophyletic Group

### Definition

Taxon that includes all descendants of a last common Ancestor.

## Monoplegia

### Definition

Paralysis of one limb. If occurring without muscle wasting, the most frequent cause is a local lesion to the ▶ [cerebral cortex](#) (e.g., a vascular lesion such as thrombosis or embolism; local injury, tumor of abscess); if occurring with muscle atrophy, the lesion affects the ▶ [motor unit](#) (e.g., ▶ [brachial plexus trauma](#) or neuritis, ▶ [poliomyelitis](#), ▶ [syringomyelia](#), ▶ [amyotrophic lateral sclerosis](#)).

- ▶ Amyotrophic Lateral Sclerosis (ALS)
- ▶ Brachial Neuralgia
- ▶ Poliomyelitis
- ▶ Syringomyelia

## Monopolar Recording

### Synonym

Unipolar Recording

### Definition

Recording of an electrical potential difference between an active region (by means of a small electrode: different electrode) and an inactive region (by means of a large-surface electrode: indifferent electrode) of an excitable tissue (e.g., nerve or muscle).

- ▶ Extracellular Recording

## Monotreme

### Definition

Platypus and echidna are monotremes (trema means hole and refers to the cloaca). These animals are the only mammals that lay eggs and do not give birth to live young. They are also the first and only mammals which were shown to have electroreception.

► [Electric Senses in Monotremes: Electroreception and Electrolocation in the Platypus and the Echidna](#)

## Morbus Bleuler

► [Schizophrenia](#)

## Mormyromasts

### Definition

Tuberous organ subtype found in mormyrid fishes, used primarily for electrolocation.

► [Evolution of Mechanosensory and Electrosensory Lateral Line Systems](#)  
 ► [Electroreceptor Organs](#)

## Morning/Evening Oscillators

MICHAEL N. NITABACH

Department of Cellular and Molecular Physiology,  
 Yale School of Medicine, New Haven, CT, USA

### Definition

Morning (“M”) and evening (“E”) oscillators are distinct circadian oscillators that control the peaks of activity of twilight-active animals that occur during the morning and evening twilight.

## Characteristics

### Theoretical and Descriptive Analysis of M and E Oscillators

In animals, the circadian clocks that control the timing of rest and activity are embodied in groups of ► [circadian pacemaker neurons](#) in the central nervous system. Many animals are crepuscular – i.e. twilight-active – and thus concentrate their activity around dawn and dusk. It was theorized in the 1970s that crepuscular rodent activity rhythms are controlled by independent, but coupled, ► [Morning and Evening \(M and E\) oscillators](#) [1]. Later measurements of circadian rhythms of pacemaker neuron firing in the rodent ► [suprachiasmatic nucleus \(SCN\)](#) revealed two distinct subpopulations of neurons whose firing rhythms were out of phase, suggesting that these could be the M and E oscillators [2]. However, it has not been possible to experimentally test the hypothesis that a particular subset of rodent pacemaker neurons does indeed function as an M or E ► [oscillator](#). This would require functionally inactivating the subset of pacemaker neurons constituting a putative M or E, followed by measurement of the effect of this inactivation on the morning and evening peaks of activity.

### Experimental Demonstration of M and E Oscillators

Like many rodents, *Drosophila melanogaster* fruit flies are crepuscular, exhibiting peaks of activity centered on the transitions from night to day and from day to night. And unlike in rodents, readily available techniques exist for functionally inactivating defined subsets of pacemaker neurons. In one study, flies were generated that lacked either the lateral–ventral anatomical subset of pacemaker neurons or several dorsal anatomical subsets of pacemaker neurons [3]. Flies lacking the lateral–ventral subset lost the morning peak of activity, but retained the evening peak. Flies lacking the dorsal subgroups lost the evening peak of activity, but retained the morning peak. In a different study, flies were generated that had functional ► [cellular clocks](#) either only in the lateral–ventral subgroup, or in both the lateral–ventral and dorsal subgroups [4]. Flies with functional cellular clocks solely in the lateral–ventral subgroup exhibit only the morning peak of activity, while flies with functional cellular clocks in both subgroups exhibit both the morning and evening peaks of activity. These findings demonstrate that the fly M and E oscillators reside in the lateral–ventral and dorsal pacemaker neurons, respectively.

### Communication of Phase Information Between M and E Oscillators

Those experiments were performed in 12 h:12 h light:dark (LD) conditions, where both M and E oscillators

can be independently synchronized to the environment and thereby maintain a constant phase relationship. When flies are synchronized to LD and then released into constant darkness (► [constant conditions, DD](#)), the morning and evening peaks still occur – although they ► [free-run](#) and gradually drift out of phase with the rotation of the Earth. But even in free-running conditions, the morning and evening peaks maintain a constant phase relationship with each other. So there must be some mechanism for keeping that relationship constant in free-running DD conditions even in the absence of any environmental cues.

One possible mechanism for maintaining constant phase between M and E oscillators is a ► [master–slave](#) relationship, so-called because one of the oscillators controls the other. To test this hypothesis, flies were genetically modified so that the M and E oscillators run with intrinsic periods that differ by 3–4 h [5]. Under ► [free-running](#) DD conditions, the period of the behavioral rhythm of locomotor activity is always determined by the intrinsic period of the M oscillator, suggesting both that there is a master–slave relationship and that M is the master. Furthermore, the period of oscillation of the cellular clock in the E cells is determined by that of M, and not by the intrinsic period of the E cells themselves. These results demonstrate that M cells send a signal to the E cells that controls the oscillation of their cellular clocks. A good potential candidate for this signal is a neuropeptide produced and secreted by the lateral-ventral M pacemaker neurons and known to be important for circadian function [6].

## References

1. Pittendrigh CS, Daan S (1976) A functional analysis of circadian pacemakers in nocturnal rodents V. Pacemaker structure: a clock for all seasons. *J Comp Physiol* 106:333–355
2. Jagota A, De la Iglesia HO, Schwartz WJ (2000) Morning and evening circadian oscillations in the suprachiasmatic nucleus in vitro. *Nat Neurosci* 3(4):372–376
3. Stoleru D, Peng Y, Agosto J, Rosbash M (2004) Coupled oscillators control morning and evening locomotor behaviour of *Drosophila*. *Nature* 431(7010):86286–86288
4. Grima B, Chelot E, Xia R, Rouyer F (2004) Morning and evening peaks of activity rely on different clock neurons of the *Drosophila* brain. *Nature* 431(7010):869–873
5. Stoleru D, Peng Y, Nawathea P, Rosbash M (2005) A resetting signal between *Drosophila* pacemakers synchronizes morning and evening activity. *Nature* 438(7065):238–242
6. Renn SC, Park JH, Rosbash M, Hall JC, Taghert PH (1999) A pdf neuropeptide gene mutation and ablation of PDF neurons each cause severe abnormalities of behavioral circadian rhythms in *Drosophila*. *Cell* 99(7):791–802

## Morphogen

### Definition

A substance whose concentration varies across a tissue and to which cells respond differently at different concentrations.

► [Morphogens and Neural Development](#)

## Morphogenetic Compartment

### Definition

Subdivision of an organ or body part (for example, a specific area or sector of the neuroepithelium) specified by a particular combination of developmental regulatory genes, that gives rise to a particular body division or subdivision. It constitutes a major unit of development and evolution, and the natural comparison character for homology considerations.

► [Evolution and Embryological Development of the Forebrain](#)

## Morphogens and Neural Development

ESTHER T. STOECKLI

Institute of Zoology/Developmental Neuroscience,  
University of Zurich, Zurich, Switzerland

### Definition

In the development of organisms the organization of cells into tissues is a major achievement. Precursor cells or undifferentiated cells have to be organized in a spatial pattern that allows their differentiation to distinct cell types. To this end, positional information has to be transferred to cells. The term morphogen describes such positional signals that are secreted by a source, and therefore form a gradient emanating from this source by mechanisms that are still unclear (see below). Cells responsive to a particular morphogen will then sense their position in response to the concentration of the morphogen. Thus, ► [morphogens](#) are capable of specifying body axes or give polarity to tissues, in other words are responsible for the patterning of the

embryo. In vertebrates, morphogens include members of the Hedgehog, the ►Wnt, the FGF (Fibroblast Growth Factor), and the TGF- $\beta$  (Transforming Growth Factor- $\beta$ ) families. In human there are three Hedgehogs (Sonic, Indian, and Desert Hedgehog), 19 Wnts (Wnt1 – Wnt16), and 22 FGFs. The TGF- $\beta$  family is subdivided into several subfamilies, the TGF- $\beta$ s, activin, and the bone morphogenetic proteins (BMPs). For the developing nervous system, the BMP subfamily is most relevant. In *Drosophila*, where development starts in a ►syncytium, transcription factors, e.g. bicoid, have also been identified as morphogens. In this essay I will concentrate on vertebrate morphogens, however.

### Characteristics

Neural development starts with neural induction and neurulation giving rise to the neural tube, which will form the central nervous system, and to the ►neural crest, from where cells will delaminate to form the peripheral nervous system. A hallmark of neural development is the considerable distances that cells migrate to reach their final destination from where they send out their long processes, ►axons and ►dendrites, to connect to their target cells. This is particularly true for the brain. The migratory routes are much shorter and less complicated in the caudal neural tube, the ►spinal cord. Therefore, early events of neural development, ►neurogenesis, ►cell differentiation, and patterning have been studied extensively in the spinal cord. Cell migration has been studied predominantly in the brain. Morphogens are involved in all steps of neural development from neural induction to axon guidance and ►synaptogenesis, the final step in neural circuit formation.

### Methods to Study Morphogen Function

Common to all morphogens is their involvement in the regulation of ►cell proliferation, differentiation, and patterning. Because all morphogens are involved not only in spatially distinct but also in temporally distinct processes, their functional analysis has to take time into account. This is quite difficult to achieve with classical genetic tools, as they allow only for the analysis of gene function in the first window of activity. Analysis of later events is often prevented by aberrant development due to the absence of gene activity during early time windows or even early embryonic lethality. Inducible knockout strategies or ►RNAi approaches have opened new possibilities in temporal control of gene expression and are therefore better suited for functional analyses of morphogens [1].

### Morphogens in Early Neural Development

Neural induction starts with or even before gastrulation: Cells of the ►ectoderm are set aside to become neural ectoderm [2]. This process requires blocking the

activity of ►bone morphogenetic proteins (BMPs), a subfamily of the TGF- $\beta$  family of morphogens. BMPs drive differentiation to epidermis, thus, neural ectoderm will be formed only where this activity can be blocked by Chordin, Noggin, and Follistatin, three BMP inhibitors originally identified in *Xenopus*. In addition to BMPs, members of the FGF, and the Wnt family of morphogens have also been implicated in neural induction [2]. Once the neural epithelium has been defined it starts to undergo changes in shape, i.e. it folds up in a process called neurulation (Fig. 1).

### Morphogens and Neural Crest Formation

►Neural crest cells give rise to cells of the peripheral nervous system, pigment cells (melanocytes), and skeletal elements of the head. Neural crest cells arise from the border between the neural and the non-neural ectoderm and depend on the presence of BMPs (Fig. 1). The requirement for BMP signaling in neural crest cell formation was demonstrated for instance in zebrafish mutants (for references see [3]). In addition to BMPs, other morphogens, such as Wnts and FGFs were also implicated in neural crest induction and proliferation. Because neural crest specification cannot be separated from cell migration along distinct pathways, roles of morphogens in neural crest migration have also been demonstrated (reviewed by [3]).

### Morphogens in Differentiation and Patterning

The newly formed neural tube is specified from the beginning with respect to the antero-posterior and the dorso-ventral orientation. At the anterior end of the neural tube, the brain will form, the caudal neural tube will develop into the spinal cord. The ►notochord, a mesodermal structure underlying the neural plate, specifies the ventral midline of the neural tube, called the ►floor plate (Fig. 1). The roof plate originates during the closure of the neural tube and marks the dorsal midline of the spinal cord. Both the floor plate and the roof plate are important signaling centers, as they are the source of morphogens [4]. BMPs are produced in the roof plate, ►Sonic hedgehog (►Shh) is produced by the floor plate. Wnts are also expressed in the roof plate and in the adjacent dorsal neural tube. Under the influence of these morphogens ►neuroepithelial cells differentiate to distinct types of cells. In the dorsal neural tube, cells are predominantly under the dorsalizing effect of the BMPs, whereas cells in the ventral neural tube turn into ventral interneurons or motoneurons depending on the concentration of Shh [4]. High concentrations of Shh will induce V3 interneurons and motoneurons, successively lower concentrations will give rise to V2, V1, and V0 interneurons, respectively. These broad domains are distinguished by their characteristic expression of transcription factors used as markers. These transcription factors regulate

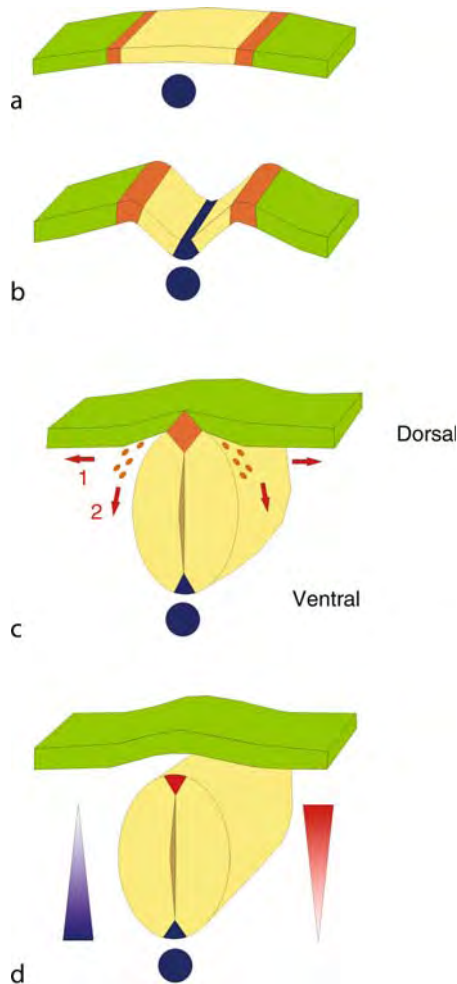

### Morphogens and Neural Development.

**Figure 1** During neural induction ectodermal cells that are under the influence of BMP inhibitors develop into neural ectoderm (yellow in (a)). The remaining ectoderm (green) develops into epidermis. The notochord, a mesodermal structure underlying the neural ectoderm (blue), acts as an organizer for the neural tube. It expresses high levels of Shh and is responsible for the differentiation of the ventral midline cells of the developing neural tube into floor-plate cells (blue in (b)). The border between the neural and the non-neural ectoderm expresses BMPs and Wnts (orange) that are responsible for the delamination of neural crest cells during the closure of the neural tube (c). Neural crest cells migrate along a dorsal route (1) to turn into melanocytes and along a ventral route (2) to turn into cells of the peripheral nervous system. The fusion of the neural tube results in the formation of the roof plate (red triangle in (d)). Thus, the newly formed neural tube contains two organizing centers, the floor plate (blue triangle in (c) and (d)), the source of Shh with ventralizing activity, and the roof plate, the source of BMPs with dorsalizing activity. Cells along the dorsoventral axis adopt different cell fates depending on the concentration of BMPs and Shh that they experience (d).

specific gene expression patterns. The segregation of cells driven by selective cell-cell adhesion concludes the formation of the final classes of neurons along the dorso-ventral axis of the spinal cord. Similar processes are thought to occur in the brain but due to the increased complexity of the anterior neural tube the specific interactions and molecular processes are less well understood. In contrast, patterning of the antero-posterior axis of the neural tube has been studied in more detail in the brain [5]. The anterior end of the neural tube is subdivided into forebrain, midbrain, and hindbrain. The hindbrain and the borders between the individual segments of the hindbrain, the **▶rhombomeres**, are thought to be local signaling centers for the anteroposterior axis. The mid-hindbrain boundary, or isthmus, is the source of FGFs, in particular FGF8 that was shown to be most important for the organization of the midbrain and the **▶cerebellum** [6]. In addition to their role in differentiation and patterning morphogens regulate cell proliferation in the neural tube and thus define not only cell type but also cell number [7].

### Morphogens in Axon Guidance

More recently, a function of morphogens in axon guidance has been found [8–10]. First evidence for a role in **▶axonal pathfinding** was obtained in the visual system for FGFs in frog [6] and Shh in chicken embryos [9]. BMPs expressed by the roof plate were shown to act as axon guidance cues by repelling dorsolateral **▶commissural axons** (Fig. 2).

At the same time, these axons are attracted by **▶Netrin-1**, the first **▶chemoattractant** that was identified. Interestingly, the attractive effect of Netrin is supported by Shh that is expressed by the floor plate, as is Netrin. The activity of Shh is much weaker than the activity of the classical axon guidance cue, Netrin-1. Therefore, the attractive effect of Shh on commissural axons could only be detected in the absence of Netrin-1. More recently, Shh was identified as a **▶repellent** for the same commissural axons once they have crossed the ventral midline [9]. Interestingly, the repellent effect of Shh on postcommissural axons did not depend on the same receptor and the same signaling mechanism that was responsible for the patterning and axon guidance activities of Shh during earlier stages of development. Shh was shown to act as repellent for postcommissural axons that expressed Hedgehog-interacting protein (Hip). While the axon guidance function of Shh on postcommissural axons was detected in chicken embryos *in vivo*, a similar function was found for Wnt4 in mouse using *in vitro* assays. However, Wnt4 was shown to act as an attractant in accordance with its graded expression in the floor plate, with high levels rostrally and low levels caudally. Interestingly, Wnts were also found to act as repellents in longitudinal axon guidance in the corticospinal tract, where Ryk

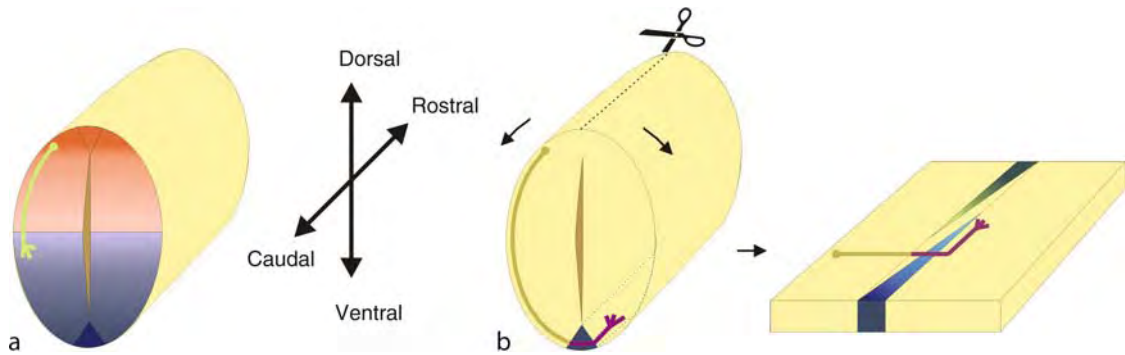

**Morphogens and Neural Development.** **Figure 2** Commissural neurons located in the dorsolateral spinal cord (green in (a)) send out their axon under the repellent influence of BMPs emanating from the roof plate (red) and the attractive effect of Netrin-1 and Shh (blue). Patched and Smoothed expressed by commissural neurons mediate the attractive effect of Shh. When commissural axons reach the floor plate (blue triangle in (b)) they express Hedgehog-interacting protein (Hip; purple). Cells that express Hip no longer perceive Shh as attractive, and instead respond with repulsion. Thus, postcommissural axons are directed rostrally along the contralateral border of the floor plate in response to the decreasing Shh gradient, with high levels caudally and low levels rostrally. At the same time, a Wnt gradient with high levels rostrally and low levels caudally attracts postcommissural axons (see text and references [8–10] for details).

is involved as a co-receptor with the Wnt receptor Frizzled.

### Morphogens in Topographic Mapping

Axons reaching their target area have to select individual cells to form a **synapse**. In the visual system **topographic mapping**, i.e. the connection between the retinal ganglion cell (RGC) axons with the appropriate target cell in the tectum, has been studied for decades. Two coordinate systems, with perpendicular orientation to each other, specify the target for each incoming RGC axon. **Eph-Ephrin** interactions are responsible for both the antero-posterior and the medial-lateral orientation [10]. Recent studies have now added a Wnt gradient for medial-lateral retinal axon mapping, another example where a morphogen acts in parallel to a classical axon guidance cue (see above), in this case EphrinB1.

### Morphogens in Synaptogenesis

Finally, morphogens have also been implicated in the last step of neural circuit formation, synaptogenesis [7]. In the spinal cord, Wnt3 expressed by motoneurons was shown to play a role in the formation of terminal branches of proprioceptive neurons that contact dendrites of motoneurons in the ventral spinal cord. Similarly, in the cerebellum, **mossy fibers** that form a special type of nerve ending called rosettes with dendrites of **granule cells** undergo morphological changes that depend on the presence of Wnt7a in granule cells. In the absence of Wnt7a, axonal remodeling is perturbed and appropriate presynaptic structures fail to form [7].

### Morphogen Transport

The mechanism of morphogen gradient formation is not well understood, as morphogens are not freely diffusible due to **posttranslational modifications**, such as palmitoylation in the case of Wnt and Shh, or the covalent attachment of a cholesterol molecule in the case of Shh. Models for morphogen transport and gradient formation include transcytosis, i.e. the repeated endocytosis and release of morphogen molecules, or their transport in form of lipoprotein particles or argosomes. Furthermore, facilitated diffusion by binding to cell surface heparan sulfate **proteoglycans** has also been suggested for Wnt, Shh, and FGFs.

### Morphogen Signaling

In general, signaling by morphogens results in the activation of gene expression in the nucleus. Signaling by BMPs and FGFs has obtained a lot less attention than Wnt and Shh signaling. FGFs bind to one of four FGF receptors that are single-pass transmembrane receptor tyrosine kinases [6]. Heparan sulfate proteoglycans are co-factors for the activation of FGF receptors by FGFs. BMPs bind to a receptor complex consisting of type I and type II serine/threonine kinases. Receptor activation results in **phosphorylation** of SMAD family members [3]. Common to signaling of the Wnt and Shh families are structural features of the surface receptors. Both use seven-pass transmembrane receptors, Frizzleds in the case of Wnts and Smoothed in the case of Hedgehogs. It is important to note, however, that Hedgehogs do not bind to Smoothed directly but rather to the twelve-pass transmembrane receptor Patched. Upon binding of Hedgehogs, Patched

de-represses Smoothed activity. The mechanism of Patched/Smoothed interaction is not yet known.

Intracellular components of both the Hedgehog and the Wnt signaling cascade are multiprotein complexes containing a ►[scaffold protein](#) and kinases. These complexes phosphorylate and stabilize  $\beta$ -catenin downstream of Wnts, and control levels of Gli repressor and Gli activators downstream of Shh.

Wnt signaling includes three different pathways, the canonical and the non-canonical pathway with the latter being subdivided into planar cell polarity (PCP) and  $\text{Ca}^{2+}$  pathways. The canonical pathway involves the stabilization of  $\beta$ -catenin. In the absence of Wnt,  $\beta$ -catenin is recruited to a multi-component complex consisting of the scaffold protein Axin, the tumor suppressor APC and two kinase families, CK1 and GSK. Subsequent ►[ubiquitination](#) results in degradation of  $\beta$ -catenin. If Wnt binds to the surface receptor Frizzled and co-receptors, such as Lrp5/6, phosphorylation of  $\beta$ -catenin is suppressed. Thus,  $\beta$ -catenin accumulates and can be transported to the nucleus, where it activates transcription by binding to LEF/TCF transcription factors.

In general signaling downstream of morphogens has only been studied in detail during early stages of development, including neural induction, differentiation and patterning. Signaling involved in later stages of development, such as axon guidance or synaptogenesis is not well understood. In axon guidance along the longitudinal axis of the spinal cord, the receptor for Shh is Hedgehog-interacting protein and no longer Patched [9,10]. Wnts appear to use Frizzled receptors for both axon guidance and earlier functions, but the intracellular signaling pathways have not been identified and do not seem to be identical to any of the well-known pathways (see above). In contrast to the classical roles of morphogens in tissue patterning, their role in axon guidance does most likely not involve changes in gene transcription but is restricted to more rapid changes in signaling affecting directly the cytoskeleton of growth cones.

## References

1. Baeriswyl T, Stoeckli ET (2006) In ovo RNAi opens new possibilities for temporal and spatial control of gene silencing during development of the vertebrate nervous system. *J. RNAi Gene Silencing* 2:126–135
2. Stern CD (2005) Neural induction: old problem, new findings, yet more questions. *Development* 132:2007–2021
3. Liu A, Niswander LA (2005) Bone morphogenetic protein signalling and vertebrate nervous system development. *Nat Rev Neurosci* 6:945–954
4. Jessell TM (2000) Neuronal specification in the spinal cord: inductive signals and transcriptional codes. *Nat Rev Genet* 1:20–29

5. Kiecker C, Lumsden A (2005) Compartments and their boundaries in vertebrate brain development. *Nat Rev Neurosci* 6:553–564
6. Mason I (2007) Initiation to end point: the multiple roles of fibroblast growth factors in neural development. *Nat Rev Neurosci* 8:583–596
7. Ciani L, Salinas PC (2005) WNTs in the vertebrate nervous system: from patterning to neuronal connectivity. *Nat Rev Neurosci* 6:351–362
8. Charron F, Tessier-Lavigne M (2005) Novel brain wiring functions for classical morphogens: a role as graded positional cues in axon guidance. *Development* 132:2251–2262
9. Stoeckli ET (2006) Longitudinal axon guidance. *Curr Opin Neurobiol* 16:35–39
10. Zou Y, Lyuksyutova AI (2007) Morphogens as conserved axon guidance cues. *Curr Opin Neurobiol* 17:22–28

## Mosaic Analysis with a Repressible Cell Marker

VERONICA G. RODRIGUEZ MONCALVO,  
ANA R. CAMPOS  
Department of Biology, McMaster University,  
Hamilton, ON, Canada

### Synonyms

MARCM

### Definition

Mosaic Analysis with a Repressible Cell Marker or MARCM is a set of genetic tools developed in the fruitfly *Drosophila melanogaster* for the positive labeling of individual cells or groups of cells derived from the same lineage. In addition, labeled cells may be generated that are homozygous mutant for genes of interest or that express constructs that modulate gene expression and/or function. This system was created by Liquan Luo and Tzumin Lee [1] and has been used extensively in this model organism for the analysis of neuronal differentiation, cell lineage and other biological processes outside of the nervous system.

### Characteristics

#### Overview

The nervous system is arguably one of the most complex tissues in the animal kingdom. Even in the simplest of the model organisms, its assembly requires not only the generation of a large number of diverse cell types but also the complex wiring of these cells. Therefore, the study of nervous system development and function is aided by the identification and genetic manipulation of a small number of neurons. Genetic tools unique to the *Drosophila* model system have



greatly facilitated the analysis of the molecular mechanisms underlying neuronal pattern formation by providing investigators with exquisite spatial and temporal control of gene expression and function. In this context, mobile DNA elements (▶P-elements), carrying heterologous transcription factors (e.g. *GAL4*) under the regulation of *Drosophila*-specific promoters have been used extensively for the targeted expression of reporter molecules, genetically modified alleles or more recently constructs capable of mediating gene silencing via RNA interference (▶RNAi).

The ability to induce, isolate and characterize the phenotypic consequence of single gene mutations has been fundamental to our current understanding of nervous system development and function in *Drosophila* and other model organisms. Relevant genes are for the most part expressed in a temporal and spatial complex pattern, which is reflected in the pleiotropic phenotype displayed by mutant organisms. Moreover, homozygous mutant animals may not survive to adulthood making it difficult to study the consequence of lack of gene function beyond a certain stage. In order to overcome these limitations, developmental biologists have relied on genetic ▶mosaic organisms in which homozygous mutant clones are generated in an otherwise wild type and heterozygous background. This approach has been used extensively in *Drosophila melanogaster* as well as in mice and *C. elegans*, to investigate the stage-specific cell autonomous requirement of gene function. Recent improvements to this system include the ability to generate small homozygous clones at specific times during development and to unambiguously identify individual homozygous mutant clones such that the cellular phenotype can be studied appropriately.

### Mechanism

Traditionally, genetic mosaics in *Drosophila* have been generated through chromosomal loss (e.g. ring X chromosome) or X-ray induced mitotic recombination. More recently, sequence-specific recombination systems (FLP/FRT or Cre/LoxP) have been introduced allowing efficient gene-specific mitotic recombination. While the generation of genetically distinct somatic clones is technically straightforward, a reliable way to unambiguously label specific cell types within mutant clones has been missing. In the past, external markers have been used to infer the genotype of internal tissue. An improvement on this approach was the introduction of reporter constructs whose loss would mark the presence of homozygous clones in an otherwise heterozygous-labeled organism. The shortcoming of this method was that mutant clones still remained unlabelled and thus not available to detailed morphological analysis.

MARCM is a major advance because it combines the ability to positively label small numbers of cells with the FLP-FRT recombination system previously

used to generate genetic mosaics (Fig. 1). This was made possible by the introduction of a repressible cell marker. In MARCM, the expression of reporter genes such as ▶GFP, driven by a tissue-specific *GAL4* construct, is repressed due to the ubiquitous expression of a *GAL4* inhibitor, *GAL80*. The *GAL80* gene is inserted in the same chromosomal arm as the wild type allele of a gene of interest *X*. The homologous chromosome carries a mutant allele of the gene *X* and no copy of *GAL80*. Mitotic recombination generates two daughter cells that differ from the parental cell regarding the genotype of the *FRT*-bearing chromosome in that they are homozygous for one or the other homologous chromosome. Therefore, the mitotic recombination event not only yields homozygous mutant cells but also relieves in these cells the repression of the *GAL4* construct through the loss of *GAL80* ▶transgene. The outcome is the generation of flies carrying single or multiple cells derived from a single progenitor that are homozygous mutant for a gene of interest. Specific cell types within the mutant clone will be positively labeled by the expression of a reporter construct that facilitates their morphological analysis. The size of the labeled clone depends upon the timing of FLP expression (refer to [2] for a detailed protocol). Moreover, as illustrated below, MARCM can be used to label clones of specific neurons without manipulating gene function. In this context, MARCM has been employed to investigate the developmental architecture – pattern of projection and clonal relationship – of specific neurons (see Fig. 2 for examples of MARCM generated clones).

The caveat is that, while labeling is found only in cells homozygous for the mutant chromosome (not carrying the *GAL80* repressor), not all mutant cells are labeled. Labeling of mutant cells is restricted to the cell types in which *GAL4* driver is expressed. Modifications to this method introduced recently address this issue but have not yet been used as extensively as MARCM [3].

### Components

All constructs described below are found within P-element vectors and were inserted into the *Drosophila* genome via ▶P-element mediated transformation.

1. *GAL4* is a yeast transcription factor that binds to specific DNA elements known as upstream activating sequence (*UAS*) and activates RNA transcription of reporter genes. It is often referred to as a “driver element.” In *Drosophila*, expression of *GAL4* under the control of tissue-specific regulatory sequences has been employed to activate the expression of reporter genes such as *GFP* or  $\beta$ -Galactosidase in specific cell types. Alternatively, one can increase the expression of a target gene (up-regulation), by introducing a full-length cDNA downstream from the *UAS* or silence a gene

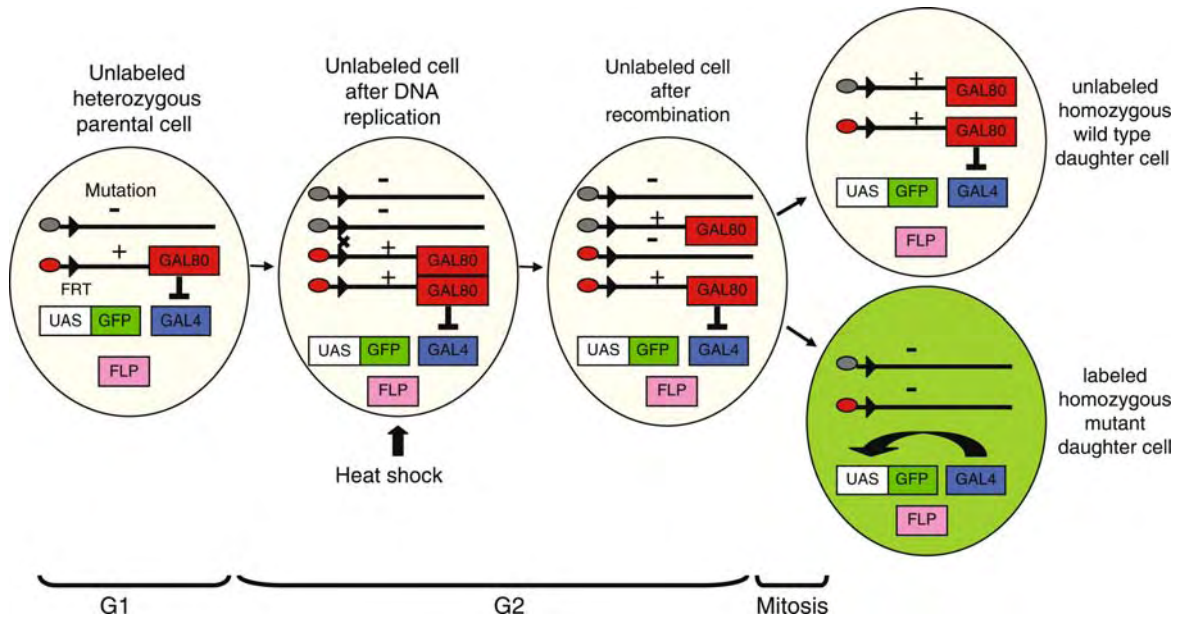

**Mosaic Analysis with a Repressible Cell Marker. Figure 1** Schematic representation of the MARCM system. MARCM requires two *FRT* sites (<sup>TM</sup>) situated at the same location and one copy of the *GAL80* gene downstream to one of the *FRT* sites. The genes encoding Flipase (FLP) recombinase, the tissue-specific *GAL4* driver, and the *UAS-GFP* may be located anywhere in the genome. Additionally, the *FRT*-bearing, non-*GAL80* chromosome may carry a mutation (-) distal to the *FRT* site. A brief heat shock induces *FLP* expression. At the *FRT* sites, FLP recombinates the wild type (+) *GAL80*-containing chromosome with its homologous mutant (-) chromosome. The resulting wild type (+/+) daughter cell will carry two copies of *GAL80*, which suppresses *GAL4*-dependent expression of the *UAS-GFP* (unlabeled cell). In the other daughter cell, which may be homozygous mutant for a gene of interest (-/-), the absence of *GAL80* allows for *GAL4*-mediated expression of the GFP (labeled cell). (Adapted from [2]).

- (knock-down), by introducing a construct capable of mediating RNA interference (RNAi).
2. *UAS-mCD8-GFP* This construct encodes a *GAL4* responsive reporter gene. In this case, the reporter is the green fluorescent protein (GFP), which has been fused to the transmembrane mouse lymphocyte marker CD8. This allows for targeting of GFP to the cell surface.
  3. Flipase (FLP) recombinase. FLP recombinase is a yeast enzyme that catalyzes mitotic recombination at *FRT* sites. *Drosophila* strains have been created carrying the FLP gene under the regulation of a ubiquitous promoter, such as the *tubulin* gene promoter (*tubP*), or a conditional promoter such as that of the *Heat Shock Protein 70* gene (*HSP70*).
  4. *FRT* sites. *FRT* sites are DNA sequences recognized by FLP recombinase. High frequency mitotic recombination is catalyzed by FLP at these sites. In flies heterozygous for a recessive allele of a gene of interest (+/-) in which *FRT* sequences are also present in the same chromosome, mitotic recombination at these sites yields homozygous mutant clones (-/-) as well as homozygous wild type twin clones (+/+). The latter are indistinguishable from the wild type heterozygous background (+/-).

5. *tubP-GAL80*- *GAL80* is a yeast protein that represses *GAL4* function as a transcription factor. In MARCM, the *GAL80* gene is under the control of the *tubulin* promoter (*tubP*) thereby providing ubiquitous repression of *GAL4* function. Mitotic recombination at *FRT* sites catalyzed by the *FLP* gene product eliminates the *GAL80* gene from one of the daughter cells thereby relieving *GAL4* from *GAL80* repression while at the same time inducing a loss of heterozygosity event in the same chromosome.

### Uses of MARCM

Since it was first published, MARCM has been used extensively. It has become an essential component of the ever-expanding *Drosophila* genetics toolbox. Below we describe briefly a few examples in which the use of MARCM system played an essential role in the genetic analysis of nervous system development.

### Neuronal Morphogenesis

MARCM has been effective in the investigation of axonal and dendritic branching patterns as well as neuronal wiring and circuitry formation. For instance, Grueber and colleagues employed MARCM to study dendrite

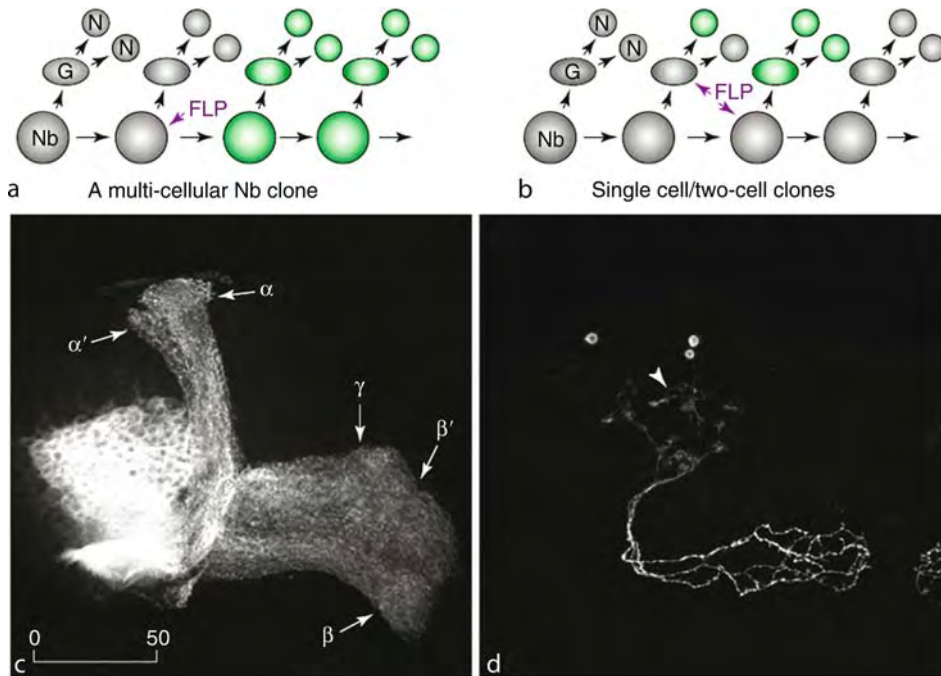

**Mosaic Analysis with a Repressible Cell Marker. Figure 2** MARCM clones in *Drosophila* mushroom bodies (MB). A neuroblast (Nb) generates a series of ganglion mother cells (GMC, G in Fig.). Each GMC generates two post-mitotic neurons (N). (a) A GAL80-negative Nb (GAL80<sup>-</sup>) gives rise to a multi-cellular clone. (b) If a GMC loses GAL80, a two-neuron labeled clone is generated. If mitotic recombination occurs in a dividing GMC, only one of the two post-mitotic neurons will be labeled. (c) and (d) Confocal images of MARCM clones of MB neurons. (c) A MB Nb clone produced by an early mitotic recombination event consists of hundreds of neurons at the adult stage visualized by mCD8-GFP expression. There are five axon bundles in the adult MB:  $\gamma$ ,  $\beta'$  and  $\beta$  projecting towards the midline and  $\alpha'$  and  $\alpha$  projecting dorsally. (d) Single cell labeling shows that each cell body extends a single process from which dendrites (arrowhead) branch out. (Modified with permission from Lee T, Luo L (2001) *Trends Neurosci* 24(5):251–254).

branching morphology and the establishment of dendritic territories of specific neurons of the *Drosophila* third instar larva peripheral nervous system [4]. They focused their studies on the dendritic arborization neurons (da), which spread their dendrites in a two-dimensional coverage of the larval epidermis. By examining single cell clones generated using MARCM and labeled by the expression of a pan-neuronal driver (*elav-GAL4*), da neurons were grouped into four morphological classes (I–IV) according to differences in dendrite branching complexity. Most importantly, these authors reported that neurons of the same class show dendritic exclusion or heteroneuronal tiling whereas those in different classes show extensive overlap of their dendritic fields. These pioneer studies set the stage for further investigations addressing the molecular genetic mechanisms underlying dendritic branching and tiling briefly discussed below.

#### Gene Function Requirement

The MARCM system has been successfully employed to assess the role of candidate genes in different biological processes. Of particular note are recent findings that further elucidate the role of *Down's syndrome cell adhesion molecule* (*Dscam*) in dendrite self-avoidance or

isoneuronal tiling. The *Drosophila Dscam* gene shows a remarkable degree of alternative splicing with the potential to generate more than 38,000 different isoforms and has been implicated in axonal and dendritic patterning. Using MARCM, three different groups addressed the cell autonomous requirement for *DsCam* gene in the patterning of the larval epidermis da sensory neurons [5,6,7]. These workers showed that *Dscam* mediates isoform-specific homophilic interactions required for self-avoidance within a single sensory neuron arbor. Interestingly, heteroneuronal tiling such as that of class II and IV sensory neurons is not affected by *Dscam* mutations suggesting the existence of an additional pathway. Thus, the current view of the molecular underpinnings of dendrite morphogenesis in *Drosophila* has been made possible by the high level of resolution afforded by single cell labeling and genetic manipulation unique to the MARCM system.

#### Mosaic Genetic Screens

Mutant screens constitute a powerful tool in the identification of genes essential for diverse biological processes. A forward genetic approach can be combined with the MARCM system, thereby bypassing pleiotropic

effect of mutations (i.e. early lethality) and increasing the sensitivity of the phenotype analysis. This strategy is well illustrated in the report of Reuter et al. [8]. These investigators carried out a genetic screen aimed at identifying genes that play a role in the morphogenesis of the larval MB neurons. To that end, homozygous mutant clones generated by MARCM were examined by virtue of expression of MB-specific *GAL4* drivers, which in turn activated the transcription of target reporter constructs (*UAS-mCD8-GFP*). In order to increase the frequency of MB clones, FLP expression was heat-induced in newly hatched larvae. At that time, the only dividing neuroblasts are those giving rise to the MB neurons. Nearly 20% of the genome was sampled by this approach. Larvae bearing mutant clones showing abnormal distribution of GFP, large cells, defective axonal transport and abnormal axon and dendrite morphogenesis were isolated. Further characterization of these mutations led to identification of new genes that play a role in neuronal morphogenesis as well as discovery of new functions of previously identified genes.

### Cell Lineage Analysis

The ability to induce mitotic recombination at different times during development makes MARCM particularly well suited for cell lineage analysis. Several investigators have taken advantage of these properties to investigate clonal relationships in the olfactory glomeruli and the mushroom body (MB), the area of the insect brain involved in olfaction-mediated learning and memory. As one of the earliest contributions of MARCM system, Lee et al. [9] showed that, in the *Drosophila* CNS, a single identified neuroblast sequentially gives rise to at least three distinct types of neurons. More interestingly, their projection into different MB lobes depends upon their birth order [9]. Similar strategy when applied to clonal relationship of projecting neurons of the *Drosophila* olfactory system demonstrated that their dendritic arborizations in the antennal lobe and thus odour representation, depends upon their birth order (reviewed in [10]).

### Acknowledgements

This work was supported by Canadian Institute of Health Research and Natural Sciences and Engineering Research Council grants to A.R. Campos. V.G. Rodriguez Moncalvo is supported by a Canadian Institute of Health Research grant to A.R. Campos (MOP-12700).

### References

1. Lee T, Luo L (1999) Mosaic analysis with a repressible cell marker for studies of gene function in neuronal morphogenesis. *Neuron* 22:451–461
2. Wu JS, Luo L (2007) A protocol for mosaic analysis with a repressible cell marker (MARCM) in *Drosophila*. *Nat Protoc* 1(6):2583–2589

3. Lai S-L, Lee T (2006) Genetic mosaic with dual binary transcriptional systems in *Drosophila*. *Nat Neurosci* 9(5):703–709
4. Grueber WB, Jan LY, Jan YN (2002) Tiling of the *Drosophila* epidermis by multidendritic sensory neurons. *Development* 129:2867–2878
5. Hughes ME, Bortnick R, Tsubouchi A, Baumer P, Kondo M, Uemura T, Schmucker D (2007) Homophilic *Dscam* interactions control complex dendrite morphogenesis. *Neuron* 54(3):417–427
6. Matthews BJ, Kim ME, Flanagan JJ, Hattori D, Clemens JC, Zipursky SL, Grueber WB (2007) Dendrite self-avoidance is controlled by *Dscam*. *Cell* 129(3):593–604
7. Soba P, Zhu S, Emoto K, Younger S, Yang SJ, Yu HH, Lee T, Jan LY, Jan YN (2007) *Drosophila* sensory neurons require *Dscam* for dendritic self-avoidance and proper dendritic field organization. *Neuron* 54(3):403–416
8. Reuter JE, Nardine TM, Penton A, Billuart P, Scott EK, Usui T, Uemura T, Luo L (1999) A mosaic genetic screen for genes necessary for *Drosophila* mushroom body neuronal morphogenesis. *Development* 130:1203–1213
9. Lee T, Lee A, Luo L (1999) Development of the *Drosophila* mushroom bodies: sequential generation of three distinct types of neurons from a neuroblast. *Development* 126:4065–4076
10. Komiyama T, Luo L (2006) Development of wiring specificity in the olfactory system. *Curr Opin Neurobiol* 16:67–73

## MOSAIC Model

### Definition

Modular selection and identification control (MOSAIC) model, proposed for solving a large-scale sensorimotor problem using multiple pairs of a forward (estimation) model and an inverse (control) model. An important ingredient in the model is how well a forward model predicts movement outcome or reward, defined as a responsibility signal. Those responsibility signals in turn determine which controllers will be used for a particular movement and which internal models will be updated accordingly. The MOSAIC model attempts to decompose a large-scale sensorimotor problem automatically by making each module specialized for a particular situation or task.

### ► Theories on Motor Learning

## Mossy Fibers

### Definition

Most afferents from the brainstem or spinal cord to the cerebellum terminate in the granule cell layer of the

cerebellar cortex as “mossy fibers”. They are so named because of the appearance of their terminals under the microscope. Mossy fibers carry almost all the information to the cerebellar cortex that affects the short-term firing rates of granule cells and other cells in the cerebellum. Mossy fibers terminate bilaterally in discrete areas of the vermis and of the hemispheres, evidencing a partial somatotopic arrangement. They are differentiated from “climbing fibers” that originate only in the inferior olive, terminate on Purkinje cells, and affect the firing rate of cerebellar neurons over the long-term.

- ▶ Cerebellum
- ▶ Cerebellar Functions

---

## Motion Aftereffect

### Definition

A visual motion illusion that occurs as a negative aftereffect of adaptation to motion. Often called the waterfall illusion after Robert Addams’ description of his experience when viewing the Falls of Foyers in Inverness, Scotland. The effect is produced by adapting to a stimulus that moves in a particular direction for a prolonged period. On subsequent viewing of a stationary object, e.g., the rocks beside the waterfall, results in their appearing to move in the opposite direction. Addams (1834) commented: “I saw the rocky surface as if in motion upwards, and with an apparent velocity equal to that of the descending water, which the moment before had prepared my eyes to behold this singular deception.”

- ▶ Perceptual Filling-in
- ▶ Visual Illusions

---

## Motion Analysis

STEPHEN J. PIAZZA

Department of Kinesiology, The Pennsylvania State University, University Park, PA, USA

### Definition

For the purposes of this essay, “motion analysis” is defined as the recording of the three-dimensional movements of human body segments, and the subsequent computation of meaningful parameters that describe the movement from raw kinematic data. The

collection of motion data may be accompanied by measurements of external forces acting on the body. In such cases, ▶[inverse dynamic analysis](#) may be performed to estimate joint forces and moments internal to the body.

### Purpose

It is often necessary to track the motions of the human body in three dimensions in order to answer questions about the biomechanics and neural control of movement. Examples of such investigations include studies of posture, gait, movement perturbation, and reaching. Motion analysis is applied on a routine basis in ▶[clinical gait analysis](#), for the purpose of gathering data that is used to inform surgical decision-making for patients with gait abnormalities secondary to neurological conditions such as cerebral palsy and stroke.

### Principles

#### *Motion Analysis Systems: Image-Based*

Three-dimensional image-based motion analysis involves the use of two or more cameras to track markers applied to the skin of a subject. Markers are usually spherical and covered with reflective tape in order to maximize the reflection of either visible or infrared light. Image-based motion analysis came of age in the 1970s, when sufficient computing power became available to rapidly transform two-dimensional camera views into three-dimensional marker coordinates. Making this transformation requires information about the position and orientation of each camera, as well as camera-specific corrections to account for optical distortion. The process of determining these parameters is known as ▶[camera calibration](#). One widely-used calibration procedure is called the ▶[direct linear transformation](#) [1], and involves linear least-squares determination of camera parameters given a set of control points whose locations within the laboratory are known. Today, most commercially available systems use a two-step calibration process consisting of a static calibration followed by a dynamic calibration, with the correction for lens distortion handled separately. The static calibration establishes a laboratory-fixed coordinate system and involves the placement of stationary markers that define this coordinate system in view of all cameras. In the dynamic calibration, a rigid rod fitted with two markers is waved in front of the cameras, and parameters defining the position and orientation of the cameras are determined by iteratively minimizing deviations in the intermarker distance throughout the motion. In a process called ▶[reconstruction](#), camera parameters determined during the calibration procedure are used to compute three-dimensional marker locations following actual motion trials.

To establish the position and orientation of a body segment within the laboratory coordinate system, it

is necessary to locate a minimum of three markers attached to that segment during each timeframe. If these three markers are placed on bony landmarks, they may be used to define both an **anatomical coordinate system** and a  $4 \times 4$  matrix specifying a **homogeneous transformation** [2] between the laboratory coordinate system and the anatomical coordinate system. Alternatively, a cluster of three or more markers not located on landmarks may be tracked. If the segment-fixed locations of the cluster markers within the anatomical coordinate system are known, it is possible to determine the homogeneous transformation between the laboratory and segment anatomical coordinate systems using a least-squares approach [3].

### Motion Analysis Systems: Magnetic

Motions may also be tracked in three dimensions using magnetic tracking devices. Such devices consist of a transmitter unit, which broadcasts three superimposed electromagnetic fields in the volume of interest, and one or more sensors that are applied to body segments. Each sensor contains three mutually-orthogonal passive antenna coils. Measurement of the currents induced in the sensor coils permits computation of the homogeneous transformations between the transmitter and each sensor.

### Measurement of Ground Reaction Force

Measurements of human movement are often accompanied by determination of the ground reaction force carried out using a force plate. A force plate is a flat steel plate supported at each of its four corners by a pillar instrumented for measurements of triaxial force (gauges affixed to these pillars actually measure strain) [4]. Forces measured at the four corners are summed to obtain the three-dimensional ground reaction force vector. A force plate gives no information about the distribution of ground reaction force underfoot, but forces measured at the individual pillars can be used to locate the **center of pressure**, the point at which

the resultant ground reaction force could be assumed to act if it acted at a single point. The motion of the center of pressure during standing is a commonly-used indicator of postural stability.

### Computation and Reporting of Joint Angles

Once laboratory-to-anatomical homogeneous transformations have been determined, it is possible to compute from them the transformations between the anatomical coordinate systems of adjacent segments. These transformations may then be decomposed in a variety of ways to arrive at the joint angles that are often of experimental or clinical interest. For example, we might use a motion analysis system to establish the locations of the thigh and shank anatomical coordinate systems, and then decompose the transformation between those two coordinate systems to the flexion-extension, abduction-adduction, and internal-external rotation angles of the knee joint. The most commonly used technique for obtaining joint angles is **Euler/Cardan angle decomposition** (Fig. 1).

A set of Euler/Cardan angles describes the three-dimensional rotation of one coordinate system into another, by starting with the coordinate systems initially aligned and applying a series of three rotations about the axes of one of the coordinate systems [2]. These rotations may occur about the axes of the coordinate system considered to be moving (resulting in “body-fixed” rotations) or about the axes of the fixed coordinate system (“ground-fixed” rotations). Rotation sequences must be specified (e.g. X-Y-Z) when reporting joint angles, as their selection will influence the angles computed [5], and a sequence may include two rotations about the same axis (e.g., Z-X-Z). Care must be taken when choosing a rotation sequence to avoid selecting one that will result in singularities that will prevent decomposition of the transformation matrix. A widely-used convention for reporting human knee joint angles [6] has been adapted for use at other joints and involves rotation of the tibia first about the

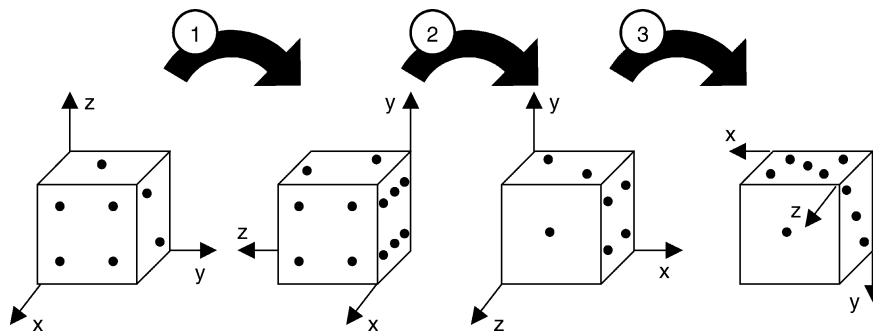

**Motion Analysis. Figure 1** Example of an Euler/Cardan rotation sequence of the type often used to describe three-dimensional joint rotations. In this example, the first rotation is  $90^\circ$  about the x-axis and is followed by a second rotation of  $90^\circ$  about the new y-axis. The third rotation is  $180^\circ$  about the twice-rotated z-axis. This is an example of an X-Y-Z body-fixed rotation sequence.

flexion axis (shared by femur and tibia), then about a tibia-fixed abduction-adduction axis, and finally about a tibia-fixed internal-external rotation axis. An alternative method for quantifying the relative rotations between body segments is ►**helical axis decomposition** [5]. It is always possible to describe the transformation from one coordinate system into another using a single rotation about an axis fixed in both coordinate systems coupled with a translation along that axis. Scaling the unit vector along the rotation axis by the magnitude of the rotation gives three components of the rotation that are analogous to joint angles. A second alternative to Euler/Cardan angles for reporting three-dimensional rotations involves the use of Euler parameters (or quaternions), a singularity-free method that is more robust computationally though less intuitively appealing.

### Inverse Dynamic Analysis

The direct measurement of muscle forces is too invasive to perform on a routine basis, but muscle actions are often estimated from motion and force data in inverse dynamic analysis. This procedure involves computing the internal joint reaction forces and moments acting at the proximal end of a body segment for which the external force acting at the distal end is known. The external force may be measured (using a force plate in the case of a foot on the ground) or assumed to be zero (when the distal segment does not contact the ground). The Newton-Euler equations are used to compute proximal forces and moments from external forces and the position, velocity, and acceleration of the segment. Masses and moments of inertia that appear in the Newton-Euler equations must be determined using anthropometric estimation techniques. The forces and moments computed for the most distal segment are then used to compute the forces and moments at the next most proximal joint, and so on. The joint moments computed in this manner do not give information about the actions of individual muscles, but muscle forces are often obtained from these moments by applying optimization theory. Joint moments may be combined with measurements of the rate of joint rotation to compute the joint power, the rate at which energy is generated or absorbed by the muscles crossing a given joint.

### Advantages and Disadvantages

Modern motion analysis systems are capable of highly accurate measurements of the locations of individual markers. Marker location errors are typically less than 1 mm for image-based systems that use digital cameras. These systems permit image processing to occur at the individual cameras rather than at a central processor, and thus permit increased resolution and capture rates. Despite this high degree of marker location accuracy, significant methodological barriers remain to the

accurate measurement of joint kinematics. As markers cannot be mounted on bones, movements of skin and other soft tissues contribute to errors in measured motion. Attempts to reduce these errors have included the identification of locations on body segments that are less susceptible to skin movement [7], and mathematical weighting techniques that correct for soft tissue deformation [8].

The reliable establishment of anatomical coordinate systems is sometimes difficult in practice. When coordinate systems are not created properly, one potential consequence is “kinematic crosstalk,” which is the misinterpretation of motion about one joint axis as motion about another axis [9]. For example, if the knee flexion axis is misidentified, then pure knee flexion may be taken to be a combination of flexion and abduction. The accurate location of joint centers is important for the creation of anatomical coordinate systems, and for effectively carrying out inverse dynamic analyses, but some joint centers, such as that of the hip are deep, and thus difficult to locate from bony landmarks. This issue

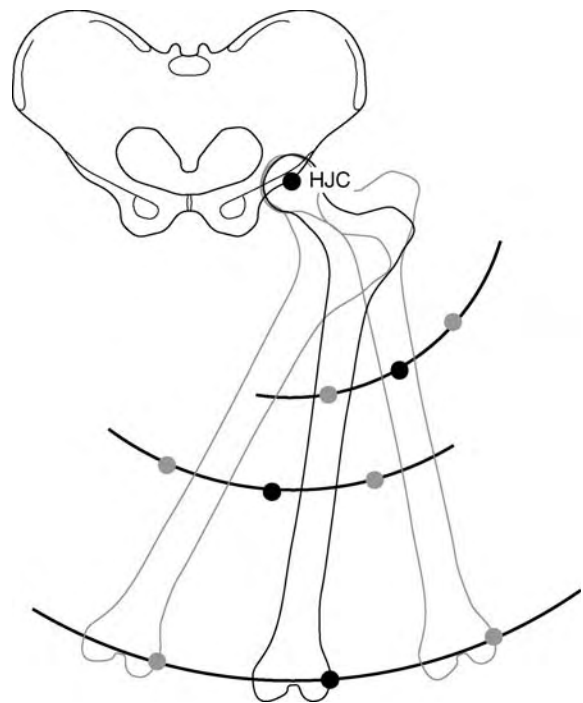

**Motion Analysis. Figure 2** Illustration of the basis for functional location of the hip joint center. Markers affixed to the thigh trace out paths on spheres whose shared center is the hip joint center. Measurement of the motions of these markers and subsequent sphere-fitting permits location of the hip joint center, which does not rely upon location of bony landmarks near the joint center. Similar techniques have been employed to establish the joint centers or joint axes of all the joints of the upper and lower extremities.

has been addressed by the development of “functional” methods for fitting joint centers and joint axes to measured motions [10] rather than predicting their locations from the locations of bony prominences (Fig. 2).

Conventional motion analysis methods serve well when used to track the motions of large body segments, but fall short when they are employed to measure motions of less well-defined segments. Motion analysis of the foot, for example, is problematic because it contains joints, such as the subtalar and tarsometatarsal joints, which join body segments not easily tracked with external markers.

## References

1. Abdel-Aziz YI, Karara HM (1971) Direct linear transformation from comparator coordinates into object space coordinates in close range photogrammetry. In: Proceedings of Symposium on Close Range Photogrammetry, Falls Church, VA, pp 1–18
2. Craig JJ (1986) Introduction to robotics: mechanics and control, 2nd edn. Addison-Wesley, Reading, MA
3. Veldpaus FE, Woltring HJ, Dortmans LJ (1988) A least-squares algorithm for the equiform transformation from spatial marker co-ordinates. *J Biomech* 21:45–54
4. Winter DA (2004) Biomechanics and motor control of human movement. Wiley, New York
5. Woltring HJ (1994) 3-D attitude representation of human joints: a standardization proposal. *J Biomech* 27:1399–1414
6. Grood ES, Suntay WJ (1983) A joint coordinate system for the clinical description of three-dimensional motions: application to the knee. *J Biomech Eng* 105:136–144
7. Cappello A, Cappozzo A, della Croce U, Leardini A (1997) Bone position and orientation reconstruction using external markers. In: Allard P, Cappozzo A, Lundberg A et al. (eds) Three-dimensional analysis of human locomotion. Wiley, New York, 1997, pp 147–171
8. Andriacchi TP, Alexander EJ, Toney MK, Dyrby C, Sum J (1998) A point cluster method for in vivo motion analysis: applied to a study of knee kinematics. *J Biomech Eng* 120:743–749
9. Piazza SJ, Cavanagh PR (2000) Measurement of the screw-home motion of the knee is sensitive to errors in axis alignment. *J Biomech* 33:1029–1034
10. Cappozzo A (1984) Gait analysis methodology. *Hum Mov Sci* 3:27–50

## Motion and Direction Sensitivity in Cutaneous Mechanosensation

### Definition

Motion and direction sensitivity is studied using air jets, brushes and probes applied to different body regions. Its

functional significance relates to both manual dexterity and postural control. The capacity for human subjects to identify the direction of stimulus motion on the skin is dependent on stimulus velocity, contact force and length of movement. It also varies in proportion to the innervation density of the fast and slowly adapting type I mechanoreceptive afferents.

- ▶ Cutaneous Mechanoreceptors, Anatomical Characteristics
- ▶ Cutaneous Mechanoreceptors, Functional Behavior
- ▶ Processing of Tactile Stimuli

## Motion Correspondence in Vision

### Definition

When viewing a series of discrete frames, such as a video sequence, objects and their features in motion relative to the camera change position from one frame to the next. The motion correspondence problem is to track motion by identifying the correspondence between features across time.

- ▶ Visual Motion Processing

## Motion Opponency in Vision

### Definition

A mechanism is said to be motion opponent if it is excited by motion in one direction and inhibited by motion in the opposite direction.

- ▶ Visual Motion Processing

## Motion Parallax in Vision

### Definition

Motion parallax is a cue resulting from our own motion to the relative distance of objects. As we move, objects that are closer to us move farther across our field of view than do objects that are in the distance.

- ▶ Visual Motion Processing



## Motion Perception

### Definition

The ability to perceive movement.

## Motion Sickness

BILL J. YATES

Department of Otolaryngology, University of Pittsburgh, School of Medicine, Eye & Ear Institute Building, Pittsburgh, PA, USA

### Definition

Motion sickness is a malady triggered by movement or perceived movement in the environment. In humans it is characterized by the presence of nausea and vomiting, pallor, cold sweating and a large increase in the circulating levels of the hormone arginine vasopressin.

### Characteristics

#### Conditions that Produce Motion Sickness

Typically, motion sickness is elicited during conditions where multiple sensory inputs are present that provide contradictory information regarding body position in space [1]. Often, the sensory mismatch involves the vestibular and visual systems, as well as the somatosensory system. For example, when an individual is traveling within a boat or aircraft, there may be no tangible visual cues indicating the presence of movement, whereas vestibular receptors and proprioceptors signal that movement is taking place. Moving visual scenes, such as those generated by virtual reality devices, can also induce motion sickness, as the visual system indicates that the individual is moving whereas the vestibular system indicates that the head is stationary. However, other mismatched sensory inputs can also induce motion sickness. For example, many astronauts experience “space motion sickness” after entry into zero gravity, which is presumably triggered during head movements because the semicircular canals provide inputs indicating that the head is rotating, but the vestibular otolith organs (which are no longer subjected to gravitational forces, and thus do not signal the presence of head tilts) fail to indicate that head position has been altered [2].

The most critical signals required for the generation of motion sickness come from the vestibular system,

as evidenced by that fact that this malady cannot be induced in individuals with bilateral vestibular dysfunction by stimuli that are typically highly provocative [3]. Furthermore, diseases that affect the vestibular system, such as inner ear infections, often produce signs and symptoms that are similar to those that occur during motion sickness. Fortunately, the vestibular system is very plastic and rapid adaptation occurs during conditions involving the disruption of the normal pattern of inputs from the inner ear to the brainstem. Such plasticity in the vestibular system probably explains why space motion sickness resolves after a few days of spaceflight. Visual inputs are not essential for producing motion sickness, since blind individuals have normal sensitivity for this condition (see [4] for a review).

Minimizing sensory conflict can often reduce the susceptibility for motion sickness. For example, motion sickness is less prevalent in drivers of automobiles, who are attending to visual cues reflecting the presence of movement, than in passengers who may be minimizing visually related movement cues by focusing their eyes on objects within the vehicle. Furthermore, repeated exposure to a provocative environment reduces the incidence and severity of motion sickness when that environment is experienced again. For instance, space motion sickness is less prevalent in veteran astronauts than individuals experiencing their first space flight [2]. Nonetheless, there are considerable individual differences in susceptibility to motion sickness that probably have a complex etiology and are not well understood.

### Physiological Manifestations of Motion Sickness

Motion sickness in humans is typically associated with several prominent symptoms and signs, including nausea and vomiting, pallor and cold sweating. Another physiological manifestation of the malady is a large increase in the levels of the posterior pituitary hormone arginine vasopressin circulating in the blood [1]. However, these indicators are not present in all species. For example, many animals, including rodents and lagomorphs (i.e. rabbits and hares), lack the ability to vomit and thus do not exhibit this hallmark sign of motion sickness. Non-emetic species often will ingest non-nutritive substances such as clay after exposure to stimuli that would produce vomiting in humans. Animals that lack the capacity to vomit exhibit increases in the posterior pituitary hormone oxytocin rather than vasopressin, after exposure to nauseogenic stimuli (see [4] for discussion).

### Neural Mechanisms that Produce the Physiological Manifestations of Motion Sickness

Retching and vomiting are mainly the result of the coordinated contractions of the major respiratory

muscles and upper airway muscles [5]. The pattern of contraction of these muscles differs during breathing and emesis. During breathing, inspiratory muscles such as the diaphragm and expiratory muscles such as the abdominal muscles contract out of phase, to generate the forces that move air into and out of the lungs. In contrast, the diaphragm and abdominal muscles contract together during retching and vomiting to place considerable pressure on the stomach, thereby pushing the gastric contents towards the mouth. The autonomic nervous system contributes to generating vomiting by producing marked reductions in gastric tone and motility, changes in gastric myoelectric activity and a retrograde giant contraction that moves contents from the upper part of the small intestine back into the stomach before expulsion. Furthermore, a longitudinal contraction of the esophagus occurs that pulls open the relaxed gastroesophageal junction and thus forms a funnel that facilitates free flow of gastric contents to the esophagus.

It is generally believed that a common neural circuitry mediates vomiting, elicited by a variety of triggering signals, including motion-related inputs relayed to the vestibular nuclei, circulating toxins detected by the area postrema, visceral signals conveyed to the nucleus solitarius and even psychological perceptions (e.g. thought of a disgusting situation) processed through the limbic system. Figure 1 provides a synopsis of current information regarding the neural circuitry that produces the contractions of inspiratory and expiratory respiratory muscles that generate retching and vomiting.

The rhythmic contractions of the diaphragm and expiratory muscles during breathing are controlled by neurons located in the dorsal and ventral respiratory groups in the brainstem. However, the firing of many of these respiratory group neurons, particularly neurons with inspiratory-related activity, is inhibited during vomiting. This suggests that separate pattern generators coordinate the contractions of respiratory muscles during breathing and emesis. Recent anatomical [6] and physiological [7] evidence suggests that some of the neurons that are part of the vomiting pattern generator are located within the medial reticular formation of the medulla. Presumably, a neural integrator processes trigger signals for vomiting and when appropriate activates the pattern generator that produces this response. The identity of this neural integrator is unknown, although there is evidence that the neurons that form the integrator are located in the medulla. Vomiting can be produced in a reduced animal preparation in which all parts of the nervous system except the medulla and spinal cord are removed, indicating that the essential neural circuitry for producing emesis is confined to these regions [8].

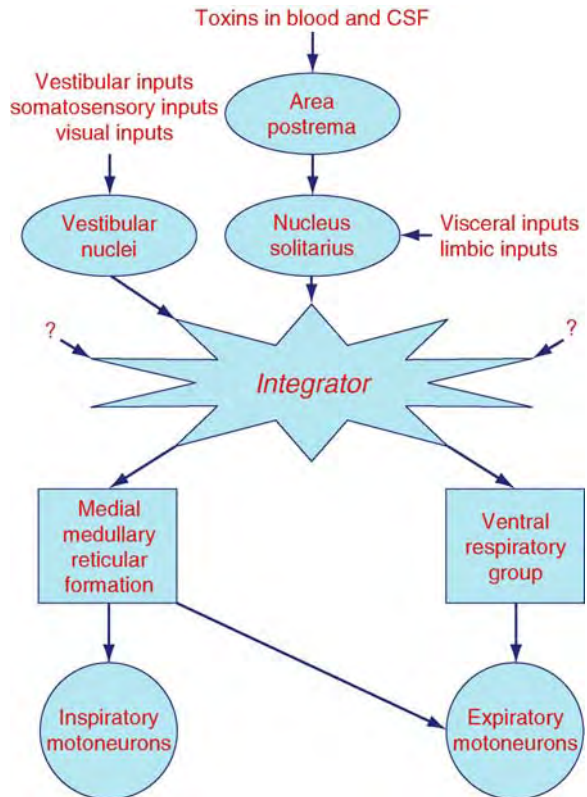

**Motion Sickness. Figure 1** Neural pathways that produce vomiting. A common circuit produces vomiting in response to a number of triggering signals, including conflicting motion information, toxins in the blood or visceral inputs. This circuit includes an integrator that processes the triggering signals and a pattern generator that mediates the contractions of respiratory muscles that produce vomiting. The pattern generator is comprised in part of neurons located in the medial medullary reticular formation and the ventral respiratory group.

The neural pathways that produce nausea have remained elusive, but almost certainly are distinct from the pathways that generate vomiting (i.e. although nausea and vomiting are frequently triggered together, distinct circuits coordinate each response). The level of nausea is typically correlated with the concentration of the hormone vasopressin circulating in the blood, although this hormone does not appear to be critical for the production of nausea and is released as part of a parallel physiological response [4].

As noted above, conflicting sensory information regarding the position of the body in space is believed to be the primary trigger for motion sickness-related nausea and vomiting. Stimulation of the vestibular nerve can produce vomiting in animal preparations lacking the cerebellum, suggesting that the cerebellum is not a necessary component of the circuitry

that produces motion sickness. Nonetheless, there is evidence to suggest that regions of the cerebellum particularly the nodulus and uvula are typically engaged in generating the signs and symptoms of motion sickness.

### Pharmacological Agents that Suppress Motion Sickness

Drugs employed to treat motion sickness fall into two categories: (i) those that are only effective in alleviating motion-related nausea and vomiting and not the symptoms produced by other emetic triggers and (ii) those that serve as broad-spectrum anti-emetic drugs and suppress nausea and vomiting despite the trigger. Drugs in the former category presumably affect receptors in the vestibular nuclei and central vestibular system, whereas those in the latter category probably act on receptors of cells that form the central integrator responsible for producing nausea and vomiting [4].

Anticholinergic drugs that act on muscarinic receptors are the most effective agents in clinical use for treating motion sickness, but have limited efficacy in ameliorating nausea and vomiting elicited by other trigger signals. Scopolamine, which blocks all five subtypes of muscarinic receptors, is the most commonly employed anticholinergic drug for treating motion sickness. Scopolamine has a number of significant side effects, including sedation and dry mouth and is only available by prescription in most countries.

Antihistamines form another class of drugs that have some efficacy in reducing the symptoms of motion sickness, but not nausea and vomiting elicited by triggers such as toxins and visceral signals. Most “over the counter” anti-motion sickness drugs, such as dimenhydrinate (marketed under the brand names Dramamine and Gravol) and meclizine (Antivert, Bonine), belong to this drug class. Antihistamines are less effective than anticholinergics in combating motion sickness, but have a longer duration of action and are considerably safer and thus are used more frequently. Nonetheless, antihistamines do produce some drowsiness and dizziness.

A third type of drug employed to treat motion sickness has mixed antimuscarinic and antihistamine actions. An example of such a drug is promethazine (Phenergan), which is employed by NASA to treat space motion sickness in astronauts. The side effects of promethazine are similar to those of anticholinergics and antihistamines and include drowsiness.

Drugs that increase the release of norepinephrine in the central nervous system (sympathomimetics) also have efficacy in treating motion sickness. Drugs in this class include amphetamine and ephedrine. Sympathomimetics do not produce drowsiness, a side effect shared by anticholinergics and antihistamines, and thus have been used by individuals who must perform work

while in an environment that may induce motion sickness. However, amphetamine is addictive and some states and countries have forbidden the use of this drug to treat motion sickness. Similarly, benzodiazepines such as diazepam (Valium) have some effectiveness in treating motion sickness, but are not commonly used for this purpose due to the risk of addiction and the occurrence of side effects when minimal required doses are delivered.

Several drugs are broad-spectrum anti-emetics and have promise in reducing the nausea and vomiting elicited by any trigger. Amongst these drugs are agonists for the serotonin 5-HT<sub>1A</sub> or 5-HT<sub>2</sub> receptors, antagonists of n-methyl-d-aspartate (NMDA) or neurokinin type 1 (NK-1) receptors and some calcium channel blockers.

### Evolutionary Significance of Motion Sickness

Since all individuals with an intact vestibular system have some predisposition for developing motion sickness, it is tempting to speculate that this condition has evolutionary significance. Treisman [9] hypothesized that motion sickness is a poison response in that toxins could affect the processing of visual and vestibular inputs and induce the sensory conflict that elicits nausea and emesis. In other words, modern circumstances such as space and air travel that result in conflicting sensory information regarding body position in space can trigger mechanisms that evolved to prevent poisoning. However, there is little experimental evidence to support Treisman’s theory. It is now well established that the vestibular system provides influences on the brainstem circuitry that regulates blood pressure and respiration and elicits the changes in blood distribution in the body and alterations in respiratory muscle activity that are needed during movement and changes in posture [10]. It is thus feasible that the signs and symptoms of motion sickness are due to an aberrant activation of neural circuits that typically function to maintain homeostasis. Such a notion is impossible to test experimentally, but it raises the possibility that motion sickness has no evolutionary significance and is in fact a “mistake” that was never corrected because the circumstances that generate the condition (e.g. travel in airplanes and boats) have only become commonplace in the modern world.

### References

1. Money KE, Lackner JR, Cheung RSK (1996) The autonomic nervous system and motion sickness. In: Yates BJ, Miller AD (eds) Vestibular autonomic regulation. CRC, Boca Raton, pp 147–173
2. Oman CM (1998) Sensory conflict theory and space sickness: our changing perspective. *J Vestibular Res* 8:51–56

3. Cheung BS, Money KE, Jacobs I (1990) Motion sickness susceptibility and aerobic fitness: a longitudinal study. *Aviat Space & Environ Med* 61:201–204
4. Yates BJ, Miller AD, Lucot JB (1998) Physiological basis and pharmacology of motion sickness: an update. *Brain Res Bull* 47:95–406
5. McCarthy LE, Borison HL (1974) Respiratory mechanics of vomiting in decerebrate cats. *Am J Physiol* 226:738–743
6. Billig I, Foris JM, Enquist LW, Card JP, Yates BJ (2000) Definition of neuronal circuitry controlling the activity of phrenic and abdominal motoneurons in the ferret using recombinant strains of pseudorabies virus. *J Neurosci* 20:7446–7454
7. Miller AD, Nonaka S, Jakus J, Yates BJ (1996) Modulation of vomiting by the medullary midline. *Brain Res* 737:51–58
8. Miller AD, Nonaka S, Jakus J (1994) Brain areas essential or non-essential for emesis. *Brain Res* 647:255–264
9. Treisman M (1977) Motion sickness: an evolutionary hypothesis. *Science* 197:493–495
10. Yates BJ (1996) Vestibular influences on the autonomic nervous system. *Ann NY Acad Sci* 781:458–473

## Motion Vision

- ▶ Visual Motion Processing

## Motivation

### Definition

Motivation is a theoretical construct employed by experimental psychologists and philosophers when they seek to explain specific patterns of behavior. This term also refers to processes by which behavior is activated and directed. Physiological psychologists postulated that homeostatic imbalance within specific regulatory systems such as those responsible for energy, fluid or thermoregulation, gave rise to specify “drive” states. Reduction of a specific “drive” state by consumption of food or water reduced motivation to seek these stimuli and also provided reinforcement to repeat action patterns that brought the organism into contact with these natural reward stimuli.

- ▶ Learning and Motivation

## Motoneuron

### Definition

Motoneurons are neurons whose cell bodies lie in motor nuclei of cranial nerves in the brainstem or in the anterior horn of the spinal cord and whose efferent axons leave the central nervous system (CNS) to innervate muscle fibers. There are three classes of motoneurons. Large motoneurons with extensive dendritic trees and fairly thick myelinated axons and high action potential conduction velocity innervate skeletal muscle fibers and may thus be called skeleto-motoneurons. Among these, one class innervates skeletal muscle fibers only and is called  $\alpha$ -motoneuron. A second class innervates skeletal muscle fibers and intrafusal muscle fibers of muscle spindles and is called  $\beta$ -motoneuron. The third class of smaller motoneurons with thinner myelinated axons innervates intrafusal muscle fibers of muscle spindles only and is called  $\gamma$ -motoneuron (or fusimotor neuron).

- ▶ Motor Units
- ▶ Muscle Spindle

## Motoneuron Pool

### Definition

The set of spinal or brainstem skeletal motoneurons that innervate a given skeletal muscle.

- ▶ Motor Cortex – Hand Movements and Plasticity

## Motor Actions

### Definition

Any changes in state variables; may be elicited by external forces while control variables remain constant (involuntary actions, e.g., motion of the arm to a new position elicited by unloading) or by changes in control variables (e.g., intentional actions), or both.

- ▶ Equilibrium Point Control

## Motor Axon

### Definition

The axonal projection of a motoneuron that leaves the spinal cord via a ventral root (or the brain stem via a cranial nerve), travels through a peripheral nerve, and terminates within its target muscle in multiple fine twigs, each of which projects to a single muscle fiber.

► Motor Units

## Motor Centers

### Definition

Broad term used to describe all structures in the brain concerned with motor behavior.

► Evolution of the Optic Tectum: In Amniotes

## Motor Command

### Definition

Signals carried by neurons of brain descending systems, for example, corticospinal neurons, to motoneurons in the spinal cord or brainstem. These signals are the final product of the central motor process that translates the plan for a movement into descending signals specifying the muscle synergies and activation profiles needed to achieve the desired movement.

► Corticospinal Neurons  
 ► Motor Cortex: Output Properties and Organization  
 ► Muscle Synergies

## Motor Control

UWE WINDHORST  
 Göttingen, Germany

### Introduction

In order to live, grow, survive and reproduce, organisms must be capable of at least two things. Firstly, they

must be able to move because movement is the very prerequisite of life, even at the molecular level. Secondly, they must be able to ► **control** this movement in relation to relevant aspects of their natural environment, which in turn implies that they must be able to detect, categorize, recognize, and act on, aspects of their environment. The term “motor control” encompasses all these aspects. This overview article concentrates on some general aspects and principles of motor control.

As an introductory concrete example, consider the cat’s, dog’s or turtle’s scratch “reflex” (► **Scratching**). In cats or dogs, the scratch reflex is “switched on” by a stimulus to a defined skin area on the upper forelimbs, neck, pinnas and adjacent skin areas (for review see [1]). The reflex consists of several components. Since an ipsilateral hindlimb needs to be flexed for scratching and, hence, taken off the ground, the posture (► **Postural control**) of the body must be changed and equilibrium re-stabilized by the other three limbs. The flexed hindlimb is then brought into a “postural” position for aiming at the stimulus. Subsequently, the scratching limb falls into a sequence of oscillations with long flexor and short extensor phases.

This example suggests that the system organizing the scratch reflex is composed of several subsystems executing particular tasks:

- ► **Sensory systems**, that are adequately tuned to detect, locate and identify the stimulus as well as the positions of the body parts throughout the sequence of events, involving cutaneous mechanoreceptive and proprioceptive senses, in particular.
- **Motor system** with
  - Central control system that organizes the goal-directed movement.
  - Executive system (skeleton, ► **muscles** etc.).
- **Interfaces** connecting the sensory and motor systems.

At a closer look, this simplified scheme can be elaborated by including

- ► **Information systems**, that select, represent, transfer, process, store and retrieve pertinent information (see ► **Sensory systems**).
- ► **Central pattern generators (CPGs)**, which generate the rhythmical components of movement, and other generators of goal-oriented movements.
- **Coordinate transformations**, here from a sensory frame of reference into a motor frame of reference (► **Sensory Systems**). Such transformations are required because the sensory and motor frames are different. For example, cutaneous receptors are distributed across a 2D surface intricately folded in 3D space, while scratching movements are executed in multi-dimensional joint space, with certain restrictions such as exclusion of the own body.

- *Body schema*, i.e., a neural representation of the body's anatomical (spatial) configuration, which allows the localization of sensory stimuli and motor events with respect to the body, and integrates and aligns various reference frames (see ▶ [Sensory systems](#)).
- *Adaptability* of neuronal connections to particular circumstances, conditions and contexts.

## Classes of Movement

A cat's or dog's scratch reflex is composed of several components. We may suspect that these components are organized by different neural sub-systems. In order to explore this idea further, we will start by provisionally classifying movements into the following categories, with subsequent qualifications:

- ▶ *Rhythmic movements* (e.g., over-ground ▶ [locomotion](#), ▶ [swimming](#), ▶ [flying](#), scratching, ▶ [mastication](#), ▶ [Respiration – neural control](#)).
- ▶ *Reflexes*: Reflexes provide an appropriate response closely coupled to a sensory input of some sort.
- *Motor activity to maintain equilibrium and posture* (▶ [Postural control](#)).
- *Free, goal-oriented movements*, such as reaching, grasping and object manipulation (▶ [Voluntary movement](#); ▶ [Reaching movements](#)).

Actually, most movements involve aspects of more than one of these classes, as evidenced by the above scratch reflex. All movements in some way require posture as a basis to work on. In terrestrial vertebrates, whose bodies are maintained above the ground by legs, posture depends on some basic excitatory “tone” of anti-gravity muscle groups as well as on reflexes. Also, rhythmic and free goal-oriented movements may be modulated by, or make use of, reflexes. Conversely, reflexes may incorporate rhythmic components, or can be modulated by free goal-oriented or other activities of the organism. However, these classes may still be useful guidelines to unveil neuronal networks and their operations underlying movements.

## Rhythmic Movements

Generally, movements should be as easy to generate, efficient and economic as possible. This “design principle” is readily apparent in rhythmic movements. Even unicellular organisms such as *Paramecium* easily move by rhythmic beats of flagellae. The ease in generating rhythmic movements is likely due to the repetitive succession of similar movement components and patterns. While, in multi-cellular organisms, the actual movement pattern is of course profoundly co-determined by the mechanics of the body components (to include invertebrates) and the environment, the driving and organizing control signals must be delivered

by the nervous system. Conceptually, this task can be divided into two components:

- *Clock (oscillator)*: There should be a mechanism providing the basic rhythm.
- *Pattern generator*: Additionally, the specific ▶ [coordination](#) of muscle activations required for a particular movement must be orchestrated in detail.

## Central Pattern Generators

In order to produce these features, the central nervous system (CNS) contains complex networks of neurons, which are generally called ▶ [central pattern generators](#) (CPGs) (e.g., [2–5]). In such CPGs or their constituent nerve cells, the two tasks defined above (clock (oscillator) and pattern generation) may or may not be identifiable as separate components (for respiration see [6]). In the first case, there are potential ▶ [pacemaker neurons](#), which oscillate spontaneously due to intrinsic properties of their membranes and then impose their intrinsic rhythmic activity onto the network [7]. In the second case, the entire network may oscillate without any single inherent neuron being able to oscillate on its own, the rhythm thus being an emergent network property. In many invertebrates, CPGs have been identified and analyzed, and much progress has been made in this respect in lower vertebrates (i.e., lamprey), but not so in higher vertebrates such as mammals [2,4,5]. This applies to locomotion (swimming, walking, running, flying), mastication, feeding and breathing, respiration being a special case in that in many animals it goes on uninterrupted throughout life, as does the heart beat.

Neuronal networks generating rhythmic motor activities almost constantly reorganize and reconfigure themselves according to the task at hand and the context in which they operate. In fact, the operation of CPGs must be adaptable to various extrinsic circumstances and conditions:

- *Peripheral conditions* monitored by sensory signals.
- *Higher-level influences such as* ▶ [motivation](#), [visual guidance](#) etc.
- *Internal conditions of the CNS*.

## Role of Sensory Inputs

Since rhythmic movements occur in complex and changing environments, it is obvious that they must adapt. For example, an uneven ground must be taken into account while walking on it, which in turn necessitates sensory inputs. In other words, CPGs must be amenable to, and change their properties and activities in response to, sensory inputs, to the extent that some of these inputs are able to reset the rhythm. In particular, the switch between different locomotor phases, e.g., the transition from stance to swing of a limb, depends on certain states of sensory inputs

or combinations thereof. Thus, rather than regulating motor output variables in an analog way, sensory inputs are often used to make discrete choices between motor alternatives, akin to technical finite-state systems [8]. These systems work using “if-then” rules as follows. The general rule is: IF sensory state 1 AND sensory state 2, THEN perform this particular action. For example, for slow forward gait of a cat: IF in a hindleg the extensor force is low AND the hip is extended AND the contralateral leg is loaded, THEN flex the ipsilateral leg. Or, for backward gait: IF the extensor force is low AND the hip is flexed AND the contralateral leg is loaded, THEN flex the ankle and knee and extend the hip. This description in terms of rules is likely to be heuristic and does not say anything about how the nervous system really performs this action [8].

Conversely, sensory inputs and their processing must be weighted according to the prevalent tasks in different phases of a rhythmic movement. For example, in human walking, the leg currently supporting the body weight must extend and should not easily yield to a flexor reflex initiated by a noxious stimulus to the foot (see below), while the situation is not that pressing in the other leg flexing anyway. This calls for a *CPG-dependent modulation of reflex effects*.

This discussion underscores the notion that classes of movement, in this case reflexes and rhythmic movements, are not absolutely separated, but depend on each other. Although rhythmic activities in the scratch reflex may be triggered by sensory stimuli, the CPGs do not depend on somatosensory ►feedback to maintain their activity. The CPG generating the scratch reflex is probably different from that generating locomotion [9].

### Descending Control

In vertebrates, the spinal CPGs provide the basic rhythm and pattern-generating networks for locomotion, scratching and paw shakes. However, left on its own, e.g., in spinalized cats, the spinal cord has problems providing sufficient locomotor vigor and speed, ensuring lateral stability, and dealing with foreseeable obstacles. To do so, the spinal cord needs sensory feedback for timing, support and adaptive functions. In addition, it needs signals from supraspinal neural sources, such as [10–12]:

- *General activating systems* arousing the animal to new and unexpected stimuli and initiating appropriate actions. For example, sudden attack by a predator must alert the animal to make an immediate decision about *fight*, *flight* or *play dead*, in all cases implicating changes in posture and locomotion.
- *Motivational drive*. Locomotion mostly serves a purpose in being directed towards a goal. The pursuit of goals is in part determined by motivational brain systems, in particular the ►limbic system.

- *Supraspinal locomotor drive* provides energizing sources for posture and for “stirring up” the CPGs.
- *Adaptive fine-tuning of locomotor functions*, in particular anticipatory reactions to upcoming events, whose detection and processing need higher-level senses.

Many different supraspinal structures are involved in various sub-functions, including the brainstem, basal ganglia, cerebellum, and cerebral cortex. These structures exert their influences directly or indirectly via various descending tracts to several brainstem and spinal targets.

### Neuromodulation of Central Pattern Generators

An important influence on locomotion and supporting posture is exerted by a variety of ►neurotransmitters and ►neuromodulators. These can (i) tonically facilitate or depress motor patterns; (ii) initiate motor activity and/or prime neuronal networks to more strongly respond to other inputs; (iii) modify cellular and synaptic properties [4]. Among the known neuromodulators are amino acids, ►neuropeptides, ►histamine, ►serotonin, ►catecholamines, and purinergic substances [13].

Neuromodulators generate temporal variability in many of the cellular, synaptic and network properties of CPGs. Neuromodulators may also change the properties of short-term ►synaptic plasticity, which in turn co-determine how networks operate in a task- and context-dependent way [14]. The effects of neuromodulators on network properties make each particular network a versatile instrument that is able to perform or contribute to a number of different motor tasks. On the other hand, similar tasks can actually be carried out by different types of network configurations [4].

### Reflexes

The term “reflex” traces back to René Descartes (“*Traité de l’homme*” 1680) who lived in a time when research on optics surged. Ever since, a reflex has often been defined as a stereotypic motor response tightly coupled to a sensory stimulus. However, the term is now used in a wider sense. Consider a few examples.

#### Withdrawal Reflex

Reflex responses must occasionally be fast, for example, in emergency situations when potentially noxious stimuli must be avoided or evaded. The basic concept seems best exemplified by the withdrawal reflex, which was discussed by Descartes himself. The withdrawal reflex [15] is the motor response to a noxious stimulus to a body part, e.g., the withdrawal of the hand from a hot plate inadvertently touched. At first glimpse, this reflex seems to be the “simplest possible” response in that it appears generated by an causal chain

of events leading from a stimulus to a motor reaction, and represented, in technical terms, by a ►**feedforward** system. However, while there are true feedforward reflexes (e.g., the ►**vestibulo-ocular reflex**), in which the motor response (output) does not have a feedback effect on the stimulus (input), things usually are a bit more complicated. Many reflexes have a feedback effect, such that the motor (or other) response influences the stimulus. For instance, the withdrawal and scratch reflexes eliminate the original stimulus, thereby reverting the organism to the initial non-stimulated situation. Thus, for proper evaluation of many reflexes, the environment and its relation to the body must be taken into account. This latter factor may also force the withdrawal reflex to include more complicated actions. For instance, if during bipedal quiet upright stance, a human being is hit by a noxious stimulus to one foot, he or she will withdraw the injured leg by flexing the leg joints (►**flexion reflex**); but in order to secure upright stance and equilibrium, the extensor muscles of the contralateral leg must be activated (crossed extension reflex) so that the body mass can be shifted to the contralateral side. Finally, and most importantly, even the “simple” withdrawal reflex depends on the context. For example, during walking, a human may withdraw (flex) his swinging leg a bit further when the foot is hit by a noxious stimulus, but withdrawal of the stance leg would be counterproductive. This implies that *reflexes must be, and are, context-dependent in that their magnitude and at times their sign (excitatory or inhibitory) can be modulated, for example as a function of the phase of the locomotor cycle.*

### Stretch Reflex

Feedback action is also exerted by the so-called ►**stretch reflex**. When a physician uses his reflex hammer to hit, say, the Achilles tendon, the calf muscles contract after some short delay (in this narrow paradigm, the reflex is also called “tendon reflex”). What happens here is that the hammer indents the tendon and thereby slightly and transiently stretches the attached (calf) muscle fibers (►**Muscle**; ►**Skeletal muscle architecture**). Dispersed among these muscle fibers are ►**muscle spindles**, sensory receptors, which are excited by the stretch. The excitation is conveyed to the spinal cord by afferent nerve fibers that innervate the sensory receptors of the muscle spindles, where it activates skeleto-►**motoneurons** that in turn activate muscle fibers to contract. Note that the stretch stimulus is, at least partially, counteracted by the reflex contraction. It thus looks as if the reflex would serve to control muscle length by keeping it fairly constant.

The notion of “►**control**” resonates with that of ►**feedback systems** conceived to regulate the actual value of a control variable so as to keep it close to some *set value* or *reference value*. Regulation is often

achieved by negative feedback systems (►**Negative feedback control**), which are capable of suppressing effects of disturbances. An inanimate example is the thermostatic control of room temperature by a heating or air conditioning system, and a biological example is the regulation of core temperature in warm-blooded animals. Other output variables can be made to change with time and, if these changes are also effected by negative feedback systems for the sake of disturbance suppression, the control process is called a ►**servo-mechanism** (see ►**Computational motor control**). An inanimate example is power steering in cars. A biological example is, again, the stretch reflex. As a matter of fact, skeleto-motoneurons receive inputs other than those from muscle spindles. After all, muscles should not just be kept at approximately constant length, but shorten and lengthen in movements of different sorts. There must therefore be time-variable reference signals that are handled by the muscle stretch reflex to yield the output. However, the situation is a bit more complicated in the case of the stretch reflex (►**Feedback control of movement**).

### Multiple-Loop Feedback Systems

Most often, several loops are meshed to control single or several variables, which in turn may act on single or several controllers. Indeed, even a closer look at the muscle stretch reflex reveals a complicated picture.

Firstly, the sensory fibers emanating from muscle spindles in a particular muscle exert actions on motoneurons other than those innervating the muscle of origin. Conversely, motoneurons innervating a particular muscle receive convergent inputs from spindle fibers originating in different muscles (e.g., [16]). This is the structure of a multiple input-multiple output system, which couples muscle activities via sensory feedback.

Secondly, muscle contraction is regulated by more than one type of feedback system. For simplicity, just one more system is mentioned here. In addition to muscle spindles, there are other receptors in the muscle, among which so-called ►**Golgi tendon organs** play an important role. These receptors lie at the transition from muscle to tendon fibers and are stretched and excited whenever the muscle fibers produce force. Their afferent nerve fibers exert widely divergent reflex effects, via ►**interneurons**, on many different motoneuron pools, such that the sign and distribution of these effects depend on the instantaneous motor task. Under rest conditions, the nerve fibers emanating from Golgi tendon organs have inhibitory effects (via inhibitory interneurons) on the motoneurons of their muscles of origin (particularly extensors), so that increases in muscle force reduce motoneuron activation. This would constitute another negative feedback circuit, but with muscle force being the controlled variable. It is still not



clear why two systems based on muscle spindles and Golgi tendon organs are needed to control muscle contraction [17]. This picture is still very simplified and needs qualification. An important one is task-dependency based on modulation of reflex magnitude and sign. For instance, during the stance phase of normal walking (e.g., in cats), sensory afferents from Golgi tendon organs in hindlimb extensor muscles exert not inhibitory but excitatory effects on extensor motoneurons, thus inverting the sign from rest and creating a positive feedback system [18,19], with its own problems of stability [20].

### Complexity of Reflexes

Today, the term “reflex” has lost its original connotation of simplicity and stereotypy, except for a few examples, such as the artificial tendon reflex. There are several major reasons that make reflexes complex.

- *Composition.* Today, the notion of “reflex” subsumes complicated sequences of events, such as the scratch reflex of the cat or dog, or the frog’s wiping reflex [1,21–23]. The wiping, scratch and similar reflexes are intricate behaviors involving sequences of postural, goal-oriented and rhythmic components triggered by sensory input.
- *Modulation.* Reflexes are not stereotyped and hard-wired, as is often maintained even today, but flexible and modifiable. Firstly, reflexes are task- and context-dependent. Examples have been given above. Secondly, the magnitude and sign of reflexes often vary throughout a movement, e.g., during locomotion (e.g., [24]).
- *Sensory-motor transformations.* The complex effects of sensory inputs on muscle activities via skeleto-motoneurons involve transformations, of two basic kinds:
  - *Spatial transformations.* Vectors of spatially distributed sensory signals are converted into vectors of spatially distributed muscle actions. For example, in the scratch or wiping reflex, the 2D array of cutaneous receptors must be transformed into 3D space of limb movement [23].
  - *Kinematic-to-kinetic transformations.* Sensory inputs are, at least to some extent, cast in kinematic terms related to movement, while muscle activities also express kinetic (dynamic) variables related to forces. This requires kinematic-to-kinetic transformations ([23]; see below).
- *Plasticity.* Reflexes are not fixed in time, but subject to “adaptation” and “learning” (see ►[Learning and memory](#); ►[Motor learning](#), and Computational motor control), such as gain adaptation (spinal reflexes: [25]; vestibulo-ocular reflex: [26], ►[habituation](#), ►[sensitization](#) and others [27]). Hence, reflexes are very versatile instruments indeed.

### Posture and Equilibrium

When an animal performs a movement, it changes the coordinates of body parts in relation to each other and to the surrounding world. It is reasonable to assume that this change should not end up in chaos, but in some other ordered state. To define this order requires references and constraints, in regard to the outside world and the own body.

- *Outside-world references* are needed and used for orientation and ordered movement in the outer world. One important reference is up and down, where ►[gravity](#) supplies a convenient potential signal (►[Graviception](#)). In fact, gravity is not only a load acting on the body and its appendages, but is also used by the CNS as a dynamic orienting reference for the organization of movement [28]. Some animals may use other fields as reference, such as electromagnetic fields (sunlight, earth magnetism (►[Vision](#); ►[Magnetic and electric senses](#))). For many sea and terrestrial animals, the proper alignment of one of their body axes with the up-down axis is essential for organizing movement. This is particularly evident for terrestrial animals standing and moving on legs with the trunk suspended above the ground. These animals, including humans, need to maintain equilibrium and must therefore have sensory-motor mechanisms to do so.
- *Own-body references* are needed to define a framework, within which one body part (e.g., a limb) moves with respect to the rest of the body. Such a framework is usually called a body schema (see ►[Sensory systems](#)). The geometric relation of body parts to each other are subsumed under the rubric of posture. Posture is subject to constraints imposed by anatomical means such as ►[joints](#) and ►[ligaments](#).
- *Statics and dynamics.* Whereas the above distinctions are valid for both static and dynamic conditions, dynamic movements pose another important problem resulting from acceleration. For instance, when a limb is accelerated, the generating force is counteracted by a reaction force that affects the rest of the body. There must be neuromuscular mechanisms accounting for these effects in order to prevent disturbances of equilibrium.

Thus, an essential basis and frame for the execution of dynamic movements, whether rhythmic, reflexive or freely goal-oriented, are equilibrium and posture. The two closely related aspects of equilibrium and posture (often simply referred to as posture) may be considered as reference values, which must be maintained against internal or external disturbances [29].

### Reference Values

The reference value of equilibrium is, in humans under static conditions, the projection of the body’s center of

gravity (►Center of mass (CoM)) onto the supporting surface defined as the area of contact of the feet or other body parts with the ground. Reference values of posture are the positions of certain body segments, e.g., the arm, leg, trunk or head. Dynamic movements of some body parts interfere with these reference values, and appropriate compensations must therefore be pre-programmed in parallel with them. This ►anticipatory compensation, though highly significant, is often not easily recognizable. Massion [29] wrote that “in fact, the motor act might be compared to an iceberg, the apparent being the movement and the hidden part, which is often the most important, being the maintenance of reference values” (p. 36). Such anticipatory compensatory adjustments are generated in an open-loop (feedforward) fashion in parallel with the movement command.

### Learning Anticipatory Adjustments

Such anticipatory adjustments are mostly learned from experience, many of them in early childhood. Apparently, the postural disturbance is first corrected for in a feedback mode which is then transformed into a feedforward mode by modification of some as yet unknown adaptive network building up an internal representation of the disturbance to be minimized or the control signal used to cancel it [29].

### Free Goal-Oriented Movements

There is a class of movements that appear freer and less restricted than reflexes and locomotion and typically include reaching, grasping and object manipulation. Still, they may make use of reflexes and CPGs as subsidiary devices. And, as a matter of fact, they require postural adjustments. These skilled forearm movements may have their evolutionary precursors in food-handling behavior, dating back to early tetrapods [30], and are expressed in mammals (e.g., cats) in precision walking on complex ground, where accurate foot placement is of essence, and in arboreal locomotion of monkeys, which requires precise reaching for, and grasping of, tree branches [31]. They usually require excellent visuomotor coordination at cerebro-cortical level (►Viscomotor integration).

Many of the processes involved in organizing free goal-oriented reaching/grasping movements can be inferred from one’s insight, experience and common sense. Others, however, must be hypothesized from a careful analysis of human and animal movements, often using conceptual frameworks borrowed from robotics and computational motor control [32,33].

For the purpose of discussion, suppose a monkey is hungry and in search for food. He moves close to an orange, tennisball-sized object. What neural processes need to take place to make the monkey reach out and successfully grasp the object? The following is a

conceptual account that does not imply that the processes are run in a series of distinct steps.

- *Target perception*: Obviously, the object (possible target) must first be noticed and then visually perceived and recognized, in terms of its physical properties (size, shape, color), and location and orientation (►Vision).
- *Evaluation*: Once perceived, the object’s physical properties must be evaluated in relation to the monkey’s ►attention, drive and motivation, and to ►procedural memories (internal representations) of previous experiences with the present or similar objects.
- *Decision*: Once the object has been recognized as edible, desirable and attainable, a decision must be taken whether or not a movement should be made towards that object.
- *Planning*: If the decision is positive, the reaching/grasping movement must be planned, which involves several sub-processes, some of which take place in the posterior parietal cortex and premotor cortex [34,35].
- *Sensory-motor transformations*.
- *Selection processes*: A number of selections must be made, initially as reasonable guesses in a predictive feedforward mode, based on previous experience:
  - *Particular among equivalent motor acts*. Since there are many ways of moving the hand to a target, one among the possible ways must be selected.
  - *Adequate postural adjustments*. By intersegmental mechanical interactions, movement of the arm alters the equilibrium conditions of the whole body, which requires the selection of adequate compensatory postural adjustments executed in anticipation of, and in parallel with, the arm movement.
  - ►Kinematic and ►kinetic parameters. Reaching/grasping requires anticipatory, initially tentative, parameter settings based on internal representations of the object and on ►internal models of the own motor apparatus.
  - *Grip force*. Before contact, grip forces must be selected tentatively, small enough so as not to squeeze the object and large enough so as not to drop it.
  - *Expected feedback signals* must be estimated, using internal models, in order to be able to compare them with the actual feedback generated during the motor act.
- *Execution*: The desired hand path thus planned must be transformed into appropriate muscle activation patterns by some poorly understood implementation process composed of many sub-processes involving essentially the entire neuraxis.

- *Sensory update*: During the ongoing movement, the central selections listed above are updated by sensory feedback from various sensory systems, including visual and cutaneous receptors and proprioceptors. The sensory feedback serves for:
  - *Fast error correction*.
  - *Triggering of successive steps* in the movement sequence.
  - *Revision and updating of the internal model* of body and limb [32,36].
- *Memory*: The role of memory systems in the above processes cannot be overestimated. In fact, they dynamically interface sensory systems with motor commands. In addition to providing the basis for ►*motor learning* (see below), memory systems serve to retrieve pertinent object properties based on visual, haptic or olfactory information, identification of task features and the initial state of the skeleto-motor system and of sensory events during task progress [37].

### Degrees of Freedom and Constraints

The diversity, speed, accuracy and elegance of animal movements provide the overwhelming impression of freedom. However, these qualities can be fully appreciated only when due consideration is given to the delicate interplays between freedom and its constraints, which give rise to problems as well as to solutions.

Although musculo-skeletal assemblies may vary widely, their basic structures appear to be more consistent than body shape itself. Still, these elements have adapted by specializing to the particular demands of particular organisms. While these specifications open certain options to an organism, they also constrain it. Internal constraints have a mechanical component in that the peripheral instruments or tools that an organism uses to move not only enable movement, but also limit its extent, speed etc., by their specific properties. These also have to be taken into account by the nervous system when controlling and thereby using these tools [38].

### Problems and Constraints

Moving organisms meet many problems and constraints, which, on the one hand, arise in the organism's environment and, on the other, in its internal structure.

### External Problems and Constraints

External problems and constraints arise from properties of the world, in which the organism lives and moves. The main properties are:

- *Mechanics*. Movement in the external world is subject to its mechanical properties, the most important ones being (►*Classical mechanics*; ►*Mechanics*):
  - *Newtonian mechanics*, defining the movements of bodies in space and including *inertia* and *gravity*.

Gravity is, however, of different importance in different habitats.

- *Material nature of habitat(s)*. Movements meet with different resistances and dynamics in gaseous (air), liquid (water), or solid (soil) media and have to be adequately adjusted and controlled.

### Internal Problems and Constraints

Internal problems and constraints arise from the very means that have been developed by organisms to move under conditions on earth. The materials used, and their combinations, could not, and cannot, be chosen entirely freely. Skeletons (►*Bone*), ►*joints*, ►*articular cartilages*, capsules, ►*ligaments*, ►*tendons* and ►*muscles* have properties that, on the one hand, provide opportunities for movement, but on the other hand impose constraints (e.g., [39,40]). Opening new opportunities by solving one problem may in parallel open new problems calling for new solutions. In the end, the solutions must and will be provided by the nervous system that controls the actions of muscles and, in so doing, must take into account the properties of its peripheral instruments in addition to those of the external world [38]. It comes as no surprise that ►*proprioception* (see ►*Sensory systems*), in particular, appears well suited to contribute to the solution of problems resulting from the mechanics of the musculo-skeletal system. It has been proposed [17,38] that proprioception contributes to: (i) ►*linearization* of (correction for) nonlinear muscle properties; (ii) compensation for a muscle's lever-arm variations at joints; (iii) correction of interjoint interaction effects (see below).

### Degrees of Freedom

The vertebrate skeleton immediately unveils the fundamental principles of construction and the potentials afforded. It is a multi-segmented structure made up of hundreds of bones linked at joints. This construction principle should provide for a multitude of options for moving the segments relative to each other and through space. The options are commonly referred to as "degrees of freedom" (DOFs).

Degrees of freedom (DOFs) are the number of variables (coordinates) needed to describe a body's motion in space [41,42]. The DOF of a system of rigid segments is obtained by the general relationship:

$$\text{DOC} = (\text{number of generalized coordinates}) - (\text{number of constraints})$$

The DOFs can change during a motor act, as easily seen when a human being lands from a jump. In the sagittal plane, the number of DOFs decreases by 2 when the toes make contact with the ground and by 1 more when the sole is flat on the ground. In vertical jumping, this sequence is reversed, with the number of DOFs increasing [42].

### Bernstein's Problem

Upon closer examination, the multi-segmented skeleton poses serious problems (see ►[Coordination](#)).

Dependent upon the type of joint, the distal segment (bone) can be moved in up to three DOFs with respect to the proximal segment. For example, in a ball-and-socket joint, such as the human shoulder joint, there are two dimensions for, say, extension-flexion and abduction-adduction, and one for rotation. This allows the humerus to be aimed at any point in almost half a sphere. Assembling bones into limbs with several joints increases the number of DOFs. This leads to the effect that, for instance, some desired position of the index finger in external 3D space could principally be realized by an infinite number of different combinations of joint angles. This problem arises whenever the combined number of directions, into which joints of multi-joint limbs can move, exceeds the three-dimensionality of external space. For example, the position of the hand (wrist) can be specified by three coordinates in external space, but it is defined by four joint angles (elevation and yaw of both the shoulder and the elbow; [43]). This ►[redundancy of degrees of freedom](#) (see ►[Coordination](#)) holds for many postures and movements. Hence, theoretically, there should be an infinite number of possible movement trajectories to reach the same target. Nonetheless, most arm and hand movements do not take advantage of the theoretical redundancy afforded, but are performed in fairly stereotyped manners, suggesting that there must be solutions for reducing the redundancy. The problem of providing such solutions has been clearly highlighted by Bernstein [44].

The query for solutions to ►[Bernstein's problem](#) has to be conducted at various levels. A rough distinction can be made between mechanical constraints deriving from specifics of the musculo-skeletal system itself and the nervous system dealing with the peripheral system.

### Constraining Freedom

Consider the cat hindlimb with its three large joints: hip, knee and ankle joint. If, in a first approximation, each of these joints is assumed to be a hinge joint of one DOF, the limb would be a 3-DOF assembly of segments, allowing for 2D movement of the limb endpoint in the parasagittal plane. Hence, despite the possibility of movements about three joints, the end-point movements are confined to two dimensions, implying a reduction in DOFs. How is this implemented? One possibility is to restrict the independence of movements in the different joints, i.e., to tightly couple changes in the three joint angles. This is indeed what happens during both passive and active hindlimb movements. That is, the relationship among the three joint angles shows a planar or 2D co-variation over a large range of limb positions [23,45].

►[Biomechanics](#). In the passive limb, the mechanism underlying the joint-angle coupling is presumably of biomechanical nature, as indicated by post-mortem assessment. For example, biarticular muscles spanning two joints as well as passive structures such as joint shapes, joint capsules and ligaments may play a role in coupling different joints. During movements, inertial intersegmental interaction forces (see below) may contribute to couple the movements of limb segments [45].

*Neural Control Mechanisms*. In addition to passive biomechanical factors, neural control mechanisms may come into play. Awake cats trained to maintain quiet upright stance on a tilting support platform also show a linear co-variation of hindlimb joint angles. This pattern of joint-angle covariance is, however, different from that in the passive limb. Firstly, the coupling is tighter, suggesting that neural control may actually further reduce any independent motion in the individual limb segments. Secondly, the co-variance plane has a different orientation in 3D joint space, due mostly to a sign inversion of the relationship between the hip and ankle angles [23,45]. The difference between the passive state and the active state shows that the CNS should determine the particular form of joint angle co-variation (the orientation of the plane in joint space). Similarly, in human reaching movements, segment excursions are coupled, and so are joint torques [46].

### Exploiting Freedom

While there are mechanical and neural mechanisms that constrain the freedom of movement, the redundancy in DOFs also has advantages. Indeed, it allows for flexibility, stability and accuracy. Again taking the example of fingertip localization, arm orientation at the shoulder joint is usually less precise than fingertip location, such that more distal joints can compensate for errors committed by more proximal joints [47]. Therefore, redundancy can also be considered a virtue to be exploited rather than a problem that should be solved. One method to exploit the redundancy is to represent all the possible solutions by means of a multiple controller [48]. Another approach is to exploit redundancy in order to minimize the variance by means of optimal control [49]. Yet another recent approach has hypothesized a "principle of abundance," stating that no DOF is ever eliminated or frozen, but instead all DOFs always participate in all the tasks, thereby assuring both flexibility and stability of performance ([50,51]; see also ►[Coordination](#)).

### Representations of Space

Since movements take place in space and time, a basic requirement for any meaningful action based on perception and orientation is the construction by

the CNS of spatial frames of reference and their transformations (►Sensory Systems). This involves:

- *Spatial orientation*, depending on the perception of the position, orientation and motion of external objects and that of an animal's own body parts within reference frames. There is more than one frame that the nervous system makes use of. The particular subjective reference frame that an observer takes as stationary is called "rest frame." It is selected according to availability of sensory cues, convenience and circumstances. For example, on earth, astronauts choose a rest frame based primarily on gravity and visual scene polarity, while in microgravity (in a spaceship), the rest frame is based on visual scene polarity cues from the spaceship interiors and other crew members as well as on the internal head and body  $z$ -axes (ideotropic vector). It appears as if astronauts switch between rest frames depending on variables such as the task being performed [52].
- *Multiple representations of sensory spaces and muscle spaces*. The representations of the position, orientation and motion of external objects and those of an animal's own body parts are based on different sensory signals, which are coded in different frames of reference. For instance, reaching and grasping require the localization of the object in peripersonal space as well as the localization of the initial position of arm and hand. Object location is coded predominantly by ►vision (and/or hearing audition), arm/hand position by vision and/or proprioception, which each possesses its own reference frame (see ►Sensory systems). Finally, spatial aspects of muscle actions are coded in their own frame. All this calls for:
- *Sensory-motor transformations* characterized by several aspects [34,53,54]:
  - *Multi-sensory integration* (►Multimodal integration): Signals from different senses must be integrated and thus converge onto common neurons. This also applies to other senses such as hearing (for sound-emitting objects) and touch (for tactile shape perception after contact with the object).
  - *Construction of a unified sensory frame of reference*. The different sensory reference frames must be put in register and thus unified; for arm (►Voluntary movement) and eye movements (►Neural control of eye movement) this appears to be an eye-centered (oculocentric) frame established in the posterior parietal cortex.
  - *Sensory-motor coordinate transformation*: The sensory coordinate frame must be transformed into the motor frame.

## Kinematics

The spatio-temporal representations that the nervous system needs have several aspects and dimensions.

The first important distinction to be made is between kinematic and kinetic (dynamic) descriptions, which nonetheless are closely related. The kinematic description simply deals with the spatio-temporal paths or trajectories of objects (head, eyes, limbs etc.). For this purpose, the kinematic description requires reference frames or coordinate systems to relate a moving object to for quantification. The dynamic aspect deals with the forces involved in, and required to drive, movements. Since forces are spatially directed and hence vectors, their description, too, involves spatial coordinate systems. Another connection between kinematic and dynamic descriptions is Newtonian dynamics.

## Extrinsic and Intrinsic Coordinate Systems

As exemplified in Fig. 1, the position (and movement) of the hand (wrist) can be described with respect to two coordinate systems. For simplicity, the right arm is here supposed to be held in a horizontal plane, and the arm is viewed from above (direction of the  $z$ -axis). The hand position can be given in terms of an extrinsic, rectangular Cartesian coordinate system, where the  $x$ -axis is in a parafrontal and the  $y$ -axis in a parasagittal plane through the right shoulder. (Alternatively, it could be described in *polar coordinates* as the direction and distance of the hand from the shoulder.) A second

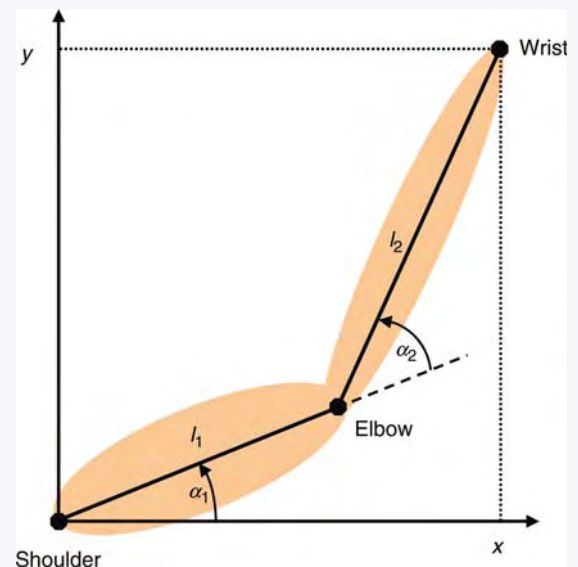

**Motor Control. Figure 1** Representation of hand (wrist) position in two frames of reference. For simplicity, the right arm is supposed to be held in a horizontal plane, and the arm is viewed from above (direction of the  $z$ -axis). The hand position can then be given in terms of a rectangular Cartesian coordinate system, where the  $x$ -axis is in a parafrontal plane through the shoulders, and the  $y$ -axis in a parasagittal plane through the right shoulder, or in terms of segment lengths,  $l_1$  and  $l_2$ , and joint angles,  $a_1$  and  $a_2$ .

way of determining hand position with respect to the shoulder is by segment lengths,  $l_1$  and  $l_2$ , and joint angles,  $a_1$  and  $a_2$ , establishing an intrinsic system based on body geometry (see ► [Arm trajectory formation](#)).

### Coordinate Transformations

The existence of different coordinate systems requires the nervous system to continuously transform the positions of limbs and their trajectories during movements from one system into the other. For example, consider the transformation from joint angles to Cartesian coordinates (Fig. 1), which is given by the trigonometric relations:

$$x = l_1 \cos(a_1) + l_2 \cos(a_1 + a_2) \quad (1a)$$

$$y = l_1 \sin(a_1) + l_2 \sin(a_1 + a_2). \quad (1b)$$

This transformation is referred to as forward or direct kinematics [55]. It is called forward because it describes the natural causal flow of events from muscle activations, which determine muscle lengths, which determine joint angles, which finally determine hand position in relation to the body.

There is also the *inverse transformation* from extrinsic to intrinsic coordinates, which is obtained by solving (1a and b) for the joint angles  $a_1$  and  $a_2$ , each of which will be a function of both  $x$  and  $y$  [55]. This transformation is called *inverse kinematics*. At first glimpse, it does not appear to have a natural counterpart as does the forward kinematics. However, it has been suggested that, at the highest stages of movement planning, the final hand position or the movement towards it is planned in extrinsic coordinates,  $x$  and  $y$  [23], from which the related set of joint angles would have to be obtained by an inverse transformation (however, there are other suggestions; see below). It merits emphasis that, in this case, there is a unique solution only because we consider the relation between two extrinsic and two intrinsic coordinates in a plane. In 3D space, three external coordinates and four joint angles are needed to specify hand position, leading to the well-known redundancy problem without a unique solution, as discussed above.

Another important implication can also be drawn from (1a,b). Any neuronal network to implement one or the other of the above transformations would have to incorporate neural elements, which would receive convergent input signals from the independent variables. This requirement may be one of the reasons for the widespread existence of *convergence* of many inputs onto many central neurons. Conversely, the inputs may affect more than one output, which in neural terms accounts for *divergence* of neural signals to affect more than one output. In general, of course, transformations between coordinate systems involve many more than just sets of two variables as in Fig. 1; they therefore become exquisitely complex.

### Algorithms for Inverse Transformations

In principle, there are several possibilities of performing inverse transformations, as illustrated here for inverse kinematics [55].

- *Computer program*: In robotics, inverse kinematics can be solved by a computer program. Obviously, the CNS cannot do it exactly this way, although the term “program” is being used in the field of biological motor control in a loose analogous way. Its use may be misleading, though, and has been criticized [56].
- *Lookup table*: Another possibility is that the CNS could use is a lookup table, which contains entries associating particular pairs  $(x,y)$  and  $(a_1,a_2)$ . In general, these tables can come as “computational maps” [57,58], which map values of a particular sensory and/or motor variable along at least one spatial dimension of nervous tissue. Such maps indeed exist in several places in the CNS. For example, the ► [superior colliculus](#) (tectum opticum in lower vertebrates) contains maps of spatial sensory information as well as motor maps of the amplitude and direction of orienting movements of the eye (gaze), head, pinna and vibrissae [59–61]. These maps are dynamically maintained or altered according to experience during development, but also in adults. Sensory and motor maps have to be aligned, with early visual experience being highly important in doing so [59].
- *Internal model*: The equations describing the inverse kinematics could also be solved by special analog circuits representing an internal model. For limb and trunk motor control, such models would certainly be much more complicated than that which has been considered to be at work in certain ► [eye movements](#), because as compared to the latter systems, the former ones have to deal with varying loads including those resulting from gravity. Yet, internal models probably exist, at least for certain purposes [33,36,62–64].

### Kinetics (Dynamics)

The kinetic (dynamic) aspect of movement organization results from the fact that the body or its parts have viscoelastic and inertial properties and are suspended in a gravitational field (albeit to very different extents in different species living in different habitats). Hence, their movement requires forces in order to counteract viscoelastic forces or achieve acceleration against inertial and gravitational forces. The description in terms of forces or torques at joints is by kinetic (or dynamic) variables [55].

### Muscles and Intersegmental Interactions

However, dynamics play a role not only in the interactions of the body and its segments with the environment, but also in the interactions between the different body

segments themselves. Since body segments are movably coupled at the joints, motion of one segment acts on those of other segments. This implies that any individual muscle not only accelerates the segments that it originates from and inserts on, but also remote segments via intersegmental dynamic interactions, which in addition depend in complicated ways on the joint angles and angular velocities [38]. These interactions in turn yield new insights into the functions of individual muscles and into how many muscles must be coordinated in order to serve movement goals (e.g., [65]). Consider a few examples.

### Swinging a Leg during Walking and Running

During human walking, stance and swing phases follow each other in each leg. From a naive standpoint, we might assume that, in order to lift and clear the swing leg from the ground and move it forward, all joints should be flexed, with the flexions to be initiated by concomitant activation of hip, knee and ankle flexor muscles. However, simple mechanics suggests another possibility. If the hip flexors alone were activated, then the thigh would be accelerated forward relative to the trunk and, due to inertia, the shank would lag behind, resulting in (passive) knee flexion. This indeed plays a major role in the hindlimb of cats during gallop, where knee flexion is sustained by inertial torques related to linear hip and angular leg acceleration, rendering activation of the knee-flexor semitendinosus muscle unnecessary. By contrast, at lower gait speeds, this muscle shows two bursts of activity during the movement cycle [66]. Conversely, the extension of the knee at the end of the swing phase is assisted by a whip-like forward movement of the lower leg while the upper limb is already decelerating. In human walking, there is only one problem concerning the ankle. If joint motions during the initial swing phase were sustained by hip flexor activation only, the foot would also remain behind due to its inertia, thus extending the ankle. This would be too little to clear the foot from and above the ground during swing. Hence, ankle dorsi-flexor activity (mainly in the tibialis anterior muscle) is also required. This is evident in patients suffering from paralysis of the nerve innervating the tibialis anterior, which leads to dragging of the foot in the swinging leg. In any case, intersegmental mechanics clearly contribute to dynamic motor acts, which must be taken into account by the nervous system in organizing the coordinated muscle activations.

### Paw Shake

During the cat's oscillatory paw shake elicited by an irritant stimulus to the paw, the hip, knee and ankle joints undergo rhythmic angle changes at ca. 11–12 Hz, with a proximo-to-distal increase in amplitude. At the ankle joint, interactive and gravitational torques do not contribute significantly to net joint torques, whereas at the knee joint they do. Here, torques related to the

angular acceleration of the paw dominate over interactive contributions to the knee torque. At the ankle, the torques produced by ankle muscle activation account for much of the net joint torque and thus directly determine the paw segment dynamics. In contrast, knee muscles produce torques, which rather compensate for interactive torques, thus controlling intersegmental dynamics between paw and shank [67].

### Pedaling

A deeper insight into muscle functions during complex motor acts is provided by dynamical simulations of seated pedaling of humans. Seated pedaling is mechanically simpler than walking because it has fewer mechanical DOFs, the hips being essentially stationary and the foot path being constrained by the pedal trajectory [65]. The important points can be summarized as follows.

(i) The intersegmental interactions depend in a complicated way on joint angles and velocities, and the dynamics are different at different joints. If these interactions were to be described by sets of dynamic equations, different sets of equations would have to be set up for different situations. (ii) To understand the role of muscles in the above processes, deriving their function from their anatomical position, knowing just their origins and insertions alone, is insufficient. (iii) In fact, a muscle's function depends on the configuration of the body and its parts and on their interaction with external objects such as the ground or obstacles; it can thus vary with motor task and within a motor task [42]. (iv) Since muscle activations depend on peripheral circumstances, in order to organize their activations properly, the CNS needs information on these circumstances, that is, sensory feedback [38].

### Forward Dynamics

Consider the causal sequence of events in the musculo-skeletal periphery, say an arm, referred to as *forward or direct dynamics* [76]. In this system, motoneuron activity provides the inputs, and body motions are the outputs. Thus, if there are  $m$  muscles, their inputs are reflected in the electromyographic signals,  $EMG^1 \dots EMG^m$  (► **Electromyography (EMG)**). These activation signals are transformed into the set of muscle forces,  $F^1 \dots F^m$ . These in turn are converted, depending on musculo-tendon dynamics and moment arms  $R(F^i)$ , into a set of muscle torques at  $n$  joints,  $T_1^{mus} \dots T_n^{mus}$ . These torques finally are transformed into sets of joint angles  $\Theta_1 \dots \Theta_n$ , their velocities and accelerations, which ultimately result in the motion of the limb endpoint. Note that there are some ► **feedback loops** because, for example, joint angles determine muscle lengths and these in turn co-determine muscle forces. On the whole, however, this is a feedforward scheme,

which indicates that the input signals should be precisely tuned to achieve the correct output.

### Inverse Dynamics

It has been suggested that the CNS plans reaching/grasping movements in terms of extrinsic coordinates, say of hand position and/or trajectory in extrapersonal space (e.g., [23]). Although other suggestions have been put forward (e.g., planning in terms of kinetic variables such as joint torques; [46]), it is instructive to consider the consequences of the kinematic model. The CNS must perform a number of transformations in order to provide the appropriate muscle activation patterns. The sequence of transformations is as follows:

*Desired trajectory (assumed to be coded in kinematic extrinsic coordinates) → joint angles → joint torques → muscle forces → muscle activation patterns.*

If the CNS used this approach, it would have to take into account the forward dynamics discussed in the preceding section by “inverting” them. That is, in order to achieve the desired movement trajectory, the planned trajectory must be implemented by a process compensating for the forward dynamics described above. Thus, from the desired end-point movement in extrinsic coordinates, intrinsic joint angles (muscle lengths) and their first two time derivatives must be derived via an “inverse kinematics” algorithm. Through an “inverse dynamics” algorithm, joint angles and their first two time derivatives would determine the net muscle torques needed to achieve them, and subsequently the muscle forces needed to generate the torques, and then the excitations needed to generate the forces. The desired excitations thus computed from the desired trajectory could serve as the template of motoneuronal activations.

However, this approach would raise formidable problems. The computation of such inverse dynamics is complex and often requires non-unique transformations. For example, individual muscle forces are not uniquely determined by net muscle torques, i.e., the torques can be achieved with many combinations of muscle forces. Also, the neuromuscular periphery has complex nonlinear properties. Furthermore, the different segments in multi-joint limbs exert mutual interaction forces on each other (intersegmental interactions). These complexities result in myriads of equations of motion, all of which would be task-dependent. In order to solve the problems, then, the CNS would have to “know” these equations as well as precise estimates of the initial and boundary conditions and parameters involved, such as the masses, locations of the centers of mass, principal axes of inertia, moments of inertia (see [68–70]). Moreover, the computation itself would have to be extremely accurate because even small errors, or

small mis-estimates of initial and boundary conditions, would lead to large movement errors. Because of the complex computational capacity required, the inverse-dynamics computations have usually been thought to be performed, if at all, by the cerebral cortex or cerebellum, although the vertebrate spinal cord might also contribute its share [23]. Still, completely precise inverse-dynamics computations do not appear feasible.

The above considerations are based on the presumption that the inverse-dynamics calculations are performed in a feedforward (open-loop) fashion, i.e., without the CNS receiving feedback on the results of its actions, which could be used to correct for errors. Incorporating such feedback would alleviate some of the problems. However, this would raise new problems. First, in the neuro-muscular system, sensory feedback occurs with considerable delays (for visual or proprioceptive processing). Therefore, fast (ballistic) movements, precisely those movements posing the most severe dynamic problems, would have to do without it, at least initially. (However, CNS-internal feedback based on an **efference copy** of the motor command and sensory information as well as an internal model of peripheral dynamics could make early corrections to the unfolding motor plan; [62]). Second, the gains in feedback systems are usually low because high gains with long delays run the risk of instability (e.g., [71,72]). Perhaps this is one reason for ballistic movements being more imprecise than slow movements, unless well learned.

### Motor Control Schemes

#### Equilibrium-Point Hypothesis

A concept purported to dispose of all the dynamic issues and thus provide a simpler solution than the inverse-dynamics approach is the so-called **equilibrium-point hypothesis (EPH)** [21,68,69,73,74]. The basic ideas are:

- Passive and active muscles have (nonlinear) spring-like properties (like rubber bands).
- At each moment of time, the relative levels of activity in the sets of agonist and antagonist muscles and the resulting muscle forces (or joint torques) specify a virtual position of each joint, at which all the torques, including those deriving from external loads, are in equilibrium, i.e., the net torque is zero.
- Following its dynamics, the limb moves to this equilibrium position unless some obstacle interferes with it.

The important point is the concept of the virtual equilibrium position because this is the “attractor” pulling on the limb. Movement comes about by a smooth and continuous change in virtual equilibrium position, which has to be specified by the CNS in terms of appropriate muscle activation patterns. Once the brain has acquired the ability to represent and control equilibrium positions, it can master movements as temporal



sequences of such positions [68]. The adherents of this hypothesis claim that the inverse-dynamics problem is simplified (or even obviated) because explicit representations of inertial, viscous, gravitational and other opposing forces are unnecessary.

One of the merits of this hypothesis is that it has stimulated attempts at taking into account real neuronal networks. This has been tried by both groups of its major proponents [73,75]. Feldman et al. [73] original approach is more explicit in dealing with particular networks including the stretch reflex, ►reciprocal inhibition and ►recurrent inhibition. However, it suffers from the weaknesses outlined above as to sensory feedback [71].

### Adaptable Internal Models

Another solution is to revert to the inverse model concept, but conceive of these models as *adaptable*. Such a model would then represent some properties of the musculo-skeletal periphery, and well so, by adapting to them through learning (see ►Computational Motor Control; ►Adaptive control). In this scheme, sensory feedback (e.g., vision and proprioception) attains a novel significance by being used to update internal models before the event rather than correcting for movement errors in real time.

Depending on the requirements, inverse models can also be combined with forward models that represent the forward dynamics of the “plant” (i.e., the physical system to be controlled; see ►Control). If plant and forward model are fed with the same motor command, the difference in outputs will tell how well the model represents the plant. This output can be used in various ways, one way being as an error signal teaching the model to adapt optimally. The keywords then are adaptation and learning.

### Neural Networks

The distinction between kinematic and dynamic aspects of movement control can be avoided in neural network models. In such networks, kinematics could be encoded by sensory receptors at the input level and dynamics by effectors at the output level, so that kinematics or dynamics, or both, or neither, are encoded anywhere in the brain [76].

### Plasticity and Sensory-Motor Learning

The CNS must adapt its actions to changing conditions of its environment, including the body, and learn from their effects, at very different levels of organization and time scales. This requires its neuronal networks to be not rigid, but plastic. The terms plasticity, learning and memory are not precisely defined, but are commonly applied to a diversity of processes. In a narrow ►behavioral sense, motor learning implies the acquisition of new behaviors or skills by practice [77]. But the

term is often used with wider connotations including processes and mechanisms at much lower levels of complexity (►Learning and memory; ►Motor learning). The structures subject to plasticity are manifold and distributed throughout the neuraxis, even extending to the neuromuscular junction [78].

There are a number of different processes and mechanisms that contribute to learning (in the wide sense), such as axonal sprouting or pruning and modifiability of synaptic efficacy. The establishment of the proper neuronal connections and topographical maps at some critical stage of ontogenetic development in part relies on such processes, as does the adaptive change in such maps in adult life. Many of the basic events underlying learning, information storage (memory) and retrieval are thought to take place at a molecular level, in particular at ►synapses. Synaptic transmission is vastly flexible or plastic, at time scales ranging from the order of milliseconds to probably life-long.

### Acknowledgment

*Dedicated to the outstanding scientist, academic teacher and friend Rainer F. Greger (3.1.1946–16.12.2007). I am grateful for encouragement and suggestions for improvement to Marc D. Binder, Amir Karniel, and Douglas G. Stuart.”*

### References

1. Gelfand IM, Orlovsky GN, Shik ML (1988) Locomotion and scratching in tetrapods. In: Cohen AH, Rossignol S, Grillner S (eds) Neural control of rhythmic movements in vertebrates. Wiley, New York, pp 167–199
2. Arshavsky YI (2003) Cellular and network properties in the functioning of the nervous system: from central pattern generators to cognition. *Brain Res Rev* 41:229–267
3. Grillner S, Markram H, De Schutter E, Silberberg G, LeBeau FEN (2005) Microcircuits in action – from CPGs to neocortex. *Trends Neurosci* 28:525–533
4. Pearson KG (1993) Common principles of motor control in vertebrates and invertebrates. *Annu Rev Neurosci* 16:265–297
5. Stein PSG, Grillner S, Selverston AI, Stuart DG (eds) (1997) *Neurons, networks, and motor behavior*. MIT, Cambridge (Mass)
6. Smith JC (1997) Integration of cellular and network mechanisms in mammalian oscillatory circuits: insights from the respiratory oscillator. In: Stein PSG, Grillner S, Selverston AI, Stuart DG (eds) *Neurons, networks, and motor behavior*. MIT, Cambridge (Mass), pp 97–104
7. Ramirez J-M, Tryba AK, Peña F (2004) Pacemaker neurons and neuronal networks: an integrative view. *Curr Opin Neurobiol* 14:665–674
8. Prochazka A (1996) The fuzzy logic of visuomotor control. *Can J Physiol Pharmacol* 74:456–462
9. Burke RE (1999) The use of state-dependent modulation of spinal reflexes as a tool to investigate the organization of spinal interneurons. *Exp Brain Res* 128:263–277

10. Armstrong DM (1988) The supraspinal control of mammalian locomotion. *J Physiol (Lond)* 405:1–37
11. Garcia-Rill E, Homma Y, Skinner RD (2003) Arousal mechanisms related to posture and locomotion: I. Descending modulation. *Prog Brain Res* 143:279–286
12. Grillner S, Georgopoulos AP, Jordan LM (1997) Selection and initiation of motor behavior. In: Stein PGS, Grillner S, Selverston AI, Stuart DG (eds) *Neurons, networks, and motor behavior*. MIT, Cambridge (Mass), London, pp 3–19
13. Katz PS, Harris-Warriss RM (1990) Actions of identified neuromodulatory neurons in a simple motor system. *Trends Neurosci* 13:367–373
14. Nadim F, Manor Y (2000) The role of short-term synaptic dynamics in motor control. *Curr Opin Neurobiol* 10:683–690
15. Sandrini G, Serrao M, Rossi P, Romaniello A, Cruccu G, Willer JC (2005) The lower limb flexion reflex in humans. *Prog Neurobiol* 77:353–395
16. Windhorst U (1996) On the role of recurrent inhibitory feedback in motor control. *Prog Neurobiol* 49:517–587
17. Stuart DG (1999) The segmental motor system – advances, issues, and possibilities. *Prog Brain Res* 123:3–28
18. Donelan JM, Pearson KG (2004) Contribution of sensory feedback to ongoing ankle extensor activity during the stance phase of walking. *Can J Physiol Pharmacol* 82:589–598
19. Duysens J, Clarac F, Cruse H (2000) Load-regulating mechanisms in gait and posture: comparative aspects. *Physiol Rev* 80:83–133
20. Prochazka A, Gillard D, Bennett DJ (1997) Implications of positive feedback in the control of movement. *J Neurophysiol* 77:3237–3251
21. Berkinblit MB, Feldman AG, Fukson OI (1986) Adaptability of innate motor patterns and motor control mechanisms. *Behav Brain Sci* 9:585–638
22. Fukson OI, Berkinblit MB, Feldman AG (1980) The spinal frog takes into account the scheme of its body during the wiping reflex. *Science* 209:1261–1263
23. Poppele RE, Bosco G (2003) Sophisticated spinal contributions to motor control. *Trends Neurosci* 26:269–276
24. Zehr EP, Stein RB (1999) What functions do reflexes serve during human locomotion? *Prog Neurobiol* 58:185–205
25. Wolpaw JR, Tennissen AM (2001) Activity-dependent spinal cord plasticity in health and disease. *Annu Rev Neurosci* 24:807–843
26. Du Lac S, Raymond JL, Sejnowski TJ, Lisberger SG (1995) Learning and memory in the vestibulo-ocular reflex. *Annu Rev Neurosci* 18:409–441
27. Hawkins RD, Clark GA, Kandel ER (1987) Cell biological studies of learning in simple vertebrate and invertebrate systems. In: Plum F (ed) *Handbook of physiology, Sect. 1: The nervous system, vol V: Higher functions of the brain, Part 1*. Am Physiol Soc, Bethesda, pp 25–83
28. Pozzo T, Papaxanthis C, Stapley P, Berthoz A (1998) The sensorimotor and cognitive integration of gravity. *Brain Res Brain Res Rev* 28:92–101
29. Massion J (1992) Movement, posture and equilibrium: interaction and coordination. *Prog Neurobiol* 38:35–56
30. Iwaniuk AN, Whishaw IQ (2000) On the origin of skilled forelimb movements. *Trends Neurosci* 23:372–376
31. Grillner S, Wallin P (2004) Innate versus learned movement – a false dichotomy? *Prog Brain Res* 143:3–12
32. Ghez C, Hening W, Gordon J (1991) Organization of voluntary movement. *Curr Opin Neurobiol* 1:664–671
33. Schaal S, Schweighofer N (2005) Computational motor control in humans and robots. *Curr Opin Neurobiol* 15:1–8
34. Andersen RA, Buneo CA (2002) Intentional maps in posterior parietal cortex. *Annu Rev Neurosci* 25:189–220
35. Graziano MS, Gross CG (1998) Spatial maps for the control of movement. *Curr Opin Neurobiol* 8:195–201
36. Baev KV, Shimansky YP (1992) Principles of organization of neural systems controlling automatic movements in animals. *Prog Neurobiol* 39:45–112
37. Johansson RS, Cole KJ (1992) Sensory-motor coordination during grasping and manipulative actions. *Curr Opin Neurobiol* 2:815–823
38. Hasan Z, Stuart DG (1988) Animal solutions to problems of movement control: the role of proprioceptors. *Annu Rev Neurosci* 11:199–223
39. Alexander RMcN (1981) Mechanics of skeleton and tendons. In: Brooks VB (ed) *Handbook of physiology, vol II, Part 1: The nervous system*. Amer Physiol Soc, Bethesda, pp 17–42
40. Nigg BM, Herzog W (eds) (1994) *Biomechanics of the Musculo-Skeletal System*. Wiley, Chichester
41. Shrive NG, Frank CB (1994) Joints. In: Nigg BM, Herzog W (eds) *Biomechanics of the musculo-skeletal system*. Wiley, Chichester, pp 154–190
42. Zajac FE, Gordon ME (1989) Determining muscle's force and action in multi-articular movement. *Exerc Sport Sci Rev* 17:187–230
43. Lacquaniti F (1989) Central representations of human limb movement as revealed by studies of drawing and handwriting. *Trends Neurosci* 12:287–292
44. Bernstein NA (1967) *The co-ordination and regulation of movements*. Pergamon, London
45. Bosco G, Poppele RE (2001) Proprioception from a spinocerebellar perspective. *Physiol Rev* 81:539–568
46. Thomas JS, Corcos DM, Hasan Z (2005) Kinematic and kinetic constraints on arm, trunk, and leg segments in target-reaching movements. *J Neurophysiol* 93:352–364
47. Darling WG, Miller GF (1993) Transformations between visual and kinesthetic coordinate systems in reaches to remembered object locations and orientations. *Exp Brain Res* 93:534–547
48. Karniel A, Meir R, Inbar GF (2001) Polyhedral mixture of linear experts for many-to-one mapping inversion and multiple controllers. *Neurocomputing* 37:31–49
49. Todorov E, Jordan MI (2002) Optimal feedback control as a theory of motor coordination. *Nature Neurosci* 5:1226–1235
50. Latash ML, Scholz JP, Schöner G (2002) Motor control strategies revealed in the structure of motor variability. *Exerc Sport Sci Rev* 30:26–31
51. Scholz JP, Schöner G (1999) The uncontrolled manifold concept: identifying control variables for a functional task. *Exp Brain Res* 126:289–306
52. Reschke MF, Bloomberg JJ, Harm DL, Paloski WH, Layne C, McDonald V (1998) Posture, locomotion, spatial orientation, and motion sickness as a function of space flight. *Brain Res Rev* 28:102–117

53. Crawford JD, Medendorp WP, Marotta JJ (2004) Spatial transformations for eye-hand coordination. *J Neurophysiol* 92:10–19
54. Engel KC, Flanders M, Soechting JF (2002) Oculocentric frames of reference for limb movement. *Arch Ital Biol* 140:211–219
55. Atkeson CG (1989) Learning arm kinematics and dynamics. *Annu Rev Neurosci* 12:157–183
56. Alexander GE, DeLong MR, Crutcher MD (1992) Do cortical and basal ganglionic motor areas use “motor programs” to control movement? *Behav Brain Sci* 15:656–665
57. Knudsen EI, du Lac S, Esterly SD (1987) Computational maps in the brain. *Annu Rev Neurosci* 10:41–65
58. Nelson ME, Bower JM (1990) Brain maps and parallel computers. *Trends Neurosci* 13:403–408
59. Knudsen EI (1991) Dynamic space codes in the superior colliculus. *Curr Opin Neurobiol* 1:628–632
60. Sparks DL (1991) The neural control of orienting eye and head movements. In: Humphrey DR, Freund HJ (eds) *Motor control: concepts and issues*. Wiley, Chichester New York Brisbane Toronto Singapore, pp 263–275
61. Sparks DL, Mays LE (1990) Signal transformations required for the generation of saccadic eye movements. *Annu Rev Neurosci* 13:309–336
62. Desmurget M, Grafton S (2000) Forward modeling allows feedback control for fast reaching movements. *Trends Cogn Sci* 4:423–431
63. Kawato M (1999) Internal models for motor control and trajectory planning. *Curr Opin Neurobiol* 9:718–727
64. Wolpert DM, Gharhamani Z (2000) Computational principles of movement neuroscience. *Nat Neurosci* 3:1212–1217
65. Zajac FE, Neptune RR, Kautz SA (2002) Biomechanics and muscle coordination of human walking. Part I: Introduction to concepts, power transfer, dynamics and simulation. *Gait Posture* 16:215–232
66. Smith JL, Chung SH, Zernicke RF (1993) Gait-related motor patterns and hindlimb kinetics for the cat trot and gallop. *Exp Brain Res* 94:308–322
67. Smith JL, Zernicke RF (1987) Predictions for neural control based on limb dynamics. *Trends Neurosci* 10:123–128
68. Hasan Z (1991) Biomechanics and the study of multijoint movements. In: Humphrey DR, Freund HJ (eds) *Motor control: concepts and issues*. Wiley, Chichester New York Brisbane Toronto Singapore, pp 75–84
69. Bizzi E (1993) Intermediate representations in the formation of arm movements. *Curr Opin Neurobiol* 3:925–931
70. Bizzi E, Hogan N, Mussa-Ivaldi FA, Giszter S (1992) Does the nervous system use equilibrium-point control to guide single and multiple joint movements? *Beh Brain Sci* 15:603–613
71. Kawato M, Gomi H (1992) The cerebellum and VOR/OKR learning models. *Trends Neurosci* 15:445–453
72. Rack PMH (1981) Limitations of somatosensory feedback in control of posture and movement. In: Brooks VB (ed) *Handbook of physiology, Sect. 1: The nervous system, Vol 2, Part 1: Motor control*. Am Physiol Soc, Bethesda, MD, pp 229–256
73. Feldman AG, Adamovitch SV, Ostry DJ, Flanagan JR (1990) The origin of electromyogram – explanations based on the equilibrium point hypothesis. In: Winters JM, Woo SL-Y (eds) *Multiple muscle systems*. Springer, Berlin Heidelberg New York, pp 195–213
74. Feldman AG, Latash ML (2005) Testing hypotheses and the advancement of science: recent attempts to falsify the equilibrium point hypothesis. *Exp Brain Res* 161:91–103
75. Bizzi E, Giszter SF, Loeb E, Mussa-Ivaldi FA, Saltiel P (1995) Modular organization of motor behavior in the frog’s spinal cord. *Trends Neurosci* 18:442–446
76. Soechting JF, Flanders M (1998) Movement planning: Kinematics, dynamics, both or neither? In: Harris L, Jenkin M (eds) *Vision and action*. Cambridge University Press, New York, pp 352–371
77. Doyen J, Benali H (2005) Reorganization and plasticity in the adult brain during learning of motor skills. *Curr Opin Neurobiol* 15:161–167
78. Schouenborg J (2004) Learning in sensorimotor circuits. *Curr Opin Neurobiol* 14:693–697

---

## Motor Control Hierarchy

### Definition

The motor systems are organized in both a hierarchical and parallel fashion. For example, cortical motor areas stand above motor neurons in the spinal cord in a hierarchical fashion, and can command lower motor neurons to activate. However, there are multiple routes from cortical and brainstem motor areas to lower motor neurons, also allowing a parallel control. Aspects of motor planning are also hierarchically organized. At the top of the hierarchy seem to be invariant properties of movements that are independent of the particular patterns of muscle activations used to achieve a motor goal.

---

## Motor Control Models

STAN C. A. M. GIELEN

Department of Biophysics, Radboud University Nijmegen, Nijmegen, The Netherlands

### Definition

The aim of models in motor control is to reproduce experimental data and to make predictions for new experiments, where different models make different predictions so as to discriminate between various models for human movement control. Typically, models have been developed for different levels of motor control: for specific parts of the neuromuscular system as well as for neural feedback and feedforward control mechanisms. For each model, the modeller has to specify (i) the

family of admissible control signals, (ii) the characteristics of the neuromusculo-skeletal model, and (iii) a quantitative definition of task performance.

## Characteristics

### Introduction

A pointing or reaching movement to a target in three-dimensional space defines a redundant task at the geometric, kinematic and dynamic level of control. An infinite number of possible hand trajectories can be selected for moving the hand to the target, leading to an infinite set of possible arm postures for every hand location in 3D space. In this perspective, it is remarkable that human movements are quite reproducible and that the variability of movements starting from the same beginning position towards the same end position is relatively small. This observation has been considered to reflect some underlying principles, which reduce the number of degrees of freedom.

Several models have been proposed to explain the characteristics of human movements. The aim of these models is not only to see whether they can reproduce the experimental observations, but also to make predictions about movement characteristics for movements in new, complex situations, which have not been studied so far. The use of models to predict the behavior for complex movements is important to test and validate models and to suggest new experiments to discriminate between models.

### Kinematics

One of the influential theories in movement control, was the equilibrium-point (EP) hypothesis [1]. This theory assumes that the neuromuscular system has (nonlinear) elastic properties. For a linear spring force  $F$  depends on the stiffness  $K$  and the excursion from the equilibrium point  $x_0$ :  $F = K(x - x_0)$ . The EP-model postulates that the position of a limb corresponds to the position, where the external force (e.g. gravity, weight of objects) is equal (but opposite) to the force exerted by the muscles. Therefore, kinematics should follow directly from the elastic properties of the neuro-muscular system and the properties of external loads.

In general, the position of an end effector, like the finger tip, can be obtained by multiple postures of the arm. Yet, the variability of postures for the same position of the end effector is small. This reproducibility of postures has often been described as Donders' law, which states that limb postures for a given finger, eye, or head position are invariably the same for the same pointing or gaze direction, respectively. This law is certainly not trivial since it is well known that rotations in 3 dimensions do not commute. This implies that the orientation of an object after two rotations along different rotation axes, depends on the order of rotations. Eye movements perfectly obey Donders' law. The specific relation

between direction of gaze and eye orientation is known as Listing's law [2]. However, Donders' law is not valid for limb postures. Experimental results by Soechting et al. [3] revealed consistent variations of postures for the same position of the index finger depending on the history of previous finger positions. These authors suggested that the history-dependence of limb postures could be explained by the minimal-work model, which assumes that movements are made under the constraint of minimal work (see below). This is consistent with the observation that final posture after a movement does not depend on **▶movement velocity** [4].

### Dynamics

In general **▶point-to-point movements**, which start and end at rest, follow a more or less straight path and have a bell-shaped velocity profile (**▶Bell-shaped speed profile**), in agreement with predictions by the minimum jerk-model (see Fig. 1).

However, movement paths may differ depending on the instruction to the subject or depending on movement task. When subjects are instructed to make point-to-point movements in the dark, the movement trajectory is curved. This curved path has been interpreted as the result of movement planning in joint space, where joint rotations may give rise to curved movement paths of the end effector. However, when subjects are instructed to move an object (for example a cursor or mouse) between the same to positions with vision, the movement path is straight, suggesting that movement planning is in external work space. This illustrates that the movement trajectory is task-dependent, presumably because movement planning takes place in different frames of reference (e.g. joint space versus work space).

### Models to Explain Human Movements

In general, models to explain human movement control belong to the general class of **▶optimal control models** [5]. Optimal control assumes that movements are made based on some **▶optimization principle**. Optimal control seeks to find the control (i.e. the muscle activation pattern), which optimizes the time-integral of some cost. This cost might be related to extrinsic features, such as e.g. end-point variability, smoothness of movement, and collision avoidance (see Fig. 2).

However, the cost should also include the properties (e.g. noise) in afferent sensory signals and in neuronal feedforward and feedback signals. The cost may be different for different types of movements. For example, movements, which have to be as fast as possible, require that movement time is minimal, whereas accurate movements require that the variability at the end of the movement is as small as possible.

Most models in the literature to explain properties of human movements focus on a single optimization principle. The most well-known models are

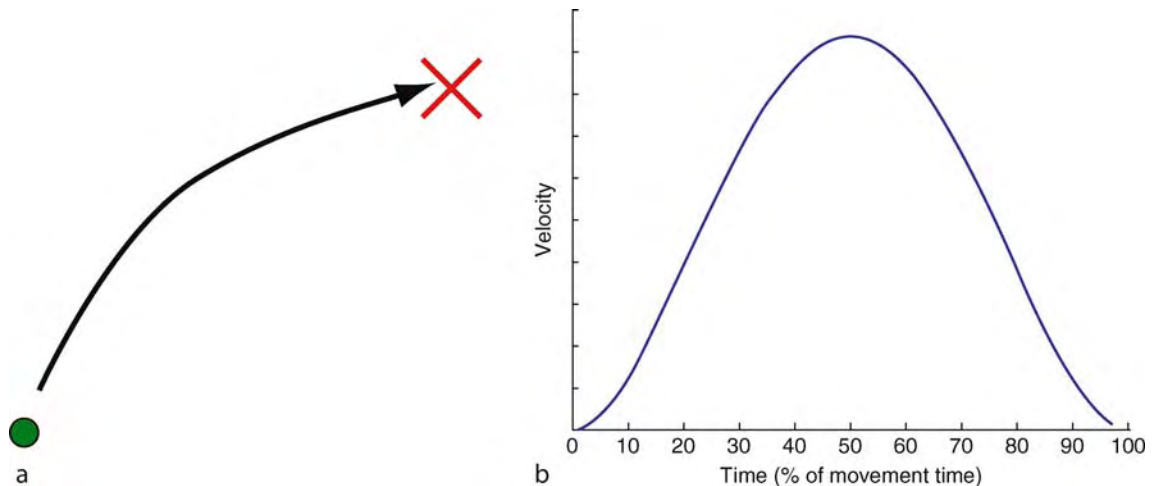

**Motor Control Models. Figure 1** For a typical movement (start position at the green circle) to target (red cross, Fig. 1a) the corresponding velocity profile (Fig. 1b) has a bell-shaped profile.

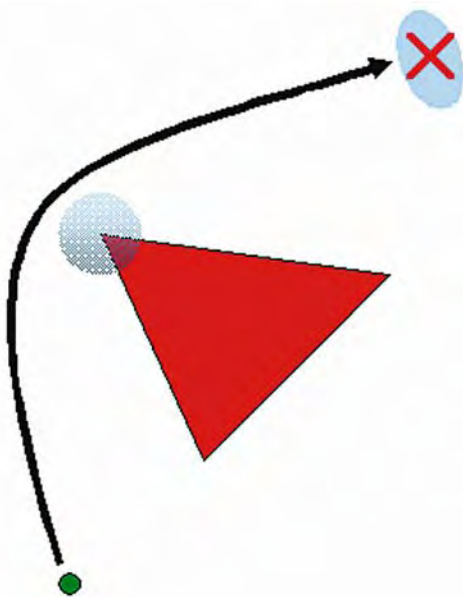

**Motor Control Models. Figure 2** For a movement from the green circle to the red cross the movement path should keep a sufficiently large distance from the triangle to avoid collision. Given the intrinsic noise of action potential firing and force generation in muscle, this requires that the movement path should remain outside a circle centered at the corner of the triangle. It should also reach the target with a particular accuracy (indicated by elliptic shape). For optimal control, there are several cost criteria, depending e.g. on the internal noise of the motor system, on target accuracy of the movement, on movement time. The total cost  $C$ , which should be minimized, is a weighed summation of the various cost criteria  $C_i$  involved ( $C = \sum w_i C_i$ ), where the weighting coefficients  $w_i$  depend on the relative importance of the cost criterion  $C_i$ .

- Minimum jerk model. Jerk is the third derivative of position. Minimization of jerk assumes that movements are smooth and predicts that movement velocity profiles are bell-shaped [6].
- ▶ Minimum torque-change model [7]. This assumes that changes in joint torque are minimized. A variation on the minimum-torque-change model is the minimum force-change model, which assumes that changes in muscle force are minimized. Since torque is the product of force and lever arm, the predictions by the minimum-torque change and minimum force-change models are very similar.
- Minimum-work model [3] assumes that work is minimized. This is equivalent to assuming that kinetic energy at peak velocity is minimized.
- Minimum variance model [8] uses the fact that muscle noise increases proportionally with muscle force and assumes that those forces are selected that minimize variance at the end of the movement.

Advanced mathematical analyses make it possible to calculate the best control given an optimality criterion in the absence of noise. However, the human motor system has to deal with internal noise [8] and movements are made in an environment, which may change in an unpredictable way. The theoretical framework for these cases (called “stochastic optimal control”) is far from complete and is an important topic for further research.

Quite surprisingly, many models make the same predictions for planar movements but differ greatly in their predictions for movements in three dimensions [9]. Because of the complexity of simulating models for 3D movements and of analyzing and interpreting movements in three dimensions, a thorough comparison

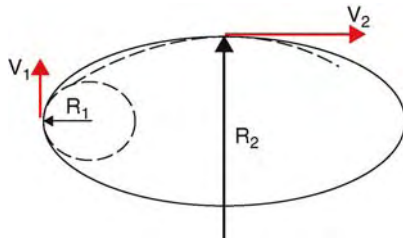

**Motor Control Models. Figure 3** For periodic movements along an elliptic path, the relation between radius  $R$  of the movement path and tangential velocity  $v$  is given by  $V = CR^{1/3}$ . The dashed and dashed-dotted lines are local fits of a circle segment to the ellipse. For a high curvature (small radius  $R_1$ ) the corresponding tangential velocity  $V_1$  is smaller than the tangential velocity  $V_2$  for the less curved part of the ellipsoid. The ratio  $V_1/V_2$  is equal to  $\sqrt[3]{R_1/R_2}$ .

between predictions of various models and experimental data for movements in 3 dimensions has not been made yet.

### Two-Third Power Law

It is a well-known phenomenological observation that velocity of curved movements is tightly related to the curvature of the movement. This relation has been referred to as the **two-third power law**, since angular velocity  $\omega$  appears to be related to curvature  $\kappa$  of the movement path by the exponential relation  $\omega = C\kappa^{2/3}$ . Since for circular movements tangential velocity  $v$  is related to angular velocity  $\omega$  by the radius  $R$  of the movement ( $v = R\omega$ ) with  $R$  equal to the inverse of curvature  $\kappa$ , the two-third power law can also be written as  $v = CR^\beta$ , where the exponent  $\beta$  equals  $1/3$  (see Fig. 3).

This relation can be derived mathematically when it is assumed that planar movements, such as elliptic movements, are made by a superposition of two orthogonal components with a sinusoidal and cosine modulation in time. As an alternative to the explanation that movements are built up by sine- and cosine modulated orthogonal components, Richardson and Flash [10] demonstrated that the two-third power law also follows from the smoothness constraint that underlies the **minimum-jerk model**.

### References

1. Feldman AG (1986) Once more on the equilibrium point hypothesis (lambda model) for motor control. *J Motor Behav* 18 (1):17–54
2. Tweed D, Vilis T (1987) Implications of rotational kinematics for the oculomotor system in three dimensions. *J Neurophysiol* 58:832–849
3. Soechting JF, Buneo CA, Herrmann U, Flanders M (1995) Moving effortlessly in three dimensions: Does Donders' law apply to arm movement? *J Neurosci* 15:6271–6280

4. Nishikawa KC, Murray ST, Flanders M (1999) Do arm postures vary with the speed of reaching? *J Neurophysiol* 81:2582–2586
5. Todorov E (2004) Optimality principles in sensorimotor control. *Nat Neurosci* 7:907–915
6. Flash T, Hogan N (1985) The coordination of arm movements – an experimentally confirmed mathematical model. *J Neurosci* 5:1688–1703
7. Uno Y, Kawato M, Suzuki R (1989) Formation and control of optimal trajectory in human multijoint arm movement – minimum torque-change model. *Biol Cybern* 61:89–101
8. Harris CM, Wolpert DM (1998) Signal-dependent noise determines motor planning. *Nature* 394:780–784
9. Hermens F, Gielen S (2004) Posture-based or trajectory-based movement planning: a comparison of direct and indirect pointing movements. *Exp Brain Res* 159:340–348
10. Richardson MJE, Flash T (2002) Comparing smooth arm movements with the two-thirds power law and the related segmented-control hypothesis. *J Neurosci* 22:8201–8211

## Motor Cortex

### Definition

A general term that historically has been used to refer to primary motor cortex. This term is now also used in a more general way to refer collectively to primary and secondary motor areas of the frontal lobe.

- ▶ Motor Cortex – Hand Movements and Plasticity
- ▶ Motor Cortex - Output Properties and Organization
- ▶ Primary Motor Cortex (M1)

## Motor Cortex – Hand Movements and Plasticity

MARC H. SCHIEBER

Departments of Neurology and of Neurobiology and Anatomy, University of Rochester School of Medicine and Dentistry, Rochester, NY, USA

### Definition

The primary motor cortex, in primates located just anterior to the central sulcus, plays a crucial role in control of fine hand and finger movements. The organization of movement representations in the motor cortex undergoes

plastic changes in response to altered internal and external requirements for finger movements.

## Characteristics

### Voluntary Use of the Hand and Fingers

► **Grasping** an object is the most frequent voluntary use of the hand. Depending on the object and goal, humans use a wide variety of grasps – from precision (► **Grip – precision grip**) pinch between the tip of the thumb and index finger as used in picking a raspberry, to power grip (► **Grip – power grip**) as used in holding a hammer [1]. As the hand is transported toward an object by the reaching movement of the arm, the fingers open and form into a shape that approximates the shape of the object to be grasped. Such visually guided pre-shaping of the hand is mediated by a flow of information from the anterior intraparietal area (AIP) to the ventral premotor cortex (PMv) to the primary motor cortex (M1) [2]. As the fingers close on the object, forces at the contact surfaces on the fingers and palm must be balanced to provide a stable grip that does not rotate or crush the object unintentionally.

Less frequently the hand is used to perform delicate manipulation or even such specialized acts as typing on a keyboard, or playing a musical instrument. Although one often has the impression that during such movements each finger is moved independently, recordings show considerable correlated motion of adjacent fingers [3]. Even when normal humans are asked to exert flexion force with one finger only, force is produced in adjacent digits, a phenomenon referred to as ► **enslavement** of the adjacent digits. Similarly, when asked to move only one finger, motion appears in other fingers as well. In part, this incomplete ► **individuation** results from biomechanical coupling of the digits, and in part it reflects control from the nervous system as well.

For both grasping and fine manipulation, use of the right versus left hand is not necessarily random. Hand preference has three levels: (i) individual subjects tend to use the same hand repeatedly for a given task; (ii) individual subjects prefer to use the same hand for many different tasks; and (iii) most individuals in a population tend to prefer the same hand. Whereas non-human primates systematically show only the first level of hand preference, humans show all three levels. Approximately 80% of any human population is right-handed. In general, right-handed people prefer to use the right hand for delicate tasks that require precise control of dynamically changing forces, while the left hand may perform better in tasks requiring accurate control of static position [4].

### Control of the Fingers From the Motor Cortex

Control of such relatively independent finger movements relies heavily on the hand representation in the primary motor cortex, and its corticospinal projection (► **Motor**

**cortex – output properties and organization 06078**). When lesions affect this pathway, individuated finger movements are the first and most severely affected, and the last to recover. In macaque monkeys, a central core of Brodmann's area 4 representing hand movements and muscles is surrounded by a horseshoe-shaped band representing the more proximal upper extremity. This entire upper extremity representation lies between the representations of the face laterally and the lower extremity medially.

Throughout the M1 hand representation, neurons in cortical layer V send corticospinal axons to the lower cervical enlargement to control the motoneurons of hand muscles. Corticomotoneuronal (CM) cells that make monosynaptic connections to hand motoneurons are restricted to the posterior part of the hand representation, which in macaque monkeys lies in the anterior bank of the central sulcus [5]. CM cells are thought to be particularly important in the fine control of relatively independent finger movements. The firing rate of single neurons in the M1 hand representation – including corticospinal neurons and CM cells – varies depending on which type of grasp is used, or depending on which finger is moved. Although single neurons only rarely discharge selectively for a particular type of grasp, or for movement of a particular finger, the discharge of a large population of M1 neurons transmits information that specifies the hand or finger movement being made.

The M1 hand area classically was thought to contain an orderly somatotopic representation of the digits, with the thumb most lateral and the little finger most medial, but the representation of each digit now is known to be more widely distributed. This results from a number of structural features [6]. First, the cortical territory from which corticospinal axons converge on the motoneurons of a given hand muscle occupies several square millimeters. Given the number of hand muscles, these territories are so large that they overlap extensively with one another. Second, single cortical neurons often provide monosynaptic output connections to the spinal motoneuron pools of multiple muscles. Single cortical neurons thus may provide output to muscles acting on multiple digits, and even on the wrist, elbow and shoulder as well. Third, the entire M1 upper extremity representation is interconnected by horizontal axon collaterals that interlink not only the central digit core, but also the surrounding representation of more proximal muscles. As a consequence of this convergence, divergence and horizontal interconnectivity, neuronal activity appears throughout the hand representation during voluntary movement of even a single finger. In addition to this widely distributed base of activation, in humans a somatotopic gradient is superimposed, with more activation laterally during thumb movements, and more activation medially during movements of the little finger.

## Plastic Changes in Cortical Finger Movement Representations

The widely distributed organization provided by convergence, divergence and horizontal connectivity in the pathway from the primary motor cortex to spinal ►motor neuron pools also provides a flexible substrate that can undergo plastic reorganization. Some plastic changes are mediated very rapidly by altered patterns of intracortical inhibition. The hetero-synaptic processes of long-term potentiation and depression also contribute to plastic reorganization. As time passes, some existing synapses are pruned away and new synaptic connections form. All these underlying processing contribute to reorganization of ►motor maps.

Plastic reorganization occurs during motor learning (►Motor learning) in normal subjects [7]. Repeated practice of particular hand and finger movements expands the representation of the practiced movements and of the muscles involved in producing them. Reorganization also occurs after injury [8]. After amputation of the hand, stimulation of the M1 hand representation evokes larger than normal contractions of the remaining proximal muscles. Voluntary attempts to move the phantom hand result in contractions of proximal muscles that would not normally contract during hand movements [9]. Reorganization of the motor map occurs as well after damage to the primary motor cortex [10]. If damage to the hand representation is partial and the subject is made to use the affected hand, some cortical territory that previously had represented proximal movements changes to represent distal movements. If damage to the primary motor cortex hand representation is complete, representation of finger movements in other cortical motor areas expands. Plastic reorganization of finger movement representations thus underlies both normal motor learning and recovery from nervous system injury.

### Acknowledgments

This work was supported by R01/R37-NS27686 from the National Institute of Neurological Disorders and Stroke.

### References

1. Napier JR (1956) The prehensile movements of the human hand. *J Bone Joint Surg* 38:902–913
2. Rizzolatti G, Fogassi L, Gallese V (2001) Neurophysiological mechanisms underlying the understanding and imitation of action. *Nat Rev Neurosci* 2(9):661–670
3. Schieber MH, Santello M (2004) Hand function: peripheral and central constraints on performance. *J Appl Physiol* 96(6):2293–2300
4. Sainburg RL (2005) Handedness: differential specializations for control of trajectory and position. *Exerc Sport Sci Rev* 33(4):206–213

5. Rathelot JA, Strick PL (2006) Muscle representation in the macaque motor cortex: an anatomical perspective. *Proc Natl Acad Sci USA* 103(21):8257–8262
6. Schieber MH (2001) Constraints on somatotopic organization in the primary motor cortex. *J Neurophysiol* 86(5):2125–2143
7. Sanes JN, Donoghue JP (2000) Plasticity and primary motor cortex. *Annu Rev Neurosci* 23:393–415
8. Chen R, Cohen LG, Hallett M (2002) Nervous system reorganization following injury. *Neuroscience* 111(4):761–773
9. Reilly KT, Mercier C, Schieber MH, Sirigu A (2006) Persistent hand motor commands in the amputees' brain. *Brain* 129(Pt 8):2211–2223
10. Nudo RJ (2003) Adaptive plasticity in motor cortex: implications for rehabilitation after brain injury. *J Rehabil Med* (41 Suppl):7–10

## Motor Cortex, Primary

### Synonyms

- Gyrus precentralis; ►Precentral gyrus
- Precentral Gyrus (Area 4)
- Telencephalon

## Motor Cortex, Supplementary

### Definition

Together with the premotor cortex, forms the secondary motor field. Involved in planning movement.

- Telencephalon

## Motor Cortex: Output Properties and Organization

PAUL CHENEY

Dept. Molecular and Integrative Physiology,  
University of Kansas Medical Center,  
Kansas City, Kansas, USA

### Synonyms

Corticospinal system organization; Pyramidal system organization; Upper motor neuron organization



## Definition

Movement planning and execution are the products of distributed neural processing involving many areas of the brain. This essay focuses on the role of motor areas of cerebral cortex, particularly primary motor cortex, in movement execution. Cortical motor areas are identified and their output capability is summarized in terms of the movements evoked by electrical stimulation. The synaptic organization of ▶**corticospinal neurons** with motoneurons in the spinal cord is explained in terms of the selection of muscle synergies needed for producing coordinated limb movements.

## Characteristics

### Identification and Somatotopic Organization of Cortical Motor Areas

The cerebral cortex of mammals can be categorized into a number of specialized sensory, motor and association areas. In primates, these areas are particularly well developed and large. The motor areas of cerebral cortex are contained within the frontal lobe and include primary motor cortex or M1 located in the precentral gyrus just anterior to the central sulcus as well as several ▶**secondary motor areas**. Six secondary motor areas have been identified in primates including the ▶**SMA** (supplementary motor area) medial and anterior to primary motor cortex, dorsal and ventral ▶**premotor areas** (PMd and PMv) on the lateral surface of the frontal lobe anterior to M1 and three ▶**cingulate motor areas** located ventral to SMA in the cingulate gyrus [1,2]. The location of the primary and secondary motor areas is shown in Fig. 1 for a rhesus monkey cerebral hemisphere. Analogous areas have been identified in the human brain.

Primary motor cortex was first identified in the 19th century by applying electrical currents to the cerebral cortex of anesthetized animals. It was discovered that this electrical current evoked movements of specific body parts and that the representation followed an orderly pattern paralleling the anatomy of major body parts. The neuronal representation of motor and sensory functions associated with specific body parts is termed ▶**somatotopic organization** and is a distinctive feature of cortical motor areas. The discovery of a somatotopic organization of electrically evoked movements in the cerebral cortex was strong evidence for localization of function in the brain. Cortical areas from which movement could be evoked were referred to as “electrically excitable”. Electrical excitability or the ability to evoke movements with electrical stimulation is used as a means of identifying motor areas of the cerebral cortex. Movements can be evoked from both primary and secondary cortical motor areas, although significantly higher currents are required for secondary motor areas.

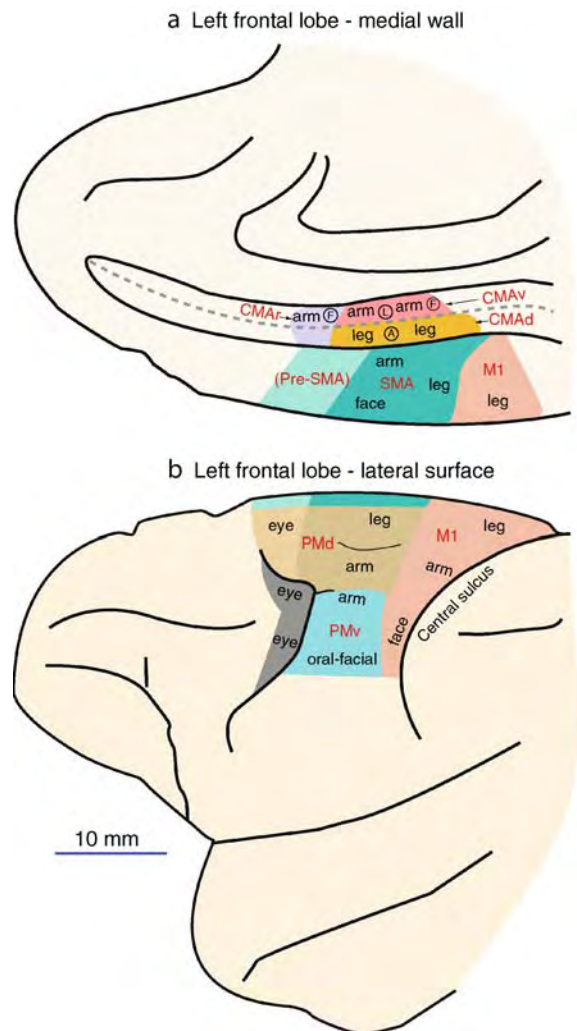

**Motor Cortex: Output Properties and Organization.** **Figure 1** Location and general somatotopic organization of cortical motor areas of the macaque monkey brain based on ICMS evoked movements. (a) Motor areas on the medial wall of the left frontal lobe. (b) Motor areas on the lateral surface of the left frontal lobe. Motor areas are labeled in red and include primary motor cortex (M1), supplementary motor area (SMA), cingulate motor areas (CMA) and lateral premotor areas (PMd and PMv). The cingulate gyrus has been “unfolded” and represented as a two dimensional map. The dotted line represents the fundus (bottom) of the sulcus. The small-circled letters in the cingulate motor areas are included to show that in addition to the principal representation indicated, small patches of representation of the face (F), arm (A) and leg (L) also exist. (Modified from [3]).

Primary and secondary cortical motor areas can also be identified on the basis of their distinctive histological appearance including the thickness of various layers and the size of various cell types. This approach is

referred to as cytoarchitectonics. Based on this type of analysis, the cerebral cortex has been divided into numerous separable regions. An important principle of cortical organization is that areas of cerebral cortex identified on the basis of these anatomical criteria are often found to align closely with regions identified by functional criteria. For example, primary motor cortex corresponds with Broadman's cytoarchitectonic area 4.

Another identifying feature of cortical motor areas is the presence of corticospinal neurons. These are neurons that have a cell body contained within the cortex and an axon that projects to the spinal cord for the control of limb and trunk musculature. Similar neurons for control of facial and tongue muscles are called corticobulbar neurons because their axons terminate in the brainstem where motoneurons of these muscles are located. In primates, some corticospinal neurons, referred to as corticomotoneuronal cells, make monosynaptic connections directly with motoneurons and these connections are thought to be an important neural substrate underlying skilled use of the distal extremities, particularly the ability to make independent finger movements. Corticospinal neurons are found throughout primary motor cortex and secondary cortical motor areas, although the number of neurons is smaller for secondary cortical areas because the size of these areas is much smaller than primary motor cortex [1,2].

Electrical stimulation of cerebral cortex has been a highly informative approach to understanding cortical motor output organization. The classical early studies in humans by Penfield [4] and in non-human primates by Woolsey established the major features of body somatotopic organization that can be found today in nearly every textbook of neuroscience. Penfield and Woolsey summarized the general pattern of evoked movements from cortical stimulation by drawing a body surface representation, superimposed on the cortical surface and distorted in size to reflect the amount of cortex devoted to movements of each body part. These body surface representations, referred to as homunculi and simunculi for humans and monkeys respectively, indicate the location along the precentral gyrus where movements of different body parts can be evoked by electrical stimulation. The major features of the somatotopic organization of motor output from ►primary motor cortex (M1) are (i) largely separate areas devoted to the representation of the lower extremity, trunk, upper extremity, face and tongue with the lower extremity located medially and the tongue most laterally along the precentral gyrus, (ii) the representation is contralateral except for tongue, jaw and upper facial muscles and (iii) there is preferential representation of distal muscles, particularly muscles of the hand, face and tongue. These are the muscles most heavily involved in skilled movements and require

the highest degree of fractionation in the patterns of activity across different muscles.

While the basic body plan of somatotopic organization revealed by the early stimulation studies is universally accepted, the degree to which a consistent and orderly somatotopic organization exists for muscles/movements within a major body segment has only been addressed in more recent studies [5]. Some of these studies have used cortical microstimulation in monkeys to identify activated muscles of the forelimb. Microstimulation consists of applying weak current pulses through a recording microelectrode. Using this approach, a consistent representation of forelimb muscles has been identified, consisting of a core representation of distal muscles (wrist and digit), a peripheral zone of proximal muscle (shoulder and elbow) representation and a large zone representing combinations of distal and proximal muscles separating the pure distal and pure proximal representations [6]. This pattern of forelimb representation is also supported by anatomical studies in which distal and proximal forelimb corticospinal neurons have been labeled with tracers and identified histologically [1,2]. Does the existence of a consistent somatotopic organization extend to movements of the hand including the wrist and individual digits? The homunculi and simunculi drawings based on early work would suggest this but the answer to this question is clearly no. Neurons involved in motor responses of the wrist and individual digits are completely overlapping within primary motor cortex [5]. In part this is due to the fact that the simplest movement of an individual digit actually involves the activation of a large number of distal muscles, not just the muscles of the digit to be moved but also muscles involved in stabilizing the other digits. Another factor is that individual corticospinal neurons rarely make synaptic connections with motoneurons of just one muscle. Rather these neurons activate combinations of muscles as functional synergies [7].

Cortical mapping using repetitive microstimulation of the cortex has typically involved applying brief (30 ms) trains of high frequency stimuli (330 Hz) to evoke twitch like movements. This has been and continues to be a very useful approach to cortical output mapping. However, if the stimulus train duration is lengthened from 30 ms to 500 ms, more complete movements can be evoked. These movements more closely resemble the time course, trajectory and velocity profile of normal voluntary movements. Graziano and colleagues [8] have exploited this approach to map the movements evoked from primary motor cortex and premotor areas on the lateral surface of the hemisphere (PMd and PMv). An important feature of these movements is that long duration repetitive stimulation brings the hand to the same end point in space regardless of the starting position. The cortical map

obtained using this approach contains four subregions from which different, seemingly purposeful movement responses can be elicited. Long duration stimulation of one subregion tends to bring the contralateral hand to locations in space in front of the chest. Stimulation within this part of the map also evokes a variety of hand postures similar to ones observed during object manipulation behavior including (i) grip with the thumb against the forefinger, (ii) fist formation, (iii) opening of the hand with all digits splayed, (iv) various rotations of the wrist and (v) pronation and supination of the forearm. The cortex from which these movements can be evoked corresponds to the forelimb representation of primary motor cortex, an area that has long been known to emphasize the control of manual dexterity. A second subregion corresponds to hand locations at the mouth and stimulation within this region produces a grip posture with movement of the hand to the mouth and often opening of the mouth. This area corresponds to a part of area PMv known to be involved in the cortical representation of grasp postures and interactions between the hand and mouth. A third subregion termed PZ or polysensory zone contains neurons that respond to tactile stimuli on the face and arms and visual stimuli near the face and arms. Stimulation of sites in the polysensory zone evokes apparent defensive movements. This is a multimodal subregion that is also largely within area PMv. The fourth subregion is contained within PMd. Stimulation within this subregion produces reaching movements in which the wrist straightens, the fingers open as if to prepare for grasp and the arm extends outward from the body.

### Organization of Corticospinal Output

Historically, a major controversy has existed over the issue of what is represented by the corticospinal neurons that constitute primary motor cortex output. Is it muscles that are represented or movements? To some extent, this controversy has lingered on because terms have not been adequately defined, but also because there is a genuine and important issue to be resolved. Obviously muscles are represented in the sense that corticospinal neurons make synaptic connections with motoneurons and activate muscles. However, the real issue might be redefined in terms of the way in which muscles are represented and its possible significance. For example, what would be the implication of an output representation in which small pieces of motor cortex, like pieces of a mosaic or keys of a piano, were devoted to the representation of single muscles? This would constitute a muscle representation in the most extreme sense. In this case, the central motor program, containing information about the movement to be produced would select the appropriate keys (muscles) of the motor cortex keyboard to produce the desired movement. The role of motor cortex output would then

simply be to devote a piece of tissue and corresponding corticospinal neurons to each individual muscle and give appropriate parts of the brain access to these muscle specific representations. It is now known that this is not the way motor cortex output is organized. In large part, individual corticospinal neurons do not have synaptic contacts confined to motoneurons of individual muscles. Rather, individual corticospinal neurons make synaptic contacts with motoneurons of multiple muscles representing functional muscle synergies [7,9–11]. The set of muscles influenced by a corticospinal neuron are referred to as its **muscle field**. Corticospinal neurons have a clustered organization in layer V of primary motor cortex and there is evidence that the individual neurons within a cluster have similar muscle fields. The set of corticospinal cells selected for activation by the central motor program is obviously dependent on the desired movement. Simple isolated movements of the wrist involve coactivation of forearm, wrist and digit synergist muscles and the corticospinal neurons activated for this task tend to have only distal muscle fields. Most importantly, single neurons engaged in isolated wrist movements do not act upon single muscles; rather, these neurons activate combinations of wrist and digit synergist muscles. Many of the same corticospinal neurons that facilitate motoneurons of multiple agonist muscles also simultaneously inhibit motoneurons of multiple antagonist muscles. To aid with the movement, the activity of the antagonist muscles must be suppressed as the agonist muscles contract and shorten. This combination of multiple facilitated agonist muscles and suppressed antagonist muscles constitutes a simple functional synergy for movement about a single joint. The representation of such functional muscle synergies goes beyond a simple muscle representation – it is the representation of a set of muscles for a particular movement. Hence, it can be argued that movements are, in fact, represented in the synaptic output organization of primary motor cortex. The corticospinal representation of functional muscle synergies also extends to more complex multi-joint movements. Reaching to grasp an object requires coactivation of muscles at multiple proximal and distal joints. Many corticospinal neurons involved in such reaching tasks make synaptic connections with motoneurons of both distal and proximal muscles [7]. These muscle combinations represent multi-joint functional synergies involved in reaching. To conclude, the output organization of primary motor cortex can be viewed in terms of the functional muscle synergies represented in the synaptic connections of corticospinal neurons with motoneurons. These muscle synergies and their combinations are the cortical building blocks the central motor program must work with to produce the diversity of skilled movements characteristic of primates.

## References

1. He SQ, Dum RP, Strick PL (1993) Topographic organization of corticospinal projections from the frontal lobe: motor areas on the lateral surface of the hemisphere. *J Neurosci* 13:952–980
2. He SQ, Dum RP, Strick PL (1995) Topographic organization of corticospinal projections from the frontal lobe: motor areas on the medial surface of the hemisphere. *J Neurosci* 15:3284–3306
3. Rizzolatti G, Luppino G, Matelli M (1998) The organization of the cortical motor system: new concepts. *EEG and Clin Neurophysiol* 106:283–296
4. Penfield W, Rasmussen AT (1950) Cerebral cortex of man. A clinical study of the localization of function. Macmillan, New York
5. Schieber MH, Hibbard LS (1993) How somatotopic is the motor cortex hand area? *Science* 261:489–492
6. Park MC, Belhaj-Saif A, Cheney PD (2001) Consistent features in the forelimb representation of primary motor cortex of rhesus macaques. *J Neurosci* 21:2784–2792
7. McKiernan BJ, Marcario JK, Hill-Karrer J, Cheney PD (1998) Corticomotoneuronal (CM) postspike effects on shoulder elbow wrist digit and intrinsic hand muscles during a reach and prehension task in the monkey. *J Neurophysiol* 80:1961–1980
8. Graziano MS (2006) The organization of behavioral repertoire in motor cortex. *Ann Rev Neurosci* 29:105–134
9. Buys EJ, Lemon RN, Mantel GWH, Muir RB (1986) Selective facilitation of different hand muscles by single corticospinal neurons in the conscious monkey. *J Physiol* 381:529–549
10. Fetz EE, Cheney PD (1980) Post-spike facilitation of forelimb muscle activity by primate corticomotoneuronal cells. *J Neurophysiol* 44:751–772
11. Woolsey CN (1964) Cortical localization as defined by evoked potential and electrical stimulation studies. In: cerebral localization and organization (Eds. G. Schattenbrand and CN Woolsey). The University of Wisconsin press, Madison.

## Motor Disorders

### Definition

Motor disorders may be neurologically classified as (i) paralysis due to dysfunctions of ►skeletal muscle, ►neuromuscular junction, ►brainstem or spinal skeletal-motoneurons; (ii) paralysis due to damage to the ►corticospinal tract, ►corticobulbar tracts, or fibers descending from the brainstem (see ►spasticity); (iii) non-paralytic and ►apraxic dysfunctions of purposive movements resulting from lesions of the ►cerebral hemispheres; (iv) disorders of the ►basal ganglia (see ►Parkinson disease, Huntington’s disease; Tourette’s syndrome); (v) dysfunctions of coordination (►ataxia)

resulting from lesions of the ►cerebellum and its inputs and outputs.

- Basal Ganglia
- Cerebellar Functions
- Corticospinal Tract
- Huntington’s Disease
- Neuromuscular Junction
- Parkinson Disease
- Spasticity
- Tourette’s Syndrome

## Motor Efference

### Definition

The motor commands from the brain leading to movement.

- Large-Fiber Sensory Neuropathy
- Effect on Proprioception

## Motor Equivalence

### Definition

Motor equivalence implies that the same movement or motor program can be executed by different muscle and/or joint assemblies.

- Motor Control Models

## Motor Error

### Definition

The difference between the present location of an effector (e.g., the hand or the eye) and its desired location. Neural correlates of motor error have been described in a variety of brain centers.

- Movement Sequences
- Eye-Hand Coordination

## Motor Evoked Potential (MEP)

### Definition

Electrical potential recorded over a muscle, evoked by electrical or magnetic stimulation of the nervous system.

- ▶ Transcranial Magnetic Stimulation

## Motor Fluctuations in Parkinson Disease

### Definition

Fluctuations in the severity of motor symptoms of Parkinson disease several times per day, related to the long term use of levodopa and disease progression

- ▶ Parkinson Disease
- ▶ Structures/Processes/Conditions: Parkinson Disease

## Motor Imagery

### Definition

The ability to mentally simulate a particular movement without actual execution. Neuroimaging studies have shown the involvement of several motor brain areas during motor imagery.

- ▶ Action Representation

## Motor Invariant

### Definition

An invariant is a quantity that remains unchanged under a set of transformations. For example, the curvature of a curved hand movement trajectory is invariant under the transformations of rotation and translation.

- ▶ Arm Trajectory Formation

## Motor Learning

VLASTISLAV BRACHA, JAMES R. BLOEDEL  
Department of Biomedical Sciences, Iowa State University, Ames, IA, USA

### Definition

▶ **Motor learning** is the process of acquiring new motor skills. Common examples of motor learning are learning to ride a bicycle or to play tennis. Motor learning is essential for success under novel or changing environmental contexts and is thus ubiquitous. It participates in speech acquisition, in learning to use tools and machines, in the acquisition of artistic and athletic skills, in tuning motor performance during development and aging, and in compensating for movement deficits associated with a bodily injury.

### Characteristics

In the current literature, the term motor learning has been applied to a heterogeneous group of adaptive phenomena and as such it defies a simple definition. In general, motor learning pertains to processes of adaptively modifying the spatio-temporal structure of movements, of forming new or adjusting existing sensori-motor transformations and of forming new movement sequences.

Motor learning is distinct from other forms of learning, such as learning the spatial structure of the environment, remembering events and temporal associations between events, learning symbols and concepts, or autobiographical memory. The outcome of motor learning is an acquired modification of sensori-motor processing resulting in meaningful changes in motor performance that achieves a desired behavioral goal in specific environmental and motivational circumstances. A typical property of motor learning is that it progresses through a series of trial and error performances. Motor learning usually requires a large number of repetitions to achieve an asymptotic performance. The ▶ **motor error**, which is derived from the difference between the expected and actual results of movement, is a pivotal notion in conceptual and computational models of motor learning.

Similar to other forms of learning and memory, motor learning is thought to have explicit and implicit components or phases. When learning a new motor skill, successful movement generation frequently requires involvement of attention and awareness. At this stage, the movements are under an explicit, i.e., conscious and verbally describable control. As the learning progresses, movements become smoother, faster and automated. Eventually, well-trained movements become implicit, i.e. fully automatic, requiring

little or no conscious effort. However, some types of motor learning, such as the adaptation of hand movements to altered visual feedback or the classical conditioning of eyeblink responses, can occur exclusively in the implicit domain, with the subject either being unaware of the learning or being unable to report on the relevant details of learning.

Motor learning in natural conditions involves the complex coordination of a number of motor sub-systems. For example, an efficient tennis stroke requires hitting the incoming ball at a precise time and place relative to the tennis player's body with a tennis racquet having precise speed, orientation and trajectory of movement. To achieve this, the player has to learn to observe the ball and extrapolate its trajectory, to run to the anticipated place of stroke execution, assume the appropriate posture and execute a complex and precisely timed kinetic chain of leg, torso and arm movements. These movements are synchronized with eye and head movements and with respiration, and they have to be adapted to the physical properties of the court, ball and the tennis racquet. To reduce this complexity to a level amenable to scientific analysis, motor learning is studied in simplified motor learning models.

### Models of Motor Learning

The neural substrates of motor learning are investigated in experimental models that focus on its specific aspects in specific motor sub-systems. The motor learning paradigms are usually designed to control the learning environment, to provide reliable measurements of executed movements and access to measurements or manipulations of the nervous system. The most common learning paradigms fit in one of the following categories.

#### *Adaptive Modifications of the Vestibulo-ocular Reflex*

The purpose of the vestibulo-ocular reflex (VOR) is to stabilize images on the retina during head movements. Head movements stimulate the vestibular apparatus and the resulting sensory information is processed in VOR neural circuits to produce compensatory eye movements that stabilize the visual field. The VOR is under strong visual control. Inadequate VOR operation produces slip of the visual image on the retina, and this visual error signal drives adaptive VOR modifications. To induce VOR adaptation, experimenters usually introduce an artificial visual error by moving the subject's surroundings or by placing reversing or magnifying optical devices in the visual path. By using these tools, the VOR could be canceled, its direction reversed or its amplitude changed. VOR adaptation is one of the oldest models of motor learning, and it has yielded an advanced understanding of cerebellar and brainstem circuits controlling this adaptive process.

This knowledge makes the VOR model well suited for studies at the neural network and cellular levels [1].

#### *Classical Conditioning of Withdrawal Reflexes*

Withdrawal reflexes protect body parts from injury by withdrawing them from aversive stimuli. Withdrawal reflexes, such as an eyeblink response or a limb withdrawal, can be classically conditioned. In classical conditioning, subjects are presented with an initially irrelevant stimulus (conditioned stimulus) that is followed by the withdrawal-eliciting aversive stimulus (unconditioned stimulus). During repeated pairings of these stimuli, the subject learns to respond to the conditioned stimulus before the unconditioned stimulus reaches the body surface. The learned anticipatory response is called the conditioned response. Although eyeblink conditioning was originally studied in the context of associative learning, more recently it has also been categorized as a form of motor learning, most likely because of its dependence on the cerebellum and because it results in the formation of new, well timed motor response. Similar to the VOR, researchers employing the eyeblink conditioning model have been extremely successful in delineating involved neural circuits and in developing experimental strategies that address the nature and location of underlying plastic changes [2,3]. It has been shown that a simple form of eyeblink conditioning, known as ▶*delay eyeblink conditioning*, is controlled predominantly by cerebellar, mesencephalic, pontine and medullar neural circuits. The more complex forms of conditioning, such as ▶*trace eyeblink conditioning*, recruit additional CNS components, such as the hippocampus.

#### *Learning New and Optimizing Existing Visuo-motor Skills*

This broad category of motor learning paradigms incorporates movements executed under visual feedback. An example of visuo-motor skill adaptation is learning to trace two-dimensional objects by hand or learning to reach for visually detected objects. In a typical tracing task the subject traces repeatedly a two-dimensional object with a pen. It has been shown that with training, tracing movements become faster, smoother and more accurate. The tracing task can be experimentally manipulated by altering the visual feedback. This can be achieved by asking the subject to trace the image reflected in a mirror, which reverses the normal relationship between directions of the eye and hand movements. Another common variant of this task involves tracing objects on a computer screen with an input device such as a computer mouse or tablet. The relationship between the direction and amplitude of the hand and cursor (and therefore the eye) movements can be manipulated with appropriate software. Since tracing tasks require close coupling between eye and hand movements, disrupting their normal relationship

leads to motor errors that drive a powerful and surprisingly fast motor learning.

Visuo-motor learning attracted large attention following the discovery that amnesiac subjects with injuries of the medial temporal lobe and hippocampus can learn the mirror tracing task despite being severely deficient in explicit memory tasks. This observation led to the modern concept of relatively independent explicit and implicit memory systems. It should be noted, however, that although motor learning is frequently considered to be a form of implicit memory, many motor learning tasks have explicit components or could be affected by explicit factors.

### **Adaptation to Movement Perturbations**

Models in this category utilize external forces to interfere with ongoing movements. Some paradigms perturb movements with continuously applied mechanical loads that are attached to moving body parts or with robotic devices that can apply arbitrary force fields to the moving limb. Other paradigms in this category use temporary interference of the movement, such as a sudden presentation of an obstacle in the movement trajectory, a sudden change of the speed of a treadmill on which the subject walks, or a sudden movement of a platform on which the subject stands. The motor learning in these tasks results in formation of various task-dependent anticipatory feedforward strategies and feedback adjustments that counter the effects of the interference and improve task performance.

### **Learning of Movement Sequences**

This popular category of motor learning paradigms requires subjects to learn sequences of movements [4]. Common variants are the serial reaction time task (SRT) and the 2xN task. In the SRT task subjects are presented with a series of targets that appear, one by one, on the computer screen in one of several possible positions. Subjects are required to press as fast as possible a key that corresponds to the presented target position. The repeated presentation of a specific sequence of targets leads to motor learning as evidenced by a significant decrease in key press reaction time. The 2xN task was originally developed to make sequence learning amenable for studies in primates. In this task, subjects are presented with a sequence of N (5 or 10) pairs of lighted keys on a 5 × 5 or 10 × 10 keypad. The subject is required to press the keys in each pair in the correct order (initially unbeknown to the subject). Once the subject determines by trial and error the correct order in the first pair, the next pair of keys in the sequence is presented. Any error resets the sequence, and the sequence presentation starts with the first pair of keys again. The presentation of the sequence continues until the correct order in each pair is mastered and the movement sequence is learned.

Sequence learning tasks are popular among neuropsychologists, who use them to address questions such as the participation of awareness in motor learning or the role of explicit and implicit memory systems.

### **Rodent Motor Learning Paradigms**

Advancements in motor learning research will depend on a thorough knowledge of how the underlying neural circuits become modified during learning and what are the cellular and molecular mechanisms of this process. For studies at the cellular and molecular levels, developing motor learning models in rodents will be necessary. Much progress has already been made in exploring neuronal function using genetically modified rodent models (e.g. knockout mice). Traditional models of motor learning in rodents are learning of the skilled forelimb reaching movement, modifications and conditioning of licking movements and learning acrobatic tasks, such as maintaining balance on a rotating horizontal cylinder. More recently, the eyeblink conditioning paradigm and the adaptation of the VOR were successfully implemented in rodents.

### **Neural Substrates of Motor Learning**

Motor learning depends on motor circuits that generate the movement to be learned and on associated components of sensory systems. Since the sensory and motor systems are organized in a modality-specific and somatotopic manner, circuits for specific forms of motor learning should be at least partially segregated based on involved parts of the motor system and on the type of sensory information utilized.

Research on motor learning involves several stages of analysis. At the first stage, an adequate model of motor learning is developed and its behavioral properties are characterized. Next, circuits that are involved in and essential for the studied form of motor learning are identified. This second stage involves a variety of methods, such as the recording of brain activity, lesions or pharmacological manipulations of individual circuit components, and neuroanatomical tracing techniques. At the third stage, the operating mechanism of the circuit that produces and modifies the behavior is addressed to reveal components that likely undergo plastic changes resulting in motor adaptation. At this stage, a combination of brain activity recording, brain stimulation and neuropharmacological techniques is most relevant. By the fourth stage, the techniques of cellular and molecular biology are deployed to reveal the cellular mechanisms of plasticity in brain regions identified during the previous stage of investigation.

The more complex forms of motor learning, such as learning of motor sequences, now are mostly at stages one and two where their properties and the underlying circuits are being identified. Because a large portion of these studies are being done in human subjects, most of

them focus on testing patients with brain pathologies and on using non-invasive brain imaging methods, such as functional MRI. A common conclusion from several paradigms is that at higher levels, the complex forms of motor learning are executed by circuits that include motor, sensory and associative areas of the cerebral cortex, basal ganglia and cerebellum [5,6]. This lively area of research produced important insights into the roles of awareness and explicit and implicit processes in movement sequence learning [4]. In another interesting development, circuits participating in movement sequence learning and in perturbation adaptation were shown to change over the course of learning, with some structures being more active at initial stages of learning and less involved during the recall of consolidated memory traces [7,8].

Research on simple forms of motor learning, such as VOR adaptation and eyeblink conditioning, has reached the more advanced stages. Their underlying circuits have been described in large detail, and although not all important issues pertinent to circuit operation have been resolved, some investigators are pursuing possible molecular mechanisms of neural plasticity. This research is driven mostly by the cerebellar learning hypothesis, which proposed the cerebellar cortex as a likely place of motor learning plasticity [1,9]. One intriguing feature of these models is that the underlying learning most likely occurs within circuits that generate the learned or modified response. Consequently, most attempts to interfere with learning at the circuit level also affect response execution. This produces uncertainty in whether the failure to learn was related to the animal's incapacity to execute the behavior properly (a performance deficit) or to the disruption of learning mechanisms. This dilemma, the conflicting of learning and performance hypotheses, has been partially overcome in the eyeblink conditioning model using techniques of temporary inactivation during response acquisition or consolidation. This is uniquely possible in eyeblink conditioning because the animal does not need to generate responses in order to learn them.

One major challenge in neuronal circuit level studies of eyeblink conditioning is that the underlying neuronal networks are comprised of mutually interconnected structures with an abundance of feedback connections. In networks of this kind, contributions of individual nodes to properties of the behavior or learning are difficult to discriminate, because neuronal activity patterns at a particular node of the network are usually influenced by a set of both up-stream and down-stream structures, and because effects of manipulations of individual parts of the circuit can propagate to much larger areas of the network via non-specific tonic interactions [10]. Such network properties of motor learning circuits will have to be accounted for during cellular and molecular studies. Ultimately, a full

understanding of motor learning will include the synthesis of multi-paradigm hierarchical knowledge acquired at the behavioral, neural network and cellular levels.

## References

1. Boyden ES, Katoh A, Raymond JL (2004) Cerebellum-dependent learning: the role of multiple plasticity mechanisms. *Annu Rev Neurosci* 27:581–609
2. Bracha V, Bloedel JR (1996) The multiple pathway model of circuits subserving the classical conditioning of withdrawal reflexes. In: Bloedel JR, Ebner TJ, Wise SP (eds) *Acquisition of motor behavior in vertebrates*. MIT Press, Cambridge, pp 175–204
3. Christian KM, Thompson RF (2003) Neural substrates of eyeblink conditioning: acquisition and retention. *Learn Mem* 10:427–455
4. Rhodes BJ, Bullock D, Verwey WB, Averbeck BB, Page MP (2004) Learning and production of movement sequences: behavioral, neurophysiological, and modeling perspectives. *Hum Mov Sci* 23:699–746
5. Halsband U, Lange RK (2006) Motor learning in man: a review of functional and clinical studies. *J Physiol (Paris)* 99:414–424
6. Sanes JN (2003) Neocortical mechanisms in motor learning. *Curr Opin Neurobiol* 13:225–231
7. Ungerleider LG, Doyon J, Karni A (2002) Imaging brain plasticity during motor skill learning. *Neurobiol Learn Mem* 78:553–564
8. Krakauer JW, Shadmehr R (2006) Consolidation of motor memory. *Trends Neurosci* 29:58–64
9. De Zeeuw CI, Yeo CH (2005) Time and tide in cerebellar memory formation. *Curr Opin Neurobiol* 15:667–674
10. Zbarska S, Holland EA, Bloedel JR, Bracha V (2007) Inferior olivary inactivation abolishes conditioned eyeblinks: extinction or cerebellar malfunction? *Behav Brain Res* 178:128–138

## Motor Map

### Definition

A map of the movements or muscle contractions evoked by stimulation of a brain region at multiple different locations, typically using electrical or magnetic stimuli.

► [Motor Cortex – Hand Movements and Plasticity](#)

## Motor Neuron Pool

### Definition

► [Motoneuron Pool](#)



## Motor Nucleus

### Definition

- ▶ Motor Neuron Pool

## Motor Pattern

### Definition

The rhythmic, repeating sequence of motor neuron activity produced during an actual or fictive motor act.

## Motor Pattern Generator

### Definition

Motor pattern generator in neuroscience is sometimes called “central pattern generator,” which can be defined as neural networks that can endogenously, without rhythmic sensory or central input, produce rhythmic patterned outputs or as neural circuits that generate periodic motor commands for rhythmic movements such as locomotion. Central pattern generator produces rhythmic outputs even in isolation from motor and sensory feedback from limbs and other muscle targets.

- ▶ Central Pattern Generator (CPG)
- ▶ Rhythmic Movements

## Motor Primitive

### Definition

A building component of body movements, usually consisting of coordinated kinematic variables (i.e., joint angles) or dynamic variables (i.e., muscle activations). In animal locomotion, for example, motor primitives are coordinated hip, knee, and ankle angles that operate cooperatively either inphase or antiphase. Motor primitives are believed to be a neural mechanism that realizes coordinated body movements, without handling all individual degrees of freedom in body movements independently.

- ▶ Degrees of Freedom
- ▶ Rhythmic Movements

## Motor Responsiveness

- ▶ Sleep – Motor Changes

## Motor Schema

### Definition

Set of non-conscious programmes and habits underpinning skilled automatic movements. These involve both sensory input to coordinate and motor output to effect.

- ▶ Large-Fiber Sensory Neuropathy
- ▶ Effect on Proprioception

## Motor Set

### Definition

The process by which the central nervous system optimizes the capacity to perform a movement prior to movement onset. This is achieved by invoking predictive or feed forward control mechanisms usually derived based on previous, related experience under the same behavioral conditions.

## Motor Stereotypies

### Definition

Motor stereotypy refers to repetitive motor behaviors that do not produce tissue damage, such as the same movement occurring multiple times in a short time period like arm-waving, body-rocking, leg-kicking, and head-nodding. Stereotypic motor behavior is a widespread phenomenon of many neurologic and psychiatric disorders. Studies on the mechanisms controlling motor stereotypies have suggested roles of nigrostriatal dopamine and an enhanced activation of neurons located in the striosomal compartment in the striatum.

- ▶ Dopamine
- ▶ Sensorimotor Learning and the Basal Ganglia
- ▶ Striatum

## Motor Strategy

### Definition

A specific way of performing a behavior. Examples of choices between different motor strategies are forward walk vs. backward walk, trot vs. gallop, and rostral scratch vs. caudal scratch.

► Scratching

## Motor Synergy

### Definition

Effective reduction of degrees of freedom in body movements by coordination and regulation of kinematic (i.e., joint angles) or dynamic (i.e., muscle tensions) variables.

► Degrees of Freedom  
► Theories on Motor Learning

## Motor Threshold

### Definition

The minimal intensity of magnetic or electrical stimuli, which evokes muscle activation. Note that when stimulation is applied over the scalp, the motor threshold corresponds to the cortical threshold and can be taken as an estimate of the global excitability of the motor pathway.

► Transcranial Magnetic Stimulation

## Motor Unit

### Definition

The motor unit is a single motoneuron plus the number of muscle fibers it innervates. In fine movements made by, for example, the small muscles of the hand or the

eye muscles, there are only a few muscle fibers per motor unit, whereas in large muscles like the gastrocnemius, a muscle used in walking, there are 2,000 muscle fibers per unit.

## Motor Unit Action Potential

### Definition

Extracellular potential detected when all of the muscle fibers in a single motor unit are stimulated.

► Electromyography

## Motor Unit Enlargement

### Definition

When some of the nerve supply to a skeletal muscle is disconnected to partially denervate the skeletal muscle, the nerve fibers or axons that have intact connections with muscle fibers can sprout axons to reinnervate denervated muscle fibers. Thereby each motor unit will include more muscle fibers than normal – motor unit enlargement.

► Axonal Sprouting in Health and Disease

## Motor Units

ROBERT E. BURKE

Laboratory of Neural Control, National Institute of Neurological Disorders and Stroke, National Institutes of Health, Bethesda, MD, USA

### Definition

First defined by Sherrington in 1925, the ► **motor unit** is the combination of an ► **alpha motoneuron** or a ► **beta motoneuron** (or motor neuron) and the set of extrafusal striated muscle fibers (called the ► **muscle unit** portion) that are innervated by it. ► **Gamma motoneurons** that exclusively innervate specialized muscle fibers in muscle spindle stretch receptor organs do not form conventional motor units. In normal limb and trunk

muscles, each muscle fiber in a muscle unit receives a synaptic contact, or ►**neuromuscular junction**, from the same motoneuron and no other. The motoneurons that innervate muscle units in a given muscle are arranged within the spinal cord or brain stem in localized groupings called “motor nuclei,” which occur in predictable locations in the ventral horn of the spinal cord. From a functional standpoint, muscles are simply populations, or “pools,” of muscle units arranged more or less in parallel to generate force.

## Characteristics

### Quantitative Description

Muscles vary widely in size and function, from tiny muscles that move the eyeball and eardrum, to relatively huge masses that control limbs and trunk movements. Motor unit populations exhibit an equivalent range of characteristics that represent important functional specializations. In limbs and trunk, the number of muscle units in a given muscle (or motoneurons in its ►**motor nucleus**) is usually larger in more massive muscles than in small ones, varying from dozens in small intrinsic finger muscles to hundreds in knee extensors in man. In normal muscles, the fibers in an individual muscle unit are intermingled with those of dozens of other units, such that few fibers of a given unit are contiguous. The average number of muscle fibers in a given muscle unit (►**innervation ratio**) also varies in a similar pattern, i.e., generally larger in large muscles than in small ones. These generalizations do not apply to small, specialized muscles innervated by cranial nerves (e.g., extraocular muscles), which can contain many hundreds of individual muscle units, many of which receive innervation from more than one motoneuron.

### Higher Level Structures

Motor units are the final elements in the control of body movements by the central nervous system. Motoneurons integrate synaptic information delivered by peripheral sensory afferents, local neural circuits within the spinal cord itself, and control signals descending from the brainstem and higher centers in the brain, to produce trains of action potentials that activate muscle units that generate output force. These control systems are organized to produce coordinated patterns of action by multiple motor nuclei.

### Lower Level Structures

The motor units in virtually all mammalian muscles can be divided into two broad groups, called slow twitch or fast twitch, based on the mechanical, morphological, and biochemical properties of their muscle unit fibers (►**muscle fiber types**). In general, all fibers in a muscle unit display the same muscle fiber type. Slow twitch muscle units (called type S) contract relatively slowly

because of the molecular forms of contractile and regulatory proteins that they contain. Type S generally produces relative small forces, but they exhibit great resistance to mechanical fatigue during prolonged activation because they contain a high proportion of enzymes and mitochondria that provide energy by efficient oxidative, or aerobic, metabolism. Fast twitch units obviously contract more rapidly because they have a different complement of contractile and regulatory proteins, and they exhibit a wide range of resistance to mechanical fatigue. In many muscles, the fast motor units fall into two subgroups, one (called type FR) that is much more resistant to fatigue than the other (called type FF). Although the FR and FF muscle units have slightly different molecular species of contractile proteins, the major difference between them is that FR units have higher concentrations of oxidative enzymes and mitochondria than the FF units. However, both FR and FF units have a relatively high abundance of enzymes that can metabolize substrates like glycogen anaerobically, while type S units have much less anaerobic capacity. Both FR and FF fibers contain large stores of glycogen, a polymerized sugar that represents a stored source of energy that enables them to function during short bursts of forceful activity. In contrast, type S fibers have relatively little glycogen and anaerobic enzymes. These differences have important functional consequences. In general, type S motor units produce the smallest force output, type FF units are the largest forces, and type FR units are intermediate. These differences are related to the numbers of muscle fibers in the respective muscle units ( $FF > FR > S$ ), by differences in the cross-sectional areas of the individual fibers ( $FF \geq FR > S$ ), and, to a lesser degree, by the specific force that can be generated by each fiber ( $FF = FR > S$ ).

### Structural Regulation

Motoneurons differentiate early during embryonic spinal cord formation and migrate to the ventral part of the gray matter. The motoneuron axons that will innervate a specific muscle leave the spinal cord via the ventral roots and find their way to the primordial muscle, where they branch repeatedly to make neuromuscular synaptic junctions on the newly formed muscle fibers. During fetal and early postnatal life, immature muscle fibers receive innervation from multiple motoneurons. However, this polyneuronal innervation subsequently disappears during a competitive process that leaves only one motoneuron per muscle fiber in the mature muscle. At the same time, muscle fibers differentiate into the three major types described above. There is evidence for a strong element of genetic pre-specification of both motoneurons and muscle fibers, which results in the relative proportions of the different ►**motor unit types** found in various muscles.

### Higher Level Processes

Increasing and decreasing the number of motor units active in a given muscle (►recruitment and de-recruitment, respectively) is the major mechanism by which the central nervous system adjusts muscle force. The identities (i.e., types) of the active motor units are also critical to this process. Under many conditions, units in a given muscle (a motor unit pool) are recruited in a predictable sequence starting with type S, progressing to include type FR, and ending with type FF units as more and more force is required. De-recruitment ordinarily follows the reverse sequence. This sequence is often referred to as the “size principle,” because the first units (type S) recruited generally produce small forces, while the largest force (type FF) units are normally activated only when maximum force is demanded. Simultaneous activation of an entire motor unit pool can occur in sudden, ballistic movements. In unusual situations, such as rapid alternating movements, there may be selective recruitment of the larger, fast twitch units. A second mechanism for force control, often called “rate coding,” involves highly non-linear relations between the frequency and pattern of motoneuron firing and the force output from its muscle unit. Orderly recruitment sequences and rate coding both depend on interactions between intrinsic properties of the motoneurons themselves and the organization of synaptic input to them.

### Lower Level Processes

The motoneurons of type S motor units exhibit greater intrinsic excitability than those of the fast twitch units because of a complex interaction between their smaller size, the higher density of certain synaptic input systems, and the influence of active membrane conductance channels that promote repetitive firing. Certain voltage-sensitive conductances (including calcium and persistent sodium channels), located mainly in motoneuron dendrites, can produce self-sustained depolarization (“plateau potentials”) and firing under certain conditions, particularly in the presence of neuromodulator substances such as serotonin. Specialized membrane conductances activated by action potentials produce after hyperpolarizations that limit the maximum frequencies at which motoneurons can fire, which are lower in slow than in fast twitch cells. These features of motoneurons fit the properties of their muscle units. Type S units attain their maximum force output at lower frequencies than fast twitch units. The pattern of motoneuron firing also affects force output, because insertion of short intervals in a train can generate sustained, non-linear enhancement of output force.

### Process Regulation

The properties of muscle units are malleable to some extent by usage. For example, endurance exercise training (e.g., distance running) can greatly enhance the

oxidative capacity of muscle fibers, as well as their blood supply. Muscle fibers shrink somewhat, facilitating oxygen and substrate entry, which increases their resistance to fatigue at the price of some loss of overall force capacity. On the other hand, resistance training (e.g., weight lifting or sprint running) favors growth of muscle fiber diameter (hypertrophy), particularly among the fast twitch fibers, greatly enhancing force production but with little change in oxidative capacity or fatigue resistance. Neither form of exercise training produces significant change in the molecular nature of the contractile or regulatory proteins in muscle fibers (i.e., fiber types remain basically unaltered).

### Function

Motor units are the quantum elements in all movements. Type S motor units are ideally suited to maintain posture, which requires sustained activity without fatigue but generally small forces. Precise postural adjustments can be made by recruitment and de-recruitment of the small force type S units. Movements that are more vigorous like walking and running require more rapid contraction with moderate forces, with considerable resistance to fatigue. Such actions can be generated by recruitment of the type FR units. Greater force demands, such as during jumping and lifting heavy weights, are intermittent actions that need power but little fatigue resistance. Recruitment of the large force but fatigue-sensitive type FF motor units occurs mainly during this type of activity. The proportions of S, FR, and FF motor units in different limb and trunk muscles accurately reflect differences in the way muscles are used in different mammals. Muscle units with greater oxidative capacities exert a relatively high cost on metabolic maintenance, so their proportions are adjusted quite precisely to fit lifestyle demand.

### Pathology

The most common cause of motor unit dysfunction is trauma to peripheral nerves. Motoneurons usually survive damage to their axons unless the site is very close to the spinal cord. ►Motor axons have considerable ability to re-grow to reinnervate muscles, although the specificity found in the original process during embryonic life is largely lost in adult animals. Muscle fibers that are reinnervated after nerve damage are re-specified to the type dictated by the motoneuron, but there is eventually some return to the coordinated properties described above. Motoneurons are especially susceptible to viral infection in poliomyelitis, which can cause cell death and permanent disability. There are several neurodegenerative diseases that cause motoneuron death, the most well known being amyotrophic lateral sclerosis (ALS). In most victims, these dreadful diseases progress inexorably to complete motor disability.

## Therapy

Prompt surgical repair to injured peripheral nerves can result in good recovery of motor functions, although the process is slow. Happily, thanks to vaccination programs, poliomyelitis has almost disappeared in industrialized countries. Unhappily, the cause of motoneuron degeneration in ALS and allied disorders remains unknown, and there are no effective therapies for them.

## References

1. Binder M, Heckman C, Powers R (1996) The physiological control of motoneuron activity. In: Rowell L, Shepherd J (eds) *Handbook of physiology*. Oxford University Press/American Physiological Society, New York, pp 3–53
2. Burke RE (2001) The structure and function of motor units. In: Karpati G, Hilton-Jones D, Griggs R (eds) *Disorders of voluntary muscle*. Cambridge University Press, Cambridge, UK, pp 3–25
3. Burke RE (1981) Motor units: anatomy, physiology and functional organization. In: Brooks VB (ed) *Handbook of physiology*, vol. II. American Physiological Society, Washington, DC, pp 345–422
4. Edgerton VR, Bodine-Fowler S, Roy RR, Ishihara A, Hodgson JA (1996) Neuromuscular adaptation. In: Rowell LB, Shepherd JT (eds) *Handbook of physiology*. Oxford University Press, New York, pp 54–88
5. Kernell D (1992) Organized variability in the neuromuscular system – a survey of task-related adaptations. *Arch Ital Biol* 130:19–66
6. McComas AJ (1996) *Skeletal muscle: form and function*. Human Kinetics, Champaign, IL
7. Powers R, Binder M (2001) Input–output functions of mammalian motoneurons. *Rev Physiol Biochem Pharmacol* 143:137–263
8. Winderbank A, Mulder D (1994) Motor neuron disease in adults. In: Engel A, Franzini-Armstrong C (eds) *Myology*, 2nd edn. McGraw-Hill, New York, pp 1854–1869
9. Zajac FE (1990) Coupling of recruitment order to the force produced by motor units: the “size principle hypothesis” revisited. In: Binder M, Mendell L (eds) *The segmental motor system*. Oxford University Press, New York, pp 96–111

---

## Movement Direction

### Definition

The line or course pursued by a moving body part (e.g. the hand). If the position in space of the body part, at a given instant, is represented by a vector (i.e. a triple of coordinates in a specific reference frame), its motion is described by a vector-valued function of time (movement trajectory). The time derivative of this function, the movement velocity, is a vector-valued function. At each instant, this vector is tangent to the trajectory and describes the instantaneous direction of movement as

well as the instantaneous rate of change of the distance traveled along the trajectory (speed or tangential velocity).

► Reaching Movements

---

## Movement Discrimination

► Proprioception and Orthopedics

---

## Movement Field (of a Neuron)

### Definition

The region of space that will elicit a discharge in a motor-related neuron when movements are directed to the region. In particular, for eye movements, movement fields are regions of visual space for which saccade-related neurons will discharge when the saccade terminates in the region.

► Saccade, Saccadic Eye Movement  
 ► SC – Motor Map terminates in the region

---

## Movement Field (of Saccade-related Neurons)

### Definition

The oculomotor space occupied by saccades accompanied by the discharges of the neuron in question (often defined in retinotopic coordinates but other coordinate systems are sometimes used).

► Saccade, Saccadic Eye Movement  
 ► SC – Tectal Long-Lead Burst Neurons

---

## Movement (or Motor) Planning

### Definition

Processes whereby the global goal of the action is strategically defined, and the sequence of elementary

movements between intermediate goals is organized. These processes are based on the use of a large set of sensory and memorized information about the subject's environment, as well as on the subject's motivational drive resulting from the behavioral value of the anticipated outcome of the upcoming action.

#### ► Eye-Hand Coordination

## Movement (or Motor) Programming

### Definition

The motor program comprises all information necessary to send to the motor apparatus the motor commands to execute a movement. Whereas movement planning processes specify how the global action will be implemented, motor programming processes are invoked for the detailed preparation of each individual movement (localization of the target, choice of a desired final posture and/or trajectory, and of response duration or speed, ...). The result of this pre-movement programming phase is a set of motor commands which, when launched will activate the motor apparatus in a proper way to bring the effector close to its desired position (even accurately programmed movements require additional online control to reach optimal accuracy).

#### ► Eye-Hand Coordination

## Movement Sense

JANET L. TAYLOR

Prince of Wales Medical Research Institute and University of New South Wales, Sydney, NSW, Australia

### Synonyms

Kinesthesia; Proprioception

### Definition

Movement sense is the process by which movements of parts of the body relative to one another are perceived. The sense includes detection of movements as well as

sensations that convey the timing, distance and velocity of such movements. Examples of such movements include movements about a single joint e.g. bending the elbow, simple movements about multiple joints e.g. turning the head and complex movements about multiple joints e.g. closing the hand. Both passive movements, which are imposed on body parts by an external force while the muscles remain relaxed and active movements, which are made by the contraction of muscles, can be perceived. It is difficult to separate movement sense from position sense. A movement is a change of position and a position can only be reached by a movement. However, if a change of position is imposed extremely slowly, then no sensation of movement arises. This implies that joint position and movement can be sensed separately.

### Characteristics

#### Quantitative Description

Movement sense can be tested by determining the smallest imposed movement that subjects can detect with the muscles relaxed [1]. Such testing has been performed for movements about most joints in the limbs and for movements of the neck and trunk. For all joints, faster movements can be detected more easily than slower movements. At velocities  $>1^\circ/\text{s}$ , movements of  $0.1\text{--}0.5^\circ$  are commonly reported as detectable at limb joints and for rotation of the neck and trunk. At slower velocities (down to  $0.1^\circ/\text{s}$ ) larger amplitudes ( $\sim 1\text{--}3^\circ$ ) are needed for movements to be detected. At even slower velocities ( $<0.1^\circ/\text{s}$ ), the threshold amplitude for detection no longer depends on velocity and subjects have no sensation of movement. Here, subjects detect change of position. The movement velocity is below that required to engage the movement sense. At the interphalangeal joints of the fingers and toes, much larger movements are needed for detection. The big toe has the largest reported detection thresholds ( $\sim 2^\circ$  for velocities  $>10^\circ/\text{s}$  and  $\sim 20^\circ$  at  $1^\circ/\text{s}$ ) [2]. Movements can also be imposed during muscle contraction. It is not clear whether detection of movement is improved or impaired by active contractions as both results have been reported.

Movement sense includes the perception of velocity of movement. Discrimination between velocities of imposed movement has been tested at the finger, elbow and shoulder joints. Subjects are able to detect smaller differences in velocity when the reference velocity is slower. For movements of  $\sim 50^\circ/\text{s}$ , differences of  $\sim 10^\circ/\text{s}$  can be discriminated. For movements of  $15^\circ/\text{s}$ , differences of  $\sim 4^\circ/\text{s}$  can be discriminated at the elbow. At the shoulder, differences as small as  $2^\circ/\text{s}$  can be detected. When subjects match the velocity of an imposed movement with a movement of the other limb they are accurate to within  $\pm 5^\circ/\text{s}$  over a range of velocities from  $15^\circ/\text{s}$  to  $78^\circ/\text{s}$  [3].

### Higher Level Structures

Movement sense is one of the components of the sense of proprioception, which allows perception of events intrinsic to the body. The other senses of vision, hearing, touch, taste and smell allow perception of events outside the body. Of all the senses, proprioception is most closely connected with the control of voluntary movement. Explicit knowledge about the body can be used to plan and direct movements. In addition, neural signals that contribute to the sense of proprioception can act directly at different levels of the motor system to influence muscle contractions.

### Lower Level Components

Perception of movements of parts of the body involves sensory receptors in the muscles, in the skin and in the joints. Muscle spindle primary endings are activated dynamically by stretching of the muscle. They respond to the velocity and acceleration of muscle stretch. Slowly adapting type II endings respond to the skin stretch that accompanies joint movements. Receptors located in joint capsules and ligaments respond to stretch of these structures. All of these sensory receptors are at the termination of fast conducting afferent neurons, which have cell bodies in the dorsal root ganglia. Signals from the receptors are mostly conveyed via these neurons directly to the medulla, although signals from the muscle receptors in the legs pass through a synapse in the spinal cord. From the medulla, signals are conveyed via the thalamus to the contralateral primary somatosensory cortex. The signals also go to other areas of the brain including the secondary somatosensory cortex, motor cortical areas and the cerebellum.

### Higher Level Processes

#### Central Nervous System

Signals from muscle, joint and skin receptors are all conveyed to the contralateral primary somatosensory cortex. Imaging studies show that a number of other cortical areas are also activated when movements are imposed on a limb or when illusions of movement are generated by tendon vibration. These include the secondary somatosensory cortex, primary motor cortex, supplementary motor area, supplementary somatosensory area and the primary and associative auditory cortex [4]. The specific functions of the different cortical areas in perceiving movements are not known. However, the activation of the primary motor cortex appears to be strongly related to the perception of illusions of movement [5]. The cerebellum and basal ganglia are also activated by passive movements. Additional areas of the brain are activated during voluntary movements. One of these areas, the superior parietal lobe, may aid in matching

internal knowledge about the production of the movement with the afferent signals that the movement generates [6].

### Lower Level Processes

#### Sensory Receptors

Sensory receptors in the muscles, joints and skin respond both when movements are imposed on parts of the body and during movements made through active contraction of muscles.

#### Muscle Spindles

Muscles on one side of a joint lengthen with a movement while those on the other side shorten. Muscle spindles lie in parallel with muscle fibers and respond to lengthening of muscles. They contain two types of sensory endings, primary and secondary muscle spindle endings. While both types of endings increase their firing with stretch of a muscle, the primary endings have a larger dynamic response. They respond to the velocity of a stretch and to its acceleration, as well as to the change in length. Primary muscle spindle endings are major contributors to the sense of movement. Activation of these endings by vibration over the tendon of a muscle can generate an illusion of movement [7]. For example, when vibration is applied over the tendon of the biceps brachii, subjects feel that the arm is moving into extension. Higher frequencies of tendon vibration generate faster illusory movements. This implies that the velocity of movement is encoded by the frequency of firing of the muscle spindle endings.

Muscle spindles are under the control of the nervous system. In actively contracting muscles, muscle spindles fire in response to output from the nervous system as well as to any stretch of the muscle. Despite this complication, signals from the contracting muscle are still interpreted as movements.

#### Joint Receptors

Joint receptors are located in joint capsules and ligaments and respond to stretch of these tissues. Although most joint receptors fire near the ends of joint range, occasional receptors signal joint angle across the range of movement and could contribute to a sense of joint movement. When the axons of individual joint afferents are stimulated in humans, sensations of joint movement including twisting are reported. Muscle contraction can increase the stress on joints and ligaments and can increase signals from joint receptors.

#### Skin Receptors

Some areas of skin are stretched during movement of parts of the body. For example, in the leg, when the knee is bent, the skin over the kneecap is stretched while that behind the knee is compressed. Slowly adapting type II

(SAII) receptors in the skin fire in response to the direction, speed and extent of stretch and are therefore likely to contribute to the sense of movement. Illusions of movement of the fingers can be generated by pulling on the skin over the joints to mimic the stretch and compression of the skin that usually accompanies joint movement.

## Function

### Sensory

Movement sense allows detection of movements imposed on parts of the body and perception of the velocity and timing of such movements. It also allows perception of the velocity and timing of movements made by active muscle contractions and of movements to which external forces and muscle contractions both contribute. Perception of movements imposed by external forces including gravity allows reaction to such perturbations to prevent injury. Ongoing knowledge of where and how the parts of the body are moving is crucial for motor control.

Movement signals can be processed in conjunction with various other proprioceptive signals.

1. Perception of the current position of the parts of the body has contributions from movement sense, position sense and sensations of muscle force and effort. Limb positions are most accurately detected immediately after movement to a new position.
2. Judgment of weight combines sensations of muscle force and effort with movement sense. If an object does not move when force is applied, its weight cannot be judged.
3. Judgment of stiffness also relies on sensations of muscle force and effort combined with movement sense.
4. Perception of the orientation and movement of the trunk relative to the outside world combines vestibular sensations, which signal position and movement of the head relative to the world, with sensations of movement and position from the neck.

Together with other senses, like vision and touch, proprioceptive sensations including movement sense generate a body image and awareness of self. If illusions of arm movement are generated by activating muscle spindles with tendon vibration while a person touches a finger to their own nose, remarkable changes in body image can occur, e.g. the nose may seem to grow or may feel like it is pushed into the face.

### Motor Control

Apart from providing perceptions, the signals that convey sensations of movement as well as other proprioceptive signals are integrated into the motor system. Movement sense provides feedback for the control of

movement. Even common movements like lifting a cup to the lips, do not always require the same muscle activity. When the cup is full it is heavier and the movement requires more muscle activity than when the cup is empty. Feedback of the results of motor output is crucial to guide the muscle activity. Even if an action is too fast to allow ongoing correction, the sensations of movement can be used to adjust motor output in subsequent attempts, i.e. movement sense is used when learning motor tasks through repetition.

Coordination of muscle actions about different joints also relies on movement signals. For example, if a ball is thrown to hit a target, the hand must be opened when the velocity and direction imparted by shoulder, wrist and elbow movements are appropriate [8].

### Pathology

Impairment of movement sense can occur with non-pathological occurrences like muscle fatigue as well as in a range of pathological conditions. These include:

1. Musculoskeletal disease or injury including sprains, ligament damage, osteoarthritis, back pain, whiplash
  - Impairment can result from change in the mechanical properties of the tissues around the sensory receptors. Pain without tissue changes can also impair movement detection. This may occur through a reduction in muscle spindle sensitivity or through interactions in the central nervous system.
2. Peripheral nerve injury or peripheral neuropathy
  - Whether it occurs through disease or injury, damage to the neurons that carry the movement signals from the periphery to the spinal cord, will impair movement sense in the affected region.
3. Lesions or pathology in the central nervous system
  - Lesions anywhere in the sensory pathway to the cortex, e.g. in the spinal cord, brainstem or thalamus
    - i. *Basal ganglia lesions.* Patients with Parkinson's disease have a reduced ability to detect passive movements.
    - ii. *Cerebellar lesions.* Patients with cerebellar pathology have a normal ability to detect passive movements but have impaired discrimination of velocity and duration.
    - iii. *Cortical lesions.* Lesions of the primary somatosensory cortex can lead to loss of movement sense. Lesions of somatosensory association areas can impair kinesthesia [9]. Lesions of other areas (e.g. secondary somatosensory cortex, superior parietal lobule) may disrupt the perception of active movements.

### ► Proprioception Role of Joint Receptors



## References

1. Goldscheider A (1889) Untersuchungen über den Muskelsinn. Arch Anatomie und Physiologie, Leipzig 3:369–502
2. Refshauge KM, Taylor JL, McCloskey DI, Gianoutsos M, Mathews P, Fitzpatrick RC (1998) Movement detection at the human big toe. J Physiol 513:307–314
3. Kerr GK, Worringham CJ (2002) Velocity perception and proprioception. Adv Exp Med Biol 508:79–86
4. Radovanovic S, Korotkov A, Ljubicavljjevic M, Lyskov E, Thunberg J, Kataeva G, Danko S, Roudas M, Pakhomov S, Medvedev S, Johansson H (2002) Comparison of brain activity during different types of proprioceptive inputs: a positron emission tomography study. Exp Brain Res 143:276–285
5. Naito E, Roland PE, Ehrsson HH (2002) I feel my hand moving: a new role of the primary motor cortex in somatic perception of limb movement. Neuron 36:979–988
6. MacDonald PA, Paus T (2003) The role of parietal cortex in awareness of self-generated movements: a transcranial magnetic stimulation study. Cereb Cortex 13:962–967
7. Goodwin GM, McCloskey DI, Matthews PB (1972) The contribution of muscle afferents to kinaesthesia shown by vibration induced illusions of movement and by the effects of paralysing joint afferents. Brain 95:705–748
8. Cordo PJ (1990) Kinesthetic control of a multijoint movement sequence. J Neurophysiol 63:161–172
9. Roland PE (1987) Somatosensory detection of micro-geometry, macrogeometry and kinesthesia after localized lesions of the cerebral hemispheres in man. Brain Res 434:43–94

---

## Movement Sequences

JOHN F. SOECHTING

Department of Neuroscience, University of Minnesota,  
Minneapolis, MN, USA

### Definition

It has long been hypothesized that complex movements are generated by concatenating simpler, elementary movements in a serial order. This hypothesis seems intuitively obvious for motor behaviors such as speech, handwriting and typing, the elementary movements in these instances being the vocalization of phonemes, the generation of individual letters or strokes and the production of targeted keypresses. However, the hypothesis has been extended more generally to skilled motor tasks. With respect to this hypothesis several questions (that have been addressed experimentally to varying degrees) arise: (i) How is the proper serial order of elements in a sequence established? (ii) To what extent is there overlap between the expression of elements in the sequence and to what extent does

the expression of one element depend on the preceding and succeeding movement in a sequence? and (iii) What are the properties of elemental movements?

### Characteristics

The strongest evidence that complex movements are generated by serially ordering simpler movements arises from motor deficits following damage to the frontal lobe in human subjects [1]. For example, Luria [2], in patients with damage to the premotor region, described the phenomenon of **perseveration of movement**, which he defined as the “continuation of a voluntary movement once it has started.” On simple tasks such as drawing a circle, this deficit was expressed as the repeated production of the same circle. However, on more complex tasks, such as drawing a human figure, only some individual elements such as the fingers or the legs were drawn repeatedly. Additional evidence in favor of this hypothesis is provided by spontaneous errors in normal subjects, especially in speech and typing. In such behaviors, errors in serial ordering are not uncommon; most typically, they involve the transposition of adjacent phonemes or keystrokes.

### Serial Ordering

The question of how a proper serial ordering of elements in a sequence would be established was taken up in an influential work by Lashley [3] in 1951. He considered two alternative processes according to which serial order of a movement sequence could be established. In one, the associative chaining theory, each element in a sequence would trigger the generation of the succeeding element. For example, a sensory event signaling the completion of one element could trigger the initiation of the next one. Based primarily on spontaneous errors in speech and typing, Lashley argued against this hypothesis in favor of an alternative, in which all elements of a sequence are prepared in parallel. He left open the problem of how one particular element would be selected at the proper time. One possibility would be that the element that was most strongly represented in neural activity at any point in time would be translated into action, and that representations for individual elements could mutually inhibit each other.

The question is still largely unresolved. However, recently Averbeck et al. [4] have provided electrophysiological evidence in support of Lashley’s proposition. They recorded activity of prefrontal cortical neurons while monkeys performed a task that required them to copy geometric figures such as squares and triangles by moving a joystick to control the motion of a cursor on a screen. They used standard criteria (minima in speed, see below) to determine the extent of each

segment. Distinct patterns of activity of neural ensembles (obtained from averages over each of the segments) were used to determine classifiers for each of the segments, using discriminant analysis. They then used these classifiers to determine the extent to which each of the segments was represented at different intervals during a trial. Their main result is presented in Fig. 1, which shows the average over all ensembles when the monkey drew a square, consisting of five segments. The fact that the strength of the representation for a particular segment is maximal when that segment is drawn is not remarkable, since that was the basis for constructing the classification scheme.

However, it is remarkable that the strength of representation throughout the trial, and in particular prior to the onset of the drawing at time 0, reflects the temporal order in which the segments were drawn.

### Serial Execution

Assuming all of the segments of a movement sequence are planned in parallel, this still leaves open the question of how they are executed. Specifically, parallel planning would still be consistent with the possibility that each of the segments is executed in strict sequential order, without overlap. Such a possibility would imply that the kinematics of each segment would be identical to the kinematics if that segment were executed in isolation. This question has been addressed most extensively in speech, where it is known that the acoustic quality of a given phoneme can depend on the phonemes that precede and follow it, a phenomenon known as coarticulation [5]. The motions of the articulators

responsible for sound production are difficult to measure, thus little is known about exactly how they are modified in generating words from individual phonemes.

The evidence from studies in limb motions suggests that, in that case, there is a preference to produce segments in a strictly serial fashion. Thus in typing [6], it was found that the finger and hand movements to generate a particular keypress did not depend on the preceding or subsequent keypress. Anticipatory modification of hand movements was observed in some instances in piano playing, for example in executing the thumb-under maneuver as a pianist played an ascending scale [7]. The clearest evidence for the equivalent of coarticulation was provided by a study of fingerspelling by signers fluent in American Sign Language [8]. In that study, signers spelled a set of words, all containing the same set of three letters (e.g., “isc”) but with different vowels following the trigram. In one set of trials, the letter preceding the trigram was always the same, whereas in another set, each terminal vowel was associated with a different initial letter (Fig. 2).

Hand and finger movements were recorded as the signers spelled the words, and discriminant analysis was used to determine the time at which the final vowel could be predicted from the handshape. As is shown in Fig. 2, there was an anticipatory modification of the handshape about 1.5 letters prior to the generation of the vowel (reverse influence, beginning between the “s” and the “c”). A particular letter also influenced subsequent handshapes (forward influence in right panel of Fig. 2).

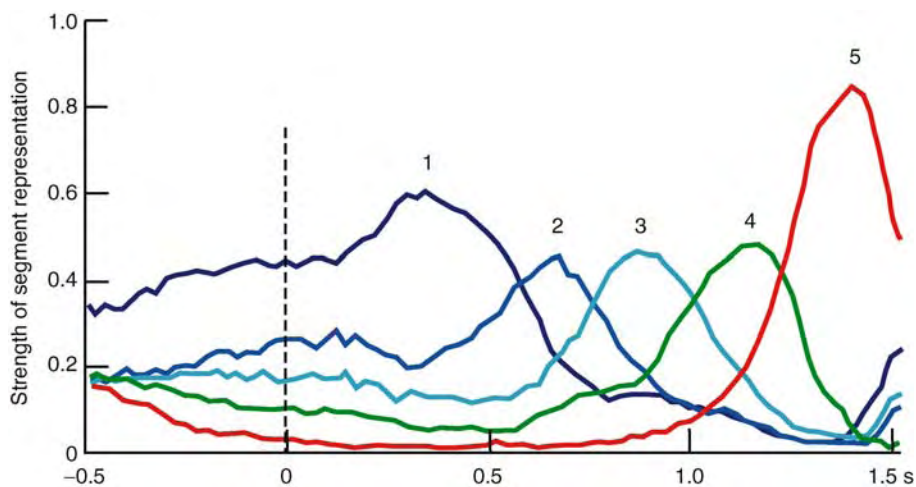

**Movement Sequences. Figure 1** Strength of representation of movement segments in the activity of prefrontal cortical neurons as a function of time. The drawn shape (a square) consisted of five segments and the traces depict the proportion of neuronal ensembles whose pattern of activity encoded a specific segment at a given time. Note that the relative strength of representation encodes the serial order in which the segments were drawn. Adapted from [4].

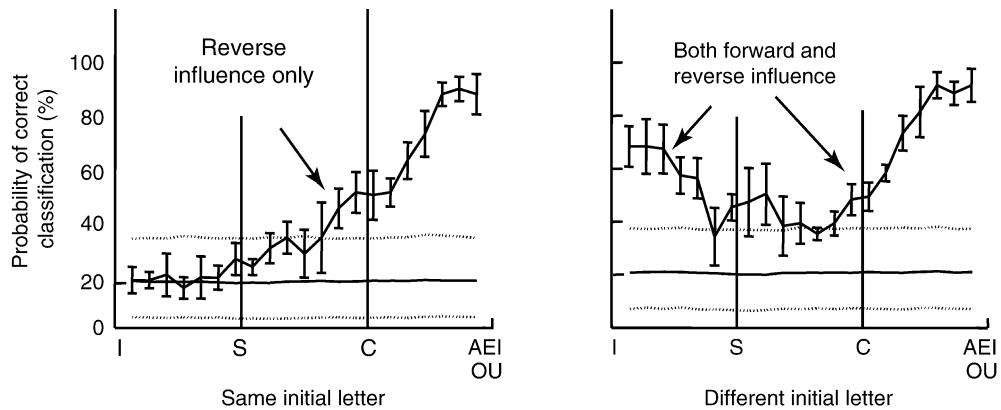

**Movement Sequences.** Figure 2 Probability of correctly predicting the vowel following the trigram “isc” from the shape of the hand during fingerspelling in American Sign Language. The letters at the bottom of each panel denote the time at which handshape was static; intervening points denote the transition from one handshape to another. The solid horizontal line at 20% indicates chance performance, and the dotted lines indicate 95% confidence limits. In the left panel, the letter preceding the “i” was always the same; in the right panel it was different for each of the vowels following the “c.” Adapted from [8].

The modifications of the finger movements during signing could take two different forms: a “dissimilation” in which differences between the handshapes for subsequent signs were emphasized, and an “assimilation” in which the motion at a joint was minimized during the transition from one handshape to the next one. Assimilation and dissimilation were found to occur, at different joints, in the same movement sequence, suggesting a sophisticated level of control of the execution as well as the planning of serial movements.

### Defining Segments in a Movement Sequence

This topic has received relatively little attention and the question is largely unresolved. Investigators have typically assumed that each segment of a sequence would have the same kinematic characteristics as a simple movement executed in isolation. Since such simple movements typically demonstrate a “bell-shaped” speed profile, kinematic landmarks such as local minima in speed have been used to demarcate individual segments. In other instances, abrupt changes in the plane of limb motion have been observed [9], and they have been assumed to denote transitions from one segment to another. Neurons in the supplementary and presupplementary motor area (SMA) have been shown to encode the transition from one segment to another while other neurons encoded the rank order of a particular movement [10]. Thus it appears possible to answer this question more definitively on the basis of neural activity.

### References

1. Ashe J, Lungu OV, Basford AT, Lu X (2006) Cortical control of motor sequences. *Curr Opin Neurobiol* 16:213–221

2. Luria AR (1966) Higher cortical functions in man. Basic Books, New York
3. Lashley KS (1951) The problem of serial order in behavior. In: Jeffress LA (ed) *Cerebral mechanisms in behavior*. Wiley, New York, pp 112–136
4. Averbeck BB, Chafee MV, Crowe DA, Georgopoulos AP (2002) Parallel processing of serial movements in prefrontal cortex. *Proc Natl Acad Sci USA* 99:13172–13177
5. Kent RD, Minifie FD (1977) Coarticulation in recent speech production models. *J Phonetics* 5:115–133
6. Soechting JF, Flanders M (1992) Organization of sequential typing movements. *J Neurophysiol* 67:1275–1290
7. Engel KC, Flanders M, Soechting JF (1997) Anticipatory and sequential motor control in piano playing. *Exp Brain Res* 113:189–199
8. Jerde TE, Soechting JF, Flanders M (2003) Coarticulation in fluent fingerspelling. *J Neurosci* 23:2383–2393
9. Soechting JF, Terzuolo CA (1987) Organization of arm movements: motion is segmented. *Neuroscience* 23:39–51
10. Shima K, Tanji J (2000) Neuronal activity in the supplementary and presupplementary motor areas for temporal organization of multiple movements. *J Neurophysiol* 84:2148–2160

## Movement Time

### Definition

The time from the onset of a movement to its end, usually derived by setting a threshold on speed.

- Movement Sequences
- Eye-Hand Coordination

## Movement Velocity

### Definition

Movement velocity is the first derivative of 3D position.

► Motor Control Models

## Moving-Average Model

### Definition

A model of a system as a differential equation where the output at a given time instant is a linear combination of the inputs at previous time instances and at the current time.

► Signals and Systems

## MRI

### Definition

► Magnetic Resonance Imaging

## mRNA

### Definition

Messenger RNA is the intermediate between information encoded on the DNA and the ribosomes that translate this information into proteins. DNA is transcribed into mRNA after which ribosomes read the information encoded on triplets of the RNA bases, and translate it into a polypeptide chain.

## mRNA Targeting: Growth Cone Guidance

BARBARA LOM

Biology Department and Program in Neuroscience, Davidson College, Davidson, NC, USA

### Synonyms

Local protein synthesis; Axonal RNA translation; Translational regulation; Local translation; Extracellular translation; Compartmentalized protein synthesis; Cytoplasmic mRNA localization; RNA localization

### Definition

Growing axons are tipped by highly dynamic and motile growth cones that navigate through the brain by detecting and responding to guidance molecules. When a growth cone reaches its target location it transforms into a presynaptic terminal. Thus, accurate growth cone guidance is critical in establishing functional brain circuitry. Messenger RNA (mRNA) targeting to growth cones refers to the selective transport of specific mRNAs along an axon out to the growth cone so translation of these mRNAs can occur locally within the growth cone, away from the soma. Growth cones contain protein synthetic machinery including ribosomes, translation factors, and specific mRNAs. Previously it had been thought that proteins were synthesized in the cell body then transported to specific regions of the neuron, but evidence now indicates that some mRNAs can be translated into proteins locally within the growth cone and this local translation is required for growth cones to respond to a variety of guidance cues. mRNA targeting allows new protein supplies to be rapidly and regionally mobilized that change growth cone motility via ► [cytoskeletal](#) alterations and change growth cone sensitivity to guidance cues by up- or down-regulating receptor expression.

### Characteristics

#### Growth Cones

Neurons are extremely polarized cells with axons that extend long distances from the cell body. Most proteins are thought to be synthesized and modified in the cell body then transported along the axon via fast and slow axonal transport mechanisms. The growth cone region has autonomous local navigation and steering mechanisms because growth cones can navigate accurately *in vitro* and *in vivo* even after being separated from their somas. A variety of guidance molecules (including extracellular matrix components, secreted factors, and molecules associated with the membranes of other cells) steer growth cones by signaling through specific

receptors expressed on the growth cone. When a growth cone detects an attractive or repulsive guidance cue (or combination of cues) the growth cone's shape, trajectory, and/or motility are altered to steer it toward its appropriate target and/or away from inappropriate regions. Specific guidance molecules are located at precise locations along a growth cone's route and the growth cone's responsiveness to these guidance cues can change dramatically as the expression of specific receptors are up- or down-regulated *en route*. Rapid changes in ►cytoskeletal structure underlie a growth cone's remarkable motility. A growth cone's ►cytoskeleton contains both microfilaments and microtubules, with actin-based microfilaments occupying the growth cone's particularly dynamic finger-like filopodia that sample the molecular terrain and steer the axon's growth. Guidance cues trigger changes in growth cone trajectories by inducing asymmetric filopodial extension and/or collapsing particular regions of a growth cone. Translation of mRNAs targeted to the growth cone can cause rapid and localized changes in protein composition that are necessary for accurate growth cone navigation.

### Protein Synthetic Machinery Localized to Growth Cones

Growth cones are equipped to synthesize proteins locally. Essential components of protein synthetic machinery including polyadenylated mRNAs, polyribosomes, ribosomal RNA, and factors that regulate translation such as elongation factors, ►ZBP, and ►RNA interference (RNAi) have been observed within vertebrate growth cones [1,2]. Functional evidence for local translation comes from experiments that separated growth cones from their cell bodies and measured the synthesis of new proteins in isolated growth cones [3]. The ability of isolated growth cones to navigate properly without contributions from somatic protein synthesis suggests that the cellular machinery to detect and respond to guidance cues is contained within the growth cone. Guidance molecules can functionally alter translation factors within growth cones. For example, the guidance cues netrin-1 and semaphorin 3A (Sema3A) cause a rapid rise phosphorylation of eIF-4PB1, which liberates the translation initiation factor eIF-4E [3]. The identities of mRNAs targeted to growth cones have not yet been thoroughly cataloged, but many of the mRNAs identified thus far code for proteins that comprise, influence, and/or associate with the cytoskeleton [4]. As an example,  $\beta$ -actin mRNA has been observed in association with microtubules in growth cones and has been implicated as a key player in protein synthesis dependent growth cone guidance [2,5].

### Growth Cone Responses to Guidance Cues Require Local Protein Synthesis

In just the past few years it has become apparent that local protein synthesis is involved in several distinct

and important aspects of growth cone responsiveness to molecular guidance cues: directed movement, ►cytoskeletal organization, receptor expression, and sensitization. For example, neurotrophin-3 (NT-3) can stimulate axon elongation and act as a guidance cue for growth cones that express the appropriate neurotrophin receptor(s). Within minutes, NT-3 application causes  $\beta$ -actin mRNA to localize to growth cones *in vitro* in a cAMP-dependent manner [6]. NT-3-regulated  $\beta$ -actin mRNA localization to the growth cone requires interaction of the ►zipcode sequence in  $\beta$ -actin mRNA's ►3' untranslated region (UTR) with ►zipcode binding protein 1 (ZBP1) to form ribonucleoprotein particles (RNPs). RNPs are heterogeneous complexes of translational components that can include ribosomes, mRNA binding proteins, elongation factors, and mRNAs. RNPs are thought to be transported by motor proteins to targeted subcellular locations where they become tethered to the ►cytoskeleton and translation regulators then allow precisely localized translation of targeted mRNAs. The identities of specific mRNA ►zipcode sequences and the ways they interact with other molecules to form RNPs are currently being elucidated. Experimentally disrupting interactions between  $\beta$ -actin mRNA's ►zipcode region and ►ZBP1 revealed that zipcode-ZBP1 binding is essential to the mRNA localization, protein levels, and growth cone mobility [6].

Several well-characterized guidance cues stimulate local translation within growth cones. Normally growth cones change their trajectory dramatically toward a netrin-1 gradient and turn away or collapse when they encounter Sema3A. When the ability to synthesize new proteins is pharmacologically inhibited, isolated growth cones cannot respond to either the attractive netrin-1 or the repulsive Sema3A guidance cues [3]. Other guidance cues including Slit2 and BDNF (brain-derived neurotrophic factor) also require protein synthesis to guide growth cones [2,4]. Thus, local protein translation is critical to a growth cone's ability to respond to a variety of guidance molecules in its pathway.

Translation of mRNAs within the growth cone also plays a critical role in regulating a growth cone's ►cytoskeleton. Evidence comes from observations of asymmetrical  $\beta$ -actin translation in growth cones orienting in response to netrin-1 gradients [5] and BDNF gradients [2]. When netrin-1 is presented on one side of a growth cone, a homolog of ZBP1 rapidly translocates into filopodia and both the translation initiation regulator 4EBP and  $\beta$ -actin translation become rapidly enhanced on the side nearest the netrin-1 source. These translational asymmetries within the growth cone are observed even before growth cones physically turn toward an attractive netrin source, indicating a netrin-induced mechanism can bias actin polymerization to steer growth cones. In another example of local translation affecting growth cone ►cytoskeleton and motility, the

repulsive guidance molecule Sema3A induced localized translation of RhoA, a member of the Rho family of small GTPases that are widely implicated in regulating actin alterations underlying filopodial dynamics [7]. RhoA transcripts localize to growth cones via targeting sequences with their ▶3' UTR and localized RhoA translation is necessary for Sema3A-induced growth cone collapse. In addition, the repulsive cue Slit2 initiates both a protein synthesis dependent decrease in growth cone F-actin and an increase in the actin depolymerizing protein cofilin within growth cones [4]. Taken together, these studies indicate that local translation of proteins that compose or influence the ▶cytoskeleton can play critical roles in steering growth cones toward attractive cues and in collapsing in response to repulsive cues.

Local translation also alters a growth cone's responsiveness to guidance cues. Evidence for this role emerged from experiments that examined local translation in the distal regions of developing spinal axons as they crossed the midline of the spinal cord. These axons are initially attracted to the midline but after they have reached and crossed the midline their responsiveness to guidance cues expressed at the midline changes, presumably to prevent the axon from getting trapped at this intermediate target and/or to allow the axon to respond to subsequent cues that will guide it to its ultimate target. The EphA2 receptor is normally expressed in the distal regions of some spinal commissural axons after they have crossed the midline. When RNA containing a sequence in the ▶3' UTR of the EphA2 receptor fused with a green fluorescent protein (GFP) reporter construct was introduced into these neurons, GFP was expressed within growth cones only after crossing the midline, spatially and temporally similar to EphA2 expression [8]. Moreover, growth cones separated from their cell bodies demonstrated similar upregulation of gene expression, indicating that growth cones are capable of local protein synthesis. While this study did not demonstrate the existence of endogenous EphA2 mRNAs in growth cones, it suggests a plausible mechanism by which local translation could rapidly alter the expression receptors on a growth cone. In addition to changes in growth cone receptor expression, growth cones can adapt to persistent guidance cues, demonstrating desensitization and resensitization behaviors *in vitro*. Local protein synthesis is required for the resensitization phase of adaptation in netrin-1, BDNF, or Sema3A gradients [9]. Thus, changing a growth cone's responsiveness to guidance cues uses a protein synthesis-dependent mechanism.

### Signal Transduction Mechanisms and Translational Regulation

How do extracellular guidance cues stimulate protein synthesis within the growth cone cytoplasm? The intracellular signaling cascades that transduce guidance

cue signals into local translation are only beginning to be elucidated, but it is clear that different guidance cues enlist different signaling molecules to regulate translation within growth cones. Caspase-3, TOR (target of rapamycin), p38 MAPK (mitogen activated protein kinase), and p42/44 MAPK have been differentially implicated in protein synthesis stimulated by the distinct guidance molecules Sema3A and netrin-1 [10]. By mobilizing distinct intracellular signaling cascades, different guidance cues could elicit the translation of target mRNAs into the proteins necessary for a growth cone's response. Translational regulators are likely the targets of signal transduction cascades stimulated by receptor activation. Mechanisms that regulate targeted translation of mRNAs within growth cones are just beginning to be identified. ▶RNAi, which can repress translation or trigger degeneration of specific mRNAs, has recently been implicated in Sema3A-induced growth cone collapse [1].

### Proteolysis in the Growth Cone

In order to regulate the protein composition of a subcellular structure such as a growth cone, cells must coordinate protein synthesis and protein degradation. Both processes occur within growth cones, though proteolytic contributions to growth cone guidance mechanisms are not as well characterized. Proteolysis machinery such as proteasomes, signalosomes, ubiquitin, and the ubiquitin-activating enzyme E2 have been detected within growth cones [3]. Functionally, netrin-1 can induce rapid, local increases in ubiquitin-protein conjugates within growth cones and inhibiting proteolysis can abolish an isolated growth cone's ability to respond to the cue netrin-1 [3]. Sema3A, however, does not rely on proteolysis in the same way as netrin-1 in guiding growth cones, further suggesting that individual guidance cues regulate protein synthesis and degradation within the growth cone by distinct signaling mechanisms.

### Localized Protein Synthesis Elsewhere in the Nervous System

While the roles of localized protein synthesis are just becoming established in embryonic growth cones, it is becoming evident that regenerating axons also require localized protein synthesis when reestablishing neuronal connections. Moreover, the ability to translate specific mRNAs locally is not unique to growth cones. Spatially regulated translation within dendrites plays an important role in facilitating synaptic plasticity and insights into mechanisms of targeted dendritic translation have great potential to inform future studies of growth cone translation. Thus, it is becoming clear that neurons use localized protein synthesis as a rapid mechanism to reconfigure regional protein

composition in response to stimuli for navigation, repair, and memory.

## References

1. Hengst U, Cox LJ, Macosko EZ, Jaffrey SR (2006) Functional and selective RNA interference in developing axons and growth cones. *J. Neurosci* 26:5727–5732
2. Yao J, Sasaki Y, Wen Z, Bassell GJ, Zheng JQ (2006) An essential role for  $\beta$ -actin mRNA localization and translation in  $\text{Ca}^{2+}$ -dependent growth cone guidance. *Nat Neurosci* 9:1265–1273
3. Campbell DS, Holt CE (2001) Chemotropic responses of retinal growth cones mediated by rapid local protein synthesis and degradation. *Neuron* 32:1013–1026
4. Piper M, Anderson R, Dwivedy A, Weinl C, van Horck F, Leung KM, Cogill E, Holt C (2006) Signaling mechanisms underlying Slit2-induced collapse of *Xenopus* growth cones. *Neuron* 49:215–228
5. Leung K-M, van Horck FPG, Lin AC, Allison R, Standart N, Holt CE (2006) Asymmetrical  $\beta$ -actin mRNA translation in growth cones mediates attractive turning to netrin-1. *Nat Neurosci* 9:1247–1256
6. Zhang HL, Eom T, Oleynikov Y, Shenoy SM, Liebelt DA, Dictenberg JB, Singer RH, Bassell GJ (2001) Neurotrophin-induced transport of a beta-actin mRNP complex increases beta-actin levels and stimulates growth cone motility. *Neuron* 31:261–275
7. Wu KY, Hengst U, Cox LJ, Macosko EZ, Jeromin A, Urquhart ER, Jaffrey SR (2005) Local translation of RhoA regulates growth cone collapse. *Nature* 436:1020–1024
8. Brittis PA, Lu Q, Flanagan JG (2002) Axonal protein synthesis provides a mechanism for localized regulation at an intermediate target. *Cell* 110:223–325
9. Piper M, Salih S, Weinl C, Holt CE, Harris WA (2005) Endocytosis-dependent desensitization and protein synthesis-dependent resensitization in retinal growth cone adaptation. *Nat Neurosci* 8:179–186
10. Campbell DS, Holt CE (2003) Apoptotic pathway and MAPKs differentially regulate chemotropic responses of retinal growth cones. *Neuron* 37:939–952

## MS

- Multiple Sclerosis

## MT1, Mel1a, MTNR1A

- Melatonin Receptors

## MT2, Mel1b, MTNR1B

- Melatonin Receptors

## MT Complex

### Definition

The middle temporal (MT) complex is a region of extrastriate visual cortex containing a high concentration of direction-selective neurons receiving input largely from the magnocellular pathway.

- Extrastriate Visual Cortex
- Visual Motion Processing

## MTPT

### Definition

- 1-Methyl-4-phenyl-1,2,3,6-tetrahydropyridine

## Mucus on Olfactory Epithelium

### Definition

The mucus is physiological liquid, which is a one of the body's defense systems. It contains numerous proteins to protect epithelium. In the case of olfaction, the mucus traps small particles and bacteria, which may enter the nose as a person breathes. It contains also high concentrations of proteins called odorant-binding proteins, which are good candidates for carrying airborne odorants towards olfactory receptors.

- Odorant-Binding Proteins
- Olfactory Epithelium

## Multiform Layer

### Definition

The multiform layer of the cerebral cortex is layer VI. It has this name because it contains neurons of a wide variety of sizes and shapes. Projection neurons in layer VI send their axons to terminate in other parts of the cerebral cortex and to the thalamus.

## Multilayer Networks

### Definition

Neural networks composed of multiple layers, namely the input layer and the output layer with or without hidden layers between them.

► Neural Networks

## Multimerization (of Ion Channels)

### Definition

Multimerization is the process in which individual subunits (monomers) aggregate to form a functional ion channel. For example, voltage-gated potassium channels and glutamate receptors form tetramers of four subunits, the Cys-loop channel family (acetylcholine (ACh), GABA, glycine) consist of five subunit pentamers. These multimers may be derived from a single gene subunit (homomultimer) or from many different genes (heteromultimers).

- Acetylcholine
- GABA
- Glutamate Receptors
- Glycine
- Ion Channels from Development to Disease
- Neuronal Potassium Channels

## Multimodal Enhancement

### Definition

Enhanced modulation of the activity of a sensory neuron when the target activates more than one sensory modality.

## Multimodal Integration

NICHOLAS P. HOLMES<sup>1</sup>, GEMMA A. CALVERT<sup>2</sup>, CHARLES SPENCE<sup>3</sup>

<sup>1</sup>Espace et Action, Bron, France

<sup>2</sup>Department of Experimental Psychology, Oxford University, Oxford, UK

<sup>3</sup>Department of Psychology, University of Bath, Bath, UK

### Synonyms

Crossmodal integration; Multisensory integration; Intermodal; Heteromodal; Polymodal; Supramodal

### Definition

Multimodal (or ► multisensory) integration refers to the neural integration or combination of information from different sensory modalities (the classic five senses of vision, hearing, touch, taste, and smell, and, perhaps less obviously, proprioception, kinesthesia, pain, and the vestibular senses), which gives rise to changes in behavior associated with the perception of and reaction to those stimuli [1,2]. Information is typically integrated across sensory modalities when the sensory inputs share certain common features. For example, although vision is concerned with a certain frequency band of the electromagnetic energy spectrum, and hearing is concerned with changes in pressure at the ears, stimulus features such as spatial location, movement, intensity, timing, and duration, as well as other higher-order features such as meaning and identity can apply equally to information from several (or all) sensory modalities.

► Crossmodal integration is often used synonymously with multimodal integration, however the latter term has various other associations in different disciplines, including in describing the use of more than one measuring system. The former term, crossmodal, may therefore be preferable.

Multimodal integration is more often used to refer to integrative processes operating at the systems level, and studied most commonly using brain imaging techniques alongside behavioral and perceptual measurements. ► Multisensory integration on the other hand, tends to refer to the combinatorial effects of stimulation of two or more senses on the activity of single neurons, measured electrophysiologically in experimental animals. Since multisensory integration is more commonly used in the context of single-cell recordings, often made under anesthetised recording conditions, causal relationships to the behavioral outcomes of multisensory integration are less certain, although this is currently an area attracting considerable research interest.



## Characteristics

### Upstream Events/Conditions

An extensive body of experimental research has shown that many cognitive systems operate in a multimodal manner. Such systems include those responsible for selective attention and orientation to external stimuli, along with both more elementary perceptual effects, and higher-level cognitive systems such as memory. For example, the familiar experience of both hearing another person speak in natural conversation, and seeing the speaker's lip movements while they speak, is an everyday example of multimodal integration involving both low-level perceptual features, such as detecting sounds and lip movements, as well as higher-level linguistic and semantic factors [3].

In a typical experiment designed to study multimodal attentional orienting, participants may be asked to pay attention and respond only to tactile stimuli presented to a certain hand (e.g., their left hand), and to ignore both tactile stimuli presented to the other hand (i.e., the right hand) or visual stimuli presented to either hand. Typically, visual stimuli presented close to the attended hand result in larger activation (as measured, for example, using electroencephalographic (EEG) or functional magnetic resonance (fMRI) techniques) than for visual stimuli presented to the unattended side. This is true even though the visual stimuli were not relevant to the participants' task. These, and many other similar results, suggest that the mechanisms of spatial attention may operate in a multimodal or supramodal fashion, facilitating the detection and discrimination of stimuli from a given location regardless of the stimulus modality. The behavioral and neurophysiological effects of attending to a primary modality on the response to the secondary modality, however, are usually smaller than the effects in the primary modality itself. This latter result suggests that both unimodal and multimodal perceptual and attentional mechanisms operate in concert.

### Downstream Events/Conditions

In order for multisensory or multimodal integration to occur, information must have been processed initially within the component unimodal sensory systems. The level and extent of this prior unimodal processing, however, depends on the system under study. In the superior colliculus (SC), for example, visual and auditory inputs are integrated very early on, after transmission along only several synapses following sensory transduction at the periphery. The retina sends visual projections directly onto the SC, while auditory inputs reach the SC only several neural synapses after initial sensory transduction at the cochlea. Conversely, those stimuli that are involved in multisensory integration in the cerebral cortex may undergo substantial unimodal

processing prior to integration, lasting many tens or even hundreds of milliseconds. Recent research, on the other hand, is beginning to detail the extent to which different sensory processing streams interact at very early stages of processing – as early as 45 ms in the example of visual and auditory processing. This physiological evidence is supported by the existence of distinct anatomical connections between the primary sensory areas of several different sensory systems. More and more it appears that multimodal integration and interaction is the rule, not the exception, at all levels of processing.

### Involved Structures

Following many years of detailed study on the integration of multisensory inputs in neurons of the superior colliculus, several guiding principles of multisensory integration have emerged [4]. These principles have later been applied in order to determine whether a particular brain region is involved specifically in multisensory integration, both at the level of single-cells, in neurophysiology, and the whole-brain, in neuroimaging.

First, inputs to any given neuron or any given brain area must typically arrive at that area at the same time in order to be integrated and to have significant behavioral consequences. Depending on the specific brain area, “at the same time” typically refers to a “temporal window for multisensory integration.” The width of the temporal window, that is, the maximum temporal delay between the arrivals of inputs from different sensory modalities, may be on the order of 100–300 ms.

Second, in many brain areas, particularly those concerned with spatial representations of visual, tactile, and auditory stimuli, multisensory integration is enhanced for those stimuli that arise from the same external spatial location as compared to different locations. The “same” location in the case of audio-visual speech integration, for example, would be the speaker's mouth, from which both visual and auditory signals arise. In the case of visual and tactile stimuli, the same location might refer, for instance, to the lower left portion of the visual field, and to the animals' front left leg, or the lower-left side of the organism's face.

Third, one important aspect of multisensory integration at the neural level relates to the relative strength of inputs from different sensory modalities and the relative amplification that occurs in the process of multisensory integration. This “principle of **inverse effectiveness**” thus states that the relative enhancement due to multisensory integration is larger for those stimuli that produce weak sensory effects on their own, and is smaller for stimuli that cause strong activations at the neural level.

The *Superior Colliculus* in the midbrain integrates visual, somatosensory, and auditory inputs in the

generation and control of spatial orienting behaviors, particularly those concerning eye and head movements. The SC has been studied intensively as a potential model system for multisensory integration in animals. More recent research has examined the extent to which the ►[spatial rule of multisensory integration](#) and ►[temporal rule of multisensory integration](#) as measured in the SC also apply to higher-order behaviors and cognition.

The *posterior parietal cortex* contains multiple cortical regions, which respond in a variety of ways to visual, somatosensory, auditory, proprioceptive, and vestibular inputs, such as Brodmann's areas 5 and 7 (or the superior and inferior parietal lobules, respectively), and the multiple, heterogeneous areas within the intraparietal sulcus (e.g., ventral, anterior, and medial intraparietal areas). Somatosensory information is processed initially in Brodmann's areas 3 and 1, the primary somatosensory cortices. Somatosensory processing then proceeds posteriorly through areas 2 and 5, into the anterior or medial bank of the intraparietal sulcus. Visual stimuli are processed initially in the primary and secondary visual cortices, proceeding along the dorsal and ventral visual streams. In the intraparietal sulcus (IPS), the dorsal visual stream meets the somatosensory processing stream. Neurons in area 5 have been shown to integrate proprioceptive stimuli with visual information in the representation and updating of postural information.

At the *fundus of the intraparietal sulcus*, the *ventral intraparietal area* (VIP) contains a variety of neurons with responses ranging from purely somatosensory to purely visual. The *lateral intraparietal area* (LIP), on the posterior or lateral bank of the intraparietal sulcus is thought to be involved in the planning, generation, and control of eye movements. This area, dubbed the "parietal eye field" because of its close functional association with the frontal eye fields, integrates multisensory information in generating eye movements to expected, current, and remembered target locations originally specified in a variety of different possible sensory modalities. Other areas in the intraparietal sulcus display a variety of multisensory responses. The *anterior intraparietal area* (AIP) integrates visual and somatosensory information in planning and generating object-related movements such as grasping, while the *medial intraparietal area* (MIP), as part of the *parietal reach region* (PRR) is involved in the generation and control of reaching movements.

Neurons in the *superior temporal sulcus* in macaques and humans, and the *anterior ectosylvian gyrus* in cats respond to stimulation in a number of sensory modalities, but have been studied particularly in connection with audiovisual speech and vocalizations, in both monkeys and man. This area is often activated

in studies that pair both audible and visual (lip movements) speech.

The *premotor cortex* in the frontal lobe is thought to integrate multisensory information involved in the planning and execution of movements. A small portion of the *ventral premotor cortex*, known as the *polysensory zone*, responds to somatosensory, visual, and auditory inputs, and seems to be involved in representing multisensory "peripersonal space" – the space immediately surrounding certain parts of our bodies, particularly the hands and face. This area is connected to functionally similar areas in the posterior parietal cortex such as the ventral intraparietal area. Neurons in the polysensory zone of the premotor cortex respond both to objects approaching a certain portion of the animal's skin (i.e., a visual receptive field surrounding the neuron's corresponding somatosensory receptive field), and to the generation of defensive or avoidance movements in response to these objects.

Certain areas of the orbitofrontal cortex also respond to multisensory stimuli, particularly those concerned with appetitive rewards, such as food, flavors, tastes, and aromas, along with emotionally salient multisensory signals.

Multiple feedforward and feedback connections between the frontal and parietal cortices subserving the processing of multisensory information, and the planning, and execution of movements following multisensory stimulation probably constitute a network of multimodal perception-action or attentional systems. Neural studies of multimodal integration, at least in recent years, have been based largely on the findings of multisensory integration in the SC concerning the generation of orientation movements. Since these early studies, however, research has unveiled numerous brain areas that process and integrate information from a number of sensory systems. Each of these areas seems to be specialized for particular domains of environmental stimuli, or for particular forms of action. Underlying the various approaches to the study of multisensory integration is the hope that general rules of multisensory integration can be discovered that apply to a wide range of behavioral situations, and across a variety of distinct brain regions.

### Methods to Measure this Event/Condition

Multisensory integration is typically measured via single-unit recordings in cats, ferrets, barn owls, or macaque monkeys. Both anesthetized and awake behaving preparations have been used, often in conjunction with behavioral studies in the same species and under similar stimulus conditions, or with human studies under similar experimental conditions.

A variety of neuroanatomical and neurophysiological techniques have been used in the model system of the SC,

including single-unit recording and stimulation, lesion studies, tract-tracing, cooling and other forms of inactivation and deactivation of the colliculi themselves, or of brain regions projecting to or receiving from the SC [4]. These studies have shown, for example, that selective lesions or deactivation of the SC abolishes the integration of auditory and visual information arising in those regions of space that the affected portion of the SC represented. Multisensory integration in those parts of the SC left intact was unaffected. Early work on the SC focused on the developmental time-course of multisensory integration, the temporal and spatial characteristics of the stimuli required for effective multisensory integration, the spatial arrangement of the different multisensory representations in the SC, and the ways in which this particular organization came about. (i.e., in part genetically determined, but influenced very strongly by visual and multisensory experience throughout development).

A number of behavioral methods are available to measure multimodal integration in human participants, including reaction-time measures, threshold determination, two (or more)-alternative-forced-choice measures (speeded or unspeeded) and signal detection analyses, which have been used on studies of sensory modalities in isolation for many years. The variety of experimental techniques now available for studying multimodal integration in healthy human participants as well as in brain-damaged neuropsychological patients is now considerable, and an adequate summary is beyond the scope of this article. However, certain important recent trends can be highlighted.

Modern neuroimaging techniques, such as fMRI, positron emission tomography (PET), and magnetoencephalography (MEG), are increasingly being used to address questions concerning multisensory integration. Such experiments often require the development of new stimulation equipment that can be brought into the scanner environment itself. Studying the effects of tactile, olfactory, and gustatory stimulation in the scanner has involved overcoming some difficult technical problems, due to the very strong electromagnetic fields involved in fMRI, and to the very sensitive equipment required to detect small changes in electrical (EEG) or magnetic (MEG) fields over the scalps of human participants. But it is now possible to present stimuli in a number of sensory modalities simultaneously to participants lying in the scanner while they perform simple behavioral tasks. This line of research will provide much-needed theoretical and empirical links between the neurophysiological literature derived from experimental animals, typically macaque monkeys, cats, or ferrets on the one hand, and the human behavioral, psychophysical, and neuropsychological literature on the other hand. It will be crucial to know, for example, to what extent the principles and properties of multisensory integration at the single-neuron level

measured in experimental animals can be related to the principles and properties derived from human behavioral studies. In short, do those behaviors that reflect multimodal integration depend directly on cells displaying multisensory integration?

There has been much interest in the effects of a variety of brain lesions in adult humans on multimodal integration and associated behaviors. Several neuropsychological syndromes that have traditionally been studied as if they were unimodal deficits, such as tactile [▶extinction](#) and unilateral visuospatial neglect, have, upon closer inspection, been found to be multisensory in nature ([▶crossmodal extinction](#)). For example, many patients with unilateral visuospatial neglect often have deficits in the detection of auditory and tactile stimuli that occur on their affected side, in addition to visual impairments. Similarly, patients suffering from tactile extinction (a condition where contralesional tactile stimuli are easily detected in isolation, but when two stimuli are presented together on opposite sides of the body, the detection of the contralesional stimulus is impaired), may also have impairments in detecting tactile stimuli on the contralesional hand, for example, when a simultaneous *visual* stimulus is presented near to the ipsilesional hand. The discovery of deficits that cut across the senses in disorders that have typically been thought of as being confined to a single sensory modality, suggests that disorders such as neglect and extinction may also be characterized as disorders of supramodal functions and processes such as spatial perception, and attention, rather than as impairments of a more sensory-specific ([▶modality-specific](#)) perceptual nature.

Another important line of research involving human participants involves examining the multimodal consequences of sensory-specific impairments, for example in blind and deaf adults and children [5]. Such work has shown that impairments in a single modality have rather intriguing consequences for other sensory systems. In neuroimaging experiments, for example, it has been shown that, when blind participants read Braille, their visual cortex is activated suggesting a functional role for “visual” cortex in complex tactile spatial discrimination. Such visual activations are not observed when participants with unimpaired vision read Braille, nor in people who lose their sight late in life (i.e., after puberty). This neural activation was shown to be functionally relevant to the Braille reading task by the significant disruptive effects of transcranial magnetic stimulation (TMS) over the *occipital* cortex of the same volunteers that exhibited visual activations during Braille reading. Additionally, and perhaps more strikingly, it has recently been shown that normal participants, when completely blindfolded for 5 days while learning to recognize Braille characters, also show activation in the visual cortex, along with an

improved ability to learn the Braille task. These changes were not seen in normal participants who were blindfolded only during the learning and testing phases of the experiment, suggesting that this form of neural plasticity may take several days to take effect. Several different forms of ►crossmodal plasticity seem to be operating – one that occurs only in those patients who lose their sight before puberty, and another that results from the short-term recruitment of visual cortex following temporary blindfolding. Further research is needed to understand what neural mechanisms underpin these physiological changes.

The consequences of such findings for our views of the functional organization of the brain could hardly be more important: the assignment of visual cortex as strictly visually responsive may be rather premature. Rather, the visual cortex may be specialized for processing detailed spatial information in order to make complex spatial discriminations (e.g., in reading Braille). In normal circumstances, visual inputs are functionally the most useful for such spatial discrimination tasks, but in the absence of input from the eyes, inputs from the tactile and auditory receptors may help to perform such tasks. A similar line of research on the multimodal consequences of hearing impairments has reached analogous conclusions.

Finally, and quite recently, multimodal integration is now being approached from a mathematical modeling perspective, particularly with regard to modeling the precision and reliability of information arising from different sensory modalities [6]. Bayesian and maximum-likelihood methodologies have been used to model a variety of phenomena in multimodal integration. Such work suggests that the central nervous system integrates information from the different sensory modalities in an optimal fashion, based on the variability of responses under increasingly noisy stimulus conditions. This relates well to the foregoing conclusions of the work in blind and deaf people – the brain is a highly interconnected network dealing with vast quantities of information, and different neural subsystems are able to share that information effectively to the best advantage of the organism. The visual cortex will receive and process auditory and tactile inputs given a certain amount of visual deprivation, in order to process the relevant information and complete the designated task. Under less extreme conditions of visual deprivation, where the quality of the visual signal is degraded (e.g., on a misty day, or when we remove correcting lenses), information from other modalities may be weighted more strongly in the performance of certain cognitive tasks.

In conclusion, multimodal integration is an exciting and rapidly developing field of enquiry that spans numerous academic disciplines, from basic neuroscience, to medicine, physiology, psychology, cognitive science, and mathematical modeling. From each of these disciplines,

multiple well-developed methodological approaches are now available to facilitate the study of the multimodal brain. By progressively questioning the assumption that we are born with only five senses, and that, throughout life, these five senses are both anatomically and phenomenologically distinct, the study of multimodal integration is beginning to provide intriguing answers to historically difficult questions.

## References

1. Calvert GA, Spence C, Stein BE (2004) The handbook of multisensory processes. MIT Press, London
2. Spence C, Driver J (2004) Crossmodal space and cross-modal attention. Oxford University Press, Oxford
3. de Gelder B, Bertelson P (2003) Multisensory integration, perception and ecological validity. *Trends Cogn Sci* 7:460–467
4. Stein BE, Meredith MA (1993) The merging of the senses. MIT Press, Cambridge, MA
5. Pascual-Leone A, Hamilton R (2001) The metamodal organization of the brain. *Prog Brain Res* 134:427–445
6. Ernst MO, Bühlhoff HH (2004) Merging the senses into a robust percept. *Trends Cogn Sci* 8:162–169

## Multi-Oscillator System

ERIC L. BITTMAN<sup>1</sup>, TANYA L. LEISE<sup>2</sup>

<sup>1</sup>Department of Biology, University of Massachusetts, Amherst, MA, USA

<sup>2</sup>Department of Mathematics, Amherst College, Amherst, MA, USA

### Definition

A multi-oscillator system is composed of potentially dissociable but normally coordinated rhythmic mechanisms which exist within the same organism, and may fall into mutual or hierarchical coupling arrangements.

### Characteristics

#### Organization of Multi-Oscillator Circadian Systems

Many physiological functions are intrinsically rhythmic, and oscillations underlie the operation not only of organs, but also of individual cells. Sensory neurons fire action potentials in bursts, the frequency of which carries biological information such as the coding of stimulus intensity. Circadian oscillations provide another excellent example of physiological encoding of information, in this case, time of day. Multiple circadian ►oscillators occur in many different organisms, forming a complex network of internal clocks that increase the ability to coordinate internal functions and

execute them at appropriate times with respect to the environment.

The organization of circadian multi-oscillatory systems can take different forms and involve multiple levels of clock interactions. However, there is a common thread underlying all such systems: the constituent oscillators entrain, i.e., they match periods and maintain a steady relative phase (Fig. 1). This communication between oscillators does not require that they be synchronous. In other words, they often do not have the same phase; some components may even be antiphase to others so that incompatible processes occur at diametrically different times of day. In order for a set of heterogeneous oscillators (differing in period and other properties) to become mutually entrained, components with shorter periods must experience a **phase delay** each cycle (to lengthen the effective period), while components with longer periods must experience a **phase advance** (to shorten the effective period). The coupled components respond to coupling signals with appropriate delays and advances at specific phases (i.e., manifest a phase response curve) in order to achieve hierarchical or mutual **entrainment**. This coupling along with the intrinsic period of each component determines the phase differences between the components.

In multi-oscillator systems that are organized in a hierarchical manner, the **pacemaker** entrains “slave”

oscillators. Some slaves may not be capable of sustaining oscillations in the absence of the pacemaker, i.e., they are damped oscillators. The pacemaker is often entrainable by an external signal, e.g., the 24 h light-dark cycle, and the pacemaker in turn entrains the rest of the circadian system. The nature of the signal from pacemaker to slave determines the entrained phase of the slave, just as the photic **phase response curve** of a pacemaker determines its entrained phase relative to dawn and/or dusk. The phase of an entrained slave oscillator can be either earlier than (leading) or later than (lagging) the phase of the pacemaker. For example, the **suprachiasmatic nucleus (SCN)** of mammals acts as a pacemaker that is believed to entrain circadian oscillators in peripheral tissues. The system is probably not strictly hierarchical, as the peripheral tissue clocks may in turn generate signals that influence the phase, amplitude, or **period** of the pacemaker. Other circadian systems are composed of autonomous oscillators which couple as a network through mutual interactions, with no dominant pacemaker involved.

Oscillatory tissues contain cells that generate circadian rhythms via a molecular clock mechanism that is composed of multiple loops in which rhythmic transcription of genes is achieved through feedback effects of the proteins they encode. In some circadian systems however, post-transcriptional events may play a predominant role in the clock mechanism. The roles of

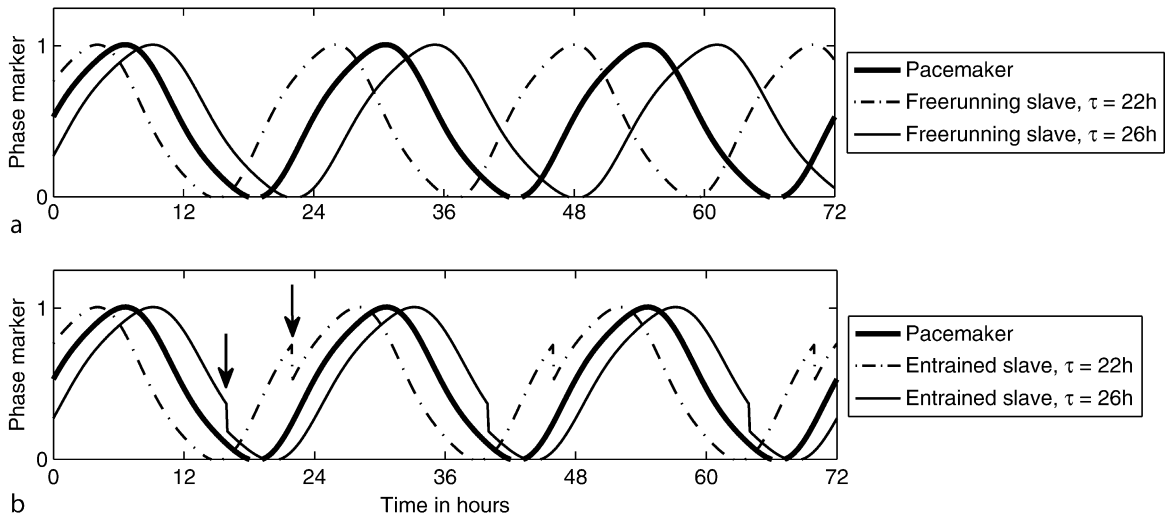

**Multi-Oscillator System. Figure 1** (a) Three oscillations that are not coupled are depicted. Note that the phase difference between the **pacemaker** and each “slave” increases over time. The “phase marker” may be an mRNA or protein level resulting from rhythmic expression of a clock gene, for example. Sinusoidal waveforms are indicated for simplicity, but need not be reflected in a biological system. (b) Appropriate signals from the pacemaker can entrain the slave oscillators, resulting in steady phase angles. Note that the two slaves take different phase angles to the pacemaker. A pacemaker signal reset the phase of the short period slave with a pulse at time 22 (and every 24 h thereafter) to correct for the difference in oscillator periods. This achieves a delay of 2 h, so that the slave repeats a 2 h portion of its cycle. The pacemaker entrains the long period slave with a pulse that falls at time 16 (and every 24 h thereafter) to advance its phase by 2 h, so that the slave skips 2 h of its cycle.

specific genes may differ between tissues, leading to qualitatively different clocks in the pacemaker and the peripheral tissues. Multi-oscillatory systems can be quite complex, spanning cell, tissue, and organismal levels. Furthermore, groups of organisms can act as multi-oscillatory circadian systems where mutual coupling is achieved through social cues.

### Evidence for Multi-Oscillatory Circadian Systems

The idea that independent oscillators couple to achieve a common period with a specific phase relationship may be traced to the Dutch astronomer Christian Huygens, who observed such phenomena in mechanical clocks. In the biological realm, Erwin Bunning proposed that individual organs including segments of gut were capable of sustained circadian oscillations when isolated from the whole animal. It was Colin Pittendrigh, however, who first established that circadian systems are comprised of multiple oscillators. Pittendrigh applied entrainment theory to model inter-oscillator coupling. He showed that although pupal eclosion of *Drosophila* is driven by a temperature-compensated circadian (“A”) pacemaker, the phase of emergence depends upon temperature. Pittendrigh offered as an explanation the existence of

slave (“B”) oscillators that have circadian properties but are not temperature-compensated. The slave oscillators are thought to most directly control hormone release, motor patterns, etc., that lead to emergence of the adult fly. As environmental temperature changes, the intrinsic period of the slave changes, but not that of the pacemaker. Thus whether the slave must advance or delay its phase in order to adopt the period of the master pacemaker depends upon temperature. This implies that the entrained phase of the slave relative to the pacemaker must change as the temperature changes. Determination of this phase difference by temperature through the differential sensitivity of master and slave oscillators may serve an adaptive purpose, because the optimal time of emergence relative to sunrise depends upon season and relative humidity.

Pittendrigh extended the idea of multiple circadian oscillators to the phenomenon of splitting, which takes place upon exposure of hamsters to constant light. A high percentage of animals maintained in such conditions show bimodal activity rhythms, with two components free running with different circadian periods until they couple in an antiphase relationship (Fig. 2a). Pittendrigh argued that the capacity of an organism to sustain multiple

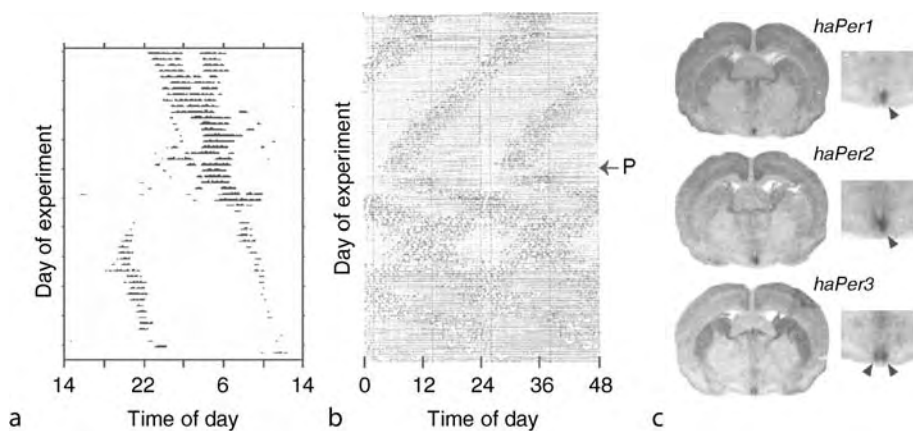

**Multi-Oscillator System. Figure 2** Activity rhythms can dissociate to reflect multioscillatory circadian organization, and pacemaker anatomy reflects dissociation among cell populations. (a) Splitting of activity rhythms (►split rhythm) in a golden hamster. Actogram represents locomotor activity of an animal maintained in constant light. Each horizontal line represents 24 h of wheel running behavior; successive days are represented one below the other. After about 30 days, two circadian components dissociate and free run with different periods before coupling in an antiphase relationship. (b) Pinealectomy of a Texas spiny lizard (*Sceloporus olivaceus*) induces dissociation of circadian components of locomotor activity. The animal was held in constant light for the duration of the record. After about 2 months, during which the animal showed a free running period of less than 24 h, the pineal was surgically removed (P). It was necessary to also remove the parietal eye in order to gain access to the pineal, but other experiments indicate that parietalectomy by itself has no consistent effect on circadian rhythms. Note that rhythmic components free ran with different periods and did not couple in the months following the surgery. From [1], reprinted with permission from AAAS (c) Splitting in constant light is accompanied by lateralization of clock gene expression in hamster SCN. Film autoradiograms illustrate expression of the clock genes *Per1*, *Per2*, and *Per3*, as assessed by *in situ* hybridization, in coronal sections of the brains of hamsters sacrificed 3 h before the anticipated onset of activity. Insets show that expression of *Per1* and *Per2* in the SCN (arrows), which normally peaks during subjective day, is laterally asymmetrical in split animals. Expression of *Per3* is not altered. From [2], reprinted with permission from AAAS.

periods, at least transiently, indicates the existence of dissociable, and hence multiple, oscillators. He subsequently developed the idea of a “temporal program” whereby the multi-oscillatory organization of the circadian system would lead to complex, seasonally changing scheduling of physiological events and might explain phenomena such as ►jet lag and ►photoperiodism [3].

Multi-oscillatory models of circadian organization are supported by studies in a variety of species. For instance, Page [4] discovered that removal of the optic lobes of cockroaches eliminates circadian rhythms of locomotor behavior. The powerful technique of transplantation of optic lobes between animals with different circadian periods established that the period of the rhythm reinstated by the transplant was that of the donor. This proved that the optic lobe contains a pacemaker, rather than acting merely to permit expression of rhythmicity by a clock located elsewhere in the organism. Since the insect has bilateral optic lobes, it follows that there must be at least two circadian oscillators in the organism. Page further showed that the period of the intact animal is shorter than that of either optic lobe alone, arguing for coupling between the bilaterally paired pacemakers.

Other experiments in which circadian oscillators were localized to particular structures facilitated further insight into the multi-oscillatory structure of the circadian system. Electrophysiological recordings in the gastropod mollusks *Aplysia californicus* and *Bulla gouldiana* demonstrated that retinal neurons show circadian oscillations in action potential frequency. Dissociation of basal retinal neurons demonstrated their capacity to oscillate independently, proving the existence of multiple cellular oscillators. Among vertebrates, the ►avian pineal gland provided further evidence of multiple circadian oscillators. Not only do individual pinealocytes oscillate in their synthesis and

secretion of ►melatonin, but in some species removal of the ►pineal gland causes a gradual decay of circadian rhythms of locomotor behavior. This argues for the existence of damping circadian oscillators whose coherence is normally maintained by the pacemaker. Using lizards, Underwood [1] showed that pinealectomy can lead to dissociation of circadian rhythms that free run with different periods (Fig. 2b). This not only indicates the multi-oscillatory structure of the circadian system, but also suggests a role for the pineal in maintaining coupling relationships between oscillators.

The suprachiasmatic nucleus (SCN) of mammals contains a set of neurons that can each generate a ~24 h rhythm via an intracellular molecular clock mechanism. While this group of oscillatory SCN neurons collectively forms the mammalian pacemaker, subpopulations can dissociate from each other. Antiphase patterns of gene expression have been observed in the left and right SCN of hamsters induced to split their circadian activity patterns by constant light ([2]; Fig. 2c). Ventral and dorsal regions of the rat SCN appear to dissociate when driven to the limits of entrainment. When SCN neurons interact synaptically, a consensus period emerges and neurons fall into phase-grouped populations (Fig. 3; [5]). Deficiency of vasoactive intestinal polypeptide (VIP) or the VPAC2 receptor compromises synchrony of both cellular oscillations and behavioral circadian rhythms. This suggests a role for these molecules in coupling between SCN neurons.

### Cellular Oscillators: Molecular Mechanisms

Demonstrations that individual basal retinal neurons of snails, suprachiasmatic neurons of rodents, and pinealocytes of chicks can sustain circadian oscillations not only force the conclusion that multiple oscillators exist within tissues, but also raise the question of whether individual cells may contain more than one oscillator.

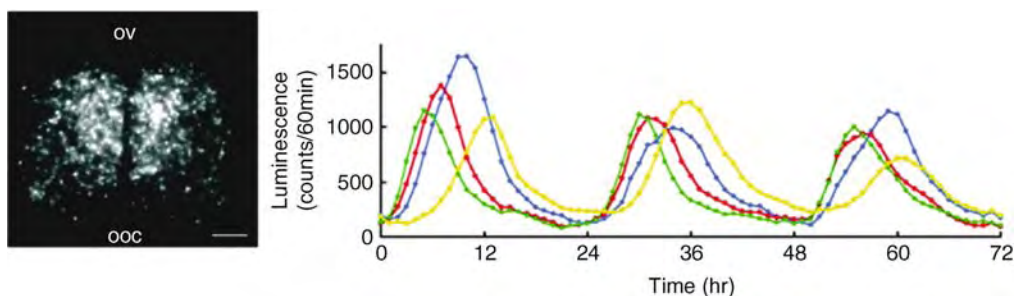

**Multi-Oscillator System. Figure 3** Expression of core circadian clock genes can be visualized in organotypic slices of the SCN, and in individual SCN neurons in culture. (a) Photomicrograph of an SCN slice prepared from a transgenic mouse carrying a *Per1::Luciferase* reporter construct. Ooc, optic chiasm; ov, third ventricle. Scale bar, 10  $\mu$ m. (b) Luminescence due to reporter expression, reflecting PER concentrations, in four individual neurons visualized in the slice over a 3-day interval in culture. Note that individual neurons exhibit circadian periodicity of bioluminescence, but that the neurons depicted in blue and yellow peak at a phase later than the main cluster shown in green and red. From [5], reprinted with permission from AAAS.

Hastings and Sweeney found that the alga *Gonyaulax polyedra* expresses at least three distinct circadian oscillations: the intensity of bioluminescent glow, the frequency of flashing rate, and vertical migration in the water column. When these events occur with the same period, even in constant conditions and different phases, it remains possible that all are driven by a common oscillator mechanism. Under some lighting conditions, however, these three rhythms dissociate so that they free run with different periods. This argues for the existence of multiple oscillators within a single cell.

The modern era of study of multioscillator circadian systems began with characterization of molecular mechanisms that generate rhythmicity. In *Drosophila* the protein products of the ▶*Period*, ▶*Timeless* and ▶*Cryptochrome* loci are engaged in a reciprocal interacting feedback loop with those of ▶*Cycle* and ▶*Clock*. Elegant studies utilizing a fluorescent reporter demonstrated not only that *Per* expression oscillates in individual isolated organs of the fly, but that these separate peripheral oscillators may be entrained by light in culture. With the discovery that several orthologs of *Period* are expressed in vertebrates, it became possible to investigate the multioscillatory organization of

mammalian tissues and to study circadian rhythms in cell lines. Balsalobre et al. [6] demonstrated that a serum shock initiates an oscillation in cultures of immortalized cells and in primary hepatocytes. They proposed that the damping of cyclic *Per* expression that occurs after a few cycles reflects differences in period of individual cell oscillations leading to loss of phase coherence. This speculation has been validated through microscopic visualization of *Period* or ▶*Bmal1*-driven luminescent reporters [7,8]. A mammalian organization similar to that of *Drosophila*, in which circadian oscillations persist in isolated organs, has now been demonstrated in mice ([9]; Fig. 4).

Not only do such studies establish that individual cells are oscillators, but they recall Pittendrigh's models of how a central neural pacemaker may coordinate and control the phasing of circadian rhythms throughout the body. According to the current model, entraining signals that originate in the pacemaker are relayed through appropriate pathways in order to set the phase and determine the period of peripheral oscillators. This communication may occur through innervation: the SCN in mammals communicates with paraventricular neurons that drive sympathetic output and thus may

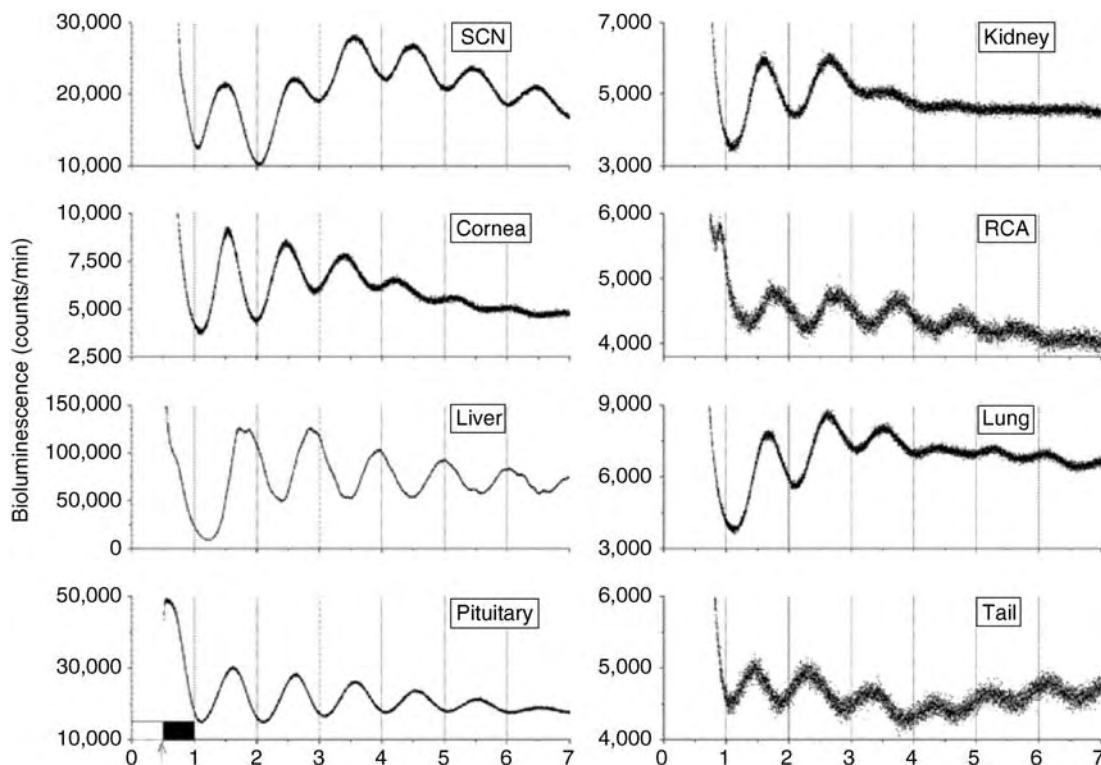

**Multi-Oscillator System. Figure 4** Circadian rhythms of expression of *mPer2*, a core clock gene whose protein levels are reflected by bioluminescence in a mouse reporter strain, persist after isolation of brain regions (SCN, RCA: retrochiasmatic area) and peripheral organs (cornea, kidney, liver, lung, pituitary, tail) *in vitro*. The light:dark cycle experienced by the mouse prior to sacrifice and organ removal is depicted at the lower left. From [9]; copyright (2004) National Academy of Sciences, USA.



regulate the autonomic control of peripheral organs. Indeed, trans-synaptic retrograde tracing indicates the existence of multisynaptic pathways that connect the SCN with multiple visceral organs [10]. Furthermore, removal of vagal input interferes with rhythmicity of clock gene expression in the lung. On the other hand, humoral signals may carry SCN signals to the periphery. Secretion of a variety of pituitary hormones is clearly under circadian control, and glucocorticoids can set the phase of clock gene expression in liver and kidney. Importantly, cultured fibroblasts show a high amplitude phase resetting response to dexamethasone, a glucocorticoid analog [8]. Furthermore, circadian rhythms of fibroblasts fall under central control soon after their implantation to subcutaneous sites that lack innervation. Also among time cues that may serve to regulate peripheral circadian oscillators are those that arise from meal patterns. These could include carbohydrates, fats, and amino acids absorbed from the gut, or other food-associated signals. Fluctuations in temperature that may result from feeding or activity, whose rhythmicity may be pacemaker-regulated, can also regulate clock gene expression and thus potentially set the phase of peripheral oscillations. Cues arising from social signals may also play an important role in vertebrates. Regulation of clock gene expression by any of these signals – or perhaps more likely, by several in combination – may fit the definition of entrainment. It remains to be determined whether any such cues set the phase of ►peripheral oscillators in a physiological situation. It is also possible that physiological cues (such as hormones) that influence the period or amplitude of slave oscillators in the periphery alter temporal programs by determining the phase they take to signals from the pacemaker.

## References

- Underwood H (1977) Circadian organization in lizards: the role of the pineal organ. *Science* 195:587–589
- de la Iglesia HO, Meyer J, Carpino A Jr, Schwartz WJ (2000) Antiphase oscillation of the left and right suprachiasmatic nuclei. *Science* 290:799–801
- Pittendrigh CS (1981) Circadian organization and the photoperiodic phenomena. In: Follett BK, Follett DE (eds) *Biological clocks in seasonal reproductive cycles*, Colston Papers No. 32. Sciencetechnica, Bristol, pp 1–35
- Page TL (1982) Transplantation of the cockroach circadian pacemaker. *Science* 216:73–75
- Yamaguchi S, Isejima H, Matsuo T, Okura R, Yagita K, Kobayashi M, Okamura H (2003) Synchronization of cellular clocks in the suprachiasmatic nucleus. *Science* 302:1408–1412
- Balsalobre A, Brown SA, Marcacci L, Tronche F, Kellendonk C, Reichardt HM, Schütz G, Schibler U (2000) Glucocorticoid hormones can reset time in peripheral tissues. *Science* 289:2344–2347
- Welsh DK, Yoo S-H, Liu AC, Takahashi JS, Kay SA (2004) Bioluminescence imaging of individual fibroblasts reveals persistent, independently phased circadian rhythms of clock gene expression. *Curr Biol* 14:2289–2295
- Nagoshi E, Saini C, Bauer C, Laroche T, Naef F, Schibler U (2004) Circadian gene expression in individual fibroblasts: Cell-autonomous and self-sustained oscillators pass time to daughter cells. *Cell* 119:693–705
- Yoo S-H, Yamazaki S, Lowrey PL, Shimomura K, Ko CH, Buhr ED, Sieppka SM, Hong H-K, Oh WJ, Yoo OJ, Menaker M, Takahashi JS (2004) PERIOD2::LUCIFERASE real-time reporting of circadian dynamics reveals persistent circadian oscillations in mouse peripheral tissues. *Proc Natl Acad Sci USA* 101:5339–5346
- Kreier F, Kap YS, Mettenleiter TC, van Heijningen C, van der Vliet J, Kalsbeek A, Sauerwein HP, Fliers E, Romijn JA, Buijs RM (2006) Tracing from fat tissue, liver, and pancreas: a neuroanatomical framework for the role of the brain in type 2 diabetes. *Endocrinology* 147:1140–1147

## Multiple Innervation

### Definition

The excess number of axonal innervations converging on a single target cell in the immature brain. The redundant inputs are eliminated through the process of synapse elimination and axon retraction during development.

### ►Synaptic Elimination

## Multiple Realization

### Definition

The thesis in the philosophy of mind that a given mental property, state or event is realized by different physical properties, states or events, which share no significant description at the physical level. Functionally defined kinds can be realized in a variety of physical states and processes, e.g. the kind “clock” can be multiply realized by a sun dial, a water clock, a mechanical mechanism or a silicon chip. If mental states like belief or pain are characterized functionally, i.e. in terms of their causalinferential relations to sensory input, to other mental states and to behavioral output, then they can in principle be realized by a variety of physical states and properties, e.g. by neural states in human beings and by silicon in Martians. The prospect of multiple realization

has served as an argument against the mind-body identity theory, which claims that types of mental states are identical to types of physical states, and against the reduction of the mental to the physical more generally.

► Theory Theory (Simulation Theory, Theory of Mind)

## Multiple Sclerosis

SYLVIA LUCAS

Department of Neurology, University of Washington Medical Center, Seattle, WA, USA

### Synonyms

MS; Variants of MS include acute disseminated encephalomyelitis (ADEM), neuromyelitis optica (NMO or Devic's disease) and Balo's concentric sclerosis

### Definition

Multiple sclerosis (MS) is an inflammatory, demyelinating disease of the central nervous system characterized by a clinical course of neurologic dysfunction (relapses), periods of improvement (remissions) and for most patients a loss of functional capability which may be physical as well as cognitive. Focal demyelinated lesions or plaques are found in the white matter of the brain and spinal cord. Recent evidence [1] has shown that MS may include demyelination in the cortex and deep gray matter nuclei and diffuse axonal injury in normal-appearing white matter.

### Characteristics

#### Epidemiology

MS affects approximately 350,000–400,000 Americans and 1.1 million patients world wide. It is second only to

trauma as the most disabling neurologic condition in young adults. There is a female to male ratio which may be increasing and has been reported as high as 4:1. Though the clinical onset of the disease is uncommon under age 15 and over 45, it is most often diagnosed in young women of reproductive age in the 20's or 30's. A latitudinal prevalence exists which is lowest at the equator and increases above 40° north latitude and below 40° south latitude [2].

Besides environmental risk, there appears to be a genetic susceptibility as well, with a family history of MS in 15–20% of patients. The risk of a second sibling developing MS if one sibling has it is 3–5% with concordance in monozygotic twins of 31% compared to dizygotic twins.

Polygenic inheritance is likely and the major histocompatibility complex (MHC) on chromosome 6p21 encoding antigen-presenting proteins to T cells is an important susceptibility region. HLA-DR2 is associated with a three to four-fold increased risk of sporadic and familial cases of MS [3].

### Clinical Features

The onset of MS can be insidious without clinical symptoms (as evident on MRI obtained for other reasons) or abrupt and rapidly progressive. MS presenting symptoms are extremely varied and depend on lesion location in the brain or spinal cord (Table 1). An initial clinical event is known as clinically isolated syndrome (CIS) with a recurrent or second event (in time and space) defining clinically definite MS (CDMS). Any MS event may be monosymptomatic, involving a single clinical symptom with focal nervous system involvement, or polysymptomatic indicative of involvement of multiple areas of the nervous system.

Signs or symptoms of MS are non-specific and include all symptoms resulting from injury to any part of the brain or spinal cord. Approximately 85% of patients will have a relapsing-remitting course (RRMS) at disease onset. Acute attacks (the relapse) evolve over

**Multiple Sclerosis. Table 1** Initial symptoms of MS

Symptom	Percent of cases	Symptom	Percent of cases
Sensory Loss	37	Lhermitte	3
Optic neuritis	36	Pain	3
Weakness	35	Dementia	2
Paresthesia	24	Visual Loss	2
Diplopia	15	Facial Palsy	1
Ataxia	11	Impotence	1
Vertigo	6	Myokymia	1
Paroxysmal Attacks	4	Seizures	1
Bladder	4	Falling	1

Source: After WB Matthews et al. (1991) McAlpine's multiple sclerosis, New York, Churchill Livingstone

several days to weeks followed by stabilization and spontaneous recovery of symptoms (the remission). Between attacks patients are neurologically stable. As the disease progresses, however, attacks may become less frequent but MS patients may experience a steady deterioration in neurological function and accumulate disability (secondary progressive MS; SPMS). Prior to the advent of disease-modifying therapies, approximately 50% of MS patients with RRMS would develop SPMS after 15 years [4]. SPMS represents a late evolution of MS and is likely associated with axonal loss and loss of compensatory mechanisms (Fig. 1).

Because MS is thought to be predominantly a disease of white matter, inflammation and demyelination of myelinated tracts lead to common symptoms of sensory disturbances (paresthesias, numbness, dysesthesias), optic neuritis (usually unilateral), pyramidal symptoms, cerebellar symptoms (e.g. ataxia), or brainstem involvement (e.g. internuclear ophthalmoplegia). Less common presentations are Lhermitte's sign (►[Lhermitte's Symptom](#)) (flexion of the neck produces electrical sensations or paresthesias along the spine or extremities), cortical symptoms or extrapyramidal syndromes. Bladder and bowel involvement is common (Table 1).

Symptoms which may also cause significant disability are fatigue, ►[Uhthoff's phenomenon](#) (symptoms

exacerbated by increasing body temperature), primary pain syndromes (e.g. trigeminal neuralgia, flexor and extensor spasms, optic neuritis), spasticity, dementia, and mood disorders. Secondary pain syndromes may also occur such as hip or back pain from postural or gait abnormalities, decubital ulcers from skin breakdown, or compression palsies.

Attempts have been made to quantify neurologic impairment in MS to provide a current clinical description of the disease status of a patient as well as to follow disease course over time. The ►[EDSS \(Kurtzke Expanded Disability Status Score\)](#) and the Functional Status (FS) Score are used most commonly. Patients with EDSS scores <3.5 usually have RRMS and walk normally. Patients with EDSS scores >5.5 have symptom evolution indicative of progressive MS (SPMS or PPMS), are gait impaired and may be disabled [5].

### Diagnosis

There is no single definitive test for MS. The diagnosis is based on clinical and paraclinical criteria of "dissemination in time and space." CDMS requires documentation of two or more distinct episodes of symptoms lasting at least 24 h and two or more exam signs indicative of neurologic dysfunction in different white matter tracts of the CNS. Paraclinical studies used

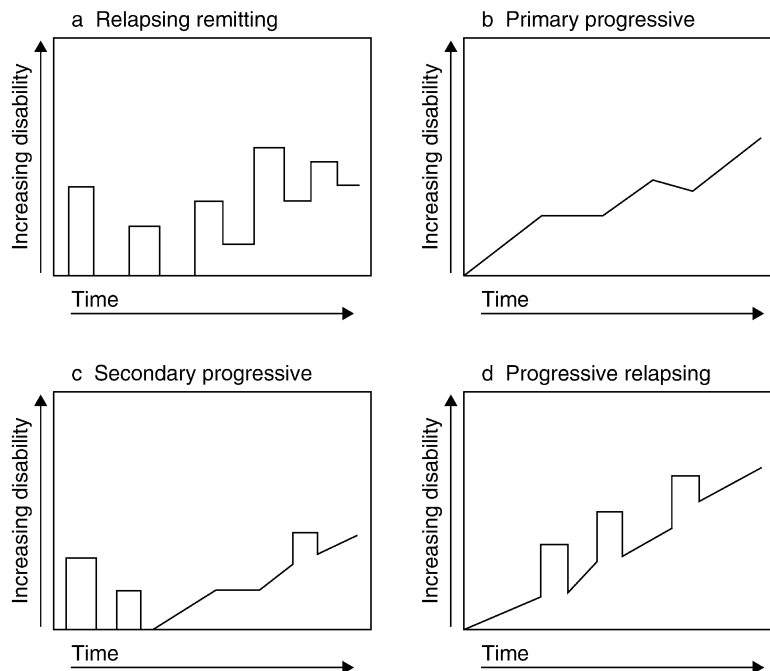

**Multiple Sclerosis. Figure 1** Clinical course of MS. (a) Relapsing-remitting MS (RRMS) is characterized by acute attacks with full recovery or by a residual deficit after recovery. Times between relapses have no disease progression. (b) Primary progressive MS (PPMS) is characterized by progression of disease from the onset without periods of remission and no improvement in function. (c) Secondary progressive MS (SPMS) begins with an initial relapsing-remitting course followed by progression with or without relapses. (d) Progressive relapsing MS (PRMS) shows progression from the onset with superimposed relapses.

to diagnose MS include MRI, CSF findings and ▶evoked potentials (EP) and may be useful to indicate disease activity even in the absence of any clinical activity.

MRI is 90–97% sensitive with typical lesions seen in periventricular white matter, corpus callosum, and juxtacortical white matter. Lesions are hyperintense on FLAIR and T2-weighted imaging (more useful than FLAIR for posterior fossa lesions), and may enhance with Gadolinium representing blood-brain barrier breakdown in acute disease activity. Chronic lesions may become hypointense on T1-weighted images (black holes) and other MRI findings of progressive disease are whole-brain atrophy, thinning of the corpus callosum and ex-vacuo dilation of the ventricles which correlate with cognitive impairment ([6]; Fig. 2).

CSF examination usually has a normal cell count or mild lymphocytosis, normal or slightly increased protein, and the presence of ▶oligoclonal bands (OCBs) is highly sensitive (90–95%) for diagnosis, though they are not always present initially. There may be an increased IgG synthesis rate, IgG index and the presence of myelin basic protein [7].

Evoked potentials are most useful in patients with a history of optic neuritis and are abnormal in 90% of these patients. Visual, sensory or brainstem auditory evoked potentials are less sensitive (65–85%) and are usually unnecessary with the use of modern MRI imaging.

### Pathophysiology

In the autoimmune hypothesis of MS, T lymphocytes become “activated” expressing receptors for myelin

components in the central nervous system. They enter the CNS through the specialized endothelial blood-brain barrier, attacking target antigens and triggering an inflammatory cascade.

The entry of activated T lymphocytes is mediated by chemotactic cytokines and cell adhesion molecules (e.g., VCAM-1) displayed on the inner surface of CNS microvascular endothelial cells. Interaction between VLA-4 (integrin molecules expressed on T cell lymphocytes) and Vcam-1 leads to T cell production and secretion of gelatinases, which break up perivascular basal lamina and allow entry into CNS interstitial spaces.

In a process similar to immune surveillance, these auto-reactive T lymphocytes find their specific antigen and start the inflammatory process. There are two roles for these T cells, one as Th1 cells producing proinflammatory cytokines such as IFN-gamma and TNF alpha. Th2 cells produce anti-inflammatory cytokines (IL-4, IL-5, IL10 and are regarded as having a role in downregulation of brain inflammation and may lead to myelin repair and/or oligodendrocyte precursor activation.

Evidence in favor of the autoimmune hypothesis comes from lesion pathology [8]. Early active lesions are characterized by perivascular round cell inflammation, and are similar to inflammatory pathology seen in models of experimentally induced autoimmune encephalomyelitis (EAE). Additionally, disease susceptibility is associated with the polymorphic major histocompatibility complex (MHC) genes whose class II products are required for antigen presentation by the T lymphocytes.

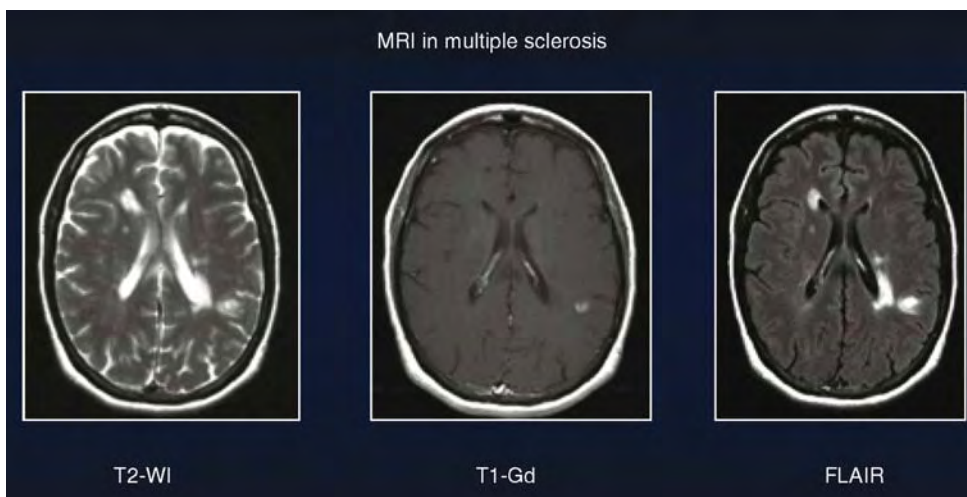

**Multiple Sclerosis. Figure 2** MRI findings in a patient with relapsing-remitting multiple sclerosis. T2-weighted imaging (*left*) and FLAIR (*right*) imaging show several lesions in the periventricular white matter and juxtacortical areas. The T1 Gad image (*middle*) shows the left posterior lateral ventricular lesion enhancing with gadolinium indicative of an acute or active lesion.

The current working model of pathogenesis is based on evidence from human disease, EAE and other animal models of demyelination. This is a heterogeneous disorder with varying patterns of immune pathogenesis. In neuropathologic studies of MS lesions [9] four major patterns of demyelination are described. All patterns of these active MS lesions contain T lymphocytes and macrophages and though lesion patterns differ between patients, a given patient has a single lesion type. Patterns I and II (seen in 15% and 58% of patients, respectively) are characterized by oligodendrocyte survival and remyelination, with myelin appearing to be the principal target. Pattern I demyelination is probably mediated by macrophage toxins, whereas pattern II finds antibody deposition (Ig) and activated complement at sites of myelin destruction. Patterns III and IV (26 and 1% of patients, respectively) are characterized by oligodendrocyte loss and apoptosis with limited remyelination; oligodendrocytes appear to be the target of injury. Pattern III lesions show degeneration of distal oligodendrocyte processes with selective loss of myelin associated glycoprotein (MAG) and apoptosis. Pattern IV shows extensive oligodendrocyte degeneration in a small rim of periplaque white matter and no MAG loss or complement activation is present.

### Treatment of Multiple Sclerosis

There is no cure for MS. However, the results of controlled clinical trials with immunomodulatory and immunosuppressive therapy suggest that the natural course of MS may be modified. Additionally, it is important that diligence in the recognition and satisfactory treatment of symptoms of MS may dramatically improve a patient's quality of life.

Treatment of MS falls into three categories: (i) treatment for the acute attacks or relapses of MS, (ii) disease-modifying therapies that may change the natural course and long-term disability of MS and (iii) treatment of the symptoms of MS.

High dose corticosteroid therapy is used to manage either an initial attack or an acute relapse (breakthrough disease). It may provide a short-term benefit by shortening an attack and decreasing its severity though it is generally thought not to affect the long-term outcome of the disease. Typical treatment for relapses is a 3–5 day course of intravenous methylprednisolone at 1 g/day which may be followed by a tapering dose of oral corticosteroids for 1–2 weeks. Plasma exchange may be useful in patients with severe attacks refractory to corticosteroid treatment.

Immunomodulatory treatment is available for the treatment of CIS and RRMS with interferons and glatiramer acetate which may be self-injected, and natalizumab which is delivered by intravenous infusion. Interferon beta-1A and interferon beta-1B have been

shown to decrease relapse rate, accumulation of lesion volume, and to decrease the number of enhancing lesions on MRI compared to placebo treatment. Though mechanism of action is not well understood, interferons are thought to reduce cell trafficking through the blood-brain barrier, shift T-cell response from Th1 to Th2, increase IL-10 and IL-4 production, and decrease antigen presentation and T-cell proliferation. Glatiramer acetate (a random polymer mixture of four amino acids) may shift T-cell response from Th-1 to Th-2, induce antigen-specific suppressor T cells, and compete with myelin basic protein on MHC II sites. It has effects similar to the beta-interferons on exacerbation frequency, however effects on MRI lesions or disability progression are less well established. These therapies were studied in 2- or 3-year clinical trials and long-term benefit is still unknown [10].

Natalizumab is a humanized monoclonal antibody which binds to alpha/4-beta 1 integrin on T-cells preventing association with VCAM-1 receptors on CNS endothelium and inhibits trafficking of T-cells into the CNS. It is delivered by intravenous infusion every 30 days has been approved for treatment of relapsing forms of MS. Though not directly compared to the interferons or glatiramer acetate in head-to-head trials, it may be more effective than prior approved therapies in reducing relapses and MRI activity. Close attention to safety issues via a specialized educational and reporting process was instituted following two cases of progressive multifocal leukoencephalopathy (PML) seen in the clinical trial setting with long-term use of natalizumab in combination with an interferon.

Treatment with the immunosuppressant mitoxantrone has been approved for SPMS and worsening RRMS. Mitoxantrone inhibits T cell, B cell, and macrophage proliferation, antigen presentation, and increases T cell suppressor activity. Mitoxantrone is an analogue of doxorubicin and has a cumulative dose ceiling to limit risk of cardiotoxicity. Delivery is by intravenous route every 3 months. Echocardiograms or other tests of cardiac function are recommended prior to each dose.

The aim of symptomatic therapy is to give relief from symptoms which have negative impact on function or quality of life. For example, bladder dysfunction in MS is common. Most often seen is the condition of a neurogenic bladder, with urgency, frequency and occasional incontinence. This and other bladder dysfunction such as detrusor/sphincter dyssynergia may be evaluated with urodynamic testing. Medication such as oxybutinin, hyoscamine, tolteridine, solifenacin, or trospium is usually helpful.

Depression may be seen in up to 50% of patients with MS and can be treated with medication or psychotherapy. The selective serotonin reuptake inhibitors (e.g. fluoxetine), selective serotonin reuptake/

norepinephrine reuptake inhibitors (e.g. duloxetine), or bupropion are most often used.

Fatigue may be dramatic and is the symptom most often causing disability in the workplace. Besides behavioral strategies to conserve energy, medication such as amantadine, modafinil and CNS stimulants (methylphenidate or amphetamines) usually help.

Constipation is the most common bowel problem in MS. A bowel program is often necessary and may consist of high-fiber diet, fluid intake, and laxatives administered orally or by suppository.

Spasticity is often seen with brainstem or spinal cord involvement in MS. Disinhibition of motor systems can manifest as tone changes, jerking or twitching, or a stiff-legged spastic gait. Stretching and exercise may help, and baclofen, tizanidine or diazepam are often helpful, though may cause sedation. For severe spasticity, intrathecal pump delivery of baclofen has improved function.

Pain symptoms are under-recognized in MS and can be due to a primary central pain syndrome (neuropathic pain) or secondary to other causes such as decubital ulcers, poor biomechanics, or osteoporosis. Central pain syndromes may respond to anticonvulsant medication, tricyclic antidepressants (e.g. amitriptyline), or selective serotonin/norepinephrine reuptake inhibitors. The addition of nonsteroidal anti-inflammatories and opioids may be of benefit.

### Prognosis

The clinical pattern or course of the disease is difficult to predict for an individual patient at disease onset. Certain patterns of disease are associated with slower progression and less disability. Optic neuritis or sensory symptoms at diagnosis, complete recovery between attacks, women and patients with one or two relapses in the first year of their MS will probably do better than those without these features. A progressive course has a worse prognosis for disability. Some patients have a more benign variant of MS and never develop disability. Mortality as a direct consequence of MS is highly uncommon. MRI has shown new or active lesions even in the absence of clinical disease. Known as “clinically silent lesions,” these expressions of MS progression make it imperative that MS patients are followed with serial imaging studies as well as with office visits for clinical examination. If there is evidence of either clinical or radiological disease progression, more aggressive treatment to slow the course is likely to be of benefit. A comprehensive care approach to the treatment of MS by a caring, experienced physician can improve the quality of life for MS patients.

► **Autoimmune Demyelinating Disorders: Stem Cell Therapy**

### References

1. Trapp BD, Peterson J, Ransohoff RM et al. (1998) Axonal transection in the lesions of multiple sclerosis. *N Engl J Med* 338:278–285
2. Weinschenker BG (1996) The epidemiology of multiple sclerosis. *Neurol Clin* 14:291
3. The Multiple Sclerosis Genetics Group (1996) A complete genome screen for multiple sclerosis underscores a role for the major histocompatibility complex. *Nat Genet* 13:469
4. Weinschenker BG, Bass B, Rice GP et al. (1989) The natural history of multiple sclerosis: a geographically based study. 2. Predictive value of the early clinical course. *Brain* 112:1419–1428
5. Kurtzke JF (1983) Rating neurologic impairment in multiple sclerosis: an expanded disability status scale (EDSS). *Neurology* 33:1444–1452
6. McDonald WI, Compston A, Edan G et al. (2001) Recommended diagnostic criteria for multiple sclerosis: guidelines from the International Panel on the diagnosis of multiple sclerosis. *Ann Neurol* 50:121–127
7. Freedman MS, Thompson EJ, Deisenhammer F, Giovannoni G et al. (2005) Recommended standard of cerebrospinal fluid analysis in the diagnosis of multiple sclerosis: a consensus statement. *Arch Neurol* 62:865–870
8. Pittock SJ, Lucchinetti CF (2007) The pathology of MS: new insights and potential clinical applications. *Neurologist* 13:45–56
9. Lassman H, Bruck W, Lucchinetti CF (2007) The immunopathology of multiple sclerosis: an overview. *Brain Pathol* 17:210–218
10. Goodin DS et al. (2002) Disease modifying therapies in multiple sclerosis: report of the therapeutics and technology assessment subcommittee of the American Academy of Neurology. *Neurology* 58:169

## Multiple Sclerosis: Macrophages and Axonal Loss

ELLY J. F. VEREYKEN, CHRISTINE D. DIJKSTRA, CHARLOTTE E. TEUNISSEN  
Department of Molecular Cell Biology and Immunology, VUMC, Amsterdam, The Netherlands

### Definition

► **Multiple sclerosis** is a disease of the central nervous system in which a progressive destruction of ► **myelin**, a fatty layer surrounding neurons, and transaction of neurons takes place. The mechanisms causing this destruction are largely unknown. ► **Macrophages** are thought to play a major role in the neuronal damage that occurs, through the release of inflammatory substances like ROS, ► **cytokines** and glutamate. Macrophages are not only detrimental in this disorder, but can also

be involved in axonal repair, e.g. by production of neutrophic factors.

### Characteristics

Multiple Sclerosis (MS) is a chronic inflammatory autoimmune disease of the central nervous system (CNS) and the most common cause of neurological disability among young adults. The prevalence of MS is approximately 1.5 million people worldwide and women are affected more often compared to men [1]. Three major clinical courses are recognized: the relapsing-remitting (RR-MS), the secondary-progressive (SP-MS) and primary progressive (PP-MS) subtype. Approximately 80% of the cases start with the RR subtype, which is characterized by clinical attacks that are followed by a clinically silent period with almost complete recovery. After a period of 10–15 years most cases of the RR-MS subtype develop progressive neurological deterioration without apparent remission, the SP-MS subtype. The last subtype, PP-MS, is less common and is characterized by progressive neurological impairment without relapses or remissions.

The major neuropathological hallmarks of MS are demyelinating lesions associated with perivascular infiltrates containing macrophages and lymphocytes. Most lesions also have some degree of astrogliosis, which is hypertrophy of and an abnormal increase in the number of ►astrocytes. The animal model that is most often used to study MS is ►experimental allergic encephalomyelitis (EAE). EAE is an inflammatory demyelinating autoimmune disease. The symptoms of EAE can be characterized as either acute or chronic-relapsing. To induce EAE animals are injected with CNS homogenate, myelin proteins or parts of these myelin proteins in adjuvant. Adoptive transfer of autoreactive CD4<sup>+</sup> T-cells or autoantibodies can also induce EAE passively.

Historically, MS has been viewed as a primary demyelinating disease with relative axonal sparing, although early papers did describe axonal damage and loss [2]. However, the view that axonal damage is important in MS pathology is now being widely accepted.

### Axonal Damage in MS

Demyelination has long been considered the main cause of disability in MS. However, more recent reports suggest that axonal injury is the correlate of irreversible clinical disability in MS patients. Early axonal damage may be either compensated for and/or repaired, but the continuous progression of axonal loss could ultimately lead to irreversible clinical dysfunction. A current hypothesis is that the transition from the RR to the SP subtype takes place once the loss of a critical number of ►axons is exceeded [2].

An indication that axonal damage might be important in MS pathology was that axonal transections are

common in MS lesions, even in the periplaque white matter. It was most extensive in areas of active demyelination and inflammation. In chronic MS patients, axonal density was significantly decreased in both normal appearing white matter (NAWM) and lesions in the cervical spinal cord compared to controls. The decrease in axonal density was more extensive inside most lesions compared to the adjacent NAWM [2]. A marker for axonal injury is the amyloid precursor protein (APP). During acute injury anterograde axonal transport is interrupted causing APP to accumulate. In lesions with active demyelination APP accumulation was found, suggesting that axonal damage is a feature of early pathology and possibly associated with inflammation. In inactive lesions significant, though low-level axonal damage was observed associated with residual inflammation.

Magnetic resonance imaging (MRI) and spectroscopy (MRS) were used to visualize neuronal damage in living patients. Progressive brain atrophy was found to correlate with a decline in EDSS in MS patients. These findings suggest that brain atrophy leads to functional impairment. A more specific marker for axonal damage in MS is *N*-acetylaspartate (NAA), which can be detected *in vivo* in the brain using MRS. NAA is a mitochondrial amino acid that is primarily localized in neurons and neuronal processes, which means that a change in NAA signal reflects axonal injury and/or neuronal loss [2]. A relationship was observed between the decrease in NAA levels measured by MRS in MS lesions and the decrease in axonal density in corresponding biopsy specimens [2].

Changes in cerebrospinal fluid (CSF) concentrations of axon specific markers also point to a role of axonal damage in MS pathology and progression. In CSF of MS patients the NAA concentration was found to correlate with EDSS, a lower brain volume and a higher lesion load [3]. Other biomarkers for axonal damage in the CSF, as reviewed by our group, are proteins like Tau and neurofilament. The autoantibody index for the neurofilament-light chain has been found to correlate with atrophy [4].

All these data confirm the importance of axonal damage in MS pathology, which can already be observed early in the disease course. The mechanisms causing this damage are largely unknown. A hypothesis is that infiltrating macrophages might play a crucial role in axonal damage.

### Macrophages in Axonal Damage

It is generally accepted that macrophages/►microglia are involved in the pathogenesis of MS and EAE, for example through the removal of myelin debris by phagocytosis. Some indirect evidence has been found supporting a role for macrophages in axonal damage. Several studies have found correlations between

macrophages and axonal damage in MS lesions. The first example is the correlation observed between the location of axonal damage and cellular infiltrates in both MS and EAE [2]. Secondly, a correlation between the number of infiltrating macrophages and axonal damage, as viewed with both APP and axonal transections, was observed. Finally, the elimination of infiltrating macrophages or resident microglia in the CNS has a suppressive effect on the clinical signs of EAE, indicating a direct effect of macrophages on axonal function [1].

Macrophage and microglial activation are associated with an upregulation of a plethora of inflammatory mediators that could mediate the acute damage seen in the axons. Many studies have shown increased concentrations of markers for oxidative stress, like oxidized proteins, lipids and DNA [1]. These markers have been found in the CNS of EAE animals and sera of MS patients. This oxidative stress is caused by both ROS, like superoxide and hydrogen peroxide, and nitric oxide (NO). Treatment with ROS scavengers and antioxidants reduced inflammation and axonal damage in acute EAE [1]. By activating nuclear transcription factor-kappa B, ROS can induce the transcription of many genes involved in the pathogenesis of EAE and MS such as tumor necrosis factor-alpha (TNF- $\alpha$ ), inducible nitric oxide synthase and intracellular adhesion molecule 1 [5]. The contribution of this pathway to the axonal damage in MS has not been investigated. ROS and NO could also lead to axonal damage by inducing oxidative stress in mitochondria. Axons are metabolically very active, especially due to impulse conduction and axonal transport. Mitochondria produce this energy and are therefore an intracellular source of ►reactive oxygen species (ROS). This makes them especially sensitive to exposure to extracellular ROS from macrophages. Mitochondrial dysfunction, due to the oxidative stress, leads to energy deficiency and can thereby lead to impairment of axonal transport and accumulation of APP. Impairment of axonal transport has been observed in many neurodegenerative disorders, like MS and Wallerian degeneration, indicating it plays an important role in axonal loss [6]. The precise mechanism behind decreased transport leading to axonal degeneration is not known. Reduced energy levels also cause increased sodium leakage into the axon and thereby reversal of the operation of the sodium-calcium exchanger and axonal swelling. This reversal of operation leads to increased intracellular calcium concentrations, bringing about the induction of apoptosis [6].

In CSF, blood and urine of MS-patients increased concentrations of markers of NO production, like peroxynitrite and 3-nitrotyrosine, have been observed. Peroxynitrite, which correlates with disease severity, is toxic and can damage both axons and myelin [1].

NO can induce a reversible conduction block in axons exposed to low frequency stimulation, while exposure to NO during higher frequency stimulation leads to axonal degeneration [7].

Both pro- and anti-inflammatory cytokines are upregulated, seemingly simultaneously as they are all detected in serum, CSF, and cultured mononuclear cells of MS patients. Cytokines have many different functions and in a complex disorder like MS it is not always clear whether they are beneficial or detrimental. For example moderate overexpression of TNF- $\alpha$  can lead to demyelination and axonal damage, very similar to that observed in EAE and MS [1]. However, no correlation was observed between axonal damage in MS patients and TNF- $\alpha$  expression in the CNS or serum levels, nor is treatment with TNF- $\alpha$  antibodies beneficial in MS. The same holds true for Interleukin-6 (IL-6), which has been implicated in induction of ►excitotoxicity, but also has been reported to have neuroprotective effects [1].

Glutamate is the most common excitatory neurotransmitter in the CNS. However, excessive concentrations of glutamate lead to excitotoxicity. Excitotoxicity is thought to play a role in MS since increased concentrations of glutamate have been observed in CSF of MS patients and this increase was found to be associated with the severity and course of the disease [1]. Treatment of EAE mice with an AMPA/kainate antagonist led to significant decrease in clinical scores, which corresponded pathologically to a reduction in axonal damage and oligodendrocyte loss [1].

### Macrophages in CNS Regeneration and Repair

Recently, evidence has been found pointing to not only a detrimental but also a beneficial role of macrophages in axonal regeneration/repair. Several studies have found macrophages to be involved in axonal regenerative processes at different locations. At these different locations different macrophage derived mediators were implicated. For example, it was found that increased brain derived neurotrophic factor (BDNF) expression by macrophages could lead to locomotor recovery and axonal outgrowth [8]. Four weeks after a spinal cord compression injury, causing paraplegia in rats, an injection of granulocyte macrophages-colony stimulating factor (GM-CSF) promoted increased expression of BDNF by macrophages at the lesion site and thereby axonal regeneration. Also *in vitro* microglia activated by GM-CSF produced more BDNF, causing co-cultured neurons to generate more neurites. This effect could be blocked by anti-BDNF antibodies.

After optical nerve crush, lens injury induced regenerative effects due to an influx of macrophages. Macrophage infiltration corresponded with an upregulation in growth-associated protein (GAP)-43 expression levels. GAP-43 is a marker for axonal growth and



synaptogenesis. Intraocular Zymosan injection, which also results in massive macrophage infiltration, led to increased GAP-43 expression and axonal regeneration in absence of lens injury. *In vitro*, medium from Zymosan stimulated macrophages was able to enhance axon regeneration, with the axon-promoting effects being mediated by oncomodulin [9].

Finally, macrophages could be positively involved in axonal outgrowth through expression of the axon guidance molecule EphrinB3 [10]. Macrophages recruited to the site of nerve crush express this axon guidance molecule EphrinB3, while injured retinal ganglion cells express the receptor for EphrinB3. This was further confirmed by the fact that a reduction of EphrinB3 function led to a greatly decreased retinal ganglion cell axon re-extension or sprouting, after optic nerve injury in EphrinB3 heterozygous and homozygous null mutants.

### Subtypes of Macrophages

A current hypothesis poses that different activation subtypes of macrophages exist. These different macrophages have different functions in the immuneresponse and tissue repair. Interesting for the CNS could be the difference in their contribution to repair. The three main subtypes are: (i) the classically activated macrophages (CA-M $\Phi$ , also called M1), induced by IFN- $\gamma$  and LPS; (ii) type II activated macrophages (M $\Phi$ -II), produced by exposure to IFN- $\gamma$  in the presence of immunoglobulin G immunocomplexes; and the alternatively activated macrophages (AA-M $\Phi$ , also called M2), stimulated by IL-4 and/or glucocorticoids. The CA-M $\Phi$  is cytotoxic and secretes high amounts of NO and IL-12. The M $\Phi$ -II induces a Th2 response, through its release of IL-10. Finally, the AA-M $\Phi$  seems to be involved in immunosuppression and tissue repair, due to production of neurotrophic factors, extracellular matrix components and failure to produce NO [11]. Markers for the different types of macrophages are presented in Table 1. The most common used distinctive marker for AA-M $\Phi$ , in mice, is the higher expression and activity of arginase, leading to release of neurotrophic factors and extracellular matrix molecules [11]. Both CA-M $\Phi$  and M $\Phi$ -II are efficient antigen presenting cells, while AA-M $\Phi$  are not [11]. Until now, little research has been done about the presence and function of these different subsets of macrophages in neurodegenerative diseases like MS.

### Macrophages and Axonal Repair in MS

Removal of myelin debris by macrophages is thought to be important for axonal repair/regrowth, since myelin debris have been found to be growth inhibiting. In MS lesions activated macrophages/microglia are a source of growth factors, neurotrophins and their receptors that actively promote axonal regrowth, such as BDNF and the receptor for NGF [30]. It has been shown that both

*in vivo* and *in vitro* macrophages/microglia in the CNS express nerve growth factor, neurotrophin-3 and BDNF [30]. Furthermore, macrophages could contribute to the resolution of the inflammation in MS thereby inhibiting further injury to the axons. It was found that myelin-laden foamy macrophages in active lesions expressed anti-inflammatory molecules, with the exact molecules expressed depending on the precise location in the lesions, while pro-inflammatory molecules were not expressed in any of the lesion locations [31]. *In vitro*, myelin ingestion induced foamy macrophage morphology and expression of anti-inflammatory molecules and inhibited the response to pro-inflammatory stimuli. This indicated a strong immunosuppressive function for foamy macrophages [31]. These foamy macrophages displayed functions and activities that might put them in the category of AA-M $\Phi$ . Another study also indicated that foamy macrophages in MS lesions might be AA-M $\Phi$ , since they express CD163, although the expression of mannose receptor is low in these cells [32]. Furthermore, periventricular macrophages, which are located at the blood brain barrier, have an AA-M $\Phi$  phenotype, since they do express both CD163 and mannose receptor. This could be important since their location at the blood brain barrier means they occupy a strategic position to control innate and adaptive immune responses in the brain [32].

Another indication that macrophages could be involved in axonal repair was found in our studies showing that activated macrophages are present in the areas of increased GAP-43 expression [33]. Levels of GAP-43 were higher around lesions. Although no correlation was found between the intensity of GAP-43 staining and macrophage presence, their presence was consistently observed in areas of increased GAP-43 expression. Macrophages producing neurotrophic factors, like neurotrophic growth factor and BDNF could induce the increase in GAP-43 expression [33]. We are planning to investigate the phenotype of the macrophages present in the areas of GAP-43 expression.

### Future Perspectives

Our hypothesis is that alternatively activated macrophages and classically activated macrophages may be different phenotypic forms of macrophages during different phases of MS pathology. This is schematically represented in Fig. 1. Classically activated macrophages could play an important role in causing axonal damage early in lesion development, through the release of soluble mediators like NO, ROS and glutamate. When lesions develop further and macrophages are present in the tissue longer, our idea is that the classically activated macrophages change into alternatively activated macrophages. Alternatively activated macrophages can play a role in the resolution of inflammation due to their anti-inflammatory nature

**Multiple Sclerosis: Macrophages and Axonal Loss. Table 1** Markers for the different macrophage subtypes

Marker	CA-MΦ	MΦ-II	AA-MΦ	Observed in	Reference
<b>Enzymes</b>					
iNOS mRNA expression	↑	↑	–	Mouse	[11]
iNOS activity					[12]
NO release					
Arginase mRNA expression	–	–	↑	Mouse	[11]
Arginase activity					
SPHK1 mRNA	–	↑	–	Mouse	[11]
12,15-lipoxygenase	↓	?	↑	Human, mouse	[13]
<b>Membrane receptor expression</b>					
CD163 protein expression	–	–	↑	Human	[14]
CD163 mRNA	–	–	↑	Mouse	[11]
Mannose receptor protein expression	–	–	↑	Mouse	[15]
β-glucan receptor (Dectin-1)	–	–	↑	Mouse	[16]
MGL1/2 mRNA	–	?	↑	Human, mouse	[17]
MGL1/2 protein expression					
FcγR	↑	?	↓	Human	[18]
LIGHT mRNA	–	↑	–	Mouse	[11]
<b>Antigen presentation</b>					
MHC class II protein expression	↑	↑↑	↓	Human, mouse	[11]
CD86 protein expression	↑	↑	↓	Human, mouse	[11]
MS1-HMWP	↓	?	↑	Human	[19]
<b>Cytokines</b>					
IL-12 release	↑	–	–	Human, mouse	[11,20,21]
IL-12 mRNA	↑↑	↑	–		
IL-10 release	–	↑	–	Mouse	[11,21,22]
IL-10 mRNA	–	↑	–		
Ratio IL-10/IL-12	↓	↑	–	Mouse	[21,22]
IL-23 release	↑	–	–	Human	[23]
IL-6	↑	↑	↓	Mouse	[21]
TNF	↑	↑	↓	Human	[24]
IL-1Ra/IL-1 decoy receptor release	–	–	↑	Mouse	[19]
<b>Chemokine</b>					
AMAC-1 release	–	?	↑	Human	[25]
MIP-1a mRNA	↑	–	–	Human	[19,22]
<b>MDC (CCL22) mRNA expression</b>					
MDC release	–	–	↑	Human	[26]
TARC (CCL17)	↓	?	↑	Human, mouse	[27,28]
<b>Secretory proteins</b>					
FIZZ1 mRNA	–	–	↑	Mouse	[29]
YM1/2 mRNA	–	–	↑	Mouse	[29]

↑: an increase in expression/activity. –: no change in expression/activity. ↓: a decrease in expression/activity. ?: unknown

Abbreviations: AA-MΦ = alternatively activated macrophage; APP = amyloid precursor protein; BDNF = brain derived neurotrophic factor; CA-MΦ = classically activated macrophage; CNS = central nervous system; CSF = cerebrospinal fluid; EAE = experimental allergic encephalomyelitis; EDSS = expanded disability status scale; GAP-43 = growth-associated protein 43; GM-CSF = granulocyte macrophage colony-stimulating factor; MΦ-II = type II activated macrophage; MBP = myelin basic protein; MRI = magnetic resonance imaging; MRS = magnetic resonance spectroscopy; MS = multiple sclerosis; NAA = *N*-acetylaspartate; NAWM = normal appearing white matter; NO = nitric oxide; PP-MS = primary progressive multiple sclerosis; ROS = reactive oxygen species; RR-MS = relapsing-remitting multiple sclerosis; SP-MS = secondary progressive multiple sclerosis; TNF-α = tumor necrosis factor-alpha.

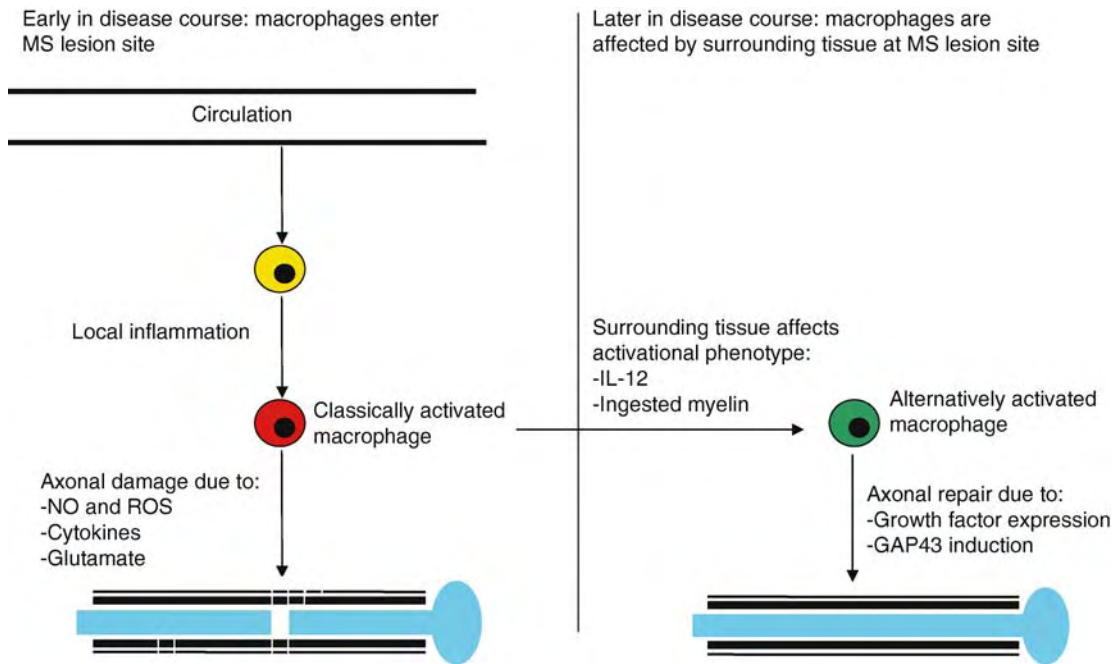

**Multiple Sclerosis: Macrophages and Axonal Loss. Figure 1** Hypothesis of macrophage activation in MS lesions. As the macrophages enter the lesion site, they are classically activated due to the local inflammation. These classically activated macrophages induce axonal damage due to secreted factors like NO, pro-inflammatory cytokines and glutamate. The macrophages at the lesion site spent time in the CNS tissue. Slowly the surrounding tissue starts to affect the activational phenotype of the macrophages. Due to IL-12 secreted by astrocytes and ingestion of myelin, the macrophages take on an alternatively activated phenotype. These macrophages are involved in axonal repair due to the expression of growth factors, induction of GAP-43 expression in neurons and secretion of anti-inflammatory cytokines.

and axonal repair/regeneration through the release of neurotrophic factors.

It has been shown that classically activated macrophages can still become alternatively activated and vice versa [34]. The activational subtype of the macrophage is therefore not fixed and could be influenced by the surrounding environment, such as CNS cells like astrocytes. For example, the ingestion of myelin, which makes macrophages foamy, could induce an alternative phenotype in macrophages [31]. In Gaucher disease glycolipids also accumulate inside macrophages, which subsequently show an alternatively activated phenotype. This seems to implicate that glycolipids could induce alternative activation. It might be that accumulation of glycolipid constituents of myelin directs macrophage gene transcription to induce the alternatively activated phenotype in MS. However, it is still a question whether foamy macrophages, which have been shown to be anti-inflammatory [31], can be really characterized as alternatively activated. Another question is whether foamy macrophages are able to directly induce GAP-43 expression in axons and whether this also leads to functional repair. Furthermore, it has been shown that astrocytes secrete IL-12, which could influence the

macrophage activational subtype and skew it more to the alternative side.

Future therapeutic interventions should aim at reducing activation of classically activated macrophages during early phases of lesion development, while stimulating the formation of alternatively activated macrophages. Since axonal damage occurs early during disease course, perhaps specifically blocking the activity of classically activated macrophages could be a candidate therapy. It may also be a good option to treat patients early during disease course with substances able to induce the alternative phenotype, thus reducing inflammation, axonal damage and consequently clinical dysfunction.

#### Acknowledgements

This research is sponsored by both the MS Research Foundation (grants 05-559 MS and 02-358b MS) and ZON-MW (veni grant).

#### References

1. Hendriks JJ, Teunissen CE, de Vries HE, Dijkstra CD (2005) Macrophages and neurodegeneration. *Brain Res Brain Res Rev* 48:185–195

2. Bjartmar C, Trapp BD (2001) Axonal and neuronal degeneration in multiple sclerosis: mechanisms and functional consequences. *Curr Opin Neurol* 14:271–278
3. Jasperse B, Jakobs C, Eikelenboom MJ, Dijkstra CD, Uitdehaag BM, Barkhof F, Polman CH, Teunissen CE. N-acetylaspartic acid in cerebrospinal fluid of multiple sclerosis patients determined by gas-chromatography-mass spectrometry. *J Neurol* 2007 May; 254(5):631–637
4. Teunissen CE, Dijkstra C, Polman C (2005) Biological markers in CSF and blood for axonal degeneration in multiple sclerosis. *Lancet Neurol* 4:32–41
5. Gilgun-Sherki Y, Melamed E, Offen D (2004) The role of oxidative stress in the pathogenesis of multiple sclerosis: the need for effective antioxidant therapy. *J Neurol* 251:261–268
6. Coleman M (2005) Axon degeneration mechanisms: commonality amid diversity. *Nat Rev Neurosci* 6:889–898
7. Smith KJ, Lassmann H (2002) The role of nitric oxide in multiple sclerosis. *Lancet Neurol* 1:232–241
8. Bouhy D, Malgrange B, Multon S, Poirrier AL, Scholtes F, Schoenen J, Franzen R (2006) Delayed GM-CSF treatment stimulates axonal regeneration and functional recovery in paraplegic rats via an increased BDNF expression by endogenous macrophages. *FASEB J* 20:1239–1241
9. Yin Y, Henzl MT, Lorber B, Nakazawa T, Thomas TT, Jiang F, Langer R, Benowitz LI (2006) Oncomodulin is a macrophage-derived signal for axon regeneration in retinal ganglion cells. *Nat Neurosci* 9:843–852
10. Liu X, Hawkes E, Ishimaru T, Tran T, Sretavan DW (2006) EphB3: an endogenous mediator of adult axonal plasticity and regrowth after CNS injury. *J Neurosci* 26:3087–3101
11. Edwards JP, Zhang X, Frauwirth KA, Mosser DM (2006) Biochemical and functional characterization of three activated macrophage populations. *J Leukoc Biol* 80:1298–1307
12. Doyle AG, Herbein G, Montaner LJ, Minty AJ, Caput D, Ferrara P, Gordon S (1994) Interleukin-13 alters the activation state of murine macrophages *in vitro*: comparison with interleukin-4 and interferon-gamma. *Eur J Immunol* 24:1441–1445
13. Conrad DJ, Kuhn H, Mulkins M, Highland E, Sigal E (1992) Specific inflammatory cytokines regulate the expression of human monocyte 15-lipoxygenase. *Proc Natl Acad Sci USA* 89:217–221
14. Buechler C, Ritter M, Orso E, Langmann T, Klucken J, Schmitz G (2000) Regulation of scavenger receptor CD163 expression in human monocytes and macrophages by pro- and antiinflammatory stimuli. *J Leukoc Biol* 67:97–103
15. Stein M, Keshav S, Harris N, Gordon S (1992) Interleukin 4 potently enhances murine macrophage mannose receptor activity: a marker of alternative immunologic macrophage activation. *J Exp Med* 176:287–292
16. Willment JA, Lin HH, Reid DM, Taylor PR, Williams DL, Wong SY, Gordon S, Brown GD (2003) Dectin-1 expression and function are enhanced on alternatively activated and GM-CSF-treated macrophages and are negatively regulated by IL-10, dexamethasone, and lipopolysaccharide. *J Immunol* 171:4569–4573
17. Raes G, Brys L, Dahal BK, Brandt J, Grooten J, Brombacher F, Vanham G, Noel W, Bogaert P, Boonefaes T, Kindt A, Van den BR, Leenen PJ, De BP, Ghassabeh GH (2005) Macrophage galactose-type C-type lectins as novel markers for alternatively activated macrophages elicited by parasitic infections and allergic airway inflammation. *J Leukoc Biol* 77:321–327
18. te Velde AA, Huijbens RJ, De Vries JE, Figdor CG (1990) IL-4 decreases Fc gamma R membrane expression and Fc gamma R-mediated cytotoxic activity of human monocytes. *J Immunol* 144:3046–3051
19. Mosser DM (2003) The many faces of macrophage activation. *J Leukoc Biol* 73:209–212
20. Skeen MJ, Miller MA, Shinnick TM, Ziegler HK (1996) Regulation of murine macrophage IL-12 production. Activation of macrophages *in vivo*, restimulation *in vitro*, and modulation by other cytokines. *J Immunol* 156:1196–1206
21. Gerber JS, Mosser DM (2001) Reversing lipopolysaccharide toxicity by ligating the macrophage Fc gamma receptors. *J Immunol* 166:6861–6868
22. Anderson CF, Mosser DM (2002) A novel phenotype for an activated macrophage: the type 2 activated macrophage. *J Leukoc Biol* 72:101–106
23. Verreck FA, de BT, Langenberg DM, Hoeve MA, Kramer M, Vaisberg E, Kastelein R, Kolk A, de Waal-Malefyt R, Ottenhoff TH (2004) Human IL-23-producing type 1 macrophages promote but IL-10-producing type 2 macrophages subvert immunity to (myco)bacteria. *Proc Natl Acad Sci USA* 101:4560–4565
24. Hart PH, Vitti GF, Burgess DR, Whitty GA, Piccoli DS, Hamilton JA (1989) Potential antiinflammatory effects of interleukin 4: suppression of human monocyte tumor necrosis factor alpha, interleukin 1, and prostaglandin E2. *Proc Natl Acad Sci USA* 86:3803–3807
25. Kodolja V, Muller C, Politz O, Hakij N, Orfanos CE, Goerdts S (1998) Alternative macrophage activation-associated CC-chemokine-1, a novel structural homologue of macrophage inflammatory protein-1 alpha with a Th2-associated expression pattern. *J Immunol* 160:1411–1418
26. Bonecchi R, Sozzani S, Stine JT, Luini W, D'Amico G, Allavena P, Chantry D, Mantovani A (1998) Divergent effects of interleukin-4 and interferon-gamma on macrophage-derived chemokine production: an amplification circuit of polarized T helper 2 responses. *Blood* 92:2668–2671
27. Imai T, Nagira M, Takagi S, Kakizaki M, Nishimura M, Wang J, Gray PW, Matsushima K, Yoshie O (1999) Selective recruitment of CCR4-bearing Th2 cells toward antigen-presenting cells by the CC chemokines thymus and activation-regulated chemokine and macrophage-derived chemokine. *Int Immunol* 11:81–88
28. Liddiard K, Welch JS, Lozach J, Heinz S, Glass CK, Greaves DR (2006) Interleukin-4 induction of the CC chemokine TARC (CCL17) in murine macrophages is mediated by multiple STAT6 sites in the TARC gene promoter. *BMC Mol Biol* 7:45
29. Raes G, De BP, Noel W, Beschin A, Brombacher F, Hassanzadeh GG (2002) Differential expression of FIZZ1 and Ym1 in alternatively versus classically activated macrophages. *J Leukoc Biol* 71:597–602
30. Kerschensteiner M, Stadelmann C, Dechant G, Wekerle H, Hohlfeld R (2003) Neurotrophic cross-talk between the nervous and immune systems: implications for neurological diseases. *Ann Neurol* 53:292–304

31. Boven LA, Van MM, Van ZM, Wierenga-Wolf A, Hintzen RQ, Boot RG, Aerts JM, Amor S, Nieuwenhuis EE, Laman JD (2006) Myelin-laden macrophages are anti-inflammatory, consistent with foam cells in multiple sclerosis. *Brain* 129:517–526
32. Fabrick BO, Van Haastert ES, Galea I, Polfliet MM, Dopp ED, Van Den Heuvel MM, Van Den Berg TK, De Groot CJ, Van DV, Dijkstra CD (2005) CD163-positive perivascular macrophages in the human CNS express molecules for antigen recognition and presentation. *Glia* 51:297–305
33. Teunissen CE, Dijkstra CD, Jasperse B, Barkhof F, Vanderstichele H, Vanmechelen E, Polman CH, Bo L (2006) Growth-associated protein 43 in lesions and cerebrospinal fluid in multiple sclerosis. *Neuropathol Appl Neurobiol* 32:318–331
34. Porcheray F, Viaud S, Rimaniol AC, Leone C, Samah B, reুদ্ধre-Bosquet N, Dormont D, Gras G (2005) Macrophage activation switching: an asset for the resolution of inflammation. *Clin Exp Immunol* 142:481–489

---

## Multiple Sleep Latency Test

### Definition

A standardized, objective, clinical and research tool used to assess physiologic sleepiness. The test is based on the idea that the sleepiness can be measured by the speed of falling asleep under controlled environmental conditions of lying in bed with the lights off. Polysomnographic recordings of electroencephalogram (EEG), electrocardiogram (EKG), chin electromyogram (EMG), and eye movements are analyzed for four to five 20-min nap opportunities provided every 2 h across the day (e.g., naps at 1000, 1200, 1400, 1600, 1800 h). The average time that it takes to fall asleep across naps is calculated. Average sleep latency below 5 min is considered to be indicative of pathological or excessive sleepiness. Average latencies of between 5 and 10 min are considered to be in the grey zone and average sleep latency above 10 min is considered to indicate a normal or low level of physiological sleepiness.

- ▶ Electroencephalography
- ▶ Electromyography
- ▶ Sleep – Motor Changes
- ▶ Sleep – Sensory Changes

---

## Multiple System Atrophy

### Definition

Distributed disease affecting many neuronal systems. Symptoms mostly start in the early fifties and include:

signs of ▶ [autonomic failure](#), ▶ [Parkinsonism](#), ▶ [cerebellar ataxia](#), and pyramidal signs, severe ▶ [dysarthria](#), stridor, and occasionally contractures and ▶ [dystonia](#). The major pathological changes include cell loss and gliosis in the ▶ [basal ganglia](#), ▶ [substantia nigra](#), ▶ [locus coeruleus](#), ▶ [inferior olives](#), ▶ [pontine nuclei](#), cerebellar ▶ [Purkinje cells](#), and intermedialateral cell columns of the spinal cord, and others.

- ▶ [Ataxia](#)
- ▶ [Basal Ganglia](#)
- ▶ [Dysarthria](#)
- ▶ [Dystonia](#)
- ▶ [Locus Coeruleus](#)
- ▶ [Parkinsonism](#)

---

## Multipolar Neuron/Cellular

### Definition

A multipolar neuron is a neuron with many processes and a variety of shapes. Common example is the motoneuron and stellate cells.

---

## Multipotency

### Definition

Multipotency is a word describing the ability of a progenitor cell or tissue stem cells to give rise to a limited number of cell types. If a progenitor cell of the central nervous system is capable of turning only into neurons, astrocytes, and oligodendrocytes, for example, the cell is said to be “multipotent.”

---

## Multisensory

### Definition

Refers to neurons that are capable of responding to stimuli from more than a single sensory modality and to the neural processes associated with these responses (e.g., multisensory integration).

- ▶ [Multimodal Integration](#)

## Multisensory (Convergence, Integration)

### Definition

Many neurons of the central nervous system outside the specific sensory nuclei respond to peripheral stimuli of more than one modality, e.g., visual, auditory, somatic. They display thus a property of multisensory convergence.

When presented simultaneously, stimuli of different modalities can produce stronger or weaker responses, as compared to the sum of responses to separate presentations of unimodal stimuli. Because interaction of modalities at the level of single neurons is far more complex than a simple summation, it is described by the term “multisensory integration.” An example of multisensory integration is given by tectoreticulospinal neurons (TRSNs) which transmit motor command for a gaze shift and display, at the same time, a multisensory convergence.

- ▶ Multimodal Integration
- ▶ SC-Tectoreticulospinal neurons (TRSNs)

## Multi-Track Disposition

### Definition

A disposition whose manifestations can widely vary. e.g. the softness of an object can manifest itself in uncountable ways, whereas water-solubility is a single-track disposition which can only manifest itself by dissolving in water.

- ▶ Behaviorism
- ▶ Logical

## Multi-Unit Recording

### Definition

Simultaneous recording from multiple nerve, glia or muscle cells (units) by means of a single electrode or pair of electrodes.

- ▶ Extracellular Recording

## Muscarinic Receptors

### Definition

Muscarinic receptors are G-protein coupled receptors that respond to acetylcholine and muscarine, and that are blocked by atropine and related anti-muscarinic agents. They occur in five subtypes. Muscarinic M3 receptors have been considered to be an effector cell receptor, M1 a ganglionic, and M2 a presynaptic inhibitory one. In the peripheral nervous system, more than one type of the excitatory muscarinic M1, M3 and M5 receptors and of the inhibitory muscarinic M2 and M4 receptors may however co-occur on effector cells as well as on nerve fibers.

These receptors are expressed in smooth muscle, cardiac muscle and glands as well as in the peripheral and central nervous system. Muscarinic receptors mediate the excitatory effects of parasympathetic nerves in the urinary bladder.

- ▶ Acetylcholine
- ▶ G-protein Coupled Receptors (GPCRs): Key Players in the Detection of Sensory and Cell-Cell Communication Messages
- ▶ Micturition, Neurogenic Control
- ▶ Parasympathetic Pathways

## Muscle

C. J. HECKMAN, ERIC PERREAU, THOMAS SANDERCOCK, HUUB MAAS  
Departments of Physiology, Physical Medicine and Rehabilitation, and Biomedical Engineering, Northwestern University, Sheridan Road Evanston, IL, USA

### Introduction

Skeletal muscle is the actuator for all vertebrate movements. As such, it has been the focus of scientific inquiry since the time of Erasistratus in the third century BC. While the earliest studies of muscle function focused on whole muscle properties, more recent investigations have been performed at levels ranging from mechanics within functional muscle groups down to the molecular interactions responsible for the active modulation of these mechanics. In accordance with the goals of this Encyclopedia, this section will focus on the role of muscle properties in the neural control of posture and movement. Hence, an emphasis will be

placed on the properties and control of individual motor units, the fundamental element of neural control, and how these units contribute to the regulation of whole muscle properties relevant to normal movement conditions. However, we also provide an overview of seminal findings across the spectrum of muscle research, from the molecular level to whole muscle behavior.

### Muscle Structure

The macroscopic properties of muscle relevant to the neural control of movement arise from the underlying microstructure and corresponding molecular interactions involved in the chemical to mechanical energy conversion process known as muscle contraction. Each whole muscle is composed of many long thin cells, or muscle fibers, arranged parallel to each other (Fig. 1). Most fibers terminate in microtendons, which merge to form the aponeurosis and tendon that connect to the skeleton. Because of this parallel organization, the total force a muscle can produce is proportional to the summed cross-sectional area of all the fibers. The fibers are, in turn, composed of several thousand parallel myofibrils. Each myofibril is composed of repeating microscopic units (2–3  $\mu\text{m}$  in length) called sarcomeres, which are the basic contractile units of muscle. Since sarcomeres within a fiber are linked in series and contract together, many key muscle properties, such as the maximum speed at which a muscle can shorten, are proportional to the length of the fiber. For this reason, muscle contractile properties are often normalized by both the muscle cross-sectional area and the fiber length (see essay ► [Muscle: Tendon, Intramuscular Force Transmission](#)).

The sarcomere is the basic contractile element (Fig. 1). It is composed of two sets of interdigitating protein filaments, called thin and thick filaments, which can slide by each other. The sarcomere is held together by large molecules that form the Z lines at each end and by the giant protein titin, which forms a spring between Z line and thick filament. Titin helps to maintain sarcomere shape as well as transmit force from the contractile proteins to the Z lines [1]. Each thick filament consists of a few hundred myosin molecules; the helix part of the myosin molecules aggregate to form the dominant part of the thick filament. A portion of the helix for each molecule extends out from the thick filament to form the myosin head, which has the capacity to swing up and attach to actin on the thin filament [2]. The myosin head and the portion of its helix that protrudes from the thick filament is known as a crossbridge. The thin filament is dominated by actin, but also includes the proteins tropomyosin and troponin, which regulate the interaction between actin and myosin. Actin monomers are connected end to end to form two

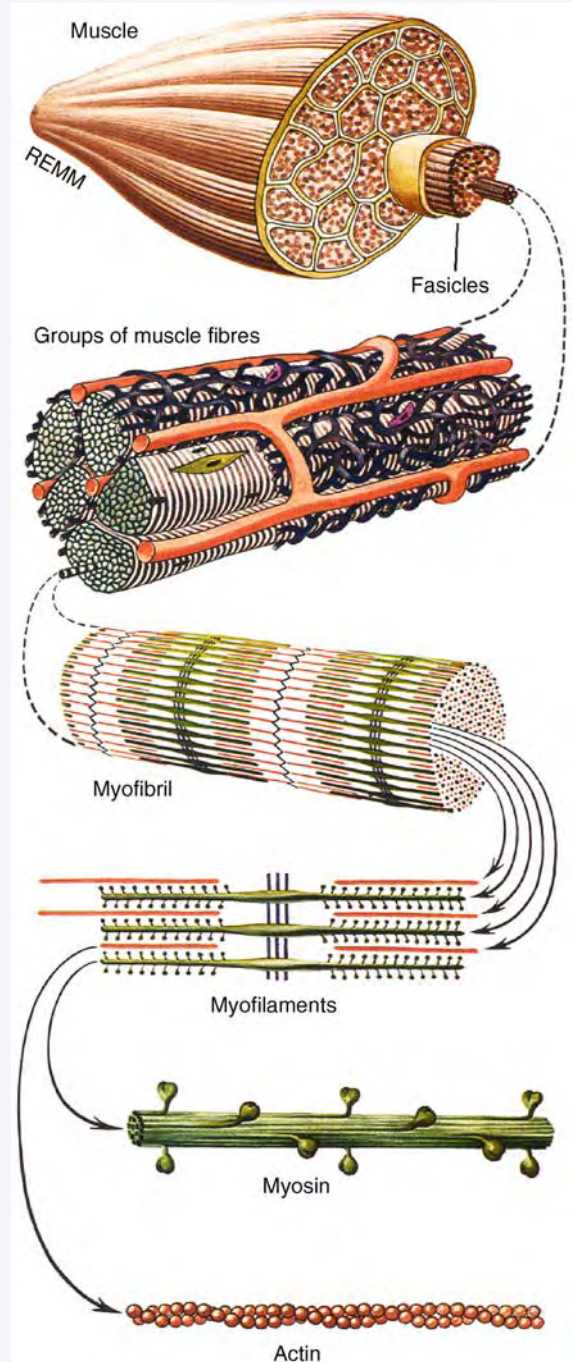

**Muscle. Figure 1** Muscle structure. Diagram shows the organization of an idealized muscle. (from Gray's Anatomy, Warwick and Williams).

fibrous strands that are wrapped around each other in a helical form. Tropomyosin is a chain structure that lies in the groove between the strands of actin, whereas troponin is a globular complex that binds to tropomyosin periodically (see essays ► [Sarcomere structural proteins](#)).

Muscle contraction occurs when calcium ( $\text{Ca}^{2+}$ ) binds to troponin and causes a shift in the position of tropomyosin, uncovering binding sites for the myosin heads on actin. Depolarization of the muscle fiber via an action potential causes  $\text{Ca}^{2+}$  release from the sarcoplasmic reticulum where it is sequestered at rest (see below). Large populations of crossbridges on the thick filaments interact with receptor sites on the actin, to produce force and relative motion between the two sets of filaments. Adenosine triphosphate (ATP) is the energy source and is needed to detach the bridges and maintain movement. Several different substrates (e.g. glycogen, fat) are broken down via different biochemical pathways to provide the ATP for cross-bridge cycling. The forces thus produced between the two filaments are in a direction to cause each sarcomere to shorten. The actin and myosin filaments are approximately inextensible, and sarcomere shortening occurs because of the relative sliding of the filaments past each other (sliding filament theory) [3] (see essay ►Muscle: the molecular motor, ►Energy sensing and signal transduction in skeletal muscle).

Muscle has specialized structures to allow a quick contraction following an action potential in the motor neuron. This complex process includes the following steps: release of acetylcholine at the neuromuscular junction in a response to the action potential, generation of a muscle fiber action potential, depolarization of the t-tubules that protrude into the muscle fiber, activation of ryanodine receptors, and release of  $\text{Ca}^{2+}$  from the sarcoplasmic reticulum. Pumps on the sarcoplasmic reticulum rapidly re-sequester  $\text{Ca}^{2+}$ , so that each action potential produces only a single pulse of  $\text{Ca}^{2+}$  and a single muscle twitch (see 1 Hz trace, Fig. 2a). The rate at which action potentials arrive at the muscle determine the sarcoplasmic level of  $\text{Ca}^{2+}$ , and hence, the strength of the contraction. This complete process is referred to as excitation contraction coupling (see essay ►Excitation Contraction Coupling).

### Basic Muscle Properties

Muscle has four basic properties that are essential for understanding its control by the CNS (Figs. 2–4). These are: the force-frequency (F-f) relationship, the force-velocity (F-V) relationship, the length-tension (L-T) relationship, and muscle stiffness. Each will be discussed in the following paragraphs. Their fundamentals have been understood since the 1950s, but the details about the interaction between these properties, how they are used in normal movement, and how they relate to the properties of single motor units, are still incomplete.

### Force-Frequency

In general, a single muscle action potential does not produce full muscle force; rather, most actions require a

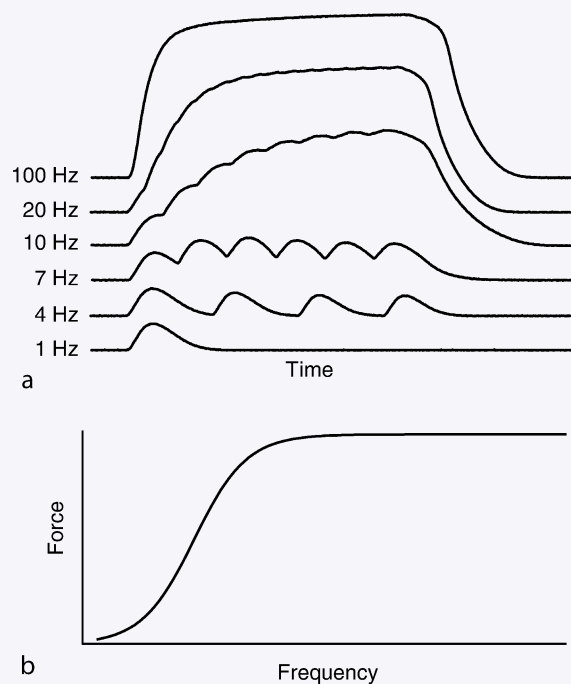

**Muscle. Figure 2** Force-Frequency characteristics of a muscle (cat soleus). (a) shows the force waveforms produced when a muscle is held isometrically and stimulated at different frequencies (action potentials per second). (b) Sigmoidal curve obtained when the mean force is plotted against the stimulation frequency. This relationship is, at best, a rough approximation and depends strongly on the exact experimental procedures to measure it.

sequence of action potentials. Summarizing the relation between an action potential train and the resulting muscle force has proven difficult. However, a useful steady state relationship can be determined by plotting action potential frequency against muscle force (Fig. 2). As the frequency is increased, single muscle twitches fuse and force increases (Fig. 2a). At high enough stimulus rates, which is dependent on the motor unit composition (see below), force is smooth. A further increase in action potential rate does not produce more force. This sigmoidal relation is shown in Fig. 2b. Stimulation rates and the details of the temporal pattern have important implications for the study of muscle function and its restoration following trauma or disease (see essay ►Force-Frequency; Muscle).

### Force-Velocity

The relationship between force and velocity is of fundamental importance when considering the power output and work performed by a muscle. Basically, when an active muscle shortens, it produces less force compared to that produced when it is held isometrically. A plot of the steady state relationship between



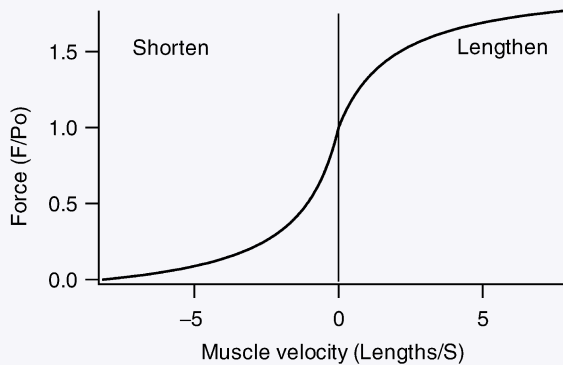

**Muscle. Figure 3** Force-Velocity Relationship. When a muscle is activated and allowed to shorten against a load, it reaches a steady state velocity. When this relationship is plotted for different loads Hill's hyperbolic relationship is obtained (left side of plot). Similar measurements can be made using loads large enough to stretch the muscle (right side of plot). However, a true steady state is not reached during stretch and different results are obtained depending on whether a constant load or constant velocity is imposed on the muscle.

shortening velocity and muscle force results in a characteristic hyperbolic curve [4] that has been demonstrated in all skeletal muscles tested (Fig. 3). The maximum shortening velocity,  $V_{max}$ , is the point where the muscle can no longer produce any force. Peak power is obtained from a muscle at a velocity between zero and  $V_{max}$ . Huxley [3] showed this relationship can be explained using a probabilistic model of crossbridge dynamics. The relationship between force and velocity is more complex during lengthening contractions. A steady state relationship is never really achieved. The muscle may also be damaged by active stretch. An approximate relationship between stretch velocity and force shows force initially increases but soon a plateau is reached at moderate lengthening velocities [5] (see essay ►Force-Velocity Relationship of Skeletal Muscle).

### Length-Tension

Muscle force is strongly affected by its length. During maximal stimulation the length-tension relationship (Fig. 4a) has a characteristic shape with an ascending limb, a plateau region of optimal force generation (defining an optimal length,  $L_0$ ) and a descending limb. During tetanic stimulation the relationship is nicely explained by changing filament overlap within the sarcomere (Fig. 4b) [6]. However, the high frequencies used to induce a tetanic contraction in the laboratory are unlikely to be encountered during the physiological activation of motor units. At lower rates of activation, the length-tension relationship changes such that the peak shifts to longer lengths [7] (see essay ►Length-Tension).

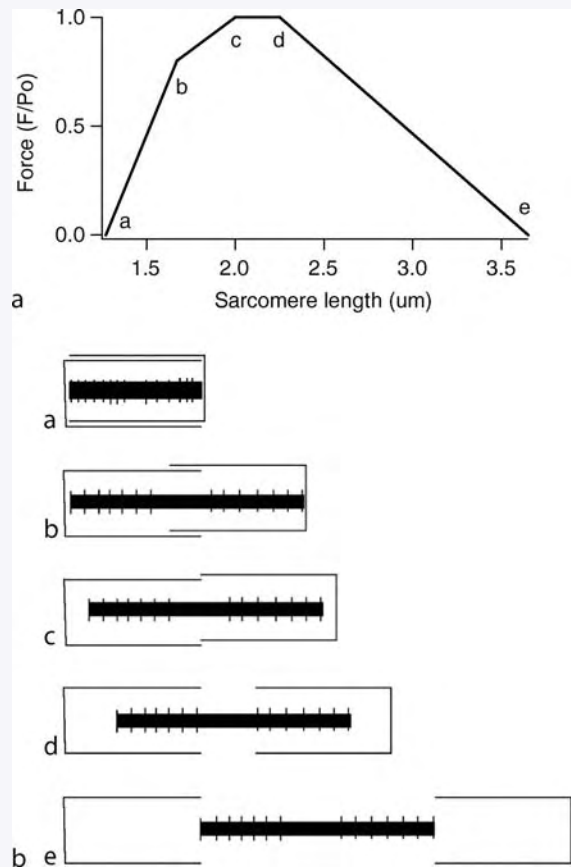

**Muscle. Figure 4** Active Length-Tension relationship during tetanic activation. Idealized length tension relationship (top) and the sarcomere position (bottom) believed to produce it. (Redrawn from [6]). Force from passive muscle structures are also important. They are not shown in this figure.

### Muscle Stiffness

The CNS not only has to give commands to muscle to produce movement, but must also deal with stability of muscle in response to perturbations from the environment. The response of muscle to a perturbation, either lengthening or shortening, defines its stiffness (here we use "stiffness" in its most general form, to include all resistance to externally imposed displacements). For short perturbations muscle has a very linear spring-like response due to the spring-like behavior of the crossbridges. For larger perturbations, the response becomes complex and is determined by the L-T and F-V properties of sarcomeres. The passive structures within a muscle are also very important. The tendon and aponeurosis are connected in series with the muscle fibers and thus provide a series-elastic element (SEC). At long lengths, the passive molecules like titin that maintain the structure of the sarcomere also contribute substantially to total muscle stiffness [1]. These structures are in parallel with the force generated by

crossbridges and thus form the parallel elastic element (PEC). The PEC also includes the connective tissue surrounding muscle fibers as well as structures like the muscle fiber cell membrane. While the crossbridge dependent properties (L-T, F-V) are important determinants of stiffness at all lengths, tendon and other connective tissues are usually slack at short muscle lengths and the PEC does not contribute until muscle is stretched beyond its optimal length (see essays ►[Muscular Stiffness, Tendon](#)).

## Muscle Models

Many different models of muscle force generation have been constructed. Perhaps the most widely used for the purposes of motor control is the Hill model. Originally, the Hill model contractile element consisted solely of the F-V function during shortening, which was placed in series with a spring representing tendon (i.e. the SEC) and in parallel with a spring representing the PEC. Recent models typically add the lengthening F-V function and use the L-T and F-f relationships to scale the F-V curve in order to account for more realistic behavior [8]. Also important are models based on crossbridge dynamics. Such a model was initially developed by Huxley [3] and models of this type are usually referred to as Huxley-type models or cross-bridge models. These models can be modified to include reasonably detailed mathematical descriptions of  $\text{Ca}^{2+}$  dynamics to provide activation functions [9]. Muscle models face many tough challenges, primarily because the behavior of muscle is complicated. Thus far, we have only considered the “classic” muscle properties. Even these relatively simple muscle behaviors constitute a rather complicated mechanical interface: muscle force varies not only as a function of its neural activation but also as a function of its length and velocity. However, few studies have addressed the role of these and other complex properties in the neural control of movement. Recent studies attempting to assess muscle properties during normal movement conditions, including the use of advanced imaging techniques, hold much promise for both understanding muscle function and validating the models used to describe and predict that function (see essays ►[Muscle Modeling](#); [Muscle Imaging, Techniques: Computerized tomography, Magnetic resonance imaging, Ultrasound](#)).

## Complex Muscle Mechanical Behaviors

As mentioned above, attached crossbridges exhibit a spring-like response to small stretches, known as short range stiffness (SRS). For stretches greater than approximately 1–2% of fiber length, the attached crossbridges are broken causing a sudden drop in stiffness known as yielding [10]. Yielding is most

pronounced in slow twitch muscle fibers because of their slow re-attachment rates. Although SRS varies with muscle fiber type, these differences do not appear to play a significant role at the whole muscle level [11]. The participation of crossbridges in the SRS means that it varies as a function of muscle activation: increased activation results in more attached crossbridges, higher muscle force and increased SRS. In addition, tendon itself exhibits increasing stiffness with increasing applied force.

Activation also plays a pivotal role in regulating F-V and L-T properties. This occurs in two ways. First, there exist interactions between the F-f, L-T and F-V functions. Perhaps the most important interaction is that between the F-f and L-T functions. [7] showed that as stimulation rate is reduced below that needed to achieve maximal force, the  $L_O$  point of the L-T function progressively shifts to longer lengths. Thus, the L-T function at low stimulation rates is not simply a scaled-down version of that at high rates. Interactions between the F-V and F-f functions are also important, especially during lengthening where, for example, yielding is greater at low stimulation rates [5]. There also exists an L-T/F-V interaction. At longer lengths, stretching at a given velocity produces more force [5]. A second important form of activation dependence is that F-V properties are very different in muscle fibers of different contraction speeds. These differences reflect both differences in the myosin ATPase on crossbridge heads and in the  $\text{Ca}^{2+}$  release system [12]. Thus as motor units of different speeds are recruited as force increases, F-V behavior changes (see the section on “Motor Units” below). Finally, it is important to realize that the activation of muscle in itself is affected by movement. That is, the  $\text{Ca}^{2+}$  system for control of crossbridge interactions is sensitive to both length and velocity [13]. Thus one reason that  $L_O$  shifts to longer lengths at lower stimulus rates is that  $\text{Ca}^{2+}$  release is length-dependent. In addition, movement may enhance  $\text{Ca}^{2+}$  release and thus speed the decay of force in a velocity dependent manner [14] (see essays ►[Muscle Stiffness](#), ►[Length-Tension](#), ►[Force-Velocity Relationship of Skeletal Muscle](#), ►[Force Potentiation in Skeletal Muscle](#)).

Muscle also exhibits a number of behaviors that can be thought of as being history dependent, in that their occurrence depends on a particular sequence of events. Perhaps the F-f function is most influenced by muscle history because its shape is highly sensitive to the measurement protocol [15]. A simple change as reversing the order of the test frequencies has a profound effect. In addition, in isometric conditions, muscle force can be strongly potentiated by a brief high frequency activation (post-tetanic potentiation) or even by a single pair of closely spaced stimuli (doublet potentiation) [16]. Of course, if stimulation is prolonged, fatigue ensues. Fatigue is a complex

phenomenon acting at multiple locations within the muscle. These mechanisms are not yet fully understood, but it plays a key role in motor function. For example, the normal activation pattern of motor units appears to be designed to minimize the impact of fatigue (see below). Movement history also strongly influences muscle function. For example, muscle generates a greater isometric force (force enhancement) when it has been stretched during activation compared to when it has been stretched passively and then activated [17]. The converse phenomenon is also often seen: less isometric force following shortening of an active muscle (force depression) (see essays ►[History-Dependent Properties of Skeletal Muscle](#)).

### Muscle Architecture

Provided the sarcomeres in a muscle are identical, and provided the fibers in a muscle are the same length and parallel to each other, the whole muscle can be viewed as a scaled version of the sarcomere. Few, if any, mammalian muscles fit the idealized profile above. Muscles come in a vast array of sizes and shapes and complex architecture is more the rule than the exception. Muscle fibers often lie at an angle to the direction in which the entire muscle changes length. This angle, called the angle of pennation, allows more muscle fibers to be arranged in parallel thus increase the force to weight ratio. Assuming the pennate fibers are attached to two bony surfaces that slide by, but do not approach each other, muscle force and length can be calculated by scaling fiber force and length by the cosine of the angle of pennation. This is the correction most models use to compensate for pennation. The true effects of pennation are more complex when the fibers are attached to connective tissue sheets, called aponeurosis, that show local deformation. Furthermore, connective tissues link adjacent muscles and, as a consequence, deformations in one muscle may influence force generation in another [18] (see essays ►[Skeletal Muscle Architecture](#), ►[Epimuscular Myofascial Force Transmission and Intermuscular](#)).

Muscles are often composed of fibers of different lengths to accommodate for skeletal dimensions. Longer muscle fibers increase the maximum velocity of shortening by increasing the number of sarcomeres in-series. Recent studies have shown many seemingly long fibered muscles do not have fibers that run the length of the muscle (from tendon insertion to the tendon of origin), but rather are composed of fibers connected serially [19]. A portion of the force from these nonspanning muscle fibers must be transmitted to the tendon via myofascial pathways [20]. Serial fibers likely add to muscle compliance (see essays ►[Intramuscular Myofascial Force Transmission](#), ►[Epimuscular Myofascial Force Transmission and Intermuscular](#), ►[Skeletal Muscle Architecture](#)).

### Motor Unit Types

The CNS controls not individual muscle fibers but motor units, which are the quantal elements of motor control. The motor unit consists of a motor neuron in the ventral horn of the spinal cord, its axon, and the muscle fibers that the axon innervates [21]. The muscle fibers belonging to a single motor unit are often termed the muscle unit. There exist a very wide range in both the electrical properties of motoneurons (see essay [Motoneurons](#)) and in the mechanical properties of their muscle units [21]. Slow twitch motor units exhibit not only slow contraction speeds but also low maximum forces and very high fatigue resistances. At the other end of the spectrum, the fastest contracting motor units generate the highest forces and have very little fatigue resistance. In between are fast contracting units with moderate forces and moderate fatigue resistances. These differences have been used to divide motor units into three or more types (S for slow, FR for fast fatigue resistant and FF for fast fatigable) [21], but it should be kept in mind that there is a more or less continuous distribution of contraction speeds, forces and fatigue resistances (see essay ►[Motor Unit Types](#)).

For the usage pattern of motor units, the most important factor is that the amount of synaptic current required to bring the motoneuron to threshold covaries with the mechanical properties of its muscle unit (see the [Motoneuron](#) section). Thus, the activation (recruitment) of motor units always begins with the small, slow twitch, low force units followed by recruitment of progressively faster and higher force units (i.e.  $S > FR > FF$ ). As a result, overall contraction speed of the muscle increases as its activation level rises while fatigue resistance decreases. This recruitment-dependent behavior is rarely considered in muscle models.

### Electromyography

Normally, a motoneuron action potential produces a corresponding action potential in each of the fibers of its muscle unit. Hence motoneuron firing patterns can be measured from muscle motor units in both humans and animals. Single fiber or single motor unit action potentials directly assess motoneuron firing patterns (motoneurons are the only CNS cells whose firing pattern can be individually measured in human subjects). Less selective electrodes measure the summed electrical activity of many motor units, the electromyogram (EMG). Both single fiber and whole muscle EMGs are valuable tools for assessing muscle and CNS function in normal and disease states (see essay ►[Electromyography](#), ►[Neuromuscular Junction](#)).

### Muscle Plasticity and Disease

Muscle is likely the most plastic tissue in the body. To support the metabolic costs of the protein synthesis

required for this adaptability, muscle fibers are multinucleate. In fact, small animal fibers of only 1–2 cm length have approximately 2000–5000 nuclei [22]. All of the major components of muscle fibers, including contractile machinery of the sarcomere, mitochondria, enzymes for anaerobic energy production, and connective tissue, exhibit adaptations to exercise, disuse and injury. Thus motor units can adapt for either greater strength or fatigue resistance, but in exercise, the pattern of these adaptations are set by the orderly recruitment sequence mentioned in the previous section. For example, only types S motor units will exhibit increases in mitochondria in response to low intensity endurance training, while all motor units, S, FR, and FF, will exhibit hypertrophy in response to high resistance training.

Plasticity is also a hallmark of many muscle diseases and age related changes. There are a broad range of muscle diseases, or myopathies, many of which lead to or arise from structural and metabolic changes in the muscle such as fiber degeneration, mitochondrial dysfunction, fibrosis, nuclear abnormalities, fiber type reorganization and changes in fiber architecture to name a few. Muscle diseases can be acquired or inherited and can be classified broadly into primary diseases of the muscle or secondary diseases brought about via injury or dysfunction to the neural systems mediating muscle activity. Examples of the former include Myasthenia Gravis and the various forms of muscular dystrophy and myositis, while those of the latter include amyotrophic lateral sclerosis and other diseases or conditions that result in motorneuron damage and dysfunction (see essays ►Muscle: Duchenne Muscular Dystrophy, ►Muscle: Age Related Changes).

### Which Muscle Properties are Most Important in Normal Movements?

Although muscle exhibits an impressive array of properties in laboratory settings, the tightly controlled conditions so desirable for isolating specific properties often bear little relation to the highly dynamic conditions of normal movements. Consider first the normal neural activation pattern. Increasing neural activation produces a complex overlapping pattern of recruitment and rate modulation of a large population of motor units with very heterogeneous properties. This natural activation pattern stands in marked contrast to the usual techniques in the lab, such as activation of a single skinned muscle fiber via  $\text{Ca}^{2+}$  or stimulation of an entire muscle by electrical pulses applied to its nerve. At the same time, the muscle is often experiencing mechanical conditions that are highly dynamic. The primary measurement of muscle dynamics in the lab, the F-V relationship, is measured during constant activation and constant velocity conditions. In contrast, in a natural movement such as locomotion, both

activation and velocity undergo dramatic and continuous variations [23].

The question of how muscle is used in normal movements has received considerable attention in the past 10–20 years. One fundamentally important issue is to identify the operating range for the basic properties of the F-f, L-T and F-V relations in normal movements. For the F-f relation, the fundamental question concerns the firing patterns of individual motor units. Studies in humans indicate that low threshold units (likely S) are not only recruited before high threshold (FR, FF) but also tend to exhibit higher firing rates (e.g. [24]). Presumably, at the highest forces, rates for FR and FF units eventually exceed those of S units [25], because the high contraction speeds of these units require higher firing rates to reach fusion [26]. Few studies have measured firing rate in dynamically moving muscles, but the same pattern of higher firing rates for lower threshold units does appear to occur [27].

Some animal studies suggest that muscle lengths remain near  $L_O$  [28]. However, other studies suggest that substantial force generation often occurs on either side of  $L_O$  - that is to say, on either the ascending or descending limbs of the L-T function. For example, the positions of the cat ankle extensor L-T functions in relation to the physiological range of motion is skewed, such that  $L_O$  occurs at a relatively long length [29]. While the peak force occurs during the stretch at the onset of the stance phase and is thus at a relatively long length near  $L_O$ , after this point, the ankle extensors exert substantial forces while rapidly shortening and most of this occurs on the ascending limb of the L-T function. In addition, studies of L-T functions in the hindlimbs of frogs suggest that much of the normal range of motion for thigh muscles can occur on the descending limb [30]. Finally, some specialized muscles operate over a very small range of the L-T function, serving primarily to transmit force and energy to the tendons connecting the muscle to the skeleton [31] (see ►Muscle and Tendon Energy Storage).

For the F-V functions, muscle velocities during locomotion have been estimated by inverse calculation from video records in numerous species (e.g. [32]) and from direct measurement in cats [33]. Clearly, even at the modest locomotor speeds associated with walking or slow running, the velocities reach peak values that result in substantial modulation of force due to the F-V relationship.

An approach that has great potential for delineating the role of various muscle properties in movement is to replicate the conditions of normal movements in isolated preparations, where the high degree of experimental control is highly advantageous for identifying the effect of each muscle property. An example from this type of experiment are shown in Fig. 5 [34]. A locomotor like movement was imposed on a cat

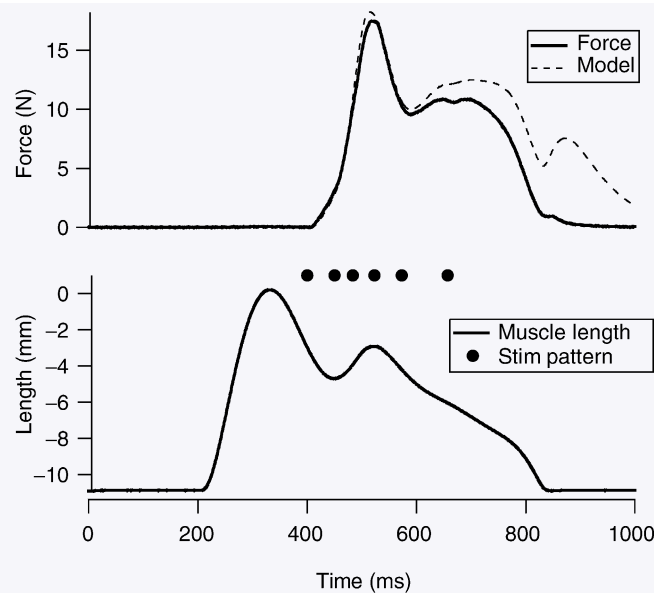

**Muscle. Figure 5** Performance of a Hill model during a simulated locomotor movement in cat soleus. The experimentally measured force, and the force predicted by a Hill type model are shown in the top plot. The onset of the stance phase approximately corresponds with the onset of force generation. The lower plot shows the length imposed on the muscle and the time of the stimulus pulses. Note the largest error occurs during muscle relaxation.

ankle extensor muscle while it was stimulated with a locomotor-like frequency pattern. The resulting force was then compared to the output of a Hill-type model, which included both F-V and L-T effects as well as an accurate estimate of the activation function obtained during isometric conditions. The model prediction was remarkably good during the initial stance phase, but greatly overestimated force during the decay phase. In fact, the model predicted that force would last long after the push-off ended. Similar studies were carried out using random patterns of length changes and stimulation patterns [35]. The Hill-type model did a reasonable job predicting force at high activation levels with electrical stimulation but an extremely poor job during natural activation via a reflex, which generates relatively modest motor unit firing rates. Increasing muscle velocity also increased errors. In both the locomotor and random cases, it is likely that the model errors were due to the Hill model's inability to account for the coupling between muscle activation and force-velocity-length properties. Thus this coupling may be the most important factor to add to muscle models.

### Summary

Muscle is a complex and adaptable organ. While great strides have been made toward understanding the molecular processes underlying muscle contraction, whole muscle function and its role in the neural control of movement remain an active and important area of research. New approaches that strive to link muscle

ultrastructure to the whole muscle properties that emerge during the normal control of movement hold great promise for advancing our understanding of muscle and how it impacts the actions of the CNS controlling its function.

### References

1. Granzier HL, Labeit S (2006) The giant muscle protein titin is an adjustable molecular spring. *Exerc Sport Sci Rev* 34:50–53
2. Rayment I, Holden HM, Whittaker M, Yohn CB, Lorenz M, Holmes KC, Milligan RA (1993) Structure of the actin-myosin complex and its implications for muscle contraction. *Science* 261:58–65
3. Huxley AF (1957) Muscle structure and theories of contraction. *Prog Biophys Biophys Chem* 7:257–318
4. Hill AV (1938) The heat of shortening and the dynamic constants of muscle. *Proc Royal Soc Ser B* 126:136–195
5. Joyce GC, Rack PMH, Westbury DR (1969) The mechanical properties of cat soleus muscle during controlled lengthening and shortening movements. *J Physiol Lond* 204:461–474
6. Gordon A, Huxley A, Julian F (1966) The variation in isometric tension with sarcomere length in vertebrate muscle fibres. *J Physiol Lond* 184:170–192
7. Rack PM, Westbury DR (1974) The short range stiffness of active mammalian muscle and its effect on mechanical properties. *J Physiol* 240:331–350
8. Zajac FE (1989) Muscle and tendon: properties, models, scaling, and application to biomechanics and motor control. *Crit Rev Biomed Eng* 17:359–411

9. Zahalak GI, Motabarzadeh I (1997) A re-examination of calcium activation in the Huxley cross-bridge model. *J Biomech Eng* 119:20–29
10. Rack PMH, Westbury DR (1969) The effects of length and stimulus rate on tension in the isometric cat soleus muscle. *J Physiol Lond* 204:443–460
11. Cui L, Perreault EJ, Sandercock TG (2007) Motor unit composition has little effect on the short-range stiffness of feline medial gastrocnemius muscle. *J Appl Physiol* 103:796–802
12. Close R (1972) Dynamic properties of mammalian skeletal muscles. *Physiol Rev* 52:129–197
13. Balnave CD, Allen DG (1996) The effect of muscle length on intracellular calcium and force in single fibres from mouse skeletal muscle. *J Physiol* 492:705–713
14. Caputo C, Edman KA, Lou F, Sun YB (1994) Variation in myoplasmic Ca<sup>2+</sup> concentration during contraction and relaxation studied by the indicator fluo-3 in frog muscle fibres. *J Physiol* 478 (Pt 1):137–148
15. Binder-Macleod SA, Clamann HP (1989) Force output of cat motor units stimulated with trains of linearly varying frequency. *J Neurophysiol* 61:208–217
16. Sandercock TG, Heckman CJ (1997a) Doublet potentiation during eccentric and concentric contractions of cat soleus muscle. *J Appl Physiol* 82:1219–1228
17. Herzog W, Lee EJ, Rassier DE (2006) Residual force enhancement in skeletal muscle. *J Physiol* 574:635–642
18. Huijing PA (2003) Muscular force transmission necessitates a multilevel integrative approach to the analysis of function of skeletal muscle. *Exerc Sport Sci Rev* 31:167–175
19. Trotter JA, Richmond FJR, Purslow PP (1995) Functional morphology and motor control of series-fibered muscle. *Ex Sport Sci Rev* 23:167–213
20. Street SF (1983) Lateral transmission of tension in frog myofibers: a myofibrillar network and transverse cytoskeletal connections are possible transmitters. *J Cell Physiol* 114:346–364
21. Burke RE (1981) Motor units: anatomy, physiology, and functional organization. In: Brooks VB (ed) *Handbook of physiology, the nervous system, motor control*, vol sect. 1 vol. II, Part 1. American Physiological Society, Bethesda, MD, pp 345–422
22. Tseng BS, Kasper CE, Edgerton VR (1994) Cytoplasm-to-myonucleus ratios and succinate dehydrogenase activities in adult rat slow and fast muscle fibers. *Cell Tissue Res* 275:39–49
23. Gregor RJ, Smith DW, Prilutsky BI (2006) Mechanics of slope walking in the cat: quantification of muscle load, length change, and ankle extensor EMG patterns. *J Neurophysiol* 95:1397–1409
24. De Luca CJ, LeFever RS, McCue MP, Xenakis AP (1982) Behavior of human motor units in different muscles during linearly varying contractions. *J Physiol Lond* 329:113–128
25. Bellemare F, Woods JJ, Johansson R, Bigland-Ritchie B (1983) Motor-unit discharge rates in maximal voluntary contractions of three human muscles. *J Neurophysiol* 50:1380–1392
26. Kernell D, Eerbeek O, Verhey BA (1983) Relation between isometric force and stimulus rate in cat's hindlimb motor units of different twitch contraction time. *Exp Brain Res* 50:220–227
27. Hoffer JA, Sugano N, Loeb GE, Marks WB, O'Donovan MJ, Pratt CA (1987) Cat hindlimb motoneurons during locomotion. II. Normal activity patterns. *J Neurophysiol* 57:530–553
28. Lutz GJ, Rome LC (1994) Built for jumping: the design of the frog muscular system. *Science* 263:370–372
29. Herzog W, Leonard TR, Renaud JM, Wallace J, Chaki G, Bornemisza S (1992) Force-length properties and functional demands of cat gastrocnemius, soleus and plantaris muscles. *J Biomech* 25:1329–1335
30. Lieber RL, Boakes JL (1988) Sarcomere length and joint kinematics during torque production in the frog hindlimb. *Am J Physiol* 254:C759–C768
31. Biewener AA, Konieczynski DD, Baudinette RV (1998) In vivo muscle force-length behavior during steady-speed hopping in tammar wallabies. *J Exp Biol* 201 (Pt 11):1681–1694
32. Goslow GE, Reinking RM, Stuart DG (1973) The cat step cycle: hindlimb joint angles and muscle lengths during unrestrained locomotion. *J Morphol* 141:1–42
33. Walmsley B, Hodgson JA, Burke RE (1978) Forces produced by medial gastrocnemius and soleus muscles during locomotion in freely moving cats. *J Neurophysiol* 41:1203–1216
34. Sandercock TG, Heckman CJ (1997b) Force from cat soleus muscle during imposed locomotor-like movements: experimental data versus Hill-type model predictions. *J Neurophysiol* 77:1538–1552
35. Perreault EJ, Heckman CJ, Sandercock TG (2003) Hill muscle model errors during movement are greatest within the physiologically relevant range of motor unit firing rates. *J Biomech* 36:211–218

## Muscle: Age-related Changes

JAN LEXELL

Department of Rehabilitation Medicine, Lund University Hospital, Lund, Sweden

Department of Clinical Science, Lund, Division of Rehabilitation Medicine, Lund University, Lund, Sweden

Department of Health Sciences, Luleå University of Technology, Boden, Sweden

### Synonyms

Sarcopenia

### Definition

Age-related changes are those attributed primarily to increasing age. These changes are quantitative as well as qualitative and affect all parts of the ►motor unit, from the ►alpha motor neuron to the ►muscle fibers and various sub-cellular structures (►Muscle – ultrastructure and proteins). The main effects of increasing age are reductions in muscle mass and muscle strength and

alterations in the quality of the remaining muscle tissue, all referred to as sarcopenia. Sarcopenia leads to reduced functional capacity for the older individual, with an increased risk of falls, fractures, and dependency. The underlying mechanisms of these age-related changes are multifactorial (Fig. 1) and only partly known. Progressive ►resistance training (heavy-resistance strength training) (►Muscle: exercise adaptations) has become the most effective therapy to counteract the age-related changes in the skeletal muscle.

### Characteristics Higher Level Processes

The reduction in muscle volume and muscle cross-sectional area is one of the most noticeable age-related muscle changes. With modern imaging techniques (►Muscle imaging), such as ultrasonography, computed tomography (CT) and magnetic resonance imaging (MRI), muscle mass and muscle cross-sectional area can be assessed. With ultrasonography, a 25–35% reduction in the cross-sectional area of the quadriceps muscle in older compared to younger men and women

has been found. CT has shown similar age-related reductions in the cross-sectional area of the psoas major and sacrospinalis muscles, the quadriceps muscle the brachial biceps and triceps muscles, and the plantar-flexors. These CT studies have also shown increases in fat and connective tissue within the older muscle. MRI has confirmed these earlier studies, and also shown an age-related reduction in muscle cross-sectional area and an increase in non-contractile tissue, i.e. fat and connective tissue (Fig. 2), which can be more than twofold [1].

Direct assessments of the muscle cross-sectional area have been very limited, mainly due to the technical limitations in such analysis. Large cryomicrotomes and modified morphometric procedures have made it possible to study cross-sections of whole human (autopsied) muscles. The vastus lateralis of previously healthy men between 15 and 83 years of age have been analyzed [2], and the average reduction in muscle area between 20 and 80 years was 40% (Fig. 3).

The reduction began as early as 25 years of age. By the age of 50 years, ~10% of the muscle area was lost, and thereafter the reduction accelerated. A majority

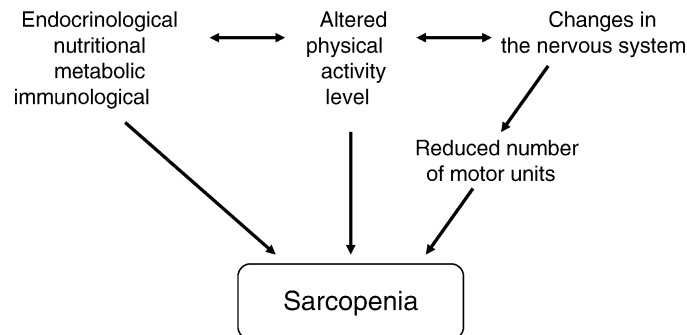

**Muscle: Age-related Changes. Figure 1** Proposed mechanisms leading to sarcopenia, i.e. reductions in muscle mass and muscle strength and alterations in the quality of the remaining muscle tissue.

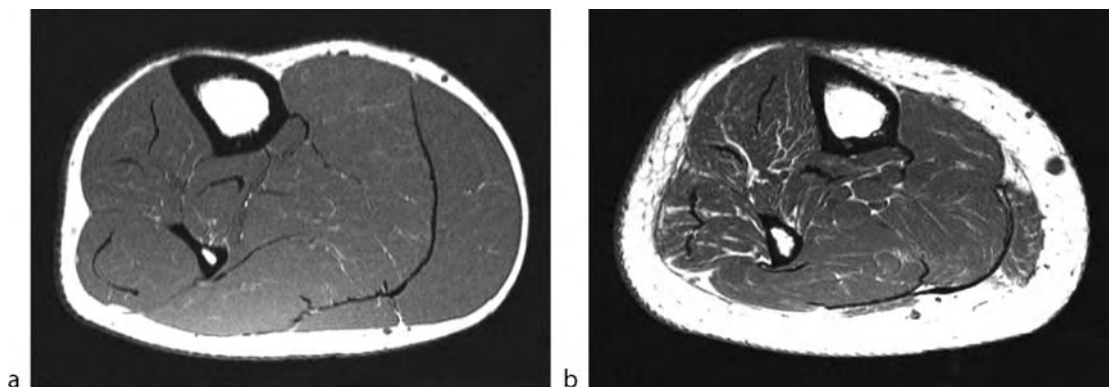

**Muscle: Age-related Changes. Figure 2** Magnetic resonance image (MRI) of the lower leg of a healthy female, age 23 years (a), and healthy female, age 75 years (b). Note the reduced cross sectional areas of most muscles with an increase in non-contractile tissue.

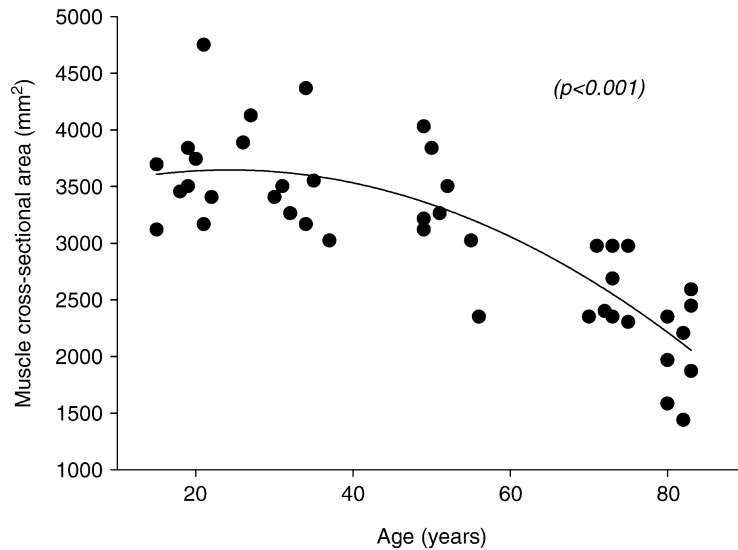

**Muscle: Age-related Changes. Figure 3** Relationship between age and muscle cross-sectional area.

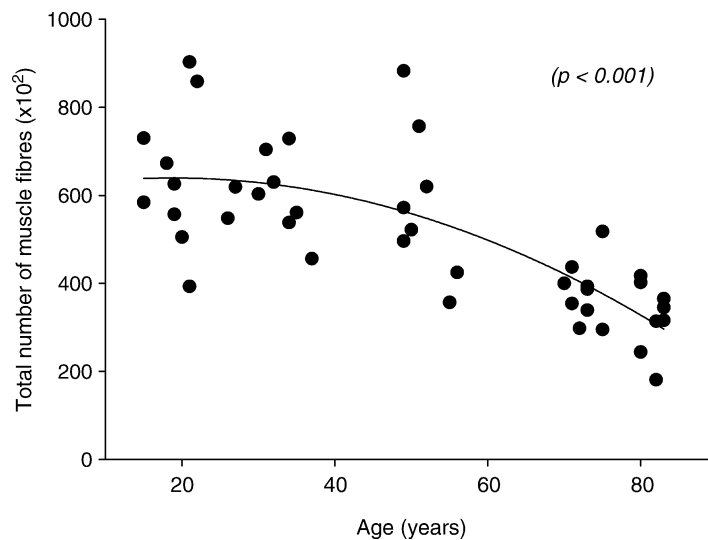

**Muscle: Age-related Changes. Figure 4** Relationship between age and total numbers of fibers.

of studies on muscle mass have been performed on men, but data implies that increasing age affects muscle mass in women in a similar way.

Muscle biopsy studies of the vastus lateralis of the quadriceps muscle, and of the biceps brachii and the anterior tibial muscles, have consistently shown that the ►type II (fast-twitch) fiber size is reduced with increasing age, while the size of ►type I (slow-twitch) fibers are much less affected [3]. With techniques allowing assessments of whole muscles, it has been shown that the total number of fibers is significantly reduced with increasing age [2]. The reduction in muscle cross-sectional area of the vastus lateralis muscle was caused mainly by a loss of fibers and to a

smaller extent by a reduction in the size of fibers, mainly of type 2 (Figs. 4 and 5).

This loss of fibers began as early as 25 years of age and thereafter accelerated. The age-related reduction in fiber number, at least in the vastus lateralis muscle, affected both types to the same extent. Overall, there is a decrease in the relative amount of type II fiber tissue, due to the combined reduction in the number and size of type II fibers [3]. Muscles other than the vastus lateralis have not been studied in any detail, nor have muscle biopsies from older individuals with different physical activity levels been compared.

As a result of the reduced muscle mass, increasing age leads to a significant decrease in muscle strength.



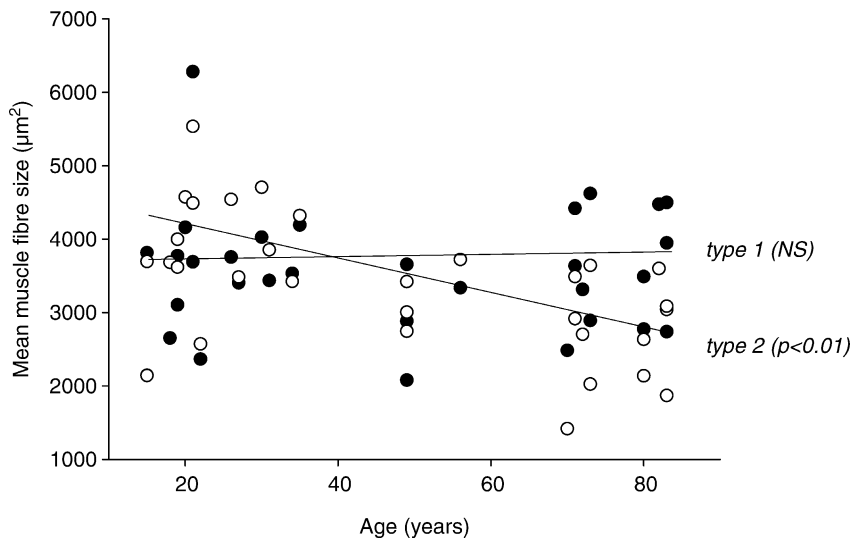

**Muscle: Age-related Changes. Figure 5** Relationship between age and mean area of type 1 and type 2 fibers.

Studies of both upper and lower limb muscles have been compared between groups of young, middle-aged and older adults, showing that decreases in voluntary strength do not become readily apparent until after the age of 60 [4]. Small variations exist from muscle to muscle, but for all muscles in both men and women, the age-related reduction in strength tends to be curvilinear, with a relative plateau through the third, fourth and fifth decades. Most frequently studied has been the quadriceps femoris muscle group, measured extensively in test conditions involving all three actions of muscles: isometric, concentric and eccentric (► **Isometric force**; ► **Contraction-concentric**; ► **Contraction-eccentric**). Healthy people in the seventh and eighth decades score on average 20–40% less during isometric and concentric strength tests than young adults, and the very old show an even greater (50% or more) reduction. Differences between young and older groups of men and women are less for the eccentric type of muscle action than during either isometric or concentric.

With regard to the volitional component of maximal strength tests, healthy older individuals are able to recruit and activate all their available motor units (► **Motor unit – usage patterns**) maximally or near maximal, indicating that the age-related declines in strength in healthy older people is due mainly to a decreased excitable muscle mass.

Tests of voluntary muscular effort, with variations in submaximal versus maximal contractions, and sustained versus intermittent efforts, have not found any age-related increase or decrease in ► **muscle fatigue** [5]. Despite the relatively greater proportion of type I fibers available, fatigue-resistance of aged muscle is not significantly enhanced.

One of the factors leading to sarcopenia in old age is a progressive degeneration of the nervous system, particularly after the age of 60 years [6]. Studies have shown an age-related reduction in the number of functioning motor units with an increase in the size of remaining/surviving motor units, suggesting cycles of denervation followed by reinnervation that ultimately stems from death of motor neurons in the spinal cord and from irreparable damage to peripheral nerve axons. As a consequence, the muscle fibers innervated by these neurons will also be affected, which leads to changes in the function of aging muscles.

Quantitative ► **electromyography** (EMG) has shown changes in both duration and amplitude of motor unit action potentials (MUAP) with increasing age. It has also been shown that the axonal conduction velocity (CV) is slower with aging, an effect that could reflect a variety of changes in the nerve fibers, such as a dropout of the largest fibers, a segmental demyelination and a reduced internodal length. Assessment of the number of motor units have shown a reduced number of functioning motor units with increasing age, mainly after the age of 60 years. The estimated reduction in the number of motor units of older individuals has been reported to be as large as 50%, and this loss also seems to be greatest among the largest and fastest motor units, i.e. ► **type II (fast) motor units**.

Studies of the muscle fiber population have shown evidence of neuropathic changes, such as small angulated fibers and grouped atrophy, of old/very old individuals (Fig. 6). ► **Fiber type grouping** has also been found in muscles from individuals above the age of 70 years (Fig. 7). Macro EMG has confirmed these studies and shown an increase in motor unit size in the vastus lateralis, the tibialis anterior and the biceps

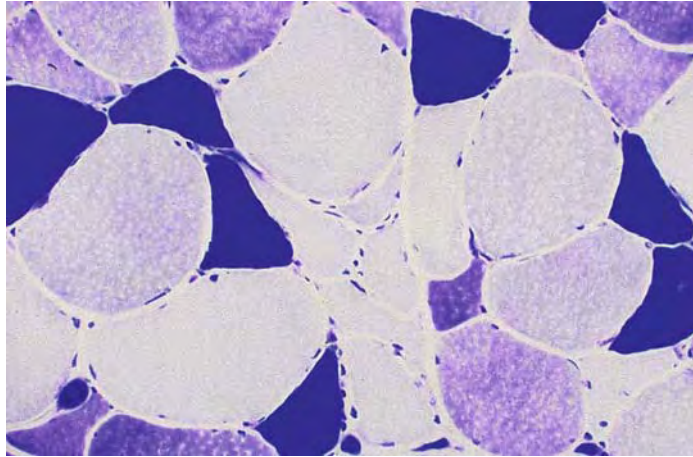

**Muscle: Age-related Changes. Figure 6** Small part of a muscle biopsy from a healthy man, age 73 years. The biopsy is stained for toluidine blue mATPase. Type 1 (slow-twitch) fibers are darkly stained whereas type 2 (fast-twitch) fibers are lightly stained. Note the variability in fiber and the increase in angulated fibers.

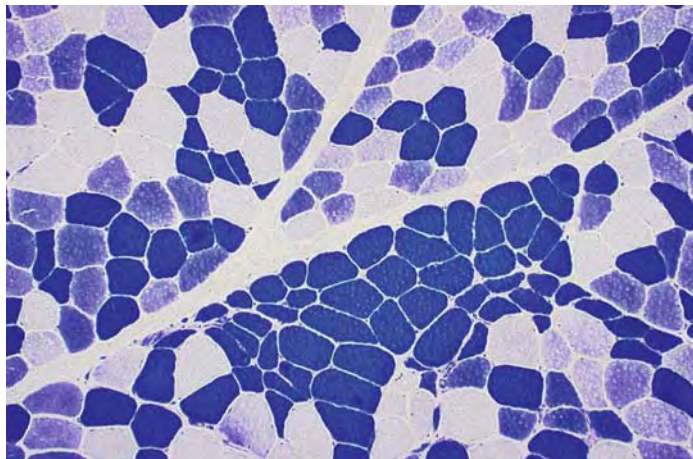

**Muscle: Age-related Changes. Figure 7** Small part of a muscle biopsy from a healthy man, age 73 years. The biopsy is stained for toluidine blue mATPase. Type 1 (slow-twitch) fibers are darkly stained whereas type 2 (fast-twitch) fibers are lightly stained. Note the increased occurrence of grouping of type 1 fibers.

brachii from subjects above the age of 60 years, indirectly indicating an increased number of muscle fibers per motor unit.

#### Lower Level Processes

Several other factors contribute to the age-related changes in muscle structure and function (cf. Fig. 1). Muscle biopsy studies of the tibialis anterior muscle has shown a reduction (40%) of muscle ▶ [satellite cells](#) [7]. As satellite cells are also considered to be skeletal muscle stem cells, they can generate daughter cells that become new satellite cells following myotrauma or exercise. It is possible that this age-related reduction in the satellite cell pool may impair the regenerative

capacity of skeletal muscles, but evidence so far is insufficient to support this.

Studies of single muscle fibers from the vastus lateralis of older men and women have found a significant age-related reduction in shortening velocity of both type I and IIA fibers [8], which also contribute to the reduced muscle function in older individuals.

Several studies have found decreases in four major anabolic hormones – testosterone, growth hormone (GH), insulin-like growth hormone (IGF-1) and dehydroepiandrosterone (DHEA) – with increasing age [9]. The exact implications of these decreases and whether hormone supplementation is a feasible therapeutic strategy and prevention of sarcopenia remain to be

determined. So far, the long-term risks have not been well defined and the side-effects have been significant. Muscle protein synthesis rates have also been shown to decline with increasing age, whereas muscle protein breakdown seem to be less affected [9], which may contribute to the age-related loss of muscle mass.

### Therapy

As a reduced neuromuscular capacity is related to limitations in activities of daily living, an important question has been whether muscles of older individuals can increase in size in response to resistance training, and to what extent resistance training can lead to motor learning or neural adaptations.

In 1988, Frontera and colleagues [10] presented strength and muscle biopsy results from a heavy-resistance training study in older men, and reported striking improvements in leg muscle strength, as well as significant increases in muscle fiber sizes. Since then, an increasing number of studies have documented the benefits of resistance training for older men and women, even above the age of 90 years [4]. Studies involving low intensity training in older adults report strength increases <20%, whereas high intensity training (>70% of one ►repetition maximum (RM)) has resulted in increases of up to 227% in one RM. Men are generally stronger than women, but there seems to be a remarkable similarity in their response to training. Moreover, ethnicity and previous experience of physical exercise do not seem to limit the response to heavy-resistance training; studies from North America and Scandinavia have yielded similar results.

Strength gains following heavy-resistance training in both young and older people may be explained by several factors. These include changes in muscle morphology, muscle/connective tissue biomechanics, central nervous system activation, motor skill coordination and motivation. Varying degrees of ►hypertrophy of both type 1 and type 2 fibers have been demonstrated following both short- and long-term heavy-resistance training in older individuals. When changes in fiber areas are minor and non-significant, they are consistent with small strength gains. Increases in fiber size as a result of strength training are generally small in comparison with the improvements in strength. Thus, the response to heavy-resistance training in older people can be mediated to some extent through hypertrophy of both fiber types, although the main part of the strength improvement, at least during the first 3 months of training, is caused by nervous system adaptation.

### References

1. Kent-Braun JA, Ng AV, Young K (2000) Skeletal muscle contractile and non-contractile components in young and older women and men. *J Appl Physiol* 88:662–668
2. Lexell J, Taylor CC, Sjöström M (1988) What is the cause of the ageing atrophy? Total number, size and proportion of different fiber types studied in whole vastus lateralis muscle from 15- to 83-year-old men. *J Neurol Sci* 84:275–294
3. Lexell J (1995) Human aging, muscle mass and fiber type composition. *J Gerontol* 50A(Special Issue):11–16
4. Porter MM, Vandervoort AA, Lexell J (1995) Ageing of human muscle: structure, function and adaptability. *Scand J Med Sci Sports* 5:1129–1142
5. Allman BL, Rice CL (2002) Neuromuscular fatigue and aging: central and peripheral factors. *Muscle Nerve* 25:785–796
6. Lexell J (1997) Evidence for nervous system degeneration with advancing age. *J Nutr* 127:1011S–1013S
7. Kadi F, Charifi N, Denis C, Lexell J (2004) Satellite cells and myonuclei in young and old women and men. *Muscle Nerve* 29:120–127
8. Krivickas LS, Suh D, Wilkins J, Hughes VA, Roubenoff R, Frontera WR (2001) Age- and gender-related differences in maximum shortening velocity of skeletal muscle fibers. *Am J Phys Med Rehabil* 80:447–455
9. Greenlund LJS, Nair KS (2003) Sarcopenia – consequences, mechanisms, and potential therapies. *Mech Ageing Dev* 124:287–299
10. Frontera WR, Meredith CN, O'Reilly KP, Knuttgen HG, Evans WJ (1988) Strength conditioning in older men: skeletal muscle hypertrophy and improved function. *J Appl Physiol* 64:1038–1044

## Muscle and Tendon Energy Storage

ANDREW A. BIEWENER

Concord Field Station, Department of Organismic and Evolutionary Biology, Harvard University, Cambridge, MA, USA

### Synonyms

Elastic energy savings; Muscle-tendon elasticity

### Definition

Muscle and tendon energy storage refers to strain energy that is stored and elastically recovered within a muscle-tendon complex during each contractile cycle of a muscle.

### Characteristics

#### Quantitative Description

Muscle and tendon energy storage represents the strain energy that is stored within a muscle-tendon complex as a muscle and tendon are stretched by the force developed by the muscle when it contracts. This energy may be subsequently recovered elastically when the muscle relaxes. The elastic elements of a muscle-tendon

complex are generally divided into “parallel” and “series” elastic elements, based on their role in force transmission relative to the muscle’s force-generating cross-bridge elements. The interaction between a muscle’s contractile elements – the cross-bridges formed between myosin and actin filaments – and its parallel and ▶series elastic elements, determines the relationship between a muscle’s force development and length change, as well as its elastic energy storage [1]. For parallel-fibered muscles that have little or no tendon in series with the muscle’s fibers, elastic energy storage is limited to parallel and series elastic elements within the muscle, which include the cross-bridges themselves. For pinnate-fibered muscles that have a substantial tendon, considerably more energy is stored and recovered elastically within the tendon that is in series with the muscle’s fibers. Consequently, elastic energy savings is greatest in pinnate muscles that attach to the skeleton via long tendons [2].

#### **Mechanical Properties of Elastic and Viscoelastic Materials**

Elastic materials are those that exhibit spring-like properties. When elastic materials are loaded, they store strain energy via deformation of their molecular bonds in combination with conformational changes in the protein’s tertiary or quaternary structure. In the case of tendons and ligaments, this primarily results from the stretching of collagen. In the case of muscles, this involves additional elastic proteins, such as those within the cross-bridges (myosin I) and within the sarcomeres (titin), in addition to collagen. These proteins constitute the parallel and series elastic elements within a muscle, which are linked to a muscle’s tendon as an external series elastic element [1]. During unloading, the stored strain energy is released and may be recovered to assist in mechanical movements of the body or limb segment, reducing the amount of work that the muscles must perform. The work performed by a muscle is the product of its force and its net length change (muscle shortening by definition corresponds to positive muscle work, whereas muscle lengthening corresponds to negative muscle work, or energy absorption). For pure elastic elements, all of the energy that is stored during loading is returned during unloading. However, most biological materials are non-linearly elastic and exhibit some degree of inelastic or viscous energy dissipation, which is ultimately lost as heat (Fig. 1c).

Due to this, materials like tendon are referred to as being “viscoelastic.” The amount of strain energy that is elastically recovered relative to the amount of energy that is stored defines a material’s resiliency. The resiliency of collagenous tendons is in the range of 90–94%, indicating that only 6–10% of the stored strain energy in a tendon is lost as heat during each contraction cycle of a muscle.

#### **Elastic Energy Storage in Relation to the Force-Length Properties of a Muscle**

The force that a muscle develops depends on its length, which specifically reflects the amount of overlap between its myosin (thick) and actin (thin) filaments [1]. This is most often measured as the isometric force that a muscle can develop when it is stimulated to contract at different lengths. The force that is measured can be separated into two components: the active force that is developed by the cross-bridges formed between myosin and actin, and the passive force that is developed when the muscle is stretched to longer lengths without being stimulated (Fig. 2).

The slope of a muscle’s passive force versus length curve defines its ▶passive stiffness. A muscle’s passive stiffness increases as it is stretched to longer lengths, typically beyond the length that a muscle develops its maximal isometric force. Elastic energy that can be stored within a muscle when it contracts is generally associated with its passive force-length properties, because these depend on the amount of non-contractile connective tissue within the muscle. Muscles that are pinnate typically have more titin and collagenous connective tissue than parallel-fibered muscles and, as a result, display greater passive force when they are stretched. Consequently, pinnate muscles store more strain energy than parallel fibered muscles when force developed by cross-bridges is transmitted to the parallel and series elastic elements of the muscle. However, even for pinnate muscles, the strain energy stored in a muscle’s tendon greatly exceeds that in the muscle’s fibers [2,4].

#### **Muscle-Tendon Design in Relation to Elastic Energy Storage**

Muscle-tendon units with long thin tendons are most favorably designed for elastic energy savings. This is because strain energy varies with the square of tendon stress (force/area). Consequently, for a given muscle-tendon force, strain energy storage per unit mass (or volume) of tendon varies inversely in proportion to the square of the tendon’s area ( $\propto 1/A^2$ ). The advantage of having slender tendons is evident in animals, such as antelope, horses and kangaroos, which have evolved particularly economical modes of locomotor transport [2]. The distal limb muscle-tendon units of these animals are often comprised of muscles with very short fibers and long tendons. The length of some tendons can exceed their muscle’s fiber lengths by tenfold or more. As a result, the length change of the tendon, as it is stretched, may exceed the fibers’ lengths in the muscle. The role of these muscle-tendon units, therefore, is mainly to facilitate elastic energy storage and recovery and to generate force economically, and not to do substantial mechanical work [5]. Even though the muscle’s fibers may not perform much

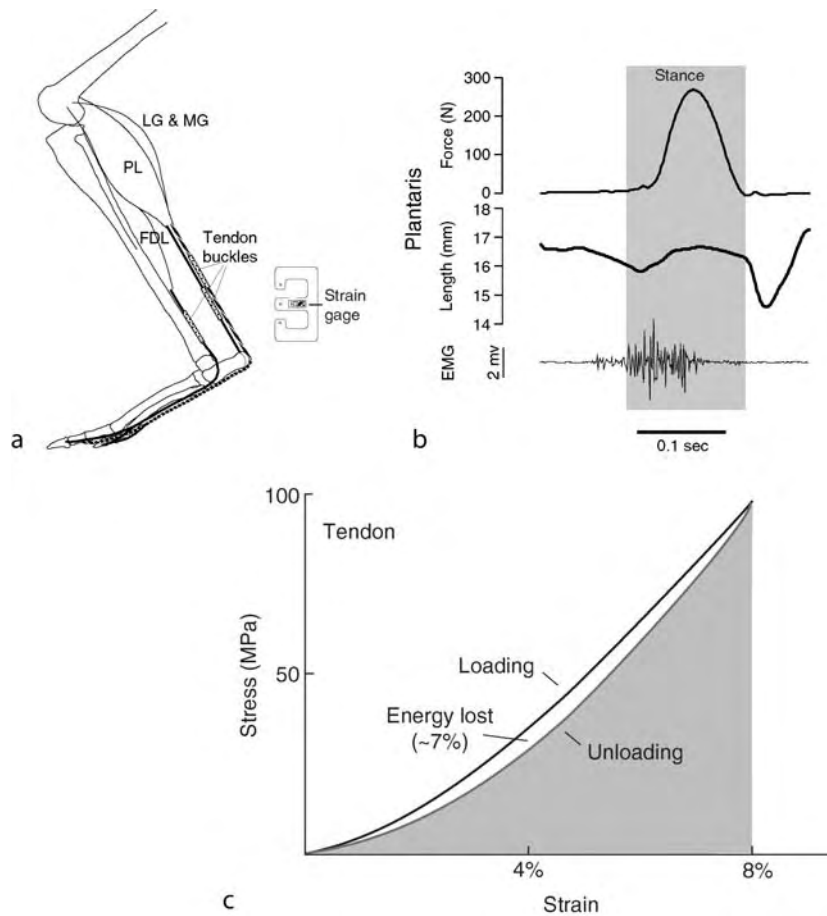

**Muscle and Tendon Energy Storage. Figure 1** (a) Schematic drawing of the hind limb muscle-tendon units of a wallaby, comprising the lateral and medial gastrocnemius (LG + MG), the plantaris (PL), and the flexor digitorum longus (FDL). “E”-shaped force buckles are shown attached to the tendons of these three muscles, and were used in [3] to record in vivo muscle-tendon forces in relation to muscle fascicle length change and indwelling electromyographic (EMG) activation of the muscles. (b) Representative in vivo recordings of muscle-tendon force, muscle fascicle length change from sonomicrometry, and EMG of the plantaris muscle-tendon are shown for one hopping cycle. (c) Tendon stress-strain curve used to calculate the elastic energy storage and recovery within the tendon over a cycle of loading and unloading.

useful work, they may provide a means for dissipating energy associated with unwanted vibrations in the limb when it impacts the ground [6].

### Measuring Elastic Energy Storage

Measurements of elastic energy storage and recovery depend on measurements of the material properties of muscle and tendon in combination with measurements of their structural dimensions and the forces that a muscle-tendon complex transmits during a given activity. Isolated in vitro or in situ force-length measurements allow the elastic and viscoelastic properties of a muscle and its tendon to be determined. The

force-length properties of the muscle and tendon can then be normalized to muscle-tendon stress and strain (defined as their change in length/resting length). This allows a muscle's stiffness and a tendon's stiffness (ratio of force/length change) to be defined in terms of their elastic modulus (stress/strain). Whereas the (passive) force-length or stress-strain behavior of a muscle depends strongly on a muscle's architecture (i. e. whether or not a muscle is parallel- or more pinnate-fibered), the stress-strain behavior of various tendons in vertebrate animals is fairly uniform [2,4]. Consequently, the stress-strain behavior and elastic modulus of tendon can be generally characterized and used to

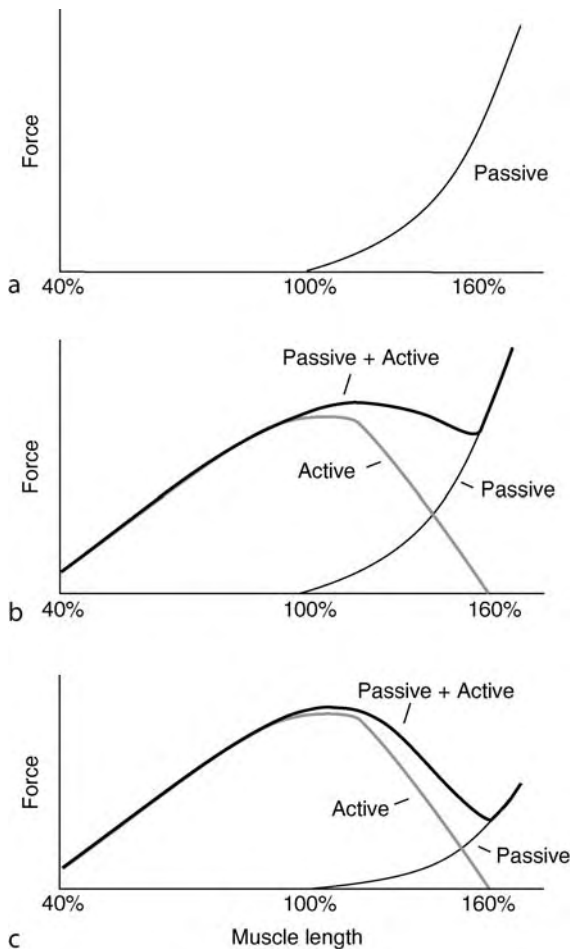

**Muscle and Tendon Energy Storage. Figure 2** (a) Representative passive force-length properties of a pinnate muscle. (b) Active isometric force-length properties of the muscle when stimulated to generate force over different percentages of its resting length (100%) in relation to passive properties shown in A, yielding the overall active + passive properties of the muscle. (c) Representative comparison of passive and overall force-length properties of a parallel-fibered muscle that has similar normalized active properties, but exhibits less passive stiffness than the pinnate muscle shown in (b).

calculate the elastic strain energy that is stored in a tendon of a given size and shape.

To determine the amount of elastic energy stored and recovered in a muscle-tendon complex, the force that muscle and its tendon transmit and their structural dimensions must be known. It is generally difficult to determine with accuracy the amount of strain energy stored within a muscle and its aponeurosis

versus that in its external tendon. Consequently, unless direct measurements are obtained, it is usually assumed that the large majority of elastic energy is stored within the in-series elastic elements of a muscle-tendon complex [4]. Nevertheless, it is likely that significant elastic energy is stored and recovered from the aponeurosis and internal elastic elements of pinnate muscles, such as the quadriceps, which act to extend the knee. Muscle-tendon forces can be either calculated indirectly based on kinetic analyses of limb and joint forces and moments [7], or measured directly using tendon buckle transducers [3,8] (Fig. 1a, b).

Indirect measurements of muscle-tendon forces are derived from measurements of external ground reaction forces, applied to the limb using a force platform in combination with a free-body analysis of joint forces and joint moments [2,7]. This approach depends on assumptions of muscle force distribution among muscle agonists in cases where more than one muscle-tendon unit transmits force across a joint, and when bi-articular muscles play a role in force and energy transmission between joints. This is typical of many limb muscles involved in elastic energy storage. Direct measurements of muscle-tendon forces depend on the tendon being sufficiently long to attach the transducer without disrupting normal function of the muscle-tendon unit and the animal (Fig. 1a). This approach is, therefore, generally limited to more distal muscle-tendon units in the limbs of animals.

The force transmitted by a muscle-tendon unit that is determined directly or indirectly can then be used to calculate the tendon's stress and resulting strain, based on the elastic modulus and resiliency of the tendon over the range of strain that the tendon operates. Knowing the structural dimensions of the tendon (overall length –  $L$ , average cross-sectional area –  $A$ , and total volume –  $V$ ) allows the total strain energy stored and recovered in the tendon to be calculated for the level of force ( $F$ ) that it transmits. As tendon is non-linearly elastic, this formally involves integrating over the stress-strain curve of the tendon and multiplying by the tendon's volume. However, in most cases, an average elastic modulus ( $E_{avg}$ ) characteristic of the functional stress-strain range of the tendon can be used to simplify the equation for calculating tendon strain energy:

$$U_{elas} = 0.5\sigma\epsilon VR = 0.5F\Delta LR$$

where  $\sigma$  is the tendon stress ( $= F/A$ ),  $\epsilon$  is tendon strain ( $= \sigma / E_{avg}$ ),  $V$  is tendon volume, and  $R$  is the tendon's resiliency (typically 0.9–0.95), which equals the product of tendon force and total tendon length change ( $\Delta L = \epsilon L$ ).

### Role of Elastic Energy Storage in Locomotion and Movement Control

Elastic energy storage in muscle and tendon is important in at least three contexts (i) metabolic energy savings derived from reduced muscle work, (ii) amplification of muscle-tendon power during jumping, and (iii) stabilization of muscle-tendon force transmission for control of movement. Indirect [4,9] and direct [3] measurements show that elastic energy storage in tendons and ligaments is an important means of energy saving during running or trotting and galloping gaits, reducing the amount of work that muscles must perform to move the animal's body and to swing its limbs (Fig. 1b). Although some elastic energy is stored within the cross-bridges and ►parallel elastic elements of the muscle, this is generally considered to be quite small in comparison with that stored and recovered in the muscle's tendon and aponeurosis. In addition to horses and wallabies, tendon energy savings also serve to reduce the metabolic energy expenditure of running in humans and many other animals [2]. Like the distal tendons of cats, dogs, horses and kangaroos, the human Achilles tendon and ligaments in the foot have been estimated to contribute as much as a 30% saving of muscle work [9]. In hopping wallabies, elastic energy savings in leg tendons provide as much as a 100% saving of muscle work, reducing the metabolic cost of locomotion by 50% [3].

Elastic energy storage is also an important mechanism by which the work produced by a muscle in series with a tendon can be used to amplify the power output (work/time) of the muscle-tendon unit as a whole [4]. This allows muscle-tendon units to serve as catapults when an animal jumps or when a person throws a ball. The work done by a muscle to stretch its tendon and store elastic strain energy is limited by the rates of muscle activation and cross-bridge cycling as the muscle shortens. These generally occur much more slowly than the rate of strain energy release from the tendon when it recoils. Consequently, although the work done by the muscle can never exceed the work returned by elastic recoil, power output is amplified relative to power input because the energy return from stored strain energy in the tendon occurs over a much briefer period of time. Amplification of muscle power is an important mechanism in the jumping of many animals, and likely also humans, resulting in muscle-tendon power outputs that can exceed the maximum power output of the muscle alone by threefold or higher [10].

Compliance and elastic energy storage in a muscle's tendons can also play an important role in stabilizing force transmission and improving the control of position for fine scale motor tasks, such as those that involve finger movements, which underlie manipulation and gripping [4]. Although excessive compliance (tendon stretch/force transmitted) can compromise a

muscle's ability to control for position, moderate compliance enables elastic energy stored in the tendon during a rise in force to be released as force declines, stabilizing the force output at a more steady level. This is achieved by introducing a time-delay between the induced stretch of the muscle spindles relative to small changes in muscle-tendon force, when the task is to hold force and finger position at a steady level. The time-delay introduced by the tendon's compliance improves the timing of force-feedback achieved via spindle Ia afferents to counter declining muscle force. The result is that a finger muscle can hold force at a steadier level and the finger's position is better controlled.

### References

1. Herzog W, ed. (2000) Skeletal muscle mechanics: from mechanisms to function. Wiley, New York, p. 572
2. Biewener AA (2003) Animal locomotion. Oxford University Press, Oxford, p. 281
3. Biewener AA, Baudinette RV (1995) In vivo muscle force and elastic energy storage during steady-speed hopping of tammar wallabies (*Macropus eugenii*). *J Exp Biol* 198:1829–1841
4. Alexander RM (1988) Elastic mechanisms in animal movement. Cambridge University Press, Cambridge
5. Biewener AA, Roberts TJ (2000) Muscle and tendon contributions to force, work, and elastic energy savings: a comparative perspective. *Exer Sport Sci Rev* 28 (3):99–107
6. Wilson AM et al. (2001) Horses damp the spring in their step. *Nature* 414:895–899
7. Zajac FE, Zomlefer MR, Levine WS (1981) Hindlimb muscular activity, kinetics and kinematics of cats jumping to their maximum achievable heights. *J Exp Biol* 91:73–86
8. Gregor RJ, Abelew TA (1994) Tendon force measurements and movement control: a review. *Med Sci Sports Exer* 26(11):1359–1372
9. Ker RF et al. (1987) The spring in the arch of the human foot. *Nature* 325:147–149
10. Roberts TJ, Marsh RL (2003) Probing the limits to muscle-powered accelerations: lessons from jumping bullfrogs. *J Exp Biol* 206:2567–2580

## Muscle Atonia

### Definition

Muscle paralysis that occurs during rapid eye movement (REM) sleep resulting from active inhibition of motor neurons.

► Sleep – Motor Changes

## Muscle Atrophy

### Definition

Wasting away of formerly normal skeletal muscle (up to 70-80 percent of original muscle bulk), for example as a result of denervation.

## Muscle Compartment

### Definition

The working location of a group of agonistic muscles (with similar function) delimited by the general fascia, intermuscular septum, periost and interosseal membrane.

- ▶ Epimuscular Myofascial Force Transmission and Intermuscular Interaction
- ▶ Intramuscular Myofascial Force Transmission

## Muscle Endplate

### Definition

The region of the muscle fibers where the motor nerves terminate on each skeletal muscle fiber, is termed the muscle endplate. It is at this endplate that the perisynaptic Schwann cells are found interspaced between the nerve terminal and the muscle fiber. The muscle endplate is where the acetylcholine receptors are concentrated and bind the acetylcholine released from the activated nerve terminals to elicit muscle contraction.

- ▶ Acetylcholine
- ▶ Axonal Sprouting in Health and Disease
- ▶ Neuromuscular Junction (NMJ)

## Muscle Fiber Conduction Velocity

### Definition

Velocity with which the transmembrane action potential propagates along the muscle fiber.

- ▶ Action Potential
- ▶ Electromyography

## Muscle Fiber End-Effect

### Definition

Non-propagating component of the extracellular action potential waveform due to the extinction of the transmembrane action potential at the fiber termination.

## Muscle Fiber Types

### Definition

A constellation of coordinated biochemical, metabolic, structural, and mechanical characteristics of muscle fibers that differentiate them into a relatively small number of recognizable categories.

- ▶ Motor Units

## Muscle Field

### Definition

The set of muscles whose motoneurons have a relatively direct synaptic linkage to a particular corticospinal neuron. Muscles that are part of a neuron's muscle field are referred to as target muscles. The target muscles of corticospinal and other descending system neurons have been identified in alert monkeys using signal averaging methods to detect the synaptic effects of the neuron's excitatory and inhibitory postsynaptic potentials (EPSPs and IPSPs) on motor unit firing probability.

- ▶ Corticospinal Neurons
- ▶ Motor Cortex: Output Properties and Organization

## Muscle Hyperalgesia

### Definition

Muscle hyperalgesia occurs when either noxious or ordinarily innocuous stimulation of muscle evokes a state of increased pain sensation.

- ▶ Hyperalgesia and Allodynia



## Muscle Imaging Techniques: Computerized Tomography

YASIN Y. DHAHER

Department of Biomedical Engineering, McCormick School of Engineering, Department of Physical Medicine and Rehabilitation, Feinberg School of Medicine, Northwestern University, Senior Research Scientist, Sensory Motor Performance Program, The Rehabilitation Institute of Chicago, Chicago, IL, USA

### Synonyms

CT

### Definition

A CT scan is a computer aided imaging technique performed by subjecting the object of interest to a series of X-rays and measuring the attenuation along multiple projections using several detectors. With each projection, detectors measure X-ray absorption, which is used to construct cross-sectional images (tomograms) of the object.

### Purpose

New developments in data-analysis techniques have facilitated the recent use of CT in the quantification of muscle cross-sectional area and volume [2,3]. For example, using a 345 mm<sup>2</sup> field of view and a 7 mm slice thickness CT scan, Mitsiopoulos et al. [3] showed that the computed muscle cross-sectional area strongly correlated with the muscle cross-sectional area obtained from actual cadavric measurements on the same muscle ( $r < 0.99$ ;  $p < 0.001$ ).

### Principles

Subsequent tomograms consist of black–gray–white color scale picture elements. Each element of the picture is called a pixel and is characterized by a CT value or density value. These pictures are then combined using computer algorithms to reconstruct two- and three-dimensional images of the object. These algorithms include iterative solutions of simultaneous linear equations, Fourier transform techniques, and approaches that use a combination of back projection and deconvolution. Scan parameters are defined in terms of the size of the field of view and image thickness. For additional material on the mathematical basis of CT, the reader is referred to Shung et al. [1].

### Advantages and Disadvantages

The use of CT in muscle imaging has been limited due to large estimation errors reported in early CT muscle imaging literature [4]. However, advances in post

processing and reconstruction techniques, and recent developments in CT technology such as helical CT and multi-detector row helical CT, could further improve resolution in the estimation of muscular volumetric and cross-sectional geometries obtained from CT scans.

### References

1. Shung KK, Smith MB, Tsui BMW (1992) Principles of medical imaging. Academic, San Diego
2. Mitsiopoulos N, Baumgartner RN, Heymsfield SB, Lyons W, Gallagher D, Ross R (1998) Cadaver validation of skeletal muscle measurement by magnetic resonance imaging and computerized tomography. *J Appl Physiol* 85(1):115–122 (see comment)
3. Tracy BL, Ivey FM, Jeffrey Metter E, Fleg JL, Siegel EL, Hurley BF (2003) A more efficient magnetic resonance imaging-based strategy for measuring quadriceps muscle volume. *Med Sci Sports Exerc* 35(3):425–433
4. Beneke R, Neuerburg J, Bohndorf K (1991) Muscle cross-section measurement by magnetic resonance imaging. *Eur J Appl Physiol Occup Physiol* 63(6):424–429

## Muscle Imaging Techniques: Magnetic Resonance Imaging

YASIN Y. DHAHER

Department of Biomedical Engineering, McCormick School of Engineering, Department of Physical Medicine and Rehabilitation, Feinberg School of Medicine, Northwestern University, Senior Research Scientist, Sensory Motor Performance Program, The Rehabilitation Institute of Chicago, Chicago, IL, USA

### Synonyms

MRI

### Definition

MR imaging technique is based on the detection of the interactions between protons in liquid phase molecules (e.g., water and lipids) and the abilities of certain atomic nuclei, when exposed to a magnetic field, to absorb and release electromagnetic radiations at specific frequencies (Larmor frequency). These radiations are detected via receiving coils which are then used to construct the MR images of the object of interest. Computer integration and transformation of the signals detected by the receiving coils allows a two-dimensional map of proton density to be constructed, which can be visualized as a slice through the object (muscle).

## Purpose

MRI imaging has been successfully used to measure stationary muscle volume and cross-sectional area (Tracy et al., 2003). Although both T2 and T1 weighted images have been used, T1 weighted imaging has been particularly successful for muscle tissues [2].

MRI has also been used to estimate muscle fiber direction. The estimation of fiber direction via MRI is based on the fact that muscle striations seen in MRI images are generated by fat that runs parallel to and between the muscle fascicles [3]. It is assumed that these striations represent the true fascicle orientation within the muscles. When the imaging planes are coplanar to the fascicle orientation, fascicle length and pennation angles can be computed [3]. However, the use of MRI is limited when fascicle orientation is difficult to identify, such as in complexly pennated muscles.

To circumvent this, a diffusion tensor magnetic resonance imaging technique (DT-MRI) has been used to estimate fiber direction. In DT-MRI, measurements are independent of the orientation of the image plane, and three-dimensional fiber directions can be obtained immediately. DT-MRI was introduced in 1988 by LeBihan [4]. It is based on the measurement of the apparent diffusion of water in a (biological) tissue. For muscle tissues, diffusion is not the same (isotropic) in all directions. Hence, applying diffusion sensitization in six independent directions on a series of diffusion-weighted images, a diffusion tensor can be calculated in each voxel [5]. The eigenvalues and eigenvectors of this tensor provide information about local tissue anisotropy. Anisotropic diffusion can be geometrically interpreted as an ellipsoid with its three axes oriented along these eigenvectors and with the three semi-axis lengths proportional to the square root of the eigenvalues of the tensor (mean diffusion distances). The geometric nature of the diffusion tensors can quantitatively characterize the local structure of the muscle. The eigenvector belonging to the largest eigenvalue of the diffusion tensor is assumed to coincide with the local muscle fiber direction in striated muscle [5,6]. DT-MRI based fiber orientation has been successfully verified against histological slices [6].

Van Donkelaar et al. [7] used DT-MRI to measure fiber orientation in the tibialis anterior muscle of the rat. Using a 0.6 mm slice thickness, a field of view of  $70 \times 35 \text{ mm}^2$  and a voxel size of  $0.09 \text{ mm}^3$ , they found that computed fiber orientations corresponded to fiber orientations obtained from actual longitudinal sections of the same muscle. More recently Damon et al. [8] provided a more quantitative validation study of fiber orientation estimates using DT-MRI. In the lateral gastrocnemius of Sprague-Dawley rats, Damon et al. [8] showed a strong correlation ( $r = 0.89$ ) between DT-MRI based local fiber orientation estimates and the

measured orientations obtained from direct anatomical inspection of the same muscle.

Cine Phase Contrast (Cine-PC) MRI, originally developed to measure blood flow and heart motion, initially showed promise as a non-invasive technique to also measure human muscle fiber velocity in vivo under dynamic conditions. At each time frame, the Cine-PC MRI produces a series of anatomic and velocity images of skeletal muscles synchronized with a periodic motion cycle in three orthogonal planes. The velocity images are then integrated to determine the position of the muscles in vivo. Cine-PC MRI has been shown to accurately measure skeletal muscle fiber velocity in vivo during a dynamic task [9]. Previous studies by the same authors have demonstrated that Cine-PC MRI tracks skeletal muscle motion with a root mean error of 1 mm [9]. However, conventional cine-PC MRI requires multiple cycles of motion; typically 60–120 repetitions are needed to acquire composite images representing one motion cycle. Image quality degrades significantly with small discrepancies among the consecutive motion cycles, resulting in a significant limitation for the use of the conventional Cine-PC MRI in musculoskeletal applications [10].

## Principles

A background magnetic field is used to align all atomic nuclei within the object of interest along the direction of the background field, producing a nuclei net longitudinal magnetic field. External energy is then applied using radiofrequency (RF) excitation pulses to change the direction of the nuclei net longitudinal magnetic field to point in a perpendicular direction to the background magnetic field and thus create what is known as transverse magnetization. Initially, all nuclei point along the same perpendicular direction representing the transverse magnetization in terms of one vector perpendicular to the direction of the background magnetic field. Because each nucleus has its own Larmor frequency, as time elapses, the transverse magnetization component eventually spans all directions, bringing the net nuclei magnetization component perpendicular to the background magnetic field to zero. T1 relaxation time is defined as the time the atomic nuclei needs to revert to equilibrium (regain their longitudinal mechanism) following the termination of the excitation pulses (RF). T2 (known as the spin echo relaxation time) is the time it takes for the net transverse magnetization to go to zero (decay). T2 (0.05–0.15 s) is always less than or equal to T1 (0.2–1.2 s) and both are intrinsic properties of tissues.

To obtain a successful imaging sequence, the technician defines a set of imaging parameters. These include: (i) repetition time (TR) or the time between two successive radio frequency (RF) excitation pulses measured in milliseconds; (ii) echo delay time (TE), or the time interval between RF pulse and the measurement

of the first echo measured in milliseconds; (iii) field of view (FOV) and slice thickness (interslice distance) both measured in millimeters and; (iv) receiver bandwidth measured in kHz. Tissues with short T1 have greater signal intensity than tissues with longer T1 at a given TR. TE on the other hand determines how much decay of the transverse magnetization is allowed to occur before the signal is read. The application of RF pulses at different TRs and the receiving of signals at different TEs produce variations in contrast of the MR images. For example, by selecting a relatively short TR (on the order of 300–600 ms generally) the image contrast will be primarily influenced by differences in the tissue's T1 relaxation times and hence T1-weighted images are created. On the other hand, selecting a relatively long TE (on the order of 80–120 ms) will generate a T2-weighted image where the image contrast is primarily influenced by differences in tissue's T2 relaxation times. For further discussion on the underlying physics involved in MRI, the reader is referred to Buxton [1].

## References

1. Buxton RB (2002) Introduction to functional magnetic resonance imaging: principles and techniques. Cambridge University Press, Cambridge
2. Mitsiopoulos N, Baumgartner RN, Heymsfield SB, Lyons W, Gallagher D, Ross R (1998) Cadaver validation of skeletal muscle measurement by magnetic resonance imaging and computerized tomography. *J Appl Physiol* 85(1):115–122 (see comment)
3. Scott SH, Engstrom CM, Loeb GE (1993) Morphometry of human thigh muscles. Determination of fascicle architecture by magnetic resonance imaging. *J Anat* 182(Pt 2):249–257
4. LeBihan D, Breton E, Lallemand D, Aubin M-L, Vignaud J, Laval-Jeantet M (1988) Separation of diffusion and perfusion in intravoxel incoherent motion MR imaging. *Radiology* 168:497–505
5. Basser PJ, Mattiello J, LeBihan D (1994) MR diffusion tensor spectroscopy and imaging. *Biophys J* 66(1):259–267
6. Hsu EW, Muzikant AL, Matulevicius SA, Penland RC, Henriquez CS (1998) Magnetic resonance myocardial fiber-orientation mapping with direct histological correlation. *Am J Physiol* 274(5 Pt 2):H1627–H1634
7. Van Donkelaar CC, Kretzers LJ, Bovendeerd PH, Lataster LM, Nicolay K, Janssen JD, Drost MR (1999) Diffusion tensor imaging in biomechanical studies of skeletal muscle function. *J Anat* 194(Pt 1):79–88
8. Damon BM, Ding Z, Anderson AW, Freyer AS, Gore JC (2002) Validation of diffusion tensor MRI-based muscle fiber tracking. *Magn Reson Med* 48(1):97–104
9. Drace JE, Pelc NJ (1994) Skeletal muscle contraction: analysis with use of velocity distributions from phase-contrast MR imaging. *Radiology* 193(2):423–429
10. Asakawa DS, Nayak KS, Blemker SS, Delp SL, Pauly JM, Nishimura DG, Gold GE (2003) Real-time imaging of skeletal muscle velocity. *J Magn Reson Imaging* 18(6):734–739

## Muscle Imaging Techniques: Ultrasound

YASIN Y. DHAHER

Department of Biomedical Engineering, McCormick School of Engineering, Department of Physical Medicine and Rehabilitation, Feinberg School of Medicine, Northwestern University, Senior Research Scientist, Sensory Motor Performance Program, The Rehabilitation Institute of Chicago, Chicago, IL, USA

### Synonyms

ULT

### Definition

Ultrasound or sonography is based on the application of high frequency sound pulses using an ultrasound transducer (probe; a transmitter and receiver) to a stationary (conventional ultrasound) or a moving (real-time ultrasonography) muscle and recording the echoes (reflections) returning from the muscle-tissue interface. The echoes are processed based on the location of origin and amplitude. From this information, two-dimensional gray scale images are constructed. These images can be analyzed to obtain quantitative structural and functional information from the muscle of interest.

### Purpose

Several studies have used ultrasonography techniques to quantify muscle fiber length and direction under static conditions [3] and dynamic [4]. Under static conditions, measurements obtained by ultrasound were consistent with direct anatomical measurements on cadavers [3]. Under dynamic conditions, several studies have tested the effectiveness of real-time ultrasonography in estimating changes in human muscle architecture in vivo during muscle contractions [4]. However, direct validation studies on the use of ultrasonography under dynamic conditions are warranted.

### Principles

The fundamental principle of ultrasound is based on the idea that sound waves are transmitted through soft tissue relative to the acoustic impedance of each tissue. Sound wave frequencies used in ultrasound technology are in the 2–10 MHz range. The acoustic impedance of a particular tissue is the product of the transmission velocity of sound and the tissue density. For example, the wave velocity in pure fat is approximately 1,450 m/s whereas the velocity through muscle tissue is approximately 1,580 m/s. When two

tissues with different densities/wave velocities are located next to each other, an acoustic impedance mismatch is created and sound waves are reflected by the mismatch. For example, muscle imaging via ultrasound is possible because muscle fascia is a highly echoic structure (provides a significant acoustic mismatch), allowing for muscle differentiation. Scans used to estimate muscle fiber length and directions identify echoes from fascicle interspaces.

Image resolution is divided into spatial and temporal components (important when imaging moving muscles; real-time ultrasonography). The spatial component (the ability to differentiate between two adjacent tissues) consists of axial (the smallest axial distance that must be resolved) and lateral resolution. Axial resolution is dependent on sound wave pulse width and frequency. Two structures will be seen as separate structures only if the pulse length is shorter than the distance between the structures. Also, higher frequency sound waves have shorter pulse lengths and generally greater axial resolution. Lateral resolution is dependent on beam width and sound wave frequency. Narrower beam width and higher frequencies provide greater lateral resolution. Hence, in mapping small structures like muscle fibers, high frequency (>7MHz) ultrasounds are commonly used. It is important to note, however, that as a wave propagates through a material, the signal amplitude is attenuated. Attenuation within a tissue increases with increasing wave frequency. For example, a 5-MHz transducer will generally image to a depth of 12–15cm, but a 10-MHz transducer may image to a depth of only 3–4cm. Thus improving image resolution comes with the loss of distal information when scanning deeper structures.

The temporal resolution of ultrasound is determined by the number of image frames that can be acquired per second. For real-time ultrasonography, images are obtained at a pre-specified rate, usually 65 images per second, during the dynamic task [1]. For more on the underlying physics and the image processing techniques involved in ULT, the reader is referred to Shung et al. [2].

### Advantages and Disadvantages

Improvement in image resolution in an attempt to scan small structures or differentiate between structures with close acoustic impedances limits the field of view hence hindering the ability to scan deep muscles. In addition, muscle architectural properties such as fiber length and angle obtained using ultrasonography are calculated from a two-dimensional image and thus represent the projection of these values on that plane. Recent developments in three-dimensional ultrasonography may prove useful in addressing this limitation of the two-dimensional ultrasonography.

### References

1. Martinson H, Stokes MJ (1991) Measurement of anterior tibial muscle size using real-time ultrasound imaging. *Eur J Appl Physiol Occup Physiol* 63(3–4):250–254
2. Shung KK, Smith MB, Tsui BMW (1992) Principles of medical imaging. Academic, San Diego
3. Narici MV, Binzoni T, Hiltbrand E, Fasel J, Terrier F, Cerretelli P (1996) In vivo human gastrocnemius architecture with changing joint angle at rest and during graded isometric contraction. *J Physiol (Lond)* 496(Pt 1):287–297
4. Ichinose Y, Kawakami Y, Ito M, Kanehisa H, Fukunaga T (2000) In vivo estimation of contraction velocity of human vastus lateralis muscle during “isokinetic” action. *J Appl Physiol* 88(3):851–856
5. Fukunaga T, Miyatani M, Tachi M, Kouzaki M, Kawakami Y, Kanehisa H (2001) Muscle volume is a major determinant of joint torque in humans. *Acta Physiol Scand* 172(4):249–255
6. Tracy BL, Ivey FM, Jeffrey Metter E, Fleg JL, Siegel EL, Hurley BF (2003) A more efficient magnetic resonance imaging-based strategy for measuring quadriceps muscle volume. *Med Sci Sports Exerc* 35(3):425–433
7. Van Donkelaar CC, Kretzers LJ, Bovendeerd PH, Lataster LM, Nicolay K, Janssen JD, Drost MR (1999) Diffusion tensor imaging in biomechanical studies of skeletal muscle function. *J Anat* 194(Pt 1):79–88

## Muscle Modeling

ERIC J. PERREAULT

Department of Biomedical Engineering, Department of Physical Medicine and Rehabilitation, Northwestern University, Chicago, IL, USA

### Definition

For the purposes of this essay, a muscle model is defined as a set of mathematical equations that can be used to predict the whole muscle forces generated in response to changes in muscle activation and external loading.

### Purpose

The use of muscle models can be categorized broadly into two domains. The first focuses on the properties and function of individual muscles. These applications are often designed to test the limits of our knowledge with respect to how muscle functions. By developing quantitative descriptions of the physiological processes contributing to muscle function, it should be possible to assemble these descriptions into a model describing whole muscle behavior. Comparing the results of such models against experimental data allows the accuracy of the mechanistic descriptions and the assumptions

contained within to be evaluated, a process that can assist in guiding future experimentation.

The second class of applications falls into the category of musculoskeletal modeling. Such applications typically incorporate multiple muscle models to study how muscle properties contribute to the control of movement and posture. The goals of this class again may be to examine the limits of our understanding by comparing experimental data to that predicted by the model, or to predict muscle function in applications where direct measurements are difficult or unfeasible. Examples include investigating how specific muscle activation patterns influence joint contact forces, how different neural control strategies alter movement production or predicting the outcomes of specific surgical interventions.

**Principles**

**Contractile Properties**

Muscle contracts and realistic models of muscle force generation need to describe this contractile process. There are two different approaches to describing the contractile machinery. Mechanistic models attempt to describe the physiological mechanisms underlying muscle force generation. In contrast, phenomenological models use empirical descriptions to describe how force is generated under a range of conditions.

**Mechanistic Models**

Most current mechanistic models stem from the work of Huxley [1]. In his seminal paper, Huxley described the contractile properties of muscle in terms of the number of currently attached cross-bridges. Each cross-bridge was assumed to be elastically linked to the myosin filament and to move randomly about a neutral equilibrium point due to thermal agitation, as depicted in Fig. 1a.

Further, it was assumed that cross-bridges could be in one of two states, either attached or detached to an actin binding site, and that there were no interactions between neighboring cross-bridges. Under these conditions, the rate equation for cross-bridge attachment is given by Equation 1, where  $n(x,t)$  is the fraction of attached cross-bridges at time  $t$  and displacement  $x$  from

the equilibrium point,  $f(x)$  is the rate at which cross-bridges attach and  $g(x)$  is the rate at which they detach.

$$\frac{\partial n(x,t)}{\partial t} = f(x)(1 - n(x,t)) - g(x)n(x,t) + v(t)\frac{\partial n(x,t)}{\partial x} \tag{1}$$

$$F(t) = k \int n(x,t)xdx \tag{2}$$

Fig. 1b illustrates the shape of the rate functions originally proposed by Huxley; the asymmetry of these functions leads to muscle shortening. Each cross-bridge is assumed to be elastic. Hence, when attached, a cross-bridge produces a force proportional to its distance from the equilibrium point. The total force generated is given by Equation 2, in which  $k$  is defined as the cross-bridge stiffness.

Since Huxley’s original work, a variety of extensions have been made to his proposed model including the incorporation of length-tension properties, changes in the attachment and detachment rate functions, the addition of intermediary states between cross-bridge attachment and detachment and the allowance for cooperativity between neighboring cross-bridges.

**Phenomenological Models**

A number of linear and nonlinear phenomenological muscle models have been proposed. The most widely used of these stem from the work of A.V. Hill [2], and the modifications outlined by Zajac [3]. These Hill-type models have a structure as shown in Fig. 2. The parallel elastic element (PEE) is often ignored, as it contributes little force within the working range of most muscles and the stiffness of the series elastic element (SEE) is combined with that of the tendon. The contractile element (CE) of a Hill-type model is described in terms of the instantaneous force-length, force-velocity and activation properties of muscle. Many Hill-type models assume that these properties are independent (see Winters [4] for discussion), and that the contractile element force,  $F_{CE}$ , can be characterized by Equation 3, where  $\tilde{A}(t)$  is the normalized muscle activation,  $\tilde{F}_{FL}$  is the normalized tetanic force-length relationship, and

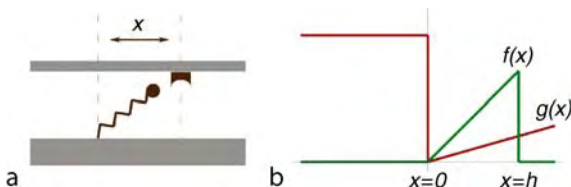

**Muscle Modeling. Figure 1** Schematic of original Huxley model. (a) Assumed mechanism. (b) Proposed rate functions.

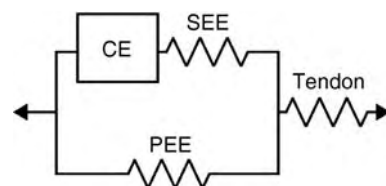

**Muscle Modeling. Figure 2** Schematic of a typical Hill model.

$\tilde{F}_{FV}$  is the normalized tetanic force-velocity relationship, measured at the muscle length corresponding to the peak of force-length curve. Alternative formulations assume that the maximum shortening velocity varies with muscle length and activation, requiring that  $\tilde{F}_{FV}$  be dependent upon instantaneous muscle velocity and activation.

$$F_{CE}(t) = F_{\max} \cdot \tilde{A}(t) \cdot \tilde{F}_{FL}(L(t)) \cdot \tilde{F}_{FV}(V(t)) \quad (3)$$

The above descriptions outline the elements common to all Hill-type models. However, a number of extensions to this model have been developed. These include incorporating geometrical parameters to account for changes in muscle architecture, allowing for significant coupling between the  $\tilde{F}_{FV}$  and  $\tilde{F}_{FL}$  properties and acknowledging the fact that these properties do not scale simply with changes in activation level. Each of these modifications has been shown to improve model performance for specific experimental conditions, although head-to-head comparisons of these modified models have not been performed yet, and there is no consensus as to which is most appropriate for a specific application.

### Activation Dynamics

Both mechanistic and phenomenological models need to account for the scaling of muscle force with changes in neural input. This is accomplished through the use of an activation function, which characterizes the processes triggered by the occurrence of a muscle fiber action potential and ending with the binding of calcium to troponin. A number of activation functions have been proposed, ranging from the first-order activation dynamics often incorporated into Hill-type muscle models [3], to detailed descriptions that attempt to account for the physiological processes underlying calcium release and reabsorption [5]. Between these extremes are the many phenomenological descriptions that use the activation function to account for activation-dependent muscle responses such as fatigue, nonlinear summation of neural inputs and movement-related history dependence. A good example of this approach is provided by the work of Brown and Loeb [6].

### Structural Properties

#### Intramuscular Structure

There are wide variations in muscle structure and these variations significantly impact muscle function. Hence, whole muscle models must take structural variations into account. Fiber length, cross-sectional area and pennation angle are the factors most often considered. At a minimum, these can be used to scale model parameters such as maximal isometric force and shortening velocity. More involved approaches consider how these factors vary and influence force

generation throughout the physiological range. This has been attempted using both 2D and 3D models of muscle architecture. Recent studies have used finite element approaches to investigate and model how these architectural features influence force generation during normal movement conditions [7]. This approach may also prove to be useful for assessing the role of passive mechanical structures such as tendons and aponeuroses. Currently, these are modeled most often as elastic elements in series with the contractile machinery (e.g. SEE in Fig. 2).

#### Intermuscular Structure

Significant force can also be transmitted between muscles via myofascial structures. Such transmission poses enormous challenges for the modeling of multiple muscle systems and is ignored in most musculoskeletal models. The essay by Huijting, *Epimuscular Myofascial Force Transmission and Intermuscular Interaction*, covers this topic in detail. It should be noted, however, that most studies demonstrating significant intermuscular force transmission have examined this phenomenon by disrupting the normal transmission pathways. Recent data from our laboratory suggests that intermuscular transmission is less than 5% between muscles with intact tendons and intermuscular linkages. Hence, the problem of intermuscular transmission may be most important when modeling injuries or surgical interventions in which the normal transmission pathways are disrupted.

#### Advantages and Disadvantages

There are many choices to be made when choosing or designing a muscle model for a particular application. The advantages and disadvantages of each are driven at least as much by the application as by the model. As always in modeling, there is a tradeoff between physical realism and computational efficiency. A related issue is the ability to estimate appropriate model parameters, for even an accurately modeled system will produce inaccurate results if the parameters cannot be set appropriately. In reviewing the relative merits of the available modeling approaches, we focus on three common applications.

#### Mechanisms of Muscle Contraction

Models designed to investigate the mechanisms underlying muscle contraction are typically derived from the Huxley models presented above. Such models are attractive because they have the ability to link macroscopic phenomena, such as force-velocity properties, yielding and short-range stiffness, to the underlying microscopic structure of muscle. As a result, they are the models of choice for muscle biophysicists, and represent an enticing structure upon which to incorporate additional physiological information as it becomes available. A limitation of Huxley-type models is the

difficulty associated with measuring model parameters and choosing appropriate forms for the rate functions. Indeed, many rate functions and parameter estimates have been proposed to match different sets of experimental data. These models are also computationally intensive, which has limited their use in studies of multiple muscle systems as well as those assessing the impact of structure on function, although a reformulation of the Huxley equations by Zahalak and colleagues [8] has a reduced computational cost and helped bridge the gap between mechanistic and phenomenological models.

### **Muscle Mechanics**

The mechanical properties of muscle describe the dynamic relationship between imposed displacements and the corresponding changes in muscle force. These properties, which are influenced by the contractile properties and passive structures, are critical for understanding the role of muscle in the control of posture and movement. Some mechanical responses, such as yielding and short-range stiffness, appear to be cross-bridge phenomena and are characterized well by Huxley-type mechanistic models. However, a number of phenomena, such as movement history-dependent changes in muscle force, cannot be attributed to cross-bridge dynamics alone.

Hill-type models describe the forces generated during isovelocity movements reasonably well, since they specifically incorporate force-velocity characteristics, but are less capable of describing the forces generated in response to more complex movements, especially at non-tetanic levels of activation [9]. A number of groups have proposed modifications to the Hill model that broaden the range of mechanical responses that can be predicted [6,10]. Often, these modifications rely on coupling the contractile properties of muscle to the activation dynamics. A process that may also be useful for extending the utility of Huxley-type models.

Realistic representations of muscle architecture and the passive structures responsible for transmitting muscle force are essential for modeling muscle mechanics. Currently, finite element models represent the best opportunity for assessing how these structural features impact whole muscle mechanics. The current drawbacks of these methods include the computational demands required for simulation and the lack of reliable parameter estimates for the material properties of muscle.

### **Multiple Muscle Systems**

In neuroscience, muscle models often are incorporated into multiple muscle systems used to study the neural control of movement. Under these circumstances, computational efficiency becomes a primary concern. As a result, most simulations of multiple muscle systems rely on Hill-type muscle models or even linear

visco-elastic models. As discussed above, these models are known to be inaccurate. However, these inaccuracies for predicting the details of muscle force generation may become less important when these forces are filtered by the musculoskeletal system. In contrast, errors may be magnified when such models are used to estimate the activation patterns required to generate an observed set of movements. The difficulties associated with such inverse problems are well described by Hatze [11].

The inability to estimate muscle activation accurately is a major limitation in the use of multiple muscle models for studying the neural control of movement. During physiological conditions, muscle force is graded via changes in motor unit recruitment and firing rate, and it is currently not possible to obtain reliable estimates of these processes during the control of voluntary movement. As an alternative, the whole muscle electromyograms (EMGs) are often used to approximate muscle activation and as inputs to the muscle models in a multiple muscle system. Rectified EMG can be a good predictor of isometric muscle force. However, this relationship is muscle specific. In addition, the EMG-force relationship for a given muscle depends upon recording electrode placements and movement of the electrodes with respect to the muscle. Hence, the use of EMG as an approximation of muscle activation is problematic, and multiple muscle models that rely on EMGs need to assess how these limitations impact model performance.

### **References**

1. Huxley AF (1957) Muscle structure and theories of contraction. *Prog Biophys Mol Biol* 18:257–318
2. Hill AV (1938) The heat of shortening and the dynamic constants of muscle. *Proc R Soc (London)* B126:136–195
3. Zajac FE (1989) Muscle and tendon: properties, models, scaling, and application to biomechanics and motor control. *Crit Rev Biomed Eng* 17:359–411
4. Winters JM (1990) Hill-based muscle models: a systems engineering perspective. In: Winters JM, Woo SL (eds) *Multiple muscle systems: biomechanics and movement organization*. Springer, Berlin Heidelberg New York, pp 69–93
5. Cannell MB, Allen DG (1984) Model of calcium movements during activation in the sarcomere of frog skeletal muscle. *Biophys J* 45:913–925
6. Brown IE, Loeb GE (2000) Measured and modeled properties of mammalian skeletal muscle: IV. dynamics of activation and deactivation. *J Muscle Res Cell Motil* 21:33–47
7. Johansson T, Meier P, Blickhan R (2000) A finite-element model for the mechanical analysis of skeletal muscles. *J Theor Biol* 206:131–149
8. Zahalak G (1981) A distribution-moment approximation for kinetic theories of muscular contraction. *Math Biosci* 55:89–114

9. Perreault EJ, Heckman CJ, Sandercock TG (2003) Hill muscle model errors during movement are greatest within the physiologically relevant range of motor unit firing rates. *J Biomech* 36:211–218
10. Shue GH, Crago PE (1998) Muscle-tendon model with length history-dependent activation-velocity coupling. *Ann Biomed Engl* 26:369–380
11. Hatze H (2002) The fundamental problem of myoskeletal inverse dynamics and its implications. *J Biomech* 35:109–115

## Muscle Moment Arm

### Definition

The distance from the line of action of a muscle to the center of rotation of a joint.

► Impedance Control

## Muscle/Muscle Fiber Stiffness

### Definition

Muscle and muscle fiber stiffness are typically evaluated by quick stretch experiments or sinusoidal oscillations of the preparation. Stiffness is then evaluated as the resistance to stretch (for example, as the instantaneous slope of the force elongation curve during stretch). Muscle stiffness has played an important role in muscle physiology and mechanics as it has been viewed as a measure of the proportion of attached cross-bridges.

- Cross-bridge Theory
- Force Depression/Enhancement in Skeletal Muscles
- Muscular Stiffness

## Muscle Nociceptors

### Definition

Free nerve-endings on small-diameter myelinated (Group III) or unmyelinated (Group IV) muscle afferent nerve fibers. Group IV corresponds to cutaneous C

fibers and group III to A $\delta$ -fibers. Conduction velocities for cat muscle afferent fibers are below 2.5 m/s for group IV and 2.5–30 m/s for group III fibers [7].

- Muscle Pain Including Fibromyalgia
- Nociceptors and Characteristics

## Muscle Pain, Including Fibromyalgia

LARS ARENDT-NIELSEN,  
THOMAS GRAVEN-NIELSEN  
Center for Sensory-Motor Interaction (SMI),  
Department of Health Science and Technology,  
Aalborg University, Aalborg, Denmark

### Synonyms

Musculoskeletal pain; Myofascial Pain; Deep somatic pain

### Definition

Pain from deep somatic structures.

### Characteristics

Musculoskeletal pain is an important factor in many disorders, including chronic pain conditions, work related disorders, injuries, degenerative diseases, and cancer, but the peripheral and central mechanisms underlying musculoskeletal pain are still poorly understood. The typical characteristics are drilling, aching pain often referred to other somatic structures. Musculoskeletal disorders can be classified as articular (e.g., rheumatoid arthritis, osteoarthritis (see ► [Immune system and pain](#)) or non-articular (e.g., myofascial pain syndrome, fibromyalgia (FM)). This essay will present manifestations and methods for assessment of human non-articular pain with focus on muscle pain.

### Manifestations of Selected Painful, Musculoskeletal Disorders

Myofascial pain syndromes are regional muscle pain disorders characterised by localized tenderness in muscles (trigger points), leading to persistent, regional pain such as back pain, neck pain, shoulder pain, headaches, and orofacial pain. The affected muscles often display an increased fatigability, stiffness, subjective weakness, pain in movement, and slight restricted range of motion unrelated to joint restrictions. The exact etiology of myofascial pain syndromes is unclear.

Widespread pain is defined as pain lasting for more than three months present as follows: (i) Pain in both



sides of the body, pain above and below the waist, (ii) Axial skeletal pain (cervical spine, anterior chest, thoracic spine, or low back pain) must be present. Widespread pain includes classes of syndromes such as FM, fatigue syndrome, exposure syndromes (e.g., Gulf War illnesses). FM is a chronic, painful musculoskeletal disorder of unknown etiology and defined by chronic widespread pain, involving three or more segments of the body plus the finding of at least 11 out of 18 designated tender points often developing after localised pain problems. However, not all people with chronic, localized or regional muscle pain develop FM. Hereditary factors might be important. Serotonin- and dopamine-related genes have been suggested to be involved in the development of FM. Studies of the endocrine profile of FM patients have indicated elevated activity of corticotropin releasing hormone (CRH) neurones which may not only explain some symptoms of FM, but may also cause alterations observed in the hormonal axes [1]. Hypothalamic CRH neurones may play a role not only in resetting various endocrine loops, but possibly also for nociceptive and psychological mechanisms as well.

FM patients show differentiated ►**hyperalgesia** to different sensory stimuli indicating that only specific parts of the sensory and nociceptive systems are influenced and that the sensory disturbances are accentuated as the syndrome progresses [2].

Myalgia can be related to a variety of medical conditions, and common terms for the symptom are stiffness, soreness, aching, spasms, or cramps. The associated pain is often described as having a dull, aching quality and can be exacerbated by muscle contractions. The manifestation of pain in some of the myalgias, however, is not the most prominent problem.

For example, in myositis (e.g., polymyositis and dermatomyositis) muscle weakness is often the prominent feature.

Muscle pain of neurogenic origin can be difficult to dissociate from other manifestations of ►**neuropathic pain**. Examples include cervical radiculopathy with pain radiating into the myotomal distribution of the roots or nerve compressions (e.g., carpal tunnel syndrome), where the pain radiates into muscles in the region. Little is known about muscle sensitization in relation to neuropathic pain as normally only the cutaneous manifestations of neuropathic pain (allodynia, hyperalgesia) are investigated.

Musculoskeletal disorders and pain are more prevalent in females than males, with female predominance in painful musculoskeletal syndromes such as widespread pain, temporomandibular disorders, neck pain, shoulder pain, back pain, joint pain, FM, whiplash, and headache. High rates of comorbidity, particularly in women, have been reported between

temporomandibular dysfunctions and other clinical musculoskeletal disorders (e.g., FM). Fluctuations in hormonal levels have been implicated in symptom severity in women with rheumatoid arthritis, temporomandibular disorders, and FM. The many symptoms of FM could be explained by the fact that there are bidirectional connections between the nociceptive system and the immune, sleep regulating and the stress regulating systems. Furthermore, it has recently been described that descending facilitatory pathways may cause widespread hypersensitivity [3]. One mechanism by which hormones may affect ►**muscle nociceptor** sensitization could be related to nerve growth factor (NGF) and one of its high-affinity receptors (trkA). TrkA receptor expression is influenced by gonadal hormones. Injection of NGF into muscle causes muscle tenderness to pressure which lasts for weeks. There has been some speculation that hormone replacement therapy may increase a woman's risk of developing musculoskeletal pain.

### Fundamentals of Musculoskeletal Pain

The manifestations of musculoskeletal pain include spread of pain and ►**referred pain**, somatosensory changes in referred pain areas, and interaction with the motor system (e.g., muscle coordination and activation, postural stability, movement initiation, and reflex pathways) [4].

Localization of pain is poor in skeletal muscles, and it is difficult to differentiate pain arising from tendons, ligaments, and bones as well as from joints and their capsules. Referred muscle pain is typically described as a sensation from deep structures in contrast to referred visceral pain, which is described as located both superficially and deeply. The characteristic pattern of referred muscle pain was initially observed by Kellgren in the late 1930s, who injected hypertonic saline into skeletal muscles and ligaments and characterised the referred pain. Similar characterization has been performed clinically when activating trigger points in various muscles [5].

It is obviously important to distinguish the painful tissue, but it may be very difficult due to poor localization and referred pain. Examples can be pain from an arthritic hip, which may refer to the thigh muscles or knee joint, carpal tunnel syndrome, which may refer to forearm muscles, and cervical spondylosis, which may refer to arm muscles. Pain from joints and their capsules tends to be more localised than myalgia, and arthralgia is often worsened by passive joint movements. Capsular pain may be present only in specific joint positions. Bone pain also tends to be poorly localized but, unlike myalgia, usually worse at night and tends to be unaffected by either movement or muscle activity.

Referred muscle pain has been known and described for more than a century and is used extensively as a diagnostic tool. The pattern of referred pain frequently follows the distribution of sclerotomes (muscle, fascia, and bone) rather than the classical dermatomes. A clear distinction between spread of pain and referred pain is not possible, and these phenomena may also share common pathophysiological mechanisms. Firm neurophysiologically-based explanations for referred pain do not exist, but it has been shown that wide dynamic range and nociceptive specific neurons in the spinal cord and brain stem of animals receive convergent afferent input from the mucosa, skin, muscles, joints, and viscera. This may cause a misinterpretation of the afferent information coming from muscle afferents and reaching high levels in the central nervous system, and hence be one reason for the diffuse and referred characteristics of muscle pain. Referred pain is a combination of central processing and peripheral input [6] as it is possible to induce referred pain to limbs with complete sensory loss due to an anesthetic block. However, the involvement of peripheral input from the referred pain area is not clear because anesthetizing this area shows inhibitory or no effects on the intensity of the referred pain. ► **Central sensitization** may be involved in the mechanism of referred pain. A complex network of extensive collateral synaptic connections for each muscle afferent fiber onto multiple dorsal horn neurons is assumed [7]. Under normal conditions, afferent fibers have fully functional synaptic connections with dorsal horn neurons as well as latent synaptic connections to other neurons within the same region of the spinal cord. Following ongoing strong noxious input, latent synaptic connections become operational, thereby allowing for convergence of input from more than one source. Animal studies show development of new and/or expansion of existing receptive fields after a noxious muscle stimulus. For example, recordings from a dorsal horn neuron with a receptive field located in the biceps femoris muscle show new receptive fields in the tibialis anterior muscle and at the foot after noxious stimulation of the tibialis anterior muscle [7]. In the context of referred pain, the unmasking of new receptive fields due to central sensitization could mediate referred pain [4]. The area of the referred pain is correlated with the intensity and duration of the muscle pain, and the appearance of referred pain is delayed (20–40 s) compared with the local muscle pain, indicating that a time-dependent process, like the unmasking of new synaptic connections (see above), is involved in the neural mediation of referred pain. Recently it has been emphasized that referred pain and central sensitization are closely related [4].

The pattern and size of referral seem to be changed in chronic musculoskeletal pain conditions. For example,

FM patients experience greater pain and larger areas of referral after experimental muscle pain compared with matched controls [4]. Interestingly, these manifestations were present in lower limb muscles where the patients typically do not experience ongoing pain. Normally, pain from the tibialis anterior is projected distally to the ankle and only rarely is it projected proximally. In FM patients, substantial proximal spread of experimentally-induced referred pain was found. Enlarged areas of referred pain in pain patients suggest that the efficacy of central processing is increased (central sensitization). Moreover, the expansion in the area of referred pain in FM patients is partly inhibited by ketamine (an *N*-methyl-d-aspartate (NMDA) receptor antagonist) targeting central sensitization. Extended areas of referred pain from the tibialis anterior muscle, indicating central sensitization, have also been shown in patients suffering from other chronic musculoskeletal pain conditions such as whiplash, low back pain, and osteoarthritis.

Somatosensory changes in areas of referred muscle pain have been reported, and it seems that the duration and intensity of pain are important for such manifestations. As well as hypoalgesia, hyperalgesia has been reported in areas of referred muscle pain. Referred muscle hyperalgesia can also be a result of visceral pain due to viscerosomatic convergence. This may occur for example in gastrointestinal, gynaecological/urological, or in chronic visceral painful conditions without known etiology (e.g., irritable bowel syndrome, endometriosis). The degree of referred muscle hyperalgesia is related to the severity of the visceral pathology and hence the degree of visceral pain. Persistent referred muscle hyperalgesia can be manifested not only by chronic conditions, but also after recurrent painful visceral attacks such as in dysmenorrhic women, where lumbar muscles are hyperalgesic to pressure, or after colic attacks following calculus of the upper urinary tract, where hyperalgesia to pressure is found in muscles in the left lumbar region [8].

#### **Assessment of Muscle Pain in Experimental and Clinical Studies with Focus on FM**

Several methods exist to assess pain sensitivity of musculoskeletal structures. The methods are based on application or induction of standardized pain to musculoskeletal structures to evaluate how sensitive the structure is to that specific stimulus modality. Such procedures can be applied to healthy volunteers in the laboratory for basic experimental studies or to patients for clinical examinations [4].

Pressure algometry is the most commonly used technique to induce muscle pain and hence assess tenderness in myofascial tissues and joints (e.g., tender points, FM, work-related myalgia, myofascial pain, strain injuries, myositis, chronic fatigue syndrome, arthritis/

arthroses, and other musculoskeletal inflammatory conditions). The American College of Rheumatology's classification criteria for FM requires 11 or more tender points to pressure out of 18 specified anatomical sites. Widespread hypersensitivity in chronic musculoskeletal pain conditions means general reduction in pressure pain thresholds assessed from many sites.

Another way to experimentally assess pain sensitivity is to apply repetitive painful pulses and investigate temporal integration/summation and the involvement of central NMDA receptors. ► **Temporal summation** means that repetitive, identical stimulation at frequencies lower than 5 Hz give rise to gradually increasing pain responses. FM patients show increased and prolonged responses to repetitive stimulation and ketamine (an antagonist of the NMDA receptor) can inhibit this.

Referred pain can be assessed experimentally from muscles by injection of various chemical substances such as hypertonic saline, capsaicin, and glutamate [4].

The balance between descending inhibition and facilitation can be assessed experimentally.

The phenomenon of descending inhibition, in which "muscle pain inhibits pain," has been extensively investigated and the heterotopic character demonstrated in many human studies (for references see [4]). Painful heterotopic conditioning stimuli (thermal, mechanical, electrical, or chemical) decrease pain perception induced by phasic noxious stimulation given elsewhere in the body. Recent data have shown that endogenous pain modulation in FM is impaired [9]. Descending facilitatory pathways originating in frontal cortical areas can contribute to generalized, increased neuronal responses along the neuraxis, suggesting that emotions such as fear may drive the development of wide spread pain and sensitization [3].

Muscle blood flow impairment during and post contractions, resulting in ischemia, has been suggested as contributing to FM pain. Other studies support that decreased relaxation between contractions, which has been found in patients with FM, means that not only static, but also dynamic muscle contractions might cause ischemic pain.

Muscle pain and musculoskeletal pain have implications on many aspects in daily life, and questionnaires for assessment of different dimensions have been developed for general and regional (e.g., back pain and neck pain) pain problems (General Function Score, Roland and Morris Disability Scale, Oswestry Pain Disability Index, West Haven-Yale Multidimensional Pain Inventory, Bournemouth questionnaire, fear avoidance beliefs, life satisfaction) [10].

Verbal assessments of musculoskeletal pain intensity and other subjective characteristics of the pain are obviously needed in clinical and experimental muscle

pain studies. Visual analog scales (VAS), verbal descriptor scales (VDS), the McGill Pain Questionnaire (MPQ), and similar scales and questionnaires may be very helpful for the assessment of perceived pain intensity and quality [10]. Musculoskeletal pain is most frequently characterised by descriptors as: "drilling," "aching," "boring," and "taut."

The intensity of musculoskeletal pain is easily measured using VAS. However, this is only a one-dimensional aspect of the pain experienced, and additional VAS should be applied to monitor unpleasantness and soreness for example. Word descriptors on the VAS are important as muscle tenderness and muscle pain may not reflect the same mechanisms. In addition to verbal assessments, psychophysical tests are valuable adjuncts for the examination of musculoskeletal pain [10].

### Summary

A significant part of the manifestations of muscle and myofascial pain (e.g., tenderness and referred pain) in chronic musculoskeletal disorders may be the result of peripheral and central sensitization. Reliable methods for quantitative induction and assessment of muscle sensitization, referred pain and muscle sensitivity are available. Sensory assessment procedures can provide complementary clinical information and give qualified clues to revise and optimize treatment regimes.

### References

1. Adler GK, Geenen R (2005) Hypothalamic-pituitary-adrenal and autonomic nervous system functioning in fibromyalgia. *Rheum Dis Clin North Am* 31:187–202, xi
2. Carli G, Suman AL, Biasi G, Marcolongo R (2002) Reactivity to superficial and deep stimuli in patients with chronic musculoskeletal pain. *Pain* 100:259–269
3. Suzuki R, Rygh LJ, Dickenson AH (2004) Bad news from the brain: descending 5-HT pathways that control spinal pain processing. *Trends Pharmacol Sci* 25:613–617
4. Graven-Nielsen T (2006) Fundamentals of muscle pain, referred pain, and deep tissue hyperalgesia. *Scand J Rheumatol* 35 (Suppl 122):1–43
5. Simons DG, Travell JG, Simons L (1999) Myofascial pain and dysfunction. The trigger point manual. Lippincott Williams and Wilkins, Philadelphia
6. Graven-Nielsen T, Arendt-Nielsen L, Mense S (eds.) 2008 Fundamentals of Musculoskeletal pain. IASP Press
7. Mense S, Simons DG (2001) Muscle pain. Understanding its nature, diagnosis, and treatment. Lippincott Williams and Wilkins, Philadelphia
8. Giamberardino MA (1999) Recent and forgotten aspects of visceral pain. *Eur J Pain* 3:77–92
9. Julien N, Goffaux P, Arsenault P, Marchand S (2005) Widespread pain in fibromyalgia is related to a deficit of endogenous pain inhibition. *Pain* 114:295–302
10. Turk DC, Melzack R (1992) Handbook of pain assessment. Guilford, New York

## Muscle-specific Receptor Tyrosine Kinase (MuSK)

### Definition

In the development of the neuromuscular junction (NMJ), acetylcholine clustering at endplates depends on MuSK as knockout mice fail to form NMJs and die at birth. MuSK may mediate acetylcholine receptor (AChR) pre-patterning by agrin-dependent and -independent activation pathways.

- ▶ Agrin
- ▶ Acetylcholine
- ▶ Neuromuscular Junction (NMJ)
- ▶ Synapse Formation: Neuromuscular Junction Versus Central Nervous System

## Muscle Spindle

### Definition

A stretch-sensitive muscle receptor. The mammalian muscle spindle is 2–6 mm long and is attached at each end to the (extrafusal) skeletal muscle fibers that envelop it. Two or more sensory endings are located within a capsule near the middle of the spindle. When extrafusal muscle fibers lengthen and shorten, the spindles stretch and shorten too, which modulates the firing rates of their sensory endings. Much of the spindle comprises intrafusal muscle fibers whose sole function is to alter the stretch-sensitivity of the spindle's sensory endings. These muscles fibers are activated by  $\gamma$ -motoneurons (also known as fusimotor neurons). There are typically 100–200 muscle spindles in a medium-sized muscle, each innervated by up to 6 sensory afferents (group Ia and II afferents) and 10 fusimotor neurons.

- ▶ Feedback Control of Movement
- ▶ Motoneuron
- ▶ Proprioception: Role of Muscle Receptors

## Muscle Sympathetic Nervous Activity

### Definition

Muscle sympathetic nervous activity (MSNA) refers to neural traffic of sympathetic nerves that innervate skeletal

muscles, regulating vascular resistance in skeletal muscles and controlling systemic blood pressure.

- ▶ Autonomic Function in Space
- ▶ Sympathetic Pathways

## Muscle Synergies

ANDREA D'AVELLA

Department of Neuromotor Physiology, Santa Lucia Foundation, Rome, Italy

### Definition

The term “synergy” literally “working together,” has been used in the motor control literature with various meanings. Here a muscle synergy is defined as the coordinated recruitment of a group of muscles with specific activation balances or specific activation waveforms. Recent experiments have indicated that many motor behaviors are controlled through the flexible combination of a small number of muscle synergies. This mechanism is believed to simplify the selection of the appropriate muscle commands for a given behavioral goal.

### Characteristics

To control goal-directed movements the central nervous system (CNS) must map sensory input into motor output. For example, ▶reaching movements usually require selecting the appropriate muscle activation patterns to move the arm to visually specified targets. This transformation is thought to be performed by an ▶internal model implemented in the neural circuits. However, given the complexity of the computations required to select the appropriate activation waveforms of many muscles acting on many articulated body segments, it is not clear what mechanisms allow for an efficient implementation of an internal model. One possibility is that this mapping is simplified by a low-dimensional representation of the motor output. The key idea is that, if all useful muscle patterns can be constructed by the combination of a small number of basic elements, selecting the appropriate muscle pattern for a given goal requires only determining how these elements are combined.

### Two Types of Synergies

Muscle synergies are suitable basic elements for constructing a low-dimensional representation of the motor output because they capture a set of features

shared by a variety of muscle patterns. Such features can be identified in the spatial domain and in the temporal domain. In the spatial domain, i.e. across muscles, a muscle synergy captures a specific relationship in the muscle activation amplitudes. Considering a set of  $D$  muscles, a muscle synergy can be expressed as a  $D$ -dimensional vector  $\mathbf{w}$  of weighting coefficients that specify the activation balance among the muscles (Fig. 1a).

Different levels of activation may be generated by a single muscle synergy by scaling in amplitude the entire vector:

$$\mathbf{m} = c \mathbf{w} \quad (1)$$

where  $\mathbf{m}$  is a  $D$ -dimensional vector that specifies the recruitment level of each muscle and  $c$  is a scaling coefficient (Fig. 1b, columns 1–3). More generally, a set of  $N$  synergies,  $\{\mathbf{w}_i\}_{i=1\dots N}$ , can generate many distinct muscle patterns by linear combination:

$$\mathbf{m} = c_1 \mathbf{w}_1 + c_2 \mathbf{w}_2 + \dots + c_N \mathbf{w}_N = \sum_{i=1}^N c_i \mathbf{w}_i \quad (2)$$

where  $c_i$  is the scaling coefficient for the  $i$ -th synergy (Fig. 1b, rows 4–6).

Since the muscle activation vectors involved in most behaviors are time-dependent, synergistic relationships may also be found in the temporal domain. With respect to time, a synergy may be time-invariant or time-varying. A synergy is time-invariant if the same

muscle activation balance, expressed by a vector  $\mathbf{w}$ , holds at all times, i.e. for all the time-varying activation vectors comprising a muscle patterns. If all the synergies are time-invariant, eq. 2 can be written, taking time into account, as:

$$\mathbf{m}(t) = \sum_{i=1}^N c_i(t) \mathbf{w}_i \quad (3)$$

where  $\mathbf{m}(t)$  is the muscle activation at time  $t$  and  $c_i(t)$  is the scaling coefficient for the  $i$ -th synergy at time  $t$  (Fig. 1c). Since each time-invariant synergy contributes to the waveform of different muscles with the same  $c_i(t)$  waveform, the muscle waveforms associated with each synergy are synchronous. In contrast, a time-varying synergy is comprised by a collection of waveforms, each one specific for a muscle, and thus not necessarily synchronous (Fig. 2a).

These waveforms can be expressed by a time-varying synergy vector  $\mathbf{w}(t)$  and eq. 2 can be written as:

$$\mathbf{m}(t) = \sum_{i=1}^N c_i \mathbf{w}_i(t - t_i) \quad (4)$$

with one scaling coefficient ( $c_i$ ) and one time delay ( $t_i$ ) for each synergy. In this case, the time dependence of the muscle activation waveforms is captured by the temporal structure of the synergies and by their relative delays (Fig. 2b). Time-varying synergies represent parsimoniously the motor output because, once the

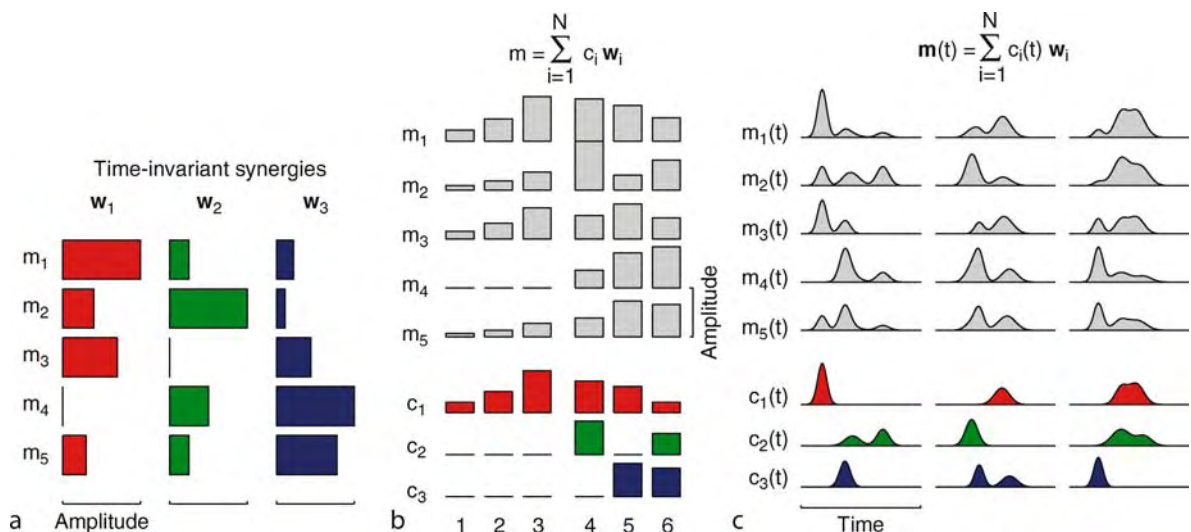

**Muscle Synergies. Figure 1** Generation of muscle patterns by combination of time-invariant synergies. (a) Three different activation balances among five muscles are expressed by three vectors ( $\mathbf{w}_i$ ), whose components are represented by horizontal bars of different lengths. (b) Different muscle patterns (1–6) are generated by multiplying the three vectors by three scaling coefficients ( $c_i$ ) and summing them together. (c) A time-varying muscle pattern ( $\mathbf{m}(t)$ ) is generated by combining the synergies with time-varying scaling coefficients ( $c_i(t)$ ). Different patterns can be obtained by changing the scaling coefficient waveforms.

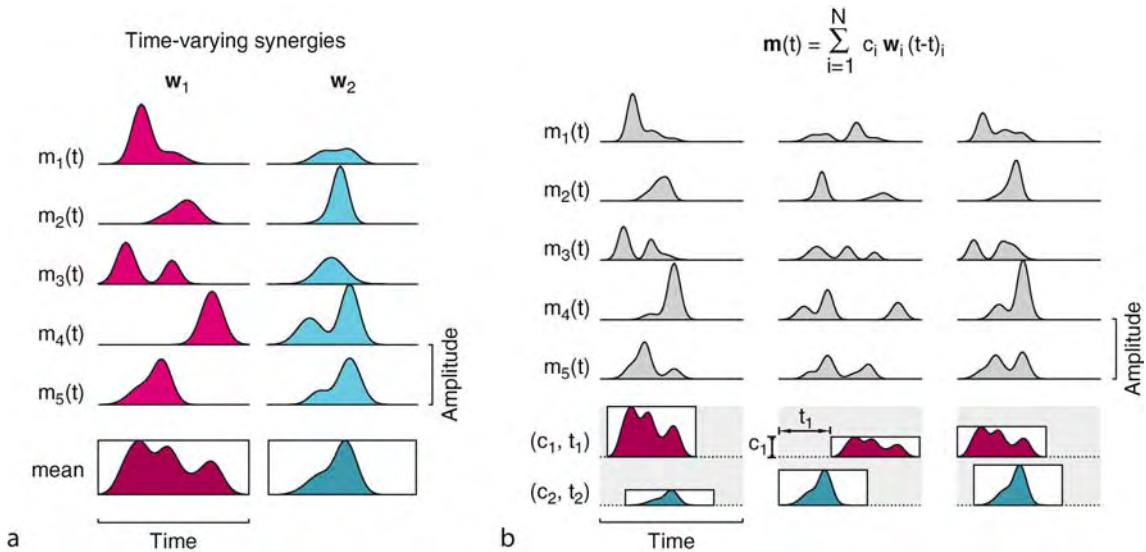

**Muscle Synergies. Figure 2** Generation of muscle patterns by combination of time-varying synergies. (a) Each one of the two synergies illustrated is composed by a collection of muscle activation waveforms. The profile inside the rectangle below each synergy represents the mean activation waveform for that synergy. (b) A time-varying muscle patterns ( $m(t)$ ) is generated by multiplying all waveforms of each synergy by a single scaling coefficient ( $c_i$ ), shifting them in time by a single delay ( $t_i$ ), and summing them together. In this example, different patterns are obtained by changing two scaling coefficients and two delays.

synergies are given, a few scaling and delay coefficients are sufficient to specify many muscle patterns.

### Muscle Synergy Identification

Muscle synergies provide a useful representation of the motor output if they can generate all muscle patterns observed during the performance of either a task in variety of conditions or multiple tasks. Thus, to test the validity of a synergy model it is necessary to identify a set of synergies from the observed muscle patterns and to show that they capture most of the variability in the data.

The identification of the synergies according to a model that allows for the simultaneous recruitment and combination of multiple synergies (eq. 2) requires a multivariate decomposition algorithm. For time-invariant synergies, the identification of the combination coefficients and synergies of eq. 3 can be obtained with a number of decomposition algorithm such as Principal Component Analysis (PCA), Factor Analysis (FA), Independent Component Analysis (ICA), and Non-negative Matrix Factorization (NMF) [1]. The number of synergies ( $N$ ) is a free parameter for each decomposition algorithm. While the selection of this parameter is performed with different criteria for each algorithm, in general the goal is to determine the minimum number of synergies that explain all the structured variation in the data, interpreting the remaining unstructured variation as noise. Often this minimum number is determined by inspecting a plot of the reconstruction error as a

function of the number of synergies. As the number of synergies increases the reconstruction error decreases and the number at which the error curve changes slope, indicating that additional synergies only explain a small additional amount of variation due to noise, is usually taken as correct number of synergies. The identification of time-varying synergies, according to the model of eq. 4, can be accomplished with the same methods used for time-invariant synergies if the simplifying assumption that the synergies are not time-shifted relative to each other is introduced [2]. More generally, to identify a set of time-varying synergies that can be time-shifted with respect to each other, it is possible to use an iterative optimization algorithm [3].

### Experimental Evidence

Qualitative observations of stereotyped muscle activity patterns in specific tasks, suggestive of a synergistic organization, have long been reported. However, whether muscle synergies are fixed or require task-dependent flexible adjustment has been a controversial issue. Recently, systematic investigations and quantitative analyses of the muscle synergies according to synergy combination models have addressed this issue with a new perspective. Studies conducted on frogs, cats, and humans have provided evidence that the CNS flexibly combines fixed muscle synergies for generating the muscle patterns necessary to perform many motor tasks and behaviors.

Electromyographical (EMG) activity recorded from many hindlimb muscles of spinalized frogs during withdrawal reflexes [4], decerebrated frogs during spontaneous behavior [5], and intact frogs during defensive kicking [3] and locomotion, has revealed a synergistic organization. These studies have shown that a variety of muscle patterns used in different behaviors are generated by the combination of a small number of time-invariant and time-varying synergies. For example, 90% of the variability in the EMG responses associated with the withdrawal reflexes evoked by skin stimulation at a variety of sites on the frog limb is explained by the combination of four time-invariant synergies.

The study of postural control in cats and humans has also provided evidence for muscle synergies. The activations of cat hindlimb muscles during postural responses to perturbations of the support surface (translations and rotations in multiple directions) are captured by the combination of a five time-invariant synergies [6]. These muscle synergies are associated with specific force vectors applied by the paw against the support, suggesting that they encode task-level biomechanical variables. In humans, the muscle patterns used for shifting the center of pressure during balancing while standing are constructed by combinations of three time-invariant synergies [7].

The muscle patterns in leg and trunk muscles during human locomotion at different speeds and with different fractions of the body weight supported by a harness are accounted by the combination of five time-invariant synergies [8]. The time-varying amplitude scaling coefficients, once the muscle patterns are time-normalized to equal gait cycle duration, have similar waveforms across conditions.

Time-varying muscle synergies have been identified in the patterns of activation of extrinsic and intrinsic hand muscles during fingerspelling [2]. The synergy, identified with PCA, which explains the largest fraction of the data variation has asynchronous waveforms with activity waves unfolding in time across muscles.

Finally, there is evidence that the combinations of time-varying muscle synergies are used for controlling reaching movements in humans [9]. The phasic EMG patterns recorded in arm and shoulder muscles during fast reaching movements to targets arranged in different directions on two vertical planes are generated scaling in amplitude and shifting in time four or five time-varying muscle synergies. The amplitude modulation of the synergy has a simple dependence on the direction of movement, well captured by a cosine function.

In summary, a growing number of studies are unveiling the existence of regularities in the spatiotemporal organization of the muscle patterns observed during the performance of a variety of tasks in many conditions.

These regularities are well described by a synergy combination model suggesting that the CNS uses a low-dimensional representation of the motor output and simple combination rules for mastering the complex task of selecting the appropriate muscle pattern for achieving a desired goal.

### ► Postural Synergies

## References

1. Tresch MC, Cheung VC, d'Avella A (2006) Matrix factorization algorithms for the identification of muscle synergies: evaluation on simulated and experimental data sets. *J Neurophysiol* 95(4):2199–2212
2. Klein Breteler MD, Simura KJ, Flanders M (2007) Timing of muscle activation in a hand movement sequence. *Cereb Cortex* 17(4):803–815
3. d'Avella A, Saltiel P, Bizzi E (2003) Combinations of muscle synergies in the construction of a natural motor behavior. *Nat Neurosci* 6(3):300–308
4. Tresch MC, Saltiel P, Bizzi E (1999) The construction of movement by the spinal cord. *Nat Neurosci* 2(2):162–167
5. Hart CB, Giszter SF (2004) Modular premotor drives and unit bursts as primitives for frog motor behaviors. *J Neurosci* 24(22):5269–5282
6. Torres-Oviedo G, Macpherson JM, Ting LH (2006) Muscle synergy organization is robust across a variety of postural perturbations. *J Neurophysiol* 96(3):1530–1546
7. Krishnamoorthy V, Goodman S, Zatsiorsky V, Latash ML (2003) Muscle synergies during shifts of the center of pressure by standing persons: identification of muscle modes. *Biol Cybern* 89(2):152–161
8. Ivanenko YP, Poppele RE, Lacquaniti F (2004) Five basic muscle activation patterns account for muscle activity during human locomotion. *J Physiol* 556(Pt 1):267–282
9. d'Avella A, Portone A, Fernandez L, Lacquaniti F (2006) Control of fast-reaching movements by muscle synergy combinations. *J Neurosci* 26(30):7791–7810

---

## Muscle-tendon Elasticity

### ► Muscle and Tendon Energy Storage

---

## Muscle-tendon Unit

### ► Tendon

## Muscle: The Molecular Motor

C. J. HECKMAN

Department of Physiology and Department of Physical Medicine and Rehabilitation, Feinberg School of Medicine, Northwestern University, Chicago, IL, USA

### Definition

Muscle consists of an exceedingly complex array of molecules. The exertion of force and the production of movements thus rely on the summation of forces and movements of many molecules. The sarcomere provides the basic structural organization of a muscle fiber (see Fig. 1 in ►Muscle). From the perspective of the molecular motor, the sarcomere structure can be divided into three components: the thick filaments (made of up myosin molecules), the thin filaments (made of actin molecules), and the structural proteins that transmit forces to the ends of the sarcomere and among sarcomeres. The primary basis of the molecular motor for movement consists of a configuration change in myosin. This configuration change, however, does not produce movement or force unless the myosin is attached to actin; the forces so produced are transmitted via the structure of the sarcomere to neighboring sarcomeres and so on through to the tendon (see ►Length-Tension) and even to other muscles (see ►Intramuscular myofascial force transmission and Epimuscular Myofascial Force Transmission and Intermuscular Interaction).

### Characteristics

#### Quantitative Description

The myosin in muscle is one of a large set of molecular motors consisting of various families of myosins, kinesins and dyneins. Myosins move along actin filaments; kinesins and dyneins along microtubules [1]. These motors provide functions such as moving substrates within the cell. The myosin II family in muscle is unique in being part of the structure of the sarcomere, and produces summed movements that generate the huge forces that muscles are capable of producing. Muscle myosin contains a long helix, which with other myosin molecules, forms the thick filament of the sarcomere. A portion of this helix (called the S2 subfragment) protrudes from the thick filament and connects to a head region (S1 subfragment). For some years, it was assumed that the configuration change in myosin that generated movement involved rotation of the S1 head with respect to actin at the attachment site between these two molecules. However, studies from a number of labs have now demonstrated that the angle between the attached part of the S1 head and actin stays constant during force generation [2,3–5]. Instead, the configuration change occurs within the S1 head. The S1 head comprises of two distinct regions: a regulatory domain that contains the myosin light chains and a catalytic domain for hydrolysis of ATP to ADP + Pi. Force is generated when the angle between the regulatory domain and the catalytic domain changes. The regulatory domain rotates with respect to the catalytic domain, as shown by the cartoon in Fig. 1.

This is known as the “lever arm” hypothesis, with the lever arm being the regulatory domain of S1.

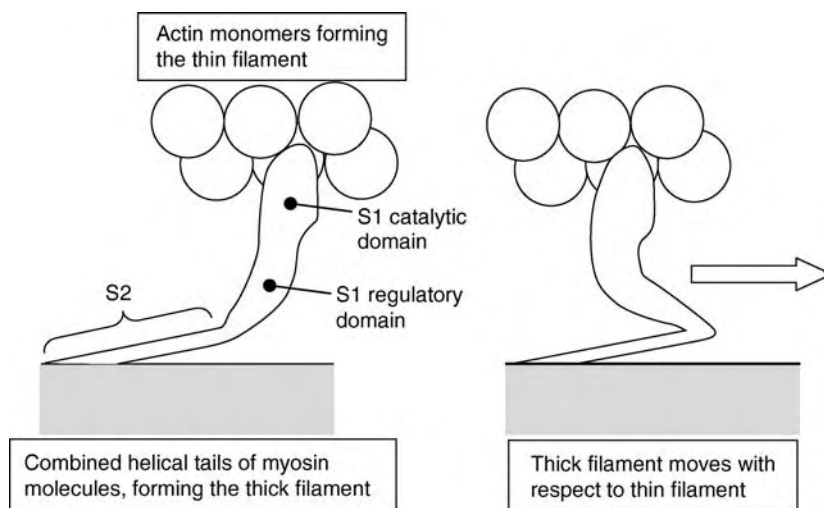

Muscle: The Molecular Motor. Figure 1



The hydrolysis of ATP is of course essential for this configuration change. The basic features of how the steps of hydrolysis of ATP are related to the contraction cycle is as follows: (i) binding of ATP to S1 catalytic domain: unbinding of actin and myosin; (ii) hydrolysis of ATP to ADP and Pi: S1 lever arm straightens, moving S1 head to next attachment site; and (iii) release of ADP and Pi from the S1 head: lever arm bends to produce movement of thin versus thick filaments (this is the step illustrated in Fig. 1) [2,5]. Myosin is only tightly bound to actin for about 5% of the total crossbridge cycle; the rest of the cycle involves either weak binding or the unbound state [5]. Speed of the crossbridge cycle is related both to the various subforms of the myosin ATPase, as well as to differences in the myosin light chains. Immunohistochemical techniques to identify these subtypes are the basis of the standard identification of type I (slow), IIa and IIb (both fast) muscle fibers.

### Higher Level Structures

Myofilament, myofibril, muscle fiber, muscle.

### Higher Level Processes

Forces are also transmitted between muscles (see ►Epimuscular Myofascial Force Transmission and Intermuscular Interaction).

### Process Regulation

The interaction of actin and myosin is dependent on calcium; release of calcium is controlled via action potentials from motoneurons (see ►Neuromuscular Junction).

### Function

The function of the molecular motor is clear: generation of movement.

### Pathology

Genetic mutations in the molecular machinery produce severe pathological deficits. Nemaline myopathies can be produced by genetic defects in action, tropomyosin and other sarcomere proteins.

### References

1. Schliwa M, Woehlke G (2003) Molecular motors. *Nature* 422(6933):759–765
2. Geeves MA, Holmes KC (1999) Structural mechanism of muscle contraction. *Annu Rev Biochem* 68:687–728
3. Highsmith S (1999) Lever arm model of force generation by actin-myosin-ATP. *Biochemistry* 38(31):9791–9797
4. Tyska MJ, Warsaw DM (2002) The myosin power stroke. *Cell Motil Cytoskeleton* 51(1):1–15
5. Spudich JA (2001) The myosin swinging cross-bridge model. *Nat Rev Mol Cell Biol* 2(5):387–392

## Muscle Tone

### Definition

Muscle tone is defined as the resistance that a relaxed muscle opposes to passive stretch.

► Postural Muscle Tone

## Muscle Torque

### Definition

The product of muscle force and muscle moment arm.

► Impedance Control

## Muscle Twitch

### Definition

An action potential in a skeletal or oculomotor motoneuron axon produces, after neuromuscular synaptic transmission, a propagating action potential in the innervated muscle fibers followed by an increase in intracellular calcium. The calcium activates the actin-myosin cross-bridges and the buildup of force (a process called excitation-contraction coupling). Force peaks at a characteristic “twitch time” that is dependent on the rate of calcium release (fast in most skeletal and extraocular muscles) and the interaction between the muscle’s series elastic component (embodied in the connective tissue and muscle proteins) and the force-velocity relationship. In the initial part of the twitch, the muscle contracts rapidly internally as the series elastic component stretches, so less force is produced. Force declines slowly after the peak due to the re-sequestering of calcium. The time course of the contraction depends on the muscle fiber type (type-I, type-II, and subtypes) to the extent that the terms “slow-twitch” and “fast-twitch” fibers are also used as synonyms of type-I and type-II respectively.

► Actin

► Cross-bridge Theory

► Excitation-contraction Coupling

► Force-velocity Relationship of Skeletal Muscle

► Myosin

## Muscle Unit

### Definition

The set of striated muscle fibers in a specific anatomical muscle that receives innervation from a single motoneuron.

► Motor Units

## Muscular Dystrophy

### Definition

A group of ~40 inherited heterogeneous disorders that result in progressive muscle weakness and muscle wasting.

► Duchenne Muscular Dystrophy

## Muscular Stiffness

T. RICHARD NICHOLS,  
CLOTILDE M. J. I. HUYGHUES-DESPOINTES  
Department of Physiology, Emory University, Atlanta,  
GA, USA

### Synonyms

Elasticity; Impedance; Stretch resistance

### Definition

Muscular stiffness is defined as the change in force divided by the corresponding change in length, when the length change is imposed by an external agent or by a change in the external load on the muscle. In the present context, stiffness is time-varying and therefore has dynamic attributes. Classically, stiffness refers only to the elastic, and therefore static, component of impedance. However, muscular properties are nonlinear, and therefore muscular impedance cannot easily be partitioned into components corresponding to the derivatives of position. Researchers in motor systems have chosen to retain the term “stiffness” to describe the resistance of muscle to length change.

## Characteristics

### Quantitative Description

#### Stiffness of Inactive Muscle

The stiffness of inactive skeletal muscle is dominated by the elastic properties in-parallel and in-series connective tissue. This stiffness increases at long muscle lengths and can effectively limit extreme joint angles, but is normally low enough through the physiological range of the muscle so as not to offer significant resistance to joint motion. However, inactive muscle can offer some resistance for small disturbances. Evidence does exist that some cross-bridges that cycle either slowly or not at all remain attached at rest. The additional stiffness contributed by these cross-bridges is reduced by stretching the muscle beyond the working range of the cross-bridges or by prior activation of the muscle. These non-cycling cross-bridges can reform over a period of seconds, and re-establish elevated stiffness for small (1% of muscle length) amplitudes of stretch. These “thixotropic” properties of inactive muscle have been observed in experiments on animals and human subjects [1], and may be important during the maintenance of steady postures.

#### Stiffness of Active Muscle

When a muscle is activated, the stiffness becomes considerably larger through the physiological range of joint angles. The magnitude of this stiffness, which is intrinsic to the contracting muscle, depends on a number of factors, including the level of motor unit recruitment, length and force, and movement history. The stiffness of actively contracting muscle is thought to arise from the mechanical properties of cycling cross-bridges. Cross-bridges are believed to have spring-like properties, so they contribute to muscular stiffness when attached. In a muscle fiber with a population of cycling cross-bridges, the stiffness of the fiber depends on the average number of attached cross-bridges and the rate of turnover. The contribution of a given cross-bridge to the stiffness of the muscle fiber increases with the length change over which it is attached. For a given rate of stretch, this contribution will decrease with an increase in the rate of turnover. These basic principles can be used to explain how muscular stiffness changes under different contractile conditions and how it depends on the fiber type composition of the muscle.

If, after a period of isometric contraction, a muscle fiber is stretched by a small amount so that the length change remains within the working range of the attached cross-bridges, the muscle fiber exhibits spring-like behavior known as *short-range stiffness*. If the disturbance carries the muscle fiber beyond the working range of cross-bridges, then stiffness abruptly declines as cross-bridges are mechanically disrupted [2] (Fig. 1).

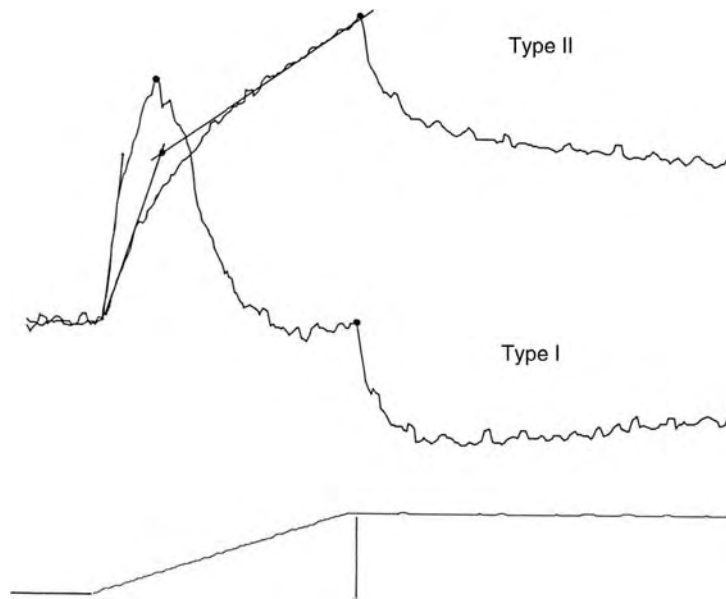

**Muscular Stiffness. Figure 1** Responses of chemically-skinned muscle fibers to constant velocity stretch. The fibers were submaximally activated to the same background force levels in solutions containing calcium and ATP. Stretches lasting 100 ms and 0.05 muscle lengths in amplitude were delivered after periods of isometric contraction in activating solutions. The type II fiber was obtained from the lateral gastrocnemius muscle and the type I fiber from the soleus muscle of the cat. Both fibers show short-range stiffness followed by yielding, but the short range stiffness (indicated by the initial *fitted lines*) and yield were both greater in the type I fibers. This figure was modified from Fig. 2 of [3].

The extent of this decline, or yield, and short-range stiffness depend on the rate of stretch and on the rate of cross-bridge turnover. Increasing the rate of stretch can lead to an increase in short-range stiffness, since the cross-bridges remain attached over a larger change in length [3]. Yield can also increase since there is more synchronous detachment and a decrease in the time for reattachment relative to the rate of stretch. An increase in the rate of turnover would lead to a small decrease in stiffness since cross-bridges remain attached for shorter periods of time and a decrease in yield occurs due to the more rapid reattachment. Therefore, a previously isometric muscle responds to forcible lengthening with short-range stiffness followed by a yield that in some cases can result in a transient reduction in force (Fig. 1). One way to summarize this behavior is that active muscle shows significant damping [4], albeit nonlinear damping, which can have a stabilizing influence on the musculoskeletal system. If the muscle is allowed to shorten instead, force declines throughout the shortening, but the stiffness is also greater over the short range. When the responses to lengthening and shortening are compared, stiffness is greater during shortening [5].

If the muscle fiber is perturbed after a period of motion, its mechanical properties are different from those described above. Constant motion leads

to increased turnover and a tendency for cross-bridges to be in positions of lower stress than in the isometric state. As might be expected, the yield decreases and the short range is extended. As a result, the responses of the muscle to length change more closely resemble those of linear springs with some damping [6] than the highly nonlinear behavior described above (Fig. 2).

Under conditions of quiet standing, stability is achieved in part by intrinsic mechanical properties of muscle, including thixotropic properties of inactive muscle, and short-range stiffness and damping of active muscle. During ongoing movements, muscular stiffness is less dependent on amplitude of the perturbation, and thixotropy in inactive muscles is greatly reduced, in keeping with the requirements of a wide dynamic range of joint motion.

#### **Dependence of Muscular Stiffness on Motor Unit Composition and Recruitment**

Muscular stiffness is strongly dependent on the motor unit composition of a muscle and the level of recruitment in the muscle. For muscles that are used for standing or braking and that are rich in slow twitch muscle fibers, the cycling rate of cross-bridges tends to be lower. Consequently, these predominantly slow-twitch muscles exhibit higher short range stiffness and yield to a greater extent than muscles with substantial

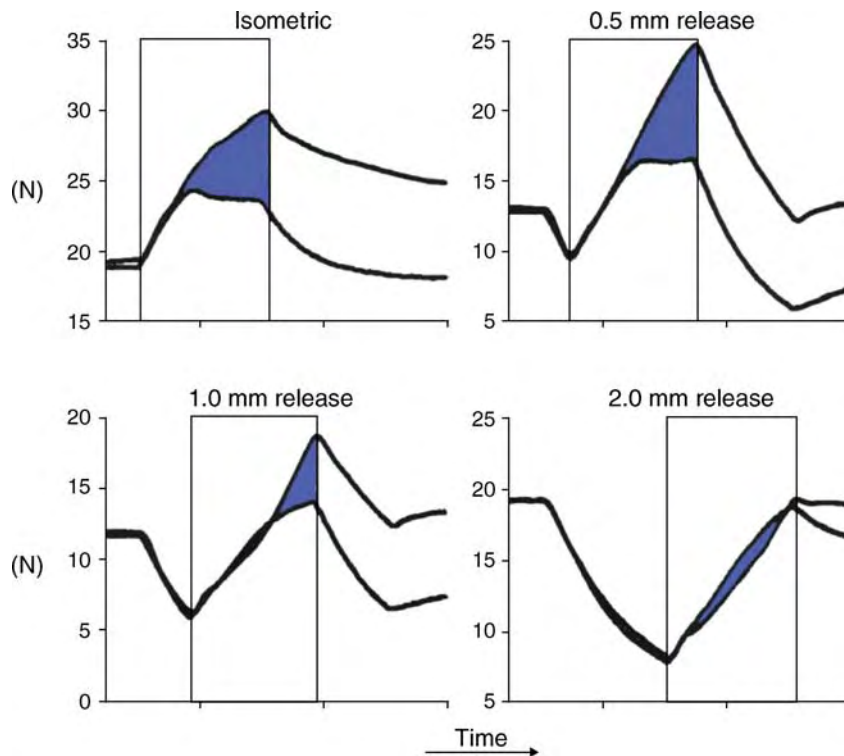

**Muscular Stiffness. Figure 2** Dependence of muscular stiffness on movement history. Reflexive and areflexive soleus muscles from a decerebrate cat were subjected to 2 mm ramp stretches following releases of progressively larger amplitude, from 0 to 2 mm. In each panel, the lower trace corresponds to the areflexive muscle. The portions of the responses obtained during the 2 mm stretch are denoted by the rectangles. Note that the yields of the intrinsic responses become progressively small and more delayed as the prior release increases. Reflex action also becomes reduced and delayed, until there is no contribution from the reflex with the largest prior release. This figure is modified from Fig. 1a of [6].

populations of fast-twitch muscle fibers (see Fig. 1). As motor units are recruited into activity, force and stiffness both increase. A dependence of stiffness on force contrasts with the property of a linear spring that stiffness is constant with force. Intrinsic muscular force and stiffness increase together with recruitment, but not in exact proportion (Fig. 3).

Stiffness increases slightly less rapidly than force due to the presence of series elastic elements [7,8]. The consequence of these nonlinear properties is that high intrinsic stiffness can only be achieved by recruiting many motor units. Co-contraction is one strategy for increasing the stiffness of a joint. Under these conditions, agonist and antagonistic muscles are activated together to provide high joint stiffness with no net joint torque. At low background activity, such as occurs during quiet standing, intrinsic muscular stiffness is low.

### Structural Regulation

Muscular stiffness is influenced by the architecture of the muscle. Stiffness increases with the cross-sectional

area of muscle and decreases with length, according to the in-parallel and in-series arrangement of sarcomeres, respectively.

### Process Regulation

The mechanical properties of muscle are subject to local control by reflex circuits in the spinal cord. The initial response of a muscle, and therefore the musculoskeletal system, to a mechanical perturbation depends on the intrinsic mechanical properties described above. After a brief delay, feedback from muscle spindle receptors can increase or decrease the recruitment of motor units as well as influence firing rate modulation in response to muscle lengthening or shortening, respectively, through the monosynaptic (stretch) reflex. Muscle spindle receptors, which contain specialized muscle fibers (intrafusal muscle fibers), signal length changes and the dynamics of length change. Due to the high sensitivity of the primary receptors of the muscle spindle, the monosynaptic reflex can recruit substantial numbers of motor units even at low forces, making the stiffness

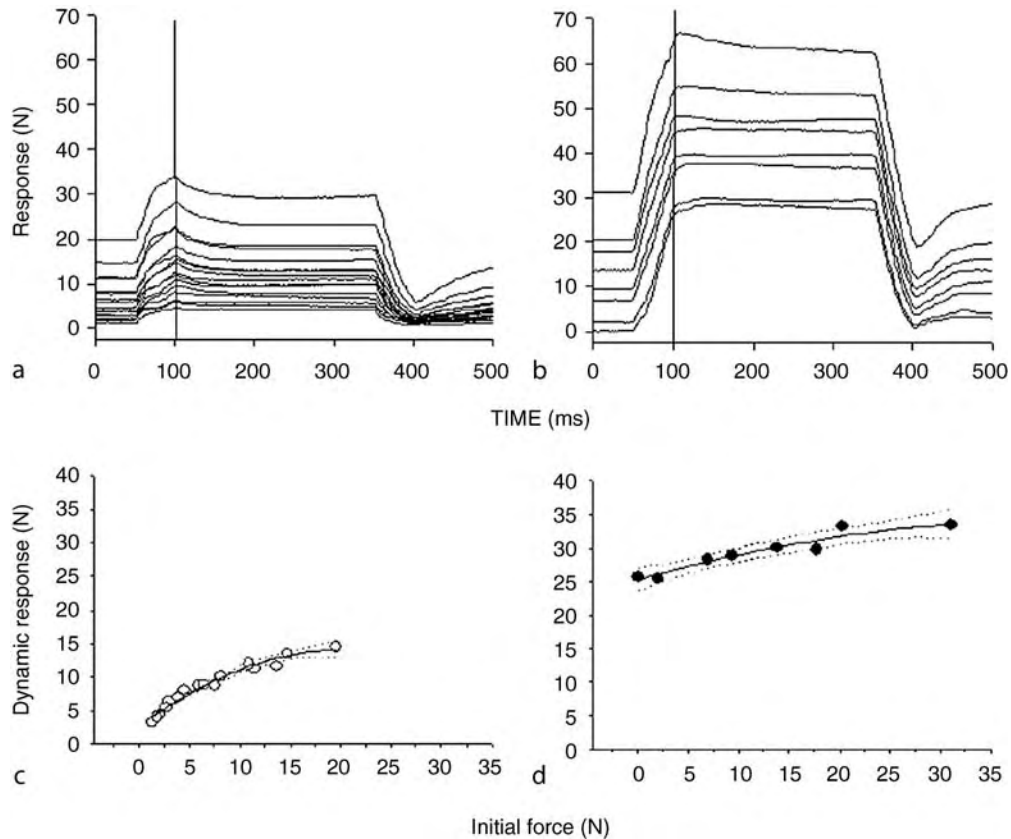

**Muscular Stiffness. Figure 3** Dependence of muscular stiffness on initial force. Reflexive and areflexive gastrocnemius muscles of a decerebrate cat were subjected to ramp-and-hold stretches. (a) Responses of muscles in which reflexes were disrupted by prior reinnervation of the muscle obtained at different initial forces. Dynamic responses were computed by subtracting the initial (pre-stretch) force for each trace from the corresponding force measured at the time of ramp completion denoted by the vertical line. These responses are shown plotted against initial force in (c). (b) Responses of untreated contralateral muscles with intact reflexes. Note the greater magnitude and less abrupt yielding of these responses compared to those shown in (a). The dynamic responses are shown plotted against initial force in (d). The amplitude of the ramps was 2 mm, so dynamic stiffness (N/mm) can be computed by dividing the dynamic responses by 2. These plots indicate that intrinsic muscular stiffness increases with force. In the presence of reflexes, stiffness is larger and less dependent on force. This figure is modified from Fig. 3 of [7]. Further experimental details can be found in this paper.

of the muscle-reflex system less dependent on background force than intrinsic muscular stiffness (Fig. 3). As stiffness remains force-dependent to some extent, however, co-contraction still results in an increase in the stiffness of the joint.

Due to the filtering properties of the intrafusal muscle fibers, the length signals are subject to similar history-dependent properties as found in extrafusal muscle fibers as described above [9]. The monosynaptic reflex compensates for muscular yield through recruitment of additional motor units, but compensates less during ongoing motion when the yield is less [6] (Fig. 2). In these ways, the stretch reflex can regulate muscular stiffness over a wide range of forces and movement histories, and therefore reduce the computational burden on the central nervous system.

### Function

The initial response of a muscle to length change is determined by the intrinsic stiffness of the muscle. Reflex pathways then regulate the response after a brief delay. These intrinsic and extrinsic mechanisms regulate the mechanical response properties of joints in a three-dimensional manner according to the attachments of the muscles crossing the joint. For a given axis or rotation, the stiffness of synergistic and antagonistic muscles add together to determine the stiffness of the joint. Muscular stiffness influences interjoint coordination by virtue of the regulation of individual joints, as well as by the mechanical coupling of multi-articular muscles. These intrinsic and extrinsic mechanisms therefore influence the endpoint stiffness of the limb and coordination of the component joints.

## Pathology

Muscular growth and maintenance are strongly influenced by muscular load and length [10]. In disorders that involve prolonged shortening, such as spastic diplegia, muscle fibers may become shortened with the consequent equine posture. In addition, the tendon will account for a greater proportion of total muscle length. The shortened muscle fibers will consequently have reduced shortening velocity, increased active stiffness, and increased overall stiffness.

## References

1. Proske U, Morgan DL, Gregory JE (1993) Thixotropy in skeletal muscle and in muscle spindles: a review. *Prog Neurobiol* 41:705–721
2. Joyce GC, Rack PMH, Westbury DR (1969) The mechanical properties of cat soleus muscle during controlled lengthening and shortening movements. *J Physiol* 204:461–474
3. Malamud JG, Godt RE, Nichols TR (1996) Relationship between short-range stiffness and yielding in type-identified, chemically skinned muscle fibers from the cat triceps surae muscles. *J Neurophysiol* 76:2280–2289
4. Lin DC, Rymer WZ (1993) Mechanical properties of cat soleus muscle elicited by sequential ramp stretches: implications for control of muscle. *J Neurophysiol* 70:997–1008
5. Nichols TR, Houk JC (1976) The improvement in linearity and regulation of stiffness that results from action of the stretch reflex. *J Neurophysiol* 39:119–142
6. Huyghues-Despointes CM, Cope TC, Nichols TR (2003b) Intrinsic properties and reflex compensation in reinnervated triceps surae muscles of the cat: effect of movement history. *J Neurophysiol* 90:1547–1555
7. Huyghues-Despointes CM, Cope TC, Nichols TR (2003a) Intrinsic properties and reflex compensation in reinnervated triceps surae muscles of the cat: effect of activation level. *J Neurophysiol* 90:1537–1546
8. Sandercock TG (2000) Nonlinear summation of force in cat soleus muscle results primarily from stretch of the common-elastic elements. *J Appl Physiol* 89:2206–2214
9. Haftel VK, Bichler EK, Nichols TR, Pinter MJ, Cope TC (2004) Movement reduces the dynamic response of muscle spindle afferents and motoneuron synaptic potentials in rat. *J Neurophysiol* 91:2164–2171
10. Burkholder TJ (2003) Permeability of C2C12 myotube membranes is influenced by stretch velocity *Biochem Biophys Res Commun* 305:266–270

## Musculoskeletal Pain

► Muscle Pain, Including Fibromyalgia

## MuSK

### Definition

► Muscle-specific Receptor Tyrosine Kinase (MuSK)

## Mutagenesis, Structure-Function

### Definition

The process by which selective changes to the amino acid sequence of a protein are made and the functional consequences of such mutations then determined. This process is used to identify functionally important parts of proteins (e.g. ion channels, enzymes), and thus provides insight into the molecular mechanisms by which these proteins function. Such changes are usually made to a cDNA clone of the target protein using recombinant DNA techniques. The choice of which residues to alter is often guided by predictive models of the protein as made by hydrophathy or secondary structure analysis of the primary amino acid sequence. Assessment of the functional consequences of such mutations is usually done by expressing the protein in a cell type that is null for this protein.

► Heterologous Expression

## Mutual Information Maximization

### Definition

A principle of feature extraction and dimension reduction of multi-dimensional data from multiple information sources. Effective low dimension features are obtained by transforming data to maximize mutual information between them.

## Myasthenia Gravis

MASAHARU TAKAMORI

Neurological Center, Kanazawa-Nishi Hospital and Kanazawa University, Kanazawa, Japan

### Definition

Myasthenia gravis (MG) is a disease of neuromuscular transmission, with clinical features of weakness and

fatigue that is mainly caused by an autoimmune response to the nicotinic ▶acetylcholine receptor (AChR) in skeletal muscle (Fig. 1).

Anti-AChR antibodies directed against the specific sites of AChR molecular structure, depending on their pathogenic actions, are detected in the sera of 80–90% of generalized MG patients.

The remaining 10–20% of MG patients lack anti-AChR antibodies in sera, termed “seronegative MG (▶Seronegative Myasthenia Gravis)”, but have a humorally mediated disorder, as evidenced by that their Sera, passively transferred to mice, results in neuromuscular weakness. The seronegative MG could therefore be caused by non-AChR antibodies. The search for non-AChR pathogenic antigens has recently been focused on ▶muscle-specific tyrosine kinase (MuSK) (Fig. 1).

## Characteristics

### Seropositive (Anti-AChR-Positive) Myasthenia Gravis

#### Pathogenesis: Antibodies to AChR

Anti-AChR antibodies cause the accelerated degradation of AChR, complement-mediated destruction of postsynaptic membrane, and blockade of ACh-binding to AChR resulting in impairment of neuromuscular transmission (Fig. 2).

The search for epitopes bearing on AChR, which are implicated as targets for myasthenic antibodies, has developed through the information about the AChR primary structure comprising of four homologous polypeptide subunits. Based on this, myasthenic domains are localized at the segment alpha 67–76 [1] and alpha 125–147 [2] as the sites recognized by antibodies causing the accelerated AChR degradation and the complement-mediated destruction of postsynaptic

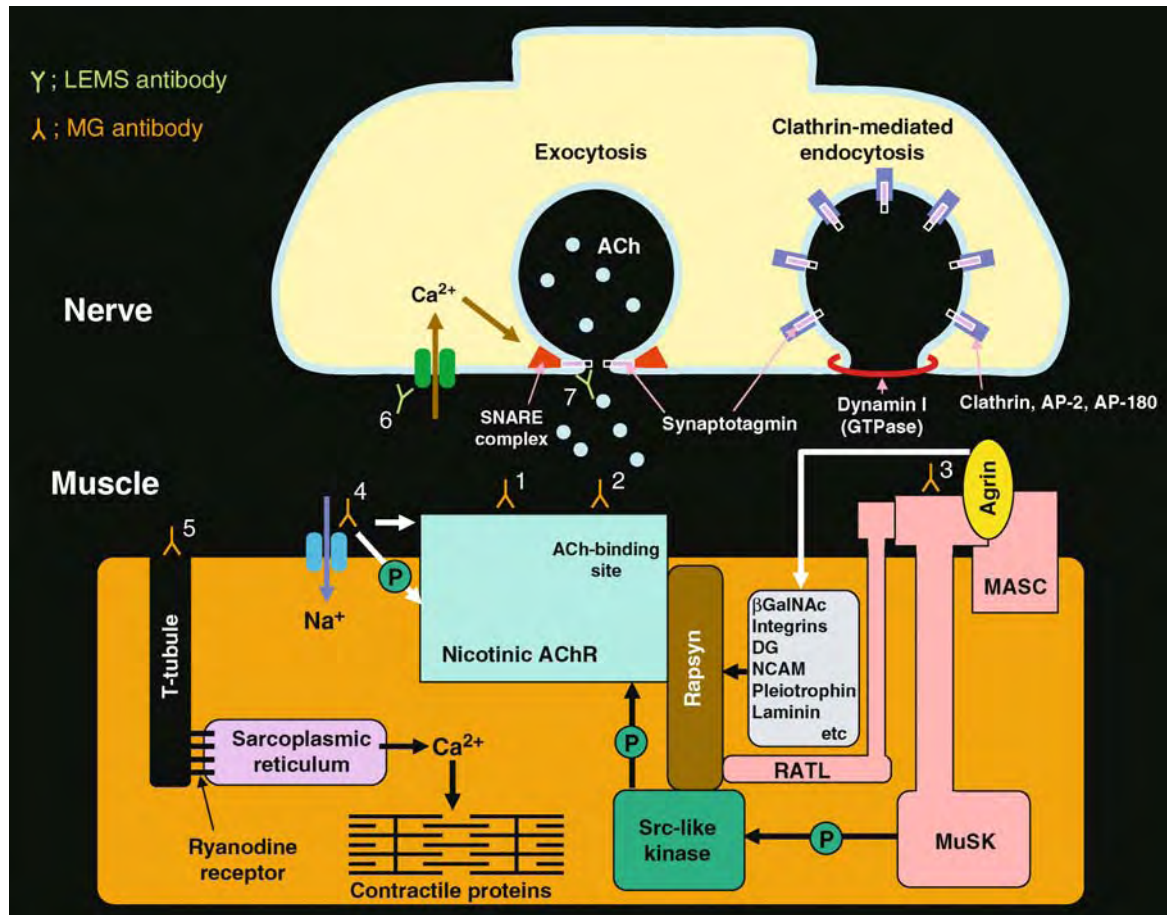

**Myasthenia Gravis. Figure 1** Schematic representation of neuromuscular synapse. Myasthenia gravis (MG) is caused by antibodies to the acetylcholine receptor (AChR) (antibodies-1 and 2), and modified by those to muscle-specific tyrosine kinase (MuSK) (antibody-3), muscle membrane sodium channel (antibody-4) and ryanodine receptor (antibody-5). The antibody-4 (non-IgG) also provides an AChR desensitization through cGMP-mediated protein kinase G or allosteric inhibition. Antibodies numbered 6 and 7 are referred to the section of Lambert-Eaton myasthenic syndrome (LEMS).

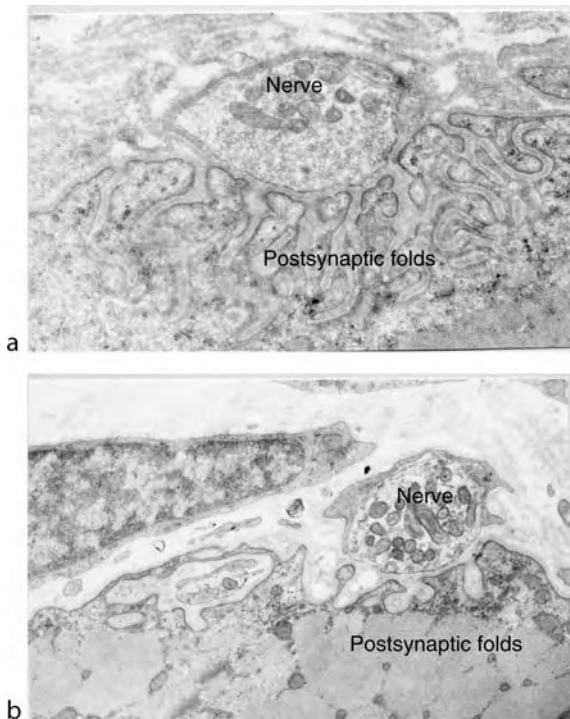

**Myasthenia Gravis. Figure 2** Ultrastructure of neuromuscular junction. Postsynaptic folds are richly developed in normal skeletal muscle (a). In myasthenia gravis, in which anti-AChR antibodies cause the complement-mediated destruction of postsynaptic membrane, the folding becomes less dense than that of the mature configuration in normal muscle, resulting in the AChR loss leading to transmission failure; the synaptic gap becomes widened (b). No abnormality is seen in the nerve terminal.

membrane (Fig. 1, antibody-1), and the segment alpha 183–200 as the site recognized by antibodies preventing the ACh-binding to AChR (Fig. 1, antibody-2) [3]. The factors involved in the initiation or induction of autoimmune MG are unknown. However, MG is associated with other immune system abnormalities, particularly in the ►thymus (thymoma or thymic hyperplasia).

### Clinical Features, Diagnosis and Treatments

Only the motor system is impaired with the cardinal features of weakness and fatigability in skeletal muscles. Frequently involved are extraocular muscles, neck extensors, facial and bulbar muscles, and proximal limb muscles. When the muscles concerning swallowing and respiration are involved, the intubation for artificial respirator and feeding is emergently required. There is usually a history of fluctuation of symptoms and fatigability (worse with repeated activity, improved by rest). In women, weakness may worsen in relation to the menstrual cycle. Transient weakness of an infant born to a

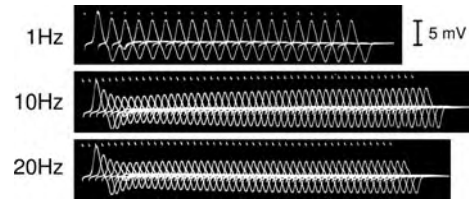

**Myasthenia Gravis. Figure 3** Muscle action potentials evoked by repetitive nerve stimulation at rates of 1, 10 and 20 Hz. The initial response is normal in size; during repetitive stimulation, muscle responses show an early rundown (1st–4th responses) even with a slow rate such as 1 Hz, followed by a maintained plateau or partial recovery in amplitude. These phenomena are provided by a narrow safety margin of neuromuscular transmission due to the AChR loss caused by myasthenic antibodies.

myasthenic mother may occur in 15%. Approximately 75% of patients have thymic abnormalities including thymoma (15%). The diagnostic test is (i) muscle responses to repetitive peripheral nerve stimulation (Fig. 3), (ii) ►single-fiber electromyography, (iii) edrophonium (anti-cholinesterase) injection, and (iv) anti-AChR antibody radioimmunoassay [4].

Anti-cholinesterase agents (pyridostigmine bromide etc.) are used as symptomatic management. The long-term immune-directed treatment includes immunosuppressive drugs such as corticosteroids, azathioprine, cyclosporine A, tacrolimus and mycophenolate mofetil. In thymoma-associated MG, thymectomy is indicated universally, occasionally followed by postoperative radiation. In non-thymomatous generalized MG, thymectomy is advocated empirically and possibly reduces the long-term exposure to immunosuppressive drugs, but requires up to 2–5 years for demonstrable efficacy; this estimation is based on data from nonrandomized studies, however. The short-term immune-directed treatment to overcome severe myasthenic states such as respiratory crisis includes ►plasmapheresis and intravenous human immunoglobulin; their effect is short-lasting but tends to be prolonged with the concomitant immunosuppressive drugs [5].

### Seronegative (Anti-AChR-Negative) Myasthenia Gravis Pathogenesis: Antibodies to MuSK

AChR is clustered to effectively receive the ACh-derived information from the nerve through a pathway in which agrin is a critical nerve-derived signal; MuSK is a key component of the postsynaptic agrin receptor, and rapsyn is a cross-linker of AChR [6] (Fig. 1). The z-site spliced isoform of agrin specifically clusters AChR and is, independently of it, required for neuromuscular junctional differentiation. Jointly with the co-receptor (muscle-associated specificity component, MASC), agrin binds to the first of four Ig-like domains



of MuSK [7]. The fourth Ig-like domain of MuSK is required for interaction with rapsyn through the rapsyn-associated transmembrane linker (RATL) [7]. The MuSK intracellular domain (kinase domain) activates AChR phosphorylation but is not sufficient for AChR clustering; the MuSK ectodomain plays a required role for the clustering process, perhaps by helping to recruit neuromuscular junctional components to a MuSK-based scaffold. Although anti-MuSK antibodies (Fig. 1, antibody-3) inhibit agrin-induced clustering of AChR in cultured muscle cells, the pathogenic role of the anti-MuSK IgG antibody is not clear. The non-IgG fraction, probably including the IgM antibody which blocks the sodium channel, from anti-MuSK-positive and anti-MuSK-negative seronegative (anti-AChR-negative) MG patient sera exerts an inhibitory effect on AChR function [8] (Fig. 1, antibody-4). There is the MuSK-independent agrin-rapsin signal transduction pathway including integrins, beta-linked N-acetylgalactosamine, alpha-dystroglycan, neuronal cell adhesion molecule, heparin-binding growth-associated molecule, beta-2 laminins and heparan sulfate proteoglycan [7] (Fig. 1). Also, antibodies raised against the extrajunctional component, which conducts a signal into the sarcoplasmic reticulum [[ryanodine receptor \(RyR\)](#)], can be found in some of [myasthenia gravis](#) patients, often those with thymoma [9] (Fig. 1, antibody-5). These suggest a research direction to search for non-AChR, non-MuSK antibodies pathogenic to the disease.

### Clinical Features, Diagnosis and Treatments

Forty to 70% of seronegative MG patients are positive for anti-MuSK antibodies and clinically characterized by a relative prevalence of female patients, the age at onset ranging from 3 to 68 years, prevalent involvement of cranial, bulbar and neck muscles, high incidence of respiratory crisis; wasting of facial and bulbar muscles is evident in some patients [10]. Unlike seropositive MG, the [repetitive nerve stimulation](#) and edrophonium tests are not necessarily diagnostic; the single-fiber electromyography is only reliable for diagnosis [10]. No satisfactory benefit is provided by [anti-cholinesterase drugs](#), conventional immunosuppressive therapy and thymectomy [10]; a short-term response to plasmapheresis can be striking [10]. Thymic histology is reportedly normal. However, the clinical features reported by a recent series do not clearly distinguish MuSK antibody-positive from MuSK antibody-negative serotypes.

### References

1. Tzartos SJ, Kokla A, Walgrave SL, Conti-Tronconi EM (1988) Localization of the main immunogenic region of human muscle acetylcholine receptor to residues 67–76 of the alpha subunit. *Proc Natl Acad Sci USA* 85:2899–2903

2. Lennon VA, McCormick DJ, Lambert EH, Griesmann GE, Atassi MZ (1985) Region of peptide 125–147 of acetylcholine receptor alpha-subunit is exposed at neuromuscular junction and induces experimental autoimmune myasthenia gravis, T-cell immunity, and modulating autoantibodies. *Proc Natl Acad Sci USA* 82:8805–8809
3. Takamori M, Okumura S, Nagata N, Yoshikawa H (1988) Myasthenogenic significance of synthetic alpha-subunit 183–200 of Torpedo californica and human acetylcholine receptor. *J Neurol Sci* 85:121–129
4. Drachman DB (1994) Myasthenia gravis. *N Engl J Med* 330:1797–1810
5. Richman DP, Agius MA (2003) Treatment of autoimmune myasthenia gravis. *Neurology* 61:1652–1661
6. Gautam M, DeChiara TM, Glass DJ, Yancopoulos GD, Sanes JR (1999) Distinct phenotypes of mutant mice lacking agrin, MuSK, or rapsyn. *Dev Brain Res* 114:171–178
7. Liyanage Y, Hoch W, Beeson D, Vincent A (2002) The agrin/muscle-specific kinase pathway: new target for autoimmune and genetic disorders at the neuromuscular junction. *Muscle Nerve* 25:4–16
8. Plested CP, Tang T, Spreadburg I, Littleton ET, Kishore U, Vincent A (2002) AChR phosphorylation and indirect inhibition of AChR function in seronegative MG. *Neurology* 59:1682–1688
9. Takamori M, Motomura M, Kawaguchi N, Nemoto Y, Hattori T, Yoshikawa H, Otsuka K (2004) Anti-ryanodine receptor antibodies and FK506 in myasthenia gravis. *Neurology* 62:1894–1896
10. Vincent A, Bowen J, Newsom-Davis J, McConville J (2003) Seronegative generalized myasthenia gravis: clinical features, antibodies, and their targets. *Lancet Neurol* 2:99–106

## Mydriasis

### Definition

Pupillary dilation, particularly when the pupil approaches maximum dimensions.

► [Neural Regulation of the Pupil](#)

## Myelencephalon

### Synonyms

► [Medulla oblongata](#)

## Definition

The lowest portion of the brainstem. Here in the transition region to the spinal cord are important nuclear regions (olive, pyramid, gracile nucleus, cuneate nucleus), the cranial nerve nuclei of nerves V-XII as well as the centers of respiratory control. Important pathways are the medial lemniscus (somatosensory), lateral lemniscus (auditory) and vestibulospinal tract.

## Myelin

### Definition

CNS myelin consists of many layers of tightly wound membranes formed from the cytoplasmic extensions of oligodendrocytes. Myelin forms regular patches around axons, called the *internode*. The space between the internodes is the *Node of Ranvier*. The size of the internode and the thickness of the myelin sheath depend on the diameter of the axon it is associated with. The main role of myelin is to insulate the axonal membrane and thus speed the rate of conduction of the action potential, which jumps for one node to the next, a process called *saltatory conduction*. Myelin also contains molecules that can inhibit axon growth and regeneration. Myelin is composed of lipids (about 70%) and proteins (about 30%) such as myelin basic proteins, myelin-associated glycoprotein, proteolipid PLP.

- ▶ Inhibitory Molecules in Regeneration
- ▶ Node of Ranvier
- ▶ Schwann Cell

## Myelin Basic Protein

### Definition

Myelin basic protein (MBP) is the second most abundant protein in central nervous system (CNS) myelin, comprising about 30% of the myelin proteins. It is localized to the cytosolic surface of the cell membranes of oligodendrocytes, which are the cells that produce myelin in the CNS. It mediates adhesion to the cytosolic surface of the adjacent oligodendrocyte membrane that results in compaction of the myelin sheath. MBP can undergo a variety of post-translational modifications, such as phosphorylation, methylation, and deimination. Modifications such as phosphorylation and methylation promote the compaction of myelin, protect MBP from proteolysis, and serves to

maintain the integrity of myelin. Deimination of MBP on the other hand makes it more susceptible to proteolysis and induces myelin breakdown. MBP therefore plays a crucial role in the formation and maintenance of the myelin sheath, and imbalance in its normal post-translational modification states may lead to myelin pathology and disease.

- ▶ Inhibitory Molecules in Regeneration

## Myelin Stain

### Definition

Myelin stains (such as the Weil or Weigert stains) are those that react with the lipoprotein sheath of myelinated axons making them dark.

## Myelin-associated Glycoprotein (MAG)

### Definition

A glycoprotein found on central nervous system (CNS) myelin which inhibits axon growth.

- ▶ Regeneration

## Myelinated Axons

### Definition

Axons surrounded by a compact spiraled sheet of Schwann cell plasma membrane are called myelinated axons.

- ▶ Schwann Cell

## Myelination

### Definition

Myelination is the process by which glial cells wrap axons with an insulating sheath. This is done by the

oligodendrocyte in the central nervous system, and by the Schwann cell in the peripheral nervous system.

---

## Myelitis

### Definition

Myelitis is an inflammation of the spinal cord. One group of diseases is named according to whether primarily white matter or gray matter is affected (see leukomyelitis and poliomyelitis); another group is defined by whether there is coexistent disease of the meninges (►meningomyelitis) or the brain (►encephalomyelitis). In practice, the term is also used to denote non-inflammatory lesions of the ►myelin sheath of the spinal cord.

---

## Myeloencephalitis

### Definition

Inflammation of the spinal cord and brain (also called ►encephalomyelitis).

---

## Myelomalacia

### Definition

A process of tissue softening within the spinal cord. It may result from a stroke, trauma or a degenerative process.

- Gliomas
- Stroke

---

## Myelopathy

### Definition

Disease of the spinal cord or the bone marrow.

---

## Myeloperoxidase

### Definition

It is a peroxidase enzyme, a lysosomal protein stored in the azurophilic granules, abundantly present in neutrophil granulocytes. It is also detected in the macrophages.

---

## Myenteric Plexus

### Definition

The myenteric plexus is a plexus of small groups of nerve cells (ganglia) and connecting nerve fiber bundles that lies between the longitudinal and circular muscle layers of the gut wall and forms a continuous network from the upper esophagus to the internal anal sphincter.

- Enteric Nervous System

---

## Myocardium

### Definition

The heart muscle that makes up the walls surrounding the heart ventricles.

- Cardiovascular Mechanics

---

## Myoclonus

### Definition

Involuntary, abrupt, brief, rapid jerks of limbs or trunk, which may occur spontaneously at rest, in response to sensory stimuli or with voluntary movements. Myoclonus occurs in a variety of generalized metabolic and neurological disorders.

## Myofascial Force Transmission

### Definition

Transmission of force between muscle fibers and surrounding connective tissue fascia.

- ▶ Intramuscular Myofascial Force Transmission

## Myofascial Pain

- ▶ Muscle Pain, Including Fibromyalgia

## Myofibril

### Definition

Multiprotein complex in striated muscle cells, in which the contractile proteins actin and myosin are organized into a paracrystalline fashion.

- ▶ Actin
- ▶ Myosin
- ▶ Sarcomere Structural Proteins

## Myofibrillogenesis

### Definition

Process of the assembly of myofibrils during embryonic development.

- ▶ Myofibril
- ▶ Sarcomere Structural Proteins

## Myogenic Musculature

### Definition

Myogenic musculature refers to the spontaneous generation of electrical and contractile activity by the

musculature itself, independent of nerves, hormones or other signaling mechanisms.

## Myoglobinuria

### Definition

Appearance of myoglobin (O<sub>2</sub> carrier in skeletal muscle) in urine, for example in ▶ mitochondrial myopathies.

## Myopathies

### Definition

Myopathies can be inherited (▶ Duchenne muscular dystrophy, ▶ fascioscapulohumeral dystrophy, ▶ limb-girdle dystrophy, ▶ myotonic dystrophy) or acquired (▶ dermatomyositis, ▶ polymyositis syndrome, ▶ endocrine myopathies, ▶ myoglobinurias).

- ▶ Dermatomyositis
- ▶ Duchenne Muscular Dystrophy
- ▶ Facioscapulohumeral Dystrophy
- ▶ Limb-girdle Muscular Dystrophy (LGMD)
- ▶ Myoglobinuria
- ▶ Myotonic Dystrophy
- ▶ Polymyositis Syndrome

## Myosin

### Definition

Myosin (sometimes also referred to as the thick filament) is the second contractile protein in muscle. Myosin contains the cross-bridge heads that interact with actin to produce contraction. The cross-bridges are arranged uniformly on the myosin filament, they contain a binding site for actin and an enzymatic site that catalyzes the hydrolysis of ATP, which is needed for muscle contraction.

- ▶ Sliding Filament Theory

## Myosin Motor

### Definition

Myosin motor is a protein that acts as a motor to move along a surface, such as microtubules. The energy for such movement comes from the hydrolysis of ATP. A myosin motor often functions in the active transport of proteins and vesicles in the cytoplasm.

---

## Myositis

### Definition

Myositis means muscle inflammation.

---

## Myotendinous Force Transmission

### Definition

Transmission of force between muscle fibers and its microtendon, made up of aligned collagen fibers. The site of such a transmission of each fiber is called the myotendinous junction.

▶ [Intramuscular Myofascial Force Transmission](#)

---

## Myotendinous Junction

### Definition

The specialized region where fingerlike extensions of the sarcolemma at the ends of muscle fibers interdigitate

with similar extensions of the connective tissue of the tendon. This is one region for force transmission.

▶ [Skeletal Muscle Architecture](#)

---

## Myotonia

### Definition

Muscle stiffness, in which muscle relaxation after voluntary contraction is impaired. Myotonic diseases are hereditary muscle diseases falling into two large groups: ▶ [myotonic dystrophies](#) and ▶ [non-dystrophic myotonias](#).

---

## Myotonia Congenita

### Definition

▶ [Non-dystrophic Myotonias](#)

---

## Myotonic Dystrophy

### Definition

Group of hereditary muscle diseases inherited via a dominant mutant gene on chromosome 19. There are three groups: Myotonic dystrophy type 1 (DM-1), proximal myotonic myopathy/myotonic dystrophy type 2 (PROMM/DM-2), and proximal myotonic dystrophy (variant of DM-2). The disease may be so mild as to be nearly asymptomatic or so severe as to appear in early life. In addition to weakness in limb and cranial muscles, characteristic symptoms are ▶ [myotonia](#), which is a delayed relaxation of muscle after strong voluntary contraction or electrical stimulation, and often cataracts, baldness and testicular atrophy in men.

## Na<sup>+</sup> Channels

### Definition

► Sodium Channels

## Na<sup>+</sup>-Ca<sup>2+</sup> Exchanger (NCX)

### Definition

A plasma membrane enzyme that exchanges 3 Na<sup>+</sup> for 1 Ca<sup>2+</sup>. It can operate in the forward mode (extrusion of Ca<sup>2+</sup> from the cytosol) or in the reverse mode (uptake of Ca<sup>2+</sup> into the cytosol).

► Influence of Ca<sup>2+</sup> Homeostasis on Neurosecretion

## Na<sup>+</sup>K<sup>+</sup>-ATPase

### Definition

The Na<sup>+</sup>K<sup>+</sup>-ATPase transports three Na<sup>+</sup> ions out of and two K<sup>+</sup> ions into the cell, using the energy of ATP hydrolysis (electrogenic transport). It maintains the high sodium and potassium gradient across the cell membrane. The Na<sup>+</sup>K<sup>+</sup>-ATPase (also called the “cellular sodium pump”) is selectively inhibited by cardiac glycosides.

## Naked DNA Vaccination

► Neuroinflammation – DNA Vaccination Against Autoimmune Neuroinflammation

## Naloxone

### Definition

Drug used to antagonize opioid compounds such as morphine. Chemical name = N-allyldihydrohydroxy-normorphinone. Also known by the trade name Narcan.

► Gender/sex Differences in Pain

## NANC Transmitters

### Definition

NANC transmitters are non-adrenergic, non-cholinergic transmitters; i.e. other than the classical autonomic transmitters (noradrenaline and acetylcholine).

► Salivary Secretion Control

## Narcolepsy

DANIEL A. COHEN

Harvard Medical School; Department of Neurology, Beth Israel Deaconess Medical Center; Division of Sleep Medicine, Brigham and Women’s Hospital, Boston, MA, USA

### Synonyms

Gelineau syndrome

### Definition

Narcolepsy is a neurological disorder that interferes with the normal regulation of sleep and wakefulness. It has been conceptualized as a condition of behavioral state instability in which there is a low threshold to transition between waking, rapid eye movement (REM)

sleep, and ►non-rapid eye movement (NREM) sleep [1]. This view accounts for the associated symptoms, including daytime sleepiness, disrupted sleep, automatic behavior cataplexy, sleep paralysis, and hypnagogic hallucinations.

## Characteristics Clinical Features

Excessive daytime sleepiness is a prominent complaint and generally the initial reason for seeking medical attention. The feeling of sleepiness is generally higher than normal throughout the day, and there may also be sleep attacks, with an irresistible urge to sleep that arises with very little warning. Semi-purposeful activities may continue during the transition from sleep to wakefulness, a phenomenon known as automatic behavior. Just as sleep may intrude upon wakefulness, nocturnal sleep is often disrupted by excessive awakenings. Increased daytime sleepiness and fragmented nocturnal sleep are symptoms of a variety of sleep disorders and are not specific to narcolepsy. The more specific aspects of narcolepsy relate to the unusual propensity for elements of ►REM sleep to intrude into wakefulness.

Components of REM sleep include: the rich emotional content and perceptual imagery of ►dreams; paralysis of most skeletal muscles; and phasic bursts of muscle activity, including rapid eye movements. These components of REM sleep may be dissociated from each other in narcolepsy and may intrude into wakefulness. Symptoms of REM intrusions during wakefulness include: hypnagogic hallucinations, sleep paralysis, and cataplexy. Hypnagogic hallucinations are hallucinatory experiences that occur at sleep onset. These are vivid perceptual experiences superimposed on the conscious experience of the background environment. There may be a strong emotional context, often a feeling of fear or dread. These symptoms may reflect inappropriate activation of neuronal networks normally activated during REM sleep, including areas that regulate emotional and visual processing [2]. Sleep paralysis reflects the occurrence of REM related muscle atonia that is present upon awakening. This may last seconds to minutes, and it is often a very frightening experience. Patients may try to scream for help, although in the context of muscle atonia there may be little to no actual sound. Tactile stimulation from an outside observer may terminate the episode. Cataplexy is another example of inappropriate REM atonia. It is the most specific clinical symptom of narcolepsy.

Cataplexy is distinguished from sleep paralysis in that the episodes of muscle atonia arise from a background of wakefulness. Strong emotion, particularly laughter, can trigger episodes of cataplexy. The distribution and degree of muscle weakness varies between individuals and may also vary within individual attacks. Episodes may be subtle, such as a change in facial expression or slurred speech, to gross impairment

in the ability to retain postural control. Usually there is enough warning to prevent serious falls. The episodes usually last seconds to a couple of minutes, but in rare cases repeated episodes may not allow the return of normal muscle tone for much longer periods, a condition referred to as status cataplecticus. In addition to inappropriate motor inhibition seen in sleep paralysis and cataplexy, patients with narcolepsy may also have excessive motor activity during sleep, including REM sleep without atonia, increased phasic muscle twitches during REM sleep, and increased ►periodic limb movements of sleep [3].

## Prevalence

Narcolepsy is generally divided into cases of narcolepsy with cataplexy and narcolepsy without cataplexy. It is unclear whether these entities represent distinct diseases, or rather a spectrum of phenotypic differences with common underlying mechanisms [4]. The prevalence of narcolepsy with cataplexy is estimated to be roughly 50 per every 100,000, with a slightly higher prevalence of cases without cataplexy. The onset of symptoms is often during the second and third decade, but this can vary greatly.

## Etiology

Recent insight into the pathophysiology of narcolepsy relates to the discovery of the ►hypocretin (►orexin) neuropeptides, a pair of peptides produced in the lateral hypothalamus that play a role in neurotransmission. Canine narcolepsy has been linked to mutations in the gene encoding the hypocretin (orexin) receptor 2 [5]. A mouse model of narcolepsy was developed by targeted disruption (knock out) of the mouse hypocretin (orexin) gene, confirming the role of this peptide system in the control of sleep-wake behavior [6]. In humans, a low cerebrospinal fluid level of hypocretin 1 is a highly sensitive and specific test for narcolepsy with cataplexy [4]. In addition, hypocretin (orexin) staining in the hypothalamus of human narcoleptic patients is decreased by up to 95%, and recent evidence suggests that this reduction in hypocretin (orexin) staining is the result of targeted cell loss of hypocretin neurons rather than decreased hypocretin production [7].

An autoimmune etiology for human narcolepsy has long been suspected. Focal gliosis, essentially a form of scarring in the brain, has been demonstrated in patients with narcolepsy. Gliosis can occur as the result of an inflammatory process, such as occurs with autoimmune diseases, but this finding is non-specific and can occur with a variety of insults to the brain. Speculation about the autoimmune nature of hypocretin cell loss largely comes from a strong association of narcolepsy with cataplexy and specific alleles of the human leukocyte antigen (HLA) presenting system, particularly the allele DQB1\*0602. This allele is present in the majority of narcoleptic patients, but it has a low specificity due

to the relatively high frequency of this allele in the general population. Beyond genetic factors, an association of narcolepsy with ▶**seasonality**, with a peak in March births, suggests that early environmental factors may play a role in the pathogenesis of narcolepsy and is consistent with an autoimmune mechanism. Efforts to find specific auto-antibodies in the sera of narcoleptic patients have been mixed, with both positive and negative results. An autoimmune process targeting the destruction of hypocretin (orexin) neurons has been the prevailing hypothesis, but there is recent evidence that circulating antibodies may play a direct functional role in the altered neurotransmission in narcolepsy [8]. The role of the immune system in the pathogenesis of narcolepsy remains to be clarified, and a neurodegenerative mechanism remains a possibility. There are no clear modifiable risk factors for narcolepsy at this point.

### Pathophysiology

The regulation of sleep and wakefulness is a complex process, incorporating factors such as: the phase of the endogenous circadian cycle, recent sleep and wake history, food intake, posture, environmental stresses or demands, and emotional state. These inputs act on a relatively discrete set of brain structures that form the basic circuitry for switching between the waking and sleeping states. There has been tremendous progress in the recent years in the development of models to understand the basic mechanisms of these circuits. The role of hypocretin (orexin) neurons in the sleep-wake circuitry has been particularly instrumental in understanding the clinical features of narcolepsy.

A prominent model for the regulation of sleep and wakefulness centers on the concept of a “flip-flop” switch [9]. A flip-flop switch is a circuit in which two opposing sides are mutually inhibitory. By inhibiting the competing side, activity on one side reinforces its own advantage in controlling the state of the system. Transitions between states tend to occur relatively rapidly. The major structures involved in the sleep-wake switch reside in the ▶**brainstem** and hypothalamus. Structures that promote wakefulness include: ascending projections from serotonergic neurons of the dorsal ▶**raphe** nucleus, the noradrenergic neurons of the locus coeruleus, histaminergic neurons of the tuberomammillary nucleus, cholinergic neurons of the pedunculopontine and lateral dorsal tegmental nuclei, cholinergic neurons of the basal forebrain, and dopaminergic neurons of the ventral tegmentum. Neurons that promote sleep are predominantly found in the ▶**ventrolateral preoptic nucleus (VLPO)** of the hypothalamus and contain the inhibitory neurotransmitters GABA and galanin. Projections from the hypocretin (orexin) neurons of the lateral hypothalamus activate the wake promoting structures, which tends to stabilize the sleep-wake switch in the wake state.

Individual nuclei within the pons contribute to the regulation and generation of components of REM sleep. There are ▶**REM-off** and ▶**REM-on** regions, both of which are mutually inhibitory and also act together as a flip-flop switch so that all components of REM tend to switch on or off with very little transitional states [10]. Hypocretin (orexin) neurons activate the REM-off cell groups. Therefore, the lack of a functional hypocretin (orexin) system in narcolepsy may destabilize both the sleep-wake switch as well as the REM on-off switch, causing relatively frequent transitions between sleep and waking states and inappropriate activation of components of REM sleep.

### Diagnosis

The diagnosis of narcolepsy is generally considered in the evaluation of a patient with excessive sleepiness. Occasionally the diagnosis is considered for symptoms of inappropriate REM fragments during wakefulness, such as isolated episodes of sleep paralysis. However, this can occur in healthy individuals or those who tend to wake during REM sleep such as patients with sleep disordered breathing. Cataplexy is specific to narcolepsy and rarely can be the presenting symptom before the onset of significant daytime sleepiness. Careful clinical history can usually distinguish between the paroxysmal loss of muscle tone in cataplexy and other conditions of transient neurological dysfunction or spells from conditions such as: seizure, syncope, cerebrovascular disease, periodic paralysis, myasthenia, or hyperventilation.

Excessive sleepiness may occur from: processes that disrupt sleep such as ▶**obstructive sleep apnea**, ▶**periodic limb movement disorder**, mood disorders, pain syndromes, and noisy or uncomfortable bed environments; ▶**chronic insufficient sleep syndrome**; medical conditions such as thyroid dysfunction; medication side effects; central nervous system causes such as narcolepsy, ▶**idiopathic hypersomnia**, or ▶**recurrent hypersomnia**. It is not possible to distinguish the etiology based on the degree of sleepiness, since a sudden and irresistible urge to sleep may occur from many causes besides narcolepsy.

A diagnosis of narcolepsy with cataplexy can be made by history and does not necessarily require confirmatory testing. Overnight ▶**polysomnogram** is helpful to search for co-morbid, treatable causes of sleep fragmentation and daytime sleepiness. In order to diagnose narcolepsy without cataplexy, it is necessary to perform the ▶**multiple sleep latency test (MSLT)**, which is a daytime napping test. This test is also generally recommended to confirm a diagnosis of narcolepsy even when there is definite cataplexy, but it is less essential when the history of cataplexy is clear. Generally, patients are given five nap opportunities during the daytime, each 20 min in duration and spaced at 2 h intervals. The average time to fall asleep across all naps is roughly 3 min for patients with narcolepsy,



whereas it is greater than 10 min for healthy individuals. To minimize both false positive and false negative tests, a cutoff of 8 min or less has been suggested to document pathological sleepiness. In addition to pathological sleepiness, which is not specific to narcolepsy, the presence of REM sleep during at least two of the naps (►[sleep onset REM periods](#)) is required for a diagnosis of narcolepsy. The specificity of this finding for narcolepsy is greater than 90%. The MSLT requires that patients are off REM suppressing medications for at least 15 days for valid interpretation of REM periods during naps, which may be difficult in patients that require stimulant medications to function. Treatment of co-morbid disorders such as sleep disordered breathing is also necessary for accurate interpretation of the MSLT. In patients with questionable cataplexy, particularly those who have the HLA DQB1\*0602 allele, CSF testing for hypocretin-1 levels can be done instead of the MSLT. Hypocretin-1 levels that are <110 pg/ml support the diagnosis of narcolepsy. Low CSF hypocretin levels have a specificity of 99% and a sensitivity of 87% in narcolepsy with cataplexy [4]. The sensitivity of this test in narcolepsy without cataplexy is very low.

### Treatment

It is conceivable that therapy targeting the deficient hypocretin system will eventually play a fundamental role in the management of narcolepsy, particularly in patients with cataplexy. However, current treatment options are intended to promote daytime alertness as well as suppress the tendency for inappropriate activation of REM fragments during wakefulness. Stimulant medications such as modafinil, methylphenidate, D-amphetamine, or caffeine are generally used to promote daytime alertness. Medications that increase levels of norepinephrine or serotonin, such as many antidepressants, tend to activate REM-off cells and minimize REM intrusions into wakefulness such as cataplexy [10]. Sodium oxybate (gamma hydroxybutyrate), taken before sleep and a second dose during the sleep period, has recently been demonstrated to minimize both cataplexy and daytime sleepiness in patients with narcolepsy. Non-pharmacological interventions include: scheduled naps, which narcoleptic patients usually find very refreshing; psychosocial support and counseling to minimize the functional disability from this chronic disorder; and treatment of co-morbid sleep disorders such as sleep disordered breathing.

### References

1. Mochizuki T et al. (2004) Behavioral State Instability in Orexin Knock-Out Mice. *J Neurosci* 24(28):6291–6300
2. Braun A et al. (1997) Regional cerebral blood flow throughout the sleep-wake cycle: an H215O PET study. *Brain* 120:1173–1197

3. Dauvilliers Y et al. (2007) REM sleep characteristics in narcolepsy and REM sleep behavioral disorder. *Sleep* 30(7):844–849
4. Mignot E et al. (2002) The role of cerebrospinal fluid hypocretin measurement in the diagnosis of narcolepsy and other hypersomnias. *Arch Neurol* 59:1553–1562
5. Lin L et al. (1999) The sleep disorder canine narcolepsy is caused by a mutation in the hypocretin (orexin) receptor 2 gene. *Cell* 98:365–376
6. Chemelli RM et al. (1999) Narcolepsy in orexin knockout mice: molecular genetics of sleep regulation. *Cell* 98:437–451
7. Blouin AM et al. (2005) Narp immunostaining of human hypocretin (orexin) neurons: loss in narcolepsy. *Neurology* 65:1189–1192
8. Smith AJF et al. (2004) A functional autoantibody in narcolepsy. *Lancet* 364:2122–2124
9. Saper CB, Scammell TE, Lu J (2005) Hypothalamic regulation of sleep and circadian rhythms. *Nature* 437(27):1257–1263
10. Lu J et al. (2006) A putative flip-flop switch for control of REM sleep. *Nature* 441:589–594

---

## Nasal Airflow

### Definition

Nasal airflow is the mechanism by which odorant molecules are delivered to the olfactory receptors although the movement of air through the nose serves important functions beyond odor identification. Nasal airflow allows inspired air to be brought to the temperature and humidity of the lungs and particles ranging from combustion products to airborne bacteria to be trapped in the mucus and removed. In very dry environments nasal airflow also allows water vapor in expired air to be trapped in the mucus and saved.

### ► Nasal Passageways

---

## Nasal Passageways

DAVID E. HORNUNG

Dana Professor of Biology, St. Lawrence University,  
Canton, NY, USA

### Synonyms

Nasal airflow; Inspiration; Breathing cycle

### Definition

In mammals, the nasal passageways provide the channel through which odorant molecules are delivered to the

airspace above the olfactory receptors thereby allowing the animals to detect and respond to chemical signals in the inspired air [1]. According to some investigators, the structure of the nose itself may even be directly responsible for one of the mechanisms contributing to odor discrimination [2,3,4]. The internal structure of the nose allows air from the outside to be brought to the temperature and humidity of the lungs. It also facilitates a trapping of particles in the inspired air in the nasal mucus thus protecting the lungs from many airborne insults. In very dry environments the structure of the nose allows water vapor in expired air to be trapped in the mucus and saved [5].

### Characteristics

From an evolutionary point of view, the nasal passages begin as simple blind sacs and at their pinnacle become multi-functional, anatomically complex structures. The earliest stage of evolution of nasal passages is exemplified in elasmobranchs (some sharks for example) where the olfactory organs are paired, blind nasal sacs located well anteriorly on the head. The openings of these blind sacs are the external nares which in some sharks are divided into two sections allowing for the inflow and outflow of sea water. Chemoreception through the first cranial nerve (olfaction) in these animals is accomplished as receptors sample the contents of the water trapped in these blind sacs. In animals slightly higher up on the phylogenetic tree, the nasal sacs are connected to the mouth through internal nares. This anatomical development makes olfaction more dynamic by permitting water to flow from the external naris, by the olfactory receptors and into the mouth via the internal naris [2,3].

In air breathing animals the internal naris and accompanying connection to the mouth assumes a major role is respiration. For example, as tadpoles undergo the process of metamorphosis into frogs, the connection between the nasal cavity and the mouth is the pathway by which air enters the lungs from outside the animal. In air breathing animals, it is necessary in the mouth to separate the food destined for the stomach from the air heading toward the lungs. As a result olfaction becomes ancillary both to feeding and respiration.

### Structure

In air breathing vertebrates the structure of the nasal ►nasal airflow passageways can be as simple as the tube located between the external to internal nares as is observed in some salamanders. In these animals, the incoming air follows a straight path through the nasal air passageways (and by the olfactory receptors) on its way to the lungs. In frogs the nasal airflow patterns are slightly more complex as incoming air is deflected by a baffle plate called the eminentia which is located on the floor of the main nasal cavity [2].

In mammals the surface area of the nasal air passageway is greatly expanded through the elaboration of scrolls of bone (turbinates) from the lateral wall of the nasal chamber. In some species, these scrolls produce a very complex nasal labyrinth as is observed in animals like rodents and canines. In general the greater the complexity of the nasal air passageways the better the animal will be at detecting and identifying low concentrations of airborne odors. The turbinates are also important in reducing water loss from expired air associated with the high ventilation rate that accompanies the maintenance of a constant internal body temperature [5]. The volume of the nasal cavity has been estimated to be 0.4 cm<sup>3</sup> in rats, 20 cm<sup>3</sup> in beagle dogs and 25 cm<sup>3</sup> in humans.

In most mammals the left and right nasal passageways are anatomically distinct structures separated by a bony plate called the nasal septum. As a result, the inspired air flowing through the left and right nostrils does not mix until it gets to the nasopharynx located in the back of the throat. In rodents, however, there is an incomplete nasal septum which allows some of the air flowing through the nostrils to mix just downstream from the olfactory receptor area.

In primates, the nasal air passageways are much less complicated than what is found in rodents or canines. In humans the internal anatomy of the nose is defined on the lateral side by the inferior, middle and superior turbinates (Figs. 1 and 2) [2]. The respiratory and olfactory epithelial cells lining the inner surface of the nasal cavity are bathed in mucus which is secreted by the goblet cells interspersed in the respiratory epithelium and Bowman's Glands found in the olfactory receptor cell area. The mucus located at the air/epithelium border is watery and it is continually flowing into the back of the throat by the beating of the cilia of the respiratory epithelial cells.

### Blood Supply

The nasal mucosa has a very rich blood supply. As a result, the size of the airspace defined by the turbinates can be changed quickly and dramatically by changing the amount of blood flow to the dense capillary beds servicing the nasal epithelium. In this regard the lining of the nose is similar to other better known human erectile tissue. The extensive bleeding sometimes seen following nasal trauma reflects this extensive capillary bed. Additionally, the semi-erectile nature of the nose partially accounts for the nosebleeds that are occasionally observed after a sexual organism.

### Nasal Cycle

A pattern has been observed in the nose where congestion on one side of the nose is accompanied by decongestion on the other. This pattern is called the nasal cycle and has been observed in over 50% of the adult human population. The periodicity of the cycle is between

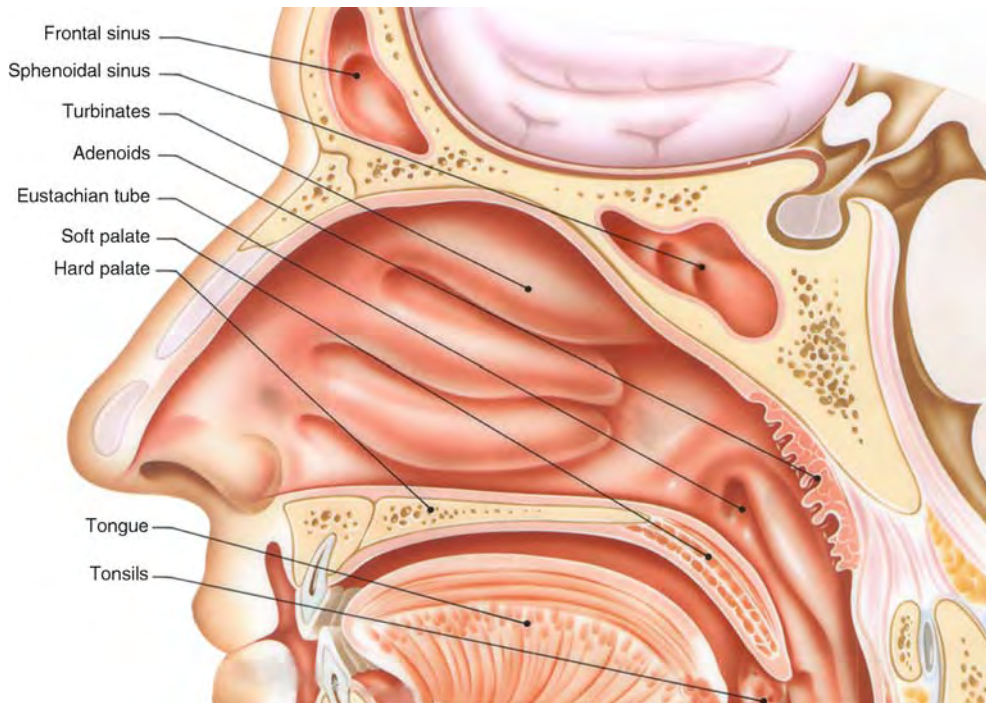

**Nasal Passageways. Figure 1** A cut away view of the human head. The inferior, middle and superior turbinates are in order located above the hard palate. The olfactory area is around the superior turbinate (marked “turbinates”; from Merrell Dow Company).

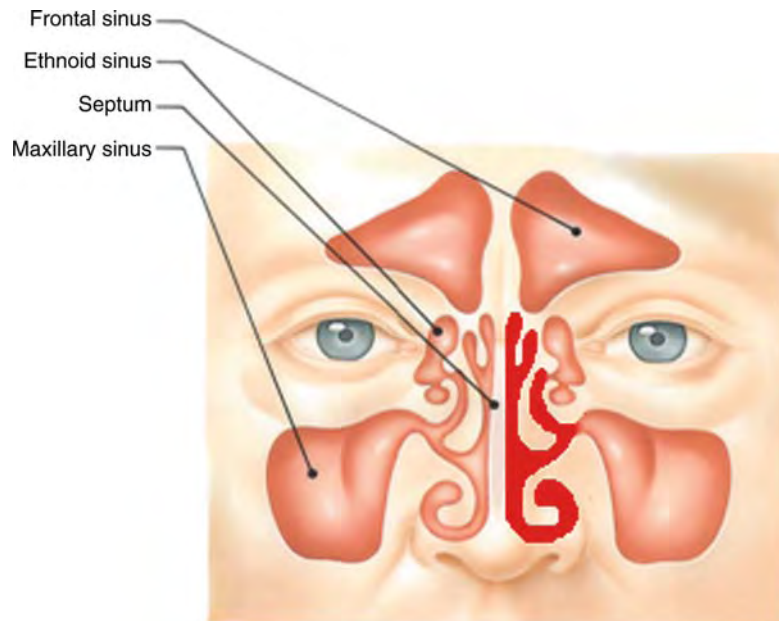

**Nasal Passageways. Figure 2** A cross-sectional view of the airspaces in the human nose. The lighter area represents bone and other nasal structures. The nasal air passageways have been darkened on the subject’s left side.

50 min and 7 h. There has even been a correlation reported between handedness and the nostril that is open for a larger percent of a 24 h period, such that left handed individuals are more likely to have a more open left nostril

and visa versa for right handers. Regardless of the more open nostril, the internal structure of the nose produce convoluted (sometimes turbulent) flow paths for the inspired air. The high airflow seen during sniffing may

increase the amount of turbulence and so may improve the sensitivity to smells [1,2].

### Role in Odor Identification

The olfactory receptors in humans are located high in the nose along the septum and on the medial side of the superior turbinate. Because of their location, and because the airspaces defined by the middle and inferior turbinates are relatively much larger than those leading up to the olfactory receptor region, during a ▶sniff only about 10% of the inspired air is directed toward the airspace above the olfactory receptors.

The structure of the nose may play a role in odorant identification as incoming odorant molecules interact with the nasal epithelium as they are directed toward the airspace above the olfactory receptors. The physical and chemical properties of these interactions depend on the natures of the odorants themselves [1,3,4]. For example, for an odorant that is very soluble in the respiratory mucosa, many of the incoming odorant molecules would be expected to be sorbed early in the flow path. As a result, it will take longer for these molecules to get to the receptors as compared to molecules of odorants that were not very mucosa soluble. In addition, there will be a spatial distribution pattern across the receptor sheet itself with most of the mucosal soluble odorant molecules being concentrated early in the flow path as compared to a more even mucosal distribution pattern that would be seen for less mucosa soluble odorants. It has been hypothesized these different arrival times and olfactory mucosal distribution patterns may play some role in odorant identification. These distribution patterns have been called “imposed” patterns. Although imposed patterns may play a role in olfactory function, the fine tuning and spatial distribution of receptors within the olfactory receptor area (inherent patterns) are thought by most investigators to be the primary peripheral mechanism for odorant detection and identification.

### Non-Olfactory Functions – Nasal Air Conditioning

The non-olfactory nasal functions of the nasal cavity are together referred to as nasal air conditioning [5]. Some evolutionary biologists suggest the primary selective pressure on nasal structures comes from these non-olfactory functions. During the process of nasal air conditioning, the inspired air is brought to the temperature and humidity of the lungs. In addition, a filtration process occurs in which particles ranging from combustion products to airborne bacteria that are found in the inspired air are trapped in the mucus and removed as the mucus is carried to the back of the throat.

### Swell Space

Because of the speed and magnitude of the diameter change that can occur in the area around the inferior turbinate, this area of the nose is sometimes referred to as the “swell space.” As cold air enters the nose during

inspiration the blood flow to the swell spaces increases dramatically. This increased blood flow causes a swelling of the nasal erectile tissue and so reduces the size of the airspace the incoming air must traverse on its way through the nose. Because the air passageways are now narrower, heat can be more efficiently transferred from the respiratory and olfactory mucosae to the incoming air. As a result, the cold air is effectively warmed before it gets to the back of the throat and the lungs [5].

### Humidification

When warmer air (especially if it is also humidified) enters the body the reverse happens and the swell spaces shrink, resulting in a more open nasal air passageways. This temperature and humidity related widening of the nasal cavity explains why, when the nose is blocked because of an upper respiratory infection, breathing warmed, humidified air can sometimes reduce the feeling of stuffiness.

Because the nasal mucus has such a high water content, it is able to humidify the incoming air such that when the inspired air has a low humidity, water evaporates from the mucus into the air. As a result of the evaporation from the mucus to the inspired air, the surface of the mucosa is cooled, so that when it is time to discharge the air from the lungs the expired air passes over the cooled surface of the mucosa. Because of the lower surface temperature along the mucosa, some of the water in the expired air condenses and so it is not lost. This process is not very efficient in humans since the air passageways are not very convoluted [5]. However, this process can be very efficient in animals with narrower and more convoluted air passageways. For example, this process is so efficient that animals like the Kangaroo Rats of Australia lose no water during breathing even with ambient temperatures in excess of 50°C.

### Particle Trapping

In addition to supplying water for humidification purposes, the nasal mucus serves as a trap for particulate matter including smoke, dust particles and airborne bacteria. The respiratory epithelium lining the nasal passageways contain cilia, hair-like protrusions extending into the overlying mucus layer. As these cilia beat, they create a slow wave-like action in the mucus that is responsible for moving the mucus through the nose and to the nasopharynx, where the mucus is then swallowed. The trapped particles flowing with the mucus are more easily dealt with by the alimentary canal than they would be by the blind sacs in the alveoli of the lungs. The mucus likely even contains some white blood cells to deal with trapped airborne bacteria. Cigarette smoke, with its high levels of carbon dioxide, can temporarily anesthetize the beating of respiratory cilia, thereby slowing the flow of mucus. This would be expected to make it more difficult for the nose to clear trapped particles and may even contribute to the “smoker’s cough.”

## References

1. Hornung DE (2006) Nasal anatomy and the sense of smell. In: Hummel T, Welge-Lüssen A (eds) Taste and smell an update. Kerger, Basel, pp 1–22
2. Hornung DE, Mozell MM (1986) Smell – human physiology. In: Rivlin RS, Meiselman RH (eds) Human taste and smell, measurements and uses. Macmillan Publishing, New York, pp 19–38
3. Kent PF, Mozell MM, Murphy SJ, Hornung DE (1996) The interaction of imposed and inherent olfactory mucosal patterns and their composite representation in a mammalian species using voltage-sensitive dyes. *J Neurosci* 16:345–353
4. Zhao K, Scherer PW, Hajiloo SA, Dalton P (2004) Effect of anatomy on human nasal airflow and odorant transport patterns: implications for olfaction. *Chem Senses* 29(5): 365–379
5. DeWeese DD, Saunders WH (1968) Textbook of otolaryngology, 3rd edn. Mosby, C. V. St. Louis

## Nasopharynx

Passageway from the back of the mouth to the nasal cavity retronasal route: air breathed out passes through the nasopharynx to the nasal cavity.

► [The Proust Effect](#)

## Natural Hypothermia

### Definition

A naturally occurring regulated sub-euthermic body temperature state of endothermic animals. Natural hypothermia is subject to thermoregulation: animals can recover from hypothermia without outside help.

► [Hibernation](#)

## Natural Kinds

### Definition

Natural kinds are categories of things that share some essence (physical, chemical, etc.), e.g. being H<sub>2</sub>O. This essence can be used in explanations of the perceptible

properties of members of the natural kind, e.g. transparency, melting point, etc.

► [Information](#)

## Natural Stimulus Statistics

### Definition

► [Sensory Systems](#)

## Naturalism

### Definition

In the philosophy of mind naturalism is usually thought of as the view that, at a minimum, philosophical theories should be consistent with our scientific picture of the world. A stronger view, which is also sometimes called naturalism, is the view that philosophical investigation really has no place in our understanding of the world, that philosophers, rather than devising theories of their own, should defer to the scientists.

Finally, naturalism is sometimes thought of the view that philosophical investigation should itself be a sort of scientific investigation.

► [Physicalism](#)

## Naturalized Epistemology

### Definition

In its broadest sense a naturalist in epistemology claims that epistemological theorizing is closely tied to theorizing in the natural sciences. There is much disagreement among naturalists as to what exactly the role of the natural sciences within epistemology is or should be.

► [Knowledge](#)

## Naturally Occurring Cell Death

► [Programmed Cell Death](#)

## Nausea Syndrome

### Definition

Syndrome characterized by epigastric awareness and discomfort, nausea and vomiting.

## Nauta Technique

### Definition

The Nauta technique is a reduced silver impregnation method for the staining of degenerating axons. It was used to trace the connections of a particular part of the brain by damaging that part and then describing the position and course of degenerating axons. Modifications of the basic Nauta technique have been developed to localize degenerating axons near axon terminals to characterize where the axons of neurons in the damaged area terminate.

## Navigation

### Definition

Navigation is the process of calculating and executing routes. Animals use navigation to optimize the collection of spatially dispersed resources, to find safety or to interact with individuals. In simple forms of navigation the animal moves towards or away from the goal location which is also to source of beacon signals.

For example, if an animal wants to interact with another, the simplest mechanism to approach the second animal using sensory cues emanating from the second animal.

In many cases navigation is inferential. The animal uses stationary environmental cues – landmarks – to estimate the location of the goal. Landmarks can serve as beacons, where the animal moves in the direction of the landmark to approach the goal, or part of a group, where the animal uses the configuration of landmarks to estimate the location of the goal. When animals compute navigation routes using the relationship among landmarks, the process is considered “mapbased”.

Path integration or dead reckoning may be used to return from the current position to the starting position.

Path integration requires knowledge of the starting position and direction and the estimation of the current position and direction from the path traveled. It may rely on optic flow and/or internally available information without the use of external landmarks (e.g., in darkness or in visually unstructured environments), which capacity is shown by animals as simple as ants and bees. This in turn requires the continuous monitoring of the intermittent self-generated movements. Location and direction in space are represented by distinct neuronal populations, place cells and head-direction cells.

► [Spatial Learning/Memory](#)

## NCF

### Definition

Nucleus cuneiformis.

## Near Response

### Definition

Convergence, accommodation of the lens and constriction of the pupil (also called triple response or near reaction).

► [Eye Movements Field](#)

## Near Response Neurons

LAWRENCE MAYS

University of North Carolina at Charlotte, Charlotte, NC, USA

### Synonyms

Vergence neurons; Convergence neurons

### Definitions

Ocular convergence (► [Convergent eye movement](#)) refers to the nasalward movement (► [Ocular adduction](#)) of the eyes required to binocularly view a nearer visual

target. Divergence (►Divergent eye movement) is the opposite movement (►Ocular abduction) of the eyes as gaze is shifted from a near to a far object. These ►vergence (►disparity dependent vergence, ►radial flow dependent vergence) movements are accomplished by the coordinated actions of the medial and ►lateral rectus extraocular muscles. Convergence requires contraction of the ►medial rectus and relaxation of the lateral rectus muscles, while the opposite occurs for divergence. Vergence eye movement may be initiated by the need to reduce binocular disparity, which is the difference between locations of an image of a single target on the two retinas. Convergence of the eyes is accompanied by lens accommodation (►Accommodation of the lens), which is an increase in the refractive power of the crystalline lens needed to focus on the near object.

## Characteristics

### Higher Order Structures

Single binocular vision requires very precise ( $\approx 0.25^\circ$ ) alignment of the two eyes on the object of regard if ►diplopia, or double vision, is to be avoided. Processing of this error signal, which is termed binocular disparity, takes place initially in the primary visual cortex [1]. The mechanism by which binocular disparity is transformed into a motor command signal to converge or diverge the eyes is not known, but such a motor command is seen on midbrain neurons termed near response cells.

### Parts of this Structure

The location of midbrain near response cells (including convergence cells) has been identified in macaques, but not yet in humans. They are located in two areas within the midbrain; a peri-oculomotor area, just dorsal and lateral to the oculomotor nucleus and a second area in the ►preectum [2]. The properties of the neurons in these two zones appear to be similar.

### Functions of this Structure

The function of near response cells is to provide the downstream motor elements with appropriate signals to generate vergence eye movements and associated changes in lens accommodation. Considering vergence movements first, the ►extraocular motoneurons encode signals to move the eye by means of a position-rate code and an eye velocity code [3]. The commands for all eye movements include these two elements. Extraocular motoneurons fire at a remarkably ( $\approx 5\%$  variation) constant rate for a given eye position, and this rate increases linearly as the eye moves in the motoneuron's on-position. This activity is needed to overcome the elastic restoring forces operating on the oculomotor plant (the mechanical properties of the eye and associated muscles, tendons, and ligaments). In addition, a phasic burst of neural activity by the motoneurons,

proportional to eye velocity, overcomes the viscous drag of the oculomotor plant. Medial rectus motoneurons receive inputs related to conjugate eye movements (e.g. ►saccades, smooth pursuit) via the ►medial longitudinal fasciculus (MLF), but this is not the source for vergence commands [4]. Instead, vergence signals are likely due to projections from near response cells in the peri-oculomotor region. Many of these near response cells have tonic firing rates directly proportional to vergence angle and so were termed "convergence cells". A subset has been shown to project to the medial rectus subdivisions of the oculomotor nucleus [5]. Some convergence cells have a position signal and no velocity signal, some show both, and others appear to have a signal related to vergence velocity but not position. Near response cells do not have conjugate eye movement signals. The firing pattern of a convergence cell for convergence is shown in Fig. 1. This activity pattern corresponds to that needed by the medial rectus motoneurons to execute vergence eye movements. In addition to near response cells which increase their activity for convergence, about 25% of near response cells show a linear decrease in activity for convergence, and an increase for divergence. These are termed "divergence cells" [2]. Some of these cells have a divergence velocity signal (divergence burst) alone, or in addition to the divergence position signal. Although no direct projection to the abducens nucleus has been shown, divergence cells have a firing pattern which is appropriate for abducens neurons.

In addition to the signal related to vergence, most ►near response neurons also carry a signal related to lens accommodation. Although it has not been conclusively demonstrated, it is likely that some near response cells provide an input to the Edinger-Westphal nucleus, which in turn provides an input to the ciliary ganglion to effect lens accommodation.

### Higher Order Function

Ocular convergence is associated with lens accommodation (see ►Accommodation-vergence interaction) and it is very likely that near response cells are critical elements in this interaction. The model for this interaction is described in the Accommodation-vergence interaction entry, and the role of near response cells in this interaction is described in the following section.

### Quantitative Measure for this Structure

With disparity open loop (e.g. one eye occluded), lens accommodation drives convergence, and convergence cells increase their firing rate. Similarly, with accommodation open loop, convergence drives lens accommodation, and convergence cells also increase their firing rate. In order to quantitatively assess the roles of near response cells in the accommodation-vergence interaction, it is necessary to dissociate accommodation

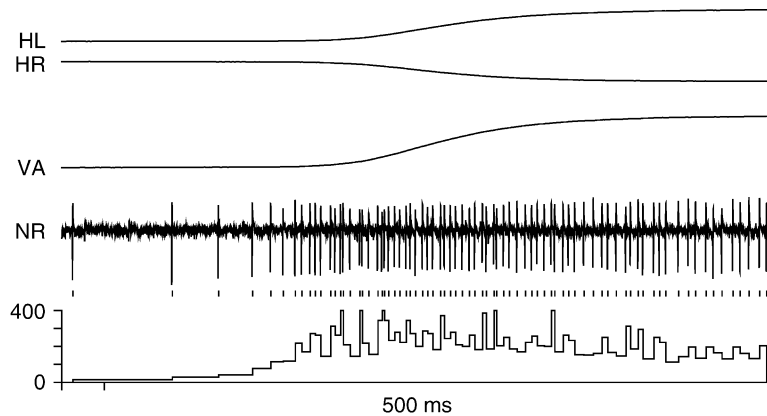

**Near Response Neurons. Figure 1** Firing pattern of midbrain near response cell for convergence. Traces are *HL*, horizontal left eye position; *HR*, horizontal right eye position; *VA*, vergence angle (*HL*-*HR*); *NR*, extracellular recording of action potentials of near response cell. The histogram at bottom is the firing rate in spikes/s (scale = 400 spikes/s). The time base is 500 ms. This cell shows a linear increase in activity for convergence as well as a small vergence velocity signal.

and vergence in the closed loop condition. This can be accomplished, at least partially, by requiring the subject to maintain clear focus on a target while forcing the eyes to converge, or alternatively, by requiring a constant vergence angle while changing the accommodative response by means of lenses. To the extent to which the accommodative and vergence responses can be dissociated, it is possible to characterize near response cells by the following equation:

$$\Delta FR = R_0 + k_y \times \Delta CR + k_a \times \Delta AR$$

where *FR* is the firing rate of the cell,  $R_0$  is the firing rate for zero accommodation and convergence, *CR* is the convergence response, *AR* is the accommodative response, and  $k_v$  and  $k_a$  are the coefficients describing the influence of vergence and accommodation, respectively. If a near response cell has a zero  $k_a$  value and a non-zero  $k_v$  value, then its activity is related exclusively to vergence; if the  $k_v$  value is zero and the  $k_a$  value is non-zero, then it is related exclusively to accommodation. An analysis of a relatively large number of convergence cells showed that most were not related to accommodation or vergence exclusively, but were related to both (i.e. had a non-zero  $k_a$  value and a non-zero  $k_v$  value) [5]. Indeed, some near response cells which increased their activity for convergence and accommodation (convergence cells) decreased their activity for convergence when accommodation was held constant (i.e. had a negative  $k_v$  value) and *vice versa*. The mechanism for this pattern of results is shown in Fig. 2.

Figure 2 is a representation of the dual-interaction model of accommodation and vergence. Both the accommodative and vergence systems are controlled by negative feedback, and they are cross-linked by the

diagonal connections. The near response cells (labeled 1–6) are presumed to be in both systems. Consider the situation in which a subject is required to keep the accommodative response constant while increasing the convergence response. This action will increase the output of the vergence controller (required for more convergence), but it will also increase the cross-link drive to the accommodative system, which is not needed. The accommodation controller will then produce a negative output to counteract this unwanted drive, if accommodation is to remain constant. However, this negative accommodation drive will be sent to the vergence system through the accommodative vergence link, and so will require an increased output from the vergence system to counter it. As long as the cross-link gains are not too high, the system will stabilize at a point at which the increased output of the vergence controller will be great enough to produce the required convergence response and counteract the accommodative vergence cross-link input. In addition, the negative output of the accommodative controller will cancel the input from the convergence accommodation cross-link. Consider near response cell 5, which receives a cross-link input that is equivalent to the average for the accommodative vergence cross-link. For this cell, the negative cross-link input exactly cancels the extra output that the vergence system supplies to deal with the conflicting viewing cues. In this case, the activity of this cell is always associated with the convergence response and is independent of the accommodative response. This cell will have a positive vergence gain ( $k_v$ ) and a zero accommodative gain ( $k_a$ ). Consider near response cell 4, which receives a relatively weak cross-link input from the accommodative controller. In the conflict viewing situation described above, this cell's activity will be



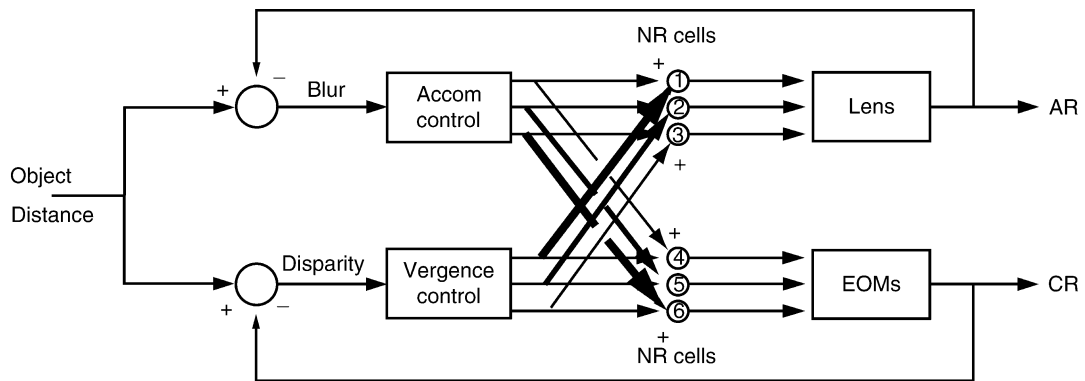

**Near Response Neurons. Figure 2** Putative role of near response cells in dual-interaction model of accommodation-vergence interaction. Abbreviations are: *AR*, accommodative response; *CR*, convergence response; *EOMs*, extraocular muscles. The accommodation (top half of figure) and vergence systems (lower half) are controlled by negative feedback mechanisms responding to the distance of the object of regard (object distance). In addition, the accommodative controller provides an input to the vergence system (downward angled cross-link arrows), and the vergence controller also drives the accommodative system (upward angled cross-link arrows). Near response cells (1–6) are thought to be elements in this linkage.

driven primarily by the output of the vergence controller, and thus will fire at a higher rate for a given convergence response when the accommodative response is restrained. Since reinstating the accommodative response would cause this cell to fire at a lower rate, the accommodative gain ( $k_a$ ) must be characterized as negative, even though the cell's vergence gain ( $k_v$ ) is positive. Similarly, near response cell 3 would have a positive  $k_a$  and a negative  $k_v$ , while near response cells 1 and 6 would have positive (non-zero)  $k_a$  and  $k_v$  values. In this way, small differences in the relative gains of the cross-link and direct inputs to near response cells allow the activity of these cells to be related to both accommodation and vergence. The overall pattern of accommodation and vergence gains of near response cells strongly implies that they are involved in the linkage between accommodation and vergence, but this has not yet been confirmed by more direct physiological or anatomical evidence.

## References

1. Freeman RD (2004) Binocular interaction in the visual cortex. In: Chalupa LM, Werner JS (eds) *The visual neurosciences*. MIT, Cambridge, MA, pp 765–778
2. Mays LE (1984) Neural control of vergence eye movements: convergence and divergence neurons in mid-brain. *J Neurophysiol* 51:1091–1108
3. Gamlin PDR, Mays LE (1992) Dynamic properties of medial rectus motoneurons during vergence eye movements. *J Neurophysiol* 67:64–77
4. Gamlin PDR, Gnadt JW, Mays LE (1989) Abducens internuclear neurons carry an inappropriate signal for ocular convergence. *J Neurophysiol* 62:70–81
5. Zhang Y, Mays LE, Gamlin PDR (1992) Characteristics of near response cells projecting to the oculomotor nucleus. *J Neurophysiol* 67:944–960

## Nearfield

### Definition

The area surrounding an acoustic or hydrodynamic source wherein source energy is dominated by inertial rather than viscous forces. In the nearfield, bulk movements of the medium, (hydrodynamic flow) is of much greater energy than the elastic motions of the medium that make up the propagating pressure wave (i.e., sound in common parlance). The spatial extent of the nearfield depends upon the density of the medium and the frequency of the sound source. The majority of biological relevant sound sources in water have extensive (several meters or more) nearfields, and most fish hearing occurs within the nearfield.

### ► Evolution of Mechanosensory and Electrosensory Lateral Line Systems

## Necessity

### Definition

Some statements are not only true but necessarily true (see truth). The fact that they state cannot possibly be otherwise. Consider the necessary “My mother is a woman” versus the non-necessary (i.e. accidental or contingent) “I have a brother.” There are, however, different kinds of necessity: a logical necessity, like

“It is raining or it is not raining,” has its source in the rules of logic; a conceptual necessity, like “Bachelors are unmarried men,” is true in virtue of the meanings of the words of the statement; a metaphysical necessity, like “Water is H<sub>2</sub>O,” is said to be necessarily true because it is the essence of water to be H<sub>2</sub>O. Nomological necessity, finally, is grounded in the laws of nature:

“Increased heat at constant volume necessitates (or causes) higher pressure” (see also reasoning – a priori).

► [Meaning](#)

## Necessity, Conceptual

### Definition

A statement that cannot turn out to be false, no matter what in fact is said to be necessarily true (opposite: contingently true; see truth). If this necessity has its source in the meaning of the words used in the statement one speaks of conceptual necessity (or analyticity). Examples: “All bachelors are unmarried” or “If an object is red then it has a color.” Denials of conceptually necessary truths are baffling if not meaningless: “My car is red but it does not have a color”.

- [Analyticity](#)
- [Meaning](#)
- [Necessity, Nomological](#)

## Necessity, Nomological

### Definition

Scientists and philosophers who do not think that laws of nature are mere summaries or descriptions of the regular events happening in our world claim that the laws bring about or necessitate those events. If it is a law that every C event (or property instantiation) is followed by an E event (or property instantiation), then C nomologically necessitates E. In other words, if C then, according to the law, it must be the case that E. The relation of nomological necessity between events or properties is often thought to be identical to the causation relation (or, at least, a derivative thereof).

Compare nomological to conceptual necessity, which is supposed to be a property of sentences or statements rather than a relation between events or properties.

► [Meaning](#)

## Nef

### Definition

This protein is released by HIV and found to be associated with HIV pathogenesis. It is known to perform an important role in HIV associated neurological disorders and viral replication.

► [Central Nervous System Disease – Natural Neuroprotective Agents as Therapeutics](#)

## Negative Feedback Control

### Definition

A mechanism used to regulate the value or time course of an output variable or signal when the output variable is determined by the value of an input signal or the time course of an input signal. The control mechanism is said to be closed loop when the value of the output variable is sensed or measured, is fed back and compared to some desired reference value and is then used to determine the value of the input signal. The closed loop control mechanism is referred to as negative feedback control when a given change in the output variable is compensated for by changing the input signal to produce an opposite change in the output. Negative feedback control is associated with homeostasis and regulatory processes, but a system regulated by negative feedback control can become unstable.

- [Control Theory](#)
- [Posture – Sensory Integration](#)

## Negative Schizophrenic Symptoms

### Definition

Lack of drive and initiative, social withdrawal, depression-like symptoms, anhedonia.

► [Schizophrenia](#)

## Nematode

- ▶ [C. elegans Neuroethology](#)

## Neocerebellum

### Definition

Phylogenetically, a very young part of the cerebellum. The neocerebellum contains the two cerebellar hemispheres and receives afferents mainly from the pons, thus being called also the pontocerebellum.

- ▶ [Cerebellum](#)

## Neocortex

### Definition

The evolutionarily most modern part of the vertebrate forebrain that covers with many convolutions most of the visible surface of the human brain. Also called isocortex because of the six-layered structure.

- ▶ [Isocortex](#)

## Neocortical Circuits: Computation in 3-D

RODNEY DOUGLAS<sup>1</sup>, HENRY KENNEDY<sup>2,3,4</sup>,  
KENNETH KNOBLAUCH<sup>2,3,4</sup>, KEVAN MARTIN<sup>1</sup>

<sup>1</sup>Institute of Neuroinformatics, University/ETH, Zurich, Switzerland

<sup>2</sup>Inserm U846, Bron, France

<sup>3</sup>Stem cell and Brain Research Institute, Bron, France

<sup>4</sup>Université de Lyon, Université Lyon I, Lyon, France

### Definition

Connections between neurons within and between cerebro-cortical areas.

## Characteristics

### Cortical Architecture and Processing

Every thought, every idea, every memory, every decision, and every action we have to make, arise from the activity of neurons in our brains. The results of some of this activity surround us: household objects, books, technology and art. Of all brain structures, the ▶ [neocortex](#), which forms over 80% of the volume of the human brain is, arguably, the most critical to what makes us human. This is a paradox, because the basic local architecture of the neocortex in all mammals, from mouse to man, appears to be very similar and is determined by the laminar distribution of relatively few types of excitatory and inhibitory neurons organized according to common principles of connectivity. These local circuits are organized in a framework of a six-layered columnar architecture, in which neurons with functional properties in common lie in discrete layers and in vertical slabs or columns [1] (▶ [Striate cortex functions](#)).

The uniformity of its construction suggests that the neocortex provides circuits that are optimized for a class of cortical “algorithm” that can be implemented for the full range of demands of behavior, including perception, cognition, and action. A number of models indicate the forms of general computation that could be carried out in a uniform cortical architecture. Typically these models address a single principle of operation in a small group of neurons; in others a more detailed model is imposed on the columnar architecture of cortex. Experimental results in alert behaving primates and together with theoretical studies, suggest that cognitive operations proceed very rapidly across different cortical areas (▶ [Cerebro-cortical areas](#); ▶ [Extrastriate visual cortex](#)) by feedforward categorization and feedback modulation, with slower refinement by lateral local interactions. Specification of local and long-distance connections in the cortex will go some way to explaining the implementation of these processes.

### Structural Specification of Cortical Connectivity: Integration of Intra- and Inter-Areal Connectivity

What is so special about the circuits of the neocortex? What makes them so efficient and so adaptable to different tasks? A major contribution to our understanding of the structure of the cortical circuit came with the model of a “canonical cortical microcircuit” [1]. This circuit expresses the functional relationships between the excitatory and inhibitory neurons in the different cortical layers and shows how the inputs to a local region of cortex from the sensory periphery via the ▶ [thalamus](#), or from other cortical areas, are integrated by the cortical circuits. The most critical feature of the canonical circuit is that the neurons are connected in a series of nested positive and negative feedback loops called “recurrent circuits.” Because the

excitatory and inhibitory neurons are interconnected, excitation and inhibition remain in balance and so the positive feedback does not overexcite the circuit. This organization explains how it is that the relatively tiny numbers of neurons that provide the external inputs to this circuit are nevertheless effective, as they are amplified selectively by recurrent excitatory circuits [1]. Explorations of this model in the visual cortex (► [Visual cortex – neurons and local circuits](#)), e.g. [2] have shown how this key notion of recurrent amplification explains the emergence of cortical properties, such as direction sensitivity and velocity sensitivity, orientation selectivity (► [Striate cortex functions](#)), masking, and ► [contrast adaptation](#).

The canonical model provides for a richer array of behaviors than the simple feedforward models that preceded it, and is readily applied across the cortex. For example, it is clear that the interlaminar connections have characteristic patterns across cortical areas and across species and thus may perform a generic computation [3]. What has been lacking until very recently is a quantitative model of the vertical (interlaminar) circuits. However, the studies by Binzegger et al. now clearly indicate that, in general, the contribution of the spiny neurons to interlaminar connections exceeds that of their intralaminar connections [4]. Hence, in the infragranular layers (layers 5 and 6), the majority of ► [pyramidal cells](#) connect outside their layer of origin. Layer 4 spiny neurons do connect within layer 4 (the “granular” layer), but their major projection is to layer 3. It is only in the supragranular layers (layer 1, 2 and 3) that the pyramidal cells make the majority of their synaptic connections to the same layer. The consequence of this is that the monosynaptic recurrent connectivity of layer 2 and 3 pyramidal cells predominates more than recurrent connectivity in any other layer. The recurrent connectivity of layers 2/3 is intriguing in that the local axons of the pyramidal cells are not uniformly distributed, but form patches or clusters. This pattern of patchy connections, referred to as “lattice connections” by Rockland are embedded within inter-areal feedforward and feedback connections [5]. Because of its appearance when viewed from the surface of the cortex we refer to the local horizontal network formed by a small cluster of pyramidal neurons as a “Daisy” In the neocortex many pyramidal neurons serve a dual function: all of them form the major excitatory neurons in the local cortical circuit, but many of them also project outside their own cortical area to other cortical areas or subcortical structures. Thus many of the same neurons that form a Daisy could also project to other cortical areas.

### Inter-Areal Projections

The inter-areal connections come in three flavors: feedforward, feedback, and lateral connections [5,6]

(► [Visual cortex – neurons and local circuits](#)). Feedforward connections originate principally from the supragranular layers, target layer 4 and connect lower to higher visual areas (► [Extrastriate visual cortex](#)) in a sequence tending to show increases in ► [receptive field](#) ([Visual cortical and subcortical receptive fields](#)) size and response latency. Feedback connections originate from principally infragranular layers, and connect higher to lower visual areas in a sequence suggesting decreases in receptive field size and response latency. It has been suggested that feedforward neurons have a “driving” and feedback neurons a “modulatory” influence. This is why the feedforward and feedback pyramidal cells located in the supragranular layers could also participate in the local Daisy circuits. The feedback neurons located in the infragranular layers likewise may participate in the local Daisy circuit via the local vertical connections with the supragranular layer pyramidal cells [3]. The infragranular feedback neurons probably provide an input to the Daisy, because one of the principal targets of the feedback projections are the supragranular layers (particularly layer 1).

Thus far, most of our knowledge concerning the local horizontal network is derived from studies of the ► [primary visual cortex](#) ([Visual cortex – neurons and local circuits](#)) of cats and monkeys, where it has been claimed that the horizontal clusters link columns of cortex with representations of like-orientation (► [Striate cortex functions](#)). In other cortical areas, including areas of ► [prefrontal cortex](#) in the monkey, such as area 46, horizontal clusters are equally apparent, but the representations they link have yet to be defined. At a structural level there are important regularities, whose functionality has yet to be divined. Across all areas and species examined (which include the major divisions of neocortex), there is a linear relationship between the size of the clusters and their spacing [3]. The size of the patches also correlates with the diameter of the lateral spread of the dendrites of pyramidal cells, which increases from ► [occipital cortex](#) to prefrontal cortex. It is not known what determines the constancy in the relations of these dimensions.

### Inter-Areal Hierarchies

Van Essen and colleagues have gone a long way in exploring the particular hierarchy to be found in the visual system and beyond. They showed that pair-wise comparison of the laminar organization and connections linking cortical areas made it possible to define all inter-areal pathways as either feedforward, feedback or lateral (linking areas on the same hierarchical level) (► [Extrastriate visual cortex](#)). While the Felleman and Van Essen model has continued to exert a powerful influence on concepts of neocortical function and brain organization, it has been questioned by the group of Malcolm Young that showed that there are 150,000

equally plausible solutions to the Felleman and Van Essen model [7].

In order to obtain a determinate model, it is necessary to define the hierarchical distance between stations. Precise quantification of the laminar organization of inter-areal connectivity provides a useful measure of hierarchical distance [5,6]. Injections of retrograde tracers in a mid-level target area show that afferent areas contain both labeled supra- and infragranular layer neurons. Feedforward projections originate predominantly from supragranular layers, and the exact proportion of supragranular neurons labeled relative to all labeled neurons in the same area depends on the hierarchical distance from the target area. Feedforward projections to far-distant areas originate almost exclusively from supragranular layer neurons, and as one approaches the target area, there is a smooth increase in the contribution from the infragranular layers. Likewise in the case of feedback projections, as the hierarchical distance increases there is a steady increase in the proportion of infragranular layers so that far-distant feedback projections are almost uniquely from infragranular layers. This regularity has been encapsulated in a “distance rule” that has the power to define the hierarchical organization of a cortical network from the analysis of the projections to only a small number of key areas [6].

Tracing experiments reveal that around 90% of the projections are local (within 1–2 mm), that is, most of the projections onto a cell are from neurons within the same area. Of the remaining 10%, about two thirds come from neighboring areas and are lateral, so that information flow across the hierarchy is assured by a truly minute proportion of feedforward and feedback neurons. The observation of dense local connections coupled with sparse long-range connections conforms to the idea of a “Small-World” network and goes along with a model of areas as functionally specialized modules, with the long-distance connections serving to communicate the information processed locally within areas rapidly across the cortex.

### Physiological Integration of the Daisy Architecture with the Connections between Cortical Areas

How long-range connections influence local circuit functions is an important step in understanding the computational function of the neocortex. One approach is to temporarily inactivate the area by cooling and study what effect the inactivation has on a target area the projecting regions. Cortical areas ▶V2 (Cerebro-cortical area V2) and MT (▶Cerebro-cortical area MT) have feedback connections to the primary visual cortex (area V1 (▶Cerebro-cortical area V1)), and cooling area V2 or area MT reduces the receptive-field center response of area V1 neurons. This suggests that there may be a summing of feedback activity with feedforward input from the thalamic ▶lateral geniculate

nucleus (LGN), which relays ▶retinal activity to area V1. Integration is further suggested by the evidence that feedback projections from extra-striate cortex overlap with clusters of area V1 cortical output neurons [8].

One way to investigate the dynamics of the interaction of inter- and intra-connectivity is to examine the visuo-topic scales of both systems and compare them to the receptive field response of neuronal aggregates in area V1 [8]. In these studies the representation of the ▶visual field (▶Vision) is determined for the extent of the local Daisy connection as well as for the inter-areal connections. These studies suggest that Daisy connections have the appropriate spatial extent to mediate a restricted portion of the visual response of area V1 neurons, which corresponds to the spatial summation zone within the receptive field. The extent of the Daisy connections was however insufficient in extent to account for the full surround response from beyond the classical receptive field (▶Vision). This makes sense because the relatively long delays of the suppressive orientation-selective effects of surround stimulation are similar to those reported for the slow propagation of excitatory activation mediated by horizontal connections.

The visuotopic representation of feedback projections from extra-striate cortex to area V1 are commensurate with the full center-surround response of the area V1 neurons (▶Visual cortical and subcortical receptive fields). The influence of extra-striate cortex on Daisy connectivity is coherent with the temporal constraints: the timing of the visual responses of higher visual areas largely overlap with area V1 responses, the conduction velocities of the large-caliber fibers projecting from extra-striate cortex to area V1 are considerably faster than those of the horizontal intrinsic fibers, and the inactivation of extra-striate cortex influences the early part of the area V1 neuron visual response. Hence, it would seem that the physiology and the visuo-spatial correspondence between the intra- and inter-areal connection systems provides the basis for the integration of local and global signals in the primary visual cortex [8].

### Conclusions

One fundamental question about feedback and feedforward pathways is whether they constitute distinct functional systems, as implied by the terminology used. Taking the geniculo-cortical pathway (▶geniculo-striate pathway) as a model, cortical feedforward pathways supposedly mediate driving influences and feedback mediate modulatory influences. Physiological studies support this general view, e.g. cooling area V1 in the monkey leads to silencing of area V2 neurons, whereas cooling area V2 has only marginal effects on the activity of area V1 neurons. However, if a small driving projection was contained in the feedback pathway that

remains dominated by a modulatory function, the driving function might not show up in the cooling experiments. The distance rule suggests that the physiology of feedforward and feedback pathways linking cortical areas is determined by the composition of the parent neurons in terms of supra- and infra-granular layers [6]. The differences in the physiology of feedforward and feedback pathways could be the consequence of (i) differences in the cellular targets and/or (ii) differences in the intrinsic properties of the parent neurons.

The idea that a cortical area is homogenous both in function and structure has been floating for over a century. In a seminal paper, Daniel and Whitteridge [9] showed that while the amount of cortex devoted to a degree of the visual field (the “magnification factor”) (► [Striate cortex functions](#)) does change across the cortex, there appears to be a constant ratio between the numbers of peripheral receptors and the number of visual degrees represented in the cortex. In the 1970s, Hubel and Wiesel took this a step forward in suggesting that the entire apparatus for representing a point of the retinal image is contained in a small region of cortex a few millimeter in area, which they called a “► [hypercolumn.](#)” The primary visual cortex thus consists of many such hypercolumns. However, the dynamic properties of neuron response have been shown to change dramatically within a visual cortical area at different eccentricities, and a recent paper shows marked differences in the inputs to the central and peripheral representation of area V1 [10]. The dominance of inter-areal projections by nearby areas could lead to such a specialization because the layout of the visual areas results in different sets of areas being closer to central than peripheral visual field representations. This in turn leads to the prediction that the central representation of early visual areas will be preferentially connected to the ventral processing stream and peripheral to the dorsal processing stream (► [Extrastriate visual cortex](#)). Thus while a given cortical area may be formed by multiple copies of a canonical circuit, each region of the area could be modulated independently by its nearest neighbors. Eccentricity-dependent differences in organization would be consistent with the anatomical specializations in the retina (fovea vs. periphery) as well as the behavioral evidence of eccentricity dependence of different tasks (for example, object recognition in central vision vs. global spatial localization in the periphery). Such observations raise questions about how a cortical area should be defined, since it cannot be done by assuming that one area behaves as a single functional entity.

Our approach to investigating cortical hierarchy is based on Graph Theory, in which the distribution of connections between areas is analyzed over the whole network to infer the connective distances between areas [7]. Such an analysis shows that the distribution of

areas bears a close resemblance to their spatial layout in the cortex suggesting organizational principles linking connectivity, adjacency and cortical folding. This study, however, is based only on the presence or absence of a connection between two areas and does not take into account the strength of connections. Because strong connections are very short-range, integrating the strength of neural connections in these models will strongly emphasize the importance of adjacency. Given that the strength of connectivity is eccentricity-dependent, comparing graphs across the cortex will allow us to explore structural features of contextual processing. The challenge will then be to extract the rules allowing integration of Daisy architecture in the contextual process. Significant efforts are now being made to understand how graphical processing can be instantiated in networks of uniform processing elements, how this can be done using asynchronous event-based methods, which are the essence of neuronal computations, and whether graphical processing can be promoted from simple uniform propagation between nodes (whether defined as neurons, clusters of neurons, or cortical areas) to a dynamic “intelligent” selective propagation. The solution to such problems will be an important step to understanding the principles by which biological brains achieve their intelligence.

### Acknowledgments

This work was supported by FP6-2005 IST-1583; ANR-05-NEUR-088 (HK, KK); SNF NCCR Neural Plasticity and Repair (KM).

### References

1. Douglas RJ, Martin KAC, Whitteridge D (1989) A canonical microcircuit for neocortex. *Neural comput* 1:480–488
2. Douglas RJ, Koch C, Mahowald M, Martin KA, Suarez HH (1995) Recurrent excitation in neocortical circuits. *Science* 269:981–985
3. Douglas RJ, Martin KA (2004) Neuronal circuits of the neocortex. *Annu Rev Neurosci* 27:419–451
4. Binzegger T, Douglas RJ, Martin KA (2004) A quantitative map of the circuit of cat primary visual cortex. *J Neurosci* 24(39):8441–8453
5. Kennedy H, Bullier J (1985) A double-labelling investigation of the afferent connectivity to cortical areas V1 and V2 of the macaque monkey. *J Neurosci* 5 (10):2815–2830
6. Barone P, Batardiere A, Knoblauch K, Kennedy H (2000) Laminar distribution of neurons in extrastriate areas projecting to visual areas V1 and V4 correlates with the hierarchical rank and indicates the operation of a distance rule. *J Neurosci* 20(9):3263–3281
7. Vezoli J, Falchier A, Jouve B, Knoblauch K, Young M, Kennedy H (2004) Quantitative analysis of connectivity in the visual cortex: extracting function from structure. *Neuroscientist* 10(5):476–482

8. Angelucci A, Bullier J (2003) Reaching beyond the classical receptive field of V1 neurons: horizontal or feedback axons? *J Physiol Paris* 97(2–3):141–154
9. Daniel PM, Whitteridge D (1961) The representation of the visual field on the cerebral cortex in monkeys. *J Physiol* 159:203–221
10. Falchier A, Clavagnier S, Barone P, Kennedy H (2002) Anatomical evidence of multimodal integration in primate striate cortex. *J Neurosci* 22(13):5749–5759

---

## Nephron

### Definition

The functional unit of the kidney is the nephron. A nephron consists of a glomerulus and a tubule. The glomerulus is a cluster of blood vessels from which the filtrate forms. The tubule is an epithelial structure consisting of many subdivisions designed to convert the blood filtrate into urine.

- ▶ Blood Volume Regulation

---

## Nerve Cell Membrane

### Definition

A thin membrane comprised of phospholipids, proteins and carbohydrates that encloses the cell cytoplasm, nucleus and other intracellular organelles.

- ▶ Membrane Components

---

## Nerve Grafting

### Definition

Bridging a gap in nerve continuity by inserting cables of another nerve, transplanted from another part of the body.

- ▶ Regeneration: Clinical Aspects

---

## Nerve Growth Factor (NGF)

### Definition

Nerve Growth Factor is the first of a series of neurotrophic factors that were found to influence the growth and differentiation of sympathetic and sensory neurons.

- ▶ Neural Development
- ▶ Neurotrophic Factors
- ▶ Regeneration

---

## Nerve Regeneration

### Definition

Nerve regeneration is the ability of the nervous system to reestablish functional connection after nerve injury.

The central nervous system is not capable of functional regeneration. The peripheral nervous system has a limited ability to regenerate, although regeneration is often incomplete, misdirected and resulting in neuropathic pain.

- ▶ Extrasomal Protein Synthesis in Neurons
- ▶ Neuropathic Pain
- ▶ Peripheral Nerve Regeneration and Nerve Repair
- ▶ Regeneration

---

## Nerve Transfers

### Definition

The deliberate direction of a proximal donor nerve to a foreign distal denervated one. Axons from the donor nerve enter into the denervated one and then reinnervate the previously denervated foreign end-organ to allow functional recovery.

- ▶ Peripheral Nerve Regeneration and Nerve Repair
- ▶ Regeneration: Clinical Aspects

## Nervous, Immune and Hemopoietic Systems: Functional Asymmetry

VALERY V. ABRAMOV, IRINA A. GONTOVA,  
TATJANA YA. ABRAMOVA, VLADIMIR A. KOZLOV  
Laboratory of Neuroimmunology, State Research  
Institute of Clinical Immunology of SB RAMS,  
Novosibirsk, Russia

### Synonyms

Asymmetry – absence of symmetry; Contralateral lobes – left and right lobes; Thymocytes – cells of thymus; Splenocytes – cells of spleen; Syngeneic mice – compatible on H-2 antigens mice; Immunization – injection of antigens; Paw preference – preference of paw in taking food; Maturation of cells – differentiation of cells

### Definition

The ►**asymmetry** of the brain hemispheres has been studied for a long time. While studying this phenomenon, numerous facts on structural, functional, and molecular-biological differences of the hemispheres have been accumulated. Based on these data, some studies have been conducted showing that there is asymmetry of not only the brain hemispheres but also of the neuroendocrine system as a whole, including the gonads, adrenal glands, and lobes of the thyroid gland. For example, our experiments discover the existence of functional asymmetry of adrenal glands in ►(CBAx $C57BI/6$ )F1 hybrid mice.

At the same time, it is known that the hemopoietic and lymphoid organs (bone marrow, thymus, lymph nodes, etc.) as well as the brain hemispheres are presented by two morphologically-divided lobes (contralateral lobes). This enabled us to suppose and prove that not only the neuroendocrine system but also the hemopoietic and immune systems demonstrate the functional asymmetry of bilateral organs.

### Characteristics

#### The role of Functional Asymmetry of a Bone Marrow and of Brain's Hemispheres in Hemopoiesis

##### Design for Experiment

The recipient mice were prepared by exposure to a whole-body-radiation dose (950 R). Marrow cells were obtained from the femora of mice-donors, suspended in saline and the nucleated cells were counted with a hemacytometer. These suspensions were kept at ice-water temperature until they were injected. The recipient animals then received an intravenous injection with  $10^5$  of marrow cells (0.5 ml). The effect of functional asymmetry of the bone marrow on hemopoiesis

was evaluated by injections of cells from the left or right femoral bone of left- or right-pawed donors to irradiated recipient animals (left- or right-pawed). Eight days after injection of the transplanted cells, the mice were killed and the number of colonies (i.e. in the number of 8-day colony-forming units in spleen – ►CFUs-8) in their spleens was determined by Till and McCulloch method.

### Results

Our experiments discovered the existence of functional asymmetry of the bone marrow cells [1–6]. For example, the evaluation of functional asymmetry of the bone marrow showed significant differences in the hemopoiesis (CFUs-8) only in irradiated left-pawed recipients receiving an intravenous injection of marrow cells from the right or left femoral bones of left-pawed donors. No appreciable differences in the formation of CFUs-8 were observed in cases when left and right femur marrow cells were transplanted from right-pawed donors to left-pawed recipients (►left-pawed and right-pawed mice), or marrow cells from either femur of left- and right-pawed donors were injected to right-pawed recipients. These results indicate that the: (i) hemopoietic potential of the bone marrow from the right and left femoral bones is different; and (ii) manifestation of asymmetry of bone marrow hemopoietic functions depends on motor asymmetry of donors and recipients [4–6].

#### The role of Different Lobes of the Thymus and Different Hemispheres of the Brain in the Development of Humoral Immune Response

##### Design for Experiment

The mice recipients were thymectomized to evaluate the role of the cells from either left or right thymus lobes in the ►**humoral immune response**. Five weeks after thymectomy, left and right-pawed recipients animals were intravenously injected with thymocytes from the right or left thymus lobes of left-pawed syngeneic donors ( $10^7$  cells/mouse). These recipient mice were subsequently immunized with sheep red blood cells (►SRBC) 10 days after thymocyte administration. The humoral immune response (antibody-producing cells) in the spleen was counted by the method of Cunningham 4 days after the immunization.

### Results

Our experiments showed the existence of functional asymmetry of the thymus and demonstrated that the asymmetry in the nervous and immune systems (hemispheres of the brain and the thymus) plays an important role in the development of humoral immune response to SRBCs. So, the *in vivo* experiments showed that the properties of cells from contralateral lobes of the thymus proved to be a deciding factor that defines the differences at the level of humoral immune response in recipient



mice with left-dominant hemispheres. This effect was less pronounced in mice with right-dominant hemispheres. Further analysis showed that left and right-dominant hemisphere mice differ according to the immune response only if mice from both groups received cells from the left but not from the right lobes of the thymus. That is, in the formation of the humoral immune response to SRBCs the functional asymmetry of both the brain and thymus is of great importance [7–9].

### **The role of Motor Asymmetry of Brain Hemispheres and Functional Asymmetry of Regional Lymph Nodes in the Development of Cellular Immune Response**

#### **Design of Experiment**

While studying the ► **cellular immune responses** in the paws, mice were intraperitoneally immunized with 0.5 ml of 5% SRBCs. On the fourth day, the delayed-type hypersensitivity (DTH) reaction was used as an *in vivo* measure of antigen specific T-lymphocyte reactivity. In order to study the cellular immune response, 50% suspension of SRBCs in 0.05 ml of physiologic saline was injected under aponeurosis of the left paw. In addition, 0.05 ml of physiologic saline was injected under aponeurosis of the right paw as a control. The cross-section of a paw at the site of injection was measured 24h later. In order to study the cellular immune response in the right paw, mice were injected with 50% suspension of SRBCs in 0.05 ml of physiologic saline under aponeurosis of the right paw. Further, 0.05 ml of physiologic saline was injected under aponeurosis of the left paw as a control. The index of reaction (DTH) was calculated for each mouse by the formula:  $IR = (P_o - P_c) / P_c$ , where  $P_c$  – paw cross-section in control;  $P_o$  – paw cross-section in experiment.

#### **Results**

The results obtained showed that the degree of cellular immune response in (CBAx57Bl/6) F<sub>1</sub> mice depends on the functional asymmetry of regional lymph nodes and paw preference. The thymus functional asymmetry is of insignificant importance in DTH reaction. For example, we found that the intensity of the DTH reaction to SRBCs in the front paws of (CBAx57Bl/6) F<sub>1</sub> mice depends not only on whether the antigen is injected into the left or right paw but also on the motor asymmetry of the hemispheres. While comparing the DTH reaction in the hind left and right paw of mice, we showed that in both right- and left-handed mice it was much more pronounced in the left paw than in the right one [6,10].

#### **Discussion**

It is known that autonomic nerves are well presented in the bone marrows, thymus lobes and lymph nodes of mice where, together with specialized cells, they form the neuroendocrine microenvironment that influences the maturation of cells. These data together with our

results on differences in the functional properties of cells from contralateral (left or right) bone marrow and lymph nodes, and thymocytes from the thymus lobes allow us to suggest the following: (i) there are differences in the sympathetic and parasympathetic innervation of the contralateral lobes of the organs; and (ii) differences in the functional properties of cells from the contralateral lobes of the organs are caused by differences in the neuroendocrine environment of the lobes mentioned; i.e. preferential influence of catecholamines, acetylcholine and peptides on the cells.

It has been established that sympathetic and parasympathetic activity is preferably regulated by different brain hemispheres. So, sympathetic activity is preferentially regulated by the right hemisphere, whereas parasympathetic activity is regulated by the left hemisphere. In this connection, one can speak about the lateralizing effect of the brain hemispheres on the organs by creating differences in the neuroendocrine environment of the right and left lobes.

At the same time, our data, for example, on the different roles of cells from the contralateral lobes of the thymus in the formation of a humoral immune response confirm the supposition that thymocytes from the lobes mentioned have different functional properties. Moreover, we speculate that the number of T-helper precursors of type 2 might be different in the thymus lobes and/or the precursors mentioned are at different stages of their differentiation. Since the injection of thymocytes from the left thymus to thymectomized recipients is accompanied by the greatest effect on the formation of a humoral immune response, there might be more T-helper precursors in the left lobe and/or they are more mature in comparison with cells from the right lobe. That sympathetic and parasympathetic activity is mainly regulated from different brain hemispheres can help explain their role in the formation of a humoral immune response in thymocyte recipients. If functional differences in cells from the contralateral lobes of the thymus of donors define the preferential influence of catecholamines and acetylcholine, the influence mentioned can also explain the role of the hemispheres in the formation of antibody-forming cells in the recipients who received thymocytes from a given lobe. For example, specific receptors to definite neuromediators might be expressed on the surface of the thymocytes mentioned.

We speculate that the more pronounced DTH reaction on the left than on the right may be connected too with asymmetry of peripheral innervation of contralateral lymph nodes that, in its turn, is controlled by brain hemispheres. That is, peripheral vegetative innervation of regional lymph nodes, regulated by brain hemispheres, might be very important in asymmetrical development of reactions of cellular immunity in front and hind paws of mice. The data testify to an important role of sympathetic innervation in DTH reaction. For

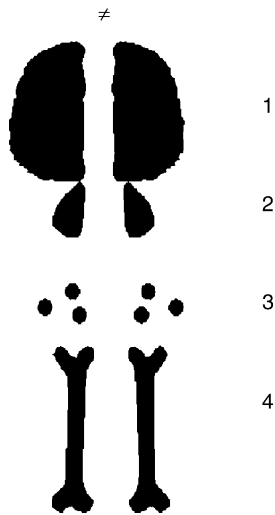

**Nervous, Immune and Hemopoietic Systems: Functional Asymmetry.** **Figure 1** Structural-functional asymmetry of Hemopoietic, Immune, Endocrine and Nervous systems (HIMEN system). ≠ – symbol of asymmetry 1 – neuroendocrine system (hemispheres); 2 – thymus; 3 – lymph nodes; 4 – bone marrow.

instance, they showed that stroke lateralized T-cell-mediated cutaneous inflammation. This effect may be mediated by alteration of the cutaneous sympathetic nerve traffic. The authors also demonstrated that there is lateralization of cutaneous inflammatory responses in patients with paresis after poliomyelitis. This lateralization of DTH responses is related to deficiencies in motor and sympathetic innervation of the paretic extremity.

It is possible that sympathetic and parasympathetic activity that is mainly regulated from different brain hemispheres can help to explain their role in the formation of CFUs-8 in mice-recipients.

### Conclusion

Thus, our data allow us to speak about the asymmetry of the integrated Hemopoietic, Immune, Endocrine and Nervous systems, i.e. the HIMEN system (Fig. 1) [1,6,9].

### References

1. Abramov VV, Abramova TY (1996) Functional asymmetry of hemispheres of brain. In: Komarova LB (ed) Nervous, endocrine, and immune systems asymmetry. Nauka, Novosibirsk, pp 30–43 (in Russian)
2. Grebenshikov AY, Poveschenko AF, Abramov VV (1999) Expression of IL-1 beta gene in brain after peripheral administration of thymus-dependent and thymus-independent antigens. Dokl Biol Sci 366(1–6): 294–296
3. Abramov VV, Karmatskikh OL, Kozlov VA, Oskina IN (1996) Functional asymmetry of adrenal glands in (CBAXC57Bl/6)F1 mice. Dokl Akad Nauk 347 (6):831–833

4. Abramov VV, Kozlov VA, Karmatskikh OL (1990) The asymmetry of exogenous CFUs-12 forming in mice. In: Korneva EA, Polyak AI, Frolov BA (eds) The interactions between the nervous and immune systems. Printing House im. MI Kalinina, Leningrad, Rostov-na-Donu, pp 172
5. Abramov VV, Gontova IA, Kozlov VA (2002) Functional asymmetry of the brain and bone marrow in hemopoiesis in (CBAXC57Bl/6)F1 mice. Byull Eksp Biol Med 133 (5):468–470
6. Abramov VV, Gontova IA, Kozlov VA (2006) Functional asymmetry in hematopoietic, immune and nervous systems. In: Yegor Malashichev B, Wallace Deckel A (eds) Behavioural and morphological asymmetries in vertebrates. Landes Bioscience – Chapter 12, pp 1–12
7. Abramov VV, Kononov VI, Gontova IA (1992) Asymmetry of phenotypical and functional characteristics of the cells from lymphoid organs. Dokl Rossiisk Akad Nauk 322(4):802–805
8. Gontova IA, Abramov VV, Kozlov VA (2001) Asymmetry in cerebral hemispheres and thymus lobes during realization of humoral immune response in mice. Byull Eksp Biol Med 131(1):64–66
9. Abramov VV, Gontova IA, Kozlov VA (2001) Functional asymmetry of thymus and the immune response in mice. Neuroimmunomodulation 9(4):218–224
10. Gontova IA, Abramov VV, Kozlov VA (2004) The role of asymmetry of nervous and immune systems in the formation of cellular immunity of (CBAXC57Bl/6)F1 mice. Neuroimmunomodulation 11(6):385–391

## Nervousness

N

### Definition

State of hyperarousal, irritability, hyperactivity, unrest and becoming tired quickly. As this vague term is frequently used in common speech, it is rarely used in medical terminology.

► Personality Disorder

## Nervus Terminalis

► Evolution of the Terminal Nerve

## Net Torque

### Definition

The sum of all muscle torques acting at a joint.

► Impedance Control

## Netrins

### Definition

Family of bifunctional diffusible guidance molecules with attractive or repulsive effects towards different types of neurons. The role of netrins and their receptors DCC and UNC-5 in guidance of commissural neurons has been extensively studied in vertebrates, worms and flies. DCC receptors mediate attraction and repulsion, while UNC-5 receptors appear to function exclusively in repulsion. These receptors can also mediate cell death.

► [Growth Inhibitory Molecules in Nervous System Development and Regeneration](#)

## Network

### Definition

Neurons that are connected to form a functional unit.

## Network Error

### Definition

In supervised learning, neural networks learn to approximate a given data set with the help of a teaching signal. During the training process, the network processes input exemplars with its current set of connection weights, resulting in a corresponding output signal. This output is compared to the teaching signal, representing the desired output. The network error is computed as the sum of squared differences between the actual and desired output for each output unit.

- [Connectionism](#)
- [Neural Networks for Control](#)

## Network Interneurons

### Definition

Pre-motor neurons that are part of the central pattern generator (CPG).

- [Central Pattern Generator \(CPG\)](#)
- [Excitatory CPG Interneurons](#)

## Network Oscillations

### Definition

Oscillatory activity generated in distinct brain regions by networks of often electrically coupled neurons are fundamental to information processing in the mammalian brain. Many of these rhythms correlate with distinct behavioral states. Electrical synapses appear to play a role in the generation and synchronization of these network oscillations.

- [Electrical Synapses](#)

## Network Oscillations in Olfactory Bulb

### Definition

Oscillatory variations of the field potential can be revealed by extracellular recordings. It presumably results from the synchronized activity of a group of neurons. Several types of oscillations have been described in diverse brain areas. They are classified with respect to their oscillatory frequency. For example, in the main olfactory bulb, there are three types of oscillations. Slow “ $\Theta$ ” oscillations (1–8 Hz) are generated by respiratory cycle. Fast “ $\beta$ ” (15–30 Hz) and “ $\gamma$ ” (40–80 Hz) oscillations are induced by inhalation of odorant molecules and reflect information processing by the olfactory bulb neuronal network.

- [Olfactory Bulb](#)

## Network Oscillator

### Definition

A neuronal network that produces a rhythmic activity pattern in response to a general excitation as a result of the synaptic connections between the individual neurons. Each neuronal type may discharge during a different phase of the rhythm. In a network oscillator none of the component neurons possess endogenous bursting properties (i.e. the individual neurons on their own would not produce any rhythmic activity). Instead, generation of the rhythmic activity is due to synaptic interactions. The simplest network oscillator configuration is the half-center oscillator that consists of two neurons or groups of neurons, which are connected

by mutual inhibitory connections. This configuration can lead to rhythmic switching of activity between the two half-centers producing a biphasic activity pattern.

- ▶ Central Pattern Generator
- ▶ Half-center
- ▶ Respiratory Network
- ▶ Rhythmic Movements

## Network Reconfiguration

### Definition

A process that alters the interactions and output pattern of a neuronal network by changing the number of active neurons, their intrinsic membrane and/or synaptic properties. Network reconfiguration is typically mediated by endogenously released neuromodulators.

The reconfiguration of neuronal networks imbues the nervous system with a high degree of plasticity. It enables, for example, a behaving animal to alter the output of a neuronal network in response to changes in the behavioral, environmental and metabolic conditions.

- ▶ Bursting Pacemakers
- ▶ Neuromodulator

## Neural and Behavioral Responses to Immunologic Stimuli

ALEXANDER KUSNECOV

Rutgers University, Department of Psychology,  
Piscataway, NJ, USA

### Introduction: What the Brain Cannot See But Needs to Know

From a behavioral perspective, the nervous system evolved for organisms to approach and avoid stimulus components of their environment. This is predicated on the existence of sensory systems that transduce physical information into the electrochemical events of neural transmission, and which forms the basis for information processing. Each stimulus, no matter how discrete, is an informational package, and can be arranged along a continuum varying in the intensity and magnitude of some specific criterion. For the nervous system, differentiation and identification of objects includes such characteristics as size, texture, and weight, information

which is processed and acted on to orchestrate an appropriate response. Thus, pot plants falling off balconies, oncoming motor vehicles, a baseball speeding through the air, all signify to an individual appropriate steps to take in avoiding or engaging a potentially dangerous stimulus. However, this form of signal detection fails in the realm of stimulus encounters with the microbial world of bacteria, viruses and other parasitic entities that represent biological threats against the organism. It is against biological agents at this end of the continuum of environmental stimuli that the nervous system is at a loss to avoid and/or engage with an appropriate response. To address this problem, vertebrate animals evolved a cell-mediated molecular recognition system that recognizes and eliminates microbial organisms. This is the immune system, a heterogeneous collection of cells (collectively referred to as leukocytes) that consists of macrophages and monocytes, which represent the first line of immunologic defense by ingesting and degrading particulate cellular invaders, while T and B lymphocytes (or T and B cells) serve to regulate immune responses, produce antibodies (by B cells) and exert cytotoxic effects by killing virally infected cells. A general review of the immune system is not possible here, although for a general introduction the reader is referred to other sources [1].

### The Immune System Communicates with the Brain

For many years it was thought that the immune system functioned independently in exercising this defensive function, and to a large extent in the ▶initial phase of encountering and responding to pathogens, it is the main system involved. However, the past several decades have emphasized that the immune system can be influenced by the central nervous system (CNS), and in reciprocal fashion, the activity of the immune system can affect the CNS. A number of publications have compiled reviews of empirical research attesting to this mutually interactive functional relationship [2]. In retrospect, this interaction makes considerable sense, given that the behavior of an organism can serve to control levels of exposure to environments that may contain infectious microorganisms. However, in the absence of foresight, exposure to bacteria or viruses renders too late any evasive and/or protective measures. Therefore, some form of learning and/or knowledge about each infectious episode must be relayed to the CNS to ensure control over future potential encounters. For this reason pathways of communication exist from the immune system to the brain, activating brain mechanisms that essentially perceive the presence of infection in the body. One of the most instructive examples of this is the behavioral phenomenon of conditioned taste aversion (CTA; also referred to as food aversion) a form of avoidant learning in which tastes and foods are rejected if their ingestion had

previously been associated with illness. This behavior can be elicited by immune responses and molecular products of the immune system, illustrating the notion that the immune system, as it engages microbial pathogens, simultaneously alerts the brain to initiate adaptive behavioral responses.

The immune system engages microbial antigens by generating *inter alia* a cascade of chemical mediators called cytokines which regulate the cells of the immune system, but in addition, are capable of binding to receptors on afferent nerves (e.g., the vagus) as well as the endothelial cells of the vasculature. The production of cytokines during the immune response signals to the CNS the presence of potential pathogens, leading to the elaboration of various efferent mechanisms (viz., endocrine and autonomic nervous system activity) that result in physiological changes that contribute to the removal of the pathogen. In addition, and perhaps the most important from an adaptational perspective, the CNS response to cytokines initiates behavioral adjustments that result in cognitive processing of all relevant information pertaining to the potential source of the illness and how it can be managed. Returning to the CTA example introduced above, infectious illness following ingestion of a novel food should result in a memory for the contextual circumstances surrounding food intake. Indeed, it is known that memory is enhanced shortly after ingestion of food, and perhaps this phenomenon ensures that in the face of food poisoning there is more effective retrieval of information pertaining to the “eating event.” As discussed below, these behaviors are part of a constellation of changes called “sickness behaviors.”

### The Immune System as a Stressor

Stress is a much used and abused term. The intended (and commonplace) connotation of the term is either as a threat to the organism or a state of the organism that is potentially harmful to health. In order to allow for effective communication of the conditions leading to “stress,” investigators use the term “stressor” to denote any stimulus or condition that produces a biological state significantly different from that observed prior to stressor exposure. In recent years, a distinction has been made between two classes of stressors: (i) those that operate through cognitive and exteroceptive sensory stimulation (e.g., pain), and (ii) those occurring within the internal milieu – the molecular signals arising from the cells and tissues of the organism. The former are referred to as *processive* stressors, and involve psychogenic components, while *systemic* stressors involve endogenous changes in the internal milieu which signal the CNS through alternative interoceptive pathways (blood, afferent nerves) [3]. Examples of systemic stressors can include metabolic changes such as insulin elevations and reductions in blood glucose, as

well as changes in the chemical composition of the blood as a result of exposure to a pathogen. Therefore, the immune system and the cytokines produced following its stimulation are now viewed as systemic stressors, generating a similar profile of changes in the brain that are produced by processive stressors. These changes include an elevation of the production and release of classical neurotransmitters, including the monoamines (serotonin, dopamine and norepinephrine), in regions of the brain that are known to be involved in the generation of fear, anxiety, reward evaluation, decision-making, and memory. Such regions include the septum, amygdala and associated areas (which process fear and anxiety), hippocampus (involved in memory), prefrontal cortex (decision-making), nucleus-accumbens and other components of the mesolimbic dopaminergic pathway (reward evaluation). All these areas are part of the brain circuitry involved in emotion regulation. Activation of these areas has been determined by measuring the appearance of immediate-early genes (e.g., *c-fos*) that reflect excitation of neurons, as well as through electrophysiological recording of the firing rates of neurons generating action potentials. Many of the changes in these brain regions are observed following exposure of laboratory animals to painful and/or fearful stimuli (i.e. processive stressors). And while the study of these brain regions and their role in cognition and emotion continues to evolve, it is apparent that they are essential to the ability of organisms to adapt in the face of challenges to survival and/or well-being. Consequently, it must be the case that similar engagement of such areas by immunologic factors serves to mediate similarly adaptive behavioral and physiological changes.

### The Role of Cytokines

In the early 1970’s and 1980’s CNS activation by the immune system was demonstrated using sheep red blood cells (SRBC) as the antigen [4], and showed that during the peak of the antibody response there were increases in plasma corticosterone, brain electrophysiological activity, and release of monoamine neurotransmitters in regions of the brain involved in stress and adaptation. This work has been extended to include protein antigens, bacterial toxins, and viruses. Collectively, it is now well established that the CNS is a recipient of “sensory” signals from the activated immune system. Indeed, this was recognized early and led to the concept of the immune system as a “floating brain” or “sensory organ” [4,5].

The search for molecules that might be responsible for the CNS activation observed during the immune response to specific antigens led to important discoveries that opened wide the field of neural-immune research. As stated above, cytokines are the chemical mediators of the immune system, responsible for

suppressing, enhancing, and fine-tuning the various cellular mechanisms of the immune system. Cytokines play an important role in the final stage of an immune response which involves an effector component that constitutes the ultimate death blow to an invading pathogen. This effector stage includes T lymphocytes being cytotoxic for bacteria or virally infected cells and B lymphocytes producing antibody that binds and neutralizes antigen. Antibodies also serve as tags that allow macrophages to bind the antibody-bound antigen (e.g., bacterial cell) and summarily eliminate the antigen through cytotoxic means and phagocytosis. The role of cytokines in these processes is to either augment, suppress or maintain control of the effector arm of the immune response. Failure to regulate this process can result in immunopathology, including autoimmune disease and prolonged infection. Numerous cytokines have now been identified, and many more await characterization. However, a number of cytokines have already been designated with neuromodulatory functions. A substantial body of evidence exists on the neural effects of the cytokines interleukin-1 (IL-1), IL-6 and tumor necrosis factor (TNF  $\alpha$ ). Many other cytokines, including IL-2, interferon  $\alpha$  (IFN $\alpha$ ) and IFN $\gamma$ , and transforming growth factor (TGF), have been linked to brain function either through demonstrations of behavioral and neurophysiological changes, or through their involvement in neuropathology. Many more cytokines will continue to be implicated in neuromodulation through research on degenerative and regenerative events in the brain, as for example, in animal models of stroke, dementia and neurological impairment. However, in terms of influences affecting ongoing neural and behavioral functions due to systemic immune responses, there is general acceptance that IL-1, IL-6 and TNF $\alpha$  are involved, given that their administration replicates many of the effects seen in response to many of the experimental antigens shown to activate the brain. Indeed, these cytokines are also produced within the brain by glial cells (*viz.*, astrocytes and microglial cells) which can support neuronal function through regulation of nutrient and neurotransmitter biosynthetic pathways. The production of cytokines by glial cells is an area of intense interest, and clarity of conceptual understanding in terms of precisely how intra-CNS cytokines promote brain function is yet to be realized.

The direct effects of cytokines on CNS function reinforced the principle of immune-derived activation of neural processes. However, demonstrations of the contribution provided by endogenous cytokines, focused largely on the use of lipopolysaccharide (LPS), which has been studied as a model of gram negative bacteremic infection. Exposure of animals to LPS produces significant *in vivo* production of IL-1, IL-6 and TNF $\alpha$ ; and many of the neural and behavioral effects of

administered cytokines can be easily induced by LPS. However, LPS activates the cells of the myeloid lineage, such as monocytes and polymorphonuclear phagocytic cells (*i.e.* macrophages). The study of other antigens that engage T cells, is also needed. These cells are a significant source of cytokines, some of which are exclusive to T cells (e.g., IL-2 and IL-4), while others are produced by both T cells and macrophages (e.g., IL-1, TNF, IL-6, IL-10 and IL-12). A more complete image of the immunological influence on brain function requires the use of antigens that also stimulate T cells.

### Bacterial T Cell Superantigens and the CNS

The term “superantigen” (SAg) was coined by Marrack and colleagues [6] to describe the unusually exaggerated proliferative and cytokine response of T cells to staphylococcal enterotoxins derived from gram positive bacteria. The appellation “super” served to contrast these enterotoxins with regularly tested protein antigens (e.g., egg albumin or keyhole limpet hemocyanin), which are highly selective and do not engage as large a T cell population as SAGs, and fail to induce readily observable *in vivo* T cell proliferation and **measurable** concentrations of cytokines in the blood. A fuller discussion of SAGs and their unique neuroimmunological uses can be found in [7].

The best characterized SAGs are the staphylococcal enterotoxins, which are identified by letter codes, such as A, B, C, and so on (e.g., staphylococcal enterotoxin A, SEA; staphylococcal enterotoxin B, SEB). The impact of SAGs on CNS function has been demonstrated with SEA and SEB, which produce activation of the hypothalamic-pituitary-adrenal (HPA) axis. The HPA axis is exquisitely sensitive to the effects of stress, and its activation is detected by blood plasma or serum measures of glucocorticoids (e.g., corticosterone) released by the adrenal gland, ACTH released by the pituitary gland, and corticotropin releasing hormone (CRH) released by neurons of the hypothalamus in the brain. Collectively, CRH, ACTH and corticosterone represent different hormonal components of the HPA axis, a neuroendocrine pathway essential to the survival of the organism under conditions of stress. Indeed, it is well known that optimal activation of the HPA axis is necessary using models of infection, such as exposure to LPS. Moreover, while SAGs have been shown to activate the HPA axis at all levels, similar activation had also been demonstrated using cytokines, such as IL-1, TNF and IL-6.

Bacterial SAGs also activate stress-related brain pathways that are known to influence the HPA axis. For example, regions previously mentioned, such as the amygdala, hippocampus and septum were activated after injection of SEA and SEB. Activation of these areas likely produces anxiety and/or stress-like states in the animal, supporting much of the research on the

effects of LPS and cytokines like IL-1 and TNF $\alpha$  on sickness behavior [8]. Sickness behavior is characterized by lethargy, anorexia and reduced exploration, and is also associated with anhedonia, somnolence, and deficits in learning and memory [9]. The wide range of behavioral changes observed speaks to a general behavioral adjustment in keeping with the protective goals of the immune system. Interestingly, the sickness behavior profile is similar to the symptomatology of depressive illness, which has led many to consider that dysregulation of the immune system may contribute to clinical depression [10,11]. Whether this compelling hypothesis is true remains to be determined.

Evidence exists that the neurobiological effects of bacterial SAGs noted above involve behavioral changes that approximate sickness behavior, but appear to lack signs of malaise that might account for anorexia and lethargy. Administration of SEA and SEB reduces food intake, but only if the food is novel (i.e. unfamiliar). Moreover, there is no evidence of weight loss, although increased body temperature has been noted. Why animals would show reduction of a novel, as opposed to familiar food, has been suggested to reflect an increase in anxiety. It is well known that exposure to novel food causes a neophobic (i.e. fear of novelty) reaction in animals. Therefore, if SAGs activate stress pathways in the brain, this may be altering the threshold level of processing and responding to mildly arousing stimuli. Indeed, the augmented reactivity to a novel food after SAG treatment was also seen in regard to exploration of a novel object, which similarly produces a neophobic reaction (i.e. reduced or more wary exploration). Further discussion of the behavioral effects of SAG treatment is provided elsewhere [7].

### Concluding Comments

This brief overview focused primarily on the idea and fundamental findings relating to immunological activation of brain and behavioral functions. The emphasis was in illustrating that defense against challenges to biological integrity are the province of both the nervous system and immune system, and with this common purpose, evolution has ensured that some form of cooperative signaling exists between the two. Ultimately, the organism learns and refines its behavioral repertoire of protection, and in doing so, relies on information relayed by the activities of the immune system. The sensation of illness communicated by elevated cytokines creates a state of arousal that generates a memory for the illness state in and of itself, and through the host of different cognitive mechanisms at the host's disposal, lays down a neural memory that can be used to plan and avoid future exposures to illness. More recent evidence, not covered here, has also demonstrated that cytokines (such as those mentioned in this article) are synthesized and released by glial cells in the brain. The distinction

between the immune system and nervous system has become blurred, and it is clear that where defense against infection is concerned, both systems must eventually play a critical role [12].

### References

1. Mims C (2000) *The war within US: everyman's guide to infection and immunity*. Academic Press, New York
2. Ader R (2006) *Psychoneuroimmunology*, 4th edn. Elsevier, Academic Press, New York
3. Herman JP, Cullinan WE (1997) Neurocircuitry of stress: central control of the hypothalamo-pituitary-adrenocortical axis. *Trends Neurosci* 20(2):78–84
4. Besedovsky HO, del Rey AE, Sorkin (1985) Immune-neuroendocrine interactions. *J Immunol* 135 (2 Suppl):750s–754s
5. Blalock JE (1984) The immune system as a sensory organ. *J Immunol* 132:1067–1070
6. Scherer MT, Ignatowicz L, Winslow GM, Kappler JW, Marrack P (1993) Superantigens: bacterial and viral proteins that manipulate the immune system. *Annu Rev Cell Biol* 9:101–128
7. Kusnecov AW, Goldfarb Y (2005) Neural and behavioral responses to systemic immunologic stimuli: a consideration of bacterial T cell superantigens. *Curr Pharm Des* 11 (8):1039–1046
8. Dantzer R, Kelley KW (2006) Twenty years of research on cytokine-induced sickness behavior. *Brain Behav Immun* 21(2):153–160
9. Anisman H, Merali Z, Poulter MO, Hayley S (2005) Cytokines as a precipitant of depressive illness: animal and human studies. *Curr Pharm Des* 11(8):963–972
10. Maier SF, Watkins LR (1998) Cytokines for psychologists: implications of bidirectional immune-to-brain communication for understanding behavior, mood, and cognition. *Psychol Rev* 105(1):83–107
11. Maes M (1999) Major depression and activation of the inflammatory response system. *Adv Exp Med Biol* 461:25–46
12. Haddad JJ, Harb HL (2005) L-gamma-Glutamyl-L-cysteinyl-glycine (glutathione; GSH) and GSH-related enzymes in the regulation of pro- and anti-inflammatory cytokines: a signaling transcriptional scenario for redox (y) immunologic sensor(s)? *Mol Immunol* 42:987–1014

---

## Neural Bases of Spatial Learning and Memory

KARIM BENCHENANE, MICHAËL ZUGARO,  
SIDNEY WIENER  
LPPA, Collège de France, CNRS, Paris, France

### Definition

For survival many animals have evolved neural mechanisms permitting to localize resources, protection and conspecifics in changing environments. During

exploration, information is acquired about cues, cue gradients, landmarks, and appropriate movements for dead reckoning, wayfinding, piloting and other types of spatial navigation. The goal of studying the neural bases of spatial learning and memory is to understand how specific patterns of brain activity underlie these complex spatial capabilities, and in particular how they emerge in novel environments, and how they are dynamically reorganized in changing environments.

*Lesion and comparative anatomy studies* have pinpointed the ►hippocampal formation as integral for the formation of spatial memory, as well as various types of contextual memories. However, long-term storage of these memories is attributed to other structures, in particular the parahippocampal cortex in humans. *Immediate early gene* imaging and *inactivation* studies by the group of Bontempi have shown that the hippocampus and posterior cingulate cortex are involved in the early phase of spatial memory, but later phases depend on anterior cingulate and prefrontal cortex (it was also found that different layers of the parietal cortex are sequentially involved in spatial memory formation). While the hippocampus is involved in more elaborate navigation capabilities, the striatum is associated with learning spatial habits triggered by simple or more complex cues. For example, in the *Morris water maze*, efficient swimming to a visible platform requires an intact dorsal striatum, while navigating to an immersed, non-visible platform requires an intact hippocampus. Whereas learning spatial layouts is primarily attributed to the hippocampal formation, exploitation of this information for spatial and other contextual based decision-making engages other closely associated structures such as the amygdala, prefrontal cortex and nucleus accumbens. *Brain imagery studies* in humans and studies of brain damaged patients indicate that the right medial temporal lobe, in particular the hippocampal and parahippocampal regions, is important for spatial cognition (see chapter 8 in [1] and chapter 12 in [2]).

*Neurophysiological studies* in the hippocampal formation and associated structures have demonstrated ►single unit and ►local field potential activity that *computational studies* show to be sufficient to support spatial learning and memory (see chapter 14 in [2]). The primary single unit responses are ►place cells, head direction cells and ►grid cells (Fig. 1) – although spatial responses have also been recorded in other areas (e.g., place selective responses in the subiculum, presubiculum and parasubiculum [8]).

## Characteristics

### Place Cells

►Place cells (discovered by O’Keefe and Dostrovsky, in 1971; see Chapter 11 of [2]) are hippocampal pyramidal cells that discharge selectively when the recorded subject occupies a delimited region of its

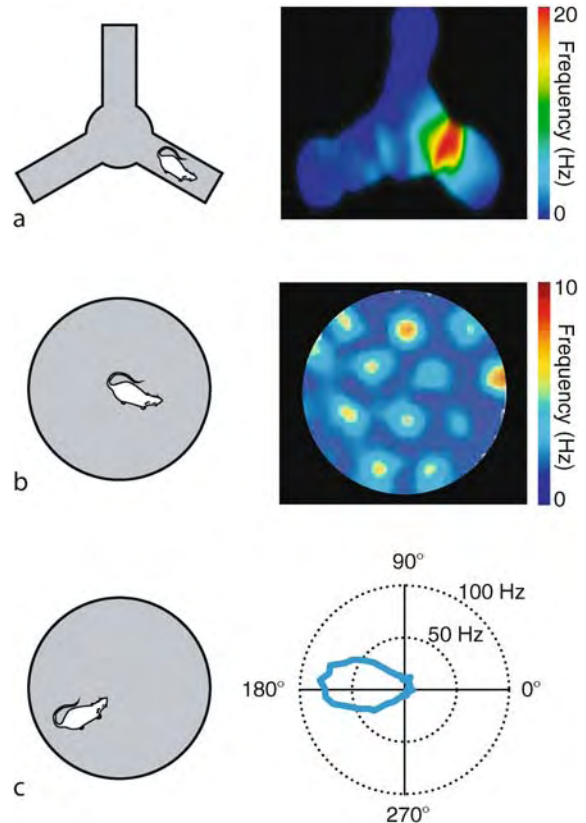

## Neural Bases of Spatial Learning and Memory.

**Figure 1** (a) Place cells selectively discharge when the animal is in a specific location (“place field”) in the environment. *Left*. The rat explores a Y-shaped maze (*top view*). *Right*. Color-coded rate map (*blue*, zero firing; *red*, maximal firing rate; *black*, area not visited by the animal). This place cell fires when the animal enters the South-East arm (Benchenane, Larrieu, Wiener and Zugaro, unpublished data). (b) Grid cells fire when the animal is located at one of the nodes of a regular hexagonal lattice. *Left*. The rat explores a circular arena (*top view*). *Right*. Color-coded rate map (adapted from 4). (c) Head direction cells discharge when the head of the animal is oriented in a specific (“preferred”) direction of the horizontal plane. *Right*. Tuning curve in polar coordinates. This cell fires maximally when the rat faces 180° (Zugaro, Berthoz and Wiener (2001), *J Neurosci* 21:RC154).

environment referred to as a “firing field” or “place field” [3,10]. Within a given environment, only a fraction of neurons recorded have firing fields. Of these, at any given moment while the animal explores its environment, a different ensemble of place cells are active. Taken together, place cells potentially code for the entire environment: this activity is a supporting pillar of the theory [3] that the hippocampal formation is the neural basis of a ►cognitive map, an internal representation of space which Tolman (1948) postulated in his riposte to



► **behaviorism**. There is no anatomically topographic arrangement of firing fields (as opposed to, for example, ► **somatotopic** or ► **visuotopic** organization in corresponding sensory areas). Place cell activity has been found in the hippocampal formation of various species: rats, mice, birds, bats, and primates (by Ono and colleagues, although Rolls' group observed "view cells" selective for where the monkey looks, rather than its position) including humans.

Place responses in hippocampal neurons demonstrate several properties suggesting that they are key elements for circuits enabling high level cognitive processing [5]. In particular, place cells exhibit *supramodal responses*: although visual cues can dominate the polarization of place responses (e.g., in a cue-controlled environment, if the constellation of background cues is rotated, the positions of the firing fields will rotate in a similar manner), place responses are maintained in darkness and in blind rats, presumably on the basis of idiothetic (vestibular, proprioceptive, and perhaps efferent collaterals of motor commands) and ► **somatosensory processing**. Thus the same responses can be arrived at independently of sensory modality. Another remarkable property of place cells is their *abstract, stimulus-invariant responses*: during unrestricted movement in an open field, place responses are not directionally modulated - that is, the cell fires when the rat is in the firing field regardless of what direction it is facing and what is in its field of vision. Hippocampal pyramidal cells also have *context-sensitive responses*: they have place responses as well as non-place responses, for example in delayed ► **eye-blink conditioning** which depend on the current situation. An example in the spatial domain is *remapping*, which refers to the observation that when a rat is transferred from one environment to another, firing fields can shift in relative position, or disappear, while other initially silent neurons may now manifest firing fields. Interestingly, although in markedly different environments the respective layouts of firing fields are uncorrelated, when the rat is exposed to two novel environments with more subtle differences, place cell firing fields are initially similar in both environments, and only gradually shift to more dissimilar positions with repeated exposure.

Recent findings indicate that hippocampal activity reflects more dynamic information than initially envisioned. Many place cells fire maximally or remain virtually silent in the very same location depending on the past or future trajectory. At the population level, hippocampal activity includes information not only about current position, but also about ongoing trajectories. Indeed, it was shown that as the animal walks through the firing field of a place cell, the cell fires at earlier and earlier phases relative to the ongoing theta (7-12Hz) oscillation of the hippocampal local field potential. This property is known as *theta phase*

*precession*. As a consequence, during each theta cycle, cells coding for recently visited locations fire first, then cells coding for current location, and then cells coding for locations further down the trajectory: that is, at each theta cycle, hippocampal discharges encompass information about past, present and future positions.

Strikingly, these patterns of sequential activation observed while the animal explores its environment are later "replayed" during subsequent sleep, in particular during short lasting fast (200 Hz) oscillatory field events called ► **ripples**, that occur repeatedly during slow wave sleep [7]. This is believed to be a critical mechanism underlying memory consolidation, possibly via ► **long term potentiation** of ► **synapses** targeted by the reactivated neurons, consistent with the observation that such *replay* occurs at accelerated rates relative to the original experience.

How are hippocampal place responses generated? Virtually all neocortical inputs to the hippocampus synapse first in the entorhinal cortex (EC). Two principal loops have been highlighted, the *indirect pathway* EC → dentate gyrus → CA3 → CA1 → subiculum + EC, and the *direct pathway* where EC projects directly to CA1. Numerous computational modelling studies have suggested that the recurrent connectivity of area CA3 could endow the hippocampus with ► **continuous network attractor** properties: this would ensure that at any given moment only a small subset of coactive cells could fire, while the rest remain silent; activity could then be propagated within the network by velocity modulated signals as the animal moves, or be directly imposed onto the network by external signals of sensory origin, the influence of which would be acquired through learning. Surprisingly however, it was shown experimentally that surgical isolation of CA1 from CA3 inputs neither disrupts the ability of CA1 pyramidal cells to acquire place fields nor the capability of the animal to learn a spatial task. This indicates that direct inputs from the EC are sufficient to support the emergence of place cell firing in CA1.

### Grid Cells

Grid cells of the dorsolateral part of the medial EC [4] discharge selectively at multiple locations distributed in a regularly spaced (30-70 cm) hexagonal grid - i.e., each node is surrounded by a hexagon of adjacent nodes). The internode spacing and node diameter increase gradually in more ventral zones. At a given depth, nearby neurons have grids laterally displaced relative to one another and can also have different angular polarizations of the grids.

The EC is the principal high-level input to the hippocampal formation. Thus, place cell activity is likely to emerge from a combination of intra-hippocampal dynamics with grid cell and other entorhinal signals.

This can be observed using a protocol known to induce hippocampal remapping (see *Place Cells*, above). There are actually two ways in which hippocampal place cells can remap: either the relative firing rates of the recorded cells change in an unrelated manner, while the spatial position of their firing fields are maintained (“rate remapping”), or the firing fields are relocated in an unpredictable manner (“global remapping”). Interestingly, entorhinal grid cells also demonstrate this dichotomy: in conditions where place cells undergo rate remapping, grid cells maintain stable fields; but when place cells undergo global remapping, grids are shifted and rotated consistently with modifications observed in the hippocampus. Thus, the relative locations of hippocampal firing fields depend on the relative grid layouts of their input grid cells.

In addition, precise spike timing of entorhinal outputs might also influence spike timing in the hippocampus. Similar to place cells, layer II entorhinal grid cell firings also show phase precession relative to the ongoing theta oscillation. Note that the EC is a principal source of the theta rhythm in hippocampus. It is possible that hippocampal phase precession is not generated purely endogenously, but is at least partly inherited from EC, consistent with previous work where transient perturbation of hippocampal theta rhythm and cell firings did not disrupt phase precession.

### Head Direction Cells

Complementary to place cells, head direction (HD) cells (discovered by Ranck, in 1984) discharge selectively when the head is oriented in a particular direction in the horizontal plane, independent of position in space [6]. These responses are not controlled by the geomagnetic field; instead, they are thought to emerge from the interaction between intrinsic neural dynamics and multisensory and possibly motor signals (see chapter 18 of 6). HD cell responses are anchored to background visual cues (likely identified from ►[optic field flow](#) cues), but responses are maintained in darkness, presumably engaging ►[vestibular](#) and other self-movement cues (see Chapters 6 and 7 of [6]. Different cells are selective for different “preferred” directions, and all directions are equally represented. No anatomically topographic organization of directional responses has been reported. HD cells have been found in rats, mice, chinchillas and monkeys.

Unlike remapping in place cells, after environmental changes the preferred directions of simultaneously recorded HD cells rotate coherently, maintaining their angular differences. Thus the HD cell system may provide a more stable spatial reference.

HD cells have been found in over ten different brain areas including parts of Papez’ circuit: dorsal tegmental nucleus of Gudden (DTN; which also has cells selective for head velocity) → lateral mammillary nucleus

(LMN) → anterior-dorsal thalamic nucleus → post-subiculum + retrosplenial cortex → dorsal part of medial EC → hippocampus (which also has a low incidence of HD cells). Other areas with HD cells include lateral-dorsal thalamic nucleus, dorsomedial striatum and medial precentral cortex (FR2 or AGM).

HD and place responses are both suppressed by inactivation of the vestibular nuclei (sensitive to linear and angular accelerations of the head) which send axonal projections to the DTN. Neurocomputational and neuroanatomical data point to the DTN-LMN circuit as the generator of head direction responses by means of attractor network dynamics. From a computational point of view, this system would effectively compute a mathematical integration of the head angular velocity signal to yield head angular orientation. Progressive drift of this representation due to imperfect integration could be corrected for by sensory inputs (e.g., triggered by familiar visual landmarks).

### Space-Related Neuronal Responses and Navigation

A key issue is whether the spatial responses of place cells, grid cells and HD cells do subservise complex navigation capabilities, consistent with theoretical considerations, correlative experimental results and computational models and simulations.

To date, finding a clear link between HD cell responses and behavioral performance in spatial navigation tasks has remained elusive. Given that grid cells have only been discovered in 2005, it should not come as a surprise that no experimental results support their role in spatial navigation yet.

There is however an increasing amount of evidence for a critical role of place cells in spatial learning and memory. Initial support was brought by studies using either ►[long term potentiation](#) (LTP) induction protocols, or pharmacological or transgenic approaches. For instance, protein synthesis inhibitors and NMDA antagonists, the two major blockers of LTP, alter both place cell stability and spatial behavior. Similar results have been obtained in mice where the major proteins involved in the molecular cascade of LTP were knocked-out, such as CA1 NMDA knock-out mice, R(AB) mice (with reduced forebrain PKA), GluR2 mutant mice (knock-out for the GluR2 sub-unit of AMPA receptors),  $\alpha$ CaMKII-T286A mice (with altered calcium sensitivity of CaMKII) and CREB $\alpha\Delta$ - mice (deficient for the  $\alpha$  and  $\Delta$  isoforms of CREB). Remarkably, these studies show relatively good correlations between the level of LTP, place field stability and performance in spatial memory tasks [9].

In addition to these studies, perhaps some of the most convincing evidence to date that place cells do underlie spatial navigation capabilities is that in rats trained to find an unmarked goal in order to receive food rewards, experimental shifts of environmental cues

that provoke displacements of place fields relative to the goal location are associated with impaired spatial performance, provided that goal localization requires map-based navigation (see chapter 10 in [1]).

## References

1. Jeffrey KJ (ed) (2003) *The neurobiology of spatial behavior*. Oxford University Press, Oxford, 316 pps
2. Anderson P, Morris R, Amaral D, Bliss T, O'Keefe J (eds) (2007) *The hippocampus book*. Oxford University Press, New York, 832 pps
3. O'Keefe J, Nadel L (1978) *The hippocampus as a cognitive map*. Clarendon Press, Oxford, 570 pps
4. Hafting T, Fyhn M, Molden S, Moser MB, Moser EI (2005) Microstructure of a spatial map in the entorhinal cortex. *Nature* 436:801–806
5. Wiener SI (1996) Spatial, behavioral and sensory correlates of hippocampal CA1 complex spike cell activity: implications for information processing functions. *Prog Neurobiol* 49:335–361
6. Wiener SI, Taube JS (2005) *Head direction cells and the neural mechanisms of spatial orientation*. MIT, Cambridge, MA, 480 pps
7. Buzsáki G (2006) *Rhythms of the brain*. Oxford University Press, Oxford, 464 pps
8. Redish AD (1999) *Beyond the cognitive map: from place cells to episodic memory*. MIT, Cambridge, MA
9. Tonegawa S, Nakazawa K, Wilson MA (2003) Genetic neuroscience of mammalian learning and memory. *Philos Trans R Soc Lond B Biol Sci* 358:787–795
10. Wilson MA, McNaughton BL (1993) Dynamics of the hippocampal ensemble code for space. *Science* 261:1055–1058

## Neural Cell Adhesion Molecules (NCAM)

### Definition

Belongs to the immunoglobulin superfamily. It mediates cell-cell interactions by homophilic binding, especially during axon fasciculation and nerve sprouting and cell migration.

## Neural Coding

### Definition

Neurons create, store and convey information. There are two basic codes they may use: rates of action potentials (unitary signals) or timing of action

potentials. From a different perspective, neural coding also refers to the question whether specific information is stored in one neurons or in networks of neurons (see Ensemble Coding, Grandmother Neuron).

## Neural Coding of Taste

MARTIN WITT

Smell and Taste Clinic, Department of Otorhinolaryngology; Department of Anatomy, University of Technology Dresden, Medical School, Dresden, Germany

### Synonyms

Gustatory neural coding; Taste coding

### Definition

Basic gustatory stimuli are conveyed to the brain via activation of neurons connected in series or in parallel. The gustatory information needs several “simple” codes for representation at various neuronal levels. However, “taste” encompasses more than just the activation of the gustatory system by chemical stimuli, but include also touch, vision, olfaction, which all contribute to the perception of foods or drinks. Components of the gustatory pathway are taste receptors, gustatory nerve fibers, as well as relay stations within the brainstem (nucleus of the solitary tract), diencephalon (thalamus, parts of the ventral striatum), and telencephalon (insula/ frontal operculum, orbitofrontal cortex, amygdala).

### Characteristics

The sense of taste is regarded as the main mechanism protecting the individual from intake of hazardous food. Usually, “taste” comprises at least five relatively distinct sensations such as “salty”, “▶bitter,” “sweet,” “acid,” and “umami.” Other sensations include trigeminally mediated, painful sensations, or the sensations of fattiness or astringency. Identical stimuli may elicit distinct reactions under various behavioral or environmental conditions, implying that various modulatory systems in the central nervous system interact with taste-selective pathways. Most flavors (e.g., cherry or chocolate) are the result from the complex interaction between trigeminal, olfactory and gustatory activations.

These multimodal properties contribute to an understanding how variable taste stimuli may be related to the activity of one or more neurons. In its stricter sense, “taste coding” comprises taste characteristics, which are translated into a specific neuronal firing pattern.

## What can be Coded?

- The relative number of stimulus molecules per volume of solution is coded by the rate of impulses in taste-responsive neurons: spike rate.
- Quality of taste stimuli, represented as “breadth of tuning” of ► **gustatory neurons**. The entropy measure (H) compares how selectively a cell responds to a standard array of chemical stimuli, usually NaCl, quinine hydrochloride, sucrose, and HCl. This method is a mathematical expression with H values ranging from 0.0 representing one of the five basic stimuli, to 1.0 representing equal responses to all five stimuli [1].

## Coding of Taste Qualities

There are two competing hypotheses how basic taste qualities may be relayed to the brain:

1. The labeled-line hypothesis: One taste quality is conveyed by one specific neuron type.
2. The across-fiber pattern theory: Taste qualities are coded by the relative activities across the population of responsive neurons.

### The Labeled-Line Hypothesis

The old observation that certain regions of the tongue are relatively specialized to convey various taste qualities led to the idea that neurons innervating taste buds in different regions were specialized for these taste sensations. Specifically, certain gustatory neuron types were specific coding channels for taste quality [2]. For example, the strict application of this theory would imply that the perception of the quality “sour” would arise from the activation of only one “sour” neuron type. As an example, Hellekant et al. [3] observed sweet-cluster fibers in the ► **Chorda tympani** nerve of chimpanzees, which could be specifically blocked by gymnemic acids. However, individual ► **gustatory neurons** were activated also by different taste stimuli. Consequently, as a variant of the labeled-line theory, taste cells were associated with neuron populations which evoke the greatest number of action potentials after a given gustatory stimulus. This number of neurons reacts as, for example, “sucrose-best” or “NaCl-best” [4]. On the other hand, some animals may behaviorally discriminate between related stimuli, for example, sucrose and maltose, which requires more subtle discrimination abilities than expected for specifically tuned cells. Also, neurophysiological recordings demonstrated that more than one basic taste stimulus was able to activate peripheral gustatory neurons. This strengthens the hypotheses related to an across-fiber pattern taste quality code (see below).

### The Across-Fiber Pattern Theory

The across-fiber pattern (ensemble) theory assumes that large ensembles of neurons contribute to the quality of a taste stimulus, because there is no absolute stimulus

specificity in the responsiveness of afferent gustatory fibers [2]. On the other hand, reception of complex taste qualities may be understood as a parallel activation of several labeled lines, making the labeled-line theory a special case of the across-fiber pattern theory. The validity of various models of the neural coding of taste quality suffers from a nearly complete reliance on correlative statistical procedures and a lack of available techniques that allow selective manipulation of putative classes of gustatory neurons [5].

## Taste Coding in the Gustatory Periphery: Convergence within the Taste Bud vs. Labeled Lines of Gustatory Nerves

Taste stimuli can be mediated either by receptor proteins or apical ion channels. Do taste sensor cells (TSC, Type II cells) respond to a single quality or are they broadly tuned to multiple qualities? TSC are rather neuroepithelial cells than neurons; only a few exhibit synaptic contacts to nerve fibers. Recent studies show that about 80% of TSC (Phospholipase C  $\beta$ 2-positive, SNAP-25-negative, i.e., lacking synapses) are narrowly tuned and respond to only one taste quality. In contrast, most presynaptic cells (SNAP-25-positive) are broadly tuned and respond to two or more taste qualities [6]. What is more, TSC may communicate with presynaptic cells by secreting ATP via pannexin-1 hemichannels. Only these broadly-tuned cells form synapses to afferent gustatory nerve fibers [7]. Presumptive transmitters are ATP, serotonin and possibly neuropeptides. Moreover, one afferent nerve fiber branches and synapses to more than one presynaptic taste bud cell, which leads to convergence and breadth of tuning. Chorda tympani fibers of rodent and monkeys have been subdivided into narrowly-tuned S-, N-, and Q-fibers (for sweet, sodium, and bitter), as well as more broadly tuned A- and H-fibers (for acids and electrolytes). Though some authors argue most taste stimuli seem to be transferred in selective populations of neurons in a labeled-line manner [5], others are hesitant to such a conclusion because of difficulties in interpretation of salty stimuli and the fact that neurons are more broadly tuned at higher concentrations [1].

## Taste Coding in the Central Nervous System

### Central Taste Pathways

Generally, central taste neurons are relatively broadly tuned. Gustatory information is conveyed by afferent fibers of three cranial nerves: [1] Fungiform papillae of the anterior portion of the tongue are innervated by the chorda tympani (CT), a branch of the intermedio-facial nerve complex (CN.VII), which runs with the lingual nerve [2]. Vallate and foliate papillae are innervated by gustatory fibers of the glossopharyngeal nerve (CN.IX), and taste buds on the laryngeal surface of the epiglottis, larynx, and proximal part of the

oesophagus are supplied by the superior laryngeal branch of the vagal nerve (CN.X). Their nuclei lie in various peripheral ganglia, but the first central relay stations in the gustatory pathway are in the nucleus of the solitary tract (NST) of the brainstem. In humans, ipsilateral monosynaptic neurons run immediately to the ventral posteromedial nucleus of the thalamus, whereas in rodents an additional relay, the parabrachial nucleus, is interconnected. Dorsal neurons terminate in the “gustatory cortex,” the anterior insula/frontal operculum and caudolateral orbitofrontal cortex. In rodents, a ventral affective pathway turns to the lateral hypothalamus, central nucleus of the amygdala, substantia innominata, and bed nucleus of the stria terminalis of the ventral striatum, but the exact pathways are somewhat less clear in primates/humans [8].

### **There is a Remarkable Intra-Individual Coding Stability, but no Clear Topographical Projection for Basic Taste Qualities in Structures of the CNS**

A clear chemo-topographical organization of particular taste qualities is a matter of debate. Recent functional magnetic resonance tomography investigations in humans show inter-individual differences for taste stimuli; taste fields of individual subjects do barely overlap, but there is stable intra-individual activity over a prolonged period of time [9]. In mice, coding stability is maintained over time, even after taste nerve crush and regeneration. Moreover, activity in taste neurons encodes also information about the hedonic value of a gustatory stimulus, regardless if there is a segregation or convergence of taste stimuli in central pathways.

Different neurons of the rodent NST respond best to NaCl, glucose, HCl, and quinine-HCl, but they have relatively broad tuning to different stimuli, as compared to the peripheral gustatory fibers [1]. This is mostly due to convergence of peripheral fibers. Also, many central taste neurons also carry thermal and mechanosensory information. In primates, a similar distribution has been found in neurons of the insular and opercular primary taste cortices [10] showing statistically independent neuron types for the basic taste qualities. Neurons devoted to bitter (quinine) quality comprise approximately 22% of measured insular/opercular cells, and those responding to sweet and salty account for 73%. Only 5% of all measured neurons were activated for the detection of acids [10].

### **Conclusion**

Taste information processing is based on complex interconnections. It has been hypothesized that it exhibits specific cerebral representation fields for the basic gustatory qualities which are nevertheless difficult to identify. Based on molecular, electro-physiological, and behavioral findings, the breadth of tuning at all anatomical levels and multimodal sensitivities of mostly central neurons render it difficult to clearly decide

which coding algorithm is “used” for taste processing. Most likely various neuron types define specific across-neuron patterns. New insights have yet to come before clearly understanding syndromes related with taste deregulations such as the ► [gourmand syndrome](#).

### **References**

1. Smith DV, Travers J (1979) A metric for the breadth of tuning of gustatory neurons. *Chem Sens Flav* 4:215–229
2. Pfaffmann C (1959) The afferent code for sensory quality. *Am J Psychol* 14:226–232
3. Hellekant G, Ninomiya Y, Danilova V (1998) Taste in chimpanzees. III: Labeled-line coding in sweet taste. *Physiol Behav* 65(2):191–200
4. Frank M (1973) An analysis of hamster afferent taste nerve response functions. *J Gen Physiol* 61(5):588–618
5. Spector AC, Travers SP (2005) The representation of taste quality in the mammalian nervous system. *Behav Cogn Neurosci Rev* 4(3):143–191
6. Tomchik SM, Roberts CD, Pereira E, Stimac R, Roper SD (2007) Responses of taste receptor cells and presynaptic taste cells to taste stimuli. XXIXth Annual Meeting of the Association for Chemoreception Sciences (AChemS), Sarasota, FL, USA, April 25–30, 2007
7. Huang Y-J, Maruyama Y, Dvoryanchikov G, Pereira E, Chaudhari N, Roper SD (2007) The role of pannexin 1 hemichannels in ATP release and cell-cell communication in mouse taste buds. *PNAS* 0611280104
8. Small DM (2006) Central gustatory processing in humans. *Adv Otorhinolaryngol* 63:191–220
9. Schoenfeld MA, Neuer G, Tempelmann C, Schussler K, Noesselt T, Hopf JM, Heinze HJ (2004) Functional magnetic resonance tomography correlates of taste perception in the human primary taste cortex. *Neuroscience* 127(2):347–353
10. Scott TR, Plata-Salman CR (1999) Taste in the monkey cortex. *Physiol Behav* 67(4):489–511

## **Neural Computation**

### **► Connectionism**

## **Neural Control of Eye Movements**

ADONIS MOSCHOVAKIS

Institute of Applied and Computational Mathematics, FO.R.T.H., Department of Basic Sciences, University of Crete, Heraklion, Greece

Understanding the neural control of actions is a central goal of the Neurosciences. It is for ► [eye movements](#) that we are closest to attaining this goal, at least in the

case of fairly complex brains such as those of mammals. Accordingly, ►**oculomotor control** has become a test bed of theories encapsulating general principles of motor control potentially applicable to additional effectors such as the head or the arm. In part this is due to the simplicity of ►**oculomotor dynamics** and kinematics. It is also due to the simplicity of the muscular apparatus that controls the eyes (just six ►**extraocular muscles** per eye). Finally, ►**eye orbital mechanics** are straightforward and because the eye is a spherical joint, its movements have a small number of degrees of freedom (just three). As with other motor systems, this number is often further reduced in behaving subjects. For example, ocular ►**torsion** is determined from the horizontal and vertical rotation of the eyes, measured in a coordinate system that moves with it. This fact has been known for more than a century, ever since ►**Donders** enunciated it in the form of the law that bears his name. It results from a more fundamental one, ►**Listing's law** [1], according to which for all eye positions, defined as single rotations from primary position, rotation axes lie on a plane perpendicular to the line of sight at primary position (i.e., the position of the eyes when looking approximately straight ahead and the head is upright).

In terms of metrics and kinematics, eye movements can be classified into several distinct types (Fig. 1). Figure 1a provides typical examples of ►**saccades** (marked with an asterisk). These are the eye movements that rapidly redirect the line of sight in a variety of circumstances, i.e., when exploring the visual world (scanning saccades), toward targets (►**pro-saccades**) which may appear suddenly in the extrafoveal visual field (►**foveating** or ►**reflexive-saccades**) or away from visible targets (►**anti-saccades**). On the average, the time

that elapses between the presentation of a visual target and the onset of a saccade to it (saccadic latency) is equal to about 200 ms. In some human subjects, latency histograms demonstrate a second early peak, made of ►**express saccades**. Human saccades often undershoot their targets by about 10% and are followed by secondary shorter latency movements, called ►**corrective saccades**. The goal of other eye movements is to stabilize the projection of visual images on the retina. For example, movements of the head engage the ►**vestibulooculomotor system**, which evokes compensatory eye movements (slow phases of the ►**vestibuloocular reflex – VOR**) whose velocity is usually less than or equal, and opposite in sign, to that of the head (Fig. 1d). This ►**rotatory VOR** is engaged when the head rotates on the neck, and is driven by modulation of afferent signals arising in the semicircular canals. Linear acceleration of the head (e.g., during its forward propulsion on a walking body) evokes the ►**translational VOR** while keeping the head bent toward the shoulder evokes a static ►**ocular counter-rolling response**; both of these responses are driven by the otolith organs. Dynamic rotations about off-vertical axes activate both canal and otolith responses. Slow phases can be cancelled when the line of sight fixates a target moving with the head (►**VOR suppression**) and are interrupted by quick phases (Fig. 1b asterisks) which correspond to saccades. Sequences of slow and quick phases, collectively called ►**nystagmus**, are also produced after the end of constant velocity rotation (►**postrotatory nystagmus**), and when the vestibular sensorium is activated by stimuli other than the natural ones, such as after ►**caloric stimulation of labyrinths**. They are also produced by visual stimuli evoking ►**optokinetic eye movements** (►**optokinetic response – OKR**; Fig. 1e), e.g., during rotation of a drum

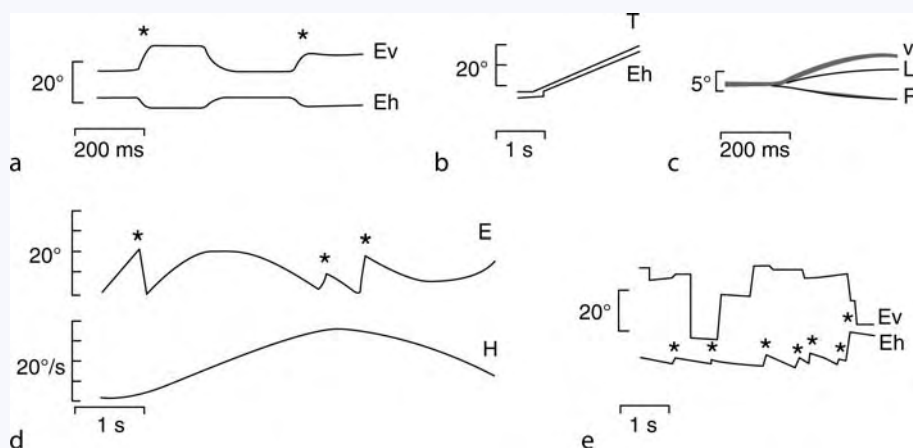

**Neural Control of Eye Movements. Figure 1** Distinct types of eye movements readily observed in monkeys. (a) Saccades. (b) Smooth pursuit. (c) Vergence. (d) VOR. (e) OKR. Note the difference in the time scales employed. Upward trace deflection indicates rightward movement. Asterisks in (a), (d) and (e) mark saccades. Abbreviations: dH/dt, head velocity; E, eye position; Eh, horizontal eye position; Ev, vertical eye position; L, eye position – left eye; R, eye position – right eye; T, target position; v, vergence angle.

around the subject at a constant velocity (▶**optokinetic nystagmus – OKN**). Finally, ▶**ocular following responses (OFR)** are the relatively low velocity eye movements that subjects use to follow slowly moving visual scenes. They are further developed in primates which are able to generate ▶**smooth pursuit eye movements** (Fig. 1b) to accurately track small objects moving across a stationary background. Smooth pursuit eye movements can be preceded by saccades (▶**catch-up saccades**; Fig. 1b) and they can be interrupted by saccades. Saccades, smooth pursuit, vestibular and optokinetic eye movements are ▶**conjugate** in the sense that during such movements both eyes move simultaneously in the same direction and by roughly the same amount. Other eye movements (▶**disjunctive**) are not (Fig. 1c). This is the case when the line of sight shifts from near objects to far ones (▶**divergent eye movements**) and vice versa from a far to a near object (▶**convergent eye movements**). The ▶**near response** reflects the intimate relationship of the system that controls the angle between the lines of sight of the two eyes (▶**vergence angle**) and the system that controls the focal point of the lens (▶**accommodation-vergence interactions**).

The ability to accurately record the instantaneous position of the eyes with the ▶**electrooculogram (EOG)** and ▶**electronystagmographic** methods provided the impetus for a large number of studies of the relation between the instantaneous discharge of oculomotor related cells and the parameters of ocular movements. To date, two large families of theories have been proposed to account for the control of movements of body parts. On the one hand, position control theories suggest that neural signals guide effectors to a particular position in space. Alternatively, neural signals could dictate the metrics of the movements that the effectors should execute, as suggested by movement control theories. Recording from the neurons which innervate extraocular muscles, the ▶**extraocular motor neurons (MNs)**, allows one to test which of these two families of theories is correct. If a position control theory were implemented in the brain, extraocular motoneurons should be activated in proportion to the position of the eyes in the orbit. Their remarkable conceptual simplicity notwithstanding, the discharge pattern of extraocular motoneurons does not fulfill expectations based on position control theories. During saccades, for example, extraocular MN discharge is characterized by transient bursts accompanying movements and sustained tonic discharges whose intensity is proportional to the position of the eyes in the orbit. This pattern of discharge underscores the use of the term ▶**burst-tonic (BT) ▶neurons** to refer to extraocular MNs. In a more quantitative vein, their firing rate ( $F_R$ ) approximately obeys the expression  $F_R = \alpha + \beta \cdot E + \gamma \cdot dE/dt$ , where  $E$  the instantaneous position of the eyes (vertical or

horizontal depending on the cell),  $dE/dt$  is the instantaneous velocity of the eyes and  $\alpha$ ,  $\beta$ ,  $\gamma$ . constants of proportionality which differ for different neurons. To obtain an intuitive feeling for these parameters, consider that some neurons discharge at a low rate (small  $\alpha$ ) and others at high rate (large  $\alpha$ ) when the eyes point straight ahead, some are deeply (large  $\beta$ ) and others little (small  $\beta$ ) modulated with eye position while some emit modest (small  $\gamma$ ) and others emit considerable (large  $\gamma$ ) bursts for saccades in their on direction.

Saccades, smooth pursuit, vestibular, optokinetic and vergence/divergence ocular movements are separately controlled by five, largely distinct neural circuits all of which feed into the final common path embodied by the extraocular MNs. Some of these circuits are anatomically simple. For example, the anatomical substrate of the VOR is a three neuron arc, composed of: (i) primary afferent vestibular fibers, (ii) ▶**vestibulo-oculomotor connections** primarily arising from ▶**position-vestibular-pause (PVPs) neurons**, (iii) extraocular motor neurons. The system that controls disjunctive eye movements is more complex. It comprises ▶**near response neurons** and ▶**divergence neurons** in the brainstem which are in turn driven by ▶**disparity dependent vergence** and ▶**radial flow dependent vergence** cortical signals. At the other extreme of the simplicity-complexity spectrum, saccades rely on more than 30 distinct cell classes found in more than ten widely distributed brain areas [2]. To cope with its structural complexity it is meaningful to divide the saccadic system into smaller sub-circuits, each one of which can be thought of as a central pattern generator responsible for a conceptually distinct operation: the ▶**brain stem burst generators (BG)** in the reticular formation, the horizontal (▶**Neural integrator - horizontal**) and vertical (▶**Neural integrator - vertical**) ▶**neural integrators (NI) in the brain stem**, and the metric computer in the ▶**superior colliculus**. Although largely independent from the point of view of anatomy and physiology, to efficiently control the line of sight, systems responsible for different kinds of eye movements need to interact with each other. For example, the saccadic system needs to interact with the vestibular one (during nystagmus), as well as with the systems controlling smooth pursuit (▶**pursuit-saccade coordination**) and vergence (▶**saccade-vergence interactions**). It also needs to interact with systems controlling the movements of other effectors such as the ▶**head** (▶**eye-head tracking**), the hand (▶**eye-hand coordination**), the eye-lids, etc.

The burst generators (BG) in the brain stem supply MNs with the high frequency signals they need to cause the contraction of the muscles they innervate during a saccade in their pulling direction. They contain cells that exhibit a brief burst of activity before saccades of particular directions (▶**burst neurons**). Depending upon

the latency of the burst in relation to the onset of the movement, they are called ▶medium lead burst (MLB) neurons or ▶long lead burst (LLB) neurons [3], the term ▶short lead burst neurons being reserved for the neurons with the shortest burst latencies, i.e., the MNs. The amplitude and direction of saccades are specified in terms of the amplitude of their horizontal and vertical components which are determined relatively independently by distinct groups of premotoneuronal MLB neurons. ▶Horizontal (left and right) ▶MLB (HMLB) neurons are located in the ▶paramedian pontine reticular formation while ▶vertical (up and down) ▶MLB (VMLB) neurons are located in the ▶rostral interstitial nucleus of the medial longitudinal fasciculus (▶riMLF). Axons of MLB neurons convey the output of the burst generators directly to extraocular MNs, thus directly providing them with the excitatory drive they need for ipsiversive saccades. One of the most prominent projections of the horizontal ▶excitatory burst neurons (▶EBNs) is to the ipsilateral abducens nucleus [4] (which contains MNs innervating the ipsilateral lateral rectus muscle, a muscle engaged for ▶lateral gaze deviations). Similarly, VMLB neurons ramify extensively within regions of the oculomotor complex housing MNs with vertical pulling directions. For the eyes to move conjugately, which is the case for saccades, synergistic muscles of the two eyes should be activated simultaneously and by roughly the same amount (an expectation known as ▶Hering's law of equal innervation [5]). To implement Hering's law, axonal terminations of single VMLB neurons contact motoneurons innervating yoked muscles of both eyes [6]. In the horizontal system, Hering's law is implemented through an additional class of neurons, the abducens ▶internuclear ones [7]. The axons of these neurons travel with the ▶medial longitudinal fasciculus (MLF) and their interruption causes the syndrome of ▶internuclear ophthalmoplegia. In addition to the coactivation of MNs innervating synergist muscles of both eyes, extraocular MNs supplying antagonist muscles are inactivated during saccades (Descartes' principle). For example, activation of abducens MNs in one side of the brain is accompanied by inhibition of the contralateral abducens MNs as well as disfacilitation of ipsilateral medial rectus (MR) MNs (these innervate the MR muscle of the ipsilateral eye). Both are mediated by projections of ▶inhibitory burst neurons (IBNs) to the contralateral abducens nucleus [8].

Not all MLB neurons deploy axonal terminations appropriate for influencing extraocular motoneurons. For example, the interstitial nucleus of Cajal (NIC) contains cells whose bursts of discharge are identical to those of downward premotoneuronal MLBs [9]. However, instead of supplying the oculomotor nucleus, their terminal fields overly the riMLF, i.e., a nucleus housing VMLBs and other burst neurons. Such neurons

are better suited for conveying corollary discharges through the feedback paths of a BG configured as a ▶local feedback loop controller. LLB neurons also vary a lot in terms of projections, discharge pattern and function. Some, such as the ▶pontopontine long-lead burst ▶(PPLL) neurons, are likely to embody the front stage of the BG thus receiving presaccadic commands from the superior colliculus (SC) as well as feedback from the MLBs. Other LLB neurons, such as the ▶burster-driving neurons (BDNs), are probably involved in the generation of vestibular quick phases. ▶“Trigger” neurons, i.e., interneurons mediating higher order commands to initiate saccades, and ▶“latch” neurons, i.e., interneurons inverting the sign of MLB discharges to prevent ▶omnipause neurons (OPNs) from firing during saccades, may also belong to the LLB class. Not all neurons of the BG burst for saccades. Instead, some pause for saccades in all directions and are for this reason called omnipause neurons (OPNs). Coupling orthogonal (vertical and horizontal) burst generators through OPNs can help coordinate them so that the vertical and horizontal components of oblique saccades have roughly similar duration despite their dissimilar size thus giving rise to oblique saccades with fairly straight trajectories [10].

In addition to the phasic eye displacement signals produced by the BG, extraocular MNs are supplied with tonic signals proportional to eye position. The latter are generated from the former through a process akin to mathematical integration; because it is less than perfect it is referred to as ▶leaky integration. The medial vestibular nucleus and the nucleus prepositus hypoglossi are thought to house the ▶horizontal neural integrators (HNI) while the interstitial nucleus of Cajal is thought to house the ▶vertical neural integrators (VNI). Other oculomotor subsystems, such as those responsible for the VOR, the OKN and the smooth pursuit eye movements, also rely on the neural integrators to function properly [11]. Again contrary to expectations based on position control theories, the discharge of most of the neurons that comprise the vertical and horizontal neural integrators does not reflect the position of the eyes alone. Instead, their discharge resembles that of the extraocular motoneurons they contact and justifies the use of the term burst-tonic (BT) neurons when referring to such cells as well. Intrinsic cellular membrane properties, synaptic mechanisms and network properties could in principle account for the fact that the time constant of the neural integrator (30 s; estimated from the time course of ▶ocular drifts in the dark) is more than three orders of magnitude higher than that of single neurons (about 5 ms). A second device with roughly similar impulse responses, known as the ▶“velocity storage integrator,” is also employed by the rotatory VOR to extend the dynamics of its afferent input into the low frequency range.



The **▶superior colliculus** (SC) is a layered midbrain structure that computes the amplitude and direction of desired saccades and relays appropriate commands to the burst generators. It also plays a crucial role in **▶sensorimotor integration** in the sense that sensory signals about target location must also be taken into consideration before the requisite motor commands can be issued [12]. The superficial layers of the SC contain a map of visual space while its deeper layers contain additional **▶sensory maps** as well as a **▶motor map** of oculomotor space. These are embodied by partially overlapping classes of cells, several of which can be distinguished in the primate SC. The best studied are the **▶saccade related burst neurons** (in short **▶SRBNs**), which are characterized by low levels of spontaneous activity and high frequency bursts which they emit shortly before (about 20 ms on the average) saccades of the appropriate amplitude and direction [13]. The SC also contains **▶buildup neurons** (in short **▶BUNs**) whose activity increases about 80–100 ms before saccade onset, reaches a peak value preceding saccades by 10–20 ms, and then wanes (discovered by Sparks and his colleagues [14]). Other deeper layer neurons, called **▶Visually Triggered Movement cells** (**VTMs**), emit discrete bursts in response to visual stimuli and before saccades to the same stimuli, but not before spontaneous saccades of the same metrics [15]. Each of these neurons discharge only before saccades having a relatively narrow range of sizes and directions, which defines an area known as the cell's **▶movement field**. Optimal saccades are measured from initial eye position, and not in a frame of reference centered in the head, so the SC works in an **▶oculocentric frame of reference**. Movement fields are arranged in an orderly topographic map of the SC. Cells discharging for upward saccades are located medially and cells discharging for downward saccades are located laterally while cells preferring small saccades are located more rostrally than cells preferring bigger saccades. It is for this reason that the SC can be thought to use a **▶place code** to implement the motor map it contains. A particular class of SC presaccadic neurons, the **▶tectal long lead burst neurons** (**▶TLLBs**), have been characterized both functionally and morphologically [16]. Their axons are responsible, at least in part, for conveying command signals from the SC to the burst generators. To determine saccade size, the strength of these projections to the horizontal and vertical BG increases linearly with the size of the saccades coded by the region they originate from [17]. TLLBs also deploy a rich plexus of recurrent connections which may be instrumental in determining the intensity of discharge and the spread of TLLBs engaged for particular saccades [18]. Another crucial aspect of TLLB physiology is the strong and

tonic inhibitory input they receive from the **▶basal ganglia**, in particular the pars reticulata of the **▶substantia nigra**. This is relaxed for saccades due to the inhibitory input nigral neurons receive from the **▶caudate nucleus**.

The input to the saccadic system is retinal error (i.e., the distance of visual targets from the fovea). This is represented in the superficial layers of the SC, retinotopically, in terms of the location of active cells in a neural map of visual space. To account for the subsequent activation of the appropriate presaccadic cells in the deeper SC layers, an early hypothesis of tectal function, the "**▶foveation hypothesis**" [19], invoked the spread of excitation from superficially located visual neurons to underlying presaccadic cells. Because the visual receptive fields of superficial SC cells are aligned with the movement fields of deeper SC cells, flow of information from the superficial to the deeper SC layers would enable the eyes to move accurately and foveate the target. Consistent with the "foveation hypothesis," axons originating from a particular class of superficial SC cells, the L neurons (**▶interlayer neurons**), deploy dense terminal fields in the deeper layers of the primate SC [20]. The ability to make accurate saccades toward targets briefly flashed before the onset of a saccade to a previous target (**▶double-step saccade paradigm**) or elicited in response to the electrical stimulation of the SC demonstrates that the "foveation" hypothesis was too simplistic. An alternative, the "vector subtraction" hypothesis [16], assumes that a neural replica of the eye displacement due to the first saccade is fed back to the SC where it is subtracted from the retinal error vector that signals the location of the second target. The vector that results from this subtraction (represented by a new focus of excitation in the deeper tectal layers) drives the burst generators in a way that produces the correct saccade [18]. Additionally, the "vector subtraction" hypothesis provides an explanation for the response properties of two more classes of neurons. Firstly, it explains the discharge of **▶Quasi-visual** (**Qv**) neurons [21] for targets initially presented outside their receptive field and extinguished before saccades such that their location is encompassed by the cell's receptive field. The corollary discharges needed to account for the discharge of Qv neurons are carried by the **▶Reticulo-Tectal Long Lead Burst** (**RTLLB**) neurons of the **▶central mesencephalic reticular formation** [16].

Besides determining saccade metrics, the deeper layers of the SC are also involved in **▶eye-head coordination** in part due to the **▶tectoreticulospinal neurons** (**TRSNs**) they contain [22]. The response properties of TRSNs are more complex than those of primate SRBNs in that they display multisensory

convergence, and their bursts are non-obligatorily coupled to saccades. Their projections also target widespread midbrain and rhombencephalic areas. Together with ►reticulospinal long-lead burst (RSLLB) neurons [23] and eye-neck reticulospinal neurons [24] they could cause the fairly widespread facilitation of premotor extracollicular circuits needed to reorient the body, the head and the eyes toward a crudely defined region of space (►orienting reflex). In this manner, body and ►head movements are coordinated with saccades and the VOR to generate shifts of the line of sight (►gaze shifts).

►Precerebellar long-lead burst (PCbLLBs) ►neurons convey to the ►cerebellum saccade related signals originating in the SC and other higher structures [23]. Similarly, mossy fibers arising from several brainstem nuclei (including the dorsolateral pontine, the reticular pontine tegmental and the vestibular ones) supply it with smooth pursuit related signals. Electrical stimulation of the ►cerebellum, in particular lobules VI and VII of the vermis, has been long known to elicit saccades [25]. The saccade related discharges of neurons located in the ►oculomotor vermis influence the contralateral BG in the brain stem through the caudal part of the fastigial nucleus (the ►fastigial oculomotor region) as well as parts of the interpositus and dentate nuclei [26,27]. Both the oculomotor vermis and the fastigial oculomotor region participate in the control of smooth pursuit eye movements, as well [28,29]. At least two more cerebellar regions are also involved in the control of smooth pursuit eye movements: the ►flocculus, which also participates in the modulation of the gain of the VOR (►VOR adaptation) possibly through its projection to ►flocculus target neurons, and the ventral paraflocculus. Both areas contain Purkinje cells discharging for horizontal eye velocity during smooth pursuit and for horizontal head velocity during VOR cancellation (i.e., when the subjects' eyes follow a target moving with the head). Because eye and head velocity signals are roughly equal, and almost cancel each other during VOR in the dark, these neurons are thought to encode the horizontal angular velocity of gaze in space (►horizontal-gaze-velocity Purkinje cells). Purkinje cells with preferred directions other than horizontal can also be found in these regions. Given the variety of oculomotor related signals encoded by cerebellar neurons and the variety of ocular movements evoked in response to the electrical stimulation of several distinct cerebellar regions, it is reasonable to expect that cerebellectomy would cause a variety of oculomotor deficits. These include partial neural integrator failure and impairment of smooth pursuit eye movements [30] as well as ►saccadic dysmetria [31] and disruption of ►saccadic adaptation and VOR adaptation [32].

The neocortex contains several areas participating in the control of ocular movements. One of the best studied is the ►frontal eye field (FEF; [33]), in and near the arcuate sulcus (AS). It contains cells discharging briskly before saccades [34] and its electrical stimulation evokes contraversive saccades [35]. Neighboring subregions of the arcuate sulcus are devoted to the control of eye movements other than saccades. For example, the ►frontal pursuit area is a small region in the depths of the arcuate fissure, sandwiched between the small saccade area of the FEF and the somatic premotor cortex; its electrical stimulation evokes smooth pursuit eye movements and it contains cells discharging for smooth pursuit eye movements. Another subregion, located more rostrally in the prearcuate convexity, contains cells active during the vergent, divergent and accommodative movements accompanying near or far viewing and its electrical stimulation induces convergence and ocular accommodation [36]. Also, a small part of the fundus of the AS near its genu corresponds to a ►fixation zone. The notion that the primate FEF participates in the ►fixation system is supported by the fact that its removal interferes with ►visual fixation and the fact that it contains neurons which discharge tonically while gaze is held stable toward a ►fixation point and pause for saccades (►fixation neurons). Other frontal lobe saccade related areas include the ►supplementary eye field in the dorsal premotor cortex, the principal and periprincipal cortex and the ►anterior cingulate. Finally, regions of the parietal and temporal cortex are also important for the higher order control of ocular movements. The ►parietal eye fields, including the ►lateral intraparietal area (►LIP) in the lateral bank of the intraparietal sulcus, contain saccade related neurons and their lesion causes ►ocular apraxia. Areas in and around the superior temporal sulcus (STS), such as the middle temporal (MT), the medial superior temporal (MST), are also activated for saccades and their lesion impairs smooth pursuit eye movements [37].

## References

1. Helmholtz H (1910) Treatise on physiological optics, 1962 Dover Publications, Inc., New York
2. Moschovakis AK, Scudder CA, Highstein SM (1996) The microscopic anatomy and physiology of the mammalian saccadic system. *Progr Neurobiol* 50:133
3. Luschei ES, Fuchs AF (1972) Activity of brain stem neurons during eye movements of alert monkeys. *J Neurophysiol* 35:445
4. Strassman A, Highstein SM, McCrea RA (1986) Anatomy and physiology of saccadic burst neurons in the alert squirrel monkey. I. Excitatory burst neurons. *J Comp Neurol* 249:337
5. Hering E (1868) The theory of binocular vision, 1977 edn., Plenum, New York

6. Moschovakis AK, Scudder CA, Highstein SM (1990) A morphological basis for Hering's law: projections to extraocular motoneurons. *Science Wash DC* 248:1118
7. Baker R, Highstein SM (1975) Physiological identification of interneurons and motoneurons in the abducens nucleus. *Brain Res* 91:292
8. Strassman A, Highstein SM, McCrear RA (1986) Anatomy and physiology of saccadic burst neurons in the alert squirrel monkey. II. Inhibitory burst neurons. *J Comp Neurol* 249:358
9. Moschovakis AK, Scudder CA, Highstein SM, Warren JD (1991) Structure of the primate burst generator. II. Medium-lead burst neurons with downward on-directions. *J Neurophysiol* 65:218
10. Scudder CA (1988) A new local feedback model of the saccadic burst generator. *J Neurophysiol* 59:1455
11. Moschovakis AK (1997) The neural integrators of the mammalian saccadic system. *Front Biosci* 2:552
12. Hall WC, Moschovakis AK (eds) (2003) *Techniques in neuroscience, the superior colliculus: new approaches for studying sensorimotor integration*. CRC Press, Boca Raton
13. Sparks DL (1978) Functional properties of neurons in the monkey superior colliculus: coupling of neuronal activity and saccade onset. *Brain Res* 156:1
14. Sparks DL, Holland R, Guthrie BL (1976) Size and distribution of movement fields in the monkey superior colliculus. *Brain Res* 113:21
15. Mohler CW, Wurtz RH (1976) Organization of monkey superior colliculus: intermediate layer cells discharging before eye movements. *J Neurophysiol* 39:722
16. Moschovakis AK, Karabelas AB, Highstein SM (1988) Structure-function relationships in the primate superior colliculus. II. Morphological identity of presaccadic neurons. *J Neurophysiol* 60:263
17. Moschovakis AK, Kitama T, Dalezios Y, Petit J, Brandi AM, Grantyn AA (1998) An anatomical substrate for the spatiotemporal transformation. *J Neurosci* 18:10219
18. Bozis A, Moschovakis AK (1998) Neural network simulations of the primate oculomotor system. III. A one-dimensional one-directional model of the superior colliculus. *Biol Cybern* 79:215
19. Schiller PH, Koerner F (1971) Discharge characteristics of single units in the superior colliculus of the alert rhesus monkey. *J Neurophysiol* 34:920
20. Moschovakis AK, Karabelas AB, Highstein SM (1988) Structure-function relationships in the primate superior colliculus. I. Morphological classification of efferent neurons. *J Neurophysiol* 60:232
21. Mays LE, Sparks DL (1980) Dissociation of visual and saccade-related responses in superior colliculus neurons. *J Neurophysiol* 43:207
22. Grantyn A, Berthoz A (1985) Burst activity of identified tectoreticulo-spinal neurons in the alert cat. *Exp Brain Res* 57:417
23. Scudder CA, Moschovakis AK, Karabelas AB, Highstein SM (1996) Anatomy and physiology of saccadic long-lead burst neurons recorded in the alert squirrel monkey. II. Pontine neurons. *J Neurophysiol* 76:353
24. Grantyn A, Ong-Meang J, Berthoz A (1987) Reticulospinal neurons participating in the control of synergic eye and head movements during orienting in the cat. II. Morphological properties as revealed by intra-axonal injections of horseradish peroxidase. *Exp Brain Res* 66:355
25. Ron S, Robinson DA (1973) Eye movements evoked by cerebellar stimulation in the alert monkey. *J Neurophysiol* 36:1004
26. Fuchs AF, Robinson FR, Straube A (1993) Role of the caudal fastigial nucleus in saccade generation. I. Neuronal discharge patterns. *J Neurophysiol* 70:1723
27. Helmchen C, Büttner U (1995) Saccade-related Purkinje cell activity in the oculomotor vermis during spontaneous eye movements in light and darkness. *Exp Brain Res* 103:198–208, 103:198
28. Fuchs AF, Robinson FR, Straube A (1994) Participation of the caudal fastigial nucleus in smooth-pursuit eye movements. I. Neuronal activity. *J Neurophysiol* 72:2714
29. Krauzlis RJ, Miles FA (1998) Role of the oculomotor vermis in generating pursuit and saccades: Effects of microstimulation. *J Neurophysiol* 80:2046
30. Zee DS, Yamazaki A, Butler PH, Gücer G (1981) Effect of ablation of flocculus and paraflocculus on eye movements in primate. *J Neurophysiol* 46:878
31. Lhermitte F (1958) Le syndrome cerebelleux: etude anatomo-clinique chez l'adulte. *Rev Neurol* 98:435
32. Optican LM, Robinson DA (1980) Cerebellar-dependent adaptive control of the primate saccadic system. *J Neurophysiol* 44:1058
33. Moschovakis AK, Gregoriou GG, Ugolini G, Doldan M, Graf W, Guldin W, Hadjidimitrakis K, Savaki HE (2004) Oculomotor areas of the primate frontal lobes: a transneuronal transfer of rabies virus and [14C]-2-deoxyglucose functional imaging study. *J Neurosci* 24
34. Bizzi E (1968) Discharge of frontal eye field neurons during saccadic and following eye movements in unanesthetized monkeys. *Exp Brain Res* 6:69
35. Robinson DA, Fuchs AF (1969) Eye movements evoked by stimulation of frontal eye fields. *J Neurophysiol* 32:637
36. Gamlin PD, Yoon K (2000) An area for vergence eye movement in primate frontal cortex. *Nature* 407:1003
37. Dürsteler MR, Wurtz RH, Newsome WT (1987) Directional pursuit deficits following lesions of the foveal representation within the superior temporal sulcus of the macaque monkey. *J Neurophysiol* 57:1262

---

## Neural Control of the Lower Urinary Tract

### ► Micturition, Neurogenic Control

---

## Neural Control of Voiding

### ► Micturition, Neurogenic Control

## Neural Correlates of Imprinting

ANNA KATHARINA BRAUN

Otto von Guericke University Magdeburg, Institute of Biology/Faculty for Natural Sciences, c/o Leibniz Institute of Neurobiology, Magdeburg, Germany

### Definition

The term imprinting, derived from Oskar Heinroth and Konrad Lorenz, defines rapid learning events with remarkably stable and long-lasting behavioral outcomes, which occur during specific time windows or sensitive periods in newborn and juvenile vertebrates. The term imprinting is used not only by ►[ethologists](#), but also in more recent literature by psychologists and clinicians in a broader sense, implying a particular ►[aetiology](#) of adult behaviors in both animals and human beings. Darwin, who showed great interest in child development, including infancy learning, was one of the first scientists who tried to link child psychology and animal behavior. He thereby prepared the ground for the study of the interplay of instinct and early learning, soon to be taken up by Spalding, and later, in different ways, by both Freud and the ethologists. D. A. Spalding published in 1873 a paper entitled “Instinct, with Original Observations on Young Animals,” in which he described the behavior of young domestic chicks. He observed that these animals’ ability to recognize the parents is not instinctive, but is in fact learned. Spalding also reported that this learning was confined to a short period soon after hatching, and we now say that during such a critical or sensitive period a chick becomes imprinted to the mother-figure when it learns her characteristics, and forms an emotional bond to her. Heinroth described this type of ►[attachment](#)-behavior by the verb “einprägen,” corresponding to the English “to stamp in” or “to imprint”; and the word “stamped in” had earlier been used by, among others, Spalding and Thorndike in relation to firmly acquired modes of behavior. Lorenz used the noun *Prägung*, or imprinting, in his seminal paper in 1935, to refer to the process of rapid bond-formation early in the life of the so-called ►[nidifugous](#) birds (e.g., fowl). Accordingly, imprinting occurs when an animal learns to recognize a stimulus that will later release instinctive behavior. For example, a gosling follows the first moving object it sees after hatching. The young goose “recognizes” the moving object as its parent and it later “recognizes” similar objects as members of its own species. Lorenz went further than Spalding in that he claimed that imprinting differed fundamentally from, what he called, ordinary learning, because of its restriction to a brief critical period in the individual’s life, its rapid occurrence, and its irreversibility. It was later

questioned whether these features would separate imprinting sharply from other forms of learning, and the modern view of imprinting is that it might be continuous with, or be a form of, ►[conditioning](#).

Imprinting can be considered to be an evolutionary old concept of juvenile learning, which is critical for the survival and fitness of the offspring and which occurs in many species including man. Imprinting entails much more plastic mechanisms than were claimed by Lorenz, thus, imprinting is a phenomenon that is of great interest to ontogenetic studies of animal behavior and it has important implications for human developmental psychology and psychopathology. Imprinting is an important aspect of early learning not only in birds but also in ►[precocial](#) mammals (e.g., guinea pigs, ►[degus](#), sheep, horses, etc.), and it also plays an important part in the socialization of ►[altricial](#) species (e.g., dogs or monkeys) including human and non-human primates. Newborn zebra foals follow any object near to them during the first few days of life, and because of this their mothers show aggressive behavior towards any other zebras that come too close. Many animals, e.g., giraffes, give birth to their young in isolation away from other family members to prevent the newborn from confusing them with its mother, and they only return to the family unit when imprinting has taken place, which usually occurs after three days. Animals can also imprint on humans, and this could be one of the reasons why many captive animals in zoos fail to breed, and similarly, cross fostering in the wild can also lead to fostered animals failing to breed. It appears likely that this failure is due to “faulty” sexual imprinting, i.e., another form of juvenile learning during which the preference of a mate later in life is determined. The sensitive period for sexual imprinting is dependent on the species and lifespan of the animal. Lions, for example, live in prides and form their sexual preference through community bonding over an extended period of time, whereas an animal with a shorter life span, such as insects, need to find a mate quickly and therefore have a shorter sensitive period for sexual imprinting. A third example of imprinting is vocal learning in songbirds (see essay by M. Gahr), and, at least in part, speech learning in humans. The critical period hypothesis of language acquisition claims that a sensitive period exists from birth to puberty, and that during this time window the brain is receptive to language, and is learning rules of grammar quickly. After puberty, language learning becomes more difficult, which is attributed to a drastic change in the way the brain processes language after puberty. The common feature of all forms of imprinting is that “templates” or “concepts” about the species, vocal repertoire/language or behavioral strategies are shaped during early life periods, which are incorporated into adult behaviors.



acoustic template is stored, the long-term consequence of filial imprinting, for example, is not so much to form memories for specific details of the imprinting object, the mother, but to establish the “grammar” of social, emotional and cognitive behavioral strategies. On the “hardware” side, imprinting could be viewed as formatting the harddrive, if we compare the brain with a computer, and this will determine its capacity to operate the “software” i.e., behavioral strategies, cognitive and emotional concepts etc. later in life. In fact, there is considerable experimental evidence from a variety of studies on filial imprinting and song learning (cp also essay by M. Gahr) in support of this view, which have shown that such juvenile learning events are accompanied by massive molecular-genetic, neurochemical, physiological and structural changes of neurons and their synaptic circuits.

### Structural Regulation

Imprinting is a rapid, efficient and rather stable form of learning that occurs in a more or less immature brain, i.e., in a brain that is still growing. The characteristic features of imprinting (speed and stability) might be explained by the fact that it occurs during developmentally “critical” or sensitive time windows of elevated cellular plasticity. Thus, imprinting takes advantage of the entire spectrum of the molecular, genetic and metabolic cellular cascades, which are highly activated during early postnatal brain development. For visual imprinting, a “time course” of a variety of changes have been described in the chick forebrain region intermediate medial mesopallium, IMM, the earliest changes involve the induction of the ▶**immediate early gene** *c-fos*, followed by changes in ▶**phosphorylation** of the ▶**protein kinase C** substrate MARCKS, morphological changes in ▶**axospinous synapses**, an increase in ▶**NMDA** receptor number and increases in neural ▶**cell adhesion molecules** [2]. The initial phase of acoustic imprinting is characterized by the activation of the immediate early genes and ▶**transcription factors** *zenk* and *arg3.1* in the chick forebrain regions MNM and the IMM [3]. Quite comparably, during the initial phase of sexual imprinting in male zebra finches, i.e., the first exposure to a female after an isolation period, enhanced *zenk* expression was measured in a variety of brain areas including lateral nidopallium/mesopallium (formerly termed lateral neostriatum/hyperstriatum LNH), MNM, and the optic tectum. At later stages of acoustic imprinting, an enhanced release of ▶**glutamate** in response to the learned acoustic imprinting stimulus has been observed in the MNM of domestic chicks, which is paralleled by an increased neuronal activation during the presentation of the acoustic imprinting stimulus [4]. Similarly enhanced neuronal responses have been reported in the IMM after visual imprinting [2]. Results from

*in vivo* ▶**microdialysis** experiments in domestic chicks suggest that the emotional bond that develops through auditory imprinting entails an addictive process, which is mediated by the release of ▶**endorphins** and altered ▶**dopamine** and ▶**serotonin** release [5]. Functional imaging revealed elevated metabolic activation in the MNM and Ndc areas of successfully imprinted domestic and guinea chicks in response to the acoustic imprinting stimulus [6]. Quite similarly, young rodents display activations in the anterior cingulate cortex in response to the presentation of the learned acoustic stimulus (maternal vocalizations). Such stimulus-evoked neuronal responses, which occur during filial imprinting, in particular those mediated via the glutamatergic NMDA receptor, appear to trigger the long-term structural changes. There is convincing evidence from several series of experimental studies that acoustic imprinting is linked to a synaptic selection process [7] that serves the fine-tuning of limbic circuits. Successfully imprinted chicks, but not chicks that have been passively, i.e., without the chance to form an association, exposed to the identical acoustic stimulus, display reduced densities of excitatory ▶**spine synapses** in higher associative brain regions (MNM, Ndc) compared to naïve, “Kaspar-Hauser” control animals. Interestingly, during sexual imprinting in zebra finches similar metabolic changes, activations of immediate early genes and reductions of dendritic spines were reported in the MNM and Ndc, and the vocal motor nucleus MMAN of zebra finches undergoes successive pruning of spine synapses during song imprinting [8]. Thus, in contrast to the adult brain, where primarily increased numbers of synaptic connections have been reported after learning [7], imprinting appears to leave its “footprints” within the juvenile brain mainly by using the opposite plasticity mechanism, namely the pruning of synapses. These imprinting-induced synaptic changes may be compared to a sculptor, who creates a statue by removing material from an unshaped marble block, and it may reflect the formatting of the “harddrive.” In particular, the long-term structural changes may explain the speed and stability of the memory for a learned imprinting object, stimulus or behavioral strategy.

### Function

All animals perform both instinctive actions and learned actions. Instinct almost completely determines the behavior of most insects, spiders, and crustaceans. These animals can learn comparably little, and therefore their survival depends mainly on innate behavioral patterns. Higher animals, including fish, amphibians, reptiles, birds, and mammals can learn more, and they can also modify their instinctive behavior by learning. The primary function of imprinting is to enable the young animal to shape and adapt its behavior, and to optimize the underlying brain circuits (in particular

the limbic system) for the behavioral output within its environment.

### Pathology

The most fascinating aspect of imprinting is the timely establishment of a particular preference over the course of the animal's development, which is particularly evident in primates, including humans, where "critical periods" develop from neonatal to early childhood, through juvenile to adulthood. For instance, monkeys who are reared separately from all other monkeys will not develop normal social or sexual behavior if, after reaching adulthood, they are placed with other monkeys. As pointed out earlier, brain development requires adequate sensory and also emotional stimulation, provided during filial imprinting, to develop and maintain synaptic connections and to fine tune synaptic circuits. Functional imaging in young rodents revealed that acute separation from the parents induces a massive downregulation of brain metabolism in most limbic regions as well as in sensory and polysensory cortices, whereas the presentation of a learned acoustic imprinting stimulus (the mother's voice) induces metabolic activation in the limbic cortex [9] (Braun and Scheich 1997). Long-term consequences of repeated separation from the parents (causing the disruption of the imprinting process?), chronic social isolation and early weaning are changes of excitatory as well as monoaminergic modulatory synaptic inputs in cortical and subcortical limbic areas. In the rodent anterior cingulate cortex, orbitofrontal cortex, hippocampus, and amygdala region-, cell-, and dendrite-specific changes of synaptic densities [10] have been found in parentally deprived animals. These observations confirm that the prevention or disruption of filial imprinting can affect synaptic development in the prefrontal cortex and other limbic areas. Since the limbic system is critical for a variety of emotional behaviors and associative aspects of learning, such experience-induced morphological changes may lead to altered behavioral and cognitive capacities in later life.

### Therapy

Animal studies unveiled the remarkable influence of the parent-infant contact (and most likely also other imprinting-like juvenile learning events) on brain development, in particular on the functional maturation of the limbic pathway. Therefore, learning early in life has always been of great interest on the one hand to all involved in child care and education, but also with indoctrination, and on the other hand to clinical research in child and adult psychiatry, where imprinting also fits into Freud's and other's conception of the aetiology of neurotic symptoms and other mental disorders. The detailed knowledge of the neurobiology of such self-organizing plastic systems may begin to change our

conceptual approaches to psychopathology, and open new avenues of therapeutics for the major psychiatric illnesses that are critically dependent on such learning and memory mechanisms. Furthermore, the knowledge of the basic principles of learning- and memory-related neuronal plasticity may in the future be applied to innovative educational concepts for the preschool/elementary school levels.

### References

1. Metzger M, Jiang Sh, Wang J, Braun K (1996) Organization of the dopaminergic innervation of fore-brain areas relevant to learning: a combined immunohistochemical/retrograde tracing study in the domestic chick. *J Comp Neurol* 276:1–27
2. Horn G (2004) Pathways of the past: the imprint of memory. *Nat Rev Neurosci* 5:108–120
3. Bock J, Thode C, Hannemann O, Braun K, Darlison M (2005) Early socioemotional experience induces expression of the immediate-early gene *Arclarg 3.1* in learning-relevant brain regions of newborn chicks. *Neurosci* 133:625–633
4. Gruss M, Braun K (1996) Stimulus-evoked glutamate in the medio-rostral neostriatum/hyperstriatum ventrale of domestic chick after auditory filial imprinting: an in vivo microdialysis study. *J Neurochem* 66:1167–1173
5. Baldauf K, Braun K, Groß M (2005) Opiate modulation of monoamines in the chick forebrain: possible role in emotional regulation? *J Neurobiol* 62:149–163
6. Maier V, Scheich H (1983) Acoustic imprinting leads to differential 2-deoxy-D-glucose uptake in the chick forebrain. *Proc Natl Acad Sci USA* 80(12):3860–3864
7. Scheich H, Wallhäußer-Franke E, Braun K (1991) Does synaptic selection explain auditory imprinting? In: Squire LR, Weinberger NM, Lynch G, McGaugh JL (eds) *Memory: organization and locus of change*. Oxford University Press, New York, pp 114–159
8. Nixdorf-Bergweiler BE, Wallhausser-Franke E, DeVoogd TJ (1995) Regressive development in neuronal structure during song learning in birds. *J Neurobiol* 27:204–215
9. Poeggel G, Braun K (1996) Early auditory filial learning in degus (*Octodon degus*): behavioural and autoradiographic studies. *Brain Res* 743:162–170
10. Poeggel G, Helmeke C, Abraham A, Schwabe T, Friedrich P, Braun K (2003) Juvenile emotional experience alters synaptic composition in the rodent cortex, hippocampus and lateral amygdala. *Proc Natl Acad Sci USA* 100:16137–16142

---

## Neural Crest

### Definition

The neural crest is derived from embryonic ectoderm. It is located in the small space between the dorsolateral part of the neural tube and the overlying ectoderm,

extending from the diencephalon to the tail. Cells of the neural crest give rise to glial cells, neurons of sensory, sympathetic, and parasympathetic ganglia, chromaffin cells, and melanocytes.

- ▶ Neural Crest and the Craniofacial Development
- ▶ Neural Development
- ▶ Neural Tube

## Neural Crest and the Craniofacial Development

SHIGERU KURATANI

Laboratory for Evolutionary Morphology, Center for Developmental Biology, Riken, Kobe, Japan

### Definition

An epithelial neural ridge developing on either side of the neural plate of the early vertebrate embryo. The crest is secondarily de-epithelialized becoming migratory mesenchymal cells called “neural crest cells” (Fig. 1). These move in a stereotypical manner within the embryo following certain specific migratory

pathways to be distributed in various locations within the embryo and differentiate into various cell and tissue types, including peripheral neurons, supporting tissues of the peripheral nervous system and some skeletal muscles, endocrinal cells (or many of the cell types belonging to the category of “paraneurons”), pigment cells, smooth muscle cells associated with arteries, cartilage and bones.

### Characteristics

Embryonic environments are crucial for the differentiation of the crest cells. Skeletogenic differentiation especially, is specific to the neural crest cells in the region ranging from the head to the neck [2]. Here the cells form an extensive mesenchyme, often called “ectomesenchyme” (meaning the “mesenchyme” derived from the ectoderm; Fig. 1). Thus the neural crest is generally divided into “cephalic” and “trunk” neural crest, depending on the differences in migration pathway, distribution pattern and repertoire of differentiating cell types. The boundary between these two categories, is not clear. Between these two regions, a third population of crest cells, called “vagal crest,” has been inferred, corresponding to the region of the neural crest that gives rise to enteric neurons [2]. This part also includes the crest that contributes to the septation of the outflow tract of the amniote heart primordia and is thus alternatively called the “cardiac crest” [3].

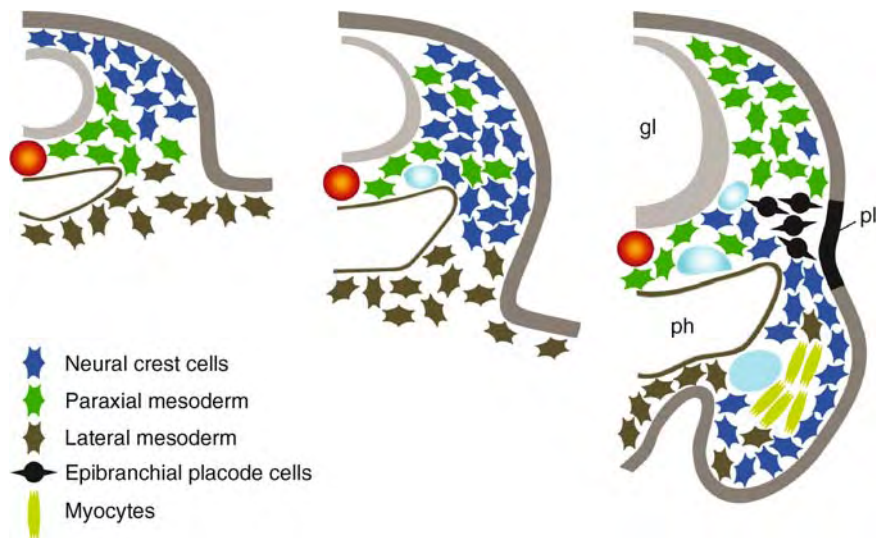

**Neural Crest and the Craniofacial Development. Figure 1** Schematic representation of three successive stages of neural crest migration in the head of chicken embryo. The neural crest cells (*blue*) migrate laterally and ventrally from the dorsal aspect of the neural tube to the pharyngeal arch to form an extensive ectomesenchyme. The pharyngeal arch ectomesenchyme will later differentiate into branchial arch skeletons. Note that during crest cell migration, cephalic paraxial mesoderm (*green*) barely changes its position. Also note that there is another group of cells derived from the ectoderm (epibranchial placodes). The placode-derived cells and neural crest cells together form a cranial sensory ganglion. Based on [1].



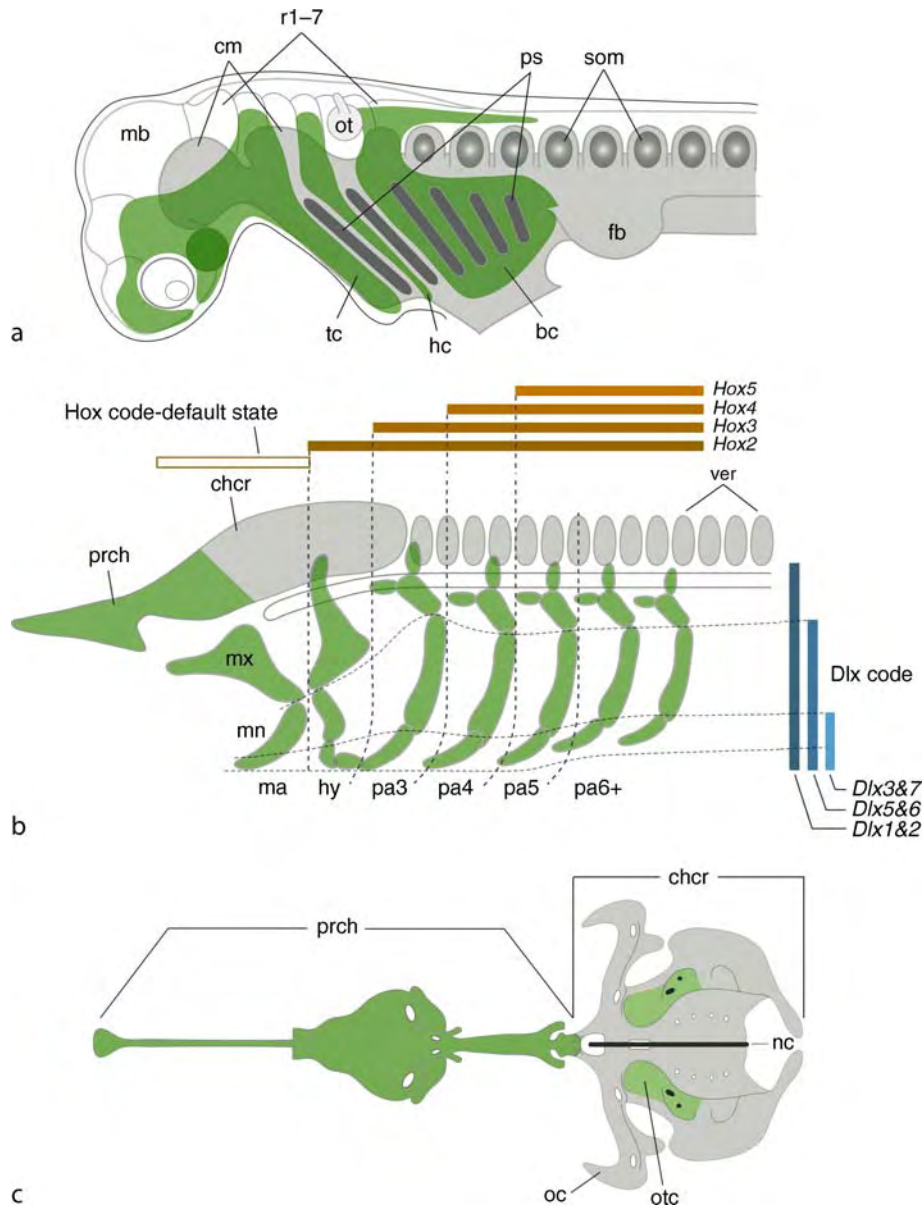

**Neural Crest and the Craniofacial Development. Figure 2** Ectomesenchyme in the gnathostome pharyngula, and craniofacial development in the vertebrate head. (a) Schematized model based on a shark embryo. Cephalic crest cells (green) form three distinct cell populations called, from anterior to posterior, the trigeminal crest- (tc), hyoid crest- (hc) and branchial crest- (bc) cells. These cells are located laterally to the cephalic mesoderm (cm), proximally attached onto even-numbered rhombomeres (r1–7), separated distally by pharyngeal slits (ps) to be distributed in each pharyngeal arch. (b) Generalized vertebrate chondrocranium based on the morphology of a sturgeon larva. Putative mesodermal derivatives are colored gray, and crest-derivatives green. The chondrocranium consists of dual anatomical components, the dorsal neurocranium and the ventral viscerocranium (pharyngeal arch skeletons). The neurocranium is further divided anteroposteriorly into the crest-derived prechordal (prch) and mesodermal chordal (chcr) parts. Position-dependent specification of the arch skeleton is based on the Cartesian grid of homeobox gene expression domains, consisting of Hox code along the anteroposterior axis and Dlx code along the dorsoventral axis. Note that the mandibular arch is patterned by the absence of Hox transcripts. (c) Mesenchymal origin of chicken chondrocranium. The scheme B is largely based on this mapping performed by Couly et al [6]. Abbreviations: fb, fin bud; mb, midbrain; nc, notochord; oc, orbital cartilage; ot, otocyst; otc, otic capsule; som, somites; ver, primordial vertebrae.

The pluripotency of the crest cells as well as their highly sophisticated morphogenetic capability are defining features of the neural crest. Although non-vertebrate chordates, including amphioxus and tunicates, share the same basic body plan as vertebrates, for example the notochord and the dorsal neural tube, they do not appear to possess the neural crest or crest-derivatives. In this context, the origin of the neural crest has recently drawn the interest of biologists investigating the evolutionary origin of vertebrates. Vertebrates are characterized by the possession of an overt head with well-developed sensory organs, brain and cranium, associated with vertebrate-specific cell lineages derived from neural crest and ►placodes (both sensory and ganglionic, Fig. 1). The theory of “New Head” by Gans and Northcutt [4] regards the acquisition of placodes and the neural crest as a key innovation that has permitted the development of the vertebrate head. The most recent study, however, has implied the presence of crest-like cells in tunicate larva, although this animal does not develop an extensive ectomesenchyme that characterizes the true vertebrates [5]. Consequently the evolutionary relationship may not be so simple.

Crest-derived cephalic ectomesenchyme is predominantly found in the ventral portion of the head, subdivided into ►pharyngeal arches [1] (Fig. 2a).

This mesenchyme will differentiate into skeletal and connective tissues, that is, the craniofacial and branchial arch skeletal elements, whether they are bones or cartilages, are all of neural crest origin (Fig. 2b). The rostral part of the ►neurocranium is also of crest origin, unlike the more caudal part that is derived from the cephalic mesoderm and somites [6] (Fig. 2c). There still remain controversies as to the origin of the dermal calvarium and there is a possibility that these dermal bones may have different origins of cell lineages regardless of their morphological homology. Nevertheless, the rostral elements such as the amniote frontal and nasal bones are unanimously thought to have a crest origin.

The crest-derived vertebrate cranial skeleton offers a model for the understanding of the morphological specification of the skeletal system, both in development and evolution. Of particular interest is the developmental mechanism that provides positional values to each part of the ectomesenchyme through the spatially organized expression of homeobox genes. One well-known example is the Hox code, the nested pattern of *Hox* gene expression along the anterior–posterior axis of the head. In the pharyngula embryo, no *Hox* genes are expressed in the rostral part of the head including the mandibular arch, *Hox2* genes are expressed in the second (hyoid) and more posterior arches, *Hox3* genes in arch 3 and posteriorly (Fig. 2b).

*Hox* genes are tandemly assembled on the DNA as a cluster, with *Hox1* toward the 3' end and *Hox13* toward the 5' ends of the cluster. Thus the order of the *Hox* genes roughly coincides with the axial levels of the embryo at which the genes are expressed (colinearity), giving an impression that the genome plays a role as a blueprint for embryonic development [7] (Fig. 2b).

Each *Hox* gene contains a domain called a “homeobox” encoding a DNA-binding protein that recognizes a specific DNA sequence. Thus the Hox proteins can act as a “switch” to regulate specific target genes and the Hox code provides positional values or “identity of pharyngeal arches” to the ectomesenchyme [7]. Consistent with this idea, disruption of *Hoxa-2*, the gene expressed in the hyoid arch, leads to the homeotic transformation of this arch into the identity of the

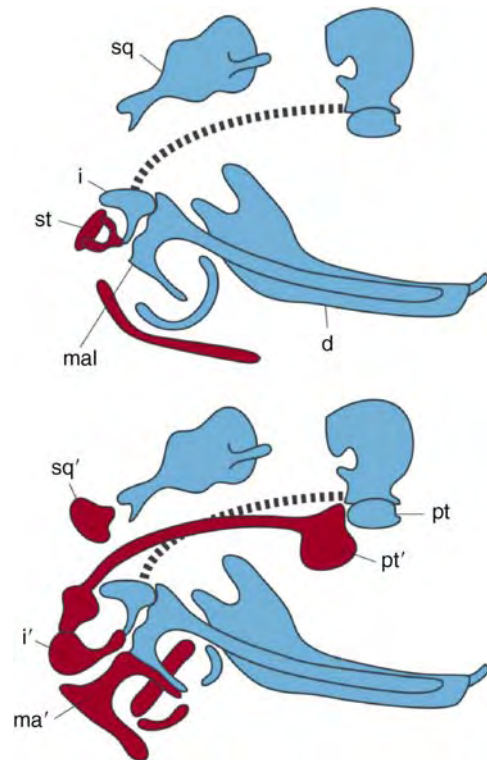

### Neural Crest and the Craniofacial Development.

**Figure 3** Disruption of *Hoxa-2* in the mouse. *Top*. Wild type morphology. Mandibular arch-derivatives are colored blue and the hyoid arch-derivatives red. In the *Hoxa-2*-mutant mouse, the morphological identities of the hyoid arch derivatives are transformed into those of the mandibular, resulting in a mirror-image duplication of mandibular arch skeletons. Based on [8]. Abbreviations: *d*, dentary; *i*, incus; *mal*, malleus; *pt*, pterygoid; *sq*, squamosal; *st*, stapes.

mandibular, presumed to be a “Hox-code-default state” (Figs. 2b and 3) [8].

The Hox code appears to be conserved in all vertebrates. Even the invention of the jaw seems to have taken place in the mandibular arch based on the same basic code, since the lamprey also seems to have *Hox*-negative mandibular arch [9].

Nested expression of another set of homeobox containing genes, the *Dlx* code, has been recognized in the head ectomesenchyme of the mouse [10] (Fig. 2b). This code is thought to direct the dorsoventral pattern of each arch by the dorsoventrally nested expression of the *Dlx* genes. Specifically, *Dlx1* and *Dlx2* are expressed in the entire arch ectomesenchyme, *Dlx5* and *Dlx6* in the ventral half and *Dlx3* and *Dlx7* in the ventral tip. Thus the Cartesian grid pattern of homeobox gene expression as a whole is the basis of the skeletal patterning of the vertebrate head (Fig. 2b). To establish such a pattern, epithelial–mesenchymal interaction may play fundamental roles, since information on which skeletal identities the ectomesenchyme is to acquire is not necessarily predetermined in the premigratory crest, but appears to be instructed secondarily by the rostral endoderm of the embryo. The actual shape of the skeletal elements however may rather be obtained

through downstream developmental pathways mainly exerted cell-autonomously in the crest cells themselves, since interspecific grafting of cephalic crest results in the host gaining the craniofacial morphology of the donor animal [1] (Fig. 4). The neural crest and its derivatives thus characterize most conspicuously the body plan of vertebrates and its evolution.

## References

1. Kuratani S (2005) Craniofacial development and evolution in vertebrates: the old problems on a new background. *Zool Sci* 22:1–19
2. Le Douarin NM (1982) *The neural crest*. Cambridge University Press, Cambridge
3. Kirby ML, Waldo KL (1990) Role of neural crest in congenital heart disease. *Circulation* 82:332–340
4. Gans C, Northcutt RG (1983) Neural crest and the origin of vertebrates: a new head. *Science* 220:268–274
5. Jeffery WR, Strickler AG, Yamamoto Y (2004) Migratory neural crest-like cells form body pigmentation in a urochordate embryo. *Nature* 431:696–699
6. Couly GF, Coltey PM, Le Douarin NM (1993) The triple origin of skull in higher vertebrates: a study in quail-chick chimeras. *Development* 117:409–429
7. Hunt P, Gulisano M, Cook M, Sham MH, Faiella A, Wilkinson D, Boncinelli E, Krumlauf R (1991) A distinct Hox code for the branchial region of the vertebrate head. *Nature* 353:861–864
8. Rijli FM, Mark M, Lakkaraju S, Dierich A, Dollé P, Chambon P (1993) Homeotic transformation is generated in the rostral branchial region of the head by disruption of *Hoxa-2*, which acts as a selector gene. *Cell* 75:1333–1349
9. Takio Y, Pasqualetti M, Kuraku S, Hirano S, Rijli FM, Kuratani S (2004) Lamprey *Hox* genes and the evolution of jaws. *Nature* 429:1 p following 262. [http://www.nature.com/cgi-taf/DynaPage.taf?file=/nature/journal/v429/n6989/full/nature02616\\_fs.html](http://www.nature.com/cgi-taf/DynaPage.taf?file=/nature/journal/v429/n6989/full/nature02616_fs.html)
10. Depew MJ, Lufkin T, Rubenstein JL (2002) Specification of jaw subdivisions by *Dlx* genes. *Science* 298:371–373

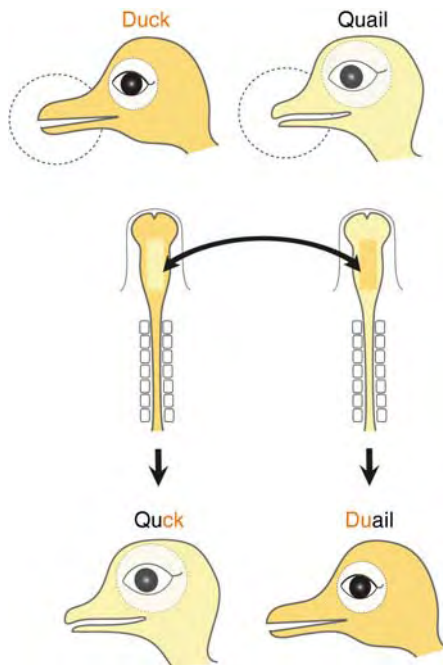

### Neural Crest and the Craniofacial Development.

**Figure 4** Species-specific shape of face? The cephalic neural crest was transplanted between embryos of quail and duck, birds with distinct faces. The cranial shape of the chimera resembles the donor of the crest more than that of the host. Based on [1].

## Neural Crest Cells

### Definition

Unique to vertebrates, these cells are derived from the edges of the folds of the neural plate. They migrate to different regions of the body and give rise to a wide variety of tissues, including autonomic and sensory nerves, pigment cells and some cartilage in the head.

### ► Neural Development

## Neural Development

FUJIO MURAKAMI

Laboratory of Neuroscience, Graduate School of Frontier Biosciences, Graduate School of Engineering Science, Osaka University, Suita, Osaka, Japan

### Neural Induction

The formation of the nervous system follows ►[the body plan](#), which is composed of the definition of body axes and the allocation of each organ into the body. A portion of dorsal ectoderm is induced to become ►[neural ectoderm](#). This region is called the ►[neural plate](#), which gives rise to the ►[neural tube](#). The tube is formed as the cells surrounding the neural plate. The neural plate cells proliferate, invaginate and pinch off from the surface to form a hollow tube.

The induction of the neural plate occurs owing to signals emanating from the mesoderm of the ►[organizer](#) region. In amphibians, the cells that develop in the region of the gray crescent, a light-colored band that appears opposite the point where the sperm enters, migrate into the embryo during gastrulation and form the ►[notochord](#). By utilizing transplantation experiments, Spemann and Mangold demonstrated that this region is capable of inducing a nervous system and called this region as “organizer” [1].

Several molecules that act as antagonists against bone morphogenic protein (BMP) are involved in ►[neural induction](#). These include ►[noggin](#), ►[chordin](#) and ►[follistatin](#). These molecules bind to BMP4 suppressing its activity as an inhibitor of neural fate. Fibroblast ►[growth factor](#) (Fgf) also seems to be involved in neural development.

### Neural Tube Formation

#### Regionalization

##### *Regionalization along the Rostrocaudal Axis*

►[Regionalization](#) of the neural tube is associated with changes in the shape of the neural tube. Early in development, the neural tube differentiates into three distinct regions along the rostrocaudal axis: ►[prosencephalon](#), ►[mesencephalon](#) and ►[rhombencephalon](#). Caudal to the rhombencephalon, the ►[spinal cord](#) differentiates. As development proceeds, the prosencephalon is divided into the ►[telencephalon](#) and ►[diencephalon](#), and the rhombencephalon into the ►[metencephalon](#) and ►[myelencephalon](#). The telencephalon eventually differentiates into the ►[cerebral cortex](#), ►[hippocampus](#) and ►[basal ganglia](#), the diencephalon into the ►[thalamus](#) and ►[hypothalamus](#), the metencephalon into the ►[cerebellum](#) and the ►[pons](#), and the myelencephalon differentiates into the ►[medulla oblongata](#).

The anteroposterior patterning of the neural tissue is dominated by the head organizer and tail organizer. The former includes FGFs, Wnts and retinoic acids, and the latter includes Cerberus, which inhibits the activity of BMPs, Wnts and nodal-related molecules by strongly binding to these molecules.

##### *Regionalization along the Dorsoventral Axis*

The ►[differentiation](#) of the neural tube along the dorsoventral axis also takes place concurrent with differentiation along the rostrocaudal axis. In the spinal cord, distinct types of neurons differentiate depending on the position along the dorsoventral axis: Motor neurons, for example, differentiate in the ventral spinal cord and commissural neurons that receive sensory inputs differentiate in the dorsal spinal cord. The differentiation of distinct cell types in the ventral neural tube is dependent on inductive signals derived from axial midline of the notochord and the ►[floor plate](#). The signal is mediated by the secreted protein ►[Sonic Hedgehog \(Shh\)](#) [2]. Neurons generated in progressively more ventral positions are exposed to higher concentration of Shh, which is required for their development.

The differentiation of the dorsal neural tube is also dependent on inductive signals but derived from ectodermal cells; one of the responsible molecules is BMP. Another secreted molecule, Wnt, also appears to function as a dorsalizing signal. These signals and Shh antagonize one another, creating opposing gradients along the dorsoventral axis, which induces expression of different ►[transcription factors](#), ►[PAX6](#) and ►[PAX7](#) dorsally, and ►[Nkx2.2](#) ventrally, for example. Expression of a transcription factor or a combination of different transcription factors gives rise to distinct types of neurons along the dorsoventral axis [3].

##### *Secondary Induction from the Midbrain/hindbrain Boundary*

The boundary region between the midbrain and hindbrain, the isthmus, has an inducing activity and contributes to the differentiation of the cerebellum and the ►[tectum](#) [32,33]. Some brainstem nuclei such as the ►[substantia nigra](#) and ►[locus coeruleus](#) are also under the influence of molecules released from the ►[isthmus organizer](#). This region expresses several transcription factors such as Pax2, Pax5, Engrailed1 and Engrailed 2, and secreted factors such as FGF8 and Wnt1, which are thought to contribute to the differentiation of the structures adjacent to the isthmus [3]. These molecules are distributed in a graded manner. This, in turn, contributes to the graded expression of guidance molecules in the tectum.

### Segmentation

#### *Segmentation in the Hindbrain*

The neural tube becomes segmented at some stage of the development. This is an important step for

the development of the central nervous system (CNS). The segmentation has been most extensively studied in the hindbrain. Developing hindbrain show 7–8 bulged structures called ►**rhombomeres**. Rhombomere boundaries are characterized by the expression of a paralogous set of ►**Hox genes**. Experiments such as the deletion and mis-expression of Hox genes indicate that these genes are involved in specification of rhombomeres. In each rhombomere, a unique set of motor neurons is generated, and these neurons project axons towards unique targets defined by their levels along the rostrocaudal axis. Similarly, sensory axons at different axial levels project to corresponding rhombomeres.

### Forebrain

Segmentation of the neural tube can also be seen in the forebrain region. For example, a transcription factor *emx1* is expressed in the anterior half of the forebrain and *emx2* in the posterior half. The expression pattern of additional genes allows to define six rostrocaudally aligned compartments, called ►**prosomeres**, in the forebrain region (Fig. 1).

### Patterning of the Neocortex

The cerebral cortex can be divided into functionally distinct areas such as the ►**motor, sensory and visual**

**cortex**, which are differentially connected to subcortical structures. Cortical areas appear to be under the control of two transcriptional factors, *pax6* and *emx2*, which are distributed along the anteroposterior axis in a graded manner. The gradient of these genes appears to be regulated, in part, by *fgf8* [4].

### Migration and Differentiaion of Neural Crest Cells

A specialized type of cells, called ►**neural crest** cells emerge from the dorsal-most region of the neural tube at the level of the hindbrain and the spinal cord. These cells migrate ventrally away from this region and differentiate into several types of neuronal and non-neuronal cells. This includes cells of the ►**dorsal root ganglia**, sensory ganglia of cranial nerves, ►**sympathetic chain ganglia**, pre-aortic ganglia, ►**enteric ganglia**, chromaffin cells of the adrenal medulla and melanocytes.

### Differentiation and Proliferation of Neurons Neurogenesis

►**Neurogenesis** takes place mostly during embryonic stages. Most neurons are generated from progenitors situated in the ventricular zone of the neural tube by symmetric and asymmetric divisions from progenitors, or multipotent neuroepithelial cells or neural stem cells. During the early stage of development, the cells in the

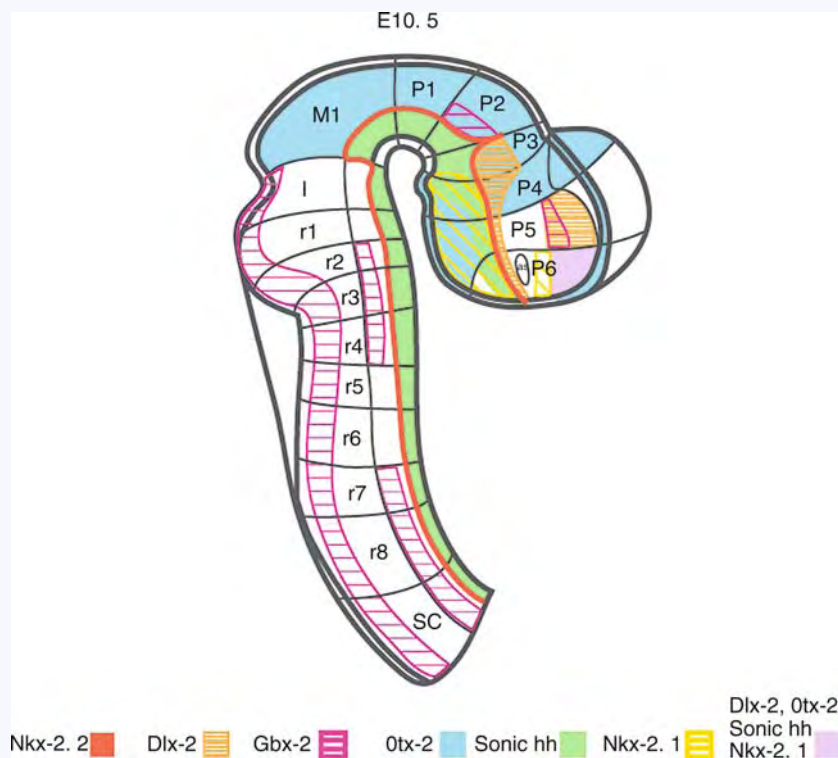

**Neural Development. Figure 1** Expression patterns of five transcription factors (Dlx-2, Gbx-2, Nkx-2.1, Nkx-2.2, Otx-2) and one morphogen (sonic hedgehog) in E10.5 mouse neural tube. I, isthmus; M, mesencephalon-midbrain; os, optic stalk; p, prosomere; r, rhombomere; sc, spinal cord (modified from [34]).

ventricular zone extend their process to the pial surface and the nuclei of these cells undergo specialized interkinetic movement, in which the position of the nuclei depends on the phase of ►**cell cycle**: the nuclei accumulate at the ventricular surface during M phase, but in the superficial margin of the neuroepithelium during S phase. Studies of neurogenesis in the neocortex revealed that the subventricular zone is not only the site of ►**gliogenesis** but also a site of neurogenesis for late-born neurons.

### Neuronal Fate

Neural stem cells can produce neural progenitors, neurons and glial cells, but the nervous system is composed of balanced numbers of neuronal and glial cells. There is evidence that secreted factors such as FGF2 and ►**Neurotrophin3** promote neural fate, while ►**ciliary neurotrophic factor (CNTF)** and ►**epidermal growth factor (EGF)** promote the differentiation into astrocytes. For the generation of neural progenitors and their commitment to the neuronal fate, ►**basic helix loop helix (bHLH)**-type proneural genes play a pivotal role. These include factors that inhibit the neural differentiation, such as *Hes*, and neural differentiation promoting factors such as ►**Mash1**, ►**Math1** and ►**Neurogenin1**. The expression of the latter is regulated by several factors such as ►**Notch**, which negatively regulates the neurogenesis, and BMP.

### Migration of Neurons

#### Mode of Migration

When neurons become post-mitotic, the neurons must emigrate from the ependymal layer to their future (mature) place/layer/lamina/nucleus. The same is true for the cells from the neural crest, which must find their final (mature) destinations. Such changes in the location of neurons are called ►**neuronal migration**. Neuronal migration in the neural tube is categorized into two modes; one is radial migration and another is tangential migration: The former occurs in directions of radial glia and perpendicular to the ventricular and pial surfaces and the latter occurs tangential to the pial surface. In the CNS, neurons generated from neuroepithelial cells typically migrate radially (Fig. 2), although some neurons show ventricle-directed radial migration after tangentially traveling over a long distance. Radially migrating neurons are thought to use the process of radial glial cells as substrate and tangentially migrating neurons use axons of other neurons. However, neuronal migration occasionally occurs obliquely to either of these processes, indicating that migration of neurons does not necessarily require physically defined structures.

It is noteworthy that tangential migration of neurons often occurs underneath the pial surface. This would be quite advantageous for migrating neurons, because this region is not crowded by other cells and facilitates migration.

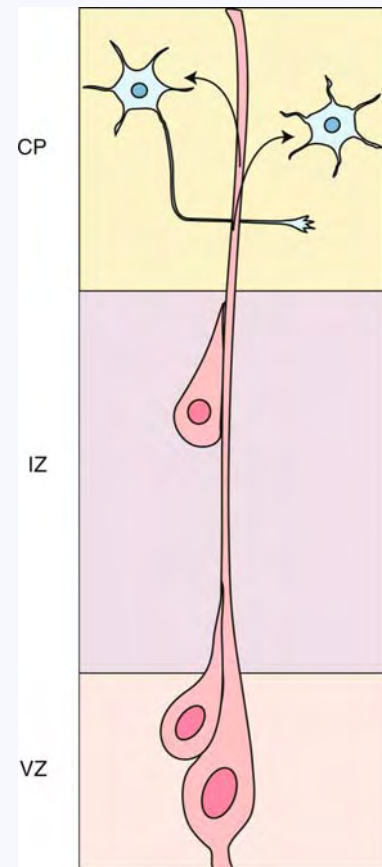

**Neural Development. Figure 2** Radial migration of neurons along radial glia and differentiation into postmitotic neuron. CP, cortical plate, IZ, intermediate zone, VZ, ventricular zone.

#### Significance of Migration

Migration of neurons is required for the establishment of proper laminated structures such as the cerebral cortex, hippocampus and the cerebellum. In the ►**pallium** of the cerebral cortex, late-generated neurons migrate radially past early-generated neurons, giving rise to inside-out laminated structures of excitatory neurons. Inhibitory cortical neurons also form birthdate-dependent laminated structures, although the route of their migration to their final destinations appears to be more complicated than those of excitatory neurons. These neurons, which originate from ganglionic eminences in the basal forebrain, initially migrate tangentially towards the cortex mainly along the intermediate and subventricular zones, translocate towards the marginal zone, and then descend into the cortical plate to settle in their final destinations. In the marginal zone, these neurons execute multidirectional migration, possibly contributing to dispersion of these neurons [5,6]. A part of these neurons may directly penetrate into the cortical plate without passing through the marginal zone.

The migration of neurons also contributes to the establishment of non-laminated neuronal aggregates, nuclei. A subset of nuclei is formed as a result of a combination of radial and tangential migration. A typical example is a group of ►**precerebellar nuclei** in the hindbrain, a set of neurons that relay information to the cerebellum. Neurons that are destined to form precerebellar nuclei originate from a germinal zone in the dorsal recess of the hindbrain, called rhombic lip, and migrate circumferentially beneath the pial surface and then they change the direction of migration from tangential to radial. They eventually terminate radial migration at a distance from the pial surface forming aggregates of neurons, namely, nuclei [7]. During the tangential migration, subsets of these neurons cross the ventral midline. Thus, ►**nucleogenesis** is a consequence of successive events with distinct modes of migration.

Neuronal migration is also important to achieve a balance of excitation and inhibition in mature brain. In the cerebral cortex, for example, excitatory and inhibitory neurons have different origins but are intermingled as a result of neuronal migration [8], creating an opportunity for inhibitory neurons to terminate nearby excitatory neurons.

### Molecular Mechanisms

Several molecules are known to be involved in neuronal migration. *In vitro*, migrating neurons respond to diffusible molecules that are known as ►**axon guidance molecules**. These include Slits, Netrin-1 and ►**Semaphorins**. Netrin-1, whose role as chemo-attractant for spinal cord and hindbrain commissural axons has been well established, attracts a subset of precerebellar neurons [9], while Slit repels cortical interneurons and inferior olivary neurons. A chemokine, SDF-1, whose expression is prominent in the meningeal tissue, also regulates migration of several types of neuronal cells. SDF-1, for example, attracts GABAergic interneurons *in vitro* and their distribution is disrupted in SDF-1 knock out mice [10]. For radial migration of cortical neurons, a secreted molecule derived from Cajal-Retzius cells, ►**Reelin**, has been shown to play a pivotal role.

Defects in neuronal migration lead to various ►**developmental disorders**. This includes human classical ►**lissencephaly** (smooth brain) and ►**double cortex**. Genes responsible for these defects are *lissencephaly-1*, encoding Lis1 and *NUDEL*. These molecules form a complex together with ►**dynein**, which is essential for nucleokinesis, movement of the cell nucleus towards neurites. Doublecortin, loss of which causes human ►**subcortical heterotopia**, is a microtubule-associated protein and may probably stabilize microtubules. Manipulation of this gene both *in vitro* and *in vivo* affects migration of neurons.

Migrating neurons *in vitro* typically exhibit bipolar morphology headed by a leading process and a trailing

process. In many instances, extension of the leading process from migrating neurons *in vitro* is followed by its shrinkage that is associated with forward movement of the cell body. Real-time imaging of cortical neurons revealed that there are at least two modes of migration. One is locomotion and another is translocation [11]. Translocating cortical neurons retain their leading process attached to the pial surface, and their somata move as their leading process shrinks, while locomoting neurons are guided by glial fibers with their processes unrestrained.

Recent progress of imaging technology demonstrated that migrating neurons exhibit a more intricate morphology than has been thought. They have multiple leading processes showing extension and retraction, and the direction of their migration depends on the direction of the longest leading process [5].

### Survival of Neurons

The number of neurons is regulated not only by the regulation of its proliferation but also by their naturally occurring death, namely, apoptosis of neurons. The reason for occurrence of the death is not known, but there is evidence suggesting that survival of neurons depends on their synaptic target. The number of neurons of the dorsal root ganglion and motor neurons of the chick, for example, is reduced when the limb bud is removed, whereas more neurons can survive, compared to intact animals, when an extra limb bud is transplanted [12].

The survival of neurons is supported by various growth factors, called ►**neurotrophins**. The most well known and the first discovered neurotrophin is the ►**nerve growth factor (NGF)**. NGF is secreted from target tissues and supports survival of a subset of neurons.

There is a family of neurotrophins. This includes ►**neurotrophin (NT)-3**, ►**brain-derived neurotrophic factor (BDNF)** and ►**NT-4/5**. Different members of neurotrophins show differential distribution in the nervous system and affect different sets of neurons but by a similar mechanism. These molecules bind to neurons via a family of high affinity receptors, ►**TrkA**, **B** or **C**, with distinct affinities as well as a low-affinity receptor, ►**p75**. Although these molecules generally support survival (prevent suicide) of neurons, recent studies revealed proNGF, a precursor of NGF can also bind to p75 and negatively regulates cell survival.

### Axon Pathfinding Growth Cone

Postmitotic neurons extend axons, after or during migration. Growing axons are headed by a swelling called ►**growth cones**, which is a highly motile structure and known to express receptors for various guidance molecules. Growth cones are characterized by

thin protrusions called filopodia, which are bounded by sheet-like structures called lamellipodia. Microtubules extending from the axon reach the base of the lamellipodia. The structure of filopodia is supported by a bundle of actin filaments and polymerization of actin molecules causes extension of filopodia. In addition to having motility, growth cones have the capability of detecting environmental cues. They find their growth directions and pathways by responding to such cues (see below).

### Long-range Diffusible Cues

A number of guidance molecules are involved in their guidance and are categorized into repulsive and attractive molecules. They can also be categorized into long- and short-range cues.

The most well characterized guidance of axons by a long-range cue is chemo-attraction of commissural axons by the ventral midline floor plate. *In vitro*, a floor plate explant can attract commissural axons derived from the dorsal spinal cord or the cerebellar primordium in the hindbrain. This is in harmony with *in vivo* behavior of these axons which course circumferentially through the floor plate. This attraction *in vitro* can be mimicked by ►laminin-related molecules, Netrin-1 and Netrin-2 [13,14], mRNAs of which are expressed in the floor plate. In mice deficient in Netrin-1 or its receptor, DCC, spinal commissural axons fail to reach the midline [15].

Growth cones that are attracted by a source of chemo-attractant might stall when they arrive at the source. This, however, is not the case. Commissural axons in the hindbrain, for example, continue growing after arriving at the midline. This is because the growth cones lose responsiveness to the midline attractant on their arrival at the midline [16]. In the spinal cord, commissural axons seem to use a similar but somewhat different mechanism: they acquire responsiveness to midline repellent on their arrival at the midline [17].

Floor plate explants also exhibit a repulsive activity to subsets of axons *in vitro*. Candidate molecules for this repulsion are Slits, which typically exert repulsive influence on growth cones via their receptors, Robos.

Long-range attractants expressed by an intermediate target thus contribute to the regulation of crossing and uncrossing axons, but they also serve to guide axons to their final target. Long-range repellents restrict the pathway along which growing axons can advance.

A different kind of diffusible cues contributes to the growth polarity of axons along the rostrocaudal axis. There is evidence that a family of secreted proteins, Wnts, guide post-crossing spinal commissural axons rostrally and corticospinal axons caudally [18,19].

### Short-range Cues

Short-range cues can be extracellular matrix molecules such as laminin or membrane-associated proteins such

as ►Cadherins and NCAM. It is well established that a number of ►immunoglobulin superfamily cell adhesion molecules are involved in axon guidance. These molecules exert their effect by way of elevating or reducing adhesiveness between growth cones and their environment. In some occasions, these molecules are expressed by pre-existing axonal tracts and later growing axons follow these tracts by utilizing adhesion molecules expressed by them.

Some guidance molecules such as transmembrane ►Semaphorins are associated with cell membranes, and growth cones respond to these molecules by a direct contact with cells expressing such molecules. A member of ►Eph receptors and their ligands, ephrins also play important roles in axon guidance. A notable example of their roles is the establishment of retinotopic organization in the optic tectum [20]. In the tectum, Ephrin A2 and A5 are expressed in a graded manner along the rostrocaudal axis, while one of their ligands, EphA3, is expressed in a graded manner in the retina along the temporal-nasal axis. *In vitro* experiments along with analyses of knockout mice of these molecules indicate that these molecules play pivotal roles in the targeting of retinal axons. Ephrin A/EphA signaling also plays an important role in the regulation of axonal growth polarity along the rostrocaudal axis [21].

### Axon Targeting

Targeting of axons is thought to be initially diffuse, but is followed by a sculpturing process, which leads to sharper targeting. For example, corticorubral projections in the cat are initially bilateral but become unilateral as development proceeds [22,23]; rat retinotectal projections, which are initially diffuse become to be topographically organized. These sculpturing processes are associated with elimination of incorrectly projecting axonal branches and proliferation of axon branches in correct targets. Previously, the importance of regressive events such as retraction of axonal branches and death of inappropriately projecting neurons was stressed. However, with development, the proliferation of axonal branches, axon terminals as well as ►dendritic growth takes place, all of which are progressive. Indeed, recent studies have revealed the importance of a progressive process such as the proliferation of axons terminals. In any case, these processes are believed to be regulated by synchronized activities of presynaptic and postsynaptic neurons: synchronized activities of pre- and post-synaptic elements might lead to reinforcement and non-synchronized activity leads to weakening of connections.

### Plasticity of Neuronal Connections in the Developing Brain

Developing animals show marked plasticity of neuronal connections compared to adults. Diffuse axonal



projections in young animals appear to be related to prominent plasticity of neuronal connections that takes place after early brain damage. Projections of the deep cerebellar nuclei, for example, are bilateral in early postnatal developmental stages in the cat, but become unilateral (crossed projections) as the animal matures [24,25]. On the other hand, removal of the nucleus on one side during the time when bilateral projections are present, causes permanent bilateral projections from the cerebellum. The period during which the lesion of the nucleus is effective in inducing the bilateral connection coincides with the period when bilateral projections are present in normal animals. A similar coincidence of the period of plasticity and the period of the exuberant projection existence can be found in the cortico-rubral system [22,26,27]. Thus, an interesting possibility is that a denervation causes proliferation of pre-existing axonal branches [27].

## Synaptogenesis

### Structure

The synapse is a key structure for synaptic transmission and the site of transmitter release. The synapse is morphologically defined by electron microscopy: the synaptic differentiation includes the presynaptic density, postsynaptic density, accumulation of synaptic vesicles in the presynaptic membrane and the synaptic cleft, although immature synapses exhibit less pronounced synaptic specialization with few numbers of synaptic vesicles. Typically, synapses are formed on somata and dendrites in mammalian neurons and can be excitatory or inhibitory.

On arrival at their final destinations, growth cones cease growing and form many branches. These branches are associated with swellings both along their length and terminals; such swellings or varicosities contain synaptic vesicles and often form synapses. Synaptogenesis takes place during late developmental stages and is pronounced postnatally.

### Process of Synaptogenesis

Synaptogenesis requires the accumulation of synaptic vesicles in the presynaptic site and receptors on the postsynaptic site and adhesion of pre- and postsynaptic membranes. Studies using the ►[neuromuscular junction](#), where acetylcholine serves as a neurotransmitter, indicate that the presynaptic terminal is capable of inducing aggregation of neurotransmitter receptors. Actually, a molecule that has a receptor aggregating activity, ►[Agrin](#), has been identified [28]. Agrin is a proteoglycan synthesized in the motor neuron and released from its terminal. Although Agrin mRNA can be found in the brain, it does not appear to play a role in receptor aggregation in CNS synapses.

Postsynaptic neurons show remarkable dendritic growth during the period of synaptogenesis. In particular, numerous thin filopodial protrusions emerge from

dendrites. Although the significance of the presence of these structures remains unknown, these filopodial structures may possibly search for growing axons from presynaptic neurons, and once they encounter growing axons, these structures may retract and form mature synapse [29,30].

### Molecules

Several molecules are implicated in synaptogenesis between central synapses. These include Neurexin and its receptor, neuroligin, which are expressed on the pre- and postsynaptic sites, respectively. These molecules can induce synaptic contacts by bidirectional signaling [31].

There is evidence that neuronal activity plays a role in the aggregation of receptor molecules. In this case, the neurotransmitter itself should be involved in maturation of synapses.

During the period of synaptogenesis, other morphological maturation processes proceed. This includes myelination and thickening of axons, both of which contribute to upregulation of conduction velocities.

## References

1. Bouwmeester T (2001) The Spemann-Mangold organizer: the control of fate specification and morphogenetic rearrangements during gastrulation in *Xenopus*. *Int J Dev Biol* 45:251–258
2. Roelink H, Augsburger A, Heemskerk J, Korzh V, Norlin S, Ruiz i Altaba A, Tanabe Y, Placzek M, Edlund T, Jessell TM (1994) Floor plate and motor neuron induction by vhh-1, a vertebrate homolog of hedgehog expressed by the notochord. *Cell* 76:761–775
3. Hynes M, Rosenthal A (1999) Specification of dopaminergic and serotonergic neurons in the vertebrate CNS. *Curr Opin Neurobiol* 9:26–36
4. Fukuchi-Shimogori T, Grove EA (2001) Neocortex patterning by the secreted signaling molecule FGF8. *Science* 294:1071–1074
5. Tanaka DH, Maekawa K, Yanagawa Y, Obata K, Murakami F (2006) Multidirectional and multizonal tangential migration of GABAergic interneurons in the developing cerebral cortex. *Development* 133: 2167–2176
6. Tanaka D, Nakaya Y, Yanagawa Y, Obata K, Murakami F (2003) Multimodal tangential migration of neocortical GABAergic neurons independent of GPI-anchored proteins. *Development* 130:5803–5813
7. Kawachi D, Taniguchi H, Watanabe H, Saito T, Murakami F (2006) Direct visualization of nucleogenesis by precerebellar neurons: involvement of ventricle-directed, radial fibre-associated migration. *Development* 133:1113–1123
8. Marin O, Rubenstein JL (2003) Cell migration in the forebrain. *Annu Rev Neurosci* 26:441–483
9. Taniguchi H, Tamada A, Kennedy TE, Murakami F (2002) Crossing the ventral midline causes neurons to change their response to floor plate and alar plate attractive cues during transmedian migration. *Dev Biol* 249:321–332
10. Stumm RK, Zhou C, Ara T, Lazarini F, Dubois-Dalcq M, Nagasawa T, Holtt V, Schulz S (2003) CXCR4 regulates interneuron migration in the developing neocortex. *J Neurosci* 23:5123–5130

11. Nadarajah B, Brunstrom JE, Grutzendler J, Wong RO, Pearlman AL (2001) Two modes of radial migration in early development of the cerebral cortex. *Nat Neurosci* 4:143–150
12. Hollyday M, Hamburger V (1976) Reduction of the naturally occurring motor neuron loss by enlargement of the periphery. *J Comp Neurol* 170:311–320
13. Kennedy TE, Serafini T, de la Torre JR, Tessier-Lavigne M (1994) Netrins are diffusible chemotropic factors for commissural axons in the embryonic spinal cord. *Cell* 78:425–435
14. Serafini T, Kennedy TE, Galko MJ, Mirzayan C, Jessell TM, Tessier-Lavigne M (1994) The netrins define a family of axon outgrowth-promoting proteins homologous to *C. elegans* UNC-6. *Cell* 78:409–424
15. Serafini T, Colamarino SA, Leonardo ED, Wang H, Beddington R, Skarnes WC, Tessier-Lavigne M (1996) Netrin-1 is required for commissural axon guidance in the developing vertebrate nervous system. *Cell* 87:1001–1014
16. Shirasaki R, Katsumata R, Murakami F (1998) Change in chemoattractant responsiveness of developing axons at an intermediate target. *Science* 279:105–107
17. Stein E, Tessier-Lavigne M (2001) Hierarchical organization of guidance receptors: silencing of netrin attraction by slit through a Robo/DCC receptor complex. *Science* 291:1928–1938
18. Liu Y, Shi J, Lu CC, Wang ZB, Lyuksyutova AI, Song XJ, Zou Y (2005) Ryk-mediated Wnt repulsion regulates posterior-directed growth of corticospinal tract. *Nat Neurosci* 8:1151–1159
19. Lyuksyutova AI, Lu CC, Milanesio N, King LA, Guo N, Wang Y, Nathans J, Tessier-Lavigne M, Zou Y (2003) Anterior-posterior guidance of commissural axons by Wnt-frizzled signaling. *Science* 302: 1984–1988
20. Lemke G, Reber M (2005) Retinotectal mapping: new insights from molecular genetics. *Annu Rev Cell Dev Biol* 21:551–580
21. Zhu Y, Guthrie S, Murakami F (2006) Ephrin A/EphA controls the rostral turning polarity of a lateral commissural tract in chick hindbrain. *Development* 133: 3837–3846
22. Higashi S, Yamazaki M, Murakami F (1990) Postnatal development of crossed and uncrossed corticorubral projections in kitten: a PHA-L study. *J Comp Neurol* 299:312–326
23. Song WJ, Murakami F (1998) Development of functional topography in the corticorubral projection: an in vivo assessment using synaptic potentials recorded from fetal and newborn cats. *J Neurosci* 18:9354–9364
24. Song WJ, Murakami F (1990) Ipsilateral interpositorubral projection in the kitten and its relation to post-hemicerebellectomy plasticity. *Brain Res Dev Brain Res* 56:75–85
25. Song WJ, Kobayashi Y, Murakami F (1993) An electrophysiological study of a transient ipsilateral interpositorubral projection in neonatal cats. *Exp Brain Res* 92:399–406
26. Murakami F, Higashi S, Yamazaki M, Tamada A (1991) Lesion-induced establishment of the crossed corticorubral projections in kittens is associated with axonal proliferation and topographic refinement. *Neurosci Res* 12:122–139
27. Murakami F, Song WJ, Katsumaru H (1992) Plasticity of neuronal connections in developing brains of mammals. *Neurosci Res* 15:235–253
28. Nitkin RM, Smith MA, Magill C, Fallon JR, Yao YM, Wallace BG, McMahan UJ (1987) Identification of agrin, a synaptic organizing protein from Torpedo electric organ. *J Cell Biol* 105:2471–2478
29. Saito Y, Song W-J, Murakami F (1997) Preferential termination of corticorubral axons on spine-like dendritic protrusions in developing cat. *J Neurosci* 17:8792–8803
30. Ziv NE, Smith SJ (1996) Evidence for a role of dendritic filopodia in synaptogenesis and spine formation. *Neuron* 17:91–110
31. Dean C, Dresbach T (2006) Neuroligins and neuroligins: linking cell adhesion, synapse formation and cognitive function. *Trends Neurosci* 29:21–29
32. Nakamura H, Katahira T, Matsunaga E, Sato T (2005) Isthmus organizer for midbrain and hindbrain development. *Brain Res Brain Res Rev* 49:120–126
33. Nakamura H, Watanabe Y (2005) Isthmus organizer and regionalization of the mesencephalon and metencephalon. *Int J Dev Biol* 49:231–235
34. Rubenstein JL, Martinez S, Shimamura K, Puelles L (1994) The embryonic vertebrate forebrain: the prosomeric model. *Science* 266:578–580

## Neural Filters

### Definition

Filters are instruments that let pass only selected information or particles. Tea leaves are filtered out by a tea filter, because they are too large. Likewise, neurons also may filter the incoming information a let pass only a selected part. The mechanisms may be multiple. Thresholding, by which potentials with small amplitudes do not generate an action potential at the output of a neurons, is a powerful means. Other possibilities are coincidence detection or more complex processes.

## Neural-Immune Interactions: Implications for Pain Management in Patient with Low-Back Pain and Sciatica

ANGELA STARKWEATHER  
Intercollegiate College of Nursing, Washington State University, Spokane, WA, USA

### Synonyms

Neural-immune interactions; Neuroimmunology; Low-back pain; Lumbago; Sciatica; Radiculopathy; Sciatic neuritis

## Definition

This essay reviews neuroimmune pathways involved in the initiation and maintenance of low-back pain and sciatica.

## Characteristics

Quantitative description: Bidirectional communication between the immune system and the brain and the implications of this communication are emerging concepts in pain research. Although representing a small portion of the disc degeneration syndromes, lumbar herniated discs can cause significant symptoms that may persist even after surgical interventions. Evolving evidence demonstrates that proinflammatory cytokines are key mediators in the process of disc degeneration as well as in the pain experienced by those afflicted with lumbar herniated discs. Activated immune cells release proinflammatory cytokines, which signal the brain through humoral and neural routes. The brain responds by altering neural activity and promoting further production of proinflammatory cytokines within the brain and spinal cord. Increased local cytokine production by disc tissue irritates spinal nerve roots resulting in pain and functional changes in neural activity. This essay explores the importance of cytokine and other related ►[neuroimmunology](#) pathways within the context of lumbar disc degeneration and lumbar spine ►[pain](#).

Description of the structure/process/conditions: Disc degeneration is the initial process leading to non-traumatic disc herniation (Fig. 1). This theoretical pathway explains the biomechanical and biochemical events implicated in the process of disc aging, or degeneration, which ultimately leads to the experience of pain phenomena (low-back pain and ►[sciatica](#)). Traditionally, it has been believed that the displaced disc tissue was a by-product of the disease and not an interactive element in the disease process itself. However, the discovery of elevated levels of proinflammatory cytokines within injured disc tissue led researchers to conceptualize it as a biologically active tissue. Since that time, connections between the immune system, nervous system, and pain behavior in disc injury have continued to evolve. The current understanding of the mechanisms of disc degeneration and nontraumatic herniation will be reviewed in relationship to the aforementioned Fig. 1.

## Regulation of the Structure/Process/Conditions Mechanical Shear Stress

The function of the intervertebral disc is to provide the spine with mobility while retaining axial stability. While physiological loading helps to maintain metabolism and function in intervertebral discs, excessive mechanical loading appears to be detrimental. Lifestyle, occupational, genetic and biochemical factors influence the effects of mechanical loading on disc degeneration [1].

## Neovascularization

Small nonmyelinated nerve fibers grow into the intervertebral disc in areas where there is local production of nerve growth factor (NGF) (“►[The role of the NGF family in the regulation of neuroinflammation](#)”). NGF is produced by microvessels, which populate the normally avascular (and aneural) intervertebral disc by extension from adjacent bone. This pattern of nerve growth and receptor expression is implicated in the innervation of painful tissues through NGF-driven axonal growth and maturation. The stimulus that promotes microvessels to release NGF, triggering the process of nerve and vessel ingrowth, remains uncertain. However, IL-1 has the ability to switch chondrocytes from anabolism to catabolism, inducing cartilage breakdown at molecular and morphological levels through stimulating ►[matrix metalloproteinases](#) (MMPs). Thus, there is growing evidence of the role of proinflammatory cytokines in matrix degradation (disc degeneration), nerve and vessel ingrowth, and pain. In fact, there is mounting evidence that immune factors are involved not only in the initiation of disc degeneration but also in the progression of disc disease. As the injured disc tissue continues to produce elevated levels of MMPs, thereby losing proteoglycans, the diseased tissue begins to wear down. Annular tears form along the outer wall of the disc, making it more susceptible to splitting, and thus herniating, in the face of exertional forces that raise the intervertebral pressure [2]. Disc-related biomarkers of degeneration are currently being investigated [3].

## Direct Mechanical Stimulation and Sensitization of the Dorsal Root Ganglion

Dislocation of intervertebral disc tissue (IVD) by nucleus pulposus (NP) protrusion or extrusion (i.e., herniated disc) is a common source of severe pain. Herniated NP can potentially contact and compress the dorsal root ganglion (DRG) and spinal root that enters the spine at the vertebral level. Acute mechanical compression is sufficient to produce spontaneous activity in the sensory afferents, supporting the classic assumption that mechanical compression is the cause of pain and other neurological symptoms. Mechanical compression has been thought to account for the ischemia, edema, and demyelination that occur in the DRG and the pain that may arise from nerve endings in the outer annulus fibrosus.

## Nucleus Pulposus-Induced Nerve Injury

Pathological pain can arise as a consequence of the protrusion of the NP into contact with the DRG and dorsal root. Although pressure per se has classically been considered as a major cause of pain, there is growing evidence that immune-derived substances may be involved as well. Diverse immune cells and equally

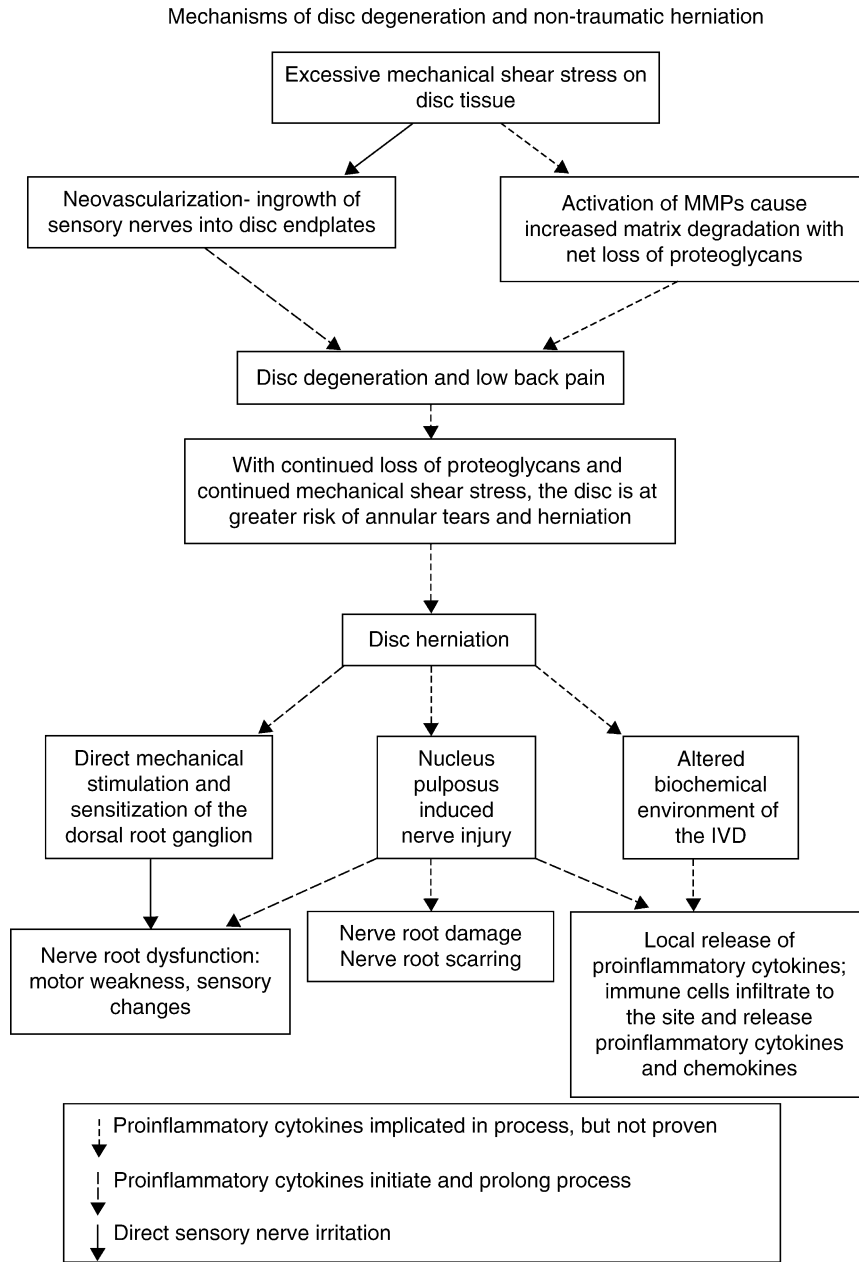

**Neural-Immune Interactions: Implications for Pain Management in Patient with Low-Back Pain and Sciatica.**  
**Figure 1** Mechanisms of disc degeneration and non-traumatic herniation. MMP = matrix metalloproteinases; IVD = intervertebral disc.

diverse immune cell products are potential mediators. Of these, proinflammatory cytokines have received by far the most attention. Data to date suggest a strong case in support of proinflammatory cytokine involvement in the pain of herniated discs through astrocyte and microglia activation (“►[Functions of microglia in immune mechanism in the central nervous system \(CNS\)](#)”) [4]. The cytokines may do this by inducing expression of receptors within DRGs. Also, axonal

interactions with proinflammatory cytokines could increase electrical conductivity. Each of these processes could then lead to pain processing.

**Biochemical Mediators in Herniated Disc Tissue**

Neuropathic pain can occur as a consequence of nerve trauma, with physical damage to nerves altering pain perception and the function of pain transmission pathways (“►[Spinal immunology and neuropathic](#)



pain”). However, neuropathic pain can also occur in the absence of any detectable physical injury. In these situations, pathological pain appears to be a consequence of immune activation and inflammation, which can also amplify pain as a consequence of physical trauma. The role of immune activation in neuropathic conditions has been firmly established, and a consistent picture has emerged from these models of traumatic and/or inflammatory neuropathic pain. The key cellular mediators are most likely inflammatory cells recruited into the affected area from the general circulation along with locally stimulated cell populations. These cells produce proinflammatory cytokines (tumor necrosis factor [TNF], IL-1, IL-6) within the affected area and create and maintain pathological pain [5].

#### **Alterations in the Biochemical Environment of the Intervertebral Disc (IVD)**

Nucleus pulposus-induced effects on adjacent nerve root(s), include alterations in nerve conduction velocity, mechanosensitization, pain behavior, histological degeneration, reduced blood flow, and increased endoneurial fluid pressure. The biochemical changes initiated by exposed NP and the increased production of proinflammatory cytokines create an environment of degradation. This process has been hypothesized to be part of disc resorption, influenced by migrating macrophages. The synergistic effects of nerve compression and the altered chemical environment of the IVD appear to produce the pathophysiologic network leading to the pain experienced by those with herniated discs.

#### **Function**

Lifestyle, body weight, aging, and genetics all influence the load environment of the normal IVD. Lifestyle (including occupation) and body weight are capable of accelerating the rate of degeneration and thus further complicates the starting point from which to assess IVD degeneration. The studies to date provide evidence of connective tissue degradation, nerve and vessel ingrowth, and increased production of proinflammatory cytokines that characterize IVD degeneration and herniation. There is considerable need for more investigation into the precise role of cytokines for each of these biological processes. Concurrently, the study of immune involvement in neuropathic pain is in its infancy. Many more immune cells and immune-derived substances may be implicated in the etiology of pathological pain syndromes. Much remains to be learned about the dynamics of immune system modulation of pain and neural function.

The recognition that the immune system may be involved in neuropathic pain has important potential implications. If proinflammatory cytokines contribute to pain and to neuropathological changes in the sensory neurons, it may be possible to devise much-needed

alternative approaches for treatment of patients with low-back pain. Surgery for herniated discs is not without cost, and surgical treatment of disc herniation is advised only if nonsurgical treatment fails. Furthermore, resolution of pain is not guaranteed with surgery, as complications and failure rates remain relatively high. Understanding the role of the immune system in disc-related pain may lead to a better appreciation of not only the nature of organic pain but also alternative therapeutic approaches or drug strategies to treat pain and its antecedents. Moreover, the evaluation of immune markers as indices of pain and of immune responsiveness consequent to pain may provide insight into the means by which to fine-tune the therapy provided to individual patients.

A remaining conundrum in clinical practice is how to define disc degeneration. It has been proposed that Modic changes may be an objective marker of discogenic low-back pain. Modic changes are signal intensity changes on plain radiograph X-rays and magnetic resonance imaging that reflect a spectrum of vertebral body marrow changes associated with degenerative disc disease. A correlation between Modic changes on spinal magnetic resonance images and the production of proinflammatory cytokines has been made: Modic 1 changes were more common in patients with discogenic low-back pain, whereas Modic 2 changes occur in patients suffering from sciatica (with increased production of proinflammatory cytokines). Advances in imaging techniques are being applied to disc degeneration which will hopefully lead to a standard method of quantifying disc degeneration in humans [6].

Traditional treatment for low-back pain includes non-steroidal anti-inflammatory medication, which inhibits prostaglandin synthesis, as first-line therapy. Patients exhibiting ►sciatic symptoms are often prescribed steroids (by mouth or epidurally) to decrease swelling in the affected nerve root. The use of these substances in long-term therapy, however, must be weighed against their side effects. Gabapentin has been added to the armamentarium for treating sciatic pain. Although its mechanism of action is unknown, it is structurally related to the neurotransmitter  $\gamma$ -aminobutyric acid. All of these medications have limited success in relieving symptoms of low-back pain and sciatica, and none prevent progression of degenerative disease.

The recognition of peripheral and central immune cell involvement in neuropathic pain of diverse etiologies may offer a new avenue or approach to pain control. There are multiple situations in which immune-derived proteins (TNF, IL-1, IL-6) have been correlated with and are the likely cause of neuropathic pain conditions. The pervasive and potentially key involvement of the proinflammatory cytokines within an affected body region or within the spinal cord are likely and desirable targets for drug development. The role

of gene therapy in disc degeneration is currently being investigated [7–9]. Using genes introduced into target cells, proteins are produced within the degenerate disc, which provide a chemical environment conducive to restoring cell function toward normality. Although some pathologic conditions require immediate decompressive surgery, as in cauda equina syndrome, the role of surgery in disc degeneration syndromes is becoming less clear. As new therapies continue to evolve that are able to target the biochemical factors involved in pain transmission, perhaps the ultimate test will be whether a pathway can be found that reverses the degenerative condition.

## References

1. Battié MC (2006) Lumbar disc degeneration: epidemiology and genetics. *J Bone Joint Surg* 88(A):3–8
2. Benoist M (2002) The natural history of lumbar disc herniation and radiculopathy. *Joint Bone Spine* 69:155–160
3. Poole AR (2006) Biological markers and disc degeneration. *J Bone Joint Surg* 88(A):72–75
4. Watkins LR, Maier SF (2002) Beyond neurons: evidence that immune and glial cells contribute to pathological pain states. *Physiol Rev* 82:981–1011
5. Wieseler-Frank J, Maier SF, Watkins LR (2005) Central proinflammatory cytokines and pain enhancement. *Neurosignals* 14:166–174
6. Haughton V (2006) Imaging intervertebral disc degeneration. *J Bone Joint Surg* 88(A):15–20
7. Freemont AJ, Watkins A, Le Maitre C, Jeziorska M, Hoyland JA (2002) Current understanding of cellular and molecular events in intervertebral disc degeneration: implications for therapy. *J Pathol* 196:374–379
8. Le Maitre CL, Freemont AJ, Hoyland JA (2006) A preliminary in vitro study into the use of IL-1Ra gene therapy for the inhibition of intervertebral disc degeneration. *Int J Exp Pathol* 87:17–28
9. Le Maitre CL, Richardson SM, Baird P, Freemont AJ, Holyland JA (2005) Expression of receptors for putative anabolic growth factors in human intervertebral disc: implications of repair and regeneration of the disc. *J Pathol* 207:445–452

## Neural Integrator

### Definition

A neural network that integrates, in a mathematical sense, its input signals. For example, if a pulse of neural activity was the input to a neural integrating circuit, the circuit's output would be a sustained step of neural activity.

- ▶ [Neural Integrator – Horizontal](#)
- ▶ [Neural Integrator – Vertical](#)

## Neural Integrator – Vertical

YANNIS DALEZIOS<sup>1</sup>, ADONIS MOSCHOVAKIS<sup>2</sup>

<sup>1</sup>Institute of Applied and Computational Mathematics, Crete, Greece

<sup>2</sup>Department of Basic Sciences, Faculty of Medicine, University of Crete, Heraklion, Crete, Greece

### Definition

An ensemble of neurons of the vertical oculomotor system that engage in integration in the sense of Newtonian calculus. They receive signals roughly indicative of vertical eye velocity (such as those produced by the vertical burst generators in the rostral interstitial nucleus of the MLF) and generate signals proportional to vertical eye position that they convey to the appropriate ▶ [extraocular motoneurons](#) (those with vertical pulling directions).

### Description of the Theory

Although originally thought as a unitary brain device responsible for all eye velocity to position transformations, it is now clear that several cell assemblies are needed to implement neural integration in different planes and for different kinds of eye movements. The nucleus prepositus hypoglossi is crucial for integration in the horizontal plane (▶ [see Neural Integrator – Horizontal](#)) and the same is true for the ▶ [interstitial nucleus of Cajal \(NIC\)](#) for integration in the vertical plane. For example, unilateral chemical inactivation of the NIC prevents monkeys from holding eccentric vertical eye positions but does not affect their ability to hold eccentric horizontal eye positions. The same is true of human patients suffering from midbrain lesions that encroach on the NIC; they display vertical (but not horizontal) gaze holding failure [1].

The oculomotor subsystem subserving the ▶ [vestibuloocular reflex \(VOR\)](#) also relies on velocity to position integration. Its input, carried by primary vestibular afferents, encodes (and is in phase with) the angular velocity of the head whereas its output (motoneuron discharge) encodes (and is in phase with) eye position. There is evidence from several species to indicate that the NIC participates in this process, at least in the vertical plane. Its lesions impair the pitch VOR (as documented by gain reduction and phase advancement) while the horizontal VOR remains normal. Because vertical VOR impairments are not as profound as would be expected from the concurrent impairment of vertical gaze holding, it is unlikely that a single neural integrator underlies the generation of both saccadic and VOR signals [2].

To understand how integration is achieved neurally it is important to know the discharge pattern and

connections of relevant neurons. Of the several classes of cells contained in the NIC (for reviews see [3,4]), it is the burst-tonic neurons that are of particular interest for the purposes of this essay. The discharge of a typical such unit is illustrated in Figs. 1 and 2.

As shown here, it remains roughly constant in between saccades at a value specified by the vertical position (usually both up and down) of the eyes and its bursts precede saccades with an upward component, whether rightward or leftward. The firing rate ( $F_R$ ) of such units is described by the expression

$$F_R = F_0 + kE + rE/dt \quad (1)$$

Where  $E$  is the instantaneous vertical position of the eyes.  $F_0$  (the neural discharge at primary position),  $k$  (the slope of the rate-position curve) and  $r$  (the slope of the rate-velocity curve) are constants that differ for different cells. The average values they obtain have been determined in several species (for a review see [4]). For example,  $F_0 = 88$  spikes/s,  $k = 3.1$  spikes/s/deg and  $r = 0.8$  spikes/s/deg/s (when  $r$  was evaluated from smooth pursuit eye movements), in a sample of units of

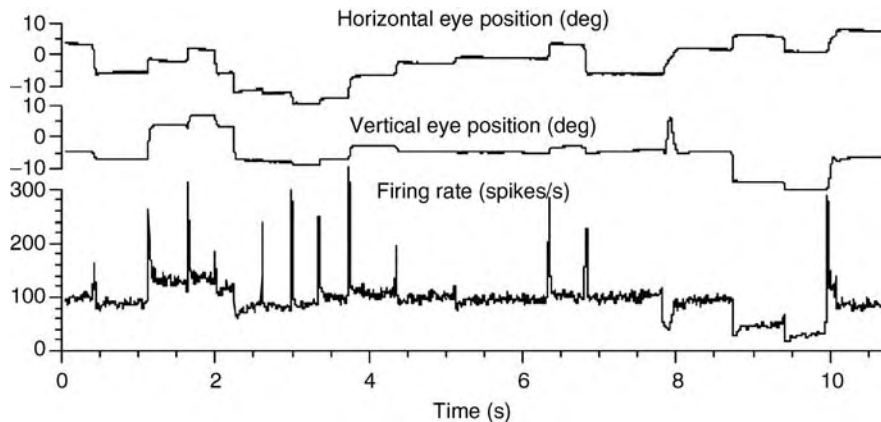

**Neural Integrator – Vertical. Figure 1** Oculomotor related discharge pattern of a regular upward efferent fiber of the NIC. (modified from [5], used with permission). Traces from top to bottom illustrate the instantaneous horizontal and vertical eye position and the instantaneous firing rate.

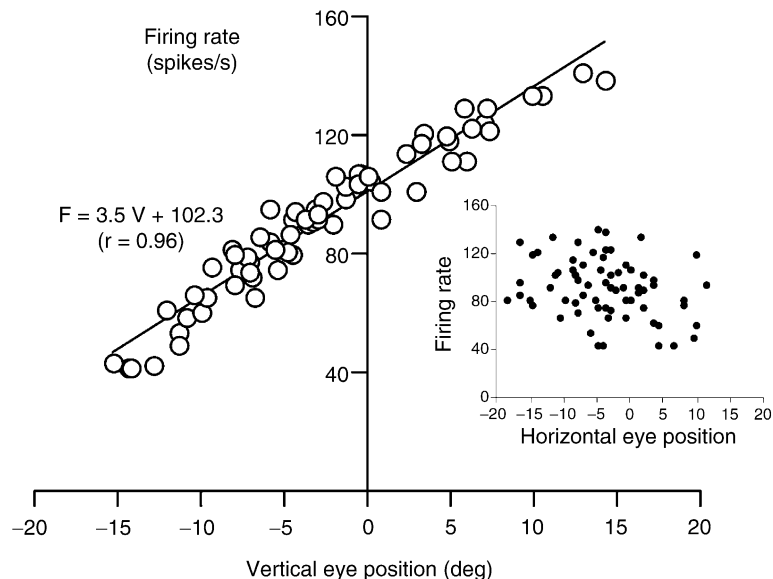

**Neural Integrator – Vertical. Figure 2** Quantitative analysis of the relationship (modified from [5], used with permission) between the mean intersaccadic firing rate (ordinate) of the unit shown in Fig. 1 and the mean intersaccadic vertical eye position (abscissa). The solid line is the linear regression line through the data (open circles). The inset is a plot of horizontal eye position (abscissa) versus firing rate (ordinate).

the squirrel monkey, while the same units also emitted about 0.6 spikes per degree of vertical displacement of the eyes during saccades [5]. Differences between NIC burst-tonic units can be appreciable as shown by the fact that 25% of these units modulated their discharge in relation to upward or downward eye position, but not both, while about 25% of them did not emit any bursts for saccades (tonic neurons).

Axons arising from burst tonic units of the NIC have been shown to travel with the posterior commissure (PC; [6]). The trajectory of such PC fibers and the terminal fields they deploy in the contralateral NIC, the oculomotor nucleus and the trochlear nucleus are illustrated in Fig. 3.

Their virtual disappearance, after PC lesions that preceded the injection of tracer in the NIC, indicates that PC fibers are likely to be the conduit of most of the NIC output to these nuclei [7]. Their integrity is necessary for normal velocity to position integration in the vertical plane since inactivation or lesion of the PC disable vertical gaze holding and advance the phase of the vertical VOR in the dark [8].

To gain insight into the operation of this network and understand how the properties of its neurons endow it with the ability to transform velocity signals into position signals it is instructive to consider a model of the vertical neural integrator that captures the crucial biological facts that are known about it such as those described above. To recapitulate, such a model should account for the qualitative (e.g., whether they emit saccade related bursts or not) and quantitative (e.g., the range of values of the parameters  $F_0$ ,  $k$  and  $r$ ) properties of discharge of its units, the cross-connections between neural integrators located in opposites sides of the brain (via the PC) and the properties of the eye movement deficits which result from lesions of its units (e.g., drifts of appropriately short time constants).

Figure 4 is a block diagrammatic illustration of a lumped version of this model together with typical signals encountered at several of its stages for saccades of two different directions (up, blue; down, red).

The same color code is used to distinguish upward (UNI) from downward (DNI) units while solid lines indicate connections arising from excitatory (UNI<sub>e</sub>,

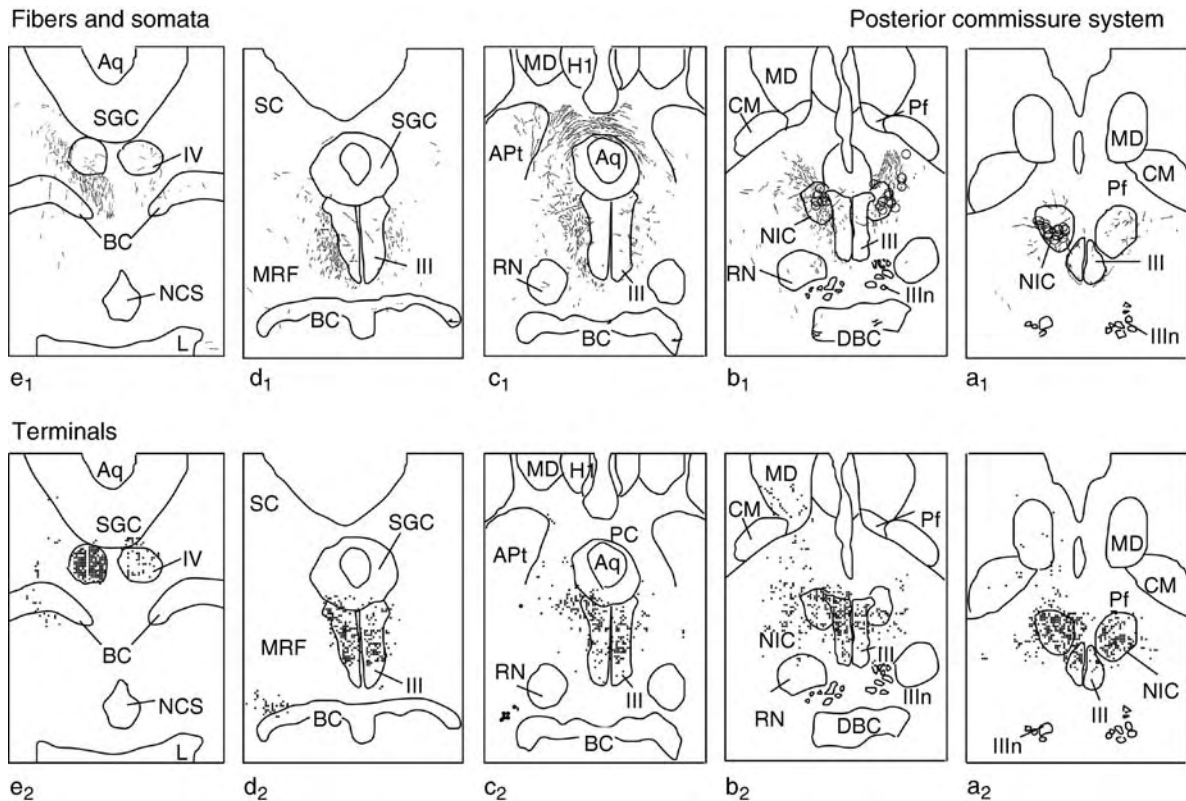

**Neural Integrator – Vertical. Figure 3** Location of retrogradely labeled somata ( $a_1$ – $e_1$ , open circles), trajectory of PC fibers ( $a_1$ – $e_1$ ) and terminal fields in and around the oculomotor and trochlear nuclei ( $a_2$ – $e_2$ ) following biocytin injection in the NIC (reproduced from [7] and used with permission). Sections are shown in the frontal plane and are arranged from rostral (a) to caudal (e).



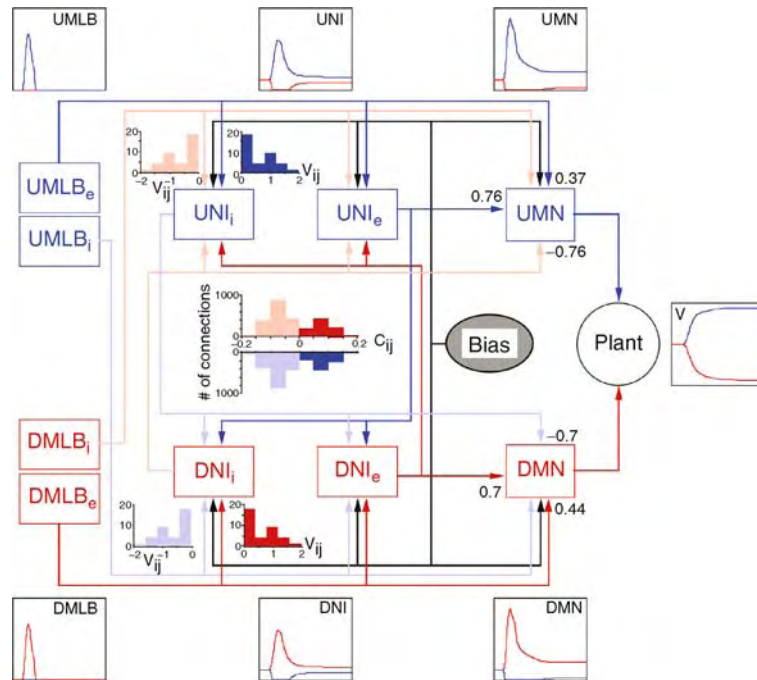

**Neural Integrator – Vertical. Figure 4** Schematic illustration of a lumped version of a model of the vertical neural integrator (reproduced from [9], with permission). Units with upward on-direction and the signals carried by all units during upward saccades (waveforms placed inside boxes) are shown in blue. Units with downward on-direction and the signals carried by all units during downward saccades are shown in red. Boxes illustrating discharge patterns measure 200 ms (abscissa) and 800 spikes/s (ordinate). The size of the box containing examples of the eye position output of the system is 200 ms (abscissa) and 20 deg (ordinate). Solid arrows indicate excitatory connections. All other connections are inhibitory. Insets are histograms of connection strengths. Abbreviations: *DMLB*, downward medium-lead burst neuron; *DMN*, downward motoneuron; *DNI*, downward neural integrator; *UMLB*, upward medium-lead burst neuron; *UMN*, upward motoneuron; *UNI*, upward neural integrator. Subscripts indicate the excitatory (e) or inhibitory (i) influence units exert on their targets.

$DNI_e$ ) units and stippled lines those arising from inhibitory ( $UNI_i$ ,  $DNI_i$ ) units. Each model unit is assumed to establish excitatory ( $NI_e$  units) or inhibitory ( $NI_i$  units) connections onto NI units with opposite on-direction. They all project to motoneurons as well. The strength of these connections ( $c_{ij}$ ) and the precise number of excitatory and inhibitory units is less critical. Provided that the number of excitatory neurons is not greater than or equal to the number of inhibitory ones it is always possible to find an average value (of  $c_{ij}$ ) such that  $T = 20$  s. When inhibitory neurons are sufficiently more numerous than excitatory ones (e.g., when  $n_i = 2n_e$ )  $T$  is about equal to 20 s (dashed line), if  $c$  is equal to 0.0835. However, there is no need to assume that the weights of all interconnections ( $c_{ij}$ ) between the NI units of the distributed model obtain this absolute value. Instead, they can vary quite freely around it forming a normal distribution with a coefficient of variation equal to 0.5. This relatively large number implies that the model is quite impervious to the precise values obtained by any of these connection strengths. The histograms near the center of Fig. 4 (solid, excitatory; stippled, inhibitory) illustrate

distributions that were obtained with the help of a random number generator after specifying the mean and the standard deviation of the populations and are compatible with a normally operating neural integrator.

The signals carried by the units of such a model (e.g., insets of Fig. 4) are remarkably similar to the discharge pattern of primate NIC neurons. Just like primate neurons, model units generally burst for vertical saccades (up or down) and their tonic discharge in between saccades is proportional to vertical eye position. The similarity is not just a broad, qualitative one. For example, the position sensitivity ( $k$ ) velocity sensitivity ( $r$ ) and primary position rate ( $F_0$ ) of upward model units are statistically indistinguishable from the the position and the velocity sensitivity and the primary position rate of the burst-tonic upward efferent neurons of the NIC [5]. Although most model units ( $N = 62$  of 72) modulated their discharge for saccades and eye position in the same direction (in-phase units) a few behaved quite differently in that they display opposite on-directions for saccades and eye position (anti-phase units). The same is true of NIC neurons found in both cats [3] and monkeys [5]. Finally, as with primate

NIC neurons, a few model units did not emit bursts for saccade which again agrees well with the discharge patterns of neurons encountered in the NIC [5]. Although few in number, such tonic neurons are of particular importance as it has been argued that they carry the output of the neural integrators in contrast to burst-tonic cells that are limited to computational stages closer to its input (see the chapter on ► [Neural Integrator – Horizontal](#)). Efforts to test this argument experimentally have had mixed results. Tonic neurons have been shown to project to the abducens nucleus more frequently than burst-tonic cells of the horizontal neural integrator (in the NPH; [10]). In contrast, burst-tonic cells have been shown to comprise the majority of efferent fibers conveying the output of the vertical neural integrators to extraocular motoneurons [5]. All in all, work in the vertical system demonstrates that the neural integrator need not be more than one layer deep and that both its tonic and burst-tonic units send their output to motoneurons.

Given the large variety of their response properties, it is meaningful to ask if the units of the model integrator of Fig. 4 comprise a functional continuum, or alternatively, whether they can be broken up into distinct functional classes and, if so, which. To this end we plotted their position sensitivity ( $k_v$ ) against their velocity sensitivity ( $r_{(s)}$ ) in Fig. 5.

In this scatter-plot, the units occupy two distinct clouds, to the right and to the left of zero  $k_v$ , corresponding to upward and downward units, respectively. No other demarcation point can be found to further subdivide units according to their position sensitivity (high or low).

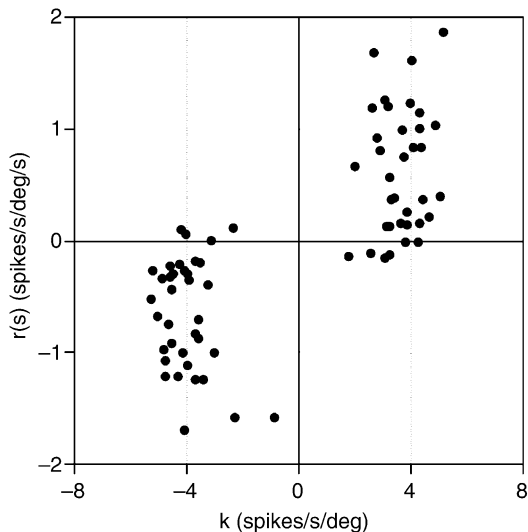

**Neural Integrator – Vertical. Figure 5** 2-D scatterplot of the slope of the rate position curves ( $k_v$ , abscissa) against the slope of the rate-velocity curves ( $r_{(s)}$ , ordinate: evaluated from saccades) of all 72 units of the model (reproduced from [9], with permission).

Similarly, no demarcation can be found on the orthogonal axis to subdivide units according to their velocity sensitivity. Both up and down units form elongated clouds straddling zero  $r_{(s)}$ . Most of the points are confined to the upper right (up units) or lower left (down units) quadrants. These correspond to units that are generally sensitive to up or down ocular deviation and emit more or less strong bursts for saccades in the same direction. Both clouds encompass points on or close to the horizontal abscissa of the scatterplot; these correspond to tonic units. Finally, both clouds encompass a few points belonging to the lower right (up units) or the upper left quadrant (down units); these correspond to anti-phase units.

Selective lesions of subpopulations of integrator units could help elucidate how each of these distinct subtypes contributes to neural integration. Such experiments cannot be carried out *in vivo* with presently available techniques. Instead they exemplify one of the strong points of computational approaches. As expected, elimination of the inhibitory units of the model shown in Fig. 4 abolishes integrator function. On the other hand, elimination of excitatory units does not lead to integrator failure provided that the weights of commissural connections are readjusted “postlesionally”. Instead, it abolishes anti-phase activity and more importantly, it raises the slope of the rate position curve dramatically, to between  $\pm 23.5$  and  $\pm 33.5$  spikes/s/deg. With rate position slopes such as these, and since the eyes reach eccentricities as high as  $\pm 45^\circ$ , NI neurons would have to sustain very high firing rates (often exceeding 1,000 Hz). In other words, the vertical neural integrator could function normally even if all connections between its neurons were inhibitory ones but not if the dynamic range of the neurons involved must be kept within physiological bounds.

## References

1. Ranalli PJ, Sharpe JA, Fletcher WA (1988) Palsy of upward and downward saccadic, pursuit, and vestibular movements with a unilateral midbrain lesion: pathophysiologic correlations. *Neurology* 38:114–122
2. Helmchen C, Rambold H, Fuhry L, Büttner U (1998) Deficits in vertical and torsional eye movements after uni- and bilateral muscimol inactivation of the interstitial nucleus of Cajal of the alert monkey. *Exp Brain Res* 119:436–452
3. Fukushima K, Kaneko CRS (1995) Vestibular integrators in the oculomotor system. *Neurosci Res* 22:249–258
4. Moschovakis AK (1997) The neural integrators of the mammalian saccadic system *Front. Bioscience* 2:552–577
5. Dalezios Y, Scudder CA, Highstein SM, Moschovakis AK (1998) Anatomy and physiology of the primate interstitial nucleus of Cajal. II. Discharge pattern of single efferent fibers. *J Neurophysiol* 80:3100–3111
6. Moschovakis AK (1995) Are laws that govern behavior embedded in the structure of the C.N.S.? The case of Hering’s law. *Vision Res* 35:3207–3216

7. Kokkoroyannis T, Scudder CA, Highstein SM, Balaban C, Moschovakis AK (1996) The anatomy and physiology of the primate Interstitial Nucleus of Cajal. I. Efferent projections. *J Neurophysiol* 75:725–739
8. Partsalis A, Highstein SM, Moschovakis AK (1994) Lesions of the posterior commissure disable the vertical neural integrator of the primate oculomotor system. *J Neurophysiol* 71:2582–2585
9. Sklavos SG, Moschovakis AK (2002) Neural network simulations of the primate oculomotor system. IV. A distributed bilateral stochastic model of the neural integrator of the vertical saccadic system. *Biol Cybern* 86:97–109
10. Escudero M, de la Cruz RR, Delgado-García JM (1992) A physiological study of vestibular and prepositus hypoglossi neurones projecting to the abducens nucleus in the alert cat. *J Physiol* 458:539–560

## Neural Network in Olfactory Bulb

### Definition

Group of interconnected neurons, which are together responsible for a particular neural function, either at the periphery or at the central brain level. The network typically comprises different types of neurons, having different electrical and/or physiological properties. A typical example is the olfactory bulb, primary olfactory center of vertebrates that comprises different neuron types within a number of anatomical and functional units, the glomeruli. Olfactory sensory neurons at the periphery (olfactory mucosa) detect odorants and convey this information to the glomeruli. There, sensory neurons connect onto output neurons (mitral cells/tufted cells), which will further convey olfactory information to higher brain centers (cortex, etc.). Most importantly, two types of local bulb neurons (periglomerular and granule cells) carry out lateral inhibition to neighboring glomeruli. All these neurons constitute the neural network of the olfactory bulb, whose function is to format odor representation, increase signal to noise, and improve odor discrimination ability. Because of the very high number of connections between neurons within neural networks, and the fact that the action of one neuron on the other can be excitatory or inhibitory, neural networks usually induce highly non-linear results at their output. Consequently, their activity should not be studied at the “single-neuron” level but techniques taking into account the connectivity and complexity of the network, like multi-unit electrophysiological recordings or optical imaging techniques should be applied. Furthermore, computational neural networks have proved useful to reproduce the architecture of biological neural networks, in order to understand their processes and outcomes. Such

mathematical models have become a whole field in computational neuroscience, and they are now used for developing artificial intelligence applications, for instance for voice or face recognition, automated image analysis, etc.

### ► Olfactory Bulb

## Neural Networks

KAZUYUKI AIHARA<sup>1</sup>, MASATO OKADA<sup>2</sup>,  
MASAHARU ADACHI<sup>3</sup>, MASATAKA WATANABE<sup>4</sup>

<sup>1</sup>Institute of Industrial Science, The University of Tokyo, Tokyo, Japan

<sup>2</sup>Graduate School of Frontier Sciences, The University of Tokyo, Kashiwa Chiba, Japan

<sup>3</sup>Department of Electrical and Electronic Engineering, School of Engineering, Tokyo Denki University, Tokyo, Japan

<sup>4</sup>Department of Systems Innovation, Graduate School of Engineering, The University of Tokyo, Tokyo, Japan

### Definition

#### Neural Networks and Architectures

Neural networks, here, mean mathematical models of biological neural networks composed of neurons. There have been many works on neural networks since the seminal paper by McCulloch and Pitts in 1943 [1]. Although neurons are connected through synapses in complicated ways in the living brain, typical architectures of neural network models are classified into ►feedforward networks and ►feedback networks as shown in Fig. 1.

While the former is ►multilayer networks with the input layer, the output layer, and hidden layers between them, the latter is recurrent networks with feedback connections. Typical examples of the feedforward networks are ►perceptron [2] and ►back-propagation learning networks [3]; recently, forward-propagation learning is also proposed [4]. The feedback networks, on the other hand, have been used in many models such as ►associative memory and combinatorial optimization where nonlinear dynamics plays important roles like deterministic ►chaos in ►chaotic neural networks and stochastic synchronization.

### Characteristics

#### Learning Theory in Neural Networks

Learning in models of neural networks is incorporated as rules to update and establish synaptic weights between neurons. The learning rules are classified

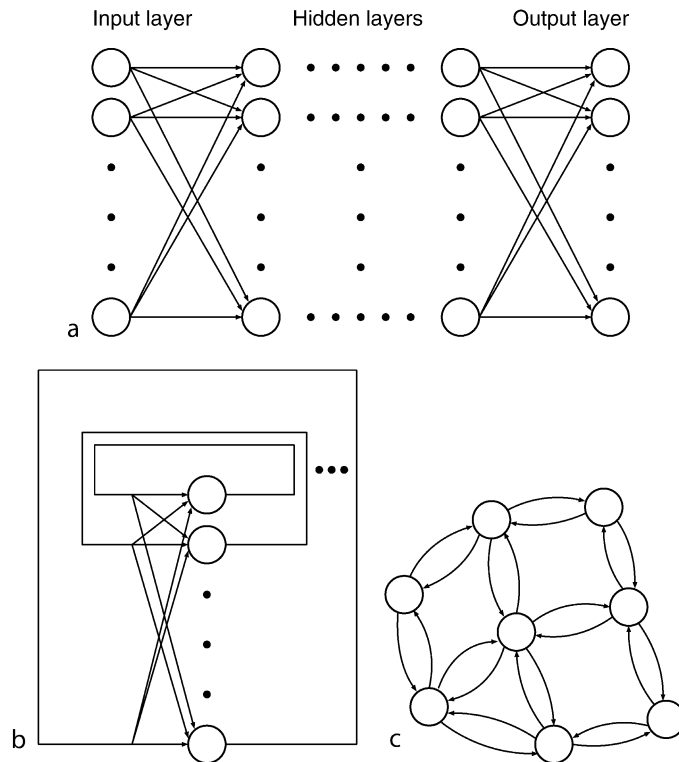

**Neural Networks. Figure 1** Network architectures: (a) feedforward networks and (b) feedback networks which are equivalent to (c) networks composed of mutually connected neurons. Each circle represents a neuron.

into supervised and unsupervised learning, respectively, with and without teaching signals. Examples of the former are perceptron [2] and back-propagation learning [3] in feedforward networks, while a typical example of the latter is the Hebbian learning. The beauty of learning in neural networks is its generalization property; acquisition of desired responses to a training data set in feedforward networks can result in correct responses to a new data set. Therefore, unlike conventional software programming, we do not need to figure out the rules and logics behind a given problem, but simply provide examples of correct responses to the networks with respect to input signals.

The learning algorithm in feedforward networks can be roughly categorized into two. One is that the network receives a target vector signal, that is, desired output values of the output layer like the perceptron and the back-propagation learning. Another is reinforcement-learning-based algorithm that assumes only a scalar “reward” signal that tells how much good or bad the present output is, like forward-propagation learning [4].

### Perceptron

The perceptron is a multilayer feedforward neural network where changes in synaptic weight take place only at the final output layer [2]. It is a type of

supervised learning where a target vector is provided to the final layer as teaching signals.

Let us consider the following two-layer network only with input and output layers for the sake of simplicity:

$$z_i = 1 \left( \sum_j w_{ij} a_j \right),$$

where  $z_i$  denotes the output of neuron  $i$  in the output layer,  $a_j$  input  $j$  in the input layer with  $a_j = 0$  (nonfiring) or 1 (firing),  $w_{ij}$  the synaptic weight from input  $j$  to neuron  $i$ , and function  $1(\bullet)$  is the Heaviside output function with  $1(u) = 1$  for  $u \geq 0$  and  $1(u) = 0$  for  $u < 0$ . We omitted the neuronal threshold, since the threshold can be represented as the synaptic weight from a constantly firing input unit.

The update rule of synaptic weights is given as

$$\Delta w_{ij} = \eta(\delta_i - z_i)a_j,$$

where  $\delta_i$  denotes the desired output of neuron  $i$  and  $\eta$  the learning coefficient. The synaptic weight is changed in the direction to decrease the difference between  $z_i$  and  $\delta_i$ , whenever the outputs do not match the target vector. The perceptron learning has been mathematically proven to realize appropriate values of synaptic weights under a condition that a set of input patterns are linearly separable.

### Back-propagation Learning

Back propagation is a learning rule that updates synaptic weights in hidden layers together with the output layer, provided a target vector [3]. Learning ability is much higher than the perceptron, and many practical problems that are nonlinearly separable can be solved with a moderate number of hidden layer neurons.

For simplicity, we assume a three-layer network with a single hidden layer as follows:

$$z_i = f\left(\sum_j s_{ij}x_j\right),$$

$$x_j = f\left(\sum_k w_{jk}a_k\right),$$

whereas  $x_j$  denotes the output of neuron  $j$  in the hidden layer,  $f$  is a continuously differentiable output function like the sigmoid function  $f(u) = 1/\{1 + \exp(-u/\varepsilon)\}$  with the steepness parameter  $\varepsilon$ ,  $s_{ij}$  the synaptic weight to output neuron  $i$  from hidden layer neuron  $j$ , and  $w_{jk}$  that to hidden neuron  $j$  from input  $k$ .

To derive the update rules of synaptic weights in each layer [3], we define an error function  $E$  as follows:

$$E = 1/2 \sum_i (\delta_i - z_i)^2,$$

which is the sum of squared errors at the output layer.

Here, the synaptic changes in the final layer are implemented as the gradient descent of the error function

$$\Delta s_{ij} = -\eta \frac{\partial E}{\partial s_{ij}}.$$

Defining the learning signal  $r_i$  as

$$r_i = (\delta_i - z_i) f' \left( \sum_j s_{ij} x_j \right),$$

the learning rule becomes as follows:

$$\Delta s_{ij} = \eta r_i x_j.$$

Likewise, necessary synaptic change in the hidden layer to decrease the error at the output layer is derived as follows:

$$\Delta w_{jk} = -\eta \frac{\partial E}{\partial w_{jk}}$$

$$= \eta \tilde{r}_j a_k,$$

where

$$\tilde{r}_j = \left( \sum_i r_i s_{ij} \right) f' \left( \sum_m w_{jm} a_m \right).$$

The term ‘‘back propagation’’ originates from the interesting behavior that learning signals in the output layer seem to propagate backward through synaptic weights  $S_{kj}$ ,  $S$  and become learning signals in the hidden layer. Moreover, although the back-propagation learning rule may get stuck in local minima, it has been shown that the learning rules work well in a wide variety of learning tasks.

While the back-propagation learning provides a powerful method to train multilayer neural networks, it suffers from the lack of biological plausibility. Therefore, attempts have been made to train multilayer networks using scalar reinforcement signals like dopaminergic activity [5], which only tell the networks whether the current output is good or bad. The difficulty in this approach is that the reinforcement signal is assumed to be broadcasted to the local neural circuit and hence leads to nonconvergence of learning when directly applied to feedforward network models. Recently, a method to overcome this problem, or forward-propagation learning [4] was introduced, where learning propagates from the input to the output layer under certain neuronal activity conditions that could be observed in the monkey prefrontal cortex. In short, each layer does its best to provide additional dimensions to solve the problem, eventually transforming it linearly separable with a moderate number of hidden neurons.

### Associative Memory and Nonlinear Dynamics

Next let us consider a simple feedback neural network model consisting of  $N$  mutually connected neurons where output  $x_i(t)$  of neuron  $i$  at the time step  $t$  takes 1 (firing) or 0 (resting) as follows:

$$x_i(t+1) = 1 \left( \sum_{j \neq i}^N w_{ij} x_j(t) \right),$$

$$w_{ij} = \frac{1}{N} \sum_{\mu=1}^p (2\xi_i^\mu - 1)(2\xi_j^\mu - 1),$$

where  $w_{ij}$  is the synaptic weight from neuron  $j$  to neuron  $i$ . The neuron  $i$  receives inputs from all the other neurons through  $w_{ij}$ . Stored patterns  $\xi^\mu = (\xi_1^\mu, \dots, \xi_N^\mu)$  ( $\mu = 1, \dots, p$ ) are embedded as fixed-point attractors of convergent nonlinear dynamics in the recurrent neural network through the Hebbian learning. This model is called the associative memory model. The number of patterns that can be stored as stable fixed points has a certain limit [6]. This limitation is termed storage capacity, which can be theoretically derived by the statistical mechanical methods. The basin of attraction of stored patterns in the convergent dynamics of the feedback networks means error-correcting ability of the associative memory model. It is known that there exist stable fixed points, the number of which increases

exponentially with  $N$ , besides the stored memory patterns. These are called spurious memory patterns. We can not distinguish the stored patterns and the spurious ones without the information of the memory patterns themselves, since both of them are fixed point attractors of convergent dynamics in the feedback networks of the associative memory.

### Chaotic Neural Networks

Neuron models with chaotic dynamics are called chaotic neurons [7]. A discrete-time chaotic neuron model consists of the following terms: the internal states of the external inputs, the feedback inputs, and the relative refractoriness, where the refractoriness means the property of a biological neuron that the firing threshold increases for a certain period after firing. Essential features of the model to exhibit chaotic responses are that all the internal states show exponential decay and the output function of the neuron is continuous like a sigmoid function [7]. Neural network models that are composed of chaotic neurons are called chaotic neural networks. The dynamics of constituent neuron  $i$  in the chaotic neural network is represented by the following equations [8]:

$$\xi_i(t+1) = \sum_{j=1}^M v_{ij} \sum_{d=0}^t k_e^d A_j(t-d),$$

$$\eta_i(t+1) = \sum_{j=1}^M w_{ij} \sum_{d=0}^t k_f^d x_j(t-d),$$

$$\zeta_i(t+1) = -\alpha \sum_{d=0}^t k_r^d x_i(t-d) - \theta_i,$$

$$x_i(t+1) = f(\xi_i(t+1) + \eta_i(t+1) + \zeta_i(t+1))$$

$\xi_i$ ,  $\eta_i$ , and  $\zeta_i$  are internal state terms,  $k_e$ ,  $k_f$ , and  $k_r$  are the decay parameters for external inputs, feedback inputs from the neurons in the network, and refractoriness of neuron  $i$ , respectively.  $x_i$  and  $f$  denote the output of neuron  $i$  and the output function that is usually a sigmoid function, respectively.  $A_j$  and  $\theta_i$  are external input  $j$  and the threshold of neuron  $i$ , respectively.  $v_{ij}$  and  $w_{ij}$  denote synaptic weight to neuron  $i$  from external input  $j$  and synaptic weight to neuron  $i$  from neuron  $j$ , respectively.  $M$  and  $N$  are the number of the external inputs to neuron  $i$  and that of the neurons in the network, respectively.

The model of the chaotic neural networks is applied to associative memory networks and combinatorial optimization networks with chaotic dynamics beyond convergent dynamics of conventional models. An example of recalling behavior of dynamically associative memory in a chaotic neural network [8] is shown in Fig. 2.

In this example, 100 chaotic neurons are interconnected with synaptic weights to store four patterns in Fig. 2a. The filled and open squares in each pattern represent 1 (firing) and 0 (resting) in the neuronal output  $x_i$ , respectively. As shown in Fig. 2b, the process of recalling the stored patterns is neither convergent to a fixed point of a stored pattern nor periodic even if the synaptic connection weights among constituent neurons in the network are determined by the Hebbian learning with the stored patterns like the conventional associative memory. Such aperiodic recalling of the stored patterns is caused by the characteristics of the constituent neurons that can exhibit chaotic dynamics as a single neuron.

### Synchronization of Neurons and its Modeling with Coupled Phase Oscillators

A visual object is processed in parallel at different visual areas of the brain. Each visual area extracts such specific visual features as orientation, brightness, color, and motion. To recognize the visual object as a whole, these features should be bounded. This is called the binding problem. One hypothesis of the feature binding mechanism is synchronization of neurons in the different visual areas. Some physiological experiments support the synchronization hypothesis. The coupled phase oscillator system is one of the simplest models, which captures essential properties of a general class of nonlinear oscillator systems [9]. Let us consider the following system of two phase oscillators,

$$\frac{d\phi_1}{dt} = \omega_1 + \Gamma(\phi_2 - \phi_1) + \xi_1,$$

$$\frac{d\phi_2}{dt} = \omega_2 + \Gamma(\phi_1 - \phi_2) + \xi_2,$$

where  $\theta_i \in [0, 2\pi)$  and  $\omega_i$  denote the phase of a periodic oscillation and its natural frequency for oscillator  $i$ , and  $\xi_i$  is additive noise. The function of the phase response curve (RPC)  $\Gamma(\cdot)$ , which is periodic with the period  $2\pi$  represents the interaction between the two oscillators. Here,  $\Gamma(\cdot)$  is assumed to be an odd function. In the case without the additive noise, the dynamics of the phase difference  $\Delta\theta$  with  $\Delta\theta = \theta_2 - \theta_1$  is described by the following equation,

$$\frac{d\Delta\phi}{dt} = \Delta\omega - 2\Gamma(\Delta\phi),$$

$$\Delta\omega = \omega_2 - \omega_1.$$

The synchronization of the two oscillators occurs under the equilibrium condition that  $\Delta\omega = 2\Gamma(\Delta\theta)$ , while they desynchronize otherwise [9,10]. The stochastic synchronization emerges even in the case that the frequency mismatch  $\Delta\omega$  is large enough to be

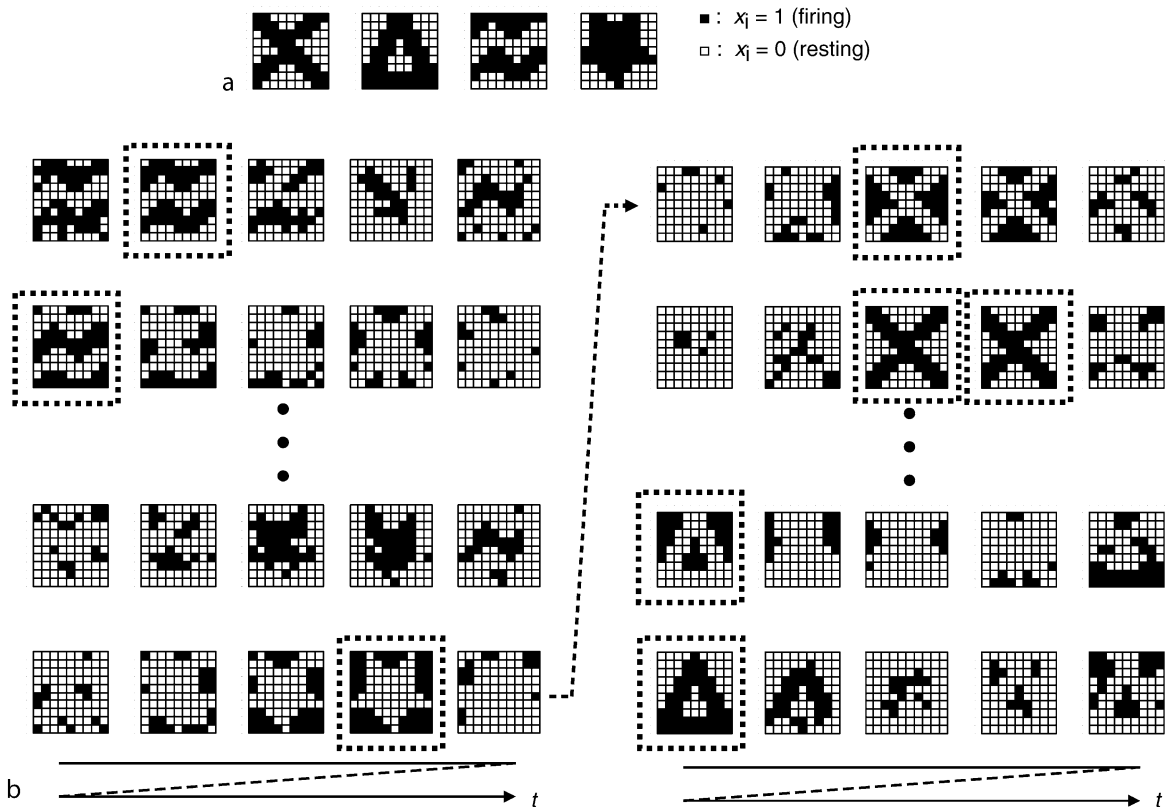

**Neural Networks. Figure 2** Associative memory in a chaotic neural network. (a) Stored patterns of the dynamically associative memory [8]. (b) Example of the recalling pattern sequence of the dynamically associative memory in a chaotic neural network.

$\Delta\omega \neq 2\Gamma(\Delta\theta)$  for any  $\Delta\theta$  if the noise has appropriate characteristics. Thus, interaction between nonlinear dynamics and noise is an important problem.

## References

- McCulloch WS, Pitts WH (1943) A logical calculus of the ideas immanent in neural nets. *Bull Math Biophys* 5:115–133
- Rosenblatt F (1961) *Principles of neurodynamics*. Spartan, Washington, DC
- Rumelhart DE, McClelland JL PDP Research Group (1986) *Parallel distributed processing*, vols 1/2, MIT Press, Cambridge
- Watanabe M, Masuda T, Aihara K (2003) Forward propagating reinforcement learning: biologically plausible learning method for multi-layer networks. *Biosystems* 71:213–220
- Waelti P, Dickinson A, Schultz W (2001) Dopamine responses comply with basic assumptions of formal learning theory. *Nature* 412:43–48
- Okada M (1996) Notions of associative memory and sparse coding. *Neural Netw* 9:1429–1458
- Aihara K, Takabe T, Toyoda M (1990) Chaotic neural networks. *Phys Lett A* 144:333–340
- Adachi M, Aihara K (1997) Associative dynamics in a chaotic neural network. *Neural Netw* 10:83–98
- Kuramoto Y (1984) *Chemical oscillations, waves, and turbulence*. Springer-Verlag, Berlin
- Pikovsky A, Rosenblum M, Kurths J (2001) *Synchronization*. Cambridge University Press, Cambridge

## Neural Networks for Control

URI ROKNI

Center for Brain Science and Swartz Center for Computational Neuroscience, Harvard, Cambridge, MA, USA

### Definition

In this essay we deal with **neural networks** which interact with the external environment, referred as a **plant**, in order to achieve a specified goal (Fig. 1). The network receives goal related inputs and sensory inputs from the plant, and in response influences the plant by activating **effectors**. At any given time, the state of the plant is fully specified by a set of variables termed the **state variables**. The dynamics of the plant is described

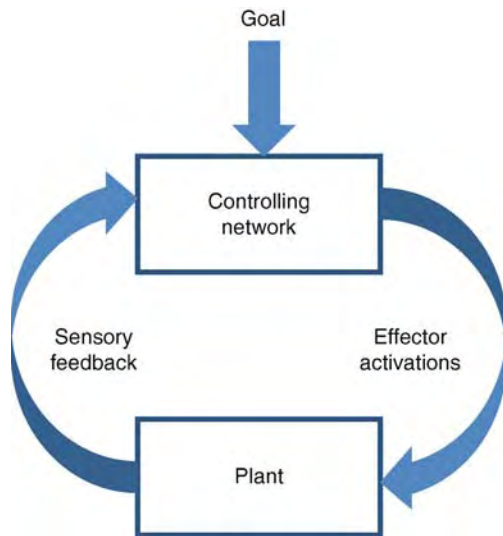

**Neural Networks for Control. Figure 1** A controlling network. The network interacts with the external environment, referred as the plant, to achieve a desired goal.

by equations of motion which dictate how the state changes as a function of the current state and the current activation of the effectors. The goal may be to reach a desired state, or more generally to minimize a specified **►cost function**. Generally, a device which solves such problems is referred as a **►controller**. In this essay we are concerned specifically with the implementation of controllers by neural networks in the **►central nervous system (CNS)**.

### Description of the Theory

**►The reaching example.** Consider the problem of arm reaching to a specified target. The plant is the arm and the effectors are the arm muscles. The arm state variables are the joint angles and joint velocities. The equations of motion of the arm specify the joint angle accelerations as a function of the arm state and muscle activations. To reach the target, the controller needs to convert goal related inputs, which represent the target position, and sensory information on the arm state into the appropriate muscle activations.

### The Operation of Controllers

Controllers which do not use online sensory feedback from the plant are referred as **►feedforward (open-loop) controllers** (Fig. 2). Feedforward controllers are often termed **►inverse models** of the plant, because they map the desired outcome of the plant to effector activations, inversely to how the plant maps the effector activations to the actual outcome. For example, the arm plant maps muscle activations into hand acceleration. To properly control the arm, a feedforward controller needs to invert this relation and map the desired hand

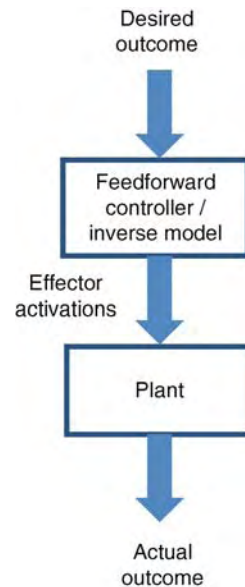

**Neural Networks for Control. Figure 2** A feedforward controller. The feedforward controller does not use sensory feedback. It maps the desired outcome to effector activations, inversely to the mapping from effector activations to actual outcome performed by the plant.

acceleration to the appropriate muscle activations. Feedforward controllers may be inaccurate because of noise in the plant, or because they do not invert the plant dynamics accurately. In these cases, online sensory feedback to the controller may improve its performance. Controllers which use online sensory feedback are referred as **►feedback (closed-loop) controllers**.

Usually, in order to control the plant effectively at any given time, the controller needs to know the plant state, at least implicitly. Therefore, the operation of a controller can be divided into: (i) estimating the plant state, and (ii) mapping the estimated plant state and goal related inputs to effector activations (Fig. 3).

To estimate the plant state at a given time the system may rely on: a previous estimate of the plant state, current sensory feedback, knowledge about the plant dynamics and copies of the current effector activations (referred as **►efferent copies**). A module which estimates the plant state from the efferent copies is known as a **►forward model**, because it models the plant dynamics in the normal flow from effector activations to plant state. Typically, the different sources of information on the plant state are noisy. For accurate **►state estimation**, the system needs to combine these different sources optimally, giving more weight to the more reliable sources of information. An optimal state estimator is known as a **►Bayesian filter**. Commonly, engineers approximate the plant dynamics by linear dynamics, and the noise by Gaussian noise. In these



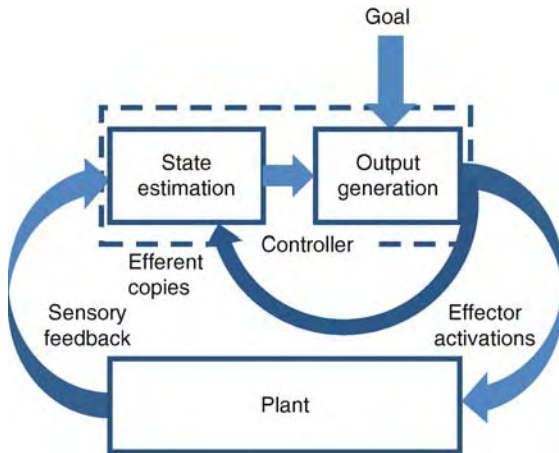

**Neural Networks for Control. Figure 3** The control problem is decomposed into two problems. First, estimate the plant state from the sensory feedback and efferent copies of the effector activations. Second, map the estimated plant state and the goal to effector activations.

cases, there is a closed form solution of the Bayesian filter, known as a [Kalman filter](#).

The problem of generating the appropriate effector activations given the current plant state may be straightforward when the effector activations can set the plant in its desired state, immediately. But typically, the plant responds gradually and the controller needs to generate the current effector activations that are best *in the long term*. For example, at the beginning of reaching, activating the arm muscles strongly may bring the arm closer to its target at first, but later cause the arm to overshoot. To reach optimally, the controller needs to take into account the future effects of the current effector activations. This problem has been extensively studied in the field of [optimal control theory](#).

### Computing and Learning with Neural Networks

Neurons are believed to be the basic computational elements in the CNS. A neuron integrates action potentials from different cells, performs temporal filtering and transmits the result to other neurons in the form of action potentials. By combining neurons into networks much more complicated computations can be carried out. Networks that are arranged in layers of neurons, each layer projecting to the next, are known as [feedforward networks](#) (Fig. 4a). Inputs traveling through several layers of neurons may undergo complicated nonlinear transformations. Networks with connections that allow activity to travel in loops are known as [recurrent networks](#) (Fig. 4b). Inputs traveling through multiple loops in the network may undergo complicated temporal filtering.

To learn a desired input-output relation the strengths of the synaptic connections between neurons need to be

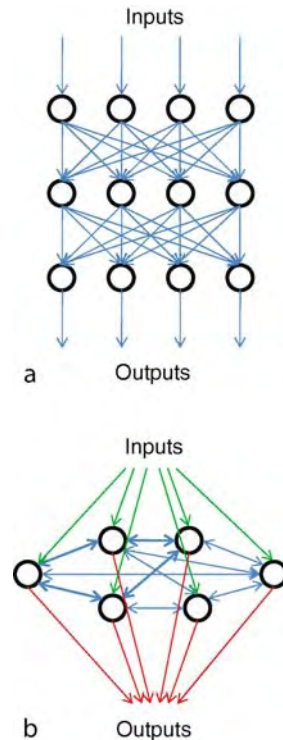

**Neural Networks for Control. Figure 4** Feedforward versus recurrent networks. (a) Feedforward networks are arranged in layers without loops in their connections. (b) Recurrent networks contain loops in their connections.

tuned. Training data may consist of pairs of inputs and desired outputs. A rule that specifies how synaptic strengths are changed, given the training data, is generally referred to as a [learning rule](#). A successful learning rule should decrease the output errors of the network (at least on average), so that after repeated applications of the rule the network performance improves. The [back-propagation](#) learning rule achieves this for feedforward networks by propagating measured output errors back through the network layers to obtain errors of the synaptic strengths. The back-propagation learning rule has been generalized for tuning the synaptic strengths of recurrent networks as well (for a review of neural network theory see [1]).

### Control with Neural Networks

The CNS is believed to implement controllers by networks of neurons. In particular, it has been suggested that controllers are implemented by networks that are feedforward, except for recurrent projections from the output layer back to the input layer [2,3, fig. 5]. Static goal related inputs to the network travel through the layers to produce the effector activations. Efferent copies of these muscle activations are fed back to the input layer, thus affecting the effector activations at the

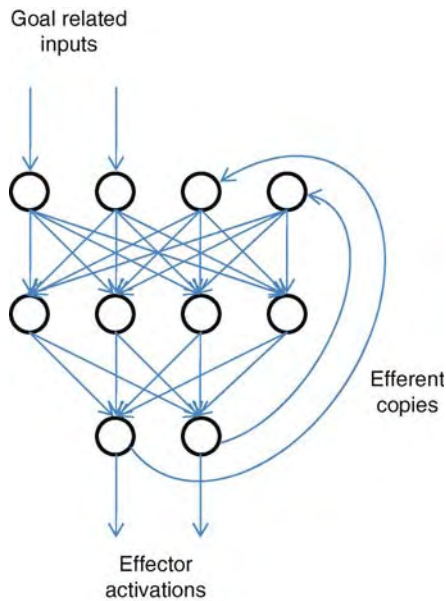

**Neural Networks for Control. Figure 5** A sequence generating network. By sending efferent copies back to the input layer the network generates a sequence of effector activations. The network may be used as a feed forward controller.

next time step. In this fashion, the network implements a feedforward controller that maps static goal related inputs to a sequence of effector activations. This approach was generalized to feedback control by adding delayed sensory feedback to the network, and assuming the network is fully recurrent [4].

An alternative model asserts that prior to movement the entire trajectory of the effector activations is represented by static neural activity, where different neuron populations represent the planned effector activations at different times [5]. Recurrent network dynamics are used to find a trajectory that obeys task constraints, e.g. reaching the target, and minimizes a smoothness cost function. To execute the movement, the static representation of the planned trajectory is converted to effector activations that unfold in time.

Another study proposes how the CNS may estimate the plant state [6]. This study implements a Kalman filter for estimating the state of a linear arm model with Gaussian noise, by a recurrent neural network. The activity of the population of neurons in the network represents the current estimate of the arm state. This state estimate is modified by external inputs which convey sensory information on the plant state. The state estimate is also affected by the previous state estimate via the recurrent network connections. Thus, the recurrent connections encode knowledge of the arm dynamics. When simulating the network dynamics its activity estimated the plant state nearly optimally.

### Learning Neural Networks for Control

When the CNS encounters an unknown environment (e.g. new loads applied to the arm) it needs to adjust the controlling network. This adjustment is believed to occur by changing synaptic connections between neurons. To implement conventional network learning algorithms, such as back-propagation, the CNS needs to provide the output errors of the network. However, in control problems rather than being provided with the output errors of the network it is provided with the output errors of the plant. Not knowing the plant, which is the problem to begin with, how can the network translate the plant errors into network errors?

The **direct inverse learning** approach solves this problem by obtaining training data from the plant when it is randomly activated [7]. Each input-output pair of the plant is provided to the network *inversely*, as desired output-input, respectively. By training the network with this data it learns the inverse model of the plant. This method suffers from several problems. First, it learns offline. Second, the plant may be non-invertible, meaning that different plant inputs generate the same output. Thus, for a given input (plant output) the network may learn the mean of multiple desired outputs (plant inputs). Generally, this mean will not be either of the correct network outputs (plant inputs). Finally, direct inverse learning minimizes the error in the plant *inputs*, which may not be optimal for minimizing the error in the plant *outputs*.

These problems are solved by an alternative method, known as **distal supervised learning**, which learns the inverse model in tandem with a forward model [8, fig. 6]. During operation of the system, the forward model is trained to imitate the plant by providing the plant input-output pairs as training data. At the same time, the plant errors are back-propagated through the forward model to obtain the output errors of the inverse model. These error signals are used to train the inverse model.

Another approach for learning an inverse model, known as **feedback error learning**, assumes a sensory feedback loop in parallel with the inverse model [9, fig. 7]. The same feedback loop that is used for control, is also used as an error signal for training the inverse model. This approach requires a stable sensory feedback loop to begin with, and leaves open the question of how the feedback loop is learned.

Finally, a different approach, known as **reinforcement learning**, uses noise in the controlling network and a **scalar** performance measure known as the **reward signal** [10]. By correlating the noise with the reward signal, the reinforcement learning rule changes synaptic weights such that outputs that yield greater reward become more likely. Over time the average reward increases to its maximum. Reinforcement learning does

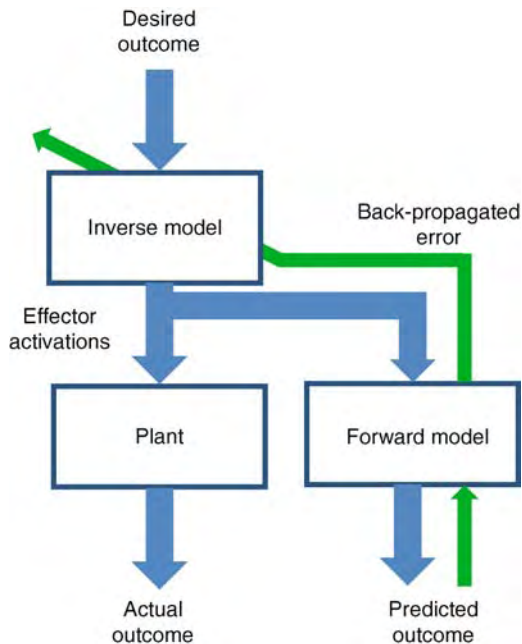

**Neural Networks for Control. Figure 6** Distal learning. A network which unites the plant, referred as a forward model, is learned. At the same time, the errors in the plant output are backpropagated through the forward model network to obtain the errors of the inverse model (green arrow). These errors are used to train the network of the inverse model.

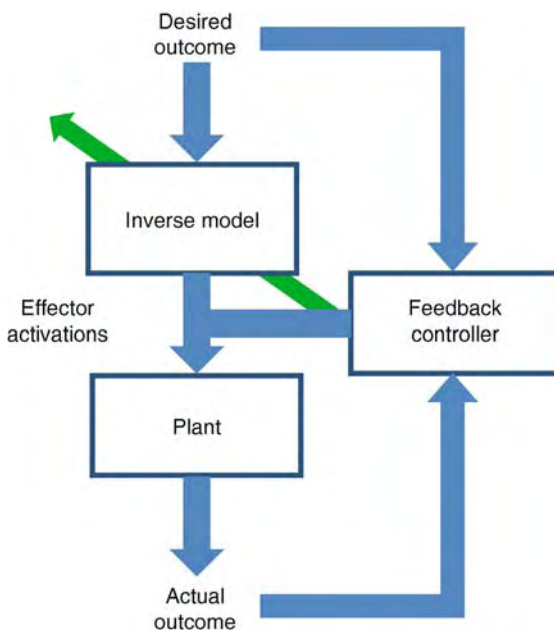

**Neural Networks for Control. Figure 7** Error feedback learning. The same sensory feedback that is used for controlling the plant is also used for training the inverse model (green arrow).

not rely on back-propagation of errors. But, it is slower than other methods because it requires averaging over noise and because it uses a scalar performance measure, which is less informative than a **vector** of output errors.

## References

1. Hertz J, Krogh A, Palmer G (1991) Introduction to the theory of neural computation. Perseus books, Reading, MA
2. Massone L, Bizzi E (1989) A neural network model for limb trajectory formation. *Biol Cybern* 61(6):417–425
3. Jordan MI (1986) Attractor dynamics and parallelism in a connectionist sequential machine. In proceedings of the eighth annual conference of the cognitive science society. Erlbaum, Hillsdale, NJ
4. Joshi P, Maass W (2005) Movement generation with circuits of spiking neurons. *Neural Comput* 17(8): 1715–1738
5. Kawato M, Maeda Y, Uno Y, Suzuki R (1990) Trajectory formation of arm movement by cascade neural network model based on minimum torque-change criterion. *Biol Cybern* 62(4):275–288
6. Denève S, Duhamel JR, Pouget A (2007) Optimal sensorimotor integration in recurrent cortical networks: a neural implementation of kalman filters. *J Neurosci* 27 (21):5744–5756
7. Kuperstein M (1988) Neural model of adaptive hand-eye coordination for single postures. *Science* 239 (4845):1308–1311
8. Jordan MI, Rumelhart DE (1992) Forward models: supervised learning with a distal teacher. *Cognitive Science* 16:307–354
9. Miyamoto H, Kawato M, Setoyama T, Suzuki R (1988) Feedback-error-learning neural network for trajectory control of a robotic manipulator. *Neural Netw* 1(3): 251–265
10. Seung HS (2003) Learning in spiking neural networks by reinforcement of stochastic synaptic transmission. *Neuron* 40(6):1063–1073

---

## Neural Oscillator

► Central Pattern Generator

---

## Neural Pattern Generator

► Central Pattern Generator

## Neural Progenitors/Radial Glia

### Definition

Generic terms for immature or neural stem cells that can differentiate into a number of neural cell types (different types of neurons, astrocytes, oligodendrocytes).

► Evolution of the Posterior Tuberculum and Preglomerular Nuclear Complex

## Neural Regulation of the Pupil

PETER G. SMITH

Department of Molecular and Integrative Physiology and Kansas Intellectual and Developmental Disabilities Research Center, University of Kansas Medical Center, Kansas City, KS, USA

### Definition

The pupil is an aperture formed by the margins of the iris. Pupillary diameter determines the amount of light traversing the lens to focus on the retina, producing a visual image. The primary factor determining pupil diameter is the concentration of autonomic transmitters at contractile cells of the iris. This is regulated by the ► **sympathoadrenal** and parasympathetic nervous systems.

### Characteristics

#### Quantitative Description

Pupillary diameter is determined by the relative tone of two opposing contractile elements within the iris. The pupillary sphincter (constrictor) muscle abuts the margin of the pupil. It consists of smooth muscle fibers with their long axes oriented circumferentially with respect to the pupil (Fig. 1).

When these cells contract, the pupil margins are drawn closer together, causing a decrease in pupil diameter (constriction, or ► **miosis**).

The iris contains a second contractile component, the pupil dilator (radial) muscle. This structure is composed of myoepithelial cells oriented radially, with their long axes directed outward from the pupil center as if spokes in a wheel (Fig. 1). When they contract, the pupil margins are drawn away from the center, increasing pupil diameter (dilation, or ► **mydriasis**).

Pupil diameter of is thus determined by the relative activity, or tone, of these two opposing muscles.

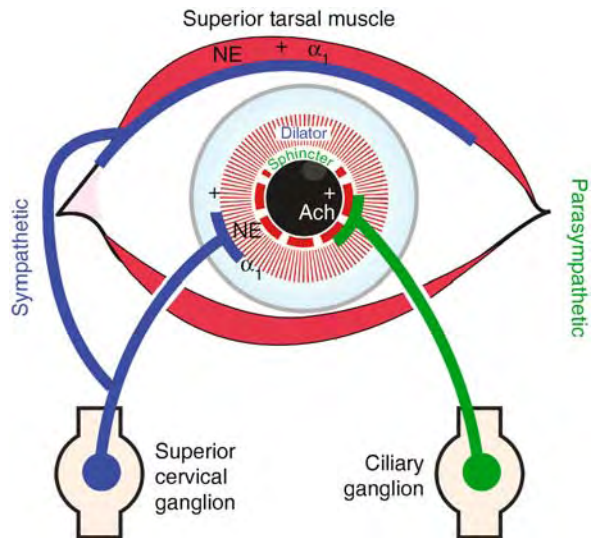

**Neural Regulation of the Pupil.** Figure 1 Schematic diagram of the innervation of the iris and related structures. The iris sphincter (constrictor) muscle contains smooth muscle cells oriented circumferentially. It is innervated by parasympathetic excitatory (+) nerves from the ciliary ganglion, which release acetylcholine (ACh). The dilator (radial) muscle consists of myoepithelial cells oriented radially. This muscle, as well as the superior and inferior tarsal muscles of the eyelids, is innervated by excitatory (+) sympathetic nerves which release norepinephrine (NE) that act on alpha-1 adrenergic receptors.

### Higher Level Structures

Regulation of pupil diameter involves integration of afferent information transmitted by the optic nerve to diencephalic processing structures, as well as emotive pathways incorporating fear, anxiety, pleasure and pain.

**Constrictor pathways.** Light elicits pupil constriction by way of a subcortical reflex initiated by light passing through the anterior eye and impinging upon photoreceptor cells of the retina. Photoreceptive impulses travel along retinal ganglion cell axons in the optic nerve, which hemi-decussate at the optic chiasm, and travel to the superior colliculus to enter the pretectal nucleus where they synapse on pretectal neurons (Fig. 2).

These neurons send projections to the ipsilateral and contralateral Edinger–Westphal nucleus [1]. This nucleus contains preganglionic parasympathetic neurons, which send axons in cranial nerve III (oculomotor) to postganglionic neurons of the ciliary ganglion, whose axons travel in the short ciliary nerves to innervate the sphincter muscle of the iris (Fig. 2).

Pupillary constriction is also elicited in association with accommodation, which occurs when viewing near objects. Photoreceptive impulses conducted to the visual cortex activate efferent projections to the

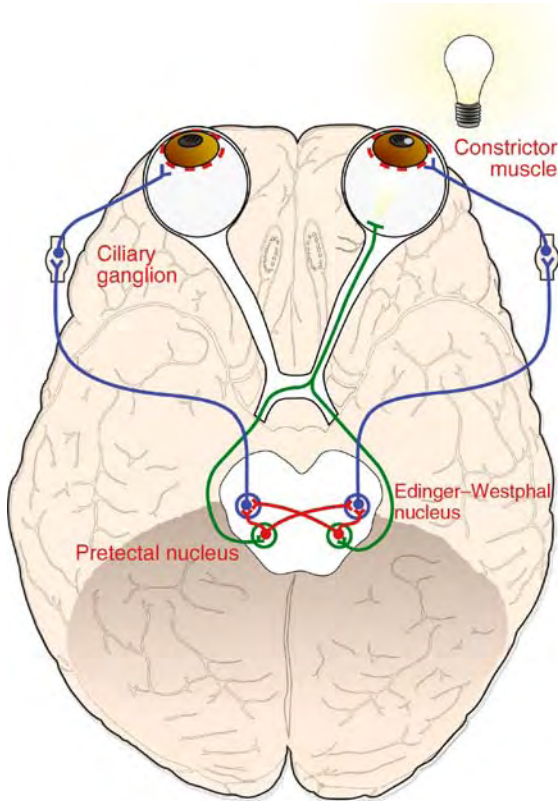

### Neural Regulation of the Pupil. Figure 2

Parasympathetic light reflex pathway. When the eye is illuminated, retinal ganglion neurons projecting axons (green) to midbrain excite pretectal neurons (red). Pretectal neurons project excitatory synapses to the ipsilateral and contralateral Edinger–Westphal nucleus, which contains parasympathetic preganglionic neurons (blue). These neurons provide excitatory innervation to postganglionic neurons in the ciliary ganglion, which innervate the pupillary constrictor (sphincter) muscles in each eye, where they elicit pupil constriction.

Edinger–Westphal nucleus, which activate oculomotor nerve pathways to the iris constrictor muscle (Fig. 3).

Dilator pathways. Central nervous system pathways mediating pupil dilation are complex and less well defined. Generally, factors leading to sympathoadrenal activation cause pupil dilation. The hypothalamus serves as a central integrative center for pupil dilation [1]. Structures that influence hypothalamic output include inputs from cognitive centers (prefrontal cortex), limbic system including the amygdala, sensory pathways involved in pain perception, and sensory pathways involved in homeostatic regulation such as blood chemical composition (glucose, oxygen, carbon dioxide, pH) and blood pressure. Hypothalamic neurons project to neurons in the lateral medulla, which innervate ipsilateral spinal cord intermediolateral neurons (ciliospinal center of Budge). Axons from these preganglionic

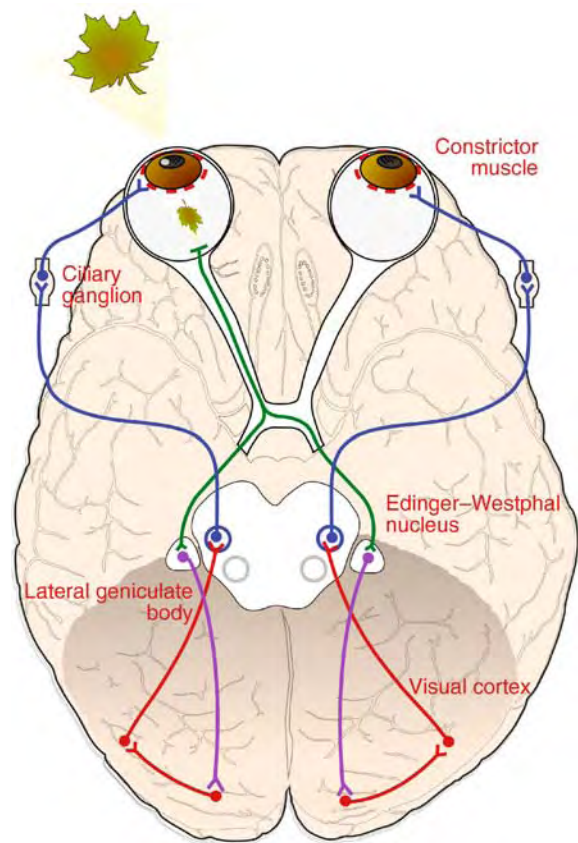

**Neural Regulation of the Pupil. Figure 3** Pupillary constriction associated with accommodation. When an object is placed close to the eye for near vision, retinal ganglion axons (green) excite neurons bilaterally in the lateral geniculate body (purple), which project to the visual cortex and associated structures. Descending pathways provide excitatory innervation ipsilaterally to neurons in the Edinger–Westphal nucleus (blue), which excite postganglionic neurons in the ciliary ganglion to elicit constrictor muscle contraction and pupil constriction.

neurons exit at C8–T2 and ascend proximate to the carotid artery to the superior cervical ganglion. Postganglionic axons travel in the internal carotid nerve and enter the orbit with the ophthalmic division of the trigeminal nerve. Sympathetic fibers travel in the nasociliary branch of the trigeminal nerve ophthalmic division and long ciliary nerves to innervate the iris dilator muscle (Fig. 4).

### Higher Level Processes

Constrictor pathway. The primary stimulus activating parasympathetic pathways is photoreceptive input. The pupillary light reflex is responsive to the intensity of ambient light impinging on retinal rods and cones, as well as melanopsin-expressing retinal ganglion cells that are directly photosensitive [2]. Increasing photointensity produces graded activation of axons projecting to the

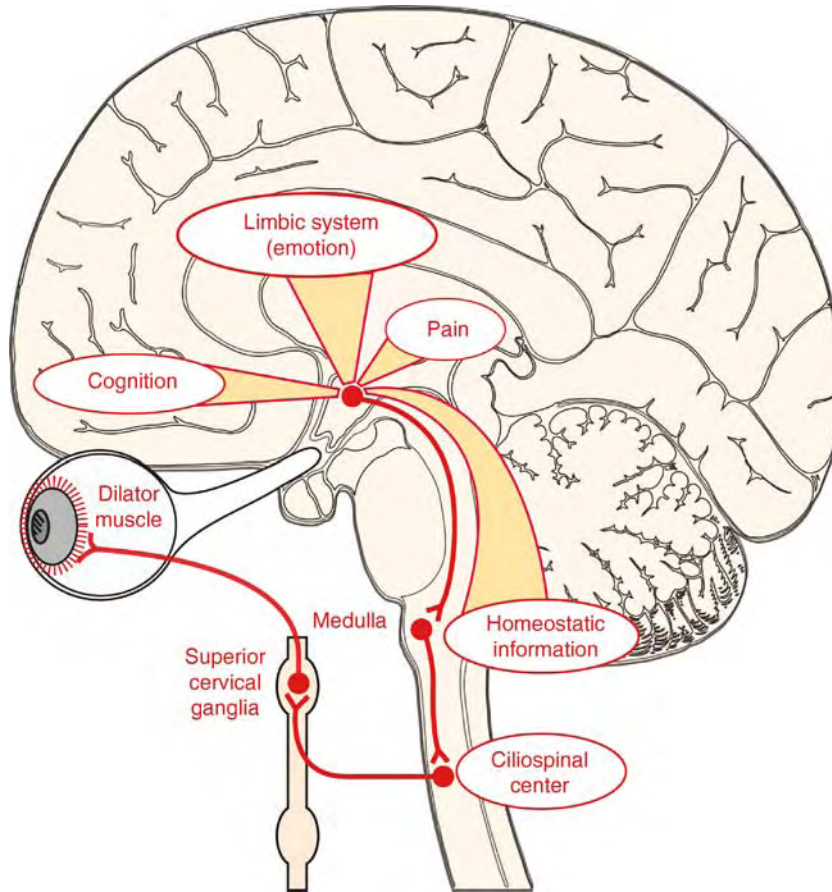

**Neural Regulation of the Pupil. Figure 4** Sympathetic pathways mediating pupil dilation. Neurons in the paraventricular region of the hypothalamus receive input from multiple pathways encoding cognitive information from the cortex, emotion from the limbic system, pain from somatosensory pathways, and homeostatic information concerning blood pressure and composition from ascending pathways. Hypothalamic neurons project to neurons in the medulla, which send axons to the ciliospinal center of the intermediolateral column of the spinal cord. Preganglionic ciliospinal neurons project axons through the ventral roots, which ascend with the paravertebral chain to synapse upon postganglionic sympathetic neurons of the superior cervical ganglion. Postganglionic axons traverse intracranially to enter the orbit and innervate the dilator (radial) muscle of the eye.

pretectal and Edinger–Westphal nuclei, which elicits graded firing of oculomotor neurons bilaterally. The net result is pupillary constriction corresponding roughly to light intensity.

Pupil constriction also occurs when the eye focuses on a near object. A coordinated triad of responses is initiated, involving bilateral ocular convergence, ciliary muscle contraction leading to a more spherical lens with greater refractive index, and pupil constriction. In contrast to the light reflex, accommodation involves higher visual cortical structures associated with near object focality, activating efferent preganglionic motor neurons of the Edinger–Westphal nucleus.

While light intensity and accommodation are major factors eliciting pupil constriction, it is noteworthy that somatic input can also influence this pathway. For example, lingual nerve stimulation can actually inhibit

preganglionic activity, thus attenuating pupillary constriction [3].

**Dilator pathways.** Activation of the pupillary dilator pathway is closely linked to sympathoadrenal tone. The sympathetic nervous system in conjunction with the adrenal medulla is activated when the organism enters into a “fight or flight” response. This occurs when a challenge is perceived – as innocuous as mental arithmetic or as threatening as being confronted by a bear. Visual information recognized as threatening is conveyed via the thalamus to the amygdala and on to the hypothalamus, where descending pathways lead to sympathetic activation and adrenomedullary catecholamine release, leading to a number of responses including pupillary dilator muscle contraction. This response can be further modified by visual information from the sensory and prefrontal cortex, which can alter

amygdala output by reinforcement or inhibition. Conditions producing mild or intense anxiety, mental concentration, or sexual arousal can also lead to pupil dilation through similar pathways.

Other types of sensory stimuli promote pupil dilation. Loud noises can lead to startle and result in dilation. In particular, mild to intense pain activates the sympathoadrenal system and promotes pupil dilation, and olfactory inputs leading to emotive activation can influence pupil diameter. Pupillary diameter can also be influenced by baroreceptor pathways, which monitor blood pressure and elicit sympathetic nerve activation when blood pressure falls [4].

### Lower Level Processes

The iris dilator and sphincter muscles receive innervation from three ipsilateral sources: parasympathetic axons from the ciliary ganglion, sympathetic axons from the superior cervical ganglion, and sensory axons from the trigeminal ganglion.

Sensory innervation to the iris derives primarily from small diameter trigeminal ganglion neurons giving rise to C fibers, which innervate the dilator and sphincter muscles. These presumptive nociceptor axons display a peptidergic phenotype that includes immunoreactivity for substance P, calcitonin gene-related peptide, galanin and somatostatin. These sensory neurons also express a splice variant of choline acetyltransferase that is largely restricted to peripheral neurons [5]. The function of iridial sensory fibers remains unclear, but they likely provide the CNS with information on noxious stimuli and intraocular pressure, and may subserve efferent functions via postjunctional effects of peptides and possibly acetylcholine on iris smooth muscle, and prejunctional actions on co-projecting autonomic axons.

Postganglionic neurons from the ipsilateral ciliary ganglion provide parasympathetic excitatory innervation to the iris sphincter muscle. Acetylcholine from parasympathetic varicosities elicits contraction via  $M_3$  muscarinic receptors [5].

The primary neural mechanism for pupil dilation is noradrenergic sympathetic innervation of the dilator muscle. Sympathetic axons release norepinephrine within the radial muscle, which acts on excitatory alpha 1A adrenergic receptors [6].

While cholinergic effects dominate in the sphincter muscle and noradrenergic effects dominate in the dilator muscle, it should be noted that sympathetic and parasympathetic nerves co-project to both muscles [5], implying cross-talk between spatially proximate axons. Indeed, acetylcholine from parasympathetic nerves acts on sympathetic prejunctional  $M_2$  muscarinic receptors to inhibit norepinephrine release [7], indicating parasympathetic presynaptic inhibition of sympathetic neurotransmission. Sympathetic neurotransmission can be inhibited prejunctionally by other mechanisms, including

$\alpha_2$  autoreceptors and histaminergic receptors. Noradrenaline released by sympathetic nerves may elicit additional effects, including  $\beta$ -mediated sphincter muscle relaxation and inhibition of sensory neuropeptide release [8].

### Process Regulation

The contractile states of iris dilator and constrictor muscles are determined primarily by 3 factors: ambient light, near vision, and emotional state. With moderate ambient light intensity, the primary variable determining differences in pupil diameter is sympathoadrenal activation. If an individual is normotensive and not emotionally aroused, an intermediate pupil diameter is expected (somewhere in the midrange between about 2 mm minimum and 8 mm maximum). In total darkness, pupil diameter increases toward its maximum.

With increasing light, pupil constriction occurs as parasympathetic nerves release acetylcholine to contract the sphincter muscle and to inhibit release of norepinephrine from sympathetic axons innervating the dilator muscle. If only one eye is exposed to light, both ipsilateral and contralateral pupils constrict (► [consensual light reflex](#)). This occurs because midbrain pretectal fibers project to the contralateral as well as the ipsilateral Edinger–Westphal nucleus (Fig. 2). A similar mechanism occurs with near-vision in which pupil diameter is constricted directly and consensually, although this does not involve pretectal neurons (Fig. 3).

### Function

By constricting the pupil in bright light, light entering the posterior chamber is reduced, preventing excessive bleaching of rods and cones and protecting the eye from possible damage. A reduction in pupil diameter in near vision increases depth of field. As in photography where a smaller aperture provides a greater range of distances in which objects appear in focus, reduced pupil size works similarly, which is important in near vision where greater refractive index of the lens limits the depth of field.

Sympathoadrenal activation dilates the pupil, which has converse effects. In fight or flight, mydriasis serves two functions. First, under threatening conditions, it may be useful to have an enlarged pupil to gather more light and to have a larger peripheral field, making the individual more perceptive to environmental cues. Second, mydriasis occurs in conjunction with alpha adrenoceptor-mediated contraction of the superior and inferior tarsal smooth muscles of the eyelid, which increase palpebral fissure width. Together, these provide important body language cues. The individual may appear “wide-eyed” with rage, signaling a state of emotional activation. On a more subtle note, pupil diameter increases when an individual perceives another to be romantically attractive, thus providing another important cue.

## Pathology

Neurological disturbances can occur at several sites, leading to differences in diameters of the two pupils (► **anisocoria**). Loss of afferent transmission along one optic nerve results in a normal consensual pupillary light reflex when the eye with intact innervation (contralateral to the lesion) is illuminated, but diminished response (apparent dilation) when the light is alternated to the affected eye. This is referred to as the Marcus Gunn pupil.

Degenerative conditions in the central nervous system can affect the light reflex. A fairly common one in advanced syphilis is the ► **Argyll–Robertson pupil**. The affected eye fails to respond to light but the pupil constricts normally during near vision accommodation. The reason appears to be that pretectal neurons mediating the light reflex degenerate selectively in this disease. Since pretectal neurons are not involved in accommodation, that reflex is preserved.

Damage to efferent postganglionic parasympathetic axons can lead to loss of constriction in response to light and accommodation. This is referred to as Adie's pupil. It is frequently accompanied by an elevated response to cholinomimetic drugs due to parasympathetic denervation supersensitivity.

Interruption of the sympathetic pathway to the pupil results in Horner's syndrome. This consists of unilateral miosis (constrictor predominance in the absence of dilator tone), ptosis (drooping of the upper eyelid and diminished palpebral fissure width due to loss of alpha adrenergic activation of the tarsal smooth muscle), anhydrosis (loss of sympathetically mediated facial sweating), and facial flushing (loss of sympathetic vasoconstrictor tone). These symptoms are all due to interruption of sympathetic innervation to the head. Damage can occur anywhere along the pathway, including higher level first order neurons of the hypothalamus or medulla (frequently due to a stroke or tumor), second order preganglionic neurons leaving the spinal cord and traveling with the carotid artery (tumor, aneurism, trauma) or to the third order postganglionic axons (internal carotid artery dissection, viral infection). Third order lesions can be distinguished from higher order deficits by placing a drop of the hydroxyamphetamine onto the eye. This drug releases norepinephrine from intact sympathetic varicosities. If the lesion involves postganglionic axons, then hydroxyamphetamine will not cause mydriasis normally seen in the normal eye because the nerve terminals have degenerated.

## Therapy

Adie's pupil often occurs in young females and frequently resolves spontaneously. Because it often accompanies migraines or cluster headaches, it may improve with effective headache management. In Marcus Gunn pupil or Horner's syndrome where a tumor may compress

neural pathways, surgical resection or chemotherapy may reverse the deficit. In Horner's syndrome, nerve regeneration and functional restoration usually is more complete if the lesion involves only postganglionic axons. In Argyll–Robertson pupil where a diagnosis of syphilis is confirmed, patients often respond beneficially to antibiotics.

## References

1. Pickard GE, Smeraski CA, Tomlinson CC, Banfield BW, Kaufman J, Wilcox CL, Enquist LW, Sollars PJ (2002) Intravitreal injection of the attenuated pseudorabies virus PRV Bartha results in infection of the hamster suprachiasmatic nucleus only by retrograde transsynaptic transport via autonomic circuits. *J Neurosci.* 22:2701–2710
2. Hattar S, Lucas RJ, Mrosovsky N, Thompson S, Douglas RH, Hankins MW, Lem J, Biel M, Hofmann Foster RG, Yau KW (2003) Melanopsin and rod-cone photoreceptive systems account for all major accessory visual functions in mice. *Nature* 424:76–81
3. Tanaka T, Kuchiwa S, Izumi H (2005) Parasympathetic mediated pupillary dilation elicited by lingual nerve stimulation in cats. *Invest Ophthalmol Vis Sci* 46:4267–4274
4. Heymans C, Neil E (1958) Reflexogenic areas of the cardiovascular system. Little, Brown & Co, Boston
5. Yasuhara O, Aimi Y, Shibano A, Matsuo A, Bellier JP, Park M, Tooyama I, Kimura H (2004) Innervation of rat iris by trigeminal and ciliary neurons expressing pChAT, a novel splice variant of choline acetyltransferase. *J Comp Neurol* 472:232–245
6. Yu Y, Koss MC (2003) Studies of alpha-adrenoceptor antagonists on sympathetic mydriasis in rabbits. *J Ocul Pharmacol Ther* 19:255–263
7. Jumblatt JE, Hackmiller RC (1994) M<sub>2</sub>-type muscarinic receptors mediate prejunctional inhibition of norepinephrine release in the human iris-ciliary body. *Exp Eye Res* 58:175–180
8. Fuder H (1994) Functional consequences of prejunctional receptor activation or blockade in the iris. *J Ocul Pharmacol* 10:109–123

## Neural Respiratory Control During Acute Hypoxia

DIETHELM W. RICHTER, MICHAEL MÜLLER  
DFG Research Center Molecular Physiology of the Brain, Department of Neurophysiology,  
Georg-August-Universität Göttingen,  
Göttingen, Germany

## Definition

In mammals, breathing movements are driven by an oscillatory activity generated by a neuronal network located in the lower ► **brainstem**. Being exposed to



severe ►[hypoxia](#) this network shows a typical sequence of responses. This essay focuses on the molecular physiology underlying the acute hypoxic responses of this respiratory rhythm generating network (►[respiratory network](#)) without considering hypoxia-induced changes in gene regulation.

## Characteristics

### Structural and Functional Organization of the Respiratory Network

Breathing originates from respiratory movements of the chest and abdomen that are driven by rhythmic discharges of motoneurons innervating inspiratory muscles (diaphragm, external intercostal muscles) and expiratory muscles (internal intercostal muscles and abdominal muscles). The normal (eupneic) pattern of this central respiratory activity is separated into three discrete phases – inspiration, post-inspiration and expiration (Fig. 1).

The phasic activity pattern is generated by a neuronal network composed of distinct sub-populations of pre-motoneurons located within the lower brainstem (medulla oblongata). The kernel of the network is localized bilaterally in the ►[pre-Bötzinger complex](#) (►[pre-Bötzinger neurons and rhythm generation](#)) – a distinct region in the “ventral respiratory group”, in the neighboring Bötzinger complex, and – within the “dorsal respiratory group” – in the ventrolateral nucleus of the solitary tract. Another rhythmically active region is localized around the retrotrapezoid nucleus/parafacial respiratory group containing expiratory neurons (►[parafacial neurons and respiratory control](#)). In summary, several brainstem regions cooperate to generate a neural respiratory activity that controls effortless quiet breathing movements (►[eupnea](#)) (►[medullary raphe nuclei and respiratory control](#); ►[pontine control of respiration](#)). The medullary respiratory network communicates synaptically with several other vital neuronal control systems by which it essentially influences amongst others the control of vocalization, swallowing and cardiovascular regulation.

The respiratory neurons receive tonic synaptic excitation from arterial chemoreceptors (►[carotid body chemoreceptors and respiratory drive](#)) and the reticular formation that provides a basic activity level on top of which rhythmic activity is generated. An alternating volley of excitatory and inhibitory synaptic inputs then ensures a powerful membrane voltage management and vigorously controls activation or inactivation of ►[voltage-gated ion channels](#) (“synaptic voltage clamp”), thereby effectively determining a characteristic rhythmic discharge pattern [1].

Inhibitory synaptic interconnections between the respiratory neurons are vital. ►[GABA](#) and ►[glycine](#) largely control chloride ion ( $\text{Cl}^-$ ) currents that do not only terminate neuronal discharges, but also precisely define

the onset of activity, the activity pattern and the duration of discharge for the different types of respiratory neurons. Furthermore, these currents shape a smooth transition between the individual respiratory phases.

### Energy Supply of the Network

Just as other parts of our brain, the respiratory network requires a constant  $\text{O}_2$  supply to maintain normal oxidative phosphorylation. “►[Cellular respiration](#)” occurs at complex IV of the mitochondrial electron transport chain where  $\text{O}_2$  accepts 2 electrons – donated from either NADH or  $\text{FADH}_2$  – and is reduced to water. In the presence of  $\text{O}_2$ , the electron transport chain generates and maintains an inwardly directed proton gradient across the inner mitochondrial membrane, thereby supplying the driving force fueling ►[ATP](#) synthesis by the mitochondrial ATP synthase (complex V or  $\text{F}_0\text{F}_1$  ATPase). Yet, when tissue  $\text{pO}_2$  drops below 5 mm Hg the proton gradient collapses and ATP synthesis by oxidative phosphorylation ceases. Under such conditions of severe ►[hypoxia](#), only anaerobic glycolysis remains intact, which contributes no more than 1–5% of the normal ATP production. This is, however, not sufficient to ensure undisturbed neuronal function over a longer period of time.

The duration of acute hypoxia that can be tolerated varies among the different brain regions. Neurons are more vulnerable than glial cells, and among the most ►[anoxia](#)/►[ischemia](#) vulnerable neurons are hippocampal CA1 and cortical pyramidal neurons, cerebellar Purkinje neurons and medium spiny neurons of the striatum. In contrast, most of the brainstem including the respiratory network is far less vulnerable to anoxic/ischemic insults.

In neurons cultured from mouse respiratory center, mitochondria form functionally coupled, dynamically organized aggregates such as “chains” and “clusters.” Mitochondrial chains predominate in dendrites and reveal a directed movement that is arrested upon mitochondrial depolarization or blockade of mitochondrial ATP synthesis as it occurs under severe hypoxia [2]. Depolymerization of the cytoskeleton also disrupts mitochondrial chain movements and the mitochondria accumulate in the soma. The consequence of such immobilized mitochondria is that the local energy supply at energetically hot spots like dendritic synapses is no longer assured.

Impaired mitochondrial metabolism is also associated with a change in reactive oxygen species output inducing a strong modulation of the cytosolic redox status. To what degree such redox changes are involved in the hypoxic modulation of the respiratory network is as yet unclear. From the “rhythmic brainstem slice preparation” (►[respiratory network analysis: rhythmic slice](#)

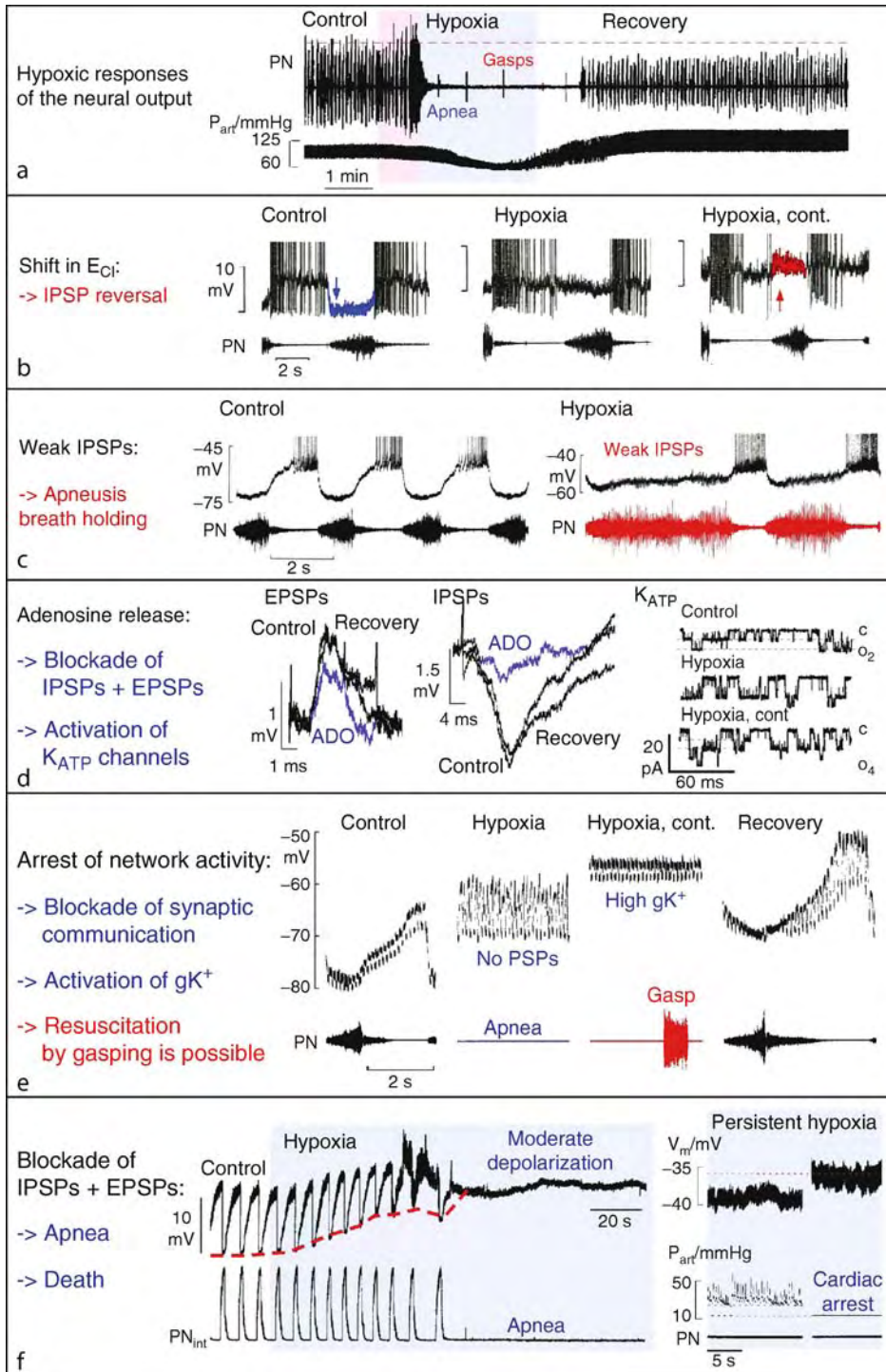

**Neural Respiratory Control During Acute Hypoxia. Figure 1** The sequence of hypoxic responses consists of 5 discrete phases. Exposed to severe hypoxia the neural output in the phrenic nerve innervating the diaphragm shows an initial, transient phase of augmentation. This turns into apneustic ( $\blacktriangleright$ Apneusis) breathing with prolonged inspiratory bursts (the neural equivalent of breath holding), proceeding into respiratory depression and protective  $\blacktriangleright$ apnea if hypoxia persists.  $\blacktriangleright$ Gasping constitutes the final attempt of auto-resuscitation. If it fails, terminal apnea and irreversible cellular damage will occur.

preparation) of neonatal rats we know, however, that redox changes modulate rhythmic activity. A reducing shift causes an augmentation, while an oxidative shift leads to a depression of inspiratory activity.

### Hypoxic Changes in Ionic Homeostasis

Most energy is consumed by ATP-driven pumps that maintain ionic homeostasis. Among these the ubiquitous  $\text{Na}^+/\text{K}^+$  ATPase is most demanding. Due to the extraordinary number of neurons and glial cells in the brain, the  $\text{Na}^+/\text{K}^+$  ATPases account for approximately 60% of total ATP consumption. Accordingly, depletion of cellular ATP results in a failure of the  $\text{Na}^+/\text{K}^+$  ATPase and thus a severe disturbance of ionic homeostasis in and around neurons and glial cells.  $\text{Na}^+$  continues to leak into cells and  $\text{K}^+$  which is released by the neurons accumulates in the narrow interstitial space, causing a progressive depolarization of neurons and glial cells. Accordingly, irreversible decline of membrane potential and destruction of neural tissue will occur, if  $\text{O}_2$  supply is not restored in time. However, such high sensitivity and rapid voltage decline is only seen in hippocampal and cortical brain regions, where hypoxia induces a quick rise in extracellular  $\text{K}^+$  to a ceiling level of approximately 9 mM, before it finally continues to rise to levels beyond 40 mM, when the anoxic/terminal depolarization (►ischemic stroke) occurs [3]. In the lower brainstem, however, such massive changes in the extracellular ion levels do not occur as quickly. It is surprising that in the fully intact *in vivo* preparation extracellular  $\text{K}^+$  rises only by maximally 1–1.5 mM, even though tissue  $\text{pO}_2$  had dropped to zero levels for a duration of several minutes. The robust protection of the respiratory network against hypoxia might in part be referred to a slower decline of ATP, possibly due to an efficient utilization of alternate metabolites and the “loose” tissue architecture of the reticular formation. Together with a “distributed organization” of the respiratory network along the rostrocaudal axis of the medulla this might efficiently protect the network against disturbances in extracellular ion concentrations.

### Hypoxic Disturbances of Respiratory Network Functions

A fall of the arterial and tissue  $\text{pO}_2$  provokes a sequence of responses that is composed of at least five discrete phases (Fig. 1). As long as the network has not entered the state of terminal apnea, all these changes are reversible and normal network function can be restored by reoxygenation.

#### Augmentation

In the intact *in vivo* preparation, the respiratory network activity increases very sensitively from the very beginning of hypoxia, because the slightest fall in arterial  $\text{pO}_2$  causes an arterial chemoreceptive activation of the entire

respiratory network (►carotid body chemoreceptors and respiratory drive). If this reflex activation of breathing movements does not quickly reset normal  $\text{pO}_2$  levels and hypoxia persists, a sequence of cellular and systemic trials is initiated, aiming to protect the network.

#### Apneusis or Breath Holding

During the initial phase of hypoxia, glutamate mediated synaptic excitation is progressively enhanced, but remains stable. Release of increased amounts of glutamate can even activate ►metabotropic receptors of the mGluR1/5 type and ryanodine receptors gating intracellular  $\text{Ca}^{2+}$  stores. A concomitant activation of Ca(L) channels seems to contribute to a cytosolic  $\text{Ca}^{2+}$ -rise. This is, however, followed by the activation of hyperpolarizing  $\text{Ca}^{2+}$ -activated  $\text{K}^+$  conductances (►calcium-activated  $\text{K}^+$  channels).

Fairly soon, however, synaptic inhibition starts to be diminished until  $\text{Cl}^-$  mediated (GABA and glycine induced) IPSPs (inhibitory postsynaptic potentials) finally disappear completely [4] (Fig. 2b, d).

This correlates with the finding that increased release and extracellular accumulation of GABA occurs only initially, is transient and comparably weak and then declines below control levels [5]. Diminished synaptic inhibition disturbs the discharge patterns of the different neuronal subtypes that are no longer phase-locked. As a consequence, inspiration inhibitory processes are fading, resulting in a loss of inspiratory patterning and off-switching and thus pathologic prolongation of inspiratory bursts, which is equivalent to the frequently observed ►breath holding (Fig. 2c). This is a severe disturbance of highest clinical relevance because the dramatic fall in respiratory frequency potentiates hypoxia.

A declining release of GABA indicates an early failure of synaptic inhibition in mature preparations due to a higher anoxia vulnerability of inhibitory interneurons. There is common agreement that the key reason is a disruption of the  $\text{K}^+$  and  $\text{Cl}^-$  gradients. An important player regulating this gradient is the  $\text{K}^+$ - $\text{Cl}^-$  cotransporter KCC2 that is found at inhibitory synapses. It seems that hypoxia induces a rapid loss of tyrosine phosphorylation of KCC2 resulting in a functional disturbance of transport activity and thus intracellular  $\text{Cl}^-$  accumulation. Consequently the  $\text{Cl}^-$  gradient across the membrane declines and with a shift of the  $\text{Cl}^-$  ►equilibrium potential above  $-70$  mV IPSPs that normally hyperpolarize become depolarizing (Fig. 2b). Accordingly, KCC2 knockout mice die immediately after birth due to abolished breathing.

In the rat preparation, IPSPs of respiratory neurons are depolarizing at birth and obviously not yet essential for rhythmogenesis. But interestingly, shortly before delivery, maternal oxytocin release induces a transient reduction in the intracellular  $\text{Cl}^-$  concentration and an excitatory-to-inhibitory switch of GABA actions in the

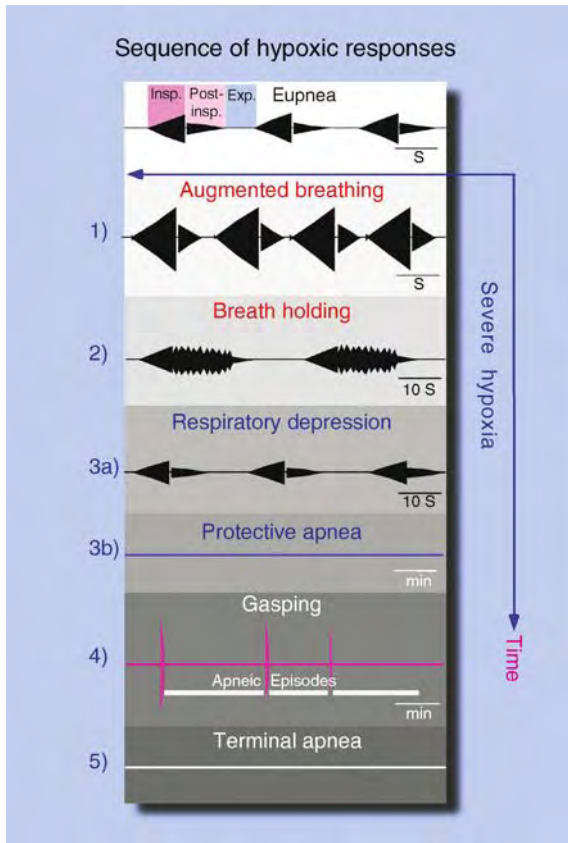

**Neural Respiratory Control During Acute Hypoxia.** **Figure 2** Molecular mechanisms of the hypoxic response. The molecular and cellular mechanisms contributing to the failure of the respiratory network during severe hypoxia originate from a functional loss of synaptic interactions, not the loss of membrane potential or severely disturbed ionic homeostasis. The key processes are firstly reversal of IPSPs, but then attenuation and finally block of synaptic transmission that originates from a strong activation of ATP sensitive pre- and postsynaptic  $K^+$  conductances. Prominent depolarization of the single neurons does not occur even after the network has passed the point of no return and has entered the state of terminal apnea.

fetus. Thus, maternal oxytocin generates hyperpolarizing IPSPs in fetal neurons and protects the fetus against excitotoxic insults during delivery.

### Protective Apnea

During progressive periods of hypoxia depression of respiration becomes the principal strategy that is typified by only moderate membrane depolarization of respiratory neurons (Fig. 2f). The release of ▶adenosine [5] blocks synaptic transmission by inhibition of  $Ca^{2+}$  conductances in axon terminals. Postsynaptically it inhibits the formation of ▶cyclic adenosine monophosphate (cAMP and activates ▶ATP-sensitive  $K^{\pm}$

channels ( $K_{ATP}$  channels) (Fig. 2d) [6]. This ATP/ADP/adenosine regulated  $K_{ATP}$  conductance keeps the membrane potential of neurons at a relatively negative level of approximately  $-40$  mV to  $-50$  mV and thus protects neurons against massive intracellular  $Ca^{2+}$  accumulation that would destroy neurons in such a hypoxic situation. The unfavorable consequence of such a negative membrane potential firmly “clamped” by  $K^+$  currents is that synaptic drive potentials are further reduced and respiratory neurons are completely silenced. Most respiratory neuronal spike discharges cease, although the neurons in fact remain excitable by antidromic stimulation [4].

This “cell-endogenous” protection is getting competent assistance by “cell-external” support through a variety of neurotransmitters and -hormones, such as ▶serotonin [5] and endorphins or leucine enkephalin to mention just a few. Together they reinforce protective  $K^+$  effluxes through their action on G protein coupled signaling pathways, inhibiting intracellular cAMP production [7]. Such concerted action of neuromodulatory substances is capable to protect the respiratory neurons for a astonishingly long time that might last up to 20 min as measured in the anesthetized cat [8].

In this respect, it should be mentioned that the time course of hypoxic responses clearly differs between perinatal and adult respiratory networks. In embryonic day E21 rats and in the isolated brainstem of neonatal (1–3 days old) rats, breathing movements even continue relatively unchanged for 25–50 min of hypoxia.

### Auto-Resuscitation Through Gasping

After prolonged hypoxia, gasping is the ultimate time point at which re-oxygenation of the blood is still able to completely re-establish brain stem function [9]. Basically, gasping resembles the last operative mechanism and the final attempt to mechanically defeat airway obstruction and anoxia and thus to ensure auto-resuscitation (Fig. 2e). Voltage sensitive dye imaging (▶respiratory network analysis: calcium/voltage sensitive dyes imaging) revealed that gasping involves extensive medullary regions covering a much larger region of the rostral ventrolateral medulla and probably the recruitment of additional regions that are normally not active during eupnea [10]. Mechanistically, gasping involves activation of a persistent sodium current ( $I_{Nap}$ ) that is also discussed to contribute to the endogenous bursting properties of *in vitro* isolated respiratory neurons.

### Terminal Apnea

The gasping effort declines steadily in strength and frequency as the respiratory network approaches the “point of no return” and irreversible damage starts to occur. This is the period when the respiratory network proceeds into the terminal and irreversible apnea. Cell swelling occurs, which affects the cytoskeleton and in

turn activates the persistent  $\text{Na}^+$  current, L-type  $\text{Ca}^{2+}$  channels (►voltage-gated calcium channels), and  $\text{Ca}^{2+}$ -sensitive non-selective cationic channels (►calcium-activated non-specific cation current). The resulting accumulation of cytosolic  $\text{Ca}^{2+}$  is massive and causes irreversible damage of neurons and the collapse of network functions. The cardio-respiratory part of the network also fails and the blood circulatory control is lost as well (Fig. 2f).

**In conclusion**, the five phases of the hypoxic response, the underlying molecular mechanisms and their time courses impressively demonstrate that the medullary respiratory center is astonishingly resistant to hypoxia. It remains vital even after prolonged periods of severe hypoxia which is due to an efficient protection through metabolic and neuromodulatory adjustment of  $\text{K}^+$  conductances. Lack of spontaneous breathing movements, therefore, is not at all a reliable sign for cell destruction (see Fig. 2f) and brainstem death, although most of the structures rostrally of the brainstem including the cerebellum, the striatum and the cortex are definitively irreversibly damaged at that time.

## References

1. Richter DW, Ballanyi K, Schwarzacher S (1992) Mechanisms of respiratory rhythm generation. *Curr Opin Neurobiol* 2:788–93
2. Müller M, Mironov SL, Ivannikov MV, Schmidt J, Richter DW (2005) Mitochondrial organization and motility probed by two-photon microscopy in cultured mouse brainstem neurons. *Exp Cell Res* 303:114–27
3. Müller M, Somjen GG (2000)  $\text{Na}^+$  and  $\text{K}^+$  concentrations, extra- and intracellular voltages, and the effect of TTX in hypoxic rat hippocampal slices. *J Neurophysiol* 83:735–45
4. Richter DW, Bischoff A, Anders K, Bellingham M, Windhorst U (1991) Response of the medullary respiratory network of the cat to hypoxia. *J Physiol* 443:231–56
5. Richter DW, Schmidt-Garcon P, Pierrefiche O, Bischoff AM, Lalley PM (1999) Neurotransmitters and neuromodulators controlling the hypoxic respiratory response in anaesthetized cats. *J Physiol* 514:567–78
6. Pierrefiche O, Bischoff AM, Richter DW (1996) ATP-sensitive  $\text{K}^+$  channels are functional in expiratory neurones of normoxic cats. *J Physiol* 494:399–409
7. Lalley PM, Pierrefiche O, Bischoff AM, Richter DW (1997) cAMP-dependent protein kinase modulates expiratory neurons in vivo. *J Neurophysiol* 77:1119–31
8. Richter DW, Mironov SL, Büsselberg D, Lalley PM, Bischoff AM, Wilken B (2000) Respiratory rhythm generation: Plasticity of a neuronal network. *The Neuroscientist* 6:181–198
9. Tomori Z, Benacka R, Donic V, Tkacova R (1991) Reversal of apnoea by aspiration reflex in anaesthetized cats. *Eur Respir J* 4:1117–25
10. Potts JT, Paton JF (2006) Optical imaging of medullary ventral respiratory network during eupnea and gasping in situ. *Eur J Neurosci* 23:3025–33

## Neural Stem Cells

### Definition

Neural stem cells (NSC) are an heterogeneous population of mitotically active, self-renewing, multipotent cells of both the developing and the adult central nervous system (CNS). A single NSC is capable of generating various kinds of cells within the CNS, including neurons, astrocytes, and oligodendrocytes.

In vivo and in vitro lineage analyses have shown that the multilineage potential of NSCs is at least partly mediated by the generation of cell-lineage-restricted intermediate progenitor cells, which produce only neurons (neuronal progenitor cells), and glial progenitor cells that produce only astroglial or oligodendroglial cells. Thus, the cellular diversity of the CNS is likely to be generated in a stepwise fashion. NSCs have been successfully isolated from the entire embryonic as well as adult CNS.

The ganglionic eminence(s), in the embryo, and both the subventricular zone (SVZ) of the lateral ventricles and the sub-granular zone (SGZ) of the hippocampus dentate gyrus (DG), in the adult, have been shown to consistently contain stem-like cells capable of driving neuro- and glio-genesis. These regions are then defined as highly specialized CNS germinal niches. Protocols to obtain in vitro large-scale numbers of NSCs are available, thus supporting the concept that these cells might represent a renewable source of uncommitted ready-to-use cells for transplantation purposes.

- Autoimmune Demyelinating Disorders: Stem Cell Therapy
- Neural Development
- Regeneration
- Transplantation of Neural Stem Cells for Spinal Cord Regeneration

## Neural Tube

### Definition

In vertebrates the presumptive neural ectoderm of the future brain and spinal cord folds dorsally into a tube, the neural tube, from which all neurons and glia in the central nervous system are derived.

- Neural Development

## Neuralgia

### Definition

Neuralgia denotes a sharp and paroxysmal pain along the course of a nerve, e.g., in ▶trigeminal neuralgia)

▶Trigeminal Neuralgia (Paroxysmal Facial Pain, Tic Douloureux)

with repeated sequences. These sequences are similar to sequences in laminin A, slit and agrin, which are proteins shown to be important for axon guidance and synaptogenesis.

- ▶Agrin
- ▶Laminin
- ▶Slits
- ▶Synapse Formation: Neuromuscular Junction Versus Central Nervous System

## Neurally Controlled Animals

▶Computer-Neural Hybrids

## Neuraxis

### Definition

Central nervous system. Composed of the encephalon located in the skull and the spinal cord running in the vertebral canal.

▶General CNS

## Neurite

### Definition

Often used for nerve cell processes which are in an early stage of growth, or which can not be identified with certainty as an axon or dendrite. The latter is often the case when nerve cells are cultured. Neurons have two kinds of processes, one axon and several dendrites.

Axon is specialized for conduction of action potentials and dendrites for receiving sensory or neural signals.

- ▶Action Potential
- ▶Membrane Components
- ▶Neuronal Changes in Axonal Degeneration and Regeneration

## Neuregulin

### Definition

Neuregulin is a family of four structurally related proteins that are part of the epidermal growth factor (EGF) family. They exert their action by activation of ErbB receptors. They have diverse roles in the development of the nervous system.

- ▶Growth Factors
- ▶Synapse Formation: Neuromuscular Junction Versus Central Nervous System

## Neurite Extension

▶Axon Outgrowth

## Neurexins

### Definition

Neurexins are neuronal cell surface proteins and contain single transmembrane region and extracellular domains

## Neurite Outgrowth

### Definition

Neuronal outgrowth begins at the cell body and extends outwards and is strongly influenced by the surrounding cellular environment. Outgrowth is a complex process that requires numerous ultra-structural changes in the growing neurons. These include the insertion of newly synthesized functional membrane, generation of new

cytoplasm and the continued expansion and modification of the cytoskeleton as neurites grow and branch.

- ▶ Axonal Pathfinding and Network Assembly
- ▶ Cytoskeleton

## Neuritis

### Definition

Neuritis is an inflammation of a nerve associated with continuous pain, paralysis and sensory disturbances.

## Neuroactive Steroids

- ▶ Neuroendocrinological Drugs

## Neuroanatomical Tracer

### Definition

Neuroanatomical tracers are molecules that neurons will absorb and move within axons, via intracellular transport mechanisms, either from the neuron cell body to the axon terminals (called orthograde or anterograde transport) or from axon terminals to the cell body (called retrograde transport) or both (called bidirectional transport). Neuroanatomical transporters are visible in tissue either because they are fluorescent, i.e., they emit light at a particular wavelength when illuminated by light of another wavelength, or because they have been reacted with chemical agents that turn them a dark color.

## Neuroanatomy

### Definition

The branch of biology that explores the structure and organization of tissue that arises as a portion of the nervous system.

## Neurocan

### Definition

One kind of axon growth inhibitors. It is a secreted molecule and undergoes posttranslational modification in the CNS resulting in a 150 kDa C-terminus and 130 kDa N-terminus fragment.

- ▶ Growth Inhibitory Molecules
- ▶ Regeneration of Optic Nerve

## Neurochemical Remodeling in Retina

### Definition

Altered synaptic and/or neurochemical organization secondary to retinal degeneration or retinal damage

- ▶ Inherited Retinal Degenerations

## Neurochemicals

- ▶ Respiratory Neurotransmitters and Neuromodulators

## Neurodegeneration and Neuroprotection – Innate Immune Response

GRIFFITHS M.<sup>1</sup>, NEAL J. W.<sup>2</sup>, GASQUE P.<sup>1,3</sup>

<sup>1</sup>Brain Inflammation and Immunity Group, Department of Medical Biochemistry, Cardiff University, Cardiff, UK

<sup>2</sup>Department Histopathology School of Medicine, Cardiff University, Cardiff, UK

<sup>3</sup>GRII LBG, Faculty of Sciences and Technology, University of la Reunion, Saint Denis, Reunion, France

### Definition

Brain infection, hemorrhage and aging are associated with activation of the innate immune system as expressed by resident glial cells and neurons. The innate immune

response (▶[innate immunity](#)) relies on the detection of “self” and “non-self” (▶[self, non-self and altered-self](#)) structures in mounting a protective response to promote the clearance of pathogens, toxic cell debris and apoptotic cells accumulating within the brain parenchyma and the cerebrospinal fluid (CSF). Innate immune molecules can also stimulate neurogenesis and contribute to brain tissue repair. However, in some diseases, these protective mechanisms lead to neurodegeneration on the ground that several innate immune molecules can promote neuronal loss. The response is a “double-edged sword,” representing a fine balance between protective and detrimental effects. Several key regulatory mechanisms have now been evidenced in the control of the innate immune response and which could be harnessed to explore novel therapeutic avenues.

## Characteristics

### Quantitative Description: Cellular and Molecular Innate Immune Responses

Classically, innate immune cells are known as neutrophils, natural killer (NK) cells, dendritic cells and macrophages involved in the selective recognition and the clearance of pathogens and toxic cell debris during infection or tissue injury [1]. However, there is little evidence of an immunosurveillance of the brain by these peripheral cells and it is now evident that resident cells, glial cells and neurons, are capable of mounting a robust innate immune response. The local innate immune response is based on the recognition of “non-self” and “altered-self” (self, non-self and altered-self) patterns, also called ▶[danger signals](#), by molecules and receptors expressed by microglia, astrocytes, oligodendrocytes and neurons [2]. These molecules and receptors are called pattern-associated recognition receptors (PARRs) and are displayed on the cell membrane or released in soluble forms. The decoding and sampling of the microenvironment for danger signals will contribute to the removal of the harmful intruders. In addition, there is mounting evidence that innate immune molecules (e.g., C3a) can contribute to tissue repair notably by stimulating the mobilization of neural stem cells and with the production of growth factors [3,4]. Critically, several innate immune molecules have also cytotoxic and cytolytic activities and must be controlled to avoid neuronal loss (neurodegeneration) and robust inflammation. Cellular and regulatory mechanisms have recently been described and thought to be at the route of neuroprotective mechanisms.

## Description of the Process

### Innate Immune Response in Health: The Key Role of Physical Barriers

The brain is isolated from the systemic circulation by a protective blood brain barrier (BBB) composed of endothelial cells linked by tight junctions and

surrounded by the end feet of astrocytes (Fig. 1). A further protective barrier composed of specialized ciliated glia, the ependyma, lines the ventricles preventing entry of pathogens from the cerebro spinal fluid (CSF) into the brain. Within the ventricles is the choroid plexus containing Kolmer phagocyte cells. Cells within the choroid plexus and the ependymal layer express receptors that are capable of detecting pathogens in the CSF and regulating the inflammatory response. These innate immune receptors are highly conserved and include Toll-like receptors (TLR), CD14 and ▶[complement](#) receptors CR3 and CR4. The details regarding the recognition and interaction between glia and pathogens will be discussed below.

### Immunoprivileged Status of the Brain by Preventing the Infiltration of Potentially Harmful Systemic Immune Cells

The active destruction of infiltrating T lymphocytes through induction of apoptosis provides the brain with a degree of low immuno-surveillance, preventing the entry of lymphocytes and down regulating inflammation (Fig. 1). Active apoptosis of infiltrating T lymphocytes is induced by neurons and glia utilising the “death signaling pathways” based upon CD95FasL/CD95 (Fas) and the TNF lymphotoxin receptor-TNF receptor 1 (TNFR1) pathway. The initiator of apoptosis, CD95L, is expressed by both astrocytes and oligodendroglia and transmits an apoptotic signal to target T cells. This interaction at the cell surface induces the activation of caspases and subsequent apoptosis of the target cell, with engulfment by microglia and down regulation of their activation. For instance, recovery from experimental EAE is increased through induction of apoptosis in inflammatory T cells by the TNFR signaling pathway and in TNFR knock out mice T cell apoptosis is reduced by 50% in the periphery of demyelinating plaques. In multiple sclerosis, it is possible that this death signaling pathway is functional in reducing the severity of demyelination.

The induction of apoptosis in infiltrating T lymphocytes and virally infected cells will reduce host tissue destruction, but only if they are rapidly cleared by resident cells. Apoptotic cells contain large amounts of toxic enzymes that are able to activate proinflammatory cytokine release. Phagocytosis of apoptotic cells is termed non-phlogistic and is accompanied by a down regulation of proinflammatory cytokines contributing to the limitation of tissue damage and “self” defense [5].

Apoptotic cells are “altered self” and express apoptotic cell associated molecular patterns, ACAMPS. The identity of ACAMPS has not been fully elucidated but includes nucleic acids, sugars, oxidized low density lipoproteins and alteration of membrane electrical charge. The best characterized ACAMP to date is phosphatidylserine (PS). Glia and macrophages express a range of PARRs that recognize ACAMPS including the



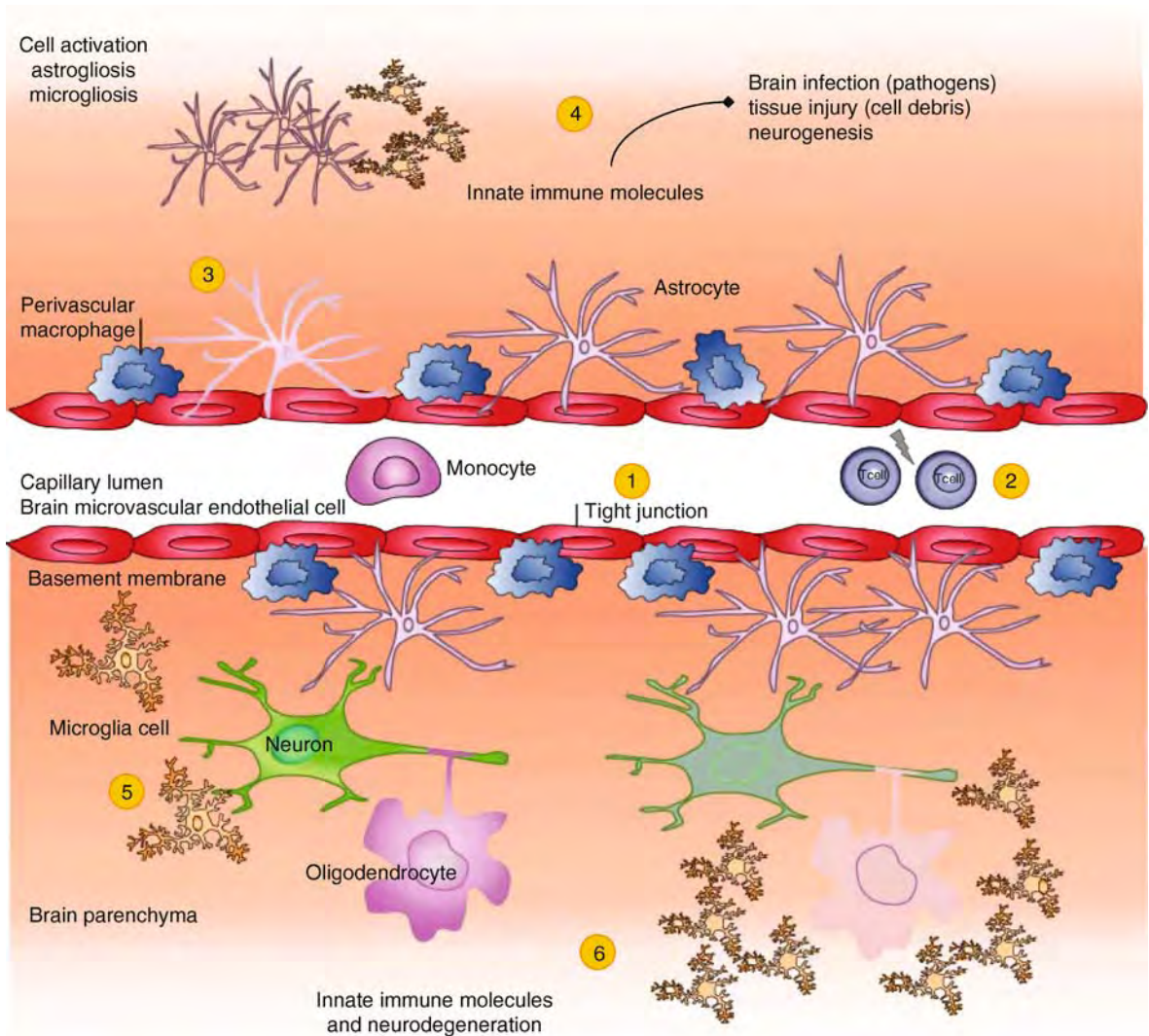

**Neurodegeneration and Neuroprotection – Innate Immune Response. Figure 1** Innate (natural) defense mechanisms in health and diseases of the CNS: (i): The physical blood brain barrier composed of endothelial cells linked by tight junctions and surrounded by the end feet of astrocytes prevents the infiltration by pathogens. (ii): Brain cells such as microglia and astrocytes can also induce apoptosis of autoimmune T lymphocytes through the Fas/FasL pathway. (iii): In response to infection or tissue injury, resident cells will be activated, i.e., reactive gliosis with the activation and proliferation of astrocytes and microglia. (iv): Remarkably, innate immune molecules will contribute to the selective recognition and removal of pathogens and toxic cell debris (apoptotic corpses, amyloid fibrils) while preserving self cells. Furthermore, several innate immune molecules will initiate tissue repair (neurogenesis). (v): This response will have to be kept under safe guard through the expression of inhibitory/regulatory molecules for example by neurons to control phagocytosis by microglia. (vi): In sharp contrast, several innate immune molecules have been involved in neuronal loss and oligodendrocyte damage in diseases such as Alzheimer's disease and multiple sclerosis, respectively. For example, host defense complement proteins are known to induce adverse cytotoxic activities against myelin-forming cells and neurons. Hence, a fine balance must exist and which is at the route of future therapeutic strategies.

phosphatidylserine receptor (PSR), CD14, CD36 and milk fat globulin (MFG-EGF 8).

Activation of the classical innate immune complement pathway by virtue of C1q recognition of nucleic

acids initiates the generation of **opsonins** C3b and iC3b that bind to apoptotic cells and act as targets for the phagocytic CR3 and CR4 receptors expressed by macrophages and microglia.

### **Protective Innate Immune Response During Brain Infection and Inflammation: To Promote the Clearance of Pathogens, Apoptotic Cells and Other Cell Debris**

After penetrating a damaged BBB, an infiltrating pathogen will encounter the innate immune response delivered by professional (microglia) and non-professional phagocytes (astrocyte, ependyma neurons and oligodendroglia) (Fig. 1). These cells provide the second line of the brain's innate defense against infection, but must also be regulated to prevent destruction of host "self" cells. Astrocytes and microglia express a large array of membrane and soluble PARRs. These include lectins (e.g., phagocytic macrophage mannose receptor (MMR)), scavenger receptors (e.g., SRA), TLRs and associated molecules (TLR2 and 4, CD14) and complement molecules (e.g., C1q, C3, CR1, CR3, CR4). These innate immune receptors are capable of detecting unique arrangements of lipopolysaccharides (LPS) and peptidoglycan (PG) molecules termed pathogen associated molecular patterns (PAMPS) within the cell walls of microorganisms. PAMPS are uniquely expressed by pathogens and therefore distinguish "self" (host) from "non-self" (pathogen). Removal of pathogens therefore reduces the severity of an inflammatory response before its destructive effects outweigh the benefits of pathogen clearance. The recognition of pathogens or "not self" also relies upon the defense collagens, a group of PRRs composed of a globular carboxy sequence that recognizes PAMPS together with an amino terminal sequence that binds to specific phagocytic receptors on the surface of phagocytic cells. These include C1q, the first component of the complement classical pathway, mannan-binding lectin (MBL) and surfactant protein A (SPA). C1q and MBL have been shown to be expressed by astrocytes whereas the expression of SPA in the CNS is yet to be defined. The complement receptors (CR), CR3 and CR4 are important for identifying pathogens and apoptotic cells opsonised with complement components C3 fragments (C3b and iC3b).

### **Innate Immune Responses in Neurodegeneration and Demyelination**

Any disruption of the BBB invariably permits entry into the brain of neurotoxic systemic proteins, including thrombin a serine protease vital for blood coagulation and complement proteins. Thrombin, at low concentrations (50–100 pM) is neuroprotective, regulating NGF synthesis and synaptic outgrowth; it is protective against oxygen and glucose deprivation due to its modulation of intracellular calcium. At high levels (500 nM), as found following intra cerebral hemorrhage, thrombin is neurotoxic as it activates NMDA excitotoxic receptors and PAR-1 inhibiting neurite extension and neuronal repair [6].

The complement system is a vital component of the CNS innate immune defense system as it recognizes and

clears pathogens and apoptotic cells, but its activation must be closely regulated to prevent excessive tissues destruction. High levels of complement proteins from plasma could infiltrate the brain from a damaged BBB. Moreover, the expression of complement components of both the classical and alternative pathways has been well described in astrocytes, microglia and neurons in vitro and in vivo. The classical complement pathway is activated by C1q interacting with neurons, myelin basic protein (MBP) myelin oligodendrocytic protein (MOG). The alternative pathway is activated independently of C1q and immune complex formation, but through a binding of C3 to activating surfaces that cleaves C5 to initiate the terminal pathway. One component, C3b is abundantly deposited on target cells and functions as an opsonin for microglia and Kolmer cells expressing the PARRs CR1 (CD35), CR3 and CR4 receptors to promote robust phagocytosis. Uncontrolled C3b opsonisation of oligodendrocytes and neurons will lead to demyelination and neuronal loss by phagocytes expressing CR3 and CR4. The terminal pathway provides the membrane attack complex (MAC) composed of C5b-9. This complex is capable of producing cell lysis unless inhibited by complement regulator proteins (regulators of complement activation, RCA), see below. Complement is activated in Alzheimer's Disease as the result of C1q binding to fibrillary beta amyloid, activating complement and increasing C1q, C3 and C5 as part of the protective response promoting clearance of the amyloid plaque. Amyloid plaque formation in complement deficient mice was significantly increased supporting the interpretation that amyloid clearance was related to microglia phagocytosing complement opsonised amyloid. However, in the context of acute inflammation associated with robust expression of complement proteins by microglia and astrocytes, it is plausible that complement activation by myelin/neuronal debris contributes to secondary brain injury. The formation of the MAC and non-specific binding to surrounding cells would cause bystander damage. Complement activation is also present in the tauopathies (including Pick's disease) resulting in localization of complement products on ballooned neurons; the details regarding the identity of the C1q binding molecule in these diseases is not yet known. Interestingly, administration of a C1 inhibitor C1-INH, resulted in neuroprotection after experimental ischaemia, but its protective effect was interpreted as independent of C1q activating the complement pathway. Experimental models of demyelination and multiple sclerosis have demonstrated C9 and MAC deposition in at least half of the MS cases with active myelin destruction. Knock-out mice for CD59, a natural MAC inhibitor, increased the severity of EAE whereas the failure to produce MAC in C6 deficient animals reduced the severity of axon damage in diseased animal compared with the control group.

## Regulation of the Process

### *Innate Immune Regulatory Molecules*

To counter the neurotoxic effects of innate immune molecules, both glia and neurons express a range of “self” defense proteins. These include the serine protease inhibitors (serpins) that prevent the synthesis of thrombin. The serpins include the anti thrombin colligin (Hsp47) expressed by microglia and astrocytes, plasminogen activator inhibitor (PAI-1) and protease glial derived nexin-1 (PN-1) both of which are expressed by astrocytes and neurons. Neuroserpin, an inhibitor of plasminogen (tPA) expression is restricted to neurons and astrocytes.

In the systemic organs and brain, the activation of the classical and alternative complement pathways is tightly regulated in order to prevent unrestrained activity resulting in cytolytic destruction of host cells, brain cells being particularly vulnerable to complement attack. The complement regulators can be divided into two groups, the membrane bound and those located within the extracellular fluid, the so called fluid phase regulators. Together they inhibit the activation of the complement pathways (for detailed review see [7]). In brief, the membrane bound regulators, CR1 (CD35) and membrane cofactor protein (MCP, CD46) expressed on nucleated cell membranes bind to C4b or serve as cofactors to increase its cleavage inhibiting this step in the C pathway. Decay accelerating factor (DAF, CD55) inhibits the C3/C5 convertase step and CD59 blocks MAC formation in the terminal pathway. The fluid phase regulators are composed of C1 inhibitor (C1-INH) an effective inhibitor of the C1 component of the classical pathway; Factor H and FI (alternative pathway) accelerates C3b/C4b degradation, whereas S protein and clusterin prevents C5b-7 assisting formation of MAC pathway, inhibiting the final the terminal pathway.

In primary culture, fetal neurons spontaneously activate C classical pathway with formation of MAC resulting in significant lysis because in vitro they express low levels of the membrane regulators (CD59, CD46, C1 INH and FH) and no CD55. By comparison with neurons, astrocytes and microglia express a wider range of inhibitors such as, CD46, CD59 and CD55 together with the fluid phase regulators. Initial observations demonstrated rat oligodendrocytes in culture were susceptible to C attack and did not express CD59. However in human, CD59, CD46 and CD55, together with C1 INH, FH, S protein and clusterin are all expressed and do not spontaneously activate complement. In Alzheimer’s disease, AD, and Picks diseases neurons did not express CD35, CD59, CD46 and CD55, whereas in Huntington’s disease (HD) neurons expressed high levels of CD46. Overall, the combined data from in vitro and in vivo experiments indicates that astrocytes, microglia and oligodendrocytes are well protected from the effects of direct or bystander

complement lysis because they express high levels of CD59, CD46 and CD55. Neurons, particularly lacking CD55, are vulnerable to the detrimental effects of complement attack.

Interestingly, there is a growing body of evidence that neurons may be capable of evading detection by activated microglia and macrophages by expressing the so-called “don’t eat me” signals or SAMPs (self associated molecular patterns). SAMPs are markers of “self” preventing recognition of host cells and reducing the severity of any inflammatory response through inhibition of innate immune cells such as microglia and infiltrating macrophages [8].

A number of SAMPs have been identified including CD200 (and its receptor CD200R), the integrin CD47 with its receptor SIRP $\alpha$ , both regulating myeloid cell and lymphocyte activity and, hence, protecting from autoimmunity [9]. On the basis of their regulatory activity in vitro and in vivo CD46, CD55 and FH could also be important don’t eat me signals. A further group of SAMPs is sialic acids ubiquitously expressed and interacting with the newly described immunoglobulin (Ig)-like lectins, the siglecs expressed on lymphocytes and microglia.

CD200 is a 41–47 kDa surface molecule and a member of the immunoglobulin Ig supergene (Igsf) family characterized by two IgSF domains [10]. It is a highly conserved molecule found in the invertebrates and vertebrates and many of the glycoproteins containing this arrangement are involved with regulation of the immune system. In the brain OX2 now CD200 is expressed by cerebellar and retinal neurons, together with vascular endothelium. Astrocytes do not express CD200 in contrast to microglia.

The counter receptor to CD200, CD200R, also contains two IgSF domains and is expressed by myeloid cells and brain microglia. In CD200 deficient mice the number of activated microglia and macrophages were more numerous after a lesion, than the wild type animal providing evidence that the CD200/CD200R interaction is related to regulation of microglial activation and local inflammation. This interpretation is supported by experiments in mice inoculated with MOG peptide to induce EAE. Animals that received a blocking monoclonal antibody against CD200R had an increased disease severity as compared with animals without the monoclonal antibody treatment. Furthermore, after EAE in CD200 $^{-/-}$  mice, microglia became rapidly activated as compared with type animals. Interestingly in CD200 deficient animals the increased number of phagocytic cells in the retina could also represent the failure to inhibit macrophage entry across the BBB into the eye.

CD47 is constitutively expressed by endothelium, neurons, macrophages and dendritic cells. CD47 has five transmembrane regions with alternatively spliced

isoforms of CD47 having a tissue specific expression, form 2 is present in bone marrow, whereas form 4 is highly expressed in brain. The counter receptor for CD47 is signal regulatory protein SIRP alpha (CD172a) a plasma membrane protein with three Ig domains in its extracellular component. CD172 is expressed by myeloid cells and neurons. The interaction between CD47 on a host cell and CD172a recruits tyrosine phosphatases SHP-1 and SHP-2 with down regulation of macrophage phagocytosis, complement activation and cytokine synthesis including TGF  $\beta$  all contributing to the reduction of any inflammatory response.

The interaction between CD47 and CD172a has been shown to reduce neutrophil migration across endothelium and blocking CD47 reduced bacterial induced expression of inflammatory cytokines by dendritic cells. Furthermore CD47 is capable of inducing apoptosis in T cells and cells deficient in CD47 are rapidly cleared from the systemic circulation by the spleen. Hence, CD47 represents an important “don’t eat me signal” preventing inappropriate phagocytosis of host cells. Whether or not the CD47-CD172a pathway is capable of regulating microglial activity in disease remains to be determined.

Siglecs represent a group of at least 11 recently identified Ig lectins expressed by a wide range of myeloid cells, lymphocytes, macrophages and microglia [11]. Two siglecs, myelin-associated glycoprotein (MAG) and Schwann cell myelinated protein (SMP) are restricted to the CNS and expressed by oligodendrocytes; they are considered important for myelin-axon interaction and control of neuron growth after injury. The non-neural siglecs are characterized by their specific binding to the sialic acids groups, (a group of nine carbon sugars) derivatives of either neuraminic acid or keto deoxynonulosonic acid). Typically these molecules are expressed by “non-self” pathogens and (potentially) apoptotic cells. The interaction between a pathogen expressing the appropriate sialic acid residue and a siglec on microglia will activate phagocytosis and clearance, whereas the absence of the sialic acid residue, for example on a neuron, provides a signal defining “self” and “don’t eat me.” CD33 (siglec 3) is expressed by myeloid stem cells, monocytes and dendritic cells. CD22 (siglec 2) is expressed by B cells and siglecs 5–7 on macrophages, neutrophils and eosinophils. Microglia express siglec 11 and the tyrosine phosphatases SHP-1 and SHP2, both known to participate in down regulation of phagocytosis.

Moreover, the expression of sialic acids also inhibits the activation of the alternative complement pathway through binding to the complement regulator fH.

Activation of the complement pathway produces C3a and C5a chemoattractant to myeloid cells expressing the anaphylatoxin receptors C3aR and C5aR and contributing to proinflammatory activities. However,

C3a also has regulatory properties based on its capacity to block LPS stimulation of macrophage TNF alpha cytokine expression as well as IL 6 and IL1 beta expression by lymphocytes increasing synthesis of IL-10 and NGF. This new “self defense” role for C3a is supported by the presence of C3aR on adrenal and pituitary gland cells, both glands having important roles in the synthesis of corticosteroids to control systemic and central inflammation and infection. More recently, it has been shown that complement anaphylatoxins may be involved in the control of neurogenesis and with anti-apoptotic activities by its capacity to reduce NMDA induced neuronal death.

### **Innate Immune Regulatory Cells**

The presence of large numbers of T lymphocytes inside the brain would normally be expected to have a detrimental effect upon neuronal survival because of increasing the inflammatory response and uncontrolled tissue damage. However, data has accumulated to show that a regulated innate inflammatory response can be beneficial to neuronal survival and enhance axonal repair. Recovery from retinal cell death induced by glutamate was increased in animals with an intact T cell response whereas in those without T cells, recovery was poor. Similarly passive transfer of T cells from injured animals into recovering animals increased the likelihood of recovery, as did immunization against the same antigen/with glutamate. The vital observation was the protective T cells had to be activated specifically against antigens at the site of axon and neuron injury, this was termed protective autoimmunity. The mechanism responsible for T cell neuroprotection is not clear, although lymphocytes can express neurotrophic growth factors including brain derived neurotrophic factor (BDNF) and ciliary trophic growth factor as do macrophages. These findings have therapeutic implications and studies have shown human T cells in vivo stimulated with glatiramer acetate express BDNF as well as the anti-inflammatory cytokine IL 10. Currently a clinical trial involving this compound in MS patients has found some benefit especially reducing the number of new lesions on MRI scanning.

### **Function**

The balance between the protective and harmful effects of the innate immune response mounted against pathogen invasion and brain injury has been termed a “double edged sword.” This balance must be critically regulated in order to promote conditions supportive of brain repair but without excessive destruction of “self” or host cells. The CNS innate immune response is regulated by a number of “self defense” pathways. “Self” is distinguished from “non-self” by the detection of surface PAMP and ACAMP molecules and by the expression of SAMPs by host cells. The CNS has a range of defense strategies at its disposal, each capable of regulating the protective

components of the innate immune response while at the same time limiting the extent of accompanying brain injury. The therapeutic manipulation of the immunoregulatory and defense strategies designed to reduce brain injury and promote repair, as described in this review, is now becoming a clinical reality.

## References

1. Taylor PR, Martinez-Pomares L, Stacey M, Lin HH, Brown GD, Gordon S (2005) Macrophage receptors and immune recognition. *Annu Rev Immunol* 23:901–944
2. Medzhitov R, Janeway CA Jr (2002) Decoding the patterns of self and nonself by the innate immune system. *Science* 296:298–300
3. Gasque P, Neal JW, Singhrao SK, McGreal EP, Dean YD, Van BJ, Morgan BP (2002) Roles of the complement system in human neurodegenerative disorders: pro-inflammatory and tissue remodeling activities. *Mol Neurobiol* 25:1–17
4. Schwartz M, Moalem G, Leibowitz-Amit R, Cohen IR (1999) Innate and adaptive immune responses can be beneficial for CNS repair. *Trends Neurosci* 22:295–299
5. Savill J, Dransfield I, Gregory C, Haslett C (2002) A blast from the past: clearance of apoptotic cells regulates immune responses. *Nat Rev Immunol* 2:965–975
6. Gingrich MB, Traynelis SF (2000) Serine proteases and brain damage - is there a link? *Trends Neurosci* 23:399–407
7. Morgan BP, Meri S (1994) Membrane proteins that protect against complement lysis. *Springer Semin Immunopathol* 15:369–396
8. Elward K, Gasque P (2003) “Eat me” and “don’t eat me” signals govern the innate immune response and tissue repair in the CNS: emphasis on the critical role of the complement system. *Mol Immunol* 40:85–94
9. Hoek RMRS, Murphy CA, Wright GJ, Goddard R, Zurawski SM, Blom B, Homola ME, Streit WJ, Brown MH, Barclay AN, Sedgwick JD (2000) Down-regulation of the Macrophage Lineage Through Interaction with OX2 (CD200). *Science* 290:1768
10. Barclay AN, Wright GJ, Brooke G, Brown MH (2002) CD200 and membrane protein E interactions in the control of myeloid cells. *Trends in Immunology* 23:285–290
11. Crocker PR (2005) Siglecs in innate immunity. *Curr Opin Pharmacol*

immune and inflammatory mechanisms mediated by resident cells such as ▶[microglia](#) and ▶[astrocytes](#) contribute to their pathogenesis through the secretion of potent regulatory mediators, including an expanding array of ▶[cytokines](#), ▶[chemokines](#), proteases, complement proteins and reactive oxygen species.

- ▶[Astrocytes](#)
- ▶[Chemokines](#)
- ▶[Cytokines](#)
- ▶[Gene Therapy for Neurological Diseases](#)
- ▶[Microglia](#)

## Neurodegenerative Diseases – MAPK Signalling Pathways in Neuroinflammation

ROMMY VON BERNHARDI  
Department of Neurology, Faculty of Medicine,  
Pontificia Universidad Católica de Chile,  
Santiago, Chile

### Synonyms

Mitogen-activated protein kinases

### Definition

▶[Neurodegenerative diseases](#) refer to degenerative changes of the nervous system dependent on multiple mechanisms resulting in neurological disease. Acute and chronic immune and inflammatory mechanisms mediated by resident cells such as ▶[microglia](#) and ▶[astrocytes](#) contribute to their pathogenesis through the secretion of potent regulatory mediators, including an expanding array of ▶[cytokines](#), chemokines, proteases, complement proteins and reactive oxygen species (ROS). Whether inflammatory changes within the brain tissue are a consequence or a primary cause of brain damage still is a matter of debate. However, inflammatory mediators and cellular processes are known to be central to the pathogenesis of many neurodegenerative diseases, such as multiple sclerosis (MS), Alzheimer’s disease (AD), stroke, HIV-dementia and others. On the other hand, there is compelling evidence indicating that inflammatory cells and mediators also have beneficial functions in the CNS, assisting in repair and recovery processes. The dual role for glial-mediated ▶[neuroinflammation](#) suggests that glial cells dysregulation may be involved in the genesis of neurodegenerative diseases. As crucial components of the regulatory machinery underlying inflammation

## Neurodegenerative Disease

### Definition

A disease that gradually affects the function of the nervous system due to the degeneration of specific populations of neurons in response to various conditions, including inflammation. Acute and chronic

and other phosphorylation/dephosphorylation-dependent mechanisms, ►Mitogen-Activated Protein Kinases (►MAPKs) are good candidates to be involved in the regulation of glial cells and on the progression of neurodegenerative diseases such as AD [2].

## Characteristics

### Quantitative Description of the Process

Dementia associated with neurodegenerative diseases is accompanied by morphological changes in the brain, including the development of characteristic lesions, but underlying mechanisms ensue before the clinical disease is established. Evidence suggests that the activation of glial cells in response to injury, illness, ageing, or other causes begins a cascade of events leading to a chronic inflammatory process. Through various pathways, inflammatory mediators cause neuronal death, which further activates glial cells that in turn release more inflammatory mediators in a self-amplifying process. Factors secreted by ►microglial cells in response to injury induce activation of astrocytes. Activated astrocytes secrete growth factors promoting microglial growth and activation, but also modulate their cytotoxicity. It has been proposed that microglia-derived factors are responsible for neurotoxicity whereas astrocytes secrete neuroprotective factors. However, astrocytes may also cooperate with microglia enhancing oxidative stress. The association of several pro-inflammatory molecules with neurodegenerative lesions suggests a state of persistent inflammatory activation that could escape endogenous control and become cytotoxic. Genetic research identified susceptibility genes influencing the inflammatory process of

neurodegenerative diseases. Polymorphisms in the interleukin genes, IL-1 $\alpha$  and IL-1 $\beta$ , are associated with increased risk of early onset AD and the C allele of IL-6, associated to reduced IL-6 activity decreases the risk and delays the onset of sporadic AD. Thus, inherited variations in inflammation mechanisms may influence AD as well as other neurodegenerative diseases pathogenesis.

Astrocytes and microglia are highly reactive to environmental changes and work cooperatively, exerting mutual regulatory activity (Fig. 1). There is constitutive expression of interleukin-1 (IL-1) by astrocytes, microglia, neurons and endothelium. Activation of glial cells induces the release of cytokines, such as tumor necrosis factor- $\alpha$  (TNF- $\alpha$ ) and IL-1 $\beta$ , which participates at early stages of neuroinflammation [10] and IL-6 at latter stages. IL-1 $\beta$  has been described as a potent activator of host inflammatory responses within and outside the CNS. Microglia appear to be its early source following experimental CNS injury, infection or inflammation. Production by astrocytes usually follows slightly later [10] (Fig. 2).

Besides the central role of cytokines in neuroinflammation, they also influence neuronal and synaptic function via diverse mechanisms contributing to cognitive impairment, including regulation of neurotransmission, neurotransmitters receptors and synaptic efficacy [6]. A cohort study of healthy ageing individuals showed that high levels of IL-6 correlates with lower cognitive functioning in cross-sectional analysis, also predicting subsequent cognitive impairment. Cytokines are also involved in the pathophysiology of neurodegenerative diseases of vascular origin, by

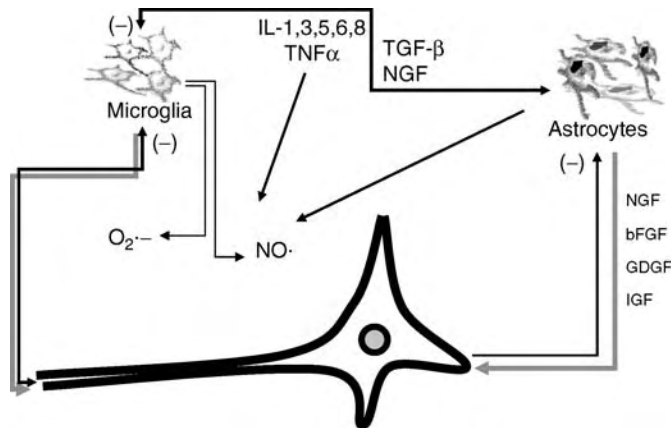

**Neurodegenerative Diseases – MAPK Signalling Pathways in Neuroinflammation. Figure 1** Modulation of the CNS: neuron-glia interaction. Homeostasis in the nervous tissue depends on a finely tuned cross talk among glial cells and neurons. There is a reciprocal structural and functional regulation of glial cells and neurons by growth factors and cytokines. Pro-inflammatory cytokines induce the production of NO and ROS, which are deemed as responsible for cell damage. Factors, such as TGF- $\beta$ , modulate the activation of glial cells. Neurons have an inhibitory regulatory role on glial activation. Neuroinflammation could depend on the inability of microglial cells to respond to modulatory effect or on the failure to establish the modulatory mechanism.

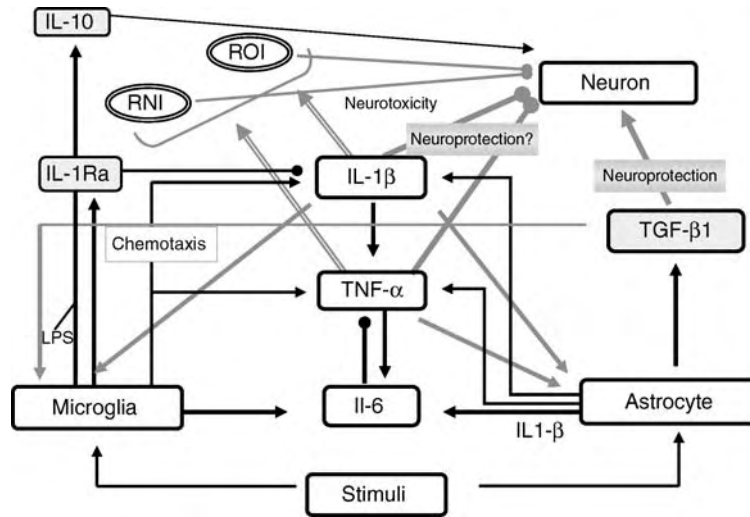

**Neurodegenerative Diseases – MAPK Signalling Pathways in Neuroinflammation. Figure 2** Major inflammatory cytokines involved in glial activation. Schematic overview of the principal cytokines produced by glial cells in response to pro-inflammatory stimuli. Stimuli lead to the activation of microglial cells and later of astrocytes. Glia secrete pro-inflammatory cytokines. This, in turn, induces second line cytokines with pro- and anti-inflammatory cytokines, such as IL-6 and TGF- $\beta$ , IL-10 and IL-1Ra, which also modulate production of pro-inflammatory cytokines, and reactive short life molecules such as oxygen radicals and NO. Pro-inflammatory cytokines and reactive species can promote neurotoxicity. However, pro-inflammatory cytokines also have neuroprotective functions.

influencing the response to ischemia, influencing the coagulation cascade favoring thrombosis and promoting the atherogenic process.

Activated astrocytes and microglia release mediators like **nitric oxide** (**NO**) and activated microglia also secrete important amounts of **reactive oxygen species** (**ROS**) like superoxide ( $O_2^{\bullet-}$ ) deleterious oxidative molecules capable of inducing hippocampal cell damage [11]. Several neurodegenerative conditions show enhanced oxidative damage. Increased amounts of  $O_2^{\bullet-}$  and NO are among the proposed mechanisms for neuronal death and demyelization. Cerebrospinal fluid have increased levels of nitrite and demyelinating lesions show increased levels of nitrotyrosine in multiple sclerosis patients. Increased NO production depends on transcriptional up-regulation of inducible nitric oxide synthase (iNOS) and release of  $O_2^{\bullet-}$  by the multicomponent phagocyte NADPH oxidase. Activated microglia also express myeloperoxidase, which generates the potent oxidizing agent hypochlorous acid.

Pro-inflammatory cytokines activate a number of signaling mechanisms (Fig. 3). Activation of IL-1 receptor leads to translocation of NF $\kappa$ B to the nucleus and activation of mitogen-activated protein kinases (MAPKs) ERK1/2, P38 and JNK1 [10]. Inhibition of each of the MAPK pathways inhibits inflammation-induced IL-1 $\beta$  production in a concentration-dependent manner. In astrocytes, IL-1 $\beta$  plus TNF- $\alpha$  induce the

expression of pro-inflammatory cytokines and iNOS and the production of NO through the activation of ERK1/2 and NF $\kappa$ B [7]. Although IL-1 $\beta$  or TNF- $\alpha$  alone is capable of activating NF $\kappa$ B, the expression of iNOS appears to require activation of additional transcription factors modulated by MAPKs. IL-1 $\beta$  and IFN- $\gamma$  induce the activation of the transcription factor AP-1, but the combination of both cytokines markedly inhibits its activation. It has been defined that the activation of AP-1 and expression of iNOS depends on the activation of JNK, an effect observed only during low level of iNOS induction but not during high level of induction by IL-1 $\beta$  and IFN- $\gamma$ . IL-1 also increases expression and processing of amyloid precursor protein (APP), which could favor production of amyloid  $\beta$  ( $A\beta$ ) in humans and animal models of AD. Activity of ERK and JNK kinases appear to be required for the induction of APP processing by IL-1.

The main signal pathways induced by IFN- $\gamma$  are the signal-transducer and activator of transcription-1 (STAT1) and MAPKs (Fig. 3). STAT-1 is the main transcription factor involved in the induction of iNOS by IFN- $\gamma$ . NF $\kappa$ B does not play a key role in the regulation of iNOS expression in response to IFN- $\gamma$ . However, extracellular signal-regulated kinase (ERK)1/2 MAPK plays an important modulatory role. STAT-1 is activated by a JAK-dependent phosphorylation of a tyrosine residue (pSTAT1<sup>TYR</sup>), whereas its full activation depends on a second phosphorylation at a serine residue

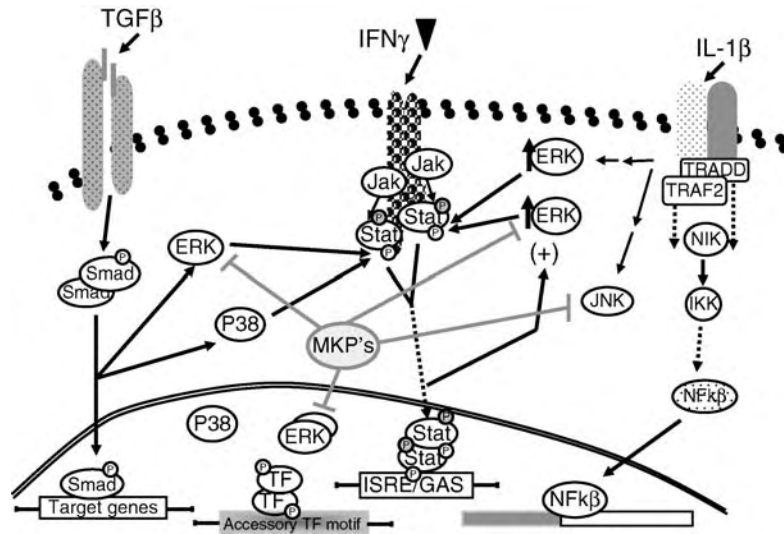

**Neurodegenerative Diseases – MAPK Signalling Pathways in Neuroinflammation. Figure 3** Effect of ERK and P38 on IFN- $\gamma$  signaling. Binding of IFN- $\gamma$  induces receptor dimerization and their phosphorylation by Jaks. The phosphorylated receptor serves as a docking site for STATs, and adaptors linking to MAPK and PI-3-kinase/Akt. Phosphorylated STATs dimers translocate into the nucleus, regulating the transcription of target genes. TGF- $\beta$  signaling depends on phosphorylation of Smad proteins and their translocation to the nucleus. Activated Smads regulate diverse effects resulting in cell-state specific modulation of transcription. TGF- $\beta$  signaling also has Smad-independent pathways, including ERK, JNK and P38 MAPKs. IL-1 $\beta$  binds to IL-1R associated to Nuclear factor- $\kappa$ B (NF- $\kappa$ B) proteins. IL-1 $\beta$  triggers phosphorylation of I $\kappa$ B leading to its degradation, freeing NF- $\kappa$ B. Active NF- $\kappa$ B translocate to the nucleus where, either alone or with other transcription factors including AP-1, Ets and STAT, induce target gene expression. The MAPK/ERK signaling cascade is activated by many receptors. The pathway usually involves small GTP binding proteins (Ras, Rap1), which in turn activate the kinase cascade composed of a MAPKKK (Raf), a MAPKK (MEK1/2) and MAPK (ERK). Activated ERK regulates targets in the cytosol and translocate to the nucleus phosphorylating several transcription factors. Stress-activated protein kinases (SAPK)/Jun N-terminal kinases (JNK) are activated by a variety of signals that are delivered by small GTPases (Rac, Rho, cdc42). SAPK/JNK kinases and P38 MAPKs activation is similar to that of ERKs. P38 is involved in regulation of several transcription factors including ATF-2, Stat1, Max/Myc complex, MEF-2, Elk-1 and indirectly CREB via activation of MSK1. Specific phosphatases for **MAPK** (MKP) end **MAPK** signaling.

(pSTAT1<sup>ser</sup>). ERK and P38 signaling are implicated in the expression of iNOS and the generation of NO [5,7]. IFN- $\gamma$  induce ERK1/2 and P38 phosphorylation while their inhibitors attenuate IFN- $\gamma$ -induced NO, suggesting that those MAPK signaling pathways are important on the modulation of NO production by glial cells. In contrast, O<sub>2</sub><sup>-</sup> production induced by IFN- $\gamma$  is associated to increased levels of pERK1/2, but not pP38. Inhibition of P38 pathway potentiates LPS-induced ROS production. There is evidence that NADPH oxidase component p67<sup>PHOX</sup> is phosphorylated by ERK2, suggesting that NADPH oxidase activity is ERK1/2 dependent. Besides regulation of NADPH oxidase, there is a complex cross-talk between ROS and MAPK through multiple mechanisms. MAPKs are implicated in the regulation of pro-inflammatory cytokines, including TNF- $\alpha$  and several ILs, which in turn induce ROS production. On the other hand, ROS signaling modulates not only cytokines transduction pathways but also appears to regulate the MAPK-induced transcription of some pro-inflammatory cytokines [1]. Further more, ROS

inactivation of MAPK phosphatases leads to prolonged activation of MAPK pathways.

There is a differential temporal contribution of ERK1/2 and P38 in the full-activation of the STAT-1 pathway in glial cells. pERK1/2 and pP38 levels are increased in glial cultures exposed to IFN- $\gamma$ . However, whereas phosphorylation of ERK1/2 persisted after 24 h, phosphorylation of P38 rapidly decreased to control levels. Their differential timing suggests that both ERK and P38 modulate STAT-1 at short times, but only ERK1/2 participates after long time stimulation [3]. There are also differences depending on the glial cell type. IFN- $\gamma$ -induced phosphorylation of P38 only increases in microglial cells but not in mixed glial cell cultures. Similarly, soluble factors secreted by astrocytes decreases IFN- $\gamma$ -induced phosphorylation of STAT-1 and ERK1/2 in microglial cell cultures [11]. There is evidence that microglial cells are more reactive than mixed glial culture, which is supported by the fact that astrocytes modulate microglial cell reactivity [9].



### Lower Level Processes

MAPKs include ERK1/2, ERK3 and ERK5, P38 Hog and JNK/SAPK. Genetic or epi-genetic alterations of MAPKs or of the signaling cascades that regulate them have been implicated in a variety of human diseases including inflammation. Activated MAPKs act in the cytoplasm or translocate into the nucleus phosphorylating other proteins, like transcriptional factors. MAPK signaling is ended by a specific family of phosphatases for MAPK (MKP). ERK1/2 and P38 appear to be key actors in the production of free radicals by glia [7].

### Higher Level Processes

Neuroinflammation requires the coordinated activity of a network of intracellular pathways. MAPKs are signaling molecules capable of mediating crosstalk among pathways allowing the generation of complex responses to different combinations of pro-inflammatory stimuli or the presence of other modulatory conditions. It can be achieved through several mechanisms, ranging from direct communication between intracellular pathways to feedback processes depending on autocrine signaling.

The presence of various pro-inflammatory signals, depending on their underlying molecular mechanisms, could be additive (their combined effect is the sum of the effect expected for each of the stimuli), could show a synergy or inhibition as manifestation of a regulatory crosstalk, or saturation if a common upstream signaling component is involved [8]. Factors as age, cell damage, metabolism or oxidative stress are just some of the many input that will influence an inflammatory response involving activation of MAPK, making the response dependent on the context of the environment. MAPK could be involved in the both the magnitude and the temporal pattern of the response. Different outcomes, such as cell proliferation, expression of cytokines or production of ►ROS among others can be expected to be differentially regulated by a certain combination of stimuli.

### Regulation of the Process

Feedback mechanisms mediated by crosstalk among brain cells restrain the amplitude and duration of ►glial activation, and restore glial cells to their resting state. Neurons have an inhibitory role on glial activation, regulating the production of many proteins associated with reactive gliosis. Astrocytes attenuate activation of microglial cells and confer protection to hippocampal cells [9]. Hippocampal cells and activated astrocytes secrete transforming growth factor  $\beta_1$  (TGF- $\beta_1$ ). TGF- $\beta_1$  modulates ►microglial activation inhibiting production of IL-1 and TNF- $\alpha$ , expression of Class II-MHC and Fas glycoprotein, NOS induction, release of NO [11] and  $O_2^{\bullet-}$  production.

There is controversy regarding the negative or beneficial effects of IL-1 $\beta$ , although IL-1 $\beta$  is considered a pro-inflammatory ►cytokine, it can both contribute to

and limit neuronal damage serving neuroprotective functions [10]. Beneficial effects are particularly observed when low concentrations are released. IL-1 $\beta$  appears to be capable of inhibiting further activation IL-1 $\beta$  at early stages of inflammation reducing production of NO by microglial cells [11]. In contrast, anti-inflammatory cytokines, like TGF- $\beta_1$ , exerts a delayed effect on the modulation of microglial cell activity. The fact that pro-inflammatory cytokine have inhibitory effects suggests that the timing for the activation of the different pathways is important for the cell response outcome.

TGF- $\beta_1$  plays a prominent role in homeostasis and tissue repair. Functions exerted mainly through its receptor-activated Smad signaling. It also has neuroprotective effects through the activation of PI3 kinase/Akt and ERK1/2 pathways [12]. The effect of TGF- $\beta_1$  on glial cell activation is mediated by regulation of ERK1/2 and P38 MAPKs (Fig. 3). Activation of MAPKs in response to TGF- $\beta_1$  is transient and renders microglial cells refractory to further activation by pro-inflammatory cytokines. TGF- $\beta_1$  induces a strong expression of MAPK phosphatase type 1 (MKP-1) persistently up-regulated under pro-inflammatory conditions. An increased MKP-1 activity could be the mechanism responsible for the decrease of IFN- $\gamma$ -induced pERK1/2 in cells exposed to TGF- $\beta_1$  [3].

It has been proposed the existence of complex regulatory interactions between TGF- $\beta_1$  and IFN- $\gamma$  involved in tissue repair. IFN- $\gamma$  null mice have an increased amount of TGF- $\beta_1$  and activation of Smad signaling pathway [4]. On the other hand, TGF- $\beta_1$  null mice have high levels of IFN- $\gamma$  and over-expression of STAT-1, iNOS and NO production. The over-activation of STAT-1 in TGF- $\beta_1$  null mice supports the notion that TGF- $\beta_1$  is an essential immune-regulator for the control of inflammatory events. In glial cells, TGF- $\beta_1$  treatment results in a reduction of IFN- $\gamma$ -induced pERK1/2, STAT-1 phosphorylated at serine<sup>727</sup> (pSTAT-1<sup>ser</sup>) and tyrosine<sup>701</sup> (pSTAT-1<sup>tyr</sup>), and total STAT-1. After long lasting stimulation, IFN- $\gamma$  decreases TGF- $\beta_1$ -induced pP38 signal transduction. IFN- $\gamma$ -TGF- $\beta_1$  crosstalk regulates the production of oxidative molecules through the reduction of STAT-1, ERK1/2 and P38 activation [3]. ERK is involved in the modulation of microglial response by both anti-inflammatory cytokines (TGF- $\beta_1$ ) and pro-inflammatory cytokines (IL-1 $\beta$ ). TGF- $\beta_1$  and IL-1 $\beta$  decrease phosphorylation of ERK and the NO production induced by IFN- $\gamma$ . IL-1 $\beta$  inhibits ERK1/2 phosphorylation after 30 min of activation with IFN- $\gamma$  and the inhibition is short-lived. In contrast, TGF- $\beta_1$  inhibits ERK1/2 phosphorylation only after several hours of activation (24 h) and inhibition persists for a long time (Fig. 4). Only certain pro-inflammatory cytokines, like IL-1 $\beta$  has an orchestrating role, TNF- $\alpha$  is unable to inhibit neither production of radical species nor ERK1/2 phosphorylation.

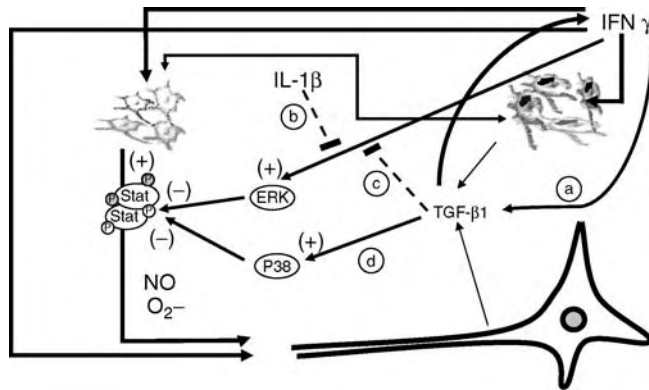

**Neurodegenerative Diseases – MAPK Signalling Pathways in Neuroinflammation. Figure 4** Modulation of microglial activation by TGF- $\beta$  and IL-1 $\beta$ . IFN- $\gamma$  activates glial cells and neurons. Microglia secrete radical species mediated by the activation of JAK/STAT and MAPK. ERK-dependent phosphorylation of STAT1 in the serine position potentiates its activation. (a) IFN- $\gamma$  also induce production of cytokines, IL-1 $\beta$  at early times and later TGF- $\beta$ . IFN- $\gamma$  and TGF- $\beta$  show several reciprocal modulatory effects. The increased secretion of TGF- $\beta$  modulates the production of radical species. (b) IL-1 $\beta$  inhibited IFN- $\gamma$ -induced activation of ERK. The effect could be part of an early mechanism to limit inflammation when stimuli are mild ending glial cell activation. (c) If the inflammatory stimulus persists, the increased secretion of TGF- $\beta$  could further inhibit ERK and P38 activation. (d) At later times, activation of P38 will be inhibited by IFN- $\gamma$ , further reducing the positive modulation on STAT1.

### Function

MAPK-regulation in neuroinflammation allows for the integration of specific signaling pathways to yield unique output responses. MAPK can be involved in both convergence and divergence of signaling cascades (see Fig. 3). The combinatorial complexity of signaling may account for the fact that depending on specific background determined by both genetic and environmental factors, pro-inflammatory stimuli can result in limited inflammation and repair or cell damage resulting in a neurodegenerative disease.

### Pathology

In a large number of neurodegenerative diseases, including ►multiple sclerosis (MS), Alzheimer's disease, Parkinson's disease, cerebro-vascular diseases and CNS trauma among others, inflammatory response is evident, including complement activation, elevated pro-inflammatory cytokines, chemokines and glial activation. There is increasing evidence that neurotoxicity is mediated by CNS inflammatory processes.

### Therapy

The participation of neuroinflammatory mechanisms in the genesis or progression of neurodegenerative diseases has led to extensive investigation of the therapeutic effect of anti-inflammatory and anti-oxidant treatments. There are mixed results depending on the type of neurodegenerative disease and among basic research and clinical trials. Whereas treatment of MS with IFN- $\beta$  and treatment of CNS trauma or inflammation secondary to radionecrosis with corticosteroids are generally approved, most trials of anti-inflammatory agents report

no significant beneficial effect on Alzheimer's patients. Nevertheless, epidemiological studies suggest that the risk of the disease is reduced in patients treated with non-steroidal anti-inflammatory drugs (NSAIDs). Observational studies also suggested that intake of antioxidants, such as vitamin E, could reduce the risk of disease. However randomized controlled clinical trials show at the best only marginal benefits.

Candidate protein kinase inhibitors have been tested in vitro assays and in mouse models for their ability to suppress putative mechanisms of neuroinflammation including iNOS induction and production of IL-1 $\beta$ . The use of MAPKs inhibitors for the treatment of inflammatory disorders has been suggested for infectious diseases, but MAPK cascades have been not proposed as possible therapeutic targets for neurodegenerative diseases. However, due to the variation in responses due to cell type and dose-dependence, the therapeutic use of these inhibitors will demand extensive evaluation. Therapeutic approaches including combination of drugs, each aimed at a different inflammatory target, probably will be more effective than single agents.

### Acknowledgements

The author's research was supported by grant FONDECYT 1040831.

### References

1. Haddad JJ, Land SC (2002) Redox/ROS regulation of lipopolysaccharide-induced mitogen-activated protein kinase (MAPK) activation and MAPK-mediated TNF- $\alpha$  biosynthesis. *Br J Pharmacol* 135:520–536

2. Haddad JJ (2004) Mitogen-activated protein kinases and the evolution of Alzheimer's: a revolutionary neurogenetic axis for therapeutic intervention? *Prog Neurobiol* 73:359–377
3. Herrera-Molina R, von Bernhardt R (2007) Modulation of Interferon  $\gamma$ -mediated activation of glial cells by Transforming Growth Factor  $\beta$ 1: A role for STAT1 and MAPK Pathways. *JBC*, submitted
4. Ishida Y, Kondo T, Takayasu T, Iwakura Y, Mukaida N (2004) The essential involvement of cross-talk between IFN- $\gamma$  and TGF- $\beta$  in the skin wound-healing process. *J Immunol* 172:1848–1855
5. Kim SH, Kim J, Sharma RP (2004) Inhibition of p38 and ERK MAP kinase blocks endotoxin-induced nitric oxide production and differentially modulates cytokine expression. *Pharmacol Res* 49:433–439
6. Li Y, Liu L, Barrer SW, Griffin WS (2003) Interleukin-1 mediates pathological effects of microglia on tau phosphorylation and on synaptophysin synthesis in cortical neurons through a p38-MAPK pathway. *J Neurosci* 23:1605–1611
7. Marcus J, Karackattu S, Fleegal M, Summers C (2003) Cytokine-stimulated inducible nitric oxide synthase expression in astroglia: Role of Erk Mitogen-activated protein kinase and NF- $\kappa$ B. *Glia* 41:152–160
8. Natarajan M, Lin KM, Hsueh RC, Sternweis PC, Ranganathan R (2006) A global analysis of cross-talk in a mammalian cellular signaling network. *Nature cell biology online publication* DOI:10.1038/ncb1418
9. Ramírez G, Toro R, Döbeli H, von Bernhardt R (2005) Protection of rat primary hippocampal cultures from  $A\beta$  cytotoxicity by proinflammatory molecules is mediated by astrocytes. *Neurobiol Dis* 19:243–254
10. Rothwell N, Luheshi G (2000) Interleukin 1 in the brain: Biology, pathology and therapeutic target. *Trends Neurosci* 23:618–625
11. Saud K, Herrera-Molina R, von Bernhardt R (2005) Pro- and Anti-inflammatory cytokines regulate the ERK pathways: Implication of the timing for the activation of microglial cells. *Neurotox Res* 8(3,4):277–287
12. Zhu Y, Culmsee C, Klumpp S, Krieglstein J (2004) Neuroprotection by transforming growth factor- $\beta$ 1 involves activation of nuclear factor- $\kappa$ B through phosphatidylinositol-3-OH kinase/Akt and mitogen-activated protein kinase extracellular-signal regulated kinase1,2 signaling pathways. *Neurosci* 123:897–906

## Neurodegenerative Diseases: Tryptophan Metabolism

GILLES J. GUILLEMIN  
Centre for Immunology and Department of  
Pharmacology, Faculty of Medicine, University of New  
South Wales, NSW, Australia

### Synonyms

Kynurenines

### Definition

► **Tryptophan** is an essential amino acid required by all forms of life, for metabolic functions and synthesis of essential proteins including serotonin and melatonin. More than 95% of dietary tryptophan is catabolized through the kynurenine pathway (Fig. 1). The kynurenine pathway leads to the biosynthesis of nicotinamide adenine dinucleotide (NAD), which is an essential cellular cofactor for many cellular reactions, ranging from adenosine tri-phosphate (ATP) synthesis to DNA repair. This metabolic step appears to be highly conserved. In the process, several neuroactive intermediates are produced including kynurenine, kynurenic acid, 3-hydroxykynurenine, 3-hydroxyanthranilic acid, picolinic acid and quinolinic acid [1,2].

### Characteristics

#### Quantitative Description

In physiological conditions, concentrations of most of the kynurenine pathway metabolites are very low. Significant quantitative changes happen in pathological conditions (see below).

#### Higher-Level Structures

- The cellular location of the kynurenine pathway is only partly understood. It is known to be complete in monocytic lineage cells, including macrophages, microglia and dendritic cells. Whereas in astrocytes, neurons, brain microvascular endothelial cells and oligodendrocytes, the kynurenine pathway is only partly present [3].
- Expression of the enzymes and production of the compounds of the kynurenine pathway vary significantly between species and between cell lines and the respective primary cell type [4].

### Process Regulation

The kynurenine pathway is regulated by its first and rate limiting enzyme indoleamine 2,3 dioxygenase (IDO) [5]. IDO is activated during neuroinflammation. Inflammatory molecules such as platelet activating factor, lipopolysaccharides, lentiviral proteins Nef and Tat, amyloid aggregates, and cytokines can induce IDO expression. Among the cytokines, interferon gamma (IFN $\gamma$ ) is the most potent IDO inducer. Interferons beta and alpha, interleukin 1 and tumor necrosis factor  $\alpha$  induce IDO to a lesser extent. IDO can also be down regulated by interleukin 4 and nitric oxide.

### Functions

The kynurenine pathway has a role in physiological functions.

- The involvement of the kynurenine pathway in psychological functions is mainly due to its ability to divert tryptophan catabolism from the serotonergic

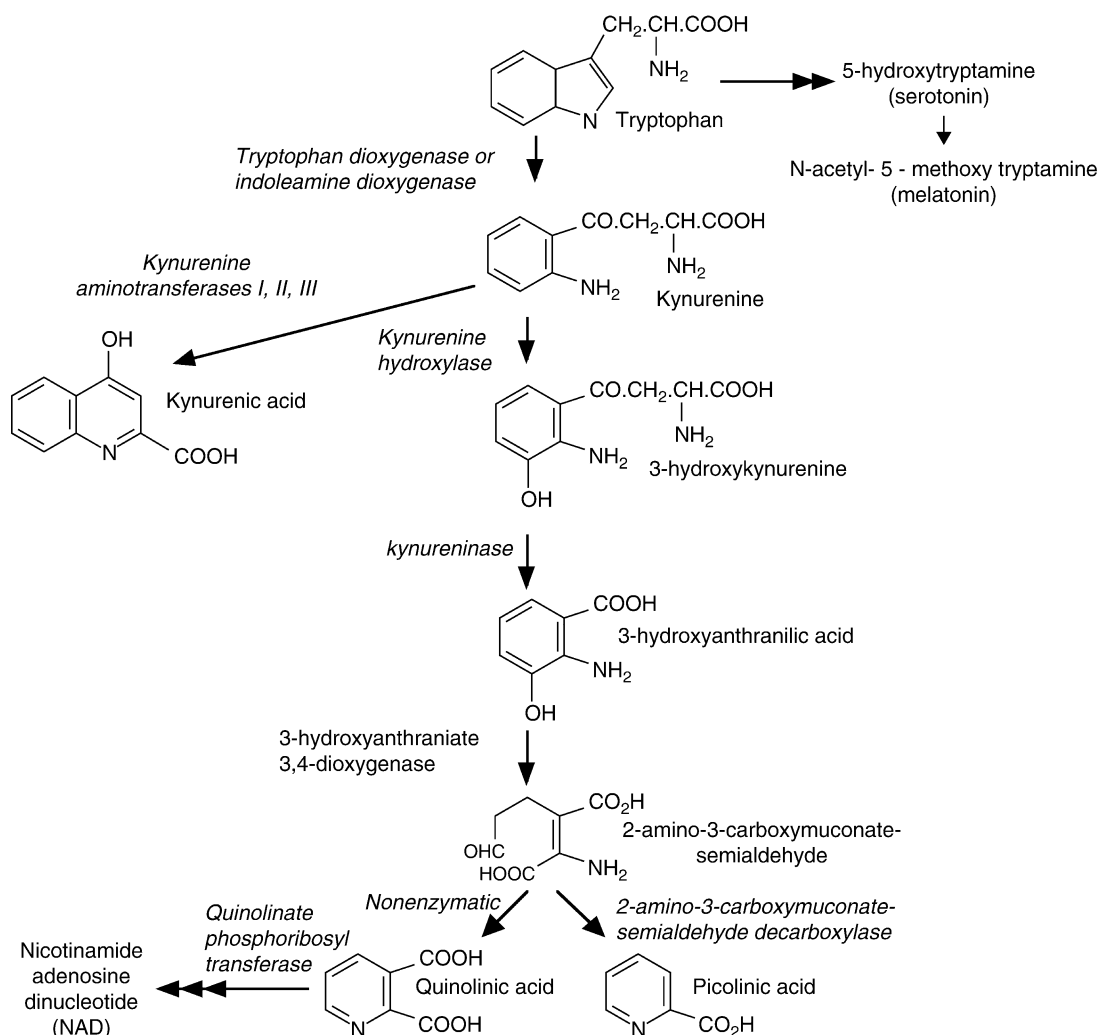

**Neurodegenerative Diseases: Tryptophan Metabolism. Figure 1** Simplified diagram of the kynurenine pathway.

pathway (Fig. 1). Modulation of serotonin (5 hydroxytryptophan; ►5HT) levels is associated with changes in behavior, mood, sleep regulation, and thermoregulation.

- Recent findings have shown that the kynurenine pathway is one of the major regulatory mechanisms of the immune response [6]. Two theories have been proposed: (i) that tryptophan degradation suppresses T cell proliferation by dramatically depleting the supply of this critical amino acid; (ii) that some downstream kynurenine pathway metabolites act to suppress certain immune cells. Induction of the kynurenine pathway in dendritic cells completely blocks clonal expansion of T cells.
- Tryptophan depletion is associated with IDO and kynurenine pathway activation are implicated in the development of immuno-tolerance associated with pregnancy. IDO activation plays a key role in the protection of the fetus by suppressing T cell-driven

local inflammatory responses against the fetal alloantigens [7].

### Pathophysiological Conditions

The kynurenine pathway is involved in the antibacterial, anti-parasites and anti-viral immune defenses.

- Since tryptophan is an amino acid essential for many metabolic processes, depletion of available tryptophan is an important mechanism for the control of rapid-dividing microbial pathogens including bacteria, parasites and viruses.

### Pathology

Two sides have to be considered here: decrease of tryptophan levels and production of kynurenine pathway metabolites (Fig. 2).

- Tryptophan depletion has been associated with mood and psychiatric disorders such as schizophrenia,

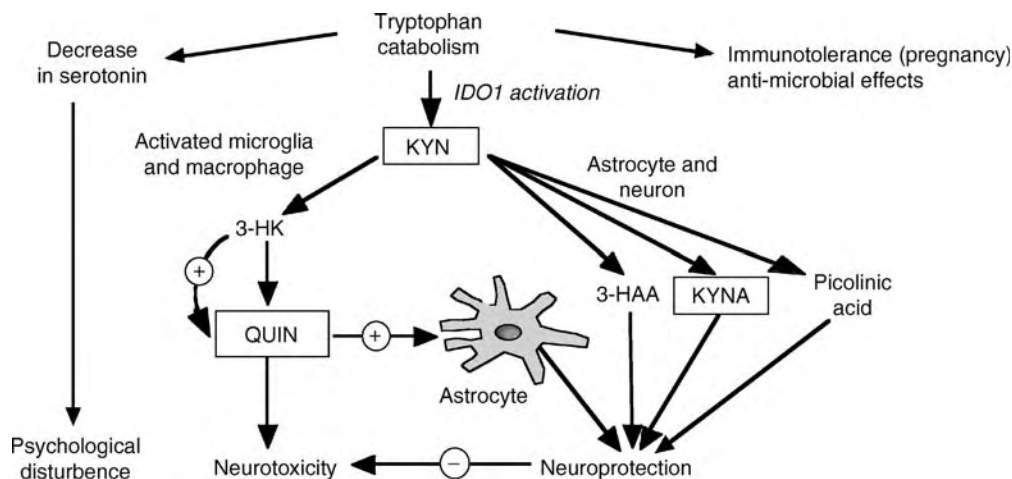

**Neurodegenerative Diseases: Tryptophan Metabolism. Figure 2** Summary of the effects of tryptophan depletion through the kynurenine pathway.

depression, panic disorder, seasonal affective disorder and obsessive-compulsive disorder.

- Activation of the kynurenine pathway and production of neuroactive metabolites have been shown to be involved in a number of neurodegenerative disorders, such as Huntington's disease, Parkinson's disease, Alzheimer's disease, amyotrophic lateral sclerosis, multiple sclerosis, AIDS dementia complex, stroke and epilepsy [1,8].

Products derived from the kynurenine pathway can have either neurotoxic and neuroprotective effects. At least four of them are known to have marked effects on neuronal survival: quinolinic acid, 3-hydroxykynurenine, kynurenic acid and picolinic acid.

### Quinolinic Acid (QUIN)

Among the kynurenine pathway intermediates, QUIN is the main toxic compound produced (see Fig. 1). In 1981, Stone and Perkins showed for the first time the ability of QUIN to selectively activate neurons expressing NMDA receptors. QUIN neurotoxicity was demonstrated by Schwarcz et al. who showed that intra striatal and intra hippocampal injection of QUIN in the rat brain led to neurodegeneration around the injection site. QUIN leads acutely to human neuronal death and chronically to dysfunction by at least five mechanisms. (i) Activation of the NMDA receptor in pathophysiological concentrations. Neurons within the hippocampus, striatum and neocortex are more sensitive to QUIN, than cerebellar and spinal cord neurons; (ii) QUIN increases glutamate release by neurons and inhibits glutamate uptake by astrocytes leading to excessive microenvironment glutamate concentrations and neurotoxicity; (iii) More recently, it has become clear that a major mechanism of QUIN neurotoxicity is through lipid peroxidation; (iv) QUIN can potentiate its

own toxicity and that of other excitotoxins (for example NMDA and glutamate) in the context of energy depletion and (v) Lastly, QUIN leads to astrocyte apoptosis with consequent loss of detoxifying and neurotrophic support of neurons. It is also likely that QUIN toxicity is additive or synergistic with other immune system-derived toxins, which act also via or modulate the NMDA receptor (Fig. 3).

### 3-Hydroxykynurenine

3-Hydroxykynurenine can produce neuronal damage by the induction of oxidative stress rather than an action on glutamate receptors. 3-Hydroxykynurenine also acts synergistically with QUIN and potentiates its toxicity.

### Kynurenic Acid

Kynurenic acid is an antagonist of all ionotropic glutamate receptors including N-methyl-D-aspartate (NMDAR), kainic acid and  $\alpha$ -amino-3-hydroxy-5-methyl-4-isoxazole (AMPA) receptors. Furthermore, kynurenic acid non-competitively inhibits  $\alpha$ 7-nicotinic acetylcholine presynaptic receptors (nAChRs). Kynurenic acid is the only known endogenous NMDA receptor inhibitor, which act at the glycine site of the NMDAR and can antagonize some of the effects of quinolinic acid and other excitotoxins. It is noteworthy that in disease states where a large excess quinolinic acid is produced there is insufficient kynurenic acid to block quinolinic acid.

### Picolinic Acid

Picolinic acid has been shown to be neuroprotective. Picolinic acid protects against quinolinic acid and kainic acid-induced neurotoxicity in the brain. However, picolinic acid blocks the neurotoxic but not the excitatory effects of QUIN. The mechanism of its

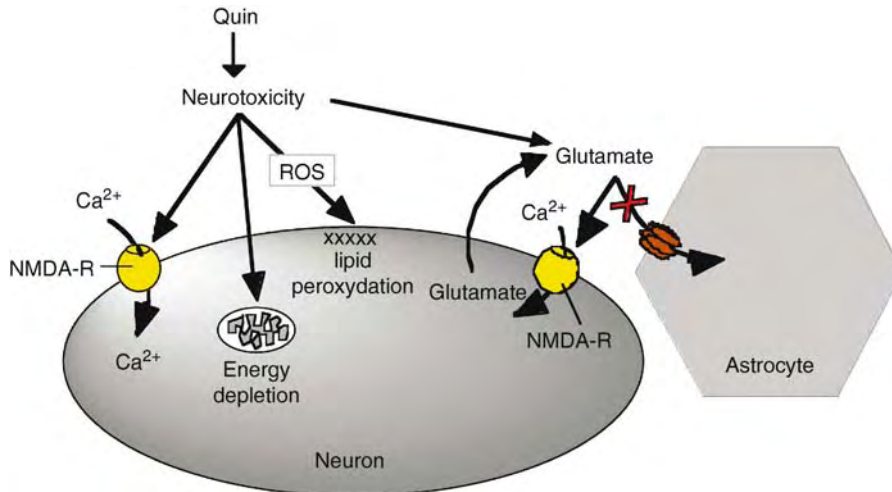

**Neurodegenerative Diseases: Tryptophan Metabolism. Figure 3** Mechanisms of quinolinic acid neurotoxicity.

anti-neurotoxic action is unclear but might involve zinc chelation and/or inhibition of nitric oxide synthase. Picolinic acid can influence the immune response and has antifungal, antitumoral and antibacterial activities.

### Therapy

Over the last two decades, manipulation of the kynurenine pathway has led to the development of a large number of neuroprotectant and anticonvulsant drugs [9,10].

- Some of these drugs target specific enzymes of the pathway. For example, tryptophan analogs such as 1-methyl tryptophan or 6-chlorotryptophan inhibit IDO activity; another family of compounds such as Ro 61-8,048 and m-nitrobenzoyl-alanine inhibit kynurenine hydroxylase activity.
- Other drugs are developed for their ability to block glutamate receptors and stop excitotoxic mechanisms. Kynurenine and kynurenic acid have been used as the original molecules for several groups of this kind of compounds. For example, 4-chlorokynurenine crosses the blood brain barrier and blocks quinolinic acid toxicity at the glycine site on NMDA receptors. Some kynurenic acid analogues are in or about to enter clinical trials for treatment of epilepsy, stroke and possibly Parkinson's disease.
- More recently, small interfering RNA (siRNA) targeting IDO, a new generation of inhibitors, has shown a great capacity to block the kynurenine pathway.

### References

1. Stone TW (2001) Kynurenines in the CNS: from endogenous obscurity to therapeutic importance. *Prog Neurobiol* 64:185–218

2. Botting NP (1995) Chemistry and neurochemistry of the kynurenine pathway of tryptophan metabolism. *Chem Soc Rev* 24:401–412
3. Guillemin GJ, Kerr SJ, Smythe GA, Smith DG, Kapoor V, Armati PJ, Croitoru J, Brew BJ (2001) Kynurenine pathway metabolism in human astrocytes: a paradox for neuronal protection. *J Neurochem* 78:1–13
4. Allegri G, Costa CV, Bertazzo A, Biasiolo M, Ragazzi E (2003) Enzyme activities of tryptophan metabolism along the kynurenine pathway in various species of animals. *Farmacol* 58:829–836
5. Takikawa O (2005) Biochemical and medical aspects of the indoleamine 2,3-dioxygenase-initiated l-tryptophan metabolism. *Biochem Biophys Res Commun* 338:12–19
6. Mellor AL, Munn DH (2004) IDO expression by dendritic cells: tolerance and tryptophan catabolism. *Nat Rev Immunol* 4:762–774
7. Munn DH, Zhou M, Attwood JT, Bondarev I, Conway SJ, Marshall B, Brown C, Mellor AL (1998) Prevention of allogeneic fetal rejection by tryptophan catabolism. *Science* 281:1191–1193
8. Guillemin GJ, Kerr SJ, Brew BJ (2005) Involvement of quinolinic acid in AIDS dementia complex. *Neurotox Res* 7:103–123
9. Schwarcz R (2004) The kynurenine pathway of tryptophan degradation as a drug target. *Curr Opin Pharmacol* 4:12–17
10. Stone TW (2001) Endogenous neurotoxins from tryptophan. *Toxicol* 39:61–73

## Neuroeffector Junction

### Definition

A neuroeffector junction is the gap, typically 20–100 nm wide, between a varicosity of an autonomic axon and an effector cell in the target organ. These junctions

are wider and not as specialized in structure as synapses in autonomic ganglia or the central nervous system, or motor end plates in skeletal muscle.

► [Postganglionic Neurotransmitter](#)

## Neuroendocrine Axis

### Definition

It provides the structural and functional basis for interactions between brain, hormones, and glands that allow an organism to respond to external stimuli with complex, sometimes long-lasting physiological changes, such as during stress or reproduction.

Typically, it refers to any of these three pathways and their respective feedback mechanisms: the “Hypothalamus-Pituitary-Adrenal (HPA) axis,” which extends from the hypothalamus in the brain via the anterior part of the pituitary gland to the adrenal cortex, the “Hypothalamo-Pituitary-Thyroid (HPT) axis,” which leads to the thyroid gland, or the “Hypothalamo-Pituitary-Gonadal (HPG) axis,” involving the male and/ or female gonads.

- [Hypothalamo-Pituitary-Adrenal \(HPA\) Axis, Stress and Depression](#)
- [Hypothalamo-Pituitary-Thyroid \(HPT\) Axis](#)

## Neuroendocrine Regulation

### Definition

In the central nervous system several specialized neurons produce peptides and/or proteins that are released as hormones in the circulation. One class of these hormones is the ‘releasing factors’ secreted in the portal system of the median eminence in order to target especially the adenohypophysis, where they liberate or inhibit the secretion of pituitary hormones. The other class of hormones is directly released into the main circulation either via the neural lobe part of the pituitary or via the pineal. The autonomic nervous system has important influences on the release and the efficiency of all these hormones.

- [Hypothalamo-Pituitary-Adrenal \(HPA\) Axis, Stress and Depression](#)
- [Hypothalamo-Neurohypophysial System](#)
- [Neuroendocrine Regulation and the Autonomic Nervous System](#)

## Neuroendocrine Regulation and the Autonomic Nervous System

RUUD M. BUIJS<sup>1,2</sup>, ANDRIES KALSBECK<sup>2</sup>

<sup>1</sup>Instituto de Investigaciones Biomedicas, UNAM, México

<sup>2</sup>Netherlands Institute for Neuroscience, Amsterdam, The Netherlands

### Definition

#### Neuroendocrine Regulation

In the central nervous system several specialized neurons produce peptides and/or proteins that are released as hormones in the circulation. One class of these hormones is the “releasing factors” secreted in the portal system of the median eminence in order to target especially the adenohypophysis, where they liberate or inhibit the secretion of pituitary hormones. The other class of hormones is directly released into the main circulation either via the neural lobe part of the pituitary or via the pineal. The ► [autonomic nervous system](#) has important influences on the release and the efficiency of all these hormones.

#### Autonomic Nervous System

The autonomic nervous system is that part of the central nervous system that operates outside voluntary control. The executing part of the autonomic nervous system is divided into a parasympathetic and a sympathetic branch. These two branches have, in general, antagonistic functions with an anabolic role for the parasympathetic and a catabolic function for the sympathetic branch. In addition information about the functional condition of our organs is transmitted back to the brain via these two branches.

### Characteristics

#### Quantitative Description

Very soon after the discovery of the principle of neurotransmission, Ernst and Bertha Scharer proposed that certain specialized neurons in the hypothalamus would be able to produce hormones and release them into the blood stream. However, it took the scientific community more than 20 years to get used to this idea and only after Wolfgang Bargmann confirmed and elaborated on these findings was their “Neurosecretion” theory accepted. At about the same time, Frederick Banting and Charles Best made their groundbreaking discovery of insulin as a hormone of the pancreas that could save the life of many diabetic patients. These two findings should have made scientists aware that the areas of endocrinology and neuroscience are intimately integrated. Instead the complexity of the brain and the

enormous life saving potential of hormones drove these fields further apart. Now the restoring movement is in progress and more and more it becomes clear that body and mind cannot be separated. Via the autonomic nervous system (ANS), the brain not only affects the production and efficacy of its own hormones but also of the hormones produced by the other organs of the body. Here special attention will be paid to the organization within the central nervous system (CNS) of structures that affect autonomic output and integrate autonomic information in relation with ►neuroendocrine regulation.

### Hypothalamus and the Organization of Autonomic Output and Input

ANS outflow to the periphery is organized in sympathetic and parasympathetic pathways that have, by and large, opposing functions. Autonomic motor neurons responsible for driving this outflow are located in the brain stem and spinal cord respectively. Tracing and stimulation studies demonstrated that mainly the prefrontal cortex, amygdala and hypothalamic nuclei have direct access to autonomic motor centers. Within the ►hypothalamus, the paraventricular nucleus (PVN) is the single most important structure for neuroendocrine and autonomic integration. The PVN consists of neuroendocrine neurons projecting to the neurohypophysis and median eminence and of pre-autonomic

neurons projecting to sympathetic and parasympathetic motor neurons in the intermediolateral column (IML) of the spinal cord and the dorsal motor nucleus of the vagus (DMV) in the (Fig. 1) brain stem respectively.

SCN projections seem to reach the neuroendocrine neurons in the PVN (i.e. CRH, TRH) via an indirect pathway. Interneurons are mainly located in the MPO, subPVN and DMH. As described in the text, this indirect pathway is involved in the control of the daily rhythm of corticosterone release. The neuroendocrine CRH neurons in the PVN project to the median eminence. CRH released in the median eminence will stimulate ACTH secretion from the anterior pituitary, which will finally reach the adrenal cortex via the general circulation and stimulate corticosterone secretion.

The PVN output to non-autonomic sites in the brain in contrast is limited and mainly organized to support its hormonal and autonomic output. For instance, the PVN projects to sites where visceral (sensory) information is transmitted from autonomic sensory fibers to neurons of the CNS (Fig. 2). Via these projections, the PVN is able to modulate incoming information as well. Recent studies have shown that PVN axons projecting to sympathetic and parasympathetic motor neurons have collaterals to the NTS, suggesting that “a copy” of the outgoing signal is sent to the neurons receiving incoming information, as if to inform them what the

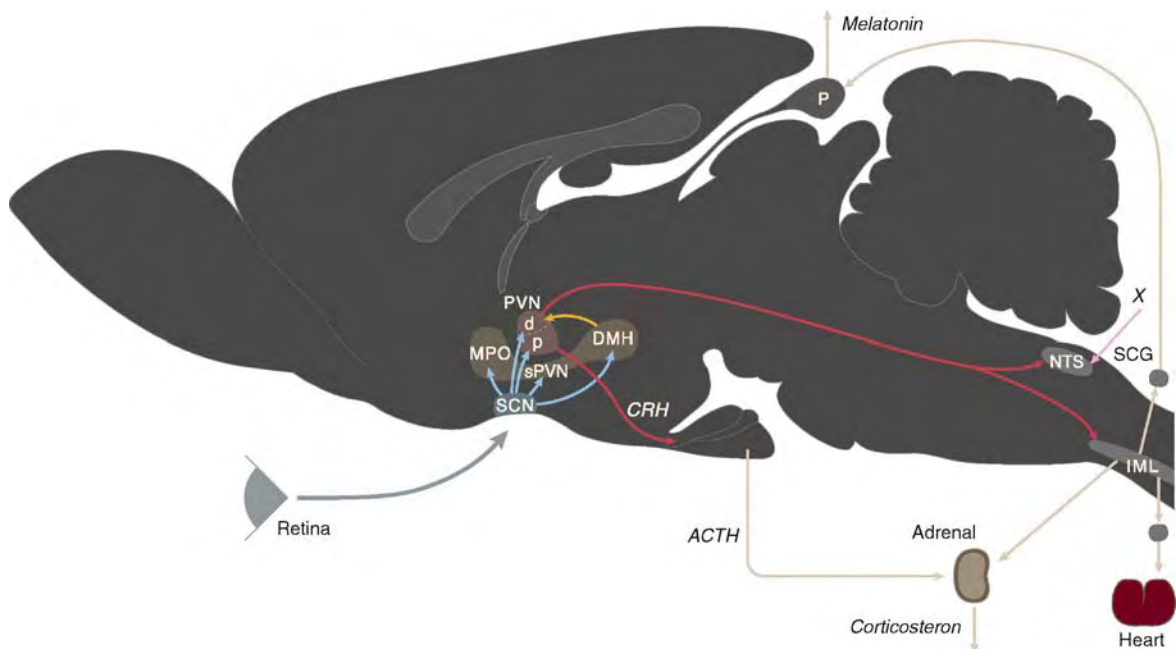

**Neuroendocrine Regulation and the Autonomic Nervous System. Figure 1** Pathways via which light affects hormonal and autonomic output by the hypothalamus. Via the retina, light information is transmitted to the SCN and passed on to the pre-autonomic neurons in the PVN via direct SCN–PVN connections. The autonomic neurons of the PVN pass the light information to the sympathetic motor neurons in the IML, with collaterals to the NTS (see Fig. 2) and directly inhibit melatonin secretion from the pineal. Along the same pathway, light will also change the sensitivity of the adrenal cortex to ACTH and thereby affect corticosterone secretion and reduce the heart rate in rats.



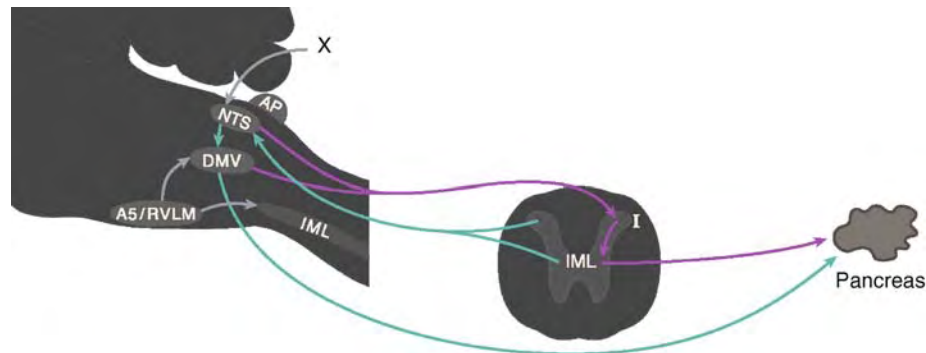

**Neuroendocrine Regulation and the Autonomic Nervous System. Figure 2** The autonomic circuit. The parasympathetic-sympathetic interaction illustrates the relationship between the cell groups that may influence the vagal output in *green* or the sympathetic output in *pink*. It is clear that both vagal and sympathetic output influence each other.

action of the brain is. To make this picture of the organization of the autonomic output of the brain complete, it is essential to keep in mind that within the parasympathetic DMV and sympathetic IML, not only motor neurons are present but also interneurons that project to respectively the IML and DMV. In this way the autonomic output and input forms a feedback circuit that can function on its own and forms the basis for the autonomic control that can operate in decerebrate animals. Via the PVN this “autonomic” circuit is open to central (hypothalamic, amygdalar and cortical) modulation (Fig. 2).

Consequently, the PVN can be seen as the major center, controlling the neuroendocrine and autonomic output of the brain.

### Balancing Autonomic Output

Our evolutionarily shaped homeostatic systems have “learned” to adapt to the ever-changing light/dark cycle so that the body anticipates coming periods of sleep or activity. In all organisms, mechanisms have developed that can predict when the day ends or starts. These mechanisms are known as the “circadian system.” In all cells of the body, clock mechanisms have evolved that in one way or another can keep track of time. However, the brain is the only location where an autonomous biological clock is located, i.e. in the suprachiasmatic nuclei (SCN) of the ventral hypothalamus. By enforcing its message to the PVN, the SCN is able to transmit its daily signal via hormones and the autonomic nervous system to all tissues of the body. Via these signals body tissues are prepared for activity or sleep. The SCN needs to activate body organs and tissues depending on their function at different times of the day, for example muscles work in the active phase when the digestive tract slows down. Thus, during the active phase, an opposite autonomic tone on vasculature will redirect blood away from the abdominal compartment towards

the movement compartment. At the same time cerebral blood flow is kept constant. The major advantage of an endogenous oscillator is that it allows the body to anticipate these changes. One of the questions that puzzled investigators for a long time is how SCN neurons, that are mainly active during the daytime, are connected to these two different autonomic systems. Thus in a series of tracing experiments a strict separation between sympathetic and parasympathetic projecting neurons at the level of the PVN was shown to persist up to the SCN (Fig. 3).

The complete segregation of parasympathetic and sympathetic pre-autonomic neurons provides the anatomical basis for a differential control of these two autonomic branches by the hypothalamus. Functionally this separation between parasympathetic and sympathetic pre-autonomic neurons makes perfect sense. For instance, at night the SCN slows down heart function, resulting in a dip in blood pressure. The sympathetic and parasympathetic autonomic nervous systems are proposed to have opposing functions, with alternating activities over the sleep-wake cycle. Moreover, even when we consider sympathetic input alone, it cannot be activated over the whole body at the same moment. At the time when melatonin secretion from the pineal is stimulated by sympathetic terminals, the sympathetic input to the heart needs to be inhibited, at least in humans.

### The Autonomic Nervous System Differentiates Between Functionally Different Body Compartments

Recent studies indicate that the body can be divided into different functional autonomic compartments and that at least a thoracic, a movement and a visceral compartment should exist. In this setting, a balanced and flexible autonomic nervous system can oscillate the activities of the organs within the different compartments according to the actual needs of the body. Using

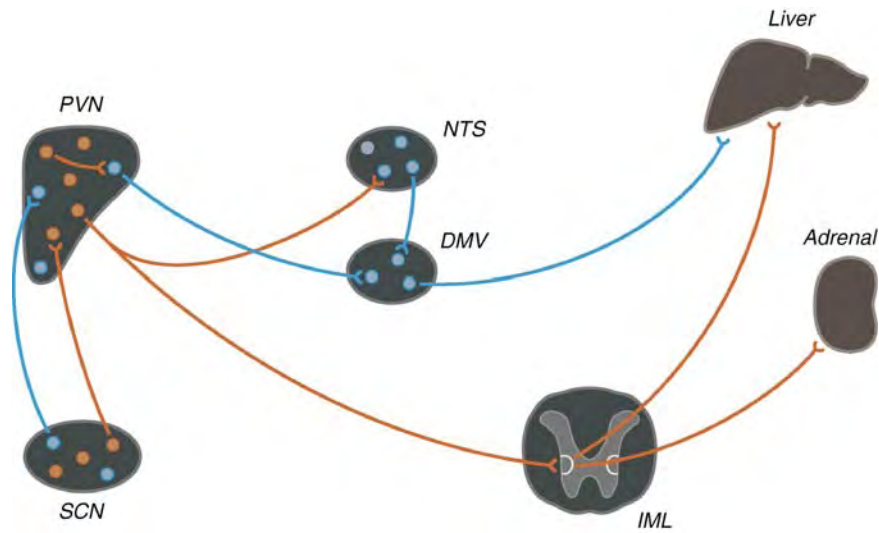

**Neuroendocrine Regulation and the Autonomic Nervous System. Figure 3** Sympathetic and parasympathetic differentiation. Scheme of interaction between the hypothalamic suprachiasmatic nucleus (SCN) and paraventricular nucleus (PVN). Separate sympathetic (red) or parasympathetic (blue) neurons of the SCN project to pre-autonomic neurons of the PVN, where a similar sympathetic-parasympathetic separation can be observed. Pre-autonomic neurons of the PVN project either to the preganglionic sympathetic neurons in the intermediolateral (IML) column of the spinal cord or to the preganglionic neurons of the dorsal motor nucleus of the vagus (DMV). The pre-sympathetic PVN neurons have axon collaterals to pre-parasympathetic neurons, either in the PVN itself or via the nucleus tractus solitarius (NTS).

viral retrograde tracers to label the motor neurons that innervate specific organs, abdominal organs such as liver, pancreas and intra-abdominal fat were shown to share the same vagal motor neurons. In contrast, distinct sets of vagal motor neurons project to fat tissue that is located in the intra-abdominal or subcutaneous compartments. Again this somatotopic organization was shown to exist up to the hypothalamic biological clock and the amygdalar limbic system. Most probably this astonishing capacity of hypothalamic neurons to specialize also coordinates the “dawn phenomenon,” where enhanced glucose production by the liver coincides with enhanced glucose uptake by the target organs at the beginning of the daily activity phase. These two processes will need different actions of the sympathetic neurons that project to the liver (i.e. activity) and to the muscular vasculature (i.e. inactivity). On the other hand, when unbalanced, the shared command of intra-abdominal organs may also result in the simultaneous occurrence of diabetes type 2, dyslipidemia and visceral obesity.

### The Hypothalamus Targets the Organs of the Body both by Hormones and by Autonomic Output

The PVN is a hypothalamic center that is able to adapt and coordinate hormonal and autonomic responses, not only by virtue of a highly differentiated hormonal output but also by an equally well-differentiated autonomic output. The enormous variety of different

neuroendocrine and autonomic neurons offers the PVN a great potential for integration and harmonization of function. In fact, several studies have demonstrated the presence of an anatomical network for intra-PVN integration and coordination. As an example, the daily rhythm in the activity of the hypothalamo-pituitary-adrenal axis will be discussed in somewhat more detail. The SCN has both direct and indirect connections with the CRH producing neurons in the PVN to control CRH and thus ACTH secretion. The indirect connections run via SCN projections to the interneurons in the DMH that project to the PVN. Next to these neuroendocrine connections the SCN also has direct connections with the pre-autonomic neurons in the PVN projecting to sympathetic motor neurons in the IML that are in direct contact with the adrenal. Probably the SCN also has indirect connections (via the DMH) with the pre-autonomic neurons in the PVN. Using this myriad of connections, the SCN synchronizes its actions so that it affects the autonomic output of the PVN and thus sensitizes the adrenal cortex for ACTH at the same moment that ACTH secretion from the pituitary is stimulated. As a result, the response of the adrenal cortex to ACTH is greatly facilitated.

It is proposed that by the combination of hormones and autonomic output not only the biological clock, but also other brain structures will be able to optimally affect the functioning of organs. Naturally it is also possible that the functionality of organs is affected only

by changing their sensitivity and that the hormones are regulated by another mechanism.

## References

1. Buijs RM, Kalsbeek A (2001) Hypothalamic integration of central and peripheral clocks. *Nat Rev Neurosci* 2:521–526
2. Buijs RM, Kreier F (2006) The metabolic syndrome: a brain disease? *J Neuroendocrinol* 18:715–716
3. Buijs RM, Scheer FA, Kreier F, Yi C, Bos N, Goncharuk VD, Kalsbeek (2006) Organization of circadian functions: interaction with the body. *Prog Brain Res* 153:341–360
4. Cottrell GT, Ferguson AV (2004) Sensory circumventricular organs: central roles in integrated autonomic regulation. *Regul Pept* 117:11–23
5. Kreier F, Yilmaz A, Kalsbeek A, Romijn JA, Sauerwein HP, Fliers E, Buijs RM (2003) Hypothesis: shifting the equilibrium from activity to food leads to autonomic unbalance and the metabolic syndrome. *Diabetes* 52:2652–2656
6. Pavlov VA, Tracey KJ (2004) Neural regulators of innate immune responses and inflammation. *Cell Mol Life Sci* 61:2322–2331
7. Swaab DF (1997) Neurobiology and neuropathology of the human hypothalamus. *Handbook Chem Neuroanatomy* 13:39–137
8. Yi CX, Van DV, Dai J, Yin G, Ru L, Buijs RM (2006) Ventromedial arcuate nucleus communicates peripheral metabolic information to the suprachiasmatic nucleus. *Endocrinology* 147:283–294

---

## Neuroendocrine System

### Definition

Hormone producing neurons.

- ▶ [The Hypothalamo Neurohypophysial System](#)
- ▶ [Hypothalamo-Pituitary-Adrenal Axis](#), ▶ [Stress and Depression](#)

---

## Neuroendocrinological Drugs

CYNTHIA L. DARLINGTON

Department of Pharmacology and Toxicology, School of Health Sciences, University of Otago Medical School, Dunedin, New Zealand

### Synonyms

Steroid hormones; Neurosteroids; Neuroactive steroids

### Definition

Neuroendocrinological drugs may be naturally occurring steroid hormones, or synthetic hormones that mimic the activity of the naturally occurring steroid hormones. These steroid hormones, referred to as neurosteroids are synthesized in the CNS and in the peripheral nervous system. Neuroactive steroids are steroid hormones that act on neurosteroid receptors, regardless of the origin of the steroid. Examples of neuroactive steroids include ▶ [estrogens](#), ▶ [progesterone](#), and progesterone metabolites including allopregnanolone, testosterone and metabolites including 3 $\alpha$ -androstane-20-one. In this entry, “estrogen” is used as a generic term to refer to any neuroactive steroid with estrogenic activity while “progesterone” refers to the naturally occurring ▶ [progesterone](#) or a progesterone metabolite. “▶ [Androgens](#)” refers to neuroactive steroids with masculinizing effects. Corticosteroids may also be neuroactive steroids.

### Characteristics

#### Overview

Neuroactive steroids, or their synthetic analogs, exert their actions in the CNS by binding to specific neurosteroid receptors or by binding to neurosteroid binding sites on other types of receptors in the CNS, e.g. the GABA<sub>A</sub> receptor.

Neuroactive steroids, like all steroid hormones, are synthesized from cholesterol via discreet enzymatic pathways. Neuroactive steroids are secreted largely under the control of the hypothalamic-pituitary-adrenal (HPA) axis. Specific neurosteroids are secreted within the CNS by several types of cells including oligodendrocytes. The factors controlling neurosteroid secretion are less well understood. In addition, in pregnant females, the neuroactive steroids estrogen and progesterone, are secreted by the placenta and the corpus luteum, respectively.

Neurosteroid receptors are members of the large family of “ligand-dependent nuclear transcription factors” (steroid receptors), with cytosolic or nuclear binding complexes that, in the case of the cytosolic receptors, are translocated to the nucleus, and bind to a promoter region on DNA. The binding of the receptor complex to the promoter region initiates the release of mRNA from the nucleus into the cytoplasm and ultimately, to the production of new protein by the endoplasmic reticulum. However, not all neuroactive steroid activities are modulated by intracellular receptors. It is evident from a number of experimental results that membrane-bound neurosteroid receptors are also active in the CNS. In addition, an allosteric binding site for a ▶ [progesterone](#) metabolite has been identified on the GABA<sub>A</sub> receptor and sigma receptors, nicotinic acetylcholine receptors and the NMDA, kainate and AMPA subtypes of the glutamate receptors have been demonstrated to be

modulated by neuroactive steroids [1]. As these neurotransmitter receptors are the targets of many non-steroidal neuroactive drugs, the importance of neuroactive steroids as potential therapeutic agents is clear.

One ramification of the discovery and identification of neuroactive steroids has been to identify a mechanism for sex differences in brain function, specifically in brain activity not related to reproductive status. Estrogen, progesterone and androgen receptors are distributed throughout the brains of both females and males. The levels of the hormones, as measured in blood plasma, differ markedly between females and males, depending upon the timing of the measurement. In males, testosterone is released in a pulsatile manner throughout the 24 h cycle, while the low levels of estrogen and progesterone in males remains fairly stable. In females, estrogen and progesterone levels fluctuate on an approximately 28 day cycle, with an estrogen peak on day 14 and a lower estrogen peak again around cycle day 20. Finally, it tapers off by day 28. Progesterone, on the other hand is extremely low until cycle day 17, when it increases rapidly and peaks around day 21, dropping rapidly again by day 28. Changes in mood and behaviour have been associated with these hormonal changes. It is only recently that the implications of the hormonal changes for neurotransmitter function have been recognized.

### Historical Perspective on Neurosteroids and Neuroactive Steroids

McEwen and colleagues [2] were responsible for landmark experiments in the 1960s demonstrating the presence of steroid hormones in the brain tissue of rats. Over the next 10 years, extensive research demonstrated the presence of steroid hormone receptors throughout the mammalian brain, and many of these receptors were found outside areas of the CNS associated with reproductive behaviour. This latter result led to the suggestion that steroid hormones might modulate brain activity associated with non-reproductive behaviour. Baulieu [3] coined the term “neurosteroids” in 1981 and in the following years identified many of the neuroactive steroids.

Elucidation of the binding characteristics of neurosteroid receptors has been a major focus of research since the 1980s. While it has been clearly established that neurosteroid receptors have response characteristics in common with most members of the steroid receptor family, some experimental results have not been consistent with intracellular receptor binding. It has been demonstrated that some neuroactive steroids activate membrane bound receptors associated with ion channels and G-proteins, some transporter systems are sensitive to neuroactive steroids, a number of neurotransmitter systems are modulated by neuroactive steroid activity (see above) and both estrogen and

progesterone have been reported to modulate the expression of different subunits of the GABA<sub>A</sub> receptor [4,5]. It is the interactions with the GABAergic and serotonergic system that have been of particular interest to the development and administration of psychoactive drugs such as benzodiazepines and selective serotonin reuptake inhibitors for the treatment of anxiety and depression [6].

Numerous studies have demonstrated that neuroactive steroids modulate memory and cognition [6]. Estrogen is generally considered an “activator” in the brain, administration of estrogen lowers seizure threshold, prolongs the duration of seizures. The relationship of estrogen to seizure activity is recognized as the term “catamenial epilepsy,” a form of epilepsy that is linked to the menstrual cycles in females. Progesterone is known to have sedative effects, administration lowers the seizure threshold, shortens seizure duration, and it has been used as an anesthetic.

### Current Therapeutic Strategies

The use of neuroactive steroids as therapeutic agents is relatively recent. Corticosteroids, such as methylprednisolone, have been and continue to be used to prevent and treat edema following head injury. This anti-inflammatory effect is, however, independent of the actions of neuroactive steroids that are the focus of this discussion.

Estrogen has been used in conjunction with conventional treatments in females suffering from Parkinson’s disease or Alzheimer’s disease with limited success [7]. Dementia occurs in some patients with Parkinson’s disease and it has been reported that hormone replacement therapy (HRT) decreases the incidence of dementia in older patients. It has also been reported that taking HRT decreases the risk of developing Alzheimer’s disease. There are numerous studies showing that estrogen, when taken alone, has a positive effect on mood and cognitive function, but that with the addition of progesterone, the positive effects disappears [6]. This observation on progesterone administration raises one of the potential problems for the use of estrogen as a therapeutic agent. Estrogen has a proliferative effect, enriching the endometrium, causing tissue thickening in preparation for implantation of a fertilized ovum. When fertilization does not occur, the release of progesterone causes the retraction and ultimate sloughing of the excess tissue. If estrogen is given without progesterone administration, either concomitantly or sequentially, the endometrial thickening continues unchecked, increasing the risk for the development of endometrial cancer. In HRT and the contraceptive pill, progesterone is an essential component. An area where the actions of progesterone could be an advantage is in the treatment of catamenial epilepsy. Given the antiepileptic properties of progestagens, the

choice of a progestagen only contraceptive might provide antiseizure activity to enhance the action of antiepileptic drugs, while providing the desired contraceptive effect.

A current impediment to the use of neuroactive steroids as therapeutic agents is the side effect profile and adverse events associated with their administration. Deep vein thrombosis, for example, is associated with both progestagen and estrogen administration. Estrogen is contraindicated for administration to individuals with a history of cardiovascular disease, stroke, blood clotting disorders, focal migraine, hypertension and some kinds of cancers. Progestagen, when administered alone as an injectable contraceptive, is associated with a disruption of calcium metabolism and is currently only recommended for an administration period of 2 years.

### Future for Drug Development

The therapeutic uses of neuroactive steroids will depend upon the specificity of the action that can be achieved. There are two known types of estrogen receptors (ER),  $\alpha$  and  $\beta$ , with different actions and distribution for each. ER $\alpha$  are found predominantly in the amygdala, septum and hypothalamus, and in smaller numbers in brainstem nuclei including the periaqueductal grey, locus coeruleus and area postrema. ER $\beta$  are found in lower concentration than ER $\alpha$  with the highest numbers being found in the amygdala, septum, hypothalamus and olfactory cortex. There are two types of progestagen receptors with functions that are yet to be clarified. Androgen receptors are also found in the brain. Undoubtedly, there are additional types and subtypes of these receptors yet to be discovered. There are also neurosteroid binding sites associated with classical neurotransmitter receptors as allosteric binding sites. There are different estrogens (17 $\beta$ -estradiol, estrone and estradiol), progestagens (e.g. progesterone, allopregnanolone, 17 $\alpha$ -hydroxyprogesterone, 20 $\alpha$ -hydroxyprogesterone) and **androgens**, with slightly differing chemical structures (Table 1). Targeting specific populations of neurosteroid receptors is one obvious direction for drug development. Another direction is the targeting of allosteric binding sites on particular populations of neurons with classical neurotransmitter receptors or transporter proteins such as the dopamine transporter.

The GABA<sub>A</sub> receptor is a particularly good candidate for this approach. The GABA<sub>A</sub> receptor, in addition to the GABA binding site, has allosteric binding sites for benzodiazepines, barbiturates, progestagens and alcohol. It is the primary inhibitory neurotransmitter receptor found in the brain. The GABA<sub>A</sub> receptor is composed of assemblies of subunits arranged around a central chloride channel (see Chapter on Anxiolytics and Hypnotics). The subunits are found in different combinations of subunit type ( $\alpha$ ,  $\beta$ ,  $\gamma$ ,  $\delta$ ,  $\epsilon$ ,  $\pi$ ,  $\rho$ ). The

**Neuroendocrinological Drugs. Table 1** Examples of neuroactive steroids

Class	Neuroactive steroid
Estrogen	17 $\beta$ -estradiol
	Estrone
	Estradiol
Progestagen	Progesterone
	Allopregnanolone,
	17 $\alpha$ -hydroxyprogesterone
	20 $\alpha$ -hydroxyprogesterone
Androgen	Testosterone
	3 $\alpha$ -androstane-2,17-dione
Corticosteroid	3 $\alpha$ , 5 $\alpha$ -tetrahydrodeoxycorticosterone (THDOC)

subunit combination of any given receptor determines the pharmacological actions associated with activation of the receptor. Receptors with certain subunit combinations are distributed differently throughout the brain. Binding of ligands to the allosteric binding sites enhances the effect of GABA. It is conceivable that a neurosteroid could be synthesized to target the progestagen binding site, and by modifying the action of benzodiazepines, barbiturates or alcohol overcome some of their adverse side effects.

Epidemiological studies show that females have a higher incidence of anxiety and depressive disorders. Serotonin levels are significantly lower in the female brain than in the male brain. Females are also receive more prescriptions of anxiolytic and antidepressant drugs than males [7]. It may, in the future, be possible to capitalize on the changing levels of neuroactive steroids associated with the menstrual cycle to target and refine drug effects.

The progesterone metabolite allopregnanolone (which may act only on the GABA<sub>A</sub> receptor and not progestagen receptors) has been reported to have detrimental effects on mood, memory, cognitive function and has been reported to be associated with premenstrual mood changes. One possibility would be to develop antagonists to allopregnanolone that act specifically to reduce the adverse events associated with its administration. 3 $\beta$ -hydroxypregnane has recently been reported to reduce the learning deficits produced by allopregnanolone administration [6] suggesting that this may be a useful direction for drug development.

### References

- Dubrovsky BO (2004) Steroids, neuroactive steroids and neurosteroids in psychopathology. *Prog Neuropsychopharmacol Biol Psychiatry* 29:169–192

2. McEwen BS, Weiss JM, Schwartz LS (1968) Selective retention of corticosterone by limbic structures in the rat brain. *Nature (London)* 220:911–912
3. Baulieu EE (1998) Neurosteroids, a novel function of the brain. *Psychoneuroendocrinology* 23:963–987
4. Macguire JL, Stell BM, Rafizadeh M, Mody I (2005) Ovarian cycle-linked changes in GABA<sub>A</sub> receptors mediating tonic inhibition alter susceptibility and anxiety. *Nat Neurosci* 8:797–804
5. Pierson RC, Lyons AM, Greenfield LJ Jr (2005) Gonadal steroids regulate GABA<sub>A</sub> receptor subunit mRNA expression in NT2-N neurons. *Mol Brain Res* 138:105–115
6. Birzniece V, Backstrom T, Johansson IM, Lindblad C, Lundgren P, Lofgren M, Olsson T, Ragagnin G, Taube M, Turkmen S, Wahlstrom G, Wang MD, Wihlback AC, Zhu D (2006) Neuroactive steroid effects on cognitive functions with a focus on the serotonin and GABA systems. *Brain Res Rev* 51:212–239
7. Darlington CL (2002) The female brain. In the series *Conceptual advances in brain research*. Taylor & Francis, London

## Neuroendocrinology

DICK F. SWAAB<sup>1</sup>, PAUL J. LUCASSEN<sup>2</sup>

<sup>1</sup>Netherlands Institute for Neuroscience, Amsterdam, The Netherlands

<sup>2</sup>Centre for Neuroscience, Swammerdam Institute of Life Sciences, University of Amsterdam, The Netherlands

### Definitions

► **Neuroendocrinology** is the field that studies hormone production by neurons, the sensitivity of neurons for hormones, as well as the dynamic, bidirectional interactions between them. These processes function in concert to allow maintenance of homeostasis for the organism. The central region of interest in this field is the ► **hypothalamus**, as many endocrine cascades are initiated there and ► **feedback** regulation of these very same cascades also takes place in this area. In addition to the hypothalamus, most other brain areas are sensitive to hormonal action as well.

The human hypothalamus is a small (4 cm<sup>3</sup>) but very complex heterogeneous brain structure. Together with its adjacent areas it is composed of some 20 well-defined (sub)nuclei between 0.25 and 3 mm<sup>3</sup> in size, with very different chemical components and functions (Fig. 1). Their neurons contain one or more of all four types of neuroactive substances; acetylcholine, amines, amino acids, and a multitude of ► **neuropeptides**.

A special characteristic of the hypothalamus is that some neurons projecting to the ► **neurohypophysis** or to the portal vessels of the pituitary in the ► **median**

**eminence**, release their peptide into the blood and act as ► **neurohormones**. Other neurons project to neurons within and outside the hypothalamus, where they function as ► **neurotransmitters** or ► **neuromodulators**, and regulate central functions, including the ► **autonomic innervation** of all our body organs [1]. In this way, the hypothalamus acts as a center that integrates endocrine, autonomic, and higher brain functions. The fact that neuropeptides are generally very stable after death makes them very suitable as markers of hypothalamic nuclei that enables the identification of structural and functional changes in key hypothalamic nuclei and transmitter systems in postmortem material obtained from patients with e.g. different ► **neuroendocrine disorders**.

The hypothalamus regulates essential processes throughout all stages of life, and is also the primary structure involved in a number of disorders. A few examples of such hypothalamic disorders will be presented in this synopsis in relation to the different hypothalamic areas.

### The Classical Neuroendocrine Neurons in the Supraoptic (SON) and Paraventricular Nucleus (PVN)

The ► **supraoptic and paraventricular nucleus** (SON and PVN) and their axons running to the neurohypophysis form together the ► **hypothalamo-neurohypophysial system** (HNS), which represents the classic example of a neuroendocrine system. ► **Vasopressin** (= ► **antidiuretic hormone**, ADH) and ► **oxytocin** are key hormones produced in the large, magnocellular neurons of the SON and PVN, and are e.g. involved in ► **antidiuresis**, ► **labor** and ► **lactation**. A second type of smaller neuroendocrine cells, the parvicellular neurons, is found in the PVN. They release their peptides into the ► **portal capillaries** that transport them to the ► **anterior lobe of the pituitary**. Examples are ► **corticotrophin releasing hormone** (CRH) and ► **thyrotrophin releasing hormone** (TRH). A third type of PVN cells projects to other neurons, where the peptides act as neurotransmitters/neuromodulators. These involve e.g. vasopressin, oxytocin, CRH and TRH neurons that thereby regulate the autonomic nervous system [1]. The entire SON contains some 78,000 neurons on one side from which 88% contains vasopressin and 12% contains oxytocin. The PVN has been estimated to contain about 56,000 neurons of which some 25,000 express oxytocin and 21,000 produce vasopressin. A large number of other, often co-expressing peptides are found in both nuclei [2].

The SON is the main source of circulating vasopressin. Disorders of this vasopressin system involve familial central ► **diabetes insipidus** with mutations in the vasopressin precursor, autoimmune diabetes insipidus with antibodies against the vasopressin neurons, pregnancy-induced diabetes insipidus due to increased breakdown of plasma vasopressin, ► **nephrogenic**

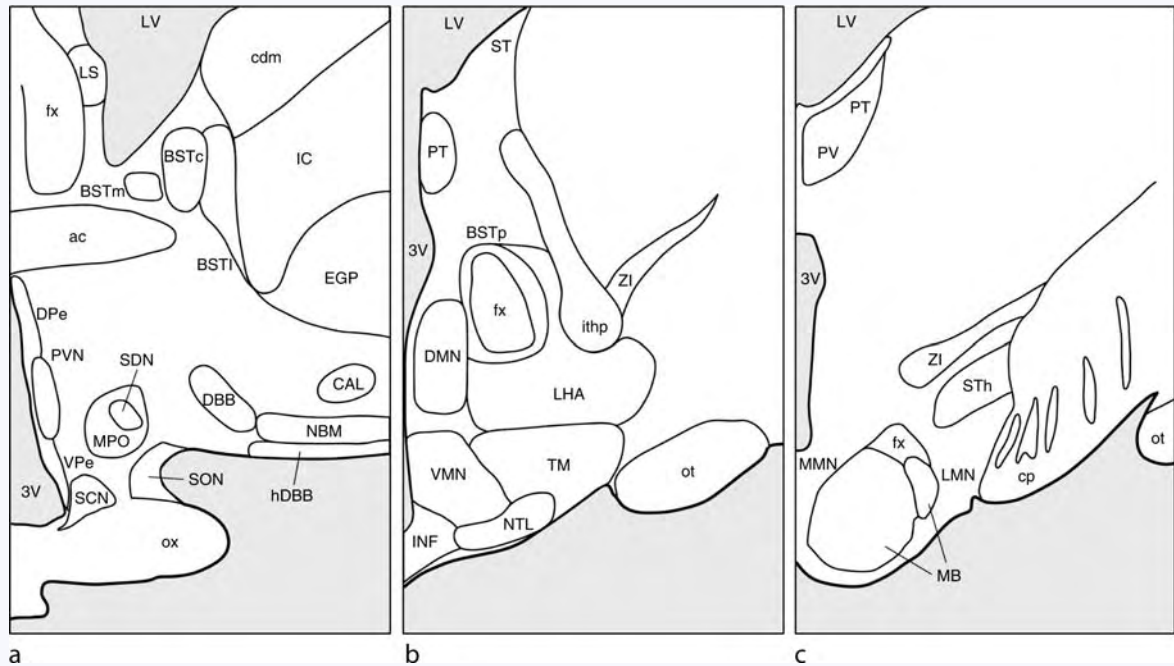

**Neuroendocrinology. Figure 1** Schematic representation of the nuclei of the human hypothalamus. Abbreviations: ac: anterior commissure, BST: bed nucleus of the stria terminalis, (c = centralis; m = medialis; l = lateralis; p = posterior); cp: cerebral peduncle, DPe: periventricular nucleus dorsal zone, fx: fornix, hDBB: horizontal limb of the diagonal band of Broca, INF: infundibular nucleus, MB: mamillary body i.e. MMN: medial mamillary nucleus: LMN: lateromamillary nucleus, NBM: nucleus basalis of Meynert, OT: optic tract, Ox: optic chiasma, PVN: paraventricular nucleus, SCN: suprachiasmatic nucleus, SDN: sexually dimorphic nucleus of the preoptic area, SON: supraoptic nucleus, 3V: third ventricle, VMN: ventromedial hypothalamic nucleus, VPe: periventricular nucleus ventral zone (adapted from [2]; Fig. 1.6).

diabetes due to mutations in the gene of the vasopressin receptor-2 or in the gene of the water channel protein aquaporin-2, nocturnal diuresis, ►inappropriate secretion of vasopressin (Schwartz–Barter syndrome), ►Wolfram’s syndrome, and glucocorticoid administration, in which we found a processing disorder of vasopressin, and ►septo-optic dysplasia (De Morsier’s syndrome), in which we observed that the SON and PVN were virtually absent [2].

The PVN contains a large number of different neuropeptides [2]. CRH is produced by parvicellular neurons and is a crucial neuropeptide in the regulation of the ►hypothalamo-pituitary-adrenal (HPA)-axis, the final common pathway in the ►stress response. Once a stressor is perceived, rapid rises in CRH in the PVN subsequently stimulate the release of ►adrenocorticotropic hormone (ACTH) from the anterior pituitary into the circulation. The ACTH-releasing activity of CRH is strongly potentiated by vasopressin when co-produced by the same CRH containing parvicellular neurons. ACTH is released into the blood and frees ►cortisol from the adrenal, the main steroid hormone in humans that coordinates various aspects of the stress response throughout the body and CNS. These include changes in behaviour, such as rises in alertness and anxiety, an

activation of the autonomic nervous system, causing increases in heart rate and respiration, redistribution of the bloodstream and mobilization of energy sources. At the same time, various processes and bodily systems are temporarily inhibited that are of lesser importance during an acutely threatening situation, including suppression of gastrointestinal function, sleep, sexual activity and growth. In addition, cortisol is one of the most powerful endogenous feedback compounds on the ►pro-inflammatory signal transduction machinery. Hyperactivity of the HPA axis is furthermore a key phenomenon in ►depression and is held responsible for symptoms like decreased ►food intake, decreased sexual activity, disturbed sleep and motor behavior and increased anxiety. The HPA-axis is also activated in ►multiple sclerosis (MS).

After being released from the adrenal, cortisol inhibits its own release through feedback inhibition on the very same brain areas where its release was initially coordinated, through binding to glucocorticoid receptors (GR) in the pituitary and PVN. ►Corticosteroids, at least in rodent, also target the hippocampus that is richly endowed with corticosteroid receptors and is involved in modulation of the stress response. In addition to cortisol, also exogenously applied

corticosteroids inhibit CRH production in the PVN [3]. In addition to a crucial role in initiation of the stress response, CRH also has central effects, including cardiovascular regulation, respiration, appetite control, stress-related behavior and mood, cerebral blood flow regulation and stress-induced analgesia.

TRH is released in the median eminence as the major hypothalamic hormone stimulating thyroid function, acting on thyroid ▶stimulating hormone (TSH) cells of the pituitary, whereas ▶somatostatin and dopamine inhibit TSH secretion. The large number of dense TRH fiber terminations in the hypothalamus suggests an important role of this neuropeptide as a neuromodulator [4]. The human PVN is furthermore densely innervated by fibers from the ▶infundibular nucleus. In juxtaposition to the TRH neurons in the PVN, NPY, agouti-related peptide (AGRP) and  $\alpha$ -MSH-containing fibers are found, which are involved e.g. in eating behavior. The TRH neurons of the PVN are less active, not only in depression, where decreased amounts of TRH mRNA were found in the PVN [5], but also in ▶sick euthyroid syndrome (or ▶nonthyroidal illness), a condition often seen in serious illness conditions [6].

### The Suprachiasmatic Nucleus (SCN)

The SCN is the biological clock of the brain that regulates the ▶circadian and seasonal variations occurring in many endocrine and other functions. The ▶circadian pacemaker is localized in the SCN, on top of the optic chiasm, and the clock is entrained to fluctuations in light intensity during the day–night cycle by direct innervation from the ▶retinohypothalamic tract. Vasopressin and ▶vasoactive intestinal polypeptide (VIP) expressing neurons of the SCN project to the ▶dorsomedial nucleus, the subparaventricular zone, and the PVN. Transmeridian flights and shiftwork might lead to disturbances in the functional organization of the biological clock. Moreover, disorders of the circadian timing system are held responsible for advanced and delayed sleep syndrome, a number of other ▶sleep disorders, and nightly restlessness in patients with ▶Alzheimer's disease. In addition, day–night fluctuations in the SCN may be the basis of the clear day–night differences found in the course of various diseases and conditions. For example, the moment when death occurs from myocardial infarction, intracerebral hemorrhage, or ischemic stroke, or the moment when complaints about migraine, depressive symptoms, tremor in Parkinson's disease, and sleep disorders in depression are at their most serious, do not occur at random over the day but all have a strong preference for a particular moment of the day [2]. We have shown a decreased amount of vasopressin mRNA in the SCN of depressed patients [7], indicating a diminished activity of the biological clock that might be the neurobiological basis of sleep disturbances and circadian disorders in these patients.

### Hypothalamic Nuclei with Structural Sex Differences

▶Sex differences in the size of the ▶sexually dimorphic nucleus of the preoptic area (SDN-POA) were first described in the rat by [8]. We have found a similar nucleus in the human hypothalamus. Morphometric analysis of the human SDN-POA revealed that its volume is more than twice as large in young adult men as it is in women, and contains about twice as many cells in men [9]. It seems to be homologous to the SDN-POA in the rat in view of its sex difference in size and cell number, localization, cytoarchitecture, and neurotransmitter/neuromodulator content. [10] gave this nucleus another name: ▶Interstitial nucleus of the anterior hypothalamus-1 (INAH-1) and also described two other cell groups (▶INAH-2 and -3) in the preoptic-anterior hypothalamic area of humans that were larger in the male brain than in the female brain. [11] found a sex difference in INAH-3. Another sex difference was described by [18], in what they called the “▶darkly staining posteromedial component of the bed nucleus of the stria terminalis” ▶(BNST-dspm). The volume of the BNSTdspm was 2.5 times larger in males than in females. We found a similar sex difference in the ▶central nucleus of the bed nucleus of the stria terminalis (BSTc). The BSTc is defined by its dense VIP innervation and by its somatostatin fiber plexus and somatostatin neuron population. The BSTc in men is 40% larger than in women, and men have almost twice as many somatostatin neurons as women [12,13]. We have furthermore found a female-sized central nucleus of the bed nucleus of the BST in male-to-female ▶transsexuals [13]. These data were confirmed by neuronal counts of somatostatin cells, the major neuron population in the BSTc [12].

### Infundibular (Arcuate) Nucleus

The horseshoe-shaped infundibular (or ▶arcuate) nucleus surrounds the lateral and posterior entrance of the ▶infundibulum and is situated outside the blood–brain barrier. The infundibular nucleus contains some 520,000 neurons [14] and is involved in reproduction, pain, eating behavior and metabolism, thyroid hormone feedback, growth, and dopamine regulation.

In addition, the infundibular nucleus is continuous with the ▶stalk/median eminence region that contains the ▶portal capillaries of the adenohypophysis. The ▶neuropeptide-Y (NPY) fibers in the median eminence are mainly restricted to the internal zone and only scarcely innervate the neurovascular zone, whereas CRH, LHRH, ▶opiomelanocortins, somatostatin, ▶GHRH, ▶galanin, TRH, and ▶substance-P fibers do innervate the stalk/median eminence region. The NPY neurons project to the PVN and NPY together with ghrelin e.g., is one of the most active food intake stimulating peptides.



The infundibular nucleus is chemically characterized by the presence of (pre)proopiomelanocortin neurons, containing e.g. ►**α-melanocyte-stimulating hormone** (α-MSH). The sites of fiber termination of the opiomelanocortin neurons are consistent with the brain sites where pain relief was obtained by deep brain stimulation. Moreover, this nucleus contains peptides that inhibit feeding like α-MSH that acts by the ►**MC-4 receptor** and ►**cocaine- and amphetamine-regulated transcript** (CART). AGRP and NPY stimulate feeding and co-localize in the infundibular nucleus. GHRH neurons are involved in metabolism and are activated during prolonged illness [2,15]. Severe ►**obesitas** has been reported due to mutations in the genes for preproopiomelanocortin-, MC-4 receptor-, ►**leptin**, the ►**leptin receptor** and ►**prohormone convertase-1**.

The infundibular nucleus also contains ►**luteinizing hormone-releasing hormone** (LHRH; gonadotropin releasing hormone)-containing cell bodies that, like opioid peptides, play a role in reproduction and sexual behavior, the latter in erections. ►**Estrogen** and ►**androgen** receptors and all four thyroid hormone receptors (TR) isoforms are present in the infundibular nucleus.

A subdivision of the infundibular nucleus in ►**postmenopausal women** and in hypopituitarism was named the ►**subventricular nucleus** after its location beneath the floor of the third ventricle. The production of neurokinin-B (NKB), substance-P, and estrogen receptor transcripts is strongly increased in postmenopausal women due to the diminished inhibitory action of estrogens. The NKB neurons are presumed to be involved in the initiation of menopausal flushes [16].

### Lateral Hypothalamic Area (LHA), Including the Perifornical Area

The LHA is involved in the regulation of food intake and body weight. The classic syndrome following lesions of the lateral hypothalamus involves ►**aphagia** and ►**adipsia**. ►**Melanin concentrating hormone** (MCH) is a neuropeptide produced in the LHA, perifornical and periventricular areas, and in the tuberomammillary and posterior nuclei. MCH increases food intake and lowers plasma glucocorticoid levels in the rat. Quite recently two novel neuropeptides were discovered, designated ►**hypocretin 1 and 2** (from hypothalamus and secretin), or ►**orexin A and B**, that stimulate food consumption in rat. These peptides are localized in the lateral and posterior hypothalamus and accumulate in the perifornical area. The hypocretins are involved not only in food intake, but also in sleep and neuroendocrine control. In ►**narcolepsy** patients that are ►**cataplectic** a 85–95% loss of hypocretin neurons was found without gliosis or signs of inflammation, possibly as the result of an autoimmune process [17].

### Other Hypothalamic Nuclei

Following destruction of the ►**ventromedial hypothalamic nuclei (VMN)** e.g. by a tumor or neurosurgical intervention, a classic tetrad of symptoms has been described, i.e. (i) episodic rage, (ii) emotional lability, (iii) hyperphagia with obesity and (iv) intellectual deterioration, mainly based upon memory loss.

The ►**tuberomammillary nucleus (TMN)** contains the only ►**histaminergic system** of the brain and participates in the modulation of the state of arousal, the control of vigilance, sleep and wakefulness, cerebral circulation and brain metabolism, locomotor activity, neuroendocrine and vestibular functions, drinking, sexual behavior, stress, food intake, analgesia, and the regulation of blood pressure and temperature.

The ►**nucleus tuberalis lateralis (NTL)** can only be recognized as a distinct nucleus in man and higher primates, and contains somatostatin as its main transmitter. The NTL is hypothesized to play a role in feeding behavior and metabolism.

The ►**corpora mamillaria**, its input from the ►**fornix** and the efferent ►**mamillo-thalamic tract** of Vicq d'Azyr are involved in memory processes. In neurodegenerative diseases such as ►**Huntington's disease**, Alzheimer's disease, and ►**Down syndrome**, the nucleus tuberalis lateralis, tuberomammillary nucleus, and corpora mamillaria are seriously affected. The latter structure is also destroyed in ►**boxer's dementia** (punch drunk syndrome).

### References

1. Buijs RM, Kalsbeek A (2001). Hypothalamic integration of central and peripheral clocks. *Nat Rev Neurosci* 2:521–526
2. Swaab DF (2003) The human hypothalamus. Basic and clinical aspects. Part I: Nuclei of the hypothalamus. In: Aminoff MJ, Boller F, Swaab DF (Series eds) *Amsterdam Handbook of clinical neurology*, Elsevier, 476 pp
3. Erkut ZA, Pool CW, Swaab DF (1998). Glucocorticoids suppress corticotropin-releasing hormone and vasopressin expression in human hypothalamic neurons. *J Clin Endocrinol Metab* 83:2066–2073
4. Fliers E, Noppen NWAM, Wiersinga WM, Visser TJ, Swaab DF (1994) Distribution of thyrotropin-releasing hormone (TRH)-containing cells and fibers in the human hypothalamus. *J Comp Neurol* 350:311–323
5. Alkemade A, Unmehopa UA, Brouwer JP, Hoogendijk WJG, Wiersinga WM, Swaab DF, Fliers E (2003) Decreased thyrotropin-releasing hormone gene expression in the hypothalamic paraventricular nucleus (PVN) of patients with major depression. *Mol Psychiatr* 8:838–839
6. Fliers E, Guldenaar SEF, Wiersinga WM, Swaab DF (1997) Decreased hypothalamic thyrotropin-releasing hormone (TRH) gene expression in patients with nonthyroidal illness. *J Clin Endocr Metab* 82: 4032–4036

7. Zhou JN, Riemersma RF, Unmehopa UA, Hoogendijk WJ, Van Heerikhuizen JJ, Hofman MA, Swaab DF (2001) Alterations in arginine vasopressin neurons in the supra-chiasmatic nucleus in depression. *Arch Gen Psychiatry* 58:655–662
8. Gorski RA, Gordon JH, Shryne JE, Southam AM (1978) Evidence for a morphological sex difference within the medial preoptic area of the rat brain. *Brain Res* 148:333–346
9. Swaab DF, Fliers E (1985) A sexually dimorphic nucleus in the human brain. *Science* 228:1112–1115
10. Allen LS, Hines M, Shryne JE, Gorski RA (1989) Two sexually dimorphic cell groups in the human brain. *J Neurosci* 9:497–506
11. LeVay S (1991) A difference in hypothalamic structure between heterosexual and homosexual men. *Science* 253:1034–1037
12. Kruijver FPM, Zhou JN, Pool CW, Hofman MA, Gooren LJG, Swaab DF (2000) Male-to-female transsexuals have female neuron numbers in a limbic nucleus. *J Clin Endocrinol Metabol* 85:2034–2041
13. Zhou JN, Hofman MA, Gooren LJG, Swaab DF (1995) A sex difference in the human brain and its relation to transsexuality. *Nature* 378:68–70
14. Abel TW, Rance NE (2000) Stereologic study of the hypothalamic infundibular nucleus in young and older women. *J Comp Neurol* 424:679–688
15. Goldstone AP, Unmehopa UA, Swaab DF (2003) Hypothalamic growth hormone-releasing hormone (GHRH) cell number increased in human illness, but is not reduced in Prader-Willi syndrome obesity. *Clin Endocrinol* 59:266
16. Rance NE (1992) Hormonal influences on morphology and neuropeptide gene expression in the infundibular nucleus of post-menopausal women. *Prog Brain Res* 93:221–236
17. Mignot E (2001) A commentary on the neurobiology of the hypocretin/orexin system. *Neuropsychopharmacology* 25(5 Suppl):S5–S13
18. Allen LS, Gorski RA (1990) Sex difference in the bed nucleus of the stria terminalis of the human brain. PMID: 1707064 [PubMed - indexed for MEDLINE] *J Comp Neurol* Dec 22; 302(4): 697–706

## Neuroendocrinology of Eating Disorders

DICK F. SWAAB<sup>1</sup>, PAUL J. LUCASSEN<sup>2</sup>

<sup>1</sup>Netherlands Institute for Neuroscience, Meibergdreef, Amsterdam, The Netherlands

<sup>2</sup>SILS Centre for Neuroscience, University of Amsterdam, Amsterdam, The Netherlands

### Definition

The crucial role of the human hypothalamus in eating and metabolic disorders may, in the case of a disorder, lead to either increased or decreased body weight. An

increasing number of such disorders and mechanisms are distinguished. In disorders of eating and metabolism, frequent hypothalamic co-morbidity occurs in terms of mood, sleep and rhythm disorders that are due to the intense hypothalamic interconnectivity and integrative mechanisms. Moreover, these symptoms often occur in an episodic way and generally have a differential prevalence between the sexes.

### Characteristics

Obesity is one of the most pressing health problems in the Western world; anorexia nervosa is a serious psychiatric disorder leading to death in some 10% of the cases. Although for anorexia nervosa the cause is as yet unknown, for many other eating and metabolic disorders, clinical studies have for a long time established a central role for the hypothalamus. In diencephalic syndrome or hypothalamo-optic pathway glioma, emaciation of the entire body is found in infancy and childhood. Lesions in the ventromedial hypothalamus cause increased appetite and obesity, whereas tumors in the lateral hypothalamic area (LHA) can cause anorexia. Seasonal fluctuations in the hypothalamus are the basis for the increases in eating behavior and body weight in fall/winter that reflects the expression of a basic evolutionary process, i.e. ensuring a maximum conservation of energy when food supplies become scarce. Although adaptive in evolution, the same process has become maladaptive in humans when highly palatable, high caloric foods are readily available in present Western society, which may lead for example to the seasonal weight gain in seasonal affective disorder. Narcolepsy is characterized by a tetrad of symptoms, excessive daytime sleepiness, cataplexy, hypnagogic hallucinations and sleep paralysis. There is a substantially (85–95%) reduced number of neurons producing hypocretins/ orexins in the lateral hypothalamus of narcoleptics with cataplexy. An autoimmune cause is considered but not proven.

### Genetic Factors

Human obesity certainly has an important inherited component. Yet the genetic factors responsible for obesity in the general population have remained elusive. As far as single gene mutations are concerned, mutations in the gene encoding for leptin or for the leptin receptor have been described in obese subjects. Another genetic defect leads to extreme childhood obesity, abnormal glucose homeostasis, hypogonadotropic hypogonadism, hypocortisolism and elevated plasma proinsulin and (pro-opiomelanocortin) POMC concentrations, but a very low insulin level. This disorder is based upon a mutation in the prohormone processing endopeptidase, prohormone convertase 1 (PC1). Severe early onset obesity, adrenal insufficiency and red hair pigmentation were found to be caused by POMC mutations. Mutations in the MC-4 receptor gene seem

to be the cause of monogenic human obesity in up to 4–6% of severely obese humans. A glucocorticoid receptor polymorphism is further associated with obesity and dysregulation of the HPA axis. The brain derived neurotrophic factor (BDNF) Met66 variant is strongly associated with all eating disorders, including bulimia [1]. Even though the inheritability of anorexia nervosa is estimated to be around 70%, it remains difficult to distinguish “psychogenic” and “organic” causes. Psychological disturbances without neurological manifestations may in some cases be due to occult intracranial tumors that can result among other things in anorexia nervosa.

Prader-Willi syndrome (PWS), the most common syndromal form of human obesity, is characterized by grossly diminished fetal activity and hypotonia in infancy, mental retardation (mean IQ of 65) or learning disability and a number of hypothalamic symptoms, i.e. feeding problems in infancy that later develop into insatiable hunger and gross obesity (Fig. 1). The patients usually have a *de novo*, paternally derived, deletion of the chromosome region 15q11–13. Severe fetal hypotonia is often already noticed by the mother during pregnancy; the baby does not seem to move much. Apart from the baby’s low level of activity, its position in the uterus at the onset of labor is often abnormal. Timing of the moment of birth is often also

abnormal; many children with PWS are born either prematurely or too late. So far, research into the hypothalamus has revealed an intact Neuropeptide-Y (NPY)/Agouti-Related Protein (AGRP) and Growth Hormone Releasing Hormone (GHRH) system in PWS, which is inhibited in a normal way by obesity, but the number of oxytocin expressing neurons in the PVN is clearly diminished. Oxytocin is a satiety peptide and may thus be related to the eating disorder in this syndrome.

### Hormones

Cushing syndrome may result from exogenous administration of glucocorticoids or from ectopic ACTH production by a tumor often in the lungs or in the pituitary gland, a supra- or extra-sellar microadenoma. High levels of corticosteroids may lead to central or visceral obesity, hypertension and atypical depression. Metabolic syndrome includes the symptoms insulin resistance, abdominal or visceral obesity, elevated lipids and high blood pressure.

### Episodic Disorders

Many eating syndromes are closely related, include a number of hypothalamic symptoms and often have a recurrent nature. Bulimia nervosa for example is characterized by recurrent, often seasonal episodes

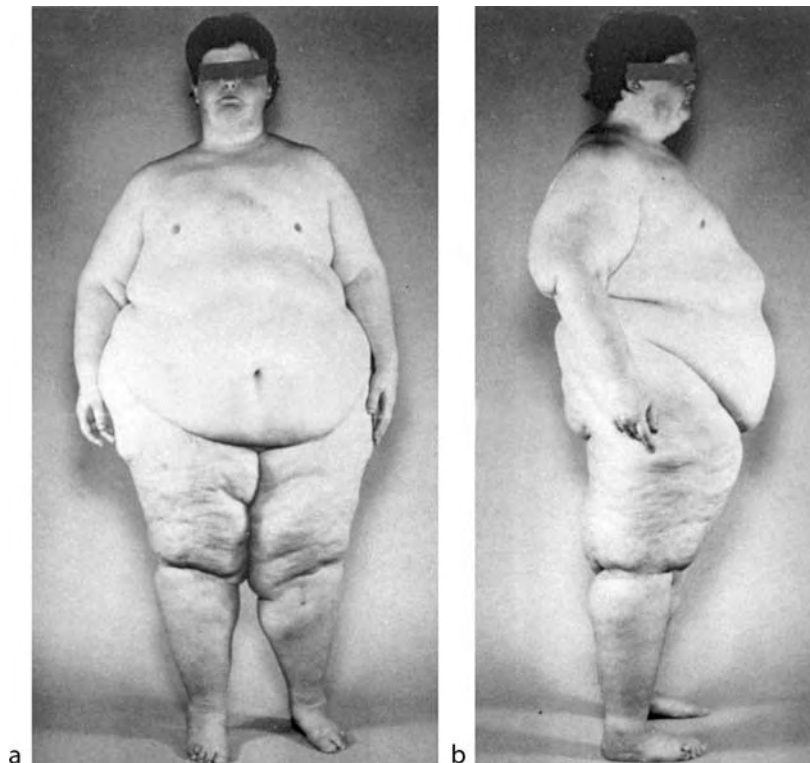

**Neuroendocrinology of Eating Disorders. Figure 1** Characteristic pattern of obesity in a patient with Prader–Willi syndrome. (From [2] Fig. 1 with permission.)

of binge eating and a depressed mood. There is also inappropriate compensatory behavior to prevent weight gain such as vomiting or excessive exercise. Light therapy not only improved mood but also the eating disorder in these patients, suggesting an involvement of the hypothalamic circadian timing system. Binge eating disorder differs from bulimia nervosa in that there is little or no behavior related to weight control, such as self-induced vomiting and laxative misuse. A characteristic of this disorder is a mutation in the MC4 receptor. The night eating syndrome is characterized by morning anorexia, evening hyperphagia and insomnia and occurs during periods of stress. In “nighttime eating syndrome” a disconnection is present between the circadian control of eating relative to sleep.

### Major Depressive Disorder

Major depressive disorder is not only characterized by a depressed mood but also by a significant weight loss or decrease or increase in appetite. Classically, the melancholic type of depression features anorexia or weight loss. Patients with bipolar disorder may have elevated rates of overweight, obesity and abdominal obesity. The typical patient with seasonal affective disorder (SAD) is a premenopausal woman with marked craving for high carbohydrate/high fat foods and significant weight gain during winter depression. These patients have a high prevalence of the seven repeat allele of the dopamine-4 receptor gene (DRD4). A strong argument for a close relationship between the pathogenetic mechanism of depression and the circadian timing system is the effectiveness of light therapy in patients suffering from SAD.

### Fetal programming

Fetal undernutrition has been well documented in a selected group of subjects in follow up studies on the effects of the Dutch Hunger Winter in Amsterdam, 1944–1945 during the German occupation. This condition, which may also occur in the case of placental insufficiency, leads to an adaptive reaction based upon the “fetal expectation” of the presence of a scarcity of food in the environment. This has long-term clinical consequences that are induced by programming effects on fetal hypothalamic function. It leads to an increased risk of obesity, hypertension, hyperphagia, hyperinsulinemia and hyperleptinemia in the offspring. In addition, the offspring have a reduced locomotor behavior and such children are at risk of depression and schizophrenia.

The physiological mechanisms involving the same hypothalamic systems that regulate eating and metabolism in the adult are also proposed to be involved in the fetus for the initiation of parturition. The decreased levels of fetal glucose, increased levels of cortisol and changes in leptin are presumed to activate NPY neurons in the fetal infundibular nucleus, activating the fetal

hypothalamo-pituitary-adrenal (HPA) axis and thereby inducing a cascade that will lead to birth. Cortisol not only triggers an increased fetal hypothalamic CRH production, but also a rise in placental CRH. The observation that in anorexia nervosa patients an increased prevalence of obstetric problems is present around the period when they were born indicates that the glucose sensitivity of the hypothalamus of these children was possibly already abnormal at the moment of birth.

### References

1. Ribasés M, Gratocòs M, Fenández-Aranda F, Bellodi L, Boni C, Anderluh M, Cavallini MC, Cellini E, Di Bella D, Erzegovesi S, Foulon C, Gabrovsek M, Gorwood P, Hebebrand J, Hinney A, Holliday J, Hu X, Karwautz A, Kipman A, Komel R, Nacmias B, Remschmidt H, Ricca V, Sorbi S, Wagner G, Treasure J, Collier DA, Estivill X (2004) Association of BDNF with anorexia, bulimia and age of onset of weight loss in six European populations. *Hum Mol Genet* 13:1205–1212
2. Kaplan J, Fedrickson PA, Richardson JW (1991) Sleep and breathing in patients with the Prader-Willi Syndrome. *Mayo Clin Prog* 66:1124–1126
3. Swaab DF, The human hypothalamus in metabolic and episodic disorders. In: Kalsbeck, Fliers, Hofman, Swaab, Van Someren, Buijs (eds) *Prog Brain Res Vol 153:3–45*

## Neuroendocrinology of Multiple Sclerosis

INGE HUITINGA

Netherlands Institute for Neurosciences, Amsterdam, The Netherlands

### Definition

Multiple sclerosis (MS) is an inflammatory demyelinating disease of the central nervous system that causes severe motor impairment, sensory disturbances and cognitive and memory deficits [1].

### Characteristics

MS is the major paralyzing disease amongst young people in the Western World. The disease mostly starts at 25–35 years of age and two thirds of MS patients are female. World wide there are 2.5 million MS patients [1].

### Process

In MS, activated macrophages and microglial cells phagocytose myelin, resulting in demyelinated lesions (Fig. 1).

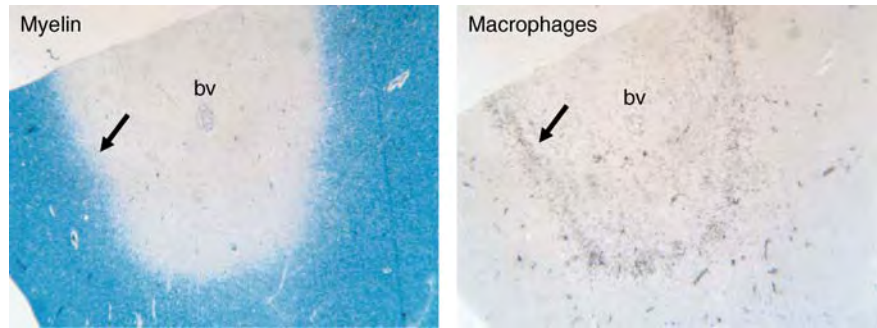

**Neuroendocrinology of Multiple Sclerosis. Figure 1** Macrophage mediated demyelination in a chronic active MS lesion. The *left* photograph is a Kluver staining in which myelin is *blue* and demyelination is *white*. The *right* picture is of the same chronic active MS lesion stained for human leukocyte antigen (HLA) DR-DP-DQ. This stains activated demyelinating macrophages *grey-brown* (magnification x 2.5). Note that MS lesions are in many cases surrounding a blood vessel (*bv*). The shelving edge of demyelinating macrophages (*arrow*) moves towards the myelinated area, leaving a gliotic hypocellular plaque behind. Magnification x 2.5. Tissue was obtained from the Netherlands Brain Bank.

Demyelination is confined to the central nervous system (CNS). In the absence of myelin, conduction in the axons is impaired, resulting in neurological deficits. Active demyelinating lesions turn into inactive hypocellular and sclerotic plaques. MS owes its name to the presence of multiple sclerotic plaques. In addition to demyelination, axonal damage also occurs frequently. Axonal damage is caused by the direct effects of inflammatory cells but the harsh environment of the demyelinated sclerotic areas is also thought to induce loss of naked axons. The cause of MS is unknown but involves both genetic and environmental factors. As the cause is unknown, therapeutic approaches are tentative. Most used therapies include anti-inflammatory drugs like synthetic glucocorticoids and immune modulating therapies like beta-interferon and glatimer. MS runs either a relapsing remitting course (RR-MS) or can be primary progressive (PP-MS). In the end stage of relapsing remitting MS, the clinical course often becomes secondary progressive (SP-MS) [1].

### Neuroendocrinology of MS

The neuroendocrinology of MS includes the functioning and effects of the hypothalamus-pituitary adrenal (HPA) axis, the hypothalamus-pituitary-gonadal (HPG) axis and the hypothalamus-pituitary-thyroid (HPT) axis in MS.

### Quantitative Description

There are several indications that the endocrine status contributes to the start and severity of MS. Sex hormones and glucocorticoids especially have been implicated in both susceptibility to and severity of MS. MS presents itself after adolescence when sex hormone levels rise. Also, pregnancy, especially the third trimester, protects from exacerbations of MS. The period shortly after delivery is highly prone to exacerbations and the first

exacerbation of MS often occurs shortly after delivery. The premenstrual period also triggers relapses. In fact, 45% of all exacerbations seem to start in this period. Interestingly, estrogen levels are low just before menstruation, whereas levels comparable to those in the third trimester of pregnancy reduce the number and size of MS lesions as observed by MRI, suggesting a protective role for estrogens [2].

Psychological stress has been considered a contributing factor in MS exacerbation and accumulating evidence is summarized in a recent meta-analysis [3]. How exactly stress influences MS is not known but the stress response systems, the hypothalamus-pituitary-adrenal (HPA) axis and the autonomic nervous system are powerful modulators of immune responses. Indeed the synthetic glucocorticoid methylprednisolone is the major drug used to treat relapses of MS. Interestingly, the activity of the HPA system increases with age as the susceptibility and severity MS decreases [4].

### Regulation of the Process

#### The Hypothalamus-Pituitary-Adrenal (HPA) Axis in MS

Pioneer experiments in the animal model for MS, ►experimental allergic encephalomyelitis (EAE), suggested that decreased activity of the HPA axis may play a role in increased susceptibility and severity of the disease [5]. Glucocorticoids are anti-inflammatory and at physiological concentrations shift antigen specific immune responses from a ►T helper 1 phenotype as is seen in MS, towards a ►T helper 2 phenotype. In turn, inflammatory mediators that are produced in MS lesions such as interleukin-1 (IL-1) activate the HPA axis at the level of the corticotrophin-releasing hormone (CRH) in the hypothalamus and induce a rise in plasma corticosterone levels, the main glucocorticoid in the rat [6]. Indeed, during a clinical episode of EAE, plasma

levels of glucocorticoids rise and this rise in corticosterone levels is crucial for recovery from the clinical episode. Rat strains that have a genetically determined low responsive HPA axis are prone to develop EAE. Recently it has been shown that during a chronic model of EAE a first episode of disease was accompanied by high plasma levels of corticosterone. However, during subsequent relapses, plasma glucocorticoid levels were significantly lower. Subsequent experiments showed reduced sensitivity of the HPA system to IL-1 during the course of chronic EAE. Importantly, compensation of plasma corticosterone levels as seen during the first relapse of EAE ameliorated the clinical signs of CR-EAE, indicating that inadequate HPA responses contribute to a more severe course of this chronic model of EAE.

Inspired by the neuroendocrine findings in the animal model for MS, several clinical studies aimed at revealing inadequate cortisol responses related to MS [5]. However, in contrast to the findings in EAE, the HPA system in MS is highly activated. There are indications that this chronic activation of the HPA system relates to both active inflammation in the CNS and neurodegeneration.

Postmortem studies show enlarged adrenals and increased cortisol in the cerebrospinal fluid (CSF) and increased numbers of corticotrophin releasing hormone (CRH) neurons in the hypothalamus, that drive the HPA axis. The increased numbers of CRH neurons concerned solely those CRH neurons that colocalized vasopressin, a sign of chronic activation of the system. Clinical studies showed normal or increased basal cortisol levels. The dexamethasone suppression test showed diminished or normal suppression of cortisol in MS. Activity and responsiveness of the HPA system appeared to depend on the type of MS (i.e. PP-MS, RR-MS or SP-MS) and the lesion activity in the CNS. In RR-patients in relapse, it was found by using the **▶combined dexamethasone-CRH (Dex-CRH) suppression test** that cortisol was elevated. This hyper-responsiveness correlated with inflammatory activity in the brain, as assessed by white cell counts in the CSF and **▶gadolinium enhancing (GD<sup>+</sup>) lesions** on MRI. Interestingly, in a group of both RR-MS and SP-MS patients who were not in relapse, hyper-responsivity in the Dex-CRH test showed no correlation with inflammatory markers in blood and CSF. A negative correlation between hyper-responsivity in the Dex-CRH test with numbers and volume of GD<sup>+</sup> lesions in this study may furthermore indicate that adequate cortisol responses in MS are needed to control MS lesions.

There are several indications that with progression of the disease and increased axonal damage and disability, the activity of the HPA axis also increases. There is a positive correlation between HPA activity in the Dex-CRH test and atrophy as assessed by MRI.

Also, hyperactivity of the HPA system in the progressive stage of the disease (PP-MS and SP-MS) correlates with disability. Recently, in a first longitudinal study, Dex-CRH reactivity significantly predicted disease progression, which implies that the Dex-CRH test might be a prognostic tool.

MS pathology implies the possibility of the occurrence of inflammatory MS lesions within structures controlling the HPA system, i.e. the hippocampus and hypothalamus. Although memory deficits in MS are frequently reported, not much is known about the incidence of lesions in the hippocampus. However, the hypothalamus is prone to the development of MS lesions. Several cases of autonomic disturbances, i.e. temperature and sleep control have been reported in relation to hypothalamic lesions. Systematic post mortem pathological analysis of the hypothalamus in MS showed the occurrence of many MS lesions (Fig. 2).

Although the mean duration of the disease was 20 years in this study, the majority of the lesions in the hypothalamus contained actively demyelinating macrophages. Hypothalamic grey matter was also frequently demyelinated. Apparently the hypothalamus is prone to MS lesion formation. Interestingly, the more active the hypothalamic MS lesions, the less active the CRH neurons were found to be. Whether active MS lesions suppress CRH neurons or MS patients with a genetic predisposition for low CRH develop many MS lesions is currently not clear. The fact is that MS patients that have many MS lesions in the hypothalamus also have a low HPA activity and very severe MS. This favors the idea that low cortisol relates to uncontrolled inflammation and consequently to a severe course of MS.

In the presence of a hyperactive HPA system, the glucocorticoid sensitivity of the immune system is decreased in MS. IL-6 and TNF production by leukocytes is reduced in relapsing remitting MS patients, whereas in progressive MS this reduced sensitivity to glucocorticoids is less pronounced [5]. Mechanisms of glucocorticoid resistance of leukocytes in MS have not yet been elucidated.

In summary, in MS the HPA system is hyperactivated. There is a correlation between activation of the HPA system and inflammation only during a relapse, indicating that inflammatory mediators may activate the HPA system in MS. Hyperactivity of the HPA systems correlates with progressive stages of MS and atrophy and correlates with disease progression. There seems to be a subgroup of MS patients with severe MS and active MS lesions in the hypothalamus that have impaired activation of the HPA system. In particular, younger patients with RR-MS suffer from impaired restraint of inflammation by cortisol due to reduced glucocorticoid sensitivity.

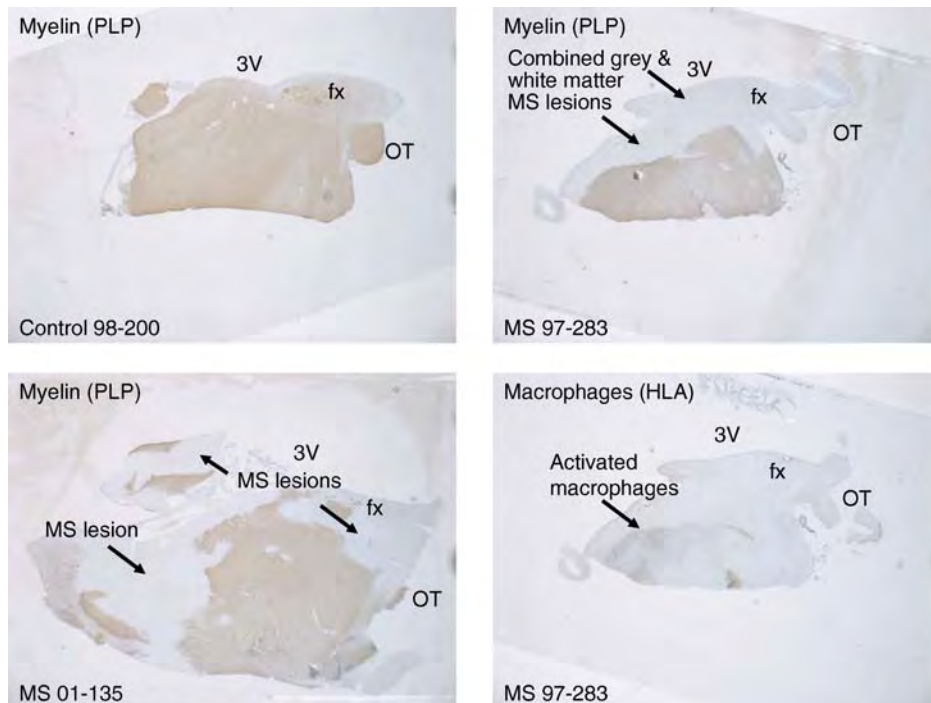

**Neuroendocrinology of Multiple Sclerosis. Figure 2** Hypothalamic MS lesions. Immunohistochemical staining of proteolipid protein (PLP) shows myelin (brown) on one side of the hypothalamus of control subject NBB # 98–200 (upper left) and MS patients NBB #01–135 (lower left) and # 97–283 (upper right) and HLA DR-DP-DQ to identify activated macrophages in MS patient #97–283 (lower right panel). Note the presence of both grey and white matter lesions in the hypothalamus in MS (arrows). The lesion in MS #97–283 is active as indicated by the presence of many activated macrophages (arrows). 3V = third ventricle, fx = fornix, OT = optic tract. Magnification x 1.8. Tissue was obtained from the Netherlands Brain Bank.

### The Hypothalamus-Pituitary-Gonadal System in MS

The functioning of the HPG axis is only sporadically investigated in MS. Sex hormones have major effects on immune cells and pregnancy related high levels of estrogens have been related to suppression of relapses during pregnancy, whereas prolactin has been proposed to be responsible for the strongly increased risk of developing relapses of MS after delivery. Increased levels of prolactin, follicle stimulating hormone (FSH) and luteinizing hormone (LH) have been reported in MS, as have decreased levels of estrogens [8]. In several studies, a relationship between altered hormone plasma levels and hypothalamic lesions was observed. Sexual dysfunctions commonly occur in both men and women with MS; some of these cases have been related to decreased sex hormone levels [2,9].

### The Hypothalamus-Pituitary-Thyroid System in MS

Like the HPG axis, there have been only a few studies addressing the functioning of the HPT axis in MS. Decreased levels of T3 have been reported in the presence of normal levels of T4 and TSH. Interferon-beta, one of the major drugs for treating MS has been

demonstrated to increase the risk of hyperthyroidism slightly. The immune system is known to modulate the activity of the HPT axis at several levels, but much less is known about the effect of TSH, T3 and T4 on the immune system. Interestingly, thyroid hormones are crucial in brain development including myelination and therapeutic possibilities for thyroid-potentiated remyelination in MS have been suggested [10].

### References

1. Noseworthy JH, Luchinetti C, Rodriques M, Weinshenker RG (2002) Multiple sclerosis. *N Engl J Med* 343:983–985
2. El-Etr M, Vukusic S, Gignoux L, Durand-Dubief F, Achiti I, Baulieu EE, Conafréux C (2005) Steroid hormones in multiple sclerosis. *J Neurol Sci* 233:49–54
3. Mohr DC, Hart SL, Julian L, Cox D, Pelletier D (2004) Association between stressful life events and exacerbation in multiple sclerosis. *Brit Med J* 328:731–736
4. Swaab DF (2004) Neuroimmunological disorders. In: Aminoff MJ, Boller F, Swaab DF (eds) *The human hypothalamus: basic and clinical aspects, pt 2: Neuropathology of the human hypothalamus and adjacent brain structures. Handbook of clinical neurology*, Elsevier, Amsterdam, 101–123

5. Gold SM, Mohr DC, Huitinga I, Flachenecker P, Sternberg EM, Heesen C (2005) The role of stress response systems for the pathogenesis and progression of MS. *Trends Immunol* 26:644–652
6. John CD, Buckingham JC (2003) Cytokines: regulation of the hypothalamo-pituitary-adrenocortical axis. *Curr Opin Pharmacol* 3:78–84
7. Huitinga I, Erkut ZA, van Beurden D, Swaab DF (2004) Impaired hypothalamus-pituitary-adrenal axis activity and more severe multiple sclerosis with hypothalamic lesions. *Ann Neurol* 55:37–45
8. Grinsted L, Heltner A, Hagen C, Djursing H (1989) Serum sex hormone and gonadotropin concentrations in premenopausal women with multiple sclerosis. *J Int Med* 226:241–244
9. Foster SC, Daniels C, Bourdette DN, Bebo BF Jr (2003) Dysregulation of the hypothalamic-pituitary-gonadal axis in experimental allergic encephalomyelitis and multiple sclerosis. *J Neuroimmunol* 140:78–87
10. Calza L, Fernandez M, Giuliani A, D'Intino G, Pirondi S, Sivilia S, Paradisi M, DeSordi N, Giardino L (2005) Thyroid hormone and remyelination in adult nervous system: a lesson from an inflammatory-demyelinating disease. *Brain Res Rev* 48:644–346

## Neuroendocrinology of Psychiatric Disorders

AI-MIN BAO<sup>1</sup>, PAUL J. LUCASSEN<sup>2</sup>, DICK F. SWAAB<sup>1</sup>

<sup>1</sup>Netherlands Institute for Neurosciences, Meibergdreef, Amsterdam, The Netherlands

<sup>2</sup>Swammerdam Institute of Life Sciences, Centre for Neuroscience, University of Amsterdam, Amsterdam, The Netherlands

### Definition

Hypothalamic and neuroendocrine alterations in some important psychiatric disorders diagnosed according to DSM-IV will be discussed.

### Characteristics

The hypothalamus plays an important role in emotional expression. Tumors, e.g. in the third ventricle region or in the area of the ventromedial hypothalamic nuclei (VMN) may cause overt psychiatric symptoms such as visual hallucinations, violent psychomotor agitation, personality changes and aggression. In addition, changes in hypothalamic nuclei and transmitter/receptor systems are present in different psychiatric disorders and may lead to endocrine alterations that can contribute to the signs and symptoms of these disorders [1].

### Depression and Mania

Depression is thought to result from an interaction between environmental stressors and genetic/

developmental predispositions that cause a permanent activation of the CRH neurons of the ►HPA axis [2]. The CRH neurons project to the median eminence and co-express vasopressin (AVP) that potentiates the effects of CRH. In addition, the CRH neurons project into the brain. Both centrally released CRH as well as the elevated cortisol levels contribute to the signs and symptoms of depression (see Lucassen and Swaab, HPA-axis). The AVP neurons in the hypothalamic paraventricular nucleus (PVN) and supraoptic nucleus (SON) that project to the neurohypophysis are also activated in depression, which may contribute to the increased release of ACTH from the pituitary. Increased levels of circulating AVP are associated with an increased risk of suicide. The increased activity of oxytocin (OXT) neurons has been implicated in the eating disorder in depression, since OXT acts as a satiety peptide. Moreover, opioid peptides inhibit the HPA-axis, while fewer  $\beta$ -endorphin containing neurons are found in the infundibular nucleus and lower numbers of  $\beta$ -endorphin innervated neurons are present in the PVN of depressed patients. Despite a normal ►body mass index (BMI), lower levels of leptin are found, which may also relate to the changes in appetite, food intake and weight in depressed patients.

In depression nitric oxide synthase containing neurons are found to be reduced in the PVN, but not the SON, which may be related to the increased neuropeptide production of CRH, OXT and AVP in the PVN. ►The hypothalamo-pituitary-thyroid axis also shows a decrease in thyrotropin releasing hormone mRNA in the PVN [3] parallel to alterations in basal thyrotropin (TSH) and thyroxin levels. Consistently with this, thyroid hormone supplements increase the efficacy of antidepressant drugs. Depressed patients showed decreased cerebral spinal fluid (CSF) levels of ►somatostatin in a state related way, while in suicide attempters somatostatin levels are significantly increased.

There is a clear sex difference in depression; the prevalence, incidence and morbidity risk is higher in females than in males, which may be due to both organizing and activating effects of sex hormones on the HPA axis besides social factors. Fluctuations in sex hormone levels, e.g. in the premenstrual period, ante- and post-partum, during the transition phase to the menopause and from the use of oral contraceptives are also involved in the etiology of depression. In mood disorders, the activation of neurons expressing CRH in the PVN is accompanied by increased estrogen receptor (ER $\alpha$ ) colocalization in the nucleus of these neurons (Figs. 1 and 2) [4].

Estrogen responsive elements are found in the CRH ►gene promoter region and can stimulate CRH expression. Activation of androgen responsive elements in this region, however, initiates a CRH suppressing effect.



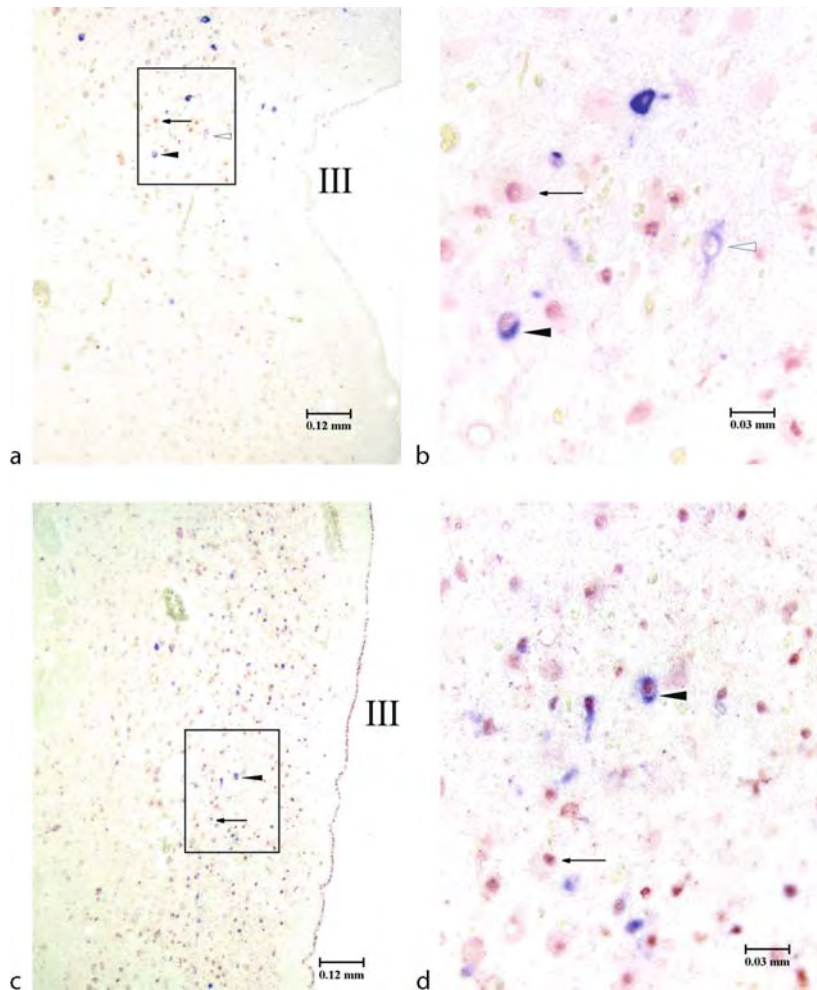

**Neuroendocrinology of Psychiatric Disorders. Figure 1** Frontal section of the PVN in a control subject (a, b) and a patient with mood disorder (c, d) stained for CRH (blue) and ER $\alpha$  (red). b and d represent a 4 x higher magnification of a and c. The arrows, solid and hollow arrowheads in (a, b) and (c, d) indicate the same place in the preparation to facilitate comparison. Both sections show the central part (mid-level) of the PVN and contain the largest number of stained neurons. It is clear by comparing (a) with (c) and (b) with (d) that the number of stained neurons is markedly increased in the patient with mood disorder. III: the third ventricle. The arrow points to an ER $\alpha$  nuclear single staining cell; the solid arrowhead points to a cytoplasmic CRH-ER $\alpha$  nuclear double staining cell and the hollow arrowhead points to a CRH single staining cell.

A decreased activity of the suprachiasmatic nucleus (SCN), the ►hypothalamic clock, is the basis for disturbances of circadian and circannual fluctuations in mood, sleep and other rhythms found in depression [5]. Light therapy for depression activates the SCN, while melatonin improves both sleep and mood.

It should be noted that the interactions between the peptidergic and aminergic networks such as serotonin (5-hydroxytryptamine or 5-HT), noradrenalin, histamine and dopamine contribute to the endocrine changes in depression.

Mixed manic patients, i.e. patients who have both manic and depressive symptoms, have higher HPA axis

activity than pure manics. Afternoon plasma cortisol and CSF cortisol levels correlate significantly with a depressed mood, while urinary free cortisol correlates with anxiety indices. Patients with a first episode mania demonstrate significantly larger third ventricular volumes, indicating large hypothalamic changes. In addition, manic patients show hypersecretion of AVP and its ►neurophysin both in CSF and in plasma. Seasonal fluctuations in admissions to psychiatric wards are obvious in mania. Manic-depressive patients generally showed lower levels of melatonin, which again implies the involvement of the circadian and seasonal timing systems.

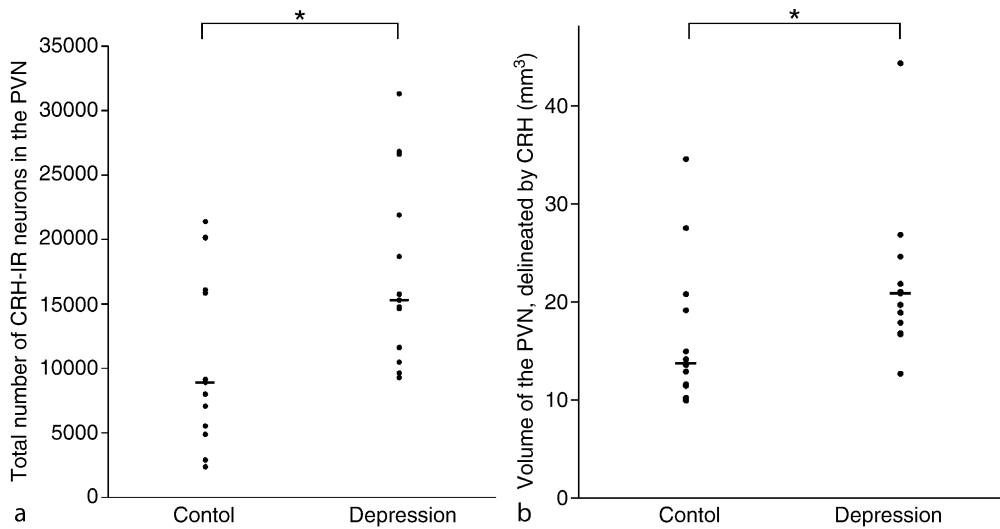

**Neuroendocrinology of Psychiatric Disorders. Figure 2** Graph depicting total numbers of CRH-IR neurons in the PVN (a) and the volume of the PVN as delineated by the presence of CRH neurons (b) of control subjects (n = 13) and patients with mood disorders (n = 13). Note that the total number of CRH neurons and the PVN volume in the patients with mood disorders were significantly larger than in controls (a:  $z = -2.128$ ,  $p = 0.034$ ; b:  $z = -2.282$ ,  $p = 0.022$ ). Horizontal line indicates the median value.

### Anxiety Disorders

Females show a two-fold increased risk for panic disorder as compared to males. Moreover, higher rates have been found in thyroid disease patients. Panic disorder is characterized by hypercortisolemia and increased nocturnal melatonin levels. A hyporesponsive hypothalamic growth hormone system is indicated by blunted growth hormone responses to specific chemical challenges. Patients with a generalized social phobia show significantly higher cortisol response to psychological stressors, although no peripheral HPA axis pathological change has been found, suggesting no basal alterations are present.

Higher rates of ► **obsessive compulsive disorder** have been found in thyroid disease patients. CSF CRH and somatostatin levels are significantly elevated and the increased secretions of AVP and CRH presumably contribute to persistent behavior. However, it should be noticed that there is no clear relationship between CSF CRH levels and symptom severity.

### Posttraumatic Stress Disorder

The clinical symptomatology of post-traumatic stress disorder (PTSD) involves flashbacks, nightmares, sleep problems, emotional numbness or emotional outbursts, anhedonia, inappropriate startle reflexes and problems with memory and concentration. Deficits in short-term verbal memory have been associated with a smaller right side hippocampal volume in these patients. Victims of childhood abuse also have a smaller left side hippocampus. Smaller ► **hippocampi** may be a risk factor for PTSD rather than the result of this disorder. It

is unlikely that hypercortisolism is responsible for the hippocampal atrophy, since PTSD is associated with decreased HPA axis activity and glucocorticoid supersensitivity rather than feedback resistance [6]. Victims of rape or motor vehicle accidents who later developed PTSD appeared to have – by a few hours after the traumatic event – lower cortisol levels than victims who do not subsequently develop a psychiatric disorder or major depression. Pituitary and adrenal hyperactivity to exogenous CRH and ACTH has been demonstrated in these patients. An increased sensitivity or up-regulation of glucocorticoid receptors in PTSD, lowered basal cortisol levels accompanied by an increased sympathetic drive and a pre-existing smaller hippocampal volume thus seems at present the best explanation for all the data.

### Aggressive Behavior

Aggression is determined by genetic factors such as ► **polymorphisms** of enzymes involved in the production and degradation of neurotransmitters, hormones in development and adulthood and specific lesions in the hypothalamus and other brain areas.

Neoplastic or surgical destruction of the VMN may cause the ventromedial hypothalamus syndrome that is characterized by a tetrad of symptoms including episodic rage, emotional lability, hyperphagia with obesity and intellectual deterioration. High rates of aggression are also found in children with ► **gelastic seizures** due to hypothalamic ► **hamartomas** or following exposure to androgen based synthetic progestins during gestation. Children and adolescents with

conduct disorder are found to have low HPA axis activity correlated with severe and persistent aggression. Adrenal androgen functioning as measured by dehydroepiandrosterone (DHEAS) levels is elevated in patients with conduct disorder. Men are much more aggressive than women, mainly due to the difference in testosterone levels *in utero* and in adulthood. Individuals whose life histories involve numerous antisocial behaviors and personality disorder criminals with multiple offences tend to have higher testosterone levels. Women with bulimia nervosa have increased plasma testosterone levels that correlate with aggression. The use of anabolic androgenic steroids may also lead to aggressive reactions and accompany antisocial personality traits.

The SCN may be involved in rhythmic occurrence of aggressive behavior. Excessive ▶**cholinergic** stimulation can promote serious aggression in man. Central AVP also plays a facilitative role in aggressive behavior.

### Schizophrenia

The hypothalamus is atrophied in schizophrenia. Third ventricle enlargement is significantly associated with the persistence of auditory hallucinations and poor response to treatment. The symptoms of schizophrenia can be induced by a tumor in the hypothalamic region [1], which also suggests possible involvement of the hypothalamus in this disease.

Water intoxication, ▶**polydipsia** and ▶**hyponatremia** are serious symptoms of chronic schizophrenia. However, no indication of a corresponding hyperactivity of AVP neurons could be found in schizophrenic patients [7]. ▶**Hypothalamo-pituitary-gonadal axis** abnormalities may also be involved, as evidenced by an irregular menstrual cycle, loss of hair, mid-cycle bleeding and hirsutism. The typical onset of schizophrenia is found during late adolescence and early adulthood when increased levels of sex hormones reach the brain. In women, there is an additional small peak in incidence around the age of 45 when estrogen levels drop. Estrogens may protect against schizophrenia although this is not consistent with the increased incidence of schizophrenia around puberty. Alternatively, androgens may be considered as a risk factor. Abnormal growth hormone responses to TSH and ▶**luteinizing hormone releasing hormone** are present in adolescents but not in adults. There is a high prevalence of thyroid function abnormalities in chronic schizophrenia. In spite of the fact that 36% of schizophrenic patients fulfilled the criteria for major depression, the ▶**dexamethasone suppression** rates were very low, suggesting that depression in schizophrenia may have a different neuroendocrine profile from that in major depressive disorder. A decreased response of the HPA axis to psychological stress or to the stress of lumbar puncture

has been found in schizophrenic patients. Reduced numbers of nitric oxide synthase containing neurons in the PVN have also been reported, while plasma leptin levels are decreased in patients with normal BMI.

SCN disorder seems to be present in a subgroup of schizophrenic patients, since circadian rhythm disturbances occur in chronic cases. In addition, in drug free paranoid schizophrenic patients, plasma melatonin circadian rhythm is completely absent, whereas the 24 h profile of plasma cortisol is preserved. A smaller pineal gland has been observed, while high dose melatonin treatment may exacerbate psychosis, both implying a possible relationship between the pineal gland and schizophrenia. The CSF hypocretin levels correlate significantly and positively with sleep latency, which is obviously increased in schizophrenia. ▶**Hypocretin** is produced in the perifornical area of the lateral hypothalamus and involved in ▶**narcolepsy**. The concentrations of  $\alpha$ - and  $\gamma$ -▶**endorphins** are elevated, whereas the number of  $\beta$ -endorphin containing neurons in the PVN and the innervation of PVN neurons by  $\beta$ -endorphin containing fibers are reduced in schizophrenic patients. Intravenous injection of  $\beta$ -endorphin resulted in statistically significant but not clinically apparent reduction of symptoms. Increased levels of norepinephrine were found in ▶**the bed nucleus of the stria terminalis**, ventral septum and ▶**mammillary body** in postmortem tissues of patients. The hypothalamic tuberomammillary nucleus (TMN) is proposed to be involved in the pathogenesis of schizophrenia, although both favorable effects of histamine injections, indicating decreased activity of the histaminergic system and elevated CSF histamine metabolite levels, indicating increased activity of the TMN, have been observed in schizophrenia.

### Autism

Autism is a developmental disorder characterized by stereotypical repetitive behaviors and disturbed social interactions and communications. The prevalence is four times higher in boys than in girls. AVP and OXT are involved in socialization skills. Male autistic children have lower plasma OXT levels and there is some evidence that OXT infusions significantly reduce repetitive behaviors. A deficiency in AVP was also reported in this disorder. An association of the OXT receptor gene and the AVP receptor-1 $\alpha$  gene with autism has recently been described. Some data indicate further HPA axis dysfunction, e.g. abnormal diurnal cortisol rhythm and changes in the ▶**dexamethasone suppression test**. In addition, lower basal levels of TSH, a diminished response of TSH to TRH and abnormalities in dopaminergic and noradrenergic neurotransmission have been found. Increased cell packing density, reduced neuron size and swollen axon terminals (spheroids) are present in different hypothalamic nuclei,

suggesting a defect in axonal transport or synaptic transmission.

### Chronic Fatigue Syndrome

Noradrenaline, 5-HT and CRH are presumed to be involved in the mechanism of central fatigue. The hypothalamus shows a significant perfusion reduction. HPA axis function is unaffected or reduced, although depression is ubiquitous in this syndrome. Some patients have excessive thirst with a low plasma level of baseline AVP. Lower morning and higher evening cortisol levels further suggest a deficient SCN function.

### Fibromyalgic Syndrome

Abnormal function of the HPA-axis has been reported in this disorder. Both the histaminergic TMN system and the SCN have been hypothesized to participate in the daytime somnolence characteristic of fibromyalgia. Some patients show impaired hypothalamic somatotrophic reactivity. The nociceptive neurotransmitter substance P is elevated in the CSF. Both growth hormone replacement and DHEAS replacement show beneficial effects.

### Postviral Fatigue Syndrome

Most patients with this syndrome have a hypothalamic dysfunction, including changes in body weight and appetite, minor fluctuations in body temperature, excessive sweating, a reversed pattern of sleep or rather excessive sleep, an impaired libido, menstrual irregularities, depression and sometimes fluid retention. Secretion of AVP may be erratic. In addition, an increased sensitivity of hypothalamic 5-HT receptors has been reported (for more detailed references see [1]).

### References

1. Swaab DF (2003) The human hypothalamus. Basic and clinical aspects, pt. 2: neuropathology of the hypothalamus and adjacent brain structures. In: Aminoff MJ, Boller F, Swaab DF (eds) Handbook of clinical neurology. Elsevier, Amsterdam
2. Swaab DF, Bao AM, Lucassen PJ (2005) The stress system in the human brain in depression and neurodegeneration. *Ageing Res Rev* 4:141–194
3. Alkemade A, Unmehopa UA, Brouwer JP, Hoogendijk WJ, Wiersinga WM, Swaab DF et al. (2003) Decreased thyrotropin-releasing hormone gene expression in the hypothalamic paraventricular nucleus of patients with major depression. *Mol Psychiatry* 8:838–839
4. Bao AM, Hestiantoro A, Van Someren EJ, Swaab DF, Zhou JN (2005) Colocalization of corticotropin-releasing hormone and oestrogen receptor-alpha in the paraventricular nucleus of the hypothalamus in mood disorders. *Brain* 128:1301–1313
5. Zhou JN, Riemersma RF, Unmehopa UA, Hoogendijk WJ, van Heerikhuizen JJ, Hofman MA et al. (2001) Alterations in arginine vasopressin neurons in the suprachiasmatic nucleus in depression. *Arch Gen Psychiatry* 58:655–662
6. Yehuda R (2001) Biology of posttraumatic stress disorder. *J Clin Psychiatry* 62:41–46
7. Malidelis YI, Panayotacopoulou MT, van Heerikhuizen JJ, Unmehopa UA, Kontostavlaki DP, Swaab DF (2005) Absence of a difference in the neurosecretory activity of supraoptic nucleus vasopressin neurons of neuroleptic-treated schizophrenic patients. *Neuroendocrinology* 82:63–69

## Neuroendocrinology of Tumors

DICK F. SWAAB<sup>1</sup>, PAUL J. LUCASSEN<sup>2</sup>

<sup>1</sup>Netherlands Institute for Neuroscience, Meibergdreef, Amsterdam, The Netherlands

<sup>2</sup>SILS Centre for Neuroscience, University of Amsterdam, Amsterdam, The Netherlands

### Definition

Primary tumors and metastases when located in, or in the vicinity of the hypothalamus can, depending on their size, location and age induce a wide range of nonspecific symptoms including brain edema, nausea, headaches, vomiting, aphasia, papilledema and even seizures. They can further induce specific autonomic and/or endocrine disturbances that are characteristic for this brain structure.

### Characteristics

Tumor related symptoms characteristic for the hypothalamus are hyperphagia, obesity, amnesia, diabetes insipidus, dysthermia, circadian rhythm alterations, cachexia, hypogonadism, changes in sexual behavior and precocious puberty. Some of the typical hypothalamic symptoms are in fact nonspecific symptoms of tumors elsewhere. For instance, plasma and cerebrospinal fluid (CSF) levels of vasopressin are increased in those types of brain tumors that are accompanied by brain edema.

Tumors themselves, but also damage inflicted by brain tumor surgery, may affect overall hypothalamic function or induce specific hypothalamic symptoms such as diabetes insipidus (due to destruction of the supraoptic and paraventricular nucleus, SON, PVN), absence of thirst (characteristic of a lesion of the anterior hypothalamus destroying osmoreceptors), hyperphagia (based upon lesion of the PVN or ventromedial nucleus, VMH), diabetes mellitus resulting from hyperphagia, an impairment of temperature regulation (following damage to for example, the preoptic area), or an abnormality of sleep pattern and a reversal of the diurnal-nocturnal sleep rhythms, probably due to a lesion of the suprachiasmatic nucleus. Other

symptoms may be present depending on the size of the tumor and its location.

Tumors that affect the posterior region of the hypothalamus, in particular the corpora mammillaria or the pineal region may cause precocious puberty. Tumors of the tuberal and preoptic region of the hypothalamus are often found in hypogonadism. Following a hypothalamic glioma, a patient's sexual orientation has been reported to change from heterosexual to pedophile with impotence (Fig. 1).

Other symptoms of hypothalamic tumors are hyperphagia and obesity, subcutaneous fat depletion, cachexia,

autonomic seizures, paroxysm of hypertension, tachycardia and sweating (in diencephalic syndrome) and fits of rage (ventromedial hypothalamus syndrome), amnesia and attacks of laughter or crying (in the case of hamartomas). When tumors cause ventricular obstruction with a rise in intracranial pressure and/or hydrocephalus, a loss of circadian temperature fluctuations and changes in posture and walking pattern or incontinence may occur. Hypothalamic lesions due to craniopharyngioma (Fig. 2) or pilocytic astrocytoma may be accompanied by decreased nocturnal melatonin levels and increased daytime sleepiness.



**Neuroendocrinology of Tumors. Figure 1** An infiltrating hypothalamic glioma in a patient with a change in sexual orientation from heterosexuality to pedophilia. (From [1] Fig. 3 with permission.)

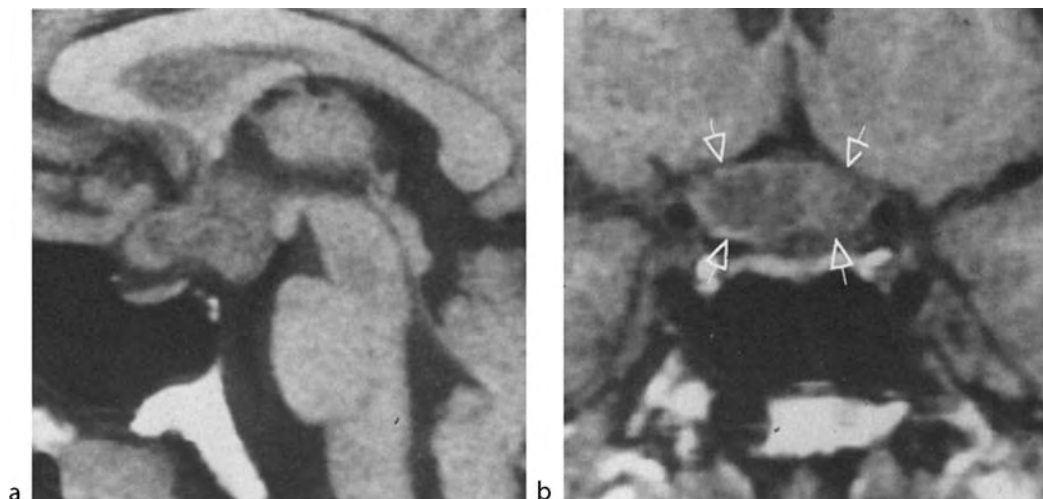

**Neuroendocrinology of Tumors. Figure 2** Intrachiasmal craniopharyngioma. Sagittal (a) and coronal (b) T1-weighted MR scans. The tumor has a slightly heterogeneous appearance and has caused marked expansion of the chiasm (arrows). (From [2] fig. 20 with permission.)

Other hypothalamic symptoms frequently found in cases with tumors are retarded growth, amenorrhea, panhypopituitarism, dysthermia, bulimia, hydrocephalus, prolonged fever and hyponatremia. Tumors in the region of the optic pathway or infundibulum may cause optic atrophy, visual deficits, visual field defects or visual hallucinations.

Cognitive and psychiatric symptoms are also observed in the case of hypothalamic disorders. Examples are a psychosis and misdiagnosis of schizophrenia, hypersexual behavior, manic excitement, confusional syndromes and hallucinations. Patients with tumors of the region of the third ventricle may exhibit the symptoms of Korsakoff's syndrome i.e. some impoverishment of intellect, changes of personality (usually euphoria or apathy), disorientation, confabulations and memory impairment (for example in the case of tumors that cause bilateral destruction of the fornix). The memory defects caused by hypothalamic tumors may concern both imprinting and retrieval. Akinetic mutism was observed following surgical removal of an epidermoid cyst from the anterior hypothalamus, by a procedure that had probably destroyed the median forebrain bundles that contain the dopaminergic projections. Selective destruction of the hypocretin/orexin system by a tumor in the lateral hypothalamus may cause symptomatic cataplexy.

Hormone production by the tumor itself has also been described. In men, germinomas of the pineal region may cause precocious puberty because these

tumors may secrete chorionic gonadotropins (HCG) that stimulate the secretion of testosterone. Hypothalamic neuronal hamartomas are rare malformations that may arise from the mammillary bodies or the tuber cinereum and that occur at the ventral aspect of the posterior hypothalamus. Some of them contain corticotropin releasing hormone (CRH), LHRH, metenkephalin or growth hormone releasing hormone containing neurons. Gelastic seizures, characterized by attacks of laughter, have been noted in 48% of the hamartomas. In addition, visual disturbances, precocious puberty, a great number of psychiatric disorders and cognitive deficits, acromegaly, diabetes insipidus or other endocrinopathies have been reported. Precocious puberty is found in over 74% of the cases and usually small, autonomous LHRH-producing pedunculated hamartomas are present.

Diencephalic syndrome is caused by a hypothalamo-optic glioma or optic pathway glioma (Fig. 3).

This low grade astrocytoma accounts for 5% of all brain tumors. The main clinical features of the diencephalic syndrome include a failure to thrive, extreme cachexia with normal height, hyperkinesia, alert appearance, vomiting, surprisingly happy affect or euphoria, pallor without anemia, hypothermia, excessive sweating, nystagmus and decreased visual acuity. The age of onset ranges from the newborn period to four years.

A low-grade developmental neoplasm, craniopharyngioma, is thought to be derived from Rathke's

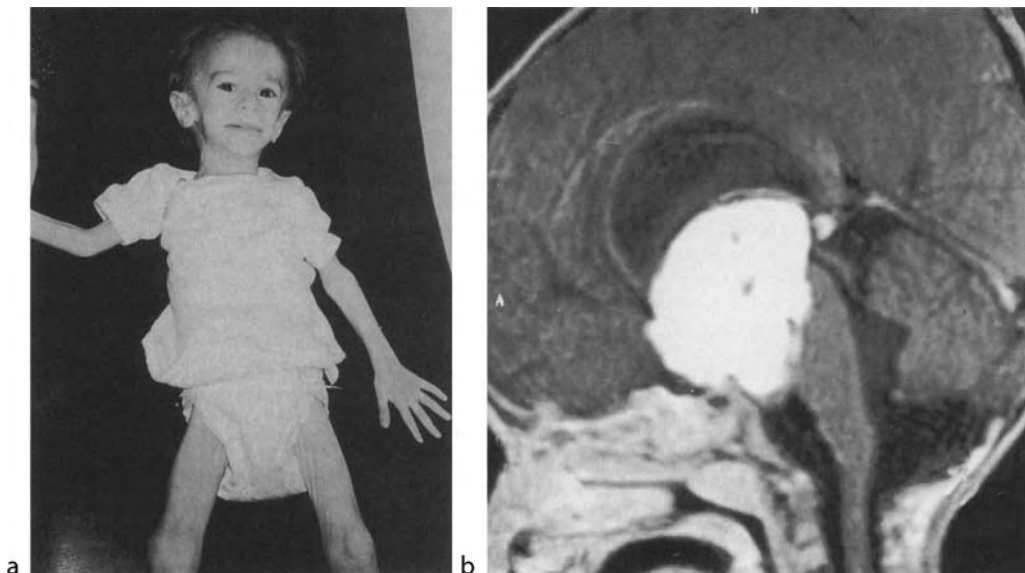

**Neuroendocrinology of Tumors. Figure 3** (a) Diencephalic syndrome. Note the severe emaciation of the whole body and the characteristic "pseudohydrocephalic" appearance. (b) MRI of the brain. T1-weighted sagittal images (repetition time/echo time: 570/15) after gadolinium enhancement demonstrate the presence of a large tumor involving the hypothalamic region, distorting the chiasm and brainstem and extending into the third ventricle. Neuropathologically, the tumor proved to be a hypothalamic astrocytoma with pilomyxoid features. (From [3] figs. A, B, with permission.)

pouch, the pituitary anlage and can arise anywhere along the craniopharyngeal canal. This canal is usually obliterated during the 12th week of gestation. In the majority of cases, the craniopharyngioma does not remain confined to the sella and hypopituitarism often ensues. This frequently extends into the third ventricle and stretches the optic chiasm (Fig. 2). The signs and symptoms of a craniopharyngioma are characteristic and the most prominent ones include headache, nausea and vomiting, a failure to grow, increased intracranial pressure and visual loss, depending on the size of the tumor and its location, as well as the age of the patient. Endocrine complaints are infrequently presented, but some typical hypothalamic symptoms may include diabetes insipidus, inappropriate antidiuretic hormone secretion, hyperprolactinemia, deficiencies of LH, FSH, ACTH, TSH or cortisol, panhypopituitarism and hypogonadism.

Brain metastases are common in patients whose systemic cancer is quiescent. Diabetes insipidus due to a tumor in the infundibulum or neurohypophysis is the usual clinical manifestation, especially seen in the terminal stages. Since the posterior lobe and not the anterior lobe of the pituitary is directly supplied by arterial blood from the systemic circulation, the predilection for metastasis in this structure is understandable. The most common sources of metastatic tumors in the pituitary-hypothalamic region are carcinomas of the lungs or breasts and leukemia/lymphoma. Metastatic carcinomas originating from the gastrointestinal tract have also been described.

In the chiasmal and sellar region, approximately 10% of the neoplasms are meningiomas. They may originate from the superior leaf of the diaphragma sellae anterior or posterior of the pituitary stalk or from the inferior leaf of the diaphragma sellae.

A large adenoma of the pituitary may exert upward pressure on the front of the chiasm or between the optic nerves. The first symptom is usually bitemporal hemianopia and there is optic atrophy. Less often the tumor may impinge on the back of the chiasma. Physical pressure exerted on or in the hypothalamus may lead to fatigue and sleepiness, excessive eating or anorexia, hypothermia, diabetes insipidus, hydrocephalus and hypopituitarism. The patient may also “feel cold” due to subsequent hypothyroidism, may perform less well in daily life activities and suffer from headaches.

## References

1. Miller BL, Cummings JL, McIntyre H, Ebers G, Grode M (1986) Hypersexuality or altered sexual preference following brain injury. *J Neurol Neurosurg Psychiatry* 49:867–873
2. Chong BW, Newton TH (1993) Hypothalamic and pituitary pathology. *Radiol Clin North Am* 31:1147–1183

3. Zafeiriou DI, Kolioukas D, Vargiami E, Gombakis N (2001) Russell’s diencephalic syndrome. *Neurology* 57:932
3. Choudhury RP (1969) Effects of cholera on the human hypothalamus and hypophysis, pt. 2. *J Trop Med Hyg* 72:185–192
5. Swaab DF (2003) The human hypothalamus. Basic and clinical aspects, pt. 2: neuropathology of the hypothalamus and adjacent brain structures. In: Aminoff MJ, Boller F, Swaab DF (eds) *Handbook of clinical neurology*. Elsevier, Amsterdam

## Neuroepithelium

### Definition

The tissue lining the inside of the neural tube, and containing embryonic neural stem cells. In later stages of mammalian brain development, neuroepithelial cells are sometimes called “radial glial cells” because they have long processes both towards apical (luminal) and basal (pial) sides.

### ► Neural Tube

## Neuroethics

BERND LADWIG

Otto-Suhr-Institut für Politik-Nissen Schaft, Freie Universität, Berlin, Germany

### Definition

Neuroethics is a field of research concerned with normative and *metaethical* (► *Metaethics*) problems posed by increasing knowledge of the central nervous system and especially the brain. As the term is not yet established in moral philosophy and neuroscience, other definitions highlight only specific aspects of the field, the *ethical* (► *Ethics*) implications of treatments for neurological diseases, *moral* principles and rules guiding neuroscience itself or the consequences of neuroscience for the understanding of moral reasoning and moral behavior. Most contributions however, cover a broader range of topics [1–3] for which a more comprehensive definition is appropriate.

### Description of the Theory

Research on the brain is research concerning the mind. It is closely connected to the way mankind sees itself as sentient and sapient beings. It also seems to offer new

possibilities of reading and controlling mental states and manipulating character traits. Most prominent among the scientific advances in the field are functional neuroimaging, insights into the neurochemistry of thought and a better understanding of the molecular mechanisms of neurotransmitting [4]. For an ethical evaluation it is crucial to weight chances and risks, gains and losses in a principled and nonarbitrary way, aiming at ►norms that are rationally justified for everyone concerned. Normative and metaethical problems associated with new knowledge of the brain can be differentiated as follows:

1. Consequences for ►individual well-being and ►personal autonomy
2. Consequences for ►justice
3. Consequences for the ►common good and for objective ►values
4. Consequences for the idea of ►moral agency

#### **Individual Well-being and Personal Autonomy**

A central purpose of ►morality is the protection and promotion of fundamental interests that can be subsumed under the terms “individual well-being” and “personal autonomy.” Both individual well-being and personal autonomy may be seriously impaired by diseases connected with the central nervous system. Neuroscience can help to identify, cure and prevent shortfalls from normal functioning that cause suffering and reduce the range of individual opportunities. As in bioethics more generally, moral restrictions are justified for the sake of sentient beings – human beings as well as animals – potentially or actually used in research and medical testing. Morality does also matter in the evaluation of serious side effects. It seems reasonable that a significant chance to cure a disease justifies a higher level of risks than a prospect of enhancements beyond the level of normal functioning [4]. This is especially important with respect to young children and other individuals who cannot take responsible decisions by themselves.

Specific problems concerning neuroscience arise whenever interventions in the brain cause personality disorders (e.g. temporarily occurring “religious” experiences induced by magnetic stimulation). Generally speaking, interventions in the brain may affect character traits that are central for an individual’s qualitative identity. Forcing a mature person to use pharmacology in order to change her thoughts, feelings or behavior is a clear violation of her autonomy. Taken to the extreme, the subject of the decisions and actions would become blurred and therefore the attribution of autonomy would lose its target.

Autonomy is also diminished if someone voluntarily decides to use mind-enhancing drugs or implants but

lacks appropriate information in the light of which he or she would have decided otherwise. Neuroscience might encourage a climate of hope that in turn might make unenlightened decisions more likely. There is some evidence supported by evolution theory that a normally healthy human brain is almost perfect, optimized for purposes of human problem solving. As a consequence, a mentally healthy person might buy a gain in one dimension, e.g. memory, at the price of losses in another dimension, e.g. generalizing [5].

Apart from this assumption, we can ask whether enhancements of brain functions, as distinguished from mere remediation of diseases, would really contribute to individual well-being [6]. Enhancements might consist in the avoidance of challenges that would confront a person with important insights and/or would offer him or her worthwhile opportunities for agency. It is implausible to reduce well-being to pleasant feelings and success without effort. Maybe a lot of problems and even painful feelings are a price that has to be paid for leading full lives as responsible agents.

The more there can be reasonable disagreement on these matters the more important autonomy proves to be. This does also affect duties towards non-autonomous individuals. Persons taking decisions in the name of others should refrain from enhancements, at least from irreversible ones, for which a hypothetical agreement of the persons affected is disputable. Parents projecting and technically imposing their own particular values onto their children neglect the fact that everyone has to lead his or her own life and therefore has a right to an open future [7]. On the other hand, respecting personal autonomy includes respecting decisions made by mature individuals to use mind-enhancing drugs or technologies as long as the enhancement does not result in harming others, violating valid principles of justice or the like. Enhancements as such are a normal objective of human strivings, as the widespread use of caffeine, viagra, and cosmetic surgery shows. It is far from clear whether continuing to do so on a molecular or genetic level would confront mankind with totally new problems.

Functional neuroimaging is another source of threats to autonomy. Although literally reading another person’s thoughts is now and for the foreseeable future sheer science fiction, neuroscientists are successful in correlating some psychological states and traits like neuroticism, racial prejudices and intentional deception with distinct patterns of brain activity [8]. This might encourage the use of neuroimaging for the purpose of lie detection, especially in societies obsessed by security issues. Even if neuroimaging cannot really decipher propositional states, its use against the will or without the informed consent of the patient would violate the right to privacy in an especially intimate domain, the privacy of what goes on in the mind.



### Justice

The availability of mind-enhancing drugs and techniques as well as neuroimaging can also become a source of discrimination. In order to reduce their risks, insurance companies and employers might expect persons to undergo examinations and pharmacological treatment of the brain. This could lead to different classes of people with the willing on the one hand and the unwilling on the other. Results of those tests could also be used to stigmatize still healthy persons and to look at them as if they were already ill or handicapped. Discrimination of this sort is incompatible with a fundamental principle of justice in modern societies, to treat everybody with equal respect and concern [9]. As far as enhancements are possible, e.g. improving the working memory of older people, they might be expensive and therefore not accessible to all. Without equal access to the new advantages however, equality of opportunity would decline. Preventing some (categories of) people from taking unfair advantage is a well known requirement of justice that is already in tension with respecting the autonomy of parents e.g. in choosing schools for their children. Again, not all that looks new at first sight is new in principle.

### The Common Good and Objective Values

Harmful testings, bad side effects, forced interventions, violations of privacy, discrimination and unfairness do not sufficiently explain why many people are disturbed about the new developments in genetics as well as in neuroscience. A fear in the background might be that a society in which those techniques and opportunities would be available and used on a large scale would in important respects be a dehumanizing society. For example, such a society might leave less room for human excellence. There might no longer be reasons to admire other people, e.g. professionals in sports or brilliant thinkers, for what they perform using their natural endowments. Another worry might be that the social relations in such a world would be dominated by reciprocal blaming in domains that are at present up to nature: “Why didn’t you enhance my affiliative behavior and my higher cognitive functions when I was in school?” Taken to the extreme, it might no longer be possible to identify what really belongs to a person and the sense of personal responsibility might become pointless. An even more familiar, yet more dubious ►reason might be that many people take “the natural” to be objectively valuable, independent of its contributions to well-being or goal-attainment. Nature, it seems to them, is a necessary counterpart to human hubris; it is the epitome of what man still cannot and never shall master [10].

Images of a good society and objective values have in common that they do not directly relate to goods that can be possessed by individuals as such. Some goods

are essentially shared, e.g. a climate of tolerance and creativity in the public sphere. Other goods might even be totally independent of any interests. They might be good as such, as for many nature seems to be. Such evaluations, however widespread they may be, are much more controversial and even unclear in status, than those concerning fundamental interests and justice. The more disputable they are, the less should they serve as grounds for preventing other people from taking free decisions. Nevertheless, an unrestricted and ongoing public debate about strong evaluations concerning the common good and probably also non-subjective values is an essential part of any reasonable will formation in a political community confronted with developments that might modify the way in which mankind and the world are seen.

### The Idea of Moral Agency

Probably the most fundamental change concerns understanding of moral agency and responsibility. Neuroscience and genetics seem to support naturalist positions in the philosophy of mind that in turn seem to undermine the ideas of free will and justified blame. This is not the right place to discuss such positions. If they were true, all that has been said so far about the agenda of neuroethics would prove to be senseless. When engaged in moral deliberations it is necessary to presuppose that it is possible to act out of insights. Every “ought” refers to ►rationality. It is far from self-evident that sense could no longer be made of these presuppositions if the progress in neuroscience were taken seriously. For example, it is in no way metaphysically convincing to see the author of free decisions and actions as a causally independent agent (an *homunculus*) within the person. It is much more convincing to ascribe responsibility to the entire person; given that he or she is able to do what he or she is reasonably convinced he or she has to do. Neuroscience can inform us about the neurological states and processes that enable people to act with reasons – or that prevent people from doing so. It can sharpen the sense of the individual limits of moral responsibility. But that is totally different from undermining the very idea of responsibility.

### References

1. Marcus S (2002) *Neuroethics: mapping the field*. Dana, New York
2. Farah MJ (2002) Emerging ethical issues in neuroscience. *Nat Neurosci* 5:1123–1129
3. Wolpe PR (2003) Neuroethics on enhancement. *Brain Cogn* 50:387–395
4. Cardiff Centre for Law Ethics, and Society (2003) Brain research and neuroethics. <http://www.ccels.cardiff.ac.uk/issue/caplan.html>

5. McClelland JL, McNaughton BL, O'Reilly RC (1995) Why there are complementary learning systems in the hippocampus and neocortex: insights from the successes and failures of connectionist models of learning and memory. *Psychol Rev* 102:419–457
6. Kass LR (2003) Beyond therapy: biotechnology and the pursuit of human improvement. The president's council on bioethics. <http://www.bioethics.gov/background/kasspaper.html>
7. Feinberg J (1980) The child's right to an open future. In: Aiken W, LaFollette H (eds) *Whose child? Children's rights, parental authority and state power*. Rowman and Littlefield, Totowa, NJ
8. Canli T, Amin Z (2002) Neuroimaging of emotion and personality: scientific evidence and ethical considerations. *Brain Cogn* 50:414–431
9. Dworkin R (1990) Bürgerrechte ernstgenommen. Frankfurt am Main, pp 297–302
10. Sandel M (2002) What's wrong with enhancement? The president's council on bioethics. <http://www.bioethics.gov/background/sandelpaper.htm>

## Neuroethological Aspects of Learning

FRANK W. OHL  
BioFuture Research Group, Leibniz Institute for  
Neurobiology, Magdeburg, Germany

### Definition

From an ethological viewpoint, ►learning is the process by which animals and humans can adapt their behaviors and internal states to an ever-changing environment. Simultaneously, from the viewpoint of evolutionary biology, equipping animals with the ability to learn frees natural selection processes from having to genetically fixate a vast variety of different behaviors and signal processing mechanisms to differentially recruit these behaviors in appropriate situations. From the viewpoint of neurophysiology, learning is made possible by a capacity of the nervous system to respond to certain classes of experiences encountered by an animal with changes in some of its functional features, a capacity called ►neural learning-induced plasticity.<sup>1</sup>

As the phenomenon of learning will be treated in more generality elsewhere in this volume [1], this essay will focus on some neuroethological aspects of learning. Learning can be defined as the process by which relatively permanent changes occur in behavioral potential as a

result of experience [1]. In this definition, the attribute “*relatively permanent*” aims to exclude short-lasting changes in behavior, like fatigue. Experience-induced changes are referred to the “*behavioral potential*”, rather than to behavior, because it is known that learning can be “behaviorally silent,” i.e., need not express itself in immediate behavior. Finally, the definition clarifies that these changes should be due to *experience*, because other reasons exist for changes in behavioral potential, like the state of arousal, the state of (ontogenetic) development, age, injury, etc.

Central to neuroethological accounts of learning is the question of the relationship between learning and ►neural plasticity. This relationship is non-trivial, as the former is an ethological or psychological concept and the latter a physiological concept. Establishing the exact role of neuronal plasticity for learning is therefore predictably difficult, similar to other fields of science where conceptually different levels have to be linked, like for example in the relation between Newtonian mechanics and thermodynamics<sup>2</sup>, or in the case of the mind-body problem. Historically, attempts to conceptualize the role of neuronal plasticity for learning have moved from the appreciation of the capacity of the nervous system for rerouting the flow of excitation through a neuronal network in simple learning situations [2], to neural processes that reflect the subjective creation of meaning in cognitively demanding learning situations like category learning and concept formation [3].

This essay will address the following neuroethological aspects of learning: (i) Structure of stimulus relationships that lead to learning, (ii) Motivational aspects of learning, and (iii) Neural aspects of information processing and meaning generation during learning.

### Characteristics

#### Higher Level Processes

##### Structure of Stimulus Relationships that Lead to Learning

It is now realized that many generalities in learning behavior across species reflect the fact that they are evolutionary designed solutions to similar demands, rather than reflecting similar neuronal mechanisms. Therefore, generalities on the level of learning behavior cannot in general be expected to be supported by generalities on a physiological level [1]. Much research has been conducted to reveal those generalities in environmental or laboratory situations that lead to learning. Studies of the early twentieth century, e.g., by Ivan P. Pavlov, Edward L. Thorndike, Clark L. Hull, Edward C. Tolman, B. F. Skinner, and others, focused on classical conditioning and instrumental conditioning paradigms, and identified the temporal relationship

<sup>1</sup>The addition “learning-induced” distinguishes this form of neuronal plasticity from those observed during ontogeny (►developmental plasticity) or after injury (►compensatory plasticity).

<sup>2</sup>In this example, a conceptual link between both levels has been possible to provide, at least for the equilibrium state of matter, by the framework of .

(►contiguity) between stimuli or events as facilitating behavioral changes that could be interpreted as being the result of formed associations between these stimuli or events. Later studies, e.g., by Rescorla and Wagner [4], revealed that the contiguity is neither sufficient nor necessary for the formation of associations. For example, by carefully varying the probabilities of occurrences of events conditional on the occurrence of other events, it was shown that animals can show different levels of association even under constant contiguities. Learning mechanisms rather seem to exploit the probability structure of stimulus relationships, estimated from previous experience, to form associations. Animals can therefore use the information that one stimulus or event carries about the occurrence of another stimulus or event (►contingency).

### Motivational Aspects of Learning

For methodological reasons, one of the events referred to above was typically a stimulus that elicits a defined, easily observable, behavioral response. Such stimuli are most often reward stimuli or aversive stimuli that will elicit approach or escape responses, respectively, and are called ►reinforcers. In experiments where reinforcers are applied in dependence of behaviors produced by a subject, reinforcers change the probability with which such behaviors will be emitted in the future. Reinforcers act by at least two discernable mechanisms [5]. The first mechanism, the ►enhancing function [5], works by enhancing the “storage” of information about situations in which they are encountered. This does not require that the animal learns anything about the reinforcer itself. The second mechanism, ►conditioned motivation [5], works by conditioning motivating effects of reinforcers to other brain activity present at a temporal relationship to the experience of the reinforcer. The dopamine system and the striatum have been associated with both types of action [5].

On theoretical grounds, the task of neural coding for reinforcers can be distributed to a number of hypothetical functions [6]. Among those are the *detection* of a reinforcer, i.e., a neural representation of whether a reinforcer is present or not, the *prediction* of a reinforcer, i.e., a neural response to a stimulus which the subject associates with a reinforcer to be followed, and the *expectation* of the reinforcer, i.e., a neural activity which develops temporally between reinforcement prediction and reinforcement detection, for example to support processes of maintaining attention. For all such functions neurons have been found whose firing properties could be associated with all of these functions and their combinations in such structures as the striatum, the prefrontal cortex and orbitofrontal cortex. As learning can be viewed as a process of reducing the discrepancy between a predicted and actually experienced outcome of a learning situation (a magnitude called

the ►prediction error), such neurons are likely to have an important function for the neuronal mechanisms underlying learning. For example, in the striatum of monkeys tonically active interneurons have been reported that respond more frequently to unpredicted rewards than to predicted ones [7]. Analogously, microdialysis studies in the rodent medial prefrontal cortex have revealed an increased dopamine efflux in the *very early phase* of the establishment of a behavioral avoidance strategy, but not in later acquisition phases when performance was still increasing or during retrieval sessions. The hypothesis that the dopamine efflux in medial prefrontal cortex correlates with the establishment of *new behavioral strategies* for solving problems in learning situations could be further supported by relearning paradigms [8].

### Neural Aspects of Information Processing and Meaning Generation during Learning

For the neuroethological perspective on learning, those learning paradigms of particular importance are those that contain aspects beyond mere associations between stimuli or between stimuli and responses. This is because such paradigms preclude explanation of learning phenomena by a broad class of simple neurophysiological models that are otherwise discussed as elemental for physiological theories of learning. For example, while classical conditioning can in principle be explained by very simple neuronal networks [2], this is not possible for cognitively more demanding learning phenomena like *category learning (concept formation)*. A few animal models of category learning have been designed to allow the study of the neural basis of such aspects of learning. For example, the Mongolian gerbil (*Meriones unguiculatus*), a rodent with exquisite auditory learning abilities amenable to physiological investigation [e.g., 9], can be trained using frequency-modulated tones to form the categories “rising” and “falling” and sort even novel, previously unheard, frequency-modulated tones into these categories depending on how the pitch of these sounds develops over time [10]. The formation of categories involves development of a new cognitive structure that represents qualities beyond the information given. It allows that a particular meaning (defined by the category) is assigned to even novel stimuli that are processed by a sensory system. The neurophysiological analysis of this learning behavior [3] revealed that during category formation particular spatio-temporal activity states emerge in the auditory cortex. These states have a *metrical structure*, i.e., similarity relations between spatio-temporal patterns correspond to similarities in the perceived category belongingness. This metrical structure is unlike the topographic maps known from various brain structures in which physical stimulus attributes are represented, because it represents the only subjectively valid perceptual scaling experienced by a given individual. These neuronal observables represent

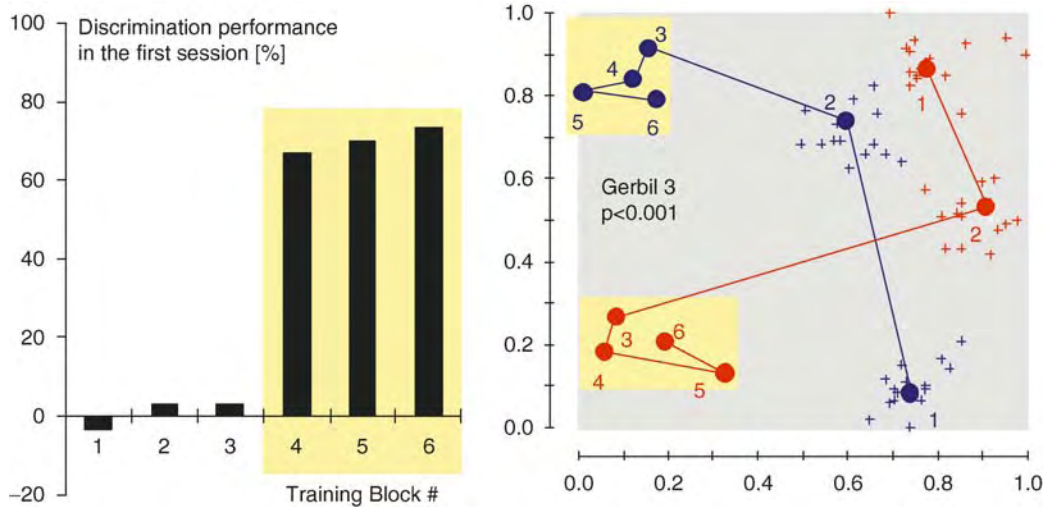

**Neuroethological Aspects of Learning.** Figure 1 Neurodynamics in auditory cortex during learning of acoustic categories exemplifying the physiological correlate of a learned cognitive structure. Example of behavioral and electrophysiological data from a Mongolian gerbil, which was trained to discriminate rising from falling frequency-modulated tones in a sequence of training blocks. In each training block, a novel pair of a rising and a falling frequency-modulated tone was trained. The left panel displays discrimination performance (quantified by the difference between hit rate and false alarm rate) at the beginning of a training block when the stimuli were novel to the subject. In training blocks 1–3, (*discrimination phase*) initial performance was insignificant but would improve in later sessions of the block (not shown). Starting with training block 4 and for subsequent blocks the subject showed transfer of the learned behaviors to the novel stimuli (*categorization phase*), indicating that a new cognitive structure had been formed in the subject. The transition from discrimination phase to categorization phase occurs abruptly, and for different individuals at different points in time. This behavioral *state transition* is accompanied by a transition in the neurodynamical states of auditory cortex. The right panel is a graphic representation of the similarity and dissimilarity relations between cortical activity patterns during different phases of the learning. Points represent activity states, numbers correspond to the training block, and colors red and blue to the categories “rising” and “falling,” respectively. The spatial distance between any two points in the graph is a measure of the dissimilarity between the corresponding cortical activity states. For blocks 1 and 2 patterns for all trials (+) are shown together with their center of gravity values (\*), for subsequent blocks only the center of gravity values are shown to avoid cluttering of the graph. It can be seen that as long as the subject remained in its discrimination phase (blocks 1–3), dissimilarities of cortical activity patterns *within* a category were of the same order of magnitude than *between* categories. After the transition to the categorization phase (blocks 4–6), dissimilarities within a category were abruptly reduced compared to dissimilarities between categories<sup>3</sup>. This indicates the establishment of a new metric in cortical representation of stimuli. This metric does not reflect physical stimulus attributes (as topographic feature maps do), but reflects the subjective perceptual scaling experienced by a given individual. Modified after [3].

an objectively accessible physiological representation of a subjectively existing cognitive structure [3] (Fig. 1).

## References

1. Anderson JR (2000) Learning and memory. An integrated approach. Wiley, New York
2. Hawkins RD, Kandel ER (1984) Is there a cell-biological alphabet for simple forms of learning? *Psychol Rev* 91:375–391
3. Note that the clustering of the state vectors is due to the fact that in the fourth (and subsequent) training blocks, i.e. when the animal has entered the categorization phase, the state vectors remain in the vicinity of the previously attained vectors.
3. Ohl FW, Scheich H, Freeman WJ (2001) Change in pattern of ongoing cortical activity with auditory category learning. *Nature* 412:733–736
4. Rescorla RA, Wagner AR (1972) A theory of Pavlovian conditioning: variations in the effectiveness of reinforcement and nonreinforcement. In: Black AH, Prokasy WF (eds) *Classical conditioning II: current research and theory*, Appleton Century Crofts, NY, pp 64–99
5. White NM, Milner PM (1992) The psychobiology of reinforcers. *Annu Rev Psychol* 43:443–471
6. Schultz W (2004) Neural coding of basic reward terms of animal learning theory, game theory, microeconomics and behavioural ecology. *Curr Opin Neurobiol* 14:139–147
7. Apicella P (2002) Tonicly active neurons in the primate striatum and their role in the processing of information about motivationally relevant events. *Eur J Neurosci* 16:2017–2026

8. Stark H, Rothe T, Wagner T, Scheich H (2004) Learning a new behavioural strategy in the shuttle-box increases prefrontal dopamine. *Neuroscience* 126:21–29
9. Schulze H, Neubauer H, Ohl FW, Hess A, Scheich H (2002) Representation of stimulus periodicity and its learning induced plasticity in the auditory cortex: recent findings and new perspectives. *Acta Acoustica united Acoustica* 88:399–407
10. Wetzel W, Wagner T, Ohl FW, Scheich H (1998) Categorical discrimination of direction in frequency-modulated tones by Mongolian gerbils. *Behav Brain Res* 91:29–39

---

## Neuroethology

### Definition

Part of ethology that deals with the neural basis of behavior.

---

## Neuroethology of Biosonar Systems in Bats

HANS-ULRICH SCHNITZLER, ANNETTE DENZINGER  
Tierphysiologie, Zoologisches Institut, Universität  
Tübingen, Tübingen, Germany

### Definition

Evolution has equipped microchiropteran bats for nocturnal life by morphologically, physiologically, and behaviorally adapting their sensory and motor systems. Bats' abilities to echolocate and to fly play a particularly important role in allowing them to exploit resources which are not accessible to other animals. Around 800 species of echolocating bats (suborder Microchiroptera) emit tonal signals and analyze the returning echoes to detect, localize and classify the reflecting targets. All bats use their biosonar systems for spatial orientation and many of them also for food acquisition. Like technical systems bats have a transmitter which produces and radiates the echolocation signals and a receiver which analyzes and evaluates the returning echoes. Comparative neuroethological studies reveal how sound production and hearing in bats have been adapted during evolution to perform habitat-specific echolocation tasks.

## Characteristics

### The Action-Perception-Loop of Echolocation

Bats' echolocation systems are comparable to other active orientation systems such as radar and sonar systems, and are therefore referred to as biosonar systems. In active systems, the transmitter is connected to the receiver in an action-perception loop (Fig. 1).

Various neuroethological approaches to the study of bats' biosonar systems have been, as demonstrated in Fig. 1, describing the action-perception-loop of echolocation. The ►evolutionary aspect of these systems is examined in studies that develop plausible scenarios for the evolution of echolocation. The ►acoustical aspect is addressed by research that describes the various types of echolocation signals, measures the directionality of signal emission and echo reception, and characterizes the information content of echoes from various targets. The ►behavioral aspect is investigated in studies that define the constraints acting on signal structure, and explain the adaptive value of signal design according to the echolocation tasks and the bats' performance in natural echolocation situations. This aspect is also addressed by psychophysical experiments in the laboratory. The ►structural and functional aspects of echolocation are addressed by studies on the morphology, neuroanatomy, physiology, and pharmacology of the sensory and motor parts of echolocation systems. The ►analytical aspect is explored by those who develop computational theories of echolocation by defining problems related to echolocation tasks, searching for algorithms to solve these problems, and testing these algorithms by implementing them in biomimetic sonar systems. Here, we summarize these different approaches to investigating biosonar systems in bats, by presenting a survey of the reviews that we believe are relevant to understanding the neuroethological basis of echolocation in bats.

### The Evolutionary Aspect of Echolocation

The key characteristics that distinguish bats from other mammals are their ability to fly and their use of an active orientation system. Due to the paucity of fossil records, scenarios explaining the evolution of flight and echolocation are speculative and have been developed on the basis of plausibility (Denzinger et al. 2004). The evolution of echolocation presumably took place in several steps (Schnitzler et al. 2004). Echolocation signals may have evolved from high-pitched communication signals, and may have been used by pre-bats to estimate distances before jumping from one branch to the next. With the evolution of gliding and finally of flapping flight, echolocation may have become useful for obstacle avoidance during flight and improved landing control. With increasing maneuverability, the demand for spatial information increased and bats may have used echolocation to identify landmarks and habitat elements, i.e. for spatial orientation within

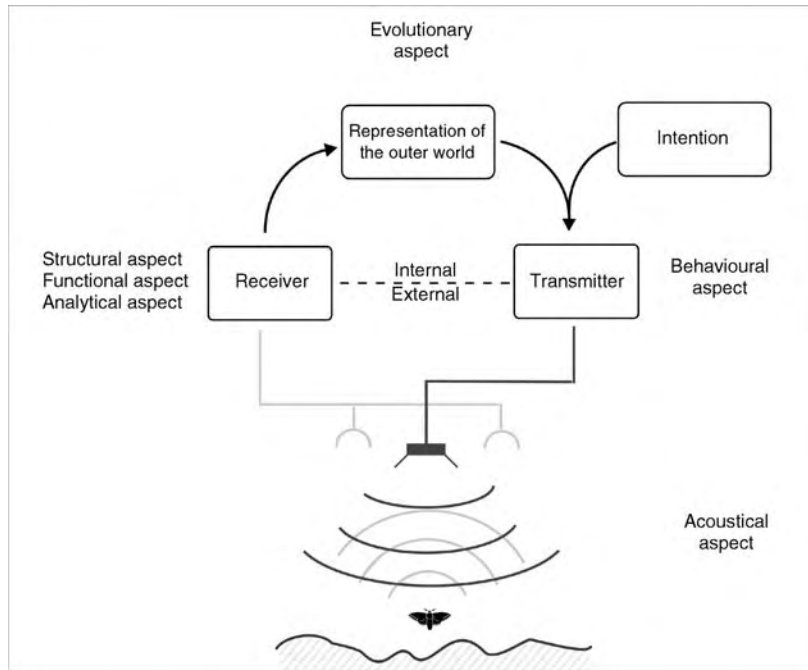

**Neuroethology of Biosonar Systems in Bats. Figure 1** The action-perception-loop consists of a transmitter, which generates signals transmitted via a sender antenna, and a receiver, which picks up the returning echoes with receiving antennae and decodes the information contained in the echoes to create a spatial representation of the area covered by the sonar footprint of the emitted signals (Denzinger and Schnitzler 2004). Bats produce their signals in the larynx (phonation), filter them in the vocal tract (articulation), and transmit them either through the open mouth or the nose (transmitter antenna, depicted in black)). The returning echoes are picked up with both ears (receiving antennae, depicted in grey) and echo information is evaluated in the auditory system (receiver). The resulting representation of the outer world and the behavioral intentions determine which signal type of the repertoire will be the next to be generated and transmitted (adapted from Denzinger and Schnitzler 2004).

their home range. Thus, echolocation is likely to have evolved primarily for spatial orientation, and its use for the detection of prey was a later step in evolution. Bats may have encountered situations in which the acoustical cues of an insect colliding with vegetation were preceded by the flight tone of the insect. By reacting with foraging flights towards the flight tones, bats evolved the ability to approach the moving sound source guided by echolocation. Finally, they made the transition to detecting flying insects on the basis of echolocation alone and to hunting for airborne prey on the wing.

#### Acoustical and Behavioral Aspects of Echolocation

When performing echolocation tasks, microchiropteran bats continuously emit signals that are mostly in the ultrasonic range. These signals differ between species in terms of their duration, pulse interval, frequency, harmonic content, and sound pressure level (SPL). Each species has a specific signal repertoire containing a variety of signal types evolved to perform species-specific echolocation tasks. The tasks performed by bats depend on their behavioral intentions and also on

where bats fly and forage, what they eat, and how they acquire their food. Echolocation tasks can be attributed either to spatial orientation or to food acquisition.

All bats use echolocation for spatial orientation. Information derived from returning echoes is used to move in relation to stationary targets along routes and to build up a spatial representation of the environment. Little is known about which part of the information contained in echoes is used to orient in space. Extended targets such as landmarks contain many reflecting facets that generate stochastic echo sequences. Random process parameters distinguish between different vegetation types (Müller and Kuc 2000) and could be used by bats for landmark classification. There is behavioral evidence that bats are able to distinguish between echo trains differing in roughness (Grunwald et al. 2004). In addition, bats emit short, broadband, highly frequency-modulated (FM) signals in classification tasks. Due to the wide range of wavelengths and the strong directionality of high frequencies in such signals, they are well-suited for target classification (Siemers and Schnitzler 2004). Important information might also be encoded in changes within echoes over time.

Theoretical studies show that changing echo parameters create time-variant echo features, such as acoustic flow, that might contain information about the position of targets in relation to the bat's motion. Long, constant-frequency (CF) signals are especially well-suited for evaluating acoustic flow information (Müller and Schnitzler 1999, 2000).

Many bats also use echolocation to find their food. Comparative studies reveal that the proximity of prey to background targets is the most relevant ecological constraint on the design of bats' echolocation signals, and can therefore be used to define foraging habitats. Three main habitat types have been described: in the open, or "open space," between and along vegetation, or "edge space," and within vegetation and close to it and the ground, or "narrow space" (Aldridge and Rautenbach 1987; Neuweiler 1990; Fenton 1995; Schnitzler and Kalko 2001; Schnitzler et al. 2003). In open space, bats forage so far off from the background that they do not react to it in their echolocation behavior. In edge space, bats react to the background but the prey echo does not overlap with background echoes. In narrow space, the echoes of prey positioned on substrate or flying very close to the background overlap with background echoes, which may result in masking.

Ecological conditions exert strong selective pressure on signal design, thus favoring species-specific signal types closely connected to habitat type, foraging mode,

and prey. This connection can be used to define functional groups based on the preferred habitat type and foraging modes of various bat species. Members of each functional group are confronted by a common set of constraints and must solve similar echolocation tasks. This results in many similarities in signal design within functional groups (Schnitzler et al. 2003). "Open space aerial foragers" catch flying insects and use rather long, narrowband, shallow FM signals of low frequency that are adapted for long-range detection (Fig. 2).

"Edge space aerial/trawling foragers" search for insects flying near vegetation edges, in gaps, near the ground, or drifting on flat water surfaces. They often emit mixed search signals of medium duration. These signals consist of a narrowband, shallow FM component adapted for medium-range detection and a broadband, steep FM component adapted for orienting with respect to background targets. Narrow space bats that either glean their food from the substrate or capture prey close to it face the problem that overlapping clutter echoes may mask the prey echo. Three different strategies have been evolved to cope with this problem. "Narrow space active aerial/gleaning foragers" find their food by echolocation. They either use target-specific echo cues or specific echolocation strategies to separate prey from the background (Denzinger and Schnitzler 2004). "Narrow space passive gleaning foragers" cannot solve the masking problem and use

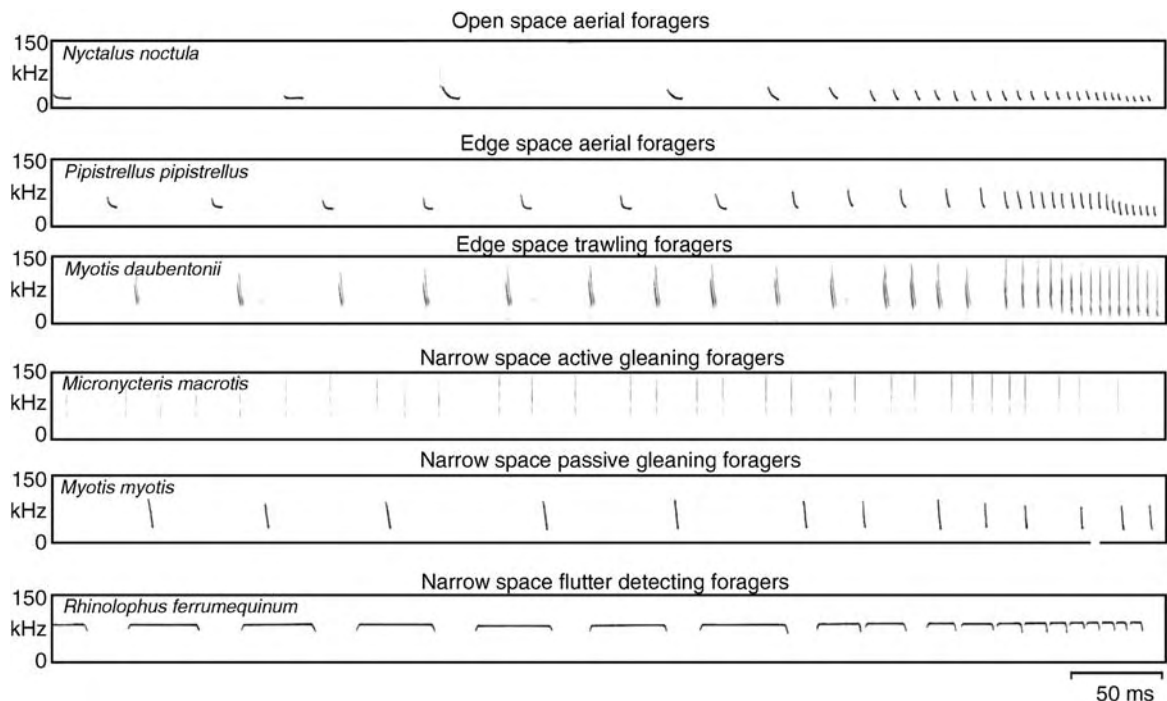

**Neuroethology of Biosonar Systems in Bats. Figure 2** Search and approach signals of different functional groups.

prey-generated acoustic or olfactory cues to find their food. Bats in both functional groups emit broadband uni- or multi-harmonic signals of short duration and low sound pressure level. Active gleaners use these signals both for spatial orientation and for food acquisition, whereas passive gleaners use them for spatial orientation only. “Narrow space flutter detecting foragers” have a very specialized echolocation system with signals consisting of a long component of constant frequency followed by a terminal FM component. With Doppler shift compensation and a specialized hearing system, these bats are able to recognize echoes from fluttering prey insects modulated by the rhythm of beating wings in unmodulated background echoes (Schnitzler and Ostwald 1983; Neuweiler 1990; Moss and Schnitzler 1995). Bats have highly variable foraging and echolocation behavior and often forage in more than one habitat (Fenton 1990). According to their behavioral goals and to incoming information, bats choose the most suitable signal types from their repertoire to perform specific echolocation tasks.

A multitude of psychophysical experiments have been conducted to investigate auditory information

processing in bats and to clarify which receiver type is implemented in the bat’s auditory system. These studies include behavioral audiograms, performance in target echo detection, range estimation and resolution, horizontal and vertical localization, movement discrimination (Moss and Schnitzler 1995; Masters and Harley 2004) and, recently, the bats’ performance in stochastic echo parameter evaluation tasks (Grunwald et al. 2004).

Bats hear over a wide range of mainly ultrasonic frequencies, often spanning several octaves. The frequency range of bats’ echolocation signals corresponds closely to the range in which they have high auditory sensitivity (Fig. 3). Sensitivity to frequencies below the range of the echolocation signal is crucial for social communication and the detection of prey and predators through passive listening.

For detection, a bat has to decide whether it perceives an echo of its own signal or not. Detection thresholds depend on the bat’s signal structure, environmental conditions, and the bat’s sonar receiver. Thresholds between 0 and 60 dB SPL have been obtained in various experimental procedures. This variability may have been caused by different masking situations.

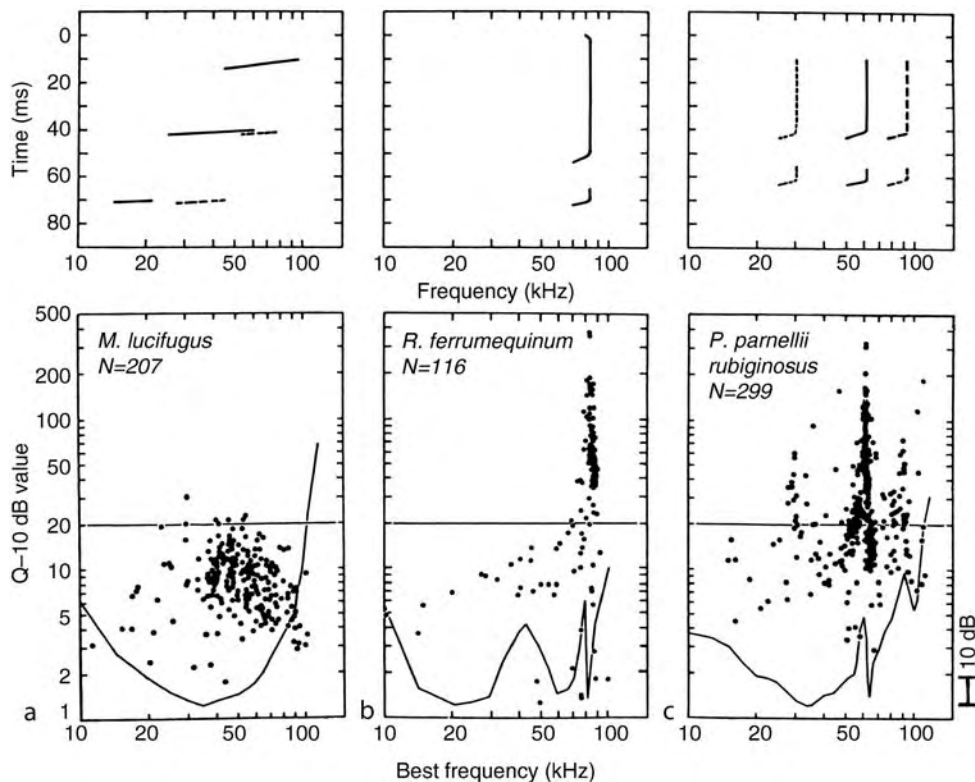

**Neuroethology of Biosonar Systems in Bats.** **Figure 3** Comparison of sonograms (*upper row*) with audiograms (*solid line*), and  $Q_{10\text{dB}}$  values of single auditory fibers (*dots*) (*lower row*) of a bat using broadband steep FM signals (*Myotis lucifugus*, A) and of two flutter-detecting foragers (*Rhinolophus ferrumequinum*, B and *Pteronotus parnellii*, C) (adapted from Grinnell 2004). The sonograms are tilted so that the frequency is displayed in the x-axis as in the audiograms below.



For localization, a bat determines the range and the angle of a target of interest. The range is encoded in the time delay between the emitted signal and the returning echo. The ranging performance of bats has been tested using three different tasks: range difference discrimination, range jitter discrimination, and range resolution. Range difference experiments revealed an accuracy of about 1 cm, which is close to the accuracy estimated from successful prey interception experiments. In range jitter experiments, in which one target jitters while the other is stable, discrimination thresholds down to 10 ns (corresponding to 1.7  $\mu\text{m}$ ) have been reported (Simmons et al. 1990). These results have often been questioned because it is hard to imagine how such minimal differences in echo arrival time could be processed in the nervous system. Studies on range resolution tested bats' perception of target depth structure. In range resolution experiments, bats using FM signals were able to discriminate one-wavefront echoes from interfering two-wavefront echoes when the delay offset within the two-wavefront echo was about 12  $\mu\text{s}$ . Range perception is most likely not a single process, but rather a set of perceptual processes in the bat's receiver; the described experimental approaches may be tapping into different processes in the set.

Binaural and monaural echo cues encode the horizontal and vertical angles of targets. Accuracy in determining these angles has only been measured in the FM bat *Eptesicus fuscus*. Threshold estimates were 1.5° in the horizontal plane and about 3° in the vertical plane.

To classify targets, bats use target-specific spectral and modulation patterns in the echoes or stochastic parameter distributions. Flutter information is used by bats to identify insect echoes and to discriminate them from the stationary background. CF-bats also use flutter information for the classification of insect prey. In behavioral experiments, horseshoe bats were able to sense 8–9% differences in wing beat rate. They also discriminated between different insect species even if they had the same wing beat rate and were presented at novel aspect angles. It has only recently been proven that bats are able to classify echoes according their roughness (Grunwald et al. 2004).

### Structural and Functional Aspects of Echolocation

A multitude of publications deal with the question of how echo information is processed in the auditory systems of bats (recently summarized in the books "Hearing by Bats," Popper and Fay (eds.) (1995) and "Echolocation in Bats and Dolphins," Thomas, Moss and Vater (Eds.) (2004)). Most studies were conducted with either vespertilionid bats that use broadband, steep FM signals, or rhinolophids, and the mormoopid bat *Pteronotus parnellii* that uses long, CF-FM signals. The auditory systems of the two groups differ in many ways,

reflecting structural and functional differences that are critical to echolocation. Nevertheless, the auditory systems of bats consist of the same basic elements as those of other mammals.

In all bats, the cochlea is specialized for the analysis of high frequencies. Bats that rely on broadband, steep FM signals possess a non-specialized mammal-like frequency representation on the basilar membrane. In flutter-detecting bats, a so-called acoustic fovea is used for the analysis of a narrow band of frequencies around the second harmonic of the CF component of the Doppler-compensated echoes (Grinnell 1995; Kössl and Vater 1995; Vater and Kössl 2004; Vater 2004). Both this difference in frequency representation in the cochlea and in increased sharpness of frequency tuning of neurons connected to the auditory fovea are found throughout the entire ascending auditory pathway (Fig. 3).

In no other mammal is the auditory system proportionally larger and more differentiated than in echolocating bats. Studies on the processing of echo information in the central auditory system of bats focus on the question of how and where the information bearing spectro-temporal attributes of pulse-echo trains are decoded (Covey and Casseday 1995, 1999; Pollak and Park 1995; Wenstrup 1995; O'Neill 1995; Fuzessery et al. 2004).

Between the cochlea and the midbrain, parallel pathways provide multiple transformations of the cochlear signal through the interplay of excitatory or inhibitory outputs, which differ in their temporal discharge patterns and latencies. This results in auditory midbrain neurons that are tuned to parameters relevant for echolocation, such as signal duration, delay between two signals, FM sweep direction, and the rate of periodic frequency and amplitude modulation (Covey and Casseday 1995, 1999). Binaural processing of interaural intensity (and perhaps time differences) in the superior olivary complex provides angular information. However, there is some controversy surrounding the question of whether or not the large and specialized medial superior olive is equivalent to this structure in non-echolocating mammals (Covey and Casseday 1995).

The processing of echolocation information in the colliculo-thalamo-cortical pathway leads to a further decoding of the features that describe echolocation scenes (Suga 1990; Pollak and Park 1995; Wenstrup 1995). Feature extraction is species-specific and reflects the adaptations of the corresponding echolocation systems to species-specific echolocation tasks. Such differences become evident when one compares the analysis and representation of relevant echolocation features in flutter-detecting bats such as *Rhinolophus ferrumequinum* and *Pteronotus parnellii* and bats that use broadband, steep FM signals such as *Myotis lucifugus* (O'Neill 1995; Suga 2004; O'Neill 2004;

Wong 2004). For instance, the functional organization of the auditory cortex of the flutter-detecting forager *Pteronotus parnellii* is characterized by three distinct areas representing different task-relevant features. One region contains neurons that respond solely to certain signal frequencies and amplitudes. There, the area around the second harmonic of the echolocation signals corresponds to the auditory fovea and is greatly enlarged, as it is in all lower nuclei and in the cochlea. A second region contains combinatorial neurons that respond solely to frequency differences between signals. The combinatorial neurons of a third region represent echo delays measured as the time interval between two signals. Within these regions, information-bearing parameters such as echo delay and relative velocity are arranged in maps (Suga 1990, 2004; Pollak et al. 1995; O'Neill 1995, 2004) (Fig. 4).

In rhinolophids, which are also specialized for flutter detection, the functional organization of the cortex is in part similar to that of *Pteronotus parnellii*, but there are also notable differences in the arrangement of feature-encoding cells (Schuller et al. 1991). The cortices of other bats also contain combinatorial neurons that express echolocation features by combining information from two signals that simulate signal echo pairs. The functional organization of the cortex in bats that use broadband, steep FM signals, such as *Myotis lucifugus* and *Eptesicus fuscus*, is very different from that of flutter-detecting foragers. In *Myotis lucifugus*, the cortex consists of two tonotopic regions. One region covers the frequency range of the echolocation signals. It can dynamically change to provide multidimensional feature extraction, which meets the behavioral needs of echolocation in this species (Wong 2004).

Recent studies indicate that cortifugal systems are essential in shaping the response properties of subcortical neurons, thus adjusting and improving signal processing according to auditory experience (Jen et al. 2004; Suga et al. 2004).

Successful echolocation depends on the coordination between auditory and motor systems. Therefore, the control of signal production is tightly coupled to auditory processing of pulse-echo trains (Moss and Shina 2003; Schuller and Moss 2004). Several nuclei at different levels of the brain have anatomical connections and functional responses that indicate their importance for audio-vocal control. The emission of sonar signals is also linked to breathing and other motor activities such as wing beat, pinna movements, and middle ear contraction.

### The Analytical Aspect of Echolocation

A model of echolocation based on spectrogram correlation and transformation (the SCAT receiver model) describes the auditory computations necessary to estimate target range (Saillant et al. 1993; Simmons

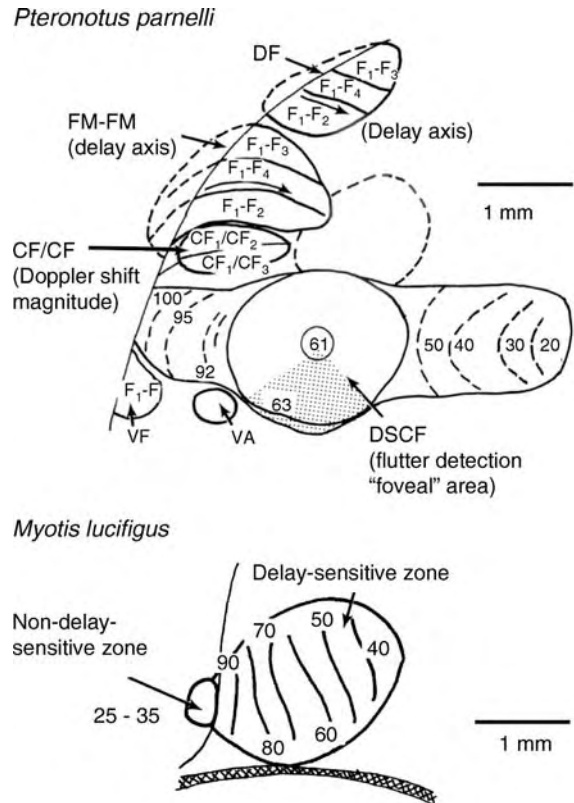

### Neuroethology of Biosonar Systems in Bats.

**Figure 4** Functional organization of the auditory cortex in *Pteronotus parnellii* and *Myotis lucifugus*. In *Pteronotus*, a tonotopically-organized field with an overrepresentation of foveal neurons (DSCF area) is surrounded by areas containing maps that represent either relative velocity (CF/CF area), as indicated by Doppler shift magnitude, or echo delay (FM-FM and DF area). Neurons in the foveal area are sensitive to flutter information. *Myotis* has two tonotopically-organized fields. The larger delay-sensitive zone covers the frequency range of sonar pulses and contains delay-sensitive neurons. The tonotopic gradient of the smaller non-delay sensitive zone is reversed and only covers frequencies from 25–35 kHz (adapted from O'Neill 1995).

et al. 1996). This model is used to explain the extraordinary range accuracy found by Simmons in his range jitter experiments, results that other authors have cast in doubt (Schnitzler et al. 1985; Pollak 1988, 1993). Another model delivers a biologically-plausible framework for auditory perception in FM bats, by using functional units inspired by what is presently known about the neurobiological elements of the bat's auditory system (Palakal and Wong 2004). In other approaches, properties of bat echolocation systems have been implemented in biomimetic sonar systems. Such systems were able to recognize objects directly from

their echo waveform (Kuc 2004) or from stochastic echo properties (Müller and Kuc 2000), or they were able to determine echo direction using pinna morphology and motion (Walker et al. 2004). A computational theory for the classification of natural biosonar targets was developed on the basis of echoes from real targets recorded with a biomimetic sonar system (Müller 2003).

### Outlook

There is still a long way to go before we have attained a complete understanding of echolocation in bats and its neural underpinnings. Most behavioral studies have focused on the detection and localization of single targets, and neurobiological studies have simulated auditory scenes by simply mimicking pulse echo pairs using two succeeding signals. In nature, however, bats are confronted with echolocation scenes that generate complex echo trains from which the relevant information has to be extracted. Further research should therefore focus on the echolocation behavior in natural situations, with a strong emphasis on the adaptive value of signal design and on the adaptive strategies that bats apply to perform complex echolocation tasks. For a better understanding of the neuronal mechanisms underlying echolocation, it will be necessary to study echo processing in vocalizing animals, thereby producing pulse echo trains that are comparable to those occurring in natural scenes. Studies that evaluate the bat's ability to use stochastic echo properties are a promising new approach that may shed new light onto the complex information processing involved in echolocation.

### References

- Aldridge HDJN, Rautenbach IL (1987) Morphology, echolocation and resource partitioning in insectivorous bats. *J Anim Ecol* 56:763–778
- Covey E, Casseday JH (1995) The lower brainstem auditory pathways. In: Popper AN, Fay RR (eds) *Hearing by Bats*. Springer-Verlag, New York, pp 235–295
- Covey E, Casseday JH (1999) Timing in the auditory system of the bat. *Annu Rev Physiol* 61:457–476
- Denzinger A, Schnitzler H-U (2004) Perceptual tasks in echolocating bats. In: Ilg UJ, Bühlhoff HH, Mallot HA (eds) *Dynamic Perception*. Akademische Verlagsgesellschaft Aka GmbH, Berlin, pp 33–38
- Denzinger A, Kalko EK, Jones G (2004) Ecological and evolutionary aspects of echolocation in bats. In: Thomas JA, Moss CF, Vater M (eds) *Echolocation in Bats and Dolphins*. The University of Chicago Press, Chicago, pp 311–326
- Fenton MB (1990) The foraging behaviour and ecology of animal-eating bats. *Can J Zool* 68:411–422
- Fenton MB (1995) Natural history and biosonar signals. In: Popper AN, Fay RR (eds) *Hearing by Bats*. Springer-Verlag, New York, pp 37–86
- Fuzessery ZM, Feng AS, Supin A (2004) Central auditory processing of temporal information in bats and dolphins. In: Thomas JA, Moss CF, Vater M (eds) *Echolocation in Bats and Dolphins*. The University of Chicago Press, Chicago, pp 115–122
- Grinnell AD (1995) Hearing in bats: An overview. In: Popper AN, Fay RR (eds) *Hearing by Bats*. Springer-Verlag, New York, pp 1–36
- Grunwald JE, Schornich S, Wiegrebe L (2004) Classification of natural textures in echolocation. *Proc Natl Acad Sci USA* 101:5670–5674
- Jen PHS, Sun X, Chen QC, Zhang J, Xiaoming Z (2004) Cortifugal modulation of midbrain auditory sensitivity in the bat. In: Thomas JA, Moss CF, Vater M (eds) *Echolocation in Bats and Dolphins*. The University of Chicago Press, Chicago, pp 196–200
- Kössl M, Vater M (1995) Cochlear structure and function in bats. In: Popper AN, Fay RR (eds) *Hearing by Bats*. Springer-Verlag, New York, pp 191–234
- Kuc R (2004) Biomimetic sonar objects from echos. In: Thomas JA, Moss CF, Vater M (eds) *Echolocation in Bats and Dolphins*. The University of Chicago Press, Chicago, pp 501–506
- Masters WM, Harley HE (2004) Introduction: Performance and cognition in echolocating mammals. In: Thomas JA, Moss CF, Vater M (eds) *Echolocation in Bats and Dolphins*. The University of Chicago Press, Chicago, pp 249–259
- Moss CF, Schnitzler H-U (1995) Behavioral studies of auditory information processing. In: Popper AN, Fay RR (eds) *Hearing by Bats*. Springer-Verlag, New York, pp 87–145
- Moss CF, Sinha SR (2003) Neurobiology of echolocation in bats. *Curr Opin Neurobiol* 13:751–758
- Müller R, Schnitzler H-U (1999) Acoustic flow perception in cf-bats: Properties of the available cues. *J Acoust Soc Am* 105:2958–2966
- Müller R, Schnitzler H-U (2000) Acoustic flow perception in cf-bats: Extraction of parameters. *J Acoust Soc Am* 108:1298–1307
- Müller R, Kuc R (2000) Foliage echoes: A probe into the ecological acoustics of bat echolocation. *J Acoust Soc Am* 108:836–845
- Müller R (2003) A computational theory for the classification of natural biosonar targets based on a spike code. *Network*, 14:595–612
- Neuweiler G (1990) Auditory adaptations for prey capture in echolocating bats. *Physiol Rev* 70:615–641
- O'Neill WE (1995) The bat auditory cortex. In: Popper AN, Fay RR (eds) *Hearing by Bats*. Springer-Verlag, New York, pp 416–480
- O'Neill WE (2004) Feature extraction in the mustached bats auditory cortex. In: Thomas JA, Moss CF, Vater M (eds) *Echolocation in Bats and Dolphins*. The University of Chicago Press, Chicago, pp 176–184
- Palakal MJ, Wong D (2004) A biologically plausible framework for auditory perception in FM bats. In: Thomas JA, Moss CF, Vater M (eds) *Echolocation in Bats and Dolphins*. The University of Chicago Press, Chicago, pp 459–467
- Pollak GD (1988) Time is traded for intensity in the bat's auditory system. *Hear Res* 36:107–124
- Pollak GD (1993) Some comments on the proposed perception of phase and nanosecond time disparities by echolocating bats. *J Comp Physiol A* 172:523–531

27. Pollak GD, Winer JA, O'Neill WE (1995) Perspectives on the functional organization of the mammalian auditory system: Why bats are good models. In: Popper AN, Fay RR (eds) *Hearing by Bats*. Springer-Verlag, New York, pp 481–498
28. Pollak GD, Park TJ (1995) The inferior colliculus. In: Popper AN, Fay RR (eds) *Hearing by Bats*. Springer-Verlag, New York, pp 296–367
29. Saillant PA, Simmons JA, Dear SP, McMullen TA (1993) A computational model of echo processing and acoustic imaging in frequency-modulated echolocating bats: The spectrogram correlation and transformation receiver. *J Acoust Soc Am* 94(5):2691–2712
30. Schnitzler H-U, Menne D, Hackbarth H (1985) Range Determination by Measuring Time Delays in Echolocating Bats. In: Michelsen A (eds) *Time Resolution in Auditory Systems*. Springer-Verlag, New York, pp 180–204
31. Schnitzler H-U, Ostwald J (1983) Adaptation for the detection of fluttering insects by echolocation in horseshoe bats. In: Ewert JP, Capranica RR, Ingle DJ (eds) *Advances in Vertebrate Neuroethology*. Plenum Press, New York, pp 801–827
32. Schnitzler H-U, Kalko EKV (2001) Echolocation by insect-eating bats. *BioScience* 51:557–569
33. Schnitzler H-U, Kalko EKV, Denzinger A (2004) Evolution of echolocation and foraging behavior in bats. In: Thomas JA, Moss CF, Vater M (eds) *Echolocation in Bats and Dolphins*. The University of Chicago Press, Chicago, pp 331–338
34. Schnitzler H-U, Moss CF, Denzinger A (2003) From spatial orientation to food acquisition in echolocating bats. *Trends Ecol Evol* 18:386–394
35. Schuller G, Moss CF (2004) Vocal control and acoustically guided behavior in bats. In: Thomas JA, Moss CF, Vater M (eds) *Echolocation in Bats and Dolphins*. The University of Chicago Press, Chicago, pp 3–16
36. Schuller G, O'Neill WE, Radke-Schuller S (1991) Facilitation and delay sensitivity of auditory cortex neurons in CF-FM bats, *Rhinolophus rouxi*, and *Pteronotus p. parnellii*. *Eur J Neurosci* 3:1165–1181
37. Siemers BM, Schnitzler H-U (2004) Echolocation signals reflect niche differentiation in five sympatric congeneric bat species. *Nature* 429:657–661
38. Simmons JA, Ferragamo M, Moss CF, Stevenson SB, Altes RA (1990) Discrimination of jittered sonar echoes by the echolocating bat, *Eptesicus fuscus*: The shape of target images in echolocation. *J Comp Physiol A* 167:589–616
39. Simmons JA, Saillant PA, Ferragamo MJ, Haresign T, Dear SP, Fritz J, McMullen TA (1996) Auditory computations for biosonar target imaging in bats. In: Hawkins HL, McMullen TA, Popper AN, Fay RR (eds) *Auditory Computation*. Springer-Verlag, New York, pp 401–468
40. Suga N (1990) Biosonar and neural computation in bats. *Sci Am* 6:60–68
41. Suga N (2004) Feature extraction and neural activity: advances and perspectives. In: Thomas JA, Moss CF, Vater M (eds) *Echolocation in Bats and Dolphins*. The University of Chicago Press, Chicago, pp 173–175
42. Suga N, Zhang Y, Olsen JF, Yan J (2004) Modulation of frequency tuning of thalamic and midbrain neurons and cochlear hair cells by descending auditory system in the mustached bat. In: Thomas JA, Moss CF, Vater M (eds) *Echolocation in Bats and Dolphins*. The University of Chicago Press, Chicago, pp 214–221
43. Vater M, Kössl M (2004) The ears of whales and bats. In: Thomas JA, Moss CF, Vater M (eds) *Echolocation in Bats and Dolphins*. The University of Chicago Press, Chicago, pp 89–98
44. Vater M (2004) Cochlear anatomy related to bat echolocation. In: Thomas JA, Moss CF, Vater M (eds) *Echolocation in Bats and Dolphins*. The University of Chicago Press, Chicago, pp 99–103
45. Walker A, Peremans H, Hallam J (2004) An investigation of active reception mechanisms for echolocators. In: Thomas JA, Moss CF, Vater M (eds) *Echolocation in Bats and Dolphins*. The University of Chicago Press, Chicago, pp 507–514
46. Wenstrup JJ (1995) The auditory thalamus in bats. In: Popper AN, Fay RR (eds) *Hearing by Bats*. Springer-Verlag, New York, pp 368–415
47. Wong D (2004) The auditory cortex of the little brown bat, *Myotis lucifugus*. In: Thomas JA, Moss CF, Vater M (eds) *Echolocation in Bats and Dolphins*. The University of Chicago Press, Chicago, pp 185–189

## Neuroethology of Sound Localization in Barn Owls

TERRY TAKAHASHI

Institute of Neuroscience, University of Oregon,  
Eugene, OR, USA

### Synonyms

Spatial hearing

### Definition

Sound localization is the ability to determine the spatial relationships of sound sources in the environment.

### Characteristics

#### Higher Level Structures

The barn owl can hunt in pitch darkness guided by auditory neurons with discrete ► **spatial receptive fields** (SRFs) [1,2]. These neurons form a topographic map of frontal auditory space in the external nucleus of the inferior colliculus (ICx). The SRFs of these space-specific neurons are based on neuronal sensitivity to interaural differences in the timing and level of sounds (► **ITD (interaural time difference)** and ► **ILD (interaural level difference)**), which are also the major cues (► **spectral-shape cues**) for sound-localization in humans and other mammals [3–5]. Lesions of the space map lead to scotoma-like defects in sound localization, and microstimulation of the optic tectum (OT), which receives a direct, topographic projection from the ICx, and evokes a rapid head turn to that area of space

represented at the point of stimulation [6,7]. Finally, the smallest angular separation of sources that the owl can resolve has recently been traced to the granularity of the focal activity evoked on the map [8].

Neurons that are sensitive to the location of sources or the binaural cues associated with source location are found not only in the ICx, but also in Field L, the analog of the mammalian primary auditory cortex, and in the archistriatum, the analog of the mammalian basal ganglia [9–11], although maps of space have not been found [12]. Lesions of the OT lead to inaccurate and long-latency head turns, but do not obliterate these movements, suggesting that forebrain regions may serve as parallel pathways for sound localization [13].

### Lower Level Components

**Acoustical Cues** Barn owls rely primarily on two cues, ITD and ILD, to localize sounds. For the owl, ITD varies with the sound source's azimuth due to the ears' separation along the horizontal axis. For a given azimuth, ITD remains largely constant across the entire range of frequencies (▶**best frequency**) [14] that owls use for sound localization (3–9 kHz) [15]. ILD also varies with the source's azimuth at low frequencies (2–4 kHz), but as frequency increases, the axis along which ILD changes becomes increasingly vertical, allowing for the representation of elevation [14]. This, in turn, is due to the asymmetry in the morphology of the two ears, which causes the right and left ears to be more sensitive to sounds coming from above and below eye-level, respectively.

The manner in which the ears and head alter the magnitude and phase of sounds in a location-specific manner is called the ▶**head-related transfer function (HRTF)**. By filtering sounds with the HRTFs for a location in space, we can re-create, over headphones, the sound wave that would have arrived at the eardrums from a sound source at that location. The stimulus is said to have been presented in virtual auditory space (VAS), and the application of VAS techniques allows not only the rapid assessment of neural spatial tuning, but also the analysis of the contribution of the two binaural cues to the neural responses.

**Computation of ITD** The computation of ITD begins with the encoding of the phase angles of each spectral component by ▶**phase locking** neurons of the nucleus magnocellularis (NM), one of the cochlear nuclei [16]. In the barn owl, phase-locking extends to neurons with best frequencies as high as 9 kHz where strong ILDs are generated. It is for this reason that ITD and ILD can operate over the same frequency range, allowing the owl to localize sounds in two dimensions. NM projects bilaterally to the nucleus laminaris (NL), the avian analog of the mammalian medial superior olive (MSO). In the NL, the ITD of each spectral component is computed by a ▶**binaural cross-correlation** operating

over short segments of time [17–22], thus resulting in neurons selective for the ITD.

The NL projects directly to the core of the contralateral ICc that, in turn, projects to the lateral shell of the opposite ICc [23]. As a result of this doubly-crossed pathway, the lateral shell gains a representation of contralateral space. Neurons of the core and lateral shell of the ICc are selective for ITD and frequency and are organized into tonotopic columns. Cells in a column of the ICc-lateral shell project convergently onto a cluster of space-specific neurons, thus endowing them with selectivity for the ITD preserved by the column [24].

**Computation of ILD** We understand less about the processing of ILD. The sound level in the ipsilateral ear is encoded by cells in the nucleus angularis (NA) [16], which project contralaterally to the nucleus ventralis lemnisci lateral pars posterior (VLVp) [25]. The VLVp of the two sides are interconnected by an inhibitory commissure. The neurons of the VLVp are excited by stimulation of the contralateral ear, via the direct input from NA, and are inhibited by stimulation of the ipsilateral ear, via the commissural input [26,27]. The VLVp projects bilaterally to the lateral-shell of the ICc [28], where ILD and ITD cues are merged. A clear topographical representation of ILD, however, has never been found [29].

The application of VAS techniques has recently shown that if space specific neurons were sensitive to ILD alone, their SRFs would be horizontal swaths of space at the elevation of the cell's normal spatial ▶**spatial receptive field (SRF)**. If neurons were sensitive to ITD alone, their SRFs would be a vertical swath at the azimuth of the cell's normal SRF [30,31]. The normal RF thus lies at the intersection of the ITD and ILD-alone RFs where the cell's optimal ITD and ILD-spectra are present and are combined by a multiplication-like process [32].

### Higher Level Processes

**Multiple sound sources.** When there are multiple sources, as is typical in nature, the sound waves from each source will add in the ears, and if the sounds have broad, overlapping spectra, the binaural cues will fluctuate over time in a complex manner [33,34], making it difficult for the space map to image the sources accurately. One key to the space-specific neurons' ability to resolve two simultaneous sources is the difference in spectra [34]. When two sources of identical broadband noises were passed through a neuron's SRF, the neuron discharged maximally when the two speakers flanked the SRF, generating a response function with a single peak. This is to be expected, because the frequency-specific superposition generates binaural cues that are the vector average of those of the two individual sources. When the two sources emitted comb-filtered noises with the energy from each source

in alternate frequency bands, the neurons responded when each speaker was in their SRFs, generating bimodal response functions. This too is expected, because superposition of the waves happens within frequency-specific channels and the two sources' energy is contained in alternate bands, resulting in less spectral overlap. Interestingly, neurons were also able to resolve two speakers that emitted ►**uncorrelated broadband noises** as well as identical broadband noises that were temporally reversed versions of one another. In both cases, the moment-by-moment spectrum differed enough for the neuron to resolve. Thus, the neurons are capable of resolving sounds from two sources as long as their ►**short-term** spectra differ.

**Echoes** Early psychophysical studies demonstrated that directional information conveyed by the sound coming directly from the active source (leading source) dominates perception, and that listeners are relatively insensitive to directional information conveyed by reflections (lagging sources). The perceptual dominance of the leading sound and a host of related perceptions are collectively referred to as the “precedence effect.” (For reviews, see [33,35,36]).

When two identical sounds are presented within 100  $\mu$ s of one another from two separate sources, owls and their space-specific neurons respond as though there was a single target located between them [37,38]. This phenomenon, termed “summing localization” can be explained largely by binaural cross-correlation [37]. If the delay between leading and lagging sources is increased to the 1–5 ms range in humans, the single fused phantom target is localized close to the leading source. This is termed “localization dominance” [36,39,40]. At the same time, spatial information regarding the lagging source is degraded, a phenomenon, termed “lag discrimination suppression” [41–46].

Localization dominance has also been reported in studies with non-human subjects, including owls [38,47,48]. At delays between 1 and 10 ms, the owls turned their heads to the side of the leading source. At delays above 10 ms, owls aimed their heads at the lagging source or made double-head turns, first localizing one speaker then turning to the other [38]. The latter observation indicates that the lagging source had become localizable at the longer delays. To our knowledge, the only study of lag discrimination suppression in non-human species is the recent study in the owl [8], which measured the minimal audible angle (MAA), the smallest perceptible change in sound-source location, in the presence of echoes. For a sequence of two noise bursts from locations separated horizontally by 30° and in time by 3 ms, the MAA for lag sources was considerably larger than for lead sources, suggesting that the owl experiences lag discrimination suppression. The MAA for the lead sources was also found to be larger than that for single sources. This

ordering of effects,  $MAA_{\text{single}} < MAA_{\text{lead}} < MAA_{\text{lag}}$ , replicates findings with humans for similar stimuli [49].

There are a growing number of neurophysiological studies of the precedence effect, which generally show that a cell's response to the lag source is weaker than its response to the lead source or to a single source [37,38,50–56]. A recent study in owls has shown that neuronal MAAs, estimated using signal detection theory, have the same ordering found behaviorally; specifically,  $MAA_{\text{single}} < MAA_{\text{lead}} < MAA_{\text{lag}}$  [57].

**Motion** The best evidence for the owl's sensitivity for the direction of object motion is an early observation that whenever an owl struck a mouse in darkness, it arranged its talons so that it grasped the long axis of the mouse's body [1]. When the mouse's trajectory was colinear with the owl's flight-path, the owl put one set of talons in front of the other to strike, but when the mouse's trajectory was perpendicular to the owl's, the owl arranged its talons side-by-side. Since visual cues were not available in this experiment, the mouse's path was likely determined by acoustical cues.

A number of neurophysiological studies have documented neuronal sensitivity to motion direction using either an array of sequentially-activated speakers simulating saltatory motion [58–62] or continuously varying binaural cues [63,64]. A recent survey demonstrated that neurons in the left and right colliculi prefer, respectively, motion in the clockwise and counterclockwise directions [62]. The authors suggest that the cells may be involved in orienting movements to the contralateral auditory hemisphere.

Neuronal directional sensitivity has been modeled as a circuit in which the motion-direction sensitive neuron receives an excitatory input from a spatially-selective neuron and a delayed inhibitory input from a second spatially-selective neuron with an SRF some distance away. If a sound source travels from the excitatory neuron to the inhibitory neuron, the excitatory input to the motion sensing neuron arrives first, causing a discharge. If the source travels in the opposite direction, the delay causes the inhibitory input to coincide with the excitatory input (which is stimulated later), nullifying it. This mechanism depends on the delay imposed on the inhibitory input and the distance separating the two spatially tuned inputs, thus allowing for some selectivity for speed. Kautz and Wagner [61] demonstrated that bicuculline reduces sensitivity to motion direction, suggesting GABA-mediated inhibition.

Takahashi and Keller [63] reported auditory motion-unmasking. Using ►**binaural beats**, which simulates a moving pure-tone source, they showed that space-specific neurons detected the moving tone in noise more easily than static ones. This finding could not be replicated, however, with saltatory-motion [60]. Two psychophysical studies in humans have yielded conflicting results [65,66].

Attention and Working Memory Studies of audio-spatial cognition are rare. Knudsen and Knudsen [67] showed that an owl's ability to remember the locations to which it recently oriented is affected by lesions of the archistriatum, suggesting its role in spatial working memory [67].

In a study of attention, the reaction time of owls trained to turn their heads toward a sound source when visual stimuli provided a truthful or a misleading cue to the side from which the sound would appear [68]. As in humans [69], the owl's reaction times were significantly faster when the cues were valid than when they were invalid, suggesting that attention is capable of modulating the owl's orienting behavior. Interestingly, however, even the validly cued trials had reaction times that were considerably longer than when an owl was trained simply to turn its head toward a sound source, without a cue. This may indicate that the cued reaction-time task is difficult for owls.

### Process Regulation

Once the binaural cues are computed, these cues must be translated into space. In a baby bird, which has a small head, the maximal ITD, generated by a source to the extreme right or left, may be some 90  $\mu$ s. A neuron tuned to an ITD of, say, 30  $\mu$ s represents a location about 30% of the distance to the extreme periphery. The adult, by contrast, has a maximal ITD of about 200  $\mu$ s [14], so the same neuron represents a more central location.

This process of translation occurs during a critical period, of up to ca. 200 days, during which visual input is crucial [70]. Birds that are blind may form inverted and otherwise distorted maps of auditory space [71,72]. Moreover, if a baby bird matures with a pair of prisms that laterally shifts the visual scene, the now mature bird mis-localizes a sound by the amount that the prisms shifted the visual world [73]. Correspondingly, a space-specific neuron will shift its **▶auditory** SRF by an amount equal to the prism shift. The plasticity is thought to occur in the ICx, and involves the inputs from the OT, which contributes a visual input, and the ICc, which contributes the spatially selective auditory input [74]. The mechanism of audiovisual calibration in the owl is an example of supervised learning and has been thoroughly investigated and reviewed [75].

### Function

Audiospatial Discrimination and Localization Audiospatial discrimination is the ability to detect changes in the position of a sound source. This is to be distinguished from "localization," the ability to point to a sound source in space. In the owl, whose eyes and ears are nearly immobile, sound localization is measured by its head turns. Owls can point their heads to within 2.5° to 5° of a target in azimuth and 3.5° to 8° in elevation [3,76,77].

For both dimensions, accuracy and precision decline slightly with target eccentricity.

Spatial discrimination was recently investigated in the barn owl using a newly developed method based on pupillary dilation response (PDR) [78,79]. In the barn owl, the pupil dilates upon presentation of a sound, and habituates when the same sound is repeated. When the stimulus is changed, for example, by presenting the identical waveform from a different location, the PDR recovers. The degree of recovery is proportional to the magnitude of the difference between the habituating and testing loci, making the PDR similar to a psychophysical **▶rating task**. The magnitude of the PDR evoked by test stimuli can be expressed in terms of the variance of the PDR evoked by habituating stimuli to derive a **▶z-score**-like statistic called the "standard separation,"  $D$  [80]. The MAA, defined as the spatial separation between habituating and test loci at which  $D = 0.8$ , was found to be about 3° in azimuth and 7° in elevation [81]. This value is considerably finer than that of animals with heads of comparable sizes.

How does owl's MAA compare with the acuity of its space-specific neurons? Such comparisons are often confounded by the lack of a common metric. Signal detection theory, which is based on the premise that the variance in neuronal responses limits behavioral discrimination, provides such a metric [82]. By scaling a neuron's responses to its variance, we can estimate how well an animal might be able to discriminate between two stimuli, if its higher centers were relying strictly upon that neuron's firing. Recent application of this approach by Bala and colleagues [79] to the owl's space-specific neurons predicted its horizontal MAA. It is particularly interesting to note that the SRFs of the space specific neurons are about 2–3 times taller than they are wide. This corresponds roughly to the ratio of the vertical and horizontal MAAs [81].

### References

1. Payne RS (1971) Acoustic location of prey by barn owls (*Tyto alba*). *J Exp Biol* 54(3):535–73
2. Knudsen EI, Konishi M (1978) Space and frequency are represented separately in auditory midbrain of the owl. *J Neurophysiol* 41(4):870–84
3. Knudsen EI, Konishi M (1979) Sound localization by the barn owl (*Tyto alba*) measured with the search coil technique. *J. Comp. Physiol. A* 133:1–11
4. Moiseff A, Konishi M (1981) Neuronal and behavioral sensitivity to binaural time differences in the owl. *J Neurosci* 1(1):40–8
5. Pena JL, Konishi M (2001) Auditory spatial receptive fields created by multiplication. *Science* 292:249–252
6. Wagner H (1993) Sound-localization deficits induced by lesions in the barn owl's auditory space map. *J Neurosci* 13(1):371–86
7. duLac S, Knudsen EI (1990) Neural maps of head movement vector and speed in the optic tectum of the barn owl. *J Neurophysiol* 63(1):131–46

8. Spitzer MW, Bala AD, Takahashi TT (2003) Auditory spatial discrimination by barn owls in simulated echoic conditions. *J Acoust Soc Am* 113(3):1631–45
9. Cohen YE, Knudsen EI (1994) Auditory tuning for spatial cues in the barn owl basal ganglia. *J Neurophysiol* 72(1):285–98
10. Cohen YE, Knudsen EI (1995) Binaural tuning of auditory units in the forebrain archistriatal gaze fields of the barn owl: local organization but no space map. *J Neurosci* 15(7 Pt 2): 5152–68
11. Cohen YE, Knudsen EI (1998) Representation of binaural spatial cues in field L of the barn owl forebrain. *J Neurophysiol* 79(2):879–90
12. Cohen YE, Knudsen EI (1999) Maps versus clusters: different representations of auditory space in the midbrain and forebrain. *Trends Neurosci* 22(3):128–35
13. Knudsen EI, Knudsen PF, Masino T (1993) Parallel pathways mediating both sound localization and gaze control in the forebrain and midbrain of the barn owl. *J Neurosci* 13(7):2837–52
14. Keller CH, Hartung K, Takahashi TT (1998) Head-related transfer functions of the barn owl: measurement and neural responses. *Hear Res* 118:1–13–34
15. Konishi M (1973) Locatable and nonlocatable acoustic signals for barn owls. *Amer Nat* 107:775–785
16. Sullivan WE, Konishi M (1984) Segregation of stimulus phase and intensity coding in the cochlear nucleus of the barn owl. *J Neurosci* 4(7):1787–99
17. Jeffress L (1948) A place theory of sound localization. *J Comp Physiol Psychol* 41:35–39.
18. Carr CE, Konishi M (1990) A circuit for detection of interaural time differences in the brain stem of the barn owl. *J Neurosci* 10(10):3227–46
19. Yin TC, Chan JC (1990) Interaural time sensitivity in medial superior olive of cat. *J Neurophysiol* 64(2):465–88
20. Yin TC, Chan JC, Carney LH (1987) Effects of interaural time delays of noise stimuli on low-frequency cells in the cat's inferior colliculus. III. Evidence for cross-correlation. *J Neurophysiol* 58(3):562–83
21. Overholt EM, Rubel EW, Hyson RL (1992) A circuit for coding interaural time differences in the chick brainstem. *J Neurosci* 12(5):1698–708
22. Wagner H (1992) On the ability of neurons in the barn owl's inferior colliculus to sense brief appearances of interaural time difference. *J Comp Physiol [A]* 170(1):3–11
23. Takahashi TT, Wagner H, Konishi M (1989) Role of commissural projections in the representation of bilateral auditory space in the barn owl's inferior colliculus. *J Comp Neurol* 281(4):545–54
24. Wagner H, Takahashi T, Konishi M (1987) Representation of interaural time difference in the central nucleus of the barn owl's inferior colliculus. *J Neurosci* 7(10):3105–3116
25. Takahashi TT, Konishi M (1988) Projections of nucleus angularis and nucleus laminaris to the lateral lemniscal nuclear complex of the barn owl. *J Comp Neurol* 274(2):212–38
26. Takahashi TT, Keller CH (1992) Commissural connections mediate inhibition for the computation of interaural level difference in the barn owl. *J Comp Physiol [A]* 170(2):161–9
27. Takahashi TT, Barberini CL, Keller CH (1995) An anatomical substrate for the inhibitory gradient in the VLVp of the owl. *J Comp Neurol* 358(2):294–304
28. Adolphs R (1993) Bilateral inhibition generates neuronal responses tuned to interaural level differences in the auditory brainstem of the barn owl. *J Neurosci* 13(9):3647–68
29. Mazer J (1995) Integration of parallel processing streams in the inferior colliculus of the owl., in *Division of Biology*. California Institute of Technology: Pasadena
30. Euston DR (2000) From spectrum to space: The integration of frequency-specific intensity cues to produce auditory spatial receptive fields in the barn owl inferior colliculus., in *Department of Psychology*. University of Oregon: Eugene 152
31. Spezio ML, Takahashi TT (2003) Frequency-specific interaural level difference tuning predicts spatial response patterns of space-specific neurons in the barn owl inferior colliculus. *J Neurosci* 23(11):4677–88
32. Pena J, Konishi M (2002) From postsynaptic potentials to spikes in the genesis of auditory spatial receptive fields. *Journal of Neuroscience* 22(13):5652–5658
33. Blauert J (1997) *Spatial Hearing. The Psychophysics of Human Sound Localization*. Cambridge: MIT
34. Takahashi TT, Keller CH (1994) Representation of multiple sound sources in the owl's auditory space map. *J Neurosci* 14(8):4780–93
35. Zurek PM (1987) Yostand WA Gourevitch Editors. *G The precedence effect.*, in *Directional Hearing*, Springer Verlag: New York
36. Litovsky RY et al. (1999) The precedence effect. *J Acoust Soc Am* 106(4 Pt 1):1633–54
37. Keller CH, Takahashi TT (1996) Binaural cross-correlation predicts the responses of neurons in the owl's auditory space map under conditions simulating summing localization. *J Neurosci* 16(13):4300–9
38. Keller CH, Takahashi TT (1996) Responses to simulated echoes by neurons in the barn owl's auditory space map. *J Comp Physiol [A]* 178(4):499–512
39. Haas H (1951) Ueber den Einfluss eines Einfachechos auf die Hoersamkeit von Sprache. *Acustica* 1:49–58
40. Wallach H, Newman E, Rosenzweig M (1949) The precedence effect in sound localization. *Amer. J. Psycho* 57:315–336
41. Shinn-Cunningham BG, Zurek PM, Durlach NI (1993) Adjustment and discrimination measurements of the precedence effect. *J Acoust Soc Am* 93(5):2923–32
42. Yost WA, Soderquist DR (1984) The precedence effect: Revisited. *J Acoust Soc Am* 76:1377–1383
43. Yang L, GD Pollak (1997) Differential response properties to amplitude modulated signals in the dorsal nucleus of the lateral lemniscus of the mustache bat and the roles of GABAergic inhibition. *J Neurophysiol* 77(1):324–40
44. Yang X, Grantham DW (1997) Cross-spectral and temporal factors in the precedence effect: discrimination suppression of the lag sound in free-field. *J Acoust Soc Am* 102(5 Pt 1):2973–83
45. Saberi K, Perrott Dr (1990) Lateralization thresholds obtained under conditions in which the precedence effect is assumed to operate. *J Acoust Soc Am* 87:1732–1737
46. Freyman RL, Clifton RK, Litovsky RY (1991) Dynamic processes in the precedence effect. *J Acoust Soc Am* 90(2 Pt 1):874–84
47. Cranford JL (1982) Localization of paired sound sources in cats: effects of variable arrival times. *J Acoust Soc Am* 72(4):1309–11



48. Kelly JB (1974) Localization of paired sound sources in the rat: small time differences. *J Acoust Soc Am* 55(6):1277–84
49. Litovsky RY (1997) Developmental changes in the precedence effect: estimates of minimum audible angle. *J Acoust Soc Am* 102(3):1739–45
50. Fitzpatrick DC et al. (1999) Responses of neurons to click-pairs as simulated echoes: Auditory nerve to auditory cortex. *J Acoust Soc Am* 106:3460–3472
51. Fitzpatrick DC et al. (1995) Neural responses to simple simulated echoes in the auditory brain stem of the unanesthetized rabbit. *J Neurophysiol* 74(6):2469–86
52. Litovsky RY, Yin TC (1998) Physiological studies of the precedence effect in the inferior colliculus of the cat. II. Neural mechanisms. *J Neurophysiol* 80(3):1302–16
53. Litovsky RY, Yin TC (1998) Physiological studies of the precedence effect in the inferior colliculus of the cat. I. Correlates of psychophysics. *J Neurophysiol* 80(3):1285–301
54. Litovsky RY et al. (1997) Psychophysical and physiological evidence for a precedence effect in the median sagittal plane. *J Neurophysiol* 77(4):2223–6
55. Litovsky RY, Delgutte B (2002) Neural correlates of the precedence effect in the inferior colliculus: effect of localization cues. *J Neurophysiol* 87(2): 976–94
56. Yin TC (1994) Physiological correlates of the precedence effect and summing localization in the inferior colliculus of the cat. *J Neurosci* 14(9):5170–86
57. Spitzer MW, Bala AD, Takahashi TT (2004) A neuronal correlate of the precedence effect is associated with spatial selectivity in the barn owl's midbrain. *J Neurophysiol* 92:2051–2070
58. Wagner H, Takahashi T (1990) Neurons in the midbrain of the barn owl are sensitive to the direction of apparent acoustic motion. *Naturwissenschaften* 77(9):439–42
59. Wagner H, Takahashi T (1992) Influence of temporal cues on acoustic motion-direction sensitivity of auditory neurons in the owl. *J Neurophysiol* 68:2063–76
60. Wagner H, Trinath T, Kautz D (1994) Influence of stimulus level on acoustic motion-direction sensitivity in barn owl midbrain neurons. *J Neurophysiol* 71(5):1907–16
61. Kautz D, Wagner H (1998) GABAergic inhibition influences auditory motion-direction sensitivity in barn owls. *J Neurophysiol* 80(1):172–85
62. Wagner H, Campenhausen M von (2002) Distribution of auditory motion-direction sensitive neurons in the barn owl's midbrain. *J Comp Physiol A Neuroethol Sens Neural Behav Physiol* 188(9):705–13
63. Takahashi TT, Keller CH (1992) Simulated motion enhances neuronal selectivity for a sound localization cue in background noise. *J Neurosci* 12(11):4381–90
64. Wang J (1994) Processing of dynamic stimuli by the auditory system of the barn owl (*Tyto alba*), in Department of Physiology and Neurobiology. University of Connecticut: Storrs. 147
65. Xiao X, Grantham DW (1997) The effect of a free-field auditory target's motion on its detectability in the horizontal plane [letter]. *J Acoust Soc Am* 102(3):1907–1
66. Deliwalwa P (1999) Effects of spatial separation and apparent signal movement on masked detection; energetic and informational maskers., in Sargent College of Health and Rehabilitation Sciences. Boston University: Boston. 165
67. Knudsen EI, Knudsen PF (1996) Disruption of auditory spatial working memory by inactivation of the forebrain archistriatum in barn owls. *Nature* 383(6599):428–31
68. Johnen A, Wagner H, Gaese BH (2001) Spatial attention modulates sound localization in barn owls. *J Neurophysiol* 85(2):1009–12
69. Posner MI, Nissen MJ, Ogden WC (1978) Pick HL, Saltzman. IJ Attended and unattended processing modes: The role of set for spatial location. Modes of perceiving and processing information., Earlbaum: Hillsdale
70. Brainard MS, Knudsen EI (1998) Sensitive periods for visual calibration of the auditory space map in the barn owl optic tectum. *J Neurosci* 18(10):3929–42
71. Knudsen EI (1988) Early blindness results in a degraded auditory map of space in the optic tectum of the barn owl. *Proc Natl Acad Sci USA* 85(16):6211–4
72. Knudsen EI, Esterly SD, du Lac S (1991) Stretched and upside-down maps of auditory space in the optic tectum of blind-reared owls; acoustic basis and behavioral correlates. *J Neurosci* 11(6):1727–47
73. Knudsen EI, Knudsen PF (1989) Vision calibrates sound localization in developing owls. *J Neurosci* 9:3306–3313
74. Brainard MS, Knudsen EI (1993) Experience-dependent plasticity in the inferior colliculus: a site for visual calibration of the neural representation of auditory space in the barn owl. *J Neurosci* 13(11):4589–608
75. Knudsen EI (2002) Instructed learning in the auditory localization pathway of the barn owl. *Nature* 417(6886):322–8
76. Poganiatz I, Wagner H (2001) Sound-localization experiments with barn owls in virtual space: influence of broadband interaural level difference on head-turning behavior. *J Comp Physiol [A]* 187(3):225–33
77. Whitchurch EA, Takahashi TT (2003) Behavioral and physiological characterization of bimodal interactions in the barn owl. *Abst. Soc. Neurosci*
78. Bala ADS, Takahashi TT (2000) Pupillary dilation response as an indicator of auditory discrimination in the barn owl. *J. Comp. Physiol. A* 186:425–434
79. Bala AD, Spitzer MW, Takahashi TT (2003) Prediction of auditory spatial acuity from neural images on the owl's auditory space map. *Nature* 424(6950):771–4
80. Sakitt B (1973) Indices of discriminability. *Nature* 241(5385):133–4
81. Bala AD, takahashi TT (2001) Vertical and horizontal minimal audible angles of the barn owl. *Assoc. Res. Otolaryngol. Abs.* 264
82. Green DM, Swets JA (1966) Signal Detection Theory and Psychophysics. New York: Wiley

## Neuroethology of Visual Orientation in Flies

ANNE-KATHRIN WARZECHA<sup>1,2</sup>, ROLAND KERN<sup>1</sup>  
<sup>1</sup>Lehrstuhl Neurobiologie, Fakultät Biologie, Universität Bielefeld, Bielefeld, Germany  
<sup>2</sup>Institut für Psychologie II, Münster, Germany

### Definition

The central goal of neuroethological research is to account for the behaviour of an animal in terms of

the underlying neuronal mechanisms. The blowfly (*Calliphoridae*) has proven to be a very fruitful model system for the analysis of how the nervous system controls visually guided orientation behaviour (reviews: [1,2]).

When the blowfly, or any other agent equipped with eyes, moves around, the retinal images of the surroundings are continually displaced. This ►**optic flow** is characteristic of the animal's path of locomotion and the spatial layout of the environment. Flies exploit optic flow information for controlling various behaviours such as course stabilisation, compensatory head movements, landing, the detection and fixation of objects, and the pursuit of conspecifics in the context of mating behaviour (review: [2,3]). Due to technical advances, it has recently become possible to record the flight behaviour of freely moving flies with great precision. When cruising around, flies usually fly straight and then very quickly change their flight direction by abrupt, saccadic turns of the head and trunk (Fig. 1 review: [1,2]), reminiscent of eye movements in primates. This behaviour constrains the optic flow patterns experienced during cruising flight and may thus facilitate an evaluation of the retinal information.

The computations underlying optic flow processing can partly be understood in terms of the biophysical properties of individual nerve cells and their synaptic interactions.

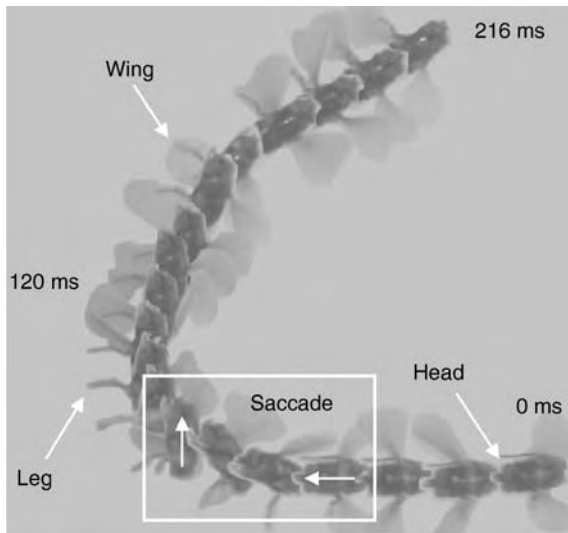

### Neuroethology of Visual Orientation in Flies.

**Figure 1** Flight sequence of blowfly that was videotaped from above with a high-speed camera. Here video images of the fly taken every 12 ms are superimposed. The fly performs a short saccadic turn (indicated by the arrows on the fly's body long axis). Within only 36 ms, it has turned by almost 90°. During such turns the animal can reach turning velocities of more than  $3,000^\circ \text{ s}^{-1}$  (R. Kern unpublished data).

### Characteristics

Motion information is not explicitly represented at the level of the retina. Instead, several processing steps are necessary in order to obtain a neuronal representation of optic flow information (Fig. 2).

### Local Information Processing

Optic flow is initially processed by successive layers of retinotopically arranged columnar neurons. The retinal luminance changes are sensed by photoreceptors and are spatio-temporally filtered by them, as well as by their postsynaptic elements, in the lamina. This filtering is thought to remove spatial and temporal redundancies and to play a role in adapting the system to the ambient light level (reviews: [4,5]).

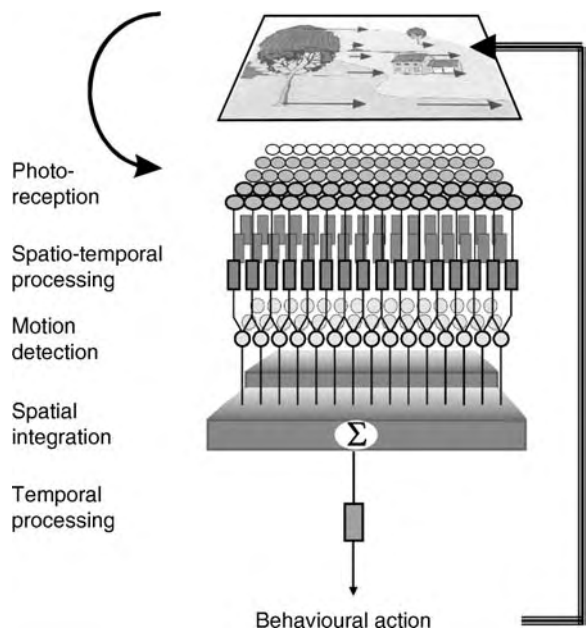

### Neuroethology of Visual Orientation in Flies.

**Figure 2** Scheme of the principle processing steps in visual course control. When moving through a landscape, the images of the surroundings move across the retina of the observer. This optic flow is indicated by the arrows in the uppermost box. The local luminance values of the scene are sensed by a two-dimensional array of photoreceptors. The next layer indicates that this information is spatially and temporally processed in parallel for the entire array of retinotopically organised, local elements. Consecutively, motion is computed on a local basis. Motion information is then spatially pooled over extended parts of the visual field. Again, this process takes place in parallel for different parts of the visual field. In the simplest case, this global motion information is then temporally filtered, and used directly to control behaviour that in turn changes the retinal input. The connections between consecutive elements are only indicated for the foremost row.

### Computation of Local Motion Information

Directionally selective responses to motion are computed on a local retinotopic basis in the second visual neuropile, the medulla. The cellular mechanism underlying ▶**motion detection** is still largely unknown because of the difficulties in recording the activity of the extremely small neurons in this brain area (review: [6]). However, the computational properties of this processing step have been revealed in detail. They can be described by a computational model, the so-called correlation-type movement detector (Fig. 3b, reviews: [1,2]). This movement detector is composed

of two mirror-symmetrical subunits. In each subunit, the input arising from two neighbouring points in visual space are compared by a multiplication after one of them has been delayed. Subtracting the outputs of the two subunits yields the final detector response.

### Dendritic Integration of Local Motion Information

In order to evaluate the global structure of optic flow fields, local motion information needs to be combined from large parts of the visual field. This is accomplished by the large motion-sensitive neurons in the third visual

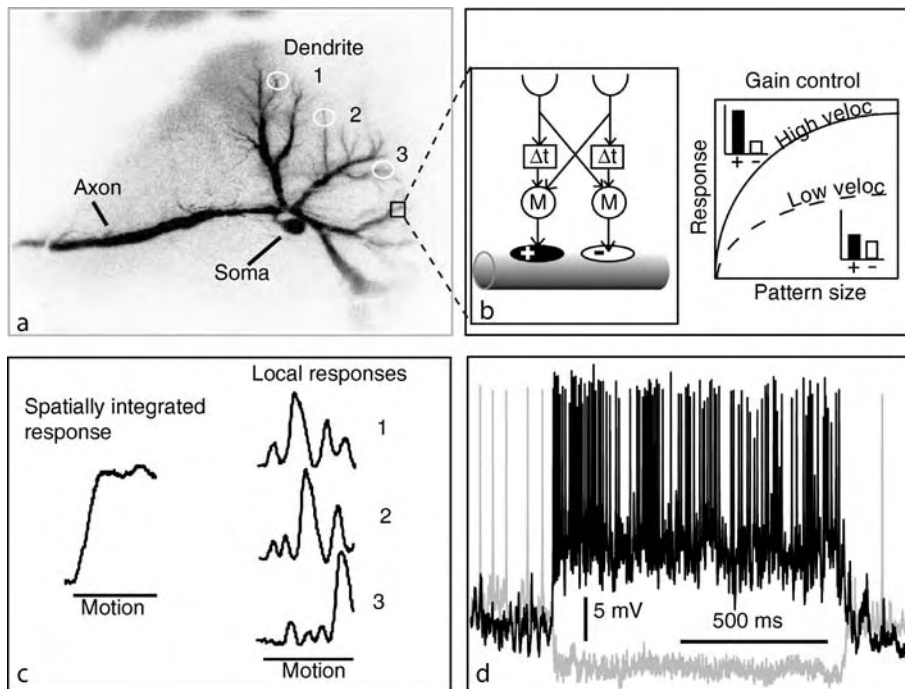

**Neuroethology of Visual Orientation in Flies. Figure 3** ▶**Dendritic integration** and response properties of fly tangential cells (TCs). (a) Image of a TC after it has been injected with a fluorescent dye (Warzecha A-K, unpublished fluorescent photography). (b) TCs acquire their direction selectivity by dendritic integration of the signals of two types of input elements with small receptive fields and opposite preferred directions (*left*). One type of input element is excitatory whilst the other is inhibitory. Many properties of the local input elements can be modelled successfully by correlation-type movement detectors. This type of detector consists of two mirror symmetrical subunits that share their input signals. The delayed ( $\Delta t$ ) signal of each movement detector input line is multiplied (M) with the un-delayed signal of the other input line. The outputs of the two subunits are subtracted from each other. Due to the fly's panoramic vision, nearly every point in visual space is subserved by such an input pair. Both subunits of the movement detector are activated even during preferred direction motion. Several hundreds of such local movement detectors impinge onto the TC dendrite. With increasing pattern size, i.e. with an increasing number of activated input elements, the postsynaptic potential saturates at a level between the excitatory and the inhibitory reversal potentials (*right diagram*). The exact value of saturation is set by the activation ratio of excitatory and inhibitory input elements, which in turn is a function of stimulus parameters such as velocity or contrast (*right diagram*). (c) Dendritic integration smoothes out pattern dependent fluctuations in the time course of the local inputs. The local responses elicited in three different areas of the dendrite (schematically indicated by *white circles* in a) are plotted underneath each other. In the axon, these time-varying signals are integrated and the fluctuations are largely smoothed out. (d) Single responses of a TC to preferred (*black*) and null (*grey*) direction motion. This TC responds even close to its output terminal with graded changes of the membrane potential that are superimposed by spikes. Electrophysiological data courtesy of Jan Grewe.

neuropile, known as tangential cells (TCs). With their large dendritic trees, they pool motion information from up to about 3,000 retinotopically arranged directionally selective input elements (reviews: [1,2,7,8]). Two types of input elements with opposite preferred direction of motion converge onto the dendrite of TCs, one excitatory and the other inhibitory. Consequently, TCs respond directionally selective to motion in a large part of the visual field (Fig. 3).

The preferred directions of the local retinotopic elements that synapse onto a given TC have been concluded to coincide with the directions of velocity vectors characterising the optic flow induced during particular types of self-motion [8]. Hence, the spatial input organisation of TCs forms a basis for their sensitivity to optic flow.

Approximately 60 different TCs can be individually identified on the basis of their physiological and anatomical characteristics. Some TCs have been suggested to respond specifically to the optic flow resulting from certain types of self-motion (but see below), whereas others detect movements of small objects. Depending on the cell type, TCs respond to visual motion by graded shifts of their membrane potential, by spike-like events superimposed on graded membrane potential shifts (Fig. 3d) or by large amplitude action potentials (reviews: [1,2,7]).

► **Dendritic integration** of the local motion signals influences the representation of optic flow in several ways (Fig. 3, [1,3]): (i) Representation of velocity: The responses of the retinotopic input elements of the TCs modulate in time even during constant-velocity motion depending on the local luminance changes of the moving pattern (► **dendritic integration/dendritic processing**). By pooling over many input elements that all experience phase-shifted luminance changes, these response modulations are smoothed out and the integrated signal becomes to some extent proportional to the velocity of the stimulus (Fig. 3c). (ii) Gain control: Saturation nonlinearities of the pooling TCs render their responses largely independent of pattern size while they still depend on other stimulus parameters such as velocity or contrast.

### Integration of Global Motion Information from Populations of Motion-Sensitive TCs

Dendritic pooling of local motion information is not the only computation that takes place in the blowfly visual motion pathway to obtain a representation of global optic flow. Instead, motion information from various TCs is pooled at the level of the lobula plate (reviews: [1,10]). This processing step is assumed to render TCs more specific to particular types of self-motion, such as rotation or translation, or to tune them to the detection of a nearby object moving in front of a more distant background.

Pooling motion information from several TCs requires synaptic transfer. Unless the intervening synapses are carefully adjusted to the presynaptic activity levels that occur during sensory stimulation, synaptic transmission may distort the information being transmitted. The properties of the transmission of pre- to postsynaptic signals has been investigated in detail by electrophysiological and optical imaging studies for various pairs of TCs that differed with respect to the response modes of the pre- and postsynaptic neuron (reviews: [2,9]). For one synaptic connection, it could show, for instance, that signal transfer is linear for frequencies up to about 10 Hz (Fig. 4). This synaptic tuning appears to be adaptive, because in this frequency range TCs transmit most information about changes in the velocity of motion stimuli.

### Reliability of Encoding Visual Motion Information

In order to understand the performance of motion-sensitive neurons in real time, the analysis of the mechanisms of motion computations need to be complemented by investigating how reliably these neurons represent visual motion information. Due to noise from several sources, neuronal responses to repeated presentation of the same stimulus are variable. Although the spike count variance across trials is relatively small in blowfly TCs (review: [10]), significant neuronal response variability still constrains the timescale on which time varying optic flow characteristic of behavioural situations can be conveyed. The noise sources limiting the performance are still under investigation. However, photon noise could be shown not to limit the reliability of a TC in representing a motion stimulus, at least under photopic conditions (Fig. 5a, review: [2]).

The process of generating spikes from the postsynaptic potential is generally thought not to limit the timescale of motion information processing. Accordingly, spikes in TCs time-lock with a millisecond precision to a motion stimulus, if the stimulus induces fast membrane potential fluctuations that are larger than the membrane potential noise (Fig. 5b, c). If, however, the motion stimulus induces only slow membrane potential fluctuations, the exact timing of spikes is determined by the high frequency components of the membrane potential noise. Then spikes are not precisely time-locked to the stimulus and the spike rate rather than spike timing reflects the stimulus induced changes. Since the computations underlying motion detection require time constants of some tens of milliseconds, motion computation inevitably attenuates the neural representations of high frequency velocity fluctuations. Hence only when the velocity changes in the motion stimulus are very rapid and large, the resulting depolarisations of the TCs are sufficiently pronounced to elicit spikes at a millisecond precision. It is still under debate to what extent rapid and slow velocity

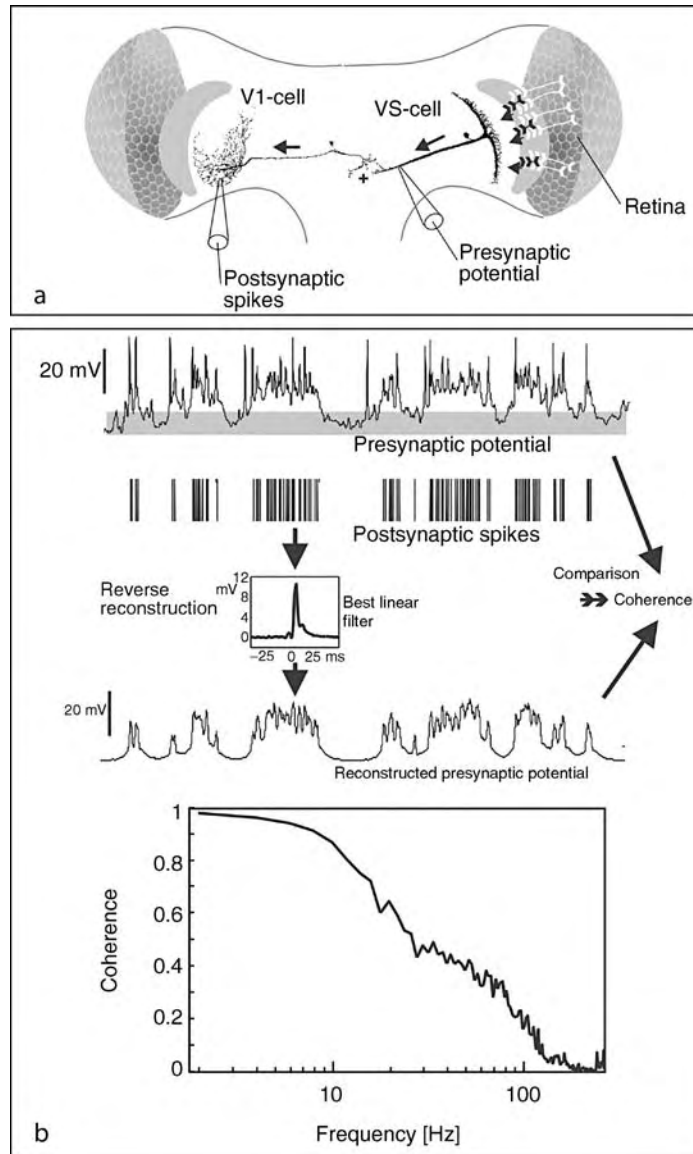

**Neuroethology of Visual Orientation in Flies. Figure 4** Synaptic transmission between two motion sensitive tangential cells (TCs). (a) Schematic of the visual motion pathway of the fly illustrating the compound eyes, the local retinotopically organised local elements involved in the local computation of motion, and a particular TC, a so-called VS-cell, that spatially pools the output of the small-field motion sensitive elements with its large dendrite. The VS-cell is synaptically coupled to the V1-cell that transmits optic flow information to the contralateral half of the brain via its extended output arborisation (anatomical reconstructions taken from Hausen K, Egelhaaf M (1989) Neural mechanisms of visual course control in insects. In: Stavenga DG, Hardie RC (eds) Facets of vision. Springer, pp 391–424; and Krapp et al (1998) J Neurophysiol 79:1902–1917, with permissions). (b) Presynaptic membrane potential of a VS-cell and postsynaptic spike train of the V1-cell (occurrence of a spike indicated by a vertical line) during presentation of white noise velocity fluctuations. In order to quantitatively relate the time-dependent postsynaptic signal to the presynaptic input, the reverse reconstruction approach was applied as schematically outlined in the figure. For this approach, the linear filter was determined that when convolved with the presynaptic spike train leads to the best estimate of the presynaptic potential. Since hyperpolarisations do not have much effect on the activity of the postsynaptic neuron, the presynaptic potential was rectified at the resting potential (shaded bar underneath the presynaptic potential trace). The coherence function serves as a measure of the similarity of the recorded and the estimated presynaptic membrane potential traces. Coherence values close to 1 for frequencies up to 10 Hz indicate that the system can be regarded as very reliably and approximately linear in this frequency range (modified from Warzecha A-K et al (2003) Neuroscience 119:1103–1112, with permission from Elsevier).

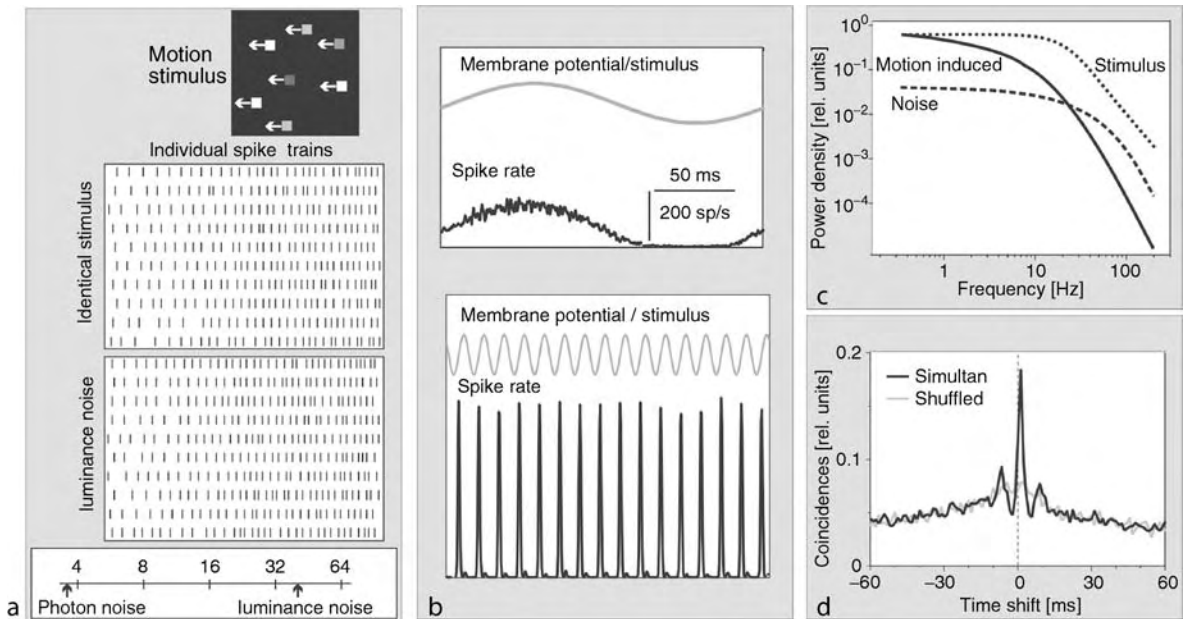

**Neuroethology of Visual Orientation in Flies. Figure 5** Reliability of motion sensitive neurons in the fly. (a) Origin of **neuronal variability**. The equivalent noise paradigm was adapted to investigate whether photon noise limits the reliability of the motion detection system. In order to mimic photon noise, the luminance of individual dots was chosen randomly. The motion stimulus consists of a group of coherently moving dots with variable luminance. The two raster plots illustrate a 300 ms section of the responses of a spiking TC. Each vertical bar denotes the occurrence of a spike. Consecutive responses are plotted underneath each other. Either exactly the same luminance values were presented (*upper raster*) or new luminance values were drawn randomly for each trial (*lower raster*). Even if exactly the same stimulus was presented from trial to trial, there is considerable neuronal variability. Analyses derived from signal-detection theory revealed that the response statistics are affected only when luminance noise is much larger than photon noise (*bottom*). Hence, photon noise does not limit the reliability of a motion sensitive neuron under photopic conditions (details in Grewe et al (2003) *J Neurosci* 23:10776–10783). (b) Time-locking of spikes to sinusoidal stimulus-induced membrane-potential fluctuations (5 and 80 Hz) in a model cell. The model is adjusted to fit the responses of a fly TC to motion stimuli. The stimulus-induced membrane potential fluctuations fed into the model cell were superimposed by stochastic fluctuations mimicking **neuronal noise**. PSTHs illustrate that fast stimulus-induced membrane potential fluctuations are necessary to trigger spikes with a high temporal precision. Slow stimulus-induced fluctuations lead to spike activity with a rate about proportional to the membrane potential (details in Kretzberg et al (2001) *J Comput Neurosci* 10:79–97, with permission). (c) Dynamic properties of membrane potential fluctuations of a fly TC (HS-cell) elicited by band-limited white-noise velocity fluctuations. Power spectra of the motion stimulus (*dotted*), the motion induced response component (*solid*) and the stochastic membrane potential fluctuations (*dashed*). The motion induced response component was obtained by averaging many individual response components thereby smoothing out stochastic response fluctuations. The stochastic response component results from the difference of each individual response trace to the motion-induced component. The motion-induced component contains most power below 20 Hz, although the stimulus contained higher frequencies. In the low frequency range, the motion-induced response component is larger than the stochastic response component. At higher frequencies, the relationship reverses (details in Warzecha et al (1998) *Curr Biol*). (d) Cross-correlogram of responses of two TCs (H1 and H2) to band-limited white-noise velocity fluctuations. Either synchronously recorded responses were cross-correlated (*black*) or responses were not recorded synchronously but obtained from the same cell pair in repetitive presentations of the same stimulus (*grey*). Although TCs can generate spikes very precisely (*black*), most spikes time-lock even to dynamical motion stimulation on a much coarser time scale (reprinted from Warzecha et al (1998) *Curr Biol* 8:359–368, with permission from Elsevier).

changes and thus the exact timing of spikes are functionally significant (review: [10]). This issue can only be resolved if the dynamics of the retinal image displacements as experienced by the blowfly in different behavioural contexts are taken into account.

### Encoding of Visual Stimuli Under Naturalistic Conditions

The functional significance of the information that is processed in the visual motion pathway of the blowfly can be assessed only by analysing the neuronal

performance under conditions the blowfly experiences in a normal behavioural situation. These conditions comprise of the properties of the visual stimuli with respect to e.g. their dynamics, brightness and textural properties, as well as the context in which they appear with respect to the stimulus history and the internal state of the animal. The stimulus history has been shown to affect the properties of several processing stages along the visual motion pathway including TCs (review: [9]).

Due to technical advances, it has recently become possible to confront the blowfly with visual stimuli that come close to those the blowfly is confronted with in natural situations. Natural stimuli differ largely from those usually employed for an analysis of the mechanisms underlying visual motion processing. This difference in particular pertains to the dynamics of natural optic flow, which is largely determined by the animal's self-motion. Since it is not yet possible to record from neurons in freely moving flies in order to assess the functional role of TCs, an alternative approach has been chosen (review: [3]). The trajectories of freely moving flies were recorded in known surroundings; the optic flow experienced by the flies was reconstructed and then replayed to the animal while recording the activity of a TC in electrophysiological experiments. Using a naturalistic behaviourally generated optic flow led to conclusions that partly contradict those obtained with simple experimenter-designed motion stimuli. The neuronal responses of a TC previously thought to encode rotations of the animal about its vertical body axis astonishingly provide information about the spatial relation of the animal to its surroundings. Thus, one of the great issues of future research is to understand how the neuronal hardware that underlies a given behaviour processes information under natural operating conditions.

### Outlook

With their relatively simple and accessible nervous system, blowflies are excellent organisms in which to investigate how visual information is acquired and processed to guide locomotion. Many important aspects of the neuronal computations that underlie visually guided behaviour in blowflies have been elucidated in recent years, ranging from the biophysical properties of individual neurons and their synaptic interactions, to the performance under conditions that come close to what the animal might encounter in normal behaviour. In almost all parts of the above mentioned aspects, models have proved to be an essential element for unravelling the mechanisms underlying visual orientation behaviour in flies (reviews: [1,2]). Also in future research, models will serve as touchstones to challenge our hypotheses about how the blowfly manages to control its virtuosic flight behaviour. It thus appears possible, by studying the blowfly visual system, to understand

visually guided behaviour under naturalistic conditions at the level of individual neurons and small neuronal networks.

### References

1. Borst A Haag J (2007) *Invertebrate Neurobiology*. Cold Spring Harbor Laboratory Press, Cold Spring Harbor, NY, pp 101–122
2. Egelhaaf M et al. (2005) *Methods in Insect Sensory Neuroscience*. CRC Press LLC, Boca Raton, FL, pp 185–212
3. Egelhaaf M et al. (2002) Neural encoding of behaviourally relevant motion information in the fly. *Trends Neurosci* 25:96–102
4. Laughlin SB (1994) Matching coding, circuits, cells, and molecules to signals: general principles of retinal design in the fly's eye. *Prog Retin Eye Res* 13:165–196
5. Juusola M, French AS, Uusitalo RO, Weckström M (1996) Information processing by graded-potential transmission through tonically active synapses. *Trends Neurosci* 19:292–297
6. Douglass JK, Strausfeld NJ (2001) Motion vision: computational, neural, and ecological constraints. Zanker JM, Zeil J (eds) Springer, Berlin Heidelberg New York, pp 67–81
7. Hausen K (1984) Photoreception and vision in invertebrates. Ali MA (ed) Plenum, New York, pp 523–559
8. Krapp HG (2000) Neuronal processing of optic flow. Lappe M (ed) Academic, San Diego, CA, pp 93–120
9. Kurtz R, Egelhaaf M (2003) Natural patterns of neural activity. *Mol Neurobiol* 27:1–19
10. Warzecha AK, Egelhaaf M (2001) Processing visual motion in the real world: a survey of computational, neural, and ecological constraints. Zanker JM, Zeil J (eds) Springer, Berlin Heidelberg New York, pp 239–277

---

## Neurofibroma

### Definition

Neurofibroma is a benign neoplasm composed of the fibrous elements of a nerve.

---

## Neurofibromatosis Types I (NF-I) and Type II (NF-II)

### Definition

Autosomal-dominantly inherited neuro-cutaneous disorders presenting with a plethora of manifestations involving the central and peripheral nervous systems, the circulatory system, the skin, and the skeleton.

Lifespan is reduced, frequently due to malignant tumors and hypertension. The common *neurofibromatosis type 1 (NF-1)* results from an alteration in the long arm of chromosome 17. The diagnosis is clinically based on the presence of two of seven criteria. One criterion is the presence of neurofibroma (a benign peripheral nerve sheath tumor), which is one of the most frequent tumors of neural origin. Others include are central nervous system tumors, skin lesions (café au lait spots), bone malformations and vascular abnormalities. *Neurofibromatosis 2 (NF2)* is clinically and genetically distinct from NF-1 by being rarer, exhibiting less skin manifestations and malignant tumors, with the cardinal sign being bilateral vestibular ▶[schwannomas](#) and ocular abnormalities (cataract).

## Neurofilament

### Definition

Neurofilaments are intermediate type cytoskeletal proteins which lend structural support to especially axons. They are thought to play a major role in determining the axonal caliber (diameter of the axon). These proteins are intermediate filaments being composed of three different proteins: NF-L (low weight), NF-M (medium weight) and NF-H (high weight).

Developing neurons produce few neurofilaments, however once the growth phase is complete neurofilaments are seen extending from the soma into both axons and dendrites providing structural support to these processes. Neurofilaments can be used to identify and visualize mature neurons using histochemical techniques.

- ▶ [Axonal Pathfinding and Network Assembly](#)
- ▶ [Cytoskeleton](#)
- ▶ [Extrasomal Protein Synthesis in Neurons](#)
- ▶ [Neuronal Cell Death and Axonal Degeneration: Neurofilaments as Biomarkers](#)

## Neurofilament Heavy Chain (NfH)

### Definition

A 190–210 kDa protein depending on the degree of phosphorylation, encoded on chromosome 22q12.2.

- ▶ [Neuronal Cell Death and Axonal Degeneration: Neurofilaments as Biomarkers](#)

## Neurofilament Light Chain (NfL)

### Definition

A 68 kDa protein encoded on chromosome 8p21.

- ▶ [Neuronal Cell Death and Axonal Degeneration: Neurofilaments as Biomarkers](#)

## Neurofilament Medium Chain (NfM)

### Definition

A 150 kDa protein encoded on chromosome 8p21.

- ▶ [Neuronal Cell Death and Axonal Degeneration: Neurofilaments as Biomarkers](#)

## Neurogenesis

KOJI OISHI, KAZUNORI NAKAJIMA

Department of Anatomy, Keio University School of Medicine, Tokyo, Japan

### Definition

In the narrow sense, “neurogenesis” is the process by which neurons are generated by their progenitor cells. However, the term “neurogenesis” is occasionally used in the broad sense to refer to the entire process of generating functionally mature neurons, including the process of proliferation and neuronal fate specification of progenitor cells and regulation of the cell death of neurons/progenitor cells.

Neurogenesis in the mammalian central nervous system (CNS) used to be thought to occur only during early embryonic development and only recently has it come to be generally accepted that new functional neurons are generated in at least two regions of the adult brain, the ▶[subventricular zone](#) (SVZ) along the lateral ventricle and the subgranular zone (SGZ) of the dentate gyrus in the hippocampus [1].

### Characteristics

#### Quantitative Description

Approximately 100 billion neurons are thought to be present in the human CNS, and even in mice the number is estimated to be about 40 million. Since each neuronal progenitor cell produces one or two neurons for each



neurogenic cell division, a comparable number of progenitor cells is necessary. Moreover, 50–80% (depending on the region) of the neurons generated undergo apoptosis during formation of the neural network in the neonatal CNS, suggesting that much more neurogenesis has to occur to establish the mammalian CNS [2].

It is estimated that about 80,000 and 9,000 new neurons a day are produced in the SVZ and SGZ respectively of the adult rat brain. However, more than 50% of them are eliminated by apoptosis within a week.

### Higher Level Structures

Before neurogenesis, the neural plate and neural tube are composed of neuroepithelial cells that form a pseudostratified epithelium. Neuroepithelial cells are bipolar and each of them extends from the apical (ventricular) surface to the basal lamina (radial orientation). Neuroepithelial cells translocate their nucleus from the top to the bottom of the ►neuroepithelium during the cell cycle (referred to as interkinetic nuclear migration or elevator movement) [3]. As the neuroepithelial walls thicken at around E12.5 in the mouse telencephalon, the primitive neuroepithelial cells elongate, while maintaining their orientation and become ►radial glial cells, which are defined as cells with a radial morphology and some glial characteristics (e.g. glycogen granules). The cell bodies of the radial glial cells are in the ►ventricular zone (VZ) and the cells undergo cell divisions at the ventricular surface. One of the most exciting recent discoveries is that radial glial cells, which used to be thought of primarily as migratory scaffolds for young neurons and as glial progenitors, are neurogenic progenitors. A distinct type of progenitor cells, referred to as basal progenitors (also called SVZ, intermediate, or non-surface-dividing progenitors), has been identified as cells that lose contact with the ventricular surface and undergo cell

division away from the surface. At later stages basal progenitors are mainly present in the SVZ, a histologically distinct structure adjacent to the VZ. These three cell types, neuroepithelial cells, radial glial cells and basal progenitors, all contribute to the generation of neurons (Fig. 1; see also higher level processes) [4,5].

A primate-specific layer of progenitor cells called the outer SVZ has recently been described and shown to be one of the major sites of cortical neuron production in primates. In contrast to the basal progenitors in rodents, these cells in primates possess radial morphology, strongly suggesting that they are polarized cells [6].

What is the site of neurogenesis? In the embryonic stages, CNS neurons are produced from almost all regions of the neuroepithelium in the neural tube with the exception of a few specialized areas, such as the optic stalk and the floor plate and roof plate of the spinal cord. The onset and period of neurogenesis vary greatly depending on the location along the neuraxis. During the development of the dorsal pallium, for example, neurogenesis, including developmental changes in cell cycle dynamics, maturation of the cortical plate and later events (such as the development of callosal projections or synaptogenesis), progresses along a latero-rostral to medio-caudal gradient.

Neurons in the peripheral nervous system (PNS) are generated from neural crest cells that originate at the border between the neural plate and the prospective epidermis. Around the time of neural tube closure, neural crest cells emigrate from the neural tube, migrate along defined paths in the embryo and differentiate into a wealth of derivatives, including PNS neurons [7].

In most mammals, active neurogenesis occurs throughout life in discrete regions of the intact adult CNS. From rodents to primates, neurons are generated continuously in the SVZ along the lateral ventricle and migrate anteriorly through the rostral migratory stream

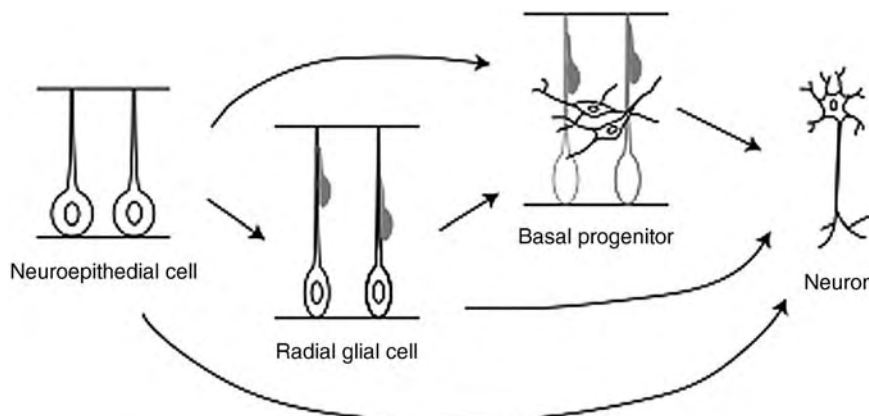

**Neurogenesis. Figure 1** Various lineage relationships have been shown to exist or are thought to exist between neuroepithelial cells, radial glial cells, basal progenitor cells and neurons. Three types of progenitor cells contribute to the generation of neurons in the mammalian central nervous system.

into the olfactory bulb to become interneurons. In the SGZ of the dentate gyrus of the hippocampus, new granule neurons have been found to be continuously produced locally in all mammals examined, including humans. Neurogenesis in the intact adult mammalian CNS outside these two regions appears to be extremely limited or nonexistent. After pathological stimulation, such as by a brain insult, adult neurogenesis appears to occur in regions otherwise considered non-neurogenic [1].

### Higher Level Processes

Neuroepithelial cells, radial glial cells and basal progenitors have been shown to generate CNS neurons. All three types of these progenitor cells are known to undergo symmetric or ►**asymmetric cell divisions** during neurogenesis. ►**Symmetric cell divisions** generate two daughter cells having the same fate while asymmetric cell divisions generate one daughter cell that is identical to the mother cell and a second cell of a different type. Progenitor cells are thought to produce neurons by a variety of processes (Fig. 1) [4,5].

Early in development both neuroepithelial cells and radial glial cells increase in number by undergoing symmetric divisions that lead to the expansion of the progenitor pool and the neural tube wall. There is another type of ►**symmetric cell division** that produces two neurons. Some neuroepithelial cells and radial glial cells and almost all basal progenitors are thought to divide by this type of cell division. However, the symmetric neurogenic divisions may very well be asymmetric in terms of neuronal subtype, consistent with the observation that some pairs of neurons arising from single progenitors have been found to differ in the expression of certain transcription factors.

Most radial glial cells divide asymmetrically, with some divisions generating another radial glial cell and a neuron, while others generate a radial glial cell and a basal progenitor. This type of cell division enables progenitor cells to generate neurons without losing the characteristics of the original cell.

Neuroepithelial cells and radial glial cells undergo cell division at the ventricular surface, whereas basal progenitors divide away from the surface. Investigation of the relationship between the location of the dividing cell and cell fate has shown that basal divisions only generate neurons, consistent with the expression of neuronal markers in basal progenitors. This finding suggests that basal progenitors are committed to the neuronal lineage. The length of the cell cycle of the basal progenitors is also different. They have a longer G2 phase than progenitors that divide at the ventricular surface [4].

### Lower Level Processes

How do the immature neurons generated behave after neuronal differentiation? Various classes of CNS neurons migrate from their birthplace to their final positions [8].

In the developing neocortex, neurons are generated in the VZ and/or SVZ and then move to the developing cortical plate via radial migration. Recent studies by time-lapse imaging in slice cultures have revealed three modes of radial movement by cortical neurons. They are described briefly as ►**somal translocation**, in which the cell body moves toward the pial surface by shortening its radial process, ►**locomotion**, i.e. guided migration in which neurons move to a position beneath the pial surface along the basal process of radial glia and ►**multipolar migration**, migration of neurons residing in the SVZ and intermediate zone in which neurons with multiple processes extending and retracting dynamically move slowly toward the pial surface. In addition, most cortical interneurons in mice are known to derive from the subpallial telencephalon, including the medial and caudal ganglionic eminences and to migrate tangentially into the pallium. While medial ganglionic eminence-derived cells migrate laterally and spread widely throughout the cerebral cortex, caudal ganglionic eminence-derived cells migrate caudally toward the caudal-most end of the telencephalon (named the caudal migratory stream) and spread into the hippocampus and posterior cerebral cortex. There may be additional modes of neuronal migration in distinct areas that lead to the construction of elaborate structures.

### Process Regulation

A number of pathways regulating neurogenesis in the CNS have recently been identified [9]. Extrinsic cues, including cell-cell interactions and secreted molecules, are key determinants of progenitor cell fate regulation. Exposure to growth factors, such as fibroblast growth factor (FGF)-2 and epidermal growth factor (EGF), as well as activation of the transmembrane receptor Notch, inhibits neuronal differentiation from progenitor cells, while several extrinsic factors (such as platelet-derived growth factor [PDGF], vascular endothelial growth factor [VEGF], neurotrophic factors, etc.) promote neuronal differentiation.

The molecular machinery governing whether progenitor cells divide symmetrically or asymmetrically has recently begun to be unraveled and centrosomal proteins and heterotrimeric G-proteins have been reported to control these divisions. Nde1, a central component of the centrosome, is expressed in the VZ and Nde1-deficient mice have smaller brains as a result of an increase in asymmetric cell divisions that leads to premature neurogenesis and depletion of the progenitor pool. Other centrosomal proteins, such as ASPM (abnormal spindle-like microcephaly associated), CDK5RAP2 and CENPJ, have been shown to be crucial determinants of cerebral cortex size, suggesting that these proteins also participate in the regulation of symmetric and asymmetric cell divisions. In addition, the G $\beta\gamma$  subunits of heterotrimeric G-proteins have recently been reported to play a key role

in regulating spindle orientation and the asymmetric cell fate of progenitor cells [5].

Two transcription factors have been reported to have a role in determining whether progenitor cells undergo symmetric or asymmetric progenitor cell division. *Emx2*, a homeodomain transcription factor, promotes symmetric cell divisions by progenitor cells, whereas the paired-type homeodomain transcription factor *Pax6* promotes asymmetric, neurogenic cell divisions. These transcription factors may therefore regulate cell fate and the appropriate mode of cell division in a coordinated manner.

### Pathology

One of the neurodevelopmental disorders, autosomal recessive primary microcephaly (MCPH), has been suggested to be the result of deficient neurogenesis within the neuroepithelium [10]. MCPH is characterized by two principal features, microcephaly (small brain) present at birth and nonprogressive mental retardation. There are at least seven MCPH loci, and four of the genes have been identified, *MCPH1*, *Microcephalin*; *MCPH3*, *CDK5RAP2*; *MCPH5*, *ASPM* and *MCPH6*, *CENPJ*. Present evidence suggests that these genes are involved in mitosis by neural progenitor cells and are presumably related to DNA repair and control of mitotic spindles. Autosomal recessive periventricular heterotopia with microcephaly (ARPHM) is another disorder related to deficient neurogenesis and it has recently been reported that mutations in the *ARFGEF2* gene cause ARPHM. This finding suggests that vesicle trafficking in neural progenitors is an important regulator of their proliferation and migration during cerebral cortical development.

Genetic studies of human malformations have proved a surprising source for discovery of molecules that regulate neuronal migration [8], including doublecortin and *Lis1*, mutations of which cause a profound migratory disturbance known as classical lissencephaly (smooth brain). There are other lissencephaly syndromes and mutations in the *RELN* (reelin) gene have been found in lissencephaly with cerebellar hypoplasia. X-linked lissencephaly with abnormal genitalia is associated with agenesis of the corpus callosum and ambiguous or underdeveloped genitalia. Mutations in the *Aristaless*-related homeobox transcription factor gene, *ARX*, have recently been found in these patients.

### ► Evolution and Embryological Development, of the Cortex in Amniotes

### References

1. Ming GL, Song H (2005) Adult neurogenesis in the mammalian central nervous system. *Annu Rev Neurosci* 28:223–250
2. Oppenheim RW (1991) Cell death during development of the nervous system. *Annu Rev Neurosci* 14:453–501

3. Fujita S (2003) The discovery of the matrix cell, the identification of the multipotent neural stem cell and the development of the central nervous system. *Cell Struct Func* 28:205–228
4. Gotz M, Huttner WB (2005) The cell biology of neurogenesis. *Nat Rev Mol Cell Biol* 6:777–788
5. Huttner WB, Kosodo Y (2005) Symmetric versus asymmetric cell division during neurogenesis in the developing vertebrate central nervous system. *Curr Opin Cell Biol* 17:648–657
6. Smart IH, Dehay C, Giroud P, Berland M, Kennedy H (2002) Unique morphological features of the proliferative zones and postmitotic compartments of the neural epithelium giving rise to striate and extrastriate cortex in the monkey. *Cereb Cortex* 12:37–53
7. Nieto MA (2001) The early steps of neural crest development. *Mech Dev* 105:27–35
8. Kubo K, Nakajima K (2003) Cell and molecular mechanisms that control cortical layer formation in the brain. *Keio J Med* 52:8–20
9. Temple S (2001) The development of neural stem cells. *Nature* 414:112–117
10. Woods CG, Bond J, Enard W (2005) Autosomal recessive primary microcephaly (MCPH): a review of clinical, molecular, and evolutionary findings. *Am J Human Genet* 76:717–728

## Neurogenesis and Inflammation

LILIANA BERNARDINO, FABIENNE AGASSE,  
JOÃO O. MALVA

Center for Neuroscience and Cell Biology, Institute of Biochemistry, Faculty of Medicine, University of Coimbra, Coimbra, Portugal

### Definition

Inflammation and ►neurogenesis is a research area devoted to dissect the functional interplay between brain immune response and inflammation and production of new neurons and self-repair capacity of the brain.

### Characteristics

#### Introduction

Until recently, the brain was considered as an immune privileged organ, unable to respond with an immune reaction in response to neurodegeneration or to infection, a property mainly attributed to the special protection conferred by the endothelial barrier. However, in the last decade the immune privileged status of the brain has been questioned mostly because in pathological conditions, molecules and cells of the immune system enter the brain and target the brain parenchyma [1]. In healthy conditions, the Central Nervous System (CNS) is routinely surveyed by few immune cells (e.g., T lymphocytes) in search of pathogens. Nevertheless, under pathological

conditions, T cells accumulate and can reach relatively high density in inflammatory sites in brain parenchyma. Moreover, it is now well known that the inflammatory response in the CNS (►**neuroinflammation**) comprises a complex and integrated interplay between different cellular types of the immune system (macrophages, T and B lymphocytes, dendritic cells) and resident cells of the CNS (►**microglia**, astrocytes, oligodendrocytes, neurons).

Recently, neurogenesis in the CNS has emerged as an important physiological process, especially for plastic structures like the hippocampus and the olfactory bulb. The identification of stem cell niches in the adult brain opens new and fascinating perspectives for future development of strategies for ►**brain repair**. With this major challenge in mind we must better understand how local cell microenvironment and inflammation (usually accompanying neurodegeneration) affects the final outcome of stem cell proliferation and differentiation.

## Inflammation in the Brain

### **Microglia: The Brain Immune Survey**

Microglial cells are the major resident immunocompetent population of cells in the CNS parenchyma. Under physiological conditions, microglia cells display a resting-like phenotype with a ramified morphology and a low or absent expression of immunological molecules and their receptors. Although, in response to an injury, microglial cells became rapidly activated, changing to a round-shaped morphology with thickened and short or retracted processes, proliferate, are recruited to the site of injury and strongly up-regulate the expression and the release of inflammatory mediators such as pro-inflammatory ►**cytokines**, ►**chemokines**, reactive oxygen species and nitric oxide [2]. Equipped with receptors and ion channels, microglia can sense their microenvironment and detect the appearance of unusual concentrations of several soluble factors such as neurotransmitters, abnormal endogenous proteins such as beta-amyloid peptide, cell debris and exogenous compounds such as the endotoxin lipopolysaccharide (LPS) and some viruses. LPS, a component of the outer membrane of Gram-negative bacteria, is a well known inducer of cytokines, chemokines and other inflammatory mediators in brain experimental models of neuroinflammation. The most well accepted assumption is that the primary role of activated microglia is to support neuronal function; however, the sustained or excessive activity of these cells may have detrimental consequences and can be associated with the onset and/or exacerbation of neuronal death associated with neurodegenerative disorders [2].

### **Cytokines**

An essential feature of the early immune response to pathogens and cell debris is secretion of pro-inflammatory

cytokines by immune cells. Cytokines are low molecular weight proteins responsible for the communication between glial, neuronal and immune cells. Upon binding to their receptors, either soluble or located on the cell membrane, several intracellular pathways are usually triggered, which in turn regulate the activity of transcription factors such as NF- $\kappa$ B, and AP-1. The expression of these molecules and their respective receptors in the CNS are barely detectable under normal conditions, but become stimulated in response to pathological conditions, like ischemia, excitotoxicity and epilepsy. In the brain, cytokines can be originated from two different sources: (i) from infiltrating peripheral immune cells (lymphocytes and macrophages); (ii) from CNS resident cells (neurons, microglia, astrocytes, oligodendrocytes, endothelial cells and perivascular microglia). Functionally, cytokines have been described as being either pro-inflammatory (e.g., Tumor Necrosis Factor (TNF)- $\alpha$ , Interleukin (IL)-1 $\beta$ ) or anti-inflammatory (e.g., IL-10, Transforming Growth Factor (TGF)- $\beta$ , IL-1ra) depending on the final balance of their effects. Although, contributing to the complexity of this classification, the functional role of individual cytokines in CNS inflammation can shift from beneficial to detrimental [3]. Moreover, many cytokine actions are indirect, acting by stimulating the synthesis and function of other cytokines, resulting in a complex “cytokine cascade” triggered by immune and inflammatory responses. Cytokine activity can also be modulated by neurotransmitters, neuropeptides, growth factors and hormones. Therefore, cytokines can act in the CNS as both immunoregulators and neuromodulators in health and disease.

### **Chemokines**

Chemokines are a family of chemo-attractant proteins, structurally related to cytokines with a major role in chemotaxis. In the CNS, chemokines and their receptors are constitutively expressed, at low levels, in astrocytes, microglia, oligodendrocytes, neurons and endothelial cells both in the developing and healthy adult brain, and their expression is induced by inflammatory mediators [4]. They have been reported to be involved in the developmental organization of the brain and in the maintenance of normal brain homeostasis by regulating the migration, proliferation and differentiation of glial and neuronal precursor cells. Moreover, other physiological functions of chemokines have been reported in CNS, such as regulation of synaptic transmission and plasticity, regulation of neurotransmitter release, modulation of ion channel activity, and cell death and survival. Up-regulation or dysregulation of chemokines expression plays a crucial role in neurodegeneration and excitotoxicity, being involved in the communication between damaged neurons and surrounding glial cells and in the regulation of neuronal signaling by a diversity of

processes. Moreover, the expression of chemokines can be regulated by cytokines, and this has been associated with several acute and chronic inflammatory conditions in the CNS.

### Inflammation in Brain Diseases

The efficient regulation of the inflammatory cascade results from a fine-tune equilibrium of events regulating both immune privilege, in health, and effective responses to injury or disease. In general, acute inflammation is beneficial to the organism in limiting the survival and proliferation of invading pathogens and promoting regeneration of the tissue. However, prolonged, excessive inflammation is highly detrimental, leading to the onset and/or to the exacerbation of cell damage in neurodegenerative diseases. Increasing evidence has shown that neurotransmitters released from nerve terminals are involved not only in the communication between neurons, but also between nerve terminals and glial cells, including microglia. Most forms of neuronal injury have been associated with excitotoxicity, i.e., excessive release of excitatory amino acids such as glutamate, and subsequent activation of NMDA and AMPA/Kainate receptors. Besides glutamate, ATP is a co-transmitter released by injured or dying neurons. Thus, glutamate and ATP, play important roles in modulating microglia activation and in determining the fate and extent of neuronal injury. In particular, both IL-1 $\beta$  and TNF- $\alpha$ , released mainly by microglia, can be neuroprotective and/or neurotoxic, contributing directly or indirectly to the initiation, maintenance and outcome of neuronal cell death, including acute insults such as ischemia, trauma and seizures and chronic neurodegenerative disorders such as Parkinson's and Alzheimer's disease.

### Neurogenesis in the Brain

#### Stem/Progenitor Cells and Neurogenesis

New neurons are constantly generated in the adult mammalian brain. This process called neurogenesis occurs mainly in two restricted regions: the subventricular zone (SVZ) and the dentate gyrus of the hippocampus (DG) (Fig. 1). The new neurons generated in the SVZ migrate long distances towards the olfactory bulb where they differentiate into functional interneurons, and contribute to improve odor memory and discrimination [5]. In the hippocampus, new neurons migrate out of the subgranular zone (SGZ) of the dentate gyrus (DG) and differentiate into the granule cell layer (GCL) where they mature and participate in hippocampal functions associated with learning and memory.

In both regions, new neurons arise from a particular population of cells: the **stem cells/progenitor cells**. In vitro, the stem/progenitor cells constantly proliferate in the presence of growth factors (EGF, FGF-2). Proliferation of a single stem cell leads to the formation of a floating spherical neurosphere formed by a clone of immature cells. Plated on an adherent support, cells differentiate and migrate out of the sphere, where it is possible to identify the presence of neurons, astrocytes (Fig. 2) and oligodendrocytes.

#### Neurogenesis/Gliogenesis and Self-Repair

Upon brain injury, neurogenesis is modulated in both the SVZ and the DG. Neurogenesis increases in the SVZ following injury, including neurodegenerative diseases, and newly born neurons can migrate towards lesion areas where they can differentiate and replace damaged neurons or oligodendrocytes [6,7]. Neurogenesis also increases in the DG after ischemia or epilepsy. However, in epilepsy, aberrant migration and synaptic

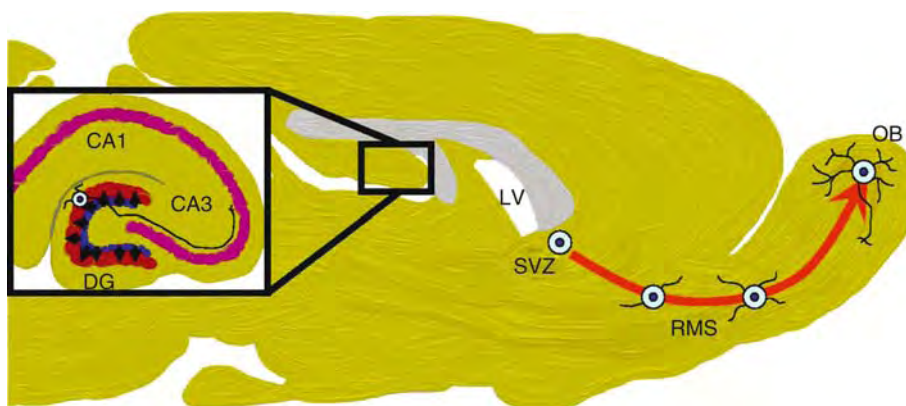

**Neurogenesis and Inflammation. Figure 1** Sagittal view of a rodent brain showing the localization of the neurogenic areas: subventricular zone (SVZ) and the dentate gyrus (DG) of the hippocampus. The new neurons generated in the SVZ, adjacent to the lateral ventricles (LV), migrate long distances through the rostral migratory stream (RMS) and integrate in the olfactory bulb (OB) where they differentiate into interneurons. The new neurons generated in the subgranular layer of the hippocampus migrate locally into the granular layer, of the DG, where they differentiate into new granular cells (adapted from Taupin and Gage, 2002, J. Neurosci. Res. 69:745–749).

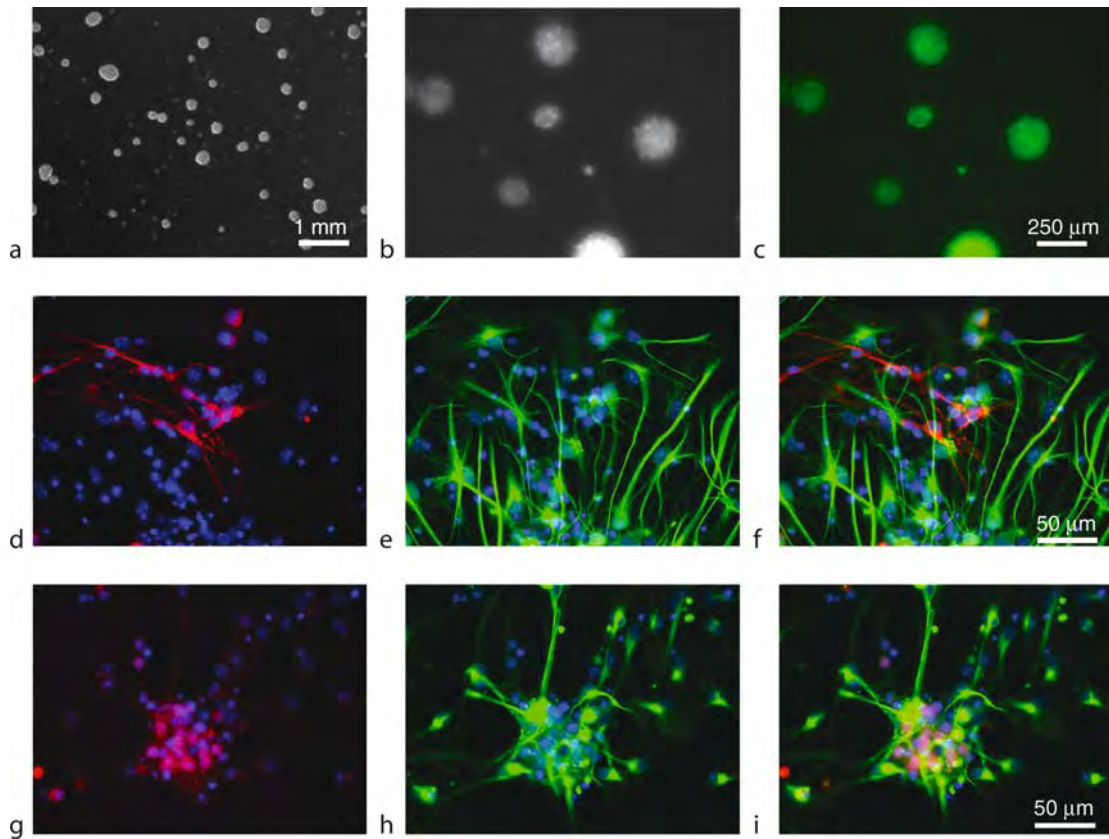

**Neurogenesis and Inflammation. Figure 2** Representative photos of SVZ cell cultures from newborn mice in proliferation (a–c) and differentiation conditions (d–i). (a)–(c): in serum free medium with the growth factors EGF and FGF-2, SVZ cells generate clonal aggregates of cells called neurospheres (a–c). SVZ neurospheres obtained from GFP mice represent a useful tool for grafting studies (c). d–i: after plating on poly-D-lysine and withdrawal of the growth factors, cells arise from the edge of the neurosphere and develop into neurons expressing MAP-2 (d) and NeuN (g), and glial cells such as astrocytes expressing GFAP (e, h). (f) and (i) photos are merged of (d), (e) and (g), (h), respectively.

connections of newborn neurons may exacerbate recurrent seizures.

In spite of our growing knowledge about stem/progenitor cell physiology, efficient replacement of the damaged neuronal circuits is far away from full accomplishment using cell-based strategies of brain repair.

#### Neurogenesis and Inflammation in the Brain

Inflammation, activation of glial cells and release of inflammatory mediators play ambiguous effects on neurogenesis with stimulatory or inhibitory roles, depending on the specific players and brain disorder.

#### Inflammation Promotes Neurogenesis/Gliogenesis

Following injury, a great diversity of factors is secreted around the damaged area and these factors can diffuse, act on progenitor cells inducing neurogenesis/gliogenesis. For instance, injury-activated astrocytes and microglial cells produce the growth factors VEGF and FGF-2 and the pro-inflammatory cytokine (TNF- $\alpha$ ) able to promote

SVZ neurogenesis and proliferation. These processes involve the activation of transcription factors, including NF- $\kappa$ B.

In experimental demyelination, microglial cells secrete IL-1 $\beta$  that induces the secretion of IGF-1 by astrocytes, promoting proliferation of oligodendrocyte progenitor cells and remyelination [8].

#### Inflammation Inhibits Neurogenesis

On the other edge of the sword, inflammation can inhibit neurogenesis and regeneration. Indeed, activated astrocytes that accumulate in the lesion core forming a glial scar can limit the propagation of the injury. However, the glial scar is also rich in repulsive axon guidance molecules such as proteoglycans, ephrins, semaphorins and Nogo. So, on the one hand the glial scar limits the propagation of the injury, but also constitutes a barrier for efficient regeneration.

In the hippocampus, seizure activity promotes neurogenesis, but subsequent neuronal death and

microglial activation inhibits neurogenesis hampering brain repair. In these conditions, systemic administration of minocycline, which inhibits microglia activation, restores neurogenesis in the dentate gyrus. Part of these effects may involve TNF- $\alpha$ , IL-6 and TGF- $\beta$  since these cytokines are secreted by activated microglial cells and impair neurogenesis in the dentate gyrus [9].

In conclusion, the glial scar and “the dark side” of the inflammatory response appear to hold in check brain repair endeavors.

### SVZ Cells as a Tool for Brain Repair

The results of several studies show that SVZ cells are good candidates for cell-based therapy. For instance, in animal models of Parkinson’s and Huntington’s diseases, SVZ cells grafted in the striatum are able to differentiate respectively into dopaminergic neurons and spiny neurons with a concomitant improvement of motor performance. SVZ cells have also been used in models of multiple sclerosis where chronic inflammation is a major cause of demyelination of the axons. Grafts of SVZ cells into the subcortical white matter of myelin-deficient mice results in the migration of PSA-NCAM progenitors cells, differentiation of oligodendrocytes and successful remyelination [10].

### References

1. Nguyen MD, Julien JP, Rivest S (2002) Innate immunity: the missing link in neuroprotection and neurodegeneration? *Nat Rev Neurosci* 3:216–227
2. Hanisch UK (2002) Microglia as a source and target of cytokines. *Glia* 40:140–155
3. Bernardino L, Xapelli S, Silva AP, Jakobsen B, Poulsen FR, Oliveira CR, Vezzani A, Malva JO, Zimmer J (2005) Modulator effects of Interleukin-1 beta and Tumor Necrosis Factor- $\alpha$  on AMPA-induced excitotoxicity in mouse organotypic hippocampal slice cultures. *J Neurosci* 25:6734–6744
4. Ubogu EE, Cossoy MB, Ransohoff RM (2006) The expression and function of chemokines involved in CNS inflammation. *Trends Pharmacol Sci* 27:48–55
5. Rochefort C, Gheusi G, Vincent JD, Lledo PM (2002) Enriched odor exposure increases the number of newborn neurons in the adult olfactory bulb and improves odor memory. *J Neurosci* 22:2679–2689
6. Picard-Riera N, Decker L, Delarasse C, Goude K, Nait-Oumesmar B, Liblau R, Pham-Dinh D, Evercooren AB (2002) Experimental autoimmune encephalomyelitis mobilizes neural progenitors from the subventricular zone to undergo oligodendrogenesis in adult mice. *Proc Natl Acad Sci USA* 99:13211–13216
7. Kokaia Z, Lindvall O (2003) Neurogenesis after ischaemic brain insults. *Curr Opin Neurobiol* 13:127–132
8. Mason JL, Suzuki K, Chaplin DD, Matsushima GK (2001) Interleukin-1beta promotes repair of the CNS. *J Neurosci* 21:7046–7052
9. Monje ML, Toda H, Palmer TD (2003) Inflammatory blockade restores adult hippocampal neurogenesis. *Science* 302:1760–1765
10. Cayre M, Bancila M, Virard I, Borges A, Durbec P (2006) Migrating and myelinating potential of subventricular zone neural progenitor cells in white matter tracts of the adult rodent brain. *Mol Cell Neurosci* 31:748–758

## Neurogenetic Diseases

THOMAS D. BIRD

Department of Neurology, UW Medical Center, Seattle, WA, USA

### Synonyms

Hereditary neurological disorders

### Definition

Neurogenetic Diseases are disorders of the central and peripheral nervous systems caused by molecular defects in heritable material (usually DNA).

### Characteristics

Neurogenetic diseases can be classified on the basis of the clinical syndromes or on the basis of the genetic etiology and inheritance pattern [1–3]. The genetic classification is used here with each category containing examples of clinical syndromes.

### Chromosomal

Major aberrations of chromosomal material usually produce defects in multiple organ systems and are frequently recognized at birth. They may be caused by a variety of chromosomal aberrations including deletions, duplications, translocations, and ring chromosomes. They are often associated with mental retardation, epilepsy, and dismorphic features. Examples include Down syndrome (trisomy 21), Cri du chat (5p-) and Miller-Dieker Lissencephaly syndrome (17p-).

### Mendelian

Diseases in this category are caused by mutations in nuclear DNA, including missense, nonsense, deletions, and duplications of one or more nucleotides. The disease is inherited as an autosomal dominant if the clinical syndrome is present in heterozygous carriers of a single mutation. Examples include Huntington’s disease, Myotonic muscular dystrophy, Fascioscapulo-humeral muscular dystrophy, tuberous sclerosis, Charcot-Marie-Tooth hereditary neuropathy, ►familial spastic paraplegia, and hereditary ataxias [4]. If clinical manifestations occur only in carriers of two mutations, one on each of the homologous chromosomes (homozygotes or compound heterozygotes), the disease is

autosomal recessive. Examples include Friedreich's ataxia, Tay-Sach's disease, Neimann Pick diseases, and phenylketonuria. Mutations on the X chromosome produce x-linked inheritance in which the mutations are usually confined to, or more severe in males and absent or much milder in carrier females. Examples include Duchenne's muscular dystrophy, Pelizaeus-Merzbacher leukodystrophy, and x-linked Charcot-Marie-Tooth hereditary neuropathy.

Many of these neurogenetic syndromes show remarkable genetic heterogeneity. For example, there are more than 20 genetic subtypes of hereditary neuropathy and more than 30 subtypes of familial spastic paraplegia and dominant hereditary ataxias.

Nucleotide repeat expansions: A special category of neurogenetic diseases is caused by abnormally large expansions of normally occurring nucleotide repeats. Many are trinucleotide repeats, often CAG. They are inherited in a mendelian fashion and age of onset is correlated with the size of the repeat expansion (larger expansions having earlier age of onset). Huntington's disease and several autosomal dominant spinocerebellar ataxias (SCA) are caused by CAG repeat expansions. Type 1 myotonic muscular dystrophy is caused by a CTG repeat expansion in the non-coding region of a gene and this expansion interferes with RNA transcription of multiple other genes. This explains the systematic nature of the clinical syndrome affecting many organ systems. X-linked Spinobulbar muscular atrophy is caused by a CTG repeat expansion in the androgen receptor gene on the X chromosome. One form of autosomal recessive myoclonic epilepsy is caused by expansion of a 12 nucleotide repeat (dodeca repeat).

### Mitochondrial

► **Mitochondrial diseases** are the result of primary abnormalities in the respiratory chain electron transport system of mitochondria. Mutations of mitochondrial DNA are inherited from the cytoplasm of the mother's egg. All children of a mother with the mutation will also inherit the mutation. However, males with the mutation do not pass the mutation on to any children. Whether or not the individual expresses clinical signs of the mutation depends on the numbers of mitochondria with the relevant mutation in any given tissue (heteroplasmy). Mitochondrial diseases often have a combination of signs and symptoms frequently including cognitive deficits, seizures, visual loss, hearing loss, peripheral neuropathy, or myopathy. Examples include MELAS (mitochondrial encephalomyopathy with lactic acidosis and stroke), MERRF (myoclonic epilepsy with ragged red fibers), and NARP (neuropathy, ataxia and retinitis pigmentosa). Some mitochondrial disorders are caused by mutations in nuclear genes that control mitochondrial enzymes and these are inherited in a mendelian fashion.

### Polygenic/Multifactorial

Individual autosomal, x-linked and mitochondrial neurogenetic diseases are each relatively rare. However, many common neurological disorders also have important genetic contributions to their pathogenesis. It is assumed that they represent the additive affect of several genes (polygenic) interacting with multiple environmental factors (multifactorial) [5]. Examples would be Alzheimer's disease, Parkinson's disease, Epilepsy, Stroke and Multiple Sclerosis. In some instances (e.g. Alzheimer's, Parkinson's and epilepsy) rare forms of the disease are caused by identified mutations in single genes, but the more common form of the disease in the general population is thought to be polygenic/multifactorial. In most instances the multiple genes and environmental factors are unknown. However, genome wide association studies are beginning to identify many candidate genes for these common complex diseases.

### References

1. Rosenberg RN, Prusiner SB, DiMauro S, Barchi RL, Nestler EJ (eds) (2008) *The Molecular and genetic basis of neurologic and psychiatric disease*, 4th edn. Butterworth and Heinemann, PA, USA
2. Pulst SM (ed) (2000) *Neurogenetics*. Oxford University Press, Oxford, England
3. Lynch DR, Farmer JM (eds) (2006) *Neurogenetics: scientific and clinical advances*. Taylors and Francis, NY, USA
4. Bird TD, Jayadev S (2008) Genetic diseases of the nervous system. In: Rosenberg RN (eds) *Atlas of clinical neurology*, 3rd edn. Current Medicine, PA, USA
5. Bird TD, Tapscott SJ (2008) Clinical neurogenetics. In: Bradley WG, Daroff RB, Fenichel GM, Jankovic J (eds) *Neurology in clinical practice*, 5th edn. Butterworth and Heinemann, PA, USA pp. 781–806

## Neurogenic Inflammation

### Definition

Precapillary arteriolar vasodilation generated by activity in peptidergic afferent C-fibers and A $\delta$ -fibers and postcapillary plasma extravasation generated by activity in peptidergic afferent C-fibers. The vasodilation is generated by release of calcitonin-gene-related peptide (CGRP) and (to a lesser degree Substance P) and the plasma extravasation by release of Substance P.

► **Complex Regional Pain Syndromes: Pathophysiological Mechanisms**



## Neurogenic Niche

MARIANA ALONSO

Institut Pasteur, Perception and Memory Laboratory,  
Paris, France

### Synonyms

Neuronal regeneration in the nervous system

### Definition

A neurogenic niche is a region where neurogenesis takes place. Neurogenesis refers to the entire set of events leading to the production of new neurons from ►precursor cell in the brain. The degree of neurogenesis depends on the interaction of the microenvironment (niche) with precursor cells that have neurogenic potential.

### Characteristics

The adult mammalian central nervous system (CNS) has traditionally been divided into four major cell types: the neurons, the myelinating-forming oligodendrocytes, the astrocytes, and the ependymal lining of the central lumen. All of those cell types are generated during development from a common source, the neuroepithelial cells that arise in early embryos in the form of the neural tube. There are three different cell types that contribute to neurogenesis, early neuroepithelial cells for the first neurons, radial glial cells for most neurons in most brain regions, and subventricular zone (SVZ) precursors predominantly at later stages of neurogenesis.

Moreover, it has become clear over the past decades that new neurons are continually generated in the adult brain. This postnatal neuronal production is a conserved biological phenomenon throughout evolution – it has been reported in fishes, amphibians, reptiles, birds, rodents and primates, including humans [1] – but its adaptive functions deserve yet to be explored.

Places where neurogenesis takes place are called ►neurogenic niches. In this neurogenic niche, specialized cells are neural stem cells, capable of self-renewing and generating neurons and glia. In general, stem cell niches are composed of microenvironmental cells that nurture stem cells and enable them to maintain tissue homeostasis. An appropriate spatiotemporal dialog occurs between stem and niche cells in order to fulfill lifelong demands for differentiated cells. The niche concept was introduced in 1978 by Schofield [2]. In ecological terms, an organism's niche refers to where it lives, what it does, and how it interacts with its close environment. Altering an ecosystem (or neurogenic environment) can produce disastrous consequences for an organism (or stem cell). Niche cells provide a sheltering environment that sequesters stem cells from differentiation stimuli, and other stimuli that

would challenge stem cell reserves. The niche also safeguards against excessive stem cell production that could lead to cancer. Stem cells must periodically activate to produce ►progenitor or transit amplifying cells that are committed to produce mature cell lineage. Thus, maintaining a balance of stem cell quiescence and activity is a hallmark of a functional niche. Importantly, stem cells themselves extensively interact with and participate in the niche. Furthermore, niches may in fact be dynamic structures that alter their characteristics over time concomitant with tissue remodeling.

### Regulation of the Neurogenic Niches

It is clear now that complex bidirectional interactions between intrinsic programmes and extrinsic cues take place in the neurogenic niches to control its behavior. We can define intrinsic programmes here as the ensembles of factors expressed by stem cells and progenitors that control different neurogenic phases. By contrast, external factors are produced by surrounding tissues to act on stem cells and progenitors. Consequently, whether a cell undergoes self-renewal or differentiation is the result of the spatial and temporal convergence of niche cues and intrinsic state of the cell.

For instance, cell-cell interactions and diffusible signals are key elements allowing feedback control of stem cell activation and differentiation from progeny or the niche support cells (see Fig. 1).

Moreover, an emerging feature of several stem cell niches is the close association with endothelial cells forming blood vessels, which regulate stem cell self-renewal and differentiation. Within a niche, stem cells are frequently anchored to a basal lamina or stromal cells that can provide a substrate for oriented cell division. The basal lamina is also an important regulator of the accessibility of growth factors and other signals, as associated extracellular matrix molecules and glycoproteins can both concentrate and sequester factors in inactive or active forms. In addition, cell anchoring may orient cell division resulting in the segregation of key determinants into one or both daughter cells depending on the plane of division [3]. In this line, given that multipotent progenitor cells can give rise to neuronal and glial cell types in a characteristic order of birth, it is clear that progenitor cell proliferation must be precisely regulated.

Finally, the processes of newborn neuron production, migration, maturation and survival are all subject to modulation by external factors. Neurotransmitters, hormonal status, growth factors and injuries are known to influence proliferation [4] (Fig. 1).

### Neurogenic Niches in the Adult Mammalian Brain

Two regions, the olfactory bulb (OB) and the dentate gyrus (DG) of the hippocampus, have been shown beyond doubt to receive and integrate constitutively

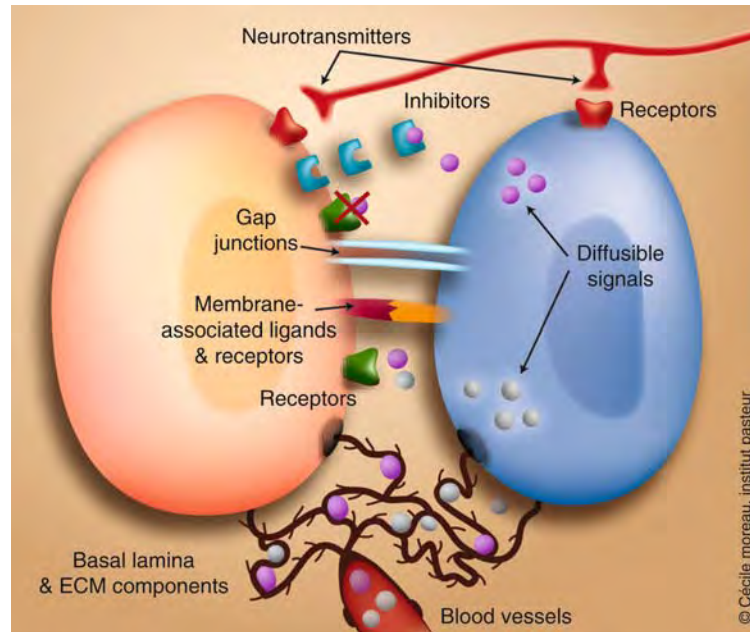

**Neurogenic Niche. Figure 1** Membrane-associated receptors and ligands mediate cell-cell contacts, defining cell self-renewal and differentiation. In addition, gap junctions coordinate behavior between couple cells. Diffusible signals can direct stem cells to either self-renew or generated differentiated progeny. The availability of diffusible factors that bind to receptors in turn can be regulated by ligand inhibitors which can sequester these factors and prevent signaling. An extracellular matrix-rich basal lamina, which can be associated with blood vessels, has several functions in stem cell niches, including anchoring cells to the niche, sequestering and presenting diffusible signals, and linking cells and the extracellular matrix. Endothelial cells and the vasculature can regulate stem cells fate decisions. Stem cells can also be regulated by the release of neurotransmitters and other factors from axons.

newborn neurons throughout adult life in the mammalian brain [5] (see Fig. 2a and 2b).

In adult mammals, neurogenic zones where neural stem cells are harbored, exists at least, in two discrete areas of the brain: the subgranular zone (SGZ) of the DG (Fig. 2a) and the SVZ located near the lateral wall of the lateral ventricles (Fig. 2b). The neuroblasts that originate from SVZ precursor cells migrate long distances through the rostral migratory stream (RMS) to populate the OB where they differentiate into granular and periglomerular interneurons and establish contacts with their neuronal targets.

Thousand of young neurons migrate into the OB every day but only a fraction of them survive to complete their differentiation. The newborn cells recruited into the OB and the DG became truly neurons, throughout a unique sequence of events that leads to their functional maturation followed by complete integration.

In the two neurogenic areas of the adult brain, a subset of astrocytes, are the *in vivo* precursors for adult neurogenesis. In the SVZ, some of these cells contact the ventricle lumen and have a single cilium. Rapidly dividing, transit-amplifying cells derived from stem cells give rise to neuroblast.

As we mentioned before, the neurogenic behavior in both regions appears determined by signals restricted

to their niches. Stem cells are in intimate contact with all other cell types, including the rapidly dividing transit amplifying and the neuroblasts (Fig. 2a and 2b).

Therefore, neural stem cells occupy niches formed by both astrocytes and endothelial cells. In general, endothelial cells encourage stem cells to renew themselves, and astrocytes instruct them to become neurons. More surprisingly, mammalian neural stem cells are not passive elements of their microenvironment: they can, under certain conditions, give rise to endothelial cells. This suggests that, if the need arises, stem cells can populate their niche with the features that they need to thrive.

Transplantation studies in mammals support the principle of defining neurogenic and non-neurogenic regions and provide evidence for the role of microenvironment in influencing the potential of neural precursors. If precursor cells are transplanted into neurogenic regions, they can differentiate into neurons in a region-specific manner. SVZ precursor cells generate hippocampal neurons when transplanted into the hippocampus, and SGZ precursor cells generate olfactory interneurons after transplantation into the RMS. When implanted outside the neurogenic regions, both types of precursor cells generate only glia. An inhibitory environment that is refractory to neurogenesis is therefore present throughout

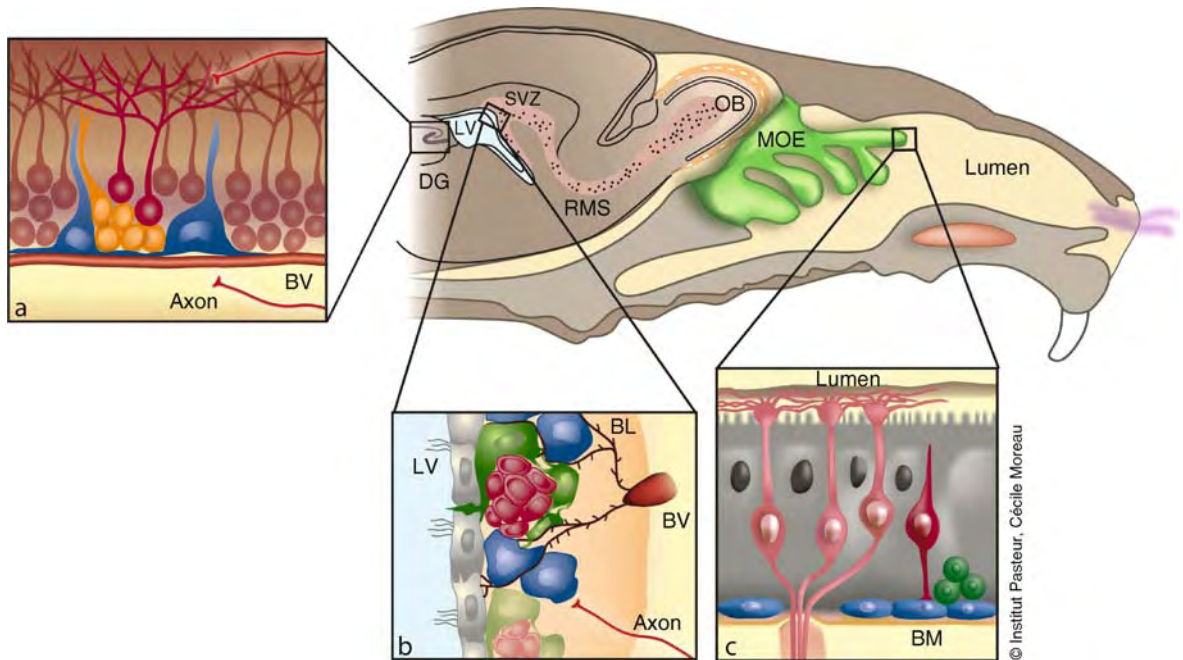

**Neurogenic Niche. Figure 2** Neurogenic niches in the adult mammalian brain. Simplified sagittal view of rat head showing neurogenic niches. (a) Dentate gyrus (DG) neurogenic niche. Astrocytes (blue) give rise to progenitors (orange), which mature into new granule cells (red). (b) Subventricular zone (SVZ) neurogenic niche. Astrocytes (blue) are the SVZ stem cells and also serve as niche cells. Transit-amplifying cells (green) derived from stem cells give rise to neuroblast (red) that migrate to the olfactory bulb. The basal lamina (BL, brown) extends from the blood vessel (BV) and interdigitates extensively with the SVZ cells. Ciliated ependymal cells (gray) line the lateral ventricle (LV) are shown. (c) Main olfactory epithelium (MOE) neurogenic niche. Horizontal (blue) and globose basal cells (green) are the stem cells. Some globose basal cells are transit-amplifying cells that give rise to olfactory sensory neurons (red). Basement membrane (BM) and supporting cells (gray) are shown. RMS, rostral migratory stream.

most of the adult brain. Thus, adult neurogenic niches have an instructive role in directing neuronal production and stem cell maintenance and shield ongoing neurogenesis from possible external inhibitory influences. Although the components of adult neurogenic niches that mediate these processes are still being elucidated, it is clear that both neural and non-neural cell types are key players. Finally, if it were a static, merely restorative process, adult neurogenesis could not be regarded as a mechanism for adult brain plasticity. However, we know that every aspect of adult-born cell production is tightly regulated and modulated. This strongly suggests that the adult brain can tailor its production of new neurons to match the demands of its environment.

### Neurogenesis in the Olfactory Epithelium

In the olfactory system, the main olfactory epithelium (MOE) is also submitted to continual neurogenesis in adults (Fig. 2c). The olfactory sensory neurons (OSNs), which detect odors in the air we breathe, are located within this epithelium and continue to be generated throughout life. This lifelong neurogenesis occurs as a result of continual proliferation and differentiation of

progenitors cells located near the base of the epithelium. The olfactory neuroepithelium is in direct contact with the external environment and, as a consequence, has evolved a remarkable ability to replenish sensory neurons lost during natural turnover and in the event of extensive lesions or traumatic injuries. This ongoing adult neurogenesis is essential for maintaining olfactory sensory function.

In the postnatal brain of rodents, and continuing into adulthood, three cell types comprise the OSNs lineage within the olfactory epithelium: the horizontal basal cells (HBCs) which lie directly against the basal lamina, the globose basal cells (GBCs) which are primarily situated immediately apical to the HBCs, and the OSNs (Fig. 2c).

HBCs function as adult olfactory neuroepithelium stem cells and are competent to regenerate both neuronal and non-neuronal lineage in this region (Fig. 2c). HBCs serve as a reservoir of long-lived progenitors that remain largely quiescent during normal neuronal turnover or even after acute, selective loss of mature neurons. Under these conditions, GBCs are largely responsible for tissue maintenance. This characteristic is unique showing a

model of adult neurogenesis in which distinct cell population within the same niche mediate normal neuronal turnover and neuronal replacement upon traumatic injury [6]. As was describe previous, different factors that are both made by and found within the microenvironment of the MOE stem and progenitor cells exert crucial growth regulatory effects on these cells. Thus, as with other regenerating tissues, the basis of regeneration in the MOE appears to be a population of stem cells, which resides within a microenvironment (neurogenic niche) consisting of factors crucial for maintenance of its capacity for proliferation and differentiation.

### Relevance to Humans

Elucidating the nature of microenvironmental factors released by host tissue in the neurogenic niches that might affect these processes became particularly interesting given that it was demonstrated that adult neurogenesis occurs also in adult human brain. Adult neurogenesis was demonstrated in human hippocampus [7]. As well, a ribbon of SVZ astrocytes lining the lateral ventricles of the human adult brain that proliferate *in vivo* and behave as multipotent progenitor cells *in vitro* was recently describe [8]. In addition, a recent study demonstrates the presence of a human RMS containing migratory progenitor cells some of which become mature neurons in the OB [9]. Moreover, adult neurogenesis was also found in the human MOE [10].

In this context, adult neurogenesis is attracting a lot of attention because of the hope raised by the use of adult neuronal stem cells in regenerating and reconstructing the damaged brain, for instance, in the therapies of neurodegenerative diseases. However, before elaborating strategies aimed at using endogenous progenitors and their relevance to human clinics, it is urgent to precise theirs normal function(s) in a non-pathological brain.

### References

- Alvarez-Buylla A, Garcia-Verdugo JM (2002) Neurogenesis in adult subventricular zone. *J Neurosci* 22:629–634
- Schofield R (1978) The relationship between the spleen colony-forming cell and the haemopoietic stem cell. *Blood Cells* 4:7–25
- Moore KA, Lemischka IR (2006) Stem cells and their niches. *Science* 311:1880–1885
- Abrous DN, Koehl M, Le Moal M (2005) Adult neurogenesis: from precursors to network and physiology. *Physiol Rev* 85:523–569
- Lledo PM, Alonso M, Grubb MS (2006) Adult neurogenesis and functional plasticity in neuronal circuits. *Nat Rev Neurosci* 7:179–193
- Leung CT, Coulombe PA, Reed RR (2007) Contribution of olfactory neural stem cells to tissue maintenance and regeneration. *Nat Neurosci* 10:720–726
- Eriksson PS, Perfilieva E, Bjork-Eriksson T, Alborn AM, Nordborg C, Peterson DA, Gage FH (1998) Neurogenesis in the adult human hippocampus. *Nat Med* 4:1313–1317
- Sanai N, Tramontin AD, Quinones-Hinojosa A, Barbaro NM, Gupta N, Kunwar S, Lawton MT, McDermott MW, Parsa AT, Manuel-Garcia Verdugo J, Berger MS, Alvarez-Buylla A (2004) Unique astrocyte ribbon in adult human brain contains neural stem cells but lacks chain migration. *Nature* 427:740–744
- Curtis MA, Kam M, Nannmark U, Anderson MF, Axell MZ, Wikkelso C, Holtas S, vanRoon-Mom WM, Bjork-Eriksson T, Nordborg C, Frisen J, Dragunow M, Faulk RL, Eriksson PS (2007) Human neuroblasts migrate to the olfactory bulb via a lateral ventricular extension. *Science* 315:1243–1249
- Hahn CG, Han LY, Rawson NE, Mirza N, Borgmann-Winter K, Lenox RH, Arnold SE (2005) In vivo and in vitro neurogenesis in human olfactory epithelium. *J Comp Neurol* 483:154–163

## Neurogenic Pain

### ► Neuropathic Pain

## Neurogenic Vasodilatation

### Definition

Vasodilatation induced by depolarization of nociceptive nerve terminals in the body periphery. These terminals release calcitonin-gene-related peptide (CGRP), a vasoactive substance. Synonyms: neurogenic inflammation, axon reflex flare.

### ► Calcitonin Gene Related Peptide (CGRP)

### ► Nociceptors and Characteristics

## Neurogliaform Cells

### Definition

Neurogliaform refers to the neuroglial ectodermal cell type. Neurogliaform cells, neuroglial cells, and glial cells are synonymous terms.

## Neurogram

### Definition

Multi-unit recording from a nerve.

- ▶ Extracellular Recording

## Neurohormone

### Definition

A compound released by a neuron into the circulation, with other neurons as its major target.

## Neurohumoral Agent

### Definition

Synonym for neurotransmitter. A chemical substance released at a synapse from a presynaptic neuron that binds on a receptor of a postsynaptic neuron and stimulates or inhibits it.

- ▶ Neurotransmitter
- ▶ Synapse

## Neurohypophysis

### Definition

Neurohypophysis or the posterior lobe of the pituitary, is the site where the terminals of the Supraoptic and Paraventricular nuclei release neurosecretory granules containing vasopressin or oxytocin.

- ▶ Drinking Disorders and Osmoregulation
- ▶ Posterior Lobe of the Hypophysis
- ▶ Diencephalon

## Neuroimaging

### Definition

The use of radiographic studies and magnetic resonance imaging to detect structural abnormalities in the central nervous system; visual display of structural or functional patterns of the nervous system as a whole or any of its parts for diagnostic evaluation or visualization of anatomical structures; includes measuring physiologic and metabolic responses to physical and chemical stimuli.

- ▶ Magnetic Resonance Imaging (MRI)

## Neuroimaging

Modern techniques applied in order to assess alterations of the central nervous system.

- ▶ Forensic Neuropsychiatry

## Neuroimmune Interactions – Serotonin

DAVID DUBAYLE, D. MENETREY  
CNRS UMR 8119, Neurophysique et Physiologie,  
Université René Descartes, UFR Biomédicale,  
Paris, France

### Synonyms

5-Hydroxytryptamine (5-HT) Neuroimmunomodulation

### Definition

The role of ▶ serotonin (5-hydroxytryptamine or 5-HT) in the bidirectional influences that the nervous and immune systems exert over each other by biochemical and cellular routes.

### Characteristics

#### Characteristics of Serotonin

##### Dual Location

Serotonin (5-HT) is common to both the nervous and immune systems and, in consequence of its dual

location, is involved in the bidirectional interactions these systems generate with each other. By extension, serotonin must be regarded as a fundamental element of the defence system that living organisms have developed against stressors.

### Metabolism

Serotonin is formed by tryptophan (5)-hydroxylase from L-tryptophan. L-tryptophan is common to the immune-related ▶**kynurenine** synthesizing pathway (Fig. 1). An increase of kynurenine biosynthesis will lead to a decrease in the availability of L-tryptophan, and reduce 5-HT levels.

### Receptors

Serotonin acts through a variety of receptor subtypes. Fourteen subtypes have been recognized to date, with specific location within the central nervous system, and at least four (5-HT<sub>1A</sub>, 5-HT<sub>1B/1D</sub>, 5-HT<sub>2</sub> and 5-HT<sub>3</sub>) are present on immunocompetent cells [2]. 5-HT<sub>1B/1D</sub> receptor activity is down-regulated by an endogenous tetrapeptide named 5-HT-moduline, likely originating from the adrenal medulla and released by stress.

### Functions in Immune Regulation

Four major serotonin actions have been recognized in immune regulation: (i) the activation of T-cells and natural killer-cells, (ii) the production of chemotactic factors, (iii) the modulation of delayed-type

hypersensitivity responses, and (iv) the regulation of the natural immunity delivered by macrophages [3].

### Responses to Immune Activity

Immune activity affects 5-HT brain levels. Effects depend on circumstances. Acute peripheral immunization raises brain 5-HT turn-over through the local release of specific inflammatory cytokines, mostly interleukin-1, and via sympathetic nervous system activity. On the other hand, chronic immune activation, which is common in normal ageing and accompanies ▶**neurodegenerative disorders** such as Alzheimer's, Huntington's and Parkinson's diseases, leads to 5-HT depletion [1] by promoting L-tryptophan degradation via the kynurenine synthesizing pathway. 5-HT lowering could account for the mood alteration and impaired cognition that accompany ageing and chronic pathological conditions. Light exposure raises 5-HT levels [4] and fights moodiness.

### Anatomical Substrate

The anatomical substrate for 5-HT-based neuroimmune interactions is triple including: (i) the central serotonergic system of the brain stem raphé nuclei (▶**raphé nuclei system**), (ii) the “serotonergic/noradrenergic” nerve terminals of the peripheral ▶**autonomic nervous system (NS)** and, (iii) the 5-HT-positive immunocytes that penetrate the nervous system. 5-HT cellular-mediated actions are essential for neuroimmune cross-talk since access of blood-borne 5-HT and

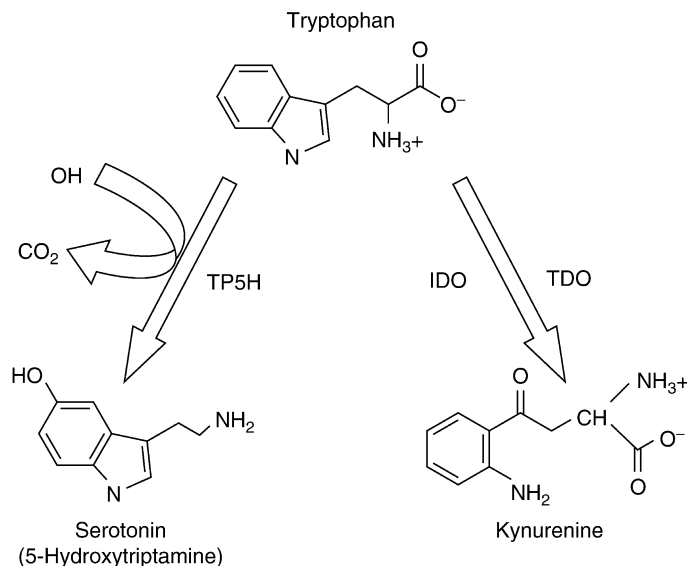

**Neuroimmune Interactions – Serotonin. Figure 1** The dual catabolic pathway of tryptophan. On the left, tryptophan (5)-hydroxylase (TP5H) initiates the production of serotonin (5-hydroxytryptamine); on the right, tryptophan (2,3)-dioxygenase (TDO) and indoleamine (2,3)-dioxygenase (IDO) catalyze the formation of kynurenine. Adapted from [1].

L-tryptophan to the brain is highly restricted by the endothelial ►blood-brain barrier (BBB) except for the circumventricular organs where this later is disrupted. The metabolism of L-tryptophan by microvascular endothelial cells is primordial in restricting microbial expansion in the nervous system [5].

### Characteristics of the Raphé Serotonergic System

#### Anatomy

This system, which is the only source of central nervous serotonergic innervation, widely distributes to the brain via arborescent efferents bearing thousands of 5-HT containing varicosities enabling it to interfere with widespread target cells. Both synaptic and non-synaptic contacts have been described suggesting that neuronal communication is relevant of both synaptic – a point-to-point contact – and volume – a passive at distance tissular diffusion – transmission mechanisms. The raphé serotonergic system influences the immune system through two pathways: (i) via the caudal raphé nuclei (nucleus pallidus, obscurus and magnus) brain stem and spinal cord projections that contact the preganglionic motoneurons of both the sympathetic and parasympathetic columns, thus interfering with the autonomic nervous system outflow, (ii) via the rostral raphé nuclei (nucleus median and dorsalis) ►hypothalamic-pituitary gland axis projections, thus interfering with the pituitary neuroendocrine outflow.

#### Serotonin and Pituitary Hormones

Pituitary hormones and related substances modulate immune functions. Corticosteroids have immunosuppressive effects while prolactin and growth hormone favor immune functions and counter the immunosuppressive effects of the former. 5-HT modulation of pituitary activity would be 5-HT<sub>1B/1D</sub> receptor dependent [6]. Sumatriptan, a specific agonist for 5-HT<sub>1B/1D</sub> receptors, lowers levels of plasma prolactin, increases those of growth hormone, but does not affect cortisol concentration. Since 5-HT<sub>1B/1D</sub> receptors concentrate in the median eminence on non-serotonergic fibers, possibly of hypothalamic origin secreting neuropeptides acting as releasing factors for pituitary neurohormones, 5-HT could interact with the release of these products, finally altering the internal status of the organism [6].

#### The Peripheral Autonomic Nervous System

The nerve terminals of the peripheral autonomic nervous system are possibly fundamental in neuroimmune interactions as they anatomically ensure the interface between the nervous and immune systems at local peripheral levels. Nerve fibers of the autonomic innervation developing close contacts with lymphocytes, hemopoietic elements, thymocytes,

macrophages, ►mast cells and T cells, have been described for a long time. Autonomic fibers comprise noradrenergic terminals that take up and accumulate non-neuronal peripherally released 5-HT in a process that can alter their functions when both transmitters, noradrenaline and 5-HT, are simultaneously released. 5-HT positive immunocytes mast cells are potential providers for this peripheral 5-HT. The 5-HT content of peripheral tissue will evidently increase in inflammatory pathological circumstances. Central nervous autonomic outflow regulation through raphé 5-HT innervation of preganglionic motoneurons also exists, suggesting a central-mediated modulation of local autonomic-immune interactions. Finally, 5-HT could also modulate peripheral nervous inflow since 5-HT<sub>1B/1D</sub> receptors are present on primary afferent fibers [7]. Primary afferent fibers are one of the ways through which immune changes induced during the course of an infection can generate the central release of cytokines (interleukin 1 and tumor necrosis factor), which in turn acts on 5-HT levels.

#### The Brain Immunocytes

The CNS of healthy animals is classically viewed as an immune-privileged organ because of the blood-brain barriers ( blood-brain, blood-nerve and blood-cerebrospinal fluid barrier) that limit the access of systemic immune cells. This immune privilege is not, however, as strict as it has long been claimed. Both activated T-lymphocytes and mast cells are known to penetrate the brain. Activated T-lymphocytes patrol the brain for immune surveillance; nervous resident mast cells (nsMCs) are present at both ends (primary afferent fibers, diencephalon) of the sensory network and in sympathetic ganglia where they provide a direct cell-to-cell contact opportunity for 5-HT-based neuroimmune cross-talk. nsMCs activities result in significant nervous changes depending on their location.

#### Primary Afferent Fibers-Associated Mast Cells

These cells lie in close apposition with unmyelinated fibers, contacting both peripheral terminals and ganglionic cells of origin (spinal and nodose ganglia). They promote peripheral fiber elongation and excitability in inflammatory conditions.

#### Sympathetic Ganglia-Associated Mast Cells

These cells increase ganglionic synaptic transmission when sensitised by immune challenge.

#### Diencephalon-Associated Mast Cells

These cells comprise several subpopulations that are present in (i) the parenchyma of both the ►thalamus (thalamic mast cells) and main olfactory bulb, as the

final central relays for sensory and olfactory inputs before cortex, (ii) the leptomeninges including those surrounding the median eminence, as the key structure for the hypothalamic-pituitary neuroendocrine process, and (iii) the choroid plexus where the cerebrospinal fluid is secreted.

### Thalamic Mast Cells

These cells have recently received much attention. Evidence has been given that they (i) have a predominant perivascular location, lying at the vascular interface in the adventitia of the arterioles and venules, excluding capillaries, (ii) show some phenotypic specificities, (iii) release substances, including 5-HT, over piecemeal rather than overt degranulation and (iv) constitute a dynamic population that is triggered behaviorally, hormonally, pharmacologically and respond to sensory challenges. Interestingly, they do not express c-kit receptor and cyclooxygenase-2 as their peritoneal and leptomeningeal homogeneous counterparts do, thus precluding classical proliferating and pro-inflammatory properties. Considering properties related to 5-HT dependent mechanisms, evidence have been given that they store 5-HT in proteoglycan-free granules [8] and do not express 5-HT<sub>1B/1D</sub> receptors although they respond to a systemic injection of sumatriptan [6] (Fig. 2). Recent evidence has been given that thalamic mast cell activation results in

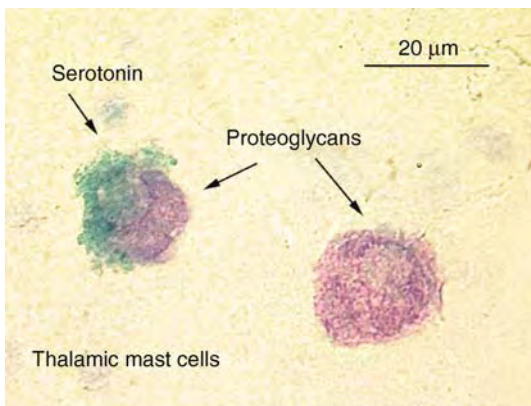

### Neuroimmune Interactions – Serotonin.

**Figure 2** A micrograph (brightfield illumination) of two thalamic mast cells in double-stained material in which purplish-red granules identify proteoglycans (toluidine blue histochemistry) and therefore mast cells, while brilliant green granules identify serotonergic contents (5-HT immunohistochemistry). The fact that granules kept their specific colors, either red or green, suggests that they are mediator-specific. The nuclei remain visible for both cells. Modified from [6]. The staining technique is from [8].

neuronal activity variations [9]. Their prevalent location within the thalamic nuclei having cortical projections has been argued for a role in integrative and cognitive sensory processes. It has also been proposed that thalamic mast cells could act on the permeability of the endothelial blood-brain barrier [10], thus making local parenchymal cell populations accessible to humoral signals. Effects at neuronal level could affect the thalamic nuclear receptivity to incoming sensory events; effects at glial level could influence either neuronal or immune surveillance activities.

### Overview

Given its widespread distribution and the variety of its receptors, 5-HT and its precursor L-tryptophan appear to be involved in the regulation of a number of physiologic functions linked to the afferent and efferent pathways of communication between the nervous and immune systems. 5-HT-based cross-talk between these two systems could be essential for an adapted immune regulation and preventing immune mediated disorders.

### References

- Schröcksnadel K, Wirleitner B, Winkler C, Fuchs D (2006) Monitoring tryptophan metabolism in chronic immune activation. *Clin Chim Acta* 364:82–90
- Hoyer D, Martin G (1997) 5-HT receptor classification and nomenclature: towards a harmonization with the human genome. *Neuropharmacology* 36:419–428
- Mossner R, Lesch KP (1998) Role of serotonin in the immune system and in neuroimmune interactions. *Brain Behav Immun* 12:249–271
- Roberts JE (2000) Light and immunomodulation. *Ann NY Acad Sci* 917:435–445
- Adam R, Russing D, Adams O, Ailyati A, Sik Kim K, Schroten H, Daubener W (2005) Role of human brain microvascular endothelial cells during central nervous system infection. Significance of indoleamine 2,3-dioxygenase in antimicrobial defence and immunoregulation. *Thromb Haemostasis* 94:341–346
- Dubayle D, Servièrè J, Menétrey D (2005) Evidence for serotonin influencing the thalamic infiltration of mast cells in rat. *J Neuroimmunol* 159:20–30
- Potrebic S, Ahn AH, Skinner K, Fields HL, Basbaum AI (2003) Peptidergic nociceptors of both trigeminal and dorsal root ganglia express serotonin 1D receptors: implications for the selective antimigraine action of triptans. *J Neurosci* 23:10988–10997
- Menétrey D, Dubayle D (2003) A one-step dual-labeling method for antigen detection in mast cells. *Histochem Cell Biol* 120:435–442
- Kovacs P, Hernadi I, Wilhelm M (2006) Mast cells modulate maintained neuronal activity in the thalamus in vivo. *J Neuroimmunol* 171:1–7
- Zhuang X, Silverman AJ, Silver R (1996) Brain mast cell degranulation regulates blood-brain barrier. *J Neurobiol* 31:393–403



## Neuroimmunology

JOHN J. HADDAD

Cellular and Molecular Signaling Research Group, Division of Biological Sciences, Departments of Biology and Biomedical Sciences, Faculty of Arts and Sciences, Lebanese International University, Beirut, Lebanon; Department of Medical Laboratory Sciences, Faculty of Health Sciences, St Georges Hospital Complex, University of Balamand, Achrafieh, Beirut, Lebanon

### Introduction

The nervous system is the body's master controller. It monitors changes inside and outside the body, integrates sensory input and activates an appropriate response. In conjunction with the ►endocrine system, which is the body's second important regulating system, the nervous system is able to constantly regulate ►homeostasis. The nervous system, along with the endocrine and immune systems, thus forming the nexus of neuroimmune-endocrine interactions, help keep controlled conditions within limits that maintain homeostasis [1]. The nervous system is practically responsible for all of our behaviors, memories and movements. The branch of medical science that deals with the normal functioning and disorders of the nervous system is collectively called neurology and that of neuroimmune interactions neuroimmunology.

### Neuroimmunology: Neuroimmune Interactions, Pathways and Mechanisms

Burgeoning research over the past few decades and continuing apace has shown that the immune, nervous and endocrine systems, or the "trio," are tightly linked via specialized communication pathways and mechanisms [1]. Interactions between the nervous and immune systems, specifically, provide a physiological (homeostatic) basis for understanding neuroimmune-associated disorders and medical conditions emanating from them. In approximately 200 AD, the Greek author Galen wrote that "melancholic women were more susceptible to breast ►cancer than sanguine women." Since then, a wealth of anecdotal evidence has convinced physicians and researchers of the importance of psychological factors in the prognosis of disease. This belief is now bolstered by substantial evidence that the nervous system output can indeed modulate immune functions and mechanisms of action [2].

Neuroimmune interactions are not by any chance unidirectional. The bidirectional influence emanates from the fact that the immune system can have substantial influence on the nervous system [1]. Anomalies of immune system function or malfunction can certainly cause diseases of, or

relating to, the nervous system. It is clear that effective defense mechanisms against infections or immune disorders requires a complex coordination of the activities of the nervous and immune systems, and that abnormalities in the relationships between the two of them can cause disease or pathophysiological aberrations [3].

Classically, the brain has long been regarded as an "immunologically" privileged site [1]. The relative non-immune responsiveness of the brain has been attributed to a lack of lymphatic drainage, the presence of the ►blood-brain barrier (BBB) (as emphasized above), the lack of constitutive expression of the ►major histocompatibility complex (MHC) cluster and the presence of chemical mediators or cofactors purported as capable of inhibiting ►lymphocyte traffic during inflammation [1] (►neuronal cell death and inflammation). This evasion of systemic immunological recognition confers a *privilege* property that is so unique and, in many ways, plays a major role in shaping the grounds for neuroimmune interactions. However, accumulating evidence indicates that immune responses propagate in the nervous system in a manner similar to that in other tissues (non-immune).

The nervous system, in fact, has a number of attributes that influence local immune responses, hence the "bidirectional" effect concept [1]. The experimental evidence for neuroimmune interactions can be summarized as follows: (i) alterations or changes in immune responses can be conditioned and regulated; (ii) electrical stimulation or lesions of specific brain sites can alter and modulate immune functions; (iii) ►stress (and the ►hypothalamo-pituitary-adrenal (HPA) axis; see below) alters immune responses and infections in experimental and physiological models; and (iv) activation of the immune system is correlated with altered neurophysiological, neurochemical and neuroendocrine activities of brain tissue [4].

This evidence is elaborated on below, but it is pertinent for now to consider first what the potential links between the nervous and immune systems might be. There is little scope for understanding neuroimmune interactions, but with the benefit of hindsight I can postulate a number of specific neuroimmune mechanisms by which the nervous system might affect immune function. (*This is also evident by the various entitled contributions authors have made to the Neuroimmunology field.*) These interactions include ►glucocorticoids (discussed later) secreted from the ►adrenal cortex, ►catecholamines secreted from ►sympathetic nerve terminals and the ►adrenal medulla, other hormones secreted by the ►pituitary (►hypophysis) and other endocrine organs, and peptides (including endorphins) secreted by the adrenal medulla and autonomic nerve terminals [1]. This network includes not only the ►autonomic nervous system (ANS) and classical neuroendocrine mechanisms, but involves an endocrine function of the immune system. A variety of immune system products (e.g., ►cytokines,

peptides and other factors) that function to coordinate the immune response may also provide important signals for the nervous system [2]. Thus, chemical messengers can account for a variety of interactions between both systems. The illustrations in Fig. 1a and b provide a hypothetical schematic model of the most well-known interactions between the nervous system and components of the endocrine and immune systems.

### Immunity and the Immune System – An Overview

The immune system is critical to our survival. Examples of what happens when it fails (▶ [acquired immunodeficiency syndrome; AIDS](#)) or when it fails to develop

properly (▶ [severe combined immunodeficiency; SCID](#)), just to cite few examples, are abounding [5]. The body is a rich place for microorganism growth. Without our immune system, we, conspicuously, are an excellent propagating growth medium.

### What is the Immune System?

Likened it to a colony of ants within us; the immune system is, nonetheless, a restless microenvironment [5]. Instead of separate organisms, however, there are many different cellular components distributed in our organs and tissues and blood stream. These cells are not static but rather move throughout the body, “looking” for

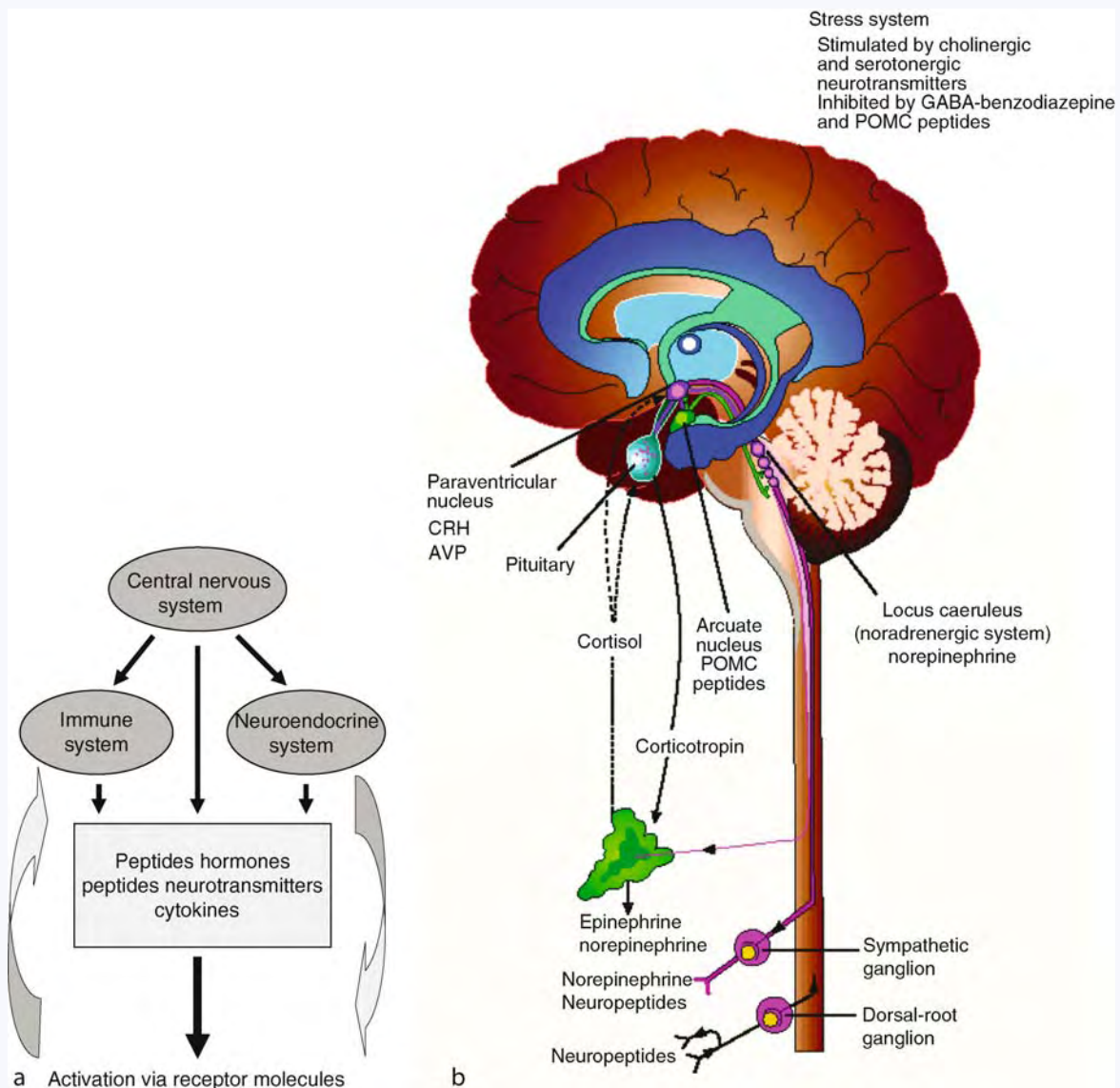

**Neuroimmunology. Figure 1** (a) A hypothetical schematic for substantial molecular communication circuits existing between the immune and neuroendocrine systems and involving shared ligands and receptors. (b) Classic components of the CNS systems and the connections with stress and immune system [1].

situations that demand a response. Generally, communication between two or more cells is required before an attack is launched – a system of checks and balances. When we talk about immunity, we must be careful to say just what kind of immunity is meant. For example, there is *innate immunity*. This is a response that is not specific for a particular microorganism or strain of microorganism. It is rather set off by a property that is shared by a whole class of microorganisms (▶neurodegeneration and neuroprotection – innate immune response).

### Types of Immunity

Innate immunity involves cell surface polymers characteristic of classes of microorganisms. These are referred to as ▶pathogen-associated molecular patterns (PAMPs) [6]. They involve major molecular signatures of classes of microorganisms, such as: (i) ▶Lipopolysaccharide (▶LPS; ▶endotoxin) for Gram-negative bacteria (▶endotoxic fever); (ii) Lipoteichoic acid for Gram-positive bacteria; and (iii) Lipoproteins for *Mycobacteria*, *Mycoplasma* and *Spirochetes*. PAMPs are recognized by ▶pattern recognition receptors (PRRs) on the surface of macrophages – phagocytic cells – and also on lymphocytes. The PRRs in mammals resemble Toll, one of a family of receptors in the invertebrate fruit fly, *Drosophila melanogaster* [6]. On binding of infectious organisms to Toll and similar receptors in *Drosophila*, anti-fungal or anti-microbial peptides are released that are appropriate to the infectious organism [7].

▶Toll-like receptors (TLRs) share the following molecular properties: (i) an extracellular ▶leucine-rich domain (LRD); (ii) a small cysteine-rich domain that differs among different toll-like receptors; and (iii) a cytoplasmic domain that is homologous to the ▶interleukin (IL)-1 receptor (IL-1R), a receptor that binds the vertebrate cytokine, IL-1; it is referred to as a ▶Toll/IL-1R homology domain (TIR). In mammals, cells interacting with PAMPs through their PRRs appear to release cytokines – small glycoproteins that recruit cells involved in a form of immunity not present in invertebrates like *Drosophila* – *specific acquired immunity* [7].

In specific acquired immunity or *specific adaptive immunity*, the response is against a particular organism and, in fact, usually against multiple aspects of that organism. For example, you may mount a response against a single strain of influenza virus and even against many proteins of that strain. But that particular response will not protect you against a different strain of influenza virus. This is why ▶vaccination against one strain does not protect the human body against a different strain [7].

We will learn how the colony of cells that mediate specific acquired immunity is set up and how it operates. In brief, during embryonic development and

throughout life, a very large number of cells called lymphocytes are generated. There are several different classes of lymphocytes and millions to billions of cells in each class. Each lymphocyte has a receptor on its cell surface (in fact, many copies of a receptor, but all identical). But each lymphocyte has a different receptor. The job of the receptor on each lymphocyte is to bind to or recognize a potential foreign invader – what is commonly referred to as ▶antigen. Antigens, the invading organism or part of organisms against which our immune system must fight, may take many forms [7].

The immune system does not “know” what invaders exist out there in the world. The system has evolved to express such an enormous number of different receptors – each on a different lymphocyte – that at any one time, it contains lymphocytes that could recognize any invader that we encounter. Of course, the particular cell must be able to find and interact with that invader in order to make its protective response. That is the function of the specialized immune tissues (spleen, thymus, lymph nodes) and the circulation of lymphocytes in the blood stream – to bring the protective lymphocytes into contact with the invaders that they must fight [7].

When an invader is encountered by protective lymphocytes and the validity of that encounter is verified, a process is set in motion whereby the lymphocyte is caused to divide multiple times to generate a clone of identical cells expressing the same receptor. These cells set about destroying the invader in one of two major ways: (i) they manufacture and secrete ▶antibodies, proteins that bind to the invader and contribute to its demise by one of several means that we will discuss later on. This is called *humoral immunity*; and (ii) the cells destroy the invader directly by direct action of the cells. This is called *cellular immunity* [1] (▶stress effects during intense training on cellular immunity, hormones and respiratory infections).

After the invader is effectively beaten down, there now remain an increased number of antibodies, antibody-producing cells, and memory cells than there were before the invader appeared on the scene. These persist in the body and are, in fact, scattered throughout via the blood. If the same invader strikes again, the protective response occurs more quickly and is stronger than it was at first due to the presence of more cells at the outset that recognize the invader. This is called ▶immunological memory, and it is why vaccination works (▶neuroinflammation – DNA vaccination against autoimmune neuroinflammation).

### Developmental Immunity

Immunologists, furthermore, have learned about how this remarkable system is set up during development. In fact, the immune system is perhaps the best-understood developmental system, largely because many of the

key cell types are “free floating” (lymphocytes, macrophages), which are much more easily manipulated than solid tissues [1]. This attribute, combined with the ability to study the genetics of immune responses and of the molecules that mediate these responses, has allowed a wealth of information to accumulate – mostly for mice and humans.

### Self/Non-self Recognition

How does our immune system distinguish between an invader and our own tissues – our “self?” After all, if we can produce lymphocytes that have receptors that can recognize any invader, surely we produce lymphocytes that recognize molecules in and on our own cells. Why does our own immune system not destroy us? In fact, we do produce lymphocytes that recognize ourselves all the time, but only rarely do they cause ▶autoimmune disease (▶central nervous system degeneration caused by autoimmune cytotoxic CD8+ T cell clones and hybridomas). We will learn a lot about self-recognition and why it is generally not a serious problem. In the course of addressing this question, we will deal with a subject that I will refer to as the *genetics of the self*. It underlies both our ability to set up a safe and functional immune system, and also the whole area of tissue and organ transplantation.

It revolves around a set of closely linked genes that are lumped together and referred to as the major histocompatibility complex (MHC) of genes. The MHC is the focus for how the immune system avoids attacking our own bodies. The cellular and molecular biology that is involved in MHC-related recognition is one of the most fascinating aspects of how the immune system works. Finally, one should always be considering how we might apply our knowledge of how the immune system works to improve human health. This may involve using vaccines or mediators produced by the immune system itself to enhance immunity when the body’s own system is not mounting a strong enough response. In other instances, we may wish to squelch immune activity when it has been misdirected against our own tissues. Also of great interest is the possible use of ▶gene therapy to enable the body to manufacture a needed substance that it was unable to make due to an inherited mutation or deletion in an important gene [8–10].

### What is the Functionality of the Relationship Between the Nervous and Immune Systems?

There is considerable evidence suggesting that immune system signaling and activation are communicated to the nervous system via specific pathways [1]. This communication essentially occurs through the release of peripheral soluble factors (particularly cytokines, commonly known as “*biologic response modifiers*”) by cells of the immune system (lymphoid vs. myeloid) and cells of non-immune origin [11] (▶central nervous

system inflammation – cytokines and JAK/STAT/SOCS signal transduction). These factors or cofactors function as hormones or modifiers to affect and modulate the responses of the central nervous system (CNS) and peripheral nervous system (PNS). They can affect the CNS directly by crossing (bypassing) the blood-brain barrier (see above) or indirectly by stimulating the ▶vagus nerve (see Fig. 1a and b). As a consequence of the diversity of specialized cells and subcellular components in the nervous system, there is a wide range of potential target antigens and clinical syndromes associated with that [1].

### Bidirectional Influence: Immune System Effects on the Nervous System – Types of Signaling Molecules and Cofactors

Amongst biological modifiers, cytokines, particularly, can directly influence the electrophysiological function of neurons in the CNS or PNS; this is especially evident during the ensuing inflammation of the brain or PNS, despite the immunologically privileged status [8]. ▶Chemokines, on the other hand, resemble a family of proteins associated with the trafficking (emigration) of ▶leukocytes in physiological immune surveillance and inflammatory cell recruitment in normal host defense mechanisms [1]. Beside their well-established role in the immune system, evidence indicates that chemokines also play an integral role in the CNS. In fact, they are constitutively expressed by ▶microglial cells (or macrophages of the brain) (▶microglia – functions in immune mechanisms in the central nervous system), ▶astrocytes and neurons, and their expression can be induced with inflammatory mediators, such as cytokines. Chemokines can also modulate neuronal signaling via the regulation of the flow of Ca<sup>2+</sup> currents [12].

Immunologically active molecules, not necessarily involved with inflammatory reactions, similar to cytokines or chemokines (secreted from cells invading the tissue from the blood stream or secreted centrally by local microglia or astrocytes (▶central nervous system inflammation – astroglia and ethanol) as well as bacterial-derived (like lipopolysaccharide (LPS)) or virus-derived molecules can affect voltage-dependent ion currents and ▶transmitter receptor-operated ion currents of peripheral or central neurons [1]. Cytokines released by the immune system can influence cognitive processes, for example, and thus modify central neurotransmission and the function of PNS. In addition, cytokines and neuropeptides secreted by peripheral immune cells have dramatic effects on behavior or behavioral aspects of the CNS. Pro-inflammatory cytokines, furthermore, can activate the HPA (discussed below) and thus induce, for example, ▶sickness behavior (weakness, malaise, listlessness, inability to concentrate, decreased food and water intake) during the inflammatory ▶acute phase response (APR) [1].

The acute phase response has been reported to have specific components (physiological and inflammatory): (i) fever: cytokines such as IL-1, IL-6 and **▶tumor-necrosis-factor- $\alpha$  (TNF- $\alpha$ )** act at the level of the **▶hypothalamus** to install and activate thermocenters [1] (**▶brain inflammation – tumor necrosis factor receptors in mouse brain inflammatory responses**); (ii) sickness behavior can be induced by systemic circulating IL-1 $\beta$  and TNF- $\alpha$ ; this phenomenon is likely mediated by the vagus nerve since **▶vagotomy** (severance of the vagus nerve) has been shown to attenuate the behavioral actions of peripheral cytokines; IL-1 $\beta$ , moreover, binds to vagal fibers and thus can increase vagal discharge; (iii) blood-brain barrier: IL-1 $\beta$  can slowly diffuse across the parenchymal blood-brain barrier and activate the basolateral **▶amygdala** (involved with depressive effects on social behavior) and **▶area postrema** (this brainstem region activates the HPA axis and gives rise to feelings of nausea) (**▶bickerstaff's brainstem encephalitis**).

### **Nervous System Components Associated with and/or Affected by Immune Responses**

Neurons carry information coded in the form of electrical signals (**▶Membrane potential**, **▶Action potential**). Evidence indicates that neurons can counter-regulate brain immunity in intact CNS areas. For example, microglia are kept in a quiescent state in the CNS by interactions between the microglia receptor **▶cluster of designation (CD)200** and its ligand, which is inducibly expressed on neurons [13]. Furthermore, neurons can downregulate MHC expression in surrounding glial cells, in particular microglia and astrocytes (**▶glial and neuronal reactivity to unconjugated bilirubin**). Certain chemokines are also associated with the surface of many neurons (e.g., **▶fractalkine** is bound to the outside of neurons in the dorsal horn of the spinal cord). Microglia, moreover, have been shown to express fractalkine receptors (CX3CR1). When **▶spinal cord dorsal horn** neurons are activated by nociceptive stimuli, for example, they release fractalkine, which binds to the microglial receptors and stimulates the microglia, causing the release of cytokines [1]. This seems to be a vital mechanism in the generation of **▶chronic pain** condition [9] (**▶neural-immune interactions – implications for pain management in low-back pain and sciatica**).

Glia (neuroglia) can also form an innate immune system offshoot, within the “immune privileged” CNS, which has the potential to initiate immune responses to exogenous antigens or endogenous degenerative processes [13]. **▶Oligodendrocytes** (components of the CNS) and **▶Schwann cells** (components of the PNS), which produce a **▶myelin sheath** around axons, are sensitive to injurious and/or pharmacologically active agents including antibodies, complements and cytokines (**▶autoimmune demyelinating disorders – stem cell therapy**). Astrocytes, on the other hand, affect

neuronal function by the release of **▶neurotrophic factors (▶neurotrophins)**, guide neuronal development physiologically, contribute to the metabolism of neurotransmitters and regulate extracellular pH and K<sup>+</sup> concentrations and currents. The astrocyte, specifically, is an immuno-competent cell in the CNS. The reason is that these cells can express MHC class II and co-stimulatory molecules (B7-1 and B7-2 [CD80/CD86] and CD40) that are critical for antigen presentation and subsequent T-cell (lymphocyte) activation [1]. Microglia essentially resemble brain macrophages, the phenotype of which is thought to represent an adaptation to the specialized neural microenvironment. These features include, but are not restricted to, the following: (i) Microglia exhibit a downregulated (less differentiated) phenotype; (ii) serve major homeostatic and reparative functions (can secrete cytokines and neurotrophic factors); (iii) play a role in host defense (can become activated to perform several innate immune functions, such as induction of inflammation; cytotoxicity and regulation of T-cell responses through presentation of antigen); and (iv) are involved in CNS immune surveillance and response [1] (**▶neuroinflammation – modulating pesticide-induced neurodegeneration**).

### **Nervous System Influence on the Immune System – Unidirectional or Bidirectional?**

Converging evidence has demonstrated that the immune system is not regulated in an autonomous fashion, but is influenced by external factors particularly mediated by the nervous system (**Fig. 2a** and **b**). What are the major connecting mechanisms mediating neuroimmune interactions? There are at least three putative pathways by which the nervous system can communicate or crosstalk with the immune system: (i) Autonomic nervous system (ANS) route via direct nerve fiber connections; (ii) sensory portion of the nervous system via primary afferent nerve fibers; and (iii) neuroendocrine output via the HPA axis. In particular, accumulating evidence indicates that neural control in immunological phases ranges from induction and activation to effector functions and inactivation zones [1]. Autonomic nervous system influence on the immune system involves the following mechanisms: (i) Sympathetic fibers innervate lymphoid organs; (ii) noradrenergic fibers make synapse-like contacts with systemic lymphocytes (spleen) and release **▶noradrenaline (NA)**; also norepinephrine, NE), **▶vasoactive intestinal peptide (VIP)** and **▶neuropeptide Y (NPY)**; lymphocytes and macrophages can express  $\alpha_2$  and  $\beta_2$  adrenoceptors, and lymphocytes also express the Y<sub>1</sub>-NPY receptor; (iii) Noradrenaline suppresses immune responses by tonically inhibiting pro-inflammatory cytokine biosynthesis; (iv) sympathetically released NPY inhibits **▶natural killer (NK) cell** cytotoxic responses and

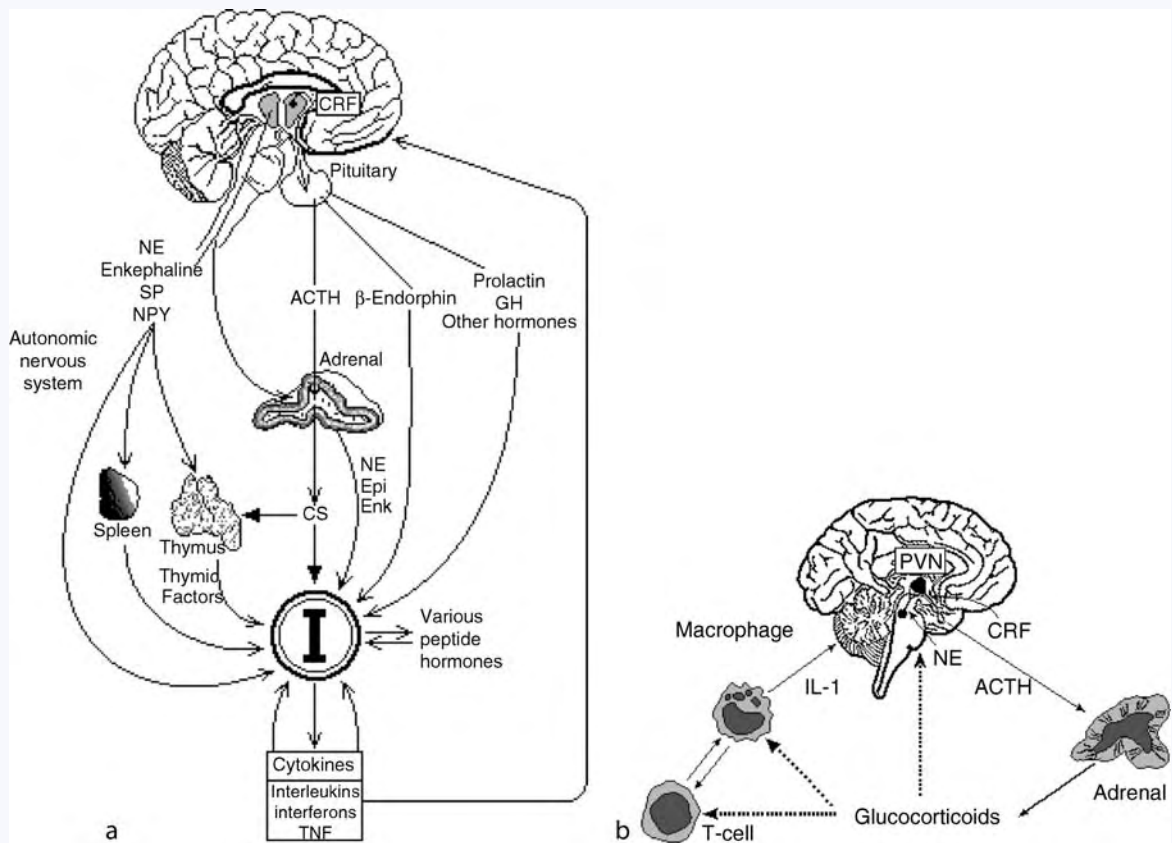

**Neuroimmunology. Figure 2** (a) A schematic diagram of the interactions between the brain and components of the endocrine and immune systems. The ability of the brain to alter immune system function by a variety of endocrine pathways and the autonomic nervous system is emphasized, and the effects of peptides and cytokines produced by the immune system on immune cells and the brain is indicated. *CRF*, corticotropin-releasing factor; *CS*, corticosteroids; *Enk*, enkephalin; *Epi*, epinephrine; *GH*, growth hormone; *I*, immunocytes; *NE*, norepinephrine; *NPY*, neuropeptide Y; *SP*, substance P; *TNF*, tumor necrosis factor. (b) A schematic diagram of the relationship between the brain, the HPA axis, and immune cells and the role of glucocorticoids. Interleukin-1 (IL-1) produced by lymphocytes during the immune response activates noradrenergic (NE) projections for the brainstem to the hypothalamic paraventricular nucleus (PVN). This input activates the hypothalamic-pituitary-adrenocortical (HPA) axis, stimulating the release of corticotropin-releasing factor (CRF) in the median eminence region of the hypothalamus, which in turn stimulates the secretion of ACTH from the anterior lobe of the pituitary, which then activates the adrenal cortex to synthesize and secrete glucocorticoid hormones. The glucocorticoids in turn provide a negative feedback on cytokine production by lymphocytes [1].

humoral antibody production; and (v) vasoactive intestinal peptide inhibits IL-12 and ▶nitric oxide (NO) production by resident macrophages [1].

The major influence of the ▶sympathetic nervous system (SNS) on the immune system is to inhibit immune responses. However, there appear to be regional (localized) differences in the effects of NA on immune function. In the thymus, for example, it modulates T-cell proliferation and differentiation; in the spleen and lymph nodes it enhances the primary antibody response. Primary afferents and peptidergic innervations, in particular, exert great influence on the immune system. A number of neuropeptides released from primary afferent nerve fibers have been shown to affect the immune system.

For example, ▶substance P (SP), a pro-inflammatory undecapeptide, has been localized in the CNS, peripheral sensory neurons, in nerve plexuses of the gut and in the spleen, lymph nodes and thymus (primary and secondary lymphoid organs) [1]. This peptide is found particularly at sites of inflammation and appears to be a regulator of cell-mediated and humoral immune responses. Substance P is involved in (to cite a few examples): (i) early induction of local and systemic host defense responses to inflammation/injury (▶traumatic brain injury – rat model of neuroinflammation and expression of matrix metalloproteinases); (ii) causing vasodilatation and increased vascular permeability; (iii) enhancing phagocytosis by neutrophils and/or

macrophages; (iv) induction of the release of ▶histamine (secondary allergic mediators) and other substances from ▶mast cells; and (v) controlling bacterial infections of the gut (▶gut-associated lymphoid tissue; GALT); SP blockade has been shown to increase the susceptibility to *Salmonella* infections. Another example is ▶calcitonin gene related peptide (CGRP), localized in the bone marrow, lymph node, spleen and thymus where it is released by primary afferent fibers [1]. It has the following properties: (i) it has binding sites on T-cells; (ii) it is a potent vasodilator; and (iii) it inhibits mitogen-stimulated proliferation of T-cells and inhibits T-cell stimulation of ▶epidermal Langerhans cells (antigen-presenting cells of dendritic cell origin).

### Influence of Hypothalamic/Pituitary Neuroendocrine Hormones on the Immune System

Early studies identified the pituitary gland as an essential component in the regulation of immune system development and activity. Following surgical removal of the pituitary, Gisler and Schenkel-Hulliger [14], for example, observed reduced antibody responses (sera-localized immunoglobulins were diminished); growth-hormone treatment restored antibody production. Since these early observations, numerous studies have implicated neuroendocrine hormones in immune regulation (Fig. 2a). A list of a few major hormones that influence immune function is succinctly provided below (elaborations are expressed in the section entitled “neuroimmune interactions”).

#### Adrenocorticotrophic Hormone (ACTH)

▶Adrenocorticotrophic hormone (ACTH) is extracted from the pituitary glands of animals or made synthetically. ACTH stimulates the adrenal glands to release glucocorticoid hormones. These hormones are anti-inflammatory in nature, reducing edema and other aspects of inflammation. Data from the early 1970s indicate that ACTH may reduce the duration of ▶multiple sclerosis (MS) exacerbations (▶multiple sclerosis – macrophages and axonal loss). In recent years it has been determined that synthetically produced glucocorticoid hormones (e.g., cortisone, prednisone, prednisolone, methylprednisolone, betamethasone, dexamethasone), which can be directly administered without the use of ACTH, are more potent, cause less Na<sup>+</sup> retention and less K<sup>+</sup> loss, and are longer-acting than ACTH. ACTH, in brief, has the following properties: (i) it is derived from ▶pro-opiomelanocortin (POMC), an unusual hormone complex manufactured by the anterior lobe of the pituitary (hypophysis). This complex is metabolized into four separate hormones: ACTH, ▶melanocyte stimulating hormone (MSH), ▶enkephalin and ▶β-endorphin; (ii) it is secreted by the anterior pituitary into blood stream; (iii) its release is regulated by ▶corticotropin-releasing

factor (CRF) (or ▶corticotropin-releasing hormone (CRH) or ▶corticoliberin), a polypeptide hormone involved in the stress response, stress and hypoglycemia (Fig. 2b); (iv) ACTH initiates the release of adrenal corticosteroids and increases the growth of adrenal cells through actions on ▶melanocortin receptors; (v) ACTH receptors are present on both B-cells (lymphocytes) and T-cells; (vi) it reduces antibody responses in vitro and reduces ▶IFN-γ (interferon) production; and (vii) systemic injection of lipopolysaccharide (LPS) increases ACTH and corticosterone [1].

#### Gonadal Steroids

Several lines of evidence implicate sex steroids in immune regulation and in the regulation of neuronal gene expression (transcriptional regulation) [1]. In general, ▶androgens (hormones promoting the development and maintenance of male sex characteristics) exert suppressive effects on both humoral and cellular-mediated immune responses and seem to represent natural anti-inflammatory hormones; in contrast, ▶estrogens (type of hormones that help develop and maintain female sex characteristics and the growth of long bones) exert immuno-enhancing activities, at least on humoral immune response.

This is based on the following observations: (i) sexual dimorphism exists within the immune system: females usually have higher concentrations of ▶immunoglobulin (Ig)G, IgM and IgA than males; (ii) antibody responses to antigens are greater in magnitude and essentially more prolonged in females than males; (iii) females have a higher incidence of autoimmune disease (multiple sclerosis (MS), ▶rheumatoid arthritis (RA), systemic lupus erythematosus (SLE)); (iv) manipulation of testosterone or estrogen alters autoimmune disease progression or onset in animal models; (v) sex steroids may influence the immune system, at least in part, via the thymus, where they play a role in development and atrophy; (vi) regulation of the immune system by estrogens is particularly important during pregnancy; in this case the balance between glucocorticoid and estrogen regulation probably plays a role in suppression of the maternal immune system to prevent rejection of the fetus; (vii) estrogen and testosterone can regulate IL-6 expression with loss of IL-6 effect in postmenopausal women and postandropausal men, thus resulting in increased IL-6 being associated with increased occurrence of inflammatory diseases with old age (RA, ▶inflammatory bowel disease, osteoporosis); and (viii) in general, females are more sensitive to pain than males, and this is due, in part, to the presence of estrogen, which appears to be pronociceptive or of hyperalgesic nature [15].

Adrenocorticotrophic hormone (ACTH), glucocorticoids and gonadal steroids can also directly affect nervous system function. For example, corticosteroid

and estrogen receptors are found in discrete locations in the brain and spinal cord (►[neuroinflammation – brain and spinal cord injury](#)). Electrical properties of brain neurons are specifically regulated by glucocorticoid-receptor activation.  $\beta$ -Estradiol has been shown to inhibit L-type ►[voltage-gated  \$\text{Ca}^{2+}\$  channels](#) in brain neurons. Estrogen receptors (a class of proteins found inside the cells of the female reproductive tissue, some other types of tissue, and some cancer cells; estrogen will bind to the receptors inside the cells and may cause the cells to grow) have been found to be coupled to ►[metabotropic glutamate receptors](#) in the ►[hippocampus](#) of the brain and thus can affect second messenger systems involved in memory and learning [1].

### Immunological Surveillance of the Nervous System by Lymphocytes

Studies on the migration of labeled T cells following intravenous injection have shown that activated T lymphocytes of a rather broad specificity enter the normal CNS parenchyma as early as 3h following administration [1]. Thus, T-cell traffic in the CNS appears to be governed by the same principle as applies to other organs, namely that activated T cells preferentially migrate from the blood into tissues, whereas resting cells exit in lymph nodes via high-endothelial venules (HEVs) (found in lymphoid tissues, excluding the thymus; since endothelial cells are tall and lack tight junctions, this facilitates entry of lymphocytes into lymphoid tissue from the blood.) Low numbers of T cells are consistently demonstrable in normal human and rat brains, indicating that the CNS is continuously patrolled by activated lymphocytes [1].

### Conditioning of the Immune Response

Compelling evidence for the influence of the nervous system on the immune system arises from studies that indicate that behavioral conditioning can modify immune responses. A landmark study by Ader and Cohen [16] indicated that after the immunosuppressive drug, cyclophosphamide (a class of drugs known as alkylating agents; it slows or stops the growth of cancer cells), had been paired with the taste of saccharin (the oldest artificial sweetener; in the European Union also known as E954), subsequent ingestion of the saccharin prevented the production of antibodies in response to sheep red blood cell (SRBC) administration (serologic manifestation). This technique has been particularly used to prolong the lives of mice with systemic lupus. There can be little doubt that conditioning can alter immune responses, but the immunological specificity of the effects is not clear, and the mechanisms remain to be unraveled. It is possible that at least some of the immunosuppressive effects are from a conditioning of hormone and neurotransmitter secretion (e.g., glucocorticoids or catecholamines) [1].

### Effects of Brain Lesions on Immune Function

Although evidence has indicated that brain lesions may have effects on immunity, consistent coherence is, at best, fragmented, incomplete and complex. Effective lesions are most commonly located in the hypothalamus and are generally inhibitory. Lesions in other ►[limbic](#) areas may also be effective, notably in the ►[septum](#), hippocampus and amygdala. Some studies have indicated that cortical lesions can affect immune responses and that the effects depend upon the laterality of the lesion [1]. Renoux and colleagues [17] have reported evidence that lesions of the left cortex, but not the right, produced pronounced immune deficits in spleen cell number, lymphocyte proliferation, and natural killer cell activity (►[nervous, immune and hemopoietic systems – functional asymmetry](#)). The lateral specificity indicates that the aforementioned observation cannot be from nonspecific effects of the lesion, and it could account for the greater number of left-handed individuals who exhibit diseases of the immune system. Lesions of the central noradrenergic systems have also been shown to impair various aspects of the immune response (►[neurodegenerative diseases – MAPK signaling pathways: cytokine regulation and glial activation](#)).

### Effects of Stress on the Immune System

It is established that stress may impair the immune system (see below) [1]. The dogma that stress suppresses immunity is to some extent based on the well-established immunosuppressive effects of glucocorticoids. However, the supra-physiological doses of the steroids used in most of the studies do not allow simple extrapolation to the normal physiological state. In fact, endogenous glucocorticoids at physiological doses are not universally immunosuppressive and actually may enhance immune function. Furthermore, glucocorticoids may not even be the major mechanism by which stress suppresses immune function. Experimental evidence has confirmed the immunosuppressive effect of stress. However, it is important to emphasize that there is considerable evidence to suggest the opposite.

### The Role of the Adrenal

Adrenalectomy (surgical removal of one or both adrenal glands) has been shown to prevent the immunosuppressive effects of stress, but other studies have indicated that stress-induced changes in immunity persist in adrenalectomized animals. Adrenalectomy appears to be effective in studies that have examined acute responses to brief stressors (for which the immunosuppressive effects are rapidly reversed), but may be less important for the effects of chronic stress. Adrenalectomy, furthermore, does not permit a distinction among the effects of steroids, catecholamines, or even of neuropeptides secreted by the adrenal gland. More recent studies



have suggested an important role for the circulating catecholamines, derived from the sympathetic nervous system and adrenal medulla [1].

The choice of immune parameters measured may also influence the results. Earlier studies relied heavily on mitogen-stimulated proliferation assays, which assess the responsiveness (i.e., cell division measured by DNA synthesis) to lectin mitogens [such as concanavalin A (Con A), phytohemagglutinin (PHA), lipopolysaccharide (LPS), or pokeweed mitogen] in vitro (▶[anti-DNA antibodies against microbial and non-nucleic acid self-antigens](#)). The interpretation of such assays is questionable, because the results are susceptible to a large number of extraneous influences, and the assays are conducted after several days of in vitro incubation separated from normal physiological influences [2]. A measure used more often has recently been that for natural killer cells. There is good evidence that natural killer cells are involved in the rejection of tumors, and therefore at least one of their immunophysiological functions is clear. Stressful treatments have been shown to suppress natural killer cell function. The major effector for the stress-induced effects on natural killer cell function appears to be ▶[opiates](#) and catecholamines through  $\beta$ -▶[adrenergic receptors](#). Because most of the studies of stress on immune function have used ex vivo procedures, another important factor is whether or not the population of cells sampled may be altered by the in vivo treatment. Cell trafficking, the movement of lymphocytes around the body, is known to be regulated by hormones and other secretions, including those secreted during stress, and it is likely, therefore, that the stressful treatments alter the population of cells harvested for the in vitro analysis [1].

### **The Role of Glucocorticoids**

The best-known mechanism for an influence of the nervous system on the immune system is circulating glucocorticoids secreted by the adrenal cortex (Fig. 2b). Glucocorticoids have long been known to have immunosuppressive effects. The data derive in part from the medical practice of using glucocorticoids postsurgically to decrease tissue inflammation and the rejection of transplanted tissues. However, considerable experimental data suggest that the effects of glucocorticoids are not exclusively immunosuppressive [18] (▶[neuroinflammation – LPS-induced acute neuroinflammation, rat model](#)). Although it is well established, it is too often forgotten that glucocorticoids are essential for normal immune responses. For example, adrenally compromised individuals are more susceptible to infections. Of particular importance, it was also shown that corticosteroids were essential for normal recovery from infections in adrenalectomized animals [1].

Nevertheless, the extensive evidence for the immunosuppressive effects of glucocorticoids should not

be ignored. It should, however, be viewed in the light that most of the data were generated using high doses of synthetic glucocorticoids (e.g., prednisolone, triamcinolone, or dexamethasone, amongst others), which are considerably more potent than the native steroids. The concentrations of these compounds used clinically can cause lysis of immune cells, especially immature ones. The more careful studies have used natural steroids at relatively physiological doses; these have noted stimulatory effects of steroids at lower doses. Inhibitory effects occur at higher (supra-physiological) doses, typically  $10^{-6}$  M, which is close to the maximum concentration of free corticosterone or cortisol found in stressed animals after correcting for that bound by corticosteroid-binding globulins. It is also important that elevations of plasma glucocorticoids following acute stressors are short-lived [1].

Although there are direct effects of glucocorticoids on immune cells in vitro, there may also be indirect ones in vivo. One of the oldest known physiological correlates of stress is the involution of the thymus. This involution, which can decrease thymus weight by more than half (also ageing-related phenomenon), occurs largely because lymphocytes that normally reside there are driven out to the periphery. Stress-induced thymic involution is prevented by adrenalectomy and can be induced by administration of glucocorticoids. Thus glucocorticoids can alter the body's distribution of lymphocytes, which may in itself be an important factor marshalling the immune response to infection. Moreover, as mentioned above, the population of lymphocytes derived by harvesting tissues from animals subjected to experimental treatments may be altered by the redistribution of cells due to glucocorticoid secretion. This should be an important consideration in interpreting the results of ex vivo data [1].

### **The Role of Catecholamines**

Lymphocytes bear both  $\alpha$ - and  $\beta$ -adrenergic receptors. Catecholamines appear in the circulation from both the adrenal medulla [noradrenaline (NA) and adrenaline] and from sympathetic terminals (NA). In addition, lymphocytes may be exposed more directly to neuronal secretions while they are resident in the thymus, spleen, and lymph nodes. Anatomical studies have clearly demonstrated a sympathetic innervation of immune structures, such as the bone marrow, thymus, spleen, and lymph nodes. Thus lymphocytes could be exposed to high local concentrations of catecholamines, as well as neuropeptides (▶[microglial signalling regulation by neuropeptides](#)). A parasympathetic (i.e., cholinergic) innervation of these organs has not been confirmed [19].

In vitro studies have revealed adrenergic effects on lymphocytes. Early studies suggested separate  $\alpha$ - and  $\beta$ -adrenergic effects;  $\beta$ -adrenergic receptors were largely inhibitory, whereas  $\alpha$ -adrenergic receptors were

stimulatory. This generalization has endured to some extent, but the detailed results are very complex. There appear to be separate  $\alpha$ - and  $\beta$ -adrenergic stimulatory effects on antibody production *in vitro*, whereas natural killer cell activity appears to be inhibited by  $\beta$ -adrenergic stimulation. The results of *in vivo* studies have been of bewildering complexity. Depending on the parameters used, sympathectomy has been shown to impair, enhance, or not change immune responses. In general, sympathectomy in adult animals depresses immune reactivity, but there are also paradoxical effects on lymphocyte proliferation and B-cell differentiation. Among the confounding factors that may contribute to the complexity are compensatory increases in adrenomedullary output, redistribution of lymphocytes, compensatory changes in the number and kind of adrenergic receptors, and the coexistence in sympathetic terminals of peptides, such as NPY [1]. Several studies have suggested that a major mechanism by which natural killer cell activity is regulated *in vivo* involves catecholamines released by the sympathetic nervous system. For example, the inhibitory effect of intra-cerebroventricular injection of corticotropin-releasing factor (CRF) on natural killer activity is blocked by the ganglionic blocker, chlorisondamine, as is the immunosuppressive effect of IL-1. There is also direct evidence that  $\beta$ -adrenergic receptor blockade can prevent stress-induced effects on natural killer cell activity [19].

### **The Role of Peptides**

Sympathetic nerve terminals contain not only noradrenaline, but also neuropeptides, including endorphins, which may act on the immune system. The presence of NPY, substance P (SP) and vasoactive intestinal peptide (VIP) in the thymus, spleen and lymph nodes, as well as calcitonin gene related peptide (CGRP) in the thymus and lymph nodes, enkephalin and somatostatin in the spleen, tachykinin in the thymus, and peptide histidine isoleucine in lymph nodes have been described [1]. It has been shown that lymphocytes can synthesize and secrete certain peptides. The spectrum of peptides synthesized is large, and includes many of the known peptide hormones, as well as the hypophysiotropic factors. The peptides include ACTH, CRF, growth hormone (GH), thyrotropin (TRH), prolactin, human chorionic gonadotropin, the endorphins, enkephalin, SP, somatostatin and VIP. The quantities of the peptides produced are typically very small, and their biochemical characterization has often been perfunctory. Sometimes their existence has been inferred only from the results obtained in the very sensitive assays used to detect their messenger ribonucleic acids (mRNAs), which should not be construed as unequivocal evidence for the presence of the peptides themselves. More careful analyses have not always substantiated the original claims, especially for the endorphins. There is

probably considerable variability in the ability of lymphocytes from different sources to produce a specific peptide, but this issue has received no serious attention in the literature [1].

The physiological significance of this production of peptides is not at all clear. Because in many cases lymphocytes display receptors for these same peptides, they may function as chemical messengers within the immune system. However, Blalock has suggested that the peptides may also have systemic functions; for example, ACTH could activate the adrenal cortex. Although there is no good experimental support for this specific example, it is possible that there may be a local bidirectional communication between lymphocytes and other cells. One example of this communication may be in the spleen, where CRF appears to be present in the innervating neurons and CRF-receptors are present on resident macrophages. Another example involves endorphins;  $\beta$ -endorphin produced by lymphocytes in an area of inflammation may exert an analgesic action directly on sensory nerve terminals. Such a mechanism is attractive, because the concentrations of the peptides produced locally may be adequate to exert such effects, and the metabolic lability of peptides would ensure that the effect was localized [1] (see Fig. 2a and b).

### **Other Hormones of the Hypothalamo-Pituitary-Adrenocortical Axis**

Many other hormones are known to affect the immune system. Firstly, there are the hormones of the HPA axis, each of which has been reported to affect immune function: CRF, ACTH, and the endorphins. Corticotropin-releasing factor (CRF) itself has been reported to have a variety of effects. The reported direct effects of CRF on immune cells have generally been stimulatory. For example, CRF has been shown to stimulate B cell proliferation and natural killer activity, as well as IL-1, IL-2, and IL-6 production. Receptors for CRF have been found on immune cells, providing a mechanism for these effects. Although it seems unlikely that CRF in the general circulation ever achieves concentrations high enough to stimulate these receptors, it is possible that local actions may occur, for example, in the spleen. By contrast, CRF injected intra-cerebroventricularly (icv) has largely inhibitory effects on immune function. A major effect of icv CRF is evident on natural killer cell activity and appears to be mediated through the sympathetic nervous system. The footshock-induced reduction of natural killer cell activity appears to be mediated by cerebral CRF, because an antibody to CRF injected icv but not peripherally prevented the shock-related response [1].

Although ACTH has been shown to have some direct effects on immune function, including an inhibition of antibody production and modulation of B cell function, the effects have not been striking. On the

other hand, the endorphins have been shown to exert a plethora of effects on immune function. Lymphocytes possess binding sites for opiates, but at least some of these are not sensitive to the opiate antagonist, naloxone. Interestingly, binding sites have been found for N-acetyl- $\beta$ -endorphin, which is the commonest form of  $\beta$ -endorphin secreted from the anterior pituitary and has no opiate activity.  $\beta$ -Endorphin and other opioid peptides can exert effects on lymphocytes *in vitro*. By and large, the effects are facilitatory. Such effects have been observed on natural killer cell activity as well as on proliferative responses. Opioid peptides are also chemoattractants for lymphocytes. In contrast to the enhancing effects *in vitro*, *in vivo* opiates are largely inhibitory, especially on natural killer cell activity. This apparent contradiction can be explained, because, at least in the case of morphine, the site of opiate action appears to be in the CNS. Moreover, the effects appear to be mediated by the adrenal gland, most probably by catecholamines [1].

#### Other Hormones

Perhaps the most interesting effect of a pituitary hormone on the immune system is that of prolactin; its effects are largely stimulatory. Reduction of pituitary prolactin secretion (e.g., by dopaminergic agonists or opiate antagonists) impairs immune function and increases susceptibility to infections, such as by *Listeria monocytogenes*, whereas stimulation of prolactin secretion (e.g., by D2 dopaminergic antagonists or opiates) can enhance it. It is postulated that prolactin may be the counter-regulatory hormone to glucocorticoids and thus acts by opposing interactions between these two hormones on immune function as can be demonstrated *in vivo*. Direct effects of prolactin on lymphocyte function have been difficult to demonstrate, but prolactin antibodies do impair proliferative responses *in vitro*. Lymphocytes can produce a prolactin-like protein, although its identity with prolactin has not been demonstrated. Thus it appears that prolactin is yet another example of a multifunctional peptide produced by both the pituitary and the lymphocytes [1].

#### Immune System Signaling of the Brain – Infection as a Stressor

Not that many would technically challenge the notion that sickness is stressful. In his autobiography, Hans Selye (Selye János (1907–1982) was a Canadian endocrinologist of Austrian-Hungarian origin who did much important theoretical work on the non-specific response of the organism to stress.) indicates that it was the common characteristics of sickness regardless of the underlying disease, i.e., “the syndrome of just being sick,” that first interested him in stress research and led him to advance his much maligned proposal of the *non-specificity* of stress. That the HPA axis is activated

following infections has long been known. During World War I, it was noted that fatalities from infections were associated with striking morphological changes in the adrenal cortex. It was later discovered that endotoxin (lipopolysaccharide, LPS), a potent stimulator of the immune system, stimulated the HPA axis. Subsequently, it was shown that infection of rats with *Escherichia coli* increased the secretion of ACTH [1].

#### Cytokines, Neuropeptides and the Mechanics of Neuroimmune Interactions

Cytokines are mediators of inter- and intracellular communications [20]. These peptides contribute to a chemical signaling language that regulates development, tissue repair, hemopoiesis, inflammation and the specific and non-specific immune responses [21].

Potent cytokine polypeptides (such as IL-1, IL-6, IL-8 and tumor-necrosis-factor- $\alpha$  (TNF- $\alpha$ )) have pleiotropic (redundant) activities and functional redundancy [1]; in fact, they act in a complex, intermingled network where one cytokine can influence the production of, and response to, many other cytokines. It is also now clear that the pathophysiology of inflammatory  $\blacktriangleright$ hyperalgesia, infection and autoimmune and malignant diseases can be explained, at least in part, by the induction of cytokines and the subsequent protracted cellular responses [21]. Of note, cytokines and cytokine antagonists have also exhibited therapeutic potential in a number of chronic and acute diseases [1].

The mechanisms, from both the neural and immunological perspective, involved in stress-induced alteration of immune function are being studied. The immune system is regulated in part by the CNS, acting principally via the HPA axis and the sympathetic nervous system [1]. In recent years, our understanding of the interactions between the HPA axis and immune-mediated inflammatory reactions has expanded enormously. This section outlines the influences that the HPA axis and immune-mediated inflammatory reactions exert on each other and discusses the mechanisms whereby these interactions are mediated. Furthermore, I discuss HPA interactions and oxidative stress evolution within the context of a potential role for the  $\blacktriangleright$ transcription factor NF- $\kappa$ B ( $\blacktriangleright$ NF- $\kappa$ B – activation in the mouse spinal cord following sciatic nerve transection), which regulates a plethora of cellular functions including pro-inflammatory mediated processes [22], and the role of gaseous transmitters ( $\blacktriangleright$ brain aging and Alzheimer’s disease).

#### Cytokines in the CNS: Neuro-Immune-Endocrine Interactions

The communication between the neuroendocrine and immune systems is bidirectional (see Fig. 1a). The neuroimmune-endocrine interface is mediated by cytokines, such as IL-1 and tumor-necrosis-factor- $\alpha$

(TNF- $\alpha$ ), acting as autocrine/paracrine or endocrine factors regulating pituitary development, cell proliferation, hormone secretion, and feedback control of the HPA axis [1]. Increasing evidence supports the hypothesis that there are bi-directional circuits between the CNS and the immune system. Soluble products that appear to transmit information from the immune compartment to the CNS include ►thymosins, ►lymphokines and certain complement proteins.

Opioid peptides, ACTH and ►thyroid-stimulating hormone (TSH) are additional products of lymphocytes that may function in immunomodulatory neuroendocrine circuits. It was proposed that the term “immunotransmitter” be used to describe molecules that are produced predominantly by cells that comprise the immune system but that transmit specific signals and information to neurons and other cell types [1].

Several cytokines are known to affect the release of anterior pituitary hormones by an action on the hypothalamus and/or the pituitary gland. The major cytokines involved are IL-1, IL-2, IL-6, tumor-necrosis-factor- $\alpha$  (TNF- $\alpha$ ) and interferon (IFN) (see Fig. 2a). The predominant effects of these cytokines are to stimulate the HPA axis and to suppress the ►hypothalamic-pituitary-thyroid (HPT) axis and gonadal axis, and growth hormone (GH) release. However, the relative importance of systemically and locally produced cytokines in achieving these responses and their precise sites of action have not been fully established [1]. There is accumulating evidence that there are significant interactions between the immune and neuroendocrine systems which may explain, at least in part, some of the effects on growth, thyroid, adrenal and reproductive functions which occur in acute and chronic disease (►central nervous system disease in primary sjögren’s syndrome). During stimulation of the immune system (e.g. during infectious diseases), peculiar alterations in hormone secretion occur (hypercortisolism, hyperreninemic hypoaldosteronism, euthyroid sick syndrome, hypogonadism). The role of cytokines is being elucidated [1,23].

### IL-1/IL-6/TNF- $\alpha$ and HPA Responses

The bilateral communication between the immune and neuroendocrine systems plays an essential role in modulating the adequate response of the HPA axis to the stimulatory influence of interleukins and stress-related mediators [24] (see Fig. 2a) (►neuroinflammation – IL-18). It is thus reasonable to assume that inappropriate responses of the HPA axis to interleukins might play a role in modulating the onset of pathological conditions such as infections and related pathologies [1]. Ever since two distinct molecules of IL-1 (IL-1 $\alpha$  and IL-1 $\beta$ ) were cloned, sequenced and expressed, it has been a matter of investigation whether these two forms of IL-1 possess an identical spectrum of biological activities (►immunomodulation – brain areas involved).

In situ histochemical techniques were used to investigate the distribution of cells expressing type I IL-1 receptor mRNA in the CNS, pituitary and adrenal gland of the mouse. For instance, hybridization of <sup>35</sup>S-labeled antisense cRNA probes derived from a murine T-cell IL-1 receptor cDNA revealed a distinct regional distribution of the type I IL-1 receptor, both in brain and in the pituitary gland [1]. In the brain, an intense signal was observed over the granule cell layer of the ►dentate gyrus, over the entire midline ►raphe system, over the choroid plexus and over endothelial cells of postcapillary venules throughout the neuraxis. A weak to moderate signal was observed over the pyramidal cell layer of the hilus and CA3 region of the hippocampus, over the anterodorsal ►thalamic nucleus, over ►Purkinje cells of the ►cerebellar cortex and in scattered clusters over the external-most layer of the ►median eminence. In the pituitary gland, a dense and homogeneously distributed signal was observed over the entire anterior lobe. Furthermore, no autoradiographic signal above background was observed over the posterior and intermediate lobes of the pituitary, or over the adrenal gland, providing evidence for discrete receptor substrates subserving the central effects of IL-1, thus supporting the notion that IL-1 acts as a neurotransmitter/neuromodulator in the brain. It also supports the fact that IL-1-mediated activation of the HPA axis occurs primarily at the level of the brain and/or pituitary gland [1].

IL-1 and other related pro-inflammatory cytokines are potent activators of the HPA axis [1]. Current studies of IL-1 and its involvement in the HPA axis have indicated that there is a clear-cut differential response to IL-1 $\alpha$  and IL-1 $\beta$ . For example, the intravenous injection of human recombinant IL-1 $\beta$  in conscious, freely-moving rats significantly increased the plasma concentrations of ACTH in a dose-related manner, whereas IL-1 $\alpha$  did not, suggesting that the two members of the IL-1 family may have a different spectrum of biological actions.

Furthermore, additional investigations clarified the mechanism by which IL-1 activates the HPA axis. For example, the ACTH response to IL-1 was completely abolished by pre-injection of rabbit antiserum generated against corticotrophin-releasing factor (CRF) but not by normal rabbit serum [1]. The IL-1-induced ACTH release did not seem to be caused by a general stress effect of IL-1 because plasma prolactin (PRL) concentrations, another indicator of a stress response, were not altered by IL-1 injection, suggesting that IL-1 acts centrally in the brain to stimulate the secretion of CRF, thereby eliciting ACTH release, and that a direct action of IL-1 on the pituitary gland is unlikely. In addition, it has been reported that intra-peritoneal injection of recombinant IL-1 into mice increased the cerebral concentration of the noradrenaline (NA) catabolite,

3-methoxy-4-hydroxyphenylethyleneglycol (MHPG), probably reflecting increased activity of noradrenergic neurons [1]. This effect was dose-dependent and was largest in the hypothalamus, especially the medial division. Of note, ►tryptophan concentrations were also increased throughout the brain and the increase of MHPG after IL-1 administration paralleled the increase of plasma corticosterone (►neurodegenerative diseases – tryptophan metabolism). In contrast to prior observations [1], both the  $\alpha$ - and  $\beta$ -forms of IL-1 were effective, but the activity was lost after heat treatment of the IL-1 [25].

Noradrenergic neurons with terminals in the hypothalamus are known to regulate the secretion of CRF, thus suggesting that IL-1 activates the HPA axis by activating these neurons. Because the initiation of an immune response is known to cause systemic release of IL-1, this cytokine may be an immuno-transmitter communicating the immunologic activation to the brain. The IL-1-induced changes in hypothalamic MHPG may explain the increases of electrophysiological activity, the changes of hypothalamic noradrenaline metabolism

and the increases in circulating glucocorticoids reported to be associated with immunologic activation and frequently observed in infected animals [25]. In support of these observations, ACTH secretion by the anterior pituitary has been shown to be stimulated by catecholamines in vivo and in vitro [1] (Fig. 3).

In concert, it has been reported that intracerebroventricular injections of IL-1 can cause the release of ACTH. For instance, IL-1 $\beta$  produced an immediate increase in plasma corticosterone and ACTH [1]. Using a potent steroidogenic dose of IL-1 $\beta$ , intra-cerebroventricular injection resulted in the suppression of splenic macrophage IL-1 secretion following stimulation by lipopolysaccharide-endotoxin (LPS) in vitro. Macrophage ►transforming growth factor (TGF)- $\beta$  secretion, however, was not affected, indicating a differential action of IL-1 $\beta$  on macrophage cytokine production. Following adrenalectomy, the suppressive effect of IL-1 $\beta$  was reversed and resulted in the stimulation of macrophage IL-1 secretion, indicating that the suppression was

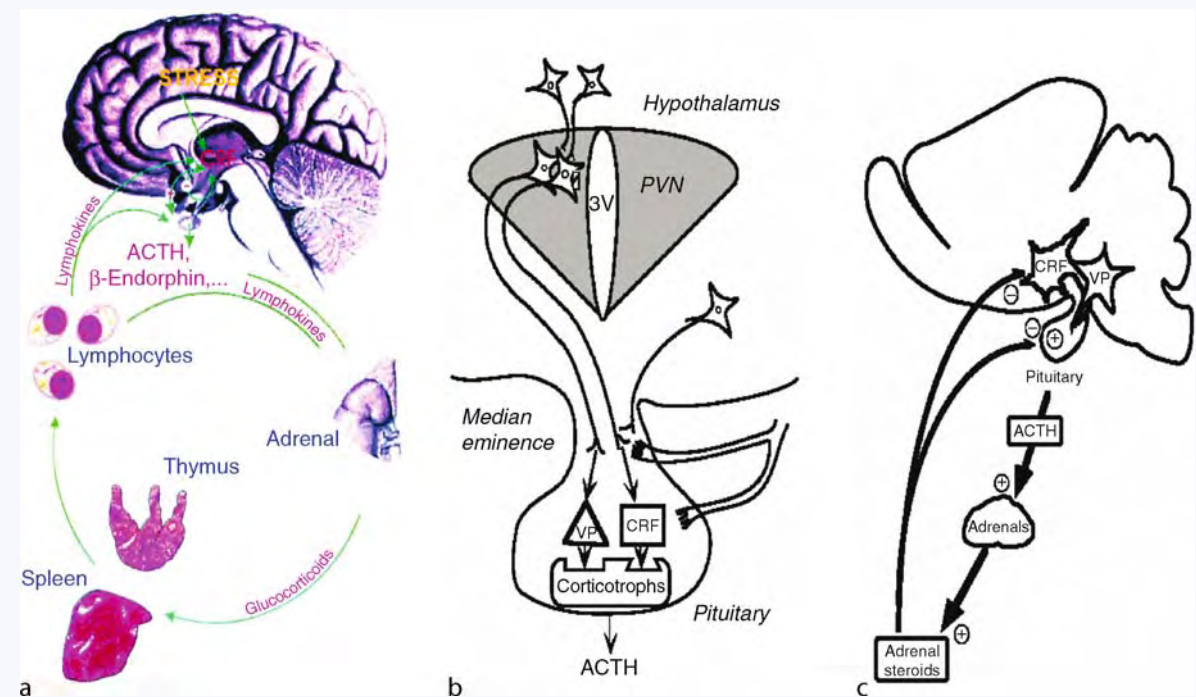

**Neuroimmunology. Figure 3** The HPA doctrine. (a) Classic components of the HPA-CNS-immune systems. (b) Neurons of the hypothalamus that synthesize CRF and vasopressin are found in an area called the paraventricular nucleus (PVN). These cell bodies send axons to the median eminence, here peptides are released from the nerve terminals and are transported through vessels of the portal system. When they reach the anterior pituitary, these peptides act on their respective receptors, thereby stimulating ACTH secretion. (c) Following its release into the general circulation, ACTH acts on the cortex of the adrenal glands, which manufacture and secrete glucocorticoids (corticosterone in rodents and cortisol in humans). These glucocorticoids exert a classical negative feedback influence on the pituitary, where they inhibit the effect of CRF and VP, and on the PVN, where they inhibit the synthesis of CRF. Thus after a stimulus stimulates CRF and ACTH release, the production of glucocorticoids will eventually terminate this release, thereby ensuring the maintenance of homeostasis [1].

mediated by adrenocortical activation. However, surgical interruption of the splenic nerve to eliminate autonomic innervation of the spleen also prevented the macrophage suppressive signal.

Further conflicting reports, however, have been published with regard to a crucial role of catecholamines in IL-1-mediated regulation of the HPA axis [1]. The hypothalamus seems to be an important site of action of IL-1 on the HPA axis, thereby inducing CRF secretion (catecholamines are important modulators of CRF secretion); in turn, IL-1 stimulates catecholamine release from the hypothalamus. In this respect, using an *in vitro* rat hypothalamic continuous perfusion system, the possible involvement of hypothalamic catecholamines in the effect of IL-1 $\beta$  on hypothalamic CRF secretion was investigated. For instance, neither *in vivo* pretreatment with an inhibitor of catecholamine synthesis nor *in vitro* exposure to  $\alpha$ - or  $\beta$ -adrenoceptor antagonists (phenoxybenzamine or propranolol, respectively), nor combination of both treatments altered the effect of IL-1 on CRF secretion from superfused hypothalami, indicating that catecholamines are not involved in the *in vitro* stimulatory action of IL-1 on hypothalamic CRF secretion. In contrast, IL-1-induced corticosterone release was shown to occur by an adrenergic mechanism from rat adrenal gland [1].

An interesting mechanism was reported for IL-1-mediated regulation of the HPA axis. A primary route of peripheral cytokine signaling was proposed through the stimulation of peripheral vagal afferents rather than, or in addition to, a direct cytokine access to the brain. Sub-diaphragmatic, but not hepatic vagotomy, blocked IL-1 $\beta$ -induced hypothalamic norepinephrine depletion and attenuated IL-1 $\beta$ -induced increases in serum corticosterone, suggesting that IL-1 activates the HPA axis via the stimulation of peripheral vagal afferents and further support the hypothesis that peripheral cytokine signaling to the CNS is mediated primarily by stimulation of peripheral afferents [1].

Another major mechanism reported for the action of IL-1 on the HPA axis involves the amygdala. For example, bilateral ibotenic acid lesions of the central amygdala substantially reduced ACTH release and hypothalamic corticotropin-releasing factor and oxytocin cell c-fos expression responses to IL-1 and IL-8, suggesting a facilitatory role for this structure in the generation of HPA axis responses to an immune challenge [1]. Since only a small number of central amygdala cells project directly to the **▶paraventricular nucleus**, the authors then examined the effect of central amygdala lesions on the activity of other brain nuclei that might act as relay sites in the control of the HPA axis function. It was found that bilateral central amygdala lesions significantly reduced IL-1 $\beta$ -induced c-fos expression in cells of the ventromedial and ventrolateral subdivisions of the bed nucleus of the

stria terminalis and brainstem catecholamine cell groups of the **▶nucleus tractus solitarii** (A2 noradrenergic cells) and ventrolateral medulla (A1 noradrenergic and C1 adrenergic cells). These findings, in conjunction with previous evidence of **▶bed nucleus of the stria terminalis** and catecholamine cell group involvement in HPA axis regulation, indicated that ventromedial and ventrolateral bed nucleus of the stria terminalis cells and medullary catecholamine cells might mediate the influence of the central amygdala on the HPA axis responses to an immune challenge. Thus these related data established that the central amygdala influences HPA-axis responses to a systemic immune challenge but indicate that it acts primarily by modulating the activity of other control mechanisms [1] (see Fig. 3).

Similarly, an interesting mechanism implicates the vagus nerve. For instance, direct electrical stimulation of the central end of the vagus nerve induced increases in the expression of mRNA and protein levels of IL-1 $\beta$  in the hypothalamus and the hippocampus. Furthermore, expression of CRF mRNA was increased in the hypothalamus after vagal stimulation. In addition, plasma concentrations of ACTH and corticosterone were also increased by this stimulation, indicating that the activation of the afferent vagus nerves can induce production of cytokines in the brain and activate the HPA axis. Therefore, the afferent vagus nerve may play an important role in transmitting peripheral signals to the brain in infection and inflammation. In concert, dorsal and ventral medullary catecholamine cell groups were reported to contribute differentially to systemic IL-1 $\beta$ -induced HPA axis responses. Medial parvocellular paraventricular corticotropin-releasing hormone (mPVN/CRH) cells are critical in generating HPA axis responses to systemic IL-1 $\beta$ . However, although it is understood that catecholamine inputs are important in initiating mPVN/CRH cell responses to IL-1 $\beta$ , the contributions of distinct brainstem catecholamine cell groups are not known [1] (Fig. 4a and b).

The *in vivo* release of ACTH by IL-1 is reportedly blocked by acute treatment with indomethacin, a non-steroidal anti-inflammatory drug (NSAID), suggesting an involvement of endogenous **▶prostaglandins** in the effect of cytokines on the HPA axis [1]. However, indomethacin also increases plasma corticosterone concentrations, raising the possibility that inhibition of ACTH release is due to suppressive effects of hypercorticoemia rather than to blockade of the stimulatory effects of IL-1 $\alpha$ . It was observed that the intraventricular administration of indomethacin completely abolished the rise in plasma ACTH levels caused by the peripheral injection of this lymphokine to intact rats. In contrast, implantation of intact rats with indomethacin pellets only partially interfered with IL-1-induced ACTH secretion. To determine whether the effect of indomethacin was due to corticosteroid feedback

or represented a modulating action of prostaglandins themselves, a similar series of experiments were carried out in adrenalectomized rats. In the absence of corticoid replacement therapy, acute treatment with indomethacin did not measurably interfere with the stimulatory effect of IL-1 $\alpha$ . In contrast, indomethacin blunted, but did not abolish, the effect of IL-1 $\alpha$  in adrenalectomized rats pretreated with cortisone or dexamethasone to normalize basal ACTH levels. Thus, the acute ability of indomethacin to totally block IL-1-induced ACTH secretion by intact rats appears to be primarily mediated through corticosteroid feedback. However, results obtained when a similar experiment was carried out in adrenalectomized/corticosteroid-treated rats suggested that the ability of IL-1 $\alpha$  to activate the HPA axis might be partially dependent on the release of prostaglandins. In concert, the effects of various cyclo- and lipoxygenase inhibitors on the neuro-chemical and HPA responses to IL-1 indicated a role for prostaglandins in IL-1-mediated activation of the HPA axis ([►neuroinflammation – PDE family inhibitors in the regulation of neuroinflammation](#)). For example, pretreatment of mice with the cyclooxygenase (COX) inhibitors indomethacin or ibuprofen failed to prevent the elevations of plasma cortisone, or hypothalamic MHPG or tryptophan that followed intraperitoneally administered IL-1 [1].

In contrast, pro-inflammatory cytokines can reduce glucocorticoid receptor translocation and function. Specifically, several studies have found that cytokines induce a decrease in glucocorticoid receptor function, as evidenced by reduced sensitivity to glucocorticoid effects on functional end points [26]. These observations clearly suggested that cytokines produced during an inflammatory response may induce glucocorticoid-receptor resistance in relevant cell types by direct effects on the glucocorticoid receptor, thereby providing an additional pathway by which the immune system can influence the HPA axis [1].

Administration of lipopolysaccharide (LPS) (and other inflammatory mediators) results in the activation of the HPA axis [1] (Fig. 4b). The mechanisms through which LPS stimulates the HPA axis are not well understood, however. In initial studies, the hypothesis that LPS increases plasma ACTH levels by releasing IL-1 was tested. Two experimental tools reported to interfere with the biological activity of IL-1 were used: antibodies directed against IL-1 receptors and  $\alpha$ -melanocyte releasing hormone ( $\alpha$ -MSH) [27] ([►melanin and neuromelanin in the nervous system](#)). The results suggested that LPS activates the HPA axis through a mechanism involving the activation of IL-1 receptors and that the effect of IL-1 $\beta$ , but not IL-1 $\alpha$ , on ACTH secretion can be partially blocked by  $\alpha$ -MSH. Therefore, LPS acts both at the level of the brain and the gonads to stimulate the HPA axis and inhibits the hypothalamic-pituitary-gonadal (HPG) axis [1].

Exogenously administered IL-1 mimics most of the effects of LPS on pituitary activity. In addition, antibodies against IL-1 receptors can interfere with LPS-induced ACTH secretion, indicating that at least part of the ability of LPS to alter endocrine functions appears to depend upon endogenous IL-1. Of interest, IL-1 and IL-6 share a number of biological functions. Because IL-1 induces IL-6 *in vivo*, the extent to which IL-6 mediates the effects of IL-1 has come under investigation. The stimulation of the HPA axis by IL-1 and IL-6 is recognized as a critical component of the inflammatory response. In this respect, it was demonstrated that the administration of IL-6 alone did not duplicate the stimulatory effect of IL-1 $\alpha$  on ACTH release. On the other hand, sub-optimal amounts of IL-1 $\alpha$  and IL-6 synergized to induce an early (30–60 min) ACTH response and produce a later (2–3h) response that was similar to the one observed after IL-1 $\alpha$  was administered alone, suggesting that the late response to IL-1 may be dependent on synergy with the endogenous IL-6 it induces systemically and in the CNS (including the hypothalamus and the pituitary gland) [1].

Another mechanism implicates histamine receptors in LPS/IL-1-induced activation of the HPA axis and ACTH release [1]. Lipopolysaccharide (LPS) and LPS-derived cytokines stimulate the release of histamine. Histamine is a known hypothalamic neurotransmitter and activates the HPA axis. To elucidate the role of histamine in LPS- and cytokine-induced ACTH release, Perlstein and colleagues [28] evaluated the effects of several histamine H1 and H2 receptor antagonists on the ACTH response to LPS, IL-1 $\alpha$  and histamine in mice. Although all three of the H1 receptor antagonists administered (mepyramine, diphenhydramine or promethazine) were able to block the 10-min ACTH response to histamine, only promethazine (a less selective H1 receptor antagonist than mepyramine) was able to reduce the LPS- or IL-1 $\alpha$ -induced ACTH responses. In addition, ranitidine, a powerful and selective H2 receptor antagonist, had little effect on the LPS- and IL-1 $\alpha$ -induced ACTH responses, while metiamide, a much less potent first-generation H2 receptor antagonist, substantially diminished ACTH release. It was concluded that the greater effectiveness of promethazine, in contrast to mepyramine or diphenhydramine, probably relates to the ability of phenothiazine derivatives to inhibit non-HA-dependent pathways involved in the stimulation of the HPA axis by cytokines [1].

### IL-2 and HPA Responses

The cytokine IL-2 exerts numerous effects within the immune as well as the central nervous system and is thought to serve as a humoral signal in their communication. A major role for IL-2 has been noted in the regulation of the HPA axis responses. Brain-derived or blood-borne

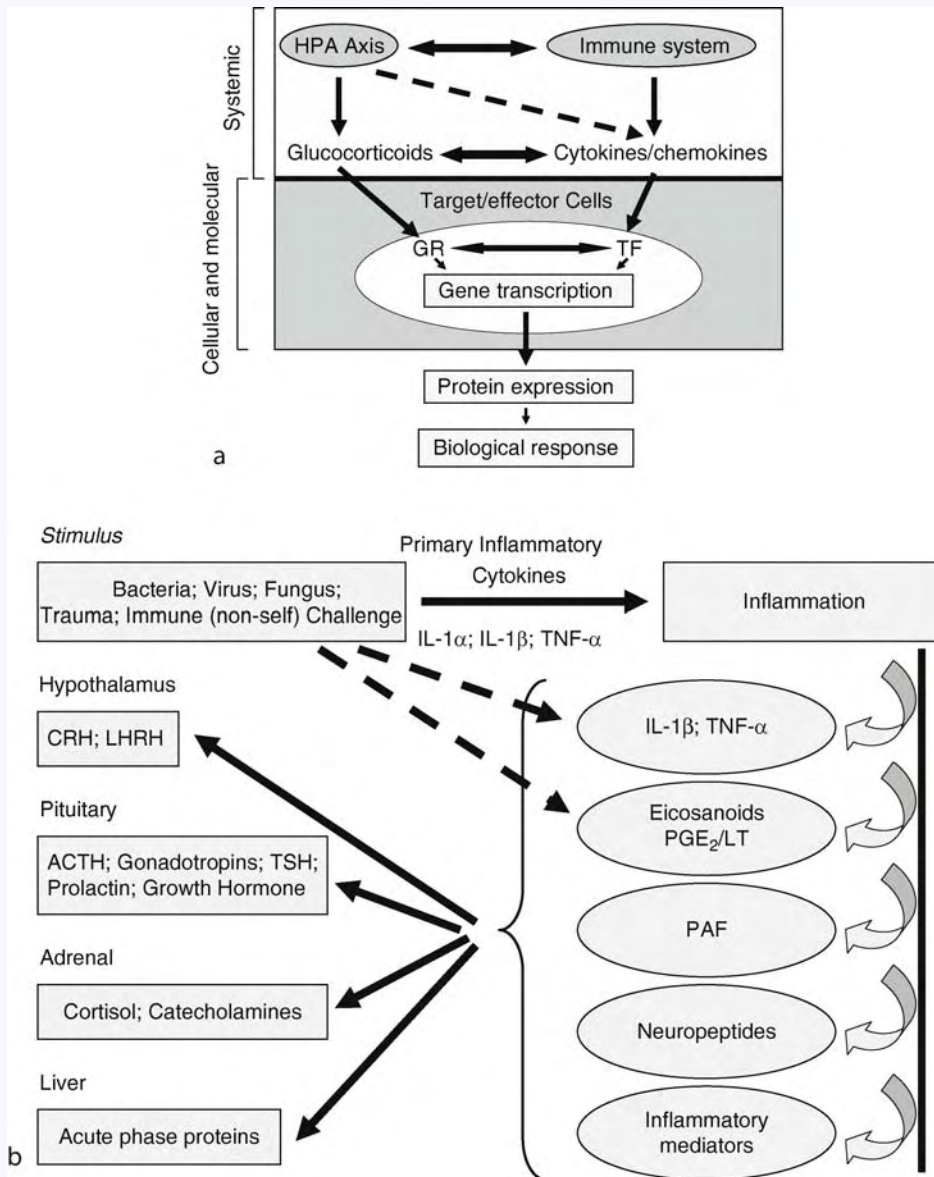

**Neuroimmunology. Figure 4** (a) Scheme depicting systemic and cellular/molecular interplay between the HPA axis and the immune system in the regulation of glucocorticoid/cytokine secretion and gene expression. *GR*, glucocorticoid receptor; *TF*, transcription factors. (b) The inflammatory response and the HPA axis. Some of the effects of the inflammatory response on the neuroendocrine system are illustrated. A stimulus such as trauma, stress, immune challenge, or bacterial, viral and fungal toxins acts to provoke the inflammatory process. Inflammatory cells respond by secreting inflammatory mediators such as cytokines. A profound process of inflammation ensues and propagates itself with the auto-induction (autocrine) of inflammatory mediators, including cytokines, eicosanoids, platelet activating factor, neuropeptides and various other mediators. These agents, particularly inflammatory cytokines, act either directly or indirectly to increase the production of releasing hormones in the hypothalamus (HPA axis), pituitary hormones, cortisol and catecholamines. In addition, the liver participates in this inflammatory-HPA axis by releasing acute-phase proteins. *ACTH*, adrenocorticotropic hormone; *CRH*, corticotropin releasing hormone; *LT*, *IL*, leukotriene, interleukin; *LHRH*, luteinizing hormone releasing hormone; *PAF*, platelet activating factor; *PGE<sub>2</sub>*, prostaglandin; *TSH*, thyroid stimulating hormone; *TNF*, tumor necrosis factor [1].

IL-2 may also control the activity of the HPA axis at various levels of regulation. IL-2, for example, caused a dose-dependent stimulation of secretion of arginine vasopressin (AVP; also called antidiuretic hormone,

ADH) from both the intact rat hypothalamus in vitro and hypothalamic cell cultures [1]. IL-2, however, did not increase the secretion of corticotrophin-releasing factor (CRF) in either preparation, nor did it prime



the cells to respond to a subsequent dose of IL-2. Both preparations, nevertheless, were able to respond to known CRH secretagogues, such as ▶serotonin (5-HT) and  $K^+$ . This may provide yet another line of communication between the immune and neuroendocrine systems. In another study [1], it was investigated whether persistently elevated concentrations of central IL-2, which are associated with several diseases or induced during immuno-therapeutic use of this cytokine, could induce long-term activation of the HPA axis. Adult male *Sprague-Dawley* rats received an intra-cerebroventricular infusion of the recombinant cytokine; control animals received heat-inactivated IL-2. IL-2 caused a significant increase in ACTH concentrations during the later portion of the dark phase of the cycle.

Plasma corticosterone concentrations were significantly elevated over almost the whole diurnal cycle. In addition, measurements of corticosterone-binding globulin concentrations revealed IL-2-induced decreases during the dark phase, resulting in a marked increase in free corticosterone. Furthermore, after prolonged chronic infusion, both groups of animals underwent restraint stress. For instance, IL-2-treated animals showed stress-induced increases in plasma ACTH and corticosterone that were not significantly different from those of animals treated with heat-inactivated IL-2. Along with the alteration of HPA activity seen in the IL-2-treated animals, chronic delivery of the cytokine caused periventricular tissue damage and gliosis. Taken together, the data reflected the capacity of IL-2 to modulate neuroendocrine activity over an extended period of treatment [1].

### IL-3/IL-6 and HPA Responses

Accumulating evidence indicate that IL-3 can activate the HPA axis [1]. For example, IL-3 and IL-6 equipotently stimulated basal cortisol secretion. The stimulatory effect was significant and maximum cortisol levels were induced later. In contrast to ACTH, which significantly induced cAMP levels in parallel to its steroidogenic effect, IL-3 (or IL-6) had no significant effect on cAMP. Furthermore, the authors showed that specific inhibition of the cyclo-oxygenase (COX) pathway by indomethacin completely blocked the steroidogenic effect of IL-6 while the effect of IL-3 was not affected. In contrast, co-incubation with nordihydroguaiaretic acid (NDGA), a specific inhibitor of the lipoxygenase system, abolished IL-3-stimulated steroidogenesis but had no effect on IL-6-stimulated cortisol secretion, indicating that IL-3 and IL-6 directly stimulate the steroidogenesis at the adrenal level through activation of different, cAMP-independent pathways.

While the stimulatory effect of IL-6 on cortisol secretion from adult human adrenocortical cells seems

to be mediated through the cyclo-oxygenase (COX) pathway, the effect of IL-3 on adrenocortical cortisol secretion is dependent on the lipoxygenase pathway. Similarly, the effect of IL-3 and IL-6 on cortisol secretion of bovine adrenocortical cells in primary culture under serum-free conditions was further explored. For instance, both IL-3 and IL-6 stimulated basal cortisol secretion dose-dependently to a similar extent at a similar time course [1]. After incubation with IL-3 or IL-6, a maximum 4.1-fold increase of the cortisol secretion was reached after 12h. Co-incubation of IL-3 and IL-6 revealed, however, no significant synergism. To elucidate a possible involvement of arachidonic acid metabolites in the signal transduction, IL-3 or IL-6 were co-incubated with indomethacin or nordihydroguaiaretic acid. Co-incubation with indomethacin completely abolished the stimulatory effect of IL-6 but had no effect on IL-3-stimulated cortisol secretion. In contrast, specific inhibition of the lipoxygenase system by nordihydroguaiaretic acid blocked IL-3-stimulated steroidogenesis while the effect of IL-6 was not affected. Neither IL-3 nor IL-6 altered cAMP levels significantly, whereas ACTH significantly induced cAMP levels in parallel to its steroidogenic effect. While the stimulatory effect of IL-3 seems to be dependent on the lipoxygenase pathway, the effect of IL-6 on adrenocortical cortisol secretion is mediated through the cyclo-oxygenase (COX) pathway [1].

### IL-4/IL-5/IL-10 and HPA Responses

Glucocorticoids are widely used in the therapy of inflammatory, autoimmune, and allergic diseases [1] (Fig. 5a and b). As the end-effectors of the HPA axis, endogenous glucocorticoids also play an important role in suppressing innate and cellular immune responses. The influence of dexamethasone on IL-10 production and the type 1 (T1)/type 2 (T2) T cell balance found in rheumatoid arthritis was studied to determine a possible role for IL-4 in HPA-related responses to rheumatoid arthritis. Peripheral blood mononuclear cells (PBMNC) were isolated from 14 rheumatoid-arthritis patients both before and 7 and 42 days after high-dose dexamethasone pulse therapy. The ex vivo production of IL-10, IFN- $\gamma$  (T1 cell) and IL-4 (T2 cell) by PBMNC was assessed, along with parameters of disease activity (erythrocyte sedimentation rate, C reactive protein, Visual Analogue Scale, Thompson joint score).

The pro-inflammatory cytokines, IL-1 and tumor-necrosis-factor- $\alpha$  (TNF- $\alpha$ ), were among the first to be recognized in this regard. A modulator of these cytokines, IL-10, has been shown to have a wide range of activities in the immune system. IL-10 is produced in pituitary, hypothalamic and neural tissues in addition to lymphocytes [29]. IL-10 enhances CRF and ACTH production in hypothalamic and pituitary tissues, respectively. Further downstream in the HPA axis,

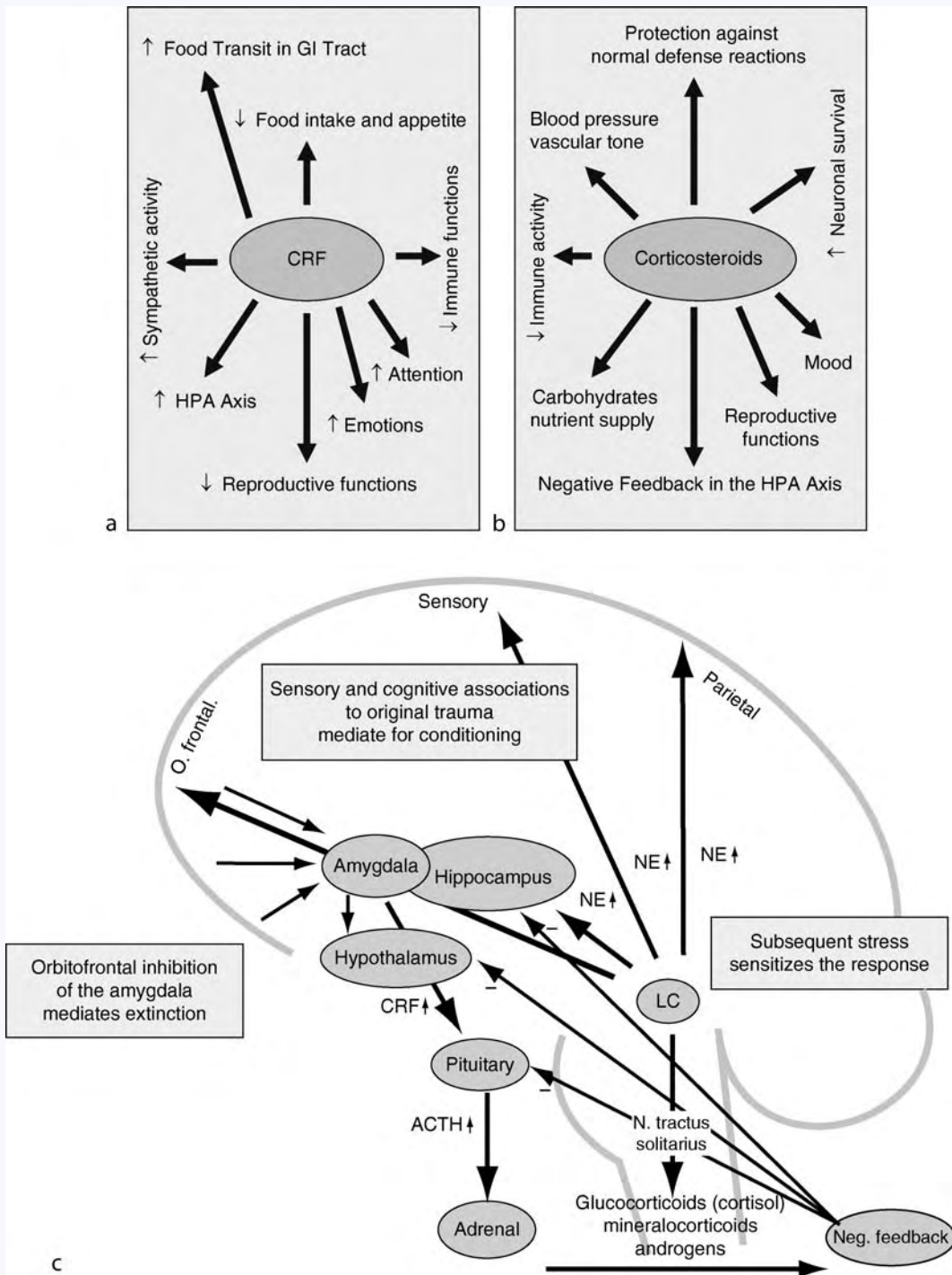

**Neuroimmunology. Figure 5** (a, b) The effects of CRF and corticosteroids (glucocorticoids) on a variety of body mechanisms. These wide-ranging effects underscore the significance of HPA axis interactions and the mechanisms involved. (c) Neurochemical-immunologic mechanisms and their sites of action. *ACTH*, adrenocorticotropic hormone; *CRF*, corticotropin-releasing factor; *LC*, locus coeruleus; *NE*, norepinephrine [1].

endogenous IL-10 has the potential to contribute to regulation of glucocorticosteroid production both tonically and following stressors. Evidence indicated that IL-10 might be an important endogenous regulator

in HPA axis activity and in CNS pathologies [30]. Thus, in addition to its more widely recognized role in immunity, as anti-inflammatory cytokine, IL-10's neuroendocrine activities point to its role as an

important regulator in communication between the immune and neuroendocrine systems (see Fig. 3a).

### **IL-12 and HPA Responses**

Recent studies have indicated that IL-12 promotes Th1 (T helper lymphocytes type 1) cell-mediated immunity, while IL-4 stimulates Th2 (T helper lymphocytes type 2) humoral-mediated immunity [1]. The regulatory effect of glucocorticoids on key elements of IL-12 and IL-4 signaling were further examined. On the analysis of the effect of dexamethasone on IL-12-inducible genes, it was shown that dexamethasone inhibited IL-12-induced IFN- $\gamma$  (interferon) secretion and IFN regulatory factor-1 expression in both natural killer and T cells. This occurred even though the level of expression of IL-12 receptors and IL-12-induced Janus kinase phosphorylation remained unaltered. However, dexamethasone markedly inhibited IL-12-induced phosphorylation of Stat-4 (a transcription factor) without altering its expression. This was specific, as IL-4-induced Stat-6 phosphorylation was not affected, and mediated by the glucocorticoid receptor, as it was antagonized by the glucocorticoid receptor antagonist RU-486. Moreover, transfection experiments showed that dexamethasone reduced responsiveness to IL-12 through the inhibition of Stat-4-dependent IFN regulatory factor-1 promoter activity. It was concluded that blocking IL-12-induced Stat-4 phosphorylation, without altering IL-4-induced Stat-6 phosphorylation, appears to be a new suppressive action of glucocorticoids on the Th1 cellular immune response and may help explain the glucocorticoid-induced shift toward the Th2 humoral immune response [1] (see Fig. 3b).

### **IL-18 and HPA Responses**

Vertebrates achieve internal homeostasis during infection or injury by balancing the activities of pro-inflammatory and anti-inflammatory pathways (►central nervous system infections – humoral immunity in arboviral infections). The CNS regulates systemic inflammatory responses to lipopolysaccharide (LPS), for instance, through humoral mechanisms (see Fig. 2b). Activation of afferent vagus nerve fibers by LPS or cytokines specifically stimulates HPA anti-inflammatory responses. In this respect, it was described that a previously unrecognized, parasympathetic anti-inflammatory pathway, by which the brain modulates systemic inflammatory responses to LPS, is active at the level of the HPA axis [1,21]. Acetylcholine, the principal vagal neurotransmitter, significantly attenuated the release of pro-inflammatory cytokines, including IL-18, but not the anti-inflammatory cytokine IL-10, in lipopolysaccharide-stimulated human macrophage cultures. Furthermore, direct electrical stimulation of the peripheral vagus nerve in vivo during lethal

endotoxemia in rats inhibited tumor necrosis factor (TNF) synthesis in liver, attenuated peak serum TNF amounts, and prevented the development of shock. Similarly, increased parasympathetic tone and acetylcholine significantly attenuate the release of TNF- $\alpha$ , IL-1 $\beta$ , IL-6 and IL-18 [1].

### **Neuro-Immune Interactions and Oxidative Stress: A Role for the Transcription Factor NF- $\kappa$ B**

The mammalian stress response evokes a series of neuroendocrine responses that activate the HPA axis and the sympathetic nervous system (Fig. 5c). Coordinated interactions between the stress response systems, occurring at multiple levels including the brain, pituitary gland, adrenal gland, and peripheral tissues, are required for the maintenance of homeostatic plateau. Adaptation to stress evokes a variety of biological responses, including activation of the HPA axis and synthesis of a panel of stress-response proteins at cellular levels. For example, expression of thioredoxin (TRX), a non-thiol antioxidant, is significantly induced under oxidative conditions. In this regard, it was demonstrated that either antisense TRX expression or cellular treatment with hydrogen peroxide (H<sub>2</sub>O<sub>2</sub>) negatively modulated glucocorticoid-receptor function and decreased glucocorticoid-inducible gene expression. In addition, impaired cellular response to glucocorticoids is rescued by overexpression of TRX, possibly through the functional replenishment of the glucocorticoid receptor. Moreover, not only the ligand-binding domain but also the DNA binding domain of the glucocorticoid receptor was also suggested to be a direct target of TRX [1]. Together, these observations presented conclusive evidence showing that cellular glucocorticoid responsiveness is coordinately modulated by redox state and TRX level and, thereby, it was proposed that crosstalk between neuroendocrine control of stress responses and cellular antioxidant systems may be essential for mammalian adaptation processes.

Employing primary neurons and clonal cells, it was demonstrated that corticotropin-releasing hormone (CRH; or factor, CRF) has a neuroprotective activity in corticotropin-releasing-hormone-receptor type 1 (CRH-R1)-expressing neurons against oxidative cell death [1]. The protective effect of corticotropin-releasing hormone was blocked by selective and nonselective CRH-R1 antagonists and by protein kinase A (PKA) inhibitors. In addition, overexpression of CRH-R1 in clonal hippocampal cells lacking endogenous CRH-receptors established neuroprotection by corticotropin-releasing hormone (central nervous system disease – natural neuroprotective agents as therapeutics). The activation of CRH-R1 and neuroprotection were accompanied by an increased release of non-amyloidogenic soluble A $\beta$  precursor protein, characteristic of Alzheimer's disease [1] (►brain aging and alzheimer's disease).

At the molecular level, corticotropin-releasing hormone caused the suppression of the DNA-binding activity and transcriptional activity of the oxygen- and reduction-oxidation (redox)-sensitive transcription factor, ►nuclear factor (NF)- $\kappa$ B [31]. Suppression of NF- $\kappa$ B (an inflammatory transcription factor) by overexpression of a super-repressor mutant form of inhibitory- $\kappa$ B (I $\kappa$ B)- $\alpha$ , a specific inhibitor of NF- $\kappa$ B, led to protection of the cells against oxidative stress (►Nf- $\kappa$ B – potential role in adult neural stem cells; NF- $\kappa$ B – activation in the mouse spinal cord following sciatic nerve transection). These observations strongly demonstrated a novel cytoprotective effect of corticotropin-releasing hormone that is mediated by CRH-R1 and downstream by suppression of NF- $\kappa$ B and indicate corticotropin-releasing hormone as an endogenous protective neuropeptide against oxidative cell death in addition to its function in the HPA-system. Moreover, the protective function of corticotropin-releasing hormone proposes a molecular link between oxidative stress-related degenerative events and the CRH-R1 system. Further elaborating on the role of transcriptional regulation in HPA responses, dysregulation of the serotonergic system and abnormalities of the HPA axis function have been implicated in ►neuropsychiatric disorders. Corticosteroid hormones in a variety of animal models suppress serotonin-1A receptors. This effect may play a central role in the pathophysiology of depression. However, little is known about the molecular mechanism underlying this suppressive effect of corticosterone [1].

In this respect, Wissink and colleagues [32] showed by functional analysis of the promoter region of the rat serotonin-1A receptor gene that two NF- $\kappa$ B elements in the promoter contribute to induced transcription of the rat serotonin-1A receptor gene. Furthermore, it was shown that corticosterone represses this NF- $\kappa$ B-mediated induction of transcription. Remarkably, only the glucocorticoid receptor and not the mineralocorticoid receptor was able to mediate this repressive effect of corticosterone, thus arguing that negative cross-talk between the glucocorticoid receptor and NF- $\kappa$ B may provide a basis for the molecular mechanism underlying the negative action of corticosterone on serotonin signaling in the brain [1].

### Neuro-Immune Interactions and Oxidative Stress: A Role for Gaseous Transmitters

Recent work has demonstrated that the brain has the capacity to synthesize impressive amounts of the gases nitric oxide (NO) and ►carbon monoxide (CO) [1]. There is growing evidence that these gaseous molecules function as novel neural messengers in the brain. Abundant evidence is presented which suggests that NO has an important role in the control of reproduction due to its ability to control ►gonadotropin-releasing hormone (GnRH) secretion from the hypothalamus.

Nitric oxide potently stimulates GnRH secretion and also appears to mediate the action of one of the major transmitters controlling GnRH secretion, glutamate (►glutamate-mediated injury to white matter – mechanisms and clinical relevance). Evidence suggests that NO stimulates GnRH release due to its ability to modulate the heme-containing enzyme, guanylate cyclase, which leads to enhanced production of the second messenger molecule, cGMP. A physiological role for NO in the pre-ovulatory ►luteinizing-hormone (LH) surge was also evidenced by findings that inhibitors and antisense oligonucleotides to ►nitric oxide synthase (NOS) attenuate the steroid-induced and pre-ovulatory luteinizing hormone (LH) surge.

Carbon monoxide (CO) may also play a role in stimulating GnRH secretion as heme molecules stimulate GnRH release in vitro, an effect that requires heme oxygenase activity and is blocked by the gaseous scavenger molecule, hemoglobin. Evidence also suggests that NO acts to restrain the HPA axis, as it inhibits HPA stimulation by various stimulants such as IL-1, vasopressin (VP) and inflammation (►neurogenesis and inflammation). This effect fits a pro-inflammatory role of NO as it leads to suppression of the release of the anti-inflammatory corticosteroids from the adrenals. Although not as intensely studied as NO, CO has been shown to suppress stimulated corticotropin-releasing-hormone release and may also function to restrain the HPA axis [1].

Evidence implicating NO in the control of prolactin (PRL) and growth hormone secretion is plausible, as is the possible role of NO acting directly at the anterior pituitary. Taken as a whole, the current data suggest that the diffusible gases, NO and CO, act as novel transmitters in the neuroendocrine axis and mediate a variety of important neuroendocrine functions. To recapitulate, NO is an unusual chemical messenger. NO mediates blood vessel relaxation when produced by endothelial cells. When produced by macrophages, NO contributes to the cytotoxic function of these immune cells. Nitric oxide also functions as a neurotransmitter and neuromodulator in the central and peripheral nervous systems. The effects on blood vessel tone and neuronal function form the basis for an important role of NO on neuroendocrine function and behavior. NO mediates hypothalamic portal blood flow and, thus, affects oxytocin and vasopressin secretion; furthermore, NO mediates neuroendocrine function in the hypothalamic-pituitary-gonadal (HPG) and hypothalamic-pituitary-adrenal (HPA) axes. Nitric oxide influences several motivated behaviors including sexual, aggressive and ingestive behaviors. Nitric oxide also influences learning and memory (►neuroinflammation – chronic neuroinflammation and memory impairments). Thus, NO is emerging as an important chemical mediator of neuroendocrine function and behavior [1].

Nitric oxide synthetase (NOS), the enzyme responsible for NO formation, is found in hypothalamic neurons containing oxytocin, vasopressin and to a lesser extent corticotropin-releasing factor. Because NO is reported to modulate endocrine activity, the hypothesis that endogenous NO participates in ACTH release by various secretagogues was investigated *in vivo*. In the adult male rat, the intravenous injection of IL-1 $\beta$ , vasopressin and oxytocin increased plasma ACTH and corticosterone levels [1]. Pretreatment with the L-form, but not the D-form, of *N*-omega nitro-L-arginine-methylester (L-NAME), a specific inhibitor of NOS, markedly augmented the effects of these secretagogues. Blockade of NOS activity also caused significant extensions of the duration of action of IL-1 $\beta$ , vasopressin and oxytocin. In contrast, L-NAME did not significantly alter the stimulatory action of peripherally injected corticotropin-releasing factor, or centrally administered IL-1 $\beta$ . In addition, administration of L-arginine, but not D-arginine, used as a substrate for basal NO synthesis and which did not by itself alter the activity of the HPA axis, blunted IL-1-induced ACTH secretion and reversed the interaction between L-NAME and IL-1 $\beta$ . Then, following prenatal alcohol exposure, immature offspring showed blunted ACTH released in response to the peripheral administration of IL-1 $\beta$  ([▶ prenatal brain injury by chronic endotoxin exposure](#)). Further studies were conducted to investigate the role of changes in corticosteroid feedback (measured by altered adrenal responses to ACTH), corticotropin-releasing-factor content of the median eminence (ME) and the influence of endogenous NO. For instance, the injection of several doses of ACTH failed to indicate measurable differences between the corticosterone responses of offspring born to dams fed *ad libitum* [control (C)], pair-fed (PF), or fed alcohol [ethanol (EtOH)]. Corticotropin-releasing-factor content in the median eminence, taken as an index of the amount of releasable peptide, showed a small, but statistically significant, decrease following prenatal alcohol exposure. A comparable change, however, was also noted in PF rats. As expected, the subcutaneous injection of IL-1 $\beta$  induced smaller increases in plasma ACTH levels of EtOH than C pups. The response of PF animals was intermediate between that of EtOH and C rats. It was also observed that inhibition of NO formation by the administration of the arginine derivative L-NAME augmented ACTH secretion in all three experimental groups and reversed the decreased corticotrophs' response to IL-1 $\beta$  caused by prenatal alcohol [1,33].

### Conclusions and Future Prospects

The foregoing indicates that there is now substantial evidence for bidirectional communications between the nervous and immune systems. Communication occurs via chemical messengers, just as it does within the

nervous and immune systems. Many of the messengers are already familiar as hormones, neurotransmitters, and cytokines, but presently the messages are poorly understood. Certain messengers from the neuroendocrine system appear to facilitate or inhibit the functions of immune cells, but the specificity remains to be elucidated. Cytokines are clearly potent activators of the HPA axis, but also exert a variety of other physiological effects. In all likelihood, many other messengers remain to be discovered [1,7,8,15,18].

Although our current understanding of the system is limited, it may be important to distinguish local from systemic effects. Whereas circulating concentrations of catecholamines and steroids are probably adequate to exert physiological effects, and this also appears to be true for cytokines, the role of the peptides is less clear. Their systemic concentrations are very low and are unlikely to be sufficient to modulate immune system function in a general way. However, it is possible that peptides secreted by nerve terminals in the thymus, spleen, and lymphoid tissue may achieve local concentrations sufficient to affect immune cells. Such effects may also be possible locally in tissue at sites of inflammation [1,8].

Messengers that can travel more readily and are more stable metabolically may be active systemically, whereas the less stable peptides may be confined to local actions. The chemical nature of the messengers may be suited to their functions. As lipophilic molecules, the glucocorticoids can readily penetrate membrane barriers and affect cells in all bodily tissues, whereas the hydrophilic catecholamines are more labile and their action may be limited to the circulatory systems. Our present knowledge indicates that the glucocorticoids and catecholamines predominantly inhibit immune responses, whereas the peptides are largely facilitatory. When the organism is threatened, the systemic activity of the glucocorticoids to limit immune responses may be important to depress immune activity to prevent undesirable autoimmune actions [1]. By contrast, peptides could facilitate immune responses in small areas close to the site of their release, for example, in an area of inflammation induced by infection or tissue damage. Catecholamines may occupy an intermediate position, existing in sufficient concentrations to have systemic actions but not having broad access to tissues and having relatively short durations of action, except when chronically elevated. Such an arrangement would permit focusing of the activation of immune response in local areas of inflammation, while preventing potentially damaging autoimmune actions that could be triggered by widespread activation ([▶ brain inflammation – biomedical imaging](#)).

The neuroimmune systems communicate bidirectionally (see Fig. 5c). The neuro-immune-endocrine interface is mediated by cytokines acting as auto/paracrine or endocrine factors regulating pituitary

development, cell proliferation, hormone secretion and feedback control of the HPA axis. Soluble products that appear to transmit information from the immune compartments to the CNS act as immunotransmitters and function in immunomodulatory neuroendocrine circuits. The relative importance of systemically and locally produced cytokines in achieving these responses and their precise sites of action have been the focus of a burgeoning number of investigations over the past few decades. There is now accumulating evidence that there are important interactions between the immune and neuroendocrine systems, which may explain, in part, some of the effects on growth, thyroid, adrenal and reproductive functions that occur in the pathophysiology of acute and chronic disease [1].

### Acknowledgments

The author's work is, in part, supported by the Anonymous Trust (Scotland), the National Institute for Biological Standards and Control (England), the Tenovus Trust (Scotland), the UK Medical Research Council (MRC, London) and the Wellcome Trust (London). Dr. John J. Haddad held the distinguished Georges John Livanos prize (London, UK).

### References

- Haddad JJ, Saade NE, Safieh-Garabedian B (2002) Cytokines and neuro-immune-endocrine interactions: a role for the hypothalamic-pituitary-adrenal revolving axis. *J Neuroimmunol* 133:1–19
- Correa SG, Maccioni M, Rivero VE, Iribarren P, Sotomayor CE, Riera CM (2007) Cytokines and the immune-neuroendocrine network: what did we learn from infection and autoimmunity? *Cytokine Growth Factor Rev* 18:125–134
- Engelhardt B (2006) Regulation of immune cell entry into the central nervous system. *Results Probl Cell Differ* 43:259–280
- Carson MJ, Doose JM, Melchior B, Schmid CD, Ploix CC (2006) CNS immune privilege: hiding in plain sight. *Immunol Rev* 213:48–65
- Bukovsky A (2007) Cell commitment by asymmetric division and immune system involvement. *Prog Mol Subcell Biol* 45:179–204
- Aderem A, Ulevitch RJ (2000) Toll-like receptors in the induction of the innate immune response. *Nature* 406:782–787
- Albiger B, Dahlberg S, Henriques-Normark B, Normark S (2007) Role of the innate immune system in host defence against bacterial infections: focus on the Toll-like receptors. *J Intern Med* 261:511–528
- Galea I, Bechmann I, Perry VH (2007) What is immune privilege (not)? *Trends Immunol* 28:12–18
- Haddad JJ (2007) Cellular and molecular regulation of inflammatory pain, nociception and hyperalgesia – the role of the transcription factor NF- $\kappa$ B as the lynchpin nociceptor: hyperalgesic or analgesic effect? *Curr Immunol Rev* 3:117–131
- Haddad JJ, Harb HL (2005) L- $\gamma$ -Glutamyl-L-cysteinyl-glycine (glutathione; GSH) and GSH-related enzymes in the regulation of pro- and anti-inflammatory cytokines: a signaling transcriptional scenario for redox(y) immunologic sensor(s)? *Mol Immunol* 42:987–1014
- Dinarello CA (2000) Pro-inflammatory cytokines. *Chest* 118:503–508
- Biber K, de Jong EK, van Weering HR, Boddeke HW (2006) Chemokines and their receptors in central nervous system disease. *Curr Drug Targets* 7:29–46
- Neumann H (2001) Control of glial immune function by neurons. *Glia* 36:191–199
- Gisler RH, Schenkel-Hulliger L (1971) Hormonal regulation of the immune response. II. Influence of pituitary and adrenal activity on immune responsiveness in vitro. *Cell Immunol* 2:646–657
- McEwen BS (2002) Sex, stress and the hippocampus: allostasis, allostatic load and the aging process. *Neurobiol Aging* 23:921–939
- Ader R, Cohen N (1975) Behaviorally conditioned immunosuppression. *Psychosom Med* 37:333–340
- Renoux G, Biziere K, Renoux M, Guillaumin JM, Degenne D (1983) A balanced brain asymmetry modulates T cell-mediated events. *J Neuroimmunol* 5:227–238
- Tischner D, Reichardt HM (2007) Glucocorticoids in the control of neuroinflammation. *Mol Cell Endocrinol* (in press)
- Oberbeck R (2006) Catecholamines: physiological immunomodulators during health and illness. *Curr Med Chem* 13:1979–1989
- Oppenheim JJ (2001) Cytokines: past, present and future. *Int J Hematol* 74:3–8
- Safieh-Garabedian B, Poole S, Haddad JJ, Massaad CA, Jabbur SJ, Saadé NE (2002) The role of the sympathetic efferents in endotoxin-induced localized inflammatory hyperalgesia and cytokine upregulation. *Neuropharmacology* 42:864–872
- Haddad JJ, Olver RE, Land SC (2000) Antioxidant/pro-oxidant equilibrium regulates HIF-1 $\alpha$  and NF- $\kappa$ B redox sensitivity: evidence for inhibition by glutathione oxidation in alveolar epithelial cells. *J Biol Chem* 275:21130–21139
- Haddad JJ, Lauterbach R, Saadé NE, Safieh-Garabedian B, Land SC (2001)  $\alpha$ -Melanocyte-related tripeptide, Lys-D-Pro-Val, ameliorates endotoxin-induced nuclear factor- $\kappa$ B translocation and activation: evidence for involvement of an interleukin-1 $\beta$ <sup>193–195</sup> receptor antagonism in the alveolar epithelium. *Biochem J* 355:29–38
- Spangelo BL, Judd AM, Call GB, Zumwalt J, Gorospe WC (1995) Role of the cytokines in the hypothalamic-pituitary-adrenal and gonadal axes. *Neuroimmunomodulation* 2:299–312
- Payne LC, Weigent DA, Blalock JE (1994) Induction of pituitary sensitivity to interleukin-1: a new function for corticotropin-releasing hormone. *Biochem Biophys Res Commun* 198:480–484
- Pariante CM, Pearce BD, Pisell TL, Sanchez CI, Po C, Su C, Miller AH (1999) The proinflammatory cytokine, interleukin-1 $\alpha$ , reduces glucocorticoid receptor translocation and function. *Endocrinology* 140:4359–4366

27. Rivier C, Chizzonite R, Vale W (1989) In the mouse, the activation of the hypothalamic-pituitary-adrenal axis by a lipopolysaccharide (endotoxin) is mediated through interleukin-1. *Endocrinology* 125:2800–2805
28. Perlstein RS, Mehta NR, Mougey EH, Neta R, Whitnall MH (1994) Systemically administered histamine H1 and H2 receptor antagonists do not block the ACTH response to bacterial lipopolysaccharide and interleukin-1. *Neuroendocrinology* 60:418–425
29. Smith EM, Cadet P, Stefano GB, Opp MR, Hughes TK Jr (1999) IL-10 as a mediator in the HPA axis and brain. *J Neuroimmunol* 100:140–148
30. Safieh-Garabedian B, Haddad JJ, Saade NE (2004) Cytokines in the central nervous system: targets for therapeutic intervention. *Curr Drug Targets CNS Neurol Disord* 3:271–280
31. Haddad JJ (2004) On the antioxidant mechanisms of Bcl-2: a retrospective of NF- $\kappa$ B signaling and oxidative stress. *Biochem Biophys Res Commun* 322:355–363
32. Wissink S, Meijer O, Pearce D, van Der Burg B, van Der Saag PT (2000) Regulation of the rat serotonin-1A receptor gene by corticosteroids. *J Biol Chem* 275:1321–1326
33. Abreu-Villaca Y, Medeiros AH, Lima CS, Faria FP, Filgueiras CC, Manhaes AC (2007) Combined exposure to nicotine and ethanol in adolescent mice differentially affects memory and learning during exposure and withdrawal. *Behav Brain Res* 181:136–146
34. Hillhouse EW (1994) Interleukin-2 stimulates the secretion of arginine vasopressin but not corticotropin-releasing hormone from rat hypothalamic cells in vitro. *Brain Res* 650:323–325
35. Xu Y, Day TA, Buller KM (1999) The central amygdala modulates hypothalamic-pituitary-adrenal axis responses to systemic interleukin-1 $\beta$  administration. *Neuroscience* 94:175–183

## Neuroimmunomodulation

### Definition

Neuroimmunomodulation is the modulation of the immune system through the nervous system.

- ▶ [Neuroimmune Interactions – Serotonin](#)
- ▶ [Neuroimmunomodulation: The brain areas involved](#)
- ▶ [Neuroimmunology](#)

## Neuroinflammation

### Definition

Neuroinflammation is the inflammation of a nerve or of the nervous system.

- ▶ [Neurogenesis and Inflammation](#)

## Neuroinflammation – DNA Vaccination Against Autoimmune Neuroinflammation

ANNA LOBELL

Department of Medical Sciences, Uppsala University, University Hospital, Uppsala, Sweden

### Synonyms

DNA immunization; Naked DNA vaccination; Genetic vaccination

### Definition

To prevent or treat [▶autoimmune neuroinflammation](#) by [▶vaccination](#) with DNA encoding one or more autoantigen(s) ([▶DNA vaccination against autoimmune neuroinflammation](#)). The autoantigen, usually a myelin autoantigen, is transcribed and translated *in vivo*, processed and presented to T cells in the context of major histocompatibility complex after vaccination. Toll-like receptor (TLR) 9 ligand CpG DNA within the plasmid backbone acts as adjuvant to activate the innate immune system. Presence of CpG DNA and the expressed autoantigen are both essential for the protective immune reaction to occur.

### Characteristics

#### Introduction

Failure of immunologic self-tolerance often leads to development of autoimmune disease, which is estimated to afflict up to 5% of the human population. Genetic factors, such as both major histocompatibility complex (MHC) and non-MHC genes, contribute to the risk for most autoimmune diseases. The same non-MHC gene may predispose for several different organ-specific inflammatory diseases such as rheumatoid arthritis and multiple sclerosis (MS). Environmental factors also play an important role in the risk for autoimmune disease. Many infectious agents have been investigated for crossreactivity towards self antigens, potentially leading to an autoimmune disease (molecular mimicry). Dysregulation of inflammatory cells or regulatory T cells has also been suggested as a cause of autoimmunity.

MS is a common disabling disease characterized by inflammation, neurodegeneration and demyelination in the central nervous system (CNS). The major hallmark of MS is the presence of sclerotic plaques in the CNS that are characterized by demyelination, which is associated with an inflammatory reaction that is orchestrated by activated lymphocytes, macrophages and glial cells. The etiology of MS is unknown, necessitating research into the mechanisms underlying

pathogenesis. Myelin autoantigens such as myelin basic protein (MBP), proteolipid protein (PLP) and myelin oligodendrocyte glycoprotein (MOG) are candidate autoantigens in MS. Because it is difficult to study CNS autoimmunity in humans, experimental models such as experimental autoimmune encephalomyelitis (EAE) are used. EAE is actively induced by injection of myelin proteins or encephalitogenic myelin peptides together with a proinflammatory adjuvant such as complete Freund's adjuvant (CFA). EAE was previously thought to be a T helper 1 cell (Th1)-mediated autoimmune disease whereas Th2 cells were thought to suppress EAE by inhibiting the Th1 responses. However, interleukin (IL)-23-driven proinflammatory IL-17-producing T cells mediate EAE. The IL-17-producing Th cell (Th17) is a distinct lineage from Th1 and Th2 cells and naïve CD4 T cells surprisingly differentiate into IL-17-producing T cells in the presence of soluble TGF- $\beta$  or regulatory T cells if IL-6 is present. Th17 cells are then maintained by IL-23. Differentiation of naïve CD4 T cells into Th17 cells is inhibited by Th1, Th2 and regulatory T cells. Thus, the characteristics of the pathogenic T helper cell response in EAE is different from what was previously thought. As a consequence, Th1/Th2 ratios are no longer relevant, as both these T cell lineages suppress pathogenic Th17 cell responses. However, most of the studies described herein were done before the role of Th17 cells in EAE was discovered and Th1/Th2 ratios are therefore discussed.

DNA vaccines can induce antigen-specific CD4 T helper cell and CD8 cytotoxic T cell responses as well as antibody responses. Initially, ►DNA vaccination was thought to prime cytotoxic T cells in a unique manner through intracellular processing of antigen produced in transfected somatic cells. However, ►antigen-presenting cells prime cytotoxic T cells both by direct transfection and by cross-priming after endocytosis of antigen upon DNA vaccination. In fact, antigen-presenting dendritic cells in the spleen process and present the antigen encoded by the DNA vaccine.

DNA vaccines are plasmids produced by *E. coli* and all bacterial DNA contains unmethylated CpG DNA motifs. CpG DNA are pathogen associated molecular patterns (PAMP) which specifically binds the pattern recognition receptor TLR9. The recognition of PAMP by TLR triggers intracellular signaling pathways resulting in the induction of proinflammatory ►cytokines, type I ►interferon (IFN), chemokines and dendritic cell maturation that leads to activation of adaptive immunity. Each TLR recognizes different PAMP: TLR4 recognizes LPS and TLR2 plus TLR1 or TLR6 recognizes bacterial lipopeptides. TLR3 and TLR9 are expressed in endosomes and are involved in the recognition of double-stranded RNA and unmethylated CpG DNA respectively. Because the intracellular pathways of the TLR differ, TLR9 ligation mainly induces type I IFN production, whereas e.g.,

TLR4 ligation induces IL-12 and IFN- $\beta$  production. CpG DNA is essential for efficient DNA vaccination and is currently used in therapeutic trials against allergy and as vaccine adjuvant. Furthermore, DNA vaccines coding for antigens can be combined with plasmids encoding various cytokines or ligands important for the ensuing immune response, thus providing methods to specifically modulate the vaccine effect.

In this essay, the effects of DNA vaccination against rodent EAE will be described.

### The DNA Vaccine

Mammalian expression vectors, e.g., pCI, pTarget and pcDNA3, are used as plasmid backbones for DNA vaccines. A strong promoter such as the human CMV immediate/early enhancer-promoter controls the transcription of the autoantigen and a Kozak box is introduced around the start codon to enhance transcription. DNA encoding myelin autoantigens or immunodominant myelin protein-derived peptides are ligated into the plasmid backbone. Minigenes encoding myelin protein-derived peptides can be inserted in tandem [1,2]. The DNA insert encoding the myelin autoantigen can be expressed in all mammalian cells, when a strong promoter such as CMV promoter is used. Additionally, presence of CpG DNA within the plasmid backbone of the DNA vaccine is required. Common plasmids such as pCI, pTarget and pcDNA3 all contain at least two immunostimulatory CpG DNA motifs.

### Immunization Protocols

The DNA vaccine is either injected before or after induction of EAE. In successful preventive trials in rats, the vaccine is administered in PBS as a single injection either intra muscularly or intra dermally three to eleven weeks before induction of EAE [1,3,4], whereas in therapeutic trials the DNA vaccine is given as weekly intra muscular injections after the onset of EAE [5,6]. If the DNA vaccine is injected intra muscularly, the muscles are often pretreated with compounds such as cardiotoxin, to enhance DNA uptake.

### Protection from EAE After Vaccination with DNA Encoding Myelin Autoantigens

DNA vaccination prevents EAE [1–4,6–8] with few exceptions [9] (Table 1). Vaccination with DNA encoding myelin peptides or proteins suppresses EAE induced with the corresponding peptide [1,4,7]. Treatment of ongoing EAE has been successful in murine EAE models [5,6]. Despite similar clinical outcomes, the ensuing immune response after DNA vaccination differs in rat and murine EAE models, which suggests that the protective mechanism differ in the two species. Antigen specificity, impact of CpG DNA and the protective mechanism are discussed below.



**Neuroinflammation – DNA Vaccination Against Autoimmune Neuroinflammation. Table 1** EAE prevention or treatment using DNA vaccines encoding myelin proteins or peptides

Animal	DNA vaccine	Main findings	Reference
<i>Rat EAE</i>			
Lewis	MBP68-85	Improvement	[1]
Lewis	MBP86-85 and MBP89-101	High antigen specificity	[2]
Lewis	MBP68-85 +/- CpG DNA MBP68-85 + IL-4, IL-10 or TNF- $\alpha$	CpG DNA is required, cytokine coinjection inhibits the suppressive effect	[3]
Lewis 1Av1, DA, Lewis 1N	MOG91-108 +/- CpG DNA	Improvement, CpG DNA is required	[7]
Lewis 1Av1	MOG91-108	Higher IFN- $\beta$ expression, lower MHC II expression, lower IL-23p40 expression	[8]
<i>Murine EAE</i>			
SJL/J	PLP139-151	Improvement, lower B7 expression	[4]
SJL/J	MOG	Worsening	[9]
SJL/J	PLP139-151 + IL-4	Improvement	[6]
SJL/J	PLP, MOG, MBP, MAG cocktail + IL-4	Treatment, improvement in relapses	[5]
SJL/J	PLP, MOG, MBP, MAG cocktail + IL-4 + GpG DNA	Treatment, improvement	[10]

### Antigen Specificity of DNA Vaccination

Epitope spreading defines the expansion of antigen-specific immune responses beyond those targeted in the initial immunization. EAE and other autoimmune diseases are associated with spreading of autoreactive T and B cell responses. Treatment with a cocktail of DNA vaccines encoding several myelin proteins reduces the number of relapses in EAE and reduces spreading of the autoreactive B cell response, although the treatment does not affect disease severity [5].

Local production of IL-4 or TGF- $\beta$  is instrumental for a regulatory immune response inhibiting pathogenic T cells of any specificity (bystander suppression) in oral tolerance or altered peptide ligand therapy. Is DNA vaccination acting through bystander suppression, or is the effect antigen specific? A single amino acid exchange in position 79 from serine (non-self) to threonine (self) in MBP68-85 dramatically alters the protective effect of a DNA vaccine encoding MBP68-85 in rats. Furthermore, the DNA vaccine encoding MBP68-85 does not protect from MBP89-101-induced EAE and vice versa [2]. Thus, the protective effect is highly specific and there is no evidence for bystander suppression, nor epitope spreading of tolerance.

### The Impact of CpG DNA

DNA vaccines are produced by bacteria and thus contain unmethylated CpG DNA that specifically binds TLR9 and thereby promotes innate immunity and type I IFN production. Treatment with a DNA vaccine containing two CpG DNA motifs suppresses clinical signs of EAE, while a corresponding DNA vaccine without such CpG DNA has no effect [3,7]. Moreover, there are no reports

on successful DNA vaccination using plasmid DNA that lacks CpG DNA. Thus, the presence of CpG DNA is decisive for protective DNA vaccination against EAE.

In contrast, co-administration of an antagonist to CpG DNA, GpG DNA, enhances the suppressive effect of DNA vaccination against murine EAE by promoting Th2 immunity [10].

### Protective Mechanisms of DNA Vaccination Against EAE

The immune mechanisms involved in protective DNA vaccination are not fully understood, and differ between rat and murine EAE models. Also, the previous work done may have to be re-evaluated in the light of the recent discovery that Th17, but not Th1, responses are responsible for disease. A summary of the main findings is presented in Fig. 1 and Table 1.

The nature of the attenuated T cell function after DNA vaccination against rat EAE has until recently remained elusive since no induction of Th2 or regulatory T cells is observed, and neither the secretion of IFN- $\gamma$ , nor the proliferative response, can be correlated to the suppressive capability of the DNA vaccine [7]. Instead, coinjection of IL-4 or IL-10 gene with the DNA vaccine inhibits the protective effect, which suggests that Th2 immunity is not involved in the protective mechanism. However, the antigen-specific IL-17 production by T cells is significantly reduced after DNA vaccination and subsequent induction of EAE, compared to controls. Moreover, T cells do not express IL-17 after DNA vaccination – but before induction - of EAE (A. Lobell et al., unpublished). Thus, priming of myelin-specific Th17 cells is indeed impaired after induction of EAE in DNA vaccinated rats which likely contributes to the reduced EAE symptoms (Fig. 1).

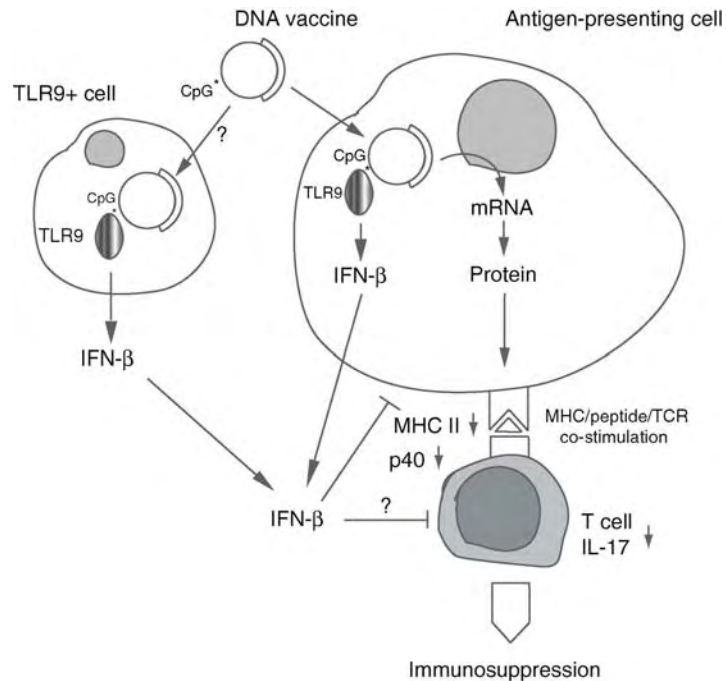

**Neuroinflammation – DNA Vaccination Against Autoimmune Neuroinflammation. Figure 1** Illustration of the proposed mechanism for suppressive DNA vaccination against rat EAE. Administration of a DNA vaccine encoding a myelin self peptide results in transcription and translation of the self peptide by antigen-presenting cells. The self peptide is processed and presented on MHC II to Th cells. In either the same antigen-presenting cell or other TLR9-expressing cells, CpG DNA motifs of the DNA vaccine binds TLR9 in the endosome, which induces IFN- $\beta$  production. Priming of DNA vaccine-induced myelin-specific T cells in the presence of IFN- $\beta$  results in suppression of subsequently induced EAE and dampened encephalitogenic Th17 responses. IFN- $\beta$  may act via downregulation of antigen-presenting cell activation and maturation via reduced IL-23 and MHC II expression, and/or directly on encephalitogenic Th17 cells. Lines with bars represent inhibition.

IFN- $\beta$  expression is upregulated after DNA vaccination, both before and after induction of rat EAE [8]. Silencing of IFN- $\beta$  *in vivo* reveals a crucial role for the cytokine in suppressive DNA vaccination (A. Lobell et al., unpublished). It is unclear how the CpG DNA-induced IFN- $\beta$  leads to impaired Th17 responses and protection from EAE. Antigen-presenting cell function may be altered. Indeed, the MHC II and IL-23/IL-12p40 expression are lower in DNA vaccinated rats compared to controls [8], which indicates impaired maturation and activation of antigen-presenting cells.

In contrast, induction of Th2 immunity increases the efficacy of DNA vaccination in mice. Coinjection of IL-4 gene with a DNA vaccine suppresses EAE. The IL-4 gene delivery activates STAT6 locally which shifts the antigen-specific T cells to a protective Th2 phenotype [6]. Th2-promoting CpG DNA antagonist CpG DNA enhances the suppressive effect [10]. *In vitro* exposure of a DNA vaccine to murine splenocytes slightly reduces the expression of costimulatory B7 molecules, which may suggest that anergy is induced by DNA vaccination [4].

### DNA Vaccines Targeting Chemokines/Cytokines

Substantial data support the notion that coinjection of cytokine-coding cDNA with DNA vaccines can selectively modulate the ensuing immune response. However, other reports suggest that vaccination with DNA encoding cytokines or chemokines can induce the production of specific antibodies directed against the gene product which in turn suppress EAE.

Nathan Karin and coworkers demonstrate that injection of DNA encoding rat chemokines MIP-1 $\alpha$  or MCP-1 suppresses subsequently induced rat EAE, whereas the same strategy for MIP-1 $\beta$  slightly aggravates disease. Likewise, injection of DNA vaccines encoding the proinflammatory cytokine TNF- $\alpha$  confers resistance to EAE and induces antibodies directed against TNF- $\alpha$ . In contrast, production of the respective cytokine seems responsible for the effects in other DNA vaccine trials. Injection of DNA encoding TGF- $\beta$ 1 or an IL-4-IgG1 fusion into rats prior to induction of EAE leads to detectable *in vivo* production of these cytokines and prevention of EAE. An immunization regimen with multiple injections could account

for the autoantibody production in the former cytokine/chemokine experiments.

### Conclusion

Autoimmune neuroinflammation can be prevented or treated by DNA vaccination. The effect is highly antigen specific and requires CpG DNA within the plasmid backbone of the vaccine.

### References

- Lobell A, Weissert R, Storch MK, Svanholm C, de Graaf KL, Lassmann H, Andersson R, Olsson T, Wigzell H (1998) Vaccination with DNA encoding an immunodominant myelin basic protein peptide targeted to Fc of immunoglobulin G suppresses experimental autoimmune encephalomyelitis. *J Exp Med* 187:1543–1548
- Weissert R, Lobell A, de Graaf KL, Eltayeb SY, Andersson R, Olsson T, Wigzell H (2000) Protective DNA vaccination against organ-specific autoimmunity is highly specific and discriminates between single amino acid substitutions in the peptide autoantigen. *Proc Natl Acad Sci USA* 97:1689–1694
- Lobell A, Weissert R, Eltayeb S, Svanholm C, Olsson T, Wigzell H (1999) Presence of CpG DNA and the local cytokine milieu determine the efficacy of suppressive DNA vaccination in experimental autoimmune encephalomyelitis. *J Immunol* 163:4754–4762
- Ruiz PJ, Garren H, Ruiz IU, Hirschberg DL, Nguyen LV, Karpuz MV, Cooper MT, Mitchell DJ, Fathman CG, Steinman L (1999) Suppressive immunization with DNA encoding a self-peptide prevents autoimmune disease: modulation of T cell costimulation. *J Immunol* 162:3336–3341
- Robinson WH, Fontoura P, Lee BJ, de Vegvar HE, Tom J, Pedotti R, DiGennaro CD, Mitchell DJ, Fong D, Ho PP, Ruiz PJ, Maverakis E, Stevens DB, Bernard CC, Martin R, Kuchroo VK, van Noort JM, Genain CP, Amor S, Olsson T, Utz PJ, Garren H, Steinman L (2003) Protein microarrays guide tolerizing DNA vaccine treatment of autoimmune encephalomyelitis. *Nat Biotechnol* 21:1033–1039
- Garren H, Ruiz PJ, Watkins TA, Fontoura P, Nguyen LT, Estline ER, Hirschberg DL, Steinman L (2001) Combination of gene delivery and DNA vaccination to protect from and reverse Th1 autoimmune disease via deviation to the Th2 pathway. *Immunity* 15:15–22
- Lobell A, Weissert R, Eltayeb S, de Graaf KL, Wefer J, Storch MK, Lassmann H, Wigzell H, Olsson T (2003) Suppressive DNA vaccination in myelin oligodendrocyte glycoprotein peptide-induced experimental autoimmune encephalomyelitis involves a T1-biased immune response. *J Immunol* 170:1806–1813
- Wefer J, Harris RA, Lobell A (2004) Protective DNA vaccination against experimental autoimmune encephalomyelitis is associated with induction of IFN $\beta$ . *J Neuroimmunol* 149:66–76
- Bourquin C, Iglesias A, Berger T, Wekerle H, Linington C (2000) Myelin oligodendrocyte glycoprotein-DNA vaccination induces antibody-mediated autoaggression in experimental autoimmune encephalomyelitis. *Eur J Immunol* 30:3663–3671
- Ho PP, Fontoura P, Platten M, Sobel RA, DeVoss JJ, Lee LY, Kidd BA, Tomooka BH, Capers J, Agrawal A, Gupta R, Zernik J, Yee MK, Lee BJ, Garren H, Robinson WH, Steinman L (2005) A suppressive oligodeoxynucleotide enhances the efficacy of myelin cocktail/IL-4-tolerizing DNA vaccination and treats autoimmune disease. *J Immunol* 175:6226–6234

## Neuroinflammation – IL-18

PHILIP F. STAHEL<sup>1</sup>, URSULA FELDERHOFF-MUESER<sup>2</sup>, SCOTT R. BARNUM<sup>3</sup>

<sup>1</sup>Department of Orthopaedic Surgery, Denver Health Medical Center, University of Colorado School of Medicine, Denver, CO, USA

<sup>2</sup>Department of Neonatology, Charité Universitätsmedizin Berlin, Campus Virchow Klinikum, Berlin, Germany

<sup>3</sup>Departments of Microbiology and Neurology, University of Alabama at Birmingham (UAB), Birmingham, AL, USA

### Synonyms

Interferon (IFN)- $\gamma$  inducing factor (IGIF)

### Definition

► **Interleukin (IL)-18** is a member of the IL-1 family of pro-inflammatory ► **cytokines**. It was first cloned in the late 1980s and originally designated “interferon (IFN)- $\gamma$  inducing factor” (IGIF). ► **IL-18** is synthesized as an inactive precursor which is cleaved into its active form by ► **caspase-1** for functional activity. IL-18 is an important mediator of innate immune responses against infection and has been shown to be critically involved in the pathogenesis of autoimmune diseases [1]. Resident cells of the central nervous system (CNS) express IL-18 and caspase-1 constitutively, thus providing a functional IL-18-dependent immune response in the intracranial compartment. Several studies in recent years have highlighted a crucial role of IL-18 in mediating ► **neuroinflammation** under a variety of pathological conditions in the CNS, such as bacterial and viral infections, autoimmune demyelinating diseases, hypoxic-ischemic, hyperoxic and traumatic brain injury [5,9].

### Characteristics

IL-18 is initially synthesized as an inactive 24 kD precursor protein (pro-IL-18) which is subsequently processed by ► **caspase-1 (ICE)** (IL-1 $\beta$  converting enzyme) into its mature and biologically active form with a molecular weight of 18 kD. In addition, the secreted pro-form of IL-18 can also be processed into its active form by a variety of extracellular enzymes which

are constitutively expressed by leukocytes, such as proteinase-3 (PR-3). The active form of IL-18 can either bind to its heterocomplex IL-18 $\alpha$ / $\beta$  receptor (IL-18R $\alpha$ / $\beta$ ) or be neutralized by its natural antagonist, IL-18 binding protein (IL-18BP). At least ten IL-1 gene family members have been discovered, which all map to the same region on human chromosome 2, with the notable exception of IL-18, which is encoded for by a single gene located on human chromosome 11q22.2-q22.3.

### Biology

As a member of the IL-1 family of cytokines, IL-18 possesses a wide variety of inflammatory and immunoregulatory properties [4]. Human and murine IL-18, which show 65% sequence homology, are secreted by first-line immune cells capable of antigen presentation, such as macrophages, dendritic cells, and Kupffer cells. Other cell-types reported to express IL-18 include T- and B-lymphocytes, vascular endothelial cells, smooth muscle cells, keratinocytes, osteoblasts and synovial fibroblasts. In the rodent brain, IL-18 and its receptor were shown to be constitutively expressed by astrocytes, microglia, neurons and by ependymal cells [2,3]. Different studies have emphasized the important role of IL-18 expression and LPS-dependent up-regulation in microglia. IL-18 was also shown to induce signal transduction pathways in microglia. The IL-18 promoter includes binding sites for the transcription factor nuclear factor  $\kappa$ B (NF $\kappa$ B). Furthermore, the proteasome inhibitor MG-132 – which regulates NF $\kappa$ B signaling – was found to block LPS- and IFN- $\gamma$ -mediated IL-18 up-regulation in microglia. These findings imply an important role in IL-18-mediated activation of NF $\kappa$ B in the brain. The IL-18 activating enzyme, caspase-1, was also found to be constitutively expressed in microglia and astrocytes. Thus, maturation and activation of IL-18 can occur in the brain under physiological and inflammatory conditions [7]. The biological effects of IL-18 receptor binding include the induction of other inflammatory mediators, such as IFN- $\gamma$ , tumor necrosis factor (TNF), IL-1 $\beta$ , IL-8, and of the so called “death proteins” of the extrinsic apoptotic pathway, such as TNF and Fas ligand (FasL). Thus, IL-18 represents a “key” cytokine which controls two distinct immunological regulatory pathways. These include the regulation of monocyte/macrophage function by induction of IFN- $\gamma$  synthesis by T- and B-lymphocytes, as well as the induction of **▶apoptosis** through up-regulation of TNF and FasL. Both mechanisms may lead to extensive local inflammation and tissue destruction mediated by IL-18 under pathological conditions, as reported for various autoimmune and inflammatory diseases of the CNS.

### Function

IL-18 was first identified as an essential factor promoting IFN- $\gamma$  production by T cells in the presence

of IL-12. This is the most salient biologic property of IL-18 that separates it from IL-1. IL-18 enhances T cell maturation (Th1 > Th2), cytokine production, and cytotoxicity [4]. Other major targets of IL-18 include macrophages, NK cells, B-cells, basophils, and neutrophils. A wealth of data indicate that IL-18 contributes to host defense and inflammation through synergism in a cascade of cytokines associated with innate responses, including IL-12 and IL-15.

The action of IL-18 appears to go beyond immune regulation, as IL-18 (like IL-1) appears to induce sleep in mice, rats and rabbits. IL-18 injected into the brain increases non-rapid eye movement sleep. The sleep effects of IL-18 introduced directly into the brain coincides with increased brain temperature. In contrast, intraperitoneal IL-18 fails to induce fever or sleep. IL-18 mediates its biological functions through binding of a widely expressed heterodimeric receptor consisting of  $\alpha$ - and  $\beta$ -chains expressed on many different cell-types including T-lymphocytes, natural killer (NK) cells, monocytes/macrophages, neutrophils, and endothelial cells. Receptor activation by binding of IL-18 leads to the activation of the transcription factor NF $\kappa$ B via a complex intracellular signaling cascade. While the receptor’s  $\alpha$ -chain (IL-18R $\alpha$ ) is essential for signaling, it binds IL-18 at a relatively low affinity. In contrast, the IL-18R $\beta$  chain, also termed “IL-1 receptor accessory protein-like” (AcPL), binds to the complex formed by IL-18 and the IL-18R $\alpha$  chain, thus generating a high affinity tricomplex interaction. Both IL-18R $\alpha$  and IL-18R $\beta$  are structurally related and belong to the extended IL-1 receptor family. The signal transduction pathway subsequent to ligand binding of the IL-18 receptor complex is virtually identical with that of the IL-1 receptor complex. Both IL-18R $\alpha$  and IL-18R $\beta$  chains are required for signal transduction through the “myeloid differentiation factor 88” (MyD88), the serine-threonine “interleukin-1 receptor-associated kinase” (IRAK), and the “TNF $\alpha$  receptor-associated factor 6” (TRAF6) adapter molecules and involves a series of phosphorylation events that take place during the first few minutes after IL-18R binding. These steps ultimately result in the phosphorylation of the “inhibitor of  $\kappa$ B kinase” (IKK) complex, as well as specific “mitogen-activated kinase kinases” (MKKs). The IKKs phosphorylate the NF- $\kappa$ B inhibitor I $\kappa$ B, leading to its ubiquitination and subsequent degradation by the proteasome. This allows NF- $\kappa$ B to translocate to the nucleus and bind to specific promoter sequences. Activated MKKs phosphorylate and activate members of the “c-Jun N-terminal kinase” (JNK) and p38 “mitogen-activated protein kinase” (MAPK) family. These also translocate to the nucleus where they can phosphorylate several transcription factors of the basic leucine zipper family, like c-Jun and c-Fos.

## Pathology

### CNS Autoimmune Disease

The implication of IL-18 and caspase-1 in contributing to autoimmune neuropathology was investigated in patients with ►multiple sclerosis (MS) and its animal model, ►experimental autoimmune encephalomyelitis (EAE). Caspase-1 was shown to be elevated in EAE brain tissue as well as in peripheral blood mononuclear cells from MS patients, where expression levels correlated with disease activity. In addition, IL-18 levels were found to be slightly elevated in MS patients as compared to healthy controls. In the experimental setting of EAE, the importance of IL-18 on generation of Th1 response has been validated by demonstrating a significant attenuation of disease by administration of neutralizing anti-IL-18 antibodies. Similarly, the neuropathological sequelae of EAE were attenuated by either pharmacological inhibition of caspase-1 or in caspase-1 gene knockout mice. IL-18 and caspase-1 mRNA expression in the CNS was shown during the acute stage of EAE and implicated the IL-18/caspase-1 pathway in the amplification of Th1-mediated immune response in autoimmune CNS disease. This notion was supported by recent findings of resistance to EAE in IL-18 gene-deficient mice, whereas the administration of recombinant IL-18 enhanced the severity of EAE in wild-type mice and restored the ability to generate Th1 immune responses in the IL-18<sup>-/-</sup> mice.

In human MS patients, IL-18 levels were detected in cerebrospinal fluid taps only in about 3% of all patients studied. However, postmortem brain tissue section analysis from MS patients revealed an increased local expression of IL-18 and IFN- $\gamma$  in demyelinating cerebral lesions, suggesting that cerebrospinal fluid levels do not accurately reflect the local tissue expression of these mediators in autoimmune CNS disease. This hypothesis is corroborated by a clinical study on patients suffering from the relapsing-remitting form of MS, where individuals with acute exacerbations and active gadolinium-enhancing lesions in MRI had significantly elevated IL-18 levels in serum and cerebrospinal fluid, as compared to MS patients without positive MRI lesions and to control patients without neurological disease. Furthermore, the enhanced expression of IL-18 and its receptor was reported on oligodendrocytes of human tissue samples from patients with active MS, as compared to brain sections from patients with silent MS or from neuropathologically normal subjects. Altogether, these findings imply an important involvement of IL-18 and caspase-1 in the pathogenesis of active stages of autoimmune CNS disease.

### Ischemic and Traumatic Brain Injury

IL-18 has been involved in the development of ischemia-induced inflammation in experimental models of middle cerebral artery occlusion (MCAO). As such, focal ischemic brain injury in rats has been shown to induce

IL-18 expression in microglia and monocytes/macrophages in the infarcted cortex [6]. In those studies, both mRNA and protein levels increased within 24 hours and reached peaks at 6 days post injury. Interestingly, the expression profile of caspase-1 paralleled the increase of IL-18 levels, but not of IL-1 $\beta$ , suggesting a temporal diversity of expression within cytokines of the IL-1 family and implying a role of the IL-18/caspase-1 pathway in late-stage neuroinflammatory responses to focal cerebral ischemia. In ►stroke patients, elevated IL-18 levels in serum were shown to correlate with the extent of hypodense area volumes in craniocerebral CT scans and with functional disability. Moreover, serum IL-18 levels were shown to be higher in patients with a non-lacunar stroke subtype than in those with lacunar types of stroke. Affirmative data in an experimental model of hypoxic-ischemic brain injury in rats and mice reported the up-regulation of IL-18 and caspase-1 both at the mRNA and protein level within 12 h to 14 days after stroke. While microglia were determined as the major cell-type expressing IL-18 and caspase-1 in the injured hemisphere, IL-18 receptor expression was detected mainly on neurons in the cortex and thalamus. Interestingly, post-injury infarction area and neuropathological scores were significantly decreased in IL-18<sup>-/-</sup> mice, as opposed to wild-type littermates, suggesting that IL-18 may be functionally involved in the development and exacerbation of hypoxic brain injury.

Similarly to the demonstrated role of IL-18 in contributing to detrimental secondary effects in the injured brain after hypoxic-ischemic injury, IL-18 was shown to represent a “key player” in the pathophysiology of ►traumatic brain injury (TBI) [5]. First evidence of upregulated IL-18 gene and protein expression following optic and sciatic nerve crush injury was reported in rodent models. Interestingly, the constitutive levels of IL-18 mRNA expression were found to be higher in the CNS (optic nerve) than in peripheral nerve tissue (sciatic nerve). After experimental axonal crush injury, IL-18 expression dramatically increased both on injured optic and sciatic nerves. The cellular sources of increased IL-18 levels were determined to be mainly constituted by infiltrating ED1-positive macrophages within two to eight days after axonal injury. In addition, local resident microglia were shown to exhibit enhanced IL-18 expression mainly at sites of myelin degradation, suggesting an involvement of IL-18 mediated microglial neurotoxicity. This notion was confirmed by clinical and experimental data based on studies of severe closed head injury in humans, rats, and mice [8,10]. Significantly elevated IL-18 protein levels were reported in cerebrospinal fluid samples of patients with severe closed head injury for up to 10 days after trauma, as compared to normal controls. Notably, the peaks of intrathecal IL-18 levels in brain-injured patients were almost 200-fold higher than in

cerebrospinal fluid from control subjects without neuroinflammatory disease [10].

### CNS Infection

Several studies have highlighted a role of IL-18 in mediating the inflammatory response to bacterial, viral and fungal infections of the CNS. In models of pneumococcal and cryptococcal meningitis, IL-18 was shown to be up-regulated in the infected brain and to contribute to the neuroinflammatory response. IL-18  $-/-$  mice with pneumococcal meningitis had a prolonged survival and a decreased neuroinflammatory response compared to infected wild-type littermates. These data were supported in a model of fungal infection of the CNS, where mice with cryptococcal meningoencephalitis had increased IL-18 mRNA expression in the infected brain with associated potent

neuroinflammatory events. In models of viral CNS infection, IL-18 was shown to play a key role in activating microglial functions by inducing neuronal IFN- $\gamma$  release in brain parenchyma and thus supporting the viral clearance of infected neurons.

The different roles and pathological effects of IL-18 in the immature and adult brain are outlined in Table 1.

### Therapy

Several functional antagonists and inhibitors of IL-18 have been described, which neutralize its pro-inflammatory effects. The most important naturally occurring antagonist is IL-18 binding protein (IL-18BP), a secreted protein which displays high-affinity binding to mature IL-18, but not to the IL-18 precursor. A single copy of the IL-18BP gene exists for humans, mice, and rats. The highest expression of IL-18BP was detected in the spleen

**Neuroinflammation – IL-18. Table 1** Role of IL-18 in neuroinflammatory diseases

Neuroinflammatory disease	IL-18 levels in the CNS	Functional role of IL-18
Experimental autoimmune meningoencephalitis (EAE)	Increased IL-18 gene expression in EAE spinal cord and brain	Neutralizing anti-IL-18 antibodies block the development of EAE
Multiple sclerosis	Elevated IL-18 and receptor protein expression in active MS lesions	n.d.
Experimental dopaminergic neurodegeneration	Increased microglial IL-18 in substantia nigra	Reduced susceptibility to dopaminergic neuronal loss and reduced microglial activation in IL-18 gene-deficient mice
Bacterial meningitis	Increased IL-18 levels in cerebrospinal fluid of bacterial meningitis patients, upregulation of IL-18 protein and gene expression in infected murine brain tissue	Prolonged survival and reduced neuroinflammation in IL-18 gene-deficient mice
Viral encephalitis	Induction of IL-18 and caspase-1 gene expression in murine brains	Protective effect of IL-18 by enhanced clearance of neurovirulent Influenza A infection
Cryptococcal meningoencephalitis	Increased IL-18 gene expression in infected brains	n.d.
Ischemic stroke	Increased intracerebral IL-18 and caspase-1 gene expression in injured brain, elevated IL-18 serum levels	IL-18 levels in serum are predictive of outcome
Axonal injury	Enhanced IL-18 expression on infiltrating macrophages after nerve crush injury	n.d.
Traumatic brain injury (TBI)	Elevated IL-18 protein levels in cerebrospinal fluid and brain tissue	Inhibition by IL-18BP is neuroprotective
Neonatal hypoxia-ischemia	Elevated IL-18 and receptor, IL-1 $\beta$ , caspase-1 protein and gene expression in the injured brain	Reduced infarct volume and neuropathology score in IL-18 $-/-$ mice. IL-18 contributes to white matter injury in neonatal brain
Neonatal hyperoxic injury	IL-1 $\beta$ , IL-18 and receptor/caspase-1 protein and gene expression	Inhibition by IL-18BP is neuroprotective

n.d., not determined; CNS, central nervous system; IL-18BP, IL-18 binding protein; MS, multiple sclerosis; EAE, experimental autoimmune encephalomyelitis; TBI, traumatic brain injury.

and intestinal tract which are both immunologically active tissues. Four distinct isoforms of human IL-18BP and two isoforms of murine IL-18BP have been described which are formed by alternative splicing of the respective genes. Two of the four human isoforms and both murine isoforms are biologically functional by neutralizing IL-18. Experimental studies on TBI models revealed that the systemic administration of recombinant IL-18BP after trauma resulted in a significantly improved neurological recovery, both in the adult and immature brain [8, 10]. This neuroprotection was associated with an IL-18BP-dependent downregulation of intracerebral IL-18 levels in mice. Furthermore, hyperoxia-induced neonatal brain injury was largely attenuated by administration of recombinant IL-18BP. Based on these findings, the pharmacological administration of IL-18BP may represent a promising future therapeutic strategy for attenuating the IL-18-mediated neuroinflammation and neurodegeneration in the immature and adult brain.

## References

1. Bombardieri M, McInnes IB, Pitzalis C (2007) Interleukin-18 as a potential therapeutic target in chronic autoimmune/inflammatory conditions. *Expert Opin Biol Ther* 7:31–40
2. Conti B, Park LC, Calingasan NY, Kim Y, Kim H, Bae Y, Gibson GE, Joh TH (1999) Cultures of astrocytes and microglia express interleukin 18. *Mol Brain Res* 67:46–52
3. Culhane AC, Hall MD, Rothwell NJ, Luheshi GN (1998) Cloning of rat brain interleukin-18 cDNA. *Mol Psychiatry* 3:362–366
4. Dinarello CA, Fantuzzi G (2003) Interleukin-18 and host defense against infection. *J Infect Dis* 187(Suppl 2): S370–S384
5. Felderhoff-Mueser U, Schmidt OI, Oberholzer A, Bühler C, Stahel PF (2005) IL-18: a key player in neuroinflammation and neurodegeneration? *Trends Neurosci* 28:487–493
6. Hedtjäm M, Leverin AL, Eriksson K, Blomgren K, Mallard C, Hagberg H (2002) Interleukin-18 involvement in hypoxic-ischemic brain injury. *J Neurosci* 22:5910–5959
7. Sekiyama A, Ueda H, Kashiwamura S, Nishida K, Kawai K, Teshima-Kondo S, Rokutan K, Okamura H (2005) IL-18: a cytokine translates a stress into medical science. *J Med Invest* 52(Suppl.):236–239
8. Sifringer M, Stefovská V, Endesfelder S, Stahel PF, Genz K, Dzietko M, Ikonomidou C, Felderhoff-Mueser U (2007) Activation of caspase-1 dependent interleukins in developmental brain trauma. *Neurobiol Dis* 25:614–622
9. Stoll G, Jander S, Schroeter M (2000) Cytokines in CNS disorders: neurotoxicity versus neuroprotection. *J Neural Transm Suppl* 59:81–89
10. Yatsiv Y, Morganti-Kossmann MC, Perez D, Dinarello CA, Novick D, Rubinstein M, Otto VI, Rancan M, Kossmann T, Redaelli CA, Trentz O, Shohami E, Stahel PF (2002) Elevated intracranial IL-18 in humans and mice after traumatic brain injury and evidence of neuroprotective effects of IL-18-binding protein after experimental closed head injury. *J Cereb Blood Flow Metab* 22:971–978

## Neuroinflammation – LPS-induced Acute Neuroinflammation, Rat Model

MEHRNAZ JAFARIAN-TEHRANI

Laboratoire de Pharmacologie (UPRES EA2510),  
Université Paris Descartes - UFR Pharmacie, Paris,  
France

### Definition

Characterization of a rat model to study acute neuroinflammation induced by ►lipopolysaccharide (LPS), based on histopathological and biochemical outcomes.

Acute neuroinflammation is a common process accompanying acute brain injuries such as traumatic brain injury (TBI) and cerebral ischemia [1]. Acute inflammatory response due to central nervous system (CNS)-specific glial response within the injured brain exerts detrimental effects by releasing neurotoxic mediators. The model described here mimics some aspects of acute brain injuries with a specific regard to acute neuroinflammation *in vivo*. Lipopolysaccharide (LPS), a known potent immunostimulant, a cell constituent of the cell wall of Gram negative bacteria, is used to induce the inflammatory response within the brain [2]. This model is a powerful tool for mechanistic studies and evaluation of the potential neuroprotective strategies.

### Characteristics

#### Quantitative Description

In the model described here, the LPS used is from *E. Coli* (serotype 0127:B8, Sigma L-3129). The intensity of inflammatory response may differ depending on the dose and source of LPS (*Salmonella* versus *E. Coli* and the LPS serotype) used, and also the site of the LPS injection. Therefore, caution should be taken in the interpretation and comparison of the data available from the literature.

#### Description of the Structure

In the model described here, the site of the LPS injection is located in the right hippocampus, precisely in the dentate gyrus at the ►stereotaxic coordinates [3] relative to the ►bregma (Fig. 1).

The hippocampus is a part of the brain which is involved in memory and learning. It belongs to the limbic system and its name is due to its seahorse shape. Dentate gyrus is a part of the hippocampal formation containing granule cells, the principal excitatory neurons of the dentate gyrus, which project to the pyramidal cells and interneurons of the CA3 subfield of hippocampus.

#### Description of the Conditions

Rats are anesthetized with chloral hydrate and placed on a stereotaxic frame. During surgery, animals are placed

on a heating blanket system, the scalp is incised and a craniotomy is made following the coordinates described above. The injection cannula is implanted unilaterally (Fig. 1), and maintained in the site of injection for 5 min before and after LPS or vehicle (NaCl, 0.9%) infusion. Finally, the scalp is sutured and the animals are returned to their home cage in a room warmed to 26–28°C to recover from the anesthesia.

### Description of the Process

Following LPS injection, tissue damage and induced-inflammatory mediators are evaluated by ►cresyl violet staining, ►immunohistochemistry (IHC) and biochemical methods. Brains are removed at different times after LPS injection to establish a time course study. For histological studies, brains are quickly frozen in isopentane at –40°C. Brain sections (20 µm) are prepared at –20°C (Cryostat Jung CM3000) every half-millimeter at six coronal planes, from 2.8 to 5.3 mm posterior to the bregma, to establish a spatial study. Some sections are stained with cresyl violet to assess the tissue damage. Adjacent sections are processed for IHC after being dried and fixed in chilled acetone for 5 min [2].

To assess the inflammatory response, inducible nitric oxide synthase (iNOS) [4] can be used as a marker of inflammation. In fact, iNOS is one of three isoforms of NOS which is inducible under inflammatory conditions and produces a high amount of NO and has a detrimental role especially at the acute phase [5].

Other markers such as Neuronal Nuclei (NeuN), Glial Fibrillary Acidic Protein (GFAP), and OX-42 can be used to visualize the damage to neurones, astrocytes and microglia, respectively. NeuN is a marker of neuronal cell nucleus, GFAP is a marker of astrocytic cytoplasm and OX-42 (or complement receptor 3, CR3) is a marker of microglial cell membrane.

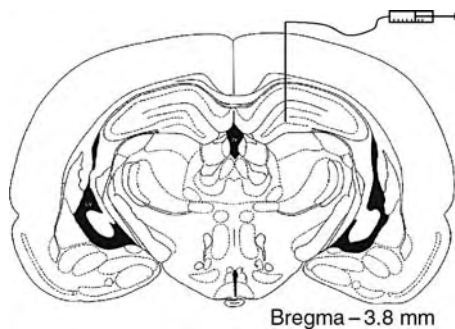

**Neuroinflammation – LPS-induced Acute Neuroinflammation, Rat Model.** Figure 1 Illustration of LPS injection site in the dentate gyrus at the level of Bregma –3.8 mm [3]. LPS is dissolved in sterilized physiological saline and infused at the dose of 15 µg in a volume of 2 µl, at a rate of 1 µl/min, by using Hamilton syringe (10 µl) and syringe pump.

For biochemical studies, ►ipsilateral and ►contralateral hippocampi are dissected out and quickly frozen to perform one of the following assays. They include NOS activity evaluating iNOS activity [2,6] and also ►myeloperoxidase (MPO) activity which represents an index of monocyte/neutrophil infiltration [7]. The samples can be processed online for tissue NO end products assay, nitrate plus nitrite (NOx) which is an indirect index of NO production [8]. For brain MPO activity assay, caution should be taken to wash out the blood cells from the vasculature by transcardial perfusion through the aorta with NaCl 0.9%. The study of inflammatory mediators can also be extended to pro-inflammatory cytokines such as interleukin-1β (IL-1β), IL-6 and tumor necrosis factor α (TNFα) by using commercially available rat ►ELISA kits.

### Regulation of the Structure: Histopathological and Biochemical Outcomes After LPS Infusion

Saline infusion in the hippocampus does not lead to tissue damage and iNOS induction except at the site of injection due to the cannula penetration. In contrast, LPS infusion causes tissue damage, characterized by loss of cresyl violet staining, due to cell necrosis, in the ipsilateral dentate gyrus compared to contralateral side (Figs. 2a and 2b). Furthermore, the cellular loss is due in part to neuronal cell loss observed by a marked decrease

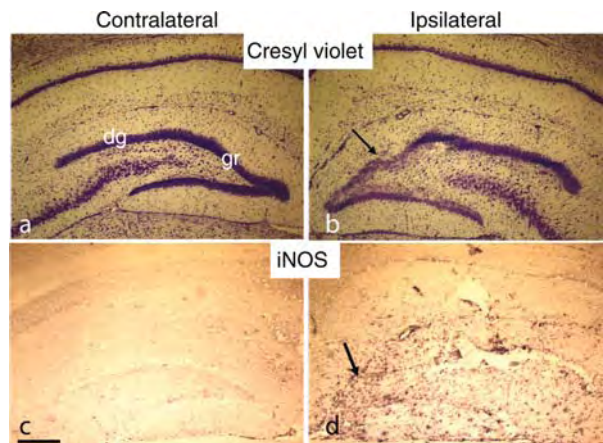

### Neuroinflammation – LPS-induced Acute Neuroinflammation, Rat Model.

**Figure 2** Representative photomicrographs of coronal brain sections for cresyl violet staining (a, b) and iNOS immunoreactivity (c, d) at 0.5 mm posterior to the LPS injection site. Contralateral (a, c) and ipsilateral (b, d) sections to injection site in rats submitted to LPS after 15h. At the site of LPS injection, cell loss was accompanied by an intense iNOS immunoreactivity. Arrows show the site of brain damage (b) and iNOS immunolabeled cells (d). dg, dentate gyrus; gr, granular layer. Scale bar = 400 µm.



in NeuN immunolabeling [2]. An intense iNOS immunolabeling is also detected in the lesion area compared to contralateral side (Fig. 2c and 2d). This observation is consistent with intense iNOS activity and brain NOx levels indicating that iNOS is active in the brain parenchyma [2,9]. Following LPS infusion, induction of iNOS is acute and transient, peaked at 24h, with a coronal expansion of 2 mm around the injection site, preceding the peak of cellular loss in the hippocampus at 48–72h [2]. A high level of MPO activity is also observed in the hippocampus showing the infiltration of monocyte/neutrophil in the brain parenchyma following LPS infusion [2]. This model leads to an intense inflammatory response *in vivo* causing neuronal cell loss restricted to the hippocampus. It is a very reproducible model with no mortality over a week post-LPS infusion.

### Function Alterations After LPS Infusion

Neuroinflammation induced by LPS in this model is accompanied by some alterations in neurological functions such as impairment in sensorimotor function [2] and spatial memory [9]:

1. Contralateral sensorimotor functions are examined by assessing placing reactions (leg hanging and visual), grasping reflex (left forepaw and left hindpaw), and righting reflex (head tilted; left side and right side) in rats placed on a table [10]. Abnormal postures (thorax twisting and left forelimb flexion) are also examined. The scores for each item are summed and used as a global neurological score. The maximum score is for non-operated rats; the lower the neurological score the more severe the deficit.
2. Spatial memory is a more specific function to examine the function of hippocampus after tissue damage. This function is assessed by both spontaneous alteration behavior in a Y-maze and performance in the Morris water maze task.

### Therapy

LPS-induced tissue damage and neuronal dysfunction are limited by reducing the production of inflammatory mediators at its acute phase. One strategy is based on the use of iNOS inhibitors reducing iNOS-derived NO. It is noteworthy that treatment with an iNOS inhibitor prevents LPS-induced spatial memory dysfunction showing the detrimental role of iNOS in LPS-induced brain injury [9]. Since the early and late post-injury inflammatory response may play dual roles, detrimental vs. beneficial, caution should be taken on the timing of anti-inflammatory strategy [1].

### References

1. Leker RR, Shohami E (2002) Cerebral ischemia and trauma-different etiologies yet similar mechanisms: neuroprotective opportunities. *Brain Res Rev* 39:55–73
2. Ambrosini A, Louin G, Croci N, Plotkine M, Jafarian-Tehrani M (2005) Characterization of a rat model to study acute neuroinflammation on histopathological, biochemical and functional outcomes. *J Neurosci Meth* 144:183–191
3. Paxinos G, Watson C (1982) *The rat brain in stereotaxic coordinates*. Academic, Sydney
4. Alderton WK, Cooper CE, Knowles RG (2001) Nitric oxide synthases: structure, function and inhibition. *Biochem J* 357:593–615
5. Louin G, Marchand-Verrecchia C, Palmier B, Plotkine M, Jafarian-Tehrani M (2006) Selective inhibition of inducible nitric oxide synthase reduces neurological deficit but not cerebral edema following traumatic brain injury. *Neuropharmacology* 50:182–190
6. Louin G, Besson VC, Royo NC, Bonnefont-Rousselot D, Marchand-Verrecchia C, Plotkine M, Jafarian-Tehrani M (2004) Cortical calcium increase following traumatic brain injury represents a pitfall in the evaluation of Ca<sup>2+</sup>-independent NOS activity. *J Neurosci Meth* 138:73–79
7. Bateau-Parmentier S, Margail I, Plotkine M (2000) Modulation by nitric oxide of cerebral neutrophil accumulation after transient focal ischemia in rats. *J Cereb Blood Flow Metab* 20:812–819
8. Grandati M, Verrecchia C, Revaud ML, Allix M, Boulu RG, Plotkine M (1997) Calcium-independent NO-synthase activity and nitrites/nitrates production in transient focal cerebral ischaemia in mice. *Br J Pharmacol* 122:625–630
9. Yamada K, Komori Y, Tanaka T, Senzaki K, Nikai T, Sugihara H, Kameyama T, Nabeshima T (1999) Brain dysfunction associated with an induction of nitric oxide synthase following an intracerebral injection of lipopolysaccharide in rats. *Neuroscience* 88:281–294
10. Wahl F, Renou E, Mary V, Stutzmann JM (1997) Riluzole reduces brain lesions and improves neurological function in rats after a traumatic brain injury. *Brain Res* 756:247–255

## Neuroinflammation – PDE Family Inhibitors in the Regulation of Neuroinflammation

TETSUYA MIZUNO

Department of Neuroimmunology, Research Institute of Environmental Medicine, Nagoya University, Furo-cho, Chikusa, Nagoya, Japan

### Definition

► **Phosphodiesterase (PDE)** is a group of enzymes that degrade key second messengers, cyclic AMP (cAMP) and cyclic GMP (cGMP). ► **Phosphodiesterase inhibitors (PDEIs)** inhibit the function of PDE and elevate

cAMP, thereby upregulating PKA/CREB signaling and downregulating NF- $\kappa$ B signaling. Consequently, PDEIs have anti-inflammatory and neuroprotective effects and may ameliorate the neuroinflammation accompanying demyelinating, ►neurodegenerative, and neuroinfectious diseases.

## Characteristics

### Quantitative Description

Neuroinflammation is involved in the demyelinating diseases, neurodegenerative diseases and neuroinfectious diseases. Activated ►microglia play a key role in the inflammatory processes of these diseases by releasing inflammatory mediators. PDEIs that inhibit the function of phosphodiesterases and elevate cAMP have anti-inflammatory and neuroprotective effects. PDEIs are one of the effective drugs capable of suppressing inflammatory functions of activated microglia.

### Involvement of Activated Microglia in Neuroinflammation

Neuroinflammation is a component of demyelinating diseases such as multiple sclerosis (MS) and is observed in an animal model for this disease, experimental allergic encephalomyelitis (EAE). Activated microglia play a key role in inflammatory process by releasing proinflammatory mediators including interleukin (IL)-1 $\beta$ , IL-6, tumor necrosis factor (TNF)- $\alpha$ , nitrite oxide (NO), and reactive oxygen species (ROS). These molecules damage myelinating oligodendrocytes to produce demyelinating lesions.

There is increasing evidence that inflammatory mechanisms are also involved in the pathogenesis of neurodegenerative diseases, such as amyotrophic lateral sclerosis (ALS), Parkinson's disease (PD) and Alzheimer's disease (AD). An immunological mechanism of ALS pathogenesis has been proposed and is supported by the presence of activated microglia within the gray matter of the spinal cord and motor cortex of patients with ALS. In PD, neuroinflammation contributes to the degeneration of neurons in the substantia nigra. Activated microglia and increased levels of inflammatory mediators have been detected in the striatum of PD patients and a large number of animal studies support a role for inflammation in the loss of dopaminergic neurons. In AD, neuroinflammatory mediators are upregulated in affected areas of the brain while fibrillar and oligomeric forms of amyloid  $\beta$  peptide (A $\beta$ ) stimulate activation of microglia.

Activated microglia have a key role in chronic neuroinfectious diseases such as human immunodeficiency virus (HIV) encephalitis and prion diseases. Microglia are major targets of infection by HIV-1, and infected microglia are activated to produce inflammatory mediators. The pathogenic isoform of prion protein also stimulates microglia to produce inflammatory

mediators. Therefore, inhibiting the release of inflammatory mediators by microglia may be an effective strategy for treating neuroinflammatory, neurodegenerative and neuroinfectious diseases. As PDEIs suppress the inflammatory response of activated microglia, these drugs are good candidates for therapeutic intervention.

### Anti-Inflammatory Mechanism of PDEIs

PDEs hydrolyze cyclic nucleotides, and may be specific for cAMP/cGMP or both cAMP and cGMP. There are 11 families of proteins with this enzymatic activity (PDE1-PDE11) and more than 50 isoforms in total [1]. Cyclic nucleotides are second messengers for several G proteins. PDEIs that block one or more PDEs enhance the function of cyclic nucleotides to promote a variety of pharmacologic actions. For example, some PDEIs elevate intracellular cAMP and activate the protein kinase A (PKA) signaling pathway. This suppresses NF- $\kappa$ B-mediated transcription without preventing nuclear translocation of NF- $\kappa$ B complexes [2]. Consequently, PDEIs inhibit the production of inflammatory mediators regulated by NF- $\kappa$ B such as IL-1 $\beta$ , IL-6, TNF- $\alpha$ , and NO (Fig. 1).

PDEIs block one or more phosphodiesterases and elevate intracellular cyclic AMP. Subsequently, they activate PKA signaling pathways that suppress NF- $\kappa$ B-mediated transcription and upregulate CREB. Consequently, PDEIs limit the production of inflammatory mediators and promote LTP that is regulated largely by CREB.

PDE4 and PDE10 are highly expressed in the central nervous system (CNS). The PDE4 inhibitor rolipram has anti-inflammatory, anti-depressant, and memory-enhancing effects. Ibudilast, which has been used in Japan to treat both bronchial asthma and cerebrovascular disorders since 1989, is a broad range PDEI that inhibits PDE3A, PDE4, PDE10 and PDE11(1). Inhibiting of PDE3A and PDE4 may affect tracheal smooth muscle contractility while inhibiting PDE4 and PDE10 has positive effects on neurological conditions.

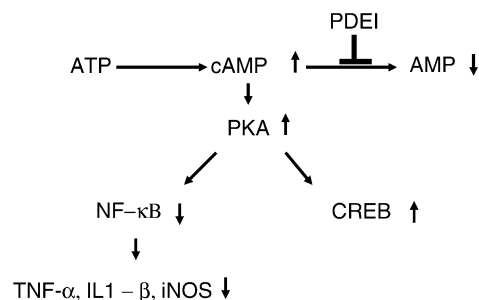

### Neuroinflammation – PDE Family Inhibitors in the Regulation of Neuroinflammation.

**Figure 1** Mechanisms of action of PDEIs.

### The Effect of PDEIs on Demyelinating Diseases

Activated microglia perform several functions in the inflammatory process. They are antigen-presenting cells that present myelin-specific antigens to invading T cells in the induction phase of MS and EAE. In addition, they are effector cells that damage oligodendrocytes and neuronal cells by secreting inflammatory cytokines, radicals, and glutamate during the effector phase. However, these cells may also protect neural functions by producing neurotrophic factors. Ibudilast suppresses the production of IL-1 $\beta$ , IL-6, TNF- $\alpha$ , NO, and reactive oxygen species (ROS) by activated microglia. Moreover, it enhances the production of the inhibitory cytokine, IL-10, and neurotrophic factors including nerve growth factor (NGF), glia-derived neurotrophic factor (GDNF), and neurotrophin (NT)-4 by these cells [3].

MS is a T-helper 1 (Th1) lymphocyte-mediated disease. Th1 cells initiate proinflammatory activity while Th2 initiate anti-inflammatory activity. Ibudilast suppresses differentiation of Th1 cells in the CNS, and can shift the cytokine profile such that is dominated by Th2 rather than Th1 cells. Ibudilast significantly suppresses the production of IL-12 by microglia; this cytokine is critical for Th1 differentiation. In addition, ibudilast also suppresses the production of interferon-gamma, but not IL-4 or IL-10, by myelin oligodendrocyte glycoprotein (MOG)-specific T cells reactivated with MOG in the presence of microglia. Thus, PDEIs suppress

the activities of activated microglia that contribute to the pathology of MS and EAE.

PDEIs have been examined in clinical studies of MS. The combination of three PDEIs suppresses the frequency of relapse in relapsing remitting MS (RRMS) at the standard therapeutic doses [4]. A randomized, double-blind, placebo-controlled multi-center Phase II clinical trial of ibudilast in patients with RRMS was initiated in Eastern Europe in July, 2005. Enrollment of 297 patients was completed in February, 2006. Interferon (IFN)- $\beta$  is the first approved therapy for RRMS. However, IFN- $\beta$  treatment causes several common side effects such as flu-like symptoms (fatigue, chills, and fever) which may be a consequence of elevated levels pro-inflammatory cytokines. PDEIs suppress the upregulation of inflammatory mediators induced by IFN- $\beta$ . The PDE3 and PDE4B inhibitor pentoxifylline synergistically functions with IFN- $\beta$  to reduce the production of inflammatory cytokines and upregulate the anti-inflammatory cytokine IL-10 in peripheral blood mononuclear cells from patients with active MS [5]. Ibudilast also suppresses the production of the inflammatory mediators TNF- $\alpha$ , IL-1 $\beta$ , IL-6, and NO concurrent with IFN- $\beta$  treatment [6] (Fig. 2).

LPS treatment activates microglia to produce TNF $\alpha$ , IL-1 $\beta$  and IL-6. IFN- $\beta$  enhances the production of these cytokines. Ibudilast significantly suppresses this effect in a dose-dependent fashion. Similarly, LPS and

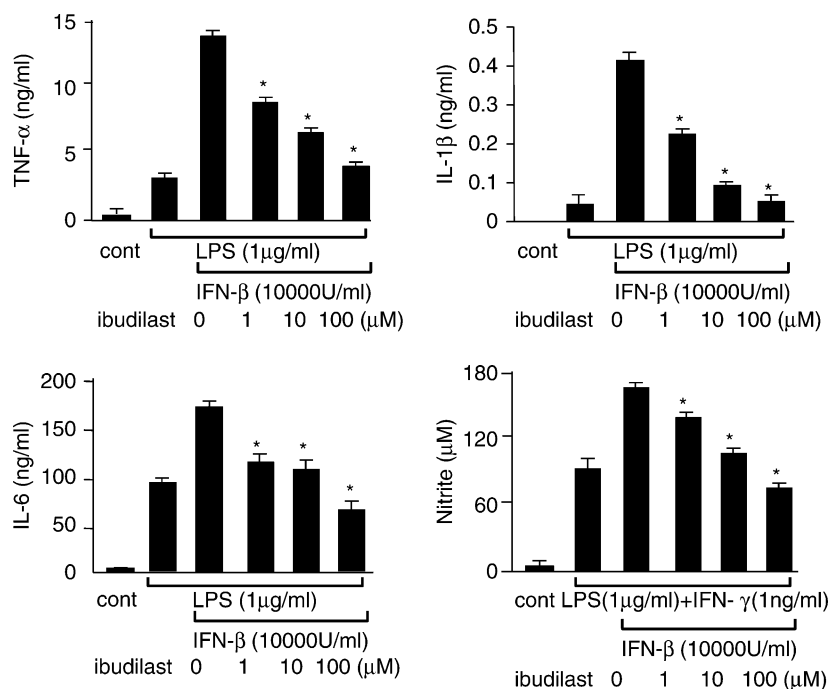

**Neuroinflammation – PDE Family Inhibitors in the Regulation of Neuroinflammation. Figure 2** Ibudilast suppresses the enhanced production of inflammatory cytokines and NO induced by IFN- $\beta$ .

IFN- $\gamma$  induce the production of NO and its derivative nitrite. Addition of IFN- $\beta$  enhances the production of these factors as well. Ibudilast significantly inhibits the upregulation of NO in a dose-dependent fashion.

### The Effect of PDEIs on Neurodegenerative Diseases

Activated microglia contribute to neuronal degeneration by producing proinflammatory cytokines, glutamate, and peroxynitrite, a product of NO and superoxide. As neuronal degeneration is related to the functional prognosis in MS, suppressing the production of these factors by activated microglia with PDEIs may be an effective strategy for treating the neuronal degeneration associated with MS. For example, ibudilast inhibits the neuronal cell death induced by activated microglia with lipopolysaccharide (LPS) and IFN- $\gamma$  (Fig. 3).

Microglia activated with LPS (1  $\mu\text{g/ml}$ ) and IFN- $\gamma$  (100 ng/ml) induce neuronal cell death. Addition of ibudilast inhibits this neuronal cell death.

Experimental evidence supports a model for ALS neurodegeneration in which microglia contribute to the cell death of motor neurons. It is generally believed that oxidative stress and glutamate-mediated excitotoxicity are important mechanisms in ALS. NADPH oxidase, the main ROS-producing enzyme during inflammation, is activated in the spinal cord of ALS patients as well as in the spinal cord of animals with a genetic animal model of this disease. Inactivating

NADPH oxidase in ALS mice delays neurodegeneration and extends survival [7]. A double-blind, randomized, multicenter, placebo-controlled trial of the PDE4B inhibitor, pentoxifylline, has been conducted with ALS patients. Unfortunately pentoxifylline had a negative effect on survival [8].

Activated microglia play a key role in the initiation and progression of PD. Exposure to a common herbicide, rotenone, induces features of parkinsonism. Rotenone stimulates the release of superoxide from microglia, resulting in the selective destruction of the nigrostriatal dopaminergic system. In animal models, 1-methyl-4-phenyl-1,2,3,6-tetrahydropyridine (MPTP) damages the nigrostriatal dopaminergic pathway to induce parkinsonism. Neuronal damage induced by MPTP is mediated by activated microglia, and postmortem examination of human subjects exposed to MPTP reveals the presence of activated microglia decades after drug exposure. In contrast, PDEIs are reported to stimulate the uptake of dopamine and enhance intracellular dopamine levels in rat mesencephalic neurons.

Neuroinflammation is a characteristic of AD, with activated microglia being the driving force. As non-steroidal anti-inflammatory drugs (NSAIDs) are the most commonly used of all anti-inflammatory agents, many studies have examined whether NSAIDs might have protective effects on AD. Cyclooxygenase (COX)-1 is upregulated in activated microglia and

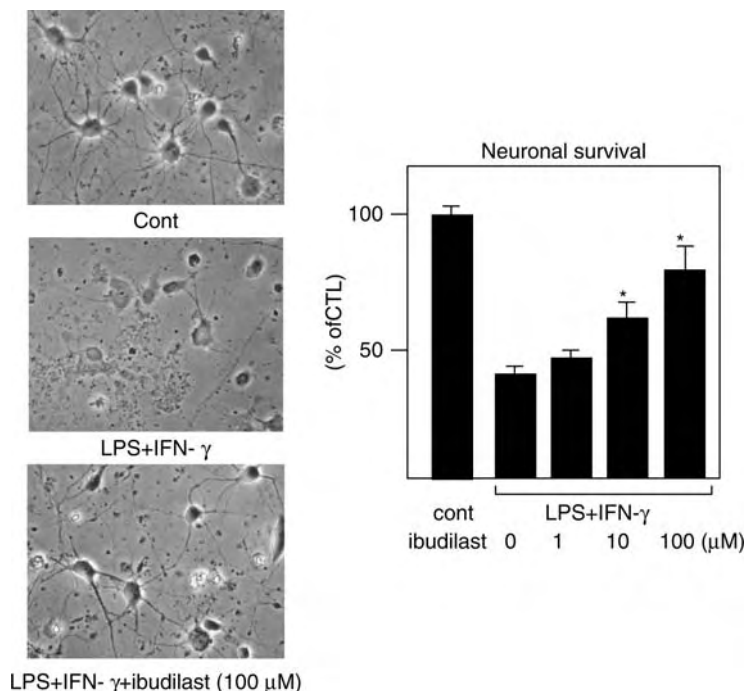

**Neuroinflammation – PDE Family Inhibitors in the Regulation of Neuroinflammation. Figure 3** Neuroprotective effects of ibudilast.

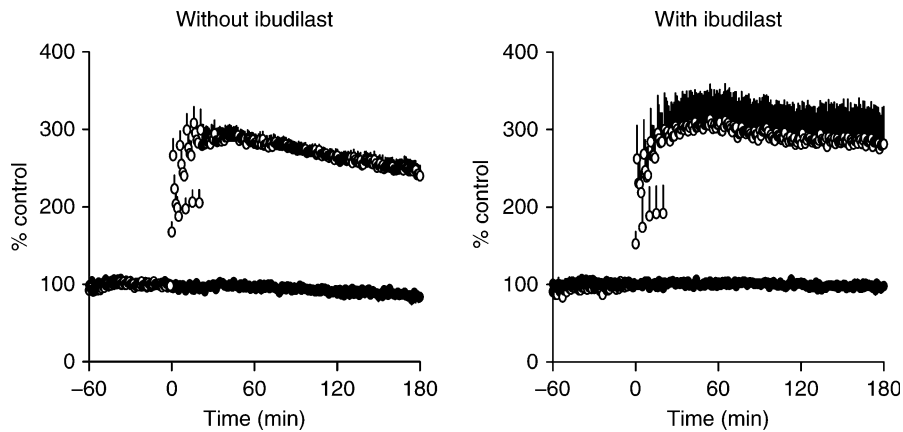

**Neuroinflammation – PDE Family Inhibitors in the Regulation of Neuroinflammation. Figure 4** Effect of ibudilast on the suppression of LTP by LPS and IFN- $\gamma$ .

NSAIDs that block this enzyme could have an ameliorating effect on the disease [9]. Similarly, the effects of PDEIs on activated microglia may also slow the progression of AD.

In addition to its roles in limiting the proinflammatory activity of microglia, PDEIs also affect neuronal activity. PDEIs that activate PKA and the cAMP responsive element-binding protein (CREB) pathway promote **long-term potentiation (LTP)** (Fig. 1). LTP in hippocampal CA1 neurons is essential for memory acquisition. Treating cultured hippocampal neurons with A $\beta$  inactivates the PKA/CREB pathway and inhibits LTP. The PDE inhibitor, rolipram, reverses this inhibition. Moreover, rolipram ameliorates deficits in both LTP and contextual learning in the double-transgenic AD mice [10]. Treating hippocampal slices with LPS and IFN- $\gamma$  prior to inducing LTP activates microglia and causes the magnitude of LTP decrease gradually. Ibudilast reverses this inhibition (Fig. 4). Thus, PDEIs may have the potential as therapeutics for treating dementia. Recently, novel PDE4 inhibitor, MEM-1414 was developed for treating AD, mild cognitive impairment and depression.

The mean population EPSP slope after tetanic stimulation was gradually attenuated with LPS (1  $\mu$ g/ml) and IFN- $\gamma$  (100 ng/ml) (A). Addition of 100  $\mu$ M ibudilast during LPS and IFN- $\gamma$  stimulation returned LTP to normal levels (B). The horizontal line indicates control levels at unstimulated sites.

### The Effect of PDEIs on Neuroinfectious Diseases

The HIV-1 virus infect macrophages and microglia in the CNS and frequently cause neurocognitive impairment. HIV-1 infected microglia are activated and inflammatory mediators. The HIV-1 envelope glycoprotein 120 (gp120), which is shed from the virus, can cause neuronal cell death. HIV-1 gp120 inhibits LTP, and HIV-1 replication is enhanced by TNF- $\alpha$ .

Therefore, PDEI treatment could inhibit cytokine secretion associated with HIV-1 infection and transcriptional regulation of HIV replication. Rolipram is reported to inhibit HIV-1 replication in vitro.

Activated microglia are a predominant feature prion-related encephalopathy. The pathogenic isoform of prion protein causes microglial activation and has a crucial role in neuronal cell death. However, there are few reports examining whether PDEIs are effective in prion diseases.

### References

- Gibson LC, Hastings SF, McPhee I, Clayton RA, Darroch CE, Mackenzie A, Mackenzie FL, Nagasawa M, Stevens PA, Mackenzie SJ (2006) The inhibitory profile of ibudilast against the human phosphodiesterase enzyme family. *Eur J Pharmacol* 538:39–42
- Parry GC, Mackman N (1997) Role of cyclic AMP response element-binding protein in cyclic AMP inhibition of NF- $\kappa$ B-mediated transcription. *J Immunol* 159:5450–5456
- Mizuno T, Kurotani T, Komatsu Y, Kawanokuchi J, Kato H, Mitsuma N, Suzumura A (2004) Neuroprotective role of phosphodiesterase inhibitor ibudilast on neuronal cell death induced by activated microglia. *Neuropharmacology* 46:404–411
- Suzumura A, Nakamuro T, Tamaru T, Takayanagi T (2000) Drop in relapse rate of MS by combination therapy of three different phosphodiesterase inhibitors. *Mult Scler* 6:56–58
- Weber F, Polak T, Gunther A (1998) Synergistic immunomodulatory effects of interferon-beta1b and the phosphodiesterase inhibitor pentoxifylline in patients with relapsing-remitting multiple sclerosis. *Ann Neurol* 44:27–34
- Kawanokuchi J, Mizuno T, Kato H, Mitsuma N, Suzumura A (2004) Effects of interferon-beta on microglial functions as inflammatory and antigen presenting cells in the central nervous system. *Neuropharmacology* 46:734–742

7. Wu DC, Re DB, Nagai M, Ischiropoulos H, Przedborski S (2006) The inflammatory NADPH oxidase enzyme modulates motor neuron degeneration in amyotrophic lateral sclerosis mice. *Proc Natl Acad Sci USA* 103:12132–12137
8. Meininger V, Asselain B, Guillet P, Leigh PN, Ludolph A, Lacomblez L, Robberecht W, Pentoxifylline European Group (2006) Pentoxifylline in ALS: a double-blind, randomized, multicenter, placebo-controlled trial. *Neurology* 66:88–92
9. McGeer PL, McGeer EG (2007) NSAIDs and Alzheimer disease: epidemiological, animal model and clinical studies. *Neurobiol Aging* 28:639–647
10. Gong B, Vitolo OV, Trinchese F, Liu S, Shelanski M, Arancio O (2004) Persistent improvement in synaptic and cognitive functions in an Alzheimer mouse model after rolipram treatment. *J Clin Invest* 114:1624–1634

## Neuroinflammation: Brain and Spinal Cord Injury

W. DALTON DIETRICH<sup>1,2</sup>, ROBERT W. KEANE<sup>3</sup>

<sup>1</sup>The Miami Project to Cure Paralysis, University of Miami Miller School of Medicine, Miami, FL, USA

<sup>2</sup>Neurological Surgery, University of Miami Miller School of Medicine, Miami, FL, USA

<sup>3</sup>Department of Physiology and Biophysics, University of Miami Miller School of Medicine, Miami, FL, USA

### Synonyms

Cell death after CNS trauma

### Definition

#### Inflammation and Apoptosis after Brain and Spinal Cord Injury

Central Nervous System (CNS) destruction in traumatic brain (TBI) and ► [spinal cord injury \(SCI\)](#) is caused by a complex series of cellular and molecular events. Recent studies have concentrated on signaling by receptors in the interleukin 1 (IL-1) (► [interleukin \(IL\)](#)) and tumor necrosis factor receptor (TNFR) family that mediate diverse biological outcomes. From the basic science research perspective, understanding how receptor signaling mediates these divergent responses is critical in clarifying events underlying irreversible cell injury in clinically relevant models of CNS trauma. From a clinical perspective, this work also provides novel targets for the development of therapeutic agents that have the potential to protect the brain and spinal cord from irreversible damage and promote functional recovery. Here, we discuss how the formation of alternate signaling complexes and receptor membrane

localization after TBI and SCI can influence life and death decisions of cells stimulated through IL-1 and TNFR superfamily.

### Characteristics

The pathophysiology of acute TBI and SCI is characterized by the shearing of cell membranes and axons, disruption of the blood-spinal cord barrier, cell death, immune cell transmigration, and myelin degradation [1–3]. Deleterious factors such as pro-inflammatory cytokines, proteases up-regulated by immune cells and toxic metabolites, and neurotransmitters released from lysed cells can induce further tissue damage [1–3]. These molecules can also stimulate an inflammatory reaction, with the subsequent release of neurotoxic molecules [1,3]. This subsequent damage, termed the “secondary injury,” causes neuronal cell death and progressive axonal loss over time (days to weeks) laterally and longitudinally to areas undamaged by the initial trauma [2,3]. A primary goal of CNS trauma research has been to prevent or limit secondary cell death that produces further axonal degeneration and creates a significant barrier to the regeneration of descending and ascending fibers [3].

### Description of Process

IL-1 family members are known to alter the host response to an inflammatory, infectious, or immunological challenge [1,4]. The best-known members of this family are IL-1 $\alpha/\beta$ , IL-1Ra, and IL-18. IL-1 $\alpha/\beta$ , IL-18 and IL-33 are highly inflammatory cytokines, and dysregulation of their expression can lead to severe pathobiological effects. Accordingly, the expression of these cytokines is highly regulated via soluble receptors (type 2 IL-1 receptor) and natural antagonist proteins (IL-1Ra and IL-18 binding protein), as well as alternatively spliced forms of both ligands and receptors [4]. IL-1 cytokines exert their function through the Toll-like receptor (TLR)-IL-1 superfamily that can be divided into two groups, the TLRs and receptors of the IL-1 family. Currently there are 10 members of the IL-1 receptor family, and IL-1 ligands typically bind to a cellular receptor complex that consists of two members of this family. For example, the receptor complex for IL-1 $\alpha/\beta$  consists of IL-1R and IL-1RAcP, with IL1Ra acting as a natural antagonist of IL-1 $\alpha/\beta$  by trapping IL-1R1 molecules. The hallmark of IL-1 receptor signaling is the activation of the mitogen-activated protein (MAP) kinases p38, JNK and ERK 1/2 and the transcription factor ► [nuclear factor kappa beta \(NF- \$\kappa\$ B\)](#) [4].

Excessive levels of the proinflammatory cytokines IL-1 $\beta$  and IL-18 are associated with secondary damage following SCI and TBI [3]. Both IL-1 $\beta$  and IL-18 are synthesized as inactive cytoplasmic precursors that are proteolytically processed as biologically active mature

forms in response to proinflammatory stimuli by caspase-1, a cysteine protease. IL-33 has also been described as being processed by caspase-1. The processing of pro-IL-1 $\beta$  involves the activation of a multiprotein caspase-1-activating complex termed the ►inflammasome [5,6]. The inflammasome is formed by a member of the NALP protein family, such as NALP1, NALP2 or NALP3, and the adaptor protein ASC that connects the NALPs with caspase-1 [5]. Activation of the inflammasome ultimately results in activation of proinflammatory IL-1 $\beta$  that is secreted by macrophages and triggers another cascade of molecular events that result in inflammation [4]. To date, only neurons have been reported to contain the inflammasome in the CUS [6]. Thus, there is a need to establish the events critical to the assembly and activation of the inflammasome, and to determine if these principles apply to inflammatory processes within the CNS.

### Higher Level Structures

CNS inflammatory responses that occur after SCI and TBI are initiated by peripherally-derived immune cells (macrophages, neutrophils, and T-cells), and activated glial cells (astrocytes and microglia) that proliferate or migrate into the lesion site following injury [2,3]. T-cells are essential for activating macrophages and mounting a cellular or immune response. Macrophages and neutrophils have also been proposed to participate in tissue destruction and enlargement of the lesion [2,3]. Macrophages and microglia contribute to the secondary pathological and inflammatory response, in part through the release of cytokines, tumor necrosis factor (►tumor necrosis factor (TNF)), interleukin-1 (IL-1), IL-6, and IL-10, interferon [4], and activation of interleukin receptors (IL-4R and IL-2R) [4]. Cytokines facilitate CNS inflammatory responses by inducing expression of additional cytokines, chemokines, nitric oxide (NO), and reactive oxygen [3]. Since inflammation contributes to both constructive and neurodestructive processes, a more thorough understanding of the autoimmune events that occur following CNS injury may allow us to develop strategies that will harness the beneficial effects of inflammation and, hopefully, help to promote functional recovery [3].

### Therapy

Prevention of production of inhibitory proinflammatory molecules by activated mononuclear phagocytes has been demonstrated to be neuroprotective [3]. Various strategies including drug delivery as well as mild hypothermia [3] have been shown to reduce the inflammatory cascade after SCI and provide neuroprotection and improvement in functional outcome. Another strategy has concentrated on targeting selections on the surface of endothelial or inflammatory cells [3]. Interactions of endothelial cell-adhesion molecules with integrins on the white blood cell surface have been

shown to promote leukocyte extravasation through the blood-spinal cord barrier and movement into the injured spinal cord.

It is likely that other agents that prevent the synthesis and secretion of IL-1 family members will be effective in CNS trauma. These are the IL-1 Trap, IL-1 $\beta$ -specific monoclonal antibodies, and the caspase-1 inhibitor [4]. It is also possible that agents that target IL-1 $\beta$  secretion may function to limit inflammation after CNS trauma. Moreover, once released, IL-1 $\beta$  must compete for receptor occupancy with the naturally occurring IL-1Ra, the binding and neutralization by the IL-1 type II decoy receptor and the formation of inactive complexes with constitutively secreted soluble IL-1 accessory protein, each of which also limit IL-1 $\beta$  responses. Moreover, we have recently found that therapeutic neutralization of the inflammatory after SCI reduces IL processing, resulting in significant tissue sparing and functional improvement [6]. Thus, continued investigations into the mechanisms underlying the activation of IL-1 $\beta$  inflammatory cascades after SCI and TBI could lead to new strategies to inhibit secondary injury and thus to promote recovery in injured patients.

### Regulation of Processes

TBI induces upregulation of TNF- $\alpha$  protein and mRNA in the injured cortex [7,8], and increased levels of TNF- $\alpha$  have been reported in plasma and cerebrospinal fluid of human head injured patients [7]. Gene-targeting studies indicate that the presence of TNF- $\alpha$  in the acute posttraumatic period may be deleterious, whereas this cytokine may play a beneficial role in the chronic period after TBI [7,9]. In a similar fashion, spinal cord trauma leads to increased expression of TNFR1 and TNFR2 receptors and their ligands as well as activation of ►caspases and calpain, but there are conflicting reports as to the role of TNF signaling after SCI that probably reflect the known capacity of TNF to be both pro and anti-apoptotic [7,9]. A solution to this paradox has been proposed in the recent findings that tumor necrosis factor receptor (TNFR) submembrane localization and the formation of alternate signaling complexes can alter the fate of cells stimulated through TNFRs [10].

Mammalian TNF- $\alpha$  signals through two cell surface receptors, TNFR1 (CD120a), and TNFR2 (CD120b). Most cells constitutively express TNFR1 while TNFR2 expression is highly regulated. Activation of TNFR1 leads to the recruitment of the adaptor ►TRADD (TNFR-associated death domain protein) that serves as a platform to recruit additional signaling adaptors [9]. TRADD binds the Ser/Thr kinase receptor-interacting protein (►RIP) and TNF-receptor-associated factors 2 (►TRAF2) and 5 (TRAF5). This TRADD-RIP-TRAF complex causes activation of NF- $\kappa$ B, through an unknown mechanism

[9]. TRAF2 can also recruit secondary adaptors that modulate signaling, i.e. TRAF1 and cellular inhibitor of ▶apoptosis protein-1 (▶cIAP-1) and -2 (cIAP-2) [9]. cIAP-1 supports ubiquitination and proteasomal degradation of TRAF2 [8], while TRAF2 inhibits signaling through TNFR2 by an unknown process [8]. Additionally, TNFR1 can recruit caspase-8 via TRADD and Fas-associated death domain protein (▶FADD) to induce apoptosis [9].

Redistribution of TNFR1 in the plasma membrane is one possible mechanism for regulating efficiency of TNF signaling. Recent *in vitro* evidence suggests that redistribution of TNFR1 into specialized microdomains (▶lipid rafts) may account for the outcome of some TNF- $\alpha$ -activated signaling pathways [7,8,9], but TNFR1 localized to nonraft regions of the plasma membrane are capable of initiating different signaling responses [7]. Recently, the role of microdomains in signal transduction emanating from the TNFR family *in vivo* has been addressed [8].

### Higher Level Processes

The TNFR superfamily mediates a wide spectrum of important cellular functions ranging from acute inflammation and lymphocyte co-stimulation to apoptosis and other forms of programmed cell death [7,9]. The divergent cellular signaling responses orchestrated by these receptors are dependent on cell-type and environmental factors [9]. In most instances, TNFR1 triggers cellular activation via NF- $\kappa$ B. However, when new protein synthesis is inhibited prior to TNF stimulation, TNFR1 can initiate apoptosis by activation of apical caspases [7,9]. Recent experimental evidence has provided information about how receptor submembrane localization and the formation of alternative signaling complexes by two members of the TNFR family, TNFR1 and Fas, can alter the fates of cells [8,10]. Here, we discuss how programmed cell death after CNS trauma is a tightly regulated process that can be initiated by activation of a specific TNFR family member TNFR1. Deletion of TNFR1 or blocking ligand interactions with different TNFR family members has emerged as a clinically effective therapy for experimental CNS injury.

In cells of the immune system, TNFR1 signaling involves assembly of two molecularly and spatially distinct signaling complexes that sequentially activate NF- $\kappa$ B and caspases [10]. Early after TNF binding to TNFR1, a TNFR1 receptor-associated complex (complex I) forms and contains TRADD, RIP1, TRAF1, TRAF2 and cIAP-1. Complex I transduces signals that lead to NF- $\kappa$ B activation through recruitment of the I- $\kappa$ B kinase “signalsome” high molecular weight complex [10]. TNFR1-mediated apoptosis signaling is induced in a second step in which TRADD and RIP1 associate with FADD and caspase-8 to form a cytoplasmic complex

(complex II) that dissociates from TNFR1. However, when complex I triggers sufficient NF- $\kappa$ B signaling, anti-apoptotic gene expression is induced and the activation of initiator caspases in complex II are inhibited. If NF- $\kappa$ B signaling is deficient, complex II transduces an apoptotic signal. Thus, early activation of NF- $\kappa$ B by complex I serves as a checkpoint to regulate whether complex II induces apoptosis at a later time point after TNF binding.

Our recent study has shed new light on how membrane proximal events control fate decisions in signaling by TNFR1 in the CNS after TBI [8]. The results support a model in which a small amount of TNFR1 is constitutively expressed in the lipid raft microdomains. It has been proposed that lipid rafts serve as signaling platforms for variety of receptors including TNFR1 and Fas. TNFR1 signaling complexes in the normal CNS contain adaptor molecules TRADD, RIP, TRAF1, TRAF2 and cIAP-1 (Fig. 1) [8]. Since the TNFR1-TRADD-RIP-TRAF2 complex initiates the pathway leading to survival [9], it is probable that the TNFR1 signaling complex in the normal CNS initiates a survival signal. Moreover, this signaling complex is devoid of FADD, cIAP-2 and caspase-8 [8].

CNS trauma induced rapid translocation of TNFR1 to lipid rafts, altered associations with signaling intermediates, and induced transient activation of NF- $\kappa$ B. RIP and cIAP-1 dissociate from TNFR1, whereas FADD and cIAP-2 increase association with this receptor-signaling complex in lipid rafts. Because the TNFR1-TRADD-FADD complex initiates the pathway leading to apoptosis [9], it is possible that alterations in association of adaptor molecules in the signaling complex are responsible for the switch in the signal transduction pathway from survival in the normal CNS toward apoptosis after trauma (Fig. 1). Dissociation of RIP from the TNFR1 signaling complex induced by trauma may ablate or downregulate the NF- $\kappa$ B pathway and facilitate cell death. Additionally, cIAP-1 and cIAP-2 and TRAF1 have been identified as NF- $\kappa$ B target genes [9]. Trauma-induced interference of the NF- $\kappa$ B pathway may result in altered actions of the caspase-8 inhibitory TNFR1-TRAF-IAP complex to further promote apoptosis [9]. By 30 min after CNS trauma, caspase-8 was present in TNFR1 signaling complexes, supporting the idea that the association of FADD with TRADD initiates the apoptotic program by recruiting caspase-8. Thus, in contrast to TNFR1-mediated signaling in cultured cells, these *in vivo* studies do not reveal an essential role of complex II in the regulation of TNF- $\alpha$  responses after CNS trauma, but rather indicate that in both the normal and traumatized CNS, lipid rafts appear to promote the formation of a receptor-associated signaling complex (complex I) to produce different biological outcomes dictated by these complexes. Moreover, complex I in the traumatized CNS



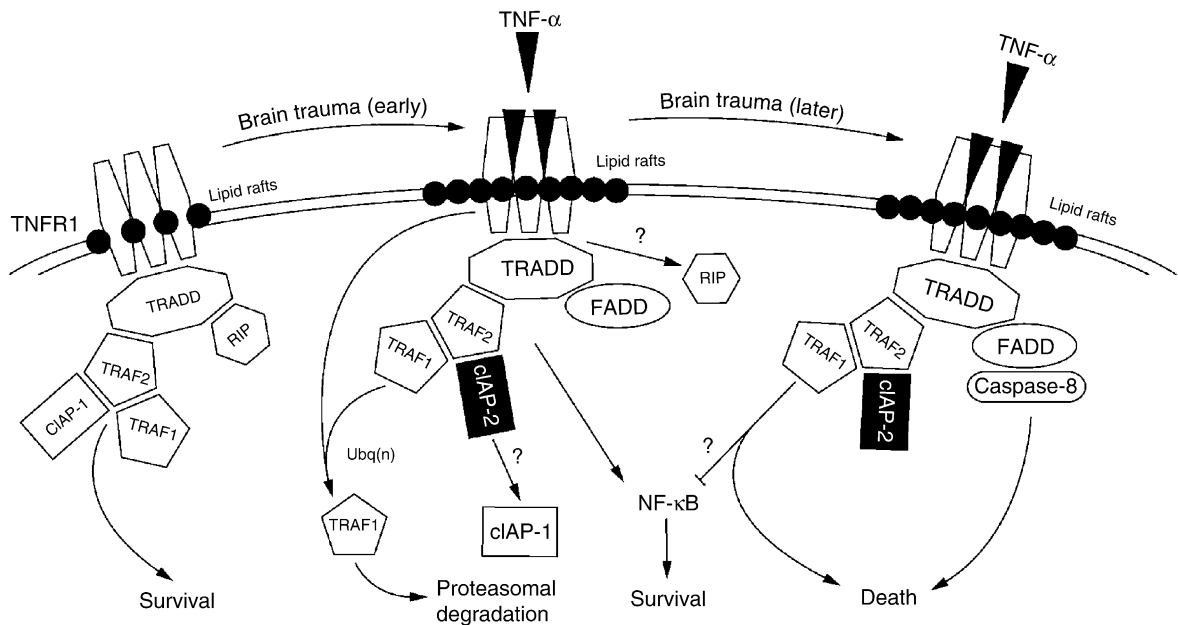

**Neuroinflammation: Brain and Spinal Cord Injury. Figure 1** Model of lipid raft mediated TNFR1 signaling after CNS trauma. In a normal rat CNS low levels of TNFR1 are present in lipid rafts and are in complex with TRADD, TRAF1, TRAF2, RIP and cIAP-1 and signals survival. Early after trauma, increased levels of TNFR1 recruit into lipid raft microdomains (●), where they associate with the adaptor protein TRADD, FADD, TRAF2, TRAF1, and cIAP-2. TNFR1 and TRAF1 are polyubiquitinated (Ubq(n)) in lipid rafts after trauma, which leads to degradation via the proteasome pathway. In later stages after injury, RIP and cIAP-1 appear to dissociate from TNFR1 complex by an unknown mechanism, and this complex signals death by activating caspase-8 [8].

harbors activated caspase-8 by 30 min after insult, indicating involvement in downstream signaling cascades. Therefore, the death domain of TRADD may act as a central platform for the recruitment and activation of FADD after CNS trauma, leading to subsequent binding of caspase-8 triggering their activation. These studies support recent evidence that the roles for lipid rafts in Fas and TNFR1 signaling varies between cell types [8,10]. Thus, TNFR signaling is dependent on cell type and subject to influence of other signaling pathways, genetic and environmental factors.

The IL-1 and TNF family of cytokines have been mainly characterized in the immune system and are primarily involved in regulating inflammatory and apoptotic responses. However, these cytokines are detectable in other tissues, for example the normal and traumatized CNS, raising the possibility that these cytokines and their receptors have a role in neurological trauma and disease. There is increasing interest in the role of inflammatory processes in CNS injury, since inactivation neuroprotection in animal models of SCI, stroke and multiple sclerosis [3]. However, a true understanding of how reducing inflammation after CNS injury leads to inhibition of cell death and enhance functional recovery will require more detailed knowledge. For example, the signaling pathways initiated by the IL-1 and TNF receptors in CNS cells have not been delineated. It is

not clear if CNS cells exhibit differences in the efficiency of IL-1 or TNF signaling and thus can be categorized as cells in the immune system. The cellular source and target of the ligand in damaged CNS tissues need to be identified, and protocols need to be developed to deliver antibodies to the lesion at later stages to clearly evaluate this therapeutic approach.

Recent experimental evidence has provided information about how receptor submembrane localization and the formation of alternative signaling complexes can alter the fates of cells *in vitro*, but whether these principles apply to signaling mediated by TNFR family members in the normal CNS and after trauma awaits further experimentation. Thus, activation of these signaling pathways might become promising therapeutic targets for the acute treatment of neurological trauma and disease.

#### Acknowledgments

We would like to thank Dr. George Lotocki for the illustration. The work was supported in part by NIH PO1 NS 38665.

#### References

1. Benveniste EN (1992) Inflammatory cytokines within the central nervous system: sources, function, and mechanism of action. *Am J Physiol* 263:C1-C16

2. Bethea JR, Dietrich WD (2002) Targeting the host inflammatory response in traumatic spinal cord injury. *Curr Opin Neurol* 15:355–360
3. Dietrich WD, Chatzipanteli K, Vitarbo E, Wada K, Kinoshita K (2004) The role of inflammatory processes in the pathophysiology and treatment of brain and spinal cord trauma. *Acta Neurochir (Suppl)* 89:69–74
4. Dinarello CA (2005) Blocking IL-1 in systemic inflammation. *J Exp Med* 201:1355–1359
5. Martinon F, Burns K, Tschopp J (2002) The inflammasome: A molecular platform triggering activation of inflammatory caspases and processing of proIL- $\beta$ . *Mol Cell* 10:417–426
6. de Rivero Vaccari JP, Lotocki G, Marcillo AE, Dietrich WD, Keane RW (2008) A molecular platform in neurons regulates inflammation after spinal cord injury. *J Neurosci* 28:3404–3414
7. Keane RW, Davis AR, Dietrich WD (2006) Inflammatory and Apoptotic signaling after spinal cord injury. *J Neurotrauma* 23:335–344
8. Lotocki G, Alonso OF, Dietrich WD, Keane RW (2004) Tumor necrosis factor receptor 1 and its signaling intermediates are recruited to lipid rafts in the traumatized brain. *J Neurosci* 24:11010–11016
9. Wajant H, Pfizenmaier K, Scheurich P (2003) Tumor necrosis factor signaling. *Cell Death Differ* 10:45–65
10. Micheau O, Tschopp J (2003) Induction of TNF receptor I-mediated apoptosis via two sequential signaling complexes. *Cell* 114:181–190

## Neuroinflammation: Chronic Neuroinflammation and Memory Impairments

JUNG-SOO HAN

Department of Biological Sciences, Konkuk University, Seoul, South Korea

### Synonyms

Neuroinflammation, VSAIDs

### Definition

#### Neuroinflammation and NSAIDs

Neuroinflammatory responses are characteristics of pathologically affected tissue in several neurodegenerative disorders, including Alzheimer's disease (AD). Epidemiological studies have shown that conventional long-term treatments with non-steroidal anti-inflammatory drugs (▶NSAIDs) reduce the risk of AD, delay the onset of this disease, ameliorate symptomatic severity, and slow cognitive decline. A transgenic AD Tg2576 mouse has amyloid pathology and activated microglia. Daily intake of ibuprofen, a NSAID, reduces the levels of the inflammatory cytokine, reactive ▶astrocytes

with glial fibrillary acidic protein (GFAP),  $\beta$ -amyloid deposits, and activated microglia in these AD mice. Rats with intraventricular chronic infusion of  $\beta$ -amyloid or ▶lipopolysaccharide (LPS; ▶endotoxin) show microglial activation and ▶memory impairment. NSAID treatments rescued memory impairment of these rats and lowered inflammatory responses. Thus, these anti-inflammatory agents can significantly delay inflammatory responses characterized by activated glial cells and increased expression of cytokines surrounding amyloid deposits of AD pathology and prevent cognitive decline, as inflammation clearly occurs in the AD brain.

### Characteristics

#### Alzheimer's Disease and Neuroinflammation

AD typically leads to progressive and incapacitating memory loss followed by additional cognitive and behavioral impairments. A neuropathological diagnosis of AD is made upon the detection of amyloid plaques and neurofibrillary ▶tangles (NFTs) in the limbic and neocortical areas of the brain. However, AD is now also characterized by neuroinflammatory changes and increased free radicals, as well as classic neuropathological features such as amyloid plaques, neuronal loss, and NFTs [1,2]. *In vivo* measurements of microglial activation using positron emission tomography (PET) and magnetic resonance imaging (MRI) show that inflammation is an early event in the pathogenesis of AD [3]. Further, a chronic inflammatory response characterized by activated microglia, reactive astrocytes, complement factors, and increased inflammatory cytokine expression is associated with amyloid plaques in the AD brain [4].

Chronic inflammatory processes play an important role in the pathogenesis of AD [4]. Clumps of activated microglia and reactive astrocytes appear on ▶senile plaques [1]. The levels of inflammatory cytokine interleukin-1-alpha (IL-1 $\alpha$ ) are increased in the AD brain [5]. The increase in IL-1 $\alpha$  might both underlie and be due to widespread astrogliosis in the AD brain. Additionally, IL-1 $\alpha$  could induce the expression of the  $\beta$ -amyloid precursor protein ( $\beta$ -APP). Senile plaques contain both  $\beta$ -amyloid and reactive microglial cells that excessively express inflammatory cytokines, including IL-1 $\alpha$  and tumor necrosis factor-alpha (TNF- $\alpha$ ). Further, activated microglia is a source of free radicals and neurotoxic materials. One potential neurotoxin released by activated microglia is glutamate. Chronic increase of extracellular glutamate impairs the glutamatergic receptor function, leading to the entry of toxic amounts of calcium into neurons and subsequently potentiation of neurotoxicity [3].

There is now overwhelming evidence that a state of chronic inflammation exists in affected regions, although it must still be determined whether inflammation

merely occurs to clear the detritus of already existent pathology (plaques/tangles) or inflammatory molecules and mechanisms are uniquely or significantly elevated in the AD brain [6].

### Animal AD Model for Neuroinflammation

Well-characterized animal models with important neuropathological features seen in AD have significantly advanced our understanding of the molecular mechanisms of AD and are important in predicting future therapeutic intervention. In the following, I introduce two animal AD models currently used extensively by neuroscientists.

#### A Transgenic Mice Model for AD

Targeted gene mutation technology represents a powerful new tool for biomedical research. A new gene or an additional copy of an existing gene is added to the genome in the transgenic mice and a gene is missed in the knockout (KO) mice. Transgenic mice expressing mutated human amyloid, human presenilin 1, or both show dramatic parallels to AD. However, none of the models appear to have the full pathological characteristics of human AD.

The most popular Alzheimer transgenic mouse model is the Tg2576 mouse, which carries a human familial AD gene (amyloid peptide protein;  $\beta$ -APP with the "Swedish" double mutation). The model displays age-related neuritic plaque pathology, activated microglia, and reactive astrocytes with increased GFAP (glial fibrillary acid protein) in the hippocampal and neocortical areas. More importantly, these mice show age-related memory deficits linked to defective **long-term potentiation (LTP)**.

These AD transgenic models are being used to devise therapeutics strategies for AD. Specifically drugs or procedures that reduce the accumulation of  $\beta$ -amyloid in the mouse models are considered to be potential treatments for AD. One limitation of this approach is that such mice are only partial models of AD. They show abundant  $\beta$ -amyloid deposits, which are comparable to those observed in AD. However, in contrast with AD, the mice do not demonstrate the presence of NFTs. In the transgenic mice, complement staining of the deposits is weak, whereas as in AD it is very strong.

With the emergence of the transgenic/KO mouse models, the need for behavioral studies measuring the cognitive abilities of the mouse has become more urgent. Despite this, few studies to characterize cognitive behaviors with many different mouse strains have been reported. Furthermore, because the behaviors of mice are different from those of the rat, direct comparison of results for mice with those for rats is not fruitful. Therefore, much caution is needed in conducting behavioral experiments measuring memory impairment or enhancement by a given treatment when working with

transgenic mice (for example background strains or wild-type littermate controls for a null mutation).

On the contrary, behavioral tasks for measuring cognitive abilities with rats have been well studied and characterized. Conclusive and reliable decisions regarding rat behavioral data can be easily reached through comparison with the results of reported studies. On this basis, an AD rat model has been introduced.

#### Chronic LPS Infusion Rat Model

$\beta$ -Amyloid or proinflammagen (such as LPS and interleukin (IL)-2) was chronically infused into the rat ventricle at a very low dose. LPS is a component of the cell wall of gram-negative bacteria and has been used experimentally to stimulate production of endogenous IL-1,  $\beta$ -APP and complement proteins. The chronic infusion of LPS into the brain via the fourth ventricle for 4 weeks reproduces important aspects of the pathology of AD.

Chronic LPS infusions increased the number and density of OX-6-positive reactive microglia, the immune competent cells of the CNS, in the hippocampus of Fischer-344 rat (see Fig. 1). The number and density of astrocyte, observed by GFAP, was also affected. Rats with chronic LPS infusion take longer to find a hidden platform in the Morris water maze, relative to rats with artificial cerebrospinal fluid (aCSF) (see Fig. 2). *Arc* is an immediate-early gene that was cloned from the brain and is a good indicator of neuronal activation by physiological stimuli including LTP induction and seizures. Exploration-induced *Arc* protein expression within the dentate gyrus (DG) is altered in the hippocampus of rat with cognitive impairment by neuroinflammation. LPS activates microglia to initiate a series of inflammation-induced changes within the hippocampus and entorhinal cortex. The inflammation leads to a reduction in the number of NMDA glutamate receptors within the DG and CA3 hippocampal area without neuronal loss. Furthermore, LPS-induced neuroinflammation impairs the induction of LTP. According to MRI results, the size of the hippocampal formation and the temporal region was decreased. These aspects of the chronic LPS infusion model make it useful for testing potential pharmacotherapies for the prevention of AD [3].

#### Neuroinflammation of AD and NSAID

Because the inflammatory process is the pathological hallmark associated with AD, it is not surprising that conventional anti-inflammatory therapy using NSAIDs has been shown to slow the progress, or delay the onset, of AD. Untreated elderly demented patients with senile plaques have almost three times more activated microglia than do those patients with senile plaques chronically taking NSAIDs. Neuronal cyclooxygenase (COX)-2 is elevated in the AD brain: long-term

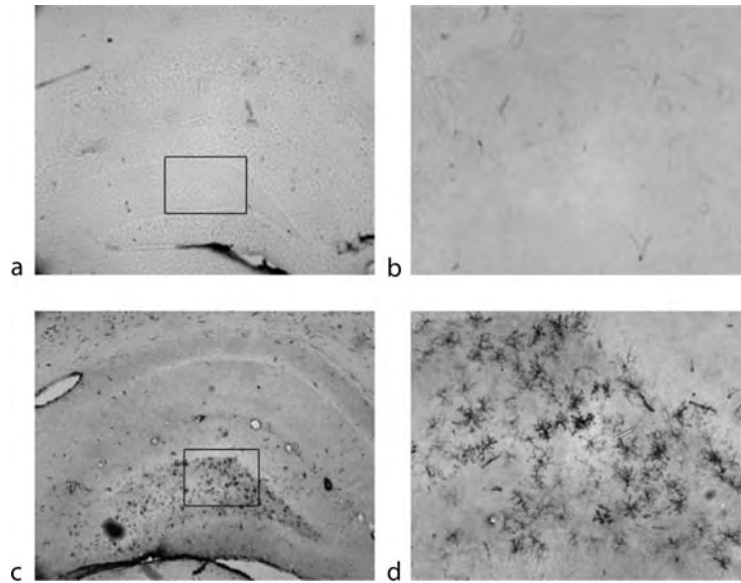

**Neuroinflammation: Chronic Neuroinflammation and Memory Impairments. Figure 1** Reactive microglia stained with OX-6 in the hippocampus. Fischer-344 rats infused with aCSF have only a few activated microglia (a, b). Chronic infusion of LPS into the fourth ventricle produces activated microglia distributed throughout the hippocampus of the Fischer-344 rat brain. Activated microglia were expressed highly in dentate gyrus (c, d). (courtesy of Jung-Soo Han).

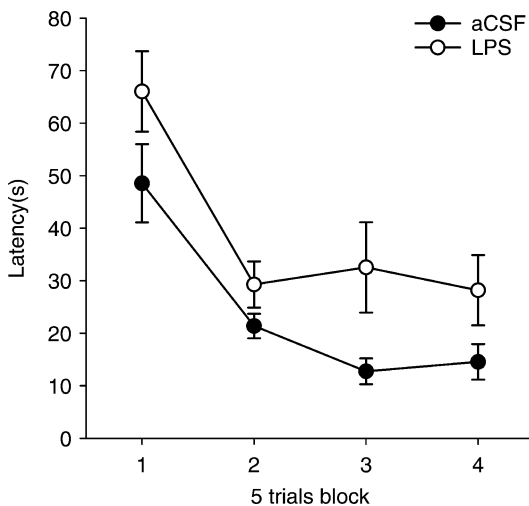

**Neuroinflammation: Chronic Neuroinflammation and Memory Impairments. Figure 2** Assessment of spatial learning in rats with LPS infusion and rats with aCSF infusion. Mean latency ( $\pm$ ) to reach the escape platform across four blocks of five training trials during the spatial learning task. Fischer-344 rats with LPS or aCSF infusion received three trails/day trainings (1 min intertrial interval, maximum trail duration of 90 s with 30 s on the platform at the end each trial) in the hidden platform training. Rats with LPS infusion perform more poorly in the spatial learning task than rats with aCSF. (courtesy of Jung-Soo Han).

inhibition of this enzyme might underlie the beneficial effects of NSAID therapy in AD [7].

Ibuprofen is a NSAID, and is widely used to reduce pain, fever, and inflammation. The drug inhibits COX enzymes and activates peroxisome proliferator-activated receptors gamma ( $\blacktriangleright$ PPAR $\gamma$ ); both of these actions result in reduced inflammation. In addition, ibuprofen suppresses cerebral plaque formation and inflammation in a mouse model of Alzheimer's disease [8]. However, a major limitation of NSAIDs, such as ibuprofen with respect to the prevention of AD is gastrointestinal and occasional liver and kidney toxicity caused by cyclooxygenase (COX-1) inhibition. These side effects have stimulated a search for alternative anti-inflammatory drugs and, alternatively, attempts to structurally modify existing NSAIDs so as to eliminate their COX-1 inhibition. Many modified NSAID or natural products are tested in animal models or clinically. Two alternatives among them are introduced below.

NO-flurbiprofen, a novel NSAID that lacks gastrointestinal side effects, attenuated the neuroinflammatory reaction and reduced inflammation-induced memory deficit in the chronic LPS infusion rat model [3].  $\beta$ -Amyloid is also reduced in doubly transgenic (Tg) amyloid precursor protein plus presenilin-1 mice when NO-flurbiprofen is administered between 7 and 12 months of age [9].

Oxidative damage and neuroinflammation are closely associated with the progression of AD and

other neurological diseases. In the search for antioxidant and anti-inflammatory agents to reduce ROS and inflammation, the phenolic antioxidant ► **curcumin**, a yellow curry spice derived from turmeric, has proved to be of interest. This spice is used as a food preservative and herbal medicine in India, where the prevalence of AD in patients between 70 and 79 years of age is 4.4-fold less than that of the United States. In comparison with vitamin E used clinically [10], curcumin is several times more potent as a free radical scavenger. Based on these considerations, curcumin has been evaluated in some animal studies. In an AD transgenic Tg2576 mouse model, curcumin lowers oxidized proteins and IL-1 $\beta$ . The astrocytic marker GFAP and  $\beta$ -amyloid is also reduced by curcumin treatment [11]. Preventive effects of curcumin on the cognitive deficits have also been tested in a rat model with intracerebroventricular infusion of  $\beta$ -amyloid peptides. Dietary intake of curcumin prevents  $\beta$ -amyloid-infusion induced spatial memory deficits in the Morris Water Maze [12].

### Summary

Inflammation clearly occurs in the AD brain. In the periphery, degenerating tissue and the deposition of insoluble materials are classical stimulants of inflammation. Likewise, in the AD brain, damaged neurons, neuritis, deposits of insoluble  $\beta$ -amyloid, and neurofibrillary tangles stimulate the inflammation. Direct and bystander damage in AD is cumulated over many years and significantly exacerbates the pathological process. Thus, animal models and clinical studies suggest that inflammation in AD contributes to AD pathogenesis. While anti-inflammatory approaches (for example, NSAID) may not cure AD, it is possible that they will delay onset and slow the progression of this disease as well as slow cognitive decline.

### References

- McGeer EG, McGeer PL (2003) Inflammatory processes in Alzheimer's disease. *Prog Neuropsychopharmacol Biol Psychiatry* 27:741–749
- Haddad JJ (2004) Mitogen-activated protein kinases and the evolution of Alzheimer's: a revolutionary neurogenetic axis for therapeutic intervention? *Prog Neurobiol* 73:359–377
- Wenk GL, Hauss-Wegrzyniak B (2003) Chronic inter-cerebral LPS as a model of neuroinflammation. In: Wood PL (ed) *Neuroinflammation*, 2nd edn. Humana Press, Totowa, NJ, pp 137–150
- Akiyama H, Barger S, Barnum S, Bradt B, Bauer J, Cole GM, Cooper NR, Eikelenboom P, Emmerling M, Fiebich BL, Finch CE, Frautschy S, Griffin WS, Hampel H, Hull M, Landreth G, Lue L, Mrak R, Mackenzie IR, McGeer PL, O'Banion MK, Pachter J, Pasinetti G, Plata-Salaman C, Rogers J, Rydel R, Shen Y, Streit W, Strohmeyer R, Tooyoma I, Van Muiswinkel FL, Veerhuis R, Walker D, Webster S, Wegrzyniak B, Wenk G, Wyss-Coray T (2000) Inflammation and Alzheimer's disease. *Neurobiol Aging* 21:383–421
- Zhu SG, Sheng JG, Jones RA, Brewer MM, Zhou XQ, Mrak RE, Griffin WS (1999) Increased interleukin-1 $\beta$  converting enzyme expression and activity in Alzheimer disease. *J Neuropathol Exp Neurol* 58:582–587
- Rogers J, Webster S, Lue LF, Brachova L, Civin WH, Emmerling M, Shivers B, Walker D, McGeer P (1996) Inflammation and Alzheimer's disease pathogenesis. *Neurobiol Aging* 17:681–686
- Ho L, Purohit D, Haroutunian V, Luterman JD, Willis F, Naslund J, Buxbaum JD, Mohs RC, Aisen PS, Pasinetti GM (2001) Neuronal cyclooxygenase 2 expression in the hippocampal formation as a function of the clinical progression of Alzheimer disease. *Arch Neurol* 58:487–492
- Lim GP, Yang F, Chu T, Chen P, Beech W, Teter B, Tran T, Ubeda O, Ashe KH, Frautschy SA, Cole GM (2000) Ibuprofen suppresses plaque pathology and inflammation in a mouse model for Alzheimer's disease. *J Neurosci* 20:5709–5714
- Jantzen PT, Connor KE, DiCarlo G, Wenk GL, Wallace JL, Rojiani AM, Coppola D, Morgan A, Gordon MN (2002) Microglial activation and beta-amyloid deposit reduction caused by a nitric oxide-releasing nonsteroidal anti-inflammatory drug in amyloid precursor protein plus presenilin-1 transgenic mice. *J Neurosci* 22:2246–2254
- Zandi PP, Anthony JC, Khachaturian AS, Stone SV, Gustafson D, Tschanz JT, Norton MC, Welsh-Bohmer KA, Breitner JC (2004) Reduced risk of Alzheimer disease in users of antioxidant vitamin supplements: the Cache County Study. *Arch Neurol* 61:82–88
- Lim GP, Chu T, Yang F, Beech W, Frautschy SA, Cole GM (2001) The curry spice curcumin reduces oxidative damage and amyloid pathology in an Alzheimer transgenic mouse. *J Neurosci* 21:8370–8377
- Frautschy SA, Hu W, Kim P, Miller SA, Chu T, Harris-White ME, Cole GM (2001) Phenolic anti-inflammatory antioxidant reversal of A $\beta$ -induced cognitive deficits and neuropathology. *Neurobiol Aging* 22:993–1005

## Neuroinflammation: Modulating Pesticide-induced Neurodegeneration

HASSAN R. DHAINI<sup>1,2</sup>

<sup>1</sup>Faculty of Health Sciences, University of Balamand, Ashrafieh, Beirut

<sup>2</sup>Faculty of Health Sciences, American University of Beirut, Lebanon, Beirut

### Synonyms

Biomagnification: high environmental persistence; Reactive oxygen species: superoxide anions; Hydroxyl free radicals; Pesticide: insecticide; Herbicide

### Definition

The term ► **pesticide** describes a chemical capable of being used to control pests to humans, agricultural crops, commercial operations, and households.

Promoting research in this area has resulted in a clear understanding of pesticide toxicological properties. Today, pesticides are considered to be one of the most thoroughly understood chemicals from a toxicological standpoint. Modern strategies in pest control have attempted to design compounds of high selectivity and low ►environmental persistence. Ideally, a pesticide would be selective only to the targeted species and would be non-persistent in the environment. However, these attempts have not been entirely successful. Non-persistent insecticides, such as carbamates and organophosphates, are currently in use but they are not considered as truly selective compounds. Most pesticides currently in use are toxic to humans, and present an environmental and occupational hazard [1].

Many of the used pesticides, whether applied as systemics, aerosols, baits, or fumigants, have been associated with some form of nervous toxicity. Moreover, increasing indications suggest that the pathogenesis of a number of chronic neurodegenerative diseases such as Idiopathic Parkinson's disease (PD), Alzheimer's disease (AD), multiple sclerosis, trauma, and stroke, may be influenced by exposure to infectious agents and pesticides. On the other hand, emerging evidence indicates that the development of these neurological disorders may be mediated by a complex cycle of atypical inflammation steps involving brain immune cells, mainly astrocytes and microglia.

Microglia, considered as the macrophages of the central nervous system (CNS; brain), are normally present in a down-regulated state, and serve the role of immune surveillance. When exposure to an environmental toxicant takes place, microglia change morphology and become active in phagocytosis and in producing inflammatory molecules. In parallel, astrocytes, which normally maintain neuronal homeostasis, also become active and serve in up-regulating the expression of neurotrophic factors and local mediators, and limiting the area of injury. Astrocytes are believed to react whenever the brain is injured by putting down glial scar tissue as part of healing. This whole process, mechanistically distinct from peripheral tissues inflammation, is known as neuroinflammation.

Whether neuroinflammation is harmful or protective to the nervous system, especially in cases of exposure to pesticides, is still a controversial issue. Studies using strategies aimed at both suppressing and inducing the process of neuroinflammation may be successful in identifying new treatments for common neurodegenerative diseases.

## Characteristics

### Description of Neuroinflammation

Inflammation is the first response of the immune system to infection or irritation. It is characterized by redness (*rubor*), heat (*calor*), swelling (*tumor*), and pain (*dolor*), and constitutes the body's initiation of healing.

Although inflammation is considered a defensive mechanism, an exaggerated inflammatory response has been shown to cause additional injury to cells of the host. In the adult CNS, mainly the brain, damage often leads to persistent deficits due to the inability of mature post-mitotic axons to regenerate after injury [2]. This makes host cells in this particular area highly susceptible to injury and inflammatory processes. Inflammation associated with the CNS, known as neuroinflammation, differs from that found in the periphery. It does not involve any pain due to absence of pain fibers in the brain, and does not show any classic signs of inflammation such as redness, swelling, or heat. The process is usually mediated by cytokines following a direct injury to the nervous system, and systemic tissue injury in rare cases. Neuroinflammation involves neural-immune interactions that activate immune cells, glial cells, and neurons in response to injury [3].

### Activation of Astrocytes and Neurons

Astrocytes are considered as the most abundant cells in the brain. They are involved in maintaining the functional integrity of neuronal transmission and general activity. Astrocytes become activated in response to brain injuries and produce many pro-inflammatory molecules such as interleukins, prostaglandins, leukotrienes, thromboxanes, coagulation factors, complement proteins, and proteases. In addition, activated astrocytes promote repair of damaged tissues. Certain chemokines released by activated astrocytes attract microglia, which amplifies production of pro-inflammatory molecules. On the other hand, neurons themselves participate in the production of inflammatory molecules, mainly complement proteins.

An increasing amount of data has shown that the production of these molecules by astrocytes and neurons may in fact create an oxidative stress microenvironment that leads to neuronal toxicity and cell death. Studies on neuro-immune-endocrine interactions have shown that the hypothalamic-pituitary-adrenal axis (HPA) plays a key role in protecting cells from oxidative stress through suppression of redox-sensitive transcription factor, nuclear factor (NF)- $\kappa$ B [4]. Several studies have demonstrated that the accumulation of pro-inflammatory and cytotoxic factors by activated glia induces ►neural degeneration. Neurotoxicity has been associated with high levels of nitric oxide (NO), superoxide anions, and other toxic intermediates [5]. Reports on lipid-derived mediators of inflammation, mainly prostaglandins E<sub>2</sub> and I<sub>2</sub>, were shown to induce edema, which is deleterious to neuronal function and survival. In addition, several ►reactive oxygen species, such as superoxide anion and hydroxyl radical, were found to be released as byproducts of cyclooxygenase Cox-2 catalytic activity, a key enzyme in inflammatory response, thus leading to brain damage [6]. Emerging experimental evidence demonstrates that the inhibition of the inflammatory response can slow down degeneration of

dopamine-containing neurons in PD models. In fact, the use of anti-inflammatory steroids was reported to decrease the production of cytokines and NO, and consequently attenuating degeneration of dopamine-containing neurons in models mimicking PD [7]. Another study conducted in rat animal models has shown that inhibition of neurotoxic factors production, such as tumor necrosis factor alpha (TNF- $\alpha$ ), superoxide, and NO, reduces damage to dopamine-containing neurons [8].

### **Role of Reactive Microglia in Neuroinflammation**

The activation of microglia is seen as a major step in brain inflammation. Microglial cells support and protect neurons of the CNS. They are mainly composed of mesodermally-derived macrophages and are able to release a number of inflammatory molecules including pro-inflammatory cytokines, chemokines, superoxide anions, and complement proteins. In addition, microglia have phagocytic and surveillance properties. Studies have shown that microglia are sensitive even to minor disturbances in CNS homeostasis [9]. More importantly, microglia play a key role in cellular responses to pathological lesions such as those of dopaminergic neurons in PD, and such as extracellular deposits of  $\beta$ -amyloid and intracellular neurofibrillary plaques seen in AD. These lesions can recruit and activate microglia around them in the brain. In addition, microglia can express scavenger receptors that facilitate their adhesion to injury sites [10,11].

Reactive microglia exert a protective role through clearance of cellular debris, destruction of foreign particles and release of neurotrophic factors such as the glia-derived neurotrophic factor (GDNF), and the insulin-degrading enzyme (IDE) that destroys damaged protein deposits. However, several studies have demonstrated that the production and buildup of pro-inflammatory and cytotoxic factors may have a negative impact on neurons leading to neurodegeneration. Resulting neurotoxicity is thought to be caused by increased production of NADPH-derived superoxide anions, which leads to additional neuronal damage. In addition, neurotoxicity is aggravated by microglial release of interleukins IL-1, IL-6, IL-8, tumor necrosis factor alpha (TNF- $\alpha$ ), and other inflammatory proteins. In addition, increased levels of nitric oxide (NO) have been associated with neurotoxicity [12].

### **Association between Pesticide Exposure and Neurodegeneration**

All chemical pesticides in use today are poisonous to the nervous system of the target species. Pesticides are not highly selective and may affect humans. Exposure to pesticides has long been suspected as a risk factor for a number of neurodegenerative diseases including PD and AD [13]. The identification of chemicals inducing neurodegeneration symptoms, as in the case of 1-methyl-4-phenyl-1,2,3-tetrahydropyridine MPTP-induced

Parkinsonian symptoms, is in support of the search for environmental factors at the basis of neurodegenerative diseases. Extensive literature suggests that exposure to pesticides is a risk factor for PD and AD. Many studies have established an association of PD risk with living in rural areas, drinking well water, and farming.

### **Neurotoxicity of Organochlorines in PD**

Organochlorines are a diverse group of agents belonging to three distinct chemical classes that include dichlorodiphenylethane, chlorinated cyclodienes, and chlorinated benzenes. Organochlorines are effective pesticides due to low volatility, chemical stability, lipid solubility, and slow rate of biotransformation and degradation. As a result, these compounds have high persistence and high biomagnification which makes them a serious hazard. Several studies have linked exposure to organochlorines and increased risk of neurodegeneration [14].

One organochlorine, dieldrin, has been detected in postmortem brain samples from PD patients. Studies have shown that dieldrin exhibit selective dopamine-depleting neurotoxicity effects by causing superoxide formation and **lipid peroxidation**. Similarly, dichlorodiphenyl-trichloroethane (DTT), another commonly used organochlorine, has been detected in postmortem brain samples from AD patients. Studies on other members of the organochlorine family showed that production of a direct toxic effect is a function of individual genetic factors, mainly drug-metabolizing enzymes such as cytochromes P-450 (**cytochrome P-450**) genetic polymorphism, in addition to frequency of exposure to pesticides [15].

### **Description of Organophosphates-Induced Neurodegeneration**

Currently used organophosphorus ester insecticides (OP) are at least four generations of development away from the early nerve gases. Organophosphates elicit their toxicity through inhibition of acetylcholinesterase AChE, the enzyme responsible for terminating the activity of the neurotransmitter acetylcholine at the level of post-synaptic neurons. Case reports have associated development of Parkinsonism with exposure to organophosphate insecticides.

In addition to general central nervous toxicity symptoms, OPs have been shown to cause a persistent neuropathy with a delayed onset known as organophosphate-induced delayed neuropathy (**OPIDN**). This involves slow degeneration of the nervous system seven to fourteen days after exposure to certain OPs at high doses. Causes of OPIDN are still not very well understood; it is hypothesized that OPIDN is caused by the inhibition of Neurotoxic Target Esterase (NTE), an enzyme involved in lipid metabolism. In cases of chronic exposure, initial binding of the pesticide to the enzyme is reversible. However, the AChE-OP complex might undergo what

is commonly known as “aging.” This occurs when the complex dealkylates itself to form an irreversibly inhibited AChE enzyme ultimately leading to neurodegeneration in the axons [16].

### Mechanisms of Neurodegeneration by Rotenone

Rotenoids are another class of insecticide whose environmental exposure has been associated with increased neurodegeneration. The naturally occurring rotenone is a widely used rotenoid that inhibits complex I, the first enzyme of the mitochondrial respiratory chain. Complex I dysfunction is a feature of idiopathic PD and is linked to many other neurodegeneration disorders, such as that of retinal ganglion cells in ▶Leber’s optic neuropathy. Moreover, exposure to rotenone in rats has been shown to produce highly selective neural degeneration similar to that found in PD. In recent years, several studies have demonstrated that continuous exposure to rotenone in rats leads to degeneration of the nigrostriatal dopaminergic system accompanied by movement disorders. In addition, rotenone was shown to exhibit a markedly high toxicity by activating microglia, which releases superoxide free radicals and facilitates degeneration of dopaminergic neurons. Further studies using enzyme inhibitors suggest that rotenone-induced release of superoxide is mediated by microglial NADPH oxidase, a major superoxide generator in immune cells of the nervous system. In addition, rotenone and certain inflammogens

have been reported to exert synergistic dopaminergic neurotoxicity [17].

### Association between Exposure to Paraquat and PD

Most herbicides are formulated to be toxic to plant biochemical systems that are absent in mammals. Human exposure to paraquat (PQ), a very commonly used weed killer, is known to cause lung fibrosis in addition to liver and kidney damage. Lately, studies on PQ have suggested that this herbicide may be an environmental factor contributing to PD. Paraquat was found to cause damage through generation of highly toxic superoxide anion. Although the biochemical mechanism is not yet fully understood, some evidence suggests that PQ-induced lipid peroxidation and resulting cell death of dopaminergic neurons may underlie the onset of the Parkinsonian syndrome or, to the least, influence the natural course of the disease [18].

### The Role of Inflammation in Modulating the Effect of Pesticides

The activation of microglia and astrocytes observed in patients with neurodegenerative disorders, mainly PD and AD, and in animal models suggest an involvement of neuroinflammation in the progression of these diseases. The observed synergism in neurotoxicity between pesticides and inflammogens, in addition to pesticide-pesticide interaction, may support

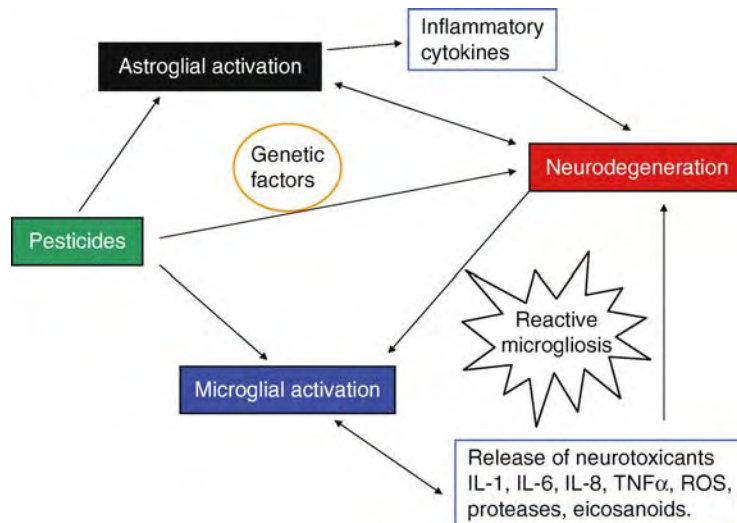

**Neuroinflammation: Modulating Pesticide-induced Neurodegeneration. Figure 1** Proposed mechanism of pesticides-induced neurodegeneration and deleterious glial modulation. Exposure to pesticides induces astrocytes and microglia activation while directly causing neuronal injury. Activated glia produce a wide array of pro-inflammatory factors and neurotoxicants, mainly cytokines, Interleukins, reactive oxygen species, proteases, and eicosanoids, which aggravate neuronal damage. This in turn will lead to further microglia activation. A self-propelling cycle is formed: microglial activation cause neurodegeneration while neuronal injury due to direct interaction with pesticides leads to additional glial activation; this further exacerbates neurodegeneration. Abbreviations: *IL*, interleukins; *TNF- $\alpha$* , tumor necrosis factor-alpha; *ROS*, reactive oxygen species.



a multifactorial hypothesis underlying observed neurodegeneration. Experimental evidence showing that inhibition of inflammation correlates with attenuated neuronal damage supports such notion.

Following exposure to pesticides, microglia and astroglia are activated, thus releasing a wide range of neurotoxic endogenous factors, such as superoxide and cytokines. These factors bind directly to their receptors on the targeted neurons to activate an apoptotic pathway. In addition, cytokines lead to release of NO through the induction of NO synthase and Cox-2 within glial cells. Nitric oxide may react with superoxide to form a more potent intermediate: peroxynitrite (ONOO<sup>-</sup>). Peroxynitrite can cross the cell membrane and cause neuronal injury. In addition, superoxide may convert to hydrogen peroxide (H<sub>2</sub>O<sub>2</sub>), thus adding to neuronal toxicity directly or by amplifying other neurotoxic factors in microglia [19]. Overall, activated glial cells produce a variety of pro-inflammatory and neurotoxic factors that aggravate neuronal damage. At the same time, direct interaction of pesticides with nerve cells causes neuronal injury. Damaged neurons stimulate an inflammatory response including reactive microgliosis and astrogliosis. These, in turn, will cause further neuronal damage. In fact, regardless of the origin of triggering factors, a vicious cycle is created. Pesticide-induced neuronal damage and neuroinflammation amplify each other in the form of a self-propelling vicious cycle (Fig. 1). Microglial activation leads to neurotoxicity while neuronal injury due to interaction with pesticides leads to additional glial activation; this further exacerbates neurotoxicity leading ultimately to neurodegeneration [20]. The progress of such cycle over a long period of time, especially in cases of chronic or occupational exposure to pesticides, in addition to potential genetically predisposing factors such as drug-metabolizing enzymatic pathway alterations, may lead to synergistic neurodegeneration and the development of symptomatic PD and AD [21].

Much remains to be investigated about the role of pesticides in neurodegeneration, and the potential role of microglial cells in the development of neurodegenerative diseases, mainly PD and AD. However, one thing is certain, the brain's immune system is deeply involved in both diseases, and further studies on neuroinflammation seems promising in contributing significantly to the discovery of new treatments.

## References

1. Timbrell J (2002) Introduction to toxicology, 3rd edn. CRC Press, Boca Raton, FL, pp 109–120
2. Hiu G, He Z (2006) Glial inhibition of CNS axon regeneration. *Nat rev Neurosci* 7(8):617–627
3. Haddad JJ (2007) On the enigma of pain and hyperalgesia: a molecular perspective. *Biochem Biophys Res Commun* 353(2):217–224
4. Haddad JJ, Saade NE, Safieh-Garabedian B (2002) Cytokines and neuro-immune-endocrine interactions: a role for the hypothalamic-pituitary-adrenal revolving axis. *J Neuroimmunol* 133(1–2):1–19
5. Gayle DA, Ling Z, Tong C, Lauers T, Lipton JW, Carvey PM (2002) Lipopolysaccharide (LPS)-induced dopamine cell loss in culture: roles of tumor necrosis factor-alpha, interleukin-1beta, and nitric oxide. *Brain Res Brain Res Rev* 133:27–35
6. Basu N, Krady J, Levison S (2004) Interleukin-1: a master regulator of neuroinflammation. *J Neurosci Res* 78:151–156
7. Kurkowska-Jastrzebska I, Wronska A, Kohutnicka M, Czlonkowska A, Czlonkowska A (1999) The inflammatory reaction following 1-methyl-4-phenyl-1,2,3,6-tetrahydropyridine intoxication in mouse. *Exp Neurol* 156:50–61
8. Wang MJ, Lin WW, Chen HL, Chang YH, Ou HC, Kuo JS, Hong JS, Jeng KC (2002) Silymarin protects dopaminergic neurons against lipopolysaccharide-induced neurotoxicity by inhibiting microglia activation. *Eur J Neurosci* 16:2103–2112
9. Tuppo E, Arias H (2004) The role of inflammation in Alzheimer's disease. *The International J Biochem Cell Biol* 37:289–305
10. Minghetti L (2005) Role of Inflammation in neurodegenerative diseases. *Curr Opin Neurol* 18:315–321
11. Streit W, Conde J, Fendrick S, Flanary B, Mariani C (2005) Role of microglia in the central nervous system's immune response. *Neurol Res* 27:685–691
12. Liu B, Hong J (2003) Role of microglia in inflammation-mediated neurodegenerative diseases: mechanisms and strategies for therapeutic intervention. *J Pharmacol Exp Ther* 304:1–7
13. Kamel F, Hoppin J (2004) Association of pesticide exposure with neurologic dysfunction and disease. *Environ Health Perspect* 112:950–958
14. Sanchez-Ramos J, Facca A, Basit A, Song S (1998) Toxicity of dieldrin for dopaminergic neurons in mesencephalic cultures. *Exp Neurol* 150:263–271
15. Kanthasamy A, Kitazawa M, Kanthasamy A, Anantharam V (2005) Dieldrin-induced neurotoxicity: relevance to Parkinson's disease pathogenesis. *Neuro Toxicology* 26:701–719
16. Ecobichon D (2003) Toxic effects of pesticides. In: Klaassen C, Wakins J III (eds) *Casarett & Doull's essentials of toxicology*, 2003 edn. McGraw-Hill, New York, pp 333–347
17. Gao H, Hong J, Zhang W, Liu B (2003) Synergistic dopaminergic neurotoxicity of the pesticide rotenone and inflammogen lipopolysaccharide: relevance to the etiology of Parkinson's disease. *J Neurosci* 23:1228–1236
18. Dinis-Oliveira R, Remiao F, Carmo H, Duarte J, Navarro A, Bastos M, Carbalho F (2006) Paraquat exposure as an etiological factor of Parkinson's disease. *Neurotoxicology* 27(6):1110–1122
19. Liu G, Gao H, Hong J (2003) Parkinson's disease and exposure to infectious agents and pesticides and the occurrence of brain injuries: Role of neuroinflammation. *Environ Health Perspect* 111:1065–1073
20. Gao H, Liu B, Zhang W, Hong J (2003) Novel anti-inflammatory therapy for Parkinson's disease. *Trends Pharmacol Sci* 24:395–401

21. Thiruchelvam M, Richfield EK, Baggs RB, Tank AW, Coryslechta DA (2000) The nigrostriatal dopaminergic system as a preferential target of repeated exposures to combined paraquat and maneb: implications for Parkinson's disease. *J Neurosci* 20:9207–9214

## Neurokinin-1 Receptor (NK1R)

### Definition

The tachykinin receptor that is most selective for the endogenous neuropeptide ligand substance P.

- ▶ Tachykinins

## Neurokinin-2 Receptor (NK2R)

### Definition

The tachykinin receptor that is most selective for the endogenous neuropeptide ligand neurokinin A.

- ▶ Tachykinins

## Neurokinin-3 Receptor (NK3R)

### Definition

The tachykinin receptor that is most selective for the endogenous neuropeptide ligand neurokinin B.

- ▶ Tachykinins

## NeuroLab Project

### Definition

An international research project on neuroscience carried out in the space shuttle Columbia launched in 1998.

- ▶ Autonomic Function in Space

## Neurolabyrinthitis

### Definition

Inflammation of the neural structures of the labyrinth in the inner ear.

- ▶ Disorders of the Vestibular Periphery
- ▶ Peripheral Vestibular Apparatus

## Neuroleptic Drugs

### Definition

Drugs used to treat psychosis (also called antipsychotic drugs).

- ▶ Antipsychotic Drugs

## Neuroligins

### Definition

Neuroligins are localized to the surface of postsynaptic membranes. They play a role in pre- and postsynaptic differentiation and maintain the functional balance of excitatory and inhibitory synapses.

- ▶ Synapse
- ▶ Synapse Formation: Neuromuscular Junction Versus Central Nervous System

## Neurolipomatosis

### Definition

A condition characterized by the formation of subcutaneous multiple fat deposits, with pressure on the nerves resulting in tenderness, pain, and ▶ paresthesias.

## Neurology

WILLIAM J. SPAIN

Department of Neurology, University of Washington,  
Veterans Affairs Puget Sound Health Care System,  
Seattle, WA, USA

### Introduction

Neurology is the main clinical branch of neuroscience. It is a medical discipline practiced by health care professionals. Neurology focuses on the diagnosis and treatment (excluding surgery) of people with afflictions of the central and peripheral nervous system and the skeletal muscles. As more is learned about the biological bases of disorders of thought and behavior, the boundaries between the practice of neurology and psychiatry are becoming less distinct. Medical doctors who practice neurology are called neurologists. To become a neurologist one must first complete a medical degree, followed by a general medical internship. Subsequent resident training normally entails at least 3 years of additional supervised training in providing care for people with neurological disorders. In most countries, there is a governing body that certifies a person as qualified to practice Neurology (boarding). This boarding organization typically sets the training requirements, administers an initial set of exams and periodic recertification exams to insure that those who have gone through the prescribed training have successfully incorporated a broad knowledge base of the elements of neurology and that they are capable of applying that knowledge base to the care of individuals with neurological diseases.

### A Brief History of Neurology

The history of neurology is ancient and colorful [1]. A few key milestones are listed here. The earliest known written reference to injury and treatment of the nervous system is contained in the Egyptian Edwin Smith Papyrus that was written around 1700 B.C. It is believed by some to be a copy of work done about a 1000 years earlier by Imhotep, the founder of Egyptian medicine. In ~400 B.C. Hippocrates wrote a treatise entitled *On The Sacred Disease* in which he debunked the idea that epilepsy is a spiritual affliction. He recognized that seizures come from abnormal functioning of the brain. About 200 years later Galen, another Greek physician, documented one of the earliest lesion studies to determine neurologic function. He noted that when the recurrent laryngeal nerve is cut, the “voice of the animal is damaged and its resonance is lost.” However, it took about 2000 more years for Neurology to become a well defined and distinct medical discipline. The term neurology was coined by Thomas Willis in his 1664 book on the anatomy of the brain and nerves, *Cerebri anatomi*. This document laid the framework for modern

neuroanatomic and neurophysiologic investigations. Neurology became a formal clinical discipline in the 1800's led by the writings and teachings of Jean-Martin Charcot in France, John Hughlings Jackson in England and Silas Weir Mitchell in America. Their observations and methods of clinical evaluation of malfunction of the nervous system formed the basis for the current practice of neurology.

### How Neurology is Practiced

A neurologist begins the process of diagnosis by first *talking* to a person who has experienced some set of symptoms, thus obtaining their medical history. The history is obtained in a question and answer format starting with general, open ended questions designed to screen a wide variety of potential problems, followed by more specific questions customized to a person's specific complaints. To paraphrase the great American neurologist H. Houston Merritt of The Neurologic Institute of New York, “the medical history when applied diligently is the most important and revealing tool a doctor has. In the vast majority of cases, a detailed history obtained by a knowledgeable neurologist will usually provide a good idea about the etiology of a person's symptoms. The physical exam and laboratory tests are for the most part confirmatory.”

Armed with the information obtained from the history, the neurologist can then form a set of testable hypotheses as to the etiology of the person's complaints. With such a framework, the neurologist makes a set of predictions as to what will be observed on the physical exam and on further laboratory testing. During the physical exam, the neurologist first observes the body structure for asymmetries and abnormalities. Next is a systematic check of mental function, speech, sensory perception and motor functioning obtained by having the patient perform a standard set of simple behaviors or tasks. Because the nervous system is organized through interconnecting circuits, the neurologist (like an electronics repairman) can draw on their detailed knowledge of the nervous system's organization to localize and identify the abnormal structures, cell types and molecules. The logic of diagnosis relies on recognizing common denominators that cause the patients constellation of signs and symptoms from which the neurologist makes a list of the most probable etiologies. This list is called the differential diagnosis.

Sometimes, laboratory testing is needed to narrow the list or confirm the suspected diagnosis. Because there are literally hundreds of tests to choose from, it is essential that the neurologist have a well formed and justified hypotheses in order to keep the workup focused and thereby avoid a lengthy and expensive fishing expedition. The spectrum of tests routinely available include: examining the blood and cerebral spinal fluid for chemical abnormalities, infection and acquired or inherited molecular changes, tissue biopsy for histological

examination of cells and molecules, imaging of the internal structures using x-rays, nuclear magnetic resonance signals and scanning techniques for tracer uptake, and physiological testing which can measure electrical activity and the dynamics of metabolism or blood flow in the central nervous system. The results of such testing usually either confirm or confute the initial hypotheses. Throughout the evaluation of the patient, the neurologist draws on prior experience and knowledge of the published experience of others (both anecdotal and results of controlled studies) in order to weigh the historical information, physical findings and results of testing to determine the most probable cause of the disease. Finally, the neurologist chooses the best available course of treatment.

### Treatment of Neurological Disease

In the mid 1900s, neurology was primarily a discipline of diagnosis. Knowledge of the chemical and molecular basis of neurologic disease was so limited that only a few effective pharmacologic agents were available for treatment. As a consequence, neurologists were frequently the butt of jokes and sarcasm amongst other physicians; that all they were good for was informing their patients what was wrong with them and what type of suffering and deterioration to expect over what remained of their waning existence. Fortunately, the vast advances in basic and applied neuroscience research in the past 20 years have resulted in numerous effective remedies for diseases of the nervous system. There is, of course, still a long ways to go, as there are no effective means for altering the course of Alzheimer's disease, amyotrophic lateral sclerosis, glioblastoma multiforme and other debilitating diseases of the nervous system.

The treatment of neurological disorders falls into two broad categories; curing the underlying disease and alleviating the symptoms that result in suffering and loss of function. Choosing the best course of treatment is a mixture of applied science, empathy and common sense. The scientific component of treatment is based on the results of controlled studies of the various treatment options in specific situations. The empathy and common sense components of providing care to individuals are sometimes referred to as "the art of medicine." In addition, there is another important aspect to treatment of neurological diseases, namely prevention. Regrettably, patients rarely contact neurologists until they are ill, so that preventative treatment is only a small part of what the typical neurologist does in practice (except for the small number of neurologists involved in public health and education).

### Development of Knowledge in Neurology

Until recently much of the knowledge encompassed by the discipline of neurology was derived from the observation of human beings (i.e., uncontrolled experience

and "chance experiments of nature"). As such, the descriptions of neurological diseases are often phenomenological. This stands in marked contrast to the basic neurosciences that are founded in the scientific method of asking questions and then drawing conclusions from the results of controlled, hypothesis driven experimentation. Although neurology and basic neuroscience have these fundamental differences, many of the questions asked by basic neuroscientists are motivated by observations that were initially made by neurologists. Further, the comparison of how things work during disease versus during times of health forms a powerful foundation for forming hypothesis. For example, the observation of overactive deep tendon reflexes in patients with motor weakness due to stroke compared to the underactive reflexes in people with weakness due to polio has led to numerous studies of the mechanisms underlying the coupling of somatosensory input to motor output. Similarly, posing the question "why do people who suffer from Alzheimer's disease have problems remembering things?" has motivated many basic studies that have provided insight into how animals learn and remember things. Progress in our understanding of how the brain works has been driven by the combination of innate curiosity and pragmatics.

Classically, the development of knowledge about the normal and abnormal workings of the nervous system followed a method of careful observation of people with neurologic illness for correlative symptoms. These methods are still in practice and complement the modern revolution in laboratory based methods of obtaining knowledge. First, people with similar constellations of signs and symptoms are grouped into syndromes or categories of disease. Then correlations with these abnormal phenotypes are looked for in two main arenas. One involves careful pathological examination of the structures of the nervous system at a gross, cellular and (now with modern techniques) at a molecular level. If differences are found between diseased and normal individuals, they can be correlated with the syndromic grouping and thus, serve to define structures and molecules that are essential to a particular function. So for example, the observation that a lesion in the cerebellum leads to problems with the coordination of motor activity provided insight into the function of the cerebellum. This method of correlation has been advanced by non-invasive methods for high resolution imaging of structures in living patients. The quality of imaging has advanced such that it can provide information formally obtained only from pathological specimens after death (e.g., like Hypocrites did more than 2000 years ago when he correlated the occurrence of epilepsy in individuals with injury to the brain).

Another method of gaining insight from correlation is to find common patterns of behavior and culture within a syndromic grouping (i.e., epidemiology). A notable example of this type of analysis [2] concerned

a recent incident when more than one hundred people on Prince Edward Island in Canada became similarly ill with headaches followed by confusion, loss of memory, disorientation, and (in some cases) seizures, coma and death. Their common experience was the recent consumption of cultured blue mussels. This “clue” led to some laboratory-based detective work that identified the accumulation of domoic acid in the mussels as the cause of the illness. Further experimentation revealed that domoic acid is a powerful excitotoxin that activates glutamate receptors. The hippocampus is particularly susceptible to the actions of domoic acid thus explaining the loss of memory and the seizures. (Interestingly, this syndrome which is now known as “amnesic shellfish poisoning” is thought to have caused the 1961 attack of the seaside town of Capitola, California by hundreds of crazed birds – the incident that inspired Alfred Hitchcock’s movie *The Birds*.)

Occasionally, a single dramatic case unlocks a mystery of how the nervous system works. Perhaps the most famous is the oft cited case of Phineas P. Gage [3]. In 1848 Gage, while doing railroad work, was the victim of a mishap in which a tamping iron passed through his skull, and the frontal lobes of his brain. This injury changed his personality so much so that his friends said he was “no longer Gage.” The scientific reporting of Gage’s behavioral changes and associated pathology led to changes in perception about the function of the frontal lobes, particularly with regards to their role in emotion and personality. Before Gage’s accident, most scientists thought the frontal lobes had little or no role in behavior. A limitation of the knowledge that comes from such chance “experiments” is that interpretation is confounded by the lack of controls performed in parallel. The case of Phineas Gage was partially responsible for simplistic reasoning behind frontal lobotomies as a cure for unwanted behavior. Lobotomy as a medical treatment has been abandoned, but not before it resulted in many undesirable and irreversible outcomes. Fortunately, neurology has moved beyond the insights it gained as a primarily observational scientific discipline. Now there is a large academic branch of experimental neurology that uses animal-based models of disease and modern methods of analysis of population data.

## References

1. McHenry LC Jr (ed) (1969) Garrison’s history of neurology. Charles C Thomas Pub Ltd
2. Perl TM, Bard L, Kosatsky T, Hockin JC, Todd E, Remis RS (1990) An outbreak of toxic encephalopathy caused by eating mussels contaminated with domoic acid. *New Engl J Med* 322:1775–1780
3. Harlow JM (1868) Recovery from a passage of an iron bar through the head. *Publ Mass Med Soc* 2:327–347

## Neuroma

### Definition

Tumor in the nervous system. Here referred to the tumor-like structure formed at the end of an injured peripheral nerve, in which some or all of its axons are unable to regenerate to the target tissue. Many lesions formerly called neuromas are now given more specific names such as ganglioneuroma, neurilemmoma, or neurofibroma.

- ▶ [Neuronal Changes in Axonal Degeneration and Regeneration](#)

## Neuromalacia

### Definition

Necrosis and softening of nerves.

## Neuromast

### Definition

The sense organ of the mechanosensory lateral line system. Sensitive to minute displacements of an apical cupula.

- ▶ [Evolution of Mechanosensory and Electrosensory Lateral Line Systems](#)

## Neuromast Cell

### Definition

Hair cell of the lateral line system.

- ▶ [Evolution of the Vestibular System](#)

## Neuromatosis

### Definition

Any disease characterized by multiple ▶ [neuromas](#).

- ▶ [Neuroma](#)

## Neuromelanin

### Definition

Neuromelanin is a brown-black intracellular polymeric pigment derived from dopamine or norepinephrine found within catecholaminergic neurons.

► Melanin and Neuromelanin in the Nervous System

## Neuromelanosome

### Definition

Neuromelanosome denotes an aggregate of brownblack intracellular pigment granules of varying sizes (0.5–2.5  $\mu\text{m}$ ) associated with tightly bound protein and lipid components found within some dopaminergic and noradrenergic neurons.

► Melanin and Neuromelanin in the Nervous System

## Neuromere

### Definition

Segmental unit of the developing brain. In vertebrates, constrictions seen along the neuraxis. Neuromeres in the hindbrain region are called rhombomeres and have been shown to be lineage restriction units. In insects neuromeres of the thorax and abdomen are largely stereotypical and correspond to the body segments.

Neuromeres of the head are more complex structured.

- Evolution of the Brain: In Fishes
- Evolution of the Brain: Urbilateria
- Evolution of the Telencephalon: In Anamniotes

## Neuromeric Model

### Definition

Assumes transverse (neuromeres) as well as longitudinal units (roof, alar, basal, floor plates) along the entire anteroposterior neural tube axis, and that their

arrangement is guided by selective regulatory gene expression that allows for regionalized developmental processes.

- Evolution of the Brain: In Fishes
- Evolution of the Telencephalon: In Anamniotes

## Neuromimes

### Definition

Electronic circuits or instruments that mimic the action of neurons or brains.

## Neuromodulation

### Definition

Actions that change the baseline intrinsic properties of neurons and synapses. Neuromodulators alter the firing properties of neurons (for example, from silent to bursting) and change the strength of synapses. They often act through second-messenger mechanisms such as protein phosphorylation.

## Neuromodulation in the Main Olfactory Bulb

NATHALIE MANDAIRON, ANNE DIDIER  
Neurosciences Sensorielles, Comportement, Cognition,  
Université de Lyon, Université Claude Bernard Lyon1,  
Villeurbanne, France

### Synonyms

Centrifugal or feed-back connections to the main olfactory bulb

### Definition

Centrifugal connections to the main olfactory bulb refer to the fiber systems originating from central structures, projecting to main olfactory bulb and contributing to olfactory processing.

## Characteristics

### Noradrenaline

#### Anatomical Organization

The mammalian main olfactory bulb (MOB) receives a significant noradrenergic input from the ►**locus caeruleus**. In fact, studies in rat show that approximately 40% of locus caeruleus neurons project to MOB. Noradrenergic fibers are localized in the subglomerular layers where they terminate densely in the internal plexiform and the granule cell layers, and moderately in the external plexiform and mitral cell layers. There are three known classes of noradrenergic receptors:  $\alpha 1$ ,  $\alpha 2$  and  $\beta$ .  $\alpha 1$  receptors are particularly dense in the external plexiform layer, and moderate in mitral cell layer and granular cell layer. Cellular localization studies demonstrate that mitral/tufted and granule cells express  $\alpha 1$ ,  $\alpha 2$  and  $\beta$  receptors.

#### Cellular Effects

Dendrodendritic reciprocal synapses between mitral and granule cells in the MOB have been recognized as a critical locus where noradrenaline influences the processing of olfactory information.

In the turtle or rat dissociated MOB cultures, noradrenaline disinhibited mitral cells. This effect was attributed to  $\alpha 2$  receptor-mediated presynaptic inhibition of granule cell dendrites. Moreover, it has been shown a direct excitatory action on mitral cells by iontophoretic application of noradrenaline in the MOB or by activation of  $\alpha 1$  adrenergic receptors in rat [1]. However, field potential studies suggested that noradrenaline, acting at  $\alpha 1$  receptors, depolarized granule cells, an effect that would inhibit mitral cells. Finally, in the rat, locus caeruleus activation decreases spontaneous mitral cell discharge but enhances the responses to weak olfactory input.

Locus caeruleus stimulation was also reported to initially decrease and then increase paired-pulse depression of mitral cell-evoked field potentials in the granule cell layer via activation of  $\beta$  receptors in the MOB [2]. It was concluded that noradrenaline release initially decreases then increases mitral cell glutamate release onto granule cells. It should be noted however, that other studies have reported that  $\beta$  receptor agonists have no effect on mitral cells or mitral-to-granule cell transmission. Noradrenaline may thus support opposing actions on the output neurons depending on the type or subtype of activated receptors.

#### Functional Implications

It now well established that the action of the noradrenaline on the MOB is critical for different kinds of olfactory learning. Olfactory cues trigger rapid increases in noradrenaline levels in the olfactory bulb. Noradrenaline release in the main and accessory OB is critical for the

formation and/or recall of specific olfactory memories, pheromonal regulation of pregnancy, postpartum maternal behavior and rapid learning of conditioned odor preferences thought  $\beta$  receptor activation in early postnatal rodents [3]. In addition, noradrenaline levels are increased by sensory deprivation, possibly in order to increase the sensitivity of the mitral cells, in line with their increased response to weak stimuli reported under locus caeruleus stimulation (see above).

### Acetylcholine

#### Anatomical Organization

The cholinergic innervation of the MOB is exclusively extrinsic and originates in the horizontal limb of the ►**diagonal band of Broca** (Ch3) as demonstrated by the absence of choline acetyl transferase (ChAT)-positive cells revealed by immunohistochemistry or *in situ* hybridization. Using either of these markers or localization of binding to high-affinity uptake sites, cholinergic fibers are found throughout the different layers of the MOB but with great laminar variations: the highest density is found in the glomerular layer and the lowest in the subventricular layer. The cholinergic innervation develops during the first three postnatal weeks in rodents. It is present at birth first in a subset of posterior and medio-dorsal glomeruli, the so called atypical glomeruli, which remain particularly rich in cholinergic fibers in adult and whose function remains unknown [4]. Cholinergic fibers synaptically target dendrites of periglomerular and granular bulbar interneurons. No cholinergic synapses could be identified on mitral cells but rather cholinergic varicosities in close apposition to secondary mitral cell dendrites in the external plexiform layer.

Both nicotinic (ionotropic) and muscarinic (G protein-coupled) receptors are present in the MOB. Nicotinic receptors are pentameres of various subunits ( $\alpha 2-10$ ;  $\beta 2-4$ ) whose combinations form cationic channels with distinct functional properties. High affinity heteromeric receptors, among which the abundant  $\alpha 4\beta 2$  combination, and low affinity  $\alpha 7$  homomeric receptors are retrieved in the MOB and show a specific laminar distribution. Quantitative autoradiography indicates that heteromeric receptors are found at high levels in the granular cell layer. In contrast,  $\alpha 7$  receptors are concentrated in the glomerular layer and to a lesser amount in the deeper layers of the MOB. Less is known about the cell types expressing the different nicotinic receptors.  $\alpha 2$  subunit is expressed by a small group of neurons in the internal plexiform layer and additional rare neurons of the glomerular and external plexiform layers. The  $\beta 2$  subunit strongly labels mitral cells and cells located in the superficial part of the external plexiform layer.

Five subtypes of muscarinic receptors (M1–5) have been cloned in the brain that can be grouped in two

families based on their G-protein coupling mechanism and ligand's binding selectivity. The M1 family (M1, 3 and 5) is positively coupled to the activation of phospholipase C and receptors of the M2 family (M2, 4) are negatively coupled to adenylate cyclase and classically act as presynaptic auto- or heteroreceptors. In the MOB, M1-like and M2-like receptors are most abundant in the external plexiform layer compared to the deeper layers while their expression is low in the glomerular layer. Accordingly, M2 receptors have been localized by immunocytochemistry presynaptically on the dendrites of granule cells at synaptic loci in the external plexiform layer and post synaptically on soma of second order bulbar interneurons in the inframitral layers. In the glomerular layer, M2 receptors are expressed by a subset of GABAergic/dopaminergic periglomerular neurons.

### Cellular Effects

In line with the heterogeneous distributions of cholinergic fibers and receptors in the MOB, the cellular effect of Ach in the MOB proved to be complex [5]. Through nicotinic receptors, acetylcholine facilitates olfactory information transmission by directly exciting mitral cells in a paracrine manner. Nicotinic receptors activation also induces an increase in periglomerular cells activity which in turn inhibits mitral cells thus supporting an effect opposed to the direct action of Ach onto mitral cells. These two actions are likely mediated by heteromeric high affinity and low affinity  $\alpha 7$  containing receptors respectively, in accordance with their laminar distribution (see above).

Through muscarinic receptors, acetylcholine also exerts two distinct actions on two compartments of granule cells. On the soma, it reduces their firing rate, thus producing a disinhibition of mitral cells. Pre-synaptically, through M1 receptors acetylcholine enhances GABA release by granule cells onto mitral cells, thus reinforcing inhibition of the output neurons. Through the several loci at which it influences the bulbar network, acetylcholine actions regulate both the entry and the output signals of the MOB, and is thus a key modulators of olfactory processing.

### Functional Implications

Given the well known implications of acetylcholine in memory processes in cortices, most of the studies on the role of acetylcholine in the MOB focused on odor memorization using pharmacological approaches. Systemic administration of scopolamine, a muscarinic antagonist impairs short term olfactory memory in rats and lamb recognition by parturient ewes without affecting olfactory detection.

In addition, a model of cholinergic modulation of the bulbar network suggested that cholinergic inputs

may sharpen mitral cell receptive fields, allowing for better discrimination abilities [6]. This assumption was confirmed by the demonstration that intrabulbar administration of a nicotinic antagonist abolished spontaneous discrimination between perceptually close odorants and muscarinic receptors blockade impairs discrimination performances. In both cases, at the doses used in this study, a reward-associated discrimination task was left unaffected [7]. Taken together these data suggest that acetylcholine influences olfactory perception and memorization and thus interdependence between these two aspects of olfactory processing is likely.

## Serotonin

### Anatomical Organization

The olfactory bulb receives a dense serotonergic input from the **►raphe nuclei**. In rats, serotonergic fibers display specific laminar and regional distributions in the MOB. The density of 5-HT fibers in the glomerular layer is 2–3 times greater than in any other layer in MOB. Some serotonergic fibers were observed in the external plexiform layer, internal plexiform layer, mitral cell layer and granule cell layer. Several types of serotonin receptors are expressed in the MOB, including 5HT1A and 5HT1B and 5HT2C. 5HT2 receptors are mainly distributed in the glomerular, granular cell layers and in the mitral (M) cell layer. By contrast, 5HT1A and 5HT1B receptors are mainly present in the external plexiform and granular cell layers respectively.

### Cellular Effects

Serotonin inhibits a subset of mitral cells through an indirect mechanisms involving GABA release by granule or periglomerular cells, an effect that might be modulated by the vigilance states. In contrast, another subset of mitral cells is directly depolarized by serotonin acting at 5HT2A receptors. In addition, serotonin depolarizes some periglomerular cells through 5HT2C receptors [8].

### Functional Implications

In the MOB, 5HT has been demonstrated to be involved in olfactory learning. In the literature there is evidence that damage to the MOB or to his serotonergic innervations may alter olfactory coding and/or memory. For instance, neonates with serotonergic denervation of the MOB exhibit altered acquisition or expression of an olfaction-based learned behavior. Pharmacological studies indicated that 5HT2 receptors are more likely involved in promoting conditioned olfactory learning in neonatal rats although, it is not clear whether 5HT2A or 5HT2C subtypes are predominantly involved. 5HT2 receptors seem to be required in the acquisition stages but not in the consolidation and retrieval ones [9].



Rats with 5,7-dihydroxytryptamine (5,7-DHT) lesions of serotonergic fibers lose their ability to discriminate odors. It was also shown that damage to serotonergic afferents of the MOB does not induce complete anosmia and does not disrupt the basic mechanisms of olfactory recognition. 5HT depletion caused glomerular layer atrophy. Moreover, the 5HT innervation was hypothesized to act in collaboration with the noradrenergic (NA) innervation in olfactory learning, even if NA alone seems to be able to compensate for the deficit of 5HT in certain learning conditions.

### Orexin

Centrifugal orexin-containing fibers originating from the hypothalamic feeding centers (lateral and posterior hypothalamic areas and perifornical area) terminate in the glomerular and mitral cell layers. In addition, a few fibers are seen in the granular layer. Receptors to orexin (G-protein coupled receptors, ORX1–2) are localized to mitral cells principally and to subsets of periglomerular and granular cells. Orexin indirectly hyperpolarize mitral cells through an increase in GABA release by granule cells while it seems to directly depolarize a small fraction of mitral cells [10]. Orexin infused in the brain stimulate food intake. In the MOB, it is proposed to participate in the regulation of olfactory perception by the feeding status but this remains to be assessed.

### Neuromodulators Interfere with Neurogenesis

Bulbar neurogenesis consists of the permanent renewal in the adult of the two populations of interneurons, periglomerular and granular cells. Nicotinic receptors activation increases the death rate of newborn granular neurons, while other studies have shown that Ach promote their survival, possibly then through muscarinic receptors. Chronic administration of a selective 5HT1A and 5HT2C receptor agonists induces an increase in the rate of neurogenesis. Similarly, stimulation of the noradrenergic system by an  $\alpha 2$  antagonist promotes adult born cell survival. Neuromodulators are thus able to modulate olfactory processing not only by influencing the existing network but also by regulating the permanent maturation of the MOB circuits.

### References

1. Hayar A, Heyward PM, Heinbockel T, Shipley MT, Ennis M (2001) Direct excitation of mitral cells via activation of alpha1-noradrenergic receptors in rat olfactory bulb slices. *J Neurophysiol* 86:2173–2182
2. Okutani F, Kaba H, Takahashi S, Seto K (1998) The biphasic effects of locus coeruleus noradrenergic activation on dendrodendritic inhibition in the rat olfactory bulb. *Brain Res* 783:272–279
3. Brennan PA, Keverne EB (1997) Neural mechanisms of mammalian olfactory learning. *Prog Neurobiol* 51:457–481

4. Durand M, Coronas V, Jourdan F, Quirion R (1998) Developmental and aging aspects of the cholinergic innervation of the olfactory bulb. *Int J Dev Neurosci* 16:777–785
5. Castillo PE, Carleton A, Vincent JD, Lledo PM (1999) Multiple and opposing roles of cholinergic transmission in the main olfactory bulb. *J Neurosci* 19:9180–9191
6. Linster C, Cleland TA (2002) Cholinergic modulation of sensory representations in the olfactory bulb. *Neural Netw* 15:709–717
7. Mandairon N, Ferretti CJ, Stack CM, Rubin DB, Cleland TA, Linster C (2006) Cholinergic modulation in the olfactory bulb influences spontaneous olfactory discrimination in adult rats. *Eur J Neurosci* 24:3234–3244
8. Hardy A, Palouzier-Paulignan B, Duchamp A, Royet JP, Duchamp-Viret P (2005) 5-Hydroxytryptamine action in the rat olfactory bulb: in vitro electrophysiological patch-clamp recordings of juxtglomerular and mitral cells. *Neuroscience* 131:717–731
9. McLean JH, Darby-King A, Hodge E (1996) 5-HT 2 receptor involvement in conditioned olfactory learning in the neonate rat pup. *Behav Neurosci* 110:1426–1434
10. Hardy AB, Aioun J, Baly C, Julliard KA, Caillol M, Salesse R, Duchamp-Viret P (2005) Orexin A modulates mitral cell activity in the rat olfactory bulb: patch-clamp study on slices and immunocytochemical localization of orexin receptors. *Endocrinology* 146:4042–4053

## Neuromodulation of Central Pattern Generators

### ► Neurotransmitters and Pattern Generation

## Neuromodulators

### Definition

A neuromodulator is a chemical compound released by particular neurons modulating the activity of targeted cells. In contrast to classical neurotransmitters, a neuromodulator is not reabsorbed by the presynaptic cell. Thus, it can diffuse more widely in the tissue and act on several neurons. Neuromodulators are typically amines or peptides that can phosphorylate ion channels, alter second messenger pathways and intracellular calcium. These modulatory effects change ion channel properties, which in turn lead to the alteration of neuronal discharge patterns.

They can enhance or decrease the activity of neurons or the efficiency of excitatory or inhibitory synapses

mediated by classical neurotransmitters as GABA or glutamate.

► Neuropeptides

## Neuromodulators in Nociception

### Definition

In the transmission from primary nociceptive afferents to central neurons, the combination of glutamate (transmitter) and calcitonin gene related peptide (CGRP) and Substance P (neuromodulators) are most important. Neuromodulators modify and enhance the synaptic transmission.

- Calcitonin Gene Related Peptide (CGRP)
- Nociceptors and Characteristics
- Substance P

## Neuromorphic Device

### Definition

Electronic chip that emulates biological neural systems by means of analog and/or digital Very Large Scale of Integration (VLSI) technologies. Existing systems have been used to reproduce the functionality of biological sensors (such as silicon retinas and cochleas) and/or implement single neocortical processing modules (such as selective attention modules). Several single-chip neuromorphic systems have been developed, mainly focusing on the sensory periphery (e.g. silicon retinas, silicon cochleas, motion sensors, etc.). More recently, the development of general, standard communication infrastructures also enabled the creation of complex multi-chip systems.

- Computer-Neural Hybrids

## Neuromuscular

### Definition

Affecting or characteristic of both nerve and muscle.

## Neuromuscular Junction

MARK M. RICH

Department of Neuroscience, Cell Biology and Physiology, Wright State University, Dayton, OH, USA

### Synonyms

Endplate; NMJ

### Definition

The synapse between a lower motor neuron and a skeletal muscle fiber.

### Characteristics

**Quantitative Description:** The neuromuscular junction in mammals is, on average, 20–40  $\mu\text{m}$  wide and 20–150  $\mu\text{m}$  long.

**Higher Level Structures:** Neuron, muscle fibers.

**Lower Level Components:** Synaptic vesicles, sodium channels, calcium channels, acetylcholine receptors, synaptic cleft.

**Structural Regulation:** The neuromuscular junction consists of a presynaptic motor nerve terminal that contacts the skeletal muscle at a single point along its length. Directly underneath the nerve terminal is a region of specialized postsynaptic muscle membrane in which there is a high concentration of acetylcholine receptors (Fig. 1).

Within the neuromuscular junction there are a number of specialized release sites known as active zones where synaptic vesicles fuse and release acetylcholine (the neurotransmitter at the neuromuscular junction). Between the pre- and postsynaptic cells is extracellular space in which there are a number of structural proteins. This extracellular collection of proteins is known as the basal lamina. The enzyme that breaks down acetylcholine (acetylcholinesterase) is located in the basal lamina and serves to terminate signaling between the pre- and postsynaptic cells.

During development, there is rearrangement of synaptic connections at the neuromuscular junction that is mediated by synaptic activity [2]. This rearrangement results in the mature structure in which only one presynaptic axon innervates each muscle fiber. In the adult, little further rearrangement occurs and the structure of the neuromuscular junction is thought to remain fairly stable. However, the capacity for rearrangement persists at the adult neuromuscular junction and such rearrangement may become important when synaptic function is disrupted in diseases of ► [neuromuscular transmission](#) (Fig. 1).

**Higher Level Processes:** Motor unit function, force generation.

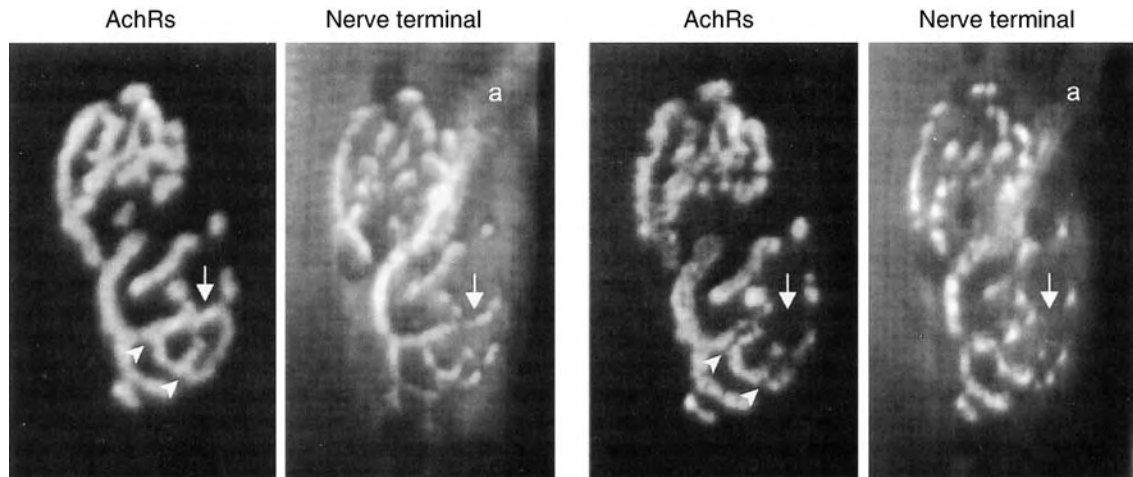

**Neuromuscular Junction. Figure 1** Regions of acetylcholine receptors (AChRs) and nerve terminal staining are lost from the neuromuscular junction in autoimmune myasthenia gravis. Shown are images of the AChRs and nerve terminal from an individual mouse endplate before, and 1 week after an immune attack on the postsynaptic AChRs. Prior to immune attack (*on the left*) the structure of the endplate is normal. The postsynaptic AChRs are stained uniformly and precisely align with the nerve terminal. One week after exposure to antibody against AChRs (images of AChRs and nerve terminal on the *right*), regions of AChR staining present in the first view, have been eliminated (*arrows*). Nerve terminal overlying the eliminated regions of AChRs has retracted. In addition, regions of faint AChR staining are present throughout the endplate. Synaptic plasticity of the neuromuscular junction, such as that shown in this figure, may play an important role in various disease states that affect the neuromuscular junction. Each image is 40  $\mu\text{m}$  wide. The presynaptic axon can be seen entering the endplate from the *upper left* in the image of the nerve terminal (*a*). From [1].

Lower Level Processes: Synaptic vesicle fusion, action potential propagation.

Process Regulation: Synaptic activity regulates function of the neuromuscular junction on both short and long timescales. There is regulation of synaptic function over a millisecond timescale in which the number of synaptic vesicles that fuse following a presynaptic action potential is modulated by previous activity. This category of synaptic plasticity is termed short-term synaptic plasticity and consists of depression, **facilitation** and **post-tetanic potentiation** [3]. In normal calcium there is thought to be a depletion of vesicles that are release-ready by previous pulses, such that fewer vesicles are released during subsequent presynaptic action potentials. This is termed **synaptic depression** and is used clinically to diagnose diseases of neuromuscular transmission such as myasthenia gravis [4]. When extracellular calcium is lowered (or calcium entry is lowered), an opposite response occurs to repetitive stimulation and more vesicles are released following each presynaptic action potential. This is known as facilitation and is a hallmark of diseases of neuromuscular transmission such as Lambert Eaton Myasthenic syndrome in which presynaptic calcium entry is decreased. The cause of facilitation is thought to be summing of the calcium signal from each pulse of the train. A third type of short-term plasticity is known as post-tetanic potentiation and can last for

10s of seconds after a train of pulses given at a high frequency. Post-tetanic potentiation is thought to be due to residual calcium following a train of stimuli.

There is also activity-dependent regulation of neuromuscular function that occurs over the time period of days to weeks. When neuromuscular activity is blocked for several days, nerve terminals at inactive junctions grow new processes that grow over the muscle and form new connections. This process is known as **sprouting** and serves to increase synaptic strength.

Function: The neuromuscular junction's function is to cause the postsynaptic muscle fiber to fire an action potential every time the presynaptic motor neuron spikes. This function differs from that of synapses in the central nervous system. In the central nervous system synapses integrate signals to process information. At the neuromuscular junction there is no information processing. The only time that abnormalities of neuromuscular transmission cause problems is when they become severe enough to cause the muscle fiber to no longer faithfully follow trains of action potentials fired by the presynaptic terminal.

The series of events necessary for neuromuscular transmission occur as follows. An action potential enters the presynaptic nerve terminal. During the action potential there is opening of presynaptic calcium channels, which allows calcium entry. Calcium binds

to a calcium sensor (thought to be synaptotagmin) and this leads to fusion of the membrane of synaptic vesicles to the nerve terminal. The precise series of molecular events that underlie vesicle fusion is currently an area of intensive study. The total number of synaptic vesicles that fuse during a presynaptic action potential at mammalian neuromuscular junctions varies between species and ranges from 20 to 100. Following fusion of synaptic vesicle there is release of acetylcholine which diffuses across the synaptic cleft and binds to acetylcholine receptors, causing them to open. Opening of acetylcholine receptors allows for flow of sodium and potassium ions, with the net result being depolarization of the postsynaptic muscle membrane. This depolarization opens muscle sodium channels and triggers a muscle action potential. The total amount of time for this cascade of events is 1 ms.

**Pathology:** The three diseases most commonly responsible for failure of neuromuscular transmission are myasthenia gravis, botulism, and Lambert-Eaton myasthenic syndrome (LEMS). These diseases present with weakness in the absence of sensory symptoms. Prominent symptoms often include difficulty swallowing as well as double vision. One of the primary diagnostic tests is repetitive nerve stimulation which reveals failure of neuromuscular transmission.

Weakness in myasthenia gravis is most often caused by an autoimmune attack directed at postsynaptic acetylcholine receptors. The result of the attack is that postsynaptic acetylcholine receptor density is reduced (Fig. 1). Thus, when a synaptic vesicle releases acetylcholine, there are fewer acetylcholine receptors available to respond and a smaller postsynaptic current is generated. This reduces the postsynaptic depolarization following a presynaptic action potential. If the postsynaptic depolarization is still large enough, the muscle fiber fires an action potential and there is no weakness. However, during trains of action potentials there is synaptic depression (see above). Depression of acetylcholine release during trains (a normal phenomenon) cause the postsynaptic depolarization caused by opening of acetylcholine receptors to become insufficient to trigger a muscle fiber action potential. Failure to activate muscle fibers causes weakness and a decrement on EMG that is diagnostic of a failure of neuromuscular transmission [4].

In botulism, failure of neuromuscular transmission is caused by cleavage of synaptic proteins that are critical for fusion of synaptic vesicles [5]. The synaptic protein cleaved in botulism depends on the subtype of botulinum toxin. Botulinum A and E cleave SNAP-25, botulinum B and D cleave synaptobrevin (also known as VAMP), and botulinum C cleaves syntaxin. Cleavage of these proteins greatly reduces the number of vesicles that fuse during a presynaptic action potential. This

results in reduced release of acetylcholine and failure of neuromuscular transmission.

LEMS is caused by an autoimmune attack on presynaptic calcium channels that reduces calcium entry into the presynaptic terminal. Reduced calcium entry causes a reduction in the number of vesicles that fuse and thus reduces acetylcholine release. During repetitive stimulation of the neuromuscular junction in LEMS, there is dramatic facilitation of the EMG signal due to facilitation of release of synaptic vesicles [4].

Although the three diseases described above are thought to be the primary diseases in which there is failure of neuromuscular transmission, evidence has begun to emerge that neuromuscular dysfunction may be an important contributor to weakness in motor neuron disease as well. The most common form of motor neuron disease is amyotrophic lateral sclerosis (ALS). It has been thought that motor neuron cell death is the sole cause of weakness in ALS. In large part, this is due to the relative ease with which motor neuron cell death can be demonstrated with routine histological examination of autopsy material. Human autopsy results, however, are dominated by disease end stage phenomena, and while there is no doubt that cell death explains the permanent loss of motor units and paralysis of ALS, it remains uncertain whether cell death fully accounts for weakness in earlier stages of the disorder.

Evidence that dysfunction at the neuromuscular junction causes weakness in advance of cell death comes from studies of animal models of motor neuron disease. In both mouse and canine models of motor neuron disease, there is emerging evidence suggesting that loss of neuromuscular innervation (denervation) occurs before motor neuron cell death has begun. In the canine animal model there is further evidence that physiological dysfunction occurs at an even earlier stage of the disease, when no denervation is apparent histologically [6]. The cause of the failure of neuromuscular transmission is a reduction in the number of vesicles that fuse following a presynaptic action potential. If the sequence of events is similar in human motor neuron disease this would suggest that weakness in patients is initially caused by failure of neuromuscular transmission in the absence of a clear structural abnormality. This is then followed by degeneration of the presynaptic terminal, and only at very late stages, when a motor unit is generating almost no force, is there death of the motor neuron. Such a sequence of events would have important treatment implications, since it would mean that treatments aimed at slowing the progression of neuromuscular dysfunction may be important in helping patients with ALS.

**Therapy:** There are two categories of treatments for diseases of neuromuscular transmission. The first

is symptomatic treatment that is aimed at improving neuromuscular transmission and the second is aimed at the underlying disease process. The drug most commonly used to improve neuromuscular transmission is an inhibitor of acetylcholinesterase (usually pyridostigmine). By slowing breakdown of acetylcholine in the synaptic cleft pyridostigmine increases the amplitude and prolongs the time-course of the postsynaptic current. The increase in postsynaptic current allows increased depolarization of the muscle fiber, and thus allows more muscle fibers to reach threshold for action potential initiation. Block of acetylcholinesterase is most appealing on a theoretical basis for disorders such as botulism and LEMS where the underlying problem is a reduction in release of acetylcholine; however, pyridostigmine is most commonly used in treating myasthenia gravis. Another drug, 3,4 diaminopyridine, is used to treat LEMS. This agent inhibits presynaptic potassium channels, and thus prolongs the action potential to allow for increased calcium entry. Treatment for botulism is primarily supportive.

In both myasthenia gravis and LEMS the underlying problem is an autoimmune attack on the neuromuscular junction. Thus, in both of these disorders reversing the underlying disease process by reducing the immune attack on the endplate is the most important part of treatment. LEMS is often a paraneoplastic syndrome in which the antibodies to the neoplasm cross-react with the neuromuscular junction. In these cases, treatment of the neoplasm often results in improvement. Corticosteroid treatment, azathioprine, plasmaphoresis and treatment with intravenous immunoglobulin are all methods of immunosuppression used to treat myasthenia gravis and LEMS. In addition, in myasthenia gravis, thymectomy is often performed to treat more severe cases. For further details on treating these disorders see [7,8].

## References

1. Rich MM, Colman H, Lichtman JW (1994) In vivo imaging shows loss of synaptic sites from neuromuscular junctions in a model of myasthenia gravis. *Neurology* 44 (11):2138–2145
2. Sanes JR, Lichtman JW (1999) Development of the vertebrate neuromuscular junction. *Annu Rev Neurosci* 22:389–442
3. Zucker RS, Regehr WG (2002) Short-term synaptic plasticity. *Annu Rev Physiol* 64:355–405
4. Kimura J (1989) *Electrodiagnosis in diseases of nerve and muscle: principles and practice*. F.A. Davis Company, Philadelphia
5. Huttner WB (1993) Cell biology. Snappy exocytosis. *Nature* 365(6442):104–105
6. Pinter MJ et al. (2001) Canine motor neuron disease: a view from the motor unit, in motor neurobiology of the spinal cord. In: Cope TC (ed) CRC Press, New York, pp. 231–250
7. Richman DP, Agius MA (2003) Treatment of autoimmune myasthenia gravis. *Neurology* 61(12):1652–1661
8. Newsom-Davis J (2003) Therapy in myasthenia gravis and Lambert-Eaton myasthenic syndrome. *Semin Neurol* 23(2):191–198

---

## Neuromuscular Transmission

### Definition

The cascade of events at the neuromuscular junction that causes an action potential in the presynaptic nerve terminal to be propagated to the muscle fiber contacted by that nerve terminal.

#### ► Neuromuscular Junction

---

## Neuromyelitis

### Definition

Inflammation of nervous and medullary substance; myelitis associated with neuritis.

#### ► Myelitis

#### ► Neuritis

---

## Neuromyelitis Optica (NMO or Devic's Disease)

### Definition

NMO belongs to the group of ► **idiopathic inflammatory demyelinating diseases** of the central nervous system and has been distinguished from ► **multiple sclerosis (MS)** by the presence of (usually bilateral, simultaneous, and often severe) ► **optic neuritis**, spinal cord abnormalities (extending contiguously over three or more vertebral segments), absence of brain abnormalities, and often rapid progression to debility and even death. Pathologically, an antibody-dependent, complement-mediated process is thought to underlie the axonal loss, demyelination and necrosis. A specific serum biomarker, neuromyelitis optica immunoglobulin G (NMO-IgG), which distinguishes neuromyelitis optica from ► **multiple sclerosis**, targets the blood brain barrier and the water channel aquaporin-4, which is lost in

neuromyelitis optica lesions and classifies NMO as an autoimmune ▶[channelopathy](#). NMO-IgG is the first specific marker for a central nervous system demyelinating disease. Corticosteroids are used to treat acute attacks and immunosuppressants are the treatment of choice.

▶[Multiple Sclerosis](#)

## Neuromyopathy

### Definition

Any disease of both muscles and nerves, especially a muscular disease of nervous origin.

## Neuron

### Definition

A late nineteenth century Greek term, refers to highly specialized “nerve cells”. A neuron exhibits a highly complex repertoire of specialized membranous structures, embedded ion channels, second messengers, genetic and epigenetic elements and unique complements of various proteins such as the receptors.

Neurons are excitable cells (i.e., able to conduct electrical impulses of action potentials), which form elaborate networks through axons and dendrites. This ensemble is responsible for integrating, processing and transmitting information, and forms the basis for e.g., coordinated muscle movements and brain functions, including learning and memory formation.

▶[Action Potential](#)

▶[Cell Membrane: Components and Functions](#)

## Neuron–Astrocyte Interactions

YOSHIHISA KUDO

School of Life Science, Tokyo University of Pharmacy and Life Science, Tokyo, Japan

### Synonyms

Tripartite synapse

### Definition

Classically the roles of astrocytes in neuron–astrocyte interaction in the central nervous system (CNS) have been as passive and supportive elements, which remove the released neurotransmitters by specific transporters (such as GLT-1, a glutamate transporter), maintain the ionic environment in the ▶[extracellular space](#) via ion channels and transporters ( $K^+$  channels,  $Na^+/K^+$  exchanger, etc.), supply the energy source through blood vessels to neurons and limit the passage of some toxic substances as a ▶[blood brain barrier](#), all optimizing the conditions for neurons and synapses in the CNS (Fig. 1).

However, since the expression of neurotransmitter receptors on astrocytes has been revealed by the dynamic responses in intracellular  $Ca^{2+}$  concentration ( $[Ca^{2+}]_i$ ) to neurotransmitters, the possibility of cross-talking between neurons and astrocytes has been emphasized as a much more important interaction between those cells. The possibility became much more probable after the discovery of the ability of astrocytes to release neurotransmitters, such as glutamate and ATP. The finding of dynamic interaction between neurons and astrocytes urged the renewal of the concept of astrocytes as possible elements participating in the information processing mechanisms in the brain. Now neuron–astrocyte interaction has been accepted as one of the important systems for establishing higher order brain functions, which had been investigated based

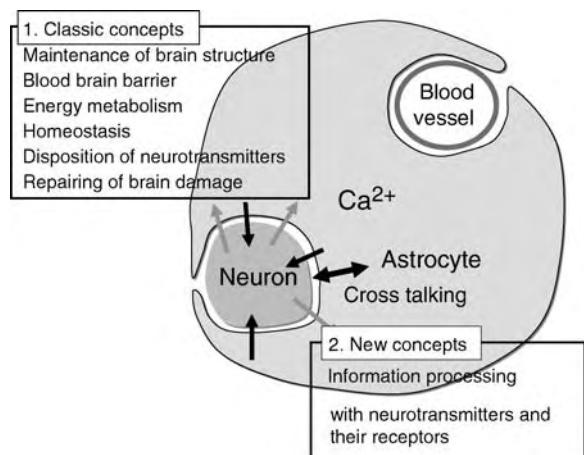

**Neuron–Astrocyte Interactions. Figure 1** Classic concepts and new concepts of neuron–astrocyte interaction. According to classic concepts astrocytes are recognized as passive and supporting elements in the brain. Since the discovery of neurotransmitter receptors on astrocytes and the release of transmitters from them, new concepts of neuron–astrocyte interaction as information processing elements have been established.

upon a “neuroncentric” concept until the end of the twentieth century [1,2] (Fig. 1).

## Characteristics

### Quantitative Description

Astrocytes were named after their stellate shape observed under the light microscope after staining with silver. The cytoskeleton stained by such methods was only 15% of the total volume of the cell. The astrocytes located in the gray matter, called ►**protoplasmic astrocytes**, have profuse processes that give the cells an appearance that has been referred to as “spongiform.” The average volume of a single astrocyte has been calculated to be about  $66,000 \mu\text{m}^3$ . Together with a study that showed that there are about 213 synapses/ $100 \mu\text{m}^3$  in the adult rat hippocampal CA1 subfield, it is estimated that a single astrocyte would be in contact with about 140,000 synapses. A recent 3D high voltage electron microscopic study on protoplasmic astrocytes in the hippocampal CA3 subfield demonstrated the average surface volume ratio as  $26.2/\mu\text{m}$  and taking this value into account, the surface area of a single astrocyte would be about  $2,000,000 \mu\text{m}^2$ . Since the density of astrocytes in the cerebral cortex is high ( $12,000\text{--}30,000/\text{mm}^3$ ) and the number of astrocytes in the mammalian brain is estimated to be 1.3–1.4 times larger than the number of neuronal cells, the surface of neuronal cells would be almost completely covered with astrocytes [2].

The percentage of the coverage of astrocyte processes on a single synapse has been estimated by 3D reconstruction studies on electron microscopic images. According to these studies, percentages of all synapses associated with astrocytes have been estimated as 57% in hippocampus, 29% in visual cortex, 69% of parallel fiber–Purkinje cell synapses in the cerebellum and 94% of ascending fiber–Purkinje cell synapses [3]. However, these values may be low estimates because of the difficulty of reproducing the real shape of astrocytes in the preparation for electron microscopy.

### Description of the Structure/Process/Conditions

As mentioned above, the fine processes of a single astrocyte envelop numerous synapses in the brain. This structural association strongly suggests possible interaction between neurons and astrocytes, not only in structural and metabolic support but also in information processing. To establish the information processing between them, astrocytes should express some receptors for detecting the molecules released from neighboring neurons and should also release some factors to talk back to neuronal cells. Neurotransmitter receptor expression and dynamic responses were found as early as 1986, in C6Bu1, a clonal astrocyte in culture. The clonal astrocytes responded to serotonin by an increase

in intracellular  $\text{Ca}^{2+}$  concentration ( $[\text{Ca}^{2+}]_i$ ), which was measured by a specific  $\text{Ca}^{2+}$  indicator, fura-2. Since then increases in  $[\text{Ca}^{2+}]_i$  induced by glutamate, GABA, noradrenalin, ATP and acetylcholine have been demonstrated in astrocytes isolated from hippocampus and other brain regions in culture [4]. The majority of receptors expressed on the astrocytes that cause an increase in  $[\text{Ca}^{2+}]_i$  have been classified as Gq-type G-protein coupled receptors, which will cause  $\text{IP}_3$  production and thus stimulate the  $\text{IP}_3$  receptors on endoplasmic reticulum to release stored  $\text{Ca}^{2+}$  into the cytosol. However, the Bergman glia cells in the cerebellum express  $\text{Ca}^{2+}$ -permeable alpha-amino-3-hydroxy-5-methyl-4-isoxazolepropionic acid (AMPA)-type glutamate receptors assembled without the GluR2 subunit [5]. When the increase in  $[\text{Ca}^{2+}]_i$  induced by neurotransmitters was found in astrocytes, researchers expected the role of the  $[\text{Ca}^{2+}]_i$  to be as an activator for transmitter release from the cells. Activation of astrocytes sometimes induces the release of ATP, but the response is not always  $\text{Ca}^{2+}$  dependent. Although  $\text{Ca}^{2+}$  dependent release has been found in astrocytes, the processes are shown to be distinct from exocytosis in neuronal terminals. Recently ►**gap junction hemichannels** have emerged as an additional molecular pathway for transmitter release from astrocytes [6]. The hemichannel of the gap junction has been shown to be activated by lowering the concentration of extracellular divalent cation. The other important pathway is P2X7, a purinergic receptor, which seems to be modulated by intracellular divalent cations (Fig. 2).

Using such multiple machineries, astrocytes can release glutamate, ATP, ►**D-serine** and some other substances. These substances can send information to neurons by the activation of receptors expressed on their pre- and post-synaptic sites. The structure consisting of astrocyte and pre- and post-synaptic neurons has been emphasized by the coining of the term “►**tripartite synapse**” [7] (Fig. 3).

### High Level Structure/Process/Conditions (Fig. 4)

#### Astrocyte–Astrocyte Intercommunication

As mentioned above a single protoplasmic astrocyte in gray matter has profuse processes referred to as spongiform, which will make contact at its boundaries with other astrocytes. The processes of adjacent astrocytes do not project into neighboring domains. Thus each astrocyte seems to occupy a separate anatomic domain. Each astrocyte domain makes connections with others using specific gap junction proteins called connexins, which can mediate the passage of current and of rather large molecules (up to 1,000 molecular weight) between astrocytes. This structural feature stabilizes and equalizes membrane potential among groups of astrocytes and ensures common levels of ions and presumably other molecules as well.

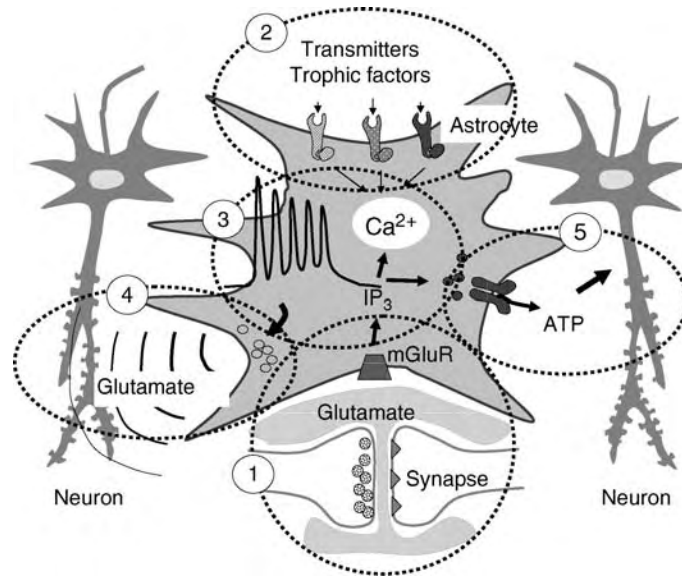

**Neuron–Astrocyte Interactions. Figure 2** Neuron–astrocyte interactions. (a) Diffusion of neurotransmitter in extracellular space (spill over). Before disposal of the released neurotransmitters by specific transporters, they diffuse into the extracellular space and activate neurotransmitters expressed on the astrocytes. (b) Expression of many kinds of receptors. Astrocytes have been demonstrated to express receptors for neurotransmitters, such as glutamate, noradrenalin, serotonin, GABA and acetylcholine and also for trophic factors. Activation of these receptors induces the increase in  $[Ca^{2+}]_i$ . (c) Characteristic  $Ca^{2+}$  increase. The activation of astrocytes through receptors results in an oscillatory increase in  $[Ca^{2+}]_i$ . (d) Neurotransmitter release. Activation of astrocytes sometimes causes release of neurotransmitters, such as glutamate and ATP. Released glutamate will activate neuronal cells. (e) Inhibitory regulation by ATP released from astrocytes has been demonstrated to depress neuronal activities.

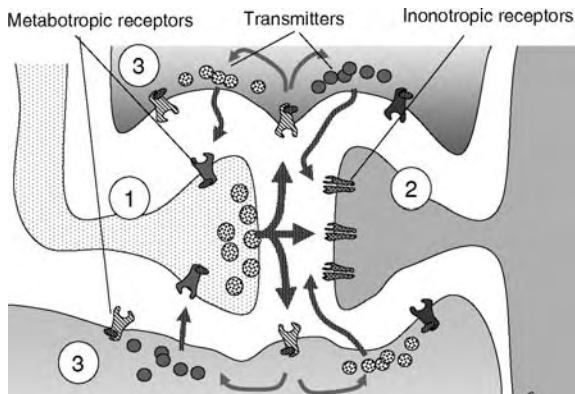

**Neuron–Astrocyte Interactions. Figure 3** Tripartite synapse. The structure consisting of (a) pre-, (b) post-synaptic neurons and (c) astrocytes has been emphasized by the coining of the term “tripartite synapse.” Information processing between pre- and post-synaptic neurons receives further modulation from astrocytes, which express neurotransmitter receptor and release neurotransmitters.

### Astrocyte–Vascular Interaction

New lines of work have shown that receptors and channels essential for the function of astrocytes are densely concentrated in their vascular end-feet.

Especially intriguing is the observation that the water channel aquaporin-4 and purine receptors – mediators of astrocytic  $Ca^{2+}$  signaling – are expressed primarily at the [gliovascular interface](#) [2]. The array of these astrocyte-delimited microdomains along the capillary microvasculature allows the formation of higher-order gliovascular units, which serve to match local neural activity and blood flow while regulating neuronal firing thresholds through coordinative glial signaling. By these means, astrocytes might establish the functional as well as the structural architecture of the adult brain.

### Neuron–Astrocyte Intercommunication

Activation of astrocytes by neurotransmitters released from the neighboring neuron can evoke the increase in  $[Ca^{2+}]_i$  and the increase can propagate as  $Ca^{2+}$  waves for several hundred micrometers [4]. The propagation, however, was found to be limited within a certain area, suggesting the existence of a local circuit. Intercellular communication among astrocytes using  $Ca^{2+}$  waves provides astrocyte networks by which astrocytes can signal each other independently from the neuron network and can modulate the activities of neurons over a relatively wide range within the network. The brain structure as an information-processing machine should be recognized as an extraordinarily refined system consisted of the neuron network into



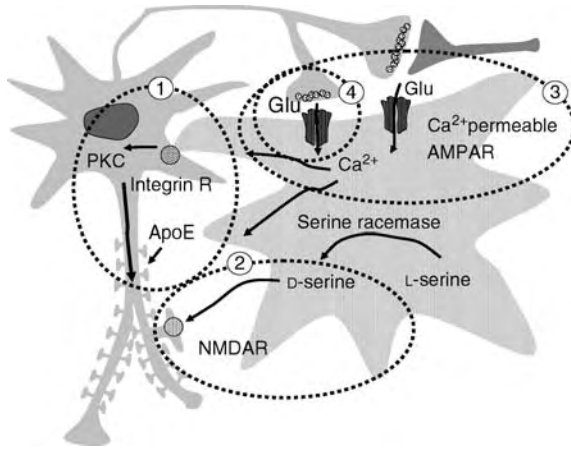

**Neuron–Astrocyte Interactions. Figure 4** Interactions among astrocytes, synapses and vasculature. The  $[Ca^{2+}]_i$  increase in astrocytes induced by neurotransmitter propagates intra- and inter-cellularly. The propagation may be promoted by two mechanisms. One is diffusion of IP<sub>3</sub> inside the cell and also through the gap junctions formed between astrocytes. The other is the response mediated by released ATP and its receptor (purinergic receptor). ATP released through the gap junction hemichannel diffuses to adjacent astrocytes and activates their ATP receptors. Functional molecules for regulating the astrocytes, such as purine receptor and aquaporin-4 are expressed mainly on the endfoot of astrocytes, which makes tight contact with a blood vessel. Since synaptic activities give and receive information between astrocytes, the size of the blood vessel may also be regulated depending upon the neuronal activities. The structure consisting of astrocyte, blood vessel and neuron will provide dynamic regulation of information processing in the brain. The gap junction hemichannel will participate in the release not only of ATP but also of some other transmitters and of trophic factors.

which the astrocyte network may be woven tightly and widely. Higher order brain function may be dependent upon this highly sophisticated structure. Although the participation of the “neuron astrocyte network” in the expression of higher order brain functions has not been established yet, these marvelous structures must be taken into account for further understanding the brain function [8].

#### Regulation of the Structure/Process/Condition

Although the developmental profiles of the regulation of neuron–astrocyte interaction seem to be important in understanding the structure and functions of the brain, only ▶*synaptogenesis* will be discussed in this essay. Some instances of the regulation of the neuron–astrocyte interaction in adult brain will be described (Fig. 5).

#### Regulation of Synaptogenesis by Astrocytes

The co-culture of purified neurons with astrocytes has been demonstrated to facilitate synaptogenesis. Although the mechanisms of this facilitation have not been elucidated yet, some diffusible factors such as cholesterol complexed with apolipoprotein E-containing lipoproteins have been identified as candidates. Recently astrocytes have been demonstrated to affect neuronal synaptogenesis by the process of adhesion. Local contact with astrocytes via ▶*integrin* receptors elicited protein kinase C activation, which was initially focal but soon spread throughout the entire neuron. This suggests that the propagation of PKC signaling represents an underlying mechanism for synaptogenesis [9].

#### Regulation of NMDA Receptor Activation by D-Serine Released from Astrocytes

The activation of NMDA receptor by glutamate requires to be co-activated by glycine, which binds a specific binding site. Recently several lines of evidence indicate that D-serine, the stereo-isomer of L-serine, is an endogenous co-activator for NMDA receptor and is three times more potent than glycine in activating its binding site. The D-serine degrading enzyme has been shown to attenuate NMDA mediated transmission. D-serine and serine racemase, a D-serine synthesizing enzyme, have been found to be localized only in astrocytes. Since NMDA receptor is recognized as participating in synaptic plasticity, its regulation by D-serine suggests the important participation of astrocytes in higher order brain functions.

#### Structural Regulation by the Activation of Ca<sup>2+</sup> Permeable AMPA Receptors in Bergmann Glia

As mentioned above, Bergman glia cells in the cerebellum express Ca<sup>2+</sup>-permeable AMPA-type glutamate receptors assembled without the GluR2 subunit [5]. Conversion of these Ca<sup>2+</sup> permeable receptors into Ca<sup>2+</sup> impermeable ones by adenoviral mediated delivery of GluR2 results in the retraction of glial cell processes from the spine of Purkinje cells and also the multiple innervation of Purkinje cells by the ascending fibers. The glial Ca<sup>2+</sup>-permeable AMPA receptors are indispensable for proper structural and functional regulation of Bergmann glia and glutamatergic synapses. Transfer of information from the ascending fiber to the Bergman glia has been shown to depend on the “▶*ectopic release*” of glutamate from the ascending fiber to the receptor expressed on the Bergman cell. This means the existence of active and specific transmission between neuron and astrocyte.

#### Function

##### Functions Estimated by In vitro Preparations

Many important findings on neuron–astrocyte interaction have been demonstrated in primary culture or

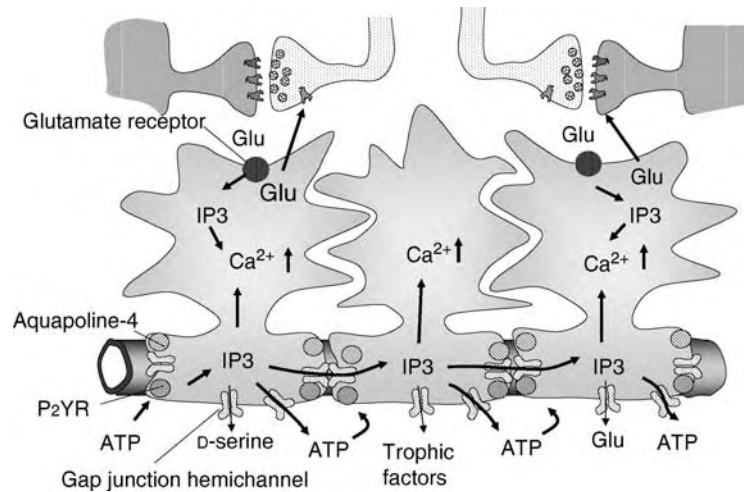

**Neuron–Astrocyte Interactions. Figure 5** Regulatory neuron–astrocyte interaction. (a) Synaptogenesis Astrocytes play important roles in synaptogenesis during development. Apoptosis-inducing factor released from astrocytes has been shown to be a factor facilitating synapse formation. Direct contact of astrocytes and neuronal cells through integrin receptor induces drastic synaptogenesis, which is mediated by protein kinase C (PKC) activation. (b) Activation of N-methyl-D-aspartic acid (NMDA) receptor by D-serine. D-Serine is produced from L-serine inside astrocytes by a specific enzyme, serine racemase. The amino acid is an effective activator for NMDA receptor, a key receptor for synaptic plasticity. (c) Regulation of neuron–astrocyte interaction by Ca<sup>2+</sup>-permeable AMPA receptors Ca<sup>2+</sup>-permeable AMPA-type glutamate receptors expressed on the Bergman glia are indispensable for proper structural and functional regulation of the Bergmann glia and glutamatergic synapses. (d) Ectopic release of glutamate from neuron to astrocyte. The ascending fiber terminal releases glutamate and directly activates Ca<sup>2+</sup>-permeable AMPA receptor expressed on the Bergman cell.

organotypic culture preparations. These studies showed the wide range of inhibitory effects of ATP released from an astrocyte, the facilitatory and inhibitory interactions between astrocytes and neurons due to glutamate released from either cell [10] and facilitation of synaptogenesis [9]. However, since the functions of astrocytes are structure- and environment-dependent as mentioned in this essay, real functional profiles of the neuron–astrocyte interaction in *in vivo* brain may be difficult measure in such simple *in vitro* experiments. One possible breakthrough for this difficulty may be provided by *in vitro* study of retina, which has a closely similar structure to brain. The synapses in the retina are contacted by Müller cells (astrocyte-like radial glia) and make regulatory configurations with neuronal networks similar to those in brain.

#### Functions Estimated from Pathological Conditions

Recent pathological studies demonstrate that dysfunction of “neuron–astrocyte interaction” is an important causal factor in the development of schizophrenia, depression and some other psychiatric disorders. The activities of a glutamate transporter (GLT-1 type) in astrocytes obtained from schizophrenic patients were significantly higher than in those obtained from normal brain. Furthermore the level of D-serine, a coactivator for NMDA receptor and a product of astrocytes is significantly lower in the schizophrenic brain than

in normal brain. These facts suggest that appropriate activities of glutamatergic synapses required for expression of higher order brain functions are regulated by astrocytes.

Many other brain dysfunctions due to abnormality of astrocyte functions, such as epilepsy and dementia, have demonstrated the importance of neuron–astrocyte interactions for the establishment of higher order brain functions.

#### References

- Haydon PG (2001) Glia: listening and talking to the synapse. *Nat Rev Neurosci* 2:185–193
- Nedergaard M, Ransom B, Goldman SA (2003) New roles for astrocytes: redefining the functional architecture of the brain. *Trends Neurosci* 26:523–530
- Reichenbach A, Wolburg H (2005) Astrocytes and ependymal glia. In: Kettenmann H, Ransom BR (eds) *Neuroglia*, 2nd edn. Oxford University Press, Oxford, pp 19–35
- Conell-Bell AH, Frankbeiner SM, Cooper MS, Smith SJ (1990) Glutamate-induced calcium waves in cultured astrocytes: long range glial signaling. *Science* 247:470–473
- Iino M, Goto K, Kakegawa W, Okado H, Sudo M, Ishiuchi S, Miwa A, Takayasu Y, Saito I, Tsuzuki K, Ozawa S (2001) Glia-synapse interaction through Ca<sup>2+</sup>-permeable AMPA receptors in Bergmann glia. *Science* 292:926–929

6. Ye ZC, Wyeth MS, Baltan-Tekkok S, Ransom BR (2003) Functional hemichannels in astrocytes: a novel mechanism of glutamate release. *J Neurosci* 23:3588–3596
7. Araque A, Papura V, Sanzgiri RP, Haydon PG (1999) Tripartite synapses: glia, unacknowledged partner. *Trends Neurosci* 22:208–215
8. Baltan-Tekkok S, Ransom BR (2004) The glial-neuronal interaction and signaling: an introduction. In: Hatton GI, Pappas V (eds) *Glial neuronal signaling*. Kluwer, Amsterdam, pp 1–20
9. Hama H, Hara C, Yamaguchi K, Miyawaki A (2004) PKC signaling mediates global enhancement of excitatory synaptogenesis in neurons triggered by local contact with astrocytes. *Neuron* 41:405–415
10. Morita M, Higuchi C, Moto T, Kozuka N, Suswuki J, Itofusa R, Yamashita J, Kudo Y (2003) Dual regulation of calcium oscillation in astrocytes by growth factors and pro-inflammatory cytokines via mitogen-activated protein kinase cascade. *J Neurosci* 23:10944–10952

---

## Neuron/Cell

### Definition

The neuron is the functional unit of the nervous system, specialized for the conduction of electrochemical impulses along neuron processes, and the transmission of information from one neuron to another usually by the release of a neurotransmitter from one neuron onto another that expresses receptors for that neurotransmitter.

---

## Neuron/Cellular Doctrine

### Definition

The neuron cell doctrine states that the neuron with its processes is a single cell and forms the functional unit of the nervous system. In this doctrine nerve networks (interconnections) and pathways (connections from one collection of neurons to another) are made by synaptic contacts between neurons.

---

## Neuron-Glia-Imaging

ARAYA RUANGKITTISAKUL, KLAUS BALLANYI  
 Department of Physiology, Perinatal Research Centre,  
 Faculty of Medicine & Dentistry, HMRC, University  
 of Alberta, Edmonton, AB, Canada

### Synonyms

Neuronal imaging; *in situ* microscopy

### Definition

► **Neuron-glia-imaging** means videocamera, ► **confocal** or ► **multi-photon microscopy** of dynamic changes in the activity and/or morphology of living ► **neurons** and ► **glia** at the (sub) cellular level. A rapidly increasing number of cellular processes is being monitored with neuron-glia-imaging *in vitro* and *in vivo* using genetically encoded fluorescent dyes expressed in targeted cells.

### Purpose

For most central nervous tissues, the relation between structure and function is largely unknown at the cellular level. Brain structures are monitored *in vivo* with powerful techniques such as ► **positron emission tomography** (PET). However, analysis of fast activity in central nervous micro-networks is not feasible with such functional brain imaging due to a low temporal and spatial resolution. Rather, video, confocal or multi-photon microscopy (mostly ► **two-photon microscopy**) is used *in vivo* and *in vitro* for simultaneous imaging of brain cell activity and morphology. Optical techniques are being developed further in conjunction with engineering of genetically encoded fluorescent dyes to allow for neuron-glia-imaging of nervous structures in deeper brain layers of freely moving mammals. This may allow for future endoscopic investigation of neuron-glia networks plus microcirculation in the almost intact mammalian brain and spinal cord, possibly with the attractive option to diagnose and treat nervous diseases such as focal epilepsy.

### Principles

#### Biological Activity Dyes

Biochemical, physiological and morphological features of ► **brain cells** can be assessed with a variety of (fluorescent) dyes [1–4]. In a morphological study on living ► **taste organs** of frogs [5], the H<sup>+</sup> - thus, pH-sensitive dye BCECF and the Ca<sup>2+</sup>-sensitive dye Indo-1 stained glia-like cells, while ► **type-II receptor cells** were stained with the Cl<sup>-</sup>-sensitive dye MQAE. In contrast, ► **Merkel-like basal cells** were only stained with the membrane-labeling dye FM1–43 that is also used for recording synaptic processes such as ► **vesicle recycling**. The above ion-sensitive dyes as well as the Na<sup>+</sup>-sensitive dye SBFI and the K<sup>+</sup>-sensitive dye PBFI are well suited to image nervous activity which is typically associated with notable changes of cellular ions [2–4,6,7]. Neuronal signals in the upper μs-lower ms range are well resolved with high-speed video-microscopy using voltage-sensitive dyes, e.g., Di-8-ANEPPS [1,4] or Ca<sup>2+</sup>-sensitive dyes [1–4,6–9] (see below). Some dyes stain quite selectively organelles. Amongst these, Rhodamine-123 is used to monitor both mitochondrial structure and membrane potential [1,4]. Dual dye labeling allows for ► **ratiometric measurements** for a better signal-to-► **noise** ratio and/or calibration of concentrations of cellular factors [1,3,4]. Ratiometric measurements can

also be done with single indicators showing an excitation or emission spectral shift upon ion binding. If ratiometric  $[Ca^{2+}]$  measurements are not possible, the change in **fluorescence** can be calculated as  $\Delta F/F$ , i.e., as the background-corrected change in fluorescence ( $\Delta F$ ) divided by resting fluorescence ( $F$ ). This calculation allows comparison of fluorescence transients in cellular compartments with different thickness, for example, **soma** or **spines** and/or indicator concentration [1,3,4,7].

Molecular techniques offer a most powerful approach for neuron-glia-imaging [2,4]. For example, cameleons are protein-based, resulting from the fusion of calmodulin with a calmodulin-binding peptide with cyan and yellow mutants of **green-fluorescent-protein**. They utilize **fluorescence-resonance-energy-transfer** for coupling  $Ca^{2+}$  binding to changes in fluorescence. In general, this spectroscopic technique allows to monitor changes in both, distance (20–100 nm) and orientation of two **fluorophores**. In addition to  $Ca^{2+}$ -sensitive cameleons, specific macromolecule pairs have been designed to use fluorescence-resonance-energy-transfer to record biochemical or physiological signals such as **membrane potential**, **cyclic-adenosine-monophosphate** or protein-protein heterodimerization. Besides, some mutants of green-fluorescent-protein are sensitive to pH and/or  $Cl^-$ . Genetically encoded fluorescent probes are being targeted to different tissue and cell types and/or various subcellular structures such as **endoplasmic reticulum** or **synapses**, using **viral transfection** and transgenic techniques [2,4].

### Labeling Neurons and Glia

Cultured brain cells form a thin layer and can thus be visualized at reasonable optical resolution with a standard fluorescence microscope attached to a videocamera-based imaging system [1,4]. Neurons and glia in culture can easily be labeled with morphological dyes of the “Alexa Fluor” or “BODIPY” families, or with  **$Ca^{2+}$ -sensitive dyes** for  **$Ca^{2+}$  imaging** [1,2,4]. Loading with  $Ca^{2+}$ -sensitive dye is achieved by adding to the culture medium the membrane-permeant, acetoxymethyl (“AM”) form of the dye, which is cleaved into the impermeant, fluorescent form by cellular esterases [1,4]. In contrast to cultures, cells in acute **brain slices** remain in their natural environment *in situ* and thus show often features close to *in vivo* (Fig. 1) [4,6,7]. However, in particular in mature brain structures *in situ*, loading of neurons by addition of the AM form of the  $Ca^{2+}$ -sensitive dye to the superfusate may not be successful due to diffusional or uptake problems. In such cases, **pressure injection** of the AM dye can provide adequate loading of glia and neurons in both brain slices and *in vivo* (Fig. 1) [4,6].

In a different *in situ* approach, the membrane-impermeant form of the  $Ca^{2+}$ -sensitive dye is injected into a brain cell via the recording **patch-** or

**micro-electrode** (Figs. 1, 2) [4,6,7,9]. With this method, morphological features and/or activity-related  $[Ca^{2+}]$  rises can be correlated with electrophysiologically recorded biophysical parameters, such as membrane potential, resistance or capacitance. In brain tissue *in situ*, visualization of cellular structures with conventional light microscopy is usually restricted to depths of  $\sim 50 \mu m$ .

### Confocal and Videocamera Microscopy

The spatial resolution of fluorescence imaging is greatly improved by one-photon-excitation **confocal laser-scanning microscopy**, which eliminates out-of-focus and stray light via a pinhole aperture (Figs. 1–4) [4,7,8].

Confocal techniques do not principally improve neuron-glia-imaging in deeper tissue layers, in contrast to one specific subtype of two major video-microscopy techniques [4,8]. Intensified video-microscopy involves imaging a specimen when light levels are too low for standard cameras, while enhanced video-microscopy is used when the specimen is invisible to the eye, either due to lack of contrast or due to its spectral characteristics, i.e., ultraviolet or infrared [4]. As infrared light enters deeper into tissues [4,8,9], infrared **differential-interference-contrast** enhanced video-microscopy produces images of almost three-dimensional quality from cells in tissue depths of 50–100  $\mu m$ . Besides, the technique allows for dynamic recording of (re)organization of cellular structures [4]. Infrared darkfield video-imaging can be used in brain tissue *in situ* to monitor neuronal activity as cellular ion fluxes and subsequent volume changes affect light scattering. Such imaging of intrinsic optical signals can, e.g., provide cortical activity maps, although not at cellular resolution [1,4].

### Two-Photon Microscopy

Two-photon-excitation laser-scanning fluorescence microscopy enables *in situ* visualization of brain cells in tissue depths up to  $\sim 2 mm$  [4,6,9]. For two-photon-excitation, femtosecond pulses from a mode-locked Ti:sapphire infrared laser at megahertz repetition rates are focused to a point in the tissue and scanned over a horizontal optical plane (Figs. 2–4). Within a focus of only about one femtoliter in the tissue, two infrared photons can be simultaneously absorbed by the fluorophore and produce an excited state similar to that from the absorption of a single photon of twice their energy. The fluorescence is collected by a photomultiplier and fed into a computer. Specific software is used to reconstruct a plane of fluorescence intensity reflecting the activity and/or morphology of brain cells within that plane. As for **confocal microscopy**, three-dimensional images can be produced if consecutive image planes are scanned while a stepmotor moves the objective or specimen stage along the z-axis (Figs. 2–4) [4,8,9].

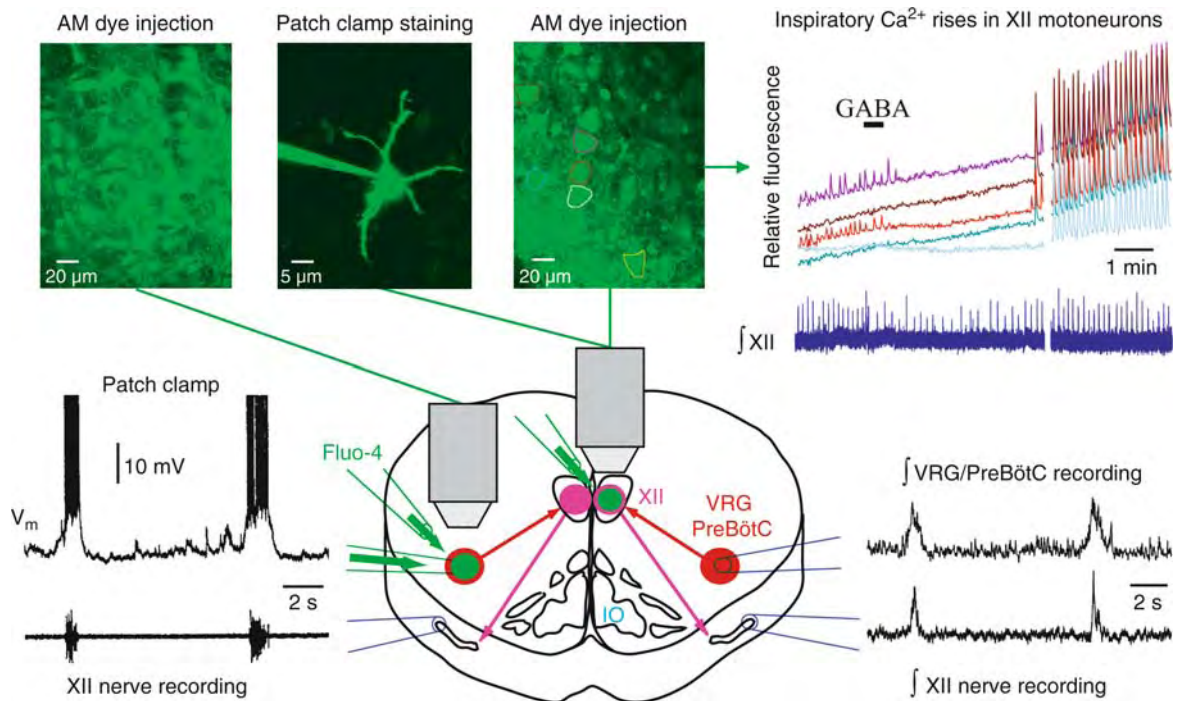

**Neuron-Glia-Imaging. Figure 1** Confocal and two-photon  $\text{Ca}^{2+}$  imaging in respiratory neurons. The schematic shows a newborn rat transverse brainstem slice containing the neuronal network that initiates and controls inspiratory-related breathing movements. Rhythmogenic interneurons are located within the pre-Böttinger Complex (preBötC), a subregion of the bilateral rostrocaudal columns of the ventral respiratory group. preBötC neurons transmit their inspiratory activity to motoneurons of the hypoglossal (XII) nucleus whose axons project within the same transverse plane to XII nerve rootlets. The left lowermost trace shows two bursts of inspiratory XII nerve activity, while the right lowermost trace displays the integrated form of such activity in a different slice. An integrated extracellular signal of preBötC neuron population activity is shown above the latter recording, while the trace on top of the XII nerve recording in the left part of the figure shows rhythmic membrane potential ( $V_m$ ) fluctuations of a single VRG-preBötC neuron. Individual respiratory neurons can be labeled via the recording patch-electrode with fluorescent dye as exemplified in the central confocal image of the upper part of the figure for an inspiratory XII motoneuron stained with the  $\text{Ca}^{2+}$ -sensitive dye Fluo-4. In addition, the activity and morphology of multiple VRG-preBötC neurons (left, two-photon image) and XII motoneurons (right, confocal image) can be visualized with  $\text{Ca}^{2+}$  imaging. For that purpose, the membrane-permeant form of Fluo-4 (0.5 mM) is pressure-injected (0.5–1 psi, 5–15 min) into the VRG-preBötC or XII nucleus. The upper right part of the figure illustrates that two of seven XII motoneurons show  $\text{Ca}^{2+}$  rises in phase with inspiratory XII nerve activity. Bath-applied (1 mM)  $\gamma$ -aminobutyric acid (GABA) slightly depresses respiratory rhythm and abolishes inspiratory  $\text{Ca}^{2+}$  rises. Upon washout of GABA,  $\text{Ca}^{2+}$  oscillations of the two cells are potentiated severalfold while pronounced rhythmic activity is induced in further XII motoneurons, probably due to decrease of tonic extracellular GABA levels by stimulated GABA-uptake. All recordings from A. Ruangkittisakul and K. Ballanyi, unpublished.

Two-photon microscopy can easily be combined with electrophysiological recording of single brain cell or neuronal population activity, even *in vivo* (Figs. 1, 2), while miniature two-photon-microscopes enable neuron-glia-imaging in freely moving animals [4,6]. Currently, optical fibers and lenses with a diameter  $<1$  mm are being developed for two-photon microscopy. This enables visualization of deep brain structures, such as the hippocampus, which is crucial for memory processes while its dysfunction can constitute a focus for epilepsy [4,6]. Besides revealing brain cell properties, two-photon imaging enables

visualization of brain microcirculation, which is involved in various nervous diseases such as angiopathy or stroke [4,6]. The high spatial resolution of two-photon microscopy, but also of other types of neuron-glia-imaging, is further improved by image processing and deconvolution techniques [1,4,8]. Computer power is steadily growing while ultra-fast scanning techniques, such as acousto-optical tuning deflectors, are currently being implemented into modified two-photon microscopy (Fig. 3) [4,8,10]. Thus, four-dimensional imaging of deeper brain structures in real-time is becoming feasible soon. This opens the

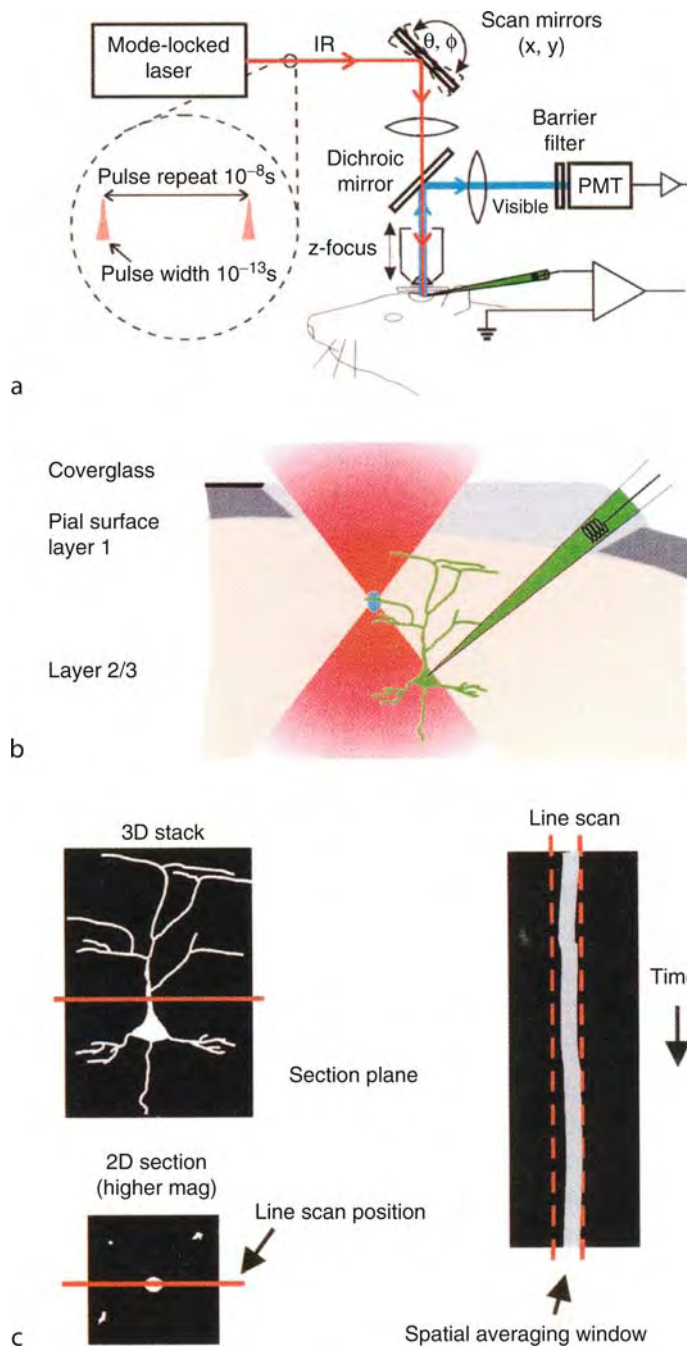

**Neuron-Glia-Imaging. Figure 2** *In vivo* two-photon microscopy combined with sharp **▶micro-electrode** intracellular recording in the **▶neocortex** of anesthetized rats. A neuron was filled via the micro-electrode with the  $\text{Ca}^{2+}$ -sensitive dye Calcium-Green-1. This allowed for recording of activity-induced intracellular  $\text{Ca}^{2+}$  transients in **▶dendrites** (located in **▶cortical layer 1**) or **▶soma** (in layer 2/3) of the neuron simultaneous with electrophysiological recording of membrane potential. (a) Schematic of the microscope. (b) Schematic of the **▶craniotomy** and recording geometry. (c) Schematic illustrating various imaging modes. Reproduced from Svoboda, Tank, Stepnoski and Denk in [4], with kind permission.

long-term perspective for two-photon microscopy to be used for endoscopy of brain structures to analyze normal and pathophysiologically disturbed neuronal functions [4,6].

### Confocal and Two-photon Microscopy of the Isolated Mammalian Respiratory Network

The neuronal network which ultimately initiates and controls muscles mediating inspiratory breathing movement

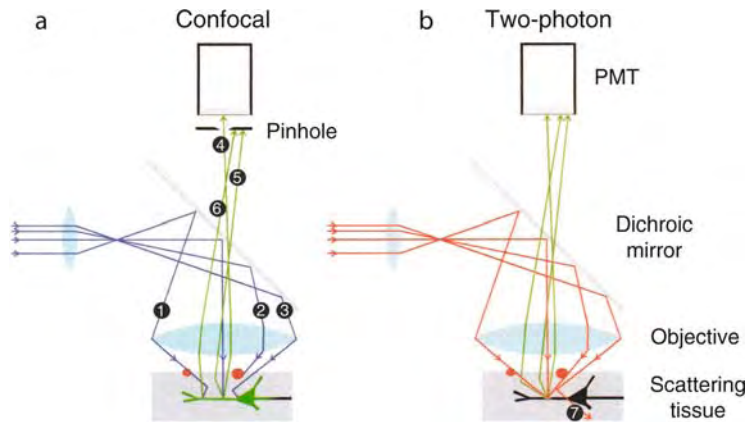

**Neuron-Glia-Imaging. Figure 3** Comparison between confocal and two-photon Laser-Scanning microscopy in the intact brain. The fates of typical excitation (*blue and red lines*) and fluorescence (*green lines*) photons are shown to illustrate the advantages of two-photon microscopy. The sample consists of a scattering neural tissue permeated by blood vessels (*red ovals*) and containing a labeled neuron. In the confocal case (*left*), the short-wavelength excitation photons have a relatively high chance of being scattered (1,3) or absorbed (2). Only unscattered fluorescence photons originating at the focus contribute to the signal (4). Scattered (5) and out-of-focus (6) photons are blocked by the pinhole, which is necessary to reject out-of-focus fluorescence. Spurious excitation, and hence photobleaching and phototoxicity, occur throughout a large part of the cell (*green region*). In the two-photon case (*right*), the long-wavelength excitation photon has a relatively low chance of being scattered or absorbed; scattered photons are too dilute to excite (7) and excitation is therefore localized to the tiny focal volume. Since no pinhole is necessary to reject out-of-focus fluorescence, all fluorescence photons entering the objective contribute to the signal. Reproduced from Svoboda, Tank, Stepnoski and Denk in [4], with kind permission.

is currently studied by various groups in transverse brainstem slices of newborn and juvenile rodents (see also essays on “brain slices” and “isolated respiratory centers”). These brain slices contain a kernel of rhythmogenic interneurons within the ►pre-Bötzinger Complex (preBötC), a subregion of the bilateral rostrocaudal columns of the ventral respiratory group (Fig. 1). The preBötC has a rostrocaudal extension of about 200  $\mu\text{m}$  and provides within the slice an inspiratory excitatory drive to ►hypoglossal motoneurons whose axons exit the preparation in the same transversal plane (Fig. 1). This kernel of the ►inspiratory network is devoid of afferent influences from ►sensory systems mediating, e.g., peripheral ►chemosensitivity or the ►lung-stretch reflex. Despite this, the respiratory active brain slices retain central chemosensitivity for  $\text{CO}_2$ , thus pH, and  $\text{O}_2$  and respond to ►neuromodulators in a fashion very similar to that in more intact *in vitro* preparations, and even in (preterm infant) humans. In slices with a rostrocaudal thickness of 500–700  $\mu\text{m}$ , a regular inspiratory rhythm can be recorded at physiological superfusate  $[\text{K}^+]$  (3 mM) for several hours from hypoglossal ►nerve roots or within the preBötC. Such recording can routinely be combined with ►patch-clamp measurement of oscillatory membrane properties of rhythmogenic preBötC ►interneurons or hypoglossal motoneurons (Fig. 1).

Figure 1 shows that the activity and structure of the cellular elements of this neuronal network can be

analyzed with two-photon or confocal microscopy. Individual respiratory neurons are labeled via the recording patch-electrode with fluorescent dye as exemplified for a hypoglossal motoneuron stained with the  $\text{Ca}^{2+}$ -sensitive dye Fluo-4. Also the activity and morphology of populations of ventral respiratory group/preBötC neurons or hypoglossal motoneurons can be visualized with  $\text{Ca}^{2+}$  imaging. For that purpose, the membrane-permeant form of Fluo-4 (0.5 mM) is pressure-injected (0.5–1 psi, 5–15 min) into the ventral respiratory group/preBötC or the hypoglossal nucleus. Figure 1 also illustrates that two of seven hypoglossal neurons show  $\text{Ca}^{2+}$  rises that are in phase with inspiratory hypoglossal nerve activity. Bath-applied ► $\gamma$ -aminobutyric acid (GABA) slightly depresses the ►respiratory rhythm and abolishes the inspiratory  $\text{Ca}^{2+}$  rises. Upon washout of GABA, the  $\text{Ca}^{2+}$  oscillations of the two cells are potentiated severalfold while pronounced rhythmic activity is induced in further hypoglossal motoneurons, probably due to decrease of tonic extracellular GABA levels by stimulated ►GABA-uptake.

### Advantages and Disadvantages Imaging Systems

The choice of hardware for neuron-glia-imaging depends on whether speed or spatial resolution of the acquired image series is more relevant. Digital videocameras with a high pixel number provide a lateral resolution that is indistinguishable from fine-grain photography [1,4].

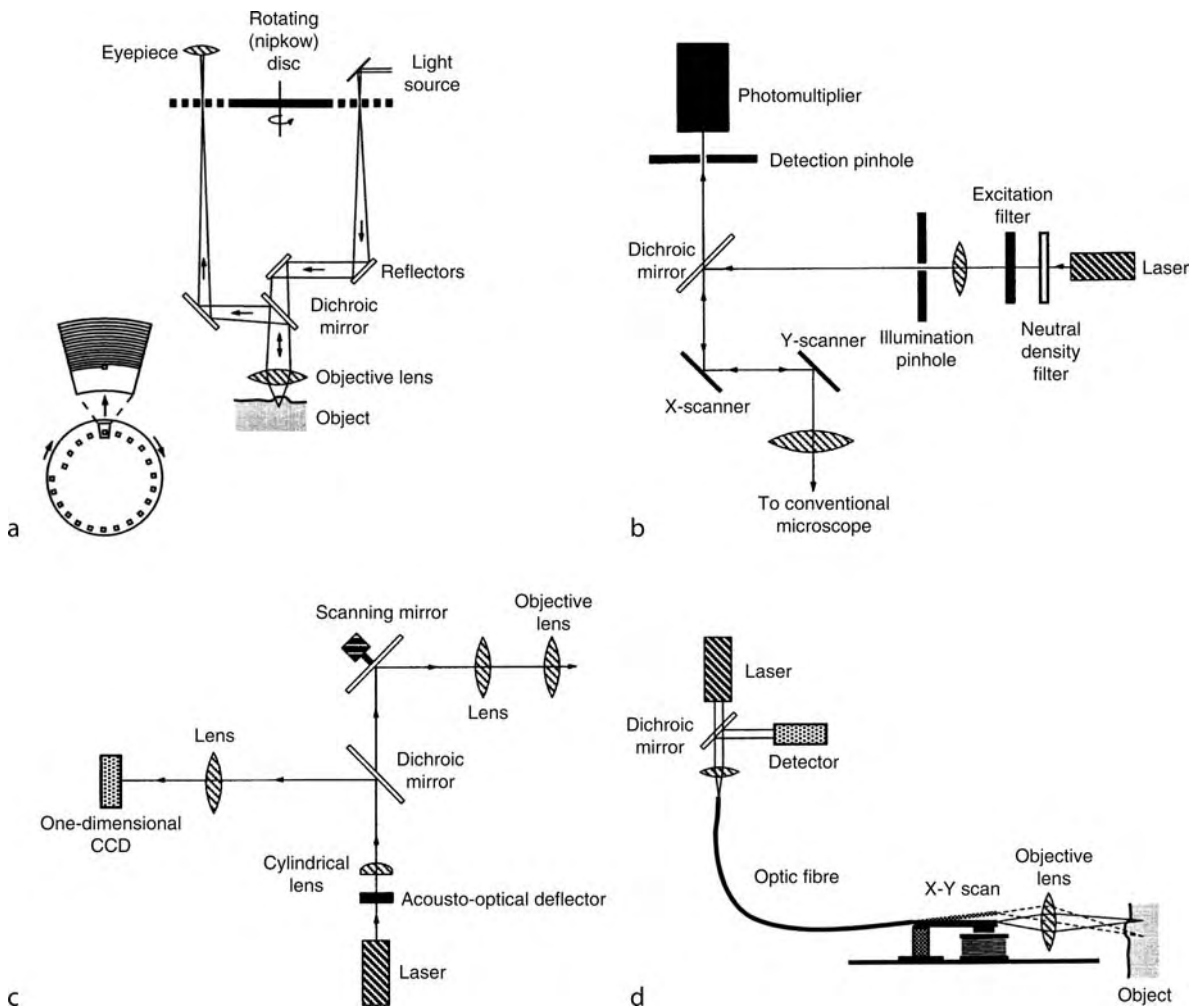

**Neuron-Glia-Imaging. Figure 4** Confocal implementation. (a) A two-dimensional image can be generated by spinning a spiral array of illumination apertures (a Nipkow disc) over a window on the specimen, thereby illuminating points on sequential lines (*insert*). A confocal image of the illuminated points is viewed through a similarly moving array in a conjugate image plane. (b) A spot of light from a fixed point source can be scanned across the specimen by mirrors; longer-wavelength fluorescence from the point is reflected back along the same light path through a dichroic reflector to a conjugate fixed-point aperture. The time-varying signal from the detector behind this aperture is converted by computer into a two-dimensional image. (c) Scanning can also be performed by an acousto-optical deflector, but the wavelength dependency of these devices prevents their use for de-scanning the longer-wavelength fluorescence. Instead, a linear detector array can be used, sampling each element in sequence corresponding to the moving point. (d) A simpler configuration uses a fiber optic, vibrating in an image plane, as both point source and detector aperture. Reproduced from A. Fine in [4], with kind permission.

But, the large amount of digital data limits the sampling rate. Conversely, recording with high-speed video-cameras provides full-frame sampling rates  $>1$  kHz at the cost of a low spatial resolution due to digital chips with a low pixel number. A further type of intensified videocameras is optimized to sample fluorescence or luminiscence, at low light intensities, often down to the single-photon level. For example, some voltage-sensitive dyes produce a  $<0.1\%$  change in fluorescence in response to nervous activity, on top of a high background fluorescence [1,4].

For all its virtues, confocal microscopy has a major flaw in that it excites fluorophores in excess, but detects only a small fraction of the generated fluorescence light [4,8]. Two-photon microscopy reduces problems associated with scattering and absorption of fluorescence compared to one-photon-excitation (confocal) techniques for several reasons. (i) The use of longer excitation wavelengths leads to a better tissue penetration; (ii) The two-photon excitation wavelengths for most useful fluorophores fall into a range (800–900 nm) characterized by low absorption due to water, blood or



other intrinsic tissue fluorophores; (iii) Scattered excitation photons are too dilute to excite and, hence, produce negligible background or damage (see below); (iv) In two-photon microscopy, three-dimensional sectioning and resolution are due to the localization of excitation alone. Thus, scattered fluorescence photons constitute useful signals, permitting greatly increased collection efficiencies (Fig. 3) [4,8,9].

In commercial confocal or two-photon microscopes, the sampling rate is limited by the mass of the galvanometric scanning mirrors (Figs. 2–4) [4,8]. It can be increased, at the cost of spatial resolution, to the hundred-millisecond or low millisecond range by acquiring only a small portion of the image plane or a line scan, respectively (Fig. 2) [4]. Considerably higher scan speed can be achieved with acousto-optical tunable filters (deflectors), which use sound to induce refraction waves that behave like a refraction grating (Fig. 4) [4,10]. Imaging of many points at once at rates >100 Hz can also be achieved by coordinated scanning of apertures, e.g., arranged in a spiral pattern of a Nipkow disc (Fig. 4) [4,8]. However, adequate simultaneous illumination of the multiple points is difficult to achieve, thus limiting sensitivity. While two-photon excitation makes ratiometric measurements with dual-excitation dyes unfeasible, dual-emission rationing is possible. For confocal imaging, the choice of  $\text{Ca}^{2+}$ -sensitive or other dyes is determined by the availability of lasers operating at the required wavelength [4,8]. This potential limitation for use of dyes can be overcome by Nipkow-disc confocal microscopy (Fig. 4) or videocamera imaging. The latter techniques do not critically depend on dye excitation via a laser and can rather make use of conventional light sources such as a xenon or halogen lamp, often in combination with a monochromator [4,8].

### Dye Properties

Due to the limited format of this article, technical considerations will be exemplified only for  $\text{Ca}^{2+}$ -sensitive dyes (in addition to those properties of such dyes already outlined above) [1,4,7].  $\text{Ca}^{2+}$ -sensitive dyes are most powerful tools for neuron-glia-imaging, as they allow simultaneous assessment of (sub)micrometer structures and millisecond electrical activities. Neuronal activity can rapidly increase cytosolic  $[\text{Ca}^{2+}]$  due to  $\text{Ca}^{2+}$  influx from the interstitial space via voltage-activated  $\text{Ca}^{2+}$  channels and/or  $\text{Ca}^{2+}$ -permeable neurotransmitter receptors, often in conjunction with  $\text{Ca}^{2+}$  release from intracellular stores. As intracellular  $\text{Ca}^{2+}$  is a **second messenger** of ultimate importance,  $\text{Ca}^{2+}$  imaging is pivotal to the understanding of nervous functions [2–4, 6–9].  $\text{Ca}^{2+}$ -sensitive dyes should be chosen according to the primary aim of a study. For assessment of morphological features, e.g., spine formation, it is important that the dye fluoresces brightly already at

low nanomolar, thus resting intracellular  $[\text{Ca}^{2+}]$  levels. For that purpose, Fura-2 can be used with most videocamera imaging systems and two-photon microscopy. Confocal laser-scanning microscopy is often not possible with Fura-2 as most commercial systems cannot use ultraviolet light, while Calcium-Green or Fluo-4 can be used with most imaging systems. Due to its relatively high resting fluorescence, Calcium-Green has a decreased dynamic range for  $[\text{Ca}^{2+}]$  measurements compared to Fluo-4, while the latter dye fluoresces less brightly at resting  $[\text{Ca}^{2+}]$  (Fig. 1). Fura-2 has a large dynamic range despite a bright fluorescence at low  $[\text{Ca}^{2+}]$ , as intracellular  $\text{Ca}^{2+}$  rises decrease its fluorescence intensity [1,3,4,7–9].

The dynamic range of activity-related  $\text{Ca}^{2+}$  imaging depends greatly also on the dissociation constant ( $K_d$ ), which describes  $\text{Ca}^{2+}$  binding to the dye.  $K_d$  is affected by many factors, including pH, temperature, protein binding and ions such as  $\text{Mg}^{2+}$ . Indicators have a detectable response in the concentration range from approximately  $0.1 \times K_d$  to  $10 \times K_d$ . A dye with a low  $K_d$  value binds most  $\text{Ca}^{2+}$  already at low  $[\text{Ca}^{2+}]$  levels and is saturated at higher values. For example, Fura-2 with a  $K_d$  of 145 nM measures effectively  $[\text{Ca}^{2+}]$  in brain cells at levels between 20–2,000 nM. In contrast, Fura-FF ( $K_d = 5,500$ ) is predestined for measurements of micromolar  $[\text{Ca}^{2+}]$  transients that are observed, e.g., during repetitive or pathological neuronal activity, in particular in small compartments such as dendrites or spines [1,3,4,7,9].

The fact that  $\text{Ca}^{2+}$  is bound to the dye means that the dye acts as a  $\text{Ca}^{2+}$  buffer. Accordingly, the magnitude of activity-related  $[\text{Ca}^{2+}]$  transients is attenuated and the kinetics prolonged. In AM  $\text{Ca}^{2+}$  dye-loaded cells, the artificial  $\text{Ca}^{2+}$  buffer adds up to intrinsic  $\text{Ca}^{2+}$  buffer systems, such as calbindin or parvalbumin. In contrast, in single brain cells loaded with the dye via a recording patch- or micro-electrode, the dye can substitute for endogenous  $\text{Ca}^{2+}$  buffers that are eventually washed out from the cell. It should be noted that different cell types express substantially different levels of endogenous buffer [1,3,4,7].

The latter considerations show that it is important to choose the right intracellular dye concentration. A high concentration may, on the one hand, provide a better resolution of structures or improve the signal-to-noise ratio for activity measurements. On the other hand, it may distort fast activity related  $[\text{Ca}^{2+}]$  transients, which often have immediate second messenger function such as activating  **$\text{Ca}^{2+}$ -gated  $\text{K}^+$  channels**. If neuronal networks in AM  $\text{Ca}^{2+}$  dye-loaded systems are studied, such as a respiratory brainstem slice (see above and section on brain slices) (Fig. 1), it must be considered that not only the excitability of the imaged cells, but rather major parts of the network, may be affected by high intracellular  $\text{Ca}^{2+}$  dye concentrations [1,3,4,6,7].

### Photobleaching, Phototoxicity, Auto-Fluorescence

A number of natural peptides is auto-fluorescent when excited at wavelengths well into the ultraviolet region. This may cause interference with probes used to measure intracellular ion concentrations requiring excitation in that range of the spectrum [1,4]. Apart from that, all fluorescent probes will photobleach to a greater or lesser extent when excited with a suitable wavelength, at a rate proportional to the intensity of the incident light. While this may not be a problem for some morphological applications, it does seriously affect any attempt to quantify intracellular concentrations using single-wavelength probes [1,3,4,7–9]. The most obvious practical way to reduce ►photobleaching is to minimize light reaching the probe. Since this reduces the amount of fluorescence, optimum conditions for image analysis must include, for example, optimal dye loading or sampling fluorescence with highly sensitive systems such as cooled CCD-type intensified videocameras or two-photon microscopes. Room light contributes to photobleaching already during the loading procedure and during storing the loaded cells prior to the actual experiment. Also oxygen plays a major role in photobleaching, at least during  $\text{Ca}^{2+}$  imaging with Fura-2. Genetically encoded fluorescent proteins can have a remarkable resistance to photobleaching in addition to their large extinction ratios and quantum efficiencies [2,4,6].

Two-photon imaging may deteriorate living tissue by production of heat, in particular when a high power of the infrared laser is needed. Accordingly, two-photon microscopy of deeper brain structures *in vivo* may induce a caloric challenge not only to the studied brain region, but indirectly, to the entire animal [4,8,9]. Fluorescent molecules in their excited state react with oxygen to make ►free radicals, which can damage cellular molecules [1,4,7,8]. There are several strategies to reduce such phototoxic cell damage, specifically (i) Use of high numeric aperture lenses allows for collecting more light, thus enabling reduction of excitation light intensity; (ii) Reduction in the number and/or rate of scans. For example, Fluo-4-loaded cells of the ►respiratory network need to be confocally scanned at a rate of 0.3–1 seconds to visualize cytosolic  $[\text{Ca}^{2+}]$  oscillations. But, it is advisable to record only for several minutes during control and pharmacological treatment and stop scanning for the rest of time; (iii) Using two-photon microscopy, ►phototoxicity is reduced by focal excitation allowing for continuous recording of respiratory oscillations for >1 h at a rate of >2 Hz. For the latter approach, it is advisable to use an external, more sensitive photo-multiplier that is located closer to the specimen to enable reduction of excitation light. In some preparations, it may be helpful to reduce potential toxicity chemically by adding antioxidants, such as oxyrase or ascorbic acid to the superfusate [1,4]. The toxicity does probably

not solely depend on the intensity of the excitation light. For example, some voltage-sensitive dyes can only be used for a limited time period to monitor nervous activity, before activity of the preparation gets impaired. More recent dyes of that class, such as Di-4-ANEPPS, can be used for up to severely hours without severely impairing nervous functions [1,4,8].

Some of the limitations of conventional dyes can be avoided, or at least attenuated, by fluorescence-resonance-energy-transfer [2,4,8]. This spectroscopic technique is general, non-destructive and easily imaged and has thus proven to be one of the most versatile readouts available to the designer of new optical probes (see above). It is particularly amenable to emission rationing, which is more reliably quantifiable than single-wavelength monitoring and is better suited than excitation rationing for high-speed and laser-excited imaging. Two-photon microscopy can be easily combined with ►fluorescence-lifetime measurements for quantitative fluorescence-resonance-energy-transfer imaging. One major domain of fluorescence-lifetime measurements is the field of ion concentration imaging. This method is insensitive to intensity effects, such as shading, photobleaching, absorption or light source noise. This can be an important advantage, especially in confocal studies of brain cells *in situ*, where absorption effects and photobleaching are important limitations [2,4,8].

### Acknowledgments

The study was supported by AHFMR, CIHR and CFI-ASRIP. We thank Dr. A. Fine for comments.

### References

1. Mason WT (1999) Fluorescent and luminescent probes for biological activity. Academic, London
2. Miyawaki A (2003) Fluorescence imaging of physiological activity in complex systems using GFP-based probes. *Curr Opin Neurobiol* 13:591–596
3. Takahashi A, Camacho P, Lechleiter JD, Herman B (1999) Measurement of intracellular calcium. *Physiol Rev* 79:1089–1125
4. Yuste R, Lanni F, Konnerth A (eds) (2000) Imaging neurons. Cold Spring Harbour Laboratory Press, Cold Spring Harbour, NY
5. Li JHY, Lindemann B (2003) Multi-photon microscopy of cell types in the viable taste disk of the frog. *Cell Tissue Res* 313:11–27
6. Brecht M, Fee MS, Garaschuk O, Helmchen F, Margrie TW, Svoboda K, Osten P (2004) Novel approaches to monitor and manipulate single neurons *in vivo*. *J Neurosci* 24:9223–9227
7. Eilers J, Schneggenburger R, Konnerth A (1995) Patch clamp and calcium imaging in brain slices. In: Sakmann B, Neher E (eds) Single-channel recording. Plenum, New York, pp 213–229
8. Pawley JB (ed) (1995) Handbook of confocal microscopy. Plenum, New York

9. Svoboda K, Denk W, Kleinfeld D, Tank DW (1997) *In vivo* dendritic calcium dynamic in neocortical pyramidal neurons. *Nature* 385:161–165
10. Bullen A, Patel SS, Saggau P (1997) High-speed, random excess fluorescence microscopy: I. High-resolution optical recording with voltage-sensitive dyes and ion indicators. *Biophys J* 73:477–491

## Neuron: Structure/Function, Cellular/Molecular

NAWEED I. SYED

Department of Cell Biology and Anatomy, Hotchkiss Brain Institute, University of Calgary, Calgary, AB, Canada

### Definition

Neuron – a late nineteenth century Greek term, refers to highly specialized “nerve cells” that conduct electrical impulses (▶ **Action potential**). This innate propensity to generate and conduct electrical potentials is a unique hallmark of all “excitable cells” of which the neurons are the most specialized. A neuron exhibits a highly complex repertoire of specialized membranous structures, embedded ▶ **ion channels**, ▶ **second messengers**, genetic and epigenetic elements and unique complements of various proteins such as the ▶ **receptors**. A “▶ **synapse**,” which is the functional building block of all communicating neurons, refers to the juxtaposed point of contact between two excitable cells. As the nerve impulse invades the “▶ **presynaptic terminal**,” it elicits the release of chemical messenger/s – the ▶ **neurotransmitter** into the synaptic cleft. The diffused chemical neurotransmitter substance, such as ▶ **dopamine**, ▶ **serotonin** or a proteinaceous ▶ **peptide** (▶ **substance P** for example) then binds to its respective receptor located on the “postsynaptic” side of the terminal and invokes an electrical response. Synapses are analogous to electrical bulbs that light up when electric current traveling through the nerve ▶ **cables** (▶ **Cable theory**) is switched on by the neuron. Thus, synapses serve as the functional unit of all neuronal connectivity upon which hinge its marvelous attributes – ranging from the control of simple ▶ **reflexes** (Reflexes) to complex motor patterns, ▶ **learning** and ▶ **memory**, cognition, emotions etc. Perturbations – emanating from either genetic, cellular and molecular malfunction or an injury – disrupt lines of communications between neurons thus rendering the nervous system dysfunctional. Therefore, central to our comprehension of all brain functions and its repair lie an in-depth understanding

of the cellular and molecular elements that make up the neuronal architecture.

### Characteristics

#### From Wiring Together to Firing Together: The Marvelous Neuron

The astonishing structural and functional traits of the human brain have eluded many intriguing minds for centuries – and yet our understanding of even the very basic neuronal elements, such as the synapse, remains pedestrian. Notwithstanding tremendous efforts by the neuroscience community over the decades, the sheer numbers of brain cells (tens of billions) and the intricate nature of their connectivity continue to offer formidable challenges. While tools are being developed to visualize and record the activities of functionally active neurons embedded deep within the brain, an alternative paradigm is to understand how the nervous system is put together during ▶ **development** in the first instance. A developmental approach to understanding nervous system function and dysfunction is aimed at drawing up the road maps that were originally used to orchestrate the neuronal connectivity patterns. Once a blue print of all such essential, cellular and molecular components used to lay down the original neuronal maps are “decoded,” one might be in a much better position to recapitulate these steps in an adult brain to help “rewire” its damaged connectivity.

A variety of animal model systems are being used to define elements that foster neuronal proliferation, migration and differentiation – steps that are central to the normal wiring of the brain. The steps that enable a neuron to get to its final and well-defined destination in the nervous system are highly complex and rely upon a variety of intrinsic cell-cell signaling and extrinsic factors. Having arrived at its final destination, a neuron begins to develop its axonal and dendritic architecture, which is highly ordered and equipped with navigational tools that would enable these newly born processes to reach out to select groups of target cells that are often located at some distance. Such “search and select” tasks are assigned by neurons to highly specialized structures, termed ▶ **growth cones** located at the tip of an extending neurite (axon or dendrite). Every growth cone, fueled by specific ▶ **chemotropic molecules** and ▶ **growth factors**, follows a precise roadmap, rarely deviating from its defined trajectory that is designed for it to seek out its specific target/s. Growth cones are assisted in their navigational tasks by a variety of cell-cell interacting and diffusible molecules comprising the extracellular milieu. A number of molecules, such as netrin, slit etc. and their interacting receptors are eloquently described and discussed in detail by Spencer et al. (▶ **axonal pathfinding and network assembly**).

In addition to various growth-permissive molecules described above, a growth cone’s navigational ability is

also empowered by a number of well-defined growth repulsive factors that are either membrane-bound or diffused along its path, *en route* towards targets. These growth-repulsive molecules such as the Samaphorins, NI35 etc. will, on the one hand, deter growth cone's entry into the wrong territory, and on the other hand, they serve to prevent wiring among functionally "unrelated" neurons. An intriguing aspect of these growth-suppressive or -repulsive molecules is their continued presence in the adult brain – which incidentally offers formidable challenge to brain repair after trauma and injury. Numerous studies in which the activities of these ►[growth-inhibitory molecules](#) were neutralized have uncovered an innate regenerative capacity of the adult neurons – thus underscoring their therapeutic importance vis-à-vis functional recovery from stroke and injury. Metz and Faraji have defined some of these ►[growth inhibitory molecules in nervous system development and regeneration](#) and have identified their underlying mechanisms. These authors have also offered several therapeutic strategies that might involve perturbation of these growth-inhibitory molecules to ensure functional regeneration and recovery after nerve injury or neuronal degeneration.

In the vicinity of its target tissue, a growth cone slows its advance and makes physical contacts with potential target cells. Cell–cell interactions via a variety of membrane-bound molecules such as neuroligands and neuregulin etc. trigger inductive changes not only in the presynaptic cells but also its postsynaptic partner. On the presynaptic side, the growth cone undergoes dramatic structural changes that begin with the retraction of filopodia while lamellopodia transform into a club shaped structure. Transmitter vesicles and other related synaptic proteins descend into the bulbous ending, which comes to rest at the juxtaposed postsynaptic site. In addition,  $\text{Ca}^{2+}$  channels (►[Calcium channels – an overview](#)) and other elements of the synaptic machinery specifically cluster presynaptically. At the postsynaptic site, neurotransmitter receptors and their respective second messenger molecules cluster – concomitant with the ►[postsynaptic density \(PSD\)](#). Initially, neurons make myriads of synaptic contacts, which are subsequently refined through ►[activity-dependent mechanisms](#). The molecular machinery mediating cell–cell contact coupled with the activity-dependent mechanisms are central to establishing a precise balance between ►[inhibitory](#) and ►[excitatory synapses](#) and their respective partners. Interplay between various molecules mediating cell–cell interactions and the underlying mechanisms have been described by Arstikaeitis and El-Husseini (►[synapse formation: neuromuscular junction vs. central nervous system](#)) and Colicos (►[activity-dependent synaptic plasticity](#)). While El-Husseini's lab takes advantage of powerful molecular techniques to unravel various elements of the synaptogenic program, Colicos lab uses

novel photoconductive stimulation techniques to decipher how activity-dependent mechanisms either strengthen or weaken certain synapses. Several recent studies from these and other labs have shed significant light on to the mechanisms by which neurons recognize their potential targets and establish synaptic connectivity. Because some developmental aspects of synapse formation are also recapitulated in the adult brain during ►[synaptic plasticity](#) that underlies ►[learning and memory](#), many investigators are taking advantage of activity- or plasticity-related changes in the adult brain to understand how synapses may form and subsequently refine during development. The plasticity-related induction of new synapses or the awakening of the ►[silent ►synapses](#) has thus provided greater insight into mechanisms that regulate synapse formation during development (activity-dependent synaptic plasticity) This area of research is not only important for our understanding of the mechanisms underlying nervous system development but also synaptic plasticity that forms the basis for learning and memory in the intact animals.

Due in large measure to the complex nature of the neuronal connectivity in the adult brain where cell–cell interactions are often difficult to study at the level of single pre- and postsynaptic neurons, a number of labs have opted to explore various model system approaches to define mechanisms underlying synapse formation. For instance, the ►[neuromuscular junction \(NMJ\)](#) and various invertebrate models have been extensively used to define both the cellular and molecular mechanisms underlying target cell selection, specific synapse formation and synaptic refinement. As a result of these studies as highlighted by Feng in the chapter ►[synaptic transmission: model systems](#) we now know a great deal about various steps that determine the specificity of synapse formation both at the NMJ and between central neurons. Molecules such as ►[Agrin](#) that are synthesized and secreted by ►[Motoneuron \(motor neurons\)](#) have been shown to bring about specific inductive changes required for the assembly of the postsynaptic machinery at the NMJ. Similarly, postsynaptic cells have been shown to induce clustering of  $\text{Ca}^{2+}$  channels and other elements of the synaptic machinery at the presynaptic terminal. Newly formed synapses have since been shown to undergo activity-dependent refinement and consolidation.

Among various proteins that are selectively targeted at both the pre- and postsynaptic sites are the ion channels. For instance,  $\text{Ca}^{2+}$  (►[Calcium channels – and overview](#)),  $\text{Na}^+$  (►[Sodium channels](#)) and  $\text{K}^+$  channels (►[Neuronal potassium channels](#)) are specifically targeted at select synaptic sites, and this targeting is essential not only for normal synapse formation but also the synaptic transmission. In the chapter ►[ion channels from development to disease](#) Pham et al. demonstrate how various ion channel sub-types are selectively gated

at various synaptic and extrasynaptic sites to serve their well-defined roles in a wide variety of cell types. Perturbation or mutations to various ion channels subtypes either in non-excitable or excitable cells may result in pathologies, such as the neonatal diabetes and ►epilepsy, respectively.

In addition to ion channel targeting to specific synaptic sites, the function of various other synapse-specific and  $\text{Ca}^{2+}$ -dependent proteins are also highly regulated. Intricate interplays between myriads of ►synaptic vesicle-associated proteins have been an area of intense investigation recently. A combination of biochemical, molecular, imaging and electrophysiological approaches have served to identify how synaptic vesicles might be targeted, primed, docked, released and recycled at the synaptic sites. As outlined by Coorssen in the chapter ►synaptic proteins and regulated exocytosis newly synthesized synaptic vesicles leave the cell body by a series of well-defined pathways. These vesicles are then specifically targeted to select synaptic sites where they get tethered, docked and primed for release. An action potential-induced  $\text{Ca}^{2+}$  influx through voltage-gated  $\text{Ca}^{2+}$  channels (VGCCs) (Calcium channels – and overview) is a critical step, which triggers fusion and exocytosis. Following their release at the synapse, the synaptic vesicles undergo endocytosis and are recycled for subsequent re-release. Although the spatio-temporal patterns of the synaptic vesicle behavior have been well characterized, this area of research, however, continues to enjoy its fair share of controversies.

The opening of the VGCCs invokes  $\text{Ca}^{2+}$  entry into the cytosol. This  $\text{Ca}^{2+}$  is then rapidly taken up by the fast ►endogenous  $\text{Ca}^{2+}$  buffers, the mitochondria as well as the ►SERCA – sarco-endoplasmic reticulum  $\text{Ca}^{2+}$ -ATPase pumps (Ion transport). These three steps thus exert a critical regulatory control over the magnitude of the rapid,  $\text{Ca}^{2+}$ -mediated signaling. In addition to these fast acting steps, the  $\text{Ca}^{2+}$  ►homeostasis is also maintained by slower endogenous  $\text{Ca}^{2+}$  buffers, such as the mitochondria, the SERCA pumps, the plasma membrane ►NCX –  $\text{Na}^+$ - $\text{Ca}^{2+}$  exchanger and the ►PMCA – plasma membrane  $\text{Ca}^{2+}$ -ATPase pumps (Ion transport) – all of which curtail subsequent  $\text{Ca}^{2+}$  signaling. The role/s of these various  $\text{Ca}^{2+}$ -regulatory steps are not only cell type-specific, but they also vary within a cell from its somal to extrasomal compartments. Recent advances in various imaging and molecular techniques are enabling a greater understanding of the mechanisms by which various regulatory steps maintain  $\text{Ca}^{2+}$  homeostasis and these are described by Amy Tse et al. (►influence of  $\text{Ca}^{2+}$  homeostasis on neurosecretion).

In contrast to classical transmitters such as dopamine, serotonin and ►acetylcholine, much less is known about the secretory machinery that regulates the release

of dense-cored vesicles containing neuro-►hormones or peptides. Fred Tse (►non-synaptic release) and colleagues have developed reliable carbon fiber ►amperometry approaches to define the kinetics of transmitters (such as ►catecholamines) release at the resolution of single granule cells. The Tse lab and others have also demonstrated the involvement of the ►SNARE complex in the release machinery to provide direct evidence that kinetics of release probability is highly variable from cell to cell and relies, in many important ways, on  $\text{Ca}^{2+}$  sensitivity of the system. Because the release of polypeptides and peptidergic neurochemical substances occurs at a relatively slower time scale, a great deal is now known about the cellular and molecular mechanisms underlying their mode of release. A variety of peptide messengers have now been shown to regulate important neuronal programs in a number of species.

In their chapter ►neuropeptides in energy balance Chee and Colmers describe how ►neuropeptides modulate hypothalamic circuitry to regulate energy balance. Their work underscores the importance of peptides such as ►melanocortin, ►corticotrophin-releasing hormones (CRH) and CRH-like peptide and ►neuropeptide Y, ►agouti-related peptide (AgRP), ►melanin-concentrating hormone (MCH), ►orexin etc. in regulating food intake and body metabolism. This is an impressive list of candidate molecules that appear to be specifically released to regulate energy balance in various animal models. Deciphering their precise roles is the focus of many laboratories and the studies are deemed important for obesity research.

While it is generally believed that most proteins such as the neuropeptides destined for various extrasomal sites (axons, dendrites and synapses), are synthesized at the soma and then selectively transported to these regions, this dogma has however, been recently challenged. Specifically, several recent studies have provided ample convincing evidence that the extrasomal compartments are able to synthesize a host of synapse- and plasticity-specific proteins *de novo*. Support for this notion stems from earlier studies where a host of mRNA species were identified in dendrites and axons where they were selectively targeted to specific synaptic sites following an activity-dependent mechanism. Subsequent studies using a number of molecular and radio-labeling techniques demonstrated that the targeted mRNA was indeed able to translate specific protein locally. Furthermore, injection of foreign mRNA into the extrasomal compartments was also shown not only to result in the production of encoded proteins but also that these proteins were functional. The impact of this research, which is highlighted by van Minnen in ►extrasomal protein synthesis in neurons are far-reaching and perhaps will be one of the most exciting areas of neuroscience in the years to come.

Once the developmental program has established a complete repertoire of synaptic connectivity, the neuronal networks are put to work through myriad modes of neuronal communication. These range from excitatory to inhibitory to mixed excitatory/inhibitory connections. While the synaptic transmission in general is predominantly chemical, the role of **▶electrically coupled** networks cannot be underestimated. Specifically, in addition to conventional chemical synapses, many neurons may also connect to each other through **▶gap junctions** where the membranes of two neurons become contiguous. Current in one cell may pass unabated to another without the need for a **▶synaptic delay**. While such gap junctions are predominant during development, their presence in the adult nervous system is only beginning to be realized in most vertebrates. In invertebrates, however, electrically coupled networks are quite common where they are often recruited to trigger fast **▶escape responses** that are critical for their survival and thus cannot afford the synaptic delays which are the hallmark of most chemical synapses. The precise nature of both structural and functional attributes of gap junction/tight junction or electrically coupled cells is wonderfully described by Wildering in the chapter on **▶electrical synapses**. Blocking gap junctions during early development has been shown to perturb nervous system development; their precise functions in the adult mammalian brain are, however, yet to be fully understood. It is nevertheless generally agreed that one of the hallmarks of gap junctions is to synchronize pattern activity either during a patterned motor program or pathological discharges such as epilepsy.

One of the most fascinating aspects of the neuronal uniqueness is the ability of a network of central pattern-generating neurons to exhibit rhythmical activity in the absence of the peripheral feedback. These networks of neurons, often termed **▶central pattern generators** (CPG), control a variety of rhythmical behaviors such as **▶locomotion**, **▶respiration**, **▶feeding**, **▶mastication** etc. Because CPG neurons can generate fictive, patterned activity underlying a rhythmical behavior, even in an isolated preparation, a great deal is known about intrinsic membrane properties that generate a well-organized motor output. In some instance, neurons are known to possess **▶pacemaker potentials**, which can generate endogenous bursting patterns; however, the **▶rhythmogenesis** is always a network phenomenon in both vertebrates and invertebrates. In a series of chapters written by Bell (**▶peripheral feedback and rhythm generation**), Straub (central pattern generator) and Whelan (**▶neurotransmitters and pattern generation**) we learn a great deal about various intrinsic membrane properties (pacemaker potential, **▶endogenous bursters**, **▶conditional bursters**, etc) and synaptic interactions (excitatory/inhibitory, **▶half-center model**,

**▶reciprocal inhibition**, **▶postinhibitory rebound** excitation, ramp generators, recurrent inhibition etc.) underlying patterned motor activity. Even though the CPG neurons have been known to generate patterned activity in the absence of any peripheral feedback, Bell (peripheral feedback and rhythm generation) demonstrates how peripheral feedback could be critical for the initiation, modulation and termination of the patterned activity. He specifically focuses on the role of hypoxia-sensitive chemosensory drive from the carotid body chemoreceptors, and how it affects the patterned respiratory discharges. Bell then discusses how these networks of rhythm-generating neurons are similar in both vertebrate and invertebrate animals – assuring us that the fundamental building blocks of CPG neurons are likely conserved throughout the animal kingdom. While Straub (central pattern generator) illuminates various membrane and network properties that are the hallmark of pattern generation, Whelan (neurotransmitters and pattern generation) examines structural, functional and transmitter (serotonin, dopamine etc) organization of the CPG underlying locomotor behavior in mammals. Whereas in some invertebrate models, **▶command neurons** are thought to be sufficient and necessary to trigger a patterned discharge, it is generally believed that the rhythm generation is a function of polymorphic nature of the network. In this configuration, the network exhibits a highly dynamic repertoire of activity patterns thus allowing greater flexibility within the network. Neuronal networks are thus known not to be hardwired, rather they exhibit great flexibility – allowing a subset of neurons to switch between inter-related networks. A similar reorganization of the network behavior is observed following trauma and injury whereby uninjured neurons either take on additional assignments or switch their roles from one to another.

In contrast to their central counterparts, most peripheral neurons are able to regenerate their axonal projections after injury (**▶Regeneration**). Although this regeneration appears to re-capitulate developmental patterns of growth, the **▶reinnervation** is often incomplete, mismatched and often accompanied with **▶neuropathic pain**. Tremendous efforts are therefore being made to improve the outcome of **▶peripheral injuries** by either manipulating the extracellular environment or the surgical interventions. Zochodne (**▶axon degeneration and regeneration of peripheral neurons**) provides a very comprehensive account for cellular and molecular changes that occur immediately after a peripheral injury (**▶neurapraxia**, **▶axonotmesis**, **▶neurotmesis** and how this signal is conveyed to the cell body to activate the “regenerative program.” It is generally believed that an immediate injury response triggers a massive  $\text{Ca}^{2+}$  influx, which in turn activates a cascade of events that lead to the **▶microtubular**

disorganization and ►neurofilament dissolution. Subsequent SC activation then results in microphage invasion, an upregulation of ►cytokines and ►chemokines – including IL-1 $\beta$ , IL-6, IFN- $\gamma$ , TNF- $\alpha$ , MCP-1 (monocyte chemoattractant protein-1) and MIP-1 $\alpha$  (►macrophage inflammatory protein 1 $\alpha$ ) followed by a complete breakdown of ►myelin. In the presence of appropriate trophic factors, ►nitric oxide, and various substrate adhesion molecules, a neuron then triggers its regenerative program, which begins with the initiation of new neurites and the re-establishment of synaptic connectivity. In contrast with the above described crush injuries, nerve transections often result in ►Wallerian degeneration (neurotmesis or Sunderland Type V injury), which involves breakdown of axons and myelin distal to the injury site. It is interesting to note that the regeneration re-activates many but not all elements of the developmental program and as a consequence the functional recovery after nerve injury is often incomplete. Several novel approaches are being developed to enhance the clinical outcomes of nerve injury and are described in detail by Midha (►peripheral nerve regeneration and nerve repair). Specifically, Midha provides extensive overview vis-à-vis the pros and cons of ►nerve grafts, electrical stimulation paradigm and ►nerve conduits that are being used clinically. This chapter also provides a detailed account of various bio-engineering approaches that are being developed to create nerve conduits that may, in the future, play “active” rather than passive roles in promoting nerve regeneration. This approach most certainly holds tremendous potential and is being perused extensively by Zochodne and Midha labs.

### Summary

A neuron is considered as the functional unit of the nervous system, whereas a synapse serves as a gate-keeper of all neuronal communication. Over the past 50 years our understanding of both the structural and functional attributes of neurons and synapses has been enhanced tremendously. Specifically, a great deal is now known about the intrinsic membrane properties that contribute to neuronal excitability and shape its unique characteristics. Every unique neuronal trait in turn, makes specific contributions to synaptic properties of the network in which it is embedded. Neurochemical, electrochemical and/or electro-electrical properties empower a network to generate rhythmical patterns, which in turn control important behaviors – ranging from simple reflexes to complex motor patterns and learning and memory. These connectivity patterns are orchestrated early during development and are constantly re-organized and reconfigured throughout life. Perturbation to either the intrinsic membrane or synaptic properties renders the nervous system dysfunctional thus resulting in the permanent loss of

neuronal function. Restoration of this connectivity is perhaps one of the greatest challenges facing the neuroscientists – an area that requires extensive efforts not only by the basic scientists, clinical investigators but also the bio-medical engineers and nano-engineers. A multidisciplinary approach is likely to yield bionic hybrids, which can then be interfaced with neurons to resort lost brain function. For instance, bio-compatible and neuron-friendly chips that can be interfaced with networks of brain cells will not only enhance our understanding of brain function but also regain the lost nervous system function. Although challenging – this appears to be the most promising avenue towards regeneration and functional repair of the injured nervous system.

---

## Neuron-to-neuron Communication

►Synapse Formation: Neuromuscular Junction Versus Central Nervous System

---

## Neuronal Cell Death and Axonal Degeneration: Neurofilaments as Biomarkers

AXEL PETZOLD

Axel Petzold, Department of Neuroimmunology, Institute of Neurology, University College London, London, UK

### Definitions

The aim of this chapter is to explain why ►neurofilaments (Nf) are a useful ►biomarker for ►axonal degeneration and can be used as a surrogate endpoint in clinical and experimental research (►surrogate outcome).

Neurofilaments: Nf are proteins which are exclusively expressed in neurons and their adjacent axons. Nf are particularly abundant in the axon, where they are key building blocks of the axonal cytoskeleton. The complex protein chemistry of Nf is briefly described.

Biomarker: A biomarker is a characteristic that is objectively measured and evaluated as an indicator of normal biologic processes, pathogenic processes, or pharmacological responses to therapeutic intervention.

Surrogate endpoint: defines a biomarker that is intended to serve as a substitute of a clinically meaningful endpoint and is expected to predict the effect of a therapeutic intervention or the evolution of disease.

## Characteristics

### Quantitative Description

Nf are obligate heteropolymers (►polymer) that are composed of four subunits: a light (NfL), a medium (NfM), a heavy (NfH) [1] chain and also ►alpha-internexin [2,3]. In some cases, peripherin may be added to the list [2]. These subunits differ not only in their molecular weight, but also in their functional properties, as discussed below.

### NfL

The ►neurofilament light chain (NFL) is coded on chromosome 8p21 and consists of 543 amino acids. The molecular mass corresponds to 61 kDa, but due to phosphorylation and glycosylation, migration in sodium dodecyl sulfate (SDS) polyacrylamide gels (PAGE) is slow, and most authors refer to a molecular mass of 68 kDa as determined in SDS-PAGE. NfL forms the back-bone of the Nf heteropolymer and can self-assemble. Mutations in the NfL gene have been associated with Charcot-Marie Tooth disease.

### NfM

The ►neurofilament medium chain (NfM) is also coded on chromosome 8p21 and consists of 916 amino acids. The molecular mass is calculated as 102.5 kDa, and runs at 150 kDa in SDS gels. NfM is important for

the radial axonal growth. One mutation in the NfM gene has been associated with Parkinsons disease.

### NfH

The ►neurofilament heavy chain (NfH) is coded on chromosome 22q12.2 and consists of 1,020 amino acids. The molecular mass of the amino acids corresponds to 111 kDa. Most authors however refer to the molecular mass derived from SDS gels which is also influenced by the charge/weight of bound phosphate and therefore ranges from 190 to 210 kDa for the various phosphoforms. NfH is important for protein-protein interactions which is regulated locally in the axon by phosphorylation. Mutations in the NfH gene have been associated with amyotrophic lateral sclerosis (ALS).

### Alpha-Internexin

The 66 kDa alpha-internexin protein is coded on chromosome 10q24.33 and able to form homopolymers. Alpha-internexin has only recently been rediscovered as one of the Nf subunits and the role of alpha-internexin is still poorly understood [3]. Extracellular deposits of alpha-internexin are an important hallmark of a newly discovered neurodegenerative dementia named neurofilament inclusion disease (NFID).

### Assembly of the Nf Heteropolymer

Figure 1 illustrated how NfL, NfM and NfH assemble to produce the Nf heteropolymer, which has a diameter of about 10 nm. Because of its size, which is intermediate

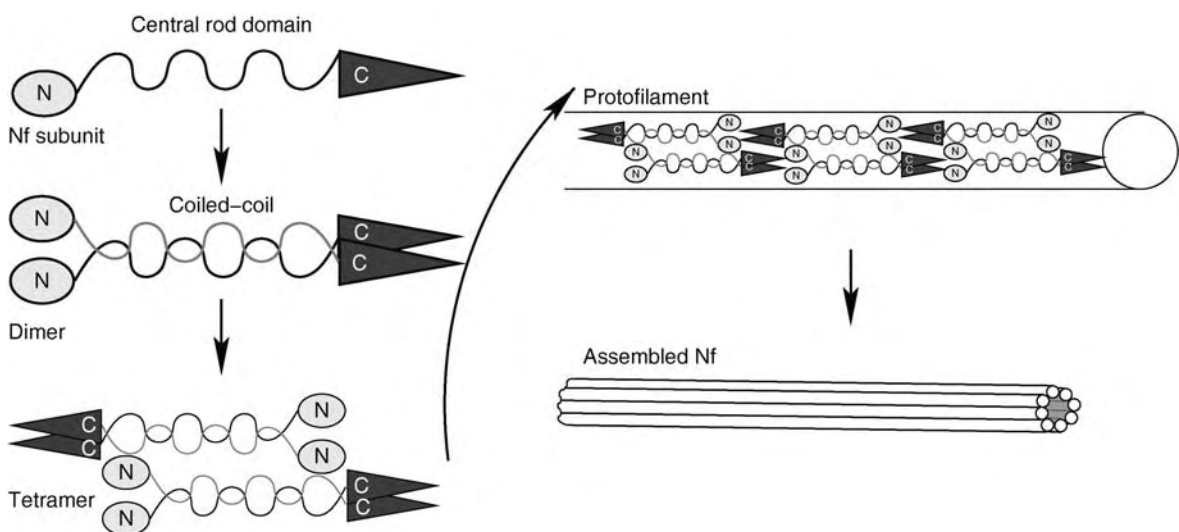

**Neuronal Cell Death and Axonal Degeneration: Neurofilaments as Biomarkers. Figure 1** Neurofilament assembly. The central rod domain of the Nf subunits is intertwined in order to form dimers. The dimers are arranged antiparallel to form tetramers. Tetramers combine to form protofilaments, which finally assemble to produce the 10 nm thick Nf (figure reprinted with permission from reference [4]).



between the smaller proteins, e.g. microfilaments (7 nm) and larger proteins such as microtubules (approximately 25 nm), the Nf heteropolymer belongs to the intermediate filaments.

### Stoichiometry of the Nf Subunits

The estimated in vitro molar ratio of isolated Nfs from the mouse optic nerve and spinal cord is 4:2:2:1 (NfL:a – internexin:NfM:NfH) [3]. The in vivo stoichiometry of Nfs in body fluids remains unknown.

### Classification of Nf

Nf are type IV intermediate filaments (Table 1).

### Nf are a Biomarker for Axonal Degeneration

Nf subunits are useful biomarkers for axonal degeneration, as illustrated in Fig. 2. Any insult causing neuronal death or axonal degeneration will inevitably result in

disintegration of the axonal membrane. Subsequently the contents of the axonal cytoplasm are released into the ►extracellular fluid (ECF). From the ECF Nfs diffuse into other body fluid compartments such as the ►cerebrospinal fluid (CSF), blood or amniotic fluid. As explained above Nf are a major structural protein component of the axon and the quantification of Nfs from body fluids therefore allows estimation of the degree of axonal degeneration.

### The Measurement of Nf Body Fluid Levels

At present, high-throughput quantification of Nfs from body fluids and tissue homogenates is best achieved using enzyme linked immune assays (ELISA). In-house ELISAs have been developed for NfL and NfH [5–8]. These assays are highly robust and have been cross-validated [9,10]. A commercial NfH ELISA kit has recently been made available (Chemicon). Alternatively immunoblots or dot-blot assays have

**Neuronal Cell Death and Axonal Degeneration: Neurofilaments as Biomarkers. Table 1** Classification of intermediate filaments and cell-type specificity

Class	Identity	Cell-type specificity
Type I	Acidic keratins	Epithelial
Type II	Neutral & Basic keratins	Epithelial
Type III	GFAP	Astrocyte
	Peripherin	Neuronal (peripheral)
	Vimentin	Mesenchymal
	Desmin	Muscle
Type IV	NfL, NfM, NfH	Neuron and axon
	Alpha-internexin	Neuron and axon
Type V	Laminin A, B, C	Most cells
Type VI	Nestin	CNS stem cells

GFAP = glial fibrillary acidic protein.

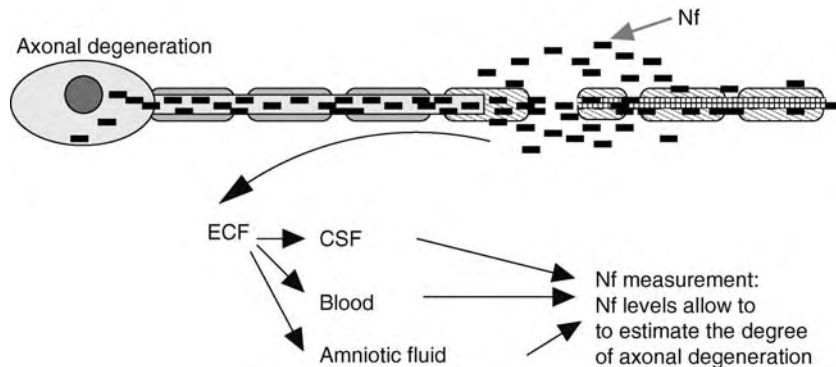

**Neuronal Cell Death and Axonal Degeneration: Neurofilaments as Biomarkers. Figure 2** Neurofilaments are released into the extracellular fluid (ECF) following axonal disintegration. From the ECF Nfs equilibrate with the adjacent body fluid compartment. Quantification of Nfs is therefore possible from the cerebrospinal fluid (CSF), blood and amniotic fluid. The degree of axonal degeneration is related to the amount of Nf measured in these body fluids. For this reason body fluid Nf levels permit the estimation of the amount of axonal degeneration. Axonal degeneration is extremely important because the loss of axons is irreversible and may therefore lead to persistent disability.

been used, but generally they are not high-throughput and only semi-quantitative.

### The Diseases Associated with High Body Fluid Nf Levels

Neuronal loss and axonal degeneration are a key feature in numerous disorders and frequently represent the endstage of a pathophysiological cascade. Not surprisingly, body fluid levels of Nf subunits have been used to estimate the degree of axonal damage in a number of diseases (Table 2). It is important to remember that body fluid Nf levels are not a diagnostic test for one single disease. In contrast Nf are a biomarker and surrogate endpoint according to the initial definitions.

### Conclusion

Neurofilaments are complex proteins composed of four subunits, expressed exclusively in the neuro-axonal compartment. Nf are released into the extracellular fluid from degenerating axons. From the extracellular fluid they diffuse into adjacent body fluid compartments. Using standard ELISA techniques Nf subunits have been quantified from the cerebrospinal fluid, the blood and the amniotic fluid. Because body fluid levels of Nf are related to the amount of neuronal death and axonal loss, they provide valuable prognostic information and correlate with disability in a number of diseases.

**Neuronal Cell Death and Axonal Degeneration: Neurofilaments as Biomarkers. Table 2** Diseases in which Nf have been used as a body fluid biomarker for neuronal death and axonal degeneration

Disease	Findings
AD	CSF NfL and NfH levels are elevated in AD. The difference from controls was marginal for CSF NfH levels and more impressive for NfL levels
ALS	CSF NfL and NfH levels are considerably increased in patients with ALS. Rapidly progressing ALS patients had the highest CSF NfH levels
CBD	CSF NfL and NfH levels are elevated in patients with CBD
FTLD	CSF NfL is elevated and CSF NfH marginally elevated in patients with FTLD. The degree of NfH phosphorylation is increased in FTLD compared to AD and controls
GBS	Elevated CSF NfH levels in patients with GBS are a poor prognostic sign, probably due to proximal axonal degeneration. Proximal axonal degeneration at the level of the nerve roots rapidly releases Nfs into the CSF. Proximal axonotmesis requires axonal regrowth over a long distance with the risk of losing chemical and anatomical guidance cues
ICH	CSF NfH levels are high in ICH, probably indicating direct axonal degeneration due to rupture and ischemia
DLB	CSF NfH but not NfL levels are elevated in DLB compared to AD and controls
MMC	Amniotic fluid NfH levels are elevated in mice with MMC and correlated with the size of the lesion
MS	CSF NfH and NfL levels are elevated in MS. CSF NfL levels are highest following a clinical relapse and return to baseline within about 3 months. CSF NfH levels are highest in the secondary progressive phase of the disease when axonal degeneration accumulates. The degree of NfH phosphorylation is increased in patient with more severe disease. High CSF NfH levels are a poor prognostic sign. Both CSF NfL and NfH levels correlate with disability
MSA	CSF NfL and NfH levels are markedly elevated in MSA compared to controls and patients with PD. This may be related to the greater degree and more rapid disease progression in MSA. The highest levels are found in patients with the cerebellar variant of MSA, which may be of help for the differential diagnosis of patients with cerebellar syndromes
NMO	CSF NfH levels are considerably elevated in NMO (synonymous with Devic's disease) suggesting that these patients suffer from substantially more axonal damage than patients with MS or ON
ON	Plasma NfH levels are increased in acute ON. CSF NfH levels are elevated in patients with subacute ON. Plasma and CSF NfH levels correlate with loss of visual function
PD	CSF NfH and NfL levels are increased in PD compared to controls
PSP	CSF NfL and NfH levels are elevated in PSP compared to controls and patients with PD. As with MSA this may be related to the greater degree of axonal loss and more rapid disease progression in PSP patients, who are also very resistant to pharmacological treatment
SAH	CSF NfL and NfH levels are elevated in SAH and correlated with the outcome. Importantly CSF NfH levels showed a secondary increase during the high risk period of vasospasm, probably indicating secondary axonal degeneration following an ischemic insult

AD = Alzheimer's disease, ALS = amyotrophic lateral sclerosis, CBD = cortico-basal degeneration, DLB = Diffuse Lewy body disease, FTLD = fronto-temporal lobar degeneration, GBS = Guillain-Barré syndrome, ICH = intracerebral haemorrhage, MMC = meningo-myelocele, MS = multiple sclerosis, MSA = multiple system atrophy, NMO = neuromyelitis optica, ON = optic neuritis, PD = Parkinson's disease, PSP = progressive supranuclear palsy, SAH = subarachnoid haemorrhage.

## Acknowledgement

I apologize to all colleagues whose work has not been cited due to space limitations. The biomarker definitions were adapted from a recent NIH meeting on biomarkers. A more complete list of references can be requested from the author (a.petzold@ion.ucl.ac.uk).

## References

1. Lee MK, Cleveland DW (1996) Neuronal intermediate filaments. *Ann Rev Neurosci* 19:187–217
2. Shaw G (1998) Neurofilaments. Springer, Berlin Heidelberg New York
3. Yuan A, Rao MV, Sasaki T, Chen Y, Kumar A, Veeranna, Liem RK, Eyer J, Peterson AC, Julien JP, Nixon RA (2006) Alpha-internexin is structurally and functionally associated with the neurofilament triplet proteins in the mature CNS. *J Neurosci* 26:10006–10019
4. Petzold A (2005) Neurofilament phosphoforms: surrogate markers for axonal injury, degeneration & loss. *J Neurol Sci* 233:183–198
5. Rosengren LE, Karlsson JE, Karlsson JO, Persson LI, Wikkelso C (1996) Patients with amyotrophic lateral sclerosis and other neurodegenerative diseases have increased levels of neurofilament protein in CSF. *J Neurochem* 67:2013–2018
6. Petzold A, Keir G, Green AJE, Giovannoni G, Thompson EJ (2003) A specific ELISA for measuring neurofilament heavy chain phosphoforms. *J Immunol Methods* 278:179–190
7. Norgren N, Rosengren L, Stigbrand T (2003) Elevated neurofilament levels in neurological diseases. *Brain Res* 987(1):25–31
8. Shaw G, Yang C, Ellis R, Anderson K, et al. (2005) Hyperphosphorylated neurofilament NF-H is a serum biomarker for axonal injury. *Biochem Biophys Res Comm* 336:1268–1277
9. Van Geel WJA, Rosengren LE, Verbeek MM (2005) An enzyme immunoassay to quantify neurofilament light chain in cerebrospinal fluid. *J Immunol Methods* 296:179–185
10. Petzold A, Shaw G (2007) Comparison of two ELISA methods for measuring levels of the phosphorylated neurofilament heavy chain. *J Immunol Methods* 319:34–40

## Definition

Excitotoxicity is a mechanism which often leads to Neuronal cell damage or death. Excitotoxicity occurs when glutamate receptors on neurons are overactivated. Neuronophagia occurs when nerve cells are phagocytosed or internalized by macrophages. This often happens to clear debris after the neurons have undergone apoptosis, but in some neuroinflammatory or neurodegenerative conditions, the neurons may be killed as the macrophages digest them. Necrosis is a process of cell death whereby cells swell, rupture, and release their contents, causing ►inflammation and damage to neighboring cells. In the nervous system, this usually happens in response to stroke or trauma. In contrast to necrosis, apoptosis is a form of cell death which does not cause inflammation, but, rather, is frequently the result of inflammatory processes. Therefore, the mechanism of neuronal cell death which usually occurs in the setting of neuroinflammatory and neuro-infectious diseases is apoptosis. Unlike necrosis, apoptosis occurs via a controlled sequence of events, starting with an initial trigger, then proceeding through a specific signaling cascade, resulting in breakdown of the chromatin and shrinkage of the nucleus and cellular contents without rupture of the cell membrane. See [Table 1](#).

Neuronal cell death is the irreversible loss of function of a neuron. Neuroinflammatory diseases such as multiple sclerosis, transverse myelitis, and neurosarcoidosis are characterized by episodic immune activation, which results in nervous system injury. Although an infectious etiology has long been suspected in these diseases, none has been conclusively demonstrated. Other chronic neurodegenerative diseases, such as Alzheimer's disease, also have chronic glial cell activation. It remains unknown if this chronic activation is needed to provide trophic support for injured neurons or if ►cytokines and other host factors released by these cells may be injurious. ►Virotoxins and other infectious agents may trigger immune cascades that can persist long after the infection has been controlled or eradicated, a mechanism of injury that has been termed the “hit and run phenomenon.” This persistent immune activation can lead to neuronal injury resulting in neurocognitive impairment. There are many in vitro and in vivo models of neuroinflammatory conditions which allow us to study the effects of immune responses on the nervous system. Although many different conditions produce a neuroinflammatory state, the host repertoire for immune response and the mechanisms for subsequent neuronal death or dysfunction are relatively limited. It is thus hoped that the study of any one of these diseases or model systems will be widely applicable to other autoimmune and neurodegenerative diseases in which immune activation is an important component.

Neuronal cell death is common in patients with both infectious and non-infectious neuroinflammatory

---

## Neuronal Cell Death and Inflammation

JEFFREY A. RUMBAUGH, AVINDRA NATH  
Department of Neurology, Johns Hopkins University  
School of Medicine, Baltimore, MD, USA

## Synonyms

Excitotoxicity; Apoptosis; Necrosis; Virotoxias; Encephalitis; Chemokines; Cytokines; Chemtaxis; Blood brain barrier; Matrix metallo Proteinases

**Neuronal Cell Death and Inflammation. Table 1** Features of necrosis versus apoptosis

Feature	Apoptosis	Necrosis
Cell size	Shrunk, small	Swollen, enlarged
Inflammation	Inflammation causes apoptosis	Necrosis causes inflammation
Leakage	Cell contents intact	Cell contents leak out
Membrane	Intact	Disrupted
Nucleus	Fragmented	Condensed
Role	Often physiological	Always pathological

conditions. Even in many infectious conditions, such as HIV infection, neurons themselves are frequently not directly infected. Thus, in all of these conditions, the observed loss of neurons is likely due to indirect effects of inflammatory mediators and/or infectious proteins. A process called apoptosis is the primary mechanism through which neurons die. Apoptosis may also be seen in some other cells of the nervous system, including astrocytes and endothelial cells. Neuronal apoptosis correlates with microglial activation and axonal damage, suggesting that the inflammatory mediators secreted by microglia and other immune cells play a major role in initiating the apoptotic cascades.

Importantly, recent studies have shown that neuronal injury may occur without cell death. The clinical manifestations of neuroinflammatory conditions are likely due to neuronal dysfunction via multiple mechanisms. Although massive neuronal loss may occur in many neuroinflammatory conditions, it often occurs late in disease, and may not be the cause of early clinical manifestations. Some inflammatory pathways, and related dysfunction, may be reversible with strategic neuroprotective and immunomodulatory strategies. Pathological studies have demonstrated injury types which are likely to be reversible, including morphological changes in dendrites and loss of neurites without neuronal cell loss. Such dendritic injury and loss, without neuronal cell body loss, is often called dendritic pruning. Similarly, axonal injury can occur without death of neuronal cell bodies. This raises great hope for the potential use of neurotrophic modes of therapy for neuroinflammatory and neurodegenerative diseases.

### Characteristics

The mechanisms by which inflammatory conditions and infections lead to neuronal cell death and dysfunction, as well as associated clinical conditions like ►encephalitis, ►vasculitis, or dementia, remain elusive. In many cases, the inflammation generated by the host, in an attempt to combat a presumed or real infection, is itself implicated as a primary factor in causing neuronal dysfunction or degeneration. In this essay, we outline the current state of knowledge regarding the pathophysiology of central nervous system injury in infectious or inflammatory

conditions. Understanding these mechanisms should ultimately enable development of immunomodulatory therapies for treating these conditions.

### Description of the Process

Inflammation in the nervous system is dependent on two main features: infiltration of monocytes from the peripheral blood into the brain, and activation of microglia, which are the immune cells that are always present in the brain. In viral infections, such as HIV, the virus itself or viral proteins can activate uninfected cells directly. In non-infectious conditions, the inciting agent(s) may be unknown, but these immune cells are likely activated in a similar fashion. Then, in an attempt to eradicate the presumed or real infection in the brain, these immune cells are likely most responsible for the neuroinflammatory and neurotoxic cascades which lead to brain injury. These cells express tumor necrosis factor- $\alpha$  (TNF- $\alpha$ ), interleukin-1 (IL-1), interferon- $\alpha$  (INF- $\alpha$ ), and nitric oxide synthase (NOS), among other inflammatory mediators [1]. It should be noted, however, that these cells may have neuroprotective properties as well. In fact, immune cells typically serve beneficial functions. This may suggest that the immune response does not become damaging until it becomes dysregulated and chronic.

Cytokines and ►chemokines are multifunctional proteins which regulate individual cells under physiological or pathological conditions. They are important mediators for communication between nervous tissues and immune cells and are thus very important in the induction and regulation of inflammation in the nervous system, and thus to the progression or inhibition of neurodegeneration [1]. They are expressed by the peripheral immune cells which have entered the brain often across a defective ►blood-brain barrier, by activated microglia, by astrocytes, and even by certain neurons. They include, but are not limited to, IL-1, IL-8, RANTES, TNF- $\alpha$ , SDF-1, and MCP-1. MCP-1 is a potent chemoattractant for monocytes, drawing them into the brain from the peripheral blood in a process called ►chemotaxis, so that they, in turn, can produce even more inflammatory cytokines. Many of these cytokines/chemokines have both deleterious and beneficial effects,

so the net effect is likely the result of a complex set of interactions and conditions and is very difficult to predict a priori or to determine experimentally.

Neuronal injury can be triggered by various mechanisms. Binding of various cytokines and chemokine receptors either by the cytokines/chemokines themselves (especially  $\text{TNF-}\alpha$ ) or by viral proteins or other neurotoxic agents will lead to increases of intracellular calcium. Similarly, inflammatory conditions may promote excitotoxicity. Neuroinflammatory proteins may either directly stimulate the neuronal glutamate NMDA receptor or may sensitize neurons to the effects of otherwise physiological levels of glutamate. Excessive or chronic stimulation of this receptor results in a long cascade, again leading to increased intracellular calcium. Increased calcium leads to loss of mitochondrial membrane potential, release of cytochrome c, activation of caspases, and apoptosis [2]. Excitotoxicity also leads to production of nitric oxide and free radicals which in turn produce oxidative damage, energy failure, and DNA damage.

Figure 1 depicts the complex interactions between toxic cellular proteins, viral proteins, and the immune response, which lead to neurotoxicity in vitro and to the neurological complications of inflammatory and/or infectious conditions clinically.

### Higher Level Processes and Conditions

Reactive astrocytes are common in these neuroinflammatory conditions and they participate in the production of neurotoxic substances, such as  $\text{TNF-}\alpha$ , and other

inflammatory mediators. Activation of astrocytes can alter their function in other ways as well, leading to loss of support for neurons, in turn making the neurons more susceptible to injury or death.

Periventricular white matter pallor is also frequently observed in these conditions. Depending on the specific condition, this can be associated with damage to the oligodendrocytes and/or the myelin sheath which wraps around neuronal axons, or, alternatively, it can be associated with subtle changes of the **▶blood–brain barrier (BBB)** secondary to inflammation. Inflammation can affect the expression and assembly of **▶tight junction** proteins, leading to cytoskeletal disruption of endothelial cells and increased endothelial permeability. White matter changes on MRI seem to correlate with perivascular macrophage infiltrates, extravasation of protein, and blood–brain barrier compromise. Endothelial cells and astrocytes functionally form the blood–brain barrier, so injury to either of these cell types can compromise the blood–brain barrier. Endothelial cells may also increase expression of adhesion molecules [3], allowing easier entry of peripheral immune cells into the brain. A compromised blood–brain barrier allows immune cells, inflammatory mediators, and neurotoxins from the peripheral blood to enter the nervous system where they can participate in damaging and killing neurons. Sometimes, however, these white matter changes are reversible, with associated improvement in clinical manifestations.

Various viral infections have been used extensively as model systems for neuroinflammatory conditions,

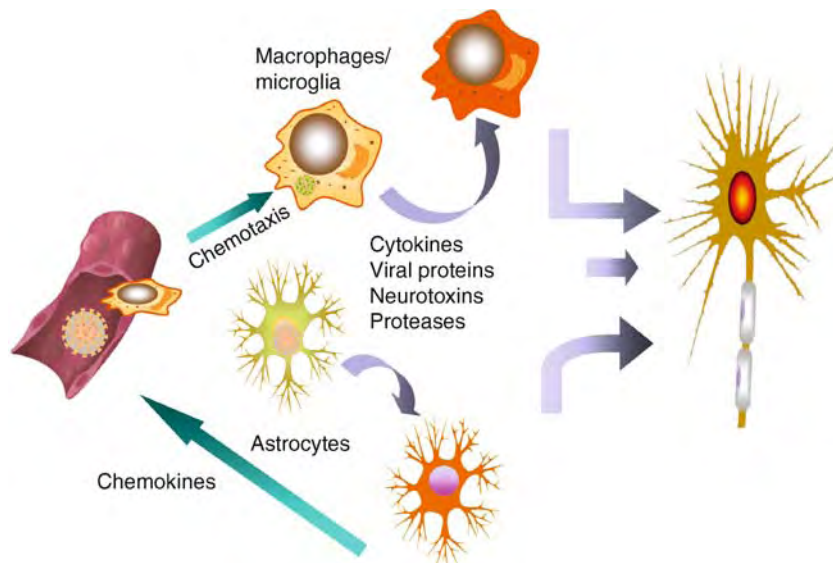

**Neuronal Cell Death and Inflammation. Figure 1** Through multiple indirect mechanisms, neurons become dysfunctional and die in the setting of inflammatory and infectious conditions. Inflammatory mediators can be toxic to neurons directly, can alter glial function, and can further activate the immune response, all of which damages the nervous system. The arrows in the figure demonstrate the existence of these complex feed back loops.

and such studies have elucidated mechanisms which are widely applicable. Neurons may die upon interaction with viral proteins, while uninfected microglia, monocytes, and astrocytes are activated upon such interaction. These activated cells release a variety of proinflammatory factors, including cytokines, chemokines, free radicals, matrix metalloproteinases (MMPs), and prostanooids, which may result in secondary neuronal toxicity or further immune cell activation and reactive gliosis. This amplification of the immune cascade after an initial trigger has been termed the “domino effect” [4]. Once the domino effect has been initiated, the inflammatory process may be self-propagating, even if the initial trigger is no longer present, resulting in the “hit and run” phenomenon [5].

MMPs are a family of endopeptidases which enzymatically degrade extracellular matrix proteins and can thus disrupt the blood–brain barrier and neuronal synapses [6]. MMP levels are elevated in the spinal fluid and/or brains of patients with many neuroinflammatory or neurodegenerative conditions, suggesting they may contribute to the neuropathogenesis of these conditions. MMPs can cleave chemokines, such as SDF-1, with the cleavage products subsequently causing neurotoxicity, and they can interact with integrin receptors on neurons, initiating apoptosis. Furthermore, they can become nitrosylated and hyperactive, contributing to neurotoxicity under conditions of oxidative stress [7]. MMP expression in monocytes can facilitate monocyte transmigration through the extracellular matrix. However, it should also be noted that cleavage of the chemokine, MCP-3, by MMP-2 has been shown to decrease the inflammatory response [8], and cleavage of HIV Tat protein by MMP-1 attenuates Tat-induced neurotoxicity [9]. Thus, MMPs may be neuroprotective under certain conditions.

### Regulation of the Process

The brains of patients with many of the neuroinflammatory conditions demonstrate up and downregulation of numerous genes compared to control brains. These changes in gene expression profiles are consistent with changes in various neurotransmitter receptor levels and ion currents, which would be expected to alter neuronal excitability. Perhaps these changes in gene expression are in response to the changes in neuronal excitability which are induced by the inflammatory cascades and processes.

### Function

Although the mechanisms of inflammation and neuronal cell death and dysfunction may be quite similar in the various neuroinflammatory conditions, the clinical manifestations may be variable. For reasons which are not well understood, certain areas of the brain may be preferentially affected over other areas [10]. For

example, as a result of the inflammation caused by HIV infection, the basal ganglia and hippocampus are preferentially damaged, with neuronal losses of up to 50–90% in patients with severe HIV encephalitis. The cortex is also affected with the frontal lobes having 40–60% neuronal loss, but parietal and temporal lobes having only 20% loss. The cerebellum has even less neuronal loss and the occipital lobe has the least. The locations of the predominant changes accounts for the predominant symptoms of HIV dementia, including psychomotor slowing and memory impairment.

It is not surprising that a prolonged, poorly controlled inflammatory reaction in the nervous system would result in neurodegeneration. Neurological outcome from these conditions depends on the interplay of a complicated network consisting of various cell types, pro- and anti-inflammatory factors, viral virulence factors, and host susceptibility factors. A successful therapeutic strategy to treat inflammation-mediated neurodegeneration will likely require a multi-faceted approach, aiming to not only inhibit proinflammatory factors but also to increase neuroprotective and neurotrophic factors.

### Acknowledgement

This work was supported by National Institutes of Health grants to JR and AN.

### References

1. Merrill JE, Benveniste EN (1996) Cytokines in inflammatory brain lesions: helpful and harmful. *Trends Neurosci* 19:331–338
2. Kruman I, Nath A, Mattson MP (1998) HIV protein Tat induces apoptosis by a mechanism involving mitochondrial calcium overload and caspase activation. *Expt Neurol* 154:276–288
3. Briscoe DM, Cotran RS, Pober JS (1992) Effects of tumor necrosis factor, lipopolysaccharide, and IL-4 on the expression of vascular cell adhesion molecule-1 in vivo. Correlation with CD3+ T cell infiltration. *J Immunol* 149:2954–2960
4. Nath A (1999) Pathobiology of HIV dementia. *Sem Neurol* 19:113–128
5. Nath A, Conant K, Chen P, Scott C, Major EO (1999) Transient exposure to HIV-1 Tat protein results in cytokine production in macrophages and astrocytes: a hit and run phenomenon. *J Biol Chem* 274:17098–17102
6. Libby RT, Lavalley CR, Balkema GW, Brunken WJ, Hunter DD (1999) Disruption of laminin beta2 chain production causes alterations in morphology and function in the CNS. *J Neurosci* 19:9399–9411
7. Gu Z, Kaul M, Yan B, Kridel SJ, Cui J, Strongin A et al. (2002) S-nitrosylation of matrix metalloproteinases: signaling pathway to neuronal cell death. *Science* 297:1186–1190
8. McQuibban GA, Gong JH, Tam EM, McCulloch CA, Clark-Lewis I, Overall CM (2000) Inflammation dampened by gelatinase A cleavage of monocyte chemoattractant protein-3. *Science* 289:1202–1206

9. Rumbaugh J, Turchan-Cholewo J, Galey D, St Hillaire C, Anderson C, Conant K et al. (2006) Interaction of HIV Tat and matrix metalloproteinase in HIV neuro-pathogenesis: a new host defense mechanism. *FASEB J* 20:1736–1738
10. Masliah E, Ge N, Achim CL, Hansen LA, Wiley CA (1996) Selective neuronal vulnerability in HIV encephalitis. *J Neuropathol Exp Neurol* 51:585–593

## Neuronal Changes in Axonal Degeneration and Regeneration

HÅKAN ALDSKOGIUS

Uppsala University Biomedical Center,  
Department of Neuroscience, Uppsala, Sweden

### Synonyms

Axon reaction; Retrograde neuron reaction; Chromatolysis

### Definition

Following injury to the ►axon, the affected nerve cell body (►soma) with its associated processes undergo a sequence of structural and molecular changes, collectively termed the ►axon reaction or ►retrograde neuron reaction. ►Chromatolysis is sometimes used as a synonym, but in a strict sense refers to the marked reduction (dissolution) of basophilic ►Nissl bodies caused by axon injury (Fig. 1).

Neuronal changes to axon injury are fundamental pathophysiological events in any neurological condition, which interrupts axons in the peripheral or central

nervous system, or in which the normal peripheral or central target for the neuron is lost.

### Characteristics

#### General Characteristics

The neuronal changes to axon injury include responses to overcome the ►cellular stress imposed by the injury, as well as a reorganization of the overall cell morphology and cellular metabolism from a “transmitting” to a “growing” mode. The latter implies that the expression of genes involved in ►neurotransmitter synthesis and release are typically down-regulated, whereas those promoting ►neurite growth are up-regulated [1,2]. As a result of this phenotypic shift, injured neurons in many ways resemble developing neurons. Under the most favorable circumstances, the injured neuron survives, ►regenerates its axon, and restores functional contact with the ►denervated cells/tissue. A sustained up-regulation of ►growth-associated genes is considered necessary for successful regeneration and target ►reinnervation. Neurons with axons in the peripheral nervous system, i.e. ►motoneurons ►sensory ganglion cells and ►autonomic neurons all have this ability, whereas neurons with axons entirely within the central nervous system usually do not.

Axon injury consistently affects ►glial cells in the surroundings of the injured nerve cell body and ►dendrites, as well as neurons with ►synapses on the injured neuron. Under certain circumstances, neurons, which are ►presynaptic or ►postsynaptic to the injured neuron undergo ►trans-synaptic changes [3].

#### The Phases of Neuronal Changes and Their Regulation

The prototypic neuronal response to injury, as seen following injury to peripheral axons, can be schematically divided in three, overlapping phases. This sequence

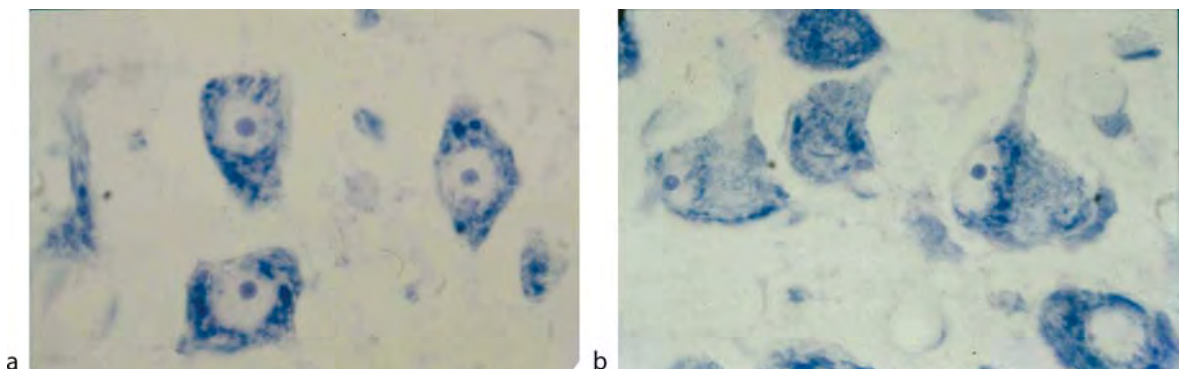

**Neuronal Changes in Axonal Degeneration and Regeneration. Figure 1** (a) Normal rat motor neurons showing clumps of dark blue cytoplasmic Nissl bodies stained with a basophilic dye. (b) Rat motor neurons after injury to their axons showing that the Nissl bodies have disappeared, and the cytoplasm acquired a pale color, so-called chromatolysis.

of events applies only in part following injury to axons in the central nervous system (see below).

- The initial phase reflecting the immediate cell stress, and adaptation to loss of target contact; in this phase numerous ▶**sprouts** are formed at the end of the proximal stump of the injured axons
- The phase of axonal elongation; in this phase a subset of the sprouts negotiate their way towards the denervated target; if conditions are sufficiently favorable, target contact is restored
- The phase of maturation of the ▶**regenerated** axon and the return of the neuron to a “transmitting” (normal) mode; in this phase axonal diameter is growing, and ▶**remyelination** of the larger axons is completed

Several factors mediate changes occurring during the initial phase. The injury causes an immediate ▶**depolarization** of the neuron resulting in changes in intracellular ion homeostasis and the release of neurotransmitters and synaptic ▶**modulators**. These early events lead to the induction of ▶**immediate early genes**, which act as ▶**transcription factors**. At a somewhat later point in time, the full transformation of the neuron into a growth state occurs by at least two different processes: (i) molecules from the extracellular environment enter the axon at the injury site and are ▶**retrogradely transported** within the axon to the nerve cell body, and (ii) specific molecules produced by the target cells, so-called ▶**trophic factors**, which normally reach the nerve cell body by retrograde axonal transport, are depleted. Concomitantly, growth promoting molecules, diffusible and associated with the ▶**extracellular matrix**, are up-regulated in cells at the injury site, and in non-neuronal cells in the distal part of the axon. These molecules play a crucial role in the creation of a growth permissive pathway from the injury to the target tissue.

### Changes in Neuronal Morphology

The most striking morphological change in nerve cells following axon injury is the loss of Nissl bodies, making the cytoplasm appear paler than normal (chromatolysis). At the same time, the nerve cell bodies often appear round with their nucleus displaced towards the periphery (away from the exit point of the axon). The ultrastructural basis for chromatolysis is loss of granular ▶**endoplasmic reticulum**. The diameter of the axon proximal to the injury gradually becomes thinner, axon collaterals are lost and the dendrites become shorter. Thus, the overall dimension of the injured neuron is reduced. Following target reinnervation, these changes are only partially reversed. The axon diameter and the normal shape of the ▶**dendritic tree** are typically not restored.

### Changes in Neuronal Gene Expression

The list of changes in gene expression following axon injury is long. Genes involved in the synthesis of the classical neurotransmitters and with ▶**postsynaptic receptors** are down-regulated, as are also genes contributing to structural stability of the neuron. The latter includes genes for proteins of ▶**neurofilaments**, the major stabilizing component of the axon, and certain classes of ▶**microtubulus-associated proteins** (MAPs), which provide structural support to dendrites. All these changes provide the basis for the morphological changes (see above). Genes belonging to the family of ▶**stress response (heat shock) protein**, and the ▶**chaperon** system are up-regulated, as well as genes supportive of axonal sprouting and extension. The latter includes intracellular molecules, which provide building blocks for the elongating axons, as well as membrane-bound and diffusible molecules, which are necessary for appropriate interactions with the environment. Important intracellular growth-associated molecules include ▶**actin**, ▶**tubulin** and several so-called ▶**growth-associated proteins** (GAPs).

### Changes in Glial Cells and Synapses

Striking changes occur in adjacent glial cells as well as in ▶**synaptic terminals**, which cover injured neurons [4–6]. In the central nervous system, non-synaptic neuronal membrane is covered by processes of ▶**astrocytes**. As a result of axon injury, these cells hypertrophy, and increase their coverage of the neuronal membrane in parallel with the disappearance of ▶**presynaptic terminals**. The predominating type of the lost terminals is ▶**excitatory**. ▶**Microglial** cells in the neighborhood of the affected neurons ▶**proliferate**, migrate towards the nerve cell body of the injured neuron, and up-regulate molecules associated with ▶**immune** and inflammatory responses. In autonomic and sensory ganglia of the peripheral nervous system, ▶**satellite cells**, which normally cover nerve cell bodies, proliferate. In addition, monocytes enter from the vascular system, and become transformed to macrophages. In the central nervous system and autonomic ganglia, a large proportion of presynaptic terminals on the cell body and dendrites disappear. The overall result of these changes is that the nerve cell body and dendrites of the injured nerve cell are partially isolated from surrounding influences.

### Differences in Neuronal Changes Following Injury to Peripheral or Central Axons

Neurons with their axons confined to the central nervous system initially respond to injury or loss of target in a similar manner as those with axons in the peripheral nervous system [7]. Central neurons produce sprouts, which are capable of making novel synaptic connections



within a limited distance [8]. However, central neurons are in general unable to mount the sustained up-regulation of growth supporting gene expression necessary for axon elongation, unless their axons are allowed to grow in a peripheral nervous system environment. The failure to sustain a prompt and long-lasting up-regulation of growth supporting genes is the result of intrinsic neuronal factors, in combination with a powerful inhibitory influence of the environment at the injury site and distal to it.

### The Special Case of Sensory Ganglion Cells

Sensory ganglion cells are unique in having one axon projecting to peripheral target tissue, and one centrally, which terminates on postsynaptic neurons in the spinal cord or brainstem. Injury to peripheral sensory axons results in the same sequence of structural and molecular changes in their cell bodies, and proximal axon as described above. In addition, the central process and its terminals are affected. These include a reduction in the diameter of the central process, and changes in the morphology and chemical properties of its central terminals. As a consequence of these changes permanent alterations arise in the transmission of sensory impulses in the spinal cord and brainstem, which may contribute to long-lasting post-injury sensory ►neuropathies, e.g. ►neuropathic pain.

Injury to the central axon is associated with an attenuated neuronal response. The “transmitting” phenotype is essentially intact, and growth supporting gene expression is minimal. The injured axons sprout and elongate, but at a significantly slower rate than after corresponding injury to the peripheral axon. By combining central axon injury with a peripheral one, both axons elongate with the higher rate, and is capable of even moderate growth in the spinal cord itself [9]. The peripheral injury induces a growth state, and act as a ►conditioning lesion that amplifies axon outgrowth from the central process.

### Long term Consequences of Axon Injury in the Peripheral Nervous System

There are three principal outcomes of axon injury: (i) neuron survival, axon regeneration, and functional recovery; (ii) neuron survival, failure of axon regeneration, and no functional recovery; (iii) neuron degeneration.

Successful axon regeneration and functional recovery is possible following injury to axons in the peripheral nervous system. This outcome requires that injured axons are able to enter the distal stump unimpeded, and that the target tissue is not too distant. A prime goal in modern research on peripheral axon injury is to eliminate obstacles to axonal elongation, and to increase its rate. With re-connection to a target, the neuron down-regulates genes expressing growth promoting molecules, the dendritic tree expands, and synaptic coverage increase, i.e. the

neuron resumes a mature, “transmitting” phenotype. A complete restoration of the pre-injury state is, however, achieved only under the most favorable circumstances.

In case injured axons fail to make functional peripheral connections, the growth state of the neuron will cease, and nerve cell body and its processes enter a state of prolonged, possibly permanent atrophy, which may be severe. Injury to the axon, e.g. by removal of the ►neuroma at the proximal stump, will re-activate the growth state, and a new attempt to regenerate the injured axon [10].

Degeneration and ►death of neurons is a common consequence of axon injury. The risk of this outcome is significantly increased if axon injury (i) affects immature individuals, (ii) the injury leads to complete separation of the proximal and distal parts of the axon, e.g. the nerve is sectioned rather than crushed, (iii) is close to the nerve cell body, (iv) is combined with injury to afferent axons, a common situation in the central nervous system, and (v) affects certain classes of neurons. Neuron degeneration after axon injury commonly occurs by an intrinsic cell death program, ►apoptosis. The relationship between neuron degeneration and regeneration is complex in the sense that injury circumstances that increase the risk of neuron death also leads to the most powerful growth response.

### Clinical Aspects

Axons in the peripheral nervous system are injured in trauma and many common disorders, e.g. diabetes. Trauma is also a common cause of axon injury in the central nervous system. More common there are axon injury because of disorders of the cerebral blood vessels (►stroke). Axon injury is at least in part a feature of many chronic disorders of the nervous system, e.g. ►Alzheimer’s disease. Nerve cell survival is a prerequisite for functional recovery. Intense research is therefore underway to develop optimal strategies for promoting survival of injured neurons, and allow them to regenerate their axon and restore useful functional synaptic contacts.

### References

1. Abankwa D, Küry P, Müller HW (2002) Dynamic changes in gene expression profiles following axotomy of projection fibres in the mammalian CNS. *Mol Cell Neurosci* 21:421–435
2. Lin H, Hao J, Sung YJ, Walters ET, Ambron RT (2003) Rapid electrical and delayed molecular signals regulate the serum response element after nerve injury: convergence of injury and learning signals. *J Neurobiol* 57:204–220
3. Ginsberg SD, Martin LJ (2002) Axonal transection in adult rat brain induces transsynaptic apoptosis and persistent atrophy of target neurons. *J Neurotrauma* 19:99–109

4. Aldskogius H (2001) Microglia in neuroregeneration. *Microsc Res Techn* 54:40–46
5. Brännström T, Kellerth JO (1998) Change in synaptology of adult cat spinal alpha-motoneurons after axotomy. *Exp Brain Res* 118:1–13
6. Linda H, Shupliakov O, Ornung G, Ottersen OP, Storm-Mathisen J, Risling M, Cullheim S (2000) Ultrastructural evidence for a preferential elimination of glutamate-immunoreactive synaptic terminals from spinal motoneurons after intramedullary axotomy. *J Comp Neurol* 425:10–23
7. Mason MRJ, Lileberman AR, Anderson PN (2003) Corticospinal neurons up-regulate a range of growth-associated genes following intracortical, but not spinal, axotomy. *Eur J Neurosci* 18:789–802
8. Chuckowree JA, Dickson TC, Vickers JC (2004) Intrinsic regenerative ability of mature CNS neurons. *Neuroscientist* 10:280–285
9. Qui J, Cafferty WB, McMahon SB, Thompson SW (2005) Conditioning injury-induced spinal axon regeneration requires signal transducer and activator of transcription 3 activation. *J Neurosci* 25:1645–1653
10. McPhail LT, Fernandes KJ, Chan CC, Vanderluit JL, Tetzlaff W (2004) Axonal injury reveals the survival and re-expression of regeneration-associated genes in chronically axotomized adult mouse motoneurons. *Exp Neurol* 188:331–340

## Neuronal Determination

► [Combinatorial Transcription Factor Codes and Neuron Specification](#)

## Neuronal Differentiation

### Definition

The process whereby uncommitted neuronal precursor cells gradually accumulate gene products specific to, and required for, the eventual form and function of a specialized neuronal cell type. This process is associated with a cessation of cell division and is usually irreversible.

► [Neural Development](#)  
 ► [Neural Stem Cells](#)  
 ► [Regeneration](#)  
 ► [Axonal Pathfinding and Network Assembly](#)  
 ► [Combinatorial Transcription Factor Codes and Neuron Specification](#)

## Neuronal Ensemble

► [Temporal Coding](#)

## Neuronal Imaging

► [Neuron-Glia-Imaging](#)

## Neural Integrator – Horizontal

JOSÉ M. DELGADO-GARCÍA

División de Neurociencias, Universidad Pablo de Olavide, Sevilla, Spain

### Definition

A neural network that receives input signals related to horizontal eye velocity and generates a signal proportional to horizontal eye position that it conveys to extraocular motoneurons.

### Description of the Theory

The eye moves in the horizontal plane under the action of two antagonist extraocular muscles: the lateral rectus and the medial rectus (see the entry devoted to extraocular motoneurons for a description of their source of innervation). To fully compensate for head movements activating vestibular or optokinetic reflexes, or to maintain a given eye position on a target following a voluntary saccade, motoneurons need to receive an eye position signal [1–5]. Although a common neuronal integrator capable of generating eye position signals for all kinds of eye movements was initially proposed [5], recent experimental data indicates that there are several integrators depending on the neural structure responsible for generating oculomotor commands and on the plane of the movement [6]. It is accepted that horizontal and vertical eye position signals are generated separately in the ► [nucleus prepositus hypoglossi](#) (PH) and in the interstitial nucleus of Cajal [2,4,7]. Other brainstem and cerebellar structures, such as the medial vestibular nucleus, the marginal zone between the latter and the PH nucleus, and cerebellar areas including the flocculus and the fastigial nucleus, also contain neurons carrying eye position signals (see [8] for references).

### How Horizontal Eye Position Signals are Generated

Permanent and transient blockage of the normal function of neuronal integration in the horizontal plane in both cats and monkeys [6,9–11], supports the assumption that it takes place inside the PH nucleus and/or in the functional interactions established by its reciprocal connections with the vestibular nuclei, the contralateral PH, and the cerebellum. However, a still – unanswered question is: how are eye position signals generated by neuronal centers or circuits? Although the intrinsic connectivity of PH neurons is not completely known,

in particular regarding the presence of axon collaterals that project in a feedback (or feedforward) fashion onto other oculomotor-related neurons [3,5,6,8], one hypothesis is that the PH neuronal integrator could generate eye position signals from successive synaptic steps in cascade, lateral, or retrograde chain systems [1,2,8]. As illustrated in Fig. 1, the presence of cascade-like, polysynaptic connections could explain the experimental observation of neuronal types with a wide range of eye motor signals (velocity, velocity-position, position-velocity, position, etc.), and the high susceptibility of

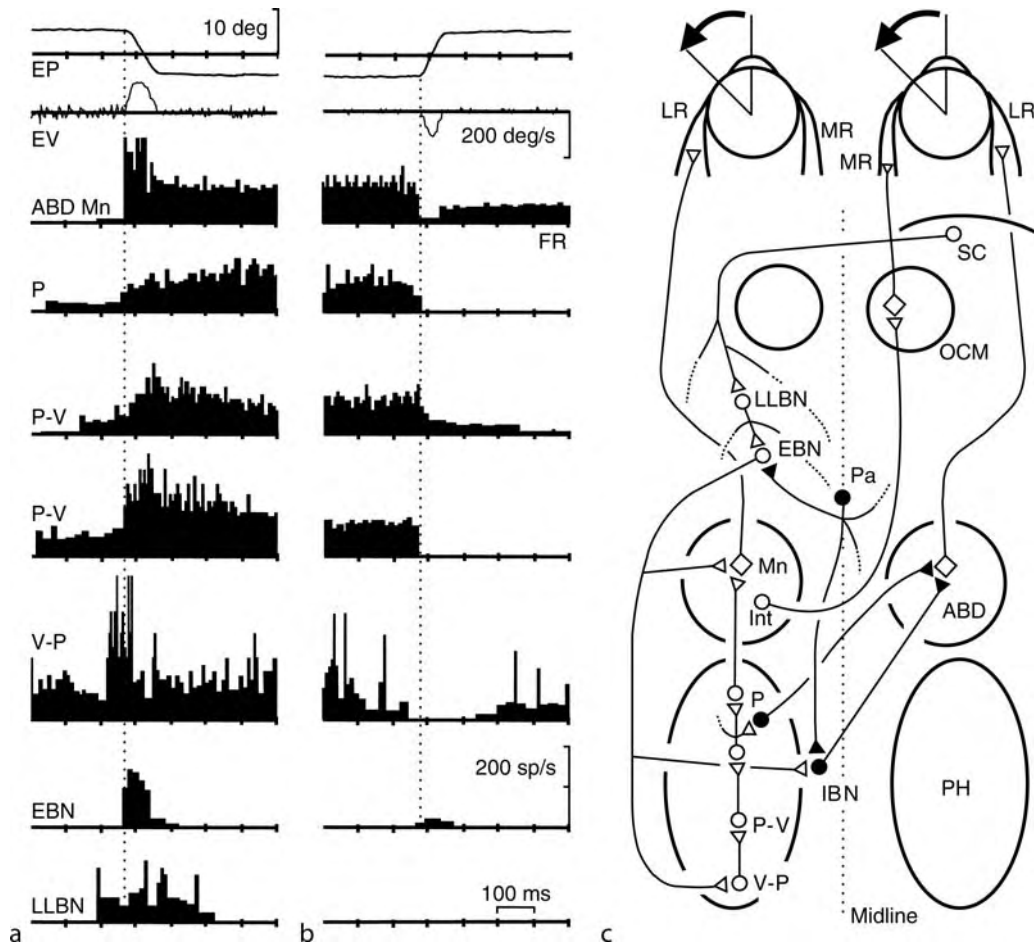

**Neural Integrator – Horizontal. Figure 1** Experimental support for a [cascade model](#) in the generation of eye position signals in the nucleus prepositus hypoglossi (PH). (a,b) Firing rate of seven different types of neuron recorded in alert cats during eye fixations before and after on- and off-directed saccades. From bottom to top are illustrated the firing rates (FR, in spikes/s) of a long-lead burst neuron (LLBN), an excitatory burst neuron (EBN), four PH neurons showing velocity-position (V-P), position-velocity (P-V), or position (P) signals, and an abducens motoneuron (ABD Mn). Abducens interneurons receive the same inputs as ABD Mns, and relay them to medial rectus Mns located in the oculomotor nucleus (OCM). Representatives horizontal eye position (EP, in deg.) and velocity (in deg/s) corresponding to these neuronal activities are illustrated in the two traces at the top. (c) A diagram illustrating the possible pathways generating eye position signals following a saccadic motor command triggered from the superior colliculus (SC). Abbreviations: LR, MR, lateral and medial rectus muscles; IBN, inhibitory burst neuron; Pa, omnipause cells. Modified from Escudero et al. [2], and reproduced with permission of the Physiological Society.

the eye position neuronal system to administration of drugs and anesthetics and to the mental state and attentive level [2,7,8,11]. Moreover, these cascade chains could be superimposed upon the shorter, direct pathways carrying eye velocity signals (Fig. 1c). Evidence supporting the participation of neuronal circuits in the generation of the persisting activity that underlies the integration of eye position signals in goldfish has been reported recently [12].

Pure horizontal eye position neurons seem to project monosynaptically from the PH nucleus onto abducens motoneurons [2]. However, other neuronal types carrying mixed vertical position-velocity signals have been reported to project monosynaptically on vertical motoneurons located in the oculomotor complex [3,4]. According to the available information [2,11,13], PH neurons classified as **principal cells** [13] are the ones responsible of the neural integration taking place in this nucleus, and/or of carrying eye position signals to oculomotor nuclei.

Once generated, horizontal (and vertical) eye position signals seem to arrive at extraocular motoneurons, where they are integrated with (i.e. added to) eye velocity signals arriving from specific reticular formation nuclei. The stabilizing role of the intrinsic membrane properties of ocular motoneurons should also be taken into account. The algebraic addition of eye velocity signals arriving preferentially onto motoneuron somata, and of these different sources of eye position signals impinging upon their distal dendrites, can still be further enhanced by the intrinsic active properties of the motoneuron membrane to produce the stable firing rate that these motoneurons display, mainly during eye fixation [1].

Since the seminal contributions of Robinson's group [5], many authors have attempted with the design of more or less realistic mathematical models simulating the generation of eye position signals in mammals. A recent example of implementation for brainstem circuits involved in oculomotor integration processes is illustrated in Fig. 2 [14].

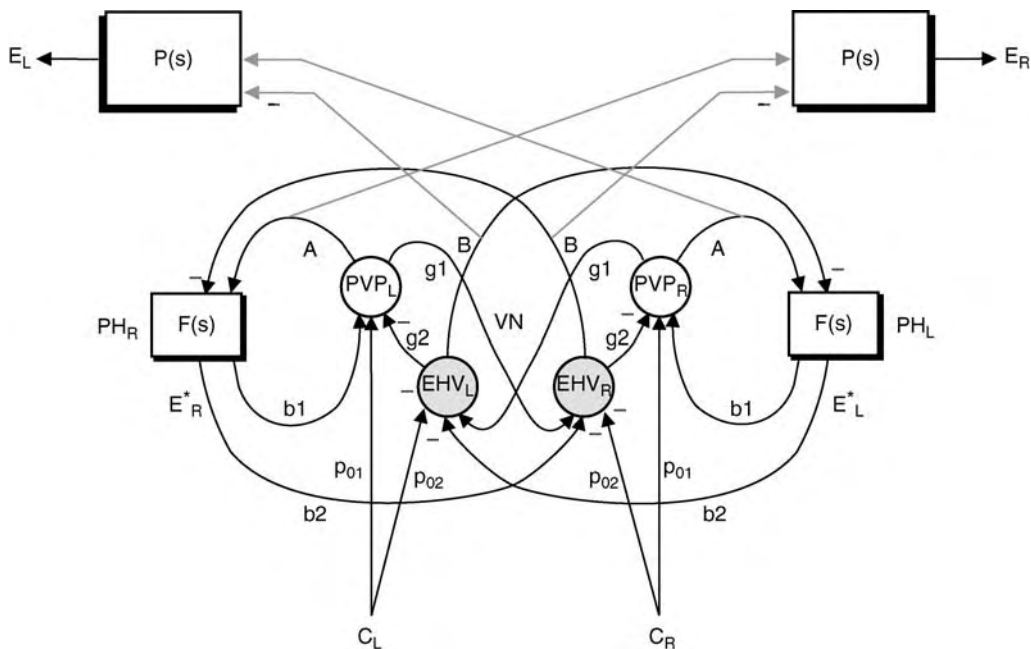

**Neural Integrator – Horizontal. Figure 2** A bilateral implementation for brainstem circuits involved in supporting the central **oculomotor integrator**. This model allows merging of both vergence and version integrator functions in the dark. All sensory inputs converge on this circuit, with only semicircular canals ( $C_{R,L}$ ) shown here on both sides.  $E_R, E_L$  are monocular eye positions on the right and left;  $P(s)$  represent dynamics of each eye plant in Laplace domain (filters);  $F(s)$  represent low-pass filters in the PH, which approximately model the true eye-plant dynamics. **Position-vestibular-pause (PVP)** and **eye-head-velocity (EHV)** cells in the vestibular nuclei (VN) are interconnected ipsi- and contralaterally with the PH. All other variables are simply scalar weights on the paths. Each PH receives branches from the same cells eventually driving the contralateral eyeball muscles – as a result, PH cells produce **monocular** efference copies. Due to mirror symmetry, the distributed loops between PH and VN imbed two large time constants, one for vergence and the other for version (conjugate) eye control. Hence, there are actually two integrators available for the two dimensions of horizontal, binocular, eye movements. Modified from A. Green, Visual-Vestibular interaction in a bilateral model of the rotational and translational vestibule-ocular reflexes: An investigation of viewing-context-dependent reflex performance, PhD Thesis, Department of Biomedical Engineering, McGill University, January, 2000.”

### Role of Neurotransmitters in the Generation of Eye Position Signals

As indicated above, the presence of separate integrators subserving the velocity storage mechanism and eye position signal generator has been proposed [7,13]. In fact, these two integrating mechanisms can be experimentally separated using some pharmacological tools. For example, injections of nitric oxide (NO) synthase inhibitors in the nucleus PH of conscious cats produce alterations of eye velocity, but not of eye position. In contrast, the injection of NO donors in the marginal zone close to the medial vestibular nucleus (i.e. an area rich in NO-sensitive guanylyl cyclase present on GABAergic afferent terminals) seems to affect the generation of eye position signals, a fact confirmed with lesion experiments in monkeys [7,8,14]. Thus, the integrative capabilities of distinct regions of the same PH nucleus subserve different eye-movement subsystems.

Other neurotransmitters (glutamate, acetylcholine) have been proposed to be related to neuronal operations taking place in the PH nucleus during eye fixation. An initial step for the integration of those early findings is represented by the suggestion that a cholinergic synaptically triggered phenomenon participates in the generation of eye position signals, subsequent to glutamatergic velocity signals arriving at the PH nucleus from the paramedian pontine reticular formation, i.e. from the site of excitatory burst neurons (Fig. 1c). It has been reported that the tonic firing present in PH neurons (►tonic neurons) that follows a velocity motor command are generated, or at least facilitated, by cholinergic inputs acting on post-synaptic muscarinic M1 receptors located on those PH neurons [10]. These findings indicate that eye position signals arriving at the abducens nucleus could be originated in the PH nucleus by the effect of cholinergic inputs, subsequent to the depolarizing effects of glutamatergic excitatory burst neuron inputs, besides the participation of cascade-like [1,2] and/or ipsilateral and contralateral reverberant circuits [12]. Thus, the PH nucleus has more than one control mechanism to transform transient velocity signals into eye position ones [10].

### References

1. Delgado-García JM, Vidal PP, Gómez C, Berthoz A (1989) A neurophysiological study of prepositus hypoglossi neurons projecting to oculomotor and preoculomotor nuclei in the alert cat. *Neuroscience* 29:291–307
2. Escudero M, de la Cruz RR, Delgado-García JM (1992) A physiological study of vestibular and prepositus neurones projecting to the abducens nucleus in the alert cat. *J Physiol (Lond)* 458:539–560
3. Fukushima K, Kaneko CRS, Fuchs A (1992) The neuronal substrate of integration in the oculomotor system. *Prog Neurobiol* 39:609–639

4. Moschovakis AK, Scudder CA, Highstein SM (1996) The microscopic anatomy and physiology of the mammalian saccadic system. *Prog Neurobiol* 50:133–254
5. Robinson DA (1981) The use of control systems analysis in the neurophysiology of eye movements. *Ann Rev Neurosci* 4:463–503
6. Kaneko CRS (1997) Eye movement deficits after ibotenic acid lesion of the nucleus prepositus hypoglossi in monkeys. I. Saccades and fixation. *J Neurophysiol* 78:1753–1768
7. López-Barneo J, Darlot C, Berthoz A, Baker R (1982) Neuronal activity in prepositus nucleus correlated with eye movement in the alert cat. *J Neurophysiol* 47:329–352
8. Delgado-García JM (2000) Why move the eyes if we can move the head? *Brain Res Bull* 53:475–482
9. Cheron G, Godaux E (1987) Disabling of the oculomotor neuronal integrator by kainic acid injections in the prepositus-vestibular complex of the cat. *J Physiol (Lond)* 394:267–290
10. Moreno-López B, Escudero M, Delgado-García JM, Estrada C (1996) Nitric oxide production by brain stem neurons is required for normal performance of eye movements in alert animals. *Neuron* 17:739–745
11. Navarro-López AD, Alvarado JC, Márquez-Ruiz J, Escudero M, Delgado-García JM (2004) A cholinergic synaptically triggered event participates in the generation of persisting activity necessary for eye fixation. *J Neurosci* 24:5109–5118
12. Aksay E, Gamkrelidze G, Seung HS, Baker R, Tank DW (2001) *In vivo* intracellular recording and perturbation of persistent activity in a neuronal integrator. *Nature* 4:184–193
13. Galiana HL, Outerbridge JS (1984) A bilateral model for central neural pathways in the vestibuloocular reflex. *J Neurophysiol* 51:210–241
14. McCrea R, Baker R (1985) Cytology and intrinsic organization of the perihypoglossal nuclei in the cat. *J Comp Neurol* 237:360–376

## Neuronal Migration

MINEKO KENGAKU

Laboratory for Neural Cell Polarity, RIKEN Brain Science Institute, Wako, Japan

### Definition

Cell migration is crucial for a variety of physiological and pathological processes, including leukocyte migration in the inflammatory response and tumor cell metastasis. During development, many cells migrate from their site of origin to their destination and reassemble with other cells for integration into functional tissues. Cell migration is a directional movement distinct from random dispersion and requires some mechanism for guiding cells to their destination. This essay focuses on migration of neurons in the developing brain, which is one of the most significant cell migration events in life.

## Characteristics

### Quantitative Description

The distance that a cell migrates varies widely from a few to a thousand cell-body diameters. Migration speed depends on the mode of migration. For instance, neurons in the cerebral cortex move at an average speed of 35  $\mu\text{m}/\text{h}$  during locomotion and 60  $\mu\text{m}/\text{h}$  during somal translocation [1]. Chain migration in the rostral migratory stream is as rapid as 120  $\mu\text{m}/\text{h}$  [2].

### Description of the Process

Neuronal migration consists of three schematic steps:

1. The ► **leading process** extends in the direction of travel along the substratum (neuronal or glial processes).
2. The nucleus and other organelles in the cell body move into the leading process.
3. The trailing process at the back detaches from the substratum and retracts to restore the original cell shape.

Harmonious repetition of these steps causes a caterpillar-like movement called locomotion [1]. In another mode of migration called somal translocation, the steps are not typically synchronized so that the cell soma moves within the preformed leading process

independently of its extension [1]. In addition, cortical neurons in the intermediate zone migrate irregularly with dynamic extension and retraction of multiple processes; this mode is referred to as multipolar migration [3].

### Higher Level Processes

Neuronal migration is classified into two distinct modes by the direction of the travel within developing neural tissue (Fig. 1).

#### Radial Migration

The vertebrate brain originates from the cylindrical neural tube. Neurons develop in germinative regions on the inner surface of the tube wall (the ventricular zone). Thus, new neurons principally move orthogonally from the ventricular zone toward the outer pial surface. In this mode of migration, which is called radial migration, neurons typically move along the fibers of radial glia traversing the entire depth of the parenchyma. Typical radial migration is thus referred to as “gliophilic migration”.

#### Tangential Migration

In tangential migration, neurons move parallel to the pial surface of the brain, often across segmental or

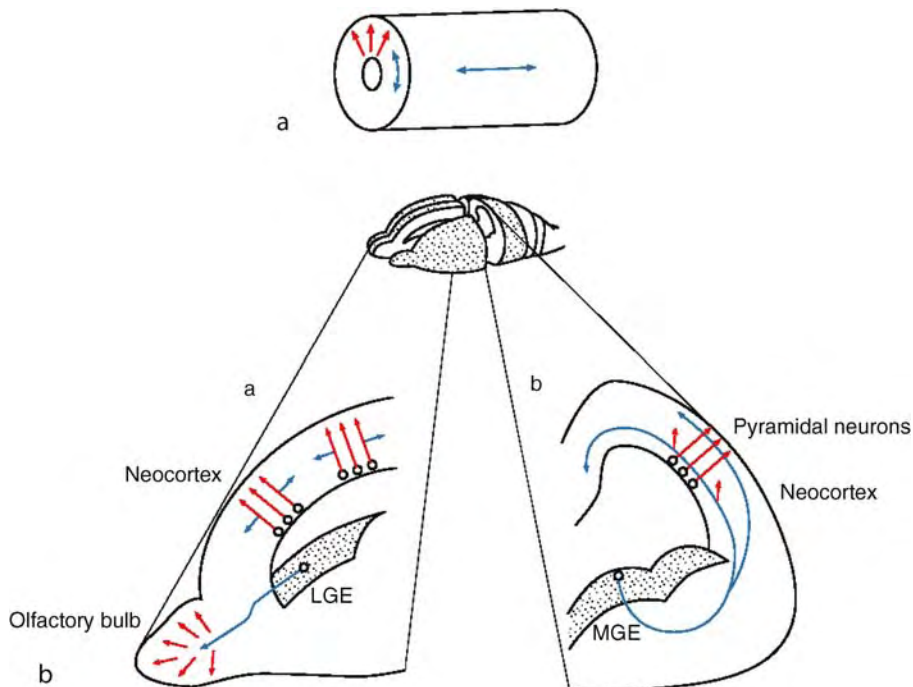

**Neuronal Migration. Figure 1** Two modes of migration in the developing brain. (a) Radial (red) and tangential (blue) migration in the neural tube (b) Neuronal migration in the developing telencephalon. The rostral migratory stream from the subventricular zone of the LGE (a sagittal plane), tangential migration of cortical interneurons from the MGE and CGE (b coronal plane), and radial migration of cortical pyramidal neurons (a and b). LGE, MGE and CGE, lateral, medial and caudal ganglionic eminences.

regional boundaries. Tangentially migrating neurons are often “neurophilic” and extend their leading process along the axons of other neurons.

### Higher Level Structure

The following are the relevant brain structures undergoing active neuronal migration during development.

#### Cerebral Cortex

The mammalian dorsal telencephalon develops into the six-layered cerebral cortex by radial migration of constituent pyramidal neurons. New neurons migrate from the ventricular zone towards the pia and accumulate below the margin of the cerebral wall to form the preplate. Subsequent neurons are deposited within the preplate to form the cortical plate and split the preplate into the superficial marginal zone and the deeper subplate. Cell dating studies have shown that neurons take their position in the cortical plate in an “inside-out” sequence, such that later developed cells migrate past the existing layers of earlier developed neurons and reside at the top of the plate (Fig. 2) [4,5].

Migration of cortical neurons can be classified into several modes with distinct kinetics. Neurons are generated from radial glia, which have a long process reaching the pial surface. Early neurons that inherit the long process from radial glia migrate into the cortical plate by translocation of their nucleus within their own processes independently of other cells. In contrast, later developing neurons often associate with other radial glia and migrate by locomotion in which the leading process moves in harmony with the cell body [1]. In addition, the later neurons have a multipolar shape and migrate in various directions (multipolar migration) in the intermediate zone, before they form a predominant leading process and enter the cortical plate by locomotion (Fig. 2) [3].

Inhibitory interneurons in the neocortex arise in the caudal and medial ►ganglionic eminences (CGE and MGE) of the ventral telencephalon and move to various levels of the developing neocortex in the dorsal telencephalon by tangential migration (Fig. 1) [4]. These neurons form one or two prominent leading processes, which follow the trajectory of axonal plexuses in the marginal zone and intermediate zone.

#### Rostral Migratory Stream in the Olfactory Bulb

Periglomerular and granule interneurons of the olfactory bulb are generated in the subventricular zone of the lateral ganglionic eminence (LGE) and reach their destination by tangential migration with a rostral orientation (Fig. 1). This migration, known as the “rostral migratory stream,” mostly occurs during the early postnatal stage in rodents, but some cells continue to migrate throughout life. Unlike classical neurophilic tangential migration, many of these rostrally migrating

cells are mitotic and migrate in chains in a glial tunnel traversing the tissue [2]. Migration of tightly associated strands of neurons is referred to as chain migration.

#### Cerebellar and Precerebellar Neurons

The developing cerebellum undergoes dynamic morphogenetic movements accompanying active cell migration. Most cell types in the three-layered cerebellar cortex migrate radially from the ventricular zone of the cerebellar anlage in the dorsal aspect of the hindbrain and caudal midbrain. In contrast, precursors of granule cells immediately take a tangential path from their origin in the rhombic lip, the anterior margin of a rhomboid-shaped roof plate lining the edge of the fourth ventricle. Granule cells undergo three successive phases of migration, each perpendicular to the others. First, precursors of granule cells undergo chain migration anteriorly to form the external granule layer over the dorsal surface of the cerebellum. After active proliferation, postmitotic granule cells extend bipolar axons and migrate tangentially following the trajectories of the preformed axons of other granule cells along the long (mediolateral) axis of the cerebellum. The third phase is radial migration along the radial fibers of Bergmann glia to reach the internal granule layer in the deep cerebellar cortex [6] (Fig. 3).

The different populations of rhombic lip cells migrate tangentially to form the precerebellar nuclei in the ventral hindbrain. These include the pontine, lateral reticular and inferior olivary nuclei, which provide the principal input to the cerebellum. The young precerebellar neurons first emit a long leading process circumferentially from the dorsal to the ventral hindbrain and then translocate the nucleus within their own leading process through a tangential migration [7].

#### Neural Crest

Neurons and glia in the peripheral nervous system arise from the neural crest and migrate dynamically to various regions of the embryo. See accompanying essay in this Encyclopedia.

#### Regulation of the Process

##### Leading Process Extension

Leading processes have distinct characteristics depending on the mode of migration. Some tangentially migrating neurons including precerebellar neurons and cerebellar granule cells extend long leading processes tipped by a large growth cone. These tangential leading processes are destined to become axons and their extension is probably controlled by a mechanism similar to that of growth cone steering without cell migration (See accompanying essay in this Encyclopedia). In contrast, gliophilic radial migration is guided by a short, tapering leading process resembling a dendritic tip. Despite some fundamental differences, leading process

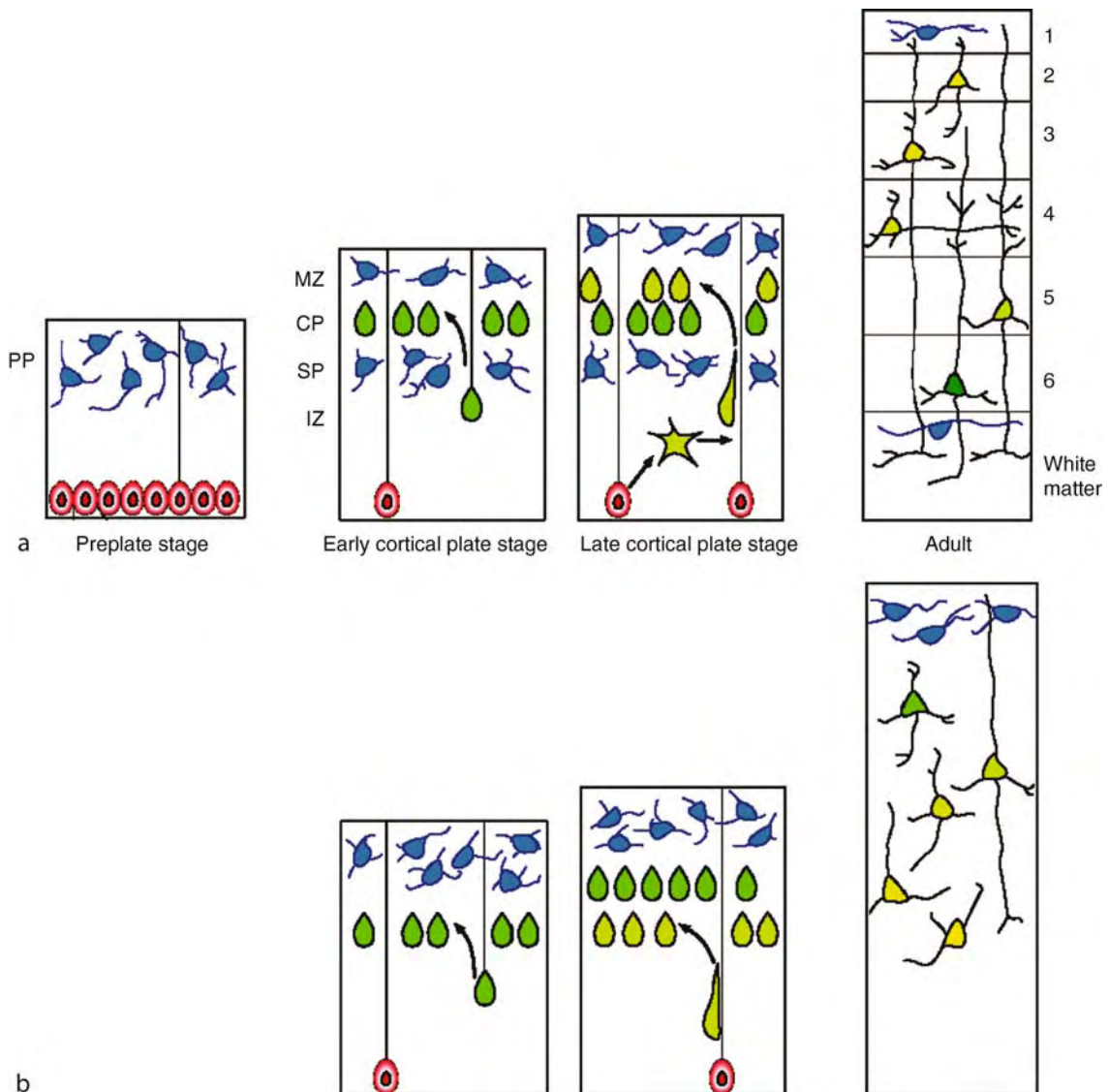

**Neuronal Migration. Figure 2** Radial migration and neocortical layer formation a normal cortical development. a The preplate (PP) is formed by the first wave of postmitotic cells (blue) differentiated from radial glia (red) in the ventricular zone (VZ). In the early cortical plate (CP) stage, new neurons migrate radially from the VZ and split the PP into the marginal zone (MZ) and subplate (SP). Many neurons adopt somal translocation within the process inherited from radial glia. In the late CP stage, new neurons first move randomly by multipolar migration in the intermediate zone (IZ) and then migrate radially toward the CP by locomotion along the fibers of other radial glia. Neurons migrate past their predecessors and expand the CP in an inside-out fashion. The adult stage is marked by the six-layered neocortex. b In *reeler* mice, neurons fail to migrate beyond earlier neurons and pile up underneath the PP. Cortical layering in the adult stage is inverted and disorganized.

extension appears to involve common steps regardless of the mode of migration.

As mentioned in Higher Level Processes above, migrating neurons typically attach to glia or neurons on the path and follow the trajectories of their processes. Cell-substratum attachment is formed by transmembrane adhesion molecules, which recruit actin filaments in the cytoplasm through actin-binding proteins, such

as integrin and L1, which immobilize actin filaments at neuron-glia or neuron-neuron contacts. At the cell-substratum attachment, the growing end of the actin filaments orients toward the tip of the leading process and generates a protrusive force for its extension [8]. An actin cross-linking phosphoprotein filamin A has been implicated in the protrusion of leading processes in cortical neurons during the transition from



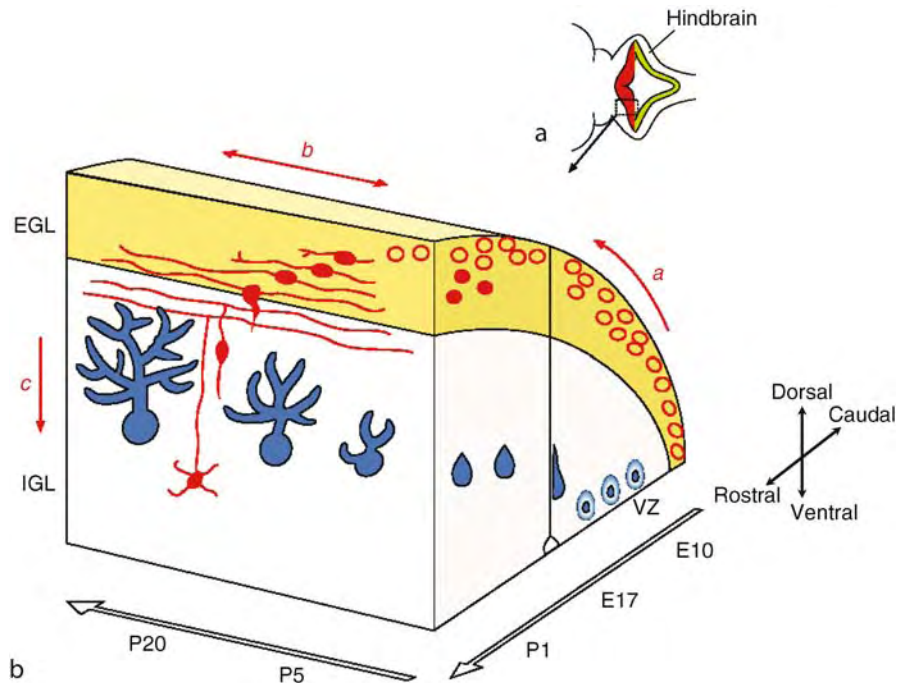

**Neuronal Migration. Figure 3** Migration of cerebellar neurons (a) Dorsal view of the developing rhombic lips. The anterior part of the lip (*red*) gives rise to granule cell precursors. Cells from the posterior part of the lip (*green*) migrate ventrally to form the precerebellar nuclei. (b) Embryonic and postnatal development of the cerebellum. Purkinje cells (*blue*) are generated in the ventricular zone (VZ) of the cerebellar anlage and reach the cerebellar cortex by radial migration. Granule cells (*red*) undergo three successive phases of migration en route to the internal granule layer (IGL) in the cortex: Mitotic precursors (*blank*) migrate rostrally in chains to form the external granule layer (EGL) on the dorsal surface (a); postmitotic granule cells first extend bipolar axons and tangentially migrate along the mediolateral axis (b); cells then make a vertical turn and move ventrally toward the IGL by radial migration (c). *Blank arrows* indicate approximate developmental stages in mice.

multipolar migration to locomotion. Actin polymerization can be promoted by guidance cues that include soluble chemicals and adhesive molecules on the path. Receptors for families of such guidance cues can directly or indirectly alter the activity of the Rho family small GTPases, which are key regulators of actin polymerization in various migrating cells (Fig. 4).

#### Nuclear Migration

Migrations of neurons and other fibroblastic cells are clearly distinguished by their mechanisms of nuclear movement. In fibroblastic cells, nuclear migration is principally served by the actin cytoskeleton in the absence of microtubules; the actin-dependent extension of the leading edge generates a cortical tension that pulls the cell body in all directions. Traction then occurs at the back, because of preferential assembly of the cortex and adhesion to the substrate at the cell front. Finally the nucleus and cytoplasm are dragged forward passively by the traction force [8]. In contrast, some neuronal migration occurs by nuclear-driven

cell migration termed “nucleokinesis” in which the nucleus moves within a highly protrusive leading process in a microtubule-dependent manner. In some migrating neurons, microtubules envelop the nucleus and also project into the leading process with the plus-end oriented toward the tip. It is hypothesized that the **▶dynein** motor complex is anchored to the cell cortex in the leading process and pulls the cell body forward by its minus-end-directed motor activity [9]. Dynein and its regulator LIS1 are colocalized in the cell cortex and **▶centrosome** and disruption of either of the genes leads to defects in nuclear migration in neurons. The centrosome is typically positioned in front of the nucleus and might mediate the pulling force from the leading process. The dynein complex on microtubules is also localized to the nuclear membrane, which could pull the nucleus toward the centrosome. The two-step nucleokinesis mediated by the centrosome – the movement of the centrosome toward the leading process followed by the movement of the nucleus toward the centrosome – is a favorable model especially for saltatory locomotion (Fig. 4).

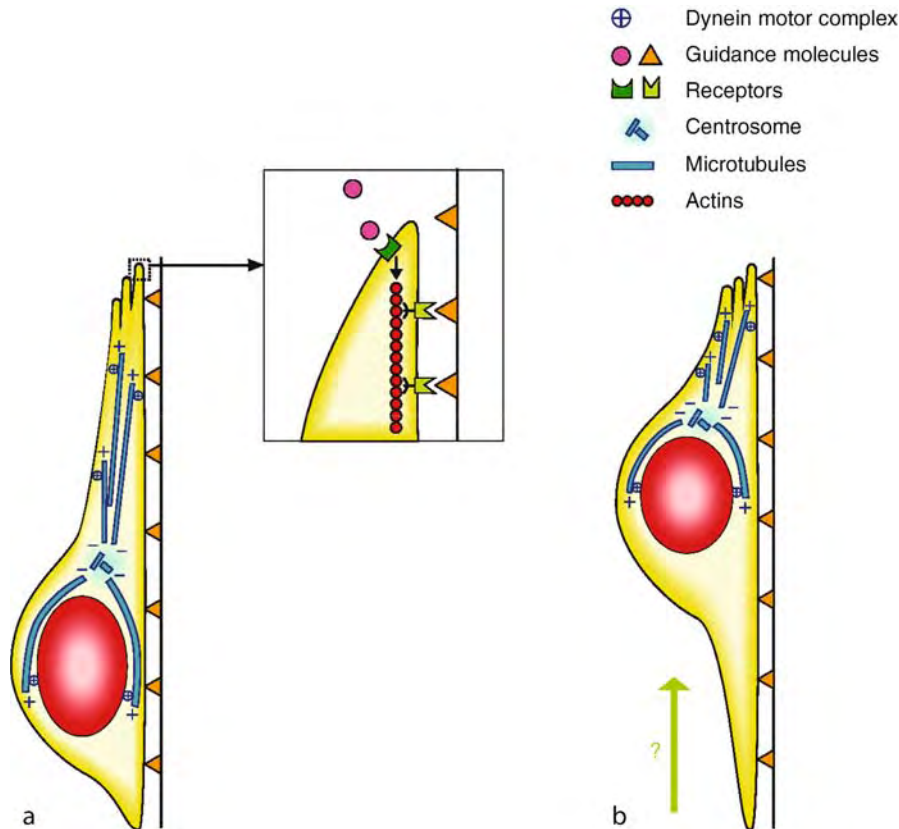

**Neuronal Migration. Figure 4** Model for kinetics of neuronal migration. (a) Leading process extension is navigated by guidance molecules, which regulate actin polymerization in the leading edge. (b) Nuclear movement is driven by microtubules radiating from the centrosome. Activation of minus-end-directed motor activity of the dynein complex on the nuclear membrane leads to a displacement of the nucleus toward the centrosome. It is also provable that the dynein motor complex is anchored to the cell cortex in the leading process and pulls the centrosome forward. Additional forces may push the nucleus from the back. The retraction of the trailing process is not well understood.

### Traction

As mentioned above, traction of the posterior of the cell is less important for nuclear migration in neurons. Indeed, the trailing processes of some neurons (e.g. cerebellar granule cells) are retained and differentiate into axons after cell migration. The mechanisms of retraction and differentiation of the trailing process are not well understood.

### Function

Neuronal migration is required for the formation of defined cell patterns for the development of specific neural circuits.

### Radial Migration

Defects in radial migration cause disruption of cortical lamination. Layering of the cerebral cortex is inverted and indistinct in the naturally occurring mouse mutant *reeler*, as radially migrating neurons are able neither to traverse their predecessors nor to assemble into distinct layers (Fig. 2) [5,10]. Reelin, the protein defective in *reeler*

mice, is a large extracellular matrix protein secreted by ►Cajal-Retzius cells in the marginal zone. Reelin is a high-affinity ligand for two members of the LDL family of lipoprotein receptors, VLDLR (very-low-density lipoprotein receptor) and LRP8 (low-density lipoprotein receptor-related protein 8, also known as ApoER2), which induce phosphorylation of the tyrosine kinase adaptor Disabled 1 (Dab1) in migrating cortical cells. Mutations in the *Dab1* gene (*scrambler* and *yotari*) or double homozygous null for the genes *VLDLR* and *LRP8*, show identical phenotypes to *reeler*. Reelin signaling might induce events related to the reorganization of microtubules and microfilaments in the cytoskeleton.

Mice deficient in cyclin-dependent kinase 5 (Cdk5), or its activator p35, display similar defects in cortical lamination. Although preplate splitting by early-developed neurons occurs normally, layering of the cerebral cortex is inverted due to the inability of later developed neurons to migrate past their predecessors. The broad substrate range of the Cdk5-p35 complex suggests that it could regulate multiple aspects of migration. Cdk5-p35

is likely to regulate cytoskeletal dynamics by phosphorylating actin- and microtubule-binding proteins. Cdk5 signaling could also regulate neuron-glia attachment. Interestingly, tangential migration of cortical inhibitory interneurons appears relatively unaffected in mice deficient in Cdk5 or p35, suggesting that the Cdk5-p35 pathway is mainly used for radial, gliophilic migration [5,10].

### Tangential Migration

Defects in tangential migration also disrupt the formation of specific brain structures and proper neural networks. Most cortical GABAergic interneurons arise in the MGE and CGE and reach the cortex in tangentially migrating streams. In *Dlx1/Dlx2* double-mutant mice, GABAergic interneurons fail to migrate from the MGE and drastically decrease in the neocortex, olfactory bulb and hippocampus [4]. On the other hand, neurons in precerebellar nuclei originate from the rhombic lip in the dorsal hindbrain and migrate tangentially toward the ventral midline secreting netrin 1. The loss-of-function mutant of netrin 1 causes defects in tangential migration of rhombic lip cells and hence the disruption of precerebellar nuclei [7].

### Pathology

Disturbances of neuronal migration are implicated in human brain malformations associated with neurological conditions including mental retardation and epilepsy [10]. Mutations in filamin 1 gene lead to X-linked periventricular heterotopia in which a subset of neurons fails to migrate from the ventricular zone. Defects in nucleokinesis by a LIS1 mutation cause type 1 lissencephaly (“smooth brain” without convolutions) characterized by abnormally thickened and incomplete neocortical layers. Another X-chromosome-linked lissencephaly locus has been identified and named doublecortin (DCX). DCX encodes a microtubule-binding protein that is thought to stabilize microtubules. Male patients with mutations in the DCX gene on their single X-chromosome give rise to a phenotype similar to type 1 lissencephaly. Female patients with a heterozygous DCX mutation exhibit double cortex syndrome (subcortical band heterotopia) in which a fraction of neurons expressing a mutant DCX gene halt migration and cluster halfway between the cortex and the ventricle.

### Reference

1. Nadarajah B, Parnavelas JG (2002) Modes of neuronal migration in the developing cerebral cortex. *Nat Rev Neurosci* 3:423–432
2. Wichterle H, Garcia-Verdugo JM, Alvarez-Buylla A (1997) Direct evidence for homotypic, glia-independent neuronal migration. *Neuron* 18:779–791
3. Tabata H, Nakajima K (2003) Multipolar migration: the third mode of radial neuronal migration in the developing cerebral cortex. *J Neurosci* 23:9996–10001

4. Marin O, Rubenstein JL (2003) Cell migration in the forebrain. *Annu Rev Neurosci* 26:441–483
5. Gupta A, Tsai LH, Wynshaw-Boris A (2002) Life is a journey: a genetic look at neocortical development. *Nat Rev Genet* 3:342–355
6. Hatten ME, Heintz N (1995) Mechanisms of neural patterning and specification in the developing cerebellum. *Annu Rev Neurosci* 18:385–408
7. Bloch-Gallego E, Causeret F, Ezan F, Backer S, Hidalgo-Sánchez M (2005) Development of precerebellar nuclei: instructive factors and intracellular mediators in neuronal migration, survival and axon pathfinding. *Brain Res Rev* 49:253–266
8. Mitchison TJ, Cramer LP (1996) Actin-based cell motility and cell locomotion. *Cell* 84:371–379
9. Tsai L-H, Gleeson JG (2005) Nucleokinesis in neuronal migration. *Neuron* 46:383–388
10. Gleeson JG, Walsh CA (2000) Neuronal migration disorders: from genetic diseases to developmental mechanisms. *Trends Neurosci* 23:352–359

## Neuronal Network

### Definition

A group of neurons that are connected by a specific set of synaptic interactions and fulfil a specific function (e.g. control of locomotion, processing of visual information, etc.). The boundaries of neuronal networks within the nervous system are often not very well defined as individual neurons can be part of a neuronal network under one set of circumstances, but not part of it under different circumstances. Entire networks can be reconfigured by modulatory influences, which enhance or suppress the activity in individual neurons and/or specific synaptic connections. These networks are described as polymorphic neuronal networks. Reconfiguration enables the nervous system to employ the same neuronal elements for the control of related, but different activities (e.g. walking, running, jumping, etc.), which is a more efficient use of resources than the existence of independent neuronal networks for each activity.

- ▶ Central Pattern Generator
- ▶ Rhythmic Movements

## Neuronal Oscillator

### Definition

A neuronal circuit or even a single neuron that, owing to the inherent electrical properties of the neuronal membranes and the synaptic connectivity of the

component neurons, produces a rhythmic pattern of activity. Central pattern generators (CPGs) include neuronal oscillators, and CPGs for segmentally distributed motor patterns often comprise of neuronal oscillators in each segment of the nervous system participating in the production of the motor pattern; they are then often called segmental oscillators.

- ▶ Central Pattern Generator
- ▶ Intersegmental Coordination
- ▶ Rhythmic Movements

## Neuronal Plasticity

### Definition

The capacity of neuronal systems (e.g., neurons, parts of neurons, populations of neurons) for change of anatomical and functional features.

- ▶ Activity-Dependent Synaptic Plasticity

## Neuronal Polarity

JOANNE SM KIM<sup>1,2</sup>, MEI ZHEN<sup>1,2</sup>

<sup>1</sup>Department of Molecular Genetics, University of Toronto, Toronto, ON, Canada

<sup>2</sup>Samuel Lunenfeld Research Institute, Mount Sinai Hospital, Toronto, ON, Canada

### Synonyms

Asymmetry in neurons

### Definition

Neuronal polarity is the asymmetry in the distribution of cellular components (▶cellular polarity) within ▶neurons. In this essay, we first describe the development and maintenance of neuronal polarity and then demonstrate its function in the nervous system.

### Characteristics

#### Development and Maintenance of Neuronal Polarity

Cells are the basic building blocks of multi-cellular organisms. Some cells appear morphologically and functionally homogeneous. For example, oxygen-carrying erythrocytes and infection-fighting leukocytes in human blood are round and even in shape. Other cells, however, display clear heterogeneity, where

specialized regions within a single cell perform different biological functions. Epithelial cells in the vertebrate digestive system are an excellent example of the latter case. Each epithelial cell has an apical side that absorbs outside materials and a basal side that transfers the absorbed materials to the bloodstream. Epithelial cells are therefore termed “polarized.”

Neurons are perhaps the most extensively-studied polarized cells. Each neuron performs two distinct functions: receipt of information from signaling cells and transmission of this information to target cells. To accommodate these different functions, neurons form multiple dendrites and in most cases, a single axon (Fig. 1a). Dendrites receive information from other neurons and relay it to the axon of the same cell. The axon then transmits the information to one or more target cells that can be neurons or tissue cells. The process of dendrite and axon differentiation is called neuronal polarization (Fig. 1).

Neuronal polarization has been well-characterized in the cultured hippocampal neurons of rat embryos [1]. This developmental process has been divided into five stages (Fig. 1a). In Stage One, newly-born neurons develop multiple outgrowth extensions called lamellipodia. Lamellipodia extend and elongate into neurites in Stage Two. In Stage Three, one of these neurites begins to grow faster than the others, adopting the axonal fate. Found at the tip of this neurite is a ▶growth cone that leads the axon to its targets. In the fourth stage, while the growing axon matures, the remaining neurites become dendrites. In the fifth and final stage, the axon and dendrites make connections with other cells, forming a neuronal network [1].

These dramatic morphological transformations during neuronal polarization are accompanied by changes in the ▶cytoskeleton structures of the developing neuron. The cytoskeleton supports membrane structure, maintains cell shape, and enables trafficking of organelles and proteins. The cytoskeleton is primarily comprised of polymers of tubulin (microtubules) and actin (actin filaments) (Fig. 1b). During neuronal polarization, microtubules and actin filaments are in highly dynamic states where their subunits assemble onto or disassemble from the filamentous structures, allowing rapid growth or shrinkage of neurites. Bradke and Dotti [2] have provided *in vitro* evidence that the one neurite destined to become the axon is associated with highly dynamic actin filaments. In addition, when a dynamic state was artificially created throughout a developing neuron with an actin-destabilizing drug, this neuron generated multiple axons. Conversely, local application of the drug to a single neurite designated axonal fate to that neurite [2], suggesting that actin dynamics in a neurite is necessary for its axonal fate. Accordingly, cytoskeleton dynamics is thought to be extensively regulated during neuronal polarization.

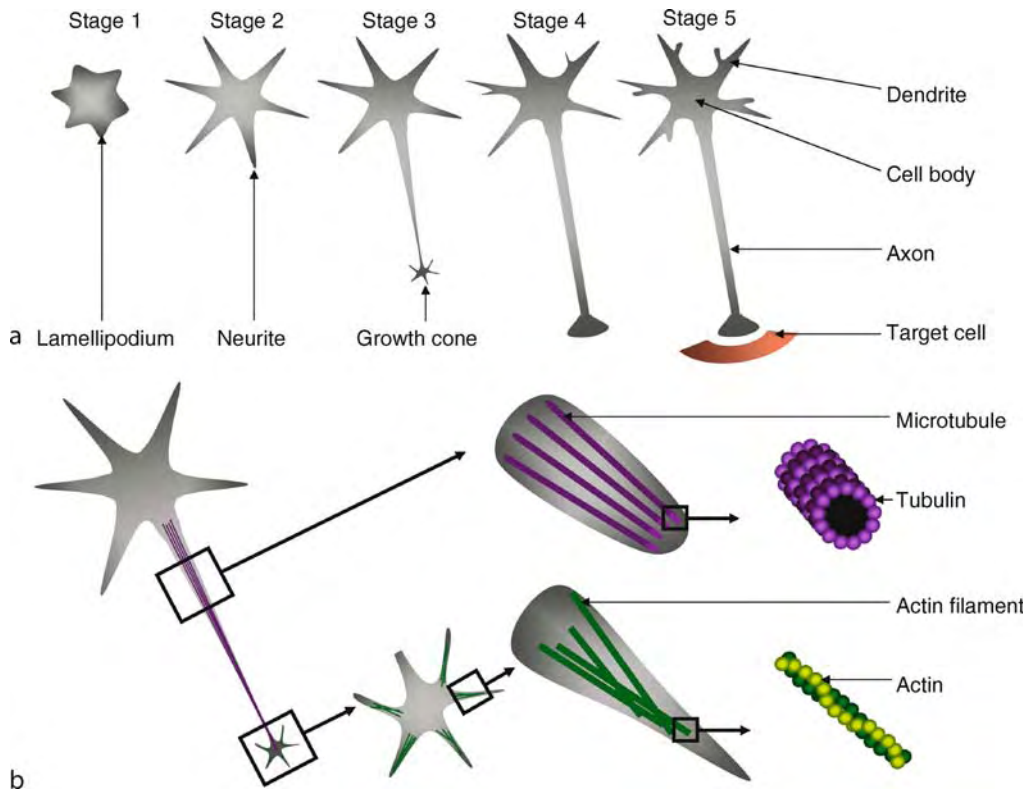

**Neuronal Polarity. Figure 1** Neuronal polarization. (a) Five different stages of polarization observed in the cultured rat hippocampal neurons. A mature neuron has multiple short dendrites and a single long axon. Information adapted from Dotti et al. (b) Cytoskeleton structures in the developing neuron. Microtubules are found along the neurite while actin filaments localize to the growth cone. Both microtubules and actin filaments are comprised of protein subunits.

A number of regulators of cytoskeleton dynamics in neuronal polarization have been discovered [3,4]. The first *in vivo* evidence for such regulator was provided by ►Synapses of Amphids Defective 1 (SAD-1) [5]. The SAD-1 protein was identified in ►Caenorhabditis elegans (*C. elegans*), a nematode model organism first developed by Nobel laureates Sydney Brenner, Robert Horvitz, and John Sulston and now widely used in the laboratory for its easy handling and amenable genetics. Animals with mutations in their SAD-1 gene showed shorter axon lengths in specific neurons. Further, axon-specific proteins were mislocalized to dendrites [5], suggesting that SAD-1 is required for accurate polarization of neurons.

Mammalian ►homologs of *C. elegans* SAD-1 have also been identified [6]. In the mouse, two SAD-1-like proteins were found and named SAD-A and SAD-B. Eliminating both SAD-A and SAD-B causes the cultured hippocampal neurons from embryos to develop multiple projections that are neither dendrites nor axons [6], strongly supporting an evolutionarily conserved role for SAD proteins in neuronal polarity. Another mammalian protein, LKB1, also regulates neuronal polarity [7,8]. Similar to mice lacking the SAD proteins, LKB1

mutant animals show neuronal projections without distinct dendritic or axonal characteristics. Biochemical analyses show that LKB1 regulates neuronal polarity through SAD-A and SAD-B [7,8].

How do the SAD proteins and LKB1 regulate the cytoskeleton dynamics in neurons? The various SAD proteins and LKB1 are ►protein kinases – enzymes that transfer phosphate groups to their target protein. In the mouse, LKB1 first phosphorylates and activates SAD-A and SAD-B [7]. The activated SAD proteins then directly or indirectly (i.e., through another kinase) phosphorylate TAU, a microtubule-associated protein (MAP) [6]. MAPs bind and subsequently stabilize microtubules. Phosphorylated MAPs on the other hand detach from microtubules, resulting in cytoskeleton instability and dynamics. Microtubule dynamics, as mentioned above, is essential for neuronal polarization. Therefore, the SAD proteins and LKB1 regulate the cytoskeleton dynamics by modulating the phosphorylation status of TAU and possibly other MAPs [6–8].

Once developed, neuronal polarity needs to be maintained throughout the animal's lifespan. Presently, little is known about the mechanisms of maintenance. Nevertheless, Hammarlund et al. [9] have identified an

essential component in the maintenance of membrane structure in *C. elegans* motor neurons. Supporting and organizing the membrane structure of mature axons is a complex called spectrin [9]. Made up of two protein subunits – alpha and beta spectrins – the spectrin complex maintains membrane integrity by stabilizing actin filaments associated with the membrane. In *C. elegans* animals with mutant beta-spectrin, neurons develop normally. However, mature axons of their motor neurons break in the adult stage [9]. When these animals were restricted from movement, no broken axons were observed, suggesting that breaks occur from the wear and tear of movements. Broken axons continue to regenerate, but fail to form functional axons due to repeated breaks. This study suggests that the membrane structure in mature axons needs to be maintained and that the development and maintenance of neuronal polarity may be governed by separate mechanisms.

### Function of Neuronal Polarity

The nervous system is essentially a network of neurons forming connections with each other and other tissues.

Communication between neurons is achieved through specialized structures called synapses (Fig. 2a). Each synapse consists of a pre-synaptic terminal in the signaling cell and a post-synaptic terminal in the target cell. Pre-synaptic terminals contain signaling molecules known as ►neurotransmitters in small membrane-bound compartments called vesicles. Upon stimulation, the vesicles release neurotransmitters outside the cell, which then diffuse to the target cells. The target cells contain post-synaptic terminals that are characterized by clusters of receptors for the neurotransmitters, often ion-channels, and other molecules required for signaling (Fig. 2a). Neurotransmitters bind the receptors in the post-synaptic terminals, trigger changes in the membrane potentials and cause subsequent effects in the target cells. In summary, information travels through the neuronal network via synapses formed by individual neurons.

What role does neuronal polarity play in synaptic functions? Dendrites and axons are different not only morphologically but also, more importantly, functionally. The dendrites of a neuron, as well as parts of its cell body, form post-synaptic terminals at the contact sites

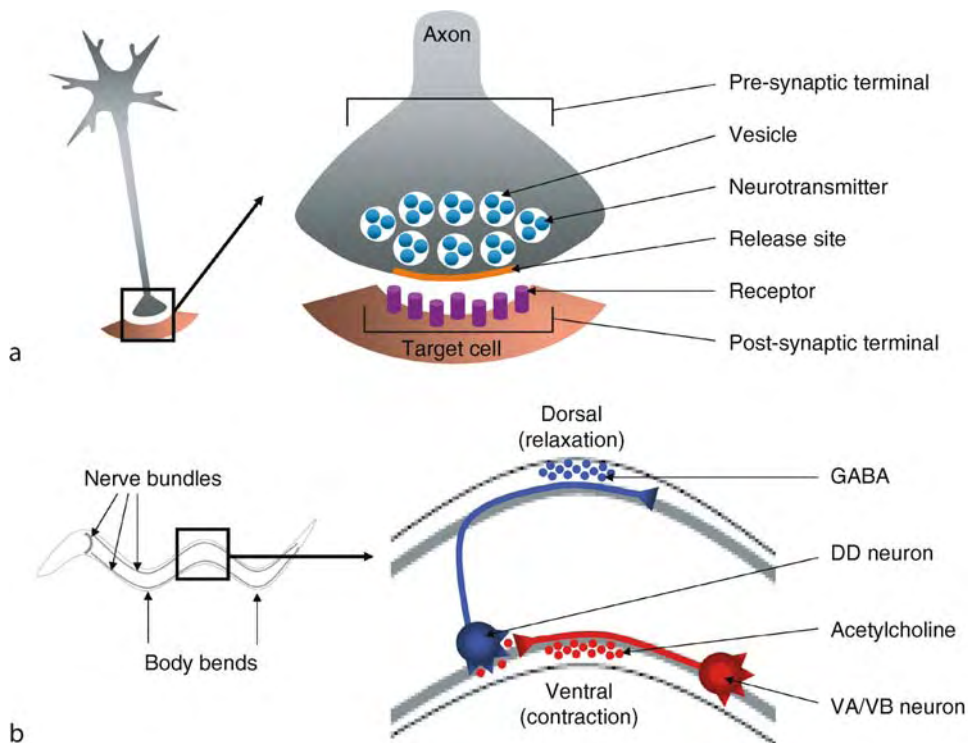

**Neuronal Polarity. Figure 2** Synapses and neuronal connectivity. (a) Key components of pre- and post-synaptic specializations. Pre-synaptic terminals contain neurotransmitters in membrane-bound compartments called vesicles. Upon stimulation, neurotransmitters are released and bind the receptors in the post-synaptic terminal of a target cell, triggering changes in that cell. (b) Characteristic body bends generated by neuronal connectivity of motor neurons in *C. elegans*. The VA/VB axon releases acetylcholine which causes contraction of ventral muscles. Acetylcholine also triggers the release of GABA from the DD axon. GABA relaxes dorsal muscles. Information adapted from Schuske et al. [10].

with the axons of signaling cells (Fig. 2a). Axons on the other hand, form pre-synaptic structures that relay signals to target cells upon stimulation (Fig. 2a). Polarity in each neuron, therefore, defines the direction in which a signal travels.

Neuronal polarity and synaptic connections together determine the route by which signals travel throughout the nervous system. A simple example is provided by the *C. elegans* motor circuit [10] (Fig. 2b). The axon of a motor neuron called VA or VB forms synapses with the dendrite of another motor neuron, DD, on the ventral side of the animal. The VA or VB neuron releases neurotransmitters called acetylcholine. Acetylcholine stimulates the DD neuron to release its neurotransmitters GABA, from its dorsally located axon. Signals continue to propagate throughout the neuronal network determined by neuronal polarity and synaptic connections.

The motor neurons also form synapses with muscle cells and control motor functions. The VA or VB axon forms synapses with ventral muscles. Acetylcholine, an excitatory neurotransmitter, causes contraction in these muscles (Fig. 2b). The DD axon, on the other hand, forms synapses with dorsal muscles. When these muscles receive GABA, they relax. The result of muscle contraction on the ventral side and relaxation on the opposite dorsal side is a body bend. This pattern of contraction and relaxation on the opposite sides is observed throughout the length of the animal's body, characteristic of roundworms. Alternating the pattern of body bends allows the forward and backward movement of the animal.

### Summary

Neuronal polarity refers to the asymmetrical distribution of cellular components within a neuron. In this essay, we described the development of neuronal polarity and its function in the nervous system. During neuronal polarization, a group of molecules work in concert to regulate the dynamics of the cytoskeleton. The cytoskeleton dynamics is essential for neurite extension and axon and dendrite formation. Once established, neuronal polarity needs to be maintained, which likely requires the stabilization of cytoskeleton structures. In the nervous system, neuronal polarity and synaptic connections determine the route by which information travels. The synapses between neurons and other cell types along this route lead to the complex sensory, motor, or cognitive functions of an organism.

### References

1. Dotti CG, Sullivan CA, Banker GA (1988) The establishment of polarity by hippocampal neurons in culture. *J Neurosci* 8:1454–1468
2. Bradke F, Dotti CG (1999) The role of local actin instability in axon formation. *Science* 283:1931–1934

3. Wiggin G, Fawcett JP, Pawson T (2005) Polarity proteins in axon specification and synaptogenesis. *Dev Cell* 8:803–816
4. Arimura N, Kaibuchi K (2005) Key regulators in neuronal polarity. *Neuron* 48:811–884
5. Crump JG, Zhen M, Jin Y, Bargmann CI (2001) The SAD-1 kinase regulates presynaptic vesicle clustering and axon termination. *Neuron* 29:115–129
6. Kishi M, Pan YA, Crump JG, Sanes JR (2005) Mammalian SAD kinases are required for neuronal polarization. *Science* 307:929–932
7. Barnes AP, Lilley BN, Pan YA, Plummer LJ, Powell AW, Raines AN, Sanes JR, Polleux F (2007) LKB1 and SAD kinases define a pathway required for the polarization of cortical neurons. *Cell* 129:549–563
8. Shelly M, Cancedda L, Heilshorn S, Sumbre G, Poo M (2007) LKB1/STRAD promotes axon initiation during neuronal polarization. *Cell* 129:565–577
9. Hammarlund M, Jorgensen EM, Bastiani MJ (2007) Axons break in animals lacking  $\beta$ -spectrin. *J Cell Biol* 176:269–275
10. Schuske K, Beg AA, Jorgensen EM (2004) The GABA nervous system in *C. elegans*. *Trends Neurosci* 27:407–414

## Neuronal Potassium Channels

ALISTAIR MATHIE, EMMA L. VEALE

Medway School of Pharmacy, Universities of Kent and Greenwich at Medway, Chatham Maritime, Kent, UK

### Definition

Potassium ( $K^+$ ) channels are proteins which span the membrane of cells and are selectively permeable to  $K^+$  ions.

### Characteristics

Potassium ( $K^+$ ) channels are proteins which span the membrane of cells and which, when open, allow the selective flow of  $K^+$  ions from one side of the membrane to the other (usually from the inside of the cell to the outside). They can be gated by a variety of stimuli including voltage, changes in intracellular  $Ca^{2+}$  and certain other physiological mediators. In neurons, they have a number of functional roles related, primarily, to the electrical properties of the membrane. As such, they determine the neuronal action potential frequency, shape the neuronal action potential waveform (►Action potential) and control the strength of synaptic contacts between neurons [see 1]. Additionally, certain  $K^+$  channels regulate the absolute excitability of neurons and set (or contribute to) the neuronal ►resting membrane potential [2] (►Membrane potential – basics). Their physiological importance has been exemplified

by the observations that mutations in  $K^+$  channel sequences in particular individuals leads to such varied clinical disorders as ►epilepsy, episodic ataxia, unregulated insulin secretion and deafness [3].

### $K^+$ Channel Families

$K^+$  channels are members of the voltage-gated-like ►ion channel superfamily [4]. Since the first molecular cloning of  $K^+$  channel subunits in the 1980s, over eighty different genes have been identified which each encodes for distinct  $K^+$  channel  $\alpha$  subunits [see, for example, [5]]. Each  $K^+$  channel consists of a primary pore-forming  $\alpha$  subunit often associated with auxiliary regulatory subunits. From the amino acid sequences of  $K^+$  channel  $\alpha$  subunits, it is possible to group them into three families (Fig. 1).

These are (i) the six transmembrane (6TM) domain channels which are gated by voltage or in a few cases by both  $Ca^{2+}$  and voltage or by  $Ca^{2+}$  alone; (ii) the two transmembrane (2TM) or ►inward-rectifier  $K^+$  channels and (iii) the four transmembrane (4TM) or two pore domain (K2P) ►leak  $K^+$  channel(s).

### The Six Transmembrane Domain K Channel Family

The 6TM family comprises a number of different subfamilies (Table 1) such as the voltage-gated  $K_V1-4$  family of channels, which underlie functional ►delayed-rectifier channels and ►A-type  $K^+$  channel(s). These channels open when the membrane is depolarized. Also in this family are the  $K_V7$  (KCNQ) and  $K_V10-12$  (EAG) channels (including hERG, which are of particular interest due to their role in certain sudden death syndromes). These are low-threshold voltage-gated channels which are often regulated by G protein coupled receptors such as ►muscarinic acetylcholine receptors and have a non-inactivating component open close to the resting membrane potential of the cell. Finally, in this family are the  $Ca^{2+}$  and  $Na^+$  activated  $K^+$  channels ( $K_{Ca}1-5$ ). These  $K^+$  channels can be divided into three broad groups. These are the large conductance maxi- $K^+$  channels (or ►BK channels) corresponding to the *slo* family of  $K^+$  channels, the small-conductance or ►SK channels (corresponding to SK1-SK3) and the intermediate conductance  $K^+$  channels, corresponding to SK4 channels. Within the 6TM family, the pore-forming

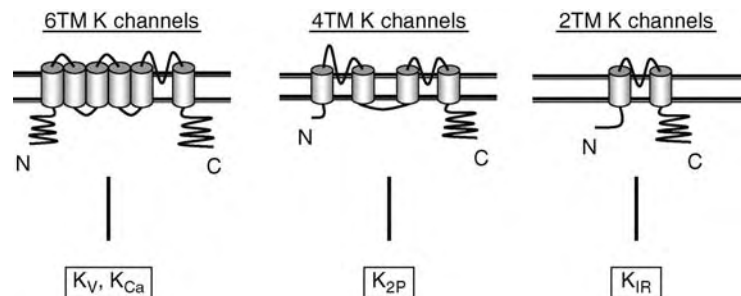

**Neuronal Potassium Channels. Figure 1** Schematic representation of the structure of the  $\alpha$  subunit of the three primary  $K^+$  channel families, 6TM, 4TM and 2TM.

**Neuronal Potassium Channels. Table 1** The 6TM K channel family

Subfamily group	Subtypes	Functional characteristics	Associated subunits
$K_V1.x$	$K_V1.1-1.8$	$K_V$ (1.1-1.3, 1.5-1.8) $K_A$ (1.4)	$K_V\beta_1$ , $K_V\beta_2$
$K_V2.x$	$K_V2.1-2.2$	$K_V$ (2.1)	$K_V5.1$ , $K_V6.1-6.3$ $K_V8.1$ , $K_V9.1-9.3$
$K_V3.x$	$K_V3.1-3.4$	$K_V$ (3.1, 3.2) $K_A$ (3.3, 3.4)	MiRP2 ( $K_V3.4$ )
$K_V4.x$	$K_V4.1-4.3$	$K_A$	KChIP, KChAP
$K_V7.x$	$K_V7.1-7.5$ (KCNQ1-5)	$K_V7.1$ – cardiac $I_{K_S}$ $K_V7.2/7.3$ –M current	minK, MiRP2 ( $K_V7.1$ )
$K_V10.x$	$K_V10.1-10.2$ (eag1 - 2)	–	–
$K_V11.x$	$K_V11.1-11.3$ ((h)erg1 - 3)	$K_V11.1$ – cardiac $I_{K_R}$	minK, MiRP1 ( $K_V11.1$ )
$K_V12.x$	$K_V12.1-12.3$ (elk1 - 3)	–	–
$K_{Ca}1.x$ $K_{Ca}4.x$ $K_{Ca}5.x$	$K_{Ca}1.1$ $K_{Ca}4.1-4.2$ $K_{Ca}5.1$	$BK_{Ca}$ $K_{Na}$	KCNMB1-4 ( $K_{Ca}1.1$ )
$K_{Ca}2.x$ $K_{Ca}3.x$	$K_{Ca}2.1-2.3$ $K_{Ca}3.1$	$SK_{Ca}$ ( $K_{Ca}2.1-2.3$ ) $IK_{Ca}$ ( $K_{Ca}3.1$ )	–



$\alpha$  subunits form tetramers. Heteromeric channels may be formed within subfamilies (e.g.  $K_{V1.1}$  with  $K_{V1.2}$ ;  $K_{V7.2}$  with  $K_{V7.3}$ ).

### The Two Transmembrane Domain K Channel Family

The 2TM domain family of  $K^+$  channels is also known as the inward-rectifier  $K^+$  channel family. Current flows through them more easily in an inward direction because they are blocked by intracellular polyamines and/or  $Mg^{2+}$  ions at depolarized voltages. This family includes the strong inward-rectifier  $K^+$  channels ( $K_{IR2}$ ), the G-protein-activated inward-rectifier  $K^+$  channels ( $K_{IR3}$ ) and the **▶ATP-sensitive  $K^+$  channels** ( $K_{IR6}$ , which combine with sulphonylurea receptors (SUR)) (see Table 2). Like the 6TM family, the pore-forming  $\alpha$  subunits of the 2TM family form tetramers. Heteromeric channels may be formed within subfamilies (e.g.  $K_{IR3.2}$  with  $K_{IR3.3}$ ).

### The Four Transmembrane Domain $K^+$ Channel Family

The 4TM family of  $K^+$  channels (TWIK, TREK, TASK, TALK, THIK and TRESK channels, Table 3) are the most recently identified  $K^+$  channel family and underlie **▶leak currents** open at all voltages and expressed heterologously throughout the nervous system. They are regulated by a wide array of **▶neurotransmitters** and biochemical mediators. The primary pore-forming  $\alpha$  subunit contains two pore domains (hence K2P) and so it is envisaged that they form functional dimers rather than the usual  $K^+$  channel tetramers. There is some

evidence that they can form heterodimers within subfamilies (e.g.  $K_{2P3.1}$  with  $K_{2P9.1}$ ).

### Structural Features of $K^+$ Channels

Whilst the structural properties of the different  $K^+$  channel families vary considerably, one region, the pore (P) region (and within this region the selectivity filter particularly), is highly conserved between  $K^+$  channels. The P region forms a hydrophobic hairpin loop in the membrane, within which is located the selectivity filter of the channel that confers  $K^+$  selectivity. The selectivity filter has a highly conserved sequence, usually TYGYG. This region allows  $K^+$  channels to be both extremely selective in which ions they allow to pass, yet still allow extremely fast transport rates, close to the aqueous diffusion limits (see Fig. 2).

The unique structure of the selectivity filter, in particular the arrangement of these five conserved residues which have their carbonyl oxygen atoms aligned towards the center of the selectivity filter pore, forms “customized oxygen cages” which mimic the arrangement of water molecules around  $K^+$  ions. The  $K^+$  ions can then enter the selectivity filter easily by diffusion. Sodium ( $Na^+$ ) ions (although smaller) have a different arrangement of water molecules around them in solution and so do not enter the selectivity filter so easily. The selectivity filter also allows multiple ion occupancy, i.e. more than one  $K^+$  ion (from two to two and a half on average) can sit in the selectivity filter at one time. The positively charged ions repel each other and ions are pushed through the

**Neuronal Potassium Channels. Table 2** The 2TM K channel family

Subfamily group	Subtypes	Functional characteristics	Associated subunits
$K_{IR1.x}$	$K_{IR1.1}$ (ROMK1)	Inward-rectifier current	–
$K_{IR2.x}$	$K_{IR2.1-2.4}$ (IRK1–4)	$IK_1$ in heart, “strong” inward-rectifier current	–
$K_{IR3.x}$	$K_{IR3.1-3.4}$ (GIRK1–4)	G-protein-activated inward-rectifier current	–
$K_{IR4.x}$	$K_{IR4.1-4.2}$	Inward-rectifier current	–
$K_{IR5.x}$	$K_{IR5.1}$	Inward-rectifier current	–
$K_{IR6.x}$	$K_{IR6.1-6.2}$ ( $K_{ATP}$ )	ATP-sensitive, inward-rectifier current	SUR1, SUR2A, SUR2B
$K_{IR7.x}$	$K_{IR7.1}$	Inward-rectifier current	–

**Neuronal Potassium Channels. Table 3** The 4TM K channel family

Subfamily group	Subtypes	Functional characteristics
TWIK	$K_{2P1.1}$ (TWIK1) $K_{2P6.1}$ (TWIK2) $K_{2P7.1}$ (KNCK7)	Leak current
TREK	$K_{2P2.1}$ (TREK1) $K_{2P10.1}$ (TREK2) $K_{2P4.1}$ (TRAAK)	Leak current
TASK	$K_{2P3.1}$ (TASK1) $K_{2P9.1}$ (TASK3) $K_{2P15.1}$ (TASK5)	Leak current
TALK	$K_{2P16.1}$ (TALK1) $K_{2P5.1}$ (TASK2) $K_{2P17.1}$ (TASK4)	Leak current
THIK	$K_{2P13.1}$ (THIK1) $K_{2P12.1}$ (THIK2)	Leak current
TRESK	$K_{2P18.1}$ (TRESK1)	Leak current

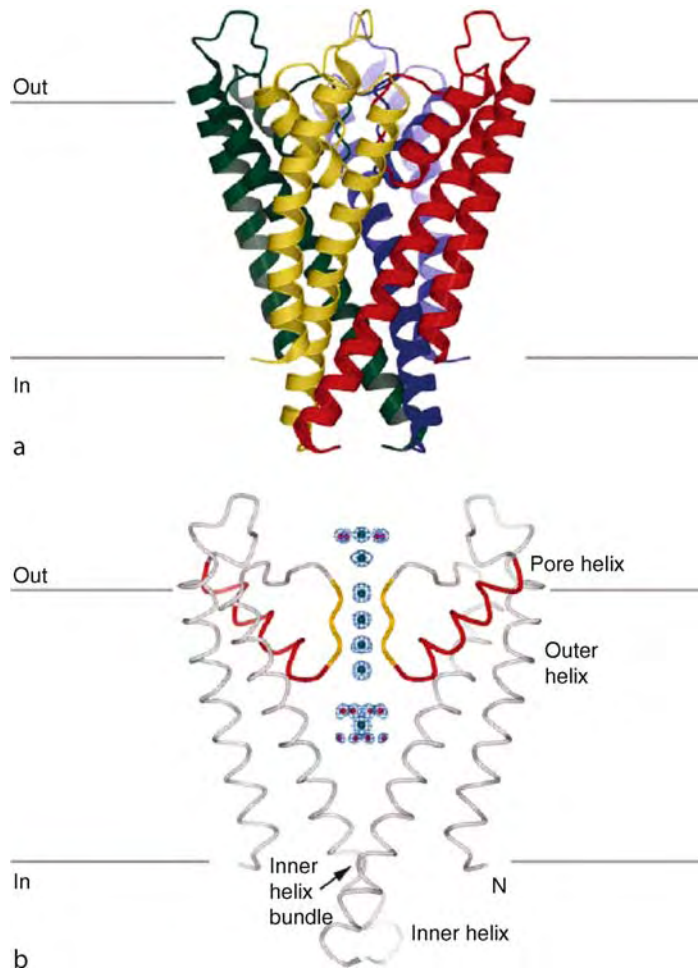

**Neuronal Potassium Channels. Figure 2** (a) A ribbon representation of the KcsA K<sup>+</sup> channels with its four subunits colored differently. (b) The same channel with front and back subunits removed. The electron density along the ion pathway is shown as a blue mesh whilst the selectivity filter is shown in yellow. From [6] with kind permission from Springer Science and Business Media.

channel, usually down their concentration gradient so that K<sup>+</sup> ions flow from inside the cell to the outside [6,7].

Other regions of K<sup>+</sup> channels vary more widely from family to family and gene to gene. These include the regions of the channel that sense stimuli which act to alter the activity of K<sup>+</sup> channels (such as voltage, Ca<sup>2+</sup>, phosphorylation, activated G protein subunits, etc), regions of the protein concerned with gating and regions which form protein/protein interactions with other proteins. For example, the fourth transmembrane domain (S4) of voltage-gated K<sub>V</sub> channels contains many positively charged amino acids and this is thought to be the region that senses changes in membrane voltage. However, exactly how this region then responds to the voltage change it senses is an area of intense debate [see 8]. For a subgroup of K<sub>V</sub> channels the intracellular N terminus region is mobile and interacts with the channel pore when the channel is open leading to current

▶ **inactivation** (termed N-type inactivation). Functionally, this is seen as fast inactivation characteristic of ▶ **A-type K<sup>+</sup> currents** (▶ **I<sub>A</sub>**) (see below).

### K<sup>+</sup> Channel Auxiliary Subunits

Most primary  $\alpha$  subunits of K<sup>+</sup> channels interact with auxiliary subunits which can act to alter both channel function and channel expression levels at the cell membrane. For example, K<sub>V</sub>  $\beta$ 1 and  $\beta$ 2 subunits accelerate inactivation when co-expressed with certain K<sub>V</sub>1 channel subunits. Furthermore K<sub>V</sub>5, K<sub>V</sub>6, K<sub>V</sub>8 and K<sub>V</sub>9 subunits do not form functional channels when expressed alone but act as auxiliary subunits to modify the function of K<sub>V</sub>2 channel subunits when co-expressed with these (see Table 1). In most cases, the detailed role and importance of auxiliary K<sup>+</sup> channel subunits has still to be established. Perhaps the most well known of K<sup>+</sup> channel auxiliary subunits described to date

are the sulphonylurea receptors which form multi-meric complexes with  $K_{IR6}$  channels to give functional ATP-sensitive  $K^+$  channels.

### Functional Properties of Neuronal $K^+$ Channels

The large number of  $K^+$  channel genes, the possibility of heteromeric combinations and the existence of both auxiliary subunits and post-translational modifications such as phosphorylation, when taken together, suggest that the potential number of functional  $K^+$  channel types in neurons is extremely large. Despite this, only a comparatively small number of distinct  $K^+$  channel currents have been characterized to date, suggesting that many channel combinations have properties that differ from each other only subtly. This often makes it extremely difficult to be certain which subunit combinations underlie which functional currents seen in particular neurons. Nevertheless a few functional profiles are seen in many neuron populations. These include delayed-rectifier  $K^+$  currents ( $K_V$ ), **A type** currents ( $K_A$ ), **M currents**, Ca-activated K currents and leak K currents.

*Delayed rectifier*,  $K_V$ , currents (e.g.  $K_V1.1$ ,  $K_V3.1$ ,  $K_V3.2$  homomers) are the main  $K^+$  current in many excitable cells (Fig. 3). Once a threshold voltage is reached, their conductance increases upon membrane depolarization rising sigmoidally and they inactivate slowly. From one cell to another (or one protein to another) they have diverse kinetics, pharmacology and voltage-dependence but they are usually sensitive to relatively low concentrations of **tetraethylammonium ions** (**TEA**). Their activity controls action potential depolarization and hence the duration of the action potential (Action potential).

► *Transient  $K^+$  currents* such as ►  $K_A$  currents or ►  $K_D$  currents (e.g.  $K_V1.2$ ,  $K_V1.4$ ,  $K_V3.4$ ,  $K_V4.2$

homomers) are usually found in cells in addition to delayed rectifier currents. Their conductance also increases with depolarization but they characteristically inactivate quickly, albeit with varying timescales when comparing one to another. They are often selectively localized within a neuron and have a role in regulating the interspike interval in a train of action potentials, thus their activity helps to determine the latency to the first action potential spike.

The *M current* is encoded by members of the  $K_V7$  or KCNQ subfamily (usually seen as  $K_V7.2$  and  $K_V7.3$  heteromers in neurons). The current gets its name because it is inhibited following activation of muscarinic acetylcholine receptors. The M current is a sustained current which activates slowly at subthreshold voltages and normally keeps the neuronal membrane hyperpolarized. However, suppression of the current following muscarinic receptor activation leads to membrane depolarization. The current controls spike frequency accommodation; thus typically on depolarization, one might see a few spikes before the M current activates fully to act as a break to further firing.

*Ca<sup>2+</sup>-activated  $K^+$  currents* are activated following a rise in intracellular  $Ca^{2+}$ . BK currents have a role in action potential depolarization whilst SK currents contribute to after hyperpolarizations which control the action potential firing rate.

*Leak  $K^+$  currents* are open at all voltages (i.e. they are not voltage gated) and contribute to the cell membrane potential and neuronal excitability. K2P channels often underlie leak  $K^+$  currents and these channels are highly regulated by agents such as neurotransmitters and other physiological mediators, thereby constantly tuning neuronal excitability.

So, why are there so many different  $K^+$  channel subunits and different  $K^+$  current functional profiles?

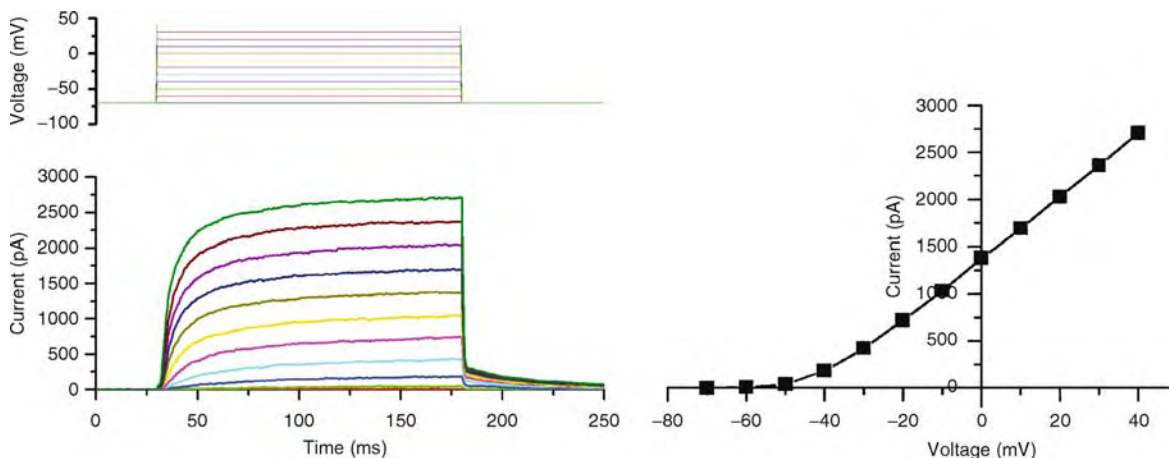

**Neuronal Potassium Channels. Figure 3** Left hand side – a family of  $K^+$  currents through  $K_V1.1$  potassium channel homo-tetramers expressed in HEK cells, evoked by step depolarizations in membrane potential. Right hand side – the peak current is plotted against the voltage for each step. Note that current is activated at voltages positive to  $-50$  mV.

The most likely explanation is that different neurons express different subsets of  $K^+$  channels in order to uniquely tailor their responses to particular synaptic inputs. For example, neurons that are required to fire at extremely high frequencies (such as neurons in the auditory brainstem nuclei [9] are often found to have high expression levels of  $K_v3$  channels. These particular channels activate and deactivate extremely quickly which allows the membrane potential to depolarize quickly following an action potential, ready to depolarize again very rapidly as required for high frequency firing. Studies into the expression levels of  $K^+$  channels are mapping their distinct distribution throughout the central nervous system [e.g. 10]. This differential distribution of  $K^+$  channels underlies the differential neuronal responses seen throughout the central nervous system to synaptic inputs.

## References

1. Bean BP (2007) The action potential in mammalian central neurons. *Nat Rev Neurosci* 8:451–465
2. Hille B (2001) Ion channels of excitable membranes. Sinauer Associates, Sunderland MA
3. Ashcroft FM (2000) Ion channels and disease. Academic Press, London
4. Yu FH, Yarov-Yarovoy V, Gutman GA, Catterall WA (2005) Overview of molecular relationships in the voltage-gated ion channel superfamily. *Pharmacol Rev* 57:387–395
5. Coetzee WA, Amarillo Y, Chiu J, Chow A, Lau D, McCormack T, Moreno H, Nadal MS, Ozaita A, Pountney D, Saganich M, Vega-Saenz de Miera E, Rudy B (1999) Molecular diversity of K channels. *Ann NY Acad Sci* 868:233–285
6. MacKinnon R (2004) Nobel Lecture: Potassium channels and the atomic basis of selective ion conduction. *Biosci Rep* 24:75–100
7. Yellen G (2002) The voltage-gated potassium channels and their relatives. *Nature* 419:35–42
8. Tombola F, Pathak MM, Isacoff RY (2006) How does voltage open an ion channel? *Annu Rev Cell Dev Biol* 22:23–52
9. Song P, Yang Y, Barnes-Davies M, Bhattacharjee A, Hamann M, Forsythe ID, Oliver DL, Kacmarek LK (2005) Acoustic environment determines phosphorylation state of the  $K_v3.1$  potassium channel in auditory neurons. *Nat Neurosci* 8:1335–1342
10. Trimmer JS, Rhodes KJ (2004) Localisation of voltage-gated ion channels in mammalian brain. *Annu Rev Physiol* 66:477–519

## Neuronal Proliferation

### Definition

Cell division of neuronal progenitor cells in the ventricular layer of the vertebrate neural tube. Cell

cycle genes control the number of neurons generated from progenitor cells in the central nervous system. Cells must withdraw from the cell cycle prior to migration and differentiation.

► Neural Development

► Neural Tube

## Neuronal Tropism

### Definition

The preference of a viral vector for infecting neurons.

► Gene Therapy for Neurological Diseases

## Neuronitis

### Definition

Inflammation of one or more neurons (former name for acute idiopathic polyneuritis).

## Neuronopathy

### Definition

Polyneuropathy involving destruction of the cell bodies of neurons.

## Neuropathic Pain

MAIKE STENGEL, RALF BARON

Division of Neurological Pain Research and Therapy, Department of Neurology Universitätsklinikum Schleswig-Holstein, Campus Kiel, Kiel, Germany

### Synonyms

Neurogenic pain

### Definition

Neuropathic pain is defined as a “Pain arising as a direct consequence of a lesion or disease affecting the

somatosensory system” [1]. The term “disease” refers to identifiable disease processes such as inflammatory, autoimmune conditions or channelopathies, while lesions refer to macro- or microscopically identifiable damage. The restriction to the somatosensory system is necessary, because diseases and lesions of other parts of the nervous system may cause nociceptive pain. For example, lesions or diseases of the motor system may lead to spasticity or rigidity, and thus may indirectly cause muscle pain. These pain conditions are now explicitly excluded from the condition neuropathic pain.

## Characteristics

### Epidemiology of Neuropathic Pain

Chronic neuropathic pain is common in clinical practice, greatly impairs the quality of life of patients and is a major economical health problem. Estimates of point prevalence for neuropathic pain in the general population are as high as 5%, a quarter of them suffering from severe pain. Moreover, a recent prospective cross-sectional survey in 13,000 chronic pain patients with both nociceptive and neuropathic pain types who were referred to pain specialists in Germany revealed that 13% of these patients suffer from the two classical neuropathic disorders, ►**post-herpetic neuralgia (PHN)** and painful diabetic neuropathy, and 40% of all have at least a neuropathic component to their discomfort (especially patients with chronic back pain and ►**radiculopathy**) [2]. Comorbidities such as poor sleep, depressed mood and anxiety are common in neuropathic pain and have a significant impact on the global pain experience.

## Classification

### Disease/Anatomy-Based Classification

It is common clinical practice to classify neuropathic pain according to the underlying etiology of the disorder and the anatomical location of the specific lesion. The majority of patients fall into four broad classes (Table 1): painful peripheral neuropathies (focal, multifocal or generalized, e.g. traumatic, ischemic, inflammatory, toxic, metabolic, hereditary), central pain syndromes (e.g. stroke, multiple sclerosis, spinal cord injury), complex painful neuropathic disorders (complex regional pain syndromes, CRPS) and mixed pain syndromes (combination of nociceptive and neuropathic pain, e.g., chronic low back pain with radiculopathy).

### Painful Peripheral (Focal, Multifocal, Generalized) Neuropathies

The anatomical distribution pattern of the affected nerves provides valuable differential diagnostic clues as to possible underlying causes. It is therefore common clinical practice to group painful neuropathies into symmetrical generalized polyneuropathies, affecting

**Neuropathic Pain. Table 1** Disease/anatomy-based classification of painful peripheral neuropathies Painful peripheral neuropathies

Focal, multifocal
Phantom pain, stump pain, nerve transection pain (partial or complete)
Neuroma (post-traumatic or postoperative)
Posttraumatic neuralgia
Entrapment syndromes
Mastectomy
Post thoracotomy
Morton's neuralgia
Painful scars
Herpes zoster and postherpetic neuralgia
Diabetic mononeuropathy, diabetic amyotrophy
Ischemic neuropathy
Borreliosis
Connective tissue disease (vasculitis)
Neuralgic amyotrophy
Peripheral nerve tumors
Radiation plexopathy
Plexus neuritis (idiopathic or hereditary)
Trigeminal or glossopharyngeal neuralgia
Vascular compression syndromes
Generalized (polyneuropathies)
Metabolic or nutritional
Diabetic, often “Burning feet syndrome”
Alcoholic
Amyloid
Hypothyroidism
Beri beri, Pellagra
Drugs
Antiretrovirals, Cisplatin, Oxaliplatin, Disulfiram, Ethambutol, Isoniazid, Nitrofurantoin, Thalidomid, Thiouracil
Vincristine, Chloramphenicol, Metronidazole, Taxoids, Gold
Toxins
Acrylamide, Arsenic, Cloquinol, Dinitrophenol, Ethylene oxide, Pentachlorophenol, Thallium
Hereditary
Amyloid neuropathy
Fabry's disease
Charcot-Marie-Tooth disease type 5, type 2B
Hereditary sensory and autonomic neuropathy (HSAN) type 1, type 1B
Malignant
Carcinomatous (paraneoplastic)
Myeloma
Infective or post-infective, immune
Acute or inflammatory polyradiculoneuropathy (Guillain-Barré syndrome)

**Neuropathic Pain. Table 1** Disease/anatomy-based classification of painful peripheral neuropathies Painful peripheral neuropathies (Continued)

Borreliosis
HIV
Other polyneuropathies
Erythromelalgia
Idiopathic small-fiber neuropathy
Central pain syndromes
Vascular lesions in the brain (especially brainstem and thalamus) and spinal cord:
Infarct
Hemorrhage
Vascular malformation
Multiple sclerosis
Traumatic spinal cord injury including iatrogenic cordotomy
Traumatic brain injury
Syringomyelia and syringobulbia
Tumors
Abscesses
Inflammatory diseases other than multiple sclerosis; myelitis caused by viruses, syphilis
Epilepsy
Parkinson's disease
Complex painful neuropathic disorders
Complex regional pain syndromes type I and II (Reflex sympathetic dystrophy, causalgia)
Mixed-pain syndromes
Chronic low back pain with radiculopathy
Cancer pain with malignant plexus invasion
Complex regional pain syndromes

many nerves simultaneously, and into asymmetrical neuropathies with a focal- or multifocal distribution or processes affecting the brachial or lumbosacral plexuses. One important subgroup of polyneuropathies is characterized by a predominant, or in some cases even isolated, involvement of small afferent fibers (i.e. unmyelinated C-fibers and small myelinated A $\delta$ -fibers). In many cases, autonomic efferent small fiber systems are also affected. Different etiologies may lead to small fiber polyneuropathies, but up to 20% of cases, however, are of unknown cause. It is important to realize that conventional electrophysiological techniques like NCS (nerve conduction study), SEP (somatosensory evoked potential), etc. only assess the function of myelinated peripheral axonal systems and the contribution of small fibers will be missed. Therefore, especially in small fiber neuropathies, alternative diagnostic procedures have to be used, like ► **quantitative sensory testing (QST)**.

### Central Pain Syndromes

Central pain is defined as chronic pain following a lesion or disease of the central nervous system. The cause of pain is a primary process within the CNS (central nervous system). The highest incidence is observed after spinal cord injury, lesions in the lower brainstem and thalamus. An involvement of spino-thalamo-cortical pathways seems to be crucial for the development of central pain, whereas isolated lesions of the lemniscal system are never associated with pain. Many kinds of lesions can induce central pain. The most common are cerebrovascular lesions, multiple sclerosis (MS) and traumatic spinal cord injuries (SCI). Central pain often develops with a latency of weeks or months after the inciting event.

### Complex Painful Neuropathic Disorders

In addition to the classical neuropathic syndromes like painful diabetic neuropathy, postherpetic neuralgia or phantom limb pain are certain chronic painful conditions that share many clinical characteristics. These syndromes were formerly called reflex sympathetic dystrophy, M. Sudeck or causalgia and are now classified under the umbrella term complex regional pain syndromes (CRPS). CRPS are painful disorders that may develop as a disproportionate consequence of trauma typically affecting the limbs. CRPS type I usually develops after minor trauma with no obvious nerve lesion at an extremity (e.g. bone fracture, sprains, bruises or skin lesions, surgeries). CRPS type II develops after trauma that typically involves a large nerve lesion.

### Mixed Pain Syndromes

Both nociceptive and neuropathic processes contribute to many chronic pain syndromes and these different mechanisms may explain the qualitatively different symptoms and signs that patients experience. In particular, patients with chronic low-back pain, cancer pain and CRPS seem to fit into this theoretical construct.

### Mechanism-Based Classification

In neuropathic pain a disease/anatomy-based classification is often insufficient. Despite obvious differences in etiology, many of these diseases share common clinical phenomena; for example, touch-evoked pain in postherpetic neuralgia and painful diabetic neuropathy. Conversely, different signs and symptoms can be present in the same disease; for example, pain paroxysms and stimulus-evoked abnormalities in postherpetic neuralgia. Classification on the basis of location also has its shortcomings, as neuroplastic changes following nervous system lesions often give rise to sensory and pain distributions that do not respect nerve, root, segmental or cortical territories. These observations have raised the question whether an

entirely different strategy, in which pain is analyzed on the basis of underlying mechanisms [3], could provide an alternative approach for examining and classifying patients, with the ultimate aim of obtaining a better treatment outcome [4,5].

### Signs and Symptoms in Neuropathic Pain

Patients with neuropathic pain demonstrate a variety of distinct sensory symptoms that can coexist in combinations. Bedside sensory examination should include touch, pinprick, pressure, cold, heat, vibration, and temporal summation ([6], definitions in Table 2).

Responses can be graded as normal, decreased or increased to determine whether negative or positive sensory phenomena are involved. Stimulus-evoked (positive) pain is classified as dysesthetic, hyperalgesic or allodynic, and according to the dynamic or static character of the stimulus. Touch can be assessed by gently applying cotton wool to the skin, pinprick sensation by the response to sharp pinprick stimuli, deep pain by gentle pressure on muscle and joints, cold

and heat sensation by measuring the response to a thermal stimulus, for example by thermo-rollers kept at 20 or 45°C. Cold sensation can also be assessed by the response to acetone spray. Vibration can be assessed by a tuning fork placed at strategic points (interphalangeal joints, etc).

### Pathophysiological Mechanisms in Patients

#### Peripheral and Central Sensitization of Nociceptive Neurons

Abnormal nociceptor sensitization and abnormal spontaneous afferent activity has been demonstrated in many peripheral nerve injury models. Partial nerve lesion is associated with dramatic changes in the regulation of receptors and channels in damaged as well as undamaged primary afferent neurons. These neurons develop spontaneous activity (ectopic discharge) and an increased sensitivity to chemical, thermal and mechanical stimuli. Ectopic impulse generation following nerve injury is associated with enhanced expression and changes in the distribution of certain voltage gated

**Neuropathic Pain. Table 2** Definition and assessment of negative and positive sensory symptoms or signs in neuropathic pain

	Symptom/Sign	Definition	Assessment bedside exam	Expected pathological response
Negative signs and symptoms	Hypoesthesia	Reduced sensation to non painful stimuli	Touch skin with painters brush, cotton swab or gauze	Reduced perception, numbness
	Pall-hypoesthesia	Reduced sensation to vibration	Apply tuning fork on bone or joint	Reduced perception threshold
	Hypoalgesia	Reduced sensation to painful stimuli	Prick skin with single pin stimulus	Reduced perception, numbness
	Therm-hypoesthesia	Reduced sensation to cold/warm stimuli	Contact skin with objects of 10°C (metal roller, glass with water, coolants like acetone) Contact skin with objects of 45°C (metal roller, glass with water)	Reduced perception
Spontaneous sensations/pain	Paraesthesia	Non-painful ongoing sensation (ant crawling)	Grade intensity (0–10)	–
			Area in cm <sup>2</sup>	
	Paroxysmal pain	Shooting electrical attacks for seconds	Number per time	–
			Grade intensity (0–10) Threshold for evocation	
	Superficial pain	Painful ongoing sensation often of burning quality	Grade intensity (0–10)	–
			Area in cm <sup>2</sup>	

**Neuropathic Pain. Table 2** Definition and assessment of negative and positive sensory symptoms or signs in neuropathic pain (Continued)

	Symptom/Sign	Definition	Assessment bedside exam	Expected pathological response
Evoked pain	Mechanical dynamic allodynia	Normally non painful light moving stimuli on skin evoke pain	Stroking skin with painters brush, cotton swab or gauze	Sharp burning superficial pain Present in the primary affected zone but spread beyond into unaffected skin areas (secondary zone)
	Mechanical static allodynia	Normally non painful gentle static pressure stimuli at skin evoke pain	Manual gentle mechanical pressure at the skin	Dull pain Present in the area of affected (damaged or sensitized) primary afferent nerve endings (primary zone)
	Mechanical punctate hyperalgesia	Normally stinging but not painful stimuli evoke pain	Manual pricking the skin with a safety pin, sharp stick or stiff von Frey hair	Sharp superficial pain Present in the primary affected zone but spread beyond into unaffected skin areas (secondary zone)
	Temporal summation	Repetitive application of identical single noxious stimuli is perceived as increasing pain sensation (Wind-up like pain)	Pricking skin with safety pin at interval <3 s for 30 s	Sharp superficial pain of increasing intensity
	Cold allodynia (hyperalgesia)	Normally non (slightly) painful cold stimuli evoke pain	Contact skin with objects of 20°C (metal roller, glass with water, coolants like acetone) Control: contact skin with objects of skin temperature	Painful often burning temperature sensation Present in the area of affected (damaged or sensitized) primary afferent nerve endings (primary zone)
Heat allodynia (hyperalgesia)	Normally non (slightly) painful heat stimuli evoke pain	Contact skin with objects of 40°C (metal roller, glass with water) Control: contact skin with objects of skin temperature	Painful burning temperature sensation Present in the area of affected (damaged or sensitized) primary afferent nerve endings (primary zone)	
		Mechanical deep somatic hyperalgesia	Normally non painful pressure on deep somatic tissues evoke pain	Manual light pressure at joints or muscle

sodium channels in primary afferent neurons, leading to a lowering of the action potential threshold [7].

As a consequence of peripheral nociceptor hyperactivity, dramatic secondary changes in the spinal cord dorsal horn also occur. Partial peripheral nerve injury leads to an increase in the general excitability of spinal cord neurons. This so-called central sensitization is

probably due to activity in pathologically sensitized C-fibers, which sensitize spinal cord dorsal horn neurons by releasing glutamate and the neuropeptide substance P. Neuronal voltage-gated calcium channels that are located presynaptically at spinal nociceptive terminals are up-regulated after peripheral nerve injury and play an important role in the process of central



sensitization by mediating the release of glutamate and substance P. If central sensitization is established, normally innocuous tactile stimuli become capable of activating spinal cord pain signaling neurons via A $\beta$ -low threshold mechanoreceptors [8] [see ►[Hyperalgesia and Allodynia](#)]. By this mechanism, light touching of the skin induces pain (i.e. mechanical allodynia).

### **Changes in the Brain**

Most animal experiments have concentrated on the dorsal horn as the location of central sensitization. However, in rodents, sensitized neurons are also found in the thalamus and primary somatosensory cortex after partial peripheral nerve injury. Furthermore, MEG, PET and functional MRI studies demonstrate fundamental changes in somatosensory cortical representation and excitability in patients with phantom limb pain, CRPS and central pain syndromes as well as experimental pain models. Interestingly, these changes correlate with the intensity of the perceived pain and disappear after successful treatment of the pain.

### **Deafferentation: Hyperactivity of Central Pain Transmission Neurons**

Although the above convincingly supports a role for peripheral and central sensitization in the generation of neuropathic pain, in some patients there is a profound cutaneous deafferentation of the painful area with no significant ►[allodynia](#). Assuming that the ►[dorsal root ganglion cells](#) and the central afferent connections are lost in such patients, their pain must be the result of intrinsic CNS changes. In animal studies, following complete primary afferent loss of a spinal segment, many dorsal horn cells begin to fire spontaneously at high frequencies. There is some evidence that a similar process may underlie the pain that follows extensive denervating injuries in humans. Recordings of spinal neuron activity in a pain patient whose dorsal roots were injured by trauma to the ►[cauda equina](#) revealed high frequency regular and paroxysmal bursting discharges. The patient complained of spontaneous burning pain in a skin region that was anesthetic by the lesion (anesthesia dolorosa).

### **Inflammation in Neuropathic Pain**

After nerve lesion, activated macrophages infiltrate from endoneural blood vessels into the nerve and dorsal root ganglia, releasing pro-inflammatory cytokines, in particular tumor necrosis factor alpha (TNF- $\alpha$ ) [see ►[Immune System and Pain](#)]. These mediators induce ectopic activity in both injured and adjacent uninjured primary afferent nociceptors at the lesion site.

In patients with inflammatory neuropathies, such as vasculitic neuropathies or HIV neuropathy, deep proximal aching and paroxysmal pain are characteristic phenomena. COX2 (cyclooxygenase 2) and

proinflammatory cytokines were found to be up-regulated in nerve biopsy specimens of these patients. In the affected extremities of CRPS patients, the fluid of artificially produced skin blisters contain significantly higher levels of IL-6 and TNF- $\alpha$  as compared with the uninvolved extremity.

### **Quantitative Sensory Testing as a Diagnostic Tool in Neuropathic Pain**

The modern theoretical concept of a mechanism-based therapy assumes that a specific symptom predicts a specific underlying mechanism [3]. However, this approach carries certain important caveats. Clinical experimental studies indicate that a specific symptom might be generated by several entirely different underlying pathophysiological mechanisms. Therefore, a specific symptom profile rather than a single symptom might be required to predict the underlying mechanism. To translate these ideas into the clinical framework, it is important to characterize the somatosensory phenotype of a patient as precisely as possible. A standardized quantitative sensory testing protocol (QST) was introduced by the German Research Network on Neuropathic Pain, including 13 parameters and encompassing thermal as well as mechanical testing procedures for the analysis of the somatosensory phenotype. To judge plus or minus symptoms in patients, an age- and gender-matched data-base for absolute and relative QST reference data for several body regions in healthy human subjects was established. The precise phenotypic mapping with QST is an important step to establish a future mechanism-based drug therapy of neuropathic pain. If the symptoms are closely related to mechanisms, clinical assessment of the symptoms may give an idea of the concert of the distinct mechanisms that operate in one individual patient. This knowledge may lead in the future to an optimal poly-pragmatic therapy with drugs that address the specific combination of mechanisms in each patient.

### **Present Medical Treatment**

The number of trials for peripheral neuropathic pain has expanded greatly in the last few years [9]. In summary, the medical management of neuropathic pain consists of five main classes of oral medication (serotonin/norepinephrine modulating antidepressants, sodium-blocker-anticonvulsants, calcium-modulator-anticonvulsants, tramadol and opioids) and two categories of topical medications mainly for patients with cutaneous ►[allodynia](#) and ►[hyperalgesia](#) (capsaicin and local anaesthetics). For central neuropathic pain, there are limited data. Since more than one mechanism is at work in most patients, a combination of two or more analgesic strategies to address multiple mechanisms will generally produce greater pain relief. Therefore, in most patients a stepwise process using successive

monotherapies is not appropriate. Early combinations of two or three drugs from different classes is the general practical approach.

- ▶ [Voltage-gated Sodium Channels: Multiple Roles in the Pathophysiology of Pain](#)
- ▶ [Development of Nociception](#)

## References

1. Treede RD, Jensen TS, Campbell JN, Cruccu G, Dastrovsky JO, Griffin JW, Hansson P, Hughes R, Nurmikka T, Serra J (2007) Neuropathic pain. Redefinition and a grading system for clinical and research purposes. *Neurology* Nov 14; [Epub ahead of Print].
2. Freynhagen R, Baron R, Gockel U, Tolle TR (2006) PainDETECT: a new screening questionnaire to identify neuropathic components in patients with back pain. *Curr Med Res Opin* 22(10):1991–1920
3. Jensen, TS, Baron, R (2003) Translation of symptoms and signs into mechanisms in neuropathic pain. *Pain* 102:1–8
4. Woolf CJ, Bennett GJ, Doherty M, Dubner R, Kidd B, Koltzenburg M, Lipton R, Loeser JD, Payne R, Torebjork E (1998) Towards a mechanism-based classification of pain? *Pain* 77(3):227–229
5. Baron R (2006) Mechanisms of disease: neuropathic pain – a clinical perspective. *Nat Clin Pract Neurol* 2(2):95–106
6. Cruccu G, Anand P, Attal N, Garcia-Larrea L, Haanpaa M, Jorum E, Serra J, Jensen TS (2004) EFNS guidelines on neuropathic pain assessment. *Eur J Neurol* 11:153–162
7. Binder A, Baron R (2007) Sodium channels in neuropathic pain – friend or foe? *Nat Clin Pract Neurol* 3(4):179
8. Tal M, Bennett GJ (1994) Extra-territorial pain in rats with a peripheral mononeuropathy: mechano-hyperalgesia and mechano-allodynia in the territory of an uninjured nerve. *Pain* 57:375–382
9. Finnerup NB, Otto M, McQuay HJ, Jensen TS, Sindrup SH (2005) Algorithm for neuropathic pain treatment: an evidence based proposal. *Pain* 118(3):289–305

## Neuropathy

### Definition

Any peripheral nerve disease, which usually causes weakness and numbness (see ▶ [peripheral neuropathy](#)).

## Neuropeptide S (NPS)

### Definition

A twenty-residue peptide expressed in a few discrete nuclei in the brainstem (pericoerulear area and

parabrachial nucleus). The name arises because its N-terminal residue is a Serine (S), which is conserved across vertebrate species. NPS receptors (formerly, GPRA receptors) are distributed widely throughout the brain. Infusion of NPS in the brain has anxiolytic-like properties and induces wakefulness.

- ▶ [Hypocretin/Orexin](#)
- ▶ [Neuropeptides](#)
- ▶ [Ventrolateral Preoptic Nucleus \(VLPO\)](#)

## Neuropeptide Y (NPY)

### Definition

A 36 amino acid neuromodulator well known as a contributor to the regulation of feeding. In the context of circadian rhythm regulation, it is important because it is synthesized in neurons of the intergeniculate leaflet (IGL) that project to the suprachiasmatic nucleus (SCN) via the geniculohypothalamic tract (GHT). NPY is released from GHT terminals in the SCN and acts as a neuromodulator mediating the ability of certain nonphotic environmental stimuli to modulate circadian rhythm phase.

- ▶ [Circadian Rhythm](#)
- ▶ [Intergeniculate Leaflet](#)
- ▶ [Neuromodulators](#)
- ▶ [Neuropeptides](#)
- ▶ [Suprachiasmatic Nucleus \(SCN\)](#)

## Neuropeptides

WILLIS K. SAMSON

Department of Pharmacological and Physiological Science, Saint Louis University School of Medicine, St. Louis, MO, USA

### Synonyms

Neuromodulators; Neurotransmitters

### Definition

▶ [Neuropeptides](#) are small proteins produced in and released from neurons. They exert potent membrane effects on both adjacent neurons (i.e., synaptic) and glia (i.e., paracrine) and can be released from neurons

to gain access to the hypothalamo-pituitary-portal vessels (i.e., neuroendocrine) or general circulation (i.e., endocrine). Within the limbic system, these small chains of amino acids exert potent behavioral effects that can be divided into several categories, motivation, appetite, fear and anxiety, arousal, memory, addiction and aggression to name but a few.

## Characteristics

### Quantitative Description

No one rule is agreed upon by the scientific community. Neuropeptides are considered to be proteins consisting of fewer than 100 amino acids, although some investigators would assign such status to peptides comprised of fewer than 50 amino acids. Clearly these biologically active factors are produced as part of a larger pre-prohormone that, following translation of the encoding mRNA, undergoes numerous catalytic modifications resulting in the assembly of the bioactive components in secretory granules. Along the way, biochemical adjustments to the amino acid backbone that are essential for expression of full biologic activity are completed, including N- and C-terminal modifications and in some cases unique changes to single amino acid structure such as bromination and surprisingly in the case of the peptide ghrelin the addition of an octanoyl group [1]. In general, neuropeptides are thought to be extremely labile and the termination of their biological activity is a combination of uptake (of bound peptide to cognate receptor) or enzymatic processing by cell surface proteases abundant in the neuropil. Many but not all the identified neuropeptide receptors are members of the G-protein classes of biologically active receptors; however, some neuropeptides bind directly to ion channels, membrane spanning guanylyl cyclases or tyrosine kinase-like growth factor receptors. While direct actions of neuropeptides can be demonstrated on the more classically described neurotransmitters (e.g., acetylcholine, norepinephrine, dopamine, glutamate, GABA), important interactions of neuropeptides with other neuropeptide producing neurons are clearly the basis for the pharmacological and in some cases the demonstrated physiologically relevant actions of the peptides. Since neuropeptides are unique products of single genes, molecular engineering technologies [2,3] have allowed for the development of informative animal models in which the peptide itself or its receptor are selectively ablated in either the embryonic stage (and thus throughout life, gene knockouts) or at any stage during postnatal development (selective gene ablation, Cre-LOX strategies) using a technique that can be initiated without the deleterious effects of loss of the neuropeptide during fetal development. These technologies also allow for continuous or regulated over-expression of the neuropeptide by insertion of a transgene that is constitutively

expressed or induced chemically for either short or long periods of time. These technologies have clearly established the importance of these “non-classical” neurotransmitters in a wide variety of neural events and provided insight into therapeutic strategies for the treatment of CNS disorders.

### Higher Level Structures

It is impossible in the space allotted to catalog all the currently identified neuropeptides, their localization in limbic structures or their multiple and diverse biologic actions. One peptide will be used as an example for each class of characteristic biologic effects exerted by neuropeptides within limbic structures.

Motivation is a behavior intimately linked to reward. The endogenous opioid systems including the neuropeptides beta-endorphin and the enkephalins are important neural factors that organize learned responses and provide signals that impact motivation [4]. Aversive stimuli are also transmitted by neuropeptides, including CCK-8 and oxytocin. Included in motivation is a component of memory and the role of vasopressin in this behavior has been demonstrated in experimental animals and humans. This neuropeptide surprisingly affects both the consolidation and recovery of memory and contributes, via actions in the medial septal nuclei, to the emotional components of memory including aggression.

By far the most comprehensively cataloged behavioral response to neuropeptides within limbic structures is appetite, although it is difficult to separate appetitive behaviors from the additional limbic actions of many of these neuropeptides such as arousal state, anxiety and even addiction. Currently there are more than 50 neuropeptides that have been characterized for their effects on appetite (Table 1).

These can be divided into those that elicit hunger and those that contribute to **satiety**. While the actions of these “feeding peptides” are exerted in many distinct limbic structures, it is in the medial-basal hypothalamus where the primary interactions take place, in particular in the arcuate nuclei, the ventromedial hypothalamic nuclei and the lateral hypothalamic nuclei. Cells in these areas integrate ascending neuronal input from brainstem structures such as the nucleus tractus solitarius (in particularly the vagal afferent relaying information relevant to ongoing and metabolic state), from temporal lobe structures including hippocampus and amygdala and from circumventricular organs such as the subfornical organ, area postrema and organum vasculosum lamina terminalis.

Circulating hormones derived from the gut and adipocytes activate cells in blood brain barrier free sites and in some cases directly affect the activity of neurons in these hypothalamic nuclei, informing these integrative centers of the fed/fast state of the individual.

**Neuropeptides. Table 1** Neuropeptides acting in limbic structures to alter feeding behaviors

Stimulators	Inhibitors
Agouti-Related Peptide (AGRP)	Adrenomedullin
Dynorphin	Amylin
Beta-Endorphin	Anorectin
Galanin	Bombesin
Ghrelin	Brain-derived neurotrophic factor (BDNF)
Growth Hormone Releasing Hormone	Calcitonin Gene Related Peptide (CGRP)
Hypocretins/Orexins	CART
Melanin Concentrating Hormone (MCH)	Cholecystokinin (CCK)
Neuropeptide Y (NPY)	Ciliary Neurotrophic Factor (CNTF)
RF-amide peptides	Corticotropin Releasing Hormone (CRH)
VGF	Enterostatin
	Galanin-Like Peptide (GALP)
	Glucagon-like Peptide 1 (GLP-1)
	Insulin-like Growth Factors
	Insulin
	Interleukin-1
	Leptin
	Motilin
	Nesfatin
	Neuromedin B
	Neuromedin U
	Neuropeptides B (NPB)
	Neuropeptide K (NPK)
	Neuropeptide W
	Neurotensin (NT)
	Obestatin
	Oxytocin
	Peptide YY (3–36)
	Prolactin Releasing Peptide (PrRP)
	POMC
	Thyrotropin Releasing Hormone (TRH)
	Urocortin

Metabolic factors themselves such as plasma glucose and free fatty acids are also sensed by neurons in these “feeding centers” and it is neuropeptides that then transmit the appropriate signals to motivational centers in brain organizing the appropriate response to ambient nutrient availability [5,6]. Central to this organization are neurons in the arcuate nucleus, which provide the critical organization of these inputs. Neuropeptide Y (NPY) and agouti-related peptide (AGRP) are produced in the same arcuate neurons and these two neuropeptides are central to the stimulatory drive for feeding [2]. They are inhibited by circulating leptin, a peptide derived from adipocytes and by insulin levels. High circulating levels of free fatty acids also exert inhibitory effects on NPY/AGRP neurons [6]. Peptide YY<sub>3–36</sub> is a gut hormone released in response to

feeding that potently inhibits NPY/AGRP neurons [7]. On the other hand ghrelin, an octanoylated peptide produced in the gastric mucosa, is released during the fasted state and exerts direct, stimulatory actions on these neurons [1]. Thus the peripheral tissues can directly regulate motivation and appetite via metabolic and hormonal factors.

Also located in the arcuate nucleus are neurons that express the pro-opiomelanocortin (POMC) gene and, after post-translational processing of the encoded mRNA package for synaptic release, the neuropeptide alpha-melanocyte stimulating hormone (alpha-MSH). This peptide binds to a family of melanocortin receptors expressed on neurons in the feeding center and exerts potent anorexigenic actions, thus reducing the motivation for food seeking behaviors. These POMC neurons

are stimulated by insulin and leptin [2,6]. They are inhibited by NPY produced in adjacent neurons and binding of alpha-MSH to its melanocortin receptors is antagonized by AGRP. The integrative nature of these neuronal systems is further demonstrated by the ability of alpha-MSH to inhibit the activity of the NPY/AGRP neurons. Thus, even simply within the small population of arcuate neurons, a push-pull mechanism exists for the integration of feeding signals from the periphery. Neurons in the adjacent lateral hypothalamic area (LHA) contribute to the integration. These neurons produce the neuropeptides orexin A and orexin B (products of the same gene, also called hypocretin 1 and hypocretin 2). They are activated by NPY and inhibited by POMC. Important efferent projections from these LHA neurons innervate reward centers and brain stem satiety centers [8]. These neurons are also responsible for the behavioral arousal (locomotor activity, autonomic nervous system activation) that accompanies food seeking and eating [3].

The orexin neurons in LHA appear to play a central role in the reward aspects of food [9] and they are influenced by recognized interactions of the ascending dopaminergic pathways from the ventral tegmental area (VTA) to the nucleus accumbens (NAc). GABA-ergic neurons from the NAc project to the orexin neurons in LHA. Thus the neuropeptide systems of the “feeding centers” in medio-basal hypothalamus are intimately associated with brain reward circuitry in limbic structures.

### Lower Level Components

As mentioned above, orexin neurons in the LHA also control behavioral arousal and are essential for normal sleep-wakefulness. Administration of exogenous orexin into the brains of experimental animals results in increased cardiovascular function (increased sympathetic outflow resulting in increased mean arterial pressure and heart rate) and in increases in spontaneous locomotor activity, including ambulatory and grooming behaviors. The behavioral arousal observed in response to pharmacological application of orexin predicted the result of loss of orexin neurons during the development of ►[narcolepsy/cataplexy](#) in animal models and humans [3].

Anxiety and fear behaviors may also play a role in the limbic responses to changes in the endocrine and metabolic state. This is best illustrated by the actions of another hypothalamic neuropeptide, corticotropin-releasing hormone (CRH) on food intake and avoidance behaviors. The main function of CRH is expressed in anterior pituitary gland where it exerts primary control of the production and release of adrenocorticotropin (ACTH). ACTH in turn stimulates glucocorticoid (cortisol in humans, corticosterone in lower mammals) production in the adrenal gland. In addition to their

mixed catabolic and anabolic effects in peripheral tissues, glucocorticoids feedback into the hypothalamus to control CRH release. In the absence of glucocorticoid negative feedback, the activity of CRH neurons increases and appetite is suppressed (the anorexigenic action of CRH). Behaviors characterized by fear and anxiety increase as well, due to the limbic actions of CRH. Alternatively, when glucocorticoid levels are high, such as in multiple models of stress and anxiety, CRH neurons are suppressed and appetite increases.

Social recognition and maternal behaviors are also regulated by the actions of neuropeptides in limbic structures. In an extensive series of studies, Thomas Insel and colleagues demonstrated the importance of the neuropeptide oxytocin in the organization and maintenance of affiliative behaviors in rodents [10]. Additional studies by Insel and others established the importance of oxytocin in the organization and imprinting of maternal behaviors.

Neuropeptides also play important roles in the organization of survival responses to changes in an animal’s external environment including physical and emotional stressors. Neuropeptides that exert important metabolic actions, particularly those that stimulate feeding (e.g., NPY, orexin) are also potent activators of the sympathetic response to stress. Oxytocin, in addition to acting on social behaviors, is one of the most important neurotransmitters controlling sodium balance and therefore fluid and electrolyte homeostasis, which in itself is essential for the appropriate responses to stress.

### Structural Regulation

As detailed above, neuropeptides are pivotal factors in the assembly and integration of interoceptive and exteroceptive information. Neuropeptide producing neurons are targets of ascending and descending neural networks and furthermore are the detectors of hormonal and metabolic information. A highly organized system of communication is being discovered in which neuropeptides interact with other neurotransmitters systems in brain to organize the appropriate responses to those changes in the internal and external milieu. Not only do these neuropeptide systems control behavior and autonomic responses in normal physiology, they serve as potential targets for therapeutic interventions in disease [7].

### Pathology

Loss of the expression of individual neuropeptides or their receptors results in distinct pathologies, reflective of the physiological role played by those peptidergic systems of communication within limbic structures. Failure of the gonadotropin releasing hormone (GnRH) neurons to migrate into the hypothalamus during development results not only in hypogonadism (loss of GnRH action in pituitary gland), but also the absence

of characteristic gender based behaviors. Obesity caused by failure of satiety factors to inhibit neurons in hypothalamic feeding centers occurs when leptin receptors are mutated or absent [6]. Behavioral arousal is severely compromised when orexin neurons in the lateral hypothalamic area begin to disappear during the onset of narcolepsy.

### Therapy

Neuropeptides are relatively easy to mass-produce by classic synthetic chemistry or recombinant technologies. Subtle modifications in peptide structure can be made, resulting in increased or decreased biological activity and thus neuropeptides are attractive compounds for the development of super-active agonists or potent antagonists. While the problem of access into the neuropil must be overcome when designing peptide analogs for therapeutic actions within limbic structures, some synthetic neuropeptides readily access the brain or at least act on blood brain barrier free sites to affect limbic function. New strategies are being developed to facilitate delivery of synthetic neuropeptides into the brain and thus take advantage of their inherent activities to treat various pathologies. Particularly in the behaviors associated with feeding, these studies show strong promise. Indeed, PYY<sub>3–36</sub> has been shown to be an effective anorexic agent in human trials because of its ability to cross the blood brain barrier and activate the neuropeptide systems in limbic centers that inhibit feeding while inhibiting those neurons that produce ►orexigenic neuropeptides [7]. The potential to reverse the catastrophic consequences of loss of orexin neurons during the development of narcolepsy/cataplexy [3] by treatment with a blood brain barrier permeant analog of the neuropeptide has stimulated intense interest in not only the physiologic actions of the neuropeptide itself, but also the convergence of feeding signals and arousal state in general.

### References

1. Hosoda H, Kojima M, Mizushima T, Shimizu S, Kangawa K (2003) Structural divergence of human ghrelin. Identification of multiple ghrelin-derived molecules produced by post-translational processing. *J Biol Chem* 278:64–70
2. Sindelar DK, Palmiter RD, Woods SC, Schwartz MW (2005) Attenuated feeding responses to circadian and palatability cues in mice lacking neuropeptide Y. *Peptides* 26:2597–2602
3. Willie JT, Chemelli RM, Sinton CM, Tokita S, Williams SC, Kisanuki YY, Marcus JN, Lee C, Elmquist JK, Kohlmeier KA, Leonard CS, Richardson JA, Hammer RE, Yanagisawa M (2003) Distinct narcolepsy syndromes in orexin receptor-2 and orexin null mice: molecular genetic dissection of non-REM and REM sleep regulatory processes. *Neuron* 38:715–730

4. Garzon M, Pickel VM (2004) Ultrastructural localization of Leu5-enkephalin immunoreactivity in mesocortical neurons and their input terminals in rat ventral tegmental area. *Synapse* 52:38–52
5. Cowley MA, Pronchuk N, Fan W, Dinulescu DM, Colmers WF, Cone RD (1999) Integration of NPY, AGRP, and melanocortin signals in the hypothalamic paraventricular nucleus: evidence of a cellular basis for the adipostat. *Neuron* 24:155–163
6. Morton GJ, Cummings DE, Baskin DG, Barsh GS, Schwartz MW (2006) Central nervous system control of food intake and body weight. *Nature* 443:289–295
7. Batterham RL, Cowley MA, Small CJ, Herzog H, Cohen MA, Dakin CL, Wren AM, Byrnes AE, Low MJ, Ghatei MA, Cone RD, Bloom SR (2002) Gut hormone PYY(3–36) physiologically inhibits food intake. *Nature* 418:650–654
8. Thorpe AJ, Mullett MA, Wang C, Kotz CM (2003) Peptides that regulate food intake: regional, metabolic, and circadian specificity of lateral hypothalamic orexin A feeding stimulation. *Am J Physiol* 284:R1409–R1417
9. Harris GC, Wimmer M, Aston-Jones G (2005) A role for lateral hypothalamic orexin neurons in reward seeking. *Nature* 437:556–559
10. Ferguson JN, Young LJ, Insel TR (2002) The neuroendocrine basis of social recognition. *Front Neuroendocrinol* 23:200–224

## Neuropeptides in Energy Balance

N

MELISSA J.S. CHEE<sup>1,2</sup>, WILLIAM F. COLMERS<sup>1,2</sup>  
<sup>1</sup>Department of Pharmacology, University of Alberta, Edmonton, AB, Canada  
<sup>2</sup>Centre for Neuroscience, University of Alberta, Edmonton, AB, Canada

### Synonyms

Polypeptide; Energy homeostasis; Energy state; Appetite regulation; Food intake; Hypothalamus

### Definition

►Energy balance refers to the homeostasis between positive and negative energy states in an organism and is controlled by the regulation of food intake and energy expenditure. In higher organisms, these processes are regulated by the brain, where the hypothalamus assumes an important role. The hypothalamic circuitry involved includes ►peptide chemical messengers. These neuropeptides can be orexigenic, stimulating increased energy intake and tending to decrease energy expenditure, or anorexigenic, reducing energy intake and promoting increased energy expenditure. Here, we discuss the main hypothalamic neuropeptides that modulate the central circuitry involved in energy

homeostasis, and their integration of peripheral peptide and protein hormone signals of energy balance.

## Characteristics

### Neuropeptide Modulation of Hypothalamic Circuitry

Early experiments investigating the role of the hypothalamus in energy balance focused on the ventromedial nucleus (VMH) and the lateral hypothalamic area (LHA). Lesions to the VMH in rats resulted in ►hyperphagia and increased weight gain, while lesions to the LHA caused anorexia and weight loss. The “dual centre hypothesis” thus proposed that the VMH and LHA were the hypothalamic ►satiety centre and feeding centre, respectively [1]. However, this hypothesis is now believed to be overly simplistic. Lesions to the VMH and LHA may have interfered with intra- and extra-hypothalamic neural pathways passing through these regions. Furthermore, lesions at other hypothalamic regions can also influence energy balance.

The regulation of energy balance is now thought to involve a number of hypothalamic nuclei and extra-hypothalamic brain regions. These include the area postrema and subformal organ, which are ►circumventricular organs (CVO) that mediate communication between the brain and peripheral appetite signals [2]; the nucleus tractus solitarius (NTS) of the brainstem, which receives inputs from vagal sensory afferents, and is capable of mediating some feeding responses [3]; the amygdala, which contributes an emotional component to the acquisition, storage, and recall of experiences with food; the nucleus accumbens and ventral tegmental area, which processes motivational and reward-mediated behaviors [4]; and the neocortex, which integrates taste, olfactory, visual, memory, and social factors that influence food intake [5].

The information regarding the nutrient and energy levels in the body is communicated to the brain, via neural and endocrine signals. The arcuate nucleus (ARC) of the hypothalamus plays an important role in integrating these signals. The ARC projects within the hypothalamus to the VMH, LHA, paraventricular nucleus (PVN), and dorsomedial nucleus (DMH) [6]. Communication within the hypothalamus is mediated by several classes of chemical messengers, including the amino acid and biogenic amine transmitters, cytokines, cannabinoids, and most notably, neuropeptides. These peptide neurotransmitters can act as either orexigenic (Table 1) or anorexigenic (Table 2) signals to stimulate or inhibit food intake, respectively. A brief discussion of some individual peptides involved in energy balance regulation follows.

### Melanocortin Peptides

Activation of the central melanocortin system reduces food intake and increases energy expenditure. It includes  $\alpha$ -,  $\beta$ -, and  $\gamma$ -melanocyte stimulating hormone (MSH), all of which are derived from the proopiomelanocortin (POMC) peptide precursor. POMC expression in the CNS is restricted to the neurons of the NTS and ARC. POMC expression in the ARC is reduced in fasted animals.  $\alpha$ -MSH is thought to represent the main melanocortin signal in this circuit. The ARC POMC neurons project to the PVN, DMH, and LH, where the melanocortins are released and act via MC3 and MC4 receptors.  $\alpha$ -MSH and  $\beta$ -MSH are the main ligands of the MC4 receptor while  $\gamma$ -MSH is the main ligand at the MC3 receptor. Acute central administration of  $\alpha$ -MSH reduces food intake and chronic administration reduces body weight. Genetic modulation of the melanocortin system, unlike most genetic models targeting specific hypothalamic circuits

**Neuropeptides in Energy Balance. Table 1** Peptides with orexigenic action(s) in the hypothalamus

Peptide		Receptor	Site of synthesis	Site of action
			Hypothalamic	Hypothalamic
AgRP		MC3, MC4	ARC	PVN, DMH
Galanin		Gal1, Gal2	PVN, ARC, DMH	ARC
GALP		Gal1, Gal2	ARC, ME, DMH	ARC, PVN, LH
MCH		MCH1, MCH2	LH	PVN, VMH, DMH
NPY		Y1, Y2, Y4, Y5	ARC, DMH	ARC, PVN, DMH, LHA, VMH, PFA
Opioids	Dynorphin	$\kappa$ -OR	ARC, PVN	PVN, DMH, LHA, VMH, ARC
	$\beta$ -endorphin	$\mu$ -OR	ARC, VMH, DMH, PVN	ARC, VMH, DMH, PVN
	Enkephalin	$\delta$ -OR	ARC	VMH, DMH, PVN
Orexins	Orexin A	OX <sub>1</sub> , OX <sub>2</sub>	LH, DMH, PFA	ARC, PVN, LH, PFA, VMH
	Orexin B			
			Periphery	Hypothalamic
Ghrelin		GHSR1a	Stomach	ARC, PVN, VMH

**Neuropeptides in Energy Balance. Table 2** Peptides with anorexigenic action(s) in the hypothalamus

Peptide		Receptor	Site of synthesis	Site of action
			Hypothalamic	Hypothalamic
CART		Unknown	ARC, PVN, DMH, LHA	PVN, DMH, LHA
CRH		CRH1, CRH2	PVN	PVN
Melanocortin	$\alpha$ -MSH	MC4	ARC	PVN, VMH, DMH, ARC
	$\beta$ -MSH	MC4		VMH, DMH, ARC
	$\gamma$ -MSH	MC3		ARC
UCN I–III		CRH2, CRH1	LHA, PVN	PVN, ARC, VMH
			Periphery	Hypothalamic
Amylin		CGRP relative	Pancreas	LH
Bombesin		BB1, BB2	GI tract	PVN
CCK		CCK1, CCK2	Small intestine	PVN, DMH
Glucagon-like peptides	GLP1	GLP1	Small intestine	ARC
	GLP2	GLP2		PVN, ARC
	OXM	GLP1		DMH
Insulin		IR-A, IR-B	Pancreatic islet	ARC, DMH, PVN
Leptin		OB-Rb	Adipose tissue	ARC, VMH, PVN, DMH
PP		Y4	Pancreas	PVN, ARC
PYY		Y2	GI tract	ARC

that regulate appetite, produces significant changes in food intake and body weight. ► **Knockout** of the MC4 or MC3 receptor results in hyperphagia and obesity in mice, and humans with MC4 receptor or POMC mutations are obese.

#### **Corticotrophin-Releasing Hormone (CRH) and CRH-like Peptides**

CRH plays a central role in mediating stress by action on the hypothalamic-pituitary-adrenal axis (HPA). Central administration of CRH also reduces appetite in rodents. However, the anorexigenic effects of the CRH-like peptides, including urocortin (UCN) I–III, are more potent than that of CRH. CRH is expressed in the PVN and UCN is expressed in both the PVN and the LHA. Interestingly, CRH can play a role in initiating food-seeking behavior via the HPA axis.

#### **Cocaine- and Amphetamine-Regulated Transcript (CART)**

CART is expressed in several hypothalamic nuclei and codes for a peptide that reduces food intake following ► **intracerebroventricular (ICV)** injection to the third cerebral ventricle. However, some orexigenic actions of the CART peptide have also been demonstrated. It has been suggested that CART can activate inhibitory autoreceptors that downregulate the anorexigenic CART signaling.

#### **Neuropeptide Y (NPY)**

NPY, a member of the pancreatic polypeptide (PP) family, is one of the most potent known orexigenic

neuropeptides. It is mainly produced by neurons in the ARC and brainstem and acts at several sites in the hypothalamus, including the PVN, VMH, DMH, LHA, and the perifornical area (PFA), a region of the LHA surrounding the fornix. Central administration of NPY stimulates food intake, which is thought to be mediated via Y1 and Y5 receptors. The greatest effect of NPY on food intake has been observed when administered into the PFA. The orexigenic actions of NPY peak during the appetitive, “food-seeking” phase of feeding. NPY release is enhanced immediately prior to the onset of feeding and gradually decreased as food intake continues. Despite the powerful acute effects of NPY on feeding, neither the overexpression nor knockout of NPY or its receptors causes profound changes in body weight. There appears to be compensatory mechanisms that protect orexigenic signaling in the hypothalamus when NPY signaling is compromised. This is observed in germline mutations of NPY signaling, which take effect throughout the development and growth of the animal. However, this is not true for adult animals, as the targeted disruption of NPY neurons in the ARC of adult mice results in lethal ► **hypophagia** [7].

#### **Agouti-Related Peptide (AgRP)**

AgRP has potent orexigenic effects by its action as an endogenous antagonist of the melanocortin receptors. This suggests that melanocortin signaling is tonic and modulated by AgRP, which is ► **co-localized** exclusively with NPY in ARC neurons. ARC AgRP expression is greatly increased in fasted animals.



Central injection of AgRP potently stimulates food intake in rodents and can increase food intake for up to one week.

### **Melanin-Concentrating Hormone (MCH)**

MCH is produced mainly by two groups of LH neurons: Type A MCH neurons co-express CART and send descending projections to the brainstem while Type B neurons do not express CART and send ascending projections to the forebrain. The orexigenic effects of MCH are mediated by MCH1 receptors. Mice overexpressing the MCH gene are more susceptible to high-fat diet-induced obesity. In contrast, animals lacking the MCH or MCH1 receptor genes are lean and are resistant to obesity. Such conditions of MCH deficiency are accompanied by a marked suppression of ARC POMC expression, perhaps responding to counterbalance the decrease in satiety and body weight.

### **Orexin**

The orexins play an important role in maintaining the arousal system, which has been associated with changes in energy homeostasis. The orexins – Orexin A and B – are also known as the hypocretins and are produced primarily in the LHA but also in the PFA and DMH. The orexigenic effects of Orexin A are more potent than that of Orexin B. Orexin A has equal affinity for the OX<sub>1</sub> and OX<sub>2</sub> receptor. The OX<sub>1</sub> receptor is expressed in the VMH and LHA. The OX<sub>2</sub> receptor is expressed in neurons of the PVN, DMH, and ARC, which receives the highest density of LHA orexin fibers. Orexin A delays the onset of satiety, thereby increasing the duration of a meal to prolong feeding behavior. Disruption of orexin signaling by the ablation of orexin neurons or knockout of the prepro-orexin gene produces a hypophagic phenotype, which is partly attributed to the development of narcolepsy in these animals.

### **Galanin and Galanin-like Peptide (GALP)**

Galanin is expressed in the PVN, DMH, and ARC. GALP expression is restricted to the ARC. The orexigenic effects of galanin and GALP are fat-sensitive. Galanin acts via the Gal1 receptor and the positive feedback circuitry between galanin and dietary fat contributes to large meal sizes. The orexigenic effects of GALP, which are mediated by the GalR2 receptor, are enhanced following a high-fat diet when preceded by a period of hypophagia.

### **Opioid Peptides**

The opioid peptides ( $\beta$ -endorphin, enkephalin, and dynorphin) are all expressed in the ARC. Dynorphin is also expressed in the PVN and enkephalin in the PVN, VMH, and DMH. The orexigenic actions of the opioids are most commonly associated with  $\beta$ -endorphin, though all opioids stimulate food intake.

The opioids preferentially increase fat ingestion over that of proteins or carbohydrates. Central blockade of opioid receptors prevents orexigenic actions of other peptides such as NPY, AgRP, orexin, and galanin.

### **Contribution of Peripheral Peptides and Hormones**

The central feeding circuitry is influenced by peripheral signals that indicate nutritional state and adiposity level. Peptides and other hormones that are produced and released from the gastrointestinal (GI) tract, pancreas, and adipose tissue play an important role in the short- and long-term regulation of energy balance. These peripheral signals can have central effects by:

1. Stimulation of vagal sensory afferents in the GI tract to signal brainstem nuclei, such as the NTS [8]
2. Stimulation of neurons in CVOs that project to the hypothalamus [2]
3. Transport across the [blood-brain barrier](#) (BBB) to act directly within the CNS [9]

### **Ghrelin**

Ghrelin is secreted by the stomach and is the only peripheral factor known to signal to the CNS to increase food intake. It plays a role in meal initiation; circulating ghrelin levels rise immediately before a meal and remain elevated during periods of food deprivation, and rapidly decline following food intake. Ghrelin can have central effects by crossing the BBB, acting via the vagal afferent pathway, and acting at CVOs. In addition, ghrelin is locally produced in the hypothalamus. In the hypothalamus, ghrelin acts at the ARC, LH, and PVN. The effects of ghrelin are mediated by NPY and AgRP release and are most potent in the PVN. In the ARC, ghrelin activates NPY neurons and inhibits POMC neurons.

### **Leptin**

Leptin is the protein product of the obese (*OB*) gene and plays a significant role in reducing food intake. Leptin is produced in white adipose tissue and levels of circulating leptin are directly correlated with body fat, glucose uptake, and food intake. Humans with congenital leptin deficiency, animals with defects in leptin (*ob/ob* mouse) or the leptin receptor (*db/db* mouse, fatty Zucker rat) are grossly obese. However, this is not a major cause of obesity, since most obese humans are leptin resistant and have elevated leptin levels. Leptin is transported into the brain via truncated forms of the leptin receptor (Ob-Ra, c, or d) and leptin signaling occurs via the long form of the receptor (Ob-Rb). In the ARC, leptin activates anorexigenic POMC neurons and inhibits orexigenic NPY/AgRP neurons. In the LHA, leptin inhibits the orexigenic MCH- and orexin-expressing neurons. Thus, when circulating leptin levels are low during periods of food-restriction or fasting, orexigenic neurons are activated and expression of orexigenic neuropeptides is increased

while anorexigenic neuronal activity and neuropeptide expression is inhibited. Conversely, high plasma leptin levels inhibit orexigenic pathways and activate anorexigenic pathways. Leptin clearly participates in long-term energy balance regulation. The absence of leptin signaling produces drastic changes in the energy state while leptin overexpression produces only mild phenotypic changes; this suggests that leptin is an essential signal indicating the adequacy of energy stores, which is required for the maintenance of vital activities such as reproduction [10].

### **Insulin**

Insulin is produced by the pancreas and, in addition to its well characterized role in the regulation of blood glucose levels, can act as a circulating adiposity signal. Plasma insulin levels change directly with changes in adiposity so that positive energy states stimulate, and negative energy states decrease, insulin secretion. Little or no insulin is produced in the brain but it can have significant central effects. Insulin moves by transporter-mediated entry into the brain and acts on insulin receptors in the ARC, PVN, and DMH. The actions of insulin in the CNS are anorexigenic. The orexigenic NPY and anorexigenic melanocortin systems are both downstream mediators of insulin signaling. Thus, insulin can increase POMC expression and prevent fasting-induced increases in NPY expression. Insulin is also implicated in the long-term regulation of energy balance as the specific deletion of neurons expressing the central insulin receptor leads to obesity.

### **Glucagon-like Peptides (GLP)**

The GLP, including GLP-1, GLP-2, and oxyntomodulin (OXM), are anorexigenic peptides released by the gut following food intake. GLP-1 and OXM, but not GLP-2 can affect food intake when administered peripherally. However, all three GLPs inhibit food intake when administered centrally; this is mediated by the GLP-1 and GLP-2 receptors. In addition, central or peripheral administration of GLP-1 potently stimulates insulin release. The anorectic effects of these peptides are mediated by the brainstem, which is reciprocally connected with the hypothalamus.

### **Cholecystokinin (CCK)**

CCK is secreted by the small intestine following food intake and is the first gut peptide to have been shown to affect food intake. The CCK1 and CCK2 receptors mediating its actions have been cloned and characterized. Its role appears to be restricted to that of a short-term satiety signal contributing to meal termination.

### **Pancreatic Polypeptide (PP)**

PP, a member of the PP fold peptide family, is released from the pancreas following the ingestion of food and

reduces appetite and food intake via the Y4 receptor. However, counter-intuitively, the global deletion of the Y4 receptor produces hypophagic mice with reduced body weight gain. PP can enter the CNS via the area postrema, a CVO rich in the expression of Y4 receptors. However, the central effects of PP are orexigenic, possibly as a result of pharmacological activation of Y5 receptors.

### **Peptide YY (PYY)**

PYY is released into the circulation from enteroendocrine cells of the gut after a meal. In the circulation, PYY is rapidly converted to the C-terminal PYY<sub>3-36</sub> fragment, the major circulating form. Peripheral administration of PYY<sub>3-36</sub> reduces food intake in rodents and humans by activation of ARC neurons. Direct administration of PYY<sub>3-36</sub> to the ARC also suppresses food intake. This is mediated by the activation of postsynaptic Y2 receptors that directly inhibits anorexigenic POMC ARC neurons and activation of Y2 autoreceptors on NPY/AgRP ARC neurons that suppresses orexigenic tone. However, ICV injection of PYY<sub>3-36</sub> increases food intake in rodents, presumably due to the pharmacological activation of Y1 and/or Y5 receptors.

### **Experimental Methods Employed**

Several experimental approaches have been used to demonstrate orexigenic or anorexigenic effects of a peptide:

1. Acute administration of orexigens such as by intracerebroventricular injection or direct microinjection into the specific hypothalamic nuclei stimulates feeding behavior in satiated animals, while anorexigens can prevent feeding following periods of food-deprivation.
2. Chronic administration of orexigens induce hyperphagia and increase body weight gain while chronic administration of anorexigens results in hypophagia and reduced body weight gain.
3. Under conditions of food-deprivation, orexigenic and anorexigenic peptide gene expression is increased and decreased, respectively; while opposite patterns emerge in animals on a high-fat diet.
4. Genetic manipulation at embryogenesis, such as by transgenic peptide overexpression, or a generation of a peptide- or receptor-knockout mouse, rarely results in animals with profound changes in feeding behavior. This implies that the regulation of energy balance is protected by a redundant system that can compensate for compromised orexigenic or anorexigenic signaling systems, during development. However, current evidence suggests that such redundancies are not effective in adult animals.

Thus the homeostatic regulation of energy intake and expenditure is remarkably complex. This is unsurprising given the importance of energy balance to the

survival of the organism. The inbuilt redundancies in the hypothalamic networks that play a key role in this regulation may explain the resistance of obesity to pharmacological interventions based on targeting single chemical signals.

## References

1. Brobeck JR (1946) Mechanism of the development of obesity in animals with hypothalamic lesions. *Physiol Rev* 26:541–559
2. Fry M, Hoyda TD, Ferguson AV (2007) Making sense of it: roles of the sensory circumventricular organs in feeding and regulation of energy homeostasis. *Exp Biol Med* (Maywood) 232:14–26
3. Grill HJ (2006) Distributed neural control of energy balance: contributions from hindbrain and hypothalamus. *Obesity* (Silver Spring) 14:216S–221S
4. Berthoud HR (2004) Mind versus metabolism in the control of food intake and energy balance. *Physiol Behav* 81:781–793
5. Berthoud HR (2006) Homeostatic and non-homeostatic pathways involved in the control of food intake and energy balance. *Obesity* (Silver Spring) 14:197S–200S
6. Schwartz MW, Woods SC, Porte D Jr, Seeley RJ, Baskin DG (2000) Central nervous system control of food intake. *Nature* 404:661–671
7. Luquet S, Perez FA, Hnasko TS, Palmiter RD (2005) NPY/AgRP neurons are essential for feeding in adult mice but can be ablated in neonates. *Science* 310:683–685
8. Schwartz GJ (2006) Integrative capacity of the caudal brainstem in the control of food intake. *Philos Trans R Soc Lond Ser B Biol Sci* 361:1275–1280
9. Banks WA (2006) Blood-brain barrier and energy balance. *Obesity* (Silver Spring) 14:234S–237S
10. Margetic S, Gazzola C, Pegg GG, Hill RA (2002) Leptin: a review of its peripheral actions and interactions. *Int J Obesity Relat Metab Disord* 26:1407–1433

Whereas the neurochemist and the neurophysiologist study the same cellular machinery of the nervous system as the neuropharmacologist, the latter does so with the chemical structure of drugs and how it affects that machinery, in mind. In this regard, neuropharmacology interacts with medicinal chemistry in order to understand how various molecular structures affect receptors and other drug targets within the cells of the nervous system. No matter how diverse different branches of pharmacology may be, what pharmacologists, including neuropharmacologists, have in common is the desire to understand how exogenous chemical structures manipulate living cells, and the discovery of drugs is of course one of the major routes for the clinical application of neuroscientific knowledge to the management of clinical neurological disorders (see chapters on ►[Analgesics](#), ►[Anticonvulsants](#), ►[Antipsychotics](#) for examples).

## A Changing Field...

Despite the neuropharmacologist's emphasis on drug action, more than ever before, neuropharmacology interacts with neurochemistry, neurophysiology and neuroanatomy, as the level of detail available on neural functions becomes ever greater. One obvious example of this is the striking increase in the understanding of the complexity of the biochemical pathways that are affected by drugs. For example, the interactions of ►[G protein-coupled receptors \(GPCRs\)](#) with other proteins and the subunit-specific actions of ►[GABA<sub>A</sub> receptor](#) agonists, are understood to a degree not possible previously (see chapters on ►[Pharmacodynamics](#) and ►[Anxiolytics and hypnotics](#)). Hence, for the last decade and a half, there has been a strong molecular influence in neuropharmacology.

## New Waves of Influence...

Neuropharmacology is influenced by progress in every area of biology and medicine. The increasing interest in the effects of growth factors and ►[cytokines](#) in the nervous system has led to the investigation of whether some of these endogenous molecules, or their synthetic derivatives, might be of use in the treatment of neurological disease (see chapter on ►[Growth factors](#)). At the same time, gene therapy, which traditionally has not been considered to be a form of drug treatment (but which must be according to Goodman and Gillman's definition of a drug as any chemical that affects living processes...) is now being investigated, in some cases instead of, and in other cases, in addition to, conventional drug therapy (see chapter on ►[Gene therapy](#)).

Another important theme in recent neuropharmacology has been the recognition of the differences in drug action in the male and female nervous system. While historically, most drugs have been tested mainly in males, even including those such as ►[benzodiazepines](#)

## Neuropharmacology

PAUL F. SMITH

Department of Pharmacology and Toxicology, School of Medical Sciences, University of Otago Medical School, Dunedin, New Zealand

### Definition

“Neuropharmacology” is the subdiscipline of pharmacology devoted to the study of the action of drugs on the nervous system. This includes the effects of therapeutic drugs as well as recreational drugs and toxins. Neuropharmacology is distinct from related subjects, such as neurochemistry, neurophysiology and neuroanatomy, in that the emphasis is on *drug action*.

that were preferentially prescribed to females, it is now recognized that there is an urgent need to understand the differences between males and females in the action of neurological drugs, and also how drugs affect females differently through the menstrual cycle (see chapter on ►[Neuroendocrinological drugs](#)).

Since 1988 when the first cannabinoid receptor was reported, cannabinoid pharmacology has undergone a revolution. The endocannabinoid system has emerged as one of major importance in human biology and in the brain it has been shown to interact with almost every neurotransmitter system. The chapter on ►[Cannabinoids](#) reviews the latest developments in this fast moving area of neuropharmacology, including the new therapeutic drugs that are developing from it.

Neuropharmacology includes not only therapeutic drugs, but also recreational and lifestyle-enhancing drugs, and an important topic in this respect is the recreational use of stimulants, such as ►[methamphetamine](#) and ►[methylenedioxymethamphetamine \(MDMA\)](#). These drugs are used and abused around the world, and the investigation of how they affect the nervous system is an active area of research in neuropharmacology (see chapter on ►[Stimulants](#)).

Finally, some topics are common to all or at least most drugs affecting the nervous system, and the analysis of drug tolerance and dependence is one such topic. Because of the fact that the nervous system adapts to any repeated stimulus, its response to a drug is rarely the same twice, and therefore understanding how its reaction changes over time and how this may be related in some cases, to dependence or addiction, is a critical issue for both therapeutic and non-therapeutic drugs (see chapter on ►[Tolerance and dependence](#)).

Neuropharmacology in the twenty-first century is an exciting, compelling discipline that has all of the attractions of other areas of neurobiology, but with a strong focus on clinical applications and drug development for the treatment of the many neurological disorders that continue to afflict society.

## Neurophilosophy

MICHAEL PAUEN

Institut für Philosophie, Humboldt-Universität Zu Berlin, Unter den Linden 6, Berlin

Neurophilosophy is an emerging field at the interface between neuroscience and philosophy. It encompasses, first, methodological, conceptual, anthropological, and

ethical questions that are of relevance to neuro- and cognitive science. Second, neurophilosophy uses results from these sciences in order to shed light on related philosophical problems.

### The Term “Neurophilosophy”

The term became popular after Patricia Churchland [1] used it as a title for a book and has since then received increasing attention, both in scientific literature and in academic teaching [2]. Still, “neurophilosophy” is not yet a received term for an established branch in academic philosophy like “philosophy of science” or “philosophy of history” with their own journals, academic programs, scientific societies, etc.

Nevertheless, the close connection to empirical science sets neurophilosophy apart from its predecessors, particularly from traditional philosophy of mind, although there is a significant overlap between both fields. Even proponents of ►[materialism](#) in the second half of the twentieth century used only placeholders for neural states like the legendary “C-fiber firings” rather than real neurobiological data. Functionalism, a widely accepted view in the 1970’s and 1980’s, held that a detailed understanding of the brain could not help us to get a significantly better understanding of conscious states. However, with the success of neuroscience, it became increasingly evident that neuroscientific findings *are* relevant for philosophical theories. Likewise, it turned out that neuroscience raises conceptual, methodological, and ethical problems that are of philosophical relevance. Neurophilosophy tries to account for these problems and it makes use of neuroscientific insights in order to solve them.

### What is the Rationale of Neuro-Philosophical Cooperation?

From the philosophical perspective, brain research is of special interest because the brain is the material substrate of those distinctive human abilities and ►[properties](#) like consciousness, ►[free will](#), the ►[self](#), cognition, memory, and emotion that have always taken center stage in philosophical thinking. Although even most ►[materialist](#) philosophers would insist that there is an important difference between ►[knowledge about](#) the brain and *knowledge about* certain cognitive abilities, the former knowledge can be of central importance if we want to know more about the details of our cognitive abilities. Given that our current views of these abilities are based on pre-scientific assumptions, it would follow that new empirical findings might lead to a profound revision of these views. Since these abilities, in turn, are substantial for human self-understanding, it is not difficult to see why neuroscience is of particular relevance from a philosophical point of view.

Conversely, there are at least two reasons why neuroscience can take advantage of philosophical work.

First, with the advent of new experimental techniques, particularly with the availability of non-invasive imaging, questions of fundamental relevance for human self-understanding like consciousness, the self, or the free will problem, became subject to neuroscientific research. One might feel tempted to conclude that this enables neuroscience to solve old philosophical problems. On reflection, however, it turns out that, in order to come up with experimental designs or to derive conclusions that are relevant for our self-understanding, we first need clear cut concepts of what it takes to be conscious, self-conscious, or to act freely. This is true, in particular, because we have strong but usually fuzzy and incoherent pre-scientific intuitions concerning these ideas, and philosophers have considerable expertise in transforming such intuitions into coherent concepts. Of course, there may be irresolvable conflicts between competing intuitions; but even then, the ensuing debates about the correct understanding are useful because they clarify the available conceptual and theoretical choices. The second reason why neuroscience can take advantage of philosophical considerations results from the complexity of the brain itself and of the related research programs. As a consequence, any theory that tries to come close to a comprehensive picture of the mind/brain raises fundamental methodological and ►epistemological questions, partly because it has to account for findings from a vast number of disciplines, ranging from molecular biology up to cognitive psychology. Philosophers have discussed these questions for quite some time, thus exposing the advantages and disadvantages of the options at hand in order to make a reasonable choice possible.

### Neurophilosophical Tools

Given that philosophy tries to explore the premises and foundations of empirical knowledge rather than providing such knowledge itself, it should not be surprising that there are neither uncontroversial philosophical results nor established methodologies. If a question becomes tractable by such a methodology or if we can come up with uncontroversial answers, then the question loses its philosophical interest. This is true for neurophilosophy, too. Still, there are certain universally accepted “tools” that are useful in this endeavor. ►Logic is, of course, one of them, especially if we try to expose the consequences and implications of a particular view. *Conceptual analysis* is another important tool. In this case, philosophers try to characterize or even define a pre-theoretic concept. In an ideal case, such a definition provides necessary and sufficient conditions for the application of a concept. Since definitions in a strict sense are often hard to come by, we must be content with *characterizations* of the typical way of using a concept. In many cases, intuitions play an important role in our pre-scientific understanding. In order to explore these

intuitions, philosophers use thought experiments as “intuition-pumps” [3]. Many of these thought experiments are based on extreme scenarios in order to enable clear distinctions in difficult cases. So if philosophers come up with their notorious Zombies, Zimbos and the like, they do not maintain the empirical possibility of suchlike beings in some distant future; rather, they try to find out how we would classify these strange beings, and knowing that can be quite useful if we want to make conceptual distinctions in less extreme cases.

### The Mind-Body Problem

In what follows, some of the most important neurophilosophical issues will be discussed. The most basic problem, of course, is the notorious mind-body problem which can also serve as an example for the “division of labor” between philosophers and scientists: While scientists try to find out facts about the relation between mind and brain, philosophers have to clarify the conceptual distinctions between the different available options, to expose the theoretical advantages and disadvantages of each of them, and to outline possible empirical evidence that would support or disprove each of these options. In doing so, neurophilosophy clarifies the criteria for the assessment of empirical evidence and limits the number of possible options for the interpretation of this evidence, thus enabling us to make a reasonable choice between these options in light of the available evidence.

Trivially, there are two fundamental alternatives: Either the mental is some kind of physical process or it is not. Monists hold that it is, Dualists hold that it is not. Due to its initial plausibility, psychophysical dualism can be found in many mythological and religious writings including the Bible, but it is also part and parcel of our commonsense beliefs about the mind-body relation. Depending on the ►causal relation between the mental and the physical, philosophers have distinguished different varieties of dualism. Psychophysical parallelism in its original form, as it was defended by Leibniz, holds that there is no psychophysical interaction at all. Mind and body run in parallel like two clocks that remain synchronized without any causal interaction between them, once they have been started together. ►Epiphenomenalism, a theory that was brought forward by T. H. Huxley [34], Jackson [4], Robinson [5], and, in principle, also by Chalmers, states that there is only a one-way causation: Neural events cause mental events, but mental events, in turn, do not cause anything; they are causally inefficacious by-products. Certainly the most widely held dualist view is psychophysical interactionism as it was defended by Descartes. More recently, interactionist views were held by philosophers like Popper but also by neuroscientists like Eccles [32] or [35]. Interactionism holds that mental events like volitional

acts cause physical events like brain processes, and physical events, in turn, cause mental events, like ▶perceptions. Philosophers have exposed at some length the implications and problems of each of the available alternatives [7]. In the case of interactionist dualism, psychophysical causation is one of the notorious difficulties because, on this view, mental processes like acts of will would have to interrupt the physical causal chain. This would violate almost uncontroversial doctrines like the principle of the causal closure of the physical realm or the law of the conservation of energy. Dualists have made various suggestions how to solve these problems, but none of them has been universally accepted. Other varieties of dualism face severe problems, too: Parallelism has difficulties to explain the synchronicity between the mental and the physical realm, given that the existence of God is not an acceptable scientific hypothesis. Epiphenomenalism is counterintuitive because mental states, due to their causal inefficacy, cannot be among the causes, why we talk about these very states, react upon them, or even design epiphenomenalist theories about them [8].

However, seen from a neurophilosophical perspective, there is still another objection against dualism as a scientific hypothesis. Presumed that natural science tries to explain empirical facts with reference to natural laws and physical entities, the postulate of a non-physical mind doesn't appear as a sensible scientific hypothesis because it implies that mental facts are not amenable to a naturalistic ▶explanation. While this does not rule out that dualism is in fact true, it seems unreasonable for natural science, including neuroscience, to start with such an assumption that would seriously limit its own explanatory scope. Natural science should extend the realm of naturalistic explanations as far as possible rather than beginning with the premise that there are facts beyond explanation in principle.

It would follow that monism is a much more plausible position to take from the viewpoint of natural science. Monists assume that there is only one type of entities. According to current versions of monism there are only physical entities; thus monism is in fact a sort of ▶physicalism. In the last five or so decades, philosophers have explored a vast number of varieties of monism that differ with respect to the status of mental states in such a physical world. While identity-theorists think that we can keep our pre-scientific beliefs about causally efficacious mental states as long as we accept that these states are physical states, more radical materialists like eliminativists and ▶logical behaviorists think that mental states and the related mentalistic idiom have no place in a scientific picture of the world.

According to eliminative materialism, the existence of mental states like beliefs and desires is more than

questionable [1,9,10]. Rather than being subject to immediate access from the first person perspective, these states are postulates of a vernacular theory, usually called “▶folk psychology”. Folk psychology has originally been introduced by our remote ancestors in order to explain and predict human behavior. In the meantime, we became so much used to this postulate that it now appears to us as if we had immediate access to the postulated mental states.

However, neuroscience will eventually provide a better theory of human behavior that gets along without any reference to beliefs and desires. This theory will replace its primitive precursor, thus eliminating not only folk psychology itself but also mental states as its theoretical postulates. Our successors will substitute the precise terminology of neuroscience for the unclear mentalistic idiom, and in the long run even the alleged “direct access” to mental states from the first person perspective will disappear. Mental states will be “eliminated” because the underlying theory has to be given up, just like phlogiston or caloric were eliminated when their theoretical basis vanished. Eliminative materialism is a substantial part of Patricia Churchland's original version of neurophilosophy [1]. If eliminativism is true, then natural science should be able to solve or better: *dissolve* the mind-body problem. All there is that needs to be explained is the brain, and it would seem that neuroscience is able, in principle, to explain neural processes.

Many philosophers think however that this solution is all too simple. Apart from the fact that it is counterintuitive to think that mental states are only postulates of a theory, eliminativism seems to undermine its own theoretical basis: Eliminativists, after all, have to believe in their own theory, but if their theory is true, then there are no beliefs.

This is one of the reasons why eliminative materialism has lost some support in the recent past. Its strongest monistic competitor is the identity theory which was proposed by Feigl [11], and Place [12] in the 1950s. Identity theorists have no doubt that mental states exist; according to their theory, one could dispense with mental states only at the cost of giving up the corresponding physical states, too. Identity theorists can even insist that mental states are perfectly adequate subjects of scientific inquiry, say in cognitive or volitional psychology. Another advantage of this theory is that it provides a simple solution to the problem of mental causation: If mental states are identical with certain physical states, then they *are* physical states and should have causal powers just like other physical states.

According to the original version of the identity theory, there is a one-to-one relation between types of mental states (say pain) and types of physical states (say some neural type *N*). Thus, each particular token of a

certain mental type (pain) will also be a token of the corresponding physical type ( $N$ ), and vice versa. Talking about a pain state and talking about a neural state of type  $N$  is talking about one and the same type of states. This is the reason why this variety of the identity theory has been called “type identity.”

The most severe objection that appeared almost detrimental to the identity theory in its original form refers to the so called “multiple realizability” of mental states. Organisms and even artificial systems whose physical makeup differs considerably from the human neuroanatomy, so the objection goes, might be able to feel pain. It would follow that, contrary to what type identity theorists would have us to believe, not all pain states are neural states of type  $N$ , or in general: Mental states of a certain type can exist in the absence of the related physical type.

Solutions to this problem have been proposed in the meantime [13], but it was originally thought that this objection forces us to reject the type identity theory. As a consequence, another variety of the identity theory emerged, namely the so-called “token identity” theory [14]. According to token identity theorists, every token of a certain mental state is identical with a token of *some* physical state. Thus, token-identity theorists postulate a one-to-*many* relation between mental and physical types: Tokens of *one* mental type (pain) can be realized by the tokens of *many* different physical types (neural states  $N$ ,  $O$ ,  $P$ , state  $Q$  in a silicon chip, etc.). Typically, token identity-theorists subscribe to functionalism [15]. According to functionalism, mental states have a distinctive functional role that can be captured in an extended ►behavioral terminology. Accordingly, being in a pain state is to have certain functional or behavioral properties, e.g. the tendency to say “ouch” under certain conditions, to take painkillers, to think about other ways to get rid of pain, etc. A complete list of these features should be able to capture what we mean if we talk about pain. Consequently, every physical state that performs this functional role would count as a “realizer” of pain because it meets the relevant conceptual criteria.

While it seems that functionalism was successful in providing a solution to the problem of multiple realization, its fundamental premise, namely that mental states can be captured by a distinctive functional role, has been challenged. It seems that, say, our concept of color-experiences cannot be captured by any distinctive functional role, given that it seems perfectly possible to imagine cognitive systems with identical functional roles that have different color-experiences or no color-experiences at all [16]. This assumption has played a major role in the discussion of the so called explanatory gap problem (see below).

One might conclude that all these ►arguments, objections, and counterarguments show that neurophilosophy has failed to provide a solution to its most basic

problem. But this would be a misunderstanding of the objectives of philosophy. Of course: Philosophers have to clarify the conceptual criteria for each of the available options, they can even rule out options with severe theoretical disadvantages, but they cannot provide the empirical data themselves. More conceptual clarity and a better understanding of the implications of each of the available options can help us to make a reasonable choice between these options, once the relevant data are available. But since it is one of the distinctive characteristics of neurophilosophy that it relies on empirical data in order to make progress on philosophical problems, it cannot provide a solution before the relevant data are in.

### Particular Questions The “Explanatory Gap Problem”

But how could we make progress towards a solution? One obvious strategy is to look for the “neural correlates of consciousness,” or better, for strict and specific correlations between distinctive and well-defined mental states on the one hand and distinctive and well-defined neural activities on the other. If there is no evidence for psychophysical interaction and if it is true that eliminative materialism, psychophysical parallelism, and epiphenomenalism are subject to severe theoretical objections, we might be justified to believe that mental states *are* physical states and some version of the psychophysical identity claim is true.

But even then, one might feel somewhat worried. It seems difficult to understand that the different qualia or qualitative properties of mental states, the “way it feels” to be in a pain state or to have a red-experience should be identical with the uniform activity of simple neurons. The worry has already been felt by Locke and Leibniz and it has received increased attention in the recent past. Many philosophers have argued that this worry results from an “explanatory gap” that cannot be closed in principle [4,17,18].

In trying to come to terms with this worry, one should note, first, that the problem does not concern the factual relation between neural activities and mental processes. Asking why neurons bring about consciousness would obviously imply a distinction between the mental and the physical that is incompatible with the claim that mental processes *just are* neural activities. Rather, the question concerns the relation between our *knowledge about* neural activities and our *knowledge about* mental processes, that would allow us to account for problems on the mental level in neurobiological terms.

Normally, we use ►reductive explanations in order to understand problems concerning higher level properties of a complex entity (e.g. heat) in terms of knowledge about the lower level constituents of this entity (e.g. mean kinetic energy of molecules), say the laws that apply to these lower level constituents. Reductive explanations

make it intelligible why an entity with certain lower level constituents has specific higher level features. A higher level property that cannot be reductively explained, in principle, is an ►emergent property.

Reductive explanations have two basic requirements: First an explanation why the constituents have a certain lower level feature (a specific kinetic energy), second a bridge between the higher and the lower level that makes it intelligible why having the lower level feature *really is* having the higher level feature in question (i.e. a certain temperature). Given these requirements, our lower level explanation should help us to understand the presence of the higher level property in question.

Provided that scientific explanations pertain to observable properties rather than to subjective features, any bridge between mental and physical properties would require a determination of subjective mental features in terms of objective observable properties which guarantees that the organism in question really has the mental features that should be explained. Many philosophers think that this is impossible, in principle. In their view, subjective, qualitative properties of mental states cannot be captured by objective properties that are observable from the third person perspective. Two organisms that are identical on the molecular level may have completely different qualitative mental properties. Consequently, a reductive explanation would be impossible, in principle. While some philosophers conclude that some sort of dualism must be true, others hold that the whole question is misguided [19] or that additional knowledge concerning mental states might eventually improve our abilities to operationalize even qualitative mental properties [20] (PS Churchland 1996). If these latter authors are right, scientific progress might eventually lead to a solution of the explanatory gap problem.

### Mental Representation

A quite similar puzzle pertains to the problem of mental representation. Basically, a theory of mental representation has to explain how individual states of a cognitive system can refer to external entities, how they can be “about” something. For a physicalist approach, the theory has to make it intelligible how this is possible in a physical system. According to the “computational theory of mind” which was popular in the 1970’s and 1980’s, the problem can be solved on the basis of an analogy between the brain and a traditional Von Neumann Computer. Following Fodor [21], mental representations are discrete symbols of an innate “►language of thought.” Cognitive operations are formal manipulation-processes of these symbols according to certain syntactic rules (the “program”), and because the semantic content of mental representation is mirrored by their syntactic properties of the symbols, the manipulation processes are sensitive to semantic content.

Many philosophers have criticized that it is implausible to assume the existence of an innate and therefore unchanging language of thought; in addition, it has been doubted whether Fodor can explain in a naturalistically acceptable way how the states of a physical system get their meaning (►naturalization of intentionality). Moreover, it seems that there are ►mental images or “iconic” representations [22] that cannot be accounted for in this theory, in principle, and scientists have pointed out that the architecture of the brain differs in several crucial respects from formal symbol manipulation devices like traditional computers [23].

Connectionism is an alternative that tries to account for these observations. According to this approach, the brain doesn’t work like a traditional computer but, rather, it is a layered neural network, and mental representations are not discrete symbols but rather neural activities that are distributed over different areas of the brain [24]. Although it has been questioned whether this theory can account for higher level cognitive processes like logical reasoning, many philosophers have come to believe that it provides a much better basis for an account of mental representation, given that this theory is not amenable to the objections against the computational theory of mind and it better accounts for the neuroscientific facts.

The ►mental model theory is another alternative [25]. While the symbols of a language of thought are only arbitrarily related to their objects, mental models preserve the relations between the objects they represent: If there is an order between certain parameters of an object in the outside world (e.g. hue, temperature, size), this order should be preserved by the model of the object in question. In addition, representations from different aspects of an object or a scene (e.g. size, weight, sound, smell) can be combined in the respective model.

### Self

Philosophers have also addressed several more detailed questions, among them the problem of the self or the problem of free will. Again, such considerations are not intended to replace empirical research; rather they try to specify the criteria that a person has to meet in order to count as self-conscious or free. While these criteria have to capture our pre-scientific intuitions they should also do justice to new scientific findings that may prompt for a revision of our concepts, just like science has prompted us to revise the concept of an atom.

It may be tempting to conceive of the self as a monolithic entity, a kind of “central-observer” that is realized by a single neural process. Since there are good reasons to believe that no such monolithic entity exists, neither on the neural nor on the psychological level, one might conclude that the self is only a fiction [3].



Many philosophers, however, maintain the self cannot be conceived of as a monolithic entity. As David Hume has noted already in the eighteenth century, we don't experience a "self" when we direct our attention inwards. This need not lead to skepticism concerning the self but it should be considered when the conceptual criteria for the ascription of a self or of self-consciousness are discussed. It seems evident that, in order to count as self-conscious, a person needs access, at least in principle, not only to her *present* feelings, experiences, and beliefs, but also to the related states in the past. The second, almost uncontroversial requirement is that a self-conscious person has to recognize these feelings, experiences, and beliefs *as her own* feelings, experiences, and beliefs. And third, she needs some kind of *self-concept*, that is, a more or less stable and coherent idea of those features and abilities that are characteristic for herself.

In addition, it would seem that being a self requires also being an agent [26]. Other issues are more controversial, e.g. whether it is really possible to understand how self-consciousness emerges, how the term "I" refers, and whether first-person access to our own mental states is privileged or even immune to error. Again, empirical findings may call for a more or less fundamental revision of our pre-scientific concepts.

In any case, even if we could determine the criteria for self-consciousness, it would be still another, empirical question, whether or not an actual person, or maybe human beings in general, meet these criteria. This raises questions concerning our autobiographical knowledge, that is, concerning our ability to remember events and experiences in our own past, and to integrate these memories as well as our present experiences into an adequate and coherent picture of our self or into a "self-model" [25,27]. Another empirical issue concerns the cognitive mechanism that is required for recognizing one's own experiences *as* one's own experiences. One promising candidate is the ability for perspective-taking as it has been identified in theory-of-mind research (► [theory-theory](#)). It seems obvious that a confirmation of this hypothesis would alter our concept of self-consciousness, demonstrating how empirical findings might lead to conceptual revisions.

### Free Will

One of the most substantial implications of our pre-scientific self-understanding is that we can be held responsible for what we do, at least in principle. Provided that responsibility requires freedom and freedom, in turn, requires the ability to do otherwise, it would seem obvious that there is no free will and thus no responsibility in a determined world. In such a world, everything including our ► [actions](#) is determined by natural laws, so only those events *could* have happened that actually *did* happen, and only those

actions *could* be performed that actually *were* performed. Conversely, freedom and responsibility would require the absence of determination.

Again, all these statements are based on certain standards for free action, and these standards need justification. Probably the most important question is whether or not freedom and determination are *compatible*. ► [Compatibilists](#) think they are, incompatibilists think they are not. Incompatibilists typically argue that freedom requires the ability to do otherwise under identical conditions which is obviously impossible in a determined world. Compatibilists, by contrast, may argue that freedom requires the ability to act according to one's will, and this seems possible even in a determined world. Unfortunately, there are many cases in which we would not say that a person who acts according to her will is free because the person's will lacks freedom. An addict may have the wish to take his drug and act accordingly, but we wouldn't say that he is free because his will is determined by his addiction.

Compatibilists have tried to respond to such objections. According to Harry Frankfurt [28], freedom requires not only that one performs the action that one wishes to perform, but also that one has the wish one really wants to have. Thus, an addict who has the desire to take his drug but despises this desire because he wants to get rid of this addiction, would *not* count as free; conversely, a person who does what she wants and approves her own wishes would be free. Compatibilists have also argued that getting rid of determination does not enhance freedom because an action that is not determined, cannot be determined by the agent either, it's just a random event.

Some philosophers even maintain that the criteria for freedom are such that it is impossible in principle that human actions are free. But even if one does not accept this view, skepticism concerning free will seems to be supported by empirical results from e.g. [29]. According to these experiments, conscious will is controlled by subconscious brain processes that are beyond a person's control. However, these experiments are still subject to a fierce debate. Apart from problems concerning the timing of the relevant mental and neural processes one might doubt that Libet has really investigated genuine decisions given that his subjects had no choice between different alternatives.

In any case, it is possible that future empirical results will show that human agents lack the abilities that are required for free actions. Philosophers have already discussed possible consequences, e.g. for our common-sense understanding of responsibility and for the justification of our legal system. Apart from that, one might suspect that neuroscientific findings may have an impact on the related concepts: If there is evidence that human actions in general fail to meet the traditional

criteria for freedom, there may still be other interesting differences that call for a revision of our current concept of freedom.

Another important issue concerns the role of emotions in action and decision. Experiments and case studies by Antonio Damasio [30] and his group show that emotions play an important role even in what seem to be purely rational decisions. This raises the question whether the traditional distinction between rational and irrational decisions has to be revised.

### Neuroethics

It seems obvious that neuroscience may have severe ethical implications. As a consequence, neuroethics as a specialized discipline has emerged in recent years. One of the reasons for this development is that neuroscience raises a number of specific issues that require a distinctive expertise. By and large, these issues fall into two categories. On the one hand, a “neuroscience of ethics” addresses neuroscientific findings that are relevant for ethics. Those findings concern the neural basis of the human ability to act according to moral standards, but also pathological alterations of the relevant structures that might affect and even destroy these abilities. On the other hand, an “ethics of neuroscience” addresses ethical standards for neuroscientific research and its applications like neuroprosthetics or psychotropic drugs. One example for these drugs is Ritalin which has well established short-term benefits in the case of ADHD (attention deficit/hyperactivity disorder). On the other hand, Ritalin seems to have long-term effects on the brain-structure, and is subject to abuse by healthy persons who seek to enhance their cognitive performance [31]. A clear distinction between treatment and enhancement might be helpful but has yet to be established; in addition, one might ask whether improving cognitive performance by a drug rather than by education or psychotherapy does not alter the way we look at humans in a fundamental way.

Neuroprosthetics, i.e. electronic devices like cochlea implants or electrodes for deep brain stimulation in the case of Parkinson’s disease, raise ethical questions because they may have psychological side effects that involve the patient’s personality. Unlike conventional prosthetics, neuroprosthetics may be regarded as a part of the person’s self, thus changing the very person whose prosthetics they are.

It would seem, then, that there are quite some fields in which neurophilosophy can help to promote scientific progress and to assess the consequences of this development. This requires close cooperation between neuroscience and philosophy but it requires also a clear distinction between those issues that can be treated empirically and those that require genuine philosophical research. Traditional armchair reasoning,

by contrast, doesn’t appear as a very promising strategy if philosophy wants to play its role in the development of the neuro- and cognitive sciences.

### References

1. Churchland PS (1986) *Neurophilosophy*. Cambridge MA
2. Bickle J, Mandik P (2002) The philosophy of neuroscience. The Stanford Encyclopedia of Philosophy (Winter 2002 edn) URL = <<http://plato.stanford.edu/archives/win2002/entries/neuroscience/>>
3. Dennett DC (1991) *Consciousness explained*. Boston
4. Jackson F (1982) Epiphenomenal qualia. *Philos Q* 32:127–136
5. Robinson WS (1982) Causation, sensations and knowledge. *Mind* 41:524–540
6. Chalmers DJ (1996) *The conscious mind*. Oxford, New York
7. Ryle G (1949) *The concept of mind*. London
8. Pauen M (2000) Painless pain. *Am Philos Q* 37:51–64
9. Rorty R (1970/71) In defense of eliminative materialism. *Rev Metaphys* 24:112–121
10. Churchland PM (1979) *Scientific realism and the plasticity of mind*. Cambridge
11. Feigl H (1958) The ‘Mental’ and the ‘Physical’. *Minnesota Studies Philos Sci* 2:370–497
12. Place UT (1956) Is consciousness a brain process? *Br J Psychol* 47:44–50
13. Pauen M (2003) Is type identity incompatible with multiple realization? *Grazer Philosophische Studien* 65
14. Davidson D (1970) Mental events. In: Davidson D (ed) *Essays on actions and events*. Oxford, pp 207–224
15. Lewis D (1980) Psychophysical and theoretical identifications. In: Block N (ed) *Readings in philosophy of psychology*, vol. I. London, pp 207–215
16. Block N (1980) Troubles with functionalism. In: Block N (ed) *Readings in philosophy of psychology*, vol. I. London, pp 268–305
17. Nagel T (1974) What Is It Like to Be a Bat? *Philos Rev* 83:435–450
18. Levine J (1983) Materialism and qualia. *Pacific Philos Q* 64:354–361
19. Dennett DC (1993) Quining qualia. In: Goldman AI (ed) *Readings in philosophy and cognitive science*. Cambridge MA, pp 381–414
20. Hardin CL (1990) Color and illusion. In: Lycan WG (ed) *Mind and cognition*. Oxford, pp 555–566
21. Fodor JA (1975) *The language of thought*. New York
22. Tye M (1991) *The imagery debate*. Cambridge MA
23. Edelman GM (1992) *Bright air, Brilliant fire*. New York
24. Rumelhart DE, McClelland JL (1986) *Parallel distributed processing*. Cambridge MA
25. Johnson-Laird, PN (1983) *Mental models*. Cambridge MA
26. Strawson G (1997) The self. *JCS* 4:405–428
27. Metzinger T (2003) *Being no one*. Cambridge MA
28. Frankfurt HG (1971) Freedom of the will and the concept of a person. *J Philos* 68:5–20
29. Libet B (1985) Unconscious cerebral initiative and the role of conscious will in voluntary action. *Behav Brain Sci* 8:529–539
30. Damasio AR (1994) *Descartes’ error*. New York

31. Butcher J (2003) Cognitive enhancement raises ethical concerns. *Lancet* 362:132–133
32. Popper KR, Eccles JC (1977) *The self and its brain*. New York
33. Strawson G (1989) Consciousness, free will, and the unimportance of determinism. *Inquiry* 32:3–27
34. Thomas H. Huxley (1904) On the Hypothesis that Animals are Automata. In: ders., *Collected Essays Bd. I*. London: Macmillan, p. 199–250
35. Benjamin Libet (1994) A testable field theory of mind-brain interaction. *Journal of consciousness studies* 1:119–126
36. Churchland, Patricia smith (1996) The Hornswoggle Problem. *Journal of Consciousness Studies* 3:S402–405

## Neurophysins

### Definition

Part of the precursors of the neurohormones vasopressin and oxytocin that are generated in the hypothalamus and released from the posterior pituitary.

► [Neuroendocrinology of Psychiatric Disorders](#)

## Neurophysiology of Sexual Spinal Reflexes

STACY L. ELLIOTT

Departments of Psychiatry and Urological Sciences, University of British Columbia, Vancouver, BC, Canada

International Collaboration on Repair Discoveries, University of British Columbia, Vancouver, BC, Canada

BC Center for Sexual Medicine, Vancouver Hospital, Vancouver, BC, Canada

### Synonyms

Sexual neurophysiology

### Definition

The ► [sexual spinal reflexes](#) are spinal cord reflexes (consisting of afferent and efferent components) which instigate the genital vasocongestion and neuromuscular tension responsible for sexual arousal (erection in men and vaginal lubrication and elongation in women), the triggering of ejaculation in men, and possibly orgasm in both sexes.

## Characteristics

### Sexual Arousal in Men and Women

Both men and women have erectile tissue in their genitalia. Nerve mediated vasocongestion to the pelvis allows for genital tissue engorgement. In men, penile erection occurs when the sinusoidal spaces (the trabeculae) of the corpora cavernosal bodies fill with blood, expanding them to their anatomical limit set by a surrounding, stocking-like, elastic tunica albuginea. Arterial penile filling, or “tumescence,” is further assisted by the cessation of venous outflow from compression of the emissary veins which pierce the tunica. This veno-occlusive mechanism, in conjunction with pelvic floor musculature contraction, increases the intracavernosal pressure making the penis rigid. In women, a similar tumescence of the cavernosal bodies of the clitoris occurs with sexual stimulation along with extensive pelvic vasocongestion (uterine, vaginal, urethral, labial and pelvic ligaments), resulting in swelling of the external genitalia, lengthening of the vagina and the production of vaginal lubrication (a transudate extruded through the vaginal epithelial cells). Physiologically, arousal is primarily a parasympathetic event. The sympathetic nervous system dominates during male ejaculation and probably also at orgasm.

### Ejaculation in Men

Ejaculation is the process of delivery of semen through the penis to the distal urethral opening. ► [Seminal emission](#), the first phase of ejaculation, involves transport of spermatozoa into the prostatic urethra via the ejaculatory ducts in the prostate. The accumulation of fluid immediately proceeds propulsatile ejaculation and contributes to the sensation of *ejaculatory inevitability*. Expulsion, or propulsatile ejaculation, the second phase of ejaculation, propels the seminal bolus distally out the urethral meatus by rhythmic contractions of the bulbocavernosus and ischiocavernosus muscles. Emission is under voluntary control, whereas expulsion is not [1].

### Orgasm in Men and Women

Orgasm is the pleasant physical and mental sensation of sexual climax. While it most often occurs in men with ejaculation, it is not synonymous with it. Orgasm can occur in men and women during sleep, during hypnotic suggestion or even after loss of external genitalia or CNS injury. However, it can still be elusive to some persons with normal physiology despite their best efforts (orgasmic dysfunction). In men, orgasm has been variously described as the result of cerebral processing of ► [pudendal nerve](#) sensory stimuli from increased pressure in the posterior urethra and prostate, and from sensory stimuli arising from the verumontanum and contraction of the urethral bulb and accessory sexual organs [1]. Women’s orgasm can be described as

a pleasurable peak sensation accompanied by involuntary rhythmic contraction of the pelvic floor, often with concomitant uterine and anal contractions. Most men have post-ejaculatory refractory periods, but women do not [2], allowing for the potential of serial orgasms.

### Characteristics

Experimental evidence demonstrates that the spinal cord contains all the neural circuitry involved in the generation of genital arousal [3]. However, sexual functioning is extremely complicated beyond the spinal cord: all body senses, emotions and social awareness will determine whether an individual person will orient towards sexual activity (the situation is safe, erotic and likely to be sexually rewarding) or lose interest (the situation is unrewarding, unsafe or nonsexual). The brain is the ultimate controller. For example, in healthy men, heightened sexual arousal sends descending signals to the spinal cord allowing for the natural unfolding of the sexual spinal reflexes, with the resultant erection acting as a positive reinforcement. This “supraspinal control” is primarily inhibitory in nature, and needs to be “removed” so excitatory signals can pass through to the spinal cord. In male rats, the anatomical site for the descending inhibitory action has been identified in the rostral pole of the paragigantocellular nucleus bilaterally located in the oblongata [4]. A human infant will have rapid reflex erection or lubrication to touch of the genitalia: when myelination of the spinal nerve tracts is complete the brain can then impose inhibition or facilitation of this reflex at a cortical level. Only men and women with complete spinal cord injury (SCI), i.e. whose cortical control is interrupted by the spinal cord injury itself, can provide data for the practical understanding of the neurology of the spinal reflexes. However, their reaction to their sexual experience will ultimately affect their sexual neurophysiology and function. In humans, recognizing this complex, moment-to-moment mind-body interaction linked to reward and expectation is what distinguishes the sexual reflexes from other more automatic physiological reflexes that are also under excitatory and inhibitory control from the brain.

Autonomic spinal nuclei are activated by excitatory descending projections from the brain. While the traditional concept of sexual responses follows a “hard wired” model with neural connections extending from the brain to the peripheral nerve receptors at the sexual end organs, there are neuroendocrine and other biological factors, as well as other non-CNS pathways that are possibly significant. For example, there is growing evidence of a nociceptive vagal-solitary tract pathway from the vaginocervix region in women with complete spinal cord injuries (so far not identified in men with SCI), consistent with pathways already described in basic rat studies and confirmed by fMRI in the human female [5].

## Organization of the Sexual Reflexes

### Central Control

Brain initiated excitatory descending signals are the result of positive “interpretation” of sexual imagery and fantasy, of visual, auditory and olfactory inputs (including the little known role of pheromones in humans), and of cerebral evaluation of ascending signals from somatic (usually tactile) stimulation from the body (particularly the genitalia, nipples, etc). The control of genital arousal is located in the limbic system (linked to processes of motivation and reward), and the hypothalamus (the coordinating center for complex autonomic responses), and other midbrain structures [3]. This has been supported by various functional imaging modalities done in humans undergoing sexual arousal including positron-emission tomography (PET) and functional magnetic resonance (fMRI) showing activation of the higher cortex, the limbic and paralimbic cortex and other subcortical regions: these studies show that sexual responses require brain areas that integrate cognitive, motivational and autonomic components [6]. Seminal emission and ejaculation are controlled by the paraventricular nucleus (PVN) of the anterior hypothalamus and the medial preoptic area (MPOA).

### Ascending and Descending Pathways

Both the lateral spinothalamic pathway (which terminates in the thalamus) and spinoreticular pathway (which crosses the cord to the opposite side and travels in the lateral spinal columns, terminating in the reticular formation) relay sexual sensory information to the brain. Descending signals from the brain travel in the dorsal and dorsolateral white matter and enter into the spinal gray matter. The spinal interneurons connect the afferent and efferent pathways and coordinate various components of the sexual response [2].

### Spinal Cord and Peripheral Innervation

The spinal cord is the integration site for afferent signals from the periphery and descending modulation (excitatory and inhibitory) of interneurons from supraspinal areas. The spinal cord contains neurons projecting to every anatomic genital element participating in the sexual response [2]. *Spinal interneurons* located in and around the intermediolateral cell column and in the medial gray form a column of neurons through segments T12–S1 [2]: these interneurons relay afferent input from the genitalia to efferent somatic and autonomic spinal neurons en route to structures involved in the sexual response. They receive projections from the supraspinal structures and are involved in modulation/coordination of the sexual response.

At the effector organ, locally released nitric oxide (NO) is the primary molecule responsible for genital arousal. Other facilitatory neurotransmitters such as vasoactive intestinal polypeptide (VIP) supplying the

arterioles of the corpora results in smooth muscle relaxation and erection in males and tumescence of clitoral tissue in women, whereas noradrenaline and neuropeptide Y (NPY) are the primary inhibitors of genital arousal response. Acetylcholine (Ach) likely acts synergistically with other vasodilators released by nerves or contained within vascular structures in both men and women: sympathetic pathways may produce erection via a cholinergic mechanism [2].

## Spinal Cord Reflex Pathways

### Genital Arousal

Recognition of genital arousal either externally or internally is a combination of both somatic cutaneous sensitivity (pressure, touch, temperature, vibration and pain) and visceral sensitivity of the internal organs (movement of the uterus and ligaments during intercourse, bladder pressure, etc) [2]. Afferent messages travel to the sacral 2, 3, 4 segments along various pathways, depending on the anatomical structure, but in general, touch and temperature signals from the clitoris and glans penis travel along the dorsal nerve which merges into the *pudendal* nerve (S1–S3), touch and vibration (especially from the vagina and cervix) travel via the ►*pelvic nerve* (S1–S3) and potentially via the ►*vagus nerve* in women (which may be related to vaginocervical stimulation only), whereas deep pressure and visceroreceptive stimuli likely travel along the *pelvic* (S1–S3) and ►*hypogastric* (►T12–L1) nerves [2]. These afferent signals reach the brain through the ascending pathways.

Descending from the brain, two areas in the spinal cord provide the main transmission of efferent signals, (i) T10–12 and L1–3 segments (sympathetic and other fibers) known to be responsible for relaying the messages responsible for psychogenic or mental arousal respectively, and (ii) sacral 2, 3, 4 (parasympathetic and motor fibers) responsible for reflexogenic arousal (genital vasocongestion and muscular pelvic floor activation).

### Clinical Correlate: Spinal Cord Injury

Depending on the level and completeness of injury, isolated SCI can disrupt either psychogenic or reflex genital arousal. Reflex arousal results from stimulation of the dorsal nerve, which propagates signals to the sacral spinal cord, synapsing with the parasympathetic efferent neurons whose axons travel back to the corpora cavernosa and pelvic viscera. If the SCI is above this sacral level, the reflex erection is rarely disrupted. Due to loss of tonic inhibitory control that reduces the sensory threshold and onset of erectile responses [7], men with SCI at the cervical level will have preserved, if not enhanced, reflex erection, especially if the lesion is complete [8]. The ability to have reflex erections or vaginal lubrication is lost if the sacral spinal cord is injured or if the pudendal nerve or pelvic nerve is

destroyed [8]. The pathways of the sympathetic nervous system can compensate for parasympathetic deficits and preserve erectile function. However, the intense mental concentration needed to maintain psychogenic erection via the sympathetic chain can also provoke seminal emission, leading to unwanted detumescence.

### Ejaculatory Reflexes

Afferent sensory information from the genitalia (primarily the glans penis) travels in the pudendal nerve (within the dorsal nerve of the penis) to the S4 level of the spinal cord. Afferent autonomic fibers within the hypogastric plexus transmit information from the sympathetic ganglia located alongside the spinal cord [1]. The efferent component involves sequential contraction of internal accessory sexual organs, which can be associated with pleasurable sensations. Spinal cord segments extending T10–S4 are involved in the ejaculatory process.

Seminal emission, consisting of sperm transport and seminal fluid formation, is under sympathetic control (T10–12), and closure of the bladder neck (internal urinary sphincter) to prevent retrograde ejaculation is controlled via the sympathetic fibers emerging at L1, 2. The actual process of expulsion (propulsatile ejaculation) of seminal fluid occurs through the intermittent relaxation of the external urinary sphincter. Spasmodic contractions of the seminal vesicles, prostate and urethra (parasympathetic fibers of S2, 3, 4) and rhythmic contractions of the bulbocavernosus, ischiocavernosus, levator ani and related muscles (somatic/motor signals of S2, 3, 4 via the pudendal nerve), propel the seminal bolus distally.

Two other local ejaculatory reflexes have been identified: stimulation of the glans penis brings semen to the posterior urethra (glans–vasal reflex) and a urethromuscular reflex is responsible for propulsion of the semen to the exterior (urethral meatus) [9].

### Clinical Correlate: Spinal Cord Injury

It is possible to trigger the ►*ejaculation reflex* through intense penile stimulation with high intensity vibrators (*vibrostimulation*) in about 60–90% of men with SCI lesions above T10 neurological level. No longer under cortical control, the T10–L2 levels can be triggered as a coordinated reflex as long as the afferent and/or efferent signals are intact, or vibrostimulation can activate enough remaining afferent fibers to complete the reflex. If the spinal cord lesion is below T10 with resultant interference of the lumbosacral reflex, then *electroejaculation*, which electrically stimulates (via the periprostatic nerves) the efferent pathways of seminal emission, will invariably work.

### Orgasm

The neurology of orgasm is not fully understood, but likely entails somatic and autonomic components [7].

Orgasm, or components of orgasm, while most often generated from external genital stimulation, are not wholly dependant on such. Orgasm triggered by non-genital stimulation (erogenous zones), or from the brain alone (as in fantasy or during sleep) may be a form of autonomic excitation and release. Furthermore, in spinal cord injured women, the vagus nerve has been identified as a non-spinal cord pathway for orgasm [5]. However, orgasm is primarily triggered by stimulation of the clitoris (and/or anterior vaginal wall) or glans penis and appears to have a reflex component that can be reinforced with practice [2,10]. An experimental model, developed in anesthetized spinalized female rats, mimics the human orgasmic response: assuming the removal of descending inhibitory inputs, the *urogenital reflex* consists of stimulation of the urethra resulting in rhythmic contractions of the vagina, uterus and anal sphincter [7].

Regarding the subjective pleasure component of orgasm (especially in women), there are two arguments: one suggests orgasm is a simple reflex stimulus-response reaction, and the other that sensations identified as orgasm are closely attached to contextual meaning at the time [7]. Confusion between orgasmic etiologies makes the reflex component of orgasm difficult to define. The distinction between genital and non-genital orgasm may help resolve these differences. For example, those men and women with SCI who have intact pain and temperature sensations from the genitalia through the lateral spinothalamic tract, and intact descending corticospinal tracts as demonstrated by voluntary anal contraction, are potentially able to experience *genital* orgasm, whereas loss of these specific ascending and descending reflex pathways do not rule out the potential for *non-genitally* induced (i.e. cerebral or other non-genital erotic zone generated) orgasm [10]. After SCI, orgasm is less likely to be experienced if there is complete disruption of the sacral reflex arc (such as occurs with conus medularis injuries), or if T10–L1 sensation is not intact [2]. Likewise, orgasm can occur despite damage to the sympathetic ganglia, but it is rarely possible after injury to the pudendal nerve.

## References

1. McMahon CG (2004) The ejaculatory response. In: Seftel AD (ed) Male and female sexual dysfunction. Mosby, London, pp 43–57
2. Giuliano F, Julia-Guilloteau V (2006) Neurophysiology of female genital response. In: Goldstein I, Meston CM, Davis SR, Traish AM (eds) Women's sexual function and dysfunction. Taylor & Francis, New York, pp 168–173
3. Allard J, Giuliano F (2004) Central neurophysiology of penile erection. In: Seftel AD (ed) Male and female sexual dysfunction. Mosby, London, pp 3–18
4. Marson L, McKenna KE (1990) The identification of a brainstem site controlling the spinal sexual reflexes in male rats. Brain Res 515:303–308

5. Komisarik BR, Whipple B, Crawford A, Liu WC, Kalnin A, Mosier K (2004) Brain activation during vaginocervical self-stimulation and orgasm in women with complete spinal cord injury: fMRI evidence of mediation by the vagus nerves. Brain Res 1024 (1–2):77–88
6. Rees PM, Fowler CJ, Maas CP (2007) Sexual Function in men and women with neurological disorders. Lancet 369:512–525
7. McKenna KE, Chung SK, McVary KT (1991) A model for the study of sexual function in anesthetised male and female rats. Am J Physiol 261 (5 Pt 2):R1276–R1285
8. Chang AT, Steers WD (1999) Neurophysiology of penile erection. In: Carson C, Kirby R, Goldstein I (eds) Textbook of erection dysfunction. ISIS Medical Media, Oxford, UK, pp 59–72
9. Shafik A (1998) The mechanism of ejaculation: the glans–vasal and urethromuscular reflexes. Arch Androl 41(2):71–78
10. Elliott S (2002) Ejaculation and orgasm: sexuality in men with SCI. Top Spinal Cord Inj Rehabil 8(1):1–15

## Neuropile

### Definition

The integration center within the central nervous system (CNS) surrounding the neuronal cell bodies and composed of a network of axonal and dendritic fibers interconnected by synapses.

N

## Neuroprostheses

### ► Computer-Neural Hybrids

## Neuroprotection

### Definition

Any therapeutic intervention that prevents or slows down secondary neurodegeneration. After an acute central nervous system (CNS) injury, and in most chronic neurodegenerative conditions, three types of neurons operate: those damaged by the primary insult that will inevitably die, healthy neurons, and marginally damaged neurons. The last two types, unless protected,

are susceptible to secondary degeneration and death. “Neuroprotection” also refers to therapeutic interventions that reduce the rate of secondary degeneration.

- ▶ Autoimmune Demyelinating Disorders: Stem Cell Therapy
- ▶ Central Nervous System Disease – Natural Neuroprotective Agents as Therapeutics

## Neuroprotective Agents

### Definition

Agents that protect neurons against various injuries such as excitotoxicity, ischemia, and hypoxia.

## Neuropsychiatry – Historical Development and Current Concepts

GEORG NORTHOFF

Department of Psychiatry, University of Magdeburg, Leipsiger Sharse 44, 39120 Magdeburg, Germany,

### Introduction: The Concept of “Neuropsychiatry”

A clinician taking care of a patient suffering from Parkinson’s disease does not have to treat motor symptoms alone (▶tremor, ▶akinesia, ▶rigor), which belong to the field of neurology, but has to diagnose and treat effective (e.g., depressions) or cognitive symptoms (e.g., ▶bradyphrenia, retardation of thinking), which belong to the field of psychiatry. However, it is quite unlikely that he will meet all requirements of both fields because he is either a neurologist or a psychiatrist, and he therefore has learned different ways of thinking and different methods. This reflects the paradox situation in contemporary relationship between neurology and psychiatry: On the one hand neurology and psychiatry are regarded as two different disciplines with different content concerning methodology, diseases, diagnostics, and therapy. On the other hand the boundaries of separation between both disciplines melt away by applying neurological methodology and diagnostics in psychiatric diseases (▶CT, ▶Spect, ▶PET) as well as by the interest of neurology in complex mental functions and psychiatric symptoms in neurological diseases. Particularly in the Anglo-American region this resulted in the foundation of the discipline of

“neuropsychiatry”: “Although half a century ago neurology and psychiatry seemed to be diverging from a common purpose and sanding as two stools apart, these recent advances have not only seen the stools bridged by a plank, but the whole structure has come gradually to resemble a bench, which for some seems quite comfortable. The last decade has seen not only an exponential growth of knowledge in the field of the neurosciences, but also a resolution of some interdisciplinary rivalry, and laid the foundations of neuropsychiatry for at least the rest of this century [1].” Neuropsychiatry in this sense can best be understood by considering its historical development, which is discussed briefly in the following. One crucial feature of Neuropsychiatry in this sense is that it considers subjective experience of mental states in First-Person Perspective, as distinguished from mere scientific observation of neuronal states in Third-Person Perspective, as crucial.

### Neurology, Psychiatry, and Neuropsychiatry *Historic Development of the Separation of Neurology and Psychiatry*

Neurology as an independent discipline has developed at the beginning of the nineteenth century when Parkinson’s disease and ▶Multiple sclerosis were defined as neural diseases [2] (see also [3]). Following advances in anatomy and pathology in the nineteenth century correlations between the clinical appearance and the pathological–anatomical substrate became possible to an increasing degree; this has been successful in numerous neurological diseases and symptoms (e.g. ▶aphasia) and consequently established the field of neurology as an independent discipline of medicine. On the contrary clinical–pathological correlations in psychiatry did not show significant success, which strengthened the separation of medicine/neurology on the one hand and psychiatry on the other. The previously apparent connection between psychiatry and philosophy/humanities [2], the latter dealing with mental states as implicated in psychiatric diseases as mental disorders, additionally supported the separation between neurology and psychiatry.

The application of scientific principles in psychiatry has later been established by Griesinger, Kahlbaum, Kraepelin, and Maudsely who created a consistent nosology and regarded psychiatric diseases as diseases of the brain. Nevertheless correlations between the clinical appearance and the pathological–anatomical substrate still remained unsuccessful. Although in the field of neurology such correlations showed rising success since neurological diseases could be localized anatomically and morphologically in the brain implying that they were regarded as “structural” diseases. The failure of structural localization of psychiatric diseases, in contrast, resulted in their acceptance as “functional”

diseases with “functional” meaning “psychological” and thus mental origin as distinguished from “structural” describing the “organic” and thus neuronal origin [2]. This opposition of “structure versus function” and “localization versus nonlocalization” accounted for the separation of neurology and psychiatry in a decisive manner; the neurologist dealt with structural diseases of the brain, the psychiatrist focused on functional diseases of the mind. This leads to the development of neurology and psychiatry as independent disciplines in the Anglo-American region whereas in the German-speaking regions both disciplines have been kept together for a long time in the common discipline of “Nervenheilkunde.”

### **Changes in the Relationship between Neurology and Psychiatry**

Different developments in the last decades question the comparison of neurology and psychiatry. These developments mounted from both the field of neurology and psychiatry, which is described briefly in the following. By the discovery of variability of the brain’s neuronal structures, i.e., the plasticity, and the introduction of new imaging techniques (►MRI, PET; see below) neurology changed its appearance: Solely static-structural observations have been replaced by a dynamic-functional anatomy [3]. This “functional neuroanatomy” not only examines different static structures but tries to point out the connections between these structures, to show plasticity of connections and structures as well as the influence of function on structure [1]. The boundaries between anatomy and physiology melt away because of this “functional neuroanatomy,” where the contrast of anatomical-static structure and physiological-dynamic function is dismantled and rather regarded as a relationship of mutual complementation: “The boundaries between anatomy and physiology, between form and function, break down at an ultrastructural level. Anatomy is not static. Pharmacotherapy may alter structure as well as function.” [3]. The new imaging techniques on the one hand allow to image anatomic structures more exactly and in detail. On the other hand they make it possible to draw a connection between functional changes and anatomic structure – they are a kind of “window for the brain function” [4]. These developments make it possible to look at psychiatric diseases too. The physiologic-functional examination, which is still getting off the ground, could shed new light on the pathophysiology of psychiatric diseases.

The development of psychopharmacology supported the hypothesis already set by Griesinger that mental diseases are diseases of the brain. The question of the mechanisms of the pharmacological effects in the brain by psychopharmacological drugs resulted in an intensive exploration of ►neurotransmitters, ►synapses, and receptors in the brain, which resulted

in a better and extended understanding of physiological brain functions. Out of this the discipline of “biological psychiatry” emerged, which tries to correlate psychopathological phenomena with functional and structural changes in the brain [5]. Initially “Biological psychiatry” mainly dealt with synapses, neurotransmitters, and receptors; by examination of the mechanisms of effectiveness one tries to gain insight into the structural and functional events in the brain in psychiatric symptoms and diseases.

Not only in psychiatry changes have happened, but also in neurology. In neurology a rising interest in complex phenomena and behavior, which could not clearly be traced back to reflexes, developed [6]. Here the insufficiency of classic neurology became clear [7] – because of this, mainly in America, the discipline of “behavioral neurology” developed. It deals with complex phenomena like aphasia and ►amnesia and tries to localize these phenomena neurologically and neuroanatomically, respectively [8]. The old method of clinical–pathological correlations (see above) is applied here in a new field of interest, the field of higher-order cognitive phenomena and complex behavior – in doing so the focus is still on structure and the aim of localization [3].

The discipline of “neuropsychology,” constantly developing in the last years, too, examines the “correlations between brain function and psychological processes” [9] closely following classical neuropathology [9,10]. The separation between neuropsychology on the one hand and “behavioral neurology” on the other hand is mainly pursued in the USA. In “behavioral neurology” mainly aphasia and amnesia are investigated. The main topic of neuropsychology is to provide objective methods for the examination of psychological function, which then can be applied on the clinical problems as dealt with in “behavioral neurology” and set into relationship to brain structure and function [11]. The “behavioral neurologist” primarily looks at the structures of the brain and secondarily their relation to complex psychological functions. The neuropsychologist, on the contrary, regards primarily the psychological functions and secondarily their relation to the structures of the brain [8]. The neuropsychologist captures affective and cognitive alterations in the Parkinson’s disease using standardized tests in an objective manner – the correlation of these results with structures and functions of the brain is left to the neurologist to a large extent. The quantitative, operationalized measurement of psychological functions, the so-called psychometrics [10], is increasingly used in psychiatry too, where psychopathological phenomena are captured quantitatively and objectively by operationalization of the psychopathological symptoms. Thus the psychopathology which previously has often been called nonscientific becomes affiliated with an



“empiric-scientific methodology” [12] thereby gaining scientific status.

The above described developments of different disciplines in the border area between neurology and psychiatry aim to bridge the contrasts between both fields from different directions (biological *psychiatry*, behavioral *neurology*, *neuropsychology*) [3]. All of these three disciplines would explain the above described example of Parkinson’s disease differently: The biological psychiatrist localizes the affective and cognitive symptoms in the microstructure of the transmitters, synapses, and receptors; the “behavioral neurologist” localizes the same symptoms in the macrostructures of the brain; the neuropsychologist objectivizes and standardizes psychological functions. All of them place motor/neurological and psychiatric symptoms next to each other and explain them more or less independently from each other – the internal connection of motor and psychological alterations in the Parkinson’s disease as experienced by the patient gets lost. Because of this in the following we want to show that neuropsychiatry could be able to demonstrate these internal connections between psyche and motor activity.

#### **Neuropsychiatry: Characterization and Definition**

The discipline of neuropsychiatry tries to bridge the gap between neurology on the one hand and psychiatry on the other – in doing so, psychological functions and neurological structures are not only to be observed at the same time but are to be connected internally coherently: “This new orientation of which Jelliffe spoke, and of which he himself was a notable exemplar, did not involve merely combining neurological and psychiatric knowledge (as every neurologist and psychiatrist does to some extent), but conjoining them seeing them as inseparable, seeing how psychiatric phenomena might emerge from the physiological, or how, conversely, they might be transformed into it – ...” [3]. The static-structural, strictly localizing observation of the classic neurology and the “behavioral neurology” will be contrasted by a dynamic-functional approach of the neuropsychiatry. Psychological and motor alterations in the Parkinson’s disease are no longer explained separately and independently but are regarded as two expressions of a uniform dynamic-functional structure – the alteration of this structure, and not of the two different symptom complexes as two different phenomena, have to be explained. Thus the “neurologization” of psychiatric functions [3] is impossible – behavior can not only be observed with neurological methodology, but has to be assessed by integration of neurological and psychiatric knowledge [3].

Biological psychiatry cannot be identified with and reduced to neuropsychology, because it does not exclusively deal with complex macro phenomena of behavior

and psychological functions, but with micro phenomena of the synapses, transmitters, and receptors – psychological functions mainly remain beyond observation [13]. While biological psychiatry uses functional neuroanatomy, restricting it to microstructures (synapses), behavioral neurology focuses on macrostructures of the brain though considering them solely in a static, anatomic-structural sense. Neuropsychiatry should aim to combine the dynamic-functional approach with the observation of macrostructures in the phenomena of behavior and higher-order psychological functions. In other terms, neuropsychiatry in this sense would take a middle position between a static-structural, localizing neurology on the one hand and a dynamic-functional, holistic/anti-localizing psychiatry on the other. As a bridge between neuroanatomy and psychopathology, neuropsychiatry has to examine functional and dynamic processes being positioned in between strictly localizable neurological functions and strictly holistic psychological processes [14]. This middle level of neuropsychiatry undermines the traditional opposition of structure versus function and localization versus nonlocalization.

#### **Function and Neuronal Integration in Neuropsychiatry**

##### **Function and Localization**

As already mentioned the contrast of structure versus function and characterized the latter as crucial for the discipline of neuropsychiatry. What does the term “function” mean? “Functional” can be understood in two senses [15]: First, “functional” means just nonorganic and thus psychological, as it has been understood in psychiatry. Second, “functional” can be understood in a physiological sense in contrast to anatomic – here “functional” describes dynamic, plastic, and variable physiological processes, being in contrast to the static, anatomic structure; this second meaning of the word “functional” has been used in the characterization of functional neuroanatomy (see above). We want to follow the second and original meaning of the word “functional” [5] and regard the physiologic-functional description as middle level between static-structural pathology and dynamic-functional psychiatry as the specific neuropsychiatric level [14]. Physiologic functions may not correlate with a specific static anatomic structure any more, but they develop in so-called functional systems [7,16]. These systems produce distinct functions by a dynamic constellation of changes between different parts of the brain reflecting what may be called neuronal integration (see below). They are plastic, show a systemic (and not a concrete) structure, and operate by dynamic autoregulation [16]. The realization of function depends then on dynamic systems that include different brain regions, which Luria characterized as “functional systems”:

“According to this view a function is, in fact, a functional system (...) directed towards the performance of a particular biological task and consisted of a group of interconnected acts that produce the corresponding biological effect. The most significant feature of a functional system is that, as a rule, it is based on a complex dynamic “constellation” of connections, situated at different levels of the nervous system, that in the performance of the adaptive task, may be changed with the task itself may be unchanged” [16].

The brain here is regarded as a network consisting of different, overlapping functional systems with an internal dynamic, a so-called “neurodynamic” [3], which has already been demonstrated in the form of “resonant oscillator circuits” for the brain [17]. For our example of Parkinson’s disease this would mean that the functional interaction of the functional systems of motor action, affect/emotion and cognition and their “interfunctional relation” [18] are altered. The motor action cannot be observed separated from affect/emotion and cognition because of the mutually overlapping systems – between the different functional systems there are so-called “functional knots” [7], enabling the motor action to influence affect/emotion and cognition directly, and reverse.

What does this neuropsychiatric network with its interconnections between the different functional systems imply for the problem of localization versus nonlocalization and consecutively for the separation between neurology and psychiatry? Historically and currently, the discussion of mental processes is often characterized by the opposition of localizationists, who claim for exact localizability of mental processes in structures of the brain, and holists or aquipotentialists, who believed that all structures of the brain are necessary for mental processes [19]. Both approaches can be considered “psycho morphological attempts” [7], which give priority to either the structural-functional differentiation/specialization of the brain (localizationists) or to the plasticity of the brain (holists) as visible in functional restitution following structural lesions. A dynamic-functional neuropsychiatry regards both positions as different aspects of the organization of the neuronal network without either aspect prevailing or dominating. Neuropsychiatry aims to combine both positions in a concept of “systemic-dynamic localization” [7]. In this concept, a function cannot be localized in a distinct anatomic structure but in a functional system with its functional interconnections. On the other hand no anatomic structure of the brain can be assigned to only one function, but it is always involved in different functional systems simultaneously or successively – Luria calls this “functional pluripotentialism” [7].

This “functional pluripotentialism” the functional overlaps the “functional knots,” of the functional systems of affection, cognition, and motor action as

well as their connection in the case of the Parkinson’s disease. This can be localized neither in a distinct anatomic structure (localizationists) nor in the whole brain (holists) – a distinct kind of alteration of the functional interaction of the functional systems of motor action, affect/emotion, and cognition is represented by the dynamic-functional localization in the Parkinson’s disease. This makes clear that traditional contrasts of structure versus function and localization versus nonlocalization, which resulted in the separation of neurology and psychiatry (see above), can no longer be maintained in the present form and could be bridged by a dynamic-functional neuropsychiatry. The middle level between structural localization and functional holism of mental states may be characterized dynamic-functional, which may be realized by what can be called neuronal integration.

### Neuronal Integration

Neuronal integration describes the coordination and adjustment of neuronal activity across multiple brain regions. The interaction between distant and remote brain areas is considered necessary for complex functions to occur, such as emotion or cognition [20]. Neuronal integration focusing on the interaction between two or more brain regions must be distinguished from neuronal segregation [20]. Here a particular cognitive or emotional function or processing capacity is ascribed to neural activity in a single area that is both necessary and sufficient; one can subsequently speak of neuronal specialization and localization. We assume that higher psychological functions as complex emotional–cognitive interactions cannot be localized in specialized or segregated brain regions. Instead, we assume that higher psychological functions require interaction between different brain regions and thus neuronal integration.

For neuronal integration to be possible, distant and remote brain regions have to be linked together, which is provided by connectivity. Connectivity describes the relation between neural activity in different brain areas. There is anatomical connectivity for which we will use the term connections in order to clearly distinguish it from functional connectivity. In addition, Friston and Price [21] distinguish between functional and effective connectivity: Functional connectivity describes the “correlation between remote neurophysiological events,” which might be due to either direct interaction between the events or other factors mediating both events. A correlation can either indicate a direct influence of one brain area on another or their indirect linkage via other factors. In the first case the correlation is due to the interaction itself whereas in the second the correlation might be due to other rather indirect factors like for example, stimuli based on common inputs. In contrast, effective connectivity describes the direct interaction between brain areas, it “refers explicitly to the (direct)

influence that one neural system exerts over another, either at a synaptic or population level” [21]. Here, effective connectivity is considered on the population level because this corresponds best to the level of different brain regions investigated here. For example, the ► **prefrontal cortex** might modulate its effective connectivity with subcortical regions thereby influencing specific functions like for example interoceptive processing. Based upon connectivity, neural activity between distant and remote brain regions has to be adjusted, coordinated, and harmonized. Coordination and adjustment of neural activity might not be arbitrarily but guided by certain principles of neuronal integration [22]. These principles describe functional mechanisms according to which the neural activity between remote and distant brain regions is organized and coordinated as for instance in top-down modulation (see also [23]).

### Top-down Modulation

Top-down modulation might be considered a typical example of specific mechanisms of neuronal integration; it can be described as modulation of hierarchically lower regions by those being higher in the hierarchy. Often top-down modulation concerns modulation of neural activity in subcortical regions by cortical regions. For example, premotor/motor cortical regions might modulate neural activity in subcortical ► **basal ganglia** like the ► **caudate** and ► **striatum** [23,24]. Yet another example is top-down modulation of ► **primary visual cortex** by prefrontal cortical regions, which has been shown to be essential in visual processing [25]. Top-down modulation might be related to the concepts of “re-entrant circuitry” [26] and feedback modulation. These concepts allow for circuiting of information and readjustment of neural activity in one area according to another rather distant area. This provides the possibility of adjusting, filtering, and tuning neural activity in the lower area according to the one in the higher area. For example, top-down modulation allows for attentional modulation of visual input, which makes selective visual perception possible.

We want to focus on the medial prefrontal cortex. Neural activity in both medial prefrontal cortex and ► **amygdala** has been shown to be involved in emotional processing [27]. Their functional relationship is supposed to be characterized by top-down modulation of the amygdala by the medial prefrontal cortex [28], [29]. Medial prefrontal cortical regions seem to exert also top-down control of neural activity in the ► **insula** [30] that is densely and reciprocally connected with subcortical medial regions like the ► **hypothalamus**, the ► **periaqueductal grey** (PAG), the ► **substantia nigra**, and various brain stem nuclei such as the ► **raphe nuclei** and the ► **locus coeruleus** [31]. Both the amygdala and the subcortical medial regions are involved in regulating internal bodily functions whereas medial prefrontal cortical

regions have been associated with emotional processing [27,32]. The three regions, medial prefrontal cortex, amygdala, and subcortical medial regions, show dense and reciprocal connections [33,34]. Therefore, one might assume modulation between all of them. This might not only include top-down modulation, as illustrated, but also the reverse kind of modulation, bottom-up modulation. In the case of bottom-up modulation a hierarchically lower area modulates activity in an area being higher in the hierarchy. For example, subcortical midline regions might modulate neural activity in medial prefrontal cortex via the insula thus concerning the same regions as top-down modulation. Accordingly, bottom-up and top-down modulation might co-occur across the same regions.

Functionally, this co-occurrence of bottom-up and top-down modulation might allow for reciprocal adjustment between emotional and internal bodily processing. Internal bodily processing concerns only stimuli from the own body, so-called internal self-related stimuli. These include, for example, stimuli from autonomic-vegetative or other humoral functions. Whereas emotional processing concerns both internal self-related and thus internal bodily stimuli and external self-related stimuli from the environment. For example, emotional processing might be induced by specific events within the environment which in turn might induce internal bodily stimuli. This is well compatible with the co-occurrence of bodily and emotional symptoms in ► **Posttraumatic Stress Disorder (PTSD)** where such top-down modulation between amygdala and medial prefrontal cortex is assumed to be altered [35]. The elucidation of specific mechanisms of neuronal integration for higher-order functions and mental states, their control by genetic and social factors, and their changes in psychiatric disorders will be the central task for future neuropsychiatry.

### References

1. Beaumont JG (1987) Einführung in die Neuropsychologie. Psychologie Verlags-Union, München, Weinheim
2. Berrios GE, Markova IS (2002) The concept of neuropsychiatry: a historical overview. *J Psychosom Res*; 53(2):629–638
3. Caine CD, Joynt RJ (1986) Neuropsychiatry again. *Arch Neurol* 43:325–327
4. Churchland PA (1986) *Neurophilosophy. Toward a unified science of the mind/brain*. MIT Press, Bradford, Cambridge
5. Cummings JL (1985) *Clinical Neuropsychiatry*. Grund & Stratton, New York
6. Davidson RJ (2002) Anxiety and affective style: role of prefrontal cortex and amygdala. *Biol Psychiatry* 51(1): 68–80
7. Filskow SB, Boll TJ (1986) *Handbook of clinical neuropsychology*, vol 2. Wiley, New York, pp 45–81
8. Friston KJ, Price CJ (2001) Dynamic representations and generative models of brain function. *Brain Res Bull* 54(3): 275–285

9. Harrington A (1989) *Psychiatrie und die Geschichte der Lokalisation geistiger Funktion*. *Nervenarzt* 60:603–611
10. Kolb B, Whishaw JQ (1985) *Fundamentals of human neuropsychology*, 2nd edn. W. Freeman Company, New York
11. Lamme VA (2004) Separate neural definitions of visual consciousness and visual attention; a case for phenomenal awareness. *Neural Netw* 17(5–6):861–872
12. Luria AR (1966) *Higher cortical functions in man* (transl: Haigh B). Basic Books, New York
13. Luria AR (1973) *The working brain. An introduction to neuropsychology* (transl: Haigh B). Basic Books, New York
14. Masterman DL, Cummings JL (1997) Frontal-subcortical circuits: the anatomic basis of executive, social and motivated behaviors. *J Psychopharmacol* 11(2):107–114
15. Mueller J (ed) (1989) *Neurology and psychiatry. A meeting of minds*. Karger, New York
16. Mundt Ch (1989) *Psychopathologie heute*. In: Kister KP et al. *Brennpunkte der Psychiatrie. Psychiatrie der Gegenwart* 9, 3. Aufl. Springer, Heidelberg, p 147–185
17. Nagai Y, Critchley HD et al. (2004) Activity in ventromedial prefrontal cortex covaries with sympathetic skin conductance level: a physiological account of a “default mode” of brain function. *Neuroimage* 22(1): 243–251
18. Northoff G (2002) What catatonia can tell us about “top-down modulation”: a neuropsychiatric hypothesis. *Behav Brain Sci* 25(5):555–577; discussion 578–604
19. Northoff G, Bermpohl F (2004) Cortical midline structures and the self. *Trends Cogn Sci* 8(3):102–107
20. Northoff G, Heinzel A et al. (2004) Reciprocal modulation and attenuation in the prefrontal cortex: an fMRI study on emotional-cognitive interaction. *Hum Brain Mapp* 21(3):202–212
21. Oepen G (ed) (1988) *Psychiatrie des rechten und linken Gehirns. Neuropsychologische Ansätze zum Verständnis von ‘Persönlichkeit,’ ‘Depression’ und ‘Schizophrenie.’* Deutscher Ärzte Verlag, Köln
22. Ongur D, Price JL (2000) The organization of networks within the orbital and medial prefrontal cortex of rats, monkeys and humans. *Cereb Cortex* 10(3):206–219
23. Panksepp J (1998) *Affective Neuroscience: the foundations of human and animal emotions*. Oxford University Press, New York
24. Pessoa L, Ungerleider LG (2004) Neuroimaging studies of attention and the processing of emotion-laden stimuli. *Prog Brain Res* 144:171–182
25. Phan KL, Wager T et al. (2002) Functional neuroanatomy of emotion: a meta-analysis of emotion activation studies in PET and fMRI. *Neuroimage* 16(2):331–348
26. Poeck K (1982) *Klinische Neuropsychologie*. Thieme Verlag, Stuttgart, New York
27. Price CJ, Friston KJ (2002) Degeneracy and cognitive anatomy. *Trends Cogn Sci* 6(10):416–421
28. Rauch SL, Shin LM, Phelps EA (2006) Neurocircuitry models of posttraumatic stress disorder and extinction: human neuroimaging research—past, present, and future. *Biol Psychiatry* 60(4):376–382
29. Reynolds EH, Trimble MR (1989) *The bridge between neurology and psychiatry*. Churchill Livingstone, Edinburgh, London, New York
30. Rogers D (1987) *Neuropsychiatry*. *Br J Psychiatry* 150:425–427
31. Singer W (1989) Search for coherence: a basic principle of cortical self-organization. *Concepts Neurosci* 1(1):1–21
32. Tononi G, Edelman GM (2000) Schizophrenia and the mechanisms of conscious integration. *Brain Res Brain Res Rev* 31(2–3):391–400
33. Trimble MR (1981) *Neuropsychiatry*. Wiley, Clichester
34. Trimble MR (1988) *Biological psychiatry*. Wiley, Clichester
35. Vygotsky LS (1978) *Mind in society. The development of higher psychological processes*. Harvard University Press, Cambridge, London

## Neuropsychopharmacology

### ► Behavioral Neuropharmacology

## Neuroregeneration

### Definition

Growth of new neural tissue to replace tissues that were injured or lost.

Unlike neuroprotection, neuroregeneration implies replacement of degenerating axons with newly formed fibers.

### ► Neuroprotection

### ► Regeneration

## Neurosarcoidosis

### Definition

Complication of sarcoidosis involving inflammation and abnormal deposits in the tissues of the nervous system.

## Neurosecretosome

### ► Synaptosome

## Neurosemiotics

RENÉ J. JORNA

Professor of Knowledge Management & Cognition  
Faculty of Economics and Business, University of  
Groningen, Groningen, The Netherlands

### Definition

Neurosemiotics is about the sign or signal related aspects of synapses, neurons and neural nets [20,29]. Because neurons are the physiological tissue within which the brain or mind resides, neurosemiotics is also about cognition or about humans as information processing and connectionist systems [30].

### Description of the Theory

To understand the complex relationships between signs, signals and semiosis as aspects of semiotics on the one hand and brain and cognition on the other hand, an aid for understanding the distinction in various (ontological) levels of description [5,26,23] is used. The explanation of this conceptual help is followed (Neuro-psychological consequences) by a description of its neuropsychological implications and after that (Neurosemiotics) by an analysis of various categorizations of signs. The article ends (The role of Neurosemiotics) with a determination of the role of neurosemiotics.

### Levels of Description

The intriguing intangible phenomenon of the human mind seems to require various perspectives at the same time. The perspectives depend on certain levels of aggregation, also called levels of description. "Levels are clearly abstractions, being alternative ways of describing the same system, each level ignoring some of what is specified at the level beneath it." [23]. The idea of levels of description for a (cognitive) system has been elaborated most elegantly by Dennett [5,6,7]. He distinguishes three independent levels: (i) the physical (or physiological) stance, (ii) the functional (or design) stance, and (iii) the intentional stance. Other authors [22,23,26] give similar accounts in which, however, the number of levels varies. Newell (1990;26, p.46) says: "Often we describe the same system in multiple ways [...]. The choice of what description to use is a pragmatic one, depending on our purpose and our own knowledge of the system and its character." In the following we use Dennett's explanation of levels [5,6].

The physical (or physiological) stance explains behavior in terms of physical properties of the states and the behavior of the system under concern. For its proper functioning the human organism requires a complex interaction of its parts and with the external

world. The central nervous system in all its subdivisions and the endocrine system are there to transmit data (signals, information) that reveal the state of one part of the system to other parts. We can also mention the transmission of currents in the synaptic system of neurons. Within the study of brain and cognition, the physiological stance is the endpoint of ontological reduction.

The second level concerns the functional design of a system. At a functional level it is important to know the components of a system, how they are defined and how the components and sub-components are connected. Stated differently, if the input and output of each component are known, then with a certain input at the beginning of the system the resulting behavior (output) can be predicted based on the characteristics of the components. The behavior of a system is conceived of as the result of the interaction between several functional components or processes. The physical structure of the system is not explicitly taken into account, although it surely imposes constraints on the behavior of the system at the higher level. The capacity limitations of human memory, for instance, impose boundary conditions on the complexity of decision making at the higher intentional level.

Thirdly, Dennett distinguishes the intentional stance. Complex behavior that is adapted to the prevailing circumstances, according to some criterion of optimality is said to be rational or intelligent. A behaving system to which we can successfully attribute rationality or intelligence qualifies as an intentional system. It is not necessary for a behaving system to "really" possess rationality or intelligence, as long as the assumption allows us to correctly predict the behavior of the system based on our knowledge of the circumstances in which the system is operating.

One may deal with this level's distinction in two different ways: instrumentalistic and ontological. Dennett [5] has taken the levels distinction in a strictly instrumentalistic way, claiming only pragmatic validity. Summarizing his position twenty years later, he wrote: "As I have put it, physical stance predictions trump design [or functional] stance predictions which trump intentional stance predictions - but one pays for the power with a loss of portability and a (usually unbearable) computational cost." [8]. In contrast to Dennett, authors such as [11,23,26] assign an ontological meaning to each level. The higher levels introduce emergent qualities into human behavior that make no sense if we maintain only an instrumentalistic point of view.

### (Neuro-)Psychological Consequences

Neurons, synapses, neuronal nets are all located at the physiological level. The most important question resulting from the levels distinction is the art of the relationship between the levels. Is the relationship reductionist? Or is

ultimate reduction not possible. If the intentional level can be reduced without loss of information to the functional level and from there to the physiological level we have a reductionist position [3]. If one accepts that levels do exist in a parallel way in which lower levels set constraints for the higher levels also implying that a higher level can be incorporated in various concrete designs at the lower levels (the so called “under-determination” issue) one is non-reductionist. Sometimes this position is called the “emergence” or “supervenient” position. In that case properties and characteristics of levels exist on their own (level) [21].

From a neurological and psychological point of view, the (non-)reductionist position and the level’s distinction determine how one sees and therefore studies human beings and how one deals with neurosemiotics. If human beings in all their complexity of behavior and cognition can be reduced to neurons, the study of humans in the long-run equals neuroscience. In that case humans as biological, psychological and social entities will be explained in an analytic and scientific way in terms of the well elaborated lowest domain of neuroscience. Neurosemiotics then is a matter of extremely complex signal analysis (see section 3). However, if behavior and cognition cannot be ultimately reduced and can only be studied at their appropriate level of description, more holistic and emergent descriptions of humans have value on their own. This implies that signs and symbols requiring an autonomous interpretation mechanism are proper object of study, even, or especially, within neurosemiotics.

One consequence of this distinction relates to the possibility of “real” artificial intelligence. If one follows the reductionist line of reasoning resulting in theories, predictions and explanations at the neuroscientific level, it is tempting to argue that the only way intelligence can be mimicked is by doing neuroscience. A neurological basis of “real” intelligence is essential. In contrast with this position one can follow Good Old Fashioned Artificial Intelligence GOFAI [12] which says that intelligent (functional or intentional) systems can “run” on different kinds of “hardware”: neurons or chips. In the latter case, the program (Deep Blue 2, see [15] that beat the world champion in chess is an intelligent system, comparable to a human, but wired with different material. However, in the former case the software program is a nice piece of programming, but is not intelligent in the real sense, because it lacks synapses, neurons and similar tissues.

### Neurosemiotics

The discussion of various levels and (non-)reductionism determines the view on neurosemiotics in two respects. First, semiotics in relation to a domain of study can never exist without a precise demarcation of that domain [28]. Second, humans whether they are conceived of as

information processing system or as neurological systems are signals, signs and symbols using systems themselves [16]. Therefore, neurosemiotics, largely, is also about our selves. I will first give a definition of semiotics and illustrate its relevance for neurons, then I will introduce and categorize various kinds of “signs” and finally I will discuss semiosis or sign interpretation.

Extending the definition of semiotics (Posner, 1979), a demarcation of semiotics is as follows: “Semiotics is the study of all sorts of sign or symbol processes in the communication and the exchange of knowledge, in the sense of data, between and inside information processing systems, such as humans, other organisms and machines” [17]. Other definitions can be found in [1,9,25,24], to name but a few. In this demarcation a sign is defined as “something that stands for something else” (aliquid stat pro aliquo), which is the same definition as for the notion of representation [18]. In the definition of semiotics three aspects in relation to neurosemiotics are important. First, signals are not mentioned and signs and symbols are equivalent. Second, data, information and knowledge seem to be interchangeable, whereas the usual distinction is that knowledge is interpreted information, which is interpreted data. Third, behind communication and exchange an interpretation mechanism is presupposed.

Within semiotics, various categorizations of semiotic elements are used. For neurosemiotics the following distinctions are relevant: (i) signal and sign, (ii) index, icon and symbol and (iii) sign or symbol sets (see for overviews: [10,14,31]).

First, we have the classical distinction in signals and in signs. Signals are positioned at the physical/chemical level of description and their modus operandi is causal. In this respect signals do not fall into the definition of “something standing for something else.” Part of the firing of a neuron is the chemical substances that are emitted: signals. A signal is part of the functioning of a cell, an organelle or a neuron as elements of the material world. Signs, however, are semantic in their functioning. For something to be a sign implies an interpretation mechanism. Smoke is part of a fire and therefore can be called a signal, but as soon as an interpreting mechanism, an animal, a human or an electronic sensor, takes action, the signal is a sign. It stands for something and it is interpreted. It is an open question whether the firing of a neuron or synapse activity is a signal or a sign. The choice has consequences for the kinds of research questions: mainly cognitive in the case of signs and merely physiological in the case of signals (see also [2], who accepts the functional level, but abandons the notion of central processors).

Second, a distinction can be made in various kinds of signs: index, icon or symbol [25]. An index is a sign that is not arbitrarily, but directly connected to what it represents. It resembles very much the signal, but a

signal is not interpreted, an index is. In case of an icon, the sign resembles, mimics or imitates what it stands for, without incorporating all characteristics. An image of a nerve with MRI resembles the nerve, without consisting of proteins or potassium (K). A symbol is a sign that has an arbitrary or conventional relationship with what it stands for. The word “apple” has an arbitrary relationship with apple (at least in English) and words of the language or codes have to be learned.

Third, [13,14] distinguishes various kinds of sign sets (Goodman speaks of symbol sets) in order to define notational systems. A notational system, such as mathematics, logic or musical scores, fulfills syntactic and semantic requirements and realizes communication without ambiguity. If the elements of a sign set meet none of the requirements it is just a collection of markers, strokes or noises. If the elements fulfill the syntactic requirements of disjointness and finite differentiation it is a notational scheme, such as language or the Arabic number system. If the elements also fulfill the semantic requirements, that is to say they are unambiguous, semantically disjoint and semantically finitely differentiated, the sign set is a notational system.

In the above categorizations neurons and synapses can be seen as signals, and if one accepts that firing of neurons involves information transmission it is a sign, that is to say an index and not an icon or a symbol, and finally in terms of Goodman’s distinction it is a set of markers, without syntactic and semantic characteristics.

The distinctive element in the question whether we are dealing with signals or signs and the comprehensive effect of neurosemiotics is the place and role of an interpretation mechanism, a signal interpreter, which activity some would call semiosis (sign understanding). An interpretation mechanism implies that meaning, sense or signification is attached to signals. If that takes place we have a sign, in whatever variety. From a neurosemiotic point of view the question is whether we can demarcate such a mechanism at the physiological or neuronal level. If the answer to this question is no, the question moves to the next functional level and it is generally agreed that cognition - in a better defined sense - does the work here, in the form of processing units [19]. Here we speak of information processing resulting in knowledge. However, if the answer to the question at the physiological level is affirmative, it is the assignment of neuroscience and neuropsychology to describe and explain an “interpreter” at this physiological level without jumping to the next higher level. Despite the vast research in this area this has not been accomplished yet.

### The role of Neurosemiotics

Neurosemiotics is definitely not the first domain where neuroscientists seek their primary inspiration.

Nevertheless, looking at neuroscience from a semiotic perspective has three advantages. It raises questions of data or information transmission in unconventional terms, in unusual conceptualizations. Because of its higher level and multi-disciplinary perspective it brings to neuroscience results from domains such as logic, systems engineering or aesthetics, where issues of sign exchange and understanding are omni-present. Third, it brings modesty to the field of neuroscience, where - with exaggeration - the dominant view at the moment is that it should and can replace psychology, physiology, cognitive science and information science. Semiotics had that dream in the past.

### References

1. Bouissac P (1998) *Encyclopedia of Semiotics*. Oxford University Press, Oxford
2. Brooks RA (1998) *Cambrian intelligence: the early history of the new AI*. MIT, Cambridge, MA
3. Churchland PS (1986) *Neurophilosophy: toward a unified science of the mind-brain*. MIT, Cambridge, MA
4. Deely J (1990) *Basics of Semiotics*. Indiana University Press, Bloomington
5. Dennett DC (1978) *Brainstorms: Philosophical essays on mind and psychology*. Harvester Press, Hassocks, Sussex
6. Dennett DC (1987) *The intentional stance*. MIT, Cambridge, MA
7. Dennett DC (1991) *Consciousness explained*. Penguin, London
8. Dennett DC (1998) *Brainchildren: essays on designing minds*. MIT, Cambridge, MA
9. Eco U (1976) *A theory of semiotics*. Indiana University Press, Bloomington
10. Eco U (1984) *Semiotics and the philosophy of language*. Indiana University Press, Bloomington
11. Fodor JA (1975) *The language of thought*. Thomas Y. Crowell, New York
12. Fodor JA (1983) *The modularity of mind: an essay on faculty psychology*. MIT, Cambridge, MA
13. Goodman N (1968/1981) *Languages of art*, 2nd edn. The Harvester Press, Brighton, Sussex
14. Goodman N (1986) *Of mind and other matters*. Harvard University Press, Cambridge MA
15. Hsu, Feng-hsiung (2002) *Behind deep blue: building the computer that defeated the world chess champion*. Princeton University Press, Princeton
16. Jorna RJ, Smythe WE (1998) Editors special issue: semiotics and psychology: the signs we live by. *Theory Psychol* 8(6):723–730
17. Jorna RJ (1990a) Wissenrepräsentation in künstlichen Intelligenzen. *Zeichentheorie und Kognitionsforschung. Zeitschrift für Semiotik* 12:9–23
18. Jorna RJ (1990b) Knowledge representation and symbols in the mind. *Probleme der Semiotik*. Tübingen. Stauffenburg Verlag
19. Michon JA, Jackson JL, Jorna RJ (2003) Semiotic Aspects of Psychology. In: Posner R, Robbering K, Sebeok TA (eds) *Semiotics: a handbook on the sign-theoretic foundations of nature and culture*. de Gruyter, Berlin

20. Müller A, Wolff JR (2003) Semiotische Aspekte der Neurophysiologie: Neurosemiotik. In: Posner R, Robbering K, Sebeok TA (eds) *Semiotics: a handbook on the sign-theoretic foundations of nature and culture*. de Gruyter, Berlin
21. Nagel E (1961) *The structure of science*. Routledge & Kegan Paul, London
22. Newell A (1982) The knowledge level. *Artif Intell* 18:81–132
23. Newell A (1990) *Unified theories of cognition*. Harvard University Press, Cambridge MA
24. Nöth W (2000) *Handbuch der Semiotik (2e Auflage)*. Metzler Verlag, Stuttgart
25. Peirce CS (1931–1958) *The collected papers of Charles Sanders Peirce*. Harvard University Press, Cambridge, MA
26. Pylyshyn ZW (1984) *Computation and cognition: towards a foundation for cognitive science*. MIT, Cambridge, MA
27. Posner R (1979) Editorial opening. *Zeitschrift für Semiotik* 1
28. Posner R, Robbering K, Sebeok TA (eds) (2003) *Semiotics: A Handbook on the Sign-Theoretic Foundations of Nature and Culture*. de Gruyter, Berlin
29. Roepstorff A (2003) *Cellular neurosemiotics: outlines of an interpretive framework*. University of Aarhus, Aarhus
30. Rumelhart DE, McClelland JL (1986) *Parallel distributed processing. Explorations in the microstructure of cognition*. MIT, Cambridge, MA
31. Sebeok TA (1994) *An Introduction to Semiotics*. Pinter Publishers. Groningen 22-01-2005, London

---

## Neurosis

### Definition

Large group of non-psychotic disorders. As defined by S. Freud, a disease that has psychological causes, due to conflicts and traumata in early life history. The symptoms are direct consequence and symbolic expression of an unconscious psychical conflict. This conflict has its origin in the early childhood. The symptoms are a compromise between an instinctual desire and its psychical defense.

► [Personality Disorder](#)

---

## Neurosphere Culture

### Definition

Neurosphere culture enables the selective expansion of NSCs in floating culture within a serum-defined medium containing growth factors, such as EGF and/

or FGF2. A neurosphere derived from a single cell has been shown by the differentiation assay to be capable of generating all the major three cell lineages of the CNS, i.e., neurons, astrocytes and oligodendrocytes, indicating the multi-potency of the neurosphere-initiating cell.

When a neurosphere is dissociated into single cells, each cell starts to form secondary neurospheres at a high frequency. For human NSCs, however, some different protocols are being used.

► [Transplantation of Neural Stem Cells for Spinal Cord Regeneration](#)

---

## Neurosteroids

► [Neuroendocrinological Drugs](#)

---

## Neurosyphilis

### Definition

Chronic infectious disease caused by *Treponema pallidum*, occurring in various forms: ► [syphilitic meningitis](#), ► [meningovascular syphilis](#), ► [tabes dorsalis](#), ► [dementia paralytica](#).

► [Dementia Paralytica](#)  
 ► [Meningovascular Syphilis](#)  
 ► [Syphilitic Meningitis](#)  
 ► [Tabes Dorsalis](#)

---

## Neuroticism

### Definition

As defined by H.J. Eysenck, hereditary poor emotional stability, that predisposes the person to develop neurotic symptoms during excessive stress. Using questionnaires neuroticism can be tested objectively.

► [Personality Disorder](#)



## Neurotransmitter

KAZUHIDE INOUE

Department of Molecular and System Pharmacology,  
Graduate School of Pharmaceutical Sciences, Kyushu  
University, Japan

### Synonyms

Chemical transmitter

### Definition

Neurotransmitter is a chemical that achieves chemically mediated transmission, a major mode of interneuronal and neuron-effector communication. The chemical should meet several criteria to be recognized as a neurotransmitter. The criteria are: (i) A neurotransmitter must be synthesized in a neuron and released from a presynaptic terminal, (ii) A neurotransmitter should reproduce the specific responses that are evoked by the stimulation of presynaptic neurons at the postsynaptic neuron or effector cells, (iii) The effect of the chemical should be blocked by antagonists in a dose-dependent manner, and (iv) A neurotransmitter must be reabsorbed into the presynaptic neuron or glia, or metabolized into an inactive form by enzymes to terminate the stimulation.

### Characteristics

#### Function

Neurotransmitters transmit information from presynaptic neurons to postsynaptic neurons or peripheral effector cells through the activation of a receptor/channel. The function of a neurotransmitter depends on the receptor/channel. A neurotransmitter that stimulates an ionotropic receptor/channel causes an excitatory or inhibitory current in a target cell resulting in depolarization or hyperpolarization, respectively. A neurotransmitter that stimulates GTP binding of a protein-coupled metabotropic receptor causes second messenger signal transduction in a target cell, resulting in cell response.

### Further reading

1. Deutch AY, Roth RH (2002) Neurotransmitter. In: Squire LR, Bloom FE, McConnel SK, Roberts JL, Spitzer NC, Zigmond MJ (eds) *Fundamental neuroscience*. Academic, San Diego, pp 163–196
2. Cooper JR, Bloom FE, Roth RH (2003) Cellular and molecular foundations of neuropharmacology. In: Cooper JR, Bloom FE, Roth RH (eds) *The biochemical basis of neuropharmacology*. Oxford University Press, New York, pp 7–64
3. Kuba K (2002) Transmission of Excitation. In: Toyoda J, Kumada K, Ozawa S, Fukuda K, Honma K (eds) *Standard textbook, Igakushoin, Tokyo*, pp 112–136

## Neurotransmitter Receptor Trafficking

### ► Receptor Trafficking

## Neurotransmitter Release: Priming at Presynaptic Active Zones

HIROSHI KAWABE, FREDERIQUE VAROQUEAUX,  
NILS BROSE

Department of Molecular Neurobiology, Max-Planck-Institute for Experimental Medicine, Göttingen, Germany

### Synonyms

Fusion competence of secretory vesicles; Readily releasable secretory vesicles

### Definition

#### The Vesicle Priming Step in the Neurotransmitter Release Process

Ca<sup>2+</sup>-triggered fusion of ►synaptic vesicles is the key step in neurotransmitter release and synaptic signalling. Before vesicles can fuse with the plasma membrane in response to an arriving action potential and concomitant Ca<sup>2+</sup> influx, they have to be translocated and tethered/docked to the plasma membrane. A subset of these tethered vesicles are then primed to fusion competence. Only these docked and primed vesicles, also referred to as readily releasable vesicles, can fuse with the plasma membrane in a Ca<sup>2+</sup>-dependent manner. In the absence of vesicle priming, transmitter release is completely blocked.

In synapses, vesicle docking and priming are spatially restricted to and temporally coordinated at active zones, which represent a highly specialized presynaptic sub-compartment (Figs. 1a and b) [1].

Vesicle translocation, tethering (►Translocation and tethering of synaptic vesicles), and priming are rather slow processes. However, the fact that these processes are spatially restricted to and temporally coordinated at active zones, leading to the generation of a readily releasable vesicle pool at synaptic release sites, guarantees that synaptic transmitter release is spatially accurate and very fast. In fact, excitation–secretion coupling at many synapses occurs in a sub-ms time frame. This, in turn, allows neuronal networks to propagate information at very high density and with very high reliability.

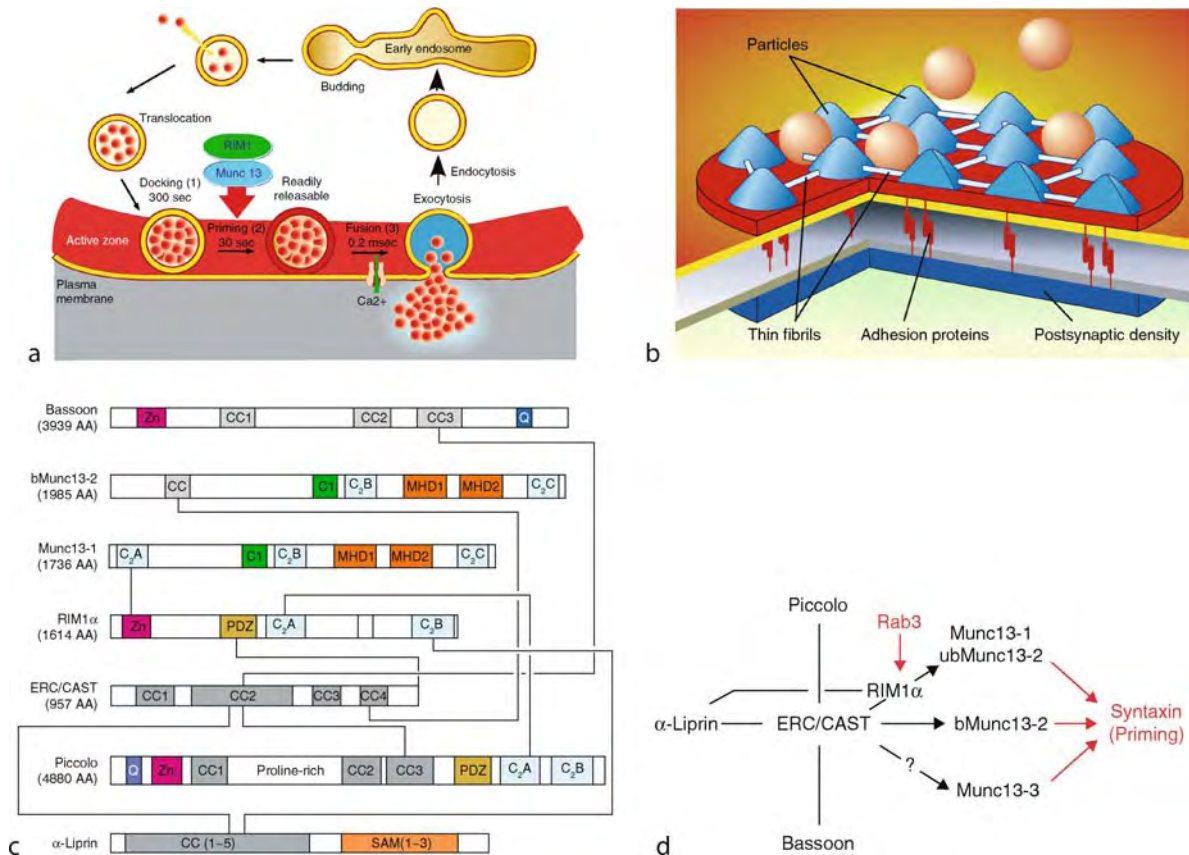

**Neurotransmitter Release: Priming at Presynaptic Active Zones. Figure 1** (a) Schematic representation of neurotransmitter release at the presynaptic active zone. Shown is a segment of a presynaptic terminal, and the trafficking and maturation steps that synaptic vesicles pass through. Synaptic vesicles filled with neurotransmitters translocate from the presynaptic cytoplasmic pool to the plasma membrane, where they dock (1) and undergo a priming step (2) to become fusion competent. Fusion competent vesicle exocytose in response to an arriving action potential and concomitant Ca<sup>2+</sup> influx (3) Note that all these steps are spatially restricted at the active zone. (b) The structure of an active zone. Pyramid-like particles are connected to each other with thin fibrils forming a particle web. Synaptic vesicles can access the presynaptic plasma membrane through a grid surrounded by fibrils. Figure adapted from the review by Dr. Hugo Bellen. (c) Structures of active zone components. Any given active zone specific protein has a multi-domain structure and interacts with several other active zone proteins. Direct binding between proteins is indicated by black lines. (d) Regulation of Munc13 proteins by ERC/CAST. ERC/CAST can bind to Munc13 proteins either directly or indirectly through RIM1. This interaction likely controls the Munc13 priming efficiency. In addition, ERC/CAST can directly interact with all other active zone components, and it is possible that this protein is at the core of an active zone protein network that forms “particles” of the active zone.

## Characteristics

### Quantitative Description

Active zones are defined morphologically on the basis of three criteria: (i) They constitute an electron dense area at the presynaptic plasma membrane that is located opposite of the **postsynaptic density**, (ii) they harbour morphologically docked synaptic vesicles, and (iii) they provide the tethering site for synaptic vesicles on electron-dense protrusions, which emanate from the active zone and form a presynaptic proteinaceous cytomatrix (Fig. 1b). The electron dense structures of active zones contain a network of at least six types of active zone specific proteins, whose functional

characteristics and interactions constitute the molecular basis of active zone morphology and function (Figs. 1c and d).

The number of active zones at each synaptic terminal can vary between synapse types and can range from one to several hundred. In cultured primary hippocampal neurons, for example, 70% of presynaptic boutons contain only a single active zone [2]. On the other hand, at the calyx of Held in the medial nucleus of the trapezoid body, one synaptic terminal contains some 550 active zones [3].

At most active zones in the central nervous system, synaptic vesicles are recruited and docked at the

presynaptic plasma membrane within about 300s, and docked vesicles are then primed within 30s or even faster. After arrival of an action potential and the subsequent influx of  $\text{Ca}^{2+}$  through voltage-gated  $\text{Ca}^{2+}$  channels, the local  $\text{Ca}^{2+}$  concentration rises beyond 10–20  $\mu\text{M}$  and fusion events occur within 0.1–1ms (Fig. 1a). Priming appears to involve multiple reversible maturation steps of synaptic vesicles, and primed vesicles are stabilized before the influx of  $\text{Ca}^{2+}$  [1].

### Higher Level Structures

Chemical synapses are asymmetric intercellular junctions that typically form between the axon of a presynaptic neuron and the dendrite, cell body, or, in some cases, the axon of a postsynaptic neuron. These junctions are maintained by adhesion and scaffolding proteins (Fig. 1b). At chemical synapses, signal propagation is achieved by transducing the axonal electric signal into the exocytosis of neurotransmitters at the presynaptic active zone. Released transmitter diffuses to the postsynaptic neuron where it binds to surface receptors. Their activation, in turn, changes the physiological state of the receiving neuron.

### Lower Level Components

Active zones vary in appearance from one synapse to another, especially in size and shape of electron dense particles [4]. The three-dimensional structure of the cytoskeletal matrix of the active zone (CAZ) at the frog neuromuscular junction has been studied in detail. It is 1–2 $\mu\text{m}$  long, 75nm wide and extends 50–75nm from the presynaptic membrane into the cytoplasm. It consists of three structures: beams, ribs, and pegs. The presynaptic membrane underneath the CAZ curves outwards forming a ridge and the beams run parallel to the ridge's long axis, whereas the pegs connect the CAZ and the presynaptic membrane. Most interestingly, the ribs extend orthogonally to the ridge's long axis and form 7–12 connections to docked vesicles located on each flank of the ridge. The actual protein constituents of these beams, ribs and pegs are unknown.

In view of these and other data, proteins forming the active zone should not only be restricted in their localization to the CAZ, but they should also be of large molecular size and contain multiple protein interaction sites. In the mammalian central nervous system, active zones form “particle web” structures (Fig. 1b), in which ~50 nm pyramid-like “particles” are spaced uniformly and connected to each other with thin fibrils forming a “web” structure. This particle web likely contains all of the known active zone components: Munc13s, Bassoon, Piccolo, RIM1,  $\alpha$ -Liprin, and ERC/CAST (Fig. 1c). Each one of these proteins binds to several others, thus forming a large multi-molecular complex (Fig. 1c and d). While it is not known if these CAZ proteins depend on each other

for localization, mutual functional regulation has been demonstrated for some combinations (e.g. RIM1 and Munc13-1).

### Structural Regulation

#### *Synaptogenesis and Active Zone Formation*

Functional synapses are formed in two steps [5]: (i) Initial contact formation between immature axons and dendrites – in this step, several classes of cell adhesion molecules, including ►*Cadherins and Protocadherins*, ►*Neurexins and Neuroligins*, and ►*SynCAMs/Nectins*, are implicated; and (ii) recruitment of pre- and postsynaptic transmembrane and cytoplasmic proteins to the sites of initial contacts.

Trans-synaptic interactions of cell adhesion molecules are thought to trigger the recruitment of presynaptic active zone components, and postsynaptic scaffolding molecules and receptors to the forming synapse. Interestingly, many postsynaptic components are recruited to the initial synaptic contact in a gradual manner, while presynaptic active zone components are recruited in a stepwise manner. A fascinating hypothesis has emerged recently to explain this difference. According to this hypothesis, active zones are formed by the delivery of precursor active zones in the form of transport vesicles. These contain active zone specific proteins such as Piccolo and Bassoon, and are thus named Piccolo/Bassoon transport vesicles or PTVs, in addition to RIMs, Munc13s, Syntaxins, and SNAP-25. Upon fusion of such vesicles with the plasma membrane of a nascent synapse, active zone proteins are deposited and localized. In cultured hippocampal neurons, one functional release site appears to be composed of 2–3 PTVs. In mature neurons, after the establishment of functional synapses, PTVs are extremely rare. Thus, it is possible that mature neurons employ alternative transport mechanisms for active zone components, and alternative mechanisms to form active zones and synapses.

### Lower Level Processes

#### *The SNARE Complex and Munc13 Proteins*

The synaptic SNARE (soluble NSF attachment protein receptors) complex is a trimeric complex composed of one synaptic vesicle protein, Synaptobrevin 2, and two synaptic plasma membrane proteins, Syntaxin and SNAP-25 (Fig. 2).

This complex catalyzes synaptic vesicle fusion by bringing the fusing vesicle and plasma membranes into close proximity, thus facilitating lipid bilayer mixing and subsequent membrane fusion.

Structural studies on Syntaxins showed that members of this protein family contain an autonomously folded N-terminal domain in addition to the C-terminal SNARE domain. These two domains can interact in an intramolecular fashion to form a “closed” conformation, which is unable to form a SNARE complex with

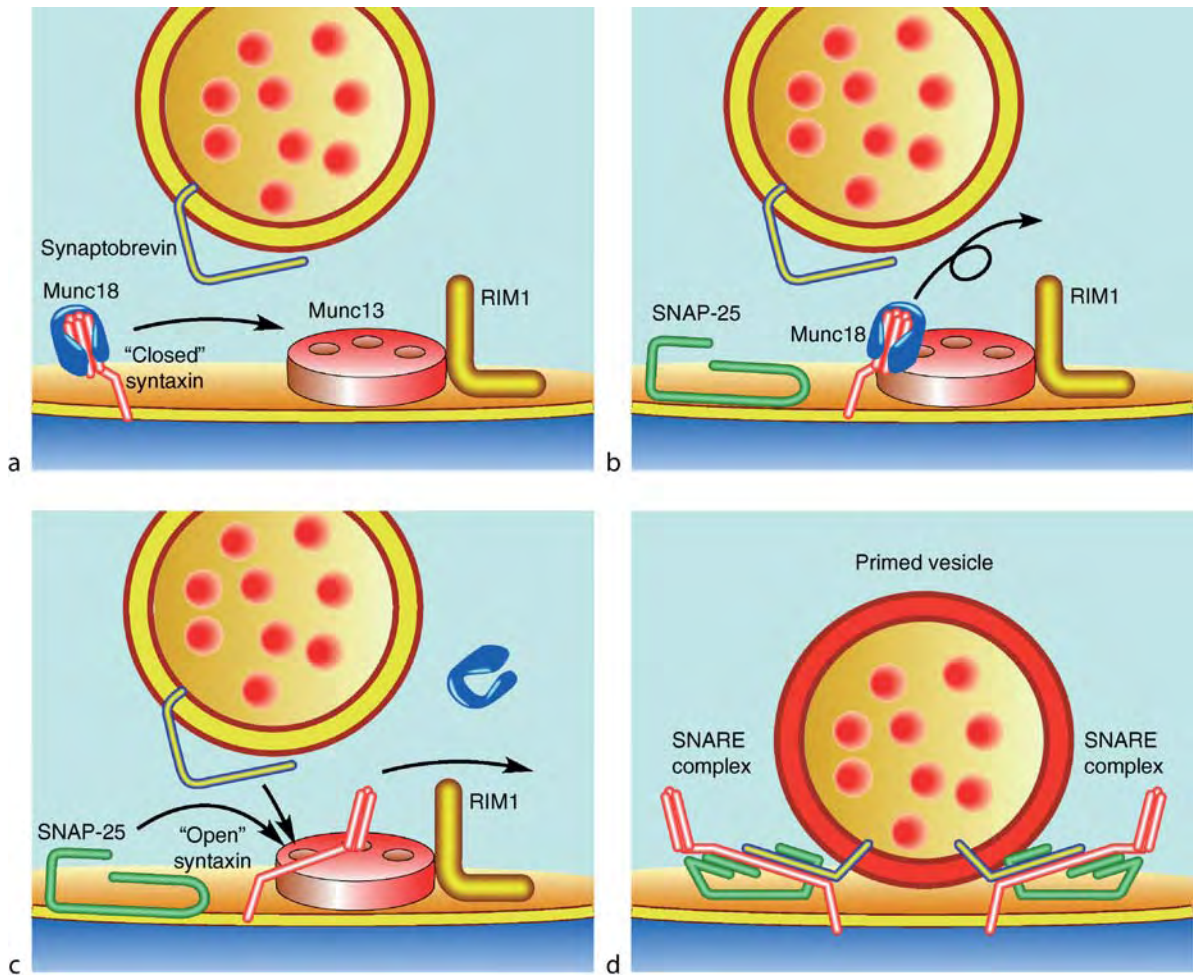

**Neurotransmitter Release: Priming at Presynaptic Active Zones. Figure 2** Hypothetical regulation of SNARE complex formation during the priming step. Syntaxin in its “closed” conformation forms a stable complex with Munc18 (a). Munc13 displaces Munc18 from the Syntaxin-Munc18 complex and facilitates the structural switch of Syntaxin from the “closed” to the “open” conformation (b and c), thus promoting the assembly of the SNARE complex (d). Figure adapted from images by Dr. Erik Jorgensen.

Synaptobrevin 2 and SNAP-25. Only “open” Syntaxins are thought to be able to enter SNARE complexes.

SNARE complex formation is controlled by several types of regulatory proteins. Two of these, Munc18-1 and Munc13s, are absolutely essential for synaptic vesicle fusion. The molecular mechanism of Munc18-1 function is still poorly understood. Based on the structure of the Syntaxin 1/Munc18-1 complex, it was postulated that Munc18-1 binds to the “closed” Syntaxin conformation and blocks its SNARE motif from participating in SNARE complex formation [6]. Thus, Munc18-1 has to dissociate from Syntaxins in order to allow SNARE complex formation.

Interestingly, Munc18-1, Syntaxin 1/2, and SNAP-25 are localized to the presynaptic terminal, but their distribution is not restricted to active zones. Specific proteins localized to the active zone plasma membrane or

cytomatrix are likely to coordinate the active zone processes of vesicle tethering, priming,  $\text{Ca}^{2+}$ -influx, and vesicle fusion, and to spatially restrict the synaptic vesicle exocytosis process to active zones. Indeed, neurons appear to employ a very simple molecular mechanism to limit transmitter release to active zones: They restrict the localization of essential components of the release machinery, Munc13s, to this subcellular compartment. Munc13-1, the best characterized Munc13 protein, binds to the N-terminal domain of Syntaxin, and likely promotes the conformational switch in Syntaxin from the “closed” to the “open” form, thus permitting the assembly of the synaptic SNARE complex (Fig. 2).

Rodents and humans express five Munc13 genes, Munc13-1, -2, -3, and -4, and Bap3. Two splice variants of Munc13-2 are known, the ubiquitously-expressed Munc13-2 (ubMunc13-2) and the brain-specifically

expressed Munc13-2 (bMunc13-2). Munc13 proteins contain two or three C<sub>2</sub> domains, one C<sub>1</sub> domain, and two Munc13-homology domains (Fig. 3a). At least one of the four Munc13 isoforms, Munc13-1, is enriched at active zones. Studies on Munc13-1 and Munc13-2 deletion mutant mice showed that Munc13 proteins are absolutely required for the priming process in central nervous system synapses. In their absence, both spontaneous and evoked transmitter release are completely blocked.

### Regulation of Readily Releasable Vesicle Pools by SNARE Proteins

Several perturbations that interfere with SNARE complex assembly or stability (e.g. antibodies to SNAP-25, deletion of SNARE regulators, or Clostridial toxins that cleave SNAP-25) also interfere with vesicle priming and the maintenance of a readily releasable pool of vesicles. This indicates that the molecular process of SNARE

complex formation resembles the functionally defined step of vesicle priming. Indeed, a recent study employing over-expression of SNAP-25 variants in chromaffin cells demonstrated a role of this SNARE protein in the priming step. Two SNAP-25 splice variants are known, SNAP-25a and -b. Over-expression of SNAP-25b increases the readily releasable vesicle pool size but leaves the kinetics of vesicle fusion or docking unchanged, indicating a role of SNAP-25b in blocking depriming.

### Process Regulation

Functionally, the synaptic vesicle priming rate defines the size of the readily releasable vesicle pool, which is a key determinant of presynaptic release probability and synaptic efficacy. During periods of high frequency stimulation, the basal priming rate and its dynamic regulation determine the speed of recovery of the presynaptic release machinery, and thus regulate short-term plasticity characteristics of synapses.

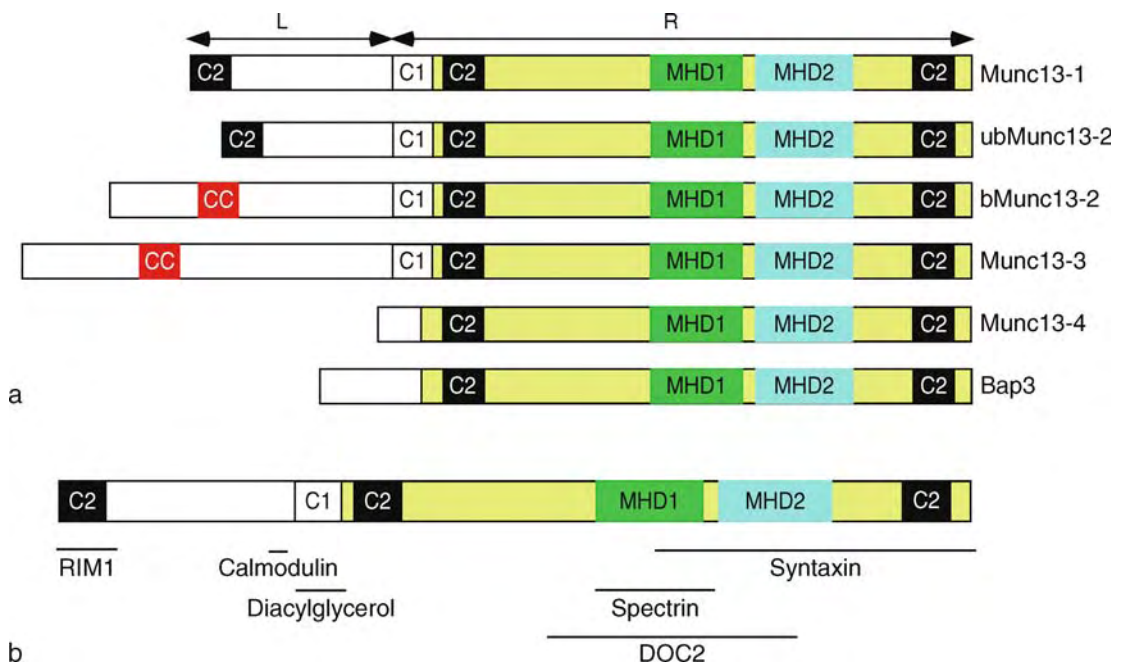

**Neurotransmitter Release: Priming at Presynaptic Active Zones. Figure 3** (a) Domain structures of Munc13 proteins. The Munc13 protein family contains five isoforms, Munc13-1, -2, -3, and -4, and Bap3. Two Munc13-2 splice variants are known, ubMunc13-2 (ubiquitously expressed), and bMunc13-2 (brain-specific). All Munc13 proteins share a common, highly homologous C-terminal region (R region) with C<sub>1</sub>, C<sub>2</sub>, and Munc13 homology domains, but have unrelated N-termini (L region). This modular structure and differential evolution indicate that the conserved R-regions play essential roles, and unrelated L-regions play regulatory roles in Munc13 function. (b) Binding partners of Munc13-1. The N-terminus of Munc13-1 binds to another component of the active zone, RIM1, and to second messengers, Ca<sup>2+</sup>/Calmodulin and diacylglycerol. These interactions are not essential for priming of synaptic vesicles, but modify the efficacy of priming and thus regulate short-term plasticity. The C-terminus of Munc13-1, -2, and -3 binds to the SNARE protein Syntxin. This interaction is thought to be essential for the actual priming step and to involve the regulation of the Syntxin conformation. In addition, the C-terminus of Munc13-1 binds to DOC2 (Double C2 protein), β-Spectrin, and Msec7, but the physiological significance of these interactions is not known.

Munc13 proteins are regulated by multiple proteins and second messengers. As a consequence, synaptic vesicle priming is a highly dynamic and tightly regulated presynaptic process (Fig. 3b) [5]. Synapses driven by Munc13-1 exhibit ►synaptic depression during high frequency stimulation, whereas synapses using ub-Munc13-2 as the main priming protein show ►synaptic facilitation during, and ►augmentation following periods of high frequency stimulation. Munc13 mediated synaptic depression, facilitation, and augmentation are regulated by two second messenger dependent processes: (i) Diacylglycerol activates Munc13s by binding to their C<sub>1</sub> domain, resulting in Munc13 activation and frequency facilitation/augmentation (in the case of Munc13-2) or at least compensation of synaptic depression (in the case of Munc13-1); (ii) Ca<sup>2+</sup>-dependent binding of Calmodulin to Munc13 proteins resulting in an increase of the priming activity and functional changes in short-term plasticity that are similar to the effects of diacylglycerol.

In addition to second messengers, several proteins bind to and regulate Munc13 proteins (Fig. 3b). The most striking example is RIM1. RIM1 is a component of the active zone and was originally identified as a target of Rab3 small GTPases. RIM1 binds to the N-terminal C<sub>2</sub> domain of Munc13-1 and ubMunc13-2. Several lines of evidence support the notion that RIM1 is a functional regulator of Munc13 proteins but not an actual mediator of the priming step: (i) Over-expression of Munc13-1 mutants lacking RIM1 binding activity leads to a 50% reduction in priming activity as compared to the over-expression of wild type Munc13-1; (ii) in the absence of RIM1 $\alpha$ , the dominant RIM isoform, the readily releasable vesicle pool size of hippocampal neurons is reduced by only 50%, while deletion of Munc13s eliminates primed vesicles entirely; (iii) RIM1 deficient mice show a 50% reduction in Munc13-1 expression levels; (iv) application of diacylglycerol to RIM1 $\alpha$  deficient neurons can still increase Munc13 mediated priming and transmitter release.

## Pathology

### Vesicle Priming and Memory Formation

Abolishing RIM1-expression in mice results in compromised ►long-term potentiation in hippocampal and cerebellar mossy fibre terminals [7,8], and dramatic deficits in associative learning and locomotor responses to novelty [9]. As one main function of RIM1 is the regulation of Munc13 priming activity, it is likely that the dynamic regulation of synaptic vesicle priming is a key process in mossy fibre long-term potentiation. These considerations, and the finding that Munc13 mRNAs are affected in fragile-X type mental retardation, indicate that the priming step regulated by the Munc13-RIM1 complex might be important for the pathology of learning disorders and mental retardation.

### Cytotoxic Granule Exocytosis Deficiency in Patients With Mutant Munc13-4 Expression

An immunoproliferative syndrome, familial hemophagocytic lymphohistiocytosis or FHL, is an often fatal childhood disorder characterized by infiltration of multiple organs by activated T cells and macrophages. One of three forms of FHL, FHL3, is caused by mutations of the gene encoding Munc13-4, a ubiquitously expressed distantly related Munc13 isoform [10]. In Munc13-4 deficient cytotoxic T cells, lytic granules are associated with the plasma membrane, indicating that Munc13-4 is dispensable for vesicle trafficking and docking in these cells, but is necessary for a step subsequent to docking. Although it is not clear whether a priming step exists in the exocytosis of lytic granules, Munc13-4 appears to play a similar role in a post-docking step of this type of exocytosis as other Munc13 proteins do in synapses.

## References

1. Sorensen JB (2004) Formation, stabilisation and fusion of the readily releasable pool of secretory vesicles. *Pflügers Arch* 448:347–362
2. Schikorski T, Stevens CF (1997) Quantitative ultrastructural analysis of hippocampal excitatory synapses. *J Neurosci* 17:5858–5867
3. Satzler K, Sohl LF, Bollmann JH, Borst JG, Frotscher M, Sakmann B, Lubke JH (2002) Three-dimensional reconstruction of a calyx of Held and its postsynaptic principal neuron in the medial nucleus of the trapezoid body. *J Neurosci* 22:10567–10579
4. Zhai RG, Bellen HJ (2004) The architecture of the active zone in the presynaptic nerve terminal. *Physiology (Bethesda)* 19:262–270
5. Rosenmund C, Rettig J, Brose N (2003) Molecular mechanisms of active zone function. *Curr Opin Neurobiol* 13:509–519
6. Jahn R, Lang T, Südhof TC (2003) Membrane fusion. *Cell* 112:519–533
7. Castillo PE, Schoch S, Schmitz F, Südhof TC, Malenka RC (2002) RIM1 $\alpha$  is required for presynaptic long-term potentiation. *Nature* 415:327–330
8. Lonart G, Schoch S, Kaeser PS, Larkin CJ, Südhof TC, Linden DJ (2003) Phosphorylation of RIM1 $\alpha$  by PKA triggers presynaptic long-term potentiation at cerebellar parallel fiber synapses. *Cell* 115:49–60
9. Powell CM, Schoch S, Monteggia L, Barrot M, Matos MF, Feldmann N, Südhof TC, Nestler EJ (2004) The presynaptic active zone protein RIM1 $\alpha$  is critical for normal learning and memory. *Neuron* 42:143–153
10. Feldmann J, Callebaut I, Raposo G, Certain S, Bacq D, Dumont C, Lambert N, Ouachee-Charadin M, Chedeville G, Tamary H, Minard-Colin V, Vilmer E, Blanche S, Le Deist F, Fischer A, de Saint Basile G (2004) Munc13-4 is essential for cytolytic granules fusion and is mutated in a form of familial hemophagocytic lymphohistiocytosis (FHL3). *Cell* 115:461–473

## Neurotransmitter Transporter

KOHICHI TANAKA

Laboratory of Molecular Neuroscience, School of Biomedical Science and Medical Research Institute, Tokyo Medical and Dental University, Bunkyo-Ku, Tokyo

### Synonyms

Uptake carrier

### Definition

► **Neurotransmitter** transporters are uptake carriers in the plasma membrane of neurons and glial cells, which pump neurotransmitters from the extracellular space into the cell (Fig. 1) [1].

### Characteristics

#### Quantitative Description

The size of neurotransmitter transporters ranges between 523 and 798 amino acids (Table 1).

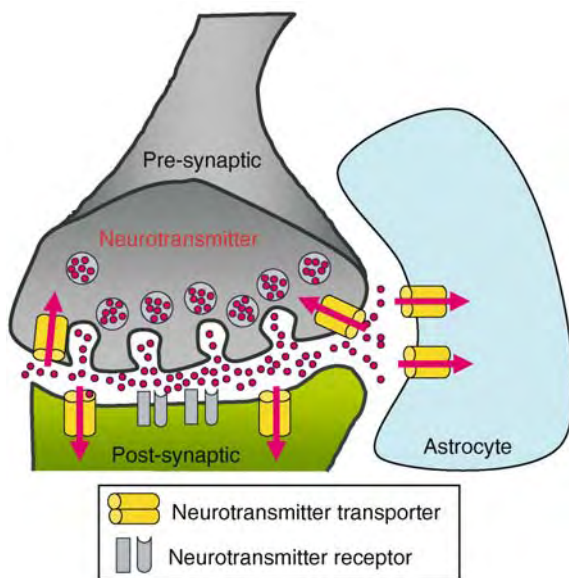

**Neurotransmitter Transporter.** Figure 1 Schematic Representation of the Main Neurotransmission Steps at a Synapse. The neurotransmitter is synthesized in the presynaptic neuron, stored in synaptic vesicles and released into the synaptic cleft by exocytosis to act on neurotransmitter receptors. To terminate the neurotransmission, the released neurotransmitter has to be removed promptly from the synaptic cleft. High-affinity neurotransmitter transporters present at pre-synaptic or post-synaptic neurons and/or astrocytes are responsible for rapid removal of neurotransmitter [1].

Chemical and stereological quantification shows that the number of glial glutamate transporter GLAST (EAAT1) is  $2,300 \mu\text{m}^{-2}$  of membrane in the hippocampus [2].

### Higher Level Structures

Since the physiological action of neurotransmitter is terminated by its ► **removal** by high-affinity neurotransmitter transporters, they are concentrated in the plasma membrane of neurons and glial cells surrounding the synaptic clefts [1].

### Higher Level Processes

Synaptic transmission is a fundamental process in neuronal communication in the brain (Fig. 1). Neurotransmitter transporters influence many aspects of synaptic transmission, including the timecourse of the postsynaptic response and the peak postsynaptic receptor occupancy, by modulating the duration and the intensity of neurotransmitters action at the synapse. Therefore, they are involved in the fine tuning of information processing in the brain. They are also responsible for the replenishment of neurotransmitter pools within nerve endings [3,4].

### Lower Level Processes

The neuronal neurotransmitter transporters shuttle transmitters from the extracellular fluid and concentrate them up to 10,000 times higher within the cytosol of the presynaptic terminal. They use the transmembrane ion gradients of  $\text{Na}^+$ , which are ultimately set up by  $\text{Na}^+/\text{K}^+$  pump, as an energy source for moving transmitter molecules up to steep concentration gradients. They also display absolute requirements for other ions and can be divided into two families depending on their ionic dependence: (i) the  $\text{Na}^+/\text{Cl}^-$ -dependent transporters, and (ii) the  $\text{Na}^+/\text{K}^+$ -dependent transporters (Fig. 2). [1]. Glutamate transporters co-transport 3  $\text{Na}^+$  and 1  $\text{H}^+$  ions, and counter-transport 1  $\text{K}^+$  ion along with one glutamate molecule [5]. In contrast, the other family of transporters for most of the amino acid (except glutamate) and amine neurotransmitters, co-transport 2–3  $\text{Na}^+$  ions and  $\text{Cl}^-$  ion [1].

### Process Regulation

Activation of kinases can modulate the activity of neurotransmitter transporters. Protein kinase C (PKC) activation inhibits the activity of gamma-amino butyric acid (GABA), serotonin, and glycine transporters. Glutamate transporters are also modulated by phosphorylation by PKC. Furthermore, several proteins have been shown to interact with neurotransmitter transporters and have effects on their activity. The most commonly observed way of dynamically regulating transport activity is thought to be the removal and recycling of the protein from the cell surface [6–8].

**Neurotransmitter Transporter. Table 1** Plasma membrane neurotransmitter transporters

Name	Substrate	Coupling ions	Size (amino acids)
GLAST	L-Glutamate	Na <sup>+</sup> , H <sup>+</sup> and K <sup>+</sup>	543
GLT1	L-Glutamate	Na <sup>+</sup> , H <sup>+</sup> and K <sup>+</sup>	572
EAAC1	L-Glutamate	Na <sup>+</sup> , H <sup>+</sup> and K <sup>+</sup>	523
EAAT4	L-Glutamate	Na <sup>+</sup> , H <sup>+</sup> and K <sup>+</sup>	561
EAAT5	L-Glutamate	Na <sup>+</sup> , H <sup>+</sup> and K <sup>+</sup>	559
GAT1	GABA	Na <sup>+</sup> and Cl <sup>-</sup>	598
GAT2	GABA	Na <sup>+</sup> and Cl <sup>-</sup>	614
GAT3	GABA	Na <sup>+</sup> and Cl <sup>-</sup>	602
GAT4	GABA	Na <sup>+</sup> and Cl <sup>-</sup>	627
GLYT1a	Glycine	Na <sup>+</sup> and Cl <sup>-</sup>	633
GLYT1b	Glycine	Na <sup>+</sup> and Cl <sup>-</sup>	637
GLYT2	Glycine	Na <sup>+</sup> and Cl <sup>-</sup>	798
DAT	Dopamine	Na <sup>+</sup> and Cl <sup>-</sup>	619
SERT	Serotonin	Na <sup>+</sup> and Cl <sup>-</sup>	630
NET	Norepinephrine	Na <sup>+</sup> and Cl <sup>-</sup>	617

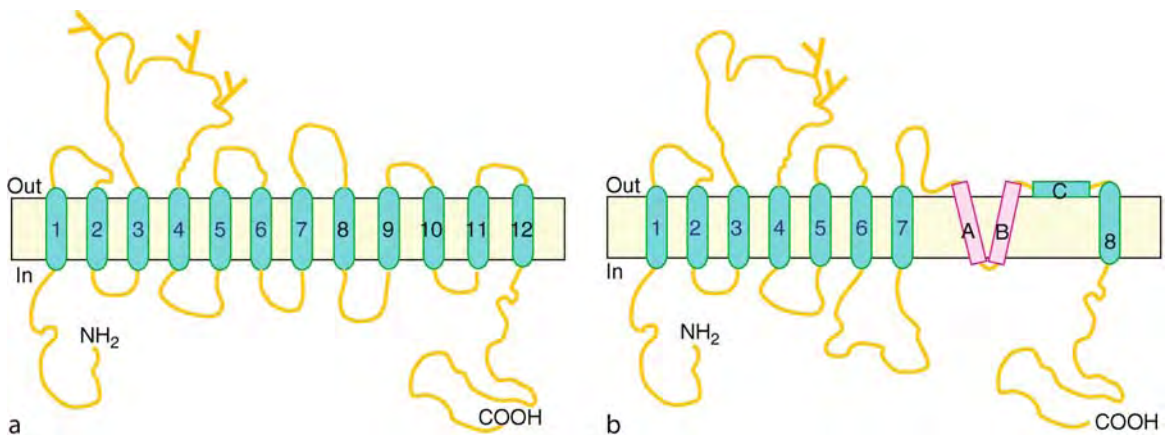

**Neurotransmitter Transporter. Figure 2** Schematic Structural Organization of Neurotransmitter Transporters. (a) Schematic topology of Na<sup>+</sup>/Cl<sup>-</sup>-dependent transporters depicting 12 transmembrane domains connected by intracellular (*in*) and extracellular (*out*) loops. Y, potentially *N*-glycosylated asparagine residue. (b) Schematic topology of Na<sup>+</sup>/K<sup>+</sup>-dependent glutamate transporters showing the transmembrane domains (1–8), the “re-entrant hairpin loops” (A and B) similar to the ion-permeating pore of ion channels, and a “loop” that is predicted to extend partially into the “translocation pore” between transmembrane domains 7 and 8.

## Function

### Glutamate Transporters [2,5,9]

Glutamate transporters are well positioned to regulate extracellular glutamate concentrations, but their contributions to shaping excitation at glutamatergic synapses vary between different types of synapses. Glutamate transporters do not determine the decay rate of the synaptic currents in the hippocampus, whereas glutamate transporters (GLAST and EAAT4) are the dominant factors that determine the kinetics of excitatory postsynaptic currents (EPSCs) at the synapses from cerebellar

parallel fibers and climbing fibers to Purkinje cells. Glutamate transporters clear glutamate not only inside the synaptic cleft, but also from the extracellular space outside the synapse. Thus, glutamate transporters play a critical role in the specificity of synaptic communication in the brain by determining the amount of glutamate efflux from the synaptic cleft and the distance it diffuses. Furthermore, glutamate transport by glial transporters triggers astrocytic glycolysis and release of lactate, which in turn nourish neurons and sustains neuronal activity.



**GABA Transporters [7]**

GABA transporters regulate the extracellular levels of GABA, the main inhibitory neurotransmitter in the mammalian brain. Four distinct genes encoding GABA transporters have been identified (Table 1). A fraction of GABA transporters is located in the vicinity of symmetric synapses and are responsible for GABA uptake at inhibitory synapses, thus contributing to terminating GABA's action and to shaping inhibitory postsynaptic responses. A study of GABAergic synaptic transmission in the hippocampus of GAT-1 knockout mice supports this view, and suggests that GAT-1 deficiency results in elevated GABA levels, thus inducing post- and presynaptic changes in GABAergic synapses.

**Glycine Transporters [6,7]**

Glycine exerts multiple functions in the central nervous system (CNS), as one of the major inhibitory neurotransmitters and as a positive modulator on glutamatergic neurotransmission through *N*-methyl-D-aspartate receptors. The synaptic action of glycine ends by active recapture through specific high-affinity glycine transporters located in neuronal and glial plasma membranes. Two genes encoding glycine transporters, GLYT1 and GLYT2, have been cloned (Table 1). GLYT1 is widely expressed in astroglial cells throughout the mammalian CNS, whereas GLYT2 is localized in the axon terminals of glycinergic neurons. Knockout mice deficient in glycine transporters revealed distinct roles of GLYT1 and GLYT2 in glycine-mediated synaptic transmission. GLYT1 is essential for regulating glycine concentrations at glycine receptors, whereas GLYT2 plays a critical role in replenishing the cytoplasmic pool of glycine that is needed for transmitter loading of synaptic vesicles in glycinergic nerve terminals.

**Dopamine Transporter [4,8]**

Dopamine is a mediator of many functions, such as movement, emotion and cognition. The dopamine transporter (DAT) is present exclusively in neurons and is the primary mechanism for clearance of dopamine from the extracellular space. Deletion of DA in mice results in disrupted clearance of dopamine, an elevated extracellular concentration of dopamine and dramatically decreased intraneuronal storage of dopamine.

**Serotonin Transporter [4,8]**

The serotonin transporter (SERT) plays a critical role in the maintenance of normal neurotransmission by serotonin, and is the primary target for several antidepressants and psychostimulants. SERT can be used as a marker of serotonergic neurons because it is present exclusively on dendrites, perikarya, axons, and nerve endings of the serotonergic neurons. The SERT knockout mice showed a six-fold elevation in the

extracellular concentration of serotonin and a marked reduction (60–80%) in intracellular concentration.

**Norepinephrine Transporter [4,8]**

Norepinephrine is an important neurotransmitter in the CNS. It regulates affective states, learning and memory, endocrine and autonomic functions. The norepinephrine transporter (NET) in the plasma membrane acts to terminate noradrenergic transmission by uptaking released norepinephrine back into the cell for cyclic use, and is a direct target of various antidepressants and psychostimulants. NET is a specific marker of noradrenergic neurons in the CNS. Similar to the findings obtained with DAT knockout mice and SERT knockout mice, the prolonged synaptic lifetime of noradrenaline in NET knockout mice results in elevation of the extracellular level of noradrenaline and depletion of intraneuronal stores.

The profound neurochemical alternations that were observed in mice lacking DAT, NET or SERT show that the plasma membrane monoamine transporters are crucial not only in terminating neurotransmission, but also in replenishing transmitter stores.

**Pathology****Glutamate Transporters [2,5,9]**

L-glutamate is the major excitatory neurotransmitter in the brain, and its interactions with specific receptors are responsible for most aspects of normal brain function including cognition, memory, movement, and sensation. However, high glutamate exposure triggers neuronal death, a process known as excitotoxicity. Excitotoxicity has been implicated as the mechanism of neuronal injury resulting from acute insults such as ischemia, epilepsy and trauma as well as chronic neurodegenerative diseases such as amyotrophic lateral sclerosis (ALS), Huntington's disease (HD), Alzheimer's disease (AD), multiple sclerosis (MS) and HIV-1-associated dementia. The linkage between impaired glutamate transporter function and a rise in extracellular levels of neurotoxic glutamate suggests that transporter malfunction is a plausible mechanism of these neurologic diseases.

Increased extracellular glutamate during ischemia triggers the death of neurons. During ischemia, the reversal of glutamate transporter (particularly GLT1), due to the depletion of energy and the rundown of ionic gradients, leads to the release of glutamate into the extracellular space, exacerbating excitotoxicity in the ischemic region.

In ALS, a decrease in the glutamate transporter activity due to the reduction of the GLT1 in affected areas of the CNS, or the expression of aberrantly spliced transcripts from the GLT1 gene, are associated with impaired glutamate uptake and increased extracellular

levels of glutamate, resulting in excitotoxic damage to motor neurons.

#### **GABA Transporters [7,10]**

Electrophysiological studies of human temporal-lobe epilepsy suggest that a loss of hippocampal GABA-mediated inhibition may underlie the neuronal hyperexcitability. Temporal-lobe epilepsy is characterized in part by a loss of reversal of GABA transport that is secondary to a reduction in the number of GABA transporters [10].

#### **Glycine Transporters [3,6]**

GLTY1 knockout mice show severe motor deficits accompanied by lethargy, hypotonia and hyporesponsivity. This overall reduction of motorsensory functions is similar to the symptoms associated with glycine encephalopathy. GLYT2 knockout mice display a severe neuromotor disorder characterized by spasticity, muscular rigidity, tremor and impaired righting response. These symptoms are similar to those associated with human hyperekplexia. Although neither of the human GLTY genes has been linked to either disease, mutations in glycine receptors and enzymes responsible for degrading glycine have been implicated.

#### **Dopamine Transporter [4,8]**

DAT is the major target for psychostimulants such as cocaine methylphenidate and amphetamine. The large increase in extracellular dopamine levels that are produced by these drugs result in continuous stimulation of target neurons, a key event leading to the rewarding action of cocaine and thus to addiction.

Mice lacking DAT display symptoms found in attention-deficit/hyperactive disorder (ADHD), and their increased locomotor activity is inhibited by the psychostimulants that are commonly used to treat ADHD. Furthermore, genetic studies indicate that the polymorphisms in the DAT gene is associated with ADHD.

DAT densities are affected in several brain disorders, including Parkinson's disease, Wilson's disease, Lesh-Nyhan disease, Tourette's syndrome, and major depression.

#### **Serotonin Transporter [4,8]**

SERT is implicated in the etiology of various neurological or psychiatric syndromes. Previous studies have shown that midbrain SERT levels were reduced in patients with impulsive aggressive behavior, alcoholism or depression. Multiple polymorphisms are found in the 5'-flanking promoter region and in the second intron of the SERT gene. The two variants in the 5' region are associated with different rates of SERT expression, and the one leading to the lower

transcriptional efficacy seems to be more frequent in subjects with anxiety-related personality traits and in alcoholics with suicidal behavior. Moreover, the polymorphisms at the second intron seem to be associated with bipolar and unipolar disorders.

#### **Norepinephrine Transporter [4,8]**

NET is a major target of tricyclic antidepressants and several psychostimulants. NET levels are reduced in the locus coeruleus in people with major depression. A single mutation in the coding sequence of NET has been linked to Orthostatic Intolerance.

### **References**

1. Masson J, Sagne C, Hamon M, Mestikawy SEL (1999) Neurotransmitter transporters in the central nervous system. *Pharmacol Rev* 51:439–464
2. Danbolt NC (2001) Glutamate uptake. *Prog Neurobiol* 65:1–105
3. Brasnjo G, Otis TS (2003) Glycine transporters not only take out the garbage, they recycle. *Neuron* 40:667–669
4. Gainetdinov RR, Sotnikova TD, Caron MG (2002) Monoamine transporter pharmacology and mutant mice. *Trends Pharmacol Sci* 23:367–373
5. Kanai Y, Hediger MA (2004) The glutamate/neutral amino acid transporter family SLC1: molecular, physiological and pharmacological aspects. *Eur J Physiol* 447:469–479
6. Aragon C, Lopez-Corcuera B (2003) Structure, function and regulation of glycine neurotransmitters. *Eur J Pharmacol* 479:249–262
7. Conti F, Minelli A, Melone M (2004) GABA transporters in the mammalian cerebral cortex: localization, development and pathological implications. *Brain Res Rev* 45:196–212
8. Torres GE, Gainetdinov RR, Caron MG (2003) Plasma membrane monoamine transporters: structure, regulation and function. *Nat Rev Neurosci* 4:13–25
9. During MJ, Ryder KM, Spencer DD (1995) Hippocampal GABA transporter function in temporal-lobe epilepsy. *Nature* 376:174–177
10. Tanaka K (2000) Functions of glutamate transporters in the brain. *Neurosci Res* 37:15–19

## **Neurotransmitters and Pattern Generation**

PATRICK J. WHELAN

Hotchkiss Brain Institute, University of Calgary, Calgary, AB, Canada

### **Synonyms**

Neuromodulation of central pattern generators

## Definition

Many motor behaviors fundamental to life such as chewing, breathing, and stepping are produced by networks of interconnected neurons termed Central Pattern Generators (CPGs). CPGs are defined as networks of neurons that can generate rhythmic behaviors in the absence of phasic input. The motor outputs of CPGs are determined by a complex interaction between synaptic, cellular and network properties. This system ensures that CPGs can produce a rich ensemble of behaviors. The purpose of this essay is to describe the components of CPGs and briefly highlight how new technology is providing tools to unravel network architecture.

## Characteristics

### Introduction to CPGs

Perhaps the first experiments suggesting the existence of an intrinsic network of neurons that could produce rhythmic patterns were published in 1911 by Thomas Graham Brown [1]. These seminal experiments demonstrated that rhythmic activity of the hindlimbs of cats could be evoked for a short period after the spinal cord was fully transected. Since that time his observations have been confirmed in a number of species and for different behaviors. An important advance in the field was the development of **▶in vitro** techniques where tissue containing CPGs could be removed and maintained outside the body. Mainly as a result of these types of experiments it was found that CPGs are formed from interconnected groups of neurons whose output is a result of a complex interaction between cellular, synaptic and network properties [2]. The rhythmic behaviors they produce must be robust and yet be capable of being modified to meet the needs of the animal. Within motor control there have been a number of classic preparations used to examine motor rhythms such as the digestive centers of crustaceans, the lamprey and xenopus swimming centers, the heart beat system of the leech and the rodent locomotor network. Here we will discuss how synaptic, intrinsic and cellular properties contribute to network function (Fig. 1).

1. *Motor rhythms are often generated by neurons that have rhythmogenic capabilities (so called endogenous and ▶conditional bursters).* Pacemaker cells have voltage-dependent ion channels that when expressed allow a neuron to oscillate and produce bursts of action potentials. Pacemaker cells come in two flavors; **▶endogenous bursters** can produce oscillations in the absence of synaptic input, while conditional bursters require synaptic input to produce oscillations. For example, the mollusk *Clione* moves through the water by alternating movements of its dorsal and ventral fins. Pacemaker interneurons critical to this behavior can generate a

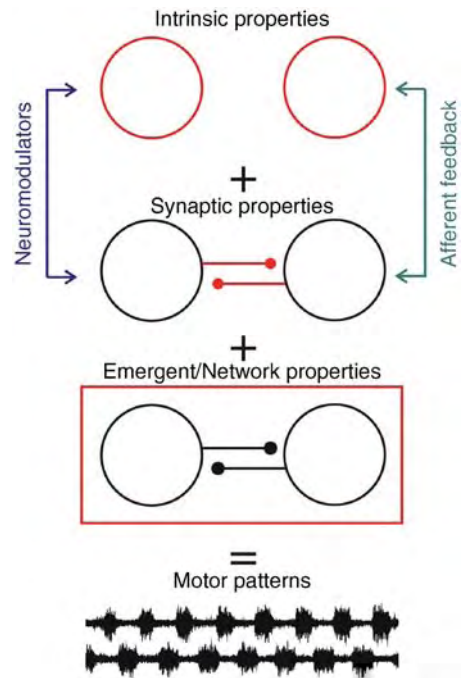

### Neurotransmitters and Pattern Generation.

**Figure 1** Schematic illustrating the components of Central Pattern Generators that interact to produce rhythmic motor output.

rhythmic membrane oscillation without external inputs. Ablation of these interneurons has established that these pacemaker neurons are necessary to produce fictive swimming. More commonly, pacemaker cells found in CPGs are conditional bursters. For example, in protovertebrates such as the lamprey, excitatory interneurons have been identified that are part of the swim CPG [3]. These excitatory neurons show oscillatory membrane properties that are N-methyl-D-Aspartate (NMDA) receptor dependent. The voltage-dependent conductances that produce endogenous and conditional oscillations can be controlled by external neuromodulators. In this way, the oscillation frequency, burst duration, and burst spike rate can all be modulated. More dramatically, cells with pacemaker properties can become non-oscillatory in a state-dependent manner. In invertebrate networks, the consequence of changes in these state-dependent properties can often be correlated with the output of the network. However, in mammalian networks that contain many thousands of cells it is difficult to ascribe a function to pacemaker cells. This is because of the redundancy that is inherent in complex interconnected networks. However, with the advent of genetic tools (see Future Directions) it may be possible to circumvent this issue by selectively silencing candidate interneuronal populations.

2. *Intrinsic cellular properties can promote and stabilize motor rhythms.* Neurons are endowed with a rich set of voltage-dependent conductances that can sculpt the firing characteristics of a neuron to a given synaptic input [4]. Therefore, two cells with similar synaptic inputs can produce very different outputs. ▶ **Intrinsic properties** can have profound effects on the behavior of networks. For example, in many CPGs, alternating activity between populations of cells are mediated by mutual inhibitory connections. When one centre is active the other is inhibited. After inhibition is removed, the inhibited side “rebounds” with a burst of activity, which then inhibits the other population of cells, leading to rhythmic bursting behavior. Cellular properties can promote oscillatory behavior. One of these properties is spike frequency adaptation [3]. Progressive increases in ▶ **intracellular**  $\text{Ca}^{2+}$  during a burst can lead to a longer after hyperpolarization thereby increasing the interval between spikes. This slowing in the spike rate over time reduces the inhibition of the mutually inhibited population of cells. Another intrinsic property that promotes oscillatory behavior is postinhibitory rebound. When cells that exhibit this property are inhibited, a long-lasting voltage-dependent mixed cationic conductance is often activated ( $I_h$  current). When inhibition is removed this excitatory conductance is still active and pushes the membrane potential above rest making the cell more excitable. At a network level this boost in cellular excitability promotes activity on the formally inhibited side.
3. *Synaptic connectivity (inhibition/excitation) within the CPG is central for establishing patterns of output, such as alternation or synchronicity.* ▶ **Synaptic properties** are important for establishing the strength of connections between neurons in the network. For example, in many vertebrates, inhibitory commissural neurons couple together populations of cells that are rhythmically active and promote alternating activity between the two active populations. Interestingly, early in development intracellular chloride concentrations are high and as a result ▶ **GABA** and glycinergic (▶ **glycine**) effects are functionally excitatory. Therefore although the inhibitory commissural neurons still couple the two populations together, the bursting pattern is synchronized across the populations [5]. Thus changes in the sign of synaptic properties can fundamentally alter the motor pattern produced by CPGs. While chemical transmission is obviously critical, electrical synapses also contribute to network function. For example, in the pyloric rhythm of crustaceans, mixed synapses consisting of both chemical and electrical synapses can result in an activity-dependent reversal of sign. In vertebrate networks electrical synapses are common early in development, where they can lead to synchronization of cellular firing. One possible function of electrical synapses is to enhance network connectivity when the level of chemical transmission is low during embryonic stages of development [5]. It is now recognized that electrical synapses are also present in mammalian networks of adults, but their role is not well understood.
4. *CPGs are not static hard-wired networks.* A general principle of CPGs is that they can be reorganized to function in more than one motor task [6]. For example, the pyloric rhythm network in the stomatogastric ganglia of crustaceans consists of a network of 14 neurons connected by electrical and chemical connections. The pyloric rhythm activates striated muscles in the stomach, which helps push food through the digestive system, and is one of four networks within the stomatogastric ganglia. Neurons are able to switch from one network to another within the stomatogastric ganglia following administration of neuromodulators. Likely of importance to vertebrate systems, neuromodulators cause separate CPGs to blend together and even form entirely new networks. An intriguing possibility is that neuromodulators reconfigure vertebrate CPG circuits, similar to what occurs in invertebrate systems. Work on a variety of vertebrate preparations has demonstrated that 5-HT, noradrenaline and ▶ **dopamine** can modulate CPGs leading to the production of distinct patterns [5]. For example application of dopamine to the spinal cord can evoke a locomotor pattern that resembles walking whereas application of ▶ **serotonin** evokes a pattern closer to that of swimming. Of interest is how neuromodulators alter intrinsic and synaptic properties of interneurons that are components of the CPG. The lamprey system is arguably the best-described vertebrate system where 5-HT and dopamine’s effects have been correlated to changes in cellular properties at the network level [3]. Both 5-HT and dopamine increase the duration of burst discharge thereby slowing the rhythm. The increase in burst discharge is due to actions on excitatory interneurons. Both neuromodulators act to decrease N, P/Q  $\text{Ca}^{2+}$  conductances, thereby indirectly reducing the amplitude of apamin sensitive  $\text{K}_{\text{Ca}}$  conductances. This leads to an increase in spike frequency and also results in longer lasting bursts of spikes. The cycle period increases because the increase in the population burst duration on one side ensures that inhibitory commissural interneurons inhibit activity on the opposite side. As a result of a longer period of inhibitory commissural activity it takes a longer time for the other side to “rebound” and the overall cycle period of the rhythm increases.
5. ▶ **Afferent feedback** can affect the timing and pattern of CPG output. Once networks are activated,

multiple changes in reflex sign and gain occur to allow afferent feedback to influence ongoing behavior. As a consequence, afferent feedback can stabilize the operation of CPGs and affect the timing and patterning of their output [7,9,10]. These types of observations have been made in many species performing diverse behaviors such as cockroach and cat walking, chewing in crustacea, feeding in the snail, scratching in the turtle and breathing in mammals. For example, under quiescent conditions, input from Golgi tendon organs that encode contractile force in extensor muscles has an inhibitory effect on motoneurons. However, when spinal CPGs are activated, input from extensor GTOs results in excitation of extensor motoneurons which delays the onset of the next flexor burst. Once CPGs are activated these effects are thought to occur by inhibition of the normal inhibitory pathway and an opening of a long-latency excitatory pathway. Afferent feedback can also select different patterns of CPG output. For example different scratch patterns in the turtle can be selected by afferent input from different regions. Similar types of results have been obtained when afferent input onto the gastric mill (crustacean chewing rhythm centre) is manipulated.

6. *Many of the patterns produced by CPGs are non-intuitive based on anatomical connectivity.* At first blush it would seem that once you understand what connects to what in a network you would be close to understanding its output. However, the output of a network also depends on the weighting of the connections, and the intrinsic properties of the neurons themselves. Importantly, these network, synaptic or intrinsic properties are interdependent and it is because of this interaction that many networks display **emergent properties**. An important tool for examining the dynamic performance of networks is to construct computational models [7]. For many reasons it is not realistic to model every parameter present in biological networks and all models make assumptions. Nevertheless, modeling a network offers several advantages for probing the operation of networks. For example, the effect of altering specific voltage-dependent conductances in a population of cells can be easily accomplished using a model, but is currently difficult to do experimentally. Modeling allows the exploration of parameter space that would be impossible to do experimentally which can lead to important insights into network function. Having said that, models should be able to offer predictions regarding network dynamics that can be tested experimentally. This process is important in order to validate the model as well as suggesting new avenues for exploration. An elegant example of the power of

modeling is a study that took advantage of the stomatogastric ganglia system and demonstrated that multiple combinations of synaptic weights and intrinsic properties could produce similar network outputs in the pyloric network [7]. This type of insight would have been impossible to gain using conventional experimental techniques.

### Future Directions

One of the attractive features of some invertebrate networks is that the number of cells in the CPG is often manageable and the cells can be identified. This allows experiments to be performed where the output of these identified cells can be manipulated by injecting hyperpolarizing or depolarizing current. On the other hand vertebrate CPGs present several challenges for experimentalists. The underlying networks are large compared to invertebrates and furthermore different classes of inhibitory and excitatory cells are often not clustered into discrete regions. Examination of mammalian spinal networks provides a perspective on these issues. The interneurons involved in spinal CPGs are not localized to specific nuclei and thus have eluded ready identification [8]. Recently, genetic approaches have provided new tools that allow classes of interneurons within the spinal cord to be identified. These interneurons can be silenced chronically or acutely allowing experimentalists to test whether the output of the network is disrupted. For example, the excitability of a class of inhibitory interneurons was recently manipulated using an allatostatin based system to silence the cells acutely [9]. Allatostatin receptors are found in insects but are not normally expressed in mammalian systems. Allatostatin receptors activate GIRK channels which hyperpolarize cells. This means that when allatostatin is applied to the spinal cord only the classes of neurons in which allatostatin receptors were artificially introduced are hyperpolarized. At the moment these are among the best tools we have for determining whether certain classes of interneurons are important for regulating network function in mammals. Having said that, approaches that examine connectivity between oscillators will be easier to interpret compared to deletion of classes that are putatively part of the oscillator itself. One of the major issues here is addressing necessity and sufficiency. If deletion of a class of interneurons blocks activity, it is difficult to conclude that they are essential components of the network. This is because deletion of the ceus may transiently reduce the excitability of the network. However homeostatic mechanisms could compensate for this reduction in excitability. Likewise, if the perturbation produces no effect we cannot easily conclude that these cells are not part of the network. Therefore, we will need to develop techniques that rigorously examine the effectiveness of manipulation techniques at a population rather than a cell-by-cell

level. To do this we will need new tools to understand network function. Critically, we need to target candidate CPG interneurons and examine their connectivity within the network. It is clear that sampling the output of each neuron using intracellular recording techniques will not be sufficient to make conclusions regarding connectivity within the population of interneurons in mammalian networks. What is needed is perhaps the use of voltage sensitive dyes combined with genetic approaches that would double label populations of interest. In the future we will likely see the merging of these two approaches to examine network connectivity. Another critical test will be the ability to quickly activate and inactivate discrete populations of cells during network activity, like those performed in other preparations such as the STG network of crustacea. Once classes of interneurons that contribute to CPG function are identified, it will be necessary to test their ►in vivo functionality. The zebrafish embryo provides an example of what is possible. The zebrafish embryo is transparent and cells in the escape network can be visualized in the behaving animal [10]. This has allowed experimenters to ablate cells in the circuit and examine changes in behavior. While similar experiments in mammals will obviously be much more difficult, the use of multiphoton approaches in combination with genetic silencing approaches should allow new insights into the operation of mammalian CPG circuits.

## References

1. Graham-Brown T (1911) The intrinsic factors in the act of progression in the mammal. *Proc R Soc Lond* 84:308–319
2. Getting PA (1989) Emerging principles governing the operation of neural networks. *Annu Rev Neurosci* 12:185–204
3. Grillner S (2003) The motor infrastructure: from ion channels to neuronal networks. *Nat Rev Neurosci* 4 (7):573–586
4. Harris-Warrick RM (2002) Voltage-sensitive ion channels in rhythmic motor systems. *Curr Opin Neurobiol* 12 (6):646–651
5. Whelan PJ (2003) Developmental aspects of spinal locomotor function: insights from using the in vitro mouse spinal cord preparation. *J Physiol* 553 (pt 3):695–706
6. Marder E, Thirumalai V (2002) Cellular, synaptic and network effects of neuromodulation. *Neural Netw* 15 (4–6):479–493
7. Prinz AA (2006) Insights from models of rhythmic motor systems. *Curr Opin Neurobiol* 16(6):615–620
8. Kiehn O (2006) Locomotor circuits in the mammalian spinal cord. *Annu Rev Neurosci* 29:279–306
9. Gosgnach S et al. (2006) V1 spinal neurons regulate the speed of vertebrate locomotor outputs. *Nature* 440 (7081):215–219
10. Fetcho JR, Higashijima SI, McLean DL (2008) Zebrafish and motor control over the last decade. *Brain Res Rev* 57(1):86–93

## Neurotransmitters in the Auditory System

RONALD S. PETRALIA, ROBERT J. WENTHOLD  
NIDCD/NIH, Bethesda, MD, USA

### Synonyms

Excitatory and inhibitory neurotransmission at synapses in the central auditory system and cochlea

### Definition

In the auditory (hearing) system, as in other parts of the nervous system, neurotransmitters are chemicals that cross a synapse and mediate nerve impulse transmission from one neuron to the next neuron, or from sensory cells (hair cells in the cochlea of the inner ear) to neurons, or from neurons to effector cells (in this case, the same sensory hair cells of the cochlea). Neurotransmitters typically excite or inhibit the neuron to enhance or reduce nerve impulse transmission, but they can also mediate long-term changes in the neuron, including maturation and learning. All of these functions involve interplay of different neurotransmitters, with some kinds modulating the effects of other kinds, to shape the response. For the auditory system, this results in accurate sound identification and localization, and the integration of audition with other sensory modalities and with locomotor responses.

### Characteristics

The auditory system is a complex system of interconnected neural centers extending from the sensory hair cells of the cochlea to the auditory cortex, and employs a wide variety of neurotransmitters and their receptors. As in other neural systems in the brain, neurotransmission in the auditory system largely involves a balanced release of excitatory and inhibitory neurotransmitters. The ascending excitatory neurotransmission from the cochlea to the cortex relays the transduced auditory information; along the way, the information is filtered and refined utilizing inhibitory neurotransmission. Excitatory neurotransmission is mediated primarily by glutamate, while GABA and glycine mediate inhibitory neurotransmission. In general, discussion here of excitatory connections within the brain will refer to glutamatergic-type connections, although the glutamatergic nature of the connection may not have been established definitively in all cases. In addition, a number of other neurotransmitter compounds (described below) can modulate neural responses in a variety of ways.

The auditory system serves to identify both the nature of a sound and its localization in space and time. In particular, sound localization requires unusually rapid

neurotransmission. Thus, several components of the auditory system are designed for this very fast transmission and include specialized ▶glutamate receptors (GluRs) for fast excitatory connections, and a preference for glycinergic inhibitory neurotransmission over the somewhat slower GABAergic neurotransmission, as discussed below.

### Basic Patterns of Excitatory and Inhibitory Innervation in the Auditory System

The component structures making up the auditory system are numerous and their interconnections are complex [1–3]. They are discussed in detail in other essays in this encyclopedia and can only be summarized here (Fig. 1).

Sound elicits vibrations in the cochlea; these vibrations are increased and sharpened by outer hair

cells (OHCs), which act as a cochlear amplifier. These vibrations are then transduced into nerve impulses by the inner hair cells (IHCs), which have a glutamatergic connection with afferent dendritic nerve endings from spiral ganglion cells. The latter send axons into the brain (auditory nerve) and these axons form glutamatergic connections with the ventral (VCN) and dorsal (DCN) cochlear nuclei. In addition to these IHC connections, OHCs form synapses with a small number of ganglion cells and these also send input to the cochlear nuclei, but their function is not well known. Axons from various neuron types in the cochlear nuclei form excitatory connections with the nuclei of the superior olivary complex (SOC) and lateral lemniscus (LL) and the inferior colliculus (IC). In the SOC, the best-studied nuclei include the lateral and medial superior olive (LSO, MSO) and the medial nucleus of the trapezoid

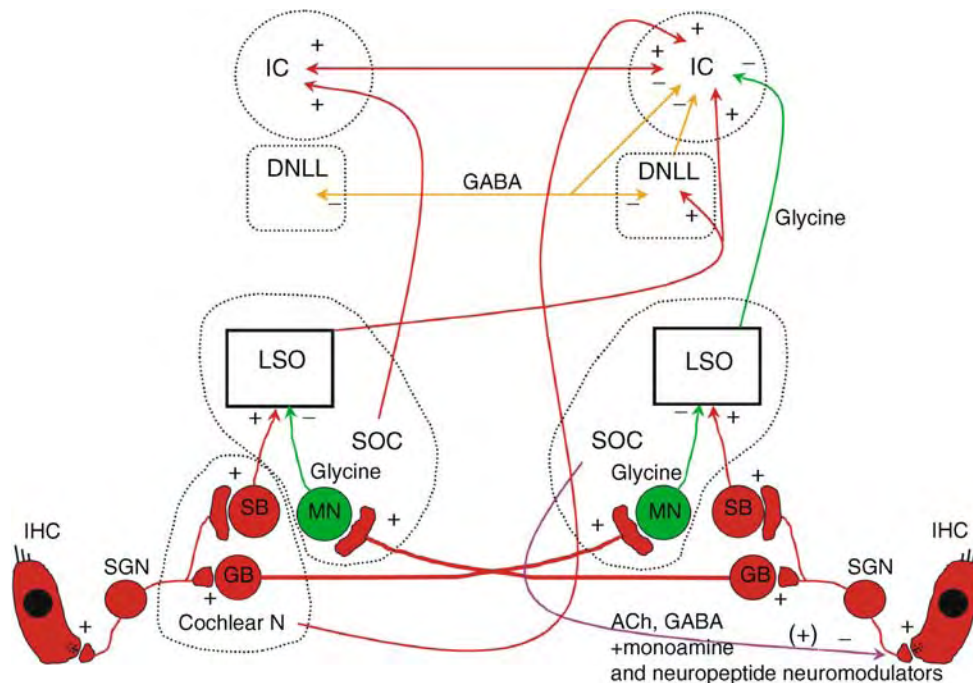

**Neurotransmitters in the Auditory System. Figure 1** *Simplified diagram of a sample of neurotransmission in the Auditory System.* Only a few of the main cell types, nuclei, and connections are shown. In the cochlea, sounds induce vibrations, which are amplified by OHCs (not shown), and these vibrations are transduced into nerve impulses by IHCs (IHCs). The first few connections are mainly rapid relays. IHCs form excitatory synapses (red color, +) with spiral ganglion neurons (SGN), and these form excitatory synapses with neurons in the cochlear nuclei. Within the cochlear nuclei, spherical bushy cells (SB) send excitatory input to LSO in the SOC. Beginning at this level, some more complicated connections allow neurons to compare sound input from both ears (i.e., for sound localization). LSO neurons receive ipsilateral excitatory input from SB and contralateral input from globular bushy cells (GB) via an excitatory synapse with neurons of the MNTB (MN). MNTB neurons make glycinergic inhibitory (green color, -) synapses with LSO neurons. In turn, cochlear nuclei and LSO and other SOC nuclei make excitatory and inhibitory connections with higher centers. Combination of excitatory (probably mainly glutamatergic) and inhibitory (GABA {orange color} or glycine {green color}) connections allows binaural integration of sound information at these higher centers (DNLL; IC). The latter brain regions then send connections to MGB, which connects to auditory cortex (not shown). In addition, sound transduction in the cochlea is modulated by the olivocochlear efferent input from the SOC to both IHCs and OHCs.

body (MNTB). The major excitatory connections from the cochlear nuclei are with the ipsilateral LSO, bilateral MSO, and contralateral MNTB. This contralateral MNTB then makes a glycinergic inhibitory connection with its ipsilateral LSO. Thus, the SOC is the lowest level where the ascending auditory inputs from the two ears converge. Next, the three nuclei of the LL (NLL) receive contralateral (i.e., monaural only) excitatory input from the cochlear nucleus. Convergence of auditory input is seen again in the IC, which receives contralateral excitatory input from the cochlear nuclei, LSO and other IC, ipsilateral excitatory input from the MSO, and ipsilateral glycinergic inhibitory input from the LSO. The IC also receives ipsilateral GABA, glycine and excitatory input from the three NLL, as well as GABA inhibitory input from the contralateral dorsal nucleus of the NLL (DNLL; i.e., 1 of the 3 NLL) and IC. The IC then sends glutamatergic excitatory and GABA inhibitory connections to the ipsilateral medial geniculate body (MGB) in the thalamus, and the MGB sends excitatory connections to the auditory cortex.

### Major Examples of Excitatory Inhibitory Control of Auditory Signal Processing

Many of the complex ipsilateral and contralateral excitatory and inhibitory connections discussed in the previous paragraph serve to localize sounds based on interaural intensity disparities (i.e., between the two ears). This is for high frequency sounds; for low frequency sounds, sound localization depends on interaural timing/phase differences. Basically, neurons that measure interaural intensity differences are excited by stimulation of one ear and are progressively inhibited by increasing stimulus intensity at the other ear, and are called EI neurons [1]. Neurons that act in this way are found in the LSO, DNLL and IC (Fig. 1). Although the combined roles of these three structures is not fully understood, the LSO may be responsible for the basic sound localization; it has an ipsilateral excitatory input, and an ipsilateral glycinergic MNTB input from neurons that receive a contralateral excitatory (cochlear nuclear) input. In contrast, the IC combines inputs from the LSO (excitatory contralateral and glycinergic ipsilateral) and DNLL (GABAergic bilateral) with other direct inputs, including those from the cochlear nuclei; the IC may utilize this input to distinguish the first sound from the typically abundant echoes that follow it.

While the previous examples look at the convergence of excitatory and inhibitory connections between different brain regions, most parts of the brain have local inhibitory interneurons within the brain structure, and these impinge on the principal excitatory (usually glutamatergic) neurons of that structure. This local inhibitory circuitry helps to refine the output of the excitatory principal neurons, making the response more specific. The best example of this is the auditory cortex [2], which

has pyramidal neurons that send glutamatergic, descending efferent fibers to lower auditory structures. These excitatory neurons receive their major excitatory input from the MGB, and receive GABA-mediated inhibition from a variety of neuron types within the cortex. Another good example is the DCN [2]. Its (pyramidal) neurons project excitatory fibers to the contralateral IC (and MGB) and receive glutamatergic input from the auditory nerve onto their basal dendrites; the auditory nerve also provides glutamatergic input to small GABA and glycinergic inhibitory neurons that then form synapses on these basal dendrites. In contrast, the apical dendrites of these fusiform cells receive glutamatergic input from small, local **granule cells**. Granule cells also form glutamatergic synapses on local glycinergic (+GABA) cartwheel cells and GABAergic stellate cells; both of these inhibitory neurons form synapses on the apical dendrites of the fusiform cells [4]. The major input to granule cells appears to come from somatosensory inputs from the external ear (pinna). Thus, basal dendrites receive auditory nerve input and associated inhibition and apical dendrites receive mainly somatosensory input and associated inhibition. This arrangement may allow the DCN to coordinate pinna orientation and sound localization [5].

Two notable exceptions to this pattern of principal excitatory neurons modified by local inhibitory neurons are found in the rat auditory system – almost all DNLL neurons are GABAergic and almost all MGB neurons are excitatory. The MGB may show an evolutionary trend, with almost no GABAergic neurons in rats and bats, while about 25% of the neurons in the MGB in monkeys and cats are GABAergic; this may reflect more complex auditory communication in the latter animals [2,6]. For rats and bats, refinement of the MGB output via inhibitory input depends on GABAergic fibers from the IC and the thalamic reticular nucleus; the latter inhibitory input may affect synchronization of MGB processing with general arousal.

### Specific Neurotransmitters of the Auditory System

Ideally, identification of a specific type of neurotransmission will include studies of neurotransmitters and their receptors, transporters and vesicular transporters using biochemistry, in situ hybridization and light and electron microscope immunocytochemical localization [7].

#### Excitatory Neurotransmitters

As noted above, most excitatory neurotransmission in the auditory system is mediated by glutamate or related compounds; we also consider acetylcholine (ACh) neurotransmission in this section, because they classically are considered excitatory.

As noted above, glutamate or a related compound probably acts as the excitatory neurotransmitter for the IHCs, spiral ganglion neurons (auditory nerve), and



principal projection neurons in most auditory brain structures. However, for many of these excitatory projections, the glutamatergic nature of the neurotransmitter has not been determined definitively. GluRs are common at auditory nerve terminals, granule cell terminals, and other kinds of terminals in neurons throughout the cochlear nuclei [8]. Both ipsilateral and contralateral glutamatergic input was confirmed for the LSO, MSO, and another SOC nucleus [9]. Cochlear nuclear input that forms giant terminals, the calyces of Held, on neurons of the MNTB is also probably glutamatergic (Fig. 2). Other studies have supported the glutamatergic nature of inputs to the DNLL, various inputs to the IC, IC commissural connections, inputs from the central nucleus of the IC to the MGB, input from the

IC and auditory cortex to the ventral division of the MGB, and in general the output of the auditory cortex, including that from the layer V pyramidal cells to the IC [2].

GluRs include ionotropic receptors, which form a sodium or calcium channel made up of four or five subunits, and metabotropic receptors, which link to G proteins to elicit long-term changes in neurons [7,8,10]. The major ionotropic GluRs that handle fast neurotransmission are AMPA receptors. AMPA receptors vary in function and properties depending on their subunit makeup (GluR1–4); the most common type contains GluR2 and passes sodium but is impermeable to calcium. While the latter type is common in many parts of the auditory system, some auditory synapses use a special kind of **AMPA receptor** that contains primarily GluR3

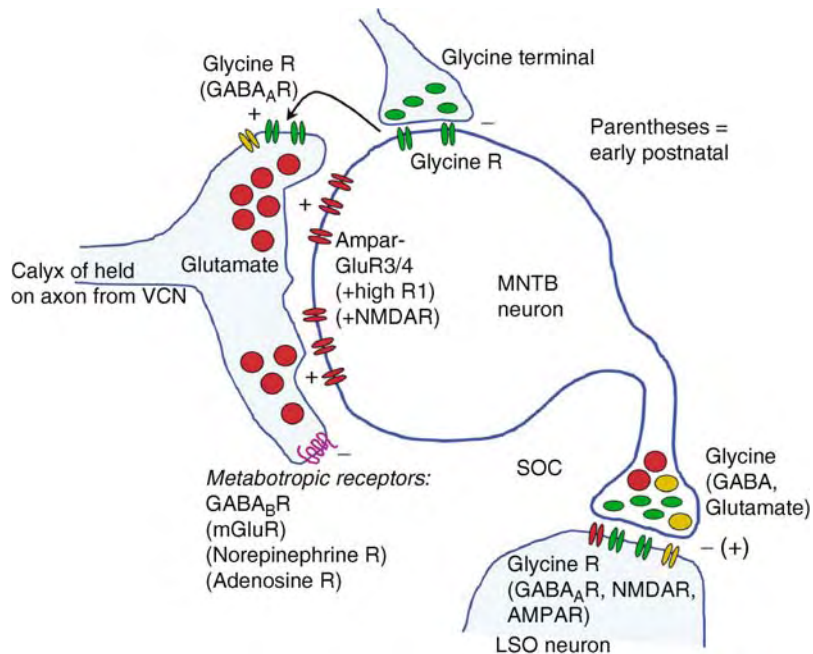

**Neurotransmitters in the Auditory System. Figure 2** Example of how various neurotransmitters and their receptors are integrated in part of the auditory system, and how this changes during postnatal development. Red, green, and orange colors represent excitatory, glycinergic, and GABAergic neurotransmission, respectively, as in Fig. 1. During early postnatal development, some neurotransmitters and their receptors are present transiently (shown in parentheses in the diagram) and mediate synaptic plasticity, e.g., establishment of final synaptic connections and maturation of their physiological properties. The basic adult circuit shown here includes a thick axon from a VCN-globular bushy cell that forms a calyx of Held-glutamatergic synapse on a neuron of the MNTB. The postsynaptic AMPA receptors contain the GluR3 and GluR4 subunits; these mediate a fast relay of the signal. In addition, presynaptic receptors (mainly glycine and GABA) help to modulate the signal. The MNTB neuron then relays the signal via a glycinergic inhibitory connection with neurons in LSO in the SOC. However, during early postnatal development, neurotransmission is slower, being mediated through postsynaptic AMPA receptors that are high in GluR1 subunit, and through NMDA receptors, as well as being modulated by several neurotransmitters impinging on presynaptic receptors. These include GABA<sub>A</sub> ionotropic receptors (later replaced by glycine receptors) and GABA<sub>B</sub>, mGluR (glutamatergic), norepinephrine, and adenosine metabotropic receptors (only GABA<sub>B</sub> remains common in adult). This early arrangement is required for maturation of this synapse. An even more radical change is seen during development of MNTB neuron synapses with LSO neurons. During early postnatal ages, these terminals secrete both excitatory and inhibitory neurotransmitters, although the adult synapse is just inhibitory. The early presence of glutamate and its associated receptors at an inhibitory synapse indicates the fundamental role that GluRs play in maturation of synapses.

and GluR4 (especially the “flop” subtype of GluR4), is calcium permeable, and is unusually fast – this facilitates the very rapid neurotransmission needed to effect the rapid relay of auditory information, such as needed for sound localization. For example, this type is found in the giant specialized endbulb-type glutamatergic synapses between the auditory nerve and the spherical ►bushy cells of the VCN, and in the ►calyx of Held between axons from globular bushy cells of the VCN and neurons of the MNTB (Fig. 2). Interestingly, neurotransmission at this synapse is relatively slow in early postnatal development, probably due to the prevalence of GluR1 in the AMPA receptors; neurotransmission becomes faster coincident with an increase in the prevalence of GluR3/4-containing AMPA receptors [11]. A similar reduction in GluR1 with development may occur in some kinds of neurons of the cochlear nuclei [7].

Another important ionotropic GluR is the ►NMDA receptor, which passes calcium and is implicated in neuronal plasticity during development and learning; it is most famous for its role in the establishment of long-term potentiation of synaptic current. Typical NMDA receptors contain the main subunit, NR1, combined with one or more NR2 subunits. NMDA receptor levels vary widely in the auditory system [2,8] and they probably participate in modification of synaptic responses where they are prevalent; this may be particularly important for the development of many synapses (Fig. 2). In addition to typical NMDA receptors, there may be other, less studied forms containing subunits of NR3. NR3A is found in a number of auditory brain regions [12] and may form a special kind of excitatory glycine receptor when combined with the most common subunit, NR1.

Delta ( $\delta$ ) ionotropic GluRs are poorly understood and do not normally form a functional channel. Interestingly, the  $\delta 1$  subunit is highly expressed in IHCs and ganglion cells of the cochlea [13]. Expression of  $\delta$ s is generally low in the adult brain, except in the cerebellum ( $\delta 2$ ) and outer DCN [8]. In the DCN,  $\delta$  labeling is high in granule cell-parallel fiber synapses of cartwheel cell neurons and those of apical dendrites of fusiform cells;  $\delta$  is relatively uncommon in basal dendrites of fusiform cells. In contrast, in these fusiform cells, the AMPA receptor subunit, GluR4, and the metabotropic GluR, mGluR1 $\alpha$ , are found only in synapses of basal dendrites. This differential distribution of GluRs is related to co-processing of functionally different sensory inputs on fusiform cells, as discussed above. Thus, fast auditory nerve transmission to basal dendrites probably requires high GluR4, while granule cell input to apical dendrites is a type that is not modulated by metabotropic GluRs. The need for high  $\delta$  in synapses between granule cells and outer DCN neurons is not understood; probably the function of these synapses corresponds to that of similar  $\delta 2$ -containing, granule cell-parallel fiber synapses in the

cerebellum and as in the latter,  $\delta$  probably plays a modulatory role.

Cholinergic neurotransmission has been studied best in the olivocochlear system. This consists of special medial and lateral groups of neurons in the SOC that send efferent axons to outer and inner cochlear hair cells, respectively [2]. Those going to OHCs probably modify OHC function to enhance transduction or signal detection, while those associated with IHCs mainly form synapses on the afferent fibers beneath the IHCs and probably have a modulatory role. Interestingly, cholinergic neurotransmission that is mediated through  $\alpha 9/\alpha 10$  nicotinic ACh receptors has an indirect hyperpolarizing effect on hair cells, and thus inhibits hair cell neurotransmitter release [14]. In addition to this efferent system to the cochlea, some cholinergic connections are seen throughout the auditory system. Both groups of olivocochlear efferents provide some collateral input to the VCN. There is also evidence for a substantial number of cholinergic neurons in the external cortex of the IC. Cholinergic input probably exerts regulatory influences on basic neural circuitry. ACh receptors in the auditory system include both nicotinic ionotropic and muscarinic metabotropic types. In particular,  $\alpha 7$  nicotinic ACh receptors may be important during postnatal development throughout the brain auditory system [15,16]. Presynaptic  $\alpha 7$  nicotinic ACh receptors at immature glutamatergic synapses, activated via diffusion of ACh from nearby cholinergic terminals, may facilitate glutamate release at these terminals and consequently help mediate maturation of these synapses [16]. The auditory system is also involved with the cholinergic system of the brain in an indirect way. Auditory stimuli activate cholinergic neurons in the reticular activating system in the brainstem; these neurons project ascending and descending tracts extending from the cortex to the spinal cord and provide an arousal mechanism that precedes locomotor response [17].

### Inhibitory Neurotransmitters

As noted above, both GABAergic and glycinergic inhibitory neurotransmission are prevalent throughout the auditory system [2,3,7]. Generally, inhibitory synapses may be distinguished from excitatory synapses by the shape of the vesicles (oval to flat in inhibitory and round in excitatory) and the proportion of pre/postsynaptic densities (thicker postsynaptic density in excitatory synapses). ►GABA receptors include both ionotropic (GABA<sub>A</sub>) and metabotropic (GABA<sub>B</sub>) types. A portion of the lateral group of neurons of the olivocochlear system, associated with IHCs, is GABAergic. In fact, in the mouse, GABA may co-localize with ACh in olivocochlear efferent terminals going to both IHCs and OHCs [18]. Auditory brain regions typically have mixtures of GABAergic and glycinergic neurons in different proportions. In the cochlear nuclei, inhibitory neurons and both GABA and ►glycine receptors are more common in

DCN than VCN. Other auditory brain regions send out particularly important groups of inhibitory fibers (as noted above) – GABAergic especially for those fibers from DNLL to IC and from IC to MGB, and glycinergic especially for those from MNTB to LSO, LSO to IC, and VNLL to IC. GABA and glycine can also occur in the same neuron populations. Glycinergic inputs tend to mediate faster neurotransmission than GABAergic. Not surprisingly, glycinergic neurotransmission may replace GABAergic neurotransmission in some neurons during postnatal development, as some auditory connections speed up (Fig. 2; as described above for a similar developmental change in AMPA-type GluRs). Thus, in the calyx of Held (glutamatergic) synapses on MNTB neurons, presynaptic glycine receptors replace GABA<sub>A</sub> receptors during postnatal development, coincident with development of inhibitory glycinergic input on postsynaptic MNTB neurons [19,20]. The presynaptic glycine receptors probably respond to spillover of glycine released from the nearby glycinergic synapses; activation of these presynaptic receptors enhances glutamate release from the calyx terminals. Another interesting association between excitatory and inhibitory neurotransmission at the same synapse is found in MNTB-neuron terminals in LSO (Fig. 2). During early postnatal development, these terminals release GABA, glycine and glutamate, and the postsynaptic membrane bears receptors for all three neurotransmitters [21]. Glutamate activation of NMDA receptors at these synapses probably mediates activity-dependent refinement of this inhibitory circuit. Finally, as this synapse matures, it becomes predominantly glycinergic.

### **Monoamine Neurotransmitters/Neuromodulators**

The monoamines (biogenic amines) include the catecholamines (dopamine, norepinephrine, and epinephrine), serotonin (=5HT), and histamine. They act as neuromodulators (▶**Monoamine Neurotransmitters/Neuromodulators**) that activate second messenger systems in the affected neuron, thus modifying synaptic responses or having other broad effects on neurons. The auditory regions of the brain are widely innervated by different monoamines, especially norepinephrine (=noradrenaline; from locus coeruleus and other brainstem cell groups) and serotonin (from midline raphe nuclei of the brainstem reticular formation), although their function in the auditory system remains mainly speculative (e.g., [22–24]). Norepinephrine helps regulate glutamate release from the calyx of Held synapses on MNTB neurons, via inhibition mediated by presynaptic norepinephrine receptors (Fig. 2; [25]).

Both norepinephrine and serotonin are involved in arousal mechanisms, so they probably affect selective attention in the auditory system [17,22]. In the cochlear nuclei, norepinephrine may have effects on detection of sounds in noise and on timing mechanisms [23]. The

cochlea contains norepinephrine, dopamine, and serotonin; changes in turnover of the former two occur in response to white noise [26]. Serotonergic fibers are closely associated with olivocochlear efferent fibers near the bases of IHCs and OHCs.

### **Neuropeptides and Other Substances as Auditory Neuromodulators**

A wide variety of ▶**neuropeptides** are found throughout the auditory system and they modulate neuron excitability and other functions, usually via metabotropic receptors [27–29]. In the cochlea, opioid peptides and calcitonin gene-related peptide (CGRP) are found in the olivocochlear efferents; these innervate hair cells and afferents to IHCs (Fig. 2). Two opioid peptides, endomorphin-1 and dynorphin B, inhibit  $\alpha$  9/ $\alpha$ 10 nicotinic ACh receptor-mediated inhibition of hair cells (see above; [14]). Opioids are probably released from cholinergic efferent terminals when the firing frequency passes a certain threshold (e.g., after noise exposure), which is sufficient to induce exocytosis of opioid-containing large dense-core vesicles. Opioid secretion has been implicated in hyperacusis and peripheral tinnitus [14,28]. In auditory brain regions, neuropeptide input includes that from other auditory regions. For example, somatostatin is found in some neuron somata in VCN, some cells near LSO, and some cells of LL and IC [27]. The greatest convergence of neuropeptide innervation may be in the ventral nucleus of the trapezoid body (VNTB) and the small cell cap plus granule cell regions of the cochlear nuclei; these include substance P, CGRP, enkephalins, dynorphins, cholecystokinin, and somatostatin [28]. These peptides exert different effects: substance P strongly excites VNTB neurons, leu-enkephalin strongly inhibits VNTB neurons, and cholecystokinin can show either excitatory or inhibitory effects on VNTB neurons, while somatostatin modulates the release of other neurotransmitters.

There are probably numerous other substances that can act as neurotransmitters or neuromodulators. Nitric oxide (NO) can act as a neuromodulator in the brain and may be involved in NMDA GluR-mediated synaptic plasticity; NO has been described in IC [2] and cochlear spiral ganglion neurons [30]. The purine ATP can act as a neuromodulator in the cochlea in the spiral ganglion neurons, and specifically at their afferent synapses with hair cells. ATP activates ionotropic ▶**purine receptors** (P2X) on spiral ganglion neuron membranes. This initiates a calcium influx that induces NO production in the neuron. Purines can also act on metabotropic receptors, including ATP-sensitive P2Y and adenosine-sensitive P1 receptors. Adenosine, converted from ATP that is probably secreted with glutamate from immature calyx of Held synapses, binds to presynaptic adenosine receptors (Fig. 2; see above), inhibiting glutamate release to help regulate high frequency neurotransmission at this synapse [31].

## References

- Pollak GD, Burger RM, Klug A (2003) Dissecting the circuitry of the auditory system. *Trends Neurosci* 26:33–39
- Malmierca MS, Merchán MA (2004) Auditory system. In: Paxinos G (ed) *The rat nervous system*, 3rd edn. Elsevier Academic, New York, pp 997–1082
- Wenthold RJ, Hunter C (1990) Immunocytochemistry of glycine and glycine receptors in the central auditory system. In: Ottersen OP, Storm-Mathisen J (eds) *Glycine Neurotransmission*. Wiley, New York, pp 391–416
- Rubio ME (2004) Differential distribution of synaptic endings containing glutamate, glycine, and GABA in the rat dorsal cochlear nucleus. *J Comp Neurol* 477:253–272
- Kanold PO, Young ED (2001) Proprioceptive information from the pinna provides somatosensory input to cat dorsal cochlear nucleus. *J Neurosci* 21:7848–7858
- Winer JA, Larue DT (1996) Evolution of GABAergic circuitry in the mammalian medial geniculate body. *Proc Natl Acad Sci USA* 93:3083–3087
- Wenthold RJ, Hunter C, Petralia RS, Niedzielski AS, Wang Y-X, Safieddine S, Zhao H-M, Rubio ME (1997) Receptors in the auditory pathways. In: Berlin CI (ed) *Neurotransmission and hearing loss: basic science, diagnosis, and management*. Singular, San Diego, pp 1–23
- Petralia RS, Rubio ME, Wang Y-X, Wenthold RJ (2000) Differential distribution of glutamate receptors in the cochlear nuclei. *Hear Res* 147:59–69
- Srinivasan G, Friauf E, Löhrike S (2004) Functional glutamatergic and glycinergic inputs to several superior olivary nuclei of the rat revealed by optical imaging. *Neuroscience* 128:617–634
- Wenthold RJ, Hunter C, Petralia RS (1993) Excitatory amino acid receptors in the rat cochlear nucleus. In: Merchan MA, Juiz JM, Godfrey DA, Mugnaini E (eds) *The mammalian cochlear nuclei: organization and function*. Plenum, New York, pp 179–194
- Joshi I, Shokralla S, Titis P, Wang L-Y (2004) The role of AMPA receptor gating in the development of high-fidelity neurotransmission at the calyx of Held synapse. *J Neurosci* 24:183–196
- Wong H-K, Liu X-B, Matos MF, Chan SF, Pérez-Otaño I, Boysen M, Cui J, Nakanishi N, Trimmer JS, Jones EG, Lipton SA, Sucher NJ (2002) Temporal and regional expression of NMDA receptor subunit NR3A in the mammalian brain. *J Comp Neurol* 450:303–317
- Safieddine S, Wenthold RJ (1997) The glutamate receptor subunit  $\delta 1$  is highly expressed in hair cells of the auditory and vestibular systems. *J Neurosci* 17:7523–7531
- Lioudyno MI, Verbitsky M, Glowatzki E, Holt JC, Boulter J, Zadina JE, Elgoyhen AB, Guth PS (2002) The  $\alpha 9/\alpha 10$ -containing nicotinic ACh receptor is directly modulated by opioid peptides, endomorphin-1, and dynorphin B, proposed efferent cotransmitters in the inner ear. *Mol Cell Neurosci* 20:695–711
- Happe HK, Morley BJ (2004) Distribution and postnatal development of  $\alpha 7$  nicotinic acetylcholine receptors in the rodent lower auditory brainstem. *Dev Brain Res* 153:29–37
- Metherate R, Hsieh CY (2004) Synaptic mechanisms and cholinergic regulation in auditory cortex. *Prog Brain Res* 145:143–156
- Skinner RD, Homma Y, Garcia-Rill E (2004) Arousal mechanisms related to posture and locomotion: 2. Ascending modulation. *Prog Brain Res* 143:291–298
- Maison SF, Adams JC, Liberman MC (2003) Olivocochlear innervation in the mouse: immunocytochemical maps, crossed versus uncrossed contributions, and transmitter colocalization. *J Comp Neurol* 455:406–416
- Turecek R, Trussell LO (2002) Reciprocal developmental regulation of presynaptic ionotropic receptors. *Proc Natl Acad Sci USA* 99:13884–13889
- Awatramani GB, Turecek R, Trussell LO (2005) Staggered development of GABAergic and glycinergic transmission in the MNTB. *J Neurophysiol* 93:819–828
- Gillespie DC, Kim G, Kandler K (2005) Inhibitory synapses in the developing auditory system are glutamatergic. *Nat Neurosci* 8:332–338
- Behrens EG, Schofield BR, Thompson AM (2002) Aminergic projections to cochlear nucleus via descending auditory pathways. *Brain Res* 955:34–44
- Thompson AM (2003) A medullary source of norepinephrine in cat cochlear nuclear complex. *Exp Brain Res* 153:486–490
- Thompson AM, Hurley LM (2004) Dense Serotonergic innervation of principal nuclei of the superior olivary complex in mouse. *Neurosci Lett* 356:179–182
- von Gersdorff H, Borst JGG (2001) Short-term plasticity at the calyx of Held. *Nat Rev Neurosci* 3:53–64
- Gil-Lozaga P, Bartolomé V, Vicente-Torres A, Carricondo F (2000) Serotonergic innervation of the organ of Corti. *Acta Otolaryngol* 120:128–132
- Wynne B, Robertson D (1997) Somatostatin and substance P-like immunoreactivity in the auditory brainstem of the adult rat. *J Chem Neuroanat* 12:259–266
- Robertson D, Mulders WHAM (2000) Distribution and possible functional roles of some neuroactive peptides in the mammalian superior olivary complex. *Microsc Res Tech* 51:307–317
- Martín F, Coveñas R, Narváez JA, Tramu G (2003) An immunocytochemical mapping of somatostatin in the cat auditory cortex. *Arch Ital Biol* 141:157–170
- Yukawa H, Shen J, Harada N, Cho-Tamaoka H, Yamashita T (2005) Acute effects of glucocorticoids on ATP-induced  $\text{Ca}^{2+}$  mobilization and nitric oxide production in cochlear spiral ganglion neurons. *Neuroscience* 130:485–496
- Kimura M, Saitoh N, Takahashi T (2003) Adenosine  $\text{A}_1$  receptor-mediated inhibition at the calyx of Held of immature rats. *J Physiol* 553:415–426

## Neurotransmitters in the Gut

### Definition

Enteric neurons synaptically communicate with each other using neurotransmitters. Acetylcholine (ACh) is the main transmitter mediating fast excitatory postsynaptic potentials (fast EPSPs, nicotinic in nature).

Many other neuroactive substances have also been identified as putative neurotransmitters for fast EPSPs

(ATP, glutamate) and slow EPSPs (serotonin (5-HT), substance P, vasoactive intestinal peptide (VIP), and other peptides) and inhibitory PSPs (noradrenalin, GABA, somatostatin) within the enteric nervous system. Furthermore, neurotransmitters released from enteric efferent neurons to intestinal effectors include: motor excitatory (substance P); motor inhibitory (ATP, nitric oxide, VIP, PACAP); and secretory (VIP). Many substances, including amines, amino acids and peptides may act as neuromodulators in the gut. So called braingut peptides are a group of peptides present both in the enteric and central nervous systems.

- ▶ Acetylcholine (ACh)
- ▶ ATP
- ▶ Bowel Disorders
- ▶ GABA
- ▶ Gutamate
- ▶ Noradrenalin
- ▶ PACAP
- ▶ Serotonin

---

## Neurotrophic Factors

### Definition

Neurotrophic factors are a family of proteins responsible for the growth and survival of neurons during development and for the maintenance of adult neurons.

They are also capable of promoting damaged axons to regenerate after various peripheral and central nervous system injuries.

- ▶ Neural Development
- ▶ Neurotrophic Factors in Nerve Regeneration
- ▶ Regeneration
- ▶ Growth Factors

---

## Neurotrophic Factors in Nerve Regeneration

MATT S. RAMER, LOWELL T. MCPHAIL  
International Collaboration on Repair Discoveries,  
the University of British Columbia, Vancouver,  
BC, Canada

### Definition

Neurotrophic factors (NTFs) are naturally-occurring multifunctional secreted proteins, expressed throughout

development and into adulthood, and in part serve to promote neuronal survival, to support axonal outgrowth and target innervation, and in some cases to modulate synaptic transmission. This essay covers only their involvement in axonal regeneration. Three families of NTFs (the neurotrophins, the glial cell line-derived NTF family, and the ▶interleukin-6 (IL-6) family), and their effects on regeneration of two classes of peripheral nerve axons (primary sensory axons, and the axons of lower motoneurons) are used to illustrate the principle that regeneration is often, but not always, accelerated or otherwise improved by endogenous or exogenous NTFs. Where known, mechanisms of action are also described.

### Characteristics

#### Quantitative Description

##### The Model Systems

Vertebrate primary sensory neurons are pseudounipolar and clustered in bilaterally-symmetrical ganglia (dorsal root ganglia, DRG) adjacent to the spinal cord (Fig. 1).

Their single axon bifurcates within the DRG: one branch travels to the periphery where it innervates sense organs in skin, muscles or viscera; the other projects via the dorsal root to the spinal cord where it innervates spinal and/or supraspinal neurons. Most (~70%) DRG neurons detect temperature or noxious (painful) stimuli. These are small-to-medium in diameter, with thin, unmyelinated and slowly-conducting axons which innervate superficial spinal laminae centrally. Large diameter DRG neurons subserve proprioception and mechanoreception and terminate in deeper spinal laminae. Many of these axons also bifurcate central to their entry point within the cord and send a long projection via the dorsal columns to nuclei in the brainstem (Fig. 1). While injury to sensory axons can occur in any of these regions (peripheral nerve, dorsal roots and spinal cord), the differing environments in which the axons are injured dictate vastly differing outcomes: peripheral nerve injury can be followed by successful regeneration and target reinnervation; axons injured within dorsal roots regenerate up to the PNS: CNS interface, but do not penetrate the spinal cord; axons injured within dorsal columns do not regenerate at all, and may retract from the injury site for several hundred microns.

Lower motoneurons are situated in the ventral spinal cord and brainstem. Their axons exit the CNS via ventral roots or cranial motor nerves. Spinal motor axons join mixed spinal nerves just distal to the DRG, and innervate intra- and extrafusal muscle fibers in the periphery (Fig. 1). Motor axons can be injured anywhere along their length, but as with sensory axons, regenerative success depends on the site of injury: if axons are severed between their exit point in the spinal cord and their peripheral targets, they may regenerate and

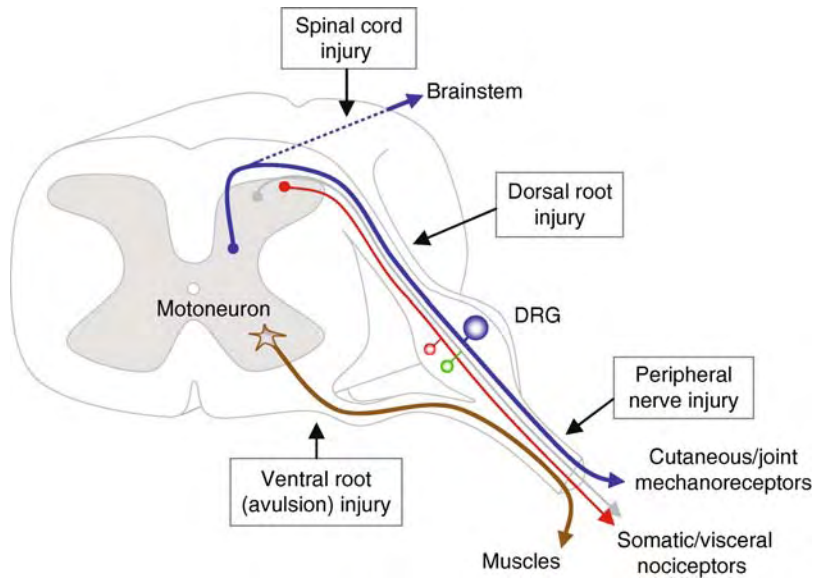

**Neurotrophic Factors in Nerve Regeneration. Figure 1** The axons of sensory neurons located in the **dorsal root ganglia (DRG)** bifurcate, one branch travels to peripheral sensory organs; the other projects via dorsal roots to the spinal cord where it innervates spinal and/or supraspinal neurons. Small DRG neurons detect temperature or noxious (painful) stimuli. These are small-to-medium in diameter, with unmyelinated, slowly-conducting axons that innervate superficial laminae in the spinal cord. Large DRG neurons subserve proprioception and mechanoreception and terminate in deeper laminae. Many of the DRG axons also bifurcate central to their entry point within the cord and send a long projection via the dorsal columns to nuclei in the brainstem. Lower motoneurons are situated in the ventral spinal cord and brainstem. Their axons exit the CNS via ventral roots or cranial motor nerves. Spinal motor axons join mixed spinal nerves just distal to the DRG, and innervate muscle fibres in the periphery.

restore function; if they are avulsed (torn from the cord such that the injury site lies deep to the pial surface), regeneration fails.

### Neurotrophic Factors

The first NTF to be discovered, based on its ability to promote neuronal survival and neurite outgrowth, was nerve growth factor (NGF). NGF is the prototypical member of a family which includes brain-derived NTF (BDNF), neurotrophin 4/5 (NT-4/5) and neurotrophin-3 (NT-3) (Fig. 2).

These molecules act through specific receptors: NGF binds to tropomyosin related kinase A (TrkA), BDNF and NT-4/5 bind to TrkB, and NT-3 binds to TrkC. All of these receptors are expressed in dorsal root ganglia, and (with the exception of TrkA) motoneurons. All neurotrophins also bind a receptor, **p75<sup>NTR</sup>**, which is co-expressed with the Trks but whose role in regeneration remains enigmatic. The neurotrophin sensitivity of DRG neurons is subtype-specific and has been repeatedly demonstrated *in vitro* and *in vivo*: half of all nociceptors/thermoreceptors express TrkA (the other half do not express any Trk but do express GDNF receptor components), whereas the majority of mechano/proprioceptors express TrkC, and a minority express TrkB. Motoneurons express both TrkB and TrkC.

The glial cell line-derived NTF (GDNF) family includes GDNF, neurturin, **artemin** and **persephin** (Fig. 2). GDNF was isolated based on its ability to promote survival of midbrain dopaminergic neurons, and the rest were identified based on sequence homology. All GDNF family members have been shown to augment neurite outgrowth *in vitro*, but only GDNF and neurturin have proved to enhance regeneration *in vivo*. GDNF family members signal through receptor complexes which involve a common signaling component (**Ret**) and ligand-specific binding components (GFR $\alpha$ 1–4). GFR $\alpha$ 1–3 are expressed in DRG neurons, mainly among thermo/nociceptors, while GFR $\alpha$ 1, 2 and 4 are expressed by motoneurons.

Three members of the interleukin-6 (IL-6) family of neurotrophic **cytokines** will be considered here: ciliary NTF (CNTF), leukemia inhibitory factor (LIF) and IL-6 (Fig. 2). Peripheral nerve injury increases the exposure of severed axons to all three factors, which are synthesized in nonneuronal cells. IL-6 upregulation also occurs following axotomy in large-diameter DRG neurons and in motoneurons. These molecules share a common receptor component, gp130, but activate it through receptor complexes: IL-6 and CNTF first bind non-signaling receptor components [IL-6R $\alpha$  and **CNTFR $\alpha$  (Ciliary Neurotrophic Factor Receptor)**] and then to a gp130 homodimer (in the case of IL-6) or a

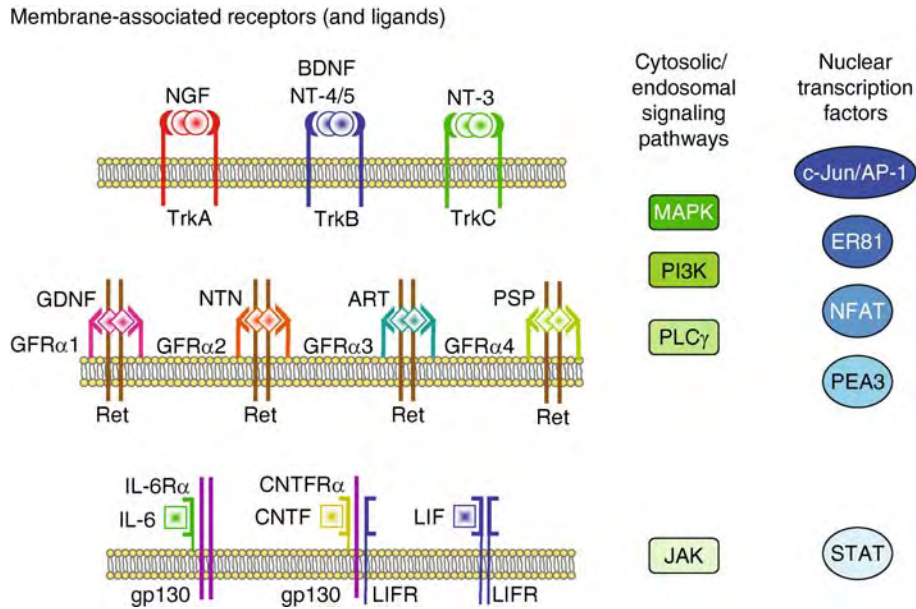

**Neurotrophic Factors in Nerve Regeneration. Figure 2** The neurotrophin family of NTFs consists of nerve growth factor (NGF), brain-derived NTF (BDNF), neurotrophin 4/5 (NT-4/5) and neurotrophin-3 (NT-3). NGF binds tropomyosin related kinase A (TrkA), BDNF and NT-4/5 bind to TrkB, and NT-3 binds to TrkC. The glial cell line-derived NTF (GDNF) family includes GDNF, ▶neurturin (NTN), ▶artemin (ART) and persephin (PSP). GDNF members signal through receptor complexes involving (Ret) and specific ligand binding components ▶Glial cell line – Derived neurotrophic factor receptors (GFR $\alpha$ 1–4). Three examples of the interleukin-6 (IL-6) family of neurotrophic ▶cytokines are, ciliary NTF (CNTF), ▶leukemia inhibitory factor (LIF) and IL-6. IL-6 members share the receptor component, ▶gp130, but activate it through specific receptors: IL-6 with ▶Interleukin-6 Receptor IL-6R $\alpha$ , CNTF with ▶CNTFR $\alpha$  and LIF with ▶LIFR. Cytosolic/endosomal signaling pathways following NTF ligand receptor binding include; Phosphatidylinositol-3-kinase (PI3K), mitogen-activated protein kinase (MAPK), Phospholipase C (▶PLC $\gamma$ ) and Janus kinase (JAK). Transcription factors induced by NTF activated pathways include; ▶c-Jun (AP-1), ▶ER81, ▶NFAT, PEAT and STAT.

heterodimer consisting of gp130 and ▶leukemia inhibitory factor receptor (LIFR, in the case of CNTF). LIF signals through LIFR: gp130 heterodimers. All DRG neurons express gp130, IL-6R $\alpha$ , and CNTFR $\alpha$ , while thermoceptors and nociceptors express LIFR. While LIFR, CNTFR $\alpha$  and gp130 are also found in motoneurons, data on motoneuronal IL-6R are lacking.

### Higher Level Processes

#### Positive and Negative Signaling Associated With Axotomy

Peripheral nerve injury results in a switch in the neurons from a transmissive to a regenerative state. The change of state of the neuron is accomplished predominately by an alteration in activation and/or expression of transcription factors, resulting in a decrease in molecules involved synaptic transmission and a concomitant increase in regeneration-associated structural and cytoskeletal proteins. Injury-induced changes are mediated by three broad classes of signals. The first is the immediate entry of ions such as sodium and calcium into the open end of the proximal axon stump, resulting in depolarization. The two other signals are those related to the retrograde transport of molecules in the

axon. There are those signals which appear as a result of injury (positive signals): factors released from cells at the injury site which have direct actions on the severed axons or are retrogradely transported to the cell body. There are also signals that disappear (negative signals) as a result of the interruption of retrogradely transported molecules from axonal targets. Positive signals include NTFs derived from Schwann cells and other non-neuronal cells at the site of injury. The loss of target-derived NTFs contributes to negative signaling. It has been proposed (although in many cases evidence is still lacking) that NTFs involved in both types of signaling promote regeneration: positive signals at the injury site may help begin the regenerative process, while target-derived signals may consolidate functional reinnervation. This reasoning has underpinned the application of exogenous NTFs following nerve injury *in vivo*.

#### Effects of NTFs at the Axonal Growth Cone

NTFs can promote regeneration through local signaling at the growth cone, where they act to increase the motility of filopodial actin and microtubules, the principal cytoskeletal elements governing growth cone

dynamics. This has been most clearly demonstrated for the Trk receptors, and for TrkA in particular [1] (Fig. 3).

phosphatidylinositol-3-kinase (PI3K) which leads to filopodial elongation via its effectors Rac and ▶Cdc42, Rho family ▶GTPases whose activation is generally associated with increased axonal outgrowth. Trk activation also leads, via increases in intracellular cyclic adenosine monophosphate (cAMP), to protein kinase A (PKA) activation, which has a number of positive effects on filopodial extension including activation of an actin anti-capping protein, ▶Ena/VASP, the effect of which is to allow for profilin-mediated increases in filopodial length. Microtubule stability is another prerequisite for regenerative growth that is positively regulated by Trk signaling. Trk-mediated activation of a pathway including the kinases Ras, ▶Raf and ▶Erk2 (a mitogen-activated protein kinase, MAPK) results in phosphorylation of microtubule associated proteins (MAPs) leading to increased stability. More recently it has been shown that TrkA activation allows microtubule plus-end capping by adenomatous polyposis coli (APC), through inhibition of glycogen synthase kinase 3β (GSK-3β). In the absence of NGF signaling, GSK-3β phosphorylates APC, preventing microtubule plus-end capping, reducing stability and decreasing motility [2] (Fig. 3). GDNF family members also activate MAPK and PI3K pathways, and have

similar effects on growth cone motility. IL-6-related NTFs are not known to have direct effects on cytoskeletal dynamics at the growth cone.

#### Effects of NTFs at the Neuronal Cell Body

Receptor-bound NTFs, including NGF, BDNF, NT-3, and NT-4/5, CNTF and LIF, are transported from the growth cone and axon to the cell body where they can effect transcription of ▶regeneration-associated genes (RAGs) (see essay in this Encyclopedia by H. Aldskogius). Such transport may be mediated by dynein-microtubule interactions, and is thought to involve a “signaling endosome”, which includes, in addition to the neurotrophin receptor and its ligand, MAPK, PI3K and ▶PLCγ pathway-associated signaling molecules [3] (Fig. 3). Therefore, the retrograde transport of the internalized neurotrophins and their receptor complex as well as the retrograde propagation of signaling pathways may work in concert to support survival and growth of the injured axon. Once at the cell body, retrogradely transported NTFs effect regeneration via both activation and *de novo* synthesis of appropriate transcription factors (TFs) (Fig. 2): the TFs CREB and ▶NFAT (Nuclear factor of activated T cells) are both activated by retrogradely transported neurotrophins; NT-3 signaling results in the upregulation of ER81 while GDNF upregulates ▶PEA3 – both are required for

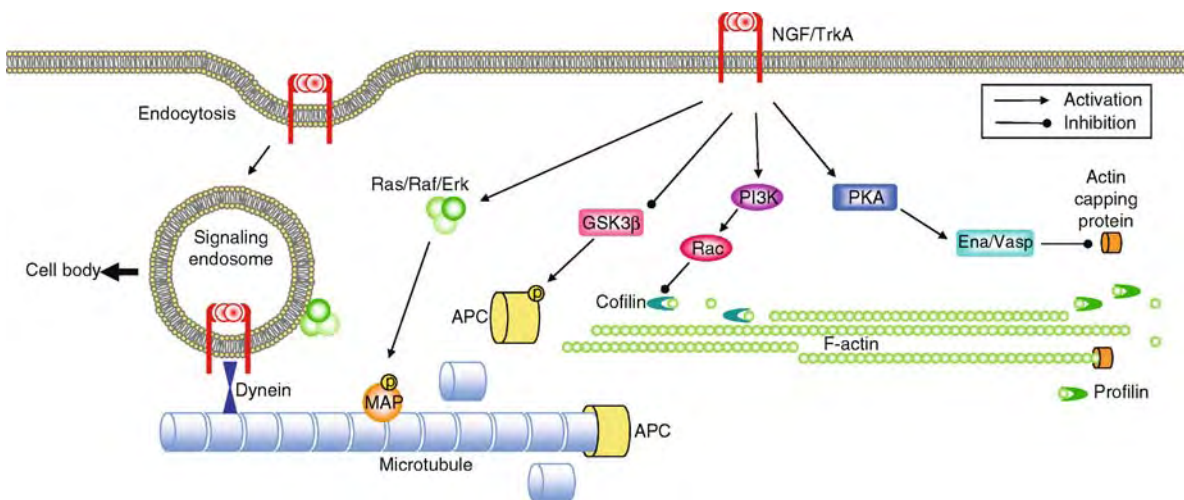

**Neurotrophic Factors in Nerve Regeneration. Figure 3** NTFs promote regeneration through signaling at the growth cone or via signaling endosomes directed towards the cell body. TrkA binding results in the activation of phosphatidylinositol-3-kinase (PI3K) and filopodial elongation/axonal growth via the ▶GTPase Rac. Trk binding activates protein kinase A (PKA) producing filopodial extension and activation of an actin anti-capping protein, ▶Ena/VASP allowing a profilin-mediated increased filopodial length. Trk-mediated activation of the kinases Ras, ▶Raf and ▶Erk2 (▶Extracellular stress regulated kinase) results in phosphorylation of ▶microtubule associated proteins (▶MAPs) and increased microtubule stability. TrkA activation also allows microtubule plus-end capping by ▶adenomatous polyposis coli (APC), through inhibition of ▶glycogen synthase kinase 3β (GSK-3β). GDNF NTFs activate MAPK and PI3K pathways, and have similar effects on growth cone motility. IL-6-related NTFs have no known direct effects on growth cone motility. Following endocytosis, the ligand-receptor complex forms a signaling endosome and is retrogradely transported to the cell body via the microtubule associated motor dynein.



NTF-mediated outgrowth. The immediate-early gene product ►c-Jun, which associates with the AP-1 TF complex, is perhaps the best characterized downstream effector of NTF signaling. Not only is c-Jun upregulated following peripheral nerve injury in sensory and motoneurons, but also it is activated by ►Jun kinases (►JNK), recently shown to be downstream effectors of neurotrophin-dependent MAPK signaling [4]. Finally, retrograde signaling by IL-6 family members results in the activation of Janus kinases (JAKs) and the subsequent nuclear translocation of activated ►signal transducers and activator of transcription 3 (STAT3), effecting RAG expression (Fig. 2).

### Regulation of the Process

#### NTFs and Regeneration of Sensory Axons

The majority of sensory neurons respond to either NGF, NT-3 or GDNF. Surprisingly little is known about the efficacy of these factors in enhancing regeneration of sensory axons following peripheral nerve injury, possibly because peripheral nerve regeneration is often successful. However, there appears to be little requirement for endogenous NTFs in naturally-occurring regeneration: axotomized TrkA- and TrkC- expressing nociceptive and mechanosensitive axons, for example, reinnervate their peripheral targets normally in the presence of antibodies which block NGF and NT-3 [5]. The effects of exogenous NTFs have been more clearly demonstrated following dorsal root lesions [6]: while sensory axons normally fail to regenerate beyond the PNS:CNS interface, NGF, NT-3 and GDNF treatment resulted in the regrowth of appropriate populations of axons into the spinal cord. Furthermore, regrowth was accompanied by functional recovery, which was demonstrated both electrophysiologically and behaviorally. Mechano/proprioceptive axons injured within dorsal columns are also able to regenerate when treated with NT-3, but not with BDNF or GDNF [7].

The neurotrophic cytokines LIF and IL-6 do not induce neurite outgrowth from ►DRG neurons directly, but collaborate with other growth-promoting factors or manipulations: LIF enhances DRG neurite elongation in NGF-treated cultures, and IL-6 has a similar effect in cultures treated with either NGF or NT-3 [8]. *In vivo*, peripheral nerve regeneration is impaired in LIF knockout mice [8]. Additionally, the growth-enhancing effect on axotomized dorsal column sensory axons of a prior peripheral nerve “conditioning” injury was abolished in the absence of IL-6 [8]. No data are available on the effect of CNTF on sensory axon regeneration.

#### NTFs and Regeneration of Motor Axons

While direct actions of NTFs on sensory axons are evident from their differential effects on distinct sub-populations of adult DRG neurons, the same cannot be

said for adult motoneurons, which are more homogenous and, by virtue of their poor survival in isolation, difficult to study *in vitro*. Like DRG neurons, motoneurons do not appear to require endogenous NTFs for successful axonal elongation, since function-blocking antibodies against BDNF, CNTF and GDNF (the most potent motoneuronal NTFs) do not prevent axonal elongation following injury to the facial nerve (a purely motor nerve) [9]. On the other hand, exogenous NTFs, including BDNF, NT-3, GDNF, CNTF and IL-6, have been shown to improve functional recovery, and in several cases increase muscle innervation, following peripheral nerve injury or ventral root avulsion. Despite these findings, it is as yet unclear how exogenous NTFs promote functional recovery. Motoneuron survival following axotomy (particularly following ventral root avulsion injury), collateral sprouting of spared axons, and even trophic or migration-enhancing effects on nonneuronal cells are all able to explain increased target reinnervation and improved motor performance [10]. While all of these factors have well-described survival promoting effects on motoneurons, there is as yet little evidence supporting direct effects of NTFs on the regeneration of motor axons *in vivo*.

### References

1. Markus A, Patel TD, Snider WD (2002) Neurotrophic factors and axonal growth. *Curr Opin Neurobiol* 12:523–531
2. Zhou FQ, Zhou J, Dedhar S, Wu YH, Snider WD (2004) NGF-induced axon growth is mediated by localized inactivation of GSK-3beta and functions of the microtubule plus end binding protein APC. *Neuron* 42:897–912
3. Zweifel LS, Kuruvilla R, Ginty DD (2005) Functions and mechanisms of retrograde neurotrophin signalling. *Nat Rev Neurosci* 6:615–625
4. Waetzig V, Herdegen T (2005) MEKK1 controls neurite regrowth after experimental injury by balancing ERK1/2 and JNK2 signaling. *Mol Cell Neurosci* 30:67–78
5. Diamond J, Foerster A, Holmes M, Coughlin M (1992) Sensory nerves in adult rats regenerate and restore sensory function to the skin independently of endogenous NGF. *J Neurosci* 12:1467–1476
6. Ramer MS, Priestley JV, McMahon SB (2000) Functional regeneration of sensory axons into the adult spinal cord. *Nature* 403:312–316
7. Bradbury EJ, McMahon SB, Ramer MS (2000) Keeping in touch: sensory neurone regeneration in the CNS. *Trends Pharmacol Sci* 21:389–394
8. Cafferty WB, Gardiner NJ, Das P, Qiu J, McMahon SB, Thompson SW (2004) Conditioning injury-induced spinal axon regeneration fails in interleukin-6 knock-out mice. *J Neurosci* 24:4432–4443
9. Streppel M, Azzolin N, Dohm S, Guntinas-Lichius O, Haas C, Grothe C, Wevers A, Neiss WF, Angelov DN (2002) Focal application of neutralizing antibodies to soluble neurotrophic factors reduces collateral axonal branching after peripheral nerve lesion. *Eur J Neurosci* 15:1327–1342

10. Boyd JG, Gordon T (2003) Neurotrophic factors and their receptors in axonal regeneration and functional recovery after peripheral nerve injury. *Mol Neurobiol* 27:277–324

regulate ligand binding specificity. GFR $\alpha$ 2 is the preferred receptor for neurotrophin.

- ▶ Glia Cell Line-derived Neurotrophic Factor
- ▶ Neurotrophic Factors
- ▶ Neurotrophic Factors in Nerve Regeneration

## Neurotrophin 4/5 (NT-4/5)

### Definition

Neurotrophin 4/5 is a neurotrophic factor that has been shown to have a protective effect on the survival of retinal ganglion cells.

- ▶ Regeneration of Optic Nerve
- ▶ Retinal Ganglion Cells

## Neurotrophins

### Definition

Neurotrophins are molecules important for the health and maintenance of neurons. They are structurally and functionally related to nerve growth factor, the first identified neurotrophin, and signal through high affinity tyrosine kinase receptors (Trk A-C) and a low affinity p75 neurotrophin receptor. Neurotrophins can stimulate neurite outgrowth and act as a long-range diffusible guidance cue. In addition, neurotrophins can stimulate gene expression and promote neuron survival.

- ▶ Neural Development
- ▶ Regeneration

## Neurotrophin

### Definition

A member of the glial cell line-derived neurotrophic factor (GDNF) family of neurotrophic factors that also includes artemin and persephin. GDNF family members use a receptor complex that consists of the common receptor tyrosine kinase signaling component Ret and one of the GPI-linked receptors (GFR $\alpha$ 1 to 4) that

## Neurovascular Tract

### Definition

The extramuscular collagen fiber-reinforced sheet of connective tissue in which nerves and blood vessels are embedded. This tract is connected to other extramuscular elements of the muscular compartment.

## Neurovegetative Function in Outer Space

- ▶ Autonomic Function in Space

## Neutralizing Antibody

### Definition

Neutralizing antibody (NA) is an antibody which inhibits the infectivity of a blood-borne virus or bacterium.

- ▶ Central Nervous System Infections: Humoral Immunity in Arboviral Infections

## Neutrophils

### Definition

Neutrophils are often called polymorphonuclear cells due to their multilobulated nucleus. As the cells that respond first, normal circulating neutrophils enter into

local tissue where infection or injury occurs. Neutrophils exert their protection mainly by phagocytosing damaged tissue, infected cells and invading pathogens.

## New Developments in G Protein-Coupled Receptor Theory

IAN MULLANEY

School of Pharmacy, Division of Health Sciences, Murdoch University, WA, Australia

### Synonyms

Cell signaling; Molecular pharmacology; Signal transduction

### Definition

Approximately 1% of the genome of higher organisms encodes the family of G protein-coupled receptors (GPCRs). These receptors are characterized by containing seven transmembrane domains, being linked to guanine nucleotide-binding proteins (GTP-binding proteins) and ubiquitously distributed on the plasma membrane of all cell types. The first wave of research into these molecules identified family members, assigned coupling to individual GTP-binding proteins, characterized signaling pathways and elucidated the molecular apparatus by which GPCRs are switched off and recycled back to the membrane. A new wave of GPCR research is underway, looking at the more complex relationship that these molecules have with a variety of processes both cellular and pharmacologic.

### Characteristics

#### Dimerization/Oligomerization

Although protein-protein interactions have been shown to be instrumental in the organizational structure and function of many cell signaling processes, it has been the belief that G protein-coupled receptors occur and function as monomeric, non-interacting species. However, it has become clear that a number of GPCR species can form dimers (both ►GPCR homodimers and ►GPCR heterodimers) and/or larger oligomeric (►GPCR oligomer) complexes. Although the precise cellular function of GPCR homodimerization is unclear, a number of roles have been proposed for this process. These revolve around the participation of dimerization at the level of synthesis or during protein maturation in the Golgi apparatus and result in the successful delivery of the protein to the cell surface. Crucial to the process is the involvement of specific dimerization motifs that occur in various structural domains within the protein. Disruption of such a motif in TMD VI (transmembrane domain VI) of the  $\beta_2$  adrenoceptor resulted in loss of

homodimerization and subsequent insertion of this receptor into the plasma membrane. With over 400 genes encoding non-sensory GPCRs now having been identified, it is no surprise that co-expression and subsequent dimerization between different receptor species has been observed. Heterodimerization has been proposed to promote the formation of receptors with unique pharmacological properties, contributing to the pharmacological diversity of GPCRs. Jordan and Devi [1] first provided biochemical and pharmacological evidence for a fully functional heterodimer comprising kappa and delta opioid receptors. This new formation resulted in a novel receptor that exhibited ligand binding and functional properties distinct from those of either receptor. Furthermore, the kappa-delta heterodimer synergistically binds highly selective agonists and potentiates signal transduction. More recently, other heterodimer receptor pairs including the orexin-1 receptor (►Orexin receptor) and cannabinoid CB1 receptor dimer and the angiotensin AT1 receptor and bradykinin B2 receptor dimer have been identified. These have been demonstrated to display changes in GTP-binding protein-coupling specificity as well as altered receptor-mediated endocytosis.

#### GPCR – Protein Complexes in Living Cells

In addition to binding to protein and peptide ligands, GTP-binding proteins and forming complexes amongst themselves, GPCRs also appear to interact with a large and diverse group of proteins that have a role in a number of receptor functions including trafficking, signal transduction, desensitization (►Receptor desensitization) and down-regulation and receptor recycling. Candidate molecules for interaction include ►GPCR kinases (GRKs), arrestins, protein kinase A, protein kinase C, molecular chaperones and receptor activity-modifying proteins (RAMPs). The use of novel biophysical techniques such as fluorescence resonance energy transfer (FRET) and ►bioluminescence resonance energy transfer (BRET), which utilize energy transferred from a fluorescent donor to an acceptor molecule, has allowed observation of protein-protein interactions to be analyzed in real time in living cells.

The receptor-activity-modifying proteins (RAMPs) are single transmembrane proteins that heterodimerize with GPCRs. To date 3 RAMPs (RAMP1,2,3) have been molecularly identified. Calcitonin-gene-related peptide (CGRP) and adrenomedullin are related peptides with distinct pharmacological profiles and signaling pathways. Each of these ligands function through the calcitonin-receptor-like receptor (CRLR). It is association with the various RAMPs that determines ligand specificity. RAMP1 presents the receptor at the cell surface as a mature glycoprotein and a CGRP receptor whilst RAMP2-transported receptors are core-glycosylated and are adrenomedullin receptors. Adrenomedullin and CGRP receptors are potential therapeutic targets for several diseases including

migraine, hypertension, pulmonary hypertension and sepsis. Thus, understanding how ligand binding to the receptor complex is regulated by RAMPs is crucial for the development of pharmaceutical agents. Recent studies showing association of RAMPs with other GPCR families has broadened the importance of this class of accessory proteins [2].

### Inverse Agonists/Constitutive Activation

GPCRs are able to achieve and maintain a spontaneously active conformation that results in a constitutively active receptor, a process termed **▶negative efficacy**.

Certain ligands (termed inverse agonists) have been demonstrated to decrease this **▶constitutive activation**. Indeed, many drugs that were originally classified as neutral antagonists, including prazosin, pirenzepine, trihexylphenidyl and losartan, can now be reclassified as inverse agonists (**▶Inverse agonism**). In 1996, five GPCR subtypes ( $\delta$  opioid receptor,  $\beta_2$  adrenoceptor, 5-HT<sub>2C</sub> receptor, bradykinin B2 receptor, M1 muscarinic acetylcholine receptor) were noted to display negative efficacy. At present several dozen constitutively active GPCR subtypes have been identified [3]. Although original studies used systems that over-expressed GPCRs, native GPCRs expressed at normal levels demonstrate constitutive activity. In addition, this activity has a physiological role. For example, in rat brain synaptosomes, inverse agonists, but not competitive antagonists, acting at the H<sub>3</sub> histamine receptor suppress K<sup>+</sup>-induced release of histamine. Thus a degree of constitutive H<sub>3</sub> receptor activity in presynaptic terminals *in vivo* limits histamine release [4].

Furthermore, the existence of this phenomenon has allowed for the consideration of inverse agonists to be used as pharmacotherapeutic agents. In diseases where mutation in receptors results in increased constitutive signaling via the receptor (such as male precocious puberty where there is a mutation in the LH receptor in the testes that results in early onset of puberty), use of an appropriate inverse agonist could eliminate the constitutive activity of the receptor [3]. A number of pharmacological agents originally determined to be neutral antagonists but now reclassified as inverse agonists, are in use within a clinical setting. Included in this category are a series of dopamine D2 receptor ligands including haloperidol, clozapine and olanzapine, that are currently used in the treatment of schizophrenia [5]. Similar results were obtained demonstrating that the putative antipsychotic agents L-745,870 and U-101958, thought to be dopamine D4-specific antagonists, display inverse agonist effects at this receptor [6].

### Free Fatty Acids as GPCR Ligands

Although originally thought primarily as direct energy sources, free fatty acids also play key roles in regulating a variety of physiological effects. Although these

responses were thought to occur as a consequence of their metabolism, it is now clear that free fatty acids including  $\alpha$ -linolenic acid and docosahexanoic acid, function directly as agonists at GPCRs. The breakthrough came when a series of orphan GPCRs (**▶Orphan receptors**) were identified from a variety of human tissues. Although most were involved with glucose metabolism in pancreatic  $\beta$ -cells, one, **▶GPR40**, was highly expressed in brain. This receptor couples to the Gq/G11 group of GTP-binding proteins and when activated by the FFA palmitate, results in substantial elevation in intracellular calcium. Although the physiological role of these receptors in brain is unclear, it has been speculated that they may play a fundamental role in the neurological disorders of aging, Alzheimer's disease, Parkinson's disease, and stroke [7].

### Addiction, GPCR Desensitization and Tolerance to Drugs

It has been well characterized that desensitization of agonist-occupied GPCR occurs first through phosphorylation of the receptor by GPCR kinases (GRKs) then subsequent binding of the phosphorylated receptor to arrestins that uncouple it from GTP-binding proteins. This in turn targets the receptors for internalization via clathrin-coated vesicles.

The frequent administration of certain drugs leads to the development of tolerance to the effects of the drug. This is best characterized by opiates such as the alkaloid morphine where the analgesic, rewarding and respiratory effects of the drug are diminished upon repeated administration, limiting its clinical usefulness (see Chapter on **▶Tolerance and Dependence**). Morphine causes its behavioral effects by activating  $\mu$  opioid receptors, an effect verified by the loss of drug effects in  $\mu$  opioid receptor knockout mice [8]. This receptor subtype couples to Gi/Go activating inwardly rectifying potassium channels, inhibiting voltage-activated calcium channels and decreasing intracellular cAMP levels through inhibition of adenylyl cyclase. As with other GPCRs, the  $\mu$  opioid receptor is rapidly desensitized upon activation with agonist. However, the route of signal attenuation is dependent on the type of agonist activating the  $\mu$  opioid receptor. DAMGO, a high-affinity peptide agonist, induces desensitization through GRK whereas morphine, which is a partial agonist at these receptors, desensitizes the GPCR through activation of protein kinase C. Although tolerance to morphine is a multi-faceted process, it is recognized that adaptive changes at the level of the  $\mu$  opioid receptor is an important factor in tolerance in the intact animal. Indeed, there are numerous reports that implicate protein kinase C in both acute and chronic tolerance to the analgesic properties of opioids. Such studies employ the use of protein kinase C inhibitors such as H7 and bisindolylmaleimide to reverse tolerance in animals even when they are administered some

days after morphine infusion [9]. Thus the development of inhibitor drugs, to be used in negating tolerance to morphine, increasing the clinical efficiency of opiate drugs and reducing the social problems that accompany recreational opioid abuse, is of prime importance.

The 5-HT<sub>2C</sub> receptor is used as a target for drug addiction. Agonists at this receptor have been demonstrated to moderate addiction-related behaviors such as hyperactivity, place preference and compulsive behavior connected with common recreational drugs including cocaine, alcohol, nicotine and cannabinoids. However the use of such agonists is associated with a series of unwanted adverse effects including anxiety, hypophagia, hypolocomotion and disturbances of motor function. Activation of these receptors with agonists results in receptor phosphorylation then dephosphorylation, a event demonstrated to mediate many of the adverse effects associated with addiction. One new strategy in the treatment of addiction has been to prevent the dephosphorylation of the receptor by inhibiting ▶PTEN, the phosphatase responsible, with specific peptides that blocks its interaction with the receptor. This mimics the agonist activation process but suppresses the adverse effects associated with dephosphorylation [10]. This approach could lead to a more effective strategy for the treatment of drug addiction.

## References

- Jordan BA, Devi LA (1999) G protein-coupled receptor heterodimerization modulates receptor function. *Nature* 399:697–700
- Parameswaran N, Spielman WS (2006) RAMPs: the past, present and future. *Trends Biochem Sci* 31:631–638
- Bond RA, Ijzerman AP (2006) Recent developments in constitutive receptor activity and inverse agonism, and their potential for GPCR drug discovery. *Trends Pharmacol Sci* 27:92–96
- Morisset S, Rouleau A, Ligneau X et al. (2000) High affinity constitutive activity of native H3 receptors regulates histamine neurons in brain. *Nature* 408:860–864
- Hall DA, Strange PG (1997) Evidence that antipsychotic drugs are inverse agonists at D2 dopamine receptors. *Br J Pharmacol* 121:731–736
- Gazi L, Bobirnac I, Danzeisen M et al. (1998) The agonist activities of the putative antipsychotic agents, L-745,870 and U-101958 in HEK293 cells expressing the human dopamine D4.4 receptor. *Br J Pharmacol* 124(5):889–896
- Brown AJ, Jupe S, Briscoe CP (2005) A family of fatty acid binding receptors. *DNA Cell Biol* 24:54–61
- Matthes HW, Maldonado R, Simonin F et al. (1996) Loss of morphine-induced analgesia, reward effect and withdrawal symptoms in mice lacking the  $\mu$  opioid receptor gene. *Nature* 383:819–823
- Bailey CP, Smith FL, Kelly E et al. (2006) How important is protein kinase C in  $\mu$ -opioid receptor desensitization and morphine tolerance. *Trends Pharmacol Sci* 27:558–565
- Ji SP, Zhang Y, Van Cleemput J et al. (2006) Disruption of PTEN coupling with 5-HT<sub>2C</sub> receptors suppresses behavioural responses induced by drugs of abuse. *Nat Med* 12:324–329

## Newtonian Mechanics

### Definition

A formulation of the laws of mechanics based on Newton's approach, whereby forces are primary quantities to be related to the motion of the system by certain vectorial laws. In the case of particle mechanics, these laws are essentially those formulated by Newton himself. In continuum mechanics, this approach is generalized by (i) the introduction of appropriate balance laws in terms of densities, (ii) the independent postulation of the balance of angular momentum and (iii) the inclusion of the first and second laws of thermodynamics for continuous systems.

▶Mechanics

## NF- $\kappa$ B

### Definition

NF- $\kappa$ B (nuclear factor-kappa B) is a transcription factor protein complex involved in many important biological processes, including the immune response to infection, learning and memory.

▶Chromatin Immunoprecipitation and the Study of Gene Regulation in the Nervous System

▶NF- $\kappa$ B – Potential Role in Adult Neural Stem Cells

## NF- $\kappa$ B – Potential Role in Adult Neural Stem Cells

DARIUS WIDERA, CHRISTIAN KALTSCHMIDT,  
BARBARA KALTSCHMIDT  
Department of Cell Biology, Faculty of Biology,  
University of Bielefeld, Bielefeld, Germany

### Synonyms

NF- $\kappa$ B: (NF-kappaB; NF- $\kappa$ B); DNA-binding subunits of NF- $\kappa$ B; p65 (RelA); p50 (NFKB1); p52 (NFKB2);

c-Rel (REL); RelB (RELB); Inhibitory subunits of NF- $\kappa$ B: I $\kappa$ B- $\alpha$  (NFKBIA); I $\kappa$ B- $\beta$  (NFKBIB); I $\kappa$ B- $\epsilon$  (NFKBIE); I $\kappa$ B- $\zeta$  (NFKBIZ)

## Definition

### Neural Stem Cells

Stem cells are defined as undifferentiated cells with the ability to (i) proliferate, (ii) exhibit self-maintenance, (iii) generate a large number of progeny, including the principal phenotypes of the tissue, (iv) retain their multi-lineage potential over time, and (v) generate new cells in response to injury or disease.

Neural stem cells can be found within their complex niche in the mammalian brain. Neural stem cells could be maintained in culture via propagation of floating cell clusters called “neurospheres.” Neurospheres contain committed progenitors, differentiated astrocytes, neurons and neural stem cells. A progenitor is defined as mitotic cell with a fast cell-division cycle that retains the ability to proliferate and give rise to terminally differentiated cells but that is not capable of indefinite self-renewal.

### Nuclear Factor- $\kappa$ B

Nuclear factor kappa B (NF- $\kappa$ B) is a **transcription factor (TF)** composed of homo- or heterodimeric DNA-binding subunits (e.g., p50 and p65). Inducible forms of NF- $\kappa$ B reside in the cytoplasm due to an interaction with one inhibitory subunit (e.g., I $\kappa$ B- $\alpha$ ). Upon activation by growth factors, etc. (see Fig. 1), the I $\kappa$ B Kinase complex

(IKK) catalyzes phosphorylation of the inhibitory subunit I $\kappa$ B, which leads to proteasomal degradation. This exposes the nuclear localization signals (see green dots in Fig. 1). Nuclear import of NF- $\kappa$ B via importins activates transcriptional target genes driving **proliferation**, such as Cyclin D1 (see Fig. 1). NF- $\kappa$ B is involved in many biological processes, such as inflammation and innate immunity, development, apoptosis and anti-apoptosis [1]. In the nervous system NF- $\kappa$ B plays a crucial role in neuronal plasticity, learning, neuroprotection and neurodegeneration. In addition, recent data suggest a crucial role of NF- $\kappa$ B on proliferation, migration and **differentiation** of neural stem cells.

In the G<sub>1</sub> phase, NF- $\kappa$ B activates cyclin D1 expression by direct binding to multiple sites in the cyclin D1 promoter. This promotes G<sub>1</sub>-to-S progression. In contrast, NF- $\kappa$ B action in the M-phase leads to differentiation or migration induction.

In this essay we suggest a model explaining the multiple action of NF- $\kappa$ B within neural stem cells.

### CNS

The Central Nervous System (CNS, systema nervosum centrale), consisting of the brain and spinal cord is one of the two major parts of the nervous system. CNS integrates all nervous activities. The second part is the peripheral nervous system (PNS) which is outside the brain and spinal cord and regulates e.g., the heart muscle, the muscles in blood vessel walls or glands.

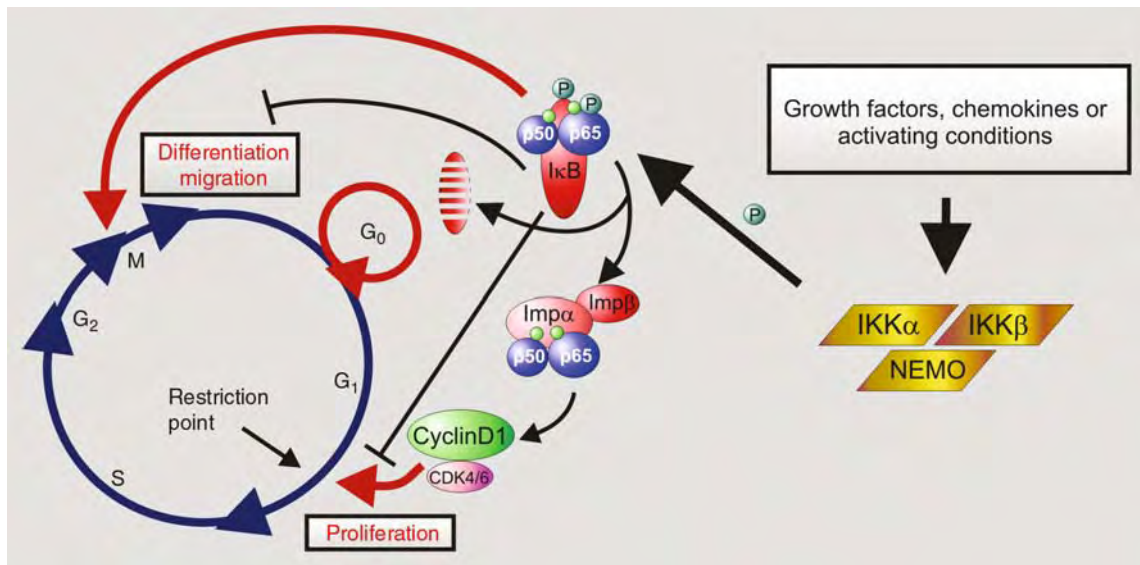

**NF- $\kappa$ B – Potential Role in Adult Neural Stem Cells. Figure 1** Model for the involvement of NF- $\kappa$ B in the molecular machinery of the cell cycle essential for proliferation, differentiation and migration of neural stem cells. Activation of IKK complex and subsequent NF- $\kappa$ B activation via growth factors, chemokines or activating conditions leads to ubiquitination and proteasomal degradation of I $\kappa$ B. After nuclear translocation NF- $\kappa$ B binds to specific promoter regions of the target genes and activates their transcription. Depending on the cell cycle point these targets are genes regulating proliferation or migration and differentiation.

On the cellular level, CNS consists of a network of nerve cells, glial cells (e.g., astrocytes and microglia) and neural stem cells. Neurons, the primary cells of the CNS, are responsible for information processing and storage. Glial tissue surrounds and supports neurons and is important for response against infection and tissue repair (e.g., microglia). Novel data define astrocytes and radial glia as a potential stem cell pools.

## Characteristics

### Adult Neural Stem Cells

Until recently, the dogma existed that stem cells are not present in the adult CNS. Currently, there are many reports clearly demonstrating neurogenesis in different regions of the adult brain [2,3]. Stem cells within the adult brain were found within the subgranular zone of the hippocampus and in the subventricular zone (SVZ). The immunocytochemical markers expressed by NSCs include inter alia the intermediate filament Nestin, the transcription factors Sox1 and Sox2, the RNA binding protein Musashi and the transmembrane protein prominin-1 (CD133) (see Table 1).

Isolated and cultured NSCs may have the ability to replace lost cells within the central nervous system, - an important issue for future therapy of neurodegenerative diseases as Parkinson's and Alzheimer's disease. Moreover NSCs also offer hope for fighting against cancer by the delivery of chemotherapy agents directly to tumor cells.

### NF- $\kappa$ B in the Nervous System

In the nervous system, the most frequent form of NF- $\kappa$ B is a heterodimer composed of p50 and p65. Activating stimuli like ► **Tumor Necrosis Factor (TNF)** (see Fig. 2) or Erythropoietin (EPO) activate a kinase complex composed of two I $\kappa$ B-specific kinases (IKK $\alpha$  and IKK $\beta$ ) and a modulatory subunit (IKK $\gamma$ /NEMO). The IKK- $\alpha/\beta$  complex phosphorylates the inhibitory I $\kappa$ B, which is then ubiquitinated and degraded via the proteasome. This degradation triggers the translocation of NF- $\kappa$ B into the nucleus followed by initiation of transcription. For a detailed discussion on the action of NF- $\kappa$ B in the CNS see also [4,5 and 6].

Apart from the inducible NF- $\kappa$ B activity, there are reports on constitutively active NF- $\kappa$ B in several cell types, such as hippocampal neurons, or numerous brain-related cancer types such as glioblastomas.

### NF- $\kappa$ B and Neural Stem Cell Proliferation

Most of the culture protocols for NSCs use bFGF (FGF-2) and EGF for keeping the cells in undifferentiated and proliferating state [2–3]. Over the years many additional molecules and cultivation conditions were identified to influence the NSC proliferation (see Table 2).

Here we summarize several evidences for a crucial involvement of NF- $\kappa$ B in proliferation control.

An enhanced proliferation of NSCs in vitro and in vivo after Erythropoietin (EPO) treatment has been reported. Demonstrably, the authors provide evidence

**NF- $\kappa$ B – Potential Role in Adult Neural Stem Cells. Table 1** Examples for immunocytochemical markers for neural stem cells

Marker	Detected in species: m: mouse; r: rat; h: human	Expression in adult NSCs	Expression in fetal NSCs
Nestin	m/r/h	+	+
Sox1	m/r/h	+	+
Sox2	m/r/h	+	+
prominin-1 (CD133)	m/h(CD133)	+	+
Musashi	m/r/h (MSI)	+	+
SSEA-1/LeX	m/r/h	+	+
L1	m/r/h	+	+
ABCG2 (Bcrp1)	r/h	+	+
PSA-NCAM	m/r/h	+	+
CD24	h	+	+
CD44	h	+	+
CD81	h	+	+
CD90	h	+	+
CD184	h	+	+
Dnmt3a	m	–	+
Vimentin	m/r/h	+	+

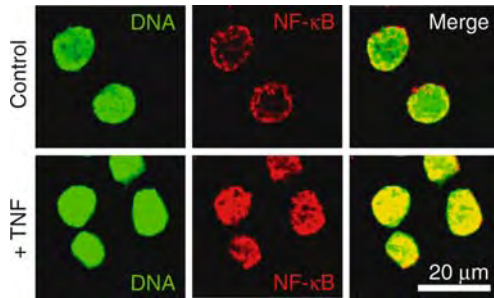

**NF-κB – Potential Role in Adult Neural Stem Cells.**

**Figure 2** TNF-induced nuclear localization of the transactivating NF-κB subunit p65 in neural stem cells. NSCs were fixed and stained with an antibody against the p65 subunit of NF-κB. Nuclei (DNA) were stained with SYTOX (*green*). The activation of the NF-κB pathway is shown as nuclear translocation of NF-κB visualised using an antibody against the p65 subunit. The nuclear translocation of NF-κB is followed by the transcription of target genes responsible for proliferation, migration and differentiation of neural stem cells.

that EPO is a homeostatic autocrine-paracrine signaling molecule with actions mainly mediated by NF-κB [7].

EPO and EPO receptors are upregulated in the CNS after hypoxia. Similarly, hypoxia activates NF-κB in neonatal rat hippocampus and cortex. Under hypoxic conditions, hypoxia-inducible-factor1α (HIF-1α), an important transcription factor for regulation of the oxygen response, translocates into the nucleus and binds to promoter region of the *epo* gene leading to upregulated expression (for review see [8]). Induction of proliferation is also conceivable for culture density. The level of reactive oxygen species (ROS) is significantly elevated under low density conditions, leading to increased proliferation. Bonello et al. recently reported that ROS activates HIF-1α itself via a functional NF-κB binding site in pulmonary artery smooth muscle cells.

We and others demonstrated that TNF-α triggers the proliferation of NSCs. NF-κB has been identified as the main driving force of TNF-mediated proliferation [9].

**NF-κB – Potential Role in Adult Neural Stem Cells. Table 2** Examples for molecules and/or conditions inducing proliferation or migration of NSCs

Proliferation	
Molecule or condition	Influence on proliferation + positive/- negative
EGF	+
bFGF	+
TNF	+
EPO	+
Hypoxia	+
L1	-
GM-CSF	+
ROS/Density	+
Neurofibromin	+
mAChR-stimulation	+
Cerebral infarction	+
Soluble amyloid precursor protein	+
Abeta	-
Sphingosine-1-phosphate	+
NO	-
Traumatic brain injury	+
Glutamate	+
Migration	
MCP-1	
SCF	
SDF-1α	
PDGF	
Cerebral cortex injury	
Microglia culture supernatants	
ischemia stroke	
Seizure	





In the nervous system glutamate is described as a potent activator of NF- $\kappa$ B. In respect of the influence on NSCs, also glutamate enhances survival and triggers the proliferation of SVZ derived NSC.

As another molecule which increases the proliferation of NSCs, Sphingosine-1-phosphate (S1P) was described. Studies investigating endothelial cells showed that S1P induces the activation of NF- $\kappa$ B-mediated transcriptional activity.

Amyloid beta-peptide (A $\beta$ ), a self aggregating peptide and responsible for Alzheimer's disease, significantly decreases the proliferation of neural stem cells in vitro and in vivo. This result correlates with the fact that high amounts of A $\beta$  acts as repressor of NF- $\kappa$ B. In contrast – the soluble secreted form of amyloid precursor protein, a well known NF- $\kappa$ B target gene, increases the proliferation of neural stem cells. In this context it is of importance that secreted beta-amyloid precursor protein counteracts the proapoptotic action of mutant presenilin-1 by activation of NF- $\kappa$ B.

Neurofibromin is able to increase the proliferation of NSCs. Neurofibromin, a product of the neurofibromatosis 1 (*nf1*) gene is one of the key regulators of the RAS oncogene. Noteworthy, expression of activated RAS stimulates NF- $\kappa$ B.

Cyclin dependent kinase 4 and 6 (CDK4/6) signaling is essential in **▶cell cycle** regulation in NSCs. In addition, the formation of the complex of CDKs 4 and 6 with Cyclin D1 is necessary for the cell cycle progression. Demonstrably, NF- $\kappa$ B controls growth and differentiation through transcriptional regulation of Cyclin D1 (see [Fig. 1](#)).

NO is a physiological inhibitor of neurogenesis. In addition, nitric oxide synthesis inhibition increases proliferation of neural precursors. It is noteworthy that NO is a well known repressor of NF- $\kappa$ B in neurons providing a link between NO dependent increase of progenitor proliferation and decreased NF- $\kappa$ B activity.

TGF- $\beta$ 1 is one of the well known inhibitors of NF- $\kappa$ B. According with our theory of proliferation control by NF- $\kappa$ B, TGF- $\beta$ 1 has been identified as a potent inhibitor of neurogenesis inducing a cell cycle arrest in the G<sub>0</sub>/G<sub>1</sub> phase.

Taken together there are numerous evidences for a crucial role of NF- $\kappa$ B in control of neural stem cell proliferation.

### NF- $\kappa$ B and Migration of Neural Stem Cells

In spite of many important proceedings on the field of neural stem cell biology, the factors that orchestrate homing of NSCs are largely unknown. There are only few reports identifying factors inducing migration of NSCs (see [Table 2](#)).

The expression of several chemokine receptors by NSCs such as CCR2, CXCR4 and c-kit (Stem Cell Factor Receptor) is well described.

MCP-1 is a very potent chemotactic factor for neural precursors [10]. Interestingly, MCP-1 expression can be strongly induced by TNF. In addition, the *mcp-1* gene contains a functional NF- $\kappa$ B binding site in its promoter region which is necessary for response to TNF. In the hematopoietic system, binding of MCP-1 to its receptor strongly activates NF- $\kappa$ B, providing a further hint for NF- $\kappa$ B regulation of migration.

In another approach Sun et al. demonstrated potent induction of migration by neuronally expressed stem cell factor (c-kit Ligand, SCF) in vitro and in vivo. Analogous to *mcp-1*, also the *scf* gene contains a NF- $\kappa$ B binding site. Stromal derived factor 1 $\alpha$  (SDF-1 $\alpha$ ), a well known ligand of the CXCR4, is described as a further chemokine, inducing migration of NSCs. Here, directed migration of neural stem cells induced by the SDF-1 $\alpha$  secreted by astrocytes and endothelium was demonstrated. Furthermore, the over-expression of I $\kappa$ B results in loss of SDF-1 $\alpha$  mediated migration of breast cancer cells in vivo.

All those results let us hypothesize that NF- $\kappa$ B is not only crucially involved in NSC proliferation, but also in control of migration.

### NF- $\kappa$ B and Neural Stem Cell Differentiation

The IL-6 family of cytokines, including the leukemia inhibitory factor (LIF) and ciliary neurotrophic factor (CNTF) promote astrocytic differentiation by activating transcription factors, such as STAT 3, AP-1 and NF- $\kappa$ B. Both CNTF and LIF triggers the recruitment of glycoprotein 130 (gp 130) to their specific receptors leading to activation of the RAS-MAP kinase pathway. Downstream of RAS MAP kinases and PKC transduce the signals to their substrates activating nuclear transcription factors (NF- $\kappa$ B, AP-1 and NF-IL6). This cross-talk of those transcription factors and co-activators induce astrocytic fate specification in NSCs.

Recent reports demonstrated that NF- $\kappa$ B is required for neuronal differentiation of neuroblastoma cells. Cells induced to differentiate with retinoic acid, show nuclear NF- $\kappa$ B localization. In contrast, over-expression of NF- $\kappa$ B super-repressor suppressed neuronal differentiation.

NF- $\kappa$ B activity, induced via activation of the Rho family of small GTPases, regulates neurite outgrowth and dendritic spine formation in neuroblastoma cells.

Some studies demonstrated that bone morphogenetic proteins (BMPs) promote astroglial lineage commitment by mammalian subventricular zone progenitor cells. In contrast other approaches suggest that BMPs promote neuronal differentiation of NSCs in SVZ. These controversial findings can be explained by dose-dependent action and complex signaling via several cooperating transcription factors. Interestingly, it has been suggested, that NF- $\kappa$ B may positively regulate BMP-2 gene transcription and that overexpression of a NF- $\kappa$ B superrepressor may lead to changes in downstream signals including BMP-4.

All these results suggest a very complex control mechanism and clearly indicate an involvement of NF- $\kappa$ B in differentiation regulation. Further studies should investigate the involved mechanisms in detail.

## References

1. Bonizzi G, Karin M (2004) The two NF-kappaB activation pathways and their role in innate and adaptive immunity. *Trends Immunol* 25(6):280–288
2. McKay R (1997) Stem cells in the central nervous system. *Science* 276(5309):66–71
3. Gage FH (2000) Mammalian neural stem cells. *Science* 287(5457):1433–1438
4. Kaltschmidt B, Widera D, Kaltschmidt C (2005) Signaling via NF-kappaB in the nervous system. *Biochim Biophys Acta* 1745(3):287–299
5. Widera D, Mikenberg I, Kaltschmidt B, Kaltschmidt C (2006) Potential role of NF-kappaB in adult neural stem cells: the underrated steersman? *Int J Dev Neurosci* 24(2–3):91–102
6. Mattson MP, Meffert MK (2006) Roles for NF-kappaB in nerve cell survival, plasticity, and disease. *Cell Death Differ* 13(5):852–860
7. Shingo T, Sorokan ST, Shimazaki T, Weiss S (2001) Erythropoietin regulates the in vitro and in vivo production of neuronal progenitors by mammalian forebrain neural stem cells. *J Neurosci* 21 (24):9733–9743
8. Haddad JJ (2003) Science review: redox and oxygen-sensitive transcription factors in the regulation of oxidant-mediated lung injury: role for hypoxia-inducible factor-1alpha. *Crit Care* 7(1):47–54
9. Widera D, Mikenberg I, Elvers M, Kaltschmidt C, Kaltschmidt B (2006) Tumor necrosis factor alpha triggers proliferation of adult neural stem cells via IKK/NF-kappaB signaling. *BMC Neurosci* 7:64
10. Widera D, Holtkamp W, Entschladen F, Niggemann B, Zanker K, Kaltschmidt B, Kaltschmidt C (2004) MCP-1 induces migration of adult neural stem cells. *Eur J Cell Biol* 83(8):381–387

## NF- $\kappa$ B: Activation in the Mouse Spinal Cord Following Sciatic Nerve Transection

KEITH R. PENNYPACKER<sup>1</sup>, GLEN POLLOCK<sup>2</sup>, SAMUEL SAPORTA<sup>2</sup>

<sup>1</sup>Departments of Molecular Pharmacology and Physiology, University of South Florida College of Medicine, Tampa, FL, USA

<sup>2</sup>Pathology and Cell Biology, University of South Florida College of Medicine, Tampa, FL, USA

### Definition

NF- $\kappa$ B is a ubiquitous nuclear ►transcription factor (TF) found in the cytoplasm that regulates a number of

physiological processes, such as inflammation, apoptosis, and cellular growth (reviewed in [1]). NF- $\kappa$ B is upregulated after injury in the central nervous system (CNS), and there have been suggestions that neurons, microglia and astrocytes upregulate NF- $\kappa$ B in response to injury. In this essay, we present data that NF- $\kappa$ B is upregulated in neurons, but not microglia or astrocytes, following peripheral nerve transection, and likely plays a role in the immediate survival of these neurons.

### Characteristics

#### Description of the Structure/Process

NF- $\kappa$ B is a family of proteins that includes p50, p52, p65/RelA, RelB, and c-Rel which form homo- and heterodimers. The inactive form of NF- $\kappa$ B consists of dimers that are complexed with an inhibitory factor, I $\kappa$ B, in the cytoplasm. Diverse extracellular signals such as TNF, IL-1, and multiple growth factors activate alternate transduction pathways that converge to activate this transcription factor, which regulates more genes than any other DNA regulatory protein. Phosphorylation of I $\kappa$ B by protein kinases, such as inhibitory factor kappa B kinase alpha (IKK $\alpha$ ), leads to its ubiquitination and ultimate degradation. Once I $\kappa$ B is degraded, NF- $\kappa$ B is released and translocated to the nucleus, where it interacts with a specific DNA sequence in the promoter region stimulating the transcription of a wide array of genes. In the CNS, neurons contain constitutively active NF- $\kappa$ B, which is upregulated after injury [2–3]. Both microglia and astrocytes have been shown to induce NF- $\kappa$ B activity in response to injury [4].

NF- $\kappa$ B activity has been implicated in opposing apoptosis [5] and enhancing neuronal survival following CNS injury [7]. For example, activated NF- $\kappa$ B increases the expression of genes that block the activation of caspase-8 and caspase-3 apoptotic factors. NF- $\kappa$ B enhances the transcription of cytokines, such as IL-6, which are reported to be neuroprotective. The activation of NF- $\kappa$ B in response to noxious stimuli may indicate a survival mechanism that blocks apoptosis. The increased activity of NF- $\kappa$ B in response to Bcl-2, which is also an NF- $\kappa$ B target gene and a known anti-apoptotic factor, supports its role in the inhibition of apoptosis and neuronal rescue. However, some evidence has been presented suggesting that NF- $\kappa$ B may enhance apoptosis in cerebral ischemia [8]. The role of NF- $\kappa$ B in neuronal survival has recently generated a great deal of interest as a possible site of future therapeutic intervention following brain or spinal cord injury.

#### Role of NF- $\kappa$ B in Spinal Cord Injury

Studies have supported the hypothesis that NF- $\kappa$ B plays a role in the survival of neurons within the hippocampus [6]. NF- $\kappa$ B activation enhances neurosurvival by increasing the expression of genes that block apoptotic signaling [5].

Complete sciatic nerve transection leads to increased NF- $\kappa$ B activation in neurons on the side of the spinal cord ipsilateral to the side of axotomy in transgenic mice [9]. This increased activation is statistically significant at 3 and 5 d, and returns to baseline 10 d after transection. The number of neurons containing NF- $\kappa$ B activation was greater in the dorsal horn than the ventral horn at all time points. Neurons that activated NF- $\kappa$ B were located bilaterally in the dorsal horn of the spinal cord in un-operated animals as well as in the experimental animals, which is consistent with previous reports of constitutive NF- $\kappa$ B expression in the spinal cord [2].

Based on the results of immunofluorescent double-labeling, we have shown that the constitutive and induced activation of NF- $\kappa$ B, which was reported by production of  $\beta$ -galactosidase, occurs in neurons and not in astrocytes or microglia/macrophages (Fig. 1). Previous studies that measured p65 (RelA) levels in the spinal cord of rats that had undergone spinal cord injury (SCI) by contusion showed an increase in NF- $\kappa$ B activity in microglia and endothelial cells as well as neurons following crush SCI. However, crush SCI violates the blood-brain barrier and subjects the spinal cord to the presence and effects of blood borne cells and their inflammatory mediators. Pollock et al. also reported a more rapid increase in NF- $\kappa$ B activity, which was increased at 24 h and remained elevated for at least 72 h, than the time course in the present study. This earlier activation is most likely the result of the direct influence of immune cells releasing inflammatory cytokines.

NF $\kappa$ B activity is also increased in experimental autoimmune encephalomyelitis primarily in microglia, macrophages and T lymphocytes. In this study, myelin basic protein specific T lymphocytes were injected into the experimental animals causing an increase in NF- $\kappa$ B activity that peaked at 6 d and returned to normal by day 14. This follows a similar timeline of NF- $\kappa$ B activation to the present study, though Kaltschmidt and colleagues [10] did not examine NF- $\kappa$ B in neurons. Their results dealt primarily with the immune cell activation and the presence of perivascular infiltrates.

The time course of NF- $\kappa$ B activity is consistent with a study that evaluated dorsal root ganglion cells following sciatic nerve injury. This study demonstrated no increase in NF- $\kappa$ B activity 14 d after complete sciatic nerve transection, but increased activity after partial sciatic nerve ligation and chronic constriction injury at this time point. Our results suggest that the upregulation of NF- $\kappa$ B activity would have returned to baseline in the dorsal horn by this time point following complete sciatic nerve transection. This time course does not correspond to degenerative changes that occur within the spinal cord following axotomy. For example,

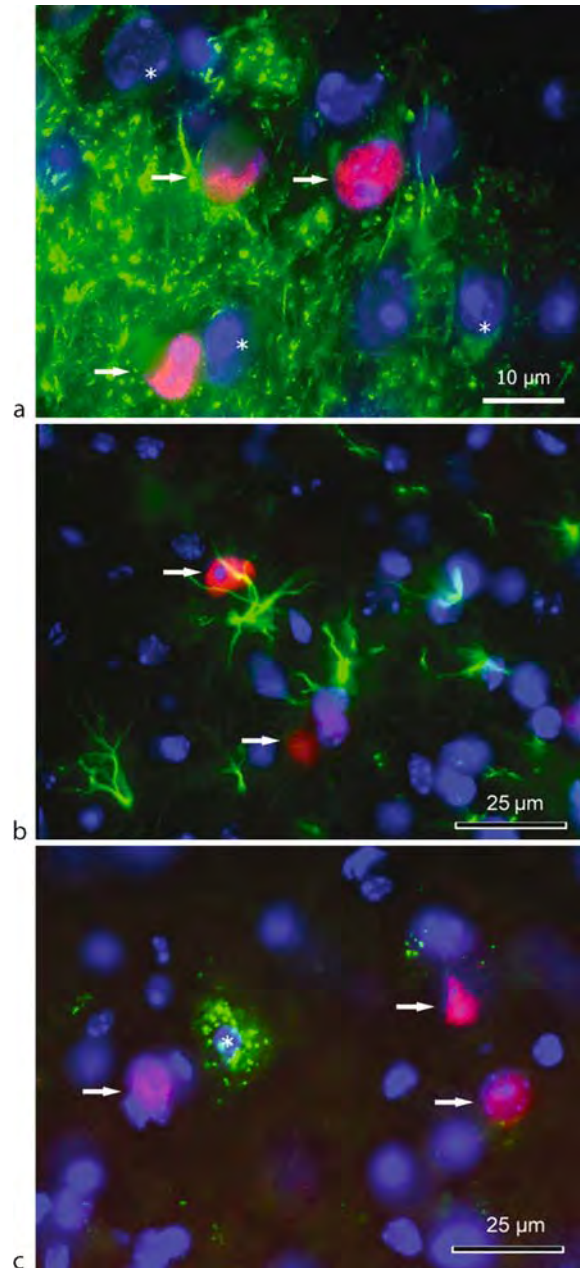

#### NF- $\kappa$ B: Activation in the Mouse Spinal Cord Following Sciatic Nerve Transection.

**Figure 1** Fluorescent photomicrographs of  $\beta$ -gal-positive cells (red) in the spinal dorsal horn double labeled with a green fluorescent chromagen for (a) MAP-2 (neurons), (b) GFAP (astrocytes) and (c) cd11b (microglia).  $\beta$ -gal-positive cells double label with MAP-2 (arrows), but not GFAP or cd11b, suggesting that they are neurons, rather than astrocytes or microglia.

degeneration of neurons in the dorsal horn in adult rats after sciatic nerve transection does not occur until 30 d post-axotomy. Reports have appeared of positive

TUNEL staining in the dorsal horn 14 d following a constricting sciatic nerve injury but not after complete transection, which showed no TUNEL positive cells at 14 d post-axotomy. Motor neurons in adult rats undergo atrophy, but not apoptosis, following sciatic nerve transection, unlike neonatal rats which show apoptosis in both the dorsal and ventral horns. Pollock and coworkers [9] showed very little NF- $\kappa$ B activity in the ventral horns and none in the alpha motor neurons at any time examined following complete sciatic nerve transection. These previous studies demonstrate a difference between sciatic nerve transection in neonatal rodents and adult rodents with significant changes in the ventral horn of young animals but minimal changes in the ventral horns of the adult animals. Our results are consistent with these findings as there is very little NF- $\kappa$ B activity in the ventral horn of any of the experimental animals.

Many studies have shown that sciatic nerve transection in the neonatal mouse or rat leads to a marked cell loss in the ventral horn. There is ample evidence that in neonatal rodents, axotomy leads to motor neuron loss via apoptosis that is usually evident by 21 d and continues to increase out to 30 and 60 d. However, there is a significant difference between adult and neonatal animals in this response. Pollin and coworkers [6] showed that age is a major determinant of the response of motor neurons to axotomy in the mouse. While neonatal mice show massive apoptosis in the ventral horn in response to axotomy, adult mice show very little apoptosis of motor neurons in response to peripheral nerve transection. These data are consistent with the lack of changes seen during this time period in the ventral horn of the adult mice used in this experiment. While actual cell loss is seen at later time periods, the changes in transcription factor activity and apoptotic pathways are seen during the first few weeks following neuronal injury.

A trend in the total number of NF- $\kappa$ B-positive cells appears to show a decrease below baseline for the animals sacrificed at the 1 d time period and then a rise above baseline for the 3 and 5 d time periods, followed by a return to baseline at the 10 d time period. An initial decrease in NF- $\kappa$ B activation could be consistent with a decrease in p65 levels which occur as a result of a decrease in the retrograde transport of trophic factors, however, the decrease in NF- $\kappa$ B activation was not statistically significant at the 1 d time point.

### Function of NF- $\kappa$ B in Glial Cells and Neurons in Spinal Cord Injury

Glial cells have been shown to proliferate in response to sciatic nerve transection in both neonatal and adult rats. There was no evidence of NF- $\kappa$ B activity in any cells other than neurons in the work by Pollock et al. [9]. It

has been shown that glial cells interact with neurons to regulate NF- $\kappa$ B activity in the CNS [2]. The sciatic nerve transection model does not violate the blood–brain barrier in the spinal cord and this may account for the lack of NF- $\kappa$ B activity seen in cells other than neurons. This may have important implications as to the NF- $\kappa$ B activity response to different types of spinal cord insults as the response appears to be only in neurons in this model but is also evident in microglia and endothelial cells in the contusion model. This may present an opportunity to target different cells in peripheral nerve injury versus direct spinal cord injury.

NF- $\kappa$ B plays a central role in promoting neuronal survival within the injured spinal cord and thus is an important target for research and future interventions. The extensive variety and availability of transgenic and knockout strains of mice provide an advantage over the rat for investigative opportunities in spinal cord injury.

### References

1. Memet S (2006) NF-kappa B functions in the nervous system: from development to disease. *Biochem Pharmacol* 72:1180–1195
2. Kaltschmidt B, Kaltschmidt C (2000) Constitutive NF-kappa B activity is modulated via neuron-astroglia interaction. *Exp Brain Res* 130:100–104
3. Mattson MP (2005) NF-kappa B in the survival and plasticity of neurons. *Neurochem Res* 30:883–893
4. Nonaka M, Chen XH, Pierce JE, Leoni MJ, McIntosh TK, Wolf JA, Smith DH (1999) Prolonged activation of NF-kappa B following traumatic brain injury in rats. *J Neurotrauma* 16:1023–1034
5. Choi JS, Kim JA, Kim DH, Chun MH, Gwag BJ, Yoon SK, Joo CK (2000) Failure to activate NF-kappa B promotes apoptosis of retinal ganglion cells following optic nerve transection. *Brain Res* 883:60–68
6. Pennypacker KR, Kassed CA, Eidizadeh S, Saporta S, Sanberg PR, Willing AE (2001) NF-kappa B p50 is increased in neurons surviving hippocampal injury. *Exp Neurol* 172:307–319
7. Kassed CA, Butler TL, Patton GW, Demesquita DD, Navidomskis MT, Memet S, Israel A, Pennypacker KR (2004) Injury-induced NF-kappa B activation in the hippocampus: implications for neuronal survival. *Faseb J* 18:723–724
8. Schwaninger M, Inta I, Herrmann O (2006) NF-kappa B signalling in cerebral ischaemia. *Biochem Soc Trans* 34:1291–1294
9. Pollock G, Pennypacker KR, Memet S, Israel A, Saporta S (2005) Activation of NF-kappa B in the mouse spinal cord following sciatic nerve transection. *Exp Brain Res* 165:470–477
10. Kaltschmidt C, Kaltschmidt B, Lannes-Vieira J, Kreuzberg GW, Wekerle H, Baeuerle PA, Gehrmann J (1994) Transcription factor NF-kappa B is activated in microglia during experimental autoimmune encephalomyelitis. *J Neuroimmunol* 55:99–106

## NG2

### Definition

One kind of chondroitin sulfate proteoglycans that is expressed by a distinct mature glial population in the adult brain and spinal cord.

## NGF

### Definition

► Nerve Growth Factor (NGF)

## NI-35/250

### Definition

Inhibitory fractions of CNS myelin with molecular weights of 35 and 250 kD. The neurite growth inhibitory (NI)-35/250 proteins are of highly conserved structure and were found to be associated with oligodendrocytes and myelin sheaths in mammals, including human tissue. NI-250 likely corresponds to Nogo-A. In vitro assays revealed that the application of NI-35/250 inhibits spreading of fibroblasts and causes collapse of growth cones thus arresting neurite growth.

► [Growth Inhibitory Molecules in Nervous System Development and Regeneration](#)

## Niche in Ecology

### Definition

An evolutionary or ecological concept that describes the precise role or place an organism holds in an ecosystem.

► [The Phylogeny and Evolution of Amniotes](#)

## Niche in Neurogenesis

### Definition

Region where the degree of neurogenesis is related to the interactions of the precursor cell with its microenvironment.

► [Adult Neurogenesis](#)

## Nidifugous

### Definition

Animals (birds) leaving the nest shortly after birth/hatching

► [Neural Correlates of Imprinting](#)

## Niemann-Pick Disease

### Definition

Niemann-Pick disease is subdivided into two classes. In types A and B, the genes for acid sphingomyelinase are deficient; in types C and D, the genes for the NPC-1 protein are deficient. Niemann-Pick disease type C (NPC) is a fatal autosomal-recessive, neuro-visceral lipid storage disorder resulting from mutations in either the NPC1 (95% of families) or NPC2 gene and presenting with a plethora of symptoms related to hepatic and pulmonary diseases, and various neuro-psychiatric disorders. The clinical spectrum ranges from a neonatal rapidly fatal disorder to an adult-onset chronic neurodegenerative disease. In the latter, symptoms include ► [cerebellar ataxia](#), movement disorders, vertical supranuclear ► [ophthalmoplegia](#), ► [dysarthria](#), ► [dysphagia](#), psychiatric and cognitive impairments as well as, less frequently, ► [epilepsy](#) and ► [cataplexy](#).

## Night Terrors

### Definition

Night terrors, also known as Sleep Terrors or Pavor Nocturnus, consist of sudden arousals from slow-wave

(delta) Non-REM sleep accompanied by a cry or piercing scream and behavioral manifestations of intense fear. There is pronounced autonomic discharge, with tachycardia, tachypnea, flushing of the skin, diaphoresis, mydriasis, and increased muscle tone.

Amnesia for the episode generally occurs, but some adults recall vivid dreaming that accompanied their sleep terrors.

► Non-REM Sleep

## Nightmare

► Dreaming

## Nigrostriatal Fibers

### Definition

Somatotopic, dopaminergic projection of the substantia nigra, pars compacta, to the corpus striatum.

► Pathways

## Nissl Bodies

### Definition

Collections of granular endoplasmic reticulum and ribosomes in nerve cells, and which show strong staining in histological sections of nerve cells impregnated with basophilic dyes.

- Chromatolysis
- Neuronal Changes in Axonal Degeneration and Regeneration

## Nissl Stain

### Definition

A method of staining brain tissue due to interactions between a basic stain (e.g. cresyl violet) and acidic

groups, e.g. in DNA, RNA (“Nissl substance”). Since most negatively charged groups (DNA, RNA) are in the soma, this technique stains somata of neurons, but not their distal dendrites and axons. The technique is named after its discoverer Franz Nissl (1860–1919).

## Nissl Technique

### Definition

The Nissl (turn of nineteenth century German Neurologist) technique is a neuron staining method that uses basic dyes to stain the chromatin material (ribonucleic acid) in the cell body.

## Nitric Oxide

### Definition

Nitric Oxide (NO) has been proposed to play a role in intercellular communication and is considered to be an unconventional transmitter. Unlike classical neurotransmitters it is not stored in vesicles, does not bind to specific target receptors on the membrane surface, and does not have an active process to terminate its action. The gas nitric oxide is synthesized from arginine a reaction that depends on the enzyme nitric oxide synthase (NOS).

## NLL

- Nuclei of the Lateral Lemniscus

## NMDA

### Definition

N-methyl-D-aspartic acid is an amino acid derivative that binds to the NMDA-type glutamate receptor.

## NMDA Receptors

### Definition

A variety of ionotropic receptors for the common excitatory neurotransmitter glutamate. They are ligand-gated ion channels that are gated open when glutamate binds to them but only when the membrane potential is relatively depolarized; thus they have voltage-dependent properties. Voltage dependence is conferred on these channels by the binding of  $Mg^{2+}$  ions in the channel pore at relatively hyperpolarized membrane potentials. NMDA (N-methyl-D-aspartate) is a specific agonist for these receptors, i.e., it is a drug that selectively activates NMDA receptors and not other glutamate receptor types.

Receptor activation induces the influx of sodium and calcium ions, and the efflux of potassium ions. The movement of ions causes depolarization of the neuronal membrane and increases the probability that an action potential will be generated. NMDA receptors consist of NR1 (GluR $\zeta$ 1) and some of NR2A (GluR $\epsilon$ 1), NR2B (GluR $\epsilon$ 2), NR2C (GluR $\epsilon$ 3) and NR2D (GluR $\epsilon$ 4) subunits and are localized at the postsynaptic site on the dendritic spine.

The NR1 subunit is an essential component of NMDA receptors and the composition of the NR2 subunits determines the properties of NMDA receptor channels.

- ▶ Glutamate Receptor Channels
- ▶ Memory, Molecular Mechanisms
- ▶ Associative Long-Term Potentiation (LTP)
- ▶ Long-Term Potentiation (LTP)

## NMDA-LTP

### Definition

LTP that requires activation of the NMDA receptor, one type of glutamate receptors, for its induction. NMDA receptors are usually activated by high-frequency activity of afferent fibers that causes strong depolarization of postsynaptic cells. A typical example is LTP in the hippocampal CA1 region.

- ▶ Memory, Molecular Mechanisms
- ▶ Associative Long-Term Potentiation (LTP)
- ▶ Long-Term Potentiation (LTP)

## NMJ

- ▶ Neuromuscular Junction

## NMR

### Definition

- ▶ Nuclear Magnetic Resonance

## Nociception

### Definition

Nociception is the process of detecting and transmitting signals in the presence of a noxious stimulus.

## Nociception and Growth Factors

- ▶ Growth Factors and Pain

## Nociceptive Modulation

- ▶ Descending Modulation of Nociception

## Nociceptive Neurons

### Definition

According to the International Association for the Study of Pain, a nociceptor is a receptor that is

preferentially sensitive to a noxious stimulus or to a stimulus which would become noxious if prolonged.

Nociceptors respond selectively to damaging stimuli and transmit information via A $\delta$  and C afferent neurons. They are broadly classified as mechanical nociceptors that respond to strong mechanical stimulation, heat nociceptors that respond to temperatures above 45°C, and polymodal receptors that respond more generally to noxious stimuli (including mechanical, heat, and chemical). Although the primary nociceptive responses are generated by nociceptors in the periphery, neurons throughout the central nervous system that respond to noxious stimuli are also nociceptive, including those in the midline and intralaminar thalamus and parts of cingulate cortex.

- ▶ Cutaneous Pain, Nociceptors and Adequate Stimuli
- ▶ Joint Pain, Nociceptors and Adequate Stimuli
- ▶ Nociceptors and Characteristics
- ▶ Visceral Pain, Nociceptors and Adequate Stimuli

## Nociceptive Pathways

### Definition

A nociceptive pathway is the pathway that the information from the nociceptor follows within the nervous system.

- ▶ Ascending Nociceptive Pathways

## Nociceptive Reflexes

### Definition

Nociceptive reflexes are motor responses to noxious stimuli.

- ▶ Integration of Spinal Reflexes
- ▶ Viscero-somatic Reflex

## Nociceptors: Adequate Stimulus

H. RICHARD KOERBER

Department of Neurobiology, University of Pittsburgh, Pittsburgh, PA, USA

### Definition

The ▶adequate stimulus for a given sensory neuron is a sensory event that is of sufficient magnitude to elicit action potentials, typically resulting in a sensory experience. A ▶nociceptor is defined by the International Association for the Study of Pain (IASP) as a receptor preferentially sensitive to a noxious stimulus (one which is damaging to normal tissues [see ▶Visceral pain for exception re. visceral nociceptors]), or to a stimulus which would become noxious if prolonged. Thus the adequate stimulus for a nociceptor would be one that has the capability to cause pain or discomfort. While most sensory neurons respond best to stimuli of a single ▶sensory modality (e.g., mechanical or thermal), nociceptors can often be activated by stimuli of different modalities (i.e., are polymodal).

### Characteristics

#### Historical Perspective

The concept of nociception was first introduced by Sherrington [1] at the turn of the twentieth century. He proposed that the sensation of pain was mediated by specific sensory organs that were responsive to painful or noxious stimuli. However, it was several decades before the existence of specific pain sensing fibers or nociceptors was firmly established [2]. During the intervening period of time, many different theories about how peripheral sensory neurons could code for the sensation of pain were hypothesized. A recent eloquent historical review of the subject by E. R. Perl [3] provides a detailed timeline of these events. In brief, the differing theories on the roles of peripheral receptors can be generalized as specificity versus intensity. In the specificity theory of pain, only those sensory neurons that respond to stimulus intensities in the noxious range would be responsible for signaling pain, whereas in the intensity theory most, if not all, sensory neurons would be responsive to innocuous stimuli, but would be more responsive (generate more action potentials over time) to stimuli of noxious intensity. This increased number of inputs would signal the fact that the intensity of the stimulus had reached a noxious level. Here, I will briefly describe what has been reported about primary sensory neurons in general, and more specifically putative nociceptors over the past several decades and then discuss how these findings fit with these two contrasting theories.



### Primary Sensory Neurons

Primary sensory neurons provide constant feedback on the external environment as well as the internal state of the body. These neurons are located in sensory ganglia that lie outside of the central nervous system. While some of these ganglia are associated with cranial nerves such as the trigeminal ganglion, the majority of these neurons are to be found in dorsal root ganglia associated with each spinal nerve (see ► [Visceral pain for role of sensory neurons in the nodose ganglion](#)). Their axons bifurcate within the ganglion and give rise to a peripheral branch that innervates various tissue types in the trunk, limbs and viscera and a central branch that travels through the appropriate dorsal root to enter the spinal cord, where it forms synapses with second-order neurons.

There are several different ways of classifying primary sensory neurons. The most common means of classification is based on the conduction velocity of their peripheral axons, which is directly related to the axon diameter and to whether the axon is myelinated. Based on the distribution of these peripheral nerve conduction velocities, primary sensory neurons are routinely divided into different groups: A $\alpha$ / $\beta$ , A $\delta$ , and C. While the actual conduction velocity of these groupings varies across different mammalian species, the A $\alpha$ / $\beta$  group consists of large myelinated axons that have the fastest peripheral conduction velocities and approach 100 m/s in some species. The A $\delta$  group contains smaller caliber fibers that are thinly myelinated and conduct at an intermediate velocity, and the C-fiber group is comprised of the smallest, unmyelinated and most slowly conducting fibers, usually <2 m/s. Another convenient means of classification of primary sensory neurons is the peripheral tissue they innervate. Fibers innervating skin are described as cutaneous sensory neurons. Similarly, afferent fibers innervating thoracic, abdominal or pelvic viscera are termed visceral afferents.

Primary sensory fibers are responsive to a variety of sensory modalities, including mechanical, thermal and chemical stimuli. Fibers responsive to a specific sensory modality are further classified according to the intensity of the adequate stimulus. Those primary sensory fibers that respond to gentle mechanical forces or innocuous thermal stimuli, and fail to encode a broad range of stimulus intensities, are classified as low threshold mechanoreceptors or innocuous cooling or warming fibers, respectively. As defined above, sensory fibers that respond only to stimulus intensities that would be considered tissue threatening or have the potential to be damaging are termed nociceptors. The majority of these nociceptive fibers is responsive to two or more stimulus modalities, and for that reason are referred to as polymodal nociceptors.

Sensory neurons responding to different intensities of peripheral stimuli are distributed across the different

conduction velocity groups. Most sensory neurons with fibers conducting in the A $\alpha$ / $\beta$  range respond to innocuous mechanical stimuli, and are classified as low threshold mechanoreceptors. A subset of these fibers can respond to relatively innocuous mechanical stimuli, but also encode stimulus intensities into the noxious range and in some cases respond to noxious heating of the skin. This trend reverses with decreasing conduction velocity as a majority of A $\delta$ -fibers and most C-fibers are classified as nociceptors. The relative numbers of functional types in specific conduction velocity groups varies between species and the areas of the body the fibers innervate. However, it is important to point out that both nociceptors and non-nociceptors exist in all three conduction velocity groups.

Primary sensory neurons also exhibit diversity in many other properties, including cell membrane properties, laminar location of central projections and neurochemical content [4]. Myelinated fibers that respond to innocuous mechanical stimulation of the skin have narrow somal action potentials without breaks in the rising or falling phase of the spike. Unmyelinated and myelinated nociceptive fibers have broader action potentials that most often have a distinct inflection on the falling phase of the spike [4]. While this relationship is quite constant for myelinated fibers, all unmyelinated fibers have broad inflected somal action potentials regardless of their peripheral response properties.

### Spinal Projections

The central branches of myelinated low threshold mechanoreceptive fibers enter the spinal cord and bifurcate into main ascending and descending branches that travel in the dorsal columns. Additional collateral branches turn ventrally and pass through the dorsal horn before terminating in lamina III-V. These laminae are largely involved in processing inputs elicited by innocuous mechanical stimuli. The central projections of myelinated nociceptors were first described by Light and Perl [5], who focused on fibers conducting in the intermediate A $\delta$  range. They found that upon entry into the spinal cord, the main branches were laterally located in the dorsal column often in or near ► [Lissauer's tract](#). Terminal arbors from these afferents were centered primarily on laminae I and II, spinal laminae largely involved in the processing of inputs elicited by noxious peripheral stimuli, with some passing ventrally to terminate in lamina V. More recently, Woodbury and Koerber [6] have demonstrated an additional central projection pattern for myelinated nociceptive fibers. These fibers have projections very similar to those of low threshold mechanoreceptors in laminae III-V, however, their projections also extend dorsally through laminae I and II.

Unmyelinated C-fibers, most of which are considered to be nociceptors, enter the spinal cord and usually

bifurcate and run rostrally and caudally along the surface of the dorsal horn in Lissauer's tract. The primary collaterals send off several additional branches that penetrate ventrally into the superficial dorsal horn laminae I and II where they end in dense terminal fields. While individual C-fibers have projections that are focused more or less in different parts of the superficial dorsal horn, most are found in both laminae I and II with the primary focus usually in lamina II [7,8].

In summary, the sensory neurons that have peripheral response characteristics of nociceptors (i.e., code stimulus intensity in the noxious range), consistently have direct projections to the superficial dorsal horn laminae known to be involved in nociceptive processing. However, it is also important to note that not all sensory neurons projecting to these spinal laminae are nociceptors.

### Neurochemical Properties

As a group, nociceptors have been the main target of neurochemical analysis in recent years, and they have been shown to exhibit the most pronounced phenotypic diversity among sensory neurons. Unmyelinated nociceptive sensory neurons contain a large number of neuroactive compounds and express receptors and have been divided into two major groups based on the combination of neurochemical phenotype and sensitivity for different ►**neurotrophins**. The first group of nociceptive neurons is sensitive to nerve growth factor and expresses its high-affinity receptor tyrosine kinase receptor A (trkA); they also usually contain ►**neuropeptides** such as calcitonin gene-related peptide (CGRP), substance P and galanin. The second group is responsive to members of the glial cell line-derived neurotrophic factor family, and expresses the cognate ►**receptor tyrosine kinase**. This group usually does not contain peptides, have binding sites for the isolectin IB4 (obtained from *Bandeiraea simplicifolia*), and contains the ►**purinergic receptor** P2X<sub>3</sub>, suggesting sensitivity to ATP [7].

Less is known about the different neurochemical phenotypes of myelinated nociceptive fibers. However, they can be divided into two groups based on whether they express the trkA receptor and contain peptides such as (CGRP), or as, it has recently been shown, contain the neurotrophic factor 3 receptor trkC and lack peptides [9].

### Nociceptors: Intensity vs. Specificity

As discussed above, it has been shown that there is a population of sensory neurons that only respond to stimulus intensities in the noxious range, corresponding to the classical definition of a nociceptor. In addition, most individual nociceptors can respond to several stimulus modalities. These sensory fibers are distinctly different from those that are responsive to innocuous stimuli and do not encode stimulus intensity.

However, not all sensory neurons fit neatly into these two different categories. It has long been known from animal studies that some fiber types are not easily classified as associated with nociceptors or non-nociceptors. For example, Burgess and Perl [2] reported a group of myelinated fibers that were distinct from low threshold or innocuous myelinated fibers, but had thresholds below those considered to be nociceptors. They referred to these as moderate pressure units. In addition, more recent experiments in humans have demonstrated that many putative nociceptive fibers, including polymodal fibers, have mechanical and/or thermal thresholds at intensities that are well below those necessary to evoke pain. However, it was also shown that there was a clear and significant relationship between the numbers of action potentials elicited by suprathreshold stimuli in these fibers and the perception and intensity of pain in these subjects [10]. Taken together, these findings suggest that while it is clear that some sensory neurons clearly fit the original concept of nociceptors put forth by Sherrington, others that have ►**absolute response thresholds** that would suggest a non-nociceptive function may also function as nociceptors (i.e., they contribute to the sensation of pain). These two groups of fibers share many other properties, including broad somal action potentials, neurochemical content and central projections in the superficial laminae of the spinal dorsal horn.

In summary, nociceptors, the necessary substrate for the specificity theory, are clearly present. However, it is also clear that sensory neurons that do not fit the Sherringtonian definition of a nociceptor do code for the intensity of a stimulus into the noxious range and thus have the potential to contribute to the sensation of pain.

### References

1. Sherrington CS (1906) The integrative action of the nervous system. Cambridge University Press, Cambridge
2. Burgess PR, Perl ER (1967) Myelinated afferent fibres responding specifically to noxious stimulation of the skin. *J Physiol* 190:541–562
3. Perl ER (2007) Ideas about pain, a historical view. *Nat Rev Neurosci* 8:71–80
4. Koerber HR, Mendell LM (1992) Functional heterogeneity of dorsal root ganglion cells. In: Sensory neurons: diversity, development and plasticity. Oxford University Press, New York
5. Light AR, Perl ER (1979) Spinal termination of functionally identified primary afferent neurons with slowly conducting myelinated fibers. *J Comp Neurol* 186:133–150
6. Woodbury CJ, Koerber HR (2003) Widespread projections from myelinated nociceptors throughout the substantia gelatinosa provide novel insights into neonatal hypersensitivity. *J Neurosci* 23:601–610
7. Snider WD, McMahon SB (1998) Tackling pain at the source: new ideas about nociceptors. *Neuron* 20:629–632

8. Sugiura Y, Lee CL, Perl ER (1986) Central projections of identified, unmyelinated (C) afferent fibers innervating mammalian skin. *Science* 234:358–361
9. McIlwrath SL, Lawson JJ, Anderson CE, Albers KM, Koerber HR (2007) Overexpression of neurotrophin-3 enhances the mechanical response properties of slowly adapting type 1 afferents and myelinated nociceptors. *Eur J Neurosci* 26:1801–1812
10. Torebjork HE, LaMotte RH, Robinson CJ (1984) Peripheral neural correlates of magnitude of cutaneous pain and hyperalgesia: simultaneous recordings in humans of sensory judgments of pain and evoked responses in nociceptors with C-fibers. *J Neurophysiol* 51:325–539

## Nociceptors and Characteristics

HERRMANN O. HANDWERKER  
 Institut für Physiologie und Pathophysiologie,  
 Erlangen, Germany

### Synonyms

Nociceptors (human)

### Definition

The term “nociceptor” has been derived from the Latin “nocere,” which means to harm or to damage. Nociceptors are characterized by two distinctive features: (i) they are responsive preferentially to tissue threatening stimuli and encode their intensity, (ii) they mediate nocifensive motor and vegetative reactions by their central connections.

### Characteristics

#### General

The nociceptor concept was introduced by the famous physiologist Sir Charles Sherrington in a monograph published in 1906. Sherrington used it to describe primary afferent neurons which were processing information on tissue-threatening stimuli in animal experiments. He observed that noxious stimuli induced withdrawal reflexes and defined nociceptors as a type of afferent nerve inducing withdrawal (nocifensive) reflexes, which became the surrogate of human pain experiences in animal experiments. In addition, nocifensive motor reflexes and the respective reactions of the autonomic nervous system (i.e., rise in blood pressure, increase in heart rate, etc.) can also be observed in human subjects, even in states of unconsciousness, when pain experiences are precluded.

For obvious reasons, a proof of nociceptor functions cannot be based solely on responses to damaging stimuli as the Latin word stem would suggest. Many

neurons may be excited by damaging stimuli at least temporarily in the process of their decay. Therefore, the concept of the nociceptor requires at least one additional element: central nervous system connections.

One may note that nociceptors are not just “pain receptors.” Pain is related to functions of the conscious central nervous system. Excitation of nociceptors is neither a necessary nor a sufficient condition for pain experiences. Nevertheless, it is true that in conscious healthy human beings a more or less linear relationship has been found (e.g., between the activation of heat sensitive nociceptors in the skin and the intensity of burning pain). In addition, the ►[hyperalgesia](#) of inflamed tissue is reflected in the increased activity of nociceptors [1], provided that no other factors interfere, such as placebo suggestions, analgesic medications, etc.

On the other hand, the term nociceptor can not be restricted to the receptor and channel molecules in the nerve terminals that are activated by noxious physical or chemical stimuli. One such a membrane receptor, which is often erroneously labeled as “the nociceptor,” is the TRPV1 (transient receptor potential vanilloid) receptor channel which is opened by binding of the pungent substance capsaicin, by heating, and by application of acids. This molecule is also expressed in non-sensory cells and in neurons with arguable nociceptive functions.

Figure 1 shows a systematic diagram of a nociceptor neuron. The cell bodies of these neurons are in the dorsal root ganglia and in the trigeminal ganglia, respectively. The peripheral terminals may be found in most tissues of the body. The central terminals form synapses with secondary neurons in the superficial dorsal horn of the spinal cord and in the nucleus caudalis of the trigeminal complex. An “ideal” nociceptor should provide the central nervous system exclusively with nociceptive information, and hence encode only stimulus intensities in or near the noxious range. In the CNS, nociceptor input must contribute to the information processing within the central nociceptive neuronal network and hence to the subjective experience of pain. Visceral afferents provide a particular challenge for the nociceptor concept. For example, in the wall of the urinary bladder and of intestines, numerous slowly conducting afferent nerve fibers have been found which may serve two purposes (see ►[Visceral Pain](#)). In the case of the urinary bladder, they control micturition and mediate sensations of increasing urgency with filling of the bladder. At higher tension of the bladder wall, these sensations become painful while the same neuronal population is more vigorously excited. Thus it seems as if these afferent nerves contribute to two functions: nociceptive and non-nociceptive. The complex issue of peripheral coding of visceral pain has been controversially discussed [3].

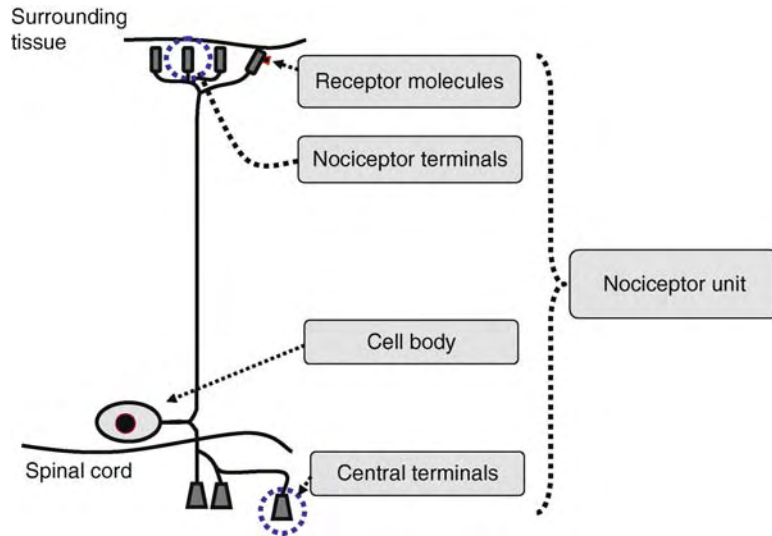

**Nociceptors and Characteristics. Figure 1** Schematic diagram of the relevant parts of a nociceptive neuron. The cell bodies (pericarya) are situated in the dorsal root ganglia and in the ganglia trigemini, respectively. Peripheral terminals can be found in most tissues of the body, central terminal make synapses with secondary nociceptive neurons in the CNS. (Reprinted from [2], by courtesy of Elsevier Pb).

### The Trp (Transient Receptor Potential) Receptor Family and Other Molecules in Nociceptor Terminals

The fast progress of the molecular analysis of receptor and channel structures in nerve terminals has led to a deeper understanding of the molecular mechanisms of stimulus transduction in nociceptor terminals [4]. This topic can only marginally be covered by this essay. A large group of nociceptor neurons express the ▶*trk-A* receptor, the high affinity receptor for nerve growth factor (NGF). This applies also to humans, since a genetic defect of the *trk-A* receptor leads to congenital insensitivity to pain (CIPA-syndrome) [5]. Recently it has been discovered that a genetic defect of the voltage dependent *NaV1.7* channel also leads to congenital pain intensity. This finding points to a major role of this molecule in safeguarding spike conduction in nociceptive nerve endings [6]. Most of the peripheral neurons expressing *trk-A* receptors are also peptidergic (their cell bodies synthesize the ▶*neuropeptides* CGRP [calcitonin gene related peptide] and to a minor extent also substance P). These neuropeptides may be released from central nerve terminals as ▶*neuromodulators* of synaptic transmission in the dorsal horn of the spinal cord. They can also be released from peripheral nerve terminals, leading to ▶*neurogenic vasodilatation* and plasma-extravasation (see ▶*Inflammatory Pain*). This is the basis of the axon reflex reaction following noxious stimulation of the skin (neurogenic flare reaction). However, from animal experiments it can be extrapolated that another group of nociceptors exists which are not dependent on NGF, but on other

nerve growth factors, in particular BDNF (brain-derived neurotrophic factor). Immuno-cytochemically, many of these neurons are characterized by staining with a plant isolectin, IB4.

Many human nociceptors are equipped with receptor channels of the *trp* family [7]. Most important is the above mentioned TRPV1. This molecule forms a nonspecific cation channel which is operated by binding of the plant derived molecule capsaicin. TRPV1 receptors are common in *trkA* expressing peptidergic primary afferent units, but it is not expressed in all nociceptors. As mentioned above, the TRPV1 receptor is also operated by noxious heating and acids. From experiments with genetically modified knockout mice, it is known that this receptor is partly, but not exclusively responsible for the nocifensive responses to acids and noxious heat. There are other ▶*trp* receptor molecules such as TRPA1 which may also explain part of the sensitivity of nociceptor terminals to algogenic chemical substances (e.g., mustard oil). Another group of receptor molecules important for the functioning of nociceptors are G-protein coupled receptors for bradykinin (B1, B2) and for prostaglandins of the E-group (EP1,2,3). Activation of these G-protein coupled receptors by endogenous algogenic substances released in the course of inflammatory tissue reactions leads to sensitization of nociceptors to mechanical, heat and chemical stimuli. Intracellularly, this process is mediated by second messenger cascades involving protein kinases, which leads to a characteristic lowering of thresholds

and greater magnitude of suprathreshold responses to mechanical and thermal stimuli, and forms the basis of hyperalgesia due to inflammation.

### Microneurography of Human Nociceptors

The functional properties of nociceptors in man are mainly studied with the methods of ►microneurography, which is the extracellular recording of spike potentials from individual afferent nerve fibers in peripheral nerves of awake healthy volunteers and patients [8]. These studies have been performed by about a dozen laboratories worldwide during the last 30 years. Studies on muscle nociceptors are difficult and rare [9] and even in cutaneous nerves, with a few exceptions, only unmyelinated C-fibers have been studied because it is difficult to obtain stable recordings from small myelinated nociceptive nerve fibers [10]. For this fiber class, one has to resort to data from monkeys which have a similar afferent nerve fiber spectrum. Apparently, myelinated nociceptors (A- $\delta$ ) are heterogeneous. Some are high threshold mechanosensors with little chemical or thermal responsiveness. These units may, however, play a role in motor withdrawal reflexes. Another group of small myelinated nociceptors are similarly equipped with molecular receptor molecules in their terminals, as is the case with C-fiber nociceptors.

As indicated above, the nociceptor nerve terminal expresses a mosaic of receptor molecules. However, this mosaic is differentially distributed in different nociceptor populations. Cutaneous nociceptors have been sorted into subclasses according to their thresholds for certain types of stimuli and the coding of suprathreshold noxious stimuli. The most common group of C-nociceptors respond to mechanical stimulation with von Frey bristles (thresholds in most cases 30–150 mN) and to heating (thresholds in most cases 40–44°C). These units have been named C-MH units because they are responsive to mechanical stimulation and to heating. They are comparable to the “polymodal nociceptors” originally described in the hairy skin of the cat. Many of those units are also responsive to capsaicin and to vasoactive endogenous agents such as bradykinin. However, on intracutaneous injection of capsaicin, responses are usually short lived and followed by desensitization of nociceptor terminals. Another group of C-units in human skin are insensitive to noxious mechanical stimulation, including pricking the skin with a hypodermic needle. Due to their insensitivity to mechanical stimuli, they have often been called “►silent nociceptors.” However, they gain mechanical sensitivity comparable to that of C-MH units in the course of inflammation; therefore, they have also been poetically named “sleeping nociceptors.” These units are sensitive to capsaicin and indeed show a greater response to capsaicin than C-MH units. Because capsaicin treatment

leads to sensitization to mechanical stimuli, the mechano-insensitive nociceptors are the source of primary mechanical and heat hyperalgesia following intracutaneous capsaicin injection. We have named this nociceptor class C-M<sub>i</sub>H or C-H units because in intact skin they are also sensitive to heating, having slightly higher thresholds than C-MH units (around 46°C). In addition, nociceptor terminals that express G-protein coupled receptor molecules seem to be different in the C-MH and C-M<sub>i</sub>H classes. A subgroup of C-M<sub>i</sub>H units is particularly sensitive to histamine and express the histamine H<sub>1</sub> receptor, and it has been shown that responses of this group of nociceptors parallels closely the itch sensation induced by intracutaneous application of histamine [9]. Discovery of histamine sensitive “itch-nociceptors” does not solve the puzzle of the peripheral mechanism of itching entirely, however. There are forms of itching which are not mediated by this group of primary afferents.

In human skin, CM<sub>i</sub>H units and not the more common C-MH units mediate sustained flare responses by releasing CGRP upon noxious stimulation [8]. All these features indicate that the class of mechano-insensitive C-nociceptors (i.e., C-M<sub>i</sub>H nociceptors) is more important for inflammatory pain and probably also for other types of pathological pain than the more common C-MH units.

### References

1. Torebjörk HE, LaMotte RH, Robinson CJ (1984) Peripheral neural correlates of magnitude of cutaneous pain and hyperalgesia: simultaneous recordings in humans of sensory judgements of pain and evoked responses in nociceptors with C-fibers. *J Neurophysiol* 51:325–339
2. Handwerker HO (2006) Nociceptors: neurogenic inflammation. In Cervero F, Jensen TS (eds) *Handbook of Clinical Neurology*, vol 81 (3rd series) pain. Elsevier, Edinburgh, pp 23–33
3. Cervero F, Jänig W (1992) Visceral nociceptors: a new world order? *Trends Neurosci* 15:374–378; Cervero F, Jänig W (1993) Reply. *Trends Neurosci* 16:139
4. Lumpkin EA, Caterina MJ (2007) Mechanisms of sensory transduction in the skin. *Nature* 445:858–865
5. Indo Y, Tsuruta M, Hayashida Y, Karim MA, Ohta K, Kawano T, Misubuchi H, Tonnoki H, Awaya Y, Matsuda I (1996) Mutations in the TRKA/NGF receptor gene in patients with congenital insensitivity to pain with anhidrosis. *Nat Genet* 13:485–488
6. Cox JJ, Reiman F, Nicholas AK, Thronton G, Roberts E, Springell K, Karbani G, Jafri H, Mannan J, Raashid Y, Al-Gazali L, Hamamy H, Valente EM, Gorman S, Williams R, McHale DP, Wood JN, Gribble FM, Woods CG (2006) An SCN9A channelopathy causes congenital inability to experience pain. *Nature* 444:894–898
7. Levine JD, Alessandri-Haber N (2007) TRP channels: targets for the relief of pain. *Biochem Biophys Acta* [Jan. Epub ahead of print]

8. Torebjörk HE, Schmelz M, Handwerker HO (1996) Functional properties of human cutaneous nociceptors and their role in pain and hyperalgesia. In: Belmonte C, Cervero F (eds) *Neurobiology of Nociceptors*. Oxford University Press, Oxford, pp 349–369
9. Simone DA, Marchettini P, Caputi G, Ochoa JL (1994) Identification of muscle afferents subserving sensation of deep pain in humans. *J Neurophysiol* 72:883–889
10. Adriaensen H, Gybels J, Handwerker HO, VanHees J (1983) Response properties of thin myelinated (A-delta) fibers in human skin nerves. *J Neurophysiol* 49:111–122

## Nocturnal Myoclonus

### Definition

Periodic stereotyped leg twitches during sleep.

## Nocturnal/Diurnal

LAURA SMALE, ANTONIO A. NUNEZ  
Psychology Department, Michigan State University,  
East Lansing, MI, USA

### Definition

A diurnal animal is one that is most active during the day, and a nocturnal animal is one that is most active at night.

### Characteristics

#### General Considerations

Virtually all organisms undergo rhythms associated with the day-night cycle, but the patterns of these rhythms can vary considerably from one species to the next. The most striking differences have to do with the coupling between the rhythms and the day-night cycle. Specifically, in some animals activity is elevated during the day, while in others activity is highest during the night. The former are referred to as “diurnal” organisms and the latter as “nocturnal” ones. In both cases, an internal “circadian” **▶clock** generates endogenous rhythms that have a period of approximately 24 h and that are synchronized, or “**▶entrained**,” to a 24 h day by environmental cues such as the **▶light-dark cycle**.

One of the key adaptations that made the evolution of mammals possible was a change in this circadian time-keeping system from one that promoted a diurnal pattern in reptiles to one that supported a nocturnal pattern of

adaptation in mammals. Although nocturnality remains most common, diurnality resurfaced in a variety of independent mammalian lineages, including our own. At each of these transitions changes occurred in the biological timekeeping mechanisms that coordinate a wide range of behavioral and physiological processes. More is known about how circadian systems operate in nocturnal than diurnal species because the animals traditionally used in biomedical research are nocturnal (e.g., mice, rats and hamsters). However, research on diurnal mammals has accelerated in recent years. Below, some of the ways in which rhythms in diurnal and nocturnal mammals are similar and different are first described briefly, and then the neural mechanisms that might cause the differences are outlined.

### Patterns of Rhythmicity in Diurnal and Nocturnal Mammals

Day- and night-active animals differ with respect not only to their patterns of general activity, but also their rhythms in virtually every aspect of behavior and physiology [1]. Peaks in rhythms in secretion of most hormones, body temperature, digestive function, heart rate, mating behavior and feeding all occur approximately 180° out of phase in diurnal and nocturnal mammals. Some examples are highlighted below.

The circadian timekeeping system produces rhythms in secretion of many hormones, almost all of which are quite different in nocturnal and diurnal species [2]. The major period of prolactin secretion occurs at night in humans, while in rats this hormone does not rise until the second half of the day. The rhythms in adrenal secretion of corticosteroids are also inverted in nocturnal and diurnal species, with the rise always occurring in this case at the beginning of the active period of the day. Pituitary hormones regulating the gonads undergo rhythms that can differ between the sexes and can change across development and with reproductive states such as pregnancy and lactation.

However, in each case these patterns are not the same in diurnal and nocturnal species. For example, as young men go through puberty, their plasma levels of gonadotropins change from being arrhythmic to rhythmic, with the highest levels during the night, and then they revert back to an essentially arrhythmic state when adulthood is reached. Such changes are not apparent in nocturnal species. Just before ovulation, the pituitary gland produces a surge in luteinizing hormone release that is precisely timed in many rodents to precede the onset of the daily active period by three to four hours. This surge thus occurs 180° out of phase in day- and night-active animals. The rhythm in secretion of the hormone **▶melatonin** is notable in that it is actually the same across species, regardless of an animals’ activity pattern. The **▶pineal gland** releases this hormone into the blood stream at night, when diurnal

animals sleep and nocturnal animals are active. The duration of the period during which melatonin is secreted varies with daylength and can consequently serve as a signal of the changing seasons, regardless of an animal's activity pattern. There is some evidence that melatonin has a soporific effect in humans, and that its administration to people whose endogenous release is low, such as the elderly, can help in the consolidation of sleep at night. As one might expect, nocturnal mammals do not exhibit this response.

Body temperature (T<sub>b</sub>) is influenced by a variety of factors that govern its pattern of change across the day. While ►**homeostatic** mechanisms can elevate T<sub>b</sub> when ambient temperatures drop in both diurnal and nocturnal animals, circadian systems have opposite effects on them, promoting a rise during the day in diurnal animals and at night in nocturnal ones. Although rhythms in T<sub>b</sub> persist when we are completely inactive, their amplitude is ordinarily increased by activity. This consequently increases the magnitude of the difference between nocturnal and diurnal animals. Many other factors, such as pregnancy and lactation, can alter the pattern of daily rhythms in T<sub>b</sub>, but the circadian drive behind the rhythms is always quite different in diurnal and nocturnal species.

Rhythms in feeding behavior also are typically inverted in day- and night-active animals, but they are quite unusual with respect to their plasticity [3]. As one might expect, when food is freely available, diurnal animals eat most during the day, and nocturnal ones at night. However, restricting the period of food availability to short intervals during daylight hours eventually causes activity of nocturnal rats to begin prior to the presentation of the food, effectively entraining the animals' circadian rhythms in activity and feeding. The result is that nocturnal rats become considerably more diurnal. Such studies have established the existence of two interacting oscillators that together shape the degree to which an animal is more, or less, active during the day than night. One of these is referred to as a "light entrainable oscillator" and the other as a "►**food entrainable oscillator**." Although their interactions are poorly understood in diurnal species, they may provide some insight into mechanisms that govern when the active phase of an animal will be.

### **The Circadian Oscillator and its Synchronization to Environmental Cycles**

At the simplest level, one way in which the nervous system might generate different circadian patterns in nocturnal and diurnal animals is that the central clock and mechanisms responsible for its synchronization with a light-dark cycle could differ, while the coupling of that clock to the physiological and behavioral functions that it regulates could be the same. However, a sizeable body of data has accumulated to support the

idea that mechanisms coupling the clock to the environment are actually the same.

This issue has been examined via behavioral studies in a variety of mammals, including humans. One line of such work has involved studies looking directly at mechanisms that synchronize the clock with a light-dark cycle. This entrainment process involves a rhythm in how the clock itself can be shifted by light. In both nocturnal and diurnal animals, light has relatively little effect during the day, but causes delays early in the night and advances late at night. As this rhythm is responsible for the pattern of entrainment of the clock itself to light, it suggests that the coupling between the clock and photic inputs to it are the same in nocturnal and diurnal species. This model is further supported by more direct studies of the brain mechanisms involved in the process.

At the center of this system is a small collection of neurons within the ►**hypothalamus** referred to as the ►**suprachiasmatic nucleus** ►(SCN) [4]. Cells within it receive input from the retina that is responsible for the entrainment of that clock to the light-dark cycle, and that emit signals that broadcast temporal information directly and indirectly to a variety of other regions of the brain [4]. Several indices of overall SCN activity fluctuate on a daily basis and have patterns that are very similar from one species to another, regardless of whether they are nocturnal or diurnal [5]. For example, rhythms in metabolism within the SCN, as measured by glucose uptake, peak during the day in representatives of widely varying taxa exhibiting a range of activity patterns (e.g., lab rats, Turkish hamsters, golden hamsters, mice, opossums, squirrel monkeys, sheep, house sparrows and cats). Another indication that the SCN functions similarly in species with different behavioral rhythms is that firing rates of neurons peak during the day in diurnal chipmunks as well as in several nocturnal rodents. The most direct evidence that the key differences between nocturnal and diurnal species lie downstream of the primary circadian ►**oscillator** has been obtained recently through direct examination of molecular elements intrinsic to it. *Per1* and *Per2* are ►**clock genes** representing important components of that clock and their expression patterns have now been examined in several diurnal and nocturnal species. In all of these, rhythms in messenger RNA (mRNA) for *Per1* and *Per2* peak during the day. Taken together, the considerations above suggest that entrainment of the circadian oscillator to the light-dark cycle are the same in nocturnal and diurnal mammals and that the coupling of the clock to the functions that it controls are therefore likely to differ.

### **Clock-Driven Output Signals**

Differences in the coupling of the circadian oscillator to the systems that it controls could theoretically reside in

the SCN or in tissues that receive direct or indirect signals from it. In nocturnal mammals the SCN uses a combination of classical axonal outputs and an as yet unidentified factor that is released into, and diffuses through, the ►ventricular system. This diffusible factor has not been identified in any species, and there are no data bearing on whether one exists in diurnal animals or not. The discussion here therefore focuses on axonal output systems. The SCN projects to a relatively restricted set of targets located primarily within the hypothalamus in nocturnal rodents. Information on this issue is more limited in diurnal mammals, but recent studies have revealed that the SCN projects to the same regions in a diurnal rodent, *Arvicanthis niloticus*, (also referred to as a grass rat), as in nocturnal ones [6].

Another feature of SCN outflow that has been examined is the nature of the molecules the SCN uses to transmit temporal information to other regions of the brain. Three such molecules have been identified in both nocturnal and diurnal species: vasopressin (VP), vasoactive intestinal polypeptide (VIP) and ►prokineticin 2 (PK2). VP has been seen in cells within the SCN of almost every species that has been examined and the projections of these cells represent a major output of the SCN. Evidence that VP release is the same in diurnal and nocturnal species was obtained originally through its measurement in ►cerebral spinal fluid in many mammals and these rhythms peaked during the day in all of them. VP mRNA in the SCN fluctuates on a daily basis in two diurnal species, (*Arvicanthis ansorgei* and *Arvicanthis niloticus*), in a pattern that is the same as in several nocturnal rodents. Thus, both transcription of its gene and the daily rhythm in its secretion suggest that the VP signal is the same in nocturnal and diurnal species.

This is likely to be the case for the VIP output as well. Neurons containing VIP exist in the SCN of all species examined to date, and their axons form a major output system. Rhythms in *Vip* mRNA are very different in male and female lab rats, with the rise occurring approximately ten hours earlier in females than in males. The same patterns are seen in the SCN of female and male *A. niloticus*, respectively.

Recent evidence has implicated prokineticin 2 (PK2) as a third output signal, contributing in this case to rhythms in locomotor activity. The gene for PK2 in *A. niloticus* is expressed according to the same rhythmic patterns as in mice.

Although there are likely to be other molecular outputs of the SCN, and these might vary across species, all of those that have now been examined are the same in the nocturnal and diurnal animals that have been looked at. The current data thus support the conclusion that the primary differences between nocturnal and diurnal species emerge from differences in responsiveness of SCN targets to SCN signals, or downstream of these

targets, rather than from temporal or spatial characteristics of output systems within the SCN. Studies of SCN targets in diurnal mammals, discussed next, are more scarce and have focused primarily on the diurnal grass rat, *A. niloticus*.

### The Lower Subparaventricular Zone (sPVZ)

It has been suggested that one source of the differences between diurnal and nocturnal mammals may be a group of cells located just dorsal to the SCN [6]. The primary projection of the SCN extends dorsally into a region known as the ►subparaventricular zone (sPVZ). The ventral portion of the sPVZ, referred to as the lower sub-paraventricular zone (LSPV), shows significant functional differences when diurnal grass rats are compared to nocturnal lab rats. This was first seen in studies of what is referred to as an ►immediate early gene called cFos which regulates the expression of a host of other genes. Rhythms in cFos are apparent in the LSPV of both lab rats and grass rats, but in grass rats the rising phase of the rhythm begins four to five hours after lights go off in a light-dark cycle with 12 h of light and 12 h of darkness, whereas in lab rats this rise does not occur until eight to nine hours later, when the lights come on. Another important difference is that, whereas in grass rats the cFos rhythm in this cell population persists in constant darkness, it goes away in lab rats held in the same conditions. This region also exhibits a rhythm in a calcium-binding protein, calbindin, in grass rats but not lab rats.

Further support for a role of the LSPV in the circadian regulation of diurnality has come from work on activity rhythms of grass rats with axon-sparing lesions in this region [6]. Animals with damage to the LSPV exhibited severe disturbances in both free-running and entrained activity rhythms. Furthermore, an increase in the proportion of activity that occurs at night was positively correlated with the extent of damage produced by these lesions. It therefore seems likely that although the LSPV is not essential for the maintenance of diurnality, it contributes to the organization of the normal stable diurnal activity rhythms in these animals.

In grass rats and lab rats the SCN and LSPV project to virtually all of the same target regions. Taken together, the data suggest that cells in the LSPV could function as oscillators that modulate the ways in which target cells respond to other signals originating in the SCN. Given the species differences in the rhythms in the LSPV, its influence on rhythms in other SCN targets is likely to differ considerably in lab rats and grass rats. It has been proposed that the LSPV could thus contribute to the maintenance diurnality through effects on rhythms within a host of other cells that receive direct input from the SCN [6]. These include cells with highly specialized functions as well as ones with more widespread projections and more general functions.



## Reproductive Rhythms

Several specialized groups of neuroendocrine cells receive direct input from the SCN, including those associated with estrus-related events. As noted above, many behavioral and neuroendocrine events associated with reproduction undergo rhythms that peak at very different times of day in diurnal and nocturnal animals [7]. This is the case for sexual behavior and for the secretion of hormones associated with it. Neuroendocrine functions are particularly amenable to analysis of SCN target systems because direct projections from the SCN to at least some neuroendocrine cells have been identified. This is the case for some neurons that contain estrogen receptors (ERs) and others containing gonadotropin-releasing hormone (GnRH). Below, the roles of the latter population of cells in regulation of the timing of the ovulatory surge in luteinizing hormone (LH), and how it differs in nocturnal and diurnal animals, are discussed.

Ovulation is triggered by a surge in LH that occurs at the end of the follicular phase of the female reproductive cycle. In female lab rats and hamsters it occurs three to four hours prior to the onset of estrus behavior, which begins at the time of lights-off. In these species, both the behavior and the LH surge are promoted by rising levels of ovarian hormones in conjunction with a signal originating in the SCN. The SCN signal reaches both GnRH neurons and estrogen receptor-containing cells in the ►preoptic area (POA), a region critical for the surge. The system is therefore one in which the circadian regulation of specific behavioral and physiological events depends upon well-defined populations of cells to which the SCN projects directly in nocturnal rodents. These pathways have now been examined in diurnal grass rats in efforts to identify where and how the system might differ in nocturnal and diurnal species.

The LH surge associated with estrus occurs 12 h apart in grass rats and lab rats, as does a rise in cFos within GnRH neurons associated with it [7]. Activation of these cells occurs 12 h apart in ►ovariectomized grass rats and lab rats that are kept in constant darkness, providing evidence that endogenous circadian mechanisms regulate the timing of GnRH neuron responses to steroid hormones. This could occur via direct projections from the SCN to these cells [6].

One important signal released by SCN cells projecting to GnRH neurons in rats is VIP. Evidence for such a projection comes from the demonstration of VIP fibers forming synapses, most of which are eliminated by SCN lesions, on GnRH cells. A role for this projection in the timing of the surge in nocturnal rodents is further suggested by evidence that it is delayed and attenuated by interference with VIP. Another way in which the SCN appears to promote the surge is through the release of VP, which, when administered into the POA generates a surge in SCN-lesioned lab rats. In diurnal grass rats,

appositions between fibers containing either VIP or VP and GnRH cells are numerous in regions critical for the generation of the LH surge [7]. As rhythms in mRNA for these two peptides are very similar in lab rats and grass rats, it is likely that VP and VIP rise and fall at the same times of day in these two species.

Taken together, the data from lab rats and grass rats suggest that the SCN releases the same rhythmic signals onto a population of cells that is very different with respect to their circadian pattern of function in diurnal and nocturnal rodents. The question of diurnality in this system is therefore a question of what might make GnRH neurons respond differently to VIP and VP in grass rats and lab rats (Fig. 1). Theoretically, the answer could be that GnRH neurons are intrinsically different with respect to the ways in which they respond to these two signals. Another possibility is that GnRH neurons are fundamentally the same in the two species, and that differences are produced by inputs to them from other regions. The LSPV could represent such an area.

## Sleep and Arousal

The neural control of the ►sleep-wake cycle involves numerous neuronal populations in the forebrain, midbrain and hindbrain [8]. Two mutually antagonistic components of this complex network are found in the in the hypothalamus-preoptic area. One of these is a small cluster of cells in the ►ventrolateral preoptic nucleus (VLPO) that contains ►galanin and provides inhibitory inputs to a series of ascending arousal systems originating in the hypothalamus and ►brainstem. In nocturnal animals these cells become active during the light phase of the cycle when levels of sleep are highest (Sherin et al., 1996). The primary ►hypothalamic system that antagonizes the sleep promoting influence of the VLPO is made up of ►orexin/hypocretin-positive cells located in the lateral hypothalamus. These neurons provide excitatory inputs to most of the arousal systems that are inhibited by the VLPO, and in lab rats these neurons are most active during the dark phase of the day-night cycle when these animals are active. The diurnal grass rat shows a very similar distribution of galanin-positive neurons in the VLPO and orexin-positive cells in the lateral hypothalamus, and rhythms in both of these cell groups are 180° out of phase in diurnal grass rats and nocturnal lab rats [5].

The question of what is responsible for this complete reversal in the rhythms in VLPO and orexin/hypocretin neurons is of considerable interest. In the case of the arousal system, fibers originating from both the LSPV and the SCN of grass rats appear to project to cells in the lateral hypothalamus that contain orexin/hypocretin. Thus, interactions between these two sources of circadian signals may influence the phase of the rhythm in activity of orexin/hypocretin cells and consequently the arousal systems to which they project. As rhythms in

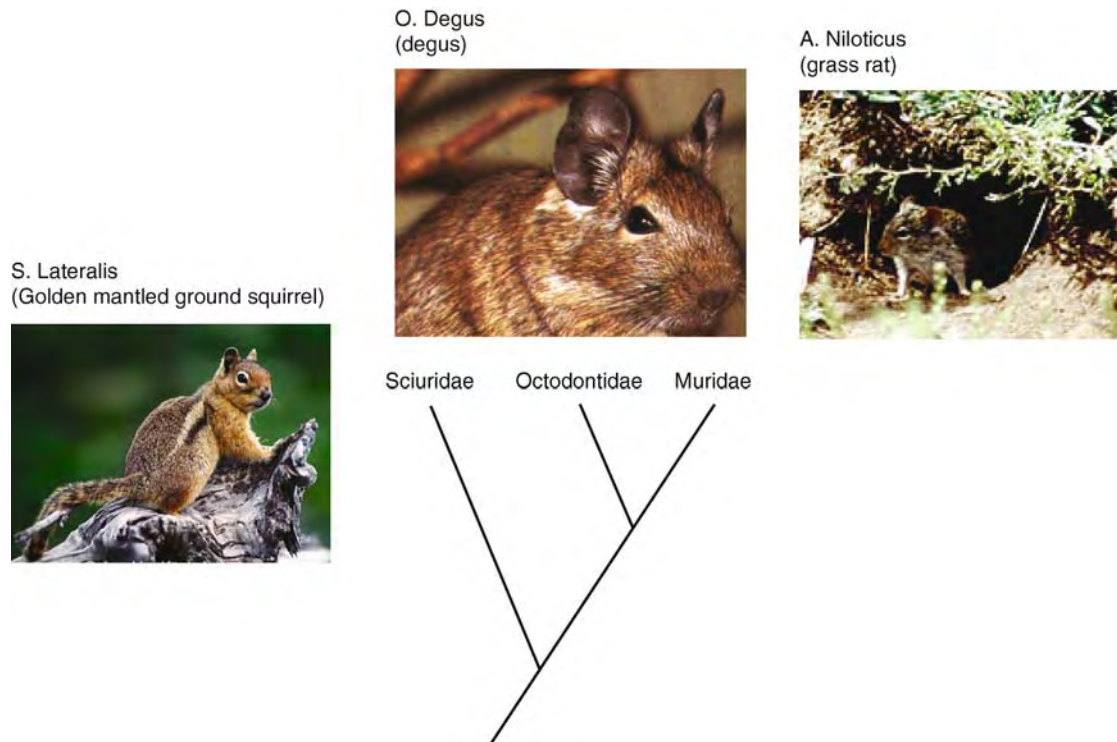

**Nocturnal/Diurnal. Figure 1** Phylogenetic relationships of three diurnal rodents that are currently being studied. Neural mechanisms associated with circadian timekeeping systems are similar in some, but not all, ways in these species. This may reflect the fact that diurnality evolved independently in the three lineages.

the LSPV are very different in grass rats and lab rats, these interactions are likely to have very different effects.

The circadian influence on the sleep-promoting system originating in the VLPO may be achieved in a more indirect fashion, as projections to this region from the LSPV and the SCN are sparse in both grass rats and lab rats. One route through which circadian signals may reach the VLPO includes SCN cells that project to the ►**dorsomedial nucleus** of the hypothalamus, which, in turn, contains cells that project to the VLPO. It has been suggested that the integration of circadian signals that influence the phase of rhythms of neural activity in the VLPO may take place in the ►**dorsomedial nucleus** [9]. Differences within these regions of the hypothalamus could therefore contribute to differences in the daily organization of sleep of nocturnal and diurnal animals.

### Summary and Significance for Humans

The system through which the SCN regulates specific rhythms comprises multiple parallel but intersecting output pathways. Rhythms within the SCN appear to be the same in nocturnal and diurnal species, but direct and indirect components of this output system differ between them in a variety of ways. Some SCN targets have widespread projections and play regulatory roles in a variety of different functions, some of which are quite specialized (e.g., VLPO) and others that play more

general roles (e.g., LSPV). Rhythms in these components of the system exhibit an array of patterns of rhythmicity with varying phase relationships in nocturnal and diurnal species. Other SCN targets, such as neuroendocrine GnRH cells, receive inputs that converge on them from a variety of regions but have very restricted output pathways, are more specialized and are linked more directly to the endpoints whose functions they regulate. In the case of GnRH cells, the rhythms are inverted by 180° in nocturnal laboratory rats and diurnal grass rats.

Taken together, the overall pattern of results emerging from recent studies on the issue suggests that there is not one simple all-or-none “switch” that determines whether an animal is diurnal or nocturnal. The ultimate differences between mammals expressing these different patterns are more likely to emerge through a variety of interrelated mechanisms operating at varying points between the SCN and the behavioral and physiological systems that it regulates. However, these data supporting this general model come from comparisons between only one nocturnal species, lab rats, and one diurnal one, grass rats. Although it seems likely that this general principle will apply to other diurnal species, including humans, the specifics of where the differences are, and the details of the rhythmic patterns in such cell populations, may vary.

## References

1. Moore-Ede M, Sulzman F, Fuller C (1983) The clocks that time us. Harvard University Press, Cambridge, MA
2. Turrek FW, van Cauter E (1994) Rhythms in reproduction. In: Knobil E, Neill JD (eds) The physiology of reproduction, Raven Press, New York, pp 487–540
3. Stephan FK (2002) The “other” circadian system: food as a zeitgeber, *J Biol Rhythms* 17:284–292
4. Klein D, Moore RY, Reppert SM (1991) Suprachiasmatic Nucleus: the mind’s clock. Oxford University Press, New York
5. Smale L, Lee TM, Nunez AA (2003) Mammalian diurnality: Some facts and gaps. *J Biol Rhythms* 18:356–366
6. Schwartz MD (2006) Neural substrates of diurnality in the Nile grass rat, *Arvicanthis niloticus*. PhD thesis, Michigan State University, East Lansing, MI
7. Mahoney M (2003) Sex, surges and circadian rhythms: The timing of reproductive events in a diurnal rodent. PhD thesis, Michigan State University, East Lansing, MI
8. Fuller PM, Gooley JJ, Saper CB (2006) Neurobiology of the sleep-wake cycle: sleep architecture, circadian regulation, and regulatory feedback. *J Biol Rhythms* 21:482–493
9. Saper CB, Lu J, Chou TC, Gooley J (2005) The hypothalamic integrator for circadian rhythms. *Trends Neurosci* 28:152–157

---

## Node

### Definition

Primary organizer present in all chordates, called node in chick and mouse, Spemann’s organizer in frog, and the shield in fish. It produces signals that are involved in neural induction.

► [Evolution and Embryological Development of the Forebrain](#)

---

## Node of Ranvier

### Definition

The node of Ranvier is a small stretch of bare axonal plasma membrane (axolemma) that separates myelin segments along individual myelinated nerve fibers.

In the peripheral nervous system, individual Schwann cells form each myelin sheath segment, while in the central nervous system, oligodendrocyte processes form myelin sheath segments. Easily identified in longitudinal sections, nodes separate the terminal paranodal loops of adjacent myelin internodes. Nodal length is related to the diameter of the axon and can vary

from less than 1  $\mu\text{m}$  in the small fibers of the optic nerve to more than 5  $\mu\text{m}$  in the large fibers of the spinal cord.

The node is the site of  $\text{Na}^+$  channels clusters to allow for saltatory conduction of action potentials, as well as the site for axonal sprout formation in peripheral nerve regeneration. (Louis Antoine Ranvier, 1835–1922).

- [Action Potential Propagation](#)
- [Oligodendrocyte](#)
- [Peripheral Nerve Regeneration and Nerve Repair](#)
- [Myelin Sheath](#)
- [Schwann Cell](#)

---

## Nodes in Acoustics

### Definition

A point, line, or surface of a standing wave in which the net energy flux is zero at all points.

► [Acoustics](#)

---

## Nodulus

### Synonyms

Nodule

### Definition

The vermis segment nodulus and the hemisphere segment flocculus together form the flocculonodular lobe.

Phylogenetically it is very old and is thus called the archicerebellum. Since its afferents come mainly from the vestibular nuclei (vestibulocerebellar tract), the “vestibulocerebellum” is another synonym.

► [Cerebellum](#)

---

## Nogo

### Definition

Member of the reticulon protein family with potent inhibitory effects for neurite outgrowth. The membrane-bound Nogo is associated with CNS myelin and

exists as three splice variants (Nogo-A, Nogo-B and Nogo-C). Neutralization of Nogo in vivo results in enhanced regeneration of severed axons, increased plasticity of uninjured fibers, and functional recovery in animal models of CNS injury.

- ▶ Growth Inhibitory Molecules in Nervous System Development and Regeneration
- ▶ Regeneration
- ▶ Regeneration of Optic Nerve

## Nogo-Neutralizing Antibody IN-1

### Definition

An antibody generated using the rat CNS myelin N1250 protein. It is raised in hybridoma cells and has been shown to promote axonal regeneration in the damaged central nervous system (CNS).

## Noise

### Definition

A signal, which is superimposed onto the signal of interest. Noise can be random or deterministic.

- ▶ Signals and Systems

## Noise, Colored

### Definition

A random noise whose spectrum is not flat, i.e., its amplitude at some frequencies is different from that at other frequencies.

- ▶ Signals and Systems

## Noise, White

### Definition

Random noise, whose spectrum is flat, i.e., its amplitude is the same at all frequencies. White noise

at different time intervals is uncorrelated, unless the interval is zero.

- ▶ Signals and Systems

## Noise-induced Transport

### Definition

A phenomenon in which the fluctuations inherent in the system create or enhance directed motion.

- ▶ Brownian Ratchet

## Nominalism

### Definition

Nominalism is the doctrine that there are no universals, i.e. no abstract, general entities like e.g. Platonic forms.

Only particular things are thought to exist. The functions of universals are attributed to the signs of human language, i.e., as predicates or common nouns that can be applied to many particular things.

- ▶ Information
- ▶ Possible World
- ▶ Property

## NOMPC

### Definition

NOMPC forms a  $\text{Ca}^{2+}$ -permeable channel in *Drosophila* mediating sensory hair cell mechanotransduction.

- ▶ TRP Channels

## Non-associative Learning

### Definition

Non-associative learning can be defined as a change in the behavioral response that occurs over time in

response to a single type of stimulus. Habituation and sensitization are typical examples.

► Learning

## Non-conceptual Knowledge

### Definition

Non-conceptual knowledge is knowledge which cannot be communicated (fully and satisfactorily) by the use of concept words, for example pictorial knowledge or knowledge how to do something.

► Knowledge

## Nondeclarative (Implicit) Memory

### Definition

Nondeclarative memory refers to a heterogeneous collection of nonconscious memory abilities such as skills (e.g., riding a bicycle), conditioned responses, priming, skills, habits and other learnings, which are displayed through performance and not conscious recollection. These components are preserved in amnesic patients.

► Amnesia

► Long-Term Memory

## Non-dystrophic Myotonias

### Definition

Heterogenous group of rare hereditary diseases characterized by ►myotonia or electrical myotonia and resulting from mutations in several ►ion channel genes ( $\text{Cl}^-$ ,  $\text{Na}^+$ ,  $\text{Ca}^{2+}$ ,  $\text{K}^+$  channels). There are three main groups. Sodium channel dysfunctions underlie paramyotonia congenita (which is cold-sensitive),  $\text{K}^+$ -aggravated myotonia, and ►hyperkalemia periodic paralysis with myotonia. Chloride channel dysfunctions underlie the myotonia congenita disorders (ClC-1 mutations cause ‘pure’ myotonia congenitalis), which are not sensitive to temperature. Channel myotonia comes in a recessive (Becker type) form and a dominant

(Thomsen type) form. In contrast to ►myotonic dystrophy, paramyotonia congenita is a non-dystrophic, rather benign disorder, in which the skeletal muscle is not dystrophic, but rather shows hypertrophy secondary to ‘exercise’ by prolonged contractions.

## Non-holonomic Constraint

### Definition

A non-integrable constraint involving the velocities of the particles of a system.

► Mechanics

## Non-invasive Imaging Techniques

### Definition

Non-invasive imaging techniques like electroencephalography (EEG), magnetoencephalography (MEG) and functional magnetic resonance imaging (fMRI) allow the study of the human brain in vivo during active processing. Whereas EEG and MEG measure the electrical neuronal activity directly with high temporal (ms) but less spatial resolution (cm), fMRI is based on the hemodynamic changes following electrical brain activity. Since the hemodynamic response is slow (several seconds), fMRI has a poor temporal resolution.

However, spatial resolution is in the range of millimeters.

► Electroencephalography

► Functional Magnetic Resonance Imaging (fMRI)

► Magnetoencephalography

## Nonlinear Control Systems

NAHUM SHIMKIN

Department of Electrical Engineering, Technion – Israel Institute of Technology, Haifa, Israel

### Definition

►Nonlinear control systems are those ►control systems where nonlinearity plays a significant role, either in the controlled process (plant) or in the controller itself.

Nonlinear plants arise naturally in numerous engineering and natural systems, including mechanical and biological systems, aerospace and automotive control, industrial process control, and many others.

Nonlinear control theory is concerned with the analysis and design of nonlinear control systems. It is closely related to nonlinear systems (►[System – nonlinear](#)) theory in general, which provides its basic analysis tools.

## Characteristics

Numerous methods and approaches exist for the analysis and design of nonlinear control systems. A brief and informal description of some prominent ones is given next. Full details may be found in the textbooks [1–6], and in the Control Handbook [7].

Most of the theory and practice focus on feedback control. A typical layout of a feedback control system is shown in Fig. 1.

A basic (finite dimensional, time invariant) nonlinear system in continuous time may be specified by the standard state-space model:

$$\begin{aligned} \frac{d}{dt} x(t) &= f(x(t), u(t)); \quad x(0) = x_0 \\ y(t) &= h(x(t), u(t)) \end{aligned} \quad (1)$$

or, more succinctly, as  $\dot{x} = f(x, u)$  (the state equations) and  $y = h(x, u)$  (the output equation). Here  $x(t) \in R^n$  is the state vector,  $u(t) \in R^m$  is the vector of input signals, and  $y(t) \in R^q$  is the output vector. This model may apply to the plant (see Fig. 1), as well as to the controller (with appropriately modified inputs and outputs). The state of the overall feedback system is then the combined state of the plant and the controller. A specific class of systems that has been studied in depth is linear-in-control systems, where  $f(x, u) = f_0(x) + \sum_{i=1}^m f_i(x)u_i$ . We limit the discussion here to continuous-time systems, although similar theory exists for the discrete-time case.

Nonlinear models may be classified into smooth and non-smooth ones. The latter are often associated with parasitic effects such as dry friction and actuator saturation. When significant, these effects may enter as constraints in the design, or even require specific compensation techniques. Our discussion below pertains mainly to smooth nonlinearities.

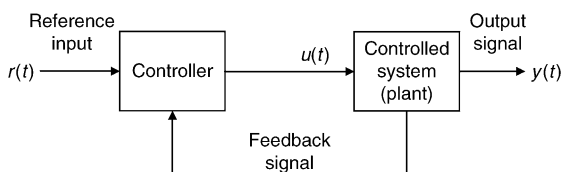

**Nonlinear Control Systems. Figure 1** Basic feedback control system.

## Basic Concepts from Systems Theory

The following notions from systems theory are of particular importance and relevance to nonlinear control, and are dealt with in depth in the cited texts.

a. *Equilibrium points*: For the nonlinear system  $\dot{x} = f(x)$ , a point  $x_e$  in the state space is an equilibrium point if  $f(x_e) = 0$ . Similarly, for the controlled system  $\dot{x} = f(x, u)$ , the pair is an equilibrium point if  $f(x_e, u_e) = 0$ .

b. *Lyapunov stability*: This is the basic notion of stability that deals with the asymptotic behavior of trajectories that start off an equilibrium point. An equilibrium point  $x_e$  of the system  $\dot{x} = f(x)$  is (weakly) *stable* if all solutions  $x(t)$  that start near  $x_e$  stay near it forever. It is *asymptotically stable* if, in addition,  $x(t)$  converges to  $x_e$  whenever started near enough to it. If this convergence occurs for any initial state then  $x_e$  is *globally asymptotically stable*. Exponential stability requires an exponential rate of convergence to the equilibrium. Note that a nonlinear system may have several ►[equilibrium points](#), each with different stability properties. For input-driven state equations with unspecified input, namely  $\dot{x} = f(x, u)$ , these stability notions are generalized by the concept of *input-to-state stability*, which requires the state vector to be close to equilibrium whenever both the initial state and the control input  $u(t)$  are close to their equilibrium values.

c. *Lyapunov's direct method*: The most general approach to date for stability analysis of nonlinear systems is Lyapunov's method, which relies on the concept of a ►[Lyapunov function](#) or generalized energy function. Essentially, a Lyapunov function for an equilibrium point  $x_e$  of the system  $\dot{x} = f(x)$  is a differentiable function  $V(x)$  which has a strict minimum at  $x_e$ , and so that its derivative  $\dot{V}(x) \triangleq \frac{\partial V(x)}{\partial x} \cdot f(x)$  along the system trajectories is negative in some neighborhood of the equilibrium. Existence of such  $V(x)$  implies stability of  $x_e$ , and further implies a asymptotic stability if  $V(x)$  is strictly negative for  $x \neq x_e$ . Many extensions and refinement of this result exist, covering various stability properties such as exponential stability, global stability, and estimates on the domain of attraction of the equilibrium.

We note that various converse theorems establish the existence of a Lyapunov function whenever the equilibrium point is stable (in the appropriate sense); however no general procedure exists for finding such a function.

d. *Linearization*: The small-signal behavior of the nonlinear system (1) around an equilibrium point  $(x_e, u_e)$  may be captured through a linear state equation of the form:  $\dot{\tilde{x}} = A\tilde{x} + B\tilde{u}$ , where  $\tilde{x}(t) = x(t) - x_e$ ,  $\tilde{u}(t) = u(t) - u_e$ , and the matrices  $(A, B)$  are computed as corresponding gradients of the system function  $f(x, u)$  at  $(x_e, u_e)$ . A similar relation holds for the output equation. A basic stability result (also known as

Lyapunov's indirect method) is that the Hurwitz-stability of the matrix  $A$  (namely, all eigenvalues have strictly negative real part) implies the asymptotic stability of the respective equilibrium point.

e. *Input-output stability and gain:* The dynamic system (1) is said to input-output stable with respect to a signal norm  $\|\cdot\|$ , if  $\|y(\cdot)\| \leq \gamma \|u(\cdot)\| + \beta$  for some constants  $\gamma \geq 0$  and  $\beta$  (and every input  $u(\cdot)$  in the input space). The name BIBO stable is also used when the norm is the max norm, namely  $\|y(\cdot)\| = \sup_t \|y(t)\|$ . The system gain is the smallest number  $\gamma$  that satisfied the above bound. For state-space models, various results relate input-output stability to corresponding stability properties of the state.

f. *Passivity:* The system-theoretic notion of passivity essentially captures the physical notion of a system that does not generate energy. As such, many mechanical and other systems satisfy this property. Passivity provides a useful analysis tool, and a basis for design methods. Notably, passivity implies stability, and the feedback connection of passive systems is passive.

g. *Controllability and Reachability:* These two closely-related concepts that apply to the state equation  $\dot{x} = f(x, u)$  concern the possibility of reaching a given state from any other state (controllability) or reaching any other state from a given state (reachability) by choosing appropriate controls. Local versions focus on small neighborhoods of any given point. These properties have been studied in depth, especially for the class of linear-in-control systems, using tools from differential geometry.

h. *Observability:* Observability concerns the ability to distinguish between two (initial) states based on proper choice of input and observation of the system output. This concept, roughly, indicates whether a feedback controller that uses only the output  $y$  can fully control the state dynamics.

### Analysis of Feedback Systems

Alongside general tools and methods from system theory, a number of results and analysis methods apply specifically to feedback systems, and some of these are described next. The basic feedback connection of two subsystems is shown in Fig. 2.

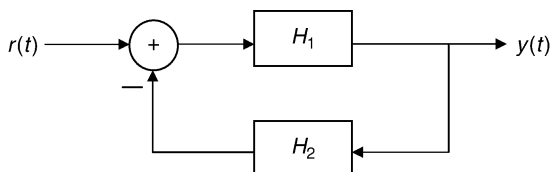

**Nonlinear Control Systems. Figure 2** Negative feedback connection.

a. *Limit Cycles and Describing Function Analysis:* Limit cycles, or sustained oscillations, are common in nonlinear feedback systems, and are usually not desired in control systems. The describing function method checks for the possibility of oscillations by (i) approximating the response of nonlinear elements to sinusoidal inputs of given amplitude and frequency by their first harmonics only (ii) checking for the possibility of a loop gain of 1 with phase shift of  $180^\circ$  (the so called harmonic balance equation, for a negative feedback system). In case of a positive answer the analysis yields estimates for the frequency and amplitude of oscillations. While the method is essentially heuristic it is often useful for initial analysis.

b. *Small Gain Theorem:* The small gain theorem allows to establish the input-output stability of a feedback system from properties of its subsystems. Assume that  $H_1$  and  $H_2$  are both input-output stable, with respective upper-bounds  $\gamma_1$  and  $\gamma_2$  on their gains. If  $\gamma_1 \gamma_2 < 1$ , then the feedback system in Fig. 2 is input-output stable, and its gain is bounded by  $\gamma_1 / (1 - \gamma_1 \gamma_2)$ .

c. *Circle Criterion:* Consider the special case  $H_1$  is a linear time-invariant system, and  $H_2$  is a static nonlinearity  $h_2(\cdot)$  that satisfies a  $[k_1, k_2]$  sector condition; in the scalar case this means that  $h_2(x)/x \in [k_1, k_2]$ . The circle criterion (and the related Popov criterion) provides frequency-domain conditions on the transfer function of  $H_1$  that imply the stability of the feedback system.

### Design Methods

Control system design in general aims to satisfy certain performance objectives, such as stability, accurate input tracking, disturbance rejection, and robustness or insensitivity to parameter uncertainty (see the Control section for further details). The diverse nature of nonlinear systems necessarily calls for a variety of design approaches of different nature, and some of the more notable ones are briefly described below.

One design viewpoint is to consider the controlled system as an approximately linear one, or linearize the system by appropriate transformation, to which well-established linear control techniques may be applied.

a. *PID Control:* The PID (Proportional-Integral-Derivative) regulator is a simple linear controller, which is often cited as the most prevalent feedback controller. In particular, it finds use in many non-linear applications, from industrial process control to robotic manipulators. On-site tuning of the PID controller parameters is often used, especially in the process control industry, and numerous manual and auto-tuning procedures exist based on direct measurement of some characteristics of the system response. Analytical

(model-based) design is of course also used, often building on one of the ►linearization methods below.

*b. Local linearization and Gain Scheduling:* The simplest analytical approach to controller design for a nonlinear system relies on fitting an approximate linear model to the controlled system, usually through local linearization around a typical working point (see above), and then designing a linear controller for this model. Evidently this method may fail when non-linear effects are significant. ►Gain Scheduling takes this approach a step further: Linear controllers are designed for a range of possible operating points and conditions, and the appropriate controller is put into play according to the current system state.

*c. Feedback Linearization:* ►Feedback linearization or ►global linearization uses input and state variable transformations to arrive to an equivalent linear system. As a simple example, the scalar system  $\dot{x} = u^3 + f(x)$  is readily transformed to  $\dot{x} = v$  by defining an auxiliary input  $v = u^3 + f(x)$ . A control law to determine  $v$  can now be designed for the linear system, and the actual control  $u$  may then be computed using the inverse relation  $u = (v - f(x))^{1/3}$ . The latter equation, which is in the form of state feedback, gives the method its name. One can distinguish between full state linearization, where the state equation is fully linearized, and input-output linearization, where the input-output map is linearized. In either case, measurement of the entire state vector is required to implement the transformation. The theory provides conditions under which feedback linearization is possible, and procedures to compute the required transformations.

The following methods approach the design problem directly using non-linear tools, notably ►Lyapunov stability and Lyapunov functions, and are notable examples of robust nonlinear control.

*d. ►Lyapunov Design and Redesign:* In Lyapunov-based design, a stable system is synthesized by first choosing a candidate Lyapunov function  $V$ , and then selecting a state-feedback control law that renders the derivative of  $V$  negative. The Lyapunov redesign method provides the system with robustness to (bounded) uncertainty in the system dynamics. It starts with a stabilizing control law and Lyapunov function for the nominal system, and adds certain (non-smooth) terms to the control that ensure stability in the face of all admissible uncertainties. While Lyapunov redesign is restricted to systems that satisfy a matching condition, so that the uncertainty terms enter the state equations at the same point as the control input, the basic approach has been extended to more general situations using recursive or backstepping methods.

*e. ►Sliding Mode Control:* In this robust design approach, also known as Variable Structure Control, an appropriate manifold (often a linear surface) in the state space is first located on which the system dynamics takes

a simple and stable form. This manifold is called the sliding surface or the switching surface. The control law is designed to force trajectories to reach that manifold in finite time, and stay there thereafter. As the basic control law is discontinuous by design around the switching surface, unwanted chattering around that may result and often require some smoothing of the control law.

Many other techniques from control engineering are applicable to the design of nonlinear systems. Among these we mention:

- **Optimal Control:** Here the control objective is to minimize a pre-determined cost function. The basic solution tools are Dynamic Programming and variational methods (Calculus of Variations and Pontryagin's maximum principle). The available solutions for nonlinear problems are mostly numeric.
- **Model Predictive Control:** An approximation approach to optimal control, where the control objective is optimized on-line for a finite time horizon. Due to computational feasibility this method has recently found wide applicability, mainly in industrial process control.
- **Adaptive Control:** A general approach to handle uncertainty and possible time variation of the controlled system model. Here the controller parameters are tuned on-line as part of the controller operation, using various estimation and learning techniques.
- **Neural Network Control:** A particular class of adaptive control systems, where the controller is in the form of an Artificial Neural Network.
- **Fuzzy Logic Control:** Here the controller implements an (often heuristic) set of logical (or discrete) rules for synthesizing the control signal based on the observed outputs. Defuzzification and fuzzification procedures are used to obtain a smooth control law from discrete rules.

A detailed description of these are related approaches, which are often considered as separate fields of control engineering, may be found in [7].

## References

1. Isidori A (1995) Nonlinear control systems, 3rd edn. Springer, London
2. Khalil HK (2002) Nonlinear systems, 3rd edn. Prentice-Hall, Englewood Cliffs, NJ
3. Nijmeijer H, van der Schaft AJ (2006) Nonlinear dynamical control systems, 3rd edn. Springer, New York, NY
4. Sastry S (2004) Nonlinear systems: analysis, stability and control, Springer, New York, NY
5. Slotine J-J, Li W (1991) Applied nonlinear control, Prentice-Hall, Englewood Cliffs, NJ
6. Vidyasagar M (2002) Nonlinear systems analysis, 2nd edn. SIAM Classics in Applied Mathematics, Philadelphia, PA
7. Levine WS (ed) (1996) The Control Handbook, CRC Press, Boca Raton, FA



## Nonlinear System

### Definition

A system whose output spectrum contains frequency components in addition to those in the input to the system.

## Nonmonotone Dynamics

### Definition

Equations specifying state transition of a recurrent neural network consisting of units with nonmonotonic output functions.

## Non-NMDA-LTP

### Definition

LTP that does not require activation of the NMDA receptor for its induction. In most cases, voltage-gated  $\text{Ca}^{2+}$  channels at presynaptic terminals play a role in its induction. A typical example is LTP in the hippocampal mossy fiber-CA3 synapse and it is believed that activation of presynaptic protein kinase A is involved in its expression.

- ▶ Memory, Molecular Mechanisms
- ▶ Associative Long-Term Potentiation (LTP)
- ▶ Long-Term Potentiation (LTP)

## Non-peripheral Vestibular Disorders

- ▶ Central Vestibular Disorders

## Non-photoc

### Definition

Circadian rhythm phase is primarily under the influence of light acting through photoreceptors connected directly or indirectly to the circadian clock. However,

certain phase shifts are induced by non-photoc stimuli that influence the clock via pathways not directly involving retinal projections. Such shifts can be as great in magnitude as light-induced phase shifts. The term, non-photoc stimulus, has had a non-specific use in reference to any non-light input to the circadian clock, including such endogenous neurotransmitters as serotonin agonists that are internally administered to test animals. A more specific application of the term is in reference to externally applied stimuli that exert phase control over the circadian clock. These non-photoc (Stimuli, Shifts, Resetting) stimuli have a phase response curve (PRC) similar to that obtained by infusing neuropeptide Y (NPY) directly into the suprachiasmatic nucleus (SCN). This “NPY-type PRC” differs from the “light-type PRC” in several respects: (i) maximum phase advances occur during the mid- to late subjective day; (ii) phase delays occur during the subjective night; and (iii) there is no dead zone. Such stimuli apparently require an intact geniculohypothalamic tract (GHT) and activation of NPY neurons in the intergeniculate leaflet (IGL) that results in NPY release in the SCN.

- ▶ Circadian Rhythm
- ▶ Intergeniculate Leaflet
- ▶ Neuropeptide Y (NPY)
- ▶ Phase Response Curve
- ▶ Suprachiasmatic Nucleus (SCN)

## Non-rectifying Gap Junctions

### Definition

Non-rectifying gap junctions conduct ionic current equally well in both directions. In contrast to electrical synapses comprised of rectifying gap junctions, electrical synapses comprised of non-rectifying gap junctions transmit electrical signals in a bidirectional fashion.

- ▶ Electrical Synapses

## Non-REM (NREM) Cells

### Definition

Also Called Sleep-Active Neurons; Neurons that exhibit increases in extracellularly recorded discharge rate during NREM sleep compared to waking and REM sleep. This type of cell is mostly located in the anterior

hypothalamus and preoptic area (POA) and some are also located in the basal forebrain area, solitary tract nucleus, and in the dorsal raphe nucleus. The neurotransmitter identity of these neurons is not definitive but they are most likely to contain the neurotransmitter GABA.

### ► Rapid Eye Movement (REM) Sleep

## Non-REM Sleep

### Definition

In mammals there are two types of sleep – rapid eye movement (REM) and non-REM (NREM). Normally, when we first enter the sleep state it is via quiet NREM sleep. We lie passively, breathing slowly. Our eyes drift slowly back and forth and every once in a while we shift our sleep position. During non-REM sleep there are decreases in blood pressure, heart rate, and respiratory rate. One could therefore characterize NREM sleep as an exceedingly dormant behavioral state. There are many important events that occur during this state, however, such as increases in pulsatile release of growth and sex hormones from the pituitary, antibody production, and elimination of unwanted and excess mental traces. REM and NREM stages are defined in terms of electro-physiological signs that are detected with a combination of electroencephalography (EEG), electrooculography (EOG) and electromyography (EMG), the measurement of which in humans is collectively termed polysomnography. In a human, NREM sleep is divided into four stages, each corresponding to an increasing depth of sleep. As the depth of sleep increases, the EEG recordings are progressively dominated by high-voltage, low-frequency wave activity. Stage I NREM sleep is characterized by relatively low voltage (<50  $\mu\text{V}$ ), mixed frequency activity (4–7 Hz: theta frequency range) and vertex sharp waves in the EEG. Stage II NREM sleep is characterized by slow (<1 Hz) oscillations with distinctive sleep spindles (waxing and waning of 12–14 Hz waves lasting between 0.5 and 1.0 s; peak amplitudes of 100  $\mu\text{V}$ ) and K-complex waveforms (a negative sharp wave followed immediately by a slower positive component). Stage III NREM sleep is demarcated by the addition to the spindling pattern of high voltage (>100  $\mu\text{V}$ ) slow waves (1–4 Hz; delta frequency waves), with no more than 50% of the record occupied by the latter. In Stage IV, the record is dominated by high-voltage (150–250  $\mu\text{V}$ ) slow waves (1–3 Hz). Collectively, stages III and IV NREM sleep are also called slow-wave sleep (SWS). Distinctions between stages of NREM sleep in animal

models (mouse, rat, cat, and non-human primates) differ slightly from that of humans. In these animals, NREM sleep is normally divided into two stages (SWS I and II). SWS-I is identified by the presence of sleep spindles in the cortical EEG. SWS-II is considered deep sleep, also termed delta sleep, and is identified by the presence of high amplitude, low-frequency waves (0.1–4.0 Hz) in the cortical EEG. NREM sleep can also be confidently identified in most reptiles and birds but is not seen with convincing clarity in either fish or amphibians.

- EEG in Sleep States
- Electroencephalography
- Electromyography
- Electrooculogram (EOG)
- Rapid Eye Movement (REM) Sleep
- Sleep States

## Nonsense Mutation

### Definition

A nucleotide substitution that causes premature termination of protein translation, which invariably results in nonfunctional proteins.

## Non-spanning Muscle Fiber

### Definition

A muscle fiber that ends in the middle of the muscle belly and is attached with a tapering end to the stroma of the muscle. It does not span the distance between two aponeuroses (tendon plates) of a muscle, but is attached to one of them by a myotendinous junction.

- Intramuscular Myofascial Force Transmission

## Nonspecific Control Parameter

### Definition

A nonspecific control parameter does not prescribe or contain the code for an emerging pattern. Rather, the nonspecific control parameter leads a dynamical system through a variety of patterns or states. When the control

parameter passes through a critical point, a qualitative change (bifurcation) occurs in the dynamical system (e.g., coupled oscillators) leading to a new output pattern.

## Non-steroidal Anti-inflammatory Drugs (NSAID)

### Definition

Non-steroidal anti-inflammatory drugs reduce pain, fever, and inflammation. The term “nonsteroidal” is used to distinguish these drugs from steroids, which have a similar anti-inflammatory action.

- ▶ Analgesia
- ▶ Neuroinflammation: Chronic Neuroinflammation and Memory Impairments

## Non-Synaptic Release

FREDERICK W. TSE, NAN WANG, LEI YAN, AMY TSE  
Department of Pharmacology & Centre for Neuroscience, University of Alberta, Edmonton, AB, Canada

### Synonyms

Exocytosis; Vesicle fusion

### Definition

Vesicular release of neurotransmitters, hormones or mediators for cellular communications at sites other than the synaptic cleft.

### Characteristics

#### Diversity of the Molecular Machinery for Exocytosis

The process of exocytosis mediates the cellular secretion of chemicals (including neurotransmitters, hormones and mediators) that are stored in intracellular vesicles or granules. In addition, exocytosis also regulates the delivery of transmembrane proteins to the plasma membrane. In the last 10 years, over a dozen proteins (each typically with multiple isoforms [1]) in the molecular machinery that mediate, or regulate, exocytosis have been identified. It is increasingly clear

that this machinery is not identical in different cell types, or even among different types of granules in the same cell. Here, we shall discuss how changes in the molecular machinery of exocytosis may contribute to some of the variability in the quantal release and  $\text{Ca}^{2+}$ -sensitivity among the different types of granules.

### Detection of Quantal Release from Different Types of Granules

In most neurons, neurotransmitters (e.g. dopamine) are stored in small synaptic vesicles (SVs; average diameter of  $\sim 50$  nm) and peptides (e.g. arginine vasopressin) are stored in large dense core granules (LDCGs; average diameter of  $\sim 200$  nm). In electron micrographs, the lumen of a SV is electron lucent but that of a LDCG is electron opaque. The electron dense material (dense core) in the LDCG is largely contributed by the presence of either a gel-like matrix, or the dense packaging of crystalline cargo. In the neuroendocrine system, secretory cells such as adrenal chromaffin cells store catecholamine hormones (e.g. adrenaline) in LDCGs. In some interneurons (e.g. in sympathetic ganglia) and chemosensory cells (e.g. carotid glomus cells), neurotransmitters are stored in small dense core granules (SDCGs; average diameter of  $\sim 100$  nm).

The development of carbon fiber **▶ amperometry** has enabled researchers to study in detail the release kinetics of easily oxidizable transmitters (e.g. catecholamines) from a single granule. Each molecule of catecholamine released from the cell is oxidized by the carbon fiber electrode (placed on the cell surface) and the resultant electrical signal is measured as an amperometric current. **Figure 1** shows an example of a large amperometric signal recorded from a rat chromaffin cell during the exocytosis of a LDCG. Upon the fusion of a LDCG with the plasma membrane, the lumen of the granule forms a transient connection (a **▶ fusion pore**) with the exterior of the cell.

The fusion pore first opens to a semi-stable state that lasts for up to tens of milliseconds, and results in a leakage of catecholamines (detected as the “foot” signal; **Fig. 1**). Occasionally some fusion pores flicker and close at this stage and give rise to the “stand-alone” foot signals. For the vast majority of LDCGs, the semi-stable fusion pore suddenly starts to dilate very rapidly and the rapid release of catecholamine gives rise to the “spike” phase of the amperometric signal. The rapid dilation of the fusion pore is significantly driven by the rapid decondensation (and probably rapid expansion) of the gel matrix. The decondensation of the gel matrix is in turn regulated by the change in vesicular pH and the concentrations of other ions (e.g.  $\text{Ca}^{2+}$ ). The amount of catecholamines released from a single granule (i.e. quantal size, Q) can be estimated from the time integral of the amperometric signal. The

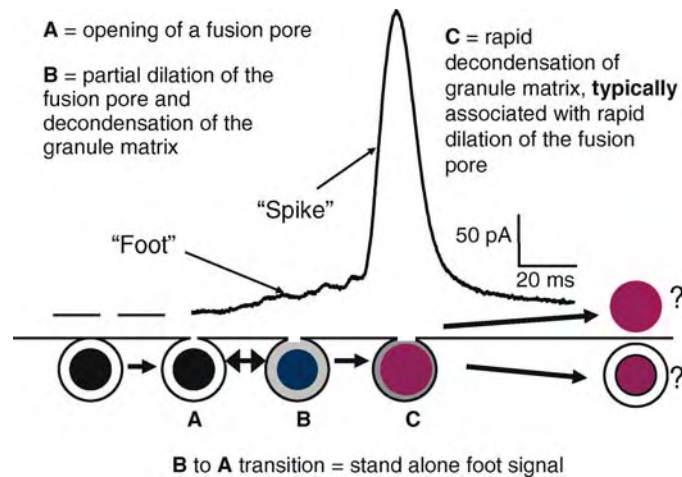

**Non-Synaptic Release. Figure 1** An amperometric signal showing the complex kinetics of catecholamine release from a large dense core granule (of a rat chromaffin cell). The overall release kinetics was determined by the complex interactions between the fusion pore and the gel matrix.

kinetics of main spike provides information on the rapid phase of release from a single granule, and the kinetics of the semi-stable fusion pore can be inferred from the foot signal.

In general, granules with larger vesicular diameters have been associated with larger values of  $Q$  as well as slower quantal release kinetics. For example, in leech Retzius cells, the LDCGs have larger  $Q$  values and the main spike of the amperometric signal from LDCGs also exhibits slower kinetics than those from SVs [2]. However, the slowing in the kinetics of quantal release does not increase monotonically with granule size. Our recent study in chromaffin cells [3] shows that in some LDCGs with very large  $Q$ s, their most rapid phase of release is comparable or even faster than LDCGs with smaller  $Q$ s. While the semi-stable fusion pore of a LDCG with a larger  $Q$  tends to persist for a longer duration, it also tends to reach a larger size before the onset of rapid dilation. Moreover, once the fusion pore of a LDCG with very large  $Q$  starts to dilate, the spike portion of the amperometric signal typically has very rapid kinetics [3]. Thus, other than the differences that are directly caused by the vesicular size, differences in fusion pore structures can also contribute to the variability in release kinetics among the different types of granules.

### Different Forms of Exocytosis

The fusion of a chromaffin LDCG shown in Fig. 1 reflects the "►full fusion" type of exocytosis in which a single granule fuses with the plasma membrane and releases its entire content (Fig. 2a). However, other forms of exocytosis have also been reported (Fig. 2).

Amperometric studies have shown that SVs in midbrain dopamine neurons [4] as well as chromaffin

LDCGs [5] can undergo "►kiss and run" exocytosis (Fig. 2b). During this mode of release, the fusion pore can either close before the complete discharge of its vesicular content, or undergo rapid flickering such that only a fraction of the vesicular content is released during each flicker [4]. This mode of release allows a vesicle to be reused with minimal reorganization of the molecular machinery that is involved in exocytosis. A recent study with two photon fluorescent microscopy [6] has shown that chromaffin LDCGs can also undergo "►serial compound" exocytosis (Fig. 2c). During this mode of exocytosis, a granule that is deeper in the cytoplasm fuses with another granule which has already fused the plasma membrane. Because of the increased distance for the diffusion of transmitters to the cell's surface, the release kinetics of granules deeper in the cytoplasm is expected to be slower. This mode of exocytosis is found to occur predominantly in the intercellular space in a cluster of chromaffin cells and only during high intensity stimulation [6]. Other forms of exocytosis, which have been described in white blood cells, include "►classical compound exocytosis" and "►piecemeal degranulation." "Classical compound exocytosis" involves the pre-fusion of granules before they finally fuse with the plasma membrane (Fig. 2d) and "piecemeal degranulation" involves the exocytosis of small vesicles that are probably formed by a fission process from certain type of LDCGs (Fig. 2e). What determines the prevalent form of exocytosis in each type of granule in a certain cell type is unclear, but both the selective expression of specific molecular machinery of exocytosis in different types of granules (see next section), as well as their selective regulation by specific intracellular messengers such as  $Ca^{2+}$  (for example, see [5] have been implicated.

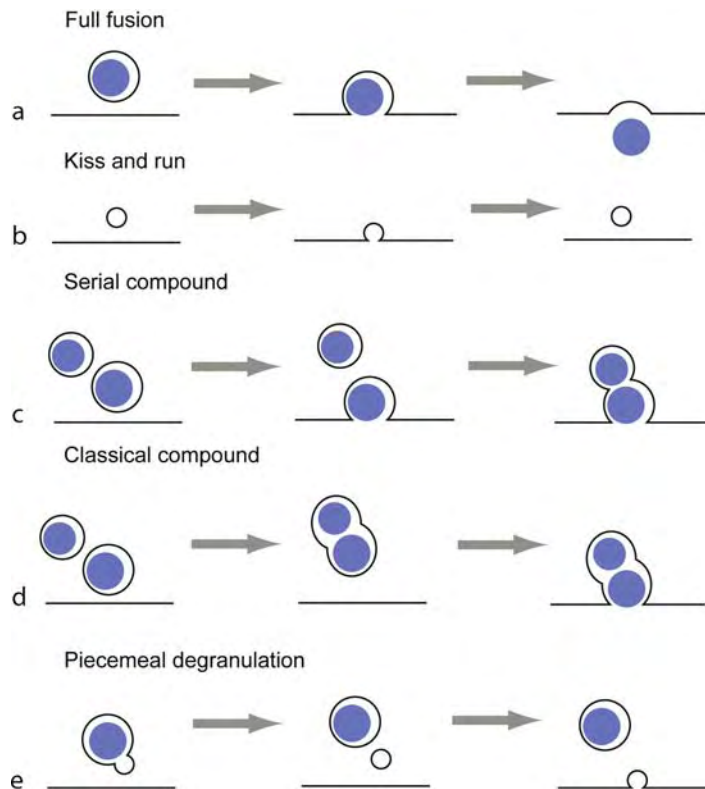

**Non-Synaptic Release. Figure 2** Different forms of exocytosis. The dense core in individual dense core granules is depicted in *blue*.

### Difference in the Molecular Machinery of Fusion may Contribute to the Variability in Release Kinetics and $\text{Ca}^{2+}$ -Sensitivity Among Granule Subtypes

As described earlier, one factor which may contribute to the differences in the release kinetics between SVs and LDCGs is the structure of the fusion pore. This raises the question whether the molecular machinery for fusion is different among the various types of granules. It is generally accepted that a protein complex, called the soluble  $\blacktriangleright$ N-ethylmaleimide-sensitive factor (NSF) attachment protein receptor (SNARE, typically concentrated at lipid rafts), can act as a physical link between a “docked” vesicle (or granule) and the plasma membrane (Fig. 3a), and is part of the essential machinery for regulating exocytosis of SVs and LDCGs.

In the presynaptic terminal, the  $\blacktriangleright$ soluble NSF attachment protein receptor (SNARE) complex comprises three proteins, syntaxin,  $\blacktriangleright$ synaptosome-associated protein of 25 kDa (SNAP-25) and synaptobrevin (also called vesicle associated membrane protein, abbreviated as VAMP). In the trans-configuration of the SNARE (Fig. 3b), syntaxin and SNAP-25 are predominantly on the plasma membrane, and synaptobrevin is on the vesicular membrane. Each of the three proteins in the SNARE complex has multiple isoforms, and different cell types express different isoforms [1].

It turns out that cell types which undergo the more unusual forms of exocytosis (such as piecemeal degranulation in some white blood cells, see Fig. 2), indeed have some unusual isoforms of SNAREs expressed on their granules. Moreover, the proportion or molecular conformation of the dominant isoform(s) in an individual cell type can also be differentially regulated (e.g. by cAMP, diacylglycerol or protein kinase C). In view of these complexities, it is likely that variations in the molecular structure of the SNARE complex contribute to the diversity among the fusion pore structure and kinetics in different types of granules.

In addition to the more rapid kinetics for quantal release, the exocytosis of SVs has been suggested to have a higher  $\text{Ca}^{2+}$  requirement than LDCGs. Moreover, even among the SVs, both synchronous (i.e. those triggered with a minimal delay after a rise in the concentrations of intracellular  $\text{Ca}^{2+}$  ( $[\text{Ca}^{2+}]_i$ ) and asynchronous (i.e. those triggered with an obviously longer delay) releases in synapses appear to have different  $\text{Ca}^{2+}$  requirements. However, a recent study suggests that the same  $\text{Ca}^{2+}$ -sensing mechanism (involving five  $\text{Ca}^{2+}$ -binding sites interacting allosterically) may mediate both synchronous, as well as asynchronous release, and interference with the SNARE-complex may affect the  $\text{Ca}^{2+}$ -sensitivity of SVs [7]. Multiple proteins

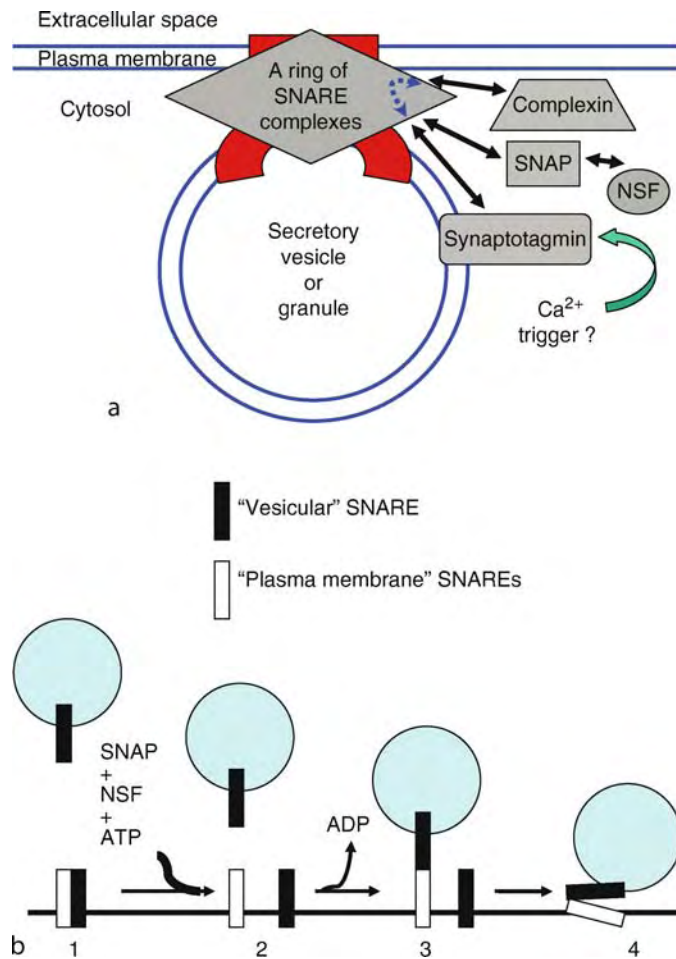

**Non-Synaptic Release. Figure 3** (a) Multiple proteins interact with the SNARE complex. The lipid raft is depicted in red. The arrow in blue represents the interactions among complexin, SNAP and synaptotagmin at the SNARE complex. (b) Cis- and trans-SNARE complexes. (1) A cis-SNARE complex (from a previous cycle of exocytosis) on the plasma membrane. (2) The cis-SNARE complex is dissociated by the recruitment of NSF (ATPase) to the complex in the presence of SNAP. (3) The formation of a trans-SNARE complex in a “loose” conformation. (4) The transformation of a trans-SNARE complex into a “tight” conformation.

are known to interact with the SNARE complex (Fig. 3a). Among these proteins is synaptotagmin, which is a key  $\text{Ca}^{2+}$  sensor for triggering exocytosis. Synaptotagmin has at least a dozen isoforms, some with vastly different  $\text{Ca}^{2+}$ -sensitivities, and the dominant expression of specific isoform(s) varies even among different types of synapses. Therefore, the absence of synaptotagmin, or the presence of specific synaptotagmin isoform(s) in different types of granules, may already contribute significantly to the variations in their  $\text{Ca}^{2+}$ -sensitivity for exocytosis.

The site on the SNARE complex that interacts with synaptotagmin also interacts with at least two other proteins: (▶ soluble NSF attachment protein (SNAP), not related to SNAP-25) and complexin (Fig. 3a). The three main known isoforms of SNAP ( $\alpha$ -,  $\beta$ -,  $\gamma$ -) all recruit the ATPase, ▶N-ethylmaleimide-sensitive factor (NSF),

to the SNARE complex. The ATPase activity of NSF is essential for breaking the cis-SNARE complex (in which all SNARE components are topologically on the same membrane, see Fig. 3b) which allows the subsequent formation of the trans-SNARE complex (the one depicted in Fig. 3a). Other than this important function of priming granules for fusion,  $\alpha$ -SNAP may also affect the  $\text{Ca}^{2+}$  sensitivity in some LDCGs. In chromaffin cells, an oversupply of exogenous  $\alpha$ -SNAP selectively enhances a component of exocytosis that is only prominent at submicromolar  $[\text{Ca}^{2+}]_i$  [8]. Since  $\alpha$ -SNAP can displace synaptotagmin from the SNARE complex, one possible interpretation is that oversupply of  $\alpha$ -SNAP allows the formation of a larger proportion of trans-SNARE complex on some LDCGs either with no synaptotagmin, or with a certain isoform of synaptotagmin that has a higher-sensitivity for  $\text{Ca}^{2+}$ . On the other

hand, binding of complexin to SNARE is suggested to activate SVs into a “superprimed metastable state.” Subsequently, the binding of  $\text{Ca}^{2+}$  to synaptotagmin 1 results in the displacement of complexin from the SNARE complex, which triggers fast synchronous synaptic release [9]. Thus, the  $\text{Ca}^{2+}$ -requirement for exocytosis in the different types of granules may be dependent on the complex interactions among synaptotagmin, SNAP and complexin at the SNARE complex, and a major challenge in the study of exocytosis is to understand how these complex sequential interactions are regulated *in vivo*.

### Do All Fusion Pores for Exocytosis have the Same Macroscopic Structure?

Currently there are two main models of the initial fusion pore for exocytosis [10]. The first model postulates

that the initial fusion pore is similar to a gap junction, which is a ring of protein complexes that connects the vesicular lumen to the extracellular space via an opening whose wall is entirely proteinaceous (Fig. 4I).

The second model postulates that a ring of protein complexes first causes hemi-fusion of the lipid monolayer of cytosolic leaflets; then when the other monolayer (on the extracellular leaflet of the plasma membrane and the luminal monolayer of the granule) also fuse to open the fusion pore, the wall of the initial fusion pore is essentially lined by lipid molecules (Fig. 4III). For both models, the existence of an initial ring of protein complexes arises mainly from the assumption that a fusion pore has radial symmetry, and each protein complex is probably a SNARE complex with some of its associated proteins. Published

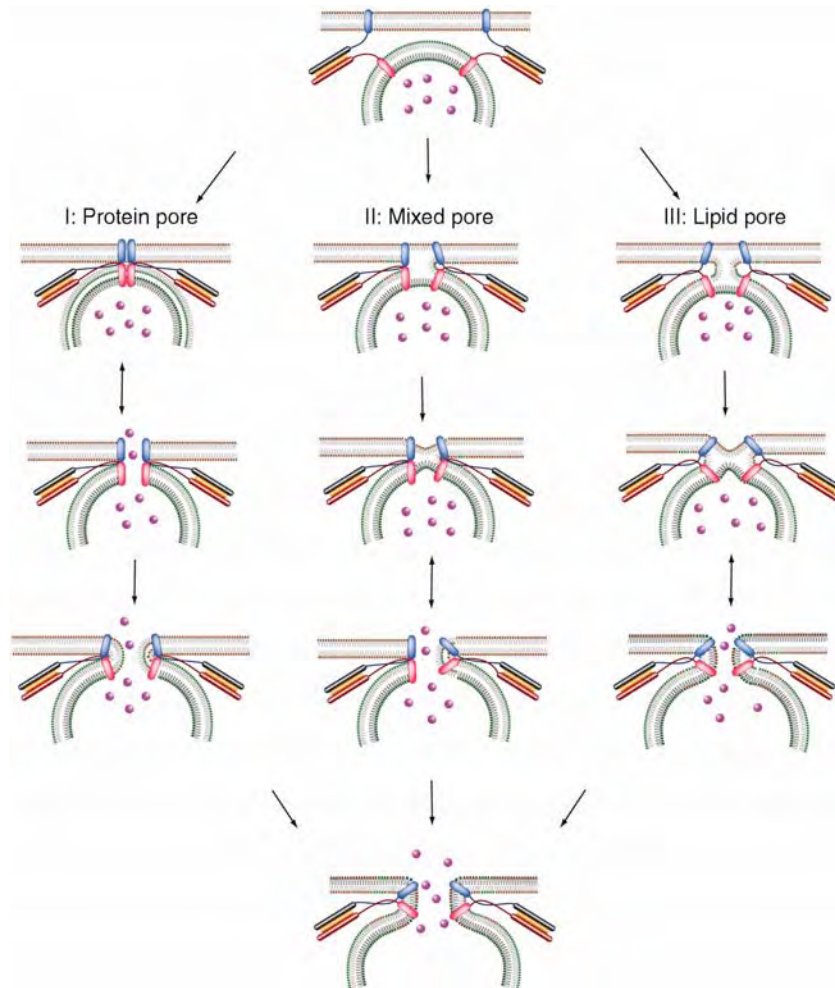

**Non-Synaptic Release. Figure 4** Three models for the macroscopic structure of a fusion pore. Note that in (I) and (III), all subunits in the ring of proteins that initially surrounded the fusion pore underwent identical conformational changes simultaneously. In contrast, the subunits in (II) underwent similar changes, but not synchronously. The opening of the semi-stable fusion pore in each model is depicted as reversible.

versions of both models typically depict that every complex in the ring simultaneously undergoes the same macroscopic structural changes to open the fusion pore. Moreover for both models, if the fusion pore indeed proceeds to further rapid dilation, there must be significant influx of lipids between at least some pairs of adjacent protein complexes.

Building on the scenario that the specific isoforms of individual SNAREs, as well as the SNARE-interacting proteins, may not be identical in every SNARE complex that form the initial ring around the fusion pore, we propose a third model in which the initial fusion pore for exocytosis can be lined with both lipids and proteins (Fig. 4II). If we consider that some SNARE complexes in the ring are more sensitive to the trigger  $\text{Ca}^{2+}$ , then with an intermediate elevation of  $[\text{Ca}^{2+}]_i$ , it is unlikely that all complexes in the ring respond synchronously. If a certain protein complex (e.g. the one on the right hand side of the fusion pore shown in Fig. 4II) can be triggered more readily to fuse the vesicular and plasma membranes near it, the resultant fusion pore can be initially lined by lipid on the right side, but lined by proteins in the left side. According to this model, the initial fusion pore can also dilate or close in ways that are very similar to the two other models (depicted in Fig. 4I & Fig. 4III). Also similar to the other two models, our model suggests that the initial size of the fusion pore is determined by the number of SNARE complexes that surrounds it. However, in our model, the influx of lipid adjacent to each triggered SNARE complex and the total number of triggered SNARE complex in each fusion pore can increase over a period of time with an intermediate elevation of  $[\text{Ca}^{2+}]_i$  (that does not trigger essentially all SNARE complexes in each fusion pore synchronously). Therefore the initial dilation of individual fusion pores up to the triggering of all SNARE complexes can vary considerably even if fusion pores with the same number of SNARE complexes are compared. Furthermore, the influx of lipid adjacent to each activated SNARE complex also predicts that the size of the dilating fusion pore is unlikely to increase in precisely “quantized” steps as each additional SNARE complex is triggered.

### Summary

The diversities among the proteins in, and associated with, the SNARE complex can contribute significantly to the variability in kinetics of release as well as the  $\text{Ca}^{2+}$ -sensitivity of exocytosis among the different types of secretory vesicles and granules. These diversities may be part of the molecular adaptation to allow different patterns of exocytosis to regulate diverse physiological functions in time scales that range from submillisecond (e.g. in synapses), to seconds (e.g. in endocrine cells) to days (e.g. in cell growth).

### References

1. Brunger AT (2005) Structure and function of SNARE and SNARE-interacting proteins. *Q Rev Biophys* 38:1–47
2. Bruns D, Jahn R (1995) Real-time measurement of transmitter release from single synaptic vesicles. *Nature* 377:62–65
3. Tang KS, Wang N, Tse A, Tse FW (2007) Influence of quantal size and cAMP on the kinetics of quantal catecholamine release from rat chromaffin cells. *Biophys J* 92:2735–2746
4. Staal RG, Mosharov EV, Sulzer D (2004) Dopamine neurons release transmitter via a flickering fusion pore. *Nat Neurosci* 7:341–346
5. Elhamdani A, Azizi F, Artalejo CR (2006) Double patch clamp reveals that transient fusion (kiss-and-run) is a major mechanism of secretion in calf adrenal chromaffin cells: high calcium shifts the mechanism from kiss-and-run to complete fusion. *J Neurosci* 26:3030–3036
6. Kishimoto T, Kimura R, Liu TT, Nemoto T, Takahashi N, Kasai H (2006) Vacuolar sequential exocytosis of large dense-core vesicles in adrenal medulla. *EMBO J* 25:673–682
7. Schneggenburger R, Forsythe ID (2006) The calyx of Held. *Cell Tissue Res* 326:311–337
8. Xu J, Xu YM, Ellis-Davies GCR, Augustine GJ, Tse FW (2002) Differential regulation of exocytosis by alpha- and beta-SNAPs. *J Neurosci* 22:53–61
9. Tang J, Maximov A, Shin OH, Dai H, Rizo J, Sudhof TC (2006) A complexin/syntaxin 1 switch controls fast synaptic vesicle exocytosis. *Cell* 126:1175–1187
10. Jackson MB, Chapman ER (2006) Fusion pores and fusion machines in  $\text{Ca}^{2+}$ -triggered exocytosis. *Annu Rev Biophys Biomol Struct* 35:135–160

## Non-verbal Communication

### Definition

Communication without words. General form of communication in the animal kingdom.

## Nootropic Drugs

PAUL F. SMITH

University of Otago Medical School, School of Medical Sciences, Department of Pharmacology and Toxicology, Dunedin, New Zealand

### Synonyms

Cognitive-enhancing drugs; “Smart” drugs



## Definition

The word “▶nootropic” is derived from the Greek word for “mind”, which is “noos.” ▶Nootropic drugs are intended to enhance cognitive function, either in individuals with neurological and psychiatric disorders that include symptoms such as memory loss, or in healthy individuals who seek to increase their cognitive function beyond the normal level. Nootropic drugs comprise a heterogeneous, often controversial, collection of drugs that work with varying degrees of success.

## Characteristics

### Cognitive Enhancement: What does it mean?

The term “cognitive enhancement” is often used to refer to an increase in memory, but it can also refer to an increase in other aspects of cognitive processing, such as attention and even elements of a behavioral response that are not easily distinguished from memory itself. There is a basic distinction between enhancing cognition in a patient who has a neurological deficit of some sort, for example, a brain lesion, and enhancing cognition in someone with normal cognitive function. In the former case, the drug therapy is intended to replace a brain chemical that is missing or reverse a pathological change; in the latter case, the drug is intended to enhance normal neurochemical function in some way. While drug treatment for memory deficits in diseases such as ▶Alzheimer’s disease have had limited success, it is debatable whether any nootropic drug has clearly been shown to enhance normal cognition in humans. In the case of drug treatment to restore memory in a neurological disorder, there is a clear objective, which is to improve a patient’s performance on a memory test to within normal limits. In the case of drug treatment to enhance normal cognition, the objective is less clear. The major obstacle for the development of all nootropic drugs is that the precise mechanisms of cognition, including memory, have not yet been identified. Consequently, it is difficult to design drugs to manipulate a neural system that is not fully understood. However, progress is being made in understanding the neural basis of memory, using models of memory such as ▶long-term potentiation (LTP), and this is gradually leading to the development of novel nootropic drugs [1,2].

### Types of Nootropic Drugs

Most nootropic drugs that are currently used to treat cognitive deficits in neurological disorders manipulate the brain neurotransmitter, ▶acetylcholine. Acetylcholine is diminished in Alzheimer’s disease [3]; therefore, these drugs are intended to replace the missing neurotransmitter. Nootropic drugs in this category include inhibitors of the cholinesterase enzymes, which metabolize acetylcholine in the synaptic cleft, in addition to drugs that activate the acetylcholine receptors (▶acetylcholine

receptor agonists). ▶Cholinesterase inhibitors prolong the action of acetylcholine in the synapse. Acetylcholine receptor agonists increase the level of activation of acetylcholine receptors. ▶Tacrine was the first cholinesterase inhibitor used to treat Alzheimer’s disease; however, ▶donepezil, ▶rivastigmine and ▶galantamine are now the first line treatments [4–8]. All three drugs inhibit acetylcholinesterase, but rivastigmine also inhibits butyrylcholinesterase, and galantamine acts as an agonist at nicotinic acetylcholine receptors [4]. Unfortunately, their beneficial effects are limited, they work more effectively in some patients than others [5], and they can cause adverse side effects such as nausea, vomiting and liver toxicity [4].

Many other drugs have been investigated for possible efficacy in the treatment of cognitive deficits, including ▶memantine, selegiline, modafanil, vitamin E, *Ginkgo biloba* extracts and a variety of other herbal extracts, and ▶α-amino-3-hydroxy-5-methylisoxazole-4-propionic acid (AMPA) receptor potentiators. Of these, only memantine and AMPA receptor potentiators have been shown to have any clinical effect [4]. Memantine blocks the calcium ion channel associated with the ▶N-methyl-D-aspartate (NMDA) subtype of glutamate receptor (an uncompetitive NMDA antagonist). Since the NMDA receptor is involved in increases in synaptic efficacy associated with LTP, it may at first seem paradoxical that memantine could benefit cognition. However, over-stimulation of the NMDA receptor causes neurotoxicity and therefore memantine may improve cognition in diseases such as Alzheimer’s disease by limiting this form of neural damage [3,4,6,7]. ▶Piracetam is one of a number of AMPA receptor potentiators that has been actively researched but is not yet prescribed for Alzheimer’s disease. Along with aniracetam, it is a pyrrolidone that increases the response of the AMPA subtype of glutamate receptor [9]. Other AMPA receptor potentiators, sometimes referred to as “▶ampakines,” include benzylpiperidines such as CX-516 and CX-546, which are in clinical trials [1,9].

Most of the drugs that are used clinically in the treatment of cognitive disorders do not enhance cognition in people without a neurological deficit. However, many drugs that were first investigated for their general nootropic effects, were then tested in patients with Alzheimer’s disease and other neurological disorders to determine whether they would have any beneficial clinical effect. Some herbal drugs such as *Ginkgo biloba* extracts have been claimed to improve memory in both Alzheimer’s disease patients and in neurologically intact individuals; however, there is no convincing evidence for a consistent effect in either case [4,10].

### Summary of Nootropic Sites of Action

Where in the brain do nootropic drugs act to produce their effects? Many areas of the brain are involved in the

encoding, consolidation and retrieval of memories. Areas such as the hippocampus and other areas of the medial temporal lobe are believed to be important for encoding new memories; the neocortex is thought to be important for long-term storage of memories [1,2].

### Molecular Mechanisms of Action of Nootropic Drugs

The precise mechanisms of the formation and retrieval of memories are not understood and therefore the precise mechanisms of action of nootropic drugs are not known. However, it is well established that acetylcholine is important for the formation new memories. Activation of acetylcholine receptors causes intracellular changes in neurons that result in the activation of proteins such as the cyclic adenosine monophosphate (cAMP) response element binding protein (CREB), which many researchers regard as a form of “molecular switch” that converts short-term memories into long-term ones [2]. The neural model of memory, LTP, has been used to better understand the increases in synaptic efficacy that are likely to underlie the formation of memories. In LTP, the activation of post-synaptic NMDA receptors is thought to be a critical step in producing the biochemical changes that lead to enhanced synaptic efficacy. While excessive activation of NMDA receptors results in excessive calcium influx and neurotoxicity, a smaller elevation of NMDA receptor activation may enhance memory. For example, the ampakines have been developed so that they elevate NMDA receptor activation indirectly, by potentiating AMPA receptor activity, which then leads to increased depolarization, thus lowering the threshold for NMDA receptor activation [1,9]. The downstream effects of AMPA receptor modulation include an increase in growth factors such as brain-derived neurotrophic factor (BDNF), which is known to be important in synaptic plasticity [9]. While still in clinical trials, these drugs may be one class of nootropic drug that is used to treat Alzheimer’s disease and other related neurological disorders in the future. Other possibilities include drugs that modulate dopaminergic and serotonergic function. Many researchers believe that no one drug with a single mechanism of action is likely to provide successful therapy for cognitive disorders.

Will the same nootropic drugs that are used to treat cognitive disorders be useful for enhancing cognition in healthy individuals? It is possible but more likely that there are natural limits to the extent that the normal neurochemical machinery of memory can be enhanced before adverse side effects develop.

### References

- Lynch G (2002) Memory enhancement: the search for mechanism-based drugs. *Nat Neurosci* 5 (suppl):1035–1038
- Barco A, Pittenger C, Kandel ER (2003) CREB, memory enhancement and the treatment of memory disorders: promises, pitfalls and prospects. *Expert Opin Ther Targets* 7:101–114
- Roberson ED, Mucke L (2006) 100 years and counting: prospects for defeating Alzheimer’s disease. *Science* 314:781–784
- Evans JG, Wilcock G, Birks J (2004) Evidence-based pharmacotherapy of Alzheimer’s disease. *Int J Neuropsychopharmacol* 7:351–369
- Rockwood K, Fay S, Jarrett P et al. (2007) Effect of galantamine on verbal repetition in AD. *Neurology* 68:1116–1121
- Beier MT (2007) Treatment strategies for the behavioural symptoms of Alzheimer’s disease: focus on early pharmacologic intervention. *Pharmacotherapy* 27:399–411
- Feldman HH, Schmitt FA, Olim JT (2006) Activities of daily living in moderate-to-severe Alzheimer’s disease: an analysis of the treatment effects of memantine in patients receiving stable donepezil. *Alzheimer Dis Assoc Disord* 20:263–268
- Brodsky H, Woodward M, Boundy K et al. (2006) A naturalistic study of galantamine for Alzheimer’s disease. *CNS Drugs* 20:935–943
- O’Neill MJ, Bleakman D, Zimmerman DM et al. (2004) AMPA receptor potentiators for the treatment of CNS disorders. *CNS Neurol Disord Drug Targets* 3:181–194
- MacLennan K, Darlington CL, Smith PF (2002) The CNS effects of *Ginkgo biloba* extracts and ginkgolide B. *Prog Neurobiol* 67:236–258

## Noradrenaline or Norepinephrine

### Definition

Noradrenaline (also called norepinephrine) is a biogenic amine neurotransmitter that is widely distributed throughout the brain and is also present in sympathetic adrenergic neurones and adrenal gland. Central noradrenergic cells are involved in the ascending arousal system and attention. Noradrenaline released from sympathetic nerve endings can cause increased heart rate and blood pressure.

## Noradrenergic Neuron/Cell

### Definition

A noradrenergic neuron uses noradrenaline (norepinephrine) as its neurotransmitter. Groups A1–A7 are examples of noradrenergic neurons located in the medulla.

▶ A1–A7 cell groups *Cellulae noradrenergicae/A1 – A7*

## Norepinephrine

► Noradrenaline

## Normosmia/Hyposmia/Anosmia

### Definition

Normosmia is the subjectively perceived normal olfactory function, usually defined as the ability to detect the great majority of tested odors in a given olfactory test. Hyposmia means the decrease of this olfactory function and anosmia the total loss of any olfactory function. Beside total anosmia, specific anosmias have been described, where only certain odors are not perceived and most odors are smelt normally.

► Smell Disorders

## Northern Blot

### Definition

A molecular assay that identifies specific messenger RNA components by using a radioactively complementary probe. mRNA from a cell is isolated and separated based on size by polyacrylamide gel electrophoresis.

The antisense probe is then used to identify the mRNA species in the gel.

## Notochord

### Definition

Axial mesoderm that lies beneath (ventral to) the neural plate/tube and extends from head to tail in chordates. It produces signals that are involved in the specification of ventral parts of the neural tube.

► Evolution and Embryological Development of the Forebrain

## Noxious (Allogenic) Chemical Stimulation of the Heart

### Definition

Cardiac afferent fibers are activated by injecting noxious chemicals via a catheter that is placed inside the pericardial sac of an anesthetized animal. The noxious chemicals are substances such as bradykinin, capsaicin or an allogenic cocktail composed of serotonin, bradykinin, prostaglandin E<sub>2</sub>, histamine and adenosine. An algogen is a chemical mediator that is usually generated within diseased or damaged tissue and produces pain behavior.

► Viscero-Somatic Reflex

## Noxious Stimuli

### Definition

Stimuli that are intense enough to potentially or actually damage body tissue. For example, thermal stimulation of the skin up to 46°C evokes a sense of warmth, while that over 48°C is noxious.

## Noxious Stimulus-evoked Vocalizations

### Definition

These are animal vocalizations that occur during noxious stimulation. These vocalizations are mediated by brainstem mechanisms and exhibit different spectrographic characteristics than vocalizations that occur after a noxious stimulus (vocalization afterdischarges, VADs). VADs are considered to be a direct index of the unpleasantness associated with the sensations evoked by noxious stimulation. VADs are mediated by brain structures involved in mediating pain unpleasantness in humans (medial thalamus, anterior cingulate cortex, amygdala) and suppressed by drug treatments that reduce pain unpleasantness in humans.

► Emotional/Affective Aspects of Pain

## NRSF

### Definition

Neuron-restrictive silencing factor (NRSF), also known as repressor element-1 silencing transcription factor (REST), silences neuronal gene expression in neural progenitors as well as non-neuronal cell types.

► [Chromatin Immunoprecipitation and the Study of Gene Regulation in the Nervous System](#)

## NRTP

### Definition

Nucleus reticularis tegmenti pontis.

## NST

► [Nucleus Tractus Solitarius](#)

## NT-4/5

### Definition

► [Neurotrophin 4/5](#)

## NTS

► [Nucleus Tractus Solitarii](#)

## Nuclear Factor Kappa Beta (NF- $\kappa$ B)

### Definition

Family of transcription factors called Rel involved with cytokine-induced activation of gene expression by

binding to the enhancer; essential for HIV expression; involved in neuroinflammation, peripheral and systemic inflammations.

► [Cytokines](#)

► [Human Immunodeficiency Virus \(HIV\)](#)

► [NF- \$\kappa\$ B: Potential Role in Adult Neural Stem Cells](#)

## Nuclear Factor of Activated T Cells (NFAT)

### Definition

A transcription factor that is activated as a result of axonal injury. Following binding of a neurotrophin to its receptor, both serine/threonine phosphatase and nuclear GSK3 $\beta$  regulate NFAT transcriptional activity and its translocation to the nucleus. NFAT interacts with members of the AP-1 complex, Fos and Jun.

► [Neurotrophic Factors in Nerve Regeneration](#)

## Nuclear Magnetic Resonance

### Definition

Nuclear Magnetic Resonance is used to describe the phenomenon where an atomic nucleus positioned in a strong magnetic field absorbs energy in the form of electromagnetic radiation at a specific frequency (Lamor frequency). A NMR signal is thereafter recorded as an induced current in a receiver coil near the sample as the atomic nuclei return to their thermal equilibrium state. The NMR technique is used to study molecular structure.

► [Magnetic Resonance Imaging](#)

## Nuclear Matrix

### Definition

The nuclear matrix is defined as the non-chromatin structure resistant to detergent extraction and nuclease digestion followed by high salt treatment.

## Nuclei of Posterior Column

### Synonyms

Nuclei columnae post.

### Definition

In the cuneate nucleus and gracile nucleus terminate the epicritic afferents of the posterior column – funiculus dorsalis – (cuneate fasciculus and gracile fasciculus), which is the reason why they are also called posterior column nuclei.

- Gracile nucleus: afferents from the trunk and lower extremities.
- Cuneate nucleus: afferents from the upper extremities and neck (medial cuneate nucleus) and vestibular organ (lateral cuneate nucleus). The efferents of both nuclei cross to the contralateral side in the medulla as the internal arcuate fibers and join the trigeminal efferents (epicritic sensibility of the face) to form the medial lemniscus, before passing to the thalamus (ventral posterolateral thalamic nucleus), from where they project into the somatosensory cortex (post-central gyrus).

## Nuclei, Telencephalic, Deep

### Definition

Nuclei that form within the basal parts of the walls of the paired telencephalic vesicles, including the amygdaloid and septal nuclei, caudate nucleus, putamen, accumbens, globus pallidus, ventral pallidum, bed nuclei of the stria terminalis and nuclei of the diagonal band.

► Striatopallidum

## Nuclei, Ventral Tier, Thalamic

### Definition

Principal or “relay” nuclei comprising anterior motor and posterior sensory groups. Anteriorly, cerebellar inputs spread widely in the ventrolateral nucleus, whereas basal ganglia inputs are more restricted in the ventromedial nucleus and anterior, medial parts of the ventrolateral (ventral anterior nucleus, in primates).

The ventral posterolateral and posteromedial nuclei relay sensory information from the dorsal column system of the spinal cord and trigeminal nerve, respectively.

► Striatopallidum

## Nuclei of the Lateral Lemniscus

ELLEN COVEY

Department of Psychology, University of Washington, Seattle, WA, USA

### Synonyms

Cell groups of the lateral lemniscus; Lateral lemniscal nuclei; NLL

### Definition

The nuclei of the lateral lemniscus (NLL) comprise several groups of neuron cell bodies in the mammalian brainstem embedded within or lying near the fiber tract known as the lateral lemniscus. Neurons in the nuclei of the lateral lemniscus constitute a major component of the ascending auditory pathway and include both monaural and binaural cell groups. They are a major source of input to the inferior colliculus.

### Characteristics

#### Quantitative Description

Figure 1 shows a schematic drawing of the nuclei of the ►lateral lemniscus (LL) as seen in a frontal section through the lower brainstem of a cat and an echolocating bat.

The NLL of the cat is typical of most mammals. In the bat, the nuclei of the lateral lemniscus are hypertrophied and much more clearly differentiated than they are in other mammals. For this reason, the bat has proven to be an ideal species in which to study the properties of specific cell types in the NLL. In all mammals the NLL can be divided into two major subdivisions, the dorsal nucleus of the lateral lemniscus (DNLL) which receives input from ►binaural structures, and a ventral complex of nuclei comprising the intermediate nucleus of the lateral lemniscus (INLL) and the ventral nucleus of the lateral lemniscus (VNLL). The INLL and VNLL receive their primary input from one ear only and collectively make up the ►monaural pathway (for review, see [1]).

#### Monaural Pathways

The INLL and VNLL receive projections from the contralateral ear, mainly via the ventral ►cochlear

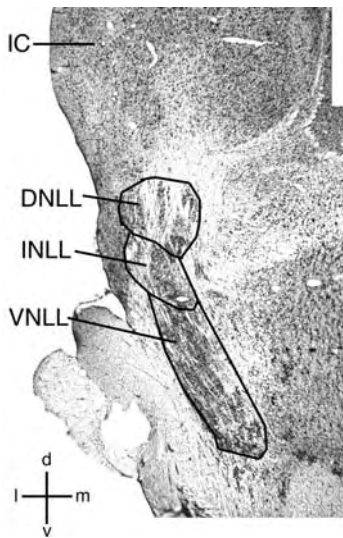

**Nuclei of the Lateral Lemniscus. Figure 1** Frontal section through the brainstem of a cat showing the nuclei of the lateral lemniscus. DNLL, dorsal nucleus of the lateral lemniscus; IC, inferior colliculus; INLL, intermediate nucleus of the lateral lemniscus; VNLL, ventral nucleus of the lateral lemniscus; d, dorsal; l, lateral; m, medial; v, ventral.

nucleus, medial nucleus of the trapezoid body, and ▶periolivary nuclei. Because their input originates mainly from one side, they are sometimes referred to as the monaural nuclei of the lateral lemniscus. Both INLL and VNLL project to the central nucleus of the ▶inferior colliculus and constitute the largest single source of projections to the auditory midbrain.

Figure 2 summarizes the principal cell types that are found in the INLL and VNLL. In all species, the INLL contains predominantly elongate cells whose dendrites are oriented orthogonal to the ascending fibers of the lateral lemniscus.

The VNLL contains a population of small round neurons with a single highly branched dendrite. These neurons resemble ▶spherical bushy cells in the cochlear nucleus, and receive ▶calyx-like terminals on their cell body. The calyces originate from cells in the ventral cochlear nucleus. In most mammals the bushy cells are intermingled with other cell types throughout the VNLL, but in echolocating bats they are segregated into a highly organized and homogeneous structure termed the ▶columnar nucleus of VNLL (VNLLc) [2,3]. Neurons in the VNLLc are ▶glycinergic, so are thought to provide inhibitory input to their target cells. The other main cell type in VNLL is multipolar neurons, which in bats are segregated into a subdivision referred to as the ▶multipolar cell region of VNLL (VNLLm). Figure 2a is a block diagram summarizing the ascending monaural pathways via the nuclei of the lateral lemniscus.

### Binaural Pathways

The DNLL receives most of its input from the binaural structures of the superior olivary complex, including projections from the ipsilateral ▶medial superior olive (MSO) and projections from the ▶lateral superior olive (LSO) of both sides. The right and left DNLLs are reciprocally connected with one another via a fiber tract, the ▶commissure of Probst. The DNLL provides bilateral projections to the inferior colliculus. Most neurons in the DNLL are ▶GABAergic and are therefore thought to be inhibitory to their postsynaptic neurons. Figure 2b is a block diagram summarizing the binaural components of the ascending pathway via the DNLL.

### Function

The nuclei of the lateral lemniscus are a major component of the complex system of parallel pathways in the mammalian auditory brainstem. However, their role in the neural processing underlying sound perception is not well understood. What we do know is that most neurons in the INLL and VNLL respond to sounds at the contralateral ear and are unaffected by sounds at the ipsilateral ear while most neurons in the DNLL are sensitive to differences in the intensity or timing of sounds at the two ears. Thus, it has been suggested that the DNLL plays a role in localizing sound sources while the monaural nuclei play a role analyzing temporal patterns of sound (for review, see [1,4]).

### Monaural Pathways: INLL and VNLL

Based on the limited evidence available, the structure, connectivity, and functional properties of INLL and VNLL seem to be similar in all mammals. However, because these structures are unusually large, clearly organized, and accessible in echolocating bats, much of what we know about their physiology comes from these animals. It is thought that the different neuron types of INLL and VNLL transform inputs from the cochlear nucleus in various ways depending on their ▶intrinsic properties, and integrate inputs from multiple sources to provide a system of ▶delay lines that are important for creating temporal ▶feature detector neurons in the inferior colliculus. Response latencies of neurons in the ventral cochlear nucleus range from about 1–6 ms, but in the INLL and VNLL, this range lengthens to include latencies from about 2–20 ms [5]. Delayed input from some neurons converging with rapid input from others provides a mechanism through which it is possible to compare sound events that occur at different times (see [6], for review).

Neurons in the INLL and VNLL respond to sounds with a variety of discharge patterns, which are probably shaped through each neuron's intrinsic properties and integration of multiple synaptic inputs. Sustained responses provide a real-time representation of a sound's duration, since the neuron fires for as long as the sound is

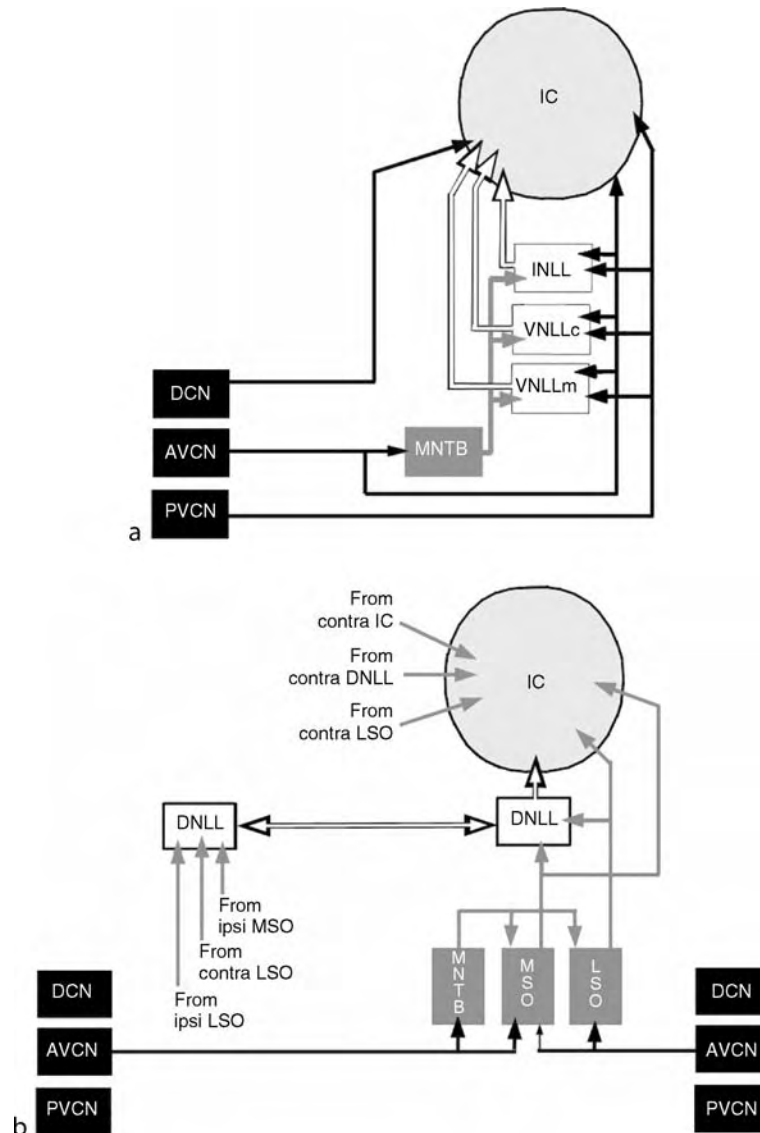

**Nuclei of the Lateral Lemniscus. Figure 2** Block diagram of monaural and binaural pathways to the midbrain via the nuclei of the lateral lemniscus. (a) Monaural pathways via INLL and VNLL. (b) Binaural pathways via DNLL. Abbreviations same as in Fig. 1; AVCN, anteroventral cochlear nucleus; DCN, dorsal cochlear nucleus; LSO, lateral superior olive; MNTB, medial nucleus of the trapezoid body; MSO, medial superior olive; PVCN, posterioventral cochlear nucleus; VNLLc, columnar nucleus of VNLL; VNLLm, multipolar nucleus of VNLL.

present. Onset responses provide a precise marker for the time when a sound begins, or when a changing sound enters the neuron's area of sensitivity. Echolocating bats have a specialized group of cells in VNLL, the columnar nucleus, which are extraordinary in having timing precision on the order of several tens of microseconds, across a wide range of conditions. It is possible that these neurons have evolved to provide precise timing markers for when the bat emits an echolocation call and when the echo of that call returns, allowing the bat's neural circuitry to calculate the distance to the object from which the echo was reflected. Although this cell type is segregated in

bats, it is present in other mammals as well, intermingled among other cell types. This suggests that the precise timing information about sound onset provided by the VNLL is important for all animals that hear, albeit on a different level of time resolution (for reviews see [1,4]).

#### **The Binaural Pathway: DNLL**

The DNLL represents an intermediate binaural processing stage between the superior olivary complex (SOC) and inferior colliculus. It receives inhibitory and excitatory input from the SOC on the same side, excitatory input from the SOC on the opposite side, and

inhibitory input from the opposite DNLL (see Fig. 2b). As a result, responses of DNLL neurons are influenced by sound at both ears, in complex ways, being binaurally facilitated under some conditions and inhibited in under other conditions. It has been suggested that DNLL may play a role in perception of sounds originating from multiple sources [7], but at present its function is not well understood.

## References

1. Covey E (1993) The monaural nuclei of the lateral lemniscus: parallel pathways from cochlear nucleus to midbrain. In: Merchan MA, Juiz JM, Godfrey DA (eds) *The mammalian cochlear nuclei: organization and function*. Plenum, New York, pp 321–334
2. Covey E, Casseday JH (1986) Connectional basis for frequency representation in the nuclei of the lateral lemniscus of the bat, *Eptesicus fuscus*. *J Neurosci* 6:2926–2940
3. Covey E, Casseday JH (1991) The ventral lateral lemniscus in an echolocating bat: parallel pathways for analyzing temporal features of sound. *J Neurosci* 11:3456–3470
4. Oertel D (1999) The role of timing in the brainstem auditory nuclei of vertebrates. *Annu Rev Physiol* 61:497–520
5. Haplea S, Covey E, Casseday JH (1994) Frequency tuning and response latencies at three levels in the brainstem of the echolocating bat, *Eptesicus fuscus*. *J Comp Physiol A* 174:671–683
6. Covey E, Casseday JH (1999) Timing in the auditory system of the bat. *Annu Rev Physiol* 61:457–476
7. Burger RM, Pollak GD (2001) Reversible inactivation of the dorsal nucleus of the lateral lemniscus reveals its role in the processing of multiple sound sources in the inferior colliculus of bats. *J Neurosci* 21:4830–4843
8. Covey E (1993) Response properties of single units in the dorsal nucleus of the lateral lemniscus and paralemniscal zone of an echolocating bat. *J Neurophysiol* 69:842–859
9. Covey E, Casseday JH (1995) The lower brainstem auditory pathways. In: Popper AN, Fay RR (eds) *Handbook of auditory research, vol 5: hearing and echolocation in bats*. Springer, New York, pp 235–295

## Nucleus, Bed, of the Stria Terminalis

### Definition

The bed nucleus of the stria terminalis is a deep telencephalic nucleus comprising a number of variably distinct subnuclei, of which all resemble, in terms of intrinsic composition and extrinsic connections, the centromedial part of the amygdaloid complex.

The bed nucleus of the stria terminalis and the centromedial part of the amygdala are densely interconnected by long associational connections of

which one part traverses the stria terminalis and another part traverses the sublenticular part of the basal forebrain. Hence, the bed nucleus is regarded as an integral part of the extended amygdala.

► [Striatopallidum](#)

## Nucleus, Caudate

### Definition

The caudate nucleus is one of the deep telencephalic nuclei consisting of a large globular head that occupies the rostral part of the hemispheric wall, an elongated body that arches upward and backward over the internal capsule and a long slender tail that arches downward and forward into the temporal lobe in relation to the hippocampus and amygdaloid complex. The caudate nucleus receives massive cortical inputs largely from the frontal lobe and a number of subcortical inputs, particularly from intralaminar thalamic nuclei and dopaminergic neurons in the substantia nigra pars compacta. It projects strongly to the globus pallidus and substantia nigra.

► [Basal Ganglia](#)  
► [Striatopallidum](#)

## Nucleus, Lentiform (Lenticular)

### Definition

The lentiform nucleus is a large cone-shaped gray mass forming the central core of the hemisphere with a convex lateralward-facing base, comprising the putamen, and medial-ward pointing apex, comprising the globus pallidus. Grouping of the globus pallidus and putamen as the lentiform nucleus reflects an artificial association, in so far as the globus pallidus is structurally and functionally dissimilar to the putamen, receiving dense projections from the striatum (caudate nucleus and putamen) and projecting to the subthalamic nucleus, substantia nigra, brainstem reticular formation, and via a relay in the thalamus, to motor staging areas of the cortex.

► [Basal Ganglia](#)  
► [Striatopallidum](#)



## Nucleus, Mediodorsal, Thalamic

### Definition

The mediodorsal (MD) thalamic nucleus is situated within the internal medullary lamina at the dorsomedial extremity of the thalamus and surrounded by nuclei of the midline-intralaminar group.

The mediodorsal nucleus (MD) is always included with the thalamic association nuclei, sometimes as a subcategory of the principal or “relay” nuclei. Comprising medial, central and lateral segments involved with, respectively, emotional expression, olfaction and visual attention, the MD is reciprocally connected with frontal lobe association cortex including the orbitomedial and agranular insular (medial and central segments) and the frontal eye field (lateral segment). In addition, the MD receives projections from basal ganglia structures including ventral striatopallidum (medial and central segments) and the substantia nigra reticulata (lateral segment). The cortical projection field of the MD has been said to define the extent of the “prefrontal” cortex.

- ▶ Thalamus
- ▶ Striatopallidum

## Nucleus Accumbens

### Definition

A large gray mass located in the medial part of the basal forebrain that, over the years, has been variably associated with the septal nuclei and striatum. Previously called the “nucleus accumbens septi”, it is interposed without clear boundaries between the ventral parts of the caudate nucleus and putamen and the olfactory tubercle or its homologue. Contemporarily regarded as an integral part of the striatal complex, it is no longer considered to be a nucleus in its own right. It receives cortical inputs from the basal amygdala, hippocampus and medial prefrontal cortex and projects to the ventral pallidum, lateral hypothalamus and ventral mesencephalon. Experimental histochemical and connectional studies have revealed that the accumbens comprises sub-territories, including a core, shell and arguably a rostral pole.

- ▶ Striatopallidum

## Nucleus Ambiguus

### Definition

Like the dorsal nucleus of the vagus nerve and the nucleus of the hypoglossal nerve, the ambiguus features a cellular column of at least 2 cm in length and also runs parallel to these nuclei. This is no surprise as it is the origin of somatomotor (actually special visceromotor) fibers of glossopharyngeal nerve (IX) and vagus nerve (X), which are responsible for innervation of the pharynx and larynx muscles.

- ▶ Myelencephalon

## Nucleus Basalis Magnocellularis

### Definition

Group of cholinergic cells in the basal forebrain, term used in nonprimates to refer to the area equivalent to the nucleus basalis of Meynert in primates

- ▶ Evolution of Subpallial Cholinergic Cell Groups

## Nucleus Basalis (NB) of Meynert

### Definition

The NB is a group of neurons in the basal forebrain that receive inputs from limbic and paralimbic regions and send cholinergic excitatory projections to the entire brain, particularly the neocortex. Projections to the sensory cortical areas are strictly topographically ordered. The NB seems to play a key role in the control of selective attention.

- ▶ Basal Forebrain

## Nucleus Intermediolateralis (IML)

### Definition

The IML is present in the thoraco-lumbar (upper lumbar) and sacral spinal cord and contains the highest

density of spinal preganglionic neurons. It is part of the intermediate zone.

► [Autonomic Reflexes](#)

## Nucleus Isthmi

### Definition

It is found at the dorsocaudal end of the dorsal tegmentum; and is homologous to the mammalian parabigeminal nucleus. Indirect visual input to the nucleus isthmi originates from the ipsilateral tectum.

An ipsilateral isthmotectal projection to several retinorecipient layers and a contralateral isthmotectal projection to only the superficial layer of retinal afferents is found in amphibians and all other vertebrate taxa. The isthmotectal projection is topographically organized and in register with the retinal maps. Recordings from isthmic neurons and lesion experiments of the nucleus isthmi reveal that the representation of the visual space differs from that of the tectal representation of the visual space. The isthmic nucleus is essentially involved in object localization and selection.

► [Evolution of the Visual System: Amphibians](#)

## Nucleus of the Optic Tract

### Definition

As the optic tract curves around the brain stem toward the lateral geniculate nucleus there are a number of terminations in a nucleus within the pretectal area, just dorsal to the superior colliculus. The subcortical neuronal substrate of the optokinetic reflex has been investigated in many mammals. In all of these animals, the pretectal nucleus of the optic tract and the dorsal terminal nucleus of the accessory optic tract (NOTDTN), with its strongly direction-selective neurons, links the visual information from the retina and visual cortex, via projections to the inferior olive, the nucleus praepositus hypoglossi, the nucleus reticularis tegmenti pontis and the dorsolateral pontine nucleus, with the cerebellum and the oculomotor structures. In most mammals, the direct retinal input to the NOT-DTN

comes almost exclusively from the contralateral eye, whereas in the monkey the retinal input is strongly bilateral. Data show that the motion-sensitive areas in the superior temporal sulcus (STS) provide the main input to the NOT-DTN.

► [The Central Mesencephalic Reticular Formation – Role in Eye Movements](#)

## Nucleus of the Solitary Tract

► [Nucleus Tractus Solitarii](#)

## Nucleus Prepositus Hypoglossi

### Definition

The nucleus prepositus hypoglossi is located on the surface of the fourth ventricle between the abducens and the hypoglossal motor nuclei. Main oculomotor-related inputs to prepositus neurons arrive from the ipsilateral paramedian pontine reticular formation, from both vestibular nuclei, and from the contralateral prepositus nucleus. Prepositus neurons project to the abducens nucleus, superior colliculus, cerebellum, and other brainstem centers related to eye movements.

- [Neural Integrator – Horizontal](#)
- [Vestibular Secondary Afferent Pathways](#)

## Nucleus Proprius

### Synonyms

Nucl proprius

### Definition

Nucleus in the middle of the posterior horn of the spinal cord. Present in all spinal cord segments, it is a synaptic center for proprioceptive afferents from the locomotor apparatus. The impulses pass on to the cerebellum via the anterior spinocerebellar tract where they are compared with setpoint values.

► [Medulla Spinalis](#)

## Nucleus Reticularis Gigantocellularis (NRG)

### Definition

The rostral and medial portion of the medullary reticular formation named for the giant cells that it contains. It is a major source of reticulospinal neurons.

► Reticulospinal Long-Lead Burst Neurons

## Nucleus Reticularis Pontis Caudalis (NRPc)

### Definition

Roughly the caudal half of the pontine reticular formation. Its borders are based on cytoarchitecture but are poorly delineated. NRPc gives way to nucleus reticularis gigantocellularis roughly at the caudal border of the abducens nucleus.

## Nucleus Reticularis Tegmenti Pontis (NRTP)

### Definition

A large reticular nucleus at the bottom of the pontine reticular formation overlying the pontine nuclei. NRTP receives input from cortical and higher-level subcortical structures and conveys (presumably integrated) information to the cerebellum. NRTP also receives substantial feedback from the cerebellum by way of efferents from the deep cerebellar nuclei.

## Nucleus Tractus Solitarii (NTS)

### Definition

► Nucleus of the Solitary Tract

## Nucleus Tractus Solitarii

R. ALBERTO TRAVAGLI

Neuroscience, Pennington Biomedical Research Center-LSU System, Baton Rouge, LA, USA

### Synonyms

Nucleus of the tractus solitarius; NTS; Nucleus of the solitary tract; NST

### Definition

The nucleus tractus solitarius (NTS) is the principal visceral sensory nucleus in the brain and comprises neurochemically and biophysically distinct neurons located in the dorsomedial medulla oblongata. The NTS conveys information from the gustatory, cardiorespiratory, esophageal and the subdiaphragmatic gastrointestinal viscera that is subsequently assimilated with homeostatic signals arriving from other integrative centers of the pons, diencephalon and forebrain.

An exceptionally large diversity of neurochemical phenotypes and receptor proteins coupled with an impressive network of connections to and from the NTS and a loose blood brain barrier characterizes this brainstem nucleus as a vital controller of homeostatic functions.

The old concept of the NTS (and the closely related dorsal motor nucleus of the vagus and area postrema) as a simple relay center is overcome by an increasingly large body of work showing that the NTS has segregated lines of specificity in controlling sensory and pre-motor visceral information.

### Characteristics

#### Anatomical and Neurochemical Description

The NTS is a Y shaped nucleus whose caudal pole is at the level of the pyramidal decussation and rostral pole is at the lower limit of the facial nucleus (VII cranial nerve). The lateral limits of the NTS are adjacent to the substantia reticulata, its medial portions are fused caudally to form the subnucleus commissuralis. Moving rostrally, the NTS abuts the ► [area postrema \(AP\)](#) medially and, rostral to AP, the walls of the fourth ventricle. The ► [dorsal motor nucleus of the vagus \(DMV\)](#) is located ventral to the NTS while the nucleus of the hypoglossus (XII cranial nerve) is located medially to NTS but only in regions rostral to the AP. Dorsally the NTS is separated from the nucleus gracilis and, rostral to AP, from the nucleus cuneatus by their respective fasciculi.

Separate subnuclei can be distinguished within the NTS of several animal species, but these subnuclei are more useful in defining the general regions of the NTS rather than its neuronal subclasses, neurochemical

characteristics, visceral representations or projection targets. In general, the visceral projections sites within the NTS reveal a rostro-caudal pattern reflecting the head-to-toe location of the viscera; the gustatory (i.e., tongue) NTS, for example, is uppermost, while the pharyngeal, cardiorespiratory and esophageal areas are somewhat overlapping at levels spanning both rostrally and caudally to the AP. The subdiaphragmatic viscera are represented in the more caudal portions of the NTS, where the distal gastrointestinal projections are denser. A loose viscerotopic organization is also recognizable along the medio-lateral extent of the NTS; moving from lateral toward medial NTS, the afferent receptive fields of the tongue, soft palate and pharynx, lungs, esophagus, baro- and chemoreceptor nerves, stomach and distal intestines, respectively, are located. Reviewed in [1–3].

The NTS integrates the inputs received from viscera with the inputs it receives from the spinal cord, the spinal trigeminal nucleus (V cranial nerve), ventrolateral medulla, raphe nuclei, several components of the reticular formation, A5 and A6 areas, parabrachial and Kolliker Fuse nuclei, dorsal tegmental regions including the periaqueductal gray, and bed nucleus of the stria terminalis. From the forebrain, the NTS receives descending input from a large and interconnected complex of neurons in the paraventricular and lateral hypothalamic areas and the central nucleus of the amygdala. Significant cortical projections also come from the medial prefrontal and insular regions. These regions projecting to the NTS are richly interconnected and the NTS itself maintains reciprocal connections with practically all of the abovementioned areas.

Neurons in the NTS are of medium size (10–15  $\mu\text{m}$  diameter) and can be distinguished morphologically into multipolar (or stellate) neurons with 3–four dendrites exiting the soma or bipolar neurons with two dendrites only exiting the soma at opposite poles. These neuronal dendrites can extend outside the boundaries of the NTS itself to make contact with adjacent nuclei or the ependymal layer of the fourth ventricle. No apparent morphological or biophysical characteristic can be correlated with certainty to a specific physiological role of any given neuron, although recent works by MC Andresen and RA Travagli's groups has started to investigate this possibility.

The NTS contains a large array of membrane receptors and an even larger variety of neurochemical phenotypes, from “classical” neurotransmitters such as glutamate, GABA, glycine, serotonin, nitric oxide and catecholamines to an assorted content of neuropeptides or neuromodulators such as neuropeptide Y, enkephalins, cholecystokinin, somatostatin, glucagon-like peptide-1, etc. Peculiar to NTS, compared to other brain regions, is the apparently fundamental role in

the modulation of neuronal NTS activity played by co-transmitters, in particular peptides such as substance P and CGRP, released from vagal afferent fibers. Similar to previous description, no specific physiologic role can be attributed to any given cell containing a particular neurochemical phenotype, although the localization of neuronal groups with a similar phenotype is, in some instances, very localized. Catecholaminergic neurons, for example, are confined to the A2 area whereas cholecystokinin-containing neurons are located in the caudal portions of the NTS.

### Physiological Description

Fibers from the trigeminal (V cranial nerve), facial (VII cranial nerve), glossopharyngeal (IX cranial nerve) and vagus (X cranial nerve) form the solitary tract (or tractus solitarius) and their terminals overlap along the rostro-caudal extent of the NTS. Afferent fibers belong to the myelinated A- and unmyelinated C-groups. Regardless of their origin or type, though, afferent fibers enter the brainstem in the tractus solitarius and activate NTS neurons via the release of excitatory neurotransmitters, mainly glutamate.

The majority of NTS neurons do not possess pacemaker activity, i.e., they do not have spontaneously occurring action potentials; thus, to convey the sensory information to other areas, NTS neuronal projections must be driven and are modulated by synaptic activity, either from the afferent fibers of the tractus solitarius, from other neuronal areas, or via circulating hormones. In fact, we have to consider that the NTS is a circumventricular organ with a leaky blood brain barrier, fenestrated capillaries and enlarged perivascular space that allows the passage of large molecules, including circulating hormones and neurotransmitters. Additionally, the adjacent area postrema, which lies entirely outside the blood brain barrier, has a series of short, communicating vessels that potentially send postremal venous drainage to the NTS. These morphological characteristics allow NTS neuronal activity to be open to modulation by a wide variety of transmitter and hormonal peptides, including, among many others, glutamate itself, cholecystokinin, leptin, and ATP.

By being subject to a vast array of modulatory activity, the synaptic connections between NTS and the motor neurons controlling cardiorespiratory, pharyngo-esophageal and gastrointestinal functions, by implication, play a major role in shaping the efferent output. Further, recent studies suggested a potential role of NTS neurons in the integration of nociceptive signals and cardiorespiratory afferent fibers.

### Role of NTS in

► **Swallowing:** NTS neurons behave as pattern generators in the initiation and organization of the sequential or rhythmic motor pattern of swallowing.

Application of excitatory amino acids (glutamate) or antagonism of inhibitory amino acids (GABA) in NTS induces sequential and rhythmic motor pattern of swallowing. Swallowing can also be evoked by cortical stimulation, however, this is abolished by lesions of the NTS indicating that the NTS is the main central system responsible for swallowing. Since batches of NTS neurons are activated sequentially during swallowing, it is likely that distinct neuronal subgroups control different regions of the swallowing canal. Integrated swallowing information from the NTS is transmitted mainly to the nucleus ambiguus, whose motoneurons innervate the esophagus, pharynx, and intrinsic laryngeal muscles [4].

► **Gustatory:** fibers from the facial (VII cranial nerve) and glossopharyngeal (IX cranial nerve) carry gustatory afferent fibers to the rostral portions of the NTS. Although morphologically distinct, the gustatory-related NTS neuronal subtypes all receive synaptic inputs that use excitatory (glutamate) or inhibitory (GABA) amino acids as the main neurotransmitters. Gustatory-related NTS neurons project rostrally to the pontine gustatory relay area, to the reticular formation and to motoneurons of cranial nerves V (trigeminal), VII (facial), IX (glossopharyngeal), X (vagus) and XII (hypoglossus) [5].

► **Cardiorespiratory:** most cardiovascular afferent fibers and practically all fibers from the aortic depressor nerve and the carotid sinus nerve converge on the dorsomedial portion of the NTS. Electrical or pharmacological excitation of NTS neurons mimics baroreceptor activation and induces a decrease in heart rate, blood pressure and sympathetic nerve activity. Baroreflexes are blocked by pressure application of glutamate antagonists in the NTS, while GABA antagonists increase blood pressure, indicating glutamate and GABA as major players in the reflexive cardiovascular control from the NTS. Cardiovascular-related neurons of the NTS provide the premotor integration to neurons of the caudal ventrolateral medulla and neurons of the nucleus ambiguus, which control sympathetic and parasympathetic output, respectively [6].

Fibers innervating the slowly- and rapidly-adapting stretch receptors and bronchopulmonary C-fibers innervating the lungs and airways terminate in the caudal lateral NTS where they target different neuronal subtypes, suggesting that each afferent fiber may contribute to several different components of the respiratory phases. Excitatory (glutamate) and inhibitory (GABA and glycine) amino acids are the main neurotransmitters used by fiber terminals onto NTS neurons. Respiratory-related NTS neurons project to areas involved in rhythm- and pattern-generating neurons of the pre-Botzinger and Botzinger regions, to cranial and bulbo-spinal premotor neurons involved in respiratory pattern formation

and to other neuronal areas devoted to a further integration with ingestive, cardiovascular, orofacial, airway protective and pain pathways [7].

► **Gastrointestinal:** mechanical or chemical manipulations of the proximal gastrointestinal tract activates NTS neurons, mainly via a vagal-mediated release of excitatory amino acids such as glutamate. Localized pressure applications of glutamate directly into the medial NTS can evoke rapid, large, and vagally mediated gastric relaxations similar to those evoked by stimulation of vagal afferent fibers. The inhibition of gastric motor function occurs probably via activation of GABAergic or catecholaminergic NTS neurons projecting to the efferent motoneurons of the DMV. Antagonism of inhibitory amino acids (GABA) in NTS induces a dramatic increase in gastric motor functions indicating the presence of a robust GABAergic tone that dampens vagal gastrointestinal motor output [3].

► **Feeding:** signals that relate to ingestive behavior are generated by the interaction of food with chemo- and mechano-sensors in the alimentary canal before and during absorption. Signals related to satiation (i.e., short term feedback signals) and meal size are detected by sensory afferent neurons terminating in the NTS, which orchestrates the basic features of reflexive ingestion and gastrointestinal needs. Since afferent fiber terminals use excitatory amino acids (glutamate) as their main neurotransmitter, blockade of ionotropic glutamate receptors delays satiation and increases meal size. Circulating hormones and robust hypothalamic projections contribute to the NTS control of the integration of food intake [8].

In summary, neurons of the NTS provide the framework for the hardware responsible for coordinating vital homeostatic responses; emerging evidence shows that NTS neurons are functionally distinct and comprise an important station in segregated lines of specificity controlling sensory and pre-motor visceral information. In its static form, one may presume that activation of any given neuronal circuit within the NTS elicits the same hard-wired efferent response. Recent studies have, however, revealed a high degree of plasticity in available responses, such as, for example, in the control over the stomach or airway circuits [9,10]. One agonist signal may “gate” another, and the tonic effects of afferent input may “gate” agonist responses that are related to the “►state of activation” of a particular NTS circuit.

## References

1. Blessing WW (1997) The lower brainstem and bodily homeostasis. Oxford University Press, Oxford
2. Barraco R, El-Ridi M, Parizon M, Bradley D (1992) An atlas of the rat subpostremal nucleus tractus solitarius. *Brain Res Bull* 29:703–765

3. Travagli RA, Hermann GE, Browning KN, Rogers RC (2006) Brainstem circuits regulating gastric function. *Annu Rev Physiol* 68:279–305
4. Jean A (2001) Brainstem control of swallowing: neuronal network and cellular mechanisms. *Physiol Rev* 81:929–969
5. Bradley RM, King MS, Wang L, Shu W (1996) Neurotransmitter and neuromodulator activity in the gustatory zone of the nucleus tractus solitarius. *Chem Senses* 21:377–385
6. Andresen MC, Kunze DL (1994) Nucleus tractus solitarius – gateway to neural circulatory control. *Annu Rev Physiol* 56:93–116
7. Kubin L, Alheid GF, Zuperku EJ, McCrimmon DR (2006) Central pathways of pulmonary and lower airway vagal afferents. *J Appl Physiol* 101:618–627
8. Berthoud HR, Sutton GM, Townsend RL, Patterson LM, Zheng H (2006) Brainstem mechanisms integrating gut-derived satiety signals and descending forebrain information in the control of meal size. *Physiol Behav* 89:517–524
9. Bonham AC, Chen CY, Sekizawa SI, Joad JP (2006) Plasticity in the nucleus tractus solitarius (NTS) and its influence on lung and airway reflexes. *J Appl Physiol* 101:322–327
10. Browning KN, Travagli RA (2006) Short-term receptor trafficking in the dorsal vagal complex: an overview. *Auton Neurosci* 126–127:2–8

## Null Mutation

### Definition

Mutation to induce no expression of a certain gene.  
Equivalent to knockout of gene.

## Nyquist Sampling Theorem

### Definition

The sampling rate needed in order to be able to reconstruct a sampled signal back to its original (continuous) form, without loss of information, should be sampled at least twice as fast as the highest frequency component in the signal.

► [Signals and Systems](#)

## Nystagmus

### Definition

The rhythmic, alternating movement of the eyes, usually consisting of a rapid or saccadic movement in one direction followed by a slower, smooth movement of the eyes in the opposite direction. Nystagmus is designated based on the direction of the rapid eye movement.

► [Cerebellar Functions](#)

► [Saccade](#)

## Nystagmus – Optokinetic (OKN)

### Definition

Nystagmus produced by movement of the visual surround relative to a subject. In primates, the slow phase velocity rises sharply and maintains a steady state value throughout the rotation.

► [Velocity Storage](#)

## Nystagmus – Pathological

### Definition

Pathological nystagmus occurs at rest and can be caused by disorders in the brainstem, cerebellum or vestibular system, and is associated with vertigo and dizziness.

► [Disorders of the Vestibular Periphery](#)

► [Ischemic Stroke](#)

## Nystagmus – Per-Rotatory Vestibular

### Definition

Nystagmus produced during prolonged rotation of the head in space. For rapid initiation of rotation, the slow

phase velocity rises sharply at the start of rotation and declines to zero as the rotation continues at a constant velocity.

▶ Velocity Storage

---

## Nystagmus – Post-Rotatory Vestibular

### Definition

Nystagmus produced upon stopping after long term rotation (>10 s) of the head in space. Its characteristics are the same as those of per-rotatory vestibular nystagmus.

▶ Velocity Storage

---

## Nystagmus – Vestibular

### Definition

Vestibular nystagmus results from an asymmetry in the resting activity between the two labyrinths. The nystagmus that occurs in cases of unilateral vestibular hypofunction has fast and slow components. The slow components are directed toward the labyrinth that has diminished activity (hypofunction).

▶ Disorders of the Vestibular Periphery

---

## Obesity

### Definition

Increased body weight due to excessive amounts of fat; partly due to genetic disposition.

---

## Object Perception

### Definition

► Form Perception

---

## Object-based Attention

### Definition

Object-based attention refers to mechanisms by which an entire object is selected for further processing. Object-based attention will spread to all features of the selected object. For instance, if subjects perform a task on the shape of an object, the processing of the color of the object will also be enhanced. In addition, if subjects are attending to only a portion of the object, attention will spread over the entire spatial extent of the object (see Visual attention).

► Visual Attention

---

## OBPs

► Odorant Receptor

---

## Observability

### Definition

Observability represents the ability to detect (observe) physical system behavior by means of the sensors connected to it. In terms of system states, it is the ability to infer state values using sensor outputs.

► Control

---

## Observational Learning

### Definition

Learning that occurs as a function of observing, retaining and replicating behavior observed in others. Observation[al] learning is a looser concept than imitation learning. Social learning is a type of observation[al] learning. Motivation, attention and/or simple pairing of novel stimuli may contribute to this process. Thus even invertebrates such as octopus can perform observation[al] learning (Florito and Scotto, 1992).

► Imitation Learning

---

## Obsessive-compulsive Disorder [OCD]

### Definition

A neurotic disease (in DSM-IV: anxiety disorder) in which the mind is flooded with persistent and uncontrollable thoughts or the individual is compelled to repeat certain acts again and again, causing significant distress and interference with everyday functioning.

► Personality Disorder



## Obstructive Sleep Apnea

SIGRID C. VEASEY

Center for Sleep & Respiratory Neurobiology,  
Department of Medicine, School of Medicine,  
University of Pennsylvania, Philadelphia, PA, USA

### Synonyms

Sleep apnea; Obstructive sleep apnea hypopnea syndrome; Obstructive sleep-disordered breathing

### Definition

► **Apnea**: a cessation in ventilatory airflow lasting for 10 s or longer.

► **Sleep apnea**: A diverse group of disorders with a common feature of repeated sleep-dependent cessations in airflow.

► **Obstructive sleep apnea**: A syndrome in which repeated cessations in airflow occur as a direct consequence of sleep-dependent collapse of the upper airway. The syndrome is characterized by sleepiness, fatigue and snoring.

### Characteristics

#### Overview

Obstructive sleep apnea is a rapidly evolving syndrome. For decades, snoring was believed to be more of an inconvenience for the bed partner than a sign of significant disease. Recent studies, however, have clearly established that snoring in association with unrefreshed sleep is a warning sign of obstructive sleep apnea, and obstructive sleep apnea is now widely recognized as an independent risk factor for significant cardiovascular and neurological morbidities. Therefore, obstructive sleep apnea is a disorder for which high clinical suspicion, early diagnosis, and effective intervention are of utmost importance.

#### Pathogenesis

A unique feature of disorders of sleep apnea is that the brief cessations in ventilation occur exclusively in sleep. In wakefulness, neural mechanisms ensure continued respiration. In sleep, both ► **non-rapid-eye-movement (NREM)** and/or ► **rapid-eye-movement (REM)** sleep, ventilatory drive may fall sufficiently to allow apneas to develop. The obstructive nature of events occurs in part because ► **NREM** and ► **REM** sleep are associated with reductions in muscle activity, with a greater decline in ► **pharyngeal muscle** activity than reduction in pump muscle activity [1]. This occurs as a normal physiological response to sleep in all individuals. However, individuals with obstructive sleep apnea rely upon specific muscles surrounding the pharynx to stent open the airway for

ventilation. Because the ► **oropharynx** is a highly collapsible tube, and one that may be collapsed from any direction, a number of pharyngeal muscles must act in concert to stent open the pharynx. These pharyngeal muscles include the tongue (► **genioglossus**), ► **soft palate muscles**, and muscles that stiffen the posterior wall or extend the lateral walls of the pharynx. In sleep, reductions in upper airway dilator muscle tone result in collapse of the upper airway [1]. Collapse of the upper airway is most likely to occur during inspiration, when negative pressures are generated in the lumen of the oropharynx [1]. Occlusion of the upper airway results in cessation of airflow, or apnea, that in turn results in ► **hypercapnia**, hypoxia and stimulation of upper airway afferents, resulting in arousal and resumption of the necessary upper airway muscle activity to reopen the upper airway. This process can be repeated up to 100 times/h of NREM and REM sleep. In many individuals, the sleep p-dependent events involve a reduction in flow, rather than complete cessation of flow. A sleep-related reduction in flow, associated with a drop in oxygen saturation and an arousal, is termed a ► **hypopnea**. These events disrupt sleep and oxygenation and are considered as clinically significant as ► **apneas**. One of these events is illustrated in Fig. 1, showing a reduction in airflow just at sleep onset, result in a drop in oxygen saturation and arousal.

The intermittent hypoxia and frequent arousals from both apneas and hypopneas can increase sympathetic activity and induce inflammatory and smooth muscle changes in vessels, exacerbating hypertension and ► **atherosclerosis**. In addition, recent studies suggest the intermittent hypoxia can result in irreversible cognitive impairments and neural injury.

#### Epidemiology

Symptomatic obstructive sleep apnea is present in 4–7% of adult males and 2–3% of adult females in North America, Europe and in select regions of Asia [2]. Despite the 2:1 male:female predominance in adults, there are no apparent gender differences in ► **OSA** prevalence in pre-pubertal children. Prevalence increases with age and is estimated to approach 40% in elderly individuals. While prevalence does not vary with race, the severity of OSA is greater in age-matched African American individuals than in Caucasians, and it appears that OSA develops at an earlier age in African Americans than in Caucasians. Familial aggregation has been established for OSA. Approximately 40% of the variance in the apnea hypopnea frequency may be explained by familial factors, and a positive family history increases the relative risk by 2- to 4-fold [2]. How much of this variance is simply ► **obesity** remains to be determined [2].

► **Craniofacial anomalies** that compromise upper airway space and stability provide additional risk

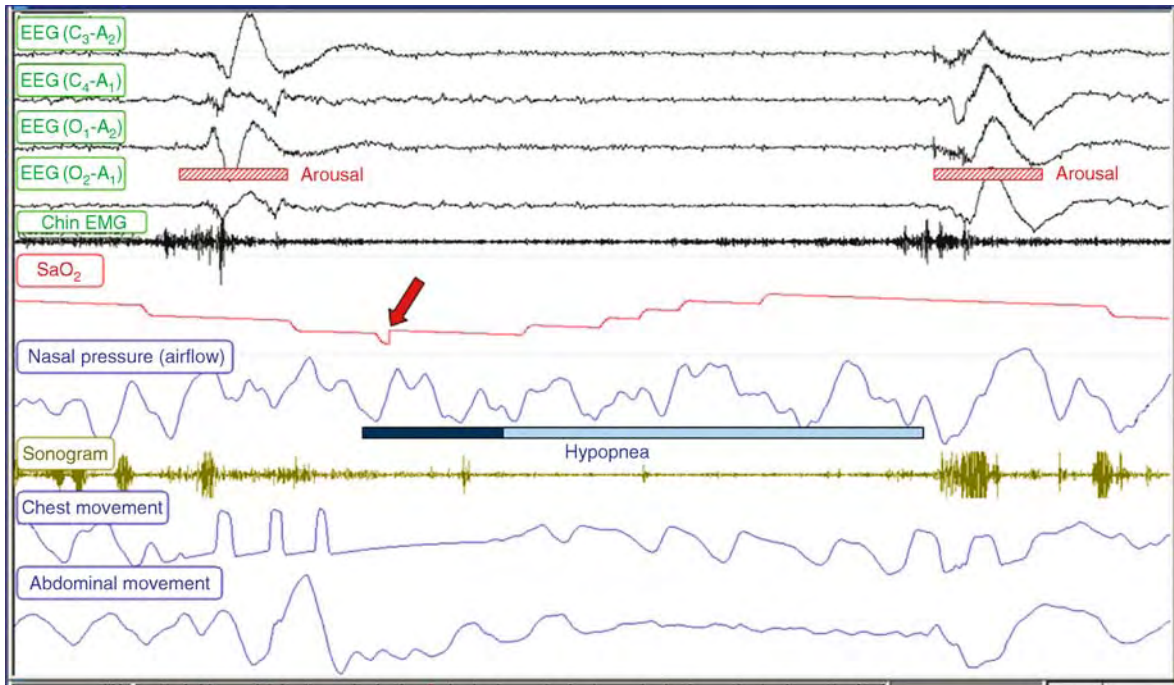

**Obstructive Sleep Apnea. Figure 1** Polysomnography for the diagnosis of obstructive sleep apnea. The electroencephalographic activity across the frontal, parietal and occipital cortices, is present in the top four channels. Channel 5 shows the chin electromyogram. The arterial saturation ( $\text{SaO}_2$ ) is presented in channel 6, and airflow measured with a nasal pressure transducer, the snore signal and chest and abdominal movements are shown below. An arousal from one hypopnea, underlined by the first red bar, is rapidly followed by sleep onset and another hypopnea. The hypopnea terminates with the second arousal, underlined by a red line. Notice the  $\text{SaO}_2$  appears to fall just after the arousal. This is attributed to a delay in circulation time required for detection of the peripheral signal. Notice the snoring is quiet across the hypopnea when little airflow is exchanged. Polysomnography typically records four additional channels for leg movements, electrocardiogram and eye movements. These signals were removed to highlight the respiratory events.

factors for OSA. For example, ►micrognathia in ►Treacher-Collins syndrome and ►Pierre-Robin syndrome and ►maxillary insufficiency in ►Down and ►Apert syndromes predispose to collapsible upper airways. ►Hypothyroidism and ►acromegaly increase tongue soft tissue that impinges upon the oropharynx. The most common risk factor for OSA, however, is obesity, defined in adults as a body mass index  $>30 \text{ kg/m}^2$ . In children, the major risk factor for OSA has been enlarged ►adenoid and ►tonsillar tissue. With the increasing prevalence of childhood obesity, obesity is becoming the major risk factor for OSA in children as well as in adults. A minority of patients diagnosed with OSA is non-obese. In these cases, chronic nasal obstruction from allergies, ►polyps or ►septal deviation, or craniofacial variances, e.g., ►retrognathia or ►macroglossia, may contribute to the increased collapsibility of the upper airway and OSA. In summary, the most important risk factor for OSA is obesity. Nonetheless, it is important to recognize that OSA occurs in diverse groups of patients, and in light of the significant neurobehavioral and cardiovascular

morbidities, it is important to explore the possibility of OSA in all individuals presenting with snoring and unrefreshed sleep or poor sleep quality.

### Presentation and Diagnosis

The presence of snoring and excessive sleepiness or fatigue despite adequate time allowed for sleep (7–9 h) in adults should prompt evaluation for OSA. It is important to recognize that in females and in children the presentation may be less straightforward. In both women and children, the snoring may be subtle, and rather than sleepiness, adult females may complain of fatigue or insomnia. Children are far more likely to exhibit increased motor activity, poor performance in school, and/or impulsive behavior than to have daytime sleepiness. Snoring alone does not make a good screening tool. In the United States, habitual snoring is present in 40% of adult males, 20% of adult females and 10% of children. Thus, it is essential to identify associated neurobehavioral complaints in snorers, e.g., unrefreshed sleep, fatigue, insomnia, restless sleep or irritability before proceeding with diagnostic testing.

The physical exam in many individuals in which a clinical suspicion for OSA is raised will suggest upper airway compromise. A neck circumference ( $>17$  in. in adult males or  $>15$  in. in adult females), a low lying soft palate, a small space behind the soft palate, large tonsils, a small mandible, and thickened lateral walls of the oropharynx all suggest increased upper airway collapsibility. Figure 2 shows a typical oropharynx in a person with mild OSA. There is no obvious obstruction.

The tonsils and tonsillar pillars are somewhat medial and may result in lateral wall collapse in sleep, but it is entirely possible that the point of initial collapse is lower in the airway or caused by retrograde placement of the tongue in sleep. Because airway examination occurs with the patient awake, a clear obstruction is unlikely to be identified.

The gold standard diagnostic tool for OSA is ►polysomnography. Polysomnography refers to the recording of multiple physiological signals during sleep [3]. Electroencephalographic and electromyographic signals are used to score specific sleep stages, as described elsewhere in this text. Airflow is measured indirectly with use of a thermistor, or with a nasal pressure transducer, and chest and abdominal movements are measured using piezosensors or strain gauges. Arterial

oxygenation is recorded with ►pulse oximetry. An example of 30 s polysomnographic recording is presented in Fig. 1.

Complimentary channels include channels to detect leg movements or snoring and the electrocardiogram. The diagnosis of OSA in adults requires  $>5$  apneas or hypopneas/h, on average, across sleep with symptoms, as above [3]. In children, neurobehavioral symptoms and an ►apnea index  $>1$  is sufficient for the diagnosis. Presently, the majority of polysomnographies are performed in clinical sleep laboratories; however, because obesity is on the rise and the clinical suspicion for OSA is heightened, it is anticipated that there will be a shift in the near future towards the implementation of simpler, more cost-effective screening tools for OSA.

### Treatment

The primary goal of therapy for OSA is to prevent collapse of the upper airway. The mainstay therapy for OSA is a remarkably effective mechanical therapy; ►positive airway pressure (PAP) titrated to an optimal pressure in each individual can fully prevent collapse of the upper airway in all stages of sleep in almost all patients with OSA [4]. Each individual with OSA will require a unique pressure to stent open her upper airway across all of NREM and REM sleep. The pressure needed will vary with sleep stage (NREM sleep vs. REM sleep) and with position and with nasal obstruction and sleeping position [4]. All of these factors must be taken into consideration when identifying the optimal pressure to alleviate OSA. Thus, a properly performed titration must confirm that apneas and hypopneas are alleviated in all sleep stages, all sleeping positions and that sleep is less fragmented. The latter ensures that subtle events have also been prevented. Prescribed pressures typically vary between 5 and 15 cm H<sub>2</sub>O. Although remarkably effective for OSA, PAP therapy is cumbersome, requiring a tightly fitted mask over the nose and/or mouth. Figure 3 shows one of the newer PAP interfaces that allows an individual improved visibility for reading prior to sleep onset.

Despite advancements in mask comfort and PAP delivery, less than half of the individuals prescribed PAP regularly use this therapy. Nonetheless, every effort should be made in individuals to encourage use of PAP regularly, as this is the only therapy for OSA shown to lessen cardiovascular and neurobehavioral morbidity. For patients with claustrophobia and other mask difficulties, behavioral therapy to adjust to mask use has been shown highly effective. Recent developments in PAP therapy include machines that can self-adjust the level of PAP based on airflow patterns, and these, too, may increase usage in select groups of patients [4].

Alternative therapies for OSA should be considered in individuals with mild sleep apnea and in individuals unable to acclimate to PAP use. These alternative

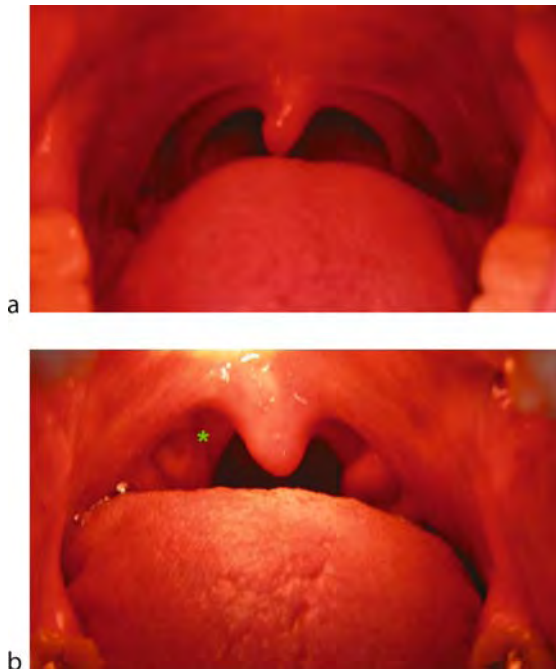

**Obstructive Sleep Apnea. Figure 2** Upper airway physical findings. (a) top panel shows a normal wide oropharynx. (b) In this individual with mild OSA, the tonsils are only mildly enlarged and the soft palate (uvula) is readily visible with some lateral wall narrowing at the tonsillar pillars (\*).



**Obstructive Sleep Apnea. Figure 3** Continuous positive airway pressure interface. This system is designed to deliver positive airway pressure to the nares and allow improved visibility. Flexible tubing connects the nasal mask to a small air pump to deliver positive pressure. Newer machines have the capability of detecting snoring, apneas and hypopneas, hours of usage and mask leaks.

therapies include surgical procedures to shorten the soft palate and reduce collapsibility of the pharynx (►uvulopalatoplasty), or to reduce the tongue volume (►genioglossectomy) or to advance the genioglossus forward (genioglossus advancement hyoid myotomy). These therapies in select groups of patients are expected to improve OSA in 50% of patients [5]. In patients with persistent symptomatic OSA, a second phase of surgery may be necessary to increase pharyngeal space (maxillary advancement or maxillary and ►mandibular osteotomy). Laser-assisted uvulopalatoplasty and temperature-controlled radio frequency are most effective for benign snoring. Some patients who do not tolerate PAP or in whom OSA is mild may benefit from oral appliances that advance the mandible. As with surgical therapies, the oral appliances are most likely to work in individuals with mild disease.

Weight loss should be recommended in all obese individuals with OSA. Dietary counseling should be the first step taken, and all patients should understand that reduced caloric intake is the critical factor for successful

weight loss. Behavioral modification programs enhance success of weight loss. Exercise may help maintain weight, but in most non-athletic individuals, healthy caloric restriction should be the primary strategy for weight loss. ►Bariatric surgery should be reserved for individuals with morbid obesity who have failed dietary weight loss programs. The majority of individuals who have substantial weight loss after bariatric surgery will experience marked reductions in OSA, if not lasting reversal of the disease [6]. Treatment of OSA in persons with hypothyroidism or acromegaly should begin with PAP therapy, but across the treatment of the underlying endocrine disorder the PAP settings may need adjusting, as the soft tissues remodel. Several medical therapies for OSA may be considered as second line therapies for mild OSA. There may be subsets of individuals who respond to supplemental oxygen, positional therapy and rarely to pharmacotherapies such as selective serotonin reuptake drugs in individuals with mild ►REM sleep-predominant apnea [7]. Because these adjunctive therapies are rarely fully effective, treatment success should be determined with repeated polysomnography.

Stimulant therapy to reduce residual sleepiness in treated OSA has been recently examined [8]. The effect size for objective sleepiness is small, and it should be understood that individuals with residual sleepiness remain at high risk for motor vehicle accidents.

### Associated Morbidities

One of the most important advances in OSA has been the substantiation of OSA as an independent risk factor for cardiovascular, endocrine and neurological morbidities. OSA is now widely accepted as an independent risk factor for several cardiovascular diseases, including hypertension, congestive heart failure, and stroke [9]. Importantly, the relative risk for hypertension increases even at levels of mild OSA (5–15 events/h), and use of PAP therapy can reduce this risk. The rates of significant cardiovascular events across 10 years in a large prospective European trial were found to be fourfold larger in untreated vs. treated untreated OSA [10]. The risk of cardiovascular death is also reduced with PAP therapy in persons with severe OSA [10]. Children with OSA show left ventricular dysfunction and increased levels of circulating inflammatory markers associated with atherosclerosis [9]. The mechanisms are poorly understood, but contributing factors include increased sympathetic activity, endothelial inflammation and ►oxidative stress [9]. In light of the seriousness of morbidities and the disease interactions associated with OSA, even in children, every effort to treat OSA effectively should be made. There have been several recent reports suggesting that OSA is an independent risk factor for insulin resistance. This risk persists after controlling for obesity, and several

studies have demonstrated improvement in glucose control and insulin sensitivity with successful use of PAP therapy. Whether long-term PAP therapy reduces the occurrence of complications of diabetes remains to be studied. Several recent reports suggest that OSA may impair liver function and might contribute to non-alcoholic fatty liver disease, a major risk for liver failure in developed countries. OSA is an independent risk factor for motor vehicle crashes, raising the relative risk by 2.5-fold, and a direct link between OSA and motor vehicle accidents is supported by the reduction in car crash risk with successful treatment of sleep apnea.

### Future Directions

► **Obstructive sleep apnea** is now widely accepted as a serious disorder, associated with significant morbidity. The importance of recognition and treatment of obesity in children and young adults is critical for reducing the prevalence of this disorder. For the millions of individuals with undiagnosed OSA, there is a readily appreciable need to improve screening methodologies to dramatically increase availability. PAP is a remarkably effective therapy and efforts to improve its acceptance must continue, while we await the development of effective pharmacotherapies.

### References

1. Remmers JE, deGroot WJ, Sauerland EK, Anch AM (1978) Pathogenesis of upper airway occlusion during sleep. *J Appl Physiol* 44(6):931–938
2. Palmer LJ, Redline S (2003) Genomic approaches to understanding obstructive sleep apnea. *Respir Physiol Neurobiol* 135(2–3):187–205
3. Redline S, Budhiraja R, Kapur V, Marcus CL, Mateika JH, Mehra R, Parthasarathy S, Somers VK, Strohl KP, Sulit LG, Gozal D, Wise MS, Quan SF (2007) The scoring of respiratory events in sleep: reliability and validity. *J Clin Sleep Med* 3(2):169–200
4. Basner RC (2007) Continuous positive airway pressure for obstructive sleep apnea. *N Engl J Med* 356(17):1751–1758
5. Elshaug AG, Moss JR, Southcott AM, Hiller JE (2007) Redefining success in airway surgery for obstructive sleep apnea: a meta analysis and synthesis of the evidence. *Sleep* 30(4):461–467
6. Fritscher LG, Canani S, Mottin CC, Fritscher CC, Berleze D, Chapman K, Chatkin JM (2007) Bariatric surgery in the treatment of obstructive sleep apnea in morbidly obese patients. *Respiration* 74(6):647–652
7. Veasey SC, Guilleminault C, Strohl KP, Sanders MH, Ballard RD, Magalang UJ (2006) Medical therapy for obstructive sleep apnea: a review by the Medical Therapy for Obstructive Sleep Apnea Task Force of the Standards of Practice Committee of the American Academy of Sleep Medicine. *Sleep* 29(8):1036–1034
8. Santamaria J, Iranzo A, Ma Montserrat J, de Pablo J (2007) Persistent sleepiness in CPAP treated obstructive sleep apnea patients: evaluation and treatment. *Sleep Med Rev* 11(3):195–207
9. McNicholas WT, Bonsignore MR (2007) Sleep apnoea as an independent risk factor for cardiovascular disease: current evidence, basic mechanisms and research priorities. *Eur Respir J* 29(1):156–178
10. Marin JM, Carrizo SJ, Vicente E, Agusti AG (2005) Long-term cardiovascular outcomes in men with obstructive sleep apnoea-hypopnoea with or without treatment with continuous positive airway pressure: an observational study. *Lancet* 365(9464):1046–1053

## Obstructive Sleep-disordered Breathing

- **Obstructive Sleep Apnea**

## Occipital Cortex

### Definition

The posterior part of the cerebral cortex.

## Occipital Lobe

### Synonyms

Lobus occipitalis

### Definition

Extends from the occipital pole to the parietooccipital sulcus.

- **Telencephalon**

## Occlusal Table

### Definition

The space between the upper and lower teeth.

- **Tactile Sensation in Oral Region**

## Occlusion

### Definition

Artificial increase in low-frequency level produced by blocking the ear canal.

▶ Hearing Aids

## Occlusion in Audition

### Definition

Artificial increase in low-frequency level produced by blocking the ear canal.

▶ Hearing Aids

## Octaval Nuclei

### Definition

Primary hindbrain recipient targets for inner ear afferents. This complex of nuclei may be homologous (in whole or in part) with the mammalian cochlear nuclei complex.

▶ Evolution of Mechanosensory and Electrosensory Lateral Line Systems

## Octave

### Definition

The ratio between two sound frequencies of two.

▶ Acoustics

## Octavolateralis System

### Definition

A set of sensory organs, both mechanosensitive and electrosensitive, in aquatic vertebrates that are innervated by the eighth cranial nerve and by the lateral

line nerves. More specifically: the sense of hearing, the sense of equilibrium, the sense of rotation, the mechanosensitive lateral line system, and the electric sense.

▶ Electoreceptor Organs  
▶ Evolution of the Mechanosensory and Electrosensory Lateral Line Systems

## Octopus Cells

### Definition

Typical neuron of the posteroventral cochlear nucleus (PVCN) that receive small auditory nerve terminals on their dendrites and project to the ventral nucleus of the lateral lemniscus.

▶ Cochlear Nucleus

## Ocular Abduction

### Definition

Horizontal movement of the eye away from the nose.

## Ocular Counter-rolling Response

### Definition

Counter-rotation of the eyes about the optic axis, i.e., torsion, during an imposed head or body tilt to the right or to the left about the naso-occipital axis (see also "VOR-tilt VOR").

▶ Vestibulo-Oculomotor Connections  
▶ Vestibulo-Oculomotor System: Functional Aspects

## Ocular Dominance

### Definition

The degree to which one eye dominates a given neuron in the visual pathway or the perception of a scene.

▶ Binocular Vision

---

## Ocular Drift Movements

### Definition

Involuntary, smooth, and mostly slow, eye movements that do not correspond to a target movement. Some types of drift occur predictably in certain behavioral contexts such as: glissades in the aftermath of saccades, anticipatory drift in the direction of an imminent target movement, centripetal drift during the attempt to maintain an eccentric eye position in darkness. Others are predominantly random such as the miniature drifts during fixation with velocities of the order of  $0.1^\circ/\text{s}$  which can cause deviations from the intended fixation point of up to  $0.2^\circ$ , or the slow wanderings of the eyes during drowsiness which result in considerably larger excursions.

- ▶ Oculomotor Control
- ▶ Saccade, Saccadic Eye Movements

---

## Ocular Following Responses (OFR)

### Definition

Smooth eye movement elicited by optic flow from relative motion between observer and visual scene (or parts thereof) in a highly automatic manner (unconscious reaction, no instruction required) and at short latency (70–80 ms). It often is initiated by a series of brief acceleration peaks creating a mean acceleration of up to  $100^\circ/\text{s}^2$ ; considerably larger values are achieved in the aftermath of saccades, though. OFR is considered to be part of the early or direct component of the optokinetic reflex.

- ▶ Oculomotor Control

---

## Ocular Micromovements

### Definition

Involuntary movements occurring during fixation consisting of (i) tremor, (ii) slow drifts and (iii) microsaccades. Tremor and drifts are uncorrelated in the two eyes whereas microsaccades have the same direction and similar – though not identical – amplitudes in both eyes. As a result of these micromovements, the

line of sight describes an erratic, two-dimensional path about the intended fixation point.

- ▶ Oculomotor Control
- ▶ Saccade, Saccadic Eye Movements

---

## Ocular Motoneurons

Motoneurons that innervate the ocular muscles.

- ▶ Evolution of Oculomotor System

---

## Ocular Muscles

Muscles that move the eye in the orbit.

- ▶ Evolution of Oculomotor System

---

## Ocular Tremor

### Definition

Involuntary ocular micromovement occurring during fixation and consisting of waxing and waning irregular oscillations with frequencies between 70 and 90 Hz and mean amplitudes of about  $0.002^\circ$ .

- ▶ Oculomotor Control

---

## Oculocentric Frame of Reference

### Definition

Also, “Retinotopic frame of reference.” A frame of reference centered on the eyes and moving with them.

- ▶ Eye Movements Field

## Oculo-manual Synergy

- ▶ Eye-Hand Coordination

## Oculomotor

- ▶ Evolution of the Vestibular System

## Oculomotor Cerebellum

### Definition

Usually refers to the medial parts of the cerebellum that regulate the generation of saccadic and smooth-pursuit eye movements.

- ▶ Cerebellum, Role in Eye Movements
- ▶ Saccade, Saccadic Eye Movements
- ▶ Smooth Pursuit Eye Movements

## Oculomotor Control (Theory)

WOLFGANG BECKER

Sektion Neurophysiologie, Universität Ulm, Albert-Einstein-Allee, Ulm, Germany

### Definition

The theory of oculomotor control aims at metaphorically understanding which types of innervation patterns are required to generate the various types of eye movements (▶ saccades, ▶ reflexive saccades, ▶ micro-saccades, ▶ express saccades, ▶ corrective saccades, ▶ pro-saccades, anti-saccades, ▶ catch-up saccades, smooth pursuit, vergence, fixation), and how afferent (mostly visual and vestibular) and efferent information is processed to shape these patterns (sensori-motor transformation). The metaphors it uses mostly draw on control systems theory and are referred to as models;

typically, the modeling approach disregards the intricacies and variety of the neural substrates, lumping many of them into a small number of processing stages with either mathematically or empirically defined transfer characteristics between input and output. Processing stages interact by way of signals which can represent a flow of neural activity along axons or physical parameters such as position or velocity. Formerly, models had to be simple to be amenable to mathematical analysis, whereas nowadays the behavior of very complex structures can be rapidly determined by simulation software.

### Characteristics

#### Description of the Theory

##### *Common Characteristics of Visual Eye Movement Control*

A prototypical scheme of visual eye movement control using a high level of abstraction is shown in Fig. 1. In particular, this and the following schemes do not explicitly show the bilateral symmetry of the oculomotor system and the elaborate push-pull interactions of its constituent elements; rather, they represent the net effect of these interactions.

Visually controlled eye movements aim at bringing the retinal image of visual target objects into the foveal area and at stabilizing them there. The basic information available to this end is  $R$ , the target's retinal eccentricity with respect to the fovea.  $R$  reflects the difference between target ( $T$ ) and eye ( $E$ ) position, and represents the current error in eye position; because of the "built-in" retroaction of  $E$  on  $R$ , that is, on the very signal it is reacting to, visual eye movement control constitutes a *negative feedback* system and is said to be *closed loop*.  $R$  is processed by a number of parallel, semi-independent pathways that perform the visuo-motor transformations required for the various types of visually controlled eye movements. In Fig. 1, these pathways are symbolized by dashed signal paths, while the typical structure of one of them is shown in more detail as a reference for the further description.

$R$  first must be detected and processed by the visual system to obtain the information (e.g., error velocity) based on which the *controller* can generate an error-correcting motor command. Detection and processing of  $R$ , but also the operation of the controller and of other stages, require considerable time. These delays can be lumped into a single delay time ( $d$ ) that represents the latency of the eye's response to a change of target position or velocity.

Interestingly, for all types of eye movements, including those controlled by non-visual signals (e.g., vestibular), the primordial motor commands issued by their respective controllers appear to specify *eye velocity* rather than eye position. In Fig. 1, these commands are shown to converge at a summing junction whose output represents a compound eye



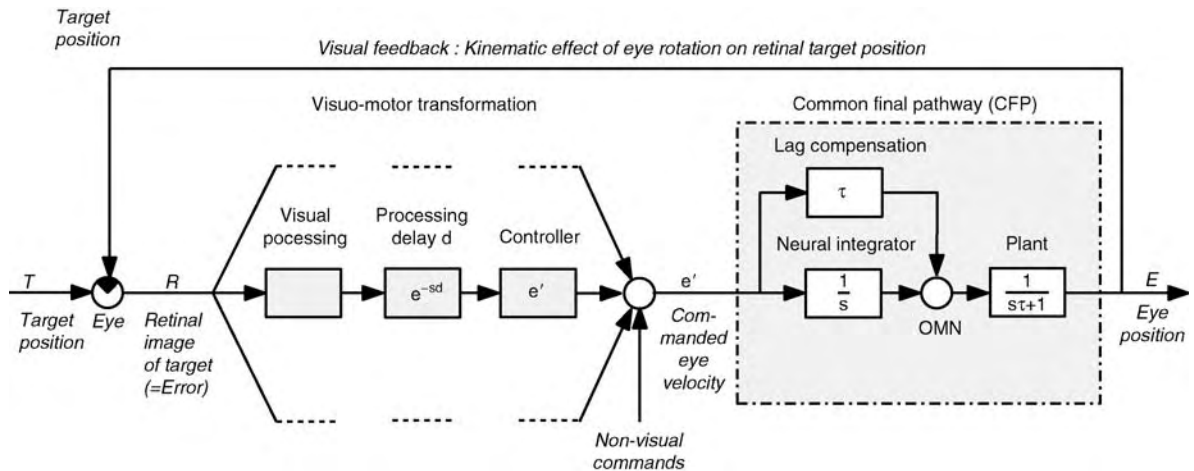

**Oculomotor Control (Theory). Figure 1** Basic structure of visual eye movement control. Italicized text and symbols denote *signals*; symbols beginning with lower case denote neural activity; upper case refers to physical quantities. Normal print describes functions and identifies the various elements of the scheme; symbols inside boxes describe global transfer characteristics of these elements by Laplace transforms ( $s$ , complex frequency;  $\tau$ , time constant of plant).

velocity command ( $e'$ ). This signal is converted into an eye position command by a stage that calculates its time integral. The substrate of this so-called *neural integrator* (NI) has been located to the medial vestibular nucleus and the nucleus prepositus hypoglossi and their reciprocal connections with the vestibulo-cerebellum. NI is also being referred to as *hold integrator* because it is responsible for holding the eyes at whatever position they have been brought to by a preceding, but now gone,  $e'$ -signal. NI has been the target of interesting attempts to explain integration in terms of a network of neurones that excite themselves via reciprocal connections to neighboring neurones [1].

The output of NI reaches the oculomotor nuclei (OMN); in the case of horizontal eye movements the abducens nucleus (nVI) in the first place, from whence it is forwarded to the rectus medialis complex of the contralateral oculomotor nucleus (nIII). OMN, in turn, send the position command to the extraocular eye muscles. The mechanical compound consisting of these muscles, the eye ball, and its connective tissue is collectively referred to as *plant*. The dynamics of the plant is dominated by visco-elastic forces, while the mass of the globe plays a minor role. As a first order approximation it can be described by a first order lag system with time constant  $\tau = 150\text{--}200$  ms. Thus, a step increase of OMN activity causes the eye to exponentially approach the position coded by this step, with fairly sluggish creeping in the final phase. To overcome this sluggishness, there is a direct projection of  $e'$  to OMN, which adds a velocity component to the position command obtained from NI. This combination of position and velocity components becomes particularly

clear during saccades, where a *pulse-step pattern* of innervation is observed in OMN.

Theoretically, if the gain of the direct projection assumes the numerical value of  $\tau$ , the compound labeled “Common final pathway” in Fig. 1 behaves like an ideal integrator which accurately converts  $e'$  into eye position  $E$ , and for many purposes such a simplification is an acceptable approximation. The term *common final pathway* (CFP) for the aggregate consisting of NI, lag compensation, OMN, and plant reflects the belief that all velocity commands – visual and non-visual, saccadic and smooth – are processed by the same integrator and that their direct projections all converge at the same pool of motoneurons. This notion is a useful approximation for many purposes but should not be overvalued. Already at the level of the extraocular eye muscles, the occurrence of different types of muscle fibres raises the suspicion of a functional division according to, for example, fast and slow eye movements. Also, as yet there is no agreement as to how far [vergence movements](#) share the integrator for [conjugate eye movements](#) or use separate pathways.

### Controllers

The oculomotor system’s closed loop character combined with its considerable delay time ( $d = 100\text{--}200$  ms) causes a major complication: If its response to a change of target position or velocity is to be accurate and fast (i.e., not much longer than  $d$ ), the gain of its controller – essentially the ratio  $E/R$  – must be large. On the other hand, long delays combined with a large gain cause instability (oscillations) in a closed loop system. Different strategies have been developed by the saccadic

and smooth pursuit systems, to arrive at a viable compromise between response velocity and accuracy on the one side and stability on the other side.

### Saccades

Basically, the control of saccades [2,3] (Fig. 2) can be likened to the operation of a sample-and-hold system: The error  $R(t_0)$  existing at time  $t_0$  is measured by the visual system and transferred to a memory and a decision stage. After a processing delay ( $d$ ), the decision stage triggers a neural pulse generator which emits a high-amplitude, short-duration pulse of neural activity, whose mathematical integral approximately equals the value of  $R(t_0)$  held in memory. Fed into CFP, this pulse acts as the saccadic velocity command  $e'$  and produces a fast, ramp-like movement of duration  $d_s$  – the saccade. At the end of this saccade, the sequence of events repeats: the now existing error  $R(t_0 + d + d_s)$  is again visually measured and, if non-zero, corrected by a further saccade. In this way the execution proper of saccades is not visually controlled, but *open-loop* with respect to visual feedback. It is, however, thought to be under *local feedback* control: a copy of the  $e'$ -command sent to CFP would be fed into a neural replica of CFP – basically an integrator – whose output therefore images current eye displacement ( $cE$ ) without incurring visual delays. Subtraction of  $cE$  from the *desired eye displacement* held in memory ( $dE$ ) yields the current *motor error* ( $mR$ ) which indicates how far the eye still has to go. If switch OPN is closed,  $mR$  drives a pool of burst neurones (BN, located in the vicinity of nIV and in the mesencephalon) which emit the  $e'$ -pulse. The pulse, therefore, would last until  $mR = 0$  (implying  $\int e' dt = dE$ , as desired). BN activity would vary linearly with

small  $mR$  but level off with large  $mR$ , thus determining the well-known non-linear relationship between saccade velocity and amplitude. Switch OPN provides for the discrete nature of saccades; to close it, a trigger impulse representing an “explicit” decision for a saccade is required, and in order to remain closed BN activity must entertain a “latch” signal. Therefore, as  $mR$  approaches zero and silences BN, the switch opens making the loop refractory for new motor errors until a new decision is issued. In the mean time, both the replica of CFP and the memory would be reset to zero (the former is often referred to as “resettable integrator”). A likely substrate of switch OPN are the omnipause neurones in the pontine raphe, which inhibit BN during fixation and are silenced before BN activity starts.

Closer experimental analysis of the saccadic system has revealed important features that are not covered by the basic scheme in Fig. 2 (i) The decision for a saccade and the desired amplitude ( $dE$ ) put into memory are not necessarily based on the same sample  $R(t_0)$ ; rather,  $dE$  reflects some kind of average of  $R(t)$  from the interval  $t_0 < t < t_0 + d$ . (ii) Processing of successive saccades does not always occur in a strictly serial manner but can considerably overlap in time. (iii) Saccades are not completely open loop but can to some degree be modulated by concurrent visual events. (iv) A local (i.e., non-visual) feedback signal also reaches the visual processing stage, where it anticipates the visual consequences of ongoing (and perhaps even of as yet only decided-upon) saccades before the visual afferents can signal the resulting change of  $R$ .

Two other aspects not dealt with by the scheme in Fig. 2 are (i) The co-ordination between the eyes and the

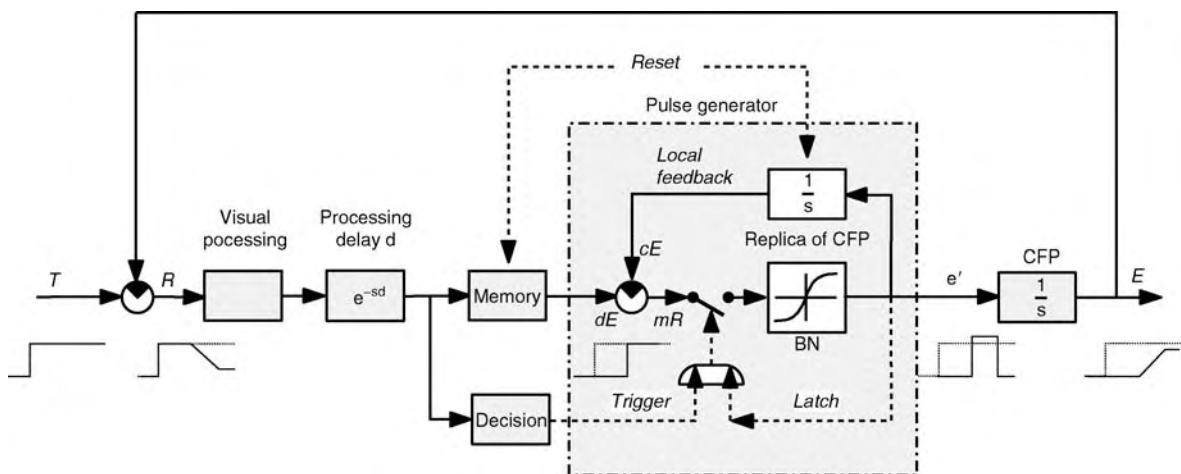

**Oculomotor Control (Theory).** Figure 2 Structure of saccadic eye movement control.  $dE$ , desired eye displacement;  $cE$ , copy of current eye displacement;  $mR$ , motor error; BN, burst neurones (icon sketches non-linear relation between motor error and magnitude of  $e'$ ); OPN, switch disabling burst neurones during fixation; other symbols and conventions as in Fig. 1. Insets show time course of signals  $T$ ,  $R$ ,  $dE$ ,  $e'$  and  $E$  in relation to a step of  $T$  (dashed).

head during natural gaze shifts, which are generally executed with the head moving in support of the eyes; several expansions and variations of the basic structure have been proposed in which vestibular mechanisms play a crucial role for this co-ordination [4]. (ii) Whereas small displacements in 2D-space can be essentially accounted for by two orthogonal systems of the type sketched in Fig. 2, the laws of spherical geometry require that not only  $R$  but also  $E$  be taken into account when creating the  $e'$ -signal for large displacements between arbitrary positions.

**Smooth Pursuit Eye Movements (SPEM)**

Basically, two alternative control structures are being discussed to account for the experimentally observed characteristics of SPEM [5] (Fig. 3). The *error-driven model* (also called *image motion model* or *closed-loop model*; Fig. 3a) posits that the motor output is driven exclusively by the current error in the way implied by Fig. 1. In accordance with SPEM’s function of stabilizing the image of moving targets on the retina, first the current *error velocity*  $r'$  (*retinal slip* of target image) is extracted from  $R$ . A second differentiating stage also calculates error acceleration  $r''$ . Signals  $r'$  and  $r''$  are then combined by weighted summation to obtain

a signal representing the desired eye acceleration ( $dE'' = g_v \cdot r' + g_a \cdot r''$ ) which in turn is converted, by integration in the controller proper, into the eye velocity command  $e'$  sent to CFP. The lumped effect of this processing is that  $E'(t + d) = g_a \cdot R'(t) + g_v \cdot \int R'(t)dt$ ; therefore, it can be likened to that of a PI-controller with delay time  $d$ . Dependent on the relative weights of the proportional and the integrating contributions, such a system can oscillate at frequencies from  $0.5/d$  ( $g_v = 0$ ) to  $0.25/d$  ( $g_a = 0$ ); given  $d = 0.1$  s, this corresponds to the range 2.5–5 Hz. The SPEM responses of man to sudden target movements indeed exhibit damped oscillations of 3.8 Hz; yet, there is no combination of  $g_v$  and  $g_a$  that would account at the same time for this frequency and other essential features of SPEM responses (e.g., rise time, steady state accuracy, and dependence on target velocity). For a satisfactory explanation of all relevant SPEM characteristics, several non-linear gain elements (saturating with increasing input) have to be inserted into the pathways preceding the I-controller of Fig. 3a.

The alternative approach, the *perceived velocity* (or *open-loop*) model (Fig. 3b), tries to reconcile the various characteristics of SPEM by assuming that SPEM oscillations are caused by an “inner,” local feedback loop rather than by the “outer,” visual loop.

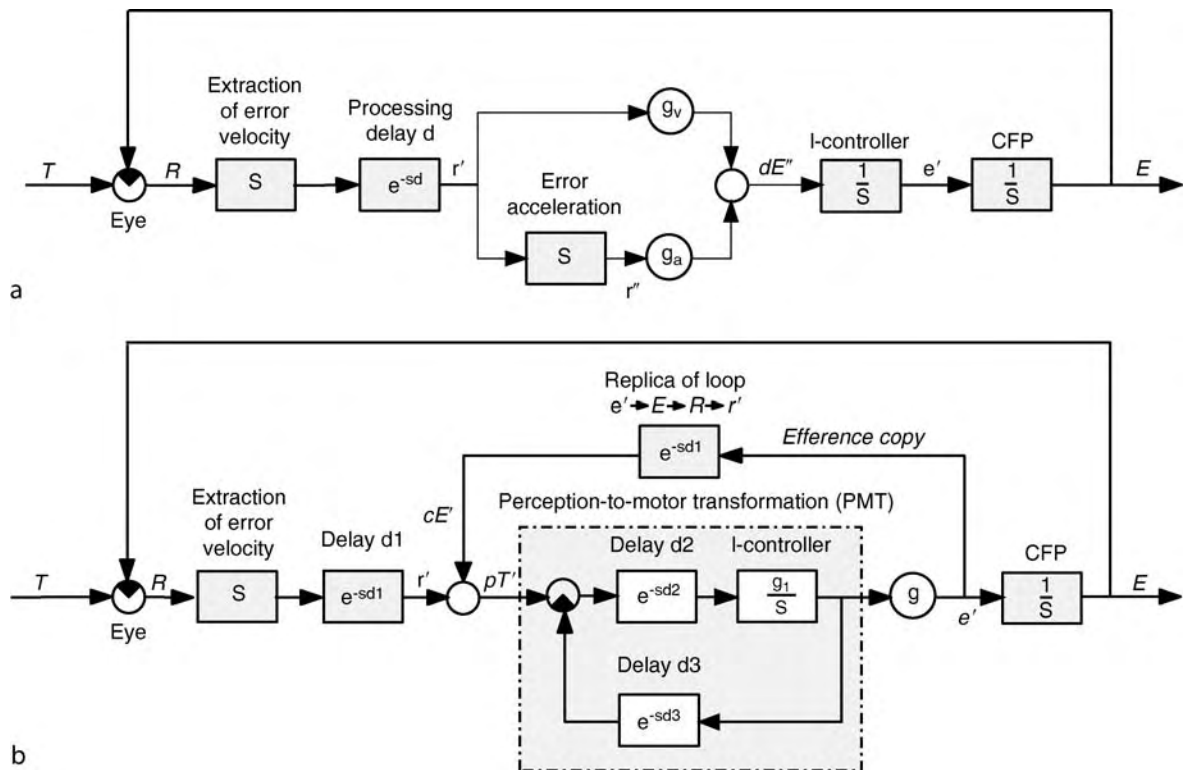

**Oculomotor Control (Theory). Figure 3** Smooth pursuit control: (a) error-driven model; (b), perceived velocity model. Conventions as in Fig. 1.  $r'$  ( $r''$ ) error velocity (acceleration);  $dE''$ , desired eye acceleration;  $cE'$ , delayed copy of eye velocity;  $pT'$ , perceived target velocity;  $g$ , gain coefficients. Other symbols as in Fig. 1.

The model posits that the target's velocity, as it existed one visual delay time ( $d1$ ) earlier, i.e.,  $T'(t-d1)$ , is *reconstructed* using delayed neural representations of (i) the retinal slip:  $r' = R'(t-d1)$ , and of (ii) eye velocity:  $cE' = E'(t-d1)$ ; their sum,  $pT' = T'(t-d1)$ , represents the "perception" of  $T'$  by the SPEM-system and may also determine conscious perception of target velocity.  $cE'$  would be obtained from an efference copy of the velocity command  $e'$ , passed through a neural replica of the pathway mediating the retroaction of  $e'$  upon  $r'$ ; with the simplifying assumptions of Fig. 3, this replica reduces to delay  $d1$  (since  $1/s \cdot s = 1$ ). If perceived target velocity  $pT'$ , is then translated one-to-one into the velocity command  $e'$ , SPEM velocity will faithfully follow  $T'$  except for a delay. During steady state operation, the *perception-to-motor transformation* (PMT) stage, when envisioned as a local feedback loop with integrating controller, has indeed a gain of one. The fact that in most people tracking a target of constant speed SPEM is slightly slower than the target, can be accounted for by gain element  $g$  (e.g.,  $g \approx 0.9$ ); a value  $g < 1$  also insures stable operation of the positive (or "regenerative") feedback loop through which the efference copy of  $e'$  entertains the perception of  $T'$ .

By adding  $cE'$  to  $r'$  a positive, non-visual loop is created which offsets the subtraction of  $E$  from  $T$  and, hence, functionally neutralizes the negative visual

feedback around the outer loop. Thus, SPEM becomes a virtually open-loop, feed-forward response to target movement. Therefore, oscillations cannot arise from the system architecture as a whole, but only in its constituents; specifically, it has been suggested that the experimentally observed damped oscillations arise in the inner (PMT-) loop, with frequency determined by delay times  $d2$  and  $d3$ , and amplitude by integrator gain  $g$ . However, to render all relevant characteristics of SPEM, the perceived velocity model also requires the addition of non-linearities. Furthermore, proponents of the closed loop model point out that it has difficulties in rendering the effects observed during artificial prolongations of the delay time.

Both models apply only to the pursuit of targets moving at constant speed. With periodically moving targets, very effective predictive mechanisms dominate behavior which can virtually eliminate the delay between target and eye and, therefore, require more sophisticated models.

#### Vergence Movements

The control of vergence movements (Fig. 4) differs from that of saccades and SPEM in several aspects: It must move the two eyes in opposite directions and it is not only driven by errors in eye position or velocity (here: by retinal disparity) but also by an input unrelated

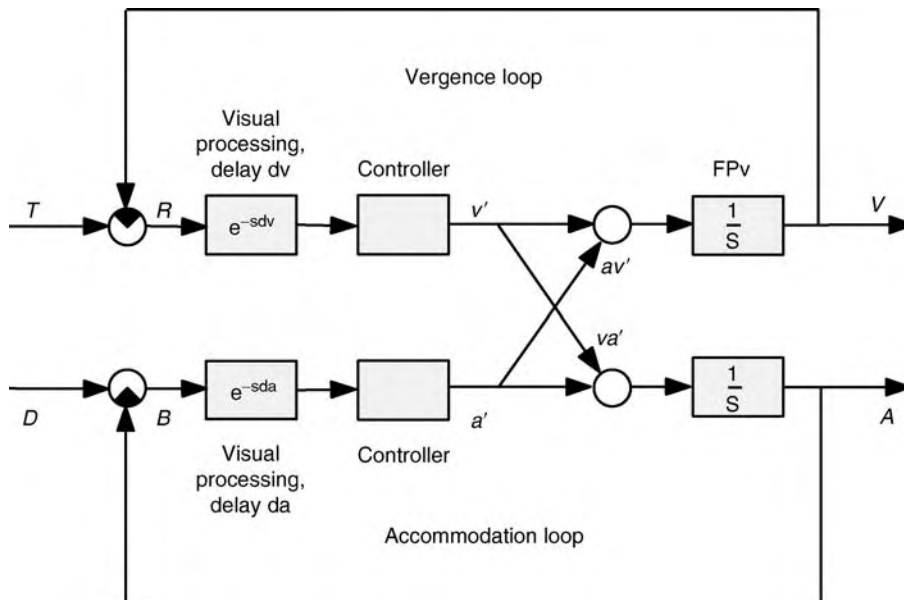

**Oculomotor Control (Theory). Figure 4** Structure of vergence control.  $T$ , convergence called for by target;  $R$ , retinal disparity;  $v'$ , commanded velocity of vergence;  $V$ , vergence angle of eyes;  $D$ , target distance<sup>-1</sup> (diopters);  $B$ , error in accommodation (blur);  $a'$ , commanded rate of change of accommodation;  $A$ , accommodation;  $av'$  and  $va'A$ , contributions of accommodation to vergence and vice versa (mostly denoted AC/A and CA/C in the literature); FPv, final pathway of vergence system (partially overlapping with CFP). Conventions as in Fig. 1. (For a broad synopsis of the use of models in oculomotor physiology see Carpenter RHS (1988) *Movements of the eyes* (2nd edition). Pion, London For examples of how models benefit the analysis of neuro-ophthalmological problems see Leigh RJ, Zee DS (1999) *The Neurology of Eye Movements* (3rd edition). Oxford University Press, New York, Oxford).

to eye position, namely the error in accommodation (retinal blur); the response to this input is known as *accommodative vergence*. As accommodation, in turn, is not only driven by blur but also by retinal disparity (*convergence accommodation*), two mutually coupled feedback circuits result with fairly similar constituent elements, except for a significantly larger delay (da) in the accommodative loop as compared to the vergence loop (dv). The situation is further complicated by the possibility that, much as with conjugate movements of the two eyes, there might be separate systems for pursuit vergence (tracking a target moving slowly in depth) and saccade-like vergence (called for by sudden changes of the fusalional demands) [6]; therefore, no details of the controller are specified in Fig. 4. As with other oculomotor subsystems, the controller signal reaches the plant both via a direct (velocity coding) and an integrating (position coding) pathway which, when lumped with the plant, could be roughly equated to an integrator (box FPv). Due to the disconjugate character of vergence, the integrating pathway cannot be identical to the neural integrator of the common final pathway (CFP) of conjugate movements, although it may partially overlap with it [7]; hence, the notion of a CFP is not applicable here in a strict sense. Finally, it is not clear whether the cross-coupling between vergence and accommodation occurs before the integration of the commanded vergence ( $v'$ ) and accommodation ( $a'$ ) velocities (as shown in Fig. 4), or thereafter [8].

## References

1. Arnold DB, Robinson DA (1997) The oculomotor integrator: Testing of a neural network model. *Exp Brain Res* 113:57–74
2. Becker W (1989) Metrics. In: Wurtz RH, Goldberg ME (eds) *The Neurobiology of Saccadic Eye Movements*. Elsevier, Amsterdam, New York, Oxford, pp 13–67
3. Scudder CA, Kaneko CRS, Fuchs AF (2002) The brainstem burst generator for saccadic eye movements. A modern synthesis. *Exp Brain Res* 142: 439–462
4. Galiana HL, Guitton D (1992) Central organization and modeling of eye-head coordination during gaze shifts. *Ann NY Acad Sci* 656: 452–471
5. Churchland MM, Lisberger SG (2001) Experimental and computational analysis of monkey smooth pursuit eye movements. *J Neurophysiol* 86:741–759
6. Zee DS, Fitzgibbon EJ, Optican LM (1992) Saccade-vergence interactions in humans. *J Neurophysiol* 65:1624–1641
7. McConville K, Tomlinson RD, King WM, Paige G, Na EQ (1994) Eye position signals in the vestibular nuclei: Consequences for models of integrator function. *J Vestib Res* 4:391–400
8. Schor CM (1992) A dynamic model of cross-coupling between accommodation and convergence: Simulations of step and frequency responses. *Optom Vis Sci* 69:258–269

## Oculomotor Dynamics

CHARLES SCUDDER  
Portland, OR, USA

### Synonyms

Oculomotor plant; Orbital dynamics

### Definition

► **Oculomotor dynamics** are the properties of the oculomotor system that determine the time-course of the rotation of the eye in response to the discharges of ocular motoneurons. These properties are a product of the inertia of the eye, the viscoelastic properties of the tissue surrounding the eye, and the dynamic properties of the extraocular muscles that control its movements. These properties are usually described mathematically using differential equations or their equivalent (e.g. computer models).

### Characteristics

#### Measurement of Oculomotor Dynamics

The time course of an eye movement is not a replica of the aggregate discharge rate of the ocular motoneurons, but is modified by oculomotor dynamics. The difference between the two can be quantified and used to describe oculomotor dynamics. This measurement is a composite of the three factors listed above. To interpret this measurement, it is also important to directly measure inertia, tissue viscoelasticity, or muscle properties in isolation using mechanical methods, as described below. Force transducers placed in series with the extraocular muscles have also helped to isolate the dynamics due to the muscles and the dynamics due to the eye and orbit [1,2].

The force produced during the generation of a saccade is illustrated in Fig. 1. The time course is divided into three components; the “pulse” that occurs during the saccade, the “slide” (decay in force) occurring after the end of the saccade, and the “step” (long-term force) that keeps the eye in a static position until the next eye movement.

#### Viscoelastic Properties of the Orbital Tissue

Rotation of the eye causes a displacement of the orbital tissue, such as the conjunctivum, Tenon’s capsule, fat in the orbit, and the connective tissue of the extraocular muscles. These tissues resist rotation, their resistance displaying both an elastic and a viscous component. The elastic component provides a static restoring force that depends only on the angle of rotation away from straight ahead. This force increases with angular deviation nearly linearly over a range of angles, but

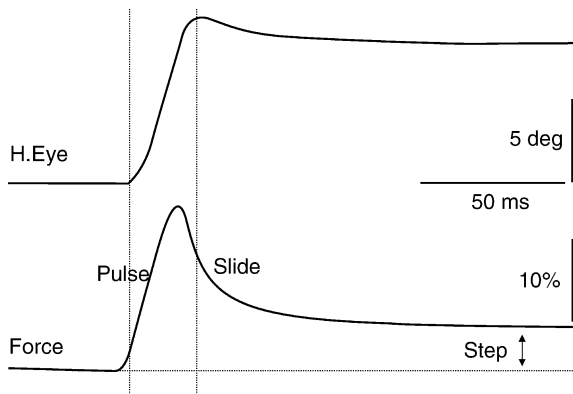

**Oculomotor Dynamics. Figure 1** Recording of the horizontal eye position (H. Eye) and muscle tension (Force) in the lateral rectus muscle recorded during an abducting horizontal saccade. Tension increases slightly before saccade onset and peaks somewhat before saccade termination. This phase is frequently called the “pulse” of force because of the waveshape of the associated motoneuron discharge, and is responsible for producing the rapid velocity of saccades. This is followed by an initially rapid and then slow decline in force commonly called the “slide.” Normally the eye would be stationary during this time, but the force transducer has caused a minor abnormality. Force never declines to its initial value, but rather, there is a persistent force (the “step”) that holds the eye in its final abducted position. Force is expressed as a percentage of the maximum force developed by the muscle during any saccade, probably 50–60 g-force. Dotted lines mark saccade onset and termination. Figure modified from Miller & Robins, Fig. 9 [2].

increases more rapidly after about halfway to the maximum of natural eye movements (see ►Orbital mechanics). The viscous component resists an ongoing rotation of the eye with a force that is proportional to the velocity of rotation.

The mechanical method of measuring the viscoelastic forces is to pull on the eye with a constant tangential force, and measure the time course of the change in angular position. The eye rotates rapidly during the first few milliseconds, but progressively slows down and continues to move increasingly slowly over succeeding seconds. The process is characteristic of most tissue in the body and is known as “tissue creep” [3]. An equivalent experiment is illustrated in Fig. 2, where the eye is held in a static position and then released (isotonic force = 0). The eye rotates back towards straight ahead as described above. Technically, the change in position is described by the sum of an infinite number of exponentials with different ►time constants [3], but practically, a very good fit to the data can be obtained with a small number of exponentials. For the data in

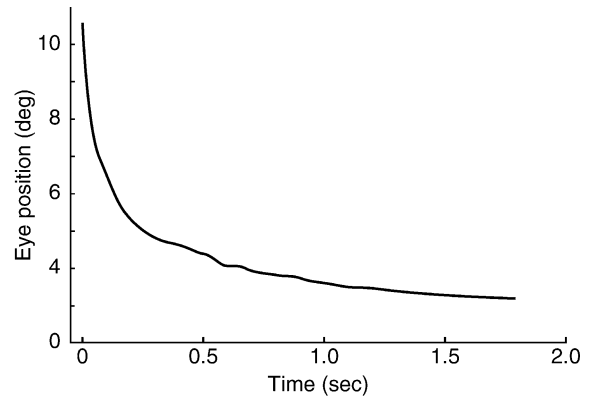

**Oculomotor Dynamics. Figure 2** The return of eye position towards straight-ahead gaze after being released from an abducted position. Movement is initially very rapid, then slows down, and finally creeps toward a final position over several seconds (not shown). Data is replotted from Sklavos et al. [4].

Fig. 1, one exponential accounts for 85% of the variance, two account for 98.5%, and four account for 99.9% [4].

For a quantitative description of the viscoelastic properties of the orbit, each exponential is modeled as the product of one “Voigt element,” which is a spring (the elastic component with spring constant  $K$ ) in parallel with a dashpot (the viscous element with viscosity  $R$ ) as in Fig. 3a. Two exponentials are modeled as two Voigt elements in series, as in Fig. 3b.

Using a single Voigt element to describe oculomotor dynamics [5] has intuitive appeal because it requires a neural controller for eye movements having only two components. One is a velocity command, such as the burst of saccadic burst neurons (see ►MLBNs) or the discharge of vestibular afferents during the ►vestibuloocular reflex (►VOR) that is needed to overcome the viscosity of the orbital tissue. The second is a position command, thought to be obtained by integrating the velocity command (see ►Neural integrator), that is needed to overcome the elasticity of the tissue. However, this model cannot explain the presence of the slide (Fig. 1) or the frequency-dependent characteristics of motoneuron firing-rate modulation during sinusoidal ►smooth pursuit [6], and predicts an unrealistically high force to move the eye during a saccade [6]. Using two Voigt elements (Fig. 3b) greatly reduces all three problems, and is quite adequate for the didactic purposes of this article.

### Muscle Dynamics

Force in the extraocular muscles varies with the number of motoneurons recruited and the firing rate of each motoneuron. Three factors contribute to the dynamics of force buildup (or decline) in the muscles; the “twitch

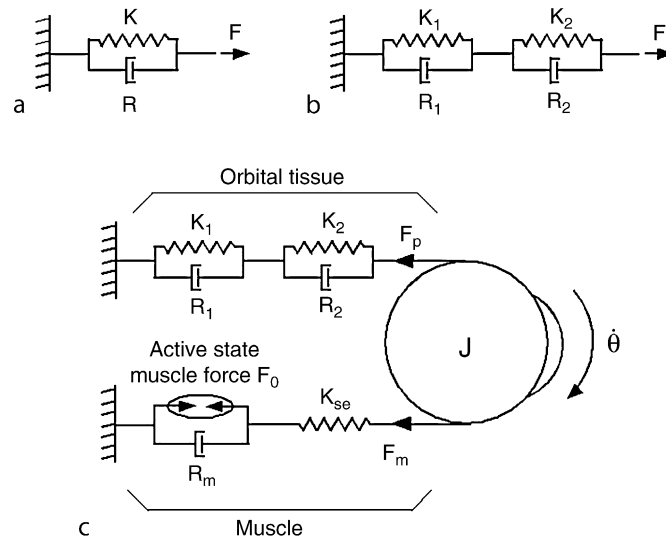

**Oculomotor Dynamics. Figure 3** Components used in modeling oculomotor dynamics, including a nearly complete model. A single Voigt element (a) is composed of a spring with spring constant  $K$  (representing elastic restoring forces in the orbit) and a dashpot with viscosity  $R$  (representing the viscous, velocity dependent, properties of orbital tissue). A single Voigt element responds to a step change in force with a change in length fit by a single exponential having a time constant of  $R/K$ . The viscoelastic properties of the orbit are more accurately modeled by two (b) or more (not shown) Voigt elements in series. This model of the orbital tissue is shown attached to the eyeball (top of (c)), with a model of the muscle attached at the bottom. The parallel elastic component of the muscle has been lumped with the other orbital tissue. The active-state force generator (muscle crossbridges) is in parallel with a dashpot with viscosity  $R_m$ , which models the reduction in force  $F_m$  according to the [force-velocity relationship](#). The series elastic component (spring constant  $K_{se}$ ) lengthens during the initial buildup of force at the onset of a saccade. For all practical purposes, the inertia of the eye (moment  $J$ ) can be ignored, meaning that the magnitude of  $F_p \approx F_m$ .

time” of the muscle, the distributed recruitment of motoneurons over time, and the firing rate of the active motoneurons. These factors make little difference during slow eye movements (smooth pursuit, VOR), but a major one during rapid saccadic eye movements [6].

An action potential in a motoneuron and the muscle fibers it innervates produces a rapid buildup to a peak of force and then a gradual decline. The time to peak is called the “twitch time” [7], and is 5–7 ms in monkeys [8]. The finite twitch time is due to the fact that connective tissue and muscle proteins are springy (series elastic component [7]) in combination with the fact that rapidly shortening muscle develops less force ([Force velocity relationship](#) [7]; see [Muscle twitch](#)).

During the repetitive firing of a motoneuron, the force of each twitch adds to the force that remains from the preceding twitches. At the start of repetitive firing, this superposition produces a cumulative force that builds up and saturates with a roughly exponential envelope whose [time constant](#) decreases as the firing rate increases [9]. During an actual saccade, there is a complex interplay between the [extraocular motoneuron](#) firing rates and the force-velocity and length-tension properties of the shortening muscle, which makes exact modeling difficult. In practice, it has

proven satisfactory to approximate all these dynamics as a single spring and dashpot in series and parallel, respectively, with the active (force-producing) components of the muscle ( $F_o$  in [Fig. 3c](#)).

The bursts of repetitive firing in extraocular motoneurons occurring just prior to saccades do not start simultaneously, but their onsets are spread over 6–8 ms in monkeys [5,9] and could be longer in humans, who have slower saccades. The effect of this distributed recruitment is to slow the initial acceleration of the eye during saccades.

### Inertia of the Eye

Calculations, modeling, and measurement all show that the force required to overcome the inertia of the eye is negligible during slow eye movements and is very small during saccades [6,10]. For all practical purposes, inertia can be ignored in models of oculomotor dynamics. However, the inclusion of an unrealistically high moment of inertia has been used in some modeling studies [11] to account for the discrepancy between the slow acceleration of the eye relative to the almost instant buildup of firing rate in single saccadic burst neurons (see [Burst cells – medium lead](#)). This discrepancy, however, is the product of finite twitch times in the extraocular

muscles and the spread of burst-neuron and motoneuron recruitment times in relation to saccade onset, with a minimal contribution from the inertia of the eye.

### Cumulative Orbital Dynamics

A model of oculomotor dynamics is illustrated in Fig. 3c. The viscoelastic properties of the orbital tissue are illustrated at the top of the eye, and the muscle is illustrated at the bottom. The agonist and antagonist muscles, which are reciprocally innervated and have mirror-image force profiles [2], have been lumped together into one muscle. The “parallel elastic component” of the muscle, which is sometimes modeled as a separate element, has been lumped into the orbital tissue. This is consistent with the fact that the passive muscle has viscous as well as elastic properties that are measured with the other orbital tissues in the release experiments described above [4,10]. The moment of inertia is denoted as  $J$ . Treating  $J$  as negligible, the differential equation describing eye acceleration as a function of muscle force ( $F_m$ ), rate of change of force, and the viscoelastic impedance is below:

$$\ddot{\theta} = \frac{1}{\mu} (F_m + T_s \dot{F}_m - K_o \theta - R_o \dot{\theta})$$

$K_s$ ,  $R_s$ , and  $T_s$  are composite spring, rate, and time constants [6,10]. Muscle force ( $F_m$ ) is the active-state force ( $F_o$ ) reduced by the rate of change of force and eye velocity:

$$F_m = F_o - T_m \dot{F}_m - R_m \dot{\theta}$$

Equations that include inertia can be found in Robinson [10]. Values for all parameters can be found in references [4,6,10].

The interaction of all the dynamic elements will be illustrated for a saccade. To begin the saccade, motoneurons begin their bursts over a range of times leading to a gradual buildup in active-state tension. The buildup of force delivered to the eyeball ( $F_m$ ) is further slowed by the dynamic properties of the muscle, as discussed above. This buildup is illustrated in Fig. 1 during the so-called “pulse” phase. Shortly after the onset of force, the eye begins to rotate. As the inertia of the eye is small,  $F_p$  is almost equal to  $F_m$ , reflecting that the primary impedance to motion is provided by the viscoelastic properties of the orbital tissue. At the end of the pulse, motoneuron firing rate drops rapidly at first, and then more gradually with a “slide” similar to that illustrated in the force trace of Fig. 1. In a normal eye (without a force transducer), the eye would stop moving at this point. The decline in muscle force compensates for the decline in the reactive force in the orbital tissues as they “creep” to a new steady state. In terms of the model in Fig. 3, the Voigt element with the faster time constant was initially stretched disproportionately, and

relaxes during the slide as the Voigt element with the slower time constant stretches. At the end of the slide, which can take several seconds in the actual eye or a model with more than two Voigt elements, there is a residual force (the “step” in Fig. 1) that is needed to maintain the eye at its new position against the just stretched elastic components of the orbital tissue.

### References

- Collins CC, O’Meara D, Scott AB (1975) Muscle tension during unrestricted human eye movements. *J Physiol (London)* 245:351–369
- Miller JM, Robins D (1992) Extraocular muscle forces in alert monkey. *Vis Res* 32:1099–1113
- Fung YC (1993) *Biomechanics; mechanical properties of living tissues*. Springer-Verlag, New York
- Sklavos S, Porrill J, Kaneko CRS, Dean P (2005) Evidence for wide range of time scales in oculomotor plant dynamics: implications for models of eye-movement control. *Vis Res* 45:1525–1542
- Robinson DA (1970) Oculomotor unit behavior in the monkey. *J Neurophysiol* 33:393–404
- Fuchs AF, Scudder CA, Kaneko CRS (1988) Discharge patterns and recruitment order of identified motoneurons and internuclear neurons in the monkey abducens nucleus. *J Neurophysiol* 60:1874–1895
- Aidley DJ (1998) *The physiology of excitable cells*. Cambridge University Press, Cambridge
- Fuchs AF, Luschei ES (1971) Development of isometric tension in simian extraocular muscle. *J Physiol (London)* 219:155–166
- Fuchs AF, Luschei ES (1970) Firing patterns of abducens neurons of alert monkeys in relationship to horizontal eye movement. *J Neurophysiol* 33:382–392
- Robinson DA (1964) The mechanics of human saccadic eye movement. *J Physiol (London)* 174:245–264
- van Gisbergen JAM, Robinson DA, Gielen S (1981) A quantitative analysis of generation of saccadic eye movements by burst neurons. *J Neurophysiol* 45:417–442

## Oculomotor Nerve (III)

### Synonyms

N. oculomotorius (N.III)

### Definition

The oculomotor nerve is a motor cranial nerve endowed with both somato- and visceromotor components, for which one complex is responsible in each case. Together with the trochlear nerve (IV) and abducens nerve (VI) it controls eye movements.



It is involved in the lateral and medial eyeball movements (lateral rectus muscle and superior oblique muscle), raising of the palpebra as well as accommodation (ciliary muscle) and adaptation (sphincter muscle of pupil). Skull: superior orbital fissure.

► Nerves

## Oculomotor Nucleus

### Definition

A nucleus which contains both motoneurons and interneurons. The motoneurons send direct projections to all extraocular muscles except for the superior oblique muscle and the lateral rectus muscle.

## Oculomotor Plant

► Eye Orbital Mechanics  
► Oculomotor Dynamics

## Oculomotor Systems

► Evolution of Oculomotor System

## Oculomotor Vermis

### Definition

The circumscribed portion of the cerebellar vermis (lobules VIc and VII) that appears to be integral to the control of saccadic and smooth-pursuit eye movements. The time course of changes in eye position or the firing rate of neurons can sometimes be described mathematically by an exponential,  $X = X_0 e^{-t/T}$ , where  $X$  is the position or firing rate,  $X_0$  is the initial value of  $X$ ,  $t$  is time, and  $T$  is the “time constant” of the exponential.

The time constant is equivalent to the amount of time required for  $X$  to decay to 36% ( $1/e$ ) of  $X_0$ .

► Cerebellum, Role in Eye Movements  
► Saccade, Saccadic Eye Movements  
► Smooth Pursuit Eye Movements

## Odor

MARTINA PYRSKI, FRANK ZUFALL  
Department of Physiology, University of Saarland  
School of Medicine, Homburg/Saar, Germany

### Synonyms

Odor; Odorant; Olfactory cue; Smell; Scent, Aroma

### Definition

“Odor” refers to an emanation composed of multiple different odor molecules termed odorants, whose individual chemical properties are perceived by the sense of smell. In humans, this term is frequently used to describe a sensation as a result of odor perception, for example the pleasure resulting from the floral smell of roses (good odor) or the disgust following the smell of spoiled food (bad odor).

### Characteristics

In contrast to the senses of vision, hearing and touch, the chemical senses - smell (and taste) - are challenged by an enormous number of molecularly distinct stimuli. Natural odors derived from food and plants and social stimuli, such as those present in urine, sweat and saliva, represent complex mixtures that contain a multitude of chemically diverse compounds. The information contained in these molecules is detected and processed by the sense of smell, a sensory modality that emerged very early in the evolution of living forms. Detection of olfactory cues is initiated by interaction of odor molecules with specific receptors located in the cellular membrane of olfactory sensory neurons in the nasal epithelium. The initial chemical odor information is then translated into neuronal activity patterns and subsequently converted into perceived odor quality and behavioral responses as a result of pattern recognition and evaluation by the brain.

### Odor Detection in Mammals Occurs Through Multiple Olfactory Subsystems

In vertebrates, the cellular, molecular and genetic mechanisms underlying odor detection and the sense

of smell are probably best understood in the mouse olfactory system. Odor detection begins in the olfactory sensory neurons (OSNs) located in the main olfactory epithelium (mOE) of the nasal cavity. Volatile odor molecules enter the nasal cavity with each breath and dissolve in the mucus covering the epithelial surface, a process that may be facilitated by small carrier molecules or odor binding proteins. The next step is a direct contact of odor molecules with the olfactory cilia which emanate from the dendritic knob of each OSN (Fig. 1).

These cilia contain all the necessary components for odor detection and subsequent chemo-electrical signal transduction. The electrical output signal produced by each OSN travels along a single axonal projection

toward the main olfactory bulb (mOB) in the forebrain, the first relay station of odor processing in the brain. The axons from several millions of OSNs coalesce to form the olfactory nerve, also known as 1st cranial nerve.

In addition to a main olfactory system, most mammals have evolved an accessory olfactory (or vomeronasal) system (Fig. 1), which is anatomically and functionally distinct from the main system. Odor detection in the accessory olfactory system begins in the paired vomeronasal organ (VNO), located ventrally at the base of the nasal septum and rostral to the mOE. Odor stimuli are actively transported into the lumen of the VNO by a vascular pumping mechanism. The sensory epithelium of the VNO covers the inner medial side of each tube and, in analogy to the mOE, contains vomeronasal sensory

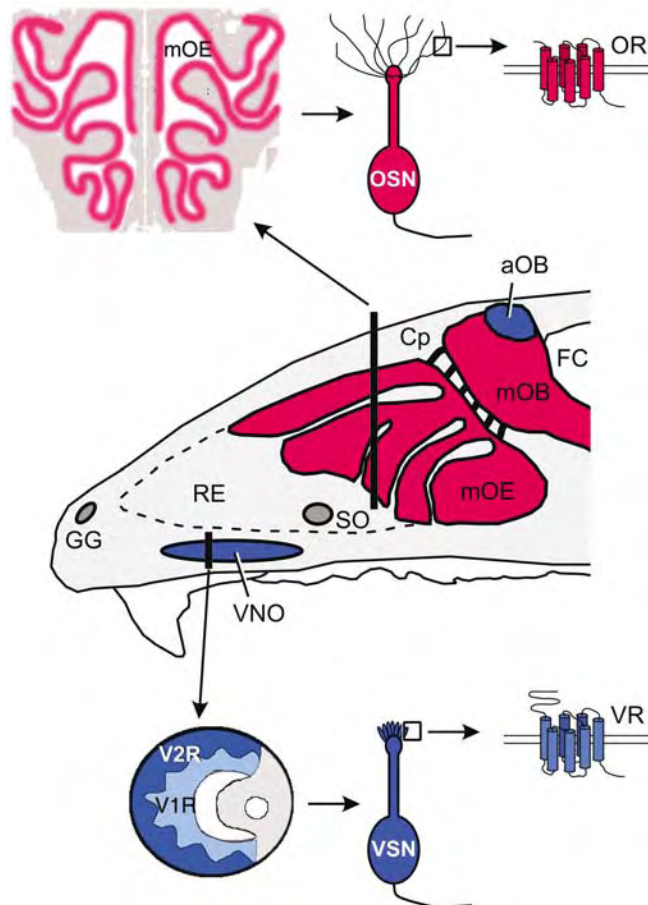

**Odor. Figure 1** Schematic of a hemisected head of a mouse (sagittal view) illustrating the anatomical location of different olfactory subsystems and key structures. *Cp* cibriform plate; *FC* frontal cortex; *GG* Grüneberg ganglion; *mOB* main olfactory bulb; *RE* respiratory epithelium; *SO* septal organ of Masera; The black bar in the main olfactory epithelium (mOE, red) refers to the coronal section at the top left (arrow) that depicts the bilateral symmetry of the mOE. Olfactory sensory neurons (OSNs, red) contain numerous cilia that carry odor receptors (OR, red) of the GPCR type. The black bar in the vomeronasal organ (VNO, blue) refers to the coronal section shown at the bottom left with V1Rs and V2Rs expressed in the apical (light blue) and basal (dark blue) halves of the vomeronasal sensory epithelium, respectively. Vomeronasal neurons (VSN, blue) carry numerous microvilli that express vomeronasal receptors (VR, blue) of the GPCR type.

neurons (VSNs). These extend microvilli instead of cilia towards the lumen of the VNO. VSN axons project to the accessory olfactory bulb (aOB) located posterior and dorsal to the mOB (Fig. 1).

The traditional distinction that the mammalian main olfactory system recognizes general odor molecules and the vomeronasal system detects pheromones is no longer valid. The emerging picture is that both systems have considerable overlap in terms of the chemosignals they detect and the effects that they mediate [1]. Other, functionally less well characterized olfactory subsystems in rodents comprise of the septal organ of Maserà and the Gruneberg ganglion (Fig. 1). Finally, some odor molecules such as menthol and phenylethyl alcohol can be detected by free nerve endings of the 5th cranial nerve which are part the somatosensory system. These nerves are often sensitive to pain as well as temperature stimuli and terminate in the nasal cavity.

### Odor Molecules

The olfactory environment is estimated to comprise hundreds of thousands of structurally distinct compounds that potentially can be detected and discriminated by the olfactory system. These odor molecules are classified by several means, most commonly by the presence of specific physical and chemical properties or encoded odor quality, but also by the characteristics of the corresponding receptors, resulting activity patterns in the brain, and function. Typical odor molecules of air-breathing species are small hydrophobic chemicals of organic origin with a molecular weight of less than 300 Da, i.e., they are volatile at ambient temperature. In aquatic animals, requirements for odor molecules are different, with non-volatile, hydrophilic compounds like amino acids being among the best odor ligands identified. Chemically, odor molecules differ by many parameters including size, functional groups, 3D-structure, and flexibility. They encompass the whole array of aliphatic acids, alcohols, aldehydes, ketones, and esters. To the human nose, changes of functional groups can cause pronounced differences in perceived odor quality, e.g., octanoic acid has the smell of sweat whereas the structurally related aldehyde octanal (Fig. 2) has the smell of oranges. The presence of functional groups is not always a prerequisite for odor. Alkenes such as 2,4,4-trimethylpentane and cyclooctane both have pronounced camphor quality as a consequence of molecular shape.

Further chemical features that are subject to olfactory discrimination include differences in carbon bond branching and saturation, as well as substitutions by aromatic, alicyclic, polycyclic, and heterocyclic ring structures or halogens in numerous possible positions. For some substances, substitutions can be exchanged without altering odor quality, e.g., exchanging the aldehyde group in benzaldehyde with other groups

of similar size and charge does not affect its bitter almond quality. Most intriguingly, humans are capable to distinguish between the enantiomers of chiral odor molecules, such as (+)-carvone (caraway) and (–)-carvone (spearmint), which is likely mediated by stereo-selective receptors (Fig. 2). Enantio-selectivity is also exemplified by the pheromonal compound androstenone that induces mating stance in female pigs. (+)-Androstenone (Fig. 2) has an unpleasant (sweat, urine) odor quality to some humans and a pleasant (floral, sweet) odor quality to others, while (–)-androstenone is generally perceived as odorless. In contrast to mice, enantio-selectivity in humans is less pronounced and restricted to few odor molecules, while most enantiomers encode identical odor quality. Furthermore, carvone and androstenone are typical examples for which specific anosmias - the inability to detect particular odor molecules - have been identified in a certain percentage of humans.

### Odor Receptors

How is the neural recognition of this almost infinite number of structurally diverse odor molecules achieved? Early on it has been noted that for a molecule to have an odor it needs to possess a molecular configuration that is complementary to specific sites of its receptor system [2]. This stereospecific theory has been validated by the discovery of a multi-gene family encoding odor receptors (ORs) [3], a finding that has set a milestone in the molecular understanding of odor detection (<http://nobelprize.org/medicine/laureates/2004/press.html>). ORs belong to the superfamily of G-protein coupled seven-transmembrane domain receptors (GPCR) (Fig. 1), and are similar in structure to the rhodopsin and  $\beta$ -adrenergic receptors. The ability of the olfactory system to recognize thousands of different odor molecules derives from the large size and diversity of the OR family. Based on genome sequencing projects (<http://www.ncbi.nlm.nih.gov/Genbank>), more than 1,000 potentially functional OR genes have been identified in mouse, while humans are left with about 400 potentially functional OR genes. Phylogenetically, ORs are preserved from fish to mammals and divide into two major classes. Class-1 or fish-like ORs are encoded by aquatic animals detecting water-soluble molecules, but are also present in  $\sim 10\%$  of the mouse gene repertoire. Class-2 ORs are unique to terrestrial vertebrates detecting volatile odors.

ORs are highly divergent, especially in transmembrane domains 3–5. As a result of multiple OR sequence alignments across species and the developing of computational prediction models, odor binding is envisioned to occur in a binding pocket formed by the OR. Specific amino acid residues in key positions, predominantly located in the highly variable transmembrane domains are thought to interact with different parts of the odor molecules. However, exactly which parts of

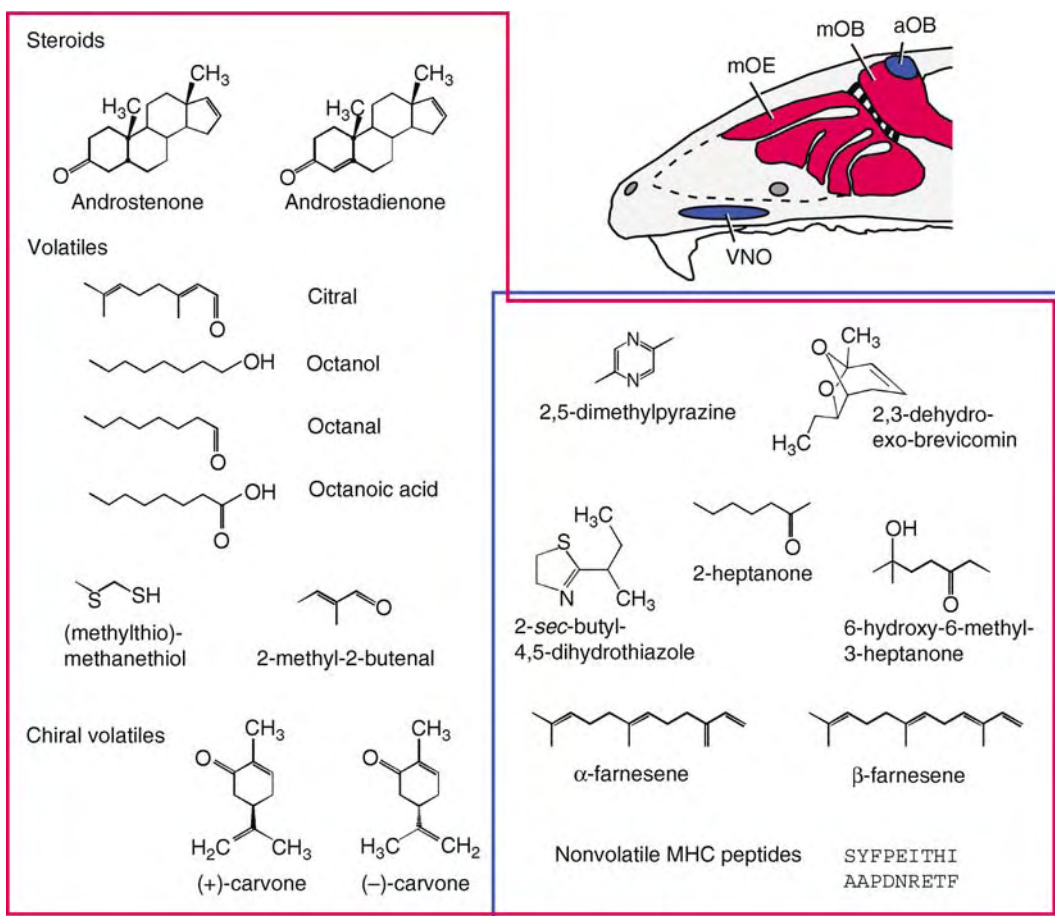

**Odor. Figure 2** Chemical structure of odor molecules detected by the main olfactory epithelium (mOE) and the vomeronasal organ (VNO, blue). Steroids, volatiles including chiral volatiles and nonvolatile MHC peptides are detected by the mOE (red box). Overlapping odor cues that are detected by the mOE and the VNO encompass volatiles as well as nonvolatile MHC peptides (overlaid red and blue boxes). The main olfactory bulb (mOB, red) receives odor information from the mOE and the accessory olfactory bulb (aOB, blue) from the VNO.

the odor molecules are recognized by the ORs is still subject to intense investigation.

In situ hybridization studies show that expression of ORs in the rodent mOE is organized in a zonal pattern and that each individual OSN expresses only one OR. OSNs that express the same OR are confined to one out of four rostro-caudal zones and axonal projections of homologous OSNs coalesce into two glomeruli (one lateral and one medial) in each mOB.

### Odor Coding: Molecular Level

Despite the large size and diversity of the OR family, the question arises how a limited number of ~1,000 different ORs is capable of detecting an exceedingly larger variety of environmental olfactory cues? Identification of the first functional OR–odor ligand pairs [4,5], a process known as the “deorphanizing” of an OR, has solved this apparent discrepancy. Functional

recordings of physiological odor responses and polymerase chain reaction analyses of single OSNs have revealed that the discriminatory power of the olfactory system depends on combinatorial receptor activation as a result of an unusually broad ligand-tuning of individual ORs. Given that single OSNs express only a single OR-type, different odor molecules activate specific, partially overlapping sets of OSNs with distinct sensitivities. In other words, a single OSN has a receptive field composed of different odor ligands that bind its OR with distinct affinity. The fact that ORs detecting the same ligands can be both highly homologous or extremely divergent suggests that these ORs recognize identical or different odotopes (i.e., functional groups of an odor molecule), respectively. The resulting neural activity patterns are thus concentration-dependent: OSNs expressing ORs with the lowest threshold for a given odor are activated first, and the less sensitive ones

are recruited at higher concentrations. This concentration dependence may explain the psychophysical phenomenon that some odor molecules are perceived differently at different concentrations. For example, with increasing concentration the perception of indole by humans ranges from “flowery” to “fecal.”

### Chemical Properties of Odor Molecules

Despite the relatively small number of ORs that have been deorphanized thus far, several features underlying odor recognition have emerged. The receptive field of a given OR appears to be determined by the functional groups, structure, and flexibility of an odor ligand. Some ORs accept 2–3 functional groups such as aldehydes, alcohols, and aliphatic acids [5] in combination with 3–4 consecutive carbons, while other ORs appear to be restricted to single functional groups. For example, the rat I7 OR is activated by straight-chained aldehydes ranging from C7–C10, with octanal (Fig. 2) representing the best ligand identified thus far [4]. Unsaturated C-double bonds that confer molecular rigidity or carbon backbone branches are, depending on position, tolerated, but structurally related molecules with different functional groups, such as octanal and octanoic acid (Fig. 2), yield no receptor activation. Aldehydes are potent ligands with low detection thresholds, and more than 30 different octanal-responsive, yet unidentified rat ORs, have been estimated from octanal evoked activity patterns in the mOE. However, not all ORs exhibit such broad tuning and some receptors appear to be specialists for a single or very few odor molecules.

Ligand binding does not always induce receptor activation. Several studies show that odor molecules exhibit dual functions and are agonists for some ORs, but antagonists for others. Citral for example strongly reduces the response of OR-I7 to octanal (Fig. 2). Antagonistic effects of odor molecules add another level of complexity to olfactory coding and may coincide with the psychophysical observation that both perceived quality and intensity of odor is not necessarily the sum of its single components, and that single substances are perceived differently than the same substances in a mix. Thus, at the molecular level, odor coding is a function of OSN activity patterns emerging from the combinatorial activation (and inhibition) of subsets of ORs both of which depend on concentration and chemical features of the odor molecules.

### Odor Sensing by the Vomeronasal Organ

The VNO expresses a different set of chemosensory receptors, termed vomeronasal receptors (VRs), that also belong to the superfamily of GPCRs but are otherwise distinct from ORs [6]. VRs consist of two unrelated families, V1Rs and V2Rs, that are expressed in the apical and basal layers of the VNO sensory

epithelium, respectively. Recent years have shown that vomeronasal sensory neurons detect a number of pheromones (see [7] for historic definition of the term pheromone) that mediate species-specific behavioral repertoires [1]. However, the VNO also detects some general odors without known pheromonal actions.

Compared to ORs, little is known about the chemical features or binding characteristics of VRs. From a chemical perspective, some of the molecules that stimulate the apical, V1R-expressing VSNs represent typical volatiles that for the human nose, would encode a specific odor quality. In some cases, the compounds are not specific for the VNO, but are detected by both mOE and VNO [1]. For example, 2, 5 dimethylpyrazine, a candidate key-food odorant for humans (with a smell of roasted beef), is also present in mouse urine and is known to delay puberty in mice (Fig. 2). The volatile 2-heptanone that has a fruity odor quality, is a male urinary compound that conveys pheromonal action by extending estrus in female mice (Fig. 2). For 2-heptanone two distinct mouse receptors have been identified, the vomeronasal receptor V1R2b and the olfactory receptor OR912–93 both of which are activated at nanomolar concentrations.

The basal, V2R-expressing layer of the VNO appears to be involved in the detection of nonvolatile ligand families, consisting of peptides and proteins, which requires direct physical with the stimulus source. One such family consists of antigenic peptides – the major histocompatibility complex (MHC) class 1 peptides – that are crucial in the context of immune surveillance and carry information about the genetic make-up of an individual [1]. Interestingly, such MHC peptides are also detected in the mOE, which gives further support to a model involving parallel processing of the same social odor cues by the two olfactory subsystems (Fig. 2). Convergent information derived from the two olfactory systems is likely integrated by higher brain centers.

### Odor Processing by Higher Brain Centers

How is odor information represented in the brain? The olfactory glomeruli of the main olfactory bulb (mOB) form the first relay station in the brain where axonal projections of OSNs synapse onto second order neurons, the mitral and tufted cells. It is well-established that odor stimulation evokes spatially and temporally distinct glomerular activation patterns in the mOB that result from the differential activation of specific sets of ORs in the mOE [8] (e.g., see <http://leonservers.bio.uci.edu>). The brain then needs to extract the features of these bulbar activity patterns. These depend to some extent on chemical odor properties, mainly functional group and structure. For example, molecules with identical functional group, but different C-chain length activate in part overlapping glomeruli that are not activated by structurally related compounds with different functional

groups; single molecules with two different functional groups activate glomeruli that are distinct from those responding to binary mixtures.

Attempts to correlate molecular and functional results on odor coding in rodents with those derived from human psychophysics show that the relation between odor structure and perceived odor quality is still poorly understood. The fact that chemically closely related molecules can confer different odor qualities, whereas molecules that smell alike do not necessarily share chemical similarity suggests that molecular properties and their translation into neuronal activity patterns and spatial odor images in the mOB are not the only determinants in defining odor quality. Further processing of olfactory information by higher brain centers that eventually produce an olfactory percept is only beginning to be understood. Many olfactory-associated brain functions derive from psychophysical studies on humans with discrete brain lesions. Functional imaging of brain activity in humans provides a promising technique to decipher the neural basis of odor perception.

Mitral and tufted cells in the mOB transmit their output signals to the olfactory cortex (Fig. 3), a broadly defined area that consists of the anterior olfactory nucleus, the olfactory tubercle, the piriform cortex, the entorhinal cortex, and the cortical amygdaloid nuclei. The amygdala, which is part of the limbic system and associated with emotional state, participates in formation and storage of olfactory memory.

The entorhinal cortex that projects to the hippocampus plays a role in associative learning and olfactory memory. The orbitofrontal cortex receives afferents from parts of the olfactory cortex through the thalamus and is involved in the conscious perception and discrimination of odor. Recent studies connect the piriform cortex with mechanisms in odor identification as well as olfactory memory and learning. Its anterior region, the principal target of mOB output signals, has been suggested to synthesize information about odor structure into a quality percept.

Mitral cells of the aOB project to the medial amygdala, which regulates social behaviors such as mating and recognition of conspecifics. Odor information of the mOB and the aOB is possibly integrated by hypothalamic gonadotropin-releasing hormone (GnRH) neurons resulting in changes in endocrine status and social/sexual behavioral outputs [9]. Furthermore, odor information undergoes additional refinement by higher cortical centers that integrate olfactory input with previous odor experience, afferents from other sensory systems, and in the case of humans, information obtained through language.

### Odor Function

Odor cues play an important role in the perception of the environment and in the overall survival of a species. During breathing, air-composition is constantly and

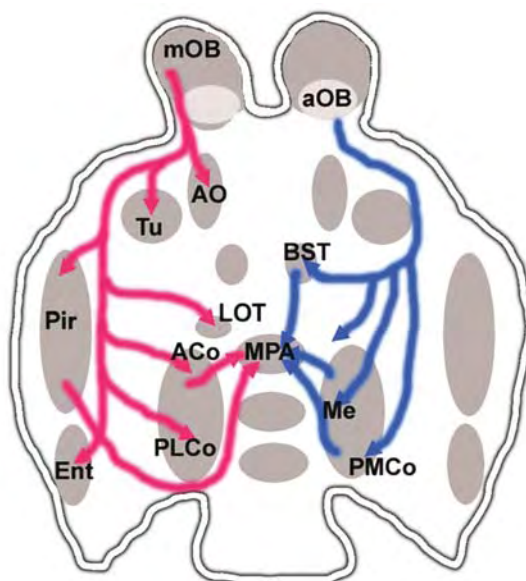

**Odor. Figure 3** Brain pathways for odor processing emerging from the main olfactory bulb (mOB, red), the accessory olfactory bulb (aOB, blue), and their predicted targets in the mouse brain. *Aco* anterior cortical amygdaloid nucleus; *AO* anterior olfactory nucleus; *BST* bed nucleus of the stria terminalis; *Ent* entorhinal cortex; *LOT* nucleus of the lateral olfactory tract; *Me* medial amygdala; *MPA* medial preoptic area; *Pir* piriform cortex; *PLCo* posterolateral cortical amygdaloid nucleus; *PMCo* posteromedial cortical amygdaloid nucleus; *Tu* olfactory tubercle.

0

involuntarily evaluated. In addition to locating potential food sources, detection (and secretion) of odor has multiple functions in inter- and intraspecies chemical communication, i.e., in the identification of prey, predators, mates, and in the adjustment of social and reproductive behavior. Social behaviors are mediated by both the main and accessory olfactory systems. Common to many mammals is the marking of landscape by depositing individual odors. These complex odor messages carry information about gender, sexual and social status, territoriality, mood, and fitness. In chemical communication, scent marks often serve to deter rivals and attract potential mates. Across many species, scent marks elicited by predators are interpreted as warning signs causing escape behavior. Dogs and wolves produce scent marks through urination and defecation, whereas foxes have developed a specialized supracaudal gland that constantly secretes a mixture of volatile terpenes.

A particularly well-established, odor-induced social behavior is the suckling behavior of rabbit pups. The milk of female rabbits contains 2-methyl-2-butenal (Fig. 2), a volatile pheromone that guides pups towards their mother's nipples and triggers immediate

suckling. Another well-known odor-mediated behavioral change depends on the steroid androstenone (Fig. 2), which induces mating stance in female pigs during heat.

In humans, the smell of androstenone is described as both unpleasant (sweat, urine) or pleasant (floral, sweet). Although present in human axillary sweat and urine, it is not yet clear whether androstenone represents a human pheromone. However, androstadienone (Fig. 2), a related compound in male human sweat, is known to affect endocrine status by maintaining high levels of the hormone cortisol in exposed women. Another example of odor-induced endocrine change in humans derives from odor stimulation of females with armpit or vagina secretions from donor females. Estrus cycles of acceptor females synchronize with that of the donor female (“McClintock” effect) by either advancing or retarding menstruation.

## References

1. Brennan PA, Zufall F (2006) Pheromonal communication in vertebrates. *Nature* 444:308–315
2. Amoore JE (1963) Stereochemical theory of olfaction. *Nature* 198:271–272
3. Buck L, Axel R (1991) A novel multigene family may encode odorant receptors: a molecular basis for odor recognition. *Cell* 65:175–187
4. Zhao H, Ivic L, Otaki JM, Hashimoto M, Mikoshiba K, Firestein S (1998) Functional expression of a mammalian odorant receptor. *Science* 279:237–242
5. Malnic B, Hirono J, Sato T, Buck LB (1999) Combinatorial receptor codes for odors. *Cell* 96:713–723
6. Dulac C, Axel R (1995) A novel family of genes encoding putative pheromone receptors in mammals. *Cell* 83(2):195–206
7. Karlson P, Lüscheri M (1959) Pheromones: a new term for a class of biologically active substances. *Nature* 183:55–56
8. Johnson BA, Leon M (2007) Chemotropic odorant coding in a mammalian olfactory system. *J Comp Neurol* 503:1–34
9. Boehm U, Zou Z, Buck LB (2005) Feedback loops link odor and pheromone signaling with reproduction. *Cell* 123(4):683–695

---

## Odor Memory

PETER BRENNAN

Department of Physiology, University of Bristol,  
Bristol, UK

### Synonyms

Memory-odor; Odor learning; Olfactory learning

## Definition

► **Odor memory** is the store of information about an odor that enables an animal to recognize an odor along with its associations and meaning and link it to an appropriate behavioral response. Olfactory learning is a process by which the nervous system forms such odor memories.

## Characteristics

The ability to learn to recognize a particular odor and associate it with a meaning or a predictive value can be demonstrated in a wide variety of vertebrates and invertebrates, and has been studied intensively in terrestrial mollusks, fruit flies, honeybees, rodents and primates. The odor stimuli used in such experiments can consist of individual ► **odorants**, odorant mixtures or complex, naturally occurring odors containing hundreds of constituents. Olfactometers can be used to carefully control the concentration of odorants and the composition of odor mixtures in the sampled air. Odorant mixtures are generally perceived and learnt as unitary sensory objects, rather than being analyzed in terms of their individual components [1].

One of the simplest forms of olfactory learning is a “Go, No-Go” successive odor discrimination, in which an animal is rewarded for making a behavioral response to the rewarded odor (CS+), with no reward delivered in response to the unrewarded odor (CS–). This type of learning is comparatively rapid, occurring within tens of conditioning trials and the memory can last for months (Fig. 1).

Furthermore, the memory for the correct responses to a pair of odors is robust to subsequent learning of other odor pairs, and the learning of subsequent odor pairs is more rapid as the animal learns a win-stay, lose-shift strategy. This results in the ability of rats to learn the correct responses to a new pair of odors after only few trials, which is comparable to the ability of primates to learn visual discriminations. Rodents can also learn to discriminate odors presented simultaneously, either at separate odor ports or in air flowing down separate arms of a Y maze. These discriminations can be made extremely rapidly and it has been estimated that the time to make the discrimination is as small as 220 ms, less than the time taken for a single sniff [2].

Short-term memory (► **memory, short-term**) for odors can be tested using a delayed non-matching to sample procedure. In this procedure, subjects are presented with a sample odor, which is removed and then, after a variable delay, the subjects are presented with the simultaneous choice of the same odor and a different odor. Responses to the odor that is different from the sample odor are rewarded. Using this task, rats can be shown to have short-term memory for odors of at least 60 s. Moreover, rats can also be trained to learn odor sequences where the correct odor choice depends on the sequence of preceding

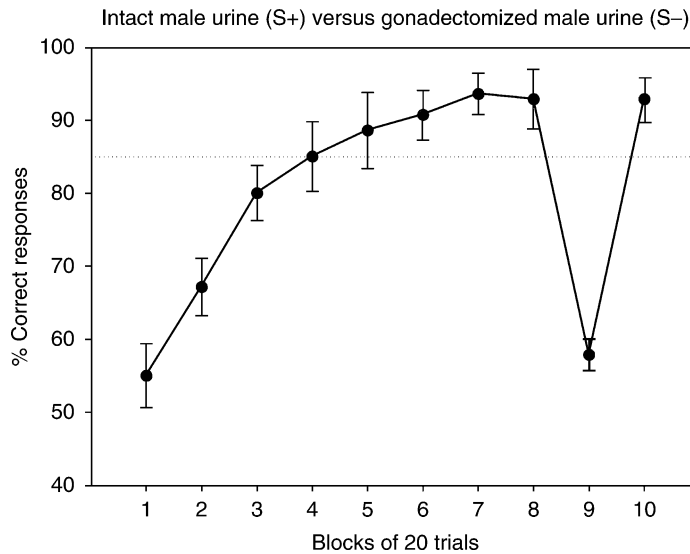

**Odor Memory. Figure 1** Typical learning curve for a “go, no-go” odor discrimination task for a group of seven inbred mice (Keller and Bakker unpublished data). The learning criterion of 85% correct responses was achieved by the fourth daily block of 20 trials. In block nine the same (S+) stimulus was used for S+ and S– trials. The drop in performance to chance levels demonstrates that the mice were using odor cues to perform the task rather than any extraneous sensory cues associated with the training procedure.

odors, which has been proposed as a test of episodic memory [3].

Rewarding and aversive training stimuli result in learning to approach or avoid the conditioned odor, respectively. However, animals can also learn about the familiarity of odors that have not been paired with any overt training stimulus. If an animal is presented with a novel odor it will initially spend time investigating it. Subsequent presentations of the same odor elicit reduced investigation, as the response habituates, whereas presentation of a novel odor elicits intense investigation. This forms the basis of the ▶**habituation/dishabituation test** of olfactory discrimination, which in some ways is a more natural test of olfactory behavior, but requires the animal to be motivated to investigate the stimulus in the first place. Many innately attractive odors, such as urine odors in the case of rodents, may contain pheromonal components that can act as rewarding stimuli for the associative learning of non-pheromonal odors [4].

In many ways, odor learning has been most extensively studied in humans, who have the advantage of not requiring explicit reinforcement for learning to occur, as they can give verbal responses. However, the very fact that humans can name odors poses problems, in that it is often difficult to dissociate the odor memory from the memory for the verbal label. The association of a verbal label with an odor is a separate process from the recognition of an odor [1]. This is demonstrated by

the “tip-of-the-nose” phenomenon in which a person reports that they recognize an odor, and its name is on the tip of the tongue, but they can’t quite recall it.

### Neural Changes Underlying Odor Learning

A vast number of individual odorants are able to stimulate ▶**olfactory receptor** proteins on olfactory sensory neurons (OSNs). If present at a sufficient concentration then the neural activity that is evoked by an odorant can lead to the perception of an odor. However, most odors in nature are not the result of single odorants, but arise from complex mixtures of many odorants. The neural activity evoked by a mixture of odorants that come from a single source are associated to synthesize a unitary neural representation of the odor, known as an odor object. This allows the odor to be discriminated from similar odors and used to recognize and locate the source of the odor. The neural representation of the odor is also associated with neural representations of the object derived from other sensory systems, as well as the context in which it is perceived, and ultimately its meaning for the animal. The ability to subsequently recall these associations in terms of recognizing the odor and its meaning constitute the odor memory. This is not a trivial task. For instance, over 500 individual odorants contribute to the odor of fresh coffee. A few major components will be common between different varieties of coffee. These are the main contributors to coffee odor and will lead to different varieties being classified as coffee. It is the differences



in the numerous minor components that give rise to the fine distinctions between the different coffee varieties, and the ability to make such fine discriminations is enhanced by prior experience with the odors and the importance of making the discrimination [1].

In mammals, the process of associating odorant features into an odor object that can be readily discriminated from similar odors is primarily a function of the ►**main olfactory bulb** (MOB), anterior olfactory nucleus and anterior piriform cortex, at the initial stages of olfactory processing. OSNs in the main olfactory epithelium express a single odorant receptor type and respond to a small range of odorants with certain shared structural and functional attributes. ►**Mitral cells** in the MOB receive input from OSNs expressing a single receptor type. However, the responses of mitral cells in the MOB do not simply depend on the input that they get from the sensory neurons. They are also influenced by the arousal and motivational state of the animal, such as whether it is hungry, or the possible presence of a predator. In addition, mitral cell activity is likely to be influenced by a centrally generated expectation of an odor arising from reciprocal connections with higher-level olfactory processes, and activated in situations such as a predator searching for a particular type of prey.

Significantly, there is accumulating evidence that the responses of mitral cells in the MOB depend not only on information provided by OSNs, but also on the meaning of the odor. Hence, the odor-evoked activity of mitral cells in the MOB has been found to change following learning a new reward association for an odor [5]. Such learning-dependent changes in the odor-evoked pattern of neural activity in the MOB are likely to be at least partially the result of changes in gain of lateral and recurrent inhibition from granule cell interneurons. The change in spatiotemporal pattern of mitral cell activity following learning has been hypothesized to “pull apart” the representation of the learned odor from those of similar odors generated by the MOB. This could increase the probability that they could be discriminated reliably and linked to different behavioral responses. There is evidence for this type of decorrelation of odor-evoked patterns of activity in the honeybee antennal lobe (the insect equivalent of the mammalian MOB) following appetitive odor conditioning [6].

Information from individual mitral cells in the MOB is distributed to a large number of pyramidal cells by virtue of their highly divergent projections to the anterior piriform cortex. Conversely, each anterior piriform cortex pyramidal neuron samples information from a large number of mitral cell neurons across a large extent of the MOB. It is thought that these pyramidal cells can therefore act as coincidence detectors. According to this hypothesis, when the pyramidal cells

in the anterior piriform cortex receive synchronized input from a sufficient number of mitral cells, the strength of those inputs is enhanced, increasing the probability that the same combination of inputs will cause that pyramidal cell to fire in the future. This is supported by evidence arising from ►**cross-adaptation** to odorant mixtures. This suggests that whereas mitral cells at the level of the olfactory bulb respond to individual odorants, pyramidal cells in the anterior piriform cortex respond to specific combinations of odorants that form an odor object [1]. Moreover, the pattern of interconnectivity of the anterior olfactory nucleus and anterior piriform cortex is thought to confer pattern completion properties on the network, in which a degraded pattern of input is able to trigger activity in the complete network of pyramidal neurons that respond to the odor object [7]. This might underlie the ability of the olfactory system to cope with the naturally occurring variability in odorant mixtures that are generalized to a particular odor memory.

#### Higher-Level Brain Areas Involved in Odor Learning

The network of cells in the anterior piriform cortex that represent an odor object communicate with cells in the posterior piriform cortex, which also receive direct input from the olfactory bulb and have widespread reciprocal connections with other brain regions. The interconnections of the posterior piriform cortex suggest that it is likely to function at a similar level to association cortex in other sensory systems and may be involved in forming multimodal representations of stimuli [7]. For instance, the posterior piriform cortex is likely to be involved in associating the sight, sound and smell of a predator into a single representation that can be recalled by input from any one ►**modality**. Perhaps the most important multimodal representations of odors are in relation to the taste, smell and texture of food, which combine to a representation of flavor, which appear to be stronger than those formed between odors and other sensory modalities. Neurons with multimodal responses to both taste and smell have been found in the orbitofrontal cortex and insular cortex of primates.

Finally these odor representations have to drive an appropriate response. This can be an innate response – especially in the case of ►**pheromones**. However for the majority of odors, the appropriate response is learned as a result of experience. The amygdala is particularly involved in eliciting learned emotional responses to odors, whereas neurons in the orbitofrontal cortex have been shown to respond to the meaning of an odor and the context in which it occurs. However, it should be remembered that there are extensive reciprocal connections among these areas, and the neural changes that underlie odor memory are distributed throughout all levels of the olfactory system (Fig. 2).

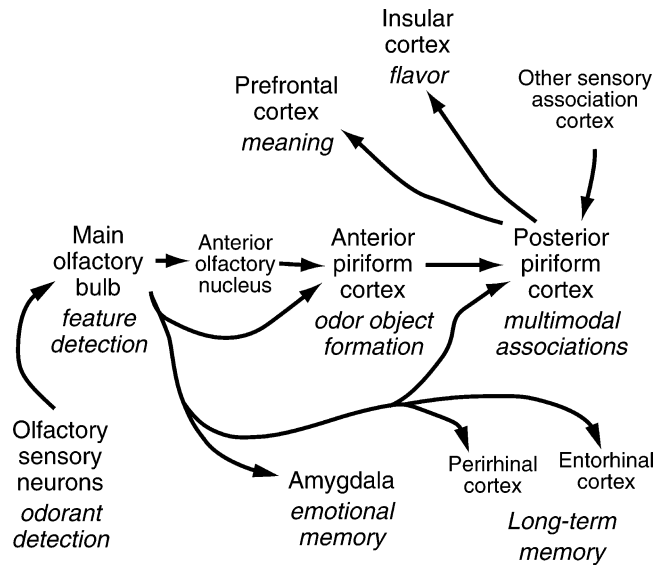

**Odor Memory. Figure 2** Major brain areas involved in distinct aspects of odor memory. Extensive reciprocal connections and interconnections between brain areas have been omitted for clarity.

### Importance of Odor Learning in Mammals

Odor memory is vital for the recognition of significant elements of the environment, such as food, predators and prey, as well as social cues that enable individual and kin recognition, and odor cues used for navigation. The sense of smell plays a particularly important part in mother-offspring interactions, which are vital for the reproductive success of most mammals. For example, ewes rapidly learn to recognize their own lamb by its odor, within a few hours of giving birth. This odor memory enables the ewe to discriminate between its own lamb, to which it shows acceptance behavior, and alien lambs, which it rejects. Formation of the memory for own lamb odors occurs during a period of a few hours, triggered by the vaginocervical stimulation of birth, and involves dramatic changes in the responsiveness of mitral cells in the MOB to lamb odors [8].

Odor learning is also important for neonatal mammals, especially those that are altricial, in which hearing and sight are poorly developed at birth. For instance, the rabbit mammary pheromone 2-methyl-but-2-enal not only acts as a pheromone to elicit nipple search behavior, but also acts as an unconditioned stimulus to induce memory formation to the maternal odors, or artificial odors that have been applied to the mother [4]. These conditioned odors are then able to elicit full nipple search behavior and therefore reinforce the innate response to the pheromone.

Adult rats can readily be trained to avoid an odor, which has previously been associated an aversive stimulus, such as a mild electric shock. This conditioned fear response is dependent on the amygdala, and is adaptive in helping the rat to avoid potentially dangerous

environmental situations. However, if rat pups are exposed to an odor that has been paired with the aversive stimulus of a mild electric shock before postnatal day 10, they will learn to approach the odor [9]. Again this odor memory is adaptive, as at this age the rat pups are normally confined to the nest and are dependent on their mother for their survival. No matter how rough the nest environment or their mother is towards them, the pups remain attracted to the maternal odor. Therefore the function of odor memory can alter to adapt to the changing behavioral priorities of an animal during the course of postnatal and adult life. Moreover, the long-term memory (▶[memory, long-term](#)) of neonates for odors learned in the nest environment, or even *in utero*, can have lasting effects on their behavior as adults, such as post-weaning food preferences or their choice of mate.

### References

1. Wilson DA, Stevenson RJ (2006) Learning to smell. The John Hopkins University Press, Baltimore, MD
2. Uchida N, Mainen ZF (2003) Speed and accuracy of olfactory discrimination in the rat. *Nat Neurosci* 6:1224–1229
3. Fortin NJ, Agster KL, Eichenbaum HB (2002) Critical role of the hippocampus in memory for sequences of events. *Nat Neurosci* 5:458–462
4. Coureaud G, Moncomble A-S, Montigny D, Dewas M, Perrier G, Schaal B (2006) A pheromone that rapidly promotes learning in the newborn. *Curr Biol* 16:1956–1961
5. Kay LM, Laurent G (1999) Odor- and context-dependent modulation of mitral cell activity in behaving rats. *Nat Neurosci* 2:1003–1009

6. Faber T, Joerges J, Menzel R (1999) Associative learning modifies neural representations of odors in the insect brain. *Nat Neurosci* 2:74–78
7. Haberly LB (2001) Parallel-distributed processing in olfactory cortex: new insights from morphological and physiological analysis of neuronal circuitry. *Chem Senses* 26:551–576
8. Brennan PA, Kendrick KM (2006) Mammalian social odors: attraction and individual recognition. *Philos Trans R Soc Lond B Biol Sci* 361:2061–2078
9. Sullivan RM, Landers M, Yeaman B, Wilson DA Good memories of bad events in infancy. *Nature* 407:38–39

---

## Odor-binding Proteins

### ► Odorant-Binding Proteins

---

## Odor Cells in Hippocampus

### Definition

In a series of studies aimed at exploring the role of hippocampal function in memory using the model system of olfactory-hippocampal pathways and odor learning in rats, it has been demonstrated that hippocampus itself is not essential to memory for single odors, but is critical for forming the representations of relations among odor memories, and for the expression of odor memory representations in novel situations. The studies that exploit the exceptional qualities of olfactory learning are helping to clarify the nature of higher order memory processes in all mammals, and extending to declarative memory in humans.

- Olfaction
- The Hippocampus: Organization

---

## Odor Code

- Odor Coding
- Olfactory Information

---

## Odor Coding

MARTIN GIURFA

Research Center on Animal Cognition,  
CNRS – University Paul Sabatier, Toulouse, France

### Synonyms

Odor code; Olfactory code; Olfactory coding; Odor representation

### Definition

The processes by which essential features of odor molecules are translated into patterns of neural activity in the olfactory circuit.

### Characteristics

A code is a set of rules allowing the translation of information from one form or dimension into a different one, in such a way that essential features of the original message are preserved and made available for further unambiguous reading and information extraction. In the case of odors, the nervous system translates the information pertaining to chemical stimuli into patterns of neural activity at the first stages of processing in the brain. We focus here on odor encoding within the vertebrate olfactory bulb (OB) and the analogous circuit in insects, the antennal lobe (AL), excluding specialized pheromonal centers and higher-order centers of the olfactory circuit.

Odor molecule determinants such as chain length (number of carbon atoms), functional group (aldehyde, alcohol, ketone, etc.) and concentration, among others, seem to be the sensory primitives that are processed by the olfactory pathways. They are transduced from the chemical world into the neural domain by differential activation of olfactory receptor proteins on the surface of olfactory sensory neurons, on the insect antenna or in the nose of vertebrates.

The olfactory message is first processed at the level of the primary olfactory centers in the brain (the AL in the case of insects and the OB in the case of vertebrates). Both the AL and the OB are organized according to similar anatomical principles. They are constituted by glomeruli, which are the anatomical and functional units involved in the first steps of odor processing in the nervous system. Olfactory receptor neurons expressing the same receptor type converge to one or a few glomeruli [1] so that the response of a glomerulus is an amplified version of the responses of the receptor type under consideration. There are up to several hundred glomeruli in an insect antennal lobe and several thousand in a vertebrate olfactory bulb. Glomeruli are not simple convergence sites of olfactory receptor axons; they are interconnected by different sets of local

inhibitory neurons, which release the inhibitory neurotransmitter GABA ( $\gamma$ -aminobutyric acid), thus producing complex patterns of firing activity in response to an odor. In insects, local inhibitory and excitatory interneurons may connect laterally few or multiple glomeruli. In vertebrates, lateral inhibitory connections are provided by periglomerular cells whose dendrites are restricted to one glomerulus and by short axon cells which have dendrites and axons extending throughout several glomeruli. In addition, a second level of powerful inhibitory connections is provided by the interaction between granular cells and output cells to the OB.

The processed signal is further conveyed to higher-order centers by such output neurons, the projection neurons in insects and the mitral/tufted cells in vertebrates. Thus, once odors activate groups of receptor neurons, the information does not simply flow through the AL/OB to downstream areas via projection neurons or mitral cells. Instead, the presence of inhibitory neurons within the neural network of the AL/OB determines a global reformatting of odor representations, in the form of a stimulus-dependent, spatio-temporal redistribution of activity across the AL/OB [2].

The olfactory code is a spatio-temporal code in that it contains two complementary components, the spatial and the temporal dimensions. Each of these two dimensions has been studied using different techniques, mainly imaging for the spatial code, and electrophysiology for the temporal code. The impression that such different analyses correspond to separate, unconnected properties of the olfactory code should be avoided. Spatial and temporal properties of the olfactory code represent, in fact, different sides of the same coin.

### Spatial Coding of Odors

Odors may be encoded at the level of the AL/OB in terms of a specific spatial pattern of glomerular activation (Fig. 1).

Such activity pattern constitutes an odor map, which is proper to each odor, symmetric between hemispheres and conserved between individuals [3]. Spatially distributed activity patterns relate to certain structural features of the odor molecules as molecules with similar structural properties are encoded in terms of partially overlapping activity patterns. Neural similarity, measured in terms of the amount of overlap of glomerular activation patterns, correlates directly with perceptual similarity, measured in terms of behavioral odor choices [4], i.e. odors judged as similar correspond to partially coincident odor maps.

Odor concentration affects the odor map as generally, the number of activated glomeruli increases with increasing concentrations of the stimulating odor. A critical question would be, therefore, how **concentration invariance** is achieved given the changing nature of this odor representation. A possible answer comes from the fact that, as mentioned above, spatial coding is not the unique form of translating chemical stimulus features into patterns of neural activity (see below “Temporal coding”).

Quantifying glomerular activity requires identifying individual glomeruli across preparations in the same or different individuals. To this end, atlases of the primary olfactory center have been established in the case of the antennal lobe of some insects (honeybees, moths, flies) where such an approach is accessible due to a lower number of constitutive glomeruli.

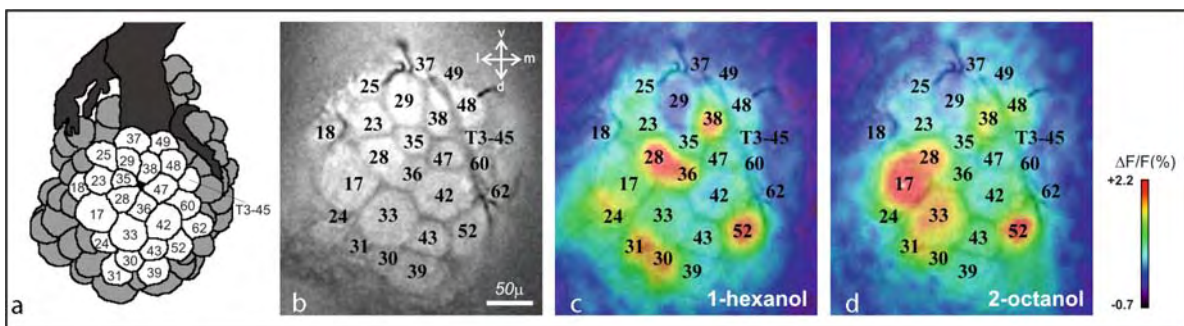

**Odor Coding. Figure 1** Spatial coding of odors at the level of the antennal lobe of the honeybee *Apis mellifera*. (a) Atlas of the honeybee antennal lobe showing 24 glomeruli individually identified. (b) Example of an anatomical staining of the frontal part of a left antennal lobe with the 24 identified glomeruli (*d* dorsal; *l* lateral; *m* medial; *v* ventral). (c) Calcium-imaging recordings of neural activity *in vivo* upon odor stimulation of a honeybee. Superimposed activity map in response to the odor 1-hexanol, showing which glomeruli were activated. The colors (see scale on the right) represent activity levels in terms of fluorescence variation ( $\Delta F/F$  %) with respect to a basal level (no olfactory stimulation). (d) Superimposed activity map in response to the odor 2-octanol. Each odorant is encoded by a specific spatial pattern of glomerular activation.

Olfactory maps can be visualized using different kinds of techniques allowing measurements of neural activity upon olfactory stimulation. Markers of neural activity vary from radiolabels ( $[^{14}\text{C}]$  2-deoxyglucose) and antibodies (*c-fos*) to fluorescent dyes (voltage-sensitive or calcium reporters), or intrinsic optical properties of the tissue. Using some of these and other techniques it is possible to disentangle the contributions of olfactory receptors conveying the olfactory message to the brain from that of local interneurons and projection neurons conveying such a message to higher-order brain centers. In this way, the role of the different neural subpopulations in the elaboration of the odor map can be understood. Assessing the respective contributions of pre- and postsynaptic elements is crucial for understanding the computations carried out at the level of the AL/OB.

Activity maps in the AL/OB are not static but dynamic odor representations. Such a dynamics mostly reflects interglomerular interactions within the AL/OB. However, at the level of sensory afferences to the glomeruli of the OB, diverse, glomerulus- and odorant-dependent temporal dynamics are already present, thus showing that glomerular maps of primary sensory input to the OB are temporally dynamic, even before further processing within the bulb. These dynamics may contribute to the representation of odorant information and affect information processing in the central olfactory system.

### Temporal Coding of Odors

Comprehensive studies on the temporal coding of odors have been performed in several species but studies on locusts have been crucial to understand the principles governing this coding [2]. Such studies have shown that both monomolecular and complex odors are encoded combinatorially by dynamical assemblies of projection neurons. Information about odor identity is contained in the timing of action potentials in an oscillatory population response, rather than on the mere spiking frequency of the response.

Indeed, each projection neuron in an odor coding assembly responds with an odor-specific temporal firing pattern consisting of periods of activity and silence. Any two projection neurons responding to the same odor are usually co-active only during a fraction of the population response. The spikes of coactivated projection neurons are generally synchronized by the distributed action of local interneurons in the AL, which release GABA. Because projection neurons convey the olfactory information to higher-order structures, the mushroom bodies, the coherence of projection neuron activity can be measured in this target area in terms of local field potential (LFP) oscillations [2]. LFP oscillations have a frequency of 20–35 Hz. Each

successive cycle of the odor-evoked oscillatory LFP can therefore be characterized by a co-active subset of projection neurons. As a consequence, each odor is encoded by a specific succession of synchronized assemblies [2]. The action potentials produced by a projection neuron during its odor-specific phases of activity are not necessarily all phase-locked to the LFP. For each odor–projection neuron combination, however, precise and consistent epochs of phase-locked or non-phase-locked activity can be identified (Fig. 2).

Increased odor concentration leads to changes in the firing patterns of projection neurons, similar to those caused by changes in odor identity, potentially confounding representations for identity and concentration. However, concentration-specific response patterns cluster by identity, resolving the apparent confound. Thus, odor encoding comprises three main aspects: the identity of the odor-activated neurons, the temporal evolution of the ensemble, and oscillatory synchronization.

Besides oscillatory synchronization, the odor-evoked responses of local interneurons and projection neurons also contain prolonged and successive periods of increased and decreased activity (slow response patterns), which are cell and odor specific and are stable from trial to trial. Hence, oscillatory synchronization and slow patterning together shape a complex, distributed representation in which odor-specific information appears both in the identity and in the time of recruitment and phase-locking of projection neurons.

Experiments on honeybees [5] showed that oscillatory synchronization between projection neurons is selectively abolished by picrotoxin, an antagonist of the GABA<sub>A</sub> receptor acting on GABA-ergic local interneurons of the antennal lobe, and that such a picrotoxin-induced desynchronization impairs the behavioral discrimination of molecularly similar odorants, but not that of dissimilar odorants. It was, therefore, suggested that oscillatory synchronization of neuronal assemblies is functionally relevant, and essential for fine, but not coarse olfactory discrimination. Interestingly, picrotoxin has no effect on the slow response patterns of projection neurons [2], thus showing that other sources of neural inhibition are at play at the level of the AL.

In vertebrates, three types of oscillatory rhythms have been distinguished in the activity of mitral cells, the pendant of insect projection neurons. Based on their frequency spectrum, one can distinguish three oscillation types:

1.  $\theta$  oscillations (1–8 Hz) are generated by the respiratory rhythm and are correlated with increased and decreased stimulation of olfactory afferences upon inspiration and expiration, respectively. Different mitral cells may exhibit different response latencies to the same odorant and odor coding

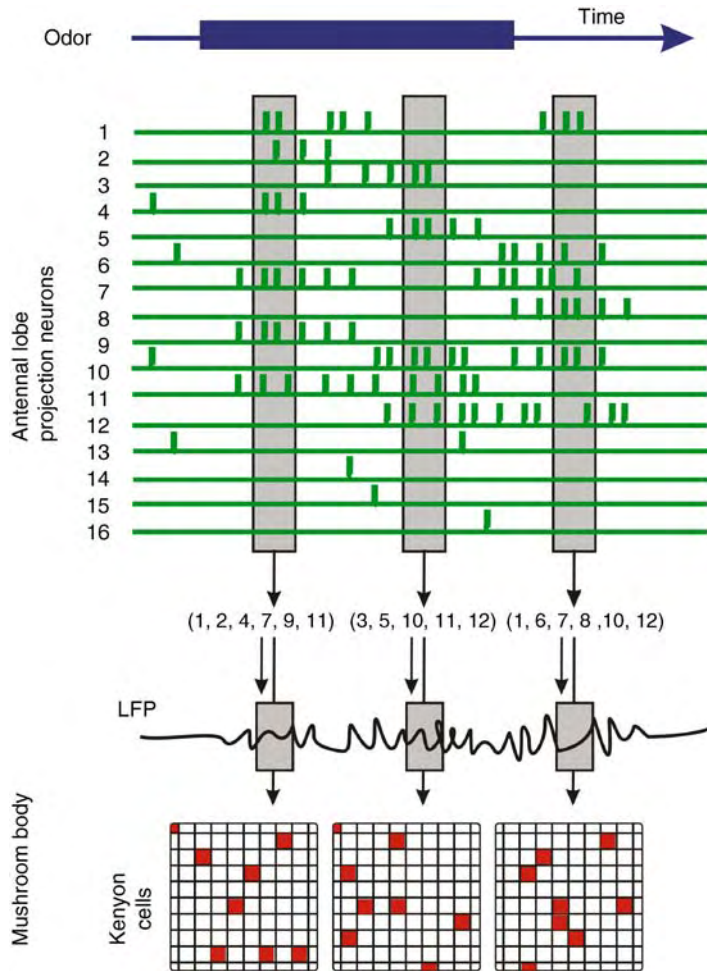

**Odor Coding. Figure 2** Temporal coding of odors in the locust olfactory system. The presumed odor representation is combinatorial, spatially distributed and relies on synchronized and evolving neural assemblies. An odor stimulus elicits spiking activity in several projection neurons (1–16), which constitute the output to the antennal lobe. For each odor–projection neuron combination, however, precise and consistent epochs of phase-locked or non-phase-locked activity can be identified. The coherence of projection neuron activity can be measured at the level of the mushroom bodies in terms of local field potential (LFP) oscillations. Only few Kenyon cells, the constitutive cells of the mushroom bodies, are activated by projection neuron input (sparse coding) (adapted from Laurent G, *Trends in Neurosci* 19:489–496, 1996).

- models have been proposed based on the phase relationship between action potentials of mitral cells and the phase of a  $\theta$  cycle [6].
- $\beta$  oscillations (15–30 Hz) are induced by the inhalation of odor molecules and their origin is a matter of debate. While some theories posit that  $\beta$  oscillations originate not in the OB itself but in downstream structures (e.g., olfactory cortex) that feedback on it, other theories postulate that rhythmic input on granular cells induce these oscillations. The function of  $\beta$  oscillations is still unclear but it has been shown that olfactory learning and habituation can enhance the prevalence of  $\beta$  rhythm over  $\gamma$  rhythm in an odor-specific manner [7].
  - $\gamma$  oscillations (40–80 Hz) are present in the olfactory system of several vertebrate species and can be related to those evinced in the olfactory system of insects (see above). These oscillations are generated in the olfactory bulb upon inhalation of odor molecules. Mitral cell activity is synchronized with  $\gamma$  oscillations and such synchronization arises from the interaction between mitral and granular cells. Glutamate released from mitral cell dendrites excites the dendrites of granule cells, which in turn mediate GABA-ergic inhibition back onto mitral cells [8]. Granular cells do not synchronize with  $\gamma$  oscillations; it has been proposed that they release GABA in a rhythmic manner and in absence of action

potentials [8]. Such a rhythmic inhibitory activity seems to play a fundamental role in the modulation of the oscillatory frequency.

Importantly, not all mitral cells are synchronized with  $\gamma$  oscillations during the response to an olfactory stimulus. In fact, the two neural populations, those exhibiting and those not exhibiting synchrony, encode different properties of the odor: non-synchronized action potentials allow encoding the fine identity of an odor while synchronized action potentials encode the category (ensemble of similar odor molecules) to which the perceived odor belongs [9]. Thus, different properties of an odor can be encoded by the same mitral cells depending on their synchronization with the neural population. The role of  $\gamma$  oscillations in olfactory perception in rodents has been demonstrated by experiments on transgenic mice presenting alterations of inhibitory activity in the OB. Such alterations result in significant changes in olfactory discrimination.

The picture emerging from studies on the temporal coding of odors in the AL/OB suggests that the transfer of odor-evoked signals from receptors to the AL/OB circuits is accompanied by a reshaping of odor representations so that stimulus-dependent, temporal redistribution of activity arises across these circuits. Such a reshaping exploits time as a coding dimension and results from the internal connectivity of the AL/OB circuits and from the global dynamics that these connections produce. Moreover, centrifugal connections from higher order centers (e.g. the mushroom bodies in insects, the olfactory cortex in vertebrates) to the AL/OB may also play an important role in reshaping of odor representations. This top-down process is specifically involved during learning condition in which neutral odorants are transformed into ►aversive or ►attractive ones.

## Conclusions

All in all, the antennal lobe of insects and the olfactory bulb of vertebrates act similarly upon olfactory stimulation: to prevent ►adaptation, they format and reshape odor representations, increase the signal-to-noise ratio and improve odor discrimination. It appears that spatial and temporal dimensions are complementary aspects of odor coding in the AL/OB circuits and that their separated analysis responds to the use of different recording techniques that have put the emphasis on one aspect or the other. As we have detailed above, temporal variations of the spatial code are observed in imaging experiments, and in the temporal code, odor-specific information appears also in the identity of the active projection neurons, i.e. a spatial-related property. For instance, synchronization of output neuron activity at specific sites within the odor map is crucial as shown by studies in the moth where odors elicit high synchrony of action potentials in paired cells connected to the same

glomerulus but low synchrony in cells connected to different glomeruli [10]. Such studies revealed a strong relationship between recording positions, temporal correlations, and similarity of odor response profiles, thus supporting the notion that the olfactory system uses both spatial and temporal coordination of firing to encode chemosensory signals [10]. As shown by this example, future neurophysiological studies should bring the spatial and the temporal dimensions of the odor code together, using recording methods that allow both good spatial and temporal resolution. In this way, characterizing the fine relationship between the temporal and the spatial dimension of olfactory coding at the level of the AL/OB will be possible.

## References

1. Mombaerts P, Wang F, Dulac C, Chao SK, Nemes A, Mendelsohn M, Edmondson J, Axel R (1996) Visualizing an olfactory sensory map. *Cell* 87:675–686
2. Laurent G, Stopfer M, Friedrich RW, Rabinovich MI, Volkovskii A, Arbanell H (2001) Odor encoding as an active, dynamical process: experiments, computation, and theory. *Annu Rev Neurosci* 24:263–297
3. Kauer JS, White J (2001) Imaging and coding in the olfactory system. *Annu Rev Neurosci* 24:963–979
4. Guerrieri F, Schubert M, Sandoz JC, Giurfa M (2005) Perceptual and neural olfactory similarity in honeybees. *PLoS Biol* 3(4):e60
5. Stopfer M, Bhagavan S, Smith BH, Laurent G (1997) Impaired odour discrimination on desynchronization of odour-encoding neural assemblies. *Nature* 390:70–74
6. Schaefer AT, Margrie TW (2007) Spatiotemporal representations in the olfactory system. *Trends Neurosci* 30:92–100
7. Martin C, Gervais R, Chabaud P, Messaoudi B, Ravel N (2004) Learning-induced modulation of oscillatory activities in the mammalian olfactory system: the role of the centrifugal fibres. *J Physiol Paris* 98:467–478
8. Lagier S, Carleton A, Lledo PM (2004) Interplay between local GABAergic interneurons and relay neurons generates gamma oscillations in the rat olfactory bulb. *J Neurosci* 24:4382–4392
9. Friedrich R, Laurent G (2001) Dynamic optimization of odor representation by slow temporal patterning of mitral cell activity. *Science* 291:889–894
10. Lei H, Christensen TA, Hildebrand JG (2004) Spatial and temporal organization of ensemble representations for different odor classes in the moth antennal lobe. *J Neurosci* 24:11108–11119

## Odor Detection

### Definition

The sensory process by which an external odorant stimulus elicits an odor sensation, without necessarily

identifying the exact quality of the detected stimulus. Odor detection is released when a stimulus reaches the detection threshold (or absolute threshold), that is the lowest stimulus capable of producing a sensation that something has changed in reference to a control stimulus. Odor detection can be conscious or unconscious. Conscious odor detection is ordinarily revealed by behavioral or verbal responses. Unconscious odor detections can be revealed by recording the alteration in the reactivity of the autonomous nervous system. Odor detection is compromised in many conditions, especially in Parkinson disease and the later stages of Alzheimer's disease and following damage to the olfactory mucosa or bulb.

- ▶ Alzheimer's Disease
- ▶ Olfactory Hallucinations
- ▶ Parkinson Disease
- ▶ Smell Disorders

## Odor Discrimination

### Definition

This is the ability to detect differences between odors. This is measured in several ways, all of which involve presenting two different smells and having the participant judge whether they are the same or different. Odor discrimination allows to extract an olfactory signal from a background and to make a distinction between different odorant molecules. Whilst compromised odor detection will always affect identification and discrimination, impaired discrimination (or identification) can occur independently of detection.

- ▶ Odor
- ▶ Olfactory Hallucinations

## Odor Expertise

- ▶ Olfactory Perceptual Learning

## Odor-exposure Learning

- ▶ Olfactory Plasticity

## Odor Familiarity

- ▶ Olfactory Perceptual Learning

## Odor Identification

### Definition

This is the ability to correctly provide a name for an odor, when no other cue to its identity is present. This may be measured by simply asking a person to generate a name, or by providing a list of names from which the person has to choose. The most well established test of olfactory functioning, the Smell Identification Test (SIT), utilizes the latter method.

- ▶ Odor
- ▶ Olfactory Hallucinations

## Odor Image

- ▶ Odor Maps

## Odor Learning

- ▶ Odor – Memory

## Odor Maps

AURELIE MOURET  
Laboratory for Perception and Memory,  
CNRS URA 2182, Pasteur Institute, Paris, France

### Synonyms

Odor image



## Definition

Extraction of information from an odor stimulus is a multi-level task for the brain, involving levels of neuronal processing from the odorant receptors up to the olfactory cortex. Sensory modality at each level is represented by activity patterns in two-dimensional neural space. Various sensory signals activate topographically distinct subsets of neurons. Such patterns represent odor ►maps.

## Characteristics

### Olfactory Epithelium

Information processing begins with the mapping of an odorant to the subset of receptors that it activates. More than 400,000 compounds are thought to be odorous to the human nose; mammals have developed nearly 1,000 types of odorant receptors to cope with this huge variety of odorants. Odorant receptors are expressed on the cilia of olfactory sensory neurons situated in the nasal olfactory epithelium. Each receptor presumably detects particular ►molecular features of odorants and thus binds to a specific range of odorants sharing common features [1]. However, each odorant can bind to multiple, but specific, odorant receptors. Thus, an odorant or a mixture of odorants will activate a specific combination of odorant receptors located within the olfactory epithelium. At this level, the odor ►map may be considered a map of receptor space, providing practically unlimited coding capacity for the olfactory system. Olfactory sensory neurons usually produce only one odorant receptor type, so the odor

map of receptor space directly translates to a map of activated olfactory sensory neurons. A spatial dimension is also present, at least in mammals in which olfactory epithelium is divided into four zones [1]. A given odorant receptor is only produced by sensory neurons distributed throughout one of the four zones (Fig. 1). Domains of receptor production have also been identified in fish and insects.

### Olfactory Bulb

In rodents, with few exceptions, olfactory sensory neurons producing the same odorant receptor converge onto two topographically fixed glomeruli, one in the lateral and the other in the medial part of the main olfactory bulb, arising from sensory neurons in the lateral and medial epithelium, respectively. In mice, there are approximately 2,000 glomeruli and their localization is roughly conserved among individuals. Each glomerulus represents a single odorant receptor; thus, the glomerular sheet of the olfactory bulb forms a map of odorant receptors [1]. Furthermore, neurons that are segregated in the epithelium extend to distinct regions of the bulb, such that the spatial topography of the nasal epithelium is preserved in the glomerular sheet, following the principle of a “zone-to-domain” projection (Fig. 1). Thus, two symmetrical sensory maps are generated; one is in the rostralateral hemisphere and the other is in the caudomedial hemisphere. However, a zone-specific expression pattern in the olfactory epithelium is not present in a small group of odorant receptors. An individual odorant receptor of

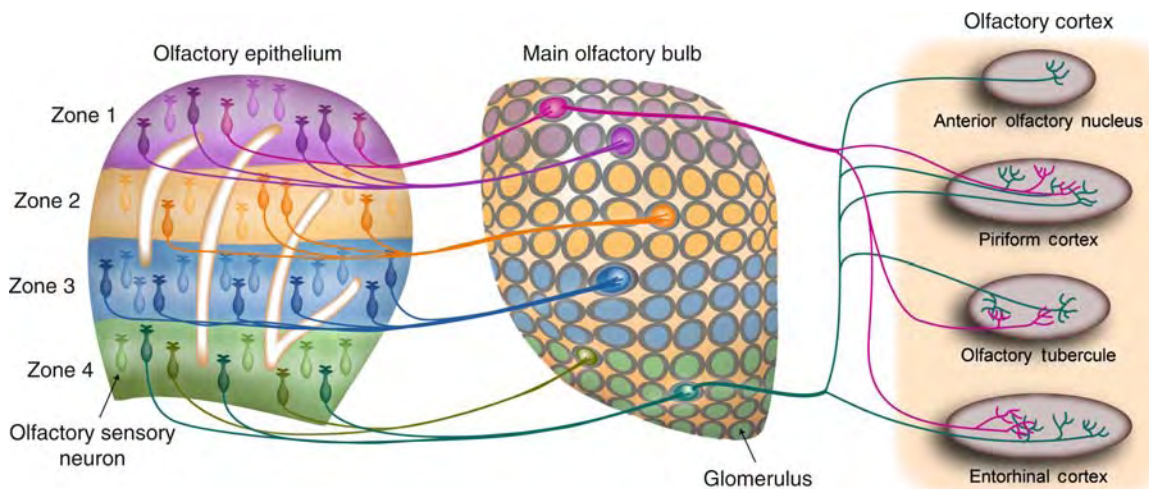

**Odor Maps. Figure 1** *From odorant receptors to the olfactory cortex:* Olfactory sensory neurons expressing a given odorant receptor are distributed widely in one of the four zones and converge their axons onto a few topographically fixed glomeruli in the olfactory bulb. Each glomerulus represents a single odorant receptor. Mitral cells from the glomeruli form synapses with clusters of neurons in multiple olfactory cortical areas. Inputs from different odorant receptors overlap spatially. (Olfactory bulb outputs from two glomeruli only are displayed for more clarity).

this group is typically represented by a single glomerulus located at the most ventral portion of the bulb [2]. Thus, the non-zonal odorant receptors generate a small map at the most ventral part of each main olfactory bulb. Convergence is less strict in the accessory olfactory system (which processes some pheromones) and similar olfactory sensory neurons can converge onto multiple neighboring glomeruli. Nevertheless, odorant quality is represented through spatial patterns of glomerular activation in both cases, reflecting differential activation of olfactory sensory neurons (Fig. 1). This principle of odor mapping is widely observed in various vertebrate species and in invertebrates, including honeybees, moths and flies. Moreover, the odorant-specific spatial positions of activated glomeruli are conserved in animals of the same species.

Individual glomeruli in the olfactory bulb function as molecular-feature detecting units: they respond to a range of odorants sharing specific combinations of molecular features. Furthermore, glomeruli with similar response properties are located in close proximity and form molecular-feature clusters [1]. This is consistent with evidence that sensory neurons expressing homologous odorant receptor genes project their axons to neighboring glomeruli. A precise chemotopic organization is sometimes present within glomerular clusters. For instance, a chemotopic progression with increasing odorant carbon number has been detected in multiple response clusters [2]. So, the glomerular sheet of the bulb topographically represents the characteristic molecular features in a systematic, gradual and multidimensional fashion.

### Olfactory Cortex

Each glomerulus is a spherical neuropil containing the axons of several thousand olfactory sensory neurons that establish synapses with dendrites of approximately 50 mitral and tufted cells (the olfactory bulb projection neurons) and local interneurons. Axons of mitral cells carrying input from a given olfactory receptor synapse with multiple specific clusters of pyramidal neurons in the olfactory cortex, generating a stereotyped map of olfactory receptor inputs that is different from that in the olfactory bulb. The projections to the olfactory cortex are diffuse and have characteristics of a combinatorial array, with extensive overlap of afferent inputs and widespread intracortical association connections. Thus, inputs from different odorant receptors are mapped onto partially overlapping clusters of pyramidal neurons [3] (Fig. 1). It appears that individual neurons receive signals from various odorant receptors. Thus, although inputs from various odorant receptors are segregated in the olfactory epithelium and olfactory bulb, single neurons in the olfactory cortex seem to combine multiple inputs. The olfactory cortex is thought to be important for integrating signals from various molecular-feature-detecting units of the bulb.

### Mapping Methods

Several mapping methods have been used to identify odor-specific spatial activation patterns in the olfactory bulb in mammals [1]. These methods can be classified into two complementary groups, each with their advantages and disadvantages. The first group has the advantage that the responses are mapped over the entire bulb and includes methods involving functional MRI (fMRI) and assessment of 2-deoxyglucose uptake, expression of immediate early genes (e.g. *c-fos*, *c-jun*, *Arc* and *zif268*) and production of phosphorylated ERK. These methods allow investigation of how individual odorants are represented within the entire glomerular sheet of the bulb. The disadvantage of this group is that, with the exception of fMRI, these methods map the response to only one odorant in each animal.

On the contrary, the second group of methods facilitate mapping of the responses to many odorants in the same bulb of an animal. This group includes optical imaging of intrinsic signals, imaging with calcium-sensitive or voltage-sensitive dyes, imaging using pHluorin, electrophysiological recording of single neuron activity and fMRI. With these methods, it is possible to determine the range of odorants that activate an individual glomerulus. However, again except for the fMRI method, these methods allow us to map only the exposed surface of the bulb. Only the dorsal and posterolateral surfaces have been successfully mapped thus far.

### Functional Relevance of the Spatial Arrangement of Glomeruli in the Olfactory Bulb

If the spatial map is important to olfactory behavior, then disrupting the map should impair one or more olfactory functions. Slotnick and colleagues tested this hypothesis in a series of behavioral experiments and showed that ablations of large portions of the olfactory bulb and other destruction of olfactory inputs did not significantly impair odor discrimination and detection. Furthermore, animals trained before such manipulations can often still recognize the same odors after ablation. Even rats with no bulb can carry out olfactory discriminations, supported by olfactory nerve inputs that reinnervate areas of the olfactory cortex [4]. Rather than concluding that spatial maps have only a minor function in the olfactory bulb, it may be argued that discrimination and detection of odors are not the computations facilitated by these mechanisms.

Moreover, the chemotopic arrangement of glomeruli in the bulb seems to have a functional relevance. Even though the relationship between the molecular structures of odorants and their subjectively perceived odors is not entirely clear, odorants with similar combinations of molecular features tend to have similar odor qualities, at least for the human nose. Thus, it is possible that molecular-feature clusters of glomeruli are

part of the representation of basic odor quality [1]. There are various lines of evidence that favor this hypothesis. Measurements of spontaneous responses show that rats generalize between odor pairs with very similar glomerular activity maps, but not between odor pairs with different glomerular maps. However, rodents can be trained by differential reinforcement to discriminate between all odor pairs tested to date with high accuracy. Nevertheless, although discrimination performance in rats is always very good, there is still a significant correlation between glomerular map dissimilarity and discrimination accuracy. Lateral inhibition among neighboring glomeruli may allow mitral cells to respond to a narrower range of stimuli than their associated sensory neurons. This possibly permits a smaller overlap in the number of highly activated mitral cells responding to two similar odorants, thus facilitating their discrimination. Lateral projections of interneurons that are distributed more densely between neighboring than distant glomeruli confirm this hypothesis. Therefore, the spatial clustering of glomerular responses may coordinate the principle responses of bulbar projection neurons by way of center-surround functionality implicating inhibitory interneuronal networks.

Despite the accepted correlation between odor maps and odorant structural commonalities, this relationship breaks down if odorant concentration is included as a variable. If odorant concentrations are increased, more glomeruli respond and odor maps broaden and intensify [5]. The recruited glomeruli are located near the originally activated glomeruli due to chemotopic clustering of glomeruli with similar odorant specificities. Higher odorant concentrations recruit additional sensory neuron populations with progressively lower affinities for the presented agonist. However, the qualitative perception of odors is usually not affected by variability in concentration, suggesting that various neural normalization mechanisms can preserve concentration-independent odor quality information. Regardless of concentration, relative levels of glomeruli activation in the bulb are stable and the representation of odor quality may rely on these activity patterns [5]. The impact of stimulus concentration is not as high in mitral cells and increasing odorant concentrations do not monotonically increase their spiking rates. The mechanisms for normalization of olfactory representations are not precisely known, but it is possible that they do not rely on center-surround inhibition, as global normalization has to be carried out for the entire bulb.

### Development of the Glomerular Map in the Olfactory Bulb

Creation of the map begins prenatally when axons of olfactory sensory neurons navigate toward the bulb, resort in a receptor-specific manner and terminate in a broad area of the bulb surface, interdigitated with other axon

populations. Only postnatally, the axons segregate into completely separate glomerular structures. This maturation process requires various amounts of time, ranging from a few days to about one month, depending on the glomerulus [6]. Very precise axonal targeting is achieved, even for populations expressing highly related odorant receptors and innervating neighboring glomeruli.

The complex processes of axon navigation, fiber sorting and cell recognition are governed by a hierarchical system of recognition and adhesion molecules. Attractive or repulsive interactions apparently drive the growing axons towards or away from regions of the bulb. However, the diversity of the guidance molecules that have been identified is not sufficient to explain the precise topographical glomerular map observed in the bulb. The odorant receptor protein is itself involved in axon guidance and may control the production of guidance molecules and adhesion molecules [7]. Whereas the initial (prenatal) process of glomerulization mainly requires molecular determinants, postnatal activity-dependent processes refine glomerular organization. Whether genetic or activity-dependent mechanisms are dominant in this process of map formation, it is clear that the cues organizing these connections must be present throughout the life of the animal and not only during the initial phases of olfactory development. The olfactory epithelium is continuously self-renewed and olfactory sensory neurons are continuously replaced by newborn neurons that can re-establish good glomerular connections. Thus, the glomerular map does not change throughout adulthood.

### Dynamics of the Odor Maps in the Olfactory Bulb

Odorant responses are often considered static spatial entities. However, various factors may influence the primary sensory input to the olfactory bulb and give rise to differences in the timing of glomerular responses to odorants. First, the nature of the airflow in the naris of rodents causes stimuli to arrive at receptors in various expression zones within the olfactory epithelium at different times [2]. There is a chromatographic effect in the nasal cavity and various odorants are chemically converted in the nasal mucosa before linking to their receptors. This may explain how various odorants can activate the same glomeruli with different kinetics. Furthermore, individual sensory neurons expressing the same odorant receptor may have identical odorant response profiles, but different activation thresholds and their axon terminals may be modulated presynaptically. This widens the range of population terminals converging into a single glomerulus. The dynamics of glomerular activation also depends on the breathing cycle and changes within a respiration cycle and from one cycle to the next [8]. Thus, whereas some glomeruli respond less strongly during the second breathing cycle, suggesting that adaptation occurs, others respond more

strongly, indicating that other processes also contribute to the dynamics observed. The active inhalation pattern of the animals also controls adaptive filtering to detect changes in odor landscape. Thus, neural representations of the same odorant sampled during low-frequency passive respiration and high-frequency sniffing differ [9]. Consequently, glomerular odorant responses differ in amplitude, latency and rise time in an odorant-specific manner and is also dependent on sniffing behavior for a particular odorant. Conjointly, mitral and tufted cell activities also demonstrate stimulus-specific temporal structure. Thus, a temporal code for odorant quality may be embedded in these temporal bulbar activation differences. Spatial distribution and the temporal structure of neuronal activity should therefore not be studied in isolation, but considered as a single entity of the same coding process. Currently, although there is increasing evidence for the importance of temporal structure in bulb odorant-evoked output, little is known about how this temporal patterning is translated within cortical neural ensembles.

Most studies on odor maps have been done with naive animals and have confirmed that they are conserved from one individual to another within the same species. Depending on the mapping method, these maps are not entirely similar because they require animals that are either awake or anesthetized. Anesthesia may itself modify odor processing. In animals that are awake, the output of the olfactory bulb represents the integration of odor stimuli and behavioral variables relevant to odor expectation, discrimination, context and predictive associations. Thus, a certain degree of map flexibility is expected, depending on the behavioral context and on the physiological state of the animal. The fact that the spatio-temporal output of the bulb is affected by learning is consistent with this theory. Training can modify the odor map [10], challenging the findings of studies that put in parallel behavioral performances of trained animals and odor maps of naive animals. Odor maps are dynamic and various changes, particularly those induced by training, may be long-lasting. The centrifugal fibers that richly innervate the bulb can modulate odorant perception and may affect spatial and temporal patterning of glomerular activation. Another factor of bulbar functional plasticity is the continuous neurogenesis occurring in the bulb. Learning induces changes in neurogenesis in the bulb, which may support long-lasting changes in odor maps.

## References

1. Mori K, Takahashi YK, Igarashi KM, Yamaguchi M (2006) Maps of odorant molecular features in the Mammalian olfactory bulb. *Physiol Rev* 86:409–433
2. Johnson BA, Leon M (2007) Chemotopic odorant coding in a mammalian olfactory system. *J Comp Neurol* 503:1–34

3. Zou Z, Li F, Buck LB (2005) Odor maps in the olfactory cortex. *Proc Natl Acad Sci USA* 102:7724–7729
4. Slotnick B, Cockerham R, Pickett E (2004) Olfaction in olfactory bulbectomized rats. *J Neurosci* 24:9195–9200
5. Cleland TA, Johnson BA, Leon M, Linster C (2007) Relational representation in the olfactory system. *Proc Natl Acad Sci USA* 104:1953–1958
6. Strotmann J, Breer H (2006) Formation of glomerular maps in the olfactory system. *Semin Cell Dev Biol* 17:402–410
7. Serizawa S, Miyamichi K, Takeuchi H, Yamagishi Y, Suzuki M, Sakano H (2006) A neuronal identity code for the odorant receptor-specific and activity-dependent axon sorting. *Cell* 127:1057–1069
8. Spors H, Wachowiak M, Cohen LB, Friedrich RW (2006) Temporal dynamics and latency patterns of receptor neuron input to the olfactory bulb. *J Neurosci* 26:1247–1259
9. Verhagen JV, Wesson DW, Netoff TI, White JA, Wachowiak M (2007) Sniffing controls an adaptive filter of sensory input to the olfactory bulb. *Nat Neurosci* 10:631–639
10. Salcedo E, Zhang C, Kronberg E, Restrepo D (2005) Analysis of training-induced changes in ethyl acetate odor maps using a new computational tool to map the glomerular layer of the olfactory bulb. *Chem Senses* 30:615–626

## Odor Memory

- Olfactory Perceptual Learning

## Odor Perception

### Definition

The ability to detect and recognize an odor

- Olfactory Perception
- Olfactory Sense

## Odor Receptor

- Odorant Receptor

## Odor Recognition

### Definition

The perceptual process by which an odor sensation is cognitively related to its source or, in humans, by which an odor sensation evokes a verbal label that designates its source. In theory, odor recognition occurs at the recognition threshold, that is when a odor stimulus reaches the quantitative level at which it can be qualitatively recognized.

► Olfactory Perception

## Odor Representation

► Odor Coding

## Odor Sampling

### Definition

Active exploration of an odor including acceleration of respiratory rhythm called sniffing behavior.

► Odor-sampling Behavior

## Odor-Sampling Behavior

GÉRARD COUREAUD<sup>1</sup>, FRÉDÉRIQUE DATICHE<sup>2</sup>

<sup>1</sup>Ethology and Sensory Psychobiology Group, European Center for Taste and Smell, CNRS/University of Burgundy/INRA, Dijon, France

<sup>2</sup>Neurophysiology of Chemoreception Group, European Center for Taste and Smell, CNRS/University of Burgundy/INRA, Dijon, France

### Synonyms

Sniffing behavior (mammals); Wing fanning (insects); Flicking behavior (crustaceans); Coughing (fishes)

### Definition

Odor-sampling designates a behavior by which animals actively collect air-borne or water-borne odor stimulus carrying information from the surroundings, in order to localize and/or identify the source of the emitted odor, and to respond in an adaptive manner (e.g. approach, avoidance) to the stimulation. To collect the odor stimulus, the organism may sniff, flick, fan, cough or bubble (according to the species and the environment), behaviors that consist in the active drive of air or water across or into the olfactory organ (sniffing, fanning, nasal sac compressing - coughing -, bubbling), or in the moving of the organ through the fluid carrying the stimulus (flicking).

### Characteristics

#### Environment as a World of Odors

In the animal kingdom, odors are important vectors of information likely to elicit behavioral decisions supporting adaptive responses to social and feeding needs. Thus, from early to late development, olfaction is involved in detection and localization of, and communication with, conspecifics, detection of competitors and predators, selection of habitats, localization of preys and more generally of food.

However, animals are only intermittently exposed to odor stimuli. Indeed: (i) the olfactory organ (e.g. nose, antenna) is a structure which anatomically protects the substructures carrying the olfactory receptors, and therefore limits or blocks the continuous access of odor molecules to the receptors; (ii) informative odor cues (signals) are often sporadically emitted from odor sources spatially dispersed; (iii) odors are transported in the environment by wind or water currents submitted to physical turbulences (i.e. odors generally consist of plumes, patches or filaments in aerial and marine environments). In other words, odors in the ambient air or water are fluctuating both temporally and spatially. This creates the necessity for animals to sample their olfactory environment, i.e. to extract and gain access to the odor cues. Odor-sampling behavior responds to this necessity, in allowing a voluntary (intermittent) exposure to specific and ephemeral olfactory information emanating from the surroundings. In addition, odor-sampling behavior, coupled to the olfactory organ morphology, may form the first level of signal filtering, before its processing at the receptor then neural levels.

#### Odor-Sampling Behavior in Terrestrial Environment

In humans, and mammals in general, odor-sampling that follows the detection of an odor is supported by a so-called “sniffing” behavior. During a sniff, air enters through the nostrils (anterior nares), and continues through the nasal cavity, then out the posterior nares to the top of the throat. Part of the airflow reaches the

olfactory epithelium, which lines the roof of the nasal cavity (below the cribiform plate). Usually, a single human sniff approximately has a duration of 1.6 s, an average inhalation velocity of 30 l/min (twice that of a normal inspiration), and a volume of 500 cm<sup>3</sup>. However, humans generally take several successive sniffs to sample odors, thus displaying sniffing episodes rather than single sniffs. During an episode, each sniff has a reduced duration and volume as compared to a single sniff, but the average inhalation velocity remains the same. Multiple sniffs are quite surprising knowing that odor presence and intensity can be determined, in laboratory conditions, in a single sniff. But sniffing episodes are certainly necessary in natural conditions, where the localization, identification and discrimination of odors constitute difficult tasks due to air turbulences and exposure to complex mixtures (emanating from biological sources) [1]. Human odor-sampling may for instance impact scent-tracking abilities, and is correlated with food neophobia.

In rodents, nostrils act as flow diverters during sniffing, permitting to inspire air from the immediate front of the snout and to expire it backward. Such aerodynamics makes sense, allowing extracting odor cues from the environment while reducing the disturbance of the olfactory sample. The sniffing behavior by itself consists in a relatively stereotyped sequence divided in two successive phases. During the first phase, the animal fixes the head, protracts the vibrissae, inhales briefly, and retracts the tip of the nose. Then, during the second phase, it retracts the vibrissae, exhales and protracts the nose. Generally, the entire sequence is repeated, after repositioning of the head, at around 4–12 Hz and occurs in bouts lasting 1–10 s. Sniffing behavior is considered to be synchronized with whisking, head bobbing and heartbeat. Recently, it was suggested to be constituted, in rats, by two successive modes: type-I sniffing, displayed with a respiration frequency of 6–9 Hz, allowing the acquisition of odor information; then type-II sniffing (9–12 Hz), preparing the animal to display the behavioral response accompanying its final decision [2].

In insects, olfactory receptors are borne by chemosensory sensilla carried by the antennae. Usually, the sensilla form a dense boundary layer between the whole antennae and the receptors. To sample odors from the surroundings, animals display particular wing motions that induce pulses of air flowing to the body, from front to rear. The consequence is an increase in the interception of chemical signals on the olfactory sensilla, due to a decrease in the depth of the boundary layer. Typical wing motions allowing such sampling happen during flight (these motions differ in angle and amplitude from those typically used to fly), or during walking in flying and non-flying insects. Wing motions displayed by walking insects to sample odors are named

“wing fanning”. This latter behavior severely increases the air penetration and rate of interception of odorant molecules both into the antennae and the sensilla: in silkworm moth (*Bombyx mori*), the airflow produced is 15 times faster at the level of the antennae, and 560 times faster at the level of the sensilla [3], as compared to walking.

Whatever the species, and in addition to the increase in the capture rate of odorants, sniffing and wing fanning may also have a second function: to replace the fluid volume being sampled, i.e. the fluid volume adjacent to the surface of the chemosensory structures. Both functions may occur with a single increase in velocity of airflow, or with periodic fluctuations in velocity (thus minimizing ►habituation and ►familiarization processes) [3].

### Odor-Sampling Behavior in Aquatic Environment

Among arthropods, crustaceans present adaptations illustrating odor-sampling behavior. Crustaceans have different chemosensory organs, among which the lateral flagella of the first antennae (lateral antennules) constitute olfactory organs. In the American lobster (*Homarus americanus*) and Spiny lobster (*Panulirus argus*), for instance, olfactory sensilla (called aesthetascs) form a dense “toothbrush” on the distal half of the antennules. The brush forms, as in insects, a boundary layer which shields the receptors from odor access. When they perceive a chemical signal, lobsters generally wave their antennae and increase the rate of “antennule flicking” (the right and left antennules may flick independently). This behavior allows water to be driven at high velocity through the brush, the boundary layer to be decreased, and then stimulus access to the chemoreceptors (carried by the antennules) to be increased. In other words, antennular flicking is a form of “sniffing” in this taxon, and allows odor perception. It constitutes a behavioral expression which can be easily quantified, and which is therefore used to determine the biological relevance of stimuli. Antennular flicking is critical for efficient orientation behavior [4].

In fishes, odor-sampling behavior has often been thought to be relatively involuntary. In teleostean fishes, olfaction occurs when the water flow is sufficient to bring odor molecules in contact with the receptors embedded in the ciliated olfactory epithelium. The epithelium is located in two nasal sacs (situated in the dorso-anterior part of the head) opened by one or two nares. “Passive” increase of the water flow is induced by ciliary action of cells from the epithelium and by the increase in swimming speed (isosmate fishes), or by continuous pumping in the nasal chambers related to respiration (cyclosmates). However, voluntary sniffing behavior, named “coughing”, has also been suggested. In pleuronectid flounders (e.g. *Lepidopsetta bilineata*, *Platichthys stellatus*; cyclosmates), coughing

consists in the rapid protrusion of the jaw, coupled with an expulsion of water from the mouth and an entrance of water in the nasal chambers through the nares. Then, the mouth closes, and water is rapidly expelled from the nares. This behavior is usually displayed into a stereotyped behavioral sequence including the lift of the head off the substratum, and the orientation to the odor source. Coughing is, for instance, strongly displayed in response to food odorants. It is suggested to support voluntary and frequent sampling of small odorant patches, allowing to gain access to specific odor cues more efficiently than through the continuous circulation of water tied to respiration. Coughing may also have another function: the ejection of foreign material from the olfactory chambers or gills [5].

Finally, it is generally considered that mammals cannot sniff and smell in aquatic environment (except fetuses in the womb) since they are not able to inspire air. However, a recent study brings evidence that in semi-aquatic mammals, a particular mechanism may allow to sample odor underwater: the star-nosed mole (*Condylura cristata*) and the water shrew (*Sorex palustris*) are indeed able to exhale air bubbles onto objects or scent trails before re-inspiring these bubbles. The re-inspiration brings back into the nose the smell of the environmental targets contacted through the bubbles. Interestingly, the volume of air corresponding to these bubbles, the rate of airflow and the frequency characterizing this behavior appear similar to that related to sniffing in small rodents living above water. Such underwater sampling behavior can therefore be considered equivalent to sniffing in the air [6].

### Functional Aspects of Odor-Sampling

Odor-sampling behavior is not only dedicated to the transport of odorants from the environment to the olfactory receptors. It is a dynamic process which directly participates in the temporal and spatial coding of odor stimuli. More generally, it constitutes a main component of olfactory processing and influences olfactory percept. For instance, in humans, functional magnetic resonance imaging (fMRI) demonstrates that odor-sampling (sniffing) induces activity in the primary olfactory cortex, and that this activation reflects the encoding of air flow as a factor contributing to the computation of odor intensity and identity [7].

The changes in air flow induced by sniffing through the nasal cavity (in mammals) could influence the mechanical component of the odor perception: in the olfactory epithelium, olfactory neurons detect the chemical but also mechanical stimulation caused by odorant molecules. Regarding the olfactory perception per se, variations in air flow result first in distinct retention of the odorants carried by the flow, and therefore in distinct perception. Thus, high or low velocities respectively optimize perception of odorants presenting higher, or lower, sorption rate.

Second, the air flow related to sniffing also influences the distribution of odorant molecules over the epithelium. By the way of this active mechanism, distinct odorants are spatially directed to distinct regions of the nasal cavity and to different populations of olfactory receptors, a process called “zonation” [8]. Subsequently, sniffing impacts the spatial representation of an odor at the level of the olfactory bulb, and influences the detection, identification, and discrimination abilities of animals.

Moreover, sniffing behavior carries temporal information about volatile cues throughout the olfactory system, from the olfactory bulb to higher cerebral structures. This impact is important knowing that temporal properties of an odor cue contribute to its representation. From this point of view, electrophysiological recordings reveal that odor-related activity in the olfactory bulb is strongly modulated by respiration and that the phase of spiking relative to the sniff cycle might encode information regarding odorant intensity and quality. Interestingly, the slow theta rhythm (4–12 Hz in rats) generally recorded during sniffing in the mitral cell layer of the bulb, is also observed in the hippocampus, a structure involved in memory and orientation behavior. Such coherence in frequency between distinct brain areas might illustrate the cooperation of sensory, motor and cognitive cerebral regions expressed when the animal is engaged in an adaptive task. For instance, theta oscillations are both displayed in the olfactory bulb and dorsal hippocampus of rats that are sniffing during the initial stages of a reversal odor learning [9].

Finally, in complex natural scenes, sniffing plays a role in odor perception through successive sniffing cycles (even if a single sniff supports odor detection and identification). Successive samplings participate in progressive change of olfactory network dynamics which may then lead to a might converge, by the repetition of sniffing actions, in a more precise odor representation. From this point of view, multiple sniffs compose a synthetic memory-based system forming “perceptual gestalts” [10], which might be determinant for analysis of complex olfactory mixtures, identification of relevant odor cues and scent-tracking.

### References

1. Laing D (1983) Natural sniffing gives optimum odor perception for humans. *Perception* 12:99–117
2. Kepecs A, Uchida N, Mainen ZF (2007) Rapid and precise control of sniffing during olfactory discrimination in rats. *J Neurophysiol* 98:205–213
3. Loudon C, Koehl MAR (2000) Sniffing by a silkworm moth: wing fanning enhances air penetration through and pheromone interception by antennae. *J Exp Biol* 203:2977–2990
4. Atema J (1995) Chemical signals in the marine environment: Dispersal, detection, and temporal signal analysis. *Proc Natl Acad Sci USA* 92:62–66

5. Nevitt GA (1991) Do fish sniff? A new mechanism of olfactory sampling in pleuronectid flounders. *J Exp Biol* 157:1–18
6. Catania KC (2006) Underwater “sniffing” by semi-aquatic mammals. *Nature* 444:1024–1025
7. Mainland J, Sobel N (2006) The sniff is part of the olfactory percept. *Chem Senses* 31:181–196
8. Schoenfeld TA, Cleland TA (2006) Anatomical contributions to odorant sampling and representation in rodents: zoning in on sniffing behavior. *Chem Senses* 31:131–144
9. Macrides F, Eichenbaum HB, Forbes WB (1982) Temporal relationship between sniffing and the limbic theta rhythm during odor discrimination reversal learning. *J Neurosci* 2:1705–1717
10. Wilson DA (2001) Receptive fields in the rat piriform cortex. *Chem Senses* 26:577–584

by the olfactory system. Odorants stimulate sensory neurons of the olfactory system in the nasal cavity by binding to odorant (olfactory) receptor proteins on the cell membrane, triggering an electrical response that can be transmitted to the brain. The ability of an odorant to bind to and activate an olfactory receptor protein depends on molecular features such as the size, shape and presence of functional groups. Naturally occurring odors may be composed of hundreds of odorants.

- ▶ Glomerular Map
- ▶ Memory – Odor
- ▶ Odorant Receptor Protein
- ▶ Odor
- ▶ Olfactory Perceptual Learning

## Odor Selectivity

### Definition

Property of neuron responses (firing rate or other measure of odor response) that varies dependent on the odorant stimulus.

- ▶ Olfactory Information

## Odor Tracking (Localization)

### Definition

The chain of motor actions by which animals search and efficiently orient to a source of odor cues over short or long distances. The recipient organism displays general body movements (as in male moth approaching a female) or local head movements (as in mammalian newborns locating the mother’s nipple) to create sensory asymmetry in the plumes released by an odor source in order to stimulate chemosensors located in or on bilateral organs (antennae, nasal fossae).

- ▶ Social Chemosignal

## Odorant

### Definition

An odorant is a volatile chemical molecule that naturally exists as a component of an odor and is sensed

## Odorant-Binding Proteins

LOÏC BRIAND

Unité Mixte de recherche FLAVIC INRA-ENESAD-  
Université de Bourgogne, Dijon, France

### Synonyms

Odor-binding proteins; Olfactory binding proteins

### Definition

Odorant-binding proteins (OBPs) are abundant small soluble proteins secreted in the ▶ nasal mucus of a variety of species, from insects to vertebrates including human beings. OBPs reversibly bind odorants with dissociation constants in the micromolar range and are good candidates for carrying airborne odorants, which are commonly hydrophobic molecules, through the aqueous nasal ▶ mucus towards olfactory receptors. Although the physiological function of vertebrate OBPs is not yet clearly established, their essential role in eliciting the behavioral response and odor coding have been demonstrated in the fruit fly [1].

### Characteristics

#### General Properties of Vertebrate Obps

OBPs are secreted by the olfactory epithelium in the nasal ▶ mucus at high concentration (~10 mM). They reversibly bind odorants with dissociation constants in the micromolar range [2]. OBPs have been identified in a variety of vertebrates including cow, pig, rabbit, mouse, rat, xenopus, elephant and human beings [2–4]. Different OBP subtypes have been reported to occur simultaneously in the same animal species, two in pig, four in mouse, three in rabbit and at least eight in



porcupine. In rat, three OBPs have been cloned with quite different sequences and binding properties [5]. Molecular weights of OBPs fall within a narrow range (around 18 kDa). They are highly soluble proteins belonging to the lipocalin superfamily. As regards their quaternary structure, some OBPs were observed as monomers, such as porcine, rat OBP-3 or human OBP, while some others are found as dimers, such as bovine OBP, rat OBP-1 and OBP-2. OBP heterodimers have also been observed in mouse. The typical isoelectric point of OBPs is in the acidic range, between 4 and 5. However, some rare OBPs exhibit a neutral or slightly basic isoelectric point, such as rat OBP-2 and human hOBP-2A. As sites of production, OBPs are synthesized within the nasal cavity, but in different glands and areas. Some OBPs have been clearly shown to be expressed in the olfactory area by the Bowman's glands.

OBPs are also found in the sensillary lymph of insect antennae. Although insect OBPs seem to play a similar role in olfaction, they do not share any amino acid sequences or structural similarities with vertebrate OBPs [5].

### Human OBPs

Two putative human OBP genes (named *hOBP<sub>Ia</sub>* and *hOBP<sub>Ib</sub>*) localized on chromosome 9q34 were first described before evidence of human OBP expression in the mucus covering the olfactory cleft [4]. The *hOBP<sub>Ia</sub>* gene codes for a protein, called hOBP-2A, which is 45.5% homologous to rat OBP-2. This gene is transcribed in the nasal cavity, in contrast to *hOBP<sub>Ib</sub>*, which is transcribed in the genitals and codes a protein that is 43% identical to the human tear lipocalin-1. The presence of human OBP expression appears limited to the uppermost region of the ►nasal passage where odorant molecules are detected by olfactory receptor neurons.

### Ligand Binding Properties of OBPs

OBPs bind with high efficiency a large number of odorants belonging to different chemical classes (Fig. 1).

Although no preferential binding was observed with the porcine and bovine OBPs, a broad specificity was revealed by the study of the 3 rat OBPs, which are specially tuned towards distinct chemical classes of odorants. Rat OBP-1 preferentially binds heterocyclic compounds such as pyrazine derivatives and OBP-2 appears to be more specific for long-chain aliphatic aldehydes and carboxylic acids, whereas OBP-3 was described to interact strongly with odorants composed of saturated or unsaturated ring structure [6].

Human OBP-2A was observed to bind many diverse odorants with dissociation constants in the micromolar range, as found in all known vertebrate OBPs [4]. However, specificity of hOBP-2A is more restricted than

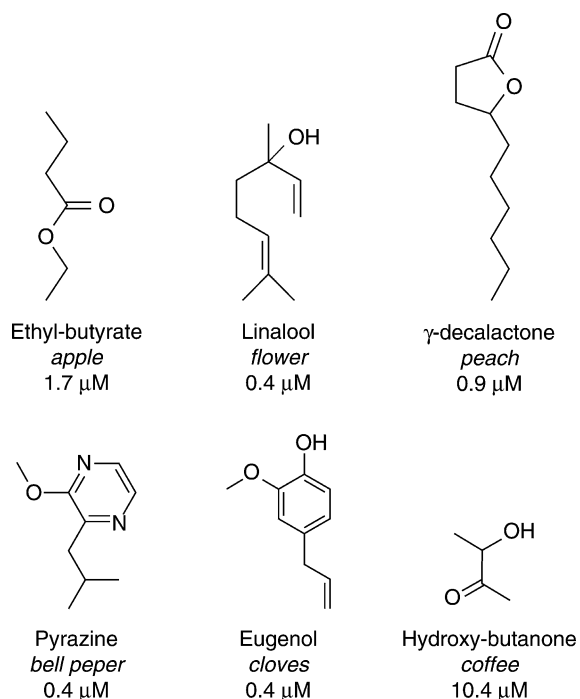

**Odorant-Binding Proteins. Figure 1** Examples of odorants presenting different odors, which bind tightly or weakly to rat OBP-1. The dissociation constants of these compounds for rat OBP-1 are indicated in italics.

those of porcine and rat OBP-1 and 3. A chemical specificity of this OBP for aldehydes, either aliphatic or aromatic, enhanced by the size of the odorant molecule, is clear comparing odorant chemical series. Note that hOBP-2A can also be characterized by its low affinity for a very potent odorant, 2-isobutyl-3-methoxy pyrazine, and a very high affinity for large aliphatic acids.

### Consensus Sequence, Homology and Disulfide Bond

All known vertebrate OBPs belong to the lipocalin superfamily. All members of this family have low sequence identity, but few characteristic signatures allow their identification: a GxW motif at about 15–20 residues from the N-terminus, two cysteines in the middle and a glycine at the C-terminal end (Fig. 2).

One of the conserved cysteine residues, located on the fourth strand of the first  $\beta$ -sheet, forms a disulfide bridge tightening the  $\alpha$ -helix C-terminal domain and the  $\beta$ -barrel. When comparing OBP sequences, note that the percentage of identity among OBPs is low (21–26% on average) with the bovine and porcine OBP showing a maximal identity (42%), whilst rat OBP-2 exhibits the lowest identity (12–19%) when compared to all other OBPs. Consequently, tissue expression (i.e. in the olfactory epithelium) and ligand binding properties should be systematically taken into account in order to classify OBPs.

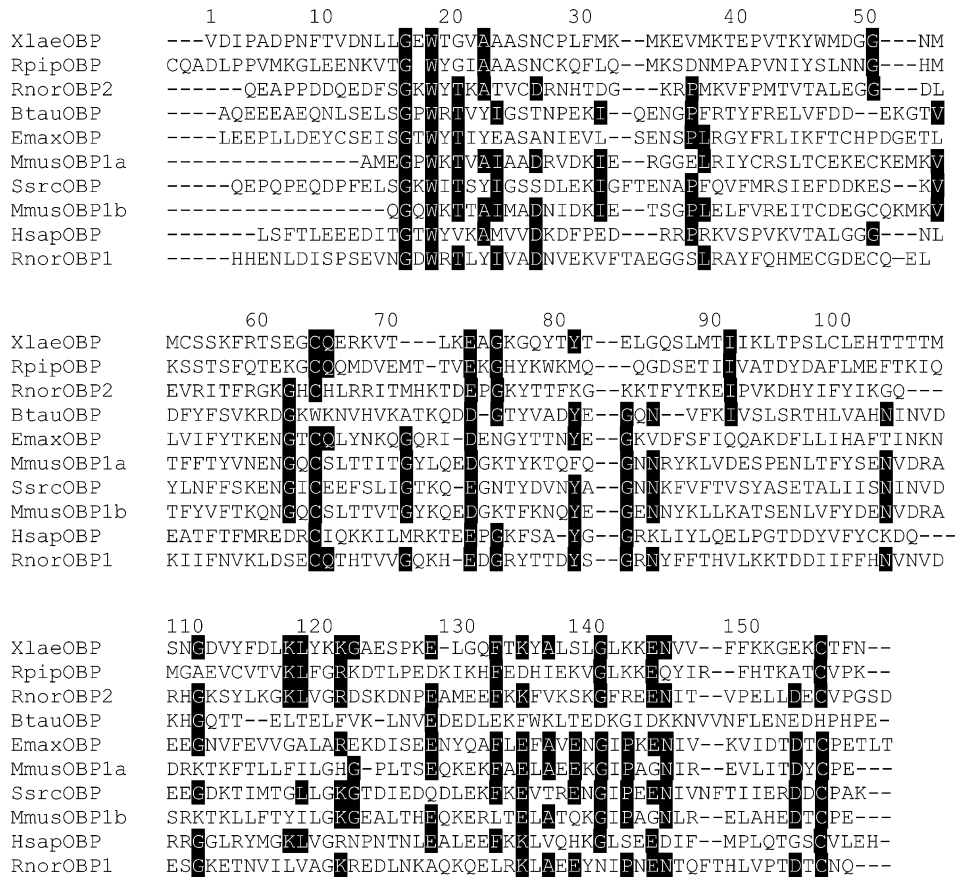

**Odorant-Binding Proteins. Figure 2** Sequence alignments of vertebrate OBPs. Conserved amino acid residues are shown white on black background. OBPs are: XlaeOBP (*Xenopus laevis* OBP), RpipOBP (*Rana pipiens* OBP), RnorOBP1 (Rat OBP-1), RnorOBP2 (Rat OBP-2), MmusOBP1a (Mouse OBP subunit IA), MmusOBP1b (Mouse OBP-1B), BtauOBP (Bovine OBP), EmaxOBP (Elephant OBP), SsrcOBP (Porcine OBP) and HsapOBP (Human OBP-2A).

### Structural Properties of OBPs

Vertebrate OBPs like other members of the lipocalin superfamily display low sequence similarities, but share a conserved folding pattern made of an 8-stranded anti-parallel  $\beta$ -barrel linked together by seven loops, and connected to an  $\alpha$ -helix (Fig. 3). The  $\beta$ -barrel defines a central apolar cavity, called the calyx, whose role is to bind and transport hydrophobic molecules such as odorants [3].

Bovine OBP, which forms a dimer with an elongated shape, was the first OBP whose structure was deciphered through X-ray crystallography [7] and was therefore considered as the prototype of OBPs, in spite of the absence of the second disulfide bridge. However, the molecule is not a classical lipocalin, since it exhibited a structural feature called domain swapping. The  $\beta$ -barrel of each monomer comprises its own strands 1–8, but the eighth strand originates from the other monomer. By this mechanism, the C-terminal part of one of the homodimers rotates and takes the place

of that of the other. In addition to the buried cavity in the middle of the  $\beta$ -barrel, as in monomeric OBPs, a central pocket, composed of residues belonging to the  $\beta$ -barrel domains and to the C-terminal ends, is located at the dimer interface in communication with the solvent.

Porcine OBP is a monomer whose 3D-structure is typical of a lipocalin. Two cysteine residues form a disulfide bridge between the C-terminal and the loop joining strands 3 and 4 of the  $\beta$ -barrel [8] and a single cavity is observed inside the  $\beta$ -barrel, which does not communicate directly with the external solvent. A few amino acid side chains, which block the access to the solvent, would therefore have to move to make the binding of odorants possible. The cavity is mainly covered with hydrophobic and aromatic side chains.

### Structure of the Odorant-Binding Pocket

Up to now, only a few odorant-OBP complexes have been submitted to structural analysis. It has been observed that two odorant molecules could occupy

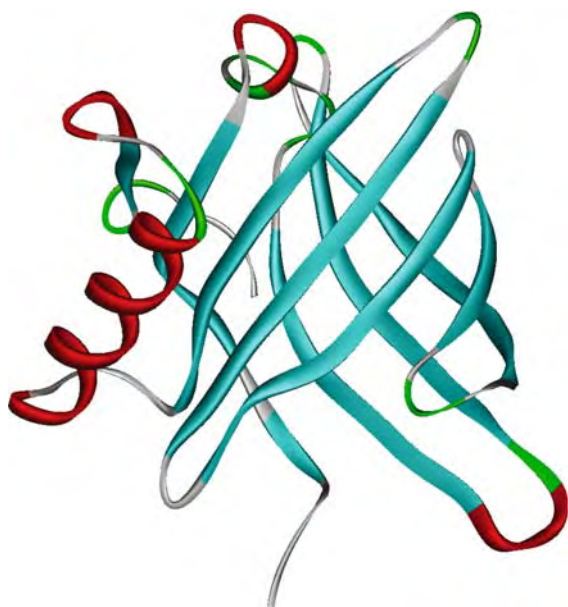

**Odorant-Binding Proteins. Figure 3** Ribbon representation of porcine OBP-1 forming a typical lipocalin eight-strand  $\beta$ -barrel, flanked by a single  $\alpha$ -helix. The color coding is according to the secondary structure; helices, red; L-strands, cyan; other motifs, green.

the  $\beta$ -barrel cavity of bovine OBP [8]. On the basis of porcine OBP data [9], the most likely binding site is inside the  $\beta$ -barrel, since this may be general for all OBPs. The size of the  $\beta$ -barrel pocket was found to be  $780 \text{ \AA}^3$  [8] for the bovine protein and about  $500\text{--}550 \text{ \AA}^3$  for the porcine OBP [9]. Using porcine OBP, a limited number of odorants, with relatively good affinity (affinity constants  $> 10^6 \text{ M}^{-1}$ ) and different chemical groups (aromatic ring, aliphatic chain or polar group) were co-crystallized with porcine OBP [9]. In the crystalline complexes, the odorant orientation inside the cavity have been proved to be opportunistic with no specific target patches for aromatic or charged group. Interactions between the different odorants and the  $\beta$ -barrel involve most of the residues in the cavity. Except for the two asparagines, which display a polar interaction between the amino acid side chain and the keto oxygen of benzophenone, all interactions are hydrophobic. The number of these interactions appears to be roughly related to the size of the odorant, but without any correlation with affinity measured in solution. Although the odorant-binding pocket is shielded from the solvent, openings have been observed using molecular simulations and it has been proposed that, tyrosine residue Y82 constitutes the door of the cavity. As regard human OBP-2A, its three-dimensional structure have not been yet described but a model has been proposed (Fig. 4). It has been shown using

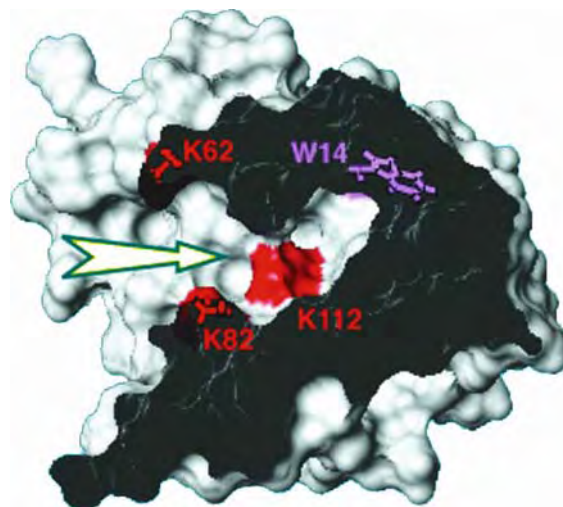

**Odorant-Binding Proteins. Figure 4** Slabbed view through the molecular surface and binding-pocket of the predicted 3D-structure of human OBP-2A. In the binding-pocket (arrow), lysine side chains and surfaces are colored in red, tryptophan in violet.

site-directed mutagenesis that affinity enhancement of OBP-2A for aldehydes compared to the corresponding aliphatic acids, could result from an interaction between aldehyde function and lateral chain of a lysyl residue K112, stabilizing odorant docking [10].

#### Hypothetical Physiological Functions

In mammals and in insects, olfactory receptors are separated from air by a protective layer of hydrophilic secretion, the nasal mucus and sensillar lymph, respectively. Hydrophobic airborne odorants have to cross this aqueous barrier to reach their neuron receptors. OBPs, which have been hypothesized to play such a transporter role, likely appeared during the adaptation to terrestrial life. This carrier role is also supported by their relatively low affinity constant for odorants associated with their high concentration in the olfactory fluids. Their involvement in olfactory discrimination has also been proposed, because of the presence in the mucus of rat of three different OBP subtypes, specifically tuned toward distinct chemical classes of odorants [6]. In addition to the solubilization of odorants, various hypotheses have been proposed for other OBP functions [2]. They could either, (i) filter and buffer odorants in the mucus, then narrow the wide range of odorant intensities, (ii) eliminate odorants after olfactory receptor binding, or (iii) directly interact with olfactory receptors. The essential role of OBPs in eliciting the behavioral response and coding of odor has only been demonstrated in insects. It has been demonstrated that drosophila OBP LUSH is mandatory for the activation of pheromone-sensitive chemosensory neurons [1]. In mammals, it is stim

matter of debate whether there might be involved  
▶specific anosmia or ▶parosmia.

## References

1. Xu P, Atkinson R, Jones DN, Smith DP (2005) *Drosophila* OBP LUSH is required for activity of pheromone-sensitive neurons. *Neuron* 45:193–200
2. Pelosi P (2001) The role of perireceptor events in vertebrate olfaction. *Cell Mol Life Sci* 58:503–509
3. Tegoni M, Pelosi P, Vincent F, Spinelli S, Campanacci V, Grolli S, Ramoni R, Cambillau C (2000) Mammalian odorant binding proteins. *Biochimica et Biophysica Acta* 1482:229–240
4. Briand L, Eloit C, Nespoulous C, Bezirard V, Huet J-C, Henry C, Blon F, Trotier D, Pernollet J-C (2002) Evidence of an odorant-binding protein in the human olfactory mucus: location, structural characterization, and odorant-binding properties. *Biochemistry* 41:7241–7252
5. Tegoni M, Campanacci V, Cambillau C (2004) Structural aspects of sexual attraction and chemical communication in insects. *Trends Biochem Sci* 29:257–264
6. Löbel D, Jacob M, Volkner M, Breer H (2002) Odorants of different chemical classes interact with distinct odorant binding protein subtypes. *Chem Senses* 27:39–44
7. Tegoni M, Ramoni R, Bignetti E, Spinelli S, Cambillau C (1996) Domain swapping creates a third putative combining site in bovine odorant binding protein dimer. *Nat Struct Biol* 3:863–867
8. Spinelli S, Ramoni R, Grolli S, Bonicel J, Cambillau C, Tegoni M (1998) The structure of the monomeric porcine odorant binding protein sheds light on the domain swapping mechanism. *Biochemistry* 37:7913–7918
9. Vincent F, Spinelli S, Ramoni R, Grolli S, Pelosi P, Cambillau C, Tegoni M (2000) Complexes of porcine olfactory-binding protein with odorant molecules belonging to different chemical classes. *J Mol Biol* 300:127–139
10. Teatchoff L, Nespoulous C, Pernollet JC, Briand L (2006) A single lysyl residue defines the binding specificity of a human odorant-binding protein for aldehydes. *FEBS Lett* 580:2102–2108

in some mammalian species, and mediate the detection of thousands of volatile odorants. They are expressed, in mammals, in the cilia of the olfactory sensory neurons residing in the olfactory neuro-epithelium in the nasal cavity. They are located, in adult insects, on either the antennae or maxillary palp. They are expressed by sperm cells, and are thought to trigger ▶chemotaxis toward the oocyte. A second class of odorant receptor proteins was described in 2001 for volatile amines, and called “trace amine-associated receptors” (TAAR). Most odorant receptors recognize multiple related odors and most odorants are recognized by several receptors.

## Characteristics

### Quantitative Description

In 1991, Buck and Axel discovered the odorant receptor gene family in rat [1]. In 2004, Linda Buck and Richard Axel won the Nobel Prize in Physiology or Medicine for this major discovery. Odorant receptors are seven-transmembrane-domain proteins encoded by large gene families. *Drosophila* has a highly diverse family of 60 odorant receptor genes [2]. In mammals, the odorant receptor family of genes, comprising some 1,100 functional genes in the mouse, 347 in the human, respectively, is the largest family of G protein-coupled receptors in the genome, which may make up as much as 3% of the genome. Only a small part of odorant receptor genes form functional ▶odor receptors. In the mouse, 1,296 odorant receptor genes (including 20% pseudo-genes) were found, which can be classified into 2,228 families [3]. Mouse odorant receptor genes are distributed in 27 clusters on all mouse chromosomes except 12 and Y. The distribution was not uniform, with more than half of the genes contained in a few large, compact clusters on chromosomes 7, 11 and 9. Class I odorant receptors correspond to fish-like receptors that bind water-soluble odorants, and separate clearly in the phylogenetic tree from the classical, mammalian-specific class II odorant receptors. There are 147 Class I odorant receptors in the mouse odorant receptor subgenome, 120 of them potentially functional. All the class I odorant receptor genes are located in a single large cluster on chromosome 7 (cluster 7–3). Class I odorant receptors are prevalent in the mammalian genome and may be centrally involved in mammalian olfaction. In the mouse, they are expressed in the most dorsal zone of the olfactory epithelium. Conversely, Class II receptors have been found in all four zones.

Humans have lost nearly two-third of the odorant receptor genes as compared to mice, providing a possible explanation for the reduced sense of smells of humans compared to rodents. The human odorant receptor genome repertoire is organized similarly to the mouse one [4]. Human odorant genes are dispersed in more than 50 chromosomal locations and organized mostly in clusters. Most subfamilies are encoded by a

## Odorant Receptor

FRANÇOISE LAZARINI  
Perception and Memory Unit, Neuroscience  
Department, Pasteur Institute, Paris, France

### Synonyms

Olfactory receptor; Odor receptor; Olfactory receptor protein; OBPs

### Definition

▶Odorant receptor proteins are G protein-coupled seven transmembrane proteins, which number more than 1,000

single locus and most loci encode a single or very few subfamilies. Odorant receptors of a single locus recognize structurally related odorants, suggesting that different parts of the genome are involved in the detection of different odorant type.

A second class of odorant receptors was described in 2001 for volatile amines, metabolic derivatives of classical biogenic amines, and called 'trace amine-associated receptors' (TAAR). Encoding TAAR are present in human, mouse and fish olfactory neurons [5]. They show sequence similarities to the receptors for the neurotransmitters serotonin and dopamine. TAAR1 is thought to be a receptor for thronamines, decarboxylated and deiodinated metabolites of the thyroid hormones, while the mouse mTAAR2- mTAAR9 receptors are most probably olfactory receptors for volatile amines.

### Description of the Structure and Pharmacology

Odorant receptors are in every species heptahelical G-protein-coupled receptors. In mammals, odor receptors belong to class A of the G protein-coupled receptors that are characterized by a long second extracellular loop, containing an extra pair of conserved cysteines, and specific short sequences [6]. Odor receptors share a similarity from 40 to 90% identity. They also have a region of hypervariability, which is the binding site for ligands. This region consists in the third, fourth and fifth alpha – helical transmembrane regions, thought to face each other and form a pocket into the membrane. Mammalian odor receptors are related phylogenetically to other chemosensory receptors (taste receptors, vomeronasal receptors and gustatory receptors). Invertebrate odor receptors bear no homology to vertebrate odorant receptors. *Drosophila* odorant receptors have a mildly conserved region in the seventh transmembrane domain [2].

Odorant receptors bind to structures on odor molecules. They are generally able to recognize multiple related but not identical molecules. They are able to discriminate between thousands of low molecular mass, aliphatic and aromatic molecules with varied carbon backbones and diverse functional groups, including aldehydes, esters, ketones, alcohols, alkenes, carboxylic acids, amines, imines, thiols, halides, nitriles, sulphides and ethers. For many odors, the dose-response curves in single cells have relatively elevated EC50 values, or midpoint, ranging from 10 to 100  $\mu$ M. They can be activated by multiple odors, and conversely most odors are able to activate more than one type of receptor.

Members of the TAAR family are activated by the trace amines found in the central nervous system (beta-phenylethylamine, tyramine, tryptamine and octopamine). Individual TAAR are specific for different amine structures; three of them are activated by volatile amines found in urine (a source of pheromonal cues of a

variety of chemical compositions), some of which have been involved in regulating reproductive behavior [5].

### Olfactory Signal Transduction

Odorant receptors are specialized to detect certain odorants and to convert external stimuli into intracellular signals [7]. Once the odorant has bound to the odorant receptor, the receptor undergoes structural changes and sequentially activates the specific olfactory-type G protein (Golf) and the lyase – adenylyl cyclase type III (ACIII)- which converts ATP into cyclic AMP (cAMP), a molecule that has numerous signaling roles in cells. See Fig. 1.

The cAMP opens specific cyclic nucleotide-gated (CNG) channels, which allow calcium and sodium ions to enter into the cell, depolarizing the olfactory sensory neuron and triggering action potentials which then carry odor information to the olfactory bulb in the brain. The second-messenger cascade of enzymes provides amplification and integration of odor-binding events. The binding of one odor molecule to an odorant receptor activates tens of Golf proteins, each of which will activate an adenylyl cyclase III molecule able to produce about a 1,000 molecules of cAMP per second. Three cAMP molecules are sufficient to open a CNG channel, which can allow the crossing of hundred of thousands of cations, depolarizing the cell and inducing an action potential. The calcium ions entering through the CNG channels are capable of activating and thus opening channels permeable to negatively charged chloride ion (Cl<sup>-</sup>). When the Cl<sup>-</sup> channels open, the Cl<sup>-</sup> efflux further depolarizes the olfactory sensory neuron, thus adding to the excitatory response magnitude. On the other hand, calcium ions entering through the CNG channels act on these channels, probably with calmodulin, to decrease their sensitivity to cAMP, thus requiring a stronger odor stimulus to produce sufficient cAMP to activate the channels. This negative feedback (inhibitory) pathway constitutes a crucial adaptation response allowing olfactory sensory neurons to adjust their sensitivity to odor stimuli. In invertebrates, both excitatory and inhibitory responses to odors have been described, suggesting the existence of multiple transduction pathways.

### Expression and Function

In insects, olfaction is a critical sensory modality for controlling behaviors such as mate selection, food choice and navigation toward suitable oviposition sites. Odorant receptors are located, in adult insects, in small subsets of olfactory receptor neurons in either the antenna or maxillary palps, which constitute the olfactory sensory organs. In mammals, the sense of smell is triggered by odorant receptors, which are expressed in the cilia of the olfactory sensory neurons of the olfactory neuroepithelium lining the nasal cavity. In mice, odorant receptors are also involved in mating and other social

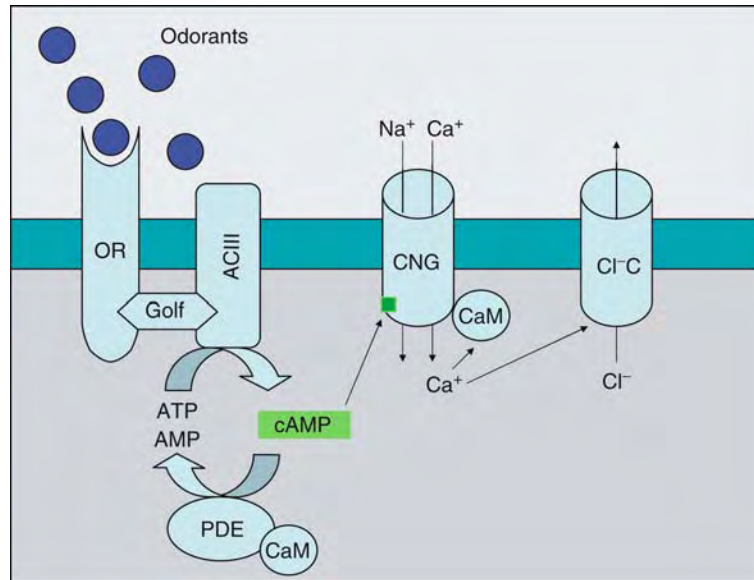

**Odorant Receptor. Figure 1** ▶ **Olfactory transduction.** Within the olfactory sensory neuron, a cascade of enzymatic activity transduces the binding of an odorant molecule to an odorant receptor into an action potential that can be transmitted to the central nervous system. OR, odorant receptor; ACIII, adenylyl cyclase III; CNG, cyclic nucleotide-gated channel; Cl-C, negatively charged chloride ion channel; CaM, calmodulin; PDE, phosphodiesterase.

behaviors. Moreover, in mammals, a subset of odorant receptors is specifically expressed in the testis and odorant receptors have been identified in spermatids and mature spermatozoa [8]. These odorant receptors may play a role in chemotaxis of spermatozoa toward the oocyte.

In *Drosophila*, each sensory neuron express only a single odorant receptor, and all sensory neurons expressing the same receptor contact a single restricted target, named ▶ **glomerulus** in a relay station called the antennal lobe of the brain, analogous to the vertebrate olfactory bulb. *Drosophila* has about 50 types of olfactory receptor neurons, corresponding to about 50 identified glomeruli in the antennal lobe [2].

In mammals, with a few exceptions, each olfactory sensory neuron expresses only one of the 1,000 odorant receptor genes [9]. All cells expressing the same receptor converge onto one or a few glomeruli, in the olfactory bulb [6]. Glomeruli (nearly 2,000 in the rat) are spherical conglomerate of neuropil (diameter of 50–100  $\mu$ ) that consists of the incoming axons of the olfactory sensory neurons and the dendrites of the main projection cells (mitral cells) in the olfactory bulb. Mitral axons of olfactory sensory neurons leaving the olfactory bulb project to higher brain structures including the piriform cortex, the olfactory cortex, hippocampus and amygdala, allowing for both the conscious perception of odors and their emotional and motivational effects. Lateral processing of the message occurs through two populations of inhibitory GABAergic interneurons in the olfactory bulb: periglomerular cells and granule cells. Each glomerular unit presents a receptive field that is thought to be

defined by the molecular range, or pharmacological profile of each odorant receptor.

The mammalian olfactory system uses a combinatorial receptor coding scheme to encode odor identity and to discriminate odors [10]. A given odor activates a set of odorant receptors, and then a set of olfactory sensory neurons, and then a set of glomeruli in the olfactory bulb, forming a spatial map of sensory information. Different odors activate overlapping but non-identical patterns of receptors and thus glomeruli. Slight changes in the structure of an odorant or changes in its concentration results in changes in the combination of receptors that recognize the odorant. Receptors that recognize similar odors (such as ▶ **enantiomers**) generally map in the same area in the olfactory bulb. Individual TAAR are sparsely expressed in discrete subdomains of the neuroepithelium, and are co-expressed with neither other TAAR, nor probably the odorant receptors. In mice, TAAR may mediate behavioral and physiological responses to amine-based social cues present in urine, as urine from sexually mature male mice, but not from females or sexually immature mice, could stimulate mTAAR5, a receptor activated by trimethylamine [5].

## References

1. Buck L, Axel R (1991) A novel multigene family may encode odorant receptors: a molecular basis for odor recognition. *Cell* 65(1):175–187
2. Vosshall LB, Wong AM, Axel R (2000) An olfactory sensory map in the fly brain. *Cell* 102(2):147–159

3. Zhang X, Firestein S (2002) The olfactory receptor gene superfamily of the mouse. *Nat Neurosci* 5(2):124–133
4. Malnic B, Godfrey PA, Buck LB (2004) The human olfactory receptor gene family. *Proc Natl Acad Sci USA* 101(8):2584–2589
5. Liberles SD, Buck LB (2006) A second class of chemosensory receptors in the olfactory epithelium. *Nature* 442(7103):645–650
6. Mombaerts P (1999) Seven-transmembrane proteins as odorant and chemosensory receptors. *Science* 286(5440):707–711
7. Firestein S (2001) How the olfactory system makes sense of scents. *Nature* 413(6852):211–218
8. Spehr M, Gisselmann G, Poplawski A, Riffell JA, Wetzel CH, Zimmer RK, Hatt H (2003) Identification of a testicular odorant receptor mediating human sperm chemotaxis. *Science* 299(5615):2054–2058
9. Serizawa S, Miyamichi K, Nakatani H, Suzuki M, Saito M, Yoshihara Y, Sakano H (2003) Negative feedback regulation ensures the one receptor-one olfactory neuron rule in mouse. *Science* 302(5653):2088–2094
10. Malnic B, Hirono J, Sato T, Buck LB (1999) Combinatorial receptor codes for odors. *Cell* 1999 96(5):713–723

## Odorant Receptor: Genomics

JEAN-FRANÇOIS CLOUTIER

Department of Neurology and Neurosurgery, McGill University, Montreal Neurological Institute, Montréal, QC, Canada

### Definition

▶**Odorant receptor** genomics refers to the study of the structure and function of genes encoding receptors involved in the sense of smell. It includes defining the number and chromosomal arrangements of odorant receptor genes present in various genomes, as well as the molecular mechanisms that regulate their expression in an organism.

### Characteristics

The survival and well being of most terrestrial vertebrates is dependent on their ability to detect ▶**odors** in their environment and to respond to social cues. Neurons located in sensory epithelia of the nasal cavity detect volatile and water-soluble molecules and transmit the information gathered to the brain where it is further processed to generate odor perception and behavioral outputs. While the detection of volatile odorant molecules plays an important role in the modulation of acquired behavior such as food foraging, detection of ▶**pheromones** is thought to control innate responses such as male-to-male aggression in many vertebrate

species. The ▶**olfactory epithelium** (OE) contains olfactory sensory neurons that express two classes of ▶**chemosensory receptors**: the odorant receptors (ORs) and the trace amine-associated receptors (TAARs). While ORs recognize odor molecules, TAARs are proposed to detect compounds that can provide social cues. In contrast to the OE, the sensory epithelium of the vomeronasal organ contains sensory neurons that express two classes of putative pheromone receptors, the V1R and V2R families. Together, these families of seven-transmembrane G protein-coupled receptors (▶**GPCRs**) allow organisms to detect a large range of molecules that regulate their behavior (Fig. 1).

### Odorant Receptors (ORs)

The ability of terrestrial vertebrates to discriminate thousands of complex odors in the environment relies on the detection of odorant molecules by ORs. A single OR can recognize a multitude of odorant molecules and a specific odorant can bind to several ORs perhaps eliciting different levels of neuronal activity. The combination of ORs activated by odorant molecules present in a complex odor leads to the propagation of signals that ultimately renders a representation of the odor in the central nervous system. In light of the complexity of this ▶**combinatorial code**, it is not surprising that ORs represent one of the largest mammalian gene families.

In some terrestrial vertebrates that rely heavily on their sense of smell for survival, such as the mouse, larger OR gene repertoires have been described than in humans whose sense of smell is considered to be more aesthetic. The mouse genome contains ~1400 genes that are organized in clusters located on almost all chromosomes [1]. While the majority of these genes encode functional ORs, ~15% of them are ▶**pseudogenes**. The coding region of OR genes consists of a single ▶**exon** preceded by an ▶**intron** that separates it from non-coding exons in the 5' region. The coding exon gives rise to OR proteins that are 300–350 amino acids in size. ORs contain structural features that are common to most GPCRs such as the seven hydrophobic stretches that form the transmembrane domains and specific conserved cysteines that form potential disulfide bonds. In addition, ORs contain sequences that distinguish them from other GPCRs including a long second extracellular loop, as well as conserved amino acid motifs in an intracellular loop and in some of the transmembrane domains. The presence of these conserved features in ORs are usually enough to classify a gene as belonging to the large family of ORs. Nonetheless, aside from these conserved features, there is on average an overall low amino acid similarity (37%) between ORs. This may allow the OR repertoire to recognize a large number of structurally diverse odorants.

The OR superfamily is subdivided into two classes of receptors. Class I ORs were originally identified in fish

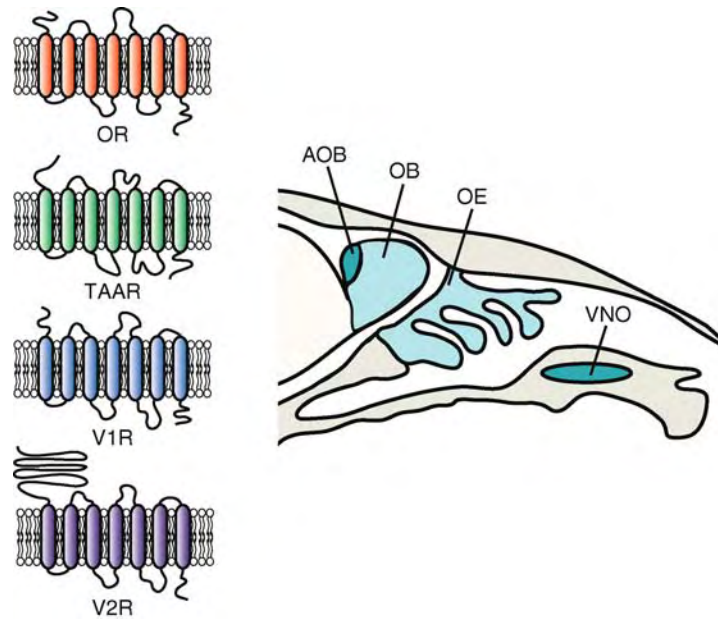

**Odorant Receptor: Genomics. Figure 1** Anatomy of the olfactory systems and structure of olfactory receptors. Olfactory sensory neurons located in the olfactory epithelium (OE) project axons that connect with second-order neurons in the olfactory bulb (OB). In contrast, vomeronasal neurons located in the vomeronasal organ (VNO) project their axons to the accessory olfactory bulb (AOB) where they form synapses with second-order neurons. The information processed by second-order neurons is relayed to various regions of the brain where an odor representation is generated. Olfactory receptors belong to the large family of G-protein coupled seven-transmembrane receptors. While odorant receptors (OR) and trace amine-associated receptors (TAAR) are expressed in the OE, two families of vomeronasal receptors (VR), V1R and V2R, are expressed in the VNO.

but later shown to represent approximately 10% of the mouse OR gene repertoire. In contrast, class II genes have so far been identified only in terrestrial vertebrates and represent the majority of the OR gene repertoire in mouse. While all Class I OR genes are segregated in a single cluster on chromosome 7, class II OR genes are located in clusters on all chromosomes except 12 and Y. The functional relevance of the sequence divergence observed between these two classes of receptors is still unclear. However, it has been proposed that Class I and II receptors bind volatile odorants that have low and high levels of hydrophobicity, respectively.

The gene structure and chromosomal arrangements of OR gene clusters observed in mouse is conserved in humans with an OR gene repertoire consisting of approximately 950 ORs [2]. While this total number may not seem that different from the number of OR genes present in the mouse genome, it is estimated that ~60–70% of these genes could be pseudogenes. Hence, humans may express approximately 300–350 functional ORs, three times less than are expressed in mice. The pseudogenization of the OR repertoire appears to parallel the evolution tree. The highest percentages of OR pseudogenes are observed in the human (~63%) and old-world monkey (~30%)

genomes, while New World monkeys have a similar fraction of pseudogenes as found in the mouse genome (~20%). The increase in pseudogenes observed in humans, as well as in old-world primates, is likely the result of decreased selective pressure for olfactory function throughout evolution.

### Vomeronasal Receptors (VRs)

The ►**accessory olfactory system** plays a critical role in the detection of and responsiveness to pheromones. Vomeronasal sensory neurons located in the ►**vomeronasal organ** express members of the Vomeronasal Receptor (VRs) superfamily that are putative pheromone receptors. These receptors are seven transmembrane GPCRs that are distinct from the OR superfamily. Two large families of VRs have been identified, V1R and V2R. In mouse, the V1R and V2R families are respectively comprised of ~200 and ~60 putative functional genes that are dispersed across several chromosomes [1,3]. While V1Rs, as ORs, are encoded by a single exon, the V2R gene structure is more complex and contains several coding exons. This difference in gene structure is also reflected in the overall V2R protein structure. In addition to features common to ORs and V1Rs, such as the seven



transmembrane domains, V2Rs contain a large extracellular N-terminal domain that binds ligands.

In humans, the majority (95%) of V1R sequences identified are pseudogenes. Five V1R genes that are predicted to encode functional receptors have been described, with at least one of them observed at the mRNA level in human olfactory mucosa [4]. Moreover, no intact V2R genes have been reported in humans. The high occurrence of VR pseudogenes in humans, as well as in primates, suggests that pheromone detection in these species is either not prevalent or mediated through other families of receptors.

### Trace Amine-Associated Receptors (TAARs)

In addition to ORs, a second class of chemosensory receptors has been identified in the OE of mice. TAARs can recognize volatile amines and at least one of them is activated by urine from sexually mature male mice [5]. These observations suggest that TAARs may be implicated in the detection of social cues in mice. The mouse genome contains 16 TAAR genes, including 1 pseudogene, that are all located in a compact region of chromosome 10 and that share high sequence identities [6]. Of these 16 genes, 8 have so far been shown to be expressed in the OE. The coding region of TAAR genes consists of a single exon, which gives rise to proteins of approximately 350 amino acids that contain seven hydrophobic stretches of amino acids and conserved extracellular cysteine residues. In humans, 9 TAAR genes have been identified, including 3 pseudogenes [6]. It remains to be determined whether they are expressed in the human olfactory mucosa.

### Regulation of odorant receptor gene expression

The development of a functional olfactory system is dependent on the tight regulation of OR gene expression in olfactory sensory neurons. Each OR is expressed in a small subset of neurons that are distributed in one of four defined but partially overlapping expression domains within the OE. Within each of these domains, neurons expressing the same OR are randomly distributed and each neuron expresses a single OR gene from the large repertoire available. Furthermore, a functional OR is expressed from only one of two gene ►alleles in a process termed ►monoallelic exclusion. The expression of a single OR per neuron is critical to define the profile of odorants recognized by this neuron. In addition, expression of the OR has also been shown to play a role in the accurate elaboration of ►topographic connections in the ►olfactory bulb. Mechanisms must therefore exist to first determine which subgroup of ORs will be expressed in a neuron based on its location in the OE. This is followed by the stochastic expression of a single receptor and by inhibition of expression of other OR

genes in the same neuron. The mechanisms underlying these two levels of regulation of OR gene expression are beginning to be unraveled.

The spatial regulation of OR genes in neurons of the OE may be achieved through the combinatorial expression of various families of transcription factors in different regions of the OE. For some class II OR genes, the presence of short sequences upstream of the transcriptional start sites have been shown to be sufficient to induce appropriate spatial expression of these ORs in the OE. These short sequences contain regions recognized by homeodomain-containing transcription factors and by Olf1/EBF (O/E) family transcription factors. The LIM-homeodomain protein, Lhx2, can bind to the promoter region of at least one OR gene and is required for expression of class II OR genes [7]. Three members of the O/E family, O/E-1 to 3, are expressed in developing olfactory sensory neurons and the presence of O/E binding sequences in several OR gene promoter regions suggests they may also control OR gene expression [8]. However, the overlapping expression of these three family members in olfactory sensory neurons has made it difficult to establish their requirement for OR gene expression using gene-targeting approaches in mice.

The stochastic selection of expression of a single OR in a neuron is first dependent on the positive activation of gene expression through a *cis* or *trans*-acting mechanism (Fig. 2). It has been proposed that a region of homology upstream of each OR gene cluster, termed H, can act as a ►locus control region (LCR) to regulate expression of these genes in *cis* [9]. A similar mechanism is used to regulate the expression of photopigment genes in the visual system. This LCR would recruit proteins to form an activation complex that can randomly promote transcription of a single gene within the locus following chromatin rearrangements. Such a regulatory sequence has been identified far upstream of the mouse MOR28 gene cluster. Alternatively, a single H region could also regulate expression of OR genes in *trans* through interchromosomal interactions. In support of this hypothesis, the H region found upstream of the MOR28 gene cluster has been shown to interact with the promoter of several OR genes located on different chromosomes [10]. However, while deletion of H from the mouse genome affects expression of OR genes proximal to the location of H, the expression of OR genes outside of this gene cluster is unaffected [11,12].

Since only one allele of an OR gene is expressed in a single neuron, a mechanism must also exist to prevent transcription of the other allele as well as to prevent expression of other OR genes in the neuron. This may be achieved through a negative feedback mechanism in OSNs [9]. Expression of a full-length mRNA giving rise to a functional OR protein

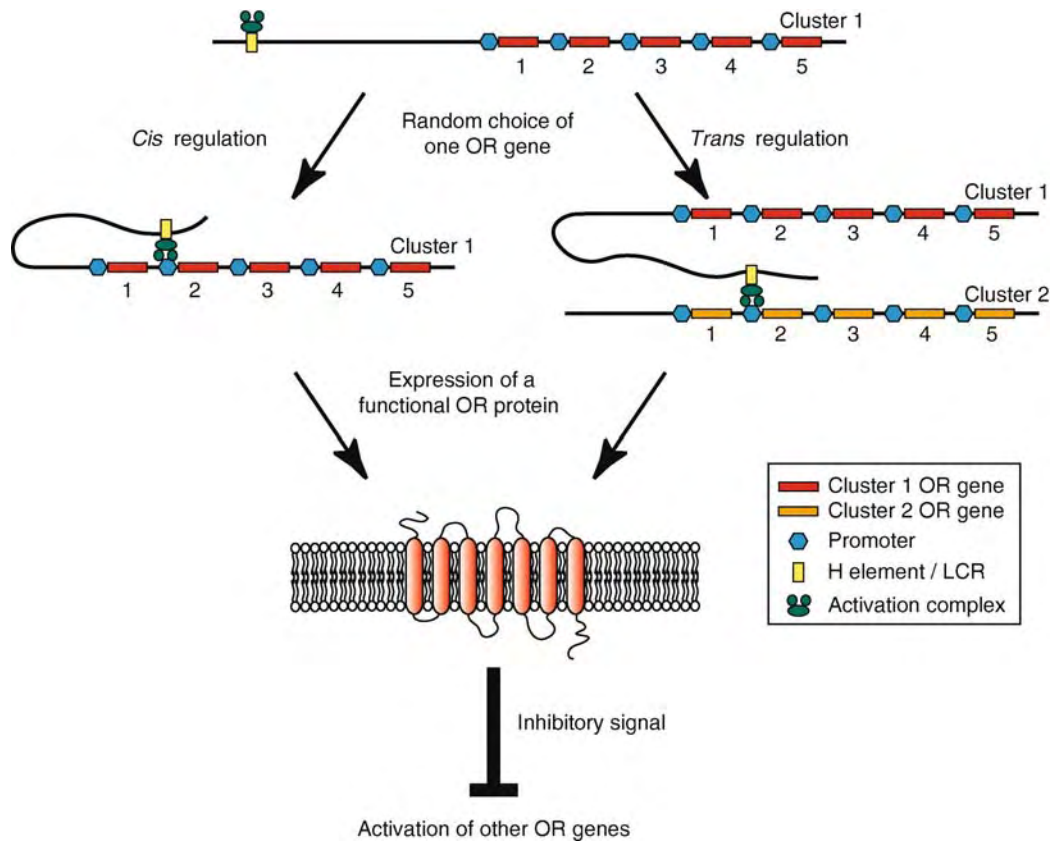

**Odorant Receptor: Genomics. Figure 2** Regulation of odorant receptor gene expression. Odorant receptor (OR) genes are arranged in clusters located on almost all chromosomes. A single OR gene is expressed per neuron through positive and negative mechanisms of regulation. An activation complex is recruited to a locus control region (LCR), termed H, located upstream of an OR gene cluster. Through chromosomal remodeling, this activation complex interacts in either *cis* or *trans* with a single OR gene promoter within a gene cluster to induce gene expression. This stochastic expression of a single OR protein leads to the generation of an unidentified signal that inhibits activation of other OR genes in the neuron by a negative feedback mechanism.

prevents the secondary activation of other OR genes. In contrast, expression of a full-length mRNA containing a premature stop codon from a pseudogene does not prevent activation of another OR gene. These observations suggest that expression of a functional OR protein leads to an as yet unidentified inhibitory signal that negatively regulates expression of other OR genes. In addition, the OR coding region contains regulatory elements important to suppress expression of additional receptors [13]. Taken together, these mechanisms do not only prevent expression... Such a mechanism does not only prevent expression of two types of receptors in a single neuron but also serves to avoid the generation of receptorless neurons. The control of VR, and possibly TAAR, gene expression also ensures that a single receptor is expressed per neuron generated. Whether regulation of these families of genes is under the control of similar mechanisms to the ones identified for OR genes remains to be determined.

## References

1. Zhang X, Zhang X, Firestein S (2007) Comparative genomics of odorant and pheromone receptor genes in rodents. *Genomics* 89:441–450
2. Glusman G, Yanai I, Rubin I, Lancet D (2001) The complete human olfactory subgenome. *Genome Res* 11:685–702
3. Yang H, Shi P, Zhang Y, Zhang J (2005) Composition and evolution of the V2r vomeronasal receptor gene repertoire in mice and rats. *Genomics* 86:306–315
4. Rodriguez I, Mombaerts P (2002) Novel human vomeronasal receptor-like genes reveal species-specific families. *Curr Biol* 12:R409–R411
5. Liberles SD, Buck LB (2006) A second class of chemosensory receptors in the olfactory epithelium. *Nature* 442:645–650
6. Lindemann L, Ebeling M, Kratochwil NA, Bunzow JR, Grandy DK, Hoener MC (2005) Trace amine-associated receptors form structurally and functionally distinct subfamilies of novel G protein-coupled receptors. *Genomics* 85:372–385

7. Hirota J, Omura M, Mombaerts P (2007) Differential impact of Lhx2 deficiency on expression of class I and class II odorant receptor genes in mouse. *Mol Cell Neurosci* 34:679–688
8. Michaloski JS, Galante PAF, Malnic B (2006) Identification of potential regulatory motifs in odorant receptor genes by analysis of promoter sequences. *Genome Res* 16:1091–1098
9. Serizawa S, Miyamichi K, Sakano H (2004) One neuron-one receptor rule in the mouse olfactory system. *Trends Genet* 20:648–653
10. Lomvardas S, Barnea G, Pisapia DJ, Mendelsohn M, Kirkland J, Axel R (2006) Interchromosomal interactions and olfactory receptor choice. *Cell* 126:403–413
11. Fuss SH, Omura M, Mombaerts P (2007) Local and as effect of the H element on expression of odorant receptor genes in mouse *Cell* 130:373–384
12. Nishizumi H, Kamasaka K, Inoue N, Nakashima A, Sakano H (2007) Deletion of the core-H region in mice abolishes the expression of three proximal odorant receptor genes in as, *Proc Natl Acad Sci USA* 104:20067–20072
13. Nguyen MQ, Zhou Z, Marks CA, Ryba NJP, Belluscio L, (2007) Prominent roles for odorant receptor coding sequences in allelic exclusion. *Cell* 131:1009–1017

---

## Odorant Receptor Protein

### Definition

- ▶ Odorant Binding Proteins.
- ▶ Odorant Receptor
- ▶ Odorant Receptor: Genomics

---

## Odorants

- ▶ Olfactory Information

---

## Odors

- ▶ Olfactory Information

---

## Odotopic Representation

### Definition

Odotopic representations involve a unique spatial pattern of activity in the olfactory system (e.g. a unique pattern of activated olfactory glomeruli) for odorant stimuli that evoke unique odor perceptions.

- ▶ Glomerular Map

---

## Off Center Cells

### Definition

- ▶ Visual Cortical and Subcortical Receptive Fields

---

## Ohm's Law

### Definition

The electrical current ( $I$ , in Amperes) that flows through an electrical resistor equals the potential difference (voltage,  $V$ , in Volts) across the resistor divided by the resistor's electrical resistance (Ohm, in  $\Omega$ ):  $I = V/\Omega$ .

- ▶ Action Potential
- ▶ Membrane Potential: Basics

---

## Old/new Recognition

- ▶ Recognition Memory

---

## Olfaction

### Definition

The sense of smell. The process whereby odorant molecules bind to receptors in the olfactory epithelium

and leading to the generation and propagation of neural signals responsible for odor perception.

- ▶ Odor
- ▶ Odorant
- ▶ Odorant Receptor Neuron
- ▶ Odor Perception
- ▶ Olfactory Epithelium
- ▶ Olfactory Sense

## Olfaction and Gustation Aging

NICHOLAS P. HAYS

Nutrition, Metabolism, and Exercise Laboratory,  
Donald W. Reynolds Institute on Aging, University of  
Arkansas for Medical Sciences, Little Rock, AR, USA

### Synonyms

Senescence; Gerontology; Elderliness

### Definition

Elderly adults often have an impaired ability to detect and recognize ▶tastes and ▶odors. Olfactory and gustatory impairment can be particularly harmful in aged individuals, given the likely contribution of such dysfunction to poor appetite, lower dietary energy and nutrient intakes, and the consumption of inappropriate food choices such as spoiled food. These phenomena may in turn influence body composition, nutritional stores, immune function, and disease status. Olfactory dysfunction can also be dangerous as it may prevent the detection of smoke or natural gas odors during household emergencies. Although the precise mechanisms underlying age-related changes in taste and smell remain uncertain, physiological changes associated with the aging process itself, diseases, medication usage, trauma, and environmental factors are all possible contributors. Flavor enhancement, increased dietary variety, and other interventions have been identified that can improve food intake and enhance eating enjoyment. Given the projected increases in the size and longevity of the elderly population in the U.S. and worldwide, additional effective interventions that can maintain or improve chemosensory function in this vulnerable population are needed.

### Characteristics

#### Introduction

It is generally accepted that all sensory modalities, including ▶gustation, olfaction [see ▶olfactory senses],

vision [see ▶binocular vision], audition [see ▶auditory system], and somatosensation [see ▶somatic sense] commonly decline with increasing age. Vision and auditory losses are perhaps most typically associated with the aging process, and these impairments are indeed highly prevalent among elderly adults, with approximately 34% of adults aged 65 years and older reporting vision and/or hearing impairment [1]. Taste and smell dysfunctions are also recognized as a common characteristic of old age, but frequently receive less attention, perhaps because their impact on mortality, morbidity, and functional status is less direct. Figure 1 illustrates the nearly exponential increase in self-reported taste and/or smell dysfunction with increasing age in a representative cohort of U.S. adults [2]. These data indicate that individuals aged 65+ years account for almost half (~41%) of the total number of individuals reporting chronic chemosensory problems. The prevalence of impairment is likely even higher when considering that self-reported data may underestimate the level of actual impairment as measured by objective testing.

The basic anatomy and neurobiology of the gustatory and olfactory systems have been fully described elsewhere [see taste, odor]. Briefly, taste signals are received by receptor cells located in ▶taste buds in the ▶gustatory papillae of the tongue and other structures of the oral cavity. Taste information is then transmitted to the ▶gustatory cortex, orbitofrontal cortex [see ▶cortex – orbitofrontal], ▶amygdala, and lateral ▶hypothalamus of the ▶brain. Smell sensations are received by a small area of ▶olfactory epithelial tissue located on the dorsal surface of the nasal cavity [see ▶nasal passages], where odorants bind to receptors in olfactory neurons, which then transmit information about the identity and concentration of the chemical signal to the ▶olfactory cortex in the brain.

Aging can influence different aspects of gustatory and olfactory sensory perception and sensitivity. Older individuals often require higher concentrations of an odorant or tastant to be present before detection and recognition of the chemical stimulus can be achieved. In other words, the detection and recognition ▶thresholds for various tastes and smells are higher in older adults compared to younger. The magnitude of these changes can also vary across specific sensory qualities; salt taste [see ▶taste – salt] thresholds appear to increase more during the aging process than sweet [see ▶taste – sweet] thresholds. In addition, older individuals may have alterations in the ▶suprathreshold perception of tastes and smells, such that more concentrated chemical stimuli are not perceived as more intense. Odor identification is also frequently poor among the elderly, although this may be due to both sensory impairment as well as cognitive and memory dysfunction resulting in difficulty with odor-naming tasks. In general, olfactory dysfunction is more common

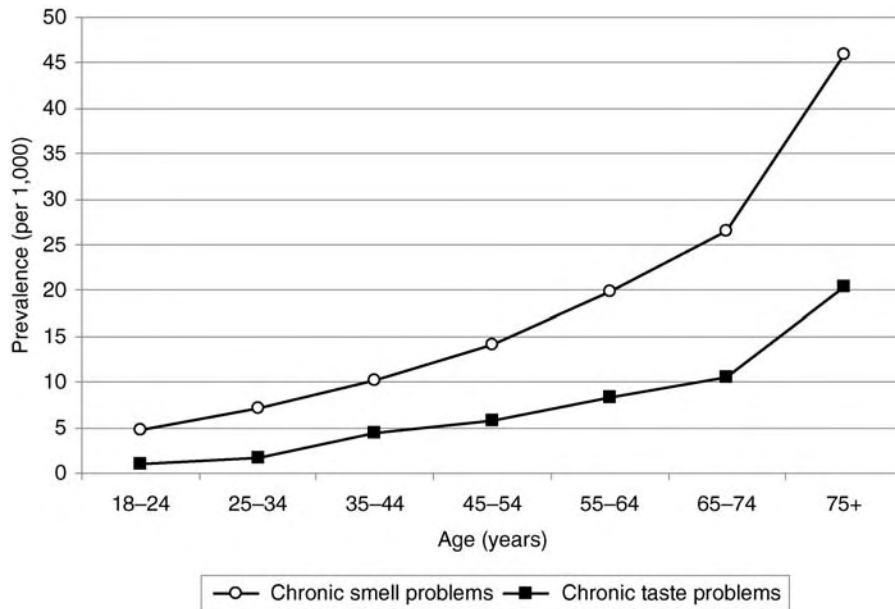

**Olfaction and Gustation Aging. Figure 1** Age specific prevalence rates (per 1,000) of self-reported chronic ( $\geq 3$  months duration) chemosensory problems among individuals living in 42,000 randomly selected U.S. households (1994 Disability Supplement to the National Health Interview Survey). Adapted from Hoffman et al. [2] with permission © 1998 New York Academy of Sciences.

than taste dysfunction among the elderly population and individuals who describe problems with their sense of “taste” typically exhibit olfactory and not gustatory dysfunction, since it is difficult to distinguish true taste from ►retronasal olfaction [3]; strictly defined changes in taste alone are rare. Olfactory perception, however, declines with increasing age even in generally healthy men and women. As shown below, smell and taste changes associated with aging can manifest along a continuum of sensitivity, and can range from the total absence of sensation (e.g. ►ageusia) to a diminished or distorted sensation (e.g. ►hypogeusia, ►dysgeusia).

#### Terminology

##### Gustation

Normogeusic	Normal taste sensory function
Hypogeusia	Diminished sensitivity of taste
Dysgeusia	Distortion of normal taste
Ageusia	Absence of taste

##### Olfaction

Normosmic	Normal smell sensory function
Hyposmia	Diminished sensitivity of smell
Dysosmia	Distortion of normal smell
Parosmia	Distortion of odor perceptions when odor is present

##### Phantosmia

Odor sensations in absence of odor stimulus (i.e. olfactory hallucination)

##### Anosmia

Absence of smell

##### Cacosmia

Feeling ill in response to odors

#### Etiology

The causes of taste and smell dysfunction among elderly individuals are not completely understood. The olfactory epithelium is particularly vulnerable to age-associated dysfunction because of its anatomical location and proximity to environmental trauma, as well as a greater susceptibility to decreased ►neurogenesis secondary to its relatively small size (1–2 cm<sup>2</sup>) and thinness. Declines in taste sensitivity were thought historically to result from a loss of functional taste buds over time, but more recent work indicates that taste bud numbers do not decrease with age and thus declines may be due to changes in taste cell membrane ion channels and receptors. The etiology of age-associated chemosensory dysfunction is further complicated by the varied environmental and medical factors that can also influence these systems and which frequently impact the elderly. Several possible causal factors are briefly described below:

*Normal aging.* One hypothesis for the decline in taste sensitivity with age is reduced taste receptor cell turnover rate, resulting in alterations in taste bud structure and subsequent dysfunction in older subjects. In addition, the olfactory mucosa may be gradually replaced by respiratory epithelium during the normal aging process, reducing smell perception and sensitivity. Animal data suggests that menopause may be associated with changes in olfactory perception, potentially contributing to further alterations in olfactory function among older women.

*Diseases/infection.* Acute or chronic nasal and sinus problems can lead to olfactory dysfunction by obstruction of the nasal passage, by viral-mediated damage to the olfactory receptors, and by altering the amount or composition of the mucus layer that odorants must traverse to reach the olfactory epithelial surface [3]. Neurodegenerative diseases such as ►Alzheimer's and ►Parkinson's disease have been associated with olfactory deficits. Recent work indicates that difficulty in odor identification predicts the transition from normal to mildly impaired cognition [4], and from mildly impaired cognition to Alzheimer's disease, suggesting that tests of olfactory perception may be useful in identifying apparently healthy and cognitively intact individuals who are at increased risk of developing severe cognitive impairment. Other representative diseases associated with impaired olfaction and gustation are listed below.

### Medical conditions associated with taste or smell dysfunction

#### Neurological

- Alzheimer's disease
- Bell's palsy
- Damage to the chorda tympani
- Down's syndrome
- Epilepsy
- Familial dysautonomia
- Guillain-Barré syndrome
- Head trauma
- Korsakoff's syndrome
- Multiple sclerosis
- Parkinson's disease
- Raeder's paratrigenital syndrome
- Tumors and lesions

#### Nutritional

- Cancer
- Chronic renal failure
- Liver disease including cirrhosis
- Niacin deficiency
- Thermal burn
- Vitamin B<sub>12</sub> deficiency
- Zinc deficiency

#### Endocrine

- Adrenal cortical insufficiency
- Congenital adrenal hyperplasia
- Cretinism
- Cushing's syndrome
- Diabetes mellitus
- Hypothyroidism
- Kallmann's syndrome
- Panhypopituitarism
- Pseudohypoparathyroidism
- Turner's syndrome (gonadal dysgenesis)

#### Local

- Allergic rhinitis, atopy, and bronchial asthma

- Glossitis and other oral disorders

- Leprosy

- Oral aspects of Crohn's disease

- Radiation therapy

- Sinusitis and polyposis

- Xerostomic conditions including Sjögren's syndrome

- Viral infections

- Acute viral hepatitis

- HIV infections

- Influenza-like infections

- Other

- Amyloidosis and sarcoidosis

- Cystic fibrosis

- High altitude

- Hypertension

- Laryngectomy

- Psychiatric disorders

Adapted from Schiffman et al. [5] with permission © 2004 Humana Press Inc.

*Medication usage.* Taste alterations can be a common side effect of many medications. Medications typically do not produce total taste losses, but may produce metallic or bitter dysgeusias. Certain medications can be absorbed and then excreted in the saliva, where they can stimulate an adverse taste sensation or alter normal taste signal transduction. Other medications can diminish salivary output, decreasing the ability of tastant molecules to be dissolved and carried to the taste buds, or alter the composition of the olfactory mucus layer, modifying the absorption of odorants [6]. More than 250 medications are thought to interfere with smell and taste acuity, with selected medications listed below.

### Medications associated with taste or smell dysfunction

- Antianxiety agents

- Alprazolam (Xanax)

- Bupirone (BuSpar)

- Antibiotics

- Ampicillin

- Azithromycin (Zithromax)

- Ciprofloxacin (Cipro)

- Clarithromycin (Biaxon)

- Enalapril (Vaseretic)

- Griseofulvin (Grisactin)

- Metronidazole (Flagyl)

- Ofloxacin (Floxin)

- Terbinafine (Lamisil)

- Tetracycline

- Ticarcillin (Timentin)

- Anticonvulsants

- Carbamazepine (Tegretol)

- Phenytoin (Dilantin)

- Antidepressants

- Amitriptyline (Elavil)

Clomipramine (Anafranil)  
 Desipramine (Norpramin)  
 Doxepin (Sinequan)  
 Imipramine (Tofranil)  
 Nortriptyline (Pamelor)  
 Antihistamines and decongestants  
 Chlorpheniramine  
 Loratadine (Claritin)  
 Pseudoephedrine  
 Antihypertensives and cardiac medications  
 Acetazolamide (Diamox)  
 Amiloride (Midamor)  
 Amiodarone (Pacerone, Cordarone)  
 Betaxolol (Betoptic)  
 Captopril (Capoten)  
 Diltiazem (Cardizem)  
 Enalapril (Lexxel, Vasotec, Vaseretic)  
 Hydrochlorothiazide (Esidrix)  
 Nifedipine (Procardia)  
 Nitroglycerin  
 Propafenone (Rythmol)  
 Propranolol (Inderal)  
 Spironolactone (Aldactone)  
 Tocainide (Tonocard)  
 Anti-inflammatory agents  
 Auranofin (Ridaura)  
 Beclomethasone (Becloment, Beconase)  
 Budesonide (Rhinocort)  
 Colchicine  
 Dexamethasone (Decadron)  
 Flunisolide (Nasalide, AeroBid)  
 Fluticasone (Flonase)  
 Gold (Myochrysin)  
 Hydrocortisone  
 Penicillamine (Cuprimine)  
 Antimanic drugs  
 Lithium  
 Antimigraine agents  
 Dihydroergotamine (Migranal)  
 Naratriptan (Amerge)  
 Rizatriptan (Maxalt)  
 Sumatriptan (Imitrex)  
 Antineoplastics  
 Cisplatin (Platinol)  
 Doxorubicin (Adriamycin)  
 Levamisole (Ergamisol)  
 Methotrexate (Rheumatrex)  
 Vincristine (Oncovin)  
 Antiparkinsonian agents  
 Levodopa (Larodopa; with carbidopa: Sinemet)  
 ► **Antipsychotics**  
 Clozapine (Clozaril)  
 Trifluoperazine (Stelazine)  
 Antithyroid agents  
 Methimazole (Tapazole)  
 Propylthiouracil

Antiviral agents  
 Ganciclovir (Cytovene)  
 Interferon (Roferon-A)  
 Zalcitabine (HIVID)  
 Bronchodilators  
 Bitolterol (Tornalate)  
 Pirbuterol (Maxair)  
 Lipid-lowering agents  
 Atorvastatin (Lipitor)  
 Fluvastatin (Lescol)  
 Lovastatin (Mevacor)  
 Pravastatin (Pravachol)  
 Muscle relaxants  
 Baclofen (Lioresal)  
 Dantrolene (Dantrium)  
 Pancreatic enzyme preparations  
 Pancrelipase (Cotazym)  
 Smoking cessation aids  
 Nicotine (Nicotrol)

Adapted from Doty and Bromley [7] with permission © 2004 Elsevier Inc.

*Trauma/surgical interventions.* Olfactory sensory information is transmitted by a single nerve (► **cranial nerve I**) which can be severed by a sharp upward blow to the nose (e.g. during an automobile accident or severe fall) proximal to the location where the nerve passes through the ethmoid bone. Gustatory sensation is transmitted via three cranial nerves (VII, IX, X) and thus is more resistant to trauma-induced dysfunction. In fact, even if one taste nerve is damaged or severed during surgery of the middle-ear region, the remaining nerves appear to compensate for the resultant loss of taste in that area of the mouth, thereby preserving overall taste perception [3].

*Environmental factors.* Olfactory neurons are the receptors for odorant chemical signals and therefore are directly exposed to potential airborne environmental toxins; taste receptors are specialized cells and thus the taste neurons are protected from this type of direct exposure. As a result, the olfactory system is vulnerable to damage from chemical fumes or metallurgical dust from occupational, industrial, household, or ambient sources. Tobacco smoke-induced hyposmia has also been documented.

*Oral health and hygiene.* Poorly fitting dentures or other dentition problems that impair chewing and mouth movements during eating can negatively impact retronasal olfaction by reducing the volatilization and movement of odor molecules from the oral cavity to the olfactory epithelium. Dentures may also cover the taste buds located in the soft palate in the roof of the mouth.

## Consequences

Age-related losses of taste and smell perception can result in poor appetite, reduced energy and nutrient

intakes, and diminished eating enjoyment and motivation to eat. Consequently, chemosensory losses can lead to impaired nutritional status, reduced immune function, protein-energy malnutrition, involuntary weight loss, increased disease susceptibility or exacerbation of existing disease states, and overall decreased quality of life [6]. Poor taste and smell perception may lead to consumption of spoiled food and subsequently increased likelihood of food-borne illness. Taste and smell signals are important factors in meal initiation (via cephalic-phase stimulation of salivary, gastric, and pancreatic secretions; see ►[food anticipatory behavior](#)), continuation of food intake during a meal, and meal termination (via sensory-specific satiety). Taste and smell enhance enjoyment of meals and are the primary reinforcements of eating; maximal chemosensory acuity is thus especially important in elderly individuals for whom other sources of personal gratification may be infrequent.

The evidence for alterations of food intake as a result of olfactory or gustatory dysfunction alone is limited, however. Although chemosensory disturbances likely play an important role, other factors may also contribute to food intake dysregulation among older adults. Additional physiological factors, such as delayed gastric emptying and altered digestion-related hormone secretion and hormonal responsiveness, often act concurrently with chemosensory losses as well as with social, psychological, and medical factors to reduce food intake and promote weight loss in elderly adults.

Other consequences of taste and smell dysfunction include a decreased ability to detect natural gas leaks, volatile chemical fumes, and fires, which can result in increased risk for serious injury and death among elderly adults, their family members, and the general public. Elderly adults can have a heightened concern with personal hygiene and may overuse perfumes and colognes as a result of a lack of ability to detect offensive bodily or breath odors.

### Therapeutic Strategies

While specific medical or pharmacological causes of olfactory and/or gustatory dysfunction can be resolved via appropriate treatment or pharmacotherapeutic modifications, chemosensory dysfunction that results from more intractable causes such as increasing age or environmental damage may be more resistant to improvement. In these cases, therapeutic strategies have been developed that improve food palatability and food intake, but do not alter impaired chemosensory pathways directly.

One intervention that is commonly employed is the use of flavor enhancements. Naturally-derived or chemically-synthesized concentrated odorants and flavorings can be added to individual foods to amplify or supplement the sensory signals provided by these

foods. Flavor enhancement has been shown to increase the appeal of certain foods, attenuate decreases in energy intake, and improve immune status among elderly individuals [e.g. 8]. Many of these studies are limited by small sample sizes, short duration, and a lack of data regarding total dietary energy intake or nutritional status, and thus additional research is warranted. Olfactory declines tend to result in the predomination of ►[bitter tastes](#), but this bitterness can be masked with salt, sweet, or flavored (e.g. coffee, chocolate) extracts. Other flavor enhancements such as spices, herbs, salt, or other compounds (e.g. monosodium glutamate, concentrated meat flavor, etc.) can improve food palatability and increase dietary intake. Recent media reports examining the increasing availability and marketing of spicy and highly flavored foods in U.S. groceries and restaurants attribute this national trend to an aging population and a resultant demand for spicier foods to overcome age-related sensory declines.

Another commonly employed strategy is to alter patterns of dietary variety in order to decrease sensory specific satiety and increase food intake. A recent study examined potential associations between low dietary variety and low body mass index (BMI) and dietary energy intake in older adults. In contrast to some but not all previous reports suggesting that dietary variety typically decreases with age, adults 61 years of age or older were shown to consume a greater total food variety compared with adults 60 years or younger [9]. However, older adults with low BMIs (<22 kg/m<sup>2</sup>) consumed a lower variety of energy-dense foods and had a lower overall energy intake compared to older adults with higher BMIs [9]. Thus the results of this study suggest that consumption of a diet containing a high variety of energy dense foods may be associated with higher energy intake and greater body weight in older adults. Presentation of a variety of palatable foods with different textures, temperatures, and appearances can also promote increased intake even though the chemosensory characteristics of the foods are not altered. The order of foods eaten can also be rotated to stimulate intake and reduce sensory-specific satiety.

Zinc supplementation and hormone replacement therapy have been suggested as additional therapeutic methods for improving taste and smell function, respectively. Hormone replacement in healthy postmenopausal women does not appear to improve performance on olfactory detection, discrimination, or recognition tasks. A recent randomized, double-blind, placebo-controlled study examining zinc supplementation in older Europeans aged 70–87 years demonstrated that supplementation with 30 mg zinc per day resulted in increased salt taste acuity, but not sweet, sour, or bitter taste acuity, among subjects recruited in one of two geographical regions [10], suggesting the efficacy of this approach may be limited to individuals with poor



baseline zinc status or another trait common to those subjects examined in this region.

Audible and visual gas detection systems exist that will notify an individual of a natural gas leak; these systems are especially important for elderly individuals with olfactory losses who may be unable to detect the “rotten-egg” smell of mercaptan which is added to natural gas as a warning agent. Novel mechanisms for visually indicating the presence of food-borne pathogens, via sensors or temperature logs integrated within food packaging materials, are in development and may ultimately help older adults who cannot discriminate spoiled from wholesome food using taste or smell cues.

### Conclusion

An awareness of changes in taste and smell in association with increased age has existed for thousands of years – the Roman statesman Cicero (106–43 BC) stated that “I am grateful to old age because it has made me less interested in good food and more interested in good conversation.” Projected increases in both the size and average lifespan of the elderly population in the U.S. and worldwide will lead to an increased prevalence of chemosensory dysfunction, with a concomitant increase in the negative health consequences of these dysfunctions. Additional effective interventions that can maintain or improve chemosensory function in this vulnerable population are needed.

### References

- Lam BL, Lee DJ, Gómez-Marín O, Zheng DD, Caban AJ (2006) Concurrent visual and hearing impairment and risk of mortality. *Arch Ophthalmol* 124:95–101
- Hoffman HJ, Ishii EK, Macturk RH (1998) Age-related changes in the prevalence of smell/taste problems among the United States adult population. Results of the 1994 Disability Supplement to the National Health Interview Survey (NHIS). *Ann N Y Acad Sci* 855:716–722
- Duffy VB, Chapo AK (2006) Smell, taste, and somatosensation in the elderly. In: Chernoff R (ed) *Geriatric nutrition: the health professional’s handbook*. Jones and Bartlett Publishers, Sudbury, MA, pp 115–162
- Wilson RS, Schneider JA, Arnold SE, Tang Y, Boyle PA, Bennett DA (2007) Olfactory identification and incidence of mild cognitive impairment in older age. *Arch Gen Psychiatry* 64:802–808
- Schiffman SS, Rogers MO, Zervakis J (2004) Loss of taste, smell, and other senses with age: effects of medication. In: Bales CW, Ritchie CS (eds) *Handbook of clinical nutrition and aging*. Humana Press Inc., Totowa, NJ, pp 211–289
- Seiberling KA, Conley DB (2004) Aging and olfactory and taste function. *Otolaryngol Clin N Am* 37:1209–1228
- Doty RL, Bromley SM (2004) Effects of drugs on olfaction and taste. *Otolaryngol Clin N Am* 37:1229–1254
- Schiffman SS, Warwick ZS (1993) Effect of flavor enhancement of foods for the elderly on nutritional status: food intake, biochemical indices, and anthropometric measures. *Physiol Behav* 53:395–402
- Roberts SB, Hajduk CL, Howarth NC, Russell R, McCrory MA (2005) Dietary variety predicts low body mass index and inadequate macronutrient and micronutrient intakes in community-dwelling older adults. *J Gerontol A Biol Sci Med Sci* 60A:613–621
- Stewart-Knox BJ, Simpson EEA, Parr H et al (2008) Taste acuity in response to zinc supplementation in older Europeans. *Br J Nutr* 99:129–136

## Olfaction/Gustation Sensing Chemical Stimuli

PIERRE-MARIE LLEDO

Pasteur Institute, Laboratory for Perception and Memory, Paris Cedex, France

### Introduction

The ►sensory systems are the devices with which we perceive the external world, while sensory perception amounts to the deconstruction of this external world for subsequent reconstruction of the internal representation. Animals indeed discriminate and recognize numbers of physical and chemical signals in their environment, which profoundly influence their behavior and provide them with essential information for survival [1].

A number of sophisticated sensory ►modalities available for that purpose all rely on a specific ►coding, that is a set of rules by which information is transposed from one form to another. For the ►chemical senses, this transposition concerns the ways by which chemical information give rise to specific neuronal responses in a dedicated sensory organ [2]. ►Olfaction is applied to chemosensory systems that detect chemicals emanating from a distant source. In contrast, when chemical senses require physical contact with the source for detection, they are called ►gustatory.

The origin of chemical detection (also called ►chemosensation) dates back to prokaryotes and has evolved into four distinct modalities in most vertebrates [3]. As we shall see below, the ►main olfactory system, the ►accessory olfactory system, the gustatory system and the so-called ►common chemical sense mostly carried by ►trigeminal sensory ►neurons, all differ with respect to receptor molecules, ►receptor cells and wiring of the receptor cells with the central nervous system (CNS).

Unlike most animals, humans primarily rely on ►vision and ►audition. The relevance of these two senses for human life have driven intense research into

the elucidation of visual and auditory perception, leaving the understanding of the more primitive chemical senses behind. Nevertheless, during the last two decades, modern neuroscience has made considerable progress in understanding how the brain perceives, discriminates, and recognizes ►odorant molecules. This growing knowledge took over when the chemical senses were no longer considered only as a matter for poetry or the perfumes industry [4]. Over the last decades, chemical senses captured the attention of scientists who started to investigate the different stages of chemosensory systems. Distinct fields such as genetic, biochemistry, cellular biology, neurophysiology and ethology have contributed to provide a picture of how chemical information is processed in the olfactory and gustatory systems as it moves from the periphery to higher areas of the brain. So far, the combination of these approaches has been most effective at the cellular level but there are already signs, and even greater hope, that the same is gradually happening at the systems level. ►Taste and olfaction researches caught up with the advance in other sensory systems through dramatic developments achieved in a recent past. All these advances started with the discovery of the genes encoding the chemosensory receptors of the olfactory [5] and taste [6] systems. Then, further achievements were performed following the development of new experimental tools brought into play by geneticists and molecular biologists and subsequently used by the physiologists.

Although far from being complete, to date we have a fairly comprehensive view about how chemicals interact with their cognate receptors to initiate signal ►transduction in the sensory receptor cells [7]. We know now how the sensory information is first transduced in the olfactory and gustatory systems by specialized ►receptor neurons located in dedicated sensory organs. Among the different relays along the olfactory and gustatory pathways, local circuits in the second- and third-order brain areas then process the simple mono-phasic sensory signal conveyed by the sensory neurons [8] to convert it into a multi-dimensional code, including among others a ►combinatorial coding. We are now about understanding how chemical information is encoded and processed, but it is the challenge for the next decade to uncover how sensory information triggers specific behavioral outputs.

### Two Distinct Chemical Stimuli

According to the phylogenetic position of the species, a number of very different but sophisticated ways, based on distinct sensory channels, have risen in order to process information from the external world in subsequently reformatted internal states [8,9]. The following synopsis describes the contributions of our understanding of chemical sensory systems that

encompasses two intermingled senses: olfaction and taste. For the sake of clarity, these two modalities are presented separately, although they act, most often, in a concerted manner that gives rise to the so-called ►flavor [10,11]. Although chemical perception of a food or a flower arises from the central integration of multiple sensory inputs, it is possible to distinguish the different modalities contributing to it, especially when attention is drawn to particular sensory characteristics. Nevertheless, our experiences of the flavor or a fragrance are simultaneously of an overall unitary perception [11]. Research aimed at understanding the mechanisms behind this integrated chemical perception is, for the most part, relatively recent. However, ►psychophysical, neuroimaging and neurophysiological studies on cross-modal sensory interactions involved in olfaction and taste perception have started to provide an understanding of the integrated activity of sensory systems that generate such unitary perceptions, and hence the mechanisms by which these signals are functionally united when anatomically separated. Below I present the emerging picture that originates from the recent researches on ►odor and taste. The current model of chemosensory information processing supposes a particular combination of sensory inputs, ►temporal and ►spatial concurrence, and ►memory functions [12].

### The Sense of Smell

Mammalian olfactory system regulates a wide range of multiple and integrative functions such as physiological regulation, emotional responses (e.g., anxiety, fear, pleasure), reproductive functions (e.g., sexual and maternal behaviors) and social behaviors (►social chemosignals are involved in the recognition of conspecifics, family, clan or outsiders, for examples) [13]. To achieve this large variety of functions, two anatomically and functionally separate sensory organs are required. First, the ►vomeronasal organ is specialized to sense chemical compounds (e.g., ►pheromones), specific regarding the origin of the source. By transferring information through the ►accessory olfactory bulb, this sensory organ provides information about the social and sexual status of other individuals within the species. However, recent evidence also suggests some cross-talk between the main and accessory systems. Recent molecular and neurophysiological approaches have offered new insights into the mechanisms of pheromone detection in rodent and into the sensory coding of pheromone signals that lead to the gender discrimination or aggressive behavior, for example. They show that the vomeronasal organ does not have an exclusive function with regard to pheromone recognition but it responds also to molecules other than pheromones, at least in rodents. Thus, it is highly debated today, to what extent only the vomeronasal organ can detect

pheromones, and also to what extent it can only detect pheromones [14].

In mammals, the second sensory organ is represented by the ►**olfactory epithelium**, which recognizes more than a thousand airborne volatile molecules called odorant compounds (or odorants) [15]. This neuroepithelium is connected to the next central station for processing ►**olfactory information**: the main olfactory bulb (referred to below as the olfactory bulb). While advances in understanding olfactory transduction were taking place, interest in the olfactory bulb, was also intensified [15]. This growing interest has been spurred on by discovering the way the sensory organ connects to the olfactory bulb. Finally, several observations indicate that descending forebrain axons from various areas can selectively modulate olfactory bulb odorant-evoked responses. These data clearly show, at the very least, that olfaction processing does not involve simple feed-forward pathways. Rather, in real world situations where information has to be continually updated, olfactory responses that originate from the periphery are modulated by forebrain circuits and their projections to the olfactory bulb circuit.

### Evolutionary Dimensions of Olfaction

The main olfactory system detects only volatile odorants, whereas the accessory system picks up less volatile or even water-soluble odorants. It is generally thought that the accessory system specializes in pheromone detection, whereas the main system detects common odorants [2]. In terrestrial environments, chemical signals can be either volatile or non-volatile. Accordingly, terrestrial vertebrates have two functionally and anatomically distinct olfactory systems: one detecting volatile cues (the main olfactory system) and another thought to process mostly non-volatile signals (the ►**vomeronasal system**). Such a dichotomy has been brought into play to support the long-standing hypothesis according to which the vomeronasal system evolved as an adaptation to terrestrial life. Today, accumulated evidence rather contests this assumption. The evolution of a vomeronasal system in aquatic species might rather provide a selective advantage for terrestrial life, and consequently it could have been retained in many species of terrestrial vertebrates. In spite of this, anatomical studies, and most recently molecular studies indicate that the selective pressure to retain vomeronasal chemosensory input has been lost in higher primates. As a result, Old World primates, apes and humans might not have retained a functional vomeronasal system. Alternatively, species without a distinct vomeronasal system may still have an accessory olfactory system intermingled within the main system. Thus, it is yet possible that the accessory system did not “arise” at some point of the vertebrate evolution, but rather it just became anatomically separated from the main system [16].

As our knowledge about the neurobiology of olfaction is growing, it is becoming incredibly evident that the main olfactory systems of animals in disparate phyla have many striking features in common. For instance, vertebrate and insect olfactory systems display common organizational and functional characteristics [17]. Further recent works that were undertaken to broaden this scope to include nematodes, mollusks and crustaceans have only strengthened this assumption. The initial common event, shared by all odorant detection systems, requires the specific interaction of odorant molecules with specific receptors expressed on the cilia of sensory olfactory neurons before conveying information to central structures [18]. Basically, four features are shared by all olfactory systems. They include: (i) the presence of ►**odorant binding proteins** [19] in the fluid overlying the receptor cell dendrite; (ii) the requirement of ►**G-protein-coupled receptors (GPCRs)** [20] as ►**odorant receptors** ([5,21]; even though some sensory neurons may use transmembrane guanylate cyclase receptors such as in *C. elegans* and mammals); (iii) the use of a two-step signaling cascade in odorant transduction; and (iv) the presence of functional structures at the first central target in the ►**olfactory pathway**. All these characteristics may represent adaptations that have evolved independently, and therefore might provide us with valuable information about the way the nervous system processes odorant stimuli. Alternatively, these shared properties may instead reflect underlying homology, or could have arisen independently due to similar constraints.

Similarly, the perception of odorant molecules arises from invariant series of information-processing steps that occur in anatomically distinct structures. In mammals, the olfactory epithelium contains several thousands of bipolar olfactory sensory neurons, each projecting to one of several modules in the olfactory bulb. These discrete and spherical structures, called ►**olfactory glomeruli**, are both morphological and functional units made of distinctive bundles of neuropil. This term reflects both the homogeneity of the sensory inputs conveyed by the ►**olfactory nerve**, and the degree to which the neurons in the same glomerular unit are interconnected. In different species, each glomerular structure results from the convergence in the olfactory bulb of 5–40,000 axon terminals of sensory neurons that express the same odorant receptor. As each group of glomerulus-specific output neurons is odorant receptor-specific, they form a morphologically defined network somewhat analogous to ►**ocular-dominance columns** in ►**visual cortex** or to ►**barrels** in the ►**somatosensory cortex** [22]. It is also worth noting that a number of mechanisms have evolved to ensure that only a single odorant receptor is expressed per sensory cell. In rodents, tight transcriptional control results in the choice of one among a possible thousand odorant receptor genes. This

extremely large repertoire of odorant receptors is undergoing rapid evolution, with at least 20% of the genes lost to frame-shift mutations, deletions and point mutations that are the hallmarks of ►pseudogenes [3,4]. Facing a changing environment, this characteristic may reflect the pressure made on a gene family to diversify and generate large numbers of new receptors that might confer new selective advantages. Interestingly, approximately 50% of human odorant receptor genes carry one or more coding region disruptions and are therefore considered pseudogenes. This massive pseudogenization of the odorant receptors repertoire in humans and Old World primates is preceded by a moderately high level of pseudogenes (approximately 30%). Thus, there has been a decrease in the size of the intact odorant receptor repertoire in apes relative to other mammals, with a further deterioration of this repertoire in humans. Since such decline occurred concomitant with the evolution of full ►trichromatic vision in two separate primate lineages, it is possible that the weakening of olfaction results from the evolution of full ►color vision in our primate ancestors [23]. However, several overlooked human features such as the structure of the nasal cavity, retronasal smell, olfactory brain areas, and language call for reassessing the status of the sense of smell in human beings [24].

### From Odorant Molecules to Cortical Centers

The olfactory system is responsible for correctly coding sensory information from thousands of odorous stimuli. To accomplish this, odor information has to be processed throughout distinct levels. At each one, a modified representation of the odor stimulus is generated. To understand the logic of olfactory information processing, one has first to appreciate the coding rules generated at each level, from the odorant receptors up to the level of the ►olfactory cortex [25,26]. In mammals, the initial event of odor detection takes place at a peripheral olfactory system, the olfactory epithelium of the nasal cavity. There, olfactory transduction starts with the activation of some of the thousand different types of odorant receptors located on the cilia of sensory neurons that comprise the olfactory neuroepithelium. The sensory neurons project to a small number of olfactory glomeruli paired on both the medial and lateral aspects of the olfactory bulb. About 20–50 second-order neurons emanate for each glomerulus and project to a number of higher centers, including the olfactory cortex. Using a trans-synaptic tracer expressed in olfactory receptor neurons under the control of two specific olfactory receptor promoters, it was possible to demonstrate that the projection of bulbar output neurons receiving sensory inputs from homologous glomeruli, form reliable discrete clusters in different regions of the olfactory cortex. Such clusters can be partly overlapping, but clearly distinct between

odorants (a process called ►odor maps). A certain overlap between more diffuse projections to higher olfactory centers may constitute the anatomical basis for crosstalk between information strands emanating from different odorant receptors. This characteristic is probably helpful to integrate multiple modules of olfactory information into a composite ►gestalt, specific for a particular scent made of numerous chemical compounds.

### From the External World of Odorants to Internal States

Even in humans, during the first hours of life in the open air, the newborn child behaves like a macroscopic animal. Meanwhile, the human being is totally dominated by ►affect. During the rest of the development period and all of adult life, olfaction will remain the sense that opens the most direct route to the affective sphere [27].

To achieve this privileged relationship between olfaction and affect, the two olfactory systems connect different areas. The vomeronasal system mainly projects to the ►hypothalamus and ►amygdala that are known to control innate endocrine or behavioral responses. In contrast, in the main olfactory system, information is processed in cortical areas, which may give rise to the conscious representation of odorant molecules. In primates, the projections from the olfactory bulb reach medial olfactory areas including the ►piriform (►primary olfactory) ►cortex, ►entorhinal cortex, cortico-medial nucleus of the amygdala, and ►olfactory tubercle. From the ►piriform cortex (Primary olfactory cortex), projections reach ►area 13, a part of the caudal ►orbitofrontal cortex, and from there on to different orbitofrontal areas.

Odors are important in emotional processing; yet relatively little is known about the representation of the affective qualities of odors in the human brain. Recent results suggest that there is a ►hedonic map of the sense of smell in brain regions such as the orbitofrontal cortex [26,27]. These results have implications for understanding the psychiatric and related problems that follow damage to these brain areas. It is remarkable that amongst all the senses, olfaction possesses a particular link with the ►limbic system that was taken to be the “nose-brain” (the actual meaning of ►rhinencephalon). Today, it is clear that the primary olfactory cortex projects to the entorhinal area, which in turn projects to the ►hippocampus. Thus, we see reintroduced, after years of fervent affirmation followed by years of fervent denial, the idea that the hippocampus receives olfactory inputs. The pathway that links olfaction to the limbic system seems to be privileged. The path from the olfactory epithelium is more direct than the path from sensory surfaces such as the skin. Moreover, the primary olfactory cortex projects to the amygdala, in large part onto a particular cell group, the lateral nucleus

of the amygdala, by bypassing the neocortex. However, while it is clear that the olfactory bulb projects to the amygdala in rodents, one wonders whether such a connection is still present in humans. For instance, the vomeronasal organ and the corresponding region of the accessory ►**olfactory bulb** are thought to form an apparatus dedicated to the processing of sexually significant odors, but in the fully formed human body none of these structures has been identified.

Non-invasive functional imaging studies of the human olfactory system revealed that the sense of smell is organized similarly to other sensory modalities, and that the specific psychological characteristics of olfaction should be attributed to an early involvement of the limbic system rather than a conceptually different mode of processing. Taking into account the high connectivity of limbic structures and the fact that activation of the amygdala immediately induces ►**emotions** and facilitates the coding of memories, one should not be so surprised to uncover the special relationship that links olfaction with emotions and memory.

In sum, as a result of unprecedented developments in methods for examining the structure, function, and neurochemistry of olfactory system circuits, research in olfaction has progressed dramatically in recent years. Applying new technologies, including those of neurophysiology and functional imaging should help to unravel the mysteries of how chemical perception gives rise to unique olfactory experiences such as those triggered by the exquisite fragrance of jasmine.

### The Sense of Taste

The ►**gustatory sense** enables animals to detect and discriminate among foods, to select nutritious diets, and to initiate, sustain and terminate ingestion for the purpose of maintaining energy balance [11]. For most mammals, the decision to ingest a particular food depends not only on its taste but also on its appearance, familiarity, odor, texture, temperature and, importantly, its post-ingestive effects (for example, the ability to reduce hunger). For humans, such factors also include cultural acceptance as well as the social, emotional and cognitive contexts under which a given food is eaten. Revealing the logic of the neural mechanism of gustation is currently a major topic in modern neurobiology, given the efforts made so far towards the understanding of how complex feeding behaviors can become dysfunctional (as in the case of anorexia or obesity) [28].

In marked contrast to the olfactory system, the gustatory system has little discriminative power. Sapid stimuli come as five basic tastes, sweet, umami, bitter, salty and sour while the olfactory sensory organ recognizes about 10,000 airborne volatile molecules, in human beings. Taste stimuli are detected by assemblies of about 100 cells that form well-known

specialized morphological structures, the ►**taste buds**, which are located in the chemosensory papillae on the tongue. However, we know astonishingly little about the precise function of these small chemosensory organs. Their characterization has largely relied on cytological and ultrastructural data [29].

### The Peripheral Gustatory System

Although the sense of taste is generally associated solely with the activation of taste buds, placing food or drinks in the mouth automatically elicit responses from several distinct systems that monitor the temperature, the sound when chewing, and texture of the food. In this regard, gustation is inherently multisensory [30]. Every gourmet worth his/her salt is aware that the list of the five basic tastes should also include further perceptual categories such as astringent, fatty, tartness, water, metallic, starchy, cooling, tingling and pungent. The subjective sensations associated with these non-primary tastes result from the co-activation of taste and specialized somatosensory neurons located in the oral cavity. These specialized neurons surround taste buds, and include different classes of mechano- and chemoreceptors that transmit information on the food's texture, weight and temperature to the brain mainly via the ►**trigeminal system**.

### Transduction Pathways for Primary Tastes

In the oral chemosensory epithelia, taste buds contain about 50–100 ►**taste receptor cells (TRCs)** of various types. These TRCs are embedded in stratified epithelia and are distributed throughout the tongue, palate, epiglottis and esophagus. On their apical end, taste cells make contact with the oral cavity through a small opening in the epithelium called the taste pore, which is filled with microvilli. The plasma membranes of these microvilli contain many of the receptors responsible for detecting the presence of various tastants. Small clusters of TRCs are electrically and chemically coupled by ►**gap junctions** allowing their synchronous activation.

On the palate and the anterior tongue, TRCs are innervated by the ►**chorda tympani nerve** and greater superior petrosal branches of the ►**facial nerve**, respectively. These nerves transmit information about the identity and quantity of the chemical nature of the tastants. On the epiglottis, esophagus and posterior tongue, TRCs are innervated by the lingual branch of the ►**glossopharyngeal nerve** and the superior laryngeal branch of the ►**vagus nerve**. These nerves are responsive to tastants and participate primarily in the brainstem-based arch reflexes that mediate swallowing (ingestion) and gagging (rejection). TRCs transmit information to the peripheral nerves by releasing ►**ATP** to ►**P2X purinergic receptors** located on the postsynaptic membrane of primary afferents. Other transmitters

such as ▶serotonin, ▶glutamate and ▶acetylcholine might also be released.

The key to understanding how TRCs transduce chemical stimuli lies in determining the identification and operation of different types of taste receptor and their downstream signaling pathways. As for olfaction, proteins belonging to the G-protein-coupled receptor superfamily have been established as the receptors for sweet tastants (taste receptor, type 1, member 2 (T1R2)/T1R3), amino acids (T1R1/T1R3) and bitter (T2Rs) tastants. The sensations associated with the other two primary tastants, sour and salt (NaCl), are mediated by ion channels of the ▶transient receptor potential (TRP) and ▶epithelium sodium channel (ENaC) superfamilies, respectively.

### Taste Pathway

Receptor cell depolarization leads to the release of neurotransmitter, which generates first post-synaptic potentials and then action potentials in the associated nerve endings. The axons, whose cell bodies lie in the sensory ganglia of the cranial nerve, enter the medulla and synapse in the region of the ▶nucleus of the solitary tract (*N. tractus solitarii*). The nerve cells in this part of the medulla are important in mediating salivation and other gastrointestinal reflexes. Their axons also cross over, and relay via the contralateral ▶medial lemniscus, to the ▶thalamus, and thence to the post-central gyrus in the region of the ▶insula.

### Coding in the Periphery

Two schemes have been proposed to explain how taste processing is achieved through the interaction of TRCs with their associated afferent nerve fibers: the ▶“labeled line” model and the ▶“across-fiber pattern” (or “distributed”) model [11]. The assessment of experimental data supporting either of these hypotheses constitutes an important source of debate in the field of gustatory physiology. The ▶labeled line hypothesis (model) implies that sensory information is processed through segregated and feed-forward circuitry that connects peripheral sensory receptors to higher-order structures in the CNS. By contrast, across-fiber pattern models propose that sensory fibers (or neurons) are broadly tuned, in such a way that stimulus identity and intensity are specified by a unique combinatorial pattern of activity distributed across populations of neurons.

At the peripheral level one can find experimental support for both labeled line and across-fiber pattern models, but recent data from genetic studies strongly favor the existence of labeled lines. The validity of either model at the periphery should not necessarily be generalized to CNS circuits. In contrast to the periphery, the CNS possesses the anatomical structure required for ▶multisensory integration and this ability might determine a difference in coding strategies between the CNS and peripheral nervous system (PNS). In fact,

much of the current neurophysiological data describe gustatory processing as multisensory and distributed across several brain regions [31].

In contrast to the highly specialized information transfers performed by TRCs and peripheral fibers, central gustatory processing seems to be distributed, probably as a result of its capacity for ▶multimodal (multisensory) integration. Approaching the encoding of a gustatory stimulus in this manner will provide new insights into how information is encoded, beyond the theories that have been historically proposed to model the mechanisms by which taste quality is coded in the periphery. Indeed, how these sensory modalities are synthesized into a single percept, which allows animals to rapidly decide whether to ingest or reject a particular food, is the greatest challenge for the near future in gustatory physiology.

The growth of our knowledge in gustation has not yet reached the level of olfaction. Many fundamental problems in the emerging field of taste are still to be resolved. For example, what is the coding logic for multisensory integration? How is a taste percept generated from activation of labeled- or distributed-lines? Answers to these basic questions might help us understand how the brain makes sense of chemical compounds that we daily place in the mouth.

### Concluding Remarks

Smell and taste problems can have a big impact on our lives. Because these senses contribute substantially to our enjoyment of life, our desire to eat, and be social, smell and taste disorders can be serious. When smell and taste are impaired, we eat poorly, socialize less, and as a result, feel worse. Many older people experience this problem. But not only chemical signaling make us happier, smell and taste also warn us about dangers, such as fire, poisonous fumes, and spoiled food. Certain jobs require that these senses be accurate – chefs and firemen rely on taste and smell. Loss or reduction of the sense of smell (▶anosmia or ▶hyposmia) may be due to damage to the olfactory mucosa (e.g., in smoking) or to the olfactory bulbs or tracts. CNS disorders (e.g., some types of ▶epileptic seizures) can cause ▶parosmia (disturbed sense of smell). Like olfaction, the sense of taste is important in regulating appetite and to some degree, dietary intake. Loss or reduction of the ability to taste is termed ▶ageusia or ▶hypogeusia and is a widely distributed feature of ageing as more than 200,000 people visit a doctor with smell and taste disorders every years in the United States.

Strikingly, olfactory and gustatory systems are endowed with rejuvenating properties throughout life. Olfactory and taste cells are one of the few cell types of the nervous system to be continuously replaced when the sensory organs become old or damaged. Scientists are examining this phenomenon,

called adult ►neurogenesis [32], while studying ways to use this potential to replace other damaged nerve cells of the CNS.

Smell and taste have here been presented separately but one should keep in mind that about 75% of what we perceive as taste actually comes from smell. It is the odor molecules from food that give us most of our taste sensation as taste buds allow us to perceive only five flavors. Of all our senses, smell is our most primal. Animals need the sense of smell to survive. Although a blind rat might survive, a rat without its sense of smell can't mate or find food. For humans, the sense of smell communicates many of the pleasures in life—the aroma of a pot roast in the oven, fresh-cut hay, a rose garden. Although our sense of smell is our most primal, it is also very complex. To identify the smell of a rose, the brain analyzes simultaneously over 300 odor molecules. The aroma of a baking apple pie sends one message when someone is hungry and quite another when that person has just finished a six-course meal!

Although recent discoveries in the field of molecular biology raise the hope of a future understanding of the transduction and peripheral coding of odors and tastes, it seems that they imply a risk: to make us forget that in the other extreme of knowledge, that of maximal complexity, the evolution of cognitive sciences allows an epistemologically fruitful reformulation of information-processing problems. In the future, we have to try to find out to what extent higher-order processes interact with the sensory level in order to produce sufficiently reliable representations, as compared with what we know about vision and audition, for instance. After all, we should not forget what Sigmund Freud, addressing the members of the Vienna Psycho-analytical Society, said about olfaction: “*the organic sublimation of the sense of smell is a factor of civilization.*”

## References

- Finger T, Simon SA (2002) The Cell Biology of Lingual Epithelia. In: Finger T, Silver WL, Restrepo D (eds) The neurobiology of taste and smell. Vol 2. Wiley-Liss, New York, 12: 287–314
- Ache BW (1991) Phylogeny of smell and taste. In: Getchell TV, Bartoshuk LM, Doty RL, Snow JB (eds) Smell and taste in health and disease. Raven, New York pp 3–18
- Mombaerts P (2004) Genes and ligands for odorant, vomeronasal and taste receptors. *Nat Rev Neurosci* 5:263–278
- Mombaerts P (2004) Love at first smell – the 2004 Nobel Prize in physiology or medicine. *N Engl J Med* 351:2579–2580
- Buck L, Axel R (1991) A novel multigene family may encode odorant receptors: a molecular basis for odor recognition. *Cell* 65:175–187
- Margolske RF (2005) Sensory systems: taste perception. *Sci STKE* 290:tr20
- Ache BW (1994) Towards a common strategy for transducing olfactory information. *Semin Cell Biol* 5:55–63
- Dalton P, Doolittle N, Nagata H, Breslin PAS (2000) The merging of the senses: integration of subthreshold taste and smell. *Nat Neurosci* 3:431–432
- Olender T, Feldmesser E, Atarot T, Eisenstein M, Lancet D (2004) The olfactory receptor universe – from whole genome analysis to structure and evolution. *Genet Mol Res* 3:545–553
- Smith DV, St. John SJ (1999) Neural coding of gustatory information. *Curr Opin Neurobiol* 9:427–435
- Simon SA, de Araujo IE, Gutierrez R, Nicolelis MAL (2006) The neural mechanisms of gustation: a distributed processing code. *Nat Rev Neurosci* 7:890–901
- Algom D, Cain WS (1991) Chemosensory representation in perception and memory. In: Bolanowski SJ, Gescheider GA (eds) Ratio scaling of psychological magnitude. Hillsdale. Lawrence Erlbaum Associates, N.J., pp 183–198
- Dulac C, Torello AT (2003) Molecular detection of pheromone signals in mammals: from genes to behaviour. *Nat Rev Neurosci* 4:551–562
- Wysocki CJ, Preti G (2004) Facts, fallacies, fears, and frustrations with human pheromones. *Anat Rec* 281:1200–1210
- Lledo PM, Gheusi G, Vincent JD (2005) Information processing in the mammalian olfactory system. *Physiol Rev* 85:281–317
- Keverne EB (2004) Brain evolution, chemosensory processing, and behavior. *Nutr Rev* 62:S218–S223
- Hildebrand JG, Shepherd GM (1997) Mechanisms of olfactory discrimination: converging evidence for common principles across phyla. *Annu Rev Neurosci* 20:595–631
- Ache BW, Young JM (2005) Olfaction: diverse species, conserved principles. *Neuron* 48:417–430
- Tegoni M, Pelosi P, Vincent F, Spinelli S, Campanacci V, Grolli S, Ramoni R, Cambillau C (2000) Mammalian odorant binding proteins. *Biochim Biophys Acta* 1482:229–240
- Ronnett GV, Moon C (2002) G proteins and olfactory signal transduction. *Annu Rev Physiol* 64:189–222
- Buck LB (2004) Olfactory receptors and odor coding in mammals. *Nutr Rev* 62:S184–S188
- Johnson BA, Woo CC, Leon M (1998) Spatial coding of odorant features in the glomerular layer of the rat olfactory bulb. *J Comp Neurol* 393:457–471
- Gilad Y, Wiebe V, Przeworski M, Lancet D, Pääbo S (2004) Loss of olfactory receptor genes coincides with the acquisition of full trichromatic vision in primates. *PLoS Biol* 2:120–125
- Shepherd GM (2004) The human sense of smell: are we better than we think? *PLoS Biol* 2:572–575
- Malnic B, Hirono J, Sato T, Buck LB (1999) Combinatorial receptor codes for odors. *Cell* 96:713–723
- Rolls ET (2001) The rules of formation of the olfactory representations found in the orbitofrontal cortex olfactory areas in primates. *Chem Senses* 26:595–604
- Bensafi M, Rouby C, Farget V, Bertrand B, Vigouroux M, Holley A (2003) Perceptual, affective, and cognitive judgments of odors: pleasantness and handedness effects. *Brain Cogn* 51:270–275
- Scott K (2005) Taste recognition: food for thought. *Neuron* 48:455–464

29. Breslin PA, Huang L (2006) Human taste: peripheral anatomy, taste transduction, and coding. *Adv Otorhinolaryngol* 63:152–190
30. Rolls ET (2004) Convergence of sensory systems in the orbitofrontal cortex in primates and brain design for emotion. *Anat Rec* 281:1211–1224
31. Cytowic RE (2002) *Synesthesia: a union of the senses*. MIT, Cambridge
32. Lledo P-M, Grubb M, Alonso M (2006) Adult neurogenesis and functional plasticity in neuronal circuits. *Nat Neurosci Rev* 7:179–193

## Olfactometer

### Definition

A device for delivering odorant stimuli with controlled odorant concentrations and durations.

- ▶ Brain States and Olfaction

## Olfactory Acuity

- ▶ Olfactory Perception

## Olfactory Adaptation

### Definition

The decrease over time in the neural response to a continuous odorant presentation is known as olfactory adaptation.

- ▶ Glomerular Map
- ▶ Odorant

## Olfactory Amygdala

### Definition

Group of nuclei of the amygdaloid complex that receives olfactory information directly from the main

olfactory bulbs or indirectly from other amygdaloid nuclei.

- ▶ Evolution of the Amygdala: Tetrapods
- ▶ Olfactory Bulb

## Olfactory Aura

- ▶ Olfactory Hallucinations

## Olfactory Awareness

- ▶ Olfactory Perception

## Olfactory Binding Proteins

- ▶ Odorant-Binding Proteins

## Olfactory Bulb

MARCO SASSOÈ-POGNETTO

Department of Anatomy, Pharmacology and Forensic Medicine and National Institute of Neuroscience, University of Torino, Torino, Italy

### Synonyms

Main olfactory bulb, as opposed to “accessory olfactory bulb”

### Definition

The olfactory bulb is the first relay station in the olfactory pathway, situated at the rostral end of the brain. It receives sensory input from olfactory receptor neurons located in the nasal cavity and sends output fibers to a group of hemispheric regions collectively termed the olfactory cortex.



## Characteristics

The olfactory bulbs develop from the ventral surface of the cerebral hemispheres and in the large majority of vertebrates they represent the most rostral extension of the neural axis. In apes and humans, however, the olfactory bulbs lie on the ventral surface of the frontal lobes, just above the nasal cavities, from which they are separated by the cribriform plate of the ethmoid bone (Fig. 1).

The unmyelinated axons of the olfactory nerve pass through this bone and reach the olfactory bulb, where they terminate in spheroidal regions of neuropil called glomeruli. Head trauma can lesion the olfactory nerve fascicles as they traverse the cribriform plate, resulting in anosmia. The olfactory tract leaves the posterior pole of the olfactory bulb. It contains the output projections of the bulb as well as afferent fibers originating from a variety of brain regions.

In most vertebrate species, the olfactory bulb is organized according to the same basic plan and, as in other cortical regions, it shows a laminated structure, consisting of seven concentric layers (Fig. 2).

The principal (output) neurons of the bulb are the mitral and tufted cells (M/T cells), which can be divided into multiple subtypes based on position, dendritic morphology and axonal projection patterns. Mitral and tufted cells receive excitatory sensory inputs in the glomerular layer and send their axons to different regions of the olfactory cortex. Apart from this straight-through pathway, there are other neurons that act locally and make predominantly inhibitory connections with

the principal cells. Synaptic inhibition plays a crucial role in the processing of olfactory information before it is transmitted to the olfactory cortex (see below).

It should be noted that neuronal excitation in the olfactory bulb is mediated primarily by glutamate, whereas GABA is the principal inhibitory neurotransmitter. In addition, the olfactory bulb is rich in several other neuroactive substances, which likely exert a neuromodulatory function.

The circuit organization of the olfactory bulb can be conveniently separated into two distinct levels [2]. Sensory inputs from the ►**olfactory sensory neurons** are first processed within the glomeruli, where they are subject to amplification and attenuation. The second level of processing involves reciprocal interactions between the principal neurons and local interneurons, which provide GABAergic inhibition through dendro-dendritic synapses.

## Input Processing

Within the glomeruli, sensory axons make excitatory synaptic connections with the apical dendrites of the output neurons and a heterogeneous class of intrinsic neurons called periglomerular cells (►**periglomerular cell in olfactory bulb**) (PG) (Fig. 3).

In addition, PG cells are interconnected with M/T cells through dendro-dendritic synapses. Several types of dendro-dendritic synapses have been described, including excitatory synapses from M/T cells to PG cells, inhibitory synapses from PG cells to M/T cells, and synapses between distinct subtypes of PG cells. While there is no evidence for dendro-axonic synapses onto olfactory nerve axons, it has been shown that GABA and dopamine inhibit glutamate release from these axons by activating presynaptic receptors (GABA<sub>B</sub> receptors and dopamine D<sub>2</sub> receptors, respectively). It is likely that the paucity of glial barriers within the glomerular neuropil facilitates the diffusion of neurotransmitter and the occurrence of nonsynaptic interactions. The current model suggests that intraglomerular microcircuits contribute to regulate transmission from the olfactory nerve to M/T cells and thus serve as a gain control mechanism of incoming sensory signals.

A remarkable specificity exists in the projection pattern of olfactory receptor neurons to the glomeruli. First, each glomerulus is the site in which thousands of sensory axons converge on the dendrites of just ~20–50 relay neurons. A notable feature is that the axon of each sensory neuron terminates in only one glomerulus and, similarly, the apical dendrite of each principal neuron (mitral or tufted cell) arborizes into a single glomerulus. Second, all of the olfactory axons terminating in a glomerulus express the same odorant receptors (out of a repertoire of ~1,000 genes in rodents). Third, olfactory sensory neurons expressing a specific type of odorant receptor usually innervate two distinct glomeruli, which

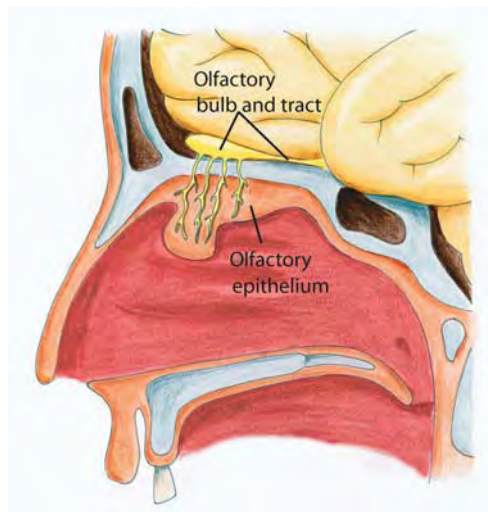

**Olfactory Bulb. Figure 1** The olfactory bulb is a small ovoid structure that lies on the cribriform plate of the ethmoid bone. It receives input from olfactory sensory neurons located in the nasal cavity and projects to the olfactory cortex through the olfactory tract. (Courtesy of Dr. Alessandro Ciccarelli.)

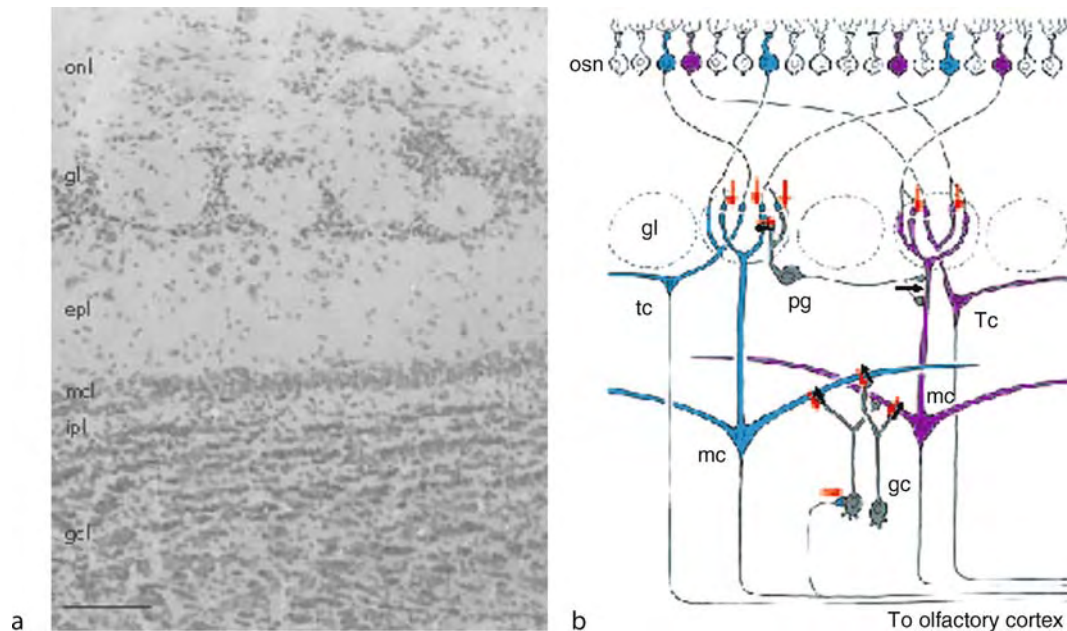

**Olfactory Bulb. Figure 2** (a) Coronal section of the rat olfactory bulb illustrating the laminar organization. The most superficial layer is the olfactory nerve layer (onl), which contains the axons of olfactory sensory neurons. Deep to the granule cells is a periventricular or subependymal layer (not visible in this micrograph), which contains migrating neuroblasts. gl: glomerular layer; epl: external plexiform layer; mcl: mitral cell layer; ipi: internal plexiform layer; gcl: granule cell layer. Scale bar: 100  $\mu$ m. (b) Circuit diagram summarizing the basic synaptic organization of the olfactory bulb. Two glomerular units are shown, each receiving input from olfactory sensory neurons (osn) expressing a given type of odorant receptor and connecting to a subset of mitral cells (mc) and tufted cells (tc). Periglomerular cells (pg) and granule cells (gc) mediate feedback and lateral inhibition of principal neurons through axo-dendritic and dendro-dendritic synapses. Red arrows indicate excitatory synapses, and black arrows indicate inhibitory synapses. (Adapted from [1]; courtesy of Dr. Alessandro Ciccarelli.)

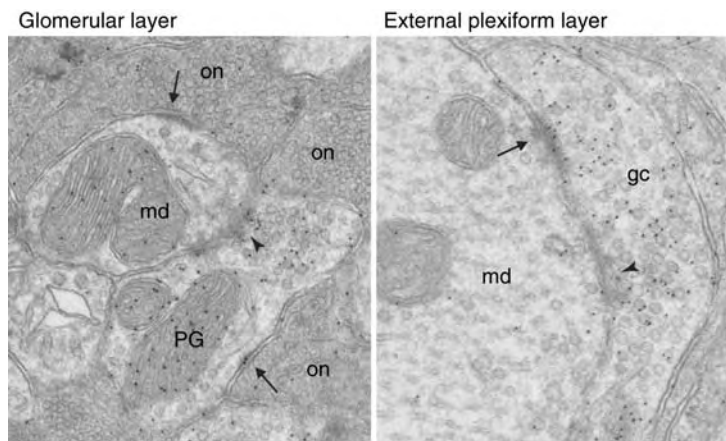

**Olfactory Bulb. Figure 3** Synaptic connections of the olfactory bulb as shown by electron microscopy after postembedding immunogold labeling with an antiserum against GABA (courtesy of Dr. Patrizia Panzanelli). Gold particles of 10 nm identify GABA-immunopositive structures. In the glomerular layer, olfactory nerve axons (on) make asymmetrical synapses (arrows) with two dendritic profiles. One dendrite is GABA-positive and therefore belongs to a periglomerular cell (pg). The other dendrite (md) likely belongs to a mitral/tufted cell. Note that the pg dendrite also makes a dendro-dendritic synapse (arrowhead) with the md profile. External plexiform layer. A reciprocal dendro-dendritic synapse between a mitral cell dendrite (md) and a granule cell spine (gc) is shown. Note that the granule cell spine is GABA-positive. The mitral-to-granule synapse (arrow) is asymmetrical, whereas the granule-to-mitral synapse (arrowhead) is symmetrical.

are bilaterally symmetrical and similarly located in the olfactory bulbs of different animals [3]. Therefore, a glomerulus can be defined as a convergence center for inputs originating from a given type of odorant receptor. This specificity implies that glomeruli represent basic functional units, analogous to cortical columns, and that different odors are represented by different patterns of spatial activity in such glomerular units [1] (see glomerular map).

### Inhibitory Control of Mitral/Tufted Cells

The second level of information processing in the olfactory bulb is based on reciprocal synapses between the principal neurons and the granule cells (Fig. 3). Granule cells are axonless neurons, whose cell bodies give rise to an apical dendrite that extends radially in the external plexiform layer [4]. The dendrites of granule cells are characterized by the presence of large spines (also called gemmules), that establish reciprocal synapses with the dendrites of M/T cells [5]. In these reciprocal connections, both sides of the synapse are dendrites capable of releasing neurotransmitter. The dendrites of M/T cells release glutamate and excite the spines of granule cells, which in turn release the inhibitory neurotransmitter GABA back onto the principal neurons (Fig. 2). As a result, activated M/T cells can inhibit themselves (feedback inhibition), as well as their neighbors (lateral inhibition).

There is compelling evidence that lateral inhibition is crucial in refining olfactory information, as it enhances the contrast between the activity of M/T cells connected to different glomerular units, and thus sharpens the tuning specificity of the output neurons to different odor molecules [1]. In other words, activation of M/T cells associated with one glomerulus results in inhibition of other glomerular units through the reciprocal dendrodendritic interactions. Therefore, the lateral inhibition mediated by granule cells enhances the contrast between strongly activated and faintly activated glomerular units and increases the specificity of individual M/T cells to odor molecules. Given that the basal dendrites of mitral cells have a projection field with a radius of about 1 mm, they potentially can influence the activity of glomerular units over long distances. This is consistent with experimental evidence that odor maps are widely distributed in the glomerular layer [6].

Lateral inhibition is also important for synchronizing the output responses of M/T cells connected to functionally related glomeruli. It has been known for a long time that stimulation with odor molecules elicits  $\gamma$ -frequency (30–80 Hz) oscillations of local field potentials, reflecting synchronized spike discharges of the principal neurons. This synchronization likely serves as a mechanism for temporal summation of signals from different glomerular units, and may play an

important role in odor discrimination [7]. Of particular interest is the possibility that plastic changes in the strength of dendro-dendritic synapses may represent one mechanism underlying olfactory learning.

### Other Neuronal Populations

In addition to PG cells and granule cells, there is a relatively small population of short-axon cells, which are distributed in the glomerular and granule cell layers. Recent studies suggest that interglomerular interactions mediated by short-axon cells represent a mechanism by which activated glomeruli can influence the activity of other glomerular units and contribute to enhance the spatial responses to odors [8]. In addition, one type of short-axon cell located in the granule cell layer provides GABAergic inhibition onto granule cells and therefore can control the strength of feedback and lateral inhibition onto the principal neurons [9].

### Centrifugal Afferents

The olfactory bulb receives a prominent innervation by centrifugal fibers from a variety of sites in the brain. The best characterized are cholinergic fibers arising from the basal forebrain and noradrenergic and serotonergic fibers arising, respectively, from the *locus coeruleus* and the mesencephalic raphe nucleus. These centrifugal afferents mediate a considerable degree of control over olfactory processing, which seems to be important for adapting olfactory function to different behavioral states. Of particular interest is the action of noradrenaline, which suppresses granule cell inhibition of M/T cells. Noradrenergic modulation of dendro-dendritic inhibition has been involved in some forms of olfactory learning.

### Parallel Processing of Olfactory Stimuli

As in other sensory systems, the olfactory bulb contains several parallel pathways for processing olfactory information. An obvious case is the accessory olfactory bulb, a structure present in most terrestrial vertebrates that receives sensory inputs from the vomeronasal organ. Within the main olfactory bulb, there is evidence for specialized glomerular units that process certain types of olfactory stimuli. For instance, the so called “modified glomerular complex” has been implicated in suckling behavior in neonatal animals. Mitral and tufted cells also appear give rise to parallel output pathways from the olfactory bulb. These neurons interact with different subpopulations of granule cells and project their axons to different cortical regions [10]. However, our understanding of how mitral and tufted cells process distinct aspects of olfactory information is still preliminary.

### Plasticity

The olfactory bulb is one of the few brain regions in which neurogenesis is maintained throughout life.

Bulbar interneurons are continuously replaced from a population of stem cells located in the subventricular zone of the lateral ventricle. Neuroblasts generated in this area migrate along the rostral migratory stream to the olfactory bulb, where they complete their differentiation into GABAergic neurons. Similarly, olfactory sensory neurons undergo continuous turnover during adult life. Remarkably, these neurons can reestablish functional synaptic connections with their target cells in the olfactory bulb. This degree of plasticity is unmatched in the brain and makes the olfactory bulb a unique model for studying the mechanisms of neural development and cell replacement.

## References

1. Mori K, Nagao H, Yoshihara Y (1999) The olfactory bulb: coding and processing of odor molecule information. *Science* 286:711–715
2. Shepherd GM (2004) Olfactory bulb. In: Shepherd GM (ed) *The synaptic organization of the brain*, 5th edn. Oxford University Press, New York, pp 165–216
3. Vassar R, Chao SK, Sitcheran R, Nuñez JM, Vosshall LB, Axel R (1994) Topographic organization of sensory projections to the olfactory bulb. *Cell* 79:981–991
4. Shepherd GM, Chen WR, Willhite D, Migliore M, Greer CA (2007) The olfactory granule cell: from classical enigma to central role in olfactory processing. *Brain Res Rev* 55:373–382
5. Price JL, Powell TPS (1970) The synaptology of the granule cells of the olfactory bulb. *J Cell Sci* 7:125–155
6. Leon M, Johnson BA (2003) Olfactory coding in the mammalian olfactory bulb. *Brain Res Rev* 42:23–32
7. Laurent G (2002) Olfactory network dynamics and the coding of multidimensional signals. *Nat Rev Neurosci* 3:884–895
8. Aungst JL, Heyward PM, Puche AC, Karnup SV, Hayar A, Szabo G, Shipley MT (2003) Center-surround inhibition among olfactory glomeruli. *Nature* 426:623–629
9. Pressler R, Strowbridge B (2006) Blanes cells mediate persistent feedforward inhibition onto granule cells in the olfactory bulb. *Neuron* 49:889–904
10. Zou Z, Horowitz LF, Montmayeur JP, Snapper S, Buck LB (2001) Genetic tracing reveals a stereotyped sensory map in the olfactory cortex. *Nature* 414:173–179

## Olfactory Bulb Glomerulus

### Definition

An olfactory glomerulus is a compartmentalized mass of neuropil in the glomerular layer of the olfactory bulb that contains synapses between olfactory sensory neuron axon terminals and dendrites of both projection neurons (mitral and tufted cell apical dendrites) and local periglomerular cell inhibitory interneurons.

Glomeruli also contain numerous dendrodendritic synapses between mitral or tufted cells and both periglomerular and so-called short-axon cells. A typical rodent olfactory glomerulus receives convergent projections only from sensory neurons expressing the same odorant receptor gene. At the neuronal circuit level, an individual glomerulus in the olfactory bulb may function as a molecular-feature detecting unit.

- ▶ Flavor
- ▶ Glomerular Map
- ▶ Olfactory Bulb
- ▶ Olfactory Bulb Mitral Cells
- ▶ Olfactory Sensory Neuron
- ▶ Periglomerular Cells in Olfactory Bulb

## Olfactory Bulb Granule Cells

### Definition

These are a large population of small GABAergic interneurons in the vertebrate olfactory bulb that do not receive sensory input directly. They form dendrodendritic reciprocal synapses with mitral cell lateral dendrites and also receive axodendritic synapses from mitral cell axon collaterals and centrifugal fibers. Most of their inputs are glutamatergic, but they also receive GABAergic inputs. Most olfactory bulb centrifugal inputs target the granule cells.

- ▶ Olfactory Bulb
- ▶ Olfactory Bulb Mitral Cells

## Olfactory Bulb Mitral Cells

### Definition

Glutamatergic projection neurons lying in the mitral cell layer of the olfactory bulb. They receive direct input from olfactory sensory neuron terminals in olfactory bulb glomeruli, and project directly to olfactory cortex. They also have multiple, complex interactions with olfactory bulb interneurons, both periglomerular cells and granule cells, through conventional and dendrodendritic synapses.

- ▶ Olfactory Bulb
- ▶ Olfactory Cortex
- ▶ Olfactory Sensory Neuron

## Olfactory Code

### ► Odor Coding

## Olfactory Coding

### ► Odor Coding

## Olfactory Cortex

GILLES SICARD  
Centre Européen des Sciences du Goût, Dijon, France

### Synonyms

Downstream neural structure of the olfactory bulb

### Definition

Referring to multiple structures receiving olfactory information and presenting the classical cyto-architecture of nervous cortex, “olfactory cortices” is a more correct definition of the topic of this article.

*Stock of knowledge.* Details of the ►primary cortical projections of the olfactory system indicate the diversity of the structures that are directly connected to the olfactory bulb neurons (Fig. 1).

### Characteristics

The graph is soon a divergence from the canonical hierarchical organization of a sensory pathway. The bulbar output is conveyed by the lateral olfactory tract. On the functional point of view, we do assume that a topographical representation of the olfactory stimulus based on the chemical features takes place in the glomerular layer of the olfactory bulb.

From the receptor level, the primary ►olfactory cortex is reached through two synapses only. The receptor neurons are connected to mitral and tufted cells in the olfactory bulb. These relay neurons feed the pyramidal cells of the cortex, a three-layered paleocortex. The primary olfactory projections are annexed to the ►limbic system, an associative area. This system plays a role in social and emotional processing and supports some of the mechanisms of the memory.

Two neurons, two synapses: It is noticeable that this short pathway bypasses the thalamus before displaying cortical representations of the stimulus. This peculiar arrangement differing from those observed in other sensorial modalities can be explained by the fact that olfactory modality got ahead the emergence of the thalamic structures in the phylogenesis. On a functional point of view, this also means that probably in the olfactory system the processes fulfilled by the thalamus are implemented in other structure(s), and logically, in the downstream structures (thus the olfactory bulb) and/or the structures described in the present chapter. It looks likely as both olfactory bulb and olfactory cortices receive modulating influences from diverse centers, including for instance the arousal or the satiety control systems.

Focusing on the functional properties of the olfactory cortices, they are considered both as the targets of relay neurons from the olfactory bulb and as the origin of neurons contacting neocortical associative territories such as the orbito-frontal cortex, the neocortical temporal cortex ... and even parts of the thalamus!

The ►primary olfactory cortex includes contiguous or dispersed structures in the medial aspect of the temporal lobe of the brain which homologous equivalents are not easy to identify among different species. In order to describe the functions of the olfactory cortex, we get information from different animal models, rat, mouse, rabbit or frog, including man. In the view of this complexity, the terminology itself can be misleading: For instance the anterior olfactory nucleus which is funded by the fibers of the lateral olfactory tract, is a true cortex, characterized by the presence of pyramidal neurons. For those reasons, we have limited the description to the main structures: the anterior olfactory nucleus, the piriform cortex, the olfactory part of the amygdala and the entorhinal cortex. A ►secondary olfactory cortical area taking information from ►primary olfactory cortices, the orbito-frontal cortex will be also envisaged in the article.

With the olfactory cortex processing, important integrations of the olfactory signal follows the first sharpening of the information captured from the chemical environment by the receptor organ. If in the olfactory bulb the chemical nature of the stimulus is decomposed (de-constructed representation of odorants), in the olfactory cortex several tasks of reconstruction (re-constructed representation) take place, add memorized information and finally these levels of processing tend to confer a “meaning” to the actual olfactory message.

### Primary Cortical Projections

*Anterior olfactory nucleus.* Natural odorants are mixtures of chemicals. To imagine the integrative processes of the neurons, one can test how the neurons are responding to chemical mixtures and to their isolated components. While bulbar neurons show a

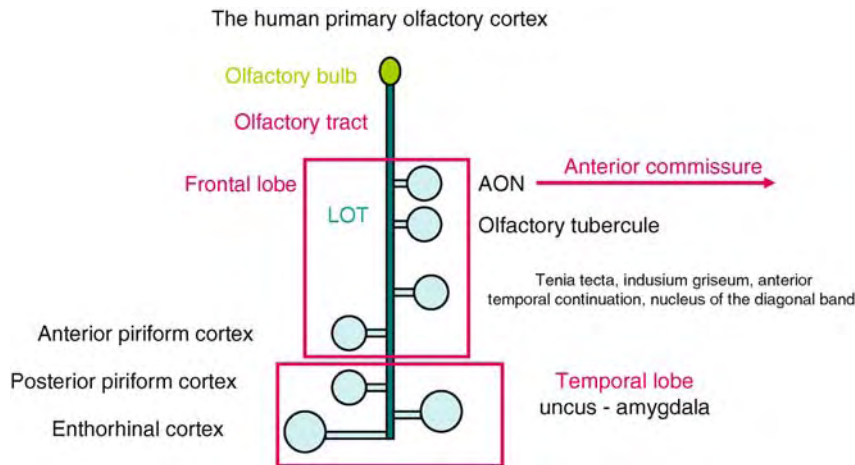

**Olfactory Cortex. Figure 1** The human primary olfactory cortex: The hierarchical representation of the olfactory pathway describes a multi-unit network: The olfactory tract is constituted of the mitral and tufted-neuron axons, the relay neurons directly connected to the receptor neurons from the olfactory receptor organ in the olfactory bulb. By this pathway a number of cortical structures receive direct sensory inputs. They are distributed in different parts – frontal temporal – of the cerebral cortex. These primary cortical elements are largely interconnected and receive modulations from different higher centers (arousal, satiety...). The first part, anterior olfactory nucleus and piriform cortex are concerned by sharpening of the sensory message. The other units are involved in control of emotional responses, behavioral responses to odorant stimulations and in olfactory learning.

sparse responsiveness they show high selectivity and they often respond to only one of the components in a mixture. In the anterior olfactory nucleus, the majority of neurons can respond to mixture of dissimilar chemicals and to their isolated components. In addition, the responses to the mixture exceed the simple sum of the responses to each of its components [1]. These properties point out a first kind of integrative process that the neuronal populations of ▶primary cortical olfactory level are able to realize: This is a simple sharpening of the sensory input message.

*Piriform cortex.* Extensively connected with higher-order cortical areas, the piriform cortex received also direct afferences from the olfactory bulb. The receptor fields of its neurons have been characterized by neuronal tracing, giving a spatial idea of the coding of the odorant stimuli [2] while electrophysiological recording of the neuronal responses to odorants gave a functional view [3]. As a ▶primary cortex, it could take part to the extraction of specific features from the olfactory message, thus used the combinatorial analytic representation of the sensory signal provided by the olfactory bulb. At this level, some neurons require particular combinations of chemicals to respond, thus suggest a combination of signals from distinct samples of bulbar neurons [4]: The cortex plays a role in discrimination of odorant signals. Nevertheless, at this early level, some modulations of the neuronal responses in behaving rats by non olfactory information (reward, expectation) were found, adding associative functions to its competences. In that sense, this “▶primary” cortex differs from

primary cortices (▶primary, secondary cortices) of the other sensorial modalities, which are rather dedicated to sharpen the input message. The olfactory piriform cortex must be regarded as a piece of olfactory learning and memory [5] It is of great importance to note that the receptive fields of the neurons in this cortex change with the experience: This property is indicative of upper-stream associative areas in the other sensorial modalities.

According to neuronal tracing, the partial overlapping of the projections from different receptor channels in the piriform cortex suggests that the cortex is able to merge different elements of the peripheral signal. In the anterior olfactory nucleus or in anterior piriform cortex, the selectivity of neurons to diverse chemical or perceptual categories appears to be broader than that of the bulbar relay neurons. This is true assuming that, due to the functional convergence of receptor neurons on bulbar glomeruli, the output neurons, mitral and tufted cells, have relatively narrow ▶selectivity profiles. (We must notice some discrepancy about the chemical selectivity of the bulbar neurons reported in different studies). Nevertheless, the complex selectivity profiles of the cortical output neurons means that these neurons integrate several odorant features.

*Odorant quality coding in the olfactory piriform cortex.* Tracing the projections area of the output bulbar neurons, it is possible to discriminate an anterior part and a posterior part of the piriform cortex [2]. This is confirmed by functional observations of the spatial organization of the responses to hedonic contrasted chemical stimuli in human [6]. While the

anterior part seems to encode the chemical features, the posterior part could discriminate stimuli along a qualitative dimension, i.e. their odor. Following the partial functional convergence shown by the bulbo-cortical relationships, the anterior piriform Cortex could reconstruct the complex environmental stimuli that have been decomposed by the topographic arrangements of the bulbar projections of the hundreds of specific olfactory receptors. The mechanisms or the rules of this reconstruction are not known. In this debate, the representation suggested by the topographical combinatorial theory plays a central role. However, one must notice that several studies on electrophysiological reports confirms that the selectivity of the bulbar neurons is scarce, but indicate that these neurons convey activations elicited by very different chemical structures [3,4]. The integration of this information on the discrimination processing by the cortical neuronal population must be further examined.

*Contributions of olfactory cortices to behavioral controls.* Several other olfactory cortices, recruiting even a larger amount of influences, are also directly connected to the olfactory bulb.

The amygdala is in fact a series of nucleus, receiving inputs from multiple ascending sensory pathways, including olfactory, gustatory, visual, auditory and visceral information, more or less directly from the sensory organ, thus after more or less stages of treatment. Here again the afferent olfactory pathway is the shortest. Extending influences on the hypothalamus, the medulla or the spinal chord, the amygdala is implicated in the modulation of the visceral functions in relation with emotional status. By its connections with the nearest olfactory structures in the rostral temporal lobe, it modulates their activity according to the mood or the emotional life of the animal.

Different implications of the olfactory amygdala on animal behavior have been investigated. In fact the different cortical olfactory structures, including amygdala, entorhinal cortex, perirhinal cortex are interconnected: Consequently, the exerted controls supported by olfactory cues are the effects of a network of specialized structures.

Fear olfactory conditioning or olfactory conditioned food or beverage aversion are examples that can give an idea of the functions of these networks.

Differential implication of these area has been shown in their contribution to olfactory and contextual fear conditioning. The amygdala participates in the acquisition and the expression of fear conditioned to both an olfactory conditioned stimulus and to the training context. The perirhinal cortex participates to olfactory, but not contextual, fear conditioning. In addition, the perirhinal cortex seems to play a prominent role in recognition of the conditioned stimuli [7].

Another behavioral register is intensively explore: the ►odor conditioned aversion. Several parts of the

primary olfactory cortex are implicated in its mechanisms. For instance, the effects of lesions of the entorhinal cortex are coherent with a role of this cortex in conditioned odor-aversion learning. A subdivision of this cortex as indicated by the heterogeneity of its connections is confirmed by functional arguments. The lateral part only is involved in the control of the olfactory memory trace during the conditioned olfactory aversion process. In addition the data are consistent with the idea that the lateral part represent the input of the structure while the medial part represent the output to hippocampus [8]. Here again, an olfactory cortex network is implicated. Interestingly, it has been shown that electrophysiological stimulations of the lateral entorhinal cortex is able to inhibit the olfactory input from the amygdala.

*Integration.* The primary olfactory cortex is of course inserted in a larger cerebral network and is a target for numerous modulating impacts. For instance, in the rat, 800 neurons from the anterior hypothalamus are secreting the peptide ►GnRH. Influence of these neurons on primary cortical structures of the olfactory system: Some neurons of the anterior olfactory nucleus, anterior and posterior piriform cortex, anterior cortical amygdaloidal nucleus and the lateral entorhinal cortex as it is shown by anterograde barley lectin labeling receive projection of the hypothalamic GnRH neurons [9]. This particular pathway illustrates one of the nervous supports of the integration of the olfactory sensitivity in the physiology and behavior. Odors signals or pheromones could have effects on the neuroendocrine status but in return, mediated by cerebral feed-back loops under the influence of sexual or reproductive hormones, other parts of the brain could modulate the olfactory abilities.

### Secondary Cortical Areas

Axons of neurons from the primary cortical areas reached a number of others brain structures. Focusing on the olfactory sense, the orbito-frontal cortex and temporo-lateral neocortical structures are the most extensively studied. At this level, it is a neocortex that receives and processes the olfactory information.

As a main property, the *olfactory orbito-frontal cortex* receives afferent axons from several other sensorial sources. Among the other important influences, the cortex receives information from the gustatory pathway and had been explored as a centre related to feeding behavior and food choice. As seen using brain imagery, the orbito-frontal cortex is consistently activated by olfactory stimuli [10] and is sensitive to context. These are functional characteristics of a secondary cortex (primary, secondary cortices). Moreover, in this cortex, we find converging fibers from multiple sensory areas, i.e. the primary somatosensory cortex, the primary taste cortex (frontal operculum), the inferior temporal visual cortex, the striatum, the amygdala and the olfactory piriform

cortex. Additional fibers from ►[hunger neurons](#) confer to this area a central role in the food-related evaluation of odor and taste. Some neurons of this cortex are responsive to odor and taste for instance. Some of them decrease their response to food eaten to satiety.

This last remark illustrates an important view of the sensory physiology: The multimodality appears as an ultimate refinement of the environment representation. In the orbito-frontal cortex, representations of taste and other mouth feels, smell sight are converging. This is why the representation of food stimuli, and finally appetite, are modulated by sensory-specific controls, involving olfactory cues.

## References

1. Lei H, Mooney R, Katz LC (2006) Synaptic integration of olfactory information in mouse anterior olfactory nucleus. *J Neurosci* 26:12023–12032
2. Zou Z, Li F, Buck LB (2005) Odor maps in the olfactory cortex. *Proc Natl Acad Sci* 102:7724–7729
3. Davidson IG, Katz LC (2007) Sparse and selective odor coding by mitral/tufted neurons in the main olfactory bulb. *J Neurosci* 27:2091–2101
4. Zou Z, Buck LB (2006) Combinatorial effects of odorant mixes in olfactory cortex. *Science* 331:1477–1481
5. Ross RS, Eichenbaum H (2006) Dynamics of hippocampal and cortical activation during consolidation of a nonspatial memory. *J Neurosci* 26:4852–4859
6. Gottfried JA, Winston JS, Dolan RJ (2006) Dissociable codes of odor quality and odorant structure in human piriform cortex. *Neuron* 49:467–479
7. Otto T, Cousens G, Herzog C (2000) Behavioral and neuropsychological foundations of olfactory fear conditioning. *Behav Brain Res* 110:119–128
8. Ferry B, Ferreira G, Traissard N, Majchzak M (2006) Selective involvement of the lateral entorhinal cortex in the control of the olfactory memory trace during conditioned odor aversion in the rat. *Behav Neurosci* 120:1180–1186
9. Boehm U, Zou Z, Buck LB (2005) Feedback loops link odor and pheromone signaling with reproduction. *Cell* 123:683–695
10. Zatorre RJ, Jones-Gotman M, Evans AC, Meyer E (1992) Functional localization and lateralization of human olfactory cortex. *Nature* 360:339–340

## Olfactory Cortex – Piriform Cortex

ALFREDO FONTANINI

Department of Neurobiology and Behavior, State University of New York at Stony Brook, Stony Brook, NY, USA

## Synonyms

Piriform cortex; Pyriform cortex; Prepyriform cortex

## Definition

At a very general level the term “olfactory cortex” can be used for all those areas in the rostro-ventral portion of the forebrain which receive direct projections from the olfactory bulb. These areas are: the anterior olfactory nucleus (also called anterior olfactory cortex), the olfactory tubercle, the ►[piriform cortex](#), the entorhinal cortex, the insular cortex and the amygdala [1]. More specifically, however, the term has been – and will be, in the context of this entry – used in reference to the piriform cortex, by far the largest cortical area primarily involved in perception and learning of olfactory stimuli.

## Characteristics

### Introduction

The piriform cortex, also referred to as paleocortex for its old phylogeny, has an evolutionarily well-conserved cellular and synaptic organization [2]. Differently from the neocortex, which appeared more recently in evolution and has a complex multilayered architecture [3], the olfactory cortex is organized in a simpler and experimentally more tractable three layered architecture. Despite this different organization, however, the olfactory cortex and neocortical sensory areas share many functional properties [4]. The study of the olfactory cortex offers, therefore, the unique opportunity to understand how general properties of cortical organization and functioning can be produced by simpler and phylogenetically older structures. As such, a deep understanding of the olfactory cortex will not only help us in the study of olfaction, but also likely advance our knowledge of the general functional organization of the cerebral cortex [4].

### Cytoarchitecture

The olfactory cortex is vertically organized into three layers, each characterized by a different composition of cell types and axonal fibers which spread horizontally [1]. Layer I, the most superficial, is a low cell-density layer composed, in its most superficial part (Ia), by afferent sensory fibers horizontally organized and coming from the olfactory bulb through the lateral olfactory tract (LOT), and in its deeper portion (Ib) by cortico-cortical (associative) horizontal axons coming from other parts of the olfactory cortex and other olfactory areas. Afferent and associative fibers contact the apical dendrites of excitatory neurons located in layer II and III and dendrites of inhibitory interneurons. The next layer, layer II, is composed by densely packed somata of excitatory (pyramidal and semilunar) and inhibitory (stellate and bipolar) cells. Finally, layer III shows a gradual decline in cell density with increasing distance from layer II, and contains somata and dendrites of deep pyramidal neurons, multipolar interneurons, basal dendrites of layer II pyramidal cells and cortico-cortical associative fibers.



As in the case of neocortex, the circuit of the olfactory cortex is organized around principal excitatory neurons. The different subtypes of excitatory neurons, which are characterized by distinct functional properties, are all embedded in the same, apparently stereotyped, circuit (Fig. 1a) [1]: pyramidal and semilunar neurons receive feed-forward excitatory input from mitral cells in the olfactory bulb and recurrent associative excitatory inputs from other principal neurons within the olfactory cortex, in turn, they send their outputs within the olfactory cortex itself and to other cortical areas

(entorhinal and perirhinal cortices, hippocampus, amygdala and orbitofrontal cortex among them [1]).

Principal neurons are also embedded into two inhibitory circuits (Fig. 1b) [1]: one of which is based on a feedforward input from inhibitory cells in layer I directly activated by afferents from the bulb, the second is a feedback inhibitory loop carried by inhibitory interneurons in layer Ib and III which are activated by associative recurrent fibers from pyramidal cells. Bipolar interneurons, which receive both afferent and associative inputs can take part to both circuits. This

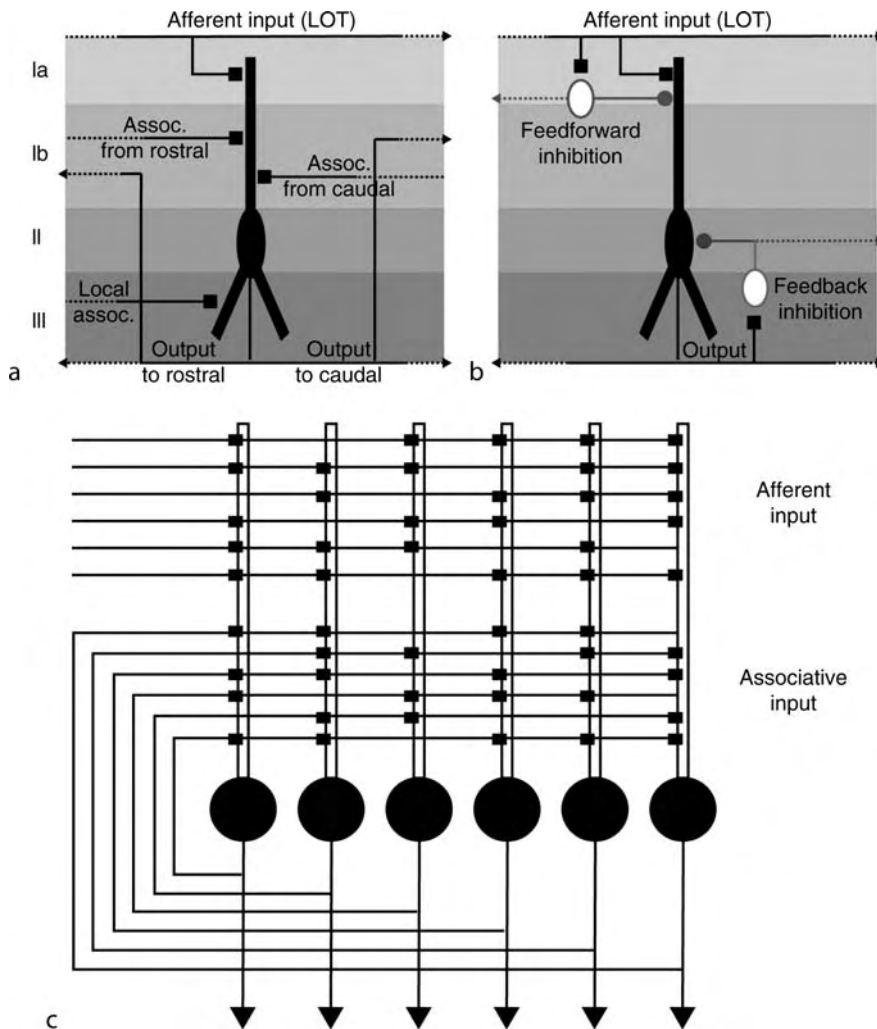

**Olfactory Cortex – Piriform Cortex. Figure 1** Architecture of the olfactory cortex and of an autoassociative network. (a) Excitatory inputs and outputs of a pyramidal neuron. All fibers are organized vertically and segregated in different layers. Afferent inputs come from the LOT, associative inputs can come from distant or be local. Black squares represent excitatory synaptic contacts, lines with arrows represent the outputs of the circuit or, in case of the LOT, the signal propagating caudally. (b) Simplified inhibitory circuit impinging on pyramidal neurons. White circles are feedforward and feedback inhibitory interneurons; grey circles represent inhibitory contacts. (c) Schematic of an autoassociative network: synaptic contacts from afferent and associative inputs are represented as black squares contacting the neural units. (a) and (b) modified from [1].

structure, which is the foundation of the olfactory cortex basic electrophysiological behavior, is however far from rigid and immutable. Previous patterns of activity, sensory experience, as well as neuromodulators play a major role in inducing synaptic plasticity at different sites, shaping this architecture and resulting in different functional configurations [5].

### Functional Organization

The characteristic extension of the associative system, and the suggestion that afferent inputs might be diffuse and without major topographical organization lead to the formulation of the most influential functional view of the olfactory cortex to date [5,6]. According to this view, the olfactory cortex can be seen as a biological analogue of a typical autoassociative artificial neural network. These types of artificial neural networks, characterized by neural units (or nodes) receiving sparse external inputs and also recurrent autoassociative inputs coming from the nodes themselves (Fig. 1c), are ideally suited for performing tasks analogous to those thought to be performed by the olfactory cortex: they can detect and discriminate complex mixtures of odors, reconstruct known mixtures on the basis of some of its components and dynamically switch between processing, storing and recalling of inputs and memories. Learning and dynamics are ensured, in this artificial network as well as in the olfactory cortex, by plasticity and neuromodulation of afferent and associative synapses [5].

This functional view of the olfactory system has been recently challenged by new results coming from genetic tracing and showing that the organization of the cortex is not as homogeneous as previously believed, but rather individual odors are processed by spatially organized quasi-specific subsets of neurons (Fig. 2) [7].

These results have given strength to a different view of the cortex, according to which odors are represented by the feedforward activation of specific sets of

partially overlapping neural populations (labeled lines) and that complex mixtures are coded – and learned – by patterns of coactivation of the subset of neurons receiving convergent inputs.

In reality these two views, the distributed/associative versus the labeled-line/feedforward, can be integrated in several ways. The olfactory cortex is divided into an anterior part and a posterior part [1]: the anterior olfactory cortex is principally driven by afferent bulbar inputs which are functionally organized into large (and to some degree also overlapping) patches; the posterior part, on the other hand, is less driven by afferent inputs and they are organized in a more distributed fashion. Taking this evidence into account it is possible to imagine that the organization of each of the two subdivisions could be biased toward one or the other coding scheme. Additionally, and more importantly, while genetic tracing shows that specific cells code for a specific odor, the degree of convergence seen in the cortex for inputs carrying information for different odors is remarkable and compatible with the model of an autoassociative network. Therefore some of the properties of the autoassociative framework, like the importance of associative fibers, the complex temporal evolution of processing due to cortico-cortical associative connections and the ability to dynamically switch between different network configurations, can be incorporated in the feedforward theory to add complexity, flexibility and ecological realism. Recent work employing simultaneous recordings from multiple neurons in the olfactory cortex has shown that odors activate spatially scattered populations of neurons, which are only partially non-overlapping, and that the patterns of activity become more complex and overlapping as the time course of the response evolves [8]. These results provide support to the fact that the simple labeled line feedforward processing scheme needs to be integrated into a more complex distributed coding paradigm.

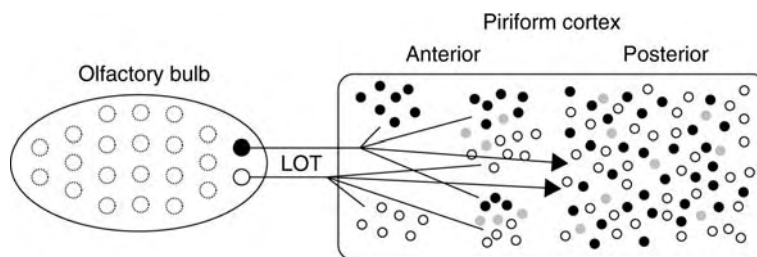

**Olfactory Cortex – Piriform Cortex. Figure 2** Topographical organization of bulbar inputs to the olfactory cortex. Outputs from different glomeruli project to partially overlapping but overall spatially distinct patches of neurons in the anterior olfactory cortex. Projections to the posterior cortex are more distributed. Black and white circles in the piriform cortex represent cells activated by distinct glomeruli, grey circles are cells receiving convergent inputs. Modified from [7].

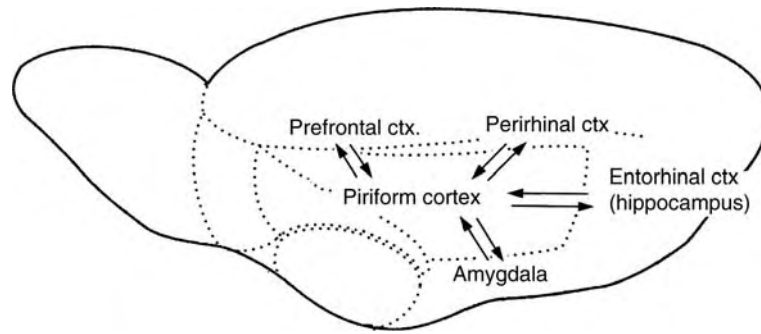

**Olfactory Cortex – Piriform Cortex. Figure 3** Bidirectional connections between the piriform cortex and other high order cortical areas. Modified from [1].

### Macroscopic Dynamics

Regardless of the coding scheme, electrophysiological recordings from the olfactory cortex of animals engaged in purposeful behaviors have revealed an even more complex picture: odor processing is inherently dependent on the behavioral and environmental context. Pioneering work from Walter Freeman [see for a review 9], for instance, has shown that the olfactory cortex produces different patterns of activity depending on the physiological and cognitive state of the animal: odors presented to hungry or thirsty cats, for instance, produce oscillatory activity larger than the one evoked by the same stimuli presented to satiated animals. These and other more recent observations imply that olfactory coding mechanisms are constantly modulated by dynamic activity from other brain areas involved in different cognitive states [10]. The anatomy is consistent with this view, as the olfactory cortex receives direct or indirect inputs from high order brain areas, such as the hippocampus, entorhinal cortex, orbitofrontal cortex, amygdala and hypothalamus; additionally several brain-stem neuromodulatory nuclei provide noradrenergic, cholinergic, serotonergic and dopaminergic modulation [1]. These projections are the anatomical substrate through which emotional states (sustained by amygdala), memories (hippocampus), expectations (amygdala and orbitofrontal cortex), hunger and thirst (hypothalamus) and arousal levels (neuromodulatory nuclei) could influence patterns of spontaneous and odor-evoked olfactory cortex activity (Fig. 3).

### Summary

The olfactory cortex is the largest area devoted to processing of olfactory information. It shares many functional properties with other sensory areas, but it has the advantage of a relatively simpler organization. The enhanced experimental and conceptual tractability deriving from this simpler organization has favored the use of the piriform cortex as a study model for complex issues such as sensory coding and behavioral

modulation of sensory responses. Future studies of the olfactory cortex will therefore help us understand not only olfaction, but also fundamental functional properties of sensory systems in general.

### References

1. Neville KR, Haberly LB (2004) Olfactory cortex, In: Shepherd GM (eds), *The synaptic organization of the brain*. Oxford University Press, New York, pp 415–454
2. Haberly LB (1990) Comparative aspects of olfactory cortex, In: Jones EG, Peters A (eds) *Comparative structure and evolution of cerebral cortex*. Cerebral cortex. Plenum, New York, pp 137–166
3. Aboitiz F, Morales D, Montiel J (2003) The evolutionary origin of the mammalian isocortex: towards an integrated developmental and functional approach. *Behav Brain Sci* 26:535–552; discussion 552–585
4. Fontanini A, Bower JM (2006) Slow-waves in the olfactory system: an olfactory perspective on cortical rhythms. *Trends Neurosci* 29:429–437
5. Linster C, Hasselmo ME (2001) Neuromodulation and the functional dynamics of piriform cortex. *Chem Senses* 26:585–594
6. Haberly LB, Bower JM (1989) Olfactory cortex: model circuit for study of associative memory? *Trends Neurosci* 12:258–264
7. Zou Z et al (2001) Genetic tracing reveals a stereotyped sensory map in the olfactory cortex. *Nature* 414:173–179
8. Rennaker RL et al (2007) Spatial and temporal distribution of odorant-evoked activity in the piriform cortex. *J Neurosci* 27:1534–1542
9. Freeman WJ (2001) *Neurodynamics: an exploration in mesoscopic brain dynamics*. Springer-Verlag, New York
10. Kay LM, Freeman WJ (1998) Bidirectional processing in the olfactory-limbic axis during olfactory behavior. *Behav Neurosci* 112:541–553

## Olfactory Cue

► Odor

## Olfactory Discernment

- ▶ Olfactory Perception

## Olfactory Disorders

- ▶ Smell Disorders

## Olfactory Ensheathing Cells

### Definition

Glial cells unique to the olfactory system, which ensheath the axons of the olfactory receptor neurons, without providing full myelination. The primary olfactory system is an unusual tissue in that it can support neurogenesis throughout life. This unique regenerative property depends, in part, on the presence of olfactory ensheathing cells, and has recently been shown to have a remarkable ability to repair spinal cord injury.

- ▶ Myelin
- ▶ Regeneration

## Olfactory Epithelium

### Definition

The olfactory epithelium is a specialized chemosensory portion of the nasal epithelial tissue that contains the olfactory sensory neurons. In humans, it occupies an area of about 5 cm<sup>2</sup> covering the posterior part of the roof of each nasal cavity and the superior nasal concha. The olfactory epithelium is composed of three types of cells: the olfactory sensory neurons, which transduce odorants into electrical signals, the supporting, glia-like cells and the basal cells, which are stem cells capable of replacing the olfactory cell population. Because of this regenerative capacity, damage to the olfactory epithelium may result in only temporary anosmia.

- ▶ Anosmia
- ▶ Evolution of Olfactory and Vomeronasal Systems
- ▶ Odorant
- ▶ Olfactory Sensory Neuron

## Olfactory Glomerular Module

### Definition

Also known as a glomerular domain, an olfactory glomerular module is a spatial cluster of olfactory glomeruli responding to chemically similar odorant stimuli. Spatial clustering of glomeruli with similar response profiles into glomerular modules may facilitate the use of local center-surround lateral inhibitory networks to restrict the molecular receptive range of mitral cell projection neurons to a more narrow range of stimuli. Thus, odorants that stimulate strongly overlapping sets of receptors may be represented by a smaller set of mitral cells.

- ▶ Glomerular Map
- ▶ Odorant
- ▶ Olfactory Bulb Mitral Cell
- ▶ Olfactory Glomerulus

## Olfactory Glomerulus

### Definition

- ▶ Olfactory Bulb Glomerulus

## Olfactory-guided Behavior Studies

- ▶ Behavioral Methods in Olfactory Research

## Olfactory Hallucinations

RICHARD J. STEVENSON

Department of Psychology, Macquarie University,  
Sydney, NSW, Australia

### Synonyms

Olfactory aura; Phantosmia

## Definition

An olfactory hallucination is a subjective experience of smell, which occurs in the absence of an appropriate stimulus.

## Characteristics

Olfactory hallucinations (OHs) can occur in normal participants, as an unaccompanied primary symptom (phantosmia), and as a secondary symptom in a range of medical and psychiatric disorders [1]. Whilst the term simple or complex has been used to classify hallucinations in the auditory and visual domains (e.g., spots of light vs. an elephant) this distinction does not readily transfer to OHs. Most OHs appear to be complex, in that the person perceives a fully formed odor object (e.g., the smell of cooked chicken) rather than an unformed olfactory event. However, something akin to the simple versus complex distinction may be reflected in the integration of the OH with other concurrent events (real or hallucinated). For example, a Charles Bonnet syndrome patient reported hallucinating both a visual image of a girl *and* the smell of her perfume.

There are several other characteristic features of OHs. First, they show the same range of odor qualities (what it smells like) as real odors and they vary in intensity and hedonics, with most OHs reported as unpleasant. Second, when an OH is first experienced, they may be accompanied by highly odor-appropriate behavior, such as searching for a “gas leak.” This is the only objective evidence we have for the presence of an OH. Third, where OHs occur repeatedly, the person may gain insight into the nature of these experiences, although this may depend upon whether there is an underlying psychopathology (e.g., insight appears more common in epileptic than in schizophrenic OHs).

There are two other features that warrant comment. The first is the perceived locus of the OH. This can be in the nose or mouth, on the surface of the body or in the external environment. A defining feature (more below) of some forms of OH is their location, notably in olfactory reference syndrome, in which a person is convinced that their own body emanates a foul smell. In these cases, the person may not in fact be hallucinating a smell, rather the person infers the presence of a smell from other people's reaction to them.

## Presentation

### Healthy Adults

Olfactory hallucinations (OHs) are widely reported in healthy adults. A large study of the frequency of all types of hallucination, conducted in Western Europe, revealed that 8.6% of the sample had experienced an OH, and that 0.9% of the sample experienced these several times a week [2]. OHs were the commonest reported daytime hallucination across all modalities.

Other studies of non-clinical populations have found that OHs occur more frequently in individuals scoring higher on measures of psychosis-proneness.

### Primary Symptom

OHs can occur as a sole presenting symptom in the condition termed phantosmia. The prevalence of phantosmia is unknown, but according to Leopold [3] it occurs more frequently in women, and is a progressively worsening, relapsing and remitting condition, with lifelong duration. Whilst OHs may be brief, phantosmia may be considerably more persistent, in some cases the hallucination may last hours or days, nonetheless even with this different time-course, it still fulfils the general definition of an OH.

### Secondary Symptom

**Schizophrenia:** With the exception of epilepsy (more below), OHs have been studied most extensively in schizophrenia. An early view was that the presence of OHs was indicative of a poor prognosis, but there does not appear to be any substantial support for this notion. Rather, OHs appear to co-occur with tactile hallucinations and other positive symptoms of the disease. Phenomenologically, schizophrenic OHs are qualitatively varied, but may occasionally include descriptions, which suggest a delusion rather than an OH (e.g., smell of aliens, devils breath and angels). In most cases the OHs are reported as unpleasant or disgusting. Prevalence estimates vary between 2–35%. Most OHs are attributed to an external source (with some notable exceptions – see [4], for an excellent and representative set of examples), are of a similar time-course to real olfactory experiences and can result in behaviors consistent with the OH (e.g., escaping a building smelling of smoke).

**Epilepsy:** OHs can occur in the hours or days before a seizure (prodromal) or immediately, within minutes, preceding a seizure. These experiences are usually termed auras and estimates vary as to their prevalence (1–30%; [5]). Phenomenologically, these OHs cover all odor qualities, are brief, localized to the environment, and are predominantly unpleasant. An interesting feature is that they may be repetitive, in that the same person always experiences the same OH.

**Migraine:** OHs can occur prior to a migraine (again described as auras), with the same time course and features (immediate vs. prodromal) as in Epilepsy.

**Post-traumatic stress disorder (PTSD):** Several papers have documented OHs in PTSD under circumstances where the person is re-exposed (or imagines) to contextual cues associated with the event (e.g., smelling smoke/gasoline whilst traveling in a car following a traumatic motor vehicle accident). In all cases, the OH appears specific and appropriate to the traumatic event.

**Brain injury:** Both traumatic brain injury, stroke and aneurysm can result in OHs. In some cases these more

closely resemble phantosmia (and may share similar causation via damage to peripheral olfactory structures) whilst in others, especially aneurysm and stroke, the OHs may be complex (integrated) and hedonically varied.

**Drug abuse:** OHs have been reported in both chronic cocaine and alcohol users, but studies are few and so prevalence cannot be estimated. These reports indicate a presentation akin to that observed in Epilepsy – predominantly negative, brief and qualitatively varied OHs.

**Miscellaneous:** OHs have also been described, albeit rarely, in Parkinson's disease, Charles Bonnet syndrome, Depression and Alzheimer's disease.

### Cause

Whilst there has been fairly long history of theoretical and empirical work on visual and auditory hallucinations, especially in schizophrenia, relatively little work has been undertaken in respect to olfactory hallucinations (OH). This section starts by examining the association between the olfactory system and the two clinical conditions in which OHs are most well documented (epilepsy and schizophrenia), and then outlines theories that may account for OHs in these conditions. The second part of this section examines phantosmia, and the final part OHs in normal participants.

### Epilepsy and Schizophrenia

The neural basis of epilepsy and schizophrenia can overlap with brain areas known to be involved in olfactory function. In epilepsy, olfactory abnormalities tend only to accompany the disorder when the focus for the seizure is in the temporal lobe. Here the seizure may start or propagate to the amygdala and uncus and then into primary olfactory processing areas located on the boundary of the frontal and temporal lobes. Not surprisingly then, OHs (auras) tend to be associated with temporal lobe epilepsy. In schizophrenia, abnormalities have been detected in the orbito frontal cortex (OFC), amygdala and medio-dorsal nucleus of the thalamus (MDNT). Respectively, the OFC is secondary olfactory cortex, the amygdala is involved in processing the hedonic valence of odors and the MDNT is one of the routes by which information flows from primary olfactory cortex to secondary olfactory cortex, and may be instrumental in attributing the source of sensory stimulation (“that’s a smell”).

There are several contemporary theories of hallucinations [6], including cortical irritation, cortical release, intrusion of imagery or dreams, and attentional/sensory impairment theories. How well do these models account for OHs in epilepsy and schizophrenia? Cortical irritation is the oldest hypothesis and suggests that excess neural activity at a particular brain loci results in the activation of memory traces that are then experienced as

real events. Whilst this was heavily based on electrical brain stimulation (EBS) studies, it turns out that EBS results in *very few* olfactory-related experiences. This conclusion is based upon a large number of reported studies, stimulating many regions in the temporal/frontal regions. The rarity of these events suggests that focal irritation in brain areas known to be abnormal, especially in temporal lobe epilepsy, is an unlikely explanation.

A second class of explanation (of varying form) is that hallucinations arise as a result of abnormal – typically reduced – sensory input. This results in cortical release or hyperexcitability, causing memories of prior sensory experience to be re-experienced as real. There is one major problem with this account for OHs in epilepsy and schizophrenia. This is that patients who experience OHs may not have reduced sensory input. Three studies have examined schizophrenic participants with OHs. They find no consistent deficit in ▶odor detection, no abnormal changes to olfactory mucosa, and no history of disease states that might affect olfactory function. With epilepsy, the picture is less clear, with no systematic studies as yet. However, olfactory deficits in temporal lobe epilepsy are usually indicative of central (i.e., ▶odor identification and ▶odor discrimination) rather than peripheral pathology (i.e., detection is typically intact). Thus there is likely to be no reduction of sensory input that this class of theory would require.

The third class of explanation suggests that hallucinations result from the intrusion of dreams into the waking state or the misattribution of imagery to the external environment, rather than correctly to oneself. Whilst both of these types of explanation have been extensively explored, especially in respect to auditory hallucinations of people conversing, they have significant obstacles to overcome as an account of OHs. Whilst olfactory dreams and images certainly do occur, the former are rare and the latter are hard to generate [7]. Indeed, some argue that we may have no capacity to consciously experience odor images at all. In this case, misattribution accounts may not have much utility in explaining OHs.

A further, and more recent class of model suggests that hallucinations arise from a combination of attentional deficits and impaired sensory functioning. As noted above, impaired sensory functioning (detection) does not appear to be a salient feature of either epilepsy or schizophrenia.

Finally, there are a number of other possible causes of OHs in epilepsy and schizophrenia that have not been widely canvassed. First, impaired odor identification might lead to what *appears* to be an OH (e.g., misidentifying the smell of table polish for smoke). Second, the likely presence of amygdala abnormalities in schizophrenia and epilepsy, the predominantly unpleasant nature of OHs and the amygdala's role in mediating aversive reactions to odors, might suggest

this as a possible neural locus for these events. In summary, there is at present no well-defined model of OHs and there is a need to test the various theoretical accounts described above more directly.

### Phantomia

Whilst epileptic and schizophrenic OHs likely involve a dominant central cause, phantomia almost certainly derives from a combination of both peripheral and central causes [3]. Evidence favoring a peripheral basis for phantomia is that it typically disappears if the olfactory mucosa is treated with a local anesthetic and that examination of excised mucosal tissue from phantomia patients reveals disordered axon growth and an abnormal ratio of mature to immature neurons. Evidence favoring a central locus comes from the finding that many phantomia patients have no detectable abnormality in odor detection and that such patients typically have no history of upper respiratory tract infection or head injury prior to onset. Interestingly, magnetic resonance spectroscopy imagining has revealed significantly lowered GABA levels in several central sites, including the amygdala [8]. Given the overwhelming predominance of unpleasant OHs in phantomia, this again suggests possible amygdala pathology as a common feature of OHs.

### Normal Participants

Several studies suggest that OHs are more common in healthy individuals who score higher on measures of schizotypy or psychosis-like dimensions, although it is not currently possible to estimate the proportion of variance accounted for by this variable [9]. What it does suggest, however, is that normal variation in schizotypy may reflect proneness to OHs, implying a similar causal explanation to those described above for schizophrenia. In addition, a proportion of OH-like experiences may also be accounted for by more mundane failures to identify an odor source, misperceptions (which may be more common in olfaction than in other senses), illicit drug use, alcohol, anxiety and depression, and lack of sleep [2].

### Conclusion

The study of hallucinations can offer important insights into clinical conditions such as schizophrenia, as well as revealing much about routine perceptual processing. The study of OHs is not well advanced, empirically or theoretically, but it will be important in testing the generality of current theories of hallucinations.

### References

- Greenberg MS (1992) Olfactory hallucinations. In: Serby MJ, Chobor KL (eds) *Science of olfaction*. Springer, New York, pp 467–499
- Ohayon MM (2000) Prevalence of hallucinations and their pathological associations in the general population. *Psychiatry Res* 97:153–164
- Leopold D (2002) Distortion of olfactory perception: diagnosis and treatment. *Chem Senses* 27:611–615
- Bromberg W, Schilder P (1934) Olfactory imagination and olfactory hallucinations. *Arch Neurol Psychiatry* 32:467–492
- West SE, Doty RL (1995) Influence of epilepsy and temporal lobe resection on olfactory function. *Epilepsia* 36:531–542
- Collerton D, Perry E, McKeith I (2005) Why people see things that are not there: a novel perception and attention deficit model for recurrent complex visual hallucinations. *Behav Brain Sci* 28:737–794
- Stevenson RJ, Case TI (2005) Olfactory imagery: a review. *Psychon Bull Rev* 12:244–264
- Levy LM, Henkin RI (2004) Brain GABA levels are decreased in patients with phantageusia and phantomia demonstrated by magnetic resonance spectroscopy. *J Comput Assist Tomogr* 28:721–727
- Bell V, Halligan PW, Ellis HD (2006) The Cardiff Anomalous Perceptions Scale (CAPS): a new validated measure of anomalous perceptual experience. *Schizophrenia Bulletin* 32:366–377

## Olfactory Information

LESLIE M. KAY

Department of Psychology, Institute for Mind and Biology, The University of Chicago, Chicago, IL, USA

### Synonyms

Odors; Odorants; Odor code; Olfactory system dynamics

### Definition

Olfactory information can refer to the chemical stimuli (odorants), the perceptual effect of the stimuli (odors), the individual neural responses which receive this input (odor code), and the dynamical interaction of the many brain subsystems which comprise the central olfactory pathways (olfactory system dynamics).

### Characteristics

▶ **Odor** signals can be viewed as stereotyped activation maps defined by neuronal ▶ **receptive fields** and also as perceptual objects in which the odorant stimuli are associated with meaning, behavior and experience. The anatomy and physiology of the mammalian olfactory system has been studied from both perspectives. The ▶ **olfactory bulb** receives direct input from ▶ **olfactory receptor neurons** in the olfactory epithelium. These neurons project in a “receptor-topic” arrangement, such

that an individual ►glomerulus receives input from only one type of receptor (Fig. 1).

Because an individual odorant can activate multiple ►olfactory receptors, glomerular input maps are fragmented and highly distributed representations in the form of glomerular activation patterns. The patterns also have a dynamic structure which can be seen using ►Ca<sup>++</sup> imaging.

The mammalian ►olfactory system is also characterized by dense bidirectional connectivity among its many structures. The ►olfactory bulb may receive more synaptic input from the brain than it does from the olfactory receptor sheet, similar to a comparison of retinal and V1 projections to the thalamic ►lateral geniculate nucleus. Olfactory bulb structure has been likened at different times to the ►retina, primary visual cortex and more recently the sensory ►thalamus [2]. This essay concentrates on the mammalian system, but some references to the analogous insect systems are made [1]. The peripheral input structure, glomerular architecture and ►centrifugal input all have perceptual and physiological consequences.

### Odor Psychophysics in Animals

Psychophysical studies examining odor similarity use generalization methods, in which animals are trained to recognize one odorant, and similarities are judged by generalization of a behavioral response to other odors. Taking the ►glomerular input maps produced by various imaging methods and ►mitral cell responses corresponding to these areas as a guide, many compounds have been shown to exhibit similarity gradients along changes in molecular features, such as carbon chain length [3].

Thus, there are similarities in chemical composition, receptor activation and input patterns, which then correspond to similarities in odor quality. On the other hand, most animals are also very good at distinguishing even very similar odorants, and ►reinforcement learning can help an individual to discern even very small differences in glomerular activation patterns (Fig. 2).

Psychophysical responses to monomolecular odorants are relatively stable over a range of concentrations, due in part to mechanisms within the input layer. A subpopulation of ►GABAergic periglomerular cells

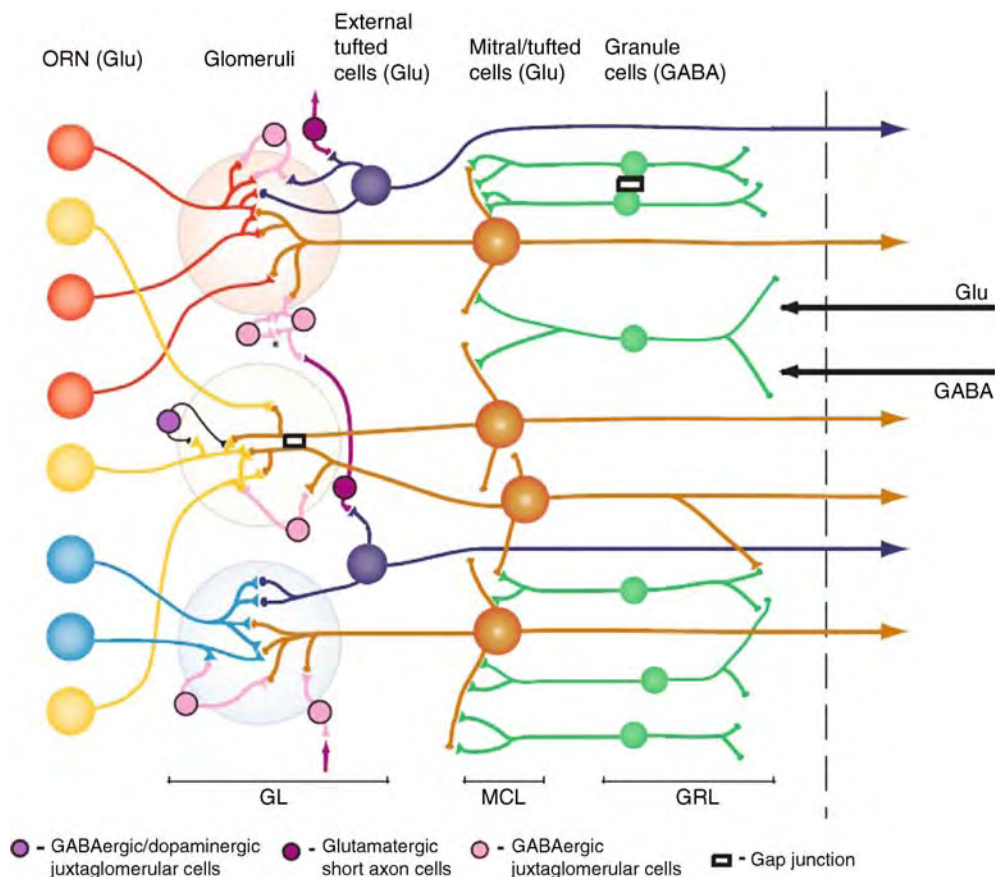

**Olfactory Information. Figure 1** Schematic of olfactory bulb architecture. GL – glomerular layer; MCL – mitral cell layer; GRL – granule cell layer. Pial surface on the *left*, centrifugal inputs on the *right* (Reprinted from [1] with permission; Elsevier).



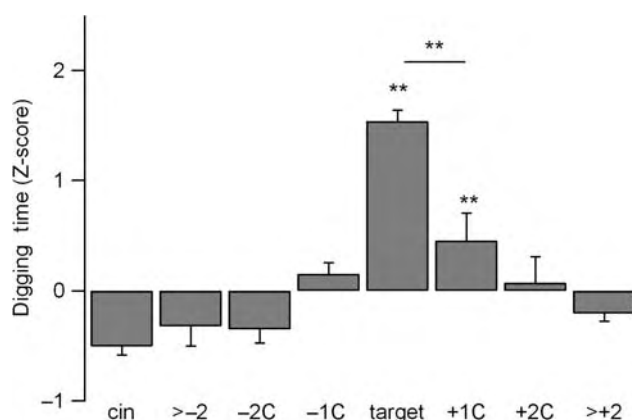

**Olfactory Information. Figure 2** Example of carbon chain length generalization pattern for a series of aldehydes. Mice trained to dig in cage bedding scented with a single aliphatic aldehyde (target) generalize the response to a nearby aldehyde (1 carbon difference in chain length). Digging times are compared to other aldehydes of chain lengths longer and shorter than the target and a control odor (cin – cineole).

receives direct input from the ▶**olfactory nerve** and mediates feedforward inhibition onto the ▶**mitral cell** apical dendrites. Release of ▶**dopamine** by ▶**juxtglomerular cells** and ▶**acetylcholine** by the horizontal nucleus of the diagonal band of Broca in the ▶**cholinergic basal forebrain** also modulate the incoming ▶**afferent** activity. ▶**Excitatory** and ▶**inhibitory** connections among glomeruli and lateral inhibition between mitral and granule cells have been proposed as mechanisms for ▶**contrast enhancement** and ▶**gain control**.

Odor mixtures present a more complex picture, and two behavioral methods have been used to investigate their perceptual properties in animals. The first looks at mixture quality, in which ▶**associative learning** or ▶**habituation** is used to train an animal to recognize a given mixture, and components are then tested in a ▶**generalization** paradigm. These studies suggest a general theoretical principle: odors that smell alike or activate significantly overlapping receptor or glomerular populations produce a ▶**synthetic** or ▶**configural** (▶**Configural/Configurational**) quality. Mixtures of dissimilar or nonoverlapping odors produce ▶**elemental** qualities. However, there is growing evidence that mixture perception may not be so simple, as compounds with similar structures can produce elemental responses, and those with very different structures can produce synthetic responses in binary mixtures. Furthermore, as the number of compounds in a mixture grows, humans experience more synthetic effects. Concentration and pungency also significantly affect mixture perception.

The second method of assessing mixture perception addresses animals' ability to recognize the ratio of various odor components, in which they choose a response associated with the component represented at higher concentration [4]. Responses in this case follow

a ▶**psychometric curve** (▶**Psychometric Curve/Psychometric Function**). This method does not specifically address odor mixture quality, but it can be used to manipulate odor discrimination difficulty. What this method has been able to show is that rodents can identify some odors in 1–2 sniffs, but as discrimination becomes more difficult this brief sampling time results in poorer performance. Training rats to sniff longer results in greater performance levels in more difficult discriminations; this suggests a ▶**speed-accuracy trade-off** in odor sampling.

The mechanisms for learning differences between odors in a behavioral context involve areas of the brain beyond the ▶**glomerular maps** and are addressed at the physiological level.

### Physiology of Olfactory Information

Ease of access to the olfactory bulb and the importance of olfactory information for rodents drove this research to very deep levels even before single unit recordings in waking and mobile animals became technically feasible or practical. Thus, this field proceeded from its beginning at the systems level, only more recently addressing issues such as ▶**odor coding** and ▶**receptive fields**. However, because of the high-dimensional nature of olfactory stimuli, we still know relatively little about the relative importance of salient molecular features, concentration, ▶**pungency** or even the existence of odor ▶**categories**. (Much of the anatomical, physiological and computational background is reviewed in a few sources [1,5,6].)

### Individual Neuron Responses

▶**Mitral cells** in the ▶**olfactory bulb** typically respond in a ▶**burst-like** manner around the peak of inhalation. They receive input from a single ▶**glomerulus**, and

those with dendrites in the same glomerulus can excite each other. In anesthetized mammals, mitral and ▶tufted cells in the ▶olfactory bulb and ▶pyramidal cells in the ▶piriform cortex can respond with an increase or decrease in firing rate upon presentation of odorants in front of an animal's nose. In this situation mitral cells show relatively stable odor responses that correspond roughly to the ordered representations suggested by mapping studies. However, there are exceptions to this simple ordering, since many mitral cells respond to many different odor classes, and in any given place in the olfactory bulb, one can often find cells that respond to an odor class.

Mitral and tufted cells in the olfactory bulb respond in a graded fashion to similar odorants, reminiscent of classical ▶receptive fields with broad ▶tuning curves that can be shifted by prolonged exposure to non-optimal odorants within a cell's ▶receptive field. This plasticity is similar to that in other sensory systems, such as receptive field ▶learning-induced plasticity in ▶auditory cortex. Mitral cells show significant cross-habituation to odors within their receptive fields. Odor responses of pyramidal cells in piriform cortex of anesthetized rats are somewhat different. While these cells exhibit tuning curve properties similar to mitral cells, the responses of single neurons to related odorants do not cross-habituate, suggesting that odor responses within the piriform cortex are more selective overall than those within the olfactory bulb.

Waking mammals present a somewhat different picture. ▶Odor selectivity has been recorded in a handful of studies, limited by the difficulty of recording isolated mitral cells in waking mammals. The phase of the respiratory cycle in which a mitral cell fires during periods of slow breathing (< 5 Hz in rats) represents the identity of a relatively long (5 s) odor stimulus associated with reinforcement. However, when rats perform odor discriminations with a briefer sampling time (1–2 s), they sniff at high rates (6–12 Hz), and mitral cells uncouple from the respiratory cycle. Firing rate responses in waking rats predict behavior most strongly, and only a small part of a cell's response varies with odor. When the behavioral association (positive or negative reinforcement) of an odor is changed, a cell's odor selectivity also changes. Studies of single neuron firing patterns in the ▶piriform cortex of waking mammals are scarce, but odor responses there are also modified by changes in behavioral associations.

### Population Activity

Population physiology presents a window into system-level dynamics. The ▶local field potential has been very useful for understanding how the various parts of the olfactory and limbic systems interact with and control each other. Many early studies described

the parameters which govern oscillatory responses in many parts of the olfactory system and those which relate local field potentials to single neuron activity [7,8]. The olfactory bulb exhibits two major classes of oscillations, slow (< 12 Hz) and fast (>12 Hz) (Fig. 3).

### Slow Temporal Structure

Slow oscillations are in the ▶theta frequency range (2–12 Hz in the olfactory bulb) for rodents and are generally correlated in phase and frequency with the respiratory cycle and with mitral cell burst firing. They are supported by afferent input and by intrinsically bursting cells like the ▶external tufted cells in the ▶glomerular layer. The burst behavior of mitral cells leads to a loose temporal structure within the olfactory bulb, in which within a 100–150 ms time window many cells are activated, and in the exhalation phase and prior to the next inhalation fewer cells are activated. Thus, the ▶theta oscillation in the olfactory bulb represents these high and low firing states. At low respiratory rates, this leads to a sampling of the olfactory environment in the nose approximately every 300 ms in a ▶saccade-like fashion. However, respiration does not completely describe these rhythms or mitral cells' firing patterns even in anesthetized animals, and there is evidence that ▶centrifugal inputs can modulate both. During fast sniffing, mitral cells tend to fire ▶tonically and the theta rhythm no longer represents high and low firing rates in the mitral cell population. Also during fast sniffing coupling between the hippocampal theta rhythm and sniffing or olfactory bulb oscillations in the high theta range (>5 Hz) have been associated with learning and performance of odor discriminations. Otherwise, these two rhythms are uncorrelated. This low frequency coupling may aid information transfer between the olfactory and hippocampal systems.

### Fast Temporal Structure: Circuit Properties

Within the respiratory cycle there is structure at a finer timescale. At the end of inhalation the ▶gamma oscillation (~40–100 Hz) is initiated. This odor-evoked oscillation was first described by Adrian [9]. The gamma burst lasts for 60–100 ms at low respiratory rates (~6–8 cycles per burst; Fig. 3). These fast odor-evoked oscillations have been well-studied at the physiological and computational levels in this system and in the analogous insect system [5]. Most researchers agree that olfactory bulb gamma oscillations arise from the reciprocal dendrodendritic (▶Reciprocal Dendrodendritic Synapse) interaction between mitral and granule cells in the ▶external plexiform layer in a ▶negative feedback circuit. Olfactory bulb mitral cells' firing times are probabilistically related to the population-level gamma oscillation (Fig. 4).

While this oscillation is often referred to as a source of ▶synchrony between individual neurons, it more

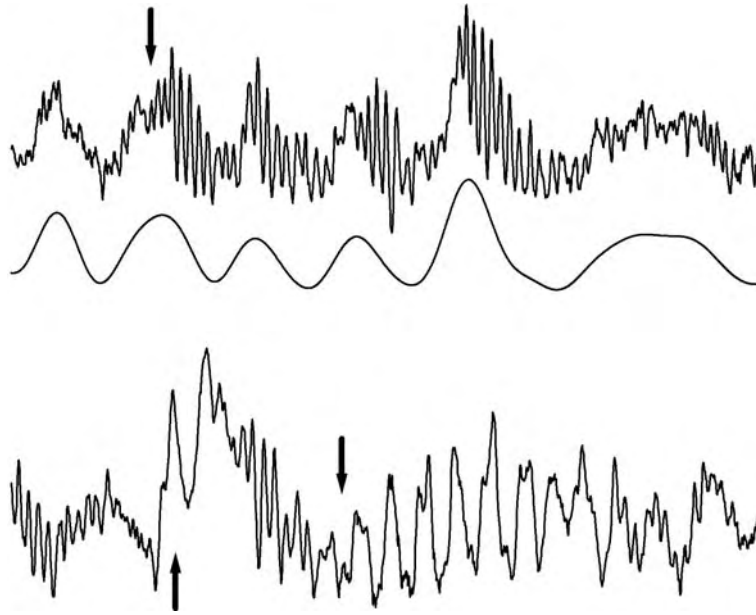

**Olfactory Information. Figure 3** Olfactory bulb oscillations (local field potential; each trace is 1 s long). *Top* trace shows gamma oscillations initiated at the peak of inhalation (*downward arrow*). The **▶theta** band part of the signal is shown just below, with each cycle representing a sniff. *Bottom* trace shows an odor-evoked beta oscillation. *Upward arrow* is the **▶sensory evoked potential**, and *downward arrow* shows the onset of the **▶beta oscillation**.

precisely represents the level of synchrony between individual neurons and the **▶emergent** local field potential. In this case, an increase in gamma oscillation power and a decrease in spectral width are associated with mitral cells firing in more restricted time windows, rather than precise temporal synchrony between neurons. This suggests increased precision in the temporal structure of the olfactory information.

Odor-evoked oscillations also occur in the insect **▶antennal lobe**, which is an analogue of the olfactory bulb, with very similar circuit properties. While insect oscillations are  $\sim 20$  Hz, they are similar to mammalian gamma oscillations in the relationship of the principal neurons' firing patterns to the oscillatory local field potential and the dependence of the oscillations on the interaction between excitatory **▶projection neurons** and the **▶GABAergic local neurons**. In the insect system it has been shown that a group of projection neurons fires in an odor-specific temporal pattern across cycles of the fast oscillations [1], which has led some to conclude that the mammalian system may use a similar mechanism during periods of high amplitude gamma oscillations.

In the mammalian system, sources of **▶desynchronization** of the local field potential associated with this system lie in the centrifugal and intrabulbar sources of drive to the **▶granule cell layer**, both **▶GABAergic** and **▶glutamatergic** (Fig. 4). Desynchronization is seen as a source of stability and flexibility in this system, and may be important for understanding the functional

differences between the mammalian systems and the simpler insect system.

In waking rats and mice, the gamma band has been further subdivided into two bands that are distinct in their behavioral associations but sometimes overlap in frequency. Gamma 1 ( $\sim 70$  Hz in waking rats and mice) is used to refer to the classical odor-evoked gamma described above. Gamma 2 ( $\sim 55$  Hz) is used to refer to the somewhat lower frequency oscillation that occurs between breaths during periods of alert immobility and low breathing rates. The source of gamma 2 oscillations is different from that of gamma 1, likely arising from **▶GABAergic** drive to the granule cells. The functional association of these oscillations is unknown, but may be related to attentional processes or dynamic stability.

### Fast Temporal Structure: Perceptual Properties

Activity in the **▶gamma frequency band** has been associated with odor discrimination circuitry in many species. Walter J. Freeman and colleagues showed that over the surface of the olfactory bulb there is a common **▶gamma band** waveform of the **▶EEG** [10]. The spatial patterns of amplitude of this waveform were the best indicator of an odor, and the patterns were produced reliably only when meaning (positive or negative reinforcement) was associated with an odor.

Gamma band (and gamma-like) oscillatory population synchrony is one specific mechanism associated with more difficult or highly overlapping odor discriminations

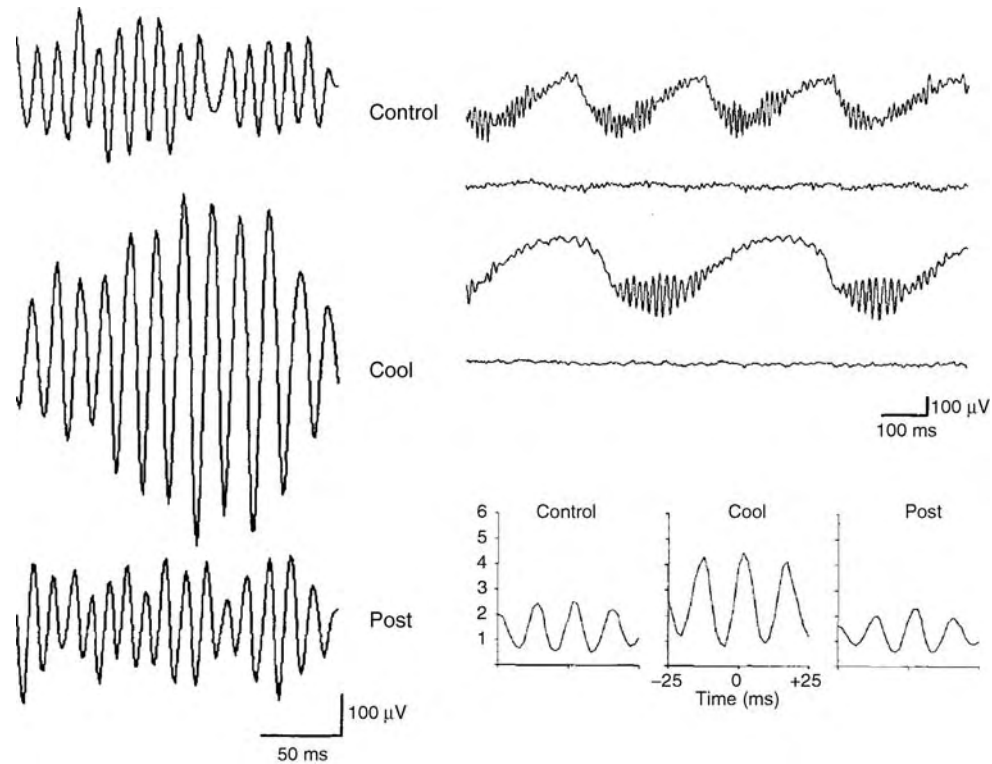

**Olfactory Information. Figure 4** Centrifugal input to the olfactory bulb causes desynchronization of the local field potential. Cooling the rear portion of the olfactory bulb effectively blocks input from the rest of the brain and produces a large increase in **▶gamma** oscillation power. Pulse probability density (*bottom traces*) shows that single mitral cells are more strongly coupled with the local field potential gamma oscillation without centrifugal input (Compiled and reprinted with permission from Springer, Gray and Skinner, *Exp Brain Res* 1988. 69(2):378–386.).

in rodents and insects. Disruption of these oscillations in honeybees leads to a selective decrease in discriminating highly overlapping odorants (fine discrimination). Increased olfactory bulb gamma power in  $\beta 3$  knockout mice leads to a selective increase in fine odor discrimination. In both studies, coarse discrimination was unaffected. Unmanipulated rats dramatically increase the power of gamma oscillations when performing fine odor discrimination, relative to coarse discrimination in a two-alternative choice task, suggesting that temporal precision in mitral cell firing patterns is enhanced.

Odor-associated beta band oscillations (15–30 Hz) are also seen in waking rats, where they predict the onset of correct performance in Go/No-Go odor discrimination tasks. Beta oscillations occur concurrently in the **▶olfactory bulb**, **▶piriform cortex**, **▶entorhinal cortex**, and dorsal and ventral **▶hippocampus**. Similar oscillations occur in the olfactory bulb, piriform cortex, entorhinal cortex and hippocampus during repeated passive odor stimulation in a **▶sensitization**-like fashion (Fig. 3). Beta oscillations differ significantly from gamma oscillations in that they require a complete bidirectional loop between the olfactory bulb and the rest of the olfactory system, suggesting temporal structure distributed across many

brain areas. In anesthetized rats, beta oscillations occur at the end of exhalation, and this period has been associated with enhanced firing in the granule cell layer.

### Summary

The combination of ordered but highly complex input maps combines with centrifugal input to the olfactory bulb and oscillatory dynamical states to produce odor perception. Input pattern overlap predicts odor similarity and discrimination difficulty, and animals can adjust their sniffing behavior along with changes in the olfactory system to interpret and respond to odors. Fast oscillations represent cell assemblies that process odors within and between olfactory areas, and slow oscillations at the respiratory frequency can serve momentary system wide coupling possibly to facilitate information transfer.

### References

1. Kay LM, Stopfer M (2006) Information processing in the olfactory systems of insects and vertebrates. *Semin Cell Dev Biol* 17(4):433–442
2. Kay LM, Sherman SM (2007) An argument for an olfactory thalamus. *Trends Neurosci* 30(2):47–53

3. Cleland TA et al (2002) Behavioral models of odor similarity. *Behav Neurosci* 116(2):222–231
4. Rinberg D, Koulakov A, Gelperin A (2006) Speed-accuracy tradeoff in olfaction. *Neuron* 51(3):351–358
5. Cleland TA, Linster C (2005) Computation in the olfactory system. *Chem Senses*, 30(9):801–813
6. Shipley MT, McLean JH, Ennis M (1995) Olfactory system. In: Paxinos G (ed) *The rat nervous system*. Academic Press, San Diego
7. Freeman WJ (1975) *Mass action in the nervous system*. Academic Press, New York, p 489
8. Rall W, Shepherd GM (1968) Theoretical reconstruction of field potentials and dendrodendritic synaptic interactions in olfactory bulb. *J Neurophysiol*, 31(6):884–915
9. Adrian ED (1942) Olfactory reactions in the brain of the hedgehog. *J Physiol*, 100:459–473
10. Freeman WJ, Schneider W (1982) Changes in spatial patterns of rabbit olfactory EEG with conditioning to odors. *Psychophysiology* 19(1):44–56

## Olfactory Learning

- ▶ Odor – Memory
- ▶ Olfactory Plasticity

## Olfactory Marker Protein

### Definition

A cytoplasmic protein expressed at high levels ubiquitously and exclusively throughout the soma, cilia, and axon of olfactory sensory neurons. Its function remains obscure.

- ▶ Olfactory Sensory Neuron

## Olfactory Nerve

MATTHEW S. GRUBB

MRC Centre for Developmental Neurobiology, King's College London, London, UK

### Synonyms

First cranial nerve; Olfactory sensory inputs

### Definition

The olfactory nerve consists of the axonal projections of olfactory sensory neurons, which extend from the olfactory epithelium in the nose through the cribriform plate of the skull to contact postsynaptic targets in the glomeruli of the olfactory bulb. Uniquely among pathways in the central nervous system, the entire nerve is continuously regenerated throughout adult life and has a remarkable capacity for recovery from injury.

### Characteristics

#### Anatomy, Morphology, and Molecular Characteristics

The olfactory nerve is the shortest of the cranial nerves, and is one of only two – along with the optic nerve – which do not project to the brainstem. It is composed primarily of the axons of olfactory sensory neurons (OSNs), which sit in the olfactory epithelium (OE) of the nasal cavity and whose job is to transduce information in airborne odorant molecules into electrical signals that are sent to the brain's olfactory bulb (OB). OSN axons are small ( $\sim 0.2\mu\text{m}$  diameter) and unmyelinated, and extend from the OE into the underlying lamina propria of the olfactory mucosa, where they coalesce into small-sized bundles. These bundles increase in size as they exit the lamina propria, and form branches of the olfactory nerve that cross through perforations of the skull's cribriform plate before entering the outer nerve layer (ONL) of the OB (Fig. 1).

Having crossed the boundary between the peripheral and central nervous systems, OSN axons then exit the

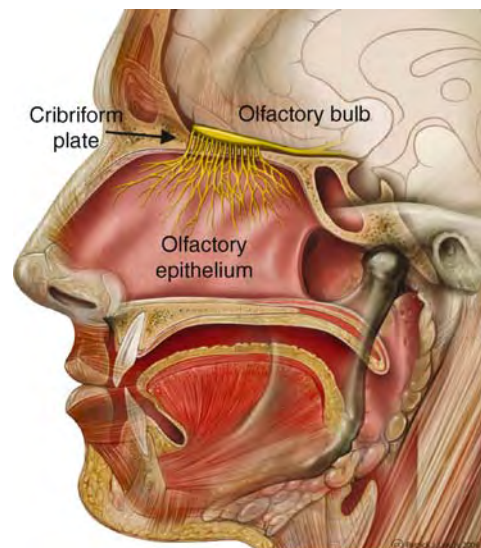

**Olfactory Nerve. Figure 1** Olfactory nerve. The axons of olfactory sensory neurons in the olfactory epithelium, shown here in yellow, project through the cribriform plate of the skull to the olfactory bulb, also shown in yellow. Illustration © PJ Lynch and CC Jaffe.

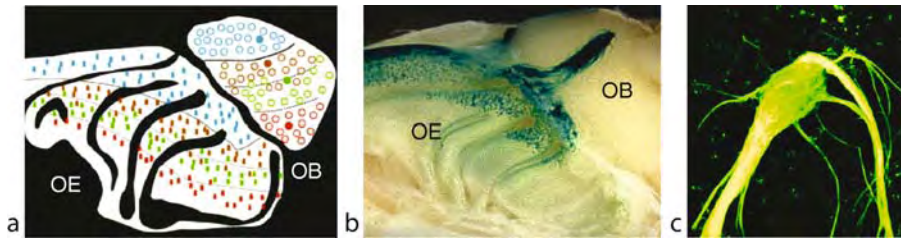

**Olfactory Nerve. Figure 2** Organization of olfactory nerve inputs to the olfactory bulb. (a) Zones in the olfactory epithelium (OE) project to particular regions of the olfactory bulb (OB). (b) Axons from olfactory sensory neurons that express a single type of olfactory receptor, labeled here in blue, project onto a single glomerulus in the medial OB. (c) Inputs to a single glomerulus are untidy, with axons entering the structure from all angles. (a) and (b) reprinted with permission from [1], (c) reprinted with permission from [2].

ONL to terminate in OB glomeruli (►**Olfactory bulb glomeruli**), specialized and highly complex arrangements of axons and ►**dendrites** that host the very first steps in odor information processing.

The organization of axons within the olfactory nerve is based on the olfactory receptor (OR) molecules expressed by OSNs. Each OSN expresses a single OR, and OSNs that express a particular OR lay scattered randomly within one of four OE zones. Each zone provides OSN axons that project to a particular region of the OB, although while the dorsal zone of the OE projects exclusively to the anterior dorsal bulb, the projections from other OE zones overlap somewhat [1] (Fig. 2a).

More striking is the astonishingly precise projection of OSN axons onto individual glomeruli: all of the OSNs expressing a given OR project onto only 2, mirror-symmetric glomeruli per bulb, and each glomerulus receives input only from axons expressing a single OR [1,3] (Fig. 2b). This huge OR-specific convergence only begins when the olfactory nerve reaches the ONL. Up to this point, axons from OSNs expressing different ORs are all completely intermingled, but on entry to the OB they begin a process of ►**homotypic fasciculation** whereby axons from OSNs with the same OR run together in bundles. These bundles then converge onto individual glomeruli, a highly specific process which is nonetheless surprisingly untidy [2] (Fig. 2c).

Once in the correct glomerulus, OSN axons make glutamatergic, excitatory synaptic connections with the dendrites of three main types of OB neuron (Fig. 3). Mitral cells (►**Olfactory bulb mitral cells**) and ►**tufted cells** are glutamatergic projection neurons that receive olfactory nerve input and project directly to olfactory cortex. ►**Periglomerular cells**, in contrast, constitute a heterogeneous population of local interneurons that receive olfactory nerve input and make modulatory connections within and between glomeruli.

Along their route from OE to OB, OSN axons are surrounded and supported by the processes of

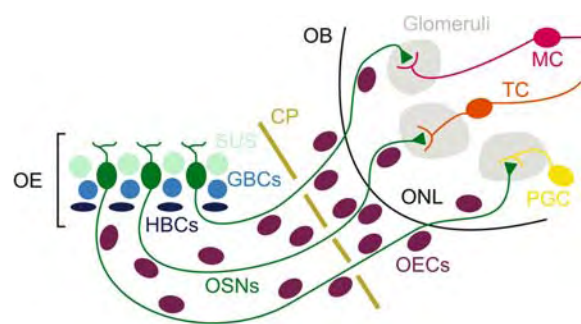

**Olfactory Nerve. Figure 3** Cell types associated with the olfactory nerve. OE olfactory epithelium; OB olfactory bulb; ONL outer nerve layer; CP cribriform plate; SUS sustentacular cells; GBCs globose basal cells; HBCs horizontal basal cells; OSNs olfactory sensory neurons; OECs olfactory ensheathing cells; MC mitral cell; TC tufted cell; PGC periglomerular cell.

►**olfactory ensheathing cells** (OECs), glia that are unique to the olfactory nerve and which possess characteristics of both Schwann cells and astrocytes [4] (Fig. 3). OECs do not provide proper Schwann cell-style myelination, but instead extend thin processes which each wrap up to 200 OSN axons, providing them with mechanical and metabolic support. In addition, it appears that OECs are essential for the growth-permitting environment of the olfactory nerve, expressing guidance cues and neurotrophic factors which allow new OSN axons to make their way to the OB. Indeed, OECs have been used successfully to promote axon outgrowth and repair in models of CNS injury [4].

As well as possessing unique glia, the olfactory nerve also contains unique axons. Adult OSN axonal compartments contain molecules that are not found in most other axons of the mature CNS. These include mRNA, which appears to be transported along OSN axons rather than locally translated, transcription

factors, and cytoskeletal proteins such as MAP5 and vimentin which are more commonly found in developing neuronal processes [5]. OSN axons also contain ►**olfactory marker protein** (OMP), a molecule expressed strongly, ubiquitously, and uniquely throughout the olfactory nerve, but whose function remains obscure. Along with the permissive environment created by OECs, these unique axonal features of the olfactory nerve may underlie, or at least reflect, its regenerative capacity (see Adult Neurogenesis below).

### Development

The olfactory nerve is initially established in rather early prenatal development. In mice, the first OSN axons arrive in the brain around embryonic day (E) 12, having extended from the OE through a “migratory mass” that includes OEC progenitors and guidepost mesenchyme cells [1]. Just before entering the presumptive OB, growing OSN axons wait for a short time before entering the ONL and fasciculating with other axons expressing the same OR. Fasciculated bundles are then directed to the region of their appropriate target glomerulus by molecular guidance cues including semaphorins, ephrins, and surface carbohydrates [1], with axons reaching specific domains in the presumptive glomerular layer as early as E15.5. The precise direction of OSN axons to their appropriate glomeruli depends at least in part on the particular ORs they express: aberrant glomerular targeting results when OR expression is genetically altered in a subset of OSNs [1]. Spontaneous, but not sensory activity in OSNs also appears necessary for the correct initial formation of OB glomeruli [6,7].

By postnatal day (P) 0, glomeruli in the rostral OB are clearly formed, while it takes a further 2–3 days for those in the caudal OB to catch up. However, the development of the olfactory nerve does not end there: at this stage, many OSNs axons expressing a particular OR terminate in two or more glomeruli. Over the next month or so of postnatal maturation, these diffuse projections are pruned to produce a tight, single glomerular target structure in each half-bulb (Fig. 4), a process that is highly dependent upon olfactory sensory experience [7].

### Adult Neurogenesis

The olfactory nerve is unique among CNS axon tracts in that its generative capacity extends past postnatal development and continues throughout adult life. Unlike other CNS neurons, the nature of OSNs’ function as detectors of airborne odorants means they are directly exposed to the external environment, and thus to the accompanying risk of damage by toxins and pathogens. In order to maintain normal olfactory nerve function in the face of this threat, OSNs keep fresh by a process of continual turnover—after a lifetime of around 3 months, those that have not been killed

already undergo programmed cell death and are replaced by new OSNs born from stem cells residing in the basal layer of the OE [8]. These cells migrate up to more superficial layers of the OE and extend an axon towards the OB, taking approximately 1 week post-mitosis to express mature markers such as OMP and to form functional glomerular synapses [8]. This normal replacement occurs with very high accuracy – there is no sign of degradation in the glomerular map with routine ageing. In addition, if a subpopulation of OSNs expressing the same OR is specifically removed, the replacement population extends axons to the OB and forms a glomerulus in precisely the right location. This entire process of OSN regeneration, and particularly the regrowth of olfactory nerve axons, probably involves many of the guidance factors and activity-dependent processes that orchestrate the initial formation of the olfactory nerve during brain development. In particular, OECs appear crucial to the growth-permissive status of the olfactory nerve environment throughout adult life.

The continual turnover of OSNs, and the presence of stem cells in the OE mean that the olfactory nerve is unique in the CNS in being able to recover from injury. After even drastic interventions such as section of the olfactory nerve or chemical lesion of the entire OE, recovery is possible – new OSN axons can extend and find the correct target zone of the OB after ~2–3 weeks [8]. There, recovery is not perfect: there are substantial targeting errors in an en-masse regenerating ON, producing multiple glomerular foci and incorrect terminal locations. However, although we currently know nothing about how the olfactory nerve functions following recovery from injury, we do know that olfactory behavior recovers extremely well. Whilst not anatomically perfect, then, the recovery capability of the olfactory nerve is easily good enough to restore useful olfactory function. Unsurprisingly, this unique ability has been the spur for many studies looking to use elements of the olfactory nerve niche to promote recovery in other models of CNS injury. Indeed, promising results have so far come from approaches involving ectopic transplantation of OECs.

### Physiology and Function

The fundamental function of the olfactory nerve is to transmit olfactory information from its site of transduction in the OE to the site of its first processing in the glomeruli of the OB. This information is carried solely in the form of sodium-based action potentials, which are propagated along unmyelinated OSN axons at a speed of ~0.5m/s. Whether or not an action potential occurs in a given OSN axon depends on the particular OR expressed by the cell, and the presence of particular odorants in the olfactory environment. Individual OSNs are actually rather broadly-tuned

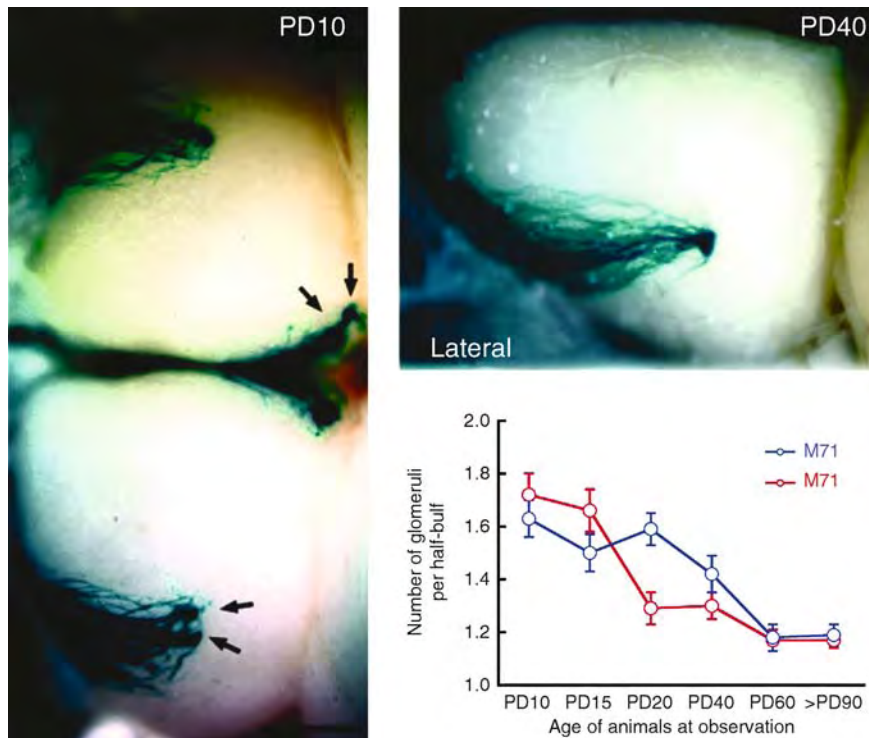

**Olfactory Nerve. Figure 4** Postnatal refinement of olfactory nerve projections in mice. At postnatal day (PD) 10 (*left*), axons from olfactory sensory neurons expressing a single olfactory receptor type converge onto multiple glomeruli in the medial and lateral olfactory bulbs (arrows). By PD40 (*right, top*), axons converge onto a single glomerulus in the lateral bulb. The plot at bottom right shows the refinement of glomeruli with postnatal development for two distinct olfactory receptor types. Reprinted with permission from [7].

to odorants, since ORs can bind a relatively large number of different odorant molecules. Furthermore, even within a subgroup of OSNs that all express the same OR, variations in transduction processes mean that odorant responses can be markedly different. This means that the information carried by any one olfactory nerve axon actually says very little about which odorants are present or absent in the environment. Only a combinatorial code for odors, embedded in the activity of the ensemble of fibers constituting the olfactory nerve, can allow olfactory detection and discrimination to take place.

As well as the type of odorant stimulus present, the information carried by the olfactory nerve also depends on the strength of the activating odorants. As in all sensory systems, increasing the intensity of the stimulus produces an increase in firing frequency in olfactory nerve fibers. But this may not be the only temporal code present in the pathway, since different odorant concentrations are also known to evoke different firing *patterns* in olfactory nerve fibers. In addition, recordings of calcium activity in olfactory nerve axon terminals have revealed glomerulus-specific dynamics – some glomeruli are quicker, or longer-lasting than others. These differences in temporal dynamics are consistent

for the same glomeruli across individual animals, and are only weakly correlated with odorant strength, suggesting they might represent another way, as well as firing frequency, that olfactory information is coded in the axons of individual OSNs.

Finally, coding in the axons of the olfactory nerve may be influenced by a rather unique process in the brain – **ephaptic interactions** between fibers. In most major axon tracts, firing in component axons is kept independent by myelination. The olfactory nerve, however, consists of bundles of hundreds of small axons loosely held together by the processes of OECs, meaning that the insulation of individual axons may not be very good. In these conditions, action potentials in one OSN axon could spread passively to activate other neighboring OSN axons. Indeed, mathematical models of the olfactory nerve suggest that such ephaptic interactions are possible, and even likely. Since OSN axons are not sorted by OR types until they reach the OB, these ephaptic effects could only act to disrupt OR-specific activity in particular fibers. If ephaptic interactions do occur in the real olfactory nerve, then, they may render the transmission of olfactory information from the nose to the brain far less than perfect.



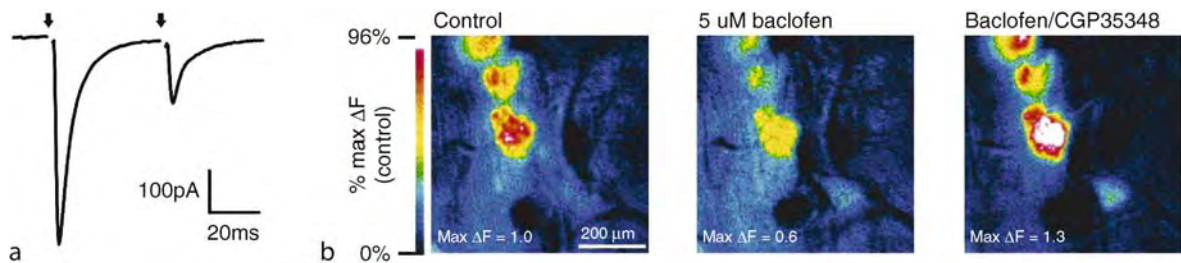

**Olfactory Nerve. Figure 5** Physiology of olfactory nerve terminals. (a) Evoked glutamatergic responses recorded in a periglomerular cell after paired stimulation of olfactory nerve inputs (arrows). Closely-spaced stimulation produces a depression of the second response, a feature characteristic of high release probability at olfactory nerve synapses. (b) Modulation of glutamate release at olfactory nerve synapses by GABA<sub>B</sub> receptors. Each blob shows release levels in an entire glomerulus in response to odorant stimulation. Release at olfactory nerve terminals is decreased by the GABA<sub>B</sub> receptor agonist baclofen, and increased by the GABA<sub>B</sub> receptor antagonist CGP35348. (a) recorded by the author, (b) reprinted with permission from [10].

In other sensory systems, primary sensory neurons transfer freshly-transduced electrical information about the world to their postsynaptic target cells via very reliable and morphologically specialized synaptic connections. In contrast, the connections of the olfactory nerve with its postsynaptic targets in OB glomeruli appear, structurally, to be rather normal glutamatergic synapses. However, functional experiments in OB slices have shown that these connections too are extremely reliable. Unusually for the brain, olfactory nerve terminals have very high release probability –  $\sim 0.8$  or more [9] (Fig. 5a) which should ensure the highly reliable transfer of olfactory information from the OE to the brain. The underlying mechanisms subserving such high release probability are not known, although it is not due to multivesicular release, and the relationship between calcium entry and glutamate release appears to be nearly linear [9].

Whilst they transmit presynaptic activity with high fidelity, olfactory nerve terminals are unique among primary sensory afferents in being sites of extensive modulation. Although ultrastructural experiments have found no synapses *onto* olfactory nerve terminals in the OB, electrophysiological experiments have revealed strong modulation of release probability by GABA acting through GABA<sub>B</sub> receptors (Fig. 5b), by dopamine acting through D<sub>2</sub> receptors, and by cyclic nucleotides acting through terminally-expressed cyclic nucleotide-gated channels. This modulation is almost all intraglomerular, meaning that the immediate periglomerular cell postsynaptic targets of olfactory nerve terminals can release either GABA or dopamine, or both, to influence both their own inputs and others in the vicinity [10]. Such feedback modulation may ensure that, despite the high release probability at olfactory nerve synapses, the dynamic range of the terminals is maintained. In other words, the modulation ensures that

the OB can still respond to a range of odorant concentrations, even after repeated or prolonged presentation of a strong stimulus.

## References

1. Strotmann J, Breer H (2006) Formation of glomerular maps in the olfactory system. *Semin Cell Dev Biol* 17:402–410
2. Potter SM, Zheng C, Koos DS, Feinstein P, Fraser SE, Mombaerts P (2001) Structure and emergence of specific olfactory glomeruli in the mouse. *J Neurosci* 21:9713–9723
3. Treloar HB, Feinstein P, Mombaerts P, Greer CA (2002) Specificity of glomerular targeting by olfactory sensory axons. *J Neurosci* 22:2469–2477
4. Fairless R, Barnett SC (2005) Olfactory ensheathing cells: their role in central nervous system repair. *Int J Biochem Cell Biol* 37:693–699
5. Nedelec S, Dubacq C, Trembleau A (2005) Morphological and molecular features of the mammalian olfactory sensory neuron axons: what makes these axons so special? *J Neurocytol* 34:49–64
6. Yu CR, Power J, Barnea G, O' Donnell S, Brown HE, Osborne J, Axel R, Gogos JA (2004) Spontaneous neural activity is required for the establishment and maintenance of the olfactory sensory map. *Neuron* 42:553–566
7. Zou DJ, Feinstein P, Rivers AL, Mathews GA, Kim A, Greer CA, Mombaerts P, Firestein S (2004) Postnatal refinement of peripheral olfactory projections. *Science* 304:1976–1979
8. Schwob JE (2002) Neural regeneration and the peripheral olfactory system. *Anat Rec* 269:33–49
9. Murphy GJ, Glickfield LL, Balsen Z, Isaacson JS (2004) Sensory neuron signaling to the brain: properties of transmitter release from olfactory nerve terminals. *J Neurosci* 24:3023–3030
10. McGann JP, Pirez N, Gainey MA, Muratore C, Elias AS, Wachowiak M (2005) Odorant representations are modulated by intra- but not interglomerular presynaptic inhibition of olfactory sensory neurons. *Neuron* 48:1039–1053

## Olfactory Pathways

ALBRECHT J, WIESMANN M

Department of Neuroradiology, Ludwig-Maximilians-University Munich, Germany

### Synonyms

Olfactory structures; Olfactory cortical areas; Olfactory cortex

### Definition

The perception of a smell is an integration of various sensations (olfactory, trigeminal, tactile, thermal, as well as gustatory sensations). This article is engaged with the olfactory pathways in particular. The human olfactory pathways can be divided into three parts [1,2] (Fig. 1):

- (1) The olfactory receptors are located in the mucosa of the nasal cavities. From there olfactory nerves run to the olfactory bulb which is located inside the bony skull beneath the orbital forebrain. From an evolutionary point of view the olfactory bulb is not a ganglion but a part of the telencephalon, one of the oldest portions of the brain. Following this it is postulated that the olfactory bulb constitutes the genuine primary olfactory cortex [3], which is contradictory to the common literature.
- (2) The olfactory tract connects the olfactory bulb to secondary olfactory cortex consisting of the anterior olfactory nucleus, the ►**olfactory tubercle**, the piriform cortex, parts of the amygdala (►**peri-amygdaloid cortex**, anterior and posterior cortical nuclei, nucleus of the lateral olfactory tract) and a small anteriomedial part of the entorhinal cortex. Since the recognition of the olfactory bulb as a cortical structure these areas are called secondary olfactory cortex [3].
- (3) Regions known to receive projections from the secondary olfactory cortex include the orbitofrontal cortex, agranular insular cortex, additional subnuclei of the amygdala, medial and lateral hypothalamus, medial thalamus, basal ganglia, and hippocampus. These regions are termed tertiary olfactory regions.

Although the current understanding of the organization of the olfactory pathways depends basically on observations made in rodents and non-human primates, it is generally assumed that the human olfactory system owns the same basic organization.

### Characteristics

#### Olfactory nerves/Primary Olfactory Cortex (POC)

►**Olfactory receptors (OR)**: Olfactory receptor neurons are located in the olfactory epithelium, on the roof of

the nasal cavity, above or below the anterior middle turbinate insertion, and are covered by a layer of olfactory mucosa. In humans, several million olfactory receptor neurons are found in both nasal cavities constituting the first-order neurons of the olfactory system. Olfactory receptor neurons are the only sensory neurons in the human body that are directly exposed to the external environment and can therefore be damaged by external harmful substances. Thus the average lifetime of the neurons is only a few months. Afterwards they are replaced through differentiation of neuronal stem cells [4]. It is known that cAMP or cGMP gated ion-channels activated by  $G_{\text{olf}}$ -protein coupled receptor proteins are responsible for odor induced activity of olfactory receptor cells. Between 350 and 400 different types of olfactory receptors are found in the human nasal mucosa. Every olfactory receptor cell expresses only one or maybe two of odorant receptor types. In addition, all neurons expressing the same receptor protein send their axons to the same two glomeruli in each olfactory bulb. In vertebrates, an olfactory stimulus, e.g., the odor of roses, does not activate one specific OR only. Instead, a large number of receptors are activated, although the intensity of activation differs between all of them. A different olfactory stimulus will activate a different set of ORs, of which some may have been activated by the first stimulus as well, while others may not. Again, however, there is a characteristic intensity pattern of the activated receptors. Hence, quality coding seems to be related to neuronal analysis of the topographical distribution of activated receptor proteins [5].

►**Olfactory nerves**: The axons from the olfactory receptor neurons group into small bundles to form the olfactory nerves, or *Fila olfactoria*. On average, 12–16 branches of olfactory nerves run along the nasal septum on each side medially and additionally 12–20 branches course along the lateral wall of each nasal cavity [2].

►**Olfactory bulb**: The olfactory nerves run upwards through the foramina of the cribriform plate of the ethmoid, entering the anterior cranial fossa. On the way from epithelium to olfactory bulb the axons regroup to form more homogeneous bundles. The olfactory nerves terminate at the ipsilateral olfactory bulb. The two olfactory bulbs, one on each hemisphere, lie in a bony groove formed by the cribriform plate. In the olfactory bulb, the axons of the olfactory receptor neurons synapse with dendrites of second-order neurons in the olfactory system (mitral and tufted cells) forming discrete glomeruli.

#### Secondary Olfactory Cortex

The olfactory bulbs are connected to the secondary olfactory cortex via the ►**olfactory peduncles**. The olfactory peduncles consist of the olfactory tracts as well as a thin layer of grey matter which belongs to

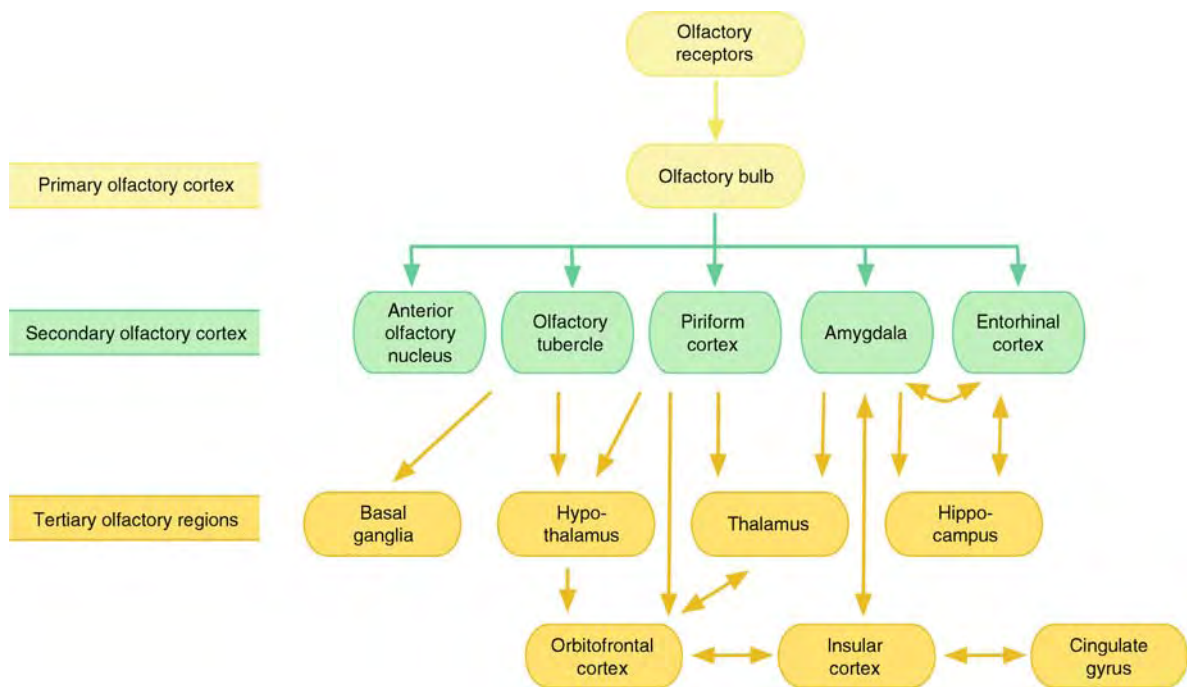

**Olfactory Pathways. Figure 1** Schematic illustration of the major central nervous projections of the olfactory receptor neurons. Shown are the three parts of the olfactory pathways (olfactory receptors/primary olfactory cortex, secondary olfactory cortex, and tertiary olfactory regions) and their connections.

the anterior olfactory nucleus. The postsynaptic axons of the mitral and tufted cells leave the olfactory bulb forming the lateral olfactory tract, one on each hemisphere. The lateral olfactory tract is situated in the ►**olfactory sulcus** of the orbital surface of the frontal lobe, lateral to the gyrus rectus. It transfers olfactory information to a number of ipsilateral brain areas within the posterior orbital surface of the frontal lobe and the dorsomedial surface of the temporal lobe [5]. Unlike in several non-mammalian species, there is no medial olfactory tract in mammals, including primates [4]. The lateral olfactory tract runs along the olfactory sulcus until it reaches the rostral part of the ►**anterior perforated substance**, where it divides into three roots, or striae. This area is called the ►**olfactory trigone**. The medial olfactory stria curves upwards to the ►**septal region**. The lateral olfactory stria curves laterally and leads to the medial surface of the temporal lobe. Delineated by the medial and lateral striae is the anterior perforated substance. The posterior border of the anterior perforated substance is delimited by a band of fibers that passes from the amygdala to the ►**septum pellucidum**. This band is called the diagonal band of Broca. The intermediate olfactory stria continues onto the anterior perforated substance, ending at the olfactory tubercle. Although well documented in animals, the intermediate and medial striae are extremely rudimentary in humans. Thus the lateral olfactory stria provides the

only source of bulbar afferents to the brain. All areas receiving a direct projection from the lateral olfactory stria constitute the secondary olfactory cortex, consisting of the anterior olfactory nucleus, the olfactory tubercle, the piriform cortex, parts of the amygdala (periamygdaloid cortex, anterior and posterior cortical nuclei, nucleus of the lateral olfactory tract) and a small anteriomedial part of the entorhinal cortex.

►**Connections within the secondary olfactory cortex:** In rodents and carnivores, it has been shown that there is an extensive system of associational connections within the areas of the secondary olfactory cortex [4]. These fibers originate in all of the olfactory areas except the olfactory tubercle. Many of the associational fibers also extend into cortical regions beyond the areas that receive fibers from the olfactory bulb, including portions of the entorhinal, perirhinal, and insular cortex, and the medial amygdaloid nucleus.

►**Contralateral connections:** The projection of the olfactory bulb itself is entirely unilateral. However, fiber bundles from the olfactory peduncle cross in the ►**anterior commissure** to reach the contralateral olfactory bulb and cortex, providing the major route of interhemispheric olfactory information transfer. Although these fibers run with the olfactory tract, they do not originate from mitral or tufted cells of the olfactory bulbs. Instead, they originate from those cells of the anterior olfactory nucleus, which are located

in the olfactory bulb. Similar commissural fibers also originate more caudally, in the anterior part of the piriform cortex [4]. In humans all contralateral olfactory projections exert inhibitory effects only.

► **Centrifugal projections to the olfactory bulb:** Many of the olfactory cortical areas, including the anterior olfactory nucleus, piriform cortex, and periamygdaloid cortex send fibers back to the olfactory bulb. The projection of the anterior olfactory nucleus is bilateral. There is also a substantial projection from the nucleus of the horizontal limb of the diagonal band to the superficial layers of the olfactory bulb.

So far, a clear transformation of the highly ordered topographic map of the bulb onto the olfactory cortex has not been demonstrated. Small areas of the olfactory bulb project to virtually the entire olfactory cortex, and small areas of the cortex receive afferents from virtually the entire olfactory bulb [6]. However the results of a recent genetic tracer study in rodents indicate that a given olfactory receptor subtype projects to discrete neuronal clusters within the olfactory cortex, suggesting a topographical organization in olfactory cortex which is similar to the bulbar organization [7].

► **Piriform cortex:** The piriform cortex is the largest olfactory cortical area in humans as well as in most mammals. It is situated along the lateral olfactory tract on the caudolateral part of the orbital cortex, near the junction of the frontal and temporal lobes, and continues onto the dorsomedial aspect of the temporal lobe. Due to this it is defining two subdivisions: the anterior (frontal) piriform (or “prepiriform”) cortex and the posterior (temporal) piriform cortex. Both parts of the piriform cortex are histologically identical. However it has been suggested that human frontal and temporal piriform cortex are functionally distinct [5]. The piriform cortex is activated by olfactory stimuli but habituates rapidly to repetitive stimulation. It has been shown “that sniffing, whether an odorant is present or absent, induces activation primarily in the piriform cortex” [8] leading to the assumption that the sniff primes the piriform cortex for an optimal perception of an odor [5]. It is suggested that the temporal part of the piriform cortex mediates basic odor perception independent of odor valence while the frontal part of the piriform cortex is receptive to hedonic value of the odor. Additionally the piriform cortex is involved in olfactory learning and memory [5].

► **Amygdala:** Projections from the olfactory bulb terminate in several discrete portions of the amygdala (periamygdaloid region, anterior and posterior cortical nuclei, nucleus of the lateral olfactory tract). The cytoarchitectonic transition from the amygdala to the temporal piriform cortex is poorly demarcated. The olfactory areas of the amygdala send projections back to the bulb as well as provide direct input to lateral, basolateral, central amygdaloid nuclei and to basal ganglia, thalamus,

hypothalamus, and prefrontal cortex [5]. It is suggested that the amygdala is highly responsive to odor stimulation. The amygdala is proposed to play an important role in affective responses in general, and in olfactory hedonics in particular. The amygdala is responsible for the interaction between valence and intensity of an odorant, as well as for olfactory memory. Of all the senses, olfaction possesses the most intimate relation with the amygdala.

### Tertiary Olfactory Regions

From secondary olfactory cortex, information is transmitted to several other parts of the brain, including orbitofrontal cortex, agranular insular cortex, additional subnuclei of the amygdala, medial and lateral hypothalamus, medial thalamus, basal ganglia, and hippocampus. These areas have been referred to as tertiary olfactory regions. Projections to and among these areas are complex and cannot be discussed here in detail. Most of these areas are not specific for processing of olfactory stimuli and show activation by other sensory inputs as well. This complex network of brain areas provides the basis for odor-guided regulation of behavior, feeding, emotion, autonomic states, and memory [5].

► **Orbitofrontal cortex (OFC):** The OFC is situated at the basal surface of the frontal lobes. It receives input from all secondary olfactory regions (except the olfactory tubercle) in the absence of an obligatory thalamic intermediary and in turn provides feedback connections to each of these regions. The OFC represents the main neocortical projection site of the olfactory cortex and is responsible for initial processing of olfactory information [5]. There is converging evidence that specialized areas within the OFC are engaged depending on the specific task of olfactory processing and that there is some functional lateralization. The posterior OFC is known to be associated with low-level aspects of olfactory processing, such as passive smelling and odor detection whereas the anterior OFC is engaged with higher-order olfactory processing, including associative learning, working memory, and odor recognition memory. Additionally there is evidence for different brain activation associated with odorants of different pleasantness. Whereas pleasant odors evoke activity in medial OFC, unpleasant odors lead to an activation in lateral OFC. Furthermore the OFC receives input from other sensory areas, especially from gustatory, visual, and visceral centers, providing the basis for multisensory integration, resulting in feeding-related and odor-guided behaviors [5]. A functional imaging study demonstrated that regions of the OFC are related to olfactory sensory-specific satiety [9]. The activation of some regions within the OFC produced by the odor of a food eaten to satiety decreased, whereas there was no similar decrease for the odor of food which was not eaten in the meal.

### Other Brain Areas Involved in Olfactory Processing

► **Cingulate:** Although there are connections between the cingulate gyrus and frontal areas involved in olfaction, the cingulate gyrus has not typically been considered as a part of the olfactory system. The cingulate gyrus is involved in processing of information of various kinds. More specifically, the anterior cingulate is frequently involved in tasks requiring attention to sensory features in the environment. In olfactory studies, activations have been reported in anterior as well as in posterior parts of the cingulum. Interestingly, the cingulate gyrus has also been reported to be of critical importance in the processing of painful sensations. Thus, one might speculate that emotions induced by either odors or pain relate to a similar pattern of brain activation in the cingulate gyrus [2].

► **Cerebellum:** In several studies, cerebellar activation following olfactory stimulation has been reported. Yet, the functional significance of these findings remains unclear. In a functional imaging study the effects of smelling versus sniffing an odor on cerebellar activation were compared and it was hypothesized that the cerebellum maintains a feedback mechanism that regulates sniff volume in relation to odor concentration [10].

In conclusion, functional imaging data support a model of hierarchical organization of olfactory processing. From the ORs and olfactory bulbs (primary olfactory cortex), information are projected to the secondary olfactory cortex. The piriform cortex is the most prominent part of the secondary olfactory cortex in man. Neuroimaging as well as neuroanatomical data suggest that this area is at least minimally engaged during all olfactory tasks. A variety of tertiary regions have been shown to receive projections from the secondary olfactory cortex, among which the OFC seems to be engaged in most tasks of olfactory processing. Thus, core areas within the olfactory system may play a mandatory initial role. However, the involvement of tertiary regions seems to vary with specific task demands, e.g., whether odor processing is related to recognition or emotional response. Finally, another level of organization appears to involve brain areas that fall outside of the typically defined olfactory system, which become engaged during specific types of processing. Examples of these areas are the activation of the cingulate cortex as a multimodal sensory processing area or involvement of the cerebellum which is involved in the adjustment of sniff volume in regard to odor concentration. The ipsilateral nature of olfactory projections, the absence of the thalamic relay during information transmission to the cortex, and the overlap with limbic brain areas are properties of the olfactory system, which sharply distinguish olfaction from other sensory modalities. In summary, odor processing seems to comprise a serial processing of information from primary to secondary and tertiary regions, and also a

parallel, distributed processing engaging a complex and distributed network of brain regions whose pattern of activation varies depending on the specific requirements of the task.

### References

1. Weismann M, Yousry I, Heuberger E, Nolte A, Ilmberger J, Kobal G, Yousry TA, Kettenmann B, Naidich TP (2001) Functional magnetic resonance imaging of human olfaction. *Neuroimaging Clin N Am* 11(2):237–250
2. Wiesmann M, Kettenmann B, Kobal G (2004) Functional magnetic resonance imaging of human olfaction. In: Taylor AJ, Roberts DD (eds) *Flavor perception*. Blackwell, Oxford, pp 203–227
3. Cleland TA, Linster C (2003) Central olfactory structures. In: Doty RL (eds) *Handbook of olfaction and gustation*. Marcel Dekker, New York, pp 165–180
4. Price JL (2004) Olfactory system. In: Paxinos G, Mai JK (eds) *The human nervous system*. Elsevier, Amsterdam, pp 1197–1211
5. Gottfried JA (2006) Smell: central nervous processing. *Adv Otol Rhinol Laryngol* 63:44–69
6. Haberly LB, Price JL (1977) The axonal projection patterns of the mitral and tufted cells of the olfactory bulb in the rat. *Brain Res* 129(1):152–157
7. Zou Z, Horowitz LF, Montmayeur JP, Snapper S, Buck LB (2001) Genetic tracing reveals a stereotyped sensory map in the olfactory cortex. *Nature* 414(6860):173–179
8. Sobel N, Prabhakaran V, Desmond JE, Glover GH, Goode RL, Sullivan EV, Gabrieli JD (1998) Sniffing and smelling: separate subsystems in the human olfactory cortex. *Nature* 392(6673):282–286
9. O'Doherty J, Rolls ET, Francis S, Bowtell R, McGlone F, Kobal G, Renner B, Ahne G (2000) Sensory-specific satiety-related olfactory activation of the human orbitofrontal cortex. *Neuroreport* 11(4):893–897
10. Sobel N, Prabhakaran V, Hartley CA, Desmond JE, Zhao Z, Glover GH, Gabrieli JD, Sullivan EV (1998) Odorant-induced and sniff-induced activation in the cerebellum of the human. *J Neurosci* 18(21):8990–9001

## Olfactory Peduncle

### Definition

The olfactory peduncle runs bilaterally from the olfactory bulb to the anterior perforated substance. The olfactory peduncle contains the olfactory tract as well as thin layers of grey matter which are part of the anterior olfactory nucleus.

- Olfactory Bulb
- Olfactory Pathways
- Olfactory Tract

## Olfactory Perception

BURTON SLOTNICK<sup>1</sup>, ELKE WEILER<sup>2</sup>

<sup>1</sup>Department of Psychology, University of South Florida, Tampa, FL, USA

<sup>2</sup>Department of Neurophysiology, Institute of Physiology, Ruhr-University Bochum, Bochum, Germany

### Synonyms

Olfactory awareness; Olfactory sensitivity; Olfactory discernment; Olfactory acuity

### Definition

Olfactory **▶perception** is a process that starts in the nose with the stimulation of olfactory sensory neurons and terminates in higher cerebral centers which, when activated, make us consciously aware of an odor. In humans this awareness is generally confirmed by verbal reports while in animal studies some sort of odor detection or discrimination task is used. In mammals, olfactory stimuli are received and processed by multiple systems (the main olfactory system, vomeronasal, and the **▶septal organ** system). Activation (particularly by irritants) of trigeminal, **▶vagal** and glossopharyngeal receptors in the respiratory tract may contribute to the perceptual experience. However, most research has concentrated on the main olfactory system which also appears to be the only functional olfactory system in humans.

Among the more remarkable aspects of olfactory perception are a seemingly infinite number of odors and odor combinations that can be discriminated, that for humans, most odors generate an emotional response that can range from extreme disgust to extreme pleasantness, and that, in many species, odor exposure can exert profound influence on social, including reproductive, behavior. The neuroscience of olfactory perception has been driven largely by these and related behavioral outcomes and may be viewed as attempts to understand their neurobiological basis.

### Characteristics

#### The Biological Basis of Odor Perception

Molecular biological studies identifying the large family of odorant receptor genes have revealed principles in the organization of sensory neurons and their pattern of projection to the olfactory bulb. Each sensory neuron expresses one of a large number of receptor proteins (about 1,000 in rodents) and the axons of neurons that express the same receptor converge to terminate in the same glomerular areas in the olfactory bulb. While receptor–ligand interactions define which odorant molecules will activate a sensory neuron, the stimulus

spectrum (range of sensitivity) of any one sensory neuron appears broadly rather than narrowly tuned. Consequently, each class of neurons may respond to a wide variety of odorants, more strongly to some, more weakly to others (depending on structural interactions of ligand–receptor binding). As a result, many and perhaps hundreds, of different classes of sensory neurons may respond more or less strongly to even simple (monomolecular) odorants [1,2].

The inputs to the bulb from sensory neurons are relayed to more central brain areas by second order (mitral and tufted) cells whose axons converge to form the lateral olfactory tract, the primary projection pathway from the bulb to the brain. Although the olfactory cortex (piriform and lateral entorhinal cortices) is the primary termination for these outputs, there are fairly direct projections to four other target areas: prefrontal orbital cortex (via the dorsal medial thalamic nucleus), hippocampus (via the lateral entorhinal cortex), the corticomedial division of the amygdala, and the hypothalamus [3]. As described below, it is tempting to associate each of these projection targets with different known olfactory functions: analysis of complex olfactory signals (primary olfactory cortex), acquisition of cognitive based olfactory tasks and, perhaps, conscious awareness of an odor (the medial dorsal thalamic-orbital frontal cortex system), excellent olfactory memory (the entorhinal–hippocampal system), emotional component of odors (amygdala, limbic system), and olfactory influenced neuroendocrine changes (projections to hypothalamus).

#### Odor Quality Perception

Perhaps the most active area of research relevant to olfactory perception concerns the neural mechanisms that code for odor discrimination and odor quality. Work here has concentrated largely on the olfactory bulb because the functional organization of its inputs is now well understood and because bulbar activity in response to odor stimulation can be visualized using a variety of methods including functional magnetic resonance imaging (fMRI), optical imaging of intrinsic signals, indexing increases in metabolic activity using 2-deoxyglucose (2-DG) and expression of molecular activity markers such as c-FOS [2].

The so-called “combinatorial” view of odor coding is the most widely accepted explanation for the physiological basis of odor quality perception. The convergence of inputs from sensory neurons expressing the same type of receptor plus the many different types of sensory neurons that respond to any one odor results in activation of multiple discrete regions in the olfactory bulb upon odor stimulation. Although structurally similar odors may activate similar or overlapping areas in the olfactory bulb, in all cases examined, each odor produced a unique pattern of glomerular activation.

This “odotopy” or odotopic map representation of different odors at the level of the olfactory bulb provides the primary evidence for the generally accepted “combinatorial” view of odor coding.

While the details of this scheme are topics in other chapters of this volume, its potential significance for understanding odor perception is clear: according to this view, the pattern of inputs from the sensory epithelium to the olfactory bulb provides the neural basis for odor discrimination and, hence, largely determines the perceived quality of an odor. In general, this combinatorial hypothesis has considerable face validity; it provides a reasonably parsimonious account of odor coding, and is solidly grounded in both the molecular biological studies on the organization of inputs to the olfactory bulb and the results of numerous mapping studies. Nevertheless, this view has been challenged by results obtained using fast imaging methods, by studies using awake, behaving animals, and by recent work suggesting that the organization of olfactory cortex may be more suitable for coding complex odor signals.

### Temporal Parameters and Early Events in the Olfactory Bulb

The minimum time required to identify a stimulus helps define the temporal period during which neural coding occurs. Both human and animal subjects can identify an odor after only a few hundred milliseconds of exposure (i.e., after one or two sniffs). What neural events occur during this brief period? Fast imaging methods demonstrate that, within the first few hundred milliseconds of odor exposure, activity across the glomerular layer of the olfactory bulb evolves, is temporally complex and that responses to different odors vary in many parameters including latency of onset, rise time, amplitude, modulation by respiration cycle, temporal dynamics of activation, sniff rate, and the extent to which rise time and amplitude are correlated [4]. The important point is that within the brief time needed to identify an odor, numerous neural events are potential candidates for odor coding. Because odotopic maps of the olfactory bulb are based on averaging activity over many seconds or minutes of odor exposure, it remains unclear whether such maps represent the temporally dynamic changes that occur during the first few sniffs of an odor [2].

### Disruption of Bulbar Inputs

One method for examining the functional significance of odor maps is to assess odor detection and discrimination after surgical or toxicant destruction of bulbar sites activated by a target odor. Surprisingly, even extensive disruption in the patterns of bulbar inputs in rats fails to produce a specific anosmia or hyposmia, or to significantly disrupt ability to

discriminate between odors [5]. In related behavioral studies only mixed results have been obtained in attempts to assess other predictions based on the proposed odotopic view of odor coding (e.g., that similarity in patterns of bulbar activation should predict perceived similarity or difficulty in discriminating between odors).

### Perception of Complex Odors and the Olfactory Cortex

The question of whether we experience the individual components of odorant mixtures (i.e., analytic perception) or as a single odor (i.e., synthetically) is complex because, in mixtures, odorants having different vapor pressures and solubilities may produce complex outcomes, and the resulting molecules probably compete for sites on olfactory sensory neurons. Nevertheless, except in the laboratory, most odors encountered represent complex mixtures of vapors. Behaviorally, the issue has been largely resolved by a variety of studies in which human subjects are asked to identify the number of or components of different odors in mixtures. Even with training, subjects are rarely able to identify individual components or accurately identify the number of components in mixtures of three or more odorants.

The evidence from these and related studies strongly supports the view that olfaction is synthetic and that complex mixtures, such as the many volatile molecules that contribute to the odor of urine or coffee, are perceived as single odor “objects.” It follows then that analytic or feature detection functions that occur at the level of the olfactory bulb may be early events in further signal processing that result in mixtures being perceived as a single identifiable odor. Where might such synthesis occur? The organization of inputs from olfactory epithelium to the olfactory bulb effects a relatively simple transformation in which signals from sensory neurons expressing the same membrane receptor are represented in spatially discrete areas of the bulb. In contrast, bulbar output neurons are subject to numerous synaptic interactions within the bulb as well as feedback from ►centrifugal projections originating in deeper brain structures and have extensive connections within olfactory cortex. These provide the opportunity for more complex modification in the representation in olfactory cortex of the initial sensory signals. For example, whereas mitral/tufted cells in the olfactory bulb receive input from just a single type of odor receptor, each neuron in the olfactory cortex appears to receive information from multiple bulbar output neurons and some neurons are activated only if two different odor receptor signals are received. Further, responses in olfactory cortex may have considerable plasticity: unit responses to components of odor mixtures are readily modified by exposure to the mixture and, in trained animals, modified as a function of whether the odor was associated with a reward [6].

In brief, our understanding of the biological basis of odor quality perception is incomplete. The results of behavioral studies with rodents, the enumeration of neural events during odor sampling and initial studies on olfactory cortex provide important data but not, as yet, an alternative scheme of odor coding.

### Perceptual Subqualities

Can odors be classified into types or subqualities? For other modalities stimulation produces only a limited number of qualitative differences or subqualities such as the basic types of tastes, skin sensation, colors or tonal frequencies that can be discriminated. For olfaction, literally thousands of monomolecular odorants may each produce a qualitatively different perception, and combinations of odorants may produce additional unique qualitative experiences. A number of odor classificatory schemes have been proposed, some of which are based on multivariate analyses of odor judgments by a panel of subjects sampling a wide variety of odors. None, however, are able to accommodate the full range of perceptual experience generated by monomolecular odors or have strong predictive value for how a novel odorant or a mixture of odorants would be judged. Nevertheless, there appears to be reasonably broad agreement for a limited number of descriptors (such as camphor, musk, floral, peppermint, ether, pungent and putrid, the seven primary odors suggested by Amoore) and such schemes have heuristic value. However, odorants within any such class often have diverse physiochemical properties and, with few exceptions, it has not proven possible to reliably predict odor quality from the molecular structure of an odorant.

### Affective Responses to Odors

Few olfactory stimuli are judged as hedonically neutral; most elicit a clear like or dislike reaction on the part of the perceiver. The ubiquitous use of odorants in cosmetics and foods attests to the fact that many odors are pleasing and can influence mood and appetite. In humans, the hedonic valence of an odor is largely learned and the experience associated with an odor probably determines its hedonic valence. There are obvious cultural differences in odor preference: for example the odor of the durian fruit is judged generally as fetid by Westerners but is described as heavenly by natives in South East Asia.

► **Trigeminal**, ► **glossopharyngeal** and vagus nerves in the respiratory tract respond to airborne irritants and their activation together with olfactory sensory neurons may contribute to perceived intensity and unpleasantness of some odors. Except for fear or aversive responses shown by some animals to the odor of predators, it has proven difficult to assess odor preferences in laboratory animals. Human fMRI studies demonstrate arousal of the amygdala by both pleasant and

unpleasant odors but, interestingly, not by more neutral odors. These outcomes are in agreement with the more general findings that the amygdala plays an important role in emotional arousal.

### Odor Memory

The “Proust effect” provides a popular example of long-term odor memory, and déjà vu phenomena are often triggered by odors. Clearly, odors, particularly those associated with an emotion arousing event, are remembered for years if not the lifetime of an individual. Studies with rodents demonstrate near perfect retention of odor discrimination tasks even after a brief exposure to the conditioning odor or after manipulations specifically designed to maximize proactive and retroactive interference with odor memory [7]. Where such long-term memories are stored is uncertain; in rats, neither surgical disruption of the olfactory thalamic-orbital prefrontal cortex or projections to the amygdala disrupt odor memory. In humans, fMRI studies reveal activation of many brain areas during the encoding of odor stimuli but more restricted areas and especially olfactory cortex and orbital prefrontal areas in recall or identification of familiar odors.

### Cognitive Function

In humans, olfaction is generally not viewed as an essential sensory modality and does not appear to play an important role in cognitive or higher mental processes (i.e., we don’t “think with our noses”). In contrast, rats, whose behavior is largely guided by and dependent on odors, become quite competent in performing complex, cognitive based tasks when odors are provided as discriminative cues. Thus, rats quickly acquire strategies for nearly errorless solutions for a series of simple discrimination tasks and more difficult matching to sample problems (i.e., they acquire a “learning set”), demonstrate paired associate learning, and even solve problems requiring a form of transitive inference. It is unlikely that other sensory cues could support such learning and, indeed, rats perform more poorly or fail when trained on learning set or matching to sample tasks if visual or auditory cues are used. These cognitive abilities appear to be dependent on thalamic-orbital frontal cortical projections: lesions of this system, including those confined largely to the olfactory component of the medial dorsal thalamic nucleus, have little or no effect on simple odor discrimination problems but disrupt acquisition of complex olfactory tasks [7].

### Odors, Reproduction and Unconscious Perception

Olfaction is a critically important sensory modality for most mammals and is used in a variety of behaviors from homing to identifying sources of food and the social status of conspecifics. The demonstration that exposure of gravid female mice to the odor of males from a different strain can disrupt pregnancy (the



“Bruce Effect”) led to studies demonstrating clearly the influence of conspecific odors on neuroendocrine changes involved in sexual maturity, mate selection and other aspects of reproduction and social interactions in rodents and, to some extent, in primates. Whether odors play a similar role in humans remains a continuing topic of interest. In humans, exposure to steroidal and other odors from exocrine glands appears to have subtle and gender-specific effects on a number of physiological indices and may alter mood [8,9]. Of particular interest is the evidence that such changes may occur without the subject’s conscious awareness of the odor stimulus. It is unclear whether this “unconscious perception” is mediated by neural pathways that bypass olfactory cortex. Such pathways exist in mammals with well developed vomeronasal/accessory olfactory bulb structures but there is scant evidence for the existence of a similar accessory olfactory system in humans.

### Olfaction, Schizophrenia and Neurodegenerative Disease

Deficits in odor identification together with signs of degeneration in central olfactory structures are a pervasive concomitant of schizophrenia, Wilson’s, Parkinson’s disease (PD) and Alzheimer-type dementia (AD). Patients diagnosed as schizophrenic perform poorly on an odor identification task despite having reasonably normal odor detection thresholds. Indeed, olfactory dysfunction may be near universal in neurodegenerative diseases and occurs even in those with cerebellar ataxia; its onset may predate the first clinical signs of the disease and, thus, be diagnostic, particularly for patients at risk for psychosis or AD (e.g., those with an ApoE4 allele).

Other sensory systems do not exhibit the extensive degenerative changes that occur in the olfactory system in PD and AD and it is unclear why a progressive loss of smell function should be characteristic of and even predate movement and cognitive disorders [10].

In brain imaging studies, identification deficits appear to be more closely associated with changes in olfactory cortex or the temporal lobe than with the frontal lobe. Interestingly, olfactory auras often precede the onset of temporal lobe psychomotor epilepsy. The temporal lobe may also be involved in other olfactory disorders including olfactory hallucinations (phantosmia) and altered or distorted perception of odors (parosmia).

### References

1. Buck LB (1996) Information coding in the vertebrate olfactory system. *Annu Rev Neurosci* 19:517–544
2. Wachowiak M, Shipley MT (2006) Coding and synaptic processing of sensory information in the glomerular layer of the olfactory bulb. *Semin Cell Dev Biol* 17:411–423

3. Carmichael ST, Clugnet MC, Price JL (1994) Central olfactory connections in the macaque monkey. *J Comp Neurol* 346:403–434
4. Spors H, Wachowiak M, Cohen LB, Friedrich RW (2006) Temporal dynamics and latency patterns of receptor neuron input to the olfactory bulb. *J Neurosci* 26:1247–1259
5. Slotnick B, Bodyak N (2002) Odor discrimination and odor quality perception in rats with disruption of connections between the olfactory epithelium and olfactory bulbs. *J Neurosci* 22:4205–4216
6. Wilson DA, Kadohisa M, Fletcher ML (2006) Cortical contributions to olfaction: plasticity and perception. *Semin Cell Dev Biol* 17:462–470
7. Slotnick B (2001) Animal cognition and the rat olfactory system. *Trends Cogn Sci* 5:216–222
8. Snowdon CT, Ziegler TE, Schultz-Darken NJ, Ferris CF (2006) Social odours, sexual arousal and pairbonding in primates. *Philos Trans R Soc Lond B Biol Sci* 361:2079–2089
9. Jacob S, Hayreh DJ, McClintock MK (2001) Context-dependent effects of steroid chemosignals on human physiology and mood. *Physiol Behav* 74:15–27
10. Albers MW, Tabert MH, Devanand DP (2006) Olfactory dysfunction as a predictor of neurodegenerative disease. *Curr Neurol Neurosci Rep* 6:379–386

## Olfactory Perceptual Learning

DONALD A. WILSON, HEATHER BELL,  
CHIEN-FU CHEN  
Department of Zoology, University of Oklahoma,  
Norman, OK, USA

### Synonyms

Odor memory; Odor familiarity; Odor expertise

### Definition

Perceptual learning is an improvement through experience in the ability or potential ability to detect and/or discriminate sensory stimuli. Perceptual learning can be demonstrated in nearly all sensory systems, for example through the enhanced ability of musicians to identify or discriminate musical notes, or of visual artists to identify similar colors. In the sense of smell, most ►odors experienced in nature or everyday life are complex mixtures of many different ►odorant molecules. Being able to discriminate these different mixtures from each other is one of the main functions of the olfactory system. In mammals, recognition and discrimination of such odors appears to involve an initial analysis of the inhaled stimulus into its component molecular and submolecular features, and a subsequent merging of those features into a unitary odor object, such as “coffee” or “rose.” As odors become more familiar, both the encoding of the features and their synthesis into objects are enhanced, leading to improvements in fine

sensory discrimination. Experience-dependent changes within the nervous system underlying this olfactory perceptual learning occur throughout the olfactory sensory pathway.

### Characteristics

Sensory discrimination - the ability to determine whether two stimuli are the same or not - can improve with experience. Slight differences between two stimuli that originally went undetectable, can become detectable with experience and training. This experience-dependent improvement is called perceptual learning, and generally regarded as a form of ▶[implicit learning](#), not requiring conscious awareness. Typical examples of perceptual learning include improvements in visual vernier acuity, where the ability to determine whether two vertical lines are either exactly in line or slightly horizontally displaced from each other can be improved through training. Similar examples have been described for auditory pitch perception and haptic (sense of touch) texture discrimination. One common characteristic of perceptual learning is that the effect is largely limited to the familiar stimulus set. Thus, improvements in vernier acuity for vertical lines does not transfer to acuity for horizontal lines.

The improvement in sensory discrimination with experience implies a change in the underlying sensory system which encodes the stimuli. Sensory systems generally encode stimuli in the external world by having populations of neurons tuned to slightly different aspects of those stimuli. Thus, peripheral receptors, transducing sensory input into neural activity, may only respond to a narrow range of energy – a certain wavelength or location of light in vision, a certain frequency of sound in audition, or a certain molecular shape or charge in olfaction. Through the cooperative action of large ensembles of such neurons, information about the identity of the original stimulus emerges, which can then guide perception and behavioral responses.

This basic sensory system function leads to several potential mechanisms through which perceptual learning may arise. Experience with a specific range of sensory inputs could lead to changes in peripheral receptor number or relative tuning distribution, tuning of neurons within the central nervous system, and/or local circuit interactions within the large ensembles. There is evidence for all of these experience-dependent changes occurring in the olfactory system associated with perceptual learning.

### Behavioral Evidence of Olfactory Perceptual Learning

In humans, experience with specific odors enhances subsequent discrimination and identification of those odors. Thus, familiar odors are more easily discriminated than unfamiliar odors [1]. This experience-dependent improvement can be induced either through specific exposure or training, or emerge

over a lifetime of experience. This latter process may contribute to strong cultural differences in perception and categorization of odors.

In animal models, as in humans, odor experience enhances discriminability of familiar odors [2,3]. Naïve rodents, for example, fail to respond differentially to many monomolecular odorants differing by a single hydrocarbon in their molecular structure. This can be tested in a habituation/cross-habituation paradigm, where one odorant is repeatedly presented until some behavioral response habituates. Then, a second odorant is presented. If the animal discriminates between the odorants, the new odorant evokes a behavioral response. If the animal does not discriminate between the odorants, the response to the new odorant is comparable to the habituated odorant. Using such a paradigm, naïve animals that were habituated to, for example the four carbon odorant molecule ethyl butyrate, showed cross-habituation to the five carbon odorant molecule ethyl valerate, suggesting they cannot discriminate between these odorants (i.e., the odors are similar). However, if given prior experience with these odorants, they subsequently do show differential responses to the two odorants. These experience-induced changes appear selective to the familiar odorants and do not create a general enhancement for discrimination of all odorants.

In addition to experience-induced enhancement of odorant discrimination, perceptual learning can also improve identification of components within odorant mixtures [4]. With simple mixtures of pure odorants, the intensity of individual components plays a major role in the ability to identify those components. Thus, as might be expected, as one component within a binary mixture becomes more intense (higher relative concentration) than the other, that component comes to dominate the perception of the mixture. However, familiarity of the components produces a similar effect. Familiar components are more easily identified within a mixture than unfamiliar components. This consequence of perceptual learning may underlie the ability of professional flavorists and perfumers to identify components with mixtures, although human psychophysical data suggest even professionals have only a limited ability to analyze complex mixtures that include greater than 3–4 components into their constituent parts.

Finally, in addition to experience-induced enhancement of discriminability, odorant exposure may also enhance detectability of odorants [5]. Perhaps the best example of this is perception of the odorant androstenone, though other odorants show similar effects. Androstenone is a component of human sweat, and is more concentrated in males than females. Many individuals appear to have very high thresholds for detecting androstenone, or are even ▶[anosmic](#) to it. However, repeated exposure over multiple days can significantly improve detection in these individuals, dramatically lowering detection thresholds. There is some evidence

that females may acquire this experience-dependent sensitivity faster than males.

### Neurobiology of Olfactory Perceptual Learning

At the neurobiological level, memory for odors and their associations is distributed throughout the sensory pathway, with evidence for changes from the receptor sheet all the way to the primary olfactory cortex [2,6]. The olfactory systems of all vertebrates and many invertebrates share several basic structural features. Peripheral olfactory receptor neurons express one or a few olfactory receptor genes which code for proteins that bind to odorant molecules sharing a particular structure. These receptor neurons then project to the second order neurons within a central nervous system structure called the olfactory bulb (vertebrates) or antennal lobe (invertebrates). The connections between receptor and second order neurons occurs within structures called glomeruli, which receive input from receptor neurons all expressing the same olfactory receptor genes. Thus, stimulation with a particular odorant activates a unique combination of glomeruli based on which receptors that odorant molecule binds. The response of second order neurons reflects the homogeneous receptor input, as well as local circuit interactions. The second order neurons then project to the olfactory cortex (mammals) or mushroom bodies (invertebrates), where convergence of the different molecular features extracted by the periphery occurs on individual third order neurons. In different behavioral paradigms and different species, olfactory experience has been found to change the response patterns of receptor neurons and glomeruli, and both single cell and ensemble activity of second and third order neurons.

Experience-induced responsiveness to odorants, such as androstenone, may involve both peripheral and central changes. Evidence in humans and rodents suggests that repeated or prolonged exposure to an odorant such as androstenone produces enhanced olfactory receptor sheet responses as measured with electro-olfactogram [7]. The electro-olfactogram is a measurement of summed receptor sheet activity, much as the electroencephalogram measures summed cortical activity. The specific mechanism of enhanced receptor sheet responsiveness to exposed odors is currently unknown. In addition to these peripheral changes, there is some evidence for central sensitization [5]. Humans exposed unilaterally to androstenone will become able to smell it through either nostril, despite the lack of a direct connection between the two receptor sheets. This suggests that central neurons, that receive convergent information from the two airways, may partially mediate the exposure-induced sensitization.

Experience-induced enhancements in discrimination appear to rely on changes within the central nervous system. Exposure to an odor for as little as a few minutes can produce a long-lasting shift in the tuning of second

order neurons, such as olfactory bulb mitral cells [3]. These shifts enhance the number of second order neurons encoding familiar odorant features. These changes in individual neuron activity are accompanied by large scale neural ensemble changes, as evidenced by changes in odorant-evoked local field potentials within the olfactory bulb. At least two mechanisms may contribute to these changes in stimulus-evoked activity. First, connectivity between existing neurons may be altered during perceptual learning through synaptic plasticity. Plasticity of synapses within glomerular and/or between second order neurons and local interneurons could affect feedback, feedforward and lateral inhibition. These changes in inhibition could influence both responses of single neurons to familiar stimuli and timing of evoked activity. A change in odorant-evoked spike timing, for example increased synchrony, is hypothesized to enhance the salience of familiar stimulus features to downstream neurons, thus facilitating their identification and discrimination.

A second mechanism of perceptual learning associated change within the olfactory bulb is anatomical restructuring of local circuits. A major class of local interneurons in the mammalian olfactory bulb, granule cells, undergo continual neurogenesis throughout life in many animals. Survival and incorporation of granule cells into local circuits is dependent on odor experience. Given the precise projections of olfactory receptor neurons to olfactory bulb glomeruli, different stimuli evoke different spatial patterns of activity across the olfactory bulb, with activation of a given glomerulus associated with activity of a local, spatially defined column of second order neurons and interneurons such as granule cells. Repeated stimulation of a given glomerulus over several weeks by exposure to a particular odorant, enhances survival of granule cells near that glomerular column, while sensory deprivation reduces granule cell survival [8]. Granule cells not only control excitability of second order neurons, but are also the target of cortical feedback to the olfactory bulb. Thus, they may play an important role in familiarity induced effects on olfactory bulb odor encoding.

Finally, olfactory perceptual learning is associated with changes within mushroom bodies of invertebrates and olfactory cortex of mammals [2,9]. As noted above, the olfactory cortex is hypothesized to synthesize disparate, co-occurring odorant features into perceptual wholes, or odor objects. As this synthesis occurs, a template is formed in cortical circuits, allowing a rapid match of subsequent input to that stored template and enhanced discrimination and recognition. This cortical learning may also contribute to perceptual stability of complex odors, even in the face of slight alterations in intensity or presence of some components [6]. Olfactory perceptual learning may involve changes in both the anterior and posterior piriform cortices, as well as the orbitofrontal cortex. In both humans [9] and rodents

[10], the anterior piriform cortex appears to encode stimulus identity, with experience creating a unique encoding of a mixture stimulus distinct from that of its components. In contrast, the posterior piriform cortex appears to encode information about odor quality (e.g., fruitiness) or categorical information, a process again enhanced by experience and odor familiarity.

The types of modifications in neural coding and perception described here associated with olfactory perceptual learning most likely occur in all cases when odors become familiar or are actively learned. The result is that our perception of familiar odors is different than our perception of novel odors, allowing enhanced discrimination and identification of the familiar.

## References

1. Rabin MD (1988) Experience facilitates olfactory quality discrimination. *Percept Psychophys* 44:532–540
2. Davis RL (2004) Olfactory learning. *Neuron* 44:31–48
3. Fletcher ML, Wilson DA (2002) Experience modifies olfactory acuity: acetylcholine-dependent learning decreases behavioral generalization between similar odorants. *J Neurosci* 22:RC201
4. Livermore A, Laing DG (1996) Influence of training and experience on the perception of multicomponent odor mixtures. *J Exp Psychol Hum Percept Perform* 22:267–277
5. Mainland JD, Bremner EA, Young N, Johnson BN, Khan RM, Bensafi M, Sobel N (2002) Olfactory plasticity: one nostril knows what the other learns. *Nature* 419:802
6. Wilson DA, Stevenson RJ (2006) Learning to smell: olfactory perception from neurobiology to behavior, Johns Hopkins University Press, Baltimore, p 309
7. Wang L, Chen L, Jacob TJ (2003) Evidence for peripheral plasticity in human odour response. *J Physiol* 554:236–244
8. Lledo PM, Gheusi G (2003) Olfactory processing in a changing brain. *Neuroreport* 14:1655–1663
9. Li W, Luxenberg E, Parrish T, Gottfried JA (2006) Learning to smell the roses: experience-dependent neural plasticity in human piriform and orbitofrontal cortices. *Neuron* 52:1097–1108
10. Kadohisa M, Wilson DA (2006) Separate encoding of identity and similarity of complex familiar odors in piriform cortex. *Proc Natl Acad Sci USA* 103:15206–15211

## Olfactory Plasticity

J. C. SANDOZ

Research Center for Animal Cognition, CNRS UMR 5169, Paul Sabatier University, Toulouse Cedex, France

### Synonyms

Olfactory learning; Odor-exposure learning; Olfactory priming

## Definition

Olfactory plasticity is a general term referring to all types of changes in odor-evoked responses resulting from individual experience. These changes, usually monitored behaviorally, rely on short- or longer-lived structural and/or functional modifications at different levels of the olfactory circuits. Olfactory plasticity is therefore a form of ►neural plasticity.

## Characteristics

A general rule of sensory systems is that they constantly adapt to environmental conditions, inducing modifications of the way they process sensory stimuli. Such modifications can be very short (in the range of seconds, for instance receptor desensitization) or very long (in the range of years, plasticity of central representations), depending on the type of experience and of the species considered. Due to obvious differences in lifespan, modifications that are considered to correspond to a medium-term range in a given species may be assigned to the long-term range in a different species.

Olfactory plasticity is found in a wide range of species, from nematodes (*C. elegans*) to humans, with prominent examples in insects (fruit flies, bees, etc.) and mammals (rabbits, rats, mice, humans, etc.). These changes can affect all levels of the olfactory circuits, from the most peripheral (olfactory receptors) to the most central ones (cortical representation). Olfactory plasticity can be demonstrated in behavioral experiments, and its neural basis is usually the subject of neurophysiological and/or neuroanatomical experiments. We will first provide a brief description of a generalized olfactory system (for details, see essays on ►olfactory perception, or ►odor coding). We will then detail the types of sensory/associative experiences that induce olfactory plasticity at the behavioral level. To finish, we will present the current view of the neural basis of olfactory plasticity.

## The Olfactory System

The anatomical organization of the olfactory system of vertebrates and of invertebrates, like insects, shows many fundamental similarities. Odors are detected at the periphery (olfactory mucosa within the nose or antenna) by olfactory sensory neurons (OSN), which each express a given type of olfactory ►G-protein-coupled receptor. These neurons relay odor information to a first olfactory centre, the olfactory bulb (OB) in vertebrates or its equivalent in insects, the antennal lobe (AL). Both structures are organized in a similar modular way: each of their subunits, the glomeruli, receives input from OSNs expressing the same olfactory receptor type. Glomeruli are sites of intensive synaptic contacts between several neuron types, in particular inhibitory neurons providing local inter-glomerular computation (periglomerular cells/local interneurons), and second-order neurons (mitral cells/projection neurons) that relay processed

information to higher brain centers. Between mitral cells, granule cells provide additional lateral inhibition in vertebrates. The complex ►neural network of the AL/OB is considered to be a major site for olfactory plasticity. It performs computations which are thought to mediate better discrimination between similar olfactory inputs, allowing more segregated spatio-temporal odor representations to be conveyed to higher brain centers such as the piriform cortex, the entorhinal cortex and the periamygdaloid cortex in mammals, or the mushroom bodies and the lateral protocerebral lobe in insects (see essay on ►odor coding). These structures are thought to be involved in higher-order processing of odor information, like providing the synthetic part of mixture representation, but also in associative learning and memory of odors, and, at least in mammals, providing emotional and hedonic values to odors. As we will see, olfactory plasticity can take place at all levels of the olfactory system.

### Sensory and Associative Experience Inducing Olfactory Plasticity

Experimentally, olfactory plasticity is often demonstrated by the result of behavioral experiments, during which a particular olfactory experience induces changes in the way animals or subjects respond to odors. We will review these types of experiences from simple olfactory exposures to much more complex forms of associative learning between particular odors and different outcomes.

#### Olfactory Exposure

Simple odor exposure, even a very short one, can have consequences on the way the olfactory system will respond to subsequent odor presentations. The most peripheral of these phenomena is called ►olfactory adaptation [1], during which exposure to an odor (from very short pulses to stimulations of a few seconds) decreases reversibly the sensitivity of olfactory receptor neurons (usually in the range of seconds to a few minutes). Functionally, this is believed to allow an animal to constantly adapt its olfactory system to environmental odors, avoiding saturation of the cellular transduction machinery and thereby keeping the ability for the animal to detect more relevant short-lasting odors. Different forms of odor adaptation have been described, depending on the length of the odor stimulation inducing it (short or long puff) and the length of the adaptation (short or long-lived). These different forms are thought to depend on slightly different but interconnected cellular feedback loops within olfactory sensory neurons. Odor adaptation is considered to be reversible. Experimentally, it has provided previous researchers an interesting way of testing whether

two odorants are detected by different or overlapping sets of olfactory receptor neurons, in so-called cross-adaptation experiments: animals are first exposed to a mono-molecular odorant A until they adapt to it. Then a second odorant B is presented. If response to B is affected by the former presentation of A, it suggests that detection of B depends on receptors used for the detection of A.

Simple odor exposures do not only affect the periphery, and the changes that they induce at the central level are then considered forms of ►perceptual learning. On a quantitative level, repeated presentations of an odor can have two kinds of effects. On the one hand, the probability of a behavioral response provided by an animal to the presentation of the odor (for instance, a startle or a sniffing response) will tend to decrease through repeated presentations of this odor. This effect is termed ►odor habituation. In some cases, even if a decrease of an odor-evoked response is observed, this effect can be more related to a reduction of the animal's attention or of its overall responsiveness than to a decrease of odor detection ability or changes in odor processing. In fact, repeated experience with an odor can have the opposite effect, reducing the olfactory detection threshold (odors are detected at lower concentration) and can even allow odor detection by seemingly anosmic subjects. On a more qualitative level, repeated experience with a range of different odors can greatly improve the discrimination ability of subjects among these, but also novel, odorants. Furthermore, experience with an olfactory mixture can strongly modify the way the individual components of the mixture are perceived. For instance, a given odor presented to a subject together with a "smoky" odor will tend to be perceived afterwards as smoky, while the same odor would smell cherry-like after being presented together with a "cherry" odor. Such effects are usually interpreted as forms of ►implicit memory and are thought to rely on neural plasticity at different levels of central areas, from the OB where it would modify the receptive range of mitral/tufted cells to the piriform cortex and the orbito-frontal cortex where the synthetic representation of odors may change. These olfactory forms of perceptual learning can take place rapidly, but are usually long-lasting.

#### Associative Learning

The most prominent forms of olfactory plasticity relate to associative conditioning, during which animals learn to associate odors with particular outcomes or behaviors, which have a positive or negative significance for the animal. It is generally accepted that most of our hedonic relationship to odors is not innate, but rather acquired throughout our lifetime by associations between these

odors and particular events or contexts. Odor learning starts even before birth from the mother's amniotic fluid, as the olfactory system is already functional in utero by 12 weeks of gestation. For instance, children of mothers who consume particular odors (garlic, cumin, etc.) and were therefore exposed to these odors during gestation and/or breast-feeding show specific preferences for these odors afterwards. Throughout young age, children learn to associate particular scents or tastes with edibility and/or positive and negative events, and it is generally accepted that by the age of 8, most of our adult olfactory preferences are acquired, although adult experience certainly continues to shape olfactory preference [2]; see also learning during a sensitive period, below].

Experimental psychology distinguishes two main forms of associative learning which both are very prominent in the olfactory domain:

1. In ► **classical (Pavlovian) ► conditioning**, an animal learns to associate an originally neutral, ► **conditioned stimulus** (CS – here an odor) with a biologically relevant, ► **unconditioned stimulus** (US). For instance, honeybees learn to associate odors with sucrose solution in the paradigm of the proboscis extension response (PER) conditioning. In a hungry bee, sucrose solution triggers the reflex extension of the mouthparts (the PER), allowing the insect to drink. Prior to conditioning, odors are ineffective. However, after a single CS/US association, the odor can now elicit the PER and after a few such associations an odor-sucrose memory is formed that can last for the bee's lifespan.
2. In ► **operant (instrumental) ► conditioning**, the animal learns to associate a behavioral action to a ► **reinforcement**, and a ► **discriminative stimulus** (e.g., an odor) can function as a signal for producing the learned behavior. For instance, an odor may act as the signal for a rat to poke its nose in a particular box in order to receive a food reward. Although conditioning creates an association between nose poking and the food reward, odor-food and odor-poking associations are also built and will drive the rat's choice.

In both learning paradigms, odor-outcome (US or reinforcement) associations are established, which can be either ► **appetitive** or ► **aversive**.

More complex olfactory learning tasks can be conceived, either in a classical or an operant framework, establishing multiple associations between different odors and multiple outcomes. A simple example of such tasks is differential conditioning (A+, B–), in which an odor A is associated with a US/► **reinforcer** and another odor B is left without consequence. Experimentally, such conditioning has often been used in the study of neural olfactory plasticity [3–4], because

it provides the experimenter with a within-animal control as the same animal has to learn to respond to odor A but not to odor B: usually, specific changes in neural responses are found for A but not for B. In some cases, learning can induce a decorrelation of the neural representations of A and B, making them more discernible for the olfactory system. More complex forms involve ambiguities between odors and outcomes, and give a special meaning to the concomitant presentation of two or more odors: for instance, in biconditional discrimination (AB+, CD+, AC–, BD–), each odor is as often reinforced as not, and the right behavioral response can only be found after linking different odor representations (here the animal should respond to odor A when it is presented together with B but not when A is presented together with C). All these different forms of olfactory learning are based on increasingly complex associations, and pose each different constraints to the olfactory system. In this case, one expects a decorrelation of the representations of odor combinations with different outcome, irrespective of the common presence of a given odor (e.g., AB+ vs. BD–).

#### **Olfactory Plasticity During a Sensitive Period**

The olfactory plasticity phenomena detailed above can take place at any moment in an animal's life. There are, however, instances of olfactory plasticity that can only happen during sensitive periods such as after mating or short after birth. Thus, newly-mated female mice learn the specific odor of the mating male, and any encounter with a different male will provoke pregnancy failure [5]. Another prominent example is neonatal learning in rabbit pups, which learn extremely fast – during the first three days after birth, odors that are present on the doe's belly. Recently, a mammary pheromone was found, which alone triggers stereotyped orocephalic movements of nipple search in young rabbit pups. Normally, odors do not elicit this response. However, a single simultaneous presentation of an odor together with the pheromone dramatically changes the pups' behavior, such that it will now respond to the odor presented alone [6]. This form of classical olfactory conditioning is particular, not only for the existence of a strict sensitive period, but also for the fact that an odor, the mammary pheromone, acts as a reinforcer.

#### **Neural Basis of Olfactory Plasticity**

Changes in odor-evoked behavioral responses can rely on neural plasticity at all levels of the olfactory circuits, from the most peripheral during olfactory adaptation to the more central, OB/AL and/or higher brain centers for perceptual and associative conditioning. Olfactory plasticity is manifested at the neuron level through both structural and functional neuronal changes.

On a structural level, the number and/or repartition of synaptic contacts between olfactory neuronal populations can be modified. For instance, differential olfactory conditioning is accompanied in ►**pyramidal neurons** of the piriform cortex by an increased density of ►**dendritic spines** linked to intra-cortex connections, but also to pruning (reduction) of spines linked to afferent input from the olfactory bulb, suggesting intense rearrangements of olfactory connectivity through learning [7]. Such structural changes can sometimes be correlated with a change in the volume or shape of neuronal structures like the glomeruli. In the particular case of the olfactory bulb, neural olfactory plasticity can take the form of the genesis and preferential survival of novel neurons that will integrate the neural network, specifically as inhibitory interneurons (periglomerular and granule cells). It could be shown that this process is increased after differential olfactory learning [3] and that the novel production (or the loss) of such interneurons has important consequences for OB activity. Structural plasticity is usually related to long-term forms of olfactory plasticity, as they need time to take place.

On a functional level, the strength and efficacy of synaptic transmission can be modified. This can imply many changes at the level of neurotransmitter release, receptor equipment, intra-cellular cascades, second messengers and for long-term forms, it relies on novel protein synthesis. Most functional work on olfactory plasticity has concentrated on describing changes observed in odor-evoked responses within olfactory structures. Depending on the recording technique, modifications are observed on the amplitude, frequency or synchronisation of electrophysiological responses [8,9], on the intensity or repartition of optically-monitored activity [4], on the pattern of production of synaptic proteins etc. In some experiments, plasticity is assessed on whole brain structures with awake and behaving animals. For instance, olfactory bulb field potential activity can be monitored from freely-behaving rats. Odor stimuli usually produce a frequency change in the ►**field potential**, with a power decrease in the  $\gamma$  frequency range (60–90 Hz) associated with a power increase in the  $\beta$  range (15–40 Hz). This pattern of response was found to be strongly amplified in animals trained in an olfactory learning task, precisely at the moment when they started mastering the task [9]. In such cases, it is difficult to determine precisely the location of this plasticity, which can reveal synaptic efficacy changes over a whole olfactory network. In other approaches, particular neuron populations can be monitored, usually in fixed animals. Thus, in rats, it could be shown in electrophysiological recordings of mitral cell activity that an olfactory exposure can modify their receptive range, so that they would

respond to a wider range of odors after olfactory exposure than before [8]. In fruitflies, associative aversive conditioning based on odor-electric shock associations can be applied on a fixed fly under the microscope. Optical imaging experiments coupled to the genetic expression of a reporter of synaptic activity (synapto-PHluorin) in particular antennal lobe populations showed that projection neurons that were initially not activated by an odor prior to conditioning could be recruited shortly after differential aversive conditioning. Recordings from sensory neuron or inhibitory local interneuron populations did not show any change, demonstrating that plasticity took place at the level of second order neurons [10].

Until now, most available data on neural plasticity underlying olfactory learning was obtained from primary olfactory centers (OB/AL) that are easier to access. However, research on higher-order structures is growing. Thus, experiments have already shown that electrophysiological responses of neurons in the olfactory cortex are strongly influenced by previous odor stimulations, and are certainly involved in perceptual learning. But the kind of activity changes appearing at this level, in contrast to those found within the primary centers, correspond to higher-order computations allowing, for instance, the discrimination between a mixture and its components, a task deemed as one of the most critical for odor perception. Moreover, such higher-order structures are good candidates for harboring associative olfactory memories. In fruitflies, Kenyon cells (third order neurons) within the mushroom bodies displayed dramatic increases of calcium responses to the learned odor several hours after a differential aversive conditioning task, with even a localization of changes within specific branches of these neurons [10]. In fact, as only a few third order neurons are activated by a given odor, as opposed to many second-order neurons, neurons in more central areas constitute an ideal substrate for the associative memory trace, giving a particular odor a particular meaning.

### **Conclusion: Odor Processing Plasticity or Odor-Reinforcement Memory?**

As detailed above, many electrophysiological, functional imaging or neuroanatomical studies find strong neural plasticity within olfactory circuits, especially after associative conditioning. However, it is often difficult to relate such neural plasticity to its exact function. Are the observed changes related to modifications of odor processing, modulating for instance the neural representation of the learned odors so that it can be better distinguished from environmental background? Or are they related to an olfactory ►**engram**,

revealing the storage of odor-reinforcement associations in the brain? The picture emerging from the studies carried out so far suggests that primary olfactory centers (OB/antennal lobe) may be responsible for the former, and higher olfactory centers for the latter, but considerable work is still needed to confirm this hypothesis. Future neurobiological studies of olfactory plasticity will have to answer these questions, using a combination of approaches, asking in particular whether the observed cells (and their plasticity) are necessary and sufficient for the expression of olfactory plasticity at the behavioral level.

## References

1. Zufall F, Leinders-Zufall T (2000) The Cellular and molecular basis of odor adaptation. *Chemical Senses* 25:473–481
2. Herz RS (2002) Influences of odors on mood and affective cognition. In: Rouby C et al (eds) *Olfaction, Taste and Cognition* Cambridge University Press, UK, pp 160–177
3. Alonso M, Viollet C, Gabellec MM, Meas-Yedid V, Olivo-Marin JC, Lledo PM (2006) Olfactory discrimination learning increases the survival of adult-born neurons in the olfactory bulb *J Neurosci* 26:10508–10513
4. Faber T, Joerges J, Menzel R (1999) Associative learning modifies neural representations of odors in the insect brain. *Nat Neurosci* 2:74–78
5. Brennan PA, Keverne EB (1997) Neural mechanisms of mammalian olfactory learning *Prog Neurobiol* 51:457–481
6. Coureaud G, Moncomble AS, Montigny D, Dewas M, Perrier G, Schaal B (2006) A pheromone that rapidly promotes learning in the newborn. *Curr Biol* 16:1956–1961
7. Knafo F, Libersat F, Barkai E (2005) Dynamics of learning-induced spine redistribution along dendrites of pyramidal neurons in rats. *Eur J Neurosci* 21:927–935
8. Fletcher ML, Wilson DA (2003) Olfactory bulb mitral-tufted cell plasticity: odorant-specific tuning reflects previous odorant exposure. *J Neurosci* 23:6946–6955
9. Martin C, Gervais R, Hugues E, Messaoudi B, Ravel N (2004) Learning modulation of odor-induced oscillatory responses in the rat olfactory bulb: a correlate of odor recognition? *J Neurosci* 24:389–397
10. Berry J, Krause WC, Davis RL (2008) Chapter 18 Olfactory memory traces in *Drosophila*. *Prog Brain Res* 169:293–304

## Olfactory Priming

► Olfactory Plasticity

## Olfactory Receptor

### Definition

Olfactory receptors are members of the seven transmembrane domain G-protein coupled family of receptor proteins. The binding of an odorant molecule to an olfactory receptor initiates a conformational change that activates the G-protein and leads to an electrical response in the olfactory sensory neuron that can be transmitted to the brain. Around 1,000 genes encoding functional olfactory receptor proteins have been identified in the mouse genome, with around 350 functional olfactory receptors identified in the human genome. Individual receptor types are typically activated by small and partially overlapping ranges of odorants. The identity of an odorant is therefore conveyed by the pattern of different odorant receptor types that it activates, i.e. an across-fiber pattern code.

► G-protein Coupled Receptors (GPCRs): Key Players in the Detection of Sensory and Cell-Cell Communication Messages

► Odorant

► Odorant Receptor

► Odor Coding

► Olfactory Sensory Neuron

## Olfactory Receptor Neuron (ORN)

### Definition

Olfactory receptor neurons are cells in the olfactory epithelium in the nasal cavity. They are bipolar neurons with an apical dendrite with cilia facing the interior space of the nasal cavity and a basal axon that via the first cranial (olfactory) nerve passes through the cribriform plate and enters the olfactory bulb. Each olfactory receptor neuron probably expresses a single type of olfactory receptor protein, and neurons with the same receptors are scattered through one of four zones in the epithelium. Olfactory sensory neurons are also sometimes called “olfactory receptors,” although this term can be confused with the odorant receptor proteins themselves. It should be noted that the olfactory epithelium is also innervated by the trigeminal nerve,



which is responsible for mechanical sensations (touch and pressure), as well as pain and temperature. Trigeminal fibers also respond to chemicals found in onions, mustard and chile powder.

- ▶ Odorant Receptor Protein
- ▶ Olfactory Bulb
- ▶ Olfactory Epithelium
- ▶ Olfactory Nerve

---

## Olfactory Receptor Protein

- ▶ Odorant Receptor

---

## Olfactory-recipient

### Definition

Parts of the basal telencephalon receiving inputs from the main olfactory bulb. Olfactory-recipient areas include the olfactory amygdala and, depending on the species, the ventral telencephalon, lateral pallidum, lateral cortex or olfactory cortex.

- ▶ Evolution of Olfactory and Vomeronasal Systems
- ▶ Olfactory Amygdala
- ▶ Olfactory Bulb
- ▶ Olfactory Cortex

---

## Olfactory Recognition

### Definition

Olfactory recognition, first and foremost, refers to the process by which an odor molecule is sensed and detected by an olfactory receptor. This process is not yet well understood, mainly because of the fact that the protein structure and function of many G-protein coupled receptors (GPCRs) is still under investigation. In contrast to most other GPCRs that recognize their ligands through ionic or hydrogen bond interactions, it appears that olfactory receptors recognize odorants primarily by weak hydrophobic and van der Waals

interactions, which allow the observed broad but selective odor ligand binding of olfactory receptors.

- ▶ G-protein Coupled Receptors (GPCRs): Key Players in the Detection of Sensory and Cell-Cell Communication Messages
- ▶ Odor
- ▶ Odorant
- ▶ Odorant Receptor Protein
- ▶ Olfactory Receptor
- ▶ Olfactory Receptor Neuron

---

## Olfactory Sense

HANNS HATT

Department of Cell Physiology, Ruhr-University Bochum, Bochum, Germany

### Synonyms

Sense of smell; Chemosensation; Odor perception

### Definition

The olfactory system enables most animals to continuously monitor their chemical environment. The sensitivity and range of olfactory systems is remarkable, enabling organisms to detect and discriminate between thousands of low molecular mass, mostly organic compounds which we commonly call odors. The task is accomplished by specialized olfactory sensory neurons which encode the strength, duration and quality of odorant stimuli into distinct patterns of afferent neuronal signals. Thus, the molecular structure of an odorant molecule is converted into a pattern of electrical activity, which intern is processed in the olfactory bulb and higher brain centres and ultimately perceived as a characteristic odor quality. Odor perception is a result of complex biochemical and electrophysiological reaction mechanisms.

### Characteristics

Measurable characteristics of olfaction are:

1. Anatomical organization
2. Signal transduction pathway (molecular basis of sensitivity and specificity)
3. Odorant information processing
4. Olfactory receptors outside the nose

The human nose is often considered something of a luxury. However, even if we have lost faith in our noses, we are still strongly influenced by smells even if only subconsciously. Smells can evoke memories and

emotions, influence our mood and are important for our enjoyment when eating. All the delicate nuances of an excellent cuisine or of a noble glass of wine are, in the final analysis, savored through our sense of smell. In addition, before the spirit and beauty of a person can fascinate us, our nose must become infatuated. The olfactory systems have developed, the main olfactory system (described here in detail) and the accessory system, known as the ▶vomeronasal system (▶Vomeronasal Organ (system)), which is specialized for chemical communication between one another (see glossary). An indication of the importance of the olfactory system in humans is the significant proportion – more than one percent – of the genome is devoted to encoding the proteins of smell. Let us follow the odor trail from molecule to perception.

### Atomical Organization

A flower or any odorous subject has to release molecules according to their vapor pressure into the air. During inhalation they can reach our nasal cavity. There is a series of conchal formations, called turbinates. In the most upper one the olfactory epithelium is located, which consists of three mature cell types: bipolar primary sensory olfactory neurons, supporting (sustentacular) cells and

basal cells (adult stem cells) which generate olfactory receptor neurons and sustentacular cells throughout our whole life (Fig. 1a). The turnover of the about 20 million olfactory neurons in less than one month. At the apical pole of the cell body of an olfactory sensory neuron (OSN) is a single dendrite that reaches up to the surface of the tissue and ends in a knob like swelling from which project some 20–25 very fine cilia. These cilia, which actually lie in the thin layer of mucus covering the tissue, contain all the molecular components necessary to convert the chemical odor stimulus into an electrical cell signal [1]. On the proximal pole the cell body of OSN narrows into an axon that joins with other axons to form small nerve bundles that then project into a region of the brain, known as the olfactory bulb. Molecular genetic studies have shown that all the neurons, expressing a particular olfactory receptor protein terminate within a single target in the olfactory bulb, called glomerulus: Spherical conglomerates of neuropil some 50–100  $\mu\text{m}$  in diameter that consist of the incoming axons of OSN and the dendrites of the main projection cells in the bulb, the mitral cells. In human, as in other vertebrates, the number of glomeruli correlates with the number of different types of OSN (about 350).

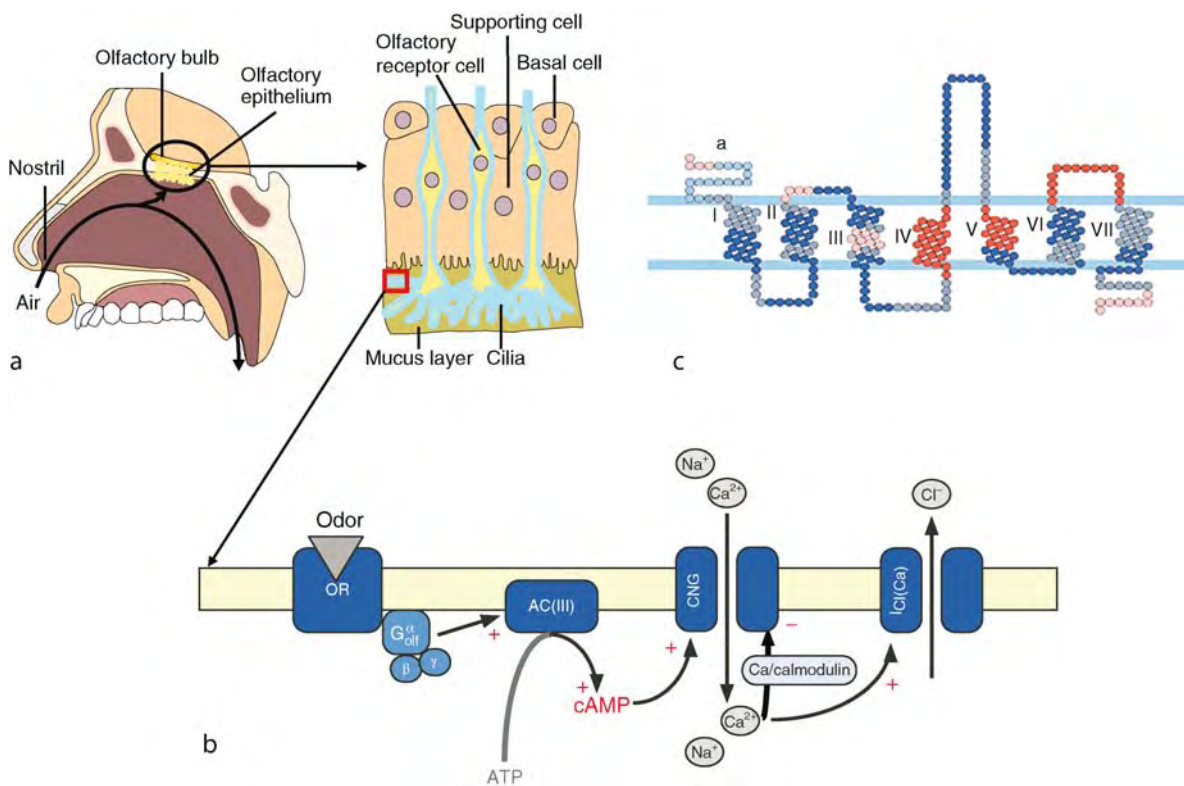

**Olfactory Sense. Figure 1** (a) General layout of the nasal chemoreceptive area (left side) and the olfactory epithelium (right side). (b) Molecular processes during transduction of odor stimuli in an electrical cell response. (c) Molecular structure of a human olfactory receptor protein. The amino acid chain passes through the cell membrane seven times.

### Signal Transduction Pathway

Recent advances of electrophysiological and molecular biological methods have provided new insights into the mechanisms of chemosensory signal transduction. The transduction process begins when odorants are dissolved in the mucus. Here the discovery of small, water soluble proteins in the mucus fluid, which are produced by glands of the nasal cavity, has led to the concept that these so-called odorant binding proteins (OBP) may accommodate hydrophobic odor molecules in an aqueous environment and enhance their access to the receptor sides. Several distinct OBP-subtypes have been identified and each subtype appears to have an unique ligand binding profile suggesting a more specific role of these proteins [1]. Meanwhile, it is generally accepted that the interaction of odor molecules with the receptor protein leads to the activation of a so-called  $\text{G}_{\text{olf}}$ -protein as mediator to activate the enzyme adenylate cyclase which produces large amounts of cyclic adenosine monophosphate (cAMP) as second messenger. The cAMP molecules now act directly within the cell membrane to change the structure (conformation) of a channel protein (cyclic nucleotide gate channel, CNG) in its open state (Fig. 1b), enabling it to conduct specific cations ( $\text{Na}^+$ ,  $\text{Ca}^{2+}$ ) from the nasal mucosa into the cell [2]. As a result, the negative membrane potential (about  $-70$  mV at rest) is shifted to more positive values, called depolarization or cell excitation. Above a certain threshold ( $-50$  mV) this analog sensor potential is converted into a digital action potential frequency near the axon hill of the soma of the OSN. The action potentials are conducted along the neurites into the olfactory bulb. This signal transduction cascade provides amplification and integration of odorant binding events. One olfactory receptor protein activated by an odor molecule can produce about a thousand molecules of a second messenger (cAMP) per second. The calcium ions entering through the CNG channel have a double function. First, they are able to activate another ion channel that is permeable to the negatively charged chloride ion [2]. Because OSN maintain an unusual high intracellular chloride concentration such that there is a chloride efflux when these channels are activated. Thus, it further depolarizes the cells and adding to the excitatory response magnitude. However, calcium ions entering the CNG-channels are also important in response adaptation through a negative feedback pathway. Calcium acts probably via a  $\text{calmodulin}$  dependent mechanism to decrease the affinity of the channel for cAMP and therefore making the channel after a longer period of opening more and more insensitive. This is one of several mechanisms for adaptation. Others include phosphorylation of olfactory receptor proteins sending them into  $\text{internalization}$ , and of fast sodium channels leading to inhibit of action potentials.

The initial step in the recognition of an odorant is its binding to the olfactory receptor protein. The discovery of a large family of genes which encode heptahelical transmembrane proteins (Fig. 1c) and are expressed exclusively in the olfactory epithelium by Linda Buck and Richard Axel (1991) was the ground-breaking work which opened new avenues of research for better understanding of odorant recognition [3]. The odorant receptor proteins are classical G-protein coupled receptors and the about 320 amino acids are highly homologous and Southern blots of genomic libraries suggested that the gene family consists in mice of at least 1,300 putative members. In the human genome about 900 olfactory receptor genes were identified, but two third of these turned out to be non-functional or "pseudogenes" which have lost their function during evolution. A total of 347 putative functional olfactory receptor genes in man was determined [4]. It is still the largest gene family in the human genome. The high proportion of pseudogenes indicate a variable repertoire of functional olfactory receptor genes in the human population. Many specific anosmia, e.g., the inability to smell particular odors, could be due to hereditary defects of OR genes. Interestingly, out of the 347 functional OR genes, each olfactory sensory cell expresses only one type which implies a sophisticated mechanism of olfactory gene choice. The members of the olfactory receptor gene family are distributed on nearly every human chromosome except 20 and Y, often found in large clusters. Chromosome 11 is particularly notable in that it contains nearly half of all olfactory receptor genes including the two largest olfactory receptor gene clusters [4].

In 1998, six years after its identification, it could be shown by functional expression and characterization of olfactory receptor genes that they encode for odorant receptors [5]. One year later the first human olfactory receptor was deorphanized. The receptor hOR17-40 reacts specifically to Helional and structurally related substances [6]. The functionality of the protein was demonstrated by a recombinant expression of the receptor in HEK 293 cells and calcium imaging measurement to demonstrate the cell response after odor application. Unfortunately, it has not been possible to get a functional expression and activation of many of the human olfactory receptors so far. The ability of olfactory sensory neurons to express cloned receptors while other cells could not is further evidence for the involvement of some olfactory specific  $\text{chaperone}$  or cofactor necessary for functional receptor expression. So only a few other human olfactory receptors have been successfully expressed and characterized. Most data existing from the receptor hOR17-4 which is activated by odorants like Bourgeonal, Cyclamal and Lilial (smelling like Lilly of the Valley). A detailed molecular receptive field (Fig. 2a) could be described [7]. From these data it was suggested that the receptor

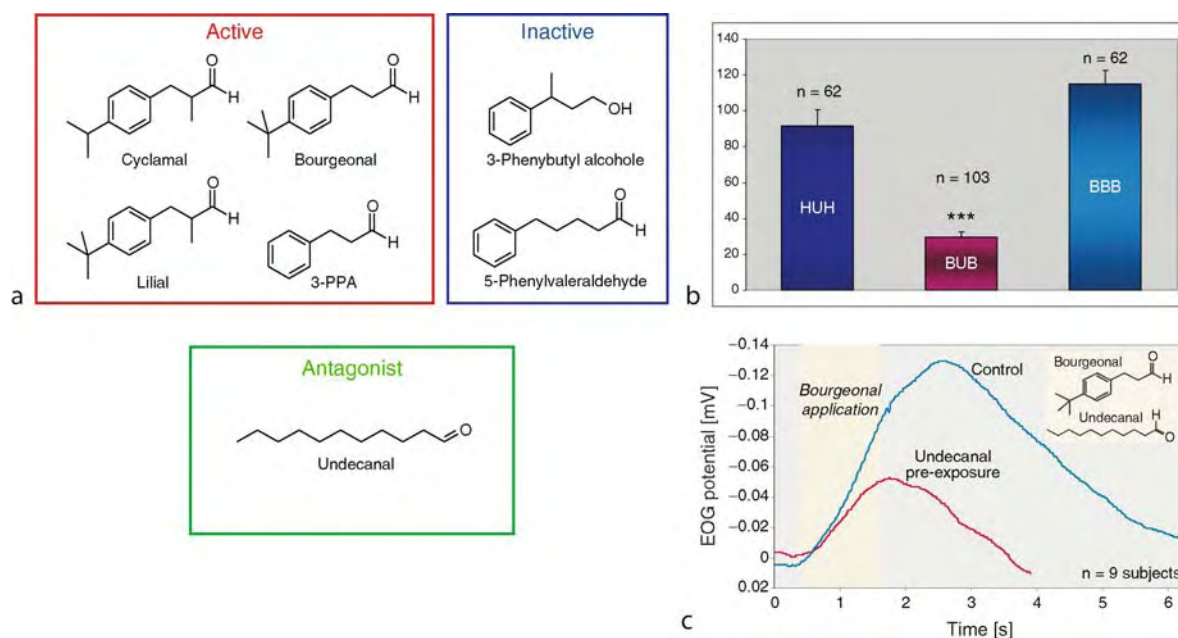

**Olfactory Sense. Figure 2** (a) Effective versus ineffective agonists and antagonists towards hOR17–4. (b, c) In psychometric measurements and electro-olfactogram recordings Undecanal was identified as ►competitive antagonist for hOR17–4.

recognizes a particular feature of different ligands, in analogy to a ►pharmacophore in medical chemistry. In addition another analogy to pharmacology, the existence and the effectiveness of antagonists, could be shown. It was speculated for many years that it should be possible to construct antagonists for olfactory receptors in a similar way as in the case of the medically used blockers of adrenergic or dopaminergic receptors. Interestingly, under the many substances tested, Undecanal showed a clear competitive antagonistic effect highly specific for the receptor hOR17–4 [8]. Variations of agonist/antagonist concentrations ratios indicate competition of both compounds for the receptors ligand binding pocket (Fig. 2b, c). Most odor molecules are recognized by more than one receptor and most receptors recognize several odor molecules, related by chemical properties. Thus, the recognition of an odorant molecule depends on which receptors are activated and to what extent. For each odorant there are best receptors, but also others that are able to recognize the odorant only in a higher concentration and will participate in the discrimination of that compound. Thus, all data indicate that the nose uses a combinatory coding scheme to discriminate the waist number of different smells [4].

### Odorant Information Process

To inform the brain, olfactory sensory neurons extend axons from the olfactory epithelium to the olfactory bulb. There is a considerable amount of data

demonstrating that all neurons expressing the same receptor type convert their axons into the same glomerulus: usually two glomeruli which are located on the lateral and medial hemisphere of the bulb, respectively [4]. These findings indicate that an individual glomerulus is dedicated to receiving input from a single receptor type and so serves as a functional unit in the coding of olfactory information. The wiring process is still largely unknown. The basic olfactory map is probably established by a developmental hardwired strategy. The convergence of signals from thousands of neurons expressing the same olfactory receptor protein onto a few glomeruli by optimize the sensitivity to low concentrations of odorants by allowing the integration of weak signals from many olfactory epithelium neurons. The invariant pattern of inputs might have a different advantage, ensuring that the neuronal representation (code) from odorant remains constant over time, even though olfactory epithelium neurons are short lived cells that are continuously replaced. Many natural odors such as flowers, scents and perfumes consist of hundreds of individual chemical compounds. When such a complex mixture reaching our nasal cavity, out of the about 350 different types of olfactory sensory cells, only those are activated which bearing receptors for one of the chemicals in the mixture. Having in mind that all the sensory cells have the same receptor proteins, wherever they may be located in the olfactory epithelium (Fig. 3), all send their neuronal processes to one and the same glomerulus in the olfactory bulb, thus producing a

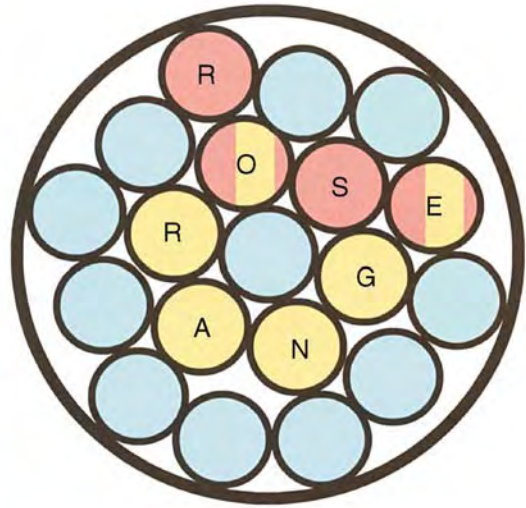
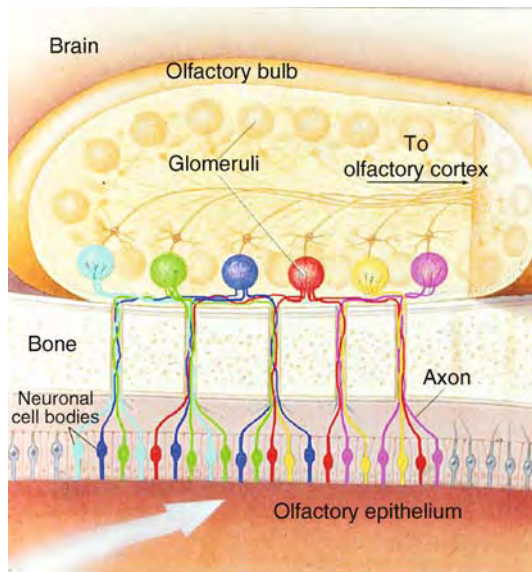

**Olfactory Sense. Figure 3** (a) Olfactory receptor neurons expressing the same olfactory receptor protein project to a specific glomerulus in the olfactory bulb. (b) Schematic activation model of the glomeruli after stimulation with the scent of rose or orange.

constant activation pattern. For instance, when we smell the odor of a rose, the complex odorant mixture in a rose essential oil activates about hundred different receptor types and a similar number of glomeruli. The result is a reproducible, but complex pattern of glomerular activation, from which it is possible to interfere by reverse logic which odor mixture has been smelt [9]. The rose scent activation pattern is clearly distinct from e.g., an orange-scent pattern (Fig. 3). Although individual chemical components are present in both odor mixtures, the patterns in activated glomeruli can overlap but are clearly discriminable. In psychology, this representation by a particular shape could be described with the terms “Odor Gestalt” or “Gestalt Recognition.” Once we have learned an odor, we can recognize it again, even though some of the information it normally contains may be missing. Many artificial rose or orange scents that are industrially produced take advantage of this knowledge.

### Olfactory Receptors Outside the Nose

Recently it could be shown that olfactory receptors also exist and play an important functional role outside the olfactory epithelium: in human sperm cells. The latter possess olfactory receptor proteins as well as all the other members of the second messenger cascade, the G-protein, adenylate cyclase (Type III) and cyclic nucleotide gated channels [7,10]. Oversimplifying one could say that a sperm cell is nothing more than an olfactory neuron with a tail. Using molecular biological techniques (►Polymerase Chain Reaction (PCR)), biochemical methods (antibodies) and proteome analysis, it was

clearly demonstrated that the receptor hOR17-4 is functionally expressed in human spermatozoa. By calcium imaging experiments it was shown that sperm cells indeed get activated by odorants like Bourgeonal or Cyclamal in a concentration dependent manner (Fig. 4). The threshold was in the micromolar range. Sperm react exactly to the same profile of active and inactive substances of the hOR17-4 as the recombinantly expressed receptor. Interestingly, the activation of hOR17-4 is completely inhibited by simultaneous presentation of the competitive inhibitor Undecanal [7]. These studies on the pharmacology of the sperm odorant receptor were then extended to the physiology of spermatozoa: Human sperm cells showed a concentration dependent positive chemotactic behavior to stimulating odorants (Bourgeonal, Cyclamal) and doubled their speed in presence of the odor. When the antagonist was applied, the effects of Bourgeonal on sperm navigation and swim speed were strongly inhibited. These data suggest that hOR17-4 signaling potentially governs chemical communication between sperm and egg cell. Additional studies made the important finding that this sperm receptor is in fact also expressed in human olfactory receptor neurons. Careful analysis of human tissue revealed bonafide expression of hOR17-4 in nasal epithelium [8]. The nose smells what sperm attracts. These data could potentially be used to manipulate fertilization with important consequences for contraception and procreation, but also to develop sniffing tests for identification of patients with fertilization problems based on functional olfactory receptors.

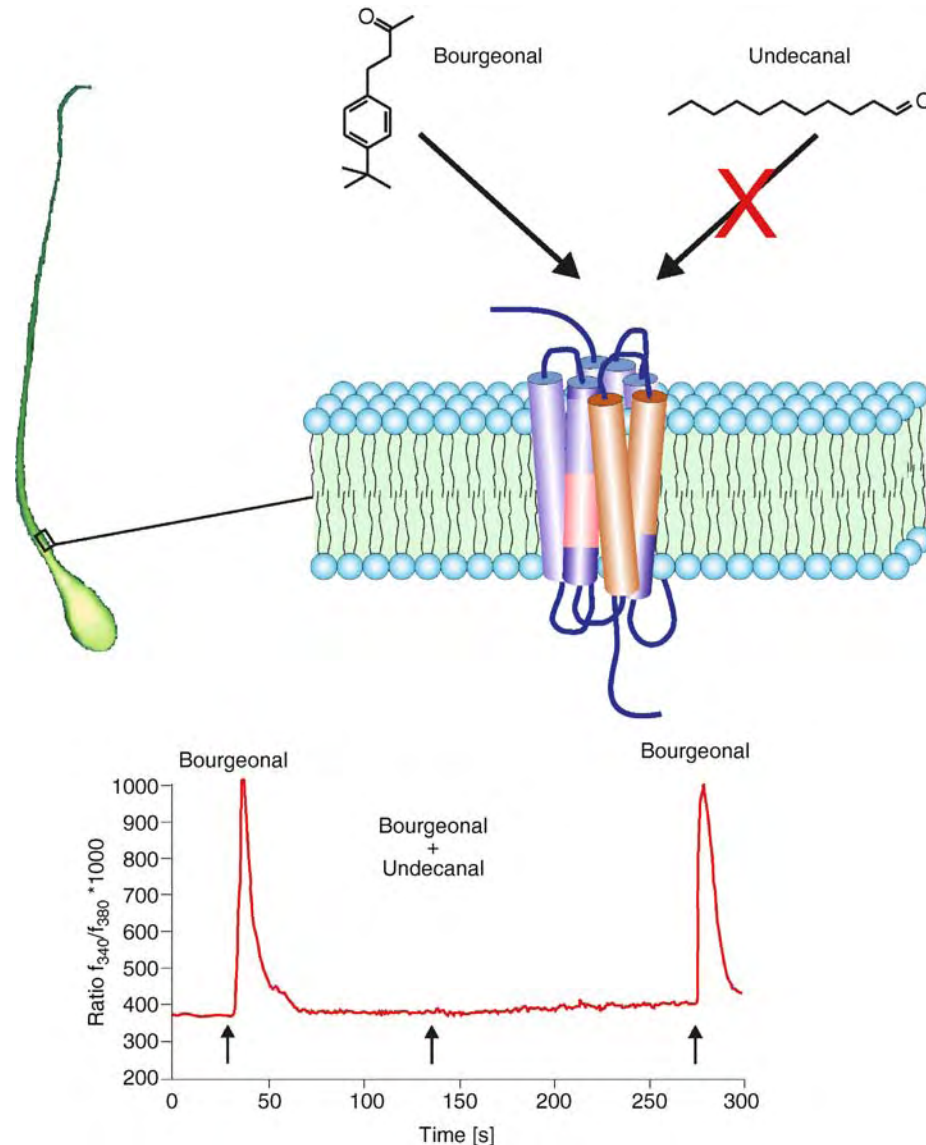

**Olfactory Sense. Figure 4** Bourgeonal works as a potent receptor agonist of hOR17-4 in human spermatozoa, whereas Undecanal inhibits this effect.

## References

- Breer H (2003) Olfactory receptors: molecular basis for recognition and discrimination of odors. *Anal Bioanal Chem* 377:427–433
- Frings S (2001) Chemolectrical signal transduction in olfactory sensory neurons of air-breathing vertebrates. *CMLS Cell Mol Life Sci* 58:510–519
- Buck L, Axel R (1991) A novel multigene family may encode odorant receptors: a molecular basis for odor recognition. *Cell* 65:175–187
- Malnic B, Godfrey PA, Buck LB (2004) The human olfactory receptor gene family. *Proc Natl Acad Sci USA* 101:2584–2589
- Firestein S (2001) How the olfactory system makes sense of scents. *Nature* 413:211–218
- Wetzel CH, Oles M, Wellerdieck Ch, Kuczkowiak M, Gisselmann G, Hatt H (1999) Specificity and sensitivity of a human olfactory receptor functionally expressed in human embryonic kidney 293 cells and *Xenopus laevis* oocytes. *J Neurosci* 19:7426–7433
- Spehr M, Gisselmann G, Poplawski A, Riffell JA, Wetzel CH, Zimmer RK, Hatt H (2003) Identification of a testicular odorant receptor mediating human sperm chemotaxis. *Science* 299:2054–2058
- Spehr M, Schwane K, Heilmann S, Gisselmann G, Hummel H, Hatt H (2004) Dual capacity of a human olfactory receptor. *Curr Biol* 14(19):832–833
- Shepherd GM (2006) Smell images and the flavour system in the human brain. *Nature* 444:316–321
- Weyand I, Godde M, Frings S, Weiner J, Müller F, Altenhofen W, Hatt H, Kaupp UB (1994) Cloning and functional expression of a cyclic-nucleotide-gated channel from mammalian sperm. *Nature* 368:859–863

## Olfactory Sensitivity

- ▶ Olfactory Perception

## Olfactory Sensory Neuron

### Definition

- ▶ Olfactory Receptor Neuron

## Olfactory Sulcus

### Definition

The olfactory sulcus runs bilaterally along the orbital surface of the forebrain. It divides gyrus rectus from medial orbital gyrus. In the olfactory sulcus the olfactory peduncle runs from the olfactory bulb to the anterior perforated substance.

- ▶ Olfactory Bulb
- ▶ Olfactory Peduncle
- ▶ Olfactory Pathways

## Olfactory System

### Definition

Main chemosensory system in vertebrates. It is composed of an olfactory epithelium, located in the postero-dorsal nasal cavity, a main olfactory bulb and olfactory-recipient areas of the telencephalon. It is able to detect numerous odorants, mainly volatiles, present in the environment.

- ▶ Chemical Senses
- ▶ Evolution of Olfactory and Vomeronasal Systems
- ▶ Odorant
- ▶ Olfactory Bulb
- ▶ Olfactory Epithelium

## Olfactory System Dynamics

- ▶ Olfactory Information

## Olfactory Tract

### Definition

Nerve fibers connecting the olfactory bulb to the olfactory cortex.

- ▶ Olfactory Bulb
- ▶ Olfactory Cortex
- ▶ Olfactory Pathways

## Olfactory Transduction

### Definition

Intracellular cascade of enzymes induced by the binding of odorants to odorant receptors. The interaction between an odorant and its cognate receptor induces a transduction pathway, involving the activation of specific Golf proteins, adenylate cyclase III, cyclic nucleotide-gated (CNG) and negatively charged chloride ion channels, providing amplification and integration of odor-binding events. This olfactory transduction ultimately transmits an electric signal to the central nervous system that results in a sensation of smell.

- ▶ Odorant
- ▶ Odorant Receptor

## Olfactory Trigone

### Definition

The olfactory trigone is a small portion of the olfactory peduncle. The olfactory peduncle runs from the olfactory bulb to the anterior perforated substance.

There, its diameter increases before it divides into three roots, or striae. This portion is termed olfactory trigone.

- ▶ Olfactory Bulb
- ▶ Olfactory Pathways
- ▶ Olfactory Peduncle

## Olfactory Tubercle

### Definition

From the olfactory trigone, the intermediate olfactory stria continues onto the anterior perforated substance. On top of the anterior perforated substance, there is a layer of gray matter, which is called the olfactory tubercle. In most mammals, the olfactory tubercle is a prominent bulge on the ventral surface of the frontal lobe situated caudally to the olfactory peduncle and medially to the lateral olfactory tract of mammals. It receives afferent input from the lateral olfactory tract. The olfactory tubercle differs from the piriform cortex in that it does not send output projections to the olfactory bulb or to any other secondary olfactory structure. The outputs of the olfactory tubercle are directed towards the thalamus, ventral pallidum, nucleus accumbens and, in monkeys, the orbitofrontal cortex. The inputs and projections to and from olfactory tubercle can vary substantially among species. The olfactory tubercle resembles the underlying corpus striatum and thus is often combined with the nucleus accumbens to the ventral striatum. In humans the olfactory tubercle is poorly developed resulting in a difficult visualization using functional imaging techniques.

- ▶ Olfactory Pathways
- ▶ Olfactory Tract
- ▶ Olfactory Trigone

## Oligoclonal Bands (OCBs)

### Definition

OCBs are distinct bands of IgG seen in electrophoretic analysis of CSF in MS patients. A few antibodyproducing plasma cell clones produce the IgG within the CNS. This pattern is not normally seen since most IgG in CSF is derived from serum and appears as diffuse

broad bands in CSF as well as in serum. In MS, two or more bands must be seen in CSF and be absent in serum indicating intrathecal synthesis of IgG. Though approximately 90% of CDMS patients have OCBs, they may also be found in patients with other CNS inflammatory or infectious diseases.

- ▶ Multiple Sclerosis

## Oligodendrocyte

### Definition

Oligodendrocytes are a type of glial cell in the CNS. The cytoplasmic extensions of these cells form myelin, which wraps around large axons. One oligodendrocyte can myelinate up to 30 axons. Oligodendrocytes are found predominantly in the white matter of the CNS. Diseases of oligodendrocytes include demyelinating diseases such as multiple sclerosis, leukodystrophies and tumors named as oligodendrogliomas.

- ▶ Inhibitory Molecules in Regeneration
- ▶ Multiple Sclerosis
- ▶ Myelin
- ▶ Regeneration

## Oligodendrocyte-Myelin Glycoprotein (OMgp)

### Definition

- ▶ Regeneration

## Olivary Pretectal Nucleus

### Definition

The olivary pretectal nucleus (OPN) is a midbrain structure that is part of the circuit mediating the pupillary light reflex. It receives direct retinal input, including inputs from melanopsin expressing retinal ganglion cells. The firing rate of OPN neurons is



directly related to the intensity of light stimulation on the retina and correspondingly to the degree of pupillary constriction.

- ▶ Neural Regulation of the Pupil
- ▶ Pupillary Light Reflex
- ▶ Retinal Ganglion Cells

receptor OMgp can cause growth cone collapse and inhibition of neurite outgrowth.

- ▶ Glial Scar
- ▶ Node of Ranvier
- ▶ Oligodendrocyte

---

## Olive

### Synonyms

- ▶ Oliva

### Definition

- Inferior olive is the actual “olive” and is located directly beneath the pons, in the myelencephalon. This large nucleus plays a major role in movement coordination.
- Superior olive: nuclear conglomeration in the
  - ▶ Mesencephalon, is a component of the auditory tract.

---

## Olivocerebellothalamic Circuit

### Definition

Neuronal circuit between the thalamus, the dentate nucleus of the cerebellum, and the inferior olivary nucleus.

- ▶ Essential Tremor

---

## OMgp

### Definition

OMgp stands for oligodendrocyte myelin glycoprotein. It is a glycosylphosphatidylinositol-anchored protein expressed mainly by oligodendrocytes in the central nervous system (CNS). It is found concentrated at nodes of Ranvier and plays a part in the control of myelination. Through its interaction with the Nogo

---

## Omnipause Neuron Area

### Definition

A small region on the midline of the brainstem near the boundary of the pons and medulla. Neurons in this structure discharge at high tonic rates whenever an animal is fixating, but then turn off sharply and completely for saccades in all directions. These cells function as an inhibitory brake on other saccade-related cells in the saccadic system during fixation and help to prevent unwanted saccades from occurring.

- ▶ Omnipause Neuron
- ▶ Saccade, Saccadic Eye Movements

---

## Omnipause Neurons

CHRIS R. S. KANEKO

Department of Physiology and Biophysics, Washington National Primate Research Center, University of Washington, Seattle, WA, USA

### Synonyms

Pause neurons (pns); OPNs

### Definition

Omnipause neurons (OPNs) are the neurons that control saccadic eye movements by inhibiting the activity of all burst neurons. Burst neurons, in turn, directly drive the saccadic burst in motoneurons that produces the saccade. These neurons are located in the medial pons between the rootlets of the abducens nerves as they leave the brainstem ([4], Fig. 1). They are normally tonically active and discharge at a constant high rate (up to 200 ▶spikes/s in ▶rhesus monkey) that is unrelated to eye position (rasters and histogram, Fig. 2 bottom two traces in each panel). They cease firing (pause) before and during all saccades (Fig. 2). Their



**Omnipause Neurons. Figure 1** OPN Anatomy. (a) Photomicrograph of the nucleus raphe interpositus (rip; arrowheads). OPNs are co-extensive with the rip and form a bilaminar columnar nucleus that straddles the midline between the rootlets of the abducens nerve [1]. (b) Tracing of the frontal section for orientation. The photomicrograph in (a) was taken from this section (dotted box). (c) Drawing of every neuron in (a) to show the distinct appearance of the OPNs is not due to poorly stained neurons, that the OPNs are larger than neighboring neurons, and are further distinguished by their isolated position between the longitudinal fiber tracks. Abbreviations: 6, abducens nerve rootlets; *pyr*, pyramidal track; *SCP*, superior cerebellar peduncle. Calibration is 1 mm in (a).

pause begins just before (~15 ms) the onset (Fig. 2, thin vertical lines) of the movement and a few ms before the burst in medium lead burst neurons (mlbns). The duration of the pause is highly linearly correlated with saccade duration (Fig. 2b, middle). Anatomical studies have shown that OPNs project directly to both horizontal and vertical burst neuron regions. Physiological studies confirm that OPNs monosynaptically inhibit burst

neurons. Based on their discharge and their connections, there is no doubt that OPNs control saccades by gating the activity of burst neurons.

OPNs are perhaps the most studied of the neurons that comprise the saccadic burst generator, and saccades may be the best characterized motor system, so we know quite a bit about OPN anatomy and physiology. In 1972, Luschei and Fuchs [1] and Cohen

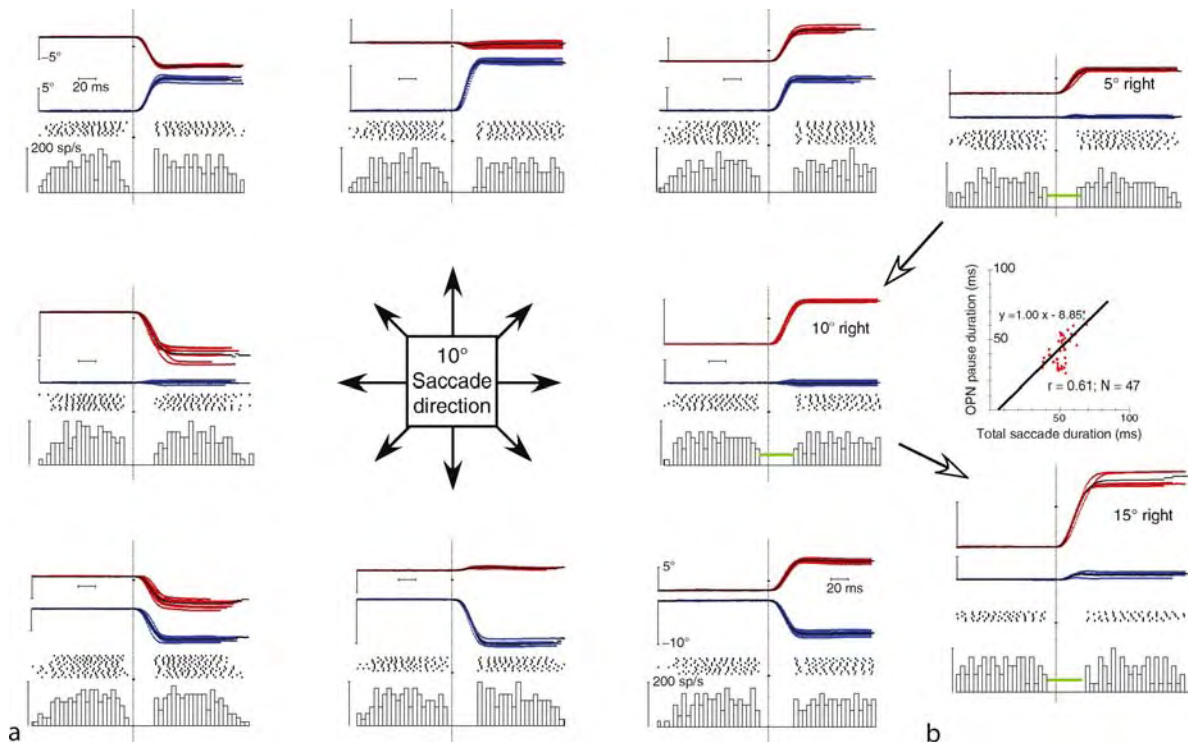

**Omnipause Neurons. Figure 2** Discharge of OPNs. (a) In each panel, the traces are (top to bottom) horizontal eye position (red); vertical eye position (blue); rasters; histogram variability at ends is due to variable duration of each trace. 7–11 saccades in the direction indicated by the center plot are overlaid and the average (black line) shows the consistency of the movements. Note the pause lead. (b) Pause duration for different size saccades. 5° (upper) and 15° (lower) saccades show comparison of pause duration with 10° rightward saccades (indicated by green horizontal bar). Note the bar (redrawn) overlaps the pause for 5° and is shorter than that for 15° saccades. Traces as in (a). Middle, scatter plot of pause duration as a function of saccade duration for rightward saccades. Linear regression is least-squares fit to plot showing slope of one, i.e. pause duration equals saccade duration.

and Henn [2] reported recording eye movement related neurons in the pontine and medullary ▶reticular formation of alert monkeys. One class, the OPNs, discharged at a high tonic rate (Fig. 2, rasters and histograms) but ceased firing in association with saccades or ▶quick phases in any direction (Fig. 2a). Shortly thereafter, Keller [3] showed that electrical microstimulation of OPNs prohibited saccades and quick phases of ▶nystagmus. This result immediately suggested their function was to control saccades by discharging at a high tonic rate in order to tonically inhibit burst neurons. These early results led to Robinson's model of saccadic control [4] that posited the role of OPNs was to prevent the discharge of the high gain, burst neurons that might otherwise cause instabilities in the system and thus, unwanted eye movements. He further suggested that saccades were initiated by a trigger signal of unknown origin mediated by an inhibitory interneuron and originating from more central structures like the superior colliculus. A final element was that the OPNs were modeled as being actively inhibited during the saccade to prevent

unwanted interruptions of the saccade by means of a latch circuit comprised of burst neuron feedback to OPNs via another inhibitory interneuron.

While the basic circuit has been confirmed thoroughly in both cats and monkeys, some of the other details of the Robinson model [4] have garnered only rudimentary support. Anatomical tracing studies (e.g. [5]) showed that OPNs projected to each of the areas that contained saccadic burst neurons (see ▶HMLBs (horizontal medium lead burst neurons), ▶PPLLs (ponto-pontine LLBs), ▶PCbLLBs (precerebellar LLBs), and ▶RSLBs (reticulospinal LLBs)). Later, intracellular staining and modern tracing studies using transneuronal labeling have unequivocally demonstrated the projection from OPNs to burst neurons. Electrophysiological studies in cats have shown that this monosynaptic connection is inhibitory in all cases. Recent immunolabeling suggests that OPNs use glycine to inhibit burst neurons. Recordings from alert cats and monkeys and anatomical studies of their afferents has shown that the high rate of tonic discharge is probably due to a multiplicity of afferent input from all sensory modalities

[6]. This surmise is corroborated by the fact that OPNs are silent when animals go to sleep, and that a burst of OPN activity can be recorded if an afferent volley is synchronized by, for example, a click of sound. On the other hand, a neural basis for the trigger and the latch is yet to be established. Intracellular recording from identified cat OPNs has shown that they are inhibited during saccades. The inhibitory ►postsynaptic potentials (ipsp) are characterized by an initial abrupt hyperpolarization that decays back to resting, with a time course that is well correlated with saccadic eye velocity, consistent with them receiving both trigger and latch inputs. The ipsp decay is expected if it is caused by burst neuron input whose discharge is also highly correlated with eye velocity. Electrical microstimulation amongst long-lead burst neurons (LLBs) suggests some of them may be appropriate inhibitory interneurons to provide some of that input, but the juxtaposition of these elements has made it difficult technically to affect each element independently and thereby produce more substantive proof.

OPNs receive their major saccadic input from the contralateral superior colliculus. The input appears to be heavier from the caudal than the rostral portions of the colliculus and more concentrated from the lateral portions than the medial. The input is both monosynaptic (excitatory) and disynaptic (inhibitory), and it is assumed that the inhibitory input is relayed via an inhibitory interneuron and acts as a trigger for saccade generation. As mentioned, their high tonic rate is maintained by multiple afferent sources that use gamma-aminobutyric acid, glycine and glutamate but not monoamines as transmitters [7].

OPNs have been identified in man by immunohistochemistry and damage to OPNs has been invoked to explain a variety of eye movement pathologies, like square wave jerks, that result in oscillopsia. However, either transient or permanent inactivation of OPNs in monkeys leads to slower saccades (longer durations and lower peak velocities), possibly due to inactivation of ►post-inhibitory rebound in the EBNs that they innervate.

## Characteristics

### Higher Order Structures

There are three higher order structures that influence OPNs directly. OPNs receive input from the contralateral superior colliculus. Whether they also receive an ipsilateral input remains controversial. There also may be inputs from the frontal eye fields. One that projects directly to the pons, but this is still uncertain, and another that is indirect via the superior colliculus. Based on anatomical evidence, OPNs may also receive direct input from the caudal fastigial nucleus of the cerebellum that is presumably excitatory. The fastigial input may play a role in adaptive plasticity of saccade amplitude and/or

saccadic error correction during on-going saccades by allowing fastigial output to terminate the saccade.

### Parts of This Structure

OPNs have been studied extensively in cat and monkey and there are a number of differences between the species. The somata of the majority of OPNs (Fig. 1) are located in the nucleus raphe interpositus (rip) [8] in the monkey and in the nucleus raphe pontis in the cat [5]. In both species, occasional OPNs can be found in the surrounding reticular formation; specifically the caudal nucleus reticularis tegmenti pontis in the monkey [5] and the superior central nucleus in the cat. In the monkey, it appears that virtually all neurons in the rip are OPNs [5]. They are medium-sized (~35 µm diameter), multipolar neurons in monkey (Fig. 1a). In cat, their shape ranges from spindle shaped to spheroid and they are slightly larger (~46 µm, [9]). In monkey, OPNs send long horizontal dendrites in both directions, and the contralateral branches extend across the midline and into the longitudinal fiber tracts that traverse this portion of the pons in the ventral portion of, and below the medial longitudinal fasciculus. In contrast, cat OPN dendritic fields are ellipsoidal and only a minority have dendrites that cross the midline. Axons arise from the soma and bifurcate either ipsilaterally, or more usually, contralaterally after crossing the midline. In the cat, the stem axons are about 4 µm in diameter and the branch axons are about 3 µm in diameter. In the cases, from cat, where axons could be traced to terminal boutons, all were found in burst neuron regions and were either en passage or terminaux endings. The former were 2.6 µm in diameter and the latter 2.8 µm. Detailed intracellular fills are not available for monkey OPNs.

### Function of This Structure

OPNs provide tonic inhibition to the saccadic burst neurons to prohibit saccades except when they are silenced. In addition, clinical and inactivation evidence suggests that the inhibition, when interrupted, contributes to activation of a post-inhibitory rebound in burst neurons that potentiates the very high-frequency discharge of burst neurons. Besides this permissive role in saccades, the OPNs also serve to coordinate various types of eye movements. The horizontal and vertical components of oblique saccades are mediated via separate horizontal and vertical burst neuron groups and are coordinated via OPN disinhibition. Thus, the OPNs serve to cross couple the burst neurons and control oblique saccade duration. This function is featured prominently in models of saccade generation that include both horizontal and vertical burst generators. The coordinating function seems to extend to other types of eye movements because OPNs are silenced during combined eye and head movements, combined ►vergence and ►version movements, as

well as during blinks. They may also have a role in slow pursuit eye movements, but the exact nature of that role is uncertain. Thus, OPNs seem to assist in the timing of coordinated eye movements in general.

### Higher Order Function

OPNs are low-level premotor neurons with no higher order (e.g., cognitive) functions yet indicated. The function of the potential direct, cortical inputs is not clear, but all of the OPN inputs seem to share at least a portion of the responsibility for triggering saccades. Although still somewhat controversial, there don't appear to be any OPNs that are specialized either for head or coordinated eye and head movements, even though some LLBs are so specialized. As mentioned, their connectivity mediates the co-ordination of oblique saccades (► [Hering's Law](#) of equal innervation), and the push-pull organization of EBNs and IBNs results in relaxation of antagonist during agonist activation (► [Sherrington's Law of reciprocal innervation](#)). There is also emerging evidence that OPNs may play a role in the coordination of smooth pursuit and saccadic eye movements in both cats and monkeys, but the nature of that role has not yet been elucidated.

### Quantitative Measure for This Structure

Just as for other elements of the saccadic burst generator, the number of OPNs is not clear because of technical limitations in marking all of them so that they may be counted. Perhaps transneuronal retrograde labeling techniques will allow an estimate in the near future. Likewise, virtually nothing is known about the unitary ipsilateral OPN output to burst neurons or the membrane biophysics of OPNs.

### References

1. Luschei ES, Fuchs AF (1972) Activity of brain stem neurons during eye movements of alert monkeys. *J Neurophysiol* 35:445–461
2. Cohen B, Henn V (1972) Unit activity in the pontine reticular formation associated with eye movements. *Brain Res* 46:403–410
3. Keller EL (1974) Participation of medial pontine reticular formation in eye movement generation in monkey. *J Neurophysiol* 37:316–332
4. Robinson DA (1975) Oculomotor control signals. In: Lennerstrand G, Bach-y-Rita P (eds) *Basic mechanisms of ocular motility and their clinical implication*. Pergamon, Oxford, pp 337–374
5. Langer TP, Kaneko CRS (1990) Brainstem afferents to the oculomotor omnipause neurons in monkey. *J Comp Neurol* 295:413–427
6. Evinger C, Kaneko CRS, Fuchs AF (1982) Activity of omnipause neurons in alert cats during saccadic eye movements and visual stimuli. *J Neurophysiol* 47:827–844
7. Horn AKE, Büttner-Ennever JA, Wahle P, Reichenberger I (1994) Neurotransmitter profile of saccadic omnipause

neurons in nucleus raphe interpositus. *J Neurosci* 14:2032–2046

8. Büttner-Ennever JA, Cohen B, Pause M, Fries W (1988) Raphe nucleus of the pons containing omnipause neurons of the oculomotor system in the monkey and its homologue in man. *J Comp Neurol* 267:307–332
9. Ohgaki T, Curthoys IS, Markham CH (1987) Anatomy of physiologically identified eye-movement-related pause neurons in the cat: Pontomedullary region *J Comp Neurol* 266:56–72

---

## On Center Cells

### Definition

- Visual Cortical and Subcortical Receptive Fields

---

## Ongoing Neurogenesis

- Adult Neurogenesis

---

## Oniric Mentation

- Dreaming

---

## Ontogenetic

### Definition

Pertaining to the biological development of an individual.

---

## Ontological Status

### Definition

Something's ontological status can be determined by answering the question whether it exists. Bill Clinton

and Sherlock Holmes, although both human beings, thus currently differ in ontological status.

► Logical

## Ontology

### Definition

Ontology is the study of being or of what there is. Typically, ontologies of philosophers might comprise concrete objects like chairs or electrons, abstract objects like numbers or ► **propositions**, properties like the property of being a chair, facts like the fact that Paris is west of Warsaw, or events like the 2004 World Series.

► Epiphenomenalism

## Opacity

### Definition

Primarily a feature of certain sentences, e.g., of many ascriptions of propositional attitudes. The truth of such ascriptions does not systematically depend on the truth or falsity of the proposition involved. Consider the following two belief-ascriptions: “Mary believes that  $1 + 1 = 2$ ” and “Mary believes that  $2756 + 488 = 3244$ .” Even though both propositions (“ $1 + 1 = 2$ ” and “ $2756 + 488 = 3244$ ”) are true, the two beliefascriptions can differ in truth-value. Whether it is true that Mary believes that  $2756 + 488 = 3244$  therefore does not systematically depend on the truth of “ $2756 + 488 = 3244$ .”

► Representation (Mental)

## Open Loop Behavior

### Definition

Behavior that is executed without feedback control. This may, in nature, be due to completing a task before feedback is possible.

## Open Reading Frame

### Definition

The region of the gene between the start and stop codon that encodes for the protein.

## Operant

### Definition

Control by the consequences, i.e. by positive or negative reinforcement (=punishment) that is the result of a particular behavior and that shapes the future expression of that behavior.

## Operant Conditioning

BJÖRN BREMBS

Freie Universität Berlin Fachbereich Biologie, Chemie, Pharmazie, Institut für Biologie – Neurobiologie, Berlin, Germany

### Synonyms

Instrumental conditioning

### Definition

Operant conditioning describes a class of experiments in which an animal (including humans) learns about the consequences of its behavior and uses this knowledge to control its environment.

### Characteristics

Our life consists of a series of experiences in which we learn about our environment and how to handle it. Learning about the environment (“the plate is hot”) and learning the skills to control it (“riding a bike”) have been experimentally conceptualized as classical and operant conditioning, respectively. The two are so intertwined that a treatment of operant conditioning is impossible without reference to classical conditioning.

### Operant Conditioning

Operant (instrumental) conditioning [1] is the process by which we learn about the consequences of our actions, e.g., not to touch a hot plate. The most famous

operant conditioning experiment involves the “Skinner-Box” in which the psychologist B.F. Skinner trained rats to press a lever for a food reward. The animals were placed in the box and after some exploring would also press the lever, which would lead to food pellets being dispensed into the box. The animals quickly learned that they could control food delivery by pressing the lever. However, operant conditioning is not as simple as it first seems. For instance, when we touch a hot plate (or the rat the lever), we learn more about the hot plate than about our touch: we avoid contact of any body part with the plate, not only the hand that initially touched it. Obviously, we learned that the hot plate burns us. It is not only confusing that this type of environmental learning is usually called classical conditioning, we cannot even be sure that it is the only process taking place during conditioning.

### Classical Conditioning

Classical (Pavlovian) conditioning [2] is the process by which we learn the relationship between events in our environment, e.g., that lightning always precedes thunder. The most famous classical conditioning experiment involves “Pavlov’s dog”: The physiologist I.P. Pavlov trained dogs to salivate in anticipation of food by repeatedly ringing a bell (conditioned stimulus, CS) before giving the animals food (unconditioned stimulus, US). Dogs naturally salivate to food. After a number of such presentations, the animals would salivate to the tone alone, indicating that they were expecting the food. The dog learns that the bell means food much as we learn that the plate is hot in the operant example above. Therefore, it is legitimate to ask if operant conditioning is in essence a classical process. Both operant and classical conditioning serve to be able to predict the occurrence of important events (such as food or danger). However, one of a number of important differences in particular suggests that completely different brain functions underlie the two processes. In classical conditioning, external stimuli control the behavior by triggering certain responses. In operant conditioning, the behavior controls the external events.

### The Relationship Between Operant and Classical Conditioning

Ever since operant and classical conditioning were distinguished in 1928, their relationship has been under intense debate. The discussion has shifted among singular stimulus-response concepts, multiprocess views, and a variety of unified theories. Today, modern neuroscience distinguishes between procedural memories (skills and habits) and declarative memories (facts or events). The intensity and duration of the debate can in part be explained by the fact that most learning situations comprise operant and classical components to some

extent: one or more initially neutral stimuli (CS), the animal’s behavior (BH), and the ►reinforcer (US). The example above of learning to avoid touching a hot plate is very instructive. Extending the hand (BH) toward the round hotplate (CS) leads to the painful burn (US). In principle, our brain may store the situation as memory of the pain associated both with the hotplate (classical conditioning, CS-US) and with the extension of the hand (operant conditioning, BH-US) to predict the consequences of touching the plate at future encounters.

### Habit Formation

A phenomenon called habit formation [3] confirms the tight interaction between operant and classical components in operant conditioning. In the early stages of an operant conditioning experiment (e.g., a rat pressing a lever for food in a Skinner box), the animal performs the lever presses spontaneously with the aim of obtaining the food (goal-directed actions). This can be shown by feeding the animals to satiety after training: they now press the lever less often when they are placed back in the box, because they are not hungry anymore. However, the same treatment fails to reduce lever pressing after the animals have been trained for an extended period. The behavior has now become habitual or compulsive; whenever the animals are placed now in the box, they frantically press the lever even if they are not hungry (or even if the food will make them sick). Although in the early stage of operant conditioning the behavior controls the environment (lever pressing to obtain food), habit formation effectively reverses the situation such that now the environment (box, lever) controls the behavior (lever pressing). One could say that overtraining an operant situation leads to a situation very similar to a classical one. Thus, operant conditioning consists not only of two components (operant and classical) but also of two phases (goal-directed and habitual behavior), with the relationship of the components changing with the progression from one phase to the next. Despite many decades of research filling bookshelves with psychological literature, our neurobiological understanding of the mechanisms underlying these processes is rather vague. What little is known comes from a number of different vertebrate and invertebrate model systems on various levels of operant conditioning. This essay is an attempt to integrate the neuroscience gained from many such disparate sources.

### Neuroscientific Principles in Operant Conditioning

If there is a consensus for a critical early-stage process in operant conditioning, it is that of refference. To detect the consequences of behavior, the brain has to compare its behavioral output with the incoming sensory stream and search for coincidences. The

neurobiological concept behind this process is that of corollary discharges (or efference copies). These efference copies are “copies” of the motor command sent to sensory processing stages for comparison. Thus, neurobiologically, any convergence site of operant behavior and the US is very interesting with regard to potential plasticity mechanisms in operant conditioning. The efference copies serve to distinguish incoming sensory signals into self-caused (reafferent) and other, ex-afferent signals [4]. Modern theories of operant conditioning incorporate and expand this reafference principle into two modules: one is concerned with generating variable behavior and another predicts and evaluates the consequences of this behavior and feeds back onto the initiation stage [5]. Some evidence exists that the circuits mediating these functions are contained within the dorsal and ventral striatum of the vertebrate brain. We have only very poor mechanistic knowledge about the first module. Behavioral variability could be generated actively by dedicated circuits in the brain or simply arise as a by-product of accumulated errors in an imperfectly wired brain (neural noise). Despite recent evidence supporting the neural control of behavioral variability, the question remains controversial. Only little more is known about the neurobiology of the second module. Promising potential mechanisms have been reported recently from humans, rats, crickets, and the marine snail *Aplysia*. These studies describe conceptually similar neural pathways for reafferent evaluation of behavioral output (via efference copies) and potential cellular mechanisms for the storage of the results of such evaluations at the convergence site of operant behavior and US. However, to this date, a general unifying principle such as that of synaptic plasticity in classical conditioning is still lacking.

From a larger perspective, there is evidence suggesting that the traditional distinction of entire learning experiments into either operant or classical conditioning needs to be reconsidered. Rather, it appears that an experimental separation of classical and operant components is essential for the study of associative learning. As outlined above, most associative learning situations comprise components of both behavioral (operant) and sensory (classical) predictors. Vertebrate research had already shown that operant and classical processes are probably mediated by different brain areas. Research primarily from the fruit fly *Drosophila* and *Aplysia* has succeeded in eliminating much if not all of the classical components in “pure” operant conditioning experiments, a feat which has so far proven difficult to accomplish in any modern vertebrate preparation. This type of operant conditioning appears more akin to habit formation and lacks an extended goal-directed phase. These paradigms successfully reduce the complexity of operant conditioning by isolating its components and as such are vital for the

progress in this research area. The new invertebrate studies revealed that pure operant conditioning differs from classical conditioning not only on the neural, but also on the molecular level. Apparently, the acquisition of skills and habits, such as writing, driving a car, tying laces, or our going to bed rituals is not only processed by different brain structures than our explicit memories, but also the neurons use different biochemical processes to store these memories.

The realization that most learning situations consist of separable skill-learning and fact-learning components opens the possibility to observe the interactions between them during operant conditioning. For instance, the early, goal-directed phase is dominated by fact learning, which is facilitated by allowing a behavior to control the stimuli about which the animal learns. Skill learning in this phase is suppressed by the fact-learning mechanism. This insight supports early hypotheses about dominant classical components in operant conditioning [6], but only for the early, goal-directed phase. If training is extended, this suppression can be overcome and a habit can be formed. Organizing these processes in such a hierarchical way safeguards the organism against premature stereotypization of its behavioral repertoire and allows such behavioral stereotypes only if they provide a significant advantage. These results have drastic implications for all learning experiments: as soon as the behavior of the experimental subject has an effect on its subsequent stimulus situation, different processes seem to be at work than in experiments where the animal’s behavior has no such consequences, even if the subject in both cases is required to learn only about external stimuli. Conversely, apparently similar procedural tasks that differ only in the degree of predictive stimuli present may actually rely on completely different molecular pathways. The hierarchical organization of classical and operant processes also explains why we sometimes have to train so hard to master certain skills and why it sometimes helps to shut out dominant visual stimuli by closing our eyes when we learn them.

## References

1. Skinner BF (1938) The behavior of organisms. Appleton, New York
2. Pavlov IP (1927) Conditioned reflexes. Oxford University Press, Oxford
3. Yin HH, Knowlton BJ (2006) The role of the basal ganglia in habit formation. *Nat Rev Neurosci* 7:464–476
4. von Holst E, Mittelstaedt H (1950) Das Reafferenzprinzip. Wechselwirkungen zwischen Zentralnervensystem und Peripherie. *Naturwissenschaften* 37:464–476
5. Dayan P, Balleine BW (2002) Reward, motivation, and reinforcement learning. *Neuron* 36:285–298
6. Rescorla RA (1987) A Pavlovian analysis of goal-directed behavior. *Am Psychol* 42:119–129



## Operant Conditioning

### Definition

A Definition of operant conditioning, also called instrumental conditioning, requires a distinction between elicited and emitted behavior. Elicited behavior is a response that is associated with a biologically relevant stimulus. Pavlovian or classical conditioning is an example of elicited behavior since there is always a formal, temporal relationship between the conditional stimulus (for example, a bell) and the unconditional stimulus (for example, meat powder to the tongue which elicits salivation). After a number of pairings, the conditional signal is seen to elicit a response that is similar to that elicited by the unconditional stimulus. Emitted behavior is behavior, which is produced by the subject in order to obtain a desirable outcome (commonly called a reinforcer): such behavior is said to operate upon the environment to produce reinforcement. In typical studies of operant conditioning, the availability of the reinforcer is signaled by a cue of some sort. Thus, the relationship between elicited and emitted behavior is complex. However, any discussion of this issue goes well beyond the subject matter of this essay.

## Operational Closure

### Definition

Operational (or organizational) closure means that certain relations and processes define a system as a unity, in determining the dynamics of interaction and transformations that the system may undergo as such a unity (Maturana/Varela). Operationally closed systems are not causally closed, i.e. they may interact causally with the environment.

## Operculum

### Definition

Part of the posterior portion of the inferior frontal gyrus of the frontal lobe in the brain.

## Ophiid (Type)

### Definition

“Snake-like,” “snake-type.”

► Evolution of the Brain: At the Reptile-Bird Transition

## Opioid

### Definition

Any compound or substance that binds to the opioid receptor resulting in the activation of the receptor.

► Analgesia

## Opioid Peptides

### Definition

Opioid peptides are short sequences of amino acids which mimic the effect of opiates in the brain. Endogenous opioid peptides are derived from three gene families,  $\beta$ -endorphins, enkephalins and dynorphins. Three types of opioid receptors,  $\mu$ ,  $\delta$  and  $\kappa$  receptors, are pharmacologically identified.

## Opisthotonus

### Definition

Arched back produced by tonic contractions of the back muscles, for example in ► tetanus.

► Tetanus (Pathological)

## OPN4

► Melanopsin

## OPNs

- ▶ Omnipause Neurons

## Opsin Evolution

- ▶ Evolution of Eyes

## Opsonin

### Definition

A terminology derived from the Greek and meaning, sauce or seasoning, in other words making the target cells such as pathogen more palatable to the phagocyte and more easily eaten. For example, C3b is an opsonin bound to target cells following complement activation and promoting phagocytosis by macrophages expressing C3 receptors.

- ▶ Neurodegeneration and Neuroprotection – Innate Immune Response

## Optic Ataxia

### Definition

Specific impairment of the visual control of limb movements observed in patients with lesion of the posterior parietal cortex. This deficit is expressed as errors both in final limb position in reaching/pointing tasks and in the shaping of hand aperture in grasping tasks. These deficits are exacerbated when the movements are programmed and executed under peripheral vision by asking the patient to keep gaze on a fixation point. Pure forms of optic ataxia, without sensory or motor deficits, indicate a role of the posterior parietal cortex in visuo-motor transformations for limb movement control.

- ▶ Eye-Hand Coordination
- ▶ Visual Neuropsychology
- ▶ Visual Space Representation for Reaching

## Optic Axis

### Definition

Where we look, i.e., roughly coincidental with the line of sight.

## Optic Chiasm

### Definition

The optic chiasm is a landmark between the optic nerve and optic tract in the pathway between the retina and lateral geniculate nucleus of the thalamus. It contains the crossing of fibers of the so-called optic nerve to form its continuation, the optic tract of the opposite side. The fibers arise from ganglion cells in the retina. The crossing fibers in the optic chiasm contain information from the temporal visual fields (retinal nasal fields) of both eyes. Uncrossed fibers in the optic chiasm contain information from the nasal visual fields (temporal retinal fields) of both eyes. The chiasm is located on the ventral surface of the brain at the level of the anterior hypothalamus.

## Optic Flow

MARKUS LAPPE

Psychologisches Institut II, Westf. Wilhelms-Universität, Fliegenerstrasse, Münster, Germany

### Synonyms

Optical flow; (optic) Flow field; Retinal flow

### Definition

Optic flow is the pattern of motion induced on the retina of a moving observer.

### Characteristics

#### Mathematical Properties

Optic flow arises from the movement of an observer through a static visual scene. The movement of the observer creates relative movement between the visual objects in the scene and the eye of the observer. The projection of the relative movement of the scene objects

onto the ►visual field of the observer creates ►visual motion. The collection of all the visual motions from throughout the visual field forms the optic flow. Since the motion in the visual field is first sensed by its projection on the retina, retinal flow is the collection of all image motion on the retina that arises from observer movement.

The retinal projection of the relative movement of a point in the scene can be described as a motion *vector*, i.e., by noting the motion direction and speed on the retina. The direction depends on the particular self-motion that the observer performs. When the observer moves to the left, all image motion is directed to the right. When the observer moves straight forward, all image motion is directed radially away from a point in the movement direction of the observer. This point is known as the ►focus of expansion. The speed of a particular motion vector in the optic flow depends on the distance of the point from the eye of the observer. Points near to the observer move faster in the retinal projection than points further away. The difference in the speeds of two points in the same visual direction but in different distances from the observer is known as ►motion parallax.

Optic flow not only arises from linear translations of the observer, such as sideward or forward movement, but also from rotations. Such rotations can occur either from moving along a curve or from eye movements of the observer. For example, when the observer performs an eye movement from right to left then rightward visual motion is induced on the retina. However, unlike in the case of leftward linear translation, the speeds of the motion vectors induced by eye rotation do not depend on the distance of the respective scene points from the observer. All points move with the same speed which is exactly opposite to the speed of the eye movement.

Thus, a single optic flow vector  $\theta$  of a point R in the scene is mathematically a function of the translation T and rotation  $\Omega$  of the eye of the observer and the distance Z of the point from the eye:  $\theta = f(T, \Omega, Z)$ . The precise equation is derived from perspective geometry [1]. Important for many aspect of flow analysis is the fact that in this equation the observer speed T and the depth Z are coupled such that the flow depends only on the quotient T/Z, not on Z directly.

The simplest optic flow is that of the radial outward movement obtained from linear forward movement. However, this is only a special case and the combination of translation, rotation, and scene distances can give rise to very different optic flow patterns. Since observer movement naturally triggers gaze stabilization reflexes such as the ►vestibulo-ocular reflex or the ►optokinetic reflex the optic flow observed under natural conditions will often result from a combination of translation and eye rotation.

Figure 1 shows a few characteristic examples. The observer moves across a ground plane. Heading is marked by a cross, gaze direction by a circle. Panels c to f show cases where the same heading is combined with different gaze directions. These gaze directions are shown in panel b. Panel c shows the retinal flow when gaze coincides with heading, i.e., when the observer looks straight into the direction of movement. In this case a focus of expansion is centered on the retina. In panel d, the observer looks off to the side. Gazing at some fixed point on the horizon allows him to keep his eyes stationary, i.e., no eye movements occur. A focus of expansion identifies heading, but now it is displaced from the center of the visual field. In panel e, the observer's gaze is directed at some element of the ground located in front of him and to the right. Because gaze is directed downward the horizon is in the upper visual field. Moreover, since the observer now looks at a point that is moving relative to himself, an eye movement is induced to stabilize gaze on this point. The resulting retinal flow field, a combination of translational and rotational flow, resembles a distorted spiraling motion around the fovea. There is no focus of expansion in the direction of heading (+). In panel f the observer looks at the same point as in panel d, but now he tracks an object that moves leftward along the horizon (for instance a car). This leftward pursuit induces rightward retinal image motion. The combination with the forward movement results in a motion pattern that resembles a curved movement and does not contain a focus of expansion.

### Behavioral Aspects

From its conception by Gibson in the 1950s [3] optic flow has been assumed to play a role in the control of self-motion. Since then, experimental studies have shown that optic flow is involved in many behavioral tasks:

*Control of Stance.* Direction and speed of the optic flow are used as feedback signals for postural stability. When standing observers are exposed to a large flow field that periodically expands and contracts they sway in phase with the flow field [4]. The coupling between optic flow and posture maintenance is particularly strong in children and decreases in strength with age as the influence of ►vestibular and somatosensory contributions to postural stability increases.

*Control of Speed.* Walking observers use the speed of the optic flow as a control signal for walking speed. Normally, a particular forward movement leads to a particular optic flow speed. If the flow speed is artificially increased, as has been done for observers walking on a treadmill in front of a projection screen on which a flow pattern was presented, walking speed increased proportionally [5]. Similar effects are seen for bicycling and car driving. When a mismatch between flow speed and walking speed is maintained for a

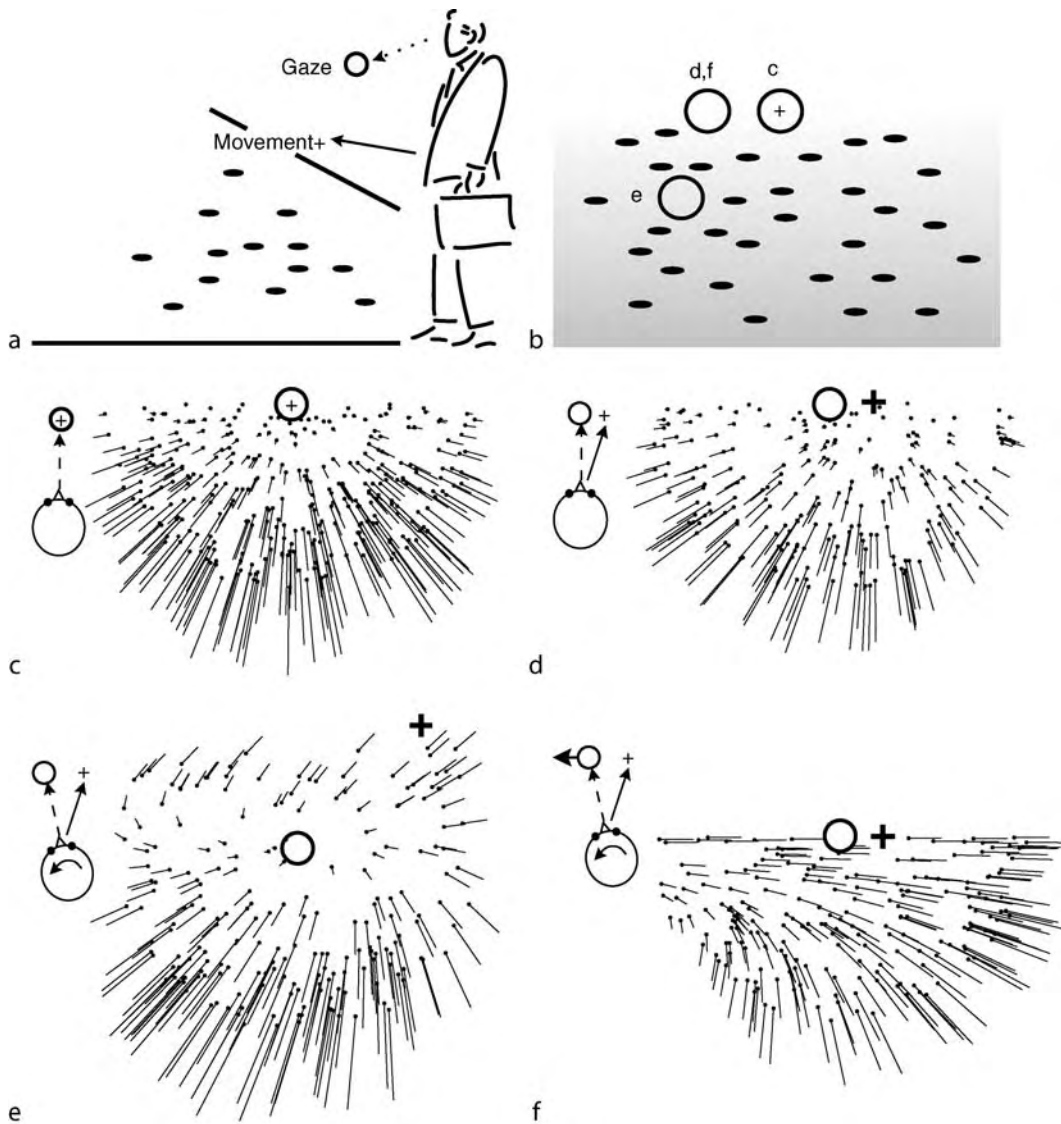

**Optic Flow. Figure 1** Examples of optic flow fields induced by combinations of forward movement and eye movement. Taken with modifications from [2]. See text for detailed explanation. (a) Observer moves towards the cross while looking at the circle. (b) different directions of gaze used in panels c to f. (c) Optic flow for straight translation into the direction of gaze. (d) Optic flow when direction of motion differs from direction of gaze. (e) Optic flow when direction of motion differs from direction of gaze and gaze stabilizing eye movement reflexes are taken into account. (f) Optic flow when direction of motion differs from direction of gaze and the observer tracks a moving object.

several minutes, for example when the flow speed is constantly lower than normal for a runner on a treadmill, an after effect is observed in which the walker inadvertently advances when attempting to run in place on solid ground with eyes closed.

**3D Scene Perception.** Because of motion parallax the optic flow contains information about the distances of the points of the scene. This information can be extracted to estimate the relative distances between objects in the scene and to recover surface layout [1]. Absolute distances cannot be retrieved from the optic

flow because flow magnitude depends on the quotient of observer speed ( $T$ ) and point distance ( $Z$ ). For example, in an airplane flying high above the ground optic flow speed is very low even for very high forward speed of the plane. Thus, distance can only be calculated when the observer speed is known, which is usually not the case.

► **Time-to-Contact.** Information in the optic flow allows to estimate the time-to-contact or the time-to-passage with an obstacle during forward motion. By itself, the speed of an optic flow vector of a particular

object is insufficient for the estimation of distance to the object (because it depends on T/Z) but a combination of speed with object size or of speed with the object's visual angle allows a direct calculation of time-to-contact. This information may be used to control braking or catching and to control running speed and direction for the intersection with a target object (for instance in ball sports). An overview can be found in [6].

► *Path Integration.* By integrating the speed of the optic flow over time an estimate of the travel distance or path length of an extended movement can be obtained. This estimate is subject to a scale factor since the speed of the flow depends on both the speed of the self-movement and the distance to the objects in the environment, but in many natural circumstances the height of the observer above the ground can provide the required scale. The estimation of travel distance from optic flow is based on an the integration of an estimate of observer velocity that is derived from the optic flow [7].

*Heading.* Heading refers to the direction of the movement of the observer. Gibson's original proposal for the use of optic flow was the identification of the heading (for example when landing an aircraft) by locating the focus of expansion in the flow field. Most optic flow research since then has centered on heading perception (overviews in [8] and [9]). Indeed, human observers are quite accurate in finding the focus of expansion in an expanding flow field. However, the situation is much more complicated because in most natural situations the optic flow on the retina is influenced by rotations and the flow field does not contain a focus of expansion (cf. Fig. 1). Yet, geometric calculations prove that the optic flow in these cases also contains sufficient information to separate the translational and rotational contributions if several flow vectors are available [1]. Many computational algorithms have been developed for this task, among them a few that are formulated as biologically plausible neurocomputational models (overview in [2]). Human observers can indeed estimate heading from flow fields of translation and rotation with reasonable accuracy (a few degrees of visual angle). An important finding was that heading estimation can be performed solely from the information in the flow field, i.e., from the direction and speed of the flow vectors, without any other sensory signals necessary. However, in natural situations eye movements that influence the structure of the retinal flow are accompanied by extra-retinal eye movement signals such as the ► *efference copy* signal or eye muscle ► *proprioception*. These signals are also used in optic flow analysis and increase the accuracy of the heading estimate. Rotational contributions to the retinal flow may also arise from movements on a curved path, in addition to, or instead of eye movements. Therefore, a separation of translational and rotational contributions may only provide the momentary or instantaneous

heading but not the full information about the future path of the observer, since the rotational contributions are ambiguous. Estimations of path curvature, which are required for steering for instance, can be derived from successive independent heading estimates or from a combination of optic flow and extraretinal eye movement signals. Alternatively, specialized behavioral strategies, such as fixating a specific point in the flow field, may allow the estimation of steering-relevant information directly from the retinal velocities.

Although the above descriptions refer to human observers, optic flow is used for such behavioral tasks throughout the animal kingdom (see [2] for several examples). The use of optic flow for the control of speed, distance, time-to-contact, and course control has been shown in insects, birds, and mammals, exemplifying the ecological importance of optic flow. Moreover, the above descriptions show that optic flow is often part of multi-modal mechanisms for behavioral control, interacting with ► *proprioceptive*, vestibular, and internal feedback signals. Exposure to optic flow is also known to induce ► *vection*, the subjective feeling of self-movement in a physically static observer.

### Neurophysiological Processing

In the visual system of primates visual motion information is routed via V1 and V2 to the ► *middle temporal (MT)* and subsequently to the ► *medial superior temporal area (area MST)* and other visual areas in the parietal lobe. Most clearly related to optic flow is area MST (detailed reviews in [2]). Many neurons in area MST respond selectively to entire optic flow patterns and not just to an individual motion vector in a particular flow field. A neuron might respond selectively to a particular flow pattern, such as an expansion as in Fig. 1c, but when tested with small stimuli the selectivities in subfields of the ► *receptive field* do not match one-to-one the pattern of the preferred large flow field. Thus, MST neurons are genuinely selective for optic flow. Their selectivity arises from complex interactions between selectivities in local subfields. Functional ► *brain imaging* in humans has confirmed an area selective for optic flow which is part of the human ► *MT± complex*.

When tested with multiple different flow patterns such as visual expansions, rotations and translations, MST reveals a continuum of response selectivities. Some neurons respond to several different patterns or to flow fields that combine translational and rotational contributions. Instead of classifying the selectivity of MST neurons by the preferred pattern of flow it is also possible to describe their selectivity in terms of heading. Indeed, it is possible to calculate heading from the firing rates of the neuronal population in MST. Next to visual motion signals, area MST also receives extra-retinal eye movement information. This information is used to counteract the effects of eye movements on the retinal

flow and maintain selectivity for heading in the presence of eye movements. There are also interactions with vestibular signals during self-motion.

Other areas of the parietal lobe, the ►ventral intraparietal area (VIP) and area 7A, as well as the ►fundus of the superior temporal sulcus (FST) also respond to optic flow. Neurons in area MT, the major input to area MST, respond to optic flow but their responses can be explained by their selectivity to local image motion within their receptive field. However, some global properties of the visual field map in MT seem related to optic flow analysis. Preferred speeds increase with eccentricity similar to the increase of speed with eccentricity in typical flow fields. The distribution of preferred directions for neurons with peripheral receptive fields is biased towards centrifugal motion similar to the radial motion directions in a typical optic flow. The increase of the receptive field sizes with eccentricity is well adapted to the size of image patches over which neighboring flow signals are uniform. These patches are small in the center of the visual field, where optic flow vectors point in different directions, and large in the peripheral visual field where neighboring flow vectors are usually very similar. Computational modeling shows that this adaptation of receptive field sizes leads to significant noise reduction in the optic flow representation in area MT.

As mentioned above, optic flow is used by many animals. A brief description of the neuronal pathways of optic flow analysis in birds can be found in the essay on *visual-vestibular interactions*. In flies, optic flow is analyzed by a small number of neurons of the horizontal (HS) and the vertical (VS) system in the lobula plate (Krapp in [2]). Unlike neurons of primate MST, which show no simple correlation between local motion selectivities and flow patterns selectivity, the flow selectivity of these neurons in the fly is matched by the sensitivity to local motion in subfields of their very large receptive fields. These neurons seem to form matched filters for particular flow patterns. Like in primate MST, information about the translation and rotation of the animal can be decoded from the population activity.

## References

1. Longuet-Higgins HC, Prazdny K (1980) The interpretation of a moving retinal image. *Proc Roy Soc Lond B* 208:385–397
2. Lappe M (ed) (2002) Neuronal processing of optic flow. *International Review of Neurobiology*, vol 44. Academic Press, New York
3. Gibson JJ (1950) *The perception of the visual world*. Houghton Mifflin, Boston
4. Lee DN, Aronson E (1974) Visual proprioceptive control of standing in human infants. *Percept Psychophys* 15:529–532

5. Prokop T, Schubert M, Berger W (1997) Visual influence on human locomotion – modulation to changes in optic flow. *Exp Brain Res* 114:63–70
6. Hecht H, Savelsbergh GJP (eds) (2004) *Time-to-contact*. *Advances in Psychology*, vol 135. Elsevier, Amsterdam
7. Frenz H, Bremmer F, Lappe M (2003) Discrimination of travel distances from ‘situated’ optic flow. *Vision Res* 43:2173–2183
8. Warren WH Jr (1998) Visually controlled locomotion: 40 years later. *Ecol Psychol* 10:177–219
9. Lappe M, Bremmer F, van den Berg AV (1999) Perception of self-motion from visual flow. *Trends Cogn Sci* 3:329–336

## Optic Flow Dependent OFR

### Definition

►Ocular Following Responses (OFR).

►Oculomotor Control

►Optic Flow

## Optic Nerve

### Definition

The optic nerve is the portion of the visual pathway between the retina and lateral geniculate nucleus of the thalamus that lays rostral to the optic chiasm. The continuation of the path caudally is the optic tract. The cell body of origin for this pathway is the ganglion cell in the retina.

## Optic Neuritis

### Definition

Sudden inflammation of the ►optic nerve occurring most often between 20 and 40 years of age, and may be a ►demyelinating disease of unknown origin or a manifestation of ►multiple sclerosis. The inflammation may occasionally be the result of a viral infection.

►Multiple Sclerosis

## Optic Radiation

### Synonyms

Radiatio optica

### Definition

The visual radiation is the term used to designate the ray-shaped fiber bundles that leave the lateral geniculate body and at the lateral wall of the lateral ventricle pass on to the area 17 (striate cortex) at the occipital pole. They conduct the visual raw material after being processed by the LGB. Also called geniculocalcarine tract.

- ▶ Geniculo-striate Pathway
- ▶ Lateral Geniculate Nucleus (LGN)
- ▶ Primary Visual Cortex
- ▶ Striate Cortex Functions

## Optic Tract

### Definition

The optic tract is the portion of the visual pathway between the retina and lateral geniculate nucleus of the thalamus that lies caudal to the optic chiasm. The portion that is rostral to the optic chiasm is the optic tract. The cell body of origin for this pathway is the ganglion cell in the retina.

## Optic Tract Nucleus

### Synonyms

▶ Nucl. tractus optici; ▶ Nucleus of optic tract

### Definition

The optic tract nucleus lies in the Myelencephalon near the superior colliculus. The nucleus is fused with the dorsal terminal nucleus and is an important center of the subcortical pathway which mediates horizontal optokinetic nystag

- ▶ Diencephalon

## Optical Coherence Tomography (OCT)

### Definition

OCT is an emerging ocular imaging technique to measure optic structures with micrometer resolution. It is useful in the measurement of retinal nerve fiber layer (RNFL) thickness and total macular volume corresponding to the ganglion cell body layer. The thickness of these unmyelinated nerve fiber layers may reflect axonal integrity, and function (vision) may be directly correlated with structure. Though RNFL thickness may be significantly decreased in multiple sclerosis (MS) patients with optic neuritis compared to healthy controls, even in MS patients with no history of optic neuritis, RNFL may still be decreased in thickness consistent with a neurodegenerative disease model of MS.

- ▶ Inherited Retinal Degenerations
- ▶ Multiple Sclerosis
- ▶ Optic Neuritis
- ▶ Retinal Ganglion Cells

## Optical Flow

- ▶ Optic Flow

## Optical Illusions

- ▶ Visual Illusions

## Optimal Control

### Definition

Optimal Control is a particular control technique in which the controller is designed to minimize a certain

performance index. For example, in human postural control, the performance index may be a combination of center of mass variance and mean squared ankle torque.

- ▶ Adaptive Control
- ▶ Modeling of Human Postural Control
- ▶ Motor Control Models

## Optimal Control Theory

### Definition

The mathematical theory of how controllers should be designed to achieve optimal performance.

- ▶ Neural Networks for Control

## Optimal Muscle Length

### Definition

The optimal length of a muscle is defined as the length at which a muscle can exert its maximal isometric steady-state force.

- ▶ Force Depression/Enhancement in Skeletal Muscles
- ▶ Length-tension

## Optimization

### Definition

An algorithm to achieve a particular goal while minimizing one, or a set of criteria. Mathematical optimization is defined by minimizing, maximizing, or optimizing a specific function (typically called the objective or cost function) while simultaneously satisfying any equality and/or inequality constraints. Mathematical Optimization has been the preferred approach to solve the distribution problem in biomechanics.

- ▶ Distribution Problem in Biomechanics
- ▶ Motor Control Models

## Optimization Model for Motor Control and Learning

### Definition

Computational models based on the idea that motor control and learning are planned and executed so as to achieve a behavioral goal, namely a tradeoff between task performance, body stability, and energy consumption. These models explain invariant movement features as a result of optimality and motor learning as a relaxation process toward a global minimum of a behavioral goal. Voluntary arm reaching, for example, has been modeled as smoothness or accuracy maximization, and locomotion as gait optimization in such a way as to maximize traveling distance using minimal muscle work.

- ▶ Theories on Motor Learning

## Optocollic Reflex

### Definition

A reflexive compensatory head movement elicited in response to motion of the entire visual world.

- ▶ Visual-Vestibular Interaction

## Optogenetic

### Definition

A method to manipulate the activity of genetically identified neurons using light-sensitive ion channels.

- ▶ Hypocretin/Orexin

## Optokinetic After-Nystagmus (OKAN)

### Definition

When subjects are placed in darkness following optokinetic nystagmus, the nystagmus continues and



the slow phase velocity has characteristics similar to Per- and Post-Rotatory Nystagmus. The presence of OKAN can be directly related to activation of velocity storage.

- ▶ Optokinetic Nystagmus
- ▶ Per-rotatory Vestibular Nystagmus
- ▶ Velocity Storage

## Optokinetic Nystagmus (OKN)

### Definition

A physiological nystagmus that occurs when a large part of the image moves uniformly over the retina, such as when viewing objects from a moving train or turning around. It consists of two components of eye movements: slow phase, which moves the eyes to follow the visual scene motion (called optokinetic response), and quick phase, which rapidly reset the eye position deviation by slow phase.

- ▶ Nystagmus
- ▶ Optokinetic Response

## Optokinetic Reflex

### Definition

- ▶ Optokinetic Nystagmus (OKN)

## Optokinetic Response

### Definition

Compensatory head, eye and body movements in response to motion of the entire visual world. They function to control gaze, posture and locomotion (alternatively known as optomotor responses).

- ▶ Visual-Vestibular Interaction

## Optokinetic Response Adaptation

CHARLES A. SCUDDER  
Portland, OR, USA

### Definition

Optokinetic response (OKR) adaptation is a behavioral change and underlying neural process that increases the ability of the optokinetic system to move the eyes and track moving large-field visual stimuli (see ▶ [Optokinetic nystagmus](#)). The adaptation is stimulated by motion of the visual image across the retina (▶ [Retinal slip](#)), and is prominent in species where the performance of the optokinetic system is normally low, such as rodents and fish. The increased efficacy of the OKR acts to reduce image motion across the retina and thereby improve visual acuity.

### Methods to Produce and Measure Adaptation

Methods to produce and measure OKR adaptation are an extension of those used to produce and measure OKR itself. Subjects typically sit at the center of a large cylindrical drum with a visual pattern on the inside that takes up most of the subject's visual field ([Fig. 1](#)).

Oscillation of the "optokinetic drum," usually in a horizontal plane, evokes eye-movements that tend to track the motion of the drum (see [Optokinetic eye movements](#)). The ability of the eye-movements to track drum motion is often measured as gain, which is the ratio of eye angular velocity to drum angular velocity. Perfect tracking would produce equal eye and drum velocities and a gain of 1.0. Actual gains are always less than one, and cannot exceed one.

Whereas measurement of OKR gain requires only a few minutes, continued drum motion is used to produce adaptation. Adaptation takes place anytime there is retinal slip, but a measurable change in OKR gain requires an hour or so of drum oscillation. [Figure 2](#) illustrates adaptation in a rabbit. OKR gain at the start of adaptation is about 0.5 (eye movement only compensates half of the drum motion). After an hour, OKR efficacy has increased to 0.74, and an additional two hours of adaptation increases gain only slightly more to 0.78.

### Characteristics

#### Species Dependencies

OKR adaptation has mainly been observed in rodents [1–3] and goldfish [4] where the gain of the OKR is typically well below 1.0 except at very low drum velocities. This is in part because gains less than one allow adequate retinal slip to produce adaptation in a suitable paradigm, and there is sufficient room below the maximum gain of one for the increased OKR efficacy to

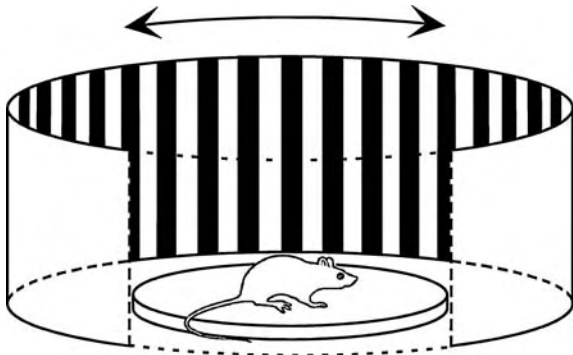

**Optokinetic Response Adaptation. Figure 1** Illustration of the apparatus used to generate and adapt the optokinetic response. A mouse sits on a stationary platform surrounded by an optokinetic drum which oscillates back and forth about a vertical axis. The mouse would be restrained in an actual experiment. The drum is illustrated as being lined on the inside with vertical black and white stripes, but other high contrast patterns have been used. Vestibular responses can be produced by rotating the platform on which the mouse sits. To induce the vestibuloocular reflex (VOR), rotation takes place in the dark, but various VOR adaptation paradigms combine rotation of the mouse with motion of the optokinetic drum in the light.

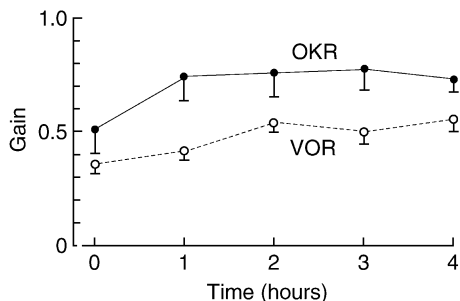

**Optokinetic Response Adaptation. Figure 2** Plot of the gain of the optokinetic response (OKR – solid line) as a function of the duration of OKR adaptation. OKR gain increases rapidly in the first hour and then plateaus. The paradigm for increasing OKR gain also has the effect of increasing the gain of the vestibuloocular reflex (VOR – dotted line) in rodents. Figure adapted from Nagao et al. [6].

be observed. In one case where OKR gain was close to one at low drum velocities, the effect of OKR adaptation could still be observed at higher drum velocities where OKR gain normally drops well below one [2].

OKR adaptation has not been reported in primates, but neither has it been systematically tested. The excellent tracking of optokinetic targets at velocities less than  $60^\circ/\text{s}$  leaves little opportunity for adaptation to

occur or to be observed. Moreover, differences between primate and rodent physiology argue that OKR adaptation is less likely in primates. Primates lack the directionally selective retinal ganglion cells that participate in rodent OKR, they have a fovea instead of a visual streak, and **smooth pursuit** rather than OKR dominates primate responses to motion in the visual field.

### Velocity Dependence

OKR adaptation has been produced using optokinetic drum velocities past the limit at which the eyes reliably track the drum. In rodents, this is at low stimulus frequencies (0.1–0.4 Hz) and at peak drum velocities of  $3^\circ/\text{s}$ – $10^\circ/\text{s}$ . Retinal slip velocities are then between  $2^\circ/\text{s}$  and  $8^\circ/\text{s}$ . It has been reported that low retinal-slip velocities ( $<1^\circ/\text{s}$ ) do not produce adaptation [3], but this has not been extensively tested.

### OKR Adaptation and Head Movement

The vestibulo-ocular reflex (VOR), which is not a visual-following reflex, acts to counter-rotate the eyes in the head whenever the head moves with the goal of stabilizing the visual scene on the retina (see **VOR**). Adaptation of the VOR occurs when this ocular compensation is imperfect, or in other words, when movement of the head produces retinal slip (see **VOR adaptation**). This retinal slip might be expected to produce OKR adaptation as a byproduct, and indeed it does [1,2]. This is best demonstrated by using different combinations of forced head motion and drum motion in order to create retinal slip velocities that are either in the same or opposite direction as eye motion. For instance, when the drum motion is in the opposite direction as head motion (a paradigm that increases VOR gain), slip velocity is in the same direction as eye velocity. However, when drum motion is in the same direction as the head motion (a paradigm that decreases VOR gain), slip velocity is in the opposite direction as eye velocity. In rodents, both paradigms produce OKR adaptation and the effect of both is to increase OKR gain [1,2]. Apparently retinal slip of any kind augments OKR gain in these animals.

However in monkeys and cats, the situation is different [5]. Paradigms that increase VOR gain also increase OKR gain, and those that decrease VOR gain also decrease OKR gain. In each case, the result is to improve the VOR in the sense that there is less retinal slip during head rotation at the end of the particular paradigm, but the concomitant reduction of OKR gain is maladaptive. This has been interpreted to mean that the primary function of the adaptive mechanisms is to adjust VOR gain, but that the VOR and OKR pathways share a common structure that changes the gain of both systems simultaneously.

Finally, there is the possibility that the OKR-adaptation paradigm (drum motion with no head motion) could

alter the VOR because of the retinal slip. In rodents and goldfish, this paradigm does increase the gain of the VOR [1,4,6] (Fig. 2). However in monkeys, the effect is negligible [7]. The above differences between rodents and primates reinforce the idea that primates are not the same as rodents and goldfish regarding the existence of OKR adaptation.

### Upstream Conditions

As noted above, the existence of retinal slip of adequate velocity is required for OKR adaptation to occur.

### Involved Structures

Adaptation of the OKR presumably involves plasticity at synapses that are part of the normal OKR pathway (see ►[Optokinetic eye movements](#)). In most species, this involves indirect projections of from the accessory optic system to the floccular lobe of the cerebellum and then to the vestibular nuclei. Rodents may have an additional pathway that has not been found in primates from the pretectum directly to the vestibular nuclei.

Experimental interventions that diminish or abolish OKR adaptation precisely parallel those that diminish or abolish adaptation of the VOR (see VOR adaptation and ►[Flocculus hypothesis](#)). Among these interventions are those known to disrupt long-term depression (LTD) at the cerebellar parallel-fiber to Purkinje-cell synapse. They include destruction or inactivation of the flocculus [6], destruction of the climbing-fiber afferent pathway to the cerebellum [3], disruption of metabotropic glutamate receptors either by direct blockage or by elimination in mutant mice [8], blockage of nitric oxide synthase [9], and disruption of phosphokinase C. The first two appear to implicate the flocculus in OKR adaptation, but the latter four are not necessarily specific. Measurements of Purkinje-cell activity during adaptation show that changes do occur within the flocculus, and that the changes probably produce the changes in OKR gain rather than reflect feedback from the altered eye velocity [6]. In different experiments, physiological changes have also been observed in synapses the vestibular nuclei [10]. Shutoh et al. [10] argue that short-term plastic changes (about a day) reside in the flocculus while long term plastic changes reside in the vestibular nuclei. As has been strongly indicated for the VOR, it seems likely that plastic changes of some sort occur in both the flocculus and the vestibular nuclei.

### References

1. Collewijn H, Grootendorst AF (1979) Adaptation of optokinetic and vestibulo-ocular reflexes to modified visual input in the rabbit. *Prog Brain Res* 50:771–781
2. Nagao S (1983) Effects of vestibulocerebellar lesions upon dynamic characteristics and adaptation of

vestibulo-ocular and optokinetic responses in pigmented rabbits. *Exp Brain Res* 53:36–46

3. Katoh A, Kitazawa H, Itohara S, Nagao S (1998) Dynamic characteristics and adaptability of mouse vestibulo-ocular and optokinetic response eye movements and the role of the flocculo-olivary system revealed by chemical lesions. *Proc Natl Acad Sci USA* 95:7705–7710
4. Marsh E, Baker R (1997) Normal and adapted visuo-oculomotor reflexes in goldfish. *J Neurophysiol* 77:1099–1118
5. Lisberger SG, Miles FA, Optican LM, Eighmy BB (1981) The optokinetic response in monkey: underlying mechanisms and their sensitivity to long term adaptive changes in V.O.R. *J Neurophysiol* 45:869–890
6. Nagao S (1989) Role of cerebellar flocculus in adaptive interaction between optokinetic eye-movement response and vestibulo-ocular reflex in pigmented rabbits. *Exp Brain Res* 77:541–551
7. Lisberger SG, Miles FA, Zee DS (1984) Signals used to compute errors in monkey vestibuloocular reflex: possible role of flocculus. *J Neurophysiol* 52:1140–1153
8. Shutoh F, Katoh A, Kitazawa H, Aiba A, Itohara S, Nagao S (2002) Loss of adaptability of horizontal optokinetic response eye movements in mGluR1 knockout mice. *Neurosci Res* 42:141–145
9. Katoh A, Kitazawa H, Itohara S, Nagao S (2000) Inhibition of nitric oxide synthesis and gene knockout of neuronal nitric oxide synthase impaired adaptation of mouse optokinetic response eye movements. *Learn Mem* 7:220–226
10. Shutoh F, Ohki M, Kitazawa H, Itohara S, Nagao S (2006) Memory trace of motor learning shifts transsynaptically from cerebellar cortex to nuclei for consolidation. *Neuroscience* 139:767–777

## Optomotor Response

### Definition

In a broad sense the motor response to a visual stimulus. In narrower sense, the response of an animal to wide-field, visual stimulation (synonym: optokinetic response).

## Oral Mucosa

### Definition

The epithelium lining the inside of the mouth, the tongue and the palate.

► [Tactile Sensation in Oral Region](#)

## Oral-facial Dyskinesias

### Definition

Repetitive, rhythmic, bizarre movements in the face region.

## Orbital Dynamics

### ► Oculomotor Dynamics

## Orbital Pulleys

### Definition

When the eyes move from the primary position, the eye muscles do not slide freely within the orbital tissue. Instead their paths are restricted, possibly by rings of connective tissue and smooth muscle that have been termed orbital pulleys.

### ► Eye Orbital Mechanics

## Orbital Tissues Definition

Orbital tissues are the fat and connective tissues that surround the eyeball in the bony orbit.

### ► Eye Orbital Mechanics

## Orbitofrontal Cortex

### Definition

The orbitofrontal cortex is a region situated at the ventral surface of the frontal part of the brain. It is the subpart of the prefrontal cortex that receives projections

from the magnocellular medial nucleus of the medio-dorsal thalamus. The orbitofrontal cortex is an important brain region for the processing of rewards and punishments. The medial orbitofrontal cortex activity is related to monitoring the reward value of many different reinforcers, whereas lateral orbitofrontal cortex activity is related to the evaluation of punishers, which may lead to a change in ongoing behavior. The subjective hedonic experience is mediated by mid-anterior orbitofrontal cortex.

## Orexigenic

### Definition

Orexigenic means possessing activity that stimulates food intake. [Anorexigenic: opposite of orexigenic.]

### ► Neuropeptides

## Orexin/Hypocretin

### Definition

Orexins (OxA and OxB) are two neuroexcitatory peptides derived from the same precursor produced in a few thousand neurons restricted to the perifornical area of the hypothalamus. The orexins bind to two receptors (Ox1 and Ox2). Orexin is a synonym of hypocretin, and was given its name (orexi, appetite in Greek) because of initial studies showing increase in food intake following infusion of pharmacological doses of the peptides in the brain. The orexin/hypocretin system stabilizes wakefulness and sets the arousal threshold, enhances catabolism and is a gate to drug reinstatement. Dysfunctional orexin may be associated with the sleep disorder narcolepsy.

- Brain States and Olfaction
- Hypocretin/Orexin
- Memory and Sleep
- Narcolepsy
- Nocturnal/Diurnal
- Sleep – Motor Changes
- Sleep – Sensory Changes
- Ventrolateral Preoptic Nucleus (VLPO)

## Organ Discharge

- ▶ Electric Organ Discharge

## Organ of Corti

### Definition

The mammalian organ of hearing proper, lying between the basilar membrane and the tectorial membrane of the cochlea. It contains the inner hair cells, the outer hair cells and the peripheral synapses of the afferent and efferent neurons of the auditory nerve.

- ▶ Cochlea

## Organizational Hormonal Effects

### Definition

Hormone-induced alterations occurring during the early development of an organism that give rise to chronic changes in structure and/or function of particular anatomic systems. For example, manipulating the gonadal hormonal milieu of neonate rodents can produce durable effects on the developing nervous system resulting in lifelong changes in nociception and antinociception.

- ▶ Gender/sex Differences in Pain

## Organizer

### Definition

Area, tissue or cell group of an embryo able to produce signals (or signaling proteins) that have an effect at a distance on the fate of adjacent tissue, in a concentration dependent manner (this requires the expression of specific receptors in the tissue). Examples of organizers are the node and the notochord, which produce signals that have an effect either on the ectoderm (node signals

related to neural induction) or on the ventral neural plate/tube (notochord signals related to dorsoventral patterning). These are cases of organizers acting early in development and are many times referred to as “primary organizers.” Later in development, there are “local organizers” inside the neural tube having an effect on patterning and specification of adjacent areas (for example, the isthmic organizer or the zona limitans intrathalamica). These local organizers of the neural tube that appear later in development are called “secondary organizers.”

- ▶ Evolution and Embryological Development of the Forebrain
- ▶ Node
- ▶ Notochord

## Organizing Centers and Patterning

### Definition

Restricted regions of the embryo that secrete specific signalling molecules, responsible for specifying distinct domains (molecularly, anatomically, functionally distinct) in competent neighbouring tissues. This process is called patterning.

- ▶ Evolution of the Brain: In Fishes
- ▶ Evolution of the Telencephalon: In Anamniotes

## Orientation Behavior

### Definition

Ability to move in space either with respect to an external reference system (passive) or by actively generating spatial information (like in echo location).

## Orientation Selectivity in Vision

### Definition

Neurons in the retina and lateral geniculate nucleus of the thalamus are sensitive to local changes in light

levels, much like sensors in a digital camera. But these cells are not able to resolve higher order features of the visual scene. By contrast, cortical cells respond best to elongated contours, or edges, formed by extended boundaries between relatively dark and bright regions of the image – contrast borders. Importantly, almost all cortical neurons are orientation selective: individual cells are strongly excited by contours that share a common spatial orientation but respond weakly if at all to stimuli tilted perpendicular to the optimal angle. Different neurons prefer different stimulus orientations. Also, some neurons are tuned to a narrow range of stimulus angles while others are less selective. Orientation selectivity is the most widely studied aspect of visual cortical function; its origin in different species and its role in visual processing remain a subject of great interest.

► Visual Cortical and Subcortical Receptive Fields

## Orienting Sensitivity in Cutaneous Mechanosensation

### Definition

Subjects can discriminate a 10% angular difference in the orientation of a cylinder indented into the fingertip. Discriminating the orientation of a grating (usually vertical vs. horizontal) is also used to assess spatial resolution. Orthogonal gratings can be discriminated for groove widths around 1 mm at the fingertips and around 4 mm at the more proximal regions of the fingerpad.

► Processing of Tactile Stimuli

## Orienting Linear Vestibulo-ocular Reflex (IVOR)

### Definition

The reflex that responds to low frequency linear accelerations of the head in space to produce eye movements that tend to align the coordinate frame of the eyes with the net direction of the linear or equivalent linear acceleration of the head. This has also been referred to as the tilt response.

► Vestibuloocular Reflexes

## Orienting Movement

### Definition

► Orienting Reflex

## Orienting Reflex

### Definition

Also known as orienting response(s). In a general sense, it is the complex behavioral pattern aimed at optimizing the perception of biologically significant events in the environment and to make rapid and efficient choice of an appropriate motor response. Orienting is truly “reflexive” toward particularly intense or previously unexperienced, novel sensory stimuli. Accordingly, the Pavlovian school used the term “what happens?-reflex.” Its earliest manifestation is the generalized alerting. Sensory events signaling a potential danger or a positive reinforcement, such as prey for a predator or food delivery for an operantly conditioned animal, are also highly efficient to induce orienting. Motor responses to such stimuli are, respectively, either avoidance or approach. To make the choice between these strategies, the source of the stimulus must be rapidly identified. Alignment of the line of sight on the stimulus (gaze shifting) is the most important motor component of orienting reflex in animals whose behavior is dominated by vision and, in particular, in those having a small central region of the retina specialized for fine-grain visual discrimination (e.g., fovea in primates, area centralis in felines).

► Operant Conditioning

► SC-Tectoreticulospinal neurons (TRSNs)

► Vision

## Orienting Responses

### Definition

Movements that direct the line of sight and/or the ears towards sensory stimuli.

## Orthodromic Action Potential Propagation

### Definition

Propagation of action potentials in the naturally occurring direction (from “orthos”, Greek for straight, correct; “dromos”, Greek for run).

► Action Potential Propagation

## Orthostatic Intolerance

### Definition

Orthostatic intolerance is difficulty in maintaining standing posture due to orthostatic hypotension. Astronauts returning on Earth after spaceflights often complain of this symptom. Similar orthostatic problems occur after long-term bed rest.

► Autonomic Function in Space

## Oscillations and Plasticity in the Olfactory System

NADINE RAVEL, RÉMI GERVAIS,  
JULIE CHAPUIS, CLAIRE MARTIN  
Laboratoire Systèmes Sensoriels, comportement et  
Cognition, UMR 5020 CNRS–UCB Lyon, IFR19  
Lyon, France

### Definition

Learning induces neural assemblies formation detectable in the network through modulation of oscillatory activities.

### Characteristics

#### The Concept of Neural Assemblies

Current theories put forward that information storage in the brain relies on changes in functional interactions within widely distributed neural areas. This concept of distributed memory suggests in turn the idea that stimuli representations could be achieved through assemblies of simultaneously active neurons. Such assemblies

could be found within a given structure or between distinct neural areas. As a consequence, memory should be considered as a dynamical process involving spatio-temporal patterns of reactivation of previously reinforced neural ensembles within and across different brain areas. These assemblies involve both sensory and limbic areas.

If we accept this concept of distributed representations one have to face the problem, commonly addressed as the “binding problem” of how such distributed activities could be put back together to elicit stable and unambiguous representations of objects in the brain. Indeed, according to this theory a given neuron would be able at different time to take part to different stimuli representations. As a consequence, neuronal elements belonging to the same assembly must be identifiable and differentiated from members of other assemblies (see Fig. 1). Twenty years ago, von der Malsburg proposed that neurons joining into an assembly should establish temporal synchronization on a millisecond time scale. This temporal tagging has two major advantages: Synchronization of neuronal activities facilitates signal transmission to target structures because temporal coincidence of action potential volleys on post-synaptic higher areas increases probability of eliciting action potentials. In addition, this coincidence is very important in voltage-dependent processes like NMDA-receptor-gated conductance which are of prime importance in induction of synaptic plasticity.

Synchronous activities in assemblies often occur in a repetitive way and give rise to well-known brain rhythms also called oscillations. They can be recorded with macro electrodes either directly from the scalp (electroencephalogram, EEG) or from intracerebral inserted electrodes (► local field potentials, LFPs). They have been observed in many different brain areas especially those showing a laminar organization like cortices. These oscillations of LFPs exhibit a large variety of frequencies from 1 to 100 Hz depending on the vigilance state (arousal, attentiveness, sleep, etc.) or the presence of a sensory stimulation or the necessity to control a motor behavior. The origin of oscillations is still a matter of debate but one major hypothesis is that they could be an emergent property of a given network resulting from inhibitory interneurons and reciprocal connections. In relay neurons of any cortical area, these oscillations likely reflect current source generated by neuronal synaptic input in the dendritic tree and action potentials generated at the cell body level. LFP activities are a good indicator of how and when a large set of neurons synchronize and desynchronize during information processing. This review will illustrate how the study of the mammalian olfactory system brings information on the functional significance of neural oscillations in sensory processing and memory.

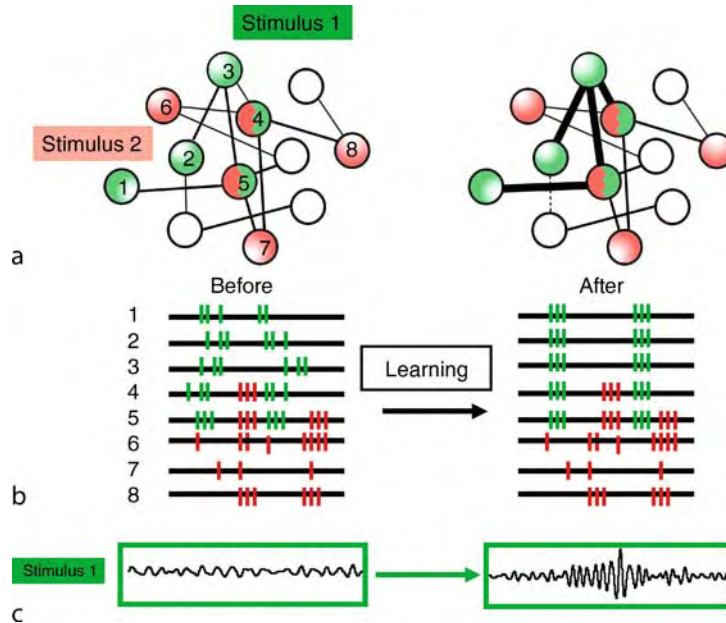

**Oscillations and Plasticity in the Olfactory System. Figure 1** Illustration of the concept of neural assemblies. (a). As symbolized by the colour code, each stimulus co activates a specific ensemble of neurons. However, some neural elements (4 and 5) could be co activated by both stimuli. Learning of stimulus 1 is associated with reinforcement of synaptic contacts between neurons previously co activated by this stimulus (*thick lines*). (b). Temporal organization of the discharge of each neuron clearly differentiates two neural assemblies (in green for stimulus 1 and red for stimulus 2). Neurons 4 and 5 could take part to both representations depending on their discharge timing. Before learning, units taking part to the same assembly are simply co-activated. Repeated presentation of stimulus 1 refines of neural discharge synchronization. As a consequence, the amplitude of **local field potential** oscillatory activity is increased and the dominant frequency corresponds to the periodicity of the synchronization.

### Oscillatory Activities in the Olfactory System

In the mammalian olfactory system, Adrian in the 50's initially described prominent oscillations in field potential activities. In **awake animals**, in the absence of any olfactory stimulation, the signal derived from the first relay of olfactory processing, the olfactory bulb, exhibits a well structured activity as shown on Fig. 2.

Slow modulations of LFP associated with inhalation are easy to observe. These high amplitude oscillations are in the theta range (2–12 Hz). They have been shown to follow the respiratory activity and hence might vary in frequency. Moreover, during period of exploration associated with active sniffing, the respiratory modulation has a frequency range which overlaps with the theta activity typically observed in limbic areas such as the hippocampus (4–12 Hz).

Recordings also show regular spindle bursts of oscillations during each inspiration phase of the respiratory cycle. This second type of oscillatory activity is in the gamma range (30–90 Hz). Interestingly, in a given animal, even in the absence of any olfactory stimulus, the distribution of amplitude of gamma bursts forms a stable map at the surface of the OB. Presentation of an odor in a specific experimental

context modifies this distribution. However, this new map is more related to the behavioral meaning of the stimulus than to its chemical quality. Indeed, if the same odor is presented in another context, a different map is obtained [1]. Recently, Kay [2] proposed to distinguish two types of gamma activity, type 1 (65–90 Hz) corresponding to the bursts associated to the peak of inhalation and type 2 (35–65 Hz), lower in frequency. These rhythms seem to be associated with different behavioral features and are likely to be produced by different synaptic interactions within the olfactory bulb.

Whereas gamma and theta activities have been studied for a long time, at first, little attention was paid to an intermediate type of periodic activity in the beta range (15–35 Hz).

This activity has now been reported by several authors to be selectively associated with **odor sampling** not only in the olfactory bulb, but also at higher level of olfactory processing like the piriform cortex and lateral entorhinal cortex. These studies pointed out to a more or less prominent increase in the amplitude of this oscillatory activity in response to behaviorally relevant odors [3,4] or odors experimentally associated with a reward [5–8].



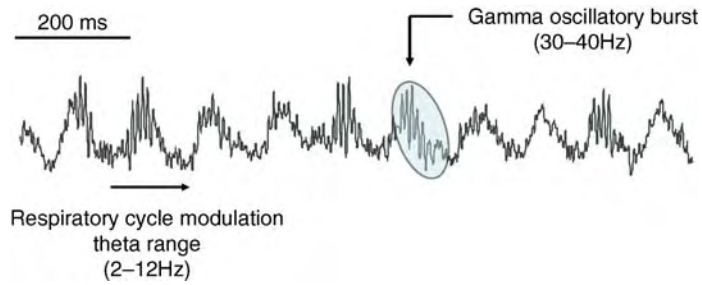

**Oscillations and Plasticity in the Olfactory System. Figure 2** Spontaneous activity recorded in the olfactory bulb in ►awake animal.

Thus, both gamma and beta oscillatory activities were associated to perception and cognitive processing of olfactory stimulus. In awake animals, gamma oscillatory activity is prominent in the absence of odor and seems more related to attention toward an expected stimulus or a given experimental context. Beta oscillatory activity has never been reported in the absence of odor. This activity emerges during odor sampling and is modulated both by the chemical nature of the odor and its behavioral significance.

### Oscillations and Construction of Odor Representations

According to the concept of neural assemblies proposed above, synchrony in a given neural network favors both signal transmission and synaptic plasticity. Hence, if this view is correct one could predict that olfactory learning should induce reinforcement of excitatory transmission between cells responding to the odor to be learned. As a consequence, learning should modify oscillatory regimes associated with the processing of learned odors. A first step toward the experimental demonstration of this hypothesis has been made by a few studies in which multisite neural recordings were performed in animals engaged in two different olfactory discrimination learning paradigms [7–9].

In the first paradigm (see Fig. 3), two odors without any a priori ►behavioral signification (►odor with behavioral signification) were assigned with two different values by pairing their presentation either with a sweet (O+) or a bitter (O-) solution. At the beginning of the experiment, the two odors induced the same behavioral response but after a few experimental sessions, thirsty rats exhibited a differential response to each odorant. Indeed, they learnt to run promptly to drink when O+ was delivered and avoid drinking when O- was presented. In parallel to this behavioral response modification, a clear oscillatory activity in the beta band (near 27 Hz) emerged in the olfactory bulb in response to odors used in the learning paradigm. In respect to a potential role in olfactory coding, we found that this activity exhibited different characteristics in amplitude and latency according to the recorded region

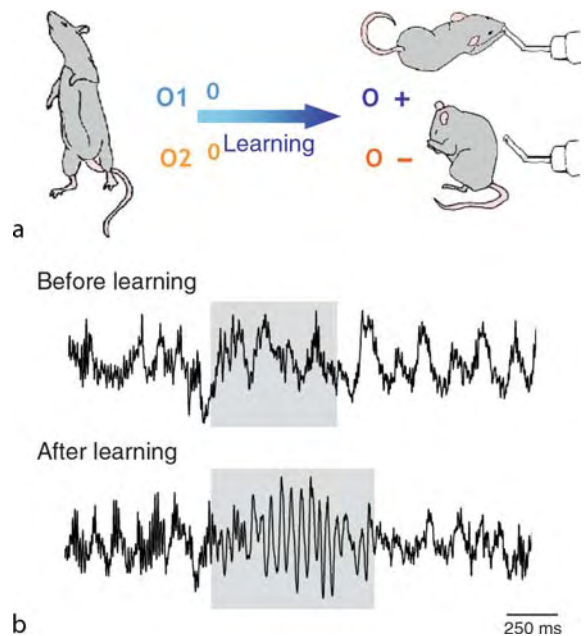

**Oscillations and Plasticity in the Olfactory System. Figure 3** Learning-induced modulation of beta oscillatory activity. (a) Experimental protocol. Two odors without any a priori behavioral signification (O1 and O2) are assigned with two different values by pairing their presentation either with a sweet (O+) or a bitter (O-) solution. (b) Comparison of odor-induced activity in the olfactory bulb before and after O1 has acquired a positive value for the rat. The shaded zone corresponds to the odor sampling period. After learning, an oscillatory burst in the beta range (around 27 Hz) is clearly observed.

in the olfactory bulb (anterodorsal vs. posteroventral) and the chemical nature of the odorants. More interestingly, the large beta oscillatory activity emerged a few trials before the animal reached the criterion level. As a whole, results stressed out the possible role of the beta oscillatory activity in both odor representation and olfactory recognition. The same type of activity

was also found in other structures involved in odor stimulus processing like the piriform cortex. Moreover, a pharmacological inactivation of feedback connections from piriform cortex to olfactory bulb prevented in both structures the emergence of beta activity in response to learned odors suggesting that this oscillatory activity could be the signature of a neural network set up through learning and involving well-known reciprocal excitatory cortico-cortical connections between the olfactory bulb and the piriform cortex.

Recently, using a two-alternative choice odor discrimination, Beshel and colleagues [9] also showed a functional link between gamma range oscillatory activities in the OB and plasticity. In this paradigm, task demand was manipulated using either dissimilar or similar odorants (“coarse” vs. “fine” discrimination). Gamma oscillatory power progressively increased over the course of fine discrimination learning in contrast to coarse discrimination. This modulation was specific to gamma frequency range (65–85 Hz) and independent of changes in the theta or beta frequency range. It was also restricted to the OB despite gamma activity was also reported during spontaneous activity in the piriform cortex. This experimental result is in favor of a functional role of gamma oscillatory activity in pattern disambiguation. However, in mammals, data establishing a direct link between oscillatory activity disruption and behavioral performance alteration are still lacking.

Until now, the only demonstration that oscillatory synchronization might play a determinant role in fine stimulus encoding and odor recognition was brought by a work on honeybees [10]. In this animal model, odors evoke oscillatory synchronizations of groups of neurons in the antennal lobe, a structure functionally equivalent to the vertebrate olfactory bulb. These oscillations, in the beta range (around 30 Hz) could be selectively disrupted with picrotoxin, a pharmacological antagonist of GABA<sub>A</sub> receptors without affecting neural response and selectivity to odors. Behavioral experiments combining pharmacological disruption of odor-evoked oscillatory activity and evaluation of olfactory discrimination performance showed that picrotoxin-treated animals failed to discriminate between similar odorants although they were unimpaired for coarse discrimination. These observations were the first real argument for a role of neural synchronization in separation of spatially overlapping neural networks. It is of course tempting to speculate that neural oscillatory synchronization might play a similar role in other animal models.

In conclusion, one can point out that the detailed investigation of neural rhythms through LFPs recordings in behaving animals brings important insight on neural correlates of sensory discrimination and recognition. One of the main advantages of this approach is the relative ease with which one can obtain signal from several recording sites simultaneously and over the course of

training (several days). This allows investigation of some neural correlates which sustain learning and memory in a time scale which characterized many forms of knowledge acquisition.

## References

1. Freeman WJ, Schneider W (1982) Changes in spatial patterns of rabbit olfactory EEG with conditioning to odors. *Psychophysiology* 19:44–56
2. Kay LM (2003) Two species of gamma oscillations in the olfactory bulb: Dependence on behavioural state and synaptic interactions. *J Integr Neurosci* 2(1):31–44
3. Zibrowski EM, Vanderwolf CH (1997) Oscillatory fast wave activity in the rat pyriform cortex: relations to olfaction and behaviour. *Brain Res* 766:39–49
4. Chabaud P, Ravel N, Wilson DA, Mouly AM, Vigouroux M, Farget V, Gervais R (2000) Exposure to behaviourally relevant reveals differential characteristics in rat central olfactory pathways as studied through oscillatory activities. *Chem. Senses* 25:561–573
5. Boeijinga PH, Lopes da Silva F (1989) Modulations of EEG activity in the entorhinal cortex and forebrain olfactory areas during odour sampling. *Brain Res.* 478:257–268
6. Ravel N, Chabaud P, Martin C, Gaveau V, Hugues E, Tallon-Baudry C, Bertrand, Rémi Gervais (2003) Olfactory learning modifies the expression of odour-induced oscillatory responses in the gamma (60–90 Hz) and beta (15–40 Hz) bands in the rat olfactory bulb. *Eur J Neurosci* 17:350–358
7. Martin C, Gervais R, Hugues E, Messaoudi B, Ravel N (2004) Learning modulation of odor-induced oscillatory responses in the rat olfactory bulb: a correlate of odor recognition? *J Neurosci* 24(2):389–397
8. Martin C, Gervais R, Messaoudi B, Ravel N (2006) Learning-induced oscillatory activities correlated to odour recognition: a network activity. *Eur J Neurosci* 23:1801–1810
9. Beshel J, Kopell N, Kay LM (2007) Olfactory bulb gamma oscillations are enhanced with task demands. *J Neurosci* 27(31):8358–8365
10. Stopfer M, Bhagavan S, Smith BH, Laurent G (1997) Impaired odour discrimination on desynchronization of odour-encoding neural assemblies. *Nature* 390:70–74

## Oscillations in the Brain

### Definition

Oscillation is the variation, typically in time, between two boundary values of some measure. In the brain, oscillatory activities have been widely observed. At the level of the neurons and networks of neurons, it has been shown that intrinsic (mainly due to ion channel) and networks properties (connectivity, inhibition and excitation), endowed the neuron and the network with

dynamical properties, including abilities to oscillate at multiple frequencies. Oscillations are grouped into categories that depend on their frequency and their relation with particular behaviors. Among other one can distinguish oscillations in the gamma band (30–90 Hz) that have been involved in perception, problem solving, fear and other higher brain function.

- ▶ Brain Rhythms
- ▶ Network Oscillations
- ▶ Network Oscillations in Olfactory Bulb

---

## Oscillator

### Definition

A device that generates a periodic signal.

- ▶ Signals and Systems

---

## Oscillator for Circadian Rhythm

### Definition

A system that produces rhythmic output or whose state varies in a periodic fashion in the absence of external stimuli. A circadian oscillator produces a rhythm whose period is approximately 24 h when the organism is maintained in constant conditions. This may be detected in the cycle of activity and rest, in gene expression as reflected by mRNA abundance or protein concentration, etc. Negative feedback loops involving regulation of transcription by translational products have been found to generate such circadian oscillations in a number of organisms. Circadian oscillators are typically entrainable by environmental cues within a range of periods close to 24 h, and often vary little in period over a range of temperatures.

---

## Oscillator Versus Hourglass Timers

### Definition

Time-measurement can be achieved by different types of mechanisms that change state in a predictable way before returning to the starting point. Once started, an oscillator may continue to generate cycles (have an

endogenous rhythm) indefinitely, or it may damp out. In contrast, an hourglass measures a fixed interval and then must be restarted (by some external stimulus) in order to measure a second interval. Whether a biological system acts as an oscillator or as an hourglass can be a function of its environment; changes in parameters may alter the behavior of an oscillator so that it damps rapidly and thus functions as an hourglass.

---

## Osmolality

### Definition

Osmolality refers to the total concentration of all particles that are free in a solution. Thus, glucose contributes one particle, whereas fully dissociated NaCl contributes two. In all body fluid compartments, humans have an osmolality – expressed as the number of osmotically active particles per kilogram of water – of approximately 290 mOsmoles/kg water (290 mOsm).

---

## Osmotic Energy

### Definition

The energy associated with a concentration gradient.

- ▶ Energy/Energetics

---

## Osseoperception

### Definition

The tactile sense relayed through dental impacts placed in the jaws to serve as replacements for lost teeth.

- ▶ Tactile Sensation in Oral Region

---

## Osteoarthritis

### Definition

Osteoarthritis is a joint degenerative disease characterized by the breakdown of articular cartilage, osteophyte formation, joint swelling, stiffness and pain. The

disease progresses from an initial hypertrophy of the articular cartilage to degeneration of the cartilage and underlying bone. Osteophytes also grow throughout the affected joint.

- ▶ Articular Cartilage
- ▶ Measurement Techniques (Pressure)

## Osteoblast

### Definition

Cell of fibroblast lineage responsible for secreting unmineralized bone matrix.

- ▶ Bone

## Osteoclast

### Definition

Cell of macrophage lineage responsible for resorbing bone.

- ▶ Bone

## Osteocyte

### Definition

Former osteoblasts, which are entombed within mineralizing matrix, reside within the bone in caverns termed lacunae, and appear to play an integral role in maintaining bone vitality and the tissue's ability to respond to altered loading states.

- ▶ Bone

## Osteoporosis

### Definition

A systemic disease in which bone mass and morphology have degraded sufficiently to elevate the risk of fracture.

- ▶ Bone

## Osteostracans

### Definition

A group of early jawless craniates that lived around 425–415 Ma BP and resembled gnathostomes in having pectoral fins, but not pelvic ones.

- ▶ The Phylogeny and Evolution of Amniotes

## Other Minds Problem

### Definition

The other minds problem is the problem of how we know (or are justified in believing) that other human beings exemplify mental properties similar to the ones we exemplify, given that their conscious mental life is not accessible from our third person point of view. The existence of other minds is typically justified by an argument from analogy, stated in its classic form by John Stuart Mill and Bertrand Russell, according to which one's own body and outward behavior are observably similar to the body and the behavior of others, so that one is justified by analogy in believing that they also exemplify similar mental properties.

- ▶ Epiphenomenalism

## Otic Placode

### Definition

Thickening of the ectoderm and precursor of the otocyst.

- ▶ Evolution of the Vestibular System

## Otoconia

### Definition

Dense calcium carbonate particles ("ear stones") that are attached to the gelatinous otolith membrane over the

utricle and saccular maculae. Otoconia serve as inertial sensors of linear acceleration.

- ▶ Evolution of the Vestibular System
- ▶ Peripheral Vestibular Apparatus
- ▶ Sacculus
- ▶ Utriculus

---

## Otocyst

### Definition

Invagination of the otic placode forming a cyst at first that later subdivides and gives rise to the complex adult three-dimensional structure of the labyrinth.

- ▶ Evolution of the Vestibular System
- ▶ Otic Placode

---

## Otoencephalitis

### Definition

Inflammation of the brain due to an extension from an inflamed middle ear.

---

## Otolith

### Definition

The vestibular receptor organ that responds to linear accelerations of the head. Otoliths contain receptor cells in a small patch of neuroepithelium termed the macula. Above the macula is a gelatinous membrane into which the stereocilia of the hair cells project. Otoconia lie embedded in and attached to the top of the membrane.

- ▶ Otoconia
- ▶ Peripheral Vestibular Apparatus

---

## Otolith Organs

### Definition

The parts of the vestibular labyrinth composed of the utricles and saccules that sense linear acceleration or equivalent linear acceleration of the head.

- ▶ Peripheral Vestibular Apparatus
- ▶ Sacculus
- ▶ Utriculus

---

## Otx

### Definition

Member of a gene family (orthodenticle)

- ▶ Evolution of the Vestibular System

---

## Otx1, Hominids

- ▶ Evolution of the Vestibular System

---

## Outer Hair Cells

### Definition

The hair cells of the mammalian cochlea responsible for amplifying the vibrations of the basilar membrane and the hair cell stereocilia.

- ▶ Cochlea

---

## Outer Plexiform Layer

### Definition

Synaptic layer in the outer (distal) retina where photoreceptors make synapses with horizontal and bipolar cells.

- ▶ Inherited Retinal Degenerations

## Output Unit

### Definition

A model network neuron that provides the network response to activity propagated through hidden units due to signals received by input units.

► Neural Networks

## Ovariectomy

### Definition

Surgical removal of the ovaries.

## Overdetermined System

### Definition

A mathematical system is called overdetermined if it has more system equations than unknowns. Overdetermined systems typically do not have a solution.

► Distribution Problem in Biomechanics

## Overfitting

### Definition

Overfitting refers to a problem that can arise during the training of artificial neural networks (or other statistical learning systems). During training the network learns a mapping from the input domain to the desired output. The target of this process is to capture the underlying regularities in the data that are to be modelled. However, since there are, in general, limited amounts of training data, the network may learn to approximate these correctly, while failing to process new data appropriately. This is referred to as overfitting: the network has learned a function that is too complex, modelling not only the regularities of the dataset, but also its noise.

► Connectionism

## Overhang (DNA)

### Definition

When a restriction cleaves DNA asymmetrically a stretch of single stranded nucleotides is left. If the single stranded bases end in a 3' hydroxyl a 3' overhang remains. Similarly, a 5' overhang remains when the single stranded bases end in a 5' phosphate. Overhangs are often generated in molecular biology by use of DNA endonucleases. Larger overhangs of several nucleotides, such as those created by restriction endonucleases, are often called "sticky-ends" since a DNA molecule with complimentary sequence in the overhang region can anneal to each other. This phenomenon is used in molecular biology to piece together DNA molecules from different sources which are then covalently linked with DNA ligase.

► Serial Analysis of Gene Expression

## Overlap Zone in Skeletal Muscle

### Definition

The overlap zone in skeletal muscle designates the area of overlap between the contractile proteins actin and myosin. At short muscle length, the overlap zone is big, and for increasing muscle length, the overlap zone becomes smaller. When there is no overlap between actin and myosin (i.e. the overlap zone has vanished), active force production is not possible anymore.

► Actin

► Force Depression/Enhancement in Skeletal Muscles

► Myosin

► Sarcomere Structural Proteins

## Overshadowing

### Definition

The ability of a conditioned stimulus (CS) to elicit a conditioned response (CR) is reduced when its pairings

with the unconditioned stimulus (US) take place in the presence of another neutral stimulus. Assessment of the magnitude of overshadowing is made through comparison with a control group that receives only pairings of the CS and the US. This is one of several examples of cue competition or stimulus selection effects that prompted development of predictive-driven learning models.

► Theory on Classical Conditioning

---

## Overshoot (of Action Potential)

### Definition

Reversal of membrane potential during the action potential peak.

► Action Potential

---

## Overtraining Syndrome (OTS)

### Definition

When prolonged, excessive training stress are applied concurrent with inadequate recovery, many of the positive physiological changes associated with physical training are reversed with overtraining. Chronic physiological maladaptations and performance decrements occur. Throughout the twentieth century, many names have been given to this chronic maladaptive state (e.g., underperformance syndrome, sports fatigue syndrome), but presently the term overtraining syndrome (OTS) is used. A large number of symptoms associated with overtraining have been reported in the literature and categorized according to physiological performance, psychological/information processing, immunological, and biochemical parameters. It is also probable that other signs/symptoms typically associated with overtraining are evident before a deterioration in performance. These might include generalized fatigue, depression, muscle and joint pain, and loss of appetite. However, it is the decline in performance frequently associated with an increased volume or

load of training that captures the attention of the athlete and coach.

► Stress Effects During Intense Training on Cellular Immunity

---

## Owl

### Definition

Mostly night active bird species of the order Strigiformes. The barn owl, especially, is a model system for investigating mechanisms of sound localization (see essay on “Sound localization in the barn owl”), depth vision and plasticity of the nervous system.

---

## Oxidative Potential

### Definition

Motoneurons, like the muscle fibers that they supply, derive their energy from metabolism that either requires oxygen or does not. The metabolism that does require oxygen to generate adenosine triphosphate for energy is referred to as oxidative energy, the cells having oxidative potential.

► Axonal Sprouting in Health and Disease  
 ► Motoneuron

---

## Oxidative Stress

### Definition

Oxidative stress is a medical term for damage to animal or plant cells caused by reactive oxygen (ROS) and nitrogen (RNS) species, which include superoxide radical, singlet oxygen, peroxy nitrite or hydrogen peroxide. It is defined as an imbalance

between prooxidants and antioxidants, with the former prevailing.

- ▶ Alzheimer's Disease – Oxidative Injury and Cytokines

---

## Oxytocin

Neuropeptide secreted as hormone by the neurohypophysis and involved in labor, lactation and reproduction.

- ▶ The Hypothalamo Neurohypophysial System
- ▶ Hypothalamo-Pituitary-Adrenal Axis
- ▶ Stress and Depression

---

## Oxytocinergic Central Pathways

### Definition

Oxytocinergic central pathways are involved in reproduction, cognition, tolerance, adaptation and the regulation of cardiovascular and respiratory functions. Centrally released oxytocin would also give rise to sedation.

- ▶ The Hypothalamo Neurohypophysial System



---

## P0

### Definition

A major protein component of the insulating myelin sheath around axons of the peripheral nervous system.

- ▶ Protein Zero

---

## P2

### Definition

Event-related brain potential approximately 150–250 ms after a stimulus during wakefulness. The P2 is linked to the N1 component, is reported to be elicited by attended and non-attended stimuli, and its amplitude is reported to be associated with the intensity of the eliciting stimulus, yet the amplitude is reported to be reduced in response to attended stimuli.

- ▶ Sleep – Motor Changes
- ▶ Sleep – Sensory Changes

---

## p53

### Definition

This is a transcription factor important for cell cycle regulation. p53 was one of the first tumour suppressor genes identified. p53 gene mutations are frequently identified in a variety of cancers.

- ▶ Chromatin Immunoprecipitation and the Study of Gene Regulation in the Nervous System

---

## p75

- ▶ Brain Inflammation: Tumor Necrosis Factor Receptors in Mouse Brain Inflammatory Responses

---

## P300

### Definition

Event-related brain potential approximately 300 ms after a stimulus during wakefulness when stimuli are both detected and attended.

- ▶ Sleep – Motor Changes
- ▶ Sleep – Sensory Changes

---

## P Element

### Definition

P element – transposable elements are a heterogeneous class of genetic elements that can move and insert at new locations on a chromosome. P elements contain terminal inverted repeat sequences and encode the protein transposase to allow for integration into the genome.

- ▶ GAL4/UAS

---

## p38 MAPK

### Definition

p38 MAPK is a member of mitogen-activated protein kinase (MAPK) family. The name MAPK was given,

because another member of the family extracellular signal-regulated kinase (ERK) was first recovered as a kinase activity in the cytosol of EGF-treated cells. Later, MAPK has been found to operate in three pathways: ERK, p38, and c-Jun N-terminal kinase/stress-activated protein kinase (JNK/SAPK). p38 MAPK is a kinase of 38 kDa that responds to stress condition such as tumor necrosis factor- $\alpha$  (TNF $\alpha$ ), UV, and H<sub>2</sub>O<sub>2</sub>.

- ▶ Microglial Signaling Regulation by Neuropeptides
- ▶ Mitogen Activated Protein Kinase (MAPK)

---

## p50 (NFKB1)

- ▶ Nf- $\kappa$ B – Potential Role in Adult Neural Stem Cells

---

## p65 (RelA)

- ▶ Nf- $\kappa$ B – Potential Role in Adult Neural Stem Cells

---

## PACAP

### Definition

Pituitary adenylyl cyclase activating peptide; a neuropeptide expressed in nervous system where it functions to regulate cellular communication. PACAP has emerged as a likely retinal messenger to the suprachiasmatic nucleus (SCN), acting in concert with glutamate to communicate photic information to the circadian system. PACAP-like immunoreactivity is found in terminals of retinal ganglion cells (RGCs) innervating the SCN and two of the receptors sensitive to PACAP (PAC1 and VPAC2) are expressed in the SCN. To date, all of the available evidence indicates that the PAC1 receptor is responsible for mediating the effects of PACAP on SCN neurons.

Mechanistically, PACAP pre-synaptically enhances the release of glutamate onto SCN neurons and postsynaptically enhances the magnitude of the response to glutamate within the SCN. PACAP can also increase calcium in SCN neurons by causing a release

from intracellular stores as well as an enhancement of voltage-dependent calcium currents. Increasing calcium has the consequence of activating the mitogen-activated protein kinase (MAPK) signaling cascade and increasing transcription. At a systems level, application of PACAP can shift the phase, or alter the magnitude of glutamate-induced phase shifts, in the circadian rhythm of SCN neuronal firing in a brain slice preparation. Similarly, microinjections of PACAP into the SCN region in vivo can cause phase shifts. Administration of a PACAP receptor antagonist or an antibody against PACAP attenuates light-induced phase delays. The circadian system of mice deficient in PACAP or the PAC1 receptor exhibit altered behavioral responses to light. Overall, these studies point to a role for PACAP in increasing the functional coupling between the melatonin-containing RGCs and the retino-recipient subpopulation of SCN neurons.

- ▶ Circadian Rhythm
- ▶ Melanopsin
- ▶ p38 MAPK
- ▶ Phase Response Curve (PRC)
- ▶ Retinal Ganglion Cells
- ▶ Suprachiasmatic Nucleus (SCN)

---

## Pacemaker

### Definition

In a rhythmically active neuronal network, the neuron or neurons that have the major role in generating the rhythm. These may exhibit spontaneous oscillations of their membrane potential leading to action potentials that are very nearly equally spaced (endogenous bursting neurons), or a mutually excitatory set of neurons. An oscillator in a multi-oscillatory system entrains the other oscillators in the system, and so sets their phase relative to the pacemaker's phase, as well as forcing each oscillator's period to equal that of the pacemaker. An entrained oscillator's phase may lead or lag (occur either earlier or later than) that of the pacemaker, depending on the type of coupling (inhibitory or excitatory) and the relative periods of the oscillators in the system. Experimental proof that an oscillator can behave as a pacemaker in a physiological system is provided when transplantation confers the period or phase of the donor to the reconstituted system.

- ▶ Stomatogastric Ganglion
- ▶ Tonic Activity of Sympathetic Nerves

## Pacemaker Neurons

### ► Bursting Pacemakers

## Pacemaker Potential

### Definition

An intrinsically generated rhythmic membrane fluctuation that is caused by voltage-dependent and voltage-independent ion fluxes. A pacemaker potential that gives rise to action potentials is called a pacemaker “burst.” Synonym for pacemaker potential: “drive potential.”

### ► Bursting Pacemakers

## Pacini Corpuscle

### Definition

Pacini corpuscles are the largest cutaneous mechanoreceptors, but are also found in deep structures (e.g., abdominal mesentery). They are exquisitely sensitive to light mechanical stimuli, including high frequency vibration (>60 Hz).

### ► Vibration Sense

### ► Pacini Corpuscle Regeneration

## Pacini Corpuscle Regeneration

CHIZUKA IDE

<sup>1</sup>Department of Anatomy and Neurobiology, Kyoto University Graduate School of Medicine, Yoshidakonoe-cho, Sakyo-ku, Kyoto, Japan;

<sup>2</sup>Department of Occupational Therapy, Aino University Faculty of Nursing and Rehabilitation, Shigashiohta 4-5-4, Ibaragi City, Osaka, Japan

### Synonyms

Vater-Pacini corpuscle; Vater-Pacini’s corpuscle; Pacini corpuscle; Pacini’s corpuscle; Pacinian corpuscle; Corpusculum lamellosum

### Definition

The Pacinian corpuscle is the largest ellipsoidal sensory corpuscle functioning as a very rapidly adapting mechanoreceptor. It consists of one straight axon terminal extending at the center of the corpuscle along its long axis, the inner core surrounding the axon terminal, and the outer core occupying the outermost part of the corpuscle.

### Characteristics Structure

The Pacinian corpuscle is ellipsoidal in shape, measuring 0.2–1 mm at the long axis, and can be seen by the naked eye in dissection. It is found in connective tissues of the subcutaneous layer, joint capsule and periosteum. The corpuscle is innervated by a single thick myelinated axon that ends as a straight axon terminal in the center. The axon terminal is sandwiched by hemispherical inner cores, so that the axon terminal is oval in cross section [1]. The inner core consists of stacks of numerous thin cytoplasmic processes of specialized Schwann cells. The outer core is composed of loose lamellae of modified perineurial cells. The inner core cells express p75 and TrkB, while the outer core cells express only p75 [2]. Small axoplasmic protrusions are formed at the oval edges as well as at the extreme end of the axon terminal. These protrusions are considered to be the site of mechano-electric transduction [3].

### Regeneration

Following denervation, the axon terminal disappears, and the inner core becomes somewhat atrophic but remains with the outer core for an extended period. Following re-innervation, an axon enters the corpuscle and the inner core lamellae become “active,” as in the case of the Meissner corpuscle. After regeneration, most Pacinian corpuscles are innervated by a single axon, but there are a few that receive two axons, or remain non-innervated. Some corpuscles have multi-terminals associated with inner cores, resulting partly from the branching of regenerating axon terminals [4]. Aberrant regenerating nerves other than sensory axons can enter Pacinian corpuscles [5].

Pacini corpuscles can be regenerated even in the non-cellular environment; the connective tissue scaffolds of the Pacinian corpuscle remain after the cellular components have been degraded by local freeze-treatment. A regenerating axon enters such acellular scaffolds, accompanied by Schwann cells migrating from the proximal stump (Fig 1). Schwann cells develop into inner core cells associated with axon terminals. Perineurial cells develop into outer core cells within the scaffold of the original outer core region. Although atypical in its organization, the newly regenerated corpuscle possesses the three basic components including axon terminals, inner and outer cores [6]. This indicates

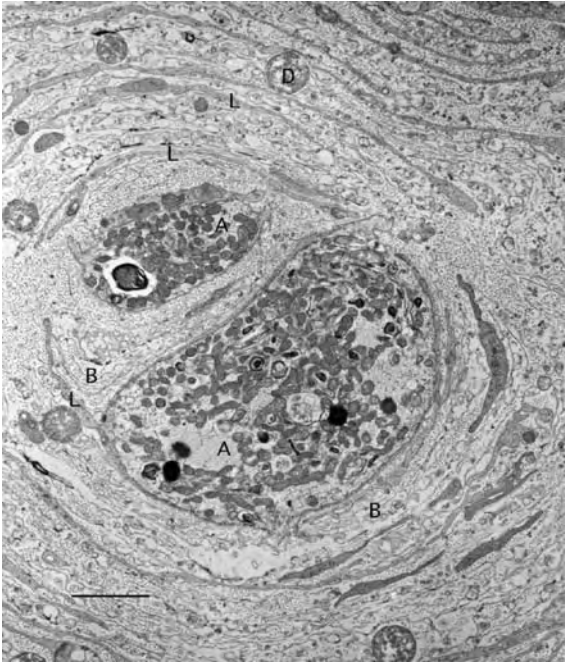

**Pacinian Corpuscle Regeneration. Figure 1** The periosteum of the tibia, in which numerous Pacinian corpuscles are located, was freeze-treated to kill cellular components of the corpuscle in the rat. The acellular matrix including basal laminae (B) of the corpuscle remained after the cellular components had been degraded. Regenerating axons accompanied by immature Schwann cells enter the matrix; the axon terminals (A) are situated at the center of the matrix and Schwann cells extend thin cytoplasmic lamellae (L) along the basal lamina scaffolds around axon terminals with a pattern similar to that of the normal corpuscle. New Pacinian corpuscles, although atypical in overall cellular structure, can develop in the acellular matrix of the old corpuscle. (D) cell debris. Scale bar: 2  $\mu$ m.

that the acellular matrix of the Pacinian corpuscle has the ability to induce the innervating axons, Schwann cells and perineurial cells to develop into axon terminals, inner core cells, and outer core cells, respectively.

## References

1. Munger BL, Yoshida Y, Hayashi S, Osawa T, Ide C (1988) A re-evaluation of the cytology of cat Pacinian corpuscle. I. The inner core and clefts. *Cell Tissue Res* 253:83–93
2. Stark B, Risling M, Carlstedt T (2001) Distribution of the neurotrophin receptors p75 and trkB in peripheral mechanoreceptors; observations on changes after injury. *Exp Brain Res* 136:101–107
3. Ide C, Hayashi S (1987) Specialization of plasma membrane in Pacinian corpuscles: Implications for mechanoelectric transduction. *J Neurocytol* 16:759–773

4. Zelena J, Zacharova G (1997) Reinnervation of cat Pacinian corpuscles after nerve crush. *Acta Neuropathol* 93:285–293
5. Zelena J, Jirmanova I, Lieberman AR (1990) Reinnervation of transplanted Pacinian corpuscles by ventral root axons: Ultrastructure of the regenerated nerve terminals. *J Neurocytol* 19:962–969
6. Ide C (1987) Role of extracellular matrix in the regeneration of a Pacinian corpuscle. *Brain Res* 413:155–169

## Paciniform Endings

### Definition

Small mechanoreceptors resembling Pacinian corpuscles, located in the deeper regions of the dermis of glabrous skin.

► [Pacinian Corpuscle](#)

► [Vibration Sense](#)

## Paedomorphosis

### Definition

The brains of amphibians appear to be much simpler than those of other vertebrates. Lissamphibians, i.e., living amphibians, have undergone secondary simplification, which arises from paedomorphosis, a form of heterochronic evolution. This process has affected the three amphibian orders differently: anurans appear to be least and salamanders most paedomorphic, while caecilians exhibit an intermediate degree of paedomorphosis.

It commonly involves different degrees of retardation, reduction or absence of traits in otherwise fully developed organisms when compared with phylogenetic outgroups. Thus, a mosaic of fully adult traits, weakly expressed traits, and missing characters appears in terminal ontogenetic stages. Accordingly, amphibian brains are expected to have fewer cells, a lower degree of morphological differentiation of cells, and reduced migration, but retain the plesiomorphic structural, functional and developmental organization found among other vertebrates.

► [Evolution of the Visual System: Amphibians](#)

## PAG

### Definition

- ▶ Periaqueductal Gray Matter (PAG)
- ▶ Pain Imaging

## Pain

G. F. GEBHART

Center for Pain Research, University of Pittsburgh,  
Pittsburgh, PA, USA

### Introduction

Pain is appreciated to be a complex sensory experience, characterized by both discriminative and emotional/cognitive dimensions. Moreover, the peripheral and central nervous system components that comprise the pain “network” are highly plastic, meaning that neural and non-neural constituents undergo changes in behavior and excitability in painful conditions. Thus, tissue insult commonly leads to changes in either or both the quality and intensity of perceived stimuli, typically beginning at peripheral sites and including central components in persistent pain states.

Stimuli that evoke pain are termed noxious and the peripheral sensory receptors/transduction sites acted upon by ▶noxious stimuli are termed ▶nociceptors. Input from nociceptors is widely distributed throughout the central nervous system and can evoke simple ▶nociceptive reflexes that are organized at the level of the spinal cord (e.g., ▶nociceptive withdrawal reflexes), engage ▶autonomic centers in the brainstem that increase heart rate and blood pressure, or lead to expression of emotional-affective responses that can be influenced by gender, age, previous experience, ▶stress and mood (among other factors) (▶Emotional/affective aspects of pain; ▶Pain in older adults; ▶Pain in children; ▶Gender/sex difference in pain).

More than 100 years ago, Sherrington [1] advanced the operational definition of a noxious stimulus and anticipated by decades the discovery of sensory receptors (nociceptors) in skin that responded only to noxious intensities of stimulation. Sherrington’s experimental work established that mechanical, thermal or chemical stimuli that damaged or threatened damage to skin were adequate for activation of nociceptors to cause pain. We know now that adequate noxious stimuli differ for skin, muscle, joints and internal organs, and also that some nociceptors can be activated by low-threshold stimuli,

revealing the importance of encoding of stimulus intensity by peripheral sensory receptors (▶Cutaneous pain, nociceptor and adequate stimuli). For example, cutting, crushing or burning stimuli, which reliably produce pain when applied to skin, are not reliable noxious stimuli when applied to internal organs. Pain arising from internal organs is more commonly produced by over-distension, traction on the mesenteries, ischemia or inflammation (e.g., appendicitis). Similarly, adequate noxious stimuli for muscle and joints, which also are not exposed to the external environment, include chemicals typically associated with inflammatory processes. In further distinction from skin, deep pain such as arises from muscle and viscera are relatively poorly localized and commonly referred to other sites, including overlying skin and muscle. The clinical presentation and characteristics of muscle pain (▶Muscle pain including fibromyalgia), ▶joint pain (▶Joint pain, nociceptors and adequate stimuli) and ▶visceral pain are discussed in detail in essays in this section of the Encyclopedia (see also ▶incisional/post-op pain; ▶Low back/spine pain).

As indicated above, tissue insult commonly alters either the quality and/or intensity of applied stimuli. Hyperalgesia (an increased response to a stimulus which is normally painful) and allodynia (pain due to a stimulus which does not normally provoke pain [▶Hyperalgesia and allodynia]) represent increases in the excitability of nociceptors (hyperalgesia) and activation of low-threshold mechanoreceptors (allodynia – by mechanisms not fully understood), respectively. Increases in excitability of nociceptors have been documented to arise from changes in ▶voltage-gated ion channels (e.g., ▶Ca<sup>2+</sup> channels, ▶K<sup>+</sup> channels and ▶Na<sup>+</sup> channels [▶Voltage-gated ion channels and pain]) and ▶ligand-gated channels and receptors (e.g., transient receptor potential [TRP] channels (▶TRP channels), purinergic receptors, including both P2X and P2Y, etc. [▶G-protein coupled receptors (GPCRs) in sensory neuron function and pain]). Such changes can be initiated by a variety of peripheral mediators, including those associated with inflammation (e.g., ▶prostaglandins, protons, etc. [▶Inflammatory pain]), ▶growth factors (▶Growth factors and pain) and the ▶immune system (▶Immune system and pain). Typically, increased excitability of nociceptors (for example produced by inflammatory mediators) is relatively short-lived and reversible. However, these changes can persist, such as occurs in ▶autoimmune diseases characterized by dysregulation of an immune response or following tissue insult early in life. ▶Rheumatoid arthritis, ▶multiple sclerosis and some viral infections can produce ▶chronic pain that is difficult to manage.

After nociceptor neurogenesis and maturation (▶Development of nociception) [2], tissue damage in the neonatal period can lead to increased pain

sensitivity [3] and exaggerated responses to noxious stimuli in adult non-human animals well after the early insult has fully recovered. For example, organ insult in neonatal animals [4,5], skin incisions/surgery as well as stressful events (e.g., maternal separation [6]; all have been shown to lead to increased sensitivity to noxious stimuli in adult life. This increased sensitivity is not always apparent when acute noxious stimuli are tested, but is clearly evident when tissue is re-inflamed or injured.

These peripheral events, whether introduced early in life or produced in adults, have far-reaching central consequences. ▶Sensitization (increased excitability of nociceptors [7]; leads to changes in excitability of neurons in the spinal cord as well as sites rostral in the brain. By analogy to the periphery, increases in the excitability of spinal and supraspinal neurons is referred to as “central sensitization” [8]. The initial impetus for the increase in excitability of central neurons arises from the increased input from peripheral nociceptors, including ▶silent nociceptors (▶Nociceptors and characteristics) [9], and increased release of ▶neurotransmitters from their central terminals. Central sensitization, either at the level of the spinal cord or at supraspinal sites, represents plasticity of central neurons, which apparently can be sustained well beyond recovery from the peripheral insult.

At the level of the spinal cord, because of similarities in neurotransmitters released from nociceptor terminals and characteristics of neuron response properties, central sensitization shares characteristics with learning (▶Synaptic long-term potentiation (LTP) in pain pathway). At supraspinal sites, nociceptive input is widely distributed to sites important for the discriminative aspects of pain (e.g., location, duration and intensity) (▶Ascending nociceptive pathways) and also to brain areas associated with emotion and cognition (▶Pain imaging; Emotional/affective aspects of pain). This nociceptive input also influences sites in the brainstem important to descending control of spinal input (▶Descending modulation of nociception). Descending influences from the midbrain and medulla were initially believed to be principally, if not exclusively, inhibitory in nature and selective for nociceptive input. We now know that descending influences can contribute to chronic pain states, either by reduced descending inhibition or active facilitation of spinal input and, moreover, and are not selective for spinal nociceptive input, but also modulate non-noxious (innocuous) spinal input. Indeed, it is now considered that chronic disorders such as functional gastrointestinal diseases, ▶fibromyalgia, etc. may be contributed to by disordered descending modulation of spinal input.

In addition to the nociceptive component of the experience of pain (e.g., activation of nociceptors, spinal pathways, mechanisms of peripheral and central sensitization, etc.), nociceptive input at supraspinal sites

also engages emotional, affective and cognitive dimensions of pain (Emotional/affective aspects of pain). That supraspinal influences can be potent is attested to by the ▶placebo analgesic response, in which expectancy has been identified as the most relevant psychological mediator. Expectancy can be manipulated by verbal instruction or by conditioning. The discriminative dimension of pain is associated with ▶thalamic and ▶somatosensory cortex and ▶motor cortex whereas the emotional/affective dimension of pain activates the amygdala, cingulate gyrus and ▶prefrontal cortex (Pain imaging). Brain imaging has thus confirmed and extended our anatomical understanding of the discriminative and emotional/cognitive anatomical dimensions of the experience of pain. Interestingly, both the discriminative and emotional/cognitive dimensions of pain may be sexually dimorphic. A growing literature reveals differences between males and females with respect to sensitivity to noxious stimuli as well as to the ability to tolerate pain (▶Gender/sex differences in pain). Women access physicians for pain-related problems far more frequently than do men, and while there may be many reasons why this is so, one contributing factor certainly relates to distinct differences in responses to noxious stimuli, likely contributed to by hormonal influences.

Despite our significantly increased knowledge about pain and pain mechanisms, there remain significant challenges in several areas. ▶Neuropathic pain, including ▶central pain, arises from damage to the nervous system, either in the periphery or centrally. Unlike *inflammatory pain*, damage to the nervous system results in pain commonly produced by normally innocuous stimuli (i.e., touch-evoked pain, or allodynia), which is difficult to manage. Pain in neonates (Development of nociception) and children (Pain in children), as well as pain in older adults, including those with ▶dementia (Pain in older adults), similarly present challenges in terms of both pain assessment/measurement (▶Pain psychophysics) and pain management. It was incorrectly assumed until relatively recently that the nociceptive system was undeveloped or underdeveloped in neonates and, accordingly, that they did not feel pain (Development of nociception; Pain in children) or require analgesia or anesthesia. This flawed thinking has fortunately been corrected and we now know that untreated, unattended pain in neonates and young children can lead to long-term changes in responses to noxious stimuli. Because young children and adults with dementia cannot effectively communicate their pain, they too tend to be under-treated.

In the United States, pain accounts for 20% of patient visits to physicians and 10% of prescription drug sales [10], figures likely comparable to those in many other countries (but not including those where governments restrict access to analgesic drugs, and unrelieved pain is

commonplace). Pain management can be daunting for health care providers, even with access to all available drugs and management strategies. As recounted in the essays in this section of the Encyclopedia, significant progress has been achieved in understanding mechanisms underlying painful disease conditions, with consequent improvement in pain management.

## References

1. Sherrington CS (1906) The integrative action of the nervous system. Charles Scribner's Sons, New York
2. Woolf CJ, Ma Q (2007) Nociceptors – noxious stimulus detectors. *Neuron* 55:353–364
3. Hermann C, Hohmeister J, Demirakca S, Zohsel K, Flor H (2006) Long-term alteration of pain sensitivity in school-aged children with early pain experiences. *Pain* 125:278–285
4. Al-Chaer ED, Kawasaki M, Pasricha PJ (2000) A new model of chronic visceral hypersensitivity in adult rats induced by colon irritation during postnatal development. *Gastroenterol* 119:1276–1285
5. Randich A, Uzzell T, DeBerry JJ, Ness TJ (2006) Neonatal urinary bladder inflammation produces adult bladder hypersensitivity. *J Pain* 7:469–479
6. Coutinho SV, Plotsky PM, Sablad M, Miller JC, Zhou H, Bayati AI, McRoberts JA, Mayer EA (2002) Neonatal maternal separation alters stress-induced responses to viscerosomatic nociceptive stimuli in rat. *Am J Physiol* 282:G307–G316
7. Bessou P, Perl ER (1969) Response of cutaneous sensory units with unmyelinated fibers to noxious stimuli. *J Neurophysiol* 32:1025–1043
8. Ji R-R, Woolf CJ (2001) Neuronal plasticity and signal transduction in nociceptive neurons: implications for the initiation and maintenance of pathological pain. *Neurobiol Dis* 8:1–10
9. Schaible H-G, Schmidt RF (1984) Effects of an experimental arthritis on the sensory properties of fine articular afferent units. *J Neurophysiol* 54:1109–1122
10. Max MB (2003) How to move pain and symptom research from the margin to the mainstream. *J Pain* 4:355–360

## Pain, Neuropathic

### Definition

► Neuropathic Pain

## Pain among Seniors

► Pain in Older Adults (Including Older Adults with Dementia)

## Pain and Growth Factors

► Growth Factors and Pain

## Pain and Immune System

► Immune System and Pain

## Pain and Ligand-gated Channels/Receptors

► G-Protein Coupled Receptors in Sensory Neuron Function and Pain

## Pain and Voltage-gated Ion Channels

► Voltage-Gated Ion Channels and Pain

## Pain Distress

► Emotional/Affective Aspects of Pain

## Pain Emotion

### Definition

Or pain emotional component. The emotional reactions and feeling states associated with thoughts (cognitions) about pain, such as anxiety, depression, fear, and despair. These feeling states involve thoughts about the present, past and future, and are distinct from the immediate feelings of pain unpleasantness that motivate

or inhibit behaviors and that are similar to other immediate feelings such as hyperthermia or the urge to breathe.

► Emotional/Affective Aspects of Pain

## Pain Hypersensitivity

► Hyperalgesia and Allodynia

## Pain Imaging

IRENE TRACEY

Department of Clinical Neurology and Nuffield Department of Anaesthetics, Centre for Functional Magnetic Resonance Imaging of the Brain, Oxford University, Oxford, UK

### Definition

Pain imaging is the capacity to identify functionally relevant neuronal activity within the central nervous system (brain and spinal cord) correlated with the subjective experience of pain. Imaging relates principally to studies in humans, but not exclusively. Different technologies provide this capability to image pain with varying degrees of invasiveness, spatial and temporal resolution.

### Characteristics Why Image Pain?

Most neuroimaging methods provide a non-invasive, systems-level understanding of the central mechanisms involved in pain processing. To date, the focus has been to dissect the physiological, psychological and cognitive factors that influence nociceptive inputs to alter pain perception in healthy subjects and patients suffering from chronic pain. Obtaining reliable objective information related to the individual's subjective pain experience provides a powerful means of understanding not only the central mechanisms contributing to the chronicity of pain states, but also potential diagnostic information. Identifying non-invasively where plasticity, sensitization and other amplification processes might occur along the pain neuraxis for an individual, and relating this to their specific pain experience or measure of pain relief, is of considerable interest to the clinical pain community and pharmaceutical industry. This is why imaging pain is useful.

### Imaging the Brain – Methods Available

Figure 1 illustrates the main imaging modalities in use today and what physiological correlate of brain activity they measure. There is a “cost” or balance between the spatial and temporal information achievable and how “invasive” you have to be if you want high resolution in both domains. Therefore, when choosing your imaging modality, pros and cons must be considered, dependent upon your hypothesis and goal. Other methods provide different sorts of information about the brain (i.e., structural or metabolic rather than functional), and these newer ways of examining the human brain are providing exciting and highly novel information about pain processing.

### Pain as a Perception

Pain is a conscious experience, an interpretation of nociceptive inputs influenced by memories, emotional,

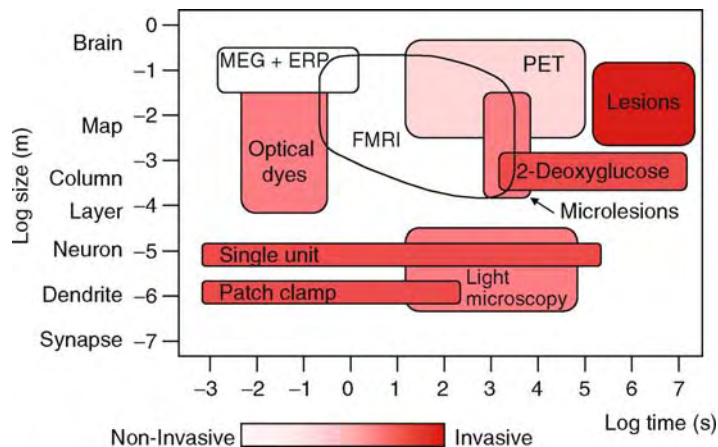

**Pain Imaging. Figure 1** A schematic displaying the relationship between the spatial and temporal resolution, as they relate to non-invasiveness, for the main current imaging tools.



pathological, genetic and cognitive factors. Resultant pain is therefore not always related linearly to nociceptive drive or input, neither is it solely for vital protective functions; this is especially true in, chronic pain states. Furthermore, the behavioral response of a subject to a painful event is modified according to what is appropriate or possible in any particular situation. Pain is, therefore, a highly subjective experience. Figure 2 illustrates the mixture of physical, cognitive and emotional factors that influence nociceptive inputs to amplify, attenuate and color the pain experience.

Clearly, the majority of factors influencing pain percepts are centrally mediated and our ability to unravel and dissect their contribution has only been feasible since neuroimaging allowed us non-invasive access to the human CNS. Determining the balance between peripheral versus central influences, and ascertaining which are due to pathological versus emotional or cognitive influences, will clearly aid decisions regarding the targeting of treatments (i.e., pharmacological, surgical, cognitive behavioral or physical rehabilitation). This is perhaps where imaging might provide its greatest contribution in the field of pain.

### The “Cerebral Signature” for Pain Perception

Because pain is a complex, multifactorial subjective experience, a large distributed brain network is accessed during nociceptive processing; this is often called the “pain matrix” and simplistically can be thought of as having lateral components (sensory–discriminatory, involving areas such as primary and secondary somatosensory cortices, thalamus and posterior parts of

insula) and medial components [affective–cognitive–evaluative, involving areas like the anterior parts of insula, anterior cingulate cortex (ACC) and prefrontal cortices]. However, because different brain regions play a more or less active role depending upon the precise interplay of the factors involved in influencing pain perception (e.g., cognition, mood, injury, and so forth), the “pain matrix” is not a defined entity [1]. A recent meta-analysis of human data from different imaging studies provides clarity regarding the commonest regions found active during an acute pain experience as measured by PET and ▶fMRI [2] (See Fig. 3).

These areas include: primary and secondary somatosensory, insular, anterior cingulate, and prefrontal cortices as well as the thalamus. This is not to say these areas are the fundamental core network of human nociceptive processing (and if ablated would cure all pain), although studies investigating acute pharmacologically induced analgesia do show predominant effects on this core network, suggesting their overall importance on influencing pain perception. Other regions such as basal ganglia, cerebellum, amygdala, hippocampus, and areas within the parietal and temporal cortices can also be active dependent upon the particular set of circumstances for that individual (see Fig. 2). A “cerebral signature” for pain is perhaps how we should define the network that is necessarily unique for each individual.

To understand how nociceptive inputs are processed and altered to subsequently influence changes in the pain experienced, it is useful to separately examine the main factors listed in Fig. 2 that alter pain perception.

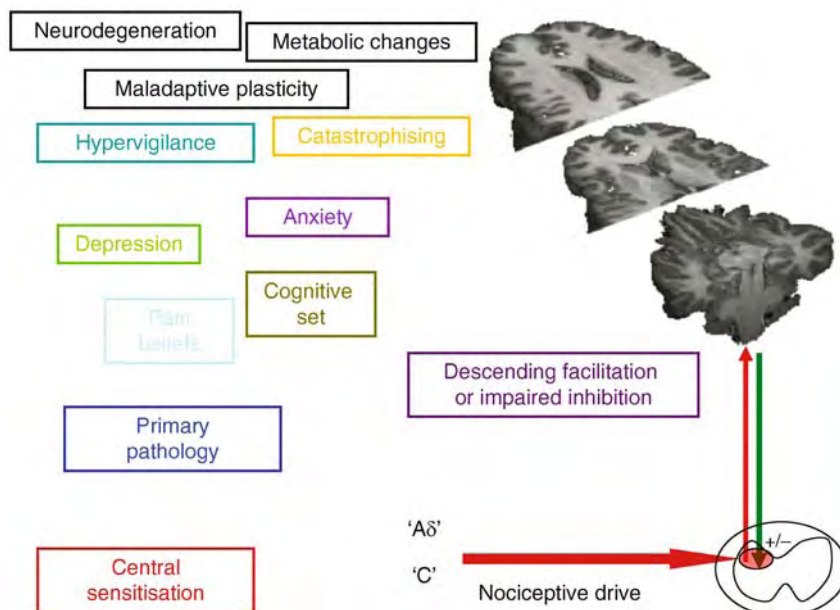

**Pain Imaging. Figure 2** Schematic illustrating the main factors that influence nociceptive inputs to alter pain perception.

Main regions activated in response to acute nociceptive stimulation (see diagram on right):

- Spinal cord
- Thalamus
- S1 and S2
- Insula (not always same division)
- Anterior cingulate cortex (not always same division)
- Prefrontal cortex

**BUT THEN ALSO perhaps:**

- Amygdala
- Hippocampus
- Posterior parietal cortex
- Basal ganglia
- Brainstem
- Etc..

..depending upon the circumstances.....

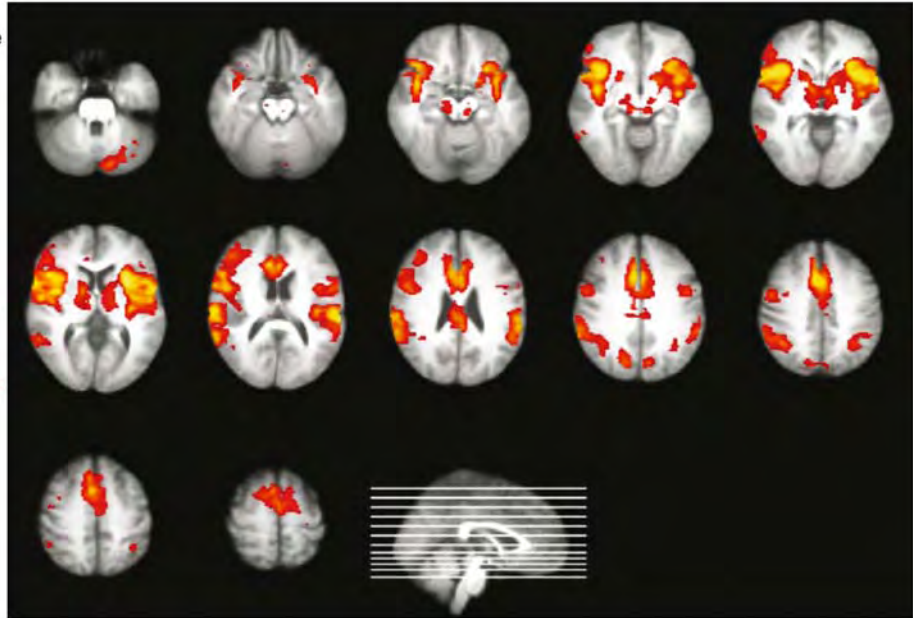

**Pain Imaging. Figure 3** Neuroanatomy of pain processing. Main brain regions that activate during a painful experience are highlighted as bilaterally active but with more dominant activation on the contralateral hemisphere (more yellow).

*Genetics:* We cannot ignore the possibility that our genes influence both how nociceptive stimuli are processed and how the brain reacts to peripheral injury and increased nociceptive inputs. Similarly, we cannot ignore the central role that our life experiences have on both these processes. Imaging studies have investigated whether individuals claiming to be more “sensitive” to pain, compared with others, activate more brain regions involved in pain perception. Early work suggests that subjects who rated the pain highest exhibit more robust pain-induced activation of ▶S1, ACC, and ▶PFC compared with those who rated pain lowest. The key question is whether this increased pain report and correlated objective readout is nature or nurture driven. Studies are beginning to link genetic influences on human nociceptive processing with physical processes within the brain. Zubieta and colleagues examined the influence of a common functional genetic polymorphism affecting the metabolism of catecholamines on the modulation of responses to sustained pain in humans using psychophysical assessment and ▶PET [3]. Individuals homozygous for the met158 allele of the catechol-*O*-methyltransferase (COMT) polymorphism (val158met) showed diminished regional μ-opioid system responses to pain (measured using PET) and higher sensory and affective ratings of pain compared with those homozygous for the valine polymorphism. This study and others are providing

good evidence regarding how our genes influence nociceptive processing within the brain and consequently our pain experience.

### Attention

We know from experience that attention is very effective in modulating the sensory and affective aspects of pain. fMRI and neurophysiological studies showed attention- and distraction-related modulations of pain-evoked activations in many parts of the pain “matrix.” From these studies, regions that appear critical during the attentional modulation of pain include the descending pain modulatory system as well as key elements of the pain “matrix.”

### The descending pain modulatory system

This is a well characterized anatomical network that enables us to regulate nociceptive processing (largely within the dorsal horn) in various circumstances to produce either facilitation (pro-nociception) or inhibition (anti-nociception) [4] (see also ▶Descending modulation of nociception). The pain-inhibiting circuitry, of which the periaqueductal grey (▶PAG) is a part, is best known and contributes to environmental (e.g., during the fight or flight response) and opioid-mediated analgesia. There are descending pathways that facilitate pain transmission, however, and it is thought that sustained activation of these circuits may underlie some

states of chronic pain (see below). Recently, researchers have investigated whether alteration in people's attention influences brainstem activity and, therefore, nociceptive processing via cortical–brainstem influences. In an early study using high-resolution imaging of the human brainstem, we showed significantly increased activity within the PAG in subjects who were distracted compared to when they paid attention to their pain, with concomitant changes in pain ratings. Indeed, the change in pain rating between attending and distracting conditions correlated with the change in PAG activity across the group, suggesting a varying capacity to engage the descending inhibitory system in normal individuals. Further work by others has extended these observations and shown that the cingulo-frontal cortex exerts top-down influences on the PAG and posterior thalamus to gate pain modulation during distraction. These studies, and others, provide clear evidence for the involvement of brainstem structures in the attentional modulation of pain perception, and recent work using diffusion tractography confirms that anatomical connections exist between cortical and brainstem regions in the human brain, thereby enabling such top-down influences.

### Placebo

Recent work in humans has helped provide a framework by which the placebo effect and subsequent analgesia is mediated (see ►[Placebo analgesic response](#)). Again, the brainstem is critically involved in mediating placebo analgesia. Descending influences from the diencephalon, hypothalamus, amygdala, ►[ACC](#) insula and prefrontal cortex that elicit inhibition or facilitation of nociceptive transmission via brainstem structures are thought to occur during placebo analgesia. Using PET, it has been confirmed that both opioid and placebo analgesia are associated with increased activity in the rostral ACC, and that a covariation between the activity in the rostral ACC and the brainstem during both opioid and placebo analgesia, but not during pain alone, exists. Wager and colleagues extended these early observations to examine placebo expectation effects [5]. Using a conditioning design, they found that placebo analgesia was related to decreased brain activity in classic pain processing brain regions (e.g., thalamus, insula, and ACC), but was additionally associated with increased activity during anticipation of pain in the prefrontal cortex (PFC), an area involved in maintaining and updating internal representations of expectations. Stronger PFC activation during anticipation of pain was found to correlate with greater placebo-induced pain relief and reductions in neural activity within pain regions. Furthermore, placebo-increased activation of the PAG was found during anticipation, the activity within which correlated significantly with dorsolateral PFC (DLPFC) activity.

This is consistent with the concept that prefrontal mechanisms can trigger opioid release within the brainstem and, thereby, influence the descending pain modulatory system to modulate pain perception during the placebo effect.

### Mood

For both chronic and acute pain sufferers, one's mood and emotional state has a significant impact on resultant pain perception and ability to cope. For example, it is a common clinical and experimental observation that anticipating and being anxious about pain can exacerbate the pain experienced. Anticipating pain is highly adaptive, but for the chronic pain patient it becomes maladaptive and can lead to fear of movement, avoidance, anxiety, and so forth. Studies aimed at understanding how anticipation and anxiety cause a heightened pain experience have been performed using imaging methods [6]. Critical regions involved in amplifying or exacerbating the pain experience include the entorhinal complex, amygdala, anterior insula and prefrontal cortices.

With regard to mood, depressive disorders often accompany persistent pain. Although the exact relationship between depression and pain is unknown, with debate regarding whether one condition leads to the other or if an underlying diathesis exists, studies have attempted to isolate brain regions that may mediate their interaction. Early studies indicated that activation in the amygdala and anterior insula appears to differentiate fibromyalgia patients with and without major depression. Another fibromyalgia study found that pain catastrophizing (defined as a set of negative emotional and cognitive processes), independent of the influence of depression, was significantly associated with increased activity in brain areas related to anticipation of pain (medial frontal cortex, cerebellum), attention to pain (dorsal ACC, dorsolateral PFC), emotional aspects of pain (claustrum, closely connected to amygdala) and motor control [7]. The construct of catastrophizing incorporates magnification of pain-related symptoms, rumination about pain, feelings of helplessness, and pessimism about pain-related outcomes. The results by Gracely and colleagues support the notion that catastrophizing influences pain perception through altering attention and anticipation, as well as heightening emotional responses to pain (see ►[Emotional/affective aspects of pain](#)).

### The prefrontal cortex and pain

It is clear from these few studies described above and others in the literature that pronounced PFC activation is consistently found across clinical pain conditions, irrespective of underlying pathology. We are only beginning to unravel the roles of specific PFC regions in pain perception; it is thought they reflect emotional,

cognitive and interoceptive components of pain conditions, as well as perhaps processing of negative emotions, response conflict and detection of unfavorable outcomes in relation to self. Interestingly, imaging studies attempting to capture the neural signature of the ongoing, spontaneous pain that patients commonly experience are finding increased medial PFC, including rostral ACC, activity during episodes of sustained high ongoing pain. These early data suggest a very different neural “signature” for the patient’s ongoing pain, compared to the acute nociceptive network found active in response to provoked stimulation, as described above in most fMRI studies. A specific role for the lateral PFC as a “pain control center” has been put forward in a study of experimentally induced allodynia in healthy subjects [8]. In this study, increased lateral PFC activation was related to decreased pain affect, supposedly by inhibiting the functional connectivity between medial thalamus and midbrain, thereby driving endogenous pain-inhibitory mechanisms.

It is important to also note that the PFC (specifically the dorsolateral PFC) is one site of potential major neurodegeneration and cell death in chronic pain patients. These latest findings suggest that severe chronic pain could be considered a neurodegenerative disorder that especially affects this region. However, determining what the possible causal factors are that produce such neurodegeneration is difficult. Candidates include the chronic pain condition itself, the pharmacological agents prescribed for pain management or perhaps the physical lifestyle change subsequent to becoming a chronic pain patient. Carefully controlled longitudinal studies are needed.

### **Pain without a nociceptive input**

Recent imaging data display activity of the near entire “pain matrix” without any nociceptive input during empathy and hypnosis manipulations, suggesting it is time to reconsider how we define central pain processing with respect to the origin of the input and resultant perception and meaning. This is not to say that pain experienced without a nociceptive input (sometimes referred to as psychogenic pain) is any less real than “physically” defined pain; indeed, neuroimaging studies have highlighted the physiological reality of such experiences due to the extensive neural activation that occurs.

### **Injury**

Recently, changes within the descending pain modulatory network have been implicated in chronic pain (central sensitization) and in functional pain disorders [9] (see also ▶[Descending modulation of nociception](#)). Changes are defined in terms of patients having either a dysfunctional descending inhibitory system or an activated and enhanced descending facilitatory system.

There has been convincing evidence advanced regarding the differential involvement of the PAG, rostroventromedial medulla (▶[RVM](#)), parabrachial nucleus (▶[PB](#)), dorsal reticular nucleus and nucleus cuneiformis (▶[NCF](#)) in the generation and maintenance of central sensitization states and hyperalgesia in both animal models and, for the first time, in a human model of secondary hyperalgesia [10]. Changes within the descending pain-modulatory network in chronic pain, in terms of patients having either a dysfunctional descending inhibitory system or an activated and enhanced descending facilitatory system, are clearly implicated in these and increasingly in other clinical studies.

Understanding which CNS areas are involved in engaging or disengaging this descending modulatory system has significant potential to not only further our understanding of how pain is perceived, but in developing mechanism-based therapies for treating different types of acute and chronic pain.

### **Spinal cord imaging**

Clearly, to determine the extent of changes present within the CNS we must develop methods that allow noninvasive access to the changes within the human spinal cord, and these are currently being successfully developed.

### **Altered opioidergic and dopaminergic pathways**

The availability of PET ligands for opioid and dopamine receptors has allowed the study of these receptor systems in several clinical pain states. Early opioid receptor ligand studies showed decreased binding in patients with chronic pain that normalized after reduction of their pain symptoms. Regional differences in ligand binding have recently been found in neuropathic pain studies with decreased binding in several key areas involved in pain perception. The dopaminergic pathways have also been implicated in pain processing in animal and patient studies. Early studies in fibromyalgia patients indicate reduced presynaptic dopaminergic activity in several brain regions in which dopamine plays a critical role in modulating nociceptive processes. Similar to the endogenous opioid system, the issue of cause and effect between a “functional hypodopaminergic state” and pain has yet to be resolved, making this an exciting area of current research.

### **Conclusion**

Knowledge regarding how pain is perceived at a central level in humans is growing. An extensive network is recruited that is highly modifiable depending upon genetics, the environment, mood and the particular injury sustained. Combined, these produce a unique cerebral signature that produces an individualized pain experience.

## References

1. Tracey I, Mantyh PW (2007) The cerebral signature for pain perception and its modulation. *Neuron* 55:377–391
2. Apkarian AV, Bushnell MC, Treede RD, Zubieta JK (2005) Human brain mechanisms of pain perception and regulation in health and disease. *Eur J Pain* 9:463–484
3. Zubieta JK, Heitzeg MM, Smith YR, Bueller JA, Xu K, Xu Y, Koeppe RA, Stohler CS, Goldman D (2003) COMT val158met genotype affects mu-opioid neurotransmitter responses to a pain stressor. *Science* 299:1240–1243
4. Fields H (2005) Central nervous system mechanisms of pain modulation. In: Wall PM, R, (ed) *Textbook of pain*. Churchill Livingstone, London, 125–142
5. Wager TD, Rilling JK, Smith EE, Sokolik A, Casey KL, Davidson RJ, Kosslyn SM, Rose RM, Cohen JD (2004) Placebo-induced changes in FMRI in the anticipation and experience of pain. *Science* 303:1162–1167
6. Ploghaus A, Narain C, Beckmann CF, Clare S, Bantick S, Wise R, Matthews PM, Rawlins JN, Tracey I (2001) Exacerbation of pain by anxiety is associated with activity in a hippocampal network. *J Neurosci* 21:9896–9903
7. Gracely RH, Geisser ME, Giesecke T, Grant MA, Petzke F, Williams DA, Clauw DJ (2004) Pain catastrophizing and neural responses to pain among persons with fibromyalgia. *Brain* 127:835–843
8. Lorenz J, Minoshima S, Casey KL (2003) Keeping pain out of mind: the role of the dorsolateral prefrontal cortex in pain modulation. *Brain* 126:1079–1091
9. Suzuki R, Rygh LJ, Dickenson AH (2004) Bad news from the brain: descending 5-HT pathways that control spinal pain processing. *Trends Pharmacol Sci* 25:613–617
10. Zambreanu L, Wise RG, Brooks JC, Iannetti GD, Tracey I (2005) A role for the brainstem in central sensitisation in humans. Evidence from functional magnetic resonance imaging. *Pain* 114:397–407

Children are not “little adults” with respect to nociceptive processing and pain perception. The ▶[developing nociceptive system](#) responds differently to injury (i.e., increased excitability and sensitization) when compared to the mature adult system [1,2]. Moreover, a child’s pain appears to have a greater degree of ▶[plasticity](#) when compared to that of adults – more influenced by cognitive, behavioral, and emotional factors [3].

## Characteristics

### Children’s Pain Problems

Like adults, children can experience many different types of pain throughout their lives – acute pain due to disease or trauma, recurrent episodes of headache, stomach ache, or limb pain unrelated to disease, and chronic pain due to injury, disease, psychological factors, or of unknown etiology. However, the prevalence of certain types of pain is different for adults and children. For example, chronic back pain is a major problem for adults but not for children. Recurrent pain syndromes (i.e., abdominal, headache, limb pains or “growing pains”) are more common pain problems for children.

Pain prevalence increases with age and certain pain conditions vary with sex and age. For example, clinical referrals indicate that Complex Regional Pain Syndrome-Type 1 affects girls more than boys with a ratio of ~6–9:1 and affects children primarily in their pre- and early teen years. Complex idiopathic pain conditions and somatization disorders seem to predominantly affect older adolescents.

Although we lack precise data on the incidence and prevalence of many childhood pain conditions, an increasing number of epidemiological studies are focused on obtaining such data, identifying individual risk and prognostic factors and documenting the long term impact for children and their families.

### Developmental Considerations

Considerable neuronal plasticity is evident throughout the developing system from the periphery to the brain (for review, [1,2]) (see ▶[Development of nociception](#)). Although basic nociceptive connections are formed before birth, these systems are immature and exhibit increased responsivity in comparison to the adult animal. The conduction velocity of afferent fibers, action potential shape, receptor transduction, firing frequencies and receptive field properties change substantially over the postnatal period. High threshold A $\delta$  mechanoreceptors (which respond maximally to noxious mechanical stimuli) and low threshold A $\beta$  mechanoreceptors (which respond maximally to innocuous stimuli) respond with lower firing frequencies than those in the adult animal. The receptive fields of dorsal horn cells are larger in the newborn. The larger receptive fields and dominant A-fiber input increases

## Pain in Children

PATRICIA A. McGRATH<sup>1,2</sup>, TRICIA WILLIAMS<sup>1</sup>

<sup>1</sup>Department of Anaesthesia, Divisional Centre of Pain Management and Research, The Hospital for Sick Children, Toronto, ON, Canada

<sup>2</sup>Neuroscience and Mental Health Program, Research Institute at The Hospital for Sick Children; Department of Anaesthesia, The University of Toronto, Toronto, ON, Canada

### Synonyms

Pediatric pain; Adolescent pain

### Definition

The unique aspects of nociceptive processing and pain perception associated with a developing pain system and a maturing child, in contrast to those of a mature adult.

the likelihood of central cells being excited by peripheral sensory stimulation and acts to increase the sensitivity of infant sensory reflexes. Some inhibitory mechanisms (►[Inhibitory mechanisms in developing system](#)) in the dorsal horn are immature at birth and descending inhibition is delayed. The lack of descending inhibition in the neonatal dorsal horn means that an important endogenous analgesic system that should attenuate noxious input as it enters the spinal cord is lacking, and thus the effects of the input may be more profound than in the adult [2].

Most studies in developmental neurobiology have been conducted on rat pups because they have comparable developmental timetables with respect to the anatomy, chemistry, and physiology of maturing human pain pathways. To study neural function in human infants, investigators have monitored behavioral and neurophysiologic responses, and revealed comparable findings of plasticity and increased excitability in the developing nervous system (for review, [1,4]). In comparison to adults, young infants have exaggerated reflex responses (i.e., lower thresholds and longer lasting muscle contractions) in response to certain types of trauma, such as needle insertion. Repeated mechanical stimulation at strong (but not pain-producing) intensities can cause sensitization in very young infants, while repeated painful procedures such as those required during intensive care can profoundly affect sensory processing in infants. Infants after surgery can develop a striking hypersensitivity to touch, as well as to pain.

While we do not know specifically how such injuries may affect the mature human pain system or influence adult pain perception, increasing attention is focused on the possible consequences of untreated pain, particularly in infants [5]. For example, circumcised newborn infants display a stronger pain response to subsequent routine immunizations at 4 and 6 months than uncircumcised infants, but application of lidocaine-prilocaine anesthetic cream at circumcision attenuates the pain response to the subsequent immunizations [6]. Studies of former premature infants who required intensive care have shown behavioral differences related to early pain experiences. The results of behavioral studies in infants, like those from neurobiological studies in animals, indicate increased responsivity to pain.

### Factors that Modify Children's Pain

A child's pain perception can be regarded as plastic from a psychological, as well as biological perspective. Tissue damage initiates a sequence of neural events that may lead to pain, but many developmental, social, and psychological factors can intervene to alter the sequence of nociceptive transmission and thereby modify a child's pain. Child characteristics, such as cognitive level, sex, gender, temperament, previous pain experience, family, and cultural background shape

generally how children interpret and cope with pain (for review [7–9]).

In contrast, ►[situational factors](#) vary dynamically, depending on the specific circumstances in which a child experiences pain. For example, a child receiving treatment for cancer may have repeated injections, central venous port access and lumbar punctures – all of which can cause pain (depending on the analgesics, anesthetics, or sedatives used). Even though the tissue damage from these procedures is the same each time, the particular set of situational factors for each treatment is unique for a child. The expectations, behaviors and emotional state of the child, parent and health care provider all play a critical role. “What children and parents understand, what they (and health care staff) do, and how children and parents feel” can profoundly impact a child's pain experience. Certain situational factors can intensify pain and distress, while others can eventually trigger pain episodes, prolong pain related disability, or maintain the cycle of repeated pain episodes in recurrent pain syndrome [3]. Parents and health care providers can dramatically improve a child's pain experience and minimize their disability by modifying children's understanding of a situation, their focus of attention, perceived control, expectations for obtaining eventual recovery and pain relief, and the meaning or relevance of the pain.

Situational factors may affect children even more than adults. Adults typically have experienced a wide variety of pains (i.e., diverse etiology, intensity and quality), providing them with a broad base of knowledge and coping behaviors. When adults encounter new pains, they evaluate them primarily from the context of their cumulative life experience. In contrast, children with more limited pain experience must evaluate new pains primarily from the context of the immediate circumstances. Children's understanding of pain, pain coping strategies, and the impact of pain increase with age, but many questions remain about the interplay of maturation, cognitive development, and experience in mediating a child's pain.

### Pain Measures for Infants and Children

Pain assessment is an intrinsic component of pain management in infants and children. Clinicians need an objective measure of pain intensity and an understanding of the factors that cause or exacerbate pain for an individual child. More than 60 pain measures are now available for infants, children, and adolescents (for review, [10]). While no single pain measure is appropriate for all children and for all situations in which they experience pain, we should be able to evaluate pain for almost every child.

►[Physiological parameters](#) including heart rate, respiration rate, blood pressure, palmar sweating, blood cortisol and cortisone content, O<sub>2</sub> levels, vagal tone and

endorphin concentrations have been studied as potential pain measures. However, they reflect a complex and generalized stress response, rather than correlate with a particular pain level. As such, they may have more relevance as distress indices within a broader behavioral pain scale. Behavioral scales record the type and amount of pain-related behaviors children exhibit. Since a child's specific pain behaviors depend on the type of pain experienced, different scales are usually required for acute and persistent pain. Clinicians monitor children for a specified time period and then complete a checklist noting which distress behaviors (e.g., crying, grimacing, guarding) occur. Behavioral scales must be used for infants and children who are unable to communicate verbally. Recently, investigators are validating pain scales for children who are ►developmentally disabled. However, the resulting pain scores are indirect estimates of pain and do not always correlate with children's own pain ratings. Even though clinicians may use diaries rather than formal scales, prospective evaluation of a child's behavior is an essential component of pain management, providing information about medication use, compliance with treatment recommendations, and the extent of pain-related disability (i.e., school attendance, physical activities, and social activities with peers).

Psychological or self-report measures include a broad spectrum of projective techniques, interviews, questionnaires, qualitative descriptive scales, and quantitative rating scales designed to capture the subjective experience of a child's pain [11]. By the age of five, most children can differentiate a wide range of pain intensities, and many can use simple ratio and interval pain scales (e.g., visual analog scales, numerical scales, faces, verbal descriptor scales) to rate their pain intensity. Many scales have excellent psychometric properties, are convenient to administer, easy for children to understand, adaptable to many clinical situations, and help parents to monitor their child's pain at home. Interviews, usually conducted independently with a child and parents, are the cornerstone of assessment for children with persistent pain, enabling clinicians to identify relevant child, family, and situational factors that contribute to children's pain and disability problems.

### Child-centered Pain Management

Pain control is not merely "drug versus nondrug therapy," but rather an integrated approach to reduce or block nociceptive activity by attenuating responses in peripheral afferents and central pathways, activating endogenous pain inhibitory systems, and modifying situational factors that exacerbate pain. Adequate analgesic prescriptions, administered at regular dosing intervals, must be complemented by a practical cognitive-behavioral approach to ensure optimal pain relief. Pain control is achieved practically by adjusting

both drug and nondrug therapies in a rational child-oriented manner based on the assessment process [12]. Analgesics include acetaminophen, non-steroidal anti-inflammatory drugs, and opioids. ►Adjuvant analgesics include a variety of drugs with analgesic properties, such as anticonvulsants and antidepressants that were initially developed to treat other health problems, but whose therapeutic uses have been expanded. The use of adjuvant analgesics has become a cornerstone of pain control for children with chronic pain, especially when pain has a neuropathic component. Children with severe pain may require progressively greater and more frequent opioid doses due to drug tolerance and should receive the doses they need to relieve their pain. The fear of opioid addiction in children has been greatly exaggerated. Neonates and infants require the same three categories of analgesic drugs as older children. However, premature and term newborns show reduced clearance of most opioids. The differences in pharmacokinetics and pharmacodynamics among neonates, preterm infants, and full-term infants, warrant special dosing considerations for infants and close monitoring when they receive opioids.

An extensive array of nondrug therapies is available to treat a child's pain including physical, psychological and complementary and alternative approaches. Counseling, attention and distraction, guided imagery, hypnosis, relaxation training, biofeedback, and behavioral management are used routinely to treat a child's procedural pain and chronic pain. Children seem more adept than adults at using psychological therapies, presumably because they are generally less biased than adults about their potential efficacy. Strong and consistent scientific evidence supports the efficacy of many psychological therapies for relieving children's procedural pain and for relieving childhood headache, but few rigorous evaluations have been conducted on their efficacy for relieving other types of chronic pain – even though they are considered an essential component of many treatment programs.

### Clinical and Research Challenges

As a result of extensive research, we have gained better insights about how the developing nociceptive system responds to tissue injury, how children perceive pain, how to assess pain in infants and children, and which drug and nondrug therapies will alleviate their pain. The emphasis has shifted gradually from an almost exclusive disease-centered focus – detecting and treating the putative source of tissue damage – to a more child-centered perspective, assessing the child with pain, identifying contributing psychological and contextual factors, and then targeting interventions accordingly. However, serious challenges remain from both research and clinical perspectives [13].

We have discovered much about the plasticity of the developing nociceptive system, but still have much to

learn about how signals from painful stimuli are processed, especially at higher levels (see ►[Pain imaging](#)). Although we need further developmental research in neurobiology, neurophysiology, and pharmacology, we now know that infants seem particularly vulnerable because of their heightened responsivity to tissue injury and we must devote particular attention to their pain management.

We need to apply the existing knowledge about pain assessment and pain management more consistently within our clinical practice. Regrettably, many hospitals still do not require consistent documentation of children's pain, preventing us from ensuring that children's pain is adequately controlled. Hospital administrators or accreditation organizations should establish children's pain control as a priority. In spite of established analgesic dosing guidelines for infants and children, the undertreatment of postoperative and chronic pain is a continuing problem in many centers.

Moreover, increasing responsibility for evidence-based practice dictates that health care providers adopt clear guidelines for determining when treatments are effective and for identifying children for whom they are most effective. We lack data from well-designed cohort studies and randomized controlled trials to validate the efficacy of many interventions (both drug and nondrug therapies) used extensively in clinical practice. Although cognitive-behavioral interventions are critical components of pain management programs for chronic pain, most of the data supporting their efficacy is derived from studies of childhood headache [14].

We critically need data on child-centered treatment efficacy – that is, when interventions are selected for the individual child with pain, based on an assessment of the specific cognitive, behavioral, and emotional factors contributing to their pain and disability. We need longitudinal studies to identify key risk factors that influence a child's vulnerability to chronic pain, in particular the apparent increased vulnerability in females. Future studies should use brain imaging technology and psychophysical measurement to evaluate the neural mechanisms underlying chronic pain and cognitive function in children. Our ultimate and continuing challenges are to better understand the experience of children's pain and to improve clinical practice, so that health care providers use the existing “state of the art” pain scales, interpret children's pain scores to guide therapeutic decisions, and document treatment effectiveness.

## References

1. Andrews Campbell K (2007) Infant Pain Mechanisms. In: Schmidt RF, Willis WD (eds) *Encyclopedic reference of pain*. Springer-Verlag, New York, pp 976–981
2. Fitzgerald M, Howard RF (2003) The neurobiologic basis of pediatric pain. In: Schechter NL, Berde CB, Yaster M (eds) *Pain in infants, children, and adolescents*, 2nd edn. Lippincott Williams and Wilkins, Baltimore, pp 19–42
3. McGrath PA, Dade LA (2004) Effective strategies to decrease pain and minimize disability. In: Price DD, Bushnell MC (eds) *Psychological modulation of pain: integrating basic science and clinical perspectives*. IASP Press, Seattle, pp 73–96
4. Johnston C, Stevens B, Boyer K et al. (2003) Development of psychologic responses to pain and assessment of pain in infants and toddlers. In: Schechter NL, Berde CB, Yaster M (eds) *Pain in infants, children, and adolescents*, 2nd edn. Lippincott Williams and Wilkins, Baltimore, pp 105–127
5. Grunau RE (2000) Long-term consequences of pain in human neonates. In: Anand KLS, Stevens BJ, McGrath PJ (eds) *Pain in neonates*, 2nd edn. Elsevier, Amsterdam, pp 55–76
6. Taddio A, Katz J, Ilersich AL et al. (1997) Effect of neonatal circumcision on pain response during subsequent routine vaccination. *Lancet* 349:599–603
7. Schechter NL, Berde CB, Yaster M (eds) (2003) *Pain in infants, children, and adolescents*. Lippincott Williams and Wilkins, Baltimore
8. McGrath PJ, Finley GA (eds) (2003) *Pediatric pain: biological and social context*. IASP Press, Seattle
9. Unruh AM, Campbell MA (1999) Gender variations in children's pain experiences. In: Finley GA, McGrath PJ (eds) *Chronic and recurrent pain in children and adolescents*. IASP Press, Seattle, pp 199–241
10. McGrath PA (2007) Pain assessment: children. In: Schmidt RF, Willis WD (eds) *Encyclopedic reference of pain*. Springer-Verlag, New York, pp 1644–1648
11. Champion GD, Goodenough B, von Baeyer CL et al. (1998) Measurement of pain by self-report. In: Finley GA, McGrath PA (eds) *Measurement of pain in infants and children*. IASP Press, Seattle, pp 123–160
12. Brown SC (2007) Analgesic guidelines for infants and children. In: Schmidt RF, Willis WD (eds) *Encyclopedic reference of pain*. Springer-Verlag, New York, pp 78–83
13. McGrath PA (2007) Pain in children. In: Schmidt RF, Willis WD (eds) *Encyclopedic reference of pain*. Springer-Verlag, New York, pp 1665–1669
14. Eccleston C, Morley S, Williams A et al. (2002) Systematic review of randomised controlled trials of psychological therapy for chronic pain in children and adolescents, with a subset meta-analysis of pain relief. *Pain* 99:157–165

## Pain in Older Adults (Including Older Adults with Dementia)

THOMAS HADJISTAVROPOULOS  
Centre on Aging and Health and Department of  
Psychology, University of Regina, Regina, SK, Canada

### Synonyms

Pain in the elderly; Pain among seniors; Pain in patients with dementia



## Definition

Most investigations focusing on pain among older adults (elderly persons) involve participants who are at least 60 or 65 years of age.

## Characteristics

### Prevalence

Although the prevalence of acute pain remains steady across the lifespan, there is an increased prevalence of chronic pain at least until the seventh decade of life [1]. Limited evidence also suggests a plateau or even a slight reduction in the frequency of pain complaints after age 80 [1].

Pain is a very common problem among older adults. Chronic pain affects at least 50% of seniors living in the community and approximately 80% of residents of long-term care facilities. Moreover, in a large scale Canadian investigation of nursing home residents, it was shown that conditions likely to cause pain occur with equal frequency in residents with and without dementia [2]. Despite the increasing prevalence of most pain problems with age, the study of pain among older adults had not received much literature attention until recently [1].

### Pain Perception, Thresholds and Tolerance

Age-related changes in peripheral, spinal and central nervous system ►[nociceptive pathways](#) would be expected to alter pain sensitivity and therefore the perception of noxious stimulation [3]. Indeed, evidence suggests that age can have an impact on the function of nociceptive pathways and mechanisms, including alterations in afferent transmission and descending modulation [1]. More specifically, for example, research on the perceptual experience that tends to accompany activations of nociceptive fibers has suggested the presence of a selective age-related impairment in A-fiber function and a greater reliance on C-fiber information in older adults. Considering that A-fibers subserve the epicritic, first warning aspects of pain, while C-fiber information is more diffuse, dull and prolonged, it might be reasonable to expect some changes in pain intensity and quality among elderly persons [3].

Research has also revealed evidence that temporal summation (i.e., the enhancement of pain sensation that is associated with repeated stimulation) is altered in older adults. Temporal summation is the result of transient, repetitive activation of dorsal horn neurons in the spinal cord and is believed to play a central role in the development of ►[hyperalgesia](#) and post-injury tenderness [3]. Based on the findings that are available in the literature, it is likely that post-injury tenderness and hyperalgesia may take longer to resolve among older adults [3]. An additional age-related change has been demonstrated by Washington, Gibson and Helme [4], who have shown that endogenous inhibitory pain control mechanisms that descend from the cortex and

midbrain onto spinal cord neurons decline with advancing age. Such a decline could be expected to reduce the ability of older adults to cope with persistent pain states [3].

With respect to neurochemical and morphological age-related changes in the central nervous system, Gibson, Gorman and Helme [5] used the pain-related encephalographic response to index the central nervous system processing of noxious stimulation. These researchers found that older adults tended to display a significant reduction in peak amplitude and an increase in response latency. They concluded that these findings were suggestive of a reduced cortical activation and slowing in the cognitive processing of noxious information. Nonetheless, it is important to remember that despite such limited laboratory evidence of reduced sensitivity to pain with advancing age, there is no evidence to suggest that seniors who report pain suffer any less than their younger counterparts [1].

Research has also examined the possible impact of dementia on pain responses. In general, the findings have shown no difference in the ►[pain threshold](#) of those with mild to moderate Alzheimer's disease, despite an increase in ►[pain tolerance](#) when compared to age matched controls [6,7]. Nonetheless, Benedetti et al. [6] have demonstrated that whereas the sensory-discriminative components of pain are preserved even in advanced stages of Alzheimer's disease, the cognitive and affective functions, which are related to both anticipation and autonomic reactivity, are severely affected. This sensory-affective dissociation is well correlated with neuropathological findings in Alzheimer's disease. Moreover, Benedetti et al. [6,7] showed that pain tolerance among older adults with Alzheimer's disease is tightly related to the severity of the disease. That is, more severe cognitive impairment and more significant electroencephalogram (EEG) changes were associated with higher pain tolerance. Thus, despite the preservation of pain thresholds in the presence of dementia, there is an increase in pain tolerance with increased severity of the disease. It is noted, however, that clinical research has shown that the reflexive reactions that dementia patients show to painful stimulation (e.g., pain due to discomforting physiotherapy exercises) are comparable or more intense than the reactions of cognitively intact patients [8]. Such clinical findings underscore the importance of managing pain effectively regardless of patient cognitive status.

### Age Differences in Psychosocial Aspects of Pain

There is evidence of psychosocial differences in the mediators and context of pain. Although not perfectly consistent across studies, the evidence shows age-related differences in beliefs and attributions about pain as well as coping strategies [9]. There is, for

example, evidence of increased stoicism among older adults when it comes to the reporting of symptoms. This stoicism could lead to an underreporting of pain among older adults [9]. Moreover, the social context and stressors that affect seniors with pain differ from those of younger persons. For example, younger adults with chronic pain conditions are often concerned about issues relating to return to work whereas older persons are often retired, may be widowed and may be more concerned about loneliness and possible social isolation.

### The Assessment of Pain in the Older Adult

Given age-related differences in the social context and co-morbidities of chronic pain, research has focused increasingly on the validation of pain assessment tools among older adults [10]. Instruments that are specialized in the assessment of the older adult have also been developed [10].

The accurate assessment of pain in the older adult is especially challenging when it comes to persons with severe dementia who have limited ability to communicate. Because pain is a subjective phenomenon, clinicians tend to rely on self-report. Recently, there have been worthwhile efforts to develop and validate observational measures of pain that rely on the recording of pain-related behaviors such as facial expressions and paralinguistic vocalizations (such assessment tools have been reviewed elsewhere [8]).

### The Treatment of Pain in the Older Adult

Although the prevalence of chronic pain increases with age, pain is always the result of pathology and is never a natural part of being old. As such, it is always important to manage chronic pain. Recommended doses of drugs used for pain management in older adults are often lower than doses used in younger persons because of age-related physiological changes (e.g., age-related changes in fat to muscle ratio, slowing of metabolic rates, lower protein levels in the blood). Although numerous drugs have been shown to be effective in treating pain in older adults, more research concerning the ►pharmacokinetics, ►pharmacodynamics, efficacy and safety of medications in older persons is needed [9]. In addition, many of the painful conditions that elderly persons tend to suffer are responsive to physiotherapy, although special adaptations may be required for frail seniors [9]. Finally, initial evidence suggests that ►cognitive behavior therapy can be helpful in assisting older adults with pain management [9].

### References

1. Charlton JE (ed) (2005) Core curriculum for professional education in pain, 3rd edn. IASP Press, Seattle
2. Proctor W, Hirdes J (2001) Pain and cognitive status among nursing home residents in Canada. *Pain Res Manag* 6:191–205

3. Gibson SJ, Chambers C (2004) Pain over the life span, in *Pain: Psychological perspectives*. In: Hadjistavropoulos T, Craig KD (eds) Lawrence Erlbaum Associates, Mahwah, NJ
4. Washington LL, Gibson SJ, Helme RD (2000) Age-related differences in endogenous analgesic response to repeated cold water immersion in human volunteers. *Pain* 89:89–96
5. Gibson SJ, Gorman MM, Helme RD (1990) Assessment of pain in the elderly using event-related cerebral potentials. In: Bond MR, Charlton JE, Woolf C (eds) *Proceedings of the VIth World Congress on Pain*, Elsevier, Amsterdam
6. Benedetti F et al. (2004) Pain reactivity in Alzheimer patients with different degrees of cognitive impairment and brain electrical activity deterioration. *Pain* 111 (1–2):22–29
7. Benedetti F et al. (1999) Pain threshold and tolerance in Alzheimer's disease. *Pain* 80(1–2):377–382
8. Hadjistavropoulos T (2005) Assessing pain in older persons with severe limitations in ability to communicate. In: Gibson SJ, Weiner DK (eds) *Pain in older persons*. IASP Press, Seattle
9. Gibson SJ, Weiner DK (eds) (2005) *Pain in older persons*. IASP Press, Seattle
10. Herr KA (2005) Pain assessment in the older adult with verbal communication skills. In: Gibson SJ, Weiner DK (eds) *Pain in older persons*. IASP Press, Seattle, pp 111–133

---

## Pain in Patients with Dementia

- Pain in Older Adults (Including Older Adults with Dementia)

---

## Pain in the Elderly

- Pain in Older Adults (Including Older Adults with Dementia)

---

## Pain in the Head

- Headache

## Pain Modulation

### ► Descending Modulation of Nociception

## Pain Psychophysics

JOEL D. GREENSPAN

Department of Biomedical Sciences, University of Maryland Dental School, Baltimore, MD, USA

### Synonyms

Quantitative sensory testing QST

### Definition

The systematic evaluation of the quantitative relationship between physical stimuli and the pain they evoke.

### Characteristics

The discipline of ► **psychophysics** was developed in the German experimental psychology laboratories of the early nineteenth Century. It has been applied to every sensory system, including pain. The earliest published work in pain psychophysics recognized today is that of Ernst Weber [1]. While most of Weber's work in psychophysics addresses tactile perception, a portion encompasses pain. The first major opus in pain psychophysics of the twentieth Century was that of James Hardy and colleagues at Cornell University. Over 200 papers from this group were distilled for the book "Pain sensations and reactions" [2]. This body of work was a principal reference for pain psychophysics for decades, despite a reliance on a narrow range of approaches that were not always found to generalize in subsequent studies.

The two essential components for psychophysical evaluation of any sensory system are (i) controlled stimuli and (ii) a valid method of quantifying sensory experience. For pain psychophysics, the development of reliable pain-evoking stimuli was complicated by the need to avoid tissue damage. The most commonly used stimulation techniques are cutaneous heating and mechanical pressure applied to cutaneous and/or deeper tissues. However, several other forms of stimulation are used for pain psychophysics, including cold, electrical, chemical, laser, and visceral distention [3].

### Pain Threshold

One principal psychophysical measure is ► **threshold**. Simply stated, threshold is the minimal level of

stimulation needed to evoke a sensation. By extension pain threshold is the minimal level of stimulation needed to evoke a sensation of pain. Accordingly, thresholds are reported in terms of stimulus values, such as temperature (in °C) or mechanical forces (kg equivalent weight, or Newtons). An alternative measure is the time it takes a constant, sustained stimulus to be perceived as painful, thus measuring pain threshold in terms of seconds.

The assessment of pain threshold is more complicated than other sensory thresholds because of the nature of pain and people's concept of it. In other sensory modalities, threshold is recognized by the "step" between no sensation and sensation. Thus, the subject is attempting to distinguish between sensing nothing and something. For pain thresholds, the subject is instead distinguishing between two types of sensation – one considered painful and one non-painful. Thus, a critical element in pain threshold determination is the particular sensory experience an individual considers painful. This factor will be influenced by, among other things, the subject's pain experience history, and the instructions given by the experimenter. For instance, thresholds are likely to be different if a subject is instructed to indicate when he perceives "pain" versus when he perceives "a sharp or burning sensation" or "an uncomfortable sensation." It is also possible that a subject's criterion for judging what sensation is painful changes in the course of an evaluation session. Furthermore, the likelihood and extent of such changes can vary depending upon the range and number of stimuli applied [4]. Several other factors can influence pain threshold values, including features of the psychophysical protocol (e.g., the specific design, stimulus parameters, the range of stimuli, the threshold calculation procedure), which makes it questionable to compare threshold values across studies that vary with respect to these and any other protocol features.

Another important fact to recognize is that threshold is a statistical entity. While we are accustomed to representing thresholds as very precise values (i.e., heat pain thresholds expressed as temperature at a 0.1°C level of precision), it is not the case that weaker stimuli are necessarily painless, and stronger ones are always painful. Instead, there is a range of stimuli for which the lower values are less frequently painful and the higher values are more frequently painful. The threshold value, in principle, is the midpoint of that range (Fig. 1).

This concept applies whether one is considering data derived from a single person tested repeatedly, or from a group of people.

Heat pain threshold has been found to be fairly consistent across many body sites. However, heat pain thresholds are significantly higher on ► **glabrous skin** than on hairy skin of the extremities. This relative consistency across the body allows one to assess regional pain threshold abnormalities by comparing

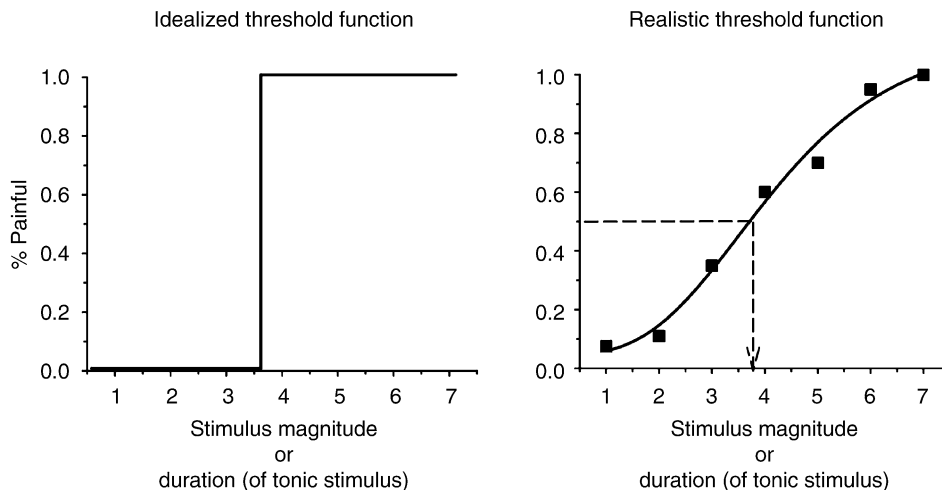

**Pain Psychophysics. Figure 1** Ideally, pain threshold can be envisioned as the stimulus intensity that divides non-painful from painful intensities of stimulation (*left*). But, in reality, there is a range of stimulus intensities that are sometimes perceived as painful and sometimes as non-painful. Thus, pain threshold is typically regarded as the stimulus intensity that is painful 50% of the time (*right*).

thresholds between two body sites, when one of them is accepted as a reference. This approach is often done by comparing thresholds between homolateral body sites in the cases of unilateral sensory abnormalities [5]. Despite this intra-personal consistency, there is considerable inter-personal variability in pain threshold. This feature has been demonstrated in studies that have evaluated a large number of subjects in attempts to develop a normative database of pain thresholds [6].

While the concept of psychophysical threshold has been used for almost two centuries, it has been criticized as a strict measure of sensory perception because it can be influenced by psychological states such as expectancy and anticipated rewards. In an attempt to account for these and other “non-sensory” factors that could influence threshold determination, the approach of [▶signal detection theory](#) (SDT) was adapted for psychophysics [7]. This approach allowed for the distinction between stimulus discriminability ( $d'$ ) and response bias ( $\beta$ ), in which the former was the “bias-free” measure of sensory detection. Threshold measures cannot make this distinction. Approaches based on SDT have been applied to pain psychophysics; however, problems particular to pain psychophysics have been noted. Despite the advantage of SDT approaches in distinguishing stimulus discriminability from response bias in psychophysical assessments, the major drawback of this approach is the need for many more stimulus trials than are needed for most threshold protocols. In addition, SDT assumes a perceptual stability over the course of testing, which is not necessarily the case for pain. Another concern is that knowing how discriminable two

(or more) stimuli are from one another is not the same information as how painful those stimuli are. Thus, the kind of information derived from STD-derived protocols are supplemental to, rather than replacements for, the type of information gathered using other psychophysical approaches to pain perception.

### Suprathreshold Pain Scaling

Another major psychophysical endpoint is evaluation of perception above threshold (suprathreshold perception). The principle is to have the subject represent the sensory experience on a quantitative continuum – often referred to as “scaling” perception. There are many ways to accomplish this, and protocols are based on either direct or indirect methods. Indirect scaling methods require the subject to use another continuum to match the perception under investigation. An example of this is to have the subject adjust the volume of a sound so that the loudness matches the intensity of another sensory dimension, such as pain. In this way, the pain intensity can be measured in terms of decibels of sound. Another approach is to have the subject draw a line length to represent the intensity of a sensation, allowing the sensation intensity to be measured in millimeters.

The direct scaling methods require the subject to choose a number that reflects perceptual intensity, and thus do not require an intermediate modality such as another sensory dimension or a motor task. These direct scaling methods have been more frequently employed for pain psychophysics over the last few decades. In most pain studies, subjects are provided a number

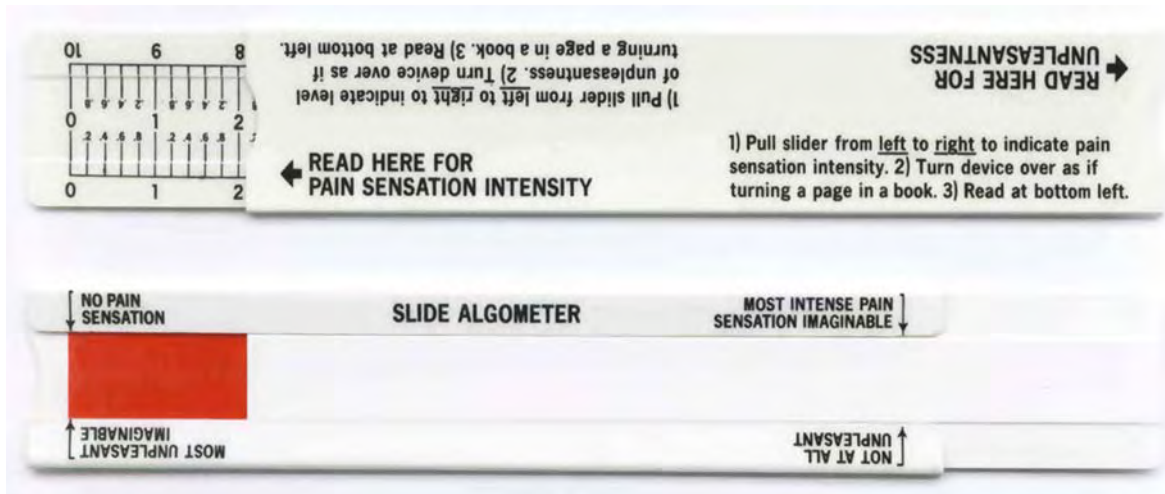

**Pain Psychophysics. Figure 2** A mechanical visual analog scale for pain rating developed by Dr. Donald D. Price and colleagues. *Bottom:* A sliding plastic piece moves to reveal a red bar. The subject adjusts the length of the red bar to match the perceived pain intensity (in the orientation shown), or the perceived unpleasantness (when rotated 180°). *Top:* The number at the edge of the adjusted plastic piece is the numerical value assigned either pain intensity or unpleasantness. Figure courtesy of Dr. Price.

Pain intensity scale		Unpleasantness scale	
20		20	
19		19	
18	Extremely intense	18	
17	Very intense	17	Very intolerable
16	Intense	16	
15		15	Intolerable
14	Strong	14	
13	Slightly intense	13	Very distressing Slightly intolerable
12	Barely strong	12	Very annoying
11	Moderate	11	Distressing
10		10	Very unpleasant
9		9	Slightly distressing
8	Mild	8	Annoying
7		7	Unpleasant
6	Very mild	6	Slightly annoying
5	Weak	5	Slightly unpleasant
4	Very weak	4	
3		3	
2		2	
1	Faint	1	
0	No pain sensation	0	Neutral

Gracely box SL

Gracely box SL

**Pain Psychophysics. Figure 3** Pain rating scales with descriptors developed by Dr. Richard H. Gracely and colleagues. The subject reports the perceived pain intensity (a) or unpleasantness (b) by choosing a number between 0 and 20. Placement of descriptors along the length of the numeric scale, which serve to provide connotative meaning to the numbers, was based on psychometric procedures described in [9]. Figure courtesy of Dr. Gracely.

scale to use, which can be as limited as 0–5, or as large as 0–100, or even unbounded. In many instances, the numeric scale also includes descriptors at specific points to give the numeric scale a qualitative frame of reference. One of the most commonly used scales for pain ratings is a 0–100 visual analog scale (VAS) with descriptors at both ends of the scale (Fig. 2).

This scale has been validated and found to produce data with ratio scale properties suitable for parametric analysis [8]. Other pain scales have been developed with more descriptors, based on psychometrically determined associations among the descriptors (Fig. 3a) [9,10].

The principle of assigning descriptors along a numeric scale for the subject can be an advantage, but also potentially problematic. On one hand, descriptive anchors serve to give the numbers a consistent connotative meaning to the subjects, and thereby help to standardize the scale. On the other hand, if different people interpret the same term differently (Is your concept of “extremely intense” the same as mine?), the presence of these terms can introduce an idiosyncratic bias, rather than standardizing the numeric scale. Despite this possibility, and the inherent uncertainty of measuring a subjective phenomenon, these types of scales have been successfully used for many psychophysical studies of pain over the last few decades.

While the aforementioned scales are designed to measure pain intensity, a similar set of scales have been developed to measure pain affect or unpleasantness (Figs. 2 and 3b). In principle, any perceptual dimension could be measured with a similarly constructed scale.

### Pain Tolerance

Pain tolerance is less frequently used than pain threshold in scientific studies, and it has some significant disadvantages: (i) For some forms of stimulation, pain tolerance cannot be reached without risking tissue injury; (ii) Pain tolerance generally shows greater variability than threshold, both within and across subjects; (iii) It is more widely altered by subject bias or past experience than threshold. However, pain tolerance measures a qualitatively different aspect of the pain experience than does pain threshold. Arguably, pain tolerance is a measure more reflective of the affective and motivational aspects of the pain experience, while threshold is a measure of the discriminative aspect. One common form of this test is the “▶cold pressor test,” which involves submersion of a body part in ice water. Another test involves ischemic pain, produced by applying a pressure cuff on the subject’s arm.

### References

1. Ross HE, Murray DJ (eds) (1978) *The sense of touch* (transl. Weber EH). Academic Press, New York

2. Hardy JD, Wolff HG, Goodell H (1952) *Pain sensations and reactions*. Williams and Wilkins, Baltimore
3. Graven-Nielsen T, Sergerdahl M, Svensson P, Arendt-Nielsen L (2001) Methods for induction and assessment of pain in humans with clinical and pharmacological examples. In: Kruger L (ed) *Methods in pain research*. CRC Press, Boca Raton, FL, pp 263–304
4. Gracely RH, Naliboff BD (1996) Measurement of pain sensation. In: Kruger L (ed) *Pain and touch*. Academic Press, San Diego, CA, pp 243–313
5. Greenspan JD, Ohara S, Sarlani E, Lenz FA (2004) Allodynia in patients with post-stroke central pain (CPSP) studied by statistical quantitative sensory testing within individuals. *Pain* 109:357–366
6. Rolke R, Baron R, Maier C, Tolle TR, Treede RD, Beyer A, Binder A, Birbaumer N, Birklein F, Botefur IC (2006) Quantitative sensory testing in the German research network on neuropathic pain (DFNS): standardized protocol and reference values. *Pain* 123:231–243
7. Green DM, Swets JA (1966) *Signal detection theory and psychophysics*. Robert E. Krieger, Huntington, NY
8. Price DD, McGrath PA, Rafii A, Buckingham B (1983) The validation of visual analogue scales as ratio scales measures for chronic and experimental pain. *Pain* 17:45–56
9. Gracely RH, McGrath P, Dubner R (1978) Ratio scales of sensory and affective verbal pain descriptors. *Pain* 5:5–18
10. Greenspan JD, Roy EA, Caldwell PA, Farooq N (2003) Thermosensory intensity and affect throughout the perceptible range. *Somatosens Mot Res* 20:19–26

## Pain System

### ▶ Ascending Nociceptive Pathways

## Pain Threshold

### Definition

The International Association for the Study of Pain defines pain threshold as the least amount of pain that a person can recognize.

### ▶ Pain in Older Adults (Including Older Adults with Dementia)

## Pain Tolerance Level

### Definition

The International Association for the Study of Pain defines pain tolerance level as the greatest amount of pain that a person can tolerate.

► Pain in Older Adults (Including Older Adults with Dementia)

## Pain Unpleasantness

### Definition

The immediate, disagreeable aspect of pain, similar to feelings of thermal distress (too hot or cold), thirst, or hunger, that motivates behaviors to reduce this feeling state. This immediate state is in contrast to the emotional reactions and feeling states associated with thoughts about pain (pain emotion), such as anxiety, depression, fear, and despair. In the case of injury, the unpleasantness of pain usually motivates movements to escape or to minimize the injury (pain evoked movement). After the injury, during the healing phase, the unpleasantness of pain may inhibit movement to protect the injured area and promote healing (movement evoked pain).

► Emotional/Affective Aspects of Pain

## Painful Neuropathies

► Voltage-gated Sodium Channels: Multiple Roles in the Pathophysiology of Pain

## Palaeocerebellum

### Synonyms

► Paleocerebellum

### Definition

Phylogenetically, a very old part of the cerebellum. Corresponds to the vermis cerebelli with its surrounding intermediate part (paravermal part). The afferents of this region come from the spinal cord, hence this part is also called the spinocerebellum.

► Cerebellum

## Palaeomagnetism

### Definition

The study of remanent magnetization of rocks and sediments to unravel information of the ancient magnetic field.

► Geomagnetic Field

## Paleocortex

### Definition

The paleocortex (Greek for old cortex) is a phylogenetically older type of cortex with less than the six layers seen in the neocortex, but more than the three layers seen in the archicortex (hippocampal formation). The parahippocampal gyrus has cortex of this type.

## Paleoencephalon

### Definition

The paleoencephalon describes phylogenetically older parts of the cerebral hemisphere that evolved along with the olfactory system. Sometimes the term rhinencephalon is used as a synonym. In the strict olfactory sense, the paleoencephalon would include the olfactory bulb, anterior olfactory nucleus, olfactory tubercle, and portions of the amygdala and nearby piriform cortex.

## Paleoneurology

### Definition

The study of the endocasts of fossil animals.

- ▶ Evolution of the Brain in Humans – Paleoneurology

## Paleopallium

### Definition

The palopallium refers to the cortex of the paleoencephalon, i.e., paleocortex (see above).

## Paleopallium and Archipallium

- ▶ Evolution of the Pallium: in Amphibians

## Pallia Dorsale and Piriforme

- ▶ Evolution of the Pallium: in Amphibians

## Pallial Amygdala

### Definition

Portion of the amygdaloid complex derived from pallial regions. It posses layered cortical and nuclear components in amniotes, whereas only a nuclear portion is present in anamniotes (anurans amphibians).

- ▶ Evolution of the Amygdala: Tetrapods

## Pallial Primordia

- ▶ Evolution of the Pallium: in Amphibians

## Palliative

- ▶ Placebo Analgesic Response

## Pallidum

- ▶ Globus pallidus
- ▶ Diencephalon

## Pallidum, Ventral

### Definition

A rostroventral extension of the globus pallidus that protrudes into the basal forebrain and olfactory tubercle beneath the anterior commissure. The ventral pallidum receives projections from the accumbens and medium cell (striatal) districts of the olfactory tubercle and projects to the lateral hypothalamus, medial extremity of the subthalamic nucleus, ventral tegmental area and adjacent medial part of the substantia nigra and ventrolateral part of the periaqueductal gray.

- ▶ Hypothalamus
- ▶ Hypothalamus, Lateral
- ▶ Striatopallidum

## Pallium

### Definition

The roof of the forebrain (telencephalon) which includes the cerebral cortex, hippocampus, olfactory cortex, claustrum, and some amygdalar groups – pallial is the adjective.

- ▶ Evolution of the Brain in Reptiles
- ▶ Evolution of the Wulst



## Pallium (Medial, Dorsal)

### Definition

The dorsal portion of the telencephalon with a cytoarchitectural organization that is primarily cortical (suggestively layered).

► Evolution of Hippocampal Formation

## Palmitoylation

### Definition

Addition of palmitic acid, a saturated fatty acid containing 16 carbon molecules via an enzymatic reaction involving a Palmitoyl-acyl transferase enzyme.

Palmitic acid is covalently attached to proteins via thioester bonds at cytosolic cysteine residues and it is reversible reaction.

► Receptor Trafficking

## PAN/PVC Tube

### Definition

Semipermeable polyacrylonitrile/polyvinylchloride polymer guidance tube for placing cells within and transplantation to the spinal cord.

► Transplantation of Olfactory Ensheathing Cells

## Papez Neuronal Circuit

### Definition

The mammillothalamic fasciculus, Vicq d'Azyr bundle conducts efferents of the mammillary body to the thalamus (anterior thalamic nucleus). This in turn projects via the cingulum to the hippocampus, while the latter projects back via the fornix to the mammillary body and anterior thalamic nucleus.

This creates a neuronal feedback circuit, which is called the Papez neuronal circuit and plays a role in memory formation. Being a vital component of the Papez neuronal circuit, the hippocampus is involved in memory formation. Lesions result in loss of the ability transfer the contents from short-term memory to long-term memory (anterograde amnesia).

► General CNS

## Par Protein

### Definition

Partitioning defective (Par) proteins include par-3, par-6, cdc42, and atypical protein kinase-C (aPKC). These proteins form a complex that exhibits a polarized distribution in the cell and is involved in establishing cellular polarity.

## Parabolic Flight

### Definition

A flight trajectory of parabolic climbs and dives in which the aircraft and its contents are in free fall during the pushover periods, simulating a 0 g environment in the sense that objects in the aircraft are weightless. The length of the weightless phases depends on the air speed of the aircraft.

► Autonomic Function in Space  
► Proprioception Effect of Gravity

## Parabrachial Area

### Synonyms

► Nuclei parabrachiales; ► Parabrachial nuclei

### Definition

The parabrachial area comprises three nuclear areas:

- Lateral parabrachial nucleus
- Medial parabrachial nucleus
- Kolliker-Fuse nucleus

Brainstem second relay station both for taste and visceral sensory pathways located in the pons. It is formed by several nuclei. The medial parabrachial area receives gustatory afferents from the nucleus of the tractus solitarius while the lateral parabrachial receives visceral afferents both vagal and from the area postrema. It is considered a primary site for taste– visceral integration relevant for conditioned taste aversion acquisition in rodents.

- ▶ Conditioned Taste Aversion
- ▶ Diencephalon
- ▶ Parabrachial Nuclei

---

## Parabrachial Complex

### Definition

A compact cluster of relay nuclei located rostrally in the dorsolateral pons, surrounding the middle cerebral peduncle (brachium conjunctivum). Individual nuclei within the parabrachial complex receive various ascending axonal inputs that provide information about viscerosensory function, metabolic status, and pain (arriving from nuclei in the spinal cord, nucleus of the solitary tract, and other brainstem sites). This ascending information is integrated with substantial descending inputs from the hypothalamus, amygdala, bed nucleus of the stria terminalis, and other brain sites. Different nuclei within the parabrachial complex deliver this integrated information to subcortical regions of the forebrain (primarily to subnuclei within the amygdala, hypothalamus, thalamus, and basal forebrain), and to nuclei in the midbrain and brainstem, thus influencing processes that include ingestive behavior, arousal, emotion, and autonomic function.

---

## Parabrachial Nuclei

### Definition

Latin: Nuclei Parabrachiales; Nuclear complex that is located in the dorsolateral tegmentum of the pons and serves as a major relay center for converging visceral, nociceptive, and thermoreceptive information to the forebrain. The parabrachial complex includes several subnuclei involved in taste sensation and control of

gastrointestinal, cardiovascular activity, and respiratory functions.

- ▶ Central Regulation of Autonomic Function
- ▶ Parabrachial Area

---

## Paradoxical Embolism

### Definition

Cardiac embolism that contains material from the venous system and reached the arterial system through a cardiac shunt.

- ▶ Ischemic Stroke
- ▶ Stroke

---

## Parahippocampal Gyrus

### Synonyms

- ▶ Gyrus parahippocampalis

### Definition

The gyrus marks the transition from hippocampus with its allocortex to the isocortical structure of the temporal lobe. A cross-section shows four discrete cortical regions: presubiculum and parasubiculum on the hippocampal sulcus, entorhinal area and the perirhinal cortex deep in the calcarine sulcus.

- ▶ Telencephalon

---

## Parallel Arrangement

### Definition

A combination of two rheological elements, such that the elongation is common to both and the forces are to be added to obtain the force of the combined element.

- ▶ Mechanics

## Parallel Processing

### Definition

In the brain information is processed not only in one stream as in a typical computer but in many parallel and independent streams. Good examples are the different sensory pathways.

- ▶ Motor Unit
- ▶ Spasticity
- ▶ Tendon Reflex

## Parallel Visual Processing Streams

- ▶ Visual Processing Streams in Primates

## Parallelism

### Definition

Mental and physical events run parallel to each other without any causal relations obtaining between mental and physical events.

- ▶ Causality

## Paralysis

### Definition

Severe loss of motor strength resulting from damage to ▶ **motor units** or to descending tracts impinging on them. Lower motoneuron paralysis presents with possible involvement of individual muscles, severe atrophy, flaccidity and ▶ **hypotonia** with absent ▶ **tendon reflexes**, possible ▶ **fasciculations** and ▶ **fibrillations**. Upper motoneuron paralysis usually presents with diffuse distribution of affected muscles, little atrophy, ▶ **spasticity**, ▶ **Babinski sign**, ▶ **fasciculations**.

- ▶ Babinski Reflex
- ▶ Fasciculations
- ▶ Fibrillations
- ▶ Motoneuron

## Paralysis Agitans

### Definition

- ▶ Parkinson Disease

## Paralytic Ileus

- ▶ Bowel Disorders

## Paramedian Pontine Reticular Formation (PPRF)

### Definition

Anatomically, the PPRF is just the medial portion of the pontine reticular formation (<2 mm from the midline in macaques), but in the oculomotor literature, the PPRF is a functional unit that contains many of the neuronal populations and much of the neuronal circuitry involved in the generation of (mainly horizontal) eye movements. It first came to prominence when it was shown that lesions of the PPRF eliminated or drastically impaired most horizontal eye movements. The PPRF includes most elements of the brainstem burst generator involved in the generation of horizontal saccades, namely excitatory burst neurons, long-lead burst neurons, omnipause neurons, and arguably, inhibitory burst neurons which are on the pontomedullary border.

Intermixed with these neurons are saccade-related neurons that project to the cerebellum, and reticulospinal neurons that mediate head movements and eye-head coordination. Embedded in the PPRF are other nuclei that are usually considered to be distinct from the reticular formation. The most important is the abducens nucleus, which contains lateral rectus motoneurons and internuclear neurons that project to

medial rectus motoneurons. There are also circumscribed precerebellar relay nuclei that convey oculomotor signals to the oculomotor vermis, fastigial nucleus, and the floccular lobe, namely raphe pontis, the intrafascicular nucleus, the rostral pole of the abducens nucleus, and medial nucleus reticularis tegmenti pontis. Finally, the PPRF contains the fibers connecting these and other oculomotor structures (e.g., the superior colliculus and the vestibular nuclei), so the drastic effects of lesions are a product of destroying both the neuronal populations and the inputs to these populations.

- ▶ Brainstem Burst Generator
- ▶ Cerebellum – Role in Eye Movements
- ▶ Long-Lead Burst Neurons (LLBNs)
- ▶ Omnipause Neurons
- ▶ Saccade, Saccadic Eye Movement
- ▶ Superior Colliculus
- ▶ Vestibular Nuclei

---

## Parameters

### Definition

Constants or variables that are not conditioned by natural laws but define essential characteristics of the system's behavior under the action of the laws.

- ▶ Equilibrium Point Control

---

## Parametric Control

### Definition

- ▶ Equilibrium Point Control

---

## Paramyotonia Congenita

### Definition

- ▶ Non-dystrophic myotonias

---

## Paraphasia

### Definition

Incorrect use of words occurring in conduction aphasia.

- ▶ Aphasias

---

## Paraplegia

### Definition

Bilateral paralysis of the lower body including the two legs, most commonly resulting from damage to the spinal cord (complete transection), spinal nerve roots or peripheral nerves.

---

## Parasomnias

### Definition

Undesired physical events that occur during the entry into sleep, within sleep or during arousals from sleep. They include sleep walking and sleep terrors.

- ▶ Sleep-Wake Cycle

---

## Parasthesia

### Definition

Altered sensation, usually ascribed to pins and needles or tingling but which can also be ascribed to burning or pricking.

- ▶ Proprioception: Effect of Neurological Disease

---

## Parasympathetic

- ▶ Central Integration of Cardiovascular and Respiratory Activity Studied In Situ

## Parasympathetic Ganglia

### ► Autonomic Ganglia

## Parasympathetic Nervous System

### Definition

Parasympathetic refers to the branch of the autonomic nervous system that arises from specific cranial nerve nuclei and from the sacral spinal segments. This system supplies visceral organs with specific functions, such as the sphincter pupillae and the ciliary body in the eye, secretory glands producing fluid including acid in the stomach, enhancing motility of stomach and distal colon, bladder, etc.

- Ageing of Autonomic/Enteric Function
- Autonomic Ganglia
- Autonomic Reflexes
- Parasympathetic Pathways

## Parasympathetic Pathways

### Definition

Beside the sympathetic pathways, the parasympathetic pathways are the second major component of the autonomic nervous system (there are also enteric pathways and an afferent or sensory component). Some parasympathetic pathways involve brain stem and cranial ganglia, and some are centered on the sacral region of the spinal cord and the pelvic ganglia.

In the brain stem the main nuclei of the parasympathetic pathways (the cranial parasympathetic outflow) are the Edinger-Westphal nucleus, the superior and inferior salivatory nuclei, dorsal vagal nucleus and nucleus ambiguus. The neurons of these nuclei issue axons then enter the oculomotor nerve, the facial, the glosso-pharyngeal nerve and vagus nerve, respectively.

The oculomotor branch projects to the ciliary ganglion (its neurons innervate the iris and the ciliary muscle, hence providing accommodation and pupil constriction).

The facial nerve branch project to the pterygopalatine and the submandibular ganglia (their neurons innervate the lachrymal, the submandibular and the sublingual glands), and the glosso-pharyngeal branch project to the otic ganglion (its neurons innervate the parotid gland). The fibers from the nucleus ambiguus and dorsal vagal nucleus enter the vagus nerve, of which they represent the motor component, and extend a long distance in the neck, thorax and upper part of the abdomen. The fibers terminate synapsing on neurons in small ganglia close to the tracheal and bronchial muscles and the esophagus and in some enteric ganglia of stomach and intestine. From these minute intramural ganglia, post-ganglionic fibers emerge that innervate glands and smooth musculature of airways, esophagus and gastro-intestinal tract. In the spinal cord, preganglionic parasympathetic neurons are assembled into columns in the second, third and fourth sacral segments. Their preganglionic fibers, predominantly cholinergic, project onto pelvic ganglia, whose post-ganglionic fibers innervate mainly the urogenital organs. In some organs, typically the heart or the pupil, which receive both sympathetic and parasympathetic fibers, these exert antagonistic effect. Many organs, however, are controlled predominantly by one or the other of the two pathways.

### ► Sympathetic Pathways

## Paraventricular Nucleus (PVN)

P

### Definition

A subdivision of the hypothalamus located adjacent to the third ventricle. The PVN contains many distinct neurosecretory cells that regulate important physiological functions in the neuroendocrine system. These cells can be anatomically and functionally divided into a magnocellular division and a parvocellular division.

Magnocellular neurons produce the hormones oxytocin and vasopressin and project to the posterior pituitary gland. Parvocellular neurons that synthesize corticotrophin releasing hormone project to the median eminence at the ventral surface of the brain where they release peptides into the blood vessels of the hypothalamo-pituitary portal system, vasculature that carries peptides to the anterior pituitary gland. Some neurons, projecting to autonomic nuclei of the brainstem and spinal cord, are activated, in a stimulus-specific fashion, by hypoglycemia, hypovolemia, cytokines, pain, and environmental stressors. The PVN receives

afferent projections from multiple brain areas, such as the brainstem and other hypothalamic regions, that provide information about the homeostatic state of the organism.

- ▶ Central Regulation of Autonomic Function
- ▶ Hypothalamo-neurohypophysial System
- ▶ Hypothalamo-pituitary-adrenal Axis, Stress and Depression
- ▶ Hypothalamus
- ▶ Pituitary Gland
- ▶ Ventrolateral Preoptic Nucleus (VLPO)

---

## Paravertebral Ganglia

### Definition

The paravertebral ganglia are interconnected autonomic ganglia that lie close to the spinal nerves and the vertebrae, from the lower cervical/upper thoracic level to the sacral level of the spinal cord. The chains of paravertebral ganglia are paired, and lie just lateral to the bodies of the vertebrae.

- ▶ Autonomic Ganglia
- ▶ Sympathetic Nervous System
- ▶ Sympathetic Pathways

---

## Paresis

### Definition

A weakening of a muscle due to pathology of the muscle, the motoneurons that innervate it, or the efferent nerve that carries the latter's axons.

---

## Paresthesia

### Definition

Abnormal sensory experiences such as numbness, pins-and-needles sensations and tingling, occurring

spontaneously without external sensory stimulation and with some sensory ▶ [peripheral neuropathies](#).

- ▶ [Peripheral Neuropathies](#)

---

## Parietal Lobe

### Synonyms

- ▶ Lobus parietalis

### Definition

Extends from the central sulcus to the parietooccipital sulcus.

- ▶ [Telencephalon](#)

---

## Parietal Organ

### Definition

A heritage of ancient, sea bottom-dweller vertebrates, an "eye" on the top of the head, the pineal body evolved in correlation with it.

- ▶ [Evolution of the Brain: At the Reptile-Bird Transition](#)

---

## Parinaud Syndrome

### Definition

This syndrome results from dorsal midbrain lesions and is characterized by impaired vertical eye movements (especially upwards) and absence of the pupillary light reflex.

- ▶ [Pupillary Light Reflexes](#)

## Parkinson Disease

ALI SAMII

Department of Neurology, University of Washington Medical Center, Seattle, WA, USA

### Synonyms

Idiopathic Parkinson's disease; Idiopathic Parkinsonism

### Definition

A progressive neurological disease named after James Parkinson.

### Characteristics

#### Clinical Features, Epidemiology, and Etiology

The four cardinal features of Parkinson disease are tremor, bradykinesia, rigidity, and ▶**postural instability**. ▶**Parkinsonism** is a non-specific term used to describe a constellation of signs on physical examination similar to those seen in Parkinson disease. Parkinson disease is defined as asymmetric Parkinsonism with no known cause, characterized by most of the four cardinal features, and responsive to anti-Parkinson medications (usually ▶**dopaminergic drugs**) [1]. The diagnostic criteria for Parkinson disease have become more rigorous with gradations of diagnostic certainty. Any one of resting tremor, rigidity, or bradykinesia would suggest clinically possible Parkinson disease. Any two of the four cardinal signs (especially if asymmetric) would suggest clinically probable Parkinson disease. Clinically probable Parkinson disease with significant improvement in motor signs with dopaminergic drugs would suggest clinically definite Parkinson disease. The non-motor features of Parkinson disease include loss of sense of smell, depression, anxiety, autonomic dysfunction (constipation, urinary urgency, sexual dysfunction, orthostatic hypotension), sleep disturbance, including ▶**rapid-eye-movement (REM) sleep behavior disorder**, and cognitive impairment. The non-motor symptoms of Parkinson disease are gaining much more attention than before since they contribute greatly to disability as the disease progresses and they do not respond to dopaminergic drugs.

The prevalence of Parkinson disease in industrialized countries is estimated at 0.3% of the general population and approximately 1% of the population aged over 60 [2]. The prevalence is slightly higher in men than in women. The mean age of onset is about 60, but approximately 5% of patients have young onset Parkinson disease, with motor symptoms appearing before age 40. *The pathology underlying the motor symptoms of PD is injury to the dopaminergic projections from the*

*substantia nigra pars compacta to the striatum. Lewy Bodies are the pathological hallmarks of PD, but they are not confined to the substantia nigra. Pathology is widespread in PD and involves the amygdala, the olfactory bulb, dorsal motor nucleus of the vagus nerve, locus ceruleus, pedunculopontine nucleus, raphe nuclei, the cortex, and the peripheral autonomic nervous system. This extensive pathology may account for the non motor symptoms of PD.* The etiology of PD is unknown, but aging, environmental factors, and genetic predisposition probably all play a role in causing Parkinson disease [3]. The recent discovery of several genetic loci related to familial Parkinson disease has led to the hypothesis that failure of the ▶**ubiquitin-proteasome system** and protein misfolding are the final common pathways in the pathogenesis of Parkinson disease [4]. Mutations of the leucine-rich repeat kinase 2 (LRRK2) gene are the most common identifiable cause of Parkinson disease, in that 1% of patients without a family history and more than 5% of patients with a first degree relative with Parkinson disease have a LRRK2 mutation [5].

### Medical Treatment of Motor Symptoms

There is no definitive agent known to slow down disease progression at the cellular level in Parkinson disease [6]. Therefore, treatment remains symptomatic with mostly dopaminergic drugs. A pilot study suggested that high dose ▶**coenzyme Q10** may slow symptom progression in early Parkinson disease [7]. These results have yet to be confirmed in larger studies with longer follow-up periods. Treatment is typically initiated when motor symptoms cause disability. The treatment of early Parkinson disease is with either a monoamine oxidase-B (MAO-B) inhibitor (selegiline or rasagiline), a non-ergot-derived dopamine agonist (pramipexole, ropinirole, transdermally absorbed rotigotine) or levodopa [8]. MAO-B inhibitors are generally safe and well tolerated, although there are warnings about certain drug interactions and tyramine containing foods when using MAO-B inhibitors. Side effects of dopamine agonists include nausea, hypotension, leg edema, vivid dreams, hallucinations (especially in the older population with cognitive deficits), somnolence (even sleep attacks), and disinhibited behavior (such as gambling). Dopamine agonists have more antiparkinson efficacy than MAO-B inhibitors, but they are less effective than levodopa. Treatment with an MAO-B inhibitor combined with a dopamine agonist may control motor symptoms for the first 2–5 years, but the likelihood of requiring levodopa after that increases significantly.

Levodopa remains the most potent anti-parkinson drug and is the backbone of therapy throughout much of the course of the disease. It is the preferred initial drug

in the older population and those with cognitive deficits or serious co-morbid conditions. Levodopa is combined with carbidopa or benserazide to prevent peripheral conversion to dopamine by dopa-decarboxylase. Side effects of levodopa are similar to those of dopamine agonists, except that somnolence, hallucinations, and leg edema are less common. Complications of long-term levodopa therapy include ▶**motor fluctuations**, including “▶**end-of-dose wearing off**”, and dyskinesia [9]. Dividing protein intake throughout the day may help reduce motor fluctuations. Controlled-release forms of levodopa may provide a longer duration of benefit, but their absorption is more unpredictable than immediate-release levodopa. ▶**Catechol-O-methyl transferase (COMT) inhibitors**, entacapone or tolcapone, prolong the half-life of circulating levodopa and improve end-of-dose wearing off. Dyskinesia can be reduced by decreasing levodopa dosage, but at the expense of worsening motor symptoms. In a patient with motor fluctuations and dyskinesia, adding a dopamine agonist to levodopa may help reduce motor fluctuations. It may also allow for levodopa reduction, which in turn alleviates dyskinesia. The subcutaneously injectable dopamine agonist, apomorphine, is useful for rapid treatment of “off” periods in Parkinson disease. However, given the severity of apomorphine-induced nausea, premedication with domperidone or trimethobenzamide is needed. Amantadine may help suppress dyskinesia. MAO-B inhibitors may also be added to levodopa to help alleviate motor fluctuations.

### Medical Treatment of Non-Motor Symptoms

Non-motor symptoms in Parkinson disease may occur as part of the disease or as complications of treatment [10]. These include depression, cognitive impairment, psychosis, constipation, sleep disturbance, orthostatic hypotension, drooling, and urinary symptoms. Depression in Parkinson disease is usually treated with a selective serotonin reuptake inhibitor (SSRI). There are no controlled head-to-head studies to suggest one SSRI is superior to another in Parkinson disease. Constipation should be treated aggressively using multiple modalities such as stool softeners, increased fiber intake, and suppositories. Disorders of sleep in Parkinson disease include daytime somnolence, sleep attacks, night-time awakenings due to over night bradykinesia, rapid eye movement (REM) behavior disorder, and restless legs/periodic limb movements. Daytime somnolence and sleep attacks may be associated with dopamine agonists and the agonist may have to be stopped. Overnight bradykinesia and restless legs may be alleviated with a bedtime dose of long acting levodopa sometimes with entacapone, or a dopamine agonist. Clonazepam is effective in treating REM behavior disorder. Psychosis in Parkinson disease is thought to be mostly drug-induced, and it occurs more frequently in demented patients.

Dopamine agonists are more likely to cause hallucinations than levodopa. First, the agonist and/or anticholinergic agent should be stopped, and the lowest dose of levodopa should be used. Adding an ▶**atypical neuroleptic** may be necessary. Quetiapine is the more popular atypical neuroleptic in Parkinson disease. It has fewer extrapyramidal adverse effects than risperidone and olanzapine and there is no need for weekly or bi-weekly blood count measurements that would be required with clozapine. ▶**Centrally acting cholinesterase inhibitors** (rivastigmine, donepezil, and galantamine) are somewhat effective in treating the dementia associated with Parkinson disease. Rivastigmine is more commonly used because the data to support its efficacy in Parkinson disease are more robust. Treatment options for hypotension include reducing the dosage of antiparkinson medications, increased salt and fluid intake, and adding fludrocortisone or midodrine. Drooling may be reduced by the peripheral anticholinergic agent, glycopyrrolate, but this drug may worsen constipation. Injection of botulinum toxin into salivary glands improves drooling. Urinary urgency may be treated with peripheral anticholinergic agents (oxybutynin and tolterodine) or alpha-adrenergic blocking agents (prazosin and terazosin). Unfortunately, the former worsen constipation and the latter exacerbate hypotension.

### Surgical Treatment of Motor Symptoms

Deep brain stimulation of “hyperactive” nuclei relieve motor symptoms in patients who have severe motor fluctuations and dyskinesia [9]. High frequency stimulation of deep brain targets presumably reduces neural activity in tissue surrounding the electrode contact. The “suppression” of the target induced by deep brain stimulation can be sculpted by adjustments of the electrode configuration, stimulation intensity, pulse width, and frequency. Bilateral stimulation of the globus pallidus internus (GPi) or the subthalamic nucleus (STN) is effective in relieving motor symptoms. Some claim that bilateral STN stimulation is superior to bilateral GPi stimulation because it allows a reduction in antiparkinson medications, but there is continued debate about the optimal stimulation target for Parkinson disease. A large randomized multi-center study comparing bilateral STN to bilateral GPi stimulation in 300 patients with Parkinson disease is currently under way in the United States, the results of which should be available by 2009. Adverse effects of deep brain stimulation surgery include brain hemorrhage, infarct, seizures, and death. Other complications include lead breakage, other hardware failure, pulse generator malfunction, and hardware infection. Side effects from the stimulation itself include worsening dyskinesia, paresthesias, and cognitive, mood, speech, and gait disturbances. The stimulation-related side effects may be reversible by adjusting stimulation



parameters. The key to successful outcome is appropriate patient selection. The surgical patient must have clinically definite Parkinson disease with documented motor improvement on levodopa. There should be no dementia, untreated psychiatric condition, or serious medical illness. ► **Fetal mesencephalic** tissue transplantation has been studied in Parkinson disease. Although there was marginal improvement in some patients, disabling dyskinesia occurred in many patients. Therefore, fetal mesencephalic tissue transplantation is not a treatment option for Parkinson disease at present.

## References

- Samii A, Nutt JG, Ransom BR (2004) Parkinson's disease. *Lancet* 363(9423):1783–1793
- de Rijk MC, Launer LJ, Berger K, Breteler MM, Dartigues JF, Baldereschi M, Fratiglioni L, Lobo A, Martinez-Lage J, Trenkwalder C, Hofman A (2000) Prevalence of Parkinson's disease in Europe: a collaborative study of population-based cohorts. Neurologic Diseases in the Elderly Research Group. *Neurology* 54 (11 Suppl 5):S21–S23
- Litvan I, Chesselet MF, Gasser T, Di Monte DA, Parker D Jr, Hagg T, Hardy J, Jenner P, Myers RH, Price D, Hallett M, Langston WJ, Lang AE, Halliday G, Rocca W, Duyckaerts C, Dickson DW, Ben-Shlomo Y, Goetz CG, Melamed E (2007) The etiopathogenesis of Parkinson disease and suggestions for future research. Part II. *J Neuropathol Exp Neurol* 66(5):329–336
- Olanow CW, McNaught KS (2006) Ubiquitin-proteasome system and Parkinson's disease. *Mov Disord* 21(11):1806–1823
- Schapira AH (2006) The importance of LRRK2 mutations in Parkinson disease. *Arch Neurol* 63(9):1225–1228
- Biglan KM, Ravina B (2007) Neuroprotection in Parkinson's disease: an elusive goal. *Semin Neurol* 27(2):106–112
- Shults CW, Oakes D, Kieburtz K, Beal MF, Haas R, Plumb S, Juncos JL, Nutt J, Shoulson I, Carter J, Kompoliti K, Perlmutter JS, Reich S, Stern M, Watts RL, Kurlan R, Molho E, Harrison M, Lew M (2002) Parkinson study group. Effects of coenzyme Q10 in early Parkinson disease: evidence of slowing of the functional decline. *Arch Neurol* 59(10):1541–1550
- Horstink M, Tolosa E, Bonuccelli U, Deuschl G, Friedman A, Kanovsky P, Larsen JP, Lees A, Oertel W, Poewe W, Rascol O, Sampaio C (2006) European federation of neurological societies; movement disorder society-European section. Review of the therapeutic management of Parkinson's disease. Report of a joint task force of the European Federation of Neurological Societies and the Movement Disorder Society-European Section. Part I: early (uncomplicated) Parkinson's disease. *Eur J Neurol* 13(11):1170–1185
- Horstink M, Tolosa E, Bonuccelli U, Deuschl G, Friedman A, Kanovsky P, Larsen JP, Lees A, Oertel W, Poewe W, Rascol O, Sampaio C (2006) European federation of neurological societies; movement disorder society-European section. Review of the therapeutic management of Parkinson's disease. Report of a joint task force of the European Federation of Neurological Societies (EFNS) and the Movement Disorder Society-European Section (MDS-ES). Part II: late (complicated) Parkinson's disease. *Eur J Neurol* 13(11):1186–1202
- Miyasaki JM, Shannon K, Voon V, Ravina B, Kleiner-Fisman G, Anderson K, Shulman LM, Gronseth G, Weiner WJ (2006) Quality standards subcommittee of the American academy of neurology. Practice parameter: evaluation and treatment of depression, psychosis, and dementia in Parkinson disease (an evidence-based review): report of the quality standards subcommittee of the American academy of neurology. *Neurology* 66(7):996–1002

## Parkinsonism

### Definition

Syndrome characterized by rigidity, tremor, and bradykinesia, of which Parkinson disease is the most common cause.

### ► Parkinson Disease

## Parosmia

### Definition

Distorted perception of smells in the presence of an odor source. Many patients not only suffer from quantitative olfactory dysfunction (anosmia, hyposmia), but also experience qualitative olfactory dysfunctions, classified under terms such as dysosmia or olfactory distortion.

These distortions can be roughly divided into parosmias (also called troposmia) and phantosmias with the major difference that distorted olfactory sensations are experienced in the presence (parosmia) or absence of an odor (phantosmia), respectively. Patients suffering from parosmia have distorted sensations of smell elicited by an odorant, therefore it is also called stimulated olfactory distortion. Parosmia is described as a qualitatively “wrong” perception of odors. For example, a patient may perceive the smell of rotten eggs whenever he takes a smell at roses. In most cases, the “wrong” smell is considered unpleasant. Parosmia is typically, but not always associated with quantitative olfactory loss (hyposmia). Parosmia mainly occurs in combination with post-traumatic or post-infectious olfactory loss. Rare causes of parosmia such

as brain tumors, side-effects of drugs, paraneoplastic syndromes, endocrine disorders, neurologic disorders, psychiatric disorders or intracerebral haemorrhage have been reported. Although the exact site of the generation of parosmia remains unknown, most parosmias are likely to be generated at the level of the olfactory epithelium and/or the olfactory bulb. On the other hand, parosmia may also be a problem of the central nervous system. Important clinically is the observation that most parosmic impressions tend to diminish over months and finally disappear after years.

- ▶ Olfactory Pathways
- ▶ Smell Disorders

## Paroxysmal Extreme Pain Disorder (PEPD)

### Definition

Previously referred to as familial rectal pain. The severe pain in PEPD patients along with redness in the lower body can start in infancy (and possibly in utero), and is induced by defecation or probing of the perianal areas, and is accompanied sometimes by tonic non-epileptic seizures, syncope, bradycardia and occasionally asystole.

Pain progresses with age to ocular and maxillary/mandibular areas and is triggered by cold, eating or emotional state. Pain episodes can last seconds to minutes (and hours in extreme cases), and gradually subside over minutes.

- ▶ Voltage-gated Sodium Channels: Multiple Roles in the Pathophysiology of Pain

## Paroxysmal Hemicrania (PH)

### Definition

Rare headache belonging to the group of ▶trigeminal autonomic cephalalgias and is characterized by severe, unilateral pain attacks localized to orbital, supraorbital, and temporal areas, lasting 2 to 30 minutes, and accompanied by ipsilateral ▶autonomic features.

- ▶ Headache

## Pars Tubualis

### Definition

An area of the pituitary stalk rich in melatonin receptors.

- ▶ Melatonin

## Partial Seizures (Focal Seizures)

### Definition

These seizures are characterized by focal motor or sensory symptoms indicating the location of brain lesions. For instance, aversive seizures characterized by deviation of eyes or head to one side indicate a focus in the opposite ▶prefrontal cortex. Focal (Jacksonian) motor seizures may result from localized lesions (injury or tumor) to the contralateral ▶primary motor cortex (M1) and may start as local rapid (clonic) contractions, often at a finger, great toe or mouth corner, and then spreading over the body with loss of consciousness (Jacksonian march).

- ▶ Jacksonian Motor Seizures
- ▶ Prefrontal cortex
- ▶ Primary Motor Cortex (M1)

## Parvocellular Cells

### Definition

Small cells located in two to four layers of the LGN of primates that have been proposed to be part of a pathway (the P pathway) from the retina to visual cortex concerned with detail and color vision.

- ▶ Evolution of the Visual System: Mammals – Color Vision and the Function of Parallel Visual Pathways in Primates

## Passband

### Definition

The frequency region in which the magnitudes of sound are not attenuated by a filter.

- ▶ Acoustics

## Passive Avoidance Learning

### Definition

Passive avoidance is a task in which animals avoid an aversive stimulus by inhibiting a previously punished response (compare with Active avoidance learning).

Behaviors that are more compatible with natural defensive responses to aversive stimuli (see SSDR in glossary) are more easily learned.

- ▶ Active Avoidance Learning
- ▶ Aversive Learning

## Patch Clamp

### Definition

Erwin Neher and Bert Sakmann developed the patch clamp in the late 1970s and early 1980s. They received the Nobel Prize in Physiology or Medicine in 1991 for this work. This electrophysiological method allows to record ion channels' activity in an individual cell using a glass electrode with an open tip diameter of about 1  $\mu\text{m}$ . There are three major configurations of this method. The "cell attached" mode (the glass pipette is tightly sealed on the cell membrane), the "excised configuration" (the patch of membrane isolated by the pipette is removed from the cell) and the "whole cell" configuration (the membrane under the pipette is broken, providing an access to the intracellular space of the cell). The "cell attached" and the "excised" configurations allow recording the activity of individual ion channels embedded in the patch of membrane isolated by the glass pipette. The "whole cell" configuration allows to record global electrical activity passing through the entire cell membrane. This technique can be used in the "voltage clamp" mode, keeping the voltage constant in order to see changes in the current. Conversely, it can be used in the "current clamp" mode, in order to see changes in the voltage.

- ▶ Intracellular Recording

## Path Integration

### Definition

A process of estimating one's own position in space by integrating (vectorially summing) the distances and

directions covered by previous self-movement (idiothetic inputs). This is also known as dead reckoning. The composite vector points from the start position to the current position. There are two forms of path integration: path integration with a map and path integration without a map. When path integration is used with a map it can be used to update the traveler's location on the map. Therefore, it is an important contributor to mapping. When path integration is used without a map it can only be used for returning to a start location, or "homing". This is done by the simple process computing the outbound vector from a start (home) location, inverting the composite vector and following the inverted vector. Homing by means of path integration has been shown in insects (ants) and rodents.

- ▶ Optic Flow
- ▶ Spatial Learning/Memory

## Pathology

### Definition

Pathology literally is the study of pathos (disease, suffering). Traditionally, pathology is a morphologic study of histological abnormalities detected by microscopic examination. More recently, pathology uses molecular, microbiological, and immunological techniques.

Pathology also means a condition produced by disease.

## Pause Neurons (pns)

- ▶ Omnipause Neurons

## Paw Preference

### Definition

Preference of paw in taking food.

- ▶ Nervous, Immune and Hemopoietic Systems: Functional Asymmetry

## Pax Genes

NORIKO OSUMI

Division of Developmental Neuroscience, CTAAR,  
Tohoku University School of Medicine, Sendai, Japan

### Definition

*Pax* genes are originally identified as homologs structurally related to the *Drosophila* pair-rule gene, *paired*, which encodes a ►transcription factor [1]. There are nine members in the *Pax* gene family, which are categorized into four subclasses (Fig. 1) [2,3].

All members have a DNA-binding paired domain (PD) together with or without an octapeptide (OP), and the members except Pax1 and Pax9 have another DNA-binding homeodomain (HD). Group 1 (Pax1, Pax9) have only PD and OP, Group 2 (Pax2, Pax5, Pax8) have PD, OP, and incomplete HD, Group 3 (Pax3, Pax7) have PD, OP, and complete HD, and Group 4 (Pax4, Pax6) have PD and complete HD. PD consists of 6 alpha-helices, and is divided into two subdomains (N-terminal PAI domain and C-terminal RED domain), each recognizing distinct half-sites of the bipartite binding site in adjacent major grooves of the DNA helix [4].

### Characteristics









Expression patterns of each *Pax* gene are highly region-specific, and observed in ►CNS, ►PNS, and various

ectodermal, mesodermal, and endodermal tissues. The importance of the *Pax* family in organogenesis can be assumed from various congenital diseases and cancers related to mutations of *Pax* genes and down- or up-regulation of *Pax* gene expressions [5]. Interestingly, there are spontaneous mouse mutants for *Pax1* (*undulated*), *Pax3* (*Splotch*), and *Pax6* (*Small eye*), which is quite in contrast with other transcriptional factors that are crucial in organogenesis. Since *Pax1* and *Pax9* are predominantly expressed in mesodermal tissues, and *Pax4* is more important in pancreatic development, the other members of the *Pax* family are taken into consideration here.

### Pax2/5/8

Pax2, Pax5, and Pax8 are structurally close and work similarly. Pax5 is originally identified as BSAP (B-cell specific activator protein) that is essential for development of B-lymphocytes. Pax2/5/8 expressed in the boundary region between the midbrain and hindbrain (midbrain/hindbrain boundary: MHB; (Fig. 2a), and important in establishment of MHB that works as an organizer for brain patterning [6].

*In ovo* mis-expression of Pax2 and Pax5 by electroporation in chick embryos can change the fate of presumptive diencephalons to the tectum. Expression of Pax2, Pax5, En, Wnt1, and Fgf8 consists of a feedback loop at the MHB in formation of the optic tectum in the midbrain and of the cerebellum in the hindbrain. Similar machineries are also work in the formation of MHB in mammalian embryos, which is shown by the phenotype

Group	Pax genes	Basic structure			Localization		Mouse mutant		Human syndrome
		PD	OP	HD	Mouse	Human	Natural	Targeted	
Group 1	<i>Pax1</i>				2	20p11	<i>Undulated</i>		Spina bifida (?)
	<i>Pax9</i>				12	14q12-q13			
Group 2	<i>Pax2</i>				19	10q25	<i>1Neu Pax2</i>	Yes	Renal coloboma
	<i>Pax5</i>				2	2q12-q14			
	<i>Pax8</i>				4	9p13		Yes	
Group 3	<i>Pax3</i>				1	2q35	<i>Splotch</i>		Waardenburg syndrome I, III
	<i>Pax7</i>				4	1p36.2		Yes	
Group 4	<i>Pax4</i>				6	7q32		Yes	
	<i>Pax6</i>				2	11p13	<i>Small eye</i>	Yes	Aniridia Peters anomaly

**Pax Genes. Figure 1** Structures and genomic positions of *Pax* genes. *Pax1-9* genes are categorized into four groups from their molecular structures. Natural mutations of *Pax* genes in the mouse and human diseases are also shown. PD paired domain; OP octapeptide; HD homeodomain.

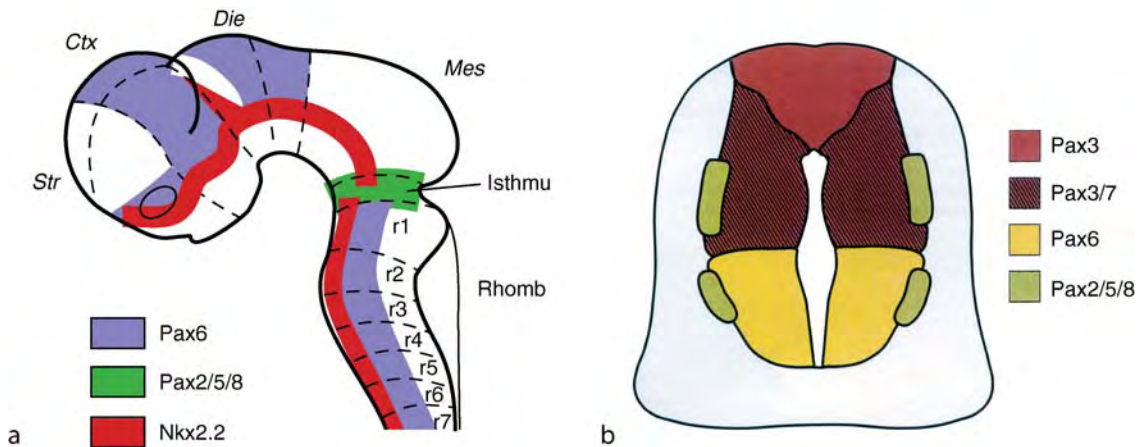

**Pax Genes. Figure 2** Expression patterns of *Pax* genes in the early neural tube. Schematic illustration of the lateral (a) and transverse (b) views showing region specific expression of *Pax* genes. (b) is taken from ref. [1]. Ctx cerebral cortex; Str striatum; Die diencephalon; Mes mesencephalon; r1-7 rhombomere 1-7.

of knockout mice of the genes. Pax2 and Pax5 are also expressed in the specific dorsoventral region of the developing neural tube (Fig. 2b) [7], and may be involved in specification of interneurons. Pax2 also works to establish the forebrain/midbrain boundary through interaction with Pax6 (see below). Mutation in *Pax2* is reported to be related to a kidney disease, renal coloboma.

### Pax3/7

Pax3 and Pax7 are structurally close and work similarly. Pax3/7 is expressed in the dorsal region of the developing neural tube (Fig. 2b) [1] and the dermomyotome, an embryonic primordium of the muscle and dermis. Electroporated Pax3/7 forces the midbrain to differentiate into the tectum in chick embryos. Spontaneous mutant *Splotch* (*Sp*) mice have mutations in *Pax3* and show abnormalities in development of tissues originated from the neural crest that is formed at the most dorsal part of the neural tube. Heterozygous *Sp*<sup>+/+</sup> mice show white spots in the abdomen, legs, and tail, which is due to abnormal development of melanocytes derived from the neural crest. Homozygous *Sp/Sp* mice show spina bifida (separated spinal bones), exencephaly (open brain), reduced or loss of dorsal root ganglia, and hypoplastic leg muscles [1-3]. Pax7 is expressed in neuronal cells of the optic tectum/superior colliculus. Neurons expressing Pax7 migrate towards the pia and concentrate in the stratum griseum superficiale, the target site for retinal axons.

In humans, patients of Waardenburg syndrome type 1 show mutation at 2q37, and those of type 3 show deletion in 2q35-37 covering *PAX3* gene [5]; both sets of patients suffer from hearing loss and abnormal skin color. The hearing loss of Waardenburg patients is thought to be caused by abnormal migration of neural crest cells into the otic primordium from the similar

phenotype seen in *Sp*<sup>+/+</sup> mice. Involvement of *Pax3* and *Pax7* in cancer is also reported [5]. For example, alveolar rhabdomyosarcoma is caused by translocation of chromosomes including *PAX3* or *PAX7*.

### Pax6

*PAX6/Pax6* gene is first isolated as a responsible gene for human congenital aniridia (lack of the iris in the eye) and mouse *Small eye* mutant [8], and more intensively studied than any other *Pax* genes. *Pax6* gene is highly conserved throughout the phylogeny, and related to development of the sense organs, eyes, brain, pancreas, and pituitary gland [1-3]. In the early eye primordium, Pax6 is strongly expressed in the head ectoderm that will form the lens and cornea, and in the optic cup that will form the neural and pigment retina. Later in development, Pax6 is expressed in prospective ganglion-cells and amacrine-cells, but not in photoreceptors. Pax6 also influences eye development through a non-cell autonomous manner by regulating migration of neural crest cells.

In the vertebrate CNS, Pax6 is expressed in the forebrain, hindbrain, and spinal cord from the earliest stage of brain development. *Small eye* mice and rats are spontaneous *Pax6* mutant strains, homozygotes which lack the eyes and nasal structures. They also exhibit severe malformation in various brain regions where *Pax6* is expressed, showing the importance of the gene in brain patterning, neuronal migration, and axon extension [9,10]. For example, mutual repression of Pax6 and Pax2 defines the boundary between the forebrain and midbrain, and that of Pax6 and Gsh2 in the telencephalon establishes the boundary between the cerebral cortex and the striatum. In the dorsal telencephalon, Pax6 and *Emx1* show gradient expression patterns in opposite directions, thereby patterning the

telencephalon along the anterior-posterior axis. In the hindbrain and spinal cord, Pax6 is essential in specification of the ventral neurons: *Pax6* homozygous mutant mouse and rat embryos lack the hypoglossal nerve (a somatic motor nerve of the XIIth cranial nerves) and En1-expressing interneurons. Pax6 is involved in navigation of certain neurons such as mitral cells in the olfactory bulb and olfactory cortex neurons, which is done by non-cell autonomous manners. *Pax6* homozygous mutant rats show defects in thalamocortical projection, which may include Neurogranin1 signaling pathways.

In the adult brain, Pax6 is expressed in neurons of the olfactory bulb, amygdala, thalamus, and cerebellum [7]. Since homozygous *Pax6* mutants die at birth and therefore cannot survive into the postnatal stage, the function of Pax6 in the adult brain remains largely unsolved. It has recently been shown that Pax6 is important in postnatal neurogenesis by maintaining neural stem/progenitor cells; Pax6 heterozygous rats show decreased cell proliferation in the hippocampus and subventricular zone of the lateral ventricle. Pax6 can also promote neuronal differentiation, so it is likely that Pax6 works multifunctionally in highly context-dependent manners.

Known target/downstream molecules for Pax6 transcription factor in CNS are a bHLH transcription factor Neurogenin2, cell adhesion molecules L1 and R-cadherin, a secreted factor Wnt7b, a fucosyltransferase FucT9, and a fatty acid binding protein Fabp7 (BLBP). It is of interest that FucT is involved in the synthesis of LewisX carbohydrate epitopes that are used as markers in blastocysts, hematopoietic stem cells, and neural stem cells, and that Fabp7/BLBP is a well-known marker of radial glia and works to maintain embryonic stem cells. For patterning the brain, mutual repression of Pax6 and other transcription factors such as Pax2 (forebrain/midbrain regionalization), Gsh2 (cortex/striatum regionalization), and Nkx2.2 (somatic motor precursor domain formation) delineates distinct brain regions.

Clinically, expression of *PAX6* is reported to be significantly reduced in glioblastoma, the most common primary malignant brain tumors, molecular mechanisms of which remain unsolved.

## References

1. Gruss P, Walther C (1992) Pax in development. *Cell* 69(5):719–722
2. Mansouri A, Stoykova A, Gross P (1994) *Pax* genes in development. *J Cell Sci Suppl* 18:35–42
3. Dahl E, Koseki H, Balling R (1997) *Pax* genes and organogenesis. *Bioessays* 19:755–765
4. Czerny T, Shaffner G, Busslinger M (1999) DNA sequence recognition by Pax proteins: bipartite structure of the paired domain and its binding site. *Genes Dev* 17(19):2048–2061

5. Chin N, Epstein JA (2002) Getting your Pax straight: Pax proteins in development and disease. *Trends Genet* 18(1):41–47
6. Nakamura H (2000) Regionalization of the optic tectum: combinations of gene expression that define the tectum. *Trends Neurosci* 24:32–39
7. Stoykova A, Gruss P (1994) Roles of *Pax*-genes in developing and adult brain as suggested by expression patterns. *J Neurosci* 14:1395–1412
8. Hanson I, Van Heyningen V (1995) Pax6: more than meets the eye. *Trends Genet* 11(7):268–272
9. Osumi N (2000) The role of Pax6 in brain patterning. *Tohoku J Exp Med* 193(3):163–174
10. Manuel M, Price DJ (2005) Role of Pax6 in forebrain regionalization. *Brain Res Bull* 66(4–6):387–393

## PC Afferents

### Definition

Rapidly adapting mechanoreceptive afferents (also called fast adapting type II) with large receptive fields, ending in relation to Pacinian corpuscles (PC).

- ▶ Pacinian Corpuscle
- ▶ Vibration Sense

## PCD

- ▶ Programmed Cell Death

## PDZ Domain

### Definition

PDZ domain is a structural domain of 80–90 aminoacids found in signaling proteins, which provides structural integrity to protein signaling complexes and helps anchor transmembrane proteins to the actin cytoskeleton. There are approximately 200 PDZ containing proteins in the human genome.

## PEA3

### Definition

A member of the ETS class of DNA-binding transcription factors. EPEA3 is phosphorylated and activated by Ras via MAP kinase signaling pathways and regulates the expression of several genes in a variety of cell types.

► Neurotrophic Factors in Nerve Regeneration

## Pediatric Pain

► Pain in Children

## Pedophilic Perpetrators

### Definition

Men who abuse children sexually for different reasons.

► Forensic Neuropsychiatry

## Pedunculopontine Tegmental Nucleus

### Synonyms

► Nucl tegmentalis pedunculopontinus (Ch.5)

### Definition

An important nucleus from the cholinergic cell group of the lateral reticular formation. It has two parts:

- Pedunculopontine tegmental nucleus, compact part
- Pedunculopontine tegmental nucleus, diffus part

## Pedunculopontine Tegmental Nucleus, Compact Part

### Synonyms

► Nucl tegmentalis pedunculopontinus; Pars compacta

### Definition

This densely packed part of the pedunculopontine tegmental nucleus lies in the caudo-lateral Mesencephalon and has reciprocal connections with the motor centers and the limbic system. Efferents go to the spinal cord. Electrical stimulation of this area causes coordinated locomotion (“mesencephalic locomotor region”) in decerebrated animals.

► Mesencephalon

## Pedunculopontine Tegmental Nucleus, Diffuse Part

### Synonyms

► Nucl tegmentalis pedunculopontinus; Pars dissipata;  
► Pedunculopontine tegmental nucleus; Dissipated part

### Definition

In addition to the pedunculopontine tegmental nucleus, compact part, the pedunculopontine tegmental nucleus also contains a cholinergic region with loosely arranged cell bodies. But their function is not clear unlike that of the locomotor tasks of the compact part.

► Mesencephalon

## Pelvic Afferents

► Visceral Afferents

## Pelvic Floor

### Definition

The pelvic organs are supported by striated muscles (levator ani and coccygeus) and connective tissue that close the caudal end of the abdomen spanning the space between the pubic bones anteriorly, the ischial spines laterally and the sacrum posteriorly.

► Micturition

## Pelvic Nerve

### Definition

The pelvic nerve connects the pelvic viscera (urinary bladder, urethra, distal bowel, vagina, uterine cervix) with the sacral S2-S4 (and in some species the lower lumbar) segments of the spinal cord. The nerve contains efferent autonomic neurons (mainly parasympathetic, but not entirely so), and also afferent nerves that convey sensory information to the central nervous system. It is responsible for the neural control of the hindgut, bladder and reproductive organs.

- ▶ Micturition
- ▶ Neurogenic Control
- ▶ Neurophysiology of Sexual Spinal Reflexes
- ▶ Visceral Afferents

## Pendular Nystagmus

### Definition

Nystagmus with a quasi-sinusoidal waveform (as opposed to “saw tooth” or “jerk” nystagmus in which there is alternation of slow and fast phases of nystagmus).

- ▶ Central Vestibular Disorders
- ▶ Nystagmus

## Penetrance in Inheritance

### Definition

In dominantly inherited disorders, penetrance refers to the proportion of persons with a mutation who show clinical symptoms. Complete penetrance refers to a situation where symptoms are present in everyone who has the mutation, and incomplete penetrance refers to a situation where symptoms are not always present in those with the mutation.

## Penumbra

### Definition

The marginally perfused area in the brain that surrounds the most deeply infarcted area during an ischemic stroke. This tissue is still viable if adequate perfusion can be maintained or restored.

- ▶ Ischemic Stroke
- ▶ Stroke

## PEPD

### Definition

- ▶ Paroxysmal Extreme Pain Disorder

## Percept

### Definition

The conscious experience of a sensory stimulus. The percept reflects stimulation of the sensory system (e.g. eye, ear, skin), but is also determined by higher-level cognitive processes (e.g. attention, memory).

- ▶ Perception

## Perception in Vision

DIRK KERZEL

Faculté de Psychologie et des Sciences de l'Éducation,  
Université de Genève, Genève, Switzerland

### Definition

Perception is the conscious experience of sensory stimulation. The perceptual process begins with the transformation of the external stimulus energy into the firing of neurons. The sensory signals originating in the sense organs are analyzed into different perceptual attributes such as pitch, color, form, or motion.



What is perceived depends not only on the raw sensory signal, but also on higher-level cognitive processes such as attention and memory. These processes are not always conscious, and they organize and interpret the information coming from the eyes (vision), ears (audition), nose (olfaction), tongue (taste), skin (tactile sense), and inner ears (vestibular senses). As a result, we perceive meaningful objects and events that are defined in both space and time. The perceptual process is very different from a mere image taken by a camera because objects and events are recognized and thereby linked to previously acquired knowledge stored in memory.

### Characteristics

Perception is our mind's window on the world. It enables us to create mental representations of objects (flowers, cars, etc.) or events (walks in a park, accidents, etc.), and enables us to interact with objects in the world. Vision is by far the most important sensory modality and this contribution is restricted to this modality. Nonetheless, most of the concepts presented here can be applied to other sensory modalities (audition, olfaction, taste, tactile and vestibular senses). The importance of vision is evident in the space allotted to it in the human neocortex: the primary visual cortex occupies about 15% of the neocortex, and more than 30 visual areas have been identified. Altogether, 60% of the human neocortex is involved in the processing of visual stimuli.

Intuitively, visual perception is a passive process; as soon as we open our eyes, we see the world around us. Another intuition about visual perception is that the basic units of visual perception are objects because we typically talk about objects (cars, flowers, etc.) when we report what we see. Both intuitions are wrong. Research in psychology and neurophysiology has shown that perception is a highly active process and that the attributes of an object such as its color or its movement are processed independently. The characteristic division of labor starts in the retina, and continues as visual

information is transmitted to the corpus geniculatum laterale (CGL) in the thalamus, and from there to the primary visual cortex. We will examine each of these stages in turn and show how complementary systems guarantee reliable perception under different conditions and for different purposes.

Light enters the eye through a small aperture, the pupil, and passes through the cornea and the lens before it reaches the retina (see Fig. 1).

Cornea and lens bring the image that is projected onto the retina into focus [1]. While the cornea has a larger focusing power (42 diopters), only the lens' focusing power (about 18 diopters) can be adjusted to bring objects into focus. To this end, the ciliary muscles contract and the curvature of the lens increases, a process that is called accommodation. A high curvature of the lens is associated with high focusing power that is necessary to project a clear image of nearby objects on the fovea. Across the lifetime, the lens loses elasticity and its maximal curvature decreases. As a consequence, a clear image would be projected on a plane behind the retina, but what is captured by the retina is blurred. This condition is known as presbyopia ("old eye"). Similar blurred retinal images result when the eye ball is too long or too short such that the focusing power of the lens is too weak or too strong, respectively. All these impairments may be corrected by glasses that either focus and thereby increase the focusing power of the optical system or disperse the light and thereby decrease its focusing power.

To be treated in the nervous system, the stimulus energy has to be transformed into electrical signals of neurons. In the visual modality, the process of transduction is achieved by two types of receptors: rods and cones. They are hidden behind a transparent layer containing amacrine, horizontal, bipolar and ganglion cells. The ganglion cells transmit the neuronal signals originating in the receptors to subcortical centers. Their axons leave the eye through an aperture in the retina

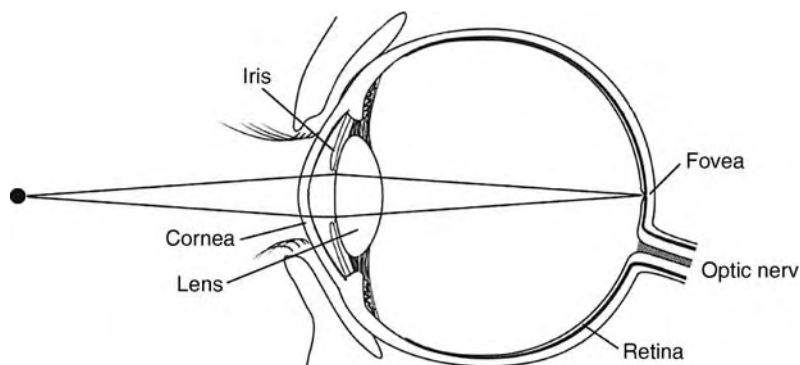

**Perception in Vision. Figure 1** A cross section of the human eye. The light passes through a small aperture (pupil) and is focused by the cornea and lens. The rays of light reach receptors in the retina that are hidden behind a translucent layer of cells (not shown).

devoid of receptors, the blind spot. Although no visual information is received in this region, we do not perceive a “hole” in our visual field when we close one eye. The visual system fills the void rather actively by extrapolating visual information from the neighboring retina.

Light entering the receptor engenders a biochemical cascade when hitting a photopigment contained in the receptor. The electrical potential of the receptor changes as a result of the cascade. This process is extremely sensitive: A single photon may change the potential of the receptor and light is perceived when only seven receptors are stimulated simultaneously. However, receptors respond only to electromagnetic energy at wavelengths between 400 and 700 nm. Small wavelengths evoke the color blue, medium wavelengths the colors green and yellow, and long wavelengths the color red. Wavelengths shorter (e.g. X-rays) than 400 or longer than 700 nm (e.g. radio waves) are not absorbed by the receptors.

The two receptor classes, rods and cones, have very different characteristics and involve different neural circuits. Rods are larger than cones and contain a photopigment that responds best to light at a wavelength of 500 nm. That is, light of this wavelength evokes a response more easily than light with higher or lower wavelengths. In contrast, cones may contain one of three different photopigments that differ in their preferred frequency: the short wave pigment (419 nm), the medium-wavelength pigment (531 nm) and the long wavelength pigment (558 nm). Taken together, the three cone types respond best to a wavelength of 560 nm. The difference in the preferred wavelength of rods and cones is evident in the Purkinje phenomenon: The colors in the lower part of the spectrum seem brighter (e.g. green objects appear more salient) when seen under conditions where rods are active compared to conditions where cones are active.

Rods enable us to see at low light intensities, but do not contribute to our visual experience in the daylight. The rod's high sensibility is achieved by summing up signals across a large number of neighboring rods. While this strategy makes the system more sensitive, it produces a loss in spatial resolution. The activity of neighboring receptors cannot be discriminated and we only see blurred outlines in the dark. Also, the rod system cannot discriminate between different wavelengths and is therefore color-blind.

Cones are active during the daylight and do not contribute to nocturnal vision. They show far less summation across space than rods and thereby allow for the discrimination of spatial detail. Because the three types of cone receptors have different spectral sensitivities, they are differently activated by the incoming light. For instance, a monochrome yellow light of 575 nm will activate the long wavelength cone more than the medium and short-wavelength cones. The pattern of

activation of the three receptors is the basis for color vision and any physical stimulus that produces the same pattern of activity in the receptors will be perceived as equal (a so-called metamer color). For instance, a blend of medium and long wavelength is also perceived as yellow. If one of the cone types is missing due to a genetic deficiency, color vision is abnormal. Dichromats are predominantly male because the deficient gene is on the X-chromosome. They cannot discriminate between red and green and their color perception is limited to a continuum from blue to yellow or from blue to red, depending on the missing cone type.

The distribution of rods and cones across the retina is not uniform. While most of the retina contains both rods and cones, there is a small area located on the line of sight, referred to as fovea, which contains only cones. Few of the foveal cones (as few as one) converge on one ganglion cell and the density of cones and ganglion cells is higher than in the periphery. Therefore, the fovea is the retinal area with the highest spatial resolution (acuity). Most of what we consciously perceive is being projected on the fovea, in part because of the disproportionately large cortical representation of the fovea with respect to the rest of the retina. The cortical magnification of the fovea is due to the high density of ganglion cells in the fovea and to a larger cortical representation of ganglion cells projecting from the fovea.

The projections from the fovea to the cortex are highly ordered [2]. Adjacent locations on the retina will also be represented in adjacent locations in V1, a principle that is referred to as retinotopy. Cells in V1 combine the circular receptive fields of ganglion cells to form elongated receptive fields. The receptive field of a neuron refers to the area on the receptor surface from where the neuron receives information. While ganglion cells are maximally stimulated by small points of light, cells in V1 respond best to lines or bars. Cells in V1 have been classified according to their preferred stimulus. Simple cells in V1 respond best to bars of a certain orientation. Complex cells respond to oriented bars moving in a certain direction. End-stopped cells are selective to oriented bars of a certain length moving in a certain direction. Another characteristic of V1 is its organization into columns that share common processing characteristics. Location columns comprise neurons that respond to one particular location of the retina. Within such a location column, each eye is represented by two ocular dominance columns with neurons responding preferably to stimulation of the left or right eye. Finally, each ocular dominance column is composed of a complete set of orientation columns covering vertical to horizontal orientations. Neurons in an orientation column respond best to lines at a certain orientation.

While we do not directly perceive the representation of the stimulus in V1, V1 is necessary for conscious perception. Lesions of V1 lead to blindness in the

affected region. While this deficit, referred to as scotoma, eliminates conscious perception of stimuli presented in the respective visual area, it may not completely eliminate perceptual processing of those stimuli [3]. If patients who deny conscious perception of stimuli presented in the scotoma are forced to respond to these stimuli, their responses may show some residual sensitivity. For instance, they may be able to point to a stimulus presented in the scotoma with above chance (but far from perfect) performance. Even if cortical stimulus processing is precluded in this condition, retinal projections to a subcortical center in the midbrain are still intact. About 10% of the projections from the retina go to the superior colliculus, a structure that is also implied in the control of eye movements. Subcortical processing via this route may enable us to localize an object while circumventing consciousness.

From V1, visual processing in the cortex continues along two major pathways: A ventral pathway from V1 to the inferotemporal cortex and a dorsal pathway from V1 to the posterior parietal cortex (see Fig. 2).

Even if there is considerable crosstalk between the two pathways, they show important functional specialization. The dorsal pathway is responsible for determining an object's location ("where" pathway), while the ventral pathway is responsible for determining an object's identity ("what" pathway). More recently, the dorsal pathway has been characterized as action pathway ("how" pathway) because it determines how a motor action is being carried out [4]. Obviously, information about where an object is located in space is crucial for successful motor interaction with it. A case study provided neuropsychological evidence for the distinction of "what" and "how." Patient DF suffered from damage to her ventral pathway after carbon monoxide poisoning. She was unable to identify simple geometrical forms or

to name objects, a condition known as visual form agnosia. For instance, she could not identify a screwdriver or describe the orientation of a slot. However, her actions toward these objects were unimpaired and she could place a card in the slot which cannot be done without information about its orientation. Presumably, information about the slot's orientation was available in the dorsal pathway that guided her actions, but not in the ventral pathway where conscious recognition of the object would usually take place. Conversely, patients with lesions in the posterior parietal area often show impairments in the visual guidance of actions, while object recognition is unimpaired.

The broad distinction between two visual pathways was further refined by the identification of cortical modules. Modules are cortical areas specialized in the processing of a particular perceptual dimension, such as form (see above), color, or motion in the visual modality. Damage to such a module results in an inability to perceive the respective dimension appropriately; a condition referred to as agnosia [5]. For instance, lesions of V4 make the perception of color difficult and patients perceive the world in shades of gray even if their cone system (see above) is intact. Lesions of V5 make the perception of motion impossible. In one such patient, moving objects appeared as static images in separate positions with no transitions between these positions. Thus, the patient was unable to pour a liquid into a glass because the liquid seemed to be frozen. Also, her interaction with other people was disturbed because she could not follow the movements of her interlocutor's mouth.

After demonstrating the modular, analytic processing of visual information, the intuitive unity of objects mentioned at the beginning requires further explanation. How can we perceive objects as basic units given that the brain analyzes objects into their component attributes? According to feature integration theory, the binding of attributes belonging to one and the same object requires attention [6]. That is, visual focal attention "glues" together the various properties of an object that are processed in a distributed manner in various modules. The role of attention has been studied using a paradigm referred to as visual search. In a typical trial, the observer is asked to look for a target, for instance a blue circle (features "blue" and "round"), and to indicate its absence or presence by a key press. The target is accompanied by a number of distractors. If the target can be discriminated from the distractors on the basis of a single attribute, the search is effortless and the target is readily detected even in a large set of distractors. For instance, the blue circle is easily seen among red circles. In this case, attention is not necessary to tie together the form and shape of the objects because the work of the color module is sufficient to signal the presence of the target. In this condition, the blue target is "salient" and will "pop out"

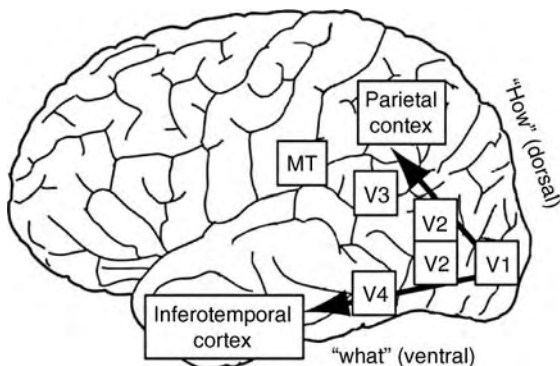

**Perception in Vision. Figure 2** Pathways from V1, in the occipital lobes, to the temporal and parietal cortices. The dorsal pathway from V1 to the posterior parietal cortex is important for object localization and action control. The ventral pathway from V1 to the inferotemporal cortex is important for object recognition.

from the red distractors. If, however, a conjunction of attributes has to be detected, the search is more effortful. For example, it is more difficult to detect a blue circle among blue squares and red circles. According to the feature integration theory, the observer has to scan one object after another and focus attention on each individual object to determine whether the required conjunction is present. The work of a single module is not sufficient (color and form is important), such that serial, attention-demanding integration of attributes is necessary. Consequently, reaction times in a conjunction search increase with the number of distractors.

There is general consensus that attention is necessary for conscious perception to occur. In a phenomenon called “inattention blindness,” observers fail to detect large changes in a picture if their attention is diverted by a secondary task [7]. For instance, observers may fail to notice a black gorilla walking through a scene if they are asked to count the passes of a team dressed in white playing against a team dressed in black. Even if the gorilla was clearly processed at the sensory level, it failed to be consciously perceived because the observer was focusing on white elements in the scene. Thus, both high-level cognitive and low-level sensory processes determine our visual world.

## References

1. Gregory RL (1997) *Eye and brain: The psychology of seeing*. Oxford University Press, Oxford, UK
2. Hubel DH, Wiesel TN (2005) *Brain and visual perception: the story of a 25-year collaboration*. Oxford University Press, Oxford, UK
3. Weiskrantz L (2004) Roots of blindsight. *Progr Brain Res* 144:229–241
4. Goodale MA, Milner D (2004) *Sight unseen*. Oxford University Press, Oxford, UK
5. Farah MJ (2004) *Visual agnosia*. MIT Press, Cambridge, MA
6. Treisman AM (1998) Feature binding, attention and object perception. *Philos Trans R Soc Lond B Biol sci* 353:1295–1306
7. Rensink RA (2002) Change detection. *Annu Rev Psychol* 53:245–277

---

## Perception, Philosophy

ALEXANDER STAUDACHER  
Otto-von-Guericke-Universitaet Magdeburg, Institut  
für Philosophie, Magdeburg, Germany

### Definition

In current philosophical debates on perception the term “perception” refers almost exclusively to sense

perception, although it can be used (like the French “perception” or the German “Wahrnehmung” as well) for the acquisition of knowledge in general. Commonly there are taken to be five senses: sight, hearing, smell, touch and taste. Discussions concentrate for the most part on the sense of sight, however. Although it was at one time argued that perceptual verbs like “to see,” “to hear” etc. don’t refer to a kind of mental state, episode or event, because they qualify certain observations as successful in the same vein as “to win” does not describe an event or episode but reports an achievement, it is common now to acknowledge the existence of perceptual states and to take perceptual verbs as referring to those states.

### Description of the Theory

One may distinguish in the philosophy of perception basically two kinds of different issues: the first issue concerns the question of how perception as a particular mental phenomenon is to be construed. The second issue concerns epistemological questions, that is, questions dealing with the role of perception in the acquisition of factual knowledge. Making such a distinction is not to deny that both issues are connected in many ways. Indeed, it seems obvious that satisfying answers to the epistemological questions presuppose that at least some questions concerning the first issue have been settled. The main focus of this article will lie, however, on the first issue. The following questions are of particular importance: How is the representational content (henceforth simply: content) of perceptual states to be understood? Mental states in general represent the world to be a certain way; they tell us how the world is in certain respects. In this sense my perception of the tree outside the window represents the world to be a certain way. Correspondingly, there can arise two cases of misrepresentation here, illusion and hallucination. Illusions are cases where something in perception appears to be different from the way it actually is (e.g. a dummy of a tree appearing as a tree). In hallucinations objects appear to be there where no such object is present at all (e.g. the rats hallucinated by a delirious alcoholic). Accordingly, the philosophy of perception not only has to specify the nature of perceptual content (including the question as to whether or not it is similar to the content of other mental states like belief or thought) but has to give also an adequate account of illusion and hallucination. Mental states and their contents are related in various ways to one another and to our actions: we entertain beliefs with certain contents (e.g. that it will rain soon) because we have other contentful mental states (e.g. we perceive a sky full of grey and heavy clouds, we believe this to be a reliable sign of coming rain etc.) and we will therefore act in a certain way (we take our umbrella with us) and so on. This leads to the question of how perceptual content is related to other mental content and to the further question of what

kind of structure it has to possess in order to be able to stand in these relations.

A further question concerning the nature of perceptual states is whether they can be exhaustively characterized by reference to their content. Perceptual states are often taken to be phenomenally conscious, that is, it is somehow for the perceiving subject to have them. They have a certain distinctive “feel” to them which distinguishes them from mere beliefs and thoughts. While seeing a tree I experience the colors of its leaves in a vividly conscious way which is lacking when I am merely thinking of these colors.

At a most general level one can divide theories of perception into two different classes which give different answers to the question what we have to take as the immediate objects of perceptual awareness. According to the one class we are immediately aware of the physical objects of perception, such as tables, trees, clouds and people etc. These objects are public in the sense that they can be perceived by more than one subject and they exist independently of whether someone perceives them. Furthermore, they change their properties neither when perceived under different perceptual conditions (e.g. varying perspectives or lighting-conditions) nor in the light of varying mental conditions of the perceiver which can influence her perceptions (e.g. expectations, drugs etc.). Theories belonging to the first class are generally called **▶direct realism**.

According to the other class we are immediately aware of “**▶sense data**.” An example of a sense datum is the more or less round, red, bulgy expanse you are immediately aware of when you are seeing a ripe tomato in normal daylight. A sense datum isn’t public in the sense that two subjects can be aware of it. Furthermore, it has been assumed that sense data cannot exist independently of our awareness of them and that they regularly change when the perceptual conditions or our mental preconditions change. If we look, for example, at the tomato under different lighting-conditions what we will be immediately aware of will be a sense datum of a different color than before. Furthermore, you will also be directly aware of sense data in cases where no physical object is present at all (hallucination) or where this object is different from the way it appears to you in perception (illusion) (see sense data).

Sense data theories have claimed that an adequate picture of our perceptual awareness in cases of hallucinations and illusions requires the assumption that we are in these cases immediately aware of sense data which instantiate the properties no physical object actually present has. Furthermore, they have tried to show that the immediate objects of our perceptual awareness in cases of veridical perception have to be sense data as well. The vividly experienced colors (felt temperatures

etc.) making up the phenomenal aspect of conscious perception can be seen according to these theories as properties of the sense data we are aware of. Concerning the question of how perceptions are related to other mental states sense data theories have traditionally assumed that perceptual states can be a secure fundament for all our empirical knowledge because we are immune against error as far as our sense data are concerned. These data will be as they appear to us. More recent defenses of sense data have put more emphasis on the role of these data in an adequate account of perceptual awareness; the epistemological presuppositions which gave rise to the search for a secure fundament of empirical knowledge have come into discredit in the last decades. There are basically two rival theories within this class, **▶indirect or representative realism** and a certain version of **▶phenomenalism**. According to **▶indirect realism** we have to distinguish between sense data and the mind-independent physical objects of the world surrounding us. Whereas we are in perception directly or immediately aware of sense data, our perceptual awareness of physical objects is only indirect in the following way: in the case of veridical perception the physical object is the cause of the sense datum; it is the first member of the causal chain that leads via the stimulation of our senses and the ensuing processes in the brain to the occurrence of the latter. Sometimes this causal account is supplemented with the claim that sense data function as natural signs for the physical objects they are caused by. In the case of hallucinations the causal chain won’t start with the physical object; in the case of illusions the physical object will play a causal role but the chain will be influenced by further factors. Historically, this account has also been strongly motivated by the claim that physical objects don’t possess the kind of properties they seem to possess according to our perceptions of them; meaning they are, e.g. neither colored in the way they appear to our eyes nor warm or cold in the way they feel to our hands, but possess only those properties physics must postulate in order to explain their causal interaction (including the interaction with our bodies). A theory of this kind can be traced back to the writings of René Descartes (1596–1650) and John Locke (1623–1704); for more recent defenses see [2].

Given that our perception of physical objects is indirect in that indicated way it seems that our knowledge of them is also indirect. We may either conclude that physical objects are the causes of our sense data or we just believe it to be that way, but are such beliefs or conclusions justified at all? According to one of the major objections to indirect realism the answer has to be negative and consequently indirect realism can’t be justified either because one of its central claims is that physical objects are often among the causes of our sense

data. According to this objection indirect realism cannot justify this claim because information about causal relationships has to be established empirically by the observation of cause and effect. But if indirect realism is right, the only available empirical information is our immediate perceptual awareness of our sense data. Therefore, the only information we can get will be about the effect but not about the cause. Consequently, indirect realism seems to undermine itself and to lead to skepticism concerning the existence of the physical world.

A typical indirect realist answer to this challenge is to use a strategy which is familiar in the philosophy of science when it comes to justifying the existence of unobservable scientific theoretical entities like molecules, atoms and so on. It is admitted that we have no empirical access to physical objects in the strict sense but it is held that we are nevertheless justified in claiming their existence, because this claim gives us the best explanation for the fact that the sequence of our sense data possesses the order and structure it actually does [2].

Phenomenalism can be traced back to central claims of the philosophy of George Berkeley (1685–1753); for a classical defense in the twentieth century see [1]. Roughly put, phenomenalism holds that physical objects can be identified with complex sequences of actual and possible sense data, and concludes that direct awareness of these comes down to direct awareness of physical objects. A tomato is then nothing but the complex sequence of sense data I have when I am actually looking at it or I would have if I took a different perspective of it or touched it and so on. If physical objects are nothing but sequences of actual or possible sense data a claim like “There exists a rock in the desert nobody has seen so far” has to be interpreted as the claim “If you go to a certain place in the desert you will enjoy sense data of a rock.”

It has been objected to phenomenalism that our talk about existing physical objects can't be replaced in that way by talk about actual and possible sense data. To be complete, the required interpretations would not only have to be of a kind of complexity no one has been able to arrive at so far (note, that these analyses would also have to comprise phrases like “you go to a certain place in the desert”), they seem to be at odds with the causal roles we ascribe to physical objects that no one perceives (think of the roots supporting the trunk of a tree); to be the cause of something requires that it actually exists. However, unperceived objects are according to phenomenalism only sequences of possible sense data a perceiver would have if he were in the right situation. More recent statements of phenomenalism have therefore tried to defend versions which don't require such interpretations [4].

Direct realism has been traced back to Aristotle (384–322 B.C.), Thomas Aquinas (c. 1224–1274), and

the Scottish common sense philosopher Thomas Reid (1710–1796), although these historical ascriptions are a matter of controversy. Direct realism comes in a variety of different forms, differing are mainly as to how the content of perceptual states is best to be construed.

According to the ► [belief-theory of perception](#), perceptions are a certain kinds of beliefs we acquire with the help of our sense organs (for more qualifications as to what special kind of beliefs perceptions are see [9]). Beliefs have propositional content, that is, content which can be specified with the help of a that-clause in which something is classified in a certain respect with the help of a concept (e.g. “Peter believes that grass is green”). The possession of concepts (“grass,” “green”) implies among other things at least the ability of the believer to recognize things as being able to under that concept. This proposal accords well with the fact that we often express the content of perceptions with the help of that-clauses and imply the possession of the relevant concepts by the perceiver when we say things like “Sarah sees that there is milk left in the fridge.” It can also explain how perceptions serve to justify other beliefs (Sarah's belief that she doesn't have to go the super-market now), because justification proceeds by inferences and inferential relations can be explained best by reference to a content with propositional structure.

Nevertheless, this account faces serious difficulties: Sometimes the content of our perceptions can't be equated with the contents of our beliefs: we may perceive the arrows of the well known Müller-Lyer figure to be of a different length, although we know quite well that they are in fact of the same length. Although we modify our beliefs in the light of new beliefs, our perceptions often aren't accessible to this kind of revision. Perception in contrast to beliefs seems to be, as it is called, “modular” (for more on modularity see [6]). With their equation of perception to belief and thought belief-theories have notorious difficulties in doing justice to the fact that perceptions are phenomenally conscious. In order to avoid the introduction of sense data at this point the so-called ► [adverbial theory of experience](#) has held that the phenomenal aspect of our sense experiences can be analyzed in the following way: a vivid conscious experience of something red (be it veridical or not) can be understood as a certain way of perceiving; that is, we are not conscious of something instantiating the property which is responsible for the character of our conscious experience (a sense datum), but our perceptual state itself is characterized by that property, in the case of an experience as of something red we “sense in a redly manner”, as it has been put [7]. It has been claimed, however, that this account cannot deal adequately with situations where we have an awareness of a manifold of different items with different colors and forms because this requires

being aware of different items instantiating these properties [2]. An alternative account that may be able to deal with the problems of the belief-theory is ►representationalism (not to be confounded with representative or indirect realism) [8]. Representationalism seems especially apt to avoid a third problem of the belief-theory, the fact that we can also perceive things without disposing of the relevant concepts; or, as it is often put, that perception can have nonconceptual content. We not only render the content of perceptions with the help of that-clauses, but by saying also things like “He sees the computer” or “He heard the Tristan-accord.” With statements like these we often don’t imply that the perceiving subject has to have the concept of a computer or of the Tristan-accord in order to see or hear these things (think of a baby or a dog as the perceiving subjects). According to representationalism we have non-conceptual perceptual representations of the items in question. The admission of the existence nonconceptual content leads to the question of how this kind of content is related to conceptual content and how it can play a role in the justification of our empirical beliefs. Here it has been argued that perceptual content can fulfill its role in the justification of empirical beliefs only if it is taken to be conceptual, which means that the representationalist claim concerning the nonconceptual character of our perceptual experience finally can’t be right [9]. Whether this objection is sound is a matter of ongoing discussions.

Representationalism also uses the idea that perceptions have nonconceptual content in order to explain the fact that perceptions are phenomenally conscious. To put it very roughly, phenomenally conscious states are conceived as nonconceptual representations which deliver information to the perceiver he which can use to form his beliefs and desires. These states acquire their nonconceptual content by being dependent in the right way on the features they represent (e.g. they are caused by them under optimal conditions; therefore the presence of red objects leads in general to perceptions of red). Because the typical phenomenal aspects of our sense experiences are experienced by the perceiver as features of the represented surroundings (e.g. in a conscious perception of the blue sky the blue is experienced as a feature of the sky), representationalism claims that perceptual states acquire their phenomenal character by being related in the right way to certain features of our surroundings: we represent the blue of the sky in a nonconceptual way. Whether such a conception of the nonconceptual content of perception can be used to explain the phenomenally conscious aspect of perception is, however, also a matter of controversy [1].

All positions considered so far share the presupposition that veridical perceptions and hallucinations have something in common. In both cases the perceiver

will either have sense data, or perceptual beliefs, or nonconceptual representations or states that can be characterized by an adverbial modification. There is, however with the so-called “►disjunctive account” of sense experience [10] a further variety of direct realism which puts this presupposition in question: according to this position a perceptual experience is either a perception or a hallucination (a disjunction of these two types of states), but these two types of states need not share a common element: perception implies that we are aware of physical objects and the content is just constituted by the perceived aspect of the physical object itself, hallucinations however don’t imply this because there is no such object present. In the case of hallucinations we simply take ourselves to perceive something although it isn’t the case.

One consequence of this position which might be hard to swallow is that it demands that we are in the case of hallucinations not only in error about the physical world but also about the conscious mental states we are in; we assume that we are perceiving while we aren’t. A second problem is that the disjunctive account has difficulties with the fact that hallucinations and veridical perceptions are the causal consequences of the same type of brain states; one may evoke a hallucination by a stimulation of those parts of the brain which are also activated in the case of veridical perception. However according to a widely held principle on causation the same kinds of causes lead to the same kind of effects. It seems, therefore, that the adherent of the disjunctive account has to give up this principle, because according to his account there is nothing in common between hallucinations and veridical perceptions eventhough they result from the same kind of brain stimulation (for further discussion see [4]).

## References

1. Maund B (2003) Perception. McGill-Queen’s University Press, Montreal
2. Jackson F (1977) Perception. A representative theory. Cambridge University Press, Cambridge
3. Ayer AJ (1940) The Foundations of empirical knowledge. Macmillan and Co., London
4. Robinson H (1994) Perception. Routledge, London
5. Pitcher G (1971) A theory of perception. Princeton University Press, Princeton
6. Fodor J (1983) The modularity of the mind. MIT Press, Cambridge/Mass
7. Chisholm R (1957) Perceiving: a philosophical study. Cornell University Press, Ithaca/NY
8. Tye M (1995) Ten problems of consciousness. MIT Press, Cambridge/Mass
9. McDowell J (1994) Mind and world. Harvard University Press, Cambridge/Mass
10. Haddock A, Macpherson F (ed.) (2007) Disjunctivism: Perception, Action, Knowledge. Oxford University Press, Oxford

## Perceptive Field

### Definition

Psychophysical counterpart of receptive field organization.

Term first introduced by Jung and Spillmann (1970) to link perceptual properties to neuronal function. Although psychophysical data represent the final stage of integration of the activity of numerous neurons, they typically resemble those obtained with single cell recordings (single neuron doctrine by Barlow 1972). Perceptive fields may thus be regarded as psychophysical equivalents of receptive fields with their various forms of center-surround antagonism and selective spatio-temporal sampling characteristics that allows for non-additive, Gestalt-like integration of the stimulus input.

► [Psychophysics](#)

## Perceptron

### Definition

The Perceptron was the first neurocomputer (artificial neural network) to be developed. The original Perceptron consisted of two layers of units (input and output layer) and used a simple learning rule for weight adjustment according to the difference of the network output and the target vector. It is capable of solving linearly separable problems. It can be proven that the network converges to a solution (i.e., reaches its error minimum) within a finite number of steps for any linearly separable problem. Multilayer Perceptrons with hidden (intermediate) layers of units are more powerful and can learn complex non-linearly separable problems.

► [Connectionism](#)  
 ► [Neural Networks](#)

## Perceptual Completion

► [Perceptual Filling-In](#)

## Perceptual Constancy (in Vision)

### Definition

The tendency of perceiving objects and scenes as being invariant in size, shape, lightness, color, etc., despite variation of sensory inputs originating in the same objects and scenes observed from varying viewing distance, at varying viewing angle, in varying illumination, etc.

► [Color Constancy](#)

## Perceptual Correlates

► [Visual Neuropsychology](#)

## Perceptual Discrimination

### Definition

Ability to distinguish between different levels of a perceptual dimension such as color, pitch, or pressure.

The perceptual dimension may map directly onto a physical dimension (e.g. the perceived length of a bar may also be measured) or may be created by the perceptual system (e.g. we perceive colors but the rays of light are not colored).

► [Perceptual Impairment](#)  
 ► [Perception](#)

## Perceptual Filling-In

IKUYA MURAKAMI  
 Department of Life Sciences, University of Tokyo,  
 Tokyo, Japan

### Synonyms

Perceptual completion

### Definition

Perceptual filling-in refers to the visual phenomenon in which a certain part of the ► [visual field](#) appears to be



overwhelmed or filled with the visual attributes, such as brightness, color, and texture, of the surrounding area. Filling-in connotes planar interpolation of surface properties; linear interpolation of contour and bar is often referred to as perceptual completion. Though filling-in at the ►blind spot has been studied most extensively, mechanisms of perceptual filling-in are considered to be rather ubiquitous in the normal visual field as well.

## Characteristics

### Phenomenal Variations

Since vision is a process of ecologically valid estimation of our outer world, our visual system has evolved so as to infer object properties from impoverished visual inputs on the ►retina. As a result, in a great variety of situations the brain assumes a surface to be filled with color and texture from outside, especially when retinal inputs to that surface part are unavailable or poor.

One of the most striking examples is filling-in at the blind spot, an oval-shaped area (approximately 5 degrees in diameter) defined for each eye, located at approximately 15 degrees horizontally from the center of the visual field. This area is insensitive to light stimulation because ►photoreceptors are totally absent at the corresponding retinal region (optic disc). Why does this visual deficit go unnoticed? As the blind spot of one eye is a normal field of view for the fellow eye, a complete visual scene is of course available with both eyes open. However, the visual world also seems as complete with only one eye open. Clearly, perceptual filling-in is constantly at work there. One can easily convince oneself of this phenomenon by looking at an annular shape fully covering the border of the blind spot (Fig. 1): the annulus appears to be a large solid disk uniformly filled with the color and texture of the figure.

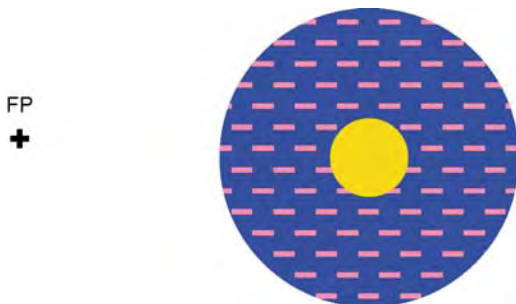

**Perceptual Filling-In. Figure 1** Perceptual filling-in at the blind spot. As the annulus covers the border of the blind spot of the right eye, the yellow inner disk perceptually disappears; the inside appears to be filled with the same color and texture as in the annulus. The reader can experience filling-in by looking straight at the fixation point labeled “FP” with only the right eye open, from an appropriate viewing distance.

Perceptual filling-in can also occur at a small deficit (►scotoma) of the visual field that arises for a few people from an acquired local damage to the retina (or other visual pathways). This might explain why patients with local ►retinal degenerations are sometimes unaware of their scotoma before they take ophthalmologic testing across the visual field. The monkey has also been shown to see perceptual filling-in both at the natural blind spot and at a scotoma caused by retinal damage [1].

Whereas perceptual filling-in at the blind spot and scotoma occurs in the region without visual inputs, filling-in also occurs in the region without visual-input *changes*. When an image is artificially stabilized on just the same part of the retina by using a special experimental device, this image is initially visible but soon fades away from one’s ►perception, filled-in with its background color. Normally, incessant ►fixational eye movements produce tiny wobbling of retinal images, preventing such perceptual fading of stationary things in everyday life. Nevertheless, by looking sideways at a faint or blurry stationary figure on a uniform background for a long time, one may experience similar image fading and filling-in with background color (►Troxler effect). Likewise, when one looks sideways at a stationary surface stimulus on a background of randomly twinkling texture, this surface gradually disappears from perception, filled-in with similar random twinkles of texture (►artificial scotoma) [2].

Other phenomena of perceptual filling-in in normal observations include the ►Craik-O’Brien-Cornsweet effect (Fig. 2a) and the ►watercolor illusion (Fig. 2b).

In these illusions, different surface parts physically share identical luminance and chromaticity, but they are perceived to have different colors when there are sharp ►contrasts of luminance and chromaticity at the very boundary [3]. In these cases, clear physical edges delineate one area to fill-in with one color and another area with another color. Interestingly, however, perceptual filling-in of surface can also be bounded by contours that are perceptually completed themselves (Fig. 2c). In a figure designed to induce an ►illusory contour, the color of certain parts of the figure perceptually fills-in the inside of the subjective square of the illusory contour but not beyond (►neon-color spreading effect). Altogether, these phenomena may be viewed as examples demonstrating that the visual system infers surface properties of featureless areas by using conspicuous cues nearby.

## Models

How are such ►percepts of filling-in accomplished? To the extent that the phenomenal variety is diverse, there may exist as many theories for the mechanisms underlying them. Of these, three influential ideas have been proposed for perceptual filling-in at the blind spot and other poor regions [4].

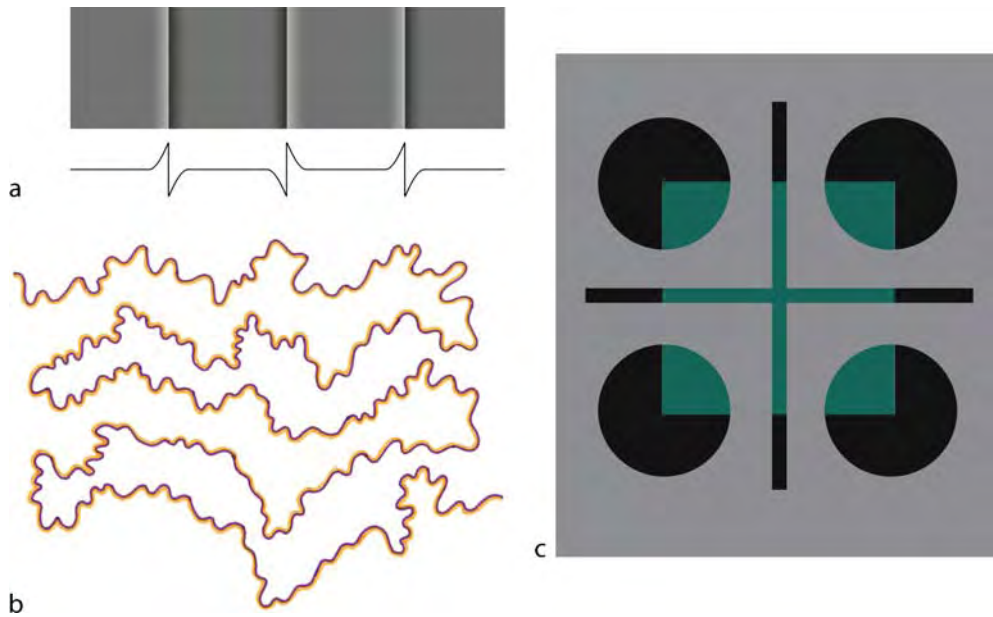

**Perceptual Filling-In. Figure 2** Various filling-in phenomena. (a) The Craik-O'Brien-Cornsweet effect. The inset indicates luminance as a function of horizontal position. The area just to the left of the central edge appears uniformly darker than adjacent areas, although the luminance changes are confined within the borders between areas. (b) Watercolor illusion. The two areas delineated by the wiggly borders appear to be filled uniformly with faint yellowish and bluish colors, although the color changes are confined within the borders, with the remaining areas left achromatic, in reality. Adapted from [3], with kind permission from the author. (c), Neon-color spreading effect. A square-shaped illusory contour is formed by the black inducers, and a bluish translucent color appears to be spreading inside the subjective square seen in front.

1. *Isomorphism.* When perceptual filling-in occurs, a two-dimensional neural map (or [▶visual topography](#)) representing that location of the visual field is actually activated as such, so that individual neurons within that map are actually excited in some fashion parallel with perceived surface properties.
2. *Symbolic Labeling.* Attributes inside a poor region can be cognitively designated by symbolic or logical operations using reliable information nearby, without invoking isomorphic activation – the brain is not “filling in but finding out” the missing surface properties.
3. *Ignorance.* One does not see a black hole of the blind spot simply because one is only aware of visual events that are abundant in the surround and “ignores the absence.”

Some recent findings have been more or less in favor of isomorphism, as we will see below, although labeling and ignorance may operate at crucial processing stages for one’s [▶conscious perception](#) and [▶awareness](#).

### Neurophysiological Studies

In the brain, visual signals from the retina are registered in visual topography, or a two-dimensional map of neurons topographically representing the visual field.

Are the neural representations of the blind spot and scotoma on this topography really activated when perceptual filling-in occurs? Physiologists are still on their way to solving this important question.

Perhaps the simplest way of neural activation would be to distort the map itself (often called the “[▶sewn-up](#)” model). The representation of the blind spot could “see” its surroundings if it received direct innervations from retinal portions surrounding the blind spot. However, current studies of functional anatomy have indicated quite orderly mapping from retina to [▶striate cortex](#) without distortion at the blind spot, and at the scotoma as well [5]. Nonetheless, some [▶single-unit recording](#) studies have suggested re-mapping of visual topography of a scotoma [6]. This scotoma was induced in an animal by producing small local lesions in the retinae. After the damage, cortical neurons that had originally coded positions inside the scotoma expanded and shifted their [▶receptive fields](#) towards the outside – as if they abandoned the damaged part and started to look out. Thus, some [▶cortical plasticity](#) might be initiated in certain conditions for adaptive compensation for retinal damage.

Besides the feedforward mapping, there are at least a couple of hypothetical schemes to make neural filling-in possible in early visual cortex. The first is lateral

propagation of visual signals into the cortical representation of the blind-spot region via horizontal connections. The second is feedback from ► [extrastriate visual cortex](#) back to early visual cortex. Yet another scenario would be that the neural correlate of filling-in resides not in early visual cortex containing neurons with tiny receptive fields, but in higher cortical areas where neurons have larger receptive fields covering the blind spot and beyond. More research is needed to determine which is the case.

A few attempts have been made to seek activities of individual neurons that parallel the filling-in phenomenon. One of the most recent findings is about the neuronal activity in striate cortex (► [primary visual cortex](#), ► [V1](#)) of a behaving monkey (Fig. 3) [7].

These neurons had receptive fields largely overlapping the blind spot of one eye, i.e., with the other eye open, the neurons were excited by visual stimuli presented in these fields. The blind-spot eye only was open. A small bar stimulus (labeled *b*) on one side of the blind spot fell onto the tip of the receptive field, and thus caused mild firing responses as expected. Interestingly, responses increased when another bar stimulus (labeled *c*) was added on the other side, so as

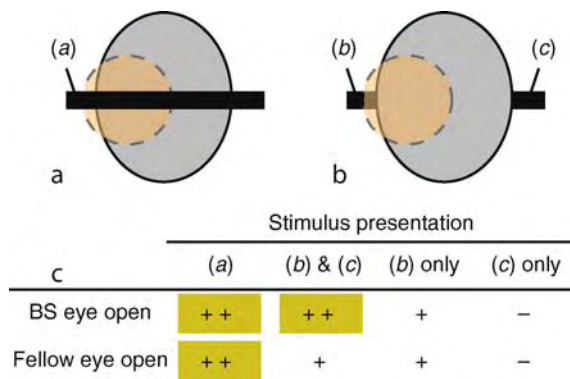

**Perceptual Filling-In. Figure 3** Perceptual completion at the blind spot and neuronal responses [7].

(a) Schematic illustration of the stimulus. The receptive field (*broken circle*) of the recorded neuron partially overlapped the blind spot (*solid oval*). A horizontal bar (*a*) was presented such that it should penetrate both the receptive field and the blind spot. (b) In other cases, the retinal input was confined within a small sub-region (*b* and/or *c*). (c) Schematic diagram illustrating increased activities during perceptual filling-in. The neuronal responses were recorded during four types of stimulus presentations while either the blind-spot eye (BS eye) only or the fellow eye only was opened. The symbols “++,” “+,” and “-” indicate strong, weak, and no responses, respectively. The *yellow boxes* indicate the viewing conditions in which the monkey would perceive a long bar across the blind spot.

to induce perceptual completion of a single bar across. The second bar stimulus per se did not cover the receptive field, but the perceptually completed bar did. In contrast, such a response increase was not observed with the fellow eye only open. Therefore, these neurons fired vigorously when the filled-in bar coincided with their receptive fields inside the blind spot.

The neural correlate of the “artificial scotoma” (see above) has also been investigated in the awake monkey [8]. A static, gray square was located to cover the receptive field of the recorded neuron, and the background was filled with twinkling random noise (Fig. 4a). Over prolonged observation, the static square was perceptually replaced with twinkling noise at some time. The firing activities of neurons in a higher visual area, ► [V3](#), were initially weak but became stronger just at the time this “artificial scotoma” would be perceptually filled-in with noise (Fig. 4b).

These findings seem consistent with isomorphic activations in the two-dimensional cortical map of the visual field during perceptual filling-in. Meanwhile, other studies indicate mixed results among different types of neurons, cortical areas, methodologies, and types of filling-in phenomena. At present, many important questions yet remain to be answered: what kinds of isomorphic activations of visual neurons are necessary and sufficient, how these could be implemented in a biologically feasible manner, and whether only one kind of architecture is enough for all kinds of filling-in to occur.

### Perceptual Studies

Other lines of evidence for explicit representations corresponding to perceptual filling-in come from ► [psychophysics](#) of ► [visual illusions](#). In one such study, a phenomenon of ► [motion aftereffect](#) was used (Fig. 5) [9].

After prolonged viewing of a moving stimulus, a static stimulus presented at the adapted location appears to move in the opposite direction, and this effect is known to transfer between eyes if different eyes are used in adaptation and subsequent test. The observer was adapted to a moving stimulus covering the blind spot of one eye and thus perceptually filling-in the inside of it. Later, the stimulus was abruptly switched to a smaller static stimulus well inside the blind spot of the adapted eye, but as it was now given to the fellow eye, the observer could see it. It was perceived to move in the opposite direction to the adapting stimulus, thus the motion aftereffect was elicited after adaptation to motion filling-in inside the blind spot without direct stimulation. This finding suggests that filled-in motion and actual motion share a common pathway.

Another observation of brightness filling-in suggests topographic representation (Fig. 6) [10]. Presented on a white background was a uniformly lit disk-shaped figure, whose luminance decreased continuously from white

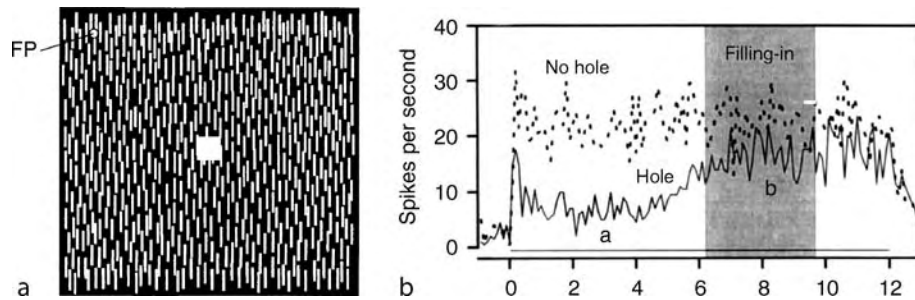

**Perceptual Filling-In. Figure 4** “Artificial scotoma” and neuronal responses [8]. (a) Schematic illustration of the stimulus, which consisted of randomly positioned bars and a gray square covering the receptive field of the recorded neuron. Three such random-bar patterns alternated at 20 Hz. The monkey was rewarded for maintaining fixation at the fixation point (FP). (b) Typical responses from a single neuron in area V3. The firing rate is plotted against time after stimulus onset. The neuron initially exhibited a transient response to the stimulus onset followed by a low firing rate (labeled “Hole”). With prolonged observation, however, the neuron’s responses gradually increased, reaching a plateau (labeled “Filling-in”) at the time observers would experience perceptual filling-in of the square with random bars. The plateau was comparable to the firing rate of the same neuron to the same stimulus without the gray square (labeled “No-hole”). Adapted from [8], with kind permission from Nature Publishing Group.

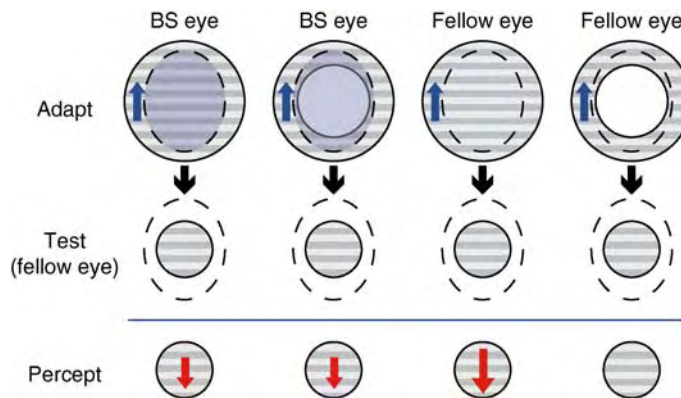

**Perceptual Filling-In. Figure 5** Perceptual filling-in of motion and a subsequent motion aftereffect inside the blind spot [9]. The adapting stimulus was a horizontal grating drifting vertically (its direction is indicated by the blue arrows). The stimulus region was either a disk covering the entire blind spot (*broken oval*) or an annulus covering the border of the blind spot. The observer was adapted with only the blind-spot eye (BS eye) or only the fellow eye open. Note that the disk and annulus were equivalent for the BS eye. The test stimulus was a stationary horizontal grating well inside the blind spot, delivered to the fellow eye. A motion aftereffect occurred (its direction indicated by the red arrows) where motion had been perceptually filled-in during adaptation.

to black in half a second. The observer saw it darkening continuously, but its brightness was perceived as inhomogeneous: the brightness change towards the center of the disk appeared to lag behind the change at its edge. In other words, the center appeared brighter than the edge at each time slice, and darkness “swept” inward. This phenomenon could be seen in a disk placed in a normal visual field and in the same disk covering the blind spot just as well, either with the blind-spot eye or the fellow eye open. This effect appears to corroborate the propagation of brightness signals from edge to interior on the cortical map, suggesting that neural filling-in operations obey the same principle all around the visual field.

### Functional Significance

The retinal image is a two-dimensional array of “raw” light intensity. From this image, the visual system has to estimate lots of things, such as object contours, surface assignment to objects, their volumetric structures, and their material properties, just to list a few. On the other hand, retinal inputs never provide the brain with sufficient information for solving these problems. For example, the brain has to determine what surface is lit by what light source, but the retinal image is only a result of their interactions. Thus, the same surface can project very different images onto the retina depending on viewing conditions. Also, the image of the same surface under the same illumination may be registered

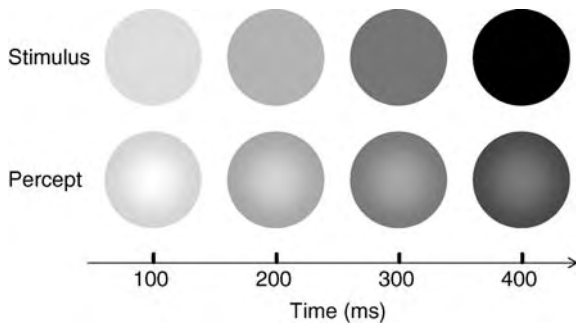

**Perceptual Filling-In. Figure 6** Brightness filling-in in a normal visual field [10]. On a computer monitor, a small spot of light (1 degree in diameter) gradually changed its luminance from white to black over time. Its perceived brightness was different between the edge and inside: the brightness at the edge appears to fill inward. The same phenomenon occurs at the blind spot as well, with a larger spot of light (8–10 degrees in diameter).

as having different values of chromaticity, because of differences in our spectral sensitivity across space and time. Furthermore, the same surface may even be partially unregistered (blind spot and scotoma). Therefore, filling-in has a clear functional significance of maintaining our [▶perceptual constancy](#) in spite of imperfection of visual information from the eye. As perceptual filling-in is viewed this generic way, a great number of puzzles remain to be solved in future research.

## References

1. Komatsu H (2006) The neural mechanisms of perceptual filling-in. *Nat Rev Neurosci* 7:220–231
2. Ramachandran VS, Gregory RL (1991) Perceptual filling in of artificially induced scotomas in human vision. *Nature* 350:699–702
3. Pinna B, Brelstaff G, Spillmann L (2001) Surface color from boundaries: a new ‘watercolor’ illusion. *Vision Res* 41:2669–2676
4. Pessoa L, Thompson E, Noë A (1998) Finding out about filling in: a guide to perceptual completion for visual science and the philosophy of perception. *Behav Brain Sci* 21:723–748
5. Smirnakis SM, Brewer AA, Schmid MC, Tolias AS, Schüz A, Augath M, Inhoffen W, Wandell BA, Logothetis NK (2005) Lack of long-term cortical reorganization after macaque retinal lesions. *Nature* 435:300–306
6. Gilbert CD, Wiesel TN (1992) Receptive field dynamics in adult primary visual cortex. *Nature* 356:150–152
7. Matsumoto M, Komatsu H (2005) Neural responses in the macaque V1 to bar stimuli with various lengths presented on the blind spot. *J Neurophysiol* 93:2374–2387
8. De Weerd P, Gattass R, Desimone R, Ungerleider LG (1995) Responses of cells in monkey visual cortex during perceptual filling-in of an artificial scotoma. *Nature* 377:731–734

9. Murakami I (1995) Motion aftereffect after monocular adaptation to filled-in motion at the blind spot. *Vision Res* 35:1041–1045
10. Paradiso MA, Hahn S (1996) Filling-in percepts produced by luminance modulation. *Vision Res* 36:2657–2663

## Perceptual Grouping

### Definition

▶Form Perception

## Perceptual Impairment

### Definition

Inability to distinguish between different levels of a perceptual dimension such as color, pitch, or pressure.

The impairment may originate at a peripheral level (e.g. absence of a particular cone type in the retina leads to color blindness) or at a central level (e.g. lesions of a cortical region). The impairment may regard particular regions of space, particular perceptual dimensions (e.g. color, movement, etc.) or the recognition of what is perceived (e.g. inability to recognize familiar faces).

▶Perceptual Discrimination

▶Perception

## Perceptual Processing

▶Visual Neuropsychology

## Perceptual Saliency (in Vision)

### Definition

Degree to which a target stimulus “pops out” in a set of stimuli. If the target stimulus differs by a single attribute (e.g. its color) from the other objects, it is highly salient.

If the target stimulus differs by a combination of attributes (e.g. a combination of color and form) from the others, it is less salient.

► Perception

---

## Perceptual Task

### Definition

Detection or classification of a stimulus or discrimination between different stimuli.

► Sensory Plasticity and Perceptual Learning

---

## Perforated Patch

### Definition

A form of patch-clamp recording in which an antibiotic such as nystatin, amphotericin, or gramicidin are included in the patch solution to create ionophores in the plasma membrane that permit intracellular recording without modifying the cytosolic contents of the neuron.

► Patch Clamp

---

## Perforated Synapse

DANIEL A. NICHOLSON, YURI GEINISMAN  
Department of Cell and Molecular Biology,  
Northwestern University's Feinberg School of  
Medicine and Institute of Neuroscience, East Chicago  
Avenue, Chicago, IL, USA

### Synonyms

Synapse with a perforated or discontinuous postsynaptic density (PSD); Synapse with subsynaptic plate perforations; Synapse with a fenestrated, Horseshoe-shaped or segmented PSD; Synapse with an annulate, Horseshoe-shaped or multifocal presynaptic vesicular grid

### Definition

► **Perforated synapses** belong to a special morphological variety of synaptic junctions, characterized by the presence of aligned discontinuities (gaps) in their postsynaptic and presynaptic densities.

### Characteristics

#### Quantitative Description

Ultrastructural features of perforated synapses, their quantitative characteristics and changes under various experimental conditions were the subject of numerous investigations. The results of these studies, which were previously reviewed in detail [1–5], are summarized below.

#### Ultrastructure

The hallmark of a synapse at the electron microscopic level is the ► **postsynaptic density** (PSD). The PSD is a plate(s) of electron-dense material on the cytoplasmic face of the postsynaptic membrane. PSDs are most noticeable in ultra thin sections of tissue conventionally prepared (i.e., osmicated) for electron microscopy (Fig. 1).

Synapses can be subdivided based on the thickness of their PSD, relative to that of the ► **presynaptic density**, into two main types: asymmetric synaptic junctions with a thicker PSD are considered to be excitatory; and symmetric ones with a PSD nearly as thin as the presynaptic density are considered to be inhibitory. Electron microscopic analyses of asymmetric synapses have demonstrated that they can be further subdivided, based on the configuration of their PSDs into either perforated or nonperforated (or macular) ones. When sections are made perpendicular or at an angle to a perforated PSD, a discontinuity or perforation is usually observed in a subset of its sectional profiles (Fig. 1a–c). Perforated PSD shapes can also be visualized in sections passing parallel to PSDs. Planar reconstructions of perforated PSDs from consecutive serial sections show that they assume three basic shapes: a fenestrated PSD exhibiting a hole(s) in its single plate; a horseshoe-shaped PSD having a single plate; and a segmented PSD consisting of several (2–4) separate plates. ► **Nonperforated synapses**, on the contrary, are characterized by a continuous PSD plate of a relatively simple shape, which may be approximated by that of a circular or elliptical disk. Sectioning of such a plate at different angles produces PSD profiles that lack perforations (Fig. 1e–h). Although dimensions of nonperforated PSDs are generally smaller than those of perforated ones, this is not an invariant feature of nonperforated PSDs because some of them overlap in size with perforated PSDs.

#### Distribution

Perforated synapses are widely distributed throughout the mammalian brain, including various neocortical areas, the hippocampal formation, striatum, putamen,

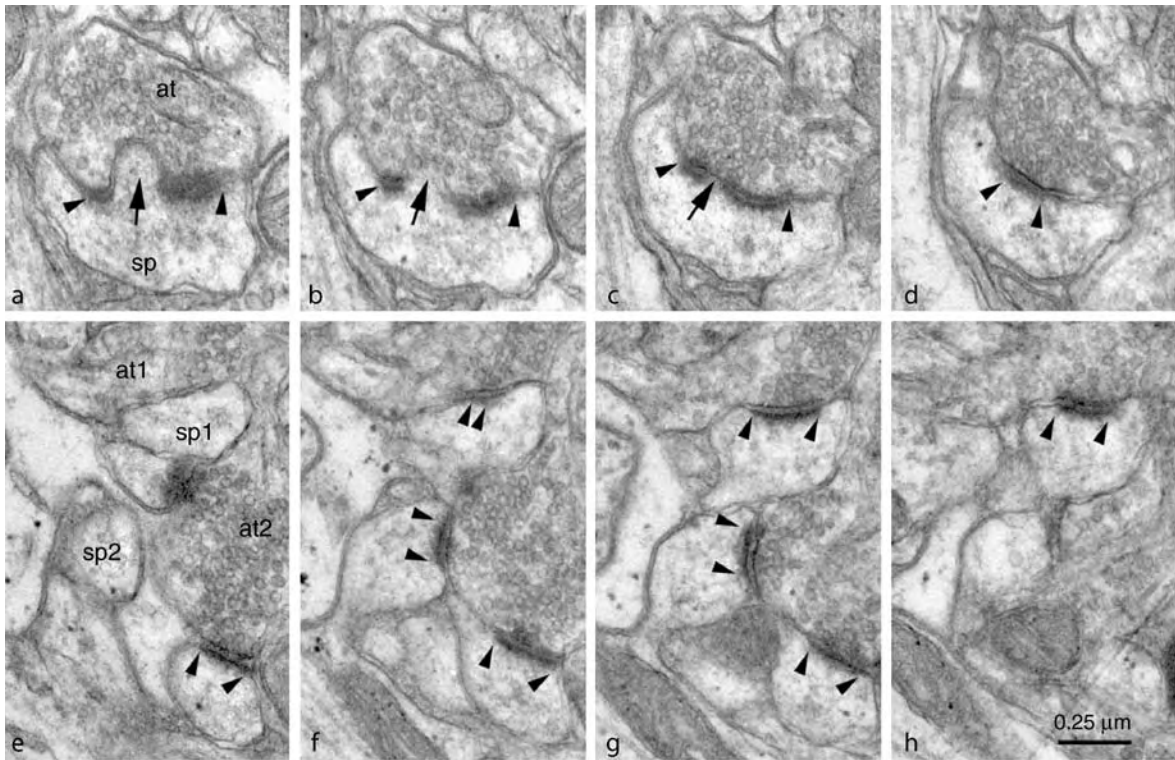

**Perforated Synapse. Figure 1** Perforated (a–d) and nonperforated (e–h) axospinous synapses, seen in electron micrographs of consecutive serial sections through the middle molecular layer of rat dentate gyrus. (a–d) The perforated synapse (its presynaptic axon terminal and postsynaptic spine head are labeled in (a) by “at” and “sp,” respectively) exhibits PSD profiles (*arrowheads*) that have a discontinuity (*arrowheads*) in some sections (a–c). A synaptic spinule (a, b) is a finger-like protrusion of the spine head, which invaginates through a discontinuity in the PSD (*arrows* in a and b) into the axon terminal. (e–h), The nonperforated synapses formed between axon terminals (labeled in (e) by “at1” and “at2”) and spine heads (labeled in e by “sp1,” “sp2” and “sp3”) display continuous PSD profiles (*arrowheads*) in all sections.

deep cerebellar nuclei, and hypothalamus. Both perforated and nonperforated **▶asymmetrical synapses** are found mainly on dendritic spines and occasionally on dendrites. Axospinous perforated synapses have been extensively studied, and the present essay is focused on these synaptic junctions, which will be referred to as perforated synapses.

### Frequency

Perforated synapses constitute 10–25% of the entire axospinous synaptic population. Nevertheless, the number of perforated synapses per neuron is substantial. For example, the total number of pyramidal neurons in rat CA1 hippocampal region is ~400,000, whereas the total number of perforated synapses in one of its layers (stratum radiatum) reaches ~800,000,000. Therefore, each CA1 pyramidal neuron receives ~2,000 perforated synapses in the stratum radiatum alone.

### Lower Level Components

A **▶synaptic spinule or spine partition** is a postsynaptic component of some perforated synapses. In single

sections, it is seen as a small outgrowth that arises from the spine head at a PSD discontinuity and protrudes into the presynaptic axon terminal (**Fig. 1a, b**). Three-dimensional reconstructions of perforated synapses demonstrate that the extent of spinules differs depending on the shape of perforated PSDs [2]. In fenestrated synapses, they assume the form of a focal partition, the base of which is limited to a hole in the PSD plate (**Fig. 2b**).

Horseshoe-shaped synapses exhibit a spinule whose base is restricted to the interval between the two arms of the PSD horseshoe (**Fig. 2c**). In segmented synapses, however, a complete spine partition divides the spine head cavity into separate compartments, each one containing a discrete transmission zone between the axon terminal and a PSD segment (**Fig. 2d**). Each perforated synaptic subtype can have or lack spine partitions (**Fig. 2e–g**). In the molecular layer of rat dentate gyrus, the proportion of synaptic junctions with partitions in total samples of fenestrated, horseshoe-shaped and segmented synapses amounts to 38, 60 and 92%, respectively.

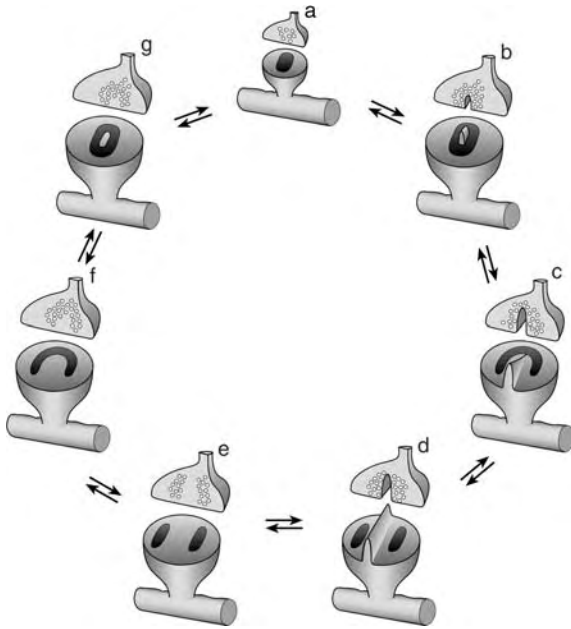

**Perforated Synapse. Figure 2** Diagram illustrating a hypothetical synapse restructuring that may underlie activity-dependent alterations in synaptic strength. The schematic shows the following axospinous synaptic subtypes: nonperforated synapse (a) perforated synapses that have a fenestrated PSD and focal spine partition (b) a horseshoe-shaped PSD and sectional partition (c) a segmented PSD and complete partition (d) or that lack spine partitions but exhibit a segmented (e) horseshoe-shaped (f) and fenestrated (g) PSD. The sequence of synapse remodeling from a through to b, and c to d is postulated to be a rapid process that supports an initial maximal synaptic enhancement. The sequence from d through to e, f and g to a may lead to the return of elevated synaptic responses to the control level.

► **AMPA receptors and NMDA receptors** (AMPA and NMDARs, respectively) are types of ionotropic glutamate receptors associated with the PSD of excitatory synapses. These PSDs also contain cytoskeletal scaffolding and adaptor proteins as well as signaling molecules, which together form a cluster of synaptic signal transduction machinery located at or near the site of synaptic transmission. Compelling electrophysiological evidence indicates that the number of postsynaptic AMPARs and NMDARs is the major determinant of synaptic strength. ► **Postembedding immunogold electron microscopy** reveals striking differences in the expression of AMPARs and NMDARs between perforated and nonperforated axospinous synapses, which may indicate corresponding differences in the strength of synaptic transmission at these synaptic subtypes [6,7]. Interestingly, some nonperforated synapses exhibit NMDAR but not AMPAR immunoreactivity, whereas

perforated synapses are invariably immunostained for both receptor types. This finding may mean that perforated synapses are never postsynaptically “silent” at resting membrane potentials. Moreover, perforated synapses from rat CA1 stratum radiatum express significantly more AMPARs (by 660%) and NMDARs (by 80%) than their immunopositive nonperforated counterparts. The total area of the PSD plate(s) is generally larger in perforated synapses as compared to nonperforated ones, and postsynaptic AMPAR content positively correlates with PSD size. The difference in the expression of glutamate receptors between the two synaptic subtypes remains significant, however, when their PSD areas are equalized, indicating that this difference is related to both PSD configuration and PSD size.

### Function

Numerous studies report activity-dependent increases in the number or proportion of perforated synapses. Such changes occur in cortical regions of the rodent brain during postnatal development and under various experimental conditions including housing of animals in complex environments, hippocampal kindling, NMDA-dependent hippocampal LTP and behavioral learning. Based on these observations, perforated synapses have been widely implicated in synaptic plasticity. It is necessary, however, to note here that many of the reported results should be considered with caution. The majority of studies published so far employed inappropriate procedures for quantification of perforated synapses. For example, in studies that analyzed synapses on single (rather than consecutive serial) sections, perforated synapses might not have been reliably recognized and quantified because they frequently exhibit nonperforated PSD profiles (Fig. 1b).

Such methodological drawbacks notwithstanding, there is a growing body of evidence in favor of the long-standing notion that an addition of perforated synapses is required to support an enhancement of synaptic strength. Especially demonstrative in this respect are the findings of LTP experiments [8,9], showing that perforated synapse number is markedly increased early (15–60 min) after LTP induction, when synaptic responses are maximally enhanced, and returns to control levels afterwards. The observed increase in the proportion of perforated synapses reflects a selective change in the number of segmented, completely partitioned synaptic junctions [8,9].

The existence of distinct morphological subtypes of axospinous synapses suggests a hypothetical model [2,4] of structural synaptic modifications associated with activity-induced alterations of synaptic strength (Fig. 2). According to this model, LTP induction triggers an enlargement of nonperforated PSDs, which is followed by the consecutive formation of perforated



synapses having initially a focal spine partition with a fenestrated PSD (Fig. 2b), then a sectional partition with a horseshoe-shaped PSD (Fig. 2c), and finally a complete partition with a segmented PSD (Fig. 2d). The latter perforated subtype has an exceptionally high level of AMPAR immunoreactivity [7], which likely translates into an unusually strong synaptic conductance relative to that at other axospinous synapses. A high number of AMPARs at segmented synapses may be necessary for mediating the maximal level of synaptic responses characteristic of certain forms of synaptic plasticity, such as the early LTP phase. The subsequent enduring retention of a relatively lower level of synaptic enhancement during the late LTP phase, and its return to control levels over time, may involve the conversion of segmented, completely partitioned synapses into nonpartitioned perforated subtypes (Fig. 2e–g) and eventually back into non-perforated synaptic junctions (Fig. 2a). The proposed model helps to explain the large degree of morphological heterogeneity among perforated synapses, and indicates a likely association between activity-dependent synaptic restructuring and enhancements in synaptic strength. It has also been postulated that the perforated synaptic subtypes may be intermediates in the process of synapse splitting and division, but there are no data demonstrating the existence of this process.

### Pathology

Recent observations indicate that learning and memory disturbances during aging are associated with structural changes in perforated synapses that are likely to have a deleterious effect on their function. It has long been known that aging-related impairments of cognitive functions do not affect all aged individuals: some of them have preserved learning and memory capacities even at advanced chronological age. The reason for such pronounced individual differences in mnemonic functions remains unknown. In a study exploring this problem [10], aged rats were behaviorally tested on a hippocampus-dependent water maze task and separated into groups with impaired or unimpaired spatial learning as compared with young adults. PSD area was estimated in perforated and nonperforated synapses from the stratum radiatum of hippocampal field CA1. The results show that aged learning-impaired rats exhibit a marked (~30%) reduction in perforated PSD area, whereas learning-unimpaired rats do not. This change is highly selective because it does not involve nonperforated PSDs. Given the strong positive correlation between PSD size and AMPAR content among perforated synapses [7], the removal of postsynaptic AMPARs from the PSD may underlie the reduction in PSD area and weaken the efficacy of synaptic transmission. Such a mechanism is also a prime candidate for contributing to the cognitive decline in the subset of aged learning-impaired animals.

### References

1. Calverley RKS, Jones DG (1990) Contributions of dendritic spines and perforated synapses to synaptic plasticity. *Brain Res Rev* 15:215–249
2. Geinisman Y (1993) Perforated axospinous synapses with multiple, completely partitioned transmission zones: probably structural intermediates in synaptic plasticity. *Hippocampus* 3:417–434
3. Jones DG, Harris RJ (1995) An analysis of contemporary morphological concepts of synaptic remodeling in the CNS: perforated synapses revisited. *Rev Neurosci* 6:177–219
4. Geinisman Y (2000) Structural modifications associated with hippocampal LTP and behavioral learning. *Cereb Cortex* 10:952–962
5. Nikonenko I, Jourdain P, Alberi S, Toni N, Muller D (2002) Activity-induced changes of spine morphology. *Hippocampus* 12:585–591
6. Ganeshina O, Berry RW, Petralia RS, Nicholson DA, Geinisman Y (2004) Differences in the expression of AMPA and NMDA receptors between axospinous perforated and nonperforated synapses are related to configuration and size of postsynaptic densities. *J Comp Neurol* 468:86–95
7. Ganeshina O, Berry RW, Petralia RS, Nicholson DA, Geinisman Y (2004) Synapses with a segmented, completely partitioned postsynaptic density express more AMPA receptors than other axospinous synaptic junctions. *Neuroscience* 125:615–623
8. Geinisman Y, deToledo-Morrell L, Morrell F, Heller RE, Rossi M, Parshall RF (1993) Structural synaptic correlate of long-term potentiation: formation of axospinous synapses with multiple, completely partitioned transmission zones. *Hippocampus* 3:435–446
9. Toni N, Buchs P-A, Nikonenko I, Povilaitite P, Parisi L, Muller D (2001) Remodeling of synaptic membranes after induction of long-term potentiation. *J Neurosci* 21:6245–6251
10. Nicholson DA, Yoshida R, Berry RW, Gallagher M, Geinisman Y (2004) Reduction in size of perforated postsynaptic densities in hippocampal axospinous synapses and age-related spatial learning impairments. *J Neurosci* 24:7648–7653

## Periamygdaloid Cortex

### Definition

The periamygdaloid cortex is a paleocortical brain region on the medial surface of the amygdala. It belongs to the uncus of the temporal lobe, and has been described as anatomically heterogeneous.

► [Olfactory Pathways](#)

## Periaqueductal Gray Matter (PAG)

### Definition

The periaqueductal gray matter is the midbrain area surrounding the cerebral aqueduct (of Sylvius) and consisting of different longitudinal columns that initiate stimulus-specific autonomic and antinociceptive responses to external stressors. The lateral column of the periaqueductal gray initiates flight-or-flight sympathoexcitatory responses associated with opioid-independent analgesia. The ventrolateral column elicits hypotension, bradycardia, immobility, and hyporeactivity to the environment, associated with opioid-dependent analgesia.

- ▶ Central Regulation of Autonomic Function

## Periaxin

### Definition

Periaxin is a Schwann cell-specific protein of 147 kDa. It is expressed exclusively by myelinating Schwann cells and is predominately localized to their abaxonal surface. Periaxin is a myelin-related protein that undergoes dynamic changes in its localization during ensheathment and myelination.

- ▶ Myelin
- ▶ Schwann Cell
- ▶ Schwann Cells in Nerve Regeneration

## Perifornical Area/Lateral Hypothalamus

### Definition

Brain area of the lateral hypothalamus surrounding the fornix, a bundle of fibers that connects the hippocampus with the septal area and tuberomammillary nucleus.

- ▶ Hypothalamus
- ▶ Hypothalamus, Lateral

## Periglomerular Cell in Olfactory Bulb

### Definition

Periglomerular cells constitute one type of intrinsic neurons of the olfactory bulb. Their cell bodies are among the smallest in the brain and surround olfactory glomeruli. They usually give rise to a single dendrite that arborizes within a glomerule, and an axon, that extends laterally in the periglomerular region, as far as five glomeruli. Therefore, periglomerular cells participate in both intraglomerular and interglomerular circuits.

Periglomerular cells are not homogeneous, but occur in several distinct subtypes that differ in connectivity, neurochemical content (expressing GABA, dopamine, calbindin, or calretinin, or combinations of these) and electrophysiological properties. Based on connectivity, they are currently classified as type 1 cells, which receive excitatory input from the olfactory nerve, and type 2 cells, which establish few or no synapses with olfactory nerve axons.

Periglomerular cells are one of the few types of neurons that undergo continuous neurogenesis throughout life.

- ▶ Dopamine
- ▶ GABA
- ▶ Olfactory Bulb
- ▶ Olfactory Bulb Glomerulus
- ▶ Olfactory Nerve

## Perilymph

### Definition

Fluid similar to cerebrospinal fluid (CSF) inside the bony labyrinth that surrounds the delicate membranous labyrinth. Perilymph has a high sodium content and low potassium content.

- ▶ Peripheral Vestibular Apparatus

## Perimysium

### Definition

The fascia that covers the full perimeter of each muscle fascicle, with the exception of its ends. It forms the wall

of a “tunnel” in which the muscle fascicle operates. It is continuous with the endomysial stroma within the fascicle.

- ▶ Intramuscular Myofascial Force Transmission
- ▶ Skeletal Muscle Architecture

## Period

### Definition

1. The time it takes a periodic function to repeat itself once, the time for the completion of a cycle.
2. Name of a clock gene whose mutation alters period length of a circadian cycle, identified originally in the fruit fly, which together with the Cryptochrome proteins suppress transcriptional activation during the dark phase.

- ▶ Acoustics
- ▶ Clock Genes
- ▶ Clock-Controlled Genes

## Period (Tau, $\tau$ ) of Circadian Rhythm

### Definition

The time that it takes for the biological oscillator to complete one cycle, to go from start to finish. In the case of circadian oscillators, the period is close to, but not equal to, 24 h. The measurement of period should be made over the course of a number of cycles when the organism is held under conditions of constant dark and fixed temperature. The periods of circadian oscillators are also temperature compensated; that is, the period length does not change in response to alterations in the external temperature. For diurnal organisms, the period is typically longer than 24 h; for nocturnal organisms, however, the period is typically less than 24 h (a finding referred to as Aschoff’s rule). The molecular genetic factors responsible for the generation of the circadian period have been the subject of much research.

Although the period length of circadian oscillations is largely determined by these genetic factors, there is also evidence for modest history-dependent regulation of period. The persistence of circadian oscillations under constant conditions and the maintenance of

period in the face of temperature changes are fundamental features of circadian oscillators.

- ▶ Circadian Rhythm
- ▶ Phase Response Curve (PRC)

## Periodic Behavior

### Definition

A rhythmic behavior which can be observed to repeat, and is separated by a regular interval of time between adjacent events.

- ▶ Peripheral Feedback and Rhythm Generation

## Periodic Brain Activation

### Definition

Periodic brain activation is associated with the REM state and plays a role in localized recuperative processes and in emotional regulation during sleep.

- ▶ Memory and Sleep

## Periodic Limb Movements of Sleep

### Definition

A sleep related movement disorder consisting of repetitive, involuntary limb movements during sleep.

Electromyographic sensors on the limbs reveal trains of muscle contractions with characteristic shape, amplitude, frequency, and distribution. The limb movements may be temporally associated with arousals from sleep.

The high association with restless leg syndrome and the same targets of therapy suggest that the two disorders share common mechanisms.

- ▶ Sleep – Developmental Changes

## Periodicity Pitch

### Definition

The pitch that is nearly equal to the frequency of a sinusoidal amplitude modulation of a tone or a complex sound.

- ▶ Acoustics
- ▶ Tonotopic Organization (Maps)

## Periodontal Ligament

### Definition

The collagenous connective tissue that attaches a tooth to the surrounding alveolar bone of the lower (mandibular) or upper (maxillary) jaw.

- ▶ Tactile Sensation in Oral Region

## Periodontal Mechanoreceptors

### Definition

Receptors that innervate the periodontal ligament and signal information about loads applied to the teeth.

- ▶ Periodontal Ligament
- ▶ Tactile Sensation in Oral Region

## Periodontal Pressoreceptors

### Definition

Rapidly conducting trigeminal sensory afferent neurons that innervate specialized receptors in the periodontal ligament that anchors the roots of the teeth in the jawbones. They respond to pressure applied to the crowns of the teeth.

- ▶ Mastication
- ▶ Periodontal Ligament

## Peri-Personal Space

### Definition

- ▶ Visual Space Representation for Reaching

## Peripheral Autonomic (Parasympathetic, Sympathetic) Pathway

### Definition

Pathway consisting of a population of preganglionic neurons and a population of postganglionic neurons transmitting impulses in the autonomic ganglia and to the effector cells. Each pathway is specified by the target cells it innervates, i.e. as muscle vasoconstrictor, cutaneous vasoconstrictor, sudomotor, cardiomotor etc pathway.

- ▶ Autonomic Reflexes

## Peripheral Chemoreception in Respiration

### Definition

The major peripheral chemoreceptors are the carotid bodies and the aortic bodies, which convert the hypoxic signals into an increased neural activity to produce reflex responses in the respiratory system. Hypoxic signals from the arterial chemoreceptors are conveyed through the carotid sinus and vagal afferents, which terminate almost exclusively in the nucleus tractus solitarii (NTS) area. The neurons in the NTS project excitatory inputs to the ventral respiratory group (VRG) neurons. Hypoxia initially increases and then slowly decreases ventilation. The initial increase is attributed to stimulation of arterial chemoreceptors and the ensuing slow decline of ventilation is due to the resulting hypocapnia and the central effects of hypoxia.

- ▶ Carotid Body Chemoreceptors and Respiratory Drive
- ▶ Neural Respiratory Control during Acute Hypoxia
- ▶ Nucleus of the Solitary Tract
- ▶ Respiratory Network Responses to Hypoxia

## Peripheral Chemoreceptors

► Respiratory Reflexes

## Peripheral Clock

► Peripheral Oscillator

## Peripheral Feedback and Rhythm Generation

HAROLD J. BELL

Department of Cell Biology and Anatomy, University of Calgary, Calgary, AB, Canada

### Synonyms

Sensory modulation of central pattern generators; CPGs; Afferent input to rhythm generating networks

### Definition

Rhythmic motor behaviors such as walking, wing beating, chewing and breathing are all governed by networks of one or more neurons, named central pattern generators (CPGs). By definition, the CPG is able to generate and maintain a basic patterned neuronal activity that is absolutely fundamental to producing the behavior which it governs. However, an animal's behavior must take into account conditions or changes in the environment such that the behavior remains relevant and appropriate. Behavior is kept relevant and appropriate by integrating sensory feedback into the rhythm generation process. Sensory feedback is a general term which refers to neural signals transduced through a wide variety of sensory modalities (chemoreception, mechanoreception (► [Mechanoreceptor](#)), etc.). Peripheral feedback specifically refers to sensory feedback that is transduced outside of the central nervous system, and provides the CPG network with neural signals encoding information relevant to behavior. Thus, peripheral feedback is intimately related to and is an important component of the process of rhythm generation.

### Characteristics

#### Rhythm Generation and Behavior

Repetitive motor acts are involved in a seemingly endless number of behaviors across animal species: walking, crawling, flying, swimming, feeding and breathing are all excellent examples. Because of the complex and repetitive nature of the motor acts involved in coordinating these behaviors, networks of neurons have evolved that are extremely efficient at generating the basic timing and pattern of motor neuron discharge that underlie them, in a highly reproducible fashion. These networks of neurons are almost exclusively located in ganglia or the nuclei of brains within intricate central nervous systems, and therefore are commonly called central pattern generators (CPGs).

By definition, a CPG network is capable of spontaneously generating a rhythmic activity that is sufficient for eliciting the motor behavior that it governs, even in the absence of other synaptic inputs.

CPGs have been studied in considerable depth for a number of behaviors observed across numerous species [1]. Given the diversity of behaviors and therefore the CPGs that govern them, it is difficult to suggest that any one specific behavior or CPG is typical of all others. Nevertheless, this diversity also means it is advantageous to focus upon a specific behavior in order to discuss how CPGs can be modulated by peripheral feedback. For this reason we shall focus our discussion upon breathing behavior, and the respiratory rhythm generator that drives this behavior.

#### Respiratory Rhythm

Breathing is perhaps the quintessential example of a rhythmic behavior, as it is essential to the survival of countless animal species from insects, to fish, to mammals. Breathing is a homeostatic motor behavior, which allows the animal to obtain oxygen from, and eliminate carbon dioxide into the external environment. Across *Animalia* many breathing patterns, from regular periodic rhythms (► [Periodic behavior](#)), to episodic patterns (► [Episodic behavior](#)) can be found, and even within some species these patterns are labile. As a motor behavior, breathing requires the coordinated activation of respiratory pump muscles. The CPGs controlling breathing in most animals are very complicated, and so in most cases very little is known about the detailed synaptic connectivity and neurons involved in respiratory rhythm generation. Indeed, if one considers the extent of behaviors and therefore related CPGs present in the animal kingdom, relatively few examples are available of fully described networks.

Invertebrate model systems have been fundamental in advancing our understanding of nearly every aspect of modern neuroscience, and in no field has this been more so than in the study of central rhythm generation.

Presently, fully described CPG networks are limited to those identified in invertebrate species. This is because the central neurons of invertebrates exist within ganglia, and many are readily identifiable based upon location and morphology, making it possible to study an individual cell involved in a particular behavior across multiple animals of the same species. Therefore invertebrates are especially amenable to the study of rhythm generation since networks can be mapped from identified cells. One model system wherein the essential central neuronal components of the respiratory CPG have been identified is the pulmonate freshwater mollusk *Lymnaea stagnalis* [2]. *Lymnaea* are aquatic air breathers, and their breathing is a hypoxia-dependent behavior. *Lymnaea* breathe through coordinated motor output to the muscles of the mantle cavity and pneumostome. Contraction of muscles in the mantle cavity and pneumostome opening muscles allow stale air to be expelled from and fresh air to subsequently be drawn into the animal's rudimentary lung. The core of the CPG controlling this behavior consists of three identified cells which have been studied both *in vivo* and *in vitro* (see Fig. 1).

By contrast, in mammals the respiratory central pattern generator is comparatively complex, and for good reason; respiratory control also needs to accommodate other related behaviors aside from breathing such as feeding, sniffing, licking, and vocalization. Not surprisingly, the intricacy of the mammalian central nervous system has made it rather difficult to characterize the respiratory CPG. Impressive progress has been made however, and central respiratory-related neuronal populations are known to be distributed bilaterally throughout a number of nuclei in the medulla and pons (see Fig. 2). Species differences aside, the mammalian CPG controlling breathing behavior is the topic of great controversy and active research [3]. Regardless of this complexity, breathing remains a motor behavior involving the rhythmic activation of respiratory pump muscles enabling lung ventilation.

Inspiratory muscles, mainly the diaphragm and external intercostal muscles, act to increase thoracic volume and draw atmospheric air into the lungs. Expiration is normally a passive process of elastic recoil during resting breathing, however expiratory muscles are required for forceful expiration at higher levels of ventilation, and these muscles are mainly the abdominal muscles and the internal intercostal muscles. During resting breathing, the most important respiratory muscle by far is the diaphragm, which contracts during inspiration and is controlled by motor innervation via the phrenic nerve. Characterization of respiratory neurons in the medulla has therefore been accomplished by describing their activity in relation to phrenic nerve activity. If the rhythmic activity of a central neuron has the same period as phrenic activity, then the cell can be designated a respiratory neuron. Further characterization takes into

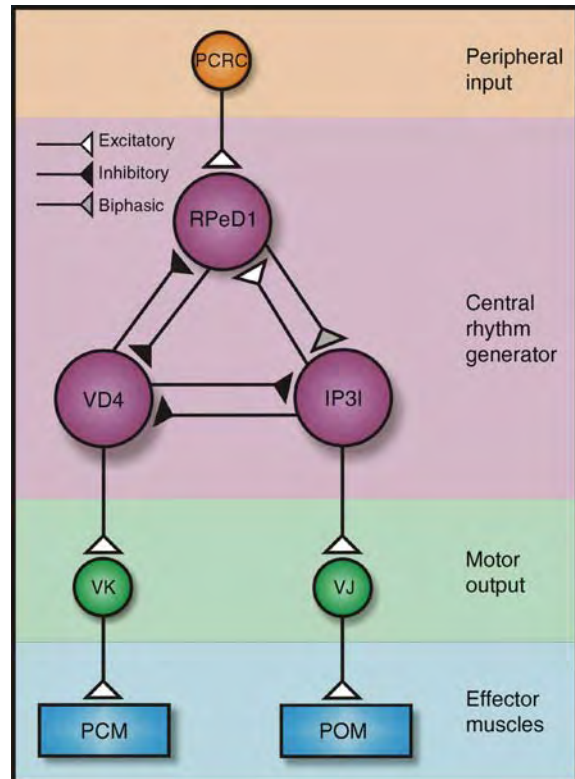

#### Peripheral Feedback and Rhythm Generation.

**Figure 1** A schematic representation of the only fully described respiratory CPG; that identified in the pulmonate freshwater snail, *Lymnaea stagnalis*. This respiratory CPG is composed of three interneurons, which have been identified and named as follows: right pedal dorsal 1 (RPeD1), visceral dorsal 4 (VD4), and the “input 3” interneuron IP3I. The opening and closing of the respiratory orifice, the pneumostome, is accomplished through patterned activity of motor neurons controlling pneumostome opening muscles (POM) and pneumostome closing muscles (PCM). Note that the central rhythm generating neuron RPeD1 receives an excitatory chemical synaptic input from oxygen-sensitive peripheral chemoreceptor cells (PCRCs) located in the periphery, which act to initiate and subsequently regulate the activity of this rhythm generator network. As such, peripheral inputs to the CPG are an important component of the rhythm generation process.

account the phase relationship between the cell and phrenic activity (see Fig. 3). For example a respiratory neuron that fires bursts of action potentials in sync with phrenic activity is called an inspiratory neuron. Conversely, a cell that fires during phrenic quiescence, it is called an expiratory neuron. More specific classification takes into account more specific phases of the respiratory cycle (e.g. pre-inspiratory, late expiratory), and the pattern of discharge of the neuron during its period of activity (e.g. augmenting, decrementing, or constant), and

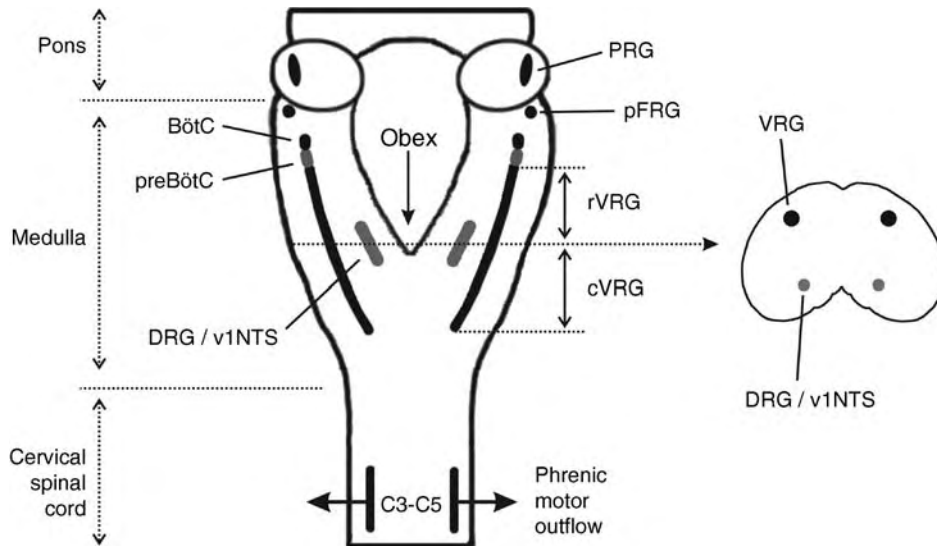

**Peripheral Feedback and Rhythm Generation. Figure 2** A schematic representation of those brainstem regions known to contain respiratory neurons in mammals, along with their approximate anatomical locations. Shown is a schematic view of the brainstem from the dorsal coronal perspective, with a transverse section at the level of the obex. In contrast to the respiratory CPG of *Lymnaea* (shown in Fig. 1), the rhythmic motor output to respiratory muscles in mammals is generated by a complex network of many neurons bi-laterally distributed throughout several regions of the pons and medulla. Relevant neuronal populations are represented as follows: *PRG*, pontine respiratory group; *pFRG*, parafacial respiratory group; *BötC*, Bötzing complex; *preBötC*, pre Bötzing complex; *DRG*, dorsal respiratory group; *cVRG*, caudal ventral respiratory group; *rVRG*, rostral ventral respiratory group; *v1NTS*, ventrolateral nucleus tractus solitarii.

these characteristics are used to functionally differentiate respiratory neurons from one another [4].

Of the populations of neurons in the medulla that have been classified as respiratory neurons, it has long been debated as to which of these were actually involved in generating the base rhythm, and could therefore be designated, “the CPG.” Two groups of neurons in the brainstem have been identified that are presently believed to be essential to the generation of a basic respiratory rhythm: (i) A region of the ventrolateral medulla named the preBötzing complex (PreBÖT), and (ii) a region of the medulla ventrolateral to the facial nucleus near the ventral surface, named the parafacial respiratory group (pFRG). While the precise role of these two neuronal populations in respiratory rhythm generation remains the focus of much ongoing research, it has recently been proposed they may form a coupled network oscillator, with the former responsible for generating inspiration, and the latter generating active expiration phases of the respiratory cycle.

### The Role of Peripheral Feedback in Respiratory Rhythm

It has been widely accepted since the early 1960s that while a CPG can independently function to generate a basic rhythmic motor behavior, sensory feedback from the periphery is necessary for modulating the timing and amplitude of events so that this behavior remains relevant to the environmental demands on the animal

[5]. In this regard, the respiratory CPG is certainly no different, and several forms of afferent information provide a potent modulating influence over rhythmic output. Input from airway receptors can elicit cough or sneeze airway defense mechanisms. Inputs from **▶carotid body chemoreceptors** provide a potent drive to ventilation when arterial blood becomes hypoxic, hypercapnic, or acidic. Group III and IV afferents in the skeletal muscle are able to stimulate breathing, and are believed to be important in coupling the cardiovascular and respiratory systems to regulate gas exchange. Stretch receptors in the lungs are important in shaping the respiratory cycle and timing the inspiratory and expiratory phases of the breathing cycle. Cutaneous thermoreceptors can elicit a powerful gasp reflex which has been documented during sudden cold water immersion. In aquatic air breathing mollusk *Lymnaea stagnalis*, mechanosensory input to the respiratory CPG is required to gate the episodic breathing rhythm so that the respiratory orifice only opens at the water surface, and a similar mechanism is likely to exist in other aquatic air breathers.

Clearly there are many different modalities of peripheral **▶sensory input** which modulate the respiratory CPG, but there are also a range of influences that sensory input can have on the characteristics of the respiratory rhythm. Some inputs typically affect rhythm only very briefly over one respiratory cycle (i.e. cough or sneeze reflexes), while some involve

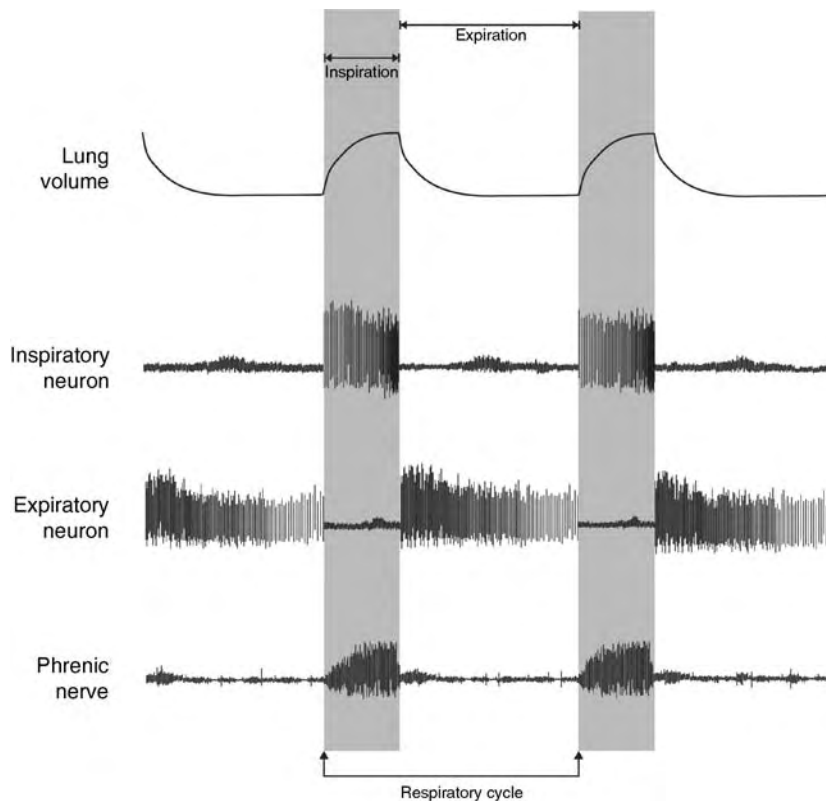

**Peripheral Feedback and Rhythm Generation. Figure 3** Phase relationships between rhythmic breathing behavior, phrenic nerve activity, and inspiratory and expiratory respiratory neurons in the mammalian brainstem. A neuron which fires during the interval of phrenic activity can be described as an inspiratory neuron, since this neuron is active during the inspiratory phase of rhythmic breathing behavior (i.e. when lung volume is increasing). Conversely, a neuron which selectively fires during phrenic quiescence can be designated a expiratory neuron since it is active during the expiratory phase of rhythmic breathing behavior (i.e. when lung volume decreases). Further characterization takes into account the firing pattern of the respiratory neuron during its period of activity (e.g. augmenting, decrementing or constant firing frequency), and the specific phase of the inspiratory or expiratory cycle in which it is active (e.g. early or late).

shaping the rhythm during each breath cycle (i.e. lung stretch receptors) and others affect the entire respiratory cycle over the course of many breaths (carotid body chemoreceptors).

### Mechanisms of Peripheral Modulation of Respiratory Rhythm

As we have seen, peripheral feedback is involved in modulating respiratory rhythm such that breathing can be matched to the needs of the organism. Whether this is a sustained respiratory drive as occurs during exercise, or a transient effect as occurs during protective airway reflexes, the respiratory rhythm is open to modulation from afferent input.

The main characteristics of respiratory rhythm that can be modulated are breathing frequency, or the number or breathing cycles per unit time, and the amplitude of the motor act, or breath size. These features of the breath cycle are shown in more detail in Fig. 4. Since the pathways and putative mechanisms of modulation of

breathing rhythm depend greatly upon the input signal, we will examine one select example at greater depth.

### Carotid Body Chemoreceptor Inputs

The mammalian carotid body chemoreceptors are arterial chemosensory organs that increase breathing in conditions of ▶hypoxia, hypercapnia, or acidosis. Increased chemoreceptor stimulation causes an increase in afferent output that can be measured in the carotid sinus nerve which innervates the organ. Carotid body afferent inputs to the brainstem are first conducted via neurons located mainly within the petrosal ganglion, subsequently via afferent fibers in the glossopharyngeal (IX<sup>th</sup> cranial) nerve. The ▶carotid body chemoreceptor inputs (▶Chemosensory input) affect respiratory rhythm as follows: Afferent input resulting from either carotid body stimulation or direct stimulation of the carotid sinus nerve elicits a decrease in inspiratory duration leading to an increase in breathing frequency, and an increase in the amplitude of integrated phrenic



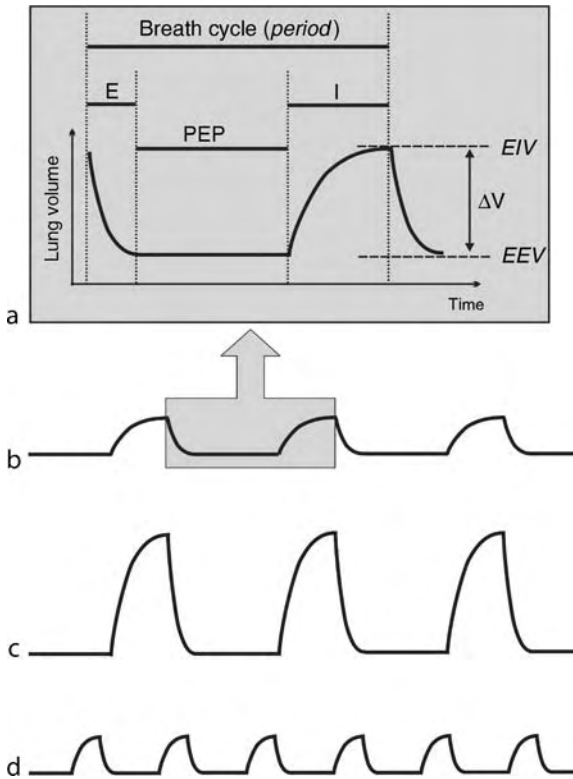

**Peripheral Feedback and Rhythm Generation.** **Figure 4** A diagrammatic representation of those aspects of the breathing cycle which are dictated by final output of the respiratory rhythm generator. (a) an expanded view of one cycle of rhythmic breathing behavior, as shown in (b). The change in lung volume during the breath cycle ( $\Delta V$ ) can be altered by changing the end-inspiratory volume (EIV) or the end-expiratory volume (EEV). In addition, the durations of inspiration (I), expiration (E), and the post-expiratory pause (PEP) can be altered so as to change the period of the breath cycle. Lung ventilation can be increased by augmenting  $\Delta V$  (as shown in (c)) or by decreasing the period of the breath cycle (as shown in (d)), or any combination of the two. Peripheral inputs modulate respiratory rhythm and therefore aspects of the breath cycle, as shown in (a), such that rhythmic breathing behavior remains relevant to the needs of the animal.

whole nerve activity. Simply stated, carotid input to the respiratory CPG leads to an increase in ventilation through increasing breathing rate and breath size.

The central respiratory pathways involved in this response have been studied in some further detail. Within the brainstem, most of the sensory afferents from the carotid sinus nerve show arborizations within the nucleus of the solitary tract, or nucleus tractus solitarius (NTS), specifically an area of the commissural subnucleus of the NTS including what has been named the dorsal respiratory group (DRG) [6]. The synaptic connectivity and therefore the mechanisms of influence of carotid

sensory afferents are not well described beyond this level of the medullary respiratory network. However, carotid sensory afferents are known to release glutamate in the NTS which is believed to be primarily responsible for the increase in breathing via its action on NMDA receptors at this site. The involvement of multiple neurotransmitters and neuromodulators is likely, though specific details remain a topic of ongoing study.

The overt effects of activation of carotid afferents terminating in the NTS upon rhythm generation have been further documented at the level of respiratory neuronal populations in the medulla including those neurons of the Pre-Böt complex believed to be an important component of the respiratory CPG. Unilateral activation of carotid afferents terminating in the NTS elicits bi-lateral changes in the rhythmic activity of inspiratory driver neurons in the rostroventrolateral medulla; these inspiratory neurons are inhibited and therefore their firing duration is decreased. Afferent stimulation also has the effect of concurrently exciting pre-motor inspiratory neurons in the caudal ventral respiratory group and in the DRG, increasing the drive to phrenic motoneurons [7].

#### **Kinetics of Neuromodulation of Respiratory Rhythm**

The activation of carotid afferents is able to elicit changes in respiratory rhythm, which take only a couple of respiratory cycles to achieve their maximal effect ( $\tau \sim 10$  s in cats). The removal of carotid input results in a return to baseline rhythmic activity that has a slightly longer time course ( $\tau \sim 45$  s, again in cats). This apparent “inertia” in the respiratory rhythm generator, which has been called “short term potentiation” (STP) [8] has been well documented, yet the mechanisms involved are not well understood. Slower onset, longer-lasting alterations in respiratory rhythm have also been documented, that can persist long after the input stimulus has returned to baseline levels. This phenomenon, called long term facilitation (LTF), results in augmented respiratory rhythm lasting for more than one hour after removal of peripheral input to the CPG. One particular stimulus that is capable of eliciting LTF is ▶ **intermittent hypoxia**, as sensed by the carotid body chemoreceptors. After repeated hypoxic episodes (for example  $3 \times 5$  min episodes, separated by 5 min of normoxia), both the frequency and amplitude of phrenic nerve discharge has been documented to remain augmented for hours post-stimulus [9]. This phenomenon has now been documented to various extents in multiple animals in different degrees of reduction, including rats, cats and rabbits. While the phenomenon has proven less robust in some cases than others, LTF in respiratory rhythm is nevertheless a fascinating example of how afferent input can modulate rhythm generation via a CPG, even long after the afferent signal has been removed.

## Summary

As we have seen, breathing is an excellent example of a rhythmic behavior that is governed by a central network of neurons. This network in mammals resides in the ponto-medullary brainstem, and receives peripheral inputs from many modalities that are capable of modulating the depth and rate of breathing. While the pathways and mechanisms by which the respiratory CPG is influenced by sensory afferents are specific to this system, it nevertheless illustrates the importance of peripheral feedback in the process of rhythm generation. This is a general neurophysiological principle that applies equally to most rhythmic behaviors across *Animalia*: afferent feedback is essential for ensuring that rhythm generation via CPG networks remains appropriate to the environmental demands on the organism.

## References

1. Marder E, Calabrese RL (1996) Principles of rhythmic motor pattern generation. *Physiol Rev* 76(3):687–717
2. Syed NI, Bulloch AG, Lukowiak K (1990) In vitro reconstruction of the respiratory central pattern generator of the mollusk *Lymnaea*. *Science* 250(4978):282–285
3. Onimaru H, Homma I (2006) Point:Counterpoint: the parafacial respiratory group (pFRG)/pre-Botzinger complex (preBotC) is the primary site of respiratory rhythm generation in the mammal. *J Appl Physiol* 100(6):2094–2095
4. Duffin J, Ezure K, Lipski J (1995) Breathing rhythm generation: focus on the rostral ventrolateral medulla. *News Physiol Sci* 10:133–140
5. Wilson D (1961) The central nervous control of locust flight. *J Exp Biol* 38:471–490
6. Finley JC, Katz DM (1992) The central organization of carotid body afferent projections to the brainstem of the rat. *Brain Res* 572(1–2):108–116
7. Morris KF, Arata A, Shannon R, Lindsey BG (1996) Inspiratory drive and phase duration during carotid chemoreceptor stimulation in the cat: medullary neurone correlations. *J Physiol* 491(Pt 1):241–259
8. Wagner PG, Eldridge FL (1991) Development of short-term potentiation of respiration. *Respir Physiol* 83(1):129–139
9. Bach KB, Mitchell GS (1996) Hypoxia-induced long-term facilitation of respiratory activity is serotonin dependent. *Respir Physiol* 104(2–3):251–260

## Peripheral Glial Cell

### Definition

Glial cells wrapping peripheral neurons in *Drosophila*.

- ▶ [Alternative Splicing and Glial Maturation](#)
- ▶ [Glial Cells](#)

## Peripheral Nerve Regeneration and Nerve Repair

RAJIV MIDHA

Division of Neurosurgery, Department of Clinical Neurosciences, University of Calgary, AB, Canada

### Synonyms

Axonal regeneration

### Definition

▶ **Nerve regeneration** is the process of axonal regrowth within peripheral nerve following injury. Basic science and clinical studies underscore both the possibilities and failure of spontaneous axonal regeneration after peripheral nerve injuries. Historical and current methods of nerve repair at the tissue level take advantage of the natural tendency of peripheral axons to grow when provided with a suitable (micro)environment. New and emerging nerve repair strategies, building on key discoveries at the cellular and molecular, have the potential to further significantly improve the outcome from the repair of nerve injuries.

### Characteristics

#### Nerve Regeneration Outcomes and Challenges

Peripheral nerves have the potential to regenerate axons and reinnervate end-organs, with resulting good functional recovery. Indeed, this is the case with all minor nerve injuries, such as neuropraxia, where the axon remains intact, and most purely axotemetic injuries, where axons are interrupted but the degree of internal damage is minimal. In the latter circumstance, regenerating axons use their existing ▶ **endoneurial pathways** to specifically reinnervate their own precise target end-organs, as confirmed in recent experiments using bioengineered fluorescent mice [1].

Outcome following more severe peripheral nerve injury (PNI) however remains variable and often very poor. At least three important factors contribute to the relatively poor outcome. The first challenge is the pathology at the tissue level. The majority of clinical PNI exhibit both a loss of axon continuity and a significant disruption in the internal connective tissue structures. The resulting scarring within the nerve or a frank gap (with lacerating injuries) presents a formidable barrier to regenerating axons, preventing them from effectively innervating the distal nerve stump. These are currently managed with a repair of the divided nerve or, for the usual scenario of longer gaps or scar segments that need to be resected, placement of interposed nerve grafts. Direct nerve or nerve graft repair unfortunately do not obviate the misdirection of axons. This

introduces the second biological challenge, which is at the cellular level. Even with the most meticulous repair, the endoneurial tubes can never be reapproximated exactly and this results in mismatching of regenerating axons at the site of suture, or within the graft, leading to inappropriate (non-specific) reinnervation and subsequent poor recovery in function. The third challenge may be considered as a quantitative one, which is associated with chronic denervation (►Chronic nerve denervation) of the distal nerve. Chronic denervation is common because of the often extensive injury zone that prevents any axonal outgrowth or (even if outgrowth occurs) the relatively slow rate of regeneration. As a consequence, the distal nerve segment remains chronically devoid of regrowing axons. The resulting prolonged denervation of Schwann cells (SCs) appears to a critical factor which makes them unreceptive for axonal regeneration, and is the single most important quantitative contributor to poor end-organ reinnervation [2].

### Spontaneous Axonal Regeneration After Nerve Injuries

The details of the basic processes involved in nerve degeneration and early regeneration are outlined in detail elsewhere in this Encyclopedic Series (see the contribution by Doug Zochodne). Herein, I will summarize some key concepts, with a more detailed focus on the critical role played by the denervated nerve, distal to the nerve injury.

The injury to an axon is associated with a plethora of changes in the neuronal cell body that shift its phenotype from a neuron involved in maintenance/neurotransmission, to a regenerating one, with a corresponding up-regulation of ►regeneration associated genes (RAGs). Regeneration from neurons requires severed axons to redeem their original axoplasmic volume by extending their processes distally. New axons sprout from one or two internodes proximal to an injury zone. These spontaneously sprouting daughter axons, supported by SCs, and surrounded by a common basal lamina tube are termed a “regenerating unit.” Therefore in regeneration, the number of neurons does not increase, but rather surviving neurons regenerate their cellular processes in concert with their surrounding microenvironment. Key components of the microenvironment involve a very close and intimate relationship between regrowing axons, and the supporting glial SCs, which must both proliferate and migrate [3]. Indeed, the initial stages of axonal regeneration are highly dependent on SCs which lead the regrowing axons across the nerve injury site.

Severance of a peripheral nerve results in ►Wallerian degeneration in all axons distal to the injury site, evidenced by the disintegration of axoplasmic microtubules and neurofilaments. The majority of axons along the distal stumps of transected nerves are reduced

to granular and amorphous debris within 24 h; by 48 h, the myelin sheath has begun to transform into short segments that then form into ovoids. Activated macrophages invade the degenerating distal nerve stump and phagocytose the disintegrating nerve fibers and myelin. There is an accompanying proliferation of the acutely denervated SCs, which now alter their gene expression, and change phenotypically from myelinating to growth supportive [4].

As axons from the proximal nerve stump arrive in the nerve distal to original injury, SCs and basal lamina tubes are reinnervated and thereby supported, which in turn, provides an excellent trophic and cell-adhesive environment for further axonal regeneration [5]. Regenerating axons, when contacting SCs, release neuregulins from their growth cones which bind to erbB receptors on the SCs to mediate a second phase of SC proliferation. SCs secrete chemoattractive factors, including cytokines such as interleukin-1 $\beta$ , leukemia inhibitory factor and monocyte chemoattractant protein-1, that recruit macrophages into the denervated nerve stumps [5]. Cytokines, derived from both the SCs as well as the macrophages that enter the nerve, drive the expression of the non-myelinating, dedifferentiated “denervated” phenotype of the SCs which proliferate, form the ►bands of Bungner (SC lined basal lamina tubes) and guide regenerating axons within the distal nerve stump [4]. The switch in SC phenotype is associated with up-regulation of several growth associated genes including several neurotrophic factors, p75 NTR, glial fibrillary acidic protein, GAP-43, netrin-1 and the transcription factor, Krox-24, which all support axonal regeneration [5]. In summary, the capacity of the denervated distal nerve to support axonal regeneration depends on proliferating acutely denervated SCs within the basal lamina tube which are essential for guiding regenerating axons to the end-organs.

### Repairing Nerve Injury Gaps: Nerve Grafts, Electrical Stimulation and Nerve Conduits

The majority of clinical PNI leave the nerve grossly intact, but nevertheless exhibit loss of axon continuity and a severe disruption in the internal connective tissue structures. Scarring within the nerve presents a barrier to regenerating axons. Nerve repair requires resection of the scarred segment and repair of the resulting lengthy nerve gap, usually with a nerve graft, typically procured from another area of the patient’s own body (nerve autograft). The nerve graft contains surviving SCs and basal lamina endoneurial tubes, which provide neurotrophic support, as well as favorable cell and endoneurial tube surface adhesion molecules to regenerating axons [5]. Nerve grafts therefore provide a seemingly optimal tissue bridge that regenerating axons from the proximal nerve stump exploit to innervate the distal stump. With the advent of the operating microscope and microsurgical techniques, Millesi improved clinical results and

popularized the use of nerve autografts. The outcomes, associated with using nerve grafts, are best for nerves which are primarily innervating one or a few discrete motor or sensory targets, and especially where the repair is close to the target end-organ. For the more proximal injuries, ones requiring lengthy grafts and ones involving nerve elements which innervate a variety of motor and sensory targets, the outcomes remain poor. Moreover, results of microsurgical repair, which is essentially at the tissue level, have reached a plateau over the last few decades.

A major shortcoming with the nerve graft technique is the biological constraint, which cannot be overcome by further progress in microsurgical techniques. Even with the most meticulous repair, regenerating axons at the site of suture, or within the graft, get misdirected or lost, leading to inappropriate (non-specific) and incomplete reinnervation, respectively. Innovative recent investigations with nanoscale engineered devices suggest that some day surgery at the cellular level to splice and repair individual axons may be feasible. Recent insights into the nuances of axonal regeneration however provide potential for some new therapies that are even readily accessible soon. We now understand that axonal outgrowth is not synchronous, but rather staggered, so that some pioneering axons grow out early, while others lag far behind. In fact, many of the lagging axons get delayed at suture repair sites, which in the case of a nerve graft are compounded, involving two separate repair locations. Emerging evidence also suggests that pioneering motor axons, for example, may prefer to associate with corresponding “motor” SCs, based on their surface-specific basement membrane molecules. These pioneering axons may start the process, and they together with their migrating SCs facilitate similar axons to follow by offering these cues as required. Studies by Brushart and colleagues show that motor axons particularly may be biased in their selection of distal targets, preferring phenotypically appropriate rather than inappropriate endoneurial pathways in the distal nerve, so that ultimately some ► **preferential motor reinnervation (PMR)** is exhibited [6]. Exciting recent work by Gordon and Brushart suggests that epochs of electrical stimulation as short as one hour have a significant influence not only on synchronizing the initial re-growth of motor axons, but also on possibly enhancing PMR. Clinical trials to assess the utility of short duration electrical stimulation on improving the outcome of nerve repair are therefore warranted.

In an attempt to provide a more suitable environment for regenerating axons to sample and respond to appropriate *endogenous* directional cues, many investigators have proposed using an artificial (non-nerve) conduit interposed between the proximal and distal nerve stumps. Moreover, a bioengineered graft may allow the introduction of *exogenous* therapies that build

on our rapidly expanding knowledge of axonal guidance. Axons are guided to their targets by growth cones, specialized structures at the tip of axons, that respond to the coordinated action of many contact-mediated cues provided directly or indirectly by SCs and diffusible cues, which are either attractive or repulsive. A short list of candidate molecules to consider include the classical neurotrophins, neurotrophic cytokines (including CNTF, IL-6, oncostatin, and LIF), other neurotrophic factors (including insulin, IGF-1 and GDNF), cell adhesion molecules (including NCAM, L1 and N-cadherin), and extracellular matrix proteins (including laminin, tenascin C, fibronectin and heparan sulfate proteoglycan) [5]. By exogenously providing the most appropriate or suitable cues, we may be able to profoundly influence axonal regeneration within the nerve conduit. The clinical utility of such a strategy is apparent when considering the example of repair of nerves to the hand, where the median nerve is paramount for sensation whereas the ulnar nerve is critical for discrete motor function of the digits. In these instances, the conduit repair can be endowed with specific growth factors or other molecules that will bias the regeneration towards a population of axons (motor vs. sensory) to achieve improved specificity of reinnervation. Artificial nerve conduits or tubes are already proven and in clinical use for short injury gaps of 3 cm or less in humans. Advances in bioengineering, coupled with our understanding of how to effectively deliver growth factors, cell adhesion molecules and other therapies within the artificial nerve graft, should lead to major advances in improving both the quantity and specificity of axonal regeneration through the nerve conduit [7].

### **Deleterious Changes Associated with Chronic Nerve Denervation**

So far, the therapies considered in this essay have focused on the repair of the nerve injury site or nerve injury gap. We now turn our attention to the critical distal nerve environment. Denervated SCs initially up-regulate neural cell adhesion molecule and basement membrane components (including laminin), which are used for attachment and growth of the regenerating axons. A growth supportive environment of the distal nerve is unfortunately not maintained unless axonal contact is re-established. Progressive regression of the capacity of the denervated SCs to sustain their growth permissive phenotype [8] and the progressive decline in numbers of SCs in the chronically denervated distal nerve stumps underlie the loss of capacity to support axonal regeneration [9]. Deleterious changes that affect axonal growth become increasingly pronounced over time, and are coupled with a progressive decline in the number of reinnervated motor units after chronic denervation [2]. In recent experiments, we have demonstrated that immediate innervation of the distal nerve, as

compared to chronic denervation, greatly improves subsequent re-innervation, confirming that the failure in regeneration is related to the profound changes in the distal stump from chronic denervation. A critical component of this unreceptive environment in the distal nerve is the chronically denervated SC whose growth support properties appears to be “turned off” [5].

The above biological issue is very clinically relevant as delayed nerve repairs occur frequently in clinical practice. The reason this occurs is because the majority of nerve injuries leave the nerve in physical continuity with an often unknown propensity to spontaneously recover, a process which unfolds over several weeks to months. Hence, most patients undergo appropriate surgical exploration several months after injury and receive a delayed nerve repair. Even patients who have immediate nerve repair are subject to distal nerve denervation for considerable periods as the rate of regeneration is relatively slow ( $\sim 1$  mm/day in humans), and, given that nerve injuries are far from their end-organs, the distances that regenerating nerve fiber need to grow very long. Hence, almost all severe human nerve injuries creates a situation in which the SCs of the distal nerve are chronically denervated [5].

### Therapies to Counteract Chronic Distal Nerve Denervation

Fortunately, the clinical paradigm of ► **nerve transfers** has emerged a powerful means of bypassing the long zone of chronically denervated nerve. Nerve transfers essentially involve the repair of a distal denervated nerve element using a proximal foreign nerve as the donor of neurons and their axons which will reinnervate the distal targets. The concept initially arose to sacrifice the function of a donor (lesser valued) nerve/muscle to revive function in the recipient nerve and muscle that will undergo reinnervation. Nerve transfers have become increasingly utilized for the repair of brachial plexus injuries, especially where the proximal motor source of the denervated element is absent because of avulsion from the spinal cord. Increasingly advocated are the use of transfers in situations where the proximal motor source is available, but the regeneration distance is so long that the outcome would be poor. A nerve transfer into the denervated distal nerve stump, but deliberately chosen so as to be very close to the motor end-organ, would then restore greater function as compared to a very proximal nerve graft repair.

Biological means of protecting the distal denervated nerve are emerging. One strategy is the exogenous use of cytokines (such as TGF- $\beta$ ), normally produced during Wallerian degeneration, to counteract the deleterious effects of chronic denervation and to maintain the growth-promoting denervated SC. In a recent experiment, chronically denervated SCs, exposed to TGF- $\beta$  and forskolin, when infused into a nerve regeneration

chamber, dramatically increased the number, size and myelination of regenerating axons, as compared to SCs without pre-treatment. Other research laboratories are exploring gene therapy approaches, using lentiviruses or other vectors to augment or resurrect the repertoire of regeneration associated molecules expressed by the denervated SC.

Since chronically denervated SCs appear to become effete, another logical approach is to support the distal denervated nerve environment by replacing lost cells with those derived exogenously. SC infusion has been successful in promoting regeneration and remyelination of the injured peripheral nerve. However, human SCs must be derived from invasive nerve biopsies and have a limited, lengthy expansion *in vitro*. It is thus desirable to identify a more accessible source of SCs for transplant therapies. Bone marrow stromal cells, adipose tissue derived stem cells and skin derived precursor stem cells have all been shown to generate functional SCs that can be used for transplantation in nerves [10]. When stem cells derived from skin were transplanted into artificial nerve guidance tubes bridging a 16-mm gap in rodent sciatic nerve, there was promising improvement in behavioral, electrophysiological, and morphometric parameters measured over vehicle control. It is therefore conceivable that skin derived SCs may be very useful in models of chronic nerve injury, either by infusing them into a chronically denervated distal nerve or perhaps immediately after injury as a protective treatment in an attempt to avoid distal changes associated with chronic injury. If experimental studies prove benefit, we anticipate that nerve repair in the future in patients will be augmented by the use of their own (autologous and cultured) skin-derived SCs, easily procured, via relatively non-invasive skin graft harvesting.

### Conclusion

Our basic understanding of nerve and axonal regeneration has increased tremendously over the last century, with corresponding gains in our ability to repair clinical nerve injuries. We can already overcome the challenge associated with lacerating nerve injuries and severe nerve injuries in continuity with precise repairs at a tissue level using microsurgical techniques, nerve grafts and short length artificial nerve conduits. We are on the verge of the next (cellular) generation of nerve repair using modalities such as specific molecular therapy, electrical stimulation, and bioengineered and micro fabricated devices. These approaches promise to allow improved synchronization of axonal regeneration and more exact specificity of reinnervation. While distal targeted nerve transfers have already had a clinical impact, in the near future gene and (stem) cell therapy approaches to augment and resurrect the distal denervated nerve environment are anticipated.

## References

1. Nguyen QT, Sanes JR, Lichtman JW (2002) Pre-existing pathways promote precise projection patterns. *Nat Neurosci* 5:861–867
2. Fu SY, Gordon T (1995) Contributing factors to poor functional recovery after delayed nerve repair: prolonged denervation. *J Neurosci* 15:3886–3895
3. Chen YY, McDonald D, Cheng C, Magnowski B, Durand J, Zochodne DW (2005) Axon and Schwann cell partnership during nerve regrowth. *J Neuropathol Exp Neurol* 64:613–622
4. Scherer SS, Salzer JL (1996) Axon-Schwann cell interactions during peripheral nerve degeneration and regeneration. In: Jessen KR, Richardson WD (eds) *Glial cell development*. Bios Scientific, Oxford, UK, pp 169–196
5. Fu SY, Gordon T (1997) The cellular and molecular basis of peripheral nerve regeneration. *Mol Neurobiol* 14:67–116
6. Brushart TM (1993) Motor axons preferentially reinnervate motor pathways. *J Neurosci* 13:2730–2738
7. Belkas JS, Shoichet MS, Midha R (2004) Peripheral nerve regeneration through guidance tubes. *Neurol Res* 26:151–160
8. Li H, Terenchi G, Hall SM (1997) Effects of delayed re-innervation on the expression of c-erb receptors by chronically denervated rat Schwann cells in vivo. *Glia* 20:333–347
9. Dedkov EI, Kostrominova TY, Borisov AB, Carlson BM (2002) Survival of Schwann cells in chronically denervated skeletal muscles. *Acta Neuropathol (Berl)* 103:565–574
10. McKenzie IA, Biernaskie J, Toma JG, Midha R, Miller FD (2006) Skin-derived precursors generate myelinating Schwann cells for the injured and dysmyelinated nervous system. *J Neurosci* 26:6651–6660

## Peripheral Nervous System (PNS)

### Definition

Peripheral Nervous System (PNS) is part of the vertebrate nervous system comprised of the nerves outside of the central nervous system and including cranial, spinal nerves and sympathetic and parasympathetic systems.

## Peripheral Neurons

### Definition

Motor, sensory and autonomic neurons with axons that connect the body to the central nervous system (brain, spinal cord).

► [Peripheral Nervous System](#)

## Peripheral Neuropathies

### Definition

Peripheral neuropathies are diseases of peripheral nerves and can occur in acute and chronic forms. Often motor and sensory fibers are afflicted together. Motor symptoms include muscle weakness and depression or loss of tendon reflexes. Sensory symptoms vary and may include ► [paresthesias](#) such as numbness, pins-and-needles sensations, tingling, impaired cutaneous pain and temperature sensations (with risk of injuries), varied impairment of cutaneous mechanical sensation and ► [proprioception](#). Often, peripheral body parts are involved most strongly, leading to the so-called glove-and-stocking pattern. There is a specific form of ► [large-fiber sensory neuropathy](#).

► [Tendon reflex](#)

## Peripheral Oscillator

ACHIM KRAMER

Laboratory of Chronobiology, Charité  
Universitätsmedizin Berlin, Berlin, Germany

### Synonyms

Peripheral clock

### Definition

The term “peripheral oscillator” refers to a circadian oscillator, which is located in cells, tissues or organs outside of the suprachiasmatic nucleus (the site of the master oscillator in mammals).

### Characteristics

#### Properties

In mammals, the circadian system is organized in a hierarchical manner. In addition to the ► [master clock](#) in the ► [suprachiasmatic nucleus](#) (► [SCN](#)), peripheral tissues (such as liver, kidney, heart, skeletal muscle etc.), some extra-SCN neuronal tissues (such as the olfactory bulb) as well as even some immortalized cell lines (e.g. rat-1 and NIH3T3 fibroblasts [1]) exhibit circadian gene expression. The molecular mechanism of these ► [oscillations](#) is similar to that in the SCN [2].

Peripheral oscillators are cell-autonomous and ► [self-sustained](#), but – in contrast to ► [cellular clocks](#) in SCN neurons – probably not synchronized within a tissue. Therefore, explants of peripheral tissues display

damped oscillations on the tissue-level *ex vivo* with self-sustained, but gradually desynchronizing individual ▶cellular oscillators [3].

*In vivo*, peripheral oscillations ▶phase-lag the rhythms in the SCN by several hours and are dominated by the circadian ▶pacemaker in the SCN (master-slave oscillators). For example, embryonic fibroblasts from ▶*Period1*-deficient mice (which have an ▶endogenous period of 20 h) exhibit wild-type period oscillations when implanted in wild-type mice [4].

## Function

Peripheral oscillators are thought to regulate ▶circadian rhythms in local physiology. Genome-wide transcriptional profiling of various peripheral tissues revealed that about 5–10% of all mRNAs show a circadian expression pattern. Interestingly, while rhythmic transcripts expressed in many or all peripheral tissues are rare (they include components of the core oscillator machinery), the majority of oscillating transcripts are either only expressed or only rhythmic in one particular tissue. In the liver, for example, some of these rhythmic genes code for enzymes involved in rate-limiting steps of rhythmic hepatocytic processes suggesting that these rhythms are generated by a local liver oscillator.

Formally, however, it is difficult to decide whether a tissue-specific rhythm is regulated by a peripheral oscillator or driven by rhythmic systemic factors or by a combination thereof. To investigate these possibilities, tissue-specific clock knockout mice have been investigated. In the liver, for example, the majority of rhythmic transcripts are only rhythmic when the liver clock is functioning. A small fraction of transcripts (including *Period2*), however, continue to oscillate without a functional liver clock suggesting that these rhythms are driven by systemic circadian cues [5]. In the ▶retina, the local clock seems to be required for a normal physiology of vision. It regulates both the rhythmic expression of genes in a ▶light-dark cycle that are not rhythmic in ▶constant conditions as well as inner retinal electrical responses to light [6]. In the heart, disruption of the local clock leads to a severely attenuated induction of myocardial fatty acid-responsive genes during fasting [7]. Together, these results indicate that peripheral clocks significantly contribute to important physiological functions *in vivo*.

The circadian expression of genes within a given tissue is often widely distributed among circadian phases. This ensures that within a single cell biochemically incompatible processes are separated in time. Molecularly, different phases of expression can be regulated in various ways: the expression of so-called first-order ▶clock-controlled genes is directly regulated by components of the core oscillator. These rhythmic gene products themselves can regulate rhythmic processes further

downstream, which may even be tissue-specific. Thereby, a complex hierarchy of rhythmic expression patterns with varying phases may emerge regulating the rhythmic physiology specific for a given tissue.

## Entrainment

While the SCN clock is synchronized to the geophysical time (▶entrainment) by light-dark cycles, peripheral cells of mammals are not light-sensitive. Hence, daily ▶non-photic resetting cues are required for a correct phase relation among SCN and peripheral tissues. Up to now, the identity of these cues is unknown, although it is likely that many factors contribute to the entrainment of peripheral oscillators. Humoral as well as neuronal signals emanating from the SCN have been suggested to entrain peripheral oscillators. There are neural outputs from the SCN to peripheral organs via the autonomic nervous system, indicating direct (multisynaptic) neural control. Glucocorticoid hormones are prominent candidate factors, since (i) they are able to strongly phase-shift peripheral oscillators both *in vitro* and *in vivo* and (ii) the SCN regulates the rhythmic expression of glucocorticoid hormones *via* the hypothalamic-pituitary-adrenal axis. In addition, several more indirect routes are discussed to be involved in the daily resetting of peripheral oscillators. (i) The SCN directly regulates daily activity-rest cycles and thus also rhythmic food consumption. While feeding time has almost no effect on the SCN clock, peripheral oscillators are strongly influenced by restricted feeding schedules [8]. If food is available only in the inactive phase, the molecular circadian clock in the periphery is completely uncoupled from the SCN and synchronizes to the restricted feeding rhythm (see also: ▶food entrainable oscillator). It has therefore been speculated that peripheral clocks sense the metabolic state, which would impinge on the molecular properties of the cellular oscillator and thereby phase-reset the molecular clock [9]. (ii) The circadian clock in the SCN regulates rhythmic fluctuations in core body temperature. These temperature rhythms are sufficient to entrain cultured fibroblasts [10]. Thus, it is conceivable that body temperature rhythms contribute to the entrainment of peripheral oscillators. Together, it seems likely that a variety of pathways are involved in the daily entrainment of peripheral oscillators, and different tissues may require different resetting cues.

## References

1. Balsalobre A, Damiola F, Schibler U (1998) A serum shock induces circadian gene expression in mammalian tissue culture cells. *Cell* 93:929–937
2. Yagita K, Tamanini F, van Der Horst GT, Okamura H (2001) Molecular mechanisms of the biological clock in cultured fibroblasts. *Science* 292:278–281

3. Nagoshi E, Saini C, Bauer C, Laroche T, Naef F, Schibler U (2004) Circadian gene expression in individual fibroblasts: cell-autonomous and self-sustained oscillators pass time to daughter cells. *Cell* 119:693–705
4. Pando MP, Morse D, Cermakian N, Sassone-Corsi P (2002) Phenotypic rescue of a peripheral clock genetic defect via SCN hierarchical dominance. *Cell* 110:107–117
5. Kornmann B, Schaad O, Bujard H, Takahashi JS, Schibler U (2007) System-driven and oscillator-dependent circadian transcription in mice with a conditionally active liver clock. *PLoS Biol* 5:e34
6. Storch KF, Paz C, Signorovitch J, Raviola E, Pawlyk B, Li T, Weitz CJ (2007) Intrinsic circadian clock of the Mammalian retina: importance for retinal processing of visual information. *Cell* 130:730–741
7. Durgan DJ, Trexler NA, Egbejimi O, McElfresh TA, Suk HY, Petterson LE, Shaw CA, Hardin PE, Bray MS, Chandler MP, Chow CW, Young ME (2006) The circadian clock within the cardiomyocyte is essential for responsiveness of the heart to fatty acids. *J Biol Chem* 281:24254–24269
8. Damiola F, Le Minh N, Preitner N, Kornmann B, Fleury-Olela F, Schibler U (2000) Restricted feeding uncouples circadian oscillators in peripheral tissues from the central pacemaker in the suprachiasmatic nucleus. *Genes Dev* 14:2950–2961
9. Rutter J, Reick M, Wu LC, McKnight SL (2001) Regulation of clock and NPAS2 DNA binding by the redox state of NAD cofactors. *Science* 293:510–514
10. Brown SA, Zumbrunn G, Fleury-Olela F, Preitner N, Schibler U (2002) Rhythms of mammalian body temperature can sustain peripheral circadian clocks. *Curr Biol* 12:1574–1583

---

## Peripheral Proteins

### Definition

Protein molecules that are anchored to either the cytoplasmic or extracellular side, such as intracellular signaling components, immunoglobulins and structural proteins.

- ▶ Membrane Components

---

## Peripheral Receptor

### Definition

The peripheral receptor is the junction site of peripheral autonomic nerve terminals on target organs. Receptors of sympathetic nerves contain noradrenaline (norepinephrine), except sweat glands, as neurotransmitter.

These include adrenergic  $\alpha$  and  $\beta$  receptors. Receptors of sweat glands contain acetylcholine as a neurotransmitter. Parasympathetic nerve receptors contain acetylcholine as a transmitter.

- ▶ Acetylcholine
- ▶ Noradrenaline
- ▶ Parasympathetic Pathways
- ▶ Sympathetic Pathways

---

## Peripheral Rhythms

### Definition

Circadian rhythms of molecular, physiological or behavioural parameters, which are generated in cells, tissues or organs outside of the suprachiasmatic nucleus (the site of the master oscillator in mammals).

- ▶ Circadian Rhythm
- ▶ Clock Coupling Factors
- ▶ Suprachiasmatic Nucleus

---

## Peripheral Sensitization

### Definition

Sensitization of nociceptors for mechanical, thermal and chemical stimuli.

- ▶ Hyperalgesia and Allodynia
- ▶ Joint Pain

---

## Peripheral Synapse

### Definition

A synapse that is located outside of the central nervous system. An example of a peripheral synapse is the neuromuscular junction where axons of motoneurons synapse with muscle fibers. Another example is the myenteric plexus of the enteric nervous system.

- ▶ Neuromuscular Junction (NMJ)



## Peripheral Vestibular Apparatus

J. DAVID DICKMAN

Department of Anatomy and Neurobiology,  
Washington University, St. Louis, MO, USA

### Definition

The *peripheral vestibular apparatus* detects head motion and position of the head in space relative to gravity. Motion detection and our sense of position in space are determined by receptors of the vestibular system that lie in the inner ear. Although not considered to be a cognitive sense, the vestibular system nonetheless contributes to the fine control of visual gaze, posture, spatial orientation and navigation. Here the peripheral receptor apparatus and its role in motion detection and spatial orientation is discussed.

### Characteristics

#### Structure of the Peripheral Vestibular Sensors

In every day life, two types of motion, rotational and linear are experienced. Orientation relative to gravity is constantly updated. Rotational motion (*angular acceleration*) is experienced during head turns, while *linear acceleration* occurs during walking, falling, leaning and during vehicular travel. *Linear accelerations* are also experienced during head tilts relative to gravity. Detection of motion and spatial position begins with the vestibular receptors lying in the inner ear. These receptors then send this information to the brain, where it is integrated into a uniform signal regarding direction and speed of motion, as well as the position of the head in space. In the brain, signals from vestibular receptors combine with information from other systems detecting motion such as the muscle proprioceptors and visual receptors. Central processing of these multimodal signals occurs very rapidly to ensure adequate coordination of visual gaze and postural responses (balance), autonomic responses and awareness of spatial orientation.

#### Vestibular Labyrinth

The vestibular labyrinth of the inner ear is located in the temporal bone, lateral and posterior to the cochlea. It consists of two parts. The *bony labyrinth* houses and protects the more fragile sensory structures contained inside the *membranous labyrinth*. Five separate receptor structures are represented in the vestibular portion of the membranous labyrinth. These include *three* ▶**semicircular canals** and *two* ▶**otolith** organs. The five vestibular receptor organs on each side of the head complement each other in function. The three semicircular canals, including the horizontal, anterior and posterior canals, lie in three different head planes and respond to rotational head movements [1]. The two

otolith organs, including the ▶**utricle** and ▶**sacculle**, perceive linear motions of the head (*linear accelerations*) and the orientation of the head relative to gravity [2]. Each of the semicircular canals and otolith organs are spatially aligned so as to be maximally sensitive to movements in specific directions. For example, the horizontal semicircular canal and the utricle both lie in a plane roughly equivalent to that of the head held during normal walking posture. In humans, that plane lies about 30° elevated from the naso-occipital axis. In contrast, the vertical canals and the sacculle lie in vertical head planes, nearly orthogonal to the horizontal semicircular canal. Each of the canals on one side of the head works in opposite fashion to their counterparts in the contralateral ear. Together, receptors inside the semicircular canals and otolith organs can respond to head motion in any spatial direction. The membranous labyrinth consists of a series of fluid-filled tubes and sacs where the mechanics of motion detection and transduction occur. Surrounding the membranous labyrinth is a fluid called ▶**perilymph**. It is similar to cerebral spinal fluid and has a high concentration of sodium. Inside the membranous labyrinth, where the vestibular receptors lie is a very different fluid called ▶**endolymph**, which is similar to intracellular fluid, with a high concentration of potassium. Endolymph is important, because it is the high potassium concentration that drives transduction of the motion detection mechanoreceptors. The receptor cells of the vestibular organs are innervated by primary afferent neurons that make up part of the *vestibulocochlear* or *VIIIth cranial nerve*. The somas of these bipolar afferents lie in the vestibular ganglion (Scarpa's ganglion) nestled in the internal *acoustic meatus*, a small shelf-like opening through which axons from the ganglion pass into the ipsilateral brainstem, cerebellum and reticular formation.

#### Hair Cells

Motion detection begins with mechanoreceptor cells in the vestibular system called ▶**hair cells** due to the many ▶**stereocilia** that project from the apical portion of the receptor cell. Each hair cell contains 50–100 stereocilia and a single longer ▶**kinocilium**. The stereocilia are oriented in a number of rows of ascending height, where the tallest stereocilia lie next to the kinocilium. There are two types of hair cells that differ in their morphology, afferent terminations and channel currents. Type I hair cells look like chalices (Fig. 1). They are completely surrounded by a unique calyx-shaped afferent terminal [3]. These type I hair cells are characterized by an inward-rectifying potassium current. Type II hair cells are cylindrically shaped and are innervated by simple synaptic boutons from the vestibular afferent fibers. Both types of hair cells exhibit excitatory synapses upon VIIIth nerve afferents, with glutamate or aspartate as the neurotransmitter. Both types of hair

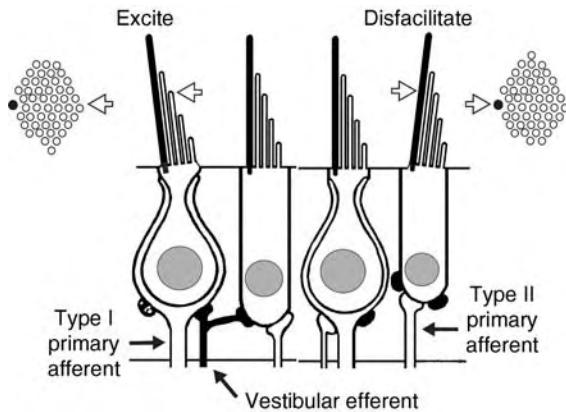

**Peripheral Vestibular Apparatus. Figure 1** Schematic of hair cells. Type I hair cells have a calyx-like form that is encapsulated by a primary afferent. Type II hair cells have a cylindrical form. The hair cell bundles contain a single kinocilium (*black*) and multiple stereocilia (*clear*). The *open arrows* indicate a deflecting force applied to hair cell bundles. To the *left*, the Type I hair cell bundle is deflected in towards the kinocilium, exciting the hair cell, increasing release of transmitter (aspartate or glutamate) and increasing the discharge of the vestibular primary afferent. To the *right*, the Type II hair cell bundle is deflected away from the kinocilium, disfacilitating the hair cell, decreasing release of transmitter and decreasing the discharge of the vestibular primary afferent. Vestibular efferents (*illustrated in black*) synapse on the primary vestibular afferents of Type I hair cells and directly on Type II hair cells.

cells also receive vestibular efferent input (acetylcholine, calcitonin gene-related peptide) from the brainstem, which is believed to be involved in controlling receptor sensitivity.

For each of the semicircular canals, the receptor hair cells lie in a specialized patch of neuroepithelium termed the *crista*. The *crista* is contained in an enlarged region of the membranous duct termed the ► **ampulla**, in the approximate center of the canal. A gelatinous structure, termed the ► **cupula**, completely covers the *crista* and forms a fluid-tight partition across the ampulla. The stereocilia of the hair cells are embedded in the gelatinous cupula. During rotational head movements, endolymph is displaced (lags behind) inside the membranous ducts due to inertia and pushes the cupular partition in a direction opposite to the head turn. In each of the three semicircular canals, the hair cells have a uniform anatomical orientation. In each hair cell the kinocilium and stereocilia have the same spatial polarization. Cupular movement causes the stereocilia and kinocilium to flex towards or away from each other. When the stereocilia bend towards the kinocilium, an excitatory generator potential is produced (see below). When they bend away from the kinocilium, hair cells become less polarized. The anatomical polarization

of hair cells within a particular semicircular canal gives rise to the directional selectivity of each vestibular organ.

Linear accelerations are detected by receptor hair cells in the otolith organs, which lie in a specialized neuroepithelium termed the *macula*. The stereocilia of the otolith hair cells extend into a gelatinous coating above the macula that is covered by thousands of calcium carbonate crystals, termed ► **otoconia** (Greek for ear stones). The otoconia, being much more dense than the surrounding endolymph are not displaced by normal endolymph movements, but instead are only moved during linear motion or changes in head position relative to gravity (linear accelerations) due to their inertia. These otoconia displacements produce bending of the underlying hair cell stereocilia.

### Mechanoelectric Transduction

Motion detection begins with the receptor hair cells, which are directionally selective to stereocilia displacement. With movements of the stereocilia towards the kinocilium, hair cell membranes are depolarized and the innervating vestibular afferent fibers increase their firing rate. However, if the stereocilia are deflected away from the kinocilium, the hair cell is hyperpolarized and the afferent fibers decrease their firing rate. This works through *mechanoelectric transduction* of specific potassium ( $K^+$ ) channels in the apical portion of the kinocilium [4]. When the stereocilia are deflected toward the kinocilium, small actin filaments open the potassium channels, allowing  $K^+$  to enter the hair cell (due to concentration gradients from the endolymph) and depolarize the cell membrane. Through a cascade of events, depolarization leads to synaptic vesicle and neurotransmitter (aspartate or glutamate) release. The transmitter binds with excitatory receptors in the post-synaptic terminal of the vestibular afferent, depolarizing the afferent and increasing its action potential firing rate. When the kinocilium and stereocilia are returned to their normal positions, voltage sensitive potassium channels at the base of the hair cell are allowed to open and release  $K^+$ , thereby repolarizing the membrane to its resting potential. When the stereocilia are deflected away from the kinocilium, more potassium channels close and further release of  $K^+$  through the basolateral potassium channels occurs, resulting in cell hyperpolarization. When the head is stationary, vestibular primary afferent fibers have a high spontaneous firing rate (approximately 90 impulses/s). The high rate allows for bidirectional response of the afferents so that silencing (rectification) of the neural response to most natural head motions does not occur.

### Morphological Polarization of Hair Cells

Since the hair cells are directionally selective, their orientation on the *cristae* and *maculae* are important for signaling direction of movement. For example, all

hair cells in the horizontal semicircular canal cristae are arranged similarly, with their kinocilium lying closest to (i.e. pointing toward) the utricle. Horizontal head rotations that produce endolymph movement toward the utricle causes deflections of the stereocilia towards the kinocilium and all of the hair cells in the horizontal semicircular canal are depolarized. Since all hair cells in each of the semicircular canals have the same anatomical orientation, the geometry of the canals determines directional selectivity (Fig. 2a).

The kinocilia of utricular hair cells are oriented towards an imaginary line that runs through the center of the utricular macula. This imaginary line corresponds to a physical structure termed the ▶ **striola**, a dense pile of small otoconia on the surface membrane of the macula. (Fig. 2c). On either side of the striola the kinocilium-stereocilia axes are oppositely polarized. The hair cells in the saccular macula have a similar polarization on opposite sides of the striola (Fig. 2b).

Hair cells in the utricular macula encode linear acceleration in the horizontal plane. Hair cells in the saccular macula encode linear acceleration in the vertical plane. However, since both the saccular and utricular maculae have curved surfaces and since the striola is also curved, linear motions along any direction in three-dimensional space will excite a subpopulation of hair cells.

### Semicircular Canal Function

The membranous semicircular duct consists of a fluid-filled tube with a partition (the cupula) in the middle. When the head is stationary, no rotational acceleration is imparted to the semicircular canals and no endolymph flow occurs. The afferents from the complementary canals on both sides of the head have nearly equivalent firing rates. When the head turns, say about the vertical axis, as in shaking the head to indicate “no,” the horizontal semicircular canals turn with it,

leaving the endolymph fluid behind (lagging the duct) due to inertial forces and viscous drag between the fluid and the walls of the canals. The relative endolymph movement on one side of the head pushes the cupula partition and produces stereocilia deflection towards the kinocilium, while the endolymph movement on the opposite side causes stereocilia deflection away from the kinocilium. Depending upon the direction (toward/away from the kinocilium) stereocilia deflection elicits either depolarization or hyperpolarization of the hair cell membrane. With a leftward head turn, the stereocilia in the left horizontal semicircular canal will be deflected toward the kinocilium resulting in increased discharge of the left VIIIth nerve afferents. Conversely, the right horizontal canal hair cells will be hyperpolarized, since the stereocilia are deflected away from the kinocilium, producing decreased firing rates in right VIIIth nerve fibers. With a rightward head turn, the opposite activation pattern in the hair cells and afferents will be produced.

This functional coupling of the two horizontal semicircular canals also applies to pairs of vertical semicircular canals. For example, the left posterior semicircular canal lies in roughly the same plane as the right anterior semicircular canal. When the head is moved in an angle of about 45° off an imaginary sagittal plane through the head, the discharge from afferents of one of these vertical canals increases and the discharge from the other decreases.

Neural information carried on vestibular afferent fibers from both the left and right semicircular canals is transmitted into the vestibular nuclei. Many neurons in the vestibular nuclei receive information from receptors on both sides of the head, so that coding of rotation direction can be very precise. Due to the mechanics of the semicircular canal system, as well as the transduction properties of pre- and post-synaptic processing, semicircular canal afferents encode head velocity and

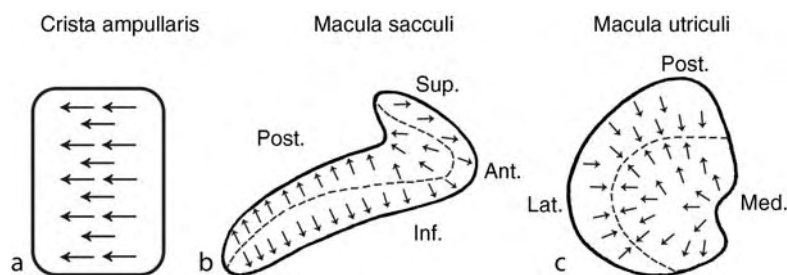

**Peripheral Vestibular Apparatus. Figure 2** Hair cell polarization in a semicircular canal crista and in saccular and utricular maculae. Hair cell polarization is indicated by the orientation of the multiple stereocilia with respect to the single kinocilium. (a) In a semicircular canal crista ampullaris the polarization of hair cells is uniform as indicated by the alignment of the arrows. (b) The polarization of hair cells in the saccular macula is opposite on either side of the dividing line that corresponds to the striola, indicated by the dashed line. Note that the saccular macula is aligned with the sagittal plane. (c) The polarization of hair cells in the utricular macula is also opposite on either side of the striola. The predominant polarization of hair cells in the utricular macula is mediolateral.

are band limited in their response to motion. Very slow head rotations (e.g. less than 3–4°/s) produce little response. Instead, afferents are most responsive to rotation speeds between 10 and 150°/s [5], which is in the most often produced range of human head movements.

### Otolith Function

Linear motion or changes of head position with respect to gravity (rolled or pitched) causes otoconial displacement due to inertia and consequent deflection of stereocilia in otolithic hair cells. Similar to semicircular canal receptors, otolith hair cells are either depolarized or hyperpolarized by stereocilial deflection toward or away from the kinocilium. Thus, a topographic coding of directional space or movement is represented by the activation of hair cells in particular regions of the maculae. The innervating VIIIth nerve fibers maintain the directional signal, since each afferent only innervates hair cells from a small region on the macular neuroepithelium. Unlike semicircular canal afferents, otolith afferents respond to static head positions, slow head movements, fast head movements and even very fast vibrations with high fidelity.

### Vestibular Efferent System

Hair cells and vestibular primary afferents receive information from the brain conveyed by vestibular efferents. The vestibular efferent system (VES) consists of a group of 100–500 cells bordering the genu of the facial nerve in the dorsal brainstem whose axons terminate on vestibular primary afferents and hair cells in the labyrinth [6,7]. Neurons of the VES are cholinergic, identified by acetylcholinesterase histochemistry [7] and choline acetyltransferase immunohistochemistry [8] as well as by the retrograde transport of [<sup>3</sup>H]-choline.

The functional importance of the VES has remained an enigma because of the technical difficulty of physiologically identifying putative neurons of the VES and analyzing the response characteristics of these neurons *in vivo*. In fish, vestibular efferents can be identified physiologically and intracellularly labeled [9]. In the chinchilla, indirect evidence suggests that vestibular efferents receive vestibular inputs from both the ipsilateral and contralateral labyrinths.

In the cat and the monkey, it is possible to study the action of the VES indirectly by electrically stimulating the region of the brain stem where the cell bodies of vestibular efferents are located and simultaneously recording the effect on the activity of single primary afferents [6]. Primary vestibular afferents in both the fish and the monkey are excited by electrical stimulation of vestibular efferents [6,9].

Two similar ideas have been proposed to explain the function of the VES. (i) Vestibular efferents are used to establish an operating point on the sensitivity curve

for primary vestibular afferents so that in different vestibular environments these afferents can be modulated within a linear range [6] and (ii) vestibular efferents detect behavioral arousal and thereby lower the threshold of vestibular primary afferents, thereby facilitating guidance of escape behaviors [9]. Implicit in these two ideas is the necessity of a central correlative efferent signal, so that changes in primary afferent activity induced by vestibular efferent signals can be distinguished from changes in primary afferent activity caused by peripheral vestibular stimulation. Such modifications could take tens of milliseconds or tens of minutes.

### Regeneration of Hair Cells

Remarkably, in many vertebrates including amphibians, reptiles and birds, hair cells and their innervating afferents spontaneously regenerate [10]. Spontaneous *regeneration* of mammalian hair cells does not occur. However, recent developments in promoting mammalian regeneration provide renewed hope for restoring hearing and balance following hair cell loss.

### References

1. Fernandez C, Goldberg JM (1971) Physiology of peripheral neurons innervating semicircular canals of the squirrel monkey. II. Response to sinusoidal stimulation and dynamics of peripheral vestibular system. *J Neurophysiol* 34:661–675
2. Fernandez C, Goldberg JM (1976) Physiology of peripheral neurons innervating otolith organs of the squirrel monkey. I. Response to static tilts and to long-duration centrifugal force. *J Neurophysiol* 39:970–984
3. Lindeman HH (1973) Anatomy of the otolith organs. *Adv Otorhinolaryngol* 20:405–433
4. Hudspeth AJ (2005) How the ear's works work: mechano-electrical transduction and amplification by hair cells. *C R Biol* 328:155–162
5. Hullar TE, Della Santina CC, Hirvonen T, Lasker DM, Carey JP, Minor LB (2005) Responses of irregularly discharging chinchilla semicircular canal vestibular-nerve afferents during high-frequency head rotations. *J Neurophysiol* 93:2777–2786
6. Goldberg JM, Fernandez C (1980) Efferent vestibular system in the squirrel monkey: anatomical location and influence on afferent activity. *J Neurophysiol* 43:986–1025
7. Warr WB (1975) Olivocochlear and vestibular efferent neurons of the feline brain stem: Their location, morphology and number determined by retrograde axonal transport and acetylcholinesterase histochemistry. *J Comp Neurol* 161:159–181
8. Schwarz DWF, Satoh K, Schwarz IE, Hu K, Fibiger HC (1986) Cholinergic innervation of the rat's labyrinth. *Exp Brain Res* 64:19–26
9. Highstein SM, Baker R (1985) Action of the efferent vestibular system on primary afferents in the toadfish, *Opsanus tau*. *J Neurophysiol* 54:370–384
10. Zakir M, Dickman JD (2006) Regeneration of vestibular otolith afferents after ototoxic damage. *J Neurosci* 26:2881–2893

## Peripheral Vision

### Definition

Vision excluding the 5°–10° most central area of the visual field (foveal and peri-foveal vision). Peripheral vision is specialized for low spatial frequency and high temporal frequency stimuli, is not sensitive to wavelength (achromatic) and has a low sensitivity/rapid adaptation to light intensity (scotopic).

#### ► Visual Field

## Peristalsis

### Definition

Peristalsis is the propagating contraction of the circular muscle layer of the bowel. The contractions develop into peristaltic waves moving along the gut and provide the forces for propelling bowel contents usually in an aboral direction. The peristaltic waves occur intrinsically at a frequency of 3 per/min, but they usually travel only a short distance.

## Peristalsis in the Small Bowel

### Definition

Peristalsis is the propagating contraction of the circular muscle layer. The contractions develop into peristaltic waves moving along the gut and provide the forces for propelling bowel contents usually in an aboral direction.

The peristaltic waves occur intrinsically at the frequency of 3/min, but they usually travel only a short distance.

#### ► Bowel Disorders

## Peristimulus Time Histogram (PSTH)

### Definition

Cumulative histogram of the number of spikes occurring within discrete time bins in and around the time of a repeated presentation of an auditory stimulus.

## Perisynaptic Schwann Cells

### Definition

Schwann cells normally encase axons in peripheral nerves to form the insulating myelin sheath. At the neuromuscular junction between the motor nerve and the endplate region of each skeletal muscle cell, there are Schwann cells that do not form myelin but normally respond to the chemical neurotransmitter substance, acetylcholine, that is released from active nerve terminals to excite the skeletal muscle fibers and in turn, lead to muscle contraction. These Schwann cells are termed perisynaptic Schwann cells because they are at the synaptic region of each muscle fiber.

- Acetylcholine
- Axonal Sprouting in Health and Disease
- Myelin
- Schwann Cell

## Periventricular Zone

### Definition

The periventricular region of the thalamus has poorly defined cell groups that are sometimes homologized with the midline thalamic groups seen in non-primates such as nucleus reunions, rhomboid nucleus, and median central nucleus. It is likely that the region is involved in visceral activities in that it has connections to the hypothalamus, amygdala, and cingulate cortex.

## Permeabilized Skeletal Muscle Fibers

### Definition

Experimental model using single muscle fibers after membrane destruction via detergents or other means. Membrane destruction renders the contractile proteins actin and myosin directly accessible to the external media.

#### ► Force Potentiation in Skeletal Muscle

## Per-Rotatory Vestibular Nystagmus

### Definition

Nystagmus produced during prolonged rotation of the head in space. For rapid initiation of rotation, the slow phase velocity rises sharply at the start of rotation and declines to zero as the rotation continues at a constant velocity.

► Nystagmus

## Persephin

### Definition

A member of the glial cell line-derived neurotrophic factor (GDNF) family of neurotrophic factors that also includes artemin and neuroturin. GDNF family members use a receptor complex that consist of the common receptor tyrosine kinase signaling component Ret and one of the GPI-linked receptors (GFR $\alpha$ 1 to 4) that regulate ligand binding specificity. GFR $\alpha$ 4 is the preferred receptor for persephin.

► Neurotrophic Factors in Nerve Regeneration

## Persistent Na<sup>+</sup> Currents

### Definition

Persistent Na<sup>+</sup> currents are TTX-sensitive, voltage-dependent Na<sup>+</sup> currents flowing at voltages between -65 and -40 mV, and thus significantly influencing sub-threshold membrane potential changes and the firing rate and pattern of discharge.

► Action Potential  
► Sodium Channels  
► Tetrodotoxin

## Persistent Vegetative State

### Definition

This state results from damage of cortical neurons (particularly ► pyramidal cells) in ► hippocampus and

► cerebral cortex after prolonged hypoxia or ischemia. One to two weeks of coma may be followed by a state similar to that of ► hydrocephalic children, in which patients appear awake, may smile, cry, fixate objects, or eat food put in their mouth, but have no cognitive relation to their environment.

## Personal Knowledge

### Definition

Personal knowledge is knowledge possessed by a person (not for example by a scientific community or culture etc.).

► Knowledge

## Personality Disorder

ANNETTE BÖLTER, JÖRG FROMMER  
Universitätsklinikum Magdeburg, Abteilung für Psychosomatische Medizin und Psychotherapie, Magdeburg, Germany

### Synonyms

Character neurosis; Characterogenic neurosis; Auto-psychic neurosis; Psychopathic personality

### Definition

A heterogeneous group of disorders, regarded as long-standing, pervasive, inflexible and maladaptive personality traits, patterns of behavior and thinking that impair social and occupational functioning.

### Characteristics

Personality disorders are coded on Axis II of DSM. They are often comorbid with an Axis I disorder and can serve as a context for Axis I problems, for example depression or anxiety disorder, shaping them in different ways. The symptoms come close to describing characteristics that all people possess from time to time and in varying degrees, however the diagnoses of a personality disorder is defined by the extremes of several traits and is not used unless the patterns of behavior are enduring, pervasive and dysfunctional.

Beside personality disorders DSM-IV distinguishes personality change, for example after a major medical condition. Five subtypes of personality change are listed: labile, disinhibited, aggressive, apathetic and paranoid.

### Categories and Clusters of Personality Disorders

DSM-IV distinguishes ten subgroups: (i) Paranoid, (ii) Schizoid, (iii) Schizotypal, (iv) Borderline, (v) Histrionic, (vi) Narcissistic, (vii) Antisocial, (viii) Dependent, (ix) Avoidant, (x) Obsessive-compulsive (►**Obsessive-Compulsive Disorder [OCD]**). In DSM-IV these subtypes are also grouped into three clusters: Cluster A (paranoid, schizoid, schizotypal) is defined by characteristics of being odd or eccentric. Because the symptoms of these disorders are similar to those of the prodromal or residual phases of schizophrenia, they are considered by some researchers to be less severe variants of schizophrenia. Individuals in cluster B (antisocial, borderline, histrionic and narcissistic) appear dramatic, emotional or erratic. Those in cluster C (avoidant, dependent and obsessive-compulsive) seem anxious or fearful.

### Diagnosis

Although there do exist some diagnostic questionnaires, personality disorders are preferably assessed by structured interviews. In recent years these diagnoses have become reliable in some degree. But it is still usual for a disordered person to meet diagnostic criteria for more than one personality disorder. The categorical diagnostic system of DSM-IV therefore may not be ideal for classifying personality disorders. A dimensional approach may be more appropriate. During recent years different contributions on personality disorders emerged from several psychological paradigms: understanding on the basis of modern psychoanalysis and attachment theory, approaches based upon the five-factor model of personality, cognitive theories and Linehan's behavioristic approach, interpersonal concepts as shown by Benjamin, neurobiological models, and a self-developed approach focusing on private theories of the patients themselves.

### Therapy

A therapist who is working with patients that have a personality disorder is typically also concerned with Axis I problems because most patients even enter treatment because of Axis I disorder. For example, a person with avoidant personality disorder may be seen for social phobia. Psychodynamic therapy of personality disorders has a long tradition. It aims to remove repressions and to correct the problems underlying the personality disorder. Transference-Focused Psychotherapy as developed by Kernberg is a psychodynamic

treatment designed especially for patients with severe personality disorders, e.g. ►**borderline personality disorders**. The focus of treatment is on a deep psychological make up – a mind structured around a fundamental split that determines the patient's way of experiencing self and others and the environment. Since this internal split determines the nature of the patient's perceptions, it leads to the chaotic interpersonal relations, impulsive self-destructive behaviors, and other symptoms. The core task in Transference-Focused Psychotherapy is to identify the patient's moment-to-moment experience of the therapist because it is believed that the patient lives out his/her predominant object relation patterns in the patient-therapist-relationship. Another successful approach is Dialectical Behavior Therapy as developed by Linehan. During individual and group therapy, therapist and client work towards improving skill use. These skills are broken down into four modules: mindfulness (derived from Zen tradition), interpersonal effectiveness, distress tolerance, and emotion regulation. In addition common treatments of personality disorder are psychopharmacological drugs. The choice is determined by the associated Axis I disorder.

### References

1. American Psychiatric Association (1994) Diagnostic and statistical manual of mental disorders, DSM-IV. American Psychiatric Association, Washington
2. Costa PT, Widiger TA (eds) (1993) Personality disorders and the five-factor model of personality. American Psychological Association, Washington
3. Frommer J, Reissner V, Tress W, Langenbach M (1996) Subjective theories of illness in patients with personality disorders *Psychother Res* 6:56–69
4. Kernberg OF (1984) Severe personality disorders: psychotherapeutic strategies. Yale University Press, New Haven
5. Lenzenweger MF, Clarkin JE (2005) Major theories of personality disorders, 2nd edn. Guilford Press, New York
6. Linehan MM (1993) Cognitive-behavioral treatment of borderline personality disorder. Guilford Press, New York
7. Millon T (1996) Disorders of personality: DSM-IV and beyond, 2nd edn. Wiley, New York
8. Yeomans FE, Clarkin JF, Kernberg OF (2002) A primer of transference-focussed psychotherapy for the borderline patient. Jason Aronson, Northvale, NJ

## Pesticide: Insecticide

►**Neuroinflammation: Modulating Pesticide-Induced Neurodegeneration**

## PET

### Definition

► Positron Emission Tomography

activities and behaviors. It might also entail enhancement of learning new information and behaviors in the adult during REM sleep.

- Rapid Eye Movement (REM) Sleep
- Sleep-Wake Autonomic Regulation

## Petit Mal Seizures

### Definition

► Absence Epilepsy

## P23H Rat

### Definition

Transgenic rat model of human Proline-23-Histidine rhodopsin mutation leading to Retinitis Pigmentosa.

► Inherited Retinal Degenerations

## PFC

### Definition

Prefrontal cortex.

► Prefrontal Cortex

## Phagocytic

### Definition

Activity of cells called phagocytes which engulfs and absorbs waste material, harmful microorganisms, or other foreign bodies in the bloodstream and tissues.

## PGO Spikes

### Definition

Ponto-geniculo-occipital; high amplitude sharp waves, which originate in the pons, are transmitted to the lateral geniculate and from there up to the occipital cortex, where they are recorded in cats during rapid eye movement (REM) sleep. PGO spikes reflect bursts of discharge by neurons in the pontine reticular formation which are transmitted rostrally into the visual and also other relay nuclei of the thalamus by which they are transmitted to cortical areas. This phasic activity is also transmitted to brainstem motor nuclei, as reflected in rapid eye movements, and spinal motor nuclei, as reflected in twitches of the distal extremities. Such twitches can be observed as manifestation of the phasic excitation through the brain during REM sleep which occurs in all mammals. As proposed by some, PGO spiking might signify a programming of the brain and organism during development in species-specific motor

## Phantom Limb Sensation and Pain

MIKE B. CALFORD

School of Biomedical Sciences and Hunter Medical Research Institute, The University of Newcastle, Newcastle, NSW, Australia

### Definition

When appropriately studied, it is usually reported that all adults who have had a limb amputated either by trauma or surgery have at some stage experienced the continued presence of the missing limb within their perceptual body image. The full range of somatosensory percepts (cutaneous touch, deep touch, vibration, itch, tickle, joint movement etc) are variously ascribed to the phantom. Attribution of pain to a phantom limb is a distinct phenomenon with widely varying reports of prevalence. Recent studies have reported higher proportions of cases with phantom limb



pain (60–80%) and there is a possibility that earlier reports were affected by patient reluctance to describe their experience.

Those with spinal cord injury (paraplegia, quadriplegia) rarely localize non-painful somatosensory percepts to their affected limbs. However they usually retain these limbs within their body image and sometimes attribute full function to them – a form of *anosognosia* also found in some cases of stroke-induced hemiplegia. There is no consensus view of the prevalence of phantom pain after spinal cord injury. This may be attributable to varying pathology and to the extent of the lesion. Irrespective of this, there are many well-described cases of phantom limb pain after complete spinal transection.

*Supernumerary limb* is a term that encompasses various presentations of the appearance of a third (or more) arm or leg in the perceptual body image. A similar misperception can occur temporarily with brachial plexus nerve block, but it is a rare chronic condition usually following transient middle cerebral artery ischemia or mild neurotrauma. *Alien hand* syndrome describes the converse condition in which, after mild neurotrauma, an intact limb is lost to the perceptual body image and its presence denied or disowned.

## Characteristics

Phantom limb experiences manifest immediately or within a few days of an amputation. In a minority of cases, phantom sensations persist relatively unchanged. In other cases, the phantom sensations and the perceptual body image alters. With upper limb amputation, a loss of the image of the arm but retention of the phantom hand is classically described – but there are many variations. The phantom sensations disappear after a few months to years in around 50% of cases. However, in laboratory conditions with stimulation of the amputation stump (or other body parts) or with imagery, elements of a phantom limb experience can be elicited in most amputees even years after they have reported loss of the phantom sensations. Cortical activation achieved through caloric ear stimulation is reported to recall lost phantom sensations and also to alleviate temporarily painful phantom sensation by replacement with a nonpainful phantom [1].

Phantom limb pain shares many characteristics with neuropathic pain and is equally difficult to account for. Pain sensations are rarely continuous but chronic presentation of repetitive bouts is common. Phantom pain can mimic the presentation of a pre-amputation chronic pain. It is becoming widespread practice to provide limb analgesia prior to a surgical amputation. This practice has followed a number of case reports indicating that such post-amputation mimicry is thereby avoided. Nevertheless, clear evidence of efficacy for pre-surgery limb analgesia is not apparent [2].

The highly plastic nature of the somatosensory perception of the limbs can be easily demonstrated. When operating a hammer, pointer, golf club, stilts or sword, we readily telescope our body image to include the extension. In such an operation, sensory inputs from receptors in the hand or arm are combined and interpreted to provide a “percept” from the tip of the extension. While training improves performance, the extension of percept to encompass tool use by either upper or lower limb is largely automatic. In complex multisensorimotor tasks with machines (such as driving a car), we are capable of integrating a variety of somatosensory, visual and auditory cues to expand our body image to the limits of the machine or task. Within this context, it is then somewhat surprising that essentially 100% of limb amputees experience a phantom experience of their missing part, rather than adapt their body image to encompass the amputation. Nevertheless, after amputation the plastic nature of the body image is not lost, for in most cases the phantom image locks onto a prosthetic and adapts to tool use.

Melzack [3] reasoned that the perceptual experience of a limb does not derive from activation of a single brain area but from the combined output of a distributed network, termed the neuromatrix. To account for the persistent nature of phantom limb perception, in the light of considerable physiological and psychophysical evidence of plasticity, it was concluded that, when activated, elements of the overall network retain the identity of the former limb. On the basis of reports of phantom limb experiences in some cases of congenitally missing limbs, it was further suggested that the identity of a given neuromatrix is genetically predetermined. This latter suggestion remains contentious, but the broader neuromatrix concept is well accepted and is consistent with recent work.

Ramachandran and others [4,5] have described many cases in which passive cutaneous stimulation of either the amputation stump or a distant body area (e.g. face for upper limb amputation) produces a dual sensation with one being localized to the phantom. In some cases, a clear topographic map of the phantom can be plotted. These demonstrations reveal both plasticity and rigidity in the somatosensory representation of the limb consistent with the concept that some elements of the neuromatrix retain their original perceptual attribution.

Extensive plasticity of the primary somatosensory representation has been demonstrated in monkeys and other mammals. With upper limb amputation or deaf-ferentation the former arm and hand representation is taken over by a responsiveness to adjacent body areas, the back of the head and the face [6]. There is a considerable immediate unmasking effect [7] such that some areas immediately switch to show new responsiveness, but the total filling-in of the former representation develops over a longer period. The

somatosensory representation in the cortex is distributed across at least seven fields in central and parietal regions. Each is organized as a topographic map of the contralateral body and there is a partial specialization of function. Thus, for example, muscle spindles are the predominant input to one field (area 3a) while cutaneous receptors dominate others. There is, however, no cortical field devoted to or dominated by pain perception. Rather the nociceptive pathway, although separate in the spinal cord and brainstem, feeds into the major (lemniscal) somatosensory thalamocortical pathway. This may be an important aspect in any explanation of phantom limb pain, as those with persistent phantom pain could be shown with neuroimaging to have a reorganization within the primary somatosensory cortex, whereas those with an innocuous phantom did not [8]. Consistent with the reorganization reported in the monkey studies, this reorganization involved expansion of the cutaneous representation of the chin and lips into the former arm and hand area. The extent of the reorganization was highly correlated with the degree of phantom pain suggesting that activation of the cutaneous receptors of other body areas provides inappropriate stimulation to the cortical representation of the former pain signaling neurons of the missing limb. It needs to be noted that such reasoning is over simplistic if applied to any single representation since pain perception is likely to involve activation of multiple fields.

A consistent approach to managing or treating phantom pain has not developed to date. The linking of phantom pain to cortical reorganization phenomena and the knowledge that cortical representations are inherently plastic has led to investigations of potential therapies based around manipulating the reorganization, using pharmacological or physical therapy approaches [2]. Use of mirrors to aid in mental imagery to “move” the phantom limb has been reported to be successful in some cases [9]. Whereas treatments (e.g. stump analgesia) aimed at silencing a supposed overly active peripheral nerve are not generally useful, there were persistent early reports that a subgroup are helped by reducing sympathetic activity and sympathetic disturbance is often found. A plausible explanation for sympathetic activity directly affecting sensory nerves has come from animal work showing sprouting of noradrenergic sympathetic axons into the dorsal root ganglion following a peripheral nerve injury. Nevertheless, overall there is no supporting evidence for using sympathectomy as a treatment for neuropathic pain and hence for phantom pain [10].

## References

1. Andre JM, Martinet N, Paysant J, Beis JM, Le Chapelain L (2001) Temporary phantom limbs evoked by vestibular caloric stimulation in amputees. *Neuropsychiatry Neuropsychol Behav Neurol* 14:190–196
2. Flor H (2002) Phantom-limb pain: characteristics, causes, and treatment. *Lancet Neurol* 1:182–189
3. Melzack R (1990) Phantom limbs and the concept of a neuromatrix. *Trends in Neurosci* 13:88–92
4. Halligan PW, Marshall JC, Wade DT, Davey J, Morrison D (1993) Thumb in cheek? Sensory reorganization and perceptual plasticity after limb amputation. *Neuroreport* 4:233–236
5. Ramachandran VS, Stewart M, Rogers-Ramachandran DC (1992) Perceptual correlates of massive cortical reorganization. *Neuroreport* 3:583–586
6. Pons TP, Garraghty PE, Ommaya AK, Kaas JH, Taub E, Mishkin M (1991) Massive cortical reorganization after sensory deafferentation in adult macaques. *Science* 252:1857–1860
7. Calford MB, Tweedale R (1990) Interhemispheric transfer of plasticity in the cerebral cortex. *Science* 249:805–807
8. Flor H, Elbert T, Knecht S, Wienbruch C, Pantev C, Birbaumer N, Larbig W, Taub E (1995) Phantom-limb pain as a perceptual correlate of cortical reorganization following arm amputation. *Nature* 375:482–484
9. Ramachandran VS, Hirstein W (1998) The perception of phantom limbs. The D. O. Hebb lecture. *Brain* 121:1603–1630
10. Mailis A, Furlan A (2003) Sympathectomy for neuropathic pain. *Cochrane Database Syst Rev* CD002918

## Phantosmia

### Definition

Describes the distorted perception of smells in the absence of an odor source. Most often, phantosmias occur after trauma or URTI and consist of unpleasant odors occurring without being elicited through environmental odor sources. Phantosmias also have a tendency to disappear over the course of years.

- ▶ [Smell Disorders](#)
- ▶ [Olfactory Hallucinations](#)

## Pharmacodynamics

### Definition

Pharmacodynamics refers to the biochemical and physiological effects of drugs on the body.

## Pharmacogenomics

### Definition

The science of understanding how an organism's genetic inheritance (i.e. genotype) affects the body's response to drugs.

routine. (Lunch typically tastes better in Paris.) In order for an oscillator to entrain to signals from a pacemaker that has a shorter period, it must execute phase advances.

- ▶ Phase Advance Curve
- ▶ Oscillator
- ▶ Pacemaker

## Pharmacokinetics

### Definition

A branch of pharmacology that concerns itself with the process in which drug is absorbed, distributed, metabolized and eliminated by the body.

## Phase Angle

### Definition

The displacement, in units of time or angular degrees, between phases of two coupled oscillators, e.g., a circadian oscillator and a light-dark cycle.

- ▶ Circadian Rhythm
- ▶ Phase Advance Curve

## Pharmacophore

### Definition

Pharmacore is defined as a set of structural features in a molecule that is recognized at a receptor site and is responsible for that molecule's biological activity.

## Phase Delay

### Definition

A shift that sets back the time of arrival of an oscillator at a particular event marker phase. For example, flying from Paris to New York results in a 6 h phase delay of the light-dark cycle, since dusk arrives 6 h later in New York than in Paris. When people are eating supper in Paris, people in New York are eating lunch – they are at an earlier phase of their daily routine. In order for an oscillator to entrain to signals from a pacemaker that has a longer period, it must execute phase delays.

- ▶ Oscillator
- ▶ Pacemaker
- ▶ Phase Advance Curve

## Phase

### Definition

Any point on a cycle; the instantaneous state of a periodic process.

## Phase Advance

### Definition

A shift that accelerates (advances) the arrival of an oscillator at a particular event marker (phase). For example, flying from New York to Paris results in a 6 h phase advance of the light-dark cycle, since dawn in Paris is 6 h ahead of dawn in New York. When people are getting up in New York, people in Paris are eating lunch – they are already at a later phase of their daily

## Phase Locking

### Definition

Phase locking is a term that describes the auditory nerve's ability to discharge in synchrony with the acoustic stimulus. Auditory neurons do not fire on

every cycle of a sinusoidal acoustic sound, but rather fire stochastically on a specific phase of the stimulus.

### ► Cochlear Implants

## Phase Locking in Auditory System

### Definition

Phase locking describes the ability of a neuron to fire action potentials that are time locked to a stimulus event. In auditory neurons, phase locking is used in the context of pure tones, consisting of a single sine wave. Auditory neurons in barn owls phase lock to as high as 10 kHz, in mammals phase locking does not occur above, roughly, 4 kHz.

Phase locking requires temporal precision in action potential timing, with standard deviations of fewer than 100  $\mu$ s at some frequencies.

- Intrinsic Properties of Auditory Neurons
- Neuroethology of Sound Localization in Barn Owls

## Phase Relations

### Definition

Phase relations refer to the temporal relationship between coupled elements expressed as a fraction (degrees or radians) of the cycle time.

## Phase Response Curve

CHRISTOPHER S. COLWELL  
Department of Psychiatry, University of California,  
Los Angeles, USA

### Synonyms

PRC

### Definition

Phase response curve (PRC) in a graph that plots the magnitude of phase shifts resulting from perturbations from discrete stimuli.

### Characteristics

The discrete stimuli often come in the form of light pulses, which induce ►phase delays and ►phase advances during early and late ►subjective night, respectively, but produce negligible phase shifts during subjective day. The phases in which light does not produce a ►phase shift ( $\Delta\Phi$ ) is referred to as the “dead zone” of the PRC. A variety of non-photic stimuli can also generate phase-dependent phase shifts and could potentially be used to entrain the circadian system [1]. In general, these non-photic PRCs are characterized by phase shifts during the subjective day and a dead zone during the subjective night. With both photic and non-photic stimuli, the amplitude of the PRC can vary with the strength of the stimulus.

The most straightforward way to generate a PRC is to have a population of animals in constant conditions and to measure their ►free-running rhythms. Based on these rhythms, individual organisms can then be exposed to stimuli at discrete phases of the daily cycle and the resulting phase shifts (see definition) measured by the next cycle. By convention, phase advances are plotted as positive values while phase delays are plotted as negative values. After some perturbations (especially those that cause phase advances), there can be a few days of transients before the full magnitude of the phase shift can be determined. Under the constant conditions required for these measurements, the ►period (Tau,  $\tau$ ) of the rhythm will not be equal to 24-h and the phase will need to be normalized by the endogenous period. Typically, the phases of the endogenous cycle are designated as circadian time (CT) 0–24 with the number of minutes in each hour of CT being equal to Tau/24 multiplied by 60. By definition, CT 0 is the time of activity onset for a diurnal organism while CT 12 is the time of activity onset for a nocturnal one. The phases of the endogenous cycle that coincide with the prior daytime are called “subjective day” while the phases that coincide with the prior nighttime are called “subjective night”.

PRCs have been used to explain how 24-h ►entrainment is maintained between an endogenous circadian oscillator (which has a period that is not equal to 24-h) and environmental cues. While a description of this model is well beyond the scope of this article, a simple example may be useful. If the PRC is known, then the phase relationship between environment and the endogenous ►oscillator can be predicted based on the periods of the biological oscillation (Tau) and the ►zeitgeber cycle (T) [2]. For example, if the circadian oscillator has a period of 25 h and is entrained to a light pulse every 24 h. Stable entrainment can only be reached when the light causes a phase shift that corrects the difference between Tau and T which in this case would be a phase delay of 1-h per cycle (Tau – T =  $\Delta\Phi$ ). Only when the light falls on the portion of the PRC

in the early night causing the 1-h phase delay will the biological oscillator be entrained to the physical cycle.

## References

1. Johnson CH, Elliott JA, Foster R (2003) Entrainment of Circadian Progenies. *Chronobiology International*. *Neuron* 20(5):741–774
2. Roenneberg T, Daan S, Merroa M (2003) The Art of Entrainment. *J Biological Rhythms* 18(3):183–194

## Phase Shift ( $\Delta\Phi$ )

### Definition

A shift in the phase of the biological oscillation. Phase ( $\Phi$ ) is one of the most important parameters describing any oscillation as it refers to the time points within the cycle. To measure the phase of the rhythm, a reliable reference point must be chosen. In the case of circadian oscillations, the onset of activity or the peak expression of a biochemical parameter are commonly used. These biological markers are typically expressed relative to the time of lights-on or lights-off when the organism is in a light cycle. For circadian oscillators, exposure to light is the most physiologically relevant and widely studied perturbation that results in phase shifts. Many treatments that cause phase shifts of the circadian system produce different effects depending on the time of day during which the treatment was applied.

- ▶ [Circadian Rhythm](#)
- ▶ [Phase Response Curve](#)

## Phase Spectrum

### Definition

A description of the relationship between starting phase and frequency of the sinusoidal components of a complex sound wave.

- ▶ [Acoustics](#)

## Phasic

### Definition

Transiently occurring at the onset or offset of an event.

Phasic responses indicate that the adaptation of the nervous system under consideration is rapid. Opposite term is tonic.

## Phenethylamine

### Definition

A simple molecule that serves as the framework for many biologically-active molecules, including dopamine, noradrenaline (norepinephrine), and certain hallucinogens. It is essentially a phenyl ring separated by a two carbon chain from an amino group.

- ▶ [Dopamine](#)
- ▶ [Noradrenaline](#)
- ▶ [Hallucinogens](#)

## Phenomenal Character

### Definition

The basic feature of many mental states to feel a certain way. It is somehow for an organism to be in pain, and it is also somehow for an organism to have a sensation of warmth. But these two mental states differ in phenomenal character in that it feels different for an organism to be in pain and to have a sensation of warmth.

- ▶ [Behaviorism](#)
- ▶ [Logical](#)

## Phenomenal Concepts

### Definition

Phenomenal concepts are those concepts that are immediately related to perceptions and sensations, in

such a way that one is immediately inclined to apply these concepts whenever one undergoes the appropriate experience and introspects on one's experience. Having a red experience, for example, makes one inclined to apply the phenomenal concept of a red experience.

- ▶ [The Knowledge Argument](#)

---

## Phenomenology

### Definition

“Phenomenology” means doctrine of appearances. In general it means the reflective inquiry into one's own [→] consciousness. It also names Edmund Husserl's philosophical project of studying how the world appears to us in [→] intentional consciousness. He held that intentional consciousness is intrinsically “directed” to objects. In some intentional episodes objects are merely “meant,” while in others (intuitions) objects are (partially) “given.” The “fulfillment” of the former episodes by intuitions is the basis of knowledge.

- ▶ [Argument](#)
- ▶ [Logic](#)

---

## Phenophysics

- ▶ [Psychophysics](#)

---

## Phenotype

### Definition

Two specimens of a diploid organism, such as a flowering plant, may look alike (same phenotype), even though one is homozygous for, say, red petal color (identical alleles for the gene concerned on the two homologous chromosomes) and one is heterozygous (one allele coding for white, the other one for red which is dominant in certain plants; different genotypes).

- ▶ [Electric Fish](#)

---

## Pheomelanin

### Definition

A polymeric pigment varying in color from yellow to red and produced from 1,4-benzothiazinylalanine derived from L-tyrosine and L-cysteine by melanocytic cells.

- ▶ [Melanin and Neuromelanin in the Nervous System](#)

---

## Pheomelanosomes

### Definition

Spherical organelles 0.7 μm diameter found within melanocytes that compartmentalize pheomelanin synthesis and storage.

- ▶ [Melanin and Neuromelanin in the Nervous System](#)

---

## Pheromone

### Definition

Pheromones were originally defined in relation to insects as “substances secreted to the outside of an individual and received by a second individual of the same species in which they release a specific reaction, for example, a definite behavior or developmental process.” This led to the distinction between two categories of pheromonal effect: releaser pheromones that elicit immediate and relatively stereotyped behavioral responses, such as sexual attraction; and primer pheromones that elicit a longer-term change in hormonal or developmental state, such as acceleration of puberty. Many in the field now regard the original definition as over-restrictive and would expand the term to include signaler pheromones that convey information such as individual identity, and modulator pheromones that have an effect on mood or emotion.

- ▶ [Accessory Olfactory System](#)
- ▶ [Chemical Senses](#)
- ▶ [Evolution of Olfactory and Vomeronasal Systems](#)

## Philosophy of Action

- ▶ Action, Action-Theory

## Phobic Neurosis

### Definition

An anxiety disorder in which there is intense fear and avoidance of specific objects or situations, most frequently fear of wide places (agoraphobia), closed spaces (claustrophobia) or animals. The fear is recognized as irrational by the individual.

- ▶ Personality Disorder

## Phoneme

### Definition

The minimal contrastive unit in the sound system of a language; substituting one phoneme for another changes the meaning of a word (e.g., /t/ vs. /n/ because/bat/ differs in meaning to /ban/).

## Phonotaxis

### Definition

Sound-induced, directional movement of an organism relative to the sound source. It is usually either directed towards the source (positive phonotaxis) or away from it (negative phonotaxis). It is most commonly found in acoustic communication behaviors in insects.

- ▶ Auditory-Motor Interactions

## Phosphacan

### Definition

One kind of axon growth inhibitors. It is expressed in the CNS as a secreted splice variant of the gene encoding the extracellular domain.

- ▶ Regeneration of Optic Nerve

## Phosphagen

### Definition

The term given to both high-energy phosphate compounds, 5'-adenosine triphosphate and phosphocreatine.

- ▶ Energy Sensing and Signal Transduction in Skeletal Muscle

## Phosphatidyl Inositol-3-kinase (PI 3-kinase or PI3K)

### Definition

Part of a family of related enzymes that phosphorylate the 3 position hydroxyl group of the inositol ring of phosphatidylinositol. The phosphorylated phosphoinositides produced by PI 3-kinases function via the phosphoinositide-binding domains, which are recruited to cellular membranes for various signaling functions.

PI3K and its downstream effector the actin-associating Protein kinase (Akt) pathway are involved in the regulation of neuronal soma size and axon caliber.

- ▶ Neurotrophic Factors in Nerve Regeneration

## Phosphene

### Definition

A phosphene is a consciously perceived visual experience, typically a localized flash of light, which, rather

than being elicited by a visual stimulus, is induced by non-visual stimulation of nerves within the visual system. Phosphenes may, for example, be produced by pressure in the eyeball inducing neural activity in the retina or by magnetic or electrical stimulation of visual areas in the cerebral cortex.

► [Blindsight](#)

## Phosphodiesterase Inhibitors (PDEIs)

### Definition

Drugs that inhibit the function of phosphodiesterases (PDEs). These molecules elevate cAMP, resulting in upregulation of PKA and CREB signaling and down-regulation of NF- $\kappa$ B. Consequently, they are neuroprotective and anti-inflammatory agents.

- [CREB](#)
- [Cyclic AMP](#)
- [Neuroinflammation – PDE Family Inhibitors in the Regulation of Neuroinflammation](#)
- [NF- \$\kappa\$ B](#)

## Phosphodiesterase (PDE)

### Definition

Denotes a class of enzymes that hydrolyze the cyclic nucleotides cAMP and cGMP (second messengers).

PDEs have an important role as regulators of signal transduction mediated by these second messengers.

There are 11 families of proteins with this enzymatic activity (PDE1-PDE11) and more than 50 isoforms in total.

- [Phosphodiesterase: A family of inhibitors in the regulation of neuroinflammation](#)
- [Neuroinflammation – PDE Family Inhibitors in the Regulation of Neuroinflammation](#)

## Phospholipids

### Definition

The major lipid molecule of the cell membrane, composed of two fatty acids linked through glycerol phosphate to a polar group.

- [Membrane Components](#)
- [Plasma Membrane - Structure and Functions](#)

## Phosphorylation

### Definition

A reaction involving the addition of a phosphate group to a molecule. Many enzymes are activated by the covalent bonding of a phosphate group. The oxidative phosphorylation of ADP forms ATP.

- [Energy Sensing and Signal Transduction in Skeletal Muscle](#)

## Photocycles

### Definition

Cycles, or rhythms, in environmental lighting condition.

As with any rhythm, these can vary with respect to several parameters such as their period, phase and amplitude. Photocycles also vary with respect to the relative duration of their different phases and their waveforms. Some, for example, are sinusoidal and others have abrupt transitions between their light and dark phases. Animals use changing photocycles to anticipate and prepare for daily and seasonal changes in the environment, and their responses to these changes can be influenced by all of the parameters noted above.



## Photo-Inactivation Technique

### Definition

A technique to selectively lesion individual neurons within the nervous system. Fluorescent dyes are intracellularly injected into cells that die upon illumination by a laser beam or ultraviolet light source. Other nearby neurons are not affected. This technique has been successfully used to isolate putative pacemaker neurons in functional neuronal networks.

- ▶ Bursting Pacemakers
- ▶ Stomatogastric Ganglion

## Photon Catch

### Definition

The number of photons absorbed over a given duration by an individual photoreceptor, or class of photoreceptors. The probability of photon absorption depends on photon wavelength, but all subsequent steps of phototransduction are wavelength-independent.

- ▶ Photoreceptors
- ▶ Phototransduction
- ▶ Retinal Color Vision in Primates

## Photoperiod

### Definition

The term “photoperiod” refers to the duration of the light phase of a light-dark cycle. In biology, the term is most commonly used in the context of changes in daylength that many temperate zone organisms use to anticipate and prepare for seasonal changes in their environments.

- ▶ Photocycle

## Photoperiodic Time Measurement

### Definition

The measurement by organisms of the duration of the light relative to the dark phase of a light-dark cycle, often abbreviated as PTM. Photoperiodic time measurement enables temperate zone organisms to anticipate and prepare for seasonal changes in their environments.

In vertebrates, the pineal gland plays an important role in the system via its seasonally changing patterns of secretion of the hormone melatonin.

- ▶ Photocycle
- ▶ Pineal Gland

## Photoperiodism

### Definition

The use of daylength by organisms to prepare for seasonal changes in their environments. Animals may use either the rising or the falling phase of the annual rhythm in photoperiod as a signal to anticipate the arrival of spring or the coming of winter conditions, respectively. In mammals, photoperiodism can promote changes in a variety of parameters including, for example, pelage, body weight, reproductive function, activity levels, and aggressive behavior. Some animals use declining photoperiods to prepare for winter conditions and others use the rising phase to prepare for the arrival of spring. In mammals, photoperiodism involves the pineal gland, which signals the changing seasons via its changing pattern of secretion of the hormone melatonin.

- ▶ Hibernation
- ▶ Seasonality

## Photic

### Definition

Daylight conditions or vision.

## Photopigments

NATHAN S. HART

School of Biomedical Sciences, University of Queensland, St. Lucia, Brisbane, QLD, Australia

### Synonyms

Visual pigments; Rhodopsins; Porphyropsins; Visual purple

### Definition

Photopigments are ►**G-protein-coupled transmembrane proteins** contained within the ►**photoreceptors**. Their function is to absorb the incident light and trigger a biochemical cascade that alters the electrical properties of the photoreceptors and, ultimately, modulates the rate of ►**glutamate** release (see ►**Phototransduction**).

### Characteristics

#### Description of the Structure

Photopigments are light-sensitive single-chain polypeptides, belonging to the family of ►**G-protein-coupled receptors (GPCRs)**, capable of activating heterotrimeric G-proteins such as *transducin* (see ►**Phototransduction**). The photopigments of all animals, and even some archaeobacteria, share a common structural conformation that consists of seven  $\alpha$ -helical transmembrane segments and an extracellular (or, in the case of vertebrate rod photoreceptors (►**Photoreceptors**), intradiscal) amino (N) terminus [1]. These similarities reflect the ancient evolutionary origin of photopigment molecules. Photopigments differ from other GPCRs in that light, rather than another molecule, is the ►**ligand** that stimulates the receptor. This photosensitivity arises from the physical behavior of a ►**chromophore** molecule embedded in a pocket formed by the protein's transmembrane domain [2].

#### Opsins

The proteinaceous component of the photopigment is called an ►**opsin**, and the amino acid sequence of its polypeptide chain determines both its receptor properties and, in combination with the chromophore, its spectral absorbance. Opsins contain 350–500 amino acids, and comparisons of sequence homology reveal that all vertebrate ►**visual pigments** belong to one of five distinct classes: SWS1, SWS2, RH1, RH2 and M/LWS [3]. Moreover, the gene duplication events that led to the separation of these different opsin classes predate the divergence of the jawed and jawless vertebrate lineages [4].

In functional terms, photopigments are classified by their wavelength of maximum absorbance ( $\lambda_{\max}$ ). In most instances, photopigments belonging to the same opsin gene class have a  $\lambda_{\max}$  value in a similar region of the visible spectrum, although there is considerable overlap between classes. SWS1 opsin genes code for ultraviolet- or violet-sensitive cone photopigments with  $\lambda_{\max}$  values between 355–440 nm. SWS2 opsin genes produce short-wavelength-sensitive (“blue”) photopigments with  $\lambda_{\max}$  values between 410 and 475 nm. RH1 and RH2 opsin genes generate medium-wavelength-sensitive (“green”) photopigments with  $\lambda_{\max}$  values between 460–540 nm in rod and cone photoreceptors, respectively. M/LWS opsin genes code for long-wavelength-sensitive (“red”) cone photopigments with  $\lambda_{\max}$  values between 505–630 nm.

Birds, turtles and some fish have retained and express all five opsin genes. These species usually possess at least four spectrally distinct cone types and have tetrachromatic color vision (►**Color processing**). However, throughout vertebrate evolution there has been a tendency for certain taxa to lose opsin classes that were present in their ancestors. For example, some reptiles (e.g. lizards) have lost the RH1 rod opsin as a consequence of the loss of rod photoreceptors from their ►**retina**. Most placental mammals lack both the SWS2 and RH2 cone opsin genes and are dichromats. Many marine mammals have even lost the SWS1 gene and with it any chance of color vision. However, some primates (including humans) have re-evolved a third cone opsin via a duplication of their M/LWS opsin gene and have trichromatic color vision.

In most species, only one type of opsin is expressed in a given photoreceptor type. However, there are instances where two or more opsins are co-expressed, giving rise to a mixture of photopigments with different  $\lambda_{\max}$  values in a single *outer segment* (►**Photoreceptors**). In mice and rabbits, SWS1 and M/LWS opsins are co-expressed within the same cone photoreceptor and the relative proportion of the two photopigments varies with retinal location. Co-expression of two or more opsins may also occur in some fish while they undergo an ontogenetic shift in habitat light environment.

#### Chromophores

Vertebrate photopigments employ two different chromophores, 11-*cis* retinal and 11-*cis*-3,4-didehydroretinal, which are the aldehydes of vitamin A<sub>1</sub> and A<sub>2</sub>, respectively. Photopigments based on 11-*cis* retinal (►**rhodopsins**), are generally found in mammals, birds and marine fish. Photopigments based on 11-*cis*-3,4-didehydroretinal (►**porphyropsins**) are characteristic of freshwater fish and turtles. Different chromophores can

be used interchangeably with the same opsin. However, a porphyropsin photopigment will have a  $\lambda_{\max}$  value shifted towards longer wavelengths compared to a rhodopsin photopigment utilizing the same opsin, a phenomenon called the “chromophore shift”.

Many aquatic species, including some lampreys, teleost fish, elasmobranchs and amphibians, are capable of producing both rhodopsin and porphyropsin photopigments. In most cases, the chromophore type changes from 11-*cis* retinal to 11-*cis*-3,4-didehydroretinal in response to an ontogenetic shift in habitat type from fresh to salt water (or vice versa). The long-wavelength spectral shift induced by porphyropsin use is considered to be an adaptation to the relatively red-shifted illumination in most freshwater or estuarine habitats compared to terrestrial or marine light environments. Intriguingly, some terrestrial reptiles, such as the true chameleons (Chamaeleonidae), maintain [▶rhodopsin/▶porphyropsin](#) mixtures of the same opsin type within individual cone photoreceptors, although in the absence of ontogenetic shifts in habitat type the functional significance is unclear.

### Spectral Absorbance

The absorbance spectrum of an unbleached photopigment is characterized by four distinct peaks (Fig. 1). The first and most visually relevant of these is the so called  $\alpha$ -peak. When classifying the spectral absorbance of photopigments, the  $\lambda_{\max}$  value quoted usually refers to the wavelength position of the  $\alpha$ -peak, which represents the main absorbance band of the bound chromophore. The  $\alpha$ -peak varies in  $\lambda_{\max}$  from about 350 to 620 nm, depending on both chromophore type and its physicochemical interactions with the opsin apoprotein

(see section entitled Spectral Tuning and the Opsin Shift). A second, smaller peak ( $\beta$ -peak) occurs at shorter wavelengths and is due to the *cis*-band of the chromophore. The wavelength position of the  $\beta$ -peak is positively correlated to that of the  $\alpha$ -peak but varies over a much smaller wavelength range (310–390 nm). The third ( $\gamma$ -peak; 280 nm) and fourth ( $\delta$ -peak; 231 nm) absorbance peaks are caused by tyrosine and tryptophan residues in the opsin and a variety of organic bonds in the photopigment, respectively [5].

Generally speaking, we are only concerned with the absorbance of the  $\alpha$ -peak because wavelengths to which the other absorbance peaks are sensitive are prevented from reaching the photoreceptors by absorption of short wavelengths by the [▶ocular media](#) or other spectral filters in the retina. For example, the human lens and macula contain carotenoid pigments (lutein and zeaxanthin) that prevent light of wavelengths shorter than about 400 nm from reaching the photoreceptors. However, in several other vertebrate (and invertebrate) species, ultraviolet light (UV, 300–400 nm) is allowed to enter the eye to stimulate specialized UV-sensitive photopigments and the  $\beta$ -peak of photopigments with longer  $\lambda_{\max}$  values may absorb some of this light.

### Regulation of the Structure

#### Chromophore Photosensitivity and the Schiff's Base Linkage

All opsins contain a lysine residue at a particular site on the interior surface of the chromophore-binding pocket that couples to the chromophore via a Schiff's base bond (aldimine linkage). In vertebrate photopigments, the Schiff's base is usually [▶protonated](#), and its positive charge is balanced by a negatively charged residue

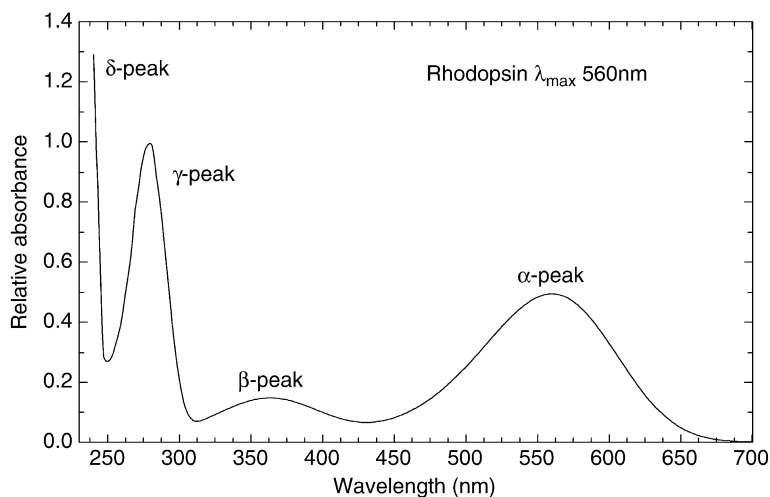

**Photopigments. Figure 1** Absorbance spectrum of a rhodopsin (11-*cis* retinal-based) photopigment. See text for details.

(almost invariably glutamate) that acts as a ►counterion to stabilize the linkage electrostatically. This charge distribution is fundamental to the photosensitivity and wavelength specificity of the photopigment. When the chromophore absorbs a photon of light, it undergoes a conformational change and flips from the less stable 11-*cis* configuration to the more stable all-*trans* ►isomer (see ►Phototransduction). This causes a major structural rearrangement that displaces the Schiff's base from its interaction with the glutamate counterion. The subsequent loss of electrostatic stability results in further structural rearrangement of the opsin, deprotonation of the Schiff's base and generation of the active form of the photopigment (metarhodopsin II) [6].

### Spectral Tuning and the Opsin Shift

Free chromophore (retinaldehyde) has a peak absorbance at 375 nm. When combined with a simple amino-group (-NH<sub>2</sub>) containing-compound (n-butylamine), the protonated retinaldehyde-Schiff's base complex formed has a  $\lambda_{\max}$  at 440 nm [7]. The difference in  $\lambda_{\max}$  between the protonated retinaldehyde-Schiff's base complex and the  $\alpha$ -peak of a given opsin-retinaldehyde photopigment is called the "opsin shift."

The magnitude and direction of the opsin shift depend on a variety of molecular interactions, all of which are directly attributable to the amino acid sequence of the opsin. In particular, the interactions of charged, polar or polarisable amino acid residues with the chromophore may affect the strength of the interaction between the protonated Schiff's base and the glutamate counterion, and/or alter the delocalization of charge along the length of the chromophore. A reduction in charge delocalisation along the chromophore, or a strengthening of the Schiff's base-counterion interaction (which helps to prevent charge delocalisation) increases the stability of the chromophore and short-wavelength-shifts the photopigment  $\lambda_{\max}$  as a result of the higher energy required for photoisomerization. In contrast, an increase in charge delocalisation, or a weakening of the Schiff's base-counterion interaction, decreases the energy required for photoisomerization and results in a long-wavelength-shifted photopigment [8].

Thus, by altering the types of amino acid present within the opsin polypeptide, at specific locations that are close enough to interact electrostatically with the chromophore, the  $\lambda_{\max}$  of a rhodopsin photopigment can be varied almost continuously from 350 to 575 nm (as far as 630 nm in the case of porphyropsin photopigments). In addition to a  $\lambda_{\max}$  500nm RH1 rod photopigment, the human retina contains three cone photopigments with  $\lambda_{\max}$  values at 430 (SWS1), 530 and 560 nm (M/LWS). The mechanisms of spectral tuning of vertebrate (especially mammalian) M/LWS

photopigments are probably the best understood of all opsin genes and, in most species, their  $\lambda_{\max}$  values are determined by various combinations of amino acid substitutions at just five locations in the opsin apoprotein, the so called "five sites rule" [3].

### Anion Sensitivity and Spectral Tuning

In addition, most vertebrate M/LWS photopigments are thought to be spectrally tuned in part by the binding of anions, more specifically chloride ions, at locations on the opsin close to the Schiff's base linkage. For example, chicken M/LWS photopigment has a native  $\lambda_{\max}$  value of 565 nm that can shift to 520 nm in the absence of chloride ions. It is thought that the Schiff's base counterion is complex, and the inclusion of an exchangeable chloride ion helps to maintain a relatively delocalized distribution of charge on the chromophore and, consequently, red shifts the  $\lambda_{\max}$  of the photopigment [9].

### Function

Photopigments absorb photons of light and trigger the enzymatic activity of the photoreceptor G-protein transducin. This leads to a biochemical cascade that ultimately results in a change in the rate of release of ►neurotransmitter by the photoreceptor and a detectable neural signal. Although the primary function of a photopigment is to detect light of any wavelength, the divergence of the ancestral photopigment gene into multiple spectral types very early in evolution suggests that there is considerable selection pressure on the spectral tuning of photopigments. Although generalisations are difficult to make, the number of different photopigment types and their  $\lambda_{\max}$  values are almost certainly determined by the spectral distribution of the available light, the need to find food and potential mates, and avoid predators.

### Pathology

►Retinitis pigmentosa (RP) (►Inherited retinal degenerations) is a collection of genetically inherited diseases that result in the degeneration of photoreceptors and the retinal pigment epithelium. Symptoms include night blindness and the loss of peripheral vision. Over 100 different point (single amino acid) mutations in the gene encoding rod opsin, located on autosomal chromosome 8, are known to cause RP, possibly as a result of the failure of the mutant opsin to fold correctly, bind retinal or activate transducin [6].

The genes coding for green- and red-sensitive cone pigments (M/LWS opsins) in humans are carried on the X chromosome. Mutations in these genes are responsible for the different forms of red-green ►color blindness and, because of their location on the X chromosome, are more apparent in males, which have only one copy of the gene.

These include amino acid substitutions that alter the  $\lambda_{\max}$  of the green- (deuteranomaly) or red-sensitive (protanomaly) photopigments and result in anomalous color vision, or cause the complete loss of green- (deuteranopia) or red-sensitive (protanopia) cones [10].

The SWS1 gene encoding the human blue-sensitive cone opsin is located on chromosome 7. Mutations in the SWS1 gene that cause a spectral shift in the expressed pigment (tritanomaly) or a loss of functional blue cones (tritanopia) result in blue-yellow color blindness. As the SWS1 gene is carried on a pair of autosomal chromosomes, mutations in both copies are required to produce tritanopia. Consequently, blue-yellow color blindness occurs less frequently than red-green color blindness.

## References

1. Stenkamp RE, Filipek S, Driessen CA, Teller DC, Palczewski K (2002) Crystal structure of rhodopsin: a template for cone visual pigments and other G protein-coupled receptors. *Biochimica Biophys Acta* 1565:168–182
2. Sakmar TP, Menon ST, Marin EP, Awad ES (2002) Rhodopsin: insights from recent structural studies. *Annu Rev Biophys Biomol Struct* 31:443–484
3. Yokoyama S (2000) Molecular evolution of vertebrate visual pigments. *Prog Retin Eye Res* 19:385–419
4. Collin SP, Knight MA, Davies WL, Potter IC, Hunt DM, Trezise AE (2003) Ancient colour vision: multiple opsin genes in the ancestral vertebrates. *Curr Biol* 13: R864–R865
5. Rodieck RW (1973) *The vertebrate retina*. WH Freeman and Company, San Francisco
6. Pepe IM (2001) Recent advances in our understanding of rhodopsin and phototransduction. *Prog Retin Eye Res* 20:733–759
7. Nakanishi K (1991) 11-cis-retinal, a molecule uniquely suited for vision. *Pure Appl Chem* 63:161–170
8. Hunt DM, Wilkie SE, Bowmaker JK, Poopalasundaram S (2001) Vision in the ultraviolet. *Cell Mol Life Sci* 58:1583–1598
9. Kleinschmidt J, Hárosi FI (1992) Anion sensitivity and spectral tuning of cone visual pigments *in situ*. *Proc Natl Acad Sci USA* 89:9181–9185
10. Rodieck RW (1998) *The first steps in seeing*. Sinauer Associates, Sunderland, MA

## Photoreception

### Definition

The sensory process by which light energy is converted into a biologically relevant signal.

## Photoreceptor, Variety and Occurrence

MEGUMI HATORI, SATCHIDANANDA PANDA  
The Salk Institute for Biological Studies, La Jolla,  
CA, USA

### Definition

Photoreceptors regulate light-dependent physiologies; image formation and non-image forming adaptation such as regulation of circadian entrainment, seasonal reproduction and body color change. The vertebrate retina contains three types of photoreceptors: rods, cones and ipRGCs. In non-mammalian vertebrates, the pineal complex, deep brain, skin, parapineal and parietal eye are also known to contain photoreceptors. Each vertebrate photoreceptor contains a photopigment consisting of a protein called opsin and vitamin-A-based light-absorbing molecule (chromophore), 11-*cis* retinal.

### Characteristics

#### Introduction

Dynamic adaptation to ambient light is central to survival of most animals. Light adaptation is achieved by two basic mechanisms: image formation for rapid adaptation to the physical environment and non-image forming adaptation of physiology and behavior to ambient light quality. The image-forming function is exclusively mediated by the eye – a specialized optical structure with a lens that projects an image to the [▶retina](#). [▶Cone](#) and [▶rod photoreceptors](#) of the retina capture the image and send the information to the visual cortex for image reconstruction [1]. The non-image forming (NIF) photoresponses vary widely, from rapid adjustment of pupil diameter to progressively slow responses, such as skin color adaptation in amphibians, adaptation of the circadian clock to the daily day–night cycle, and seasonal reproductive behavior. Accordingly, the underlying [▶photopigments](#) vary widely in (i) the cell types of expression, (ii) anatomical location and (iii) target cells or effector process.

The photopigment for most of the above responses comprises an opsin family of G-protein coupled receptor and a light-sensitive vitamin-A based chromophore. The amino acid sequence of the opsin scaffold determines (i) the spectral properties, (ii) specificity of the downstream signaling pathway and (iii) interaction with other regulatory molecules. Although flavin-based photopigments, such as [▶cryptochromes](#), have been implicated in the circadian photoresponses of insects, no such light-dependent function of cryptochrome molecules in vertebrates has been conclusively established.

In mammalian vertebrates all of the photoresponses originate from photopigments of the retina. In non-mammalian vertebrates, however, additional anatomical

structures such as the parietal eye, ►**pineal**-, parapineal-complex, deep brain, and skin are also known to contain functional photoreceptors which primarily mediate NIF photoresponses.

### Ocular Photoreceptors in the Vertebrates

The rod and cone cells are the predominant photoreceptors of the retina. They exhibit exquisite subcellular specialization such that the different cellular functions are stratified along the length of the cells. The nuclei mark a virtual functional boundary, with the distal segment functioning in photoreception, while the segment proximal to the lens makes synaptic connections to other cell types of the retina. The photopigment in these cells is tightly packed into specialized membranes that are organized into rod or cone like structures in the outer segment of rod or cone cells, respectively (Fig. 1).

The outer segment is connected to the rest of the cells by a narrow structure, the ciliary stalk. Between the ciliary stalk and the nuclei, various organelles such as

mitochondria, the Golgi apparatus and the endoplasmic reticulum are concentrated in stratified layers. The inner segment of the rod/cone cells contain the synaptic structures for signal transduction to other cell types of the retina, which ultimately connect to the ►**retinal ganglion cells (RGCs)** – the only retinal cell type that makes synaptic connections to the brain. No other cell types of the mammalian vertebrate retina were known to be directly light sensitive until the discovery of ►**intrinsically photosensitive RGCs** (see section ►**ipRGCs**).

In non-mammalian vertebrates, however, opsin photopigments are expressed in additional retina cell types. The horizontal and amacrine cells in the retina of teleost fish express vertebrate ancient (VA)-opsin. In birds and amphibians melanopsin mRNA is extensively expressed in both inner and outer nuclear layers of the retina. However, in all animals the rod and cone cells are the most characterized photoreceptors of the retina.

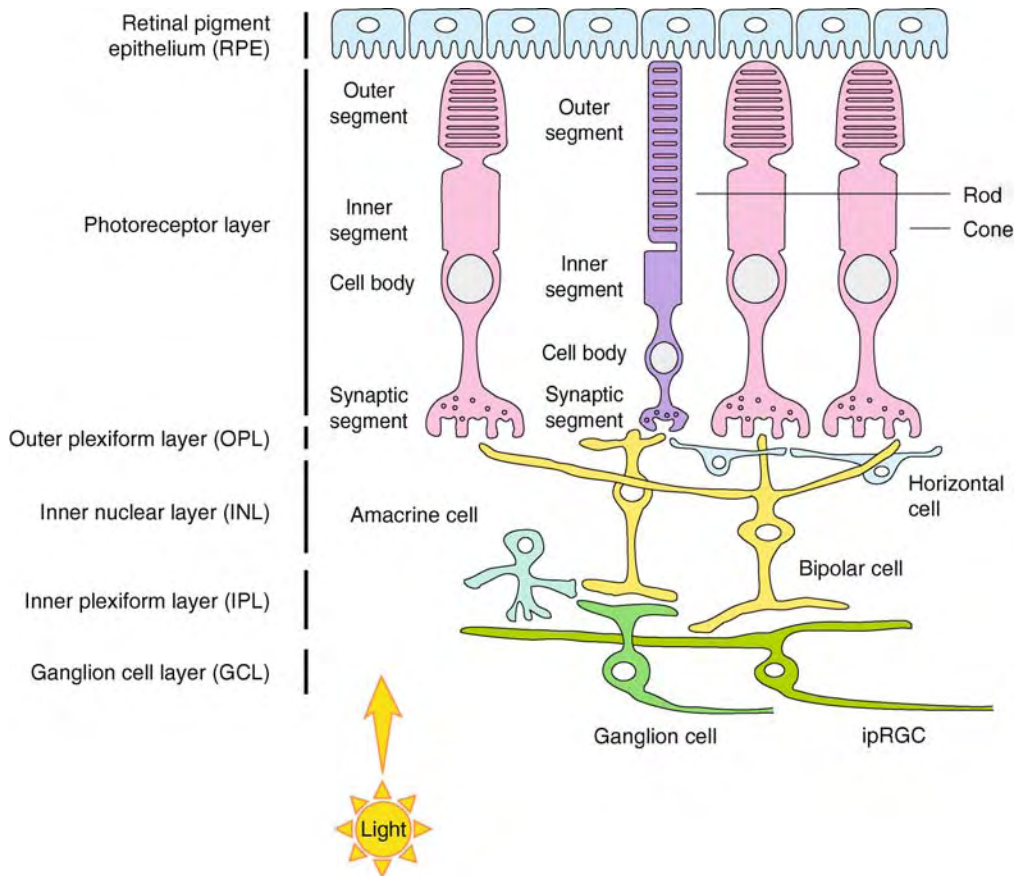

**Photoreceptor, Variety and Occurrence. Figure 1** Schematic structure of the vertebrate retina. Vertebrate retina is composed of multiple cell layers with specialized functions. The rods and cones of the outer nuclear layer and a few RGCs of the ganglion cell layers are bona fide photoreceptors or intrinsically photosensitive. Other cell types such as horizontal, bipolar, amacrine and ganglion cells participate in light signal processing and signal transduction to the brain.

### Rods

Typically, a rod cell is sensitive enough to respond to a single photon of light and therefore is responsible for scotopic or dim-light vision in night (Table 1) [1,2]. With increasing light intensity at dawn, the rods become saturated or “bleached”, thus under daylight the less sensitive cones mediate visual function. Rods respond slowly to light and have longer integration time than cones do.

Generally, each rod or cone cell expresses only one type of opsin photopigment, thus the photoresponses of the cell reflect that of the photopigment. Most vertebrate

retina contain a single type of rod expressing rhodopsin with peak sensitivity  $\sim 500$  nm (Fig. 2), although several amphibians like toads and salamanders are known to have two types of rods, called the red-rods and the green-rods, which have distinct absorbance spectra.

The photopigment in rod cells is densely packed into specialized disc membranes that are stacked to form the rod outer segment. The outer segment of both rods and cones are continuously renewed. In rods, new rhodopsin molecules are synthesized just before dawn and the distal discs are shed and phagocytosed by the retinal pigment epithelium (RPE) cells in the morning.

**Photoreceptor, Variety and Occurrence. Table 1** Comparison of rods, cones and ipRGCs. Modified from [3]

	Rods	Cones	ipRGCs
Major function	Scotopic/night vision	Photopic/daytime vision	Non-image forming photoresponses
Location	Outer nuclear layer	Outer nuclear layer	Ganglion cell layer
Photopigment	Rod opsin (rhodopsin)	Cone opsins	Melanopsin
Localization of opsins	Outer segment	Outer segment	Soma, dendrites, and axon.
Sensitivity	High	Moderate (less sensitive than rods)	Low
Integration time	Longer integration time than cones (tens of milliseconds)	Respond faster than rods	Seconds
Light response of membrane potential	Fast hyperpolarizing	Fast hyperpolarizing	Slow depolarizing
Action potentials	No	No	Yes
Role of RPE for photopigment regeneration	Essential	Essential	Apparently unnecessary
Receptive field	Very small	Very small	Very large (tens of microns)
Number of cells in human eye	$\sim 120$ million	$\sim 6$ million	$<5,000$
Spatial distribution in human eye	Peripheral	Fovea	Uniform

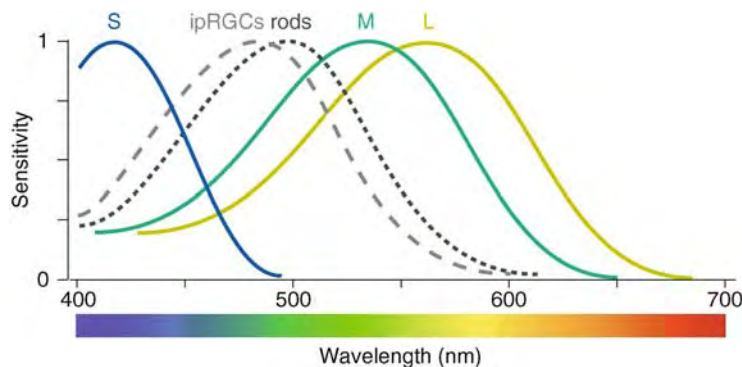

**Photoreceptor, Variety and Occurrence. Figure 2** Spectral sensitivity of mammalian ocular photoreceptors. Spectral sensitivities of cones (S-cones, M-cones and L-cones), rods and ipRGCs.

Such temporal regeneration of rods coincides with their primary role in scotopic vision.

### **Cones**

Cones are cone-shaped photoreceptors in the retina that can function under bright light and are responsible for photopic or bright-light vision (Table 1) [1,2]. Cones are less sensitive to light intensity than the rods. On the other hand, response times to stimuli are faster than those of rods, and they are also able to perceive color, finer detail and more rapid changes in images. Unlike the disc membranes of the rod, the outer segment of the cones is formed by invagination of the plasma membranes. The photopigments of the cones are primarily synthesized prior to dusk, and membranes from the tips of the cones are shed in the evening. Based on peak spectral sensitivity, most animals contain two types of cones, one at >500 nm (long wavelength cone or L-cone) and one at <500 nm (short wavelength cone or S-Cone). Some animals including teleost fish, Old World monkeys and humans have one additional cone-type absorbing in the medium wave (M-cone). There are several exceptions; for example, several nocturnal mammals like owl monkeys, a New World monkey, have only one type of cone. Sensitivities of human S-cones, M-cones and L-cones are to ~420 nm (blue), ~530 nm (green) and ~560 nm (yellowish-green) wavelengths, respectively (Fig. 2). S-cones are smaller in number than M- and L-cones and are sparse in the fovea region. The difference in the signals received from the three cone types allows the brain to distinguish millions of colors. As cones are functional under bright light, they require rapid regeneration of the *all-trans* retinal. There is some evidence that unlike the rods which depend on the RPE cells, the cones depend on a different type of retinal cycle involving cones and the Müller cells of the retina.

### **ipRGCs (Intrinsically Photosensitive Retinal Ganglion Cells)**

The ipRGCs are intrinsically photosensitive and constitute only 1–2% of the retinal ganglion cells of the adult mammalian retina. They do not play any major role in image-forming vision but are important photoreceptors for NIF photoresponses, which include light entrainment of the master circadian oscillator resident in the hypothalamic ► **suprachiasmatic nucleus (SCN)**, light suppression of pineal melatonin synthesis and release, light modulation of activity and pupillary light reflex (Table 1) [3,4].

These adaptive photoresponses are almost intact in several animal models with complete rod/cone degeneration and exhibit an action spectrum characteristic of the absorption spectrum of the opsin class of photopigments with a peak around 480 nm. ► **Melanopsin**, a novel photopigment expressed in these cells, mediates

photosensitivity (Fig. 2). Unlike the rod/cone photoreceptors, ipRGCs exhibit no polarized expression of the photopigment; melanopsin immunoreactivity is localized to membranes of the dendrites, somas and possibly axons of these cells. Cell bodies of the ipRGCs are mostly resident in the RGC sublayer, while the dendrites heavily arborize within the inner plexiform layer spreading to as many as tens-of-microns in diameter of receptive fields (Fig. 1). The dendrites make synaptic contacts with both rod and cone bipolar cells and receive rod/cone inputs, and hence are unique photoreceptor cells of the retina with two almost independent major functions: (i) to initiate photochemical reaction by melanopsin as well as (ii) to transmit rod/cone initiated photoresponse. Unlike other RGCs, axons of these ipRGCs primarily project to the SCN, where they are almost equally distributed between contra- and ipsi-lateral SCN. They also send additional projections to other brain regions implicated in NIF photoresponses.

Isolated ipRGCs depolarize in response to light and generate action potentials in a melanopsin-dependent manner. They exhibit long latency of light response and are depolarized as long as the lights are on and have long deactivation kinetics. The native molecules and channels underlying the photoresponses of the ipRGCs have not conclusively been established. However, the persistence of the non-image forming adaptive photoresponses in animal models deficient in several signaling components and channels mediating rod/cone photoresponses imply the ipRGCs recruit a distinct set of signaling molecules.

### **Phototransduction Mechanism**

In all opsin-based photopigments, the first step in photoresponse begins with the photoisomerization of a vitamin-A based *cis*-isomer of retinal to its *trans*-isomer. The resultant conformational change of the protein triggers activation and release of a *Gai/Gao* (most vertebrate opsins) or *Gaq/Gα11* (melanopsin) class of G-protein. The *Gai/Gao* class of effector G-protein of rod/cones, also known as transducin (Gt), activates a phosphodiesterase, which in turn rapidly degrades cGMP and causes closing of the cyclic nucleotide gated channels. Hence, photoactivation of rod/cone photoreceptors leads to membrane hyperpolarization and a pause in neurotransmitter glutamate release. On the other hand, it is presumed that photoactivated melanopsin activates the *Gaq/Gα11* class of G-proteins, which in turn activates phospholipase C (PLC). Activated PLC can signal through several mechanisms, including intracellular calcium release, increase in IP<sub>3</sub> and DAG, and ultimately opening of a channel leading to membrane depolarization, and release of neurotransmitters, such as glutamate and adenylylate cyclase-activating peptide 1. Signal



termination occurs at various steps including receptor, G-protein and downstream components. Finally, regeneration of active photopigment occurs, enabling another round of photoresponses to be initiated. The all-*trans* retinal from rod/cone cells is transported to the RPE cells where an elaborate multistep enzymatic process ensures sufficient retinal regeneration for use by the rod/cone photoreceptors. Melanopsin, on the other hand is presumed to isomerize the resultant all-*trans* retinal to the active 11-*cis* isomer by an intrinsic photoisomerase activity.

### Extraocular Photoreceptors in Nonmammalian Vertebrates

While mammals use ocular photopigments for all types of photoresponses, several non-mammalian vertebrates express functional photopigments outside their eyes, including the parietal eyes, pineal, parapineal glands, dermal cells, and in brain. Organisms use them primarily for physiological adaptation to the ambient light quality. Some of these tissues such as pineal and parietal eyes develop embryologically from the diencephalons, which also gives rise to the eye. Accordingly the photoreceptor cells of these organs show some morphological similarities with those of the retina, and they also express multiple photopigments in distinct or in the same cell types.

#### Pineal Photoreceptor

In lower vertebrates such as lampreys, fishes, amphibians, lizards and birds, the pinealocytes have both intrinsic photosensitivity as well as neuroendocrine function, such that under cultured conditions of isolated pineal gland, they are light-sensitive and have the ability to produce ►melatonin in a circadian and light-dependent manners.

The action spectrum of the photosensitivity of the isolated chicken pineal resembles the absorption spectrum of rhodopsin. Consistent with this prediction, an opsin-like protein was identified in the chicken pineal gland and named pinopsin (=pineal opsin), the first functional opsin to be discovered outside the retina [5]. Pinopsin upon reconstitution with 11-*cis* retinal forms a functional photopigment with peak sensitivity at 468 nm and can couple to Gt. Besides pinopsin, a chicken red-sensitive cone pigment, called iodopsin, and melanopsin are also expressed in the chicken pineal gland. Pinopsin is not detected in fish and mammals. Alternatively, the pineal gland of zebrafish expresses exo-rhodopsin (=extra-ocular ►rhodopsin). Exo-rhodopsin is expressed in the majority of pineal cells, but not in retinal cells. The pineal photopigments might function to modulate melatonin secretion in a cell autonomous manner. Additionally, they also make synaptic connections with neurons that project to various thalamic and hypothalamic regions. Mammals have lost the intrinsic photosensitivity of pinealocytes, but they still retain circadian regulation of

melatonin secretion, which is also light regulated by ocular photopigments via a multisynaptic pathway.

#### Parietal Eye Photoreceptors

Several lizards harbor an extra eye-like structure called the parietal eye that does not appear to have any role in image-forming vision, but rather helps adapt to light quality. Like the eye, the parietal eyes also contain various cell types stratified into distinct layers. However, unlike the image-forming photoreceptors, which hyperpolarize in response to light, the parietal eye photoreceptors either depolarize or hyperpolarize in response to specific wavelengths of light. These photoreceptor cells express two different types of opsins – pinopsin and parietopsin in the same cell type [6]. Distinct absorption spectra of these two opsins and functional coupling to distinct signaling mechanisms may produce such unique membrane potential properties of the parietal eye photoreceptor cells.

#### Photoreceptors in the Deep Brain

Most photoreceptor cells described above are located outside or immediately beneath the skull. However, in some vertebrates there is evidence for photoreceptors in the deep brain which largely mediate long term seasonal photo-adaptations. The photoperiodic change in gonad function persists in pinealectomized and enucleated Japanese quails and exhibits peak sensitivity around 500 nm. Actually, ~500 nm wave-length light can transmit through the scalp and skull and reach to the deep brain.

Several opsins of the eye and pineal glands are shown to be expressed in deep brain, but their functions are still almost unknown. Rhodopsin was cloned from lateral septum of pigeons, pinopsin-expressing cells exist in the anterior preoptic nucleus of toads, VAL (vertebrate ancient-long) opsin is localized in a small portion of cells surrounding the diencephalic ventricle of central thalamus in zebrafish, and melanopsin is expressed in hypothalamic sites of *Xenopus laevis*.

#### References

1. Rodieck RW (1998) The first steps in seeing. Sinauer Associates, Sunderland, MA
2. Solomon SG, Lennie P (2007) The machinery of color vision. *Nat Rev Neurosci* 8:276–286
3. Berson DM (2003) Strange vision: ganglion cells as circadian photoreceptors. *Trends Neurosci* 26:314–320
4. Nayak SK, Jegla T, Panda S (2007) Role of a novel photopigment, melanopsin, in behavioral adaptation to light. *Cell Mol Life Sci* 64:144–154
5. Okano T, Yoshizawa T, Fukada Y (1994) Pinopsin is a chicken pineal photoreceptive molecule. *Nature* 372:94–97
6. Su CY, Luo DG, Terakita A, Shichida Y, Liao HW, Kazmi MA, Sakmar TP, Yau KW (2006) Parietal-eye phototransduction components and their potential evolutionary implications. *Science* 311:1617–1621

## Phototransduction

NATHAN S. HART

School of Biomedical Sciences, University of Queensland, St. Lucia, Brisbane, QLD, Australia

### Synonyms

Visual transduction cascade

### Definition

Phototransduction is the process by which light energy that is absorbed by ►photopigments contained within ►retinal photoreceptors (►Photoreceptors) is converted into a biochemical signal that leads to a ►hyperpolarization of the photoreceptors.

### Characteristics

#### Description of the Process

##### Photoisomerization

Phototransduction begins when a photon of light is absorbed by a photopigment molecule. The energy imparted by the photon induces a conformational change in the ►chromophore (see ►Photopigments), in the case of 11-*cis* retinal causing it to flip to the all-*trans* isomer. This transition is called ►photoisomerization, and is the only light-dependent step in the phototransduction process; it is also extremely rapid, taking less than 200 fs [1]. Photoreceptor ►outer segments are densely packed with photopigment molecules to capture as much of the incident light as possible. Nevertheless, only two out of every three photons absorbed by the photopigment succeed in isomerising the chromophore; photopigments have a ►quantum efficiency of about 0.67, regardless of photon wavelength [2]. Energy from photons that are absorbed but do not induce chromophore isomerization is dissipated as heat.

The probability that a photon of light will be absorbed by a photopigment of given spectral sensitivity is dependent on the photon's wavelength. However, an individual photoreceptor is incapable of discriminating between photoisomerization events caused by photons of different wavelength and can only signal the rate of photon capture, a concept known as the "principle of univariance." Wavelength discrimination requires photoreceptors with differing photopigment spectral sensitivities and the ancillary neural mechanisms to compare their output signals, i.e. color vision (►Color processing).

##### Photopigment Activation

The change in chromophore conformation during photoisomerization alters the local structure of the chromophore-binding pocket of the photopigment

apoprotein (►opsin). These structural rearrangements propagate throughout the tertiary structure of the photopigment, which progresses step-wise through a series of physically and spectroscopically distinct photobleaching intermediates until, through deprotonation of the Schiff's base linkage that binds the chromophore to the opsin, the biochemically active form of the photopigment ( $R^*$ ) is created [3]. In the case of ►rhodopsin (11-*cis* retinal based) photopigments, the activated form of the molecule is called metarhodopsin II and appears approximately 2 ms after photoisomerization [4].

##### Transducin Activation

The next stage in the phototransduction process occurs when  $R^*$  triggers a biochemical cascade that amplifies the visual signal to a detectable threshold in a stereotyped fashion (Fig. 1). As each  $R^*$  is free to diffuse rapidly within the plane of the outer segment disk membrane, and does so randomly as a result of ►Brownian motion, it encounters and activates several hundred ►transducin molecules within about 100 ms [5]. Transducin is a membrane-bound heterotrimeric G protein that consists of three subunits,  $T_\alpha$ ,  $T_\beta$  and  $T_\gamma$ . Rods and cones contain different isoforms of the three subunits, but the proteins perform the same function in the cascade [6].

Amino acids on the cytoplasmic loops of  $R^*$  bind briefly (<0.1 ms) to ►epitopes on the transducin complex, and induce a conformational change in the structure of the  $T_\alpha$  subunit that results in the release of a molecule of bound guanosine diphosphate (GDP). When the GDP released from the  $T_\alpha$  nucleotide-binding pocket is subsequently replaced with a molecule of guanosine triphosphate (GTP), a further conformational change activates the transducin complex, causing both the detachment of  $R^*$  and the dissociation of  $T_\alpha$ -GTP from the heterotrimer [1]. At this stage,  $R^*$  is then free to move away and activate other transducin molecules before it is eventually deactivated through phosphorylation and binding to ►arrestin (see below).

##### Phosphodiesterase Activation

Activated GTP-bound transducin  $T_\alpha$  subunits have a high affinity for guanosine 3', 5' cyclic monophosphate (cGMP)-specific phosphodiesterase (PDE). PDE is a membrane-bound protein consisting of two catalytic subunits ( $PDE_\alpha$  and  $PDE_\beta$ ) and two identical inhibitory subunits ( $PDE_\gamma$ ). In the dark-adapted state, the catalytic activity of the  $PDE_\alpha$  and  $PDE_\beta$  subunits is blocked by their respective  $PDE_\gamma$  subunits [7]. Following illumination and activation of transducin,  $T_\alpha$ -GTP binds to PDE and displaces either or both of the  $PDE_\gamma$  subunits, thereby exposing its catalytic sites.

In this second stage of signal amplification, activated  $PDE_\alpha$  and  $PDE_\beta$  subunits catalyze the conversion of

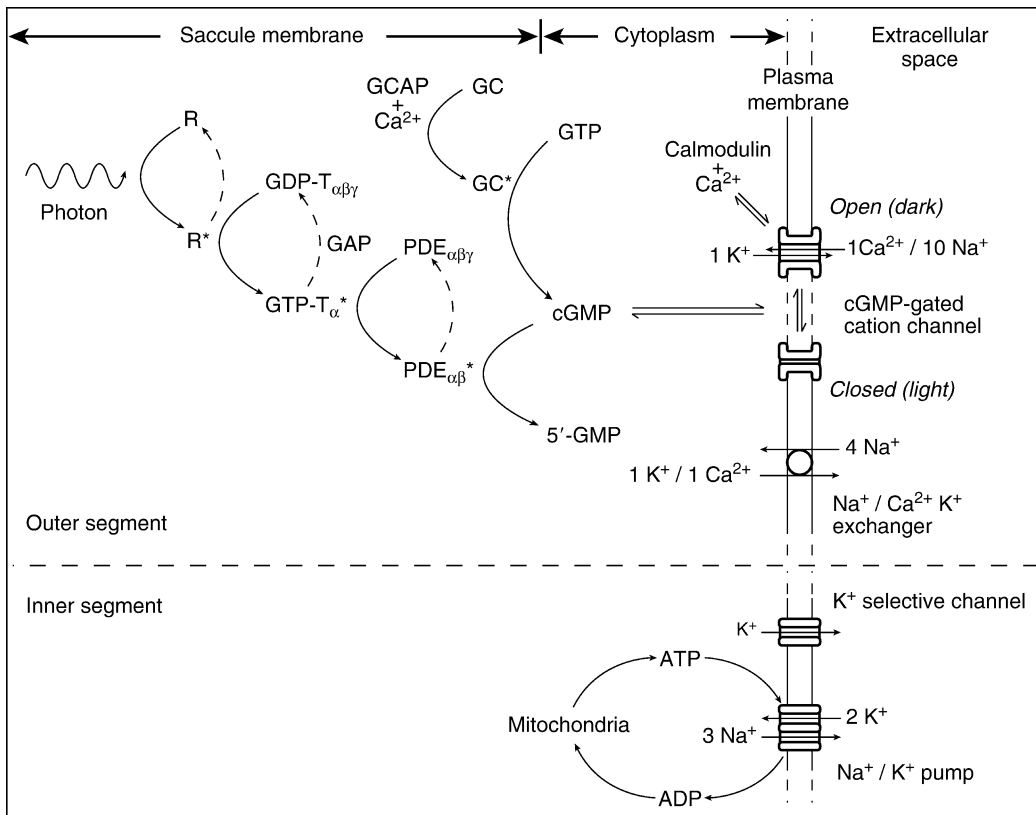

**Phototransduction. Figure 1** Simplified schematic diagram of the phototransduction cascade in a mammalian rod. Relevant membrane channels are also depicted. Abbreviations: *R*, rhodopsin; *GDP*, guanosine diphosphate; *GTP*, guanosine triphosphate; *T*, transducin; *PDE*, phosphodiesterase; *cGMP*, cyclic guanosine monophosphate; *GMP*, guanosine monophosphate; *GAP*, GTP-ase activating proteins; *GC*, guanylate cyclase, *GCAP*, guanylate cyclase activating proteins; *ATP*, adenosine triphosphate; *ADP*, adenosine diphosphate. An asterisk signifies the activated form of the enzyme. Subscripts indicate the enzymatic subunit(s) present. Dashed arrows represent regeneration steps.

many molecules of cytoplasmic cGMP to 5' guanosine monophosphate (GMP) and rapidly reduce the concentration of cGMP molecules present in the outer segment. cGMP is a **second messenger** in the phototransduction process, and the fall in its concentration is detected by cGMP-gated cation channels in the outer segment plasma membrane, which close. The closure of ionic channels reduces the influx of  $\text{Na}^+$  and  $\text{Ca}^{2+}$  ions and, because  $\text{K}^+$  ions continue to be removed from the cell via  $\text{K}^+$ -selective channels in the **inner segment**, causes a local hyperpolarization of the photoreceptor's transmembrane potential [4].

#### Photoreceptor Dark Current, Photocurrents and Hyperpolarization

Phototransduction works by changing the electrical potential across the photoreceptor plasma membrane. Like all living cells, the interior of a photoreceptor is charged negatively with respect to the extracellular space (**Membrane potential – basics**); the resting transmembrane potential of a rod is about  $-37$  mV,

whereas that of a cone is around  $-46$  mV [8]. In the dark, this transmembrane potential is maintained by a balanced flow of cations (predominantly  $\text{Na}^+$ ) into and out of the photoreceptor, known as the dark current (**Photoreceptor dark current**), which has a magnitude of up to  $-34$  pA in rods and  $-30$  pA in cones. In the outer segment, voltage-insensitive cGMP-gated ionic channels allow the entry of ten  $\text{Na}^+$  and one  $\text{Ca}^{2+}$  for every  $\text{K}^+$  they expel, and  $\text{Na}^+/\text{Ca}^{2+}\text{K}^+$  exchangers (**Ion transporters**) expel one  $\text{Ca}^{2+}$  and one  $\text{K}^+$  while allowing four  $\text{Na}^+$  to enter. The influx of  $14$   $\text{Na}^+$  to the outer segment is balanced by the activity of ATP-driven  $\text{Na}^+/\text{K}^+$  pumps (Ion transporters) in the inner segment, which admit  $2$   $\text{K}^+$  for every  $3$   $\text{Na}^+$  they expel. Several cycles of the  $\text{Na}^+/\text{K}^+$  pump are required, and the additional  $\text{K}^+$  that enter the cell reciprocally pass out of the cell down their concentration gradient via  $\text{K}^+$ -selective channels [1,4].

Each cGMP-gated cation channel consists of four subunits, and each subunit is capable of binding one molecule of cGMP at an intracellular domain close to

the C terminus of the polypeptide chain. The channel pore only allows the influx of cations when at least three molecules of cGMP are bound and, to a first approximation, the number of open channels varies as the cube of cytoplasmic cGMP concentration [4]. When the concentration of cGMP falls as a result of light-induced PDE catalytic activity, the number of open channels falls dramatically and the influx of cations to the outer segment is restricted. However, because  $\text{Na}^+$  and  $\text{K}^+$  ions are still pumped out of the inner segment there is a net loss of positive charge within the photoreceptor. The change in cation flow induced by the absorption of photons is called the **▶photocurrent**. In the case of rod photoreceptors, a single photoisomerization event can hyperpolarize the transmembrane potential with a photovoltage of 1.2 mV [8].

### Synaptic Deactivation

Initially, the transmembrane hyperpolarization induced by cGMP-gated cation channel closure is localized to the cytoplasm, near the activated segment of disk membrane (rods) or plasma membrane infolding (cones). However, this charge displacement is gradually redistributed along the entire surface area of the plasma membrane, and the hyperpolarization spreads electronically (**▶Electrotonic spread**) to the inner segment and **▶synaptic terminal**.

The effect of hyperpolarization on the synaptic terminal is to close inward voltage-gated  $\text{Ca}^{2+}$  channels (**▶Calcium channels – an overview**) in the plasma membrane. However, free  $\text{Ca}^{2+}$  ions continue to be extruded from the cell by  $\text{Na}^+/\text{Ca}^{2+}\text{K}^+$  exchangers, and so the concentration of  $\text{Ca}^{2+}$  in the synaptic terminal falls [1]. As the rate of **▶synaptic vesicle** fusion with the presynaptic membrane is proportional to the concentration of cytoplasmic  $\text{Ca}^{2+}$ , the hyperpolarization-induced closure of voltage-gated  $\text{Ca}^{2+}$  channels results in a graded reduction in the rate of **▶glutamate** release into the synapse.

### Regulation of the Process

#### Deactivation of $R^*$ and the Phototransduction Cascade

During its random diffusion across the membrane surface,  $R^*$  inevitably encounters and binds to a molecule of **▶rhodopsin kinase**, which rapidly phosphorylates serine and threonine residues on the photopigment C-terminus [6]. Phosphorylation of  $R^*$  dramatically increases its affinity for another cytoplasmic protein, arrestin, which replaces the kinase and deactivates  $R^*$ . Arrestin remains bound to the deactivated photopigment until the chromophore is reduced to all-*trans* retinol by retinal dehydrogenase, and dissociates from the opsin protein, approximately 1 s after photoisomerization.

The other components of the biochemical cascade must also be deactivated to ensure a reliable stereotyped response to each photoisomerization event and allow

recovery of the photoreceptor. Once  $T_\alpha$ -GTP has bound to and activated PDE, the complex is recognized by other membrane proteins, known as **▶GTPase activating proteins (GAPs)**. Assisted by the inhibitory  $\gamma$ -subunit of PDE, GAP stimulates the intrinsic GTPase activity of  $T_\alpha$ , which hydrolyses the bound nucleotide to GDP [9]. Phosphorylated  $T_\alpha$ -GDP subsequently detaches from the PDE $_\gamma$  subunit, thereby inactivating the catalytic activity of PDE, and reassociates with the  $T_{\beta,\gamma}$  dimer.

### Recovery and Light Adaptation

The fall in concentration of cytoplasmic  $\text{Ca}^{2+}$  associated with cGMP-gated cation channel closure and transmembrane hyperpolarization provides a mechanism for negative feedback, which controls both the recovery of the photoreceptor and its response to increasing levels of illumination. Decreasing  $\text{Ca}^{2+}$  levels stimulate, indirectly, the activity of a guanylate cyclase (GC) enzyme that synthesizes cGMP from GTP. GC is activated by guanylate cyclase activating proteins, or GCAPs, that are also  $\text{Ca}^{2+}$ -binding proteins [6]. The GCAPs in question are unable to activate GC when  $\text{Ca}^{2+}$  ions occupy two of their specific  $\text{Ca}^{2+}$ -binding sites. However, when the  $\text{Ca}^{2+}$  concentration drops, some of the GCAPs are disinhibited and stimulate GC to increase the rate of conversion of GTP to cGMP by a factor of 5–10 [4]. The subsequent increase in cGMP production counteracts the decrease caused by PDE activity and allows some of the cGMP-gated cation channels to reopen, thereby helping to restore the dark current.

Additionally,  $\text{Ca}^{2+}$  levels modulate the behavior of the cGMP-gated cation channels through the actions of another  $\text{Ca}^{2+}$ -binding protein, **▶calmodulin**. Calmodulin is a small (17 kD) protein that becomes activated when at least three of its four  $\text{Ca}^{2+}$ -binding sites are occupied by  $\text{Ca}^{2+}$  ions. The tetrameric cGMP-gated channel protein consists of two types of subunits,  $\alpha$  and  $\beta$ . The  $\beta$ -subunit is larger (155 kD) than the  $\alpha$ -subunit (80 kD), and has a calmodulin binding domain on an intracellular portion of the polypeptide chain near the N-terminus [4]. Activated calmodulin can bind to the  $\beta$ -subunit and reduce the affinity of the channel proteins for cGMP, leading to fewer open channels. However, when the cytoplasmic  $\text{Ca}^{2+}$  concentration is reduced during phototransduction, the subsequent decrease in activated calmodulin levels results in an increased affinity of the channel proteins for cGMP [5]. This leads to a greater number of bound cGMP molecules and the opening of more cation channels.

Both of these  $\text{Ca}^{2+}$ -modulated negative feedback mechanisms subserve recovery, and potentially **▶light adaptation**, by preventing saturation of the light response, and allow the photoreceptors to respond to incremental changes in light intensity over a wide range of background illumination levels [10]. The importance of these feedback mechanisms is evident

if one considers the responses of photoreceptors to dim flashes of light. At very low light levels, the magnitude of the photocurrent scales linearly with light intensity. If the dark current of a rod is  $-34$  pA and each photoisomerization event causes a photocurrent of  $0.7$  pA, the rod response would saturate with a flash intensity that caused less than 50 photoisomerizations. However, at higher flash intensities, typically those generating photocurrents of more than one third of the maximal dark current, the increase in photocurrent with increasing light intensity becomes increasingly smaller in an exponential fashion. In this way, rods are able to signal incremental changes in brightness, up to flash intensities that cause around 400–500 photoisomerizations before saturating [4].

### Function

Light is a visible form of electromagnetic radiation and, as such, exhibits both wave and particle properties. One property of the particle nature of light is that light energy travels in discrete packets (quanta) called photons. This has two important consequences for vision. Firstly, the visual system must detect quantal events that involve the transfer of miniscule amounts of energy. Secondly, the arrival of photons at the retina is a stochastic Poisson process. Photoreceptor neurons are exquisitely sensitive and can respond to the absorption of a single photon by a photopigment molecule. Phototransduction is the process by which this singular event is sufficiently amplified to create an electrical signal that can reliably be detected by the rest of the visual system.

### Pathology

A number of inherited diseases affecting the mammalian retina are caused by mutations in genes that encode components of the phototransduction cascade [1].  
 ▶ **Retinitis pigmentosa** (▶ **Inherited retinal degenerations**) – a general term for a number of inherited conditions that cause degeneration of the photoreceptors and retinal pigmented epithelium – can result from mutations in both guanylate cyclase and PDE. In addition, various forms of ▶ **night blindness** are caused by mutations in either the  $\alpha$ -subunit of transducin, which reduce the endogenous GTPase activity that mediates PDE inactivation (autosomal dominant night blindness), or in arrestin or rhodopsin kinase (▶ **Oguchi disease**).

### ▶ Evolution of Eyes

### References

1. Pepe IM (2001) Recent advances in our understanding of rhodopsin and phototransduction. *Prog Retin Eye Res* 20:733–759
2. Rodieck RW (1973) *The vertebrate retina*. WH Freeman, San Francisco

3. Sakmar TP, Menon ST, Marin EP, Awad ES (2002) Rhodopsin: insights from recent structural studies. *Annu Rev Biophys Biomol Struct* 31:443–484
4. Rodieck RW (1998) *The first steps in seeing*. Sinauer Associates, Sunderland, MA
5. McNaughton PA (1995) Rods, cones and calcium. *Cell Calcium* 18:275–284
6. Ebrey T, Koutalos Y (2001) Vertebrate photoreceptors. *Prog Retin Eye Res* 20:49–94
7. Granovsky AE, Natochin M, Artemyev NO (1997) The gamma subunit of rod cGMP-phosphodiesterase blocks the enzyme catalytic site. *J Biol Chem* 272:11686–11689
8. Schneeweis DM, Schnapf JL (1995) Photovoltage of rods and cones in the macaque retina. *Science* 268:1053–1056
9. He W, Cowan CW, Wensel TG (1998) RGS9, a GTPase accelerator for phototransduction. *Neuron* 20:95–102
10. Rebrik TI, Korenbrot JI (2004) In intact mammalian photoreceptors,  $Ca^{2+}$ -dependent modulation of cGMP-gated ion channels is detectable in cones but not in rods. *J Gen Physiol* 123:63–75

## Phrenic Nerve

### Definition

Nerve innervating the diaphragm originating from C3 to C5 cervical cord.

### ▶ Hering-Breuer Reflex

## Phrenology

### Definition

Phrenology is an outdated field of study that proposed that mental functions could be related to the position of protuberances on the skull.

## Phyletic Method

### Definition

Uses cladistic methodology (cladograms, outgroup comparison) for establishing evolutionary polarity (i.e. ancestry vs. derivedness) of characters.

### ▶ Evolution of the Brain: In Fishes

### ▶ Evolution of the Telencephalon: In Anamniotes

## Phylogenetic

### Definition

Relating to or based on evolutionary development or history.

## Phylogenetic Scale

► Evolution and the Scala Naturae

## Phylogenomic Studies

### Definition

Comparisons of whole genomes, or of large numbers of genes within genomes, to construct relationships among organisms.

## Phylogeny

► Evolution and Phylogeny: Chordates  
 ► Evolution and Phylogeny of Vertebrates

## Phylogeny and Evolution of Chordates

► Evolution and Phylogeny: Chordates

## Physical Exercise

► Stress Effects During Intense Training on Cellular Immunity, Hormones and Respiratory Infections

## Physicalism

BARBARA MONTERO

Graduate Center, City University of New York,  
 New York, NY, USA

### The Basic Formulation

The predominant philosophical theory about the world and our place in it is physicalism, the view, simply put, that everything is physical. In many circles, physicalism is not so much taken as the subject of debate but is rather assumed as the starting point around which other debates evolve. For example, a central problem in philosophy of mind is how to understand the mental given the truth of physicalism. But what, exactly, is the theory of physicalism? The simple formulation of physicalism as the view that everything is physical admits a number of interpretations, indeed, each term – “everything,” “is,” and “physical” – can be understood in different ways. To understand physicalism, then, let us look at these three aspects of the physicalist doctrine.

### Scope

For some, physicalism is a theory about everything whatsoever, where “everything” is interpreted in its broadest sense to include, for example, concrete objects such as rocks and trees, abstract objects such as numbers and sets, properties such as the property of being conscious, events such as the event of my thinking about philosophy, even God, if She exists.<sup>1</sup> Others, however, think that arguments for physicalism have to be restricted to a certain scope? go only so far and restrict its scope accordingly. For example, some take physicalism as a theory only about the concrete world, that is, roughly about phenomena<sup>2</sup> in space or time.<sup>3</sup> Others take it to be a theory about the empirical world, that is, about the phenomena that we come to know via our senses, or to put it more carefully, about the phenomena, the knowledge of which is justified via our sense experience. Still others take it to

<sup>1</sup> Or at least this is one way to state it. As a matter of terminology some physicalists reserve the term “physical” for the fundamental entities and properties of physics. Physicalism, on their view, can be true even if not everything is physical (in the narrow sense specified above), as long as everything nonfundamental is related to the physical (again, in the narrow sense) in the right way.

<sup>2</sup> I use “phenomena” in the broadest sense to include whatever exists.

<sup>3</sup> The idea that the concrete also includes anything that is either spatial or temporal is important since if it were to include only the spatio-temporal than a disembodied nonspatial soul would not count as a counterexample to physicalism.

be a theory about or the contingent world, or the causal world, or the contingent and/or causal world.

How one restricts the scope of physicalism depends on one's purposes. And since the main physicalist target is typically the mental, it is not unusual to simply focus on the question of whether the mental is physical, or in other words, focus on physicalism with respect to the mental. Indeed, it is not unusual to see the theory that the mental is physical simply referred to as "physicalism." While "physicalism" in this sense refers just to the theory that the mental is physical, a more encompassing type of physicalism is sometimes evoked to justify physicalism with respect to the mental. One finds this when physicalists argue, that the mental is very likely to be physical because everything else is physical. Here, again, one wants to know, "just what is the scope of everything else?"

In considering physicalism about the mental, one sometimes finds another sort of restriction. While typically, philosophers speak of physicalism with respect to the mental as the view that all mental properties, such as the property of feeling pain, or seeing red, are physical properties, occasionally physicalism is taken to be a theory only about things and not about properties. For example, some will claim that the view that human beings are physical things with nonphysical properties is consistent with physicalism. Most, however, would take this to be an anti-physicalist view; if physicalism is true, all properties must be physical.

The view that all properties are physical is taken to imply the view that all entities are physical. The idea being that if all of your properties are physical, then you are physical.

Let us say, then, that physicalism in the broad sense is the view that everything, or some substantial subset of everything, is physical; in the narrow sense it is the view that all mental properties are physical.

### The Dependence Relation

When the physicalist claims everything is physical or that all mental properties are physical properties, what is being said of everything or of all mental properties? Typically something is taken to be physical if its existence depends in the right way on basic or fundamental physical properties, where the fundamental physical properties are taken to be the microphysical properties countenanced by physics, such as the property of having a charge, of being a quark, and so forth. But what exactly is the [relation](#) between the fundamental physical properties and the higher level properties, such as mental properties, that suffices to make the higher level properties count as physical. In other words, when we say that everything is physical, just what is meant by "is?"

Some hold that the relation between higher level properties and fundamental physical properties is that of explanation. On this view it is thought that physicalism is true only if everything is either a fundamental physical

property or law, or it can be explained in terms of such properties and laws. As such, physicalism is an epistemic thesis that is, a thesis about what we know about the world rather than a thesis about what the world is really like. Still, it may have ontological implications since typically we think that a good indication of whether the fundamental nature of  $r$  is  $p$  is that we can explain  $r$  in terms of  $p$ .

Most philosophers, however, see physicalism primarily as an ontological thesis, a thesis that tells us about what the world is like. For this reason dependence relations are typically not formulated in terms of explanation, but rather in terms of supervenience, determination, realization, or constitution. Let us look at these relations.

Supervenience-physicalists hold that physicalism is true if everything either is a fundamental physical phenomenon or supervenes on fundamental physical phenomena. In terms of physicalism with respect to the mental, the view is simply that the mental supervenes on the fundamentally physical.<sup>4</sup> What is the relation of supervenience? There are actually many supervenience relations and a large literature discussing them. The basic idea, however, is this: to say that  $A$  properties supervene on  $B$  properties, means that there cannot be a change in  $A$  properties without a change in  $B$  properties. So, for example, mental properties are said to supervene on fundamental physical properties if and only if there cannot be a change in mental properties without a change in fundamental physical properties. If your mood changes from being happy to being sad, for example, supervenience implies that there must be a change in your fundamental physical properties as well. Sometimes, the idea is explained in terms of mind and brain: when you change from feeling happy to sad, supervenience physicalism says there must be a change in your neural structure. But since a neural change, must ultimately involve a change the fundamental level, the idea amounts to the same thing.

Is supervenience physicalism really physicalism? Some think not since it seems that one kind of property could supervene, in this sense, on another kind of property yet be utterly different in kind from that property. For example, epiphenomenalism, a type of antiphysicalism, states that pain is a nonphysical property, which nonetheless supervenes on properties of the brain. Pain, on the epiphenomenalist view, is caused by the brain yet is utterly distinct from it and has no causal influence on it. Because of concerns such as these, supervenience is often thought of as merely a necessary condition for physicalism.

Philosophers who are looking for a sufficient condition for physicalism often turn to the relations of determination, constitution, and realization. While differing in details, these relations are all supposed to capture the idea that while the higher level properties,

<sup>4</sup> What if there is no fundamental level? Physicalism needs to be reformulated. I address this in the next section.

such as mental properties, are not identical to certain lower level properties, such as neural properties, they are still not entirely distinct from these properties. The determination relation between the mental and the physical is something like the relation between, say, Mt. Everest and the little pebbles that constitute it. Mt. Everest is arguably entirely determined by its parts (once you have all the little pebbles, you have the mountain) and in this sense it is not distinct from its parts. Yet nonetheless, it might be argued, it is not identical to its parts since you could easily substitute one pebble from another mountain for a pebble from Mt. Everest without turning Mt. Everest into a different mountain. As we say that Mt. Everest is constituted or determined by its parts, the physicalist says that the mind is entirely constituted or determined by its physical parts.

Often the physicalist's claim is spelled out in terms of a thought experiment about the creation of the world. Imagine that in the beginning God created all the fundamental particles of physics and set them in motion according to a plan. If after creating the quarks and leptons and so forth and making sure that their patterns of motion were in accord with certain laws, would God have more work to do? For example, would she also need to create human minds? Physicalists think not since they think that the world we are familiar with, which includes rocks and trees and people with thoughts, is entirely constituted by complex arrangements of microphysical particles. This is not to say that physicalists must hold that there is nothing but complex arrangements of microphysical particles. Rather, most physicalists hold that higher level features of the world, such as rocks and trees and minds, do exist. It is just that the higher level features of the world are created in creating all of the microphysical aspects of the world.<sup>5</sup>

### The Physical

Now we must address the question of what is the physical? When we say, for example, that everything is determined by fundamental physical phenomena what are these fundamental physical phenomena? As I said above, most define the fundamental physical in terms of the entities and properties and perhaps laws posited by microphysics: the fundamental physical phenomena are

those entities and properties mentioned in the theories of microphysics. But what is meant by microphysics? Some take microphysics to refer to current microphysical theory. This gives us a relatively clear position: physicalism becomes the view that everything that exists either is or is determined by the entities, properties, and laws of current microphysics. Unfortunately, this is a theory that is rather difficult to accept since we know that current microphysics is most likely neither entirely true nor complete and thus we know now that it is not true that everything is determined by such phenomena.

Because formulating the microphysical in terms of current microphysics leads to a theory we currently know is false, most physicalists formulate physicalism in terms of a true and complete microphysics. As such, physicalism is the view that everything will be accounted for by the entities and properties of a true and complete microphysics. But what is a true and complete microphysics? It would seem to be a theory that tells us about the fundamental nature of everything. But if so, physicalism turns out to be true by definition since the fundamental nature of everything, of course, will be accounted for by a theory that accounts for the fundamental nature of everything. While there is nothing necessarily wrong with being true by definition, most philosophers working on the question of physicalism do not think that at this point in the debate the truth of physicalism simply follows from its definition. Rather, most think that physicalism requires argument and empirical support, support which they speculate is forthcoming.

If we can neither formulate physicalism in terms of current physics nor in terms of a true and complete physics, how are we to formulate physicalism? It is not clear that we can formulate physicalism so as to assign pride of place to physics, however, we can reformulate physicalism with respect to the mind so that it captures at least most of what physicalists and antiphysicalists think is at issue. This is done by turning physicalism into a thesis not about the fundamental physical aspects of the world, but rather about the fundamental non-mental aspects of the world. Physicalism with respect to the mind then amounts to the view that all mental properties are determined by nonmental properties. One way to think about this view is that the mind is physical if all mental properties are determined by neural properties (couldn't a physicalist concede that some mental properties may be determined by other physical properties, say those of silicon chips?) and neural properties are themselves ultimately determined by non-mental properties.<sup>6</sup>

<sup>5</sup> I have not discussed questions of the modality of the determination relation. Most physicalists think that physicalism could have been false, that God could have created nonphysical minds along with the creation of the fundamental physical particles, but some think of it as a necessary truth, that it is not possible that there could have been anything nonphysical. Moreover, while most think that physicalism could have been false, they also presumably think that it is not just by chance that it is true in our world; that is, they would deny that our world is such that if, say, two kinds of substances, which had never been brought together, were brought together, they would produce a nonphysical substance. In this sense, the creation thought experiment does not quite capture the content of physicalism.

<sup>6</sup> This formulation would not be acceptable to an externalist, that is to someone who thinks that some mental content depends on features of the world outside of the brain. Externalists, then must rely on the more general formulation of physicalism as the view that all mental properties are determined by nonmental properties.



This way of formulating physicalism captures a central point of contention between physicalists and antiphysicalist: whether mentality is a fundamental feature of the world. But what if there is no fundamental level of reality? For example, if mental properties are determined by non-mental properties, which are themselves determined by mental properties, which are determined by non-mental properties and so on *ad infinitum*, or if it is mental “all the way down,” then, in either case, all fundamental properties are non-mental properties, vacuously, since there are no fundamental properties, yet physicalists would probably want to reject these world views. To address this issue, we can formulate physicalism with respect to the mental as the view that *all mental properties are eventually decomposable into non-mental properties such that all further decompositions of these properties are non-mental*.

As a general theory of physicalism, that is, as theory about the nature of everything, this formulation is inadequate. This is because there may be phenomena that for certain purposes would be unacceptable yet are nonmental. For example, a world with fundamental moral properties or abstract entities would seem to be inconsistent with physicalism, yet such things are not mental. That there is no general theory of physicalism, however, does not mean that much interesting work cannot proceed on specific topics, including questions about the ultimate nature of the mind.

- ▶ Causality
- ▶ The Knowledge Argument

## Physiological Cell Death

- ▶ Programmed Cell Death

## Physiological Pain Parameters

### Definition

Physiological pain measures include heart rate, respiration rate, blood pressure, palmar sweating, cortisol and cortisone levels, O<sub>2</sub> levels, vagal tone and endorphin concentrations. They are indirect pain measures and reflect a complex and generalized stress response, rather than correlate with a particular pain level.

- ▶ Pain in Children

## Physiology of Body Fluid Balance

- ▶ Blood Volume Regulation

## Pia Mater

### Synonyms

- ▶ Meninges; ▶ Cisterns

### Definition

Together with the arachnoid, the pia mater forms the leptomeninges.

Whereas the arachnoid follows the course of the dura mater and hence of the calvaria, the pia mater rests on the surface of the brain, pursuing a joint course along the sulci. Lying between the pia mater and arachnoid is the subarachnoid space that is filled with CSF.

## Pick’s Disease

### Definition

Pick’s disease is a severe neuro-degenerative disease in the neocortex of the ▶ [frontal lobe](#) and anterior ▶ [temporal lobe](#), and at times of neurons in the ▶ [striatum](#).

## Pickwickian Syndrome

### Definition

Named after a Charles Dickens tale involving a character with clinical signs of the syndrome of obstructive sleep apnea and obesity hypoventilation.

The combination of upper airway obstruction and reduced lung volumes from the restrictive ventilatory effect of obesity causes low blood oxygen and elevated carbon dioxide, with their associated physiological consequences.

- ▶ Sleep – Developmental Changes

## PID Control

### Definition

A popular closed-loop control method that uses a simple (Proportional-Integral-Derivative) linear controller with easily tunable parameters.

► [Nonlinear Control Systems](#)

## Piloerection or Pilomotor Reflex

### Definition

Piloerection or pilomotor reflex, also called horripilation, consists of involuntary hair erection induced by contraction of arrectores pilorum muscles, i.e., the tiny muscles located at the origin of each body hair. It is a reaction to cold temperature or strong emotions producing the so-called cutis anserina or goose bumps/pimples. Arrectores pilorum muscles receive the contractile command by the sympathetic nervous system.

► [Sympathetic Nervous System](#)

## Pineal Body

### Synonyms

► [Glandula pinealis](#); ► [Pineal gland](#)

### Definition

This nuclear region, shaped like a pine cone, above the quadrigeminal lamina forms, together with the habenular nuclei, the so-called epithalamus. The function of the pineal body, also called epiphysis or pineal gland, is to produce the hormone melatonin, which plays a role in light-controlled circadian rhythms. Afferents come from the suprachiasmatic nucleus, pre-geniculate nucleus and posterior commissural nucleus.

► [Diencephalon](#)

## Pineal Gland

### Definition

The pineal gland (or the epiphysis cerebri, or epiphysis) is an endocrine gland located in the brain. The primary role of the pineal gland is the synthesis and release of the hormone melatonin. This hormone plays an important role in the regulation of many neurobiological aspects (e.g., circadian rhythms, sleep and reproduction).

The pineal gland receives a sympathetic innervation from the superior cervical ganglion. In nonmammalian vertebrates the pineal gland is directly photosensitive and usually contains circadian oscillators.

► [Avian Pineal Gland as “Third Eye”](#)

► [Pineal Oscillators](#)

## Pineal Hormone

► [Melatonin](#)

## Pineal Oscillators

### Definition

In many animals the pineal gland contains circadian pacemakers that directly control the synthesis of melatonin. A single pineal cell (pinealocyte) is capable of driving the circadian rhythms in melatonin release.

Therefore, it is composed of many “clocks” that are capable of producing a synchronized output (melatonin).

Indeed, in birds and in many non-mammalian vertebrates, the pineal gland acts as a circadian pacemaker that regulates the entire circadian system.

In mammals the pineal gland does not contain circadian oscillators. However, recent studies have reported that the mammalian pineal gland may also contain a circadian clock, although this circadian oscillator does not regulate melatonin synthesis and, therefore, its functional role is unclear.

► [Circadian Rhythm](#)

## Pinealectomy

### Definition

Surgical removal of the pineal gland.

- ▶ Seasonality

## Pioneer Axons

### Definition

Pioneer axons are the first axons to extend into novel regions of the developing embryo. Growth cones of pioneer axons generally have a broad hand-like appearance with filopodia, consistent with making guidance choices based on cues in the environment.

Later growing axons will often fasciculate with these pioneer axons and use them as tracks on which to grow to their target region. In most of the embryo, motor neurons of the CNS send out the pioneer axons traveling to peripheral structures and sensory axons later grow along these tracks. However, in the developing head, sensory ganglion neurons send out the pioneer axons and motor axons later travel along these tracks.

- ▶ Growth Cones

## Piriform Cortex

### Definition

The allocortical piriform cortex (also termed olfactory or pyriform or prepiriform cortex) is the largest primary area involved in the perception and learning of olfactory stimuli. It is located in the rostral part of the forebrain, ventrally to the rhinal sulcus, and it is reciprocally connected with other olfactory regions and with high order brain areas. It is commonly divided in two regions (an anterior and a posterior part) which are believed to have different functional roles.

- ▶ Olfactory Cortex

## Pit Organ

### Definition

Receptor of infrared radiation, pits near the nostrils, actually primitive “eyes,” which register not only the heat, but also the direction of its source, e.g. a small rodent.

- ▶ Evolution of the Brain: At the Reptile-Bird Transition

## Pituitary Adenylate Cyclase-Activating Polypeptide1 (PACAP)

### Definition

Neuropeptide involved in the phase shift response of the circadian clock in response to nocturnal light and also stimulates the release of melatonin from the adult pineal gland.

- ▶ Clock-Controlled Genes

## Pituitary Gland

### Definition

Also called hypophysis. The pituitary gland is an appendix to the hypothalamus at the base of the forebrain. The pituitary consists of an anterior adenohypophysis and a posterior neurohypophysis.

The hypothalamus emits a number of releasing hormones and release-inhibiting hormones, which regulate the release of hormones from the adenohypophysis.

- ▶ Hypophysis
- ▶ Hypothalamo-neurohypophysial System
- ▶ Hypothalamo-pituitary-adrenal Axis, Stress and Depression
- ▶ Hypothalamo-pituitary-thyroid Axis
- ▶ Hypothalamus
- ▶ Releasing-Hormone and Release-Inhibiting Hormone

## PKA

### Definition

► Protein Kinase A

## PKC

### Definition

► Protein Kinase C

## Place Cells

### Definition

Neurons discharging selectively when the subject is in a delimited region of its environment referred to as a “firing field” or “place field.” First discovered in the hippocampus by O’Keefe and Dostrovsky (1971).

Found in rats, mice, birds, bats, and primates including humans. Although most observers agree that the hippocampus has a critical role in learning and memory, there remains considerable debate about the precise functional contribution of the hippocampus to these processes.

Two of the most influential accounts hold that the primary function of the hippocampus is to generate cognitive maps and to mediate episodic memory processes. The well-documented spatial firing patterns (place fields) of hippocampal neurons in rodents, along with the spatial learning impairments observed with hippocampal damage support the cognitive mapping hypothesis. The amnesia for personally experienced events seen in humans with hippocampal damage and the data of animal models, which show severe memory deficits associated with hippocampal lesions, support the episodic memory account.

- The Hippocampus: Organization
- Neural Bases of Spatial Learning and Memory
- Hippocampus: Organization, Maturation, and Operation in Cognition and Pathological Conditions

## Place-versus-Response Controversy

### Definition

This controversy was a well-known debate among groups of psychologists in the early twentieth century.

The response group (behaviorists) felt that all behavior, including navigation, must be described in simple stimulus-response terms. The place group (cognitivists) felt that complex behavior could only be explained by positing that the rat brain contained a central representation – a map of the places in the environment.

► Spatial Learning/Memory

## Placebo Analgesic Response

HOWARD L. FIELDS

Ernest Gallo Clinic and Research Center, University of California, San Francisco, USA

### Synonyms

Expectancy effect; Palliative; Dummy treatment; Control treatment

### Definition

The ►placebo analgesic response is a reduction in ►pain resulting from the recipient’s expectation that a treatment received has analgesic efficacy. The term placebo is usually used when the treatment is intentionally given deceptively and has no intrinsic analgesic efficacy.

### Characteristics

Some individuals experience a reduction of their pain when they are given a completely inert substance with the understanding that it is an effective treatment. If the person giving it knows that the treatment is inert (i.e., it is given with the intention to deceive the recipient), the treatment is a placebo. However, even if the individual receiving the placebo experiences a reduction in their pain following placebo administration, it is not necessarily the case that the placebo caused the reduction. The reason for the uncertainty is that in clinical syndromes it is common to observe frequent fluctuations in pain over time in the absence of any treatment. This fluctuation is called the ►natural history of the painful condition. Consequently, one cannot conclude that a given instance of a reduction in pain is due to the preceding treatment manipulation,

whether placebo or active medication. Because of this uncertainty, well designed clinical trials of analgesic medications generally require a comparison group receiving placebo treatment. The efficacy of an analgesic medication is established by showing that it produces a reduction in pain superior to placebo.

This uncertainty about the cause of a fluctuation in pain also presents challenges for research into the mechanisms underlying the placebo analgesic response [1]. One obvious difficulty is that if the individual improves, it is uncertain whether it is because of a placebo analgesic response or would have occurred in the absence of treatment. Thus, placebo analgesic responses in an individual are usually inferred, not observed. On the other hand, placebo analgesic effects are quite robust when studied comparing two *groups* of subjects, one of which receives a placebo and the other no treatment. The ►**placebo effect** in that situation is the difference between those two groups. The difficulty in identifying individual, as opposed to group placebo analgesic responses has made it very difficult to determine whether there are specific characteristics of individuals that make them more or less likely to respond to a placebo manipulation. On the other hand, comparing groups given placebo versus no-treatment has increased our understanding of the psychological and neural mechanisms of the placebo analgesic response.

In addition to its usefulness in controlled clinical trials, responses to placebo likely play a significant role in clinical practice. Placebo administration can provide effective relief for severe pain conditions, including those following major surgical procedures. It is also important to point out that even when effective analgesic agents are given to patients, part of the pain relief obtained may be due to a ►**placebo response**. For example, when a moderate dose of morphine is given to a pain patient by hidden infusion (i.e., from a preprogrammed remote pump at an unknown time), it is much less effective than when it is given openly. When patients with postoperative pain are told that they may receive morphine, but instead are given an open administration of saline through an intravenous catheter, they obtain pain relief equivalent to a moderate dose of morphine given by hidden infusion [2]. This suggests that in many cases the relief obtained when individuals take an analgesic agent is a sum of a placebo response plus the effect of the active agent.

Studies directed at the psychological determinants of the placebo response have identified ►**expectancy** as the most relevant psychological mediator. Expectancy can be manipulated verbally for example by simply informing the subject that the treatment they are about to receive is a powerful analgesic [3]. Expectancy can also be manipulated by explicit training, which leads to ►**conditioned memory**. One form of conditioning is to treat subjects in pain with a powerful analgesic agent and

subsequently administering a similar appearing placebo treatment to them [4]. Another approach is through surreptitiously lowering the intensity of an experimental painful stimulus in the presence of a placebo treatment [5] and then re-administering the placebo treatment. For either approach, the conditioning markedly increases the analgesic effectiveness of a placebo treatment. Furthermore, there is a clear relationship between the subject's expectations and the degree of relief experienced [5].

Progress has also been made in understanding the neural mechanisms underlying the placebo analgesic effect. One of the first mechanistic proposals was that expectation of reward somehow led to the release of endogenous ►**opioid peptides** which acted at ►**opioid receptors** in the central nervous system to produce analgesia. This idea was supported by the finding that placebo relief of dental postoperative pain could be blocked by the opioid receptor antagonist ►**naloxone** [6]. Naloxone was later shown to block placebo analgesia in experimental pain models in normal volunteers [7]. Furthermore, there is a central nervous system pathway that modulates pain transmission (see ►**Descending modulation of nociception**). This pathway is organized in a top-down fashion. It includes the ►**anterior cingulate cortex** and other regions of the ►**prefrontal cortex**, the ►**hypothalamus**, ►**amygdala** and brainstem and it terminates in the ►**spinal cord** [8]. The anterior cingulate cortex and other prefrontal areas have been implicated in expectancy effects including placebo analgesia. Furthermore, endogenous opioid peptides are released throughout this pathway and contribute to its analgesic effects. Human ►**functional imaging** studies, including both ►**positron emission tomography** and ►**functional magnetic resonance imaging**, have provided evidence that supports a role for this ►**pain modulating pathway** in placebo analgesia. Placebo analgesic effects correlate with activation of prefrontal cortex and brainstem regions areas that overlap with the endogenous opioid mediated ►**pain modulatory pathway** [9,10].

In summary, the expectation of pain relief, whether induced by verbal instruction or conditioning, can bestow robust analgesic potency on a treatment that would otherwise be ineffective. The expectancy effect is mediated by a pain modulating pathway with endogenous opioid links. Placebo analgesic responses may also contribute to the efficacy of active analgesic agents through summation with direct drug effects.

## References

1. Amanzio M, Benedetti F (1999) Neuropharmacological dissection of placebo analgesia: expectation-activated opioid systems versus conditioning-activated specific subsystems. *J Neurosci* 19:484–494
2. Benedetti F, Amanzio M (1997) The neurobiology of placebo analgesia: from endogenous opioids to cholecystokinin. *Prog Neurobiol* 52:109–125

3. Bingel U, Lorenz J, Schoell E, Weiller C, Buchel C (2006) Mechanisms of placebo analgesia: rACC recruitment of a subcortical antinociceptive network. *Pain* 120:8–15
4. Fields HL, Basbaum AI, Heinricher MM (2006) Central nervous system mechanisms of pain modulation. In: McMahon SB, Koltzenburg M (eds) *Wall and Melzack's Textbook of pain*, 5th edn. Elsevier Churchill Livingstone, Edinburgh, pp 125–142
5. Hoffman GA, Harrington A, Fields HL (2005) Pain and the placebo: what we have learned. *Perspect Biol Med* 48:248–265
6. Levine JD, Gordon NC, Fields HL (1978) The mechanism of placebo analgesia. *Lancet* 2:654–657
7. Levine JD, Gordon NC, Smith R, Fields HL (1981) Analgesic responses to morphine and placebo in individuals with postoperative pain. *Pain* 10:379–389
8. Pollo A, Amanzio M, Arslanian A, Casadio C, Maggi G, Benedetti F (2001) Response expectancies in placebo analgesia and their clinical relevance. *Pain* 93:77–84
9. Price DD, Milling LS, Kirsch I, Duff A, Montgomery GH, Nicholls SS (1999) An analysis of factors that contribute to the magnitude of placebo analgesia in an experimental paradigm. *Pain* 83:147–156
10. Wager TD, Rilling JK, Smith EE, Sokolik A, Casey KL, Davidson RJ, Kosslyn SM, Rose RM, Cohen JD (2004) Placebo-induced changes in fMRI in the anticipation and experience of pain. *Science* 303:1162–1167

---

## Planes of Section

### Definition

Planes of section are usually expressed in relation to the upright midline axis of the body (or spinal column). The plane of section that passes through or parallel to the midline and extends in the dorsal-ventral direction is the sagittal plane. Parasagittal planes pass to the left or to the right of the midline sagittal plane that is marked by the sagittal suture of the skull. The horizontal plane is at a right angle to the sagittal plane and parallel with the ground. Horizontal planes progress inferiorly or superiorly. The frontal (coronal) plane is orthogonal to the other two. It is in the plane of the coronal suture of the skull. Frontal planes progress anteriorly and posteriorly.

---

## Plant

### Definition

The external environment that needs to be controlled, e.g. an arm.

► Neural Networks for Control

---

## Plasma Membrane

### Definition

► Cell Membrane Components and Functions

---

## Plasma Membrane $\text{Ca}^{2+}$ -ATPase (PMCA)

### Definition

A pump on the plasma membrane that couples ATP hydrolysis to the extrusion of  $\text{Ca}^{2+}$  from the cytosol to the extracellular space.

► Influence of  $\text{Ca}^{2+}$  Homeostasis on Neurosecretion

---

## Plasmalemma

### Definition

The term denotes the cell membrane separating the interior from the exterior of a cell except in muscle cells, where the cell membrane is called “sarcolemma.”

► Cell Membrane Components and Functions

---

## Plasmid Vector

### Definition

Small circular molecules of double stranded DNA derived from natural plasmids found in bacteria. They themselves are distinct from the chromosomal genome of bacteria. An exogenous piece of DNA can be easily inserted into a plasmid if both the plasmid and the exogenous DNA source have recognition sites for the same restriction endonuclease.

► Serial Analysis of Gene Expression

## Plasticity

### Definition

The ability of the brain to change its functional organization and neural representations (e.g. motor and sensory maps) as a result of damage or experience and in response to altered peripheral conditions or behavioral demands.

- ▶ [Motor Cortex – Hand Movements and Plasticity](#)
- ▶ [Somatosensory Cortex, Plasticity](#)

## Plasticity in Central Auditory System

DEXTER R. F. IRVINE

Department of Psychology, Monash University,  
VIC, Australia

### Definition

Changes in the structural and functional characteristics of neurons in the central auditory system (CAS), which occur in response to altered patterns of input (i.e., not as a direct consequence of aging or of other changes in the organism's state), and are not explicable as passive consequences of the altered input, but involve some form of dynamic change in neural properties [1].

### Characteristics

#### Higher Level Structures

The CAS comprises the various ▶ [auditory subcortical nuclei](#) and the multiple cortical fields that comprise the auditory cortex (▶ [auditory cortical areas](#)), together with the (ascending and descending) pathways that link these structures.

#### Lower Level Components

The lower level components are the individual neurons and their processes that make up the various nuclei and fiber tracts comprising the CAS, the synaptic connections between these neurons, and the networks they comprise.

#### Higher Level Processes

CAS plasticity has been demonstrated in a variety of experimental conditions, and is assumed to underlie a number of forms of auditory behavioral plasticity; however, it is by no means clear that the same mechanisms are involved in all cases. A broad distinction can be made between forms of plasticity that occur

only during development (in many cases within restricted ▶ [critical periods](#)), and those that are observed in both young and adult animals. In the following sections, the major paradigms that have been used to study developmental and adult plasticity will be briefly reviewed.

#### Developmental Plasticity: Neonatal Cochlear Ablation

Neonatal ablation of one ▶ [cochlea](#) in mammals, which eliminates afferent input from that ear to ▶ [binaural neurons](#) in the CAS, results in structural and functional changes in the input from the intact ear to these neurons. Axons from the ventral division of the ▶ [cochlear nucleus](#) (CN) on the side of the intact ear, which normally terminate in restricted regions of the major nuclei of the ▶ [superior olivary complex](#), project to, and make synapses in, regions of these nuclei normally innervated by the CN on the side of the ablated cochlea. Similarly, the terminal fields in the central nucleus of the ipsilateral ▶ [inferior colliculus](#) (IC) of axons from the CN on the side of the intact ear are much larger than those in normal animals [2]. Both of these results indicate that, following unilateral cochlear ablation, axons from the CN on the intact side sprout to innervate additional territory. These structural changes are associated with increased excitatory responses to stimulation of the intact ear in the ipsilateral IC and ▶ [primary auditory cortex](#) (AI) [2].

#### Developmental Plasticity: Space Map Plasticity

In barn owls, and in at least some mammals, the deep layers of the ▶ [superior colliculus](#) (SC) contain maps of auditory and visual space that are in register (i.e., bimodal neurons, or auditory and visual neurons at the same locus, have corresponding auditory and visual ▶ [spatial receptive fields](#) (RFs)). The auditory ▶ [space map](#) is derived via orderly projections from the ▶ [external nucleus of the](#) (ICX), and is based on neural sensitivity to ▶ [interaural time and level differences](#) (ITDs and ILDs, respectively) and, in mammals, on sensitivity to ▶ [spectral cues](#) produced by the effects of the head and ▶ [pinnae](#) on the sound field [2]. In both barn owls [3] and ferrets [2] reared from infancy with one ear plugged (thus altering the values of the interaural disparities associated with any given spatial location), the visual and auditory maps are in register. In the barn owl, this reflects the fact that the tuning to ITDs and ILDs of neurons in ICX and SC has changed to maintain alignment of the auditory and visual RFs. This change in neural tuning is associated with the appearance of novel projections from the central nucleus of IC (ICC) to ICX: axons sprout into, and form synapses in, regions outside their normal projection zone [3]. Immediately after ear plugging, young owls mislocalize sounds, but in parallel with the map changes, they recover accurate localization ability. Ear plugging in adult animals does not result in adaptive changes in interaural

disparity tuning, and the auditory and visual space maps therefore remain out of register while the plug is in position. Analogous developmental plasticity occurs when owls are raised wearing prismatic spectacles that displace the visual field in the horizontal plane: the tuning of SC neurons to ITDs (which serve as the cue for azimuthal location in barn owls) shifts to maintain the correspondence between auditory and visual RFs [3]. The plasticity demonstrated in these studies using experimental manipulations of sensory input occurs in all animals during development as the size of the head increases, and the values of ITDs and ILDs associated with particular spatial locations consequently change.

### Adult Plasticity: Injury-Induced

Lesions of a restricted region of the cochlea (which result in a partial hearing loss) result in a reorganization of the ►frequency map in AI. The nature of this reorganization is that the region deprived of its normal input by the cochlear lesion is occupied by an expanded representation of the frequencies represented at the edge(s) of the cochlear lesion. The thresholds, latencies, and sharpness of ►frequency tuning of neurons in this expanded representation at their new ►characteristic frequency (CF) indicate that the changed frequency organization is not a passive consequence of the peripheral lesion, but reflects a dynamic process of reorganization. Such reorganization is observed after mechanical cochlear lesions, and after lesions produced by ►ototoxic drugs or by ►noise trauma [1]. Analogous reorganization is seen in visual and somatosensory cortices after restricted retinal lesions and digit amputation, respectively [4]. After mechanical cochlear lesions, similar reorganization is seen in the major auditory thalamic nucleus (the ventral division of the ►medial geniculate nucleus), but reorganization is patchy in the ICC and is not observed in the dorsal nucleus of the CN, suggesting that this form of CAS plasticity is a characteristic of ►thalamo-cortical circuitry.

### Adult Plasticity: Learning-Induced

Changes in the stimulus selectivity of neurons in the higher levels of the auditory pathway, as a consequence of behavioral conditioning procedures in which an acoustic stimulus serves as the ►conditioned stimulus or discriminative (henceforth “training”) stimulus, were the first demonstrations of CAS plasticity in adult animals, and this remains the most active area of research on this topic. The most common finding in these studies is that the response of cortical neurons at the training frequency increases, while the response at other frequencies decreases, such that the training frequency becomes the neurons’ ►best frequency. Such effects have been described in AI and in secondary auditory cortical fields, and in the auditory thalamus [1,5,6]. These studies have commonly used ►fear

conditioning procedures, but appropriate controls, and the specificity of the effects to the training frequency, establish that the observed effects are manifestations of plasticity rather than consequences of changes in state variables [6]. A substantial body of evidence indicates that the ►cholinergic basal forebrain plays an important modulatory role in this form of CAS plasticity [1].

Another form of auditory learning that might involve CAS plasticity is ►perceptual learning, the improvement in discriminative capacity with training that is a common observation in all sensory modalities both in psychophysical experiments and in everyday life [1,7,8]. The specificity of many forms of visual perceptual learning to particular features of the training stimuli, or to the region of the receptor to which the stimuli are presented, has led to the proposal that the learning might involve changes in neural tuning in primary sensory cortex [7,8]. In the auditory system, the evidence for changes in AI associated with perceptual learning is equivocal [7], and it is possible that the learning involves changes in higher-order decision making processes. Indirect evidence for auditory cortical changes is provided by ►functional imaging evidence of larger auditory cortical responses to musical tones in trained musicians, although in this case it is not clear whether the larger cortical responses are a consequence of training, or whether people with this innate characteristic are more likely to undertake such training [1].

Two forms of auditory perceptual learning that are of great practical significance relate to speech processing. The first is the effect of language experience on the perception of speech sounds, and thus on language acquisition, during a critical period of development [9]. The second is the improvement in speech discrimination shown by people with ►cochlear implants over the months and years following implantation. Whether these forms of learning reflect plasticity in the CAS itself or in regions involved in cognitive processes is not clear.

### Adult Plasticity: Microstimulation-Induced

A series of studies in adult bats and gerbils have indicated that focal electrical stimulation of a region of AI can change the frequency selectivity of neurons around the stimulation site in AI, and in the tonotopically corresponding area of the central nucleus of the IC [5]. ►Centrifugal fibers from AI to IC have been shown to play a role in this plasticity.

### Lower-Level Processes

The cellular mechanisms of CAS plasticity (and those of plasticity in other sensory systems) are incompletely understood. Different forms of plasticity have different time courses, as do different phases of particular forms of plasticity. The first stage of injury-induced plasticity



in sensory cortices appears to be an expansion of RFs, reflecting an unmasking of normally-inhibited excitatory inputs from outside the classically defined RF [10]. A similar unmasking is involved in space map plasticity in the barn owl [3]. The subsequent establishment of smaller RFs in injury-induced plasticity presumably involves changes in the efficacy of both excitatory and inhibitory synapses, and there is evidence for the strengthening of excitatory synapses via ►NMDA-receptor mediated ►long-term potentiation in developmental plasticity in the barn owl [3] and in adult plasticity in the visual and somatosensory systems [10]. Longer-term changes in the barn owl involve axonal sprouting and ►synaptogenesis [3]; axonal sprouting is also involved in the changes observed after unilateral cochlear ablation in neonatal animals [2]. Axonal sprouting of horizontal fibers in the superficial layers of the cortex has also been shown to be involved in visual cortical plasticity after retinal lesions in adults [8]. Structural changes of this sort have not yet been shown in injury-induced auditory plasticity in adults. Finally, as mentioned previously, corticofugal projections have been shown to be involved in some forms of plasticity [5,8].

### Function

Auditory developmental plasticity and learning-induced plasticity are undoubtedly adaptive, in that they enhance the organism's ability to adjust to altered patterns of input and, in the case of human language acquisition and adaptation to a cochlear implant, make important auditory discriminations. It is less-clear that adult injury-induced plasticity is adaptive, as the organism remains deaf in the frequency range affected by the cochlear lesion, and there is little evidence that the CAS reorganization consequent on the lesion in any way compensates for this deafness. It is likely that this form of plasticity is an extreme manifestation of the processes that underlie other forms of plasticity in response to altered input, but it is also possible that similar processes are involved in recovery of function after central damage such as that produced by stroke.

### Pathology

There is little evidence that these forms of plasticity have pathological consequences, although it has been suggested that tinnitus might be a consequence of cortical reorganization consequent on a peripheral lesion [1].

### Therapy

The possibility that some forms of learning impairment might involve deficiencies in aspects of auditory processing that exhibit plasticity, such that these deficiencies can be modified by training, has resulted

in the recent development of a number of auditory training software packages. As discussed previously, the success of cochlear implants undoubtedly rests in part on the plasticity of CAS structures, and plasticity therefore contributes to the therapeutic effects of these devices.

### References

1. Irvine DRF, Wright BA (2005) Plasticity in spectral processing. In: Malmierca M, Irvine DRF (eds) Auditory spectral processing. Elsevier, San Diego pp 435–472
2. Moore DR, King AJ (2004) Plasticity of binaural systems. In: Parks TN, Rubel EW, Popper AN, Fay RR (eds) Plasticity of the auditory system. Springer, New York, pp 96–172
3. Knudsen EI (2002) Instructed learning in the auditory localization pathway of the barn owl. *Nature* 417:322–328
4. Kaas JH, Florence SL (2001) Reorganization of sensory and motor systems in adult mammals after injury. In: Kaas JH (ed) The mutable brain. Harwood Academic Publishers, New York, pp 165–242
5. Suga N, Ma X (2003) Multiparametric corticofugal modulation and plasticity in the auditory system. *Nat Rev Neurosci* 4:783–794
6. Weinberger NM (2004) Experience-dependent response plasticity in the auditory cortex: issues, characteristics, mechanisms, and functions. In: Parks TN, Rubel EW, Popper AN, Fay RR (eds) Plasticity of the auditory system. Springer, New York, pp 173–227
7. Irvine D, Brown M, Martin R, Park V (2005) Auditory perceptual learning and cortical plasticity. In: Koenig R, Heil P, Budinger E, Scheich H (eds) The auditory cortex: a synthesis of human and animal research. Lawrence Erlbaum, Mahwah, NJ, pp 409–428
8. Tsodyks M, Gilbert C (2004) Neural networks and perceptual learning. *Nature* 431:775–781
9. Kuhl PK (2000) A new view of language acquisition. *Proc Natl Acad Sci USA* 97:11850–11857
10. Calford MB (2002) Dynamic representational plasticity in sensory cortex. *Neuroscience* 111:709–738

## Plasticity in Nociception

### Definition

Plasticity with respect to nociception refers to modulation of nociceptive afferent signals. Plasticity with respect to pain refers to the modulation of pain perception. The biological response to tissue damage, and the subsequent perception of pain, can vary depending on activation of other ascending and descending sensory systems.

### ► Spinal Dorsal Horn Plasticity

## Plateau Potential

### Definition

A membrane potential depolarization that is sustained by intrinsic properties even after the stimulus that triggered it has been terminated. In contrast to a pacemaker potential, the plateau potential is not rhythmically activated and terminated by the neuron.

Instead, onset and termination of plateau potentials are typically triggered by excitatory and inhibitory synaptic inputs. Most commonly plateau potentials are caused by the action of persistent inward currents (e.g. persistent  $\text{Na}^+$  current, low-voltage activated  $\text{Ca}^{2+}$  currents, etc.). Once these currents have been activated by a synaptic input or brief depolarization, the resulting inward current is sufficient to sustain the depolarization and maintain their activation. The depolarization can be terminated by inhibitory synaptic inputs that hyperpolarize the membrane potential sufficiently to remove the activation of the persistent inward current. The plateau potential can also be terminated by intrinsic mechanisms, e.g. persistent  $\text{Ca}^{2+}$  influx can activate  $\text{Ca}^{2+}$ -dependent  $\text{K}^+$  channels that cause an outward current which will repolarize the membrane potential and terminate the plateau potential.

- ▶ [Calcium Channels – an Overview](#)
- ▶ [Central Pattern Generator](#)
- ▶ [Neuronal Potassium Channels](#)
- ▶ [Sodium Channels](#)

## Play

- ▶ [Learning and Motivation](#)

## PLC $\gamma$

### Definition

Is a member of the Phospholipase C family that consists of PLC- $\Delta$ , - $\beta$ , - $\gamma$  and - $\epsilon$  which all require calcium for their catalytic activity. PLC $\gamma$  is activated by transmembrane receptors with tyrosine kinase activity and is a key enzyme involved in the activation of protein

kinase C (PKC) leading to Akt activation and increased survival following axonal injury.

- ▶ [Neurotrophic Factors in Nerve Regeneration](#)

## Plegia

### Definition

Severe loss of motor strength by motor paralysis of entire limbs or parts thereof.

## Plexus

### Definition

A plexus (Latin for braid) is a region of exchange of nerve fibers of different spinal cord levels to form specific peripheral nerves.

## PMBSF

- ▶ [Barrel Cortex](#)

## Pneumotaxic Center

- ▶ [Pontine Control of Respiration](#)

## PNS

### Definition

Peripheral nervous system including cranial and spinal nerves.

## p75NTR

### Definition

p75NTR (p75 neurotrophin receptor) is a 75 kDa member of the Tumour Necrosis Factor (TNF) receptor family whose members share a cysteine-rich common extracellular binding domain. It was originally identified as a low-affinity receptor for NGF (nerve growth factor). It has since been shown that p75NTR binds all known members of the neurotrophin family (NGF, BDNF, NT-3, NT-4/5), and subsequent intracellular activation is upstream of both the PKC and JNK pathways resulting either survival or death. Denervated Schwann cells express high levels of p75NTR as a consequence of the loss of axonal contact. The function of p75NTR in Schwann cells is currently not known.

- ▶ Neurotrophic Factors in Nerve Regeneration
- ▶ Schwann Cells in Nerve Regeneration
- ▶ Tumor Necrosis Factor- $\alpha$

## Point Contacts

- ▶ Integrin-dependent Adhesion Contacts

## Point-to-Point Movements

### Definition

Point-to-point movements are a sequence of discrete movements, where each movement starts from one position aiming to a next position.

- ▶ Motor Control Models

## Polar Decomposition Theorem

### Definition

A theorem in linear algebra stating that every nonsingular square matrix is uniquely decomposable

into the product of an orthogonal matrix and a positive definite symmetric matrix.

- ▶ Mechanics

## Polarity

### Definition

Polarity in the case of neurons, polarity refers to the fact that neurons are polarized structures with an axon and dendrites.

## Polarity of Neurons

### Definition

In the case of neurons, polarity refers to the fact that neurons are polarized structures with an axon and dendrites.

## Poles

### Definition

The roots of the denominator of a transfer function.

- ▶ Signals and Systems
- ▶ Transfer Function

## Polioencephalitis (Anterior Poliomyelitis)

### Definition

Acute infectious viral disease affecting several parts of the central nervous system, classically involving spinal  
▶ motoneurons with final degeneration and paralysis.

---

## Poliomyelitis

### Definition

Acute infectious disease of humans, particularly children, caused by any of three serotypes of the human poliovirus; infection is usually limited to the gastrointestinal tract and nasopharynx, and is often asymptomatic. The central nervous system, primarily the spinal cord, may be affected, leading to rapidly progressive ►paralysis, coarse fasciculation and ►hyporeflexia. ►Motoneurons are primarily affected, and ►encephalitis may also occur.

---

## Poly(A) Tail

### Definition

A polyadenosine tail is the product following polyadenylation of pre-mRNA. Most messenger RNA molecules end with a poly-A stretch at their 3' ends in eukaryotic organisms. The poly(A) tail protects mRNA from exonucleases and plays a role in transcription termination. Typically 50–200 adenosines are added to pre-mRNA.

►Serial Analysis of Gene Expression

---

## Polyadenylation

### Definition

Polyadenylation is a covalently-linked tail of a long stretch of adenosines added to the 3' end of the mRNA, and is required to generate mature mRNA.

---

## Polydipsia

### Definition

A symptom in which the patient ingests abnormally large amounts of fluids.

►Neuroendocrinology of Psychiatric Disorders

---

## Polyhydramnios

### Definition

Increased amounts of amniotic fluid.

►Endocrine Disorders of Development and Growth

---

## Polymer

### Definition

A compound consisting of many repeated linked units.

---

## Polymerase Chain Reaction (PCR)

### Definition

Polymerase chain reaction (PCR) is used to isolate and amplify in an exponential fashion a DNA sequence of interest. mRNA is isolated from a cellular or tissue source, a cDNA copy is made by reverse transcriptase, and the DNA found between a 3' and a 5' nucleotide single strand DNA primer (complementary DNA sequence) is amplified by approximately 20–30 cycles that include denaturation of double stranded DNA, annealing of the primers to the cDNA, and DNA synthesis.

---

## Polymodal

►Multimodal Integration

---

## Polymodal Receptor

### Definition

Polymodal receptor denotes a sensory receptor (e.g. nociceptor) responsive to more than one modality or sub-modality (quality), e.g. to pressure, temperature

and/or certain chemical substances. Polymodality is also prevalent in central neurons.

- ▶ Nociceptors and Characteristics
- ▶ Sensory Systems

## Polymorphic Network

### Definition

A neuronal network that can change its functional connectivity in response to modulatory influences by higher order interneurons. Modulatory interneurons can enhance or suppress the function of individual synapses and neurons within a network. This can result in the functional removal or addition of neurons to a neuronal network, which leads to the reconfiguration of the network.

- ▶ Central Pattern Generator

## Polymorphism

### Definition

Sequence variants that exist naturally in the population and that do not cause disease. Polymorphisms account for all interpersonal variation (e.g., height, eye, skin and hair color, etc.)

- ▶ Bioinformatics

## Polymyositis Syndrome

### Definition

Inflammatory myopathy prevailing in proximal muscles and resulting in weakness.

## Polyneuropathy

### Definition

Disease affecting many nerves.

## Polypeptide

- ▶ Neuropeptides in Energy Balance

## Polypeptide Synthesis

- ▶ RNA Translation

## Polyradiculopathy

### Definition

Disease of many spinal nerve roots.

## Polyribosomes

### Definition

Polyribosomes are multiple ribosomes attached to a single messenger RNA (mRNA) molecule. The ribosomes translate the information encoded on the mRNA into a protein.

- ▶ Extrasomal Protein Synthesis in Neurons

## Polysomnogram

### Definition

A sleep monitoring technique combining electrophysiological technologies to determine sleep stages and other sleep phenomena. Minimally, polysomnography (PSG) includes the electroencephalogram (EEG) to record electrical activity in the brain; the electrooculogram (EOG) to record eye movements; and the electromyogram (EMG) to record muscle tone. More extensive montages including electrocardiography (ECG) and measurements of airflow, breathing effort, body position, snoring sounds, and blood oxygen saturation are used for the diagnosis and treatment of disorders of sleep.

- ▶ Alertness Level
- ▶ Brain States and Olfaction

- ▶ Electroencephalography
- ▶ Electromyography
- ▶ Electrooculography

## Polysynaptic Accessory Olfactory System

- ▶ Accessory Olfactory System

## Pons (Varolius)

### Definition

The pons (Latin for bridge, describing the large fiber bundle running across the ventral surface of the brainstem, perpendicular to its long axis) is the portion of the brainstem between the medulla and midbrain. The cerebellum sits dorsal to the pons and is attached to it by the large fiber bundles of the middle cerebellar peduncle on each side. The pons consists of two parts: base of pons and tegmentum. The typical protruding base of pons accommodates the pyramidal tracts. Interspersed here are the pontine nuclei, where corticopontine fibers synapse. The tegmentum area contains cranial nerve nuclei (V, VI, VII, VIII), trapezoid body, medial lemniscus, parts of the reticular formation and the medial longitudinal fasciculus.

## Pontine Control of Respiration

THOMAS E. DICK<sup>1</sup>, MATHIAS DUTSCHMANN<sup>2</sup>,  
KENDALL F. MORRIS<sup>3</sup>

<sup>1</sup>Division of Pulmonary, Critical Care and Sleep Medicine/Department of Medicine, Case Western Reserve University, Cleveland, OH, USA

<sup>2</sup>Department of Neuro and Sensory Physiology, Georg August University of Göttingen, Göttingen, Germany

<sup>3</sup>Department of Molecular Pharmacology and Physiology Neuroscience, University of South Florida College of Medicine, Tampa, FL, USA

### Synonyms

Pontine respiratory group; Pneumotaxic center; Ponto-medullary respiratory pattern generator

### Definition

Pontine control of respiration involves the modulation of the timing and amplitude of the muscle activities that execute breathing, and airflow in and out of the lungs. Breathing is a vital function. Together with the cardiovascular system, breathing supplies oxygen to maintain general metabolism and is thus essential for bodily function. Importantly, breathing is also integrated with other mammalian behaviors like vocalizing, swallowing, coughing, and sniffing. Thus, breathing interacts with the environment not only in terms of inhaling and exhaling gas but also in terms of communication, food consumption, airway protection, and odor detection. The pons modulates breathing not only for gas exchange but also in these different behaviors.

### Characteristics

#### Pontine Influences on the Respiratory Motor Pattern

Breathing in mammals is controlled by a distributed network of neurons located bilaterally in columns of neurons that extend from the ventrolateral medulla to the parabrachial/Kölliker-Fuse complex in the rostral dorsolateral pons [1]. The medulla generates the primary respiratory rhythm and motor pattern, while the pontine nuclei exert strong modulatory influences on the respiratory frequency and shape of the respiratory motor pattern.

The respiratory motor pattern is defined by a sequence of bursts of different motor activities that are commonly divided into three major phases: (i) inspiration, (ii) postinspiration (early expiration or passive expiration), and (iii) late expiration (active expiration) (Fig. 1).

During the inspiratory and late expiratory phases, spinal motoneurons receive excitatory drive to contract thoracic and abdominal striated muscles including the diaphragm, to pump air in and out of the lungs (Fig. 1). Complementary motor activities transmitted in the cranial nerves (glossopharyngeal (IX), vagal (X), and hypoglossal (XII) nerves) target muscles that modulate airway resistance. During the inspiratory phase, posterior cricoarytenoid muscles and laryngeal abductors decrease upper airway resistance by pulling the vocal chords apart, whereas during the postinspiratory phase, the thyroarytenoid muscles that act as adductors increase resistance by drawing the vocal chords together. Laryngeal adductor activity depends on the pons (Fig. 2). Even in resting breathing, activity of laryngeal adductors (as well as inactivity of the airway dilators) limits or “brakes” expiratory airflow to prevent ▶atelectasis especially in mammals with highly compliant chest walls. Thus, even though we separate pontine modulation of rhythm or timing from that of motor activity, these two variables are not independent. Pumping and resistance motor activities are associated with the phases of the respiratory cycle and

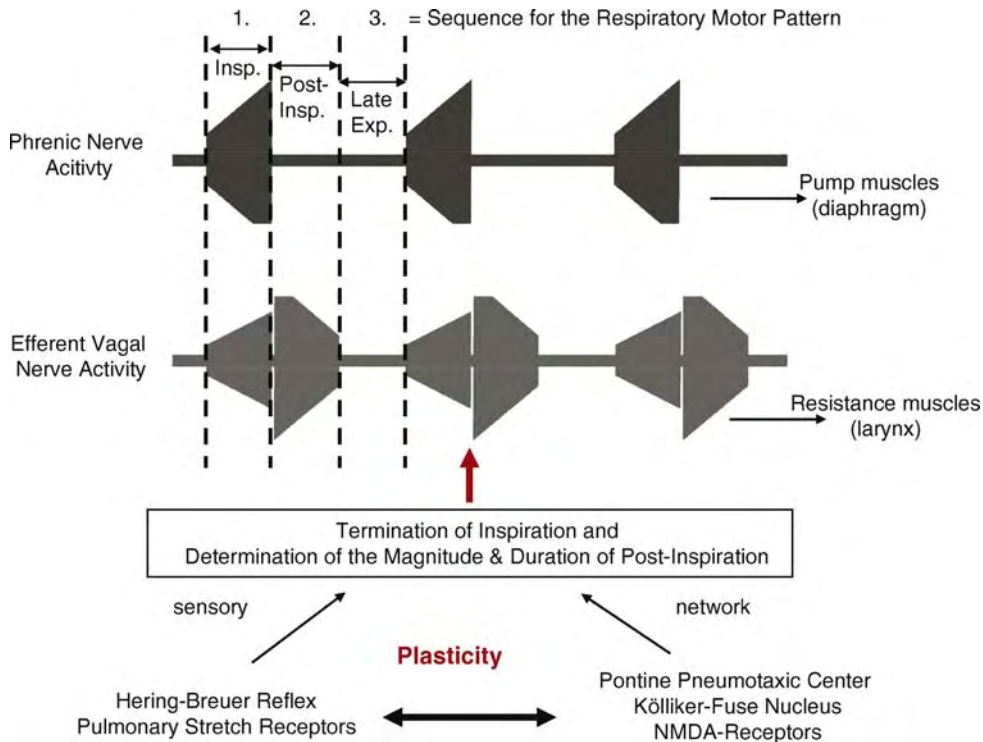

**Pontine Control of Respiration. Figure 1** Schematic drawing illustrating the coordinated pattern of two representative motor activities critical in defining the breathing pattern – phrenic nerve activity (top) and efferent vagal nerve activity (bottom). In these recordings, the sequential phases of the respiratory cycle ((i) inspiration, (ii) postinspiration, (iii) late expiration) can be identified. Two convergent pathways, an afferent pathway mediating the Hering-Breuer reflex and a central pathway that requires the dl pons, control the termination of inspiration and the duration of the postinspiratory phase of the breathing cycle. Plasticity in the expression of the breathing pattern depends on the pons and results from interaction between afferent and network pathways.

are coordinated by synaptic interactions within circuits of the pontomedullary respiratory network.

### Pontine and Vagal Afferent Interaction Influences Timing of the Pattern

The importance of the pons in the neuronal control of breathing was established by Marckwald in 1888 [1]. He investigated breathing in rabbits and noted that after transecting both vagal nerves, respiratory rhythm became apneustic (▶**apneusis**) after mid-pontine transection (compare phrenic nerve activity pattern before and after pontomedullary transection in Fig. 2). These studies complement those of Breuer, conducted in Hering's laboratory in 1868 [2]. They showed that lung inflation evokes a reflex that shortens inspiration and lengthens expiration and that this reflex, namely, the "▶**Hering-Breuer Reflex**" was vagally dependent and mediates the afferent input from pulmonary stretch receptors. An interpretation of Marckwald's work was that the pons acted like an "internal vagus" acting on the same medullary neurons that mediate the Hering Breuer reflex. Subsequent studies have supported this interpretation [3]. Stimulating the lateral pons evokes

phase switching, and recording neuronal activity in the dl pons shows that the magnitude and strength of its respiratory modulation increases in the absence of vagal input [4,5].

Interestingly, the Hering-Breuer reflex is of minor importance in the regulation of breathing in humans. However, breathing is not simply a stereotyped rhythmic activity that is controlled reflexly from the pulmonary stretch receptors of the lungs and chemoreceptors of the vasculature but rather a behavior whose function and control is incorporated into the context of other behaviors like vocalizing. Thus, the importance of the pons in respiratory control may be in determining breathing pattern in the context of behavior.

### Expression of Plasticity in the Breathing Pattern Depends on the Pons

Activity-dependent plasticity (See Encyclopedia Article Respiratory Neuroplasticity by Morris and Bolser) of the breathing pattern is evident after brief (seconds to minutes) activation of afferent pathways whether they are mechanosensory (vagal afferent) [6] or chemosensory [7] pathways. Following stimulation, the breathing

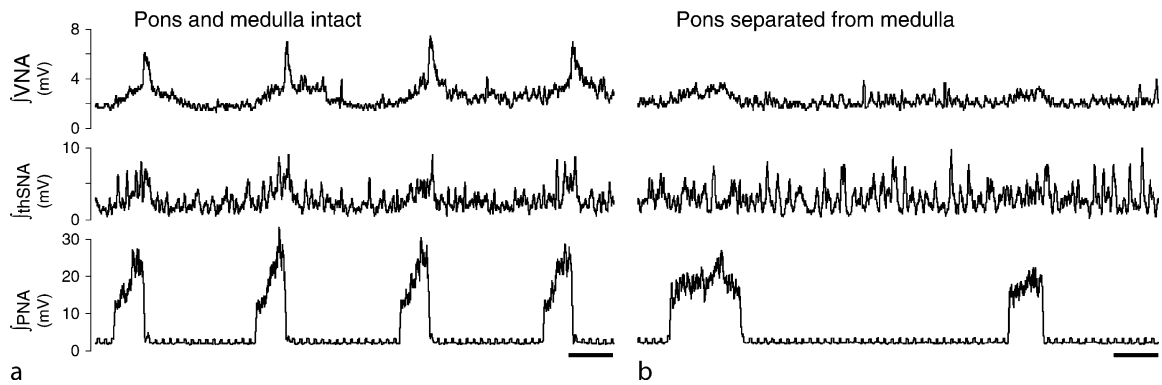

**Pontine Control of Respiration. Figure 2** Recordings of respiratory-modulated motor activities recorded from a vagus nerve (VNA, upper trace), phrenic nerve (PNA, lower trace), and thoracic sympathetic chain (thSNA), before (left) and after (right) pontomedullary transection. (a) With the pons connected to the medulla (recording from working heart brainstem preparation, see Encyclopedia Article Central Integration of Cardiovascular and Respiratory Activity Studied *In Situ* by Paton), breathing is regular as depicted by uniform pattern of activity from cycle-to-cycle. Specifically, VNA, which has some inspiratory activity increases sharply in the postinspiratory phase immediately after inspiration ceases when PNA burst ends. Sympathorespiratory coupling is evident in the inspiratory modulation of thSNA. (b) After pontomedullary transection, the respiratory rhythm as well as motor activity is irregular and disrupted, in particular, nonuniform durations of respiratory phases and no postinspiratory activity in the vagal motor nerve (Bar 1s).

pattern does not return immediately to baseline even though the controlled physiological variables such as blood gases have returned to baseline. Instead, the pattern gradually returns to baseline and this depends on the lateral pons because if input from the lateral pons is blocked, then the breathing pattern returns to baseline immediately. The pons may be acting directly on the pattern generator, particularly postinspiratory medullary neurons and may be acting through its ability to gate or regulate the incorporation of afferent information by the medulla [6]. The regulation of sensory input is a common way that behaviors override reflex control.

Anatomical studies indicate that the lateral pons and nuclei of the solitary tract (nuclei of the medulla (NTS) that receive mechano- and chemo-sensory input) are connected reciprocally (Fig. 1 – horizontal two-headed arrow at the bottom). Sensory information is transmitted to the Kölliker-Fuse nucleus and, in turn, the Kölliker-Fuse nucleus “gates” or modulates the efficacy of afferent input in the NTS; in particular, activity of the Kölliker-Fuse nucleus can suppress sensory input in NTS [8]. However, the precise synaptic interactions between NTS and Kölliker-Fuse nucleus still need to be elucidated.

### The Role of the Pons in Respiratory Pattern Dysfunction

The respiratory pattern is highly variable in a mouse model for the Rett syndrome, which is a neurodevelopmental disease with severe respiratory disorders and lack of vocalization. This respiratory disturbance is associated with impairment of pontine and vagal

modulation of postinspiratory activity [9]. These data suggest that disturbance of the postinspiratory gating mechanisms causes severe respiratory disorders and that the pons has influence over variability, especially for other behaviors like vocalization.

### Future Directions

Presently, while we know much about reflex control of the breathing and blood pressure both of which are controlled by pontomedullary networks, we know very little about the factors that integrate their control. This is especially true of those intrinsic to the brainstem. For instance, sympathorespiratory coupling is at least partially dependent on the pons (Fig. 2). Thus, the pons acts to coordinate the cardiorespiratory system to maintain homeostasis and oxygenation of vital organs including the CNS.

Oscillations (0.1 Hz) that are expressed in the blood pressure as ►Mayer Waves can influence the breathing pattern. Mayer Waves are thought to be related to baroreceptor reflex control of blood pressure. Preliminary analysis of pontine neuronal spike trains recorded continuously before and after vagal nerve transection suggests that in addition to the respiratory rhythm, a slow rhythm (~0.1 Hz) is also expressed by respiratory-modulated pontine activity. In some cases, this rhythm, which is normally masked, is strong enough that the respiratory rhythm itself becomes synchronized with it after vagotomy. The 0.1-Hz rhythm may be synchronized with Mayer Waves. In experiments in dogs, Mayer waves and the respiratory modulation of blood pressure, ►Traube-Hering waves,



were found to synchronize after vagotomy [10]. Additional preliminary analysis suggests that many pontine neurons that have respiratory modulation are also modulated with the blood pressure pulse of the cardiac cycle. These lines of evidence may indicate that individual pontine neurons are arranged in networks that help coordinate the intertwined control of breathing and perfusion. However, a great deal of work remains to elucidate the mechanisms of that coordination.

## References

1. Alheid GF, Milsom WK, McCrimmon DR (2004) Pontine influences on breathing: an overview. *Respir Physiol Neurobiol* 143:105–114
2. Ullmann E (1970) About Hering and Breuer. In: Porter R (ed) *Breathing: Hering-Breuer centenary symposium*. London, Churchill, pp 3–15
3. Cohen MI, Wang SC (1959) Respiratory neuronal activity in pons of cat. *J Neurophysiol* 22:33–50
4. Feldman JL, Gautier H (1976) Interaction of pulmonary afferents and pneumotaxic center in control of respiratory pattern in cats. *J Neurophysiol* 39:31–44
5. St John WM (1987) Influence of pulmonary inflations on discharge of pontile respiratory neurons. *J Appl Physiol* 63:2231–2239
6. Siniaia MS, Young DL, Poon CS (2000) Habituation and desensitization of the Hering-Breuer reflex in rat. *J Physiol London* 523:479–491
7. Dick TE, Coles SK (2000) Ventrolateral pons mediates short-term depression of respiratory frequency after brief hypoxia. *Respir Physiol* 121:87–100
8. Dutschmann M, Morschel M, Kron M, Herbert H (2004) Development of adaptive behaviour of the respiratory network: implications for the pontine Kölliker-Fuse nucleus. *Respir Physiol Neurobiol* 143:155–165
9. Stettner GM, Huppke P, Brendel C, Richter DW, Gartner J, Dutschmann M (2007) Breathing dysfunctions associated with impaired control of postinspiratory activity in *Mecp2-y* knockout mice. *J Physiol (London)* 579: 863–876
10. Cherniack NS, Edelman NH, Fishman AP (1969) Pattern of discharge of respiratory neurons during systemic vasomotor waves. *Am J Physiol* 217:1375–1383

## Pontine-Geniculate-Occipital (PGO) Waves

### Definition

Bursts of excitation that arise in the brainstem and are subsequently detected in the visual thalamus and visual cortex.

► Sleep States

## Pontine Micturition Center (PMC)

### Definition

The PMC mediates spino-bulbo-spinal reflexes activated by sacral afferent neurons from the urinary bladder that are involved in micturition and continence of the urinary bladder. It consists of the medial PMC (Barrington's nucleus) which triggers micturition (contraction of the detrusor vesicae and relaxation of the external vesical sphincter) and the lateral PMC which maintains continence (inhibition of mechanisms leading to micturition, activation of the external vesical sphincter).

► Autonomic Reflexes

► Micturition

## Pontine Nuclei

### Definition

A group of neuronal populations located in the pons region of the hindbrain. They are the major source of the mossy fiber input to the cerebellar cortex in birds and mammals. They receive their input from the spinal cord, the striatum of the forebrain, and the tectum of the midbrain.

► Evolution of the Cerebellum

## Pontine Respiratory Group

► Pontine Control of Respiration

## Pontine Wave (P-Wave)

### Definition

REM sleep-associated phasic field potential recorded in the pons. Lasting for 75–150 ms, the P-wave appears during REM sleep as clusters containing a variable number of waves (3–5 waves/burst) or a singlet with

amplitudes from 100 to 150  $\mu\text{V}$  and a frequency range of 30–60 spikes/min. P-wave is the pontine component of ponto-geniculo-occipital (PGO) wave. The P-wave is generated by the phasic activation of a group of glutamatergic cells in the pons. The P-wave is critically involved in the reactivation of both the hippocampus and amygdala to reprocess cognitive information and to form memory traces in the cortex.

► Sleep

## Pontocerebellum

### Definition

The hemispheres belong to the phylogenetic young neocerebellum and receive their afferences via the moss fibers of the pontocerebellar tract from the pontine nuclei. Therefore, one also likes to summarize all hemispheric sections to the so-called pontocerebellum.

► Cerebellum

## Pontomedullary Respiratory Pattern Generator

► Pontine Control of Respiration

## Ponto-Pontine Long-Lead Burst Neurons

CHARLES SCUDDER  
Portland, OR, USA

### Definition

Ponto-pontine neurons, in general, are neurons that have both their somata and terminal fields in the pontine reticular formation. Ponto-pontine ►long-lead burst neurons (►burst cells – long lead (LLBNs)) (PP-LLBNs) are ponto-pontine neurons that exhibit long-lead burst discharges during ►saccades. Although

some PP-LLBNs have been experimentally identified, those having the well defined functions expected from theory remain hypothetical at this point.

### Characteristics

#### Higher Order Processes

Based on experimental studies of the saccadic system and on models of the saccadic system that incorporate these experimental results, PP-LLBNs are needed to relay signals from higher saccadic command centers to the ►saccadic burst generator. These command centers consist of the deep and intermediate layers of the ►superior colliculus with weaker projections from ►frontal eye fields (FEF). The superior colliculus, in turn, coalesces saccade-related information from the frontal eye fields, the ►supplementary eye fields (SEF), the ►lateral intraparietal area (LIP), and the ►substantia nigra and issues the principal saccadic command. Neurons in the FEF and superior colliculus both have long-lead discharge patterns, and provide the long-lead signal to the PP-LLBNs.

#### Lower Level Processes

PP-LLBNs are thought to convey the saccadic command to the ►excitatory burst neurons (EBNs), ►inhibitory burst neurons (IBNs), and ►omnipause neurons (OPNs) of the saccadic burst generator. There are at least two, and possibly three, populations of PP-LLBNs that project to these neurons.

### Parts of the Ponto-Pontine LLBN System

#### Excitatory Relay PP-LLBNs

The generation of saccades requires a powerful excitatory input to the EBNs and IBNs. This excitation could be provided by a direct input from the superior colliculus, or by way of PP-LLBNs intercalated between the superior colliculus and the burst neurons [1]. Experimental data supports both possibilities. In the monkey, the superior colliculus does not project directly to EBNs, but does project to long-lead burst neurons (LLBNs) located in the pontine reticular formation [2]. PP-LLBNs do project to the region containing EBNs (see below), and must connect with EBNs, or else EBNs would have no suitable input. In the cat, a direct connection from the superior colliculus to EBNs has been demonstrated, but a parallel indirect pathway exists that most likely involves PP-LLBNs [3–5]. Similarly, cat IBNs receive direct and indirect input from the superior colliculus [3–6]. This set of connections is illustrated in Fig. 1a.

#### Inhibitory Trigger Neurons

Another population of PP-LLBNs, called ►trigger neurons, is needed to initiate the saccade. Activity in the superior colliculus activates the trigger neurons, which inhibit the tonically active OPNs. The pause

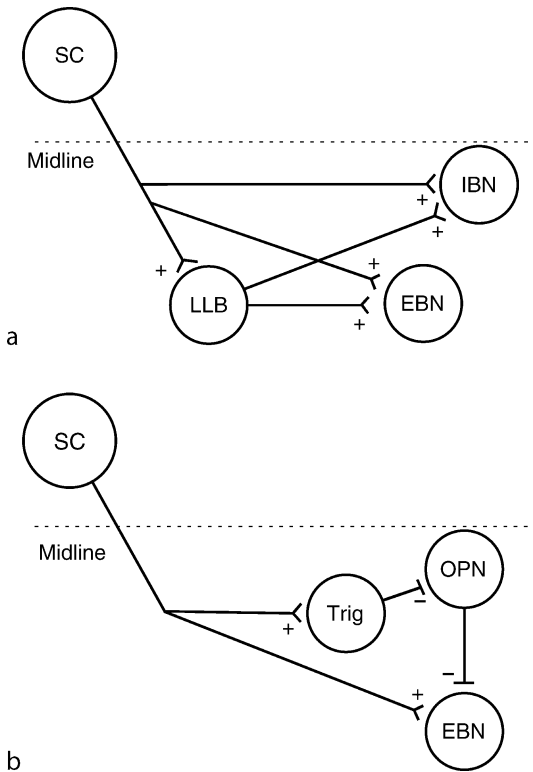

### Ponto-Pontine Long-Lead Burst Neurons.

**Figure 1** A portion of the wiring of the saccadic burst generator showing the connections of two pools of PP-LLBNs. (A) Relay PP-LLBNs (LLB) convey the output of the superior colliculus (SC) to the premotor burst neurons; excitatory burst neurons (EBN) and inhibitory burst neurons (IBN). The connections are all excitatory (+). The SC also has direct connections to the EBNs and IBNs in the cat. (B) Inhibitory PP-LLBNs (Trig) convey the output of the SC to omnipause neurons (OPN) in order to silence them and trigger the start of the saccade. Inhibition is signified by the “-” sign. A more complete diagram showing the relation of these components to the whole burst generator is presented in the brainstem burst generator section.

in OPN activity disinhibits the burst neurons (see ▶[Brainstem burst generator](#)) and allows them to discharge. The inhibitory trigger neurons intercalated between the superior colliculus and OPNs ([Fig. 1b](#)) are needed to accomplish the inhibition of the OPNs, because the efferents of the superior colliculus are excitatory. In agreement, microstimulation of the superior colliculus leads to inhibitory potentials in OPNs at disynaptic latencies, and intracellular recordings from OPNs in alert cats reveals a pre-saccadic phase of inhibition that is possibly mediated by trigger LLBNs [6–8]. Microstimulation in the ▶[paramedian pontine reticular formation \(PPRF\)](#) where LLBN somata are prevalent produces inhibition in OPNs [6].

### Identified PP-LLBNs

Definitive anatomical and physiological evidence for the existence of PP-LLBNs consists of four PP-LLBNs revealed using the intraaxonal labeling technique [9]. The small sample size probably does not reflect a paucity of PP-LLBNs, but rather the difficulty and biases of the intraaxonal technique. All four neurons are anatomically different, but nonetheless innervate many of the same parts of the reticular formation. The diversity of these neurons, together with various fragments of incompletely labeled neurons, shows that there may be a large variety of PP-LLBNs.

Somata of three neurons were located in the rostral PPRF (NRPo) caudal and ventral to the trochlear nucleus. The soma of the fourth was located at the mid PPRF just rostral to the EBN area. Axons of all four descended in the PPRF, and all four axons gave off one or two branches that ascended to, and sometimes terminated in, the ipsilateral mesencephalic reticular formation (cf. [Fig. 2](#)). Most (3/4) had branches that terminated in ipsilateral NRPo, and all had branches that terminated in the part of ipsilateral caudal PPRF (NRPC) where EBNs are located. They also all had branches that innervated ▶[raphe interpositus](#) (the locus of OPNs) or the immediately adjacent region containing OPN dendrites. Less frequent targets included ▶[NRTp](#), raphe pontis, the contralateral PPRF, the IBN area, and ▶[nucleus reticularis gigantocellularis](#) (one origin of reticulospinal pathways). One axon could be followed well into the medulla and may have been headed for the spinal cord.

As with other LLBNs, PP-LLBNs were mostly silent during fixation, and gradually began firing on average 44–107 ms preceding the start of ▶[ipsiversive](#) saccades. Firing rate peaked just before the saccade start, and ended just before saccade end. The spatial properties of their discharges were as varied as their anatomy. Two were ordinary ▶[vectorial burst neurons](#) (discharging only for saccades to a small circumscribed region of visual space – the ▶[movement field](#)), one was a vectorial burst neuron with an unusually wide movement field, and the fourth was a ▶[directional burst neuron](#) that discharged for all saccades into the ipsiversive visual space.

### Pathology

PP-LLBNs and their axonal and terminal processes are intermixed in the PPRF with a multitude of eye-movement related and other neurons. Experimental and natural lesions of the region that contains PP-LLBNs necessarily destroy these other neurons as well, so deficits cannot be attributed to one population alone. Lesions of the PPRF can impair most types of horizontal eye movements; ▶[VOR](#), ▶[smooth pursuit](#), ▶[optokinetic nystagmus](#), and saccades [10]. Many of these deficits can be traced to damage of fibers that traverse the PPRF, but

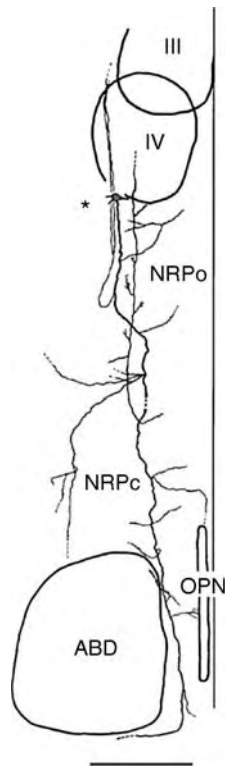

### Ponto-Pontine Long-Lead Burst Neurons.

**Figure 2** Camera lucida drawing of a PP-LLBN in the left side of the pontine reticular formation reconstructed in a horizontal plane. The soma (\*) is ventral and immediately caudal to the trochlear nucleus (IV), and the axon descends through the nucleus reticularis pontis oralis (NRPo) and ►nucleus reticularis pontis caudalis (NRPc). Terminal arborizations innervate these structures, including the part of NRPc containing excitatory burst neurons. Other branches terminate just lateral to the omnipause neurons (OPN). ABD = abducens nucleus, III = oculomotor nucleus. Dashed lines indicate fading of the label. Calibration bar is 1 mm.

deficits in saccades are surely the result of destruction of the saccade-related neurons in the PPRF. Small unilateral lesions cause a slowing and shortening of ipsiversive saccades. Larger unilateral lesions eliminate all ipsiversive saccades, and large bilateral lesions eliminate all horizontal saccades. Large caudal lesions that involve the OPNs also affect vertical saccades.

### References

1. Hepp K, Henn V (1983) Spatio-temporal recoding of rapid eye movement signals in the monkey paramedian pontine reticular formation (P.P.R.F.). *Exp Brain Res* 52:105–120
2. Keller EL, McPeck RM, Salz T (2000) Evidence against direct connections to PPRF EBNS from SC in the monkey. *J Neurophysiol* 84:1303–1313

3. Chimoto S, Iwamoto Y, Shimazu H, Yoshida K (1996) Monosynaptic activation of medium-lead burst neurons from the superior colliculus in the alert cat. *J Neurophysiol* 75:2658–2661
4. Grantyn AA, Grantyn R (1976) Synaptic actions of tectofugal pathways on abducens motoneurons in the cat. *Brain Res* 105:269–285
5. Izawa Y, Sugiuchi Y, Shinoda Y (1999) Neural organization from the superior colliculus to motoneurons in the horizontal oculomotor system of the cat. *J Neurophysiol* 81:2597–2611
6. Kamogawa H, Ohki Y, Shimazu H, Suzuki I, Yamashita M (1996) Inhibitory input to pause neurons from pontine burst neuron area in the cat. *Neurosci Lett* 203:163–166
7. Yoshida K, Iwamoto Y, Chimoto S, Shimazu H (1999) Saccade-related inhibitory input to pontine omnipause neurons: An intracellular study in alert cats. *J Neurophysiol* 82:1198–1208
8. Yoshida K, Iwamoto Y, Chimoto S, Shimazu H (2001) Disynaptic inhibition of omnipause neurons following electrical stimulation of the superior colliculus in alert cats. *J Neurophysiol* 85:2639–2642
9. Scudder CA, Moschovakis AK, Karabelas AB, Highstein SM (1996) Anatomy and physiology of saccadic long-lead burst neurons recorded in the alert squirrel monkey. II. Pontine neurons. *J Neurophysiol* 76:353–370
10. Leigh RJ, Zee DS (1999) *The neurobiology of eye movements*. Oxford University Press, New York

## Population Code

### Synonyms

Also Ensemble Code

### Definition

Population code (also ensemble code) denotes a code by which neural information is encoded in the spatiotemporal activity patterns of many neurons.

### ►Sensory Systems

## Population Vector

### Definition

An algorithm for estimating a vectorial quantity encoded by the spiking activity of a neuronal population given the response characteristics of each individual neuron to different values of that vectorial quantity (tuning curve). Originally proposed for decoding the

hand movement direction from the firing rate of a population of directionally tuned neurons in the motor cortex of macaque monkeys. To compute the population vector in a specific condition (e.g. a specific movement direction), given the tuning curve of each cell (determined from the cell's response in several conditions) and the response vector associated to its maximum (e.g. the cell's preferred direction), all the response vectors, weighted by the cell firing rates in that specific condition, are summed together.

► [Reaching Movements](#)

## Pore Loop

### Definition

The pore loop represents a short amino acid sequence that forms the ion permeation pathway of tetrameric cation channels. In voltage-gated cation channels this domain is localized between the S5 and S6 segment.

The X-ray structure of the pore loop has been resolved in the bacterial KcsA channel. The domain consists of an  $\alpha$  helical portion (the pore helix) and an uncoiled strand of 4–5 amino acid residues (the selectivity filter) forming the narrowest part of the pore.

► [Cyclic Nucleotide-Regulated Cation Channels](#)

## Pore-loop Channels

### Definition

Pore-loop channels all bear an extracellular, re-entrant loop, which provides a highly selective aqueous pore for particular ions. All pore-loop channels are structural derivatives of inward rectifying potassium ( $K^+$ ) channels, and are the largest class of channels within the ion channel family. Pore loop channels include the voltage-gated channels, including the potassium, calcium ( $Ca^{2+}$ ) and sodium ( $Na^+$ )-selective channels, the inward rectifying and two pore potassium channels and the glutamate receptors.

- [Calcium Channels – an Overview](#)
- [Ion Channels from Development to Disease](#)
- [Glutamate Receptors](#)
- [Neuronal Potassium Channels](#)
- [Sodium Channels](#)

## Porphyropsins

► [Photopigments](#)

## Position Sense

### Definition

The ability to detect the position of joints of the body. It is tested clinically as part of assessments of proprioception.

- [Joint position sense](#)
- [Proprioception and Orthopedics](#)
- [Proprioception Role of Joint Receptors](#)

## Positional Alcohol Nystagmus

### Definition

Nystagmus resulting from alcohol intoxication. The nystagmus is due to the passage of alcohol into the cupula of each of the semicircular canals, which renders them lighter than the surrounding endolymph. The semicircular canals then respond to changes in head position resulting in positional nystagmus. A second phase is noted when alcohol diffuses from the cupula and into the endolymph. An oppositely directed positional nystagmus is then noted.

- [Disorders of the Vestibular Periphery](#)
- [Semicircular Canals](#)

## Positional Cloning

### Definition

Positional cloning is a technique used to identify genes, either associated with disease or with a mutant in an animal model, based on their location on a chromosome.

## Position-Vestibular-Pause Neurons

KATHLEEN E. CULLEN

Department of Physiology, Aerospace Medical Research Unit, McGill University, Montreal, QC, Canada

### Definition

Traditionally, the vestibulo-ocular reflex (VOR) is considered to be a stereotyped reflex that effectively stabilizes gaze by moving the eye in the opposite direction to concurrent head motion. The three neuron arc responsible for mediating the VOR was first described by Lorente de No' in 1933. This pathway consists of projections from vestibular afferents to interneurons in the vestibular nuclei, which in turn project to extraocular motoneurons. The simplicity of this three neuron arc is reflected in the fast response time of the VOR; compensatory eye movements lag head movements by only 5–6 ms in the primate [1]. Horizontal and vertical position-vestibular-pause (PVP) neurons are thought to constitute most of the intermediate leg of the direct pathway that mediate the VORs, which are evoked by yaw and pitch rotations, respectively. As the response of horizontal PVP neurons have been more extensively investigated in alert animals, they are the focus of this essay.

The results of recent investigations have changed our view of the VOR. In particular, neurophysiological recordings from PVP neurons provide firm evidence that the VOR is not a hard wired reflex, as had been commonly assumed. This essay first describes the responses of PVP neurons during field standard tests including passive whole body rotations and eye-movements in head-restrained monkeys. Next, the results of studies that have characterized PVP neurons during (i) redirections of gaze that are produced by coordinated eye-head movements, and (ii) gaze stabilization while viewing near versus far targets during head movements, are summarized. These findings are considered in relation to the sensory-motor transformations needed to guide behavior in a manner consistent with current gaze strategies.

### Characteristics

#### Response During Standard Head-Restrained Rotations and Eye Movements

##### Type I Neurons

► Type I position-vestibular-pause (PVP) neuron constitute most of the intermediate leg of the direct pathway that produces the horizontal VOR (reviewed in [2]). The majority of type I PVP neurons are located in the rostral medial vestibular nucleus, and send an excitatory projection to the motoneurons of the (i) contralateral

► abducens nucleus, or (ii) ipsilateral medial rectus subdivision of the ► oculomotor nucleus (Fig. 1a). A minority send inhibitory projections to the motoneurons of the ipsilateral abducens nucleus. Within the abducens nucleus, motoneurons project directly to the ipsilateral lateral rectus muscle (LR), while a separate class of neurons (internuclear neurons) project to the contralateral oculomotor nucleus, which projects to the medial rectus muscle (MR; Fig. 1b). During horizontal eye movements, the effective force moving the eye is generated by the sum of the forces of the LR and MR.

Type I PVP neurons derive their name from the signals they carry during head-restrained rotation and eye movement paradigms. Their firing rates increase with contralaterally directed eye position; they are sensitive to

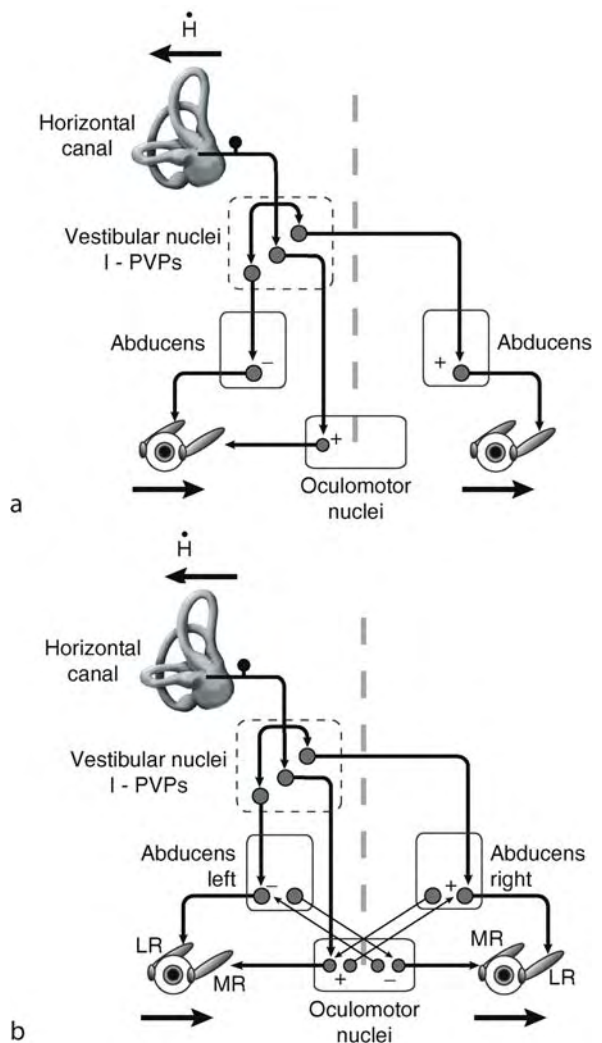

### Position-Vestibular-Pause Neurons.

**Figure 1** (a) Direct VOR pathway; rotation of the head to the left generates right eye movements. (b) Connections between the abducens and oculomotor nuclei.

ipsilaterally directed head velocity during vestibular stimulation (i.e. a type I response); and their discharges cease (pause) for ipsilaterally directed saccades and vestibular quick phases. In addition, these neurons show modulation for contralaterally directed eye movements during ►smooth pursuit tracking. The activity of a typical

PVP neuron is illustrated in Figs. 2a–c. The neuron’s mean firing rate is linearly related to eye position during periods of steady ocular fixation (Fig. 2a). During sinusoidal passive whole-body rotation in the dark at 0.5 Hz, neuronal modulation leads ipsilateral head rotation by about 10–20° (Fig. 2b), and the neuron pauses or stops

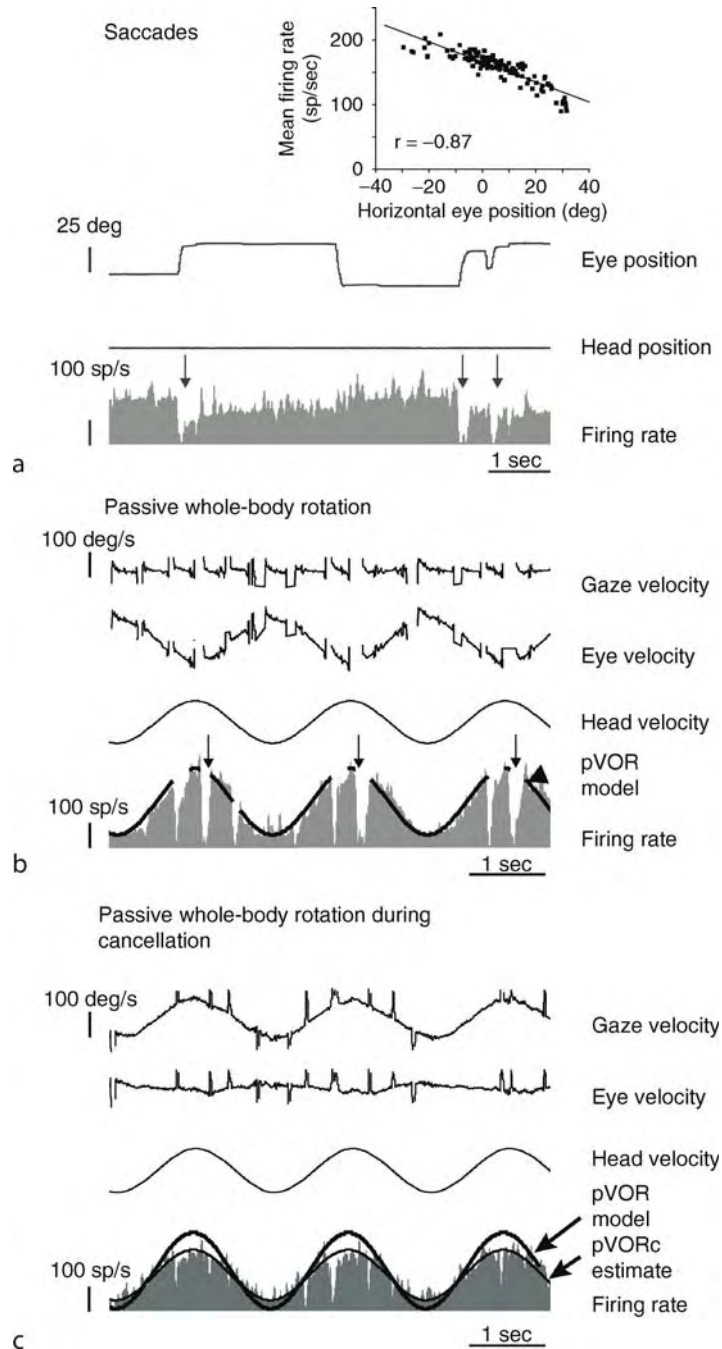

**Position-Vestibular-Pause Neurons. Figure 2** Activity of an example type I PVP neuron in the head-restrained condition. (a) Responses are correlated with horizontal eye position during periods of steady fixation. (b, c) Responses to passive whole-body rotation during (b) the VOR in the dark (pVOR), and (c) cancellation of the VOR by fixation of a target that moves with head (pVORC).

firing during ipsilaterally directed vestibular quick phases (Fig. 2b, downward arrows). The behavior of PVP neurons during the compensatory slow phase VOR evoked by passive rotation can be well described by the equation:

$$fr = a + kE + gH' + cH''$$

where  $fr$  = neuronal firing rate,  $a$  is the resting discharge,  $E$  is eye position,  $k$  is the eye position sensitivity of the neuron during ocular fixation,  $H'$  and  $H''$  are head velocity and acceleration, respectively, and  $g$  and  $c$  are neuronal sensitivities to head velocity and acceleration, respectively.

In order to dissociate the vestibular-related modulation of PVP neurons from their eye-movement related responses, vestibular physiologists have traditionally utilized a paradigm in which the monkey “cancels” its VOR by tracking a target that moves with the head. The resulting vestibular stimulation does not lead to eye motion in the opposite direction to the head motion, since trained subjects can accurately follow the target at frequencies  $<1.5$  Hz. Type I PVP neurons respond robustly to ipsilaterally directed head velocity in this condition, but show a 30% decrease in modulation as compared to VOR in the dark (Fig. 2c [3,4]). This reduction in head-velocity sensitivity occurs at latencies that are too short to be mediated by smooth pursuit pathways (see Fig. [3]), and supports the idea that there is a parametric adjustment of the gain of the direct VOR pathway while the VOR is voluntarily suppressed. Signals carried to the extraocular motoneurons by other premotor inputs help offset the residual modulation of PVP neurons, so that the eye remains immobile (see essay on VOR suppression).

### Type II Neurons

During head-restrained rotations and eye movements, the head and eye movement sensitivities of type II PVP neurons are opposite to those of type I PVP neurons; firing rates increase in response to contralaterally-directed head rotation and ipsilaterally directed eye position and velocity. Otherwise, the firing pattern of these two types of neurons is very similar. The projections of type II PVP neurons are not known, however it is thought that they support inhibitory commissural pathways between vestibular nuclei [2] and that they contribute to the weak three neuron arc that, in part, mediates the translational VOR (see section on “Translational VOR” below). In addition, it is likely that the inhibitory inputs from type II PVP neurons contribute to the pause-behavior of type I PVP neurons during ipsilaterally directed saccades, vestibular quick phases, and ►gaze shifts. This proposal is consistent with known interconnections between the brainstem saccade generator and the vestibular nuclei [5].

### PVP Neuron Modulation: Voluntary Head Movements

Recent work has shown that PVP neurons process vestibular information in a manner that depends principally on the subject’s current gaze strategy, rather than whether the head movement was actively generated or passively applied. As described below, the head velocity signal carried by the direct VOR pathway is reduced when the behavioral goal is to redirect the visual axis of gaze. In contrast, PVP neurons robustly encode head velocity signals when the behavioral goal is to stabilize the visual axis of gaze relative to space, regardless of whether head movement is actively or passively generated.

### Gaze Redirection

There is much accumulated evidence from studies in head-restrained monkeys to indicate that both type I and II PVP neurons differentially encode head-velocity during gaze redirection versus gaze stabilization. First, as described above, while PVP neurons encode head velocity during the compensatory slow phase component of the VOR evoked by passive whole-body rotation, they pause or significantly decrease their firing during vestibular quick phases where gaze is redirected. In addition, PVP neuron responses are significantly attenuated, as compared to passive rotation in the dark, when the VOR is suppressed during passive whole-body rotation by tracking a target that moves with the head. In this latter condition, the goal is to redirect the axis of gaze relative to space rather than stable gaze [3,4].

It is useful to suppress PVP transmission in each of the above circumstances, since eye movement commands generated by the direct VOR pathways would function to drive the eye in the opposite direction to the intended change in gaze. An analogous argument can be made for situations in which the axis of gaze is voluntarily redirected, a combination of eye and head movements. In order to rapidly redirect the visual axis towards a target of interest, primates commonly generate coordinated eye-head movements, termed gaze shifts. Similarly, coordinated smooth head and eye movements (i.e. ►gaze pursuit) are frequently generated in order to track moving targets. Attenuating the modulation of the direct VOR pathways (i.e. type I PVP neurons) during either gaze shifts or gaze pursuit would also be behaviorally advantageous.

Indeed, during rapid orienting gaze shifts, the head-velocity related signals carried by type I PVP neurons are dramatically reduced [2,5,6]. As shown in Fig. 3a, neuronal responses to head velocity during ipsilateral gaze shifts are consistently attenuated relative to passive whole-body rotation in the dark (i.e. during the VOR, Fig. 2c). As a result, a model based on a neuron’s response during passive rotation (Fig. 3a; heavy line: pVOR model) will systematically over-predict



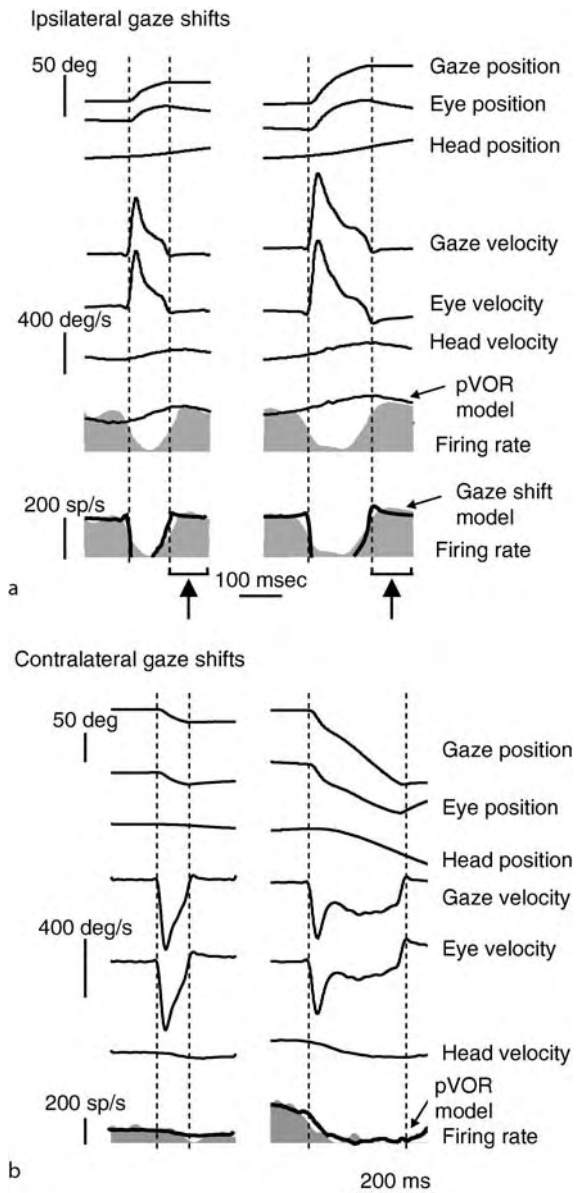

**Position-Vestibular-Pause Neurons. Figure 3** The activity of a type I PVP neuron during and following ipsilaterally (a) and contralaterally (b) directed gaze shifts. Arrows indicate the post gaze shift intervals in (a).

its discharge during gaze shifts. Moreover, neuronal modulation is increasingly attenuated for larger amplitude gaze shifts reaching 70% attenuation for gaze shifts  $>60^\circ$ , [2,5]. Type I PVP neurons also contribute little to the generation of the VOR during large contralaterally directed gaze shifts, since they are typically driven into inhibitory cut-off (Fig. 3b). Overall, the amplitude-dependent attenuation of the discharge of these neurons is consistent with the results of behavioral studies demonstrating that the VOR is more strongly

suppressed during large than during small gaze shifts (see essay on “VOR suppression”). Similar results have been obtained from characterizations of type II PVP neurons [2].

The head-velocity related modulation of PVP neurons is also reduced when gaze is redirected to follow a moving target by means of coordinated eye-head pursuit. Responses to the voluntary head movements that are generated during eye-head pursuit are attenuated by approximately 30% compared to responses to passive whole-body rotation. Thus, the attenuation observed during eye-head pursuit is comparable to that observed when the VOR is suppressed by fixating a target that moves with the head (Fig. 2c), as well as that observed during small rapid gaze shifts ( $<25^\circ$ ). The histogram in Fig. 4 summarizes the head velocity-related signals that are carried by PVP neurons across different voluntary behaviors, and emphasizes the fact that transmission through the VOR pathways is attenuated during all behaviors that involve gaze redirections.

#### Gaze Stabilization

As described above, an intact VOR is not beneficial when the behavioral goal is to redirect gaze to a new target. In contrast, a fully functional VOR is clearly critical when the behavioral goal is to maintain stable gaze. Moreover, there have been reports that VOR performance is enhanced in response to active head rotations compared to passive whole-body rotations [1]. These findings have led to the suggestion that neck proprioceptive signals and/or a copy of the command to the neck motoneurons might function to augment transmission in the VOR pathways (i.e. PVP neurons) during active head movements.

Single unit recording experiments, however, indicate that neither neck proprioceptive nor neck motor efference copy signals augment the modulation of PVP neurons during active head-on-body movements. First, in rhesus monkeys, PVP neurons encode head movement in the same manner during passive head-on-body rotations and passive whole-body rotations (Fig. 5a; [1,2]). In addition, PVP neurons are not modulated in response to passive rotation of the body under a stationary head (Fig. 5b [2]). Thus, the passive activation of neck proprioceptors does not significantly alter the sensorimotor transformations carried out at the level of the direct VOR pathways. Second, neuronal responses are comparable during passive whole-body rotations and active head movements that are produced during periods of stable gaze [2,5,6]. For example, as shown in Fig. 3a, immediately following a rapid orienting gaze shift, the head continues to move even after gaze has stabilized relative to space (intervals denoted by the arrows). During this interval, a neuron’s activity can be predicted based on its response to

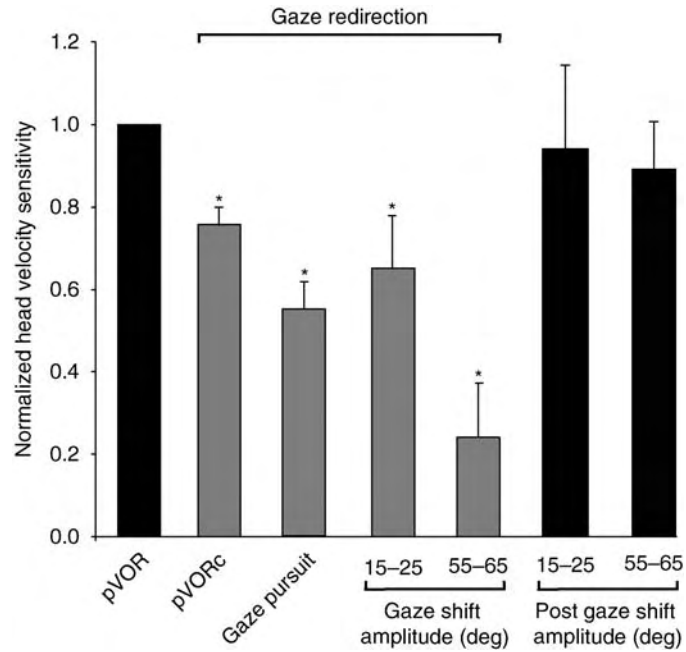

**Position-Vestibular-Pause Neurons. Figure 4** Summary of type I PVP neuron discharge activity during passive and voluntary head motion. The (\*) symbol denotes significant attenuation as compared to pVOR.

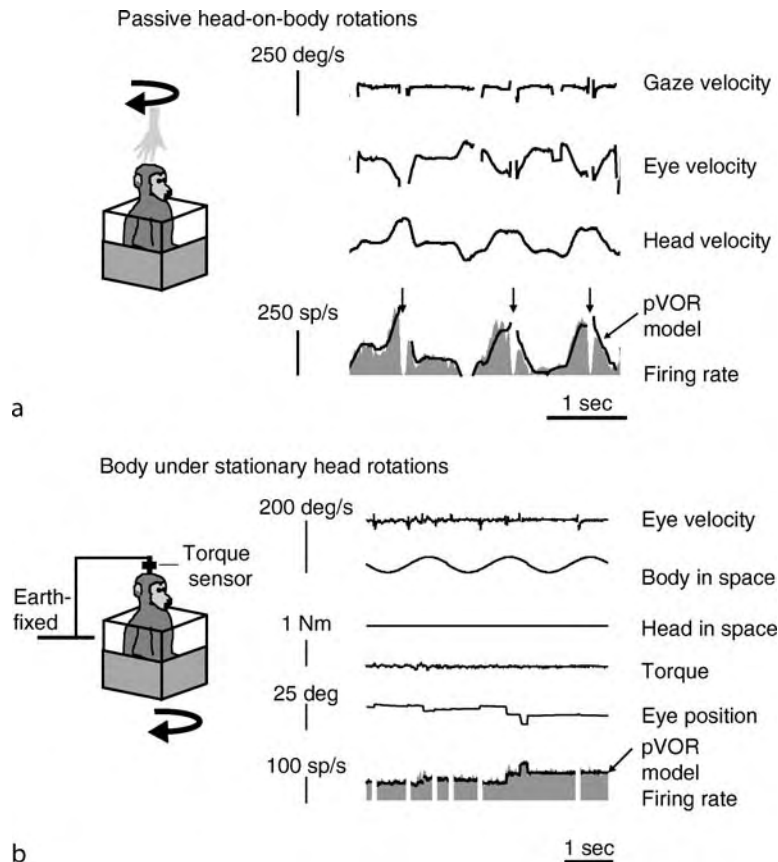

**Position-Vestibular-Pause Neurons. Figure 5** (a) The head was passively rotated on a stationary body. (b) Neuronal responses are not modulated by passive stretching of neck proprioceptors produced by passively rotating the body under a stationary head.

passive whole body rotation (heavy line). Taken together, these results are consistent with accumulating evidence from behavioral studies showing that VOR performance is generally comparable during passive and active rotations of the head-on-body in primates [1].

### Summary

Recent single unit experiments show that the head velocity signals carried by the direct VOR pathways are modulated in a manner that is consistent with the current behavioral goal. PVP neurons demonstrate robust head-velocity related modulation in response to self-generated and passively applied head rotations when gaze is stable. In contrast, when the behavioral goal is to redirect gaze relative to space, the head-velocity signals carried by PVP neurons are significantly reduced.

### PVP Neuron Modulation: Near Versus Far Viewing During Rotations and Translations

#### Angular VOR

A second situation where the VOR shows behaviorally-dependent modulation is during the fixation of near versus far earth-fixed targets. During head rotations, the eyes translate as well as rotate relative to space, since

they cannot both be perfectly aligned with the axis of rotation. Consequently, for the same amplitude of head rotation, a larger VOR gain is necessary to stabilize a near than a far earth-fixed target due to the differences in the translation of the target relative to the eyes (Fig. 6a). Differences in the responses of the type I PVP neurons that mediate the direct VOR pathways are consistent with these distance-related changes in VOR gain (Fig. 6b [7]).

#### Translational VOR

Recently, several investigations have specifically focused on the premotor pathways that generate the VOR in response to stimulation of the otoliths during translations (i.e. the translational VOR (TVOR); [8]). The latency of the TVOR is somewhat longer than that of the angular VOR; compensatory eye movements generally lag head movements by >10 ms in the primate. Although a direct disynaptic pathway has been shown to exist between the otoliths and the abducens nucleus, the longer latency of the TVOR suggests that it is primarily mediated by more complex polysynaptic pathways. During translation along the interaural axis, the gain of the horizontal TVOR response depends on

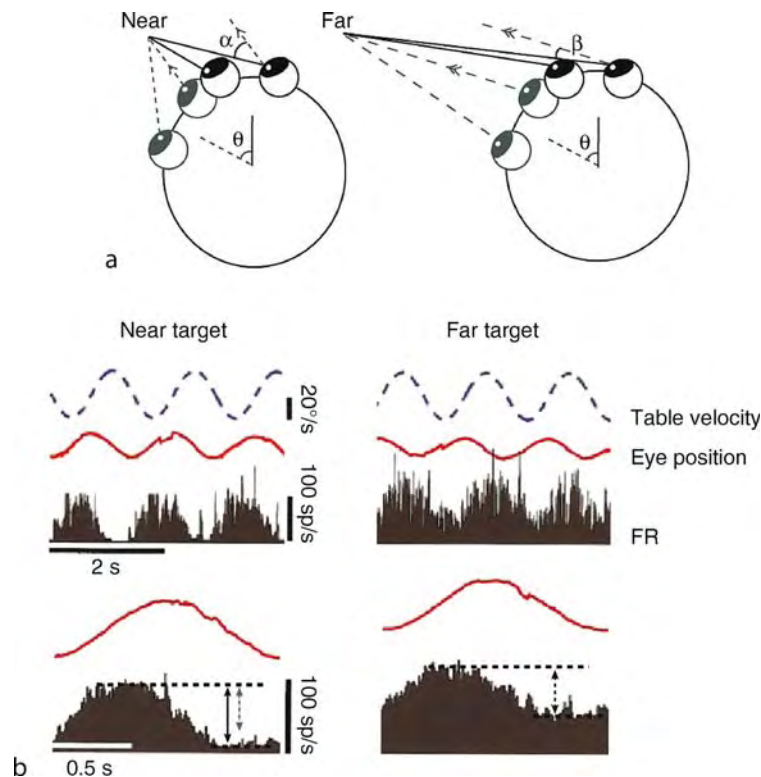

**Position-Vestibular-Pause Neurons. Figure 6** (a) Effect of varying fixation target distance ( $D$ ) on VOR gain for a fixed axis of rotation. (b) Responses of a type I PVP neuron when passive whole body rotation was applied while viewing a near (*left panel*) versus far (*right panel*) target.

the distance of the target being viewed (Fig. 7a). Moreover for translations along the nasal-occipital axis, the amplitude and sign of the eye movements evoked by the TVOR depend on gaze angle as well as viewing

distance. The latter finding is of particular interest, since it demonstrates that direction as well as the amplitude of the TVOR response is modified in a behaviorally-dependent manner.

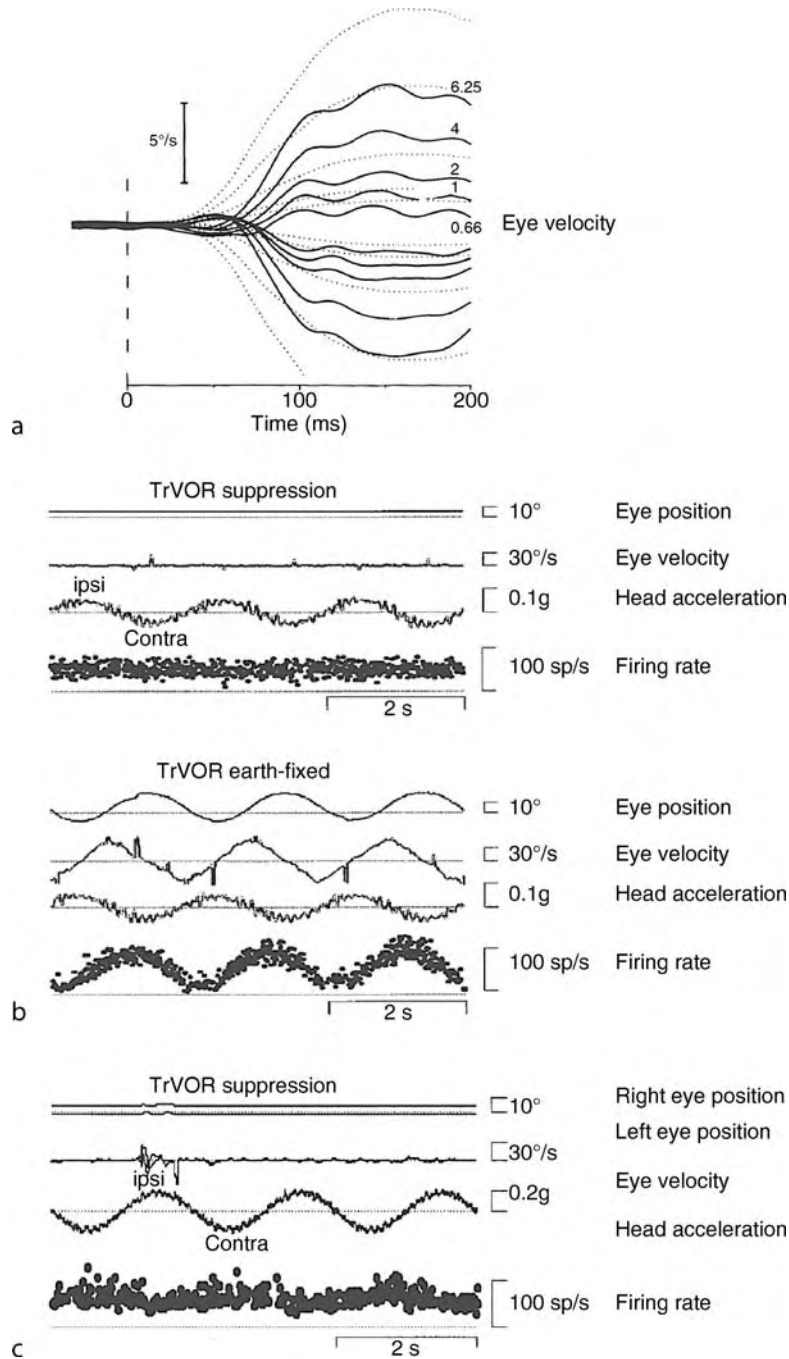

**Position-Vestibular-Pause Neurons. Figure 7** (a) Effect of varying fixation target distance on VOR gain during translation along the interaural axis. Continuous lines represent average eye velocity, while dotted lines indicate the ideal response that would be required for perfect gaze stability. (b, c) Responses of an example type I (b) and type II (c) PVP neuron during lateral translation.

Type I PVP neurons, which constitute the main interneuron in the direct angular VOR pathway, do not receive direct otolith inputs and thus do not contribute to the three neuron pathway that mediates the direct TVOR pathway. This is shown in Fig. 7b, where a typical neuron shows negligible response modulation during translation when the subject fixates a head-fixed target (TrVOR suppression; [8,9]). Comparison with Fig. 2c highlights the striking difference in response to type I PVP neurons during suppression of the TVOR and suppression of the angular VOR. However, when a subject fixates an earth-fixed target during translation (Fig. 7b, TrVOR earth fixed), neurons modulate in a manner that is consistent with their oculomotor-related response during smooth pursuit [9]. These results are in general agreement with previous studies that have compared responses during on and off-centered rotations [7,10]. Given that the type I PVP neurons show robust modulation during the TVOR, and that they project directly to the extraocular motoneurons (Fig. 1), it can be concluded that they contribute to the generation of the reflex via inputs from polysynaptic (but not direct) pathways.

In contrast, type II PVP neurons show slight response modulation during suppression of the VOR during translation (Fig. 7c), suggesting that these neurons contribute to the relatively weak ipsilaterally projecting three neuron arc that mediates the direct TVOR pathway. However, these neurons do not change their response amplitude for near versus far viewing during TVOR suppression [9]. Additional inputs, most likely transmitted via cerebellar/floccular pathways, appear to be necessary to modulate the TVOR as a function of gaze angle and viewing distance [7,8,9].

## References

1. Cullen KE, Roy JE (2004) Signal processing in the vestibular system during active versus passive head movements. *J Neurophysiol* 91:1919–1933
2. Roy JE, Cullen KE (2002) Vestibuloocular reflex signal modulation during voluntary and passive head movements. *J Neurophysiol* 87:2337–2357
3. Cullen KE, McCrea RA (1993) Firing behavior of brain stem neurons during voluntary cancellation of the horizontal vestibuloocular reflex. I. Secondary vestibular neurons. *J Neurophysiol* 70:828–843
4. Scudder CA, Fuchs AF (1992) Physiological and behavioural identification of vestibular nucleus neurons mediating the horizontal vestibuloocular reflex in trained rhesus monkeys. *J Neurophysiol* 68:244–264
5. Roy JE, Cullen KE (1998) A neural correlate for vestibulo-ocular reflex suppression during voluntary eye-head gaze shifts. *Nat Neurosci* 1:404–410
6. McCrea RA, Gdowski GT (2003) Firing behaviour of squirrel monkey eye movement-related vestibular nucleus neurons during gaze saccades. *J Physiol* 546:207–224

7. Chen-Huang C, McCrea RA (1999) Effects of viewing distance on the responses of vestibular neurons to combined angular and linear vestibular stimulation. *J Neurophysiol* 81:2538–2557
8. Angelaki DE, Green AM, Dickman JD (2001) Differential sensorimotor processing of vestibulo-ocular signals during rotation and translation. *J Neurosci* 21(11):3968–3985
9. Meng H, Green AM, Dickman JD, Angelaki DE (2005) Pursuit – vestibular interactions in brain stem neurons during rotation and translation. *J Neurophysiol* 93(6):3418–3433
10. McConville KM, Tomlinson RD, Na EQ (1996) Behavior of eye-movement-related cells in the vestibular nuclei during combined rotational and translational stimuli. *J Neurophysiol* 76:3136–3148

## Positive Feedback Control

### Definition

A mechanism used to regulate the value or time course of an output variable or signal when the output variable is determined by the value of an input signal or the time course of an input signal. The control mechanism is said to be closed loop when the value of the output variable is sensed or measured, is fed back and compared to some desired reference value and is then used to determine the value of the input signal. The closed loop control mechanism is referred to as positive feedback control when a given change in the output variable produces a change in the input signal that causes a further change in the output in the same direction.

Positive feedback control is often unstable, but when appropriately configured systems can remain stable while using positive feedback control.

► Posture – Sensory Integration

## Positive Schizophrenic Symptoms

### Definition

Symptoms associated with reality distortion; most frequently auditory hallucinations (hearing voices), feeling of being observed or persecuted.

► Schizophrenia

## Positron Emission Tomography

SVYATOSLAV V. MEDVEDEV

Institute of the Human Brain of the Russian Academy of Sciences, Laboratory of the Positron Emission Tomography, St-Petersburg, Russia

### Definition

Positron emission tomography (PET) is a nuclear imaging technique that allows quantitative evaluation of biochemical and physiological processes in vivo, by using ▶**radiopharmaceuticals** (RPs) labeled with short-lived positron-emitting radionuclides, which are detected by their annihilation radiation with electronic coincidence detector systems.

### Purpose

PET can be used in both research and clinical purposes for quantitative mapping of various physiological and biochemical processes. A number of these processes depend on the ▶**radiotracers** available.

### Clinical Purpose

**Oncology:** The most common application of PET is to determine the presence, severity and staging of cancer, its recurrences and responses to treatment. In neuro-oncology, PET has been found useful for the differentiation between radiation necrosis and ▶**glioma** recurrence with  $2\text{-}^{18}\text{F}\text{-}2\text{-deoxy-D-glucose}$  (▶**FDG**) (less with labeled amino acids), glioma grade determination (FDG), and guidance for biopsy [1].

Whole-body FDG-PET enables the identification of primary lesions as well as local recurrence, lymph node involvement and distant metastases; so far, it has been quite a useful technique for tumor staging. PET provides more benefits for patients with non-small cell lung cancer (NSCLC), malignant melanoma, breast cancer, lymphoma, and colorectal cancer. PET also proved to be useful in radiation-treatment planning as well as in monitoring treatment responses (radio- or chemotherapy) [2,3].

**Neurology:** PET has significant implications in making a precise diagnosis of various ▶**neuropsychiatry** and ▶**movement disorders**. Clinical application includes lateralization of epileptic foci in ▶**temporal lobe epilepsy** prior to surgery (FDG or rarely ▶**FMZ** – flumazenil); differentiation between various types of ▶**dementia** (FDG); assessment of dopaminergic neuron degeneration in ▶**Parkinsonism** (6-FDOPA); and recognition of ▶**depression syndrome** (WAY100635) [4].

**Cardiology:** PET is a modern tool for quantitative measurements of myocardial blood flow ( $^{13}\text{N}\text{-ammonia}$ ;  $^{82}\text{Rb}$ ) and assessment of myocardial viability (FDG), and provides important criteria for a patient's selection

for a revascularization. Imaging of the ▶**sympathetic nervous system** with PET is possible but not very common in clinical cardiology [5].

### Research

The most common research [4,6] application of PET involves ▶**activation studies** using high-sensitivity imaging of regional cerebral blood flow (rCBF) from multiple [ $^{15}\text{O}$ ]water injections. The alteration in neuronal activity in particular brain regions correlates with rCBF changes and the under performance of particular activities. Thus, PET is used to examine the spatial brain organization of the maintenance of cognitive, sensory, motor, emotional and other processes and responses to drug application.

Due to its high sensitivity and high specific activity (SA, the amount of radioactivity per mole) of the radiotracers, PET allows one to obtain quantitative information about the distribution of the target receptors throughout the brain, their affinity and density. The results are employed in fundamental studies of the pathogenesis of various neuropsychiatric disorders.

PET is a modern tool for the quantitative evaluation of drug-binding sites in living humans. By conducting PET studies with a suitable ▶**radioligand** before and after treatment by a drug, the fraction of the total number of binding sites that are occupied by the drug can be quantified (“drug occupancy study.”) Thus, the mechanism of drug action and optimal dosage can be evaluated in a very safe manner using the so-called “PET micro-dosing concept.” With this approach, the number of patients to be studied in phase II clinical trials can be minimized from thousands to tens, resulting in a reduction in the time and costs of the studies.

### Principles

#### Basic Principles in PET Imaging

When a PET [4,7] ▶**radionuclide** is introduced into the human body, at any given time, part of the nucleus will decay emitting a positron (positively charged electron) and a neutrino. The neutrino leaves the body without interaction. The positron, after a series of scatterings, annihilates with an electron. As a result, two photons (gamma quantum) of equal energy, i.e., 511 keV, are emitted in opposite directions at almost  $180^\circ$  (Fig. 1a) and can be detected by an external detector system.

If arrays of gamma detectors are gathered around the body, a coincident event – simultaneous signal from a pair of detectors – means that annihilation took place somewhere on the straight line (line of response) connecting this pair (Fig. 1b).

The next annihilation induces coincident events, usually in another pair of detectors, and gives another line of response. The density of all intersections of such lines yields a spatial distribution corresponding to the

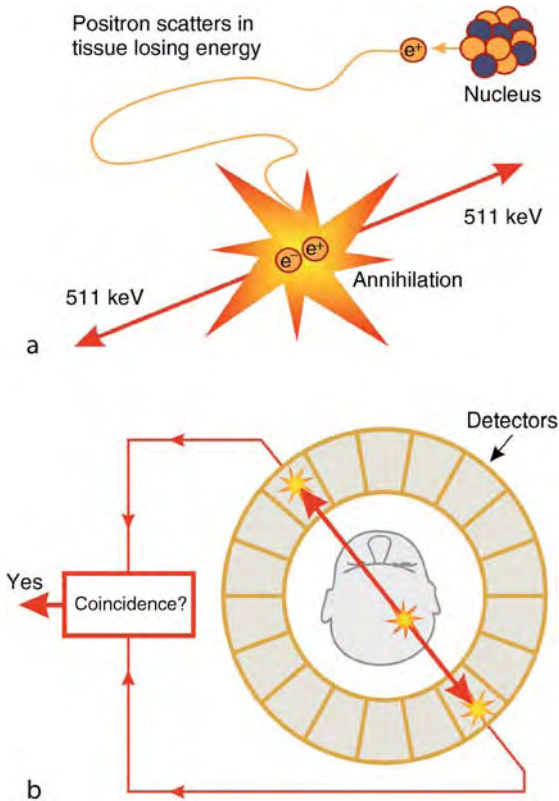

**Positron Emission Tomography. Figure 1** (a) When a PET radionuclide is introduced into the human body, at any given time part of the nucleus will decay emitting a positron. After a series of scattering, the positron annihilates with an electron. As a result, two photons (gamma quantum) of equal energy, i.e., 511 keV are emitted in opposite directions very close to  $180^\circ$  apart. (b) If arrays of gamma detectors are gathered around the body, a coincidence event – simultaneous signal from a pair of detectors – means that annihilation took place somewhere on the straight line (line of response) connecting this pair.

isotope concentration map. This method of coincidence registrations is the essence of PET and provides for its high efficiency. Information is contained in the direction of the photon movements. In other systems such as gamma cameras, this information is provided by using special metal tubes – collimators, which allow only the minority of all photons to enter the collimator and thus reach the detectors, while the majority is absorbed in the metal. Thus, in this system, each detector detects only photons coming from one given direction. The coincidence mode of registration and the use of short-lived radionuclides (2–110 min half-life) mostly contribute to the high sensitivity of PET, which allows the detection of pikomole amounts of substances. As a result, studies of drug abuse (cocaine, amphetamine) and toxic compounds become possible

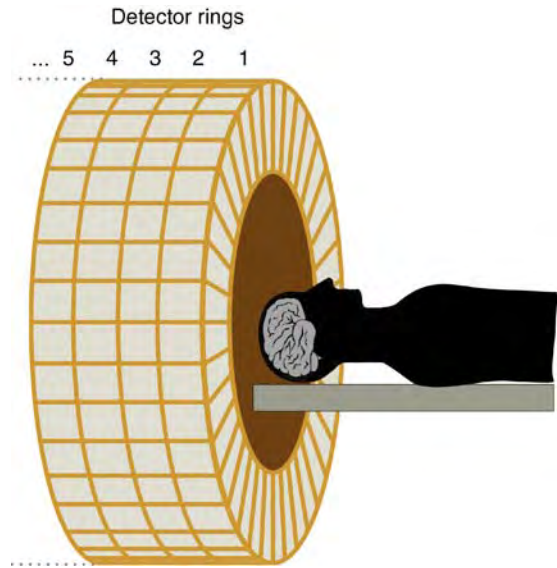

**Positron Emission Tomography. Figure 2** A PET scanner consists of up to 30,000 detectors (scintillation crystals with photomultipliers), arranged in rings, formed in a cylinder around the body.

at concentration levels that do not cause any pharmacological effect [8].

A PET scanner consists of up to approximately 30,000 detectors (scintillation crystals with photomultipliers) arranged in rings formed in a cylinder around the body (Fig. 2).

These detectors involve a coincidence registration circuit, which collects information about coincidence events – counts. Using conventional algorithms for image reconstruction including different types of corrections, a volume isotope concentration map can be obtained. The unique feature of the PET coincidence technique is that corrections for radiation losses can be performed within the body (attenuation correction). This procedure is called “transmission scan.”

Theoretically, the spatial resolution of PET scanners is limited by physical characteristics of positron flight within the tissues. When a positron is emitted, it travels a short distance from the nucleus, typically about 2–8 mm maximum range. It loses its kinetic energy during this flight and then annihilates with an electron. It is the distance between the decaying nucleus and the point of annihilation, and the fact that the annihilation photons are not emitted at exactly  $180^\circ$  apart (deviation from  $180^\circ$  is up to  $0.25^\circ$ ), which ultimately limit the spatial resolution of PET brain scanners to 4–5 mm (on average). However, in general, PET offers higher resolution than compared with 7–15 mm for single-photon emission computer tomography (SPECT).

PET allows registration of the counts per pixel, which are later transformed to counts per minute per ml of

tissue. However, in the counts acquisition process, the allowable radiation dose (regulated by the authorities) and limited acquisition time (depends on the instrumentation and study protocol) have to be considered. The result may be a poor **▶ signal-to-noise ratio**, which can be overcome by the use of spatial filtration. The latter is an additional source for degradation in resolution.

In general, the collection time varies from tens of seconds to tens of minutes. It is like an exposition time in photography and creates a strong limitation to the study protocol. Only steady states or at least quasi-steady or periodic processes should be investigated during one scan.

In modern PET scanners for data acquisition, so-called 2D and 3D modes are widely accepted. In the 2D mode, special septa between rings are installed to reduce the effect of scattering and random coincidence.

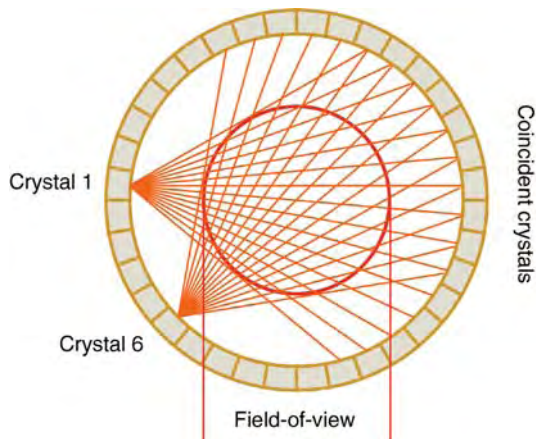

**Positron Emission Tomography. Figure 3** Each detector of the ring forms a fan with a number of opposite detectors. Overlapping of all fans forms the field of view.

As a result, each detector forms three fans between itself and an array of other detectors of the ring (Fig. 3) as well as the two nearest rings.

As a result, there is a reconstruction of three slices: one in the ring and two so-called cross slices. It means that 15 rings give 29 slices. This procedure gives better resolution and accuracy, but is rather wasteful because many lines of response between other rings are not collected. If the septa are retracted, coincidences are admitted from large axial acceptance angles. The 3D mode allows increasing the number of counts by five times. This results in increases of necessary computing resources and, what is more important, in increases of mis-positioned events caused by scattered photons and in the registration of accidental coincidences, including some caused by photons outside the field of view. This, however, reduces resolution and quantitative accuracy. On the other hand, the 3D mode allows the reduction of the injected dose, and/or the duration of study, and/or improving the signal-to-noise ratio. The 3D mode is mainly used in neurophysiology, where the duration of scan is important. The 2D mode is more often applied in oncology (Fig. 4).

Finally, PET provides a map of spatial distribution of a positron-emitting isotope density in the field of view of the rings. When a compound labeled by this isotope is introduced into humans (usually by intravenous injection), it distributes within the body via the blood circulation in accordance with the delivery, uptake, metabolism and excretion of the particular tracer. To translate the measured radioactivity distribution into functional or physiological parameters, compartment models are used for the radiotracers with known metabolism. One of the most important characteristics of cell functioning is energy consumption. It can be compared to “gasoline consumption” in an engine, so for the living cells, the gasoline is glucose. However, it is like a gas that an engine absorbs and excretes.

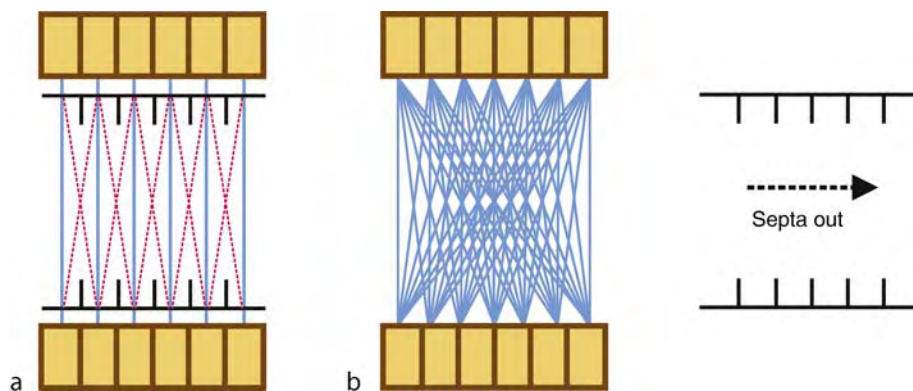

**Positron Emission Tomography. Figure 4** *Left:* 2D mode. Septa allow each detector to form lines of responses between itself and an array of other detectors of the same ring and the two nearest rings only. *Right:* 3D mode. Lines of responses between all rings are allowed.



$2\text{-}^{18}\text{F}$ -2-deoxy-D-glucose (FDG), a glucose analog, has a similar rate of consumption as normal glucose, but a different way for excretion. It is accumulated in a cell at a rate proportional to the energy consumption (metabolism) of this cell. Therefore, PET with FDG allows direct assessment of the level of glucose consumption, which is one of the most important processes responsible for vital functions [6]. As glucose metabolism is greatly enhanced in malignancies, FDG is the most important and popular radiotracer for PET oncology. In fact, this tracer has many other applications in neurology and cardiology and is considered the “working horse” of PET (like  $^{99\text{m}}\text{Tc}$  in conventional nuclear medicine).

In addition to the high sensitivity (see above), the use of short-lived radioisotopes allows injection of a relatively high activity of the tracer (185 MBq for FDG brain scan), leaving the total radiation dose within acceptable limit. As PET radionuclides belong to the major elements of life, unlimited numbers of radiotracers can be prepared to track various physiological processes. In practice, although more than 2000 RPs have been evaluated in PET, no more than 10–15 specimens have been introduced into clinical routines. The reasons are the difficult synthesis and the necessity for automation in operating high levels of radioactivity, high running costs, and very strict regulations.

The logic of a PET study is as follows. First, a field of interest has to be specified (i.e., neurophysiology, oncology, and cardiology). Within this field (let’s say oncology), the process of interest has to be identified (glycolysis or amino acid transport) and an appropriate tracer considered (FDG or  $^{11}\text{C}$ -methionine). The next steps are radiotracer synthesis and PET study design using an appropriate pharmacokinetic model, after this the PET study itself. The final stage is data processing and assignment of the image to the pathology under study.

It should be emphasized that PET is a functional imaging technique, giving an isotope distribution map, which reflects a particular biochemical process, not the anatomy. The introduction of a hybrid system (PET-CT: PET-computer tomography) has greatly enhanced the performance and accuracy of PET imaging. The CT component is used to relate the signal of radiotracer to anatomical landmarks and to correct for non-uniform attenuation (instead of traditional transmission scans) [3].

### PET Radionuclides

PET employs radiotracers (radiopharmaceuticals, RPs) labeled with short-lived positron-emitting radionuclides [9]. The four conventional radionuclides are:  $^{15}\text{O}$  (half-life  $T_{1/2} = 2$  min);  $^{13}\text{N}$  ( $T_{1/2} = 10$  min);  $^{11}\text{C}$  ( $T_{1/2} = 20.4$  min) and  $^{18}\text{F}$  ( $T_{1/2} = 110$  min). Carbon, oxygen, and nitrogen are elements of life and the building blocks of nearly every molecule of biological importance.

A fluorine-18 is often used to replace a hydrogen atom or hydroxyl group in a molecule.

Due to this short half-life, the PET radionuclides have to be produced in the vicinity, normally with a small dedicated cyclotron. PET cyclotrons accelerate charged particles (protons, deuterons) at a fixed energy (10–18 MeV for protons). Modern PET cyclotrons are negative-ions machines, which are characterized by an easy extraction process and dual beam option. PET radionuclides are produced in cyclotron targets via various nuclear reactions and delivered into a shielded hot cell by either gas flow ( $^{15}\text{O}$ ,  $^{11}\text{C}$ ) or extra-pressure of helium ( $^{13}\text{N}$ ,  $^{18}\text{F}$ ).

### PET Radiopharmaceuticals

For PET applications, the radionuclides have to be tagged to specific pharmaceuticals, referred to as “radiopharmaceuticals” [10]. PET radionuclides are produced in a simple chemical form. They have to be transferred into tracers of interest via a complex synthesis using special automated modules.

The 2-min half-life of  $^{15}\text{O}$  is very short; therefore, only very simple radiotracers like water- $^{15}\text{O}$  and  $^{15}\text{O}$ -butanol are produced as rCBF agents. Quite rarely,  $^{15}\text{O}$ -labelled gases are used in inhalation studies.  $^{13}\text{N}$ -ammonia ( $T_{1/2} = 10$  min) is available from a cyclotron target to fulfill the needs of heart-perfusion tracers.

The chemistry of carbon-11 ( $T_{1/2} = 20$  min) is extensively developed. Depending on the target gas,  $^{11}\text{C}$  is taken from the target in the form of  $^{11}\text{CH}_4$  or  $^{11}\text{CO}_2$ . The latter is a versatile agent for labeling of carboxylic acids, such as  $1\text{-}^{11}\text{C}$ -acetate, a tracer for oxidative myocardial metabolism. Most of the  $^{11}\text{C}$ -preparations are based on  $^{11}\text{C}$ -methylations, including L- $^{11}\text{C}$ -methyl-methionine, a second important tumor-seeking agent after FDG. Receptor radioligands such as  $^{11}\text{C}$ -SCH23390 ( $D_1$ ),  $^{11}\text{C}$ -raclopride ( $D_2$ ),  $^{11}\text{C}$ -PE2I (dopamine transporter),  $^{11}\text{C}$ -MADAM (serotonin transporter),  $^{11}\text{C}$ -flumazenil (central BZ),  $^{11}\text{C}$ -PK1195 (peripheral BZ), and  $^{11}\text{C}$ -OH-BTA1 ( $\beta$ -amyloids) are obtained by this method.

The longest-living  $^{18}\text{F}$  (110 min), allows several doses of the RPs to be obtained in one batch and to be delivered to other hospitals without access to a cyclotron. Irradiation of  $^{18}\text{O}$ -enriched water by protons is most commonly used for generating high amounts of  $^{18}\text{F}$  (35–70 GBq). Radionuclide is used in nucleophilic fluorination reactions to produce FDG. Although FDG is used in more than 80% of the routine PET studies, it is not a specific tracer for tumors as it enters other glucose-utilizing cells. New radiotracers for accurate characterization of tumors include *O*-(2'- $^{18}\text{F}$ -fluoroethyl)-L-tyrosine (FET) or 2-[ $^{18}\text{F}$ ]fluoro-L-tyrosine (2-FTYR). Due to the low accumulation in gray matter, these amino acids provide higher contrast

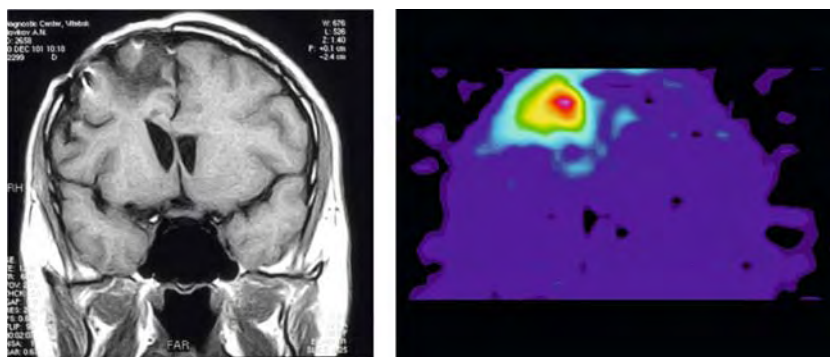

**Positron Emission Tomography. Figure 5** Patient after tumor removal and radiotherapy. *Left:* MRI diagnosis splits between radiation necrosis and recurrence of tumor. *Right:* PET with  $^{11}\text{C}$ -metionine proved recurrence.

images of brain tumors. FLT, a labeled thymidine analog, was introduced for prognostic assessment and evaluation of responses to anti-proliferative therapy in colorectal, lung and other cancers. Assessment of tumor hypoxia using hypoxia markers ( $^{18}\text{F}$ -FMISO,  $^{18}\text{F}$ -FAZA) allows one to select patients for treatments specifically designed to attack poorly oxygenated (hypoxic) tumor cells.

### Data Processing and Analysis

Modern software for PET data processing and analysis usually includes means for: (i) preliminary data processing (smoothing, filtering, co-registration of images from different modalities, spatial normalization, i.e., image deformation to match the standard one); (ii) data 2D and 3D visualization; and (iii) statistical analysis. The most widely used software for research environment is the Statistical Parametric Mapping (SPM) software package (<http://www.fil.ion.ucl.ac.uk/spm/>).

For some study purposes (activation study, some studies in oncology), it is often enough just to compare the numbers of counts from different body areas without calculating the real concentration of the radiotracer.

### Advantages and Disadvantages

At present, single-photon emission computer tomography (SPECT) makes up the majority of nuclear medicine procedures, mostly due to lower costs and availability of radiotracers from commercial sources ( $^{123}\text{I}$ ,  $^{111}\text{In}$ ) or isotopic generators ( $^{99\text{m}}\text{Tc}$ ). Due to the higher sensitivity of PET, the detectable amounts of molecules are lower than with SPECT. This is extremely important for receptor and drug development studies with very low amounts (pikomoles) of the substances involved. Unlike SPECT, PET allows a quantitative evaluation of the results using tracer kinetic modeling. In clinical studies, PET is usually used after ►magnetic resonance imaging (MRI) studies, and sometimes PET results can radically change a diagnosis

(Fig. 5). In whole-body PET studies, PET highlights peculiarities, which exist but are unrecognizable on MRI images. Due to the unlimited number of natural substrates, substrate analogs and drugs that can be labeled, PET allows the study of practically all varieties of physiological processes.

The major limitations of PET are the complexity of PET studies, high capital investments and running costs for the production of RPs requiring an on-site cyclotron. Recently, FDG has been delivered over distances corresponding to 2 h flight. Many stand-alone PET scanners are installed and served from one central “cyclotron/radiochemistry factory.” PET has proved to be cost-effective in staging and managing of certain malignancies such as NSCLC, by reducing the overall health care reimbursement. Due to the higher diagnostic accuracies of PET procedures, patients always benefit, even though the costs may be higher than with CT or MRI, which basically rely on morphological changes for tumor detection.

With respect to activation studies, functional MRI (fMRI), using the ►blood oxygenation level-dependent (BOLD) contrast method with echo-planar imaging, competes with PET. However, high levels of noise and ►claustrophobia effects result in several limitations in cognitive function assessments using this technique.

### References

1. Wiebe LI (2004) PET radiopharmaceuticals for metabolic imaging in oncology. *Int Congr Ser* 1264:53–76
2. Bergstrom M, Grahnén A, Langstrom B (2003) Positron emission tomography microdosing: a new concept with application in tracer and early clinical drug development. *Eur J Clin Pharmacol* 59:357–366
3. McQuade P, Rowland DJ, Lewis JS, Welch MJ (2005) Positron-emitting isotopes produced on biomedical cyclotrons. *Curr Med Chem* 12(7): 807–818
4. Mazziotta JC, Toga AW, Frackowiak JRS (2000) Brain mapping. The Disorders. Academic Press, New York
5. Dobrucki LW, Sinusas AJ (2005) Cardiovascular molecular imaging. *Semin Nucl Med* 35:73–81

6. Frackowiak RSJ, Friston KJ, Frith CD, Dolan RJ, Mazziotta JC (1997) Human brain function. Academic Press, New York
7. Zanzonico P (2004) Positron Emission Tomography: a review of basic principles, scanners design and performance, and current systems. *Semin Nucl Med* 34:87–111
8. Fowler JS, Ido T (2002) Initial and subsequent approach for the synthesis of 18FDG. *Semin Nucl Med* 32:6–12
9. McQuade P, Rowland DJ, Lewis JS, Welch MJ (2005) Positron-emitting isotopes produced on biomedical cyclotrons. *Curr Med Chem* 12(7):807–818
10. Welch MJ, Redvanly CS (2003) Handbook of radio-pharmaceuticals. Radiochemistry and application. Wiley, London, p 848

## Posner Paradigm

### Definition

► Visual Attention

## Possibilism

### Definition

The view that possible worlds exist in addition to the actual world and have the same ontological status.

► Possible World

## Possible World

VOLKER GADENNE

Department of Philosophy and Theory of Science,  
Johannes-Kepler-University Linz, Linz, Germany

### Definition

A possible world is a complete way things might be. Possible worlds are alternative worlds one of which is the actual world. Philosophers use the notion of a possible world to define and discuss ideas such as possibility or necessity.

### Description of the Theory

#### *Leibniz's Idea of a Possible World*

Consider the actual world, that is, the whole of what is the case, not only here and now but also in the past and in the future throughout all time. Thinking how

things are in the actual world, lots of other worlds can easily be imagined, simply by changing one or more features. In one possible world Schubert composed one more symphony. In another world, the dinosaurs did not die out, with all consequences and so on. Even the slightest difference, say one more atom in this table, makes a world different from the actual one.

Note that changes of states of affairs may have consequences. Some things that are possible in separate worlds are not possible in combination. There is a possible world in which George visits a conference in 2004 and there is another possible world in which George dies in a car accident in 2003. But there is (probably) no possible world that contains both these states of affairs.

Leibniz used the idea of possible worlds in his philosophy of creation. God had in his mind infinitely many worlds he could have created. He chose the best of these possible worlds and made it actual. On the basis of this theory, Leibniz attempted to provide a ► **theodicy**, a “justification of God” in the face of all the evils in the actual world. God had perfect reason to bring into existence the actual world despite all pain and suffering it contains, since it is the best of all possible worlds. Leibniz was convinced that even god could not create anything. He could have made other laws of nature, but not worlds that are logically impossible. [\*Vielleicht genauer: Leibniz’ Gott kann logisch Unmögliches nicht schaffen, wohl aber nomologisch unmögliches].

### *Modal Logic and Possible World Semantics*

The concept of possible worlds plays a central role in ► **modal logic**. Kripke [1,2] was most influential on the development of ► **possible world semantics** and its application to metaphysical problems (for an introduction, see [3]). Modal claims are fundamental to the ways the world is talked about. Consider, for example, the sentence: “There might be ten planets.” This is a sentence in the mode of *possibility*. Another modal notion is *necessity*, as in the sentence: “Bachelors are unmarried.” [\*Sollte man hier den modalen Charakter nicht explizit machen so wie in dem vorangegangenen Beispiel?] What makes such statements true or false? According to the traditional view, modal statements are made true or false by relations of ideas or by linguistic conventions. In this example, the meaning of “unmarried” is part of the meaning of “bachelor.” However, some philosophers find it hard to see how all ► **propositions** thought to be necessarily true should be true by convention. How could the way that a thing is talked about make it true, e.g. that John is a human being or that infinitely many primes exist? Here the idea of possible worlds has its part. With its help the proposition may be expressed as follows. “There is at least one possible world in which the sun has exactly ten planets.” Necessity can be defined as truth in all

possible worlds. “In all possible worlds bachelors are unmarried.” “In all possible worlds there are infinitely many primes.”

Generally speaking, to say that a proposition is true is just to say that it is true in the actual world. But to say that a proposition is necessary or necessarily true is to say that it is true in every possible world. And to say that a proposition is possible or possibly true is to say that it is true in some possible world. According to this theory, the modal notions of necessity and possibility are explained in terms of quantification over worlds. In order to speak of a proposition  $p$  as necessarily true, a *universal quantifier* over worlds is needed. “For all possible worlds  $W$ ,  $p$  is true in  $W$ .” To speak of a proposition  $p$  as possibly true, an *existential quantifier* over worlds has to be used. “There is at least one possible world  $W$ , such that  $p$  is true in  $W$ .”

Logicians found that on this neo-Leibnizian account they could give clear sense to the modal notions as they function in the various modal logics. Further concepts such as “validity,” “soundness” and “completeness” can be defined in terms of models constructed from sets of alternative worlds. Important results have been obtained by these methods (which can however not be presented here since they require a lot of technical details).

Modal notions are central to many of the traditional areas of philosophy, e.g. the nature of causation or free will. These notions have traditionally been challenged by empiricists. The most prominent critic was Quine [4]. In the 1950s, many philosophers became convinced that the ideas of necessity and possibility could have no place in philosophy. The development of possible world semantics gave many of them new reason to believe that the empiricist challenge can be met.

### **The Existence of Possible Worlds: Possibilism and Actualism**

One of the most difficult problems of possible world theories concerns the ontological status of such worlds. The quantification over worlds seems to require that all these worlds exist. There are two main views dealing with this question, ►*possibilism* and ►*actualism*. For *possibilism*, as held by Lewis [5], there really is a plurality of possible universes of the same kind as this one. Each of them is conceived as a very comprehensive *concrete object*, having as its parts less comprehensive concrete objects such as stones, trees and persons. All the concrete objects that inhabit the various possible worlds are fully real. They are supposed to be really out there. Lewis denies that this world, which is called the “actual” one, has a special ontological status. The actual world is just a part of total reality, it is the part spatially and temporally related to this world. There is however no causal interaction between different possible worlds, because each of them is spatiotemporally closed.

Can the same individuals exist in different worlds? Lewis denies this. There are no “transworld individuals.” Each object exists in just one possible world. But how can he then account for the idea that there are different ways the same things could have gone? Instead of relating different possible worlds by strict numerical identity of some objects he ties them by what he calls the “counterpart relation.” For example, a particular person is in the actual world and no other, but has “counterparts” in several other worlds. The counterpart is not really the person, but it resembles the person closely in important respects.

Lewis argues for his theory by emphasizing its fruitfulness. Starting with the concept of a possible world as a primitive and with the means of set theory, he could not only define necessity and possibility, but also concepts such as “property” or “proposition.” His theory is committed to the program of an austere ►*nominalism*. Properties and propositions are reduced to sets of concrete objects. However, many philosophers find it hard to accept that all those possible objects should be regarded as fully real. The strict nominalistic account of modal notions was also criticized. It leads to some unsatisfactory consequences.

Another view about the existence of possible worlds is ►*actualism*. Actualists too, start with the assumption that the actual world is not the only possible world. But unlike possibilism, actualism gives the actual world a special ontological status. Only what actually exists, exists at all. This seems to imply that possible worlds do not exist. However, not all actualists draw this consequence. The leading advocates of actualism, like Plantinga [6] and Stalnaker [7], rather think that possible worlds can be identified with something that belongs to the actual world. To express this idea, they do not restrict themselves to the resources of nominalism, but refer to abstract entities (►*abstract entity*), especially, states of affairs. Every possible ►*state of affairs* is supposed to *exist in the actual world*. However, not all states of affairs *obtain*. Not everything that might be the case (and therefore exists as a state of affairs) is really the case (obtains). For example, the state of affairs that Aristotle became Plato’s successor at the academy exists, but failed to obtain.

Possible worlds are regarded by Plantinga as “maximally comprehensive possible states of affairs.” This is a possible state of affairs,  $W$ , so comprehensive that, for any state of affairs  $S$ ,  $W$  either includes  $S$  or precludes  $S$  (and thus encompasses a whole world). As a consequence, all the possible worlds *exist*. But only one of them *obtains* – the *actual* world. Possible worlds are *abstract entities*, not concrete objects (►*concrete entity*). The same individuals can exist in different possible worlds. Actualism therefore needs no counterpart relation. Possible world theories raise a lot of problems, technical ones as well as metaphysical

difficulties, which are still unsolved. Nevertheless many philosophers are convinced of the fruitfulness of this program.

### Applications to Other Fields

The notion of a possible world has been applied to several areas of philosophy to formulate and discuss special problems, e.g. in the philosophy of mind. Kripke [2] himself used it to analyze *mind-brain identity* and he argued against identity theory. Roughly, the structure of his argument is identity theory implies that pain is identical with a certain type of brain state. Such an identity statement would have to be necessarily true, i.e. true in all possible worlds, if it was true at all. But the tie between pain and a certain type of brain state is plainly contingent. Therefore, they cannot be identical.

A central idea of contemporary philosophy of mind is *supervenience*. Kim [8] analyses mind-brain supervenience in terms of possible worlds. The assumption that two persons with the same brain states must necessarily have the same mental states can be formulated as follows. "Mental properties supervene on physical properties in that if any  $x$  (in any possible world) and  $y$  (in any possible world) have the same physical properties (in their respective worlds), then  $x$  and  $y$  have the same mental properties (in those worlds)."

### References

1. Kripke SA (1963) Semantical considerations on modal logic. *Acta Philos Fenn* 16:83–94
2. Kripke SA (1980) Naming and necessity. Harvard University Press, Cambridge
3. Loux MJ (1998) *Metaphysics*, Chap 5. Routledge, London
4. Quine WVO (1960) *Word and object*. MIT, Cambridge
5. Lewis DK (1986) *On the plurality of worlds*. Blackwell, Oxford
6. Plantinga A (1974) *The nature of necessity*. Oxford University Press, Oxford
7. Stalnaker R (1984) *Inquiry*. MIT, Cambridge
8. Kim J (1996) *Philosophy of mind*. Westview, Boulder

## Possible World Semantics

### Definition

A type of formal semantics that uses the notion of a possible world as a central concept; formal semantics is the study of the interpretations of formal languages.

- ▶ Possible World
- ▶ Property

## Postactivation Potentiation (PAP)

- ▶ Force Potentiation in Skeletal Muscle

## Postcentral Gyrus

### Synonyms

- ▶ Gyrus postcentralis

### Definition

= primary somatosensory cortex = SI  
= area 3 + 1 + 2

The postcentral gyrus lies in the parietal lobe directly behind the central sulcus. Observing strict somatotopic arrangement, the somatosensory tracts of the contralateral body half terminate here.

Conscious localization and differentiation of quality and intensity of a tactile stimulus are effected in cooperation with the postcentral gyrus. Lesions of the postcentral gyrus reduces the response to tactile, thermal and noci stimuli from the contralateral body half.

- ▶ Telencephalon

## Posterior Cerebellar Lobe

### Synonyms

- ▶ Lobus cerebelli post.; ▶ Posterior lobe of cerebellum

### Definition

The posterior lobe is the part of the cerebellum caudal to the primary fissure, and is composed of vermis portions (declive, folium, tuber, pyramid and uvula) as well as hemisphere portions (simple lobule, semilunar, gracile and biventer lobules as well as tonsil). Functionally this subdivision has practically no significance, since the cerebellum evidences a functional arrangement in a vertical direction (vermis, intermediate part, lateral part).

- ▶ Cerebellum

## Posterior Colliculus

▶ Inferior Colliculus

## Posterior Column

### Synonyms

▶ Funiculus post; ▶ Posterior funiculus

### Definition

The cuneate fasciculus and gracile fasciculus together form the posterior column and are the main axes of epicritic sensibility: – gracile fasciculus: it collects the epicritic fibers from the sacral, lumbar as well as lower thoracic cord and terminates in the gracile nucleus. – cuneate fasciculus: contains the fibers from the upper thoracic cord as well as from the cervical cord and terminates in the cuneate nucleus.

▶ Pathways

## Posterior Commissure

### Synonyms

▶ Commissura post

### Definition

Here cross the fibers that are vital for controlling vertical eye movement and consensual light reaction of the pupils, including fibers from the superior colliculus, pretectal region as well as tegmentum of Mesencephalon.

▶ Telencephalon

## Posterior Cortical Atrophy

### Definition

Degenerative disorder of the posterior part of the brain beginning with visual symptoms and then proceeding

into more general ▶ **dementia**. Initially, elementary visual functions are lost, but then more complex syndromes show up, including visual agnosia, topographical problems, ▶ **optic ataxia**, simultanagnosia, ocular apraxia (▶ **Balint's syndrome**), right-left confusion, ▶ **alexia**, ▶ **acalculia**, ▶ **agraphia** (▶ **Gerstmann's syndrome**).

▶ **Balint's Syndrome**

▶ **Gerstmann's Syndrome**

▶ **Optic Ataxia**

## Posterior Horn

### Synonyms

▶ Cornu post

### Definition

He majority of primary afferents entering through the posterior horn terminate in the posterior horn of the spinal cord. Three zones can be distinguished:

- Marginal cells
- Substantia gelatinosa
- Nucleus proprius

▶ Medulla spinalis

## Posterior Lobe of the Hypophysis

### Synonyms

▶ Neurohypophysis

### Definition

The posterior lobe of the hypophysis is also called the neurohypophysis since it is composed of hypothalamic nervous tissue. Its proximal segment is formed by the tuber cinereum and infundibulum, and its distal segment is the posterior lobe of the hypophysis. Via the infundibular nucleus, axons of the paraventricular nucleus and of the supraoptic nucleus pass to the blood vessels in the posterior lobe, where they release the hormones ADH and oxytocin.

▶ Diencephalon

## Posterior Nuclei

### Definition

The thalamic nuclei that project to the parietal somatosensory cortex, relaying nociceptive inputs from the periphery.

► Somatosensory Cortex I

## Posterior Parietal Cortex (PPC)

### Definition

Cerebral cortex posterior to the postcentral gyrus.

► Visual Space Representation for Reaching

## Posterior Spinocerebellar Tract

### Synonyms

► Tractus spinocerebellaris post

### Definition

The posterior spinocerebellar tract carries primary afferents from the spinal cord to the cerebellum.

It has its origin in Clarke's column in the thoracic cord and conducts proprio- and exteroceptive impulses (skin receptors, muscle spindles, tendon spindles) from the posterior limbs to the cerebellum.

► Cerebellum

## Posterior Tuberculum

### Definition

A caudal part of the diencephalon present in cartilaginous and bony fishes that contains some dopaminergic neurons as well as several laterally migrated nuclei of the preglomerular nuclear complex that are involved in

the relay of ascending sensory pathways, particularly for the gustatory and lateral line systems.

► Evolution of the Somatosensory System: In Non-mammalian Vertebrates

## Posterolateral Column

### Synonyms

► Tractus postervlat. (Lissauer); ► Posterolateral tract (Lissauer)

### Definition

The white matter between the ventral root and dorsal root gives rise to the lateral column, containing:

1. anterolateral column with
  - anterolateral fasciculus
  - parts of the anterior spinocerebellar tract.
2. posterolateral column with
  - posterior spinocerebellar tract
  - parts of the anterior spinocerebellar tract
  - lateral pyramidal tract.

► Medulla Spinalis

## Posteromedial Barrel Subfield

► Barrel Cortex

## Postganglionic Fiber (Neuron)

### Definition

Ganglion neurons of autonomic ganglia all issue an axon (which turns into a nerve fiber), and virtually all these fibers exit the ganglion directed toward a peripheral target organ, along different paths depending on the ganglion of origin. Some form discrete nerves (splanchnic, pelvic, urinary), others reach somatic nerves and the mixed nerves of autonomic and somatic fibers thus formed reach the periphery (the limbs in particular and all the skin). The post-ganglionic fibers

can be very long and are usually unmyelinated, hence of slow conduction velocity. Upon reaching the target organ they branch extensively and make contact with muscle elements (mainly smooth muscle cells) and with secretory elements (glands). Post-ganglionic fibers exert their effect on muscle and glands by releasing neurotransmitters that stimulate (and sometimes inhibit) contraction and secretion. The neurotransmitters are released from “terminals” that are not only the expansions at the anatomical end of each nerve branch but also at bulbous expansion (varicosities) scattered along a substantial part of the terminal portion of the axons. Each ganglion neuron issues one fiber traveling to the periphery, which has many branches within the terminal organ, which have many thousands of varicosities along their terminal branches.

In the bladder muscle, for example, a few thousand ganglion neurons directly innervate millions of muscle cells. The exact relationship between varicosities (nerve endings) and muscle cells (or gland cells) varies from a close contact (a neuro-muscular junction) in some tissues (the bladder, for example) to a loose relationship with a wide gap (some blood vessels, for example).

- ▶ Autonomic Ganglia
- ▶ Parasympathetic Pathways
- ▶ Sympathetic Pathways

## Postganglionic Nerves

### Definition

Autonomic nerves going to the end organ, e.g., cavernous nerve and the dorsal nerve of the penis and clitoris.

- ▶ Sexual reflexes

## Postganglionic Neurotransmitter

JUDY L. MORRIS, IAN L. GIBBINS  
Department of Anatomy & Histology, and Centre for Neuroscience, Flinders University, Adelaide, SA, Australia

### Synonyms

Autonomic neurotransmitter

### Definition

Postganglionic autonomic neurons have their cell body in an ▶autonomic ganglion and an axon that extends out to a target organ. These neurons regulate activity of most organs of the body by releasing combinations of neurotransmitters. Postganglionic neurotransmitters are released from multiple swellings along the axons, or ▶varicosities, separated from the target cell membrane by gaps of 20–100 nm to form ▶neuroeffector junctions (Fig. 1).

Each axon has thousands of varicosities that can release neurotransmitter from the postganglionic neuron. It is now clear that the earliest identified neurotransmitters, acetylcholine and noradrenaline (adrenaline in some non-mammalian vertebrates), do not mediate all actions of postganglionic autonomic neurons. Nearly all neurons releasing acetylcholine or noradrenaline also synthesize and release various combinations of other neurotransmitter molecules including adenosine triphosphate (ATP), nitric oxide (NO) and one or more neuropeptides such as vasoactive intestinal peptide (VIP), neuropeptide Y (NPY) or opioid peptides [1,2,3,4,5]. Furthermore, many neurons intrinsic to the gastrointestinal tract or airways use nitric oxide, ATP and one or more neuropeptides but do not synthesize acetylcholine or noradrenaline (Table 1).

The release of more than one transmitter from the same postganglionic neuron, termed ▶co-transmission, is now accepted as the rule rather than the exception. As well as regulating activity of the target organs (▶postjunctional actions), transmitters released from postganglionic neurons can act back on terminals of the same or other nearby nerve terminals to alter further transmitter release (▶prejunctional actions). Some transmitters have both pre-junctional and postjunctional actions, while others act at only one site (Fig. 1).

### Characteristics

#### Quantitative Description

Twenty or more different molecules have been identified as neurotransmitters in postganglionic autonomic neurons including enteric neurons (Table 1). Some individual neurons contain five or more co-transmitters [1].

#### Higher Level Structures

Neurotransmitters are stored in membrane-bound vesicles within axon terminals. Synaptic vesicles can vary in size from small (40–60 nm diameter) to large (80–120 nm diameter). Nerve terminals contain both small and large vesicles in varying ratios. In varicose terminals of most postganglionic autonomic neurons, small vesicles are more abundant than large vesicles. Sometimes small vesicles tend to be clustered towards the cell membrane adjacent to the neuroeffector junction, but this is not always apparent. In contrast, large vesicles are not concentrated near the neuroeffector junction. Small vesicles



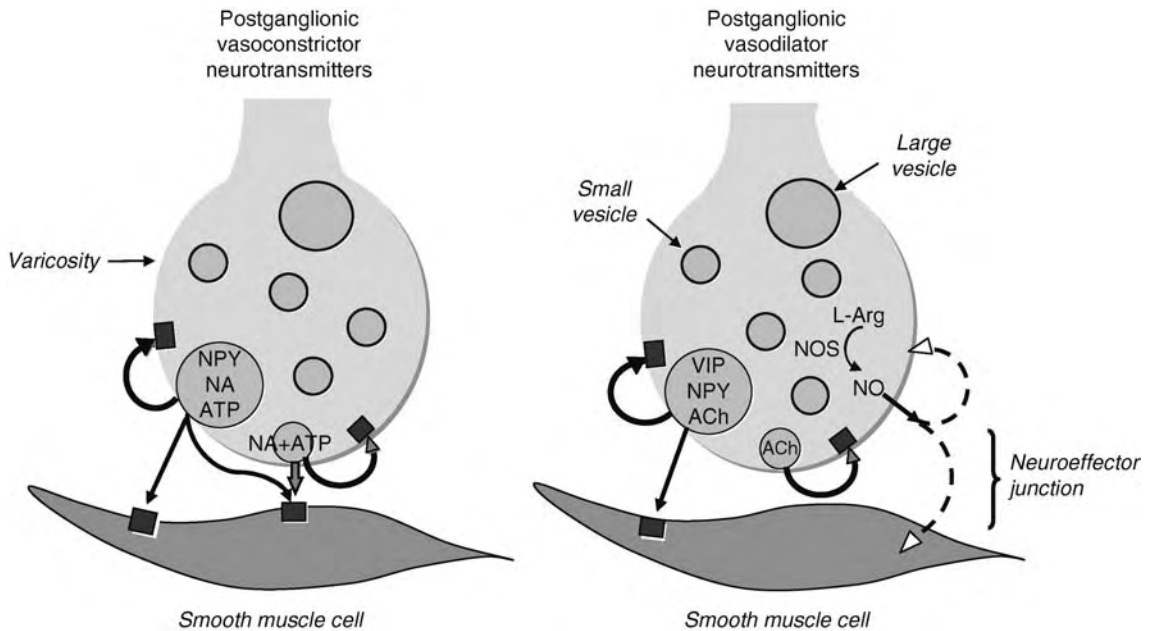

**Postganglionic Neurotransmitter. Figure 1** Example of two types of postganglionic neurons releasing multiple neurotransmitters in a single blood vessel. Co-transmitters stored in and released from varicosities of postganglionic vasoconstrictor neurons and postganglionic vasodilator neurons into neuroeffector junctions with smooth muscle cells in the uterine artery (see [1]). Large vesicles in vasoconstrictor neurons contain noradrenaline (NA), adenosine triphosphate (ATP) and neuropeptide Y (NPY), while small vesicles contain only NA and ATP. Transmitters released from small and large vesicles can act on the postjunctional receptors on the smooth muscle cells to produce vasoconstriction, as well as prejunctional receptors on the membrane of the varicosity where they usually inhibit transmitter release. Nearby varicosities of vasodilator neurons contain large vesicles with acetylcholine (ACh), vasoactive intestinal peptide (VIP), NPY and several other peptides [6]. Small vesicles contain ACh alone. Nitric oxide is synthesized in the cytoplasm by nitric oxide synthase conversion of L-arginine, before diffusing across the neuroeffector junction and into smooth muscle cells to activate cyclic GMP and relax the smooth muscle. VIP has a potent vasorelaxant action, while ACh only has a prejunctional effect to inhibit neurotransmitter release. The function of NPY released from the vasodilator neurons is not known, but it may produce relaxation of an already constricted vessel and is likely to have a prejunctional inhibitory effect on transmitter release. It is likely that postganglionic neurotransmitters also can affect neurotransmission from adjacent varicosities.

in postganglionic neurons contain noradrenaline, ATP or acetylcholine. Large vesicles often contain neuropeptides in addition to non-peptide transmitters. Nitric oxide is an unusual neurotransmitter – it is not stored in synaptic vesicles but synthesized on demand in the nerve terminals (Fig. 1).

### Lower Level Structures

The chemical structure of postganglionic neurotransmitters encompasses low molecular weight gases such as nitric oxide (and possibly carbon monoxide; [2]), purine nucleotides like ATP, catecholamines and acetylcholine, and neuropeptides ranging in size from less than a dozen amino acids (e.g., enkephalin, substance P) to more than thirty amino acids (VIP, NPY, calcitonin gene-related peptide (CGRP; Table 1). Almost all of these substances also are neurotransmitters in the central nervous system. The nature and sequence of neurotransmitters has been remarkably conserved through evolution, so that only very small if any chemical differences occur

between postganglionic neurotransmitters in different vertebrate classes.

### Higher Level Processes

As in all other neurons using chemical neurotransmission, synaptic vesicles in postganglionic neurons release their neurotransmitters by exocytosis, and vesicle membranes are recycled at the nerve terminal. Large vesicles are formed in the cell body where they are packaged with a variety of proteins (such as neurotransmitter synthesizing enzymes and transporters) and neuropeptides, then are transported down to the nerve terminal. In some neurons post-translational processing of peptides such as dynorphin can occur within large vesicles as they are transported down the axon. The non-peptide transmitters noradrenaline and acetylcholine are synthesized or taken up into vesicles in the cell body, axon and terminals. In contrast, neuropeptides cannot be taken up and repackaged into vesicles at the nerve terminal. This differential processing of peptide and non-peptide transmitters may

**Postganglionic Neurotransmitter. Table 1** Substances localized in postganglionic autonomic neurons of most vertebrates

Neurotransmitter	Molecular weight	Postganglionic neurons with neurotransmitter	Common co-transmitters
Acetylcholine (ACh)	146	Parasympathetic neurons.	NO, VIP, Som
		Enteric motor neurons, Enteric secretomotor neurons.	SP, NKA
		Subpopulation of sympathetic nerves e.g., sudomotor neurons	NPY, Som, Gal, CCK, CGRP
Adenosine triphosphate (ATP)	507	Sympathetic neurons.	NA, NPY
		Pelvic nerves to the bladder.	Ach
		Enteric inhibitory neurons.	NO, VIP
Adrenaline (Ad, epinephrine)	183	Sympathetic neurons in amphibians, fish.	NPY
Noradrenaline (NA, norepinephrine)	169	Most sympathetic neurons in mammals, birds, reptiles.	ATP, NPY
Calcitonin gene-related peptide (CGRP)	3,807	Parasympathetic neurons.	ACh, NO, VIP
		Enteric secretomotor neurons.	ACh, NPY, Som, Gal, CCK, CGRP
Cholecystokinin (CCK8)	1,142	Enteric secretomotor neurons	ACh, NPY, Som, Gal, CGRP
Dynorphin (DynA1–17)	2,148	Sympathetic neurons.	NA, +/- NPY
		Enteric neurons.	VIP, NO, GRP
Enkephalin (Enk)		Some sympathetic neurons.	NA, +/- NPY
Met-Enk, Leu-Enk	574, 556	Enteric neurons.	Dyn, VIP, NO
Galanin (Gal)	3,211	Sympathetic neurons.	NA, +/- NPY
		Intrinsic cardiac neurons.	ACh, Som
		Enteric neurons.	
Gastrin releasing peptide (GRP)	2,806	Enteric neurons.	VIP, Dyn, Gal, NO
5-Hydroxytryptamine (5-HT, serotonin)	1,76	Taken up into and released from some sympathetic and enteric neurons	NA, NPY ACh
Neurokinin A (NKA)	1,133	Enteric motor neurons.	SP, Ach
Neuropeptide Y (NPY)	4,254	Many sympathetic neurons.	NA, ATP
		Some parasympathetic neurons.	ACh, +/- VIP
		Enteric secretomotor neurons.	ACh, Som, CGRP, CCK
Nitric oxide (NO)	30	Parasympathetic neurons.	ACh, VIP
		Enteric inhibitory neurons.	VIP, ATP
Peptide histidine isoleucine (PHI)	2,996	Most parasympathetic neurons.	ACh, VIP, PACAP
		Enteric inhibitory neurons.	VIP, NO, ATP
Pituitary adenylate cyclase activating peptide (PACAP) 38	4,538	Enteric neurons	VIP, GRP
		Parasympathetic neurons.	ACh, VIP, PHI
Somatostatin (Som)	1,638	Intrinsic cardiac neurons.	ACh, +/- Gal
		Enteric neurons.	ACh, NPY, CGRP, CCK
Substance P (SP)	1,348	Cranial parasympathetic neurons.	Ach
		Enteric motor neurons.	ACh, NKA
Vasoactive intestinal peptide (VIP)	3,326	Most parasympathetic neurons.	ACh, PHI, PACAP
		Enteric inhibitory neurons.	PHI, PACAP, NO, ATP

Details of co-transmitters derived mostly from animal studies, concentrated on guinea-pegs (see [1,4]). A definitive neurotransmitter role has been established for all substances in all locations listed. Many enteric neurons do not receive direct inputs from the central nervous system but form part of intrinsic neural circuits.

contribute to selective depletion of co-transmitters after intense activation of autonomic neurons. Nitric oxide is synthesized in postganglionic nerve terminals by the calcium-dependent enzyme, nitric oxide synthase (NOS), located in the cytoplasm and not in vesicles (Fig. 1).

The action potential-dependent exocytosis of neurotransmitters from small vesicles in all neurons, including postganglionic autonomic neurons, occurs through specific interactions between proteins located on the vesicle membrane and proteins attached to the inner surface of the nerve terminal membrane, the **▶SNARE proteins** (soluble NSF attachment protein receptor proteins). Exocytosis is a multi-step process that is calcium-dependent. First, the vesicles are released from a framework of actin filaments and move close to the terminal membrane where they become docked. This is followed by fusion of the vesicle membrane with the nerve terminal membrane, allowing release of vesicle contents into the extracellular space of the neuroeffector junction. Exocytosis of transmitters from small vesicles can be inhibited by botulinum neurotoxins that act intracellularly to cleave the SNARE proteins. However, it is not clear whether exocytosis of neuropeptides from large vesicles uses the same SNARE proteins that mediate small vesicle exocytosis. Release of neuropeptides from postganglionic autonomic neurons certainly is less sensitive to blockade by botulinum toxin than release of non-peptides from small vesicles [6]. Nitric oxide release from postganglionic autonomic neurons is completely resistant to botulinum toxin, confirming that this transmitter is not associated with vesicular storage and exocytosis.

### Lower Level Processes

After release from the terminals of postganglionic neurons, noradrenaline, ATP and acetylcholine are rapidly removed from the neuroeffector junction by degradation or uptake by the nerve terminal and target tissue. These mechanisms limit the time course and distance over which the transmitters can act on prejunctional or postjunctional receptors. Nitric oxide acts on target tissues after diffusion across the membrane of both the nerve terminal and the postjunctional cell. This molecule diffuses rapidly from the neuroeffector junction and potentially can act outside the neuroeffector junction. However, superoxide radicals can rapidly inactivate nitric oxide, so diffusion of the transmitter away from the nerve terminal may be quite limited. Neuropeptides released from postganglionic neurons are not rapidly taken up across the pre- or postjunctional membrane and largely remain in the extracellular space until they are enzymatically degraded. This can result in neurally released neuropeptides interacting with receptors at considerable distances from the neuroeffector junction, a phenomenon called volume transmission. Nevertheless, neuropeptides bound to postjunctional receptors can be taken up into the

target cell via **▶endocytosis**, thus contributing to **▶receptor desensitisation**.

### Process Regulation

The actions of postganglionic neurotransmitters can be regulated by altering synthesis, transport, release, breakdown or reuptake of the transmitter itself, by altering expression or availability of neurotransmitter receptors, or by altering intracellular messengers and ion channels mediating neurotransmitter actions in the target cell. The major regulator of postganglionic neurotransmitter release is the frequency and pattern of action potentials travelling down the postganglionic axon. This is determined primarily by the pattern of impulses leaving the central nervous system via preganglionic neurons. However, this pattern can be modulated by local and circulating hormones changing the excitability of postganglionic neurons in autonomic ganglia. The excitability of postganglionic neurons also can be changed by ongoing activation of sensory nerves passing through autonomic ganglia, such as happens in inflammation. The sensory neurotransmitter substance P, and the hormone angiotensin both increase the excitability of many postganglionic neurons so that they fire more often in response to the same pattern of preganglionic nerve activity. Many substances also can modulate the expression of neurotransmitters or their synthetic enzymes by altering gene transcription in the postganglionic nerve cell body, or affect the release of transmitter from the varicosities of postganglionic neurons.

Ultimately, the pattern of firing of postganglionic neurons determines which co-transmitters are released from the varicosities. With a low frequency of impulses, <2 pulses per second (Hz), the small vesicles preferentially release their transmitters, so catecholamines, ATP and acetylcholine are released without neuropeptides. NOS also can be activated by low impulse frequency, releasing nitric oxide. Generally, large vesicles containing neuropeptides are not released until impulse frequencies reach at least 5, and up to 20, per second. An irregular pattern of high frequency activation is more effective in releasing neuropeptides from large vesicles than is a continuous high frequency firing. This frequency-dependent release of co-transmitters allows postganglionic neurons to produce a wide range of actions on their target tissues.

### Function

Neurotransmitters released from postganglionic autonomic neurons have a wide range of functions. They activate or inhibit target cells such as smooth muscle cells of blood vessels, viscera, airways and skin, cardiac muscle, secretory cells in many glands, and other neurons in autonomic ganglia including enteric neurons. These actions regulate vital processes such as

heart rate and arterial blood pressure, control of regional blood flow, the gastrointestinal system, respiration, reproduction and thermoregulation.

Many neurotransmitters can act both on the target tissue (postjunctional action), and back on the nerve terminal that released them (prejunctional action) to regulate further release of neurotransmitter (Fig. 1). Postganglionic neurotransmitters typically act via receptors on the target cell membrane that in turn can switch on or off a large array of second messenger pathways that influence intracellular calcium levels and usually affect membrane potential. Some transmitters, for example ATP, also can act via receptors that are themselves ion channels, called ionotropic receptors. In contrast, nitric oxide does not use receptors on the target cell membrane but diffuses freely across the membrane of both the nerve terminal and target cell, where it stimulates production of cyclic GMP. The detailed actions of multiple co-transmitters released from the same nerve terminal are not fully known. However, it is clear that some co-transmitters may have only a postjunctional action and some only a prejunctional action [1,6]. Further research also is required to clarify the roles of co-transmitters that potentially can have opposite effects on the target cells (Fig. 1). Nevertheless, the very different molecular sizes of co-transmitters, their different post-junctional signalling systems together with their different methods of inactivation, results in wide variations in the time course of neurotransmitter action. While noradrenaline, ATP, acetylcholine and nitric oxide typically have post-junctional actions lasting seconds to minutes, neuropeptide effects are slow in onset and can last up to tens of minutes, if not hours. Thus, release of neuropeptide transmitters by higher levels of impulse activity provides an efficient way to produce long-lasting functional changes in the target tissues.

### Pathology

Pathological conditions involving dysfunction of the autonomic nervous system include those affecting post-ganglionic transmitter synthesis, release or post-junctional actions. Congenital deficiency in ►**dopamine-β-hydroxylase (DBH)** has been demonstrated in a small number of patients with autonomic dysfunction restricted to sympathetic pathways. These patients fail to synthesize adequate noradrenaline, and noradrenaline and adrenaline are undetectable in the plasma while plasma dopamine is elevated. The most obvious symptom is severe postural hypotension from an early age [7]. Other symptoms include ptosis and retrograde ejaculation. In contrast, some forms of hypertension involve hyperactivity of cardiovascular sympathetic nerves that results in increased release of noradrenaline from postganglionic neurons. This increased sympathetic activity is thought to be involved in both the development and maintenance of arterial hypertension [7]. Autoimmune neuropathies

affecting autonomic nerve function also can occur. Autoantibodies leading to autonomic dysfunction most often are directed at nicotinic receptors in autonomic ganglia. However, autoantibodies directed at muscarinic receptors on peripheral target tissues have been reported in Sjögren's syndrome and scleroderma. These antibodies prevent acetylcholine released from parasympathetic nerve terminals from producing secretion in the lacrimal and salivary glands via post-junctional muscarinic receptors, resulting in the characteristic sicca symptoms of the disease [8].

### Therapy

Therapeutic interventions for autonomic dysfunction include use of a wide variety of agents affecting post-ganglionic transmitters. DOPS (dihydroxyphenylserine) is useful in overcoming DBH deficiency, as it is converted directly to noradrenaline by dopa-decarboxylase, thus alleviating the requirement for DBH ([7]. Antagonists for post-junctional β-adrenoceptors (beta blockers) are used widely to treat hypertension by reducing sympathetic cardio-excitation. In Sjögren's syndrome, agonists of M3 muscarinic receptors improve sicca symptoms, and use of antiidiotypic antibodies to neutralize autoantibodies has been proposed [8]. In conditions involving hyperactivity of postganglionic ►**cholinergic** nerves, such as hyperhidrosis, anticholinergic agents are sometimes used although surgical sympathectomy has long been the treatment of choice. Recently, botulinum neurotoxin treatment has been used to block exocytosis of acetylcholine from the sudomotor neurons. Botulinum toxin A (Botox) has been popular, but it has been suggested that botulinum toxin B (Neurobloc) might produce more prolonged therapy due to its decreased immunogenic nature [9]. Botox also is used increasingly to treat autonomic dysfunctions such as neurogenic urinary incontinence or oesophageal achalasia. Sildenafil (Viagra), an inhibitor of phosphodiesterase-5, is used for treatment of erectile dysfunction in males, although its benefit in females is more controversial. This agent enhances the action of nitric oxide released from pelvic autonomic nerves, by reducing breakdown of cyclic GMP in smooth muscle [10]. Thus, sildenafil is only beneficial if the pelvic nerve pathways are intact.

### References

1. Gibbins IL, Morris JL (2000) Pathway specific expression of neuropeptides and autonomic control of the vasculature. *Regul Pept* 93:93–107
2. Baranano DE, Snyder SH (2001) Neural roles for heme oxygenase: contrast to nitric oxide. *Proc Natl Acad Sci* 98:10996–11002
3. Burnstock G (2004) Cotransmission. *Curr Opin Pharmacol* 4:47–52
4. Furness JB, Costa M (1987) *The enteric nervous system*. Churchill Livingstone, Edinburgh, p 290

5. Lundberg JM, Hökfelt T (1986) Multiple coexistence of peptides and classical transmitters in peripheral autonomic and sensory neurons – functional and pharmacological implications. *Prog Brain Res* 68:241–262
6. Morris JL, Jobling P, Gibbins IL (2001) Differential inhibition by botulinum neurotoxin A of cotransmitters released from autonomic vasodilator neurons. *Am J Physiol Heart Circ Physiol* 281:H2124–H2132
7. Bannister R, Mathias CJ (eds) (1993) *Autonomic failure. A textbook of clinical disorders of the autonomic nervous system*, 3rd edn. Oxford University Press, Oxford, p 953
8. Cavill D, Waterman SA, Gordon TP (2003) Antiidiotypic antibodies neutralize autoantibodies that inhibit cholinergic neurotransmission. *Arthritis Rheum* 12:3597–3602
9. Nelson L, Bachoo P, Holmes J (2005) Botulinum toxin type B: a new therapy for axillary hyperhidrosis. *Br J Plast Surg* 58:228–232
10. Gibson A (2001) Phosphodiesterase 5 inhibitors and nitrenergic transmission – from zaprinast to sildenafil. *Eur J Pharmacol* 41:1–10

## Postherpetic Neuralgia (PHN)

### Definition

Postherpetic neuralgia (PHN) is a neuropathic pain syndrome and is the most common complication of herpes zoster (HZ, shingles). PHN occurs mainly in the 60 years plus age group and in individuals suffering more severe acute pain and rash with HZ. Herpes zoster (shingles, HZ) results from reactivation of varicella zoster virus (VZV), one of a family of human herpes viruses, which has remained latent in sensory ganglia following primary infection with varicella (chicken pox). The incidence of HZ increases with age reflecting an age related decline in cell mediated immunity (CMI).

► [Neuropathic Pain](#)

## Post-inhibitory Rebound

### Definition

The ability of a neuron to respond to a hyperpolarization with a depolarization of the membrane potential above the level of the normal resting membrane potential. This can either be due to the activation of a hyperpolarization-activated inward current,  $I_h$ , or the action of low-voltage activated inward current,  $I_{Ca(T)}$ , that is inactivated at the normal resting membrane potential. In

this case, hyperpolarization of the membrane potential removes the inactivation of the current, so that it can be activated when the membrane potential returns to its resting level at the end of the hyperpolarization. This activation causes a transient depolarization of the membrane potential, the post-inhibitory rebound, that can trigger action potentials.

- [Calcium Channels – an Overview](#)
- [Central Pattern Generator](#)
- [Omnipause Neurons](#)
- [Stomatogastric Ganglion](#)

## Post-junctional

### Definition

Post-junctional refers to the target cell distal to a neuroeffector junction, responding to neurotransmitters.

## Post-saccadic Drift

### Definition

In an ideal saccade, the eye rapidly accelerates and then abruptly stops so that gaze remains stationary during the subsequent period of fixation. In reality, many saccades are followed by continued eye movements that have sub-saccadic velocities (e.g., 2–30°/sec in primates) but sufficient durations to appreciably change the direction of gaze. These post-saccadic drifts may be onwards or backwards relative to the saccade, and have several origins. After undershooting saccades in cats, the superior colliculus may continue to fire at low rates and gaze may drift onward toward the target. It has been suggested that is one mechanism the saccadic system uses to correct the undershoot. Less pronounced drifts seen in humans may serve the same purpose. Short duration onward or backward post-saccadic drifts, often called glissades, are thought to be due to a mismatch between the neural signal that moves the eyes during a saccade (the saccadic burst) and that which holds the eyes in position after the saccade (the tonic signal). Small disconjugate glissades occur after saccades in normal subjects, but more prominent glissades can result from central (e.g., cerebellar or cortical) damage and from damage to the ocular motor nerves, muscles,

or orbital tissue. Finally, the recurring post-saccadic centripetal drift and inability to hold eccentric gaze (gaze-evoked nystagmus) that results from damage to the brainstem neural integrator is also a form of post-saccadic drift.

- ▶ Brainstem Burst Generator
- ▶ Oculomotor Dynamics
- ▶ Saccade, Saccadic Eye Movement
- ▶ Superior Colliculus

## Postsurgical Pain

- ▶ Incisional/Postoperative Pain

## Postsynaptic Currents (EPSCs and IPSCs) or Potentials (EPSPs and IPSPs)

### Definition

By the patch clamp method, it is possible to record the electrical events occurring in a postsynaptic cell as a result of neurotransmitters' release by the presynaptic terminal and the consecutive opening of ionotropic receptors. In the "voltage clamp" mode, the voltage is kept constant, so it is possible to record the current passing through the open ion channels, called "postsynaptic current" (PSC). In the "current clamp" mode, it is possible to record the changes in membrane potential induced by the opening of ion channels, called "postsynaptic potentials" (PSP).

For an excitatory synapse, the binding of neurotransmitters induces the opening of cationic channels, which is depolarizing the cell. The induced electrical events are called "excitatory postsynaptic currents" (EPSCs) and "excitatory postsynaptic potentials" (EPSPs). For an inhibitory synapse, the binding of neurotransmitters induces the opening of chloride channels, which is hyperpolarizing the cell. The induced electrical events are called "inhibitory postsynaptic currents" (IPSCs), and "inhibitory postsynaptic potentials" (IPSPs).

- ▶ Patch Clamp
- ▶ Postsynaptic Potential

## Postsynaptic Potential

MIYAKAWA, HIROYOSHI

Laboratory of Cellular Neurobiology, School of Life Sciences, Tokyo University of Pharmacy and Life Sciences, Tokyo, Japan

### Definition

At chemical synapses, transmitter molecules are released from presynaptic terminals to the synaptic cleft or extracellular space as the mediator of transmission, and bind to receptors located on the membrane surface of postsynaptic cells. Binding of transmitters often give rise to transient change in the membrane potential of the postsynaptic cells, which is referred to as postsynaptic potentials (Fig. 1) [1–5]. In the case of electrical synapses [6], electric current flows directly from one cell to the other as the mediator of transmission, and causes a change in membrane potential. Although this can also be referred to as postsynaptic potential, the term "postsynaptic" is conditional, because the electrical synapses are bidirectional. Hence, this term is used mostly for chemical synapses.

### Characteristics

#### Mechanisms for Generating Postsynaptic Potentials

Some types of receptors are directly coupled with ion channels while others are either indirectly coupled to ion channels or not coupled at all. Activation of the receptors, either directly or indirectly coupled to ion channels, gives rise to changes in the open probabilities of ion channels, which can be detected as the change in the ion conductance of the membrane. Depending upon the ion selectivity, ion conductance, composition of the ion species, and the membrane potential, electric current flows through ion channels and charges the membrane capacitance to generate postsynaptic potentials. The direction of the postsynaptic currents depends on the ion-selectivity of the ion-channels coupled to the receptors, the composition of the ion species that permeate through the ion-channels, and the membrane potential. The direction of the current reverses at a certain potential, when the membrane potential of the postsynaptic cell is varied (Fig. 2). This potential is called the reversal potential. For instance, the reversal potential of the nicotinic acetylcholine receptor is around zero mV in physiological conditions, and the reversal potential of GABA<sub>A</sub> receptor is near the resting potential.

When the direction of the induced current is inward, and hence gives rise to depolarizing potential change, the current is referred to as excitatory postsynaptic current (EPSC), and the potential as excitatory postsynaptic potential (EPSP). When the direction of the

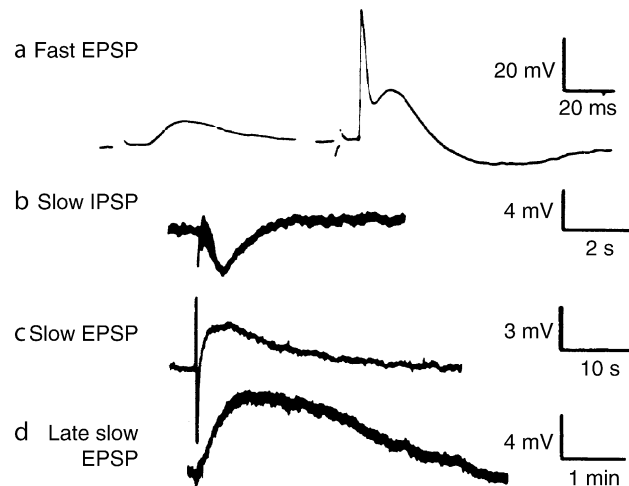

**Postsynaptic Potential. Figure 1** Various postsynaptic potentials generated in frog sympathetic ganglion neurons. a: fast EPSP induced by stimulating preganglionic fibers. This potential is mediated by nicotinic acetylcholine receptors, which is coupled directly with ion channels. A stronger stimulation induces larger depolarization, which triggers action potential (right). b,c: slow IPSP and slow EPSP induced by repetitive stimulations. The slow IPSP and the EPSP are mediated by muscarinic acetylcholine receptors. d: A late slow EPSP evoked by repetitively stimulating spinal nerves is mediated by LHRH-like peptide. (Adapted from reference [7]).

current is outward and gives rise to hyperpolarizing potential change, the current is referred to as inhibitory postsynaptic current (IPSC), and the potential as inhibitory postsynaptic potential (IPSP).

### Factors that Determine the Time Course of Postsynaptic Potentials

The time course of postsynaptic potentials range from a few milliseconds to a few minutes (Fig. 1). In general, fast postsynaptic potentials are mediated by ion-channel-coupled receptors (ionotropic receptors) for small molecule transmitters, and slow postsynaptic potentials are mediated by GTP-binding-protein-coupled receptors (metabotropic receptors). In the case of ion-channel-coupled receptors, channels open upon binding of transmitters, postsynaptic current flows through the channel, and the current charges the membrane to cause a change in the membrane potential (Fig. 3). Activation of GTP-binding-protein-coupled receptors usually generates second messengers in the cytoplasm, and the second messengers directly or indirectly regulate ion channels. Indirect regulation, in many cases, is by phosphorylation or dephosphorylation of ion channels.

In excitable cells, action potentials can be triggered when the summation of postsynaptic potential provides enough depolarization. The amplitude and the time course of postsynaptic potentials are important in triggering action potentials. Many factors are involved in determining the amplitude and the time course of postsynaptic potentials. Some of the factors are the amount and the time course of transmitter release, the structure of synapses, the lifetime of transmitters in the synaptic cleft, the properties of postsynaptic

receptors, and the electrical properties of postsynaptic cells. The lifetime of transmitters in the synaptic cleft is determined by uptake mechanisms or degrading mechanisms, and estimated to be very short in the case of small molecule transmitters, such as glutamate and acetylcholine. The opening of channels indirectly linked to the receptors usually takes longer. The activation of ionotropic receptors is usually fast; hence, the rise time of postsynaptic currents is fast. The decay of postsynaptic currents also depends not only on the lifetime of transmitters in the cleft, but on the properties of receptors, channels, and the membrane as well. Some of the ligand-gated channels for small molecule transmitters show desensitization, and may be involved in determining the time course of postsynaptic potential. In the case of fast transmission, such as transmission at a neuromuscular junction, the decay time of postsynaptic potential is close to the time constant of the postsynaptic membrane, and is usually longer than that of the postsynaptic current (Fig. 3).

Dual whole cell recordings from neurons with long dendrites, such as neocortical pyramidal neurons, show that the postsynaptic potential measured from the cell body is slower compared to the potential measured near the input sites. This kind of distortion depends on the properties of the dendrites, and is important in determining cell response.

### Higher Level Processes

The process of postsynaptic potential generation is part of **synaptic transmission**. Processes involved in synaptic transmission are classified as **presynaptic processes**, **postsynaptic processes** and the rest. The

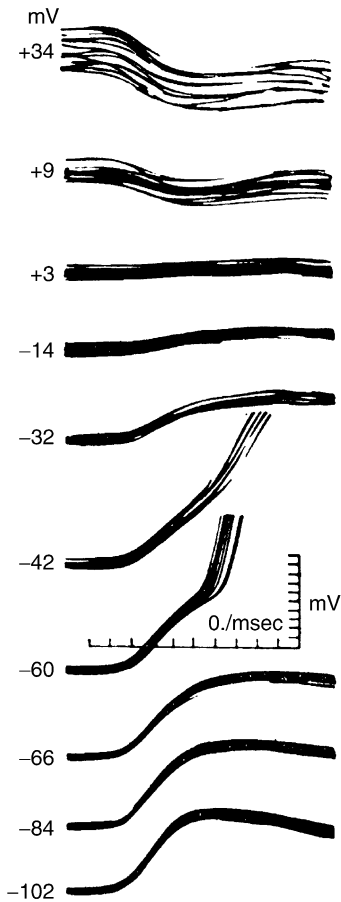

**Postsynaptic Potential. Figure 2** Reversal of Postsynaptic Potential. EPSP was measured from a cat motoneuron. The membrane potential was varied by injecting current through an intracellular electrode. The postsynaptic potential is depolarizing at potentials below 3 mV, and hyperpolarizing above 7 mV. Triggered action potentials are shown in the traces at -60 and -42 mV. (Adapted from reference [8]).

presynaptic processes are the processes concerning **▶transmitter release**, and the postsynaptic processes concerning **▶reception** of transmitters including the generation of postsynaptic potential. Upon reception of transmitters, the postsynaptic cells do not necessarily generate postsynaptic potential, but may activate intracellular signaling processes that include protein phosphorylation-dephosphorylation and protein synthesis through gene expression.

### Lower Level Processes

- Diffusion of transmitters.
  - Activation and desensitization of postsynaptic receptors.
  - Charging and discharging of membrane capacitance by postsynaptic currents.

- Intracellular signaling.
- Clearance of transmitters from synaptic cleft.

### Process Regulation

Generation of postsynaptic potential is regulated by various ligands including biogenic amines, neuropeptides, and hormones. This kind of regulation is referred to as neuromodulation. The important mechanisms for neuromodulation are phosphorylation-dephosphorylation of proteins and gene expression of proteins, which take part in the generation of postsynaptic potential. The activities of the cells themselves, which take part in generating postsynaptic potentials, also regulate the process of postsynaptic potential generation. This kind of regulation is referred to as **▶neuronal plasticity**. Neuronal plasticity shares common mechanisms with neuromodulations, and is described elsewhere.

### Function

To convey information for significant distance without decay, the neurons generate action potentials that propagate along the axonal processes. When the action potentials arrive at presynaptic terminals of chemical synapses, the information is converted into the form of chemical substances called transmitters. Upon reception of transmitters by the postsynaptic cells, the information is converted back to the form of electrical signal. The electrical signal can easily spread within the postsynaptic cell and can be summated and integrated to generate the output of the postsynaptic cells.

In the case of neuromuscular junctions, muscles receive a single presynaptic fiber. However, the amplitude of a postsynaptic potential (end-plate potential), induced by a single action potential in the presynaptic fiber, is large enough to trigger an action potential at the junction, which propagates along the entire length of the muscle fiber, and also into the transverse tubules, to induce a transient Ca rise and thereby generate a twitch response. The postsynaptic current generated by the activation of a postsynaptic receptor is greater than the current generated by the presynaptic action potential, and provide a current large enough to significantly depolarize the potential of the muscle membrane, the area of which is larger than that of the presynaptic membrane. Since the end-plate potential has large amplitude and a fast rate of rise, the muscle membrane can generate action potential. In contrast, most neurons in the central nervous system receive many thousands of inputs, and single synaptic inputs do not usually trigger action potentials in the postsynaptic cells because the amplitude of postsynaptic potentials is not large enough. Before an action potential is generated in the axons, many synaptic inputs need to be integrated. As synaptic inputs are converted into the form of an electrical signal, and electrical signals can quickly spread along the somato-dendritic axis, inputs



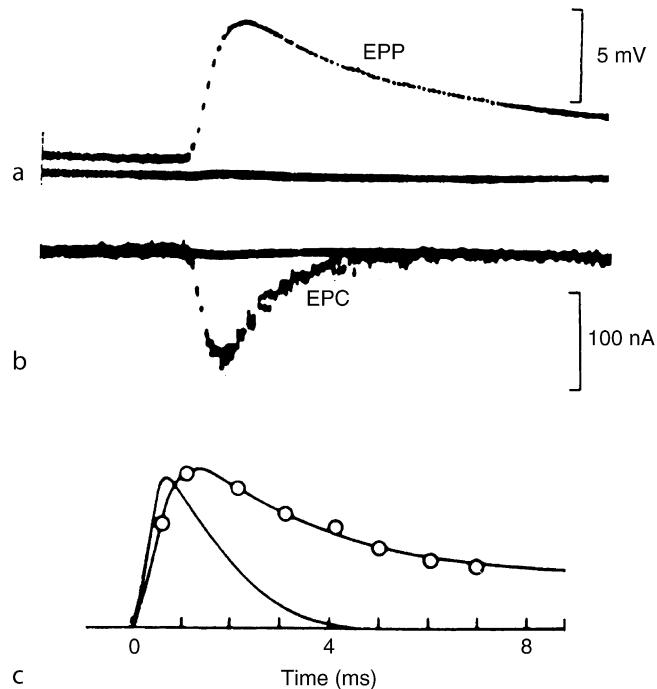

**Postsynaptic Potential. Figure 3** Postsynaptic potential and current. a: End-plate potential (EPP) in a curarized frog muscle fiber. b: End-plate current (EPC) measured from the same fiber voltage-clamped at the resting potential. c: The continuous lines show the actual EPP and EPC. The circles show the EPP calculated from the EPC, assuming the time constant of the membrane to be 25 ms (adapted from reference [9]).

that arrive at various locations at various times can easily be summated and integrated. Thus, the postsynaptic potentials serve as mediators of information integration, which can lead to generation of action potentials in the postsynaptic cells that travel down the axon, and eventually induce transient Ca rise in the presynaptic terminals to trigger transmitter release.

There are cases in which the generation of action potential is skipped and postsynaptic potentials directly trigger transmitter release. In those cases, the extent of transmitter release depends on the amplitude of the potentials, and the synaptic transmission can be graded.

## References

1. Cowan WM, Sudhof TG, Stevens CF (2001) Synapses. The Johns Hopkins University Press
2. Kuno M (1995) The synapse: function, plasticity, and neurotrophism. Oxford University Press, Oxford
3. Pappas GD, Purpura DP (ed) (1972) Structure and function of synapses. Raven, New York
4. Eccles JC (1964) The physiology of synapses, Springer-Verlag
5. Katz B (1996) "Nerve, Muscle, and Synapse," McGraw-Hill
6. Bennett MVL (2000) "Electrical synapses, a personal perspective (or history)." Brain Research Review 32:16–28
7. Kuffler SW (1980) Slow synaptic responses in the autonomic ganglia and the pursuit of a peptidergic transmitter. Journal of Experimental Biology 89:257–286
8. Coombs JS, Eccles JC, Fatt P (1955) Excitatory synaptic action in motoneurons. Journal of Physiology 130:374–395
9. Takeuchi A, Takeuchi N (1960) On the permeability of end-plate membrane during the action of transmitter. Journal of Physiology 154:52–67

## Postsynaptic Receptor Trafficking

### ► Receptor Trafficking

## Postsynaptic Receptors

### Definition

Receptors that are expressed at the postsynaptic membrane and are responsible for mediating changes in the excitability of the postsynaptic cell.

### ► Synaptic Transmission: Model Systems

## Posttetanic Potentiation

### Definition

An increase in postsynaptic response to presynaptic release of neurotransmitter following a single stimulus that is applied at various times after a train of stimuli.

The cause is thought to be increased release of neurotransmitter from the presynaptic terminal.

- ▶ Force Potentiation in Skeletal Muscle
- ▶ Neuromuscular Junction

## Posttraumatic Pain

- ▶ Incisional/Postoperative Pain

## Posttraumatic Stress Disorder

### Definition

A disorder that develops as a consequence of exposure to highly traumatic experiences, characterized by inappropriate fear responses to stimuli associated with those experiences.

- ▶ Learning and Extinction
- ▶ Stress

## Postural Control

FAY B. HORAK

Neurological Sciences Institute, Oregon Health and Science University, Portland, OR, USA

### Introduction

To inhabit the world, in all of its unpredictable, variable environments and situations, requires a powerful, yet flexible, system of postural control. For example, the ability to move from sitting to standing; to take a step; to respond to a slip or trip; to predict and avoid obstacles;

to carry a glass of wine without spilling it, even when walking across a rolling boat; and to orient your body to a speeding soccer ball, all require excellent postural control. Although neural control of postural orientation and equilibrium involves most of the nervous system and all body segments, the postural system is often forgotten because it usually operates at an automatic, non-voluntary level. Only after an injury to the nervous system or musculo-skeletal system, when we have to really “think about” our balance and postural alignment or battle dizziness and spatial disorientation, do we begin to appreciate the complex systems involved in postural control.

### Biomechanical Goals of Postural Control

Postural control involves neural control of ▶postural equilibrium and ▶postural orientation [1]. Postural equilibrium involves coordination of sensory and motor ▶strategies to maintain balance, that is, to stabilize the body’s ▶center of mass over its ▶base of support. An important goal of postural equilibrium control is to prevent falls during both self-initiated and externally-triggered disturbances of stability. The postural equilibrium system controls stability during stance posture as well as during locomotion and performance of voluntary tasks. Postural orientation involves the positioning of body alignment with respect to gravity, the support surface, visual environment and other ▶sensory reference frames. The goals of postural equilibrium and postural orientation are independently controlled and sometimes subjects give up one goal for another. For example, an athlete may give up the goal of postural equilibrium in order to achieve their goal to orient their body appropriately to a ball.

### Stance Posture

Although the musculoskeletal system affords some passive stability, humans and most animals require active postural muscle activation to maintain stance posture against gravity and to orient their body segments appropriately to their environment. To oppose the destabilizing effects of gravity, standing humans are continuously making small correction to upright body position, called ▶postural sway. ▶Postural muscle tone provides antigravity support and flexibly adjusts to changes in support, alignment, and environmental conditions [2]. Besides postural tone, control of postural sway requires integration of sensory information to detect body motion with respect to the environment and the activation of muscles to maintain equilibrium and alignment of segments. Postural sway during stance can be measured with ▶stabilometry; quantification of forces under the feet as continuous displacement of the ▶center of pressure [3]. Displacement of the center of pressure represents the combination of motion of the center of body mass as well as the

- ▶ **ground reaction forces** used to control the body
- ▶ **center of mass** over the base of foot support.

Several different types of ▶ **control theories** have been used to describe how the nervous system maintains consistent reference values for posture. Because posture is so adaptable and flexible, depending on the situation, models of human posture control include ▶ **optimal control** and ▶ **adaptive control**, such as ▶ **Kalman filters**, of more than one variable, such as position of center of body mass, orientation of the trunk and head in space, energy efficiency, etc. Postural sway during human stance is often modeled as an ▶ **inverted pendulum** biomechanical system in which the center of mass of the body is situated at the upper end of a rigid link that pivots about a joint at the base (i.e., the ankle), although actual body sway includes control of multiple segments.

### Automatic Postural Responses

▶ **Automatic postural responses** counteract unexpected disturbances to equilibrium. In humans, postural responses are triggered at 100 ms in response to external perturbations. This latency of automatic postural responses is faster than the fastest voluntary postural reactions but slower than the fastest ▶ **stretch reflexes**. Stretch reflexes are triggered by muscle spindles and result in activation of the stretched muscles but these reflexes contribute little functional torque to correct postural equilibrium. Automatic postural responses include responses in muscles that are shortened, as well as stretched, as well as muscles far from the site of perturbation that can exert torque against surfaces to correct posture [4]. The recruitment of muscles in a postural response depends on the goal of maintaining equilibrium and not on stereotyped reflexes.

Automatic postural responses depend on ▶ **central set** so that they are specific to the conditions of support and adapt to prior experience. Central set is the readiness of the central nervous system for an upcoming event based on initial conditions, prior experience and expectations. For example, leg muscles are activated in response to surface perturbations during free stance but arm muscles are activated and leg muscles suppressed in response to surface perturbations when holding onto a stable support [5]. In addition, muscles on the back of the legs are activated in response to forward body sway while standing but muscles on the front of the legs and in the arms are active when supported on the hands and feet [6]. Postural responses change even in the first trial after a change in body configuration but continue to adapt with repeated trials to continue to optimize the response for the particular conditions. For example, a gradual adaptation of the postural response can be observed during repeated trials of surface rotation. In response to the first rotation, a destabilizing response may be seen in the stretched ankle extensor muscle but

with repeated rotations this activation of the extensor is suppressed and activation of the stabilizing ankle flexor gradually increases.

Subjects can also influence which postural response is selected and the magnitude of their response based on experience, expectations, and intention [7]. For example, the stretched ankle extensor muscle responses are inhibited and the shortened tibialis muscles are triggered when subjects are instructed to step in response to a forward body perturbation [8]. Poor coordination of automatic postural responses can result in failure to return to equilibrium in response to external perturbations. Automatic postural responses can be defined by their ▶ **postural strategies** and ▶ **postural synergies**.

### Postural Strategies and Postural Synergies

Postural strategies can be defined by their functional goals and described based either on body kinematics (relationship of body segmental motion) or body kinetics (relationship of body segmental forces). Two main types of ▶ **postural movement strategies** can be used to return the human body to equilibrium when perturbed while standing: strategies that return the center of mass back over the ▶ **base of foot support** and strategies that change the base of support under the falling center of mass by stepping or reaching. The ▶ **fixed-support strategies**, that return the body center of mass over the base of foot support, form a continuum from the ankle strategy to the hip strategy. The ▶ **ankle strategy**, in which the body moves as a flexible inverted pendulum, is appropriate for small amounts of sway when standing on a firm surface [9]. ▶ **The hip strategy**, in which the body exerts torque at the hips to quickly move the body center of mass, is used when standing on surfaces not allowing adequate ankle torque or when the body center of mass must be moved more quickly such as for a faster, larger disturbance [9]. When subjects suddenly change from standing on a wide to a narrow surface, or vice versa, there is a gradual adaptation from an ankle to a hip strategy and vice versa with repeated perturbations. This gradual change in postural strategies suggest that they not only depend upon sensory feedback and current sensory conditions but also upon prior conditions based on central set.

▶ **Change-in-support strategies** of stepping and/or reaching to recover equilibrium in response to perturbations are also common, especially during gait and when it is not important to keep the feet in place [10]. However, even when subjects step in response to an external perturbation, they first attempt to return the body center of mass to the initial position by exerting angle torque. If a railing or other stable surface is available, subjects forced to extend their base of support by external displacement will also use a ▶ **reach-to-grasp** strategy [11]. Reaching reactions are initiated even faster than stepping reactions. Change-in-support

strategies are often used even under conditions in which it is biomechanically possible for subjects to return to equilibrium using a fixed-support strategy. **Figure 1** illustrates fixed-support and change-in-support strategies to correct forward and lateral postural displacements.

► **Postural synergies** are groups of muscles activated together by the nervous system to maintain equilibrium [4]. By eliminating the need to control each muscle independently, postural synergies are thought to simplify the neural control task of selecting and coordinating multiple muscles across the body. Postural synergies define the muscle activation patterns that are

used by the nervous system to implement various postural strategies. For example, **Fig. 2** shows several muscles activated in the ankle, hip and mixed ankle-hip postural muscle synergies in response to forward sway perturbations.

### Anticipatory Postural Adjustments

Voluntary movements are accompanied by ► **anticipatory postural adjustments** that act to counter, in a predictive manner, postural destabilization associated with a forthcoming movement [12]. Anticipatory postural adjustments are activated as ► **feedforward postural control**,

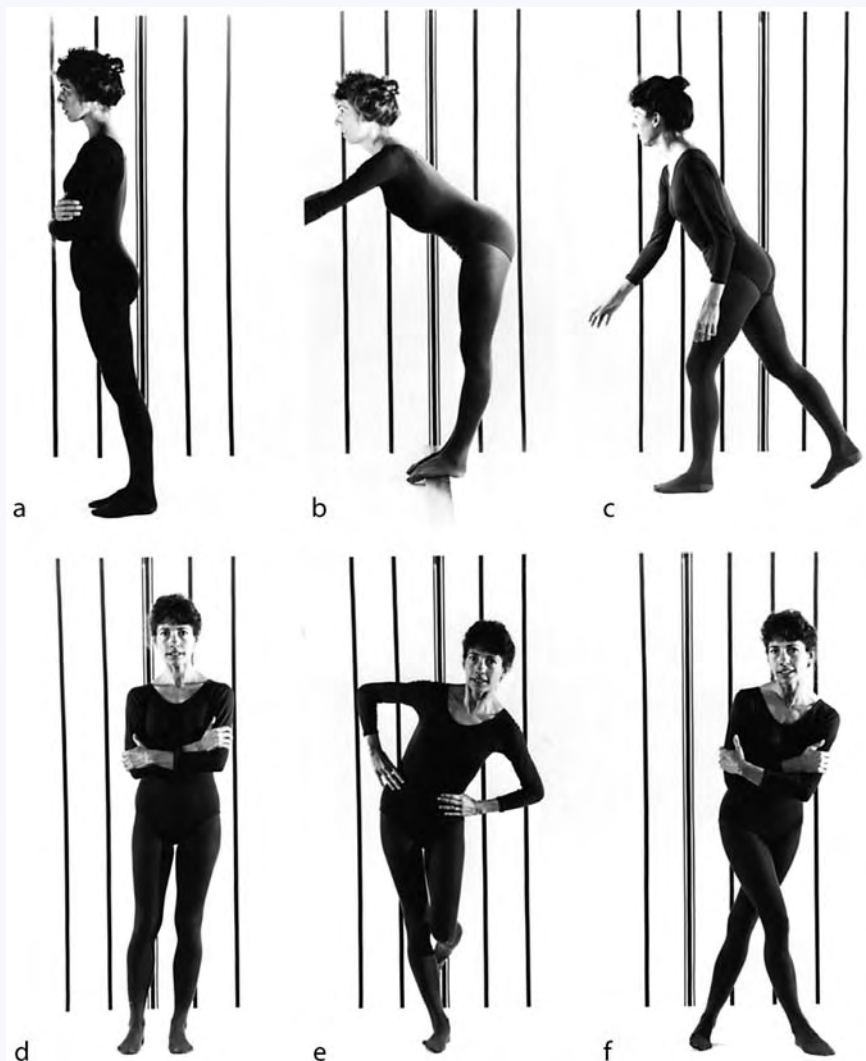

**Postural Control. Figure 1** Shows examples of feet-in-place and stepping strategies to correct forward and lateral postural displacements. In response to small CoM displacements, humans use a strategy that maintains upright trunk orientation. In response to more forceful displacements, humans add rapid trunk and hip movements to move the CoM over the base of foot support. Stepping and reaching strategies can also be used to recover equilibrium by moving the base of support under the falling CoM. Lateral stepping includes both a cross-over strategy, as shown, and a step by the loaded leg to widen the stance width.

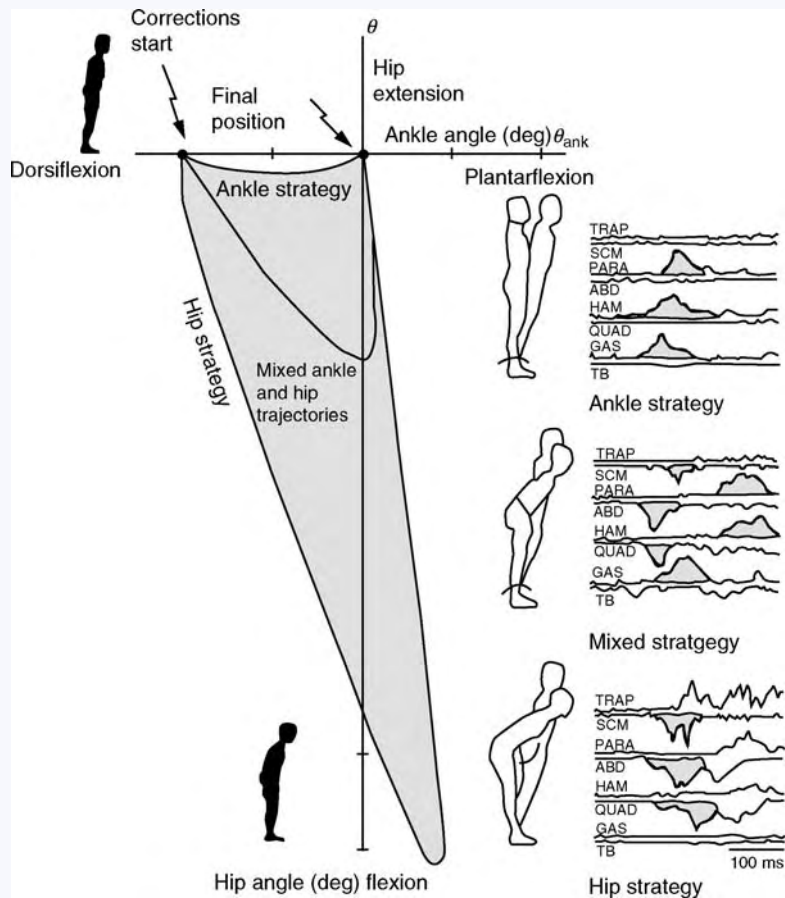

**Postural Control. Figure 2** Plots the change in ankle and hip angles using the ankle and hip strategies and the continuum of mixed ankle-hip strategies used to return the body to upright stance equilibrium after a forward sway external perturbation.

prior to any sensory feedback indicating postural instability. For example, prior to taking a step, anticipatory postural adjustments move the body forward and onto the stance leg prior to lifting the stepping leg. In addition, when a standing subject rapidly moves their arms, leg and trunk muscles are activated more than 50 ms in advance of the prime mover arm muscles [13]. Anticipatory postural adjustments are specific to the biomechanical requirements of each specific movement and adapt when the biomechanical requirements change. For example, anticipatory postural adjustments in the legs associated with arm movements are reduced or disappear when subjects are supported at the trunk and no longer need the anticipatory postural muscle activity in the legs for stability [5]. These studies suggest that there is a preselection of an anticipatory postural muscle synergy associated with every voluntary movement requiring postural stability. This pre-selection or preparation of the sensorimotor nervous system in advance of movement has been called central set [14].

During locomotion, both anticipatory postural adjustments, via feedforward control, and automatic postural

responses, via feedback control, contribute to postural stability. Unperturbed walking or running in healthy individuals consists of placing the feet under a falling center of body mass so the nervous system must anticipate where the feet need to be to maintain equilibrium during walking [15]. During bipedal locomotion, the trunk segment and thus, the body center of mass, is inherently unstable in the lateral direction and thus requires frequent corrections of lateral trunk orientation and/or lateral foot placement. When an individual slips or trips or makes voluntary movements while walking or running, the same automatic postural strategies observed during stance (See *Postural Strategies*) are added to the locomotor pattern [16]. Somatosensory feedback is also used to modify joint stiffness and quick responses to accommodate unanticipated changes in surface configuration.

### Sensory Integration

Sensory information from the ► **somatosensory, visual and vestibular systems** must be integrated in order to interpret complex sensory environments because

sensory information from a single sensory channel can be ambiguous and misleading. Postural control depends on the central neural interpretation of convergent sensory information from somatosensory, vestibular, visual systems. Thus, the nervous system controls posture via estimates of position and motion of the body and the environment by combining sensory inputs from several modalities. In addition, ►kinematic and ►kinetic body information must be integrated for control of posture. Sensory systems that signal kinematic position and motion of the body provide ►negative feedback control to minimize postural motion whereas sensory systems that signal kinetic force input provide ►positive feedback control to maximize joint torque when tilting [17]. Interpretation of sensory information by integrating sensory information across modalities is also thought to involve internal models of the body's sensory and motor dynamics, also called the body schema, as well as internal models of the environment. These internal models are based on expected sensory inputs from prior experience and provide the basis for central set. Errors between expected and actual sensory information is thought to be the basis for disorientation, dizziness, and motion sickness in both pathology and challenging environments.

Somatosensory inputs for posture include pressure information from skin in contact with surfaces, limb segment orientation from muscle proprioceptors and joint receptors, as well as muscle length, velocity and force information. Somatosensory inputs from many different types of peripheral sensory receptors converge onto neurons in the spinal cord to encode intersegmental and limb orientation in space [18]. Somatosensory inputs are important for triggering the earliest automatic postural responses in response to external perturbations. Thus, people with neuropathies that slow conduction of somatosensory inputs such as from diabetes or multiple sclerosis have longer than normal latencies of automatic postural responses. Somatosensory inputs are also important for providing information about the direction of perturbation and about the texture and stability of the support surface so that appropriate postural strategies can be selected. Somatosensory inputs can provide confusing, ambiguous information about body center of mass motion because they cannot distinguish between body motion over a stable surface and surface motion under a stable body, such as when standing on a moving boat or pier.

Vestibular inputs for posture are important for orientation of the trunk and head to gravity, especially when the surface is unstable. The vestibular system consists of two types of structures located in the inner ear, the ►labyrinths that encode head rotational acceleration and the ►otoliths that encode head linear acceleration, including gravity. The labyrinth consists of three, fluid-filled, semicircular canals that each sense

a different direction of head rotation via motion of hair cells imbedded in the ►cristae, the sensory tissue. Within the otoliths, the ►utricle senses horizontal linear acceleration such as during walking and the ►sacculle senses vertical acceleration such as during falling. Vestibulospinal inputs are particularly important for controlling orientation of the head and trunk in space but are not necessary to trigger automatic postural responses to external perturbations [19]. Vestibular inputs can provide confusing, ambiguous information about body center of mass motion because they cannot distinguish, on their own, between head motion over a stable body and head motion accompanying body center of mass motion. Vestibular information is thought to help the somatosensory system distinguish a stable from an unstable surface and then become increasingly important for controlling postural orientation the more unstable is the surface (see ►sensory re-weighting, below). Thus, patients who have lost all vestibular function can still stand and walk and show normal latencies of automatic postural responses to a slip or trip although they will orient to moving surfaces and become unstable when vision is not available [20].

Vestibular inputs must be interpreted via somatosensory inputs for the nervous system to control posture. For example, ►galvanic vestibular stimulation from direct current behind the ears can activate or inhibit the vestibular nerve and result in ►vestibulospinal responses. Vestibulospinal responses consist of medium latency activation of a group of muscles that tilt the body toward the side of the inhibited vestibular nerve when standing. The direction of body tilt depends on the direction the head is facing with respect to the base of foot support [21]. The muscles activated depend on which muscles can exert forces against the surface such that leg muscles are activated in free stance but arm muscles are activated with holding onto a stable surface [22]. Vestibular control of head orientation in space also depends on the close interaction between the vestibular and somatosensory systems via the ►vestibulocollic and ►cervico-colic reflexes.

Visual information provides knowledge of body sway and orientation in the environment and provides advanced information about potentially destabilizing situations. Vision can provide information about the direction and speed of body sway. For example, forward body sway is signaled by the visual system as backward visual flow across the peripheral retina and looming across the central retina. Visual information also allows perception and body orientation with respect to the vertical and horizontal visual environment (see perception of visual vertical, below). Thus, standing subjects exposed to slowly moving visual surrounds will sway with reference to the visual motion, even when unaware of it. Visual inputs can provide confusing, ambiguous information about body center of mass motion because

they, alone, cannot distinguish between body motion with respect to a stable visual surround and visual surround motion with respect to a stable body. For example, when stationary subjects view large moving scenes, especially in their peripheral vision, they often momentarily perceive self-motion in the opposite direction. When actually moving the body through space, vision also provides advanced, or ►feedforward, information to position body parts to avoid obstacles, navigate complex terrain, and plan motor strategies. For example, subjects tend to view obstacles in order to plan foot placement and clearance about 3 steps before they reach the obstacles [23].

The ability to orient the body with respect to gravity, the support surface, visual surround and internal references and to automatically alter how the body is oriented in space, depending on the context and task requirements is an important attribute of postural control. For example, a subject may automatically orient their body perpendicular to the support surface unless the support surface becomes unstable, when they will orient themselves to gravity or to their visual surround.

►Sensory re-weighting is an important mechanism for changing the relative contributions made by different sensory systems for postural control. Figure 3 shows a model of sensory integration for postural control in which somatosensory, vestibular and visual inputs can change weighting depending on changes in the environment. Using this model, studies have shown that in a well-lit environment with a firm base of support, healthy subjects rely on somatosensory 70%, vision 10% and vestibular 20% [20]. However, when healthy subjects stand on an unstable surface, they increase sensory weighting to vestibular and vision as

they decrease dependence on surface somatosensory inputs for postural orientation [24]. Ability to reweight sensory information depending on the sensory context is important for maintaining stability when moving from one sensory context to another, such as from a moving boat to firm ground. Individuals with loss of somatosensory, vestibular or visual input from pathology are limited in their ability to reweight postural sensory dependence and thus, are at risk of falls in particular sensory contexts. In addition, some central nervous system disorders may impair the ability to quickly reweight sensory dependence, even when the peripheral sensory systems are intact. Subjects can use ►sensory substitution to replace one sensory modality for another to help control posture. For example, light touch on a cane can be used to substitute haptic sensory cues for missing vestibular or somatosensory inputs due to pathology and thereby reduce postural sway in stance [25,26]. Biofeedback systems that provide visual, auditory or somatosensory inputs to the nervous system correlated with body sway have also been shown to provide effective sensory substitution to improve postural stability in patients with loss of sensory information.

Healthy individuals also have a conscious perception of vertical spatial orientation. ►Perception of verticality, or upright, may have multiple neural representations [27]. In fact, ►perception of visual vertical, or ability to align a line in the dark with gravity, is independent of ►perception of postural (or proprioceptive) vertical, or ability to align the body in space without vision [28]. For example, the internal representation of visual, but not postural, vertical is tilted in subjects with unilateral vestibular loss, whereas the internal representation of

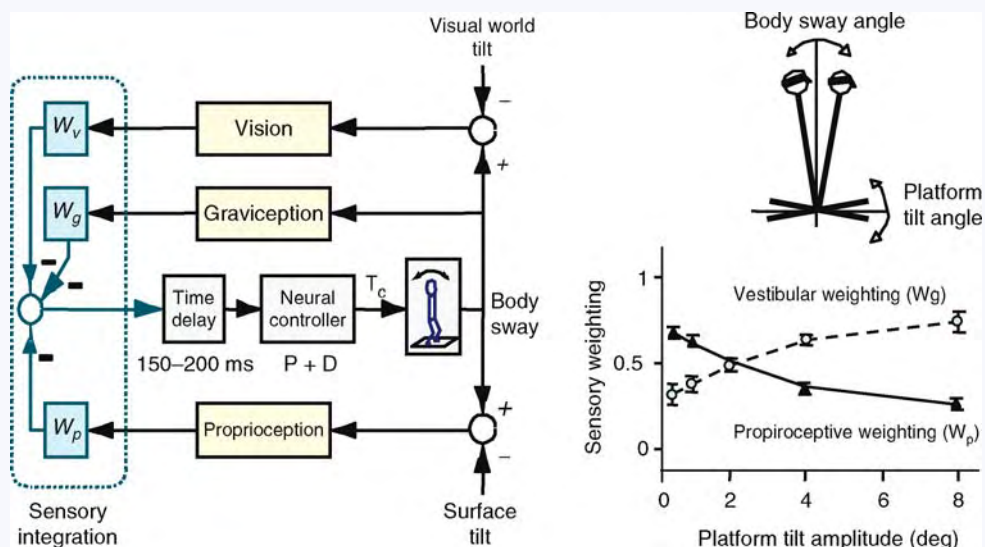

Postural Control. Figure 3



postural, but not visual vertical is tilted in some subjects with stroke. A tilted or inaccurate internal representation of vertical will result in automatic postural alignment that is not aligned with gravity.

### Neuroanatomy of Posture Control and Clinical Implications

Control of posture is distributed in the nervous system and the musculoskeletal system such that pathology almost anywhere in the nervous system or musculoskeletal system can impair postural equilibrium and/or postural orientation. The spinal cord is sufficient for maintaining antigravity support and locomotor patterns but not for maintaining balance [29]. Sensory pathways in the spinal cord carry somatosensory information about limb orientation as well as motor pathways such as the medially located vestibulospinal and reticulospinal pathways for activating postural muscle synergies. In the brainstem, the vestibular nuclei are important for integrating sensory information across modalities for postural orientation and the reticular formation is likely involved in organizing postural synergies. The important **▶role of the cerebellum** in posture can be seen by the severe problems with postural stability and postural orientation in patients with damage to the cerebellum. Damage to the spinocerebellum, specifically, impairs postural stability by causing larger than normal automatic and anticipatory postural adjustments and by impairing the ability to optimize postural strategies based on prior experience [30]. In contrast, damage to the vestibulocerebellum results in difficulty using vestibular or visual information to orient the body with reference to gravity or visual references. The basal ganglia's importance to postural control can be seen by the frequent falls in patients with pathology involving the basal ganglia, such as Parkinson's disease. The basal ganglia is important for quickly changing postural strategies when conditions change, for regulating postural muscle tone, for generating forceful anticipatory and reactive postural responses and for perception of postural orientation [31]. The cerebral cortex is involved in postural control in as many complex ways as voluntary movement [32]. The cortex is involved in changing postural responses with alterations in cognitive state, initial sensory-motor conditions, prior experience, and prior warning of a perturbation, all representing changes in central set. In addition, the supplementary motor cortex is involved in generating anticipatory postural adjustments and the primary motor cortex participates in longer latency postural responses to perturbations. Parietal and temporal association cortical areas are involved in perception of spatial orientation and in formulating the internal models of the body and the environment so important to postural control. Thus, damage to almost any part of the cortex from a cerebral vascular accident can impact postural stability or orientation.

### References

1. Horak FB, Macpherson JM (1996) Postural orientation and equilibrium. In: Rowell LB, Shepherd JT (eds) *Handbook of physiology. Exercise: regulation and integration of multiple systems*. Oxford University Press, New York, 255–292
2. Gurfinkel V, Cacciatore TW, Cordo P, Horak F, Nutt J, Skoss R (2006) Postural muscle tone in the body axis of healthy humans. *J Neurophysiol* 96(5):2678–87
3. Chiari L, Rocchi L et al. (2002) Stabilometric parameters are affected by anthropometry and foot placement. *Clin Biomech* 17(9–10):666–77
4. Ting LH, Macpherson JM (2005) A limited set of muscle synergies for force control during a postural task. *J Neurophysiol* 93:609–613
5. Cordo PJ, Nashner LM (1982) Properties of postural adjustments associated with rapid arm movements. *J Neurophysiol* 47:287–302
6. Macpherson JM, Horak FB et al. (1989) Stance dependence of automatic postural adjustments in humans. *Exp Brain Res* 78:557–566
7. Horak F, Kuo A (eds) (2000) *Postural adaptation for altered environments, tasks, and intentions. Biomechanics and neural control of posture and movement*. Springer, New York
8. Burleigh AL, Horak FB (1994) Influence of prior experience and instruction on postural organization of perturbed step initiation. *Soc Neurosci Abstr* 20:794
9. Horak FB, Nashner LM (1986) Central programming of postural movements: adaptation to altered support-surface configurations. *J Neurophysiol* 55(6):1369–1381
10. Maki BE, McIlroy WE (1997) The role of limb movements in maintaining upright stance: the “change-in-support” strategy. *Phys Therapy* 77:488–507
11. McIlroy WE, Maki BE (1995) Early activation of arm muscles follows external perturbation of upright stance. *Neurosci Lett* 184:1–4
12. Massion J (1992) Movement, posture and equilibrium: interaction and coordination. *Prog Neurobiol* 38:35–56
13. Belenkii VY, Gurfinkel VS et al. (1967) Elements of control of voluntary movements. *Biofizika* 12:135–141
14. Prochazka A (1989) Sensorimotor gain control: a basic strategy of motor systems? *Prog Neurobiol* 33:281–307
15. Winter DA, Patla AE et al. (1990) Assessment of balance control in humans. *Med Prog Technol* 16:31–51
16. Nashner LM, Forssberg H (1986) Phase-dependent organization of postural adjustments associated with arm movements while walking. *J Neurophysiol* 55(6):1382–1394
17. Mergner T, Maurer C et al. (2002) Sensory contributions to the control of stance: a posture control model. *Adv Exp Med Biol* 508:147–152
18. Bosco G, Poppele RE (1997) Representation of multiple kinematic parameters of the cat hindlimb in spinocerebellar activity. *J Neurophysiol* 78(3):1421–1432
19. Mergner T (2002) The matryoshka dolls principle in human dynamic behavior in space: a theory of linked references for multisensory perception and control of action. *Curr Psychol Cogn* 21(2–3):129–212
20. Peterka RJ, Benolken (2002) Sensorimotor integration in human postural control. *J Neurophysiol* 88(3):1097–1118
21. Lund S, Broberg C (1983) Effects of different head positions on postural sway in man induced by a



reproducible vestibular error signal. *Acta Physiologica Scandinavica* 117:307–309

22. Storper IS, Honrubia V (1992) Is human galvanically induced triceps surae electromyogram a vestibulospinal reflex response? *Otolaryngol Head Neck Surg* 107:527–535
23. Patla AE (1992) The neural control of locomotion. 1–36
24. Peterka RJ, Loughlin PJ (2004) Dynamic regulation of sensorimotor integration in human postural control. *J Neurophysiol* 91(1):410–423
25. Creath R, Kiemel T et al. (2002) Limited control strategies with the loss of vestibular function. *Exp Brain Res* 145(3):323–333
26. Dickstein R, Peterka R et al. (2003) Effects of light fingertip touch on postural responses in subjects with diabetic neuropathy. *J Neurol Neurosurg Psychiatry* 74:620–626
27. Karnath HO, Fetter M et al. (1998) Disentangling gravitational, environmental, and egocentric reference frames in spatial neglect. *J Cogn Neurosci* 10(6):680–690
28. Anastasopoulos D, Haslwanter T et al. (1997) Dissociation between the perception of body verticality and the visual vertical in acute peripheral vestibular disorders in humans. *Neurosci Lett* 233(2–3):151–153
29. Macpherson JM, Fung J (1999) Weight support and balance stance in the chronic spinal cat. *J Neurophysiol* 82(6):3066–3081
30. Horak FB, Diener HC (1994) Cerebellar control of postural scaling and central set in stance. *J Neurophysiol* 72(2):479–493
31. Horak FB, Frank J et al. (1996) Effects of dopamine on postural control in parkinsonian subjects: scaling, set and tone. *J Neurophysiol* 75(6):2380–2396
32. Jacobs JV, Horak FB (2007) Cortical control of postural responses. *J Neural Transm* 114(10):1339–1348

## Postural Equilibrium

### Definition

A state in which the body is either at rest, moving at constant velocity or executing a repeatable (periodic) pattern of motion. A stable system is one that returns to a state of equilibrium after it has been perturbed.

► Postural Strategies

## Postural Instability

### Definition

Impairment of balance when standing, walking, or turning.

## Postural Muscle Tone

VICTOR S. GURFINKEL

Neurological Sciences Institute, Oregon Health & Science University, Portland, OR, USA

### Definition

Postural tone is the steady contraction of muscles that are necessary to hold different parts of the skeleton in proper relation to the various and constantly changing attitudes and postures of the body.

### Description of the Theory

#### Decerebrate Posture

Because postural muscle tone is completely suppressed by narcosis, postural tone has mainly been studied using an experimental model called the decerebrate animal [1]. In the decerebration of mammals, the cerebral cortex and thalamus are surgically inactivated by intercollicular cross-section of the brain stem under general anesthesia. Once the effects of the anesthesia have dissipated, the condition known as “decerebrate rigidity” can be seen. This condition is characterized by a strong extended neck, trunk, tail and limbs, which resist attempts to flex them. In decerebrate rigidity, there is no sensation of pain. Because of this rigidity, when the decerebrate cat is placed on its four limbs, tension in the limb muscles is enough to maintain its body posture. This muscle tone has been named “postural tone” [1]. In decerebrate animals, the neuronal structures of the brain stem and spinal cord are in an active condition. Therefore, this model is useful for studying many questions of neurophysiology. For example, on a background of high muscle tone, it is possible to study not only influences of excitation, leading to the enhancement of muscle tone, but also to study inhibition, which results in the suppression of muscle tone.

In the past, many researchers have been devoted to studying the nature of decerebrate rigidity. It was found that deafferentation (i.e., sectioning appropriate dorsal roots) abolishes decerebrate rigidity of limb muscles [1]. In addition, it was found that the tonus of the extensor muscles is autogenous, in that each muscle is dependent on afferent nerve fibers from the muscle itself (“myotatic component” in decerebrate rigidity). These findings were reproduced many times [2]. This showed that the origin of decerebrate rigidity cannot be completely explained by the myotatic component. The actual situation is more complex. In studies of decerebrate cats, it was shown that in addition to proprioception, there are other sources of postural tonic activity that are connected to the position of the head

in space and the position of the head relative to the trunk [3]. These neck and vestibular tonic reflexes strongly influence the level of decerebrate rigidity and cause a redistribution of muscle tension.

Another type of experiment elucidated mechanisms of decerebrate rigidity. This experiment involved, as described above, the cutting of the dorsal roots to the forelimbs in a decerebrate preparation to make forelimbs flaccid. When the spinal cord was transected below the level of origin of the brachial nerves (postbrachial transection), the forelegs became rigid, although still deafferented. This effect can be explained by the fact that post-brachial transection of the spinal cord cuts off the flow of inhibitory pulses to the motoneurons that ascend from tonically active propriospinal neurons located in L2–L3 segments (the “Schiff-Sherrington inhibition”).

It is known that the cerebellum is involved in the control of muscle tone and that damage to the cerebellum is accompanied by a reduction in tone. However, it has been shown that the removal of the cerebellum in a cat that has undergone intercollicular brain stem transection increases decerebrate rigidity. This same effect can be caused by bilateral destruction of the fastigial nuclei. Here again, rigidity returns to the deafferented forelimbs of the decerebrate preparation.

Another model of decerebrate rigidity involves properties that are different from the intercollicular preparation and has extended our knowledge about the mechanisms involved in decerebrate rigidity. It is the so-called anemic decerebration (high ligation of the basilar artery and of both carotids) that functionally inactivates all the nervous structures that are supplied by blood vessels arising cephalad to the basilar ligature, including the anterior lobe of cerebellum. After anemic decerebration, strong tension in all extensor muscles also develops. However, decerebrate rigidity, after anemic decerebration, is not eliminated by transection of the dorsal roots. In the anemic preparation, rigidity is caused by the nonmyotatic component of muscle tension, represented mainly by the tonic labyrinthine influences on the spinal motoneurons. The nonmyotatic component of extensor rigidity is released by anemic damage to the anterior lobe of the cerebellum.

One cogent interpretation of the evolution of the cerebellar regulation of postural tone is that postural extensor mechanisms are tonically inhibited through bulbospinal relays by the paleocerebellum, whereas a tonic facilitating influence is exercised by the neocerebellum on the cerebral cortex [2]. After efferent innervation ( $\gamma$  innervation) of muscle spindles was established, intercollicular decerebrate rigidity was called “ $\gamma$  rigidity,” and anemic rigidity was called “ $\alpha$  rigidity” [4]. A comparison of these two kinds of decerebrate rigidity showed that they change differently under the influence of various factors, suggesting that both

muscle and labyrinthine receptors tonically support extensor rigidity. The disappearance of decerebrate rigidity following deafferentation indicated that in the intercollicular animal, the vestibular component is tonically inhibited by cerebellar and spinal mechanisms (Schiff-Sherrington). However, in anemic decerebrate animals, the importance of the myotatic component of decerebrate rigidity is reduced by  $\gamma$  paralysis, while that of the vestibular component is increased through a release mechanism. It is possible that other brain structures also participate in the formation of decerebrate rigidity. The posture of the decerebrate animal may be the consequence of a disturbance in balance between different sources of tonic excitatory and inhibitory influences.

### Postural Adaptation

As mentioned above, a decerebrate cat can be stood on its legs and will maintain this position; a position that is a caricature not only because the cat's legs are hyper-extended but also because the body is absolutely motionless due to constant muscle tension. Such immobility can also be observed naturally in intact animals (e.g., a hunting dog becomes motionless when pointing to detected game, rabbits experience immobilization catatonia when faced with danger and many animals undergo hypnosis). However, immobilization, that is muscles in a state of constant tension, is the exception not the rule. Postural tone of muscles ranges from very high tension at exaggerated decerebrate rigidity, up to complete atonia in the vertebra prominens reflex. Although the decerebrate animal exhibits rigidity, it still has the capacity to adapt to experimental conditions. In 1909, it was shown for the first time that when a decerebrate animal's limb was flexed, the limb did not move back to its initial position; rather it adapted and maintained the new position [5]. This condition was explained as: “The forced stretch causes a relaxation of the tonic extensor, and this condition of relaxed tonus persists after the forced stretch itself has ceased. This reaction, may for brevity, be termed the ‘lengthening reaction’” [5]. Similarly, when a decerebrate animal's limb is moved, the antagonist muscles shorten and adapt to their shorter length. In this shortening, the muscle insertion and origin are brought closer together, which appears to induce heightened tonus in the muscle—a reaction that has been termed the “shortening reaction” [5]. In other words, the limb that is brought by movement into a new posture remains in that new posture when released. This property is especially present in skeletal muscles when the nerve centers are operating to maintain posture [5]. Such behavior of tonically active muscles has been termed “plasticity.” Skeletal muscles in this form of reflex contraction quite readily adapt themselves to different lengths while counteracting one and the same load [6].

The shortening reaction can be observed in humans. In some neurological diseases that are accompanied by tone abnormalities, passive movement of a joint results in the contraction of shortened muscles. This contraction is tonic, that is, it persists after the movement terminates.

Another form of postural tone adaptation in decerebrate animals deals with neck and vestibular tonic reflexes [3]. In decerebrate animals, neck reflexes result in a redistribution of tonic muscle tension that is dependent on the relative position of the head and trunk. Dorsiflexion of the neck produces extension of forelimbs and flexion of hind limbs, ventriflexion of the neck produces flexion of the forelimbs and extension of the hind limbs, lateral flexion of the neck (ear toward the shoulder) produces extension of the fore and hind limbs on the side toward which the head is turned and rotation of the head on the neck produces extension of both the fore and hind limbs on the side toward which the chin is turned. The changed distribution of muscle tonus in the limbs continues as long as the head retains a specific relationship to the trunk. Changes in head position in space when neck reflexes are inactivated, also result in a redistribution of postural tone of neck, trunk and legs muscles. There is one position of the head in space in which the extensor tone of the limbs is maximal and one position of the head in space in which it is minimal. The maximal and minimal positions differ from each other by 180°. When the position of the head in space is changed when the body is in different positions, tonic neck and labyrinth reflexes combine to modify postural tone in various ways.

Another factor that influences the distribution of postural tone is how the body or limbs contact the support surface. When a limb contacts the support surface, dorsiflexion occurs in the distal part of the limb (fingers and hands, toes and feet), which results in significant enhancement (strengthening) of tone in the extensor muscles of all joints in the limb (termed “the positive reaction of support”). The limb, in this enhanced tonic state, is capable of maintaining body weight. This reaction has been observed in animals without a cerebellum [7]. In decerebrate animals, this reaction is more difficult to observe because the limbs are in an initial state of high tonic tension. This type of reaction has also been observed in humans with brain pathology. In the examples discussed above, the adaptive changes of postural tone were tonic in character, but in natural conditions, adaptive changes are also phasic in character. In natural conditions, such reactions are mainly directed to preserving balance and maintaining the stability of body parts during movement. Almost all movements of the hands and legs in natural conditions inevitably require a redistribution of postural tone. For example, when a human moves the arms to catch a falling object, contact with the object

is preceded by the contraction of appropriate hand muscles. Similarly, when a human moves a leg when taking a step, this movement is preceded by a change in muscle tone distribution in the trunk and in the opposite leg. Adaptation of muscle tonic activity maintains harmony between mobility and stability.

## References

1. Sherrington CS (1898) Decerebrate rigidity and reflex coordination of movements. *J Physiol* 22:319–332
2. Bremer F (1932) Le tonus musculaire. *Ergebn d Physiol* 34:678–740
3. Magnus R, de Kleijn A (1912) Die Abhängigkeit des Tonus der Extremitätenmuskeln von der Kopfstellung. *Arch f d ges Physiol* 145:455–548
4. Granit R (1955) Receptors and sensory perception. Yale University Press, New Haven
5. Sherrington CS (1909) On plastic tonus and proprioceptive reflexes. *Quart J Exper Physiol* 2:109–156
6. Sherrington CS (1915) Postural activity of muscle and nerve. *Brain* 38:191–234
7. Rademaker GGJ (1931) Das Stehen: Statische Reaktionen, Gleichgewichtreaktionen und Muskeltonus unter besonderer Berücksichtigung ihres Verhaltens bei kleihirlosen Tieren. Springer, Berlin Heidelberg New York

## Postural Orientation

### Definition

Postural orientation refers to the positioning of the body or body segments with respect to some reference frame.

The selection of the reference frame is arbitrary and there are many choices. A commonly used and often implicit reference is a global or earth fixed reference frame. Other common reference frames include clinical joint based frames where joint motions can be described, for example in terms of extension or flexion and local reference frames which might move with the body or be affixed to a particular body segment.

► Posture – Sensory Integration

## Postural Reactions

► Postural Strategies

## Postural Strategies

BRIAN E. MAKI

Centre for Studies in Aging, Sunnybrook and Health Sciences Centre, University of Toronto, Toronto, Canada

### Synonyms

Balance-recovery reactions; Postural reactions; Postural synergies

### Definition

Postural strategies are specific patterns of muscle activation, joint torque, joint rotation and/or limb movement that are evoked by balance perturbation. These reactions serve to prevent the body from falling and act to re-establish a state of **▶postural equilibrium**. Triggered by multiple sensory inputs, they involve polysynaptic spinal and supraspinal neural pathways and are highly adaptable to meet functional demands. Strategy selection and modulation are dependent on: (i) the features of the perturbation (timing, direction, magnitude, predictability), (ii) the “**▶central set**” of the individual (affect, arousal, attention, expectations, prior experience), (iii) ongoing activity (cognitive or motor) and (iv) environmental constraints (on reaction force generation and limb movement).

### Description of the Theory

#### Biomechanical Requirements for Postural Equilibrium

The mechanics of the upright human body can be modeled as a multi-link **▶inverted pendulum**, with each link corresponding to a body segment (e.g., foot, shank, thigh, trunk) [1]. Static postural equilibrium requires the **▶center of mass (COM)** of this linkage to be positioned over the **▶base of support (BOS)**; however, the linkage is inherently unstable, due to the force of gravity. Additional destabilizing forces arise due to movement of the body and interaction with the environment. The BOS is usually defined by the position of the feet, but may include the arms when grasping or touching an object for support. In the absence of arm support, static equilibrium requires the COM to be positioned over the feet and the perimeter of this foot area can be considered to represent the static stability limits associated with the BOS. Dynamic equilibrium takes into account the additional requirement of controlling the momentum associated with movement of the COM [2]. If the COM is moving with sufficient horizontal velocity, it is possible for the body to be dynamically unstable, even when the COM is positioned over the BOS. Conversely, it is possible for the body to be dynamically stable even though the COM is located outside the static stability limits of the BOS, provided that the COM is moving

toward the BOS with sufficient velocity that it can eventually be repositioned over the BOS.

### Postural Strategies for Responding to Perturbation

Passive muscle stiffness could, in theory, be sufficient to maintain a stable upright posture under static conditions; however, the reality is that coordinated muscle activation is required to keep the body upright in the activities of daily life. To maintain upright stance, the central nervous system (CNS) must actively regulate the static and dynamic relationship between the COM and the BOS [2]. Responses to perturbations must involve deceleration of the COM, but can also involve changes in the BOS. Accordingly there are two distinct classes of postural strategies: (i) “**▶fixed-support**” (“feet-in-place”) strategies, in which the BOS is not altered and (ii) “**▶change-in-support**” reactions, where the BOS is altered via rapid **▶stepping** or reaching movements of the limbs [3]. See Fig. 1.

Although the focus here is on reactions to perturbation of stance, it should be noted that fixed support and change-in-support reactions are also used to respond to perturbations experienced during gait. However, the gait responses may show some differences, e.g., bilateral asymmetries in muscle activation, phase dependent gating of sensory inflow and triggering of additional strategies (e.g., elevation of the swing foot in response to a trip perturbation). In addition, stepping reactions during gait may involve modulation of an ongoing step, while arm reactions may be affected by gait-related arm swing.

Postural reactions can be controlled, to some extent, in a predictive manner provided that the characteristics of the destabilization are known in advance (e.g., the “**▶anticipatory postural adjustments**” that normally precede preplanned volitional movement or the reactions evoked by a periodic sinusoidal perturbation). In general, however, sensory information about the body orientation and motion is also required, particularly when balance is disturbed unexpectedly by a sudden perturbation (e.g., due to a force applied to the body or motion of the support surface). This sensory information is used to detect instability and to generate appropriate stabilizing responses, either by triggering and scaling preprogrammed “feedforward” reactions or by continuously updating ongoing “feedback” corrections. The initial phases of the reactions to sudden, transient perturbation are thought to be triggered feedforward corrections, whereas the later phases may also involve ongoing feedback control.

Postural strategies involve multiple sensory inputs (somatosensory, vestibular, visual) and highly adaptable triggered reactions, rather than stereotyped short-latency reflexive responses arising primarily from a single source of afferent drive (e.g., vestibulo-spinal reflex, myogenic stretch reflex). The triggering afferent signals depend on the nature of the perturbation, e.g., whether the

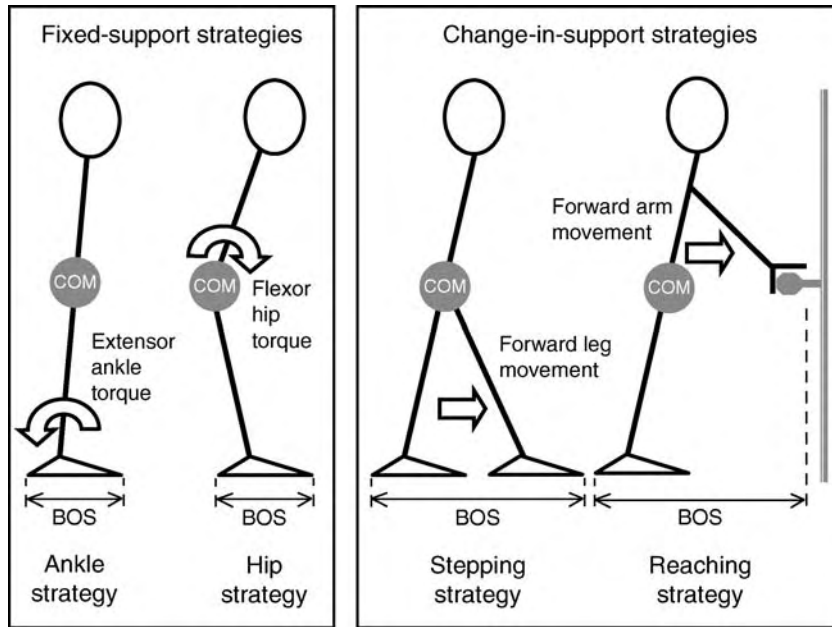

**Postural Strategies. Figure 1** Postural strategies. Static postural equilibrium requires the body center of mass (COM) to be positioned over the base of support (BOS). The *stick figures* illustrate potential responses evoked by a perturbation that induces forward falling motion of the COM. Note the large increase in BOS associated with the change-in-support strategies.

perturbation involves the movement of the support surface or a force applied to the upper body. Responses to support surface perturbations may involve ankle muscle spindles (Ia afferents); however, the role of the vestibular system and/or somatosensory inputs from other joints cannot be ruled out [4] and it appears that even visual inputs (which are generally thought to require much longer processing times) can modulate the earliest postural muscle activation in some situations. The earliest muscle activation associated with the postural reaction typically occurs at a latency of about 80 to 140 ms after perturbation onset.

The control of these reactions is mediated via polysynaptic spinal and supraspinal neural pathways [5]. Furthermore, although balance reactions are often considered to be “automatic,” it appears that control of later phases of the response (e.g., 200 to 500 ms after perturbation onset) may involve transcortical pathways and high-level cognitive and attentional systems [6]. This is supported by evidence from dual-task studies, where later phases of the balance response can be affected by performance of a concurrent cognitive task. Measurements of perturbation-evoked cortical potentials also support cognitive involvement. Thus, it appears that reactions to perturbation are not as stereotyped as once believed, but are in fact highly adaptable to the functional demands of maintaining stability, i.e., regulating the relationship between COM and BOS. Although some researchers have speculated that critical afferent information for determining the state of the COM may arise from

load receptors such as Golgi tendon organs, maintaining stability also requires information about the state of the BOS and the direction of a gravitational reference vector. In contrast to the traditional view that the vestibular otoliths provide the reference vector, some researchers have suggested a construct based on multiple sensory modalities. Determination of the BOS state is also probably dependent on multiple sensory inputs, although it appears that the plantar cutaneous mechanoreceptors may play a particularly critical role in providing information pertaining to BOS stability limits and the state of contact between foot and ground [1].

#### Fixed-Support (Feet-in-Place) Strategies

In ►**fixed-support strategies**, the COM motion that is induced by the postural perturbation is decelerated via generation of active muscle torques at the joints of the supporting leg or legs, as well as the trunk and upper limbs. These joint torques create antero-posterior “environment reaction” forces (i.e., shear force at the foot ground interface, as well as forces occurring at the hand if it is in contact with a stable object or surface) and it is these forces that act to decelerate and arrest the horizontal COM motion (Fig. 2). Fixed-support reactions occur very rapidly (e.g., onset latency of 80 to 140 ms in ankle muscles) and are essentially the first line of defense against postural perturbation.

Biomechanically, the upright human body has redundant degrees of freedom. This means that there are potentially many different combinations of muscle

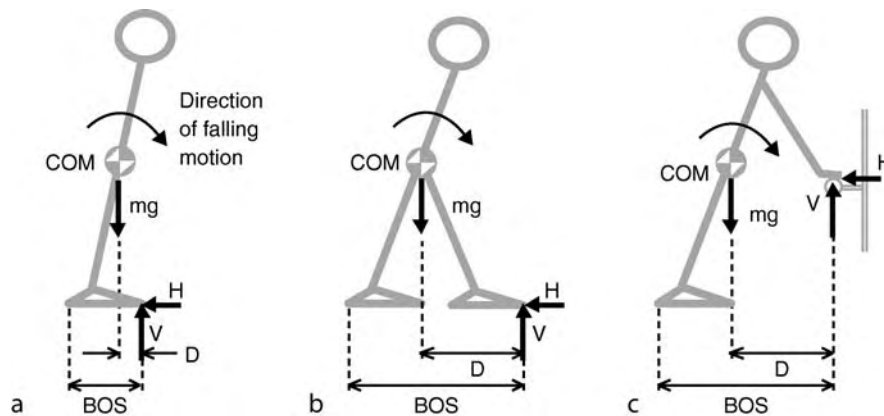

**Postural Strategies. Figure 2** Biomechanical advantages of change-in-support strategies (*panels b and c*) in comparison to fixed-support strategies (*panel a*). The postural reaction must generate a horizontal ground-reaction shear force ( $H$ ) in order to decelerate the horizontal motion of the center of mass ( $COM$ ). Note that the stepping (*b*) and grasping (*c*) reactions can greatly amplify the moment arm ( $D$ ) between the  $COM$  and the contact force ( $V$ ), which allows greater shear force to be generated ( $H$  is approximately proportional to  $D$ ). In addition, the increase in base of support ( $BOS$ ) allows a larger range of  $COM$  motion to be accommodated without loss of stability. Adapted from [1].

torques at the various joints that could be used to re-establish postural equilibrium, in responding to a given postural perturbation. It has been proposed that the CNS deals with this redundancy, and simplifies the control problem, by restricting the response to a finite number of specific response patterns (often referred to as synergies as well as strategies) or weighted combinations of these patterns.

Early research identified two major strategies for responding to antero-posterior perturbations: (i) the [ankle strategy](#) and (ii) the [hip strategy](#) [7]. Although not included in the original definitions of these strategies, activation of knee muscles can also play an important role in both ankle and hip strategies, particular for perturbations that induce a backward falling motion and hence tend to cause the knee to “collapse” in flexion [4].

In the ankle strategy, the predominant stabilizing action involves active generation of ankle torque. This strategy is characterized by activation of ventral muscles (i.e., ankle dorsiflexors, hip flexors, abdominals) in response to backward falling motion and activation of dorsal muscles (i.e., ankle plantarflexors, hip extensors, paraspinals) in response to forward falling motion. In essence, the body is controlled to behave predominantly in the manner of a single-link inverted pendulum, with joint rotation primarily occurring at the ankle. For responses to support-surface perturbations, the involved muscles fire in a distal to proximal sequence.

In the hip strategy, the predominant stabilizing action involves active generation of hip torque. This strategy is characterized by activation of muscles on the opposite side of the thigh and trunk in comparison to the ankle strategy, i.e., dorsal muscles in response to backward

falling motion and ventral muscles in response to forward falling motion. There is relatively little activation at the ankle. The main effect biomechanically is to generate stabilizing shear force (at the foot ground interface) that is larger than the shear force that can be generated using the ankle strategy.

The ankle strategy predominates at small levels of perturbation, whereas increasing levels of hip activation are added as the postural challenge increases [8]. These latter “mixed strategy” responses were originally thought to involve a weighted combination of the ankle and hip strategies; however, the “pure” hip strategy is seldom if ever observed during natural behavior (in experiments, it was learned over the course of repeated trials that involved standing on a shortened support surface, which limited ability to generate stabilizing ankle torque) [3]. This suggests that there is actually a continuum of postural responses formed by the addition of hip torque to the ankle strategy, rather than two distinct strategies.

Feet-in-place strategies for responding to medio-lateral perturbation primarily involve the hip abductors and adductors, due to the limited capacity at the ankle and knee for motion and torque generation in the frontal plane. Although one might expect responses to perturbations in “off axis” or “diagonal” directions to involve a weighted combination of the medio-lateral hip strategy and the antero-posterior ankle strategy, it appears that this construct is inadequate to explain the complex muscle responses that are evoked by multi-directional perturbations. Rather, there appears to be a continuum of strategies that are modifiable in a task-dependent manner [9]. Thus, for example, there may be co-contraction of agonist and antagonist ankle muscles

(which serves to stiffen the ankle joint) and latencies for some muscles may differ according to the perturbation direction.

Although the feet in place strategies described above primarily involve activation of the lower limb and axial (trunk and neck) musculature, postural reactions involving the upper limbs often occur in parallel. In fact, activation of the arm muscles can occur as rapidly as the earliest activation at the ankle (80 ms after perturbation onset). The functional role of these arm-reaction strategies appears to vary, depending on task conditions. In situations where the hand is in contact with a supporting object or surface at time of perturbation onset, the arm reaction can rapidly generate stabilizing “environment reaction” forces at the hand. In situations where the arms are free to move, the arm movements may serve to augment the stabilization achieved by the lower limb reactions. For example, raising the arms can help to stabilize the body by acting as a counterweight, by inducing inertial joint torques at the shoulder (due to the acceleration and/or deceleration of the arm segments) or by increasing the rotational inertia of the body. In some situations, it appears that the raising of the arms may also serve a protective function, to absorb energy and reduce the risk of injury in the event that a fall does occur. It is also possible that the arm activation is related to an aborted [reach-to-grasp](#) [change-in-support strategy](#) (see below).

### Change-in-Support Strategies

In change-in-support reactions, the BOS is altered via rapid stepping or reaching movements of the limbs. Increase in the BOS allows: (i) a larger range of perturbation-induced COM motion to be tolerated without loss of equilibrium, (ii) more time for this COM motion to be decelerated (via “environment reaction” forces generated at the foot and/or hand) and (iii) larger decelerating “environment reaction” forces to be generated (Fig. 2). Reach to grasp reactions provide a further biomechanical advantage in that they allow the body to be anchored with respect to the grasped object, provided that a sufficiently strong grip can be maintained. Change-in-support reactions can provide a much larger degree of stabilization, in comparison to fixed support reactions and are the only recourse in responding to large perturbations [1,3].

The neural control of change-in-support (compensatory) and volitional limb movements appear to differ in some fundamental ways. First, the compensatory postural movements are much more rapid. A compensatory stepping movement is typically completed in about 500 ms, approximately half the time required to step as fast as possible in reaction to a visual cue. Similarly, compensatory reaching reactions are more rapid than volitional arm movements. For example, compensatory arm activation typically begins at a

latency of 80 to 140 ms after perturbation onset, whereas the most rapid latency for volitional arm activation (single-choice reaction-time task) is about 150–200 ms (and is slower when the task involves multiple choices).

Another fundamental distinction between compensatory stepping and volitional stepping pertains to the presence or absence of an “anticipatory postural adjustment” (APA), prior to the lifting of the swing leg. Volitional movements that involve stepping or raising a leg are invariably preceded by an APA which acts to propel the COM toward the stance limb and thereby serves to reduce the tendency of the COM to fall laterally toward the unsupported side during the subsequent foot movement. The APA is typically either absent or severely truncated during compensatory stepping reactions. This allows more rapid step execution; however, the consequence is that the lateral COM motion arising during the swing phase must be arrested after the swing foot lands. A large APA does occur when task demands require a prolonged swing phase (e.g., when the compensatory step must clear an obstacle). Presumably, the APA is required in such situations because the COM has much greater opportunity to fall laterally.

Whereas antero-posterior perturbations typically (in healthy young adults) evoke a single step that is predominantly directed forward or backward, perturbations in other directions evoke a wider variety of stepping patterns. If the perturbation includes a medio-lateral component, then the perturbation induced COM motion will cause an increase in loading of one leg and a decrease in loading of the contralateral leg. Typically, when the perturbation is unpredictable, the unloaded leg is used to execute the stepping reaction. This has the advantage of allowing a more rapid foot lift, as less time is required to complete the unloading of the swing foot; however, the consequence is that a more complex stepping movement is required. This may involve a crossover step, in which the swing foot is moved across the body (either in front of or behind the stance leg). Alternatively, the unloaded leg may be used to execute a small initial medial step, which is then followed by a large lateral step with the contralateral leg (a “side-step sequence”). See Fig. 3.

The direction of perturbation-evoked reach-to-grasp reactions is highly dependent on both the direction of the perturbation and the location of potential handholds that can be grasped or touched for support. Remarkably, even the earliest portion of the arm trajectory (at a latency as early as 80 ms) is directed toward the nearest available handhold. Such a rapid response does not permit visual scanning of the environment; hence, it appears that the initial arm trajectory must either involve peripheral vision or “remembered” visuospatial information. In order to use “remembered” information,

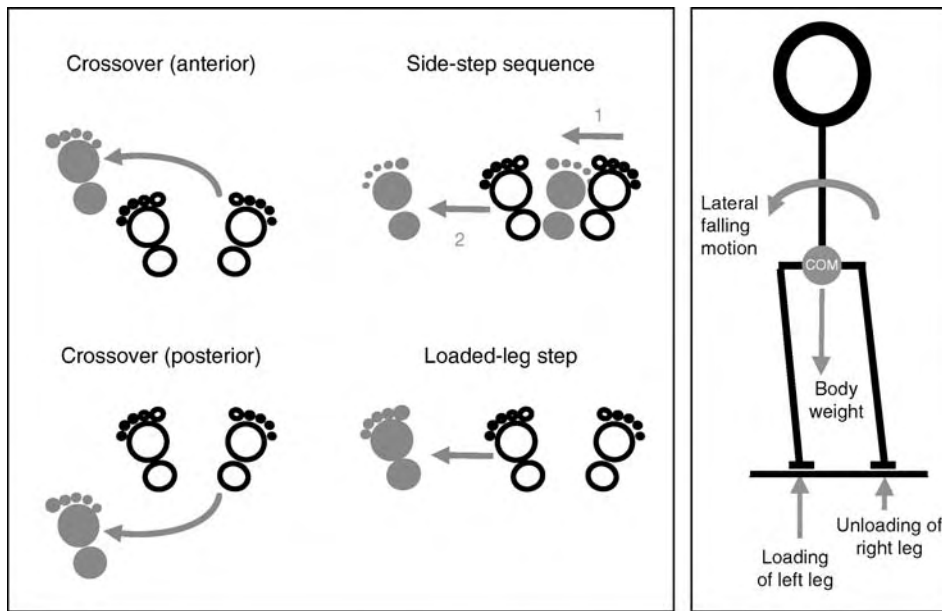

**Postural Strategies. Figure 3** ▶ **Stepping strategies** evoked when the postural perturbation includes a lateral component. The footprint drawings illustrate responses evoked by a perturbation that induces leftward falling motion of the center of mass (COM). The *unshaded* footprints indicate the starting position at time of perturbation onset, and the *shaded* footprints indicate the landing position of each step. The *stick figure* illustrates how the initial COM motion induced by this perturbation creates increased loading of the left leg. As a consequence of this loading, the stepping responses are most commonly initiated with the unloaded (right) leg, and involve either a crossover movement or a side step sequence (a small medial step followed by a large lateral step). Reactions where the initial step is taken with the loaded foot have been observed to occur very rarely in some studies, but more commonly in others. The “loaded leg” steps seem more likely to occur when the individual can preplan to step with a specific leg (e.g., if the direction of the perturbation is known in advance).

the CNS would need to maintain and automatically update an egocentric spatial map of the immediate surroundings as the person moves about in daily life. This would then allow the hand to be directed very rapidly toward the nearest available handhold, if and when sudden unexpected loss of balance occurs. A similar control mechanism would allow rapid perturbation-evoked stepping reactions to be directed appropriately, so as to avoid obstacles and accommodate other constraints on foot movement.

Although the neural pathways involved in the control of change-in-support reactions are not well established, it seems likely that the planning of the limb trajectory makes use of the same neural pathways as those thought to be involved in planning volitional limb movements, i.e., spinal pattern generators in the case of stepping reactions and cortical pathways in the case of reaching reactions. The very rapid initiation and scaling of the trajectory could then be triggered by subcortical pathways similar to those thought to be involved in triggering the early fixed-support postural reactions.

### Strategy Selection

A traditional view has been that change-in-support reactions are only used as a last resort when earlier

fixed-support reactions fail to keep the COM within the stability limits of the BOS. The basic idea is that the ankle strategy is used to respond to antero-posterior perturbation when the induced COM motion is small in relation to the BOS stability limits, the hip strategy comes into play when the COM motion is larger, and stepping and reaching emerge only when the COM motion exceeds the stability limits of the BOS. This may be true when individuals are instructed to try not to step or move the arms; however, this is clearly not the case when the person is allowed to respond naturally. It is now clear that compensatory stepping and reaching are commonly initiated very early, with the COM well within the stability limits and in fact often seem to be the preferred response. For example, individuals will almost always step and begin to move the arms when the perturbation is unexpected or novel (e.g., the very first trial in an experiment), even if the perturbation is relatively small.

It appears that initiation of reach-to-grasp reactions occurs in parallel with the earliest fixed-support reaction, as evidenced by the similarity in timing of the arm and ankle activation (latency of ~100 ms). Typically, the initiation of compensatory stepping is not quite as rapid; however, the onset of the stepping



reaction (i.e., active changes in leg loading) can occur as early as 130 ms after perturbation onset. Interestingly, the early fixed-support reaction is not eliminated, even when a rapid reach-to-grasp or stepping reaction is initiated. Presumably, the fixed-support reaction persists as an important safeguard against instability. Early initiation of the change-in-support response, regardless of perturbation magnitude, may also reflect the high priority given by the CNS to the task of safeguarding stability.

Ultimately, strategy selection can be influenced by a number of factors, including (i) the features of the perturbation (timing, direction, magnitude, predictability), (ii) the “►central set” of the individual (affect, arousal, attention, expectations, prior experience), (iii) ongoing activity (cognitive or motor) and (iv) environmental constraints (e.g., slippery surfaces that limit reaction-force generation, obstacles that constrain limb movement) [1,7,10].

### Modulation of Strategies

Both fixed-support and change-in-support reactions are highly modifiable and adaptations to meet task demands can be learned rapidly (e.g., over the course of one to five experimental trials). The same factors that affect strategy selection listed above can also modulate many of the features of the reactions *per se*.

One of the features that is not highly modifiable is the timing of the early activation of the ankle muscles in the ankle strategy. This early activation typically persists, at a similar latency, even when the individual preplans to use a stepping reaction to recover balance, despite the fact that the ankle activation may interfere with the execution of the step. In keeping with the persistent and apparently automatic nature of this response, the early ankle activation is commonly referred to as the early “automatic postural response” (APR). Nonetheless, the APR is not a stereotyped response. The magnitude of the activation is scaled according to the direction and magnitude of the perturbation and is influenced by the predictability of the perturbation, the “central set” of the individual and the instructions given (e.g., whether or not to step). The functional task demands can also have a profound effect. For example, backward horizontal support surface movements evoke activation in the ankle plantarflexors, which serves to stabilize the body. When similar ankle rotation is evoked by toes-up tilt of the support-surface, the evoked plantarflexor activation acts to amplify the destabilization, but this non-functional response quickly habituates over the course of repeated trials in healthy individuals [10].

Change-in-support reactions exhibit an even greater degree of modifiability, in both magnitude and timing [1,3]. For example, initiation of stepping reactions can be delayed substantially by instructions to try not to step.

Conversely, stepping and reaching reactions can be initiated more quickly when the person is given prior instruction to step or reach in response to the perturbation. Furthermore, the limb movements are heavily dependent on environmental constraints (i.e., location of obstacles and potential handholds). There also appears to be capacity for online modulation. For example, the limb trajectory can be altered (to at least some degree) to deal with additional perturbations or changes in environmental constraints arising after initiation of the reaction and reactions that are initiated can be aborted prior to completion.

### References

1. Maki BE, McIlroy WE (2003) Effects of aging on control of stability. In: Luxon L et al. (eds) A textbook of audiological medicine: clinical aspects of hearing and balance. Martin Dunitz, London, pp 671–690
2. Pai YC, Patton J (1997) Center of mass velocity-position predictions for balance control. *J Biomech* 30:347–354
3. Maki BE, McIlroy WE (1997) The role of limb movements in maintaining upright stance: the “change-in-support” strategy. *Phys Ther* 77:488–507
4. Allum J, Carpenter MG, Honegger F (2003) Directional aspects of balance control in man. *IEEE Eng Med Biol Mag* 22:37–47
5. Dietz V (1992) Human neuronal control of automatic functional movements: Interaction between central programs and afferent input. *Physiol Rev* 72:33–69
6. Maki BE, McIlroy WE (2007) Cognitive demands and cortical control of human balance-recovery reactions. *Journal of Neural Transmission* 114:1279–1296
7. Nashner LM, McCollum G (1985) The organization of human postural movements: a formal basis and experimental synthesis. *Behav Brain Sci* 8:135–172
8. Runge CF, Shupert CL, Horak FB, Zajac FE (1999) Ankle and hip postural strategies defined by joint torques. *Gait Posture* 10:161–170
9. Henry SM, Fung J, Horak FB (1998) EMG responses to maintain stance during multidirectional surface translations. *J Neurophysiol* 80:1939–1950
10. Horak FB (1995) Adaptation of automatic postural responses. In: Bloedel J et al. (eds) Acquisition of motor behavior in vertebrates. MIT, Cambridge MA

## Postural Sway

### Definition

In stance, a process of continuous, small corrections of the upright body position takes place to oppose the destabilizing effect of gravity. This creates a pattern known as spontaneous sway, or postural sway.

### ►Stabilometry

## Postural Synergies

LENA H. TING

Laboratory for Neuroengineering, The W. H. Coulter Department of Biomedical Engineering, Emory University and Georgia Institute of Technology, Atlanta, GA, USA

### Synonyms

Muscle synergies; functional muscle synergies; motor primitives; M-modes

### Definition

A ► **postural synergy** is a preferred pattern of muscle co-activation that is used by the nervous system to maintain standing balance. Each postural synergy specifies a pattern of muscle activation across many muscles. Through flexible combinations of postural synergies, a repertoire of postural behaviors is produced. By eliminating the need to control each muscle independently, postural synergies are thought to simplify the neural control task of selecting and coordinating multiple muscles across the body. A postural strategy defines the overall goals involved in the maintenance of balance; these can vary depending on the particular postural task, the context in which the task is performed and the postural configuration. Postural synergies define the muscle activation patterns that are used by the nervous system to implement various postural strategies.

## Description of the Theory

### Introduction

The theory of postural synergies address the basic question of whether the nervous system activates each muscle independently when it performs a task or whether the multiple muscles are activated together, thus reducing the total number of neural command signals necessary. Currently, postural synergies are thought to represent neural “building blocks” for generating a wide range of postural behaviors. Each postural synergy specifies a pattern of muscle activation across many muscles and is purportedly controlled by one neural command signal. By combining muscle synergies in various proportions, a continuum of muscle activation patterns for postural control can be generated using just a few neural command signals.

The long-standing debate within the general motor control field over the concept of muscle synergies is exemplified by the specific debate over the existence of postural synergies. Nashner first described “fixed” postural synergies in subjects standing on a moving perturbation platform [1]. Distinct patterns of muscle activation across the ankle, knee, hip and trunk were

reliably observed when the platform was moved either forwards or backwards (Fig. 1a) and were thought to represent two different postural synergies [2]. Originally, it was thought that postural synergies were activated in a mutually exclusive fashion and that each muscle was activated by only one postural synergy (Fig. 2a).

These conclusions were challenged by later studies that showed flexibility in patterns of muscle activation in response to a backward perturbation. Depending on the perturbation amplitude and prior experience of the subject, two types of responses were observed, the “ankle strategy” and the “hip strategy,” so named for the major joint motions involved. Each strategy elicits a very different pattern of muscle activation, demonstrating that postural synergies to a particular direction of perturbation are not fixed. Moreover, when perturbations were given in many directions in the horizontal plane, even more complex patterns of muscle activation emerged in both humans and cats [2]. Each different perturbation direction elicited a unique pattern of muscle activation (Fig. 1b), suggesting that muscles must be controlled independently to perform multidirectional balance control. It was for this reason that the notion of muscle synergies was then rejected as being too constraining and inflexible for the production of natural movements [3].

Recently, new computational techniques have helped to demonstrate that a motor control architecture based on muscle synergies can both simplify neural control as well as provide flexibility in motor output. In the new framework, more than one muscle synergy can be activated during a postural response and each muscle can also be activated by more than one synergy. By varying the magnitude of the neural command signals to just a few muscle synergies, many different muscle activation patterns can be generated (Fig. 2b), including the responses to multidirectional postural responses describe above [4]. The neural substrates of muscle synergies for postural control remain unknown. Where muscle synergies are encoded within the neural control hierarchy is a complex topic and may also be task dependent. It is hypothesized that postural synergies are formed in the brainstem, based on observations of postural control following neural impairment.

### Degrees of Freedom Problem

To maintain standing balance, the nervous system must confront the classic “degrees of freedom” problem posed by Nikolai Bernstein [5], where many different solutions are available due to the large number of elements or degrees of freedom involved. In postural control, a large number of muscles and joints across the limbs, trunk and neck must be coordinated to maintain the body’s ► **center of mass (CoM)** over the base of support, typically formed by the feet. The large

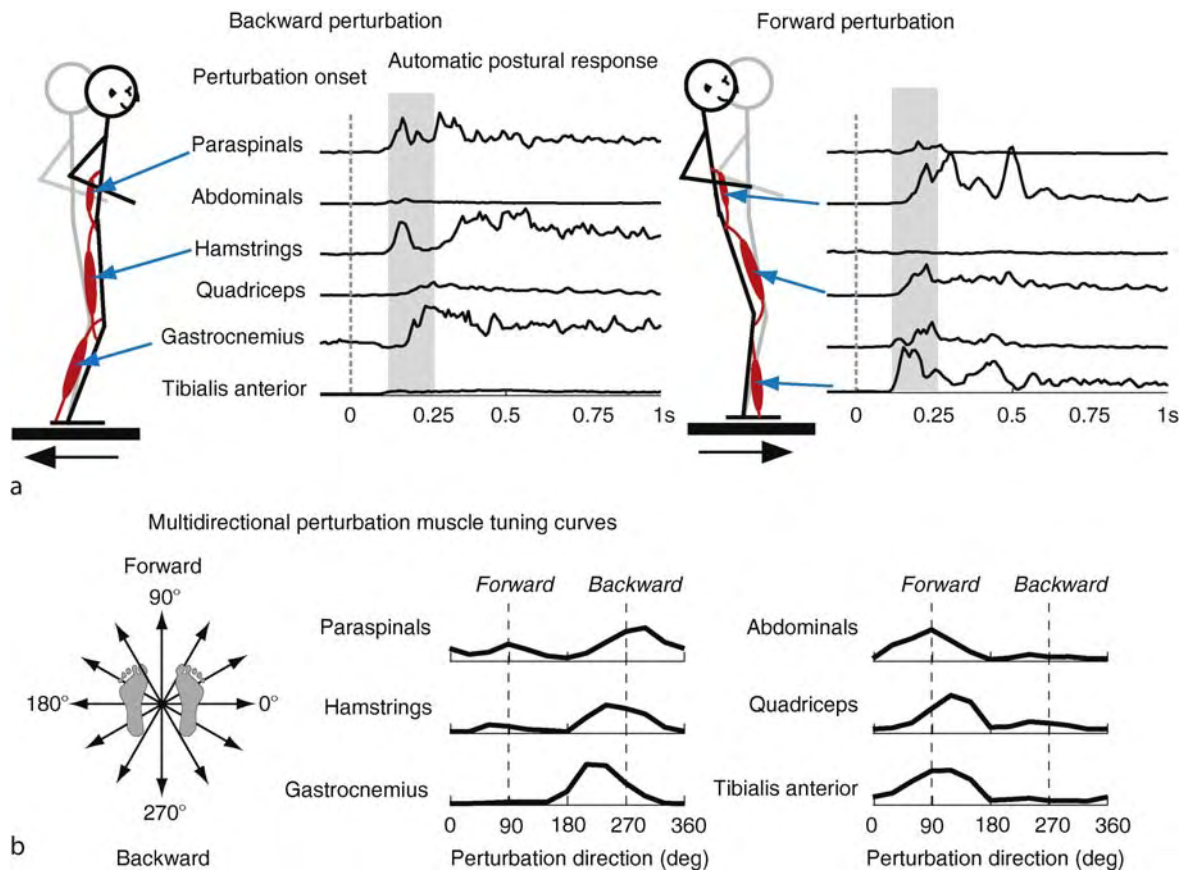

**Postural Synergies. Figure 1** Muscle activity evoked following perturbations to the support-surface. (a) Backward perturbations elicit activity in muscles on the posterior side of the body. (b) Forward perturbations elicit activity in muscles on the anterior side of the body. The gray area represents the initial muscular response to perturbation, called the automatic postural response (APR). (c) The magnitude of the response during the APR varies as a function of direction and can be plotted as a tuning curve. Each muscle has a unique tuning curve, suggesting that each muscle is activated by a separate neural command signal.

number of degrees of freedom afforded by the multiple joints and muscles in the body thus allow for many solutions that can accomplish the task goals equally well. This multiplicity or redundancy of solutions allows flexibility in performing the postural task; it also poses the problem that the nervous system must choose from a large set of possible solutions. In contrast, if the body were a simple rigid stick balanced on one end, then the angle of the stick in space would completely determine the location of the center of mass with respect to the base of support. Moreover, if only one muscle is available, there is no ambiguity as to how to activate the muscle in order to move the center of mass. Thus, the “degrees of freedom problem” occurs only when overall task requirements are not sufficient to specify multiple output variables controlled by the nervous system.

Bernstein proposed the existence of synergies as a neural strategy for simplifying the control of multiple degrees of freedom by coupling or grouping output

variables [5]. This scheme was based on experimental observations that many joint angles appear to be controlled together rather than independently during motor tasks. For example, during locomotor tasks such as running, the hip, knee and ankle joints all flex and extend at the same time, suggesting that they are not controlled independently. However, such observations only identify correlations between the joint motions. A variety of muscle activation patterns can produce similar joint movements. Therefore, joint angle changes do not necessarily have a direct relationship to neural command signals activating muscles. Since muscle activation is directly caused by motoneuron firing, correlations between muscle activation patterns can be more plausibly derived from a single neural command that is distributed across the various motoneuron pools. Thus, muscle synergies may represent a mechanism by which the nervous system can achieve repeatable multijoint coordination.

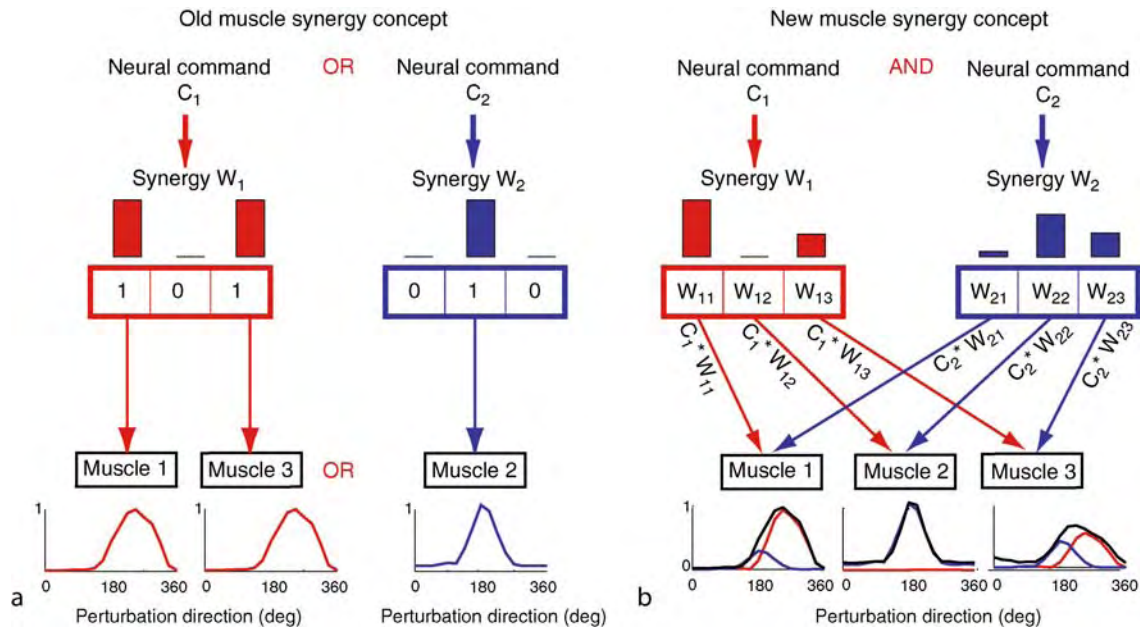

**Postural Synergies. Figure 2** Illustrations of two different muscle synergy concepts. (a) In the original muscle synergy concept, only one muscle synergy was elicited at a time, and muscles could only be activated by one synergy. Therefore, all muscles activated by the same synergy would have the same directional tuning curve, determined by the neural command  $c$  that activated it. (b) In the new concept, more than one synergy can be activated at a time. Further, muscles can participate in multiple synergies, and have different weightings in each synergy. Therefore, each muscle's tuning curve is a weighted average of the two tuning curves of each muscle synergy.

### Computational Methods for Identifying Postural Synergies

Recent computational techniques have redefined the working hypothesis of how muscle synergies can allow for flexible motor coordination while also simplifying the degrees of freedom problem. In this new formulation, a single synergy specifies a fixed muscle activation pattern that is modulated by a single neural command signal, but multiple muscle synergies can be activated at one time [4,6,7]. Mathematically, each muscle activation pattern is thus composed of a linear combination of a few ( $n$ ) muscle synergies  $W_i$ , each activated by one neural command  $c_i$ . The net muscle activation pattern vector  $M$  is therefore hypothesized to take the form:

$$M = c_1 W_1 + c_2 W_2 + \dots + c_n W_n$$

$M$  is a vector where each element is the resulting level of activation in each muscle (Fig. 3a).  $W_i$  is a vector that specifies the pattern of muscle activity defined by that muscle synergy. Each element of  $W_i$  takes a value between 0 and 1, representing the relative contribution of each muscle to that muscle synergy. Each muscle synergy is then activated by a single, scalar neural command signal  $c_i$ , which determines the relative contribution of the muscle synergy  $W_i$  to the overall muscle activation pattern,  $M$ .

The above formulation allows for flexible “mixing” of a set of muscle synergies to produce the final output muscle activation pattern. Therefore, if two muscle synergies are present, rather than defining just two output muscle activation patterns, as in previous definitions (Fig. 2a), an entire continuum of output muscle activation patterns can be generated by varying the commands  $c_1$  and  $c_2$ . Within this continuum, individual muscle activations are not strictly correlated to each other because most muscles belong to more than one muscle synergy and are thus activated independently by two different neural commands (Fig. 2b).

Linear decomposition techniques can be used to identify muscle synergies from experimentally measured muscle activation patterns. Because the number of muscle synergies is smaller than the number of muscles for any given task, the spectrum of muscle activation patterns that can be generated using muscle synergies is more limited than the case where muscles are controlled independently. However over the entire behavioral repertoire the number of muscle synergies could exceed the number of muscles. This dimensional reduction, which simplifies the degrees of freedom problem, can be identified using several mathematical analysis techniques such as principal components analysis (PCA), independent components analysis (ICA) and factor analysis (FA) [6]. Another such technique, non-negative matrix factorization (NMF),

Muscle synergies (W) and neural commands (C)

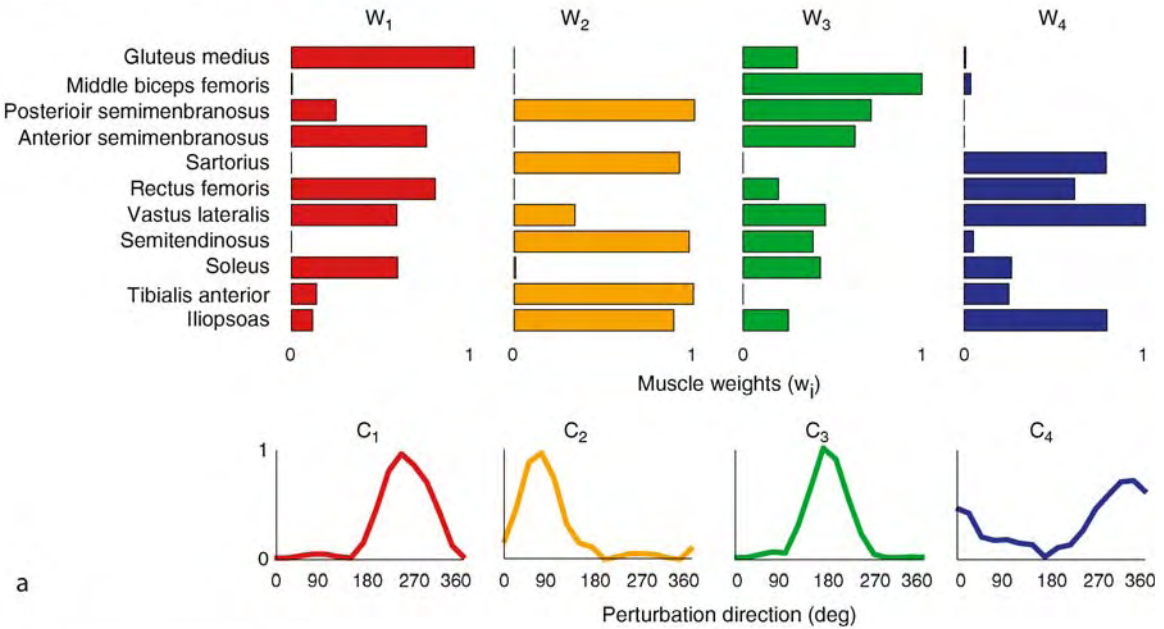

Muscle tuning curve reconstruction

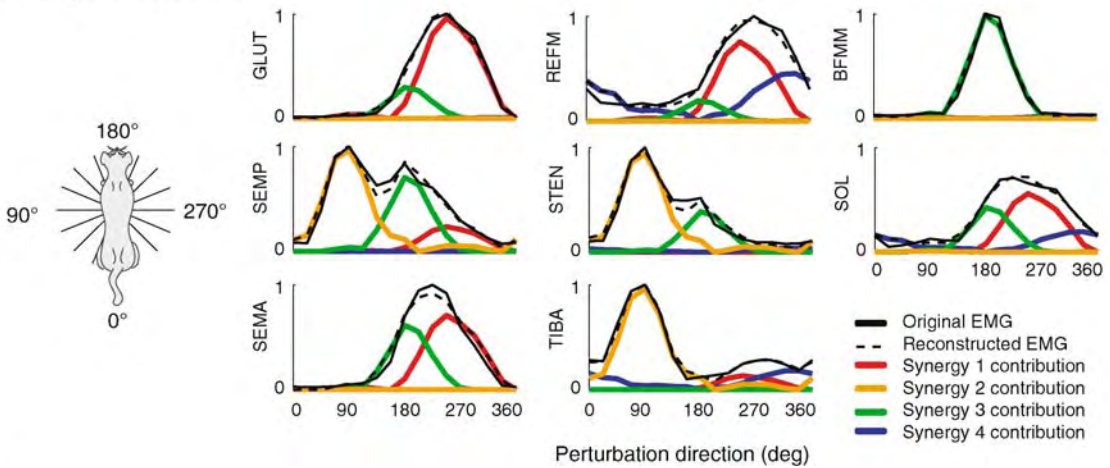

**Postural Synergies. Figure 3** Muscle synergies and neural commands used to generate muscle tuning curves during postural responses in cats. (a) Each muscle can participate in each muscle synergy with a different weight, indicated by the bars. (b) Neural commands to each muscle synergy can also be illustrated as tuning curves. Each muscle synergy therefore has preferred direction of activation. (c) EMG tuning curves can be reconstructed using muscle synergies. Each muscle’s tuning curve is found by summing the product of each tuning curve,  $c_i$  and the weighting of each muscle within the synergy  $W_i$ . All muscle tuning curves are thus constrained to be weighted averages of the synergy tuning curves. Therefore, the muscle tuning curves have more varied and complex shapes than the synergy tuning curves.

allows complex data sets to be more successfully partitioned into meaningful parts [4,6,8]. NMF is particularly useful for data that are inherently positive valued, such as neural spike trains or muscle activations. The extracted elements are based on the components forming the data set rather than on more holistic features. For example, when applied to images of faces, a non-negative extraction routine generates vectors representing

noses, ears and eyes, whereas PCA generates components that all tend to look roughly like an entire face [8].

**Muscle Synergies in Postural Control**

During postural responses to perturbations in different directions, multiple muscles across the body are activated and for each different direction of the perturbation, a different pattern of muscle activation is

elicited (Fig. 1b). In both humans and in cats, a stereotyped, directionally specific pattern of muscle activity called ▶automatic postural response (APR) is evoked after perturbations to the support surface. The muscle activation occurs after the platform motion begins, but before the center of mass moves appreciably, with a latency of around 50 ms in the cat and 100 ms in humans. In both cases, this latency is about twice the ▶stretch reflex latency for distal muscles and evokes a much larger response than the stretch reflex [2]. Each muscle's activation level can be expressed in terms of a muscle tuning curve, which shows the variation of the muscle activation with perturbation direction (Fig. 1b – human, Fig. 3b – cat). Thus, for some directions, a muscle may have high activation and for others it may not be active at all. These muscle tuning curves define the complex patterns of muscle activation evoked across many perturbation directions [2,4,9].

Although each direction of perturbation evokes a slightly different pattern of muscle activation over all muscles, these variations can be explained by a combination of just a few muscle synergies in the cat [4]. Over 95% of the variability in as many as fourteen muscle tuning curves can be explained by combining just four muscle synergies (Fig. 3b). Instead of activating each muscle independently for each perturbation direction, only four neural commands, each activating a synergy  $W_i$ , need to be specified with amplitude  $c_i$  for any perturbation direction. The net muscle activation pattern is thus found by adding up the contributions of each muscle synergy to each muscle's activation level.

Muscle synergies may coordinate the limb to produce a specific biomechanical function for stabilizing the body. In the cat, it has been suggested that each muscle synergy allows the leg to produce a force in a particular

direction in order to stabilize the leg (Fig. 4a). Variations in the components of active force generated by each leg are correlated to the variations in the neural commands of each muscle synergy (Fig. 4b). Each muscle synergy can generate a specific direction of force; the forces are distributed so that upward, downward, anterior, posterior and lateral force direction can be produced. Thus, muscle synergies may be organized to produce specific task-level biomechanical functions [4].

Even for postural perturbations of the same direction, multiple muscle synergies may exist. In backward perturbations of the support surface in humans, two types of responses can be elicited. One is called the “ankle strategy” where the body remains upright and most of the motion occurs around the ankle joint. The other is called the “hip strategy,” where the trunk tilts forwards and the hip angle motion is most predominant. Each strategy can be defined by a specific pattern of joint torques. Because joint torques directly relate to the force generation of the musculature, this suggests that there are muscle synergies underlying these two strategies. While these two strategies were initially thought to be mutually exclusive, they in fact represent two different postural synergies that can be combined to produce a whole continuum of intermediate responses [2,11]. Therefore, rather than having a simple repertoire of just two response patterns, the flexible combination of these postural synergies allows the APR to be tuned and varied with perturbation amplitude, prior experience and anticipation.

### Encoding of Muscle Synergies in the CNS

If muscle synergies reflect neural control mechanisms, then what are the neural substrates that generate muscle synergies? It is now understood that postural synergies

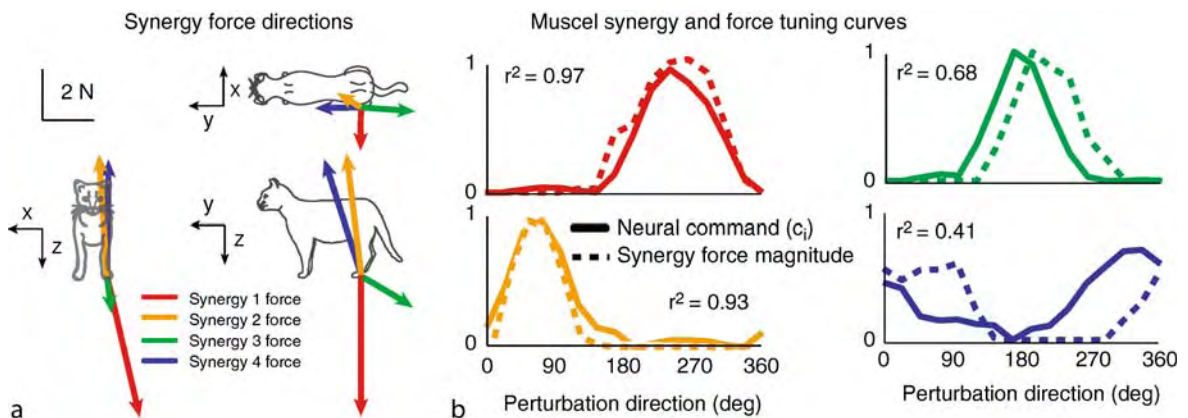

**Postural Synergies. Figure 4** Forces produced during the automatic postural response correlate with muscle synergy activations. (a) Forces produced during postural responses can be decomposed into four force vectors. (b) During postural response, the magnitude of each force vector required to reproduce the total force varies as a function of direction and can be illustrated as a tuning curve. The tuning curves of force magnitude are highly correlated with the tuning curves of the neural commands  $c_i$  activated the muscle synergies. Thus, each force vector may represent the functional output of the muscle synergy.

cannot be explained just by reflexes acting in response to muscle stretch. In both humans and cats, it has been shown that perturbations that stretch the muscles differently can activate the same muscle synergies. For example, Nashner originally demonstrated that for a backward translation of the support surface, the calf muscle is stretched as the subject falls forward and that the same muscle is subsequently activated to maintain balance, consistent with a stretch reflex. In contrast, if a toes up rotation of the support surface is given, the calf muscle is stretched but the subject falls backwards, so that the antagonist muscle is activated to restore balance, in direct opposition to the stretch reflex [1]. This same principle has been demonstrated in multidirectional perturbations in both cats and humans [9]. Moreover, the loss of a single sensory modality, such as proprioceptive, vestibular or visual loss, does not appear to significantly affect muscle activation patterns, only their activation levels. Therefore muscle synergies are not a direct response to local sensory input, but appear to be related to more global variables, such as the direction of CoM displacement caused by the perturbation, that require multisensory integration [2,9].

How postural synergies are encoded in the nervous system is not known. For locomotor tasks, the encoding of muscle synergies appear to be located within the neural circuitry of the spinal cord [7], as animals can produce locomotor activity from a spinal cord that is isolated from the brain following spinal cord transection. These same animals can support their own weight while standing, but direction specific responses to postural perturbations are lost. This suggests that postural synergies are generated within the spinal cord [10]. It is known that the brainstem is essential to the maintenance of postural orientation and equilibrium and it is possible that neural mechanisms producing postural synergies reside there. Moreover, postural synergies appear intact in patients with postural impairments due to lesions in higher brain centers. For example, Parkinson's disease is characterized by pathology of the basal ganglia, which project to brainstem areas that are important for postural control. Individuals with Parkinson's disease have the ability to generate postural synergies that are similar to control subjects, but have difficulty changing the muscle synergy that is activated when perturbation conditions change. Similarly, in individuals with cerebellar dysfunction, postural synergies are similar to control subjects, but their activation levels do not decrease with repeated perturbations as in control subjects. Therefore, the muscle synergy structure appears intact, but the ability to correctly activate the neural commands to those muscle synergies is compromised, which impairs the postural stability in these individuals [2]. The theory of postural synergies therefore contributes to our understanding of the role of various nervous system structures in postural

control and can guide experimental investigations that may further the validity of the theory.

### ► Postural Strategies

## References

1. Nashner LM (1977) Fixed patterns of rapid postural responses among leg muscles during stance. *Exp Brain Res* 30(1):13–24
2. Horak FB, Macpherson JM (1996) Postural orientation and equilibrium. In: *Handbook of physiology*, Section 12. American Physiological Society, New York, pp 255–292
3. Macpherson JM (1991) How flexible are muscle synergies? In: Humphrey DR, Freund H-J (eds) *Motor control: concepts and issues*. Wiley, New York, pp 33–47
4. Ting LH, Macpherson JM (2005) A limited set of muscle synergies for force control during a postural task. *J Neurophysiol* 93(1):609–613
5. Bernstein N (1967) *The coordination and regulation of movements*. Pergamon, New York
6. Tresch MC, Cheung VC, d'Avella A (2006) Matrix factorization algorithms for the identification of muscle synergies: evaluation on simulated and experimental data sets. *J Neurophysiol* 95:2199–2212
7. Flash T, Hochner B (2005) Motor primitives in vertebrates and invertebrates. *Curr Opin Neurobiol* 15(6):660–666
8. Lee DD, Seung HS (1999) Learning the parts of objects by non-negative matrix factorization. *Nature* 401(6755):788–791
9. Ting LH, Macpherson JM (2004) Ratio of shear to load ground-reaction force may underlie the directional tuning of the automatic postural response to rotation and translation. *J Neurophysiol* 92(2):808–823
10. Macpherson JM, Fung J (1999) Weight support and balance during perturbed stance in the chronic spinal cat. *J Neurophysiol* 82(6):3066–3081
11. Torres-Oviedo G, Ting L (2007) Muscle synergies characterizing Human postural responses. *J Neurophysiol* 98:2144–2156

## Postural Tone

### Definition

Background tension developed by the antigravity muscles. It represents a prerequisite for the maintenance of posture. The postural tone is regulated by intrinsic properties of spinal motoneurons, by the tonic activity of the corresponding muscle spindle afferents and by signals arising from brainstem systems projecting to the spinal cord, including the vestibular nuclei and the reticular formation.

### ► Postural Synergies

### ► Vestibulo-Spinal Reflexes

## Postural Tremors

### Definition

These tremors occur while trying to keep a body part in a constant position, such as an arm in outstretched posture.

## Posture

### Definition

A particular position assumed by the body.

## Posture – Sensory Integration

ROBERT J. PETERKA

Neurological Sciences Institute, Oregon Health & Science University, Portland, OR, USA

### Synonyms

Sensor fusion

### Definition

Sensory integration, as it pertains to posture, refers to the process by which ►kinematic (orientation and motion) and ►kinetic (force related) information from multiple sensory sources is combined in the nervous system for the purpose of generating motor action to compensate for the destabilizing effect of gravity and to resist external perturbations.

### Description of the Theory

#### The Task of Sensory Integration

Sensory information that is relevant to postural control is available from various sensory systems. These include the visual system, vestibular system, various aspects of somatosensation (proprioception signaling muscle stretch and joint angle, tendon force sensors, pressure sensors in the feet and other parts of the body signaling contact with the ground or the environment and tactile sensors in the skin around the joints) and the auditory system. Within each system, different subsystems encode physical variables related to different aspect of motion and orientation and related to forces applied to the body and within the body. Furthermore,

within each subsystem, the individual sensory receptors typically have a variety of static and dynamic response characteristics. The monumental task of the sensory integration process is to somehow combine this information and make it available to the motor control system so that the organism generates coordinated motor actions that maintain stability, respond appropriately to external perturbations and permit the expression of voluntary actions.

### Benefits of Sensory Integration

In many situations the orientation cues provided by different sensory systems are redundant. Consider the simplest possible case where the legs, trunk and head of a human subject move together as a single mechanical unit with body sway consisting of a rotation about the ankle joints. In this case, during stance on a level surface while viewing an earth fixed visual scene, body sway relative to earth vertical is accurately sensed by the visual system, which signals body motion relative to the visual scene, by the vestibular system, which signals body motion in space and by proprioceptors, which signal ankle joint angle. However, there is variability and therefore uncertainty associated with orientation estimates derived from each of these sensory systems. In this common situation with redundant sensory information, an orientation estimate with reduced overall variability can be obtained by appropriately combining the redundant sensory information.

What is the appropriate way to combine redundant sensory information? Previous theoretical and experimental work suggests that the nervous system may employ the principle of maximum likelihood estimation to combine sensory inputs [1]. For the case of two sensory sources,  $S_a$  and  $S_b$ , the combined maximum likelihood estimate,  $\hat{S}$ , is given by a weighted combination of the individual sensory estimates

$$\hat{S} = w_a \cdot S_a + w_b \cdot S_b$$

where the sensory weights  $w_a$  and  $w_b$  are equal to

$$w_a = \frac{\sigma_b^2}{\sigma_a^2 + \sigma_b^2}, \quad w_b = \frac{\sigma_a^2}{\sigma_a^2 + \sigma_b^2}$$

with  $\sigma_a^2$  being the variance of  $S_a$ , and  $\sigma_b^2$  the variance of  $S_b$ . In words, the sensory source with the smaller variance will have the larger weight and will make a larger contribution to the overall sensory estimate  $\hat{S}$ . Although an intuitive method for combining sensory information might be to ignore information from the more variable source, the maximum likelihood principle shows that the best (lowest variance) estimate is obtained by a weighted combination, even though one source may be considerably less reliable (i.e., large noise or variance) than the other source.



It is not currently known if the maximum likelihood principle strictly applies to sensory integration for postural control. However, it is known that a sensory weighting mechanism can account for experimental results in humans where body sway was provoked by tilts of the support surface or visual surround [2].

### Constraints on Sensory Integration

Because postural control involves motor action as well as sensory integration, there are additional constraints on the sensory integration process as well as opportunities for the sensory integration process to facilitate postural control. Consider a simplified representation (Fig. 1) of a postural control system where orientation information is provided by proprioceptors and graviceptors.

Graviceptors yield the sensory signal  $S_{bs}$  that encodes the physical variable,  $BS$  (i.e., body in space angular orientation). Proprioceptors yield the sensory signal  $S_{bf}$  that encodes the physical variable  $BF$  (i.e., body orientation relative to the feet). It can be hypothesized that a weighted combination of these sensory sources contributes to an overall estimate of orientation,  $\hat{S}$ , and this overall estimate is compared to an internal reference orientation,  $S_{ref}$ , that represents the desired body orientation. Without loss of generality, it can be assumed that  $S_{ref} = 0$  to symbolize the desired goal of remaining in an upright orientation. The difference between the orientation estimate and the reference orientation gives

a sensory “error” signal,  $e$ . This process is represented by the equation

$$e = \hat{S} - S_{ref} = w_p \cdot S_{bf} + w_g \cdot S_{bs} \text{ (for } S_{ref} = 0 \text{)}$$

where  $w_p$  is the proprioceptive weighting factor and  $w_g$  the graviceptive weighting factor. Then, through a sensory to motor transformation, a corrective torque,  $T_c$ , is generated as a function of  $e$ ,  $T_c = f(e)$ , and  $T_c$  is applied to the body to control body orientation in space.

The net result of the process of sensory encoding, sensory integration and sensory to motor transformation is that  $T_c$  is generated as a function of a weighted combination of the physical variables  $BF$  and  $BS$

$$T_c = f(w_p \cdot BF + w_g \cdot BS)$$

During stance on a level surface, the physical variables  $BF$  and  $BS$  are equal and the torque generated in relation to both proprioceptive and graviceptive cues facilitates maintenance of a stable vertical body orientation. However, on a tilting surface,  $BF$  is equal to  $BS - FS$ , where  $FS$  is the orientation of the feet in space (and equal to the tilted surface orientation assuming that the feet remain in contact with the surface). Therefore the above equation can be rewritten as

$$T_c = f(w_p \cdot (-FS) + (w_p + w_g) \cdot BS)$$

This equation shows that there are two components to  $T_c$  and these components have opposite signs. One

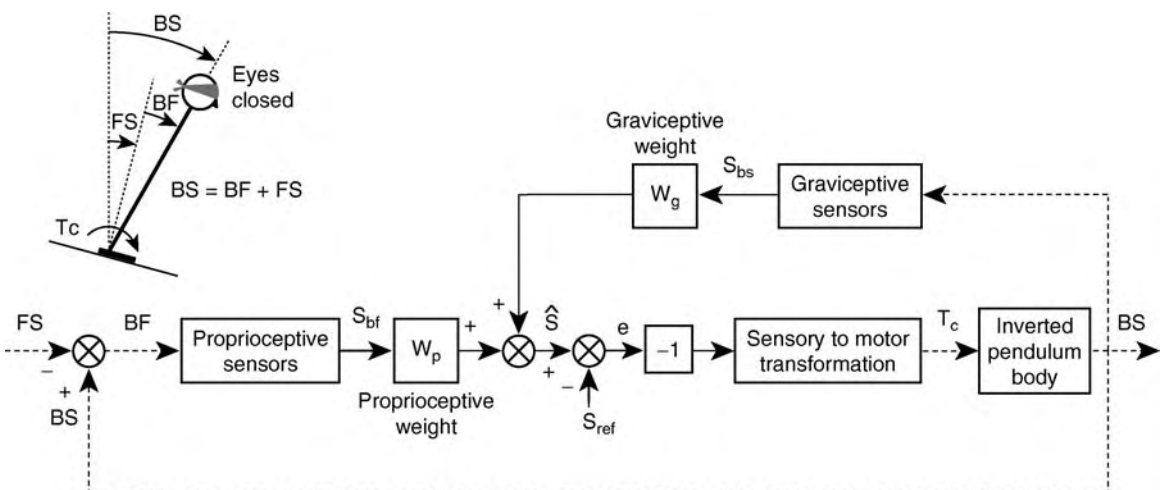

**Posture – Sensory Integration. Figure 1** A block diagram representation of a sensory integration scheme for postural control based on a weighted combination of sensory orientation signals. In this example, proprioceptors are assumed to encode body orientation relative to the feet ( $BF$ ) and graviceptors encode body in space orientation ( $BS$ ). A weighted combination of these sensory signals is compared to an internal reference orientation ( $S_{ref}$ ) and the resulting error,  $e$ , is used to generate a corrective torque,  $T_c$ , via a sensory to motor transformation process. The corrective torque acts on the body to change body orientation in space and relative to the feet. The block with  $-1$  indicates a sign inversion such that a positive value of  $e$  produces a negative  $T_c$  that tends to drive the body back toward an upright orientation. The dashed lines connecting boxes indicate physical variables, and the solid line represents neural signals. The inset stick figure defines the positive direction of the physical variables.

component is related to  $FS$ . This component can be considered to be an undesirable disturbance torque that causes the body to align with the tilted surface and therefore would be destabilizing. The other component is related to  $BS$ . This component can be considered to be a desirable, stabilizing torque that causes the body to remain oriented with respect to earth vertical.

Now it is clear that an adjustment in the sensory weights can have an influence that goes beyond the consideration of optimal maximum likelihood estimation. Specifically, a reduction of  $w_p$  reduces the disturbance torque produced by surface tilt. A reduction in the disturbance torque would seem to be a desirable effect, except that a reduction in  $w_p$  also reduces the magnitude of the stabilizing torque related to  $BS$ . The magnitude of this stabilizing torque must be maintained above the level needed to counteract torque due to gravity. Furthermore, analysis of the postural control system in Fig. 1 indicates that the overall stabilizing torque level must be closely regulated in order to maintain stable, non-resonant behavior [3]. The dual task of reducing the destabilizing torque associated with surface tilt and maintaining adequate stabilizing torque can be accomplished by increasing  $w_g$  in equal proportion to the reduction in  $w_p$  [4]. This reciprocal adjustment of sensory weights is termed a ►sensory re-weighting strategy and is also related to the concept of ►sensory substitution. Therefore, a sensory integration mechanism that uses a weighted combination of sensory orientation sources can facilitate postural control by selecting weights to provide a low variance estimate of orientation in conditions where sensory systems provide redundant information and by adjusting weights to limit the effects of external disturbances while simultaneously maintaining stability.

The sensory integration mechanism shown in Fig. 1 is easily extended to include sensory information from vision [2] and other sensory systems by adding additional feedback loops, each with its own sensory weighting factor.

### Combining Kinematic and Kinetic Information

The above discussion focused on combining information from kinematic sensors signaling body motion relative to the surface and relative to earth vertical. Integrating kinetic (force related) sensory information with kinematic information affords a further opportunity to enhance the capabilities of the postural control system. Fig. 2a shows a sensory integration scheme that includes a feedback path whereby a sensory signal encoding corrective torque contributes to the sensory error signal  $e$ .

Note that for the kinematic sensors, a forward (positive sign) body sway on a level surface produces a negative corrective torque that tends to restore body orientation to the upright position. That is, the

kinematic sensors are organized within the postural control system to provide ►negative feedback control. However, a negative corrective torque sensed by the kinetic sensors produces an even larger negative torque. That is, the kinetic sensors are organized to provide ►positive feedback control.

The benefit of integrating a kinetic contribution with kinematic sensory sources is illustrated in Fig. 2b. With only kinematic control, the Fig. 1 model predicts that a surface tilt of  $1^\circ$  produces a large body tilt of about  $2.4^\circ$  if the sensory integration relies primarily on proprioception ( $w_p = 0.8$ ,  $w_g = 0.2$ ). Body tilt is reduced to about  $0.8^\circ$  if a sensory re-weighting occurs that shifts toward increased reliance on ►graviception ( $w_p = 0.2$ ,  $w_g = 0.8$ ). When kinetic sensory information is integrated with the kinematic information using the positive feedback mechanism shown in Fig. 2a, the surface tilt induces only a transient body tilt. Note that the time course of responses to surface tilt depends on the sensory integration mechanism, the properties of the sensory to motor transformation and body mechanics. For the results shown in Fig. 2b, the sensory to motor transformation generated  $T_c$  in proportion to  $e$  and to the rate of change of  $e$ , and included a time delay representing the combined delays attributable to sensory transduction, neural transmission, central processing and muscle activation. The torque feedback loop included a low pass filter, which implies that torque feedback mainly influences tonic or low frequency behavior of the postural control system [4].

### Alternative Mechanisms for Sensory Integration

Although sensory integration can be modeled as a sensory weighting process, there are alternative representations that may correspond more closely to actual central nervous system processes. One idea is that the nervous system uses sensory information to reconstruct an internal representation of the external physical reality. As an example, Fig. 3 shows a sensory integration mechanism whereby proprioceptive and graviceptive sensory signals are used to reconstruct an internal representation of foot in space orientation.

Even though there are no direct sensors of foot in space orientation, the nervous system now has access to a derived representation of this important physical variable that encodes the surface orientation (assuming the feet are in contact with the surface). This internal representation of surface orientation provides an internal base upon which the nervous system can apply a hierarchical set of transformations that can be used to encode the orientation of various body segments relative to the surface [6].

Figure 3 also shows a scheme for combining the various internal representations of body orientation for the purpose of generating an overall error signal,  $e$ , which is the basis for generating the corrective torque

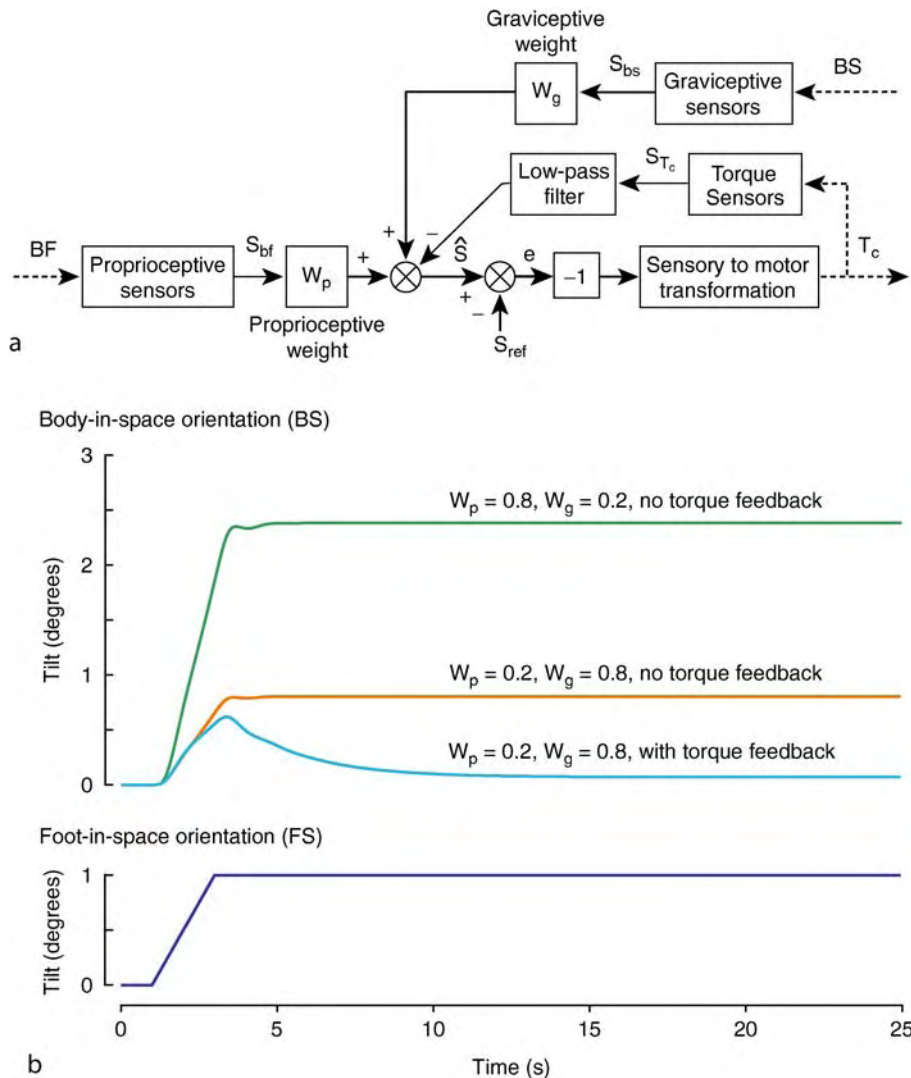

**Posture – Sensory Integration. Figure 2** a Representation of a sensory integration scheme that includes a torque feedback contribution in addition to the weighted combination of proprioceptive and graviceptive cues shown in Fig. 1. The corrective torque,  $T_c$ , is assumed to be encoded, low pass filtered and then combined with other sensory signals via a summation with a sign opposite to those of the other sensory signals. Thus a positive value of  $T_c$  produces an even larger positive value of  $T_c$ , which facilitates the return of the body toward an upright position. b Examples of body sway responses evoked by a  $1^\circ$  tilt of the surface orientation (*lower blue trace*) for different sensory integration configurations. The predicted body sway is shown for different combinations of weighted sensory feedback both with and without torque feedback. See [4] for details regarding the postural control model and model parameters.

required for balance control as shown in Fig. 1. This sensory integration process includes gain factors and thresholds that effectively perform a sensory re-weighting as a function of the amplitude of the internal sensory related signals [5].

A final sensory integration scheme that has been applied to postural control is based on the engineering concepts of optimal estimation and control [7,8,9] (Fig. 4). This scheme assumes that the nervous system possesses internal models of the body and sensor dynamics. An efference copy of the motor

command generated by the postural control system is also applied to the internal model. The internal model is used to estimate body orientation and to predict the expected sensory signals associated with motor commands applied to the body. The predicted sensory signals are compared to the actual sensory signals and any sensory error is used to improve the estimate of body orientation. This improved orientation estimate is used to generate corrective motor responses via feedback control. Furthermore, this optimal estimation and control scheme is able to account for the noise

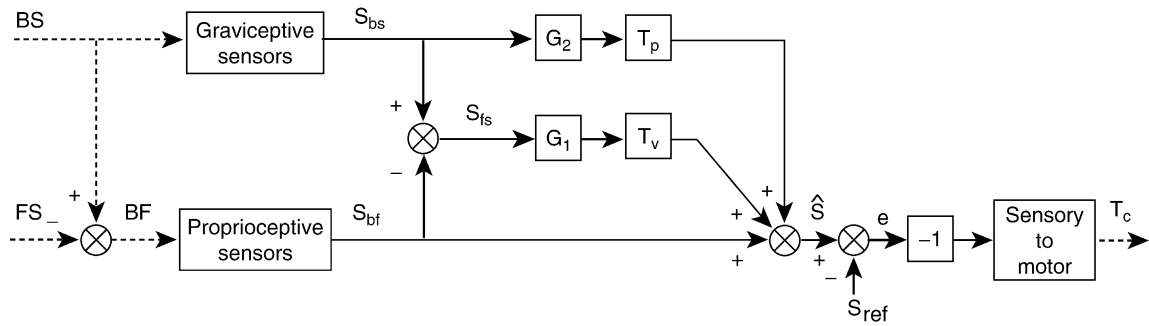

**Posture – Sensory Integration. Figure 3** A sensory integration scheme based on an internal reconstruction of external physical variables. In this example, a neural representation of foot in space orientation,  $S_{fs}$ , is formed by combining graviceptive sensory information signaling body in space orientation,  $S_{bs}$ , and proprioceptive sensory information signaling body orientation relative to the feet,  $S_{bf}$ . These three sensory signals are combined to form an overall orientation signal,  $\hat{S}$ , which is used to generate corrective torque,  $T_c$ . The boxes labeled  $G_1$  and  $G_2$  are multiplying factors,  $T_p$  is a position related threshold, and  $T_v$  is a velocity related threshold. These multiplying factors and thresholds produce a change in  $\hat{S}$  as a function of the amplitude and frequency of the sensory signals and effectively perform a re-weighting of these signals. See [5] for details.

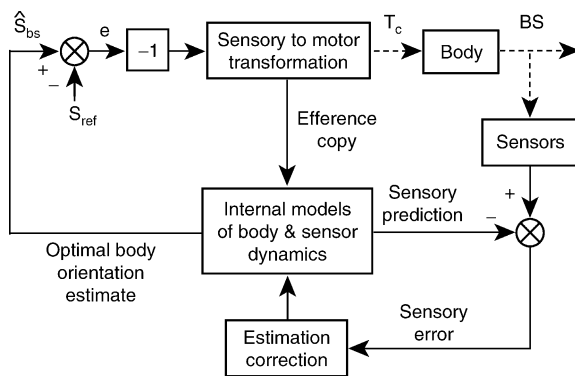

**Posture – Sensory Integration. Figure 4** A block diagram representation of a sensory integration scheme for postural control based on optimal estimation of sensory orientation information. An optimal estimate of body orientation in space,  $\hat{S}_{bs}$ , is used to generate a corrective torque,  $T_c$ , via a sensory to motor transformation process. The block with  $-1$  indicates a sign inversion such that a positive value of  $e$  produces a negative  $T_c$ , which tends to drive the body back toward an upright orientation. The optimal orientation estimate is derived via a process that accounts for the dynamic characteristics of the body and the various sensory systems that contribute information related to body in space orientation,  $BS$ . The *dashed lines* connecting boxes indicate physical variables and the *solid line* represents neural signals.

properties and dynamic characteristics of sensory and motor systems. Modifications of this scheme can also be used to generate internal estimates of external perturbations [9]. These optimal estimation and control models have been successful in predicting a variety of experimentally observed phenomena including the

apparent sensory re-weighting that occurs in response to external perturbations of varying amplitude [9] and changes in the statistical properties of spontaneous sway caused by exposure to environments which limit access to accurate sensory orientation information [8].

### Summary

The maximum likelihood principle provides an excellent foundation for understanding why the nervous system would benefit from using a weighted combination of sensory information when more than one sensory source is available. However, when sensory information is used for motor action, the physics of the body and its interaction with the environment place additional constraints on the sensory integration process. Sensory re-weighting and combined use of kinematic and kinetic sensory information provide a flexible mechanism for minimizing the effects of external disturbances while maintaining stability. Relatively simple models based on sensory reconstruction and re-weighting via threshold operations account for a wide variety of experimental data. Optimal estimation methods, developed for engineering applications and applied to postural control, also account for many experimentally observed features of sensory integration. The actual neural mechanisms for sensory integration remain to be determined.

### References

1. Ernst MO, Banks MS (2002) Humans integrate visual and haptic information in a statistically optimal fashion. *Nature* 415:429–433
2. Peterka RJ (2002) Sensorimotor integration in human postural control. *J Neurophysiol* 88:1097–1118
3. Peterka RJ, Loughlin PJ (2004) Dynamic regulation of sensorimotor integration in human postural control. *J Neurophysiol* 91:410–423

4. Cenciari M, Peterka RJ (2006) Stimulus-dependent changes in the vestibular contribution to human postural control. *J Neurophysiol* 95: 2733–2750
5. Maurer C, Mergner T, Peterka RJ (2006) Multisensory control of human upright stance. *Exp Brain Res* 171: 231–250
6. Mergner T (2002) The matryoshka dolls principle in human dynamic behavior in space: a theory of linked references for multisensory perception and control of action. *Curr Psychol Cogn* 21:129–212
7. Carver S, Kiemel T, van der Kooij H, Jeka JJ (2005) Comparing internal models of the dynamics of the visual environment. *Biol Cybern* 92:147–163
8. Kuo AD (2005) An optimal state estimation model of sensory integration in human postural balance. *J Neural Eng* 2:S235–S249
9. van der Kooij H, Jacobs R, Koopman B, van der Helm F (2001) An adaptive model of sensory integration in a dynamic environment applied to human stance control. *Biol Cybern* 84:103–115

## Posture-Movement Problem

### Definition

The problem of how the nervous system prevents the posture-stabilizing mechanisms from generating resistive forces when an active movement from an initial to a final posture is produced.

#### ► Equilibrium Point Control

## Posture Role of Cerebellum

DAGMAR TIMMANN

Department of Neurology, University of Duisburg-Essen, Essen, Germany

### Definition

The cerebellum is critical for motor coordination and motor learning. The cerebellum is involved both in voluntary movement control, for example upper limb coordination, and postural control.

► **Ataxia** of stance and gait are characteristic signs of cerebellar disease. Cerebellar disorders result in enhanced postural sway. As a compensatory response, the stance is overly wide based. If the subject attempts to stand on a narrow base, there is increase in postural sway and a tendency to fall (Fig. 1).

Many features of cerebellar gait are related to balance disorders and ways to compensate for them. For example, step length is decreased and step width is increased. Furthermore, the coordination between posture and rhythmic movements of locomotion is impaired. Likewise, postural adjustments are disordered prior to voluntary limb movements.

This chapter focuses on findings of disordered postural control during quiet stance and in response to balance disturbances in subjects with cerebellar lesions. Localizing signs of postural disturbances in cerebellar disease are reviewed first. Next, physiology and pathophysiology of cerebellar postural control is discussed.

### Description of the Theory

The structure of the cerebellar cortex is the same all over the cerebellum. Various parts of the cerebellum differ in function because of differences in fiber connections. The cerebellar cortex receives afferent input from many parts of the peripheral and central nervous system. Proprioceptive and vestibular afferents are of particular importance in cerebellar control of posture. These sensory informations are relayed to different parts of the cerebellum and probably related to different aspects of postural control.

The relative simplicity and quasicrystalline microstructure of the cerebellar cortex suggests a common computational function of this structure. As yet there is no unifying theory for cerebellar function. A number of theories and models have been proposed, including the coordination of movement across different joints, timing, an internal model for sensorimotor control or the cerebellum as a motor learning machine. These possibilities are not mutually exclusive. In the following, references to current theories of cerebellar function are made where applicable.

### Functional Compartmentalization

Gross subdivision of the cerebellum into the lateral hemispheres and medial vermis gives a first idea of functional localisation within the cerebellum. The vermis is involved in the control of posture and equilibrium as well as eye movements. The hemispheres are involved in motor execution and planning of voluntary movements. Lesions of the vermis result in disturbances of stance, gait, and ocular movements, whereas lesions of the cerebellar hemispheres primarily affect limb movements.

On the basis of the efferent projections from the cerebellar cortex to the cerebellar nuclei the cerebellum has been subdivided into a medial zone (that is the vermis) projecting to the fastigial nuclei, an intermediate zone projecting to the interposed nuclei and a lateral zone projecting to the dentate nucleus. Animal lesion studies show that lesions of the fastigial nuclei are followed by impaired or prevented sitting,



**Posture Role of Cerebellum. Figure 1** Ataxia of stance in a cerebellar subject suffering from spinocerebellar type 6 (SCA6). a Stance is wide-based. b If the subject attempts to stand on a narrow base, balance is lost (c) and subject has to make use of the wall to prevent a fall (d).

standing and walking, because of falls to the side of the lesion. This was interpreted as a deficit in equilibrium [1]. Efferents from the fastigial nuclei project to the brain stem and modify vestibular and reticular influences on posture.

The flocculonodular lobe and adjoining parts of the caudal vermis have been named the ►**vestibulocerebellum** because of heavily projecting vestibular afferents. Lesions of the vestibulocerebellum cause postural ataxia of head and trunk during sitting, standing and walking. Patients frequently fall while sitting. The classic example is medulloblastoma, which occurs most often in the cerebellum in children between 5 and 10 years of age. In subjects with such lesions, visual stabilization of posture, as evaluated by comparing sway with eyes

closed and sway with eyes open, is impaired (absence of ►**Romberg's sign**). Severe postural sway is present with eyes open and is essentially unchanged with eyes closed. Intersegmental movements are diminished.

The anterior and posterior parts of the vermis and paravermal parts of the cerebellar hemispheres are called the ►**spinocerebellum** because of their spinal afferents. Damage to the spinocerebellar parts of the ►**anterior lobe** is characterized by ataxia of stance and gait. The classic example is alcoholic cerebellar degeneration. Visual stabilization of posture is relatively preserved and the tremor is provoked by eye closure (presence of Romberg's sign). Patients rarely fall because the body tremor is opposite in phase in head, trunk, and legs, resulting in a minimal shift of the center of gravity.

Chronic damage to the lateral cerebellar hemispheres that is the cerebro- or pontocerebellum, does not result in significant postural disorders. The lateral hemispheres receive the main input from the cerebral cortex, synaptically interrupted in the pontine nuclei.

Diener and coworkers [2] measured body sway by means of a force-measuring platform in human subjects with lesions of the ponto-, vestibulo- or spinocerebellum (Fig. 2).

Postural sway was basically unaffected in subjects with lesions of the lateral cerebellar hemispheres. Lesions of the lower vermis caused omnidirectional postural sway with frequency components below 1 Hz. Lesions of the anterior lobe led to anterior-posterior body sway with a frequency of about 3 Hz. A more recent human lesion study questioned if 3 Hz body oscillations occur exclusively in lesions of the anterior lobe. Likewise, assessment of trunk sway in patients with spinocerebellar ataxias showed that postural instability was generally more pronounced in the pitch than in the roll plane, corresponding with predominant involvement of the spinocerebellum [3].

### Posture Role of the Spinocerebellum

Postural muscle tone is a primary contributor to the maintenance of upright stance. Damage to the anterior lobe in experimental animals primarily produces a change of muscle tone. In decerebrate animals, the decerebrate rigidity increases, as do the postural reflexes. In humans it is doubtful whether lesions of the anterior lobe produce increased muscle tone. Postural sway following lesions of the anterior lobe has been explained by an increased gain of posturally stabilizing (long loop) reflexes [4].

Sway can be provoked by platform perturbations or electrical stimulation of the tibial nerve. Subjects with anterior lobe atrophy show hypermetric postural responses and overshooting of the initial posture, with

larger than normal surface reactive torque responses and exaggerated and prolonged muscle activity (Fig. 3; [5]).

Latencies of postural responses provoked by platform perturbations are normal in patients with cerebellar disorders. Increased gain and prolonged duration of ▶long loop reflexes result in an overcompensation of the postural tasks and are believed to evoke (exaggerated) postural responses of the corresponding antagonists. The postural tremor supposedly continues by the same mechanism.

A more recent model of the (spino-) cerebellum supports the notion that the cerebellum may contribute to balance by long loop feedback with scheduling of linear gains at the same joint and interjoint responses between ankle, knee, and hip [6]. Explicit internal dynamics models within the cerebellum, which have been hypothesized to control voluntary limb movements, do not necessarily contribute to spinocerebellar balance control.

### Posture Role of the Vestibulocerebellum

Studies in primates have helped to understand the specific contributions of the vestibulocerebellum to postural control. Knowledge based on human studies is more limited.

The dominant afferent inputs to the vestibulocerebellum come from the semicircular canals, which signal changes in head position, and the otolith organs, which signal the orientation of the head with respect to gravity. Semicircular canal information is relayed to the flocculus and otolith information to the caudal cerebellar vermis (▶nodulus and ▶uvula).

Sensory input from the otoliths evoke vestibulocollic and vestibulospinal reflexes that maintain the head vertical with respect to gravity. Vestibulocollic and vestibulospinal reflexes are primarily static. The semicircular canals, however, have weaker influences on spinal

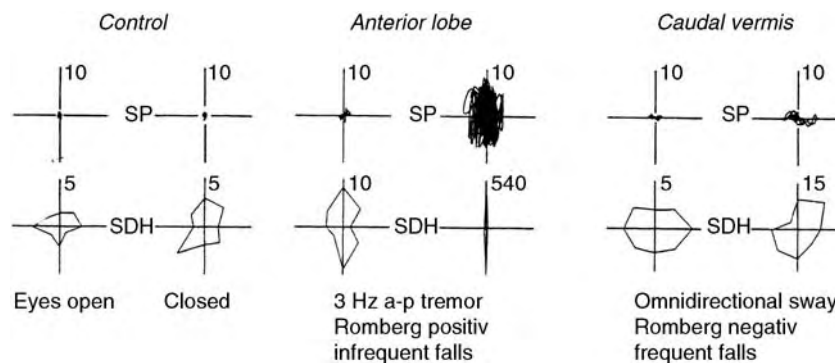

**Posture Role of Cerebellum. Figure 2** Sway path (SP) and sway direction histograms (SDH) in a control, a patient with anterior lobe atrophy and a patient with a vestibulocerebellar lesion. Note the strong preference of anterior-posterior sway in the patient with anterior lobe atrophy. (Adapted from [2]; with permission).

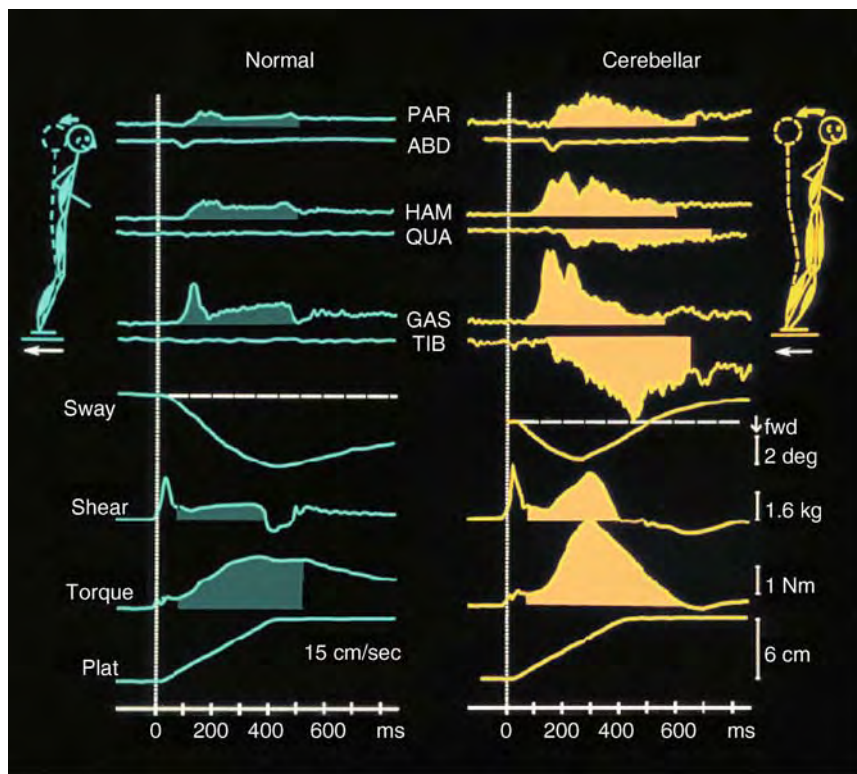

**Posture Role of Cerebellum. Figure 3** Mean postural responses evoked by a backward translation of the supportive platform in a control group and a cerebellar group with anterior lobe atrophy. Cerebellar subjects show hypermetric postural responses, exaggerated and prolonged muscle activity and larger than normal surface reactive torque responses. Latencies of postural responses are normal. Traces show (top to bottom): electromyographic (EMG) recordings from paraspinal (PAR), rectus abdominis (ABD), biceps femoris (HAM), rectus femoris (QUA), gastrocnemius (GAS), and anterior tibial (TIB) muscles; sway, shear forces, surface torque and platform displacement. (Adapted from [5]; with permission).

circuits and serve predominantly to control extraocular muscles and coordinate head and eye movements.

It has been assumed that a lesion of the vestibulocerebellum leads to disturbed gravitational set values and therefore to a loss of spatial orientation vs. gravity. The set value of determining the upright is lost.

More recent single cell recording studies in the primate provide evidence that the rostral fastigial nucleus represents a main processing center of otolith driven information for inertial motion detection and spatial orientation. Angelaki and coworkers [7] showed that cerebellar and brainstem motion sensitive neurons encode dynamically processed otolith signals appropriate to construct an internal model of inertial motion detection.

A study in children and adolescents with chronic surgical cerebellar lesions underscores the importance of the fastigial nuclei in human postural control. High-resolution magnetic resonance imaging allowed detailed analysis of the lesion side. The ability to control upright stance based on vestibular information alone (that is without visual information and unreliable proprioceptive information) was only impaired in

subjects with cerebellar lesions that included the fastigial nuclei (Fig. 4; [8]).

Findings further showed that the lesion site was critical for the motor recovery. Lesions affecting the cerebellar nuclei (but not the cerebellar cortex) were not compensated at any developmental age.

Interestingly, otolith dysfunction has been demonstrated in patients with spinocerebellar ataxia type 6 (SCA6). SCA6 is a hereditary disorder, which affects the vestibulocerebellum early in the disease.

### Role of Cerebellum in Postural Adaptation

Many studies show that the cerebellum plays an important role in motor learning, in particular in adaptation and automatization of movement. Disordered adaptation probably contributes to ataxia of stance, but has been assessed by few studies only.

Most studies investigated adaptation of early automated postural responses to changes in surface perturbations. Because the contribution of the somatosensory system is much greater than that of the vestibular system when compensating for transient surface



perturbations, contributions of the spinocerebellum are assessed. Initial findings of Nashner [9] showed that healthy subjects but not cerebellar patients adapt automated postural responses depending on context. Nashner compared postural responses to backward translations and upward rotations. Both lead to the same ankle rotation. Upright stance however, is maintained by contraction of the anterior tibial muscle in upward rotations, but of the gastrocnemius muscle in backward translations. In controls, but not cerebellar subjects, responses that stabilize posture were facilitated progressively with repeated trials, whereas responses that destabilize posture were diminished. These findings were, however, challenged in later studies. When the type

of perturbation changed from translation to rotation and vice versa both controls and cerebellar subjects showed an immediate change in the response amplitudes of the gastrocnemius and anterior tibial muscles.

Horak and Diener [5] studied whether cerebellar subjects could learn to adjust for predictable postural perturbations during standing (Fig. 5).

When different displacement amplitudes were presented in a serial (predictable) format, healthy subjects were able to appropriately scale their initial postural responses. In contrast, cerebellar subjects were unable to learn to use predictive feedforward control (in other words central set from prior experience) to scale their early automated postural responses

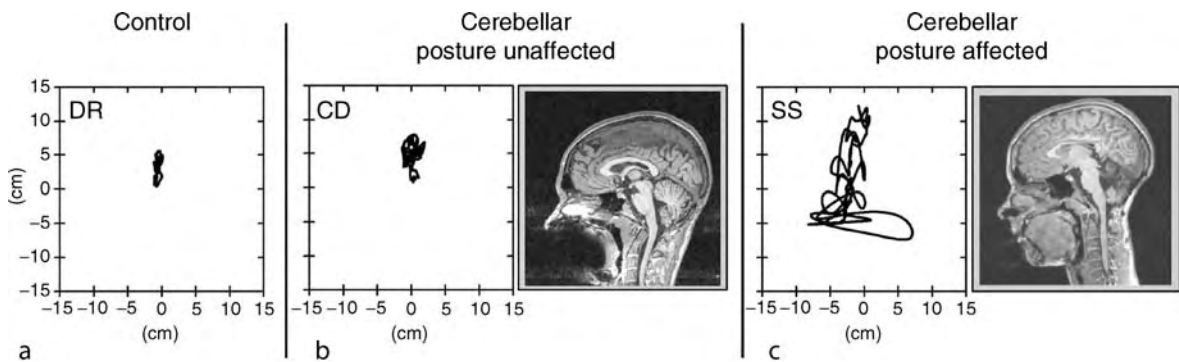

**Posture Role of Cerebellum. Figure 4** Effects of fastigii lesions on postural sway. Postural sway is increased in patient SS, but not in patient CD compared to the control subject DR. In both patients an astrocytoma had been surgically removed. The sagittal MRI images reveal that area above the 4th ventricle, that is the location of the fastigial nuclei, was affected in SS but not in CD. Shown are the center of gravity sway paths over 20 s in a condition that is dependent on vestibular function (that is eyes closed and surface sway referenced). (Adapted from [8]; with permission).

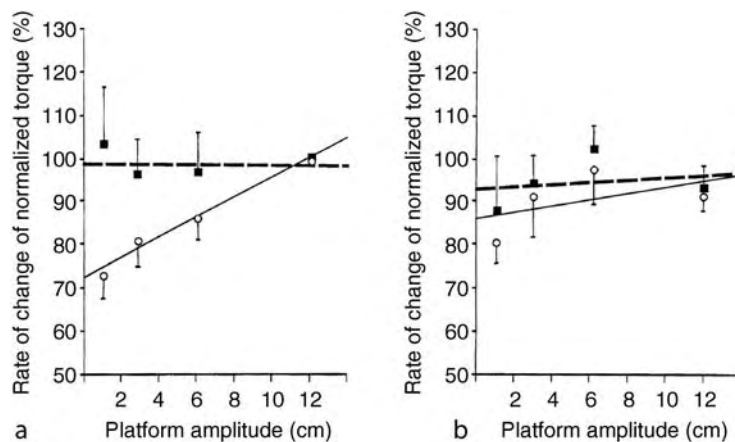

**Posture Role of Cerebellum. Figure 5** Scaling of torque responses to platform displacement amplitude in controls (*continuous line*) and cerebellar subjects (*broken line*). The mean  $\pm$ SE of normalized torque responses are indicated for serial (predictable) (a) and random (b) amplitude presentation. Control subjects scale to predictable but not random presentation of displacement amplitudes, whereas the cerebellar group scaled neither to predictable or random presentation. (Adapted from [10]; with permission).

to expected perturbation amplitudes. A subsequent study showed that cerebellar patients could predict perturbation amplitudes based on prior experience, but they could not use this prediction to modify precisely the gain of early automated postural responses [10]. The spinocerebellum may be important for accurate tuning of response gain based on prediction.

Cerebellar contribution to adaptation of vestibular reflexes is likely. Cerebellar contributions have been investigated in great detail for adaptation of the vestibulo-ocular reflex (VOR). The function of the VOR is to stabilize retinal images by generating smooth eye movements that are equal and opposite to each head movement. Learning occurs whenever image motion occurs persistently during head turns; as a result image stability is gradually restored. The cerebellar role in retention is disputed, but there is a consensus on the need of an intact cerebellum (that is flocculus) for acquisition.

The role of the caudal cerebellar vermis (nodulus and uvula) for adaptation of the “static” vestibulocollic and vestibulospinal reflexes has not been assessed in detail.

### Summary

The medial cerebellum (that is vermis) is of particular importance in postural control. The contribution of the cerebellum is two-fold. Vermal parts of the anterior lobe (that is spinocerebellum) are involved in control of automated postural reflexes evoked by proprioceptive feedback. Hypermetric postural responses and disordered adaptation can be explained by inaccurate tuning of reflex gain. Disordered coordination between head, trunk and legs (asynergia) probably contributes but is less well understood. Caudal parts of the vermis (that is the vestibulocerebellum) play an important role in spatial orientation of the body against gravity and detection of inertial body motion evoked by otolith feedback. The vestibulocerebellum appears to be important in building an internal model of inertial body motion.

### References

1. Thach WT, Bastian AJ (2004) Role of the cerebellum in the control and adaptation of gait in health and disease. *Prog Brain Res* 143:353–366
2. Diener HC, Dichgans J, Bacher M, Gompf B (1984) Quantification of postural sway in normals and patients with cerebellar diseases. *Electroencephalogr Clin Neurophysiol* 57:134–142
3. Van de Warrenburg BP, Bakker M, Kremer BP, Bloem BR, Allum JH (2005) Trunk sway in patients with spinocerebellar ataxia. *Mov Disord* 20:1006–1013
4. Mauritz KH, Schmitt C, Dichgans J (1981) Delayed and enhanced long latency reflexes as the possible cause of postural tremor in late cerebellar atrophy. *Brain* 104:97–116

5. Horak FB, Diener HC (1994) Cerebellar control of postural scaling and central set in stance. *J Neurophysiol* 72:479–493
6. Jo S, Massaquoi SG (2004) A model of cerebellum stabilized and scheduled hybrid long-loop control of upright balance. *Biol Cybern* 91:188–202
7. Angelaki DE, Shaikh AG, Green AM, Dickman JD (2004) Neurons compute internal models of the physical laws of motion. *Nature* 430:560–564
8. Konczak J, Schoch B, Dimitrova A, Gizewski E, Timmann D (2005) Functional recovery of children and adolescents after cerebellar tumour resection. *Brain* 128:1428–1441
9. Nashner LM (1976) Adapting reflexes controlling the human posture. *Exp Brain Res* 26:59–72
10. Timmann D, Horak FB (1997) Prediction and set-dependent scaling of early postural responses in cerebellar patients. *Brain* 120:327–337

---

## Posturography

### Definition

Analysis of body posture, and postural control, typically using computerized image analysis of the position and movement of body segments over time.

---

## Potential Energy

### Definition

Certain systems of forces (called conservative systems) are such that the forces can be obtained as (minus) the spatial derivatives of a single scalar function of position. This function, if it exists, is called the potential energy of the system. It is of paramount importance in analytical mechanics.

### ► Mechanics

---

## Potentiation

### Definition

Potentiation refers to the combination of two stimuli resulting in a larger response than the sum of responses to each stimulus alone.

## Potentiometer

### Definition

A variable resistor used to control an electronic device.

- ▶ Hearing Aids

## Power

### Definition

Power is the amount of energy produced per unit time. The mechanical power a skeletal muscle produces is the product of the force in the muscle and the velocity of the muscle.

## Power Density Spectrum

### Definition

A power density spectrum is a plot of the power (watts) in a signal as a function of frequency; also referred to as the autospectrum. Fast Fourier transform is used most commonly to construct the power density spectrum.

- ▶ Signals and Systems

## Power Stroke

### Definition

The power stroke of the cross-bridge cycle is the phase of force production. In the current cross-bridge thinking, the power stroke is initiated by the release of the free phosphate from ATP hydrolysis.

- ▶ Sliding Filament Theory

## PPAR $\gamma$

### Definition

Peroxisome proliferator-activated receptors act as ligand-activated transcription factors, similar to other nuclear hormone receptors. One of its isoforms, PPAR $\gamma$ , exerts anti-inflammatory activities in brain cells by reducing proinflammatory cytokines.

- ▶ Neuroinflammation: Chronic Neuroinflammation and Memory Impairments

## p55-R

- ▶ Brain Inflammation: Tumor Necrosis Factor Receptors in Mouse Brain Inflammatory Responses

## Praxis Navigation Strategy

### Definition

Behavior relying on an egocentric reference frame and directed by a specific motor sequence to get a goal location.

- ▶ Spatial Memory

## PRC

- ▶ Phase Response Curve

## Pre-Bötzinger Complex

### Definition

A physiologically defined region within the ventrolateral medulla of mammals that is critical for the

generation of inspiratory activity. The pre-Bötzinger complex can be functionally isolated in brainstem slice preparations, and is still capable of generating three specific rhythmic activities that have many characteristics of normal respiratory activity (eupnea), gasping and sighing.

### ►PreBötzinger Complex Inspiratory Neurons and Rhythm Generation

## Pre-Bötzinger Complex Inspiratory Neurons and Rhythm Generation

CHRISTOPHER A. DEL NEGRO, JOHN A. HAYES, RYLAND W. PACE  
The Department of Applied Science, The College of William and Mary, Williamsburg, VA, USA

### Definition

The ensemble of neurons in the ventral medulla that plays an important role in generating breathing behavior in mammals by synchronously producing large-magnitude bursts that drive the inspiratory phase of the respiratory cycle.

### Characteristics

The ►preBötzinger Complex (preBötC) of the ventral medulla plays an important role in generating breathing behavior in mammals. Anatomical studies have demarcated the borders of the preBötC and experiments in vivo have defined its functional purview. However an unsolved problem pertains to which neurons – and which intrinsic and synaptic properties – make up the rhythmogenic kernel? In vitro models of respiration, particularly slice preparations from neonatal rodents, make experimental tests possible. Transverse slices isolate the preBötC and provide unprecedented access to preBötC neurons for electrophysiology and imaging while maintaining spontaneous inspiratory motor activity, which can be monitored via the ►hypoglossal (XII) cranial nerve root. A diverse array of intrinsic and synaptic properties have been found, which subsequently motivated numerous attempts to subdivide preBötC neurons into various ‘types’ to assign roles in respiratory rhythm generation. Here we review and critique these classification schemes and proffer objective criteria to distinguish rhythmogenic neural properties.

### Inspiratory Drive Latency and Peptide Receptors

Rekling and colleagues [1] proposed a classification scheme that considered sensitivity to ►neuropeptides and ►inspiratory drive latency, defined as the time interval consisting of a crescendo of EPSPs and spiking activity preceding XII motor output (Fig 1). They argued that inspiratory neurons with the earliest drive latency and highest levels of excitability, which also responded to inspiratory drive latency that modulate respiratory rhythm, were most likely to be rhythmogenic. Earliest to activate were type 1 neurons with ~400 ms drive latency and highly excitable membrane properties. Type 2 neurons also exhibited high excitability with ~170 ms drive latency. The least excitable were type 3 neurons with drive latency of ~100 ms. Type 1 neurons were proposed to be rhythmogenic and to activate type 2 neurons downstream, followed by type 3, which were postulated to have a motor or premotor function.

Transient  $K^+$  current, i.e., A-current ( $I_A$ ), was expressed exclusively in type 1 neurons whereas the hyperpolarization-activated mixed cation current ( $I_h$ ) was associated only with type 2 neurons. These data suggested a genuine disparity that could distinguish a hierarchy of rhythmogenic subtypes. We measured  $I_A$  in ~60% of preBötC inspiratory neurons and found that its selective blocker, 4-aminopyridine (2 mM), caused profound disruptions in the respiratory rhythm (Fig 2), consistent with the proposal that  $I_A$  expression is a hallmark of rhythmogenic neurons (i.e., type 1-like).  $I_h$  is present in ~15% of preBötC inspiratory neurons and blocking it with  $Cs^+$  or organic agents speeds up the rhythm, which is consistent with  $I_h$  expression

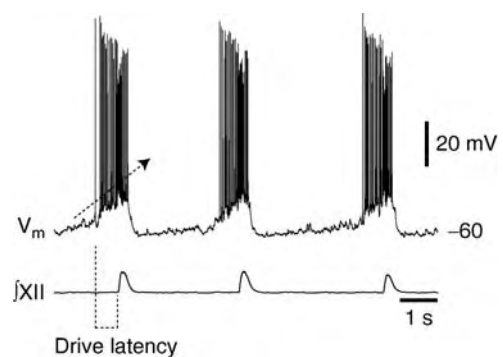

**Pre-Bötzinger Complex Inspiratory Neurons and Rhythm Generation.** Figure 1 A typical voltage trajectory for a preBötC neuron putatively involved in rhythm generation shown with respiratory-related XII motor output. Inspiratory drive latency is illustrated with dotted lines to mark the onset of inspiratory drive and the XII motor discharge. A dotted-line arrow emphasizes the incremental depolarization and spike discharge pattern that distinguishes relatively small neurons with early drive latency.



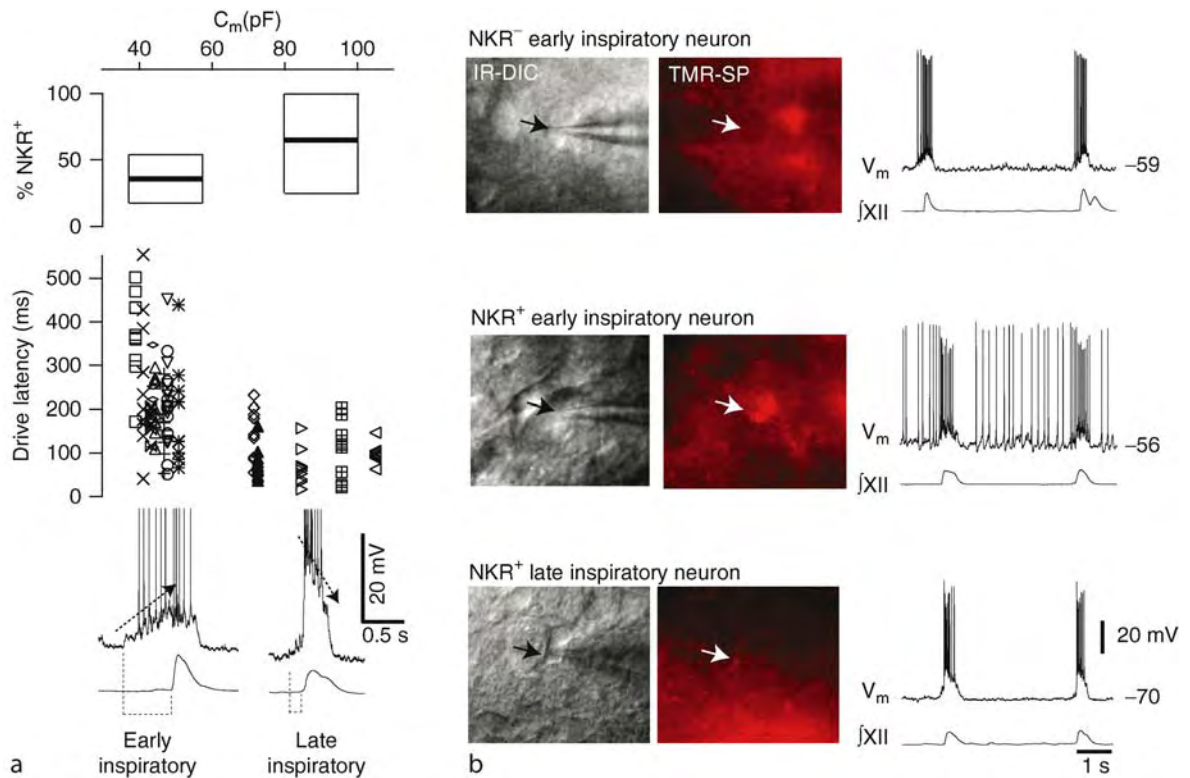

**Pre-Bötzing Complex Inspiratory Neurons and Rhythm Generation. Figure 3** Criteria to distinguish inspiratory preBötC neurons that are involved in rhythm generation. (a), Inspiratory drive latency (lower ordinate) and neurokinin receptor (NKR) expression (upper ordinate) are plotted as a function of whole-cell capacitance  $C_m$ . Box plots show mean and 95/5% credible interval range. Typical examples of early as well as late inspiratory phenotypes are shown beneath their characteristic  $C_m$  range. (b), NKR expression is shown for three typical inspiratory preBötC neurons. Two early inspiratory neurons, which are hypothesized to be rhythmogenic on the basis of membrane properties, are shown with NKR expression (NKR<sup>+</sup>) and without (NKR<sup>-</sup>). An NKR<sup>+</sup> late expiratory neuron, hypothesized to have motor or premotor function, is also illustrated. Modified from [2].

showed drive latency of  $\sim 100$  ms and were NKR<sup>+</sup> 67% of the time (Fig. 3). The majority of the preBötC neurons we recorded were small with early inspiratory activity. The early latency, small size, and incremental discharge trajectory are characteristic of glutamatergic interneurons, and resemble types 1 and 2 [1] and therefore are probably glutamatergic, not GABA- or glycinergic neurons [4]. The fraction of NK1R<sup>+</sup> neurons with early drive latency in adult rats in vivo is also near 36%, so the fraction of NKR<sup>+</sup> neurons in the preBötC appears consistent in neonate and adult rodents.

Large preBötC inspiratory neurons that activate latest in the respiratory cycle (Fig. 3a) may be premotor neurons [5]. A large fraction of these cells were NKR<sup>+</sup> (Fig. 3b) thus sensitive to saporin lesions [3]. However, because the small neurons with early drive latency are more numerous saporin lesions will probably cause a greater total reduction in NKR<sup>+</sup> rhythmogenic-like neurons. However, the destruction of a large fraction of NKR<sup>+</sup> respiratory premotoneurons must be considered

as a factor in explaining apneas resulting from saporin lesions [3].

Finally, we showed that peptide sensitivity and receptor expression were not necessarily synonymous. Even though only 36% of the putatively rhythmogenic neurons were NKR<sup>+</sup>, a much larger fraction (87%) showed a SP-evoked inward current ( $I_{SP}$ ) in voltage clamp, which suggests that **gap junctions** may provide a means for NKRs to evoke inward current in both NKR<sup>+</sup> as well as NKR<sup>-</sup> preBötC inspiratory neurons [2]. This suggests that most of the putatively rhythmogenic neurons still satisfy the three objective criteria: small size, early inspiratory drive latency, and peptide sensitivity.

### Pacemaker Properties: Not Specialized Phenotypes, Cannot Explain Rhythmogenesis

Evidence for a **pacemaker** cell-type accompanied the discovery of the preBötC [6]. In the absence of synaptic transmission, some neurons with a baseline

membrane potential between  $-57$  and  $-45$  mV spontaneously depolarize and generate rhythmic bursts, dubbed **►conditional pacemaker properties**. Voltage-dependent pacemaker properties were attractive from the standpoint of rhythmogenesis because conditional bursting in isolated cells had the same duty cycle as the network-intact XII rhythm. Pacemaker neurons were postulated to form a specialized phenotype that periodically excites so-called follower neurons and synchronizes both sets of neurons through excitatory synaptic interconnections.

PreBötC inspiratory neurons have been classified as either pacemakers or followers, yet this binary classification is more apparent than real. Voltage-dependent bursting depends on a requisite region of negative slope in the current-voltage relationship endowed by **►persistent  $\text{Na}^+$  current** ( $I_{\text{NaP}}$ ). We now know that  $I_{\text{NaP}}$  is a generic property, ubiquitously expressed throughout the preBötC and ventral medulla. Since baseline membrane potential must be within a specific voltage window, **►leakage potassium current** ( $I_{\text{K-Leak}}$ ) also becomes important to maintain voltage-dependent bursting.  $I_{\text{NaP}}$  and  $I_{\text{K-Leak}}$  are distributed continuously among preBötC inspiratory neurons, thus a small subset with conditional bursting properties arises naturally for neurons with the proper  $I_{\text{NaP}}/I_{\text{K}}$  ratio and is a byproduct of heterogeneity in membrane properties.

The real question is whether  $I_{\text{NaP}}$  is important for rhythmogenesis. To avoid caveats associated with bath-applications [7], we performed micropressure injections to apply riluzole – and low doses of TTX (20 nM) that preferentially block  $I_{\text{NaP}}$  – directly into the preBötC without affecting premotor or XII motoneurons (Fig. 4). Riluzole and 20 nM TTX microinjections did not stop the rhythm nor affect XII motor output, indicating that  $I_{\text{NaP}}$  is not obligatory for rhythmogenesis [8].

Voltage-dependent pacemaker properties do not constitute a specialized phenotype in the preBötC because  $I_{\text{NaP}}$  is commonplace and nonessential for rhythmic function. Nevertheless,  $I_{\text{NaP}}$  contributes to baseline membrane potential and facilitates high-frequency spiking, and thus helps maintain neural excitability [7,8].

Pacemaker properties unrelated to  $I_{\text{NaP}}$  were documented in 2001. Bursting was sensitive to blockade by  $\text{Cd}^{2+}$ , indicating dependence on intrinsic  $\text{Ca}^{2+}$  currents; later a **► $\text{Ca}^{2+}$ -activated nonspecific cation current** ( $I_{\text{CAN}}$ ) was shown to be involved [17,20].  $\text{Cd}^{2+}$ -sensitive bursting neurons were posited to form an additional rhythmogenic subpopulation that could drive rhythmogenesis in combination with, or in lieu of,  $I_{\text{NaP}}$  pacemaker neurons [9]. However, two key facts falsify this hypothesis: first,  $\text{Cd}^{2+}$ -sensitive pacemaker properties are sparse or nonexistent in early in post-natal development [9], yet riluzole does not stop the rhythm. Second, doses of flufenamic acid (FFA, 10–100  $\mu\text{M}$ ) that attenuate  $I_{\text{CAN}}$  to an extent that precludes  $\text{Cd}^{2+}$ -sensitive bursting – but do not completely block  $I_{\text{CAN}}$  – do not stop rhythmogenesis in the presence of riluzole or TTX at any post-natal age [8].

Unless a miniscule number of pacemaker neurons that are insensitive to  $I_{\text{NaP}}$  and  $I_{\text{CAN}}$  antagonists can drive the rhythm – or a heretofore undiscovered pacemaker phenotype exists – these observations invalidate the hypothesis that pacemaker neurons are the basis for rhythmogenesis.

### **$I_{\text{CAN}}$ Activates Synaptically and Generates Rhythmic Inspiratory Bursts in PrebötC Neurons**

**►AMPA receptors** (AMPA) are necessary for rhythmogenesis. Moreover, group I **►metabotropic glutamate receptors** (mGluRs) and **►NMDA receptors**

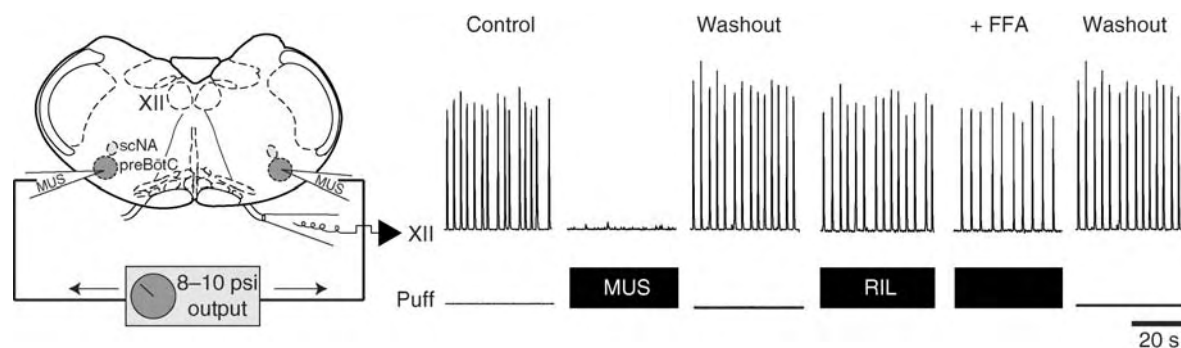

**Pre-Bötzing Complex Inspiratory Neurons and Rhythm Generation. Figure 4** Sequential drug application experiments using local microinjection of 10  $\mu\text{M}$  riluzole (RIL). Top traces show XII motor output, lower traces labeled “puff” reflect TTL pulses at 3 Hz that gate micropressure drug-delivery injections. Bilateral injection of 15  $\mu\text{M}$  muscimol (MUS) is used to verify the effective microinjection pipette locations. After recovering from MUS, RIL is microinjected for >20 min, followed by bath application of 100  $\mu\text{M}$  flufenamic acid (FFA). The rhythm did not stop, nor became perturbed in any noticeable form, after >20 min of bath-applied FFA (cumulative RIL exposure >40 min). Recovery from all drugs occurred within 1–2 h and is shown as washout. Modified from [8].

(NMDARs) provide a substantial – yet heretofore unrecognized – contribution to generating inspiratory bursts and rhythm. Both ionotropic, and metabotropic glutamate receptors activate  $I_{CAN}$  via voltage-gated  $Ca^{2+}$  channels and inositol (1,4,5)-triphosphate ( $IP_3$ )-mediated intracellular  $Ca^{2+}$  release. Additionally,  $I_{CAN}$  serves to generate robust inspiratory drive potentials in all preBötC inspiratory neurons [10].

Group I mGluRs consist of subtypes mGluR1 and mGluR5. While mGluR5 triggers  $I_{CAN}$  activation, via  $IP_3$ -mediated intracellular  $Ca^{2+}$  release, mGluR1 appears to promote inspiratory drive potentials by transiently closing  $K^+$  channels. In contrast, group II mGluRs modulate interburst period but do not contribute to inspiratory burst generation.

$Ca^{2+}$  influx via NMDARs may also contribute to  $I_{CAN}$  activation. AMPAR-mediated depolarization recruits **voltage-gated  $Ca^{2+}$  channels** and may partially relieve the voltage-dependent  $Mg^{2+}$  block of NMDARs and thus indirectly activate  $I_{CAN}$  in the preBötC. This is the first example of a convergent activation of  $I_{CAN}$  involving NMDARs,  $Ca^{2+}$  channels and intracellular  $Ca^{2+}$  release to serve burst generation in a **central pattern generator**.

How important is  $I_{CAN}$ ? We used two strategies to test its role. In the first, intracellular drug application was employed to test the role of  $I_{CAN}$  in drive potential generation in a single preBötC neuron without disrupting respiratory rhythm in the rest of the network. We recorded inspiratory drive in control using **perforated patches** (Fig. 5), which does not modify the intracellular milieu. Then we ruptured the patch and dialyzed the cytosol with patch solution containing 30 mM BAPTA, a high-affinity  $Ca^{2+}$  chelator. BAPTA abolishes the ability to activate  $I_{CAN}$  and reduced drive potentials by 70% after  $\geq 20$  min suggesting  $I_{CAN}$  that  $I_{CAN}$  is the major charge carrier underlying inspiratory drive potentials [10].

We examined whether  $I_{CAN}$  (Fig. 6) was crucial for rhythmogenesis in the network as a whole using bath application of the selective antagonist flufenamic acid (FFA). Dose is a critical issue: 100  $\mu M$  FFA incompletely blocks  $I_{CAN}$  and does not stop the network rhythm, but nonetheless reduces inspiratory drive potentials by  $\sim 40\%$  [10]. Higher concentrations of FFA (300–350  $\mu M$ ) stop respiratory rhythmogenesis. While an attractive conclusion is that FFA at  $\geq 300$   $\mu M$  stops rhythmogenesis by fully and selectively blocking  $I_{CAN}$ , FFA doses exceeding 100  $\mu M$  exert numerous side effects [10], and thus confound such a straightforward interpretation. Nevertheless, we can conclude that  $I_{CAN}$  contributes enormously to inspiratory drive on a cycle-to-cycle basis by transforming synaptic input into long-lasting membrane depolarization, and thus plays an important role in inspiratory burst generation.

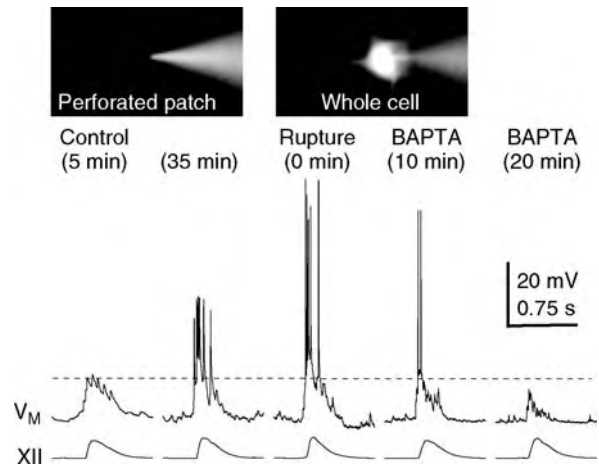

### Pre-Bötzing Complex Inspiratory Neurons and Rhythm Generation.

**Figure 5** Perforated-patch control recordings and subsequent intracellular dialysis with 30 mM BAPTA patch solution demonstrate the importance of  $Ca^{2+}$  transients and  $I_{CAN}$ . Control conditions were recorded in the perforated-patch configuration (5 and 35 min shown). BAPTA was introduced into the cytosol via patch rupture (0 min) and caused a progressive attenuation of the drive potential. Baseline membrane potential was  $-60$  mV throughout the experiment. The perforated-patch configuration (PP; *left picture*) is confirmed by the failure of the Lucifer yellow in the patch-pipette solution to dialyze the cell. The whole-cell configuration (WC; *right picture*) allows Lucifer yellow to fill the cell. The  $V_M$  traces verify that the underlying inspiratory drive potential can be accurately measured in PP mode as compared to the first minute of WC mode. In WC, the spikes are less truncated because the access impedance decreases. Modified from [10].

### The Group-Pacemaker Hypothesis of Respiratory Rhythm Generation

$I_{CAN}$  activation depends on AMPA, NMDA, and metabotropic glutamate receptors during endogenous respiratory behavior, and thus is properly considered a network property. The group-pacemaker hypothesis (Fig. 7) postulates a mechanism for rhythmogenesis wherein recurrent synaptic excitation linked to postsynaptic intrinsic currents plays a special role. In the group pacemaker, a fraction of neurons in the preBötC are spontaneously firing; baseline voltage during the expiratory phase exceeds spike threshold. In the waning expiratory phase, active neurons excite silent neurons, which in turn excite additional silent neurons and also provide positive feedback to re-excite the neurons already spiking.  $I_{CAN}$  is normally latent and unavailable except when recruited by synaptic excitation. Glutamatergic input sufficient to evoke  $I_{CAN}$  is ultimately achieved a few hundred milliseconds prior to inspiratory burst discharge. The negative feedback process that causes burst termination remains unknown. After burst termination, neurons



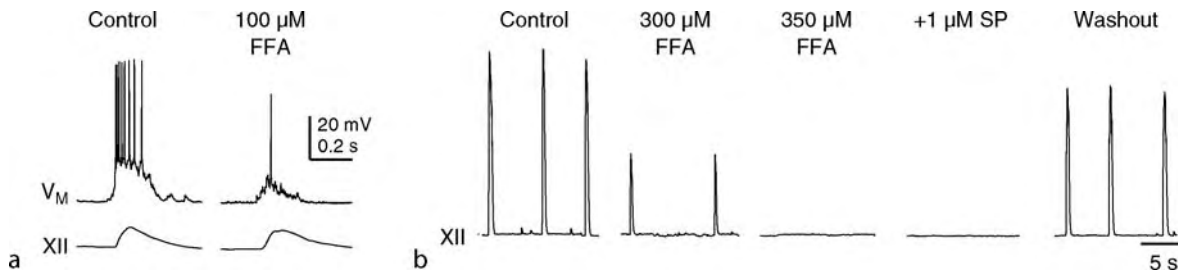

**Pre-Bötzinger Complex Inspiratory Neurons and Rhythm Generation. Figure 6** Effects of  $I_{CAN}$  antagonist flufenamic acid (FFA) on inspiratory bursts and rhythmogenesis. (a), Typical inspiratory bursts recorded in whole-cell conditions for control and 100  $\mu$ M FFA, respectively. (b), An experiment showing that 300  $\mu$ M FFA severely perturbed the respiratory rhythm (monitored via XII discharge) and 350  $\mu$ M FFA stopped it altogether. In the presence of 350  $\mu$ M FFA, even the excitatory peptide substance P (which normally stimulates rhythmogenesis profoundly) fails to revive rhythm generation. The effects of FFA were reversible, as shown by the full recovery in washout conditions. Modified from [10].

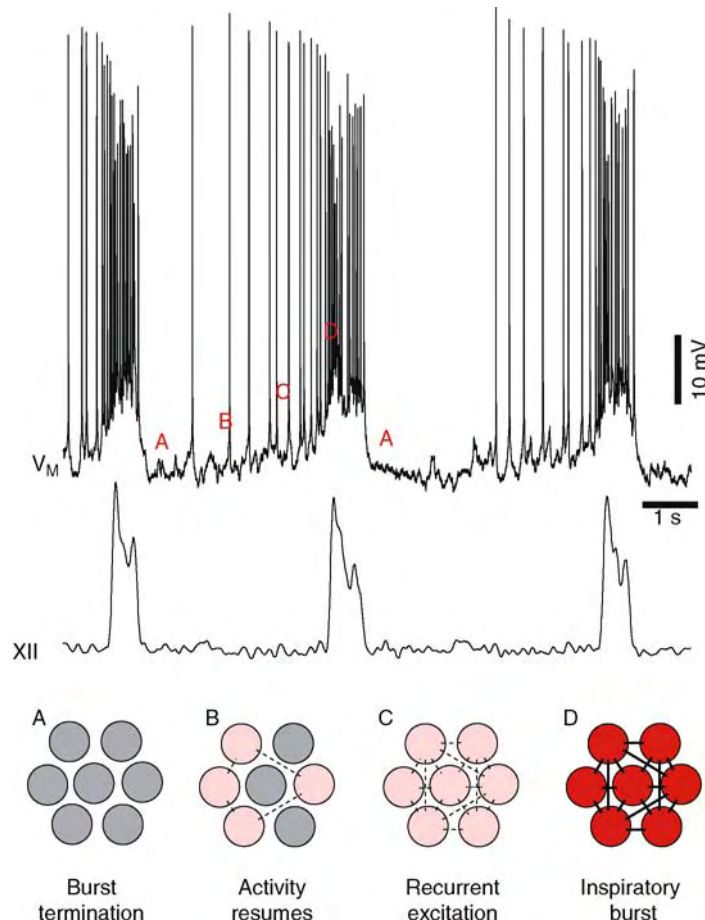

**Pre-Bötzinger Complex Inspiratory Neurons and Rhythm Generation. Figure 7** Group-pacemaker hypothesis of rhythm generation. The membrane potential of an inspiratory preBötC neuron is shown ( $V_M$ ) with XII motor output. Images at the bottom depict neuronal activity at different stages of the cycle. (a), the refractory state following the inspiratory burst. (b), some preBötC neurons recover their excitability and begin to spike low rates. (c), Spiking preBötC neurons begin to synaptically activate other silent preBötC neurons, leading to aggregation of network activity via recurrent synaptic excitation, which is positive feedback. (d), the inspiratory burst occurs when recurrent synaptic activity is sufficiently strong to recruit postsynaptic inward currents such as  $I_{CAN}$ . Inspiratory bursts terminate due to intrinsic properties that remain unknown. Modified from: Feldman and Del Negro, *Nat Rev Neurosci* 7: 232–242, 2006.

undergo a recovery phase in which they gradually approach a baseline membrane potential largely determined by  $I_{K-Leak}$  and the by tonic inputs. The most excitable neurons spontaneously cross threshold and begin the next positive feedback cycle.

Given the diminishing evidence in support of the obligatory role of pacemaker properties in respiratory rhythm generation [8], a framework in which recurrent synaptic excitation evokes postsynaptic burst-generating membrane properties available to all pre-BötC inspiratory neurons, such as the group pacemaker hypothesis, is a viable mechanism that can explain key aspects of respiratory rhythmogenesis.

### Acknowledgments

US National Science Foundation Integrative and Organismal Biology Award 0616099, The Suzann Wilson Matthews Faculty Research Award, and The Jeffress Memorial Trust.

### References

1. Gray PA, Rekling JC, Bocchiaro CM, Feldman JL (1999) Modulation of respiratory frequency by peptidergic input to rhythmogenic neurons in the preBötzingler Complex. *Science* 286:1566–1568
2. Hayes JA, Del Negro CA (2007) Neurokinin receptor-expressing preBötzingler Complex neurons in neonatal mice studied in vitro. *J Neurophysiol* 97:4215–4224
3. Gray PA, Janczewski WA, Mellen N, McCrimmon DR, Feldman JL (2001) Normal breathing requires preBötzingler Complex neurokinin-1 receptor-expressing neurons. *Nat Neurosci* 4:927–930
4. Wang H, Stornetta RL, Rosin DL, Guyenet PG (2001) Neurokinin-1 receptor-immunoreactive neurons of the ventral respiratory group in the rat. *J Comp Neurol* 434:128–146
5. Guyenet PG, Sevigny CP, Weston MC, Stornetta RL (2002) Neurokinin-1 receptor-expressing cells of the ventral respiratory group are functionally heterogeneous and predominantly glutamatergic. *J Neurosci* 22:3806–3816
6. Smith JC, Ellenberger HH, Ballanyi K, Richter DW, Feldman JL (1991) Pre-Bötzingler Complex: A brainstem region that may generate respiratory rhythm in mammals. *Science* 254:726–729
7. Del Negro CA, Morgado-Valle C, Feldman JL (2002) Respiratory rhythm: an emergent network property? *Neuron* 34:821–830
8. Pace RW, Mackay DD, Feldman JL, Del Negro CA (2007) Role of persistent sodium current in mouse preBötzingler complex neurons and respiratory rhythm generation. *J Physiol* 580:485–496
9. Pena F, Parkis MA, Tryba AK, Ramirez JM (2004) Differential contribution of pacemaker properties to the generation of respiratory rhythms during normoxia and hypoxia. *Neuron* 43:105–117
10. Pace RW, Mackay DD, Feldman JL, Del Negro CA (2007) Inspiratory bursts in the preBötzingler complex depend on a calcium-activated nonspecific cationic current linked to glutamate receptors. *J Physiol* 582:113–125

## Precentral Gyrus

### Definition

The precentral gyrus is the cerebral gyrus immediately anterior and parallel to the central sulcus. It is part of the frontal lobe and is the primary motor cortex.

- ▶ Primary Motor Cortex
- ▶ Gyrus precentralis

## Precerebellar Long-Lead Burst Neurons

CHARLES SCUDDER  
Portland, OR, USA

### Definition

Precerebellar neurons, in general, are neurons that have their somata in the brainstem or spinal cord and send their axons to the cerebellum. Precerebellar ▶ long-lead burst neurons (PCbLLBNs) (▶ burst cells – long lead (LLBNs)) are precerebellar neurons that have long-lead burst discharges during saccades. They comprise the major route for the transmission of saccadic commands to the cerebellum. All PCbLLBNs that have been identified to date have their somata in the pontine reticular formation or the pontine nuclei.

### Characteristics Higher Order Processes

PCbLLBNs receive information from higher order saccadic command centers and relay this information to the ▶ oculomotor vermis and the ▶ floccular lobe of the cerebellum (see ▶ Cerebellum – Role in Eye Movements). Projections to the oculomotor vermis comprise the first leg of a trans-cerebellar route by which saccadic commands are processed in the cerebellum and then conveyed to the saccadic burst generator. At the burst generator, these processed commands are combined with a raw command conveyed directly from the same higher command centers, and are thought to provide the detail needed for generating accurate saccadic eye movements (see cerebellum – role in eye movements). PCbLLBNs provide the major, but not the only, input to the oculomotor vermis, and provide a minor input to the floccular lobe.

Command centers that provide the major input to PCbLLBNs are the deep and intermediate layers of

the ►superior colliculus, the ►frontal eye fields (FEF), the ►supplementary eye fields (SEF), and the ►lateral intraparietal area (LIP). The superior colliculus collects information from the above three cortical areas (FEF, SEF, LIP), the ►basal ganglia, the superficial layers of the superior colliculus, and other smaller projections, and is considered the final common path for the saccadic command.

### Parts of the LLBN Pathway to the Cerebellum Groups of PCbLLBNs

Somata of PCbLLBNs reside in four principal areas within the pons, and each area receives somewhat different information. By far the largest population is in the caudal ►nucleus reticularis tegmenti pontis (NRTP), both in the medial group of cells that extends dorsally from the main body of NRTP (Fig. 1), and to a lesser extent, in the medial part of the body of NRTP. The major input to this part of NRTP is from the superior colliculus, with a smaller input from the FEF and SEF. NRTP also receives a major feedback signal from the output of the midline cerebellum, namely, the fastigial nucleus.

A second group of PCbLLBNs resides in a diffuse collection of somata amid the fascicles of the medial

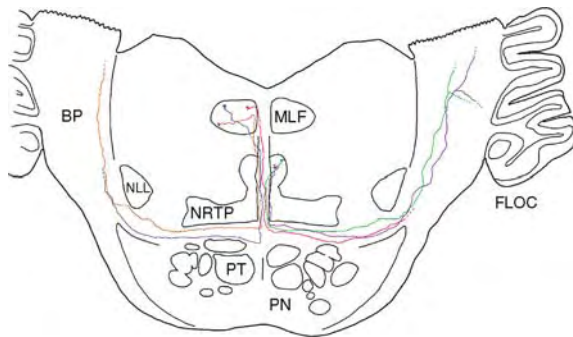

### Precerebellar Long-Lead Burst Neurons.

**Figure 1** Transverse section of the monkey brainstem at a level just rostral to the abducens nucleus is illustrated along with the somata and axons of five precerebellar LLBNs. Neurons were visualized using intraaxonal staining and were reconstructed using a camera lucida. Three somata are located in a fasciculated portion of the medial longitudinal fasciculus (MLF), and two others are located in a dorsomedial extension of nucleus reticularis tegmenti pontis (NRTP). Axons course to the midline and then ventrally to a lateral fiber tract just ventral to NRTP, where some cross and some do not (follow axon colors). Axons course laterally and then back dorsally in brachium pontis (BP). Staining faded before reaching the cerebellum (dotted lines). The NRTP neurons sent collaterals toward the floccular lobe (FLOC). NLL, nucleus of the lateral lemniscus; PN, pontine nuclei; PT, pyramidal tract.

longitudinal fasciculus (the intrafascicular nucleus of the MLF, or IFN) just rostral to the abducens nucleus (Fig. 1). The third group resides in raphe pontis, which is located below the MLF immediately rostral to the abducens nucleus (not illustrated). The known inputs to these areas based on anatomical data arise from the superior colliculus and from the ►inhibitory burst neurons (IBNs) of the saccadic burst generator (see ►brainstem burst generator), but there may be other sources of input.

Locations of cell bodies and axonal projections for two of these three groups are illustrated in Fig. 1, which was derived from intraaxonally labeled neurons [1]. Axons of all NRTP, IFN, and raphe pontis PCbLLBNs course to the midline where they travel ventrally with other fiber bundles. Just above the pontine nuclei, they sharply turn either ipsilaterally or contralaterally and travel laterally in a well defined band of fibers between NRTP and the pontine nuclei. Subsequently, they enter the brachium pontis and travel dorsally to the cerebellum without ever branching in the brainstem. Several neurons originating in NRTP were observed to send collaterals to the floccular lobe, while none originating in the IFN or raphe pontis were so observed.

One group of investigators has found a fourth group of PCbLLBNs in the dorsolateral pontine nuclei [2]. The principal input to this group is from LIP, with a smaller input from the FEF. The dorsolateral pontine nuclei also receive heavy input from visual-motion sensitive cortical areas MST and MT, but PCbLLBNs presumably receive little of this input. This latter input goes mainly to neurons discharging during ►smooth pursuit eye movements, which are intermixed with PCbLLBNs in this region.

### Discharges of PCbLLBNs

Discharges of PCbLLBNs with somata in the reticular formation have been recorded extracellularly in medial NRTP, intra-axonally along their projection route, and extracellularly in the white matter of the oculomotor vermis and floccular lobe [1,3–5]. Like other LLBNs, they are mostly silent during fixations between saccades, but have a presaccadic firing that begins 21–300 ms before saccades in a preferred direction. Firing rate usually builds up towards a peak that usually also occurs before saccade onset. Firing ends near the time of saccade end.

PCbLLBNs in the reticular formation exhibit spatial properties that are intermediate between those of two common classes, namely ►directional and ►vectorial LLBNs. Like vectorial neurons, the range of directions for which a PCbLLBN may fire is less than a full hemifield, but it is usually larger than that of the superior-colliculus neurons that provide its major input. Unlike vectorial neurons, only a few PCbLLBNs

have closed ► **movement fields**. That is, the discharge rate and number of spikes of typical PCbLLBNs first increase as saccade size increases but then might plateau with further increases in size. A few act like directional neurons, in that discharge parameters continually increase as saccade size increases. For neurons that do not have vertical preferred directions, all have an ipsilateral component to their preferred direction and none have a ► **contraversive** component. PCbLLBN responses have also been shown to depend on the torsional component of the saccade, making movement fields three dimensional [6]. These spatial characteristics are probably produced by convergent input from appropriately selected superior-colliculus efferents.

In the dorsolateral pontine nuclei, LLBNs are one population within a range of burst neurons [2]. Discharges of some burst neurons lag saccade onset, and some burst neurons also exhibit responses during smooth pursuit eye movements. All possible preferred directions for bursts are present in the population.

### Lower Level Processes

The major targets of PCbLLBNs originating in the NRTP, IFN, and raphe pontis are the “oculomotor vermis” (lobules VIc and VII) [7] and the ► **fastigial oculomotor region** (FOR; see cerebellum – role in eye movements). The fastigial nucleus is presumably innervated by collaterals of ► **mossy fibers** projecting to the vermis, but retrograde tracing data suggests that not all PCbLLBNs issue these collaterals [8,9]. PCbLLBN signals are used in the cerebellum to produce a burst in FOR neurons, whose timing and amplitude affect the duration and amplitude of the discharges of burst neurons in the saccadic burst generator. The cerebellum thus provides fine control of the size and direction of saccades (see brainstem burst generator).

Some PCbLLBNs with somata in NRTP project to the ► **flocculus** and paraflocculus as collaterals of axons projecting to the oculomotor vermis [1]. It is uncertain whether all LLBN input to the floccular lobe arises in this fashion. IFN and raphe pontis neurons also project to the floccular lobe, but these may be the burst-tonic neurons that are also found in these nuclei. There is no firm data about how PCbLLBN signals are used in the floccular lobe, but one possibility is that they are used to help remove saccade-related signals from the many inputs with mixed saccade and smooth eye-movement signals, leaving mainly the latter in the output pathway.

### Pathology

There have only been preliminary studies using experimental lesions of NRTP at the location of PCbLLBNs. Temporary inactivation of caudal NRTP with lidocaine or muscimol in monkeys has produced

hypometric saccades, deficits in convergence and accommodation to a near target after a saccade, and aberrant torsional eye-position after a saccade [6,10]. Experimental lesions of the dorsolateral pontine nuclei produced deficits in smooth pursuit with no observable deficits in saccades. Specific lesions of raphe pontis have not been performed.

### References

1. Scudder CA, Moschovakis AK, Karabelas AB, Highstein SM (1996) Anatomy and physiology of saccadic long-lead burst neurons recorded in the alert squirrel monkey. II. Pontine neurons. *J Neurophysiol* 76:353–370
2. Dicke PW, Barash S, Ilg UJ, Thier P (2004) Single-neuron evidence for a contribution of the dorsal pontine nuclei to both types of target-directed eye movements, saccades and smooth-pursuit. *Eur J Neurosci* 19:609–624
3. Crandall WF, Keller EL (1985) Visual and oculomotor signals in nucleus reticularis tegmenti pontis in alert monkey. *J Neurophysiol* 54:1326–1345
4. Kase M, Miller DC, Noda H (1980) Discharges of Purkinje cells and mossy fibers in the cerebellar vermis of the monkey during saccadic eye movements and fixations. *J Physiol (London)* 300:539–555
5. Ohtsuka K, Noda H (1992) Burst discharges of mossy fibers in the oculomotor vermis of macaque monkeys during saccadic eye movements. *Neurosci Res* 15:102–114
6. van Opstal AJ, Hepp K, Suzuki Y, Henn V (1996) Role of monkey nucleus reticularis tegmenti pontis in the stabilization of Listing’s plane. *J Neurosci* 16:7284–7296
7. Thielert CD, Thier P (1993) Patterns of projections from the pontine nuclei and the nucleus reticularis tegmenti pontis to the posterior vermis in the rhesus monkey: A study using retrograde tracers. *J Comp Neurol* 337:113–126
8. Noda H, Sugita S, Ikeda Y (1990) Afferent and efferent connections of the oculomotor region of the fastigial nucleus in the Macaque monkey. *J Comp Neurol* 302:330–348
9. Yamada J, Noda H (1987) Afferent and efferent connections of the oculomotor cerebellar vermis in the macaque monkey. *J Comp Neurol* 265:224–241
10. Kaneko CRS, Fuchs AF (2004) Muscimol inactivation of the nucleus reticularis tegmenti pontis (nrtp) eliminates ipsilesional saccades. *Soc Neurosci Abs* 880.1

## Precocial

### Definition

Young born with hair or feathers, eyes open, the ability to move about immediately after birth and capable of leaving the nest within a few days.

► **Neural Correlates of Imprinting**

## Precocious Puberty

### Definition

The appearance of any sign of secondary sexual maturation, such as pubic hair, before the age of 8 years (or menarche before the age of 9 years) in girls and 9 years in boys.

► Neuroendocrinology of Tumors

## Precuneus

### Definition

Part of the parietal lobe visible in a median section. Has a virtually square shape (hence also called quadrate lobe). The precuneus appears to be implicated in complex, sensory evaluation processes, language processing as well as spatial and temporal orientation.

► Telencephalon

## Precursor Cells

### Definition

(Neural) precursor cells occur in both fetal and adult brains and are partially specialized; they undergo cell division and give rise to differentiated cells in a site-specific manner. In their normal states, adult precursor cells do not generate a wide variety of neurons. In the injured brain, adult precursor cells can partially replace neurons that are damaged or dead.

► Adult Neurogenesis

## Predicate (Attribute)

### Definition

A predicate is what can be said of something, truly or falsely. The linguistic predicate “is red” can truly be applied to red things. The relational predicate “is larger than” can be used to state a relation between two things.

An attribute is a feature, like being red, for which a linguistic predicate stands. Realists claim, while nominalists deny, that an attribute is a special entity (universal) that can be exemplified by several particular things.

► Argument

► Logic

## Prediction Error

### Definition

A discrepancy between the expected and the experienced outcome of a behavioral situation. The prediction error is a relevant variable determining recruitment of dopaminergic action in the brain and formation of associations between events (stimuli and or behaviors).

► Dopamine

► Neuroethological Aspects of Learning

## Predictive Eye Movements

### Definition

Predictive eye movements occur whenever the motion of a target exhibits regular temporal features. Particularly with periodic movements, they compensate for the lag of the eye on the target implied by the reaction time, achieving either a nearly perfect synchronisation with the target (smooth pursuit of sinusoids at  $< 0.5$  Hz) or even a lead (saccades tracking a target stepping back and forth at regular pace).

► Oculomotor Control

► Saccade, Saccadic Eye Movement

## Preferential Motor Reinnervation (PMR)

### Definition

The bias and modest selectivity that motor axons exhibit in choosing motor endoneurial pathways and

end-organs over sensory pathways and end-organs during reinnervation.

► [Peripheral Nerve Regeneration and Nerve Repair](#)

## Preferred Direction (of a Neuron)

### Definition

Neurons that respond to motion of either discrete visual stimulus or of a structured background modulate the strength of their response as function of the direction of motion. Plots of the strength of the response, e.g., mean firing rate, against the angle of stimulus trajectory are called tuning curves. The angle corresponding to the peak of the curve defines the preferred direction of the neuron. Visuomotor neurons, such as tectoreticulospinal neurons (TRSNs) have a directional tuning for visual stimulus, as well as to the direction of orienting movement associated to motor components of their bursts. Preferred movement direction of a given neuron is determined from the tuning curves, in the same way as for visual or, more generally, sensory preferred directions.

► [Reaching Movements](#)

► [SC-Tectoreticulospinal neurons \(TRSNs\)](#)

in many of the cognitive and ► [executive control](#) functions necessary for goal directed behavior, including ► [working memory](#), shifting of ► [selective attention](#), decision-making and ► [response inhibition](#). Disturbances in function are thought to contribute to the pathophysiology of several mental conditions, including ► [schizophrenia](#), major ► [depression](#), ► [post-traumatic stress disorder \(PTSD\)](#), ► [attention deficit hyperactivity disorder \(ADHD\)](#) and susceptibility to ► [addiction](#).

### Characteristics

#### Anatomy

In common with all cortical areas, the PFC is a layered structure, with six layers in this case, and has the same major cellular constituents [1–5]. These include spiny ► [pyramidal neurons](#) with an excitatory glutamate phenotype whose axons ramify locally in addition to entering the white matter and projecting to other cortical and subcortical regions. The second major cell class consists of relatively aspiny, non-pyramidal ► [interneurons](#) whose inhibitory phenotype is GABAergic and whose axonal connections are strictly local. Several major subclasses of these local circuit neurons are distinguished by their content of calcium binding proteins or ► [neuroactive peptides](#) and by differences in their axonal targets, providing the necessary circuitry for feedback and feedforward inhibition within the cortex. Subsets of interneurons are also thought to entrain pyramidal cells to fire in ► [oscillations](#), at frequencies deemed essential for specific forms of information processing [4].

In the past, cortical territories were defined by their inputs from specific nuclei of the ► [thalamus](#), and this still constitutes a reasonable starting point for identifying cortical regions across species [3]. For the PFC, the principal thalamic division is the mediodorsal nucleus (MDTN). The MDTN is itself divided into three main subregions, each of which maintains reciprocal connections with portions of the PFC. (i) The paralamellar division is the most lateral part of the MDTN and innervates the cortical territory around the arcuate sulcus corresponding to Brodmann's area 8, also known as the ► [frontal eye fields](#). This serves as the motor command region for voluntary (► [saccadic](#)) eye movements. (ii) Medial to the paralamellar division is the parvocellular region of the MDTN, which connects to the cortex along the dorsolateral convexity (DLPFC), including Brodmann's areas 9, 10 and 46, the latter lying within and along the banks of the principal sulcus. (iii) The most medial portion of the MDTN is the magnocellular division, which is interconnected to orbital regions of the cortex (named for their position above the eye socket) and to other ventral and medial surfaces of the frontal lobe, Brodmann's areas 11, 13, 14, 24, 25, 32 and 47/12. Collectively, these are termed the orbitomedial PFC (OMPFC). Areas 24, 25 and 32

## Prefrontal Cortex

SUSAN R. SESACK

Departments of Neuroscience and Psychiatry,  
University of Pittsburgh, Pittsburgh, PA, USA

### Synonyms

Frontal cortex; Dorsolateral cortex; Orbitofrontal cortex

### Definition

The prefrontal cortex was so named because it was discovered in electrical stimulation studies to be a "silent" region in front of the motor areas of the frontal lobe. It appears to have increased in size and complexity in the course of evolution, culminating in the human brain as approximately 30% of the cortical mantle and at least 11 different cytoarchitecturally defined areas according to Brodmann's nomenclature. It is involved

lie within the ►[cingulate gyrus](#) and so are also considered parts of the ►[anterior cingulate cortex](#).

In addition to specific inputs from the MDTN, the PFC is also innervated by other thalamic nuclei within the anterior, ventral, medial and midline divisions as well as the pulvinar nucleus. As an association cortex, the PFC receives extensive inputs from other cortical regions organized in a hierarchical fashion [3]. Major afferents arise from other association areas, including those in the posterior parietal and inferior temporal regions. The sensory streams innervating the PFC appear to involve mainly visual, auditory and somatosensory projections to the DLPFC and primarily olfactory, gustatory and viscerosensory projections to the OMPFC. The OMPFC is also innervated by important structures within the ►[limbic system](#), the ►[hypothalamus](#), ►[hippocampus](#) and ►[amygdala](#) [1,3,5]. The amygdala is a quasi-cortical structure that regulates behavior by conditioned associations and its reciprocal connections with the PFC are important for facilitating appropriate emotional behaviors. It has been argued that within the OMPFC, orbital divisions are the main sites of sensory termination, whereas medial regions are the main origin of descending projections to autonomic regions [5]. Hence, these two subdivisions may function as viscerosensory and visceromotor regions, respectively.

The PFC, like most cortical structures, is extensively innervated by ►[ascending neuromodulatory projection systems](#) (see Essay of same name) arising in the brainstem and basal forebrain, including pathways conveying ►[acetylcholine](#), ►[dopamine](#), ►[norepinephrine](#) and ►[serotonin](#) inputs [3,6,7]. These projections provide essential modulation of cortical firing patterns and many studies demonstrate that either decreases or increases in critical levels of monoamines are sufficient to disrupt PFC function [6,7]. Conversely, pharmacological therapies for mental disorders (e.g., antipsychotic, antidepressant and anxiolytic medications) are often designed to alter monoamine transmission in an effort to restore more balanced activity in this region.

Many of the efferent projections of the PFC reciprocate the afferent inputs [1,3], including those to association cortices and to thalamic nuclei. Another major output of the PFC, as with many cortical regions, is to the ►[basal ganglia](#). Cortical projections to the ►[striatopallidum](#) (see Essay of same name) are relayed back to the cortex via the thalamus, forming functional “loops” for the selection of appropriate actions and suppression of maladaptive responses. The DLPFC targets mainly the head of the ►[caudate nucleus](#), forming a major associative loop that supports cognitive and executive functions, whereas the OMPFC projects to more ventral parts of the striatal complex, including the ►[nucleus accumbens](#) and participates in limbic circuitry for motivated behaviors. The brainstem

projections of the PFC include the ►[superior colliculus](#) for saccadic eye movement control and the pontine nucleus, which relays executive commands to the ►[cerebellum](#) for controlling the timing and coordination of movement and cognition. Interestingly, the OMPFC is the source of extensive projections to diencephalic and brainstem structures that are important regulators of autonomic output, including the amygdala, hypothalamus, ►[periaqueductal gray](#), ►[parabrachial nucleus](#) and ►[nucleus of the solitary tract](#) [3,5]. Moreover, portions of the OMPFC are among the only cortical regions that project directly to brainstem monoamine neurons [3], placing this division of the PFC in a position to regulate the level of modulatory drive to the cortex generally. The latter connections are no doubt important for understanding the pathophysiology of mood disorders, in which brainstem monoamines are implicated in both cause and treatment.

On the basis of these differential inputs and outputs, the DLPFC is considered to be the main region within which spatial and object working memory and other executive functions are carried out [1–4,8]. The OMPFC has been deemed a viscerosensory and visceromotor network that guides behavior based on emotional experience [1,3,5,9]. Of course, the major subdivisions of the PFC are interconnected, so that goal directed behavior is accomplished by consideration of both external and internal perceptions [3].

### Function

The PFC performs many essential cognitive functions whose complexity increases in the course of evolutionary development. The PFC guides behavior particularly when situations are novel or complex and is probably not involved in functions that are routine or well learned [1]. There is considerable consensus that the PFC is a major contributor to the processes underlying ►[working memory](#), a short form of memory in which information is held temporarily in mind until it can be used to guide immediate behavior [1,2,4]. Such information is also available for mental manipulation and the PFC has sometimes been described as the brain’s “scratch pad.” The PFC provides a mechanism for bridging time between the near past and the actions that proceed from keeping this information “in mind.” In this way, the PFC is essential for preparing the motor systems for action and hence for future planning and logical sequences of action and thought [1].

Behavioral tasks in which a delay is interposed between cue and choice (►[delayed–response tasks](#)) are important tools for evaluating working memory performance in experimental animals and humans. Such tasks assess the ability to maintain a representation of spatial location, object identity or stimulus associations in the absence of the original cue and performance of these tasks is highly sensitive to PFC damage [1,2]. The

oculomotor variant of this test, the ►**delayed saccade task** was created to minimize movement in behaving animals and so to facilitate electrophysiological recording of neuronal activity during working memory. The resultant studies have depicted cells that respond to the presentation of the cue or to the go signal for the motor response. More importantly, many of these studies have described neurons that increase their activity during the delay period between the cue and the go signal. These “delay” cells appear to represent the maintenance of critical information obtained from the cue in order to guide future responding and so are widely considered as a neural correlate of working memory. Many studies report that delay period cells are spatially tuned, responding best to cues that dictate subsequent motor responses into specific regions of space [2]. The exact cellular mechanisms that underlie delay period activity are not yet known. Collateral synapses between pyramidal cells may form local reverberatory connections that could sustain such firing. Alternatively or in addition, delay period activity probably reflects long-range interconnections between the PFC and posterior association areas where similar firing patterns have been described [1,2,4,8]. Other electrophysiological recording studies, particularly those in the OMPFC, have described neurons that appear to encode the salience or reward value of stimuli, which is likely to subsequently influence motivation in motor responses [1].

Many of these observations from animal physiology have been verified to the extent possible in humans using variants of working memory or decision making tasks and functional imaging methods [1,8,9]. Functional magnetic resonance imaging (►**fMRI**) and positron emission tomography (►**PET**) monitor signals that reflect altered blood flow as indirect measures of activation in brain regions. Performance of tasks for which working memory is an essential component produce signals consistent with an increase in blood flow to the PFC. Moreover, many studies using this methodology have produced findings that extend theories regarding the cognitive functions of this region to include stimulus ►**encoding**, sustained attention, decision making and motor preparation.

## Disorders

Although lesions caused by stroke, tumor or accidental damage are rarely circumscribed within subdivisions of the PFC, some relatively distinct syndromes have been characterized [1]. Lesions that are centered in orbital regions of the OMPFC tend to cause loss of ►**response inhibition** [9], with changes in personality that include impulsiveness and recklessness. Patients have problems with selective attention and exhibit inappropriate decision making to the point of self-destructive and sociopathic behavior. Attentional problems are also seen with damage to medial portions of the OMPFC

that include the anterior cingulate cortex, in this case accompanied by affective blunting, apathy and withdrawal [1]. Lesions of the DLPFC produce a “dysexecutive syndrome” characterized by deficits in working memory and related cognitive functions, poor planning capability, difficulty in the execution of logically ordered sequences of behavior or language and attention deficits [1]. The consistent observation of attentional problems with damage to the PFC suggests that this cortical territory is important for regulating the attentional processes necessary for goal directed behavior [1]. Functional imaging studies of the anterior cingulate cortex in particular support a major role for this region in attentional mechanisms. Partly as a result of these observations, the PFC is considered a principal site of pathophysiology in ADHD [6].

There is ample evidence from functional imaging, postmortem and neuropsychological analyses for a significant malfunction of the PFC in ►**schizophrenia** [2,4]. Schizophrenic patients show deficits in working memory and other cognitive skills, consistent with reduced blood flow to the PFC during performance of tasks designed to test these functions. These and other “negative” symptoms form the core features of the illness; they are the most predictive of long-term prognosis and are the least susceptible to pharmacological intervention. Postmortem studies show structural alterations in both pyramidal and non-pyramidal neurons and reductions in markers of synaptic communication. Some of these deficits are specific to the PFC, while others are observed throughout the cortex. Most appear to be associated with the illness and not with treatment with antipsychotic medications [4].

Functional imaging and postmortem studies also report changes in the PFC in major ►**depressive disorders**, including ►**bipolar depression** [5]. Altered metabolism/blood flow is particularly observed in the medial portions of the OMPFC and such changes are consistent with the symptom complex that accompanies lesions to this region. The earliest studies reported increased blood flow in the OMPFC with major depression, although later investigations have also shown decreased blood flow in this region. Some postmortem analyses have also reported reduced tissue volume in portions of the midline frontal cortex, primarily due to loss of glia and neuropil as opposed to a loss of neurons.

The PFC is highly susceptible to the impact of acute and chronic ►**stress** and it is well known that stress can exacerbate the symptoms of mental disorders [6,7,10]. Behavioral studies indicate that working memory performance is degraded in animals subjected to stress and several investigations report structural alterations in pyramidal neurons following exposure to chronically stressful conditions. Theories regarding the likely pathophysiology of PTSD often focus on the amygdala as a probable site of dysfunction, but these models also



suggest loss of inhibitory regulation of the amygdala by the OMPFC in this condition [10]. Stress is also a known contributor to recidivism in addiction disorders. Loss of inhibitory control of behavior by a weakened PFC system has been implicated in susceptibility to addiction and the impact of acutely stressful events on PFC activity may further destabilize individuals toward relapse [7].

## References

1. Fuster JM (2001) The prefrontal cortex – an update: time is of the essence. *Neuron* 30:319–333
2. Goldman-Rakic PS (1999) The physiological approach: functional architecture of working memory and disordered cognition in schizophrenia. *Biol Psychiatry* 46:650–661
3. Groenewegen HJ, Uylings HBM (2000) The prefrontal cortex and the integration of sensory, limbic and autonomic information. *Prog Brain Res* 126:3–28
4. Lewis DA, Hashimoto T, Volk DW (2005) Cortical inhibitory neurons and schizophrenia. *Nat Rev Neurosci* 6:312–324
5. Ongur D, Price JL (2000) The organization of networks within the orbital and medial prefrontal cortex of rats, monkeys and humans. *Cereb Cortex* 10:206–219
6. Arnsten AF, Li BM (2005) Neurobiology of executive functions: catecholamine influences on prefrontal cortical functions. *Biol Psychiatry* 57:1377–1384
7. Moghaddam B (2002) Stress activation of glutamate neurotransmission in the prefrontal cortex: implications for dopamine-associated psychiatric disorders. *Biol Psychiatry* 51:775–787
8. Postle BR (2006) Working memory as an emergent property of the mind and brain. *Neuroscience* 139:23–38
9. Bechara A, Damasio H, Damasio AR (2000) Emotion, decision making and the orbitofrontal cortex. *Cereb Cortex* 10:295–307
10. Rauch SL, Shin LM, Phelps EA (2006) Neurocircuitry models of posttraumatic stress disorder and extinction: human neuroimaging research – past, present, and future. *Biol Psychiatry* 60:376–382

centers to peripheral organs. They are known as preganglionic neurons because their axons gather into small nerves that reach autonomic ganglia (sympathetic and parasympathetic) and terminate with innumerable nerve endings synapsing on ganglion neurons.

In the brain stem the main bilateral groups of preganglionic neurons are the accessory oculomotor nuclei of Edinger-Westphal projecting to the ciliary ganglia, the superior salivatory nuclei projecting to the pterygo-palatine and submandibular ganglia, the inferior salivatory nuclei projecting to the otic ganglia, the dorsal vagal nuclei projecting to ganglia in the trachea, oesophagus and gastro-intestinal tract, and part of the nucleus ambiguus projecting to cardiac ganglia.

In the spinal cord, autonomic neurons are grouped into bilateral columns in the ventral horn; the largest ones are part of the sympathetic pathways extending from the last cervical level (C8) to the second lumbar level (L2). Other columns, which are part of the parasympathetic pathways, occupy sacral levels (between S2 and S4). The preganglionic neurons, which are all cholinergic, receive two main inputs: from higher centers, for example the pontine micturition centre, the cardiovascular centers, several autonomic nuclei in the hypothalamus, and from the periphery via afferent (sensory) autonomic neurons, directly or through an interneuron.

- ▶ Ageing of Autonomic/Enteric Function
- ▶ Hypothalamus
- ▶ Parasympathetic Nervous System
- ▶ Parasympathetic Pathways
- ▶ Sympathetic Nervous System
- ▶ Sympathetic Pathways

## Preganglionic Neuron

### Definition

Within the autonomic nervous system – which is the set of central and peripheral nerve structures that control the activity of viscera (such as bladder, heart, intestines, trachea, glands) and of blood vessels – there are large arrays of neurons located in the spinal cord and the brain stem, arranged in columns and nuclei, that project their axons outside the central nervous system (CNS) and are part of the efferent (motor) pathways leading from brain

## Preganglionic Neurotransmitters

### Definition

Neurotransmitters released from preganglionic neurons to influence the activity of postganglionic neurons within autonomic ganglia. Acetylcholine is the primary neurotransmitter used by probably all preganglionic neurons. Co-transmitters in preganglionic neurons modulate the excitability of postganglionic neurons, or have presynaptic actions to affect further release of preganglionic neurotransmitters.

- ▶ Acetylcholine
- ▶ Autonomic Ganglia
- ▶ Preganglionic Neuron

## Pregeniculate Nucleus (Primates)

- ▶ Intergeniculate Leaflet

## Prehension

### Definition

The act of taking hold, typically with the hand as in grasping.

- ▶ Coordination
- ▶ Motor Cortex – Hand Movements and Plasticity

## Prejunctional

### Definition

Prejunctional refers to the axon varicosity proximal to a neuroeffector junction, releasing neurotransmitters.

- ▶ Postganglionic Neurotransmitter

## Prelude Neurons

- ▶ SC – Buildup Neurons

## Premotor Areas

### Definition

A term used to refer to secondary motor areas of cerebral cortex, particularly the dorsal and ventral areas on the lateral surface of the hemisphere. This term may also be used to refer to brain areas containing neurons that have synaptic linkages to motoneurons.

- ▶ Motor Cortex: Output Properties and Organization
- ▶ Visual Space Representation for Reaching

## Premotor Cortex (Area 6)

### Definition

The premotor cortex (area 6) appears to play a role in regulating grasping actions. In the caudal segments fibers arise from the pyramidal tract. Lesions frequently result in impaired grasping actions. Strength regulation of the grasping hand is likewise impaired.

- ▶ Telencephalon

## Premotor Cortex (Area 8)

### Definition

Frontal eye field. Plays an important role in voluntary control of eye movement. Lesions in this area cause loss of voluntary control of eye movement.

- ▶ Telencephalon

## Premotor Interneurons

- ▶ Excitatory CPG Interneurons

## Premotor Neurons

### Definition

Neurons that have monosynaptic linkages to motoneurons.

## Premotor Processing

### Definition

Processing of information prior to generating movement that includes planning, anticipation of outcomes,

evaluation of rewards and decision making as to the best pattern of motor outputs to achieve particular goals.

- ▶ Visual Space Representation for Action
- ▶ Visual Space Representation for Reaching

## Pre-mRNA

### Definition

Transcribed RNA prior to the splicing process, containing both introns and exons.

- ▶ Alternative Splicing and Glial Maturation

## Prenatal Brain Injury by Chronic Endotoxin Exposure

SANDRA REES  
Department of Anatomy and Cell Biology,  
University of Melbourne, Melbourne, Australia

### Synonyms

Fetal brain injury; Brain inflammation

### Definition

Many factors contribute to perinatal brain injury, with the major causes likely to be hypoxia-ischemia/reperfusion [1] and infection of the fetus and/or mother [2]. Clinical studies have indicated that there are significant associations between maternal infection, preterm birth, neonatal brain damage and increased levels of ▶ **proinflammatory cytokines** in the amniotic fluid and umbilical cord; the strength of specific correlations are still being deduced. Fetal inflammatory responses can occur in the absence of overt signs of infection or fetal compromise and it is possible that subclinical inflammation underlies otherwise unexplained brain injury. Preterm birth occurs in 7–10% of pregnancies; advances in perinatal care have led to a significant improvement in the survival of very premature (less than 30 weeks) and very low birth weight (less than 1,500 g) infants. However up to 10% of these infants develop spastic motor deficits and 20–50% suffer developmental and behavioral disabilities. The most common cerebral neuropathology observed in premature infants is white

matter injury, referred to as periventricular leukomalacia. This includes diffuse gliosis (▶ **microgliosis** and astrogliosis) extending throughout the white matter and also focal cystic infarction adjacent to the lateral ventricles in about 5% of cases. It is now increasingly recognized that the cerebral cortex and deep grey matter are also likely to be affected.

Invading microorganisms are thought to gain access to the amniotic cavity and fetus, most commonly, by ascending through the vagina and cervix [3]. This induces an innate immune response with inflammation of the chorioamniotic membranes and the production of proinflammatory cytokines. The cytokines and/or other inflammatory mediators then gain access to the fetus via swallowed amniotic fluid or fetal lungs, eyes or nasal membranes. It has been suggested that these agents increase the permeability of the blood–brain barrier with enhanced leucocyte infiltration of the brain mediated by brain chemokines; brain microglia and astrocytes will be stimulated to upregulate the production of cytokines and alterations to brain structures and/or overt injury will ensue depending on the severity of the inflammatory response.

### Characteristics

#### Description of the Process

##### *Lipopolysaccharide and the Inflammatory Response*

In order to more fully understand the mechanisms involved in inflammatory-induced brain damage animal models are required with one of the specific goals being the development of therapeutic strategies. The bacterial endotoxin, lipopolysaccharide (LPS) is most commonly used to model the systemic inflammatory response induced by infection, although live bacteria have also been used. LPS is a major component of the outer membrane of gram negative bacteria. Since fetal inflammation associated with maternal infection is likely to be chronic in nature [3] models involving repeated exposure to LPS are most likely to mimic the human situation [4,5] although other models stand to contribute to an understanding of the inflammatory process. LPS has been administered to fetal rodents and sheep and neonatal rats, kittens and monkeys at a developmental age which equates to 25–30 weeks in the human fetus, a period of high vulnerability for white matter damage.

#### **Cytokines**

To contend with invading organisms, as typified by lipopolysaccharide, the innate immune response includes the generation of reactive oxygen species, phagocytosis and the production and release of cytokines and chemokines. LPS binds initially to LPS-binding protein (LBP), an acute phase protein released into the bloodstream from the liver [6]. LBP then appears to aid LPS in docking with the LPS receptor complex by forming a ternary complex with CD14 thus enabling LPS to be

presented to the LPS receptor complex consisting of Toll-like receptor-4 (TLR4) and MD-2 an extracellular adaptor protein, on the surface of myeloid and other cells. Binding to the complex activates transmembrane signaling pathways (Fig. 1) which result in the activation of the transcription factor nuclear factor (NF)- $\kappa$ B, containing subunits p50 and p65 as homo- or heterodimers. NF- $\kappa$ B binding activity can be induced by changes in the intracellular redox status and LPS is known to be one of the most potent activators of this pathway. NF- $\kappa$ B is normally present in the cell cytoplasm forming an inactive complex with an inhibitor I- $\kappa$ B $\alpha$ . Following cellular activation, I- $\kappa$ B $\alpha$  is phosphorylated by I- $\kappa$ B kinase; its subsequent degradation by cytoplasmic proteases releases NF- $\kappa$ B which is translocated to the nucleus where it regulates transcription of several genes including cell adhesion

molecules, metalloproteinases and the pro-inflammatory cytokines, IL-1 $\beta$ , IL-6 and TNF- $\alpha$ . For example TNF- $\alpha$  is elevated within 2 h of LPS exposure in the preterm ovine fetus (Fig. 2).

### Blood-Brain Barrier

Systemic cytokines (and LPS) can then bind to receptors on cerebral endothelial cells or periventricular cells initiating downstream signaling events which include an increase in prostaglandin synthesis and altered cGMP and nitric oxide levels. This results in increased blood-brain barrier (BBB) permeability for at least 24 h after LPS exposure particularly in white matter tracts; the exact molecular site within the blood vessels at which the leak to proteins occurs is not yet clear. Cytokines and proinflammatory substances can then pass into the brain activating microglia and

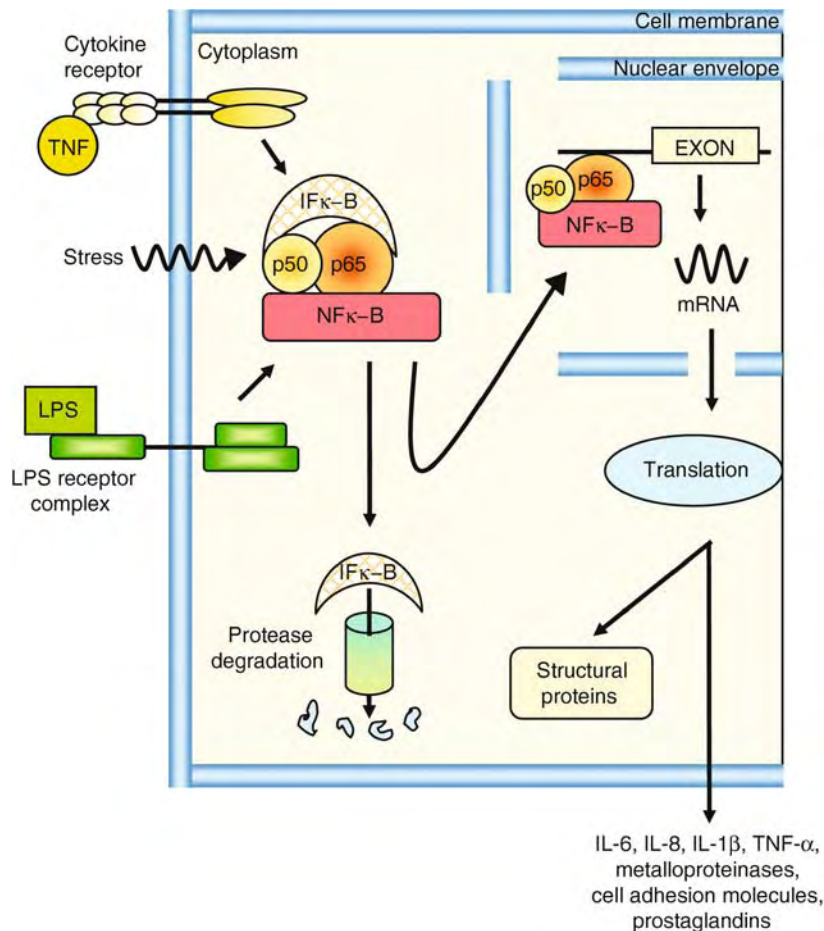

**Prenatal Brain Injury by Chronic Endotoxin Exposure. Figure 1** In response to proinflammatory cytokines, endotoxins or environmental stress, the nuclear factor (NF)- $\kappa$ B pathway is activated. NF- $\kappa$ B (containing subunits p50 and p 65) is normally present in the cytoplasm forming an inactive complex with inhibitory factor (IF- $\kappa$ B). Following cellular activation, IF- $\kappa$ B is phosphorylated and subsequently degraded by cytoplasmic proteases. This releases NF- $\kappa$ B which is translocated to the nucleus where it regulates the transcription of several genes including proinflammatory cytokines.

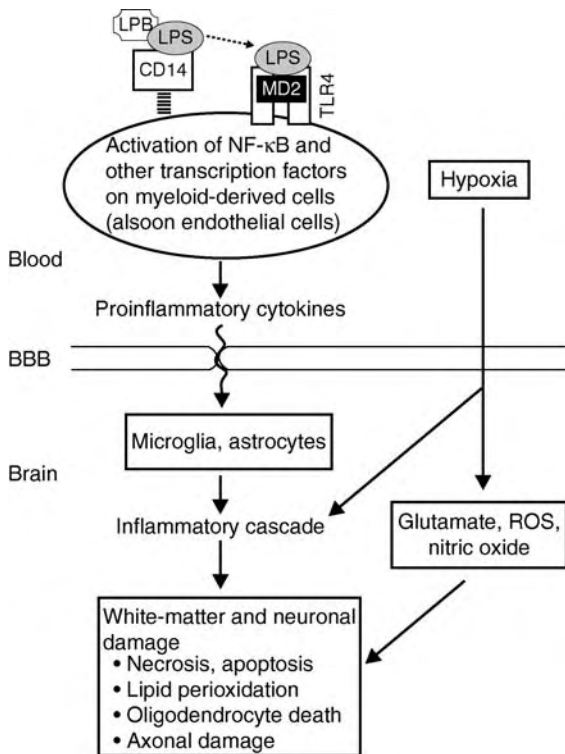

**Prenatal Brain Injury by Chronic Endotoxin Exposure. Figure 2** Possible activation of the inflammatory cascade by endotoxin (lipopolysaccharide, LPS). LPS binds to LPS binding protein (LBP) which then forms a ternary complex with CD14, enabling LPS to be presented to the LPS receptor complex consisting of Toll-like receptor 4 (TLR4) and MD-2. This activates NF-κB and other signaling pathways. Proinflammatory and other proteins are transcribed; they affect the permeability of the blood–brain barrier, perhaps via the up-regulation of prostaglandins, and allow the entry of proinflammatory substances and circulating leukocytes into the brain. Here there is activation of microglia and astrocytes to up-regulate cytokine production; this ultimately leads to white-matter and neuronal damage. If hypoxia is also involved, excess extracellular glutamate will result in further nitrosative and oxidative stress, exacerbating neuronal and axonal damage.

astrocytes to release cytokines, oxygen free radicals and other factors which will have multiple effects on the brain ranging from altered neuronal development to overt injury (Fig. 3). A recent microarray study in the LPS-exposed neonatal rat demonstrated altered gene expression of hundreds of inflammatory molecules and also cell-death associated molecules in the brain. In the adult brain, TLR4 receptors are found in regions devoid of the BBB namely the circumventricular organs (CVOs) and also the choroid plexus, meninges and scattered cells within the brain parenchyma. It has been postulated that LPS binds to TLR4 in the CVOs inducing an inflammatory reaction which is then disseminated throughout the brain. In the neonatal brain mRNA for CD14 receptors has been identified although their cellular distribution is not known.

#### **Oxidative and Nitrosative Stress**

Reactive oxygen species (ROS) are toxic oxygen metabolites produced in small quantities during the normal cellular metabolic processes in mitochondria via univalent reduction of molecular oxygen. In response to stimuli, including an imbalance in the cellular redox status, the formation of ROS increases dramatically. ROS interact with the lipid components of cell membranes, initiating lipid peroxidation resulting in the breakdown of lipid constituents into highly reactive by-products including lipid aldehydes, for example 4-hydroxynonenal (4-HNE). These reactive aldehydes then bind to and modify protein creating protein adducts. In addition to oxidative stress, nitrosative stress results from nitric oxide (NO) released from reactive microglia reacting with superoxide anions to form peroxynitrite which targets tyrosine residues of proteins to form nitrotyrosine residues. Both of these processes are highly damaging to cell membranes. Lipid peroxidation of membranes can occur in the cerebral hemispheres within 6 h of LPS exposure in the ovine fetus [7]. The major antioxidant defence system that prevents the intracellular accumulation of ROS is the glutathione system. Reduced glutathione (GSH) acts as both a free radical scavenger and as a substrate in the GSH redox cycle. During late

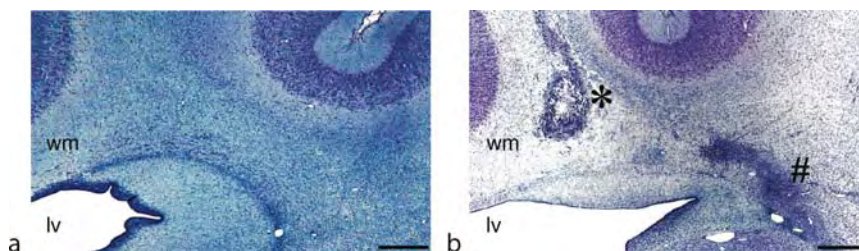

**Prenatal Brain Injury by Chronic Endotoxin Exposure. Figure 3** Section of the cerebral hemispheres from control (a) and LPS-exposed (b) fetal sheep at 70% of gestation (term ~147 days). Repeat bolus doses of LPS resulted in both focal (\*) and diffuse (#) white matter (wm) injury; lv – lateral ventricle. Image courtesy of Dr Jhodie Duncan. Scale = 528 μm.

gestation, there are marked increases in the antioxidant protective capacity. The combination of an immature defence system, LPS challenge and localized oxidative and nitrosative stress exposes the fetal brain to a high risk of ROS-mediated tissue injury.

### Glial Response

Within the preterm ovine and rat brain activation of microglia is the most prominent glial response after LPS exposure; there is a significant correlation between the intensity of microglial/macrophage invasion and the extent of white matter injury indicating a substantial role for microglial activation in the manifestation of and/or response to injury [4,5]. Currently it is not certain whether these cells are mainly microglia already resident in the brain or macrophages invading from the circulation. Of interest is the recent suggestion that the high density of activated microglia in the white matter during normal fetal human brain development might potentially prime this area for diverse brain insults characterized by the activation of microglia; this also appears to be the case in the ovine and rodent fetus.

### Axonal Injury

This could occur as a result of increased glutamate levels in the extracellular space induced by cytokine activation of glutamate-containing astrocytes and the subsequent activation of glutamate receptors on oligodendrocytes or the myelin sheath itself causing a toxic influx of  $\text{Ca}^{2+}$ . Excess  $\text{Ca}^{2+}$  will likely cause disruption to mitochondrial function and damage to the structural integrity of the axon. During the peak gestational age for white matter damage, developing oligodendrocytes (preoligodendrocytes) predominate [8]. The basis for this maturational susceptibility could be related to preferential vulnerability to free radicals, cytokines, glutamate toxicity or a mismatch of antioxidant enzymes and a subsequent imbalance of oxidative metabolism.

### NF- $\kappa$ B Activation in the Brain

Within the brain the role of NF- $\kappa$ B in neuronal survival is controversial with studies supporting both a neuro-destructive or neuroprotective role, the latter possibly by upregulation of anti-apoptotic genes [9]. Perhaps this dichotomy is due to differences in stages of neuronal development, different monomeric composition, degrees of NF- $\kappa$ B activation or different combinations of cellular stimuli. It has been suggested that activation of NF- $\kappa$ B in neurons might protect them against degeneration whereas activation in microglia promotes neuronal degeneration via cytokine production [9]. Chronic systemic administration of LPS in the ovine fetus leads to increased binding activity of NF- $\kappa$ B subunits in specific regions of the fetal brain and

placenta within 6 h of exposure [7]. There was no clear-cut relationship however between alterations in levels of NF- $\kappa$ B and the vulnerability to endotoxic damage. In the cerebral hemispheres where damage occurs NF- $\kappa$ B was not upregulated whereas in the hippocampus where damage does not occur NF- $\kappa$ B was elevated. Clearly the activation of NF- $\kappa$ B can result in several downstream signaling pathways and an upregulation does not necessarily signal that brain damage will ensue. Therefore blocking NF- $\kappa$ B transcription might not be a means of protecting against brain injury.

### Higher Level Processes

Cerebral white matter injury resulting from ►chronic endotoxin exposure in the prenatal brain (►prenatal brain injury (PBI)) is likely to have consequences on the overlying cortex; the cell bodies associated with damaged cortical efferent axons are likely to die. Cortical neurons in layers 5 and 6 demonstrate an upregulation of beta amyloid precursor protein (a marker of cellular stress) after chronic LPS exposure not only in regions of overt white matter damage as might be expected, but also in adjacent gyri. This suggests that chronic endotoxin exposure also induces damage to cortical neurons either directly or secondarily to sensory deafferentation. Progressive post-injury reorganization of the undamaged cerebral cortex will play a role in the underlying mechanisms of ensuing neurological sequelae. It is becoming increasingly recognized in human MRI studies of premature infants that subtle alterations in cerebral structure are common, particularly in the extremely immature infant. Effects of LPS on other aspects of development such as neurogenesis remains to be elucidated.

### Interaction Between Inflammation and Hypoxemia

Elucidating the mechanisms involved in inflammatory-induced brain injury is made more complex by the observation that inflammation can interrupt hemodynamic stability and that activation of inflammatory pathways is involved in the neural responses to hypoxia/ischemia. In animal models the inflammatory cascade and associated brain damage appears to be exacerbated if cerebral oxygen delivery is also reduced. LPS administered in repeat bolus doses at 70% of gestation results in fetal hypoxemia, hypotension, acidemia and associated brain damage in the ovine fetus [4]. A chronic infusion of the same or higher total dose of LPS does not result in significant alterations in fetal physiology but does cause brain injury, which is not as severe as when accompanied by hypoxemia [5]. Furthermore, endotoxin has been shown to sensitize the immature brain to hypoxic-ischemic injury [10]. In human pregnancies where intrauterine inflammation is accompanied by fetal asphyxia, there appears to be a significant increase in the risk of cerebral palsy.

Thus there are likely to be synergistic pathways between hypoxia and infection/inflammation which potentiate the evolution of brain damage although it is evident that inflammation alone can indeed cause fetal brain injury. It is possible that infection could impair oxygen delivery to the fetal brain via effects on gas exchange in the placenta. Histologic chorioamnionitis when compounded with a placental perfusion defect has been shown to enhance the risk of abnormal neurologic outcome in extremely low birth weight infants.

### Function

It is likely that altered brain structure and white matter lesions resulting from ► [brain inflammation](#) will have long term consequences for brain development and function, including cognition, behavioral and motor abilities. Inflammation might also have long term effects on autonomic and neuroendocrine responses, including the manifestation of fever. It has recently been shown that neonatal exposure to LPS attenuates the febrile and CNS neurochemical responses to an LPS challenge in later life; this might equate to an altered ability to combat diseases after birth.

### References

1. Volpe JJ (2001) Perinatal brain injury: from pathogenesis to neuroprotection. *Ment Retard Dev Disabil Res Rev* 7(1):56–64
2. Dammann O, Leviton A (1997) Maternal intrauterine infection, cytokines and brain damage in the preterm newborn. *Pediatrics Res* 42:1–8
3. Romero R, Chaiworapongsa T et al. (2003) Micronutrients and intrauterine infection, preterm birth and the fetal inflammatory response syndrome. *J Nutr* 133 (5 Suppl 2):1668S–1673S
4. Duncan JR, Cock ML et al. (2002) White matter injury after repeated endotoxin exposure in the preterm ovine fetus. *Pediatric Res* 52:1–9
5. Duncan JR, Cock ML et al. (2006) Chronic endotoxin exposure causes brain injury in the ovine fetus in the absence of hypoxemia. *J Soc Gynecol Invest* 2006 (13):87–96
6. Palsson-McDermott EM, O'Neill LA (2004) Signal transduction by the lipopolysaccharide receptor, Toll-like receptor-4. *Immunology* 113:153–162
7. Briscoe TA, Duncan JR et al. (2006) Activation of NF-κB transcription factor in the preterm ovine brain and placenta after acute LPS exposure. *J Neurosci Res* 83:567–574
8. Back SA, Han BH et al. (2002) Selective vulnerability of late oligodendrocyte progenitors to hypoxia-ischemia. *J Neurosci* 22(2):455–463
9. Mattson MP, Camandola S (2001) NF-κB in neuronal plasticity and neurodegenerative disorders. *J Clin Invest* 107(3):247–254
10. Eklind S, Mallard C et al. (2001) Bacterial endotoxin sensitizes the immature brain to hypoxic-ischaemic injury. *Eur J Neurosci* 13(6):1101–1106

## Prenatal Brain Injury (PBI)

### Definition

It involves fetal brain injury and inflammation.

- [Prenatal Brain Injury by Chronic Endotoxin Exposure](#)

## Preoptic Area

### Synonyms

- [Area preoptica](#)

### Definition

Situated at the lateral wall of the third ventricle, close to the optic recess. The region comprises three nuclear areas: periventricular nucleus, medial preoptic nucleus and lateral preoptic nucleus.

The area is also in the direct vicinity of the organum vasculosum of the lamina terminalis and plays a role in thermoregulation, hypovolemic thirst, male sexual behavior, brood care, gonadotropin secretion and locomotion.

- [Diencephalon](#)
- [Hypothalamus](#)
- [Nocturnal/Diurnal](#)

## Preparatory Postural Adjustments

- [Anticipatory Postural Responses](#)

## Prepositus Hypoglossal Nucleus

### Synonyms

- [Nucl. prepositus hypoglossi](#)

### Definition

The rod-shaped nucleus rostral to the hypoglossal nerve in the oculomotor control center which plays an important role in tracking moving objects – with the eyes, coordination of fast eye movements and fixation on objects. The nucleus has afferents from the

cerebellum, vestibular „ nuclei as well as the interstitial nucleus (Cajal). Efferents to the nuclei of the eye muscles.

► Myelencephalon

## Prepulse Inhibition

### Definition

A decrease of the response to a startle inducing stimulus, when the stimulus is preceded by a weak stimulus that does not induce a startle response.

► Startle Response

## Prepyriform Cortex

► Olfactory Cortex

## Pressure Ejection

### Definition

► Microiontophoresis and Micropressure Ejection

## Pressure Micro-ejection

► Microiontophoresis and Micropressure Ejection

## Pressure Receptors

► Cutaneous Mechanoreceptors, Anatomical Characteristics

## Presynaptic Inhibition

JORGE N. QUEVEDO

Department of Physiology, Biophysics and Neuroscience, Centro de Investigación y de Estudios Avanzados del I.P.N, Mexico City, Mexico

### Synonyms

Decrease of synaptic effectiveness

### Definition

Presynaptic inhibition (PSI) refers to a decrease of transmitter release at central synapses. Five decades ago, it was reported that activation of afferent fibers originating in flexors led to depression of monosynaptic group Ia ►excitatory postsynaptic potentials (EPSPs) evoked on extensor motoneurons in the cat spinal cord [1]. This depression occurred with no detectable changes in the time course of monosynaptic EPSPs, membrane potential or motoneurone excitability [1,2]. It is now known that PSI occurs broadly within the central nervous system of both vertebrates and invertebrates, and that synaptic efficacy at axon terminals from sensory afferents, descending systems or interneurons [3] can be subject to an inhibitory control by a number of neurotransmitters and presynaptic receptors [4].

### Characteristics

#### PSI Associated with Primary Afferent Depolarization (PAD)

##### *PAD as a Measure of PSI in the Spinal Cord*

Stimulation of sensory nerves produces a slow negative potential recorded in dorsal roots via depolarization of intraspinal terminals of afferent fibers. This depolarization, termed ►primary afferent depolarization (PAD), is electrotonically propagated to the dorsal roots and can be recorded as a ►dorsal root potential (DRP). It can also be recorded intra-axonally in the dorsal horn. When the intra-axonal membrane potential produced by PAD reaches firing threshold, back-propagating action potentials are seen, and are called ►dorsal root reflexes (DRRs). Owing to the parallel time course of PSI and PAD, it has been assumed that PAD is responsible for PSI and that both phenomena are mediated by the same mechanisms [2,3].

##### *Mechanisms Involved in the Generation of PAD*

Pharmacological and electrophysiological studies have lead to the conclusion that PAD is primarily mediated by last-order GABAergic interneurons, and generated by the activation of presynaptic ionotropic GABA<sub>A</sub> receptors [2,3]. GABA<sub>A</sub> receptors are Cl<sup>-</sup>-permeable, and their activation drives the membrane potential towards the Cl<sup>-</sup> reversal potential. Because a Na<sup>+</sup>, K<sup>+</sup>, 2-Cl<sup>-</sup> cotransporter (NKCC1) maintains the Cl<sup>-</sup> reversal



potential less negative than the membrane potential, GABA<sub>A</sub> receptor activation leads to an efflux of Cl<sup>-</sup> ions and consequent depolarization of afferent terminals, i.e. PAD (Fig. 1) [4]. The increase in Cl<sup>-</sup> conductance reduces transmitter release by inactivation of voltage-gated Na<sup>+</sup> and Ca<sup>2+</sup> channels, or by shunting the membrane current to prevent spike invasion into the axon terminals [3]. The depolarization produced by activation of GABA<sub>A</sub> receptors can also enhance spontaneous transmitter release in the dorsal horn neurons by activating voltage-gated Ca<sup>2+</sup> channels [5].

### Interneurons Mediating PAD

There is clear anatomical evidence for the existence of GABAergic axo-axonic synapses on ►muscle spindle group Ia and II, muscle ►Golgi tendon organ group Ib,

and large diameter cutaneous afferents. However, a direct identification of interneurons mediating PAD is still lacking [3]. In addition to activation of conventional interneuronal circuits, PAD on myelinated and unmyelinated cutaneous afferents may be also accounted for by non-spiking microcircuits that involve dendroaxonic GABAergic contacts or GABA spill-over [6].

The shortest pathway mediating PAD of group I, group II and large diameter cutaneous afferents fibers is thought to be trisynaptic (Fig. 2), including first order excitatory and last-order GABAergic interneurons interposed [2,3]. The long duration of PAD (Fig. 1), suggests that last-order interneurons mediating PAD produce a prolonged burst of spikes following a brief afferent input. However, since a single interneurone spike is able to generate a similarly long-lasting DRP,

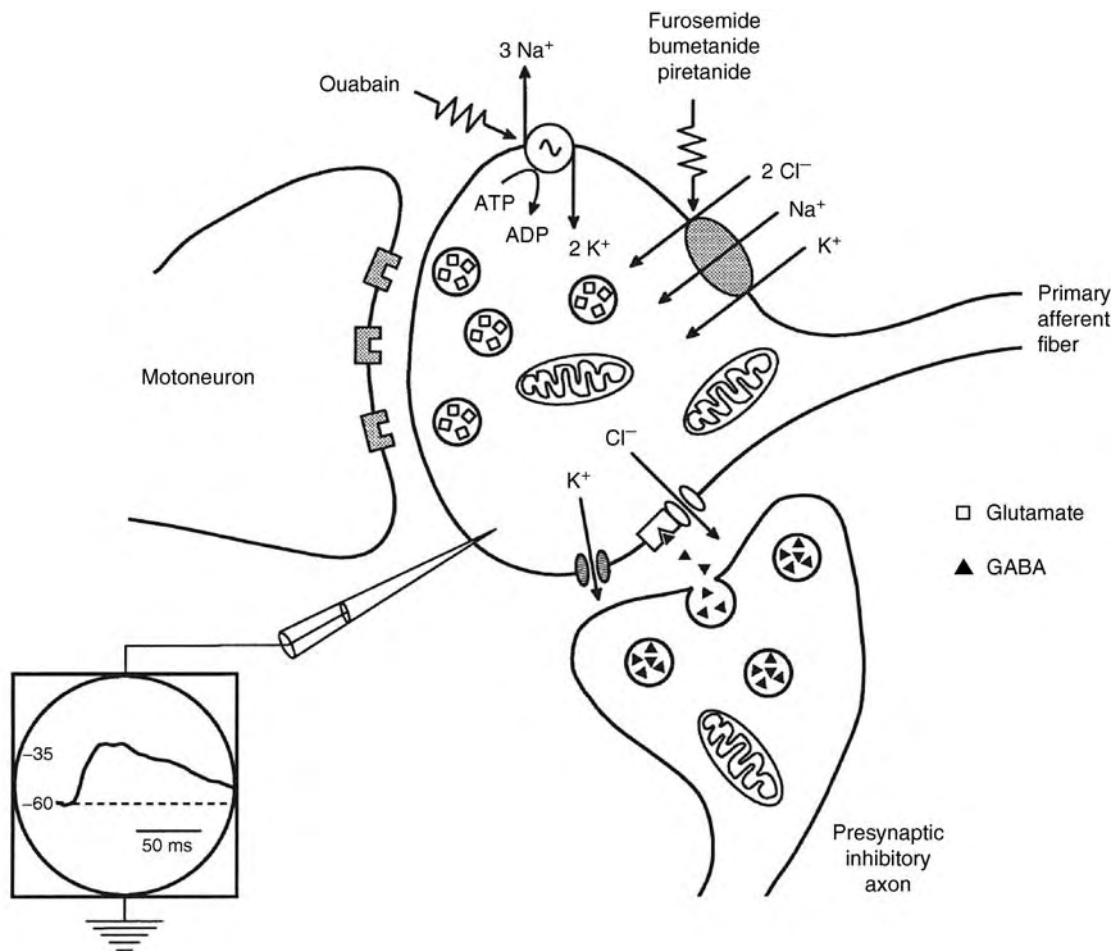

**Presynaptic Inhibition. Figure 1** Schematic representation of a presynaptic inhibitory axon from a GABAergic interneurone contacting a primary afferent fiber. The activation of GABA<sub>A</sub> receptors present on afferent terminals drives the membrane potential towards the Cl<sup>-</sup> reversal potential. Because a Na<sup>+</sup>, K<sup>+</sup>, 2-Cl<sup>-</sup> cotransporter maintains the Cl<sup>-</sup> reversal potential less negative than the membrane potential, GABA<sub>A</sub> receptor activation leads to an efflux of Cl<sup>-</sup> ions and consequent depolarization of afferent terminals (i.e. PAD). This depolarization could be recorded theoretically by a microelectrode inserted in the terminal of the primary afferent. Na<sup>+</sup> concentration inside the terminal is regulated by the Na<sup>+</sup>-K<sup>+</sup>-ATPase pump. Several drugs that can inhibit the cotransporter are indicated. (From [4]).

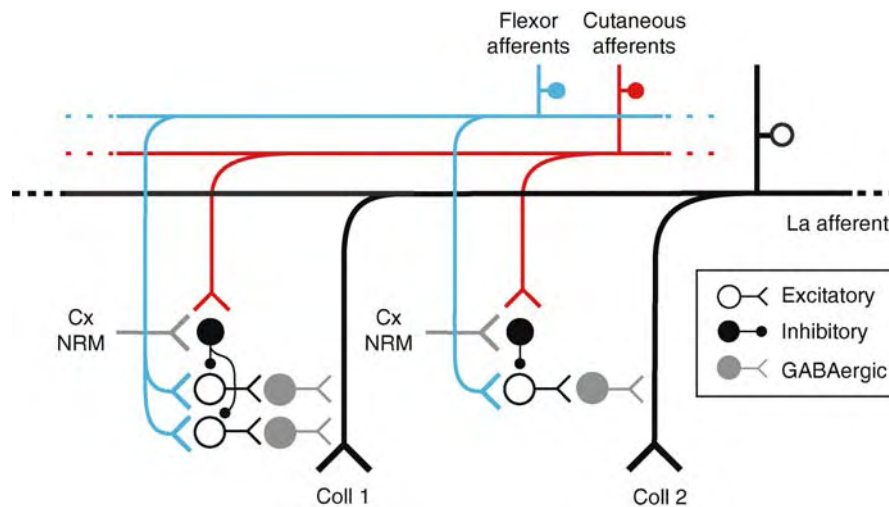

**Presynaptic Inhibition. Figure 2** Schematic diagram illustrating the local character of primary afferent depolarization (PAD) in collaterals of a single muscle spindle (Ia) afferent (black lines) ending at two different spinal levels. PAD produced by stimulation of flexor afferents (blue lines) is mediated by at least two interneurons interposed. First-order and last-order interneurons are excitatory (open circles) and GABAergic (gray circles), respectively. PAD evoked in collateral 1 (Coll 1) and collateral 2 (Coll 2) is mediated by separate sets and number of interneurons. PAD evoked by stimulation of flexor afferents in each collateral is reduced by stimulation of cutaneous (red lines), and the corticospinal (Cx) and raphespinal (NRM) (gray lines) systems via different sets of inhibitory interneurons (black circles). From [7].

PAD may be due to slow kinetics of GABA release, action, or uptake [3].

Interneurons mediating PAD are spatially segregated in the spinal cord, generally located in regions corresponding to the termination sites of the various afferent modalities. PAD of cutaneous and group I muscle afferent fibers is mediated by interneurons located in the middle and lateral parts of Rexed laminae III-IV, and medial Rexed laminae V-VI, respectively. PAD of group II afferents is produced by separated sets of interneurons into dorsal horn and intermediate zone, and the PAD of group II afferents seen in mid-lumbar and sacral spinal segments is also mediated by distinct populations of interneurons [3,8].

#### Organization of Pathways Mediating PAD

The patterns of PAD evoked by stimulation of sensory and supraspinal inputs differ for each afferent modality, suggesting that interneuronal pathways mediating PAD are modulated in a rather selective and complex manner. However, a primary mechanism of recruitment of PAD appears associated with a negative feedback control of their activated afferents.

#### Muscle Afferents

PAD of Ia afferents is most effectively produced by stimulation of group Ia and group Ib flexor afferents, and vestibulospinal inputs; it is also inhibited by stimulation of various supraspinal (corticospinal, rubrospinal, reticulospinal and raphespinal serotonergic systems) and

peripheral systems (large cutaneous and joint afferents) (Fig. 2). PAD of group Ib afferents occurs predominantly following activation of group Ib afferents from flexors and extensors, joint, and large cutaneous afferents (but may also be inhibited by these cutaneous afferents). In contrast to PAD of group Ia afferents, PAD of group Ib afferents is evoked by corticospinal, reticulospinal and raphespinal serotonergic systems, and also by the noradrenergic nucleus locus coeruleus, cerebellum and the vestibulospinal tract [3].

The different patterns of PAD of group Ia and group Ib afferent fibers produced by segmental and supraspinal inputs suggest that PAD is mediated by different sets of last-order GABAergic interneurons. Yet PAD of group I muscle afferents can be modulated differentially in afferent fibers ending at two separate spinal levels, or even in proximal collaterals of the same afferent fiber (Fig. 3). This local character of PAD is likely due to the activation of different sets of interneurons mediating PAD [3,7].

PAD of group II afferents is generally evoked by stimulation of group II, cutaneous, joint and pudendal afferents, as well as by the noradrenergic locus coeruleus and serotonergic raphespinal systems. It is most effectively evoked by group II afferents ending at the same spinal sacral or midlumbar segment. This implies that separate populations of interneurons mediate PAD of group II afferents projecting to these segments. PAD of group II afferents is generally stronger than PAD of group I afferents, indicating that PAD of group I and group II afferents is mediated by different sets of interneurons [3,8].

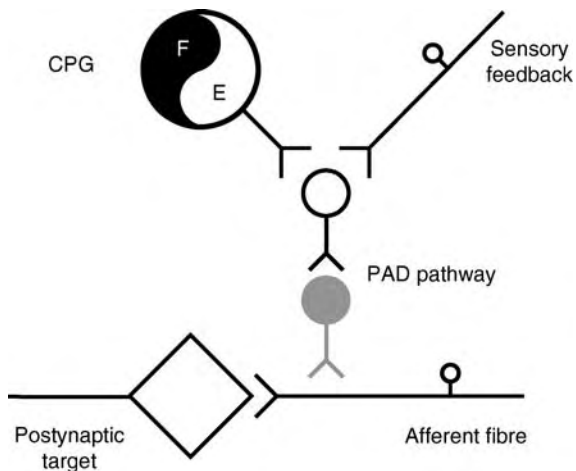

**Presynaptic Inhibition. Figure 3** Diagram of systems modulating presynaptic inhibitory pathways during locomotion. Synaptic transmission from afferent fibers to postsynaptic targets (open diamond) is modulated by PAD-related PSI mechanisms. Inputs from the locomotor pattern generator (CPG) circuitry and the sensory feedback from limbs in movement modulate PAD pathways, which are mediated by first-order excitatory (open circles) and last-order GABAergic (gray circles) interneurons. PAD-related PSI mechanisms participate in shaping motor pattern activity to adapt movement limbs to the environment. Adapted from [9].

### Cutaneous Afferents

PAD of low threshold cutaneous afferents is produced by stimulation of low threshold cutaneous, group Ib, group II, and high threshold muscle afferents, as well as by stimulation of corticospinal, reticulospinal, rubrospinal and the raphespinal serotonergic system. PAD of low threshold cutaneous afferents is larger in response to activation of their specific afferent modality (e.g. rapidly-adapting vs. slowly adapting). Therefore, PAD of low threshold cutaneous afferents plays an important role in sensory discrimination by enhancing contrast and eliminating surplus excitation. High threshold cutaneous afferents (A $\delta$  and C) are more effectively depolarized by noxious stimulation, as well as by stimulation of reticulospinal and raphespinal serotonergic systems [3]. However, because of the scarcity of axo-axonic GABAergic contacts on A $\delta$  and C fibers, spillover mechanisms may be involved in the generation of PAD in these fibers [3,6].

### PAD Evoked by Non-GABAergic Mechanisms

The accumulation of K<sup>+</sup> ions in the extracellular space following activation of spinal interneurons was proposed as a mechanism to explain PAD. However, changes in extracellular K<sup>+</sup> cannot account for all of the characteristics of PAD associated with stimulation of peripheral nerves or supraspinal pathways [3].

In addition to GABA<sub>A</sub> receptors, primary afferents contain a diversity of receptors whose activation can evoke depolarization of terminals and in consequence PSI. Stimulation of high threshold afferent fibers evokes DRPs including a large component evoked by activation of NMDA and AMPA/kainate ionotropic glutamate receptors [6]. Activation of presynaptic AMPA and kainate receptors depresses excitatory transmission in dorsal horn neurons, but increases spontaneous transmitter release, both kinds of effects being apparently produced by PAD [5]. Capsaicin depresses excitatory synaptic transmission evoked by stimulation of C afferent fibers and this depression is also related to PAD [5].

The spinal cord receives diffuse projections from several descending monoaminergic nuclei that modulate PAD pathways. For instance, stimulation of the serotonergic nucleus raphe magnus produces PAD on group Ib afferent fibers [3]. However, because iontophoretic application of serotonin and noradrenaline produces no change in the intraspinal threshold of group I afferents, it is unlikely that PAD occurs by a direct effect of these monoamines on afferent fibers [3].

Stimulation of the noradrenergic locus coeruleus and the serotonergic raphe nucleus produces PAD on group II afferent fibers associated with a concomitant depression of synaptic transmission of the same afferents, suggesting participation of a presynaptic inhibitory mechanism. Nevertheless, the decrease in transmitter release appears not to be mediated by direct actions of monoamines on group II afferents, but indirectly via modulation of the interneuronal pathways mediating PAD [3,8].

Localization of serotonin and noradrenaline receptor subtypes is apparently restricted to high threshold cutaneous afferents [3,8]. Indeed, A $\delta$  and C fibers are depolarized by direct application of serotonin, yet there is no clear association between PAD and decrease in synaptic effectiveness of these afferents [3].

### PSI not Associated with PAD

While PAD is generated predominantly by the activation of GABA<sub>A</sub> receptors, it is well known that activation of presynaptic G-protein coupled receptors, such as GABA<sub>B</sub>, can lead to PSI. This type of PSI is linked to intracellular signaling pathways that inhibit voltage-gated Ca<sup>2+</sup> channels, with no associated presynaptic depolarization. Moreover, in contrast to the activation of GABA<sub>A</sub> receptors, activation of GABA<sub>B</sub> receptors produces a longer-lasting component of inhibition of the monosynaptic EPSPs [3].

Activation of metabotropic adenosine and cannabinoid receptors also inhibits transmitter release by inhibition of voltage-gated Ca<sup>2+</sup> channels coupled to G-protein receptors [5]. The inhibitory effects of monoamines on the synaptic efficacy of high threshold cutaneous afferents may be also produced by activation

of metabotropic receptor subtypes coupled to signal transduction pathways [3,8].

A long-lasting inhibition of the monosynaptic reflex has been associated with a ►**homosynaptic depression** of the synapse between group Ia afferents and motoneurons. This depression also occurs in the absence of changes in motoneurone excitability and results from postactivation transmitter depletion [3].

### PSI and Function

PSI pathways are modulated during real and fictive motor behaviors. During ►**fictive locomotion** (i.e. in the absence of sensory information), there is a tonic PAD accompanied by an overall synaptic depression of group I, group II and cutaneous afferents. Depression of group I afferent transmission is associated with the reductions in gain of stretch reflexes and the H-reflex observed at the onset of locomotion in humans. Superimposed on the tonic PAD, there are phase-dependent fluctuations of the membrane potential in group I, group II and cutaneous afferents, with more depolarization during the flexion phase. Synaptic transmission from group I, group II and cutaneous afferents also displays a phase-dependent modulation during fictive locomotion. However, unlike the synaptic depression observed during tonic PAD, phase-dependent PAD is not correlated with a depression of synaptic transmission from Ia afferents onto motoneurons. Both tonic and phase-dependent oscillations of PAD are mediated by as yet unknown mechanisms [9].

PAD evoked by stimulation of sensory afferents is also rhythmically modulated during fictive locomotion, suggesting that the locomotors central pattern generator (CPG) circuitry has access to the pathways mediating PAD (Fig. 3). The pattern of modulation of sensory evoked-PAD is complex and appears to depend more on the specific postsynaptic targets than on the peripheral origin of the afferents. During real as opposed to fictive locomotion, the patterns of PAD depend on interactions between supraspinal, sensory feedback and CPG inputs on pathways mediating PAD. PAD-related PSI mechanisms play an important role during patterning generation and contribute in shaping motor pattern activity to adapt limb movements to the environment [9].

During voluntary muscle contractions in humans there is a decrease of PSI of afferent terminals contacting the active motoneurone pools and a concomitant enhancement of PSI of afferent terminals ending on inactive motoneurone pools. These observations indicate that corticospinal control of PSI selectively “opens” transmission in group Ia afferents to voluntarily activated motoneurons, while “closing” transmission to motoneurons of relaxed muscles [10]. Findings in humans are supported by studies in the cat showing that different collaterals of the same afferent fiber are selectively controlled by separate sets of last-order

interneurons mediating PAD (Fig. 2) [8]. The differential PAD-related PSI of individual collaterals of muscle afferents allows a selective control of sensory information according to the neuronal targets and to the motor task to be performed [8,10].

### References

1. Frank K, Fortes MGF (1957) Presynaptic and postsynaptic inhibition of monosynaptic reflexes. *Fed Proc* 16:39–40
2. Eccles JC (1964) Presynaptic inhibition in the spinal cord. *Prog Brain Res* 12:65–91
3. Rudiment P, Schmidt RF (1999) Presynaptic inhibition in the vertebrate spinal cord revisited. *Exp Brain Res* 129:1–37
4. Alvarez-Legman's FJ, Nana A, Marquez S (1998) Chloride transport, osmotic balance, and presynaptic inhibition. In: Rudiment P, Room R, Mendel L (eds) *Presynaptic inhibition and neural control*. Oxford University Press, New York, pp 50–79
5. Engelmann HS, McDermott AB (2004) Presynaptic ionotropic receptors and control of transmitter release. *Nat Rev Neurosci* 5:135–145
6. Russo RE, Delgado-Lucama R, Hungary J (2000) Dorsal root potential produced by a TTX-insensitive microcircuitry in the turtle spinal cord. *J Physiol* 528:115–122
7. Lomeli J, Quevedo J, Linares P, Rudomin P (1998) Local control of information flow in segmental and ascending collaterals of single afferents. *Nature* 395:600–604
8. Jankowska E (2001) Spinal interneuronal systems: identification, multifunctional character and reconfigurations in mammals. *J Physiol* 533:31–40
9. Rossignol S, Dubuc R, Gossard JP (2006) Dynamic sensorimotor interactions in locomotion. *Physiol Rev* 86:89–154
10. Pierrot-Deseilligny E, Burke D (2005) Presynaptic inhibition of Ia terminals. In: Pierrot-Deseilligny E, Burke D (eds) *The circuitry of spinal cord*. Cambridge University Press, England, pp 337–383

## Presynaptic Proteins

MICHAEL SEAGAR

INSERM/Université de la Méditerranée, UMR641, Faculté de Médecine Nord, Marseille, France

### Definition

Proteins that participate in neurotransmission by ensuring functions specific to the presynaptic compartment (i.e., nerve terminals). Typically, these proteins control the progression of synaptic vesicles through the steps (docking, priming, vesicle fusion) that lead up to the release of neurotransmitters into the synaptic cleft.

## Characteristics

Nerve terminals concentrate neurotransmitters in synaptic vesicles. Neurotransmitter release into the synaptic cleft then occurs when  $\text{Ca}^{2+}$  influx triggers the fusion of these vesicles with the presynaptic plasma membrane. However, only a small fraction of the total vesicle population within a nerve terminal is available to respond to the  $\text{Ca}^{2+}$  signal [1]. The presynaptic proteins described in this section, control transmitter release by holding vesicles in reserve or alternatively preparing and then accomplishing fusion.

## Synaptic SNARE Proteins and SNARE Complexes

Vesicle fusion involves assembly of *trans* ►SNARE complexes at the interface between a docked synaptic vesicle and the plasma membrane, a process that pulls the opposing membranes together. These *trans* complexes contain three proteins: one vesicle protein, the vesicular- or v-SNARE VAMP 2 (also known as ►*synaptobrevin*) and two plasma membrane proteins, the target- or t-SNAREs: ►*syntaxin 1* and ►*SNAP-25* [1,2]. VAMP and syntaxin have a similar topology with membrane anchors at their C-terminal extremities and the N-termini orientated towards the cytoplasm. SNAP-25 is attached to the membrane via palmitoylation of amino acids located in the middle of the sequence, thus both its N- and C-termini are cytoplasmic. SNARE proteins carry a characteristic 70 amino acid sequence, the SNARE motif. This sequence mediates the interactions with partner SNAREs to form complexes [3]. SNAP-25 has two SNARE motifs while VAMP and syntaxin have only one each.

The N-terminal portion of syntaxin constitutes an auto-inhibitory domain, which folds back to interact with and mask the membrane-proximal helical (H3) domain containing the SNARE motif. In this “closed” conformation, syntaxin cannot bind to SNAP-25 and VAMP. When syntaxin “opens,” four SNARE motifs (1 from VAMP, 1 from syntaxin, 2 from SNAP-25) can assemble into a four-helical bundle forming the SNARE complex. In this bundle, the alpha helices are in a parallel orientation with all the N-termini at one end and all the C-termini at the other. Zipping-up of the complex, starting at the N-termini and progressing towards the C-termini pulls the C-terminal membrane anchors of v- and t-SNAREs, and consequently the vesicular and plasma membranes, towards each other. This leads to mixing of the outer lipid leaflet of the vesicle with the inner leaflet of the plasma membrane, and can then progress to full fusion upon  $\text{Ca}^{2+}$  influx. However, the SNARE proteins themselves do not directly bind  $\text{Ca}^{2+}$ . The fusion machine probably comprises of a radial array of SNARE complexes at the synaptic vesicle/plasma membrane interface, associated with  $\text{Ca}^{2+}$ -sensor proteins such as the synaptotagmins that confer  $\text{Ca}^{2+}$ -dependency on the release process.

The synaptic SNARE proteins are the targets of botulinum neurotoxins (of which there are seven distinct types: BoNT/A to G) and tetanus neurotoxin (TeNT) [4]. These extremely potent toxins inhibit transmitter release by introducing their light chains into the nerve terminal cytoplasm. The light chains are metalloproteases that specifically cleave synaptic SNAREs at defined peptide bonds (e.g., BoNT/B & TeNT - VAMP2, BoNT/A & E - SNAP-25, BoNT/C - syntaxin 1). BoNTs and TeNT do not affect vesicle docking but block synaptic vesicle fusion by a selective proteolytic attack on the fusion machine.

In addition to driving membrane fusion, *trans* v-SNARE/t-SNARE pairing may also contribute to proofreading, ensuring that vesicles can only fuse with the appropriate target membrane. Families of SNAREs have been identified in many other subcellular compartments in a variety of eukaryotic cells. Vesicular transport thus uses the same basic fusion machinery, conserved through evolution from yeast to human nerve terminals.

Presynaptic proteins include several molecules that bind to SNARE proteins and regulate the assembly of SNARE complexes.

## Munc-18

►*Munc-18* (also called *nsec1* or *rbsec1* in mammals) is a 67 kDa hydrophilic protein, which associates with nerve terminal membranes via its interaction with syntaxin 1. *Munc-18* genes are the mouse members of the SM (*Sec1/Munc-18*) gene family, which includes yeast *Sec1* and the nematode and drosophila orthologues *Unc-18* and *Rop* [5]. The precise mode of action of *Munc18* is unknown. *Munc-18* binds tightly to the “closed” conformation of syntaxin 1 preventing SNARE complex assembly *in vitro*, but it is not simply a negative regulator of vesicle fusion. Genetic manipulations that decrease SM protein levels generally diminish secretion, consistent with the notion that these proteins are required for fusion. Yeast *SEC1* was initially identified as a gene required for exocytosis. However, in contrast to *Munc-18*, *sec1p* does not bind to monomeric yeast syntaxins but only to assembled SNARE complexes. SM proteins may act as chaperones to favor SNARE complex formation. Thus, although *Munc-18* binds to “closed” syntaxin, it might, in concert with additional factors, be involved in opening it and thus participate in priming. *Munc-18* binds to additional presynaptic proteins including the *Munc* interacting proteins (*Mint 1* and *2*). *Mints* link the vesicle fusion apparatus to adhesive proteins in the presynaptic plasma membrane that are involved in establishing synaptic connections.

## Munc-13

►*Munc-13* proteins constitute a family of three high molecular weight (200 kDa) molecules. *Munc13-1* and

Munc13–3 are brain specific, while Munc13–2 is ubiquitous. At the N-terminal extremity, Munc-13 contains a conserved  $\text{Ca}^{2+}$ -dependent calmodulin binding site followed by a C1 motif, which binds the lipid messenger diacylglycerol, and two C2 domains [6,7]. Munc-13 (Unc-13 in the nematode) is involved in synaptic vesicle priming. Gene deletions in both mice and nematodes principally affect the readily releasable pool of synaptic vesicles. Munc-13 probably acts by binding to the auto-inhibitory N-terminal domain of syntaxin 1. In the nematode Unc13 displaces Unc-18, which is bound to the closed state of syntaxin. Furthermore, expression of mutant syntaxin, frozen in a permanently open conformation, rescues worms with an Unc-13 mutation. Thus, munc-13 appears to act downstream of munc-18 by driving syntaxin from a closed to an open conformation. Regulation of Munc-13 action via  $\text{Ca}^{2+}$ /calmodulin or diacylglycerol binding has been implicated in presynaptic plasticity.

### Synaptophysin

► **Synaptophysin** was the first synaptic vesicle membrane protein to be isolated and cloned [8]. It is a major component of synaptic vesicles, thus anti-synaptophysin antibodies are widely used in immunocytochemistry to identify nerve terminals, and to evaluate diagnostically the neuroendocrine phenotype of a variety of tumors. Synaptophysin is an N-glycosylated 38 kDa protein. Like its homologue physins, synaptoporin, pantophysin and mitsugumin 29, it contains four membrane-spanning segments with N- and C-termini orientated towards the cytoplasm. It is the major cholesterol-binding protein in synaptic vesicles, and may contribute to the induction of vesicle curvature during vesicle biogenesis. Synaptophysin forms a complex in the vesicle membrane with the v-SNARE VAMP and subunits of the vacuolar proton pump (V-ATPase). The synaptophysin – VAMP2 complex prevents VAMP from entering into SNARE complex assembly. It thus constitutes an additional molecular mechanism for regulating transmitter release by determining v-SNARE availability. The amount of VAMP sequestered by synaptophysin is modulated by neuronal activity, indicating that it is functionally implicated in plasticity. However, deletion of the synaptophysin gene in mice does not result in a significant phenotype, which may reflect compensation by other members of the physin family. Mice that lack both synaptophysin and the structurally related tetraspan vesicle protein synaptogyrin do display defects in synaptic plasticity.

Additional presynaptic proteins mediate interactions of synaptic vesicles with the cytoskeletal elements. In this way, they seem to retain vesicles in a reserve pool that does not participate in regular vesicle exo-endocytotic recycling, unless mobilized by intense stimulation.

### Synapsins

► **Synapsins** are neuron-specific phosphoproteins that are among the most abundant synaptic vesicle proteins. Three synapsin genes (I-III) have been identified in mammals; each undergoes differential splicing to yield at least nine isoforms [1]. The N-terminal domains of synapsins are highly conserved, containing sites for phosphorylation by cAMP- and  $\text{Ca}^{2+}$ /calmodulin-dependent protein kinase while the C-terminal portions are variable. The central domain, which accounts for more than half the sequence, forms multimers and binds ATP. This region has structural similarities to some ATPases, suggesting that synapsin may have enzymatic activity requiring ATP.

Neither deletion of the single synapsin gene in the *Drosophila* genome, nor the deletion of individual synapsin genes in the mouse genome, has strong effects on synaptic transmission. Deletion of all three synapsin mouse genes is not lethal but does affect behavior. It induces changes in synaptic transmission and plasticity that differs in excitatory versus inhibitory synapses. The functions of the synapsins are unclear, but may include recruiting synaptic vesicles to a reserve pool. Synapsins associate with the surface of vesicles, and bind to both vesicular phospholipids and proteins. They also interact with cytoskeletal proteins including actin, spectrin and tubulin. These binding reactions are regulated by phosphorylation. Synapsins thus seem to be involved in tethering vesicles to the cytoskeleton and defining a reserve pool that is not immediately available for docking and fusion. Synaptic activity leads to phosphorylation of synapsins, which dissociate from vesicles allowing their mobilization and migration to the plasma membrane to prepare for fusion. However, synapsins may have additional functions. Mice with deleted synapsin I and II genes show a global decrease in the number of synaptic vesicles, suggesting that synapsins play a role in stabilizing vesicles. Finally, synapsins may also act at a step closer to fusion by regulating priming or fusion competence.

### Synaptic Vesicle Protein 2 (SV2)

► **SV2** is a synaptic vesicle glycoprotein of about 90 kDa, containing twelve potential transmembrane segments and N- and C-termini oriented towards the cytoplasm [1]. Sequences linking transmembrane regions are fairly short, although one highly glycosylated intraluminal loop is considerably larger. The sugar chains in this loop may contribute to the intravesicular matrix that is thought to bind neurotransmitters. Three SV2 genes in vertebrates encode homologous SV2A, SV2B and SV2C proteins that display distinct expression patterns in the brain, although SV2A is present in most neurons. The transmembrane and cytoplasmic linker sequences are

highly homologous between different SV2s, whereas the N-terminal domain and the intraluminal linkers diverge.

SV2s have significant homology to the Major Facilitator Superfamily of transporters for organic anions and cations, phosphates and sugars, and were initially thought to be transporters of neurotransmitters. However, their ubiquitous distribution rules out this possibility and indicates that they fulfill a more general function common to all synaptic vesicles. This function is still unknown, although a reasonable hypothesis is that they transport an unidentified substrate from the cytoplasm into the vesicle lumen.

Mice with deletions of the SV2A gene and the double SV2A/SV2B knockout display severe seizure activity and die postnatally. Cultured neurons from knock-out mice display increases in  $\text{Ca}^{2+}$ -dependent synaptic transmission that can be blocked by buffering cytoplasmic  $\text{Ca}^{2+}$ . Lack of SV2 thus seems to lead to abnormally high cytoplasmic  $\text{Ca}^{2+}$  levels. SV2 might therefore be involved in  $\text{Ca}^{2+}$  transport into synaptic vesicles to counterbalance the effects of burst firing in the nerve terminal. Furthermore, the N-terminal domain of SV2 interacts with, and may regulate the function of, the synaptic vesicle calcium sensor protein synaptotagmin. SV2 also constitutes the binding site for the anti-epileptic drug levetiracetam (KEPPRA), which perhaps enhances the ability of SV2 to limit electrical hyperexcitability [9].

## Pathology

### Botulism and Tetanus

These two potentially fatal diseases result from the inhibition of neurotransmitter release by BoNT and TeNT, which proteolyze presynaptic SNARE proteins. BoNT and TeNT are produced by the soil-borne bacteria *Clostridium botulinum* and *Clostridium tetani* [4]. Human botulism, mainly due to BoNT serotypes A, B and E, is typically caused by either eating contaminated food, wound infection, or in infants by intestinal proliferation of ingested clostridial spores. Botulism is a flaccid paralysis with classic symptoms: double/blurred vision, drooping eyelids, slurred speech, difficulty in swallowing, dry mouth, and muscle weakness. In severe cases, death can result from respiratory failure. Tetanus, which typically results from contamination of a deep puncture wound with *C. tetani*, involves muscular hypercontraction with symptoms including headache, muscular stiffness in the jaw (lockjaw) and neck, difficulty in swallowing, rigidity of abdominal muscles, spasms, sweating, fever and convulsions.

The differences between botulism (flaccid paralysis) and tetanus (muscle contractions and spasms) are due to differences in the neuronal populations affected. BoNT inhibits motoneurone terminals, blocking acetylcholine release and subsequent muscle contraction. In contrast,

TeNT acts specifically on inhibitory neurones in the spinal cord, diminishing tonic inhibition that indirectly activates acetylcholine release from motoneurones inducing muscle contractions.

## Therapy

BoNTs (usually BoNT/A or B) are used as therapeutic agents that can be injected into muscles to reduce hypercontractions in dystonia, blepharospasm, strabism and a multitude of other indications. They are also widely used cosmetically (e.g., Botox) to reduce the muscle activity that underlies facial wrinkles.

## References

1. Sudhof TC (2004) The synaptic vesicle cycle. *Annu Rev Neurosci* 27:509–547
2. Sollner T, Whiteheart SW, Brunner M, Erdjument-Bromage H, Geromanos S, Tempst P, Rothman JE (1993) SNAP receptors implicated in vesicle targeting and fusion. *Nature* 362:318–324
3. Sutton RB, Fasshauer D, Jahn R, Brunger AT (1998) Crystal structure of a SNARE complex involved in synaptic exocytosis at 2.4 Å resolution. *Nature* 395:347–353
4. Turton K, Chaddock JA, Acharya KR (2002) Botulinum and tetanus neurotoxins: structure, function and therapeutic utility. *Trends Biochem Sci* 27:552–558
5. Toonen RFG, Verhage M (2003) Vesicle trafficking: pleasure and pain from SM genes. *Trends Cell Biol* 13:177–186
6. Gerst JE (2003) SNARE regulators: matchmakers and matchbreakers. *Biochim Biophys Acta* 1641:99–110
7. Junge HJ, Rhee JS, Jahn O, Varoqueaux F, Spiess J, Waxham MN, Rosenmund C, Brose N (2004) Calmodulin and Munc13 form a  $\text{Ca}^{2+}$  sensor/effector complex that controls short-term synaptic plasticity. *Cell* 118:389–401
8. Valtorta F, Pennuto M, Bonanomi D, Benfenati F (2004) Synaptophysin: leading actor or walk-on role in synaptic vesicle exocytosis? *Bioessays* 26:445–453
9. Lynch BA, Lambeng N, Nocka K, Kensel-Hammes P, Bajjalieh SM, Matagne A, Fuks B (2004) The synaptic vesicle protein SV2A is the binding site for the anti-epileptic drug levetiracetam. *Proc Natl Acad Sci USA* 101:9861–9866

## Pretectal Area

### Synonyms

► Area pretectalis

### Definition

Situated immediately behind the superior colliculus, this nucleus plays a vital role in pupillary reflex and adaptation. Afferents come from the retina and

occipital cortical fields. Efferents go to the ipsi- and contralateral accessory oculomotor nucleus and superior colliculus.

The pretectal area includes the following nuclei: pretectal olivar nucleus, medial, anterior and posterior pretectal nuclei and optic tract nucleus.

▶ [Mesencephalon](#)

## Pretectal Nuclei

### Definition

Part of the subcortical visual shell. The pretectum consists of 7 nuclei in the visual midbrain, the n. of the optic tract, posterior limitans n., the olivary pretectal n., the anterior pretectal n., the posterior pretectal n., the medial pretectal n. and the commissural pretectal n. All connect substantially with the intergeniculate leaflet (IGL) and with each other.

They serve a variety of different functions. Perhaps the most well known is control of the pupillary light reflex by the olivary pretectal nucleus. This reflex is mediated by intrinsically photoreceptive retinal ganglion cells, as well as the classical rod/cone photoreceptors.

- ▶ [Intergeniculate Leaflet](#)
- ▶ [Neural Regulation of the Pupil](#)
- ▶ [Photoreceptors](#)
- ▶ [Pupillary Light Reflexes](#)
- ▶ [Retinal Ganglion Cells](#)

## Pretectum

### Definition

A midbrain region just rostral (forward) of the superior colliculus. It consists of a superficial nucleus (the nucleus lentiformis in frogs) containing migrated, large-celled neurons and a deep subnucleus. Cells of the nucleus lentiformis mesencephali are involved in horizontal optokinetic nystagm. Pretectal neurons respond more selectively to slowly moving vertical patterns, although horizontally sensitive neurons likewise been reported.

Directional information is encoded in a large population of motion-sensitive units, which includes

both narrowly and broadly tuned individual response profiles.

- ▶ [Evolution of the Visual System: Amphibians](#)
- ▶ [Optokinetic Nystagmus](#)
- ▶ [Superior Colliculus](#)

## Prevertebral Ganglia

### Definition

Prevertebral ganglia are autonomic ganglia that are found in the abdomen, around the origins from the aorta of the major vessels – the coeliac, superior mesenteric and inferior mesenteric arteries – and in the pelvis, close to the pelvic organs. The ganglia have various names applied to them the most common being: coeliac ganglia (also semi-lunar ganglia, solar plexus), superior mesenteric ganglia (inter-renal ganglia), inferior mesenteric ganglia and anterior (hypogastric) and posterior pelvic ganglia.

- ▶ [Autonomic Ganglia](#)

## Prey-catching Behavior

### Definition

Hunting animals show this type of behavior when trying to catch prey. This involves searching behavior, localization of prey and striking as well as killing of prey.

## PRG

### Definition

The Pontine Respiratory Group (PRG) is the region of respiratory neuron groups situated in the nucleus parabrachialis medialis (NPBM) and Kölliker-Fuse (KF) nuclei. The PRG is also termed as the pneumotaxic center.

- ▶ [Respiratory Neurotransmitters and Neuromodulators](#)



## Primary Acoustic Cortex

### Definition

Cerebral cortex areas in which the auditory tract terminates and which are involved in the first cortical processing steps for auditory signals. These include especially Brodmann areas 41 and 42 on the temporal plane.

► Telencephalon

One example is the posterior spinocerebellar tract which conducts impulses without interneurons from Clarke's nucleus of the thoracic cord to the cerebellar hemispheres.

► General CNS

## Primary Afferent Depolarization (PAD)

### Definition

A prolonged decrease in membrane potential usually produced by the activation of ionotropic GABA<sub>A</sub> receptors at the presynaptic terminals of afferent fibers.

This depolarization is propagated antidromically in an electrotonic manner and can be detected either (i) directly by intra-axonal recordings of afferent fibers, (ii) as a dorsal root potential (DRP) from the central stump of a cut dorsal root filament, or (iii) as a positive potential (P wave) from the cord dorsum. Given that intra-axonal recordings are normally obtained in the dorsal horn, PAD recorded intra-axonally reflects the summed membrane potential changes occurring in all the collaterals of an individual afferent fiber.

PAD is accompanied by an enhanced excitability of afferent fiber terminals. Changes in excitability of intraspinal terminals can be estimated from threshold changes in response to intraspinal current pulses. The activation of pathways mediating PAD produces a threshold decrease and a consequent increase in amplitude of the antidromic compound action potential (Wall's technique).

- Action Potential
- GABA
- Presynaptic Inhibition

## Primary Afferents

### Definition

Primary afferents are tracts ascending without interneurons.

## Primary Cultures

### Definition

Primary cultures are the first stage of cell culture in which cells removed from tissue are cultured but before cells are removed from the primary culture to start the next culture.

## Primary Hyperalgesia

### Definition

Hyperalgesia at a site of injury or inflammation.

- Hyperalgesia and Allodynia
- Joint Pain

## Primary Lateral Sclerosis (PLS)

### Definition

PLS designates a syndrome of progressive upper motor neuron dysfunction and shows consistent differences from ► amyotrophic lateral sclerosis (ALS), which is characterized by progressive degeneration of both upper and lower ► motoneurons. Unlike ALS, which is familial in 5-10% of the cases, PLS appears to be sporadic in adults. Initially, stiffness is more prevalent in PLS than in ALS patients, but limb wasting, pronounced in ALS patients, is rare in PLS patients. ► Spasticity is the most prominent sign in PLS. Cortical atrophy is most pronounced in the ► precentral gyrus and expands into the ► parietal-occipital region. The course of PLS is very slowly progressive.

► Amyotrophic Lateral Sclerosis (ALS)

## Primary Motor Cortex (M1)

### Definition

A part of the cerebral cortex that is most directly involved in controlling the activity of motoneurons. In primates, primary motor cortex is located in the precentral gyrus of the frontal lobe just anterior to the central sulcus. An orderly representation of movements by body part exists within primary motor cortex. From medial to lateral the representation is lower extremity, trunk, upper extremity, face and tongue. Many corticospinal neurons in primary motor cortex make monosynaptic linkages with motoneurons. A distinctive feature of primary motor cortex is the presence of large pyramidal cells (Betz cells) in cortical layer V.

► [Motor Cortex: Output Properties and Organization](#)

## Primary Progressive Aphasia

### Definition

Presenile progressive degenerative disorder characterized by initially isolated loss of language abilities for at least two years, but mostly transcending into muteness and ► [dementia](#) (often ► [frontotemporal dementia](#)). It is due to a degeneration of cerebro-cortical regions around the ► [sulcus lateralis \(Sylvii\)](#) of the left hemisphere. The most frequent variants are: (i) progressive non-fluent aphasia (characterized by labored speech, agrammatism); (ii) semantic aphasia (characterized by loss of word and object meaning and dyslexia); (iii) logopenic progressive aphasia (characterized by word-finding problems and impaired sentence comprehension).

## Primary Reinforcer

### Definition

Sensory stimulus with intrinsic rewarding properties such as food or water.

► [Operant Conditioning](#)

## Primary Sjögren's Syndrome

### Definition

A chronic, multisystem autoimmune disorder characterized by dryness of mouth and other mucous membranes that occurs in the absence of an associated rheumatic disease (secondary Sjögren's syndrome) and may involve extraglandular manifestations such as arthralgias, Raynaud's syndrome, pulmonary involvement, renal tubular acidosis, peripheral and central nervous system (CNS) disease.

► [Central Nervous System Disease in Primary Sjögren's Syndrome](#)

## Primary Somatosensory Cortex (S1)

### Definition

Primary somatosensory cortex comprises four cytoarchitectonic regions, areas 3a, 3b, 1 and 2 (going from rostral to caudal), located in the anterior portion of the parietal lobe. Each region has a complete representation of the body. Areas 3a and 2 receive inputs mainly from deep receptors (the hand representation is characterized by receiving inputs from both skin and deep receptors), while neurones in areas 3b and 1 largely respond to skin stimulation.

► [Somatosensory Cortex I \(SI\)](#)  
 ► [Somatosensory Cortex, Plasticity](#)

## Primary Visual Cortex

### Definition

Cerebral cortex in the occipital lobe of the mammalian brain.

The primary visual cortex (also known as Brodmann area 17, V1 or striate cortex) is the principal site at which visual information enters the cortex. It lies in the calcarine sulcus of the occipital lobe and receives visual signals from the retina relayed via the lateral geniculate nucleus (LGN) of the thalamus. Efferent projections

terminate in various visual areas in the cortex. Primary visual cortex has a complete map of visual space.

- ▶ Geniculo-Striate Pathway
- ▶ Striate Cortex Functions
- ▶ Evolution of the Visual System: Mammals-Color Vision and the Function of Parallel Visual Pathways in Primates

## Priming

### Definition

Priming refers to the effect where a prior exposure to a stimulus exerts influences on a subsequently given stimulus. Typically, priming produces a faster and/or a more accurate response to a stimulus associated with a previously presented stimulus called prime.

- ▶ Latent Learning
- ▶ Long-Term Memory

## Primordium Hippocampi

- ▶ Evolution of the Pallium: in Amphibians

## Principle of Neurological Minimization

### Definition

Underlies responses of the neuromuscular system to changes in control variables and/or external forces; a tendency of system's elements to minimize, in the limits defined by neural, biomechanical and environmental constraints, the imposed activity by returning the system to the same or bringing it to a new steady state, depending on conditions; a solution to the redundancy problem.

- ▶ Equilibrium Point Control

## Principle of Virtual Work

MARCELO EPSTEIN

Schulich School of Engineering, University of Calgary, Calgary, AB, Canada

### Definition

From the physical point of view, the ▶principle of virtual work is an attempt to characterize unequivocally an equilibrium ▶configuration of a mechanical system (as defined in statics (q.v.)) by observing how it reacts to a small kinematical perturbation, called a *virtual displacement*.

### Description of the Theory

In ▶classical mechanics (q.v.), a mechanical system is defined from the kinematical point of view by means of its *configuration space*, whose dimension is an expression of the number of *degrees of freedom* of the system. A (local) system of coordinates in the configuration space is known as a set of *generalized coordinates*. It is important to stress that the generalized coordinates  $q^i (i = 1, \dots, n)$  are mutually independent, since they already incorporate any geometrical constraints that the system may have. In the case of the double planar pendulum discussed in the article on classical mechanics (q.v.), for example, the number of degrees of freedom of the system is exactly two and so is the number of its generalized coordinates, whether the angular deviations from the vertical or any other set of appropriate geometrical parameters that are mutually independent and sufficient to define a state of the system are chosen. Another way to state this independence is to say that any description of a possible configuration of the system by means of coordinates,  $x^I (I = 1, \dots, n' > n)$  say, can be eventually boiled down to  $n'$  (smooth) functions of  $n$  generalized coordinates:

$$x^I = x^I(q^1, \dots, q^n), \quad (I = 1, \dots, n'). \quad (1)$$

In the case of the planar double pendulum, a system of Cartesian coordinates may be chosen and an arbitrary configuration of the system expressed by means of the two pairs of coordinates, each corresponding to the position of one of the two masses. Thus, in this simple case,  $n' = 4$ . Nevertheless, it is clear that (given the lengths of the two links) all four Cartesian coordinates can be expressed in terms of the two angles,  $q^1$  and  $q^2$ , formed by the links and the vertical direction. The original four coordinates are interdependent, since they must satisfy the two constraints imposed by the assumed rigidity of the links. The generalized coordinates, on the other hand, by their very nature, already take these constraints into consideration and can,

therefore, be varied independently without violating these constraints. A *virtual displacement* of a mechanical system consists precisely in a set of small (infinitesimal) perturbations or *variations*  $\delta q^i (i = 1, \dots, n)$  of the generalized coordinates away from a given configuration  $q^i (i = 1, \dots, n)$ . The forces acting on the system, whether internal or external, will in general perform work on any given virtual displacement, a scalar quantity appropriately designated as *virtual work*. In many cases, however, the forces necessary to maintain the constraints will not perform any virtual work. For example, in the case of the pendulum it is clear that the constancy of the length of the links is physically attained by intermolecular forces, which result in an internal state of tension. The work of these tensile forces would be equal to the magnitude of the force multiplied by the change of length of the corresponding link. Since, by their very definition, virtual displacements *respect the geometrical constraints* (the constancy of the length of the links) the virtual work of these internal *forces of constraint* will vanish. For a different example, consider a body that is constrained to slide freely on a surface. As long as there is no friction, the force necessary to maintain the contact between the body and the surface will be perpendicular to the surface and, therefore, will perform no virtual work on any virtual displacement. If friction is considered, however, this will no longer be the case, and it is a philosophical point of view whether or not the frictional force should be called a force of constraint. Be that as it may, it is clear that by purposely defining a virtual displacement as a possible displacement of the system, namely one that respects its geometrical constraints, the virtual work of some forces will automatically cancel out. If therefore, an equilibrium configuration is characterized by means of some property of the virtual work, it will follow that the forces of constraint will automatically play no role in the determination of equilibrium, a feature that would be almost unthinkable in an approach based on the concept of a free-body diagram of statics (q.v.). The principle of virtual work, in fact, provides such a characterization.

According to the principle of virtual work, a mechanical system in classical mechanics (q.v.) is in an equilibrium configuration if, and only if, the virtual work of all the forces acting on the system vanishes *identically* for all possible virtual displacements that can be impressed away from this configuration. This principle, therefore, characterizes an equilibrium configuration as one for which the system is work-wise indifferent to small perturbations compatible with its constraints. It is important to notice that the principle of virtual work is not an equation but an identity. Only so can it be understood that a single scalar statement is equivalent to a number of vector equations. For consistency, the principle of virtual work, when applied to a rigid plate in two dimensions, will be shown to

deliver the classical equations of equilibrium. The plate is assumed to be free to move in the  $x$ - $y$  plane (no other constraints) and to be acted upon by  $N$  concentrated forces  $\mathbf{F}^\alpha (\alpha = 1, \dots, N)$  acting at points with coordinates  $x_\alpha, y_\alpha (\alpha = 1, \dots, N)$ . In this case, the two Cartesian coordinates,  $x_p$  and  $y_p$ , of a point  $P$  of the plate and the (counter-clockwise, say) angular deviation  $\theta$  of a material line drawn in the plate from, say, the  $x$ -axis can be adopted as generalized coordinates. A virtual displacement consists of any arbitrary combination of variations  $\delta x_p, \delta y_p, \delta \theta$ . The virtual displacement of the point of application of the force  $\mathbf{F}^\alpha$  is the vector with components:

$$(\delta x_p - (y_\alpha - y_p)\delta\theta, \delta y_p + (x_\alpha - x_p)\delta\theta), \quad (2)$$

so that the principle of virtual work can be stated as:

$$VW = \sum_{\alpha=1}^N F_x^\alpha (\delta x_p - (y_\alpha - y_p)\delta\theta) + F_y^\alpha (\delta y_p + (x_\alpha - x_p)\delta\theta) \equiv 0, \quad (3)$$

with an obvious notation. Since this is an identity, any combination of  $\delta x_p, \delta y_p, \delta\theta$  may be chosen. Choosing first  $\delta x_p \neq 0, \delta y_p = \delta\theta = 0$ :

$$\sum_{\alpha=1}^N F_x^\alpha = 0. \quad (4)$$

The choice  $\delta x_p = 0, \delta y_p \neq 0, \delta\theta = 0$  yields:

$$\sum_{\alpha=1}^N F_y^\alpha = 0. \quad (5)$$

Finally, the choice  $\delta x_p = \delta y_p = 0, \delta\theta \neq 0$  yields:

$$\sum_{\alpha=1}^N -F_x^\alpha (y_\alpha - y_p) + F_y^\alpha (x_\alpha - x_p) = 0. \quad (6)$$

Equations 4, 5 and 6 are immediately recognized as the standard equations of equilibrium of a rigid body in two dimensions. In particular, Eq 6 is the equation of moment equilibrium around point  $P$ . Considering now the case in which the plate is hinged at point  $P$  by means of a frictionless hinge, the configuration space of the system becomes one-dimensional and the rotational coordinate  $\theta$  is a valid generalized coordinate. Obviously, in this case Eqs. 4 and 5 are no longer valid, and the equilibrium of the system is governed by Eq. 6 alone. Notice the essential difference with the conventional free-body diagram approach. In a free-body diagram the reactive forces at the hinge form an essential part of the package. The reactions thereat will intervene in the equations of equilibrium. In the virtual work approach, on the other hand, it is imperative not to disengage the plate from the hinge. Quite to the

contrary, the presence of the hinge, by reducing the number of degrees of freedom of the system, reduces the number of equilibrium equations. Naturally, this simple example alone would not justify the use of the principle of virtual work, but in more complicated situations its use, by eliminating the participation of reactive forces, results in a considerable simplification of the equations of equilibrium.

The virtual work expression can always be brought to the form:

$$VW = \sum_{i=1}^N Q_i \delta q^i, \quad (7)$$

by simply collecting all the terms that affect the variation of each generalized coordinate. The multipliers  $Q_i$  are called *generalized forces* and, in statics, can be at most functions of the generalized coordinates. The forces acting on a mechanical system are said to be *conservative* if there exists a scalar function  $V$  of the generalized coordinates such that:

$$Q_i = -\frac{\partial V}{\partial q^i}, i = 1, \dots, n. \quad (8)$$

This function, if it exists, is called a **potential energy** of the forces, and the forces are said to *derive from this potential* (which is determined uniquely up to an additive constant). It is important to realize that the property of the forces being conservative is independent of the particular choice of generalized coordinates, as can be verified easily by using the chain rule of differentiation. Combining Eqs. 7 and 8, it may be concluded that in a conservative system the virtual work of the forces can be calculated as the exact differential of the negative of the potential, namely:

$$VW = -\delta V. \quad (9)$$

The principle of virtual work for conservative systems establishes, therefore, that the potential energy is *stationary* at a position of equilibrium. It can be shown that the equilibrium is *stable* if the potential energy attains a strict *minimum* at the equilibrium configuration. A simple example is that of a cherry at the bottom of a wine glass (stable equilibrium, minimum gravitational potential energy), as opposed to a ball at a mountaintop (unstable equilibrium, maximum gravitational potential energy). The idea of virtual displacements as small perturbations of a putative equilibrium configuration is particularly clear in such simple examples.

In the case of continuum mechanics (q.v.), the principle of virtual work is also applicable provided the so-called *internal virtual work* is carefully accounted for, that is the work of the stress tensor upon the small virtual variations  $\delta \mathbf{F}$  of the **deformation**

**gradient**. To see how this thought can be formalized, the Lagrangian equation of equilibrium is obtained from the Lagrangian equation of balance of **linear momentum** (Eq. 15 in **balance laws** (q.v.), whose notation is adopted) by eliminating the **acceleration** terms as:

$$T_{i,l}^I + B^i = 0. \quad (8)$$

Multiplying this equation by a *virtual displacement field*, that is, a field of the form  $\delta x^i(X^1, X^2, X^3)$  and integrating over the referential volume of the body:

$$\int_{\Omega} (T_{i,l}^I + B_i) \delta x^i d\Omega = 0, \quad (9)$$

where the summation convention is used. This equation is obviously valid for any virtual displacement field. Considering the first term, the divergence operator is eliminated by invoking the divergence theorem. The price to pay is the appearance of a term at the boundary. Indeed:

$$\begin{aligned} \int_{\Omega} T_{i,l}^I \delta x^i d\Omega &= \int_{\Omega} (T_i^l \delta x^i)_{,l} d\Omega - \int_{\Omega} T_i^l \delta x^i_{,l} d\Omega \\ &= \int_{\partial\Omega} T_i^l \delta x^i N_l dA - \int_{\Omega} T_i^l \delta F_l^i d\Omega \\ &= 0. \end{aligned} \quad (10)$$

In the boundary integral the **surface traction** is immediately recognized, namely,  $S_i = T_i^l N_l$ . Putting together the results of Eqs. 9 and 10 the identity:

$$\int_{\Omega} B_i \delta x^i d\Omega + \int_{\partial\Omega} S_i \delta x^i dA \equiv \int_{\Omega} T_i^l \delta F_l^i d\Omega. \quad (11)$$

is finally obtained.

The left-hand side represents the *external virtual work* ( $EVW$ ) of the **body forces** and the surface tractions, while the right-hand side can be identified with the *internal virtual work* ( $IVW$ ) of the (first Piola-Kirchhoff) stress. It is not difficult to reverse the steps of this derivation and conclude that the identical satisfaction of the principle of virtual work in the form:

$$EVW \equiv IVW, \quad (12)$$

is equivalent to the equations of equilibrium of a deformable continuum. No restrictions have been specified upon the virtual displacement fields. Assume, however, that the **deformation** of part of the boundary is prescribed (for example, part of the boundary is fully supported). Then, the virtual displacement fields must vanish at that part of the boundary. One of the useful features of the principle of virtual work in continuum mechanics is that it delivers not only the interior equations of equilibrium, but also the appropriate

boundary conditions of the problem. The Lagrangian formulation has been presented, but a similar treatment delivers also the Eulerian form of the principle. In this case, the internal virtual work is given by  $IVW = \int_{\omega} t^{ij} \delta D_{ij} d\omega$ .

In the case of a deformable continuum, the concept of potential energy can be extended to the stresses themselves. If the constitutive equation of the material is such that the [▶first Piola-Kirchhoff stress](#) tensor is derived from a scalar potential function of the deformation gradient, the material is said to be *hyperelastic* ([▶hyperelasticity](#)). Configurations of equilibrium can be associated with a stationary value of the total potential energy of the system.

## References

1. Truesdell C, Toupin R (1960) The classical field theories. In: Flügge S (ed) *Handbuch der Physik*, vol III/1. Springer, Berlin, pp 226–793
2. Lanczos C (1970) *The variational principles of mechanics*, 4th edn. Toronto University Press, Toronto
3. Epstein M, Herzog W (1998) *Theoretical models of skeletal muscle*. Wiley, Chichester

## Principle of Virtual Work

### Definition

In analytical mechanics, the statement that the equilibrium of a system is equivalent to the identical vanishing of the work done by the external forces on all possible virtual displacements of the system.

▶Mechanics

## Prion (Proteinaceous Infectious Particle)

### Definition

Prion (proteinaceous infectious particle) is a proteinaceous infectious agent that cause bovine spongiform encephalopathy (BSE) and human variant Creutzfeldt Jakob disease in humans.

▶Creutzfeldt-Jakob Disease

## Prism Adaptation

### Definition

When a person wears laterally displacing prism glasses, he or she initially experiences difficulty in reaching an object. However, he or she soon adapts to the prism so that the object can be reached. Such a phenomenon is called prism adaptation, and involvement of the cerebellum in the adaptation is known.

▶Sensory Motor Learning/Memory and Cerebellum

## Probabilistic Inference

▶Bayesian Statistics (with Particular Focus on the Motor System)

## Procedural Learning

### Definition

Training a sensori-motor task, such as playing the piano.

▶Sensory Plasticity and Perceptual Learning

## Procedural Memory

### Definition

Memory of skill or movement improved by practice or experience is called the procedural memory. It has been regarded distinct from the declarative memory about episodes or notions etc. These two types of memories are supported with independent neuronal mechanisms.

Patients impaired in the declarative memory retain the unimpaired procedural memory and vice versa.

▶Long-Term Memory

▶Sensory Motor Learning/Memory and Cerebellum

## Process S

► Sleep Homeostasis

## Processing of Tactile Stimuli

HEATHER E. WHEAT, ANTONY W. GOODWIN  
Department of Anatomy and Cell Biology, University  
of Melbourne, Parkville, VIC, Australia

### Definition

Tactile here refers to that which is concerned with the sense of touch or the perception of touch. When we touch or manipulate objects, four classes of low-threshold cutaneous mechanoreceptor sensors are activated by the stresses and strains arising from the interaction between skin and object. These four receptor types have different response characteristics because of differences in their structure and in their location in the skin. During manipulation, the receptor responses are determined by many different features of the manipulated object and of the hand movements. Such features include: contact or grip force, the presence of shear forces, the area and shape of the contact region, the surface texture, the shape and compliance of the object, and the presence of slip between the object and the skin. This information is conveyed to the central nervous system by mechanoreceptive afferents (peripheral nerve fibers) which innervate these mechanoreceptors. A population of mechanoreceptive afferents is able to simultaneously encode multiple stimulus parameters because each parameter has a different representation in the spatial and temporal patterns of activity across the afferent population.

### Characteristics

#### Tactile Sensors of the Glabrous Skin

The glabrous (ridged) skin of the fingers consists of two main layers, an outer epidermis and an inner dermis, which are arranged in an interlocking pattern of grooves and ridges (Fig. 1).

Within the skin are thermoreceptors, nociceptors and low-threshold mechanoreceptors; these vary in structure from free nerve endings to mechanically complex end organs. In this chapter the focus is on the four low-threshold mechanoreceptors: Merkel cell-neurite complexes at the epidermal-dermal junction, Meissner corpuscles in the outer papillary layer of the dermis, and Pacinian and Ruffini corpuscles in the

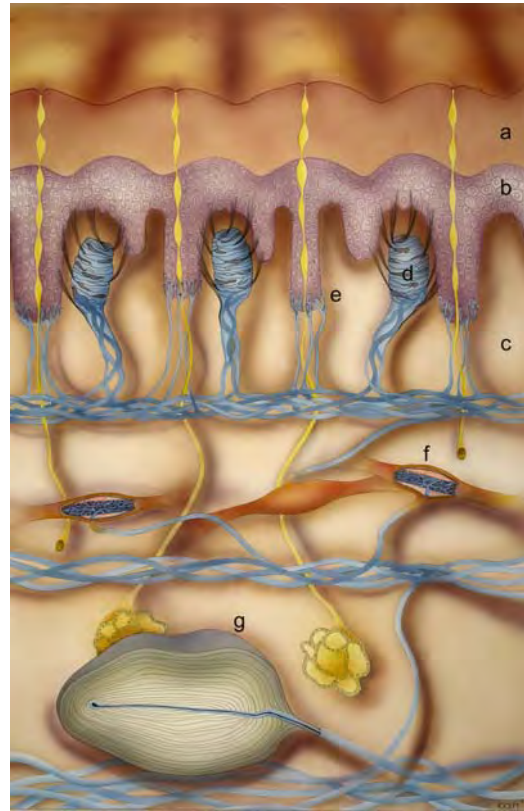

**Processing of Tactile Stimuli. Figure 1** A cross-section through glabrous skin. The upper layer, or epidermis (b), is covered in thick keratin (a). Both the epidermis and the underlying layer, the dermis (c), have a wave-like structure. Peripheral nerve fibers, shown in blue, terminate on four types of mechanoreceptors, the Meissner corpuscles (d), the Merkel endings (e), the Ruffini organs (f) and the Pacinian corpuscles (g). Reproduced with permission from Ian Darian-Smith.

deeper reticular layers of the dermis. These receptors are innervated by large-diameter myelinated nerve fibers, classified as A $\beta$  fibers, which conduct action potentials rapidly. A single fiber may end in a single mechanoreceptor, but more commonly will innervate many mechanoreceptors. Conversely, a single mechanoreceptor may be innervated by a single fiber or by multiple fibers [1].

In humans, the fibers (also termed afferents) fall into four distinct groups classified by their response properties. Slowly-adapting type I (SAI) and slowly-adapting type II (SAII) afferents are associated with Merkel endings and Ruffini corpuscles respectively and respond to both the static and dynamic components of the stimulus. Fast-adapting type I and II (FAI and FAII) afferents are associated with Meissner corpuscles and Pacinian corpuscles respectively and respond only to dynamic components of the stimulus. Monkey

glabrous skin lacks SAII afferents, but the remaining three afferent types, common to humans and monkeys, have similar response properties in both humans and monkeys. Fast adapting afferents are also referred to as rapidly adapting afferents. The density of SAI and FAI afferents innervating the hand decreases proximally from a maximum at the fingertip of  $0.7 \text{ mm}^{-2}$  for SAI afferents and  $1.4 \text{ mm}^{-2}$  for FAI afferents. The proximo-distal gradient is less pronounced for SAII and FAII afferents which in the human fingertip have lower densities than the type I afferents ( $0.1$  and  $0.21 \text{ mm}^{-2}$  respectively). The receptive fields of type I mechanoreceptive afferents (with more superficial receptors) are small and well demarcated whereas those of the type II afferents (with deeper receptors) are large and diffuse with some extending across the entire hand.

### Tactile Sensors of the Hairy Skin

The mechanoreceptors of the hairy skin are either associated with the hairs on the skin or are situated between them. There are three hair types – specialized sinus or vibrissae (which are not present in humans), vellus or pelage, and guard. The hair follicles are innervated by: free nerve endings, Merkel nerve endings associated with SAI afferents, lanceolate nerve endings associated with rapidly-adapting afferents, and Ruffini corpuscles associated with SAII afferents. Most sinus hairs are also innervated by lamellated corpuscle of Pacinian type which are associated with rapidly-adapting afferents. Between the hair follicles are dome-like elevations, the so called “touch domes” or *Haarscheiben* of Pinkus which are innervated by slowly-adapting Merkel endings and free nerve endings [2].

### Central Nervous System Pathways

The peripheral afferent nerve fibers described above are the peripheral processes of bipolar cells with cell bodies in the dorsal root ganglia, which lie in close proximity to the spinal cord. The central processes of these bipolar cells enter the spinal cord via the dorsal roots and it is at this point that axons conducting information from the low-threshold mechanoreceptive afferents become segregated from those carrying nociceptive or thermal information. The predominant spinal pathway for the low-threshold mechanoreceptive afferents is via the dorsal columns (cuneate and gracile fascicles); most axons enter the spinal cord and ascend to the brainstem without synapse.

The dorsal column axons project principally to, and synapse on, cells within the ipsilateral cuneate and gracile nuclei (the dorsal column nuclei) in the brainstem. Axons of cells in these nuclei cross to the other side of the brainstem and ascend as the medial lemniscus, synapsing primarily in the ventroposterior nuclear complex of the thalamus. The axons of these thalamic cells project predominantly to the primary

somatosensory cortices in the postcentral gyrus – Brodmann areas 3a, 3b, 1 and 2. Throughout, the ascending pathways are organized largely on somatotopic principles. Furthermore, neurons to this point retain many of the functional properties of their primary afferent input in terms of basic response functions and receptive field characteristics.

### Overview of Tactile Processing

Tactile processing falls into two separate, but overlapping, broad categories. In the first category, touch informs pattern and form perception which allows us to identify objects. Such information includes the object's shape, size, softness and its surface texture. Commonly this is a conscious process. In the second category, touch forms a vital component of the sensorimotor integration that is essential for precision grip and effective manipulation. Object characteristics such as compliance and surface microgeometry, as well as task related characteristics such as position of contact on the skin, linear and torsional loads, and contact or grip forces are relayed by touch to the central nervous system, often without deliberate or conscious tactile perception. To assess what tactile information is signaled to and used by the brain, psychophysical measurements of the human capacity to detect, discriminate, scale and identify specific features of a stimulus have been conducted. Such behavioral studies provide an indication of the minimum information about a particular stimulus parameter that must be received by the brain for conscious perception. Many of these studies have been accompanied by neurophysiological experiments, employing the same stimuli, in order to determine how the essential stimulus parameters are represented in the responses of different neural populations.

The responses of single mechanoreceptive afferents innervating the skin have been recorded by inserting micro-electrodes through the skin into human peripheral nerves and by micro-dissection (fiber splitting) of monkey peripheral nerves. The response characteristics of the different afferent types will be discussed within the context of a range of functionally relevant parameters. Important to note is that all four low-threshold cutaneous mechanoreceptive afferent types are potentially activated by contact with an object but the extent to which each class contributes to the coding of essential task-related information varies depending on the stimulus and task parameters. Furthermore, for all but the simplest stimuli the parameters of the stimulus and task are only represented or encoded unambiguously in the responses of a population of fibers, and not in the responses of isolated single fibers. The studies described in the following sections are based on single fiber responses but for the most part, because of the manner in which the stimuli were presented, they can be extrapolated to represent population responses.



## Neural Representation of Object and Task Parameters Simple Stimuli

The principal value of simple stimuli, such as punctate probes indenting the skin or vibrating in and out of the skin, has been a clear-cut classification of the afferent types (Fig. 2). The temporal characteristics of the responses divide the afferents into slowly and fast adapting groups and the spatial characteristics (mainly size) of the receptive fields define the type I and type II groups. Thresholds of the responses correspond to human detection thresholds measured psychophysically.

### Pattern and Form

The earliest measure of spatial resolution in the tactile system was the two-point limen, a simple but unreliable measure that underestimates the capacity of the system. More recently, tactile coding of spatial characteristics or fine form has been investigated using a range of relatively simple stimuli such as edges, bars and gratings as well as more complex patterns such as embossed letters and Braille-type characters [3]. Human psychophysics experiments are matched with single fiber recordings, commonly in monkeys and more rarely in humans. Such studies have found that SAI afferents resolve the spatial details of the stimuli with greater clarity than either FAI or FAII afferents in monkeys or FAI, FAII or SAII afferents in humans. Recognition and discrimination of patterned stimuli are enhanced when they are scanned across the finger, rather than pressed into the finger. This can be explained in part by the increased resolution in SAI responses when such stimuli are moved tangentially across the skin compared to stationary presentation. Variations in scanning speed and contact force have little effect on the spatial resolution of fiber responses or on human perception. Although there is strong evidence for the

role of SAI afferents in encoding fine spatial detail, the other afferents do play a role, particularly the FAI afferents when there is lateral movement between the stimulus and the skin.

### Texture

The most common perceptual descriptor of surface texture is the sensation of roughness. In early psychophysics experiments common materials, such as sandpaper, were used. More recent stimuli consist of precisely manufactured three-dimensional features, which can be defined mathematically. These allow quantitative neural studies, usually in monkeys, which can be compared with human psychophysics. Stimuli commonly used are either gratings of alternating grooves and ridges, or embossed dot arrays.

Perceived roughness increases monotonically with the spatial period of the texture up to spacings of around 3 mm for both gratings and dot arrays. The most critical feature underlying perceived roughness is the groove width for gratings and the dot spacing for dot arrays. Tangential movement between the stimulus and the skin affects roughness perception. The difference threshold for the spatial period of gratings is degraded from a threshold of 5% when there is movement to a threshold of 10% when there is no movement. Roughness perception is independent of whether the tangential movement is active or passive and is little affected by variations in the rate of movement, but perceived roughness increases when contact force increases [4].

Textures affect both the spatial and temporal patterns in peripheral neural population responses as well as intensive parameters like total neural response. How these population features are used by the central nervous system appears to depend on the nature of the stimulus and the task.

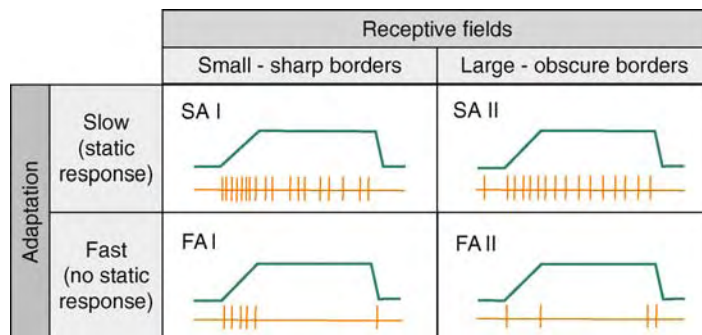

**Processing of Tactile Stimuli. Figure 2** Classification of the four types of low-threshold mechanoreceptive afferent fibers innervating the glabrous skin of the human fingerpad. Upper trace (*green*) in each panel shows the indentation amplitude (*vertical axis*) as a function of time (*horizontal axis*) for a probe indented into the skin for 1 s. Traces below (*orange*) show neural responses; each vertical tick represents an action potential. Adapted with permission from Johansson RS and Vallbo AB (1983) *Trends in Neuroscience* 6:27–32.

### Shape

The identification of an object's shape is essential for dexterous manipulation and often involves active exploration of the object. This brings into play a spectrum of sensory mechanisms which relay information about the position and movement of the joints in the hand and arm, as well as cutaneous tactile information. Objects range in shape from a simple sphere to the complex shapes of eating utensils and tools we routinely use. All shapes can be described in terms of their local curvatures. Shapes such as spheres, cylinders, and toroids can be quantified easily; this facilitates analysis of the neural representation of their shape and subsequent correlations with human performance. When simple shapes such as spheres are applied to the skin so that only cutaneous information can be utilized, humans are able to discriminate a difference in curvature (reciprocal of the radius) of the order of 10%. When spheres are indented into a monkey's fingerpad, a clear monotonic relationship exists between single fiber responses and stimulus curvature; both the SAI and FAI afferent responses are modulated but the effect is more pronounced and more reliable for the SAI afferents [5]. Comparable responses in human afferents to spheres and cylinders applied to the fingerpad have been reported; curvature significantly modulates responses in SAI, SAIL, and FAI afferents.

For any shape more complex than a sphere, more than one parameter is needed to define it. For example, a cylinder is defined by the orientation of its long axis and the radius or curvature in the orthogonal direction. A toroid is defined by three parameters – two orthogonal curvatures and an orientation. SAI afferent responses are monotonically related to the curvature of these

shapes and are modulated by stimulus orientation [6]. When stimuli such as toroids, cylinders and more complex arrays of alternating convex and concave cylindrical shapes of differing curvature are scanned across the monkey's fingerpad, both SAI and FAI afferent responses are modulated. FAI afferents however require higher stroke velocities to elicit responses. The major geometrical features of three-dimensional objects scanned across the skin such as spheres, cylinders and toroids varying in shape, orientation and stroke trajectory are reproduced in the spatiotemporal responses of SAI afferents and to a lesser degree FAI afferents.

When a complex shape is explored or handled, all the parameters of the stimulus and the manipulation affect the responses of individual primary afferent fibers. Nevertheless, independent information about each of the parameters is relayed to the central nervous system because each parameter is represented or encoded uniquely in the primary afferent population response (Fig. 3).

### Manipulation

When we manipulate objects, the sensorimotor system optimizes the forces applied by the fingers. The motor control system must adopt forces that are sufficiently large to prevent slips but are not excessive in order to avoid fatigue and to ensure that delicate objects are not damaged. In addition, force magnitudes and directions must suit the shape of the object and the load conditions, and must take account of parameters such as friction. Also, the control system must rapidly and automatically adjust the grip forces to meet the demands imposed by any unexpected changes in loads during a task. Our ability to manipulate objects with dexterity is itself

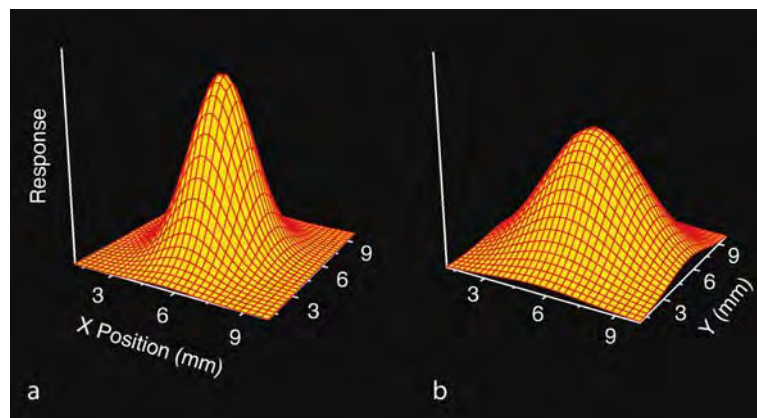

**Processing of Tactile Stimuli. Figure 3** Representation of object shape in an ideal SAI afferent population response. The stimuli are spherical with radii *A*, 1.44 mm (curvature  $694 \text{ m}^{-1}$ ) and *B*, 3.9 mm (curvature  $256 \text{ m}^{-1}$ ). The differences in object shape are reflected in the population response profiles. The smaller, more curved sphere (a) elicits a response profile which is narrower and more peaked than that elicited by the larger, less curved sphere (b). These response profiles will be distorted by the characteristics of real peripheral neural populations including the pattern of innervation and the responsiveness of the individual fibers.

testimony to the accuracy of the underlying sensorimotor control system. This is only possible because of sensory feedback from the hand, a large component of which arises from the cutaneous mechanoreceptive fibers. Studies which mimic the forces occurring in everyday manipulations, such as lifting a container of liquid and tilting it, show that humans are able to scale and discriminate, independently, forces acting normal to the skin surface (grip force), forces acting tangential to the skin (load force) and rotational forces (torques) [7]. The magnitudes and directions of these forces and torques are encoded in the responses of whole populations of peripheral afferents along with precise information about the shape of the object being manipulated and the positions of contact on the skin [8]. Such studies demonstrate that the mechanoreceptors in the glabrous skin of the digits provide a rich and accurate source of information during complex manipulations. This information underlies both feedforward and feedback motor control.

### Representation in the Central Nervous System

Many of the object and task parameters discussed above have been used in studies of the response properties of cells in the somatosensory cortices of non-human primates [9]. Studies of single cells in somatosensory cortex SI have shown that responses reproduce essential object features presented to the skin and show response patterns similar in many cases to the primary afferent input signals. For example, the configuration of embossed dot ensembles is clearly evident in the response patterns across arrays of single cortical units. Some single cortical units have characteristics which appear to combine response characteristics of more than one afferent type, e.g., SAI and FAI afferents, providing an additional layer of information. The SII somatosensory cortex appears to have some higher level functions than SI, such as extracting the orientation of a stimulus independent of the position of contact on the finger [10]. How input from tactile sources is combined with other sources of sensory input such as afferents from the joints, muscles and hairy skin is not known but information from all of these sources are potentially important in controlling precise hand movements.

### References

1. Darian-Smith I (1984) The sense of touch: performance and peripheral neural processes. In: Handbook of physiology. The nervous system III. American Physiology Society, Bethesda, MD, pp 739–788
2. Halata Z (1993) Sensory innervation of the hairy skin light- and electronmicroscopic study. *J Invest Dermatol* 101:75S–81S
3. Johnson KO, Hsiao SS (1992) Neural mechanisms of tactile form and texture perception. *Annu Rev Neurosci* 15:227–250

4. Sathian K (1989) Tactile sensing of surface features. *Trends Neurosci* 12:513–519
5. Goodwin AW, Wheat HE (2004) Sensory signals in neural populations underlying tactile perception and manipulation. *Annu Rev Neurosci* 27:53–77
6. Khalsa PS, Friedman RM, Srinivasan MA, LaMotte RH (1998) Encoding of shape and orientation of objects indented into the monkey fingerpad by populations of slowly and rapidly adapting mechanoreceptors. *J Neurophysiol* 79:3238–3251
7. Wheat HE, Salo LM, Goodwin AW (2004) Human ability to scale and discriminate forces typical of those occurring during grasp and manipulation. *J Neurosci* 24:3394–3401
8. Birznieks I, Jenmalm P, Goodwin AW, Johansson RS (2001) Encoding of direction of fingertip forces by human tactile afferents. *J Neurosci* 21:8222–8237
9. Tremblay F, Ageranoti-Belanger SA, Chapman CE (1996) Cortical mechanisms underlying tactile discrimination in the monkey. 1. Role of primary somatosensory cortex in passive texture discrimination. *J Neurophysiol* 76(5):3382–3403
10. Thakur PH, Fitzgerald PJ, Lane JW, Hsiao SS (2006) Receptive field properties of the macaque second somatosensory cortex: nonlinear mechanisms underlying the representation of orientation within a finger pad. *J Neurosci* 26:13567–13575

## Progenesis

### Definition

Paedomorphosis (retention of formerly juvenile characters by adult descendants during evolution) produced by precocious sexual maturation of an organism still in a morphologically juvenile stage.

► Evolution and Phylogeny: Chordates

## Progenitor Cell

### Definition

A progenitor cell is a cell maintaining its capacity for self-renewal and differentiation. Although the distinction between progenitor cells and stem cells is often ambiguous, the term “progenitor cell” includes undifferentiated cells with more limited plasticity and in some cases is used for cells in which multipotency is difficult to demonstrate.

► Adult Neurogenesis

## Programmed Cell Death

HIROYUKI YAGINUMA

Department of Anatomy, School of Medicine,  
Fukushima Medical University, Fukushima, Japan

### Synonyms

Naturally occurring cell death; Physiological cell death;  
Developmental cell death; PCD

### Definition

► **Programmed cell death** (PCD) in the developing nervous system is defined as spatially and temporally reproducible and species-specific loss of large numbers of individual cells (neurons and glia) during development [1].

### Characteristics

#### Types and Extent of PCD

Development of the neuronal cells can be divided into three phases, (i) proliferating neuronal precursors or founder cells, (ii) postmitotic young neurons before contacting their targets and (iii) maturing neurons after establishing synaptic contact with their targets. In early developmental stages, the neural tube consists of a population of proliferating cells organized into a pseudostratified columnar epithelium, known as the ventricular zone (VZ). Postmitotic young neurons derived from the VZ aggregate and mature between the VZ and the pial surface to form the intermediate zone (IZ). In some areas in the forebrain, such as the dorsal thalamus, a second proliferative zone, the subventricular zone (SVZ) is formed between the VZ and the IZ. In the cerebral cortex, young neurons derived from both the VZ and SVZ migrate through the IZ to form a cortical plate. Programmed cell death can be observed in all three phases of neuronal development [1,2].

After the generation of neuronal cells, glial cells differentiate from glial precursor cells that are derived from the VZ and SVZ. A considerable number of differentiated glial cells are also known to undergo PCD.

#### PCD of Neuronal Precursors

In the mouse embryo, PCD of proliferating precursor or founder cells can be observed as early as embryonic day (E) 8.5, when the closure of the neural tube is not yet completed. In early developmental stages, massive PCD occurs in specific regions of the developing neural tube. These include ventral and dorsal regions of the spinal cord, floor plate, neural crest, the lamina terminals, ventral region of the forebrain, dorsal region of the hindbrain and the optic vesicle [3,4]. Sporadic small

amounts of PCD continue to occur in the VZ and SVZ from early to later developmental stages. But because cell proliferation occurs at the same time, it is difficult to elucidate the quantity of PCD. Estimated amounts of PCD vary from 0.3% to more than 50% depending on the regions analyzed and the methods that were used to detect dying cells. However, since it is reported that inhibition of PCD of neuronal precursors resulted in malformations of the nervous system, such as exencephaly and spina bifida, cell death of proliferating neural precursors is significant for normal development.

#### PCD of Postmitotic Young Neurons

Although this type of PCD is less common, there are some examples. Approximately 25% of postmitotic motoneurons in the non-limb innervating cervical spinal cord die before they establish synaptic contact with their target muscles [5]. In the dorsal root ganglion and the retina, a significant percentage of postmitotic neurons die before their axons reach their targets [4].

#### PCD After Establishing Synaptic Contacts with the Targets

Neurons that have survived earlier phases of PCD begin to establish synaptic connections with other neurons and target cells. During this period, postmitotic differentiating neurons undergo PCD. This type of PCD has been found to occur virtually everywhere that it has been looked for and includes motoneurons, sensory neurons, autonomic neurons, retinal neurons, optic tectum, isthmo-optic nucleus, basal ganglia, cerebellum and cerebral cortex. Despite this widespread occurrence of PCD, it is also known that PCD does not occur in spinal interneurons and neurons in the medial and lateral pontine nuclei of the chick embryo. Quantitative analyses performed in the neuronal groups that are easily defined revealed that ~20–80% of postmitotic neurons undergo cell death. This type of neuronal death has been well studied and it is known that inadequate neurotrophic support derived from their targets, afferent inputs and other sources regulate this type of cell death [1].

#### PCD of Glial Cells

Both oligodendrocytes and astrocytes are known to undergo PCD. About 50% of oligodendrocytes normally die in the developing rat optic nerve and significant numbers of dying cells in the neonatal rat cerebellum are astrocytes [2].

In most cases, cells die by ► **apoptosis**. They shrink in size, the nuclear chromatin becomes pyknotic and condenses against the nuclear membrane (Fig. 1 a–c) and cytoplasmic organelles remain intact.

Eventually, the cytoplasm and nucleus break up into apoptotic bodies that are phagocytized and digested by macrophages or by adjacent healthy cells. In contrast to ► **necrosis (necrotic cell death)**, which is caused by

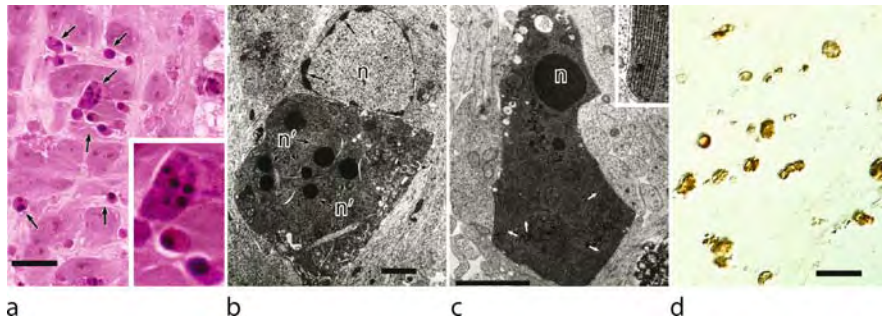

**Programmed Cell Death. Figure 1** Light and electron micrographs of the ventral horn of the cervical spinal cord of the E4.5 chick embryo showing dying motoneurons. (a) Hematoxylin and eosin staining showing pyknotic dying neurons (*arrows*). *Inset* shows higher magnification of typical pyknotic neurons. (b, c) Electron micrographs showing typical examples of apoptotic degeneration. In the nucleus (*n*) of the upper cell in b, chromatin begins to condense against the nuclear membrane (*arrows*), suggesting that this cell is in the earliest stage of apoptosis. In the lower cell in b, the nucleus has been fragmented (*n'*) and the cytoplasm has become electron dense. The condensed nucleus and cytoplasm are conspicuous in the cell in (c). Aggregated ribosomes are often observed (*arrows and insets* in (c)). (d) TUNEL staining. Bar in (a) and (d), 10 µm. Bars in b and c, 2 µm.

acute cellular injury, apoptosis occurs as an ordered process without evoking inflammation. Another feature of apoptosis is nucleosomal DNA fragmentation and degradation. This can be observed in tissue sections by terminal deoxynucleotidyl transferase-mediated dUTP nick end labeling (TUNEL) (Fig. 1d). The estimated time for the whole process of apoptosis is from a few hours to at most one half day.

### Lower Level Processes

#### *Intra-Cellular Mechanisms of PCD*

Cells in the developing nervous system share the same basic apoptosis mechanisms with all other cell types (Fig. 2).

The characteristic morphology of apoptosis is the result of activation of executioner **▶caspases**, such as caspases-3, -6 and -7. They activate a DNase (CAD) and acinus, which in turn cause DNA fragmentation and chromatin condensation (Fig. 2). Cytoplasmic and nuclear skeletal proteins are also cleaved by the executioner caspases, leading to cellular and nuclear shrinkage. The executioner caspases are activated by initiator caspases including caspase-8 and caspase-9. Caspase-8 and caspase-9 are activated through two different pathways, the death receptor pathway and the mitochondrial pathway, respectively. Association of a death receptor ligand (e.g. FasL) with its receptor (Fas) leads to recruitment of a death domain containing protein, FADD. This, in turn, recruits procaspase-8. Procaspase-8 undergoes auto-proteolysis to release active caspase-8 (Fig. 2). The key step in the mitochondrial pathway is the release of **▶cytochrome *c*** through pores formed in the mitochondrial outer membrane. Cytochrome *c*, **▶Apaf1**, procaspase-9 and ATP form the

apoptosome, which is a multimeric active holoenzyme that activates executioner caspases (Fig. 2).

**▶Bcl-2 family** proteins play fundamental roles in the process of mitochondrial pore formation. The Bcl-2 family consists of three subgroups, anti-apoptotic, pro-apoptotic and BH3-only proteins. When pro-apoptotic Bax or Bak is activated, they homo-oligomerize within the mitochondrial outer membrane to form large enough pores for cytochrome *c* release. Alternatively, Bax can change large channel proteins that reside in the outer mitochondrial membrane to allow cytochrome *c* to escape. Anti-apoptotic Bcl-2 family members, including Bcl-2 and Bcl-xL, can inhibit the effects of pro-apoptotic Bax or Bak through combining with them to form dimers. BH3-only proteins can bind to Bcl-2 and Bcl-xL to release pro-apoptotic, Bax or Bad, resulting in apoptosis. Therefore, BH3-only proteins serve as a key in the mitochondrial pathway (Fig. 2). It is also known that one BH3-only protein, Bid, can be cleaved (activated) by caspase-8 to form tBid, which in turn activates Bax and Bak. This allows cross talk between the two pathways (Fig. 2).

Besides cytochrome *c*, several other cell death-inducing molecules are known to escape through the pores formed in the outer mitochondrial membrane. These include **▶AIF (apoptosis inducing factor)**, EndoG (Endonuclease G), Smac/DIABLO and Omi/HtrA2. Reactive oxygen species (ROS) are also released from dysfunctional mitochondria. These molecules activate caspase-dependent or caspase-independent cell death pathways serving as initiators of collateral cell death pathways (Fig. 2). It is also known that there are intrinsic molecules that antagonize caspase activities to prevent apoptosis. These include **▶NAIP (Neuronal Apoptosis Inhibitory Protein)** and XIAP.

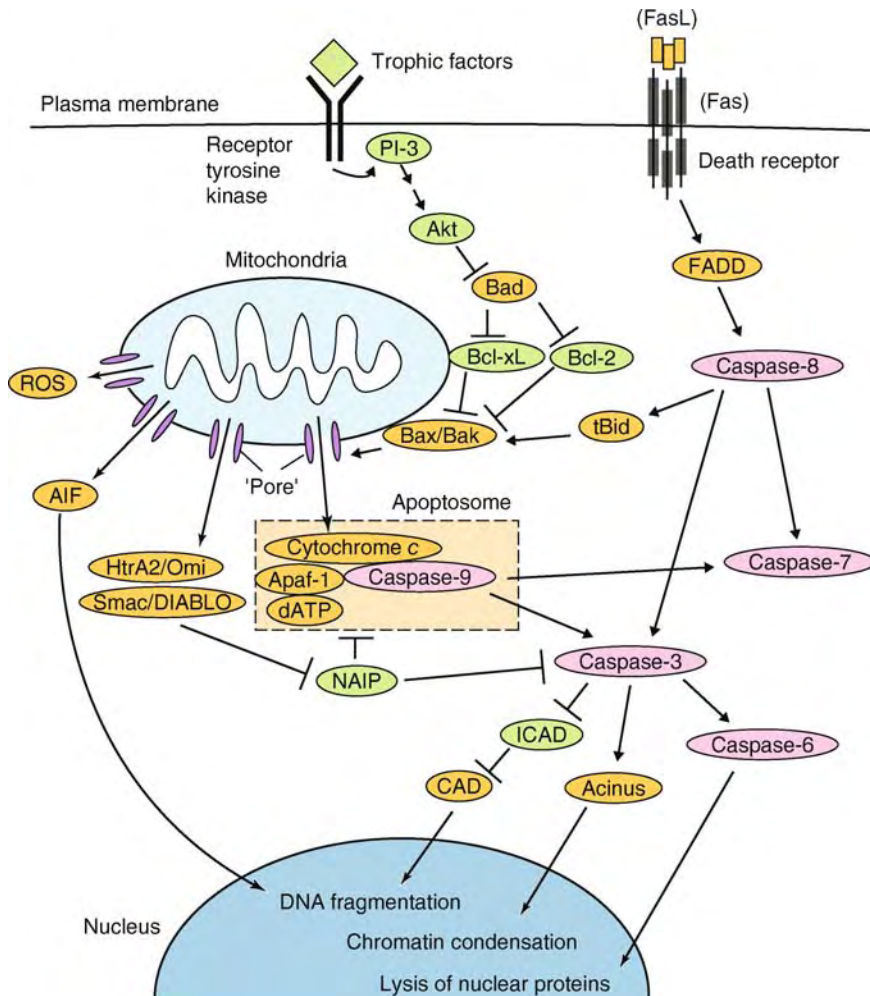

**Programmed Cell Death. Figure 2** A simplified scheme of cell death pathways in cells in the developing nervous system. ▶ **Caspases** are indicated in *pink*, pro-apoptotic members in *yellow*, anti-apoptotic members in *green*. For details, see text.

## Process Regulation

### Inter-Cellular Regulation of PCD

#### Regulation by Trophic Factors (the Neurotrophic Theory)

The favored explanation as to why neuronal and glial cells die in the developing nervous system is “the neurotrophic hypothesis.” This proposes that developing neurons and glial cells require trophic support for survival and compete for a limited supply of trophic factors. Cells that cannot obtain enough trophic support undergo cell death. This hypothesis has been supported by many experimental studies in which the quantitative relations between neuronal groups and their synaptic targets or afferent inputs were altered. For example, removal of a limb bud on E2 in the chick embryo resulted in total disappearance of limb innervating motoneurons by E10 because of excessive motoneuron death. On the other hand, addition of a supernumerary limb bud resulted in the survival of more motoneurons.

Similarly, it has been proved that alteration of afferent inputs also affects the number of surviving neurons. However, it is not yet clear whether neurons compete for limited amount of trophic factors or limited sites where trophic factors are transferred to neurons. An important source of trophic support for developing neurons is their targets. In addition, signals derived from afferent inputs as well as from nonneuronal cells, such as central and peripheral glia, are recognized as possible sources of trophic regulation of cell death and survival.

Trophic factors that are required for survival of developing neurons vary depending on the neuronal population. For example, neurons in the sympathetic ganglia require target-derived NGF as a survival factor, whereas sensory neurons in peripheral ganglia require one or more of the ▶ **neurotrophins**, NGF, BDNF, NT-3 or NT-4/5. Several candidates for muscle-derived trophic

factors for motoneurons have been identified and include BDNF, NT-4/5, IGF, HGF, CT-1 and GDNF [1].

The binding of trophic factors to their specific receptors induces rapid protein phosphorylation and the activation of complex cascades of intracellular signals. Among them, the phosphatidylinositol 3-kinase (PI3-K)-Akt pathway is known to be directly involved in inhibition of cell death. Activated Akt phosphorylates the BH3-only protein, Bad. Phosphorylation of Bad dissociates Bad and the anti-apoptotic Bcl-2 family, Bcl-xL, allowing Bcl-xL to prevent cell death by blocking pore formation in the mitochondrial outer membrane (Fig. 2).

The neurotrophic hypothesis also proposes that the intrinsic default fate of developing neurons is to undergo PCD. Although the mechanism of the intrinsic cell death pathways is not known for most kinds of neurons, it has been suggested that the death receptor pathway that is activated by FasL and Fas may play a role in the PCD of motoneurons [6].

### Regulation of Target-independent PCD

Little is known about the mechanisms that regulate PCD of proliferative precursor cells or young post-mitotic neurons. Since massive cell death of proliferative cells often occurs in specific regions of the neural tube, cell death may be the result of determination of regional specificity. In fact, following perturbation of sonic hedgehog signaling, which determines the regional specificity of the ventral half of the spinal cord, distribution of dying cells was altered [7]. Moreover, death-factor signaling may also induce early neuronal death. For example, in early retinal development, postmitotic young neurons are known to undergo cell death by NGF signaling through  $\text{p75}^{\text{LNTR}}$  and by TGF $\beta$ , which are provided by macrophages and local surrounding cells respectively [8,9].

### Function

#### Role(s) of PCD

Since perturbation of normal PCD results in various kinds of defects in the nervous system, cell death during development plays a significant adaptive role. Possible functions of cell death in the developing nervous system are:

1. Pattern formation and morphogenesis
2. System or size matching
3. Removal of cells of an appropriate phenotype or cells that have no function
4. Error correction
5. Removal of harmful cells that have defective DNA

### Pathology

One genetic disease in humans in which cell death has been implicated is infantile  $\blacktriangleright$ spinal muscular atrophy

(SMA). A clear link between SMA and failed inhibition of cell death has been proposed. In severe SMA, the neuronal specific inhibitor of apoptosis (IAP) family member known as NAIP is often dysfunctional due to missense and truncation mutations. IAPs such as NAIP potentially block the enzymatic activity of executioner caspases (3 and 7) suggesting that NAIP mutations may permit unopposed developmental apoptosis to occur in sensory and motor systems resulting in lethal muscular atrophy [1].

Since neurons need their targets for their survival, loss of one neuronal group or target tissue often results in a secondary loss of other neuronal groups. For example, the “cerebellless” mutant mouse lacks the entire cerebellar cortex. The primary defect is a specific inhibition of GABAergic neurons including Purkinje cells, resulting in secondary and complete loss of external germinal layer, pontine and olivary nuclei during development [10].

### References

1. Oppenheim RW, Johnson JE (2003) Programmed cell death and neurotrophic factors. In: Squire LR, Bloom FE, McConnell SK, Roberts JL, Spitzer NC, Zigmond MJ (eds) *Fundamental neuroscience*. Academic Press, San Diego, SA, pp 499–532
2. Roth KA (2005) Programmed cell death. In: Rao MS, Jacobson M (eds) *Developmental neurobiology*. Kluwer Academic/Plenum, New York, pp 317–328
3. Kuan CY, Roth KA, Flavell RA, Rakic P (2000) Mechanisms of programmed cell death in the developing brain. *Trends Neurosci* 23:291–297
4. de la rosa EJ, de Pablo F (2000) Cell death in early neural development: beyond the neurotrophic theory. *Trends Neurosci* 23:454–458
5. Yaginuma H, Tomita M, Takashita N, McKay SE, Cardwell C, Yin QW, Oppenheim RW (1996) A novel type of programmed neuronal death in the cervical spinal cord of the chick embryo. *J Neurosci* 16:3685–3703
6. Raoul C, Pettmann B, Henderson CE (2000) Active killing of neurons during development and following stress: a role for  $\text{p75}^{\text{NTR}}$  and Fas? *Curr Opin Neurobiol* 10:111–117
7. Oppenheim RW, Homma S, Marti E, Prevette D, Wang S, Yaginuma H, McMahon AP (1999) Modulation of early but not later stages of programmed cell death in embryonic avian spinal cord by sonic hedgehog. *Mol Cell Neurosci* 13:348–361
8. Dechant G, Barde YA (2002) The neurotrophin receptor  $\text{p75}^{\text{NTR}}$ : novel functions and implications for diseases of the nervous system. *Nat Neurosci* 5:1131–1136
9. Duenker N (2005) Transforming growth factor-beta (TGF-beta) and programmed cell death in the vertebrate retina. *Int Rev Cytol* 245:17–43
10. Hoshino M, Nakamura S, Mori K, Kawachi T, Terao M, Nishimura YV, Fukuda A, Fuse T, Matsuo N, Sone M, Watanabe M, Bito H, Terashima T, Wright CV, Kawaguchi Y, Nakao K, Nabeshima Y (2005) Ptf1a, a bHLH transcriptional gene, defines GABAergic neuronal fates in cerebellum. *Neuron* 47:201–213

## Programmed Cell Death

### Definition

Cell death by design, in which the cell uses specialized cellular machinery to kill itself. Programmed cell death is a process essential to cell termination, homeostasis, and development. This process allows metazoans to control cell number and eliminate surplus or erroneous cells.

## Progressive Bulbar Palsy

### Definition

► **Motoneuron** disease of the ► **brainstem** (*bulb* stands for ► **medulla oblongata** and *palsy* for weakness) with dysarthria (difficulty articulating) and dysphagia (difficulty swallowing).

## Progressive Multifocal Leukoencephalopathy

### Definition

Infrequent disorder of the nervous system that primarily affects individuals with suppressed immune systems (including, allograft recipients such as kidney transplant patients; patients with cancers such as leukemia or lymphoma; and nearly 10% of patients with ► **acquired immune deficiency syndrome (AIDS)**). The disorder, which is caused by a common human polyomavirus, JC virus, is characterized by ► **demyelination** or destruction of the ► **myelin** sheath that covers nerve fibers.

► **Acquired Immune Deficiency Syndrome (AIDS)**

## Progressive Supranuclear Palsy

### Definition

Progressive degenerative disease belonging to the family of tauopathies with widespread pathology involving cortical and subcortical structures. In Progressive supranuclear palsy, oculomotor disturbance, early postural instability with falls, and frontal dementia predominate. There is symmetric onset of parkinsonism,

early postural instability, severe axial rigidity, absence of tremor, and poor response to dopaminergic therapy. supranuclear gaze palsy, especially of downgaze, is the defining characteristic. Blepharospasm and eyelid opening apraxia are also common.

► **Parkinsonism**

## Pro-inflammatory Cytokines

### Definition

Pro-inflammatory cytokines such as interleukin (IL)-1 $\beta$ , IL-6, and tumor necrosis factor (TNF)- $\alpha$ , are overexpressed at the lesion site for several hours to days after central nervous system (CNS) injury. The cells of origin of these cytokines are neurons, astrocytes, microglial cells, infiltrated macrophages, and neutrophils. They are involved in the secondary tissue damage that is produced through a series of autodestructive events (e.g., apoptosis) initiated by the primary trauma. Low concentrations of pro-inflammatory cytokines can be beneficial; however, high concentrations mediate cell death and widespread tissue disruption. Thus, manipulation of this inflammatory response is one of the major therapeutic approaches for CNS injury.

► **Transplantation of Neural Stem Cells for Spinal Cord Regeneration**

► **Tumor Necrosis Factor-  $\alpha$  (TNF- $\alpha$ )**

## Pro-inflammatory Mediators

► **Central Nervous System Disease – Natural Neuroprotective Agents as Therapeutics**

## Projection Neurons

### Definition

Neurons that send (“project”) their main axon outside a morphologically defined area or nucleus in which their cell bodies are located. The length of the axon depends on the distance between the structures they connect.



Thus, in the cerebral cortex, association axons linking adjacent areas are short compared to corticospinal axons. In the superior colliculus, projection axons to the pretectum are short compared to tectoreticulospinal axons. By opposition, neurons participating exclusively in the intrinsic connections of a given structure are called “local neurons” or “interneurons.”

► [Modulatory Projection Neurons](#)

## Projections

### Definition

Axonal extensions, ranging from short to very long, that possess chemical synapses allowing for the electrochemical communication of neurons with other neurons over distance. A neuron with an axon possessing a chemical synapse in relation to another neuron at some distance is said to project to that neuron.

Axons carrying impulses away from a structure comprise efferent projections. Axons carrying impulses into a structure comprise afferent projections.

## Prokineticin 2

### Definition

A 102 amino acid polypeptide that may function as an output molecule from the suprachiasmatic nucleus (SCN) in transmitting timing behavioral circadian rhythms. It may also function locally within the SCN to synchronize cellular clocks. Receptors for PK2 (PKR2) are abundantly expressed in major target nuclei of the SCN output pathway. Intracerebroventricular infusion of PK2 at night, when endogenous PK2 mRNA levels are low, markedly reduces the nocturnal increase in locomotion.

Mice with a disruption of the PK2 gene display significantly reduced rhythmicity for a variety of circadian physiological and behavioral parameters including sleep-wake cycle, locomotor activity, body temperature, and circulating glucocorticoid as well as glucose levels.

► [Circadian Rhythm](#)  
 ► [Clock Coupling Factors](#)  
 ► [Locomotion](#)  
 ► [Sleep-wake Cycle](#)  
 ► [Suprachiasmatic Nucleus](#)

## Proliferation

### Definition

Production of new daughter cells by cell division.

► [Neural Development](#)

## Promoter

JULIA KIM, DAVID H. FARB, SHELLEY J. RUSSEK  
 Laboratory of Molecular Neurobiology, Department of Pharmacology and Experimental Therapeutics, Boston, MA, USA

### Definition

A promoter contains all the gene regulatory information that is necessary for the expression of its protein product in vivo. The DNA sequence of the promoter can be contiguous lying upstream of the transcriptional start site or it can be separated by large distances dependent upon the presence or absence of key regulatory elements, such as enhancers or silencers, in introns and exons.

The binding of transcription factors to the sequence(s) of the promoter are believed to alter DNA conformation in such a manner that stabilizes the binding of RNA polymerase to enable regulated transcription. A promoter can also be regulated at the epigenetic level through the recruitment of chromatin modulators such as HAT, HDAC, mSin3A, and Swi/snf, that control the accessibility of transcription factors to DNA elements. Cell- and developmental-specific expression often relies on the presence of promoter elements, such as enhancers or silencers, that are located at a distance from the start site in exons, introns, or intergenic regions.

### Characteristics Structure

Core: Core promoters are the minimal elements needed for RNA polymerase II to initiate transcription at basal levels using a particular ► [transcriptional start site \(TSS\)](#). The most well-known core promoter region contains a TATA box, around 35 bp upstream of the TSS, and an Initiator element (Inr) that contains the TSS. Not all core promoter regions contain TATA boxes. In fact, many of the regulated genes in the human genome are TATA-less. TATA-less core regions often contain other elements such as the GC box or a binding site for a strong activator protein such as Specificity Protein 1 (SP1). Diversity in core promoter

regions is just beginning to be identified suggesting that this region of the gene is highly specialized and plays an important role in the regulated nature of gene transcription.

**Proximal Region:** Proximal promoter region contains the Core and around 500 bp of sequence upstream of the ▶TSS. They contain upstream binding sites for activators that are necessary to increase transcription above basal levels.

**Distal Region:** Distal promoter region is upstream of the Proximal and in most cases contains the recognition sites for activators and repressors responsible for full transcriptional activation, consistent with the levels of gene expression *in vivo*. The Distal region usually contains a few kilobase pairs of DNA lying upstream of the Proximal promoter region that contains the core.

**Cis-acting elements and trans-acting factors:** A particular set of regulatory sequences that are found within the promoter of a gene are referred to as cis-acting elements. The proteins that bind to these elements, as well as to related elements in multiple genes, are referred to as trans-acting factors, also known as transcription factors.

**Gene clusters:** A set of two or more genes that are derived from a common ancestor and are functionally related, or encode related gene products, are often found in gene clusters on a particular chromosome. For example, subunit genes coding for the major inhibitory neurotransmitter receptor, type A  $\gamma$  aminobutyric acid (GABA, GABA<sub>A</sub>R) are organized as  $\beta$ - $\alpha$ - $\alpha$ - $\gamma$  or  $\beta$ - $\alpha$ - $\gamma$  on four human chromosomes [1]. This unique genomic structure suggests that there may be regulatory elements shared by the promoter regions or a single locus of control (as seen for the  $\beta$ -globin genes) that has been preserved throughout evolution.

**Alternative Promoters:** Many genes use more than one promoter to control either development or cell specific expression. The transcripts produced from these promoter regions increase the diversity of protein products or the stability of their mRNAs. The alternative promoters can be located in a downstream intron or in a distant region upstream from the dominant ▶TSS.

### Examples of Promoters, Their Elements and Transcription Factors Studied in the Brain

#### • Neural Specific Genes

**GABRB1 [2]** – A gene that codes for the beta 1 subunit of the GABA<sub>A</sub>R, the major inhibitory receptor in the nervous system that contains an integral chloride ion channel gated by GABA. GABRB1 is organized in a head-to-head orientation with the  $\alpha$ 4 subunit gene (GABRA4). The human GABRB1 promoter lacks a ▶TATA-box and contains an Inr element that by itself can determine the cell specific expression of the gene and its autologous regulation by GABA.

**GLUR2 [3]** – GLUR2 has multiple ▶TSSs that are development and cell-specific. None of the TSSs identified contain TATA boxes and their transcription is modulated by Sp1, within a methylated CpG island, and a GLUR2 silencer that shares 71% similarity to the restrictive silencing factor REST/NRSF (see below).

**GABBR1 [4]** – A gene that codes for the R1 subunit of the GABA<sub>B</sub>R, the G-protein coupled receptor that is activated by GABA. Use of alternative promoters, rather than alternative splicing as previously speculated, contributes to the generation of isoforms for the GABA<sub>B</sub>R1 subunit. GABA<sub>B</sub>R1a expression is marked in the fetal brain and may regulate the formation of presynaptic GABA<sub>B</sub> receptors while it is modest in the adult brain. GABBR1 expression is low during development and marked in the adult where it may regulate the formation of postsynaptic GABA<sub>B</sub> receptors. The promoter regions of both isoforms are TATA-less and contain functional DNA sequence elements for regulation by the cAMP regulatory binding protein (▶CREB).

**Neuropeptide Y (NPY) [5]** – NPY is the most abundant neuropeptide in the brain and is expressed in a wide variety of cell populations of the nervous system. Its promoter region contains the partial consensus sequence for transcription factors such as SP1, Activator Protein 1 (AP1) and CAAT box. However, CT-rich, instead of GC-rich, sequences are used by Sp1 to promote transcription.

#### • A signal-induced transcription factor

Early growth response gene (Egr) and Egr response element (ERE) [6,7]: While the most well known signal activated transcription factor in the nervous system is the ubiquitously expressed CREB, there is a family of immediate early gene (IEG) products known as Egrs that are increasingly being identified in the dynamics of brain function. Egrs bind to the consensus motif (depicted below) in response to signals elicited by neurotransmitters, altering the expression level of certain genes that contain a GC-rich ERE in their promoter region. Egrs link a short-term change in neurotransmission to a functional change via the synthesis of new proteins.

ERE consensus sequence

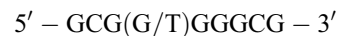

Egrs are implicated in the transcriptional control of multiple genes via their zinc-finger motif located in the C-terminal region. So far, four family members have been identified (Egr1–4). All of them recognize the same ERE sequence and are homologous, although different spatial and temporal expression is observed. Of the four members, Egr1 is the most well defined and its expression is dependant on activation of the N-methyl-D-aspartate receptor (NMDAR) and mitogen activated protein kinase (MAPK) signaling. However,

the target or the specific mechanisms controlling transcriptional regulation of the other Egr family members is not completely known. Egr3 has recently been identified as a seizure-induced protein controlled by brain derived neurotrophic factor (BDNF, see below) and it plays an important role in learning and memory. Multiple forms of Egr3 that differ in their N-terminus have been described and are being investigated.

- A major target gene for Egr 1 and 3

Activity-regulated cytoskeleton-associated (Arc) protein [8] – A putative target of Egr1 and Egr3 transcription factors, Arc expression is upregulated by robust synaptic activity, such as observed in kainic-acid induced seizures or exploration of a novel environment by rodents. Egrs bind to the ERE site in the Arc promoter. Similar to Egrs, Arc expression is dependant on NMDAR activation and MAPK signaling, highlighting its association with long-term potentiation (LTP) and learning and memory.

- Repressor factor involved in neural specific gene expression

Neuron-Restrictive Silencer Element (NRSE) and Neuron-Restrictive Silencer Factor/RE1 Silencing Transcription factor (NRSF/ REST) [9] – Neuronal specificity can be conferred via unique transcriptional activators or via repressors that silence transcription in non-neuronal cells. Identification of the silencer element NRSE is one of the most important accomplishments in neural specific gene regulation today and its importance to brain function as well as disease is accumulating in the literature. NRSE is found primarily in non-coding sequence and is evolutionarily conserved. NRSEs are found in neuronal genes coding for proteins such as the Na<sup>+</sup> channel, Synapsin I, BDNF, NMDAR, nAchR, GABAAR, and Neurofilament M, and in non-neuronal genes coding for proteins such as Keratin, human/bovine P450–11β, and skeletal actin. NRSF binds to a 21-nucleotide sequence called the neuron-restrictive silencer element (NRSE/RE1).

NRSE consensus sequence

5' – ttCAGCACCCaaGGAcAGcgcC – 3'

Uppercase letters: conserved Lowercase letters: less conserved

Although it was initially believed that NRSE containing genes are silenced only in non-neuronal cells via the binding of NRSF, more recent studies have revealed that they also bind to genes within neurons. NRSF contains a zinc-finger DNA-binding domain and interacts with the co-repressors CoREST and mSin3a via two repressor domains found at each end. Once bound to NRSF, the co-repressors recruit histone modifying proteins such as Histone Deacetylase (HDAC) and Methyl CpG binding protein 2 (MeCP2), altering

conformation of the ►chromatin to a transcriptionally silent form (heterochromatin).

NRSF expression in neuronal cells decreases as they become more differentiated and its gene targets are involved in neuronal function, such as ion channels, neurotransmitter receptors, neurotransmitter-synthesizing enzymes, neuronal cytoskeleton, neuropeptides and neurotrophic factors. A truncated splice variant of NRSF, REST 4, has been shown to bind to NRSE rather weakly in neurons and is also found at high levels in biopsies of Small Cell Lung Carcinoma patients.

- A ubiquitous transcription factor with important brain function

Sp1 [10] – Sp1 is a transcription factor that regulates the expression of genes throughout the body. Particular to the brain, it regulates expression of the acetylcholine receptor (AChR) and Huntingtin (Htt). Sp1 is known to bind specifically to GC-rich DNA elements via its zinc-finger motif. With its strong glutamine-rich activation domain, Sp1 recruits basal transcription factor TFIID to DNA and induces marked transcription. TFIID contains TATA box binding protein (TBP) and TBP-associated factors (TAFs) of variable sizes. Of these TAFs, human TAFII130 is of particular interest due to its specific interaction with Sp1. Both Sp1 and TAFII130 bind to the mutant form of Htt, an association that is implicated in Huntington's Disease.

- Activity dependent neural specific signaling molecule

BDNF [11] – There are five exons in the rat BDNF gene and exon I through IV contain promoters that are upstream of one another (designated promoters I-IV). Use of alternative promoters ensures specificity and diversity of gene regulation. For example, BDNF transcription via promoter I is activated after Ca<sup>2+</sup> influx through L-type voltage-dependent Ca<sup>2+</sup> channels (L-VDCC), whereas promoter III is activated when Ca<sup>2+</sup> influx occurs through the NMDAR. The activation of both promoters occurs via binding of phosphorylated ►CREB.

### Techniques Used to Study Promoters

Electrophoretic Mobility Shift Assay (EMSA, also referred to as gel shift assay) – EMSA is an in vitro assay used to determine whether a particular transcription factor binds to a known sequence of DNA by identifying if there is specific binding activity in a given nuclear extract when exposed to a particular sequence of DNA or RNA. Extracts of nuclear proteins are incubated with a radiolabeled DNA probe that contains a sequence of interest and the resulting DNA/protein complex is resolved using non-denaturing acrylamide gel electrophoresis. In the absence of extract the probe migrates rapidly towards the bottom, however, in the presence of specific binding protein, the probe's migration is slowed in the gel. Competing cold oligonucleotides of various sequences are used to demonstrate

sequence specificity for the binding interaction. In addition, to determine the identify of nuclear proteins, a specific antibody is added to the binding reaction and presence of a “supershift” (because of the increased size of the complex with the antibody attached, the probe will migrate even more slowly) occurs if the epitope of the binding protein is accessible.

**Luciferase Reporter Assay** – The luciferase reporter assay is especially useful in studying mammalian transcription because the natural expression of the luciferase gene product is restricted to fireflies. In molecular neurobiology, a vector containing the promoter sequence of interest is placed upstream of the luciferase reporter and promoter activity is studied in transfected primary neuronal cultures derived from different embryonic brain regions by assaying for the amount of light production from cleavage of the luciferase substrate luciferin.

**Chromatin Immunoprecipitation (ChIP)** – ChIP is utilized to examine the *in vivo* binding of a given protein to a specific promoter segment. After DNA is crosslinked to the DNA-binding proteins, the genomic DNA is sheared into small fragments of 300 bp or less and immunoprecipitated with a specific antibody that recognizes the protein of interest. Upon reverse-crosslinking, detection of the resulting precipitated DNA fragments are done using standard polymerase chain reaction (PCR) or quantitated via real-time PCR with taqman probe and primers. This assay is useful for identifying potential endogenous genes regulated by a particular transcription factor.

## Disease

**Single Nucleotide Polymorphism (SNP) within the promoter region.** Single Nucleotide Polymorphism is characterized as a genetic deviation or change in DNA of more than 1% of a population. Generally, SNPs do not result in any phenotypic changes. However, when the SNPs occur within a coding region or a promoter of a gene, consequences such as a differential response to a drug or an increased predisposition to certain diseases have been observed.

**Brain-derived Neurotrophic factor (BDNF).** In particular, a genetic variance in the BDNF promoter I was recently identified. This novel variation has a cytosine replaced by adenine at 281 bp upstream of the TSS and causes reduced DNA binding by factors yet to be identified. In addition, this “A” allele decreases BDNF promoter activity in rat hippocampal neurons and an association of the allele with a decrease in psychopathology is reported in a phenotype-genotype analysis using human samples.

**Neuropeptide Y (NPY).** Lowered activity of NPY has been implicated in the pathophysiology of Schizophrenia. A novel polymorphism within the Japanese population at –485T>C in the promoter region of the NPY gene has been reported in patients suffering from

Schizophrenia. The –485 nucleotide is contained within the Sp1 consensus site and abolishes potential binding site detection.

## References

1. Russek SJ (1999) Evolution of GABA(A) receptor diversity in the human genome. *Gene* 227(2):213–222
2. Steiger JL, Russek SJ (2004) GABA-A receptors: building the bridge between subunit mRNAs, their promoters, and cognate transcription factors. *Pharmacol Ther* 101(3):259–281
3. Myers SJ, Peters J, Huang Y, Comer MB, Barthel F, Dingledine R (1998) Transcriptional regulation of the GluR2 gene: neural-specific expression, multiple promoters, and regulatory elements. *J Neurosci* 18(17):6723–6739
4. Steiger JL, Bandyopadhyay S, Farb DH, Russek SJ (2004) cAMP response element-binding protein, activating transcription factor-4, and upstream stimulatory factor differentially control hippocampal GABABR1a and GABABR1b subunit gene expression through alternative promoters. *J Neurosci* 24(27):6115–6126
5. Minth CD, Dixon JE (1990) Expression of the human neuropeptide Y gene. *J Biol Chem* 265(22):12933–12939
6. Beckmann A, Wilce P (1997) Egr transcription factors in the nervous system. *Neurochem Int* 31(4):477–510
7. Li L, Carter J, Gao X, Whitehead J, Tourtellotte WG (2005) The neuroplasticity-associated Arc gene is a direct transcriptional target of early growth response (Egr) transcription factors. *Mol Cell Biol* 25(23):10286–10300
8. Ooi L, Wood IC (2007) Chromatin crosstalk in development and disease: lessons from REST. *Nat Rev Genet* 8(7):544–554 (Review)
9. Dunah AW, Jeong H, Griffin A, Kim YM, Standaert DG, Hersch SM, Mouradian MM, Young AB, Tanese N, Krainc D (2002) Sp1 and TAFII130 transcriptional activity disrupted in early Huntington’s disease. *Science* 296(5576):2238–2243
10. Tabuchi A, Nakaoka R, Amano K, Yukimine M, Andoh T, Kuraishi Y, Tsuda M (2000) Differential activation of brain-derived neurotrophic factor gene promoters I and III by Ca<sup>2+</sup> signals evoked via L-type voltage-dependent and N-methyl-D-aspartate receptor Ca<sup>2+</sup> channels. *J Biol Chem* 275(23):17269–17275

## Property

VOLKER GADENNE

Department of Philosophy and Theory of Science,  
Johannes-Kepler-University, Linz, Germany

## Definition

Properties are ways things are; they are features, attributes, traits, characteristics or aspects.

## Description of the Theory

### Property and Object

Suppose that Jack is bald. Jack belongs to the category of *things* (or *objects*, including persons). Baldness, by contrast, is a *property*. Jack has this property and many other individuals possess it too. Things are bearers of properties and different objects may share the very same property. Things are also said to *exemplify* or *instantiate* properties.

But things are not the only entities that possess properties. Properties can themselves have properties and so can events. “Bald” is exemplified by individual persons and has itself the property of being physical. “Bold” and “shy” are properties of persons too, they are however mental. An event, like having a toothache, may have the property of being short or of occurring after breakfast.

When philosophers speak of objects and properties, they use these concepts in a wide sense. The category of objects may include tables, trees and persons, but also electrical fields or points in space-time. As to properties, many of them are denoted by adjectives, like “green” or “round”. But there are also properties denoted by rather complex predicates. For example, a neuron instantiates (at certain times) a special property denoted by the term “resting potential.” A person may be ascribed the property of being in pain, of believing that snow is white or of wanting to study philosophy. In such cases a person can also be said to be in the *state* of being in pain or in the *state* of believing that snow is white [1].

### Ontological Status of Properties

The ontological status of properties has been discussed since Plato [2,3]. *Realists* (in a specific sense of the term) believe that words like “white” or “horse” name the ►**universals** “whiteness” and “horseness.” Unlike particulars, universals are abstract entities (►**abstract entity**). They belong to the real (►**Realism (as an ontological position)**) world though they are not located in space and time. Some realists (Platonists) think a universal can exist even if it has no instances. Others (following Aristotle) assume that for a universal to exist it has to be exemplified by at least one individual thing.

According to ►**nominalism**, abstract entities do not exist at all. There are only particulars (and perhaps classes of particulars), like individual white things or individual horses. Different things are said to have the same property or belong to the same sort or kind, if the same predicate applies to, or *is true of*, these different things. (Exchange “predicate” with “concept” to get concept nominalism.) Realists object that for a predicate to be true of a particular (or a particular to fall under a concept), that particular must be connected with some real ►**entity** to which the predicate (or concept) refers. Otherwise the ascription of predicates to particulars

would be an arbitrary matter. The nominalists’ standard reply is that predicates do not function like names (see for the controversy between realists and nominalists [4,5]).

Some philosophers believe there are *essential* and *accidental* properties. A property F is said to be essential to an entity a, if a could not exist without exemplifying F. For example, the number two has essentially the property of being even. It is hard to see how it could lack that property and still be the number two. With respect to concrete objects, it is more difficult to decide whether a property is essential or accidental. It seems that Jack is essentially a human being. In contrast, his property of being a philosopher is accidental, since he could instead have become a postman. In ►**possible world semantics**, the idea of an essential property is expressed as follows; a has the property F essentially if and only if a has F in every ►**possible world** [6]. For a critique of ►**essentialism**, see [7].

### Property and Predicate

If properties are regarded as parts of the real world, they must be distinguished from predicates. Properties are designated by predicates. In the sentence “Jack is bald,” the word “Jack” denotes an individual and the predicate “is bald” refers to a property. Unlike names and predicates, properties are not linguistic entities but real features of the world (an assumption not shared by austere nominalists). It is less clear whether properties are different from concepts (meanings of words). They are different if properties are taken as real and concepts as something in the minds of persons (or as something existing in dependence on minds). However, properties may come close to concepts, if concepts too are conceived as mind independent entities or if both properties and concepts are conceived as mind dependent.

### Intrinsic and Extrinsic (Relational) Properties

Objects possess some of their properties in their own right. For example, an object may be round (spherical) and have a mass of two kilograms and it has these features independently of how other things are. Such features are called *intrinsic* properties or *qualities*. Other properties are *extrinsic* or *relational* [1]. Socrates is a teacher of Plato and he is married to Xanthippe. These are relational properties of Socrates, since he has them not independently of other things. (According to some philosophers there are no relational properties; they regard properties and relations as ontologically different, and categorize both as attributes.) Though intrinsic properties are not themselves relational, their specification or measurement usually involves relations between objects. Consider for example how mass (an intrinsic property) is specified. To say that this rod has a

mass of two kilograms is to say that it would balance, on an equal arm balance, two objects each of which balances the standard kilogram.

### **Dispositional Properties, Causal Powers, and Functional Properties**

Special kinds of relational properties are *dispositional properties* and *causal powers*. This billiard ball has the qualities (intrinsic properties) of being spherical and solid. In virtue of these qualities, it has the disposition to roll when placed on an inclined surface. Other dispositional properties are solubility in water or fragility. Having a special disposition is to produce certain behavior under certain conditions. It seems that dispositions are always grounded in non-dispositional properties. For example, being fragile is grounded in a particular molecular structure. An object is fragile in virtue of having that molecular structure. If an object has the dispositional property G in virtue of the non-dispositional (intrinsic, qualitative) property F, F is called a *first-order property* and G a *second-order property*.

Another special kind of relational properties are *functional properties*. Many things are defined by functional descriptions, for example, a knife, a clock or an eye. An object has the property of being a clock, not because of the material of which it is made, but because it satisfies a certain job description – it keeps time. Similarly, an eye can be made of different materials and take different forms (compare our eye to that of the horse or the honeybee). What makes it an eye is a special functional property or functional role – it extracts information from light radiation and makes that information available to the system it subserves. Functional roles can best be described with the help of causal relations. Therefore, philosophers often speak of “causal roles” instead of functional roles.

### **Mental Properties**

A major problem in the philosophy of mind is the status of mental properties. Physicalists have tried to demonstrate that the mental is nothing over and beyond the physical organism and its physical/biological properties. This view includes the theory that all mental properties are realized as physical/biological properties; according to advocates of reductionist physicalism, mental properties are even reducible to physical/biological properties. Similarly, functionalists have held that mental properties can be understood as functional properties (which are themselves realized as physical properties). Consider for example the property of being in pain. According to functionalism, roughly speaking a mental state is a pain if it is caused by specific stimuli (e.g. tissue damage), gives rise to specific thoughts and wants (e.g. about how to end the unpleasant state) and causes specific behavior (e.g. withdrawal).

It has been objected against physicalism and functionalism that they could not adequately account for *phenomenal qualities* or ► *qualia* (singular: *quale*). Some mental states, especially, sensations and feelings, are characterized by specific phenomenal qualities. Think of the painful, hurting character of a sharp headache. Such phenomenal qualities seem to be intrinsic properties not extrinsic (relational) ones. It is hard to see how phenomenal qualities could be identified with or reduced to physical properties, causal powers or functional roles. But if they cannot be reduced to the physical domain, it seems difficult to understand how they can have any effect on the physical organism and its behavior. The status of mental properties, especially phenomenal ones, is still controversially discussed.

### **References**

1. Kim J (1996) *Philosophy of mind*. Westview, Boulder
2. Plato (1961) *Parmenides*. In: Hamilton E, Cairns H (eds) *Plato: the collected works*. Pantheon Books, New York
3. Mellor DH, Oliver A (eds) (1997) *Properties*. Oxford University Press, Oxford
4. Armstrong DM (1989) *Universals*. Westview, Boulder
5. Loux MJ (1998) *Metaphysics*. Routledge, London
6. Kripke SA (1980) *Naming and necessity*. Harvard University Press, Cambridge
7. Grossmann R (1983) *The categorial structure of the world*. Indiana University Press, Bloomington

## **Proposition, Propositional Attitudes**

### **Definition**

A proposition is what is asserted as the result of uttering a sentence; propositions are considered to be the meanings of closed sentences (as opposed to open sentences or predicates), and they are considered to be the bearers of truth and falsity. Propositions are expressed by that-clauses (the sentence “Hannah laughs,” for instance, expresses the proposition (means) that Hannah laughs) and can be thought of as pairs consisting of objects and properties (like <Hannah; laughs>) or relations (like <<Hannah, Fred>; is taller than>).

A subject S can have different mental postures towards a proposition P, for example believing, remembering, desiring, intending, fearing, hoping etc.

In that case, S has a propositional attitude. A propositional attitude is an intentional relation R between a subject S and a proposition P, such that S bears R to P. Propositional attitude ascriptions are made

up of a name for some thing, like “Fred,” followed by a name for an attitude, like “believes,” followed by an expression for a proposition, like “that Hannah laughs.”

- ▶ Epiphenomenalism
- ▶ Possible World

## Propositional Knowledge

### Definition

Propositional knowledge is the kind of knowledge one can communicate using some proposition, i.e. in English using some phrase of the form “that p” where “p” can be replaced by some complete declarative sentence.

- ▶ Knowledge

## Proprioception

SIMON GANDEVIA

Prince of Wales Medical Research Institute, Sydney, NSW, Australia

### Introduction

The production of ▶ **voluntary movements** usually occurs effortlessly with few errors. We rarely drop objects held in the hand or fall while walking. This requires coordinated activity involving cognitive, sensory and motor areas of the cerebral cortex. Ultimately the correct output is generated by ▶ **motorneurons** in the ▶ **spinal cord** and ▶ **brainstem** which then produce the correct changes in force and length of muscles. For muscles to exert continuously the proper forces on the skeleton requires the brain to plan, initiate and control movements. A set of sensory processes underlies this ability. It is variously termed “proprioception” or “▶ **kinaesthesia**.” These terms are now often used interchangeably, although proprioception is broader in its scope.

Proprioception and kinaesthesia refer to a class of sensations or sensory-motor processes which include the ability to detect movement and position at different joints and the ability to judge forces exerted by muscles

and the heaviness of objects they lift. Knowledge about the timing of muscle contractions and knowledge about the overall body image are now also covered by these umbrella terms. Deficits that impair proprioception impair the control of voluntary movement and posture, whereas diseases that impair movement and posture usually have deficits in some aspects of proprioception. This synopsis focuses on the sensations of joint position and movement although some other areas are briefly mentioned.

The neural mechanisms underlying proprioception have been hotly debated for more than a century [1]. Much of this controversy has arisen because experimentalists and clinicians have taken a narrow view of what proprioception encompasses. In contrast, theoreticians have proposed complex models of how proprioception might contribute to movement control, but these have been difficult to validate.

On the “input” side, groups of specialized sensory receptors in the skin, joint and muscles respond to mechanical strains and signal the state of the limb to the spinal cord and brain. Evidence of the contribution of each of these receptor groups is summarized below. For these signals to be transformed into useful sensations which can be reported verbally requires central processing so that the different input signals are calibrated to the Newtonian state of the body, and combined or amalgamated to provide a body map (or “representation”) which can help guide movement (see also ▶ **Phantom limb sensation and pain**).

Because a particular proprioceptive state (e.g., the angle of a joint) can arise under passive conditions with muscles relaxed, or active conditions with muscles contracting, most proprioceptive models also include an input from motor command signals. Peripheral signals provide feedback that is evaluated against what movement has been commanded and what proprioceptive state might be expected. Various terms for these command signals have been coined including an ▶ **efference copy** or ▶ **corollary discharge**. A requirement for such signals is not unique to evaluation of proprioceptive signals, but is equally necessary in other modalities such as cutaneous, visual and ▶ **vestibular sensation**, in which changes in the peripheral signals can be produced by self-generated forces or externally-generated events. An interesting example occurs when a tickling skin sensation is felt when generated externally but not when the same stimulus is self-generated [2].

### Peripheral Proprioceptive Signals

There are two steps in the establishment of a proprioceptive role for a particular class of sensory receptors. First, the receptors must encode variables such as the forces exerted by muscles or changes in joint angles in their discharge. Second, the discharge must be capable of producing a change in perception of that

proprioceptive variable. The first step is achieved by recording the discharge of the receptors. The second requires that changes in the discharge evoke changes in sensation. This can be achieved by finding a proprioceptive illusion when the receptors are activated selectively. Alternatively, performance in a proprioceptive test may diminish when the receptors are eliminated, such as when a diseased or damaged joint is replaced by an artificial one.

Of the peripheral proprioceptive signals, those arising in specialized muscle receptors are considered the most important [1,3,4] (see ►[Proprioception: Roles of Muscle Receptors](#), and ►[Movement Sense](#)). ►[Muscle spindle](#) endings can be activated by local length changes and their firing can also be modified by a specialized ►[fusimotor system](#) that can modulate the background firing rate and gain of the endings. The ►[primary muscle spindle endings](#) are exquisitely responsive to muscle length changes including vibration. When a muscle (or its tendon) is vibrated at ~100 Hz, subjects experience an illusion consistent with the muscle lengthening, but also occupying a more lengthened position [5]. When the vibration is adjusted so that secondary spindle endings are more effectively activated, the illusion is more one of position than of movement. The central nervous system interprets these unexpected proprioceptive signals according to the current body map (see ►[Phantom limb sensations and pain](#)), and this leads to errors in voluntary movements and posture [6]. Muscles also contain specialized receptors (►[Golgi tendon organs](#)) which encode the active forces generated by voluntary contraction. These signals probably contribute to sensation of muscle force.

Until recently, specialized receptors in the skin were not considered to have a role in proprioceptive sensations, although it had long been realized that such receptors discharge with movement of nearby joints and that their activity contributed to the reflex control of movement in activities such as walking and grasping. Some populations of ►[cutaneous receptor](#) encode the pattern of local skin strain and its change with changes in joint position [7], while others encode the timing of voluntary movement and any disturbances to it (see ►[Proprioception: Role of cutaneous receptors](#)). Stretch receptors in the skin (probably innervating ►[Ruffini endings](#)) discharge when the skin around a joint is stretched by moving it via threads attached to tape stuck to the skin. Subjects then commonly report that the underlying joints are moving in a direction consistent with the pattern of artificial skin strain. These illusory sensations of movement are amplified when combined with muscle spindle signals evoked in appropriate muscle spindle ending populations by tendon vibration. Illusions evoked by skin stretch can be evoked at joints in the hand as well as at large proximal joints such as the

elbow and knee [8]. Insight into the predictive capacity of the cortical proprioceptive decoders comes from observing that when skin and muscle receptors are activated artificially to produce proprioceptive illusions, subjects may report completely impossible anatomical positions. To the subject of the illusion, this extraordinary disruption of reality seems completely natural. Supportive evidence for the proprioceptive role of non-muscle, presumably skin receptors, derived from studies of the hand when nerves innervating the fingers (but not their muscles) have been anaesthetized [9].

Throughout most of the last century, joint receptors were considered so influential in proprioception that the term “►[joint position sense](#)” was adopted by clinicians in the belief that such receptors were crucial contributors. Evidence for the belief was much weaker than admitted. Specialized slowly adapting receptors in joint capsules and ligaments usually discharge only at one (or more) extreme of the usual physiological range of joint movement, or they discharge when abnormal stresses are put upon a joint [10]. Relatively few receptors discharge progressively across the movement range in a way that allows them to signal the angular motion (see ►[Proprioception: Role of joint receptors](#)). Electrical stimulation of digital nerves or single joint receptors can evoke illusory sensations of joint distortions and movement [11,12]. The difficulty of selectively activating a natural population of these receptors precludes a quantitative assessment of their role. Intra-articular anesthesia or joint replacement does not produce major deficits in proprioceptive sensation, which may simply indicate the redundancy in afferent sources of information (see ►[Proprioception and orthopedics](#)).

### Motor Commands and Central Processing

In the planning and execution of movement, signals related to the voluntary command are generated. These signals have a number of roles to play in the control of movement and posture [13], but exactly how this is achieved for limb movement is uncertain. Lessons from robotics and engineering, as well as studies in insects and fish, reveal that access to command signals for movement control through predictive modeling of their action on the body, and through monitoring of their outcome via feedback is likely to be important in control of human movement and posture [14].

The oculomotor system is one example where central command signals help ensure the perceptual stability of our visual world. A second example is found in the judgment of exerted force and the heaviness of objects lifted by muscle contraction. Here, signals related to the size of the outgoing command bias the judgments. As a result, we are familiar with the increase in apparent heaviness of objects we lift when muscles become fatigued [15]. This type of perceptual illusion



has been rigorously investigated under many circumstances affecting the relationship between the motor command required and the actual muscle force achieved, and the maxim holds that objects appear heavy wherever the efficiency of the neuromuscular apparatus is impaired [3]. However, the perceived force is not a simple readout of the motor command delivered (nor of the motor cortex output), because this readout must be interpreted in the light of ongoing afferent signals.

Experimental studies have usually focused on the role of command-related signals in highly volitional tasks requiring, or triggered by, an external cue. In activities such as walking in which the contractions occur more automatically, the access and processing of command signals may differ. Thus, the voluntary effort required to generate the force that can lift you onto the ball of one foot exceeds that during walking when similar forces are required. An additional complication that has not been resolved is how the muscle spindle signals from voluntarily contracting muscles are interpreted, because their signal is a resultant of the local strain on the receptor induced by the environment and that induced by the fusimotor system. This independent motor supply to muscles can alter the gain and set point of the spindle's response [16]. One way to resolve this complication is the reliance on several afferent sources of input (from the skin, joints and non-contracting muscles) rather than a signal arising solely in the active muscles.

It had long been thought that motor commands did not play a major role in sensing the position and movement of joints. However, recent work with normal subjects in whom a phantom hand has been induced by deafferentation and paralysis challenges this view. The phantom hand moves in the direction in which it is willed to move, and the size of the movement increases with the level of motor command and effort [17]. Hence, the isolated command to move, in the absence of any input from proprioceptors, generates an illusion. If this applies, as seems likely, when there are normal sensory signals, it will be clear that this group of proprioceptive sensations, like force-related sensations, is also biased by the command signals.

Presumably, the brain devises its best estimate of the proprioceptive state based on an amalgam of inputs, some command-related, some originating in different classes of sensory receptors, and some derived from internal predictive models. Visual signals and vestibular signals provide additional frames of reference against which the proprioceptive state of the limbs in extra personal space can be gauged. Vestibular signals extend the proprioceptive system by providing information about the head's position and its movement relative to gravity. Visual signals extend the proprioceptive system

by calibrating it against external objects and in some circumstances visual inputs override proprioceptive ones.

This proprioceptive amalgam can adapt to rapidly changing conditions brought about, for example, by muscle fatigue or by changes in a limb's orientation to gravity occurring acutely with natural movements and posture, and chronically in the microgravity of an orbiting spacecraft (see ►[Proprioception: Effect of gravity](#)). Here, some receptors may act as "load" sensors. Proprioception must also adapt to other changes brought about by musculoskeletal growth, damage and disease, as well as the impairments accompanying ageing (see ►[Proprioception: Effect of ageing](#)). In the elderly, reduced proprioception contributes to postural instability and falling.

Studies using non-invasive imaging of the human brain have revealed that proprioceptive inputs from muscle receptors have specific projections to major cortical areas, particularly the primary motor cortex and its adjacent area (area 3a in the so-called "somatosensory" cortex). These areas have a direct role in movement production [18] as they contain cells projecting to the spinal cord and even to motoneurons. In addition, some other cortical areas are activated in a less specific way, for example, part of the supplementary motor area is active when either the left or right hand is vibrated to produce illusory movements and part of the cingulate motor area is active when the hand or foot is vibrated on the contralateral side. Other parietal and frontal cortical areas are active in producing the proprioceptive "amalgam" that is integrated with our "body image," with visual circuits, and with cognitive centers.

## Conclusions

Proprioception is a broad term encompassing several sensations which are needed for normal movement. It is likely that the brain optimizes the use of both peripheral signals from muscle, skin and joint receptors together with signals about the timing, destination and strength of centrally generated command signals. The proprioceptive system must continually determine what changes in the proprioceptive state are self-induced and what represent changes brought about by external forces. It must also adapt to changes occurring to the musculoskeletal system.

While many of the afferent mechanisms are now well established, the central mechanisms are less well understood. Current studies are using a range of non-invasive methods to extract the location, strength and timing of the responsible neural activity. Further studies will focus on the precise deficits that occur when movement control is disrupted by a range of diseases, from schizophrenia to Parkinson's disease. Although it is clear that central processing in traditional

somatosensory, motor and associative frontal and parietal areas is involved, the way in which cerebellar and basal ganglia circuits contribute is poorly understood.

## References

1. McCloskey DI (1978) Kinesthetic sensibility. *Physiol Rev* 58:763–820
2. Blakemore SJ, Wolpert DM, Frith CD (1998) Central cancellation of self-produced tickle sensation. *Nat Neurosci* 1:635–640
3. Gandevia SC (1996) Kinesthesia: roles for afferent signals and motor commands. In: Rowell LB, Shepherd JT (eds) *Handbook on integration of motor, circulatory, respiratory and metabolic control during exercise*, American Physiological Society, Bethesda, pp 128–172
4. Proske U (2006) Kinesthesia: the role of muscle receptors. *Muscle Nerve* 34:545–558
5. Goodwin GM, McCloskey DI, Matthews PB (1972) The contribution of muscle afferents to kinaesthesia shown by vibration induced illusions of movement and by the effects of paralysing joint afferents. *Brain* 95:705–748
6. DiZio P, Lathan CE, Lackner JR (1993) The role of brachial muscle spindle signals in assignment of visual direction. *J Neurophysiol* 70:1578–1584
7. Edin BB, Abbs JH (1991) Finger movement responses of cutaneous mechanoreceptors in the dorsal skin of the human hand. *J Neurophysiol* 65:657–670
8. Collins DF, Refshauge KM, Todd G, Gandevia SC (2005) Cutaneous receptors contribute to kinesthesia at the index finger, elbow, and knee. *J Neurophysiol* 94:1699–1706
9. Gandevia SC, McCloskey DI (1976) Joint sense, muscle sense, and their combination as position sense, measured at the distal interphalangeal joint of the middle finger. *J Physiol* 260:387–407
10. Burke D, Gandevia SC, Macefield G (1988) Responses to passive movement of receptors in joint, skin and muscle of the human hand. *J Physiol* 402:347–361
11. Gandevia SC (1985) Illusory movements produced by electrical stimulation of low-threshold muscle afferents from the hand. *Brain* 108:965–981
12. Macefield G, Gandevia SC, Burke D (1990) Perceptual responses to microstimulation of single afferents innervating joints, muscles and skin of the human hand. *J Physiol* 429:113–129
13. Gandevia SC (1987) Roles for perceived motor commands in motor control. *Trends Neurosci* 10:81–85
14. Frith CD, Blakemore SJ, Wolpert DM (2000) Abnormalities in the awareness and control of action. *Philos Trans R Soc Lond B Biol Sci* 355:1771–1788
15. Gandevia SC, McCloskey DI (1977) Sensations of heaviness. *Brain* 100:345–354
16. Matthews PBC (1981) Evolving views on the internal operation and functional role of the muscle spindle. *J Physiol* 320:1–30
17. Gandevia SC, Smith JL, Crawford M, Proske U, Taylor JL (2006) Motor commands contribute to human position sense. *J Physiol* 571:703–710
18. Naito E, Nakashima T, Kito T, Aramaki Y, Okada T, Sadato N (2007) Human limb-specific and non-limb-specific brain representations during kinesthetic illusory movements of the upper and lower extremities. *Eur J Neurosci* 25:3476–3487

## Proprioception and Orthopedics

KATHRYN M. REFSHAUGE

Faculty of Health Sciences, University of Sydney, Sydney, NSW, Australia

### Synonyms

Kinesthesia; Movement detection; Position sense; Movement discrimination

### Definition

Proprioception refers to the group of sensations related to limb position and movement, muscle force, timing of muscle contractions and posture and size of a body “schema” of one or more joints. Peripheral proprioceptive signals arise from discharge of receptors located in muscle, joints and cutaneous tissue, although there is continuing debate concerning their relative contribution to conscious proprioceptive sensations and the nature of their contribution. Proprioceptive sensations are also derived from centrally generated motor commands and the interaction between the afferent and efferent signals.

### Characteristics

#### Quantitative Description

Each of the proprioceptive sensations requires a different method of testing, with consequent different levels of acuity according to the test method. Acuity varies among joints in a single individual, even when tested with the same method. The only proprioceptive sensation to be systematically measured for human joints in the same individual is the sensation of joint movement, measured using detection levels for perception of passive movement. In both the leg and the arm, proximal joints have better acuity than distal joints when expressed as angular displacement. For example, in the leg, for passive movements imposed at 0.5°/s, movements of ~0.2° can be detected at the hip, ~0.6° at the knee, ~0.5° at the ankle and ~21° at the interphalangeal joint of the big toe. Similarly in the arm, for passive movements imposed at 1°/s, movements of ~0.2° can be detected at the shoulder, ~0.6° at the elbow and ~5° at the distal interphalangeal joint of the finger.

Test conditions can be manipulated to increase or decrease proprioceptive acuity. Small contractions of the muscles around the joint can improve acuity tenfold whereas fatigue increases the error in position matching tasks. Muscle history can also alter acuity. Finally, proprioceptive acuity improves with increasing velocity and decreases with increasing age.

Proprioceptive performance cannot be generalized across the wide variety of tests in common use because there is no relationship between the different tests. Therefore a single test is not adequate to make judgments about

general proprioceptive status in health or after injury. This lack of relationship is likely to account, at least in part, for the conflicting results found for the effect of injury on proprioception.

### Higher Level Components

Cortical projections must exist for a role to be assigned to the peripheral receptor discharge measured during movements. Such projections have been established for all proprioceptors.

### Lower Level Components

Three classes of afferent contribute to proprioceptive sensibility, including cutaneous, muscle and tendon and joint capsule and ligament afferents. The adequate stimulus for all three is stretch of the tissue in which they are located, although cutaneous and joint receptors also respond to other stimuli. The major debate over the last century has concerned the contribution of each to proprioceptive sensations. It is now clear that all classes contribute to proprioceptive sensations and the debate is now directed at the nature of the contribution. Although it was hypothesized that cutaneous afferents may facilitate muscle afferents, more recent evidence suggests that such facilitation is unlikely. Based on both psychophysical and microneurographic evidence, the contemporary view is that cutaneous input is integrated with that from muscle spindles to provide accurate perception of joint position and movement.

### Function

The ability to perceive limb movement and position is essential to normal movement and posture. Without this ability, function is severely disturbed because attempts to move must be guided and monitored using vision. Proprioception underlies all normal movement and its control.

### Orthopedic Pathology

Interest in the effect of orthopedic pathology on proprioception has most often been directed at osteoarthritis, joint replacement and ligament injuries and rarely at non-specific conditions such as low back and neck pain. The effect of orthopedic pathology on proprioception varies with the pathology but a proprioceptive deficit has been found consistently in very few conditions. In most orthopedic pathologies, a deficit is not evident, the literature is inconsistent or a deficit has been found in some but not all of the different proprioceptive tests. The more important question concerns the relevance of a deficit and the magnitude of deficit required for it to impact on function.

### Osteoarthritis (OA)

Proprioception has been extensively investigated in knees with OA. All studies have consistently found

impairments in both joint position sense and detection of movement compared with healthy controls [1]. The magnitude of the deficit in movement detection was  $\sim 1.3^\circ$  (normal  $\sim 2.3^\circ$ ) and in joint position sense  $\sim 2.9^\circ$  (normal  $\sim 2.6^\circ$ ). Such a deficit has also been found in the contralateral unaffected knee, with proprioception in both knees being impaired compared with healthy controls [1], leading to speculation that this could indicate central changes. However, no correlation has been found between proprioceptive impairment and severity of disease [1], function or pain. Given the lack of correlation between proprioceptive deficit and function and the small magnitude of the deficit, the consequence of this deficit is unlikely to be functionally relevant.

### Total Joint Replacement

It is of particular interest that total joint replacement for knee OA does not necessarily impair proprioception, despite removal of the articular surface. Different studies have found total joint replacement to variously impair, not change or even improve proprioception, although probably not to normal acuity. The magnitude of reported deficits was small, being between  $0.3^\circ$  and  $0.72^\circ$  for threshold to movement detection. However, even when proprioception was found to be impaired after surgery, balance measurements remained normal and clinical outcome was reported as excellent for replaced knees [2], indicating that small proprioceptive impairments do not manifest as functional deficits.

The most common *ligament* injuries involve the anterior cruciate ligament (ACL) at the knee and the lateral ligament complex at the ankle. Proprioception has been extensively investigated in both injuries, motivated by the belief that proprioceptive deficits are associated with persisting disability.

### Anterior Cruciate Ligament Rupture

It has been suggested that the ACL has an important proprioceptive role via the fusimotor system and that its loss should therefore cause a significant proprioceptive deficit. However, the evidence does not uniformly support this proposal. A deficit in threshold to movement detection of  $1.5^\circ$  has been found compared with the contralateral uninjured knee and of  $0.5^\circ$  compared with healthy controls [3], but others found no impairment. Furthermore, no impairment was found in joint position sense in ACL deficient knees compared with healthy controls by most authors, although a deficit of up to  $4.5^\circ$  was found by others [4] and the deficit was significantly worse in the mid-range of movement [4]. When both threshold to movement detection and joint position sense were measured in the same subjects, there was no correlation in performance [5], suggesting that a deficit may be specific and that performance on a single proprioceptive test cannot be generalized. However, no study investigated proprioception in

rotation movements, the direction of instability in ACL-deficient knees.

The effect of reconstructive surgery after ACL rupture on proprioception is also unclear. After surgical reconstruction, some authors found that movement detection was restored to normal, others found improved acuity but not to normal levels and unexpectedly, Co et al. [6] found that reconstructed knees were even more accurate than healthy controls by  $0.4^\circ$ . The findings for joint position sense were also inconsistent; reconstruction was variously found to confer no benefit [6] or to improve acuity, but not to normal [3]. These conflicting results potentially arise because not all ACL-deficient knees have a proprioceptive deficit to address. It is tempting to suggest that any improvement is due to the improved stability of the joint, but proprioceptive acuity correlated poorly with mechanical stability [4,3]. Alternatively, improved joint kinematics may normalize input from the muscles, thereby enhancing proprioceptive signals.

Even when proprioceptive deficits were found, they were generally small. Nevertheless the impact on function is uncertain. Although some authors found a high correlation (range,  $r = 0.6\text{--}0.9$ ) between proprioception and function [4], others failed to find a relationship [3]. It is difficult to explain these conflicting results. It is possible that the different findings relate to different comorbid pathologies included in the studies, such as associated meniscal damage, although again the findings are inconclusive; concomitant meniscal or chondral damage was found to relate to proprioceptive deficits by some but not others [3].

#### **Lateral Ligament Sprain at the Ankle**

Persisting symptoms of pain and instability are common after ankle inversion sprain and are frequently attributed to a deficit in proprioception. Impaired movement detection has been found by most authors in the inversion-eversion plane after recurrent sprain compared with healthy controls, the deficit in movement detection being  $<1^\circ$  and in some cases  $<0.5^\circ$ . However, in the plantarflexion-dorsiflexion plane most authors found no impairment [7]. Findings for joint position sense in the inversion-eversion plane are less consistent; a significant impairment was found by some authors but not by others. Joint position sense in the plantarflexion-dorsiflexion plane has yet to be investigated. Consistent with other ligament injuries, there was no correlation between proprioceptive performance and mechanical stability.

These findings suggest that any proprioceptive deficit after ankle inversion sprain is specific to the inversion-eversion plane of movement and to particular proprioceptive tests. The deficit is potentially related to the anatomical structures involved in the sprain, particularly those that resist inversion rather

than plantarflexion forces. Damage to these structures may therefore cause impairment only in proprioceptive tests specific to the inversion-eversion plane of movement.

#### **Therapy**

Proprioceptive training is considered an integral part of rehabilitation after many orthopedic injuries to improve assumed deficits and to prevent further injury, despite lack of knowledge about: the magnitude of deficit that is clinically meaningful; whether proprioception can be trained; and, if a deficit does exist and proprioception can be trained, whether improved proprioception is associated with improved function and reduced risk of re-injury.

The magnitude of proprioceptive deficit, when it exists in orthopedic pathology, is small in most test paradigms, generally being within one standard deviation of the average performance of control subjects. Although this difference is statistically significant in some cases, it is unlikely to be functionally relevant, because a deficit has not consistently been associated with pain or loss of function. It is possible, however, that a small deficit may be critical in situations where small errors could have considerable impact on highly skilled performance.

The most common forms of “proprioceptive training” are performance of tasks on an ankle disc or wobble board and agility training. It is indisputable that such training improves motor control; however, whether proprioception is improved is largely unknown. In the two studies that examined the effect of training on joint position sense at the ankle, one found selective improvement of  $\geq 0.5^\circ$  in error reduction at some, but not all, test angles [8], while the other found no change with training. There is currently insufficient evidence to conclude that either joint position sense or movement detection can be improved.

The major purpose of “proprioceptive” training, however, is to prevent re-injury. There is no direct evidence of a role for proprioception in prevention of injuries because the relationship between proprioception and injury risk has not been established. The few studies that have investigated the efficacy of “proprioceptive” training for injury prevention, have found the risk to be reduced, although the relationship between proprioception and injury was not investigated. Risk of ACL injury was reduced by 88% by agility training compared with control intervention. The pooled results of Wedderkop et al. [9] and Verhagen et al. [10] show that ankle disc training programs significantly reduced incidence of ankle injury, with an odds ratio for the pooled data of 0.41 (95% CI 0.268–0.629). This reduction in risk of injury has not been correlated with changes in proprioception and proprioception has not been used as an outcome measure.

## Conclusions

Taken together, the findings suggest that a proprioceptive deficit has been consistently found for degenerative joint disease, but not for any other pathology and these deficits may be improved, perhaps to normal, by surgical intervention. Selective proprioceptive deficits occur in unstable joints, but the deficit is generally small. The lack of consistent findings may be attributed to the lack of relationship in proprioceptive acuity among different proprioceptive tests and therefore identification of a deficit is likely to depend on the specific proprioceptive test measured.

Given the poor relationship between proprioception and function, the relevance of small proprioceptive deficits is unknown. Potentially these small deficits could impair highly skilled performance, but are unlikely to manifest as functional problems in normal daily activities and therefore may not require remedial therapy.

## References

1. Koralewicz LM, Engh GA (2000) Comparison of proprioception in arthritic and age-matched normal knees. *J Bone Joint Surg* 82-A:1582–1588
2. Pap G, Meyer M, Weiler HT, Machner A, Awiszus F (2000) Proprioception after total knee arthroplasty: a comparison with clinical outcome. *Acta Orthop Scand* 71:153–159
3. Reider B, Arcand MA, Lee H et al. (2003) Proprioception of the knee before and after anterior cruciate ligament reconstruction. *Arthroscopy* 19:2–12
4. Fremery R, Lobenhoffer P, Zeichen J, Skutek M, Bosch U, Tschene H (2000) Proprioception after rehabilitation and reconstruction in knees with deficiency of the anterior cruciate ligament: a prospective, longitudinal study. *J Bone Joint Surg* 82:801–806
5. Friden T, Roberts D, Zatterstrom R, Lindstrand A, Moritz U (1997) Proprioception after an acute knee ligament injury: a longitudinal study on 16 consecutive patients. *J Orthop Res* 15:37–644
6. Co FH, Skinner HB, Cannon WD (1993) Effect of reconstruction of the anterior cruciate ligament on proprioception of the knee and the heel strike transient. *J Orthop Res* 11:696–704
7. Refshauge KM, Kilbreath SL, Raymond J (2003) The effect of recurrent ankle sprain on proprioceptive acuity for inversion-eversion movements. *J Orthop Sports Phys Ther* 33:166–173
8. Eils E, Rosenbaum D (2001) A multi-station proprioceptive exercise program in patients with ankle instability. *Med Sci Sports Exerc* 33:1991–1998
9. Wedderkopp N, Kalltoft M, Lundgaard B et al. (1999) Prevention of injuries in young female players in European team handball: a prospective intervention study. *Scand J Med Sci Sports* 9:41–47
10. Verhagen E, van der Beek A, Twisk J, Bouter L, Bahr R, van Mechelen W (2004) The effect of a proprioceptive balance board training program for the prevention of ankle sprains. *Am J Sports Med* 32:1385–1393

## Proprioception: Effect of Aging

STEPHEN R. LORD

Prince of Wales Medical Research Institute and University of New South Wales, Sydney, NSW, Australia

### Definition

Proprioception is the discrimination of the positions and movements of body parts based on information other than visual, auditory or verbal. The immediate stimuli come from changes in length and from tension, compression and shear forces arising from the effects of gravity, from the relative movements of body parts and from muscular contraction [1]. Studies assessing proprioceptive age changes have used the terms proprioception, kinaesthesia and joint position sense interchangeably and both passive and active movement paradigms have been used to assess proprioceptive judgments.

Ageing is an orderly or regular transformation with time of representative organisms living in representative environments.

### Characteristics

#### Function

In 1937, Laidlaw and Hamilton [2] were the first researchers to demonstrate an age related decline in proprioception. They measured the ability of 60 subjects to detect movement in the shoulder, elbow, wrist, metacarpophalangeal joints in the upper limb and hip, knee, ankle and first metatarsophalangeal joints in the lower limb. They found that subjects aged 17–35 years had lower thresholds and superior ability to detect direction of joint movements than subjects aged 50–85 years. The hip was the most sensitive joint and the metatarsophalangeal joint was the least sensitive. They also found a wide range in perceived movement threshold and that this variability was most marked in the older age group.

More recent studies and referenced in Lord et al. [3] have, in general, confirmed Laidlaw and Hamilton's findings. Kokmen et al. [3] measured the threshold at which subjects could detect metacarpophalangeal and metatarsophalangeal joint motion. These joints were passively moved in an increasing sinusoidal flexion extension mode (a nonspecific test of joint movement only). They found that there was no difference in metacarpophalangeal joint motion detection between young subjects (aged 19–34 years) and older subjects (aged 61–84 years) at all frequencies between 0.5 and 8 Hz. They did find, however, a significant difference in metatarsophalangeal joint motion detection between young and old subjects at the lowest frequency of 0.5 Hz. At higher frequencies, the older age group

showed higher but insignificant increases in metatarsophalangeal joint motion thresholds. Variability in threshold perception performance increased with age and joint motion thresholds for the metacarpophalangeal joint were significantly smaller than for the metatarsophalangeal joint in the older group at all frequencies except for 8 Hz. No such trend was evident in the young age group, which suggests that joint motion sense may decline more with age in the lower limb compared with the upper limb.

In a recent study, Ferrell et al. [3] used a position-matching task to assess the ability of subjects to detect displacements at the proximal interphalangeal joint of the index finger. These displacements were imposed at an angular velocity of  $2^\circ/\text{min}$ , which is below the threshold for movement detection. An older group of subjects (mean age = 57 years) showed significantly poorer performance in detecting the position of the index finger than a group of younger subjects (mean age = 24 years). The size of the matching error had correlation of 0.47 with age.

Two studies have examined the effect of age on the joint position sense of the knee. Skinner et al. [3] measured joint position sense of the knee in 29 subjects with normal knee joints ranging in age from 20 to 82 years. Joint position sense was determined by the threshold of detection of an experimenter-induced movement of the knee joint and by the ability to reproduce passive knee positioning. They found that joint position sense as measured by both tests deteriorated significantly with age.

Kaplan et al. [3] used a clinical goniometer to measure the ability of 29 women to match the position of each knee with the other knee and like Skinner et al. to reproduce a knee joint position after a period of rest. They found that an older age group (aged 60–80 years) performed significantly worse than a young group (aged 22–27 years) in both tests. In the experimental paradigm where subjects had to match the position of a knee with the other knee, they found no difference between the number of trials undershot and overshot in the young group, but a tendency to underestimate knee joint angle in the older group. The reported failure of the older group to reproduce the knee joint position may however have resulted from motor deficits as well as proprioceptive deficits.

In a study of 550 women aged 20–99 years Lord et al., there was a decline in proprioception with age as measured with a seated lower limb-matching task [4]. The average error in aligning the great toes either side of a vertical protractor placed between the legs increased from 0.7 degrees (SD = 0.3) in subjects in their twenties to 1.9 degrees (SD = 1.7) in subjects aged 65 plus years. Overall, there was a weak but significant association between error size and age across all age groups,  $r = 0.20$ .

Three clinical studies have investigated whether there is a decline in proprioception beyond 65 years of age. Howell [3] examined the ability of 200 patients aged 65 years and over to detect joint position sense of the great toes and to touch their noses with their eyes closed. He found that most patients could determine experimenter-induced movements of their toes but that approximately 44% of patients in all age groups above 65 showed abnormalities in the nose touching test. There were no significant changes with age in either test.

MacLennan et al. [5] also examined the ability of 308 elderly persons to identify the position of their great toes after they were manually moved by the experimenter. They found that the prevalence of inability to appreciate changes in position of the toe was significantly greater in the age group 75 years and over than in the age group aged 65–74 years for both males and females. Similarly, Brocklehurst et al. [6] measured the ability of 151 persons aged 65 years and over to detect experimenter-induced movements of the toe and ankle. They found no association between age and proprioception, but acknowledged that this may be due to the imprecision of their test.

It has been suggested that caution should be used in assessing proprioception in the lower limb when assessments are made while subjects are in the seated position [7], as is the case in the above studies. This is because thresholds in the ankle and knee are much lower when measured in the standing, weight bearing position where engagement of the leg muscles is greatly increased [1,3].

In a recent study, Bullock-Saxton et al. [7] assessed the effects of age on the accuracy of a knee joint repositioning test in both full and partial weight-bearing conditions in 60 healthy, pain-free subjects from three age groups (young: 20–35 years old, middle-aged: 40–55 years and older: 60–75 years). They found that subjects in all three groups performed better when full weight bearing than when partial weight bearing, and significant age related increases were found only in the partial weight bearing condition. However, other studies assessing position sense of the ankle joint when weight bearing have reported increased thresholds with age. Thelen et al. [3] compared the ability of young and older women to detect dorsiflexion and plantarflexion movements of the foot when weight bearing on a moveable platform and reported that the threshold for movement detection was 3–4 times larger in the older group. High detection thresholds for inversion and eversion movements of the ankle when standing either unipedally or bipedally on a rotating platform have also been found in older people [8]. Finally, Blaszczyk et al. [3] have reported that old subjects are significantly worse than young subjects in reproducing ankle joint positions when standing on a rotating platform.

## Pathology

Reduced proprioception is associated with instability and falls in older people. Hurley et al. found that reduced proprioceptive acuity at the knee was significantly associated with an increased aggregate time to perform a range of function tasks comprising a timed walk, the get up and go test and stair ascent and descent in a combined group of young, middle aged and older people. In large prospective studies Lord et al., impaired lower limb proprioception was also associated with multiple falls in older people living independently in the community [9] and in those living in residential care [10]. Brocklehurst et al. [6] also reported a significant association between impaired proprioception in the ankle and/or great toe and falls in people aged 75–84 years.

## Conclusion

There is a significant decline and an increase in variability in proprioception with age, particularly in the lower limbs. Proprioceptive thresholds for the ankle and knee are much lower when measured in the standing, weight bearing position. One study has reported no significant age related change in knee proprioception in this condition, but other studies have reported age related declines in the ankle joint when weight bearing. Reduced peripheral sensation is associated with falls in older people, when the measures of peripheral sensation are accurately and quantitatively ascertained.

## References

- Howard IP, Templeton WB (1966) Human spatial orientation. Wiley, London
- Laidlaw RW, Hamilton NA (1937) A study of thresholds in apperception of passive movement among normal control subjects. *Bull Neurol Inst* 6:268–273
- Lord SR, Sherrington C, Menz H (2001) Falls in older people: risk factors and strategies for prevention. Cambridge University Press, Cambridge
- Lord SR, Ward JA (1994) Age-associated changes in sensori-motor changes and balance in community dwelling women. *Age Ageing* 23:452–460
- MacLennan WJ, Timothy JI, Hall MPH (1980) Vibration sense, proprioception and ankle reflexes in old age. *J Clin Exp Gerontol* 2:159–171
- Brocklehurst JC, Robertson D, James-Groom P (1982) Clinical correlates of sway in old age – sensory modalities. *Age Ageing* 11:1–10
- Bullock-Saxon JE, Wong WJ, Hogan N (2001) The influence of age on weight-bearing joint reposition sense of the knee. *Exp Brain Res* 136:400–406
- Gilsing MG, Vanden Bosch CG, Lee SG et al. (1995) Association of age with the threshold for detecting ankle inversion and eversion in upright stance. *Age Ageing* 24:58–66
- Lord SR, Ward JA, Williams P, Anstey K (1994) Physiological factors associated with falls in older community-dwelling women. *J Am Geriatr Soc* 42:1110–1117
- Lord SR, Clark RD, Webster IW (1991) Physiological factors associated with falls in an elderly population. *J Am Geriatr Soc* 39:1194–1200

## Proprioception: Effect of Gravity

JAMES R. LACKNER, PAUL DI ZIO  
Ashton Graybiel Spatial Orientation Laboratory,  
Brandeis University, Waltham, MA, USA

### Synonyms

Kinesthesia

### Definition

Proprioception is the sensory registration of the ongoing spatial configuration of the body. Sherrington invented the term to denote responsiveness to the internal, self-generated state of the body based on mechanoreceptors embedded within body tissues, subserving both conscious awareness and automatic control of posture and movement [1]. The term “kinesthesia” refers more specifically to the awareness of the position and movement of body parts. The perception of force, effort or heaviness relies on some of the same sensory and central mechanisms as proprioception and kinesthesia.

On earth, posture and locomotion are always carried out against the omnipresent force of gravity that accelerates objects downwards toward the earth’s surface. The musculature of the body has to exert forces across the joints to keep the body straight so that it does not buckle and fall to the ground. In this context, proprioception is highly dependent on interrelating signals from the muscle spindle receptors within intrafusal muscle fibers to patterns of alpha and gamma motoneuron activation innervating the muscles that support the whole body or an individual limb against the acceleration of gravity [2]. Golgi tendon organs and Ruffini endings of the joints may participate as well, though their contribution is less well understood. Slowly adapting cutaneous stretch receptors are stimulated by distension of skin overlying moving joints and contribute to the sense of position and movement. The fingertip is especially rich in cutaneous mechanoreceptors and dragging or holding the finger lightly over a stable surface augments the perception and control of arm movements and of locomotor activity. During standing posture, the support surface exerts a contact

force on the soles of the feet that counteracts the downward acceleration of the body's center of mass, and the distribution of the contact forces on the soles of the feet provides information about the orientation of the body to gravity. The vestibular system is an extension of the proprioceptive system because it senses head movement relative to gravity, and various sensor types in the viscera and vasculature [3] also contribute to estimates of body orientation. Although vision and audition are not typically considered part of the proprioceptive system, there are strong interactions among seen, heard and felt body configurations and the localization of external objects [4]. A rough estimation of body configuration and motion could perhaps even be acquired through the sense of smell. These examples illustrate the domain and sources of proprioception.

## Characteristics

### Higher Level Processes

#### *Dynamic Sensory-Motor Calibrations to 1g*

Until relatively recently in history, humans were not exposed to force levels other than the 1g ( $g=9.8 \text{ m/s}^2$ ) background acceleration of Earth gravity, except momentarily, for example during jumping or running or horse riding. With the advent of powered vehicles including aircraft and space craft and orbiting space stations, exposure to weightlessness and to high force fields has become commonplace. On Earth, if an arm is raised, it is subjected to a gravity torque that must be opposed. This torque is not constant but depends on arm angle, see Fig. 1.

Nevertheless, it seems to require roughly constant effort – except in cases of fatigue – to position the arm relative to gravity. Under normal conditions, one does not sense the different force demands associated with changes in body configuration or body movements relative to gravity. The effects of gravity on movement control seem relatively transparent – as if they were not there. This transparency actually represents a form of

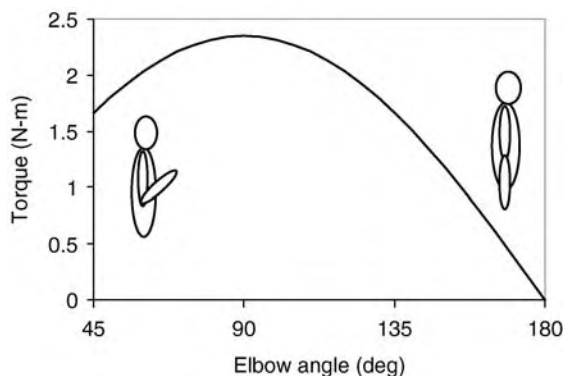

**Proprioception: Effect of Gravity. Figure 1** Joint torque.

sensory-motor calibration to earth gravity – based on an internal model of the consequences of gravity on body actions, so that equal extents of movement seem equivalent regardless of the actual muscle force demands to achieve them [5].

Muscle spindle gain is affected by background force level. As a consequence, tonic vibration reflexes are attenuated in weightless conditions and augmented in greater than 1g background force levels. These reflexes occur because mechanical vibration of a muscle can excite muscle spindle primary and secondary endings, which leads to a reflexive contraction of the vibrated muscle. The g-dependent modulation of the tonic vibration reflex probably reflects a vestibulo-spinal modulation of the gain of spindle receptors of postural muscles, but could include altered patterns of alpha-gamma coactivation as the load demands on the muscles vary with force level. Studies of arm movement control in non-earth gravity force levels indicate patterns of change consistent with variations in spindle discharge levels [6]. When individuals practice in normal conditions to make arm movements of particular velocities and amplitudes and then attempt the same arm movements in parabolic flight in 0g and 1.8g force backgrounds, they exhibit systematic changes. Movements made at a natural speed in 0g are smaller in amplitude and have more dynamic overshoots of final end positions than movements of the same attempted velocity and amplitude in 1.8g. This pattern is consistent with decreased spindle gain in 0g. With long-term exposure to weightlessness, astronauts display an adaptive modification of their internal model of the effects of gravity on movement, which also may involve a recalibration of proprioception.

### *Self/Environment Discrimination*

Proprioception figures prominently not just in the awareness of ongoing body configuration but also in the maintenance of a stable perceptual distinction between changes in afferent input due to self-motion versus motion of or within the environment. This is reflected in the adaptive resetting of internal models of the environment. The function of these tuning mechanisms becomes apparent when the body is exposed to a background force level different in magnitude from earth gravity. Then, until adaptation occurs, misperceptions of body motion and of the stability of the support surface result. Changes in background force level can be achieved in an aircraft flown in a parabolic trajectory to generate alternating periods of 1.8g (nearly twice Earth gravity) and of weightlessness (0g). In this circumstance, the body alternately becomes much heavier and much lighter than usual respectively. The consequences of this sudden weight change become apparent when an individual attempts to make deep knee bends in the 1.8g background force level [7]. Lowering the body involves eccentric



contraction (controlled lengthening) of the body's antigravity muscles (e.g. the quadriceps and gastrocnemius muscles of the legs). More activation of these muscles will be required during the course of the movement than is the case on earth, otherwise the body would descend too rapidly because of its increased weight. In this situation, the individual will experience him or herself as moving downward too rapidly and the support surface, the deck of the aircraft, as simultaneously rising upward against the feet. To return to the upright, much greater muscular force than normal is required, the body seems to rise too slowly and the aircraft deck seems to move downward. In 0.5g background force levels, the opposite pattern is experienced during deep knee bends. Body weight is less than normal and less muscle force is required throughout the movements. As the body is lowered, it seems to move downward too slowly and the deck simultaneously seems to move downward under the feet. On rising back to the upright, the body feels as if it has moved too rapidly and too far and that the deck floor has simultaneously moved upward under the feet, causing the whole body to displace farther than intended.

If an individual makes repeated deep knee bends during exposure to a steady state non-1g background force level, the movements soon begin to feel more normal and natural and the illusory displacement of the stance surface is correspondingly attenuated. After 50–100 repetitions, the movements will again feel normal and the support surface stable [8]. But then on re-exposure to a normal 1g-force background, deep knee bends will again feel abnormal and the support surface will seem to displace. Fig. 2 shows the patterns of motion and effort experienced on (a) initial exposure to 1.8g force levels in parabolic flight, (b) after the execution of many deep knee bends and (c) on return to normal 1g levels. As illustrated, full adaptation is achieved and the aftereffect experienced is opposite in sign to the effects experienced during initial exposure to the abnormally high force level.

This pattern means that motor control and position sense are recalibrated during exposure to the 1.8g force level and that this recalibration carries over on return to 1g where it is inappropriate. Animals evolved in the context of a 1g-background force level without any experience with steady state non-1g force levels. Nevertheless, significant adaptation to an unusual background force occurs within seconds or a few minutes.

The factors underlying adaptation to an increased force background can be understood as follows. As the body lowers in a deep knee bend in a 1.8g force background, the antigravity muscles that undergo controlled lengthening will be longer than normally would be the case for the levels of alpha and gamma motoneuron activation present, because body weight has nearly doubled. Consequently, these muscles need to be innervated at higher than normal levels. Signals from the spindle receptors within the muscles will be

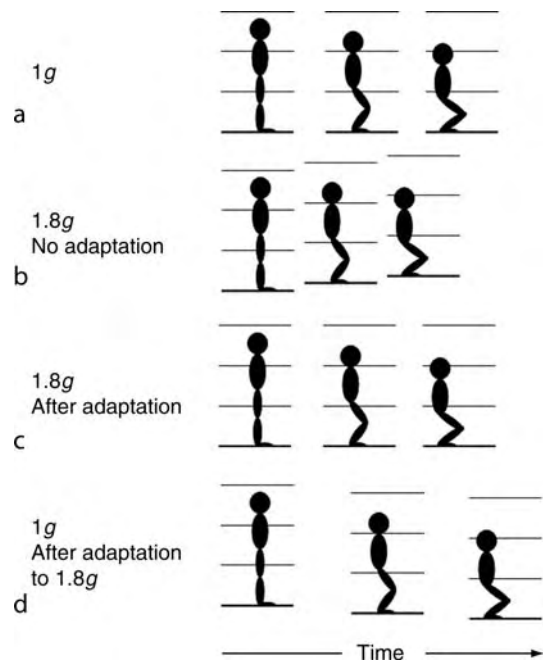

**Proprioception: Effect of Gravity. Figure 2**

(a) Schematic illustration of the sequence of actual and perceived events as one descends in a deep knee bend. (b) During the first deep knee bend made in 1.8g, one's body seems to descend too fast while the floor (*thick lines*) and visual surround (*thin lines*) rise. (c) After adaptation to 1.8g, self motion is perceived normally and the environment feels stable. (d) Returning to 1.0g elicits after effects opposite to the original illusion in 1.8g, until re-adaptation is complete.

higher than normal also, because the spindles are under a greater degree of loading than normal. Position sense is generated in part by the CNS comparing patterns of spindle feedback with patterns of alpha-gamma activity. If the pattern of spindle feedback is aberrant in relation to the alpha-gamma activation patterns, a distortion of position sense occurs. Abnormally high levels of spindle activity in skeletal muscles evoke misperceptions of the joint positions controlled by the muscles, with the muscles being interpreted as being longer than they actually are. For example, an abnormally high level of quadriceps activity is associated with the knee joint being perceived as more flexed than it actually is.

When deep knee bends are initially made during exposure to 1.8g, the abnormally high spindle activity levels present in relation to the alpha motoneuron activity are interpreted as the legs being more flexed during the course of the lowering movement than they actually are. The CNS attributes this to external motion, the aircraft deck rising under the feet causing the knees to be more flexed than intended. With repetition the deep knee bends feel progressively more normal as the

relationship between body movement, motor commands and expected spindle feedback is remapped in the internal model of movement control to be the “normal” state of affairs. On return to normal 1g background force levels, the relationship between motor commands and spindle feedback will again be abnormal. As the body is lowered, less innervation of the antigravity muscles will be necessary than in 1.8g to control the lowering of the body. Consequently, the spindle feedback generated will be less than expected; this is interpreted as the legs being less flexed than intended and attributed to the deck moving downward under the feet, preventing the knees from bending appropriately.

### **Proprioception and the Body Map**

That individuals born without a limb can still experience a phantom limb (see Phantom limb sensations and pain) attests to the fact that a map of body segments and their connectedness exists in the brain, which is complementary to proprioception. We normally experience this map as a sense of body topology, the connectedness of a set of body segments. This map both governs proprioception and can be altered transiently or be semi-permanently remapped by proprioceptive inputs, as shown by vibratory myesthetic illusions. For example, illusory forearm extension is perceived if 120 Hz vibration is applied over the biceps of the restrained arm. The perceived finger trajectory is constrained by the internal map, which represents the forearm with a specific length and the biceps muscle as acting across the elbow joint. However, if the index finger of the vibrated arm is touching the nose then illusory elongation of the nose is perceived simultaneously with arm extension, violating the internal mapping of the nose as a non-jointed semi-rigid body part [9]. Longer-term vibrotactile skin stimulation alters the cortical somatosensory map.

### **Multisensory Body Maps**

Multiple, interdependent representations of hand and arm position exist which are influenced by visual and muscle spindle inputs. This interdependence has been demonstrated in experiments involving vibratory myesthetic illusions of the forearm in a dark room with the test subject’s finger made visible by phosphorescent paint [4]. When subjects feel their forearm move, they also see their finger move as well but through a smaller distance. The magnitude of felt motion of the forearm is greater in darkness than with the finger visible. Thus, vision affects the proprioceptive representation because the optically stationary finger attenuates felt motion, and proprioception affects the visual representation because the vibration-induced muscle spindle afferent signal makes the optically stationary finger appear to move.

If a visual-proprioceptive discrepancy is introduced for a longer exposure period, then semi-permanent

adaptive changes in proprioception can occur. The nature of these changes depends on the exposure conditions. For example, a seated subject wearing laterally displacing prism spectacles will initially miss when pointing to a visual target. However, if the subject continues to reach and is allowed visual feedback of the reaches, accuracy will soon be regained. The adaptive change involves an arm-torso recalibration in terms of an internal shift in the felt position of the exposed arm but not of the other arm [10]. The adapted subject still wearing the prisms will reach accurately to the real target but see and feel the arm in its optically displaced location. The felt arm position then does not correspond to the real arm position but it does correspond to the visual arm position. By contrast, if subjects are allowed to walk around wearing the prism spectacles they are clumsy at first but ultimately learn to navigate. They also gradually adopt a deviated head posture but feel their head to be straight on their torso. This internal proprioceptive remapping of head to torso allows accurate body-relative localization and normal control of locomotion.

### **Pathology**

With the advent of manned space flight, humans have been exposed to weightless conditions for prolonged periods. On return to earth, they exhibit a variety of derangements of posture and gait. These disturbances are related to adaptive changes in neuromuscular structure and control occurring in weightless conditions that are inappropriate for terrestrial conditions. Post-flight, when astronauts walk, the ground feels unstable under their feet and their movements require greater than normal effort. The simplest movement, e.g. raising the arm, can feel as if it requires immense effort and force. If the astronaut does a deep knee bend, then it feels as if he or she has moved downward too rapidly and that the ground has simultaneously moved upward. Precisely the same patterns are experienced as those by individuals, as described above, who are adapted to earth gravity and make deep knee bends in the high force phases of parabolic flight. These changes reflect the decreased muscle spindle gain associated with weightless conditions and the lack of appropriate contact cues to signal body orientation and configuration.

Proprioceptive loss is characteristic of a variety of diseases and injuries of the nervous system. The most severe cases involve loss in adulthood of large somatic sensory fibers, including muscle spindle, joint, tendon and cutaneous mechanoreceptor afferents. An affected individual with eyes closed has no ability to localize his or her limbs even during vigorous active or passive movement. Standing and walking in darkness are not possible. Affected individuals can reacquire functional movement using visual guidance. Even partial loss of proprioception has severe consequences for balance and locomotion.

In summary, the human body has a dynamic sensory-motor spatial calibration to Earth gravity. This calibration involves an internal model of the force background and its consequences for voluntary movement control. The calibration is continuously updated based on experience within the environment. Somatosensory, proprioceptive and visual signals contingent on self-produced movements are key elements contributing to updating. The continuous ongoing nature of the calibration process is probably why movement control adjusts so rapidly when the body is exposed to force backgrounds greater or less than 1g in magnitude and why patients can adapt to proprioceptive loss.

## References

1. Sherrington CS (1948) The integrative action of the nervous system. Cambridge University Press, London
2. Matthews PBC (1988) Proprioceptors and their contribution to somatosensory mapping: complex messages require complex processing. *Can J Physiol Pharmacol* 66:403–438
3. Magnus R (1924) Körperstellung. Springer, Berlin Heidelberg New York
4. Lackner JR, Taublieb A (1984) Influence of vision on vibration-induced illusions of limb movement. *Exp Neurol* 85:97–106
5. Lackner JR, DiZio P (2000) Aspects of body self-calibration. *Trends Cogn Sci* 4:279–288
6. Fisk J, Lackner JR, DiZio P (1993) Gravitoinertial force level influences arm movement control. *J Neurophysiol* 69:504–511
7. Lackner JR, Graybiel A (1981) Illusions of postural, visual, and substrate motion elicited by deep knee bends in the increased gravitoinertial force phase of parabolic flight. *Exp Brain Res* 44:312–316
8. Lackner JR, DiZio P (1993) Spatial stability, voluntary action and causal attribution during self-locomotion. *J Vestib Res* 3:15–23
9. Lackner JR (1988) Some proprioceptive influences on the perceptual representation of body shape and orientation. *Brain* 111:281–297
10. Harris CS (1963) Adaptation to displaced vision: visual, motor, or proprioceptive change? *Science* 140:812–813

## Proprioception: Effect of Neurological Disease

JONATHAN COLE  
COPMRE, University of Bournemouth and Poole  
Hospital, Dorset, UK

### Synonyms

Large-fiber sensory neuronopathy and neuropathy; Sensory ataxia; Dorsal column ataxia; Sensory stroke

### Definition

Loss of movement and position sense due to disease of the peripheral or central nervous system.

### Characteristics

The perceptions of movement and position sense, as well as that of touch, are dependent on afferent information relayed by large myelinated sensory nerve fibers, with cell bodies in the dorsal root ganglia and which then ascend in the ipsilateral dorsal columns (DCs). They synapse in the dorsal column nuclei at the head of the spinal cord. The pathway then projects through the medulla in the medial lemniscus to synapse in the ventral-posterior thalamus and hence, via the internal capsule, to the sensory cortex. Within the brain information is relayed to coordinate movement as well as give consciousness of the position and movement states of the body and limbs. Loss of ►proprioceptive information can lead to in-coordination due to dysfunction in the motor cortex and the cerebellum. In-coordination due to peripheral ►deafferentation and cerebellar lesions can sometimes be difficult to distinguish completely.

Disease anywhere along the above pathways can result in ►proprioceptive loss, usually with cutaneous sensory loss. While selective losses are possible, in particular in the peripheral nerve cell and to an extent in the dorsal columns, more central lesions may also affect other areas, making the resultant physiological deficit more complex. Often, for instance, cortical lesions lead to reduced stereognosis (inability to manipulate and recognize objects placed in the hand without vision) and graphesthesia (ability to recognize figures touched over the hand without vision), as well as in reductions in cutaneous touch and ►proprioception.

►Proprioception is such a deep sense that in folk psychology terms it is almost unknown. People may imagine being blind or deaf, but not being without proprioception or touch. Diderot considered that of all the senses touch (and one presumes the then undiscovered ►proprioception) the most profound and philosophical. To understand what ►proprioception does therefore it is important to consider those rare individuals who have to live without it—without their witness the experience, and its effects on movement, are almost impossible to know.

Total loss of ►proprioception is rare but has been described in the ►acute sensory neuronopathy syndrome. Its effects initially are a complete inability to control or coordinate movement. When movements are made they are inappropriate in size and direction with poor coordination between both limbs and joints. With time, however, and with considerable conscious attention towards, and visual observation of, movement, people without movement or position sense may be able to move in such a fashion as to be almost able to pass unnoticed, in uncluttered, well lit areas (see Section on ►Large-Fiber Sensory Neuropathy).

Though these complete losses of ▶**proprioception** are rare their importance is that they reveal both the consequences of the loss and the ability of subjects, at least partially, to mitigate its effects. In addition, there are less severe yet still important losses of ▶**proprioception** associated with various neurological problems, from median nerve compression at the wrist to central strokes in which motor weakness predominates which may have clinical consequences and yet are often poorly recognized.

## Pathology

### Peripheral Neuropathy/Neuronopathy

The most pure form of ▶**proprioceptive** loss is disease of the large myelinated sensory nerve fibres, either in their axons or their cell bodies (see Section on ▶**Large-Fiber Sensory Neuropathy**). Lesser, but still important, losses of ▶**proprioception** can occur with less selective sensory peripheral neuropathy, especially affecting the legs, leading to ataxia and a feeling of not knowing where the feet are unless they are looked at. Patients may volunteer that they are much worse in the dark and that they find it difficult to drive a car (because of the need to control foot pedals).

The division between cutaneous light touch and ▶**proprioception** can also be somewhat artificial. In the hands and the face cutaneous information about stretch and deformation of the skin gives information about position. Then, loss of cutaneous sensation has effects on movement. This is sometimes seen in carpal tunnel syndrome. Patients with sensory loss in the thumb and first and second fingers may say they drop things, unless they look at them and think about it, without knowing why. Even small losses of cutaneous touch in the fingers may have effects on the coordination of grip strength and active touch.

### Dorsal Column Disease

▶**Proprioceptive** (and cutaneous) afferents ascend with the spinal cord in the dorsal columns; disease of these structures is a well-known cause of loss of movement and position sense. One well-known cause of ▶**ataxia** due to DC loss is vitamin B<sub>12</sub> deficiency.

Sub-acute combined degeneration of the spinal cord involves the dorsal and lateral columns of the spinal cord and presents often, in middle age, with ▶**parasthesiae** of the feet, with tingling and even burning [1]. Difficulties in walking follow, if untreated, due to sensory ▶**ataxia** and motor weakness, reflecting lateral (motor) column involvement. Loss of postural sense can be more severe than the cutaneous sensory deficit. These may be accompanied by optic atrophy and cognitive impairment. The pathology involves both demyelination and axonal loss and treatment is usually effective, especially if given early [2].

Historically, syphilis was a major pathogen affecting the dorsal columns (Wilson, 1940 for a clinical

description of neurosyphilis) [3]. Tabes dorsalis usually emerges 10–25 years after the initial infection and can present with progressive ▶**ataxia** and a high stepping gait, and with severe, intermittent, “lightning” pains in the legs and abdomen. More rarely, it can also be seen far earlier in congenital syphilis. The pathology may be demyelination and destruction of the dorsal roots. In this form of syphilis it is not solely the DCs that are affected; failing vision, impotence, deafness and arthropathy and ulceration, reflecting small fiber loss too, are often associated with it.

Others causes of DC loss are multiple sclerosis with a plaque involving the dorsal cord, tumor and, most rarely, penetrating wounds in the neck with DC dissection. It has also been associated with a rare form of retinitis pigmentosa, which offers the possibility to understand the genetic nature of DC delineation [4].

### Intracerebral Lesions

Pure sensory ▶**ataxias** after sub-cortical stroke, or plaque or tumor are rare, since these diseases do not affect single pathways or classes of neuron. For instance, Russmann et al. [5] analyzed the Lausanne Stroke Registry between 1986 and 1998 for those with an ischemic episode affecting the area of the lenticular nucleus. Of 820 consecutive patients, 13 had pure lenticular infarction with four having an ataxic sensorimotor hemisindrome, presumably due to a lesion of the internal capsule. Though examples of pure sensory stroke after small lacunar infarcts have been described after infarcts in the ventral posterior thalamus, brain stem, internal capsule and cerebral cortex, more often central lesions lead to more complex and subtle deficits.

It can, for instance, be difficult to distinguish, at the two extremes, between a pure motor weakness from an ▶**ataxia** from in-coordination due to sensory loss. Kim [6] analyzed a group of patients with thalamic stroke with motor and sensory problems. ▶**Ataxia** and involuntary movements were seen most after sensory loss, with ▶**dystonia**, and in-coordination of movements associated with proprioceptive loss. Central sensory loss due to stroke can also be associated with dysesthesia and pain.

Though the commonest pathology associated with pure sensory stroke is ischemia, this syndrome occurs after hemorrhagic stroke too [7]. Pontine strokes involving the medial lemniscus, but sparing the spinothalamic tracts, lead to selective loss of vibration sensitivity and proprioception without an effect on pinprick and temperature sensation. More rostral strokes do not always lead to pure loss of proprioception as the dorsal column/medial lemniscal and the spinothalamic tracts become closer within the brain. Thus some thalamic strokes may lead to loss of all modalities of sensation over the opposite side of the body, with reduced temperature sensation and pin prick sensation as well as dysesthesia.

In central pure stroke syndromes Fisher [8] suggested that though objective sensory disturbances can be mild, larger losses are seen in fine motor control and coordination of the hand and fingers. This may reflect on the one hand the relative insensitivity of clinical tests of sensation, and the possible use of other cortical areas for these discriminations, and on the other the crucial importance of parietal cortex in the coordination of finger movements. Occasionally this role of the cortex in movement leads to confusion as to whether weakness is peripheral, say due to an ulnar nerve lesion, or cortical [9]. A relative lack of sensory symptoms and preserved power with clumsiness and reduced coordination may point towards a cortical deficit.

In addition it is important to realize that mixed sensory-motor strokes can prove difficult to rehabilitate due to underlying **proprioceptive** loss over and above the more obvious problems with motor weakness. Loss of information about movement and position superimposed on loss of power can add a significant additional problem, especially if not recognized. Correspondingly, there are some reports that exercises designed to improve coordination can add to any spontaneous recovery that occurs [10].

Though syndromes involving exclusively loss of movement and position sense are very rare in neurology, an awareness of the effects of proprioceptive loss may allow greater understanding of mixed sensory and motor syndromes and lead to different rehabilitation strategies.

## References

- Hemmer B, Glocker FX, Schumacher M, Deuschl G, Lucking CH (1998) Subacute combined degeneration: clinical, electrophysiological, and magnetic resonance imaging findings. *J Neurol Neurosurg Psychiatry* 65:822–827
- Thomas PK (1998) Subacute combined degeneration. *J Neurol Neurosurg Psychiatry* 65(6):607
- Wilson SAK (1940) Neurosyphilis. In: Bruce AN (ed) *Neurology*, vol 1. Edward Arnold, London, pp 455–469
- Higgins JJ, Morton DH, Loveless JM (1999) Posterior column ataxia with retinitis pigmentosa (AXPC1) maps to chromosome 1q31–q32. *Neurology* 1:46–50, 52
- Russmann H, Vingerhoets F, Ghika J, Maeder P, Bogousslavsky J (2003) Acute infarction limited to the lenticular nucleus: clinical, etiologic, and topographic features. *Arch Neurol* 60:351–355
- Kim JS (2001) Delayed onset mixed involuntary movements after thalamic stroke: clinical, radiological and pathophysiological findings. *Brain* 124:299–309
- Shintani S, Tsuruoka S, Siigai T (2000) Pure sensory stroke caused by a cerebral hemorrhage: clinical-radiologic correlations in seven patients. *Am J Neuroradiol* 21:515–520
- Fisher CM (1965) Lacunes: small deep cortical infarcts. *Neurology* 15:774–784
- Timsit S, Logak M, Manai R, Rancurel G (1997) Evolving isolated hand palsy: a parietal lobe syndrome associated with carotid artery disease. *Brain* 120:2251–2257
- Smania N, Montagnana B, Faccioli S, Fiaschi A, Aglioti SM (2003) Rehabilitation of somatic sensation and related deficit of motor control in patients with pure sensory stroke. *Arch Phys Med Rehabil* 84:1692–1702

## Proprioception: Role of Cutaneous Receptors

DAVID F. COLLINS

Faculty of Physical Education and Recreation,  
Centre for Neuroscience, University of Alberta,  
Edmonton, AB, Canada

### Definition

#### Proprioception and Kinesthesia

The term proprioception (proprius = Latin for “one’s own”) describes abilities related to the perception of different aspects of one’s own movement. These include the sense of the position and movement of the body segments (kinesthesia) as well as sensations related to tension in muscles and tendons, balance and voluntary effort [1]. This essay reviews the evidence that cutaneous receptors contribute to kinesthesia, the ability to detect the position and movement of the body segments without using vision. Cutaneous receptors are sensory receptors located in the skin. During movement, the skin is stretched and compressed, activating cutaneous receptors in large areas of skin around the moving joint (Fig. 1) [2].

The pattern of skin strain is different for movements of different speeds and amplitudes and this information is encoded in signals from large numbers of receptors that discharge during movement. These signals travel along peripheral nerves to the spinal cord and pass to the brain where, along with feedback from sensory receptors in muscles and joints, they provide the information responsible for kinesthetic awareness and proprioceptive judgments (see **Proprioception: Role of Muscle Receptors and Proprioception: Role of Joint Receptors**). Kinesthetic information is used for the planning and execution of movement.

### Characteristics

#### Sensory Receptors and Kinesthesia

During movement, sensory receptors in muscles, joints and the skin send movement-related information to the brain where it is used for kinesthesia. For more than 30 years, it was thought that the muscle spindle, a

specific type of muscle receptor, was the most important source of kinesthetic information [1,3]. Muscle spindles respond to muscle stretch and thus signal the changes in muscle length that occur during joint movement. Many experiments have shown that this information is important for kinesthesia, such as those investigating the strong illusions of movement that are produced when vibration is applied over a muscle or its tendon. Vibration causes spindles to discharge rapidly and results in powerful illusions of movement consistent with lengthening of the vibrated muscle. Recently, experiments have shown that movement illusions can

also be generated by activating cutaneous receptors by stretching the skin around a stationary joint to mimic skin stretch patterns that occur during normal movement [4,5]. An example of one experiment is shown in Fig. 2 where skin stretch applied around the right elbow resulted in the illusion of elbow flexion (left panel).

The subject matched these illusory movements of the right elbow with voluntary movements of the left arm. These movement illusions initiated by skin stretch show that cutaneous receptors are also important for kinesthesia. Movement illusions also occur when skin stretch is applied around the fingers [4,5] (see Fig. 3) and knee [5]; thus cutaneous feedback is important for kinesthesia at joints throughout the body [5].

When skin stretch and vibration are applied simultaneously, movement illusions are larger than when either stimulus is applied alone (see Figs. 2 and 3). Hence, the brain uses a combination of information from muscle spindles and cutaneous receptors for kinesthesia. The role played by joint receptors for kinesthesia is unclear, but the decrease in the ability to detect movement when joint receptor feedback was removed by anesthesia suggests they also contribute [3].

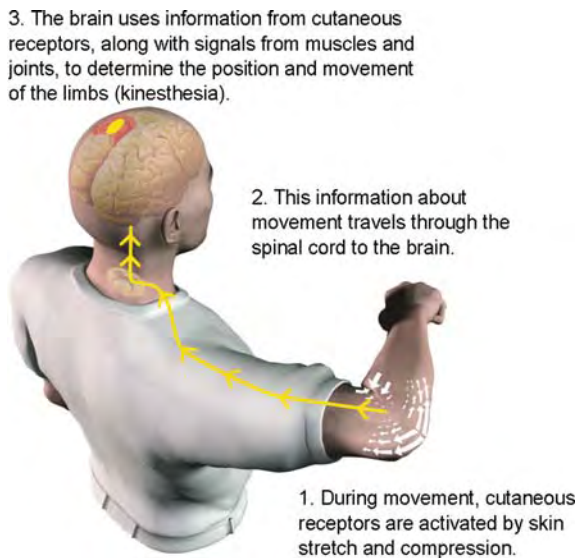

**Proprioception: Role of Cutaneous Receptors.** Figure 1 Schematic representation of the role of cutaneous receptors for kinesthesia at the elbow.

**Cortical Structures and Kinesthesia**

Kinesthetic information from sensory receptors enters the spinal cord through the dorsal horn and ascends to the brain along the dorsal columns. Before entering the brain the pathway crosses over to the opposite side of the body and projects to the main receiving area for kinesthetic information, the primary somatosensory cortex (shown in red in Fig. 1). Here, information from different parts of the body is received in different regions, resulting in a representative map of the body called a homunculus (Latin for “little man”). In the homunculus, regions of the body with the greatest

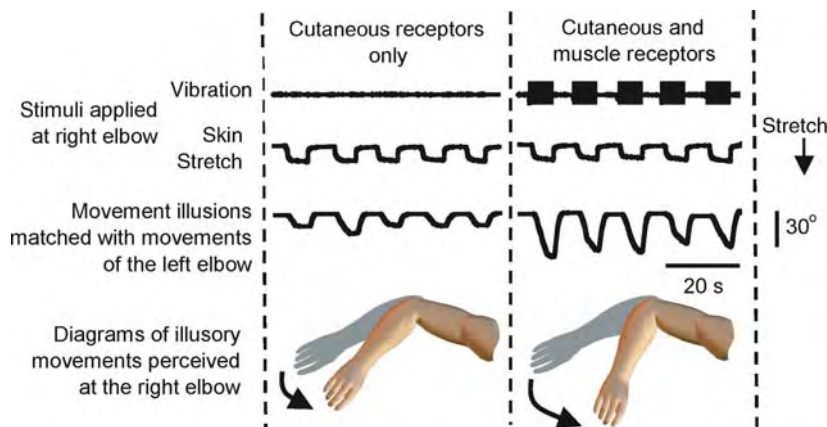

**Proprioception: Role of Cutaneous Receptors.** Figure 2 Movement illusions of the elbow produced by stimulating cutaneous receptors alone (skin stretch) or with simultaneous stimulation of receptors in muscle (vibration). Stimuli were applied to the right elbow and subjects matched perceived movements with voluntary movements of the left elbow. Adapted from Collins et al. 2005 [5].

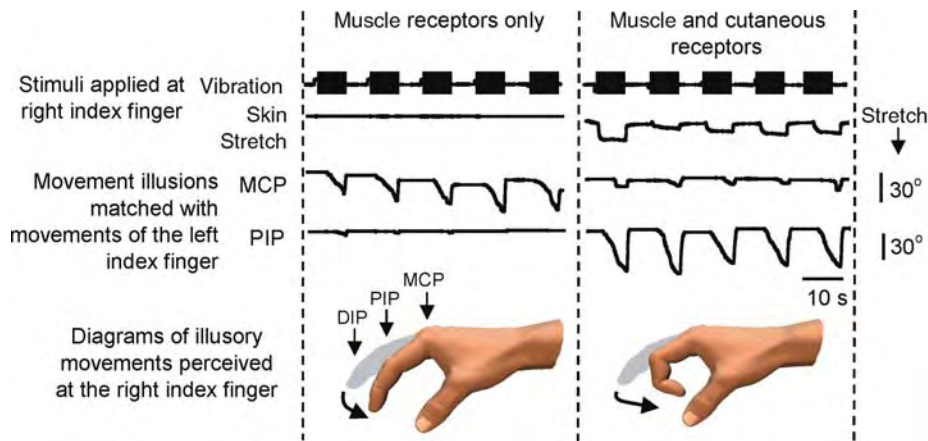

**Proprioception: Role of Cutaneous Receptors.** **Figure 3** Movement illusions produced at the index finger by stimulating muscle receptors alone (vibration) or with simultaneous stimulation of cutaneous receptors (skin stretch). The skin stretch was applied around the two distal joints (PIP, DIP) and the vibration was applied over a tendon on the back of the hand near the MCP joint. Subjects matched perceived movements with voluntary movements of the left index finger. Adapted from Collins et al. 2005 [5]. (MCP metacarpophalangeal joint; PIP proximal interphalangeal joint; DIP distal interphalangeal joint)

numbers of receptors, such as the hands, have the largest representation. The perception of movement, however, is not localized to this one part of the brain but involves activity in many brain regions [6]. Thus, kinesthesia is a distributed process involving the somatosensory cortex as well as the motor cortex, cerebellum and frontal parts of the cortex with a particular importance of the right hemisphere [6].

### Lower Level Components

#### Cutaneous Receptors

Much of our knowledge about cutaneous receptors comes from work on the hand where four morphologically distinct types of receptor have been identified [7]. Merkel discs and Meissner corpuscles lie in the superficial layers of the skin and have relatively small receptive fields ( $\leq 10 \text{ mm}^2$ ). Densities for these receptors are highest in the distal skin, with the digit tips containing 70 and 140 receptors/ $\text{cm}^2$  for Merkel discs and Meissner corpuscles, respectively [7]. Pacinian corpuscles and Ruffini endings reside in the deeper layers and have larger receptive fields ( $\leq 25 \text{ mm}^2$ ) and densities that are lower and more uniform [7]. Meissner and Pacinian corpuscles adapt rapidly to sustained stimuli such as constant velocity movements and discharge primarily at the beginning and end of movement. In contrast, Merkel discs and Ruffini endings adapt slowly to sustained stimuli and continue to discharge throughout movement with a discharge frequency that is often closely related to the amplitude and velocity of the movement. Receptors similar to those in the hand have also been found in the skin of the arm and leg, although there are regional differences in receptor densities.

### Higher Level Processes

#### Sensory Feedback and Movement Control

The control of human movement involves a complex interaction between motor output from the brain and sensory feedback from peripheral sensory receptors. Sensory feedback from the limbs provides information about movement execution, sending an error signal to the brain when movements do not proceed as planned. Sensory feedback also contributes to movement control at the level of the spinal cord. Spinal reflexes provide automatic responses to external disturbances that help to prevent for example slips of hand-held objects [7] or trips during walking. Sensory feedback also influences the timing and amplitude of muscle contractions during rhythmic movements by modifying the activity of central pattern generators in the spinal cord that are responsible for generating the basic patterns of muscle activity.

### Lower Level Processes

#### Communication in the Nervous System

Information travels through the nervous system in the form of action potentials, tiny electrical impulses generated by the transient passage of ions across the cell membrane. During movement, action potentials are initiated in a cutaneous receptor during movement of the skin within its receptive field. These signals travel along myelinated axons of the nerve cells (neurons) at 35–80 m/s to synaptic junctions with other neurons. At the synapse, the site for communication between neurons, the arrival of the action potential triggers the release of neurotransmitter, a chemical signal that activates receptors on the membrane of the post-synaptic neuron. Receptor activation initiates

ion movement across the post-synaptic membrane where, with a sufficiently large stimulus, another action potential is generated. Thus, communication between neurons (synaptic transmission) involves the conversion of an electrical signal (action potential) into a chemical signal at the synapse and back to an electrical signal in the post-synaptic cell.

## Process Regulation

### *Gating of Cutaneous Feedback During Movement*

Transmission along pathways from cutaneous receptors to the brain is suppressed during movement [8]. This suppression occurs in the spinal cord and brain and is thought to prevent these structures from becoming saturated by the massive amount of sensory traffic that is generated during movement. Control of information flow through the nervous system is selective; irrelevant signals are suppressed more than signals from receptors that provide information that is important for the successful performance of the movement [8].

## Function

### *The Cutaneous Contribution to Kinesthesia*

For many years it had been thought that cutaneous receptors play only a minor role in kinesthesia, perhaps acting to facilitate movement-related feedback from muscle spindles. This “facilitation” hypothesis was tested by measuring the ability to detect small finger movements when cutaneous feedback from adjacent digits was removed (by anesthesia) or enhanced (by skin stimulation) [9]. Movement detection was not decreased by cutaneous anesthesia nor was it enhanced by increasing cutaneous receptor discharge. Thus, the role for cutaneous feedback for kinesthesia is not one of general facilitation [9]. Instead, evidence has been mounting over the last 10 years that cutaneous receptors provide specific information about the movement itself [2] and this is used for kinesthesia [4,5]. Some idea of the relative roles of feedback from cutaneous receptors and muscle spindles has come from experiments investigating illusory movements of the fingers using vibration to activate muscle spindles and skin stretch to activate cutaneous receptors around specific finger joints (Fig. 3) [4,5]. When vibration was applied by itself, subjects perceived movements primarily at the metacarpophalangeal (MCP) joint (Fig. 3, left panel). When the skin around the proximal and distal interphalangeal joints was stretched and compressed during vibration, to mimic patterns that occur during movements of those joints, the perception of movement decreased at the MCP joint and increased at the joints where the skin stretch was applied. This supports the idea that one role for cutaneous feedback may be to help to distinguish which finger joint is moving [5]. Most muscles that control movements of the fingers are located in the forearm and cross more than one joint.

Hence, the changes in muscle length detected by muscle spindles could arise from movement at one or more joints. The proximity of cutaneous receptors around individual joints enables them to provide specific information about which joint is moving. The receptors most likely to provide this information are the rapidly adapting Pacinian and Meissner corpuscles [2]. Information from the slowly adapting receptors, particularly the Ruffini endings, is more likely to be responsible for providing ongoing information about the position and velocity of the moving joint [2]. Cutaneous feedback is also important for kinesthesia at the elbow and knee and it is likely that feedback from muscle spindles and cutaneous receptors is used for kinesthesia for joints throughout the body [5].

## Pathology

### *Clinical Implications*

The idea that cutaneous receptors contribute significantly to kinesthesia is relatively recent and the clinical implications have yet to be fully explored. It had been suggested that improvements in joint stability associated with bandaging the knee might be due to enhanced cutaneous proprioception, but this was not supported by experiments assessing movement detection with and without a bandaged knee [10]. However, the cutaneous contribution to kinesthesia should be considered for tests of proprioception that make up part of standard neurological examinations. Clinicians should be careful to avoid generating conflicting signals from cutaneous receptors when applying passive joint movements. Finally, one would predict that persons who have suffered burns to large regions of skin would have reduced kinesthetic ability due to decreased cutaneous feedback and this may influence movement performance. An increased understanding of the importance of cutaneous receptors for kinesthesia may lead to new ideas for the treatment and assessment of movement disorders.

## References

1. Proske U (2005) What is the role of muscle receptors in proprioception? *Muscle Nerve* 31:780–787
2. Edin BB, Abbs JH (1991) Finger movement responses of cutaneous mechanoreceptors in the dorsal skin of the human hand. *J Neurophysiol* 65:657–670
3. Gandevia SC (1996) Kinesthesia: roles for afferent signals and motor commands. In: Rowell LB, Shepherd JT (eds) *Handbook of physiology*. Oxford University Press, New York, pp 128–172
4. Collins DF, Prochazka A (1996) Movement illusions evoked by ensemble cutaneous input from the dorsum of the human hand. *J Physiol* 496:857–871
5. Collins DF, Refshauge KM, Todd G, Gandevia SC (2005) Cutaneous receptors contribute to kinesthesia at the index finger, elbow, and knee. *J Neurophysiol* 94:1699–1706



6. Naito E, Roland PE, Grefkes C, Choi HJ, Eickhoff S, Geyer S, Zilles K, Ehrsson HH (2005) Dominance of the right hemisphere and role of area 2 in human kinesthesia. *J Neurophysiol* 93:1020–1034
7. Johansson RS (1996) Sensory and memory information in the control of dexterous manipulation. In: Lacquaniti F, Viviani P (eds) *Neural bases of motor behaviour*. Kluwer, Netherlands, pp 205–260
8. Brooke JD (2004) Somatosensory paths proceeding to spinal cord and brain – centripetal and centrifugal control for human movement. *Canadian J Physiol Pharmacol* 82:723–731
9. Refshauge KM, Collins DF, Gandevia SC (2003) The detection of human finger movement is not facilitated by input from receptors in adjacent digits. *J Physiol* 551:371–377
10. Hewitt BA, Refshauge KM, Kilbreath SL (2002) Kinesthesia at the knee: the effect of osteoarthritis and bandage application. *Arthritis Rheum* 47:479–483

## Proprioception: Role of Joint Receptors

VAUGHAN G. MACEFIELD

Professor of Integrative Physiology, School of Medicine, University of Western Sydney, Sydney, NSW, Australia

Conjoint Principal Research Fellow, Prince of Wales Medical Research Institute, Sydney, NSW, Australia

### Synonyms

Kinesthesia; Joint sense; Position sense; Movement sense

### Definition

Proprioception, literally the “sense of self” (from Latin “*proprius*” = “own”), is the group of sensory modalities that allow us to know the positions of our limbs in space and to detect and assess the magnitudes of movements and forces without vision. Classically, it had been assumed that this sense was subserved by joint receptors, specialized mechanoreceptors located in the capsular tissues of a joint. Indeed, the term “joint sense” – the capacity to detect movements or changes in position about a joint – is still used in clinical practice, though it is generally now accepted that joint receptors themselves do not bear primary responsibility for our proprioceptive acuity. Muscle spindles – exquisitely sensitive intramuscular stretch receptors – are generally believed to be the sensory endings primarily responsible. Perceptions of joint movement evoked by small amplitude vibration applied to muscles or tendons, either intact or surgically exposed, were the first convincing demonstrations that these receptors contribute importantly to proprioception

(see ► [Proprioception, Role of Muscle Receptors](#)). The role of stretch receptors in the skin has come to increased prominence of late and there are many convincing studies implicating significant roles for cutaneous afferents in proprioception (see ► [Proprioception, Role of Cutaneous Receptors](#)).

### Characteristics

#### Quantitative Description

The consensus from the animal literature is that joint afferents mostly respond at the extremes of joint rotation [1]. Microelectrode recordings from the median and ulnar nerves of conscious human subjects have shown that mechanoreceptors associated with the interphalangeal joints and metacarpophalangeal joints do not respond to forces applied to bone when there is no movement of the joint and have very high mechanical thresholds to indentation applied over the joint capsule [2,3]. While they do respond to joint movements, they respond primarily at the limits of angular excursion. An example of a recording from a human joint receptor is shown in Fig. 1. This unit, located within the metatarsophalangeal joint of the fourth toe was spontaneously active at rest and responded to imposed extreme plantarflexion and dorsiflexion of the joint and to (unphysiological) internal and external rotation of the joint. Because joint afferents often respond in both directions (e.g. flexion and extension) and in more than one axis of rotation (e.g. abduction/adduction and extorsion/intorsion), as a group, joint afferents have a very limited capacity to encode changes in joint position. Nevertheless, a small proportion of interphalangeal joint afferents do respond across the physiological range [2,3]. Moreover, there is evidence that afferents associated with the dorsal aspects of human metacarpophalangeal joints consistently respond throughout the physiological range of joint rotation [4].

#### Lower Level Components

Much of the early work on joint receptors, carried out mostly in the knee joint of the cat, supported the idea that joint receptors could encode changes in joint position [5]. However, it turned out that many of these were actually muscle spindle afferents coursing through the nerve supplying the joint. Nevertheless, a few receptors – unequivocally articular in origin – have been found that respond throughout the physiological range of angular excursion [6]. Histological and physiological studies have shown that mechanoreceptors in the posterior capsule of the cat knee joint, identified as Ruffini organs (i.e. similar to the stretch receptive SAI endings in skin) respond in a slowly adapting manner to strains applied in the plane of the tissue but have very high thresholds to compressive stresses applied perpendicularly – the adequate stimulus is the increase in tensile strain in the immediate environment of the receptor [7]. Ruffini endings have also been identified

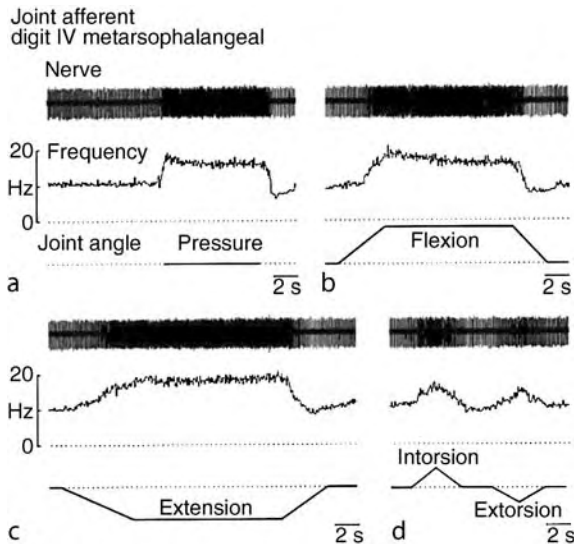

### Proprioception: Role of Joint Receptors.

**Figure 1** Microelectrode recording from a joint afferent associated with the metatarsophalangeal joint of the fourth toe in conscious human subject. The mechanoreceptor responded to pressure over its receptive field (a) and to passive flexion (b), extension (c) and longitudinal rotation of the joint (d). Changes in joint angle are represented schematically.

in the human finger and knee joints and the discharge behavior of human joint afferents associated with the interphalangeal and metacarpophalangeal joints fits with their being Ruffini endings; they have very high mechanical thresholds to indentation applied over the joint capsule and respond to joint movements that cause an increase in tensile strain within the joint capsule [2].

### Higher Level Processes

Proprioceptive acuity is optimal when inputs from muscle, skin and joints are intact [8]. Anesthesia of the joint capsule attenuates and intra-articular fluid expansion augments proprioceptive acuity at the interphalangeal joint, arguing for a role of joint afferents in proprioception [9]. Intraneural microstimulation of a single joint afferent in conscious human subjects can be perceived as pressure over the joint or as a small movement, so joint afferents do have a strong synaptic coupling to higher order sensory neurons [3]. This means that, should a joint receptor be exposed to an adequate tensile strain within the joint capsule or extracapsular ligament, it could provide useful information. But given that these tensile strains are only reached during extreme joint rotations or direct pressure, their role in normal proprioception can be considered to be limited.

### Function

As noted above, joint receptors are considered to primarily encode changes in joint angle at the extremes

of angular excursion. However, given that some joint afferents can encode joint rotation throughout the physiological range [2,6] they may play a role in proprioception when inputs from muscle and skin cannot contribute [9].

### Pathology

Loss of joint afferent input is not important; proprioceptive acuity is not greatly affected when people are fitted with prosthetic joints [10].

### References

- Burgess PR, Clark FJ (1969) Characteristics of knee joint receptors in the cat. *J Physiol* 203:317–333
- Burke D, Gandevia SC, Macefield G (1988) Responses to passive movement of receptors in joint, skin and muscle of the human hand. *J Physiol* 402:347–361
- Macefield G, Gandevia SC, Burke D (1990) Perceptual responses to microstimulation of single afferents innervating joints, muscles and skin of the human hand. *J Physiol* 429:113–129
- Edin BB (1990) Finger joint movement sensitivity of non-cutaneous mechanoreceptor afferents in the human radial nerve. *Exp Brain Res* 82:417–422
- Eklund G, Skogland S (1960) On the specificity of the Ruffini like joint receptors. *Acta Physiol Scand* 49:184–191
- Ferrell WR (1980) The adequacy of stretch receptors in the cat knee joint for signalling joint angle throughout a full range of movement. *J Physiol* 199:85–99
- Grigg P, Hoffman AH (1996) Stretch-sensitive afferent neurones in cat knee joint capsule – sensitivity to axial and compression stresses and strains. *J Neurophysiol* 75:1871–1877
- Gandevia SC, McCloskey DI (1976) Joint sense, muscle sense, and their combination as position sense, measured at the distal interphalangeal joint of the middle finger. *J Physiol* 260:387–407
- Ferrell WR, Gandevia SC, McCloskey DI (1987) The role of joint receptors in human kinaesthesia when intramuscular receptors cannot contribute. *J Physiol* 386:63–71
- Cross MJ, McCloskey DI (1973) Position sense following surgical removal of joints in man. *Brain Res* 55:443–445

## Proprioception: Roles of Muscle Receptors

UWE PROSKE

Department of Physiology, Monash University, Melbourne, VIC, Australia

### Synonyms

Kinesthesia; Proprioception

## Definition

When limbs are moved, under circumstances where vision cannot be used to monitor the movements, there is a quite accurate sense of where the limbs are in space and whether they are moving or not. This is the ►kinesthetic or the ►proprioceptive sense [1][9].

The neural basis of ►kinesthesia and ►proprioception has been the subject of debate for many years. In the mid nineteenth century it was believed that sensations arising from movements produced by contracting muscles were associated with the motor commands that produced the movements – a “sensation of innervation.” This view was not shared by Sherrington [2] who believed that the kinesthetic sense arose from afferent signals generated in the muscles themselves. Interestingly, the debate about the central and peripheral origin of the kinesthetic sense has not entirely subsided to the present day.

During most of the twentieth century it was believed that ►kinesthetic sensibility was provided predominantly by peripheral signals, although some uncertainty persisted over what kinds of receptors were involved. At one stage it was thought that joint receptors were the main source of input. This idea has not been laid to rest and in recent years, for some joints, contributions from joint receptors [3] as well as skin receptors [4] have been emphasized.

The experiments of Goodwin et al. [5] provided the first direct evidence for a role of a peripheral signal of muscle origin in ►proprioception when they described illusions of both forearm position and movement during 100 Hz vibration of elbow flexor muscles. They concluded that muscle spindles were the principal ►kinesthetic receptor.

## Characteristics

### Higher Level Structures

A difficulty with muscle receptors as the ►kinesthetic sensors was that until the second half of the twentieth century it remained uncertain whether muscle afferents had access to the cerebral cortex. It is generally accepted that a cortical projection is a necessary prerequisite for access by sensory receptors to consciousness. In the event, it was shown that both spindle Group I afferents (primary muscle spindle endings) and Group II afferents (secondary muscle spindle endings) projected to areas 3a and 4 of somatosensory cortex [6].

### Lower Level Structures

The illusions reported by Goodwin et al. [5] were of both position and movement, although vibration at 100 Hz produced principally a movement illusion. When vibration frequency was reduced to 20–40 Hz, the illusion faded from one of movement to one of limb position [7].

Animal studies had demonstrated that the primary endings of spindles had both a dynamic length sensitivity and a static length sensitivity [8]. Furthermore, primary endings were very sensitive to high frequency muscle vibration. It was therefore inferred that the movement illusions experienced during high frequency vibration were the result of signals generated by primary endings.

Secondary endings had no dynamic sensitivity but they responded with maintained changes in discharge during changes in muscle length. They responded only to low frequency vibration. It was concluded that spindle primary endings signaled both movement and position information, while spindle secondary endings contributed only positional information.

### Lower Level Processes

Since muscle spindles are stretch receptors, whenever a muscle was stretched during movement of a limb, signals would be generated in both primary and secondary endings. A proportional relationship could be described between the size and rate of stretch and the dynamic and static components of spindle discharge [8]. All of this related to responses of spindles during length changes in the passive muscle. It was known that during a graded voluntary contraction, the ►fusimotor neurons to muscle spindles were ►co-activated [10]. So impulses can be generated in spindles by two fundamentally different processes, stretch and intrafusal contraction.

### Higher Level Processes

According to the ►hypothesis that kinesthesia represents two distinct senses, the sense of position and the sense of movement, there is some evidence that central projection sites for dynamic and static spindle signals are separate [6]. Further processing of spindle information must take place to distinguish between ►fusimotor evoked spindle activity (reafference) and muscle stretch evoked activity (exafference). A central subtraction process was postulated to take place [11]. According to this scheme, the motor command goes to both alpha and gamma motoneurons as part of the ►co-activation strategy. Gamma-evoked impulses are subtracted from the total spindle signal to extract movement and position related components. It means that spindles could provide this information at all levels of voluntary activation [7].

### Process Regulation

At the present time, we know little about the central processes and their regulation in the generation of ►kinesthetic sensations. Signals from area 3a (dynamic) and area 4 (static) must combine with exafferent information to produce the felt sensation. Where this takes place remains to be shown.

## Function

The ►[kinesthetic](#) sense, making reference to a central map, allows us to locate the body and body segments in space, in the absence of vision. It also provides us with information about movement of the body. Since in everyday life many of our movements are carried out without visual guidance, the ►[kinesthetic](#) sense is important for normal motor activities.

## Pathology

An indication of the importance of ►[kinesthesia](#) and ►[proprioception](#) for motor control is provided by subjects with a large fiber sensory neuropathy. These subjects carry out all activities under close visual control. In the absence of vision they exhibit large errors in ►[kinesthetic](#) tests and they are unaware of obstacles encountered during movements, unless they can see them [1].

►[Large-Fiber Sensory Neuropathy: Effect on Proprioception](#)

## References

1. McCloskey DI (1978) Kinesthetic sensibility. *Physiol Rev* 58:763–820
2. Sherrington CS (1906) On the proprioceptive system, specially in its reflex aspects. *Brain* 29:467–482
3. Ferrell WR, Gandevia SC, McCloskey DI (1987) The role of joint receptors in human kinaesthesia when intramuscular receptors cannot contribute. *J Physiol* 386:63–71
4. Collins DF, Refshange KM, Todd G, Gandevia SC (2005) Cutaneous receptors contribute to kinesthesia at the index finger, elbow and knee. *J Neurophysiol* 94:1699–1706
5. Goodwin GM, McCloskey DI, Matthews PBC (1972) The contribution of muscle afferents to kinaesthesia shown by vibration induced illusions of movement and by the effects of paralysing joint afferents. *Brain* 95:705–748
6. Hore J, Preston JB, Cheney PD (1976) Responses of cortical neurons (areas 3a and 4) to ramp stretch of hindlimb muscles in the baboon. *J Neurophysiol* 39:484–500
7. McCloskey DI (1973) Differences between the senses of movement and position shown by the effects of loading and vibration of muscles in man. *Brain Res* 61:119–131
8. Matthews PBC (1972) Mammalian muscle receptors and their central actions. Arnold, London
9. Proske U (2006) Kinesthesia: the role of muscle receptors. *Muscle Nerve* 34:545–558
10. Vallbo AB (1974) Human muscle spindle discharge during isometric voluntary contractions. Amplitude relations between spindle frequency and torque. *Acta Physiol Scand* 90:319–336
11. McCloskey DI, Gandevia SC, Potter EK, Colebatch JG (1983) Muscle sense and effort: motor commands and judgements about muscular contractions. In: Desmedt JE (ed) *Motor control mechanisms in health and disease*. Raven, New York

## Proprioceptor

### Definition

Sensory receptor providing information about the mechanical state of the body.

- [Proprioception](#)
- [Sensory Systems](#)

## Pro-Saccades

### Definition

- [Oculomotor Control](#)
- [Saccade, Saccadic Eye Movement](#)

## Prosencephalon

### Definition

Forebrain. Anterior part of the brain. Composed of telencephalon and diencephalon.

- [Evolution and Embryological Development of the Forebrain](#)
- [General CNS](#)

## Prosomere

### Definition

Transverse, segmental divisions of the forebrain.

- [Evolution and Embryological Development of Forebrain](#)

## Prosopagnosia

### Definition

- [Visual Neuropsychology](#)

## Prospective Monitoring

### Definition

Prospective monitoring is defined as metacognitive experiences that on the basis of evaluation of the current states of memory and learning, one adjust one's behaviors (e.g., by adaptively modifying and/or changing currently inadequate learning strategies and figuring out new strategies), so as to prepare for achieving learning goals.

### ► Metacognition

## Prospero: Protein Localization in Neuroblasts

XIAOHANG YANG

Institute of Molecular and Cell Biology,  
Agency for Science, Technology and Research,  
Proteos, Singapore

### Definition

Prospero belongs to a unique group of proteins that are enriched in either the apical or basal cell cortex, just under the plasma membrane, of dividing neuroblasts. The asymmetric cortical localization of Prospero protein is controlled by a sophisticated ► [asymmetric cell division](#) mechanism that secures the exclusive

segregation of Prospero to the future ► [ganglion mother cell](#) during mitosis.

### Characteristics

The *Drosophila* embryonic central nervous system (CNS) is derived from an array of approximately 30 unique types of neuroblast. The highly diversified neurons and supporting cells in the CNS are the direct progenies of ganglion mother cells produced by neuroblast asymmetric divisions. The *Drosophila* gene *prospero* (*pros*) is required for the generation of the ganglion mother cell.

*pros* [1] was identified in the early 1990s and named after the protagonist in *The Tempest*, a play by William Shakespeare. *pros* is located on the right arm of the third chromosome (86E2–86E4) and encodes three slightly varied large polypeptides (1535, 1403 and 1374 aa) due to alternative splicing. The Pros protein is a divergent homeodomain transcription factor that acts as a switch between self-renewal or terminal differentiation of a neural precursor cell. *pros* is evolutionally conserved and vertebrate homologs of *pros*, *Prox1*, have been identified in human, mouse, zebrafish and frog.

During early *Drosophila* embryonic neurogenesis, neuroblasts delaminate from the neuroectoderm and divide asymmetrically along the apicobasal axis to produce one large and one small daughter cell. The size difference between the two daughters is so prominent that it appears as if the small daughter buds off from the basal cortex of the telophase neuroblast (Fig. 1c).

The large apical daughter cell remains as the neuroblast and continues to divide asymmetrically. The small basal cell adopts the ganglion mother ► [cell fate](#) and divides terminally to make either two neurons or glial cells.

P

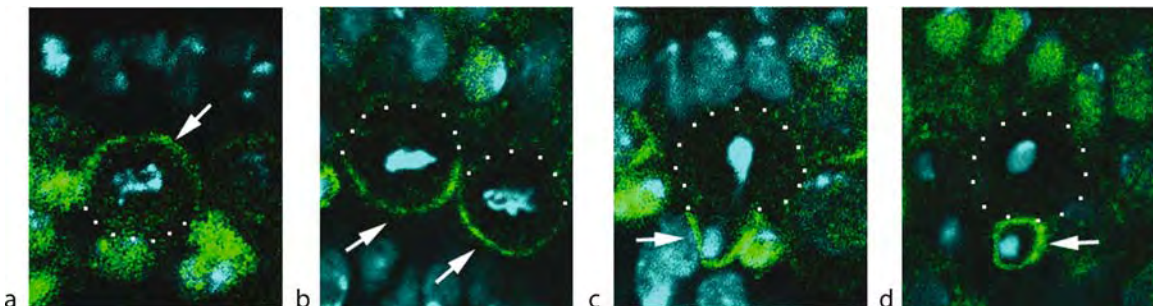

**Prospero: Protein Localization in Neuroblasts. Figure 1** Confocal images of cell cycle-dependent asymmetric distribution of Pros protein in mitotic neuroblasts. Embryos at developmental stage 10 were stained with anti-Pros (green) and ToPro3 (chromosomes, cyan). At late interphase or early prophase, Pros protein is transiently enriched in the apical cortex and forms an apical crescent (Panel a, arrow). Starting from late prophase, Pros is relocated to the basal cortex and remains basal (Panel b, arrows; late prophase and metaphase) throughout the rest of mitosis. At telophase, Pros protein is sequestered into the future ganglion mother cell (Panel c, arrow). After cytokinesis, Pros protein is exclusively inherited by the ganglion mother cell (Panel d, arrow) and translocated into the nucleus later. Apical is up. Neuroblast cell bodies are outlined with white dots.

Pros protein is made in neuroblasts and its cellular distribution is tightly regulated by the cell cycle [1]. Anti-Pros immunofluorescence staining shows that Pros protein transiently enriches in the apical cortex (membrane-associated or “apical crescent”) (Fig. 1a) in late interphase and early prophase neuroblasts. Starting from late prophase, Pros is relocated to the basal cortex of mitotic neuroblasts and remains basal (“basal crescent,” Fig. 1b) throughout the rest of mitosis. In telophase, Pros protein is sequestered into the future ganglion mother cell (Fig. 1c). After cytokinesis, Pros protein is exclusively inherited by the ganglion mother cell (Fig. 1d). In newly formed ganglion mother cells, Pros is cortical (membrane-associated, Fig. 1d) and is translocated into the nucleus later, which is essential for its function. The membrane-associated form of Pros is highly phosphorylated and its translocation to the nucleus requires dephosphorylation [2]. Interestingly, *pros* mRNA exhibits similar asymmetric cellular localization patterns in mitotic neuroblasts and gets sequestered into ganglion mother cells [3].

Pros protein appears to act as a master player (reminiscent of Prospero who has the magic power in *The Tempest*) that controls the ganglion mother cell fate. In the absence of Pros, or failure to translocate Pros to the nucleus, the smaller daughter cell fails to adopt the ganglion mother cell fate and does not produce proper neurons. Thus, Pros is also called a “cell fate determinant.” Another well studied cell fate determinant in neuroblast asymmetric division is Numb [4], which exhibits similar asymmetric basal localization and exclusive segregation into future ganglion mother cells as Pros. Numb antagonizes the Notch signaling pathway.

A number of protein complexes are involved in regulating Pros asymmetric localization in mitotic neuroblasts [5]. Proteins such as Bazooka (Baz), DaPKC, Par6, Inscuteable (Insc), Partner of Insc and the  $\alpha$ -subunit of trimeric G-protein, as well as Locomotion defects, co-localize to the apical cortex of mitotic neuroblasts from late interphase and form a functional complex (apical complex). This apically localized complex exhibits three major functions: (i) regulating the basal localization of cell fate **determinants** such as Pros and Numb; (ii) re-orientating the mitotic spindle along the apicobasal axis by metaphase; and (iii) generating an asymmetric spindle (the apical half of the spindle arm is much longer than that of the basal half) which is responsible for the distinct cell size difference between the two daughters. Loss of function of any single protein (for example, in *baz* or *insc* mutants) from the apical complex usually causes mislocalization (randomized Pros crescent position) of Pros protein in early (prior to anaphase) mitotic neuroblasts. However, starting in anaphase, Pros protein in the majority of these mutant

neuroblasts is redistributed as a crescent to the cell cortex where the future **ganglion mother cell** buds off. This redeployment of Pros protein late in mitosis in mutant neuroblasts has been referred to as “telophase rescue.”

The asymmetric localization of Pros in mitotic neuroblasts also depends on a protein called Miranda (Mira) [6], which was named after Prospero’s daughter who went into exile with him in *The Tempest*. In mitotic neuroblasts, Mira binds to Pros and functions as an adaptor protein for Pros asymmetric cortical distribution. In the absence of Mira, Pros loses its asymmetric localization and becomes cytoplasmic.

The cell-cycle dependent translocation of Pros protein from apical to basal cortex is regulated by the Snail family proteins of Zn-finger transcription factors Snail (Sna), Escargot (Esg) and Worniu (Wor) [5]. The members of the Snail family share homologous sequences and exhibit redundant functions. In the absence of all three Snail family proteins, two major players of the apical complex in the embryonic CNS, Baz and Insc, are down-regulated in the segmented CNS but not the brain. In these *snail* triple-mutant (*esg wor sna*) embryos, Pros protein remains tethered to its apical position and does not relocate late in mitosis to the basal cortex from where the future ganglion mother cells bud off. Since these small daughter cells do not inherit Pros, they do not adopt the ganglion mother cell fate. These observations indicate that in addition to the absence of Baz and Insc, the compensatory telophase rescue mechanism is also defective in *snail* triple-mutant (*esg wor sna*) neuroblasts. The detailed mechanism of telophase rescue remains largely unknown. A recent study of telophase rescue has indicated that two *Drosophila* homologs of mammalian TNF/TNFR molecules, Eiger and DTRAF1, are involved in Pros protein telophase rescue [7]. Interestingly, Numb telophase rescue requires neither Eiger nor DTRAF1, which suggests that a different pathway is involved.

Two tumor-suppressor genes, *lethal giant larvae* (*lgl*) and *discs large* (*dlg*), are also involved in the proper basal localization of Pros in dividing neuroblasts [8,9]. In contrast to its asymmetric localization to either the apical or basal cortex in wild type neuroblasts, in the absence of Lgl/Dlg Pros protein is evenly distributed in the cortex and is heavily associated with the mitotic spindle. It has been suggested that Lgl/Dlg may act in a secretory pathway involved in the basal intracellular translocation of Pros. The asymmetric basal localization of Pros protein also depends on the actin cytoskeleton, but not the microtubule structures inside cells. Disruption of the actin cytoskeleton results in loss of Pros from the membrane.

It appears that Pros asymmetric localization is only observed at embryonic stages. During late nervous system development, the asymmetric localization and

segregation mechanism do not seem to play a major role in Pros function and the conventional transcription/translation regulation mechanism prevails. For example, in the 3rd instar larval brain, Pros protein is expressed only in ganglion mother cells and not in neuroblasts, although Mira remains asymmetrically localized in mitotic larval neuroblasts and is exclusively partitioned into ganglion mother cells at telophase. Another example is the development of the adult external sensory organ. Pros protein is cytoplasmic in dividing sensory organ precursor cells and distributes equally to two daughter cells after cytokinesis [10]. Later the Pros protein level is down-regulated in one of the daughter cell (IIa), which divides to produce a hair and a socket. The daughter cell maintaining Pros protein (IIb) produces a neuron and a glial cell.

In summary, the cell fate determinant Pros protein is made in the mother cell (neuroblast) and only functions as a transcription factor in the nucleus of one of the two daughter cells (ganglion mother cell). The cell cycle-dependent asymmetric distribution of Pros protein during mitosis is a critical mechanism employed by dividing neuroblasts to secure the exclusive segregation of this protein to the ganglion mother cells. In vertebrates, it is not known whether Prox1 is involved in asymmetric divisions. Prox1 knock-out mice show embryonic lethality with impaired development of the lens, lymphatic system, liver and pancreas.

## References

- Fuerstenberg S, Broadus J, Doe CQ (1998) Asymmetry and cell fate in the *Drosophila* embryonic CNS. *Int J Dev Biol* 42:379–383
- Srinivasan S, Peng CY, Nair S, Skeath J, Spana E, Doe CQ (1998) Biochemical analysis of Prospero protein during asymmetric cell division: cortical Prospero is highly phosphorylated relative to nuclear Prospero *Dev Biol* 204:478–487
- Li P, Yang X, Wasser M, Cai Y, Chia W (1997) Inscuteable and Staufien are required for the asymmetric localisation and segregation of Prospero RNA during *Drosophila* neuroblast cell divisions. *Cell* 90:437–447
- Knoblich JA, Jan LY, Jan YN (1995) Asymmetric segregation of numb and prospero during cell division. *Nature* 377:624–627
- Chia W, Yang X (2002) Asymmetric division of *Drosophila* neural progenitors. *Curr Opin Genet and Dev* 12:459–464
- Jan YN, Jan LY (1998) Asymmetric cell division. *Nature* 392:775–778
- Wang H, Cai Y, Chia W, Yang (2006) *Drosophila* homologs of mammalian TNF/TNFR-related molecules regulate segregation of Miranda/Prospero in neuroblasts. *EMBO J* 25:5783–5793
- Peng CY, Manning L, Albertson R, Doe CQ (2000) The tumour-suppressor genes *lgl* and *dlg* regulate basal protein targeting in *Drosophila* neuroblasts. *Nature* 408:596–600
- Ohshiro T, Yagami T, Zhang C, Matsuzaki F (2000) Role of cortical tumour-suppressor proteins in asymmetric division of *Drosophila* neuroblast. *Nature* 408:593–596
- Manning L, Doe CQ (1999) Prospero distinguishes sibling cell fate without asymmetric localization in the *Drosophila* adult external sense organ lineage. *Development* 126:2063–2071

## Prostaglandins

### Definition

A group of hormone-like substance derived from arachidonic acid, which participate in a wide range of neuronal and organismal functions.

## Prosthesis

### Definition

An artificial body part.

### ► Joints

### ► Measurement Techniques (Pressure)

## Proteases

### Definition

Proteases are enzymes that break down other proteins in a cell. Normally, proteases are carefully regulated. If unregulated, severe cell damage and death can occur.

## Proteasome

### Definition

Proteasome in eukaryotes, proteasomes are large nuclear and cytoplasmic protein complexes that proteolytically degrade proteins.

## Protective Autoimmunity

MICHAL SCHWARTZ, JONATHAN KIPNIS  
The Weizmann Institute of Science, Rehovot, Israel

### Synonyms

Immune based-self maintenance, repair and renewal

### Definition

Immune response recognizing auto-antigens that contribute to maintenance, protection, repair and renewal of the relevant tissue; so far proven with respect to the central nervous system.

### Characteristics

#### Description

As a result of tissue injury, physiological compounds flood the body in toxic amounts. ▶T cells (T lymphocytes) directed to self-antigens serve as the fighting force against these self-derived threatening factors (“the ‘enemy within’”) [1,2], much as the classical immune response fights invading enemies, such as microbes.

T-cell specificity for self-antigens (▶autoimmunity) is required for homing of the T cells to the autoantigen-populated site of damage and their activation there [5]. Following activation by their relevant antigens, the T-cell effect is independent of both antigen specificity and the existing toxicity. These “▶autoimmune T cells,” via secreted factors such as cytokines, activate the local ▶microglia (brain-resident immune cells) to support neuronal survival and repair [2].

### Background

Damage to the central nervous system (CNS) results in irreversible functional loss that is often more extensive than would be expected from the severity of the primary insult [1]. This heightened impairment results from the inevitable degeneration of neurons that sustained the primary injury, as well as from failure of the tissue to withstand the self-perpetuating process of damage that spreads to neighboring neurons. The latter is due to a pathological disruption in homeostasis caused by self-compounds in concentrations that are beyond the buffering capacity of the tissue. In addition, the ability of CNS tissue to tolerate a defense mechanism mediated by its resident immune cells (microglia) is poor; thus, unless tightly controlled, microglial activation is itself likely to exacerbate the damaging conditions rather than help the tissue to withstand them. Poor recovery of the CNS is therefore a reflection of (i) the limited ability to regrow new fibers from cell bodies with damaged axons (regeneration), (ii) failure of the CNS to tolerate adverse conditions, including those caused by ineffectual

attempts at repair, and (iii) the limited capacity of the adult CNS for spontaneous ▶neurogenesis (cell renewal). T cell-based protective autoimmunity can be viewed as a means of controlling the brain’s microglia-based system of self-defense in a way that the brain can tolerate.

That the effect of the ▶immune system on CNS repair processes might be beneficial was not considered a possibility until the studies done by the Michal Schwartz group at the Weizmann Institute of Science in 1998 [3]. Up to that time, the consensus was that the healthy CNS is refractory to immune cells, and that the successful infiltration of immune cells into the damaged CNS would result in CNS malfunction and should therefore be minimized. Schwartz and her group discovered that – contrary to the traditional dogma – immune cells are pivotal for CNS repair [1,3]. T cells control the microglial response by producing growth factors and cytokines that empower the microglia infiltrating blood-brone macrophages to buffer the injury-induced toxicity [2], thereby avoiding overwhelming damage to neighboring cells. Thus, by acting as a well-controlled link between the damaged CNS and the healing immune system, suitably activated microglia/macrophages can carry out defensive tasks even in a tissue as fragile as the CNS [4].

Contrary to common wisdom, Schwartz’s group suggested that protection, repair, and recovery after a CNS insult necessitate an immune response, but that the response produced is often too weak (and requires boosting) or inappropriate (and in need of modulation and rigorous control); in both cases the resulting modification must be one that the CNS can safely tolerate [4]. In rats or mice devoid of the ability to manifest an adaptive (T cell-mediated) response to CNS injury, the post-injury loss of neural tissue is significantly increased. Moreover, immunization of injured animals with self-antigens, a procedure that boosts accumulation of self-reactive (autoimmune) T cells at the site of injury, decreases neuronal cell death [5]. This phenomenon of ▶neuroprotection mediated by autoimmune T cells residing at the site of injury, or “protective autoimmunity,” was found to be physiological response to CNS injury that spontaneously occurs but is apparently insufficient for the repair [4].

### Quantitative Aspects

Injury to the CNS induces activation of microglia at the damaged site, beginning at the time of injury and reaching a peak 7–10 days later. Astrocytes, however, disappear from the site of injury, as demonstrated by immunohistochemical analysis of glial fibrillary acid protein, an astrocyte marker. Besides activated microglia, the injury site is also populated by T cells and infiltrating blood-borne monocytes. Their accumulation



starts immediately after the injury, reaches a peak 7–10 days later, and resolves itself by 2–3 weeks following the injury. A well-synchronized response in terms of amount, time and location is pivotal for the repair. Lately protective autoimmunity has been extended to include brain plasticity, not only in disease but also in health. Neurogenesis and spatial learning/memory capabilities were found to be dependant on the availability of T cells recognizing CNS antigens [6].

### Higher-Level Structures

T cells that participate in the healing process within the injured CNS are part of the adaptive arm of the immune system. The site of the insult determines the specificity of the T cells needed for protection and repair. In the case of injuries to white matter, the protective T cells must be reactive to antigens associated with CNS myelin whereas after gray matter injuries, the protective T cells are specific to other proteins that are abundantly expressed at the injury site.

### Lower-Level Components

Upon reactivation by encountering their specific antigens at the site of injury, the T cells can produce a variety of soluble proteins that are required for normal neuronal function. These include nerve growth factor, brain-derived neurotrophic factor, glial cell-derived neurotrophic factor, and others [7].

### Anatomy and Physiology of Regulation

According to the concept of protective autoimmunity, autoimmune T cells in healthy individuals exist in a state that represents a compromise between the need for autoimmune protection and the risk of autoimmune disease. Schwartz's group discovered that a subpopulation of T cells, identified as the naturally occurring regulatory CD4 + CD25 + T cells (Treg cells), constitutively suppressed the activity of autoimmune T cells, and that this population is itself regulated (i.e. the suppression can be abolished or at least weakened) by brain-derived compounds such as the stress-related neurotransmitter dopamine [5].

### The Regulatory Process

Naturally occurring Treg cells exert tight control over circulating autoimmune T cells, so that the latter normally exist in a state often described by immunologists as "nonresponsiveness." Treg cells are produced in the thymus and are released to the periphery, where they suppress the activity of autoimmune T cells. Depletion of Treg cells predisposes animals to the spontaneous development of autoimmune diseases. Animals depleted of Treg cells also demonstrate more

efficient rejection of tumors, because their autoimmune. Lately protective autoimmunity has been extended to include brain plasticity, not only in disease but also in health. Neurogenesis and spatial learning/memory capabilities were found to be dependant on the availability of T cells recognizing CNS antigens [insert ref ziv et al] [6] T cells can be more easily activated [15]. In line with findings on cancer rejection, depletion of the Treg cell subpopulation enhances the animals' ability to withstand conditions of CNS neurodegeneration [5]. Thus, endogenous compounds such as dopamine, because of their ability to attenuate the activity of the Treg cells, might be useful as potential components of neuroprotective therapies.

### Pathology

After an injury, the damaged CNS tissue becomes accessible to immune cells. Although the post-injury inflammatory process that is mediated by self-reactive T cells is a protective physiological response, these autoimmune T cells appear to include the very cells that can also induce experimental autoimmune encephalomyelitis (EAE), an animal model for the autoimmune disease, multiple sclerosis [8]. Therefore, proper regulation is critical if the autoimmune response is to protect the organism from injury-associated damage without the concomitant induction of another kind of pathology, namely autoimmune disease [9].

### Therapy

The following immune-based therapies for CNS repair are currently under investigation:

- *T cell-based therapeutic vaccination:* This experimental treatment involves the boosting of T cells directed against weak agonists of self-antigens that cross-react with antigens residing at a site of stress or disease. The risk of autoimmune disease is avoidable by using weak agonists that exhibit only partial cross-reactivity with their relevant self-antigen. One such antigen is glatiramer acetate, also known as copolymer 1 (Cop-1), a synthetic copolymer composed of four amino acids (glutamate, lysine, alanine, and tyrosine). Immunization with Cop-1 was found to be neuroprotective in several models of CNS injury and neurodegenerative disorders [7]. Another possible way to boost autoimmune T cells is through the use of altered peptide ligands. An altered dominant peptide of myelin basic protein (MBP) that does not induce EAE upon immunization was found to be significantly neuroprotective in a rodent model of spinal cord injury [10].
- *Weakening of the activity of regulatory T cells:* Neuroprotection is enhanced in mice depleted of Treg cells [5]. In human subjects such depletion is

impossible, as most of these cells are located in lymph nodes, and there is no known way to selectively remove them. Therefore, compounds that can selectively weaken the suppressive activity of Treg cells are potential candidates for therapy. One such compound is the neurotransmitter dopamine, which alleviates the suppressive activity of naturally occurring Treg cells. Injection of dopamine or dopamine-receptor type-1 agonists after CNS injury was found to be neuroprotective [5]. An additional compound found to be effective in modulating Treg is a copolymer of glutamate tyrosine, poly YE, show to be effective in stroke [5].

- *Autologous macrophages*: These cells constitute the basis of an immune-based cell therapy for spinal cord repair. Depending on their environmental conditions, cells of the macrophage lineage can acquire either the type of activation appropriate for fighting off invading microorganisms, or – activation leading to tissue maintenance and repair. Schwartz's group discovered that macrophages with the characteristic features of antigen-presenting cells can facilitate CNS repair [3]. Once activated by autologous tissue such as skin, these macrophages produce cytokines and neurotrophic factors, but not tumor necrosis factor- $\alpha$  or other cytotoxic agents. In a therapy currently under development, macrophages are prepared from the patient's own blood, activated on the patient's own skin in such a way that they adopt a repair-promoting phenotype, and reintroduced into the margin of the lesion site at the specific time and dosing, facilitates repair. Such macrophages are reminiscent of the ones recruited by immunization with CNS self-antigen following spinal cord injury [11].
- *Dendritic cells*: Bone marrow-derived dendritic cells are professional antigen-presenting cells, which can be loaded with antigens and used to treat the acutely injured CNS. Dendritic cells prepared from autologous blood and loaded with relevant CNS antigens, can (like macrophage therapy) be applied locally to the severed spinal cord, or administered systemically as a vaccination [12].

### Concluding Remarks

The immune system is the body's primary source of defense against danger and remedial assistance in the event of injury. The CNS, however, was long thought to have relinquished its claim on the immune system for such help, possibly as an evolutionary trade-off that protected its extraordinarily complex neural network from harmful immune (inflammatory) intervention. Similarly, immune cells directed against self-antigens, traditionally viewed as autoaggressors causing autoimmune disease, acquired an unfavorable reputation as an

outcome of immune system malfunction. The studies described here, as well as studies from many other laboratories, provide persuasive evidence that the negative reputation of the immune system vis-à-vis the CNS is undeserved. Nevertheless, spontaneous activation of the CNS-resident microglia is often not sufficiently effective. Thus, additional assistance is needed from cells that constitute the adaptive arm of peripheral immunity, namely T cells specific to CNS self-antigens. Based on this concept, several approaches can be translated into workable therapies. The treatment of choice will ultimately be based on safety, feasibility, and efficacy, and the specific indication.

### References

1. Moalem G et al. (1999) Autoimmune T cells protect neurons from secondary degeneration after central nervous system axotomy. *Nat Med* 5:49–55
2. Schwartz M, Shaked I, Fisher J, Mizrahi T, Schori H (2003) Protective autoimmunity against the enemy within: fighting glutamate toxicity. *Trends Neurosci* 26:297–302
3. Rapalino O et al. (1998) Implantation of stimulated homologous macrophages results in partial recovery of paraplegic rats. *Nat Med* 4:814–821
4. Yoles E et al. (2001) Protective autoimmunity is a physiological response to CNS trauma. *J Neurosci* 21:3740–3748
5. Kipnis J et al. (2004) Dopamine, through the extracellular signal-regulated kinase pathway, downregulates CD4 + CD25 + regulatory T-cell activity: implications for neurodegeneration. *J Neurosci* 24:6133–6143
6. Ziv Y et al. (2006) Immune cells contribute to the maintenance of neurogenesis and spatial learning abilities in adulthood. *Nat Neurosci* 9(2):268–275
7. Kipnis J et al. (2000) T cell immunity to copolymer 1 confers neuroprotection on the damaged optic nerve: possible therapy for optic neuropathies. *Proc Natl Acad Sci USA* 97:7446–7451
8. Sakaguchi S et al. (2001) Immunologic tolerance maintained by CD25 + CD4 + regulatory T cells: their common role in controlling autoimmunity, tumor immunity, and transplantation tolerance. *Immunol Rev* 182:18–32
9. Schwartz M, Kipnis J (2002) Autoimmunity on alert: naturally occurring regulatory CD4(+)CD25(+) T cells as part of the evolutionary compromise between a 'need' and a 'risk'. *Trends Immunol* 23:530–534
10. Hauben E et al. (2001) Posttraumatic therapeutic vaccination with modified myelin self-antigen prevents Complete paralysis while avoiding autoimmune disease. *J Clin Invest* 108:591–599
11. Rossignol S, Schwob M, Schwartz M, Fehlings MG (2007) Spinal cord injury: Time to move? *J Neurosci* 27(44):11782–1192
12. Hauben E et al. (2003) Vaccination with dendritic cells pulsed with peptides of myelin basic protein promotes functional recovery from spinal cord injury. *J Neurosci* 23:8808–8819

## Protein Kinase A (PKA)

### Definition

Also known as cAMP-dependent protein kinase. A family of protein kinases whose activity are dependent on the level of cAMP in the cell.

## Protein Kinase C (PKC)

### Definition

An enzyme that exists in many different forms, which are central to many signal transduction mechanisms in brain cells.

## Protein Phosphatase 1, PP-1

►Protein Serine/Threonine Phosphatases in the Nervous System

## Protein Phosphatase 2A, PP-2A

►Protein Serine/Threonine Phosphatases in the Nervous System

## Protein Phosphatase 2B, PP-2B

►Protein Serine/Threonine Phosphatases in the Nervous System

## Protein Serine/Threonine Phosphatases in the Nervous System

QIN YAN<sup>1,2</sup>, YING-WEI MAO<sup>3</sup>, DAVID W. LI<sup>1,2,4</sup>

<sup>1</sup>Department of Biochemistry and Molecular Biology, College of Medicine, University of Nebraska Medical Center, Omaha, NE, USA

<sup>2</sup>Key Laboratory of Protein Chemistry and Developmental Biology of National Education Ministry of China, College of Life Sciences, Hunan Normal University, Changsha, Hunan, China

<sup>3</sup>Howard Hughes Medical Institute, Massachusetts Institute of Technology, Boston, MA, USA

<sup>4</sup>Department of Ophthalmology and Visual Sciences, College of Medicine, University of Nebraska Medical Center, Omaha, NE, USA

### Synonyms

Protein Phosphatase 1, PP-1; Protein Phosphatase 2A, PP-2A; Protein Phosphatase 2B, PP-2B

### Definition

Protein Serine/threonine phosphatases are a family of protein enzymes, which specifically remove the phosphate group from the serine or threonine residues of the substrate proteins. These phosphatases termed PPPs include ►PP-1, ►PP-2A, ►PP-2B, ►PP-2C, PP-4, PP-5, PP-6 and PP-7.

### Characteristics

The reversible ►phosphorylation and ►dephosphorylation of proteins at the serine, threonine and tyrosine residues play fundamental roles in mediating different signaling transduction pathways and thus act as a major mechanism to regulate eukaryotic cellular events such as gene expression, cell proliferation, differentiation, homeostasis and apoptosis. The two processes executed by ►protein kinases and ►protein phosphatases can trigger conformational changes in regulated proteins that finally alter their biological properties and functions. In this regard, phosphorylation may endow a protein with a favorable conformation for binding by its relative substrates or partners, which in the end brings about some cellular and morphological changes; on the contrary, its dephosphorylated form may possess these features. And at any instant, a protein's specific phosphorylation status is a balanced result between its regulatory kinases and phosphatases.

Genome research has identified 147 genes coding for the catalytic subunits of protein phosphatases. According to differences in substrates, the protein phosphatases can be divided into three groups, including ►protein serine/threonine phosphatases (PPPs), protein ►tyrosine

**phosphatases** (PTPs), and dual-specific phosphatases (DSPs). On the basis of the selective inhibition of type-1 phosphatases (PP-1) by endogenous inhibitor-1 (▶I-1) and inhibitor-2 (▶I-2), the PPP family can be further divided into type-1 (PP-1) and type-2 (▶PP-2) subgroups and a few minor phosphatases that include PP-4, -5, -6 and -7, although these phosphatases have a broad and overlapping substrate specificity. The PP-1 enzyme is composed of a catalytic subunit and one or more regulatory subunits, and it is hard to distinguish the regulatory subunit from its inhibitor or substrate. The PP-2 subgroup consists of three enzyme members, PP-2A, PP-2B and PP-2C, which can be distinguished by their substrate specificity, subunit number and the specific cations needed for function. For instance, PP-2A can dephosphorylate phosphorylase-a, while PP-2B and PP-2C do not. In addition, calcium is necessary for the function of PP-2B, which is also known as calcineurin. While PP-2A is composed of three subunits and PP-2B two subunits, PP-2C is a monomeric enzyme. In eukaryotes, 98% of dephosphorylation occurs at the serine/threonine residues, and more than 90% of protein ▶serine/threonine phosphatase activity is contributed by PP-1 and PP-2A [1].

### Protein Phosphorylation in the Nervous System

Based on morphology and physiology, the adult nervous tissue is composed of two main cell types: neurons and glial cells. Neurons transmit high speed nerve signals through depolarization potentials, while glial cells are in direct contact with neurons to provide a basic support. Existing in variable sizes and shapes, neurons are the functional units of the nervous system. All neurons consist of three parts: dendrite, cell body and axon. Dendrites receive information from another cell and transmit information to the cell body. The cell body contains the nucleus, mitochondria and other organelles typical of eukaryotic cells, and processes the neuronal signals for further transduction. The axon sends information away from the cell body. Under normal conditions, glial cells surround neurons to modulate neuronal homeostasis and detoxification, and produce neuronal survival factors. The functions of crucial proteins in the nervous system are modulated by kinases and phosphatases. This essay focuses on the functions of three major protein phosphatases in the nervous system, PP-1, PP-2A and PP-2B.

#### Protein Phosphatase-1 (PP-1)

Early studies showed that PP-1 accounts for 25–40% of the phosphorylase phosphatase activity in brain crude tissue extracts. In isolated synaptic junctions from rat forebrain, PP-1 accounts for 80% of the membrane-associated phosphatase activity. PP-1 can be inactivated by the inhibitor I-1 when phosphorylated by CAMP-dependent protein kinases, or by the inhibitor I-2 in the

dephosphorylated form. In addition to the ubiquitous I-1 and I-2 inhibitors, brain tissue also contains a unique PP-1 inhibitor, ▶DARPP-32, present predominantly in neural tissues. The localization of DARPP-32 is unique, for it is abundant in specific areas of the brain, including the basal ganglia which contains as much as 130 pmol of DARPP-32 per mg protein, but absent from most other tissues. Compared with the basal ganglia, the thalamus and cerebellum contain much less DARPP-32. In brain areas rich in DARPP-32, discrete populations of neurons show particularly high level of expression, such as the D1-receptor dopaminergic neurons, and the Purkinje cells of the cerebellum. The high phosphatase activity of PP-1 in the brain and its co-localization with the cognate inhibitors suggest that PP-1 might serve as an important regulatory enzyme in various neuronal events.

Neurons produce and transduce signals through alternative shifts in membrane potentials, which depend on different ion channels distributed in the plasma membranes. Ion channel activity can be regulated by closely associated kinases or phosphatases, which serves as a key mechanism for orchestrating neuromodulation. PP-1 is responsible for the dephosphorylation and modulation of some neuronal ion channels. In many instances, dephosphorylation is required for channel activity. An exemplary case is the peptide neurotransmitter Phe-Met-Arg-PheNH<sub>2</sub> (FMRFamide) related serotonin-sensitive K<sup>+</sup> (S-K<sup>+</sup>) channel in Aplysia sensory neurons. Two PP-1 isoforms, with apparent MW of 170,000 and 38,000, were extracted from crude membrane preparations from the Aplysia nervous system. Biochemical and physiological studies suggest that of the two major protein phosphatases, PP-1 and PP-2A, PP-1 is associated preferentially with neuronal membranes and its activity is required for the induction of outward K<sup>+</sup> currents in Aplysia sensory neurons by FMRFamide [2]. Similarly, in rat brain and cerebellar Purkinje neurons, activation of the calcium-dependent potassium channels (BK channels) by neurotrophin-3 depends on their prior dephosphorylation by PP-1 or PP-2A. In addition, certain protein phosphatases are involved in the function of the nonselective cation channel that drives the after-discharge in Aplysia bag cell neurons. It has been shown that the reversal of the nonselective cation channel after addition of ATP was prevented by the PP inhibitor, ▶microcystin-LR.

Various receptors in the nervous system play important roles in mediating signal transduction. Protein phosphatases can modulate the functions of these receptors through dephosphorylation. An example is the regulation of AMPA receptor by PP-1. The filamentous actin binding protein neurabin I (Nrb I) targets PP-1 to specific postsynaptic microdomains, where it can exert critical control over AMPA receptor-mediated synaptic transmission. PP-1 dephosphorylates

AMPA subtype glutamate receptor (GluR) 2 at Ser 880 to stabilize the basal transmission; while with long-term depression (LTD), PP-1 dephosphorylates GluR1 at both serine 845 and serine 831. These results suggest that in response to distinct synaptic activities post-synaptic targeted PP-1 could regulate the synaptic trafficking of specific AMPA receptor subunits [3]. In the western painted turtle, PP-1 or PP-2A dephosphorylates N-methyl-d-aspartate (NMDA) receptors and decreases their activity, which attenuates calcium influx and thus, excitotoxic cell death (ECD), a characteristic of mammalian brain following anoxia.

Physiological modulation of other target molecules by protein serine/threonine phosphatases also plays a role in the nervous system. Neural cell adhesion molecule (NCAM) has important functions during development and maintenance of the nervous system. NCAM 140 and NCAM 180 are transmembrane glycoproteins with large cytoplasmic domains of different lengths. PP-1 and PP-2A bind to both NCAM 140 and NCAM 180, suggesting possible functions of these two protein phosphatases during the development and maintenance of the nervous system. Further, doublecortin (DCX) is a highly phosphorylated protein in migrating neurons, whose mutation causes X-linked lissencephaly (“smooth brain”) and double cortex syndrome in humans. It was reported that PP-1, by recruitment of Neurabin II, dephosphorylates the specific sites in DCX phosphorylated by JNK, which plays an important role in normal neuronal migration [4]. Finally, PP-1 may play an important in regulating brain and eye development. We recently demonstrated that PP-1 acts as a major phosphatase dephosphorylating the transcription factor Pax-6, which is highly expressed in the developing nervous system, and attenuates its transcriptional activity.

### Protein Phosphatase-2A (PP-2A)

PP-2A, also known as a polycation-stimulated phosphatase, is very abundant in brain where it is mainly cytosolic and represents 60–75% of the phosphorylase phosphatase activity. The PP-2A core enzyme is composed of a catalytic subunit (C) and a tightly complexed scaffolding subunit A. This core enzyme associates with a regulatory subunit B, whose function is to target the whole enzyme to specific intracellular locations and substrates. There are four subgroups of the B family subunits including B/PR55, B'/PR56/PR61, B''/PR72 and B'''/PR93/PR110. The major function of the ubiquitously expressed PP-2A seems to be related with a wide range of events under both physiological and pathological conditions in the nervous system.

PP-2A is implicated in Alzheimer's disease (AD), a progressive brain disorder that gradually destroys a person's memory and ability to learn, reason and communicate. The major brain abnormalities in patients

with AD include extracellular deposits of beta-amyloid, intraneuronal neurofibrillary lesions, and the massive loss of specific subsets of telencephalic neurons. Dysregulation of the regulatory subunit of ►PP2A, B/PR55, has been implicated in AD. Since one of the major functions of the B subunit in PP-2A is to target the whole enzyme to its substrates, its dysregulation might lead to a failure of dephosphorylation of relevant brain proteins and finally AD. Further, researchers have found that the abnormal phosphorylation of paired helical filaments (PHF) tau resulting from the failure of PP-2A and PP-2B may disrupt the microtubule network, impair axonal transport, and compromise the viability of neurons, thereby also contributing to the onset and progression of AD [5]. In the non-diseased nervous system, research at the *Drosophila* neuromuscular junction suggests that the B' regulatory subunit of ►protein phosphatase 2A may regulate normal cytoskeletal organization, synaptic growth, and synaptic function.

The physiological function of PP-2A is also being revealed. It was reported that PP-2A is required for the differentiation of pluripotent neural crest (NC) cells into the sympathoadrenal lineage. A moderate activation of cAMP signaling induces both the transcription and activity of the proneural transcription factor Phox2a in NCs, whereas treatment with the ►organic phosphatase inhibitor, ►okadaic acid, at a concentration (1–10 nM) effective to inhibit PP-2A, suppresses sympathoadrenal lineage development. PP-2A also functions in the mature nervous system. During spinal cord ►central sensitization, PP-2A may play an important role in determining the excitability of ►nociceptive neurons in the spinal cord by modulating the phosphorylation state of certain critical proteins. For instance, infusion of the phosphatase inhibitor okadaic acid or ►fostriecin, a specific PP-2A inhibitor, into the ►subarachnoid space enhances secondary mechanical ►hyperalgesia and ►allodynia [6]. In addition, it was observed that blockade of protein phosphatase activity potentiates central sensitization of nociceptive transmission in the spinal cord following capsaicin injection, indicating that PP-2A may be involved in determining the duration of capsaicin-induced central sensitization. Finally, since cyclin G1 and the B' subunits of PP-2A are co-localized in neurons, the function of PP-2A in the nervous system may depend partly on its regulation of cell cycle in neurons [7].

### Protein Phosphatase-2B (Calcineurin)

PP-2B belongs to the family of  $\text{Ca}^{2+}$ /calmodulin-dependent protein phosphatases and it is the only protein phosphatase regulated by a second messenger,  $\text{Ca}^{2+}$ . Furthermore, PP-2B is highly localized in the central nervous system, especially in those neurons

vulnerable to ischemic and traumatic insults. For these reasons, PP-2B is considered to play important roles in neuron-specific functions.

PP-2B has been extensively studied in nervous tissue. It was first purified as a major calmodulin-binding protein in brain (accounting for up to 1% of the total protein), and later identified as a protein phosphatase. The whole enzyme consists of two subunits, the catalytic and calmodulin-binding subunit calcineurin A, and the calcium binding regulatory subunit calcineurin B. PP-2B is essentially a neuronal protein due to its abundance in brain, where levels are 10–20 times higher than in other tissues. Nevertheless, it is distributed amongst a wide set of tissues in many species from yeast to mammals.

Some ion channels and receptors are regulated by PP-2B. In sympathetic neurons, the M current regulates neuronal excitability. Intracellular application of a preactivated form of PP-2B inhibited the macroscopic M current, while its application to excised inside-out patches reduced high open probability M channel activity. Thus, it is suggested that PP-2B selectively regulates M channel modal gating. PP-2B may also regulate the coupling between G protein and calcium channels in rat sympathetic neurons, as the  $\alpha 2$  noradrenergic and somatostatin receptor-induced inhibition of N-type  $\text{Ca}^{2+}$  channels was greatly reduced by inhibition of PP-2B. Interestingly, PP-2B in some cases may regulate both the function and the expression of a protein. For instance, PP-2B directly regulates type 1 inositol 1, 4, 5-triphosphate receptor (IP3R) function by dephosphorylation on a short-term time scale and IP3R expression over more extended periods.

The physiological functions of PP-2B in the nervous system seem to be quite diverse. On one hand, PP-2B regulates certain signaling transduction pathways in neurons by directly dephosphorylating target protein substrates. An example is its regulation of the NF- $\kappa$ B pathway in astrocytes of the injured brain. After brain injury a reactive phenotype of astrocytes is triggered which produces inflammatory cytokines and neurotoxic free radicals and leads to brain trauma. Under such circumstances, insulin-like growth factor-I (IGF-I) regulates the NF- $\kappa$ B pathway by activating PP-2B to dephosphorylate I $\kappa$ B $\alpha$ , which leads to a stabilization of I $\kappa$ B $\alpha$  and retention of NF- $\kappa$ B in the cytosol and hence inhibition of the inflammatory reaction [8].

In other systems, the signal transduction pathways regulated by PP-2B result in the activation of different transcription factor cascades. For instance, in the mammalian nervous system, PP-2B appears to regulate the number of excitatory synapses via myocyte enhancer factor 2 (MEF2). After dephosphorylation and activation by PP-2B, MEF2 promotes the transcription of a set of genes that restricts synapse number.

Alternatively, regulation of other signaling transduction pathways by PP-2B involves the downstream transcription factor NF-AT. In calcium-regulated pathways related to learning and memory process, NF-ATc4/NF-AT3 in hippocampal neurons can be translocated rapidly from the cytoplasm to the nucleus to activate NF-AT-dependent gene transcription in response to electrical activity or potassium depolarization. The PP-2B-mediated translocation is critically dependent on calcium entry through L-type voltage-gated calcium channels. This indicates that PP-2B/NF-AT-mediated gene expression may be involved in the induction of hippocampal synaptic plasticity and memory formation. In addition, the PP-2B/NF-AT pathway is involved in neuronal axon outgrowth, the first step in the formation of neuronal connections. After stimulation by growth factors, PP-2B caused nuclear localization of NF-ATc4 and the activation of NF-AT-mediated gene transcription in cultured primary neurons. Blockade of this pathway prevented axon outgrowth, indicating that PP-2B/NF-AT signaling is required during nervous system development [9]. PP-2B also enhances NGF-induced neurite outgrowth.

The list of roles for PP-2B is ever growing in that PP-2B activity regulates synaptic function. For instance, PP-2B activity is required for three forms of synaptic plasticity in the hippocampus and associative learning in *Caenorhabditis elegans* and also reward-related learning in mice. The importance of PP-2B in synaptic function is illustrated by the fact that conditional calcineurin knockout mice exhibit multiple abnormal behaviors related to schizophrenia [10], and that PP-2B is also implicated in epileptogenesis.

## Conclusions

In summary, the protein serine/threonine phosphatases seem to be involved extensively in the regulation of neuronal development, differentiation, physiology and pathogenesis. The unscrambling of the signaling transduction pathways in nervous system would be a feasible solution for the ultimate conquering of various brain diseases such as Alzheimer's disease, epileptogenesis, and schizophrenia. Elucidation of the functional mechanisms of the protein phosphatases in the nervous system will provide a better understanding of neuronal function and brain disease.

## Acknowledgments

This work is supported in part by the NIH/NEI grant 1R01EY015765, the startup funds from the University of Nebraska Medical Center, the Changjiang Scholar Team Project Funds from the National Education Ministry of China and the Lotus Scholar Program Funds from Hunan Province Government and Hunan Normal University.

## References

1. Cohen P (1989) The structure and regulation of protein phosphatases. *Annu Rev Biochem* 58:453–508
2. Endo S, Critz SD, Byrne JH, Shenolikar S (1995) Protein phosphatase-1 regulates outward K<sup>+</sup> currents in sensory neurons of *Aplysia californica*. *J Neurochem* 64(4):1833–1840
3. Hu XD, Huang Q, Yang X, Xia H (2007) Differential regulation of AMPA receptor trafficking by neurabin-targeted synaptic protein phosphatase-1 in synaptic transmission and long-term depression in hippocampus. *J Neurosci* 27(17):4674–4686
4. Shmueli A, Gdalyahu A, Sapoznik S, Sapir T, Tsukada M, Reiner O (2006) Site-specific dephosphorylation of doublecortin (DCX) by protein phosphatase 1 (PP1). *Mol Cell Neurosci* 32(1–2):15–26
5. Trojanowski JQ, Lee VM (1995) Phosphorylation of paired helical filament tau in Alzheimer's disease neurofibrillary lesions: focusing on phosphatases. *FASEB J* 9(15):1570–1576
6. Zhang X, Wu J, Fang L, Willis WD (2003) The effects of protein phosphatase inhibitors on nociceptive behavioral responses of rats following intradermal injection of capsaicin. *Pain* 106(3):443–451
7. van Lookeren Campagne M, Okamoto K, Prives C, Gill R (1999) Developmental expression and co-localization of cyclin G1 and the B' subunits of protein phosphatase 2a in neurons. *Brain Res Mol Brain Res* 64(1):1–10
8. Sebastian Pons and Ignacio Torres-Aleman (2000) Insulin-like growth factor-I stimulates dephosphorylation of IyB through the serine phosphatase calcineurin (protein phosphatase 2B). *J Biol Chem* 275(49):38620–38625
9. Graef IA, Wang F, Charron F, Chen L, Neilson J, Tessier-Lavigne M, Crabtree GR (2003) Neurotrophins and netrins require calcineurin/NFAT signaling to stimulate outgrowth of embryonic axons. *Cell* 113(5):657–670
10. Miyakawa T, Leiter LM, Gerber DJ, Gainetdinov RR, Sotnikova TD, Zeng H, Caron MG, Tonegawa S (2003) Conditional calcineurin knockout mice exhibit multiple abnormal behaviors related to schizophrenia. *Proc Natl Acad Sci USA* 100(15):8987–8992

## Protein Synthetic Machinery

### Definition

The protein synthetic machinery of a eukaryotic cell consists of ribosomes, endoplasmic reticulum (ER) and Golgi apparatus. Proteins destined to stay within the cytoplasm (cytosolic proteins) are synthesized on ribosomes and the product is released into the cytoplasm. Luminal proteins (proteins packaged in vesicles) and integral membrane proteins are synthesized on ribosomes that are docked on the endoplasmic reticulum, and the polypeptide chain is secreted in the lumen of the ER (luminal proteins), or is inserted into the membrane of the ER (integral membrane proteins).

After trafficking through the Golgi apparatus the proteins are either released (secretory proteins), inserted into the cytoplasmic membrane (integral membrane proteins), or stored within vesicles in the cytoplasm (lysosomes).

### ► Extrasomal Protein Synthesis in Neurons

## Protein Tyrosine Kinase

### Definition

A protein that contains a domain that acts as a kinase, which transfers a phosphate group from ATP to a tyrosine of a protein.

## Protein Zero (P0)

### Definition

P0 was identified as the major protein component of Schwann cell myelin. The P0 gene is expressed throughout the Schwann cell lineage, from precursors in embryonic development to myelinating Schwann cells in the adult animal. During development, neurons do not express P0 gene, thus P0 gene expression can be used as an early marker of glial specification in neural crest development. In normal adult nerves, expression of P0 gene and protein is restricted to myelin-forming Schwann cells.

### ► Myelin

### ► Schwann Cell

### ► Schwann Cells in Nerve Regeneration

## Proteoglycan

### Definition

Proteoglycans are molecules that possess a protein core to which are attached one or more glycosaminoglycan chains at serine residues through a four sugar linker. In chondroitin sulfate proteoglycans the chains are made of repeating glucuronic acid and n-acetyl galactosamine, while in heparan sulfate proteoglycans the two

sugar repeat is glucuronic acid (which may be epimerized to iduronic acid) and n-acetyl glucosamine.

The glycosaminoglycan chains are modified by sulfation at various points on the two sugars. Particularly in heparan sulfates sulfation occurs in patches. The pattern of sulfation defines the charge pattern of the glycan and therefore its binding properties. Chondroitin sulfate proteoglycans often have barrier functions, while heparan sulfate proteoglycans are often found as part of a ternary complex presenting growth factors to their receptors.

## Proteomics and the Study of the Nervous System

JENS R. COORSSEN<sup>1,2</sup>

<sup>1</sup>Hotchkiss Brain Institute, Faculty of Medicine, University of Calgary, Calgary, Alberta, Canada

<sup>2</sup>Chair of Molecular Physiology, School of Medicine, University of Western Sydney, Campbelltown, NSW, Australia

### Definition

Proteomics encompasses a number of techniques and approaches. At its simplest, it could be described as the large-scale analysis of the proteins encoded by a given genome, or of those proteins present, at the time of sampling, in a given biological milieu (e.g., tissue/cell extract, bodily fluid, etc). The term, coined by Marc Wilkins and colleagues in 1994, describes a new discipline that has moved forward from genomics to enable a more mechanistic understanding of biological processes and disease states. While the genome provides information regarding the proteins (and mutations) potentially expressed by a specific organism, it does not identify which proteins are locally expressed at a specific time, under specific conditions, nor does it provide information concerning the myriad of potentially critical post-translational modifications that can affect specific aspects of protein localization and function. Furthermore, although assessment of mRNA levels (▶[transcriptomics](#)) is sometimes used as a surrogate for more detailed protein analyses, this often does not accurately reflect the actual protein complement (e.g., functional players) at the time of sampling. Thus, the definition of proteomics has grown to include not only the presence of an array of proteins in a sample, but also the localization, post-translational modifications, activities, and interactions of these proteins with each other and with other molecules. In many ways, the original approach has spawned a variety of sub-disciplines that might be broadly defined as follows:

Functional proteomics – the tight coupling of quantitative functional assays with detailed protein analyses as a direct route to dissecting molecular mechanisms underlying physiological processes.

Structural proteomics – perhaps most akin to structural biology, with the goal of defining the three dimensional or atomic structure of a protein as a route to understanding functional interactions/mechanism(s) of action within the cellular environment.

Discovery or Clinical proteomics – scanning of ▶[proteomes](#) to identify alterations that potentially underlie a disease pathway or that could serve as biomarkers for specific clinical conditions. The resulting “catalogues” generally serve as important databases for other ongoing work as well.

### Characteristics

What then separates proteomics from more traditional protein biochemistry/physical chemistry and cell physiology? This is generally seen to be a matter of scale, throughput, and automation. Rather than asking about the potential role of a single protein in a specific process, proteomics takes a global or systems approach to the integrated roles of proteins in physiological processes. Thus, as a discipline, proteomics has really arisen from the necessary interactions of protein (bio)chemists, cell physiologists, computer scientists, and engineers. The goal of this inter-disciplinary approach is to enhance the ▶[resolution](#) and throughput of large-scale protein analysis, while simultaneously reducing any potential user bias in the assessment process. With the introduction of computer-driven automation, robotics, and data analysis, the result has been enhanced reproducibility, sensitivity, higher throughput, more objective analyses of the resulting protein data (particularly via subtractive analysis to identify critical differences between data sets), and the establishment of a myriad of databases, making information sharing one of the more important and successful priorities in proteomics.

### Techniques

Until relatively recently, proteomics was almost synonymous with two-dimensional polyacrylamide gel electrophoresis (2DE). Building from earlier work, this technique was introduced in the mid-1970s and immediately revolutionized protein analysis. Proteins are separated by ▶[isoelectric focusing](#) in the first dimension, according to their ▶[pI \(Isoelectric Point\)](#), and in the second dimension according (approximately) to their molecular weight (MW), using sodium dodecyl sulphate polyacrylamide gel electrophoresis ▶[SDS-PAGE \(Sodium Dodecyl Sulfate Polyacrylamide Gel Electrophoresis\)](#) [1]. In principle, any physical attribute of a protein can be used to establish a separation/purification strategy; hydrophobicity is another commonly used characteristic to aid in protein isolation. For several



years, identification of specific protein spots could only be done by Western blotting (immunodetection) or Edman degradation. The real revolution in terms of proteomics developing as a discipline was the integration of ► **mass spectrometry** for protein identification. With an appropriately “clean” protein sample (see below), it is now routine to excise a spot of interest from a 2DE gel, digest it with a protease (usually trypsin) or another selective agent (such as cyanogen bromide), and analyze the resulting peptides using a variety of mass spectrometric methods. The simplest analysis is to derive a peptide fingerprint and attempt to identify the protein using computerized searches of available databases; essentially, archived protein sequences are digested *in silico*, and the best matches to the unknown protein identified. This approach has fallen out of favor due to a high rate of false-positives, although with a well-defined genome to search, this can be a useful scanning tool. More effort is now placed in using mass spectrometry for *de novo* protein sequencing and thus definitive protein identifications, as well as for the analysis of post-translational modifications [2].

Within the last several years, non-gel based approaches to large-scale protein resolution have been developed based on a combination of liquid chromatography and mass spectrometry (or other techniques “hyphenated” with mass spectrometry). Basically, a gross protein extract is proteolytically digested to yield a complex peptide mixture and this is then fractionated, generally by sequential cation-exchange and reverse-phase chromatography, and random samples of the separated peptides are then sequenced in a mass spectrometer [3]. Possible protein identifications are then made based on the presence of peptides “unique” to specific proteins. This so-called “shotgun” proteomics approach has proven to be an effective scanning tool. Most recently, additional proteomic applications for mass spectrometry have included analysis directly from tissue samples (“imaging” mass spectrometry); although not of high resolution, this technique does provide direct information on the localization of specific proteins [4].

### Pros and Cons

It is probably safe to say that 2DE remains the workhorse of proteomics and the current gold-standard in terms of protein resolution. It certainly remains the only method currently available with the capacity to resolve thousands of proteins in a single run. The major complaint that seems to be leveled against it is that it is “old,” yet it is precisely this maturity that yields analytical power: problems have been identified and effectively addressed; in the case of newer approaches, most problems have likely not even yet been effectively identified. High throughput always comes at a cost; in the case of shotgun methods, information concerning the ► **pI**, **MW**, and post-translational modifications of

proteins is lost, and the approach requires substantial computing infrastructure. Nonetheless, it is likely an integration of these scanning and higher resolution approaches that will define future proteomic efforts, particularly considering the current pace of developments in mass spectrometry.

Regardless of the analytical approach used, the biggest difficulty in proteomics is that of protein detection. While it is likely that we are currently capable of resolving most proteins, those present at lower abundance (e.g., a few to tens of copies per cell) are not detectable using currently available total protein stains [5]; if a protein of interest is known, it can however be detected by a quantitative, high sensitivity Western blotting protocol [6]. There is currently no simple solution to this general detection problem except to fractionate the sample in some way and thus increase the total protein concentration of a specific fraction prior to analysis. Such prefractionation techniques are currently under intense development, particularly for samples such as plasma and cerebrospinal fluid that are dominated by a few high abundance species that obviate the effective analysis of the rest of the proteome. Such prefractionation can be as simple as lysing a tissue sample or cell pellet and using ultracentrifugation to isolate total soluble and membrane protein fractions that can then be separately resolved [7,8]. A myriad of alternate techniques, including sequential extractions with different detergents and/or solvents, selective precipitation, or immuno-isolation of select components, each resulting in the concentration of certain proteins, are all being used. Notably, care must be taken to avoid potential non-specific alterations to the proteome using these more aggressive approaches. In this regard, it has also been found that 2DE gels can be post-fractionated to further enhance the resolution of this technique [8].

### Process

The primary caveat when embarking on any proteomic analysis is cleanliness. In the past, if all that was to be done with a 2DE gel for instance was staining or Western blotting, minor contaminants (most commonly, human skin keratin!) were of little or no consequence. Now however, the goal is to identify specific resolved proteins using mass spectrometry; more often than not, the first painful lesson is to find keratin everywhere, obviating any possible protein identification. All buffers and equipment must be scrupulously clean and maintained as such. The Brain Proteome Project initiative of the Human Proteome Organization is helping to establish criteria for sample handling and analysis ([www.hbpp.org](http://www.hbpp.org)).

The goal of proteomics is thus an analysis that accurately represents the underlying biological complexity of the sample at the instant of sampling. Thus, regardless of the analytical technique eventually used to resolve the proteins, there must be a focus on optimal sample handling. All tissue dissections, isolations, and

extractions are done in the presence of broad-spectrum protease, kinase, and phosphatase inhibitors [7,8]. In the case of tissue samples, including brain and spinal cord, we have found that the only way to ensure integrity of the protein complement is to snap freeze the sample at the instant of sampling; subsequent automated frozen disruption effectively powders the sample, ensuring optimal protein extraction [7]. In this regard, optimal solubilization of membrane proteins has always been a major concern, spurring development of multiple different detergents to supplement/supplant the most widely used, CHAPS (3 [(3-cholamidopropyl) dimethylammonio]-1-propanesulfonate); we have found that simply supplementing the CHAPS-based buffer with lysophosphatidylcholine substantially enhances the extraction and subsequent analysis of membrane proteins, particularly from neural tissue [9].

With an acceptable isolate in hand, the proteome can, as discussed above, be resolved by different techniques. In the case of 2DE, after the proteins are resolved on the second dimension gel, they must be detected. Currently, the favored total protein stain is Sypro Ruby due to its sensitivity, low variation in staining across protein species, and compatibility with subsequent mass spectrometric analysis. However, developments in this area are a major focus, and it is likely that another stain with enhanced sensitivity will be identified and widely used. Following staining, the gel is imaged, and it is this image that is then analyzed using specific software packages; these image analysis programs can warp and match images within sets of gels and then essentially overlay these, and carry out subtractive or differential analysis to identify statistically significant alterations in the proteome. In an effort to get as much information as possible from a single gel, “multiplexing” is gaining in popularity; here at least one other stain specific for a class of proteins (e.g., phosphorylated or glycosylated) is first used to identify select changes in the proteome, and then the total protein pattern is analyzed for more global changes. Proteins of interest are then excised, digested, and analyzed by mass spectrometry, as described above.

### Applications in Neuroscience

With respect to Basic research, the use of proteomics has focused largely on the analysis of synaptic vesicles and the post-synaptic density. Here the effort has been to define the protein components and, in some cases, more specifically the phosphoprotein sub-proteome due to the importance of this ► [post-translation modification](#) in neural function.

To date, the more widespread application of proteomics has been in the area of Neurological and related disorders [10]. This has included studies on

Alzheimer’s disease, spinal cord injury, muscular dystrophy, Parkinson’s disease, and epilepsy, but this is far from an exhaustive list. The focus has largely been on identifying (phospho)protein alterations that may underlie the susceptibility, progression, or fundamental mechanism of a given disorder. Both in Neuroscience and other Clinical disciplines, the initial goal is most often to identify biomarkers of the condition in question so as to ensure more objective and accurate diagnoses and prognoses. The limitation is clearly accessibility, particularly in terms of acquiring samples from age-matched, “normal” controls; simply put, it is all but impossible to obtain samples from unaffected individuals. Thus, researchers must develop experimental designs that take into account the fact that human neural tissue is an unlikely sample source except in some specific instances of surgery. Although often used, post-mortem sampling must be recognized as insufficient in many regards due principally to the fact that tissue resection generally occurs at variable time intervals after death and that the expression levels of different proteins undergo significant alterations (both increasing and decreasing) during the time that precedes tissue sampling. In most cases though, a more serious and often overlooked caveat is that of disease progression; in most cases, sampling is only possible after clinical diagnosis, and thus after the damage has already occurred. What is to be reasonably learned at this stage? It would thus seem that, without appropriate animal models, much of the application of proteomics to questions in Clinical Neuroscience/Neurology will focus on identifying alterations that occur “after the fact.” Although this is important from the standpoint of understanding the molecular mechanisms of disease progression or recovery from injury, it will unlikely be informative with regard to alterations underlying disease susceptibility and inception. Critical study design and focused application of techniques is mandatory to ensure successful experimental outcomes that will include the identification of effective diagnostic/prognostic biomarkers as well as components underlying fundamental disease mechanisms. This will largely hinge on the analysis of accessible diagnostic biofluids (e.g., cerebrospinal fluid, urine, plasma, and saliva). Thus, coupled with transcriptomics, ► [metabolomics](#), and other, developing, molecular analytical tools, proteomics promises to drive substantial advances in Basic, Clinical, and Translational Neuroscience research.

### References

1. Carrette O, Burkhard PR, Sanchez JC, Hochstrasser DF (2006) State-of-the-art two-dimensional gel electrophoresis: a key tool of proteomics research. *Nat Protoc* 1:812–823

2. Olson MT, Epstein JA, Yergey AL (2006) De novo peptide sequencing using exhaustive enumeration of peptide composition. *J Am Soc Mass Spectrom* 17:1041–1049
3. Lohaus C, Nolte A, Blüggel M, Scheer C, Klose J, Gobom J, Schüler A, Wiebringhaus T, Meyer HE, Marcus K (2007) Multidimensional chromatography: a powerful tool for the analysis of membrane proteins in mouse brain. *J Proteome Res* 6:105–113
4. Altelaar AF, Luxembourg SL, McDonnell LA, Liersma SR, Heeren RM (2007) Imaging mass spectrometry at cellular length scales. *Nat Protoc* 2:1185–1196
5. Harris LR, Churchward MA, Butt RH, Coorsen JR (2007) Assessing detection methods for gel-based proteomic analyses. *J Proteome Res* 6:1418–1425
6. Coorsen JR, Blank, PS, Albertorio F, Bezrukov L, Kolosova I, Backlund PS Jr., Zimmerberg J (2002) Quantitative femto- to attomole immunodetection of regulated secretory vesicle proteins critical to exocytosis. *Anal Biochem* 307:54–62
7. Butt RH, Coorsen JR (2006) Pre-extraction sample handling by automated frozen disruption significantly improves subsequent proteomic analyses. *J Proteome Res* 5:437–448
8. Butt RH, Coorsen JR (2005) Postfractionation for enhanced proteomic analyses: routine electrophoretic methods increase the resolution of standard 2D-PAGE. *J Proteome Res* 4:982–991
9. Churchward MA, Butt RH, Lang JC, Hsu KK, Coorsen JR (2005) Enhanced detergent extraction for analysis of membrane proteomes by two-dimensional gel electrophoresis. *Proteome Sci* 3:5
10. Drabik A, Bierczynska-Krzysik A, Bodzon-Kulakowska A, Suder P, Kotlinska J, Silberring J (2007) Proteomics in neurosciences. *Mass Spectrom Rev* 26:432–450

## Protostome/Deuterostome

### Definition

The Deuterostome clade in the animal kingdom including chordates, Hemichordates and Echinoderms.

In Deuterostome animals the Blastopore develops into the anus of the animal. The protostome clade contains most invertebrate phyla. In Protostome animals the Blastopore develops into the mouth of the animal. The Protostome clade is further subdivided into Lophotrochozoans and Ecdysozoans. The Lophotrochozoan clade most animals pass a trochophora-larva stage or use a Lophophor (tentacle like structure). In the Ecdysozoan clade most animal go through a molting process by Ecdysis.

► [Evolution of the Brain: Urbilateria](#)

## Proust Effect

GORDON M. SHEPHERD<sup>1</sup>,  
KIRSTEN SHEPHERD-BARR<sup>2</sup>

<sup>1</sup>Department of Neurobiology, Yale University School of Medicine, New Haven, CT, USA

<sup>2</sup>Faculty of English, Oxford University, Oxford, UK

### Definition

“But when from a long-distant past nothing subsists, after the people are dead, after the things are broken and scattered, taste and smell alone, more fragile but more enduring, more unsubstantial, more persistent, more faithful, remain poised a long time, like souls, remembering, waiting, hoping, amid the ruins of all the rest; and bear unflinchingly, in the tiny and almost impalpable drop of their essence, the vast structure of recollection.” (*Swann’s Way*, trans. Moncrieff, 50–51).

The best known example of the power of smell to evoke memories and emotions is the “Proust effect,” as described in the quotation above. This is based on a sensory experience described by Marcel Proust in *Remembrance of Time Past* [1]. The episode involves tasting a small cake dipped in tea, and being suddenly flooded with a childhood memory. The suddenness of the memory, and the strong emotions attached to it, have become symbolic, in both the realm of literary criticism and in sensory physiology, for the power of human taste and smell. Here we review the episode, and show that there is more than meets the eye (and nose).

### Characteristics

#### The Madeleine Incident

Proust’s character Marcel is in a depressed mood when he visits his mother. To soothe him she serves him a cup of tea and a madeleine cake. He dips the cake in the tea, tastes it, and is immediately seized by an overwhelming emotion: “an exquisite pleasure had invaded my senses, something isolated, detached, with no suggestion of its origin.” He is aware that behind this is an as yet unidentified memory. After several more tastes and an intense period of searching his memory, he is suddenly transported back to his childhood summers in a seaside resort, Combray, which are associated with happy times. With repeated tasting the power of the memory fades.

#### The Theory of Pure Memory

In Proust’s view, he had uncovered an essential truth about himself, elicited by taste and smell from a “pure memory” unadulterated by being remembered during the intervening years. From this he erected a theory of involuntary (unconscious) versus voluntary

(conscious) memory. Samuel Beckett [2] followed with the view that voluntary (i.e., adulterated) memory cannot recall the exact (i.e., pure) sensation as it was originally experienced. Many literary critics have taken up this view and built on it, regarding it as showing how memory can spring suddenly and purely into mind, triggered after a long period of being forgotten. As a byproduct, they have maintained that conscious autobiographical memory is therefore artificial, a created fiction, compared with true, involuntary memory of the type evoked from the unconscious by the tea-soaked madeleine.

### Re-Examining the Theory

We have re-examined Proust's account to test this view [3]. A close textual analysis has revealed that the memory was not sudden, but was the result of considerable effort, as described by the author. Indeed, a page and a half of text is required to describe the repeated efforts of the author to recall the memory. Thus, it appears that as soon as involuntary memory is brought into the arena of consciousness, it too, like voluntary recall, is subjected to similar processes of selection, editing and revision. We have further argued that an understanding of those processes requires knowledge of the neural pathways involved.

### What does Neuroscience Tell Us?

Given its iconic status, the madeleine incident thus serves as a useful model for asking: What was happening in Marcel's brain, from the initial sensing of the taste of the tea-soaked madeleine cake to the emotions it called forth, and the memory that finally appeared? Recent research on the sensory mechanisms involved provides several insights that are generally unappreciated even among most neuroscientists.

First, we realize that the smell of an ingested item, cake or otherwise, is due to stimulation of the smell receptors in the nose not by sniffing in, but by breathing out. The volatiles released from the ingested food and liquid at the back of the mouth are carried by exhaled air by the retronasal route through the nasopharynx to reach the receptors (Sun and Halpern, 2005). This olfactory stimulation carries the major part of what appears to be the "taste," but it goes largely unrecognized as smell because it is referred to the mouth where the food and liquid are located. To avoid the confusion, the term "flavor" can be used to refer to the combined sense of taste and smell, as mentioned in the initial quotation from Proust. In fact, flavor also includes all the other senses associated with food intake: touch, pressure, pain, temperature, sound, and even the sight of the food before ingestion.

Second, the olfactory receptor cells connect to the olfactory bulb, where their responses are converted

into spatial activity patterns, called variously odor images or odor maps [4]. Smell perception, by itself or as part of flavor, thus involves discrimination of different spatial images, which also vary with time. We can therefore hypothesize that Proust's effort to identify the memory of the smell of the madeleine involved matching the spatial pattern aroused by that smell with the similar spatial pattern contained in his memory. It may be similar to recognizing complex visual patterns such as faces.

Third, after processing by microcircuits in the olfactory bulb, the odor image is sent to the olfactory cortex, where it is converted by microcircuits into a distributed form called a content-addressable memory [5]. The output of this memory representation has two main destinations. One is to the prefrontal cortex, where it is processed by the highest cognitive centers of the brain [6]. The other is to centers in the limbic system, where emotions are generated. The olfactory pathway has privileged direct access to both these sites; hence the combination of intense emotion and intense cognitive effort experienced by Proust in recollecting the memory of Combray.

Finally, the olfactory pathway contains a series of mechanisms to reduce the stimulation with repeated odor exposure, called adaptation or desensitization, which appear to be reflected in Proust's account of the fading of the sensations with repeated tasting of his madeleine. Rather than intensifying over time, the memory/emotion diminishes with repeated tasting of the triggering stimulus.

### The Neural Basis of the Proust Effect

How is the entire memory of Combray recalled from a single sip of tea? This should not be surprising; our cognitive mechanisms have a gestalt quality, in which we perceive and recall things as integrated wholes. According to Nadel and Moscovitch [7], "recovery of remote memories always depends on re-activation of the hippocampal–neocortical complex that constitutes the memory trace." One may hypothesize that this trace, representing the memory of Combray, is distributed in the olfactory cortex and the hippocampal–neocortical complex in a content-addressable form so that a small part of it – the flavor of the madeleine – activates it in its entirety. The brain's ability to fill in the rest of the memory image is turned by Proust into metonymy.

### Conclusion

We have here summarized only briefly the Proust effect, the literary superstructures built on it, and the recent neuroscience research that gives insight into the relevant brain mechanisms. Further information may be gained from the cited references. The present account may indicate the increasing attraction of this experience as a

model for the brain circuits underlying the power of human senses in general, and the chemical senses in particular. Indeed, the Proust effect may be one of the best instances in which literary criticism can benefit from brain research, and neuroscientists can benefit from literary studies that extend the significance of their experiments into the domain of public discourse.

## References

1. Proust M (1987) *A la Recherche du Temps Perdu*. Du Cote de Chez Swann. Flammarion, Paris
2. Beckett S (1931) *Proust*. Grove, New York
3. Shepherd-Barr K, Shepherd GM (1999) Madeleines and neuromodernism: reassessing mechanisms of autobiographical memory in Proust. *Autobiography Stud* 13:40–59
4. Xu FQ, Greer CA, Shepherd GM (2000) Odor maps in the olfactory bulb. *J Comp Neurol* 422:489–495
5. Neville KR, Haberly LB (2004) Olfactory cortex. In: Shepherd GM (ed) *The synaptic organization of the brain*. Oxford University Press, New York, 415–454
6. Rolls ET (2006) Brain mechanisms underlying flavour and appetite. *Philos Trans R Soc Lond B Biol Sci* 361:1123–1136
7. Nadel L, Moscovitch M (1997) Memory consolidation, retrograde amnesia and the hippocampal complex. *Curr Opin Neurobiol* 7:217–227
8. Sun BC, Halpern BP (2005) Identification of air phase retronasal and orthonasal odorant pairs. *Chem Senses* 30:693–706

## Pseudo-bulbar Paralysis

### Definition

Disease characterized by ► [dysarthria](#), ► [dysphonia](#), ► [dysphagia](#), bifacial ► [paralysis](#), forced crying and laughing, resulting from bilateral lesions of the ► [corticospinal tract](#).

► [Corticospinal Tract](#)

## Pseudogene

### Definition

Pseudogene is a defunct version of a known gene that has lost its ability to be transcribed.

## Pseudohypertrophy

### Definition

Increase in limb size not attributed to hypertrophy (increased size) of muscle fibers but due to adipose and connective tissue deposition; occurs in Duchenne Muscular Dystrophy.

► [Duchenne Muscular Dystrophy](#)

## Pseudorandom

### Definition

A process that appears random but is not. Pseudorandom sequences typically exhibit statistical randomness while being generated by an entirely deterministic computational process.

## Pseudotumor Cerebri

### Definition

Idiopathic intracranial hypertension (opening pressure >200–250 mmH<sub>2</sub>O on CSF examination), with or without papilledema, and/or transient visual obscurations.

Headaches may have a mild to moderate intensity occurring on any part of the head or globally.

► [Headache](#)

## Psychedelics

► [Hallucinogens](#)

## Psychic Gaze Paresis

### Definition

Staring gaze for minutes or sometimes hours, mostly upwards. It cannot be suppressed arbitrarily and is due to unconscious intrapsychical processes.

- ▶ Psychic Gaze Spasm
- ▶ Personality Disorder

## Psychoacoustics

THOMAS N. BUELL<sup>1</sup>, CONSTANTINE TRAHOTIS<sup>1,2</sup>,  
LESLIE R. BERNSTEIN<sup>1,2</sup>

<sup>1</sup>Department of Neuroscience, University of Connecticut Health Center, Farmington, CT, USA

<sup>2</sup>Department of Surgery (Otolaryngology), University of Connecticut Health Center, Farmington, CT, USA

### Synonyms

Auditory psychophysics; Psychological acoustics

### Definition

Psychoacoustics is the area of auditory research in which behavioral methods are used to discern and describe how, and how well, listeners perceive sounds. Combining information obtained from such experiments with corresponding information obtained from physiological and anatomical experiments has resulted in several important descriptions, explanations, and quantitative models of auditory function. Many of the relevant data and phenomena are discussed elsewhere in this volume. Therefore, this discussion is limited to two examples chosen to help the reader understand the kinds of questions addressed by psychoacousticians. In order to provide an intuitive understanding of the field, several practical applications that incorporate knowledge derived from psychophysical experiments will also be highlighted. For further information, the reader is referred to reviews of many pertinent topic areas [1] and two excellent introductory textbooks, one at a more advanced level [2] than the other [3].

### Characteristics

#### Types of Measures

Some experiments in psychoacoustics concern thresholds of detection. They measure the smallest *amounts* of physical stimulation required to produce a reliable

behavioral response indicating that the signal is present. Other experiments concern thresholds of discrimination. Their goal is to measure the smallest *changes* in physical stimulation required for listeners to indicate reliably that two signals are different. Still other, “scaling”, methods use listeners as meters and measure one of a number of perceptual attributes of sound, such as ▶ **loudness** and pitch.

### Ties to Physiology

It should be stressed that a comprehensive understanding of hearing also necessarily requires an appreciation of the whole auditory system. Consequently, psychoacousticians have traditionally attempted to understand behavioral data in light of knowledge concerning the anatomy and physiology of the auditory system. We will illustrate such attempts in the context of two important areas of auditory processing; intensity perception and frequency discrimination/▶ **masking**.

### Stimulus Intensity

In terms of sensitivity to small changes in intensity, there are two general outcomes to be stated and understood. First, people are quite sensitive to changes in intensity, and can typically discriminate between stimuli differing by about one dB or so. This “just noticeable difference” of 1 dB corresponds to a difference of 25% in acoustic power. In turn, this degree of sensitivity is maintained over about 10–12 orders of magnitude of intensity (i.e. over a range of about 100–120 dB). One goal of psychoacousticians has been to explain this pair of findings in physiological terms. This has proved challenging, because individual neural elements that compose the peripheral auditory nerve have been shown to respond differentially only over the limited and small “dynamic range” of 20–25 dB. To overcome this difficulty, models of intensity perception have focused on ways in which information from a number of individual nerve fibers might be “pooled”. The psychoacoustic and physiological findings are fairly well reconciled, using mathematical models that combine neural responses across small sets of neural elements. Portions of the set of neural elements are characterized as operating over different, albeit limited, ranges of intensity.

In order to understand changes in the perception of loudness, much larger changes of intensity must be considered. For example, it is universally found that one must increase the intensity of a signal by a factor of ten (or 10 dB) in order for it to be judged as “twice as loud”. That is, perceptual increases along a loudness dimension are not “one-to-one” with increases in the physical stimulus, but rather increase at a much slower rate. This empirical outcome, which indicates a high degree of “compression” of the stimulus, has recently

become to be understood at a physiological level. Compression, much like that suggested by the psychoacoustic data has been found in the mechanical-to-neural transduction that occurs in the cochlea. It is of further interest that such peripherally-based effects of compression must also be considered in order to account for a variety of auditory phenomena (see the recent reviews in 4).

### **Frequency Discrimination and Masking**

In a sense, listeners are even more sensitive to changes in frequency than they are to changes in intensity. While the just noticeable increase of 1 dB discussed above corresponds to an increment of 25% in acoustic power, the just noticeable difference for listeners to discriminate between two different frequencies is typically much less. Over the range of frequency extending from about 200 to 8,000 Hz, the just noticeable differences in frequency are found to be less than 0.5%. That is, normal listeners can discriminate between tones of 1,000 and 1,005 Hz, 2,000 and 2,010 Hz, and so on.

A complementary question is how well a listener can analyze or resolve among the set of frequencies composing complex sounds (including noise, speech, music, etc). In effect, psychoacousticians determine how well a listener can “pick out” the presence of the particular frequency or set of frequencies that define the “signal”. A classic type of experiment asks how intense a signal must be in order to be detected when it is presented along with a potentially obscuring background sound, the “masker”. The number and variety of psychoacoustic experiments investigating such questions is remarkably large and constitutes the bulk of the published work in the field. One time-honored finding is that only a small fraction of frequency components composing the background masker actually affects detection of a tonal signal. For example, the detectability of a 1,000-Hz tone is determined by only the 160 Hz-wide portions of the masker that immediately surround the signal. That is, one can add or subtract large amounts of acoustic energy outside that region and not affect the signal’s detectability. This means that other attributes of the masker, including its loudness and pitch, do not, by themselves, determine the degree of masking. It is handy to know that the bandwidth of the frequencies that are “critical” for masking tonal signals (nowadays termed the auditory filter) is approximately 16% of the frequency of the signal to be detected.

The links to physiology in these realms are both strong and pervasive. First and foremost, a “place” mapping of frequency exists within the cochlea, in that it is most sensitive to higher frequencies in its more basal portions, and most sensitive to lower frequencies in its more apical portions. This place mapping is preserved and reiterated throughout the auditory nervous

system, including the auditory cortex. In addition, the frequency-tuning characteristics, or bandwidths, of individual nerve fibers are commensurate with the widths of psychoacoustically-determined auditory filters as a function of frequency. A second encoding of frequency is provided in the timing of neural discharges. That is, the time between neural discharges becomes smaller and smaller as the frequency of the signal is increased.

Many auditory scientists have debated the relative salience of place vs. time codes, while modeling a number of important auditory phenomena including frequency discrimination, masking, and the perception of pitch. Over time, one or the other view has been found to prevail. In our judgment, neither the acceptance nor the rejection of one of the two candidate codes may be logically possible, because changes in “place” and changes in “neural timing” both occur concomitantly as frequency is changed.

### **Applications**

Knowledge and techniques derived from psychoacoustic research are relevant and useful in a variety of practical endeavors. While many applications may be familiar to us all (e.g., the design of telephones for the efficient transmission and understanding of speech), others are much less apparent. Beginning with the familiar, many of the basic findings from psychoacoustic research have been used to define and depict “normal hearing.” Such findings, in turn, have been used to create and refine tests of hearing that are used in many ways to aid in the diagnosis and treatment of various kinds of hearing impairment. Otolaryngologists and audiologists use such information in order to differentiate among various hearing deficits, and in the selection and fitting of patient-appropriate hearing aids. For more than a decade, psychoacousticians have played an integral part in the development, design, understanding and evaluation of complex issues surrounding the use of cochlear implants. Knowledge from psychoacoustics has also proved beneficial in all phases of the discovery and application of specialized, non-invasive screening tests of infant hearing. Similar types of tests and guidelines have been usefully applied in industrial and governmental settings, both as part of hearing conservation programs and to develop standards concerning acceptable occupational and community noise levels.

Knowledge obtained from psychoacoustics has always been useful in designing and evaluating high-fidelity sound systems. Today, because of advances in computing power and miniaturization, psychoacoustic data have become highly relevant, if not ubiquitous. For example, one can purchase inexpensive devices that digitally store incredibly large amounts of music. This is possible because psychoacousticians and electrical engineers found ways of using knowledge concerning auditory

sensitivity in order to greatly reduce the amounts of information required for satisfying reproduction. Specifically, only the necessary information, on a moment-by-moment basis, is preserved. Success of this technique is evidenced by the fact that listeners are typically unaware that the original sound has been modified. The same types of algorithms have also proved useful in the transmission of music and speech. These include the schemes used to send audio information to cellular telephones, satellite and digital television and radio devices and over the internet.

Another important arena for application of psychoacoustics is the concert hall. Here the thrust has been first to understand what physical variables differentiate successful concert halls from less successful ones. Such knowledge has been used to establish psychoacoustic-related dimensions that guide the design and determine the perceived quality of the halls. Finally, computer-based systems now exist that enable the designer to simulate candidate designs and to “preview” them. Similar schemes and technology are being applied to other aspects of architectural acoustics including improvements in the design of highly reverberant spaces such as churches and classrooms.

## References

1. Crocker MJ (1997) Encyclopedia of acoustics, vol 3. Wiley, New York
2. Moore BCJ (2003) An introduction to the psychology of hearing, 5th edn, Academic Press, San Diego, CA
3. Yost WA (2000) Fundamentals of hearing: an introduction, 4th edn. Academic Press, San Diego, CA
4. Bacon SP, Fay RR, Popper AN (eds) (2004) Compression: from cochlea to cochlear implants, Springer handbook of auditory research, vol 17. Springer Verlag, New York

## Psychogenic

### Definition

Psychogenic refers to phenomena arising from thought processes.

## Psychological Acoustics

► Psychoacoustics

## Psychometric Curve/Psychometric Function

### Definition

Relationship between physical properties of a stimulus and a measured behavior. Typically these take the form of a sigmoid function in which low levels of stimulus produce a small psychophysical result and at some point increases produce a faster rise in response, which saturates at high stimulus levels.

## Psychomotor Seizures (Temporal-lobe Seizures)

### Definition

► Complex Partial Seizures (Temporal-lobe or Psychomotor Seizures)

## Psychopathic Personality

► Personality Disorder

## Psychopathy

Persons who often exhibit aggressive behavior and try to achieve their personal aims by illegal actions and criminal lifestyle.

► Forensic Neuropsychiatry

## Psychopharmacology

► Behavioral Neuropharmacology



## Psychophysics

WALTER H. EHRENSTEIN

Leibniz Research Center for Working Environment and Human Factors, University of Dortmund, Dortmund, Germany

### Synonyms

Phenophysics

### Definition

Psychophysics, as first established by Gustav Theodor Fechner in 1860, concerns the science of the relations between body and mind, or, to put it more precisely, between *physical* and *phenomenal* worlds [1–6]. Objectively we have physical events as reflected by brain processes, subjectively these processes appear as processes of our mind. Fechner already distinguished between *inner psychophysics* or the relation of sensory experience to its corresponding neural activity, and *outer psychophysics*, which deals with the relation between percepts and variations of the ►stimulus itself (see Fig. 1).

For much of the century following Fechner's publication of *Psychophysik* in 1860, inner psychophysics remained just a theoretical option until objective methods for the study of brain functions became available. Thus, outer psychophysics has shaped not only the development of experimental psychology and phenomenology

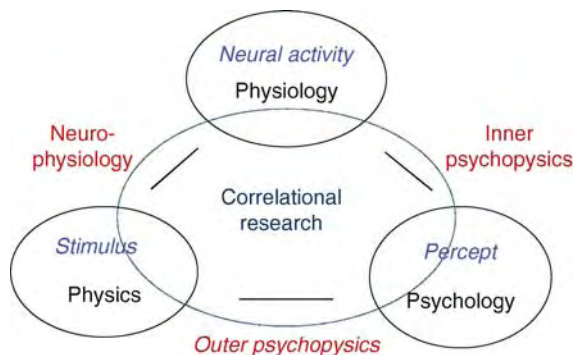

**Psychophysics.** Figure 1 *Interdisciplinary setting of psychophysics:* Percepts are related to corresponding physical stimulus properties (*outer psychophysics*) or to corresponding neural activity (*inner psychophysics*). For a long time inner psychophysics remained a merely theoretical concept, whereas outer psychophysics provided the basis for methods to study sensory and brain processes. Now various objective methods afford a direct study of sensory and brain processes. This has made possible a new interplay between classic psychophysics and modern neuroscience that has come to be called ►correlational research [2,7].

[1,6], but also of sensory physiology, affording its pioneers (Aubert, Exner, Helmholtz, Hering, von Kries, Mach, Purkinje, Weber) to gain basic insights into sensory mechanisms [2–4]. Today, sensory and brain processes can be investigated by objective methods such as electrophysiology (single-unit recordings, EEG), functional magnetic resonance imaging (fMRI), magnetoencephalography (MEG), and positron emission tomography (PET). The relative ease of use and non-invasiveness of most of these techniques has made a new interplay between classic psychophysics and modern neuroscience possible. The complementary research approach that concerns itself with subjective and objective correlates of sensory and neural processes has come to be called ►correlational research [2,7], see Fig. 1.

### Description of the Theory

Psychophysics accounts for the problem of measuring sensory experience by closely linking percepts to physical stimuli. No apparatus is necessary to obtain percepts; they are immediately present and available to each of us. The problem is thus not how to obtain sensory experience, but how to describe and investigate individual percepts so that they can be reliably communicated. An investigation might begin with a simple question such as “can you hear the tone?”. This task requires *detection*. If we want to further determine which stimulus characteristics an observer can sense (e.g., the quality or spatial location of a sound), we arrive at the problem of *identification*. Detection and identification are solved quickly and almost simultaneously when the stimuli are strong and clear. However, under conditions of weak and noisy signals we often experience a stage at which we first detect only that something is there, but fail to identify what or where it is, exactly. In such a situation we try to filter out the consistent signal attributes, for instance, the sound of an approaching car, from inconsistent background noise. This task requires *discrimination* of the stimulus, or signal, from a noisy background, and the task is performed under uncertainty. As the car approaches and its sound becomes stronger, the probability of correct discrimination between signal and noise is enhanced. Even if we clearly detect and identify an object, we may still be faced with a further problem of ►perception, such as: “Is this car dangerously close?” or “Is the rattle under the hood louder than normal?” Questions such as these, concerning “How much x is there?”, are part of another fundamental perceptual issue, that of *scaling*, i.e. to locate the magnitude of the stimulus on a psychophysical scale.

### ►Characteristics Quantitative Laws of Psychophysics

Psychophysics emerged out of the contributions of the sensory physiologist E. H. Weber (1795–1878) who

established perception as an experimental rather than observational discipline. Working with the discrimination of lifted weights, he demonstrated that the smallest difference between two weights ( $\Delta I$ ) which we can distinguish by way of feeling changes in muscle tension was a constant fraction ( $k$ ) of the reference weight ( $I$ ):

$$\Delta I/I = k \text{ (Weber's law)}$$

For example, if an increase of 1 g is needed in order to just experience that a weight is heavier than its reference of 40 g, an increase of 10 g would already be required for a weight to just appear heavier if its reference is 400 g. Accepting the validity of Weber's law, Fechner assumed that equal stimulus differences corresponded to equal perceptual differences or units. Sensory magnitudes could be assigned values according to the number of just noticeable differences. Inspired by Leibniz's concept of subliminal units of experience (*petites perceptions* or minute percepts as differential units of experience), Fechner postulated a relation between infinitesimal increase of stimulus intensity ( $dI$ ) and corresponding subliminal increase in perceptual intensity ( $dS$ ), by deriving his fundamental formula:  $dS = dI/I$ . By integration we obtain a logarithmic relation between stimulus and sensation:

$$S = c \log I \text{ (Fechner's law)}$$

where  $S$  is the subjective and  $I$  the objective intensity and  $c$  refers to a constant depending on the respective sensory modality.

Fechner's law roughly predicts that a doubling of perceived intensity requires a 10 times increase of physical intensity. It holds pretty well for stimulus intensities in a middle range of the stimulus dimension. With very low or very high stimulus intensities, however, observed and predicted values deviate markedly. As an alternative to threshold measurements supra-threshold psychophysical scaling procedures were already developed by Tobias Mayer in 1754 [4] and more systematically later by J. A. F. Plateau (1872) and Delboeuf (1873, 1875) who studied the lightness of different gray levels. S. S. Stevens [10] popularized scaling procedures, especially the procedure of magnitude estimation, in which the experimenter assigns a value to a standard stimulus, e.g., the number 100, and the observers then rate the magnitude of other stimuli in proportion to the standard. So, if a stimulus appears half or twice as intense as the standard, it would be given the numbers 50 or 200, respectively. The results obtained with these and other direct scaling methods, such as ►[cross-modality matching](#), are best described by a power function:

$$S = c I^n \text{ (Stevens's law)}$$

where  $S$  is scaled sensory intensity,  $c$  is a constant,  $I$  is physical intensity, and  $n$  is an exponent that varies for different sensory continua.

## Psychophysical Methods

The most basic function of any sensory system is to detect changes of energy which can consist of chemical (taste, smell), *electromagnetic* (vision), *mechanical* (audition, proprioception, touch) or *thermal* events. In order to be noticed, the stimulus has to reach a minimal amount of stimulus intensity that, according to Fechner [3], "lifts its sensation over the threshold of consciousness." This is the *absolute threshold*, which is the intensity an observer can just barely detect, whereas the *difference threshold* is based on stimulus intensities above the absolute threshold and refers to the minimum intensity by which a variable or *comparison* stimulus must deviate from a constant or *standard* stimulus to produce a just noticeable difference in perception.

### Method of Adjustment

The easiest way to determine thresholds is to let a subject adjust the stimulus intensity until it is just noticed or until it just becomes unnoticeable (absolute threshold); or until it appears to be just noticeably different from, or to just match some other standard stimulus (difference threshold). The observer is typically provided with a control of some sort that can be used to adjust the intensity, say of a sound, until it just becomes audible (or louder than a standard sound), and then the stimulus intensity is recorded to provide one estimate of the observer's threshold. Alternatively, the observer can adjust the sound from clearly audible to just barely inaudible (or to match the standard sound), providing another estimate of the threshold. Typically, the two series of measurement, one in which the signal strength is increased (ascending series) and one of decreasing signal strengths (descending series) are alternated several times and the results are averaged to obtain the threshold estimate. For example, if a tone is first heard at 5.0 or 5.5 dB on two ascending trials and first not heard at 4 or 4.5 dB on two descending trials, the resulting threshold estimate is 4.75 dB.

### Method of Limits

In the ►[method of limits](#) the stimulus is varied by the experimenter (or a computer program) and the observer's response is recorded to each stimulus presentation. As in the previous method, the stimulus should initially be too weak to be detected and increased until it is perceived (ascending trials). Conversely in a descending trial, stimulus intensity, say a light, is reduced from clearly seen until it becomes invisible.

### Method of Constant Stimuli

In the ►[method of constant stimuli](#) the experimenter selects a number of stimulus values (usually from five to nine) which, on the basis of previous exploration (e.g., using the ►[Method of Adjustment](#)), are likely to encompass the threshold value. This fixed set of stimuli

is presented multiple times in a quasi-random order that ensures each will occur equally often. After each stimulus presentation, the observer reports whether or not the stimulus was detected (for the absolute threshold) or whether its intensity was stronger or weaker than that of a standard (for computing a difference threshold). Once each stimulus intensity has been presented multiple times (usually not less than 20), the proportion of “detected” and “not detected” (or, “stronger” and “weaker”) responses is calculated for each stimulus level. The data are then plotted with stimulus intensity along the abscissa and percentage of perceived stimuli along the ordinate (see Fig. 2).

If there was a fixed threshold for detection, the psychophysical function should show an abrupt transition from “not perceived” (0%) to “perceived” (100%). Psychometric functions, however, seldom conform to this all-or-none rule. We usually obtain a sigmoid (S-shaped) curve that reflects that lower stimulus intensities are detected occasionally and higher values more often, with intensities in the intermediate region being detected on some trials but not on others. There are various reasons for obtaining an S-shaped rather than a sharp step function. A major source of variability is the continual fluctuations in sensitivity that occur in any biological sensory system (due to spontaneous activity or internal noise). Those inherent fluctuations mean that activity elicited by external stimulation is to be detected against a background level of activity. The threshold sensation that occurs with a certain *probability* can be defined statistically. By convention, the absolute threshold measured with the

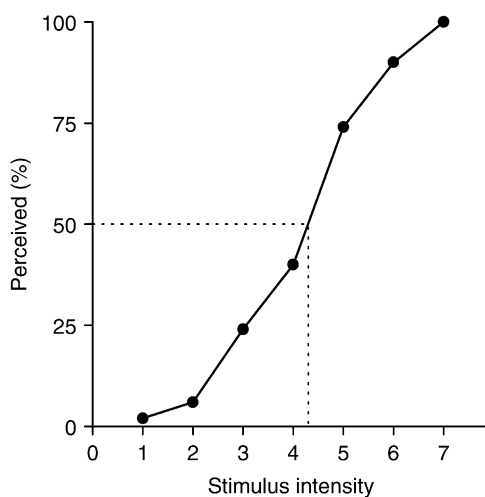

**Psychophysics. Figure 2** Psychophysical function which shows the relationship between the percentage of times that a stimulus is perceived and the corresponding stimulus intensity. The threshold is defined as the intensity at which the stimulus is detected 50% of the time [2].

method of constant stimuli is defined as the intensity value that elicits “perceived” responses on 50% of the trials. Notice that in the example shown in Fig. 2, no stimulus level was detected on exactly 50% of the trials. However, level 4 was detected in 40% and level 5 in 74% of the trials. Consequently, the threshold value of 50% lies between these two points. If we assume that the percentage of trials in which the stimulus is detected increases linearly between these intensities (which is not unreasonable given that sigmoid functions are approximately linear in the middle range), we can determine the threshold intensity by linear interpolation as follows:

$$T = a + (b - a) \cdot \frac{50 - p_a}{p_b - p_a},$$

where  $T$  is the threshold,  $a$  and  $b$  are the intensity levels of the stimuli that bracket 50% detection (with  $a$  being the lower intensity stimulus), and  $p_a$  and  $p_b$  the respective percentages of detection. For the present case we obtain the following result:

$$T = 4 + (5 - 4) \cdot \frac{50 - 40}{74 - 40} = 4 + \frac{10}{34} = 4.29.$$

Although the method of constant stimuli is assumed to provide the most reliable threshold estimates, its major drawback is that it is rather time consuming and requires a patient, attentive observer because of the many trials required.

### Adaptive Testing

Adaptive testing procedures are used to keep the test stimuli close to the threshold by adapting the sequence of stimulus presentations according to the observer’s response. Since a smaller range of stimuli needs to be presented, adaptive methods are relatively efficient. Adaptive procedures were first introduced by Georg von Békésy in 1947, who applied his [▶ staircase method](#) to audiometry [2]. The staircase method is a modification of the Method of Limits. As long as the observer says “yes” (I perceive) stimulus intensity is decreased by one step, until the stimulus becomes too weak to be detected. At this point we do not, as in the method of limits, end the series, but rather reverse its direction by increasing the stimulus intensity by one step. This continues with increasing the intensity if the observer’s response is “no” and decreasing the intensity if it is “yes.” In this way, the stimulus intensity flips back and forth around the threshold value. Usually six to nine such reversals in intensity are taken to estimate the threshold, which is defined as the average of all the stimulus intensities at which the observer’s responses changed.

### Research Fields and Applications

Psychophysics allows investigation of how living creatures perceive sensory stimuli in relation to their environmental setting as well as to compare the

phenomenal worlds of humans with closely related species (monkey, cat) or even fairly distant species (birds, insects). Comparative relational psychophysical research across different species and across different stages of development provides the intriguing option of an integrated framework of behavioral and brain research [9]. For instance, the combined psychophysical and electrophysiological study of sensory performance has established the concept of the ►perceptive field as psychophysical counterpart of receptive field organization with the conjecture that perceptual organization is largely determined by single-cell activity. Meanwhile, various perceptual properties, including contrast of brightness, color, orientation, and motion as well as Gestalt phenomena, such as illusory contours or border-ownership, have been shown to be linked to the highly specialized functions of receptive fields at various levels of the visual system [7]. Furthermore, computer-assisted adaptive psychophysical methods are increasingly used in clinical routine diagnostics to assess impairment of sensory and neuropsychological function [1,2]. Psychophysics can also assist in elementary decisions of daily life. For example, scaling of auditory intensity can provide firm evidence for the effectiveness of noise protection measures. Industrial and ergonomic norms, such as of lighting on streets or at workplaces, or individual norms, e.g., accounting for age-dependent changes of sensory performance, are or are to be based on psychophysical evaluation. Consequently, psychophysics is of utmost importance for the approach of Human Factors [10], a joint profession of engineers and psychologists to design and evaluate simple and complex systems in order to optimize working and life conditions.

## References

- Ehrenstein WH (2003) Psychophysik. In: Neuser-von Oettingen k (ed) *Psychologie von A–Z: Die wichtigsten 60 Disziplinen*, Spektrum, Heidelberg, pp 156–159
- Ehrenstein WH, Ehrenstein A (1999) Psychophysical methods. In: Windhorst U, Johansson H (eds) *Modern techniques in neuroscience research*. Springer, Berlin Heidelberg New York, pp 1211–1241
- Fechner GT (1860/1966) *Elemente der Psychophysik*. Leipzig: Breitkopf & Härtel (reprinted in 1964 by Bonset, Amsterdam); English translation by HE Adler (1966): *Elements of psychophysics*. Holt, Rinehart & Winston, New York
- Grüsser OJ (1993) The discovery of the psychophysical power law by Tobias Mayer in 1754 and the psychophysical hyperbolic law by Ewald Hering in 1874. *Behav Brain Sci* 16:142–144
- Hensel H (1974) Thermoreceptors. *Ann Rev Physiol* 36:234–249
- Horst S (2005) Phenomenology and psychophysics. *Phenomenol Cogn Sci* 4:1–21
- Spillmann L (2006) From perceptive fields to Gestalt. *Prog Brain Res* 155:67–92
- Stevens SS (1975) *Psychophysics: introduction to its perceptual, neural, and social prospects*. Wiley, New York
- Sarris V (2006) *Relational psychophysics in humans and animals. A comparative-developmental approach*. Psychology Press, Hove & New York
- Proctor RW, Van Zandt T (2008) *Human factors in simple and complex systems*, 2nd edn, CRC Press, Boca Raton, FL

---

## Psychostimulants

### ► Stimulants

---

## Psychotic Features

### Definition

These include delusions (irrational thoughts and fears) and hallucinations (seeing or hearing things that are not really there). Often psychotically depressed people become paranoid or come to believe that their thoughts are not their own (thought insertion) or that others can “hear” their thoughts (thought broadcasting). People with psychotic depression are usually aware that these thoughts are not true.

### ► Major Depressive Disorder

---

## Psychotomimetics

### ► Hallucinogens

---

## Pterosaurs

### Definition

Extinct flying reptiles (e.g. Pterodactylus, Pteranodon, Quetzalcoatlus, etc.), not ancestors of birds.

### ► Evolution, of the Brain: At the Reptile-Bird Transition

## Ptosis

### Definition

Drooping of the upper eyelid from paralysis of the third nerve.

- ▶ Endocrine Disorders of Development and Growth

## Pudendal Nerve

### Definition

A somatic nerve with cell bodies of the motoneurons located in Onuf's nucleus in the S2-S4 spinal segments; contains afferent and efferent pathways to the urethral and anal sphincters and afferent innervation to the perineum, urethra and the sex organs (penis and clitoris).

- ▶ Micturition
- ▶ Neurophysiology of Sexual Spinal Reflexes

## Pulleys

### Definition

When the eyes move from the primary position, the eye muscles do not slide freely within the orbital tissue.

Instead their paths are restricted, possibly by rings of connective tissue and smooth muscle that have been termed orbital pulleys.

- ▶ Eye Orbital Mechanics

## Pulmonary Reflexes

- ▶ Respiratory Reflexes

## Pulvinar

### Definition

A component of the thalamus, relatively enlarged in carnivores and primates. It deals with salience (visual

salience) and is involved in selective attention. It is reciprocally connected with much of the cerebral cortex. Its inferior and lateral parts also receive input from the superior colliculus. The homologous structure in lower animals is the Lateral Posterior thalamic group (LP-Pulvinar).

- ▶ Visual Attention
- ▶ Visual Role of the Pulvinar

## Punisher

### Definition

A punisher is any stimulus an animal will work to avoid, such as somatosensory pain, foot shock, timeout, or an unpleasant taste. In humans, monetary loss may also act as a punisher.

- ▶ Value-based Learning

## Punishment

### Definition

Punishment is a procedure whereby an aversive event (usually pain) following a response causes the reduction of that response. Punishment is considered by some behavioral psychologists to be a “primary process” – a completely independent phenomenon of learning, distinct from reinforcement.

- ▶ Aversive Learning

## Pupillary Light Reflexes

### Definition

Constriction of the pupils in response to increased light falling onto the retina. When light is shone on one retina, the pupil of the same eye constricts (direct response) as well as the pupil of the other eye (consensual response).

- ▶ Consensual Light Reflex
- ▶ Pretectal Nuclei
- ▶ Neural Regulation of the Pupil

## Purinergic Receptors

### Definition

Purinergic receptors are receptors that respond to adenosine triphosphate (ATP) and related agents.

Metabotropic (G-protein coupled receptors, P2Y) and ionotropic receptors (ion channels, P2X) have been identified. Excitatory P2X receptors are present in urinary bladder smooth muscle (P2X1) and in bladder afferent nerves (P2X2/3).

► [G-protein Coupled Receptors \(GPCRs\): Key Players in the Detection of Sensory and Cell-Cell Communication Messages](#)

## Purinergic Receptors in Urinary Bladder

### Definition

Excitatory P2X receptors are present in urinary bladder smooth muscle (P2X1) and in bladder afferent nerves (P2X2/3).

► [Micturition](#)  
 ► [Purinergic Receptors](#)

## Purkinje Cell, Neuron

### Definition

Large, pear-shaped, GABAergic neuron located in the cerebellar cortex characterized by an intricate dendritic arbour and many dendritic spines.

The Purkinje cell sends the sole output from the cerebellar cortex. It receives excitatory synaptic inputs from parallel and climbing fibers and inhibitory synaptic inputs from basket, stellate, and other Purkinje neurons, and sends inhibitory outputs to the cerebellar or vestibular nucleus.

► [Cerebellum](#)  
 ► [Cerebellar Functions](#)

## Pursuit Eye Movement

### Definition

An eye movement that matches the speed and direction of the eye to that of a moving target.

► [Pursuit-Saccade Coordination](#)

## Pursuit-Saccade Coordination

ROBERT H. WURTZ

Laboratory of Sensorimotor Research, National Eye Institute, National Institutes of Health, Bethesda, MD, USA

### Definition

Rapid or saccadic eye movements (► [saccade](#), ► [saccadic eye movement](#)) allow us to shift our gaze from one part of a visual scene to another. This allows us to position objects in the scene of greatest interest on the region of the retina with the highest resolution, the central or foveal region. For example, we would make these saccadic eye movements several times per second as we looked out of a window onto a busy street scene. Smooth ► [pursuit eye movements](#) allow us to keep the fovea on objects that are moving so that we can have the sharpest vision of these objects in spite of their motion. As we look out the window, these pursuit eye movements would allow us to keep a person's face centered on the fovea even though they were walking along as we watched them. We can also make a saccade to the walking person and then immediately use the pursuit eye movements to keep that person's image on our fovea. As we continually use both of these eye movements in our everyday vision, these eye movements must be coordinated and the brain mechanisms underlying this coordination are beginning to be understood.

### Characteristics

#### Upstream Event/Conditions

Control of saccadic eye movements depends upon a circuit within the brain that extends from the highest levels of visual processing in the cerebral cortex, to the neurons connecting to the eye muscles that lie in the midbrain and pons in the brainstem [1] The cortical areas devoted to this processing are centered in the lateral intraparietal area of parietal cortex and the frontal eye field area of frontal cortex. Both areas project to the brainstem, particularly to the structure on the roof of

the brainstem, the ► **superior colliculus (SC)**. Another pathway from the cortex passes through the basal ganglia to the superior colliculus. Pursuit eye movements also depend on activity in cerebral cortex for a critical feature of their function: the determination of the speed and direction of the object that is about to be followed by the eye. Areas providing this information are also distributed in cortex, but are concentrated in the visual region of cortex referred to as the middle temporal area and the medial superior temporal area, and in the frontal eye field in a region distinct from that related to saccadic eye movements. The processing related to saccades and to pursuit appears to be kept separate in the cerebral cortex.

### Downstream Events/Condition

The generation of saccades requires connections to nuclei in the midbrain and pontine reticular formations, which in turn connect to the motor neurons that innervate the eye muscles [1]. The connections necessary for pursuit eye movements are conveyed to visuomotor nuclei in the pons, primarily the dorsolateral pontine nuclei. The pathway reaches the oculomotor neurons via projections through the cerebellum to the vestibular nucleus.

### Involved Structures

The superior colliculus has a representation of the visual field spread out in each of its major layers [2]. In the superficial layers the neurons respond to visual stimulation, and in the intermediate layers the neurons are active before eye movements to that part of the visual field where the visual stimulation is located. The collicular neurons are organized into a map of the contralateral visual field, so that each neuron is active in relation to visual stimulation or eye movement in just one region of the visual field. It is in the intermediate layers that there is evidence for the coordination between saccades and pursuit. The intermediate layer neurons not only increase their discharge just before the saccade (or more generally an eye and head movement), but they show a buildup of activity that precedes that burst [3,4]. This buildup or prelude activity occurs whether or not the saccade related to the target actually occurs. If the saccade does occur, the buildup activity blends into the burst of activity preceding the saccade. If the saccade is not made, the activity decreases. Thus, the buildup activity can be largely independent of the actual generation of the movement, and it seems to be related to what must necessarily precede the movement including target selection.

One possibility is that the buildup activity simply indicates that there is an error between where the eye is looking now and where the target for the next eye movement is located – an error signal, not a saccadic movement signal. That is, each neuron on this map

might indicate the error between where the eye is and where the target is, with large differences in the caudal colliculus and smaller ones in the rostral colliculus [5]. If the difference between where the eye is looking is very small (a fraction of a degree visual angle), the monkey frequently does not make any saccade. This activity has been referred to as fixation activity, but the most parsimonious interpretation of the activity is that it is the same buildup activity seen throughout the colliculus. The difference in eye and target position is just small, the error is small, and no movement need be made. With slightly larger errors, the buildup activity precedes a saccade to the target. If the target is moving, the monkey might make a not a saccade but a pursuit movement to the target, and this pursuit movement is also preceded by the increased buildup neuron activity [6]. Increased activity for both pursuit and saccades occurs only for movements in the visual field contralateral to the colliculus in which the neuron is found. Thus, the buildup neurons can be regarded as a shared error signal available to both the pursuit and the saccadic system, and this type of shared signal has been proposed as part of the mechanisms that coordinate these two movements. Further evidence supporting this view comes from experiments which showed that electrical stimulation or chemical inactivation altered pursuit eye movements [7]. Activity of the neurons can also predict the timing of pursuit as well as saccadic eye movements [8]. Thus, the same neurons that are involved in the preparation to make saccades might also contribute to the preparation to initiate pursuit. The test of this view would be to verify this pursuit – saccade interaction at points in the pathway after the signals for movement leave the superior colliculus, but this remains to be done.

### Methods to Measure This Event/Condition

All of the observations described are derived from single neuron recording in awake behaving monkeys who select the targets and move their eyes to them [9]. The monkeys are trained on tasks that allow the comparison of neuronal activity to the same behavior on a series of similar movements, and this reveals the consistency of the relationship of the neuronal activity and the eye movement behavior. The eye movements are recorded using a precise method for recording eye position, velocity and acceleration. The monkey's behavior is controlled by online computer systems that also collect and store all the data from the experiments.

### References

1. Krauzlis RJ (2004) Recasting the smooth pursuit eye movement system. *J Neurophysiol* 91:591–603
2. Sparks DL, Hartwich-Young R (1989) The neurobiology of saccadic eye movements. The deep layers of the superior colliculus. *Rev Oculomot Res* 3:213–256

3. Glimcher PW, Sparks DL (1992) Movement selection in advance of action in the superior colliculus. *Nature* 355:542–545
4. Munoz DP, Wurtz RH (1995) Saccade-related activity in monkey superior colliculus. I. Characteristics of burst and buildup cells. *J Neurophysiol* 73:2313–2333
5. Wurtz RH, Basso MA, Paré M, Sommer MA (1998) Contributions of the superior colliculus to the cognitive control of movement. In: Gazzaniga MS (ed) *The cognitive neurosciences*, MIT Press, Cambridge, pp 573–587
6. Krauzlis RJ, Basso MA, Wurtz RH (2000) Discharge properties of neurons in the rostral superior colliculus of the monkey during smooth-pursuit eye movements. *J Neurophysiol* 84:876–891
7. Basso MA, Krauzlis RJ, Wurtz RH (2000) Activation and inactivation of rostral superior colliculus neurons during smooth-pursuit eye movements in monkeys. *J Neurophysiol* 84:892–908
8. Krauzlis R, Dill N (2002) Neural correlates of target choice for pursuit and saccades in the primate superior colliculus. *Neuron* 35:355–363
9. Wurtz RH, Goldberg ME (1972) Activity of superior colliculus in behaving monkey. III. Cells discharging before eye movements *J Neurophysiol* 35:575–586

axons derived from cortical upper motor neurons and destined for the spinal cord as the cortico-spinal path.

► [Evolution of the Wulst](#)

---

## Pyramidal Decussation

### Synonyms

► [Decussatio pyramidum](#); ► [Decussation of pyramids](#)

### Definition

In the pyramidal decussation, 70–90% of the pyramidal tract decussate to the contralateral side. The decussation lies directly below the pyramid (of the myelencephalon), in the middle of the myelencephalon. The decussation joins the lateral pyramidal tract.

► [Myelencephalon](#)

---

## Putamen

### Definition

The caudate nucleus and putamen together form the corpus striatum. Both are derived ontogenetically from the same anlagen, but are separated by incoming fibers from the internal capsule.

The corpus striatum is an important inhibitory component of motor movement programs and has manifold connections with the globus pallidus, substantia nigra and the motor cortex.

- [Basal Ganglia](#)
- [Striatopallidum](#)
- [Telencephalon](#)

---

## Pyramidal

### Definition

Refers to the triangular shape of an object; in neuroscience either to the shape of neocortical cell bodies in various laminae, or to the shape of the tract in the medulla oblongata of humans that is made up of

---

## Pyramidal System Organization

► [Motor Cortex: Output Properties and Organization](#)

---

## Pyramidal Tract

### Synonyms

► [Tractus pyramidalis](#)

### Definition

The largest descending motor tract is formed by the axons of the pyramidal cells of the motor cortex and is thus called the pyramidal tract. It courses nonstop from the cortex to the corresponding segments in the spinal cord, explaining why it is also called the corticospinal tract. At the upper margin of the myelencephalon, this tract rises to the surface as the pyramid (of myelencephalon).

70–90% of the fibers then cross in the pyramidal decussation to the contralateral side, and continue to run in the spinal cord as the lateral pyramidal tract. The remaining fibers descend in the medial pyramidal tract. The fibers project directly or indirectly to the alpha



motoneurons, especially of the distal extremities (hand/forearm), hence the pyramidal tract plays a vital role in fine motor control.

- ▶Corticospinal Neurons
- ▶Motor Cortex: Output Properties and Organization

## Pyramidotomy

### Definition

The act of sectioning the pyramidal tract.

- ▶Motor Cortex: Output Properties and Organization
- ▶Pyramidal Tract

## Pyrexia, Hyperpyrexia

- ▶Endotoxic Fever

## Pyridoxine Intoxication

### Definition

Overdose intake of pyridoxine may lead to chronic ▶sensory polyneuropathy, with symptoms of

numbness, tingling and pain in the extremities, and sensory ataxia.

## Pyridoxine (Vitamin B6) Deficiency

### Definition

Not a common disorder anymore, except in the elderly populations, where it may be associated with impaired cognitive function, ▶Alzheimer's disease, cardiovascular disease, and some types of cancer.

- ▶Alzheimer's Disease

## Pyriform Cortex

- ▶Olfactory Cortex

## Pythons

### Definition

A group of giant snakes (Boidae) in Africa and South-Asia.

- ▶Evolution, of the Brain: At the Reptile-Bird Transition

---

## Q<sub>10</sub>

### Definition

Quantification of temperature dependence of the rate of a process across a limited (10°C) temperature range. Passive rate changes of biological processes typically have a Q<sub>10</sub> between 2 and 3. Deviating values for biological processes indicate active intervention by regulatory processes.

---

## Q of a Filter

### Definition

A relative estimate of the width of the filter's passband. Q often equals the center frequency of the passband divided by an estimate of the width of the filter's passband.

▶ Acoustics

---

## Quadrantanopsia/Quadrantanopia

### Definition

Quadrantic visual field defect resulting from lesion of the ▶ [optic radiation](#). For example, lesion of the optic radiation fibers looping into the ▶ [temporal lobe](#) causes visual loss in the upper quadrant of the contralateral half of the visual field of both eyes.

▶ [Optic Radiation](#)  
▶ [Visual Field](#)

---

## Quadrigeminal Plate

### Synonyms

Lamina tecti; Tectalplate

### Definition

Also called tectum or quadrigeminal plate. Composed of two pairs of hills: superior colliculus: the two upper hills belong to the visual system (control of eye movements). inferior colliculus: the two lower hills belong to the auditory system and are an integral part of information exchange from inner ear to auditory cortex.

▶ [Mesencephalon](#)

---

## Quadripareisis

### Definition

Mild form of ▶ [quadriplegia](#).

▶ [Quadriplegia](#)

---

## Quadriplegia

### Definition

Bilateral paralysis involving all four limbs, trunk etc., with the site of lesion being at least as high as cervical level. One common cause is the ▶ [Guillain-Barré syndrome](#).

▶ [Guillain-Barré Syndrome](#)

## Qualia

### Definition

Phenomenal, qualitative, experiential features of mental states are called “qualia” in philosophy of mind. These features show something of what it is like to undergo experiences, that experiences have their particular “feel.”

- ▶ Cognitive Elements in Animal Behavior
- ▶ Emergence
- ▶ Property
- ▶ Reductionism (Anti-Reductionism, ▶ Reductive Explanation)
- ▶ The Knowledge Argument

## Qualitative Sex Differences

### Definition

Sex differences in the fundamental mechanisms underlying pain or analgesic responses (to be contrasted with quantitative sex differences). For example, that stress-induced analgesia can be reversed by opioid and/or NMDA-receptor antagonists in males, but not females indicates the presence of a qualitative sex difference.

- ▶ Gender/sex Differences in Pain

## Quantal

### Definition

Quantal refers to the mechanism by which transmitters are secreted from nerve terminals in packets released by the exocytosis of the contents of a single synaptic vesicle (a quantum). Individual quanta are released spontaneously when the  $\text{Ca}^{2+}$  concentration briefly becomes high enough at a release site in the nerve terminal. When an action potential reaches the terminal,  $\text{Ca}^{2+}$  entry is sufficient to release a quantum from many release sites, leading to a larger multiquantal response. These events are studied postsynaptically as currents or potentials.

## Quantal Release and Excitatory/Inhibitory Miniature Potential

### Definition

Quantal release refers to the mechanism by which transmitters are secreted from nerve terminals in packets released by the exocytosis of the contents of a single synaptic vesicle (a quantum). Individual quanta are released spontaneously when the  $\text{Ca}^{2+}$  concentration briefly becomes high enough at a release site in the nerve terminal. When an action potential reaches the terminal,  $\text{Ca}^{2+}$  entry is sufficient to release a quantum from many release sites, leading to a larger multiquantal response.

These events are studied postsynaptically as currents or potentials. These potentials are spontaneous activities of membrane potentials either more positive (excitatory) or more negative (inhibitory) than the resting membrane potential. Miniature potentials are due to irreducible units of transmitter release, namely quantal release.

- ▶ Membrane Potential – Basics
- ▶ Quantal Transmission
- ▶ Synaptic Transmission: Model Systems

## Quantal Transmission

HIROMU YAWO

Department of Developmental Biology and Neuroscience, Tohoku University Graduate School of Life Sciences, Sendai, Japan

### Definition

Bernard Katz and his colleague found in their series of experiments in the 1950s that synaptic transmission at the frog neuromuscular junction consists of a unit, which they referred to as a quantum [1–3]. An endplate potential (EPP) was measured from the frog muscle fiber (postsynaptic cell) by a glass microelectrode, and evoked by the electrical stimulation applied onto the innervating motor nerve (presynaptic axon). The amplitude of EPP was dependent on the  $\text{Ca}^{2+}$  concentration in the extracellular Ringer solution and was attenuated by the reduction of  $\text{Ca}^{2+}$  and the increase of  $\text{Mg}^{2+}$ . The EPP attenuation was not continuous, but rather stepwise and fluctuated between steps (Fig. 1a). Statistically, the EPP amplitude is distributed with several peaks of even gaps (Fig. 1b).

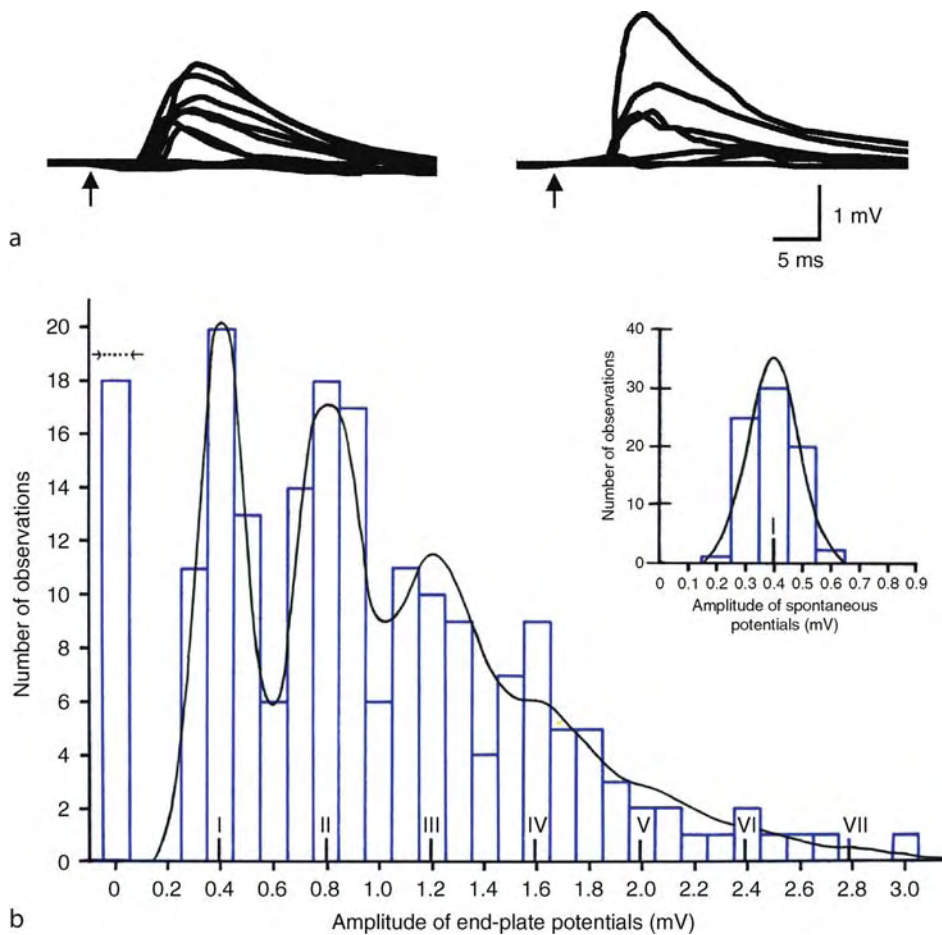

**Quantal Transmission. Figure 1** Fluctuations in the end-plate potential (EPP). (a) Superimposed sample records of EPP. The amplitude of EPP fluctuates in a stepwise manner and sometimes resulted in null response (synaptic failure) to the nerve stimulation (applied at time point indicated by arrows). Modified after Fatt and Katz (1952). (b) Amplitude histograms of EPP (blue lines) and miniature EPP (mEPP, inset). The peak of the histogram occurs at 0 (failure), one (I), two (II),  $\approx$  times of mEPP mean. The solid line represents the expected distribution according to Poisson statistics with mEPP mean and variance as units. On the experimentally obtained mean EPP amplitude (0.933 mV), the quantal content,  $m = 2.33$  is predicted. Using the number of trials (198), the expected number of “failures” may be calculated from the Poisson equation as 19 (arrows), being almost identical to the experimental value. Modified after Martin (1966).

The gap distribution was almost equal to that of miniature EPPs (mEPPs), small changes of postsynaptic membrane potential spontaneously occurs under the blockade of presynaptic activity by e.g., tetrodotoxin. They put forward the quantal hypothesis that: (i) EPP consists of a unit (quantum), (ii) the number of quanta is stochastic around a mean, and (iii) mEPPs are spontaneous quanta. It is a generally accepted idea that each quantum is the synaptic transmission induced by the exocytotic release of a single presynaptic vesicle containing a certain amount of neurotransmitters (vesicular hypothesis) [2]. Similar stochastic transmission is found in neuro-neuronal synapses in both the peripheral and central nervous system [2,3]. The fundamental

nature of this chemical synaptic transmission has provided a remarkable idea that, like the flip of coin, how a neural network performs is unreliable.

According to the quantal hypothesis, a synaptic event is mathematically described. This description enables one to estimate both presynaptic and postsynaptic parameters ([▶quantal analysis](#)), thus, enabling one to presume the presynaptic and postsynaptic contributions quantitatively, which otherwise are very difficult to estimate. The quantal analysis is applied on the peripheral and invertebrate nervous systems and provides an important quantitative description of synapses. When the synaptic transmission was changed by some neural activities or some chemicals as neuromodulators

and drugs, the primary cause could be attributed to either presynaptic, postsynaptic or both elements (pre/post problem). The pre/post problems have been revealed by quantal analysis in many synapses of peripheral and even central nervous systems. However, the quantal analysis has recently been challenged by “▶silent synapse” phenomena, and its application should be careful for the CNS synapses.

### Characteristics Quantitative Description

According to the Katz model, neurotransmitter is prepackaged in discrete quantities of fixed size, called quanta, and each quantum is released probabilistically and independently of the others in response to the activation of presynaptic terminal. Hence, the size of the postsynaptic response, such as the EPP and the postsynaptic current, vary at random because it is assumed to be proportional to the number of quanta simultaneously released. The random process is quantitatively described by the application of probability theory. The probability that  $k$  quanta are simultaneously released,  $P(k)$ , is thus assumed to follow a binomial distribution:

$$P(k) = {}_n C_k p^k (1-p)^{n-k},$$

where  $p$  is the probability of a quantum to turn on release and  $n$  is the total number of quanta. In other words,  $p$  is the probability of a vesicle to be released and  $n$  is either the total number of docked vesicles or the number of release sites if one vesicle is predocked in one release site. When  $p/n$  is very small, as in the case of Katz' experiment with extracellular low  $\text{Ca}^{2+}$  and high  $\text{Mg}^{2+}$ , this distribution is approximated to the Poisson distribution. That is;

$$P(k) = (m^k / k!) e^{-k},$$

and

$$m = np.$$

The parameter  $m$  corresponds to the mean number of quanta simultaneously released (called “▶quantal content” in the original works of Katz and collaborators). A Poisson process is one in which some event (like exocytosis) is unlikely to occur in any brief time window. The most familiar example of a Poisson process is the number of telephone calls made per day in your office. There are a large number of telephones connected to your office ( $n$ ), and the probability of any one of them being active ( $p$ ) is very low. On some days your office is quiet with no calls (“failure” response), on other days, one or perhaps two calls. Over a year, the number of days in which the number of telephone calls ( $k$ ) is 0, 1, 2, 3 or more is distributed according to the above Poisson equation, using only the mean number of telephone calls a day ( $m$ ) to determine the theoretically expected

distribution without knowing  $n$  or  $p$ . The number of “failures,” for example, should be given by:

$$n_0 = Ne^{-m},$$

where  $N$  is the total days of observation (e.g., 365). The number of single-call days by

$$n_1 = Ne^{-m} \cdot m$$

and so on.

The applicability of Poisson distribution to the ▶quantal release of transmitter has been tested as illustrated in Fig. 1b. The quantal hypothesis predicts that the mean ▶quantal size,  $q$ , a unit amplitude of quantum is equivalent to the mean amplitude of mEPP. The average size of postsynaptic response,  $E$  is thus expressed as,

$$E = qm.$$

Since mEPPs appear to be distributed normally around a mean of  $q$  with variance  $\sigma^2$ , the predicted  $n_1$  also follows this distribution. Similarly the predicted  $k$  unit responses ( $n_k$ ) are distributed normally around a mean amplitude of  $kq$  with variance  $k\sigma^2$ . The convoluted predicted distribution produces a smooth curve, as shown in Fig. 1b, which may be compared with the experimental histogram.

Since the value  $m$  consists of pure presynaptic factors,  $n$  and  $p$ , it has been widely used as a parameter sizing presynaptic releasing ability. The value  $m$  can be independently calculated either by the following equations.

If one can measure  $q$  on the ▶miniature synaptic responses:

$$m = E/q.$$

If one can count the number of “failures,”  $n_0$ :

$$m = \ln(N/n_0).$$

Since the variance of Poisson distribution is equal to  $m$ ,  $m$  is related to the coefficient of variation ( $CV = \text{standard deviation}/\text{mean}$ ) as;

$$m = (CV)^{-2}.$$

If these values are all identical, the experimental distribution of synaptic responses almost follows the Poisson process. If not, there should be some deviations.

### Higher Level Structures

The structure of synapse has been described in the accompanying essay.

### Lower Level Components

The synaptic vesicles and the molecular mechanisms of transmitter release have been described in the accompanying essay.

### Higher Level Processes

Hebb proposed in 1949 that, at the level of the synapse, learning follows a fundamental rule: “When an axon of cell A is near enough to excite a cell B and repeatedly and persistently takes part in firing it, some growth or metabolic change takes place in one or both cells such that A’s efficiency, as one of the cells firing B, is increased.” This theory led to the discovery of a cellular process, long-term potentiation (LTP), as one of the neuronal mechanisms underlying learning and memory. Since LTP requires coincidence of presynaptic activity with depolarization of the postsynaptic cell, it is indicated that a process very akin to that proposed by Hebb is involved. LTP is classically induced by the  $\text{Ca}^{2+}$  influx through postsynaptic NMDA (*N*-methyl-D-aspartate) receptor, which works as a coincidence detector of synaptic transmission and postsynaptic depolarization.

Although the postsynaptic elevation of  $\text{Ca}^{2+}$  triggers LTP induction, there have been debates on the cellular mechanisms of potentiation; either (i) enhancement of the AMPA ( $\alpha$ -amino-3-hydroxy-5-methyl-4-isoxazole propionic acid) receptor responses at the postsynaptic membrane (postsynaptic mechanism), or (ii) increase in the number of quanta of glutamate detected by the postsynaptic neuron in response to a presynaptic action potential (presynaptic mechanism). The latter mechanism is supported by the findings that LTP is associated

with a decrease in the *CV* and in the failure rate, evidence for a presynaptic expression mechanism. Some retrograde signals may induce changes in presynaptic release mechanisms on the postsynaptic elevation of intracellular  $\text{Ca}^{2+}$ . However, LTP was accompanied by a relatively selective increase in the signal mediated by AMPA receptors, with little change in the NMDA receptor-mediated components. This finding is most easily explained by an enhancement in the AMPA receptor responses at the postsynaptic membrane.

To explain this apparent paradox, the idea of “silent synapse” is proposed [4]. The synapses are non-uniform in both morphology and physiology. Some synapses have NMDA receptor responses with no AMPA receptor responses (silent synapses) whereas others have both responses. After LTP induction, silent synapses may be replaced by dual component (AMPA and NMDA receptor-mediated) signals through one or a combination of the following mechanisms. (i) AMPA receptors are preserved in the intracellular vesicles and incorporated in the postsynaptic membrane by the LTP induction. (ii) LTP induction makes postsynaptic AMPA receptors sensitive to glutamate by accumulating them in a site just opposite the presynaptic releasing apparatus. (iii) Functionally inactive AMPA receptors are made active by biochemical reactions activated by LTP induction. (iv) Glutamate released by incomplete exocytosis, through the fusion

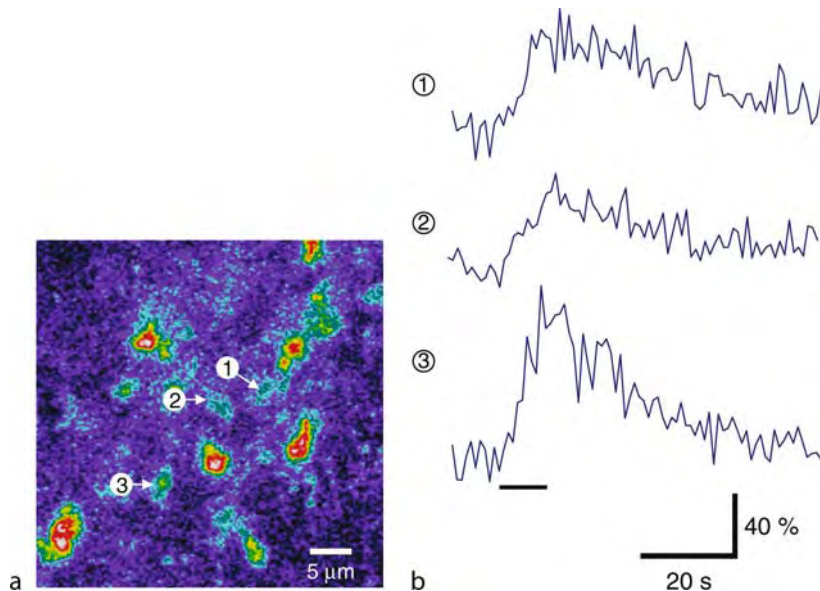

**Quantal Transmission. Figure 2** Direct measurement of quantal release by an optical imaging technique. (a) Mossy fiber presynaptic terminals were fluorometrically identified under confocal microscopy in the hippocampal slice obtained from a mouse genetically encoding synapto-pHluorin [Araki et al. 2005]. (b) The fluorescent intensity of the presynaptic terminal increased by repetitive stimulation of mossy fibers (10 Hz for 10 s, horizontal bar), indicating the relative magnitude of quantal release at the individual presynaptic terminal (numbers correspond to those in a).

pores between synaptic vesicles and presynaptic plasma membrane, (“kiss and run” mechanism) elevates the glutamate concentration to a low level that is enough to activate NMDA receptors without activating AMPA receptors. (v) The weak elevation of glutamate concentration is induced by the activation of neighboring synapses and activates NMDA receptors without activating AMPA receptors. (vi) The glutamate concentration at the postsynaptic AMPA receptors is increased by either the change of synaptic cleft geometry or the reduction of glutamate uptake by glia.

Therefore, the cellular mechanisms of LTP expression are not simple and involve both presynaptic (released amount of glutamate, mode of exocytosis) and postsynaptic mechanisms (number, distribution, functional modification). To test this, direct measurements of quantal release are promising by the use of presynaptic imaging techniques [5]: FM 1–43 and its analogue, and pH-sensitive form of green fluorescent protein (GFP) attached to the luminal portion of a synaptic vesicle protein (e.g., synapto-pHluorin (synapto-pHluorin method)). The latter method has several advantages; (i) the optical signal changes instantaneously with the formation of a fusion pore between the vesicle membrane and the presynaptic plasma membrane, (ii) since recycled vesicles are rapidly re-acidified, both exocytosis and endocytosis of quanta are repeatedly measured at an individual synapse, and (iii) the reporter protein gene can be genetically introduced in experimental animal lines (Fig. 2).

These optical methods enable one to measure quantal release directly at individual synapses and to solve the pre/post problem of LTP.

### Lower Level Processes

The quantal hypothesis is based on the prediction that there is a unit in the synaptic transmission. This is supported by the finding that mEPP is normally distributed around the mean. However, the miniatures are variable in amplitude and distributed in a highly skewed form in CNS synapses. Since focal application of glutamate at individual postsynaptic sites evoked currents less variable than the quantal EPSCs, the concentration of glutamate is assumed to be variable in magnitude or in kinetics in the synaptic cleft [6]. Several mechanisms are proposed to explain variable quantal size (Fig. 3) (i) non-uniform vesicle volume, (ii) non-uniform vesicle filling of transmitters, (iii) incomplete exocytosis of transmitters via a fusion pore with variable diameter, expansion rate, or lifetime, (iv) variable site of release relative to postsynaptic receptors, and (v) synchronous release of multiple vesicles or release of pre-fused vesicles.

Since NMDA receptors have a 100-fold higher affinity for glutamate, slower unbinding rate of glutamate

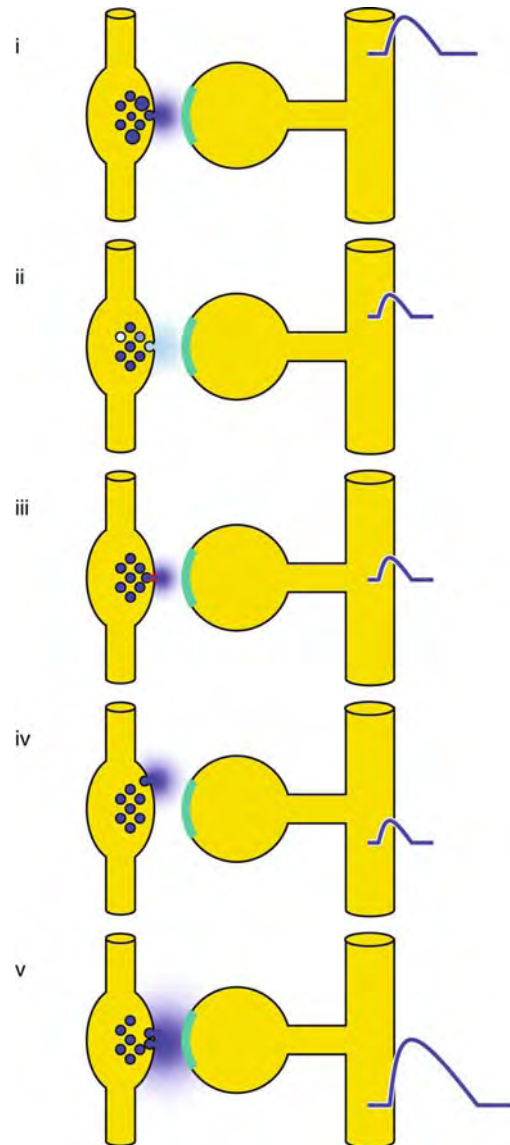

**Quantal Transmission. Figure 3** Possible mechanisms underlying variable quantal size: (i) non-uniform vesicle volume, (ii) non-uniform vesicle filling, (iii) incomplete exocytosis of transmitter via a fusion pore with variable diameter, expansion rate, or lifetime, (iv) release site variation relative to postsynaptic receptors, and (v) synchronous release of multiple vesicles. Modified after Kullmann (1999).

and slower rate of desensitization than do AMPA receptors, the occupancy and opening probability of receptors depend on both the concentration and the time course of the glutamate transient [4]. If the glutamate transient is large and extremely brief, both NMDA and AMPA receptors are activated. On the other hand, if the glutamate wave is small and slow, NMDA receptors might be selectively activated. This would be one of the

possible underlying mechanisms of “silent synapse” phenomenon [4].

### Process Regulation

Quantal transmitter release from the presynaptic terminal is regulated by various neuromodulators, which have their specific receptors on the presynaptic terminal. The inhibition of presynaptic voltage-dependent  $\text{Ca}^{2+}$  channels plays a key role in presynaptic neuromodulations [7]. Up- and down-regulation of the exocytotic machinery are also involved in neuromodulations.

Use-dependent modifications such as ►paired-pulse facilitation, ►post-tetanic potentiation and LTP are also accompanied with changes in quantal release. While induction of LTP generally requires postsynaptic activation of NMDA receptors in the brain, LTP at the hippocampal mossy fiber (MF) pathway, the synapse between the dentate granule cells and the CA3 pyramidal neurons, is NMDA-independent [8]. The synaptic transmission can be measured from the postsynaptic CA3 pyramidal cell as an EPSC. Similar to EPPs at the neuromuscular junction, the EPSC amplitude was stochastically fluctuated from trial to trial and sometimes resultant in synaptic failure. When tetanic stimulation was applied on the mossy fiber pathway, the mean amplitude of EPSCs was increased with the reduction of synaptic failures for tens of minutes. The increase in the EPSC amplitude was accompanied by a linear increase in the  $CV^2$  value. These results are consistent with a presynaptic mechanism for LTP expression in this type of synapse.

### Function

The quantal release of neurotransmitter provides unreliable processes in the neural network of brain.

Although at first glance such unreliability seems detrimental to brain functions, it is hypothesized to be utilized by the brain for the purposes of learning, in analogy to the way in which unreliable genetic replication is used for evolution [9].

### Pathology

►Lambert-Eaton myasthenic syndrome (LEMS) is a disorder of neuromuscular transmission that is characterized by muscle weakness and autonomic dysfunction. The etiology of LEMS is unknown, but is often associated with small cell lung carcinoma, and is highly prevalent with autoantibodies, particularly to thyroid and stomach constituents. Neuromuscular transmission can be investigated by microelectrode methods in biopsied patients’ skeletal muscles. The quantal analysis revealed that the quantal content ( $m$ ) of the nerve-muscle transmission (the number of acetylcholine-containing quantal release per nerve impulse) was markedly reduced, so that *in vivo* the transmission-evoked depolarization would fail to exceed the threshold required for generating an action potential in the muscle membrane. Passive transfer of LEMS IgG to mice by daily intraperitoneal injection induced the reduction of quantal content of nerve-muscle transmission (Fig. 4).

Both quantal content and the human IgG level in the serum recovered in correlation after injections were terminated. These and other experiments support the hypothesis that the quantal content of nerve-muscle transmission is decreased by the reduction of  $\text{Ca}^{2+}$  entry during presynaptic activation, probably through the increased degradation of voltage-dependent  $\text{Ca}^{2+}$  channels in the presynaptic terminals [10].

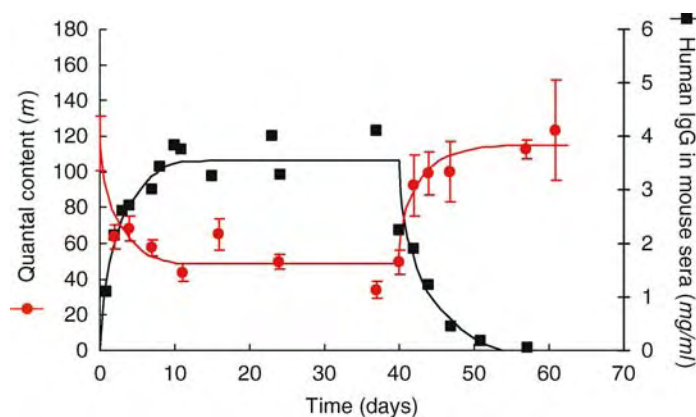

**Quantal Transmission. Figure 4** Time course of the effect on quantal content of passively transferred Lambert-Eaton myasthenic syndrome (LEMS) IgG in mice. Daily injection of LEMS IgG increased the serum level of human IgG in the mice (black squares). IgG injection was stopped after 40 days administration. The quantal content was reduced with the increase of LEMS IgG and recovered with the reduction (red circles, mean and SEM). Modified after Prior et al. (1985).



## References

1. Katz B (1966) Nerve, muscle and synapse. McGraw-Hill, New York
2. Kuno M (1995) The synapse: function, plasticity, and neurotrophism. Oxford University Press, New York
3. Stevens CF (1993) Quantal release of neurotransmitter and long-term potentiation. *Cell* 72 Neuron 10 (suppl):55–63
4. Kullmann DM (2003) Silent synapses: what are they telling us about long-term potentiation? *Phil Trans R Soc Lond B* 358:727–733
5. Ryan TA (2001) Presynaptic imaging techniques. *Curr Opin Neurobiol* 11:544–549
6. Liu G, Choi S, Tsien RW (1999) Variability of neurotransmitter concentration and nonsaturation of postsynaptic AMPA receptors at synapses in hippocampal cultures and slices. *Neuron* 22:395–409
7. Wu L-G, Saggau P (1997) Presynaptic inhibition of elicited neurotransmitter release. *Trends Neurosci* 20:204–212
8. Zalutsky RA, Nicoll RA (1990) Comparison of two forms of long-term potentiation in single hippocampal neurons. *Science* 248:1619–1624
9. Seung HS (2003) Learning in spiking neural networks by reinforcement of stochastic synaptic transmission. *Neuron* 40:1063–1073
10. Vincent A, Lang B, Newsom-Davis J (1989) Autoimmunity to the voltage-gated calcium channel underlies the Lambert-Eaton myasthenic syndrome, a paraneoplastic disorder. *Trends Neurosci* 12:496–502

including 13 parameters of sensory testing procedures for the analysis of the somatosensory phenotype. To judge plus or minus symptoms in patients an age- and gender-matched data-base for absolute and relative QST reference data in healthy human subjects was established. The QST data are then used to create zscore sensory profiles to judge altered somatosensation in patients.

- ▶ Neuropathic Pain
- ▶ Pain Psychophysics

## Quantitative Sex Differences in Pain

### Definition

Sex differences in the magnitude of pain or analgesic responses (to be contrasted with qualitative sex differences). For example, higher prevalence of pain or lower pain threshold in females represent quantitative sex differences.

- ▶ Gender/Sex Differences in Pain

## Quantitative Sensory Testing (QST)

### Definition

A sophisticated neurophysiological technique to test systems is quantitative sensory testing (QST). It uses a battery of standardized mechanical and thermal stimuli (graded v. Frey hairs, several pinprick stimuli, pressure algometers, quantitative thermotesting etc.). A standardized protocol for QST was recently proposed by the nationwide German Network on Neuropathic Pain

## Quick Phase of Nystagmus

### Definition

One of the two types of eye movement that comprise nystagmus resembling a saccade. A fast resetting eye movement that returns the globe toward center position.

- ▶ Nystagmus
- ▶ Saccade
- ▶ Saccadic Eye Movement

---

## RA Afferents

### Definition

Rapidly adapting (RA) mechanoreceptive afferents (also called fast adapting type I afferents) found in the skin. They are thought to be associated with Meissner corpuscles in glabrous skin and hair follicle and field receptors in hairy skin. Their receptive fields are generally small, and they have a low threshold to mechanical stimulation, particularly low frequency sinusoids (flutter, <60 Hz).

- ▶ Active Touch
- ▶ Cutaneous Mechanoreceptors
- ▶ Functional Behavior
- ▶ Processing of Tactile Stimuli

---

## Rabies

### Definition

Rabies is an acute, usually fatal encephalomyelitis caused by Rhabdoviridae. Highly endemic in parts of Africa, Asia, and Central and South America, rabies is almost always transmitted by an infected animal bites.

Infected people first develop fever, headache and skin sensation abnormalities (paresthesias) followed by paralysis (“dumb” form), hydrophobia, delirium or psychosis (“furious” form), then coma and death.

Confirmatory diagnosis is made by PCR assay of skin or saliva, but a negative result does not exclude the diagnosis. Pre-exposure vaccination is recommended for people who work with wild animals, travelers who anticipate prolonged stays in rural areas with high levels of endemic rabies as well as for cave explorers (spelunkers).

- ▶ Encephalomyelitis
- ▶ Polymerase Chain Reaction (PCR)

---

## Radial-Arm Maze

### Definition

An elevated maze with a central platform and, typically, eight radially-arranged alleys. The goal of a rat or mouse is to retrieve food hidden at the end of each alley without repeating an alley choice.

- ▶ Spatial Learning/Memory

---

## Radial Glia

### Definition

The radial glia is morphologically defined as a type of cell that possesses an elongated fiber spanning the developing cerebral cortex from the ventricular surface to the pial surface with an ovoid cell body located within the ventricular zone. The radial glia retains a neurogenic capacity and also its processes serve as a scaffold for migrating neurons.

- ▶ Cortical Development
- ▶ Cortical Development and its Disorders
- ▶ Neural Development

---

## Radial Histogenetic Division

### Definition

A radially arranged region or territory of the brain, whose neurons primarily derive from a specific morphogenetic field (i.e. from a restricted ventricular sector of the neural plate/tube). The radial feature of brain histogenetic divisions is based on the predominant glial fiber-guided migration of immature neurons in

their way from the ventricular (proliferative) zone to the mantle during development. Nevertheless, radial histogenetic divisions can contain immigrant cells coming from other fields by tangential migration.

► [Evolution and Embryological Development of the Forebrain](#)

---

## Radial Migration

### Definition

Projection neurons are produced locally in the telencephalic wall and migrate to the overlying cortical plate perpendicular to the pial surface.

---

## Radiation Term

### Definition

The volumetric source or sink of non-mechanical power in the balance of energy.

► [Mechanics](#)

---

## Radiculopathy

### Definition

Radiculopathy refers to disease of the spinal nerve roots (from the Latin radix for root). Damage to the spinal nerve roots can lead e.g. to pain, numbness, weakness, and paresthesia (abnormal sensations in the absence of stimuli) in the limbs or trunk. Pain may be felt in a region corresponding to a dermatome, an area of skin innervated by the sensory fibers of a given spinal nerve.

► [Neuropathic Pain](#)

---

## Radioisotope

### Definition

A radioactive isotope of an element.

---

## Radioligand

### Definition

A radiolabeled molecular probe for the visualization of a particular receptor sub-type; see Positron Emission Tomography (PET).

► [Positron Emission Tomography](#)

---

## Radiopharmaceutical (Radiotracer)

### Definition

A specific pharmaceutical, labeled with radioactive isotope.

---

## Radiotracer Imaging

### Definition

Radiotracer imaging techniques involve intravenously injecting various short-lived radiolabelled molecules and then using positron emission tomography (PET) or single photon emission computed tomography (SPECT) to measure one or more biological functions of dopaminergic neurons in a resting state.

► [Dopamine](#)

---

## Raf

### Definition

A protein kinase and member of the MAPKK Kinase family. As a result of neurotrophic factor binding, MAPKKK is activated and phosphorylates MAPKK on its serine and threonine residues. The MAPKK then activates a MAPK through phosphorylation on its serine and tyrosine residues.

► [Mitogen Activated Protein Kinase \(MAPK\)](#)  
 ► [Neurotrophic Factors in Nerve Regeneration](#)

## RAGs (Regeneration-Associated Genes)

### Definition

A series of changes in gene expression that occur in cell bodies (perikarya) of neurons with axon damage.

► Axon Degeneration and Regeneration of Peripheral Neurons

## Random Process

### Definition

The term “random process” denotes a series of uncorrelated events that are distributed either exponentially or in a Gaussian fashion.

► Circadian Rhythm

## Raphé Interpositus

### Definition

A collection of neurons lined up on either side of the midline ventral to the abducens nucleus. The neurons in raphé interpositus are the saccade-related omnipause neurons.

► Omnipause Neurons  
► Saccade, Saccadic Eye Movement

## Raphé Nuclei

### Definition

The raphé nuclei are traditionally considered to be the medial portion of the reticular formation, and they appear as a ridge of cells in the center and most medial portion of the brain stem. The raphé nuclei have a vast impact upon the central nervous system. The raphé

nuclei can be of particular interest to neurologists and psychologists since many of the neurons in the nuclei (but not the majority) are serotonergic, i.e. contain serotonin – a type of monoamine neurotransmitter.

Serotonin, also called 5-HT, seems to be the culprit in many of our modern psycho-pharmaceutical problems, such as anorexia, depression, and sleep disorders. It is not the sole culprit in the aforementioned disorders, but it is the area that the pharmacologists know how to affect in the best manner. It is important to note that pharmacology traditionally affects global serotonin levels, while the actions of the raphe nuclei are dependent on the complex interplay between nuclei.

► Serotonin

## Raphé Nuclei and Circadian Rhythm

### Definition

The midbrain dorsal and median raphé nuclei known for their widespread, extensively overlapping, ascending serotonergic projections. The projections of each nucleus, serotonergic or not, contribute to a great many different brain functions. In the context of the circadian rhythm system, the innervation by the dorsal and median raphé is somewhat unique because the raphé efferent projections of those two nuclei do not overlap in the two primary components of the system, the suprachiasmatic nucleus (SCN) and the intergeniculate leaflet (IGL). The SCN is very heavily innervated by neurons with cell bodies in the median raphé nucleus.

The majority of these contain the neurotransmitter, serotonin, but many median raphé neurons projecting to the SCN contain a different, currently unknown, neurotransmitter. Neurons of the median raphé do not project to the IGL. In contrast, both serotonergic and non-serotonergic neurons in the dorsal raphé nucleus project to IGL, but not to the SCN. In addition, the median and dorsal raphé nuclei reciprocally connect to one another via serotonergic and non-serotonergic connections. The direct serotonergic median raphé-SCN projection has been implicated as an inhibitor of retinohypothalamic tract transmission of photic input to the SCN, while the dorsal raphé serotonergic projection to the IGL has been implicated in the non-photoc regulation of circadian rhythm phase.

► Circadian Rhythm  
► Intergeniculate Leaflet  
► Serotonin  
► Suprachiasmatic Nucleus

## Raphespinal Tract

### Synonyms

Tractus raphespinalis

### Definition

Projections of the magnocellular raphe nuclei (median zone of the reticular formation) to the gray matter of the spinal cord.

#### ► Pathways

to be a highly evolved behavioral stage of terrestrial mammals.

- Atonia
- EEG in Sleep States
- Electroencephalography
- Electromyogram
- Electrooculogram (EOG)
- Non-REM Sleep
- Sleep States

## Rapid Eye Movement (REM) Sleep

### Definition

REM sleep (also called paradoxical sleep (PS) and activated sleep) is a distinctive sleep stage in mammals. Normally this stage of sleep appears after a period of non-REM (NREM) sleep and then alternates with episodes of NREM sleep throughout the sleep period. REM sleep is characterized by a constellation of events including the following: (i) low-amplitude synchronization of fast oscillations in the cortical electroencephalogram (EEG) (also called activated EEG); (ii) very low or absent muscle tone (atonia) in the electromyogram (EMG). The atonia is observed to be particularly strong on antigravity muscles, whereas the diaphragm and extra-ocular muscles retain substantial tone; (iii) singlets and clusters of rapid eye movements (REMs) in the electrooculogram (EOG); (iv) theta rhythm in the hippocampal EEG; and (v) spiky field potentials in the pons (P-wave), lateral geniculate nucleus, and occipital cortex (called ponto-geniculo-occipital (PGO) spikes). Supplemental to these polysomnographic signs, other REM sleep-specific physiological signs are: myoclonic twitches, most apparent in the facial and distal limb musculature; pronounced fluctuations in cardio-respiratory rhythms and core body temperature; penile erection in males and clitoral engorgement in females (tumescence). In humans, awakening from REM sleep typically yields detailed reports of hallucinoid dreaming, even in subjects who rarely or never recall dreams spontaneously.

REM sleep is critical for memory processing and improvement of learning. REM sleep is not identifiable in the fish, amphibian, or reptile classes. In birds REM sleep is seen only for brief periods of time, especially following hatching. Generally, REM sleep is considered

## Rapid Eye Movement (REM) Sleep Disorder

### Definition

- REM Sleep Behavior Disorder

## Rapidly Adapting Pulmonary Receptors

- Respiratory Reflexes

## Rapidly Adapting Type I Mechanoreceptors

### Definition

A mechanically sensitive sensory ending in the skin that adapts rapidly to a sustained indentation and therefore is sensitive to dynamic events such as vibration. It has small, well-defined receptive fields and the sensory terminal is believed to innervate the Meissner corpuscle.

Also known as FAI (fast-adapting type I) afferents in humans, RA (rapidly-adapting) receptors in the cat and QA (quickly-adapting) receptors in the primate.

- Cutaneous Mechanoreceptors
- Functional Behavior
- Processing of Tactile Stimuli
- Electric Fish

## Rapidly Adapting Type II Mechanoreceptors

### Definition

A mechanically sensitive sensory ending in the skin that adapts rapidly to a sustained indentation and therefore is sensitive to dynamic events such as vibration. It has large, poorly-defined receptive fields and the sensory terminal is believed to innervate the Pacinian corpuscle.

Also known as FAII (fast-adapting type II) afferents in humans and PC (Pacinian Corpuscle) receptors in the cat and primate.

- ▶ Cutaneous Mechanoreceptors
- ▶ Functional Behavior
- ▶ Pacinian Corpuscle
- ▶ Processing of Tactile Stimuli
- ▶ Vibration Sense
- ▶ Electric Fish

## Rapsyn

### Definition

Rapsyn (Receptor associated protein of the synapse) is important for initiating postsynaptic differentiation (pre-patterning) and is tightly associated with acetylcholine receptors suggesting that this complex becomes aggregated and stabilized at postsynaptic membranes.

- ▶ Synapse Formation: Neuromuscular Junction Versus Central Nervous System

## Rarefaction

### Definition

Areas of a propagating sound pressure wave of maximal decreased pressure (decrease below the static pressure).

- ▶ Acoustics

## Ras GTPases

### Definition

A family of molecules that include RhoA, Rac and CDC42, signals within growth cones.

- ▶ Axon Degeneration and Regeneration of Peripheral Neurons

## Rate Coding in Motor Units

### Definition

Control of force output from an individual motor unit by regulation of motoneuron firing frequency.

- ▶ Motor Units

## Rate of Cross-Bridge Detachment

### Definition

In the cross-bridge theory, cross-bridge attachment and detachment to the actin filament are quantitatively described by position-dependent rate functions. The detachment rate describes the first order kinetics of cross-bridge detachment from actin, while the attachment rate describes the first order kinetics of cross-bridge attachment to actin. In order for force production and contraction to always be in the same direction (i.e. a muscle always tends to shorten upon contraction and to produce tensile forces), these rate functions have to be asymmetric relative to the equilibrium point of the cross-bridge.

- ▶ Actin
- ▶ Force Depression/Enhancement in Skeletal Muscles

## Rathke's Pouch

### Definition

The pituitary anlage from which a craniopharyngioma may arise.

- ▶ Neuroendocrinology of Tumors

## Rating Task

### Definition

A psychophysical task in which a subject is asked to state the magnitude of a stimulus either in absolute terms or relative to a reference.

## Ratiometric Dye

### Definition

Some dyes respond to a metabolic change with both increase and decrease of fluorescence, depending on how they are measured. For example, the fluorescence of the calcium sensitive dye fura increases with increasing calcium when excited at 340 nm, and decreases when excited at 380 nm. FRET-dyes (FRET means Fluorescence Resonance Energy Transfer) shift their emission spectrum, with the result that fluorescence decrease in one band, and increases in another.

These dyes can be evaluated by creating the ratio (hence the name ratiometric dye) of the two signals, creating a number that is independent of the absolute fluorescence strength.

- ▶ Functional Imaging

## Ray-finned Fishes

### Definition

Also known as actinopterygian fishes. So named because of the flexible rays that provide the structural support of their fins. They make up approximately 95% of all living fishes and about half of all living vertebrate species.

- ▶ Evolution of the Spinal Cord

## RC Circuit

### Definition

Electrical circuit consisting of a resistor and a capacitor.

- ▶ Cable Theory

## RCS Rat

### Definition

Royal College of Surgeons rat model of Retinitis Pigmentosa has a mutation affecting retinal pigment epithelium. The mutation leads to an inability to phagocytose the photoreceptor outer segment. The same gene mutation is found in human patients with Retinitis Pigmentosa.

- ▶ Inherited Retinal Degenerations
- ▶ Retinitis Pigmentosa

## rd/rd or rd1 Mouse

### Definition

A mouse model of Retinitis Pigmentosa with a naturally occurring mutation of the beta-subunit of phosphodiesterase (an enzyme important in the visual transduction cascade). The same gene mutation is found in human patients with Retinitis Pigmentosa (see Inherited Retinal Degenerations).

- ▶ Inherited Retinal Degenerations
- ▶ Retinitis Pigmentosa

## Reach to Grasp Postural Strategy

### Definition

A change in support reaction to postural perturbation in which a rapid reaching movement of the arm permits a stable object to be touched or grasped for support, in order to restore equilibrium.

- ▶ Postural Strategies
- ▶ Reaching Movements

## Reaching Behavior

### Definition

Goal-directed behavior of humans and animals that requires visual information for movement of arms and hands in reach for objects.

## Reaching Movements

ANDREA D'AVELLA

Department of Neuromotor Physiology,  
Santa Lucia Foundation, Rome, Italy

### Definition

The act of reaching, bringing a part of the body in contact with an object, is a crucial component of many animal behaviors. Several vertebrate species use the distal portions of their forelimbs to explore and feed. Reaching movements are particularly important for primates, whose hands are capable of grasping and manipulating objects, and consequently these movements have been extensively investigated in humans and monkeys.

### Characteristics

To reach for an object with the hand, the central nervous system (CNS) must map sensory input, which provides information about the object and hand locations in space, into motor output, comprising activations of shoulder and arm muscles that move the hand towards the target. Considering visually guided reaching, the location of a visual target is specified in retinal coordinates, proprioception gives information on the initial hand location in terms of arm muscle lengths, and muscle activations generate forces between arm segments. Thus, the CNS must transform sensory information into motor commands that are encoded in different ►frames of reference. It is usually assumed that the CNS performs these sensorimotor transformations in two stages. First, sensory information is used to define a kinematic plan. Target location and hand location are mapped into a common reference frame and a difference vector or motor error is computed. Second, the movement is executed by mapping the plan into muscle activations. This transformation may be performed using sensory signals for correcting the motor commands while they are generated (►Feedback control) or by pre-computing the appropriate commands (►Feedforward control). Since the delays involved in the conduction and processing of sensory signals may create instabilities in a feedback controller, the control of fast reaching movements requires feedforward control. Knowledge of the dynamical behavior of the musculo-skeletal system necessary for pre-computing the appropriate motor commands is thought to be incorporated into the controller either explicitly as an ►internal model of the motor apparatus or implicitly as a collection of motor programs. The kinematic and dynamic characteristics as well as the muscle activation patterns observed during reaching movements have provided the experimental

bases for the elaboration of these and other models of the computations involved in controlling reaching movements (►Motor control models).

### Kinematics

The motion of the arm during reaching, arm kinematics, is fully specified by the rotational motion of all the joints in the arm. Considering the wrist as the arm end-point to be positioned in space, three rotations at the shoulder (flexion-extension, adduction-abduction, internal-external rotation), and one at the elbow (flexion-extension) are required to characterize reaching kinematics. Since there are four joint angles, or degrees-of-freedom, for three spatial coordinates of the wrist, the system is redundant, i.e. the same spatial location can be reached with the arm in many different configurations. For example, it is possible to raise the elbow without moving the wrist. Moreover, there are infinite paths along which the wrist can be moved to reach a target location from a given start location. Thus, to plan a reaching movement the CNS has to select one out of infinite possible kinematics.

Simple invariant features have been observed in the kinematics of reaching movements and they have provided an indication of the strategy used by the CNS for the planning stage. When performing a point-to-point reaching movement between two points on a horizontal plane, the wrist paths are straight and the wrist tangential velocity has a “bell-shaped” profile with a single peak [1]. For unrestrained movements in a vertical plane, the hand path is not always straight but it is independent of the speed of the movement [2] and of the hand-held load [3] (Fig. 1b–c).

Moreover, the tangential velocity profiles for movement at different speeds have the same shape when normalized for speed (Fig. 1d). The existence of invariant kinematic features has been interpreted as evidence for kinematic planning of reaching movements. Moreover, the straightness of the wrist path has been interpreted as evidence for planning end-point trajectories or displacements. However, since movements are executed by changing joint angles, end-point planning also requires mapping desired end-point positions into joint angles (inverse kinematics).

### Dynamics

Arm movements are generated by the forces applied on the arm segments by the contraction of the muscles interconnecting them as well as by gravity. Since the arm is a chain of articulated segments, the motion of one joint depends not only on the forces directly applied to it but also on the motion of the other joints and the forces applied to them. For example, during a sagittal-plane reach to a target at shoulder level, from a starting posture with the forearm at waist level and the upper arm vertical along the trunk, the shoulder flexes and the



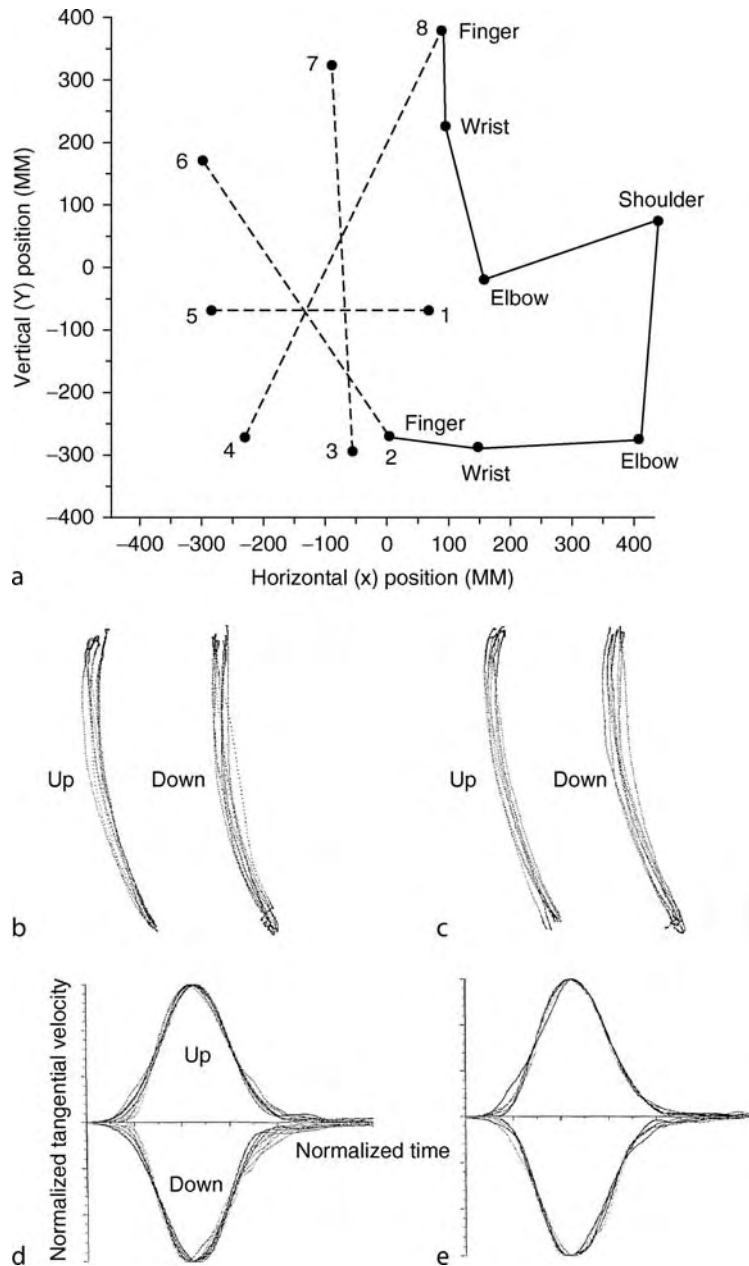

**Reaching Movements. Figure 1** Invariant wrist path and tangential velocity for point-to-point movements across speeds and loads. (a) The position in space of markers placed on the arm of subjects performing unrestrained reaching movements between two points in the sagittal plane is recorded. (b–c) The path, on the sagittal plane, of the wrist for upward and downward movements (between points 3 and 7) does not change with the speed (b, where 6 slow, 6 medium, and 6 fast movement paths are overlapped) and the hand-held load (c, where 6 unloaded, 6 with 2 lb load, and 6 with 4 lb load movement paths are overlapped). (d–e) Similarly, the tangential velocity profile for upward and downward (with inverted ordinates) movements between the same two points, once normalized for speed, does not change with speed (d) and load (e). Adapted from [3] copyright © 1985 by the Society of Neuroscience, with permission.

elbow extends. However, because of the intersegmental dynamics, the muscles generate a flexor torque at *both* shoulder and elbow joints. Thus, the transformation between kinematics and dynamics (inverse dynamics)

is not trivial and how the CNS implements this transformation is still an open question.

The characteristics of the torque profiles generated by the muscle contractions suggest that the CNS uses

simple rules to find approximate yet adequate solutions to the inverse dynamic problem. The net torque generated at each joint by all muscles acting on it can be estimated from the arm kinematics using a simplified dynamic model of the arm based on the Newtonian equations of motion. For point-to-point movements in the sagittal plane, from one central location to several peripheral locations arranged on a circle, the dynamic muscle torque (expressed as the net muscle torque minus the torque required to counteract gravity) at the shoulder and at the elbow are related almost linearly to each other [4] (Fig. 2).

Both shoulder and elbow dynamic torque profiles have similar biphasic and synchronous shapes. Moreover, the relative amplitude of the two torque profiles changes with ►movement direction, with the same biphasic torque profile scaled at each joint by a coefficient that varies as a linear function of the angular displacement at both joints. Simple torque scaling rules have also been proposed as a mechanism to generate movements with invariant paths and tangential velocity with different speeds and loads [3]. These rules derive from the observation that scaling in time the anti-gravity torque profiles and both in amplitude and in time the dynamic torque profiles generates invariant kinematics.

### Muscle Patterns

The patterns of muscle activation observed during reaching movements have a complex dependence on the movement direction and speed. For reaching in vertical planes, the electromyographic (EMG) waveforms are constructed by combining components related to both dynamic and gravitational torques [5]. The waveform components responsible for the dynamic torques (phasic activations) have an intensity and a timing that changes with the movement direction in a complex manner [6]. Each muscle has a distinct spatial and temporal pattern, with a recruitment intensity maximal in multiple directions and a recruitment timing changing gradually across directions. Moreover, the phasic activations scale in time with movement speed differently for different muscles.

Despite their complex dependence on the movement parameters, the muscle patterns for reaching are generated according to relatively simple rules. The changes in the muscle patterns for fast reaching movements in different directions on vertical planes are well captured by the combinations of a few time-varying ►muscle synergies [7] (Fig. 3).

A muscle synergy represents the coordinated activation of a group of muscle with specific activation profiles. Each synergy is modulated in intensity and

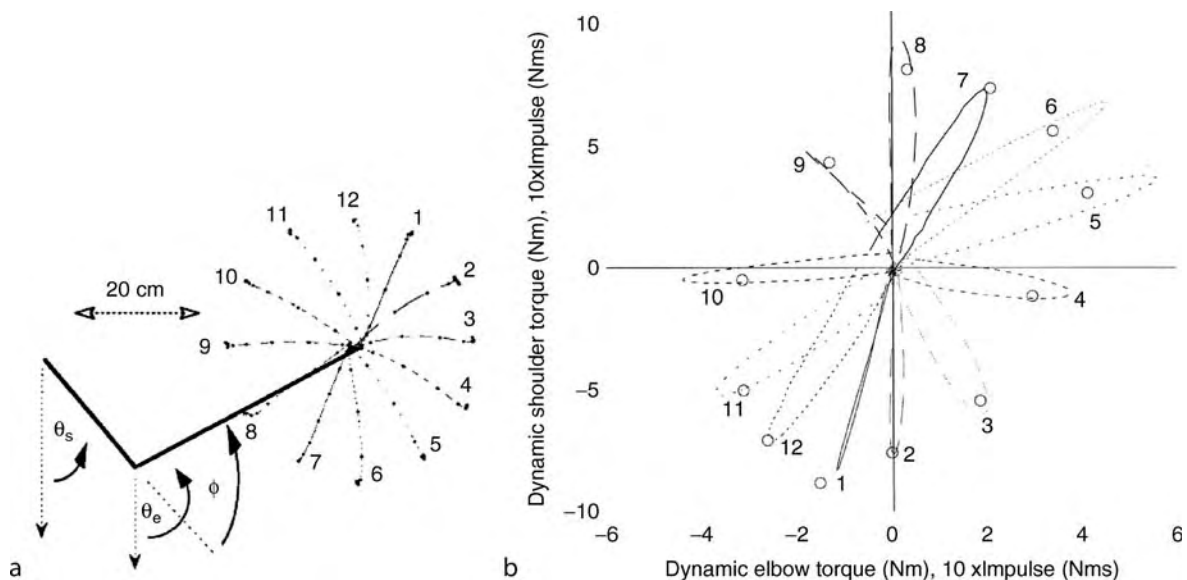

**Reaching Movements. Figure 2** Scaling of dynamic muscle torques as a function of movement direction. (a) The elbow and shoulder muscle torques necessary for performing center-out reaching movements to 12 targets in the sagittal plane are estimated from the movement kinematics. (b) The average dynamic torque at the elbow and at the shoulder, obtained removing the torque required for resisting gravity from the total muscle torque at each joint, are plotted against each other, during the initial accelerating phase, for the 12 different directions (*solid and dashed lines*; open symbols represent the integrated torque, or impulse, at elbow and shoulder). The dynamic elbow and shoulder torque are approximately linearly related for all movements with a slope depending on the movement direction. Adapted from [4] copyright © 1997 by the American Physiological Society, with permission.

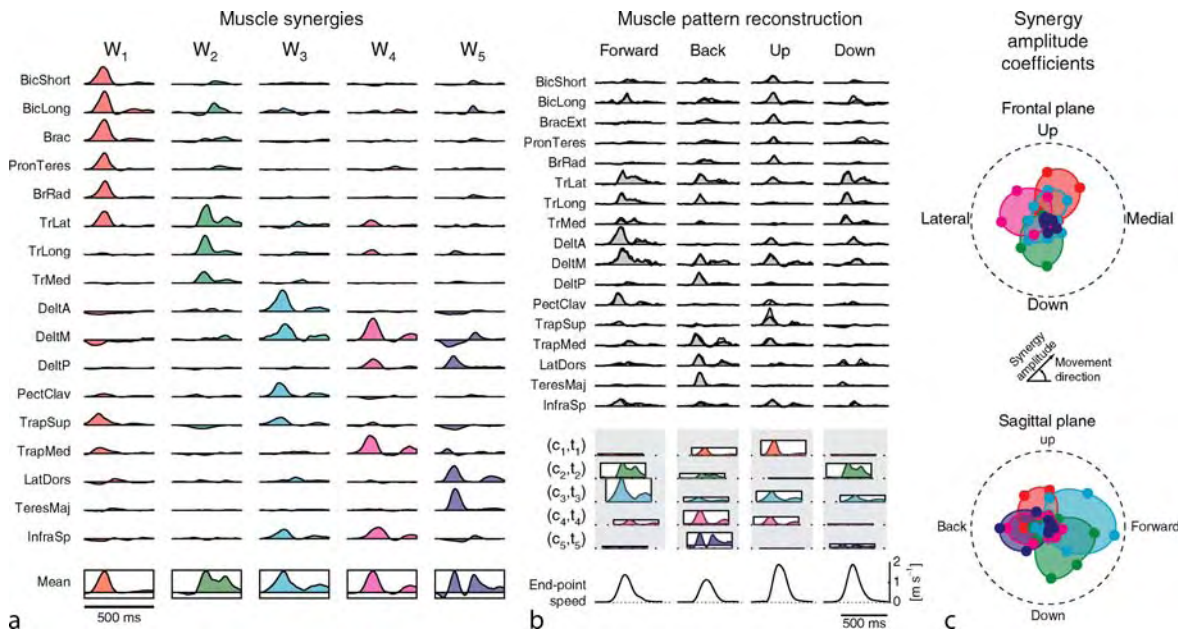

**Reaching Movements. Figure 3** Muscle synergies for reaching. (a) A set of five time-varying synergies, identified from the muscle patterns recorded during point-to-point movements between one central location and eight peripheral locations in the frontal and sagittal planes. (b) The activation waveforms of 17 shoulder and arm muscles are reconstructed (*top*, where the gray area represents the averaged EMG activity and the solid black line the synergy reconstruction) by scaling in amplitude and shifting in time (*bottom*, where the amplitude scaling coefficient is represented by the height of a rectangle and the onset latency by its horizontal position) and combining, muscle by muscle, each one of the five synergies. Different movements are reconstructed with different synergy combination coefficients. (c) The amplitude scaling coefficients are directionally tuned ([► Directional tuning](#)), with a tuning in most cases well captured by a cosine function. Adapted from [7] copyright © 2006 by the Society of Neuroscience, with permission.

delayed in time differently across movement directions and multiple synergies are combined to generate the observed muscle patterns. Such a combination mechanism may simplify the sensorimotor transformations for reaching by allowing a direct, low-dimensional mapping between kinematic plans and muscle patterns, and, thus, an implicit implementation of approximate inverse kinematics and inverse dynamic computations.

### Neural Control

A distributed network of cortical areas in the parietal and frontal cortex and subcortical structures (spinal cord, cerebellum, basal ganglia) is involved in the neural control of reaching movements. This network functions in an integrated manner and it has not been possible to associate specific stages of the sensorimotor transformations to specific areas or neuronal populations. However, each area has a different degree of involvement into the different aspects of the control process. Spatial representation of limb position, target locations, and potential motor actions are highly expressed in the parietal cortex which is thought to be mainly involved in the early sensorimotor transformations. Selection and execution of

motor actions are strongly expressed in the motor areas of the frontal cortex, from which most of the descending axons to the brain stem and the spinal cord originate, and which are believed to play a major role in transforming kinematic plans into descending commands closely related to the muscle patterns.

To understand the neural mechanisms underlying the sensorimotor transformations involved in reaching, the characteristics of the activity of individual neurons in many of the cortical areas involved have been investigated in monkeys. Recordings in the motor areas of the frontal cortex, composed by the primary motor cortex and six distinct premotor areas, have shown that the activity of most neurons is broadly tuned to the direction of movement [8]. The activity of each cell depends on the movement direction approximately as a cosine function, with a maximum in a [► preferred direction](#) that varies from cell to cell. Thus, each cell is active for a broad range of movement directions. Conversely, each movement direction is associated by a pattern of graded activation of the entire neural population. In fact, the direction of movement, either during movement preparation or movement execution,

can be approximately estimated using a “▶population vector,” the sum of the preferred direction vector of each recorded cell weighted by its firing rate change from baseline. These observations have been interpreted as an indication that the motor cortex is mainly involved in high-level movement representation in terms of spatial location of the hand. However, the activity of most of the cells in the motor cortex is also modulated by the posture of the arm [9] and by the movement dynamics [10]. Thus, the representation of both kinematic and dynamic features are likely to coexist in the motor cortex, as expected in a neural network implementing a coordinate transformation from a kinematic motor plan to dynamic motor commands.

## References

1. Morasso P (1981) Spatial control of arm movements. *Exp Brain Res* 42(2):223–227
2. Soechting JF, Lacquaniti F (1981) Invariant characteristics of a pointing movement in man. *J Neurosci* 1(7):710–720
3. Atkeson CG, Hollerbach JM (1985) Kinematic features of unrestrained vertical arm movements. *J Neurosci* 5(9):2318–2330
4. Gottlieb GL, Song Q, Almeida GL, Hong DA, Corcos D (1997) Directional control of planar human arm movement. *J Neurophysiol* 78(6):2985–2998
5. Flanders M, Herrmann U (1992) Two components of muscle activation: scaling with the speed of arm movement. *J Neurophysiol* 67:931–943
6. Flanders M, Pellegrini JJ, Geisler SD (1996) Basic features of phasic activation for reaching in vertical planes. *Exp Brain Res* 110(1):67–79
7. d’Avella A, Portone A, Fernandez L, Lacquaniti F (2006) Control of fast-reaching movements by muscle synergy combinations. *J Neurosci* 26(30):7791–7810
8. Georgopoulos AP, Kalaska JF, Caminiti R, Massey JT (1982) On the relations between the direction of two-dimensional arm movements and cell discharge in primate motor cortex. *J Neurosci* 2(11):1527–1537
9. Scott SH, Kalaska JF (1997) Reaching movements with similar hand paths but different arm orientations. I. Activity of individual cells in motor cortex. *J Neurophysiol* 77(2):826–852
10. Kalaska JF, Cohen DA, Hyde ML, Prud’homme M (1989) A comparison of movement direction-related versus load direction-related activity in primate motor cortex, using a two-dimensional reaching task. *J Neurosci* 9(6):2080–2102

## Reaction

▶Feedback Control of Movement

## Reaction Time

### Definition

The time from the presentation of a stimulus to the onset of the movement. Movement onset is usually defined either as the time a threshold in speed is exceeded or as the beginning of a burst of electromyographic activity, the latter criterion yielding smaller values.

▶Eye-Hand Coordination

## Reaction Time Task

### Definition

A class of experimental paradigms in which a response (a movement) occurs reflexively in response to the appearance of a sensory stimulus. Movement onset is usually defined either as the time a threshold in speed is exceeded or as the beginning of a burst of electromyographic activity, the latter criterion yielding smaller values. The reaction time is shorter in contrast to voluntary tasks in which the response requires the selection of a response goal that is dependent on other cognitive factors.

## Reactive Astrocyte

### Definition

When the central nervous system (CNS) is damaged, inflamed or infected the astrocytes undergo a characteristic set of changes known as reactive gliosis. The cells may proliferate.

Morphologically they hypertrophy and generally put out more and longer processes. There are characteristic changes in the cytoskeleton with upregulation of GFAP, vimentin and nestin. The cells may secrete a range of cytokines and may express class II major histocompatibility complex (MHC) receptors.

After injury the cells may be neuroprotective, play a part in controlling inflammation and in resealing the blood-brain barrier.

- ▶Astrocytes
- ▶Cytokines
- ▶Cytoskeleton
- ▶Major Histocompatibility Complex
- ▶Glial Scar

## Reactive Gliosis

- ▶ Glial Scar

## Reactive Oxygen Species: Superoxide Anions

- ▶ Neuroinflammation: Modulating Pesticide-Induced Neurodegeneration

## Readily Releasable Secretory Vesicles

- ▶ Neurotransmitter Release: Priming at Presynaptic Active Zones

## Reafferrence

### Definition

Sensory input resulting from an animal's own motor output.

- ▶ Reafferent Control in Electric Communication

## Reafferent Control in Electric Communication

BRUCE A. CARLSON

Department of Biology, Washington University in St. Louis, St. Louis, MO, USA

### Synonyms

Electrocommunication; Electrical communication

### Definition

Every motor act that an animal produces will elicit sensory input from its own receptors [1]. Termed ▶reafferrence, this self-generated sensory input can be quite useful. For example, bats listen to the echoes of their own ultrasonic calls to navigate through the night, and sensory feedback from skeletal muscles can be used to improve motor control. On the other hand, reafferent input is often not informative, and it can even interfere with the detection of external sensory input. A major problem faced by all animals is distinguishing reafferent sensory input from external sensory input. This issue is particularly relevant to the subject of animal communication. A communicating animal must produce its own signal as well as detect the signals produced by other individuals. A central question in the neurobiology of communication behavior is how sensory systems are able to discriminate self-generated from externally produced signals.

Consider the problem of reafferrence for visual perception. Any movement of the eyes, either directly or indirectly, due to movements of the head or body, causes the visual input to the retina to shift dramatically. How does the visual system compensate for this shift and maintain sensitivity to external visual stimuli? Early experiments suggested that every time a motor command that induces eye movement is issued, a copy of that command is also sent to the visual system, which generates a negative image of the visual input expected to result from that movement [1,2]. Combining this negative image with actual visual input eliminates any self-induced changes. As a result, the perceived visual world maintains its stability and only externally generated visual inputs are detected.

This basic mechanism relies on two distinct features. First, the timing of motor output must be relayed to the sensory system through what is referred to as a ▶corollary discharge [2]. Second, the corollary discharge must activate a negative image of the reafferent input, a so-called ▶efference copy [1]. Research on weakly electric fish has provided insight into the neuronal implementation of these two features [3,4].

### Characteristics

#### Quantitative Description

African mormyrid fish possess an electromotor system that generates weak electric signals from a specialized ▶electric organ, as well as an electrosensory system for detecting these signals (Fig. 1a). This unique sensorimotor system serves two functions. Through ▶active electrolocation, mormyrids are able to detect distortions in their own electric field caused by nearby objects and thereby locate and identify various features of those objects, as well as navigate through their environment. By sensing the electric signals generated by other

individuals, mormyrids are also able to communicate within the electric modality.

Electric signals in mormyrids consist of a fixed ►**electric organ discharge (EOD)** separated by a variable ►**sequence of pulse intervals (SPI)** (Fig. 1b). The EOD waveform conveys several aspects of the sender's identity, such as its species, sex, dominance, and possibly even its individual identity [5]. The total duration of the EOD is a particularly salient variable across species, ranging from as little as 100  $\mu$ s to over 10 ms, and it may also exhibit sex- and status-related differences, with dominant males having a two- to three-fold longer EOD than females. By contrast, the SPI is involved in communicating contextual information about the sender's behavioral state and motivation. A variety of different patterns in the SPI have been linked with behaviors such as courtship and aggression [5].

In order for mormyrids to utilize the information available to them in these electric signals, however, they must first be able to distinguish their own EODs from those of other individuals. This distinction is made possible by a corollary discharge pathway that relays the timing of EOD production to central electrosensory regions (Figs. 1a and 2). By comparing incoming electrosensory information with an internal copy of their electromotor commands, they are able to distinguish their own electric signals from those of other nearby fish [4].

## Higher Level Structures

### Electromotor Pathway

Each EOD is initiated by a group of neurons in the ventral hindbrain that together constitute the electric organ ►**command nucleus (CN)** [5]. The neurons in the CN project both directly and indirectly to an adjacent group of neurons that make up the medial relay nucleus (MRN). The neurons in the MRN receive the command from the CN and relay it down the spinal cord to electromotor neurons that drive the electric organ (Fig. 2). The activity in the CN, and therefore the SPI, is determined by a number of descending inputs, foremost of which is a precommand nuclear complex (PCN) consisting of two adjacent, but physiologically and anatomically distinct neuronal populations [5].

### Electrosensory Pathway

The electrosensory system of mormyrids consists of three distinct pathways, one of which is relevant for electric communication (Fig. 2). The primary sensory afferents in this pathway receive input from so-called ►**knollenorgan electroreceptors**, and project to a region of the dorsal hindbrain termed the nucleus of the electrosensory lateral line lobe (nELL) [6]. The neurons in the nELL relay this electrosensory input to a large midbrain structure termed the ►**torus semicircularis**, a sensory processing region considered homologous to the inferior colliculus of mammals.

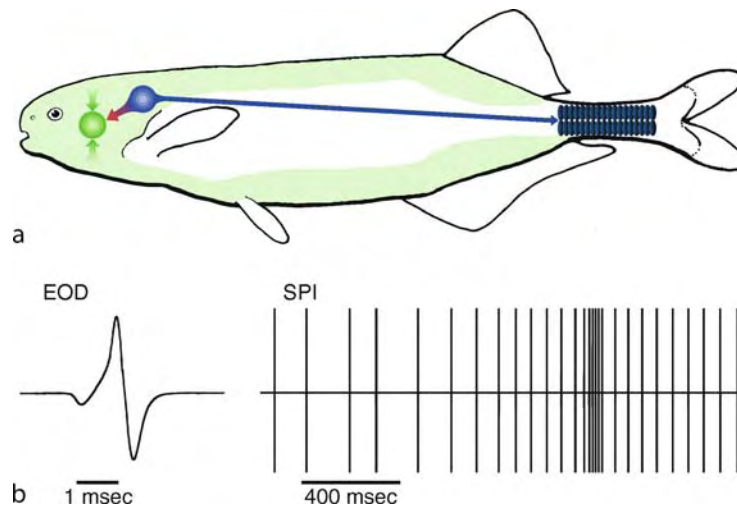

**Reafferent Control in Electric Communication. Figure 1** (a) Schematic of the electric communication system in the mormyrid *Brienomyrus brachyistius*. The electric organ, shown in blue, is controlled by a command center in the hindbrain. Each descending command drives the production of a single electric organ discharge (EOD). External electric fields are detected by electroreceptors, whose distribution on the body surface is indicated by turquoise shading. Input from the electroreceptors converges onto an electrosensory region in the hindbrain, which also receives input from the electric organ command center. (b) Structure of electric signals in mormyrids. Head positive voltage is plotted upward. The electric organ discharge (EOD) has a fixed, characteristic waveform, while the pattern of EOD production, indicated by the sequence of pulse intervals (SPI), is variable.

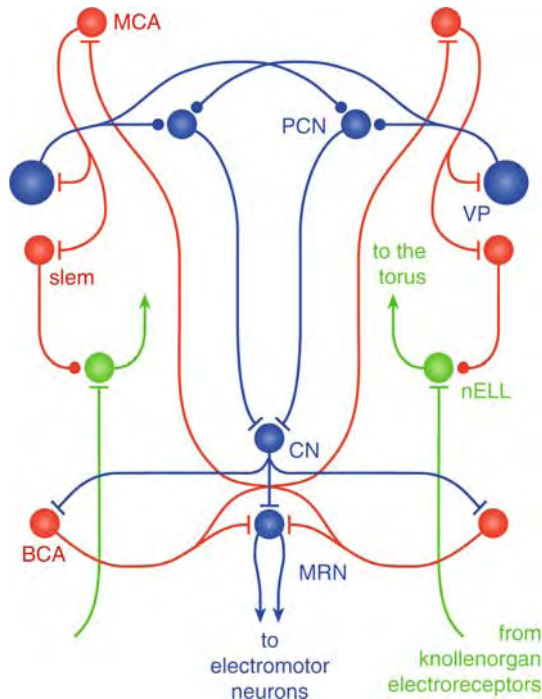

### Reafferent Control in Electric Communication.

**Figure 2** Electric communication pathways in mormyrids. The electromotor pathway is shown in blue, the electrosensory pathway in green, and the corollary discharge pathway in red. Excitatory connections are indicated by flat lines, inhibitory connections by solid circles. Abbreviations: *BCA*, bulbar command-associated nucleus; *CN*, command nucleus; *MCA*, mesencephalic command-associated nucleus; *nELL*, nucleus of the electrosensory lateral line lobe; *PCN*, precommand nuclear complex; *MRN*, medial relay nucleus; *slem*, sublemniscal nucleus; *VP*, ventroposterior nucleus.

#### Electric Organ Corollary Discharge Pathway

The EOD command issued by the CN is relayed not just down the spinal cord to the electric organ, but also to higher brain centers that provide a precise timing reference of EOD production (Fig. 2) [3,5]. This electric organ corollary discharge (EOCD) pathway plays an important role in electric communication. For electrosensory processing in the knollenorgan pathway, it gives rise to an inhibitory input to the nELL that serves to block responses to reafferent electrosensory input (Fig. 2) [4]. In addition, the EOCD pathway helps regulate EOD production, as it projects to an electromotor region that provides inhibitory input to the CN (Fig. 2). As a result, the region that drives the CN to fire is inhibited each time an EOD is generated. This negative feedback, referred to as recurrent inhibition, plays a critical role in controlling the SPI [5].

### Lower Level Components

#### Electric Organ

The electric organ of mormyrids is located at the base of the tail and consists of a homogenous population of disc-shaped, modified muscle cells called ►**electrocytes** (Fig. 1a) [7]. When they are activated in synchrony by input from spinal electromotor neurons, their individual electrical potentials summate and give rise to the EOD, the amplitude of which is typically a few volts. Differences in the EOD waveform across species and between the sexes are directly related to variations in electrocyte morphology [7].

#### Electroreceptors

The knollenorgans involved in electric communication typically contain a few receptor cells that are housed together within a single large capsule [8]. Knollenorgan receptors are broadly tuned to the spectrum of the species-specific EOD and are extremely sensitive, with thresholds as low as 0.1 mV. In response to outside positive-going voltage steps, they fire a single spike at a short fixed latency. This phase-locked activity is relayed by primary sensory afferents to the nELL.

#### Specialized Features of Time-Coding Circuitry

The electromotor and electrosensory pathways of mormyrids are characterized by several unique anatomical specializations. Both pathways contain high levels of calcium-binding protein and consist of large, spherical, adendritic cell bodies that give rise to thick, heavily myelinated axons. Synapses in both pathways are typically mixed chemical-electrical, and often form large terminals that envelope a significant portion of the postsynaptic soma. Unlike most brainstem nuclei that occur in bilateral pairs, the CN and MRN form unpaired, midline nuclei. All of these features have been associated with neural circuits in which spike timing precision is of the utmost importance [9]. For the electromotor system, this precision is critical for activating the electrocytes in synchrony and thereby maintaining a constant EOD waveform. For the electrosensory system, it is involved in accurate temporal coding of the EOD waveform.

### Higher Level Processes

#### Distinguishing Self-Generated EODs from External EODs

Knollenorgan receptors respond equally to any EOD that is above threshold, whether it is generated by the fish's own electric organ or that of another fish. In both cases, primary knollenorgan afferents generate a single spike that gives rise to an excitatory input to nELL [4]. However, the neurons in nELL also receive inhibitory input from the EOCD pathway [4], which causes the nELL neurons to respond quite differently to self-generated and external EODs (Fig. 3).

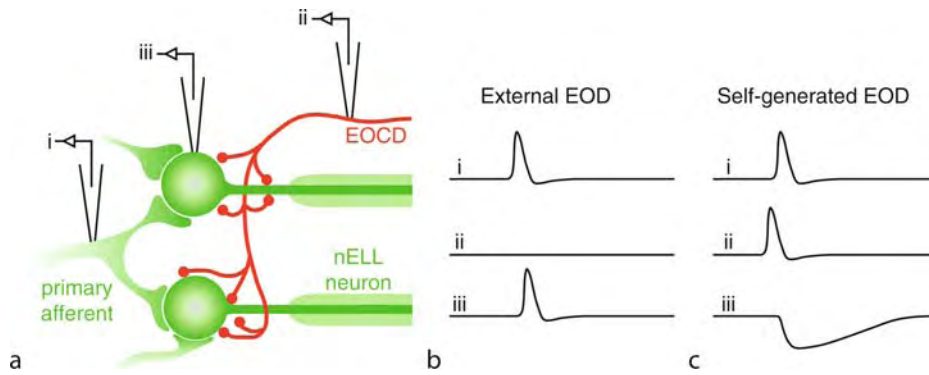

**Reafferent Control in Electric Communication. Figure 3** Corollary discharge-mediated inhibition of reafferent electrosensory input in the nucleus of the electrosensory lateral line lobe (nELL). (a) Primary knollenorgan afferents form large, excitatory, mixed chemical-electrical synapses onto the soma of large, adendritic spherical nELL neurons. The electric organ corollary discharge (EOCD) pathway also provides inhibitory input onto the soma and initial segment of nELL neurons. (b) Patterns of activity recorded from the electrode locations shown in (a) in response to an external EOD. (c) Patterns of activity recorded from the electrode locations shown in (a) in response to a self-generated EOD.

When knollenorgan afferents respond to an external EOD, the EOCD pathway is not active. As a result, the nELL neurons only receive the excitatory afferent input, which they relay to the midbrain (Fig. 3b). By contrast, when the fish generates its own EOD, the EOCD pathway also becomes active, providing inhibitory input to nELL neurons. This inhibition blocks the response of nELL neurons to afferent electrosensory input (Fig. 3c), and the signal therefore does not get relayed to the midbrain [4]. As the refferent input for this system is simply a brief excitation, the corollary discharge-driven efference copy is simply a brief inhibition.

#### Temporal Coding of the EOD Waveform

The EOD of a neighboring fish will cause current to flow into one half of the body surface and out the other, meaning that knollenorgans on these two surfaces will be exposed to opposite stimulus polarities. As knollenorgans only respond to positive-going voltage steps, those located where current is entering the skin respond to the rising edge of the stimulus, while those located where current is exiting the skin respond to the falling edge. Thus, by comparing spike times from opposite sides of the body, a mormyrid can, in principle, determine the duration of the EOD waveform [6].

A primary projection site of nELL axons is the anterior exterolateral nucleus (ELa) in the torus semicircularis (Fig. 4a). Within the ELa, there are two distinct types of neurons, large cells and small cells, both of which receive excitatory input from nELL axons. Upon entering the ELa, the nELL axons immediately terminate onto 1 or 2 large cells, and then wind their way throughout the nucleus over distances of 3 to 4 mm before branching and terminating onto a large number of small cells [6]. The large cells project exclusively within the

ELa, terminating on small cells with large inhibitory synapses [6]. Thus, the small cells receive phase-locked input from two different sources: excitatory input from nELL axons and inhibitory input from ELa large cells (Fig. 4b). However, the excitatory input is significantly delayed by the time it takes an action potential to propagate down the long, winding path of the nELL axon, suggesting an “anti-coincidence detection” model for comparing spike times from knollenorgans on opposite sides of the body [6].

As an example, the small cell shown in Fig. 4b receives delayed excitatory input in response to stimulus onset and inhibitory input in response to stimulus offset. For short duration stimuli, this delayed excitatory input will arrive during the inhibition, and the small cell will not fire (Fig. 4c). As stimulus duration increases, however, there will be a greater delay before the inhibitory input reaches the small cell. If the duration is long enough such that the delayed excitatory input arrives before the inhibitory input, then the small cell will fire (Fig. 4c). Thus, a given small cell will only respond to EODs that are longer than some threshold duration. Assuming that different small cells receive input from nELL axons of varying delays, each small cell will have a different threshold value, and EOD duration will be reflected in the total number of active small cells [6].

#### Function

##### The Refference Principle

Dealing with refferent sensory input is a problem faced by all animals [1]. In the communication system of mormyrid electric fish, this problem is solved by a very simple, yet effective solution: incoming sensory input is blocked by inhibition every time the fish produces a



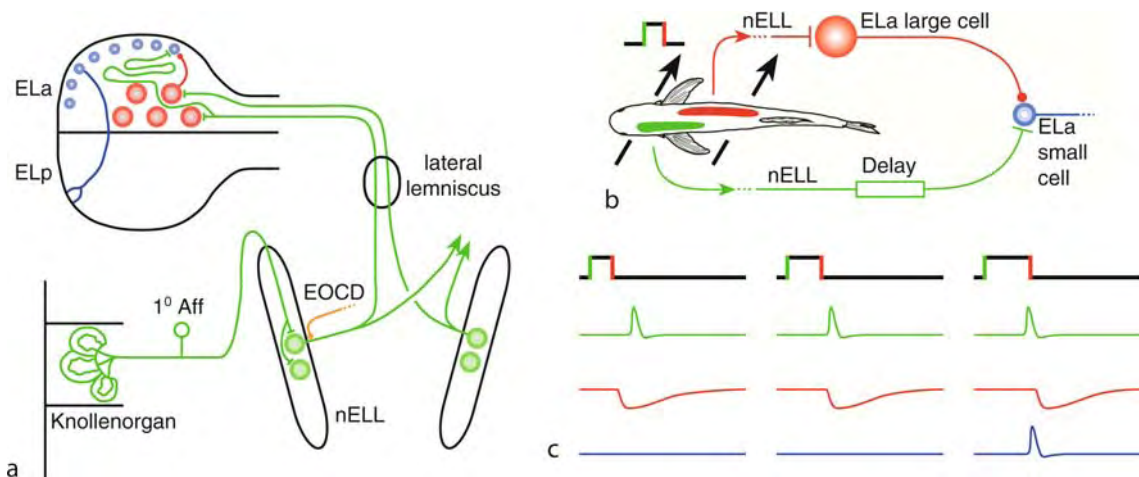

**Reafferent Control in Electric Communication. Figure 4** Model of EOD waveform discrimination in mormyrids. (a) Neuroanatomy of the knollenorgan pathway. Excitatory connections are indicated by flat lines, inhibitory connections by solid circles. Primary afferents from knollenorgans project ipsilaterally onto the nucleus of the electrosensory lateral line lobe (nELL), which also receives inhibitory input from the electric organ corollary discharge pathway (EOCD). Axons from nELL ascend through the lateral lemniscus to project bilaterally to the anterior extero-lateral nucleus (ELa) of the torus semicircularis, first onto large cells, then after winding throughout the nucleus, onto small cells. The large cells provide inhibitory input to the small cells. The small cells project ipsilaterally to the posterior extero-lateral nucleus (ELp). (b) Schematic diagram showing the inputs to the small cell shown in (a) in response to a transverse square pulse. The ipsilateral side responds to the pulse onset, providing delayed excitatory input to the small cell, while the contralateral side responds to the pulse offset, providing inhibitory input to the small cell. c. Responses of the small cell shown in (b) to square pulses of varying duration. The green traces show the excitation provided by the nELL axon, while the red traces show the inhibition provided by the large cell. The blue traces show the resulting output of the small cell.

signal. Thus, the fish only senses the electric signals produced by other individuals. Recent studies have shown that this same strategy is used by singing crickets to block auditory responses to their own song [10]. Thus, corollary discharge-driven inhibition may be a widespread solution to dealing with the problem of refference.

However, reafferent stimuli may often be much more complex, and the temporary blanking of responses afforded by simple inhibition may not be an effective solution. The earlier description of the effects of eye movement on visual processing is an illustrative example. Rather than brief excitation, the reafferent input in this case is a complex pattern of excitation and inhibition across many neurons over time, which is dependent on the specific eye movement undertaken. It is not sufficient to simply block incoming visual input during any movement, because this would result in complete blindness. In this case, rather than simple inhibition, the corollary discharge activates a spatiotemporally complex efference copy that cancels out the sensory input arriving from each portion of the visual field in response to the movement [1].

For active electrolocation in mormyrids, the fish's own EOD is the signal of interest, while those of other individuals constitute noise. Not surprisingly, then, the

EOCD pathway provides excitatory, rather than inhibitory, input to the electrosensory pathway involved in active electrolocation and thereby facilitates reafferent sensory input [3]. However, much of this input is not informative, as it signals the presence of unchanging, or predictable, environmental features. In contrast to the hard-wired inhibition provided to the knollenorgan pathway, this corollary discharge-driven excitatory input can be altered through experience so that expected sensory input is nullified and only novel, informative input gets through [3]. This system provides an example of a modifiable efference copy, one that may be adjusted to compensate for changes in the sensory consequences of motor production.

### Temporal Coding

Early research on electric communication in mormyrids focused on the SPI, because it was assumed that the EOD acted simply as a carrier signal for information encoded in a temporal pattern. The reasoning behind this was that EODs must be too brief to transmit any information. However, field recordings from mormyrids in the field revealed incredible species-specific diversity in the EOD waveform, as well as sex differences in many species [5]. Playback experiments in the field later demonstrated that these differences

were behaviorally significant. In particular, EOD duration, or the relative timing of positive and negative voltage deflections were especially important [6]. These experiments therefore demonstrated that EOD recognition was mediated by a temporal code. In this chapter, we have seen a remarkable, yet simple, example of how the information contained within such a temporal code may be extracted through dedicated neuronal circuitry.

## References

1. von Holst E, Mittelstaedt H (1950) Das reafferenzprinzip. *Naturwissenschaften* 37:464–476
2. Sperry R (1950) Neural basis of spontaneous optokinetic response produced by visual inversion. *J Comp Physiol Psychol* 43:482–489
3. Bell C, Bodznick D, Montgomery J, Bastian J (1997) The generation and subtraction of sensory expectations within cerebellum-like structures. *Brain Behav Evol* 50:17–31
4. Bell CC, Grant K (1989) Corollary discharge inhibition and preservation of temporal information in a sensory nucleus of mormyrid electric fish. *J Neurosci* 9:1029–1044
5. Carlson BA (2002) Electric signaling behavior and the mechanisms of electric organ discharge production in mormyrid fish. *J Physiol (Paris)* 96:403–417
6. Xu-Friedman MA, Hopkins CD (1999) Central mechanisms of temporal analysis in the knollenorgan pathway of mormyrid electric fish. *J Exp Biol* 202:1311–1318
7. Bass AH (1986) Electric organs revisited: Evolution of a vertebrate communication and orientation organ. In: Bullock TH, Heiligenberg W (eds) *Electroreception*. Wiley, New York, pp 13–70
8. Zakon HH (1986) The electroreceptive periphery. In: Bullock TH, Heiligenberg W (eds) *Electroreception*. Wiley, New York, pp 103–156
9. Carr CE, Friedman MA (1999) Evolution of time coding systems. *Neural Comput* 11:1–20
10. Poulet JFA, Hedwig B (2002) A corollary discharge maintains auditory sensitivity during sound production. *Nature* 418:872–876

## Realism (Metaphysical, Internal, Common Sense, Naïve, Scientific)

ALEXANDER STAUDACHER  
Otto-von-Guericke-Universität Magdeburg,  
Institut für Philosophie, Magdeburg, Germany

### Definition

Realism is a metaphysical position concerning the status of objects, facts and properties which can be of the most different kinds. One may be a realist concerning objects

in space and time like trees, rocks, and molecules, concerning abstract objects like numbers or values, properties like being red or facts like the fact that the earth is round. What does realism with respect to one or more of these types of items amount to? Unfortunately there is no shared view among the experts in the field as to how realism is best defined. The question is especially disputed among adherents of the various brands of realism and their critics, the so-called anti-realists. According to the definition shared by most (but not all) philosophers considering themselves realists, realism with respect to a certain item implies the following two claims: First, *the existence claim (EC)*: The items in question exist. Secondly, *the independence claim (IC)*: The items in question are neither themselves something mental (mere ► ideas or representations) nor is their existence in any way dependent on whether we represent them (that is, perceive them or think of them) in a particular way or not. If you believe, for example, that the earth exists independently of whether there is a being with mental states able to represent it then you are a realist about the earth. Realism is often restricted to certain types of items: one may be a realist concerning physical objects in space and time without being a realist concerning moral values. According to the two defining claims one might dispute realism concerning a certain item in two ways: by denying either (EC) or (IC). For example, realism about moral values can be denied either by denying that there are any such values in the first place or by admitting their existence but taking it to be completely dependent on our ability to devise such values.

According to the alternative definition put forward by anti-realists realism is not so much a theory about the nature of objects, facts or properties but a doctrine concerning the question of how the truth of sentences is best understood. The relevant conception of truth implies that truth is verification-transcendent, that is, a sentence might be true although we don't have the slightest possibility to find out that it is true. Anti-realists use this definition to criticize realism, because they take the verification-transcendent conception of truth to be at odds with their preferred accounts concerning the question of what is implied when a speaker understands a proposition [1]. Realists have objected to this characterization of their position that they see no need to commit themselves to any substantial notion of truth whatsoever by endorsing (EC) and (IC) [2]. This essay will therefore follow the first definition.

### Description of the Theory

Realism cannot only be held with respect to different items, it can also be formulated with varying strength. These variations in strength are mainly due to the fact that (IC) can be interpreted in various ways. According

to the strongest reading, (IC1), the items in question exist independently whether *any* mind (not only human minds but also more powerful minds) has even the *ability* to represent them. It is then not only possible that there are items with nobody represented at a certain time but with could have been represented in principle, as was probably the case with the earth one billion years ago, but that there might even be items which lie completely outside of any representational power. A somewhat weaker reading, (IC2), would restrict this claim to human minds. Still, the world might contain many items we will not even have the possibility to form a conception of just as a chimpanzee is unable to form a conception of an electron [3]. In this sense our conception and a fortiori our knowledge of the world might always be limited and partial even if we lack the slightest evidence to suppose that they are limited and partial in that way. A considerably weaker reading, (IC3), would allow that there are many items we have never represented and we will never be able to discover but could at least form a conception of, so that we could at least speculate about their existence. A still weaker reading, (IC4), would allow that there are many items we have never represented but could have represented and would have been able to discover. The weakest reading, (IC5), only allows that the items in question can exist independently of whether someone actually represents them, but not independently of whether we can discover them or not.

The last three readings all make items in the world dependent in a certain way on our ability to represent them. Therefore, one might argue that they are too weak to convey the idea of independence which is inherent in realism. Realism is generally contrasted with ►[idealism](#) which holds that everything is in some sense dependent on our minds. True enough, there are forms of idealism which even contradict the weakest reading as it is the case with the idealism of Bishop Berkeley (1685–1753), who identified the existence of things with their actually being perceived. But there are many less radical forms of idealism (laying their emphasis on different kinds of *dependence* of the world of our mind or our representational capacities) which are compatible with these two readings. Note also, that the last two readings at least don't allow for a verification-transcendent notion of truth, because they imply that truths about the world have to be discoverable by us. Therefore, they would also fail to count as reconstructions of realism according to the second, anti-realist definition of realism. This explains why the term "realism" is generally associated with the stronger readings, but as will become clear below, Hilary Putnam's ►[internal realism](#) forms a notable exception.

The first two readings allow for insurmountable ignorance about parts of the world and the first three allow for certain kinds of radical error concerning parts

of the world we have a conception of. It is not only possible that we err simply in mistaking something green for something blue or something spherical for a flat disc, we might even err in ascribing whole classes of properties to things that don't possess. In this case, the concepts we make use of in our characterizations of the world (our "conceptual schemes") don't correspond to the internal structure of the world: we take the world to be coloured in the way it appears to our eyes, but it might be that in fact nothing is coloured in that sense. In fact, science tells us that the surfaces of tomatoes aren't red in the way they appear red to our eyes, but that this appearance is largely due to the structure of our perceptual apparatus [3]. If science is right about these matters that we can say that it gives a more adequate picture of the world as it is than our everyday view. Considerations like these lead to interesting consequences concerning the question of how to deal with competing conceptions of reality which are not compatible with each other: According to realism there is a fact of the matter, how the world is. Therefore, either one of them will get closer to the true story about the world or both will fail in this attempt. Consequently, realism is opposed to various forms of relativism according to which truth and knowledge have to be relativized to culture, historical epoch, conceptual schemes and the like. Competing claims concerning the shape of the earth might then be correct relative to their specific cultural, historical and conceptual context and there might be no fact of the matter beyond these contexts allowing us to ask whether a claim, a theory or a conceptual scheme is correct or not. In contrast with these claims realism allows us to hold that the replacement of one theory or conceptual scheme by another scheme may be interpreted as progress in our endeavour to gain a picture of the world as it is independently of any of our representations of it.

Furthermore, there might be possibilities of large-scale error which open the door for certain notorious sceptical scenarios: the stronger versions of (IC) seem to allow that we could even be wrong about reality as a whole. Accordingly, it might be the case that we are always dreaming or, to cite another famous example, we might be all brains in vat filled with a nutrient and supplied not with real information about the world but only with hallucinations induced by a super-computer connected to us by nefarious neuroscientists [2,3] And considering that our revisions of our former world views also have to be couched in our conceptions of the world we can ask again whether these tensions will tell us the true story about the world as it really is [3]. In this sense realism leads to the consequence that all our epistemic accomplishments are in different respects fallible. Therefore a sceptical position which puts into doubt whether we will ever be able to gain knowledge about the world could possibly be true. A strong enough

realism seems even to be one of the central presuppositions needed in order to make these kinds of sceptical hypotheses intelligible in the first place. Most philosophers supporting such a strong kind of realism don't embrace scepticism, however. The fact that we have to admit the possible truth of scepticism should not be confounded with the fact that we have to take it seriously [2]. To the contrary, realists typically hold that they have the best explanation of how knowledge and scientific progress are possible in the first place.

“►Metaphysical realism” is often used as a name for the kind of realism based on stronger readings of (IC) like (IC1) and (IC2). The term was originally coined by Hilary Putnam who refuses this kind of realism, because he takes the idea that a conception or theory of the world might be wrong, although it fulfilling all our predictions and following all our methodological constraints (coherence, elegance, simplicity etc.) to be incoherent. Additionally he has argued that metaphysical realism has to give up a commitment not only metaphysical realists would like to subscribe to: the claim that our representations of items in the world are connected with these items in a way which gives them a definite reference (e.g., that the concept “cat” refers to cats and not to rats) [4].

Internal realism is Putnam's alternative to metaphysical realism and can be characterized roughly by following two claims: (IR1) A description of the world is true if it can be justified under epistemically ideal conditions. A description is justified if it is internally coherent and can be in principle verified, so that it is at least in principle possible for us to detect its truth. This implies that its truth does not consist of a kind of correspondence to facts in the world which are completely independent of our way of conceiving them and which might be completely inaccessible to us. (IR2) We have to acknowledge a certain kind of conceptual relativity according to which questions as to what kinds of objects there are or how many there are can't be answered independently of the choice of a certain conceptual framework. If someone asks for example “How many objects are in this room?” the right answer depends on certain decisions concerning our concept of “object.” If we admit as objects only things which are not attached to other things my nose or a lampshade will not count as objects, if we do without this restriction, they will. In this sense there is no fact of the matter of how many objects are in the room which is independent of our concept of an object [4,5].

Conceptual relativity puts internal realism close to relativism. Putnam has emphasized, however, that internal realism is to be distinguished from relativism which he takes as holding a wrong conception of truth and considers even to be self-refuting. In his eyes, relativists typically their truth to mere rational acceptability. Therefore, according to relativism, the

claim of the ancients that the earth was a flat disc was true at their time (although false today) because it was rationally acceptable in light of the available methods of investigation and evaluation at that time (but not in the light of the methods available today). However, the claim was not *ideally* rationally acceptable even at that time, because the conditions of verification were not ideal. A claim may lose its rational acceptability over time, but it can not lose its ideal rational acceptability. Relativism is self-refuting because in claiming its own absolute truth it exempts itself from the claim that all truths have to be relativized to certain historical conditions, conceptual schemes and so on [4].

Internal realism obviously only allows for weak readings of (IC) such as (IC4) and (IC5) because it takes the existence of the relevant items to be dependent on our conceptual resources and decisions and our ability in principle to verify what is the case. It can allow the existence of a certain rock in the desert even if it isn't represented by anybody at any time. But the existence of rocks remains relative to the fact that we have the concept of a rock. It can also admit that there might be facts (e.g., in the past) we are not able to verify. But it can't allow the possibility that reality might be a certain way if we can't verify this under ideal conditions. Therefore, one might ask whether internal realism should be seen as a form of realism at all. It is no wonder that many have seen internal realism as a form of anti-realism [2].

Critics of internal realism have questioned among other things (i) whether it can be successfully distinguished from relativism [6], (ii) whether the specific examples Putnam gives of conceptual relativity cannot be accommodated within metaphysical realism, so that they don't conflict with the claim that there are facts which are completely independent of our conceptual schemes [6], and (iii) whether ideal rational acceptability makes truth really accessible to us Putnam himself admitting that we can never tell whether we have reached ideal conditions and comparing this kind of idealization in question with unattainable idealizations such as frictionless surface. More recently Putnam himself has given up the claim that truth can be explained as idealized rational acceptability [7].

It is often assumed that realism with respect to spatio-temporal objects like rocks, chairs, etc., is a view dictated by common sense and held independently of any sophisticated knowledge about philosophical matters by “the plain man or woman on the street.” Realism of this kind is therefore often called “►common sense realism.” Since common sense isn't a developed philosophical doctrine it is not easy to decide to which reading of (IC) common sense realism is committed to. Arguably, common sense is not sophisticated enough to make the necessary distinctions required for any decision on these matters. Note,

however, that philosophers with wildly diverging views also use this label for their own account of realism [2,7].

► **Naïve realism** is often taken to be a position quite similar to common sense realism. In philosophical debates on perception Naïve realism is often taken to be a view according to which perception presents us the world by and large as it really is. For example, things not only appear to us as coloured (because of the specific nature of our perceptual apparatus) they really *are* coloured.

► **Scientific realism** is a theory concerning the correct understanding of theoretical terms in scientific theories. Scientific theories make intensive use of theoretical terms like “molecule” “atom,” “electron” and the like which don’t refer to observable phenomena but play an indispensable role in the scientific explanation of such phenomena. We may say that with the help of these terms respective theoretical entities have been introduced into the scientific theory in question: molecules, atoms, electrons and so on. The behaviour of the observable phenomena is explained with the help of certain claims about the behaviour or state of these theoretical entities. The fact that water begins to boil at sea-level at 100°C is for example explained with the help of claims concerning the properties and the behaviour of H<sub>2</sub>O-Molecules. Because theoretical entities like molecules or atoms are not among the things which can be observed, the question arises as to whether we ever have any good reason to believe in their existence and to accept the respective claims about their properties and their behaviour as true. Scientific realism gives an affirmative answer to these questions. According to one of its classical formulations [8] we have to interpret theoretical terms as putatively referring expressions and we often have enough reason to accept claims containing such terms as at least approximately true. Furthermore, we can see scientific progress as a steady approximation toward the truth of the observable and the unobservable. The reality described by scientific theories is largely independent of our thoughts and theoretical commitments. Therefore, we can say that we not only introduce theoretical terms in order to facilitate empirical predictions and the organization of our observation-knowledge, we also discover that there are molecules and electrons etc. In this sense scientific realism clearly endorses (EC) and a strong version of (IC), although the precise strength is often left open because the discussion concentrates more on whether theoretical entities are claimed to exist at all. One of the main arguments put forward in favour of this position is based on the claim that we can only plausibly explain why scientific theories have the predictive success they have if we suppose that the theoretical claims referring to theoretical entities are approximately true [8,2]. A classical objection to this claim is the historical observation that theories can be predictively successful although they are largely wrong [9]. A further general

objection to scientific realism is that it cannot deal with the fact that two successful theories with commitments to different theoretical entities might lead to the same empirical predictions. It is argued that in such cases there is no evidential basis allowing a decision between these theories. If theoretical statements can be literally true, however, as Scientific Realism would have it, such a decision must be possible in principle. Against this, Scientific Realists have argued that we should allow for a conception of evidential support that is not restricted to positive outcomes concerning prediction [8]. Sometimes scientific realism is and to imply a further claim which puts it into strong opposition to naïve realism or common sense realism. If there is, e.g., an irreconcilable collision between the common sense view of physical objects as continuous solids and the scientific view that they are swarms of molecules, the commitment to the existence of the theoretical entities of science demands that we give up our naïve and common sense views concerning the nature of reality [10].

## References

1. Dummett M (1993) *The seas of language*. Oxford University Press, Oxford
2. Devitt M (1997) *Realism and truth*, 2nd edn with a new afterword by the author. Princeton University Press, Princeton
3. Nagel T (1986) *The view from nowhere*. Oxford University Press, Oxford
4. Putnam H (1981) *Reason, truth, and history*. Cambridge University Press, Cambridge
5. Putnam H (1987) *The many faces of realism*. Open Court, La Salle, Ill
6. Field H (1982) Realism and relativism. *J Philos* 79:553–567
7. Putnam H (1999) *The threefold cord mind, body, and world*. Columbia University Press, New York
8. Boyd R (1984) The current status of scientific realism. In: Leplin J (ed) *Scientific realism*. University of California Press, Berkeley and Los Angeles, pp 41–82
9. Laudan L (1984) A confutation of convergent realism. In: Leplin J (ed) *Scientific realism*. University of California Press, Berkeley and Los Angeles, pp 218–249
10. Churchland PM (1979) *Scientific realism and the plasticity of mind*. Cambridge University Press, Cambridge

---

## Reality Monitoring

### Definition

Reality monitoring is defined as the ability of distinguishing between external memories (e.g., those of events directly perceived or actions actually

performed) and internal memories (e.g., those of events imagined or actions planned or intended to perform).

► [Metacognition](#)

## Realization

### Definition

Mental properties, although not identical to physical properties, are still said to be physical properties in a broad sense in virtue of being realized by physical properties, just as a machine table, for instance, is implemented by but not identical to the states of its physical implementation. A central idea is that if property F realizes property G, then G is not something distinct from or something over and above F. Unlike identity, realization is asymmetric: F realizes G only if the instantiation of F in *o* necessitates or determines the instantiation of G in *o* but not vice versa, where the necessity in question is at least nomological necessity.

► [Epiphenomenalism](#)

## Reasoning

MARKUS KNAUFF

Center for Cognitive Science, University of Freiburg,  
Freiburg, Germany

### Definition

Reasoning is a process of drawing inferences from information that is taken for granted. Formal reasoning is within the scope of mathematics and philosophy. It is the study of inferences whose validity only derives from its formal structure. Mental reasoning is a function of the human brain. It comes into play whenever people go beyond what is explicitly given. It is the cognitive activity to infer that something must be true, or is likely to be true, given that the known information is true. The problem information is given by a number of statements which are called ► [premises](#), and the task is to find a ► [conclusion](#) that follows from these premises. The following inference is a typical reasoning problem:

If a patient's left hemisphere is damaged, then he has impaired reasoning abilities.

Alan's left hemisphere is damaged.

-----

Therefore, Alan has impaired reasoning abilities.

Although the premises (above the line) do not say anything about Alan's reasoning abilities, most people immediately agree with what is stated in the conclusion (below the line). The conclusion necessarily – logically – follows from the premises. Another inference is given in the following example.

Mammals have a nervous system.

Birds have a nervous system.

Fishes have a nervous system.

-----

All animals have a nervous system.

Although a reasoner might form the belief that the conclusion could be true, the premises do not warrant the truth of the conclusion. The reasoner is generating the ► [hypothesis](#) that the conclusion is true. The former inference is an example of ► [deductive reasoning](#), while the latter is an instance of ► [inductive reasoning](#).

## Characteristics

### Deductive and Inductive Reasoning

Mental deductive reasoning is strongly related to formal logic. The latter serves as the normative model for the former (a critical assessment of this account from a neuroscience perspective can be found in [1]). To explore deductive reasoning in the psychological laboratory, people are typically asked to draw conclusions from given premises and later their responses are evaluated for logical validity. This evaluation is based on logical correctness only and does not account for the content of the statements (the deductive inference above is logically valid, although the content concerning the role of the left hemisphere is probably wrong; see below). In ► [conditional reasoning](#), the premises of the problem consist of an “if A then B” construct that posits B to be true if A is true. The two logically valid inferences are the Modus Ponens (if p then q; p; q, MP) and the Modus Tollens (if p then q; not-q; not-p, MT). Humans are pretty good in making inferences of the form MP, but they make many mistakes in the form MT [2]. In ► [syllogistic reasoning](#), the premises of the problem consist of quantified statements such as “All A are B,” “Some A are B,” “No A are B,” and “Some A are not B.” People often make many mistakes in syllogistic reasoning, in part because of the existence of a variety of biases [2]. The most frequently used sort of inferences in daily life (and in the psychological lab) are based on relations. In ► [relational reasoning](#), at least two relational terms

A  $r_1$  B and B  $r_2$  C are given as premises and the goal is to find a conclusion A  $r_3$  C that is consistent with the premises. The relations represent spatial (e.g., left of), temporal (e.g., earlier than), or more abstract information (e.g., is akin to). People are pretty good in making such inferences, but the difficulty depends on the number of premises, the order of terms and premises, the content, and the ease to envisage the content of the problem [3,4]. Moreover, in cases where a reasoning problem has multiple solutions, reasoners consistently prefer the same subset of possible answers – and often just a single solution [5].

Inductive reasoning has not as much to do with logic because the conclusion goes beyond the information given in the premises. The premises only provide good reasons for accepting the conclusion. Thus, inductive reasoning is not truth-preserving but it is the most important basis of our ability to create new knowledge. This new knowledge is often based on a limited number of observations from which we formulate a law recurring to a set of phenomenal experiences. Cognitive theories of induction typically describe it as a process in which hypotheses are generated, selected, and evaluated [6,7]. Although there is no generally accepted definition of the term “induction,” the majority of psychologists adopt the very broad definition that mental inductions are “all inferential processes that expand knowledge in the face of uncertainty” [6, p. 1]. Given that almost nothing is known about the neural basis of inductive reasoning this review is restricted to deductive reasoning. An easily accessible summary of behavioral findings on inductive reasoning can be found in Manktelow [8]. The main problems of research on inductive reasoning are summarized in Sloman and Lagnado [9].

### Cognitive Theories of Reasoning

There are two main theories of deductive reasoning. They differ in the postulated underlying mental representations and the computational process that work on these representations. In one theory, it is believed that people think deductively by applying mental **rules** which are similar to rules in computer programs. In the other theory, deductive reasoning is conceived as a process in which the reasoner constructs, inspects, and manipulates **mental models**. The **rule-based theory** is a syntactic theory of reasoning, as it is based on the form of the argument only, whereas, the **mental models theory** is a semantic theory, because it is based on the meaning (the interpretation) of the premises.

The **rule-based theories** are primarily represented by the work of Rips [10] and Braine and O’Brian [11]. These theories claim that reasoners rely on formal rules of inference akin to those of formal logic, and that inference is a process of proof in which the rules are applied to mental sentences (but cf. Stenning and Oberlander [12]). The formal rules govern sentential connectives such as

“if” and quantifiers such as “any,” and they can account for relational inferences when they are supplemented with axioms governing transitivity, such as: For any a, b, and c, if a is taller than b and b is taller than c, then a is taller than c. The rules are represented in the human brain and the sequence of applied rules results in a mental proof, or derivation, which is seen as analogous to the proofs of formal logic [10].

The **theory of mental models** has been developed by Johnson-Laird and colleagues [13–15]. According to the model theory, human reasoning relies on the construction of integrated mental representations of the information that is given in the reasoning problem’s premises. These integrated representations are models in the strict logical sense. They capture what is common to all the different ways in which the premises can be interpreted. They represent in “small scale” how “reality” could be – according to what is stated in the premises of a reasoning problem. The model theory distinguishes between three different mental operations. In the construction phase, reasoners construct the mental model that reflects the information from the premises. In the inspection phase, this model is inspected to find new information that is not explicitly given in the premises. In the variation phase, reasoners try to construct alternative models from the premises that refute the putative conclusion. If no such model is found, the putative conclusion is considered true [14].

### Reasoning and the Brain

The two reasoning theories are related to different brain areas. The rule theory implies that reasoning is a linguistic and syntactic process, and so reasoning should depend on regions located in the left hemisphere. The model theory, in contrast, postulates that a major component of reasoning is not verbal, and so the theory predicts that the right cerebral hemisphere should play a significant role in reasoning [16]. More detailed predictions are related to specific brain areas. Here the rule theory assumes that the neural computations during reasoning are implemented in the language processing regions and here specifically in the temporal cortex, while the model theory predicts that the parietal and occipital cortical areas involved in spatial working memory, perception, and movement control are evoked by reasoning [17]. The lateralization of the reasoning process has been primarily investigated in patient studies, while brain imaging techniques allow for a more detailed localization of reasoning processes.

### Patient Studies

Early studies of patients with brain-damages seemed to support the rule-based theories of reasoning. Conditional reasoning has been studied by Golding [18]. The author used the Wason-Selection-Task, which is probably the most important paradigm in behavioral research on human reasoning [19]. In the task, four

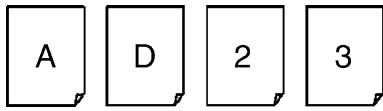

**Reasoning. Figure 1** The Wason selection task.

cards are presented to the participants (see Fig. 1) and they are instructed to verify the rule “If there is a vowel on one side of the card, then there is an even number on the other side.” The participants are allowed to turn over the cards in order to verify the rule. The visible letters and numbers on the card correspond to the four possible propositions  $p$ , not- $p$ ,  $q$ , and not- $q$ . According to the propositional calculus of formal logic the only correct choices are  $p$  (according to the MP a  $q$  must be on the other side) and not- $q$  (according to the MT a not- $p$  must be on the other side). However, only one of the left-hemisphere-damaged patients but half of the right-hemisphere-damaged patients selected the two correct cards. Deglin and Kinsbourne [20] studied syllogistic reasoning with psychiatric patients while recovering from transitory ictal suppression of one hemisphere by electroconvulsive therapy (ECT; that simulates a short-term lesion). The premises were familiar or unfamiliar and true or false. When the right hemisphere was suppressed, the participants tended to perform deductive inferences even when the factual answer was obviously false. While their left hemisphere was suppressed, the same participants used their prior knowledge and if the content was unfamiliar they completely refused to answer. Patient studies on relational reasoning have been reported by Caramazza et al. [21] and Read [22]. Caramazza et al. [21] presented relational premises such as “Mike is taller than George” to brain-damaged patients. After reading the statements they had to answer either a congruent (“Who is taller?”) or incongruent (“Who is shorter?”) question. The left-hemispheric patients showed impaired performance in all problems no matter they were congruent or incongruent. Right-hemispheric patients, in contrast, showed impaired performance only in the incongruent problems. Read [22] used two relational premises and asked patients who suffered from temporal-lobectomy to generate a conclusion from these statements. Overall, the left-hemispheric patients again performed weaker than the patients with right-temporal-lobectomy, but the right-hemispheric patients were more impaired with the incongruent conclusions.

The reported findings have been frequently used by neuroscientists to support the idea that reasoning is mainly a linguistic and syntactic process, but this interpretation seems awkward to many cognitive oriented reasoning researchers. Although lesions to the left hemisphere might result in a deficit in the processing of the linguistic elements of the problem and, thus, impair overall performance, it does not

necessarily follow that the damage will also affect the reasoning process. It is likely that left-hemisphere lesions lead to an inability to process the linguistic aspects of a reasoning problem, but that for the pure reasoning process the right hemisphere is important. This interpretation would also explain most of the findings. For instance, in the studies by Caramazza et al. [21] and Read [22] the patients had problems in logically deducing the converse of relations. Moreover, Whitaker et al. [23] examined conditional reasoning in patients that had undergone a unilateral anterior temporal lobectomy, one group to the right hemisphere and the other group to the left hemisphere. The content of the problems was related to the participants’ prior knowledge of the world. Given the premises

If it rained, the streets will be dry.  
It rained.

The right-hemisphere-damaged patients had a strong tendency to conclude “The streets will be wet” while the left-hemisphere-damaged patients concluded “The street will be dry.” In other words, these right-hemispheric patients were unable to perform the deduction in isolation from their prior knowledge, while the left-hemisphere patients relied on the linguistic content of the problem.

### Brain Imaging Studies

Brain imaging studies have been conducted on all the main types of deductive inferences. As with the patient studies the early findings have been frequently interpreted in favor of the rule-based theories of reasoning, as they have shown that reasoning activates a fronto-temporal neural network often just in the left hemisphere [24,25]. However, more sophisticated experimental paradigms suggest this might be due to the confounding of linguistic processing and deductive reasoning. Knauff et al. [17] studied conditional reasoning problems by presenting premises such as “If the teacher is in love, then he likes pizza” to the participants. In half of the problems the second premise was “The teacher is in love” and the participants had to conclude (by MP) “The teacher likes pizza.” In the other half of problems the second premises was “The teacher does not like pizza” and the participants had to conclude (by MT) “The teacher is not in love.” Both types of problems activated a bilateral occipito-parietal-frontal network, including parts of the prefrontal cortex and the cingulate gyrus, the superior and inferior parietal cortex, the precuneus, and the visual association cortex. These finding are difficult to explain based on purely linguistic processes, as the activated brain areas are implicated in the processing of visual and spatial information and visuo-spatial working memory ( $\rightarrow$ ) (cf. [26–28]). Similar findings have been reported from a study on syllogistic reasoning. Goel et al. [29] used problems with semantic content (e.g., “All apples are red; all red fruit are sweet; therefore all apples are sweet”) and



without semantic content (e.g., “All A are B; all B are C; therefore all A are C”). They found evidence for the engagement of both linguistic and spatial systems. The role of linguistic and spatial systems has been largely investigated by means of relational reasoning problems. In the study by Knauff et al. [30] such problems activated similar brain areas as the conditional problems did. However, the activity in visual association areas was even higher than during conditional reasoning. Goel and Dolan [31] addressed the question by using sentences with a spatial content. They again were either concrete (e.g., “The apples are in the barrel; the barrel is in the barn; therefore the apples are in the barn”) or abstract (e.g., “A are in B; B is in C; therefore A is in C”). They reported that all problems activated a similar bilateral occipito-parietal network no matter if they were concrete or abstract.

### Reasoning and Visual Mental Imagery

Many of the reported experiments seem to support the model theory of reasoning. However, it is essential not to confuse mental models with visual images (→) [32,33]. Visual images are structurally similar to real visual perceptions, and can represent objects, their colors and shapes, and the metrical distances between them. They have a limited resolution, but they can be scanned and mentally manipulated [34]. They are often accompanied by neural activity in visual association areas (→) and under certain conditions also activate the primary visual cortex (→) (e.g., [30,35,36]). In contrast, mental models are likely to exclude visual detail, to represent only the information relevant to inference and to take the form of multi-dimensional arrays that maintain ordinal and topological properties [33]. Visual images represent information in a modality-specific format, whereas spatial models are abstract and not restricted to a specific modality. To clarify the role of visual images in reasoning Knauff, et al. [37] conducted a combined behavioral and brain imaging study with four sorts of relations: (i) visuo-spatial relations that are easy to envisage visually and spatially, (ii) visual relations that are easy to envisage visually but hard to envisage spatially, (iii) spatial relations that are hard to envisage visually but easy to envisage spatially, and (iv) control relations that are hard to envisage either visually or spatially. This study highlighted two important findings: First, reasoners were significantly slower with the visual relations than with the other sorts of relations. This is called the visual-impedance effect [38]. And second: On the brain level, all types of reasoning problems evoked activity in the parietal cortices and this activity seems to be a “default mode” of brain functioning during reasoning. However, only the problems based on visual relations also activated areas of the visual cortices. Obviously, in the case of visual relations, reasoners cannot suppress a spontaneous visual image but its construction calls for additional

activity in visual cortices and retards the construction of a mental model that is essential for the inferential process. Interestingly, congenitally totally blind people are immune to the visual-impedance effect, since they do not tend to construct disrupting visual images from the premises [39]. For a more detailed explanation on how visual images and mental models interact in reasoning the interested reader is directed to Knauff [4].

### Content Effects and Belief Biases

How easy it is to visualize is only one aspect of the content of a reasoning problem. Another aspect is how well the content agrees with the reasoners previous experiences and prior knowledge. Many behavioral studies have shown that prior knowledge can significantly influence how efficiently a reasoning problem is solved. Technically speaking, the abstract (logical) truth value of an inference can be the same as the truth value of our prior knowledge – in this case the inference is supported. Or, the formal truth value conflicts with the truth value of the prior knowledge – then the inference is more difficult, which means it results in more errors or takes significantly longer. If an inference generated by a person is biased towards the truth value of the prior knowledge or even overwritten by it, this is called belief bias [40]. Some patient studies, as described, have therefore explored the effects of brain injuries on reasoning with concrete and abstract materials. Their findings agree with the brain imaging study by Goel et al. [29] in which evidence for the engagement of both linguistic and spatial systems have been found. Reasoning with a semantic content activated a left-hemispheric temporal system, whereas problems without semantic content activated an occipito-parietal network distributed over both hemispheres. Goel and Dolan [41] brought logic and belief into conflict and found evidence for the engagement of a left temporal lobe system during belief-based reasoning and a bilateral parietal lobe system during belief-neutral reasoning. Activation of right prefrontal cortex was found when the participants inhibited a response associated with belief-bias and correctly completed a logical task. When logical reasoning, in contrast, was overwritten by a belief-bias, there was engagement of ventral medial prefrontal cortex, a region implicated in affective processing. In the dual-processing theory, Goel, et al. therefore suggests that deductive reasoning is implemented in two separate systems whose engagement is primarily a function of the presence or absence of semantic content. Content-free reasoning seems to be stronger related to visuo-spatial cortical areas in the right hemisphere, whereas content-based reasoning recruits language-related areas in the left temporal cortex. If the content of the reasoning problem results in a conflict between belief and logic,

this conflict recruits additional areas in the right prefrontal cortex.

### Evaluation of Reasoning Theories

For a long time the psychology of reasoning was strongly committed to the assumption that reasoning should be studied in terms of computational processes. How these computations are biologically implemented in the human brain has been conceived to be not sufficient, because each computational function can be computed on each hardware (and, thus, also the brain) that is equivalent to a Turing machine (e.g., [42]). However, reasoning research is a good example of where the assumption of implementation-independency fails. As there are many mappings possible between cortical regions and cognitive functions, neuroscientific data alone are certainly too weak to test cognitive theories. But, if such data are consistent with behavioral findings this can provide strong support for a cognitive theory of human reasoning. An outstanding example is the field of relational reasoning, where hardly any researchers defend an approach based on inference rules (e.g., [3]). The behavioral and neuroscientific evidence showing that people use their visuospatial system to preserve the structural properties of the world are too overwhelming. In other fields of reasoning the situation is more complicated (cf. [43]). Many researchers will agree that mental models play a key role if humans perform inferences based on conditionals and quantifiers [8]. On the other hand, there is also evidence that verbal, linguistic, and syntactic processes are also involved. The most reasonable corollary from the field of research is that human think deductively by applying different mental algorithms and that these algorithms are implemented in different brain areas. Content-free inferences are “real logical” inferences and they seem to rely on neural computations in the right parietal cortices the precuneus, and the extrastriate and (sometimes) striate cortex. They are accompanied by executive functions and control processes in the prefrontal cortex. When the logical problem is embedded into a semantic content or related to the reasoners’ beliefs additional linguistic and semantic processes in the left temporal cortex come into play. Another corollary from the neuro-cognitive research is that reasoning is a multi-component process and that the diverse components strongly overlap with the components of other cognitive functions. There is no single “cheater detection module” as proposed for reasoning about social contracts [44,45] much as there are no “pragmatic schemas” [46] that completely spare human to reason.

### References

1. Cosmides L, Tooby J (2005) Neurocognitive adaptations designed for social exchange. In: Buss DM (ed) *Evolutionary psychology handbook*. Wiley, New York, pp 584–627
2. Evans JStBT, Newstead SE, Byrne RMJ (1993) *Human reasoning. The psychology of deduction*. Lawrence Erlbaum Associates, Hove
3. Goodwin GP, Johnson-Laird PN (2005) Reasoning about relations. *Psychol Rev* 112:468–493
4. Knauff M (2006) A neuro-cognitive theory of relational reasoning with visual images and mental models. In: Held C, Knauff M, Vosgerau G (eds) *Mental models and the mind: a concept at the intersection of cognitive psychology, neuroscience, and philosophy of mind*. Elsevier, North-Holland
5. Rauh R, Hagen C, Knauff M, Kuß T, Schlieder C, Strube G (2005) From preferred To alternative mental models in spatial reasoning. *Spatial Cognition and Computation* 5:239–269
6. Holland JH, Holyoak KJ, Nisbett RE, Thagard PR (1986) *Induction: processes of inference, learning, and discovery*. MIT, Cambridge, MA
7. Holyoak KJ, Nisbett RE (1988) Induction. In: Sternberg RJ, Smith EE (eds) *The psychology of human thought*. Cambridge University Press, New York, pp 50–91
8. Manktelow KI (1999) *Reasoning and Thinking*. Psychology, Hove
9. Sloman SA, Lagnado D (2005) The problem of induction. In: Morrison R, Holyoak K (eds) *Cambridge handbook of thinking and reasoning*. Cambridge University Press, New York, pp 95–116
10. Rips LJ (1994) *The psychology of proof*. MIT, Cambridge, MA
11. Braine MDS, O’Brian DP (eds) (1998) *Mental logic*. Lawrence Erlbaum, Mahwah, NJ
12. Stenning K, Oberländer K (1995) A cognitive theory of graphical and linguistic reasoning: logic and implementation. *Cogn Sci* 19:97–140
13. Johnson-Laird PN (1983) *Mental models*. Cambridge University Press, Cambridge
14. Johnson-Laird PN, Byrne RMJ (1991) *Deduction*. Erlbaum, Hove
15. Johnson-Laird PN (2001) Mental models and deduction. *Trend Cogn Sci* 5:434–442
16. Johnson-Laird PN (1994) Mental models, deductive reasoning, and the brain. In: Gazzaniga S (ed) *The cognitive neurosciences*. MIT, Cambridge, MA, pp 999–1008
17. Knauff M, Mulack T, Kassubek J, Salih HR, Greenlee MW (2002) Spatial imagery in deductive reasoning: a functional MRI study. *Cognitive Brain Research*, 13:203–212
18. Golding E (1981) The effect of unilateral brain lesion on reasoning. *Cortex* 17:31–40
19. Wason PC (1966) Reasoning. In: Foss B (ed) *New horizons in psychology*. Penguin, Harmondsworth, UK, pp 135–151
20. Deglin VL, Kinsbourne M (1996) Divergent thinking styles of the hemispheres: how syllogisms are solved during transitory hemisphere suppression. *Brain Cogn* 31:285–307
21. Caramazza A, Gordon J, Zurif EB, DeLuca D (1976) Right-hemispheric damage and verbal problem-solving behavior. *Brain Lang* 3:41–46
22. Read DE (1981) Solving deductive-reasoning problems after unilateral temporal lobectomy. *Brain Lang* 12:116–127

23. Whitaker HA, Markovits H, Savary F, Grou C, Braun C (1991) Inference deficits after brain damage. *J Clin Exp Neuropsychol* 13:38
24. Goel V, Gold B, Kapur S, Houle S (1997) The seats of reason: a localization study of deductive and inductive reasoning using PET (O15) blood flow technique. *Neuroreport* 8:1305–1310
25. Goel V, Gold B, Kapur S, Houle S (1998) Neuroanatomical correlates of human reasoning. *J Cogn Neurosci* 10:293–302
26. Andersen RA (1997) Multimodal integration for the representation of space in the posterior parietal cortex. *Philos Trans R Soc London B Biol Sci* 352:1421–1428
27. Smith EE, Jonides J (1997) Working memory: a view from neuroimaging. *Cogn Psychol* 33:5–42
28. Jonides J, Smith EE, Koeppe RA, Awh E, Minoshima S (1993) Spatial working memory in humans as revealed by PET. *Nature* 363:623–625
29. Goel V, Büchel C, Frith C, Dolan RJ (2000) Dissociation of mechanisms underlying syllogistic reasoning. *Neuroimage* 12:504–514
30. Knauff M, Kassubek J, Mulack T, Greenlee MW (2000) Cortical activation evoked by visual mental imagery as measured by functional MRI. *Neuroreport* 11:3957–3962
31. Goel V, Dolan RJ (2001) Functional neuroanatomy of three-term relational reasoning. *Neuropsychologia* 39:901–909
32. Johnson-Laird PN (1998) Imagery, visualization, and thinking. In: Hochberg J (ed) *Perception and cognition at century's end*. Academic, San Diego, CA, pp 441–467
33. Knauff M, Schlieder C (2004) Spatial inference: no difference between mental images and models. *Behav Brain Sci* 27:589–590
34. Kosslyn SM (1994) *Image and brain: the resolution of the imagery debate*. MIT, Cambridge, MA
35. Kosslyn SM, Ganis G, Thompson WL (2001) Neural foundations of imagery. *Nat Rev Neurosci* 2:635–642
36. Kosslyn SM, Thompson WL (2003) When is early visual cortex activated during visual mental imagery? *Psychol Bull* 129:723–746
37. Knauff M, Fangmeier T, Ruff CC, Johnson-Laird PN (2003) Reasoning, models, and images: behavioral measures and cortical activity. *J Cogn Neurosci* 4:559–573
38. Knauff M, Johnson-Laird PN (2002) Visual imagery can impede reasoning. *Mem Cogn* 30:363–371
39. Knauff M, May E (2006) Mental imagery, reasoning, and blindness. *Quart J Exp Psychol* 59:161–177
40. Evans, JStBT (1989) Bias in human reasoning. Lawrence Erlbaum, Hove
41. Goel V, Dolan RJ (2003) Explaining modulation of reasoning by belief. *Cognition* 87(1):B11–B22
42. Pylyshyn ZW (1984) *Computation and cognition: toward a foundation for cognitive science*. MIT, Cambridge, MA
43. Held C, Knauff M, Vosgerau G (eds) (2006) *Mental models and the mind. A conception in the intersection of cognitive psychology, neuroscience, and philosophy of mind*. Elsevier, North-Holland
44. Cosmides L (1989) The logic of social exchange: has natural selection shaped how humans reason? Studies with the Wason selection task. *Cognition* 31:187–276
45. Stone V, Cosmides L, Tooby J, Kroll N, Knight R (2002) Selective impairment of reasoning about social exchange in a patient with bilateral limbic system damage. *Proc Natl Acad Sci* 99(17):11531–11536
46. Cheng PW, Holyoak KJ (1985) Pragmatic reasoning schemas. *Cogn Psychol* 17:391–416
47. Fangmeier T, Knauff M, Ruff CC, Sloutsky V (2006) The neural correlates of logical thinking: an event-related fMRI study. *J Cogn Neurosci* (in press)

---

## Rebound Bursting

### Definition

Discharge of a burst of action potentials after the end of a hyperpolarizing influence, such as an inhibitory postsynaptic potential.

### ► Action Potential

---

## Recall

### Definition

Recall is the ability to not only recognize something as having been experienced in the past, but also to retrieve, on demand, spatiotemporal details of the context in which the stimulus or event was originally encountered.

### ► Recognition Memory

---

## Receiver

### Definition

In general an instrument that is able to register a signal. In communication theory, the receiver registers a signal, decodes it and reacts accordingly.

---

## Recency

### Definition

With respect to recognition, recency refers to the capacity to remember more accurately information which has just been experienced, as compared to events or items encountered further in time from retrieval.

### ► Recognition Memory

## Recent and Remote Memory

- ▶ Long-Term Memory

## Receptive Field

### Definition

The aspect (for example, a location or a temporal frequency) of the outer world that is represented by a given neuron in the brain is referred to as its receptive field.

## Receptive Field, Visual

### Definition

The receptive field of a “visual” neuron is the region of the visual field in which the presentation of a stimulus exerts a response of the neuron.

- ▶ Visual Cortical and Subcortical Receptive Fields

## Receptive Field of Retinal Ganglion Cell

### Definition

In physiological studies the visual field area over which a cell responds to light. The receptive field area corresponds roughly to the dendritic field area.

- ▶ Retinal Ganglion Cells

## Receptive Field Selectivity

- ▶ Contrast Enhancement

## Receptor

### Definition

The term receptor is an ambiguous term because, on the one hand, it is used as shorthand for sensory receptor cell. A sensory receptor (in physiology) is any structure which, on receiving environmental stimuli, produces an informative nerve impulse. The receptor recognizes a stimulus in the external or internal environment, initiates a transduction process by producing graded potentials (receptor potentials), from which all-or-none action potentials are elicited, that are conducted along afferent fibers originating in the same or adjacent cells. On the other hand, a membrane receptor, neurotransmitter receptor, etc. (in biochemistry/pharmacology) is a transmembrane glycoprotein, which is activated by ligands. Receptors to neurotransmitters are located at the plasma membrane. Upon binding by the specific transmitter, receptors can allow the passage of ions or activate enzymes, which ultimately modify the membrane potential. Ionotropic receptors are fast neurotransmitter-gated receptors formed by homomeric or heteromeric subunits outlining a channel, which allows influx or outflux of monovalent or divalent ions. Instead, metabotropic receptors are slow neurotransmitter-gated receptors, which are coupled to G proteins activating diverse effector mechanisms. Excitotoxicity is caused by ionotropic glutamate receptors of the AMPA, kainate and NMDA classes.

- ▶ Action Potential
- ▶ Glutamate Receptor Channels
- ▶ Sensory Systems

## Receptor Agonist

### Definition

A chemical substance that binds to a cell membrane receptor and mimics the regulatory effects of endogenous

signaling compounds such as neurotransmitters, neuromodulators and hormones.

► [Membrane Components](#)

are pinched off and drawn into the cytoplasm with membrane vesicles and either recycled to the cell surface or degraded.

► [Ionotropic Receptor](#)

## Receptor Cell

### Definition

► [Sensory Receptor](#)

► [Sensory Systems](#)

## Receptor Membrane

### Definition

Receptor membrane denotes that region of a sensory receptor cell, where the transformed physico-chemical stimulus is converted, by a specific process called sensory transduction, into receptor current and receptor potential.

► [Receptor Current](#)

► [Receptor Potential](#)

► [Sensory Receptor](#)

► [Sensory Systems](#)

## Receptor Channel

► [Ionotropic Receptor](#)

## Receptor Current

### Definition

Receptor current denotes the transmembrane current evoked, at the receptor membrane of a sensory receptor cell, by an impinging sensory stimulus through opening or closing of specific ion channels.

► [Sensory Systems](#)

## Receptor Potential

### Definition

Receptor potential denotes the membrane potential change evoked, at the receptor membrane of a sensory receptor cell, by an impinging sensory stimulus through opening or closing of specific ion channels.

► [Sensory Receptor](#)

► [Sensory Systems](#)

## Receptor Desensitization

### Definition

Receptor desensitization is a reduced response to a neurotransmitter or agonist drug due to a decrease in number of receptors available, or decreased activity of intracellular signaling pathways and ion channels, after prolonged exposure to the neurotransmitter or drug.

Desensitization also results from receptor internalization, the removal of receptors from a plasma membrane by endocytosis. Agonist-binding receptors

## Receptor Regulation, Editing

### Definition

A novel channel regulation of the ionotropic glutamate receptors. It occurs at a specific CAG codon for glutamine which changes to a CGG codon for arginine in the pre-mRNAs for a specific subtype of glutamate receptor subunits. The edited codon determines the  $\text{Ca}^{2+}$  permeability of the receptors containing the edited subunit.

► [Ionotropic Receptor](#)

## Receptor Regulation, Phosphorylation

### Definition

Certain types of neurotransmitter receptors, such as G protein-coupled receptors and ionotropic receptors, may be regulated by phosphorylation. These regulations are controlled by a combination of kinase and phosphatase, both of which are receptor-selective.

► Ionotropic Receptor

## Receptor Regulation, Splicing

### Definition

Alternative exon selection changes the receptor structure, modifying the property of the receptor. For example, the “flip/flop structures” of splice isoforms in the AMPA receptors determine the desensitization rate, and the C-terminal splice isoforms of many glutamate receptor subunits control their distribution in the subsynaptic membrane.

► Ionotropic Receptor

## Receptor Regulation, Subunit Change

### Definition

Almost all ionotropic receptors consist of different kinds of subunits. Their composition determines the functional properties and diversity of each receptor.

► Ionotropic Receptor

## Receptor Trafficking

FIONA K. BEDFORD

Department of Anatomy and Cell Biology, McGill University, Montreal, QC, Canada

### Synonyms

Post-synaptic receptor trafficking; Neurotransmitter receptor trafficking

### Definition

► **Receptor trafficking** is a term used to describe the movement of receptors within a neuron. It is used broadly to describe several distinct stages of receptor movement in neurons; the movement of newly synthesized receptors through the secretory pathway (Fig. 1), the movement of receptors into ► **axons** or ► **dendrites** and their targeting to the pre and postsynaptic domains of ► **synapses** respectively. In addition it is also used to describe the internalization of receptors from the plasma membrane as well as their subsequent intracellular trafficking. In all these incidents it should be noted receptor trafficking literally means the movement of receptors between distinct membrane and vesicular compartments of a neuron (Fig. 1).

### Characteristics

#### Description of the Process

In neurons, receptor trafficking is a process by which numerous neural functions, such as neuronal migration and ► **synaptic transmission** can be regulated. ► **Receptor trafficking** controls these functions by setting the capacity of a neuron to respond to an external cue. At the ► **post-synaptic density** for example, receptor trafficking can regulate the number of receptors available at any one time to respond to the ► **pre-synaptic** release of ► **neurotransmitter** molecules. As the amount of released neurotransmitter molecules often outweighs the number of available ► **post-synaptic receptors**, the process of receptor trafficking can control the efficiency and amplitude of the post-synaptic response. Over the past decade our understanding of the cellular mechanisms utilized by neurons to control postsynaptic receptor trafficking has increased significantly. We have discovered amongst other things that the basic mechanisms that control postsynaptic receptor trafficking are largely conserved with those controlling receptor trafficking in general. Therefore we have chosen to use examples of postsynaptic receptor trafficking below to illustrate the process and regulation of general ► **receptor trafficking** in neurons.

As ► **receptor trafficking** involves the movement of receptors between distinct membrane and vesicular compartments, it is intuitive that receptors must be recognized by components of these distinct compartments or by the trafficking machinery at each step. Simply put, receptor trafficking involves the recognition of discrete motifs within receptors by components of the different compartments. The motifs within receptors are defined as ► **trafficking motifs** and the components of the distinct compartments as ► **trafficking adaptors**. Hence if a receptor contains a specific trafficking motif, it has the potential to be recognized by a specific adaptor molecule of the compartment/ trafficking pathway defined by that motif and to be moved there. The

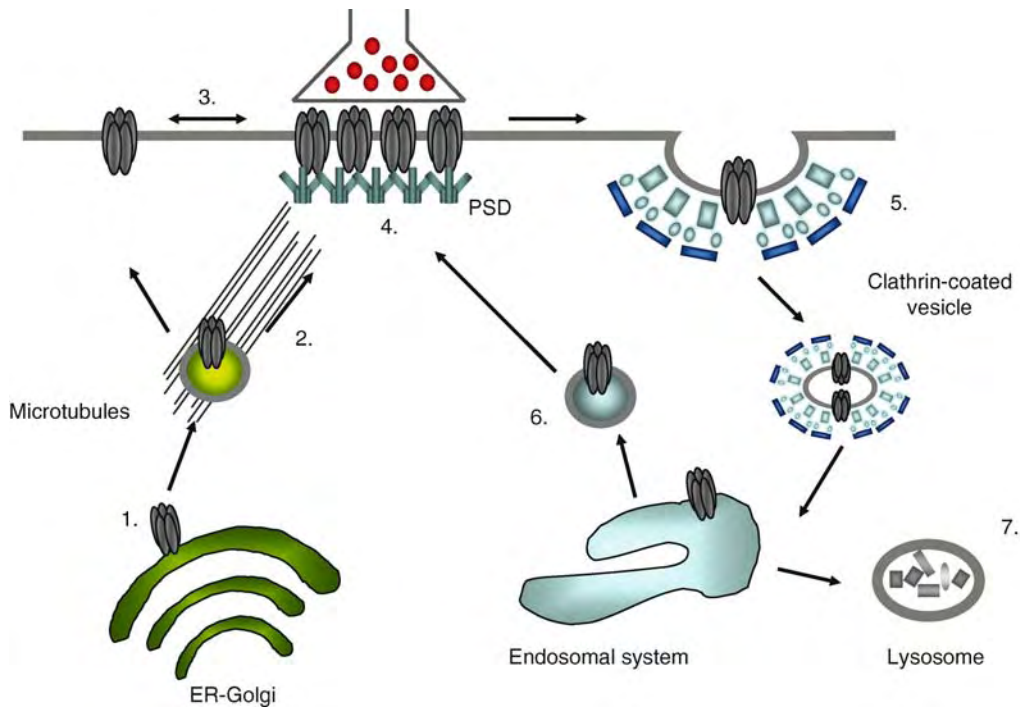

**Receptor Trafficking. Figure 1** Schematic of the cellular steps of post-synaptic receptor trafficking in neurons. (1) Post-synaptic receptors are generally synthesized and processed within the endoplasmic reticulum (ER) and Golgi of the neuronal cell body. (2) Receptors are then inserted locally into the plasma membrane or trafficked along dendritic microtubules to distal synapses. (3) In both cases receptors are either inserted directly at synapses or in the extra-synaptic membrane followed by later diffusion to the synapse. (4) Anchoring proteins within the post-synaptic density (PSD) then limit trafficking from the synapse. (5) Following release from the PSD anchoring proteins, receptors are internalized via clathrin-mediated endocytosis directly at the synapse or by lateral diffusion to designated endocytic zones. Internalized receptors then traffic within the endosome system and are either recycled back to the plasma membrane (6) or targeted for degradation within lysosomes (7). At each of these steps a specific protein-protein interaction between a trafficking adaptor(s) and a trafficking motif(s) within post-synaptic receptors dictate their trafficking itineraries.

physical movement in most cases is mediated by an indirect interaction with the cytoskeleton.

Postsynaptic receptors are multi subunit receptors frequently composed of different sub-classes of subunits. Because of this heteromeric nature, it is common that different subunits within a single receptor may contain distinct trafficking motifs dictating specific movement to discrete compartments of the neuron. In the sections below I will describe examples that illustrate our present understanding of the motifs and adaptor molecules controlling postsynaptic receptor trafficking.

#### Newly Synthesized Receptor Trafficking

In the synthesis of heteromeric receptors, active retention in the **▶endoplasmic reticulum** (ER) is a commonly used process, whereby individual subunits are retained within the ER until they are correctly assembled into the mature receptor. This process acts primarily as a quality control measure ensuring the

release of only functional molecules from the ER. The precise motifs and ER-proteins directing this retention are largely unknown for the vast majority of receptors. However it is thought and indeed the case in certain proteins that highly charged residues, which may be exposed in individual subunits but masked in the assembled receptor, play an important role in this retention process. In the case of the postsynaptic **▶NMDA receptors**, an additional layer of regulation in ER receptor trafficking exists [1].

The predominant NMDA-type glutamate receptor in the brain is composed of 2 NR1 and 2 NR2 type subunits and the trafficking of this NMDA receptor from the ER into the secretory pathway is controlled by differential splicing of the NR1 subunit. The NR1 subunit gene contains the splicing cassettes C1, C2, C2' that produce different cytoplasmic C-termini of the NR1 subunit. The NR1-1 splice variant, which is the main splice variant in the brain, encodes a C2 cassette and a C1 cassette, which contains a triple

arginine (RRR) ER retention motif. If this NR1–1 splice variant assembles with NR2 subunits in the ER, mature assembled receptors will not exit the ER efficiently, due to the presence of this ER retention motif. However if the C1 cassette is expressed in combination with a C2' cassette (NR1–3 splice variant) the assembled receptor successfully exits the ER. This is due to the presence of a specific trafficking motif within the C2' cassette (Serine-Threonine-Valine-Valine, STVV) that overrides the RRR retention motif of the C1 cassette. This STVV trafficking motif is able to override the RRR retention motif, as it belongs to the family of ►PDZ domain interacting motifs and specifically binds to the PDZ domain containing protein Sec23. Sec23 is a component of the ►COPII coat complex that promotes ER exit via COPII vesicle formation. Differential expression of these different splice variants is in addition controlled via ►neuronal activity. For example, increased neuronal activity promotes the insertion of the C2 cassette. This favors the C1 retention mechanism; reducing NMDA receptor exit from the ER and thus lowering overall surface expression of NMDA receptors and neuronal activity. In contrast blocking neuronal activity promotes C2' insertion over C2, which promotes ER exit, the secretory trafficking of NMDA receptors and increases neuronal activity. In essence, the above example neatly illustrates how a commonly used mechanism (ER retention) can be used to control receptor trafficking from the ER and how an additional process can be employed to override this retention in order to respond to the needs of the system.

#### Trafficking Along Dendrites and Targeting to Synapses

Most postsynaptic receptors are synthesized in the ►soma and once they have passed through the ER and Golgi are either inserted locally within the plasma membrane or travel large distances within ►dendrites to reach the distal dendritic synapses. The latter is achieved predominantly via vesicular transport along ►microtubules within the dendrite. To traffic receptors in this manner, specific linker proteins that bind to trafficking motifs within the cytoplasmic domain of receptors and to ►microtubule motor proteins move the vesicle along the microtubule. The microtubule motor proteins controlling this distal direction of vesicle movement (anterograde trafficking) belong to the ►kinesin superfamily proteins. It is estimated that a large anterograde transport vesicle may be associated on average with between 100–200 kinesin molecules. Once the target of this vesicle is reached (the dendritic synapse) exocytosis of these receptors occurs and the kinesin molecules are either degraded or recycled back to the soma for future use.

With respect to the linker proteins involved, an obvious pre-requisite is their ability to interact with

kinesins. Of the linker proteins identified thus far, many have the ability to bind only a single kinesin protein but to broadly bind a variety of receptor types. This occurs as these linker proteins generally contain multiple interaction domains that can bind distinct trafficking motifs within different proteins. Furthermore some receptors, such as the ►AMPA receptors, can bind multiple kinesins via different linker proteins. AMPA-receptors can bind convention kinesin via the linker protein the glutamate-receptor-interacting protein (GRIP1) and the kinesin family member, KIF1 via liprin- $\alpha$  [2]. Both interactions are mediated via carboxyl-terminal PDZ motifs in the cytoplasmic domains of the GluR2 and GluR3 AMPA receptor subunits. Thus a single postsynaptic receptor may encode multiple dendritic vesicular trafficking motifs, which can bind different linker proteins, which all participate in the anterograde movement of the receptor.

Under certain circumstances, postsynaptic receptors can also be trafficked in a retrograde fashion back to the soma. This involves a different set of linker proteins binding alternate trafficking motifs that have an affinity for retrograde microtubule motor proteins, such as the ►dynein superfamily of proteins. Finally exocytosis and insertion of receptors into the neuronal surface can occur at the synapse or at extra-synaptic sites followed by lateral diffusion of the receptors within the neuronal plasma membrane to the synaptic site. Once at the synapse, the binding of postsynaptic anchoring proteins subsequently retard further post-synaptic receptor trafficking and movement.

#### Endocytosis and Intracellular Trafficking

The next and penultimate step in the journey of neurotransmitter receptor trafficking is ►endocytosis, where the receptor is targeted for internalization from the plasma membrane. The vast majority of postsynaptic receptors are internalized via ►clathrin-mediated endocytosis (CME). Endocytosis of postsynaptic receptors can occur at the synapse, but preferentially occurs at designated internalization sites lateral to the postsynaptic density. In which case, postsynaptic receptors need to disengage from their postsynaptic anchoring proteins prior to internalization. This occurs constitutively or in a signal-regulated manner, involving a post-translational modification that alters the association of the receptor with the postsynaptic density anchoring protein.

In general CME is mediated by endocytic trafficking motifs located in the cytoplasmic domains of postsynaptic receptors, which are recognized by the tetrameric clathrin-binding endocytic adaptor protein 2 complex (AP-2). Two classical endocytic motifs exist, a tyrosine (Y) based motif, Yxx $\Phi$ , where -x- represents any amino acid and  $\Phi$  is a hydrophobic amino acid and an acidic di-leucine motif, D/ExxxLL, (D = aspartic acid,



E = glutamic acid and L = Leucine). These motifs, which have been found in the cytosolic domains of many neurotransmitter receptors, are recognized by different subunits of the cytosolic AP-2 complex. AP-2 binding in both cases however promotes membrane invagination and the recruitment of the clathrin lattice, leading to the formation of endocytic vesicles and receptor internalization. Some postsynaptic receptors encode a single endocytic motif, which is recognized by the AP-2 complex whilst others contain multiple. The inhibitory **▶GABA<sub>A</sub> receptor** heteropentamer for example, is composed of subunits that contain both tyrosine and di-leucine endocytic trafficking motifs, which all may be relevant in mediating GABA<sub>A</sub> receptor **▶endocytosis** [3].

Once internalized these postsynaptic receptor containing endocytic vesicles quickly mature, losing their clathrin lattice to first form early endosomes, which then subsequently mature into late/sorting endosomes. It is in late/sorting endosomes that internalized receptors are targeted either to be recycled back to the plasma membrane or alternatively for degradation in lysosomes. Again, the interaction between trafficking motifs within the receptor and compartment specific adaptors plays an important role. In the vast majority of cases the recycling of receptors is the default pathway, while trafficking to the lysosomal pathway involves an additional sorting step. The di-leucine motif mentioned above has been implicated in this step, through the binding of a related lysosomal specific adaptor complex to AP-2, the AP-3 complex. In addition to these peptide specific endocytic sorting motifs, the modification of receptor subunits by the addition of a 7 kilodalton(kDa) protein called **▶ubiquitin** has been identified as a targeting signal for endosomal-lysosomal sorting, which is discussed in more detail below.

### Regulation of the Process

**▶Post-translational modifications**, the addition of a molecule to a protein after it has been synthesized, provides an additional layer of regulation in receptor trafficking. Receptors can be modified by a number of different post-translational additions, such as lipids, inorganic ions or by the covalent attachment of small proteins. Listed below are some examples of how these different modifications can alter receptor trafficking itineraries.

#### Phosphorylation

**▶Phosphorylation**, the addition, or de-phosphorylation, the removal of an inorganic phosphate, are mediated by kinase or phosphatase enzymes respectively. This type of post-translational modification is used widely in neurons to regulate receptor trafficking, by altering the binding specificity of a trafficking adaptor to its

linear trafficking motif. For example, the rate of GABA<sub>A</sub>R endocytosis is regulated by phosphorylation. All GABA<sub>A</sub>R heteropentamers contain a beta-type subunit, which encodes an atypical endocytic AP-2 binding motif that encompasses an established regulatory phosphorylation site [4]. Phosphorylation at this site results in the reduced affinity of the AP-2 complex for the endocytic motif, which interferes with the rate of GABA<sub>A</sub>R endocytosis. This example neatly demonstrates a phospho-dependent regulation of endocytosis via regulation of the endocytic adaptor protein AP-2 binding affinity.

#### Palmitoylation

**▶Palmitoylation** is the reversible post-translational attachment of a saturated fatty acid, palmitic acid, to cysteine residues in a membrane protein via a thiol-ester bond. Palmitoyl acyl transferase enzymes mediate this reaction and in neurons the action of one such enzyme, the Golgi-specific DHHC zinc finger protein GODZ directs the palmitoylation of two classes of postsynaptic neurotransmitter receptors. These are the AMPA-type glutamate receptor and the GABA<sub>A</sub>R [5,6]. Palmitoylation of these receptors can modulate their membrane trafficking, by enhancing their hydrophobicity, which leads to an enhanced rate of surface expression. Palmitoylation of post-synaptic receptors therefore facilitates enhanced secretion of newly synthesized receptors.

#### Ubiquitination and Sumoylation

**▶Ubiquitin (Ub)** is a highly conserved 76 amino acid polypeptide that is covalently conjugated to lysine residues on target proteins or to itself by a reaction involving three classes of enzymes: an E1 activating enzyme, an E2 conjugating enzyme and an E3 ligase that also determines substrate specificity. Protein **▶ubiquitination** is reversible and this is controlled by the action of de-ubiquitinating enzymes that cleave the Ub-protein bond. Modification of proteins by Ub chains (Ub<sup>n</sup> > 4) primarily targets them for degradation by the multi-subunit proteolytic complex called the **▶proteasome**. In contrast, a single ubiquitin (mono-ubiquitination) as well as multi-site mono-ubiquitination, functions as a signal in the endocytic pathway controlling proteins internalization and lysosomal degradation. Mono-ubiquitination functions as an efficient endocytic-lysosomal trafficking signal, as several endocytic adaptor proteins encode ubiquitin-binding domains, which specifically recognize, bind to and traffic ubiquitinated membrane proteins.

There is now compelling evidence demonstrating a role for ubiquitination in regulating the abundance of glutamate receptors and synapse-associated proteins. Ubiquitin dependent proteasomal degradation of PSD95 for example, a glutamate receptor synaptic anchoring protein, enhances the endocytosis rate of AMPA receptors.

It does so by releasing AMPA receptors from the post-synaptic density and thereby enabling their interaction with the endocytic machinery [7]. This leads to a reduction in excitatory synaptic responses. With respect to the direct ubiquitination of glutamate receptors, a strong role for an E3 ligase complex of proteins called the Cullin E3 ligase (cul) complex has been discovered. The Cul3 adaptor protein actinfilin has been found to bind and mediate a Cul3 dependent ubiquitination of the GluR6 subunit of ▶**kainate receptors**, controlling GluR6 levels and receptor accumulation at excitatory synapses [8]. The NR1 subunit of the NMDA-type of glutamate receptor is also targeted for ubiquitination by a cullin complex protein, the F-box protein Fbx2 [9]. Ubiquitination of NR1 by Fbx2 alternatively controls its retro translocation from the ER and ubiquitin-proteasome mediated degradation in an activity dependent manner, leading to a reduction in NMDA-dependent currents. Of the third class of mammalian glutamate receptors, the AMPA receptor, subunit ubiquitination has yet to be demonstrated, but is highly probable as the signal sequences targeting ubiquitination of the related *C. elegans* GLR-1 subunit, are conserved in all mammalian AMPA type glutamate receptors.

▶**Sumo** (small ubiquitin-related modifier), also named “sentrin,” is a 101-amino acid protein that can also be covalently attached to cytosolic lysine residues, in a process that is analogous to ubiquitination. ▶**Sumoylation** was originally associated only with the functions of nuclear proteins, however more recently sumoylation of neurotransmitter receptors has been demonstrated and this modification on these proteins, like ubiquitination can regulate receptor trafficking. Sumoylation of the GluR6 kainate-type of glutamate receptor for example, regulates the rate of kainate receptor endocytosis and modifies the efficiency of synaptic transmission [10]. How precisely sumoylation facilitates this process is at present unknown, but it is likely it either release kainate receptors from an anchoring protein or alter the binding affinity of the receptor to endocytic adaptors. Sumoylation of the GluR6 subunit in neurons is rapidly enhanced in response to kainate treatment, which implies this modification is employed in an autoregulatory type of response to agonist application.

### Closing Comments

In this essay, I described the main cellular steps of neurotransmitter receptor trafficking that occur in a neuron (Fig. 1). Using specific examples of receptor trafficking for certain post-synaptic receptors, I have described how the different processes of receptor trafficking function at each step. In addition, I have outlined several post-translational modifications, which can regulate these processes of receptor trafficking and have explained how this regulation occurs and controls receptor trafficking.

## References

1. Mu Y, Otsuka T, Horton A-C, Scott D-B, Ehlers M-D (2003) Activity-dependent mRNA splicing controls ER export and synaptic delivery of NMDA receptors. *Neuron* 240(3):581–594
2. Shin H, Wyszynski M, Huh K-H, Valtschanoff J-G, Lee J-R, Ko J, Streuli M, Weinberg R-J, Sheng M, Kim E (2003) Association of the kinesin motor KIF1A with the multimodular protein liprin-alpha. *J Biol Chem* 278:11393–11401
3. Kittler J-T, Delmas P, Jovanovic J-N, Brown D-A, Smart T-G, Moss S-J (2000) Constitutive endocytosis of GABA<sub>A</sub> receptors by an association with the adaptin AP2 complex modulates inhibitory synaptic currents in hippocampal neurons. *J Neurosci* 20:7972–7977
4. Kittler J-T, Chen G, Honing S, Bogdanov Y, McAinsh K, Arancibia-Carcamo I-L, Jovanovic J-N, Pangalos M-N, Haucke V, Yan Z, Moss SJ (2005) Phospho-dependent binding of the clathrin AP2 adaptor complex to GABA<sub>A</sub> receptors regulates the efficacy of inhibitory synaptic transmission. *Proc Natl Acad Sci USA* 102:14871–14876
5. Hayashi T, Rumbaugh G, Haganir R-L (2005) Differential regulation of AMPA receptor subunit trafficking by palmitoylation of two distinct sites. *Neuron* 47:709–723
6. Keller C-A, Yuan X, Panzanelli P, Martin M-L, Alldred M, Sassoè-Pognetto M, Lüscher B (2004) The gamma2 subunit of GABA(A) receptors is a substrate for palmitoylation by GODZ. *J Neurosci* 24:5881–5891
7. Colledge M, Snyder E-M, Crozier R-A, Soderling J-A, Jin Y, Langeberg L-K, Lu H, Bear M-F, Scott J-D (2003) Ubiquitination regulates PSD-95 degradation and AMPA receptor surface expression. *Neuron* 40:595–607
8. Salinas G-D, Blair L-A, Needleman L-A, Gonzales J-D, Chen Y, Li M, Singer J-D, Marshall J (2006) Actinfilin is a Cul3 substrate adaptor, linking GluR6 kainate receptor subunits to the ubiquitin-proteasome pathway. *J Biol Chem* 281:40164–40173
9. Kato A, Rouach N, Nicoll R-A, Brecht D-S (2005) Activity-dependent NMDA receptor degradation mediated by retrotranslocation and ubiquitination. *Proc Natl Acad Sci USA* 102:5600–5605
10. Martin S, Nishimune A, Mellor J-R, Henley J-M (2007) Sumoylation regulates kainate-receptor-mediated synaptic transmission. *Nature* 447:321–325

## Receptor Tyrosine Kinase

### Definition

Receptor tyrosine kinase is a transmembrane receptor whose intracellular domain contains a kinase that is capable of transferring a phosphate group from ATP to a tyrosine of a protein. Many growth factors and extrinsic signaling molecules act through receptor tyrosine kinases.

### ▶Growth Factor

## Reciprocal Activation

### Definition

Simultaneous activation of muscles with a mechanical action on a joint (agonist) and inhibition of muscles with the opposite mechanical action (antagonists).

Reciprocal activation may be of both central and peripheral origin and it is mediated by excitation of agonist motoneurons and reciprocal inhibition of antagonist motoneurons, via inhibitory spinal interneurons, by descending fibers (in voluntary movements) and by sensory afferents (in reflexive responses).

#### ► Reaching Movements

## Reciprocal Dendrodendritic Synapse

### Definition

Principal synapse of the olfactory bulb. This is a synapse between mitral cell lateral dendrites and granule cell dendrites. Depolarization of a mitral cell releases glutamate, which excites the postsynaptic granule cell. This cell releases GABA at the same synapse and inhibits the mitral cell in a reciprocal fashion.

#### ► Olfactory Bulb

## Reciprocal Inhibition

### Definition

A pattern of synaptic connection between neurons or groups of neurons where they each make an inhibitory synapse on the other neuron or group of neurons in a mutual or reciprocal fashion. This pattern of connectivity assures reciprocity/alternation in the activity of the two neurons/groups. The term also refers to inhibition of antagonist motoneurons when the agonist motoneurons are activated either as part of a stretch reflex or as part of a voluntary movement. Ia inhibitory interneurons play an important role in ensuring reciprocal inhibition, but other mechanisms also contribute.

- Integration of Spinal Reflexes
- Intersegmental Coordination
- Reciprocal Activation

## Recognition

### Definition

Recognition is the act during which a specific item or event is identified as having been experienced or encountered on a previous occasion. Variants of items or events that are not exactly like those previously experience can also be recognized by generalization or inference.

#### ► Recognition Memory

## Recognition Memory

LUKE WOLOSZYN, DAVID SHEINBERG  
Department of Neuroscience, Brown University,  
Providence, RI, USA

### Synonyms

Familiarity; Recollection; Recency; Declarative memory; Explicit memory; Old/new recognition

### Definition

► **Recognition** memory refers to the ability of a system to classify a specific item or event as having been experienced or encountered on a previous occasion. Behavioral, neuropsychological, electrophysiological, and neuroimaging evidence indicate that recognition memory may be dissociable into the distinct processes of ► **familiarity** and recollection.

### Characteristics

The ability to form, retain and manipulate memories is necessary for an organism to adapt to its environment. The broad concept of memory is generally divided into procedural and declarative branches. Whereas procedural, or implicit, memory underlies the unconscious learning of motor, perceptual and habitual tasks, declarative, or explicit, memory refers to the conscious memory for facts and events. Declarative memory has been regarded as critical for providing temporal contiguity to conscious experience. Subsumed under the umbrella of declarative memory is recognition memory – the psychological ability to judge a particular item or event as having been previously encountered in the past. A hallmark of recognition memory is that it can both lead to a distinct feeling of oldness, or familiarity, as well as evoke vivid spatiotemporal details associated with the prior experience of the item or event. For example,

imagine having a conversation with a stranger on a subway and then seeing that same stranger in a different setting a month later. Not only will you most likely have a strong sense of recognizing this person as familiar, but you also might be able to ►recall the specific train you were on during your previous encounter. Most current theoretical models maintain that there is qualitative distinction between recognition memory that is or is not complemented by contextual recall [1].

Such dual-process models label recognition unembellished with episodic content as “familiarity” and recognition with accompanying contextual particulars as “recollection.” This view can be contrasted with the less common single-process models which posit that the difference between familiarity and recollection is purely quantitative [2]. In this latter framework, familiarity and recollection vary along a continuum that captures how much background information is recalled at the time of recognition, with recollection obviously summoning more details than familiarity. Dual-process models also posit that memory traces can vary in strength, especially within the domain of familiarity, but there is a qualitative, as opposed to a quantitative, leap when one transitions from familiarity to recollection. Although dual-process models dominate the literature, and as we will show are supported by a wealth of converging evidence, the parsimony of single-process models makes them a viable alternative.

Several different experimental paradigms have been employed to independently assess the contribution of familiarity and recollection to recognition memory [3]. The remember/know procedure asks subjects to first study a list of words or pictures and then identify, within a list including both old and new items, those items which have been previously studied. If an item is judged

as old, the subject further indicates whether he or she simply “knows” (K) this or can specifically “remember” (R) studying it (Fig. 1). Although the K judgment presumably reflects familiarity and the R judgment is analogous to recollection, it is difficult to tease these components apart because it is often the case that R judgments are preceded by implicit K judgments. Adding to the confound is the observation that the proportion of K and R judgments can be biased by manipulating the subjects’ decision criteria. A similar procedure aimed at differentiating familiarity from recollection asks subjects to rate the confidence of their old judgments, with higher confidence ratings indicating recollection. Another common paradigm used to explore familiarity and recollection is a source judgment task. In this setup, subjects again encode items that the experimenter has specifically embedded in a specific context (e.g., a particular quadrant of the screen). In the test phase, subjects may be required to not only signal whether an item is new, but to also report some aspect of the context in which the item originally appeared. In this paradigm, the proportion of trials with incorrect or correct source judgments can provide indices of familiarity or recollection, respectively.

Through the application of the above-mentioned and other experimental manipulations, an emerging consensus is that familiarity and recollection are, to a certain degree, functionally distinct. So, for example, it has been shown that recollection benefits more than does familiarity from undivided attention at the time of encoding. Similarly recollection improves when subjects are given the opportunity to encode the initial list of items in more depth, which happens, for example, when subjects generate words instead of passively reading them. Conversely, familiarity judgements are

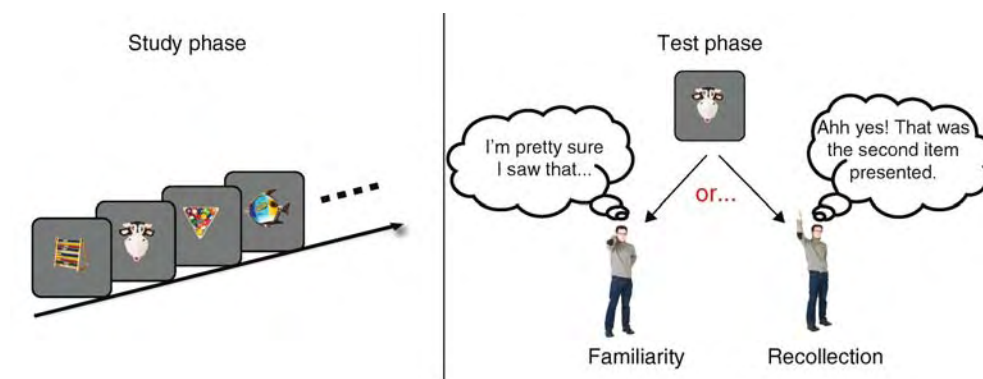

**Recognition Memory. Figure 1** A subject first encodes a set of words or pictures. Following a delay interval that is usually on the order of several minutes, subjects are presented with a list of words or pictures that include the initially studied items as well as new items. The subject’s task is to indicate which items are old and which items are new. If the subject responds old, he or she is asked to elaborate if the old judgment is simply due to some intuitive sense of “knowing” or if it is due to “remembering” specific details associated with the original encoding of the item in question. A “know” response presumably reflects a familiarity-based judgment whereas a “remember” response reveals a recollection-based judgment.

more common when duration of encoding is limited. In addition, priming has been shown to have an effect on familiarity but not on recollection. While a full discourse on the relevant findings dissociating the two types of recognition memory is beyond the scope of this article, it is generally assumed that familiarity operates automatically and quickly whereas recollection requires voluntary control and time.

Given that these distinct cognitive phenomena must have neural correlates, a logical question is whether differences between familiarity and recollection are evident at the electrophysiological level. Event-related potentials (ERP) are one means to non-invasively measure the stimulus-locked neural activity of human subjects. Indeed, early ERP studies found that recognized items, at test, generated more positive ERPs than to unrecognized items. A series of studies then demonstrated a double dissociation between familiarity- and recollection-driven ERPs [1,4,5]. Specifically, recognition judgments based on familiarity elicit ERP effects that are more localized to frontal electrode sites and have a relatively short latency, starting around 300 ms and continuing for another 100–200 ms. Not surprisingly, frontally localized ERPs corresponding to familiar items have more positive amplitudes than the ERPs of correctly rejected new items. The hypothesized electrophysiological correlates of recollection, on the other hand, appears more localized to parietal sites. It, like the early frontal effect, is more positive for correctly recognized items than for correctly rejected items but is slower to develop, usually beginning at 400 ms post-stimulus onset and persisting for another 300–400 ms. The differential latencies of the ERPs parallel the behavioral observations that familiarity is more instinctive and thus quicker than the more effortful and slower recollection. Compellingly, old items receiving incorrect “new” classifications do not elicit the early frontal effect whereas false alarms do. This suggests that familiarity allows us to perceive oldness.

ERPs have relatively poor spatial resolution, which does not allow for a finer localization of the neural substrates of recognition. To overcome this particular limitation, investigators have turned to functional magnetic resonance imaging (fMRI). Making use of behavioral paradigms similar to the ones described above, several groups have started to delineate circumscribed areas of the brain responsible for familiarity and recollection [3,6]. These results have revealed distinctions between familiarity and recollection that parallel those obtained with ERPs. Familiarity has been shown to cause activity in a network of areas, including various frontal/prefrontal regions, medial temporal lobe (MTL) structures excluding the hippocampus, and the superior parietal lobule. The most convincing evidence centers on the MTL structures, which include the perirhinal, parahippocampal and entorhinal cortices.

These structures not only exhibit reduced responses to old items, but this reduction correlates with the strength of the familiarity judgment, suggesting a neural substrate for the continuously scaled familiarity signal. Recollection-based judgments also tend to activate several brain regions, most notably the hippocampus and a left lateral parietal cortex. These observations are consistent with the widely held belief that the hippocampus is critical for the recall of associations, which presumably constitutes a large component of the episodic retrieval inherent to recollection. Crucially for dual-process models, activity in the hippocampus does not increase for familiarity judgments. Intriguingly, the activity in the left lateral parietal region has been shown to increase even when items are mistakenly classified as old, again lending support to the existence of a brain network responsible for the subjective experience of oldness.

Another localization approach, complementing the fMRI studies, has been to examine patient groups with focal lesions. Because the hippocampus is particularly susceptible to hypoxia, patients suffering from lesions of the hippocampus are relatively easy to find. Investigations of these patients have revealed mixed results in that whereas some reveal significant impairment in tasks requiring recollection, others show equivalent deficits for both familiarity and recollection [3,7]. This has led some to postulate that while there may be important distinctions between the two kinds of recognition memory, all the structures within the MTL act as one integrated unit, which in turn contributes to both familiarity and recollection.

Notwithstanding the inconclusiveness of the human results, more controlled lesion studies in nonhuman primates have revealed that some division of labor is present within the classically defined MTL structures. Because we cannot ask monkeys to introspect about their recognition processes, it is difficult to tap into their different types of recognition memory; nevertheless, ►[delayed match-to-sample \(DMS\)](#) and ►[delayed non-match-to-sample \(DNMS\)](#) paradigms have been extensively used to explore familiarity judgments. The basic format for this task requires the animal to encode an object (generally, but not always, by looking at it), to retain its identity throughout a delay interval, which can range from seconds to minutes or longer, and to then recall its identity by selecting the matching (or non-matching) object from a choice array containing two or more possible alternatives.

A meta-analysis of primate lesion studies, with the lesions restricted either to the hippocampus or to the surrounding perirhinal cortex, showed ablation of the perirhinal cortex impairs DNMS performance more than lesions of the hippocampus. Additionally, a correlation analysis showed that the magnitude of the DNMS performance deficit scaled positively with the extent of the perirhinal damage. While hippocampal

damage also had a detrimental effect on the DNMS task, the size of the hippocampal lesion was negatively correlated with performance deficit, with the deficit becoming essentially negligible for monkeys totally lacking the hippocampus. This supports the view that the surrounding MTL structures play a more vital role in familiarity judgments than does the hippocampus itself.

The lesion studies described above are consistent with single cell recordings performed in the perirhinal cortex of nonhuman primates [8]. The monkeys in these experiments performed a serial recognition task in which the goal was to press one button if the stimulus was familiar (having been seen repeatedly on a daily basis or just recently presented) and to press another button if the stimulus was novel. Three distinct classes of neurons have been reported. ► **Recency** neurons decrease their response when a displayed stimulus is one that was seen a few trials back, regardless of whether it is highly familiar or novel for that session. Familiarity neurons exhibit a reduced response to stimuli which are familiar to the monkey. Finally, novelty neurons show a marked enhanced response to the first presentation of a novel stimulus, with subsequent presentations of it or other familiar stimuli evoking much lower or shorter responses. Remarkably, some of these neurons appear to have memory spans of up to 24 h, providing persuasive evidence that they are involved in the extraordinary capacity of primates to remember stimuli for long periods of time, even following single exposures. Interestingly, the general tendency of these neurons to decrease their response to known stimuli mirrors results of fMRI studies in which the strength of the familiarity signal determines the amount of activity decrease observed in MTL structures. Additional studies have shown that the response of PFC neurons to familiar items is less affected by noise manipulations, suggesting that these items are more accurately and efficiently represented.

Recently, neurophysiologists have begun describing in more detail the properties of the neural activity underlying familiarity in primates. ERP studies have shown results similar to those obtained in humans, namely that the magnitude of the ERP differentiates between novel and familiar stimuli, with familiar stimuli eliciting a more positive ERP. These differences are present even in simple fixation conditions, which speaks to the fundamental contribution of familiarity to everyday behavior. Furthermore, as the monkey becomes more familiar with the novel set, the ERPs to the two sets of images become systematically more similar. Familiar and novel items also produce differences in the temporal dynamics of single cell responses. Specifically, both elicit a similar initial peak in the firing rate (~100 ms), but whereas the familiar response then quickly declines, the response to the novel images persists for an extended period of time. This suggests, again, that familiar items may be encoded

more efficiently than novel ones, and that the prolonged response observed for novel images might contribute to the creation of new memories.

Although recollection is difficult to study in nonverbal animals, preliminary evidence does indicate that the hippocampus is essential [9,10]. Numerous studies have shown that removing the hippocampus in rats impairs their ability to use relational knowledge, particularly with regard to spatial relationships, which has been interpreted as reflecting deficits in associative recollection. Single cell recordings in monkeys have also demonstrated that the firing pattern of hippocampal neurons correlates with the simultaneous acquisition and immediate expression of arbitrary stimuli associations. It should be pointed out, however, that the long-term storage of associations is thought to rely on the surrounding MTL structures, particularly the perirhinal cortex. Hence, a precise and accurate account of the specific neural substrates of recollection will require more time and research.

In sum, there is strong evidence suggesting a dichotomy between familiarity- and recollection-based recognition memory. The precise nature of these differences is difficult to characterize given that the two processes interact extensively at the cognitive level; however, neurophysiological data obtained from both humans and primates has begun to elucidate possible neural substrates and processes that contribute to this distinction.

## References

1. Rugg MD, Curran T (2007) Event-related potentials and recognition memory. *Trends Cogn Sci* 11(6):251–257
2. Donaldson W (1996) The role of decision processes in remembering and knowing. *Mem Cognit* 24(4):523–533
3. Rugg MD, Yonelinas AP (2003) Human recognition memory: a cognitive neuroscience perspective. *Trends Cogn Sci* 7(7):313–319
4. Jager T, Mecklinger A, Kipp KH (2006) Intra- and inter-item associations doubly dissociate the electrophysiological correlates of familiarity and recollection. *Neuron* 52(3):535–545
5. Wheeler ME, Buckner RL (2003) Functional dissociation among components of remembering: control, perceived oldness, and content. *J Neurosci* 23(9):3869–3880
6. Gonsalves BD et al. (2005) Memory strength and repetition suppression: multimodal imaging of medial temporal cortical contributions to recognition. *Neuron* 47(5):751–761
7. Squire LR, Zola-Morgan J, Clark RE (2007) Recognition memory and the medial temporal lobe: a new perspective. *Nat Rev Neurosci* 8(11):872–883
8. Brown MW, Aggleton JP (2001) Recognition memory: what are the roles of the perirhinal cortex and hippocampus? *Nat Rev Neurosci* 2(1):51–61
9. Wirth S et al. (2003) Single neurons in the monkey hippocampus and learning of new associations. *Science* 300(5625):1578–1581
10. Eichenbaum H (2000) A cortical-hippocampal system for declarative memory. *Nat Rev Neurosci* 1(1):41–50

---

## Recognition Neurons

### Definition

Neurons that are able to signal by their response that a specific, generally complex stimulus has been recognized. Face neurons in the inferior temporal cortex are an example for recognition neurons (see also Grandmother Neuron).

---

## Recollection

► Recognition Memory

---

## Recruitment

### Definition

Abnormal increase in perceived loudness.

► Hearing Aids

---

## Recruitment in Acoustics

### Definition

Abnormal increase in perceived loudness.

► Hearing Aids

---

## Recruitment of Motor Units

### Definition

Central nervous system control of force output from a muscle by regulating the numbers and identities of motor units that are activated or de-activated (de-recruitment) during a movement.

► Motor Units

---

## Rectifying Gap Junctions

### Definition

Rectifying gap junctions conduct ionic current better in one direction than in the other. In contrast to electrical synapses comprised of non-rectifying gap junctions, electrical synapses comprised of rectifying gap junctions transmit electrical signals in a unidirectional fashion.

► Electrical Synapses

---

## Recurrent Brief Depression

### Definition

Depressive episodes lasting at least 2 days but less than 2 weeks occurring at least once a month for 12 consecutive months. They often occur unpredictably but frequently. An average of two attacks a month is typical. Although the episodes are brief, symptoms are severe. Intense suicidal ideation is common.

► Major Depressive Disorder

---

## Recurrent Facilitation

### Definition

► Recurrent Inhibition

---

## Recurrent Hypersomnia

### Definition

Also known as Kleine-Levin syndrome, this disorder is characterized by periods of excessive sleepiness and long sleep times lasting days to weeks. It is most commonly found in adolescent males. During symptomatic periods, there is often increased food intake as well as cognitive and emotional dysfunction.

► Sleep – Developmental Changes

## Recurrent Inhibition

### Definition

Recurrent inhibition is a basic type of neuronal circuit throughout the central nervous system. In the spinal cord, motoneurons give off axon collaterals to excite GABAergic/glycinergic Renshaw cells, which mediate recurrent inhibition of motoneurons, Ia inhibitory interneurons, Renshaw cells and some cells of origin of the ventral spinocerebellar tract. Since the Renshaw cells also inhibit Ia inhibitory interneurons, which inhibit antagonistic motoneurons, activation of the Renshaw cells leads to removal of the inhibition of the antagonist motoneurons, and this phenomenon is termed recurrent facilitation.

- ▶ Ia Inhibitory Interneuron
- ▶ Integration of Spinal Reflexes
- ▶ Renshaw Cell

## Recurrent Network

### Definition

A neural network architecture in which both feedforward and feed-back connections between neurons are present. In a fully recurrent architecture, the neurons are fully interconnected.

- ▶ Neural Networks

## Recurrent Processing

### Definition

Information is processed in a set of stages in which activation can propagate in feedback loops.

## Red Nucleus

### Definition

The red nucleus consists of two functionally entire separate divisions, the caudal magnocellular red

nucleus and the more rostral parvocellular red nucleus. The magnocellular red nucleus is a large spherical nucleus in the midbrain containing very large neurons. It is the level of the oculomotor nucleus and the superior colliculus. It receives a very large input from the cerebellum by way of the superior cerebellar peduncle and also a small descending input from motor areas of the cerebral cortex. It projects to the contralateral facial and trigeminal nuclei in the brainstem and to the contralateral spinal cord, primarily to the cervical and lumbar enlargements that control the limbs. In fresh sections the magnocellular division of the red nucleus appears red or pinkish-yellow because of its marked vascularization, hence its name.

The parvocellular red nucleus, just rostral to the magnocellular division, consists of smaller neurons. In lower animals it is smaller than the magnocellular division but in primates, it is much larger. The parvocellular red nucleus receives a large input from the motor regions of the cerebral cortex and projects to the principle division of the ipsilateral inferior olive.

In summary, the magnocellular red nucleus is a premotor nucleus for muscles in the contralateral head and limb while the parvocellular red nucleus is a relay between the cerebral cortex and the inferior olive.

## Reductionism (Anti-Reductionism, Reductive Explanation)

ROBERT C. RICHARDSON<sup>1</sup>, ACHIM STEPHAN<sup>2</sup>

<sup>1</sup>Department of Philosophy, University of Cincinnati, Cincinnati, OH, USA

<sup>2</sup>Institute of Cognitive Science, University of Osnabrück, Lower Saxony, Germany

### Definition

In philosophy of science and in the sciences, reductionism is sometimes a methodological stance; sometimes it is a substantive position. As a methodological stance, it is committed to understanding a system's behavior analytically, i.e., in terms of the system parts and their interactions. As a substantive position, it anticipates the success of the reductionist methodology. Reduction sometimes is thought of in ontological terms; that is, as a commitment to the idea that, e.g., living systems consist of nothing other than physical constituents. This minimal commitment may be coupled with a claim that reduction holds *in principle*, even if not in practice, but does not require even this much. Reduction sometimes is an explanatory relation, either between theories or



between domains. The former is *theory reduction* while the latter is *reductive or mechanistic explanation*.

### Description of the Theory

Reductionism has been a persistent attractor for scientific thought. In physics, it led to some of the most striking successes of classical physics, such as the particle theory of light in the eighteenth century or ► [statistical mechanics](#) in the nineteenth century. In the biological sciences, the rapid growth of molecular genetics is a reductionistic triumph. In the ► [cognitive sciences](#), reductionism has been no less attractive, as is evidenced by the rise of what is called “cognitive neuroscience” in the twentieth century, or the dramatic successes of the neurosciences more generally. Opposition to reductionist approaches also has been prominent, especially in cognitive psychology. The successes of cognitive psychology and of ► [artificial intelligence](#) in the middle decades of the twentieth century encouraged the idea that reductionist methods were not necessary in order to explain human psychological capacities. In opposition to rather brute reductionistic claims such as that there is nothing but elementary particles, or that mental states are nothing but brain processes, champions of the special sciences feared they would lose their particular subject matter. Vitalistic or dualistic alternatives are not fashionable any more, but there are a number of antireductionist positions that have been recently defended.

### Varieties of Reduction: Theory reduction

Theory reduction claims to deduce or “explain” one theory (the secondary or reduced theory) from another (the primary or reducing theory), perhaps as a limiting case. Theory reduction may involve theories at the same level of organization or at different levels of organization. A classical example for same level reduction, as discussed by Ernest Nagel [1], is the reduction of Newton’s mechanics to Einstein’s relativity theory; for reduction of theories at different levels Nagel refers to the relation of classical ► [thermodynamics](#) to statistical mechanics. The reducing theory is typically thought to be more general or more exact, or both. The reduced theory correspondingly is thought of as more restricted in its domain of application, or as an approximation, by comparison with the reducing theory. Thus, Newton’s mechanics applies only to velocities far from the velocity of light. The classical gas laws in thermodynamics apply only to gases at intermediate temperatures and pressures. When reducing and reduced theories are on the same level, or cover the same domains, we have “homogeneous” reductions. If reduction is possible at all, it can be achieved relatively easily, because the theories at least appear to have the same concepts. For example, both Newton and Einstein appeal to *mass* and *velocity*, although they in

fact may not be the same concepts (insofar as the theory defines its concepts). When reducing and reduced theories refer to different levels, or cover different domains, we have “heterogeneous” reductions. If reduction is possible at all, it is more difficult in these cases, since the theories do not share the same vocabulary. For example, statistical mechanics has neither the notion of temperature nor that of pressure, though these are the key concepts of classical thermodynamics. So, in these cases, connections between the two domains or levels have to be forged, in the form of “► [bridge laws](#).” These connections are usually thought to be identifications between levels; e.g., mean kinetic energy is identified with temperature, at least within the domain of classical thermodynamics.

These identifications often lead to so-called “nothing buttery,” i.e., to the claim that the phenomena the upper level concepts originally referred to in fact are *nothing but* the entities the lower level concepts refer to. So, it is often said, temperature is *nothing but* mean molecular motion, and genes are *nothing but* nucleotide sequences. This sometimes leads to eliminativist claims concerning the reduced theory – that is, to denying the existence of things reduced [2]. In case there are suitable identifications available, reduction guarantees that the explanatory work done by the higher level theory can, at least in principle, be done by the lower level theory. The higher level theory can then, in principle, be eliminated without explanatory loss. In case the concepts of upper level theory are vaguer or more inexact, they cannot be identified with the more exact concepts of a lower level theory. Once again the original theory can be eliminated though in this case because it could *not* be reduced [3] (“phlogistaded”).

To take an example closer to the neurosciences, the trichromatic theory was an important case historically. Newton’s experiments with prisms revealed a visible spectrum ordered by wavelength. It was subsequently shown that any specific spectral hue could be matched by combining three different primary colors in different intensities. This led Thomas Young to propose, in 1801, that the retina contained exactly three different color-sensitive elements. This was subsequently confirmed and consolidated by the great physiologist, Hermann Helmholtz, with three classes of cones differing in their central sensitivities, though with substantial overlap of responses. This looked like a reduction of color theory to a trichromatic theory, which had broad acceptance into the middle of the last century. Unfortunately, not all the colors perceived by human subjects are represented in the physical spectrum. *Brown* is the most salient example of a color that is outside the physical spectrum. Hering eventually posited an “opponent process” theory which was aimed at more exactly describing the subjective phenomena of color perception. The existence of opponent processes

at the neural level was eventually confirmed in the macaque. We still lack a decisive direct test, but this sort of case also is suggestive of theory reduction.

To consider a more contemporary example, John Bickle [2] argues that contemporary neuroscience captures the phenomena on offer from psychology concerning memory. In particular, he observes that Eric Kandel's landmark work on ▶*aplysia* has forged a link between the mechanisms of long term potentiation (▶*LTP*) and ▶*memory consolidation*. Memory consolidation is particularly important as the link between short-term and long-term memory. The key psychological phenomena include the importance of stimulus repetition, the time course relevant to fixation, and ▶*retrograde interference*. The mechanisms, typically molecular, which characterize LTP capture these phenomena, at least to a first approximation. Bickle concludes that the "intended empirical applications of the two theories are virtually identical," even if the theories differ in substantial ways.

### Varieties of Reduction: Reductive or Mechanical Explanation

Reductive or mechanical explanations tell us *why* a certain entity instantiates a certain property, typically a property that is only attributed to the system as a whole [4,5]. So we might want to explain, e.g., how humans recognize faces, or how we acquire language. In trivial cases it suffices to simply add the corresponding properties of the system's components. So we get the weight of brains from the weight of its parts. However, the behavior of the brain in vision or perception – both definitely more interesting properties – cannot be deduced in an equally simple manner. Here we need to know the arrangement of the components, particularly those of the visual areas, what properties they have, and how they interact among each other and with the visual stimuli. The capacity to see would be reductively explained if it followed from the above-mentioned factors and the natural laws that hold generally. Of course, at the moment, we do not yet have such a reduction in place. That need not trouble reductionists, insofar as they are committed to what we will or (perhaps) could achieve.

So, the aim of each reductive explanation is to explain (or predict) a system's dispositions and properties solely by reference to its components, their properties, arrangement, and interactions. To be successful as a reductive or mechanistic explanation, several conditions must be met:

- i. There must be a systemic property to be explained
- ii. The property to be reduced must be functionally construable or reconstruable
- iii. The specified functional role must be filled by the system's parts and their mutual interactions

- iv. The behavior of the system's parts must follow from the behavior they show in isolation or in simpler systems than the system in question

These are demanding constraints, but without them no reductive explanation will be complete. What we are looking for, then, are functional characterizations of the properties to be reduced, and explanations of those functional properties in more fundamental terms. Usually we refer to these properties by concepts that classify properties at the system level, where specific patterns such as, e.g., learning a new person's face brings the instantiation of a capacity to our notice. The time course of memory consolidation is one such functional property. The functional analysis is a precondition for constructing appropriate explanatory connections between the components and systemic behavior. If, however, this conceptual "priming procedure" fails, as it may in the case of ▶*qualia*, the corresponding reductive explanation fails, too [6].

Reductive or mechanistic explanations can be forged in two opposite directions. Given that we already know that some system  $S$  has a systemic property  $P$  one task is to provide a reductive explanation for  $P$ . For that we refer to the microstructure  $MS(S)$  of  $S$ , to the behavior of the components, and to the interaction among the components  $C_i$  of  $S$ . With these resources, we try to show that  $S$  must have  $P$  *given the analysis of its structure*. So, in the case described above, it was important to the trichromatic theory that humans had exactly three color sensitive cones, and that these had appropriate spectral sensitivities. We also knew that humans could, typically, discriminate among spectral hues. So there was a systemic property (human discriminatory abilities) and there were microstructural features (three types of cones) that were appropriate. All this depended on adequate conceptual preparations. That is, we needed to know the range of discriminable colors. When it turned out that the systemic properties were different from those predicted by the trichromatic theory, that required a change in the understanding of the physiology.

In converse cases, we might at first only know the microstructure  $MS(S)$  of a system  $S$  and be uncertain concerning its exact capacities. The task, then, is to verify theoretically, or to forecast whether or not  $S$  has (a desired) systemic property  $P$ . To do so, we again must make use of adequate conceptual preparations and refer to the microstructure  $MS(S)$  of  $S$ , to the capacities and interactions of the components  $C_i$  of  $S$ . This is a difficult procedure, since the combinatorial possibilities are daunting. Experimental procedures that follow from imposing deficits, whether experimental or accidental, fall into this category. Ablation studies in nineteenth century physiology follow this simple approach, though there are more sophisticated methods (e.g., knock-out

genes) available to recent physiologists. So when Broca discovered a patient (Tan) that lacked the ability to produce coherent speech but who had normal comprehension, and who had damage to the left temporal lobe, he concluded that the temporal lobe was the location of articulate speech. Many fMRI experiments still follow this research strategy. They do not provide reductive explanations.

Of course, a system can be looked at from a “top down” perspective, a “bottom up” perspective, or from both simultaneously. In that case, we can stitch together the perspectives we garner from the bottom and the top.

### Anti-Reductionistic Positions

If it turns out that some purported phenomenon is not real, the property to be reduced is not accepted. In that case, condition (i) fails, and reductive explanation fails right at the outset. If telepathy is not real, there is nothing to explain or reduce. At the extreme, this becomes ►**eliminative materialism**, in which all psychological phenomena are rejected as real. Paul and Patricia Churchland [3], followed by John Bickle [2], defend largely eliminative positions, supported by an emphasis on theory reduction. If it turns out that one cannot functionalize a psychological property accepted for reductive explanation, even in principle, then condition (i) is satisfied, while (ii) is rejected. In this case, the systemic property is real but *irreducible*, and thereby it is *synchronically* (i.e., in a strong sense) *emergent*. Strong emergentism (►**Emergence**) is at least a type of property dualism [7]. The case in point is qualia. Commonly, it is held that, e.g., our sensation of red has an intrinsic character that cannot be captured in terms of function; and if this is so, then (ii) fails in this case [6]. If it turns out that the system components with their particular arrangement and interactions are not sufficient to account for the system’s behavior, then there is a failure of condition (iii). Again, a mechanistic explanation fails. If this is a consequence of limitations on our knowledge, then this is not a principled limitation. If it is a principled limitation, as the great neurophysiologists Sherrington and Eccles [8] maintained, then that is a failure of the reductionist/mechanist program. We would be driven to substantive dualism, ►**vitalism** or Cartesianism (►**Cartesian dualism**). If the behavior of components, embedded in the appropriate context, is sufficient to explain the system behavior, but the behavior of the components in simpler constellations cannot account for their interactions within the more complex system, then condition (iv) fails. In that case, we are forced to a kind of ►**holism**; which establishes one type of emergentism. Irreducibility can coexist with mechanistic explanations [9].

Theory reduction also has its detractors, who usually contend that there will be a failure to provide appropriate bridge laws to connect the theories in heterogeneous reductions. Functionalists such as Jerry Fodor [10] and

hold that psychological states are functional states (►**Functionalism**), which can be realized in multiple ways, and conclude that therefore there will not be appropriate identities available. They conclude that this supports a kind of autonomy for psychological explanations relative to physiological explanations. A more radical failure would be the absence of sufficient physical conditions to explain psychological capacities. In this case, we would be driven again to either dualism or eliminativism.

### References

1. Nagel E (1961) The structure of science: problems in the logic of scientific explanation. Routledge & Kegan Paul, London
2. Bickle J (2003) Philosophy and neuroscience: a ruthlessly reductive account. Kluwer, Dordrecht
3. Churchland PS (1986) Neurophilosophy: towards a unified understanding of the mind-brain. MIT, Cambridge
4. Bechtel W, Richardson RC (1993) Discovering complexity: decomposition and localization as strategies in scientific research. Princeton University Press, Princeton
5. Craver C, Darden L (2001) Discovering mechanisms in neurobiology: the case of spatial memory. In: Machamer PK, Grush R, McLaughlin P (eds) Theory and method in neuroscience. University of Pittsburgh Press, Pittsburgh
6. Stephan A (2001) Phänomenaler Pessimismus. In: Pauen M, Stephan A (eds) Phänomenales Bewusstsein – Rückkehr zur Identitätstheorie? Paderborn, mentis, pp 342–363
7. Stephan A (1999) Emergenz. Von der Unvorhersagbarkeit zur Selbstorganisation. 2nd printing, mentis, Paderborn 2005
8. Popper K, Eccles J (1977) The self and its brain: an argument for interactionism. Springer, Berlin Heidelberg New York
9. Boogerd FC, Bruggeman FJ, Richardson RC, Stephan A, Westerhoff HV (2005) Emergence and its place in nature: a case study of biochemical networks. *Synthese* 145:131–164
10. Fodor J (1975) The language of thought. Thomas Crowell, New York

---

## Redundancy of Degrees of Freedom

### Definition

An excess of elemental variables (degrees –of freedom) within a system as compared to a number of constraints imposed on the system in typical tasks; this term assumes that redundant elemental variables need to be eliminated to make the system controllable.

- **Coordination**
- **Degrees of Freedom**

## Redundant Set, Redundancy Problem

### Definition

Also called Bernstein's problem, named after the scientist who has considered it as a major problem in motor control research; ambiguity in transforming a set of variables into a set of more numerous variables so that a unique solution of many possible solutions of the motor task must be chosen, for example, when it is necessary to distribute total torque acting on a joint into individual torques of muscles spanning this joint, or to choose one of many possible ways of combining different degrees of freedom of the body to reach the motor goal. See also the principle of neurological minimization.

► [Equilibrium Point Control](#)

## Reference

### Definition

Reference is the relation between an expression and what it refers to. A typical unambiguous concrete singular term like "the highest mountain" or "Gottlob Frege" refers to a certain concrete particular like a thing or a person. A  $[\rightarrow]$  predicate like "is red" distributively refers to all those particulars to which it applies, i.e. to the red things. Sometimes the relation between a predicate and the set of things it applies to is also called "reference."

► [Argument](#)  
 ► [Logic](#)

## Reference Frame

### Definition

► [Sensory Systems](#)

## Reference Model

### Definition

The Reference Model is used for a certain type of control design. It is a mathematical model that

represents the desired behavior of the controlled physical system.

► [Adaptive Control](#)

## Referent Configuration

### Definition

A position of the body or its segments at which muscles are silent in the absence of co-activation or, otherwise, produce net zero joint torques but generate activity and resistive forces in response to deviations from it; modified by control levels to produce motor actions.

► [Equilibrium Point Control](#)

## Referent Trajectory of an Effector

### Definition

Comprised of the positions of the effector's associated with threshold configurations of the body at each instant of movement (see Threshold control).

► [Equilibrium Point Control](#)

## Referential

### Definition

Pointing to the meaning of an utterance.

► [Cognitive Elements in Animal Behavior](#)

## Referred Pain

### Definition

Referred pain is the phenomenon wherein nociceptive stimulation in one location results in the perception of

pain in another location. In clinical practice, this phenomenon is most often thought of as involving the projection of pain from a visceral structure to the body surface. However, nociceptive stimulation of muscle, and possibly other somatic tissues, can also lead to referred pain. A number of mechanisms have been proposed to explain referred pain. These include, most importantly, the convergence of afferent neurons from the site of insult and the site of perceived pain. This may occur through the dichotomization of afferent fibers such that one branch of an axon terminates on, for example, a visceral structure, while another branch of the same axon terminates in the skin. Alternatively, two distinct peripheral sensory neurons may both terminate on the same dorsal horn neuron. In either instance, it is proposed that the brain would have difficulty in determining the true source of nociceptive input, and would preferentially attribute pain to the more familiar source of sensory input – hence the body surface.

- ▶ [Ascending Nociceptive Pathways](#)
- ▶ [Somatosensory Projections to the Central Nervous System](#)

---

## Reflex

### Definition

Involuntary modification of activity in motoneurons in response to activation of sensory receptors.

- ▶ [Motor Control](#)
- ▶ [Feedback Control of Movement](#)

---

## Reflex Adaptation

### Definition

One of the simplest forms of motor learning. Inborn reflexes, such as an eyeblink reflex, are adaptable to new environmental conditions. For example, the force required for eyelid closure self-adjusts when the eyelid movement is impeded by an external load.

- ▶ [Motor Learning](#)

---

## Reflex Chain

### Definition

A sequence of reflexes where the action of the first reflex activates a set of receptors (e.g. proprioceptors) that trigger a second reflex, and so on. The peripheral control hypothesis proposed that complex behaviours consist of simple reflexes that are linked together in a reflex chain. This hypothesis has been superseded by the central control hypothesis.

- ▶ [Central Pattern Generator](#)

---

## Reflex Sympathetic Dystrophy (RSD)

### Definition

- ▶ [Complex Regional Pain Syndromes \(CRPS\)](#)

---

## Reflexes

ARTHUR PROCHAZKA

Centre for Neuroscience, University of Alberta,  
Edmonton, AB, Canada

### Definition

(Taken from Dr. Wilfrid Jänig's essay on ▶ [Autonomic reflexes](#)) Reflexes are functionally defined by an efferent (motor) output system that generates a distinct effector response when activated and by the population of afferent neurons stimulated. Reflexes are fragments of more complex somatomotor behaviors and are used in the laboratory as tools to study experimentally the central organization of neural regulation of movement.

### Background

There is no universally accepted definition of reflexes that distinguishes them from voluntary responses to stimuli [1]. The Roman poet Ovid used the word *reflex* to describe “turning or bringing back.” Substitute “feed” for “bring” and we have the word “feedback.” In engineering, feedback refers to information about a process monitored by sensors and supplied to the controller of that process (see ▶ [Feedback control of movement](#)).

In biology, the first attempt at a definition of reflex is attributable to Georgiy Prochaska [2]: a behavior in response to an excitation, mediated by separate motor and sensory nerves. Prochaska saw the function of reflexes to be *conservation of the individual*, later called *homeostasis* by Claude Bernard [3]. The psychologist Herbert Spencer posited that reflexes were the atoms of the psyche; that the psyche was an assemblage of reflexes, and that instincts were reflex assemblies consolidated by repetition and transmitted in an hereditary manner [4]. The Russian clinical physiologist Ivan Sechenov went one step further, proposing that all motor acts in humans as well as animals were simply chains of elemental reflexes [5]. He argued that the appearance of spontaneity and volition was illusory and that all movements were in principle predicted by the history of prior events, sensory inputs and associated thoughts. His conception of reflexes included complex responses that involved choice, as well as learned responses that his successor Pavlov would later call conditioned reflexes. The ideas of Spencer and Sechenov were taken to their literal conclusion in the behaviorist theories of Watson and Skinner. These theories rejected all non-measurable explanations of behavior and replaced voluntary movement with operants: conscious arbitrary acts that have become associated with arbitrary stimuli through learning and arbitrary reinforcement.

Hughlings Jackson argued from clinical observations that movements ranged in a continuum from the most automatic or evolutionarily primitive to the least automatic or most evolutionarily advanced [6]. Primitive reflexes in humans were unmasked or released when the higher centers were damaged. The Jacksonian continuum from automatic to voluntary probably best encapsulates the current view of most neuroscientists. In this view, reflexes are brief, automatic and invariant responses to stimuli. But even this definition is problematic: Goldstein (1939) reviewed various responses called reflexes and found them all to be variable, state-dependent and mutable [1].

Jonathan Wolpaw recently argued that a single comprehensive hypothesis related to this question of distinguishing reflexes from voluntary actions developed in the nineteenth century, namely that the whole function of the nervous system is to convert sensory input into appropriate motor output [1]. Neuroscientists who say they are studying reflex behaviors are studying behaviors in which the connections from stimulus to response, from experience to behavior, are known to be, or at least believed to be, short and simple enough to be accessible to description with presently available methods, and they are excluding by one means or another voluntary behaviors, or behaviors involving connections so long and complex as to defy present-day analysis. Implicit in these definitions is the expectation

that, as methodology and understanding advance, the class of reflex behaviors will grow larger and larger and the class of voluntary behaviors smaller and smaller.

When reading the essays on specific reflexes in this *Encyclopedia* it is useful to bear in mind the following comments of Francois Clarac [1]:

1. In normal behavior, reflexes are simple, fast reactions to the environment. The term should be confined to the simplest input-output reactions mediated by monosynaptic (or oligosynaptic) pathways at the lowest level, i.e. at the motoneuronal level. Reflexes should be viewed as elements of feedback control that each species possesses to react automatically to the environment.
2. The experimenter can induce a reflex artificially.... Reflexes then reduce to informative tests of CNS state. A reflex might be seen as a physiological “scalpel” permitting entrance into simple workings of the CNS, while not being a distinct and separable element when normal movements are considered. Thus although the understanding of motor behavior has benefited from reflex experiments, the normal functioning of the CNS, in which many afferent messages are integrated, should never be viewed as reflexive behavior even in the case of the “automatic” movements of invertebrates and lower vertebrates.

### Overview of the Essays Grouped within the Topic “Reflexes”

In the following synopsis, key points are extracted or paraphrased from each of the essays in this volume related to reflexes.

► *Autonomic Reflexes.* Reflexes related to autonomic regulation of pelvic organs, cardiovascular system, functions of skin, gastrointestinal tract, airways, eye and pineal gland are mediated by spinal cord, brain stem or hypothalamus and are functionally defined by their afferent input and efferent output. They are di- or polysynaptic, organized at the segmental propriospinal or propriobulbar level and form the building blocks of autonomic regulations. Interneurons are important for the integration and coordination of different autonomic and somatomotor systems. Command signals from higher centers act primarily via these interneurons rather than directly with the final autonomic pathways.

► *Conditioned Reflexes.* The fact that reflexes are affected by activity-dependent plasticity throughout life (and even in utero) implies that the traditional distinction between unconditioned and conditioned reflexes is merely an artificial distinction imposed by an experimenter. In reality, most and probably all reflexes are conditioned in the sense that they have been shaped by activity. Those traditionally designated as “unconditioned,” such as the normal flexion withdrawal

reflex that withdraws a limb from a painful stimulus, are reflexes that have undergone standard conditioning in the course of earlier life, and thus are similar in most normal individuals. In essence, “unconditioned reflexes” are simply reflexes that were conditioned before the experimenter began to observe them.

► **Feedback control of movement.** The word feedback is used extensively in engineering. In neurophysiology, it is used to describe the sensory signals used by the CNS to control a large number of bodily functions to maintain constancy of the internal environment (homeostasis). Signals from mechanoreceptors in muscles, joints and skin are involved in the control of movement, as well those from the eyes, ears and vestibular apparatus. All levels of the CNS from the spinal cord to the cerebellum and cerebral cortex receive feedback from mechanoreceptors and all these levels are involved in controlling even the simplest movements.

► **Integration of reflexes.** Despite more than a hundred years of research, the integration of spinal reflex circuitries and descending motor commands remains a challenge. For example, there is still no consensus about the mechanism by which the much-studied monosynaptic stretch reflex contributes to the activation of muscles during walking, if it makes a meaningful contribution at all. An understanding of spinal reflex networks is a requirement for developing useful therapeutic strategies in the rehabilitation of neurological disorders.

► **Locomotor reflexes.** Locomotor reflexes play an essential role in the patterning of motor activity for walking. These reflexes have three major functions: (i) to regulate the timing of motor commands according to the mechanical state of the limbs and body, (ii) to control the magnitude of ongoing muscle activity, and (iii) to initiate corrective responses when the limbs or body are unexpectedly perturbed by events in the environment.

► **Long loop reflexes.** transcortical reflex. By definition, long loop reflexes occur at latencies longer than the simplest reflexes mediated by *segmental* circuits within the spinal cord yet the latencies are too short to be mediated volitionally. For muscles in the hand, the fastest (spinal) reflexes to muscle stretch occur at latencies ~35 ms; long loop reflexes occur at latencies ~60 ms, whereas volitional responses occur at ~140 ms. However, automatic motor responses of comparable latencies can also be generated by tactile (cutaneous) stimuli that do not involve muscle stretch, so the term “long loop reflex” should not be restricted to those generated by muscle stretch.

► **Presynaptic inhibition.** Presynaptic inhibition (PSI) refers to a decrease of transmitter release at central synapses. For example, activation of afferent fibers originating in flexor muscles attenuates monosynaptic

► **EPSPs** in extensor motoneurons without detectable changes in the time course of the EPSPs, membrane potential or motoneurone excitability. PSI occurs widely within the CNS of both vertebrates and invertebrates. Synaptic efficacy at axon terminals from sensory afferents, descending systems or interneurons can be subject to PSI control by a number of neurotransmitters and presynaptic receptors.

► **Respiratory reflexes.** Generating an optimal breathing pattern for O<sub>2</sub> and CO<sub>2</sub> homeostasis requires the integration of sensory information from a variety of receptors including central and peripheral chemoreceptors for adjusting the magnitude of alveolar ventilation and stretch receptors for regulating the depth and rate of breathing. Sensory input is also important in the coordination of breathing with other systems, such those required for speaking, eating, walking, running, and vomiting. Finally, sensory information is necessary for protection of the airways and lungs. Receptors in the nose, pharynx, larynx and lower airways elicit a variety of reflexes including coughs, sneezes and apnea that protect the airways from inhalation of noxious substances and increase mucous secretion that aids in their removal.

► **Sexual reflexes.** Spinal reflexes consisting of afferent and efferent components instigate the genital vasocongestion and neuromuscular tension responsible for sexual arousal (erection in men and vaginal lubrication and elongation in women), the triggering of ejaculation in men, and possibly orgasm in both sexes. While the spinal cord contains all the neural circuitry involved in the generation of genital arousal, many other body senses, emotions and cognitive processes mediating social awareness determine whether an individual person will orient towards sexual activity or lose interest.

► **Concluding thoughts.** The difficulty in classifying motor acts as either voluntary, involuntary or reflexive is the inevitable consequence of the overlap in the attributes that describe these categories as well as the brain mechanisms that control them. The various essays summarized above all demonstrate this overlap in one way or another. The Jacksonian continuum, “most automatic” to “most voluntary,” should always be borne in mind when considering reflexive control of bodily functions.

## References

1. Prochazka A, Clarac F, Loeb GE, Rothwell JC, Wolpaw JR (2000) What do reflex and voluntary mean? Modern views on an ancient debate. *Exp Brain Res* 130:417–432
2. Prochaska G (1784) *The principles of physiology, Prochaska on the nervous system. (De functionibus systematis nervosi. Commentatio. Wolfgang Gerle, Prague (English translation: (1851) A Dissertation on the Functions of the Nervous System). The Sydenham Society, London, p 463*

3. Bernard C (1878) *Leçons sur les phénomènes de la vie communes aux animaux et aux des végétaux*. Baillière, Paris, pp 114–121
4. Spencer H (1855) *Principles of psychology*, 2nd edn. Published in 1873. Appleton, New York, p 648
5. Sechenov IM (1863) *Reflexes of the brain (Refleksy Golovnogo Mozga)*. In: Subkov AA (ed) *Im sechenov, selected works*. State Publishing House, Moscow
6. Hughlings Jackson J (1884) On the evolution and dissolution of the nervous system. Croonian lectures 3, 4 and 5 to the Royal Society of London. *Lancet* 1:555–739

## Regeneration

CHIZUKA IDE<sup>1,2</sup>, MARI DEZAWA<sup>1</sup>,  
 NAOYA MATSUMOTO<sup>1,3</sup>, YUTAKA ITOKAZU<sup>1</sup>  
<sup>1</sup>Department of Anatomy and Neurobiology, Kyoto University Graduate School of Medicine, Yoshidakonoe-cho, Sakyo-ku, Kyoto, Japan  
<sup>2</sup>Department of Occupational Therapy, Aino University, Ibaraki, Osaka, Japan  
<sup>3</sup>Department of Traumatology and Acute Critical Medicine, Osaka University Graduate School of Medicine, Osaka, Japan

## Reflexive Saccades

### Definition

These are also called reactive saccades, pro-saccades, or visual grasp reflex. A saccade elicited by visual, auditory and even tactile events, and direct gaze at the perceived location of these events. In freely behaving subjects they tend to be accompanied by head rotation when the eccentricity of this location exceeds 20° or so.

Depending on the modality and intensity of the stimuli, they occur at latencies of 150 to –350 ms. Considerable attentional effort is required if reflexive saccades are to be voluntarily suppressed.

- ▶ Oculomotor Control
- ▶ Saccade, Saccadic Eye Movement

## Refractory Period

### Definition

When, during an action potential, the membrane has undergone a full-blown depolarization (up to several tens of millivolts positive), the Na<sup>+</sup> system is subsequently in a state of reduced responsiveness, from which it recovers slowly over several milliseconds. This period is called refractory period. There is often an initial short period during which the Na<sup>+</sup> system cannot be activated at all, however strong the depolarization.

This is called the absolute refractory period. During the subsequent relative refractory period, the Na<sup>+</sup> system responds in part.

- ▶ Action Potential
- ▶ Sodium Channels

Regenerating axons grow well in the peripheral nervous system (PNS), but, in contrast, effective nerve regeneration rarely occurs in the central nervous system (CNS). Following ▶*axotomy*, the distal segment of the injured axon degenerates (▶*Wallerian degeneration*), whereas the proximal segment usually remains intact. The most prominent change of the neural cell body following axotomy is the disintegration of ▶*Nissl bodies* [1]. This phenomenon is called ▶*chromatolysis* (▶*Chromatolysis*). Chromatolysis that can occur in neural cell bodies in both the PNS and CNS involves not degenerating, but regenerating reactions of neurons to axotomy. Though morphological changes of neurons in relation to chromatolysis have been extensively studied, the molecular basis behind this phenomenon has not yet been clarified. Chromatolysis is a sign for neurons, when their axons are injured, to shift from the normal condition to the regenerating phase, leading to axonal growth. In the normal condition, neurons are mainly involved in the synthesis and release of ▶*transmitters*. However, following injury, neurons should change their machinery to produce molecules that contribute to regeneration. Molecular changes in association with axonal degeneration and regeneration have been studied, and gene expression involving in axonal elongation is crucial in understanding the molecular mechanism of nerve regeneration (▶*Neuronal changes in axonal degeneration and regeneration*). The molecular changes of neurons responding to axonal injury have been studied [2].

In the PNS, ▶*Schwann cells* and their basal laminae act as efficient scaffolds and sources of ▶*neurotrophic factors* required for the growth of regenerating axons, and adhesion molecules present on the surface of Schwann cells contribute to nerve regeneration. On the other hand, glial cells including ▶*astrocytes* and ▶*oligodendrocytes* in the CNS play no supporting role in the growth of regenerating axons. In addition, there exist no extracellular matrices such as basal laminae in the CNS. Although axons in the CNS



have the ability to regenerate after injury, the microenvironment appropriate for the growth of regenerating axons is not provided in the CNS. Cell transplantation using Schwann cells, ▶[olfactory ensheathing cells](#), ▶[neural stem cells](#), ▶[choroid plexuses](#), and ▶[macrophages](#) has been extensively studied to overcome this difficulty, as it could provide an efficient environment to enable regenerating axons to grow. Other studies have also been conducted on how to facilitate nerve regeneration via suppressing inhibitory factors using specific ▶[antibodies](#) or via supplying trophic factors to the lesion using genetically altered cells to produce specific trophic factors.

### Nerve Regeneration in the PNS

Axons are ensheathed by Schwann cells in the PNS, where each cell forms a ▶[myelin](#) sheath segment around the axon with ▶[nodes of Ranvier](#) intervening between the neighboring myelin sheath segments. Schwann cells of myelinated and unmyelinated fibers possess basal laminae on the surface facing the connective tissue, which are continuous even at the nodes of Ranvier. Therefore, the axon and associated Schwann cells reside within a basal lamina tube along its entire length.

Peripheral nerve fibers are located in the connective tissue compartment, an essential difference from the central nerve fibers, which are tightly packed within the brain and spinal cord without any structural extracellular component present between the nerve fibers. During Wallerian degeneration following axonal injury, remaining Schwann cells temporally proliferate and form cell strands called “▶[Schwann cell columns](#)” within the basal lamina tube. Axonal sprouts that emerge at the nodes of Ranvier adjacent to lesions of the proximal stump extend as regenerating axons through the connective tissue compartment to the distal stump, in which they further elongate along Schwann cell columns.

The tip of the regenerating axon is specialized as a ▶[growth cone](#) [3]. Growth cones are formed at the growing tip of axons during development and regeneration. Growth cones emit filopodia and lamellipodia on the surface, which actively move in various directions to survey the surrounding environment. The structure of living growth cones and their impressive movement were first observed in the culture of single-dissociated neurons under cine-microscopy in Nakai's pioneering work [4]. He proposed that filopodia and lamellipodia might represent sensors searching for appropriate targets during their extension [5]. Numerous studies have been performed regarding the structure and function of growth cones ▶[Growth cone](#).

The growth of axonal sprouts is facilitated or suppressed depending on the conditions of myelin sheath degradation that occurs during Wallerian

degeneration in the myelin sheath of the distal stump [6]. In the distal stump, regenerating axons come into contact with Schwann cell columns. Schwann cells play a critical role in nerve regeneration in the PNS; they provide cellular scaffolds for regenerating axons to grow through, and express trophic factors as well as adhesion molecules for promoting the extension and maintenance of regenerating axons. In Wallerian degeneration, Schwann cells disrupt myelin sheaths that have lost contact with axons into fragments called myelin balls that are subsequently transferred to and phagocytosed by macrophages. Thus, macrophages contribute to successful nerve regeneration. Schwann cells cooperate with macrophages not only in myelin sheath removal, but also in trophic factor production for promoting axon growth during nerve regeneration (▶[Schwann cells in nerve regeneration](#)). Schwann cells that remain “quiescent” in Schwann cell columns during Wallerian degeneration become “active” by coming into contact with regenerating axons, following which they gradually ensheath axons and finally form myelin sheaths in myelinated fibers.

Schwann cells are primary sources of trophic factors for nerve regeneration. A large number of neurotrophic factors have been identified. A well-known neurotrophic factor is ▶[nerve growth factor \(NGF\)](#), a member of the neurotrophins that include ▶[brain-derived nerve growth factor \(BDNF\)](#), ▶[neurotrophin 3](#), and ▶[neurotrophin 4/5](#). ▶[Glial cell line-derived neurotrophic factors \(GDNF\)](#) belong to another family that promotes the survival and neurite extension of neurons. ▶[Cytokines](#) also have neurotrophic activity, which include ▶[ciliary neurotrophic factor \(CNTF\)](#) and ▶[interleukin 6 \(IL-6\)](#). Neurotrophic molecules have been studied in relation to their corresponding receptors, effects on axonal cytoskeletons, and gene expression to explore the regeneration mechanisms of injured axons in the PNS and CNS (▶[Neurotrophic factors in nerve regeneration](#)).

On the other hand, in one experiment in which Schwann cells were killed by freeze-treatment, the damaged cells were removed by macrophages. Regenerating axons were then observed to vigorously grow through such basal lamina tubes in contact with the inner surface of the basal lamina [7]. This result indicates that peripheral nerve axons can grow through the acellular matrices (▶[Role of basal lamina in nerve regeneration](#)). This is the theoretical basis for the use of artificial materials for nerve regeneration in the PNS. Basal laminae serve not only as the scaffold for growing axons, but also as a supply of trophic/nutritional factors that are adsorbed by heparan sulfate present on the outer surface of the basal laminae [8]. Thus, peripheral nerves are provided with dual structural insurance, Schwann cells and basal laminae, for successful nerve regeneration.

In a regular nerve suture, regenerating axons randomly enter distal Schwann cell columns. Therefore, it is not definite that regenerating axons can reach their original targets. The clinical estimation of functional recovery is important [9]. Several different methods of treatment have been developed and used clinically. In the case of crush injury, in which basal lamina tubes (endoneurial tubes) remain undisrupted, axonal sprouts can extend through the original Schwann cell tubes to the original targets. Therefore, nerve regeneration occurs readily, and the high correspondence in axon-target reinnervation is secured for accurate functional recovery. On the other hand, in the case of transection, the proximal and distal stump should be sutured by apposing directly, or using grafts including autologous nerve grafts and artificial tubes. In stump suturing, fascicular repair to connect the corresponding nerve fasciculi has been recommended to ensure that regenerating axons can reinnervate the original targets as accurately as possible (►Regeneration: clinical aspects).

Neural connections in the ►somatosensory area of the ►cerebral cortex can be reorganized depending on the input from the peripheral nervous system. The cortical neural organization including ►sensory cortex and ►motor cortex is not fixed, but can be modified subject to the functional demand. When the sensory inputs are lost due to peripheral nerve damage including the amputation of limbs or fingers, the corresponding areas of the somatosensory cortex are reorganized to receive inputs from the neighboring skin areas including the stump. A similar reorganization occurs in the motor cortex. Thus, motor and sensory representations of the cerebral cortex become remodeled following nerve injury and regeneration in the PNS. This means that patients should relearn how to appropriately perform an action through the remodeled cerebral cortex in rehabilitation. Reorganization of the cerebral cortex is a basis for the rehabilitation of limb activity (►Somatosensory reorganization; ►Regeneration: clinical aspects).

Artificial materials have been studied as guides for the growth of regenerating axons in the PNS. Collagen gel has been most commonly used. Other biodegradable polymers that have been utilized for nerve regeneration are polyglycolic acid, polylactic acid, poly-ε-caprolactone, alginate, and chitosan. Alginate is derived from brown seaweed, and chitosan is from the crustacean exoskeleton. These materials have been used as substrates for nerve regeneration in the PNS and CNS (►Transplantation of artificial materials for nerve regeneration). A polyglycolic acid-collagen tube has been developed with good results [10].

Blood supply is a critical point for successful nerve regeneration. Blood capillaries that readily regenerate in the connective tissue compartment greatly contribute to peripheral nerve regeneration. Blood vessels, once

damaged, rarely regenerate in the CNS. This is probably because, unlike in the PNS, there is no extracellular matrix which can act as a scaffold for developing vessels in the CNS. The loss of blood supply results in severe ischemia, which in turn leads to the suppression of tissue repair and the promotion of cavity formation in the CNS.

### Motor Nerves: The Neuromuscular Junction

Motor nerves terminate at ►neuromuscular junctions, which consist of presynaptic axon terminals and postsynaptic folds of the muscle fiber plasma membrane. In addition, terminal Schwann cells cover the presynaptic axon terminals, and the basal lamina, a continuation of the ordinary basal lamina of muscle fibers, is present on the folds of the muscle fibers. Following Wallerian degeneration, the presynaptic terminal disappears, and the postsynaptic folds at the endplate become gradually less distinct, but remain as a remnant of small folds. At the same time, terminal Schwann cells persist in the preterminal region. Regenerating axons enter the empty endplate, and become presynaptic terminals, thus forming new neuromuscular junctions. The presynaptic terminal can be formed in the absence of terminal Schwann cells, such as in the acellular scaffold [11]. In addition, regenerating axons can develop a presynaptic structure when they come into contact with the basal lamina at the site of the original postsynaptic folds. This indicates that the basal lamina at the endplate contains molecules that induce the regeneration of axons and cause postsynaptic specialization.

When muscle is partially denervated, ►axonal sprouting occurs from the intact neuromuscular junction. Following motor neuron injury, axon terminals are lost from the endplates of muscle fibers belonging to injured motor neurons. Responding to the denervation of endplates, axonal sprouts emanate from axon terminals of neighboring intact endplates, reinnervating denervated endplates. Thus, the ►motor unit is enlarged, and the muscle activity can be kept almost unchanged. Terminal Schwann cells that have lost contact with axon terminals by denervation extend cell processes toward the neighboring intact endplates. Such Schwann cell processes act as guide tubes for axonal sprouts to elongate from the intact endplate to the denervated one (►Role of sprouting in sustaining neuromuscular function in health and disease).

### Sensory Nerves: Sensory Corpuscles in the Skin

Sensory nerve terminals occur as various types of organized corpuscles present in the skin. Representative sensory terminals include ►Pacinian corpuscles and ►Meissner corpuscles, which are composed of axon terminals and modified Schwann cells called lamellar cells. Following Wallerian degeneration, lamellar cells

in these corpuscles become atrophic owing to the loss of contact with axons, but continue to exist for a long period of time. Upon the arrival of regenerating axons, lamellar cells begin to proliferate and take on the same structures as those found in the original corpuscles. For the acellular corpuscle, corpuscular basal laminae deprived of lamellar cells can also serve as a scaffold that promotes the regeneration of the original corpuscle following reinnervation. However, no new corpuscle regeneration in regions other than at the original corpuscle in the skin occurs ([►Meissner corpuscle Regeneration](#); [►Pacinian corpuscle Regeneration](#)).

►Merkel cell-neurite complexes are different from Pacinian and Meissner corpuscles in that their axons make direct contact with Merkel cells. Merkel cells deprived of axon terminals tend to disappear, probably due to degeneration and/or movement to the surface of the epidermis. Upon reinnervation, Merkel cells reappear, partly due to the differentiation of keratinocytes, and then form Merkel-neurite complexes similar to the original ones present at the base of the epidermis ([►Merkel cell-neurite complex Regeneration](#)).

### Nerve Regeneration in the CNS

Nerve regeneration in the CNS, especially in the spinal cord, has been extensively studied for more than 100 years. No effective nerve regeneration or tissue repair occurs in lesions of the spinal cord, which usually results in cavity formation without distinct tissue repair. Following injury to the spinal cord, strong regenerative responses occur including the formation of growth cones and associated glial cell migration. However, such neural reactions do not develop as efficiently as they do in the PNS, and result in cavity formation without axonal extension into the lesion. As described above, the essential difference between the PNS and CNS is the presence of an extracellular matrix in the PNS, which is composed of basal laminae and collagen fibers. This means that there is no effective scaffold available for the growth of regenerating axons in the CNS. The same can be said for blood vessel regeneration, which requires an extracellular matrix scaffold to regenerate.

The [►glial scar](#) is usually produced around the cystic cavity at a chronic stage after injury. If the [►pia mater](#) is cut open, the fibroblast-like cells of the meningeal layer invade the lesion, contributing to the formation of dense glial scar of connective tissues composed of extracellular matrices including collagen fibers. In such cases, astrocytes form a barrier between the connective tissue and adjacent CNS tissue. Basal laminae are formed on the surface of astrocyte processes facing the connective tissues, and thus, the CNS tissue tends to segregate itself from the invading connective tissues using astrocytic scar tissue [12]. This kind of glial scar is regarded as the main obstacle preventing the growth of regenerating axons in the CNS. Connective tissue invasion followed

by glial scarring is therefore an undesirable phenomenon for nerve regeneration in the CNS. On the other hand, in lesions in which the pia mater is not cut open, the tissue reaction is different. When the spinal cord is crush-injured, the pia mater is usually not damaged, with the pial basal lamina kept intact. Cavities of various sizes are usually formed in the lesion at chronic stages. In such cases, there is no cell invasion from the outside. Astrocytic proliferation is found along the margin of the cavity, and oligodendrocytes line the inner surface of the cavity margin.

Usually, astrocytes, oligodendrocytes, macrophages, and microglia all contribute to the formation of glial scars. The mechanisms for scar formation, roles of contributing cells, and expression of specific molecules including proteoglycans are complicated, and yet to be understood ([►Glial scar](#)). Glial scars are thought to be the main impediments to the growth of regenerating axons. Regenerating axons from the proximal stump have to surpass the glial scar at the distal stump to invade the host spinal cord tissue. The digestion of proteoglycans has been proposed to promote axonal growth through glial scar in the spinal cord.

Cavities resulting from the degeneration of impaired tissues hamper axonal extension through the lesion. The margin of the cavity is not as thick as the astrocytic scar tissue as previously thought in the crush-injured spinal cord. Using appropriate techniques including cell transplantation, it may be possible to induce regenerating axons to grow through a region with cavities.

Functional assessment is important for nerve regeneration in the CNS, for which BBB scoring and other types of estimation of behavioral recovery have been employed [13].

At present, cell transplantation is being extensively studied to facilitate nerve regeneration in the injured spinal cord. Several varieties of cells have been used for transplantation, among which the major cell types include: Schwann cells, bone marrow stromal cells, olfactory ensheathing cells, choroid plexus ependymal cells, neural stem cells, macrophages, and those found in embryonic spinal cord tissue. Other studies have also been carried out which focused on the suppression of inhibitory factors such as [►Nogo A](#) by the specific antibody.

### Schwann Cells

Aguayo and colleagues showed that neurons within the CNS can induce the elongation of regenerating axons into peripheral nerves which were inserted at one end into the spinal cord and at the other end into the medulla oblongata [14]. This shows that regenerating axons from neurons in the CNS can extend if they are provided with an appropriate environment. Since this report, cell implantation aimed at CNS nerve regeneration has been extensively studied.

Schwann cells play a role in axonal elongation in grafted peripheral nerves, where regenerating axons come into contact with Schwann cells, which support the growth and maturation of regenerating axons, as in the case of the PNS. The utility of peripheral nerve grafts has prompted the use of cultured Schwann cells for transplantation in the CNS. Here, cultured Schwann cells mingle in matrigel, and are then placed into an artificial tube, after which the tube is subsequently grafted into the lesion of the spinal cord. Many regenerating axons extend through the tube, and some enter the distal stump. A few axons then form synapses with neurons present in the distal segment of the spinal cord, and behavioral improvement subsequently takes place [15].

Although Schwann cells also serve as effective conduits for regenerating axons in the CNS, extracellular matrices including basal laminae are inefficient as scaffolds for the growth of regenerating axons in the CNS, unlike in the PNS. Since Schwann cells possess basal laminae and the ability to produce collagen matrices, extracellular matrices can be brought into the lesion following Schwann cell transplantation. Therefore, astrocytes at the border of the lesion are apt to form barriers composed of cell processes with basal laminae on the surface facing the Schwann cell compartment, and regenerating axons cannot penetrate such astrocyte scar tissue. Studies have been concentrated to overcome this difficulty in Schwann cell transplantation ([▶ Transplantation of Schwann cells](#)).

The [▶ optic nerve](#) is frequently used as an experimental model of nerve regeneration in the CNS. Since it is an isolated bundle composed of central nerve fibers, nerve regeneration can be more precisely evaluated than by using the spinal cord. Transplantation of peripheral nerves and Schwann cells into the optic nerve has been well studied [16]. A long peripheral nerve transplanted into the optic nerve can serve as a conduit for regenerating axons traveling from the optic nerve to the [▶ superior colliculus](#), in which some synaptic connections are formed. Some functional recovery of light sensation has also been reported using this technique.

Many [▶ retinal ganglion cells](#) undergo retrograde degeneration after optic nerve injury, and this poses another major problem for optic nerve regeneration. The administration of trophic factors into the optic cup has been studied with the aim of promoting the survival of ganglion cells ([▶ Regeneration of optic nerve](#)).

### Bone Marrow Stromal Cells

Although they do not belong to the CNS, bone marrow stromal cells (BMSCs) have been used for transplantation into the spinal cord [17]. BMSCs are grafted by directly injecting them into the lesion or by infusing them through the cerebrospinal fluid (CSF) [18,19].

Some BMSCs then gather in the lesion and survive there for 2–3 weeks after grafting. BMSCs do not differentiate into neural cells after grafting into the spinal cord. In the rat, they tend to disappear from the spinal cord more than 4 weeks after grafting. Although BMSCs do not become integrated into lesions of the spinal cord, tissue repair including the suppression of cavity formation is facilitated. In addition, behavioral improvement is obvious in the spinal cord-injured rat. These findings imply that BMSCs can be used in transplants to treat [▶ spinal cord injury](#).

Since BMSCs can be obtained from the patients themselves and are not stem cells but ordinary functioning cells present in the bone marrow, they show promise for the clinical treatment of spinal cord injuries. Transplantation by infusing BMSCs into the CSF is more effective than direct injection into the lesion. Also, since BMSCs disappear several weeks after transplantation, they might release trophic factors that reverse the degeneration of damaged neural tissue. The clinical application of BMSCs by injecting them into the cerebrospinal fluid via lumbar puncture has progressed ([▶ Transplantation of bone marrow stromal cells for spinal cord regeneration](#)).

Bone marrow stromal cells can be trans-differentiated into Schwann cells and neurons, and the transplantation of trans-differentiated Schwann cells and neurons may be a promising technique for CNS as well as PNS regeneration [20].

### Neural Stem Cells

Neural stem cells (NSCs) have been regarded as appropriate for cell transplantation to treat spinal cord injuries. After transplantation, these cells survive, migrate, and become integrated into the host tissue. They also have the ability to differentiate into neurons, astrocytes, and oligodendrocytes after transplantation.

There is hope that NSCs can be used after differentiation into neurons, astrocytes, and oligodendrocytes in vitro. Although NSCs are attractive for use in clinical therapy, the source of these cells is the most critical problem. There are strict limitations regarding the use of human embryos as sources of NSCs. It is also difficult to obtain NSCs from adult tissues. However, it is possible that NSCs can be acquired from the brains of deceased human bodies within a short period after death [21].

Another difficulty in using NSCs is the potential for unlimited cell proliferation, and, thus, the formation of cancer. Even in cases for which NSCs are used after differentiation in vitro, it is possible that a few undifferentiated cells may remain, and cause undesirable cell proliferation. Neural stem cells have been transplanted for spinal cord regeneration ([▶ Transplantation of neural stem cells for spinal cord regeneration](#)).

### The Choroid Plexus

The choroid plexus is the main region where the cerebrospinal fluid (CSF) is produced. It consists of epithelial cells and associated connective tissue containing plenty of sinusoidal blood vessels, and few fibroblasts and macrophages in a scanty collagen matrix. Grafting of the choroid plexus into the injured spinal cord promotes tissue repair including the growth and regeneration of axons in lesions [22]. Other *in vitro* and *in vivo* studies have indicated that choroid plexus epithelial cells (modified ependymal cells) might have the ability to promote nerve regeneration by rescuing neural tissues from degeneration and facilitating axonal growth. Considering that the CSF plays an important role in maintaining normal brain function, it should contain a variety of factors that promote the survival and proper activity of neural cells including neurons and glial cells.

### Olfactory Ensheathing Cells

Recently, olfactory ensheathing cells (OECs) have been extensively studied for use in transplantation to promote nerve regeneration in the spinal cord. These cells possess the properties of Schwann cells and astrocytes, and grafted OECs become Schwann cells associated with axons and perineurial cells surrounding nerve fibers, as seen in the PNS [23]. Furthermore, functional recovery can be observed in accordance with histological improvement. It is obvious that OECs provide the guide for the extension of regenerating axons. OECs have had a great impact on the study of spinal cord regeneration; however, their effects have varied among such studies. In spite of the many studies performed so far, how OECs exert their effects in spinal cord regeneration has not yet been fully elucidated. Identification of OECs in *in vivo* experiments might be a crucial requisite for accurately understanding their roles in spinal cord regeneration. Genetically labeled OECs might be useful for long-term observation after transplantation (► [Transplantation of olfactory ensheathing cells](#)).

### Embryonic Spinal Cord Tissue

Satisfactory regeneration can be induced in the spinal cord in which a segment of the spinal cord obtained from an embryo has been transplanted in rats during the early postnatal period [24]. It has been proposed that embryonic tissue can overcome glial scarring of the cystic cavity in chronic injury of the spinal cord. Unfortunately, the use of embryonic tissues is greatly limited due to ethical problems.

### Genetically Modified Cells

Experiments in which cells that were genetically transformed to secrete trophic factors have been transplanted into the injured CNS tissue have been conducted. Fibroblasts and other kinds of cells including OECs have been used for such experiments

[25]. However, at present, genetically modified cells involve problems of ethics and safety that should be overcome before clinical application.

### Immune System

Following injury to the CNS, microglia and macrophages invade the lesion. Microglia, macrophages, and T-cells have been demonstrated to play important roles in CNS protection and repair. Regulatory and autoimmune T-cells are contradictory regarding CNS protection. Autoimmune T-cells activate the microglia to secrete trophic factors for CNS repair (► [Protective autoimmunity](#)). Macrophages preincubated with sciatic nerve fragments or autologous skin promoted repair of the optic nerve and spinal cord. Microglia and bone marrow-derived macrophages with the property of antigen-presenting cells secrete trophic factors that contribute to neuroprotection in the CNS (► [Autologous macrophages for central nervous system repair](#)). Studies on the functions of immune cells such as microglia, macrophages, and T-cells provide insights into the CNS mechanisms of protection against injury, and contribute to achieve CNS regeneration.

### Inhibitory Molecules

It is believed that CNS regeneration cannot occur partly due to the presence of inhibitory molecules in the CNS. The main inhibitory molecules are associated with myelin sheaths and oligodendrocytes, including myelin-associated glycoprotein (MAG), oligodendrocyte-myelin glycoprotein (OMgp), and Nogo-A. Growth cones collapse when they encounter these inhibitory molecules. The administration of anti-Nogo A antibody promotes the growth of regenerating axons in the injured spinal cord and improves behavioral function in rats [26].

Another major inhibitor is chondroitin sulfate proteoglycan (CSPG) produced in the glial scar. CSPGs serve as barriers to growing axons. Regenerating axons are thought to be blocked at the boundary of the glial scar in the spinal cord injury (► [Inhibitory molecules in regeneration](#)).

### References

1. Lieberman AR (1971) The axon reaction: a review of the principal features of perikaryal responses to axon injury. *Int Rev Neurobiol* 14:49–124
2. Kiryu-Seo S, Gamo K, Tachibana T, Tanaka K, Kiyama H (2006) Unique anti-apoptotic activity of EAAC1 in injured motor neurons. *EMBO J* 25:3411–3421
3. Dontchev VD, Letourneau PC (2003) Growth cones integrate signaling from multiple guidance cues. *J Histochem Cytochem* 51:435–444
4. Nakai J (1956) Dissociated dorsal root ganglia in tissue culture. *Am J Anat* 99:81–129
5. Nakai J, Kawasaki Y (1959) Studies on the mechanism determining the course of nerve fibers in tissue culture. I. The reaction of the growth cone to various obstructions. *Z Zellforsch Mikrosk Anat* 51:108–122

6. Torigoe K, Lundborg G (1998) Selective inhibition of early axonal regeneration by myelin-associated glycoprotein. *Exp Neurol* 150:254–262
7. Ide C, Tohyama K, Yokota R, Nitatori T, Onodera S (1983) Schwann cell basal lamina and nerve regeneration. *Brain Res* 288:61–75
8. Fujimoto E, Mizoguchi A, Hanada K, Ide C (1997) Basic fibroblast growth factor promotes extension of regenerating axons of peripheral nerve. In vitro experiment using a Schwann cell basal lamina tube model. *J Neurocytol* 26:511–528
9. Lundborg G, Rosen B, Dahlin L, Holmberg J, Rosen I (2004) Tubular repair of the median or ulnar nerve in the human forearm: a 5-year follow-up. *J Hand Surg [Br]* 29:100–107
10. Nakamura T, Inada Y, Fukuda S, Yoshitani M, Nakada A, Itoi S, Kanemaru S, Endo K, Shimizu Y (2004) Experimental study on the regeneration of peripheral nerve gaps through a polyglycolic acid-collagen (PGA-collagen) tube. *Brain Res* 1027:18–29
11. Sanes JR (2003) The basement membrane/basal lamina of skeletal muscle. *J Biol Chem* 278:12599–12600
12. Silver J, Miller JH (2004) Regeneration beyond the glial scar. *Nat Rev Neurosci* 5:146–156
13. Coumans JV, Lin TT, Dai HN, MacArthur L, McAtee M, Nash C, Bregman BS (2001) Axonal regeneration and functional recovery after complete spinal cord transection in rats by delayed treatment with transplants and neurotrophins. *J Neurosci* 21:9334–9344
14. David S, Aguayo AJ (1981) Axonal elongation into peripheral nervous system “bridges” after central nervous system injury in adult rats. *Science* 214:931–933
15. Xu XM, Zhang SX, Li H, Aebischer P, Bunge MB (1999) Regrowth of axons into the distal spinal cord through a Schwann-cell-seeded mini-channel implanted into hemisectioned adult rat spinal cord. *Eur J Neurosci* 11:1723–1740
16. Inoue T, Hosokawa M, Morigiwa K, Ohashi Y, Fukuda Y (2002) Bcl-2 overexpression does not enhance in vivo axonal regeneration of retinal ganglion cells after peripheral nerve transplantation in adult mice. *J Neurosci* 22:4468–4477
17. Chopp M, Zhang XH, Li Y, Wang L, Chen J, Lu D, Lu M, Rosenblum M (2000) Spinal cord injury in rat: treatment with bone marrow stromal cell transplantation. *Neuroreport* 11:3001–3005
18. Wu S, Suzuki Y, Noda T, Bai H, Kitada M, Kataoka K, Chou H, Ide C (2003) Bone marrow stromal cells enhance differentiation of co-cultured neurosphere cells and promote regeneration of injured spinal cord. *J Neurosci Res* 72:343–351
19. Ohta M, Suzuki Y, Noda T, Ejiri Y, Dezawa M, Kataoka K, Chou H, Ishikawa N, Matsumoto N, Iwashita Y, Mizuta, Kuno S, Ide C (2004) Bone marrow stromal cells infused into the cerebrospinal fluid promote functional recovery of the injured rat spinal cord with reduced cavity formation. *Exp Neurol* 187:266–278
20. Dezawa M, Kanno H, Hoshino M, Cho H, Matsumoto N, Itokazu Y, Tajima N, Yamada H, Sawada H, Ishikawa H, Mimura T, Kitada M, Suzuki Y, Ide C (2004) Specific induction of neuronal cells from bone marrow stromal cells and application for autologous transplantation. *J Clin Invest* 113:1701–1710
21. Xu Y, Kimura K, Matsumoto N, Ide C (2003) Isolation of neural stem cells from the forebrain of deceased early postnatal and adult rats with protracted post-mortem intervals. *J Neurosci Res* 74:533–540
22. Ide C, Kitada M, Chakraborty S, Taketomi M, Matsumoto N, Kikukawa S, Mizoguchi A, Kawaguchi S, Endo K, Suzuki Y (2001) Grafting of choroid plexus ependymal cells promotes the growth of regenerating axons in the dorsal funiculus of rat spinal cord – A preliminary report. *Exp Neurol* 167:242–251
23. Li Y, Decherchi P, Raisman G (2003) Transplantation of olfactory ensheathing cells into spinal cord lesions restores breathing and climbing. *J Neurosci* 23:727–731
24. Kawaguchi S, Iseda T, Nishio T (2004) Effects of an embryonic repair graft on recovery from spinal cord injury. *Prog Brain Res* 143:155–162
25. Blesch A, Tuszynski MH (2003) Cellular GDNF delivery promotes growth of motor and dorsal column sensory axons after partial and complete spinal cord transections and induces remyelination. *J Comp Neurol* 467:403–417
26. Schwab ME (2004) Nogo and axon regeneration. *Curr Opin Neurobiol* 14:118–124

## Regeneration Associated Genes (RAGs)

### Definition

Genes that are upregulated within the neuron following axotomy. The protein product of these genes such as tubulin, GAP43 and others are anterogradely transported to and are critical to the elongation of the growth cone and regenerating axon.

- ▶ Neurotrophic Factors in Nerve Regeneration
- ▶ Peripheral Nerve Regeneration and Nerve Repair

## Regeneration: Clinical Aspects

GÖRAN LUNDBORG

Hand Surgery/Department of Clinical Sciences, Malmö University Hospital, Lund University, Lund, Sweden

### Definition

Outgrowth of ▶ axons following clinical nerve injury and repair, resulting in functional restoration in denervated body parts.

## Characteristics

### Background

Injuries to peripheral nerve trunks constitute a major clinical problem [1,2]. Such injuries are most frequently seen in the upper extremity. The consequences are severe and the result is often permanent disturbances in sensory and motor functions of the hand. Normally, there is an interaction between the hand and the brain so that the hand is very well represented in the somatosensory cortex as well as the motor cortex [1,3,4]. A nerve injury implies a sudden de-afferentiation with arrest in inflow of sensory impulses to the brain. This results in a rapid cortical remodelling process where the “vacant” cortical area, previously representing the innervated area of the hand, is invaded by expanding adjacent cortical areas [1,3,4]. An analogous phenomenon occurs in the motor cortex.

If the nerve injury is surgically repaired, there is a regeneration of axons downstream of the distal nerve segment aiming at reinnervation of the denervated body part. To regain normal function, axons have to reinnervate their “correct” peripheral targets. However, there is always, in spite of meticulous surgical techniques, a large extent of misorientation of regenerating axons at the repair site and consequently an incorrect peripheral reinnervation [1]. With the reinnervation process, the cortical hand representation is again restored, however in a new and distorted pattern due to the peripheral mal-orientation. A relearning process is

required that can be easily managed by the child’s brain but usually not by the adult brain [5]. Therefore, fine tactile discriminative functions are seldom or never fully restored in an adult patient. The process of clinical regeneration is influenced by a number of intrinsic and extrinsic factors, some of them reviewed below.

### The Nerve Trunk and the Regeneration Process

The nerve trunk represents a composite tissue structure constructed to maintain continuity, nutrition and protection of its basic elements – the axons (Fig. 1). An axon is a long tubular process of the nerve cell body, which may be situated in a dorsal root ganglion (sensory axons), or the anterior horn of the spinal cord (motor axons). The nerve cell and its processes is called a neuron. The axons are ensheathed by Schwann cells that may produce a myelin sheath. The Schwann cell basal lamina contributes to constitute an “endoneurial tube.” The axons are closely packed within the endoneurial connective tissue inside ►fascicles [1]. Each fascicle is surrounded by a perineurium, which is a multicellular laminated sheath of considerable mechanical strength, providing a diffusion barrier. The fascicles are embedded within an ►epineurium, which is a supporting and protective connective tissue sheath carrying a longitudinal network of epineurial blood vessels.

Nerve injuries may be of several types and magnitudes. A severe compression or a crush lesion

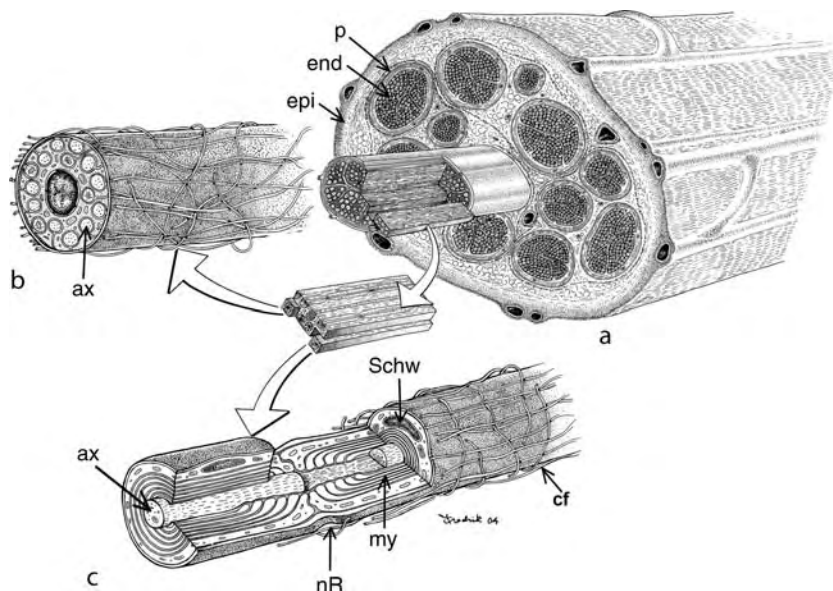

**Regeneration: Clinical Aspects. Figure 1** Microanatomy of peripheral nerve trunk and its component. (a) Fascicles surrounded by a multi-laminated perineurium (p) are embedded in loose connective tissue, the epineurium (epi). The outer layers of the epineurium are condensed into a sheath. (b and c) The appearance of unmyelinated and myelinated fibres, respectively, is shown. Schw Schwann cell; my myelin sheath; ax axons; nR node of Ranvier; end endoneurium. Reproduced with permission from Lundborg 2004.

may disrupt axons while the ensheathing chain of Schwann cells and their basal lamina may be preserved. Disruption of axons results in degeneration of their distal segments, implying disintegration of the axonal elements and the myelin sheath. A regeneration process is then required where axons grow distally, following their original pathways, hereby reinnervating correct peripheral targets. The normal cortical representation of the body part is hereby re-established [3,4]. With transection of a nerve trunk, however, the situation is quite different: the “sprouts” that are formed by the transected proximal part of the axons may orient themselves into incorrect distal “Schwann cell tubes” that result in reinnervation of incorrect peripheral targets. Before the regeneration process is initiated, an “initial delay” may last for days or weeks. As a result of the injury a large number of nerve cell bodies in dorsal root ganglia may die, which excludes possibilities for regeneration of their corresponding axons [1]. Several physical, biochemical and other factors influence the course and functional outcome of the regeneration process [1].

### Clinical Nerve Repair and Reconstruction

Repair and reconstruction of injured peripheral nerves span over a variety of techniques such as direct repair, ►nerve grafting, use of conduits, ►nerve transfer and ►end-to-side (ETS) anastomosis [1,6,7,8].

With ►epineurial repair, the nerve stumps are approximated by suturing the epineurial sheath, using external landmarks like longitudinal blood vessels to ensure a correct rotational adaptation of the nerve ends. Although the external aspect of the repair site may look perfect, this technique does not, however, ensure an absolutely correct matching of the fascicular structures inside the nerve trunk. A more correct mechanical adaptation may be achieved by fascicular repair or ►group fascicular repair, which requires an internal dissection of the nerve so that separate bundles of fascicles are adapted towards each other. This technique may be justified in cases where sensory and motor fibres are running in separate, well-defined fascicles or fascicular groups, but otherwise the technique has no advantages over the epineurial technique. The various suture techniques may be combined and supplemented by fibrin glue. In ►tubular repair, a small distance is left between the nerve ends that are enclosed in a tubular structure of biological or synthetic type. Such tubes, which may be biodegradable or non-degradable, may give equally good results as direct sutures of the nerve ends (Figs. 2, 3).

With more severe injury, there may be a defect in continuity of the nerve trunk. Such a situation may be seen in severe lacerations in the extremities or as a result of severe traction in the brachial plexus. Well-known examples are traction injuries occurring in difficult

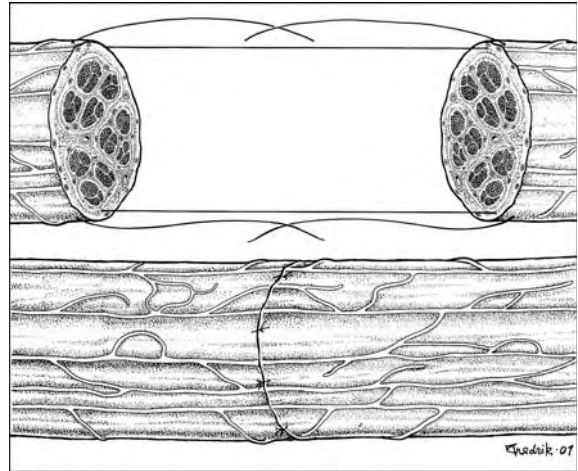

**Regeneration: Clinical Aspects. Figure 2** Epineurial suture. Adaptation of the nerve ends is achieved by single stitches in the superficial part of the epineurium along the circumference of the nerve. Reproduced with permission from Lundborg 2004.

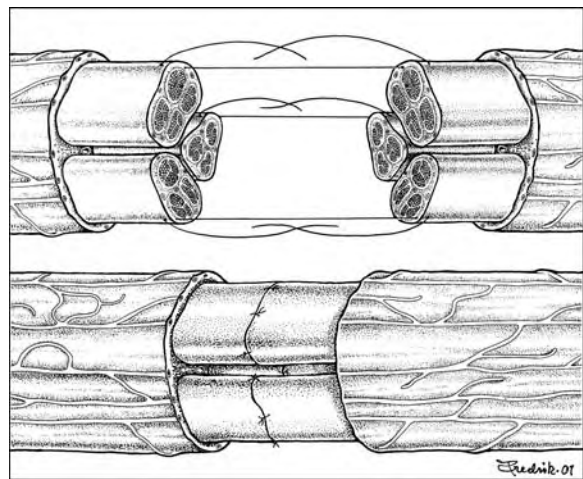

**Regeneration: Clinical Aspects. Figure 3** Group fascicular suture. After resection of the epineurial tissue fascicular groups are approximated with single sutures in the connective tissue between separate fascicles or in the outer layer of the perineurium. Reproduced with permission from Lundborg 2004.

obstetrical situations or in adults involved in motorcycle or other types of traffic accidents. In such cases, the defect has to be bridged with a conduit to allow overgrowth of nerve fibres from the proximal to the distal nerve end. The most commonly used technique is to insert a nerve graft, usually harvested from the lower limb. Several cables of thin nerve grafts such as these are inserted between both of the nerve ends, using microsurgical techniques [7].



## Nerve Transfers

In severe nerve injuries, a proximal nerve segment may not always be available. An alternate “donor nerve” may then be required to provide the distal segment of the injured nerve with axonal input from a proximal nerve segment, a so-called nerve transfer. The situation requires sacrifice of the donor nerve, which can then be transferred to the distal segment of the injured nerve [6]. Such nerve transfers are widely used in brachial plexus surgery for restoring function in paralysed muscle by using adjacent intact nerves as donors, but can also be applied to more distal nerve injuries, for instance, to achieve motor or sensory functions in the hand by transferring an intact, nearby non-injured nerve.

## End-to Side (ETS) Nerve Repair

For more than 10 years it has been known that a distal nerve segment, when sutured in an end-to-side fashion to an adjacent intact nerve, can be reinnervated by sprouts from axons in the healthy donor nerve [8]. It was assumed that the intact axons in such cases may send out lateral sprouts that may reinnervate the sutured distal nerve segment. It was soon realised that this might be a new and promising possibility in clinical cases when routine nerve-grafting procedures were not possible, such as in root avulsions in brachial plexus injuries. The clinical results from these operations, as reported in the literature, are very variable.

## Functional Remodelling of Brain Cortex

A nerve transection represents an acute deafferentiation with immediate and longstanding influence on the cortical representation of the innervated body part. For instance, deafferentiation due to median nerve transection results in rapid expansion of adjacent cortical areas, which then occupy the former median nerve cortical territories. If no regeneration occurs, as after an amputation, the extensive cortical reorganisation persists so that the cortical area, previously receiving input from the median nerve, remains occupied by expanding adjacent cortical areas. In amputation, severe cortical reorganisations in such cases may result in persistent ▶ *phantom sensations* and ▶ *phantom pain*. After a ▶ *crush injury*, regenerating axons are guided by their original Schwann cell tubes so that they reach their original skin locations, and the corresponding cortical hand representation is normalised. However, after ▶ *transection and repair*, this scenario is quite different due to peripheral axonal misorientation. The previously well-organised cortical representation is changed to a mosaic-like pattern [1,3,4] and the nerve does not recapture all of its original cortical territory.

## Sensory Relearning and Sensory Re-Education

The outcome from nerve repair in adults is far from satisfactory and often disappointing, especially with

respect to recovery of tactile discrimination [5]. One major factor is the new and distorted cortical hand representation – “the hand speaks a new language to the brain.” A relearning process is required, and it can be a difficult task for adults to require their lost functional sensibility. In hand rehabilitation, ▶ *sensory relearning* is based on the use of ▶ *sensory re-educational* protocols [9,10]. According to these strategies, the brain is reprogrammed based on a relearning process. First, the perception of different touch modalities and the capacity to localise touch is trained, followed by touching and exploration of items, presenting shapes and textures of varying and increasing difficulty to the patient with eyes open or closed. In this way, an alternate sense (vision) trains and improves the deficient sense “sensation.”

## Factors Influencing the Outcome from Nerve Repair

The functional outcome of nerve repair may vary considerably between patients although identical techniques may be used. There are several factors that are known to influence the outcome of nerve repair.

### Age

Although the functional recovery in adults is disappointing, especially with reference to recovering sensory functions, the situation is quite different among children who consistently show superior functional results after nerve repair [5]. This has usually been attributed to superior plasticity of the brain in children, with a better ability in central adaptation to the new pattern of afferent impulses presented by misdirected axons. A critical age period for recovery of functional sensibility in hands after nerve repair can be defined, the best results being seen in those younger than 10 years, followed by a rapid decline levelling out after late adolescence [5].

### Cognitive Brain Capacities

In adults, specific cognitive capacities of the brain such as verbal learning capacity and visuo-spatial logic capacity may help to explain variations in the recovery of functional sensibility after nerve repair [1].

### Timing of Repair

Nerve injuries should be repaired as soon as possible – if the condition allows. The posttraumatic nerve cell death, which usually occurs following nerve injury, can be reduced in this way. With early repair, the surgery is easier to perform since tissues may not yet be swollen, and the natural landmarks such as blood vessels can still be used to ensure a correct matching of the nerve ends. With increasing preoperative delay, there is a fibrosis of the distal nerve segment, atrophy of Schwann cells and there may be a progressive loss of neurons. After nerve transection the corresponding muscle atrophy rapidly,

and after two years the muscle fibres may fragment and disintegrate.

### Type of Nerve

The type of nerve that is injured considerably influences the functional outcome. If a pure motor nerve is injured, there is no risk of mismatch between motor and sensory cutaneous nerve fibres, thus optimising the accuracy in reinnervation. For pure sensory nerves, the situation is analogous. With mixed nerves, however, the situation is quite different with obvious risks for motor/sensory mismatch.

### Level of Injury

After nerve transection, there is an initial delay of days or weeks followed by sprouting and axonal outgrowth. The regeneration in humans has been reported to be non-linear, with a gradually decreased regeneration rate in distal parts. In humans the average outgrowth rate is at most 1–2 mm/day. When digital nerves in fingers are injured, there is only a short distance separating the regenerating axons from their distal target, while more proximal lesions may have a very substantial distance to grow. Lesions to the median nerve at wrist level may require 3–4 months before the first signs of reinnervation of the hand occur. In brachial plexus lesions reinnervation of the hand seldom or never occurs because of the long regeneration distance.

### References

1. Lundborg G (2004) Nerve injury and repair. Regeneration, reconstruction and cortical re-modelling. Elsevier, Philadelphia
2. McAllister RM et al. (1996) The epidemiology and management of upper limb peripheral nerve injuries in modern practice. *J Hand Surg Br* 21:4–13
3. Kaas JH, Florence SL (1997) Mechanisms of reorganization in sensory systems of primates after peripheral nerve injury. *Adv Neurol* 73:147–158
4. Merzenich MM, Jenkins WM (1993) Reorganization of cortical representations of the hand following alterations of skin inputs induced by nerve injury, skin island transfers, and experience. *J Hand Ther* 6:89–104
5. Lundborg G, Rosen B (2001) Sensory relearning after nerve repair. *Lancet* 358:809–810
6. Dvali L, Mackinnon S (2003) Nerve repair, grafting, and nerve transfers. *Clin Plast Surg* 30:203–221
7. Millesi H (1984) Nerve grafting. *Clin Plast Surg* 11:105–113
8. Viterbo F (1993) A new method for treatment of facial palsy: the cross-face nerve transplantation with end-to-side neurorrhaphy. *Rev Soc Bras Cir Plast Estet Reconstr* 8:29
9. Dellon AL (1981) Evaluation of sensibility and re-education of sensation in the hand. Williams and Wilkins, Baltimore
10. Rosén B, Balkenius C, Lundborg G (2003) Sensory re-education today and tomorrow. Review of evolving concepts. *Br J Hand Ther* 8:48–56

## Regeneration of Optic Nerve

MARI DEZAWA<sup>1</sup>, KWOK-FAI SO<sup>2</sup>

<sup>1</sup>Department of Anatomy and Neurobiology, Kyoto University Graduate School of Medicine, Kyoto, Japan

<sup>2</sup>Department of Anatomy, The University of Hong Kong, Hong Kong, People's Republic of China

### Definition

Regeneration of retinal ganglion cell axons.

### Characteristics

#### Higher Level Structure of Optic Nerve

The optic nerve is part of the central nervous system (CNS) and has a structure similar to other CNS tracts. The axons that form the optic nerve originate in the ►ganglion cell layer of the retina and extend through the ►optic tract. As a tissue, the optic nerve has the same organization as the white matter of the brain in regard to its glia. There are three types of glial cells: oligodendrocytes, astrocytes and microglia.

### Structural Regulation

Little structural and functional regeneration of the CNS takes place spontaneously following injury in adult mammals. In contrast, the ability of the mammalian peripheral nervous system (PNS) to regenerate axons after injury is well documented. A number of factors are involved in the lack of CNS regeneration, including: (i) the response of neuronal cell bodies against the damage, (ii) myelin-mediated inhibition by oligodendrocytes, (iii) glial scarring, by astrocytes, (iv) macrophage infiltration, and (v) insufficient trophic factor support.

### Higher Level Process

The fundamental difference in the regenerative capacity between CNS and PNS neuronal cell bodies has been the subject of intensive research. In the CNS, the target normally conveys a retrograde trophic signal to the cell body. CNS neurons die because of trophic deprivation. Damage to the optic nerve disconnects the neuronal cell body from its target-derived trophic peptides, leading to the death of retinal ganglion cells (RGCs). Furthermore, the axotomized neurons become less responsive to the peptide trophic signals they do receive. The survival of certain types of CNS neurons depends on physiological activation of electrical activity or elevation of intracellular ►cyclic AMP (cAMP). On the other hand, adult PNS neurons are intrinsically responsive to neurotrophic factors and do not lose trophic responsiveness after axotomy [1].

Oligodendrocytes, which represent the myelinating glia in the CNS, carry on their surface axon

growth-inhibiting molecules [2]. The hypothesis states that neurons in the CNS begin to lose their axonal regenerative capacity at roughly the period with the onset of myelination. Specific components of the myelin produced by the oligodendrocytes, such as ►Nogo A and ►myelin associated glycoprotein (MAG), have been shown to inhibit axonal growth, and antibodies against these proteins resulted in axonal regrowth in the CNS.

The glial scar at the injury site is a biochemical and physical barrier to successful regeneration. It contains large numbers of reactive astrocytes, oligodendrocyte precursor cells, and CNS meningeal cells. A recent study suggests that injury-upregulated ►bone morphogenetic protein 7 (BMP7) synthesized within the CNS induces differentiation of astrocytes from neural progenitors, which may also contribute to glial scar formation after CNS injury [3]. The expression of repulsive molecules such as ►semaphorin-3A, ►tenascin, ►NG2, ►neurocan, ►phosphacan, ►chondroitin and keratan sulfate proteoglycans are related to the repulsive nature of glial scars [4]. The reactive glial extracellular matrix is directly associated with the failure of axonal regeneration, whereas the myelinated white matter beyond the glial scar is rather permissive for regeneration. Nevertheless, Moon and Fawcett [5] have shown that despite the reduction of scar formation by treatment with antibodies to ►transforming growth factors (TGFs), sufficient enhancement of spontaneous CNS regeneration was not obtained. There is no doubt that glial scars have a negative impact on CNS regeneration, although their precise contribution to the inhibitory nature of the CNS environment needs to be ascertained.

The injury is very slowly and poorly infiltrated by macrophages. The importance of macrophage infiltration is illustrated by the observation that it stimulates regenerative responses in the transected rat optic nerve axons [6]. However, microglial activation is considered to be a double-edged response. The first stage of activation includes a non-phagocytic state, where microglia become hypertrophic and produce molecules that are cytotoxic to neuronal cells, such as ►tumor necrosis factor (TNF)-alpha. However, microglia also release cytokines to promote regeneration, for example ►TGF-beta, to promote tissue repair by reducing astrocytic scar formation. In addition, trophic factors including ►BDNF and ►GDNF, secreted by microglia, may also support regeneration.

### Process Regulation

The ability of the mammalian PNS to regenerate axons after injury is well documented. Studies in the past decade have shown that the Schwann cell, one of the most important myelin components of the peripheral glia, plays a key role in regeneration. The proliferation

and activation of Schwann cells leads to the production of various kinds of factors and other related molecules, to enhance the axons of the proximal nerve stump to grow through the distal stump. Activated Schwann cells express a variety of cell adhesion molecules including ►neural cell adhesion molecules (NCAM), ►L1 and their close homologues ►CHL1, ►N-cadherin and integrins, represented by ►alpha1-beta1 and alpha6-beta1-integrin ( $\alpha1\beta1$  and  $\alpha6\beta1$ -integrin), which mediate interactions between Schwann cells and axons, including growth cones. Besides these trophic factors and cell adhesion molecules, the Schwann cell supplies molecules to the extracellular matrix, such as ►fibronectin, ►laminin, ►J1/tenascin and ►merosin (laminin-2), to the injured axons, which then extend their processes. Among these extracellular molecules, ►laminin-alpha2 is known to play an important role in establishing remyelination, since its absence in mice led to reduced compactness and delay of myelination [7].

### Therapy

One strategy to elicit optic nerve regeneration is to provide a favorable environment by supplying neurotrophic factors and the transplantation of cells known to support axonal regeneration. Schwann cell is a strong candidate for transplantation, because optic nerve axons are known to regenerate, when the usual glial milieu is experimentally replaced by Schwann cells and/or peripheral nerve segments. Indeed, several experiments, involving CNS, have shown that exogenous supply of Schwann cells can improve axonal growth across the injured site [7].

Some cells such as gene-transfected astrocytes, ►olfactory ensheathing cells, ►ependymal cells, differentiated embryonic stem (ES) cells, and neuronal stem cells, can induce elongation of CNS nerve fibers, however, it has not been established that the elongated nerve fibers are remyelinated. Many CNS axons are myelinated by oligodendrocytes. The optic nerve tract is a typical example. Myelinating cells, either of Schwann cell or oligodendrocyte origin, mediate the spacing of sodium channel clusters at the nodes of Ranvier to enable saltatory conduction, which is a prerequisite for normal neuronal activity and function. Therefore, even if the CNS can elongate its axons, remyelination of regenerated axons is indispensable for the re-establishment of CNS function.

Schwann cells myelinate in peripheral axons, they also remyelinate CNS axons when transplanted. They are "cells with a purpose" and amongst the best candidates for implantation to support CNS regeneration. Thus, it is expected that transplantation of Schwann cells could become a feasible clinical treatment in the future if the technical and surgical issues can be overcome.

In addition to Schwann cell implantation, various other approaches have been attempted, as mentioned above, but a single approach alone does not appear to provide an optimal condition for optic nerve regeneration. Instead, recent studies using combined approaches, for example, ▶CNTF with ▶Nogo-neutralizing antibody IN-1 [8], and CNTF with cAMP [9] have shown a synergistic effect on RGC axon regeneration. It is therefore suggested that combining various experimental approaches including neutralizing inhibitory molecules (e.g. ▶IN-1 or ▶Nogo receptor blocker), blocking inhibitory signaling pathways (e.g. ▶Rho pathway inhibitor), supplementing appropriate neurotrophic factors (e.g. BDNF, ▶NT-4/5 or CNTF), providing a favorable environment for axon regeneration (e.g. peripheral nerve graft or Schwann cells/olfactory ensheathing glia transplantation), preventing scar tissue formation (e.g. ▶Chondroitinase ABC), and elevating intrinsic regrowth capability (e.g. cAMP elevation), will help to provide the most favorable condition for optic nerve regeneration.

## References

1. Goldberg JL, Barres BA (2000) The relationship between neuronal survival and regeneration (Review). *Annu Rev Neurosci* 23:579–612
2. Fournier AE, Strittmatter SM (2001) Repulsive factors and axon regeneration in the CNS. *Curr Opin Neurobiol* 11:89–94
3. Setoguchi T, Yone K, Matsuoka E, Takenouchi H, Nakashima K, Sakou T, Komiya S, Izumo S (2001) Traumatic injury-induced BMP7 expression in the adult rat spinal cord. *Brain Res* 921:219–225
4. Pasterkamp RJ, Giger RJ, Ruitenberg MJ, Holtmaat AJ, De Wit J, De Winter F, Verhaagen J (1999) Expression of the gene encoding the chemorepellent semaphorin III is induced in the fibroblast component of neural scar tissue formed following injuries of adult but not neonatal CNS. *Mol Cell Neurosci* 13:143–166
5. Moon LD, Fawcett JW (2001) Reduction in CNS scar formation without concomitant increase in axon regeneration following treatment of adult rat brain with a combination of antibodies to TGFbeta1 and beta2. *Eur J Neurosci* 14:1667–1677
6. Schwartz M, Moalem G, Leibowitz-Amit R, Cohen IR (1999) Innate and adaptive immune responses can be beneficial for CNS repair. *Trends Neurosci* 22:295–299
7. Dezawa M, Adachi-Usami E (2000) Role of Schwann cells in retinal ganglion cell axon regeneration. *Prog Retin Eye Res* 19:171–204
8. Cui Q, Cho K-S, So K-F, Yip H (2004) Synergistic effect of Nogo-neutralizing antibody IN-1 and ciliary neurotrophic factor on axonal regeneration in adult rodent visual systems. *J Neurotrauma* 21:617–625
9. Cui Q, Yip HK, Zhao RC et al. (2003) Intraocular elevation of cyclic AMP potentiates ciliary neurotrophic factor-induced regeneration of adult rat retinal ganglion cell axons. *Mol Cell Neurosci* 22:49–61

## Regeneration of the Central Nervous System

### Definition

Regeneration in general represents the replacement of lost body parts. Regeneration of the central nervous system (CNS) classically referred mainly to the regrowth of damaged neuronal axons. However, it has been realized that the replenishment of lost neural cells, and furthermore, the recovery of lost neural function, can be included in the concept of CNS regeneration. In fact, the attempt to recapitulate normal neural development has become a vital strategy for CNS regeneration.

### ▶Regeneration

## Regionalization of the Vertebrate Central Nervous System

HARUKAZU NAKAMURA

Department of Molecular Neurobiology, Graduate School of Life Sciences and Institute of Development, Aging; Cancer, Tohoku University, Aoba-ku, Sendai, Japan

### Definition

The vertebrate central nervous system first arises as a simple neural plate, which then forms a neural tube. The neural tube is divided into functionally and morphologically distinct regions. The first sign of regionalization in the central nervous system is the appearance of primary brain vesicles such as the prosencephalon, mesencephalon and rhombencephalon (Fig. 1).

As a result of the subdivision of the prosencephalon into the telencephalon and diencephalon and the rhombencephalon into the metencephalon and myelencephalon, five secondary brain vesicles are formed, which are the fundamental brain plan. The telencephalon differentiates into the cerebral cortex and nuclei. The diencephalon differentiates into the thalamus and hypothalamus. The retina, neurohypophysis and pineal body are also derivatives of the diencephalon. The mesencephalon differentiates into the optic tectum and tegmentum. The metencephalon differentiates into the cerebellum and the pons. The myelencephalon differentiates into the medulla oblongata.

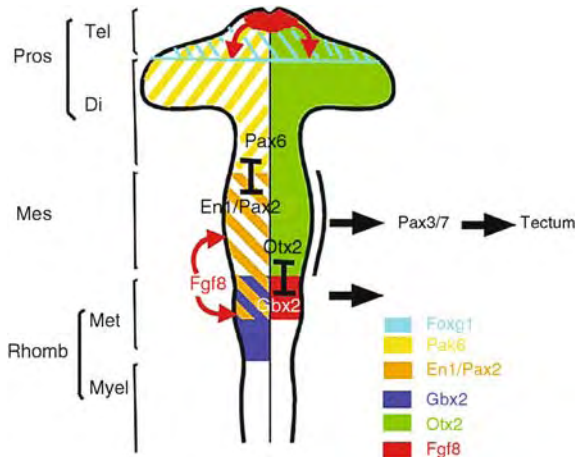

**Regionalization of the Vertebrate Central Nervous System. Figure 1** Brain vesicles The fundamental brain plan is in the brain vesicles. Primary brain vesicles (prosencephalon, mesencephalon and rhombencephalon) are transformed into secondary brain vesicles. The fate of the brain vesicles is determined by a combination of expression of transcription factors. The anterior neural ridge and mes-metencephalic boundary function as signaling centers. *Otx2* is expressed down to the mes-metencephalic boundary. *Foxg1* is expressed in the prospective telencephalon. The di-mesencephalic boundary is determined by repressive interaction between *Pax6* and *En1/Pax2* and the mes-metencephalic boundary is determined by repressive interaction between *Otx2* and *Gbx2*. The region where *Otx2*, *En1* and *Pax2* are expressed is the mesencephalon. Additional expression of *Pax3/7* in the mesencephalic alar plate confers differentiation into the optic tectum. *di* diencephalons; *mes* mesencephalon; *met* metencephalon; *pros* prosencephalon; *rhomb* rhombencephalon; *tel* telencephalon.

The sulcus limitans divides the neural tube into the dorsal alar plate and the ventral basal plate (Fig. 2).

## Characteristics

### Description of the Process

The fate of the region is determined by a combination of transcription factors expressed in the region. For the antero-posterior (AP) axis, boundaries function as organizing centers. Signals from the organizing center regulate expression of the transcription factors, thus regulating the fate of the adjacent region. For the dorso-ventral axis (DV), signaling centers are in the outside of the neural tube, the notochord and the dorsal midline ectoderm. Transcription factors that are homologous to those of *Drosophila melanogaster* are expressed in the vertebrate brain anlage and define the fate of the brain region.

### Regionalization of the Prosencephalon

*Otx1* and *Otx2*, homologs of *orthodenticle* (*otd*) of *Drosophila*, are expressed in the prosencephalon and

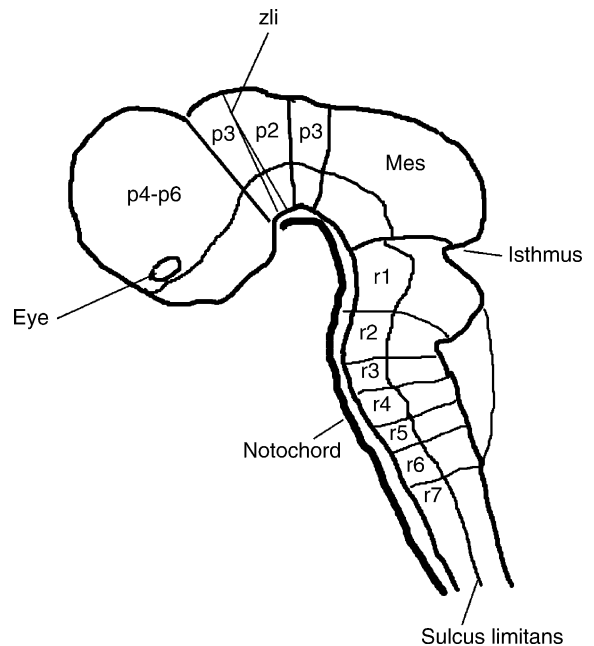

**Regionalization of the Vertebrate Central Nervous System. Figure 2** Neuromeres In the rhombencephalon, rhombomeres are formed, which are characterized by bulges and constrictions. Rhombomeres are compartments whose boundaries cells do not cross. In the prosencephalon, prosomere models are proposed. *Zli* is formed between *p2* and *p3* and functions as a signaling center. *p1-p6* prosomere 1–6; *r1-r6* rhombomere 1–6; *zli* zona limitans interthalamica.

mesencephalon. Expression of these genes differs with time; *Otx2* is expressed from a very early stage whereas the *Otx1* expression window is later. *Otx2* plays a more important role in defining the region; *Otx2* null mutant mice lack prosencephalon, mesencephalon and anterior rhombencephalon, although *Otx1* null mutant mice show abnormality in the dorsal telencephalic cortex. Since *Otx1* could be replaced by *Otx2*, it was suggested that the difference in the phenotypes of *Otx1* and *Otx2* null mutant mice stems from differences in expression patterns [1–3].

*Emx1* and *Emx2*, homologues of *empty spiracle* (*ems*) are expressed in the telencephalon. These molecules may play a crucial role in arearization in the telencephalon, rather than defining the telencephalic region. *Emx2* is expressed in a gradient, posterior high and anterior low. *Fgf8* signal from the anterior and *Wnt* signal from the posterior (cortical hem) determine the pattern of *Emx2* [1–3]. *Wnt* genes are homologs of *Drosophila wingless* (*wg*).

*Foxg1* (*BF1*) is expressed in the telencephalon and defines the telencephalic region (Fig. 1). *Six3* is expressed anterior to the zona limitans interthalamica (*zli*) and confers competence to express *Foxg1* in

response to Fgf8. *Irx3* is expressed posterior to the zli and confers competence to express *En1* and *En2* in response to Fgf8. *Six3*, *Irx* and *En* are homologs of *sine oculis*, *iroquois* and *engrailed* respectively [4].

Puelles and Rubenstein had proposed that the prosencephalon consisted of six prosomeres (p1-p6), but then reduced it to four prosomeres [5] (Fig. 2).

P1 corresponds to the synencephalon, which is a prospective preteum. P2 and P3 correspond to the parencephalon and are prospectively thalamus and prethalamus respectively. P4-P6 are the secondary prosencephalon, which gives rise to the telencephalon and hypothalamus. The zli is formed between p2 and p3 and functions as a signaling center [4–6]. P1-P3 are the epichordal part and P4-P6 are the prechordal part.

### Regionalization of the Mesencephalon

The mesencephalon is characterized by a combinatorial expression of *Otx2*, *En1* and *Pax2* [7]. *Otx2* is expressed down to the mes-metencephalic boundary (Fig. 1). The posterior limit of the mesencephalon corresponds to that of the *Otx2* expression domain. Misexpression of *Otx2* in the metencephalon changes the fate of the metencephalon to that of mesencephalon, i.e. the metencephalon differentiates into the tectum instead of the cerebellum after misexpression of *Otx2*. *Otx2* knockout mice lack prosencephalon and mesencephalon. Misexpression of *Gbx2*, which is expressed in the metencephalon, causes an anterior shift in the posterior limit of the tectum. Fgf8, *Pax2/5*, *En1/2* are in a positive feedback loop for their expression, so that misexpression of one of these molecules in the diencephalon activates the loop. Since *Otx2* is intrinsically expressed in the diencephalon, misexpression of one of these genes changes the fate of the diencephalon to that of the mesencephalon [3,7,8]. *Gbx2* is a vertebrate homolog of *Drosophila unplugged* and *Pax* genes contain a paired box, which was originally identified in the *Drosophila paired* gene.

### Regionalization of the Rhombencephalon

The rhombencephalon is characterized by seven or eight swellings called rhombomeres (r) (Fig. 2). It was shown that the ►neuromeres in the hindbrain are ►compartments [2,6]. The spinal cord also shows a metameric pattern, which is characterized by motor nerves and dorsal root ganglia. ►Metamerism in the spinal cord is not however intrinsically formed, but is a reflection of the ►segmentation of the somite [6]. It was shown that rhombomeres are true segments and form compartments whose boundaries are cell lineage restricting ones. Eph receptor tyrosine kinases and their ligands may be involved in lineage restriction. Receptors (EphA4, EphB2, EphB3) are expressed in odd-numbered rhombomeres (r3, r5) and their ephrin

B ligands are expressed in the even numbered rhombomeres (r2, r4 and r6). The ephrin-Eph system is shown to produce repulsion, since the cells in the odd-numbered rhombomeres and those in the even-numbered rhombomeres do not intermingle [2]. Each rhombomere is characterized by a set of motor neurons. Orthologues of *Drosophila Hox* genes are expressed in an ordered and nested manner [2,6].

The identity of the rhombomere is determined by the combination of the expression of *Hox* genes [6]. Regulation of rhombomere identity by *Hox* genes has been shown by gain- and loss-of-function studies. *Hoxb1* is uniquely expressed in r4. Some of the facial motor neurons that are produced in r4 migrate to r6 and vestibuloacoustic neurons migrate to the contralateral side in wild type mice. In *Hoxb1*-knock out mice, neurons produced in r4 do not migrate either to r4 or to the contralateral side, which suggests that the r4 is transformed to r2 in the mutant mice. On the other hand, misexpression of *Hoxb1* in r2 changed its fate to that of r4.

### Regulation of the Process by Signaling Centers

The fate of the brain vesicles is determined by a combination of transcription factors. Signals from the boundary regulate expression of the transcription factors. The mes-metencephalic boundary (isthmus) was first recognized to function as a secondary organizer for the tectum and cerebellum [2,7,8]. This was first shown by ectopic transplantation of the brain vesicles. The alar plate of the diencephalon changed its fate and differentiated into the tectum when it was transplanted to the posterior part of the mesencephalon. The fate change did not occur in the anterior part of the mesencephalon. Transplantation of the isthmus to the diencephalon induced the tectum around the transplant, showing that the isthmus functions as the organizer.

Implantation of an Fgf8-soaked bead into the diencephalon mimicked transplantation of the isthmus, i.e. tectum was induced ectopically in the diencephalon by Fgf8 [7,8]. Furthermore, *Fgf8* mutants in zebra fish and mice showed a disruption of the mes and r1. Later work all supported the idea that Fgf8 is a major organizing molecule in the isthmus (Fig. 1). Another secreted factor *Wnt1* is first expressed widely in the mesencephalon and restricted to the posterior margin of the mesencephalon. *Wnt1* null mutant mice show a severe deficit in midbrain and hindbrain. But later studies indicated that *Wnt1* functions as a growth-accelerating factor. Fgf17 and Fgf18 have also been shown to function as growth promoting factors. *Wnt1* is a homolog of *Drosophila wingless* (wg).

Among eight splicing isoforms of *Fgf8*, *Fgf8a* and *Fgf8b* are expressed in the isthmus. Misexpression by *in ovo* electroporation in chick embryos showed that Fgf8a changed the fate of the diencephalon to

that of the mesencephalon and that Fgf8b changed the fate of the mesencephalon to that of the metencephalon. Since electroporation with a 1/100 dilution of Fgf8b expression vector exerted Fgf8a type effects, the difference in the effects of Fgf8a and Fgf8b may be due to difference in the intensity of the signal. A strong Fgf8 signal may activate the genes for cerebellar differentiation [7].

Signaling via FGF receptors, tyrosine kinase receptors (RTK), can activate the mitogen-activated protein kinase (MAPK) and the phosphatidylinositol 3-kinase (PI3K). Blocking of the Ras-ERK (MAPK) signaling pathway by the dominant negative form of Ras changed the fate of the metencephalon to that of the mesencephalon, i.e. the tectum developed instead of the cerebellum in the metencephalic region after misexpression of the dominant negative form of Ras. These results indicate that the strong Fgf8 signal activates the Ras-ERK pathway to cause differentiation into cerebellum [7]. Ras-ERK signaling is so strong that it may need negative regulators. Sprouty2, Sef (similar expression of Fgf8) and Mkp3 are induced by Fgf8, but regulate the pathway negatively. Sprouty2 is expressed overlappingly with Fgf8 and can be induced very rapidly by Fgf8 [7]. Repression of the Ras-ERK signaling pathway by misexpression of Sprouty2 changes the fate of the alar metencephalon to become the tectum. On the contrary, excess Ras-ERK signaling by application of dominant negative form of Sprouty2 results in an anterior shift in the mid-hindbrain boundary. Application of a specific inhibitor of the PI3K pathway indicated that this pathway is also activated by Fgf8 to induce Mkp3 and En2.

The anterior neural ridge also expresses Fgf8 and functions as a secondary organizer for the telencephalon. Fgf8 induces *Foxg1* in the telencephalon (anterior to the zli), but induces *En* in the region posterior to the zli. It was shown that the difference in competence is dependent on the transcription factors expressed in the region. *Six3* confers ability to express *Foxg1* in response to Fgf8, whereas *Irx3* confers ability to express *En2* in response to Fgf8 [4]. *Six3* is a homolog of *Drosophila sine oculis*.

The zli is another signaling center. There Shh is expressed and regulates the differentiation of the thalamic nuclei. *Sox14* and *Gbx2* are expressed in the young neurons of specific nuclei in the dorsal thalamus (*Sox14*: interstitial nucleus of the optic tract, perirhinal area; *Gbx2*: nucleus rotundus, posterior nucleus). High doses of Shh induce GliI, which in turn mediates expression of *Sox14*. On the other hand, low doses of Shh induce GliII, which in turn mediates expression of *Gbx2* [4]. *Shh* (*sonic hedgehog*) is one of vertebrate homologs of *Drosophila hedgehog*, and *Gli* is the homolog of *Drosophila Cubitus interruptus*.

### Regionalization Along Dorsoventral (DV) Axis

The floor plate and roof plate, which are situated at the ventral and dorsal midline respectively, segregate the bilateral halves of the neural tube. On each side, motor neurons differentiate in the ventral third, relay neurons in the middle third and smaller interneurons in the dorsal third. *Pax3/7* and *Pax6* are expressed in the dorsal and middle thirds respectively and *Nkx2.2* is expressed in the most ventral part. Class II homeodomain proteins such as *Nkx2.2*, *Nkx6.1*, *Nkx6.2* and bHLH transcription factor *Olig2* are expressed in the most ventral part of the neural tube and Class I homeodomain (HD) proteins such as *Pax6*, *Dbx2*, *Irx3* and *Dbx1* are expressed dorsal to the Class II HD protein. Combination of these transcription factors defines the cell types along the DV axis.

Notochord was shown to have ventralizing activity. Implantation of the notochord lateral to the neural tube could induce floor plate and motor neurons near the implant. On the other hand, removal of the notochord results in extension of the dorsal markers to the ventral and motor neurons and the floor plate disappear. When notochord formation is genetically perturbed in mouse and zebra fish, ventral cell types are absent. For the ventralizing signal, Shh signaling was shown to play a crucial role. Shh is first expressed in the notochord, then the floor plate expresses Shh. Shh could elicit floor plate and motor neuron development ectopically. Centrally, Shh null mutant mice lack floor plate and motor neurons. Shh induces expression of ventral markers and the motor neuron marker *islet1*, but represses the ventral markers.

BMP4 and BMP 7 emanate from the roof plate and the dorsal ectoderm and antagonize the Shh signal. Thus, cell fate along the DV axis is determined by these signals.

For the DV axis in the mesencephalon, *Pax3/7* are expressed in the alar plate of the mesencephalon and force it to differentiate as a tectum [7]. Shh is expressed in the floor plate of the mesencephalon. Misexpression of Shh in the mesencephalon represses *Pax3/7* expression and changes the fate of the alar plate of the mesencephalon to the tectum (Fig. 1). After misexpression of Shh, motor neurons and dopaminergic neurons differentiate in the dorsal part of the mesencephalon.

### References

1. Boncinelli E (1999) *Otx* and *Emx* homeobox genes in brain development. *Neuroscientist* 5:164–172
2. Brown M, Keynes R, Lumsden A (2001) The developing brain. Oxford University Press, New York
3. Simeone A (2000) Positioning the isthmus organizer where *Otx2* and *Gbx2* meet. *Trends Genet* 16:237–240

4. Kobayashi D, Kobayashi M, Matsumoto K, Ogura T, Nakafuku M, Shimamura K (2002) Early subdivisions in the neural plate define distinct competence for inductive signals. *Development* 129:83–93
5. Puelles L, Rubenstein JL (2003) Forebrain gene expression domains and the evolving prosomeric model. *Trends Neurosci* 26:469–476
6. Kiecker C, Lumsden A (2005) Compartments and their boundaries in vertebrate brain development. *Nat Rev Neurosci* 6:553–564
7. Nakamura H, Katahira T, Matsunaga E, Sato T (2005) Isthmus organizer for midbrain and hindbrain development. *Brain Res Brain Res Rev* 49:120–126
8. Alvarado-Mallart RM (2005) The chick/quail transplantation model: discovery of the isthmic organizer center. *Brain Res Brain Res Rev* 49:109–113

## Regulation of Neurotransmitter Release by Protein Phosphorylation

ROBERT D. BURGOYNE, ALAN MORGAN  
The Physiological Laboratory, School of Biomedical Sciences, University of Liverpool, Liverpool, UK

### Definition

The release of neurotransmitters at ►*synapses* is brought about by the process of regulated ►*exocytosis*, whereby a rise in the concentration of cytosolic  $\text{Ca}^{2+}$  triggers the fusion of a ►*synaptic vesicle* with the plasma membrane and the release of the vesicle's neurotransmitter content into the extracellular space. The proteins responsible for the sensing of the  $\text{Ca}^{2+}$  signal (synaptotagmin) and for vesicle docking and fusion (the SNARE proteins, SNAP-25, syntaxin and VAMP), have been identified and well characterized. In addition, several other proteins characterized through genetic approaches in flies, worms or mice are known to be either essential for neurotransmitter release (such as Munc13, Munc18-1 and NSF) or have important regulatory roles (such as cysteine string protein (CSP), Rabs and Rab effector proteins). In many neuronal cell types and various other kinds of secretory cells, exocytosis can be modulated through signalling pathways that result in phosphorylation of one or more of the key proteins involved in the exocytotic machinery [1]. The extent or kinetics of neurotransmitter release has been found to be modified by the action of several different ►*protein kinases* including PKA, PKC, Cdk5 and calmodulin-dependent protein kinase II (CaMKII). It has also been shown that ►*protein phosphorylation* by these, and other kinases, is required for various forms of ►*synaptic plasticity*. The changes in ►*neurotransmission* that underlie synaptic modification are in part post- and in part pre-synaptic. Regulation of protein

phosphorylation is important for presynaptic changes in neurotransmitter release which is, therefore, likely to be involved in learning and memory formation. Neurotransmitter release could be modified via phosphorylation of channels or receptors, but it is clear that components of the release machinery are direct targets for protein phosphorylation and these will be the focus of this review. The protein targets for the various protein kinases, and the particular amino acids within these substrates that are phosphorylated, are increasingly being identified, and this is allowing the physiological roles of specific phosphorylation events to be established. The strategy that is being used and is most informative is the expression of mutated forms of the proteins, in which the identified phosphorylated amino acid is rendered non-phosphorylatable (e.g. by changing serine to alanine) or phosphomimetic, by mutation of serine to the acidic amino acid glutamate or aspartate. We have concentrated here on proteins known to be important, based on genetic manipulation, as part of the exocytotic machinery for neurotransmitter release, for which the mutation strategy has defined a significant functional role for protein phosphorylation on a defined amino acid. Other presynaptic proteins that are substrates for protein phosphorylation are known [1], but their importance for neurotransmission has not yet been validated genetically.

### Characteristics

Many aspects of neurotransmitter release can be modified following activation of protein kinases. These include an increase in release probability of vesicles, an increase in the size of the ►*ready-releasable pool* of synaptic vesicles, changes in  $\text{Ca}^{2+}$ -sensitivity of the release mechanism or changes in the kinetics of individual fusion and release events [1]. This has led to the search for the protein substrates involved. Several key exocytotic proteins have been shown to be substrates for protein kinases *in vitro*, and some of these have been confirmed to be phosphorylated in intact cells in response to physiological stimuli. In even fewer cases has the phosphorylation of a specific protein been convincingly linked to one of the known effects on neurotransmitter release of activation of a specific kinase. Nevertheless, a number of examples of well defined regulation by protein phosphorylation are now known. The key presynaptic proteins involved in neurotransmitter release, which have been shown to be protein kinase substrates, are shown in Fig. 1, and the identified phosphorylation sites that are known are listed in Table 1.

We will concentrate on those proteins that have been confirmed to be important for neurotransmission through genetic approaches, and whose phosphorylation has been shown to be physiologically significant for exocytosis. Phosphorylation of several proteins has been



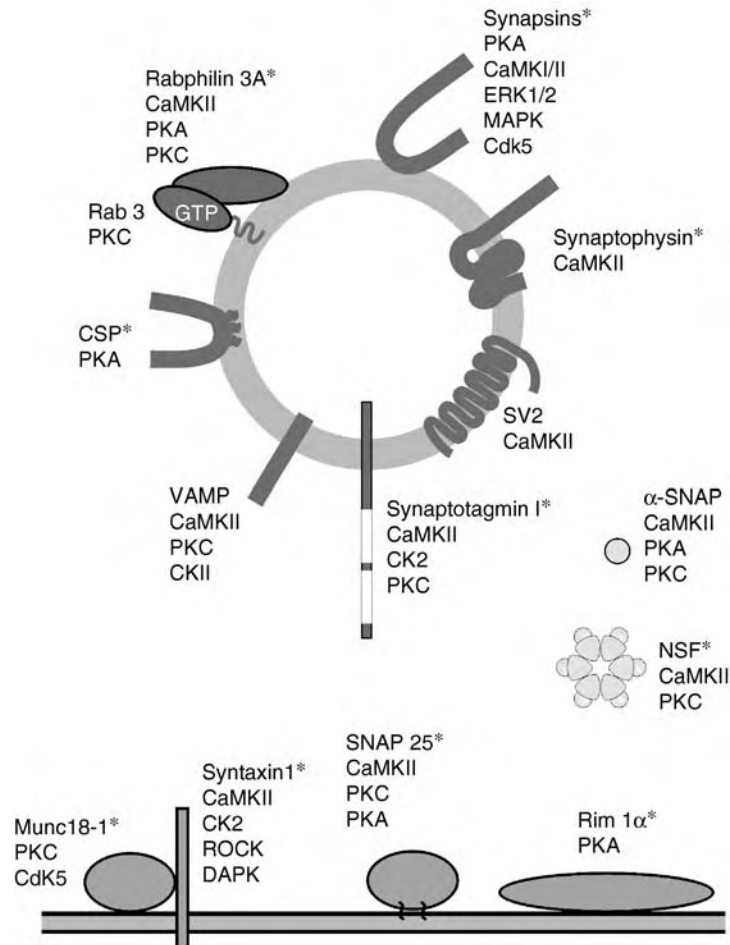

**Regulation of Neurotransmitter Release by Protein Phosphorylation. Figure 1** Protein kinase substrates with established roles in the machinery for neurotransmitter release. Key synaptic proteins present on synaptic vesicles, the presynaptic membrane or the cytosol are shown, along with the protein kinases known to phosphorylate them *in vitro*. Only those proteins that have been confirmed through genetic approaches to be required for, or to regulate neurotransmitter release, are included. Proteins that are known to be phosphorylated in intact cells are indicated by asterisks.

linked to modification at various stages in the exocytotic process including vesicle mobilization (synapsins), vesicle recruitment into a releasable pool (RIM1), the maintenance of the ready-releasable pool size (SNAP-25) and late events during membrane fusion (CSP and Munc18-1).

The first presynaptic proteins whose phosphorylation was found to regulate neurotransmitter release were the synapsins, which have been extensively characterized both biochemically and functionally [1]. These proteins cross-link the reserve pool of synaptic vesicles to each other and to the cytoskeleton. Their phosphorylation by CaMKII following nerve terminal depolarization allows the release of the vesicles and, thereby, increases their availability for exocytosis. The functional significance of synapsins in the control of vesicle availability and recycling has been well established through the study of synapses from synapsin I and synapsin II knock-out mice.

A study using neurons from knock-out mice has shown that the Rab effector Rim1, which is localized on the presynaptic plasma membrane, is required to maintain the normal level of release probability in synapses and for **long term potentiation (LTP)** at parallel fibre/Purkinje cell synapses of the cerebellum [2]. LTP at these synapses is dependent on presynaptic PKA. RIM1 is phosphorylated both *in vitro* and *in vivo* by PKA on Ser-413. The ability of this residue to be phosphorylated is necessary for the recovery of the wild-type phenotype when expressed in neurons from null mutant mice, as expression of non-phosphorylatable mutants was ineffective. In contrast, mutation of another putative PKA phosphorylation site, Ser-1548 was without effect on the recovery in knock-out mice. This study suggests that phosphorylation of Ser-413 of RIM1 is a significant mechanism for the PKA-dependent plasticity that

**Regulation of Neurotransmitter Release by Protein Phosphorylation. Table 1** Identified protein kinase substrates involved in exocytosis and the kinases that phosphorylate them

Protein	<i>In vitro</i> phosphorylation sites	<i>In vivo</i> phosphorylation sites	Functional significance tested?
CSP	PKA: S10	S10	Yes
Munc18-1	PKC: S306, S313 Cdk5: T574	S313	Yes
Rabphilin 3A	PKA and PKC: S234, S274	S234, S274	No
Rim 1	PKA: S413, S1548 CaMKII: S241, S287 (indirect)	S413	Yes
SNAP-25	PKA: T138 PKC: S187	T138 S187	Yes
Synapsin	PKA and CaMKI: S9	As for <i>in vitro</i>	Yes
	CaMKII: S566, S603		
	ERK1: S62		
	ERK2: S67		
	MAPK and Cdk5: S549		
	Cdk5: S551		
Synaptotagmin I	PKC and CaMKII: T112	T112	No
Syntaxin 1A	CK2 and ROCK: S14 DAPK: S188	S14	Yes

Key synaptic proteins are listed that have been shown to be phosphorylated *in vitro* and whose phosphorylation sites have been identified. Only those proteins that have been confirmed through genetic approaches to be required for, or to regulate neurotransmitter release, are included.

exists in certain types of synapses and that involves changes in neurotransmitter release. The mechanistic basis for the effect of RIM1 phosphorylation is, however, unknown.

SNAP-25 is one of the key SNARE proteins that associates with syntaxin and VAMP and mediates vesicle docking/fusion at the plasma membrane. Phosphorylation of SNAP-25 has been suggested to regulate the size of the ready-releasable pool of vesicles, based on data from studies on [adrenal chromaffin cells](#) [3,4]. SNAP-25 [5] can be phosphorylated both *in vitro* and *in vivo* by PKA and PKC on identified sites (Table 1), and this has been implicated in the functional effects of PKA and PKC activation on exocytosis. Activation of PKC has multiple effects on exocytosis, one of which is an increase in the rate of refilling of the ready releasable pool of vesicles. SNAP-25 is phosphorylated by PKC on Ser-187 and this reduces its association with other SNARE proteins. Expression of SNAP-25 in adrenal chromaffin cells with mutations in this residue either increased (phosphomimetic mutant) or impaired (non-phosphorylatable mutant) the rate of refilling of the [vesicle pools](#) [3]. This suggests that this effect of PKC activation could be through phosphorylation of Ser-187 of SNAP-25. In contrast, a study on hippocampal pyramidal neurons did not find any effect of mutating Ser-187 of SNAP-25 on neurotransmitter release, suggesting the existence of other functionally important PKC substrates that increase neurotransmitter release in

hippocampal synapses. Neurotransmitter release can also be increased by activation of PKA. In addition, the tonic activity of PKA is linked to the maintenance of the pool of ready releasable vesicles in adrenal chromaffin cells, and this was revealed by the use of PKA inhibitors [4]. Expression of SNAP-25 mutated at Thr138, the identified PKA phosphorylation site, to produce a non-phosphorylatable mutant reduced the size of the initial fast burst of exocytosis in chromaffin cells, suggesting that this might be the target for PKA's action on the ready releasable pool size. Phosphorylation of Thr138 has no effect on SNAP-25 binding to other SNAREs, although the effect on other protein interactions made by SNAP-25 is unknown.

CSP is a synaptic and secretory vesicle protein that has a chaperone role in the synapse. The phosphorylation status of CSP has been shown to affect late events in exocytosis that lead to changes in vesicle release kinetics and quantal size [6]. Overexpression of CSP in adrenal chromaffin cells was found to reduce the number of exocytotic events and also slowed vesicle release kinetics. CSP is phosphorylated *in vitro* on Ser-10 and this site was found to be phosphorylated *in vivo*. CSP phosphorylated on Ser-10 shows a reduced affinity for the syntaxin 1A and synaptotagmin I [6]. Expression of CSP with a mutation in Ser-10 (a non-phosphorylatable mutant) still reduced exocytosis but no longer modified the release kinetics. This suggests that Ser-10 is a target for protein phosphorylation, and that its phosphorylation

can regulate neurotransmitter release through an effect on the time course of release from individual vesicles. It is currently unclear, however, whether the regulation of CSP is a consequence of PKA-mediated phosphorylation or phosphorylation by some other kinase that recognizes the motif at Ser-10.

Munc18-1 is a member of the Munc18/Sec1 family of proteins that function in essentially all intracellular membrane fusion events. It is essential for neurotransmission in mice and knock-out animals are paralysed and die *in utero*. Munc18-1 and its orthologues in other species appears to have both negative and positive functions exerted in part through its interaction with syntaxin. Munc18-1 is phosphorylated *in vitro* by PKC on Ser-306 and Ser-313, and by Cdk5 on Thr-574. Only phosphorylation on Ser-313 has so far been confirmed to occur *in vivo* [7]. Phosphorylation of Munc18-1 by PKC or mutation of Ser-306 and Ser-313 to glutamates reduces the affinity of Munc18-1 for binding syntaxin 1A. Significantly, expression of Munc18-1 with the phosphomimetic mutations in Ser-306 and Ser-313 mimics the effects of PKC in increasing the speed of single vesicle release events in chromaffin cells [8]. Another effect of PKC, to increase the number of exocytotic events was not observed as a consequence of expressing phosphomimetic Munc18-1, suggesting that another PKC substrate (SNAP-25?) must be involved in this effect of PKC. In contrast, expression of a phosphomimetic mutation of Munc18-1 at Thr574 only partially reproduced the effect of Cdk5 activation. The evidence suggests that Munc18-1 may be a physiological substrate for PKC, but the significance of the putative phosphorylation by Cdk5 is still unclear.

Phosphorylation of syntaxin 1A *in vivo* has been demonstrated and recently implicated in the exocytotic events that are involved in the insertion of new membrane in growing neuronal processes [9]. Syntaxin 1A was found to be the substrate for both casein kinase II [10] and the Rho-associated serine/threonine kinase (ROCK) [9], and was phosphorylated on Ser-14 by both kinases. This phosphorylation site was demonstrated to be functionally important as its phosphorylation increased the affinity of binding of tomosyn to syntaxin, and thereby inhibited its ability to form productive SNARE complexes. It was suggested that this would provide a mechanism for the spatial regulation of exocytosis. Other work has shown, however, that phosphorylation of Ser-14 of syntaxin increases its binding to synaptotagmin and its recovery in complexes with SNAP-25, which would be more consistent with a stimulatory effect on exocytosis. It is not known whether phosphorylation of syntaxin 1 does regulate neurotransmitter release.

The changes in neurotransmitter release that occur following phosphorylation of synapsin, RIM1, SNAP-25, CSP and Munc18-1 are also believed to be due to modifications in specific protein-protein interactions

between these proteins and others in the exocytotic machinery. The molecular basis for the effects of phosphorylation, are in general still to be resolved. In particular, the effect of PKA phosphorylation of RIM1 and SNAP-25 on their protein-protein interactions is unknown. As noted above, more information is available on the molecular effects of other phosphorylation events. It is also possible that other substrate proteins could be crucial for mediating the protein kinase effects. We still have only limited knowledge of the significance of the phosphorylation of other exocytotic proteins, and the physiological conditions under which specific protein phosphorylation events occur and become relevant for changes in neurotransmission and synaptic plasticity. It is clear, however, that these are important mechanisms that contribute to learning and memory.

## References

1. Leenders AGM, Sheng Z-H (2005) Modulation of neurotransmitter release by the second messenger-activated protein kinases: implications for presynaptic plasticity. *Pharmacol Ther* 105:69–84
2. Lonart G, Schoch S, Kaeser PS, Larkin CJ, Sudhof TC, Linden DJ (2003) Phosphorylation of RIM1 $\alpha$  by PKA triggers presynaptic long-term potentiation at cerebellar parallel fiber synapses. *Cell* 115:49–60
3. Nagy G, Matti U, Nehring RB, Binz T, Rettig J, Neher E, Sorensen JB (2002) Protein kinase C-dependent phosphorylation of synaptosome-associated protein of 25 kDa at Ser<sup>187</sup> potentiates vesicle recruitment. *J Neurosci* 22:9278–9286
4. Nagy G, Reim K, Matti U, Brose N, Binz T, Rettig J, Neher E, Sorensen JB (2004) Regulation of releasable vesicle pool sizes by protein kinase A-dependent phosphorylation of SNAP-25. *Neuron* 41:351–365
5. Shimazaki Y, Nishiki T-I, Omori A, Sekiguchi M, Kamata Y, Kozaki S, Takahashi M (1996) Phosphorylation of 25-kDa synaptosome-associated protein. Possible involvement in protein kinase C-mediated regulation of neurotransmitter release. *J Biol Chem* 271:14548–14553
6. Evans GJO, Wilkinson MC, Graham ME, Turner KM, Chamberlain LH, Burgoyne RD, Morgan A (2001) Phosphorylation of cysteine string protein by PKA: implications for the modulation of exocytosis. *J Biol Chem* 276:47877–47885
7. Craig TJ, Evans GJO, Morgan A (2003) Physiological regulation of Munc18/nSec1 phosphorylation on serine-313. *J Neurochem* 86:1450–1457
8. Barclay JW, Craig TJ, Fisher RJ, Ciufo LF, Evans GJO, Morgan A, Burgoyne RD (2003) Phosphorylation of Munc18 by protein kinase C regulates the kinetics of exocytosis. *J Biol Chem* 278:10538–10545
9. Sakisawa T, Baba T, Tanaka S, Izumi G, Yasumi M, Takai Y (2004) Regulation of SNARES by tomosyn and ROCK: implication in extension and retraction of neurites. *J Cell Biol* 166:17–25
10. Foletti DL, Lin R, Finley MA, Scheller RH (2000) Phosphorylated syntaxin 1 is localized to discrete domains along a subset of axons. *J Neurosci* 20:4535–4544

## Regulatory Region

### Definition

Regulatory region is a promoter, enhancer or other DNA sequence of a gene that is bound by transactivating factors that control gene expression. The best-studied regulatory regions are in DNA, but they also exist in RNA where they can be bound for example by micro RNA.

## Regulatory Route

### Definition

Regulatory route refers to the pathway whereby after synthesis in the rough endoplasmic reticulum, proteins are transported via the Golgi apparatus to be stored in granules, and exocytosed from granular storage.

## Regulatory T Cells

### Definition

A sub-population of T cells, which in their resting state bear markers, e.g. CD25, characteristic of activated T lymphocytes. These cells, which originate in the thymus, ensure peripheral tolerance of autoimmune T cells by a mechanism known to be characterized by cell-cell contact and cytokine secretion, but are not yet fully understood.

► Protective Autoimmunity

## Reinforcement

### Definition

This term was first used in classical conditioning by Pavlov to describe the process by which a conditioned stimulus (CS) came to substitute for the unconditioned stimulus (US) and thus elicit a conditioned response. Its current use in the classical conditioning literature is rather casual and denotes trials on which the CS is followed by the US in contrast to the term non-reinforcement which denotes trials where the CS is presented without the US.

Reinforcement is a core concept in operant conditioning. It has traditionally been used to refer to the process of strengthening a response or behavior. Positive reinforcement is often used to describe situations in which the occurrence of an instrumental response leads to a desirable outcome (or reward). Its counterpart, negative reinforcement, is used to refer to situations in which the occurrence of an instrumental response leads to either the removal or the postponement of an undesirable event, although, depending on the particular theoretical orientation, the terms escape and avoidance learning, respectively, are more likely to be employed.

- Classical Conditioning (Pavlovian Conditioning)
- Operant Conditioning
- Theory on Classical Conditioning

## Reinforcement Learning in Neural Networks

### Definition

An approach for training noisy networks based on increasing the likelihood of outputs that yield greater reward on average.

► Neural Networks for Control

## Reinforcement Learning in Animals

### Definition

Reinforcement learning is a learning rule to search optimal value based on a reward signal, signifying to the organism which conditions are desirable and which are the undesirable ones.

► Reinforcement

## Reinforcer

### Definition

In associative conditioning theory, a reinforcer is an event that modifies the frequency of the behavior that preceded it. The term refers to operant learning (also called Skinnerian or instrumental learning), a form of associative

learning in which animals learn to associate a behavioral action (for instance pressing a lever) to an outcome, either positive (a food reward) or negative (a punishment with an electric shock). Typically, the probability of the bar pressing response would increase if it is associated to the reward, but would decrease if it is associated to the punishment, a principle termed “the Law of Effect” by Edward Thorndike at the end of the 19th century. Note however, that the removal of a punishment can also act as a reinforcer: for instance, if bar pressing induces the end of a very loud noise, this behavior can increase because the end of the loud noise acts as a positive reinforcer.

► Reinforcement

## Reinnervation

### Definition

Return of lost nerve fibers (innervation) to a cell, tissue, organ.

- Neuronal Changes in Axonal Degeneration and Regeneration
- Regeneration

## Reinnervation of Muscle

### Definition

The nerve supply to denervated muscle fibers can be restored by reinnervation; injured nerve fibers regrow their axons to reach and resupply or reinnervate the denervated muscle fibers.

- Axonal Sprouting in Health and Disease

## Reinstatement

### Definition

The return of a conditioned response following re-exposure to the unconditioned stimulus after extinction training.

- Learning and Extinction

## Relation

### Definition

In the basic binary case, a relation  $R$  is a rule specifying when an object  $a$  is related by  $R$  to  $b$ . In an abstract mathematical sense, a binary relation is simply the set of ordered pairs  $(a,b)$  upon which it holds. The domain of the relation is the set of  $a$  which are related to some  $b$ .

The range of the relation is the set of  $b$  which are related to by some  $a$ . The relation is reflexive if every object  $a$  is related to itself. The relation is symmetric if whenever  $a$  is related to  $b$ , then  $b$  is also related to  $a$ . The relation is transitive if whenever  $a$  is related to  $b$ , and  $b$  is related to  $c$ , then  $a$  is related to  $c$ . An equivalence relation is a relation that is reflexive, symmetric and transitive.

A relation  $f$  is a function if to each  $a$  in its domain, there is exactly one  $b$  to which  $a$  is related, and this  $b$  is said to be the value of the function at  $a$ , written  $b = f(a)$ .

A function is one-to-one if whenever  $a_1$  and  $a_2$  are distinct, then so also are  $f(a_1)$  and  $f(a_2)$ . The function is onto  $B$  if every object in  $B$  is in the range of the function.

A one-to-one correspondence between  $A$  and  $B$  is a one-to-one onto function with domain  $A$  and range  $B$ . That is, a one-to-one correspondence provides a way of matching objects in  $A$  to objects in  $B$  in such a way that every object in  $A$  corresponds to a unique object in  $B$  and every object in  $B$  is corresponded to by a unique object in  $A$ .

The concept of binary relation can be generalized to ternary relations, which holds of triples  $(a,b,c)$ , and so on to any dimension, even to infinite dimensions.

- Physicalism

## Relational or Configural Navigation Strategy

### Definition

Behavior relying on an allocentric reference frame and oriented by an internal spatial representation.

- Spatial Memory

## Relative Pain Unpleasantness

### Definition

The amount of pain unpleasantness associated with a specific intensity of a pain sensation. It is a measure of how much a specific pain sensation bothers an individual. Equivalent intensities of pain may vary in unpleasantness, such as laboratory pain versus the pain of childbirth, or the pain of childbirth versus late stage cancer pain.

- ▶ Emotional/Affective Aspects of Pain

## Releasing Values

### Definition

Each stimulus has a certain attractiveness and may elicit a certain behavior. The attractiveness is measured by the releasing value. The natural, adequate stimulus has a releasing value of 100. Many stimulus have a lower releasing value, but some may have higher or supernormal releasing values.

## Releasing-Hormone and Release-Inhibiting Hormone

### Definition

These chemicals (mostly peptides) are produced by specific cells (neurosecretory cells) situated mainly in the hypothalamus and transported to the anterior pituitary gland. There they stimulate or inhibit a release of various anterior pituitary hormones. They include thyrotropin (TSH)-releasing hormone (TRH), which also acts as prolactin-releasing factor (PRF); adrenocorticotropin (ACTH) – releasing hormone (CRH); growth hormone (GH) – releasing hormone, (GHRH); growth hormone release-inhibiting hormone (somatostatin); gonadotropin (GnH) – releasing hormone (GnRH), sometimes called luteinizing-hormone (LH)- releasing

hormone (LHRH), and prolactin release-inhibiting factor, now considered to be dopamine.

- ▶ Homeostasis
- ▶ Hypothalamo-pituitary-adrenal Axis
- ▶ Stress and Depression
- ▶ Hypothalamo-pituitary-thyroid Axis
- ▶ Hypothalamus
- ▶ Pituitary gland

## Reliabilism

### Definition

Reliabilists claim that knowledge is true belief arrived at in a reliable manner, i.e. in a manner that makes it likely that the resulting belief is true.

- ▶ Knowledge

## REM

### Definition

Rapid Eye Movement Sleep.

- ▶ EEG in Sleep States

## REM-off Cells

### Definition

Extracellular single-unit-recording studies show that many neurons discharge at their highest rates (<5 spikes/sec) during waking, diminish their activity during non-REM (NREM) sleep, and become silent during REM sleep. Since these cells stop firing during REM sleep, they are called REM-off cells (also called PS-off cells). The majority of these REM-off cells are located in the locus coeruleus (LC) and raphé nuclei (RN). REM-off cells located in the LC contain the neurotransmitter noradrenaline and REM-off cells located in the RN contain the neurotransmitter serotonin. Although few in number, this type of cell is also

present in the caudal part of the pedunculopontine tegmentum (PPT) and laterodorsal tegmentum (LDT).

- ▶ Locus Coeruleus
- ▶ Non-REM Sleep
- ▶ Noradrenaline
- ▶ Raphé nuclei
- ▶ Rapid Eye Movement (REM) Sleep
- ▶ Serotonin

## REM-on Cells

### Definition

Neurons that exhibit increases in extracellularly recorded discharge rate during ▶[rapid eye movement \(REM\)](#) sleep, rather than during waking and non-REM (NREM) sleep. This population of neurons is characterized by a progressively increasing mean tonic discharge rate as the animal moves from wake to NREM sleep and finally to REM sleep. This type of cell is mostly located in the pontine reticular formation, pedunculopontine tegmentum (PPT) and laterodorsal tegmentum (LDT). REM-on cells located within the pontine reticular formation contain the neurotransmitter glutamate and REM-on cells located in the PPT and LDT contain the neurotransmitter acetylcholine.

- ▶ Acetylcholine
- ▶ Glutamate
- ▶ Non-REM Sleep
- ▶ Rapid Eye Movement (REM) Sleep

## REM Sleep

### Definition

- ▶ Rapid Eye Movement (REM) Sleep

## REM Sleep Behavior Disorder (RBD)

### Definition

A parasomnia (a disorder involving abnormal behavior during sleep) characterized by the acting out of vivid, sometimes violent, confrontational or belligerent dreams during REM sleep. This happens because the

REM-related atonia of voluntary muscles is lacking, allowing the muscles to move during dreaming. REM behavior disorder causes sleep disruption and potential injury to self or to others (e.g., a bed partner).

- ▶ Alertness Level

## Remapping in Hippocampus

### Definition

Remapping is the process of replacing one map representation with another. A representation is “re-mapped” when the map elements are scrambled. In the hippocampus, changing environments, or contexts, is associated with remapping.

- ▶ Spatial Learning/Memory

## REMO

### Definition

Episodic retrieval mode; a component process of episodic retrieval that is required for remembering earlier experiences.

- ▶ Hemispheric Asymmetry of Memory

## Remote Memory

### Definition

The long-term representation of information that was learned months to years earlier.

- ▶ Memory and Dementia

## Remyelination

### Definition

Myelin sheaths are formed by Schwann cells in the peripheral nervous system, and by oligodendrocytes in

the central nervous system. If myelin sheaths are degraded due to injury or pathological changes, new myelination develops on the surviving axons. In the central nervous system, remyelination is usually incomplete with a reduced number and irregular configuration of myelin lamellae over a long period of time.

- ▶ Myelin
- ▶ Oligodendrocyte
- ▶ Regeneration
- ▶ Schwann cell
- ▶ The Role of Basal Lamina in Nerve Regeneration
- ▶ Autoimmune Demyelinating Disorders: Stem Cell Therapy

## Renshaw Cell

### Definition

Renshaw cells are inhibitory interneurons (using glycine and GABA as transmitters), which are located in the ventral horn of the spinal cord, receive their main excitatory inputs from collaterals of motoneurons and mediate recurrent inhibition of motoneurons, Ia inhibitory interneurons, Renshaw cells and cells of origin of the ventral spinocerebellar tract. Other inputs to Renshaw cells arise from sensory afferent fibers and tracts descending from supraspinal structures.

- ▶ Ia Inhibitory Interneuron
- ▶ Recurrent Inhibition

## Repetition Maximum (RM)

### Definition

Repetition Maximum represents the load used in resistance training. Performing sets of ten repetition maximum (RM) loads or less are typically used for resistance training, with one RM being the maximum weight an individual can lift once, and ten RM being the weight an individual can lift exactly ten times. These values represent 100% and ~70% of maximum capability for one RM and ten RM, respectively.

- ▶ Muscle – Age-Related Changes

## Replacement Neuromast

### Definition

A superficial neuromast (hair cell of the lateral line system) having phylogenetic continuity with a neuromast found inside a canal in other taxa. This superficial configuration is most likely due to retarded development of canals in that taxon.

- ▶ Evolution of Mechanosensory and Electrosensory Lateral Line Systems
- ▶ Neuromast

## Repolarization

### Definition

Repolarization is the return of membrane potential to its resting value. The term refers mostly to repolarization of the action potential, although more generally it also means the return to a more negative value after (forced) depolarization. Repolarization of the action potential is often carried by the outward flux of potassium ions mainly through delayed rectifying, voltage-gated potassium channels.

- ▶ Action Potential
- ▶ Neuronal Potassium Channels

## Report

- ▶ Feedback Control of Movement

## Representation (Mental)

MICHAEL SCHÜTTE  
Institut für Philosophie, Universität Magdeburg,  
Magdeburg, Germany

### Definition

The term “mental representation” is sometimes used to cover any mental item which is semantically evaluable,



i.e. which has content, ► **truth-value**, refers to something, possesses ► **truth-conditions**, or is about something. Under this broad construal its extension includes beliefs, thoughts, memories, desires, perceptions and all other mental phenomena exhibiting the feature of intentionality.

But there also is a narrower construal of “mental representation” closely associated with the agenda of cognitive science. Under this narrower construal, mental representations are certain theoretical entities, i.e., semantically evaluable particulars which are postulated by classical or other types of cognitive architectures in order to explain processes and states which count as mental representations only in the broad sense.

### Description of the Theory

Mental representations as theoretical entities postulated by cognitive scientists come in very different shapes. Think of a cognitive scientist working in the paradigm of classical architectures. Insofar as she tries to understand the mind as a complex system that receives, transforms and stores information, that is, as a complex symbol-manipulating system, her approach is based on the idea that mental phenomena should be explained by postulating mental representations (symbols). Or think of a cognitive scientist working in the paradigm of ► **connectionist architectures**. Insofar as he tries to understand human behavior and mentality as based on the activity of neural networks, his approach, too, is based on the idea that mental phenomena should be explained by postulating mental representations, although these are notably different from those of classical architectures.

Mental representations as theoretical entities postulated by cognitive scientists come in great variety including, e.g., activity vectors in connectionist networks, Marr’s  $2\frac{1}{2}$ -D sketches in his theory of vision, Kosslyn’s mental images, the mental models of Johnson-Laird, or Fodor’s “sentences in the language of thought” [1]. Ironically, most mental representations are misleadingly labeled “mental” representations, for they are explicitly understood as certain neuronal or other physical structures. But certainly, they all qualify as mental in the weak sense that they are postulated in order to explain mental features. The mental features to be explained range from pattern recognition to intentional behavior, but in the following we will concentrate on the so called propositional attitudes like believing or desiring that something is the case. Generally speaking, propositional attitudes are mental states which can be ascribed with the help of “that”-clauses.

### Representation

Representations are, of course, ubiquitous: There are words, photographs, paintings, maps, traffic signs, diagrams, graphs, music notes, X-ray photographs,

digital images, and much more. They are not bound to a specific medium or syntax, and there are virtually no limits as to which things can represent which. A representation, as a self-representation, can represent itself, and two different things can represent each other. Representation should be distinguished from mere information, at least if the latter is taken to include things like the universe containing information about the big bang or the smoky sky containing the information that there is a fire. The idea behind distinguishing representation from information is that information cannot be false (otherwise it would not be information at all), whereas misrepresentation is possible. If this is correct, smoke does not represent fire, although it “indicates” or “means” fire [2]. It is notoriously hard to spell out precisely the necessary and together sufficient conditions which make something a representation, but there is a kind of consensus that every representation purports to stand for, denote, refer to, or be about something. Another important aim of philosophical thinking about representation is to build a useful classification of the many different forms of representation (see [3] and [4] for two very influential classificatory schemes).

### Representational Theory of Mind

The best-known representational theory of propositional attitudes is developed by Fodor [1]. It is a paradigm instance of a ► **classical architecture** in cognitive science, and is best seen as an attempt to explain how propositional attitudes and reasoning processes can be physically realized. Strictly speaking, this is a two-step enterprise: The first step is concerned with the question how propositional attitudes and cognitive processes can be realized by computational relations and processes in which symbols are manipulated. The second step consists in explaining how these computational relations and processes can in principle be physically implemented. Fodor thinks that the second step is already established by the theoretical work of Turing and others and, of course, by the actual development of computers. Therefore, he sees his main task in making intelligible how propositional attitudes can be realized by computational relations. The central features of propositional attitudes which are to be explained include the following: They are (i) semantically evaluable, (ii) causally efficacious, and (iii) opaque.

In order to account for these features, Fodor does several things. First, he assumes that there are mental representations. These are held to be sentence-like physical structures in a “language of thought.” This means four things: Like sentences mental representations have propositional content; like sentences they are structured entities which have parts that themselves possess meaning; like sentences they have a compositional semantics, i.e., their meaning is a function of the

meanings of their parts and the order of these parts; and these parts are “transportable” which means that the same parts can appear in many mental formulas (Fodor [1]: 137). Fodor calls the conjunction of these claims the Language of Thought Hypothesis. Second, Fodor then uses these views to formulate the representational thesis according to which propositional attitudes are relations between organisms and mental representations. For example, to believe that grass is green means, according to the representational thesis, to stand in a certain relation (the belief-relation) to a mental representation which means that grass is green. More generally, for any organism O, and any attitude A toward the proposition P, there is a computational relation R and a mental representation M such that (i) M means that P, and (ii) O has A if and only if O bears R to M (Fodor [1]: 17). That an organism bears a certain computational relation to a mental representation M is spelled out in the following way: The representation M occupies a certain causal or functional role in the organism; i.e. it is tokened in a special functionally defined area (e.g. the “belief-box” or the “desire-box”) and will be manipulated in a specific way. Third, Fodor claims that mental processes are causal sequences of tokenings of mental representations. This is best conceived as the view that causal relations between propositional states rely on computational processes that are sensitive to the structure of the involved mental representations.

This theory neatly explains the central features of propositional attitudes mentioned above as follows. (i) That propositional attitudes are semantically evaluable is accounted for by the fact that they are realized with the help of mental representations which are semantically evaluable. (ii) The deeper point in connection with second feature (causal efficacy) is this: Often causal relations between propositional attitudes contrive to respect their relations of content. For example, my thoughts that p and that (if p, then q) often cause me to think that q. This is explained by the fact that cognitive processes are computational processes which are structure-sensitive. This sensitivity to the syntax of mental representations is enough to explain the possibility of the parallel structure of logical and causal relations, because, as is well-known from logic, logical relations can be characterized syntactically. (iii) The belief that p and the belief that p\* can be different beliefs, such that it is possible to believe that p without at the same time believing that p\* (and vice versa), even when p and p\* are both true or both false (or even possess the same truth-conditions). This feature of **opacity** can be explained by the representational theory under the assumption that the mental representations of p and p\* are syntactically different. Because syntactically different representations are typically manipulated in different ways, it is no mystery how at a certain time, there can be the mental representation

p, but not the mental representation p\* in someone’s belief-box.

Main objections to Fodor’s representational theory concern two issues. The first is the issue whether there is empirical evidence against its implication that causally efficacious attitudes require actual tokenings of mental representations. The second is the issue whether the assumption that there are physical structures which have semantic content can be made plausible at all. This is the topic of the next section.

### Physical Structures as Mental Representations

The representational theory as outlined above simply assumes that mental representations have a semantic content. Therefore, it remains another task for its proponents to explain how these representations being neural or physical entities can be semantically evaluable at all: How can physical or neuronal structures actually represent some state of affairs? This matter is not only of interest to the proponents of the representational theory, but is also of crucial interest for anyone else who takes a realistic stance on mental representations. Over the last two and a half decades, philosophers have developed several approaches to answer this question [1,5,6].

1. Dretske’s information-theoretic approach is rendered in terms of information, and analyzes the property of having semantic content as a form of carrying information: A certain structure S (e.g. a representation) has the semantic content that p if and only if S carries the information that p and the information that p is the most specific piece of information which S carries, i.e. S carries no other piece of information in which the information that p is nested (see Dretske [5]: 177). That S carries information about something X at all basically means that there is a certain causal correlation between S and X. The attractiveness of this approach lies in the fact that in principle it is no mystery how physical structures (rocks, clouds, or brains) can carry information. In order to explain how misrepresentation is possible, Dretske appeals to the learning period in which a representation is acquired. In a nutshell, the explanation is that only causal correlations during the learning period determine what S represents, whereas after the learning period S can be caused by different things which, then, are misrepresented by S. This information-theoretic account faces two major problems: (i) it only works for representations which are acquired through an individual learning history, and (ii) it cannot deal with the **disjunction problem** (Fodor [1]: 101f). The latter problem is a fundamental problem for every broadly causal account of meaning or content: If the contents of A-representations are determined by their being caused by

C-states, but sometimes A's are brought about by some other cause C\*, then how can the causal theory account for the difference between the case in which A's represent C, but sometimes are caused by C\*-states, and the case in which A's represent the disjunction C-or-C\*? Dretske's appeal to a learning period would only be of help here if it were guaranteed that during this period all and only those factors cause A's which should enter into the semantic content of A's. But this seems to be false for empirical reasons.

2. Teleological accounts try to solve the disjunction problem by appeal to the biological function or purpose of representational states [6]. According to them, the mental representation R, although sometimes caused by dogs, represents wolfs and not wolfs-or-dogs, because it is the biological function of R-type representations to indicate wolfs and not wolfs-or-dogs. A major difficulty for this type of accounts is to explicate the notion of biological function in a non-semantic way. This is typically tried to be accomplished by an appeal to the (evolutionary) history of the organism. But it has turned out over the years that this is by far no easy task. Another problem lies in the fact that teleological accounts which appeal to evolution have counterintuitive consequences. For example, most people have the intuition that a perfect physical and behavioral duplicate of a human being would also have beliefs and desires. But if this duplicate has the wrong kind of history (or literally no history at all), it is thereby precluded from having mental representations. This arguably leads to an epistemological difficulty as well: If it is the evolutionary history of an organism which determines whether and which things are represented by its inner states, we can only know whether someone believes something if we know enough about its evolution.
3. Fodor [1] developed a third type of account which is based on the notion of asymmetric dependence. It runs along the following lines: A-states (of an organism O) represent C if and only if (i) under optimal conditions all C's cause an A-token, and (ii) all A-tokens which are caused by a state C\* are asymmetrically dependent on the causation of A-tokens by C's. The idea behind Fodor's notion of dependence can be caught by a question: Would the C\*-state also have caused A-tokens if C-states did not cause A-tokens? If not, the causal relation between C\*-states and A-tokens is dependent on the relation between C-states and A-tokens. This dependence is asymmetrical if it is not the other way round, i.e. if it is not true that the relation between C-states and A-tokens is dependent on the relation between C\*-states and A-tokens. Although this is an ingenious proposal, as some philosophers

have pointed out, it might be entirely misguided. Let us assume that tokens of A in an organism O mean "bird," but sometimes are caused by big insects. According to Fodor's proposal, this is the case because big insects would not cause A's if birds did not cause A's in O. But, now, what is it that precludes big insects to cause A's in O even if there were no birds around? Why, in other words, should there be an asymmetric dependence relation at all? Certainly, if A were to mean "bird" in the first place, it would be quite plausible that some big insects cause A's in O only because normally birds cause A's in O. But that A means "bird" is exactly what Fodor's theory tries to explain and, therefore, cannot be assumed by it.

### Intentional Realism Versus Eliminativism

The representational theory of propositional attitudes and the project of naturalizing mental representations as sketched in the last section are committed to ► **Intentional Realism**. Intentional Realism is the view that humans have intentional states which (i) more or less obey the laws of folk psychology and which (ii) have a semantic content that is (iii) causally efficacious. But these assumptions can, of course, be denied. Most prominently some philosophers favor an eliminative stance towards propositional attitudes. Churchland [7] argues that folk psychology is a rather unsuccessful theory which in the long run will be substituted by a much better explanation of human behavior developed by scientific psychology or neuroscience which is incompatible with the folk assumptions. But because intentional states like beliefs and desires are only theoretical entities postulated by folk psychology, Churchland argues, they will be eliminated when folk psychology is abandoned.

Intentional Realism and Eliminative Materialism are opposing views on the ends of a spectrum and there are positions in-between. A very prominent one is Dennett's [8]. On the one hand, Dennett agrees with the Eliminative Materialists that there are in principle neuroscientific explanations of human behavior which are superior and incompatible with ► **intentional explanations**. On the other hand, he stresses that we cannot abandon intentional explanations altogether, because there are certain patterns in human behavior which can only be discovered from the intentional stance. Whether this or other "in-between" positions (as [9,10]) can be coherently defended is difficult to evaluate. What they all try to show is that the semantic contents of intentional states are real enough to underpin the autonomy of intentional explanations, but at the same time are not real enough to require their physical implementation. This can be put it in another way which perhaps is an exaggeration: These approaches aim to preserve mental representations in the broad sense (intentional states) without committing themselves to

the existence of mental representations in the narrow sense. Faced with the empirical and conceptual problems of Intentional Realism and the smell of absurdity of eliminativism, this may be an attractive direction of inquiry for further theories of mental representation.

## References

1. Fodor J (1987) *Psychosemantics*. MIT Press, Cambridge, MA
2. Dretske F (1995) *Naturalizing the mind*. MIT Press, Cambridge, MA
3. Goodman N (1976) *Languages of art*. Hackett, Indianapolis
4. Peirce CS (1935) *Collected papers*, vol. 2. Harvard University Press, Cambridge, MA
5. Dretske F (1981) Knowledge and the flow of information. MIT Press, Cambridge, MA
6. Millikan R (1984) *Language, thought, and other biological categories*. MIT Press, Cambridge, MA
7. Churchland P (1981) Eliminative materialism and the propositional attitudes. *J Philos* 78:67–90
8. Dennett D (1987) *The intentional stance*. MIT Press, Cambridge, MA
9. Beckermann A (1996) Is there a problem about intentionality? *Erkenntnis* 45:1–23
10. Cummins R (1989) *Meaning and mental representation*. MIT Press, Cambridge, MA

## Repressed Memories

### Definition

Memories for traumatic experiences that the mind supposedly banishes from conscious awareness due to their threatening nature. According to this theory, once repressed, these memories may return to consciousness.

The resulting memories are thought to be accurate in detail, and involve processes that are different from ordinary forgetting and remembering. Credible scientific support is lacking for these notions.

► [Memory Distortion](#)

## Repressor

### Definition

A transcription factor that negatively regulates the expression of a gene.

## Reproduction

### Definition

Production of offspring.

## Reproductive Organs

► [Visceral Afferents](#)

## Reptilia

### Definition

The amniote clade incorporating the last common ancestor of turtles, lizards, crocodiles and birds, and all descendents of that common ancestor.

► [The Phylogeny and Evolution of Amniotes](#)

## Repulsive Guidance Molecule

R

### Definition

The molecule by which growth cone movement is repelled.

► [Axon Pathfinding](#)

## RER

### Definition

► [Rough Endoplasmic Reticulum](#)

## Res Cogitans

### Definition

Latin phrase meaning “thinking thing,” introduced by Descartes to refer to the mind as opposed to the body (the res extensa or “extended thing”).

- ▶ Emergence

## Rescorla-Wagner Model

### Definition

This model of classical conditioning attributes variations in the effectiveness of conditioned stimulus-unconditioned stimulus (CS-US) pairings to variations in US processing. The model asserts that an US must be surprising for learning to occur. An US is defined as surprising if the discrepancy term ( $\lambda - V_T$ ) is different from zero. This discrepancy reflects the difference between the maximum conditioning the US can support ( $\lambda$ ) and the associative strength of all the stimuli on the trial ( $V_T$ ). The equation for calculating a change in the associative strength of a CS is:

$$\Delta V_{CS} = \alpha_{CS}\beta_{US}(\lambda - V_T)$$

where  $V_T$  represents the total or sum of the individual associative strengths of all CSs present on that trial;  $\alpha$  and  $\beta$  are fixed rate parameters (values from 0 to 1) determined by the salience (physical properties) of the CS and US, respectively;  $\lambda$  is the maximum conditioning that the US can support.

- ▶ Theory on Classical Conditioning

## Resetting

### Definition

Alteration of a circadian rhythm such that it occurs earlier (advance) or later (delay) than predicted in subsequent cycles.

- ▶ Circadian Cycle
- ▶ Circadian Rhythm
- ▶ Clock

## Residual Brain Cells

### Definition

Astrocytes, microglia and neurons are the residual brain cells. Along with cells of the immune system which migrate towards the brain in CNS disorders, these also play an important role in the etiology of these disorders.

- ▶ Central Nervous System Disease – Natural Neuroprotective Agents as Therapeutics

## Residual Hearing

### Definition

The amount of hearing left after hearing loss.

- ▶ Hearing Aids

## Residual Schizophrenia

### Definition

Constellation of symptoms which often occur after many years of a chronic course. Beside psychotic symptoms, patients suffer from symptoms of general cognitive impairment and affective flattening.

- ▶ Schizophrenia

## Resistance (Electrical)

### Definition

Resistance (electrical) is the reciprocal of conductance and a measure of the resistance of an object to electric current flow.

- ▶ Ohm's Law

## Resistance Training

### Definition

Resistance training or strength training can be defined as progressively overloading the neuromuscular system using near maximal muscle contractions against high resistance. Its purpose is to increase the ability to perform maximal contractions and increase muscle size.

► Muscle – Age-Related Changes

## Resonance

### Definition

The frequency at which maximum output occurs.

► Hearing Aids

## Respiration – Neural Control

PETER M. LALLEY

Department of Physiology, Medical Sciences Center,  
University of Wisconsin School of Medicine and Public  
Health, University Avenue, Madison, WI, USA

### Synonyms

Respiratory system neurophysiology; Neuroanatomy  
and neurotransmitter/neuromodulator control

### Definition

The neural control of respiration refers to functional interactions between networks of neurons that regulate movements of the lungs, airways and chest wall and abdomen, in order to accomplish (i) effective organismal uptake of oxygen and expulsion of carbon dioxide, airway liquids and irritants, (ii) regulation of blood pH.

### Introduction

The neural control of respiration is still not completely understood, although remarkable progress has been made as instrumentation, technology and analytical procedures continue to improve at an accelerated pace. (Many excellent reviews are available that have

followed progress in the field, and the interested reader is encouraged to consult them for particular areas of interest [1–14,16–18,20,21,23–26,28–31,33].)

It is axiomatic that biological cells are dependent on respiration for survival, proper function and ►**homeostasis**. They require an efficient transport system that provides oxygen (O<sub>2</sub>) for aerobic metabolism and energy production and for extrusion of its end products, carbon dioxide (CO<sub>2</sub>) and water.

In mammals respiration takes on an additional, organismal meaning and significance, synonymous with ventilation; i.e., the act of breathing ambient air in and out to deliver O<sub>2</sub> from the mouth and nasal passages to the lungs, and to transport CO<sub>2</sub> from lungs to atmosphere.

### The Respiratory Apparatus in Mammals

Effective organismal exchange of O<sub>2</sub> and CO<sub>2</sub> in mammals requires finely coordinated interactions between the organs of breathing and the ►**cardiovascular system**. The latter consists of the heart acting as the pump for blood in which O<sub>2</sub> and CO<sub>2</sub> are dissolved and the vascular network, from capillaries to major arteries and veins, which serves as the transport line between the lungs and other O<sub>2</sub>-consuming, CO<sub>2</sub>-producing organs. A system of valves in the heart and in the sphincters surrounding arterioles regulates the flow of blood.

The organs of breathing (Fig. 1) can also be subdivided into pump and flow components. The pump machinery consists of the diaphragm, chest wall and abdominal muscles, while the transport system involves the mouth, nasal passages, bronchi, bronchioles and lungs. In the lungs, the alveoli, a vast network of air-filled sacs, are in intimate contact with blood capillaries where exchange of O<sub>2</sub> and CO<sub>2</sub> takes place. Airway resistance and airflow in and out of the lungs is affected by altering the tone of bronchiole smooth muscle, pharyngeal skeletal muscle, nasal musculature, as well as tongue position and the tone of the laryngeal (vocal fold) abductor and adductor muscles.

### Performance of the Respiratory Apparatus During Inspiration and Expiration

During inspiration, airflow into the lungs and alveoli is produced as the diaphragm contracts during periodic discharges of the phrenic and inspiratory intercostal nerves (Fig. 2); the discharges are activated by excitatory synaptic drive within the ►**brainstem**-spinal cord respiratory network. Contraction of the diaphragm changes its configuration from dome shaped to relatively flat. This increases the intrathoracic volume, resulting in an increase of negative intrapleural pressure that promotes lung inflation and inward airflow from the mouth to the lungs. Discharges in intercostal nerves contract the inspiratory muscles of the rib cage,

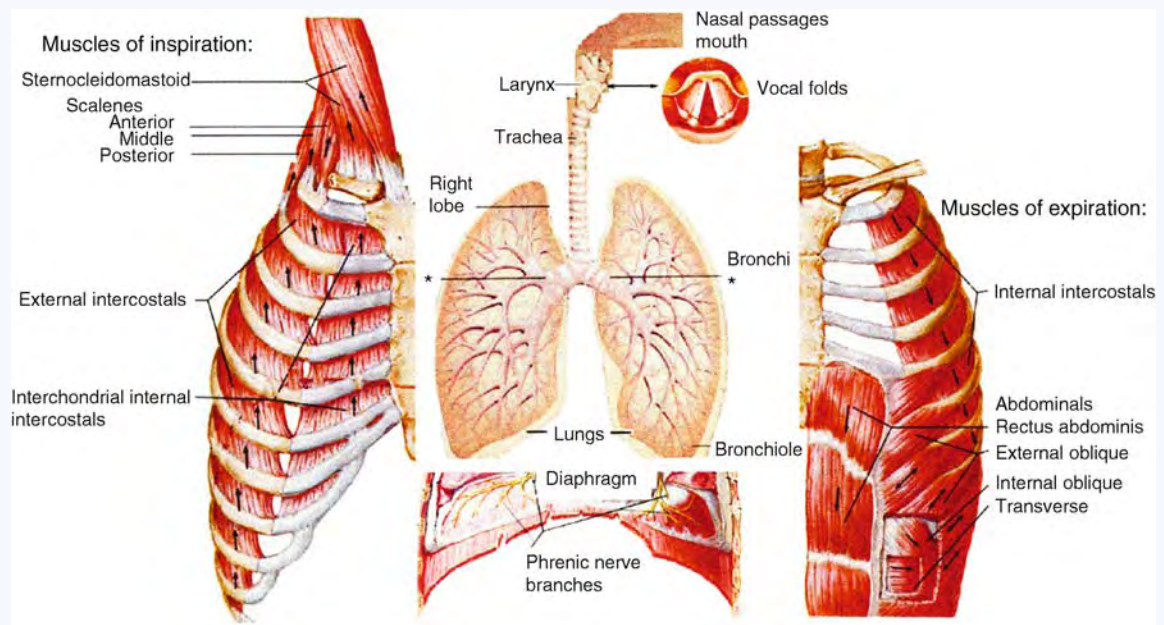

**Respiration – Neural Control. Figure 1** The respiratory apparatus. Left side, muscles that expand the chest for lung inflation during inspiration are illustrated. Arrows show the upward direction of rib movement. The middle upper segment illustrates the airways, from nasal passages to lungs. A cross section through the larynx shows the laryngeal folds in an open (abducted) state during inspiration. The middle lower segment shows the diaphragm, which contracts downward to inflate the lungs during inspiration. Phrenic nerve branches that innervate the diaphragm and cause the musculature to contract are also seen. Right, muscles of the chest wall and abdomen that contract to aid lung deflation during active expiration. Arrows show the direction of rib and abdominal muscle movements. Modified from [19].

moving the ribs upward and outward to further increase intrathoracic volume and inward airflow. (► **Spinal respiratory neurons**) Movement of air into the lungs is further supported by cranial ► **motoneuron** discharges (► **Action potential**) that reduce upper airway resistance by contracting the muscles of the nasal passages and pharynx, move the tongue forward in the mouth (► **Respiratory control of hypoglossal motoneurons during sleep and wakefulness**) and dilate the vocal folds by contracting abductor laryngeal muscles.

Until the end of the inspiratory phase, phrenic and inspiratory intercostal nerve discharges progressively increase, causing a gradual flattening of the diaphragm and expansion of the chest wall.

At the end of the inspiratory phase, phrenic, inspiratory intercostal and abductor laryngeal motoneurons stop discharging. A very brief silent period is followed by resumption of discharges that is less intense and declining as it progresses. During this transitional stage, referred to as either the postinspiratory or early expiratory phase, adductor motoneurons of the superior laryngeal nerve also discharge with declining intensity. The decrementing phrenic and laryngeal nerve discharge patterns result in a more gradual relaxation of the diaphragm, a reduced rate of outward airflow and thus a slowing in the rate of lung deflation. Alveolar

collapse is opposed and ► **functional residual capacity (FRC)** is maintained, which has beneficial pulmonary consequences. Normally, only about 15% of air in the lungs is replaced by new air during each normal inspiration, and about the same amount of old air is expired. The slow replacement of air prevents sudden changes in blood gases that would destabilize respiratory control. Excessive increases and decreases of blood  $pO_2$ ,  $pCO_2$  and pH are also prevented when respiration is temporarily interrupted, for example during swallowing or phonation. Partial inflation during a normal FRC also maintains surfactant release and thus lung compliance, because the principal stimulus for liberation of surfactant appears to be direct mechanical distortion of type II alveolar cells [35].

Expiration during quiet breathing is mainly passive. Discharges of inspiratory cranial, phrenic and inspiratory intercostal nerves are silenced by synaptic inhibition in the brainstem and spinal cord. The chest wall and diaphragm return to their resting configurations and airway patency is maintained to allow passive outward airflow from the lungs to the atmosphere.

During active expiration, for example during exercise or coughing, discharges of the internal (expiratory) intercostal nerves move the lower ribs downward and inward. In addition, lumbar motoneuron discharges

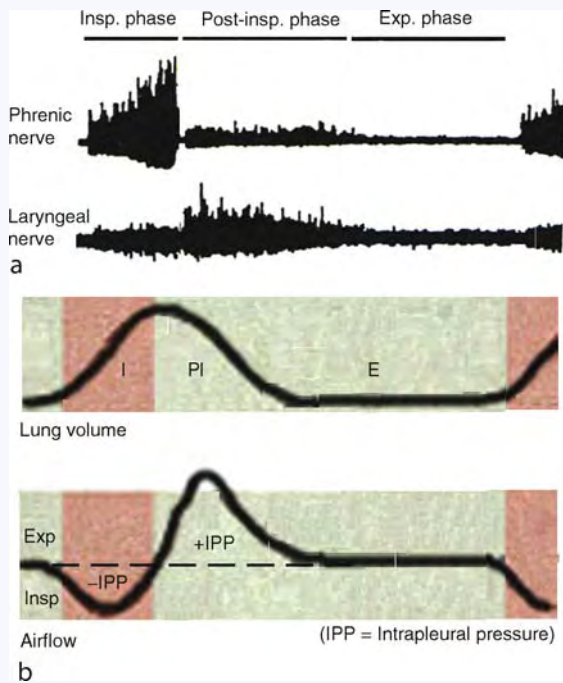

**Respiration – Neural Control. Figure 2** Discharges of the phrenic and laryngeal nerves (A) and changes in lung volume and airflow (B) during one respiratory cycle. In part B, I = inspiration, PI = post-inspiration, E = expiration. Part A adapted from Bianchi et al. 1995 [2]. Part B adapted from [24].

contract the abdominal muscles and compress the abdominal contents, pushing up the diaphragm and actively expelling air from the lungs. Upper airway patency is maintained by discharges of laryngeal abductor nerves and pharyngeal constrictor nerves.

The cycle of inspiration, postinspiration and expiration in the adult human is repeated, on average, about 15 times during quiet breathing.

### Respiratory Muscles Contract in an Ordered Sequence that Optimizes Mechanical Advantage

The inspiratory pump muscles in both humans and quadrupeds discharge with a set temporal order that optimizes the mechanical advantage, or leverage of the muscles, and reduces the work of breathing [8]. Electromyographic studies in humans show that, relative to the onset of airflow into the airways, the diaphragm and the third dorsal external intercostal muscles are the first to contract, followed by the second parasternal intercostal and scalene muscles and lastly by the fifth dorsal external intercostal muscles. The order of recruitment is consistent with the relative inspiratory mechanical advantage that each of the muscles has, and the degree of inspiratory opening pressure exerted on the airways by each. The intensity and duration of unit discharges are greater for the diaphragm and third dorsal external intercostal **▶motor**

units than for the other pump muscles. The pattern of recruitment of intercostal muscles not only expands the rib cage, but also applies stretch to the diaphragm to increase contractile strength.

Several factors have been posited for the recruitment and discharge patterns of the different pump muscles, including: (i) recruitment order of bulbospinal and spinal interneurons, (ii) different degrees of persistent and rhythmic inward currents and (iii) their spatial distribution over the soma and dendrites of motoneurons and (iv) graded distribution of inhibitory central respiratory drive potentials.

### Central Nervous Control of the Respiratory Apparatus

Aggregates of neurons that discharge periodically during inspiration, post-inspiration or expiration are distributed bilaterally in the bulbar brainstem, from the rostral **▶pons** (**▶Pontine control of respiration**) to the caudal border of the **▶medulla** (**▶Anatomy and function in the respiratory network**). Synaptic interactions among the neurons establish the network respiratory rhythm, and their connections with cranial and spinal motoneurons and interneurons set up the timing and patterns of contraction in the muscles of respiration. Three regions of the medulla in particular have been studied for their roles in respiratory rhythmogenesis: the Pre**▶Bötzing** Complex (**▶PreBötzing Complex Inspiratory Neurons and Rhythm Generation**) and the para-facial and retrotrapezoid regions (**▶Respiratory network analysis and isolated respiratory centre functions**; [12]). Their functional integrity is essential for a normal respiratory rhythm, and in the PreBötzing and para-facial areas neurons with autorhythmic pacemaker properties have been identified (**▶Respiratory network analysis, isolated respiratory centre functions**; **▶Pacemaker neurons and respiratory control**).

Respiratory neurons of the brainstem receive modulatory synaptic input from non-respiratory regions such as the **▶motor cortex**, pontine and medullary **▶reticular formation**, **▶cerebellum**, **▶hypothalamus**, other **▶limbic** and cardiovascular regions of the brainstem as well as from extrapyramidal motor areas (**▶Anatomy and function in the respiratory network**). These non-respiratory modulatory inputs adapt breathing rhythm and pattern to accommodate activities such as phonation, swallowing, coughing, physical exertion, defecation and postural change.

### Rhythm Formation in Bulbar Respiratory Neurons

The **▶membrane potential** of medullary respiratory neurons normally oscillates between cycles of depolarization and hyperpolarization. The pattern of depolarization or hyperpolarization may be augmenting (increasing in intensity from onset to termination), decrementing



(declining in intensity) or plateau (constant from onset to termination). In association with the patterns of depolarization, periodic discharges can be augmenting, decrementing or of constant intensity [9,25].

The rhythm and pattern of discharge in bulbar respiratory neurons result from a combination of intrinsic membrane ion **▶conductances**, synaptic interactions among the neurons, and input from other CNS neurons and peripheral sensory afferents.

Intrinsic membrane ion conductances initiate membrane depolarization that triggers action potential discharge, control the rate of depolarization and hyperpolarization, and terminate action potential discharge [25,26] (**▶PreBötzinger Complex Inspiratory Neurons and Rhythm Generation**). Tonic excitatory drive comes from at least two sources. One is from CO<sub>2</sub>-sensitive neurons in the medulla (**▶Central nervous chemoreceptors and respiratory drive**; **▶Medullary raphe nuclei and respiratory control**). A second is from non-respiratory reticular activating neurons. These excitatory inputs can be suppressed or reinforced by feedback synaptic input from medullary and pontine respiratory neurons. **▶Chemoreceptor** and **▶mechanoreceptor** afferents from the **▶carotid bodies** (**▶Carotid body chemoreceptors and respiratory drive**), heart, lungs, chest wall and upper airways also influence discharge properties of bulbar respiratory neurons.

All afferent inputs and synaptic interactions among the respiratory and non-respiratory neurons are regulated chemically by **▶neurotransmitters and neuromodulators**, including excitatory and inhibitory amino acids, acetylcholine, peptides, monoamines and adenosine (**▶Respiratory neurotransmitters and neuromodulators**).

### Rhythmic Properties, Connections and Functions of Respiratory Neurons in the Pons and Medulla

The roles that various types of bulbar neurons play in respiratory control have been investigated by: (i) measuring membrane potential and discharge properties during various phases of the respiratory cycle, (ii) identifying synaptic connections among them and (iii) observing their responses to changes in respiratory rhythm and ventilation. From such studies, theories of how the neurons interact as a network to generate rhythm have been proposed [2,16,25] (**▶Anatomy and function in the respiratory network**). Elegant computer modeling studies based on the experimental findings have tested and support many of the proposed connections and predict additional ones (**▶Computational modeling of the respiratory network**).

*Neurons in the respiratory-related regions of the rostral pons* discharge with waves of excitatory and inhibitory postsynaptic potentials and intermittent bursts of action potentials and that are coincident with one of the three phases of the respiratory cycle, and some discharge more intensely at the transitions between

phases (**▶Pontine control of respiration**). In unanesthetized cats prepared for chronic studies, respiratory rhythm is not obvious during sleep [2], and rhythmicity is diminished when nervous input from the lungs is intact. The pontine network of neurons modulates amplitude and timing of the respiratory muscles, and seems to promote inspiratory termination if pulmonary afferent feedback is impaired.

*In respiratory regions of the medulla*, six different types of medullary respiratory neurons differentiated by membrane potential and discharge properties have been identified: (i) Early-Inspiratory, (ii) Ramp-Inspiratory, (iii) Late-Inspiratory, (iv) Post-Inspiratory, (v) Late-Expiratory, (vi) Pre-Inspiratory (Fig. 3).

*Early-Inspiratory neurons* are propriobulbar, that is, their cell bodies, dendrites and axons are restricted to bulbar regions. They depolarize suddenly to threshold shortly before phrenic nerve discharge begins at the onset of inspiration. One type of Early-Inspiratory neuron exhibits a discharge that is intense but decrementing, in association with a declining pattern of depolarization, until it terminates late in inspiration, before the phrenic nerve inspiratory discharge ceases [25]. The other type exhibits a constant, or plateau pattern of depolarization and discharge that begins and ends with the phrenic nerve inspiratory discharge [9]. In either case, two processes seem to be responsible for discharge termination. One is weak synaptic inhibition, possibly from Late-Inspiratory neurons, but a more prominent source is the development of a **▶Ca<sup>2+</sup>-activated K<sup>+</sup> conductance** that builds up as Ca<sup>2+</sup> enters during cell discharge through high voltage-regulated channels. Thereafter, membrane potential is hyperpolarized by synaptic inhibition produced by the discharge of Post-Inspiratory and Late-Expiratory neurons. The proposed role of Early-Inspiratory neurons of the decrementing type is to impose synaptic inhibition on Late-Inspiratory and Post-Inspiratory neurons, which prevents premature termination of phrenic motoneuron discharges [25]. As for the plateau type, they seem to augment inspiratory phase excitatory synaptic drive, because input to Ramp-Inspiratory neurons has been demonstrated electrophysiologically [9].

*Ramp-Inspiratory neurons* are either propriobulbar and/or bulbospinal and provide excitatory synaptic drive to phrenic and intercostal inspiratory motoneurons and interneurons. They depolarize and discharge with an augmenting pattern at the beginning of inspiration, in parallel with phrenic nerve discharges. The pattern of depolarization and discharge in Ramp-I neurons is attributed to a combination of mutual recurrent excitation among the neurons and declining inhibitory synaptic input from Early-I neurons. Discharge is terminated by inhibitory synaptic input from Late-Inspiratory and Post-Inspiratory neurons.

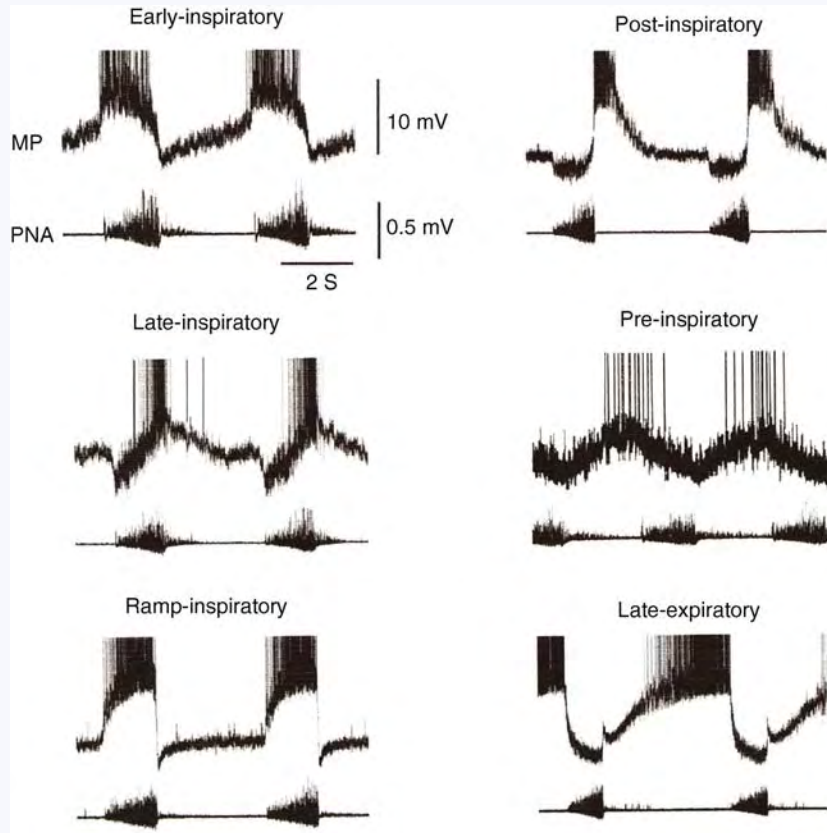

**Respiration – Neural Control. Figure 3** Medullary respiratory neurons thought to be involved in respiratory rhythmogenesis. The six types of neurons were recorded intracellularly in adult cats *in vivo* in studies performed by A. Haji and coworkers. Each pair of tracings shows neuron membrane potential (MP) and phrenic nerve activity (PNA). Figure courtesy of Prof. Dr. Akira Haji, Laboratory of Neuropharmacology, School of Pharmacy, Aichi Gakuin University, Nagoya.

*Late-Inspiratory neurons* are propriobulbar. During most of the inspiratory phase, their discharges are prevented by declining synaptic inhibition, probably set up by Early-Inspiratory neurons. They discharge coincident with the termination of Ramp-Inspiratory and phrenic nerve discharges and cease firing due to synaptic inhibition that seems to derive from discharges of Post-Inspiratory and Late-Expiratory neurons. Their proposed function is to initiate inspiratory phase termination [2,25] and mediate reflex inspiratory inhibition by slowly adapting ►lung stretch afferents (Respiratory Neurotransmitters and Neuromodulators).

*Post-Inspiratory neurons* are of two types. Some are cranial motoneurons that contract the pharyngeal constrictor and laryngeal adductor muscles. Others are propriobulbar and are thought to contribute to rhythm formation by securing termination of the inspiratory phase, and imposing a delay to the onset of expiratory neuron discharges. According to the network theory of rhythmogenesis, reciprocal inhibitory interactions between propriobulbar Post-I and Early-I neurons constitute the primary rhythm generator, and contribute

to shaping the discharge patterns of inspiratory and expiratory neurons [25]. Post-Inspiratory neurons depolarize abruptly and discharge action potentials coincident with the termination of firing in Ramp-I neurons and with the arrest of phrenic nerve inspiratory phase discharges. Membrane depolarization and discharges in Post-I neurons exhibit declining patterns, which seem to be activity-dependent and mediated by a  $\text{Ca}^{2+}$ -activated  $\text{K}^+$  conductance. Throughout the inspiratory phase, the neurons receive a declining wave of inhibitory postsynaptic potentials, evidently set up by Early-Inspiratory neurons. The rapid onset of depolarization and discharge in Post-I neurons is attributed to release from Early-I neuron inhibition and reactivation of low ►voltage-dependent  $\text{Ca}^{2+}$  currents and ►non-selective cationic currents that bring the membrane to threshold for action potential discharge. Throughout the expiratory phase, Post-I neurons receive synaptic inhibition set up by the discharge of Late-Expiratory neurons.

*Late-Expiratory neurons* are of two types, according to location and function. One group is located in the Bötzing region of the rostral ventrolateral respiratory

column (VRC) of the medulla, the other in the caudal region of the VRC (► [Alheid and McCrimmon: anatomy and function in the respiratory network](#)). Late-E neurons in both regions have similar membrane potential and discharge properties but play different roles in respiratory control. Late-E neurons located in the caudal VRC are bulbospinal and provide excitatory synaptic drive to expiratory intercostal and lumbar motoneurons and interneurons. During inspiration and postinspiration, synaptic inhibition set up by Early-Inspiratory and Post-Inspiratory neurons prevents Late-E neuron discharge. The expiratory neurons depolarize gradually to threshold during the post-inspiratory phase and then discharge steadily during the expiratory phase. The Late-E neurons in the Böttinger region of the VRC are both propriobulbar and bulbospinal. Their discharges result in inhibition of medullary, phrenic and intercostal inspiratory neurons during the expiratory phase.

*Pre-Inspiratory neurons* are propriobulbar. They discharge in short bursts at the end of expiration and sometimes at the end of inspiration. They are subject to augmenting synaptic inhibition during the inspiratory phase and declining inhibition during the postinspiratory phase. Based on these time-intensity profiles, they are thought to receive inhibitory synaptic input from Ramp-Inspiratory and Post-Inspiratory neurons. One function they might have is to initiate termination of discharge in Late-Expiratory neurons [15].

### **Network Hypothesis: How Bulbar Respiratory Neurons Express a Three-phase Rhythm that Controls Respiration in the Mature Respiratory Network [2,9,25] (Computational Modeling of the Respiratory Network)**

According to the network model, bulbar respiratory neurons receive tonic excitatory drive from pH/CO<sub>2</sub>-sensitive chemoreceptor neurons and from neurons of the brainstem reticular activating system. Inspiration begins when Ramp-I neurons are released from inhibition and low-voltage activated (LVA) Ca<sup>2+</sup> currents and non-selective cationic currents are activated. Ramp-like inspiratory discharges begin, driven by mutual recurrent excitation and by declining inhibition from Early-I neurons. Early-I discharges are terminated by Ca<sup>2+</sup>-activated K<sup>+</sup> conductances, allowing disinhibition of Late-I and Post-I neurons that terminate discharge of Ramp-I neurons and arrest inspiration. Buildup of Ca<sup>2+</sup>-activated K<sup>+</sup> conductances ends Post-I neuron inhibitory discharges, allowing discharge of Late-E neurons. Arrest of Late-E neuron discharge is initiated by Pre-I neurons and sustained by Early-I and Post-I neurons.

A key element in the cyclic regeneration of the inspiratory and expiratory phases is the termination of Early-I and Post-I discharges by activity-dependent Ca<sup>2+</sup>-activated K<sup>+</sup> conductances.

### **Post-Inspiratory Discharges in Phrenic and Intercostal Inspiratory Motoneurons**

The origin of postinspiratory discharge activity in inspiratory spinal motoneurons is not firmly established, but it does not arise from intrinsic membrane currents. Hypoxia increases its duration and hypercapnea shortens it. ► [Pulmonary irritant receptors](#) and stretch receptors inhibit it, whereas withholding of lung inflation prolongs it.

Bulbospinal neurons have been identified in the medulla of the cat that discharge with two bursts; one beginning simultaneously with the onset of phrenic nerve inspiratory discharges and, a second that begins after a very brief pause and declines in synchrony with the postinspiratory discharge of phrenic nerve activity. The discharge of these *Inspiratory-Post-I (IPI) neurons* and that of the phrenic nerve respond identically to activation of tracheal and pulmonary afferents. Thus, the postinspiratory discharge component in spinal inspiratory motoneurons may be linked to excitatory synaptic input from the medullary IPI neurons. The slow decline of the postinspiratory discharge in IPI neurons is attributed to integration of excitatory and inhibitory synaptic inputs coming from two populations of postinspiratory neurons within the medulla, one excitatory and the other inhibitory [27].

### **Cranial Motoneurons and Control of Flow in the Upper Airways**

Cranial motoneurons with respiratory periodicity in the ventrolateral medulla have axons in the trigeminal (5th), facial (7th), glossopharyngeal (9th), vagal (10th) and hypoglossal (12th) cranial nerves. They innervate the muscles of the nostrils, pharynx, tongue and larynx, coordinating their positions and movements with those of the diaphragm, chest wall and abdominal muscles during breathing. Trigeminal motoneuron discharges open the mouth during breathing, whereas facial motoneurons flare the nostrils. Glossopharyngeal motoneurons discharge with an augmenting pattern during inspiration and contract the muscles of the pharynx and palate. Laryngeal motoneurons with an augmenting inspiratory discharge pattern contract the abductor muscles, those with a decrementing postinspiratory discharge contract and narrow the opening of the glottis and slow outward airflow as the lungs gradually deflate. Vagal motoneurons with an augmenting expiratory discharge contract the pharyngeal constrictor muscles during expiration to lower upper airway resistance. Hypoglossal motoneurons (► [Respiratory control of hypoglossal neurons during sleep and wakefulness](#)) also regulate airway resistance and flow patterns by controlling tongue position.

Respiratory rhythm and pattern is derived from periodic excitatory and inhibitory synaptic input from the propriobulbar respiratory neurons described above.

For laryngeal and hypoglossal motoneurons, at least, important sources of synaptic excitation and inhibition are respiratory neurons of the preBötzinger Complex and surrounding ventrolateral medulla [20,32].

The motoneurons are assigned other duties related to sneezing, coughing, movements of the mouth, swallowing, vomiting, etc., during which their discharge properties are appropriate for the movements they promote.

### Spinal Motoneurons and Contraction of the Pump Muscles

The location, synaptic connections and electrophysiological properties of spinal respiratory neurons are described in detail elsewhere, with special emphasis on  $\alpha$ -motoneurons that innervate the extrafusal muscles of respiration (► [Spinal respiratory neurons and respiratory control](#)). Interested readers can also consult an earlier review [17].

*Phrenic motoneurons* innervating the diaphragm are located in the ventral horns of the lower cervical spinal segments, and receive bilateral excitatory synaptic drive from medullary bulbospinal Ramp-I neurons and inhibitory synaptic input from bulbospinal Late-E neurons of the Böttinger Complex. The neurons depolarize and fire with an augmenting discharge pattern during inspiration and hyperpolarize with an augmenting pattern during expiration. Not all phrenic motoneurons reach threshold simultaneously, rather, there is a scatter in the discharge latencies (recruitment times) with respect to the onset of the population discharge in the phrenic nerve. It appears that the order of recruitment derives, at least in part, from similar temporal properties of the bulbospinal neurons that provide excitatory synaptic input. Some of the excitatory drive also comes from interneurons located in the phrenic motoneuron pool and at higher cervical levels, which are driven by excitatory input from bulbospinal inspiratory neurons [34].

*Intercostal motoneurons* that contract the scalene, sternocleidomastoid and intercostal muscles are located in the ventral horn at all levels of the thoracic spinal cord. Medullary bulbospinal neurons that control phrenic motoneurons are also responsible for the periodic depolarization, discharge and hyperpolarization of intercostal motoneurons. Some of the synaptic connections are direct and others are made through interneurons located in the same segment as the motoneuron pool and in other cervical and thoracic segments.

*Lumbar spinal motoneurons* innervate the rectus abdominis, external and internal oblique and transverse abdominal muscles of the abdomen, and produce contraction during active expiration.

*Recurrent Inhibitory Interneurons* with a very high frequency of action potential firing are found near to

phrenic and intercostal motoneurons. They are activated to discharge by motor axon collaterals and in turn suppress motoneuron discharges [17]. The high-frequency discharge and the resulting feedback suppression of motoneuron discharges are reminiscent of the ► [Renshaw](#) inhibition that modulates discharge properties of limb motoneurons.

### The Effects of Hypoxia on the Respiratory Apparatus: A Multiphase Reaction Involving the Carotid Bodies and the CNS Respiratory Network

Hypoxia produces dramatic disturbances of respiration. The initial response to acute hypoxia is increased breathing in an attempt to replenish  $O_2$ . The immediate source of respiratory augmentation is stimulation of type 1 (glomus) cells of the carotid bodies (CB) located bilaterally in the bifurcation of the common carotid arteries, which leads to activation of CB afferents and reflex stimulation of the CNS respiratory network. (► [Carotid Body Chemoreceptors and Respiratory Drive](#)).

If hypoxia is maintained, disturbances of synaptic function within the CNS convert breathing rhythm to gasping and apnea. (► [Neural respiratory control during acute hypoxia](#)). The CNS-derived hypoxic ventilatory response is a 5-component process, consisting of augmentation, apneusis or breath holding, protective apnea, gasping and terminal apnea. For each component, there are related changes in endogenous neurotransmitter and neuromodulator release and alterations in ion channel permeabilities.

Here, metabolic, enzymatic, ion channel and chemical neuromodulatory mechanisms that control the carotid body oxygen sensor and trigger the respiratory response to acute hypoxia are presented. The role of the CB in  $CO_2/pH$  sensing and its importance in health and disease are also discussed (Carotid Body Chemoreceptors and Respiratory Drive). Sites and mechanisms within the CNS respiratory network that engender ventilatory disturbances and ultimate apnea are described. In one essay (► [Respiratory network responses to hypoxia](#)) the hypoxic response is defined in terms of two phases and a comprehensive description of neural pathways, neurotransmitters and neuromodulators that mediate respiratory depression during the late hypoxic ventilatory response (HVR) is presented. In another essay (► [Neural respiratory control during acute hypoxia](#)), the energy cost of hypoxia to cells and its effects on ionic homeostasis are discussed. In addition, the HVR is presented as a 5-component process: augmentation, apneusis or breath holding, protective apnea, gasping and terminal apnea. For each component, accompanying changes in endogenous neurotransmitter and neuromodulator release and ion channel changes are described.

## Concluding Comments

This overview has focused on respiratory control mechanisms in the adult mammal. Other contributions will show how the respiratory network develops before and shortly after birth (►[Development of the respiratory network](#)) and how autorhythmic pacemaker neurons in the rodent medulla regulate respiration in the postnatal period (►[Respiratory pacemakers](#)). Disturbances of respiratory control that are gene-related are also reviewed elsewhere (►[Gene-related respiratory control disturbance](#)).

Other important aspects of respiratory control not considered in this overview include: (i) neuroplasticity in the respiratory network, which allows readjustments of network responsiveness to injury and other environmental challenges (►[Respiratory neuroplasticity](#)), (ii) ►[laryngeal chemoreflexes](#) responding to liquid and chemical stimulation of laryngeal receptors, and (iii) respiratory control during sleep (►[obstructive sleep apnea](#)), (►[Respiratory control of hypoglossal neurons during sleep and wakefulness](#)).

Hopefully, the reader will appreciate the valuable insights of the contributing authors into how respiration is controlled, and the innovative methods they utilize, including imaging techniques, (►[Respiratory network analysis, functional imaging](#)) computer modeling (►[Computational modeling of the respiratory network](#)) and the use of novel preparations to study integrated cardio-respiratory regulation (►[Central integration of cardiovascular and respiratory activity studied in situ](#)).

## References

- Ballanyi K, Onimaru H, Homma I (1999) Respiratory network function in the isolated brainstem-spinal cord of newborn rats. *Prog Neurobiol* 59:583–634
- Bianchi AL, Denavit-Saubie M, Champagnat J (1995) Central control of breathing in mammals: neuronal circuitry, membrane properties and neurotransmitters. *Physiol Rev* 75:1–45
- Bonham AC (1995) Neurotransmitters in the CNS control of breathing. *Respir Physiol* 101:219–230
- Butera RJ Jr, Rinzel J, Smith JC (1999) Models of respiratory rhythm generation in the pre-Bötzinger complex. I. Bursting pacemaker neurons. *J Neurophysiol* 82:382–397
- Butera RJ Jr, Rinzel J, Smith JC (1999b) Models of respiratory rhythm generation in the pre-Bötzinger complex. II. Populations Of coupled pacemaker neurons. *J Neurophysiol* 82:398–415
- Cohen MI (1979) Neurogenesis of respiratory rhythm in the mammal. *Physiol Rev* 59:1105–1173
- Del Negro CA, Johnson SM, Butera RJ, Smith JC (2001) Models of respiratory rhythm generation in the pre-Bötzinger complex. III. Experimental tests of model predictions. *J Neurophysiol* 86:59–74
- De Troyer A, Kirkwood PA, Wilson TA (2004) Respiratory action of the intercostals muscles. *Physiol Rev* 86:717–756
- Ezure K (1990) Synaptic connections between medullary respiratory neurons and considerations on the genesis of the respiratory rhythm. *Prog Neurobiol* 35:429–450
- Feldman JL (1986) Neurophysiology of breathing in mammals. In: *Handbook of physiology. The nervous system. intrinsic regulatory system in the brain.* Am Physiol Soc, Sect. 1, vol. IV, Chap. 9. Washington, DC, pp 463–524
- Feldman JL, McCrimmon DR (2003) Neural control of breathing. In: Squire LR, Bloom FE, McConnell SK, Roberts JL, Spitzer NC, Zigmond MJ (eds) *Fundamental neuroscience*, 2nd edn, Chap. 37. Academic, Amsterdam
- Feldman JL, Mitchell GG, Nattie EE (2003) Breathing: rhythmicity, plasticity, chemosensitivity. *Annu Rev Neurosci* 26:239–266
- Greer JJ, Funk GD, Ballanyi K (2005) Preparing for the first breath; prenatal maturation of respiratory neural control. *J Physiol* 570:437–444
- Haji A, Takeda R, Okazaki M (2000) Neuropharmacology of control of respiratory rhythm and pattern in mature mammals. *Pharmacol Ther* 86:277–304
- Klages S, Bellingham MC, Richter DW (1993) Late expiratory inhibition of stage 2 expiratory neurons in the cat – a correlate of expiratory termination. *J Neurophysiol* 70:1307–1315
- Long S, Duffin J (1986) The neuronal determinants of respiratory rhythm. *Prog Neurobiol* 27:101–182
- Monteau, R, Hilaire G (1991) Spinal respiratory motoneurons. *Prog Neurobiol* 37:144–191
- Nattie EE (2001) Central chemosensitivity, sleep and wakefulness. *Respiration Physiology and Neurobiology* 129:257–268
- Netter FH (1997) *Atlas of Human Anatomy*, 2nd Edition. In: Dalley AE (ed) Novartis, Hanover, NJ. p. 523 pp. 967–990
- Ono K, Shiba K, Nakazawa K, Shimoyama I (2006) Synaptic origin of the respiratory-modulated activity of laryngeal motoneurons. *Neuroscience* 140:1079–1088
- Pierrefiche O, Shevtsova NA, St-John WM, Paton JF, Rybak IA (2004) Ionic currents and endogenous rhythm generation in the pre-Bötzinger complex: modelling and in vitro studies. *Advances in Experimental Medicine and Biology* 551:121–6
- Purvis LK, Smith JC, Koizumi H, Butera RJ (2007) Intrinsic bursters increase the robustness of rhythm generation in an excitatory network. *Journal of Neurophysiology* 97:1515–26
- Ramirez JM, Viemari JC (2005) Determinants of inspiratory activity. *Respiration Physiology and Neurobiology* 147:145–157
- Richerson GB, Boron WF (2005) Control of ventilation. In: *Medical Physiology.* WF Boron and EL Boulpaep (eds) Philadelphia, Elsevier Saunders, chapter 31, pp. 712–734
- Richter DW (1996) Neural regulation of respiration: Rhythmogenesis and afferent control. In: *Comprehensive Human Physiology.* R. Gregor and U. Windhorst (eds) Berlin, Springer, vol. 2, chapt. 105, pp. 2079–2095
- Richter DW, Ballanyi K, Schwarzacher S (1992) Mechanisms of respiratory rhythm generation. *Current Opinions in Neurobiology* 26:788–93
- Richter DW, Ballantyne D (1988) On the significance of post-inspiration. *Funtionalanalyse biologischer Systeme* 18:149–156
- Richter DW, Pierrefiche O, Lalley PM, Polder HR (1996) Voltage-clamp analysis of neurons within deep layers of the brain. *Journal of Neuroscience Methods* 67:121–131
- Richter DW, Spyer KM (2001) Studying rhythmogenesis of breathing: comparison of *in vivo* and *in vitro* models. *Trends in Neuroscience* 24:464–472

30. Rybak IA, Shevtsova NA, Paton JF, Dick TE, St.-John WM, Morschel M., Dutschmann M (2004a) Modeling the ponto-medullary respiratory network. *Resp. Physiol. Neurobiol* 143:307–319
31. Rybak IA, Shevtsova NA, Paton JF, Pierrefiche O, St-John WM, Haji A (2004b) Modelling respiratory rhythmogenesis: focus on phase switching mechanisms. *Advances in Experimental Medicine and Biology* 551:189–94
32. Shao XM, Feldman JL (2005) Cholinergic neurotransmission in PreBötzinger Complex modulates excitability of respiratory neurons and regulates respiratory rhythm. *Neuroscience* 130:1069–1081
33. Smith JC, Butera RJ, Koshiya N, Del Negro C, Wilson CG, Johnson SM (2000) Respiratory rhythm generation in neonatal and adult mammals: the hybrid pacemaker-network model. *Respiration Physiology* 122:131–47
34. Tian GF, Duffin J (1996) Connections from upper cervical inspiratory neurons to phrenic and intercostal motoneurons studies with cross-correlation in the decerebrate rat. *Experimental Brain Research* 110:196–204
35. Wood PG, Daniels CB, Orgeig S (1995) Functional significance and control of release of pulmonary surfactant in the lizard lung. *American Journal of Physiology, Regulatory, Integrative and Comparative Physiology* 269:R838–R847

## Respiratory Bursting Neurons

► Respiratory Pacemakers

## Respiratory Central Pattern Generator

► Computational Modeling of the Respiratory Network

## Respiratory Control of Hypoglossal Neurons During Sleep and Wakefulness

JOHN H. PEEVER<sup>1</sup>, JAMES DUFFIN<sup>2</sup>

<sup>1</sup>Department of Cell and Systems Biology, University of Toronto, Toronto, ON, Canada

<sup>2</sup>Department of Anaesthesia and Physiology, University of Toronto, Medical Sciences Building, Toronto, ON, Canada

### Synonyms

Respiratory control of the tongue and airway

### Definition

Hypoglossal ► **motoneurons** control the tongue muscles; genioglossus muscle (tongue protruder), hyoglossus and styloglossus (tongue retractors) and intrinsic muscles. Because the genioglossus as well as other tongue muscles participate in a range a motor acts (e.g., drinking, licking, swallowing and breathing), the hypoglossal motoneurons that innervate them receive numerous inputs from a variety of relevant brain areas. Since the tongue position affects airway patency and resistance, respiratory control is essential to coordinate respiratory muscle effort and airway resistance, minimizing resistance during inspiration and using the control of resistance during expiration to modify expiratory flow patterns. The hypoglossal control of the tongue assumes a greater importance during sleep when relaxation of the tongue can occlude the airway; a condition of ► **obstructive sleep apnoea (OSA)**.

### Characteristics

#### Hypoglossal Motoneurons Anatomical Location

Hypoglossal ► **motoneurons** are ► **somatotopically organized** bilaterally in compact columns extending along the midline of the brainstem above and below the obex. For example a recent study in dogs [1] showed that the nuclei extend from 0.75 mm caudal to 3.45 mm rostral to the obex, with cells 0.37–2.12 mm below the dorsal surface, and symmetrically centered between 0.66 and 1.33 mm from the midline. There are a number of detailed locations studies including those in rats, cats, rabbits, frogs and monkeys as well as dogs. The hypoglossal motoneurons have varied and extensive dendritic arborizations that provide the potential for a wide range of afferent contacts. (Fig. 1) shows a schematic of the medullary respiratory neurons illustrating their general location and pattern of respiratory activity.

#### Projections of Hypoglossal Motoneurons

The axons of these motoneurons course ventrally and slightly laterally to emerge from the medulla in the preolivary sulcus separating the olive and the pyramid, and form the twelfth cranial nerve (XII). The hypoglossal nerve innervates all the muscles of the tongue except for the palatoglossus muscle which is innervated by the vagus nerve (X) and the accessory nerve (XI). The tongue is a complex muscle, and the hypoglossal nerve bifurcates to form medial and lateral branches, with the medial branch innervating the protruder tongue muscles, and the lateral branch innervating the retractor tongue muscles [2].

The ventrolateral and ventromedial subnuclei contain motoneurons that innervate the genioglossus and styloglossus muscles respectively, and the dorsal subnucleus motoneurons innervate the hyoglossus and styloglossus muscles. The genioglossus muscle is of particular importance clinically because it is considered the main protruder and depressor muscle of the tongue.

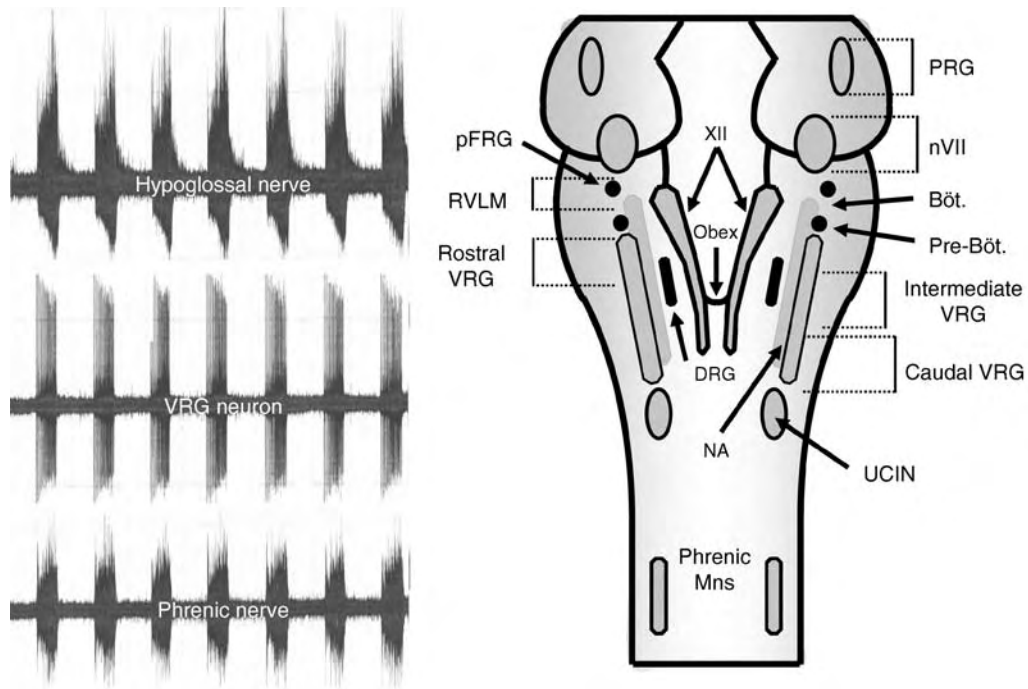

**Respiratory Control of Hypoglossal Neurons During Sleep and Wakefulness. Figure 1** A schematic showing the location of hypoglossal motoneurons relative to medullary respiratory neuron groups with representative recordings from the hypoglossal nerve, a ventral respiratory group inspiratory neuron and the phrenic nerve in an adult decerebrate rat. Abbreviations: PRG = pontine respiratory group, nVII = Facial nucleus, pFRG = parafacial respiratory group, XII = hypoglossal motor nucleus, RVLM = rostro ventrolateral medulla, Böt = Bötzinger complex, Pre-Böt = preBötzinger complex, VRG = ventral respiratory group, DRG = dorsal respiratory group, NA = nucleus ambiguus, UGIN = upper cervical inspiratory neurons.

It is co-activated during inspiration with tongue retractor muscles [3] so that airway compliance is reduced, and upper airway patency increased during inspiration.

### Respiratory Inputs to Hypoglossal Motoneurons

Hypoglossal motoneurons participate in rhythmic oro-facial motor acts such as mastication, licking, swallowing and breathing; receiving neural inputs from the brainstem rhythm-generating networks that generate these behaviors. They play a major role in respiratory airway control and the following focuses on the neural mechanisms by which respiratory drive is communicated to them.

A major function of the genioglossus muscle is to stiffen the pharyngeal airspace during inspiration so that it does not collapse during diaphragmatic contraction. Therefore, hypoglossal motoneurons are synaptically excited during inspiration (i.e., discharge action potential during inhalation); however, they are activated 200–300 ms before the ▶phrenic motoneurons that innervate the ▶diaphragm [3]. This pre-activation of hypoglossal motoneurons ensures that the airway is stiffened before the diaphragm contracts.

Although both the hypoglossal and phrenic motoneurons receive inspiratory signals from the medullary

network that generates breathing, they receive their respective inspiratory commands from separate premotor populations. Inspiratory drive is transmitted to phrenic motoneurons by premotor neurons located in the ventral respiratory group (parallel to the nucleus ambiguus), while hypoglossal motoneurons receive respiratory drive from premotor neurons located in the medullary lateral tegmental field, lateral to the hypoglossal motor nucleus (Fig. 2) [4].

Although separate premotor populations relay inspiratory drive to phrenic and hypoglossal motoneurons, both release glutamate to activate post-synaptic non-NMDA receptors to induce inspiratory activation [5]. Unlike phrenic motoneurons, which are silenced during expiration by GABAergic and glycinergic inhibition, hypoglossal motoneurons receive no such inhibitory drive; instead, they are passively disfacilitated (withdrawal of excitation) during expiration [4]. Because the genioglossus is not only involved in the control of breathing, but is also in the control of speech, the lack of inhibition during expiration enables more effective modulation of their activity and thereby tongue muscles because motoneurons are more easily excited by other non-respiratory inputs.

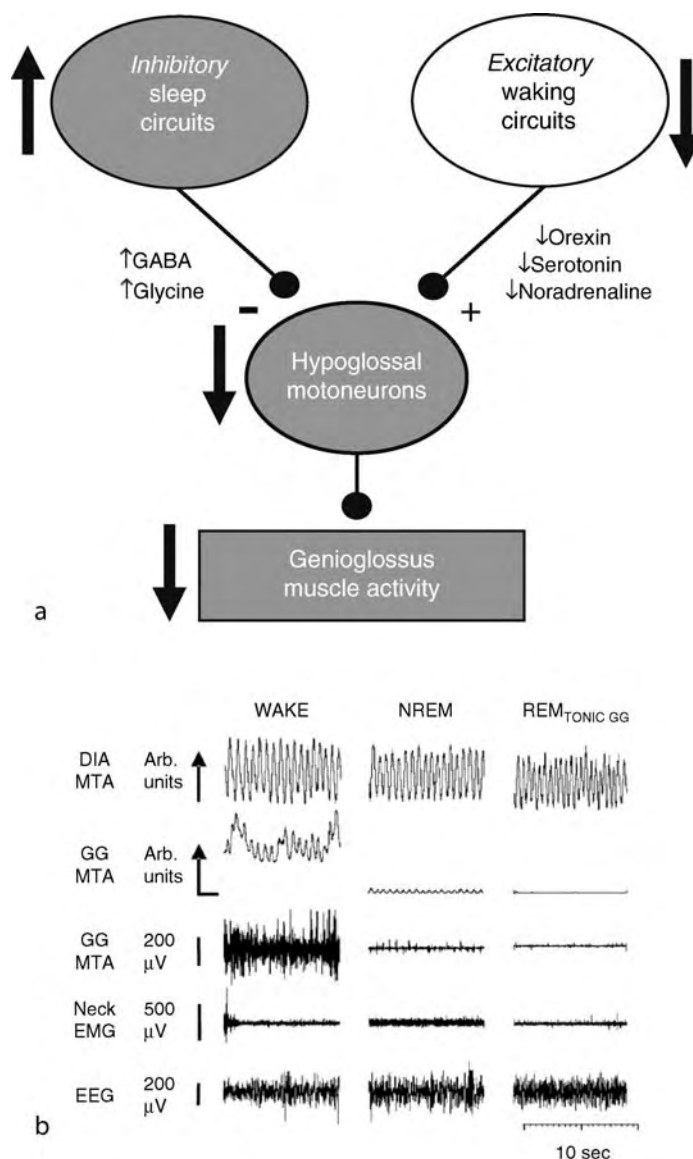

**Respiratory Control of Hypoglossal Neurons During Sleep and Wakefulness. Figure 2** A schematic representation of the neural mechanisms responsible for suppression of genioglossus muscle activity in sleep. (a) It is hypothesized that active inhibition and passive disfacilitation reduce hypoglossal (airway) motoneuron activity and hence genioglossus muscle tone in sleep. Several lines of evidence indicate that inhibitory processes play a predominant role in controlling airway motoneuron and muscle activity in sleep, particularly in REM sleep. There is also evidence indicating that withdrawal of excitatory sleep-related inputs (e.g., serotonin, orexin, noradrenaline) in sleep may reduce airway motoneuron excitability. (b) A typical example from a naturally behaving rat demonstrating that genioglossus (and neck) muscle activity is depressed in sleep, and particularly REM sleep. This figure was modified (with permission) from Morrison et al. *Journal of Physiology*, 2003, 552.3, pp. 975–991.

Hypoglossal motoneurons are not only controlled by premotor neurons in the lateral tegmental field, they also receive respiratory signals from a population of interneurons located directly within the hypoglossal motor nuclei [4]. Hypoglossal interneurons are significantly smaller than motoneurons, they are active

only during inspiration and they make inhibitory (e.g., GABA) connections with hypoglossal motoneurons. The precise role that interneurons play in transmitting inspiratory drive to hypoglossal motoneurons is unclear; however, it is hypothesized that they gate or filter pre-synaptic inputs.



### Impact of Sleep on Hypoglossal Motoneuron Activity

►Sleep suppresses the excitability of hypoglossal motoneurons. Although this review focuses on hypoglossal motoneurons, it should be made clear that the excitability of all somatic motoneurons including other airway motoneurons (e.g., trigeminal and facial) are also affected by sleep [6]. Understanding how hypoglossal motoneuron activity is regulated in sleep is clinically important because sleep-related reductions in their activity lead to reduced airway motor tone, airway narrowing and collapse in predisposed individuals (e.g., small airway). The suppression of airway motoneuron activity in sleep, and particularly during rapid-eye-movement (►REM) sleep, is the primary cause of OSA.

The root cause of hypoglossal motoneuron suppression in sleep is unknown; however, recent work from our laboratory and others has begun to shed light on potential mechanisms. It is hypothesized that the neurocircuitry generating sleep (e.g., REM and ►non-REM) also innervates and regulates hypoglossal motoneuron activity. Although multiple neural circuits are involved in sleep generation, they can be subdivided into two categories – those that are excitatory and promote wakefulness and

those that are inhibitory and promote sleep. Excitatory circuits are active during waking and project to both the cortex and motoneurons to promote behavioural arousal and high levels of motor tone [7]. Inhibitory circuits are active in sleep and project to and switch-off both the wake-promoting circuits as well as inhibiting airway motoneurons. Therefore, it is hypothesized that hypoglossal motoneurons are both actively inhibited and passively disfacilitated (withdrawal of excitatory inputs) during sleep (Fig. 3).

The primary wake-promoting circuits consist of excitatory neurons located in the noradrenergic locus coeruleus, the ►serotonergic dorsal ►raphe, the ►orexinergic (also called hypocretin) lateral hypothalamus, the histaminergic tuberomammillary nucleus and the ►dopaminergic ►periaqueductal grey and ventral tegmental area. The activity of these neural populations is highest in waking and minimal or silent in sleep. Because they project to motoneurons, it is hypothesized that withdrawal of noradrenergic, orexinergic, and serotonergic inputs may be a contributing factor to the reduction of motoneuron excitatory and hence muscle activity in sleep [6]. The major sleep-promoting

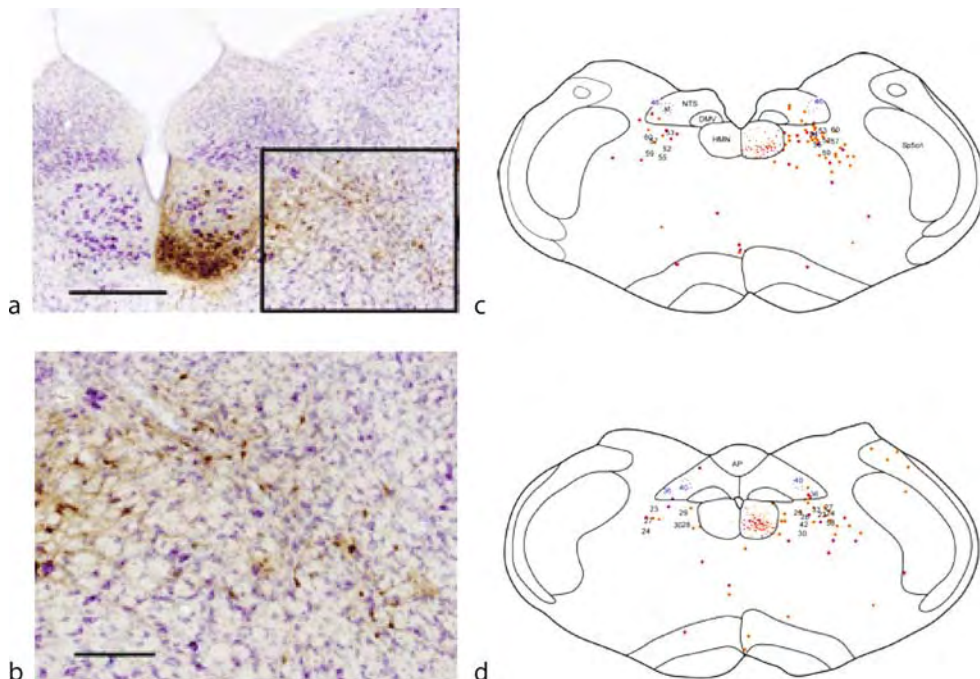

**Respiratory Control of Hypoglossal Neurons During Sleep and Wakefulness. Figure 3** Location of the premotor neurons that relay inspiratory drive to hypoglossal motoneurons. (a) Photograph of the premotor neurons in lateral tegmental field that are hypothesized to relay inspiratory drive to hypoglossal motoneurons. Premotor neurons were identified by visualizing the location of pseudorabies virus that was retrogradely transported from the genioglossus muscle where it had been injected. (b) Higher magnification of the black box in (a); brown cells represent hypoglossal premotor neurons. C and D, represent the anatomical distribution of hypoglossal premotor neurons (*small dots*) and hypoglossal motoneurons (*small dots*) plotted on schematic cross-sections of rat brainstem at 0–500  $\mu\text{m}$  rostral to obex (c) and –100 to –600  $\mu\text{m}$  caudal to obex (d). This figure was modified (with permission) from Chamberlin et al., *J. Physiology*, 579.2, 2007, pp 515–526.

system consists of inhibitory neurons located in the GABAergic ventrolateral and median preoptic areas of the anterior hypothalamus. The activity of these neurons is lowest in waking and highest in sleep (particularly non-REM sleep). Because they project to motoneurons, it is hypothesized that they actively inhibit (via GABA) hypoglossal motoneuron activity and thereby suppress airway motor tone in non-REM sleep.

Another source of motoneuron inhibition comes from the medial medullary reticular formation. Unlike neurons in the ventrolateral and median preoptic areas, these neurons contain both GABA and glycine, and are maximally active in REM sleep when genioglossus muscle tone is minimal or absent [7]. It therefore appears that together GABA and glycine play a role in regulating hypoglossal motoneuron activity in both non-REM and REM sleep. Although GABAergic and glycinergic neurons in the medial medullary reticular formation project to hypoglossal motoneurons and are active in REM sleep, they are not responsible for the ▶**muscle atonia** that typifies this state. Rather GABAergic and glycinergic inhibition are responsible for suppressing the phasic muscle twitches that characterize REM sleep [8]. The muscle atonia of REM sleep can not be explained by disfacilitation of excitatory because application of glutamate or glutamatergic receptor agonists (e.g., AMPA or NMDA) directly into airway (e.g., trigeminal) motoneurons can not reverse REM sleep atonia. Therefore, the cause

of airway motoneuron inactivity and hence airway muscle atonia in REM sleep has yet to be identified. Identification of the neurochemical responsible for REM atonia requires attention because OSA is most common and severe during REM sleep.

### Plasticity of Hypoglossal Motoneurons

Somatic motoneurons are generally considered to be passive neural relays that monotonically respond to pre-synaptic inputs; however, they are able to undergo remarkable degrees of plasticity. One type of motoneuron plasticity (▶**neural plasticity**) that is particularly relevant to hypoglossal control is respiratory ▶**long-term facilitation** (LTF). LTF is characterized by a progressive increase in the inspiratory amplitude of the hypoglossal nerve (or genioglossus muscle) activity following exposure to ▶**intermittent hypoxia** (an example is shown in Fig. 4) [9].

LTF can only be evoked by intermittent hypoxia; exposure to continuous hypoxia does not evoke LTF. The central serotonergic system is required for LTF because blocking either serotonin release or serotonin receptors nullifies LTF. It is hypothesized that LTF is induced because intermittent hypoxia activates the serotonergic medullary raphe nuclei to release serotonin onto hypoglossal motoneurons. Intermittent serotonin receptor activation subsequently causes plastic changes in the excitability of hypoglossal motoneurons perhaps via group-I ▶**metabotropic** glutamate receptors [10].

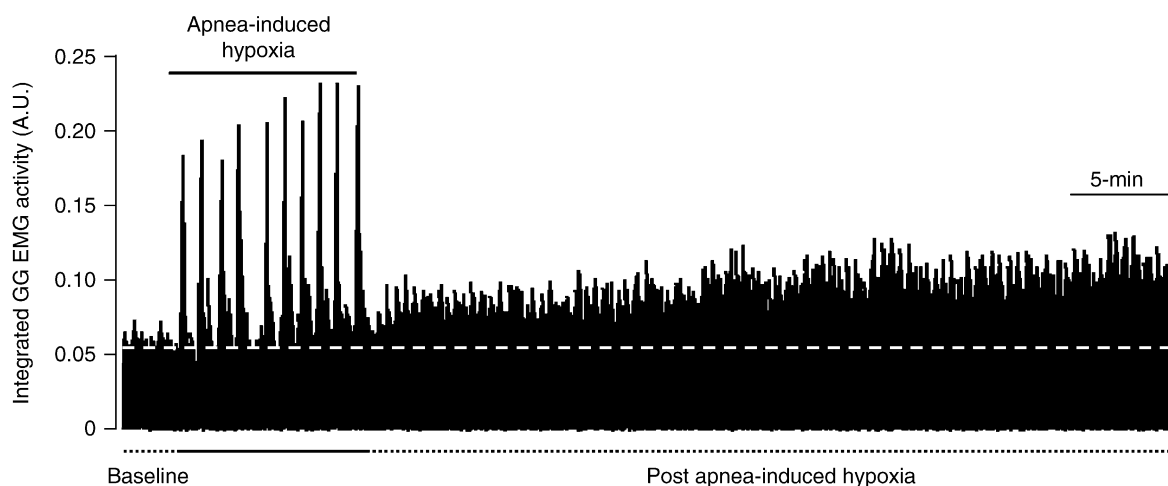

**Respiratory Control of Hypoglossal Neurons During Sleep and Wakefulness. Figure 4** A typical example of apnea-induced long-term facilitation (LTF) of genioglossus motor outflow in an anaesthetized rat. Basal levels of inspiratory genioglossus muscle activity were recorded 5-min before (*baseline*) and for 60-min after obstructive apneas (ten 15-s apneas each separated by 45 s). Each obstructive apnea caused a reflexive increase in the inspiratory activity of the genioglossus muscle (see under apnea-induced hypoxia). The cluster of ten apneas induced a persistent and progressive increase in peak inspiratory genioglossus muscle activity that lasted for over 60-min (i.e., LTF). The *dotted line* represents the average magnitude of genioglossus inspiratory efforts before apnea-induced LTF; note that genioglossus activity returned to *baseline* levels after apneas and then progressively increased to reach maximal levels at 60-min post-apnea.

Since intermittent hypoxia causes persistent increases in hypoglossal motoneuron excitability and hence genioglossus motor output, and since hypoglossal motoneuron activity is lost in sleep and contributes to airway obstructions, then inducing LTF of during sleep may be an effective method for minimizing or reversing the root cause of obstructive sleep apnea. Therefore understanding the cellular mechanisms of LTF may provide the basis for rationale development of therapeutics for treating this prevalent (it affects about 5% of adults) sleep disorder.

## References

1. Brandes IF, Zuperku EJ, Dean C, Hopp FA, Jakovcovic D, Stuth EA (2007) Retrograde labeling reveals extensive distribution of genioglossal motoneurons possessing 5-HT<sub>2A</sub> receptors throughout the hypoglossal nucleus of adult dogs. *Brain Res* 1132:110–119
2. Dobbins EG, Feldman JL (1995) Differential innervation of protractor and retractor muscles of the tongue in rat. *J Comp Neurol* 357:376–394
3. Peever JH, Mateika JH, Duffin J (2001) Respiratory control of hypoglossal motoneurons in the rat. *Pflugers Archiv* 442:78–86
4. Peever JH, Shen L, Duffin J (2002) Respiratory premotor control of hypoglossal motoneurons in the rat. *Neuroscience* 110:711–722
5. Steenland HW, Liu H, Sood S, Liu X, Horner RL (2006) Respiratory activation of the genioglossus muscle involves both non-NMDA and NMDA glutamate receptors at the hypoglossal motor nucleus in vivo. *Neuroscience* 138:1407–1424
6. Peever JH, McGinty D (2007) Why do we sleep? In: Lavigne G, Choinière M, Sessle Band oja P (eds) *Sleep and Pain*. International Association for the Study of Pain (IASP) Press, pp. 10–15
7. Siegel JM (2005) REM sleep. In: Kryger MH, Dement WC (eds) *Principles and practice of sleep medicine*. W.B. Saunders, Philadelphia, pp 120–135
8. Brooks P, Peever JH (in press) Role of chloride-mediated inhibition in the neurochemical control of airway motoneurons during natural sleep. *Adv Exp Biol Med*
9. Mahamed S, Mitchell GS (2007) Is there a link between intermittent hypoxia-induced respiratory plasticity and obstructive sleep apnoea? *Exp Physiol* 92:27–37
10. Bocchiaro CM, Feldman JL (2004) Synaptic activity-independent persistent plasticity in endogenously active mammalian motoneurons. *Proc Natl Acad Sci USA* 101:4292–4295

## Respiratory Control of the Tongue and Airway

► Respiratory Control of Hypoglossal Neurons During Sleep and Wakefulness

## Respiratory CPG

► Computational Modeling of the Respiratory Network

## Respiratory Cycle (Phase)

### Definition

The neuronal cycle of respiration consists of three phases: inspiration in which inspiratory muscles contract, post-inspiration or passive expiration (stage 1 expiration) in which inspiratory muscles cease progressively to contract while activity of the adductor muscles of the upper airway reduces exhalation, and active expiration (stage 2 expiration) in which expiratory muscles contract.

## Respiratory Kernel

### Definition

An aggregate of neurons that is essential for a respiratory function.

► Development of the Respiratory Network

## Respiratory Memory

► Respiratory Neuroplasticity

## Respiratory Network

### Definition

The central respiratory network consists of the respiratory neurons and generates respiratory rhythm and pattern.

► Anatomy and Function in the Respiratory Network  
► Computational Modeling of the Respiratory Network

## Respiratory Network Analysis, Functional Imaging

KLAUS BALLANYI<sup>1</sup>, HIROSHI ONIMARU<sup>2</sup>,  
BERNHARD KELLER<sup>3</sup>

<sup>1</sup>Department of Physiology, University of Alberta,  
Edmonton, AB, Canada

<sup>2</sup>Department of Physiology, Showa University School  
of Medicine, Tokyo, Japan

<sup>3</sup>Department of Neurophysiology, University of  
Göttingen, Göttingen, Germany

### Synonyms

Visualization of respiratory centers; Microscopy of structure-function relationships in mammalian respiratory networks

### Definition

Functional imaging of ►respiratory networks means optical analysis, with (►Confocal microscopy), ►multiphoton microscopy (two-photon microscopy) or cameras (e.g. CCD- or CMOS-type) of structure-function relationships in rhythmically active neuronal brainstem networks involved in the control of breathing in mammals. Such imaging has so far only been carried out *in vitro*, specifically in (i) respiratory active slices, (ii) *en bloc* brainstem preparations from perinatal rodents and (iii) arterially-perfused “working-heart-brainstem” preparations of both newborn and adult rodents. ►Voltage-sensitive dye imaging of the activity of neuronal populations is feasible in the latter three *in situ* models. In contrast, simultaneous ►Ca<sup>2+</sup> imaging of both the activity and basic morphology of single respiratory neurons, or clusters of such cells, has not been reported so far in the perfused preparation, and only in one case for *en bloc* medullas. In rhythmic slices, ►Ca<sup>2+</sup> imaging is primarily done in inspiratory active interneurons and hypoglossal (XII) motoneurons. The latter neuron populations are also being used for optical analyses of subcellular processes such as activity- or metabolism-related changes of mitochondrial membrane potential, Ca<sup>2+</sup> or redox state. Finally, expression of fluorescent proteins in transgenic mice and ►fluorescence labeling of neurotransmitter receptors are currently used for targeted electrophysiological recording from respiratory neurons in the slices. As outlined below, these approaches have provided important insights into both the structural organization and functional properties of respiratory centers. The following (yet mostly hypothetical scenario) would likely answer, with imaging techniques, most relevant questions regarding the neural control of breathing: Subpopulations of respiratory interneurons or output

cells will be identified via a specific pattern of intrinsically-expressed fluorescent proteins and acutely fluorescence-labeled ion channels, receptors and/or transporters. Populations of these identified cells will then be loaded with cell-permeant fluorescent dyes for, e.g., simultaneous imaging of dynamic changes of signaling factors such as Ca<sup>2+</sup> or pH in the cytosol and cellular organelles. At the same time, one or few of these cells will be whole-cell recorded (with further functional or morphological dyes in the patch electrode solution) for a correlation of dynamic changes of (sub) cellular activities with respiratory-related membrane potential oscillations or underlying membrane currents. Further improvement of computerized data processing and of the spatiotemporal resolution of fluorescent microscopy will enable simultaneous 4D-imaging of all these events for a thorough structure-function relationship of interactions between respiratory centers and (pre) motor circuits.

### Characteristics

#### Medullary Respiratory Networks

Three major bilaterally-organized respiratory groups have been identified in the lower brainstem of mammals [1]. The dorsal respiratory group is primarily involved in the transmission of (chemosensory and mechanosensory) inputs to the medullary respiratory control system. The pontine respiratory group plays a major role in orchestrating the highly complex (pre/post)inspiratory-expiratory synaptic neuronal activity pattern for the innervation of diverse groups of respiratory muscles that are active during one or several of these phases. The ventral respiratory column contains various aggregations of respiratory neurons, among which some are capable of generating primary ►respiratory rhythms. Specifically, the ►pre-Bötzinger complex (preBötC) appears to be pivotal for the generation of inspiratory-related interneuronal and motor activities. Conversely, the ►parafacial respiratory group (pFRG), located between the pons and the more caudal preBötC, generates preinspiratory (and postinspiratory) activities that drive, e.g., expiratory abdominal muscles [1,2]. Both, the preBötC and pFRG remain active in distinct transverse brainstem slices from newborn rodents (see ►isolated respiratory centers). In more intact preparations, the pFRG and preBötC constitute presumably a dual respiratory center that may interact with the pontine and dorsal respiratory groups for generation of the full spectrum of respiratory activities [1]. As described below, voltage-sensitive dye imaging has been used for characterization of all three respiratory groups, whereas other imaging approaches were so far primarily used for studying the ventral respiratory column, in fact mostly presumptive or histologically-identified preBötC interneurons and inspiratory XII motoneurons.

### Voltage-Sensitive Dye Imaging of Spatiotemporal Respiratory Patterns

Voltage-sensitive dye imaging is principally suitable to measure the activity of single cells. Though, this technique has been applied yet only to monitor, at low optical magnification, spatiotemporal activity patterns in large populations of respiratory neurons. In most studies, fluorescence signals were collected from the intact ventral brainstem surface. Two dyes are preferentially used for this approach. The agent Di-4-ANEPPS stains primarily superficial tissue layers, whereas the less lipophilic Di-2-ANEPEQ stains deeper brainstem structures in addition. Bath-application of these agents for time periods of 0.5 h to sometimes >1 h is necessary for effective staining of respiratory active regions in newborn rodent brainstems [2,3]. Decreases and increases in fluorescence intensity of the above voltage-sensitive dyes correlate with enhanced and attenuated neuronal activity, respectively, due to the fact that the fluorescence of Di-2-ANEPEQ and Di-4-ANEPPS is proportional to (neuronal) membrane potential [2]. Accordingly, in an area corresponding to the *locus coeruleus*, which is located between the pontine respiratory group and the pFRG, initial inspiratory-related voltage-sensitive dye imaged activity is followed by a pronounced period of decreased activity [3]. The time course of these optical signals is similar to that of the inspiratory depolarization and the subsequent postinspiratory hyperpolarization of single neurons in this area. In contrast, optical activity in the main area of the pFRG is primarily preinspiratory-related, with less pronounced postinspiratory activity compared to that observed with whole-cell recording from single pFRG neurons [2]. In the latter study, inspiratory-related activity was in particular pronounced in the region of cervical spinal motoneurons, and in an area located ~0.4–0.6 mm caudal to the caudal end of the facial motor nucleus [2]. The latter region corresponds well with the presumptive rostrocaudal extension of the preBötC [4]. Most areas of the ventral respiratory column, including the pFRG and preBötC, contain different classes of respiratory neurons. It is not clear at present, why no prominent respiratory-related optical activity is revealed in regions of the ventral respiratory column other than the pFRG and preBötC.

Despite these caveats, respiratory voltage-sensitive dye imaging provided important information regarding the structural organization and function of respiratory networks. In *en bloc* medullas from newborn rodents, voltage-sensitive dye imaging revealed that both the dorsal and pontine respiratory groups are active in regions similar to those previously identified in adult mammals with combined electrophysiological and histological techniques [3]. The seminal imaging study on the discovery of the pFRG [2] suggested that the area of the location of these rhythmogenic preinspiratory

neurons may extend further rostrally than previously assumed. Regarding respiratory functions, voltage-sensitive dye imaging showed that anoxia-induced slowing of ▶respiratory rhythm in newborn rat brainstems is accompanied by depressed preinspiratory and augmented postinspiratory medullary optical activities that coincide with the occurrence of inspiratory-related cervical nerve burst doublets (Fig. 1).

The latter findings suggest that anoxia synchronizes the dual respiratory rhythm generators. This may result in enhanced postinspiratory medullary activity that triggers repetitive inspiratory motor bursts. All this shows that voltage-sensitive dye imaging is a potent tool for the analysis of normal and pathologically disturbed spatiotemporal patterns of respiratory activities, in particular when this technique is combined with electrophysiological recording of cellular respiratory bursting.

### Imaging of Respiratory $Ca^{2+}$ Oscillations and (Sub) Cellular Signaling Factors

In excitable cells, a notable rise of the free cytosolic  $[Ca^{2+}]$  is associated with the  $Ca^{2+}$  influx caused by activity-related depolarization. Accordingly,  $Ca^{2+}$  imaging is a widely used tool for monitoring neuronal activity (see ▶neuron-glia imaging). The vast majority of  $Ca^{2+}$  imaging studies of the respiratory system has focused on preBötC neurons or preBötC-driven interneurons and XII motoneurons in rhythmic slices from perinatal rodents. In most of these reports, clusters of preBötC neurons were loaded with the membrane-permeant acetoxy-methyl (AM) form of ▶ $Ca^{2+}$ -sensitive dyes, in particular Fluo-4-AM, Calcium-Green-1-AM and Fura-2-AM [4–8].

In the first respiratory  $Ca^{2+}$  imaging study, cytosolic  $Ca^{2+}$  oscillations in preBötC neurons occurred synchronously with inspiratory-related XII activity [7]. Following pharmacological blockade of glutamatergic synaptic transmission, asynchronous  $Ca^{2+}$  oscillations persisted in a subpopulation of these cells, in line with the hypothesis that preBötC neurons have intrinsic bursting (“pacemaker”) properties [1,7]. For this CCD camera imaging study, Calcium-Green-1-AM was microinjected near the midline contralateral to the preBötC side to be imaged. This ensured that only cells were imaged that project their axons to the contralateral preBötC. As a caveat, such loading of cells via diffusion of dye from their axon to the cell bodies required “overnight,” i.e. >10 h, incubation times. This substantial delay between the generation of the acute slice and the start of recording may affect functional properties of rhythmogenic preBötC networks although basic inspiratory activity was preserved, at least in solution of artificially-elevated (7–8 mM)  $[K^+]$  [7]. Alternatively, inspiratory  $Ca^{2+}$  oscillations can be monitored within <20 min after the injection of AM  $Ca^{2+}$  dye into the “online histologically-identified” preBötC [4] (Fig. 1).

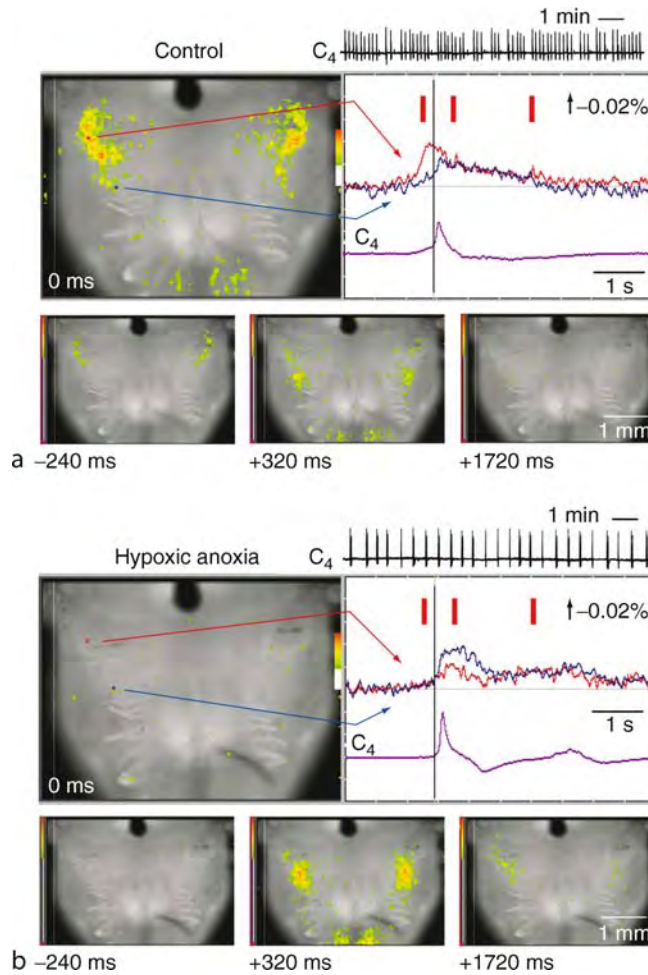

**Respiratory Network Analysis, Functional Imaging. Figure 1** Anoxic respiratory pattern shifts in newborn rat brainstem-spinal cords. (a) traces in box (50 averaged optical signals) show that pFRG activity (red dot) preceded preBötC activity (blue dot) in control. Images below box show fluorescence signals of the voltage-sensitive dye Di-2-ANEPEQ during time periods indicated by vertical red bars. (b) Hypoxic anoxia due to  $N_2$ -gassed solution decreased inspiratory-related cervical nerve ( $C_4$ ) burst rate and induced double bursts (compare integrated  $C_4$  activities in (a) and (b)). Anoxia also suppressed preinspiratory optical pFRG activity (50 averages) and elicited a second optical peak in the pFRG, preBötC and intermittent regions. The latter activity appeared in the postinspiratory phase after the augmented  $C_4$  peak and coincided with secondary  $C_4$  activity. In original  $C_4$  traces, the amplitude of the second  $C_4$  peak was similar to that of initial activity, but was attenuated by averaging due to variation in the time of burst onset. Scale bar indicates percentage change in fluorescence. (From K. Ballanyi & H. Onimaru, unpublished).

As a major advantage of this approach, preBötC rhythms can be studied for several hours in physiological (3 mM)  $K^+$  which ensures a higher sensitivity of preBötC rhythms to clinically-relevant agents such as opioids [4]. Although multiphoton microscopy was used in that report, neither the activity nor the gross morphology of preBötC neurons could be imaged at high spatial resolution at depths  $>80 \mu\text{m}$  into the tissue for yet unknown reasons. Similarly, CCD camera imaging and confocal laser scan microscopy are restricted to recording depths  $<70 \mu\text{m}$  [4–8]. Focal injection of  $Ca^{2+}$  dye limits the monitored area of active respiratory neurons to a circular spot with a diameter of

150–300  $\mu\text{m}$  [4]. This limitation is overcome by loading cells unspecifically in the entire slice via bath-application of the AM  $Ca^{2+}$  dye which, however, penetrates  $<50 \mu\text{m}$  into the tissue. As further caveats,  $Ca^{2+}$  imaging may induce phototoxic effects (**►Phototoxicity**) on (respiratory) neurons and is subjected to bleaching of dye (**►Photobleaching**). The extent of these effects increases at both higher sampling rates and enhanced optical magnification for visualizations of (sub)cellular structures. Though, at scan rates of 1.5–3 scans/s most of the peak of respiratory-related  $Ca^{2+}$  oscillations is captured and continuous multiphoton or confocal imaging is possible for time periods  $>30 \text{ min}$

[4] (Fig. 2), similar to CCD camera imaging (Fig. 3) (B.U. Keller, unpublished observations).

The correlation between inspiratory-related membrane potential oscillations (or underlying membrane currents) and intracellular  $\text{Ca}^{2+}$  can be analyzed during whole-cell recording of respiratory neurons that are loaded with  $\text{Ca}^{2+}$  dye via the recording patch-electrode (Fig. 3). The first study in that regard showed with photomultiplier-based “point” imaging in presumptive preBötC neurons that somatic  $\text{Ca}^{2+}$  rises with a magnitude of maximally 300 nM occur during the inspiratory drive potential, and that a major portion of this signal is due to  $\text{Ca}^{2+}$  influx via high voltage-gated  $\text{Ca}^{2+}$  channels [5]. The relation of membrane excitability with cytosolic  $\text{Ca}^{2+}$  transients and their buffering, or with other cellular signaling factors, has been studied thoroughly in inspiratory active XII cells [8] (Fig. 3). These cells are not only a potent model to study

the inspiratory drive from the preBötC to motor networks, but also for analysis of the selective vulnerability of particular motoneurons in amyotrophic lateral sclerosis [8]. Disturbances of (sub)cellular signaling processes such as (respiratory-related oscillations of) mitochondrial  $\text{Ca}^{2+}$  and membrane potential or redox processes are studied in XII motoneurons with regard to the latter disease [8]. Rhythmic changes of (sub)cellular signaling factors have also been optically monitored in presumptive inspiratory preBötC neurons, e.g., in the context of anoxic respiratory depression [9].

### Targeted Recording from Fluorescence-Tagged Respiratory Neurons

It is not clear, whether yet unidentified rhythmogenic respiratory neurons, in particular of the preBötC and pFRG, have specific morphological features such as a particular size and shape of the soma or the number and

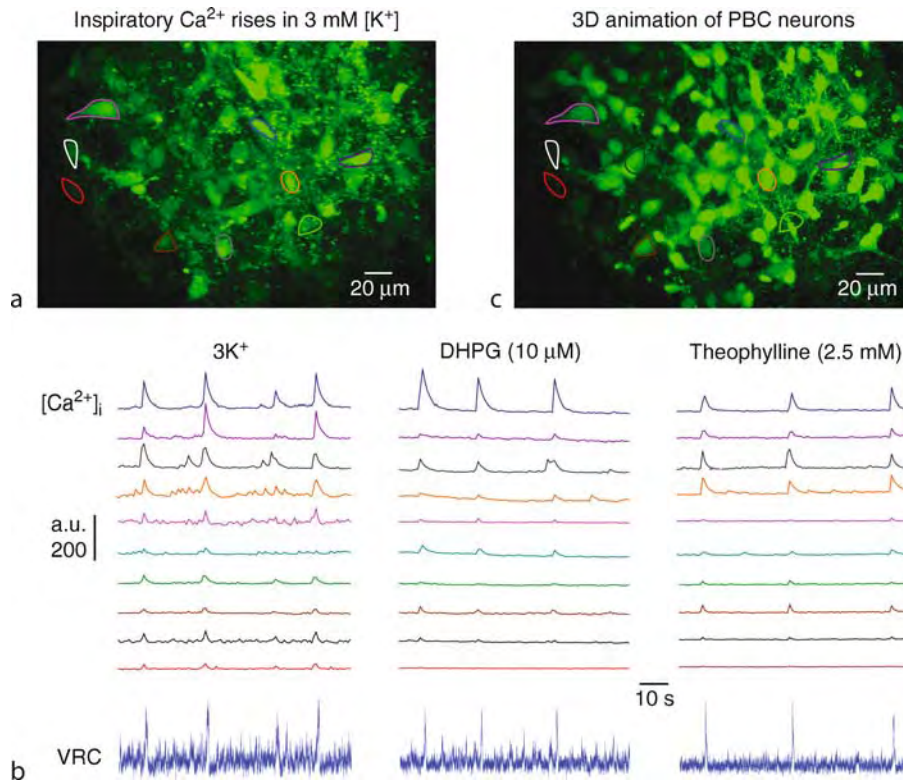

**Respiratory Network Analysis, Functional Imaging. Figure 2** Multiphoton/confocal imaging of the activity and morphology of inspiratory preBötC neurons. (a) cells located 0.59 mm caudal to the caudal end of facial nucleus in the preBötC of a 600  $\mu\text{m}$  thick newborn rat brainstem slice were stained by pressure-injection (0.7–1.0 psi, 10 min) with  $\text{Ca}^{2+}$  sensitive dye, Fluo-4-AM. Movie (*supplemental material*) shows 90 s recording in 3 mM  $[\text{K}^+]$  of  $\text{Ca}^{2+}$  oscillations in these neurons that were in phase with inspiratory population activity recorded from the contralateral PBC; bottom left trace in (b). Fluo-4-AM fluorescence intensity is plotted in arbitrary units (a.u.) against time. After washout of rhythm in 3 mM  $[\text{K}^+]$ , preBötC bursting and  $\text{Ca}^{2+}$  oscillations were restored by low concentrations of the metabotropic glutamate receptor agonist dihydroxyphenylglycine (DHPG) and the clinically used respiratory stimulant theophylline. (c) 3D animation (*supplemental material*) showing gross morphology of preBötC neurons and neighboring non-rhythmic cells obtained from z-stack (0.5  $\mu\text{m}$  single step) image series encompassing areas starting 7.5  $\mu\text{m}$  above to 7.5  $\mu\text{m}$  below image plane of (a) (reproduced from [4] with permission).

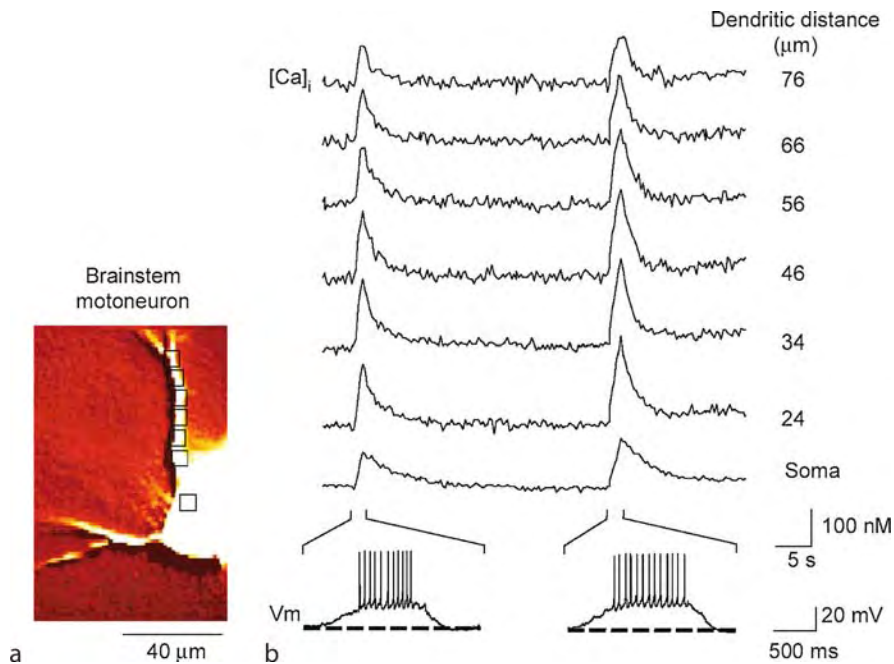

**Respiratory Network Analysis, Functional Imaging. Figure 3** Whole-cell patch-clamp recording and simultaneous Ca<sup>2+</sup> imaging of a rhythmically active hypoglossal motoneuron. (a) Fluorescence image of the soma and proximal dendrite of a patch-clamped hypoglossal motoneuron in a 700 μm thick mouse brainstem slice. (b) Whole-cell recording in current-clamp mode and simultaneous ratiometric CCD camera imaging of cytosolic Ca<sup>2+</sup> concentrations. Rhythmic electrical discharges are paralleled by notable Ca<sup>2+</sup> transients in the soma and six dendritic compartments, selected for analysis at distances of 24–76 μm from the soma (compartment positions are represented by boxes in (a)). Spontaneous bursts of action potentials, shown in the bottom trace as changes in membrane voltage (Vm) are accompanied by cytosolic Ca<sup>2+</sup> rises up to 200 nM (reproduced from [8] with permission).

array of (primary) dendrites. If this were the case, such cells could be selectively targeted after fluorescence labeling for intracellular electrophysiological recording in the rhythmic slices. The above mentioned Ca<sup>2+</sup>-sensitive fluorescent dyes, and also other functional dyes such as the marker for mitochondrial potential Rhodamine-123, can principally be used as morphological markers (Fig. 2–4) (see neuron-glia imaging).

Regarding Ca<sup>2+</sup> dyes, Fura-2 provides a robust fluorescence signal at low (resting) cytosolic [Ca<sup>2+</sup>], whereas both Fluo-4 and Calcium-Green-1 fluoresce during rises of cytosolic Ca<sup>2+</sup> (Fig. 2–4) [4–7]. Although recording from inspiratory (preBötC) interneurons in the rhythmic slices is routinely done under visual control, these superficial cells are surprisingly not routinely labeled during recording with high resolution morphological dyes, e.g., of the “Alexa” family.

Alternatively, subpopulations of respiratory neurons in acute medullary slices can be labeled with fluorescent markers for proteins in the plasma membrane or cytosol. In that context, it was assumed that rhythmogenic preBötC neurons are characterized by postsynaptic neurokinin-1 receptors that are normally activated by

substance P [1,6]. Accordingly, fluorescence-tagging of substance P uptake via these receptors revealed that preBötC neurons can indeed be targeted [6] (Fig. 4). However, as shown in the latter study, the labeling was not specific and included various other types of (respiratory) brainstem neurons. In addition, respiratory neurons can be targeted in acute slices from transgenic mice that express a fluorescent protein coupled to a promoter such as glutamic acid decarboxylase [10]. Also this approach is yet not specific enough for identifying one particular population of candidate rhythmogenic respiratory neurons. Currently, fluorescence-tagged transcription factors that may be specific for rhythmogenic respiratory neurons, are being constructed in transgenic mice. However, it may turn out that such cells are not characterized by a single characteristic feature that can be visualized in the *in vitro* models, but rather by a unique pattern of transcription factors, (pacemaker) ion channels plus neurotransmitter receptors and/or transporters.

#### Acknowledgments

Work contributing to this study was supported by the Canadian Institutes of Health Research (CIHR), the



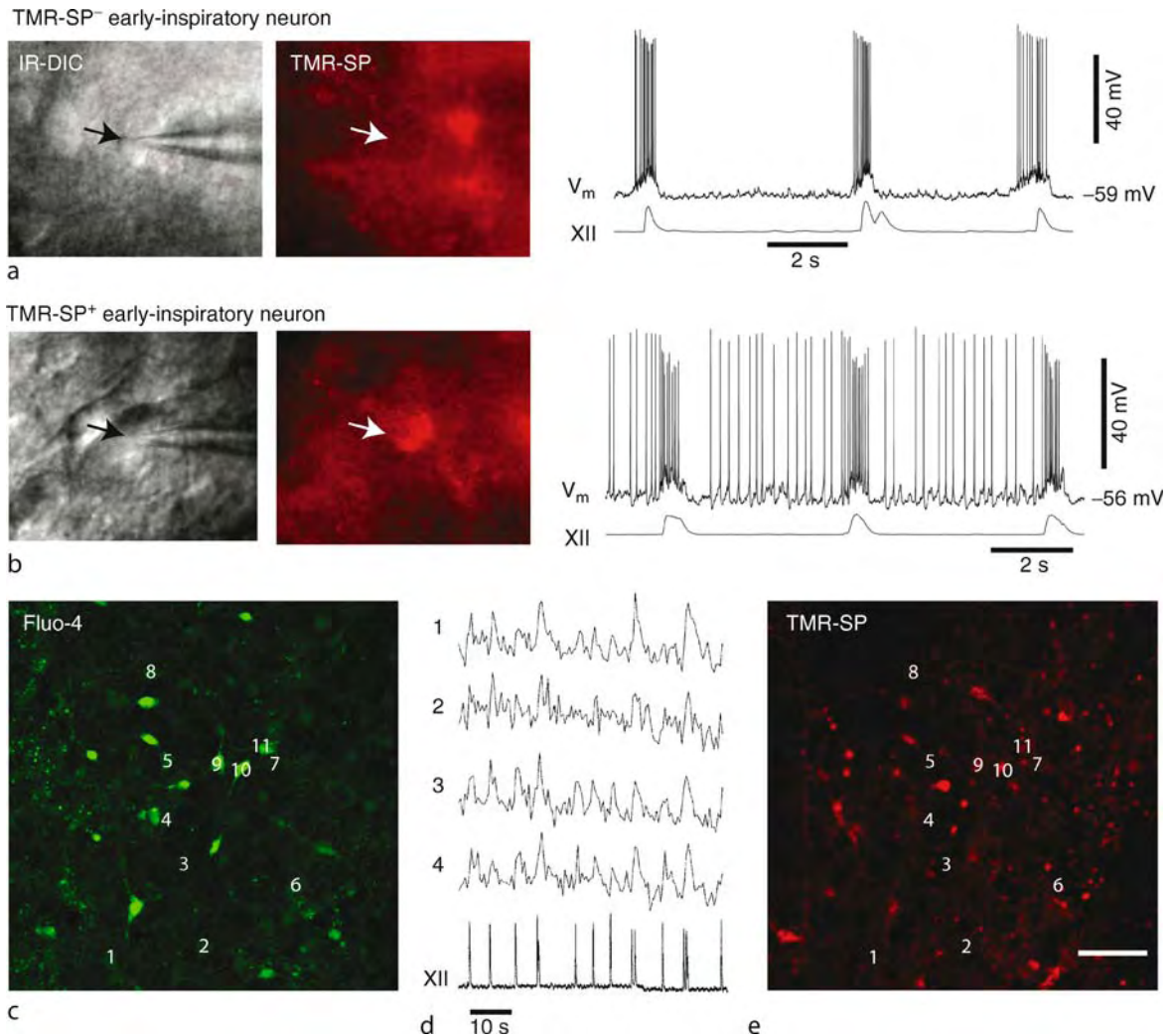

**Respiratory Network Analysis, Functional Imaging. Figure 4** Targeted recording from acutely fluorescence-tagged preBötC neurons. (a, b) tetramethylrhodamine conjugated to substance P (TMR-SP) labeling in preBötC neurons with different phenotypic properties. Infrared differential interference contrast (IR-DIC) and epifluorescence images are shown in left columns, with corresponding intracellular traces to the right. (a) TMR-SP<sup>-</sup> early inspiratory neuron with silent interburst intervals. (b) TMR-SP<sup>+</sup> early inspiratory neuron with tonic low-frequency spiking properties. Scale bar (25  $\mu$ m) applies to all images in (a, b). (c, e) simultaneous measurements of inspiratory activity and TMR-SP labeling in preBötC neurons. (a) fluo-4 image shows a peak acquisition of Ca<sup>2+</sup> labeling; TMR-SP image shows TMR-SP<sup>+</sup> cells in the same region. Scale bar: 50  $\mu$ m. (d) changes in fluorescence intensity from regions of interest (ROIs) indicated by numerals in (c), plotted with synchronized XII activity (reproduced from [6] with permission).

Alberta Heritage Foundation for Medical Research (AHFMR), the Canada Foundation for Innovation (CFI-ASRIP), the Bundesministerium für Bildung und Forschung (BMBF) and the Bernstein Center for Computational Neuroscience (BCCN).

## References

- Ballanyi K (2004) Neuromodulation of the perinatal respiratory network. *Curr Neuropharmacol* 2:221–243
- Onimaru H, Homma I (2003) A novel functional neuron group for respiratory rhythm generation in the ventral medulla. *J Neurosci* 23:1478–1486
- Onimaru H, Homma I (2005) Optical imaging of respiratory neuron activity from the dorsal view of the lower brainstem. *Clin Exp Pharmacol Physiol* 32:297–301
- Ruangkittisakul A, Schwarzacher SW, Ma Y, Poon B, Secchia L, Funk GD, Ballanyi K (2006) High sensitivity to neuromodulator-activated signaling pathways at physiological [K<sup>+</sup>] of confocally-imaged respiratory center neurons in online-calibrated newborn rat brainstem slices. *J Neurosci* 26:11870–11880

5. Fermann D, Keller BU, Richter DW (1999) Calcium oscillations in rhythmically active respiratory neurones in the brainstem of the mouse. *J Physiol* 515:119–131
6. Hayes JA, Del Negro CA (2007) Neurokinin receptor-expressing pre-botzinger complex neurons in neonatal mice studied *in vitro*. *J Neurophysiol* 97:4215–4224
7. Koshiya N, Smith JC (1999) Neuronal pacemaker for breathing visualized *in vitro*. *Nature* 400:360–363
8. von Lewinski F, Keller BU (2005) Ca<sup>2+</sup>, mitochondria and selective motoneuron vulnerability: implications for ALS. *Trends Neurosci* 28:494–500
9. Mironov SL, Richter DW (2001) Oscillations and hypoxic changes of mitochondrial variables in neurons of the brainstem respiratory centre of mice. *J Physiol* 533:227–236
10. Kuwana S, Tsunekawa N, Yanagawa Y, Okada Y, Kuribayashi J, Obata K (2006) Electrophysiological and morphological characteristics of GABAergic respiratory neurons in the mouse pre-Botzinger complex. *Eur J Neurosci* 23:667–674

## Respiratory Network Analysis, Isolated Respiratory Center Functions

KLAUS BALLANYI<sup>1</sup>, HIROSHI ONIMARU<sup>2</sup>

<sup>1</sup>Department of Physiology, University of Alberta, Edmonton, AB, Canada

<sup>2</sup>Department of Physiology, Showa University School of Medicine, Tokyo, Japan

### Synonyms

Dual respiratory center organization; Mammalian respiratory rhythm generators

### Definition

Analysis of isolated respiratory centers means a reductionistic approach for studying the neural control of breathing using *in vitro* brainstem preparations (mostly from ►perinatal rodents) in which rhythmogenic respiratory networks remain active. The ►pre-Bötzinger complex (preBötC) has been identified as a brainstem region that generates respiratory rhythm in mammals and remains active in a transverse medullary slice preparation. In a more rostral transverse medullary slice without the preBötC, the pre/postinspiratory active ►parafacial respiratory group (pFRG) continues to drive facial (VII) motoneurons rhythmically. Although both groups of rhythmogenic neurons operate autonomously in the distinct brainstem slices, they appear to constitute a ►dual respiratory center, at least in less reduced “►en bloc” brainstem-spinal cord preparations from perinatal rodents and juvenile rats *in vivo*. This hypothesis is based on a differential action of opioids on functionally inspiratory (preBötC-driven)

or expiratory (pFRG-driven) motor activities *in vivo* and *in vitro* suggesting that the pFRG provides a pivotal excitatory drive to the preBötC. Conversely, anoxia appears to synchronize and enhance the activities of both rhythm generators, resulting in pronounced postinspiratory medullary activities and lumbar/ facial motor bursting that are accompanied by inspiratory-related nerve burst doublets. The latter findings suggest that the preBötC and pFRG are capable of adjusting their interactions to cope in particular with pathological disturbances of breathing.

### Characteristics

#### Respiratory Network Organization *in vitro* and *in vivo*

Three major anatomically defined respiratory groups have been identified in the lower brainstem of mature mammals *in vivo* by microelectrode analysis of respiratory-related extra- or intracellular activities and subsequent histological identification of the recording sites [1] (Fig. 1). The ►dorsal respiratory group is a relay site of peripheral mechano- and chemoreceptor inputs to primary respiratory networks, whereas the pontine respiratory group is important for the generation of the multiphase neuronal activity pattern, which is projected to the respiratory muscles [1]. The ►ventral respiratory group (or rather column) contains arrays of interneurons, which are involved in the generation of the basic rhythm [1,3,4] (Fig. 1). In 1984, Suzue reported that respiratory activity in mammals is retained *in vitro*, specifically in isolated brainstem-spinal cord preparations from newborn rats [3] (Fig. 1). Extra- and intracellular electrophysiological recording of rhythmic drive potentials and/or action potential discharge in histologically-identified brainstem sites established that different classes of respiratory neurons are active in this *en bloc* model in areas corresponding to those in adult mammals *in vivo* [1,3,4] (Fig. 1). Neonatal rat ventral respiratory column neurons have been classified according to the phase relation of their cellular bursting with inspiratory-related cervical nerve bursting. This revealed that such neurons are active during one or several phases of the *in vitro* respiratory rhythm, which is comprised of a preinspiratory, inspiratory, postinspiratory and an active expiratory (“E-2”) component in brainstem-spinal cord preparations [3,4–7] (Fig. 1).

#### Isolation of Respiratory Centers

The findings from a large number of studies using the *en bloc* brainstem model greatly advanced the understanding of cellular mechanisms involved in the neural control of breathing [3,4]. In that regard, findings from one seminal study [8] supported in 1991 the long-standing hypothesis that breathing movements originate from a limited area, a “*noeud vitale*,” in the “upper neck” [1]. Specifically, microsection of the newborn

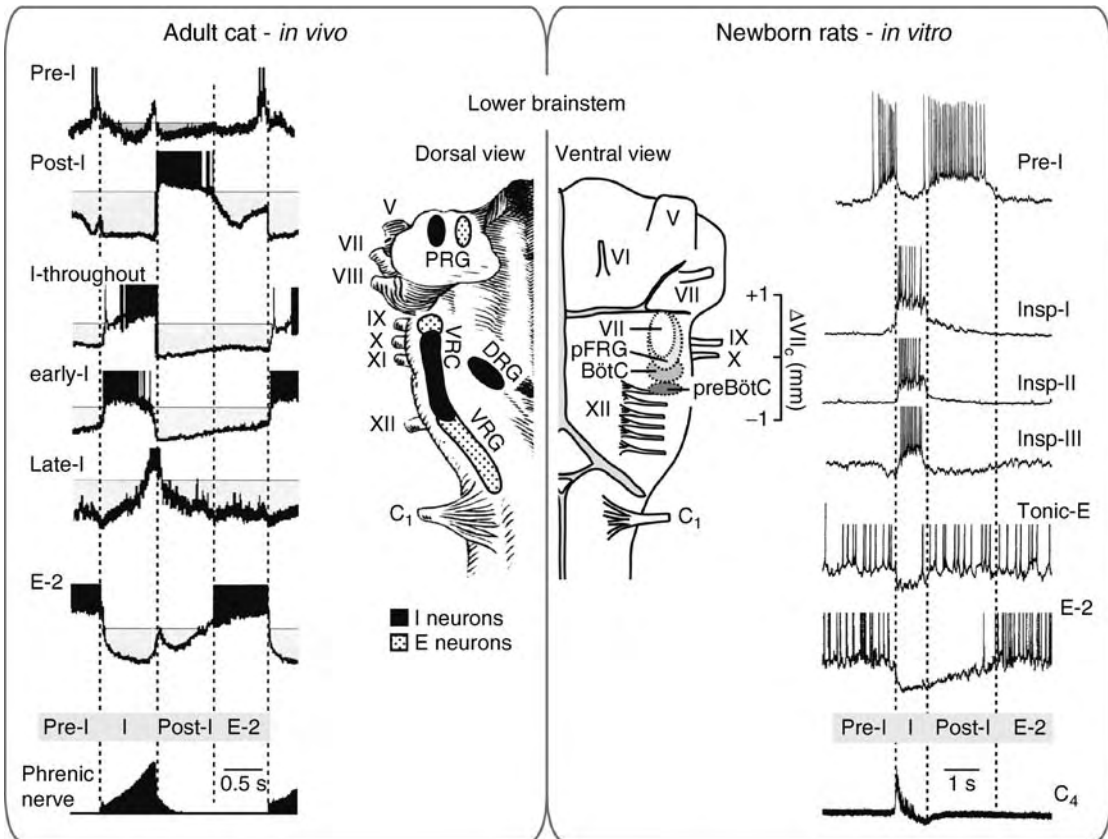

**Respiratory Network Analysis, Isolated Respiratory Center Functions.** **Figure 1** Respiratory groups, centers and neuron classes in mammals. Sharp microelectrode membrane potential recordings in the left part of the figure revealed rhythmic depolarizations in six classes of adult cat medullary respiratory neurons. These cells discharge action potentials (black bars) in a specific phase relation with the inspiratory (I) plus postinspiratory (post-I) activities of the phrenic nerve which activates the diaphragm, i.e. the main inspiratory muscle. Grey areas indicate periods of inhibition via GABA<sub>A</sub> and glycine receptors. Modified with permission from D.W. Richter (in *Comprehensive Human Physiology*, eds. R. Greger, U. Windhorst; Springer-Verlag, Berlin Heidelberg, 1996). The dorsal schematic view on an adult cat brainstem shows the simplified distribution of I neurons (black areas) and expiratory (E, dotted areas) neurons in the pontine, dorsal and ventral respiratory groups (PRG, DRG, VRG). Note that the rostral portion of the VRG is named ventral respiratory column (VRC). Modified with permission from [1]. The attached ventral view on a newborn rat brainstem shows the locations and rostrocaudal extensions of the parafacial respiratory group (pFRG) and pre-Bötzinger Complex (preBötC) rhythmogenic respiratory centers with reference to the caudal end of the facial (VII) motonucleus, VII<sub>c</sub>. The constancy of the rostrocaudal extensions of respiratory marker nuclei such as the VII nucleus and the inferior olive allowed the generation of “calibrated” newborn rat brainstem-spinal cord (“*en bloc*”) preparations with a defined content of (respiratory) brainstem tissue [2]. The ventral brainstem view also shows the location of cranial nerves and blood vessels, which are used as landmarks for insertion of “patch-clamp” electrodes in the *en bloc* model for “whole-cell” recordings of membrane potentials from different types of newborn rat VRC neurons. In the right part of the figure, the activity patterns of such neurons are aligned with reference to inspiratory-related activity of ventral cervical nerve roots (C<sub>3-6</sub>) forming the phrenic nerve. Specifically, these neurons are I neurons (sublabeled Insp-I, Insp-II, Insp-III after [3]), two types of E neurons, and preinspiratory (plus postinspiratory) active “Pre-I”-type pFRG neurons. Modified with permission from H. Onimaru, A. Arata, I. Homma (*Respiration & Circulation* 46, 773–782, 1998). Abbreviations: E-2, active expiratory phase; BötC, Bötzinger Complex; V–XII, cranial nerves, specifically V, trigeminus; VI, abducens; VIII, vestibulocochlear; IX, glossopharyngeus; X, vagus; XI, accessory; XII, hypoglossus; C<sub>1</sub>, 1st ventral cervical nerve.

rat brainstem-spinal cord preparation was combined with suction electrode recording of cranial and spinal nerve activities to consolidate first the conclusion from previous findings on that model [3] that neither the

pontine nor the dorsal respiratory group are necessary for fictive inspiratory-related rhythm [8]. Instead, inspiratory rhythm was irreversibly blocked when microsection affected a medullary area, named the

preBötC, which extended ~200  $\mu\text{m}$  in rostrocaudal direction (Fig. 2). Finally, this study demonstrated that the preBötC remains inspiratory active after isolation in a transverse brainstem slice (Fig. 2).

The view that the preBötC constitutes an essential respiratory center is supported since its discovery by numerous *in vivo* and *in vitro* studies [3,4]. However, the preBötC is not the only autonomous respiratory

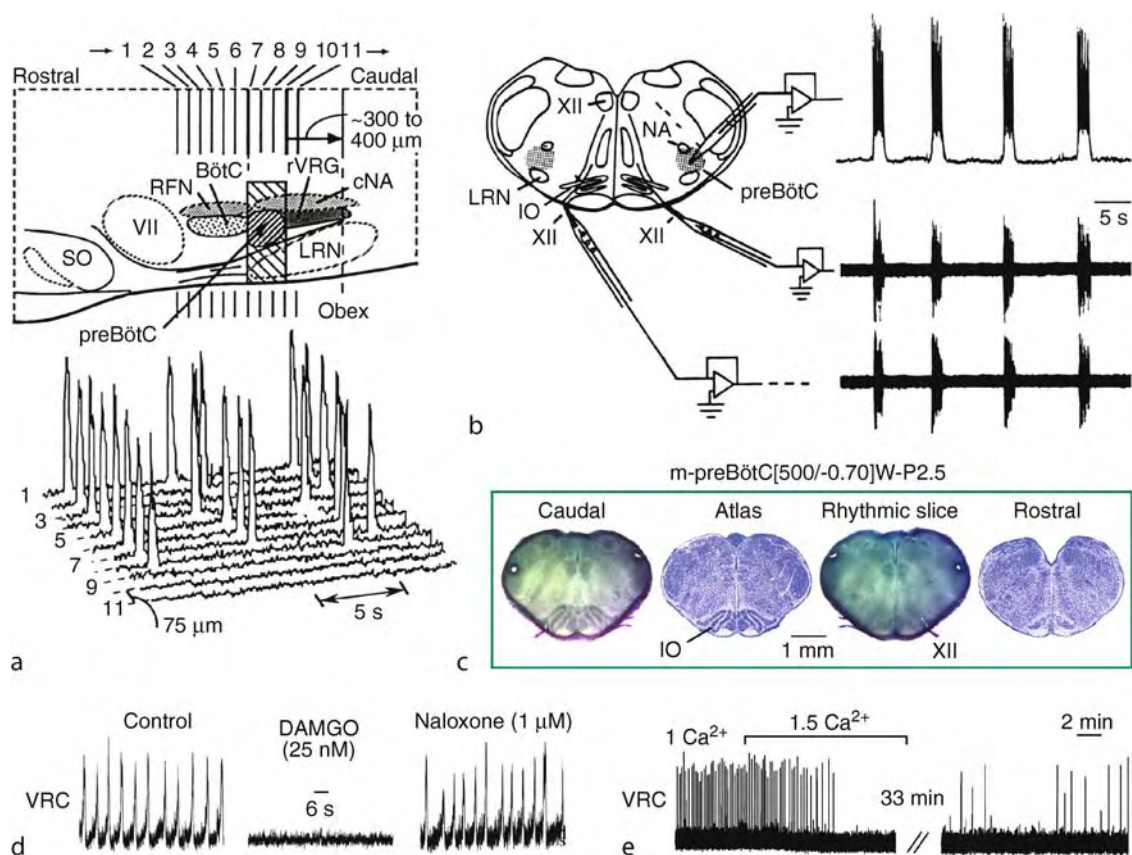

**Respiratory Network Analysis, Isolated Respiratory Center Functions. Figure 2** Isolation of the inspiratory center. (a) the upper panel shows a schematic lateral sagittal section through the ventral aspect of the newborn rat brainstem. The numbers correspond to consecutive 75  $\mu\text{m}$  transverse sections through the brainstem-spinal cord model (Fig. 1). The sections were carried out in rostral to caudal direction, while recording with suction electrodes inspiratory-related cervical nerve bursts which are displayed, after integration, in the lower panel. Such experiments revealed an irreversible block of rhythmic discharge following section 8. These findings were complemented by results from corresponding recordings from inspiratory active cranial nerves during sectioning in caudorostral direction. This identified the preBötC as a brainstem region with a rostrocaudal extension by ~200  $\mu\text{m}$  (see box) which is important for generation of respiratory rhythm. Abbreviations others than those in Fig. 1: LRN, lateral reticular nucleus; RFN, retrofacial nucleus; SO, superior olive; rVRG, rostral ventral respiratory group; cNA, caudal nucleus ambiguus. (b) The preBötC remains inspiratory active in a newborn rat brainstem slice with a thickness >175  $\mu\text{m}$ . Rhythmically active neurons in the area of the ventrolateral medulla rhythmically drive XII motoneurons which innervate via the XII nerve genioglossal tongue muscles for patency of the upper airways during inspiration. (a and b modified with permission from [8].) (c) The constancy of respiratory marker nuclei such as the inferior olive enables the generation of preBötC slices with rostrocaudal boundaries which are "calibrated" by comparison with a newborn rat brainstem atlas [9]. The latter study introduced a terminology for such slices. In this example the "m-preBötC[500/-0.70]W-P2.5" slice contains the preBötC in the middle ("m-preBötC"), is 500  $\mu\text{m}$  thick with the caudal boundary 0.70 mm caudal to VII<sub>c</sub>, and was produced from a 2.5 days-old (P2.5) Wistar (W) rat. (d) calibrated preBötC slices generate robust inspiratory-related rhythm in the area of the VRC in superfusate with physiological (3 mM) instead of routinely used 7–11 mM  $[\text{K}^+]$ . This rhythm is very sensitive to low concentrations of the  $\mu$ -opioid receptor agonist DAMGO. Note that the 3 mM  $\text{K}^+$  rhythm is effectively restored within few minutes of application of the opioid receptor antagonist naloxone (1  $\mu\text{M}$ ). c and d modified with permission from [9]. (e) in a different preBötC slice, 3 mM  $\text{K}^+$  rhythm was abolished shortly after raising superfusate  $\text{Ca}^{2+}$  from 1 mM (the lower limit of the proposed physiological range) to 1.5 mM (the upper limit). Note the incomplete recovery of inspiratory rhythm following washout of raised  $\text{Ca}^{2+}$ . Modified with permission from [2].

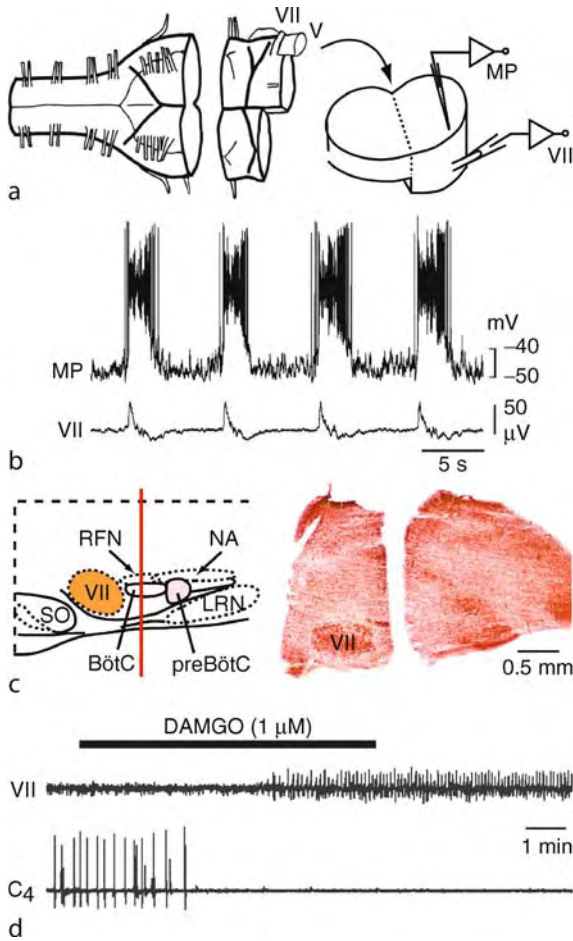

**Respiratory Network Analysis, Isolated Respiratory Center Functions. Figure 3** Rhythmic pFRG activity in a transverse slice of brainstem tissue rostral to the preBötC. (a) the newborn rat *en bloc* model was transected slightly rostral to the most rostral XII root to obtain a transverse slice for simultaneous suction electrode recording from the VII nerve and whole-cell recording of membrane potential (MP) from neurons within the ventrolateral medulla. (b) membrane potential oscillations of putative Pre-I neuron in the rostral block were synchronous with VII nerve activity in “Suzue-type” solution with 6.2 mM  $K^+$  and 2.4 mM  $Ca^{2+}$ . Shortly before the recording, the preparation was treated for 10–15 min with DAMGO (1  $\mu$ M) for enhancement of such bursting. (c) histological reconstruction revealed that the transection was between VII<sub>c</sub> and the rostral boundary of the BötC in adult mammals (compare Fig. 1). (d) in a preparation transected at a level similar to that in the experiment of a–c, but without removing the rostral block, DAMGO in 6.2 mM  $K^+$  and 2.4 mM  $Ca^{2+}$  abolished inspiratory-related C<sub>4</sub> activity in the caudal aspect of the transected preparation, but restored VII nerve rhythm, which was transiently depressed due to the transection procedure. These findings suggest that pFRG neurons in rostral medullary slices, not including the preBötC, produce rhythmic bursting which is facilitated by opioids,

center in mammals. Already more than 20 years ago, the hypothesis has been proposed that pre/postinspiratory active “Pre-I” neurons are important for maintenance of the rhythmic activity of inspiratory medullary networks in the newborn rat *en bloc* preparation [3]. More recent findings from voltage-sensitive dye imaging of spatiotemporal respiratory patterns and concomitant electrophysiological recording of membrane potential indicated that Pre-I neurons form the pFRG, a functionally and anatomically defined respiratory group [6] (Fig. 1). The pFRG remains rhythmically active and drives VII motoneurons in a transverse slice of brainstem tissue that rostrally neighbors the preBötC [7] (Fig. 3). Most pFRG neurons are active during both the preinspiratory and postinspiratory phase, but are subject to pronounced inhibition via hyperpolarizing GABA<sub>A</sub> and glycine receptor-mediated inhibitory postsynaptic potentials during the inspiratory phase [3,5–7] (Fig. 1). In contrast, pFRG neurons are continuously active for a time period of several seconds in the slices with rhythmic VII nerve activity [7] (Fig. 3). This supports earlier assumptions that the preBötC is responsible for inspiratory inhibition of Pre-I cells in the *en bloc* medullas [3]. Although “reference” inspiratory motor activity is missing in the rhythmic pFRG slices, it is likely that the sustained neuronal and VII nerve activities (Fig. 3) span the preinspiratory, inspiratory plus postinspiratory phases.

Bursting of pFRG neurons during these phases is in accordance with the finding that branches of the VII nerve innervate muscles of the *alae nasi* that decrease the nasal airway resistance in cats and dogs before, during and after inspiration [7]. Conversely, the finding that interneurons in the ventrolateral aspect of preBötC slices induce rhythmic activity of XII motoneurons (Fig. 2) strongly suggests that the rhythm in that model is inspiratory-related [8], because subgroups of XII motoneurons innervate the tongue during inspiration for patency of the upper airways [1,4].

#### Determinants of Isolated Respiratory Center Activities

The rhythmic activities of the isolated respiratory centers are not identical with those in intact animals or less reduced *in vitro* preparations such as the “working heart brainstem preparation” of rodents [see corresponding chapters]. Though, activities in the rhythmic slices share several features with respiratory behaviors *in vivo*. For example, in juvenile rats preBötC-driven inspiratory activity is blocked by opioids, whereas rhythmic contractions of pFRG-driven expiratory abdominal muscles are not inhibited [4,5]. Similar to these *in vivo* findings,

in contrast to a strong depressing action of such drugs on more caudal preBötC-driven rhythms. Modified with permission from [7,8].

opioids depress preBötC-driven (motor) rhythms *in vitro*, whereas pFRG-driven cellular and nerve activities are not inhibited [4,5,7]. The effects of various neuromodulators on the *in vitro* respiratory-related rhythms are influenced by the experimental conditions, which differ notably between laboratories. In particular the superfusate concentrations of  $K^+$  and  $Ca^{2+}$  vary between 3–11 mM and 0.8–2.4 mM, respectively, despite the notion that these cations strongly modulate neuronal excitability [2]. Regarding the action of opioids, preBötC slice rhythms in physiological  $K^+$  (3 mM) and 1 mM  $Ca^{2+}$  are blocked by low nanomolar concentrations of opioids (Fig. 2), whereas close to micromolar concentrations are needed to depress rhythms in preBötC slices or *en bloc* medullas in superfusate with elevated  $K^+$  (Fig. 3) [7,9]. Furthermore, preBötC slices generate long-term and robust rhythm in 3 mM  $K^+$  and 1 mM  $Ca^{2+}$  (corresponding to the lower range of the physiological spectrum), whereas rhythm is depressed by elevation of  $Ca^{2+}$  to 1.5 mM (the proposed upper limit of the physiological range) [2,9] (Fig. 2). In 1.5 mM  $Ca^{2+}$ , preBötC slice rhythm is reactivated by raised  $K^+$  leading to the view that isolated inspiratory center activity is determined by an extracellular “ $Ca^{2+}/K^+$  antagonism” [2].

Respiratory center rhythms depend also critically on the physical dimensions of the *in vitro* models. For example, findings in the newborn rat *en bloc* model indicated that the pFRG drives pre/postinspiratory bursting of lumbar motoneurons in spinal  $L_{1-2}$  segments via premotoneurons which are located caudal to the preBötC [5]. This view was substantiated by the observation in juvenile rats *in vivo* that brainstem transection at the caudal end of the VII nucleus, which partially overlaps with the pFRG [6] (Figs. 1 and 3), abolished pre/postinspiratory bursting of expiratory abdominal muscles innervated by  $L_{1-2}$  lumbar motoneurons [4]. Similar transection experiments in the newborn rat *en bloc* model revealed that the transection level critical for blocking pre/postinspiratory lumbar bursting is quite close to the rostral instead of the caudal end of the VII nucleus [2]. The absence of respiratory lumbar bursting in such transected preparations suggests that pFRG neurons responsible for this motor behavior are located in the most rostral aspect of the pFRG [2] (Fig. 1). However, it is for example also possible that axons from more caudal pFRG neurons inducing lumbar respiratory bursting project first rostrally and may thus have been transected [2,10]. This indicates that results from transection experiments need to be considered with caution. Furthermore, Pre-I neurons are not only found in the main area of the pFRG, but also within the preBötC, and even in regions caudal to the preBötC. In addition to Pre-I and expiratory cells, the preBötC in both perinatal rodent *en bloc* medullas and *in vivo* contains various subclasses of inspiratory neurons [3] (Fig. 1). Conversely, inspiratory (and expiratory)

neurons are also active in the main area of the pFRG. While the rostral portion of the pFRG co-locates with the VII nucleus, the caudal part of the pFRG partially covers an area corresponding to the Böttinger Complex in mature mammals. Finally, the pFRG also more or less overlaps medially with the Retrotrapezoid nucleus, which is one presumptive site of central respiratory chemosensitivity [4].

Due to the overlap of primary (rhythmogenic) areas and secondary (chemosensitive) respiratory drive regions, in concert with a rostrocaudally dispersed distribution of distinct classes of respiratory neurons, the respiratory centers can not be isolated without portions of functionally and/or anatomically different structures that may interact with these centers. Despite these caveats, the reductionistic approach has already, and will further, provide important information on the neural control of breathing. For example, [▶ multiphoton/confocal  \$Ca^{2+}\$  imaging](#) has been adapted to study the activity and gross morphological features such as soma size or shape of preBötC neurons, located in a histologically defined rostrocaudal area of “calibrated” preBötC slices that operate in physiological cation solution [9] (Fig. 2) [see [▶ Respiratory network analysis, Functional imaging](#)]. A structure-function relationship of the isolated respiratory centers may be feasible by using the calibrated *in vitro* models in combination with nerve and intracellular electrophysiological recording plus  $Ca^{2+}$  and voltage-sensitive dye imaging, which was crucial for identification of the pFRG [6] [see [▶ Respiratory network analysis, Functional imaging](#)].

### A Dual pFRG-preBötC Respiratory Center

Findings in the *en bloc* brainstem model and juvenile rats *in vivo* suggest that the pFRG and the preBötC constitute a dual respiratory center. This hypothesis has been first proposed according to the above described distinct effects of opioids on inspiratory and pre/postinspiratory motor behaviors. These findings led to the conclusion that opioids inhibit breathing, at least partly, due to depression of synaptic excitatory transmission between the pFRG and the preBötC [4,5]. This view that excitatory drive from the pFRG to the preBötC is necessary for robust activity of the preBötC has already been proposed much earlier based on the finding in the *en bloc* model that focal lesion of the area including the pFRG impairs inspiratory cervical motor output [3]. However, as stated above the preBötC slices are capable of generating robust rhythm in physiological ion solution for several hours in the absence of structures corresponding to the main location of the pFRG [2,9]. The finding that rhythmic VII nerve activity in the pFRG slices is not depressed, but rather stimulated, by  $\mu$ -opioid receptor agonists [7] (Fig. 3) supports the view that this respiratory center may be in particular important for breathing during the

perinatal period, when the brainstem is presumably subject to a surge by endogenous opioids [4].

Anoxia represents a further approach for analyzing the cooperativity of the pFRG and the preBötC. In the *en bloc* model, both hypoxic and chemical anoxia synchronize and enhance the activities of the pFRG and preBötC rhythm generators. This results in pronounced and persistent (>20 min) postinspiratory medullary activities and lumbar/ facial motor nerve bursting during anoxia which is accompanied by inspiratory-related nerve burst doublets [10]. A causal relation between the latter anoxia-related phenomena is suggested by the finding that control pre/postinspiratory lumbar bursting is absent (similar to anoxia-induced enhancement of postinspiratory lumbar bursting and inspiratory-related nerve burst doublets) upon transection of the newborn rat *en bloc* preparation between the preBötC and the caudal end of the VII nucleus [10]. These results suggest that the anoxic postinspiratory augmentation of medullary interneuronal and lumbar/ facial nerve bursting as well as inspiratory motor burst doublets require an interaction between the preBötC and the pFRG [10].

In summary, the rhythmogenic preBötC and pFRG appear to constitute a dual respiratory center, which adjusts its activity to cope with pathological disturbances of breathing. Under the influence of opioids, boosted pFRG activity may partly compensate for the depressed intrinsic preBötC interneuronal activity and provide enhanced drive for breathing efforts. During oxygen depletion, a functional reorganization of the preBötC and pFRG for synchronized and augmented bursting may optimize uptake of oxygen by enhancing single breaths. However, the extent of cooperativity between these respiratory centers during normal breathing is not clear yet. In particular, it remains to be shown that the pFRG has a similarly important role for breathing in mature mammals compared to newborns. That the pFRG is active *in vivo* after birth is indicated by the above finding of pre/postinspiratory abdominal muscle activity in juvenile rats [4,5]. It may be important to study whether the pFRG in mature mammals is closely related to the chemosensitive ►Retrotrapezoid nucleus [4]. That this may be the case is suggested by the anatomical overlap of these brainstem regions and by the findings that neurons in both regions are excited by raised levels of CO<sub>2</sub> and H<sup>+</sup> and project to other respiratory areas including the preBötC [3,4].

## References

1. Feldman JL (1986) Neurophysiology of breathing in mammals. In: Handbook of physiology. The nervous system. Intrinsic regulatory systems in the brain, vol 4, chapter 9. Am Physiol Soc, Washington, DC, Sect 1, pp 463–524
2. Ruangkittisakul A, Secchia L, Bornes TD, Palathinkal DM, Ballanyi K (2007) Dependence on extracellular Ca<sup>2+</sup>/K<sup>+</sup> antagonism of inspiratory centre rhythms in slices and *en bloc* preparations of newborn rat brainstem. *J Physiol* 584:489–508
3. Ballanyi K, Onimaru H, Homma I (1999) Respiratory network function in the isolated brainstem-spinal cord of newborn rats. *Prog Neurobiol* 59:583–634
4. Feldman JL, Del Negro CA (2006) Looking for inspiration: new perspectives on respiratory rhythm. *Nat Rev Neurosci* 7:232–242
5. Janczewski WA, Onimaru H, Homma I, Feldman JL (2002) Opioid-resistant respiratory pathway from the preinspiratory neurones to abdominal muscles: *in vivo* and *in vitro* study in the newborn rat. *J Physiol* 545:1017–1026
6. Onimaru H, Homma I (2003) A novel functional neuron group for respiratory rhythm generation in the ventral medulla. *J Neurosci* 23:1478–1486
7. Onimaru H, Kumagawa Y, Homma I (2006) Respiration-related rhythmic activity in the rostral medulla of newborn rats. *J Neurophysiol* 96:55–61
8. Smith JC, Ellenberger HH, Ballanyi K, Richter DW, Feldman JL (1991) Pre-Bötzinger complex: a brainstem region that may generate respiratory rhythm in mammals. *Science* 254:726–729
9. Ruangkittisakul A, Schwarzacher SW, Secchia L, Poon BY, Ma Y, Funk GD, Ballanyi K (2006) High sensitivity to neuromodulator-activated signaling pathways at physiological [K<sup>+</sup>] of confocally imaged respiratory center neurons in on-line-calibrated newborn rat brainstem slices. *J Neurosci* 26:11870–11880
10. Taccola G, Secchia L, Ballanyi K (2007) Anoxic persistence of lumbar respiratory bursts and block of lumbar locomotion in newborn rat brainstem-spinal cords. *J Physiol* 585:507–524

## Respiratory Network Responses to Hypoxia

NARONG SIMAKAJORNBOON<sup>1</sup>, DAVID GOZAL<sup>2</sup>

<sup>1</sup>Cincinnati Children's Hospital Medical Center, Cincinnati, OH, USA

<sup>2</sup>Kosair Children's Hospital Research Institute, Department of Pediatrics, University of Louisville, Louisville, KY, USA

### Definition

Respiratory network responses to ►hypoxia refer to the complex interactions between groups of neurons located mainly in the medulla, pons and midbrain that are responsible for control of ventilation during hypoxia. The physiologic mechanisms underlying these processes involve intricate interplay of ►neuromodulators released from respiratory neurons and glial cells.

The ventilatory response to hypoxia is precisely controlled and distinctive patterns emerge during postnatal development. The functional role of this process is not only to adapt the respiration during hypoxic conditions, but also to ensure cell survival, especially during the vulnerable period of development.

### Characteristics

The mammalian ventilatory response to hypoxia is biphasic. It consists of an initial increase in **minute ventilation**, followed by a later decline in ventilation which is termed hypoxic ventilatory depression (Fig. 1).

In developing mammals, the magnitude of hypoxic ventilatory depression is particularly prominent such that minute ventilation decreases below normoxic level [1]. The early component of hypoxic ventilatory response is mediated mainly through the **peripheral chemoreceptor** in the **carotid body**. The type I glomus cells in the carotid body are the primary site of oxygen sensing signal. The afferent signal is then transmitted to sensory terminals of the carotid sinus nerve and is subsequently projected to the nucleus of solitary tract (nTS). The nTS

is located in the brainstem region and provides the first central synaptic relay to peripheral chemoreceptor afferent inputs. Other nuclei at this level of brainstem that play a role in respiratory control and the HVR include the nucleus ambiguus, the area postrema, the dorsal motor nucleus of vagus, the hypoglossal nucleus and the pre-Botzinger complex. A variety of neuromodulators in these areas play a crucial role in the central mediated hypoxic ventilatory response. Several studies have shown that the early response to hypoxia is mediated through platelet activating factor receptor pre-synaptically [2,3] and post-synaptically by N-methyl-D-aspartate (NMDA) glutamate receptors [4,5], which then activate downstream signaling pathways such as protein kinase C, tyrosine kinases, and calcium calmodulin kinase [6]. The hypoxic ventilatory depression is mediated through several complex mechanisms. In addition to hypoxia-induced reductions in metabolism, several neuromodulators have been thus far identified as playing a role in the hypoxic ventilatory depression, namely adenosine,  $\gamma$ -aminobutyric acid (GABA), serotonin (5-HT), opioids, and platelet derived growth factor (PDGF- $\beta$ ) receptors.

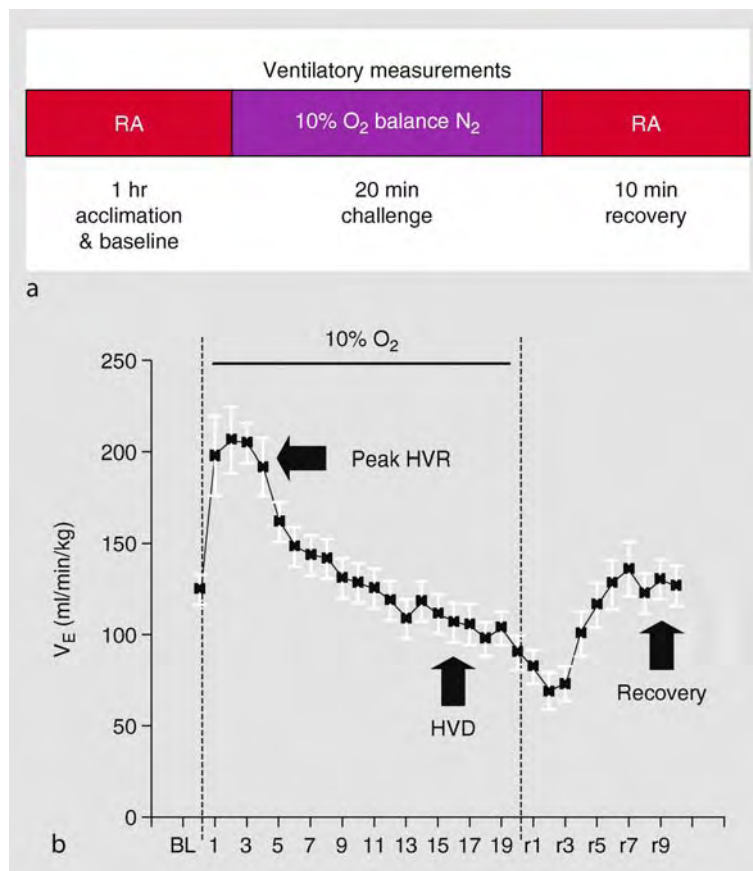

**Respiratory Network Responses to Hypoxia. Figure 1** Representative recording of minute ventilation during a 20-min hypoxic challenge followed by 10 min recovery in normoxia in a 14-day old rat pup. Please note initial increase in minute ventilation (HVR) followed by progressive time-dependent reduction in ventilatory output (HVD).



In this section, we will discuss the respiratory neuronal network with particular emphasis in the caudal brainstem, and will delineate specific neuromodulators mediating each component of hypoxic ventilatory response from a developmental perspective.

### Respiratory Neuronal Network

The peripheral chemoreceptors are located in carotid bodies and aortic bodies. These areas contain glomus cells of 2 types. The type I glomus cells in the carotid bodies is oxygen sensing cells of the peripheral chemoreceptor. The hypoxic stimulus is then transmitted to the sensory terminal of the carotid sinus nerve (CSN). From CSN, the signal projects to the several regions of the nucleus of solitary tract (nTS), the first synapses for primary afferents originating from peripheral chemoreceptors. Retrograde tracer studies reveal that the medial, dorsomedial, lateral and commissural regions of the nTS receive dense innervations from peripheral chemoreceptor afferent fibers. The nTS, the main neuronal nucleus of the ▶[dorsal respiratory group](#), has interconnections to other respiratory neurons including the pontine respiratory and the ▶[ventral respiratory group](#). The pontine respiratory group is composed of the lateral and medial parabrachial and Kollicker-Fuse nucleus, which play a role in diaphragmatic motor control and respiratory rhythm modulation. The ventral respiratory group is divided into the rostral and the caudal group. The rostral part of ventral respiratory group includes the Botzinger complex, the pre-Botzinger complex, and the parafacial respiratory group. The pre-Botzinger complex and the parafacial respiratory group are believed to encompass the kernel for ▶[respiratory rhythmogenesis](#). In addition, there are influences from many rostral brain areas to the respiratory neurons including the suprapontine nuclei, midbrain, diencephalons, hypothalamus, cerebellum, and regions of the cerebral cortex.

### Neuromodulators

#### Early HVR

##### **Platelet Activating Factor Receptors**

Platelet activating factor and its cognate receptor (PAFR) are proposed to modulate glutamatergic signaling presynaptically, thereby influencing the release of glutamate into the synaptic cleft. PAFR activity has now been conclusively implicated in the acute ventilatory response to hypoxia [2,3].

##### **NMDA Glutamate Receptors**

In the cardiorespiratory control regions, N-methyl-D-aspartate glutamate (NMDA) receptors mediate critical components of the respiratory pattern generation, cardiovascular regulation and HVR. The early response to hypoxia is mediated through NMDA glutamate receptors [4,5]. NMDA receptors are widely expressed

throughout the brain, including the respiratory control areas such as nTS. Previous studies have demonstrated that systemic and targeted brainstem administration of NMDA glutamate receptor antagonists is associated with attenuation of HVR in adult and developing animals. In addition, hypoxia induces an increase in glutamate concentration within the nTS of conscious rats, which is associated with an increase in minute ventilation. However, the hypercapnic (▶[hypercapnia](#)) ventilatory response is not affected by NMDA glutamate receptors [5]. The structure of NMDA glutamate receptors consists of heterodimeric, mandatory subunits that include one or more of the splice variants of the NMDA NR1 subunit and additional NR2 and NR3 subunits. Activation of NMDA receptors in the caudal brainstem of conscious rats involves tyrosine phosphorylation of both NR1 and NR2A/B subunits. In addition, the role of NMDA receptor in HVR is developmentally regulated such that an increasing dependency on NMDA glutamate receptor emerges over time and transition from an immature to a more mature hypoxic response requires NMDA receptor-bearing neurons within the nTS.

##### **Non-NMDA Receptors**

Previous studies have indicated the potential role of AMPA glutamate receptors in the ventilatory control and the HVR. Administration of NBQX (a selective non-NMDA receptor antagonist) did not affect ventilatory output in adult conscious mice and cats, but led to marked respiratory depression in neonatal animals. Microinjection of the AMPA glutamate receptor blocker NBQX within the nTS of anesthetized adult rats resulted in attenuation of ventilatory responses following carotid body stimulation. However, NBQX failed to modulate hypoxia-induced c-Fos activation in the adult rat. AMPA receptors appear to influence the respiratory pattern in the immature animal. The respiratory rhythm generation in neurons within the pre-Botzinger complex of neonatal rats is dependent on AMPA receptor activity. Notwithstanding, the role of AMPA glutamate receptors in the developmental of respiratory control may be limited to the regulation of timing mechanisms during normoxia, but not in mediating the hypoxic ventilatory responses [7].

##### **Intracellular Downstream Signaling Pathways Underlying the early HVR**

During the early HVR, NMDA receptors (NMDA-R) activation elicits calcium influx, and subsequent activation of phospholipase C (PLC), mitogen-activated protein kinase kinase (SEK) and calcium calmodulin kinase 2 (CaMII). Our previously proposed model suggests that activation of PLC leads to translocation of protein kinase C, and phosphorylation of serine/threonine residues in the intracellular domain of NMDA receptors. SEK phosphorylates stress activated protein kinase 2 (JNK-2) leading to activation of the activator

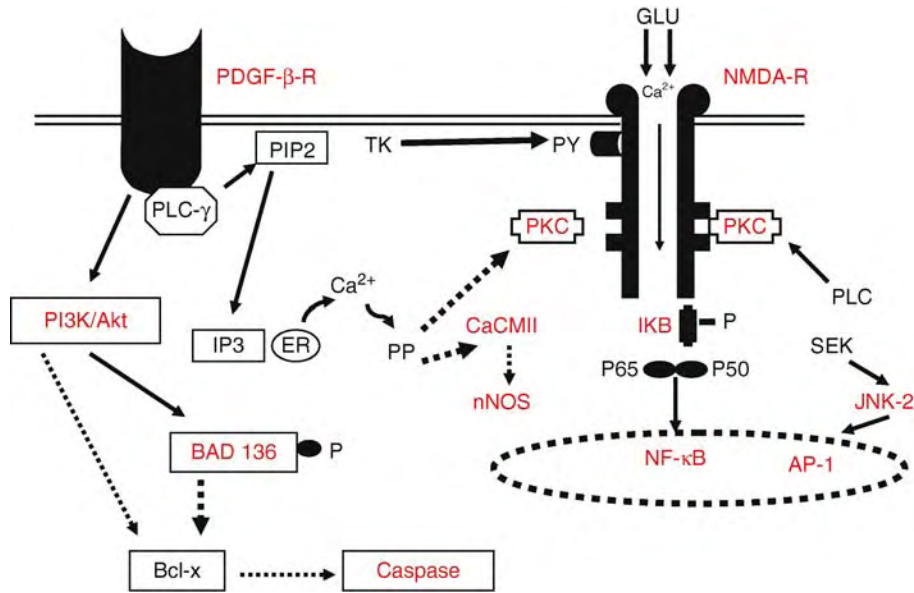

**Respiratory Network Responses to Hypoxia. Figure 2** Schematic diagram of signaling pathways that are operational in respiratory neurons within the nucleus of the solitary tract during hypoxia. Signal transduction proteins for which there is definitive evidence are shown in red. (See text for more details).

protein-1 complex (AP-1). CaMII activates neuronal nitric oxide (NO) synthase resulting in NO formation. NMDA receptor activation will also lead to phosphorylation of I $\kappa$ B with subsequent activation of nuclear kappa B (NF- $\kappa$ B) and activation of tyrosine kinase (TK) by tyrosine phosphorylation (PY) (Fig. 2).

Of all the downstream signaling pathways, the functional role of PKC on respiratory control neurons has been studied extensively. PKC activation within the respiratory neurons of the ventral medullary group is associated with increased respiratory drive potentials. Endogenous PKC activity modulates tonic activity and excitability of the expiratory neurons in the cat. PKC within the caudal brainstem underlies critical components of both tonic respiratory drive and the HVR [6]. Most of the known PKC isoforms are expressed within the dorsocaudal brainstem, and activation of both Ca<sup>2+</sup>-dependent and Ca<sup>2+</sup>-independent PKC isoforms occurs in the nTS during hypoxia [6]. PKC exerts a significant influence on respiratory timing during normoxia in the early postnatal period, and the effect decreases with advancing age. In contrast, hypoxia-induced PKC activation is absent in the immature animal and emerges concomitantly with the appearance of NMDA dependency. Nitric oxide (NO) is another important neuromodulator with a dual role in hypoxic chemotransduction. While NO derived from endothelial nitric oxide synthase (eNOS) exerts an inhibitory effect at the carotid body level, NO derived from neuronal nitric oxide synthase (nNOS) in the caudal brainstem plays a significant role in sustaining ventilation during the second phase of

the HVR. Activation of NMDA receptors will lead to opening of a voltage-dependent calcium channel, calcium calmodulin binding and subsequent nNOS activation. The intracellular NO will in turn modulate glutamate release, either through activation of cGMP-dependent protein phosphorylation cascades, or by retrograde activation of the pre-synaptic neuron. Therefore, nNOS acts an excitatory neurotransmitter during the HVR and may prevent the early onset of hypoxia-induced ventilatory depression. In addition, we have recently identified a mechanism whereby deoxyhemoglobin elicited by the presence of environmental hypoxia activates the formation of S-nitrosothiols through a very tightly regulated process, and that these compounds lead to excitation of respiratory-related neurons within the nTS, and thus contribute to the early phase of HVR [8].

#### Late HVR

As the duration of hypoxia is extended, some degree of ventilatory depression will develop. This component of HVR is extremely prominent in developing animals. Several neuromodulators including  $\gamma$ -amino-butyric acid (GABA), serotonin (5-HT), adenosine, opioid receptors, and platelet-derived growth factor (PDGF)- $\beta$  receptors have all been shown to play contributory roles to the emergence of the hypoxic ventilatory depression associated with prolonged hypoxia. We will briefly delineate the role of each neuromodulator in the late phase of HVR. GABA acts through two GABA receptor subtypes, GABA-A and GABA-B. GABA-A receptors modulate tidal volume, whereas GABA-B receptors

modulate respiratory frequency and pattern of breathing. It is postulated that the hypoxic ventilatory depression is the result of imbalance between the excitatory glutamate and the inhibitory GABA [4]. In addition, hypoxic ventilatory depression of developing animals is partly mediated through the neuro-depressant effect of GABA. Another neuromodulator, adenosine plays an important role in hypoxic ventilatory depression during the early postnatal period, and the effect decreases with maturation. Among the major 4 adenosine receptors ( $A_1$ ,  $A_{2A}$ ,  $A_{2B}$  and  $A_3$ ), adenosine  $A_1$  and  $A_{2A}$  receptors are postulated to play a role in the hypoxic ventilatory depression. The inhibitory effect of adenosine  $A_1$  receptors may involve postsynaptic hyperpolarization, presynaptic depression of synaptic transmission, modulation of cAMP mediated pathway and activation of potassium channels. While adenosine  $A_1$  receptors are involved in cardiorespiratory control during normoxia, adenosine  $A_{2A}$  receptors play a critical role in the hypoxic ventilatory depression. Serotonin (5-HT) has been shown to play a role in hypoxic ventilatory depression in both adult and developing animals. This neurotransmitter exerts multiple effects on respiratory control, and modulates both the respiratory rhythm generator and the respiratory motoneurons. Among the myriad of 5-HT receptor subtypes, 5-HT<sub>1A</sub> and 5-HT<sub>2</sub> receptors have been shown to play a role in respiratory control. While 5-HT exerts an excitatory effect on the central respiratory rhythm generator within the rostral medulla area, it inhibits the hypoglossal inspiratory output in developing animals, possibly through activation of 5-HT<sub>2</sub> receptors. The release of endogenous 5-HT may signal the termination of the early hypoxic augmentation, possibly through activation of 5-HT<sub>1A</sub> receptors. 5-HT<sub>1A</sub> receptors are present in the hypoglossal nucleus of developing rats. Their density is high in the newborn and decreases with increasing postnatal age. Since the use of morphine led to occasional onset of respiratory depression, it became apparent that opioids are involved in respiratory functions within the CNS. Interestingly, endogenous opioids have been shown to play a role in the late phase of hypoxic ventilatory response, whereby ventilatory depression may be partly mediated through opioid-mediated neuronal inhibition. Opioids modulate the respiratory frequency and tidal volume through activation of  $\mu$ - and  $\delta$ -opioid receptors respectively. The caudal brainstem, especially the nTS and the nucleus ambiguus, seem to be important sites for opioid-induced inhibition of respiration. Opioid receptors display a distinct maturation pattern during the early postnatal period. The  $\mu$ -opioid receptor binding sites are present during the mid-fetal period and are located in the cardiorespiratory-related brainstem nuclei, whereas the  $\delta$ -opioid receptors primarily appear during the postnatal period. Both  $\mu(1)$  and  $\mu(2)$  opioid receptors

are involved in opioid-induced respiratory depression in early postnatal period.

Finally, we have shown that hypoxia specifically triggers the release of the PDGF polypeptide isoform called PDGF-BB from glial cells, which in turn leads to subsequent activation of PDGF- $\beta$  receptor in the nTS, where it reduces ventilatory output [9]. Both PDGF-B chains and PDGF- $\beta$  receptors are abundantly expressed in nTS neurons of adult rats [9], and activation of the receptors leads to down-regulation of ligand-gated ion channels, such as NMDA glutamate receptors. PDGF- $\beta$  receptor activation is an important contributor to the hypoxic ventilatory depression at all postnatal ages, but is more critical in the immature animals. The increased expression of PDGF- $\beta$  receptors in the caudal brainstem of immature animals may provide additional protection against hypoxia-induced **apoptosis**. In fact, PDGF- $\beta$  receptors exert their role in promoting neuronal cells survival via two major signaling pathways, namely the phosphoinositide 3 kinase (PI3K)/Akt and the MEK/MAPK pathways. Activation of PDGF- $\beta$  receptors leads to tyrosine phosphorylation of sites that will activate Ras kinase. Ras can activate PI3K, which in turn may phosphorylate PI3K, which in turn may phosphorylate the serine-threonine protein kinase called Akt, the latter phosphorylating BAD at serine 136. Phosphorylated BAD binds to cytosolic 14-3-3 protein, whereas dephosphorylated BAD binds elements of the Bcl-2 complex such as Bcl-x to promote apoptosis (Fig. 2). In fact, hypoxia-induced phosphorylation of PDGF- $\beta$  receptors in the caudal brainstem of adult rats is temporally associated with activation of an anti-apoptotic mechanism via the PI3 kinase-dependent phosphorylation of both Akt and BAD pathways [10]. This mechanism may prevent induction of apoptosis in the respiratory neurons during hypoxia, and may contribute to the well known increased hypoxic tolerance of the brainstem neurons.

## References

1. Eden GJ, Hanson MA (1987) Maturation of the respiratory response to acute hypoxia in the newborn rat. *J Physiol* 392:1–9
2. Simakajornboon N, Graff GR, Torres JE, Gozal D (1998) Modulation of hypoxic ventilatory response by systemic platelet-activating factor receptor antagonist in the rat. *Respir Physiol* 114(3):213–225
3. Gozal D, Holt GA, Graff GR, Torres JE (1998) Platelet-activating factor modulates cardiorespiratory responses in the conscious rat. *Am J Physiol* 275(2):R604–R611
4. Kazemi H, Hoop B (1991) Glutamic acid and gamma-aminobutyric acid neurotransmitters in central control of breathing. *J Appl Physiol* 70:1–7
5. Ohtake PJ, Torres JE, Gozal YM, Graff GR, Gozal D (1998) NMDA receptors mediate peripheral chemoreceptor afferent input in the conscious rat. *J Appl Physiol* 84:853–861

6. Gozal D, Graff GR, Gozal E, Torres JE (1998) Modulation of the hypoxic ventilatory response by  $\text{Ca}^{2+}$ -dependent and  $\text{Ca}^{2+}$ -independent protein kinase C in the dorsocaudal brainstem of conscious rats. *Respir Physiol* 112(3):283–290
7. Whitney GM, Ohtake PJ, Simakajornboon N, Xue YD, Gozal D (2000) AMPA glutamate receptors and respiratory control in the developing rat: anatomic and pharmacological aspects. *Am J Physiol Regul Integr Comp Physiol* 278:R520–R528
8. Lipton AJ, Johnson MA, Macdonald T, Lieberman MW, Gozal D, Gaston B (2001) S-nitrosothiols signal the ventilatory response to hypoxia. *Nature* 413(6852):171–174
9. Gozal D, Simakajornboon N, Czapla MA, Xue YD, Gozal E, Vlastic V, Lasky JA, Liu JY (2000) Brainstem activation of platelet-derived growth factor-beta receptor modulates the late phase of the hypoxic ventilatory response. *J Neurochem* 74:310–319
10. Simakajornboon N, Szerlip NJ, Gozal E, Anonetaipat JW, Gozal D (2001) In vivo PDGF beta receptor activation in the dorsocaudal brainstem of the rat prevents hypoxia-induced apoptosis via activation of Akt and BAD. *Brain Res* 895:111–118

## Respiratory Neuroplasticity

KENDALL F MORRIS<sup>1</sup>, DONALD C. BOLSER<sup>2</sup>

<sup>1</sup>Department of Molecular Pharmacology and Physiology, Neuroscience, University of South Florida College of Medicine, Tampa, FL, USA

<sup>2</sup>Department of Physiological Sciences, University of Florida College of Veterinary Medicine, Gainesville, FL, USA

### Synonyms

Respiratory memory; Respiratory recovery from injury; Lasting alteration of breathing reflexes

### Definition

Respiratory Neuroplasticity has been defined as “a persistent change in the neural control system (morphology and/or function) based on prior experience” [1]. Plasticity exists in various forms in all of the segments of the respiratory network; the afferent, central control and efferent segments. The plasticity may be classed as recovery from injury, respiratory memory, and lasting alterations of protective reflexes such as cough.

### Characteristics

The basic respiratory rhythm and pattern is generated by neural networks in what is called the ►ventral respiratory column (VRC) of the medulla. The column spans several groupings of cells, called nuclei, in the

ventral lateral medulla from nearly the beginning of the cervical spinal cord almost to the pons. However, breathing is modulated by many other regions of the medulla, such as the midline raphe, the main source of the neurotransmitter serotonin. Neural networks in the pons, cerebellum and cerebrum can also affect breathing and play roles in breathing plasticity.

The central respiratory neural networks use information, or afferent input, from various sensors. Important examples include the carotid and ►aortic bodies that sense carbon dioxide concentrations, as well as acidity (pH) but are the predominant sensors of oxygen in the blood. There are also sensors in the lung that transmit information about lung distension, irritation and excess fluid. Sensors within the medulla itself feedback pH of the brain tissue. Since carbon dioxide and pH are in chemical balance in the body, and brain tissue only functions well in a narrow range of pH, it is important that the respiratory control system tightly control elimination of carbon dioxide produced by metabolism as well as provide oxygen.

Neurons that connect with muscles are called motor neurons. Two important groups of such neurons that reside in each side of the spinal cord are known as phrenic motor neurons. Phrenic motor neurons receive drive, or efferent input, from the VRC directly and in many species indirectly from another group of medullary cells called the dorsal respiratory group (Fig. 1a) Phrenic motor neurons send axons through the phrenic nerves to provide drive to the diaphragm, the major muscle that expands the lungs and produces inspiration of air.

### Recovery from Injury

In response to loss of partial function, such as removal of important afferent input, the respiratory neural networks can recover significant normal function. This plasticity varies among species and with age. After surgical removal of ►carotid bodies, normal response to low oxygen, hypoxia, is temporarily lost, but can be recovered in some species, such as cats or rats. Human asthmatics who have had carotid bodies removed show little or no recovery of function. Dogs, ponies and goats recover much less of this function while one-day-old goats that have carotid bodies removed completely recover normal responses to hypoxia. Mechanisms of recovery include up-regulation of alternative input, in this case that from the aortic bodies and perhaps other tissues as well as up-regulation of the efferent limb so that phrenic motor neurons become more responsive to drive.

In response to spinal cord injury, pathways that have little or no activity normally can become active. If one half of the spinal cord is cut, the diaphragm on that side becomes paralyzed because the efferent output of the VRC for phrenic motor neurons is interrupted.

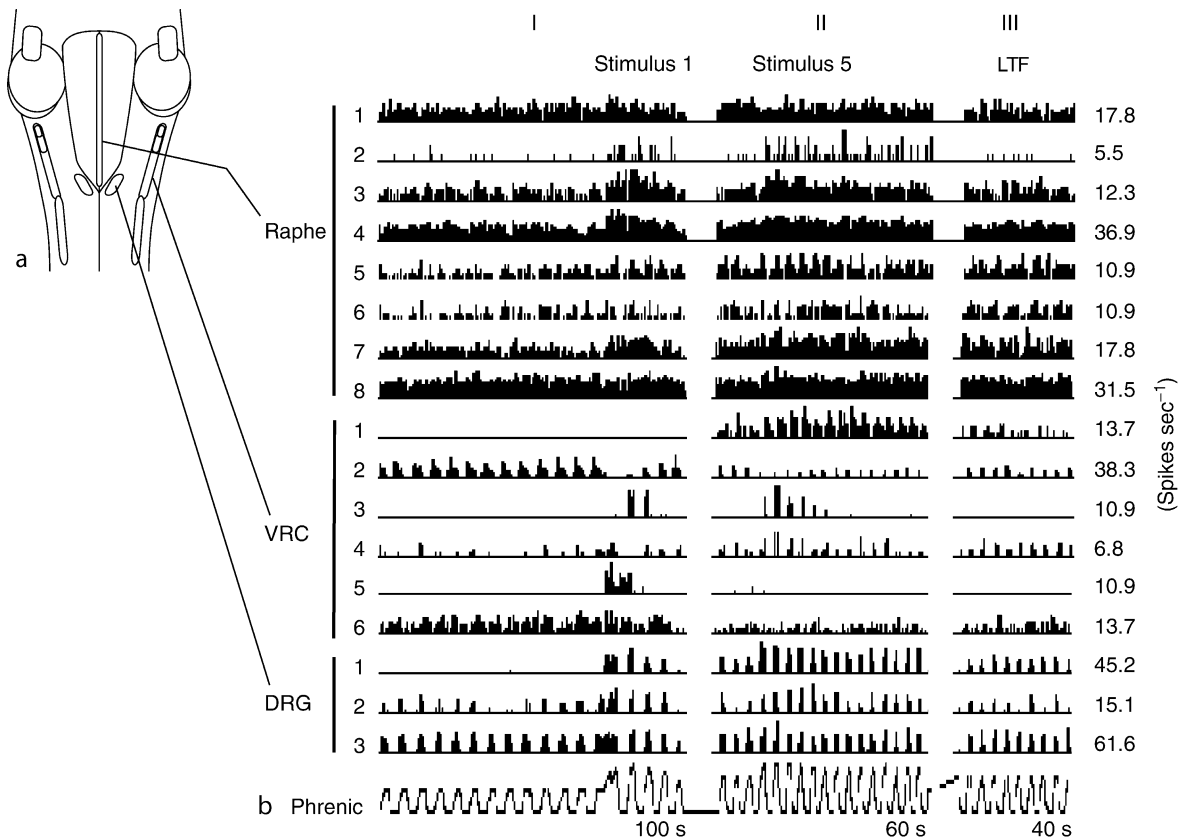

**Respiratory Neuroplasticity. Figure 1** Firing rate histograms from multi-site recordings during induction of long-term facilitation (LTF). a, schematic dorsal view of the cat brainstem showing midline raphe, Ventral Respiratory Column (VRC), and the Dorsal Respiratory Group (DRG) b, Data segments show firing rate histograms of 17 neurones and integrated phrenic nerve activity, recorded simultaneously at the indicated sites during the first (I) and fifth (II) period of carotid chemoreceptor stimulation and 6 min following the fifth and final stimulus and induction of LTF (III). Numbers on the right are the firing rates that correspond to the highest “bin.” This demonstrates that phrenic amplitude has nearly doubled, while the rate of cycling has increase. Note that some cells have persistent greater peak activity with concomitant shorter durations of activity corresponding to the shorter respiratory phases. Other cells that may be inhibitory to inspiratory activity have persistent decreases in activity (adapted from Fig. 2 of [4] with permission).

However, under increased respiratory drive, alternate, usually inactive pathways from the uninjured side can be activated resulting in partial recovery of function. This is known as the “crossed phrenic phenomenon” [1,2].

## Memory

There is a transient plasticity associated with the offset of a respiratory response to a stimulus; e.g., hypoxia, hypercapnia, or many other stimuli with an excitatory effect on breathing. This transient effect is termed short-term potentiation (STP) a slow decay of breathing back to baseline after stimulation. The exact mechanism that produces STP, although neural, remains unknown.

In many rodent strains, there is a short-term decline in respiratory cycle frequency (STFD) following an episode of hypoxia, but not other stimuli, that coincides

with STP. STFD results entirely from prolongation of time in expiration. Both post-hypoxic STFD and STP have a similar time course. These changes in pattern have been referred to as “activity-dependent” plasticity [1].

Damage or chemical blockade of regions of the pons removes the prolongation of time in expiration and the short-term decline in respiratory frequency after hypoxia, with no effect on the response to hypoxia. STFD may be mediated by changes in network connections between the medullary and pontine respiratory networks [2].

Long-term facilitation (LTF, Fig. 1b), an increase in respiratory motor output that persists more than 1 h, is another type of plasticity and a robust type of memory. Induction and expression of this memory can be blocked by serotonin and brain derived neurotrophic

factor antagonists [3]. LTF is induced by repeated brief, intermittent, but not extended, hypoxia, chemical stimulation of carotid chemoreceptors, or electrical stimulation of the carotid sinus nerve or brain stem midline but not by hypercapnia. In some experiments with cats, rats, dogs and goats, LTF can increase measures of phrenic nerve activity to approximately twice that of baseline.

Altered activity and connectivity among neurons in the VRC and raphe neurons have been identified in spike train data sets in which; (i) the constituent neurons had respiratory-modulated firing patterns, (ii) significant changes in firing rate during carotid chemoreceptor stimulation were correlated with altered respiratory efferent activity, (iii) persistent firing rate changes were expressed during LTF, (iv) there was evidence of effective connectivity between the recorded neurons appropriate to contribute to LTF, and (v) changes in measures of effective connectivity between these neurons after induction of LTF were greater than those during different control periods [2,4].

LTF has been demonstrated in rats in both the activity of the phrenic nerve and in sympathetic nerve activity that is involved in control of blood pressure [9]. Human beings who have sleep apnea are exposed to brief periods of hypoxia each night, similar to many protocols that produce LTF in animal experiments. These people have increased sympathetic nerve activity during the day when they are not hypoxic, and that activity has increased modulation with their breathing. The increased sympathetic nerve activity probably contributes to their increased incidence of high blood pressure, cardiovascular disease and stroke. Normal awake human subjects experimentally exposed to brief, intermittent hypoxia show persistent changes in breathing pattern, they breathe more shallowly and faster as well as with less variability [5]. However, they do not have an over-all increase in breathing similar to LTF in some animals. In contrast, subjects with sleep apnea have a persistent increase in breathing in response experimental intermittent hypoxia during sleep [3].

The plasticity of the neural network expressed as LTF can therefore be both adaptive and maladaptive. It may act to stabilize upper airways and prevent further hypoxia. However, if the intermittent hypoxia persists it may contribute to hypertension and attendant illness.

Sudden infant death syndrome (SIDS) is the most common cause of death in infants between 2 weeks and 1 year of age. Some SIDS cases appear to result from fetal neural damage that later compromises responses to breathing or blood pressure challenges during sleep. A major risk factor is pre- or post-natal tobacco smoke exposure. The deficits appear to involve alterations in neural network function within regions involved in

oxygen-sensing and cardiovascular control. A developmental abnormality in serotonergic neurons in the caudal raphe, i.e., a major part of the network implicated in LTF, may result in a failure of protective responses to life-threatening stressors during sleep [6].

Finally, the respiratory networks demonstrate a “metaplasticity” in that early exposure to hypoxia or hyperoxia can produce life long changes in respiratory behaviors, responses and plasticity [1]. Neonatal hyperoxia produces plastic changes that lead to blunted responses to hypoxia in later life, whereas hypoxia in infancy produces greater adult hypoxic ventilatory response and increased expression of LTF [1].

### Airway Defensive Reflexes

Cough is an essential component of pulmonary defense and is the most common manifestation of pulmonary disease. Cough is the single most common reason why sick patients visit physicians in the United States. The function of cough is to remove fluids, mucus, and/or foreign bodies from the respiratory tract by the generation of high velocity airflows. These airflows during cough are generated by a complex motor pattern involving three phases: inspiration, compression, and expulsion. The inspiratory phase of cough is generated by a large burst of activity in inspiratory muscles, such as the diaphragm. The compressive phase of cough is produced by laryngeal closure caused by a burst in expiratory laryngeal muscles during rapidly increasing expiratory thoracic and abdominal muscle activity. The resulting large increase in lung air pressure produces very high airflows (up to  $12 \text{ L s}^{-1}$  in humans) when the larynx opens and the expulsive phase begins. The expulsive phase is characterized by extremely large bursts of activity in expiratory thoracic and abdominal muscles.

In the lower airways, slowly adapting receptors (SARs), rapidly adapting receptors (RARs), and pulmonary C-fibers all can influence the production of cough. There is little doubt that RARs can elicit cough. SARs have a permissive role in the production of cough. The exact role of C-fibers in the production of cough is more controversial, with some groups supporting an excitatory role and others supporting an inhibitory role. Sensory information is processed in the ►**brainstem**, where the basic elements responsible for the production of cough are located. Pulmonary afferent information is processed by second order interneurons located near to and in various subnuclei of the nucleus of the tractus solitarius.

It was once thought that neural networks separate from those controlling normal breathing, eupnea, controlled other reflexes that defend the upper airways and lungs, such as cough. Recent research has revealed that the brainstem neural networks that produce eupnea

also are involved in coughing and sneezing as well as other less well known reflexes. The process by which the brainstem neural network for breathing can be involved in the production of other behaviors is known as *reconfiguration*. That is, the breathing network changes its “circuit diagram” to allow for the generation of a non-breathing behavior [2]. This process involves alteration of the discharge patterns and effective connectivity of neurons in the respiratory network. The reconfiguration process may also involve “con-scription” of neurons that have little to do with breathing but have activity patterns that are selective for certain behaviors, such as cough. This conscription may include recruitment of previously silent neurons and significant modification of the activities of neurons during cough that were not modulated during breathing. There is good evidence that these processes take place and that, in addition to the network that controls breathing, coughing is also controlled by another brainstem control mechanism known as a gate. In essence, the system can be functionally subdivided into a controller (the gate) and an effector (the brainstem respiratory network). The controller regulates the excitability of the behavior and the effector is responsible for the coordination of motor drive to respiratory muscles for cough. During breathing the gate, or controller, is functionally quiescent and the respiratory network is primarily involved in the production of breathing. When RARs are stimulated, the gate becomes active and the brainstem respiratory network reconfigures to produce coughing [7].

### Plasticity of the Cough Reflex

There is considerable evidence that cough can undergo significant plasticity in both humans and animals, especially during induced or naturally occurring airway disease. This plasticity is usually manifest in the form of an increased number of coughs in response to a given stimulus and/or increased sensitivity to inhaled irritants. The relative role of central and peripheral mechanisms in this plasticity is less well understood.

In humans, chronic spontaneous cough lasting for years is well documented and can occur in a variety of conditions, such as smoking, asthma, chronic obstructive pulmonary disease, upper airway disorders, and gastro-esophageal reflux. In many of these conditions, the sensitivity of humans to inhaled irritants is elevated but this enhanced cough sensitivity resolves with successful treatment of the underlying disorder. However, tobacco smoke exposure during childhood is associated with cough in adulthood, suggesting that there is a permanent alteration of some important part of the cough reflex [8]. The increased sensitivity of the cough reflex in these patients is consistent with plasticity. It is presumed that hyperexcitable peripheral afferents are responsible for the enhanced coughing in

these patients, but the potential contribution of central mechanisms has been difficult to address in humans.

Very similar observations have been made in animal models of airway disease and it is well established that airway sensory afferents responsible for cough undergo significant plasticity in many of these conditions. It also has been shown in an animal model that inflammation of one region of the airway will elicit an enhanced cough response to stimulation of a non-inflamed region of the airway. Presumably the sensory afferent responsiveness in the non-inflamed region of the airway was normal. This suggests that plasticity can occur in the central cough neural networks.

Cough can undergo hypoexcitability during neurological diseases. Stroke, Parkinson's Disease and Multiple Sclerosis are all associated with cough weakness or an inability to cough at all. This cough impairment can contribute to an increased susceptibility to aspiration in these patient groups. In stroke, cough impairment can occur even if the lesion does not include the brainstem. This fact, in combination with the knowledge that cough can be produced voluntarily suggest that suprapontine mechanisms can be important in the regulation of cough excitability in awake humans. The extent to which these mechanisms can be subject to plasticity is unknown. More research must be performed to gain a greater understanding of these mechanisms.

### References

1. Mitchell GS, Johnson SM (2003) Neuroplasticity in respiratory motor control. *J Appl Physiol* 94(1):358–374
2. Morris KF, Baekey DM, Nuding SC, Dick TE, Shannon R, Lindsey BG (2003) Invited review: Neural network plasticity in respiratory control. *J Appl Physiol* 94(3):1242–1252
3. Mahamed S, Mitchell GS (2007) Is there a link between intermittent hypoxia-induced respiratory plasticity and obstructive sleep apnoea? *Exp Physiol* 92(1):27–37
4. Morris KF, Shannon R, Lindsey BG (2001) Changes in cat medullary neurone firing rates and synchrony following induction of respiratory long-term facilitation. *J Physiol (Lond)* 532(Pt 2):483–497
5. Morris KF, Gozal D (2004) Persistent respiratory changes following intermittent hypoxic stimulation in cats and human beings. *Respir Physiol Neurobiol* 140(1):1–8
6. Sahni R, Fifer WP, Myers MM (2007) Identifying infants at risk for sudden infant death syndrome. *Curr Opin Pediatr* 19(2):145–149
7. Bolser DC, Poliacsek I, Jakus J, Fuller DD, Davenport PW (2006) Neurogenesis of cough, other airway defensive behaviors and breathing: A holarchical system? *Respir Physiol Neurobiol* 152(3):255–265
8. Joad JP, Sekizawa S, Chen CY, Bonham AC (2007) Air pollutants and cough. *Pulm Pharmacol Ther* 20(4):347–354
9. Dick TE, Hsieh YH, Wang N, Prabhakar N (2007) Acute intermittent hypoxia increases both phrenic and sympathetic nerve activities in the rat. *Exp Physiol* 92(1):87–97

## Respiratory Neurotransmitters and Neuromodulators

AKIRA HAJI

Laboratory of Neuropharmacology, School of Pharmacy, Aichi Gakuin University, Chikusa, Nagoya, Japan

### Synonyms

Neurochemicals; Endogenous receptor agonists

### Definition

Chemicals synthesized by neurons involved in generating rhythm and pattern in the ►respiratory network, and in transmitting input signals from central and peripheral chemoreceptors and mechanoreceptors to respiratory interneurons and motoneurons (Fig. 1).

### Active Phase

The period of the ►respiratory cycle (phase) in neurons characterized by membrane depolarization to threshold for the generation of action potentials [2,9].

### Silent Phase

The period of the respiratory cycle characterized by membrane hyperpolarization that prevents action potential generation [2,9].

### Characteristics

#### Neurotransmitter Functions in the Respiratory Network

Rhythmic fluctuations of membrane potential in respiratory neurons evolve from neurotransmitter- and membrane conductance-dependent, periodic barrages of ►IPSPs and ►EPSPs that occur with precise timing during the respiratory cycle. Neurotransmitter-dependent excitatory synaptic connections between synchronously active neurons evoke bursts of action potential discharge, while discharges of reciprocally activated neurons periodically release inhibitory ►neurotransmitters that hyperpolarize membrane potential away from firing threshold. Tonic neurotransmitter release provides a continual excitatory bias on what appears to be all types of respiratory neurons, whereas tonic release of inhibitory neurotransmitter can have a stabilizing effect on membrane potential.

#### Inhibitory Amino Acids (GABA and glycine)

There are three types of phasic inhibition in respiratory neuron activities; reciprocal inhibition, recurrent inhibition and phase-transition inhibition, as well as tonic inhibition. All four types are characterized by membrane hyperpolarization and lowered input resistance [1,3,4,7].

#### Phasic inhibition during the inactive phase

GABA initiates IPSPs during the inactive phase by binding to a GABA<sub>A</sub>-type of receptor in respiratory neurons. During the inactive phase, temporal summation of IPSPs hyperpolarizes membrane potential near to the equilibrium potential for chloride ions (Cl<sup>-</sup>).

#### Inhibition during Phase Transitions

The GABA<sub>A</sub> receptor-mediated mechanism plays an essential role during transition from one respiratory phase to another. During transition from the inspiratory to the expiratory phase, postinspiratory (early expiratory) IPSPs occur in augmenting inspiratory (aug -I) neurons. During transition from late expiration to inspiration, inspiratory IPSPs are observed in augmenting expiratory (aug-E) neurons. In the latter case, activation of GABA<sub>B</sub> receptors is partially involved, leading to increased potassium (K<sup>+</sup>) conductances.

#### Inhibition during the Active Phase

Glycine mediates IPSPs during the later part of stage 2 expiration in aug-E neurons, and IPSPs during late inspiration in aug-I neurons. Aug-I neurons also show IPSPs during early part of inspiration, but whether GABA, glycine or both are involved is unclear.

#### Tonic Inhibition

GABA<sub>A</sub>, GABA<sub>B</sub> and glycine receptor-mediated postsynaptic inhibitions are active in respiratory neurons to help stabilize membrane potential level.

#### Inhibition of Spinal Motoneurons

GABA mediates the inhibition of phrenic motoneurons during expiration through GABA<sub>A</sub> receptors [6,8]. This inhibition comes from aug-E neurons of the Böttinger complex. GABA<sub>A</sub> mechanisms are also involved in the raphe-stimulated inhibition of the respiratory neuronal activity. The GABA<sub>B</sub> mechanism decreases transmitter release by acting at presynaptic site and hyperpolarizing phrenic motoneurons through activation of K<sup>+</sup> conductances at postsynaptic sites [6].

#### Excitatory Amino Acid (Glutamate)

All types of respiratory neurons exhibit glutamate-activated EPSPs, in association with lowered input resistance and induction of action potential discharge. They summate temporally to bring membrane potential to discharge threshold [1,3,4,7].

#### Phasic Excitation during the Active Phase

Glutamate initiates EPSPs during the active phase in most types of respiratory neurons by activating both AMPA- and NMDA-type glutamate receptors. The sequential activation of the two types of postsynaptic receptor is required for production of respiratory-related



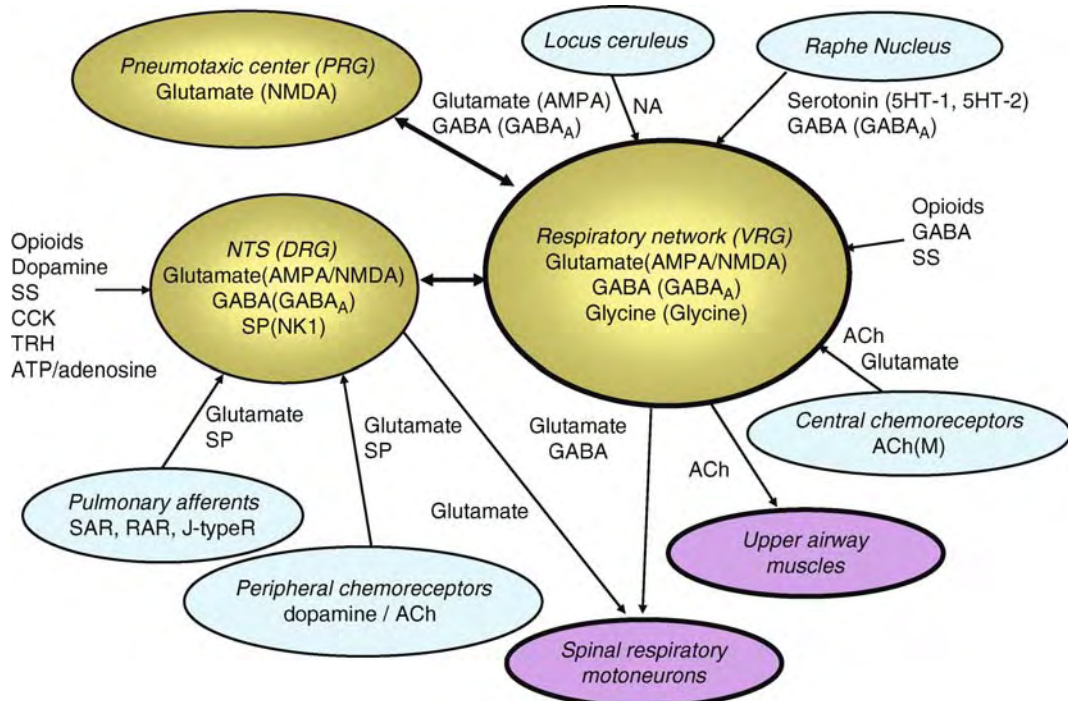

**Respiratory Neurotransmitters and Neuromodulators. Figure 1** A schematic diagram of the neuronal interactions between the respiratory center and other modulatory structures, and of putative neurotransmitters and neuromodulators involved in the neuronal control of respiratory rhythm and pattern generation. The main neurotransmitters of respiratory neurons are glutamate, GABA and glycine. Glutamate mediates excitatory transmissions through AMPA and NMDA receptors and GABA mediates inhibitory transmissions through GABA<sub>A</sub> receptors. They are also utilized in the phase-switching process which is regulated by the pneumotaxic descending inputs and pulmonary SAR afferents. Transduction of hypoxic signals within the peripheral chemoreceptors depends primarily on O<sub>2</sub>-sensitive K<sup>+</sup> channels associated with neuroactive substances such as ACh and dopamine. These signals are transmitted to relay neurons in the NTS by glutamate through AMPA receptors. Hypercapnia stimulates preferentially the central chemosensitive area near the ventral surface of the medulla, where ACh acts as a mediator of such signals. Many neuroactive substances other than amino acids have been implicated in modulating the respiratory rhythm. Serotonergic, noradrenergic and dopaminergic inputs modulate the respiratory neuronal discharge and respiratory rhythm. Muscarinic and nicotinic cholinergic modulations are also apparent. Several neuroactive peptides including SP, SS, CCK and opioids affect respiration. They act either presynaptically or postsynaptically to modulate synaptic transmission within the primary neuronal network as well as at the input and output relay nuclei. These substances are not involved in generation of a basic eupnea. Interactions among various neuroactive substances are essential for precise control of the normal functioning and adaptive processes in the central organization of respiratory rhythm and pattern.

bursts of discharge. In aug-E neurons, depolarization and discharge are due to AMPA receptor activation, as is phasic recurrent excitation in aug-I neurons. Metabotropic glutamate receptor-mediated mechanisms have no significant effect on membrane potential of ►bulbar respiratory neurons.

#### **Inspiratory Off-Switch (►IOS) Mechanism**

The NMDA mechanism plays an important role in IOS of pontine as well as medullary respiratory neurons. IOS is accomplished by a sequential activation of late inspiratory (late-I) and postinspiratory (post-I) neurons to produce barrages of IPSPs in aug-I neurons. During ►apneusis caused by NMDA blockade, active phase

depolarization of late-I and post-I neurons and their firing activity are decreased. The discharge activity of aug-I neurons is also decreased during apneusis.

#### **Tonic Excitation**

Respiratory neurons receive glutamatergic tonic inputs that activate both NMDA and AMPA receptors.

#### **Pneumotaxic Descending Inputs**

Termination of the IOS can be produced by afferents originating from the ►PRG. Glutamate through the NMDA mechanism responsible for IOS is present in the pontine structure. However, the pontine descending inputs generating fast EPSPs in bulbar respiratory

neurons are not mediated by NMDA receptors, but by AMPA receptors.

#### **Pulmonary Mechanoreceptor Afferent Inputs**

Glutamate mediates the primary afferent excitation of the NTS neurons in the ►**Hering-Breuer reflex** pathways, primarily through the activation of AMPA receptors. The Hering-Breuer inspiratory promotion reflex induced by application of lung deflation during expiration is mediated by NMDA receptors.

#### **Excitatory Drive to Bulbospinal Motoneurons**

Glutamate mediates the bulbospinal transmission of respiratory drive acting on both AMPA and NMDA receptors [6,8]. Contribution of the former is greater than that of the latter to motor outputs. AP4 receptors are located at the presynaptic sites of the inspiratory bulbospinal terminals. Short term potentiation is mediated by NMDA receptors, which augment EPSPs and prolong depolarization of phrenic motoneurons. Activation of metabotropic glutamate receptors affects the inspiratory-modulated activity of phrenic motoneurons via distinct mechanisms at pre- and postsynaptic sites.

#### **Excitatory Drive to Spinal Motoneurons**

The major glutamatergic excitatory drives to phrenic, intercostal and abdominal motoneurons come from bulbospinal neurons that activate AMPA/Kainate- and NMDA-types of receptors

#### **Neurotransmitters, Neuromodulators and Responsiveness to Hypercapnea and Hypoxia**

Carbon dioxide and its acid byproduct,  $H^+$  ion, constitute the primary respiratory stimulus within the central nervous system. Sensitivity to  $CO_2/pH$  is up-regulated or down-regulated by several different neurotransmitters and ►**neuromodulators** [5,7]. Acetylcholine (ACh) activation of muscarinic receptors on neurons close to the ventrolateral surface of the medulla increases respiratory responsiveness to  $CO_2/pH^+$ . Adrenergic cell groups have also been reported to increase respiratory responsiveness to hypercapnea/acidosis in the rostral ventrolateral medulla. Glutamate is also a neurotransmitter candidate for tonic excitation of respiratory neurons mediated by central  $CO_2/pH^+$  sensitive neurons. A GABAergic mechanism in the caudal hypothalamus dampens respiratory responsiveness to hypercapnea/acidosis.

Respiratory responsiveness to hypoxia is modulated peripherally by neuromodulators in the carotid bodies and within the central respiratory network. Generally, excitatory transmission is cholinergic, whereas dopamine (DA) plays an inhibitory role in carotid body chemoreceptors. Hypoxic release of ACh activates nicotinic receptors, leading to augmentation of hypoxia-induced depolarization and further release of ACh and

other neurotransmitters. DA release, on the other hand, suppresses carotid body discharges by activating  $D_2$ -type receptors. Glomus cells contain other compounds that are released during hypoxia, including serotonin (5-HT), enkephalins, prostaglandins, ATP, adenosine, substance P (SP), cholecystokinins (CCK), nitric oxide and atrial natriuretic peptide.

SP localized within vagal afferent fibers appears to act as a neurotransmitter or modulator of chemo- and baroreceptor fibers. Central dopaminergic mechanisms are also involved in modulating the chemoreflex respiratory control.

In the central respiratory network, glutamate release from the afferent glossopharyngeal terminals in the nucleus of the solitary tract (NTS) activates AMPA receptors on relay neurons in response to hypoxia. Release and local accumulation of GABA and/or neuromodulators, including catecholamines and opioids, are important factors leading to late hypoxic depression. GABA mediates inhibition in the NTS neurons that respond to stimulation of the carotid sinus nerve. Accumulation of metabolic byproducts such as adenosine may increase  $K_{ATP}$  channel currents in postsynaptic neurons. Hypoxia also increases endogenous 5-HT levels and increases  $K^+$  currents via  $5-HT_{1A}$  receptors in respiratory neurons, resulting in depression of respiratory neurons.

#### **Respiratory Neuromodulation by Monoamines and Peptides**

It has been more difficult to assess the neuromodulatory roles of serotonin, catecholamines and peptides in the central respiratory network. Their actions are generally slow in onset, discreet, state-variable, and dependent on a vast array of receptor subtypes. Assessment of function is often assumed from the effects of exogenous receptor agonists and antagonists, not all of which are suitably selective [1,4,7].

#### **Serotonergic Agents**

5-HT has diverse effects on respiratory neurons. Respiratory neuron excitability is increased postsynaptically by  $5-HT_2$ ,  $5-HT_{1C}$  and  $5HT_4$  receptor agonists, and decreased postsynaptically via  $5-HT_{1A}$  and  $5HT_7$  agonists. Activation of  $5-HT_{1A}$  and  $5HT_7$  receptors depresses the cAMP-protein kinase A pathway,  $5HT_4$  receptors activate it, and  $5-HT_2$  receptor activation stimulates the PLC/PLA- protein kinase C pathway.

#### **Catecholaminergic Inputs**

The effects of catecholamines (noradrenaline, adrenaline, DA) are also diverse and dependent on which subtypes of receptor are affected. Noradrenaline and adrenaline have a predominantly depressant effect on bulbar respiratory neurons. Dopaminergic mechanisms exert a tonic inhibitory influence in the central pathways involving in the hypoxic ventilatory responses through

D<sub>2</sub> receptors, and increase central respiratory responsiveness to CO<sub>2</sub> via D<sub>1</sub> receptors.

### Peptides and Hormones

SP and thyrotropin-releasing hormone (TRH) have excitatory, and somatostatin (SS) and ►**opioid peptides** have depressant effects on respiration. CCK produces either excitatory or inhibitory effects, depending on its receptor types activated. Individual neuropeptides often coexist and interact with classical neurotransmitters in respiratory neurons. They play some roles in the central control of respiratory activity including the chemoreflex [1,4,7].

### Substance P

SP mediates excitatory neurotransmission and integration of the peripheral chemoreflex in the NTS through NK<sub>1</sub> receptors. SP reverses the respiratory neuronal depression induced by SS or opioids. Hypoxia induces desensitization of NK<sub>1</sub> receptors to SP in the NTS neurons, leading to a decline of hyperventilation during hypoxia. SP is a transmitter of the pulmonary C fiber-mediated reflex which induces a rapid shallow breathing and/or apnea.

### Thyrotropin-Releasing Hormone

TRH had postsynaptic excitatory effects on neurons in the NTS, nucleus ambiguus and pre-Bötzinger complex. TRH enhances glutamatergic transmissions and counteracts the inhibitory effects of opioids. TRH also seems to be involved in central (CO<sub>2</sub>/pH<sup>+</sup>) chemoreception (►**central chemoreception**).

### Somatostatin

SS has an inhibitory effect on respiratory neurons. Anesthesia or sleep enhances the effects of SS. SS metabolites potentiate the voltage-dependent, non-inactivating outward K<sup>+</sup> currents (I<sub>M</sub> current) in the NTS neurons.

### Opioid Peptides

Opioid peptides may be the most important peptides endogenously involved in respiratory modulation in the brainstem. Opioid peptides depress respiratory neuron activity by increasing K<sup>+</sup> conductances through μ receptors. Endogenous opioids negatively interact with the CO<sub>2</sub>-sensitive cholinergic transmission, and with the glutamatergic transmission of respiratory neuronal activity.

### Cholecystokinin

CCK octapeptide (CCK<sub>8</sub>) causes various effects on respiration; It stimulates respiration by stimulating either the forebrain or the medullary region and depresses ventilation by stimulating vagal afferents. The activation of CCK<sub>A</sub> receptors causes inhibition of respiratory neurons due to an increase of K<sup>+</sup> conductances, while that of CCK<sub>B</sub> receptors produces excitation due to a decrease in K<sup>+</sup> conductances.

Further, activation of CCK<sub>B</sub> receptors by endogenous CCK reduces the GABA-mediated fast inhibitory responses in the NTS neurons.

### Progesterone

Endogenous progesterone is a respiratory stimulant [10]. It increases ventilatory responsiveness to CO<sub>2</sub>. In pregnancy and during the luteal phase of the menstrual cycle, it accounts for hyperventilation and low CO<sub>2</sub>. Endogenous progesterone also has a beneficial effect on the upper airways. It increases tonic and phasic genioglossus activities.

### References

- Ballanyi K, Onimaru H, Homma I (1999) Respiratory network function in the isolated brainstem-spinal cord of newborn rats. *Prog Neurobiol* 59:583–634
- Bianchi AL, Denavit-Saubié M, Champagnat J (1995) Central control of breathing in mammals: neuronal circuitry, membrane properties, and neurotransmitters. *Physiol Rev* 75:1–45
- Bonham AC (1995) Neurotransmitters in the CNS control of breathing. *Respir Physiol* 101:219–230
- Denavit-Saubié M, Foutz AS (1997) Neuropharmacology of respiration. In: Miller AD, Bianchi AL, Bishop BP (eds) Neural control of the respiratory muscles. CRC press, New York, pp 143–157
- Eyzaguirre C (2005) Chemical and electric transmission in the carotid body chemoreceptor complex. *Biol Res* 38:341–345
- Feldman JL, McCrimmon DR (1999) Neuronal control of breathing. In: Zigmond MJ, Bloom FE, Landis SC, Roberts JL, Squire LR (eds) *Fundamental Neuroscience*, Academic press, New York, pp 1063–1090
- Haji A, Takeda R, Okazaki M (2000) Neuropharmacology of control of respiratory rhythm and pattern in mature mammals. *Pharmacol Ther* 86:277–403
- Hilaire G, Montau R (1997) Brainstem and spinal control of respiratory muscles during breathing. In: Miller AD, Bianchi AL, Bishop BP (eds) Neural control of the respiratory muscles. CRC press, New York, pp. 91–105
- Richter DW (1996) Neural regulation of respiration: rhythmogenesis and afferent control. In: Greger R, Windhorst W (eds) *Comprehensive Human Physiology*, Vol. 2. Springer, Berlin, pp 2079–2095
- Saareanta T, Polo O (2002) Hormones and breathing. *Chest* 122:2165–2182

## Respiratory Pacemaker Neuron

### Definition

Neuron with an intrinsic ability to generate rhythmic bursts.

► **Respiratory Pacemakers**

## Respiratory Pacemakers

JAN-MARINO RAMIREZ

Department of Organismal Biology and Anatomy,  
Committees on Neurobiology, Computational  
Neuroscience and Molecular Medicine, The University  
of Chicago, Chicago, IL, USA

### Synonyms

Respiratory bursting neurons; Respiratory pacemaker neurons

### Definition

A respiratory pacemaker is a neuron with the intrinsic ability to generate rhythmic **▶bursts** that emerge through voltage-, time- and calcium- dependent ion fluxes [1]. These ion fluxes give rise to rhythmic membrane fluctuations that are defined as “**▶drive potentials**” or “pacemaker potentials.” The ion fluxes leading to drive potentials are carried by sodium, calcium, and/or non-specific cations, but many ionic conductances contribute to shape and frequency of these potentials. The drive potentials can, but do not always give rise to a series of action potentials. A drive potential that gives rise to action potentials is called a “burst”. Bursts that are generated by ionic conductances intrinsic to the neuron are often referred to as “**▶intrinsic bursting**.” Two types of pacemaker neurons have been described in the respiratory network: (i) Pacemakers that depend on CAN current and are blocked by cadmium are referred to as “**▶Cadmium-sensitive pacemakers**” [2]. (ii) Pacemakers dependent on the persistent sodium current burst even in the presence of cadmium. These neurons are referred to as “**▶Cadmium-insensitive pacemakers**” [2].

A neuron that generates pacemaker activity only in the presence of a neuromodulator is generally called a “**▶conditional pacemaker**.” As described in the next paragraph, the dynamic regulation of pacemaker neurons is the rule, and not the exception. Hence, it is conceivable that all respiratory pacemakers are “conditional”.

### Characteristics

#### Quantitative Description

The identity of a respiratory pacemaker is not fixed, but dynamically regulated. Non-pacemakers can be turned into respiratory pacemakers, and conversely respiratory pacemakers can become non-pacemakers [1]. This dynamic process is not all-or-none. A non-pacemaker can turn into a weakly bursting or strongly bursting pacemaker, and weak pacemakers can turn into strong pacemakers. Weak pacemakers are characterized by small amplitude, intrinsically generated **▶drive**

**potentials** that give rise to one or two action potentials. Bursts can occur irregularly in some, while regularly in other neurons. Thus, the discharge properties of respiratory neurons cover a wide range from non-bursting, to weak-irregular bursting to strong-regular bursting [1,3]. Transformation of pacemakers and non-pacemakers and their dynamic regulation are not unique for the respiratory system. For example the discharge patterns of neocortical and thalamic neurons change dramatically during the transition from wake to sleep [1,4,5] and there are numerous other examples in which neurons can loose or attain pacemaker properties.

Mechanistically, this is not surprising as the pacemaker property emerges through a complex, and modifiable ratio of different ionic currents in which inward currents (typically carried by  $\text{Na}^+$  or  $\text{Ca}^{++}$ ) are larger than outward currents (typically carried by  $\text{K}^+$  or  $\text{Cl}^-$  currents).

In the functional network the ratio of these ion channels is continuously modulated by endogenously released neuromodulators, such as amines and peptides. In the respiratory system, induction of pacemaker properties has been demonstrated for serotonin, acetylcholine, norepinephrine, TRH (**▶TRH: thyrotropin releasing hormone**) and substance P [1,3,6]. It is likely that many still unexamined neuromodulators can induce and suppress pacemaker properties in respiratory neurons.

In the functional network intrinsically generated drive potentials are also dynamically regulated by synaptic transmission: Intrinsically generated bursts can be activated by excitatory synaptic inputs, and thus function as a mechanism to boost or amplify synaptic inputs. But the boosting mechanism must also be considered dynamically, since concurrently occurring synaptic inhibitory mechanisms can also suppress these intrinsically generated drive potentials. Thus, in the functional network concurrent inhibitory synaptic mechanisms can regulate the bursting mechanism to the extent that excitatory synaptic drive is necessary to activate bursting in a pacemaker neuron. Synaptic mechanisms play also critical role in timing the onset of a burst, even in pacemakers that have strong intrinsic bursting properties. Thus, the bursting property must be considered as a dynamic property that is highly influenced by fine balance of synaptic as well as neuromodulatory mechanisms.

Due to the tight interaction between synaptic and intrinsic membrane properties, demonstrating pacemaker properties is challenging. It must be shown that the rhythmicity recorded in a neuron is generated intrinsically and is not the result of rhythmic synaptic input that emerges through network interactions. In the respiratory network pharmacological approaches are typically used to isolate pacemaker neurons [6,7]. Exogenously applied neurotransmitter antagonists can

block inhibitory and excitatory neurotransmission which eliminates rhythmic synaptic population inputs. The pharmacological approaches are usually combined with electrophysiological approaches that take advantage of the voltage-dependency of ion channels [7]. Brief de- or hyperpolarizing current injections can reset ongoing pacemaker activity by advancing or delaying the generation of a pacemaker burst. Long-lasting de- or hyperpolarizing current injections can accelerate or slow the frequency of pacemaker activity. Brief depolarizing current pulses can prematurely trigger, while hyperpolarizing current pulses can prematurely terminate ongoing pacemaker bursts. It is important to be aware that pharmacological approaches can be misleading. For example low concentrations of extracellular calcium can block synaptic transmission, but at the same time, this manipulation can induce pacemaker properties in non-pacemakers by blocking ► **calcium-dependent potassium currents** [2]. Conversely, low calcium concentrations could block the activation of the CAN current, which plays a major role in evoking bursts in some respiratory neurons [2]. Bicuculline, is a substance that blocks ► **GABAergic synaptic transmission**, but at higher concentration it can also block potassium channels which could induce pacemaker properties.

An even greater challenge is the interpretation of lesion experiments in a functional network. Pacemaker, synaptic and modulatory properties are highly integrated elements of the functional network and provide the respiratory network with the necessary adaptability and flexibility for survival. The removal of any of these elements will change the overall network property, and whether its removal abolishes rhythmicity is neither an indicator for its importance nor its specific role in respiratory rhythm generation [1].

### Higher Level Structures

The majority of neuronal networks in the brain generate rhythmic activity, and pacemakers are found in the majority of these networks including networks within the spinal cord, medulla, ► **neocortex**, ► **basal ganglia**, thalamus, ► **locus coeruleus**, ventral tegmentum area (VTA), ► **hippocampus** and ► **amygdala** [1,8]. In many cases it is unclear how the rhythmicity in general and how pacemakers in particular contribute to these network functions, and the respiratory network is no exception. Pacemaker neurons have been identified in various areas that belong to the respiratory network, including the NTS [6], the pre-Bötzinger complex [1] and the ► **parafacial nucleus** [9]. Pacemakers are also found in areas that are driven by the respiratory network including the locus coeruleus [10]. While most pacemakers were identified in vitro slices, it is likely that recordings in more intact networks reveal that pacemaker neurons are more abundant than generally expected. Intact networks have more active modulatory

systems that can promote pacemaker properties, such as norepinephrine and serotonin.

### Lower Level Components

In general terms, the ionic mechanisms that give rise to pacemaker activity are very heterogeneous. These mechanisms typically involve a complex interaction between voltage-dependent and voltage-independent components of ion channels within their intra- and extracellular environment [1]. In general, a neuron depolarizes and ultimately bursts either in response to the activation of inward currents that are carried by sodium and/or calcium ions, or in response to the cessation of outward currents that are carried by potassium ions. The inward currents include the hyperpolarization-activated current (I<sub>h</sub> current), the persistent sodium current, various low- and high-voltage activated calcium currents and the calcium-activated non-specific cation (CAN) current [1]. The ongoing burst is commonly terminated by either of two principal ionic mechanisms. (i) The channels responsible for the inward current inactivate. Such properties may play a major role in determining bursting in neurons dependent on persistent sodium current. (ii) The calcium or sodium influx during the ongoing burst can activate calcium- or sodium-dependent potassium currents that hyperpolarize the membrane and thereby terminate the burst. Possible mechanisms that cause a repolarization can include voltage-independent intracellular signals, and slow activation or inactivation properties of inward or outward currents.

### Structural Regulation

There is currently no characteristic anatomical structure that defines a ► **respiratory pacemaker neuron**. Similarly there are many different discharge patterns that characterize a respiratory pacemaker neuron. “Irregular-” and “regular-bursting” neurons are differentiated by the regularity of the burst periodicity. Given that rhythmic drive potentials can arise through a variety of ionic mechanisms, it is not surprising that the same anatomical region may contain different types of pacemaker neurons. The fact that the same anatomical region contains more than one type of pacemaker neuron is not the exception, but presumably the rule [1]. It is assumed that different types of pacemaker neurons play different roles in the generation of network activity, an issue of much ongoing research [1,2,3,8,9]. This complexity is not unique to the nervous system: cardiac pacemakers for example are also very diverse.

### Higher Level Processes

Pacemaker neurons are embedded in complex neuronal networks. Hence there are many synaptic and modulatory processes that govern the activity of a pacemaker neuron [1,3]. Many principle insights into

the interactions between pacemaker neurons, synaptic transmission and ►**neuromodulators** were gained from studying small neuronal networks of invertebrates. It can be expected that medullary pacemakers are modulated by various inputs from networks outside the ►**medulla**, and vice versa that pacemakers influence networks outside the medulla. Unfortunately, recordings from pacemakers in more intact networks are sparse. Thus very little is known about these potential network interactions.

### Lower Level Processes

Neuromodulators play a critical role in modulating the cellular events that govern the discharge pattern of a pacemaker neuron. Endogenously released neuromodulators can phosphorylate voltage-dependent ion channels, or alter second messenger pathways and intracellular calcium thereby changing ion channel properties. This complex interplay between neuromodulators, the intracellular milieu and voltage-dependent ion fluxes will significantly alter pacemaker activity. In doing so, neuromodulators can determine the burst frequency, the amplitude and shape of the drive potential [3]. Neuromodulators are also responsible for the fact that the pacemaker property itself is not a fixed property as described above.

### Function

As described above, pacemakers are embedded in synaptically organized networks and therefore pacemaker activity itself is influenced by synaptic inputs [1]. Thus, in general pacemaker activity can not be regarded as a “driver” of network activity. Thus assigning a specific function to a pacemaker neuron becomes difficult if not impossible, since this property can not be separated from the other properties that determine its discharge. Tonic excitatory or inhibitory synaptic inputs can determine the frequency of pacemaker activity. Excitatory synaptic input can prematurely trigger pacemaker activity, which means that synaptic inputs can determine the timing of pacemaker activity. A pacemaker burst can act as a non-linear amplifier of synaptic excitatory inputs, while synaptic inhibitory inputs can act as leak currents that will greatly suppress pacemaker activity.

Various functions have been ascribed to pacemaker neurons. It is thought that pacemakers can influence regularity, burst amplitude and frequency of respiratory activity. Due to differences in their voltage-dependence cadmium-sensitive and insensitive pacemakers may assume different roles in regulating frequency versus amplitude of respiratory bursts [3].

### Process Regulation

The number, the types of pacemakers, and the degree of their bursting properties in a functional neuronal

network will be continuously regulated by neuromodulators and synaptic interactions. Consequently, the contribution of pacemaker properties to the overall network output will not be fixed [1,2]. By altering for example the number of active pacemaker neurons a network can assume different configurations that can lead to different network outputs. These complex modulatory interactions imbue neuronal networks with a high degree of plasticity. This is an essential prerequisite for generating a rhythmic behavior that has to continuously adapt to changes in behavioral, environmental and metabolic conditions.

### Pathology

It has been hypothesized that the suppression of pacemaker properties may lead to the failure of gasping and possibly Sudden Infant Death Syndrome [1,2].

### Therapy

In vitro studies suggest that pacemaker neurons are important in regulating regularity of respiratory rhythmic activity. Hence, a better understanding of the ionic basis of pacemaker activity and their modulation may be an important step towards developing rational therapies or strategies to prevent neurological disorders associated with erratic breathing.

### References

1. Ramirez JM, Tryba AK, Peña FP (2004) Pacemaker neurons: an integrative view. *Curr Opin Neurobiol* 14(6):665–674
2. Peña F, Parkis MA, Tryba AK, Ramirez JM (2004) Differential contribution of pacemaker properties to the generation of respiratory rhythms during normoxia and hypoxia. *Neuron* 43:105–117
3. Viemari JC, Ramirez JM (2006) Norepinephrine differentially modulates different types of respiratory pacemaker and non-pacemaker neurons. *J Neurophysiol* 95(4):2070–2082
4. Pape HC, McCormick DA (1989) Noradrenaline and serotonin selectively modulate thalamic burst firing by enhancing a hyperpolarization-activated cation current. *Nature* 340:715–718
5. Steriade M (2004) Neocortical cell classes are flexible entities. *Nat Rev Neurosci* 5:121–134
6. Dekin MS, Richerson GB, Getting PA (1985) Thyrotropin-releasing hormone induces rhythmic bursting in neurons of the nucleus tractus solitarius. *Science* 229(4708):67–69
7. Tryba AK, Pena F, Ramirez JM (2003) Stabilization of bursting in respiratory pacemaker neurons. *J Neurosci* 23(8):3538–3546
8. Arshavsky YI (2003) Cellular and network properties in the functioning of the nervous system: from central pattern generators to cognition. *Brain Res Brain Res Rev* 41:229–267

9. Onimaru H, Arata A, Homma I (1989) Firing properties of respiratory rhythm generating neurons in the absence of synaptic transmission in rat medulla in vitro. *Exp Brain Res* 76(3):530–536
10. Ballantyne D, Andrzejewski M, Mückenhoff K, Scheid P (2004) Rhythms, synchrony and electrical coupling in the Locus coeruleus. *Respir Physiol Neurobiol* 143(2–3):199–214

---

## Respiratory Plasticity

### ► Respiratory Reflexes

---

## Respiratory Recovery from Injury

### ► Respiratory Neuroplasticity

---

## Respiratory Reflexes

DONALD R. MCCRIMMON<sup>1</sup>, GEORGE F. ALHEID<sup>2</sup>

<sup>1</sup>Department of Physiology, Feinberg School of Medicine, Northwestern University, Chicago, IL, USA

<sup>2</sup>Department of Physiology and Northwestern University Feinberg School of Medicine, Chicago, IL, USA

### Synonyms

Pulmonary reflexes; Breuer-Hering reflexes; Deflation reflex; Central chemoreceptors; Peripheral chemoreceptors; Carotid chemoreflex; Slowly adapting pulmonary stretch receptors; Rapidly adapting pulmonary receptors; Irritant receptors; Cough; Respiratory plasticity

### Definition

Respiratory reflexes encompass a significant repertoire of responses to a variety of sensory receptors regulating the depth and frequency of individual breaths and participating in the protection of airways from potentially damaging inhaled substances. Specifically, receptors in the airways and lungs sense the relative inflation or deflation of the lungs as well as the presence

of inhaled irritants, and elicit appropriate responses via brainstem respiratory circuits to maintain the integrity and efficient function of the lungs and airways. Central (brain) chemoreceptors and peripheral chemoreceptors in contact with arterial blood, evoke changes in breathing to maintain appropriate levels of oxygen and carbon dioxide as well as pH.

### Characteristics

Continuous, rhythmic breathing movements are essential for the homeostatic regulation of arterial blood gases, acid-base balance and, ultimately, for the maintenance of life itself. Neurons responsible for generating respiratory rhythm and shaping it into the detailed pattern of activity evident on respiratory motor output are located predominantly in two brainstem regions (see Alheid & McCrimmon this volume). One group forms a long column of cells in the ventrolateral medulla in close proximity to the nucleus ambiguus. Termed the ventral respiratory column (VRC), this group extends rostrally from the spinal-medullary junction to a region ventral to facial nucleus. A second group, termed the dorsal respiratory group, is localized in the dorsomedial medulla, mainly within the ventrolateral nucleus of the solitary tract (NTS). These neurons fire in bursts phase locked to the breathing rhythm. Most fire either during inspiration (inspiratory neurons) or expiration (expiratory neurons) although some fire in bursts that span phase transitions between inspiration and expiration.

The magnitude and rate of respiratory efforts generated by brainstem respiratory neurons are regulated to maintain brain and arterial tensions of oxygen (O<sub>2</sub>), carbon dioxide (CO<sub>2</sub>), and pH within narrow limits despite large variations in metabolic requirements. A variety of chemical and mechanical receptors located in the airways, lungs, and chest-wall provide the sensory feedback essential to optimization of the breathing pattern. Sensory feedback from arterial and central (brain) chemoreceptors as well as lung mechanoreceptors modulates the breathing pattern, e.g., tidal volume and breathing frequency.

Receptors distributed throughout the airways also help defend the respiratory system. Afferent-evoked protective reflexes include apnea (a transient cessation of breathing), shallow rapid breathing, coughing, sneezing, mucus secretion, and airway constriction. These reflexes protect the airways from irritants and facilitate the removal of inhaled substances potentially harmful to the lungs and airways.

### Chemoreceptors

Regulating the level of the metabolic product CO<sub>2</sub> and maintenance of tissue oxygenation are principal roles of the respiratory system. In performing these tasks, the

central circuitry generating respiratory pattern receives sensory input from chemoreceptors located in the brain (central chemoreceptors) and the arterial system (peripheral chemoreceptors). Through the regulation of CO<sub>2</sub>, the respiratory system also adjusts pH and hence contributes importantly to acid-base balance.

Central chemoreceptors have a relatively greater role than peripheral receptors in regulating CO<sub>2</sub> and pH and they have been identified in several regions of the brain [1]. Most are in the medulla and pons including: (i) regions at the ventral surface of the medulla, particularly in the retrotrapezoid nucleus, (ii) midline raphe serotonergic neurons, (iii) the NTS, (iv) the preBötzinger complex [a subregion of the VRC] and (v) noradrenergic neurons in the locus coeruleus. Additional chemosensitive sites have been identified in: (vi) the fastigial nucleus of the cerebellum, and (vii) the posterior hypothalamus. The relative importance of several sites including the NTS, retrotrapezoid nucleus and caudal raphe may vary with physiological conditions such as the sleep–wake state. Central O<sub>2</sub> chemoreceptors appear to exist but little ventilatory response to hypoxia is observed after peripheral deafferentation when CO<sub>2</sub> levels are held constant.

Peripheral chemoreceptors have a dominant role in eliciting the ventilatory increases in response to hypoxia [2]. Peripheral chemoreceptors are located in both the carotid and aortic bodies but the carotid bodies are quantitatively much more important in regulating breathing. The aortic bodies contribute relatively more to cardiovascular adjustments. Afferent fibers emanating from the carotid bodies have a low discharge rate at normal resting levels of arterial O<sub>2</sub> and CO<sub>2</sub> but increase their discharge in response to a decrease in the partial pressure of arterial O<sub>2</sub> (PO<sub>2</sub>) or to an increase in the partial pressure of arterial CO<sub>2</sub> (PCO<sub>2</sub>) or to decreases in pH.

Overall, chemoreceptors are remarkably sensitive to PCO<sub>2</sub>. Increasing arterial PCO<sub>2</sub> by 1–3 mm Hg from a normal resting value of about 40 mm Hg can cause a doubling of ventilation. About 60% of this response is contributed by central chemoreceptors. In contrast, there is little ventilatory response to hypoxia until arterial PO<sub>2</sub> decreases below 60 mm Hg from a normal resting value of 80–100 mm Hg.

Chemoafferent fibers from the carotid body are contained in the carotid sinus nerve (CSN), a branch of the glossopharyngeal nerve, with the cell bodies of (first order) CSN chemoafferent neurons found mainly within the petrosal ganglia. CSN chemoreceptor afferent fibers are a mixture of unmyelinated C-fiber axons and myelinated A-fibers. The principal fast transmitter in these afferents appears to be glutamate, however, dopamine appears to be present in about 40% of the C-fibers. Other potential chemoafferent transmitters include substance P and ATP.

Carotid body afferents target 2nd-order caudal NTS neurons [3], specifically within its commissural division (SolC; Fig. 1).

Within the NTS, intrinsic polysynaptic pathways provide recurrent excitatory feedback that can initially increase the excitability of 2nd- and higher-order NTS chemoafferent interneurons. Inhibitory GABAergic neurons in SolC are also activated during hypoxic stimulation of breathing and the initial activation of NTS neurons is followed by local inhibition that ultimately limits the excitatory responses of the NTS 2nd and higher order neurons.

Multiple pathways emanating from the NTS are involved in processing carotid chemoreceptor afferent activity. Both second and higher order neurons in SolC are the source of extrinsic projections to the brainstem and forebrain. Among brainstem targets are VRC respiratory neurons. Additionally, SolC neurons relay chemoafferent input to the rostral dorsolateral pons in the region of the parabrachial and Kölliker-Fuse nuclei. These nuclei contain respiratory neurons and are collectively referred to as the pontine respiratory group (PRG). Some neurons in the PRG are likely relays for chemoafferent (and other visceral) inputs to higher brain structures (in addition to the direct forebrain projections from the NTS). PRG neurons also provide descending inputs that coordinate respiratory activity with other systems such as cardiovascular control as well as with nociceptive afferent input.

### **Plasticity in Chemoreceptor Breathing Responses**

Short and long-term modifications (plasticity) occur in the breathing response to chemoreceptor activation. Respiratory plasticity accommodates the changing demands of development as well as environmental demands such as changing PO<sub>2</sub> levels at varying altitudes, and physiological demands created by pathological changes in the efficiency of the airways and lungs.

Plasticity of the hypoxia reflex is evident in changes in respiratory pattern occurring in multiple stages. The acute response to hypoxia is characterized by increases in both respiratory frequency and the volume of each breath (tidal volume). There is a progressive increase in tidal volume (termed short-termed potentiation) over a period of seconds to minutes. Upon returning to normal oxygen levels there is a slow return to the normal tidal volume. There is also a post-hypoxic decline in breathing frequency lasting several minutes in which respiratory frequency declines below pre-hypoxic levels. While the mechanisms underlying these changes are not well understood, short term potentiation may involve recurrent excitation within the chemoreceptor pathway in the NTS as well as pre-synaptic changes (e.g. calcium accumulation) in NTS or downstream neurons. Post hypoxic frequency decline, on the other hand, may require participation of neurons in the ventrolateral pons.



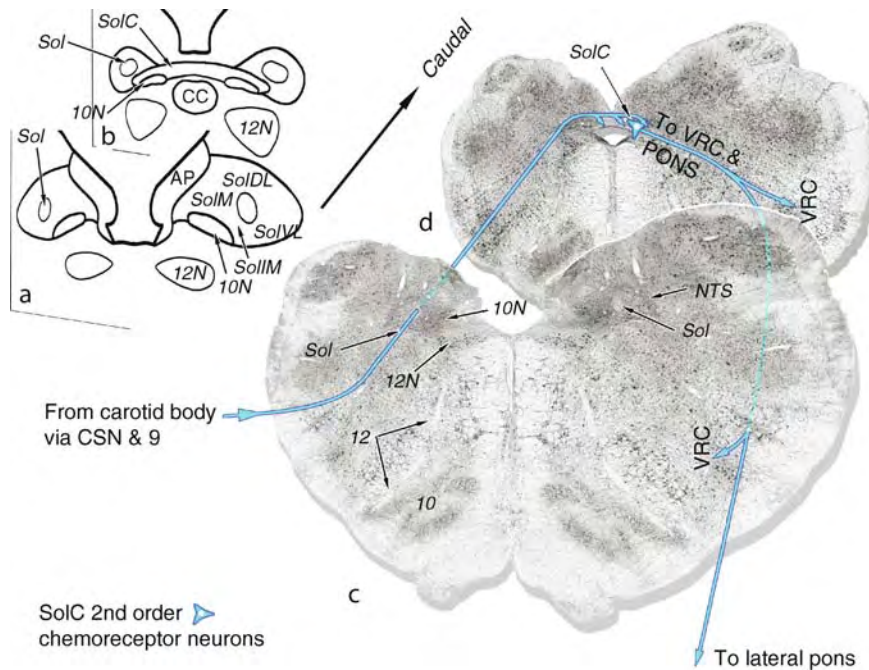

**Respiratory Reflexes. Figure 1** Carotid body chemoreceptor afferent terminations within the nucleus of the solitary tract (NTS). (a & b) NTS subnuclei at two rostrocaudal levels. (c & d) Central pathways of carotid chemoreceptors projected onto Nissl-stained coronal sections of the medulla at the levels approximating those diagramed in A & B. The axons of these sensory fibers are carried by the carotid sinus nerve (CSN), a branch of the glossopharyngeal nerve [9]. They enter the medulla near the level of the facial nucleus and run caudally within the solitary tract (sol) terminating predominantly within the commissural subregion (SolC) in the caudal aspect of the NTS. NTS 2nd-order neurons relay this afferent input directly (or indirectly via NTS higher-order neurons) to respiratory regions in the ventrolateral medulla and pons. Compare with the distribution of lung mechanoreceptor afferents in Fig. 3. Abbreviations: 10N dorsal motor nucleus of the vagus; 12 hypoglossal nerve; 12N hypoglossal nucleus; AP area postrema; CC central canal; IO inferior olive; sol solitary tract; SolDL dorsolateral subnucleus; SolIM intermediate subnucleus; SolIM medial subnucleus; SolVL ventrolateral subnucleus; VRC ventral respiratory column of the ventrolateral medulla.

As illustrated in Fig. 2, repeated episodes of hypoxia lasting from seconds to minutes result in an additional form of plasticity consisting of a long-term facilitation (LTF) of respiratory motor output that can persist for several hours [1].

LTF is observed at motoneurons innervating respiratory pump muscles (e.g. phrenic and external intercostal motoneurons in the cervical and thoracic spinal cord) and upper airway muscles (e.g. hypoglossal motoneurons) and has been related to brainstem serotonergic afferents to these cells (via 5HT-2A receptors) as well as to up-regulation of the peptide, brain derived neurotrophic factor (BDNF), and the molecular signalling proteins activated by BDNF receptors (e.g. TrkB).

In humans, an etiologic role for central chemoreceptors in the medullary arcuate nucleus (located at the medial ventral surface of the brain) has been postulated in sudden infant death syndrome (SIDS) and this has been supported by observations of abnormal development of arcuate serotonin receptors [4]. Disruption of normal chemoreceptor function is also suggested in

congenital central hypoventilation syndrome (CCHS). CCHS patients with a polyalanine expansion mutation in the *PHOX2B* gene have negligible sensitivity to elevated  $PCO_2$  or hypoxemia [5].

### Airway Receptors

Respiratory reflexes arising from the airways serve both in protecting the airways as well as in regulating the depth and frequency of breathing. Protective reflexes include apnea, cough, sneeze, mucus secretion, and airway constriction that both protect the airways from irritants and facilitate the removal of potentially harmful substances. Sensory feedback also helps coordinate breathing with other behaviours such as locomotion or vocalization.

### Receptors in the Nasal Passages and Pharynx

Receptors in the mucous membranes of the nasal cavities are sensitive to cold and pressure changes associated with breathing as well as to inhaled irritants such as cigarette smoke and ammonia. Branches of the trigeminal nerve, including the anterior ethmoidal and

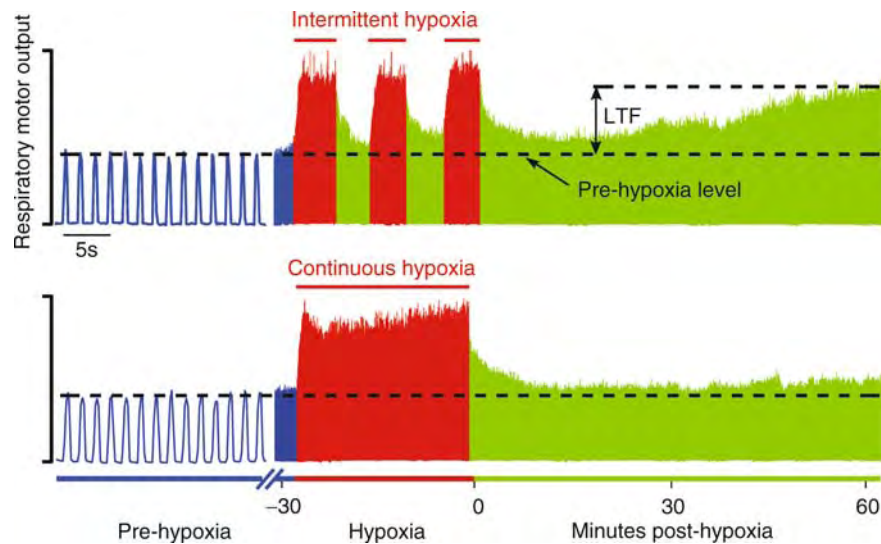

**Respiratory Reflexes. Figure 2** Respiration-related neural activity in an anesthetized and artificially ventilated rat demonstrates a form of respiratory plasticity known as respiratory long-term facilitation (LTF). On the left in each trace, electrical activity in the phrenic nerve (the nerve innervating the diaphragm, the principal inspiratory muscle) is integrated such that each peak represents a “fictive breath” that the artificially ventilated rat had intended to make. Under conditions of normal arterial oxygen and carbon dioxide (pre-hypoxia baseline; blue traces), the phrenic nerve bursts are rhythmic and relatively constant in frequency and amplitude. Ventilating the rats with lowered oxygen levels (intermittent, upper trace; continuous, lower trace) causes differential effects on phrenic nerve activity depending upon the pattern of hypoxia exposure (intermittent, upper trace; continuous, lower trace). In both conditions, phrenic bursts increase in amplitude, primarily reflecting the increased activation of carotid body (peripheral) chemoreceptors. Following either pattern of hypoxia exposure, phrenic nerve activity also asymptotes toward baseline levels over several minutes following the return to normoxia (green traces). However, after intermittent, but not after continuous hypoxia, phrenic nerve burst amplitude again increases slowly and progressively over the next hour, even though arterial oxygen and carbon dioxide are at pre-hypoxia levels. This slow increase reflects LTF that is elicited in response to the repetitive exposure to hypoxia. This facilitation requires release of serotonin in the region of the motor neurons (Data provided by T.L.

Baker-Hermann and G.S. Mitchell, reproduced with permission from *Fundamental Neuroscience*, 2nd Edition, edited by LR Squire, FE Bloom, SK McConnell, JL Roberts, NC Spitzer, MJ Zigmond, Academic Press, San Diego, 2003).

maxillary nerves convey the sensory information to the central nervous system. Respiratory motor responses to activation of these receptors include sneezing and apnea. Additional reflex components occur secondarily to alterations in the activity of the autonomic nervous system and include mucus secretion, bradycardia, and increased blood pressure.

The diving reflex is also elicited by receptors with afferent fibers in the trigeminal nerve. This reflex is elicited by water on the face or in nasal passages, and consists of apnea and peripheral vasoconstriction, along with marked increases in arterial pressure and bradycardia. Stimulation of the anterior ethmoidal nerve, which innervates the nasal passages, mimics the diving reflex. Its central terminations are found mainly in ventral aspects of the spinal trigeminal nucleus at levels caudal to the facial nucleus with additional terminations in the NTS and paratrigeminal nucleus.

### Laryngeal Receptors

The larynx is richly innervated by several subgroups of sensory receptors [6,7]. Their afferent fibers are mainly

in the recurrent and superior laryngeal branches of the vagus nerve with terminations in the NTS. The receptors are located at the entrance to the trachea and lower airways and elicit strong protective reflexes including cough and apnea. The pronounced apneas elicited from laryngeal receptors has also suggested that abnormal development of their reflex pathways could contribute to SIDS. In contrast, a subset of laryngeal receptors promotes airway patency via activation of airway dilating muscles such as the genioglossus and posterior cricoarytenoid.

### Receptors in the Lower Airways

Receptors within the lungs and lower airways, *i.e.*, those below the larynx, are classified into two main types based on whether the sensory afferent fibers are myelinated or unmyelinated [6,8,9]. The afferent axons arising from both groups travel in the vagus nerves and terminate in middle and caudal aspects of the NTS. Receptors with myelinated axons constitute airway mechanoreceptors and are activated by distension of the airway during lung inflation or by a reduction in airway

dimensions during lung deflation, especially deflations below the normal end-expiratory volume. Two groups of receptors, slowly (SAR) and rapidly (RAR) adapting receptors, are identified based on their sensitivity to distension of the airways during lung inflation and the rate of accommodation in their response. An additional group of receptors, termed deflation activated receptors (DARs), are more prominent in small animals (e.g. rats). DARs share several common properties with RARs, which are more readily observed in larger animals and activation of either RARs or DARs elicits augmented inspiratory efforts.

SARs are located in airway smooth muscle. Their activation by lung inflation inhibits inspiratory motor activity, thereby shortening inspiratory duration and reducing tidal volume (termed the *Breuer-Hering inspiration-inhibiting reflex*). Maintaining inflation into the expiratory period prolongs expiratory duration (*Breuer-Hering expiratory facilitatory reflex*). The Breuer-Hering reflexes are activated during normal resting breathing in most mammals while in humans they appear to only significantly influence breathing pattern when tidal volumes increase to 2–3 times their resting values as may occur during muscular exercise. Activation of SARs has several additional effects, including reductions in airway smooth muscle tone resulting in bronchodilation, and reductions in heart rate and systemic vascular resistance.

RARs are located in airway epithelium and submucosa. While they are activated by lung inflation they are less responsive than SARs and tend to have little activity under normal breathing conditions. Their discharge adapts rapidly to lung inflation and they typically fire irregularly, giving rise to one or a few action potentials during lung inflation. They respond with a significantly more sustained discharge to inhaled irritants. RARs are implicated in a number of potent airway protective reflexes, including augmented breaths (sighs), airway constriction, mucus secretion and laryngeal closure. While they are generally believed to trigger coughing, this function has recently been related to a specific subset of polymodal  $A\delta$ -fibers (termed cough receptors; [10]).

DARs. Some researchers group DARs with RARs and the degree to which these represent the same or separate populations requires further examination. Nevertheless, lung deflation triggers reflexes that shorten expiratory duration and increase inspiratory effort. There is also a reflex narrowing (adduction) of the glottis and stimulation of low intensity diaphragm activity during expiration that slows expiration. Together these responses help prevent alveolar collapse, and are particularly important in human infants as well as in other small mammals that have highly compliant chest walls.

C-Fibers constitute the largest class of pulmonary vagal afferent fibers (~75%). They are polymodal

and nociceptive, responding to a variety of inflammatory mediators and inhaled irritants. Reflex changes in breathing in response to C-fiber activation involve rapid shallow breathing interspersed with apneas; additional reflex effects include bronchoconstriction, mucus secretion, hypotension, bradycardia and airway mucosal vasodilation. Beyond identification of the regions of C-fiber termination within the NTS, little is known concerning central pathways mediating these responses.

## Second and Higher-Order Neurons in Reflexes From Airway Mechanoreceptors

### Central Pathways of SARs

SAR primary afferent fibers terminate within mid to caudal portions of the NTS (Fig. 3) [6]. Only two functional classes of NTS neurons receive monosynaptic input from SARs (Fig. 3).

One type, termed  $I\beta$  neurons, exhibits inspiratory discharge patterns, and activation of SARs increases the discharge rate of these neurons.  $I\beta$  neurons are bulbospinal premotor neurons that monosynaptically excite phrenic motoneurons. These motoneurons innervate the diaphragm and this reflex accordingly provides positive feedback excitation of diaphragm inspiratory activity.

A second group of NTS neurons, termed pump neurons, mediate Breuer-Hering reflex changes in respiratory rhythm. Pump neurons receive monosynaptic SAR input but are readily distinguished from  $I\beta$  neurons by the general absence of an inspiratory discharge when SAR input is removed. Consistent with the broad effects they elicit on respiratory pattern, their axons arborize extensively within pontomedullary regions (ventrolateral medulla and rostral dorsolateral pons) containing neurons responsible for generating the respiratory pattern. Many pump neurons are inhibitory, containing GABA with only a small percentage also containing glycine. Experimental evidence also suggests that there may be excitatory pump neurons, however, these cells have not yet been directly identified.

### Central Pathways of RARs

RAR primary afferent fibers terminate in caudal aspects of the NTS where they monosynaptically excite neurons termed RAR interneurons (Fig. 3) [6]. Like pump neurons, these interneurons provide extensive axonal arborizations to pontomedullary regions involved in respiratory pattern generation. RAR interneurons are believed to be excitatory and presumably facilitate the discharge of inspiratory neurons. RAR activation accordingly elicits augmented inspirations such as sighs, and the large inspiration preceding a cough. RARs are also stimulated by decreases in lung compliance that result from alveolar collapse. The resulting RAR-triggered large inspiration stretches the lung, reopening collapsed alveoli.

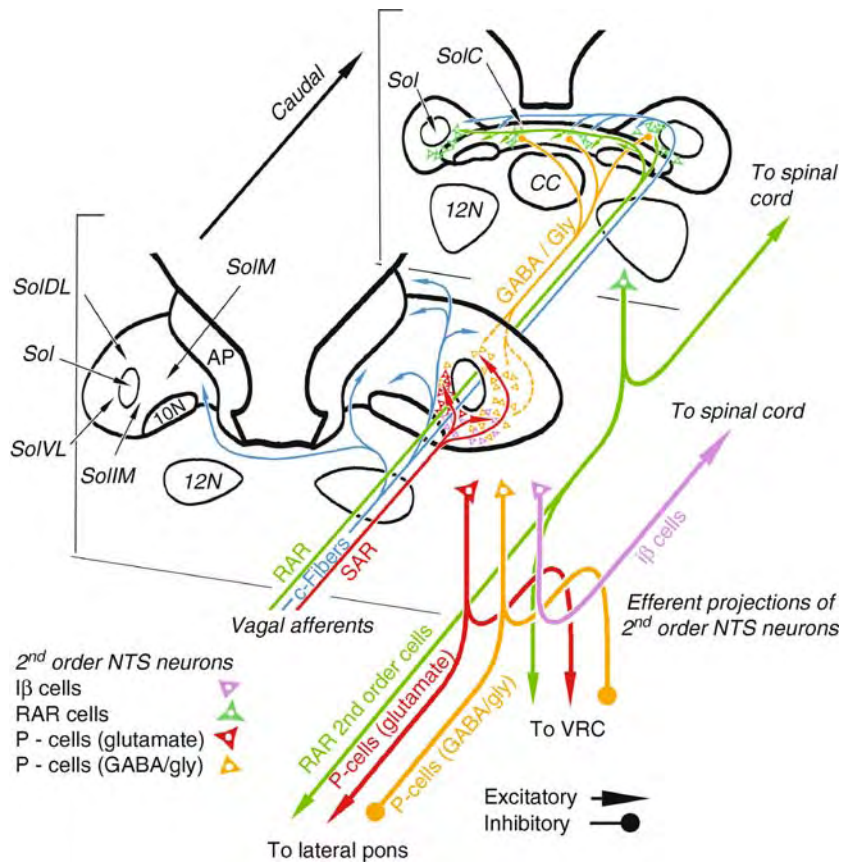

**Respiratory Reflexes. Figure 3** The topographical distribution within the NTS of three classes of pulmonary afferents. The terminal distribution slowly and rapidly adapting stretch receptors (SARs and RARs, respectively) and bronchopulmonary C-fibers is shown at two rostrocaudal levels of the NTS. The three afferent systems in general project to topographically separate NTS targets. The principal projections of their 2nd order neurons are also indicated. Among the known projections is an inhibitory projection of pump (P-) cells to RAR relay neurons in the NTS commissural subnucleus. See Fig. 1 for abbreviations (used with permission from [6]).

### Summary

Although seemingly effortless in the healthy individual, generating an optimal breathing pattern for O<sub>2</sub> and CO<sub>2</sub> homeostasis requires the integration of sensory information arising from a variety of receptors. These include multiple central and peripheral chemoreceptors for adjusting the magnitude of alveolar ventilation as well as multiple mechanoreceptors that respond to stretch of the airways and regulate the relative depth and rate of breathing to reduce energy expenditure. Sensory input is also important in the coordination of breathing with other systems, such those required for speaking, eating, walking, running, vomiting. Finally, sensory information is necessary for protection of the airways and lungs. Receptors in the nose, pharynx, larynx and lower airways elicit a variety of reflexes including coughs, sneezes and apnea that protect the airways from inhalation of noxious substances and increase mucous secretion that aids in their removal. Failure of any of these systems can be catastrophic, severely

compromising the quality of life for an individual or ultimately leading to their death.

### References

1. Lee L-Y, Pisarri TE (2001) Afferent properties and reflex functions of bronchopulmonary C-fibers. *Respir Physiol* 125:47–65
2. Yu J (2005) Airway mechanosensors. *Respir Physiol Neurobiol* 148:217–243
3. Berry-Kravis EM, Zhou L, Rand CM, Weese-Mayer DE (2006) Congenital central hypoventilation syndrome: PHOX2B mutations and phenotype. *Am J Respir Crit Care Med* 174(10):1139–1144
4. Paterson DS, Trachtenberg FL, Thompson EG, Belliveau RA, Beggs AH, Darnall R, Chadwick AE, Krous HF, Kinney HC (2006) Multiple serotonergic brainstem abnormalities in sudden infant death syndrome. *JAMA* 296(17):2124–2132
5. Powell FL, Milsom WK, Mitchell GS (1998) Time domains of the hypoxic ventilatory response. *Respir Physiol* 112(2):123–134

6. Kubin L, Alheid GF, Zuperku EJ, McCrimmon DR (2006) Central pathways of pulmonary and lower airway vagal afferents. *J Appl Physiol* 101:618–627
7. Feldman JL, Mitchell GS, Nattie EE (2003) Breathing: rhythmicity, plasticity, chemosensitivity. *Annu Rev Neurosci* 26:239–266
8. Canning BJ, Mazzone SB, Meeker SN, Mori N, Reynolds SM, Undem BJ (2004) Identification of the tracheal and laryngeal afferent neurones mediating cough in anaesthetized guinea-pigs. *J Physiol (Lond)* 557:543–558
9. Paton JFR, Deuchars J, Li Y-W, Kasparov S (2001) Properties of solitary tract neurones responding to peripheral arterial chemoreceptors. *Neuroscience* 105 (1):231–248
10. Sant’Ambrogio G, Tsubone H, Sant’Ambrogio FB (1995) Sensory information from the upper airway: role in the control of breathing. *Respir Physiol* 102:1–16

---

## Respiratory Sinus Arrhythmia

► [Central Integration of Cardiovascular and Respiratory Activity Studied In?Situ](#)

---

## Responding Conditioning

► [Classical Conditioning \(Pavlovian Conditioning\)](#)

---

## Response, Instrumental

### Definition

A voluntary, conditioned response to a cue performed for reinforcement.

► [Reinforcement](#)

---

## Response Acquisition

► [Learning and Motivation](#)

---

## Response Extinction

### Definition

The result of extinction, observed as a decrease in conditioned responses to a conditioned stimulus following non-reinforced presentations of the conditioned stimulus.

► [Learning and Extinction](#)

---

## Response Inhibition

### Definition

Inhibitory control is the ability to suppress behaviors that are inappropriate under the circumstances. Neuropsychological studies of the prefrontal cortex indicate that this function arises from the orbitomedial divisions, most probably via descending projections to structures such as the amygdala, basal ganglia and hypothalamus.

► [Prefrontal Cortex](#)

---

## Rest-Activity Cycle

### Definition

The fundamental alternation between extended periods of activity and rest that define a complete circadian cycle. Can also define ultradian (much less than 24 h) cycles.

- [Circadian Cycle](#)
- [Internal Desynchrony](#)
- [Sleep-wake Cycle](#)

---

## Resting Membrane Potential

### Definition

The resting potential is a stable membrane potential in non-excitabile cells or, in excitable cells, the most stable

membrane potential between action potentials without excitatory or inhibitory inputs. In some excitable tissues, a resting potential cannot be defined because of continuous changes in membrane potential.

- ▶ [Membrane Potential: Basics](#)
- ▶ [Action Potential](#)

## Resting Tremor

### Definition

Approximately 70% of patients notice tremor as the first symptom of Parkinson disease. Onset of tremor is usually in one hand and it may later involve the contralateral upper limb or ipsilateral lower limb.

Typically, the tremor is 3–5 Hz rhythmic “pill-rolling” movements of the thumb and index finger while the hand is at rest. There may be abduction and adduction of the thumb, or flexion and extension of the wrist, or of the metacarpophalangeal joints. The tremor may also extend to the forearm with pronation–supination or even to the elbow and upper arm. During early disease, tremor is often intermittent and is evident only under stress. Tremor is worsened by anxiety, fatigue, and sleep deprivation. It diminishes with voluntary activity but may reappear with static posture (e.g. outstretched hands) and is absent during sleep. Resting tremor is enhanced by mental task performance, such as serial seven subtractions, and by motor task performance in a different body part. The hand tremor may also be enhanced during ambulation. Compared to essential tremor, the resting tremor of Parkinson disease is generally less prone to exacerbation by caffeine or improvement with alcohol.

- ▶ [Parkinson Disease](#)

## Restless Legs Syndrome

### Definition

Restless limbs syndrome is a common disorder with a prevalence of 5–15% in western countries. It is characterized by a distressing desire to move the legs, motor restlessness brought on by rest, worsening symptoms in the evenings and at night, and periodic limb movements during sleep. Although it can be seen

with peripheral neuropathy, most cases of restless legs are not accompanied by neuropathy. There is an association between restless limbs and brain dopamine and iron deficiency. Therefore, checking iron and ferritin levels is part of the workup for restless legs syndrome. If iron deficiency is detected, it should be evaluated (anemia workup, etc.) and treated with iron supplementation. If a sleep study reveals sleep apnea together with periodic limb movements during sleep, the apnea component should be treated. Symptomatic treatment of restless legs and limb movements during sleep usually begins with a dopamine agonist (pramipexole or ropinirole). Dopamine agonists have longer durations of action compared to levodopa and one or two evening/bedtime dose(s) may suffice. If dopamine agonists are not well tolerated, a controlled release formulation of carbidopa/levodopa should be tried next, and the dose titrated as tolerated. Other adjunct medications include gabapentin, benzodiazepines, and low potency opioids as a last resort.

- ▶ [Sleep – Developmental Changes](#)

## Ret

### Definition

The signaling component of the glial cell line-derived neurotrophic factor (GDNF) family receptor complex. Ligand-binding to GPI-linked GFR $\alpha$  receptors (1–4) and subsequent induction of Ret dimerization results in Ret phosphorylation and activation of several signaling cascades, including those involving MAPK, PI3K and PLC $\gamma$ .

- ▶ [Glial Cell Line-derived Neurotrophic Factor \(GDNF\)](#)
- ▶ [Neurotrophic Factors in Nerve Regeneration](#)

## Retention

### Definition

Retention is the ability to maintain in mind information about a stimulus when that stimulus is no longer physically present. Retention span can vary from on the order of seconds or minutes to months or even years.

- ▶ [Recognition Memory](#)

## Reticular Core

### ► Reticular Formation

## Reticular Formation

STEFANIE GEISLER

Behavioral Neuroscience Branch, National Institute on Drug Abuse, Intramural Research Program, Baltimore, MD, USA

### Synonyms

Formatio reticularis; Substantia reticularis; Isodendritic core; Reticular core

### Definition

The reticular formation is a netlike structure of cells and fibers that extends throughout the core of the brainstem. It maintains vegetative functions, plays an essential role in coordinated motor behaviors and exerts control on cortical and thalamocortical activation. Extensive damage to the reticular formation is incompatible with survival.

### Characteristics

#### Anatomical Organization and Concepts

The term reticular formation was coined by anatomists in the last century to describe a region in the core of the ► **brainstem** characterized by scattered neurons of various sizes and shapes with long, sparsely branching dendrites lying in and among multiple, differently oriented fiber systems. The dendrites of neighboring neurons overlap extensively with each other, giving the structure a netlike (“reticular”) appearance. The reticular formation extends continuously from the ► **caudal medulla oblongata** to the ► **rostral mesencephalon** (and possibly beyond, see below).

Based on differences in cytoarchitecture, cytochemistry and connections, the reticular formation has been divided into three longitudinal zones, a median zone, which contains the ► **serotonergic** raphe nuclei (Greek *raphe* = seam), a medial zone, characterized by big cells intermingling with many small ones and a lateral zone, which consists predominantly of (Fig. 1) small neurons and has fewer fibers than the medial zone (Fig. 1a–c).

More recently, an intermediate zone has been delineated between the medial and lateral ones (Fig. 1a, [1]). The intermediate zone comprises large, medium and small cells and exhibits slightly stronger ► **acetylcholine**

esterase staining as compared to the adjacent medial and lateral zones. ► **Cranial nerve** nuclei (e.g. facial and cochlear) and relay nuclei (e.g. cuneate and red nuclei), which largely consist of densely packed neurons of similar appearance (Fig. 1d) are not included in the reticular formation.

### Nuclei of the Reticular Formation

By analyzing Nissl stained (► **Nissl Stain**) sections of the human and rabbit brainstem Olszewski and colleagues noted cytoarchitectural heterogeneities, which led them (and subsequently others in other species) to suggest that the reticular formation consists of different nuclei [2,10]. An overview of reticular formation nuclei is given in Table 1.

At the medullary level of the medial reticular formation, the ► **gigantocellular nucleus** has been delineated, which is composed of prominent multipolar giant cells, as well as large, medium sized and some small neurons (Fig. 1a, b). It is surrounded by the gigantocellular nucleus pars alpha and the lateral and dorsal paragigantocellular nuclei, all of which also contain large neurons. The gigantocellular nucleus extends from the obex to the rostral medulla oblongata and is continuous caudally with the ventral reticular nucleus and rostrally with the ► **caudal pontine reticular nucleus**. The caudal pontine reticular nucleus extends to the rostral pons where it merges with the oral pontine reticular nucleus, which in turn extends rostralward to the level of the decussation of the superior cerebellar peduncle. Dorsal and ventral to the caudal pontine reticular nucleus are the dorsomedial tegmental and ventral pontine reticular nuclei respectively. The lateral zone consists, in order from ► **caudal** to ► **rostral**, of the dorsal reticular (caudal medulla), parvocellular (medulla; Fig. 1c), subceruleus (pons) and cuneiform nucleus (pons, ► **mesencephalon**). The mesencephalic reticular formation is dominated by the deep mesencephalic nucleus, which some authors regard as part of the medial and others as part of the lateral zone of the reticular formation. Some of the above mentioned nuclei have been further subdivided (see [2,3]).

In addition to the above-mentioned nuclei are some that are regarded by some, but not all, authors to be part of the reticular formation, e.g. the lateral reticular nucleus, ► **parabrachial nucleus**, locus ceruleus, pedunculopontine and laterodorsal tegmental nuclei, retrorubral field, and ventral tegmental area. It sometimes seems to be a matter of personal taste whether a nucleus is included in the reticular formation or not.

### The Veticular Formation and the Ascending Reticular Activity System

In 1949, Moruzzi and Magoun published a seminal paper describing studies in which they demonstrated that stimulation of the reticular formation in lightly

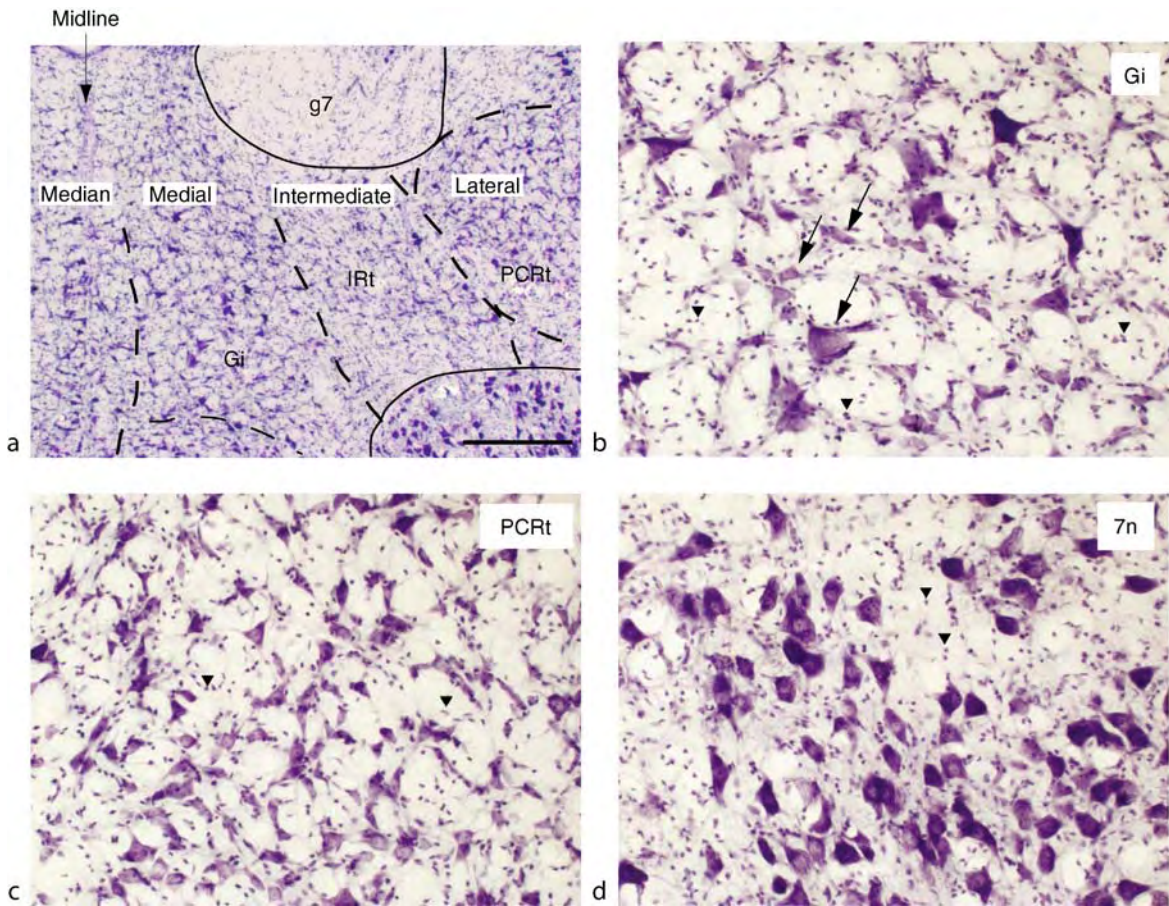

**Reticular Formation. Figure 1** (a) Photomicrographs showing some reticular formation nuclei in the median, medial, intermediate and lateral zones. Prominent, big neurons of the gigantocellular nucleus can be easily recognized. The gigantocellular nucleus is enlarged in (b), showing large and small neurons (*arrows*) side-by-side, one of the characteristics of the reticular formation. The very small cells (*arrowheads*) are not neurons, but glial cells. (c) shows an enlargement of the parvocellular reticular nucleus, which has neurons that are obviously smaller than those in the gigantocellular nucleus. Note also the different sizes and shapes of neurons. The facial nerve nucleus, which is not included in the reticular formation, is shown in (d). Its neurons are all of similar size and appearance and are more densely packed than those in the gigantocellular and parvocellular reticular nuclei (compare b, c, d). Abbreviations: *7n* facial nucleus, *g7* genu of facial nerve; *Gi* gigantocellular nucleus; *IRt* intermediate reticular nucleus; *PCRt* parvocellular reticular nucleus. *Arrows* point to neurons; *arrowheads* point to glial cells. The scale bar in (a) represents 0.5 mm in (a), 0.125 mm in (b–d).

anaesthetized cats evokes a desynchronization of the cortical **▶EEG**, closely resembling the changes observed in the human EEG upon transition from sleep to wakefulness or relaxation and drowsiness to alertness and attention [4]. Such EEG changes could be elicited by stimulation of the medial medullary, pontine and mesencephalic reticular formation and dorsal hypothalamus and subthalamus. They proposed a series of relays in the reticular formation ascending to the basal diencephalon and exerting influence on widespread areas of the cortex via a “diffuse thalamic projection system.” These and other observations led to the concept of an ascending reticular activating system (often referred to in the literature as ARAS), which spurred

extensive research and had an enormous influence on subsequent views concerning the neural basis of consciousness. Because potentials could be recorded from large cortical territories following stimulation of afferents from a particular source and impulses from several sources were found to reach the same region, it was assumed that the system would be entirely diffusely organized. Unfortunately, the term “ascending reticular activating system” describing a physiological concept was soon frequently used synonymously with the morphological term “reticular formation,” which led Olszewski to comment [5]: “There are presently two reticular formations – an anatomic one and a physiologic one – and they do not correspond to each other.”



### The Concept of the Isodendritic Core

Due to the confusion surrounding the term reticular formation and the lack of a generally accepted definition, some scientists suggested that use of the construct be discontinued altogether (e.g. [5,6]), whereas others attempted to define it more precisely [1 and refs. therein]. Based on analyses of Golgi stained (► **Golgi Stain**) brain sections of different species Ramon-Moliner and Nauta described not one defining characteristic of reticular formation, but rather an aggregation of several morphological features that they concluded are found together only in the reticular formation: i) cytological polymorphism, large and small neurons are side by side (Fig. 1b);

ii) generalized dendrites, long, radiating, relatively rectilinear and sparsely branching processes, iii) considerable dendritic overlap and iv) free intermingling of dendrites and passing myelinated and unmyelinated fiber bundles. Ramon-Moliner and Nauta called neurons (Fig. 2) with the generalized dendritic patterns found in the reticular formation “isodendritic” (from the Greek *isos*: similar, uniform, Fig. 2a) and distinguished them from allodendritic (*allos*: different) and idiodendritic (*idios*: peculiar) neurons (Fig. 2b).

Idio- and allo-dendritic neurons, also sometimes referred to as “hodophob” (*hodos*: path, pathway; *phob*: fearing), are characterized by short dendrites that ramify

**Reticular Formation. Table 1** Nuclei of the brainstem reticular formation

Median	Medial	Lateral
Raphe obscurus	Ventral reticular n.	Dorsal reticular n.
Raphe pallidus	Gigantocellular reticular n.	Parvicellular reticular n.
Raphe magnus	Dorsal paragigantocellular n.	Subceruleus n.
Raphe interpositus	Lateral paragigantocellular n.	Parabrachial n.
Median raphe	Gigantocellular n, pars alpha	Cuneiform n.
Dorsal raphe	Caudal pontine reticular n.	Laterodorsal tegmental n.
	Dorsomedial tegmental n.	Pedunculopontine tegmental n.
	Ventral pontine reticular n.	
	Oral pontine reticular n.	
	Deep mesencephalic reticular n.	

Nuclei are ordered from caudal to rostral, colored boxes indicate where the nuclei are situated in the brainstem: ► **blue** – Medulla oblongata; ► **orange** – Pons; ► **green** – Mesencephalon. At medullary levels an intermediate zone has been delineated. Whereas the zones are easily recognizable at medullary levels (caudal), it is more difficult to distinguish them at rostral pontine and mesencephalic levels. Thus, at mesencephalic levels the allocation of nuclei to distinct zones is fairly tentative. Abbreviation: *n* nucleus.

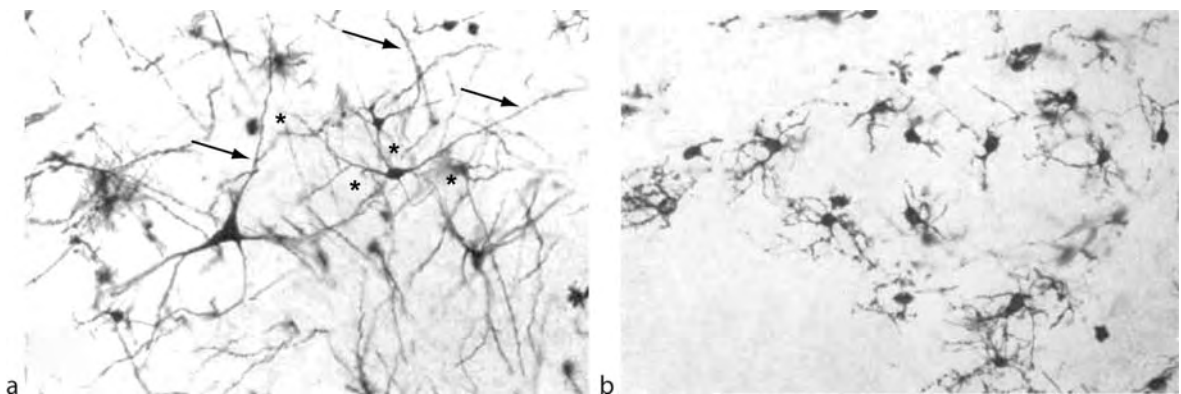

**Reticular Formation. Figure 2** (a) Isodendritic neurons have long, sparsely branching dendrites (*arrows*) and overlapping dendritic fields (*asterisks*). (b) Allodendritic neurons have short dendrites, which ramify close to the cell body. Dendrites of neighbouring neurons largely do not overlap with each other. These Golgi preparations are adapted from figs. 6 and 7 of [1], with permission from Wiley Interscience.

close to the cell body and do not extend into passing fiber bundles (Fig. 2b). These neuron types are found, e.g. in sensory nuclei, like the cuneate nucleus. In contrast, the “reticular” isodendritic neurons are regarded as “hodophil” (phil: friendly).

Ramon-Moliner and Nauta’s concept of reticular formation does not necessarily preclude the existence of regional differences and is not incompatible with parcellations suggested by Olszewski and others. Thus, although the extensively overlapping dendritic fields of reticular neurons make it difficult, if not impossible, to draw definite lines around nuclei, the division of the reticular formation into nuclei is nevertheless helpful and necessary (and widely employed today) to describe the locations of nerve cells, electrode placements and lesions within the reticular formation. Applying the criteria of Ramon-Moliner and Nauta, the lateral reticular nucleus is not part of the reticular formation because it consists of allodendritic neurons and has a restricted set of connections with the ►spinal cord and ►cerebellum. In contrast, e.g. the ►parabrachial nucleus, locus ceruleus, pedunculopontine and laterodorsal tegmental nuclei, retrorubral field and ventral tegmental area have sufficient reticular characteristics to be included. Furthermore, if these criteria are applied, the reticular formation is not confined to the brainstem, but also includes structures in the forebrain, such as the ►lateral hypothalamic and preoptic areas and the magnocellular ►basal forebrain [7]. Even if these areas are conservatively excluded from the reticular formation, their neuroanatomical organization suggests that they process information in a manner similar to that which occurs in the reticular formation of the brainstem.

### Connections and Functions of the Reticular Formation of the Brainstem

The reticular formation maintains pivotal vegetative functions (e.g. respiration, heart beat, blood pressure) and plays an essential role in coordinated motor behaviors (e.g. swallowing, chewing and ►locomotion). In addition, it functions as an intermediary through which amygdala, septum, and basal ganglia gain access to the autonomic and motor systems [8]. Via its ascending projections, the reticular formation exerts control on cortical and thalamocortical activation and functions.

### Medial Reticular Formation

Reticular neurons give rise to long ascending (e.g. to the cerebral ►cortex) and descending (e.g. to the sacral level of the spinal cord) axons that give off several collaterals along their course, thereby interconnecting different parts of the reticular formation [3]. For example the oral and caudal pontine reticular nuclei receive half of their afferents from other parts of the brainstem reticular formation. Other main afferents to the medial reticular formation arise in the ►prefrontal

and ►sensory cortices, zona incerta, fields of Forel, lateral hypothalamus, preoptic area, substantia nigra pars reticulata, superior colliculus, central gray, cerebellum and spinal cord. The medial reticular formation projects mainly to the spinal cord and motor cranial nerve nuclei and to the laterodorsal and pedunculopontine tegmental nuclei, intralaminar thalamic nuclei, fields of Forel, parafascicular thalamic nucleus, zona incerta and lateral hypothalamus. The projections of the individual nuclei of the medial reticular formation differ in degree rather than kind. Thus, all parts of the medial reticular formation project to the telencephalon, but the largest number of neurons projecting there is located at the mesencephalic level, whereas only a few are situated at caudal pontine and medullary levels. Similarly, whereas many neurons in the gigantocellular nucleus project to the spinal cord, only a few in the mesencephalic reticular formation do so [3].

Neurons in the dorsal two thirds of the caudal pontine and medullary medial reticular formation project to the intermediate and ventral horn of the spinal cord, where the premotor interneurons and motoneurons for the axial and proximal musculature (i.e. trunk, hip, back, shoulder and neck) are situated. Thus, they play an important role in the control of posture, integration of the movements of body and limbs and the orientation of body and head. Because orienting movements of the head and eye are tightly linked, it might not be surprising that parts of the medial reticular formation that project to the spinal cord also possess neurons that innervate eye muscle motor neurons (oculomotor and ►abducens nuclei), which are necessary for horizontal ►gaze control. Neurons controlling the phylogenetically later developed vertical gaze control (trochlear and oculomotor nuclei) are situated further rostrally in the medial reticular formation.

Neurons in the medial reticular formation also influence wide areas of the cerebral cortex via their strong ascending projections to the laterodorsal and pedunculopontine tegmental nuclei and, to a lesser extent, to intralaminar thalamic nuclei (see Essay on Mesopontine Tegmentum).

### Lateral Reticular Formation

The lateral reticular formation receives afferents from the primary motor and ►somatosensory cortex, ►insular cortex, ►central nucleus of amygdala, bed nucleus of stria terminalis, central gray, trigeminal nuclei, rostral part of the ►nucleus of the solitary tract, red nucleus, other parts of the reticular formation and cerebellum. Neurons in the lateral reticular formation project predominantly to motor cranial nuclei (e.g. trigeminal, facial and ►hypoglossal) and the medial reticular formation.

Sensory information from jaw muscle spindle afferents and oral cavity (via trigeminal nuclei), taste (via the rostral part of the nucleus of the solitary tract),

visceral information (via the insular cortex) and oral motor information (from the motor cortex) are relayed to and integrated within the lateral reticular formation, which in turn projects to motor cranial nuclei containing neurons for muscles involved in swallowing, chewing and salivation. In addition, inputs from structures commonly regarded as being involved in emotional processing, such as ►[amygdala](#), bed nucleus of stria terminalis and ►[periaqueductal gray](#) are integrated in the lateral reticular formation and relayed to, e.g. facial motor neurons and autonomic centers.

### The connections conceptualized

These anatomical data provide a general idea about the connections, but are insufficient to explain the precise circuits that underlie the functions of the reticular formation. Against the common perception that the reticular formation is organized in a diffuse way, the complex behaviors it is involved in require very specific and precisely tuned connections. Breathing, for example, requires the coordinated movements of jaws, lips, tongue, pharynx and larynx, can be controlled voluntarily, but usually happens automatically and has to adapt for eating, speaking, fighting or fleeing. Thus, a high level of specificity must exist in the reticular formation, but it is the very structure of the reticular formation that makes such a specificity very difficult to detect.

So, what might such an apparently disorganized structure be good for? To appreciate the functional anatomical organization of the reticular formation, it might be useful to compare it to a system that is quite differently organized, such as the primary motor or sensory system. The so-called lemniscal system carries sensory information via two synapses to the primary sensory cortex. Such a sensory pathway of minimal interruption rigorously maintains the topography of the sensory periphery and thus permits the exact localization of the source of the sensory stimulus. Hence, this system is very well suited for discriminative functions. The reticular formation, in contrast, consisting of neurons with long dendrites receiving multiple heterogeneous inputs and emitting axons that collateralize a lot, is especially well suited for integrative functions. As Nauta and Feirtag [9] state “Life depends on the innervation of the viscera: in a way all the rest is biological luxury. And vital systems ought to be organized on the principle that no single excitation should greatly affect their workings.” It remains an exciting challenge to untangle the precise underlying neuronal networks.

### References

1. Ramon-Moliner E, Nauta WJH (1966) The isodendritic core of the brain stem. *J Comp Neurol* 126:311–336
2. Paxinos G, Watson C (1986) *The rat brain in stereotaxic coordinates*. Academic, Sydney
3. Jones BE (1995) Reticular formation: cytoarchitecture, transmitters, and projections. In: Paxinos (ed) *The rat nervous system*, 2nd edn. Academic, Sydney, pp 155–171
4. Moruzzi G, Magoun HW (1949) Brain stem reticular formation and activation of the EEG. *Clin Neurophysiol* 1:455–473
5. Olszewski (1957) Reticular formation of the brain. In: Jasper HH, Proctor LD, Knighton RS, Noshay WC, Costello RT (eds) *Little, Brown, Boston, MA*, p 56
6. Blessing WW (1997) *The lower brainstem and bodily homeostasis*. Oxford University Press, Oxford, NY
7. Leontovich TA, Zhukova GP (1963) The specificity of the neuronal structure and cography of the reticular formation in the brain and spinal cord of carnivore. *J Comp Neurol* 121:347–379
8. Zahm DS (2006) The evolving theory of basal forebrain functional-anatomical ‘macrosystems’. *Neurosci Biobehav Rev* 30:148–72
9. Nauta WJH, Feirtag M (1979) The organization of the brain. *Sci Am* 241:88–111
10. Olszewski J, Baxter D (1954) *Cytoarchitecture of the human brain stem*. Karger, Basel

## Reticulospinal Cells (Neurons)

### Definition

Neurons located within the reticular formation with an axonal projection to the spinal cord. Reticulospinal cells project to different levels of the spinal cord, some activating exclusively the most rostral segments whereas others activate the caudal ones.

## Reticulospinal Long-Lead Burst Neurons

CHARLES SCUDDER  
Portland, OR, USA

### Definition

Reticulospinal neurons, in general, are neurons that have their somata in the mesencephalic, pontine, or medullary reticular formation and have axons that project at least as far as the upper-most spinal cord. Reticulospinal ►[long-lead burst neurons](#) (RS-LLBNs) (►[burst cells – long lead \(LLBNs\)](#)) are reticulospinal neurons that discharge before and during ►[gaze saccades](#) in a preferred direction that depends on the particular cell. Like other reticulospinal neurons, RS-LLBNs integrate input from

multiple sources and project to multiple targets. In the case of RS-LLBNs, the purpose is to generate coordinated eye, head, and sometimes trunk movements.

## Characteristics

### Higher-Order Processes

RS-LLBNs are part of a system of descending pathways that mediate orienting toward areas or objects of interest. The stereotypical ▶**orienting response** depends on the species. Macaque monkeys move only their eyes if the target of interest is near the current direction of gaze, but will make a combined eye and head ▶**gaze movement** for targets further away. Cats preferentially move the eyes and head together, and typically also redirect their pinnae and maybe their trunk. Rodents do all of the above with greater movement of the trunk. Human orienting is more flexible, but usually includes combined eye and head movements. The descending system that mediates this behavior includes the reticulospinal pathway, the tectospinal pathway, the corticospinal pathway, as well as less direct pathways.

The command to execute an orienting movement originates in cerebral cortex and involves many of the same structures as saccade generation. The ▶**lateral intraparietal cortex (LIP)**, the ▶**supplementary eye fields (SEF)**, and the ▶**frontal eye fields (FEF)**, which are themselves interconnected, project to the deep and intermediate layers of the ▶**superior colliculus** as well as to other brainstem locations. Signals for these cortical areas, as well as those from subcortical areas, are integrated in the superior colliculus, and the colliculus issues the principal command to move the eye, head, etc. This command is conveyed to the brainstem, including the ▶**saccadic burst generator** and reticulospinal neurons, and directly to the spinal cord. In cats, this “tectospinal” pathway is strong and consists of well studied ▶**tecto-reticulo-spinal neurons (TRSNs)**. In primates, the tectospinal pathway is weak and probably includes neurons that differ from the cat TRSNs. This means that primates rely heavily on reticulospinal pathways to orient.

The superior collicular projection to the brainstem provides the principal input to the RS-LLBNs and a smaller input to other reticulospinal neurons. Efferents from cerebral cortex provide additional input to RS-LLBNs, but not as much as to other reticulospinal neurons [1]. Cortical inputs arise from motor cortex and possibly premotor cortex. Another input to reticulospinal neurons, including RS-LLBNs, is from the ▶**fastigial nucleus** of the midline cerebellum. The fastigial nucleus, in turn, receives indirect input from the superior colliculus, the FEF, the SEF, and motor cortex, and represents another pathway by which these cortical structures can influence RS-LLBNs. In fact, orienting movements in cats and monkeys are severely disrupted by chemical inactivation of the fastigial nucleus. Many reticulospinal neurons that receive input

from the superior colliculus also receive input from the vestibular system [2], although the relevance for RS-LLBNs is controversial. Caudal reticulospinal neurons receive input from collaterals of more rostral reticulospinal neurons [1,3–5].

### Parts of the RS-LLBN System

RS-LLBNs as well as other reticulospinal neurons are found in the medullary ▶**nucleus reticularis gigantocellularis (NRG)**, pontomedullary ▶**nucleus reticularis pontis caudalis (NRPc)**, and in the mesencephalic reticular formation in and near the ▶**interstitial nucleus of Cajal (INC)** and the H-fields of Forel (called the ▶**riMLF** in the monkey). Neurons have different properties in different areas, and in different species according to current incomplete data. In general, neurons in NRPc and dorsal NRG have horizontal preferred directions and appear to innervate horizontal eye and head movers, while those in ventral NRG and in the midbrain have vertical preferred directions and appear to innervate vertical eye and head movers. Behaviorally identified RS-LLBNs have mainly been studied using intra-axonal recording and subsequent injection with horseradish peroxidase.

### Cats

The best studied RS-LLBNs are “eye-neck neurons,” which have their somata in the NRPc rostral and/or ventral to the abducens nucleus [3]. Collaterals of the descending axon arborize in the abducens nucleus, the prepositus nucleus, the medial vestibular nucleus (all related to horizontal eye movements), the facial nucleus (mediating pinna movement), the dorsal NRG and the nucleus reticularis ventralis (containing reticulospinal neurons), and paramedian cell groups projecting to the cerebellum (Fig. 1) [3].

During attempted gaze shifts in head-fixed cats having electromyographic (EMG) electrodes implanted in the neck muscles, a typical eye-neck neuron exhibits a burst of spikes that begins 66–132 ms before the saccade (hence the long-lead designation), peaks during the saccade, and slowly decays to an end after saccade end but roughly coinciding with the end of the phasic component of neck EMG activity [6]. Eye-neck neurons also have a moderate firing rate during sustained EMG activity when the head is held eccentrically. Phasic and sustained activity increases with increasing eye movement towards the ▶**ipsiversive** side and with increasing EMG activity in the ipsilateral neck muscles, but is not perfectly correlated with either alone. These discharges and the axonal arborization of these neurons both suggest a role in the coordinated activation of eye and neck muscles.

A second group of more caudally located RS-LLBNs has similar discharges but with very little sustained activity when the head is stationary [4]. Somata are

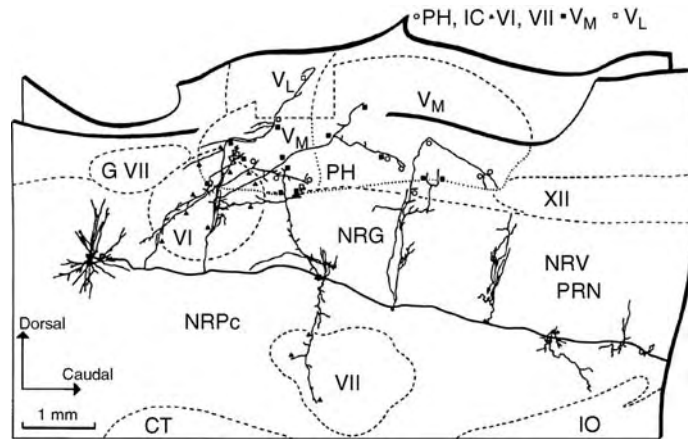

**Reticulospinal Long-Lead Burst Neurons. Figure 1** Camera lucida drawing of part of a cat reticulospinal neuron drawn in a parasagittal plane. The large soma is located in the PPRF just rostral to the abducens nucleus (VI), and the descending axon gives off branches that terminate in the abducens and facial motor nuclei (VI and VII), nucleus prepositus hypoglossi (PH), nucleus intercalatus (IC), the medial and lateral vestibular nuclei ( $V_M$  and  $V_L$ ), the nucleus reticularis gigantocellularis (NRG), and the nucleus reticularis ventralis (NRV). Symbols show where the branches left the plane of section, and are coded according to where the branches terminated (see Key). Other abbreviations; G VII = genu of the VIIth nerve, NRPC = nucleus reticularis pontis caudalis, PRN = paramedian reticular nucleus, XII = hypoglossal nucleus, IO = inferior olive, CT = corticospinal tract. Adapted from Grantyn et al. [3].

mostly located caudal to the abducens nucleus, but one was located rostral to the abducens. The axons do not collateralize to innervate any cranial motor nuclei, but rather innervate the paramedian reticular nucleus, interstitial cell groups in the MLF (which both project to the cerebellum), and nucleus reticularis ventralis. Preferred directions could have large vertical components, and one neuron had a contralateral preferred direction and an axon that descended in and innervated the contralateral medulla and spinal cord. The lack of projections to oculomotor structures, the projection to the spinal cord, and the phasic burst all imply these neurons function as head burst-neurons.

A third group of RS-LLBNs have their somata in the H-fields of Forel – the cat counterpart of the monkey **▶rostral interstitial nucleus of the MLF**. Called “augmenting neurons” by some, these neurons have a long build up beginning about 200 ms before upward gaze movements. The burst lasts about as long as the head movement in head-free alert cats and has a peak rate that is proportional to head velocity [7]. They also have a low-rate spontaneous discharge that is independent of eye position, and thus are only borderline LLBNs. Projections of augmenting neurons were studied electrophysiologically. Besides projecting to the spinal cord, augmenting neurons project to the midbrain cuneiform nucleus (containing saccade-related neurons) [8] and strongly to reticulospinal neurons both rostral and caudal to the abducens nucleus (NRPC and NRG) [5]. There are more typical LLBNs located at the caudal border of the H fields, but they do not have projections to the spinal cord.

### Monkey

Very little research has been devoted to reticulospinal neurons in monkeys. LLBNs have been recorded in NRPC that fire throughout the duration of the head movement in gaze saccades, but their potential spinal projections were not explored. Two groups of confirmed RS-LLBNs have been found in head-stabilized monkeys, but there are surely more than this.

Two RS-LLBNs with their somata in NRPC anterior and ventral to the abducens nucleus had preferred directions that were ipsiversive for one and down for the other [9]. Burst leads averaged 17 and 42 ms, and the number of spikes in the burst increased weakly with saccade size. As the monkeys had their heads stabilized, burst parameters could not be analyzed in relation to head movements. Axons traveled outside the paramedian tracts on their way to the spinal cord, and issued collaterals that innervated NRG, the middle of the prepositus nucleus, the paramedian reticular nuclei (both of which project to the cerebellum), and to the nucleus reticularis ventralis (Fig. 2). With the exception of the soma locations, these RS-LLBNs are similar to the head burst-neurons in the cat (group 2, above).

Three RS-LLBNs had their somata just lateral to the interstitial nucleus of Cajal [10]. All discharged preferentially for upward saccades beginning 25–105 before saccade onset, and the number of spikes increased with increasing saccade amplitude. The axons descended in the MLF and issued no collaterals until the caudal pons. They subsequently innervated raphe pontis, raphe obscurus, and the paramedian reticular nucleus, all of which project to the cerebellum, including oculomotor-related areas

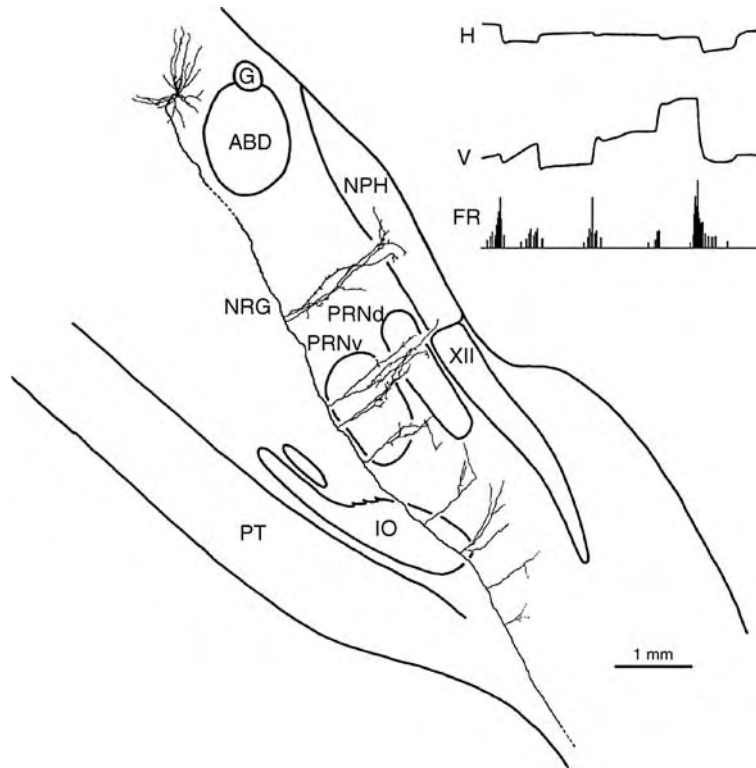

**Reticulospinal Long-Lead Burst Neurons. Figure 2** Camera lucida drawing of a monkey reticulospinal neuron drawn in a parasagittal plane. The large soma is located in the PPRF just rostral to the abducens nucleus (ABD), and the descending axon gives off dorsally-coursing branches that terminate in the medullary reticular formation, the nucleus prepositus hypoglossi (NPH), and the dorsal and ventral paramedian reticular nucleus (PRNd and PRNv). Staining faded as the main axon entered the spinal cord (dotted line). Inset shows the firing rate (FR) of the neuron during saccades, shown as a horizontal component (H) and vertical component (V). Other abbreviations; G = genu of the VIIth nerve, NRG = nucleus reticularis gigantocellularis, XII = hypoglossal nucleus, IO = inferior olive, PT = pyramidal tract. Adapted from Scudder et al. [9].

in the first two cases. Axons additionally innervated ►**raphe interpositus** and the dorsal NRG, both containing neurons that are part of the saccadic burst generator, and more ventral parts of NRG containing reticulospinal neurons.

Both types of RS-LLBNs have heavy projections to the cerebellum via relay nuclei. These projections are perhaps especially appropriate in the monkey relative to the cat because primates are credited with more flexible eye-head strategies, and could rely on the cerebellum to insure the different combinations of eye and head movements end with gaze directed at the target.

### Lower level Processes

The innervation of the spinal cord has been studied in detail for cat reticulospinal neurons, but not for RS-LLBNs specifically. This is because staining of the intra-axonally filled RS-LLBNs described above always faded before reaching their terminations in the cord. Doubtlessly, RS-LLBNs share some features of the more general

innervation. Reticulospinal neurons with somata in NRPC and NRG and receiving input from the superior colliculus project to upper cervical segments, including interneuron and motoneuron pools for the neck (Rexed laminae VII, VIII, IX). Motoneurons that are monosynaptically contacted by these reticulospinal neurons include those innervating the multisegmental dorsal muscles, splenius (a horizontal neck rotator) and biventer cervicis and complexus (a vertical neck rotator). Individual neurons in NRG innervate either splenius or biventer/complexus, but poorly innervate the other. Some NRPC and NRG reticulospinal neurons project to interneurons in the lower cervical segments (innervating forelimbs) and possibly lumbar segments (innervating hindlimbs). Activity in fore- and hind-limb muscles has been observed during orienting movements, but these could be a postural reaction as much as a direct product of orienting behavior. Reticulospinal neurons with somata in the H fields and receiving input from the superior colliculus make monosynaptic connections with biventer cervicis and

complexus motoneurons, but few with splenius, confirming the specificity of the H fields for vertical movements [1,5].

### Pathology

Excitotoxic destruction of the somata of neurons in the cat NRPC and NRG on one side produced severe to moderate deficits in producing ipsiversive gaze saccades, depending on the extent of the lesion. Vertical gaze saccades were also impaired when the head was oriented to the ipsilesional side. The loss of eye-saccades is presumably due to the destruction of the cells of the ►brainstem burst generator, and the loss of head-saccades is presumably due to destruction of the RS-LLBNs. ►Excitotoxic lesions of the H-fields in cats produced debilitating asymmetries in neck muscle tone when done unilaterally, and major deficits in vertical head saccades when done bilaterally. Lesions in humans produced by tumors or infarcts would likely result in more severe deficits due to the destruction of the many fibers of passage as well as destruction of reticulospinal neurons.

### References

1. Isa T, Sasaki S (2002) Brainstem control of head movements during orienting; organization of the premotor circuits. *Prog Neurobiol* 66:205–241
2. Peterson BW, Fukushima K (1982) The reticulospinal mechanism and its role in generating vestibular and visuomotor reflexes. In: Sjolund B, Bjorklund A (eds) *Brain stem control of spinal mechanisms*. Elsevier, New York, pp 225–251
3. Grantyn AA, Ong-Meang Jacques V, Berthoz A (1987) Reticulo-spinal neurons participating in the control of synergic eye and head movements during orienting in the cat II. Morphological properties as revealed by intraxonal injections of horseradish peroxidase. *Exp Brain Res* 66:355–377
4. Grantyn AA, Hardy O, Olivier E, Gourdon A (1992) Relationships between task-related discharge patterns and axon morphology of brainstem projection neurons involved in orienting eye and head movements. In: Shimazu H, Shinoda Y (eds) *Vestibular and brain stem control of eye, head, and body movements*. Karger, New York, pp 255–273
5. Isa T, Sasaki S (1992) Mono- and disynaptic pathways from Forel's field H to dorsal neck motoneurons in the cat. *Exp Brain Res* 88:580–593
6. Grantyn AA, Berthoz A (1987) Reticulo-spinal neurons participating in the control of synergic eye and head movements during orienting in the cat I. Behavioral properties. *Exp Brain Res* 66:339–354
7. Isa T, Naito K (1994) Activity of neurons in Forel's field H during orienting head movements in alert head-free cats. *Exp Brain Res* 100:187–199
8. Isa T, Itouji T (1992) Axonal trajectories of single Forel's field H neurones in the mesencephalon, pons and medulla oblongata in the cat. *Exp Brain Res* 89:484–495
9. Scudder CA, Moschovakis AK, Karabelas AB, Highstein SM (1996) Anatomy and physiology of saccadic long-lead burst neurons recorded in the alert squirrel monkey. II. Pontine neurons. *J Neurophysiol* 76:353–370
10. Scudder CA, Moschovakis AK, Karabelas AB, Highstein SM (1996) Anatomy and physiology of saccadic long-lead burst neurons recorded in the alert squirrel monkey. I. Descending projections from the mesencephalon. *J Neurophysiol* 76:332–352

## Reticulospinal Neurons in Eye Movements

### Definition

Neurons of the brainstem reticular formation that project to the spinal cord. Anatomical studies have demonstrated that, on their way to the spinal premotor centers, axons of reticulospinal neurons (RSNs) emit numerous collaterals to various oculomotor and vestibular centers.

Together with some superior colliculus (SC) output neurons showing a similar pattern of projections, those RSNs that receive input from the SC are thus ideally positioned to decompose the collicular “desired gaze displacement” signal into motor commands for the eye and head platforms.

- Eye-Head Coordination
- Superior Colliculus

## Reticulospinal Tract

### Synonyms

Tractus reticulospinal ant; Anterior reticulospinal tract

### Definition

The medial reticulospinal tract begins in the caudal pontine reticular nucleus and in the caudal portion of the oral pontine reticular nucleus. It descends in the medial longitudinal fasciculus in the spinal cord. Its fibers terminate mostly in lamina VII and VIII of the spinal gray matter; but they also run in lamina IX in which the motoneurons for the trunk musculature lie.

- Pathways

## Reticulotectal Long-Lead Burst Neurons

ADONIS MOSCHOVAKIS

Institute of Applied and Computational Mathematics, and Department of Basic Sciences, University of Crete, Heraklion, Crete, Greece

### Synonyms

RTLLBs

### Definition

Saccade related long-lead burst neurons of the primate mesencephalic reticular formation (►cMRF) that project to the SC.

### Characteristics

#### Higher Order Structure

Although they belong to the reticular formation, due to their location and projections RTLLBs can be thought to belong to a satellite system of the SC.

#### Parts of This Structure

Figure 1 illustrates the salient morphological and physiological features of RTLLBs following the intracellular study of their discharge in alert squirrel monkeys, their subsequent injection with a tracer and the camera lucida reconstruction of their axons in the frontal plane [1]. RTLLB somata (Fig. 1b, arrow) are located in an area receiving strong input from saccade related neurons of the SC (see TLLBs). The territory occupied by RTLLB somata probably receive input from additional classes of SC neurons, as indicated by axonal reconstructions of single X neurons of the cat [2,3] and the monkey [4,1]. The axonal terminations of RTLLBs are contained within the intermediate and deeper layers of the SC, in both sides of the brain (Fig. 1b).

#### Functions of the Structure

RTLLBs emit bursts of discharge which precede contraversive saccades, whether upward, downward or horizontal (Fig. 1a) by about 20 ms on average. They often do not discharge for saccades in the opposite direction (Fig. 1a, right-most example). Although the on-direction of many RTLLBs is roughly horizontal, the existence of RTLLBs with vertical and oblique on-directions has been documented [1]. The activity of RTLLBs provides a good estimate of the metrics of impending saccades; the correlation coefficient between the number of spikes in the burst, and the amplitude of saccades in their on-direction can be as high as 0.85.

### Higher Order Function

RTLLBs could belong to a highly conserved satellite system of the SC as cells with quite similar morphology have been encountered in lower phyla. Neurons with bilateral projections largely confined to the optic tectum have been found in the nucleus lateralis profundus mesencephali of the snake [5] and the dorsolateral tegmental nucleus in fish [6]. Also, saccade related signals were discovered in the intertectal commissure of fish [7] before the existence of saccade related signals in the superior colliculus of mammals became known. Given their discharge pattern and projections, RTLLBs are eminently qualified to supply the SC with an efference copy signal

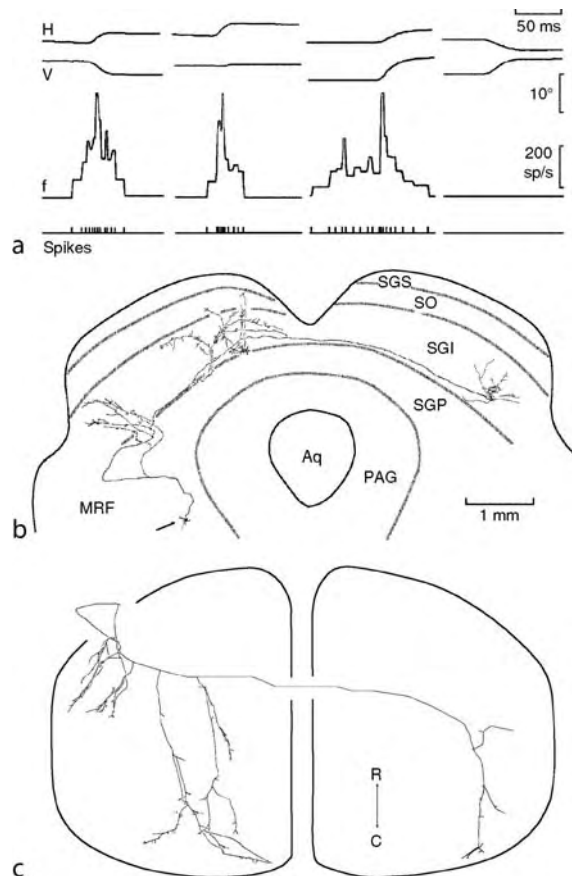

### Reticulotectal Long-Lead Burst Neurons.

**Figure 1** Salient morphological and physiological features of RTLLBs (reprinted from [1], with permission). (a) Saccade related discharge pattern for one RTLLB. (b) Frontal reconstruction of the axonal system of the same neuron from serial sections. (c) The axonal system of the same neuron as it appears when looking down upon the surface of the SC. Scale in (b) applies to both (b) and (c). Abbreviations: Aq, aqueduct; C, caudal; MRF, mesencephalic reticular formation; PAG, periaqueductal grey; R, rostral; SGI, stratum griseum intermediale; SGP, stratum griseum profundum; SGS, stratum griseum superficiale; SO, stratum opticum.



indicative of the metrics of ongoing saccades. Together with the visual input carried by L neurons (see ►[SC – interlayer neurons](#)) RTLLBs endow the SC with the machinery needed to implement the Vector Subtraction hypothesis (see ►[Foveation hypothesis](#)).

### Quantitative Measure for This Structure

Besides detailed quantitative descriptions of the pattern of their discharge, the 3D spatial distribution of the terminals deployed in the SC by single functionally identified RTLLBs has been described in squirrel monkeys [8]. When overlaid on a horizontal map of the SC, they can occupy a considerable portion of the rostrocaudal and mediolateral extent of its deeper layers (Fig. 1c).

## References

1. Moschovakis AK, Karabelas AB, Highstein SM (1988) Structure-function relationships in the primate superior colliculus. II. Morphological identity of presaccadic neurons. *J Neurophysiol* 60:263
2. Grantyn A, Grantyn R (1982) Axonal patterns and sites of termination of cat superior colliculus neurons projecting to the tecto-bulbo-spinal tract. *Exp Brain Res* 46:243
3. Moschovakis AK, Karabelas AB (1985) Observations on the somatodendritic morphology and axonal trajectory of intracellularly HRP-labeled efferent neurons located in the deeper layers of the superior colliculus of the cat. *J Comp Neurol* 239:276
4. Moschovakis AK, Karabelas AB, Highstein SM (1988) Structure-function relationships in the primate superior colliculus. I. Morphological classification of efferent neurons. *J Neurophysiol* 60:232
5. Dacey DM, Ulinski PS (1986) Optic tectum of the eastern garter snake, *Thamnophis sirtalis*. V. Morphology of brainstem afferents and general discussion. *J Comp Neurol* 245:423
6. Niida A, Ohono T (1984) An extensive projection of fish dorsolateral tegmental cells to the optic tectum revealed by intra-axonal dye marking. *Neurosci Lett* 48:261
7. Johnstone JR, Mark RF (1969) Evidence for efference copy for eye movements in fish. *Comp Biochem Physiol* 30:931
8. Bozis A, Moschovakis AK (1998) Neural network simulations of the primate oculomotor system. III. A one-dimensional one-directional model of the superior colliculus. *Biol Cybern* 79:215

## Retina

### Definition

The light-sensitive layered neural tissue that lines the posterior hemisphere of the eye and contains the photoreceptors (rods and cones) and the initial processing machinery for the primary visual pathways. It is a

highly organized structure whose function is to capture, process, and transmit visual images to the brain. The signals generated by photoreceptors are then processed by other neurons in the retina before being transmitted to the brain as trains of action potentials by the axons of the retinal ganglion cells. Additionally, the retina serves to detect changes in ambient levels of light to regulate a multitude of non-visual photoresponses such as the pupillary light reflex.

- [Pupillary Light Reflex](#)
- [Photoreceptors](#)
- [Retinal Ganglion Cells](#)
- [Vision](#)

## Retinal Bipolar Cells

ULRIKE GRÜNERT<sup>1,2</sup>

<sup>1</sup>The National Vision Research Institute of Australia

<sup>2</sup>Department of Optometry & Vision Sciences, The University of Melbourne, Australia

### Synonyms

Retinal bipolar neurons

### Definition

Bipolar cells are interneurons in the ►[retina](#) (►[Vision](#)), which transfer visual information from photoreceptors (rods and cones; ►[Photoreceptors](#)) to amacrine (►[Retinal direction selectivity: Role of starburst amacrine cells](#)) and ganglion cells (►[Retinal ganglion cells](#)). Bipolar cells consist of multiple (9–12) subtypes that differ in their morphology, synaptic connectivity, and response properties. Different types of bipolar cells process different visual modalities in parallel pathways. The following article describes the structure, distribution, synaptic connectivity, and function of bipolar cells in the mammalian retina.

### Characteristics

#### Quantitative Description

##### Morphology of Bipolar Cells

The name “bipolar cell” is derived from its morphology. Bipolar cells have a cell body in the ►[inner nuclear layer](#) from which a primary dendrite extends into the ►[outer plexiform layer](#) and an axon extends into the ►[inner plexiform layer](#) (►[Vision](#)). Morphologically two major types, cone bipolar and rod bipolar cells, can be distinguished with respect to their connections with photoreceptors (►[Photoreceptors](#)). The dendrites of cone bipolar cells contact cone photoreceptors almost

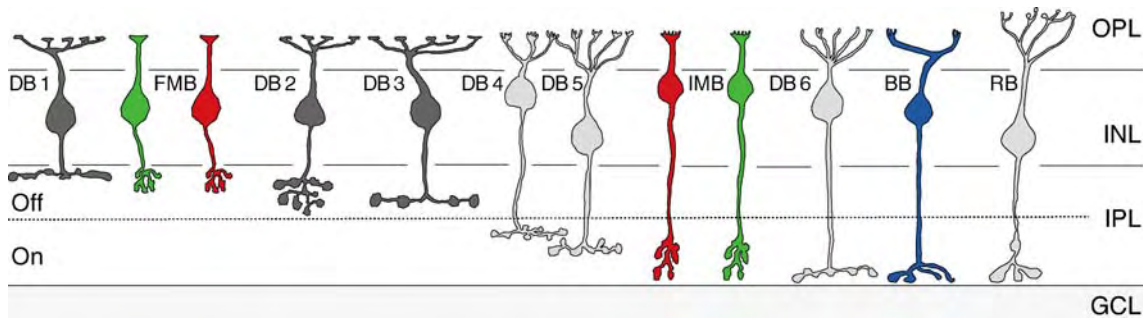

**Retinal Bipolar Cells. Figure 1** Bipolar cell types in primate retina as analysed from Golgi-impregnated macaque retina. The axon terminals stratify at different levels of the inner plexiform layer (IPL). Diffuse bipolar cells (DB1 – DB6) non-selectively contact multiple cones in the outer plexiform layer (OPL). There are two types of midget bipolars, flat midget bipolar (FMB or OFF midget) and invaginating bipolar cells (IMB or ON midget). Both types contact single M- or L-cones and carry a chromatic signal. Blue cone bipolar (BB) cells contact S-cones selectively and carry an S-cone ON signal. Rod bipolar cells contact rod spherules and transfer scotopic signals.

exclusively and are thus involved in high-acuity daytime vision and colour vision (►Color processing). The dendrites of rod bipolar cells contact rod photoreceptors and are involved in night or ►scotopic vision.

Bipolar cells make up about 40% of all retinal neurons (apart from photoreceptors) and are the most numerous interneurons in the retina [1]. Each bipolar type is found across the retina and forms a regular mosaic.

#### Diffuse Bipolar Cells

Cone bipolar cells are subdivided into OFF and ON bipolar cells [2]. The OFF bipolar cells hyperpolarise in response to light, whereas the ON bipolar cells depolarise. The axons of OFF bipolar cells stratify in the *outer* half of the inner plexiform layer. The axons of ON bipolar cells stratify in the *inner* half of the inner plexiform layer.

The OFF and ON cone bipolar types are further subdivided into at least nine subtypes with respect to their stratification in the inner plexiform layer and their connections with cones (Fig. 1) [1–6].

Most cone bipolar types contact five to ten cones, and have thus been named *diffuse bipolar* (DB) cells [3]. Some of these subtypes can be selectively labelled with immunohistochemical methods. An example of an immunohistochemically labelled ON bipolar type (DB6) from macaque retina is shown in Fig. 2.

Figure 3 shows the mosaic formed by DB6 cells in whole mount view. The fine dendrites form a dense meshwork across the outer plexiform layer. The somata are located in the outer half of the inner nuclear layer, and the axons tile the retina in a regular mosaic.

In recent years, a number of studies have estimated the density of bipolar cell types using a variety of methods including electron microscopy, Golgi-impregnation, immunohistochemistry, intracellular injection and photo-filling [3–5]. The major conclusions from these quantitative studies are that all types have comparable densities

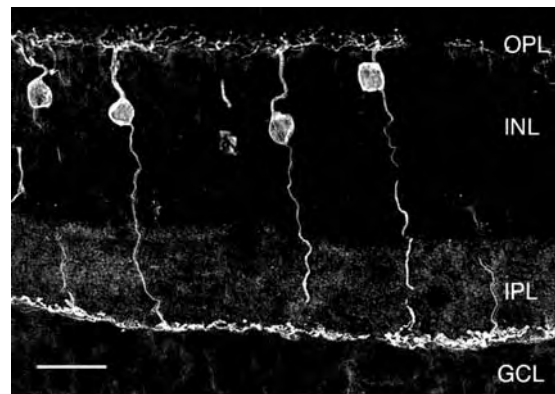

**Retinal Bipolar Cells. Figure 2** Diffuse bipolar cells in primate retina. DB6 cells (Fig. 1) are immunohistochemically labelled. Scale bar: 25  $\mu$ m.

ranging between 1,000 and 3,000 cells/mm<sup>2</sup>, and thus no type of bipolar cell usually predominates. The only exception to this rule is the midget bipolar cell in primate fovea (see below). The density of cone bipolar cells is usually lower than the cone density. However, since most bipolar cell types contact multiple cones, it is assumed that all cones provide input to all types of cone bipolar cells [1,3,6].

#### Bipolar Cell Types Involved with Colour Vision

Most mammals possess two types of cones, one that is maximally sensitive to short wavelengths of the visible spectrum (S or blue cone), and one that is maximally sensitive to long wavelengths [7]. Mammals with two cone types have dichromatic colour vision. Trichromatic colour vision is based on the presence of a third cone type that is maximally sensitive to medium wavelengths. Among placental mammals, trichromatic colour vision has only been described in primates (►Color processing) [7].

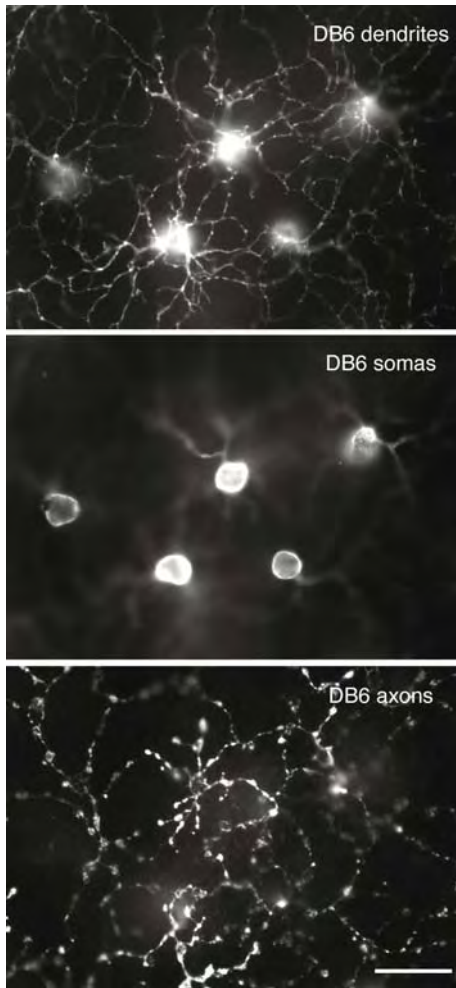

**Retinal Bipolar Cells. Figure 3** Diffuse bipolar cells in primate retina. Whole mount view of immunohistochemically labelled DB6 cells. The cells are shown at different focal levels. Scale bar: 20  $\mu\text{m}$ .

Three types of cone bipolar cells are involved with colour vision: blue cone bipolar cells, and two types of midget bipolar cells. The blue cone bipolar cells (BB, Fig. 1) are ON cells and receive input exclusively from S-cones. The axons of blue cone bipolar cells stratify close to the ganglion cell layer where they provide output to a special type of ganglion cell, the blue ON/yellow OFF ganglion cell [1,3,4,6,8].

Each blue cone bipolar cell receives input from between one and five S-cones (convergence), and each S cone contacts between one and five blue cone bipolar cells (divergence). The maximal density of blue cone bipolar cells is approximately 800 cells/mm<sup>2</sup>, thus they are among the least numerous bipolar types in the retina.

In mammals, midget bipolar cells [1,3,4,6,9] are probably unique to primate retina where they are thought to play a role in trichromatic colour vision. Midget bipolar cells can be subdivided into ON and

OFF types. The ON midget bipolar dendrites make ▶*invaginating synapses* with cones, and have thus been named invaginating midget bipolar (IMB, Figure 1) cells. The OFF midget bipolar dendrites make flat synapses with cones, and are thus called flat midget bipolar (FMB, Fig. 1) cells. In the central retina, each midget bipolar cell receives input from a single cone and in turn contacts one ON or one OFF midget (parvocellular projecting) ganglion cell. Thus, each midget bipolar cell carries the chromatic signal of the cone type it contacts to the inner plexiform layer.

In central retina, midget bipolar cells are the most numerous cone bipolar type. The density of FMB cells was estimated in macaque retina. In central retina, their density follows the cone density (> 10,000 cells/mm<sup>2</sup>). In peripheral retina, FMB cells contact more than one cone, and thus their density (< 5000 cells/mm<sup>2</sup>) drops below the cone density [9].

### Rod Bipolar Cells

In all mammalian retinæ only one type of rod bipolar cell studied to date has been described (RB, Fig. 1). Each rod bipolar cell contacts between ~20 and 100 rod ▶*spherules* (▶*Retinal ribbon synapses*) in the outer plexiform layer. Rod bipolar cells are depolarised by light, and thus are ON cells [2]. The axon terminals of rod bipolar cells are located at the border of the inner plexiform layer with the ganglion cell layer. The axon terminals of rod bipolar cells tile the retina in a non-overlapping mosaic (Fig. 4).

Rod bipolar axons provide output to AII amacrine cells, which then feed the rod signal into cone pathways [2,5,6].

The density of rod bipolar cells varies depending on the retinal location and between species. For example, in cat retina the density ranges between ~20,000 and 46,000 cells/mm<sup>2</sup>, whereas in rabbit the density ranges between ~2,000 and 5,000 cells/mm<sup>2</sup>. In macaque retina, rod bipolar cells are absent from the fovea, and the maximal density is ~15,000 cells/mm<sup>2</sup> at about 1–3 mm distance from the fovea. Thus, the density of rod bipolar cells is higher than that of individual cone bipolar cell types, but cone bipolar cells outnumber rod bipolar cells in total [1].

The ratio between rods and rod bipolar cells (numerical convergence) varies between species. It is 10:1 in central macaque retina, 15:1 in the *area centralis* of cat retina, and 50:1 in rabbit retina. However, the divergence between rods and rod bipolar cells is relatively constant. For all species studied, and at all eccentricities, between one and four rod bipolar cells are postsynaptic to each rod.

### Description of the Structure

#### Synaptic Connectivity in the Outer Plexiform Layer

The synaptic terminal of a rod photoreceptor (rod spherule) is a relatively simple structure. It contains one or two synaptic ribbons (▶*Retinal ribbon synapses*),

which are presynaptic to usually two rod bipolar and two horizontal cell processes at a single synaptic invagination. The rod bipolar cell dendrites form the central elements at this synapse [5].

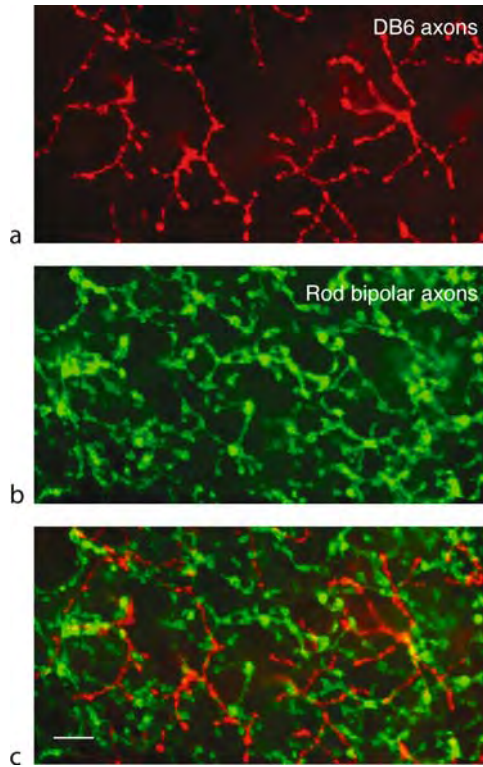

**Retinal Bipolar Cells. Figure 4** Whole mount view of the axonal terminals of two types of ON bipolar cells in primate retina (courtesy of Patricia Jusuf, NVRI, Melbourne). The two types of cell (rod bipolar and DB6) form separate mosaics but might share some postsynaptic cell types. Scale bar: 10  $\mu\text{m}$ .

The synaptic terminal of a cone photoreceptor (cone **pedicle**; **Retinal ribbon synapses**) is a much more complex synapse (Fig. 5a).

It comprises of between 20 and 50 invaginating and several hundred flat contacts. The invaginating contacts consist of a presynaptic ribbon, one or two central elements deriving from ON cone bipolar cells, and two lateral processes deriving from horizontal cells (triad). The **flat contacts** are located at the base of the cone pedicle and derive mostly from OFF bipolar cells. In total, each cone pedicle makes about 500 contacts. The number of postsynaptic cells is lower as some cells receive multiple contacts. About 10–15 individual cone bipolar cells, comprising of a variety of different types, are postsynaptic to a cone pedicle [3]. Thus, at the cone pedicle, the first synapse in the retina, the light signal is distributed into multiple pathways [1,6,10].

Until recently, all invaginating bipolar processes were thought to belong to ON bipolar cells, whereas all flat contacts were thought to belong to OFF bipolar cells. However, in primate this rule applies strictly only to ON bipolar and OFF midget bipolar cells. Most OFF bipolar types make a mixture of both types of contact [3]. It is now known that it is the type of **glutamate** receptor expressed at bipolar dendrites that determines whether they are ON or OFF types.

In addition to the layers of invaginating and flat contacts, a third postsynaptic layer has been detected at a distance of about 1.5  $\mu\text{m}$  from the cone pedicle base. This layer consists of junctions that have the appearance of desmosomes (“desmosome-like junctions”) but do not contain any known protein normally present at junctions. Instead, these structures are postsynaptic densities that are located on horizontal cell processes and express ionotropic glutamate receptor subunits [10].

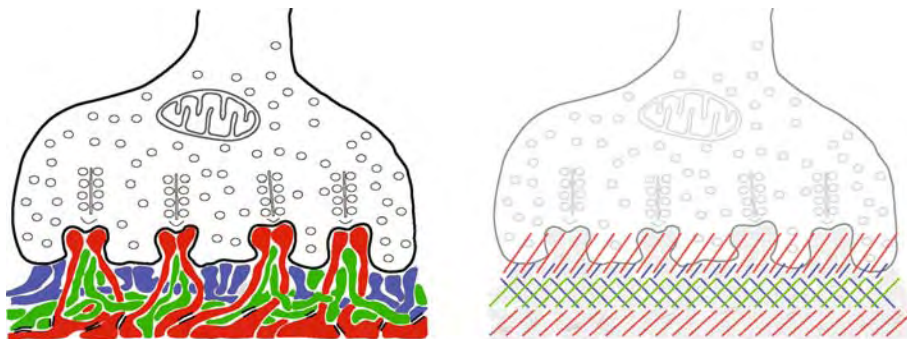

**Retinal Bipolar Cells. Figure 5** Schematic drawing of a cone pedicle in macaque monkey retina. (a) Four presynaptic ribbons and four triads are shown. Invaginating dendrites of horizontal cells (red) form the lateral elements, invaginating dendrites of ON bipolar cells (green) form the central elements of the triads. Flat contacts (blue) are mainly made by OFF bipolar cells. Desmosome-like junctions (black bars) are located at a distance of about 1.5  $\mu\text{m}$  underneath the pedicle. (b) The same pedicle with the laminated expression of postsynaptic glutamate (red and blue) and GABA receptors (blue and green) is shown.

### Glutamate and GABA Receptors in the Outer Plexiform Layer

The neurons postsynaptic to photoreceptors express different types of glutamate receptors [6]. The ON bipolar cells express sign inverting metabotropic glutamate receptors (mGluR6) that act via G-proteins. Horizontal cells and OFF bipolar cells express sign conserving ionotropic (▶AMPA,  $\alpha$ -amino-3-hydroxy-5-methyl-4-isoxazole propionic acid and ▶kainate) glutamate receptors.

The ▶neurotransmitter of horizontal cells is ▶GABA (gamma amino butyric acid). GABA<sub>A</sub> and GABA<sub>C</sub> receptors are consistently found on the dendrites of bipolar cells. The presence of different types of postsynaptic receptors on different processes at the cone pedicle base results in a laminated arrangement (Fig. 5b) [10].

### Connectivity of Bipolar Cells in the Inner Plexiform Layer

In the inner plexiform layer, bipolar axon terminals form ribbon synapses (▶Retinal ribbon synapses) onto two postsynaptic processes (▶dyads). Cone bipolar axons usually contact one amacrine and one ganglion cell process, whereas rod bipolar axons do not contact ganglion cells but form dyads onto two amacrine processes, one of which belongs to the ▶AII amacrine cell [2]. Different types of diffuse bipolar cells form different numbers of output synapses [5], but relatively little is known about the identity of their postsynaptic targets.

Bipolar axons make excitatory (sign-conserving) glutamatergic synapses. The two postsynaptic processes at a bipolar dyad usually express two different types of ionotropic glutamate receptors (AMPA, kainate and ▶NMDA) [6].

The synaptic input to bipolar cells in the inner plexiform layer derives from amacrine cells containing the inhibitory neurotransmitters GABA or ▶glycine. The axon terminals of different bipolar types vary with respect to the expression, subunit composition and frequency of GABA<sub>A</sub>, GABA<sub>C</sub> and glycine receptor clusters [1,6].

### Higher Level Structures

OFF bipolar cells transfer their signals to OFF ganglion cells, whereas ON bipolar cells contact ON ganglion cells (▶Retinal ganglion cells). The ganglion cells then transfer the bipolar signals to distinct regions in the brain. As bipolar axons stratify in distinct strata of the inner plexiform layer, they can only contact ganglion cells stratifying in the same stratum [1]. Some bipolar types provide input to only one type of ganglion cell (e.g., midget bipolar to midget ganglion cells in primate; CD15-OFF bipolar cells to ON-OFF direction-selective ganglion cells in rabbit (▶Retinal ganglion cells; ▶Retinal direction selectivity: Role of starburst amacrine cells) [4]. Some ganglion cell types receive input from

only one bipolar type (e.g., midget ganglion cells). Other bipolar cell types contact more than one type of ganglion cell, e.g., DB3 cells in primate retina presumably contact OFF parasol (▶magnocellular pathway) and the outer (OFF) tier of small bistratified cells (▶koniocellular pathway) [3]. Finally, several types of bipolar cells can provide input to the same type of ganglion cell, e.g., cat alpha and beta cells, primate parasol cells and direction-selective cells in rabbit retina (▶Retinal ganglion cells; ▶Retinal direction selectivity: Role of starburst amacrine cells) [1].

### Function

Different morphological types of diffuse bipolar cells play different functional roles [6]. Physiological differences could be based on the presence of different types of glutamate receptors on bipolar dendrites, as well as distinct patterns of inhibitory input from horizontal and amacrine cells. For example, the type b2 and b3 OFF bipolar cells in the ground squirrel stratify at different levels of the inner plexiform layer and express distinct types of ionotropic glutamate receptors in the outer plexiform layer. The b2 cells express AMPA receptors and are involved in the transmission of transient responses to light. The b3 cells express kainate receptors and are involved with sustained light response. Studies in tiger salamander showed that different types of bipolar cells, with axon terminals at different levels of the inner plexiform layer, differ with respect to their light response characteristics. The idea that parallel streams in the visual system first diverge at the level of the outer flexiform layer is thus supported in all retinas studied so far (▶Visual processing streams in primates). The question why the brain requires multiple afferent signals streams, and how these distinct streams are processed in the brain, remains a major challenge for visual neuroscience.

### References

1. Masland RH (2001) The fundamental plan of the retina. *Nat Neurosci* 4:877–886
2. Nelson R, Kolb H (2003) ON and OFF pathways in the vertebrate retina and visual system. In: Chalupa LM, Werner JS (eds) *The Visual Neurosciences*. The MIT Press, Cambridge, pp 260–278
3. Boycott B, Wässle H (1999) Parallel processing in the mammalian retina. *The Proctor lecture. Investig Ophthalmol Vis Sci* 40:1313–1327
4. Masland RH (2001) Neuronal diversity in the retina. *Curr Opin Neurobiol* 11:431–436
5. Sterling P (2003) How retinal circuits optimize the transfer of visual information. In: Chalupa LM, Werner JS (eds) *The Visual Neurosciences*. M.I.T. Press, Cambridge, pp 243–268
6. Wässle H (2004) Parallel processing in the mammalian retina. *Nat Rev Neurosci* 5:747–757
7. Jacobs GH (1993) The distribution and nature of colour vision among the mammals. *Biol Rev* 68:413–471

8. Dacey DM, Lee BB (1994) The 'blue-on' opponent pathway in primate retina originates from a distinct bistratified ganglion cell type. *Nature* 367:731–735
9. Wässle H, Grünert U, Martin PR, Boycott BB (1994) Immunocytochemical characterization and spatial distribution of midget bipolar cells in the macaque monkey retina. *Vis Res* 34:561–579
10. Haverkamp S, Grünert U, Wässle H (2000) The cone pedicle, a complex synapse in the retina. *Neuron* 27:85–95

## Retinal Color Vision in Primates

PAUL R. MARTIN

National Vision Research Institute of Australia,  
Carlton, VIC, Australia

### Synonyms

Color vision; Color processing

### Definition

#### Color Vision in the Retina

The eyes of nearly all animals contain multiple classes of cone photoreceptor (►Photoreceptors), and the ability to discriminate objects by their ►spectral reflectance (►Color processing) is an almost universal feature of animal visual systems studied so far. The neural processes that give rise to color sensations begin in the retina, where certain neurons show selectivity for

distinct regions of the visible spectrum. Color is not a property of objects or of retinal processes, but is a result of the brain's ability to interpret these neural signals. Humans and other primates normally show tri-variant (►trichromacy) color vision whereas most other mammals show more rudimentary (►dichromacy or "red-green color blind") color vision.

### Characteristics

#### Description of the Process

##### Encoding Spectral Signals

Most humans show trichromatic color vision. This means that the eye contains three distinct classes of cone photoreceptors that are sensitive to different wavelength ranges in the visible spectrum, and that differential activation of these photoreceptors can be analyzed by the brain to yield color sensations. The cone photoreceptors are active under ►photopic (daylight) conditions whereas ►scotopic (night) vision is served by a single class of rod photoreceptor and thus is color blind (►color blindness).

Figure 1 gives an overview of spectral signal processing in the primate retina. Objects in the environment (in this example, a fruit-bearing tree) reflect more or less strongly the incident ►photons in the visible spectrum (the visible range is approximately 400–700 nm in the electromagnetic spectrum). For example (Fig. 1), a ripe red fruit on the tree reflects more long-wavelength photons than a green leaf on the tree, but the leaf will reflect more medium-wavelength photons than the fruit does. The shapes of these reflectance curves are determined by the physical-

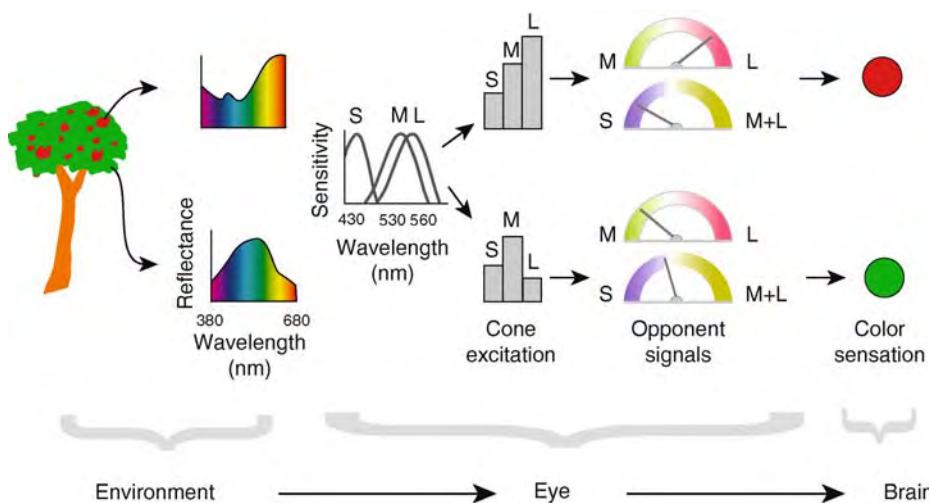

**Retinal Color Vision in Primates. Figure 1** First stages of color vision. From *left to right*: objects in the environment show different reflectance spectra (in this example, the *upper row* shows fruit and the *lower row* shows foliage). These spectra are integrated into three separate wavelength bands by the short (S), medium (M) and long-wavelength (L) sensitive cones. The cone excitations are transformed into two cone-opponent signals ( $M - L$ ) and ( $S - [M + L]$ ) for transmission to the brain. The brain interprets these signals to yield color sensations.

chemical properties of the objects, and the spectrum and intensity of the light that illuminates the objects. Thus, color is not a property of the objects *per se* but is a result of the brain's ability to interpret the spectral reflectance of an object, relative to the reflectance of other objects in the ►visual field. This is the most important fact to learn about color vision and is an essential prerequisite for understanding spectral processing in the retina.

The first stage of vision is the transduction of light by photoreceptors (►Phototransduction). Each cone photoreceptor expresses one of three types of proteins called cone ►opsins, which together with the vitamin A derivative 11-cis-retinal form the only light-dependent stage of vision. The amino acid sequence of the opsin “tunes” its spectral sensitivity towards the short (peak ~430 nm), medium (~530 nm) or long (~560 nm) wavelength regions of the spectrum [1]. In other words, the probability of photon absorption is maximal at one of three constant positions in the spectrum, yet each receptor absorbs photons across a wide band of the visible spectrum (Fig. 1). Because the absorption spectra are broad, wavelength is confounded with intensity in each receptor's response. For example, a bright light at 500 nm or a dim light at 430 nm could produce identical photon absorptions by the short-wavelength sensitive (S) cones. It is only by comparing the output of different receptor classes that specific information about wavelength can be recovered. The photoreceptor responses or “cone excitations” are thus shown as the relative heights of the bars in Fig. 1, because each receptor effectively ignores the wavelength of absorbed photons across its sensitivity range. In summary, the ripe fruit on the tree yields a red sensation because it activates long wavelength sensitive (L) cones more than it activates the medium- (M) and short wavelength-sensitive (S) cones, whereas a leaf on the tree appears green because it activates the M cones more than the L or S cones. The reflectance spectra of these objects are collapsed into this trivariant, or trichromatic, signal at the first stage of color vision.

### Neural Signals Underlying Color Sensations

How are the signals that enable color sensations transmitted to the brain? The retinal structures described in the following sections yield two main signals called “►cone opponent” signals (Fig. 1). This term conveys the idea that activity of one cone type is subtracted from or “opposes” the activity of another cone type. One opponent channel pits the activity of M against L cones, the other pits the activity of S cones against a combination of M and L cones. Distinct anatomical pathways in the retina form the substrate of these opponent channels. For simplicity these are often referred to as “red-green” and “blue-yellow” pathways in the retina, although the perceptual color axes do not correspond exactly to the cone-opponent axes. It is

also important to note that most retinal neurons respond to changes in either brightness (intensity) or color (relative spectral reflectance) of a stimulus, so do not form exclusive color-detecting channels [2] (►Color processing).

### Red-Green Pathways in the Retina

There is general agreement that the so-called “midget-parvocellular projecting” retinal pathway carries the M-L opponent signals which serve the red-green axis of color vision. This pathway forms the dominant output of the primate retina (it comprises ~80% of all ►optic nerve fibers), and carries signals serving high-acuity spatial vision in addition to signals for red-green color vision. The genes encoding M and L cone opsins diverged relatively recently in the evolutionary history of primates, yielding trichromatic color vision from the primordial dichromatic system thought to be common to most mammals [1,3]. The evolution of high-acuity spatial vision in primates may have enabled the more recent evolution of red-green color vision [4,5]. The idea is illustrated in Fig. 2. Figure 2a shows a schematic drawing of the primate eye, with the eye's output neurons (►Retinal ganglion cells) concentrated near the point of highest visual acuity (the ►fovea). The M and L cones are very tightly packed near the fovea to enable this high acuity, and each cone makes contact with two bipolar cells (►Retinal bipolar cells) of the midget-parvocellular pathway in addition to contacting other bipolar cells [6]. One of the midget bipolar cells responds to brightness decrements (off-type response) and the other responds to brightness increments (on-type response). These connections show one-to-one specificity (Fig. 2b), so the spatial acuity of the cone array can be preserved at subsequent processing stages. The spectral (M or L) signature of each cone in the array will likewise be preserved by this chain of excitatory synaptic connections, and yields four response signatures in midget-parvocellular cells: red-on, red-off, green-on and green-off. The red-green color signals thus are “piggybacked” on the system for high-acuity spatial signals.

The anatomical organization of the midget-parvocellular pathway in the peripheral retina is shown in Fig. 2c. Here, many of the midget bipolar cells make contact with two or more cones and will receive a mixed spectral signal if they contact cones of different type. The bipolar cells likewise make convergent connections with ganglion cells (Retinal ganglion cells) [2,7]. The spatial acuity and spectral purity of ganglion cell signals should thus decrease in the peripheral retina, and both spatial acuity and red-green color vision in the peripheral visual field are correspondingly poor [8].

How do the cone opponent properties of midget-parvocellular ganglion cells arise? Inhibitory interneurons (►horizontal cells and ►amacrine cells) are the most

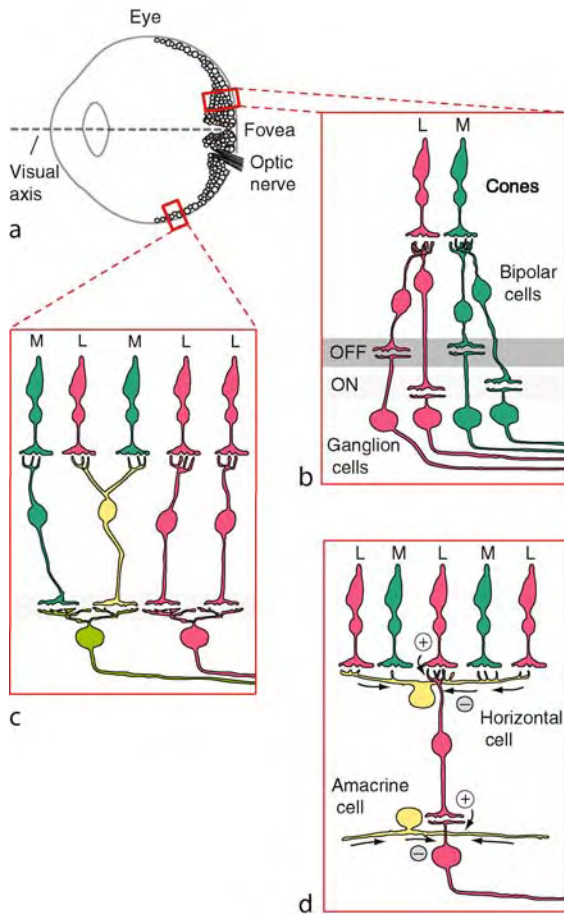

**Retinal Color Vision in Primates. Figure 2** Red-green chromatic pathways in the eye. (a) schematic cross section of the eye showing concentration of ganglion cells near the fovea (F) on the visual axis (dashed red line). Ganglion cell axons form the optic nerve. (b) connections of midget-parvocellular pathway neurons near the fovea. Each cone is contacted in a one-to-one fashion by both on-type and off-type midget bipolar cells. The bipolar cells in turn contact midget ganglion cells. (c) connections of midget-parvocellular pathway neurons in mid-peripheral retina. For simplicity, only on-type connections are shown. Some midget bipolar cells receive convergent input from multiple cones, and most ganglion cells receive convergent input from multiple bipolar cells. Both these convergent steps will degrade the spectral purity of the ganglion cell response. (d) organization of inhibitory inputs to midget-parvocellular pathway ganglion cells. Horizontal cells and amacrine cells make widespread connections and feed mixed spectral signals to ganglion cells.

likely source of the opponent cone signals (Fig. 2d). One subtype of horizontal cell in primate retina (the H1 subtype) collects signals from M and L cones and provides feedback inhibition to these cones as well as to

bipolar cells [2,7]. Anatomical connections of amacrine cells with midget-parvocellular ganglion cells are less well-understood, but as is the case with horizontal cells, amacrine cells should pool spatial signals originating in large numbers of M and L cones. Both these cell types thus provide a spectrally mixed inhibitory input to antagonize or “oppose” the spectrally pure (in the fovea) or biased (in the peripheral retina) excitatory inputs from midget bipolar cells.

There is functional (physiological) evidence that both excitatory and inhibitory inputs to parvocellular ganglion cells show greater spectral selectivity than predicted by the pure “random wiring” scheme outlined above, but to date there is no direct anatomical evidence for cone-selective connections in the midget-parvocellular pathway [2,7]. This functional selectivity likely arises from subtle changes in the strength of synaptic connections rather than specific wiring between specialized cell classes, of the type described below for the blue-yellow retinal pathway.

#### Blue-Yellow Pathways in the Retina

The short wavelength sensitive (S) cones form less than 10% of all cones in the primate retina (Fig. 3a). Molecular studies show that a distinct S cone pigment emerged before the mammalian radiation, and thus could form the basis for a primordial color vision system in mammals [1,5]. The main synaptic output of S cones in primates is to a single class of bipolar cell called the *blue cone bipolar cell*. These bipolar cells form a specific network contacting S cones (Fig. 3b) and transmit on-type signals (corresponding to increases in the photon catch of S cones) from the S cone array. The blue cone bipolar cells contact a specific class of ganglion cell called the small bistratified (blue-on) cell. The small bistratified cells get excitatory input from S cones and inhibitory input from M and L cones, to yield a “blue-on, yellow off” cone opponent response [9]. There are two sources of inhibition from M and L cones. First, the small bistratified cell receives synaptic input from off-type diffuse bipolar cells, which contact predominantly M and L cones. Second, the S cones and the blue-cone bipolar cells receive inhibitory input from the H2 subtype of horizontal cell, which gets synaptic input from all cone types. This spectrally mixed inhibitory input opposes the spectrally pure S cone input to blue cone bipolar cells [7]. The selective connections of S cones with blue cone bipolar cells and H2 horizontal cells are preserved across the primate retina, so the deterioration in blue-yellow chromatic sensitivity with increasing visual field eccentricity is not as marked as the deterioration in red-green sensitivity [8].

The question how off-type signals from S cones are transmitted to the brain has not been fully resolved. At least two types of sparsely-branched or “wide field”



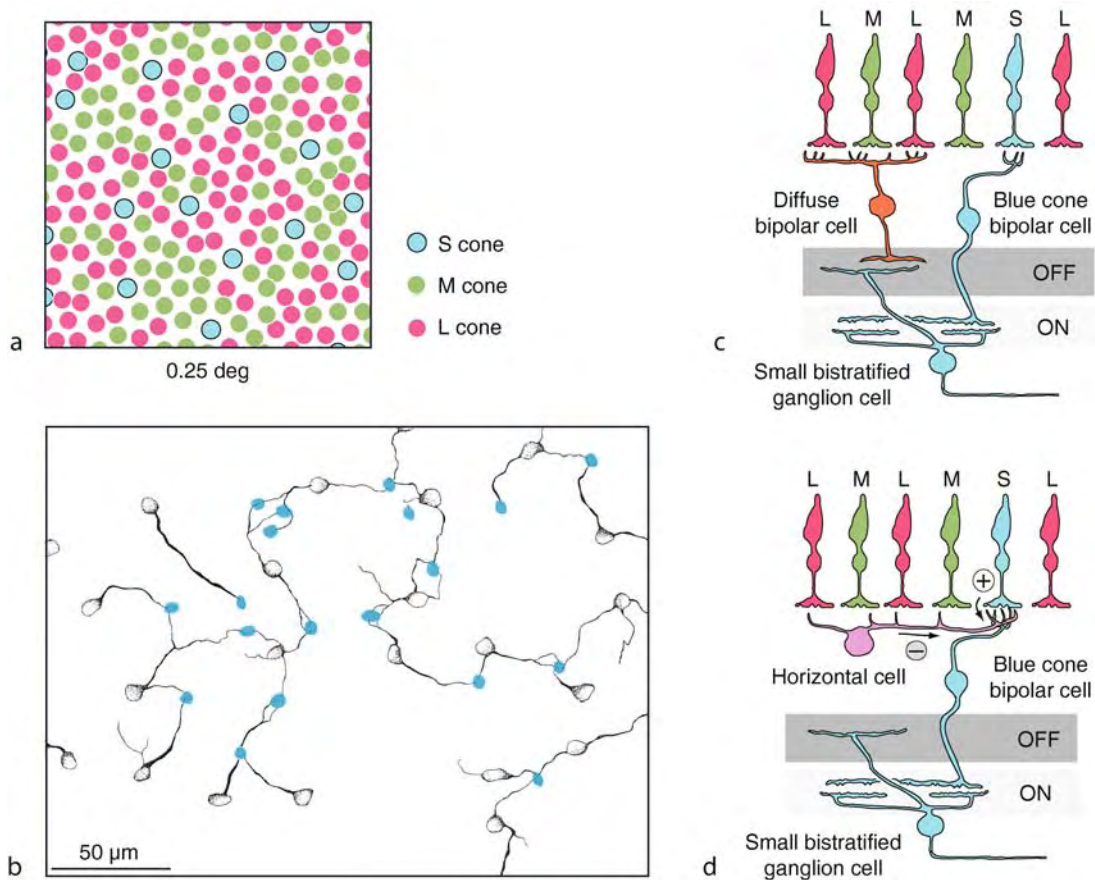

**Retinal Color Vision in Primates. Figure 3** Short-wavelength sensitive (S) cone pathway. (a) fragment of the cone photoreceptor mosaic in macaque retina [modified from ref. 15]. (b) connections of blue-cone bipolar cells (grey) with S cones (blue plaques) in marmoset retina [modified from ref. 16]. The dendrites of blue cone bipolar cells make dominant contact with S cones. (c) schematic vertical section through primate retina showing connections of a small bistratified (blue-on) ganglion cell with blue cone bipolar and diffuse bipolar cells. (d) a second source of cone opponent inputs to blue-on ganglion cells arises from inhibitory feedback by the H2 subclass of horizontal cell.

ganglion cells show blue-off type responses, and presumed targets of these cells in the brain show large receptive fields [7,10]. One of these cell types also shows intrinsic, melanopsin-based photosensitivity and may contribute to circadian entraining as well as to color vision [7,11]. Connections from S cones to off-type midget bipolar cells have been reported in macaque fovea, but S cones in marmoset retina make negligible connections to midget cells and only sparse connections with diffuse, off-type bipolar cells [6,12]. Whether these differences reflect true species differences or methodological differences is not yet clear.

In summary, there is clear evidence for a selective network transmitting on-type signals from S cones to the brain to yield a “primordial” dichromatic color vision channel. A specific network of S cone connections to bipolar cells has also been shown in mouse retina [13], and the question whether this or other

elements of S-cone circuits are common to other diurnal mammals has become an interesting topic in comparative neurology.

### Higher Level Processes

#### Central Targets for Chromatic Signals

The main target for all ganglion cell axons in primates is the dorsal lateral geniculate nucleus (LGN) of the thalamus. The dominant input to the parvocellular layers of the LGN is from midget ganglion cells, and accordingly in trichromatic primates most parvocellular cells show red-green chromatic opponent properties. Geniculocortical relay cells (Geniculostriate connections) in the parvocellular layers project to granular layer 4C $\beta$  in the primary visual cortex. By contrast, blue-on and blue-off type responses are segregated to the intercalated or koniocellular division of the LGN [10]. Koniocellular relay cells show relatively diffuse

cortical projections including supragranular layers 3 and 4A in the primary visual cortex: consistently, blue-on and blue-off type responses of presumed geniculate afferents can be recorded from these layers [14]. The two chromatic streams thus remain segregated at least to the early stages of cortical processing, and the mechanism by which these channels combine to enable color perception remains an outstanding and fascinating topic in neuroscience.

## References

1. Nathans J (1999) The evolution and physiology of human color vision: insights from molecular genetic studies of visual pigments. *Neuron* 24:299–312
2. Solomon SG, Lennie P (2007) The machinery of colour vision. *Nat Rev Neurosci* 8:276–286
3. Jacobs GH (1993) The distribution and nature of colour vision among the mammals. *Biol Rev* 68:413–471
4. Wässle H (2004) Parallel processing in the mammalian retina. *Nat Rev Neurosci* 5:747–757
5. Mollon JD (1989) “Tho’ she kneel’d in the place where they grew.” The uses and origins of primate colour vision. *J Exp Biol* 146:21–38
6. Klug K, Herr S, Ngo IT, Sterling P, Schein S (2003) Macaque retina contains an S-cone OFF midget pathway. *J Neurosci* 23:9881–9887
7. Dacey DM, Packer OS (2003) Colour coding in the primate retina: diverse cell types and cone-specific circuitry. *Curr Opin Neurobiol* 13:421–427
8. Sakurai M, Mullen KT (2006) Cone weights for the two cone-opponent systems in peripheral vision and asymmetries of cone contrast sensitivity. *Vision Res* 46:4346–4354
9. Dacey DM, Lee BB (1994) The ‘blue-on’ opponent pathway in primate retina originates from a distinct bistratified ganglion cell type. *Nature* 367:731–735
10. Szmajda BA, Buzás P, FitzGibbon T, Martin PR (2006) Geniculocortical relay of blue-off signals in the primate visual system. *Proc Natl Acad Sci USA* 103:19512–19517
11. Dacey DM, Liao HW, Peterson BB, Robinson FR, Smith VC, Pokorny J, Yau KW, Gamlin PD (2005) Melanopsin-expressing ganglion cells in primate retina signal colour and irradiance and project to the LGN. *Nature* 433:749–754
12. Lee SCS, Grünert U (2007) Connections of diffuse bipolar cells in primate retina are biased against S-cones. *J Comp Neurol* 502:126–140
13. Haverkamp S, Wässle H, Duebel J, Künér T, Augustine GJ, Feng G, Euler T (2005) The primordial, blue-cone color system of the mouse retina. *J Neurosci* 25:5438–5445
14. Chatterjee S, Callaway EM (2003) Parallel colour-opponent pathways to primary visual cortex. *Nature* 426:668–671
15. Roorda A, Metha AB, Lennie P, Williams DR (2001) Packing arrangement of the three cone classes in primate retina. *Vision Res* 41:1291–1306
16. Luo X, Ghosh KK, Martin PR, Grünert U (1999) Analysis of two types of cone bipolar cells in the retina of a New World monkey, the marmoset, *Callithrix jacchus*. *Visual Neurosci* 16:707–719

## Retinal Direction Selectivity: Role of Starburst Amacrine Cells

SUSANNE HAUSSELT, THOMAS EULER  
Department of Biomedical Optics, Max-Planck  
Institute for Medical Research, Heidelberg, Germany

### Definition

#### Direction-Selectivity in the Retina

Computing the direction of image motion is an essential task for the visual system. The retina’s ability to detect the direction of image motion (► **direction selectivity** or DS) was first described more than 40 years ago [1]. ► **Direction-selective ganglion cells** (DSGCs) (► **Retinal ganglion cells**) fire vigorously when a stimulus is moving in a certain direction (“preferred”), while remaining silent when the same stimulus moves in the opposite (“null”) direction (Fig. 1). ► **Starburst amacrine cells** (SACs) [2,3] are retinal interneurons closely intertwined with the direction-selective circuitry in the retina. While there is common consensus that SACs are crucial for the computation of motion direction, the exact nature of their involvement is still controversial. For review and further reading see [4,5].

### Characteristics

#### (Quantitative) Description

##### Direction-Selective Ganglion Cells (DSGCs)

Direction-selective ganglion cells (► **Retinal ganglion cells**) have been primarily studied in rabbit retina, where they account for 10% of the ganglion cells. They have functionally and morphologically equivalent counterparts in other mammals and in non-mammalian vertebrates. Most research has focused on the ON/OFF DSGC (Fig. 1a), which has a bistratified dendritic tree with one arborization in the outer half (the OFF sublamina) of the ► **inner plexiform layer** (IPL), and another arborization in the inner half (the ON sublamina) of the IPL.

This arrangement allows responses to the direction of image motion of dark objects on a light background – mediated by the OFF arbor – as well as to objects brighter than the background – mediated by the ON arbor. The cell comes in four functional subtypes, each preferring one particular direction of motion (as an example see Fig. 1b). A second type of retinal direction-selective cell is the monostратified ON DS ganglion cell, which prefers one of three particular directions (see *Function*). Each DSGC subtype tiles the retina with little dendritic overlap making directional information for any of the preferred directions available at every retinal location.

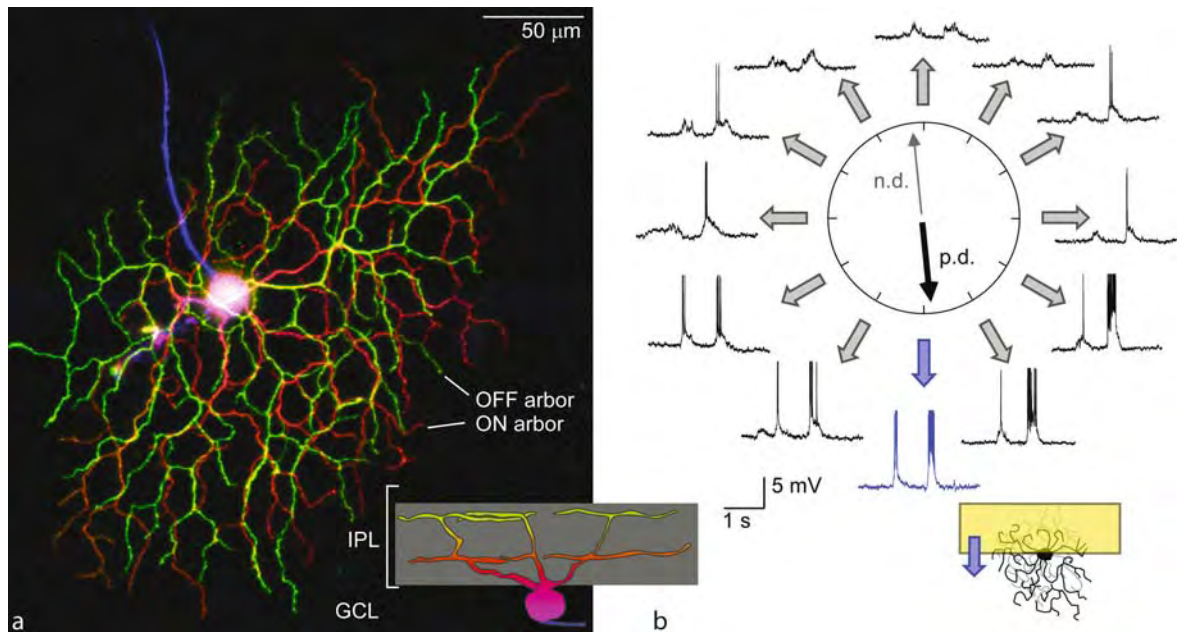

**Retinal Direction Selectivity: Role of Starburst Amacrine Cells. Figure 1** (a) Fluorescent dye-injected ON/OFF direction-selective ganglion cell in a flat mounted rabbit retina (pseudo-color codes retinal depth). The two dendritic arbors stratify in the ON (red) and OFF (green) sublaminae of the IPL. (b) Electrical responses of a DSGC to a bar moving in 12 directions across its receptive field (see inset): both the leading (ON) and the trailing edge (OFF) of the bar elicit responses (p.d.: preferred, n.d.: null direction).

### Starburst Amacrine Cells (SACs)

The dendrites of SACs closely co-fasciculate with the dendrites of DSGCs, and therefore have long been implicated in the computation of direction selectivity. (Strictly speaking, SAC neurites are not dendrites as they not only receive input, but also make output synapses – this is the case for most amacrine cells.) Unlike most other retinal neurons, SACs display a tremendous dendritic overlap (30–70 fold coverage) and, hence, offer plenty of “substrate” to provide the different DSGC subtypes with adequate neural circuitry. When SACs are removed from the circuitry, e.g., by gene-targeted cell ablation [6], direction-selective responses in DSGCs are abolished, confirming that SACs play a crucial role for direction-selectivity.

Starburst cells have been found in non-mammalian and mammalian species including primates. SAC morphology is well conserved among species: several primary dendrites radiate symmetrically from the soma before dividing into smaller branches (Fig. 2). The distal third of the branches is decorated with bead-like swellings (varicosities) [3]. SACs contain two transmitters,  $\gamma$ -aminobutyric acid (GABA) and acetylcholine (ACh). Due to the presence of ACh, they are also called “cholinergic amacrine cells.” Two subtypes of SACs exist: OFF SACs co-stratify with the OFF dendritic arbor of the ON/OFF DSGCs, whereas

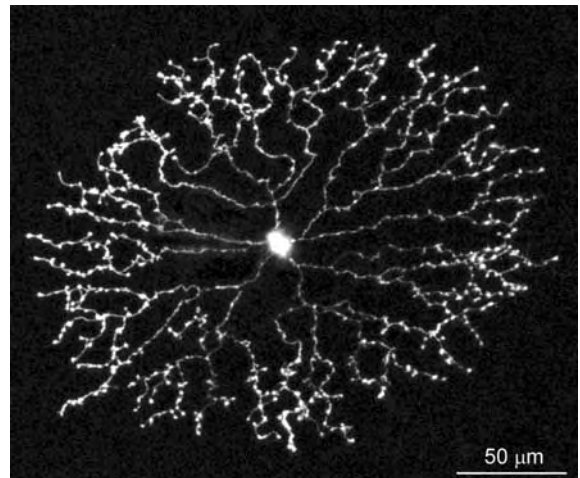

**Retinal Direction Selectivity: Role of Starburst Amacrine Cells. Figure 2** Starburst amacrine cell in a flat mounted rabbit retina injected with a fluorescent dye. The cell's morphology is reminiscent of a “starburst” fireworks display.

ON SACs co-stratify with the ON dendritic arbor of the ON/OFF DSGC and the ON DSGC dendritic arbor. Despite the opposite polarity of their light responses, ON- and OFF-SACs are considered functionally equivalent.

### Description of the Process

As recognized in the first studies on DSGCs in rabbit retina [1], the generation of direction-selectivity could be attributed to spatially offset inhibition biased towards the “null” direction. This proposal assumes asymmetrical wiring, such that the DSGC receives inhibition preferentially from interneurons displaced to one side of its ▶receptive field (Fig. 3a). It was proposed that motion in the “null” direction triggers inhibition (via the spatially displaced interneurons) before the stimulus reaches and excites the DSGC directly. If the inhibition is sufficiently delayed or, alternatively, long-lasting, it will coincide with the direct excitation and prevent the DSGC from responding. Motion in the opposite (“preferred”) direction, on the other hand, will also trigger inhibition, but too late to prevent the DSGC from responding.

### Pre- or Postsynaptic

It was originally proposed that direction-selectivity is computed by such a delay-based “veto”-mechanism from non-directional inputs in the DSGC itself. Detailed electrical recordings from DSGCs (reviewed in [5]), however, revealed that the inputs that DSGCs receive are already directionally tuned, with inhibitory input being larger for “null” direction motion, and excitatory input being larger for “preferred” direction motion. While consistent with spatially offset inhibition in general, this finding suggests that the DSGC’s response is substantially determined by the ratio of excitation and inhibition, and less by their temporal sequence in the DSGC, as originally proposed. More importantly, this indicates that direction-selectivity is already computed in interneurons presynaptic to the DSGC. Postsynaptic processing in the dendrites of DSGCs essentially supplements the

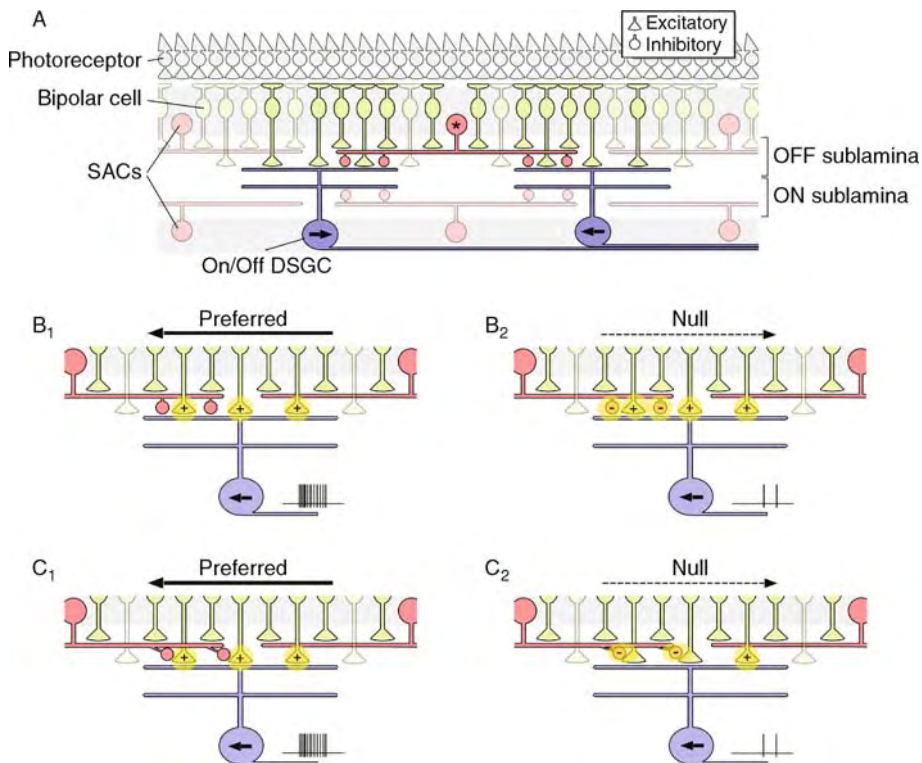

**Retinal Direction Selectivity: Role of Starburst Amacrine Cells. Figure 3** (a) Schematic retinal cross section illustrating the direction-selectivity circuitry. The central SAC (\*) serves (here: inhibits) two DSGCs with opposite preferred directions (indicated by arrow). For simplicity, cholinergic input, other amacrine cells involved and connections in the ON sublamina of the IPL are omitted. Proposed direction-selectivity mechanisms: (b) *Direction-selective inhibition*: preferred motion (i) elicits a response in the DSGC, because the left SAC’s dendrite, which is connected to the DSGC, is not activated by this motion direction, while the right SAC’s dendrite is activated but not connected. Null direction motion (ii) elicits no response in the DSGC, because the left SAC’s dendrite is activated and inhibits the DSGC. (c) *Direction-selective excitation*: the left SAC (or, alternatively, another amacrine) inhibits the excitatory input from bipolar cells presynaptically to the DSGC for null direction motion [2], but not for preferred direction motion [1]. A similar mechanism could also be implemented via excitatory (cholinergic) connections from SACs.

presynaptic direction-selective mechanisms by sharpening the directional tuning.

### Multiple Mechanisms

Retinal direction-selectivity is largely independent of contrast, mean brightness and velocity of the stimulus. This robustness alone suggests that different mechanisms at multiple levels participating in the generation and amplification of direction-selectivity [reviewed in 5]. This is also reflected by the fact that both inhibitory and excitatory inputs to DSGCs are by themselves direction-selective.

### Direction-Selective Inhibition

Pharmacologically blocking  $\blacktriangleright$ GABA<sub>A</sub> receptors has consistently been shown to abolish direction-selectivity in DSGCs, indicating that the direction-selective inhibition is mediated by GABAergic input [8]. This GABAergic input is at least partially provided by SACs (Fig. 3b). More importantly, light-evoked Ca<sup>2+</sup> signals optically recorded in the distal SAC dendrites are direction-selective (Fig. 3a) [9]. Thus, it is highly likely that GABA release from SACs is also direction-selective, because the SACs' output synapses are located in the distal dendrites [3], and their GABA release has been shown to be Ca<sup>2+</sup>-dependent [10]. Furthermore, SACs appear to make direct GABAergic synapses with DSGCs, which seem to be highly asymmetrical and fit the requirements for spatially offset inhibition. Paired recordings have shown that DSGCs receive inhibitory synaptic input from SACs located on the "null side" of the DSGC's receptive field, but do not receive synaptic input from SACs on the "preferred side" [11]. Alternatively, (additional) directionally

tuned inhibitory input may come from other, yet to be identified amacrine cells; however, direct evidence for this is lacking so far.

### Direction-Selective Excitation

The excitatory input to DSGCs is  $\blacktriangleright$ glutamatergic as well as cholinergic. The glutamatergic input comes from bipolar cells ( $\blacktriangleright$ Retinal bipolar cells) and appears to be directionally tuned, but it is not yet clear by which synaptic circuitry. Such tuning could result from suppression of bipolar cell activity for "null" direction motion (Fig. 4c); however, it is not known which amacrine cell could supply the required spatially offset inhibition to the bipolar cell terminals. The SAC is a potential candidate, and ultrastructural evidence for SAC output onto bipolar cell terminals does exist, but such contacts seem to be too sparse [3]. Alternatively, bipolar cell activity could be enhanced by motion in the "preferred" direction (facilitation), but again an appropriate pathway has not yet been unequivocally identified.

It is likely that DSGCs receive excitatory input from SACs via cholinergic synapses, because DSGCs express  $\blacktriangleright$ ACh receptors. ACh receptor blockers reduce the firing of DSGCs, and SACs are considered the only source of ACh in the retina [2]. Since ACh release from SACs is Ca<sup>2+</sup> dependent and SAC dendritic Ca<sup>2+</sup> signals are direction-selective, one would expect that ACh release is also direction-selective. Nonetheless, the cholinergic pathway is enigmatic in several ways (reviewed in [4]): Laser ablation of SACs on the preferred side of a DSGC reduced its excitatory input. However, paired recordings of SACs and DSGCs failed to show direct cholinergic connections [11]. Blocking ACh receptors appears to reduce direction-selectivity in

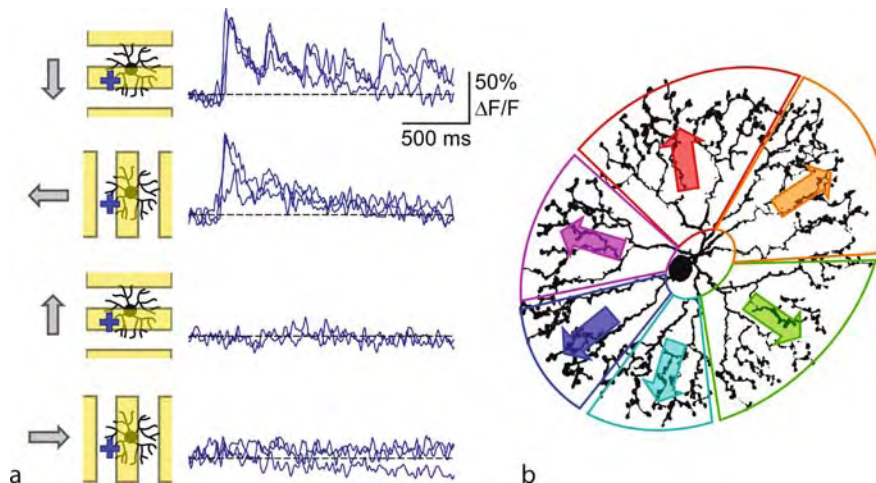

**Retinal Direction Selectivity: Role of Starburst Amacrine Cells. Figure 4** (a) Dendritic Ca<sup>2+</sup> responses (as relative change in fluorescence  $\Delta F/F$ ) optically recorded from a distal SAC dendrite to a bar grating moving in four different directions. Only motion from the soma roughly towards the tip of the imaged dendrite (indicated by a blue cross) elicits a response (from [9], Fig. 4a, modified). (b) SAC dendritic branches signal centrifugal motion.

DSGCs for certain stimuli (like bar gratings). On the other hand, in the presence of GABA receptor blockers, ACh antagonists reduce DSGC responses independent of motion direction, suggesting that cholinergic excitation is symmetrical [12].

## Higher Level Processes

### Direction Selectivity from Network Interactions

Various models of retinal direction-selectivity are based on network interactions to explain the generation of the direction-selective signals observed in the DSGCs (reviewed in [4,5,13]). The models differ in the complexity of interactions, and by the number and types of neurons recruited, but the basic principles are similar: spatially offset inhibition and asymmetrical wiring. Depending on the model, the spatially offset inhibition is provided by SACs or by not yet identified amacrine cells. In either case, most, if not all, network models assign some central role to SACs, ranging from simply relaying signals to DSGCs to providing essential direction-selective output. As a general mechanism for rendering signals direction-selective, both facilitation and suppression have been suggested.

### SAC Networks

Starburst cells form a network with attractive properties. Reciprocal cholinergic excitation among SACs is prominent in the developing retina, but seems to be strongly reduced during retinal maturation. GABAergic interactions between neighboring SACs are prominent in the adult retina, and have long been suspected to be crucial for the generation of direction-selectivity (e.g., [13]). An excited SAC inhibits its neighbors, which in turn reduces their inhibition onto the first SAC, and effectively amplifies excitation. Thus, SAC dendrites pointing in the same direction could stabilize each other's responses. Such network interaction may well serve to enhance DS [10]. Nonetheless, GABAergic inhibition appears not to be pivotal to render SAC output direction-selective, because blocking GABA receptors does neither abolish direction selectivity in the SACs' dendritic  $Ca^{2+}$  nor in their somatic voltage response [14].

## Lower Level Processes

### Direction Selectivity from Intrinsic SAC Properties

While in the network models direction selectivity arises primarily from neuronal interactions, a second group of models suggests that direction selectivity is initially generated in SAC dendrites as a result of intrinsic properties. Note that network models and intrinsic models are not necessarily mutually exclusive, but rather complementary.

At first glance SACs appear to be very symmetrical neurons (Fig. 2), which seems to disagree with the role

of a detector of motion direction. In fact, SACs are better viewed as a collection of "wedge-shaped" direction detectors represented by the primary dendrites (Fig. 4b). The dendritic branches are largely electrically isolated and respond independently to local light stimulation [8]. Thus, they can be considered as largely "autonomous" computational units [14]. In contrast to the whole cell, the dendrites are indeed highly polarized structures. Synaptic inputs and outputs are differentially distributed along the dendrites: input synapses are located along the whole length, whereas output synapses are associated with the varicosities on the distal third of the branches [3]. Each principal branch responds more strongly to centrifugal motion (towards the dendritic tips) than to centripetal motion (towards the soma) [8], thus displaying dendritic direction selectivity. The mechanism underlying dendritic direction selectivity in SACs is not yet fully understood. Several "cell-autonomous" models of SAC dendritic direction selectivity have been proposed, each of them employing different (but not necessarily mutually exclusive) intrinsic mechanisms and properties.

*Morphology and Amplification.* Computational studies have suggested that the starburst dendrite morphology, with its steady increase of input synapses towards the dendritic tips, would generate a weak direction-selective dendritic signal by itself (e.g., [13]). This small direction-dependent difference in membrane potential (► [Membrane potential – basics](#)) could be amplified by other mechanisms, such as differential activation of voltage-gated channels. Starburst cells express several types of voltage-gated  $Ca^{2+}$  channels (► [Calcium channels – an overview](#)) that would be suitable. Support for this comes from the fact that blocking  $Ca^{2+}$  channels that are predominant on SACs abolishes direction selectivity in DSGCs, while leaving the DSGC's responsiveness to light intact. It is also possible that voltage-gated  $Na^+$  channels (► [Sodium channels](#)) play a role; however, it is uncertain whether SACs generate spikes carried by  $Na^+$ .

*Chloride Gradient along the Dendritic Branches.* Immunocytochemical and physiological experiments suggest that a differential expression of the chloride transporters NKCC1 and KCC2 (► [Chloride channels and transporters](#)) leads to a chloride concentration ( $[Cl^-]$ ) gradient within the SAC dendrite (with high  $[Cl^-]$  in and near the soma) [15]. Such a gradient would render the proximal GABAergic inputs excitatory, whereas the distal GABAergic inputs would remain inhibitory. In this model, the temporal sequence in which proximal and distal GABAergic inputs occur (centrifugal vs. centripetal) lead to the generation of direction-selective transmitter release from the SAC distal dendrites.

*Intracellular "Calcium Wave".* An important question is how spatially offset inhibition can be delayed

long enough so that it coincides with excitation in the DSGC. A similar question arises for the signal propagation within the SAC dendrite: If constructive and/or destructive interactions of inputs create dendritic direction selectivity in SACs, what causes the required delay? As electrical propagation seems too fast, it has been proposed that an intracellular  $\text{Ca}^{2+}$  “wave” supported by  $\text{Ca}^{2+}$ -induced  $\text{Ca}^{2+}$  release (within the SAC) may provide suitable delays.

#### Other, Yet Unidentified Interneurons in the DS Circuitry

A general problem with proposing that interneurons other than the SAC perform essential direction-selectivity computations is lack of neuronal “substrate.” Retinal neurons usually tile the retina; such that their density appears too low to build local circuitries dedicated to each of the seven DSGC subtypes at every retinal location (see *Function*). Local dendritic processing – as implemented in SACs – may be a solution. In the case of bipolar cells, as has been proposed, this would be demanding. To tune the output of single branches of a bipolar cell axon to different preferred directions would require a tremendous locality of processing.

#### Involved Structures

##### Ultrastructural Basis of Direction Selectivity

While it is commonly agreed that retinal direction selectivity requires spatial asymmetries in the wiring of the circuitry, a directly corresponding anatomical correlate has not been unequivocally identified. It has so far not been possible to predict a DSGC’s preferred direction from its anatomy. Although at the ultrastructural level complex arrangements of amacrine cell synapses onto DSGC dendrites have been described [16], systematic asymmetries in the wiring of the direction-selectivity circuitry have not been found. The only available evidence for asymmetrical wiring comes from paired recordings [10]. Another puzzle is the location of GABA release sites on SACs. Synapses with ACh-containing vesicles could be located in the varicosities, whereas, due to the lack of conventional ultrastructural features, GABA release sites have not yet been localized on SAC dendrites.

#### Function

For visually oriented animals, it is a matter of survival to swiftly detect moving objects (▶*local image motion*) and reliably discriminate their direction of motion. In addition, motion of the whole visual field (▶*global image motion*) provides important information about head/body movements (▶*Visual motion processing*; ▶*Optic flow*). Hence, coding the direction of image motion is an important task for the visual system. The three preferred motion directions of the ON DSGCs

correspond to rotation around the axes defined by the three ▶*semicircular canals* in the inner ear (reviewed in [4]). The cells respond preferentially to global motion and project to the ▶*accessory optic system (AOS)*, thus, ON DSGCs are thought to provide a correctional signal for ▶*eye movement* and gaze-stabilization. This is supported by the finding that ablating SACs leads to a loss of the ▶*optokinetic reflex* [6]. The four preferred directions of the ON/OFF DSGCs are roughly aligned with the extraocular rectus muscles and, therefore, with the cardinal ocular rotation directions. ON/OFF DSGCs seem to contribute some input to the optokinetic system, however, they send projections to the ▶*superior colliculus* and the ▶*lateral geniculate nucleus (LGN)*, indicating that their signals also serve other functions, possibly including control of spatial attention (▶*Visual attention*). The responses of ON/OFF DSGCs to moving objects are attenuated by synchronous motion of the background, indicating that they preferentially signal local motion. Nonetheless, there is no functional evidence so far that signals from retinal DSGCs take part in higher visual processing of motion direction.

#### Development

Up to now there is no satisfactory explanation of how the direction selectivity circuitry is wired during retinal development. That direction selectivity is established at the time of eye-opening suggests that the wiring process does not require visual stimulation.

#### References

1. Barlow HB, Hill RM, Levick WR (1964) Rabbit retinal ganglion cells responding selectively to direction and speed of image motion in the rabbit. *J Physiol* 173:377–407
2. Masland RH, Mills JW (1979) Autoradiographic identification of acetylcholine in the rabbit retina. *J Cell Biol* 83:159–178
3. Famiglietti EV Jr (1983) “Starburst” amacrine cells and cholinergic neurons: mirror-symmetric on and off amacrine cells of rabbit retina. *Brain Res* 261:138–144
4. Vaney DI, He S, Taylor WR, Levick WR (2001) Direction-selective ganglion cells in the retina. In: Zanker JM, Zeil J (eds) *Motion Vision – Computational, Neural, and Ecological Constraints*. Springer, Berlin, pp. 13–56
5. Taylor WR, Vaney DI (2003) New directions in retinal research. *Trends Neurosci* 26:379–385
6. Yoshida K, Watanabe D, Ishikane H, Tachibana M, Pastan I, Nakanishi S (2001) A key role of starburst amacrine cells in originating retinal directional selectivity and optokinetic eye movement. *Neuron* 30:771–780
7. Ariel M, Daw NW (1982) Pharmacological analysis of directionally sensitive rabbit retinal ganglion cells. *J Physiol* 324:161–185
8. Euler T, Detwiler PB, Denk W (2002) Directionally selective calcium signals in dendrites of starburst amacrine cells. *Nature* 418:845–852

9. Zheng JJ, Lee S, Zhou ZJ (2004) A developmental switch in the excitability and function of the starburst network in the mammalian retina. *Neuron* 44:851–864
10. Fried SI, Münch TA, Werblin FS (2002) Mechanisms and circuitry underlying directional selectivity in the retina. *Nature* 420:411–414
11. He S, Masland RH (1997) Retinal direction selectivity after targeted laser ablation of starburst amacrine cells. *Nature* 389:378–382
12. Chiao CC, Masland RH (2002) Starburst cells nondirectionally facilitate the responses of direction-selective retinal ganglion cells. *J Neurosci* 22:10509–10513
13. Borg-Graham LJ, Grzywacz NM (1992) A model of the directional selectivity circuit in retina: transformations by neurons singly and in concert. In: McKenna T, Zornetzer SF, Davis JL (eds) *Single Neuron Computation*. Academic Press, San Diego, CA, pp 347–375
14. Miller RF, Bloomfield SA (1983) Electroanatomy of a unique amacrine cell in the rabbit retina. *Proc Natl Acad Sci USA* 80:3069–3073
15. Gavrikov KE, Dmitriev AV, Keyser KT, Mangel SC (2003) Cation–chloride cotransporters mediate neural computation in the retina. *Proc Natl Acad Sci USA* 100:16047–16052
16. Dacheux RF, Chimento MF, Amthor FR (2003) Synaptic input to the ON-OFF directionally selective ganglion cell in the rabbit retina. *J Comp Neurol* 456:267–278

## Retinal Flow

### ► Optic Flow

## Retinal Ganglion Cells

LEO PEICHL

Max Planck Institute for Brain Research, Frankfurt am Main, Germany

### Definition

The retinal ganglion cells (RGCs) are the output stage of retinal information processing. They are the only cells in the retina with axons that leave the eye. The ganglion cell axons form the ►optic nerve and transmit retinal information – in the form of spike trains – to the visual target areas in the brain. The name “ganglion cell” derives from the anatomical notion that these cells constitute the “*ganglion nervi optici*,” i.e. the cluster of somata that give rise to the fibers of the optic nerve. The ganglion cell somata are located in the ►ganglion cell layer (GCL), the innermost layer of the retina. The

dendrites of the ganglion cells ramify in the ►inner plexiform layer (IPL) where they are postsynaptic to bipolar cell axons and amacrine cell processes (►Retinal bipolar cells). There are more than a dozen different types of ganglion cell in all mammalian retinæ studied so far. They differ in dendritic field size and dendritic branching pattern, and they receive input from different bipolar and amacrine cell types, and hence have different functional properties. The various types are specialized to encode different aspects of a visual scene, e.g. fine spatial detail (visual resolution), brightness, color, or movement. These ganglion cell types are the basis of distinct parallel visual pathways relaying a decomposed representation of the visual scene to distinct target areas in the brain [1–5].

## Characteristics

### Description

Among mammals, ganglion cells have been morphologically and functionally most thoroughly studied in the cat, the rabbit, and some primates [1,2,4,6,7]. More recently, detailed morphological classifications of mouse and rat ganglion cells have been added [8]. These comparative studies suggest that there is a basically similar set of about 15–20 ganglion cell types in all mammals, but formal proofs of homology are still lacking (Figs. 1–3). The accounting of types in any one species differs between authors depending on the classification criteria applied. For historical reasons, the nomenclature of types differs between species. The present article focuses on the most thoroughly studied ganglion cell types in the cat and primates, which continue to serve as benchmarks for ganglion cell classifications.

### Alpha Ganglion Cells/Primate Parasol Cells

Alpha ganglion cells have been identified morphologically in all mammalian species studied to date [6]. At every retinal location, they are the type with the largest soma, the largest-caliber, fastest-conducting axon, and a large dendritic field. The dendritic tree is circular-to-oval with stout radial, relatively densely branched dendrites that rarely overlap, and it is monostratified in the IPL (Figs. 1, 2, and 4).

Alpha cells have been identified as the brisk-transient (Y) cells of physiology [1,6,9]. They comprise two functional subtypes, ON alpha cells and OFF alpha cells, as defined by their response to light (see *dendritic stratification* below). The ►receptive fields of alpha/Y cells are large and have a concentric organization with an excitatory centre and a larger antagonistic, inhibitory surround [9,10]. Alpha/Y cells show a vigorous transient (phasic) response whenever there is a stimulus change; their response to stationary, constant stimuli decays within the first few tenths of a second following stimulus onset. Alpha/Y cells respond best to rapid



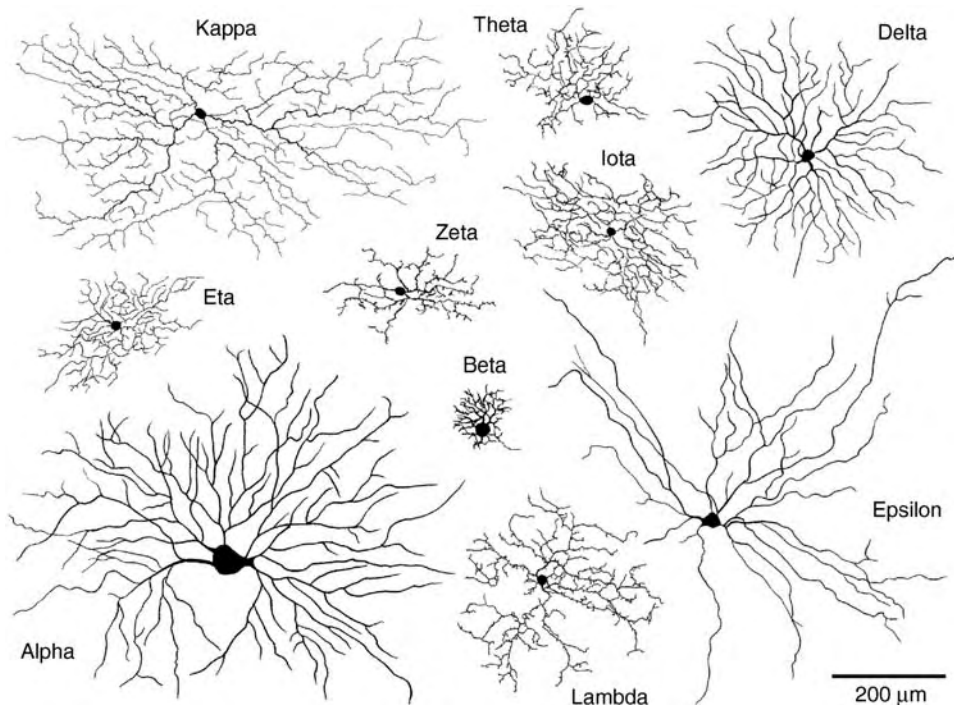

**Retinal Ganglion Cells. Figure 1** A selection of ganglion cell types in the cat retina. The cells have been dye-injected and are seen in flat view, all drawn at the same scale. Cat ganglion cell types are named by Greek letters. Each type is characterized by a specific morphology, e.g. alpha cells have a large soma and a large dendritic tree formed by stout dendrites, whereas kappa cells have a small soma and a large dendritic tree formed by fine dendrites. The axons exiting from the soma have been omitted. Cell drawings kindly provided by David M. Berson.

spatial or temporal changes of coarse patterns, hence they can be considered as “novelty detectors.” They are very sensitive to low luminance contrasts, but not to chromatic stimuli.

The corresponding cell type in primate retinæ is thought to be the ►parasol (= umbrella-shaped) cell [4,5]. Due to its axonal projection to the ►magnocellular (M) layers (of the lateral geniculate nucleus), it is also termed ►M cell. The parasol cell is morphologically very similar to the alpha cells in other species (Fig. 3).

Like the alpha cells of non-primates, the parasol cells comprise two functional subtypes, ON and OFF, and their relatively large receptive fields have an ►antagonistic centre-surround organization [10]. The response to visual stimuli is transient. Parasol cells respond well to achromatic “luminance” stimuli and poorly to chromatic stimuli. There are also, however, functional differences between primate parasol and cat alpha cells. For example, alpha cells show non-linear spatial summation whereas parasol cells show linear summation. Thus, the question of correspondence between parasol and alpha cells remains contentious [6].

### Beta Ganglion Cells/Primate Midget Cells

The beta ganglion cells have medium-sized somata and medium-caliber axons. Their dendritic trees are very

small and circular-to-oval, with radial, relatively densely branched dendrites that rarely overlap (Figs. 1, 2, and 4). Like those of alpha cells, they are monostratified in the IPL. In fact, beta cells look like miniature versions of alpha cells. Accordingly, they collect input from only a few bipolar cells and are the high-resolution (visual acuity) system of the retina. Beta cells have been identified as the brisk-sustained (X) cells of physiology [1,9]. Like the alpha/Y cells, the beta/X cells comprise two functional subtypes, ON and OFF, and their small receptive fields show an antagonistic centre-surround organization [9,10]. However, their response to visual stimuli is sustained (tonic). Beta/X cells respond well to small, high-contrast, stationary stimuli.

In primate retinæ, the ganglion cell type with the smallest dendritic and thus receptive field is termed midget ganglion cell [4,5]. Due to its axonal projection to the ►parvocellular (P) layers (of the lateral geniculate nucleus), it is also termed P cell. The midget cells may be homologous to the beta cells of cat and other mammals. Midget ganglion cells have medium-sized somata and very small dendritic trees that are relatively densely branched and monostratified in the IPL (Fig. 2). They comprise two functional subtypes, ON and OFF, with concentric antagonistic receptive fields [10]. The dendritic trees of the central-most

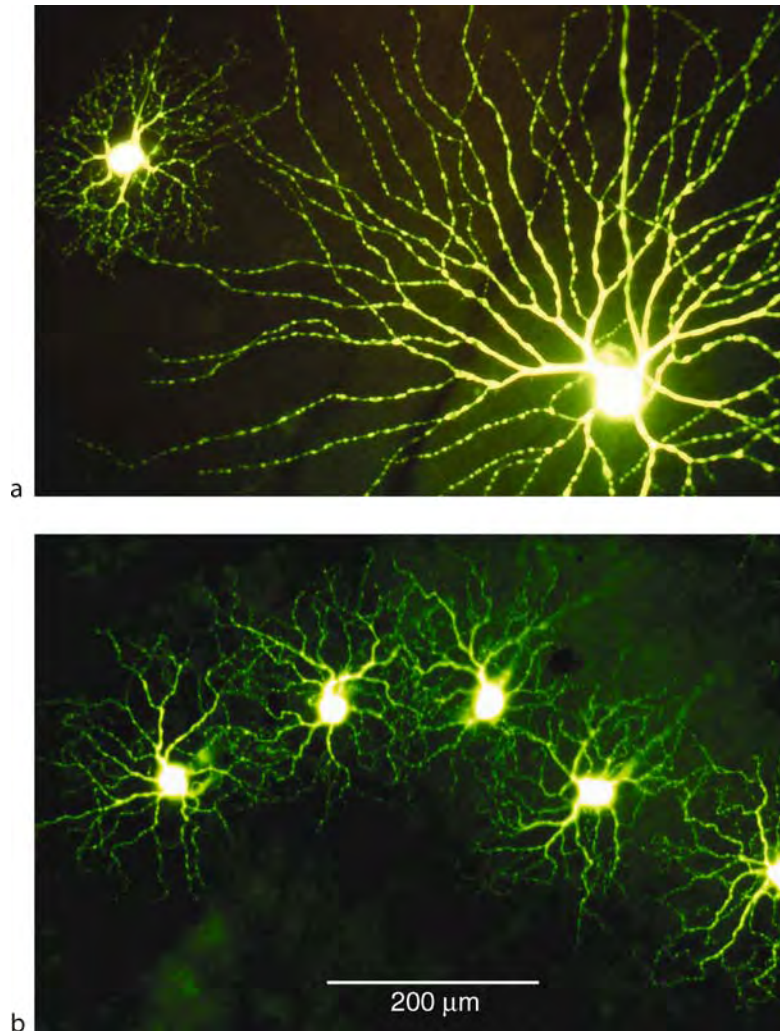

**Retinal Ganglion Cells. Figure 2** Examples of ganglion cells that have been individually injected with the fluorescent dye lucifer yellow. (a) Flat view of a neighboring alpha (*right*) and beta (*left*) ganglion cell in peripheral dog retina. (b) Flat view of a group of neighboring alpha cells in central rat retina. The scale bar applies to A & B. A, modified from Peichl (1992) *J. Comp. Neurol.* 324:590–602; B, modified from Peichl (1989) *J. Comp. Neurol.* 286:120–139.

midget cells near the ►fovea are so small that each contacts just one midget bipolar cell (►Retinal bipolar cells), which likewise contacts just one cone. This foveal 1:1:1 connectivity, termed the midget system, is the anatomical basis for the high visual acuity of diurnal primates and man. As a corollary, the single cone input conveys to a midget cell the spectral tuning of that cone. The midget cells are widely considered to be the retinal keystone of the red-green chromatic channel of trichromatic primates, doing “double duty” in spatial resolution and color vision. The blue-yellow chromatic channel is implemented by other ganglion cell types [4] (►Color processing).

Interestingly, rabbit, mouse and rat do not possess a ganglion cell type that easily fits the morphological

characteristics of beta cells [6–8]. It is possible that the beta cell is not as ubiquitous as the alpha cell, and that in some species another type of ganglion cell subserves spatial resolution.

#### Intrinsically Photosensitive, Melanopsin-Containing Ganglion Cells

A recently discovered ganglion cell type that appears to subserve “non-image-forming” functions is the “intrinsically photosensitive retinal ganglion cell” (ipRGC) [4,11]. The most intriguing feature of ipRGCs is that they contain the putative photopigment melanopsin and are directly sensitive to light. In addition, they receive conventional photoreceptor input via bipolar cells. The ipRGCs seem to play a major role in

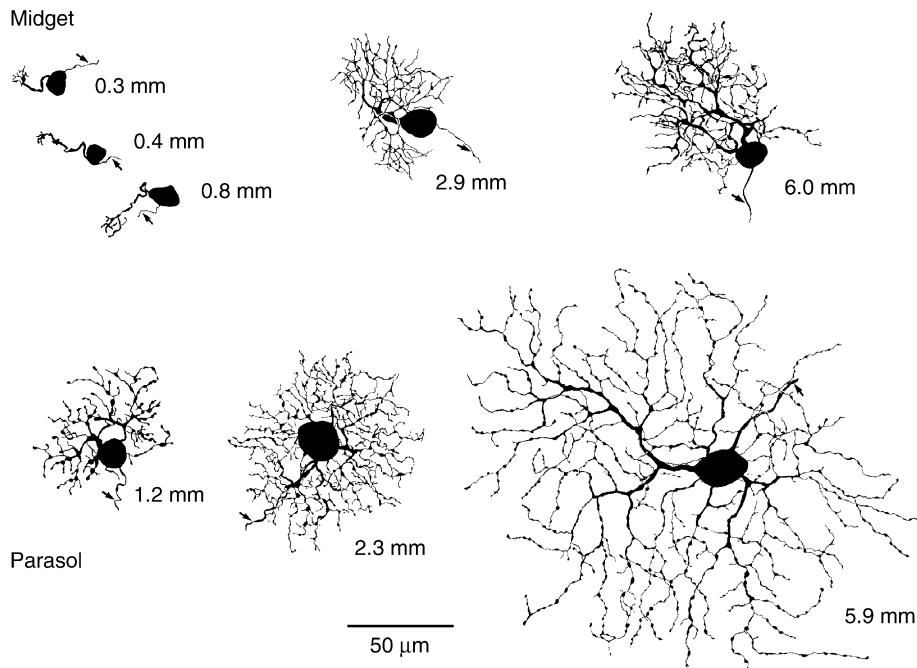

**Retinal Ganglion Cells. Figure 3** Midget (*upper row*) and parasol (*lower row*) ganglion cells in the retina of the marmoset, a diurnal primate. The cells have been dye-injected and are seen in flat view, all drawn at the same scale. Both cell types increase in size with increasing distance from the fovea (distance given for each cell), but at each location the midget cells are smaller than the parasol cells. Axons are marked by arrows. Note that these marmoset cells are smaller than their presumed counterparts in cat, the beta and alpha cells ([Fig. 4](#)); 6 mm is peripheral in the smaller marmoset retina. Modified from [5], courtesy Paul R. Martin.

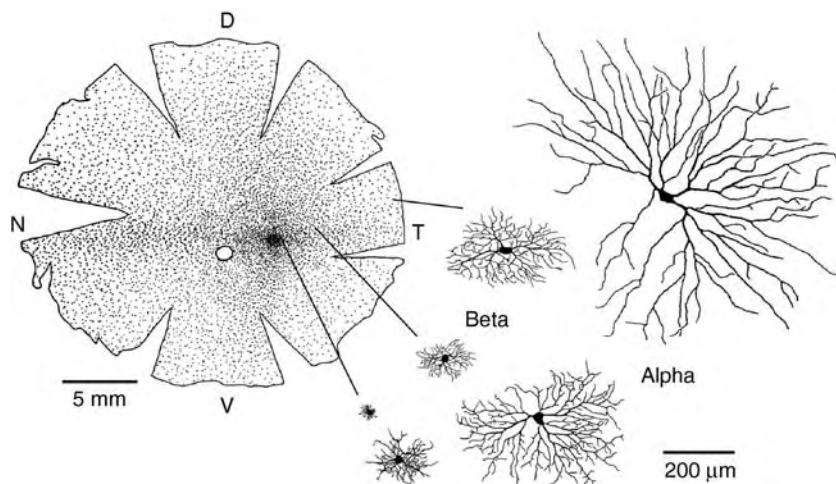

**Retinal Ganglion Cells. Figure 4** Variation of ganglion cell population density and ganglion cell size across the cat retina. *Left*: Schematic map of the ganglion cell density in a whole retina; radial cuts were made to flatten the retina. From the region of highest ganglion cell density, the *area centralis* in temporal retina, cell density decreases monotonically towards the retinal periphery. The open circle signifies the optic nerve head. *Right*: Dye-injected alpha and beta ganglion cells at three distances from the *area centralis*, showing that dendritic field size increases as cell density decreases, while the size difference between alpha and beta cells is maintained. D, dorsal; V, ventral; N, nasal; T, temporal. The left scale bar applies to the map, the right scale bar to the individual cells. Modified from Peichl (1990) *Optometrie* 3/1990:3–12.

the entrainment of ▶[circadian rhythms](#), as evidenced by their projection to the circadian pacemaker, the ▶[suprachiasmatic nucleus \(SCN\)](#), and in regulating ▶[pupil constriction](#), as evidenced by their projection to the ▶[pretectum](#). The ipRGCs constitute a small fraction of the ganglion cells (1–3% in rodent retinae, ~0.2% in primate retina). Their dendritic trees in the IPL are relatively large but sparsely branched. The cells show a sluggish, tonic ON response that is monotonically increasing with the light intensity.

### Other Ganglion Cell Types

Many of the non-alpha and non-beta ganglion cell types occur at low densities, each constituting a small fraction of the total ganglion cell population. In primates, these other types mostly have larger dendritic fields than the parasol cells; some are sparsely and some rather densely branched [4]. In the cat, there is a wider range from rather small to very large types (Fig. 1). Some of these types have a concentric antagonistic receptive field organization, others do not, and for some morphologically recognized types, functional data are lacking.

Examples of further well-studied ganglion cell types are two kinds of direction-selective (DS) ganglion cells, the monostratified ON-DS cell and the bistratified ON/OFF-DS cell (▶[Retinal direction selectivity: Role of starburst amacrine cells](#)). They are specialized to detect retinal image movement. Another example is the primate “small bistratified” cell, which shows a blue-yellow antagonism and serves in color processing [4] (▶[Color processing](#)).

### Dendritic Stratification and Light Response

ON ganglion cells have a receptive field centre that is activated by a light increase, OFF ganglion cells are activated by a light decrease in the receptive field center. These response characteristics are determined by their input neurons. The inner plexiform layer (IPL) is morphologically and functionally clearly stratified to keep these different processing circuits segregated (Fig. 5).

Cells stratifying in the *outer* part of the IPL are OFF cells, whilst those stratifying in the *inner* part are ON cells. The stratification level of the ganglion cell’s dendritic field ensures appropriate (ON or OFF) bipolar cell input. The actual thickness of the two strata differs from species to species, in some they are nearly equal, in others the ON stratum may be twice as thick as the OFF stratum (because it also contains the axon terminals of the rod bipolar cells, which are ON cells; ▶[Retinal bipolar cells](#)).

Both the alpha/parasol ganglion cells and the beta/midget ganglion cells are dichotomous, comprising equally numerous subpopulations of ON and OFF cells. Their monostratified dendritic trees ramify in the inner sublamina and the outer sublamina of the IPL,

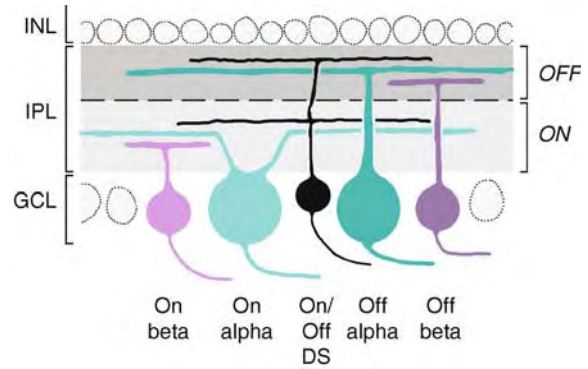

**Retinal Ganglion Cells.** Figure 5 Schematic drawing of the functional stratification of the inner plexiform layer (IPL) in the mammalian retina as seen in a transverse section. The dendritic trees of OFF ganglion cells stratify in the *outer* (distal) part of the IPL, those of ON ganglion cells in the *inner* (proximal) part. The ON/OFF direction selective (DS) ganglion cell has a bistratified dendritic tree with dendrites in the ON and the OFF stratum. Ganglion cell types are rendered in different colors. *Abbreviations:* INL, inner nuclear layer; GCL, ganglion cell layer.

respectively (Fig. 5). The ON-DS ganglion cells also monostratify in the inner sublamina, while the ON/OFF-DS ganglion cells have bistratified dendritic trees.

### Retinal Topography and Population Properties

A basic requirement of retinal organization is that the complete computing machinery has to be present at each retinal location in order to process a visual stimulus wherever it hits the retina. To achieve this, ganglion cells (and most other retinal neurons) are distributed economically across the retina. The members of each functional type (e.g. ON alpha cells, OFF alpha cells, ON beta cells, and OFF beta cells) tile the retina, such that their dendritic trees cover the retinal surface without gaps and without too much overlap [1]. The grain of this tessellation is finest in the central retina (the ▶[area centralis](#) of most mammals, and the fovea of primates), where highest visual acuity is achieved. It becomes coarser toward the retinal periphery, where complete coverage is obtained by a less dense spacing and larger individual dendritic trees for each ganglion cell type (Figs. 3 and 4). Relative size differences between the ganglion cell types are preserved across the retina.

The alpha/parasol ganglion cells with their large dendritic trees require a low packing density. Depending on species, they only constitute between 1 and 10% of the total ganglion cell population [6]. Nevertheless, they exhibit uniform coverage and contribute to processing at each retinal point. The beta/midget ganglion cells have much smaller dendritic trees and correspondingly higher

packing densities. In the cat retina, about 50% of the ganglion cells are beta cells, in the primate retina, about 80% of the ganglion cells are midget cells.

### Lower Level Processes

The response characteristics of the different ganglion cell types are thought to be set mainly by the specific mix of synaptic inputs from different bipolar and amacrine cell types [1–3,5]. The sustained (tonic) beta/midget cells are probably driven by tonic bipolar cells, and the transient (phasic) alpha/parasol cells by phasic bipolar cells (Retinal bipolar cells). A ganglion cell's specific dendritic geometry, and hence electrotonic properties (▶[Electrotonic spread](#)), also contribute to its response characteristics. The antagonistic surround of a ganglion cell's receptive field is mediated by lateral inhibitory input, partly directly from amacrine cells to the ganglion cell, and partly from horizontal cells to the bipolar cells (▶[Lateral interactions in the retina](#)). The ganglion cells operate at high (▶[photopic](#)) as well as low (▶[scotopic](#)) light levels, i.e. the cone pathway and the rod pathway converge onto the same ganglion cells. The luminance-dependent functional switch from the cone pathway to the rod pathway is regulated by dopaminergic amacrine cells [2].

### Higher Level Processes

There is homologous electrical coupling by ▶[gap junctions](#) between the dendrites of neighboring alpha/parasol cells of the same centre sign (ON with ON, OFF with OFF), and heterologous ▶[gap junctional coupling](#) between alpha/parasol cells and certain amacrine cell types. ON/OFF-DS cells also show homologous gap junctional coupling, likely to be restricted to partners with the same direction tuning. Modulated electrical coupling allows changing associations between neighboring ganglion cells. It probably is the basis for the high incidence of synchronous firing among homotypic neighbors. Synchronous firing, i.e. concerted activity among multiple ganglion cells, which has been observed in retinal multineuron recordings, may represent a “population coding” or “multiplexing” that is more powerful in encoding visual stimuli than the independent activity of individual cells [12]. Beta/midget cells do not show such electrical coupling, probably because signal spread across neighbors would decrease spatial resolution.

Each ganglion cell type projects to specific thalamic and/or midbrain target structures and specific subdivisions within these target structures [4,5]. This indicates segregation of the various retinal processing channels also at higher processing levels. The ▶[lateral geniculate nucleus \(LGN\)](#) and ▶[superior colliculus \(SC\)](#) are targets for several ganglion cell types. Other nuclei are more selectively targeted, and some ganglion cell types innervate several targets by axon collaterals.

### Function

Visual acuity, dominantly mediated by the beta/midget system, is of more importance to some species than to others. In the diurnal primates, the midget system provides the anatomically possible maximum of acuity by fully exploiting the tight foveal cone packing. In the crepuscular-to-nocturnal cat, there is a considerable convergence from cones to beta cells even in the *area centralis*, “giving away” some of the acuity theoretically possible with the cone packing density. Here perhaps, evolutionary pressure was less on high acuity and more on a good signal-to-noise ratio at dim light. The latter requires signal summation over several photoreceptors, in addition to the presence of rods in the *area centralis*.

Alpha/parasol cells, with their large receptive fields, are thought to contribute little to acuity or to color vision. Their particular responsiveness to changing stimuli (novelty detectors), and their fast conduction velocity, would make them an “alarm” or “warning” system to direct visual attention (▶[Visual attention](#)) to objects entering the visual field. Alpha/parasol cells also play an important role in global form perception (▶[Form perception](#)) and depth perception (▶[Binocular vision](#)). Both alpha/parasol and beta/midget cells project to the lateral geniculate nucleus and hence provide major inputs for cortical, “higher” visual processing.

The ON direction-selective ganglion cells project to the ▶[accessory optic system](#), the ON/OFF direction-selective ganglion cells project to the ▶[optokinetic system](#), the superior colliculus and the lateral geniculate nucleus. Both types are thought to contribute to the discrimination between self-movement and object movement (Retinal direction selectivity: Role of amacrine cells). The intrinsically photosensitive ganglion cells are specialized to encode ambient light intensities, they are involved in synchronizing circadian rhythms with the solar day and in regulating the pupillary light reflex. These three ganglion cell types are examples for retinal channels feeding into subcortical, “lower” visual processing systems.

For many of the less well-characterized ganglion cell types, we lack a clear idea of their role in image analysis. On the one hand, it is clear that there are basic parallel processing channels feeding specific parts of visual information into ganglion cell types with different response properties. On the other hand there is increasing awareness that retinal image processing works by a finely tuned and stimulus-dependent interplay of these many different channels, rather than by a strict dedication of “one type for this task, one type for that task.” For example, primate parasol cells, despite their large receptive fields, play a significant role in hyperacuity (▶[Visual acuity, hyperacuity](#)). Actually, there seem to be more types of ganglion cell (and of other retinal neurons) than we need to account for the functions we currently attribute to the retina [2].

We still have to learn a lot about this intriguing piece of neural tissue.

- ▶ [Retinal Bipolar Cells](#)
- ▶ [Lateral Interactions](#)
- ▶ [Color Processing](#)
- ▶ [Direction Selectivity](#)
- ▶ [Gap Junctional Coupling](#)

## References

1. Wässle H, Boycott BB (1991) Functional architecture of the mammalian retina. *Physiol Rev* 71:447–480
2. Masland RH (2001) The fundamental plan of the retina. *Nat Neurosci* 4:877–886
3. Wässle H (2004) Parallel processing in the mammalian retina. *Nat Rev Neurosci* 5:747–757
4. Dacey D (2004) Origins of perception: retinal ganglion cell diversity and the creation of parallel pathways. In: Gazzaniga MS (ed) *The cognitive neurosciences III*. MIT Press, Cambridge Mass, pp 281–301
5. Martin PR, Grünert U (2004) Ganglion cells in mammalian Retinae. In: Chalupa LM, Werner JS (eds) *The visual neurosciences*. MIT Press, Cambridge Mass, pp 410–421
6. Peichl L (1991) Alpha ganglion cells in mammalian retinae: common properties, species differences, and some comments on other ganglion cells. *Vis Neurosci* 7:155–169
7. Rockhill RL, Daly FJ, MacNeil MA, Brown SP, Masland RH (2002) The diversity of ganglion cells in a mammalian retina. *J Neurosci* 22:3831–3843
8. Sun W, Li N, He S (2002) Large-scale morphological survey of mouse retinal ganglion cells. *J Comp Neurol* 451:115–126
9. Levick WR (1996) Receptive fields of cat retinal ganglion cells with special reference to the alpha cells. *Progr Ret Eye Res* 15:457–500
10. Rodieck RW (1998) *The first steps in seeing*. Sinauer Associates, Sunderland Mass
11. Berson DM (2003) Strange vision: ganglion cells as circadian photoreceptors. *Trends Neurosci* 26:314–320
12. Meister M, Berry MJ (1999) The neural code of the retina. *Neuron* 22:435–450

## Retinal Implant

### Definition

Device intended to restore useful vision in pathologies that selectively affect the photo-detectors of the retina while leaving relatively intact the other retina neurons and the fibers of the optic nerve (such as retinitis pigmentosa and macular degeneration). These devices share with cochlear implants the basic design principles and requirements, but are at a much earlier stage of

development than cochlear implants (there is at least a 20–30 years gap), because of the greater information density (thousands of hair cells on the basilar membrane vs. millions of photodetectors on the retina) and the more complex structure of the sensor.

- ▶ [Computer-Neural Hybrids](#)

## Retinal Lateral Interactions

MARTIN WILSON

Department of Neurobiology, Physiology and Behavior, College of Biological Sciences, University of California Davis, Davis, CA, USA

### Synonyms

Lateral interactions in the retina

### Definition

The influence of signals generated by retinal neurons on the activity of other neurons laterally distant in the retina.

Many processes are covered by this term, some acting over short distances between immediately adjacent neurons, and others acting over virtually the entire extent of the retina [1]. Lateral interactions occur at all levels in the retina, from the ▶ [photoreceptors](#), the input neurons of the retina, through to ganglion cells (▶ [Retinal ganglion cells](#)), the output neurons of the retina. Lateral interactions may be positive or negative. Light falling on a patch of retina may augment the signal generated in neurons in an adjacent patch or it may diminish this signal. Lateral interactions are often time-dependent and may also depend on special features of the stimulus such as stimulus velocity or the wavelength of the illuminating light.

There are several different mechanisms known to mediate lateral interactions. Some forms of lateral interaction, particularly those occurring in the inner retina, are known only from indirect and incomplete evidence and are not well understood.

### Characteristics

The best known form of lateral interaction in the retina is lateral inhibition. Lateral inhibition was inferred by Ernst Mach in the 1860s on the basis of psychophysical experiments. Much later it was shown that lateral inhibition was one of the first neural operations performed in the compound eye of the horseshoe crab, *Limulus*, where eccentric cells, roughly the equivalent

of ganglion cells in the vertebrate retina, are thought to make inhibitory ►synapses with their neighbors (Fig. 1). Hartline and his colleagues quantified the effect of lateral inhibition on the steady-state firing rate of eccentric cells by writing simultaneous equations [2]. The firing of every eccentric cell is influenced by the firing of every other eccentric cell, so that, considering only a pair of illuminated eccentric cells, A and B, the responses of A and B,  $r_A$ , and  $r_B$  are given by:

$$r_A = e_A - K_{A,B}(r_B - r_B^0)$$

$$r_B = e_B - K_{B,A}(r_A - r_A^0),$$

where  $e_A$  is the response of A in the absence of stimulation to B,  $K_{A,B}$  is a term representing the strength of inhibitory connection from B to A,  $r_B$  is the response of B, and  $r_B^0$  is a threshold firing rate for B below which it exerts no inhibition on A. Terms for the response of B have analogous meanings. These simple piecewise linear equations give a good approximation of the responses of eccentric cells for different patterns of light falling on the *Limulus* eye and capture the essential features of lateral inhibition.

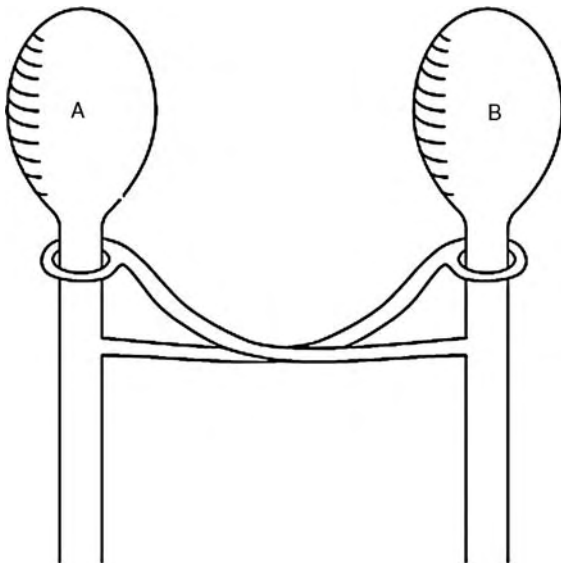

**Retinal Lateral Interactions. Figure 1** The idea underlying the quantitative description of inhibitory interactions in the *Limulus* retina [2]. A pair of adjacent eccentric cells, A and B, each capable of independent excitation by light, are shown as cell bodies with axons sending information to the brain and collaterals that make local inhibitory connections with each other. The excitation of one cell tends to reduce the response of its neighbor. A subtle but important feature of the inhibition, reflected in this diagram and in the descriptive equations, is that it is recurrent. By this is meant that for any cell, the inhibitory effects of neighbors are exerted upstream of any inhibitory output from that cell.

The organization of the vertebrate retina is radically different from that of *Limulus* and yet lateral inhibition is similarly one of its first processing steps. To understand how lateral inhibition operates in the outer vertebrate retina it is necessary to consider all three general classes of neuron found there, their lateral interactions, and their ►receptive fields.

Photoreceptors have very small receptive fields, though in many instances these are at least slightly broader than expected from the anatomical dimensions of the photoreceptor. The explanation for this enlargement is that photoreceptors are weakly coupled together via ►gap junctions (Photoreceptors) so that signals leak from one photoreceptor to its neighbors. Quantitative models of signal spread through the photoreceptor network have been based on square or hexagonal networks in which each photoreceptor is represented by a resistor and a capacitor, coupled to its neighbors through resistors representing gap junctions (Fig. 2). This kind of model gives a reasonable approximation for the spread of small signals through the network but misses some of the network's time-dependent properties. More sophisticated models, incorporating the voltage-dependent conductances of photoreceptors, show that, at least for the amphibian and turtle retina, the network has strongly time-dependent properties [4,5].

Photoreceptors pass signals to both horizontal cells and bipolar cells (►Retinal bipolar cells) (Fig. 3). Horizontal cells are strongly coupled homotypically via gap junctions, with the result that signals spread widely throughout the network of horizontal cells, giving these neurons very broad receptive fields. Because the coupling between horizontal cells is so strong, individual cells can be ignored and the network approximated

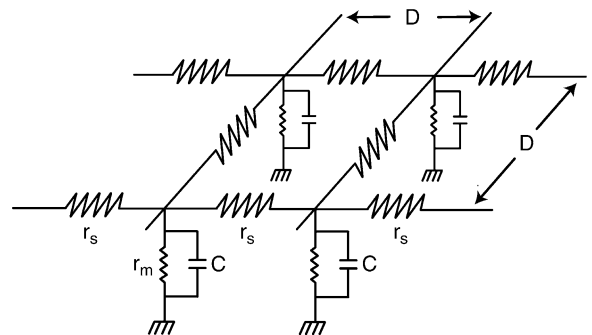

**Retinal Lateral Interactions. Figure 2** A schematic representation of part of a network of coupled photoreceptors based on [3]. In this model, photoreceptors are arranged in a square grid separated by a distance,  $D$ . The resistors,  $r_s$ , represent the coupling resistance of the gap junctions between adjacent photoreceptors while the photoreceptors themselves, positioned at every node of the grid, are represented by a capacitance and a membrane resistance.

to a continuous and homogeneous sheet. The distribution of voltage in this model is given by a second-order partial differential equation for which useful analytical solutions have been found [6].

Bipolar cells, in contrast to horizontal cells, are not strongly coupled and also differ from horizontal cells in having a receptive field comprising two distinct regions. A relatively narrow central region receives input from overlying photoreceptors but outside this lies an annulus of inhibitory, or antagonistic surround. If a spot of light falling in the central region depolarizes the bipolar cell, a spot falling in the surround would hyperpolarize the cell, and a large patch of light covering both center and surround would produce no sustained response (although it would produce transient responses when the light comes on and when it goes off). Loosely speaking, the bipolar cell receptive field is generated from the sum of the inputs from overlying photoreceptors and a sign-reversed input from horizontal cells of much larger spatial extent, as summarized in Fig. 3. How horizontal cell inputs “sum” is not entirely clear and there is evidence supporting both inhibitory synaptic feedback to photoreceptor terminals and inhibitory synaptic feedforward to bipolar cells as well. Neither of these proposed mechanisms is entirely satisfactory and an alternative

idea based on extracellular current flow has recently been revived [7].

The lateral spread of signal between neurons coupled together via gap junctions can be inferred from intracellular recording from a pair of cells. Current injected into one cell produces a voltage in the other, and by examining pairs of neurons at known separations, it is possible to measure signal spread directly and estimate the electrical parameters of the network. This direct approach has been applied to photoreceptors and horizontal cells but a less direct method has proved useful between other cell types. The injection of small tracer molecules, often fluorescent molecules, into a single cell, implies the presence of coupling gap junctions if fluorescence appears in nearby cells. This method is not easily amenable to quantitative analysis, moreover gap junctions differ in the size of tracer molecule they allow to pass, nevertheless it has the huge advantages that intracellular injection into only a single neuron is required, and even very sparse connections can be revealed this way. The tracer molecules Biocytin and Neurobiotin have revealed a previously unsuspected wealth of coupling, both homo- and heterotypic, between neurons in the inner retina. Although this coupling implies the lateral spread of signal, electrical coupling between neurons is known to serve other

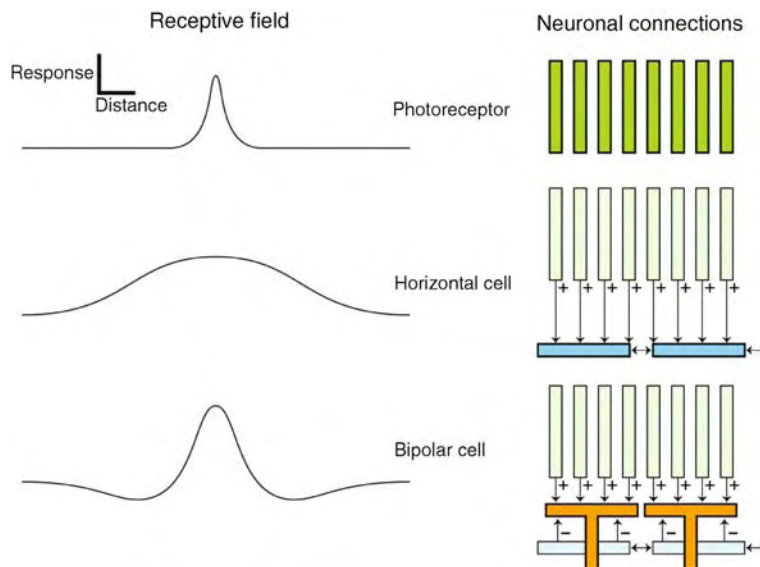

**Retinal Lateral Interactions. Figure 3** The receptive fields of the neurons in the outer retina and an explanatory schematic showing how these receptive fields are generated. For simplicity only one spatial dimension is shown, equivalent to mapping receptive fields using a long thin bar of light moved orthogonal to its long axis. Photoreceptors, shown in green, have narrow receptive fields, only slightly wider than the width of an individual receptor. Horizontal cells (blue), in contrast, have wide receptive fields because they collect signals from all their overlying photoreceptors and are strongly coupled to each other, thereby allowing signals to spread laterally. Bipolar cells (orange) collect signals from a relatively small group of overlying photoreceptors but also receive signals of opposite sign from nearby horizontal cells. This arrangement gives rise to a receptive field in which light falling in the center of the field, dominated by direct input from overlying photoreceptors, produces a response whose sign is opposite to that produced by more lateral stimuli in which horizontal cell input dominates.



functions, such as the synchronization of spiking, and it may transpire that the spatial aspects of this coupling are inconsequential.

### Higher Level Processes

Perceptual illusions (► [Visual illusions](#)), such as Mach bands and the Hermann grid illusion, originate from lateral interactions in the retina [8].

### Lower Level Components

Lateral interactions are mediated through gap junctions and synapses. In some instances it is possible to say which specific gap junction subunits are present in which retinal neurons but in many instances this is not yet known. The synapses and their ► [transmitters](#) mediating lateral interactions are known in outline but, as always, the details of the inner retina are much less clear than those of the outer retina.

### Process Regulation

A large body of evidence shows that many, but not all, of the gap junctions that mediate lateral signal spread in the retina can be functionally closed by transmitters and ► [neuromodulators](#). Best known is the example of coupling between horizontal cells in the retinas of fish and turtle [9,10]. ► [Dopamine](#), which is released by neurons in the inner retina, and plays a role in switching the retina from ► [scotopic](#) to ► [photopic](#) conditions, clearly uncouples horizontal cells by elevating intracellular ► [cAMP](#), thereby decreasing the receptive field size of these neurons and greatly restricting the ability of injected dye molecules to move between cells. A similar effect is seen in AII ► [amacrine cells](#) [11] that, in low-light conditions when rod photoreceptors dominate, are coupled together and are a crucial link in the transmission of rod signals.

In addition to dopamine, ► [nitric oxide](#) also closes gap junctions, in this case acting through ► [cGMP](#), and probably also plays a role in light/dark adaptation, though how these two agents, dopamine and nitric oxide and perhaps others, act together and what their different functional roles might be, is not known. In general though, there are good theoretical arguments for modulating the spatial dimensions of lateral inhibition to optimize it for different ambient light intensities. In flies, the measured spatial extent of lateral inhibition is reasonably well matched to theory [12] but in vertebrate retina no similar comparison has been attempted.

### Function

Lateral inhibition clearly enhances edges, which, very likely, is a necessary step in the task of parsing the visual world into separate, identifiable objects. Unfortunately, this idea does not lead easily to a quantitative theory.

Another way of looking at the function of lateral inhibition, initiated by H. B. Barlow and subsequently

built on by others, has its roots in ► [information theory](#) and is known as *predictive coding* (► [Sensory systems](#)). The starting point for this approach is the postulate that the visual system is interested in all spatial information, i.e. edges are accorded no special *a priori* value. Key ideas are (1) that the retina has been optimized for efficiency of information transfer to the brain. This is a plausible conjecture, if only because there are obvious anatomical constraints on the thickness of the ► [optic nerve](#) and therefore the number of output channels from the retina. A more subtle constraint is exercised by intrinsic noise within a neuron that limits its information carrying capacity. (2) There exist statistical regularities in the spatial and temporal structure of the images falling on the retina. For example, the intensity of light falling on any point in the retina is likely to be similar to the intensities found adjacent to that point, first, because of blurring caused by the eye's optical limitations, and second, because the visual world is not a random pattern of dots. (3) From point 2, we can say that some information is redundant and, on the basis of point 1, ought not to be transmitted to the brain.

Lateral inhibition performs this task of redundancy removal and permits the efficient use of the limited bandwidth provided by retinal neurons. Simply put, this view of lateral inhibition is that it is a way of computing a best guess for the signal expected at any point in the retina, based on a weighted sum of the signals from points around it. This best guess is then subtracted from the actual signal, thereby allowing any deviations from the guess to fill the bandwidth of that neuron.

On the basis of these arguments we would predict that the strength and extent of lateral inhibition should be matched to the statistics of different visual environments. An important contributor to these statistics is the variance in the number of photons arriving, which is a function of light intensity. At low light intensities a statistically reliable best guess requires that a large number of points be included, in other words lateral inhibition should become broader [12]. At higher light levels, where signal-to-noise ratios are higher, the best guess would include only those points in the immediate neighborhood.

The spatial characteristics of different scenes, a beach versus a forest for example, ought, from the principles of predictive coding, to elicit different lateral interactions within the retina. Some evidence from ganglion cell recordings suggests that this may be occurring in the inner retina, probably mediated by amacrine cells, though the mechanism is presently unknown [13].

While lateral inhibition has provided a path into some of the deepest questions concerning the design of the nervous system, positive lateral interactions have also stimulated a careful consideration of function.

The function of coupling between horizontal cells is fairly apparent, but what about photoreceptor coupling? At first sight this is puzzling, not only because

photoreceptor coupling is apparently the opposite of lateral inhibition, for which there is a good understanding, but also because it must degrade spatial resolution.

A crucial concept in understanding photoreceptor coupling is that photoreceptors are very high-gain detectors for which noise is an inescapable problem. Some of this noise is produced by the thermal activation of the molecules involved in transduction (►[Phototransduction](#)) but a large contribution comes from chance fluctuations in the number of photons caught. Even for cones operating in the photopic range, few enough photons are caught per integration time that these fluctuations compromise the reliability of the signal. Coupling between photoreceptors is a form of signal averaging that improves the signal-to-noise ratio by canceling out some of the uncorrelated noise found in every cell. This engineering trick necessarily involves trading a gain in reliability (improved signal-to-noise ratio) for spatial resolution. But the trade is definitely worthwhile. In the case of mammalian cones, coupling increases the signal-to-noise ratio by about 70% by allowing some signal to leak into neighboring photoreceptors. The spatial blurring this causes actually turns out to be less than the blurring caused by the imperfect optics of the eye, so in fact no resolution is sacrificed by coupling [14].

While mammalian cones have coupling that is, in effect, strong enough to spread signals only to immediate neighbors but no further, poikilothermic vertebrates have somewhat stronger coupling between their photoreceptors. Undoubtedly the same arguments about signal-to-noise ratio apply, but as first noticed by Hodgkin and his collaborators, signal spreads a long way through the rod network shortly after a light comes on, but then contracts down to a much smaller area. A plausible, though unproven idea stemming from this finding is that the retina, at the level of bipolar cells, might employ two sampling strategies to read the rod network: one with good temporal resolution but poor spatial resolution, and the other with the converse properties [5].

## References

1. Passaglia CL, Enroth-Cugell C, Troy JB (2001) Effects of remote stimulation on the mean firing rate of cat retinal ganglion cells. *J Neurosci* 21:5794–5803
2. Hartline HK, Ratliff F (1957) Inhibitory interaction of receptor units in the eye of *Limulus*. *J Gen Physiol* 40:357–376
3. Lamb TD, Simon EJ (1976) The relation between intercellular coupling and electrical noise in turtle photoreceptors. *J Physiol* 263:257–286
4. Attwell D, Wilson M (1980) Behaviour of the rod network in the tiger salamander retina mediated by membrane properties of individual rods. *J Physiol* 309:287–315
5. Detwiler PB, Hodgkin AL, McNaughton PA (1980) Temporal and spatial characteristics of the voltage response of rods in the retina of the snapping turtle. *J Physiol* 300:213–250
6. Lamb TD (1976) Spatial properties of horizontal cell responses in the turtle retina. *J Physiol* 263:239–255
7. Kamermans M, Fahrenfort I, Schultz K, Janssen-Bienhold U, Sjoerdsma T, Weiler R (2001) Hemichannel-mediated inhibition in the outer retina. *Science* 292:1178–1180
8. Spillmann L (1994) The Hermann grid illusion: a tool for studying human perspective field organization. *Perception* 23:691–708
9. Teranishi T, Negishi K, Kato S (1983) Dopamine modulates S-potential amplitude and dye-coupling between external horizontal cells in carp retina. *Nature* 301:243–246
10. Dowling JE (1992) The Charles F. Prentice Medal Award Lecture 1991: dopamine; a retinal neuromodulator. *Optom Vis Sci* 69:507–514
11. Xia XB, Mills SL (2004) Gap junctional regulatory mechanisms in the AII amacrine cell of the rabbit retina. *Vis Neurosci* 21:791–805
12. Srinivasan MV, Laughlin SB, Dubs A (1982) Predictive coding: a fresh view of inhibition in the retina. *Proc R Soc Lond B Biol Sci* 216:427–459
13. Hosoya T, Baccus SA, Meister M (2005) Dynamic predictive coding by the retina. *Nature* 436:71–77
14. DeVries SH, Qi X, Smith R, Makous W, Sterling P (2002) Electrical coupling between mammalian cones. *Curr Biol* 12:1900–1907

## Retinal Photoreceptors

NATHAN S. HART

School of Biomedical Sciences, University of Queensland, St. Lucia, Brisbane, QLD, Australia

### Synonyms

Visual cells; Rods; Cones

### Definition

Photoreceptor cells are light-sensitive neurons that respond with a graded change in the release of ►[neurotransmitter](#) (►[Glutamate](#)) from their ►[synaptic terminal](#). Photoreceptors are found in most classes of metazoan organism and vary widely in structure and function. Photoreceptors are predominantly located in the ►[retina](#) of both invertebrate and vertebrate eyes, where they are involved in vision, but they may also be located extraocularly on the integument or in the brain.

### Characteristics

#### Quantitative Description

Photoreceptors are neurons that respond with a graded change in transmembrane potential (►[Membrane potential – basics](#)), to the absorption of photons by light-sensitive proteins (►[Photopigments](#)) embedded in specialized regions of their plasma membrane. The size,

shape, ultrastructure, biochemistry, electrical properties and developmental origins of photoreceptors vary considerably across the animal kingdom. For the sake of brevity, the following descriptions are related to vertebrate visual photoreceptors (rather than non-visual retinal or extraocular photoreceptors), and in most cases, draw upon mammalian examples.

### Photoreceptor Types

The vertebrate retina is inverted by virtue of its developmental origins and, consequently, the photoreceptors are situated close to the ►sclera at the back of the eye. They point away from the incident light, which must traverse the other retinal layers before reaching the photoreceptors [1]. There are two distinct types of retinal photoreceptor: ►rods that operate under low light (►Scotopic) levels of illumination and ►cones that operate under bright light (►Photopic conditions). The rod-cone nomenclature reflects differences in aspects of photoreceptor morphology in the mammalian retina: the outer segments of rods are rod-like whereas cone outer segments are typically conical (Fig. 1).

However, it should be remembered that this is not always the case – even within the same retina – and it can be misleading to classify photoreceptors using

morphology alone; rods and cones also differ in their biochemistry, physiology and function.

The human retina contains a single type of rod photoreceptor but three spectrally distinct cone types, which each contain a different cone photopigment maximally sensitive to blue, green and red light (see ►Photopigments). The cones of humans and other placental mammals, lungfish and elasmobranchs are all of the “single” type. Amphibians, marsupials, monotremes, birds, reptiles and teleost fish possess an additional photoreceptor type that consists of a pair of closely opposed cone cells. They are usually referred to as double cones when the two members are unequal in size – with a larger “principal” and a smaller “accessory” member – and twin cones when the two members are of similar size and shape. The closely opposed outer segments of the two members are separated from those of other photoreceptors – but not each other – by the processes of ►retinal pigmented epithelium (RPE) cells; the two members are thought to be both optically and electrically coupled.

Double cones are more widely distributed among the vertebrate classes, and both members usually contain the same spectral type of photopigment. Often, but not always, the principal member (and occasionally the accessory member) contains an oil droplet (see below). Twin cones occur predominantly in teleost fishes, and may have identical or distinct photopigments in each member, even within the same retina.

### Retinal Topography

The absolute density and relative proportion of rods and cones varies as a function of visual ecology. Strongly diurnal species (e.g. most birds, turtles) have a lower rod:cone ratio than nocturnal species (e.g. many rodents) and, in some cases, lack rods altogether (e.g. lizards). The average human retina contains about 4.6 million cones and 92 million rods, giving a rod to cone ratio of about 20:1 (excluding the ►fovea). In contrast, nocturnal rodents have rod to cone ratios of around 100:1 [2].

Moreover, the topographic distribution of photoreceptors across the retina is usually non-uniform. Most animals have a retina with one or more areas of increased photoreceptor density, which permit increased spatial sampling of the retinal image and provide high acuity vision over a defined region of visual space. The areas are often circular and usually occur in the central (►Area centralis) or temporal (►Area temporalis) retina, but may also form horizontal streaks (►Area horizontalis).

In some cases, the vitreal surface of the retina is indented above the area of highest photoreceptor density. This type of area is called a fovea, and the foveal indentation or pit is a result of the lateral displacement of secondary retinal neurons from the

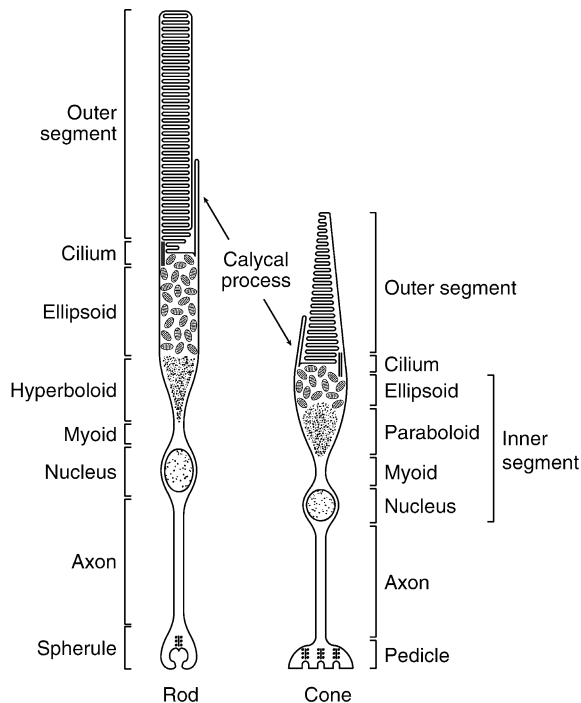

**Retinal Photoreceptors. Figure 1** Schematic representations of vertebrate rod and single cone retinal photoreceptors. Oil droplets – found in the photoreceptor ellipsoid in some species – are not shown. See text for details.

optical path, to provide the incident light with unimpeded access to the photoreceptor layer. The shape of the foveal pit varies in curvature, and may serve to magnify the image projected onto the retina by virtue of the difference in ▶refractive index between the vitreous and retina. The human fovea contains approximately 200,000 cones, with reported peak densities ranging from 100,000 to 320,000 cells  $\text{mm}^{-2}$ . Cone density falls rapidly with increasing eccentricity: at  $10^\circ$  eccentricity – or 3 mm from the centre of the fovea – it averages 7,000 cones  $\text{mm}^{-2}$ . Rods are excluded from the human fovea but attain their highest density of around 160,000 cells  $\text{mm}^{-2}$  in a perifoveal ring located at  $18^\circ$  eccentricity or about 5 mm from the centre of the fovea [3].

### Description of the Structure

Vertebrate photoreceptors are comprised of three morphologically and functionally distinct regions: the outer segment, inner segment and synaptic terminal.

#### Outer Segment

Human rod outer segments are 2  $\mu\text{m}$  in diameter and vary in length with retinal eccentricity from 24  $\mu\text{m}$  at the periphery to 40  $\mu\text{m}$  in the parafoveal region. Human foveal cone outer segments are 30–40  $\mu\text{m}$  in length, are less tapered/conical than cones located in the periphery and have a diameter of about 0.8  $\mu\text{m}$  [1]. The outer segments of cones in the peripheral retina are more conical but only about half as long. Photoreceptor outer segment dimensions also vary widely with habitat and life history. For example, nocturnal species, or those inhabiting light-limited environments such as the deep sea, tend to have longer and wider outer segments than diurnal species in order to capture more of the available light.

Rod outer segments consist of stacks of isolated membranous discs or “sacculles” bounded by the plasma membrane. Each sacculle is around 19 nm in thickness. The periodicity of sacculle spacing is 28 nm and, in humans, there are around 1,000 sacculles in each rod outer segment. In contrast, cone outer segments are formed by multiple infolding of the plasma membrane. Both the sacculle and infolded plasma membranes are packed with photopigment molecules that absorb the incident light. The high lipid content of the outer segment endows it with a high refractive index relative to the surrounding extracellular space. Consequently, the outer segment acts as a waveguide, and light entering at the base is contained and propagated along its length by total internal reflection.

The base of the outer segment is connected to the inner segment by a modified non-motile ▶cilium, which projects through a narrow cytoplasmic bridge (“ciliary stalk”) that is 1  $\mu\text{m}$  in length. In some species, such as rodents, a second contiguous cytoplasmic bridge is observed. A number of fine processes originating from the inner segment, called calycal

processes, extend distally along the outer segment for approximately one third of its length and probably provide mechanical support. In rod outer segments, the calycal processes are contiguous, with indentations in the plasma membrane that overlie – but do not invaginate – scalloped incisures in the radial edge of the saccule membrane.

#### Inner Segment

The inner segment contains all the structures necessary for cellular metabolism and protein synthesis. It may also contain organelles that help to capture and/or spectrally filter the incident light and to focus it onto the outer segment. The most important structures are described below:

#### Ellipsoid

Photoreceptors contain numerous ▶mitochondria in the distal portion of their inner segment. These are packed together in a highly refractile body called the ellipsoid, and may be oriented with their long axis parallel to that of the photoreceptor, as in mammals, or clumped randomly. Photoreceptors are energetically demanding cells and the mitochondria must generate sufficient adenosine triphosphate (ATP) to support cellular function, in particular the maintenance of ▶sodium/potassium ( $\text{Na}^+/\text{K}^+$ ) pumps (Ion transport) in the plasma membrane, the production of photopigment molecules and the turnover of guanosine 3',5' cyclic monophosphate (cGMP; see ▶Phototransduction).

In the mammalian retina, cones contain many more mitochondria than rods, but it is not readily apparent why they should do so on a metabolic basis [4]. It is possible that they also have an optical function by increasing the refractive index of the inner segment. Both the inner and outer segments have a higher refractive index than the surrounding medium and, at least in cones, the inner segment is significantly wider than the outer segment. Light striking the inner segment is funnelled by total internal reflection into the outer segment, a physical phenomenon known as waveguiding. Consequently, the cross-sectional area of the inner segment, rather than that of the outer segment, defines the photon capture area of the photoreceptor. Human foveal cones are 2.3  $\mu\text{m}$  in diameter whereas those in the peripheral retina are 7.9  $\mu\text{m}$  in diameter, a difference that confers a 12-fold increase in photon capture area and, therefore, optical sensitivity [1].

The ellipsoids of some species show further specializations. The proximal region of the cone ellipsoid in some lizards contains aggregations of extended endoplasmic reticula, known as refractile bodies, which may well have a light-gathering function in addition to any putative metabolic storage role. Similarly, tree shrews (*Tupaia* sp.) have large distended mitochondria (“megamitochondria”) with visible but irregular cristae, which may confer

an enhanced light-gathering ability to the ellipsoid. This structure could replace the colorless oil droplets present in the cones of their ancestors and retained by marsupials but lost by other placental mammals [5]. Other modified mitochondria (ellipsosomes) are present in the ellipsoids of teleost fish and contain filtering pigments that resemble reduced cytochrome C.

### Oil Droplets

The photoreceptors of a number of species contain an inclusion located either within or just distal to the ellipsoid, known as an oil droplet. As their name suggests, oil droplets are composed predominantly of lipids, but they may also contain light-absorbing ►carotenoid pigments. Pigmented oil droplets are found in the cones of birds, turtles, lizards and lungfish; colorless oil droplets occur in some geckos, anuran amphibians, chondrosteian fishes, marsupials and some monotremes. Oil droplets are absent from lampreys, teleosts, elasmobranchs, snakes, crocodylians and placental mammals [6].

Pigmented oil droplets act as filters that tune the spectral sensitivity of the photoreceptor, in most cases narrowing the spectral sensitivity function and shifting the wavelength of peak sensitivity to a wavelength longer than the wavelength of maximum absorbance ( $\lambda_{\max}$ ) of the photopigment in the outer segment. Non-pigmented oil droplets probably serve a similar function to ellipsosomes in capturing and focusing light into the outer segment.

### Paraboloid and Hyperboloid

The rod and cone inner segments of some holosteans, amphibians, birds and reptiles contain a granular structure proximal to the ellipsoid known as the paraboloid (cones) or hyperboloid (rods). It is thought to act as a store of glycogen, presumably supporting the high metabolic activity of the cell.

### Myoid

The myoid region lies proximal to the ellipsoid (and paraboloid/hyperboloid if present) but distal to the nucleus. It contains free ribosomes, rough endoplasmic reticulum (RER) and the Golgi apparatus, and it is the site of protein synthesis in the photoreceptor. Photopigment ►messenger RNAs from the nucleus migrate to the RER and are translated into opsin proteins (see ►Photopigments) that are eventually packaged into small vesicles by the Golgi apparatus. These vesicles migrate to the ciliary stalk, pass through the cytoplasmic bridge into the outer segment and become incorporated in the saccule and plasma membranes. In some lamprey and lizard species, the entire myoid contains a diffuse yellow-orange pigment that, like the pigmented oil droplets, spectrally filters the incident light before it reaches the outer segment.

In some “lower” vertebrates (e.g. fish, amphibians) the myoid is motile. Cone myoids contract in the light and elongate in the dark; the opposite is true for the rod myoid. These so called “retinomotor movements” are substantial (50–70  $\mu\text{m}$ ) and represent a form of light/dark adaptation, the function of which is to shield the rods in the retinal pigmented epithelium during the day but fully expose them at night. Myoid contraction and elongation is controlled by both light-dependent and endogenous (circadian) mechanisms [7].

### Synaptic Terminal

Beneath the myoid lies the nucleus and, proximal to this, a thin fiber (axon) that connects the inner segment to the synaptic terminal. The synaptic terminal of a photoreceptor cell ramifies in the outer plexiform layer of the retina and is the site of communication with other retinal neurons. The graded changes in outer segment transmembrane potential that occur as a result of the phototransduction process propagate electrotonically (►Electrotonic spread) to the synaptic terminal and are communicated to other retinal neurons in two ways. Firstly, the electrical potential may be transferred passively to adjacent photoreceptors via low-resistance intercellular junctions, called ►gap junctions. Secondly, changes in membrane potential at the synaptic terminal alter the internal  $\text{Ca}^{2+}$  concentration and modulate the rate at which ►synaptic vesicles fuse with the plasma membrane and release neurotransmitter (glutamate) into the synapse.

The morphology of rod and cone synaptic terminals differs markedly. The rod synaptic terminal (“►spherule”) is roughly spherical and contains a single invagination (“synaptic cleft”) within which lie the processes of two to five rod bipolar cells and two horizontal cells (►Retinal bipolar cells; ►Inherited retinal degenerations; ►Vision). The cone synaptic terminal (“►pedicle”) is much larger and almost pyramidal in shape. In the mammalian retina, peripheral cones have much larger pedicles than foveal cones and display as many as 50 synaptic clefts. Like the rod spherule, the synaptic clefts of cone pedicles contain the processes of two or more cone bipolar cells and two horizontal cells [8].

In both rod and cone synaptic terminals, the active zone immediately above the synaptic clefts contain one (cones) or two (rods) synaptic ribbons that modulate the release of neurotransmitter (see ►Ribbon synapses). Rod and cone bipolar cell processes entering the synaptic cleft are termed “central” or “invaginating” processes. Other bipolar cell processes contact the cone pedicle on either side of the invaginating processes (“semi-invaginating” processes) or diffusely across the base of the pedicle (“flat” processes). Consequently, each cone pedicle may make several hundred synapses with 10 or more postsynaptic neurons.

## Higher Level Structures

In the mammalian retina, rods contact only one type of bipolar cell, the rod ON bipolar (►[Retinal bipolar cells](#)). Cone photoreceptors synapse with up to 11 different types of ON and OFF cone bipolar cells. In other vertebrates, both rods and cones may contact the same bipolar cell, which may be either ON or OFF and either rod- or cone-dominated. Photoreceptors are presynaptic to horizontal cells in a sign-conserving manner, i.e. ►[hyperpolarization](#) of the photoreceptor transmembrane potential results in a hyperpolarization of the horizontal cell. However, horizontal cells feed back onto photoreceptors in a sign-inverting manner that antagonizes the effects of transmembrane hyperpolarization, reduces glutamate release and allows the outer retina to adapt to steady illumination [1].

## Regulation of the Structure

In the dark, a balanced flow of cations into the outer segment and out of the inner segment (known as the dark current) maintains a moderate depolarization of the transmembrane potential. The magnitude of the dark current in the rods (−34 pA) and cones (−30 pA) is similar in the macaque monkey. Stimulation of photoreceptors with light causes a reduction in the dark current due to phototransduction. This change in dark current is called the photocurrent and, although both rods and cones are capable of signaling the absorption of a single photon of light, the photocurrent produced by a single photoisomerization event (see ►[Phototransduction](#)) is much smaller in cones (33 fA) than it is in rods (700 fA) [1]. Consequently, more photons per unit time are required by cones than rods to provide a large enough change in glutamate release at the synaptic terminal to be reliably detected by the bipolar cells and, therefore, rods are better for vision under low levels of illumination.

There are also qualitative differences in the time course of the photocurrent between rods and cones. The magnitude of the photocurrent peaks about 50 ms after the onset of light in primate cones but takes up to four times longer in the rods. Moreover, the rod photocurrent decays more slowly, taking up to one second to return to zero, whereas cones recover up to five times faster. These differences in response and recovery kinetics enable cone pathways to respond to higher temporal frequencies than the rods, although at the expense of absolute sensitivity.

Photoreceptor outer segments are renewed continuously. Rod saccules are shed from the distal tip of the outer segment in packets of 8–30, where they are taken up in phagocytotic vesicles (“phagosomes”) by RPE cells. Shed saccules are replaced by the synthesis of additional membrane at the base of the outer segment, where new photopigment molecules generated in the inner segment are incorporated. Cones shed and

regenerate membrane in a similar fashion to rods, although newly synthesized photopigment molecules can diffuse to any location in the membrane, as the outer segment is not compartmentalized. Membrane shedding follows a circadian rhythm; cone membranes are shed after dusk when the visual system begins to rely on rods, and rod saccules are shed at dawn when cones become dominant [9].

## Function

The retina is a two-dimensional sensor array that extracts salient features from the image of a three-dimensional world projected onto the back of the eye by the lens and cornea (►[Vision](#)). The size, packing density, spectral sensitivity and electrical response characteristics of the photoreceptors limit the spatial, temporal and chromatic information that can be extracted from that image.

Rods are more sensitive than cones and are used in dim light (scotopic) conditions. Most vertebrates, including humans, have only one spectral class of rod and, consequently, are essentially color blind at night. Cones, on the other hand, function at higher (photopic) light levels. The possession of both scotopic and photopic photoreceptor types – otherwise known as a ►[duplex retina](#) – has the primary function of extending the range of light intensities over which the visual system is operational. For most animals, this range varies over 10 log units from starlight to bright sunlight [1].

Where multiple spectral types of cone are present, their outputs can be compared by secondary neurons to extract chromatic information from the retinal image. The ability to distinguish objects based on their color (spectral reflectance) independently of brightness is called color vision (►[Color processing](#)). Most mammals have only two spectral types of cone and have a dichromatic color vision system. Humans and some primates have three spectral cone types and are trichromats. Birds have a tetrachromatic color vision system based on four spectral types of single cone photoreceptor [10]. The function of double/twin cones is unclear, despite being the most numerous photoreceptor types in many species. Limited evidence suggests that, at least in the avian retina, double cones mediate purely achromatic (brightness discrimination) tasks, including motion detection, and are not involved in color vision.

## References

1. Rodieck RW (1998) The first steps in seeing. Sinauer Associates, Sunderland, MA
2. Ahnelt PK, Kolb H (2000) The mammalian photoreceptor mosaic – adaptive design. *Prog Retin Eye Res* 19:711–777
3. Curcio CA, Sloan KR, Kalina RE, Hendrickson AE (1990) Human photoreceptor topography. *J Comp Neurol* 292:497–523

4. Hoang QV, Linsenmeier RA, Chung CK, Curcio CA (2002) Photoreceptor inner segments in monkey and human retina: mitochondrial density, optics, and regional variation. *Vis Neurosci* 19:395–407
5. Knabe W, Skatchkov S, Kuhn HJ (1997) “Lens mitochondria” in the retinal cones of the tree-shrew *Tupaia belangeri*. *Vis Res* 37:267–271
6. Walls GL (1942) The vertebrate eye and its adaptive radiation. Hafner, New York
7. Burnside B, Wang E, Pagh-Roehl K, Rey H (1993) Retinomotor movements in isolated teleost retinal cone inner-outer segment preparations (CIS-COS): effects of light, dark and dopamine. *Exp Eye Res* 57:709–722
8. Haverkamp S, Grünert U, Wässle H (2000) The cone pedicle, a complex synapse in the retina. *Neuron* 27:85–95
9. Nguyen-Legros J, Hicks D (2000) Renewal of photoreceptor outer segments and their phagocytosis by the retinal pigment epithelium. *Int Rev Cytol* 196:245–313
10. Hart NS (2001) The visual ecology of avian photoreceptors. *Prog Retin Eye Res* 20:675–703

## Retinal Pigment Epithelium

### Definition

These cells form the outer part of the vertebrate retina, forming the outer blood-retinal barrier and providing key roles in chromophore recycling and transport of metabolites and metabolic byproducts.

- ▶ [Inherited Retinal Degenerations](#)
- ▶ [Photoreceptors](#)

## Retinal Ribbon Synapses

CATHERINE W. MORGANS, PHILIPPA R. BAYLEY  
Neurological Sciences Institute, Oregon Health and Science University, Beaverton, OR, USA

### Definition

Ribbon synapses are specialized synapses of the primary sensory neurons of the eye (retinal ▶ [photoreceptors](#)) and ear (▶ [cochlear hair cells](#) and ▶ [vestibular hair cells](#)). They are also formed by ▶ [retinal bipolar cells](#), ▶ [vestibular receptor cells](#), and fish ▶ [electroreceptors](#). Morphologically, these synapses are characterized by a presynaptic electron-dense bar, the ▶ [synaptic ribbon](#), at the site of ▶ [neurotransmitter](#) release (Fig. 1). Ribbon synapses support continuous release of the

neurotransmitter ▶ [glutamate](#), and modulate the rate of release in response to graded changes in membrane potential (▶ [Membrane potential – basics](#)).

### Characteristics

#### Description of the Structure

Anatomically, ribbon synapses are characterized by the presence of a structural specialization of the ▶ [active zone](#), the synaptic ribbon. The synaptic ribbon is a planar structure in retinal photoreceptors and bipolar cells, and a spheroid structure in inner ear hair cells where it is also referred to as a “synaptic body” (Fig. 1). The ribbons are attached to the plasma membrane and typically extend perpendicularly into the cytoplasm up to several hundred nanometers. The ribbon is surrounded by a monolayer of ▶ [synaptic vesicles](#) that are tethered to the ribbon by fine filaments. Vesicles at the base of the ribbon are docked on the plasma membrane and represent the readily releasable pool of synaptic vesicles. Those tethered further up the ribbon provide a reserve pool of synaptic vesicles. Synaptic ribbons vary in size and shape depending on the cell, but for a particular cell type, such as the mammalian rod photoreceptor, the total ribbon area and geometry vary comparatively little, even between species.

Photoreceptor ribbon synapses are the most structurally complex of ribbon synapses. Photoreceptor ribbon synapses are formed by an invagination into the photoreceptor terminal, over the apex of which lays the synaptic ribbon, and into which postsynaptic processes from ▶ [horizontal cells](#) (▶ [Lateral interactions in the retina](#), ▶ [inherited retinal degenerations](#), ▶ [vision](#)) and bipolar cells protrude (Fig. 1). Rod photoreceptor terminals (referred to as ▶ [spherules](#)) contain a single invagination that gives rise to one or two ribbon synapses [1], whereas cone photoreceptor terminals (referred to as ▶ [pedicles](#)) contain 10–30 invaginations, depending on whether they are in the central or peripheral retina, each invagination corresponding to a single ribbon synapse (Fig. 1). The large synaptic ribbons of rod photoreceptors curve around the invagination in a characteristic horseshoe shape, which can be clearly discerned at the light microscopic level by immunofluorescent staining of ribbon proteins (such as bassoon or RIBEYE, see Fig. 2).

The photoreceptor synaptic ribbon is attached to the plasma membrane via a linear, trough-shaped structure, the ▶ [arciform density](#). The arciform density defines the site of neurotransmitter release, or active zone, of the photoreceptor ribbon synapse (Fig. 2b). The plasma membrane is pinched where it contacts the arciform density to form a ridge along the underside of the invagination. Synaptic vesicles at the base of the ribbon are docked on the plasma membrane, fusing on either side of the arciform density. Two postsynaptic horizontal cell processes, known as “lateral elements,” extend

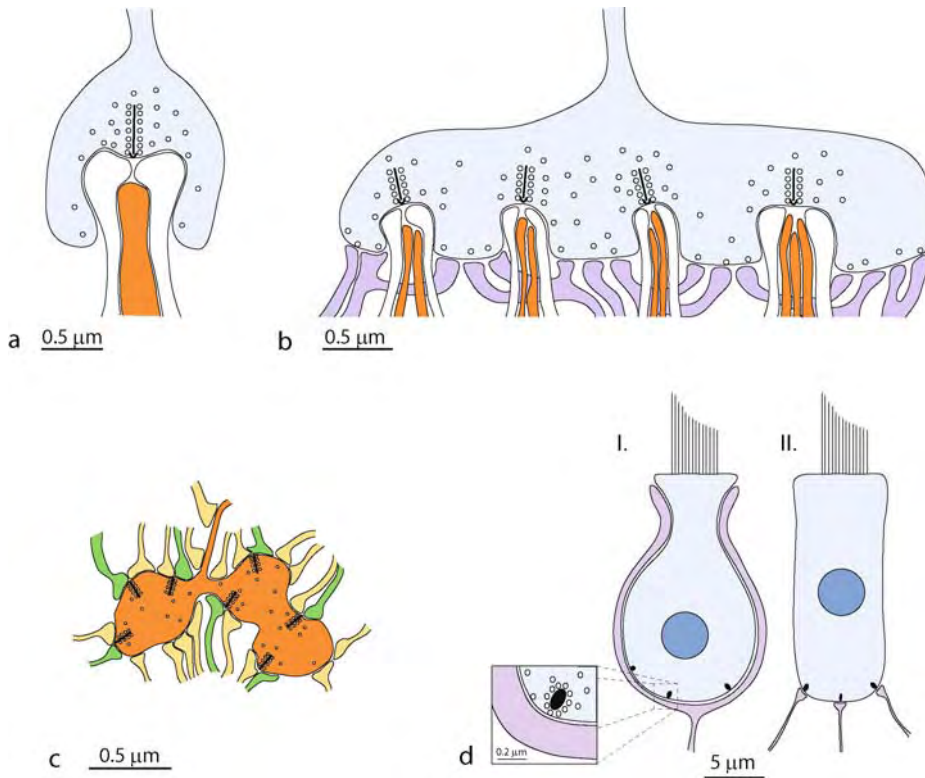

**Retinal Ribbon Synapses. Figure 1** Schematic diagrams of ribbon synapses in the retina and inner ear, drawn approximately to scale (as indicated). (a) Rod photoreceptor terminal (spherule) containing a vesicle-covered synaptic ribbon with an arciform density at its base. Postsynaptic horizontal cell (white) and rod bipolar cell (orange) processes protrude into the invagination, opposed to the site of transmitter release. (b) Cone photoreceptor terminal (pedicle) containing four separate ribbons with their associated arciform densities, and postsynaptic invaginations of horizontal cell (white) and ON-cone bipolar cell (orange) processes. OFF-cone bipolar cells (purple) make synapses at flat contacts, outside the invaginations. (c) Cone bipolar cell terminal (orange) containing multiple small ribbons. Postsynaptic amacrine cell (yellow) and ganglion cell (green) processes are opposed to the sites of neurotransmitter release. (d) Type I (I.) and type II (II.) inner ear hair cells contain spherical synaptic bodies, covered with tethered vesicles. Type I hair cells form a single calyceal terminal, whereas type II hair cells make synapses with individual afferent boutons, each bouton receiving input from a single ribbon.

their tips close to the synaptic ribbon. One or more bipolar cell processes, known as “central elements”, occupy the central region of the invagination, with their tips located at a further distance from the ribbon. An electron micrograph of a photoreceptor ribbon synapse will often exhibit a “triad” arrangement, with two horizontal cell processes flanking a single bipolar cell process within the invagination postsynaptic to the ribbon. Rods make synaptic contacts with only one type of bipolar cell, the rod bipolar cell. Cones contact both ON-bipolar cells (depolarize in light) and OFF-bipolar cells (hyperpolarize in light) ([▶Retinal bipolar cells](#)). At cone ribbon synapses it is only the ON-bipolar cells that extend their dendrites into the invagination; OFF-bipolar cells contact cone pedicles outside the invaginations at basal contacts.

Bipolar cell and hair cell ribbon synapses are simpler in structure ([Fig. 1](#)). They both lack invaginations and

arciform densities. It is unclear how the ribbons are anchored to the plasma membrane in these cells. As in photoreceptors, bipolar cell synaptic ribbons are planar structures sitting perpendicular to the plasma membrane above a linear active zone, although they are smaller than photoreceptor ribbons. Two postsynaptic processes from amacrine cells ([▶Retinal direction selectivity: role of starburst amacrine cells](#)) and ganglion cells ([▶Retinal ganglion cells](#)) abut the bipolar cell membrane, one on either side of the active zone. Each bipolar cell terminal forms multiple ribbon synapses.

Hair cells also contain multiple ribbons, averaging ~20/cell, each covered with a layer of one hundred to several hundred tethered synaptic vesicles. Each hair cell ribbon synapse releases glutamate onto a single postsynaptic ending/contact. Type I vestibular hair cells are enveloped by a single calyceal terminal, which receives the output from all of the hair cell’s ribbon synapses;



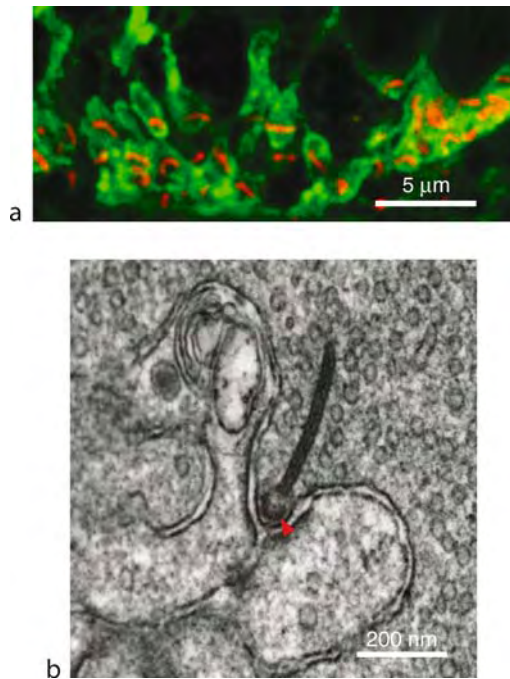

**Retinal Ribbon Synapses.** Figure 2 (a) Individual arc-shaped synaptic ribbons, labeled with an antibody to RIBEYE (red), are seen within rod and cone photoreceptor terminals (green) in a confocal micrograph through the outer plexiform layer of the rat retina. (b) Rod ribbon synapse ultrastructure is observed in more detail by transmission electron microscopy. The synaptic ribbon, in transverse section, is perpendicular to the cell membrane, and overlies an arciform density (red arrowhead). Vesicles of neurotransmitter are evident throughout the terminal, with a subset of these tethered to the ribbon. Postsynaptic horizontal and rod bipolar cell processes invade the terminal, opposed to the site of neurotransmitter release.

whereas each ribbon synapse of a type II vestibular hair cell has a separate post-synaptic dendrite [2]. Hair cells in the cochlea also have only one post-synaptic afferent/dendrite per ribbon [3]. Hair cell synaptic ribbons are often spherical, but elongated and planar ribbons are also found, especially in type II vestibular hair cells.

### Quantitative Description of Ribbon Synapses in the Retina

Reconstruction of rod spherules in the cat retina reveal a planar synaptic ribbon  $\sim 2 \mu\text{m}$  in length (or two half-sized ribbons), extending from the plasma membrane into the cytoplasm by  $\sim 0.4 \mu\text{m}$ . Each face of the ribbon binds approximately 385 synaptic vesicles, 65 of which lie along the bottom of the ribbon docked at the plasma membrane on each side of the arciform density. Cone synaptic ribbons are smaller but more numerous than in rods. Cone ribbons are  $\sim 1 \mu\text{m}$  long and extend from the plasma membrane into the cytoplasm by  $\sim 0.2 \mu\text{m}$ .

Although different ribbons within a cone terminal vary in length, the total ribbon length and number of tethered vesicles per cone is quite uniform within a retinal locus. The 20 or so ribbons in a primate foveal cone tether a total of  $\sim 3,600$  synaptic vesicles,  $\sim 720$  of which are docked at the plasma membrane [4]. Bipolar cells, depending on their type, contain from 30–100 synaptic ribbons, but they are small compared to photoreceptor ribbons, tethering several dozen vesicles each. The total number of ribbons and associated docked vesicles per synaptic terminal may be related to the information content that has to be transmitted by the neuron [4]. For example, rod photoreceptors transmit the detection of single photons in very dim light, like starlight, whereas cones must transmit finely graded changes over orders of magnitude of light intensity (Photoreceptors, Phototransduction).

The most detailed and quantitative description of a ribbon synapse has been obtained for the mammalian rod photoreceptor. Digital reconstruction of primate and cat rod spherules from serial electron micrographs has revealed the following invariant features of rod ribbon synapses [1]: Each spherule contains a single invagination approximately  $1 \mu\text{m}$  in diameter, and two synaptic units. Post-synaptically, each unit is made up of two lateral elements (horizontal cell dendrites) and at least one central element (rod bipolar cell dendrite). Although there are always two sets of postsynaptic processes, presynaptically a spherule may contain either one or two synaptic ribbons. However, even in cases where a spherule contains a single ribbon, the ribbon contacts two discrete arciform densities, each  $\sim 1.0 \mu\text{m}$  in length. Typically, the two arciform densities are in different planes, so that a single ribbon will twist to contact both. The volume of extracellular space within the invagination is small, roughly  $0.1 \mu\text{m}^3$ , and the most distant bipolar cell glutamate receptors from the active zone (as defined by the arciform density) are within  $1.5 \mu\text{m}$ . Thus, diffusion of glutamate to receptors on all postsynaptic processes should be rapid.

### Higher Level Structures

The principal component of synaptic ribbons is the ribbon-specific protein, RIBEYE, composed of a unique N-terminal domain possessing a self-aggregating activity that may be important for the polymerization of the ribbons, and a C-terminal domain that is identical (minus the first 20 amino acids) to the transcriptional co-repressor, C-terminal binding protein 2 (CtBP2) [5]. Other proteins associated with the ribbons are components of the presynaptic matrix at conventional synapses including RIM (rab3-interacting protein), and the large ( $>400 \text{ kD}$ ) scaffolding proteins bassoon and piccolo, suggesting that at least some aspects of ribbon function are equivalent to that served by the presynaptic matrix at the active zone of conventional synapses. Bassoon has

been localized by post-embedding immuno-electron microscopy to the base of photoreceptor ribbons close to the plasma membrane, whereas piccolo and RIM are localized towards the distal portion of the ribbon [6]. In mice deficient in bassoon, photoreceptor and hair cell synaptic ribbons are either absent or free-floating in the cytoplasm [7,8] suggesting that bassoon is required for anchoring the ribbons to the plasma membrane.

The presynaptic  $\text{Ca}^{2+}$  channels at ribbon synapses are localized to the plasma membrane at the base of the ribbons [6]. Ribbon synapse  $\text{Ca}^{2+}$  channels belong to the L-type  $\text{Ca}^{2+}$  channel family (►[Calcium channels – an overview](#)), and are of the subtypes Cav1.3 ( $\alpha_{1D}$ ) in cone photoreceptors and hair cells, and Cav1.4 ( $\alpha_{1F}$ ) in rod and cone photoreceptors and some bipolar cells. A distinctive characteristic of the ribbon synapse  $\text{Ca}^{2+}$  channels is that they are non-inactivating, an essential property for maintaining transmitter release during prolonged depolarization, as occurs in darkness.

The majority of synaptic vesicle-associated proteins are identical between ribbon and conventional synapses; however, there are a few significant differences [9]. For example, ribbon synapses are the only synapses known not to contain ►[synapsins](#), peripheral membrane proteins of synaptic vesicles at conventional synapses. Synapsins immobilize synaptic vesicles in the absence of action potentials by linking them to the actin-based cytoskeleton, and then release them upon  $\text{Ca}^{2+}$  influx to replenish the readily releasable pool. At ribbon synapses, which are tonically active, synaptic vesicles are in constant flux and synapsins are not needed. Retinal ribbon synapses also differ in which ►[syntaxin gene](#) they express. At conventional synapses, syntaxin 1 is one of the key proteins catalyzing synaptic vesicle fusion. Retinal ribbon synapses are the only synapses known not to contain syntaxin 1 but to contain syntaxin 3 instead. This substitution may reflect differences in the regulation of synaptic vesicle fusion between ribbon and conventional synapses.

### Function

Ribbon synapses are formed by sensory neurons of the visual, auditory, and vestibular systems. These neurons are electrotonically compact (►[Electrotonic spread](#)), and track changes in external stimuli with graded changes in their membrane potential (in contrast to axon-bearing neurons that fire action potentials). The graded changes in membrane potential in turn modulate the rate of tonic release of the neurotransmitter, glutamate. Synaptic ribbons are not found in neurons that undergo action potential-driven transmitter release. As at other chemical synapses, neurotransmitter is released at ribbon synapses by the  $\text{Ca}^{2+}$ -dependent fusion of neurotransmitter-filled synaptic vesicles with the plasma membrane. Calcium enters the nerve terminal through voltage-sensitive  $\text{Ca}^{2+}$  channels that open in response to membrane depolarization and close upon hyperpolarization. Photoreceptors

are depolarized in darkness and undergo a continuous stream of synaptic vesicle fusion in this state. Absorption of photons hyperpolarizes the photoreceptor, closing  $\text{Ca}^{2+}$  channels and reducing glutamate release (►[Phototransduction](#)). The synaptic ribbons most likely serve to maintain a pool of synaptic vesicles in close proximity to the active zone, and ensure the continual replenishment of synaptic vesicles during prolonged depolarizations. They have also been proposed to facilitate compound fusion of vesicles, or simultaneous fusion of multiple vesicles [10].

The critical role of the synaptic ribbons in ►[synaptic transmission](#) at ribbon synapses is illustrated by the phenotype of the bassoon knockout mouse. Elimination of bassoon prevents synaptic ribbons from anchoring at the plasma membrane. The physiological consequence is a drastic impairment of synaptic transmission between photoreceptors and depolarizing bipolar cells [7]. Likewise, in hair cells of the bassoon knockout mouse, patch-clamp recordings (►[Intracellular recording](#)) indicate a 50% reduction in fast ►[exocytosis](#). The hair cell recordings also reveal substantially smaller  $\text{Ca}^{2+}$  currents in the bassoon knockout mouse compared to wild-type, suggesting that recruitment and stabilization of  $\text{Ca}^{2+}$  channels at hair cell active zones may be dependent on association with synaptic ribbons [8].

Retinal Essays: (photoreceptor outer segments), (►[retinal bipolar cells](#)) and (lateral interactions in the retina).

### References

1. Migdale K, Herr S, Klug K, Ahmad K, Linberg K, Sterling P, Schein S (2003) Two ribbon synaptic units in rod photoreceptors of macaque, human, and cat. *J Comp Neurol* 455:100–112
2. Lysakowski A, Goldberg J (1997) A regional ultrastructural analysis of the cellular and synaptic architecture in the chinchilla cristae ampullares. *J Comp Neurol* 389:419–433
3. Fuchs PA, Glowatzki E, Moser T (2003) The afferent synapse of cochlear hair cells. *Curr Opin Neurobiol* 13:452–458
4. Sterling P, Matthews G (2005) Structure and function of ribbon synapses. *Trends Neurosci* 28:20–29
5. Schmitz F, Konigstorfer A, Sudhof T (2000) RIBEYE, a component of synaptic ribbons: a protein's journey through evolution provides insight into synaptic ribbon function. *Neuron* 28:857–872
6. tom Dieck S, Altmann WD, Kessels MM, Qualmann B, Regus H, Brauner D, Fejtova A, Bracko O, Gundelfinger ED, Brandstatter JH (2005) Molecular dissection of the photoreceptor ribbon synapse: physical interaction of Bassoon and RIBEYE is essential for the assembly of the ribbon complex. *J Cell Biol* 168:825–836
7. Dick O, tom Dieck S, Altmann W, Ammermuller J, Weiler R, Garner C, Gundelfinger E, Brandstatter J (2003) The presynaptic active zone protein bassoon is essential for photoreceptor ribbon synapse formation in the retina. *Neuron* 37:775–786

8. Khimich D, Nouvian R, Pujol R, tom Dieck S, Egner A, Gundelfinger ED, Moser T (2005) Hair cell synaptic ribbons are essential for synchronous auditory signalling. *Nature* 434:889–894
9. Morgans CW (2000) Presynaptic proteins of ribbon synapses in the retina. *Microsc Res Tech* 50:141–150
10. Prescott ED, Zenisek D (2005) Recent progress towards understanding the synaptic ribbon. *Curr Opin Neurobiol* 15:431–436

such as the pathways through the suprachiasmatic nucleus or pre-tectum involve smaller numbers of ganglion cells and in some cases have specialized functions (e.g. suprachiasmatic nucleus is involved in diurnal rhythms).

- ▶ [Retinal Ganglion Cells](#)
- ▶ [Suprachiasmatic Nucleus](#)
- ▶ [Vision](#)
- ▶ [Visual Processing Streams in Primates](#)

## Retinal Slip

### Definition

Motion of the visual image on the surface of the retina. Slip of the visual image across large portions of the retina is the stimulus that stimulates optokinetic eye movements, and also the stimulus that produces the adaptation (improvement) of the optokinetic system.

- ▶ [Optokinetic Response Adaptation](#)

## Retinitis Pigmentosa

### Definition

A group of hereditary retinal degenerations characterized by loss of peripheral vision (constricted visual fields) and night vision (nyctalopia). Although a vast variety of genetic mutations have been identified, patients with Retinitis Pigmentosa display similar symptoms and ocular fundus appearance in the end stage of the disease: bone spicule pigment deposits, pale atrophic optic nerve head and attenuated blood vessels.

- ▶ [Inherited Retinal Degenerations](#)

## Retino-geniculo-cortical Pathway

### Definition

A large fraction (at least 90%) of retinal ganglion cells project to visual cortex through the lateral geniculate nucleus. This pathway is thought to be most important for visual perception. Non-geniculo-cortical pathways,

## Retinohypothalamic Tract

IGNACIO PROVENCIO

Department of Biology, University of Virginia,  
Charlottesville, VA, USA

### Synonyms

RHT

### Definition

A monosynaptic neural projection that extends from the ▶ [retina](#) to the hypothalamus.

### Characteristics

#### Origin and Projections

The retinohypothalamic tract (RHT) originates from a subset of ▶ [retinal ganglion cells \(RGCs\)](#). In rodents, this small cohort of cells represents only about 1–2% of all RGCs of which 80% or more express the ▶ [photopigment melanopsin](#), thereby making them intrinsically photosensitive. However, compared to ▶ [rod and cone photoreceptors](#), these photoreceptive cells are relatively insensitive to light. The sparse, varicose dendritic arbors of murine ▶ [intrinsically photosensitive RGCs \(ipRGCs\)](#) arise from 2 or 3 primary dendrites emanating from perikarya about 20 μm in diameter. ipRGC dendritic fields have a mean diameter of 450 μm and tile the retina with substantial overlap. The arbors themselves contain melanopsin and are capable of ▶ [phototransduction](#), giving each of these cells a capture radius of approximately 15° of visual space. These overlapping dendrites coupled with the relative photic insensitivity of ipRGCs are consistent with the sensory characteristics observed in many non-visual responses to light such as the synchronization (▶ [entrainment](#)) of circadian rhythms to the astronomical day. Relative to the visual system, the circadian axis requires higher levels of light to elicit a response and can integrate photic stimuli over longer temporal intervals and broader

spatial domains. In essence, while the visual system functions like a camera, the “photoreceptive net” arising from the widely distributed ipRGCs functions like a photographer’s light meter [1,2].

In most animals examined to date, the ipRGCs are distributed evenly throughout the retina. In rats and primates, however, there is a shallow density cline peaking in the superiotemporal and parafoveal retinal domains, respectively. The principal target of the RHT is the ►suprachiasmatic nucleus (SCN), the site of a primary ►circadian pacemaker. The RHT is the anatomical route by which information about environmental light levels is conveyed from the eye to the SCN, where it is processed and used to entrain a multitude of circadian rhythms to the prevailing ►light:dark cycle. Among these are circadian rhythms of activity, daily variations in core body temperature, and 24-h rhythms in levels of hormones such as ►melatonin and cortisol [2,3].

The topography of the retinal innervation to the SCN is highly variable across mammalian species and even varies significantly among the rodents. In general, the ventrolateral aspect of the SCN receives the most dense innervation from the retina and is coextensive with the distribution of vasoactive intestinal peptide (VIP)-positive cells. However, it should be noted that the entire SCN receives some retinal afferents [3,4].

The degree to which the retina projects to each SCN also varies significantly among mammals. Contralaterality of retinal projections to central visual structures is highly correlated with the lateral placement of the eyes on the head. For example, mammals such as rodents with very limited binocular vision due to laterally positioned eyes show a high degree of contralaterality of the retinal projections to the dorsal lateral geniculate nucleus (LGN). By contrast, the retinal projections of primates and cats that have frontally positioned eyes are not contralaterally dominant, but rather extend an equal number of contralateral and ipsilateral retinal projections to the geniculate body.

The degree of bilaterality of the RHT demonstrates no such correlation to the lateralization or frontalization of the eyes. Perhaps the most striking example is that of the scaly anteater whose laterally placed eyes results in a total binocular field of only 15°, a feature that is reflected in the optic chiasm where greater than 99% of retinal fibers cross the midline and project to the contralateral lateral geniculate. However, both eyes project an equal number of axons to each SCN. As previously mentioned, primates, due to very frontalized eyes, have an extensive binocular visual field and accordingly, have equally weighted bilateral projections to central visual sites. This is in stark contrast to the projections to the SCN which are heavily ipsilaterally weighted. For example, in the gibbon, almost 90% of fibers emerging from one retina project to the ipsilateral SCN, whereas visual projections are balanced [5].

In the hamster, about 5% of the RGCs of the RHT bifurcate and send axonal collaterals to both SCN. In addition, some RGCs that project to the SCN via the RHT also send axonal collaterals to other non-visual retinorecipient sites in the brain such as the ►intergeniculate leaflet and the ►olivary pretectal nucleus. Whether this is a common feature across all mammals remains to be determined [4]. It should be noted that while the SCN is the primary and best-studied target of the RHT, other hypothalamic sites receive RHT innervation. These include the retrochiasmatic area, the subparaventricular zone, the perisupraoptic nucleus and the lateral hypothalamus [2,3]. Understanding how these regions mediate responses to light is a subject of ongoing investigation.

### Neurotransmitters

There is abundant evidence that ►glutamate is the primary neurotransmitter of the RHT [6,7]. Among this evidence is the presence of anti-glutamate immunoreactivity in presynaptic terminals within the SCN of rat and mouse. Furthermore, glutamate release can be induced in the SCN by electrically stimulating the optic nerve and glutamate application mimics that effect of light on the SCN. However, some investigators have observed that application of glutamate onto the SCN does not accurately mimic the circadian phase shifting effect of light, although administration of the glutamate agonist *N*-methyl-*D*-aspartate (NMDA) does indeed mimic light and these effects can be blocked by NMDA antagonists. Intraperitoneal injection of MK801, a competitive NMDA receptor antagonist, blocks the phase-shifting effect of light on mouse circadian locomotor rhythms [4].

A hallmark of the lateral geniculate, a well-characterized target of glutamatergic neurotransmission, is an abundance of the ►glutamate vesicular transporters VGluT1 and VGluT2. The SCN, however, shows low expression of both of these proteins. The presence of glutamate receptors in the SCN, however, reinforces a prominent role for glutamate as the primary neurotransmitter of the RHT. In addition to NMDA receptors, ionotropic receptors sensitive for the glutamate agonist  $\alpha$ -amino-3-hydroxy-5-methylisoxazole-4-propionic acid (AMPA) are found throughout the SCN. In particular, receptors composed of the GluR2 subunits are localized to the ventrolateral aspect of the SCN where most axonal terminals of RGCs are found. It must be considered that glutamate receptors are frequently expressed in astrocytes, thus raising the possibility that glutamate functions indirectly as a neuromodulator. Alternatively, astrocytes themselves may serve as a source of glutamate, released in response to some other signal originating from the RHT. Finally, derivatives of glutamate, such as *N*-acetylaspartylglutamate (NAAG) may play a role in RHT neurotransmission. NAAG is released from RGC terminals in a

calcium-dependent manner and can be converted to its constituent amino acids within the synaptic cleft. The prospect of NAAG as a primary RHT neurotransmitter is diminished by the fact that it is only found in a fraction of the retinorecipient aspect of the SCN [4].

Nitric oxide (NO) also plays a critical role in transferring information about environmental light levels from the retina to the SCN. The phase shifting effect of light (or glutamate) on SCN slice preparations can be faithfully mimicked by NO generators such as sodium nitroprusside. Moreover, these effects are blocked by the application of the competitive nitric oxide synthase (NOS) inhibitor *N<sup>G</sup>*-nitro-*L*-arginine methyl ester (L-NAME). This inhibition, however, can be reversed by increasing the availability of *L*-arginine, the natural substrate of NOS. The emerging evidence suggests that glutamate released from the presynaptic terminals of retinal afferents binds to NMDA receptors in postsynaptic SCN cells. This, in turn, results in a transient increase in intracellular calcium concentrations, thereby leading to activation of nNOS and the subsequent production of NO [4,8]. Because of the inherent instability of NO, such a mechanism could provide very fine spatial and temporal resolution to signaling occurring at the synapses of retinal afferents.

► **Pituitary adenylyl cyclase activating peptide (PACAP)** is one of a handful of peptide transmitters that may modulate the glutamatergic-based signaling of the RHT. PACAP is colocalized with glutamate and it has been suggested that all melanopsin-containing RGCs express PACAP [9]. Evidence from other systems where a small-molecule and a peptide neurotransmitter coexist in presynaptic terminals has shown that the small molecule transmitter is released upon weak or transient presynaptic stimulation. Stronger tonic stimulation results in release of both classes of transmitter, thereby encoding a broad dynamic range of stimulus strength. Similarly, weak retinal illumination may result in the release of glutamate from RHT terminals, while higher levels of light induce the release of PACAP.

Several labs have conducted experiments where PACAP has been applied *in vitro* to SCN slices or infused *in vivo* to hamsters. These experiments have not produced a consensus regarding PACAP's role in RHT neurotransmission. Additionally, mice null for PACAP show modest circadian effects. They show no re-entrainment deficits when exposed to a shifted light:dark cycle, no diminution in the lengthening of circadian period in response to constant light, and no loss of ► **masking** behavior, i.e., acute light-induced suppression of nocturnal locomotor activity. However, these animals did exhibit attenuated circadian responses to ► **phase-advancing** or ► **phase-delaying** pulses of light and they displayed a modestly shortened ► **free-running** circadian ► **period**. The PACAP-specific receptor PAC1 has been knocked out in mice. The behavioral phenotype of these

mice is rather subtle; they exhibit light-induced phase delays of circadian activity rhythms that are about 30% longer than wild-type mice [4]. By contrast, mice null for the VPAC2 receptor, which binds PACAP and VIP, are ► **arrhythmic**. This dramatic phenotype, however, is difficult to attribute to PACAP signaling because of the non-specificity of the receptor [10].

Finally, the tachykinin, substance P (SP), has been implicated as a neuromodulator of the RHT. This implication has been challenged because localization of SP to any RGCs, much less RGCs that comprise the RHT, has been equivocal. It has been reported that SP does not colocalize with PACAP in the retina and that bilateral enucleation does not abolish SP immunoreactivity. SP's proposed neuromodulatory role in RHT transmission remains to be shown conclusively [4].

### Concluding Remarks

The identification and characterization of ipRGCs has provided new insight into a major constituent of the RHT. The specifics of how information is transferred from the retinal afferents to SCN neurons, and how this information is subsequently processed by these neurons remains a critical gap in our body of knowledge. However, it also represents a fertile field for future investigations.

### References

1. Berson DM (2007) Phototransduction in ganglion-cell photoreceptors. *Pflugers Arch* 454:849–855
2. Provencio I (2007) Melanopsin Cells. 1.20:423–431 In: Basbaum AI, Bushnell M, Smith D, Beauchamp G, Firestein S, Dallos P, Oertel D, Masland R, Albright T, Kaas J, Gardner E (eds) *The senses: a comprehensive reference*, Elsevier, Amsterdam, 4640 p
3. Moore RY, Leak RK (2001) Suprachiasmatic Nucleus. In: Takahashi JS, Turek FW, Moore RY (eds) *Circadian clocks: handbook of behavioral neurobiology*, vol 12. Kluwer Publishers, New York, p xxiii, 770 p
4. Morin LP, Allen CN (2006) The circadian visual system, 2005. *Brain Res Brain Res Rev* 51:1–60
5. Magnin M, Cooper HM, Mick G (1989) Retinohypothalamic pathway: a breach in the law of Newton-Muller-Gudden? *Brain Res* 488:390–397
6. Ebling FJ (1996) The role of glutamate in the photic regulation of the suprachiasmatic nucleus. *Prog Neurobiol* 50:109–132
7. Hannibal J (2002) Neurotransmitters of the retinohypothalamic tract. *Cell Tissue Res* 309:73–88
8. Gillette MU, Mitchell JW (2002) Signaling in the suprachiasmatic nucleus: selectively responsive and integrative. *Cell Tissue Res* 309:99–107
9. Hannibal J (2006) Roles of PACAP-containing retinal ganglion cells in circadian timing. *Int Rev Cytol* 251:1–39
10. Harmar AJ (2003) An essential role for peptidergic signalling in the control of circadian rhythms in the suprachiasmatic nuclei. *J Neuroendocrinol* 15:335–338

## Retinotopic

### Definition

Topographic arrangement of visual pathways and visual centers that reflects the spatial organization of the neurons responding to visual stimuli in the retina.

► Evolution of the Optic Tectum: In Amniotes

## Retinotopic Frame of Reference

### Definition

Also, “Oculocentric frame of reference.” A reference frame specifying the location of a visual target with respect to the position of the eyes in space.

## Retinotopy

### Definition

The visual field is represented in orderly maps in occipital cortex in retinal centered coordinates. The left half of the visual field is represented in the right hemisphere and vice versa, whereas the upper visual field is mapped to the inferior occipital cortex (below the calcarine sulcus) and vice versa. Therefore, when subjects hold their eye position constant (e.g. when they maintain central fixation), the region of occipital cortex that responds to a particular stimulus in the visual field can be determined within these maps. This is known as the retinotopic representation of the visual stimulus.

► Striate Cortex Functions  
 ► Vision  
 ► Visual Field

## Retroambiguus Nucleus

### Synonyms

► Nucl. Retroambiguus; ► Retro-ambiguus nucleus

### Definition

Nuclear region of the myelencephalon continuing to the upper cervical cord and integrated in cardiorespiratory functions.

► Myelencephalon  
 ► Prosencephalon

## Retrograde Amnesia

### Definition

There is memory loss for events prior to the incident (e.g., trauma), but memories from the distant past and the period following the incident are intact.

► Amnesia  
 ► Memory Improvement

## Retrograde Degeneration

► Chromatolysis

## Retrograde Interference

### Definition

The disruption of transfer from short- to long-term memory by distractions introduced after the initial items are acquired.

## Retrograde Messenger

TAKAKO OHNO-SHOSAKU

Department of Cellular Neurophysiology, Graduate School of Medical Science, Kanazawa University, Kanazawa, Japan

### Definition

Retrograde messenger is a chemical substance that is released from postsynaptic neurons and acts on

presynaptic neurons. In the nervous system, information coded by action potentials is transferred from neuron to neuron at a specialized site called “synapse” (Fig. 1). The transmission at ►chemical synapses is generally one-directional. Neurotransmitters are released from presynaptic terminals on the arrival of action potentials, and transmit a signal to postsynaptic neurons by activating the corresponding receptors (Fig. 1a). In contrast to this fundamental anterograde information transfer, the signaling from postsynaptic to presynaptic neurons is called retrograde signaling (Fig. 1b) [1,2]. The retrograde signaling can be mediated by either a diffusible factor that is called “retrograde messenger,” or a direct interaction of presynaptic and postsynaptic membrane-bound elements. In typical cases, a retrograde messenger is released from the postsynaptic site lacking morphologically specialized structures for release (e.g. ►active zone), activates the receptors located on presynaptic terminals, and influences the function of presynaptic terminals (i.e. transmitter release) (Fig. 1b).

## Characteristics

### Quantitative Description

The substances so far proposed as retrograde messengers are ►endogenous cannabinoids (endocannabinoids) [3], ►nitric oxide (NO), ►carbon monoxide (CO), ►arachidonic acid, platelet-activating factor, neurotrophic factors, and some classical neurotransmitters or neuropeptides [2]. Among them, endocannabinoids are the most widely accepted substances as retrograde messengers in the brain. Major endocannabinoids are arachidonylethanolamide (anandamide) and 2-arachidonoylglycerol (2-AG) (Fig. 2).

Anandamide is the amide of arachidonic acid with ethanolamine, and the molecular weight is

347.54. 2-AG is the glycerol derivative in which the second hydroxyl group is linked to arachidonic acid residue by an ester bond, and the molecular weight is 378.55. The structural features of endocannabinoids are quite different from classical neurotransmitters, and shared by lipid messengers such as eicosanoids, which mediate signals of inflammation and pain.

### Lower Level Components

#### Arachidonylethanolamide

Arachidonylethanolamide, known as “anandamide,” was the first endocannabinoid to be identified. The name of anandamide is based on the Sanskrit word for bliss and tranquility, *ananda*. Anandamide binds to both CB1 and CB2 ►cannabinoid receptors, but displays lower affinity for CB2 compared to CB1 receptors.

#### 2-Arachidonoylglycerol

2-Arachidonoylglycerol (2-AG) is another major endocannabinoid, and binds to both CB1 and CB2 receptors. 2-AG is widely distributed in the brain and periphery. The level of 2-AG is reported to be much higher (ca. 170 times) than anandamide in brain tissues. This molecule is the most likely candidate for the endocannabinoid that mediates retrograde synaptic modulation at hippocampal and cerebellar synapses.

#### Other Putative Endocannabinoids

Other putative endocannabinoids include noladin ether and virodhamine. Noladin ether is an ether-linked analogue of 2-AG. Virodhamine is the ester of arachidonic acid with ethanolamine. It is not determined whether these molecules actually mediate retrograde signals.

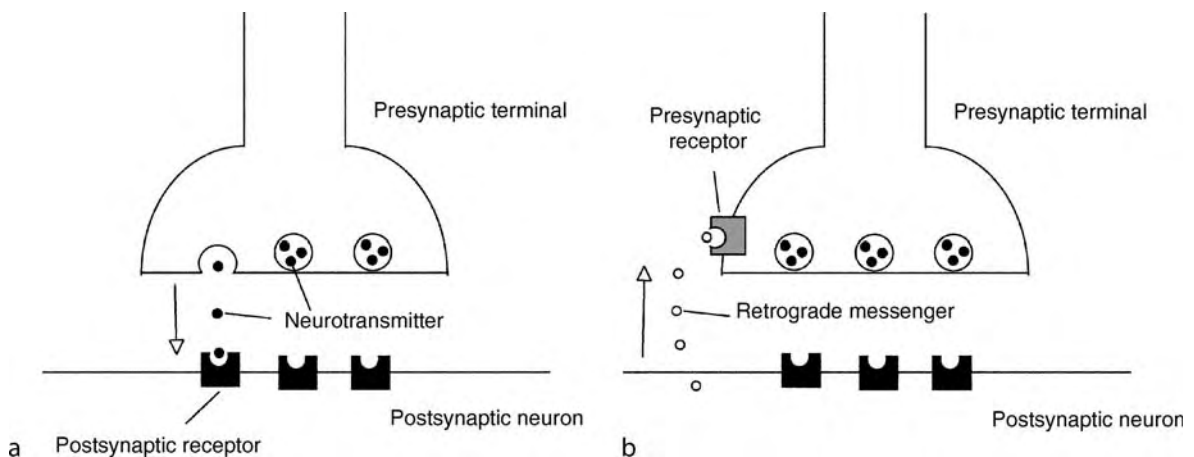

**Retrograde Messenger. Figure 1** Synaptic transmission and retrograde signaling. In synaptic transmission (a), neurotransmitters are released from presynaptic terminals, and bind to postsynaptic receptors. In retrograde signaling (b), retrograde messengers are released from postsynaptic neurons, and activate presynaptic receptors.

## Higher Level Processes

### Interneuronal Communication

In the anterograde signaling, classical neurotransmitters, neuropeptides, neurotrophic factors, and some other substances are released from presynaptic terminals, and produce rapid changes in membrane potential (i.e. generation of postsynaptic potentials) as well as long-term structural and metabolic changes in the postsynaptic cells. In the retrograde signaling, retrograde messengers including some of the substances used for the anterograde signaling are released from postsynaptic cells, and influence the function or morphology of presynaptic neurons. In addition to these diffusible factors, direct interactions of presynaptic and postsynaptic membrane-bound elements (e.g. cadherins) are also involved in interneuronal communication between presynaptic and postsynaptic neurons.

## Lower Level Processes

### Synthesis of Endocannabinoids (Anandamide and 2-AG)

Anandamide formation in neurons is a two-step process. The first step is the transfer of an arachidonic acid group from the *sn*-1 position of phosphatidylcho-

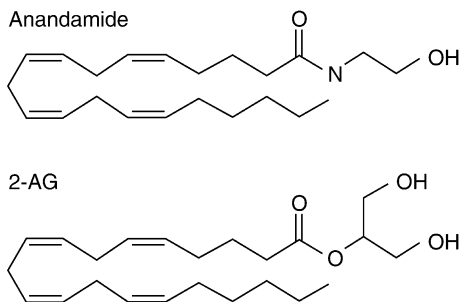

**Retrograde Messenger. Figure 2** Chemical structures of two major endocannabinoids.

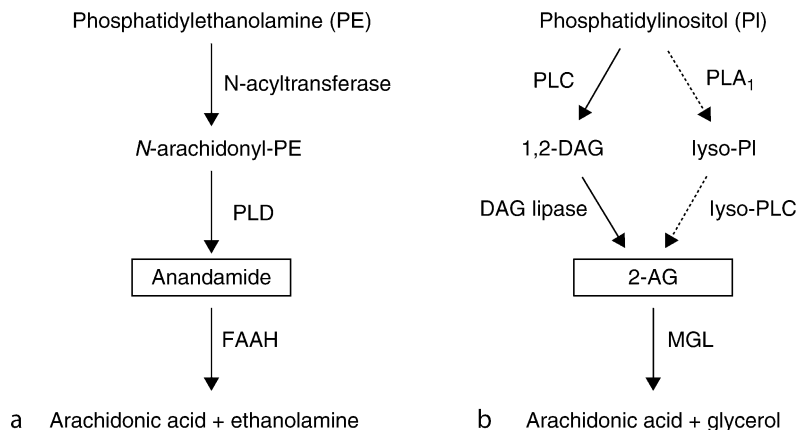

**Retrograde Messenger. Figure 3** Pathways of formation and degradation of two major endocannabinoids. *PLD* phospholipase D; *FAAH* fatty acid amide hydrolase; *PLC* phospholipase C; *PLA*<sub>1</sub> Phospholipase A<sub>1</sub>; *DAG* diacylglycerol; *MGL* monoacylglycerol lipase.

line to the head group of phosphatidylethanolamine (PE) by the enzyme *N*-acyltransferase, resulting in the formation of *N*-arachidonyl-PE. The second step is the cleavage of *N*-arachidonyl-PE by phospholipase D (PLD), which produces anandamide and phosphatidic acid (Fig. 3a) 2-AG is formed through two distinct pathways. The first step of the main pathway is the cleavage of phosphatidylinositol (PI) by the enzyme PI-specific phospholipase C (PI-PLC), producing 1,2-diacylglycerol (DAG). The second step is the further cleavage of DAG by DAG lipase, yielding 2-AG (Fig. 3b). The alternative pathway involves phospholipase A<sub>1</sub> and lyso-PLC. The PLD and DAG lipases responsible for endocannabinoid formation have been identified. Among several types of PI-PLC,  $\beta$  type PLC (PLC $\beta$ ) is the most important for 2-AG formation.

### Breakdown of Endocannabinoids (Anandamide and 2-AG)

Anandamide is broken down into arachidonic acid and ethanolamine by the enzyme fatty acid amide hydrolase (FAAH) (Fig. 3a). 2-AG is broken down into arachidonic acid and glycerol by the enzyme monoacylglycerol lipase (MGL) (Fig. 3b). These enzymes have been identified. They exhibit unique distributions in the brain. In general, FAAH is a postsynaptic enzyme, whereas MGL is presynaptic.

### CB1 Receptor Signaling at Presynaptic Terminals

The CB1 receptor is densely distributed on presynaptic axons and terminals in various regions of the brain. They include excitatory synapses on cerebellar Purkinje cells (both climbing fiber and parallel fiber synapses), inhibitory synapses on cerebellar Purkinje cells, part of hippocampal inhibitory synapses including CCK-positive basket cell to pyramidal cell synapses, and inhibitory synapses from the striatum to globus pallidus. Activation of presynaptic CB1 receptors suppresses the release of the



transmitters (glutamate or GABA). This CB1-mediated suppression can be caused by inhibition of voltage-gated  $\text{Ca}^{2+}$  channels, activation of  $\text{K}^{+}$  channels, direct effect on release machinery, or some other unknown mechanisms.

### Process Regulation

The release of retrograde messengers from postsynaptic neurons is generally controlled by neural activity. For example, endocannabinoids are produced on demand in response to depolarization-induced elevation of intracellular  $\text{Ca}^{2+}$  concentration [4,5], or activation of Gq-coupled receptors such as group I metabotropic glutamate receptors [6] and  $\text{M}_1/\text{M}_3$  muscarinic receptors [7] (Fig. 4). As endocannabinoids are membrane-permeable, they are considered to diffuse across the plasma membrane to the extracellular space immediately after production (Fig. 4).

Endocannabinoids are produced much more effectively when  $\text{Ca}^{2+}$  elevation and receptor activation coincide [8]. The released endocannabinoids then work as retrograde messengers (Fig. 4), and are removed from the extracellular space through uptake and enzymatic degradation. Other membrane-permeable factors such as NO and CO can be produced in response to certain conditions, and released to the extracellular space. In contrast, membrane-impermeable factors including classical neurotransmitters and neuropeptides are supposed to be stored in vesicles, and secreted through exocytotic mechanisms in response to certain triggering stimuli such as an elevation of intracellular  $\text{Ca}^{2+}$  concentration.

### Function

Retrograde messengers play important roles in formation, maturation, and plasticity of synaptic connections.

Among them, most attention has been focused on their crucial roles in activity-dependent modulation of synaptic transmission, including both short-term and long-term forms of synaptic plasticity.

Endocannabinoids mediate retrograde signals involved in several forms of short-term synaptic plasticity including **DSI**, **DSE**, and **receptor-driven retrograde suppression**. The CB1 receptor is widely distributed in the brain, and located densely on many, but not all, types of presynaptic terminals. At CB1-expressing synapses, endocannabinoids released from the postsynaptic neurons activate presynaptic CB1 receptors, and thereby suppress the transmitter release. Endocannabinoid release is triggered by elevation of intracellular  $\text{Ca}^{2+}$  concentration, activation of Gq-coupled receptors, or combination of the two [8] (Fig. 4). Under physiological conditions, endocannabinoid-mediated retrograde suppression is triggered by synaptic activity that can produce postsynaptic  $\text{Ca}^{2+}$  elevation and Gq-coupled receptor activation. Thus, the endocannabinoid-mediated retrograde suppression provides a feedback mechanism, by which the postsynaptic neurons receiving synaptic inputs can retrogradely influence the function of CB1-expressing presynaptic terminals. This endocannabinoid-mediated retrograde suppression is reversible and thus classified as a form of short-term synaptic plasticity. However, endocannabinoids are also involved in long-term synaptic plasticity, especially long-term depression (LTD), in some brain regions including the striatum and amygdala [9,10].

It has been reported that dopamine can be released from dendrites of dopaminergic neurons. Some other classical neurotransmitters or neuropeptides are also proposed to be released from dendrites [2]. They

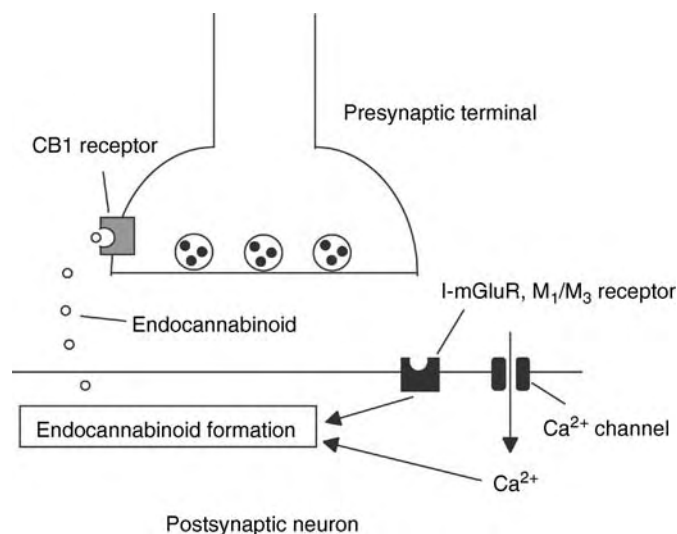

**Retrograde Messenger. Figure 4** Endocannabinoid-mediated retrograde signaling. Endocannabinoid production is induced by postsynaptic depolarization-triggered  $\text{Ca}^{2+}$  influx, or activation of Gq-coupled receptors such as group I metabotropic glutamate receptors (I-mGluRs) and  $\text{M}_1/\text{M}_3$  muscarinic receptors. The endocannabinoids that are produced are then released from postsynaptic neurons, and activate presynaptic CB1 receptors to suppress the transmitter release.

include glutamate, GABA, and dynorphin. Although the actual release mechanisms of these substances are not fully elucidated, it is likely that these substances also contribute to short-term plasticity.

Synaptic activity can induce long-term potentiation (LTP) or depression (LTD) depending on the pattern of activity. Membrane-permeable factors such as NO, CO, arachidonic acid and platelet-activating factor have been proposed to contribute to long-term synaptic plasticity, especially LTP. However, there are many controversial results, and general consensus has not yet been reached as to the possible roles of these factors as retrograde messengers in long-term synaptic plasticity.

Retrograde messengers also play important roles in formation, maturation and refinement of synaptic connections, especially at early developmental stages. These processes require information exchange between presynaptic and postsynaptic cells through anterograde and retrograde signals. Although molecular mechanisms of these signals are not clearly elucidated, it has been proposed that neurotrophic factors, including nerve growth factor (NGF) and brain-derived neurotrophic factor (BDNF), could play important roles in these processes.

## Therapy

### Cannabinoids for Therapies

Marijuana, which contains the natural cannabinoid  $\Delta^9$ -tetrahydrocannabinol, as well as several commercially-available synthetic cannabinoids (nabilone and dronabinol) are clinically effective for several disorders such as nausea from cancer chemotherapy, chronic pain, and exhaustion in AIDS patients. However, these drugs also have psychoactive side effects such as dizziness and thinking abnormalities. They are inherent problems, because the CB1 receptor is widely distributed in the brain. To avoid these problems, it has been attempted to develop drugs that enhance the endocannabinoid signaling in a target-specific manner.

## References

1. Tao HW, Poo M (2001) Retrograde signaling at central synapses. *Proc Natl Acad Sci USA* 98:11009–11015
2. Alger BE (2002) Retrograde signaling in the regulation of synaptic transmission: focus on endocannabinoids. *Prog Neurobiol* 68:247–286
2. Piomelli D, Giuffrida A, Calignano A, Rodriguez de Fonseca F (2000) The endocannabinoid system as a target for therapeutic drugs. *Trends Pharmacol Sci* 21:218–224
4. Wilson RI, Nicoll RA (2002) Endocannabinoid signaling in the brain. *Science* 296:678–682
5. Maejima T, Ohno-Shosaku T, Kano M (2001) Endogenous cannabinoid as a retrograde messenger from depolarized postsynaptic neurons to presynaptic terminals. *Neurosci Res* 40:205–210
6. Maejima T, Hashimoto K, Yoshida T, Aiba A, Kano M (2001) Presynaptic inhibition caused by retrograde signal from metabotropic glutamate to cannabinoid receptors. *Neuron* 31:463–475

7. Fukudome Y et al. (2004) Two distinct classes of muscarinic action on hippocampal inhibitory synapses: M2-mediated direct suppression and M1/M3-mediated indirect suppression through endocannabinoid signaling. *Eur J Neurosci* 19:2682–2692
8. Hashimoto Y et al. (2005) Phospholipase C $\beta$  serves as a coincidence detector through its Ca $^{2+}$  dependency for triggering retrograde endocannabinoid signal. *Neuron* 45:257–268
9. Marsicano G et al. (2002) The endogenous cannabinoid system controls extinction of aversive memories. *Nature* 418:530–534
10. Gerdeman GL, Ronesi J, Lovinger DM (2002) Postsynaptic endocannabinoid release is critical to long-term depression in the striatum. *Nat Neurosci* 5:446–451

## Retrograde Neuron Reaction

► Neuronal Changes in Axonal Degeneration and Regeneration

## Retrograde Tracing

### Definition

A method for visualizing the neurons of origin of an axonal pathway. A dye is injected into the region of the nervous system where axons are thought to terminate. The dye is absorbed by the axons and transported back to the cell bodies allowing them to be visualized.

## Retrograde Tracing Techniques

### Definition

Neuron tracing techniques take advantage of the fact that axoplasmic transport of materials goes in both directions within the axon. Retrograde flow of materials is toward the cell body. Early studies of retrograde transport used the enzyme horseradish peroxidase (HRP), which after injection into nerve tissue is picked up at axon terminals by micropinocytosis. The HRP is transported back to the cell body of the neuron where it can be made visible with a variety of chemical reactions. More recent studies use retrograde immunocytochemical and fluorescent labeling techniques to visualize neuron morphology.

## Retrograde Transport

### Definition

Retrograde transport is a process, mediated by the microtubule motor dynein, by which chemical messages are sent from the axon back to the cell. Fast retrograde transport can cover over 100 mm/day.

## Retronasal/Orthonasal Olfaction

### Definition

Orthonasal smell perception occurs when volatile molecules are pumped in through the external nares of the nose and activate the sensory cells in the olfactory epithelium. This is the route used to sense odors in the environment.

Retronasal stimulation occurs during food ingestion, when volatile molecules released from the food in the mouth are pumped, by movements of the mouth, from the back of the oral cavity up through the nasopharynx to the olfactory epithelium. It is activated only when breathing out through the nose between mastications or swallowings. This is the route used to sense aromas of food.

- ▶ Flavor
- ▶ Olfactory Epithelium

## Retrospective Monitoring

### Definition

Retrospective monitoring refers to metamemory experiences when one searches for and retrieves the origin and content of information stored in long-term memory.

It has been studied by examining the experiences of “tip-of-the-tongue” (TOT), which one has when the information one tries to remember feels like right on the edge of the tongue), and of “feeling-of-knowing” (FOK).

- ▶ Metacognition

## Retroviral Vectors

### Definition

These are retroviruses used to insert novel genes into neurons or other cells by infecting them.

## Rev-erb $\alpha$

### Definition

Member of the nuclear hormone receptors with hemin as a potential ligand. Identified as the main circadian repressor of the *Clock* and *Bmal1* genes. Nuclear orphan receptor that binds to the consensus sequence ([A/T]A[A/T]NT[A/G]GGTCA termed RORE, in the promoter of target genes. The gene is transcribed from the opposite strand of the *erba* gene, which is a cellular homolog of the viral oncogene *v-erbA*.

- ▶ Clock-Controlled Genes
- ▶ Clock Genes

## Reverberation

### Definition

The persistence of sound in an enclosed space, as a result of multiple reflections, after the sound from the source has stopped.

- ▶ Acoustics

## Reverberation Time

### Definition

The time between the offset of the originating sound and when the reverberant sound remaining in the enclosed space is 60 dB (a factor of 1,000 in pressure) less than the level of the originating sound.

- ▶ Acoustics

## Reversal Learning

### Definition

In reversal learning, a particular discrimination task is first learned and then the reinforcement contingencies are reversed. In other words, once the subject has learned to discriminate a reinforced from a non-reinforced stimulus, it has to learn to reverse its response to such stimuli. Such reversals tend to be difficult since there are negative transfer effects; e.g. the individual tends to persist in responding to the stimulus that was originally reinforced. Eventually, however, this tendency becomes weaker, and the response to the alternative stimulus becomes more frequent until it is consistently evoked.

► Reinforcement

## Reversal Potential

### Definition

Reversal potential (also called Nernst potential) is the membrane voltage at which there is no net flow of a particular ion from one side of the membrane to the other.

► Membrane Potential: Basics  
► Synaptic Transmission

## Reverse Real-Time quantitative PCR (RT-qPCR)

### Definition

Complementary DNA (cDNA) is first made from an RNA template, using a reverse transcriptase enzyme. A specific sequence of cDNA is then amplified and the amount of product produced at the end of each PCR cycle is evaluated by measuring signal strength of fluorescent markers. Since PCR generates products at an exponential rate, the relative abundance of template can be compared between samples. Alternatively the absolute abundance of template can be determined if reference dilutions of template are used. RT-qPCR can

also refer to Reverse Transcriptase quantitative PCR, Real-time quantitative PCR (PCR).

► Serial Analysis of Gene Expression

## Reverse Signaling: Nervous System Development

LI YU, YONG RAO

Centre for Research in Neuroscience, Department of Neurology and Neurosurgery, McGill University Health Centre, Montreal, QC, Canada

### Definition

Reverse signaling refers to the signaling mechanism by which a known membrane-bound ligand also functions as a receptor to trigger intracellular signaling events in the ligand-bearing cell, thereby modifying its behavior. Such dual function of a membrane protein as both ligand and receptor allows the ligand-receptor system to mediate bi-directional signal exchange between two neighboring cells, thus greatly increasing the plasticity of intercellular communications. Two major reverse signaling pathways mediated by ephrin and semaphorin have been implicated in regulating the development of the nervous system.

### Characteristics

#### Description of Reverse Signaling Mechanism

##### *Ephrin Reverse Signaling*

Ephrins were originally identified as ligands for the Eph-family receptor tyrosine kinases. Ephrins are divided into A and B subclasses. A subclass ephrins are tethered to the cell membrane by a glycosylphosphatidylinositol (GPI) anchor, while each B subclass ephrin contains a hydrophobic transmembrane segment spanning the plasma membrane followed by a short cytoplasmic domain [1–3]. Based on sequence homology and their preference for binding ephrins, Eph receptor tyrosine kinases are also classified into two subgroups, including ephrin-A-binding Eph-As and ephrin-B-binding EphBs [1–3].

Early studies of the ephrin-Eph interaction focused on understanding the signaling mechanism by which activation of Eph by ephrin modulates downstream signaling proteins to regulate cellular behaviors. This type of Eph-mediated signaling in response to ephrin binding is called ►forward signaling (Fig. 1). Each Eph family member has a highly conserved domain architecture in the cytoplasmic region that is comprised of a

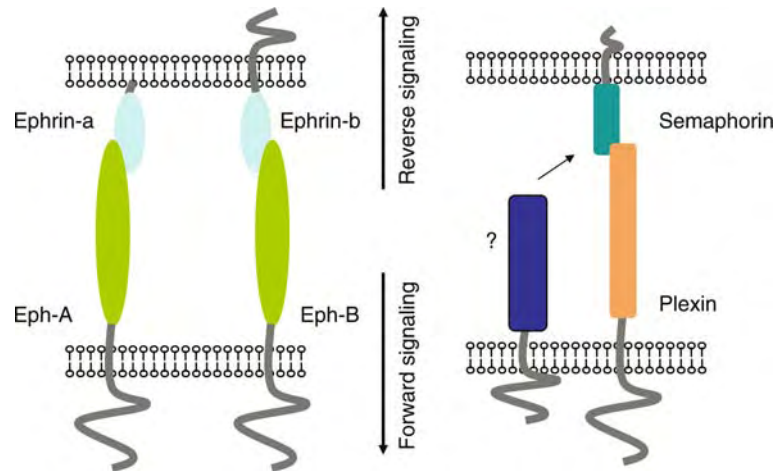

**Reverse Signaling: Nervous System Development. Figure 1** Bi-directional signaling mediated by two ligand-receptor systems. Binding of ephrin and semaphorin activates Eph and Plexin forward signaling, respectively. Binding of Eph and Plexin can also activate ephrin and transmembrane semaphorin to trigger reverse signaling, respectively. The identity of cell surface protein (colored in blue) that activates semaphorin reverse signaling during neural development is unknown.

juxtamembrane region, a kinase domain, a SAM (sterile  $\alpha$  domain) domain and a PDZ-domain binding motif [1–3]. Binding of ephrin to the extracellular region of Eph induces conformational changes, allowing the Eph cytoplasmic domain to modulate the activity and/or subcellular localization of downstream signaling proteins, which then modulate cytoskeletal reorganization leading to an attractive or repulsive response.

Later studies show that the binding between ephrin and Eph is capable of triggering downstream signaling events in both ephrin-expressing- (i.e., reverse signaling) and Eph-expressing (i.e., forward signaling) cells (Fig. 1), and thus mediates **▶bi-directional signaling** [1–3]. The action of ephrins as receptors to mediate reverse signaling relies on their ability to modulate the activity and/or subcellular localization of downstream signaling proteins in response to Ephs. EphrinBs can utilize both phospho-tyrosine residues and the PDZ domain-binding motif in its cytoplasmic domain to recruit downstream signaling proteins. For instance, Eph-induced ephrin-B1 phosphorylation of the conserved tyrosine residues provides a docking site for the **▶SH2 domain (Src Homology 2 Domain)** of the adaptor protein Grb4 [4]. Grb4 in turn links ephrin-B1 to multiple signaling pathways through the binding of its multiple **▶SH3 domain (Src Homology 3 Domain)** to proline-rich proteins (e.g., Abl-interaction protein-1 (Abi-1), c-Cbl-associated protein (CAP) and scaffolding protein axin), thus modulating **▶focal adhesion** and cytoskeletal reorganization [1,3]. Ephrin-Bs can also recruit downstream signaling proteins (e.g., glutamate-receptor-interacting-protein-1 (GRIP1), GRIP2, syntenin, protein kinase C-interacting protein-1 (PICK1),

tyrosine phosphatase PTP-BL, and PDZ-RGS3) in a phosphorylation-independent way via the PDZ domain-binding motif in their C-terminus [1,3]. Ephrin-B-mediated reverse signaling can also directly stimulate the enzymatic activity of Fak (focal adhesion kinase) to regulate focal adhesion [5].

Although ephrin-As do not have a cytoplasmic domain, they are also capable of mediating reverse signaling in response to Eph binding [1–3]. Ephrin-As are localized to **▶lipid rafts**, specific plasma membrane microdomains consisting of glycosphingo-lipids and cholesterol, where ephrin-As presumably associate with other membrane protein complexes. The activation of ephrin-As can lead to the recruitment of intracellular signaling proteins such as the **▶Src** family kinase Fyn to lipid rafts, which in turn regulates downstream proteins to modulate cytoskeletal reorganization and cell adhesion [6].

### **Semaphorin Reverse Signaling**

Semaphorins are a large family of secreted and transmembrane proteins that share a conserved ~500 amino-acid Semaphorin (Sema) domain at the amino terminus [7]. Semaphorins can also mediate bi-directional signaling. Semaphorins mediate forward signaling by functioning as ligands to bind and activate their receptors **▶Plexin** and **▶neuropilin**, which in turn initiate a cascade of signaling events in Plexin and/or neuropilin-expressing cells to regulate cytoskeletal changes for directed axonal growth and cell movement. Like ephrin-Bs, some transmembrane semaphorins can also mediate reverse signaling by utilizing their cytoplasmic domains to recruit intracellular signaling

proteins (Fig. 1). For instance, binding of Plexin-A1 to the extracellular region of Semaphorin-6D increases the association of its cytoplasmic domain with the Abl tyrosine kinase, but decreases its association with Mena, a member of the enabled (Ena)/vasodilator-stimulated phosphoprotein (Vasp) family proteins [7]. In *Drosophila*, it also appears likely that direct association of the transmembrane semaphorin-1a via its cytoplasmic domain with the fruitfly Enabled protein mediates semaphorin-1a-dependent reverse signaling [8]. The changes in the activity and/or localization of these semaphorin-associating intracellular signaling proteins contribute to the cytoskeletal reorganization necessary for cell migration and axonal projections.

### Function of Reverse Signaling in Neural Development

The function of reverse signaling in a ligand-receptor system mediating bi-directional signaling in neural development can be specifically assessed in several ways [2]. For instance, wild-type ligand or receptor in mice would be replaced with a mutant version incapable of interacting with intracellular signaling proteins by gene targeting, thus selectively inactivating reverse- or forward signaling, respectively. The contribution of reverse or forward signaling would then be assessed by comparing the phenotype displayed in the above mutants to that caused by the loss of both forward- and reverse signaling that occurs in receptor or ligand null mutants. Reverse signaling can also be selectively inactivated in zebrafish and *Xenopus* by expressing a dominant-negative version of a transmembrane ligand in which the cytoplasmic domain mediating reverse signaling is deleted. The dominant-negative mutant is still able to mediate forward signaling through binding to its receptor, but interferes with reverse signaling through competing with wild-type counterpart for receptor binding. In *Drosophila*, the contribution of reverse signaling can be determined by assessing whether null ligand mutants are rescued by expression of a mutant ligand that is capable of activating its receptor but defective in reverse signaling. The phenotype that is not rescued by the reverse-signaling-defective mutant ligand likely reflects the function of reverse signaling mediated by this ligand.

### Ephrin Reverse Signaling in the Vertebrate Neural Development

#### The Formation of Anterior Commissure Tract

The projection of both ►acP axon tract and ►acA axon tract of ►anterior commissure in mice requires ephrin reverse signaling [1,2]. Both ephrin-B2 and Eph-B2 are required for the guidance of acP axons. However, ephrin-B2 is expressed in acP axons and functions in a cell-autonomous manner, whereas Eph-B2 is expressed in cells underlying acP axons and is required non-cell-autonomously for the projection of acP axons. That the

guidance of acP axons requires an intact cytoplasmic domain of ephrin-B but not the kinase domain of Eph-B2 supports the involvement of ephrin-B2 reverse signaling in the guidance of acP axons. The activation of ephrin-B2 reverse signaling by Eph-B2 appears to initiate a repulsive response that guides acP axons toward the midline. The guidance of both acP and acA axons also requires the activation of ephrin-A reverse signaling by Eph-A4, which functions non-cell-autonomously as a ligand to attract acP and acA axons. The identity of the ephrin activated by Eph-B4 in acP and acA axons remains unclear.

#### Retinotectal Mapping Along Dorsal-ventral Axis

In the vertebrate visual system, retinal ganglion cells in the eye project axons into the optic tectum in a topographic fashion along both anterior-posterior and dorsal-ventral axes. While ►topographic projections of retinal ganglion axons along the anterior-posterior axis are directed by the ephrin-As-Eph-As forward signaling [1,3], dorsoventral topographic projections appear to require the ephrin-B-mediated reverse signaling [2]. In *Xenopus*, retinal ganglion cell axons display a decreasing dorsal-to-ventral expression gradient of ephrin-B2 and B3 in the retina, while Eph-B1 shows a complementary expression pattern (i.e., decreasing ventral-to-dorsal gradient) on cells in the optic tectum. In vivo and in vitro studies suggest strongly that Eph-B1 in the ventral tectum activates ephrin-B2 and B3 expressed on dorsal retinal ganglion axons to initiate reverse signaling leading to an attractive response, which targets dorsal ganglion axons toward the ventral tectum.

#### Establishment of Vomeronasal Map

The vomeronasal organ (VNO) is involved in detecting pheromones. VNO axons projected from the vomeronasal epithelium are targeted topographically to specific glomeruli comprised of sensory projections in the accessory olfactory bulb (AOB) during embryonic development. Topographic projections of VNO axons appear to involve an attractive response mediated by ephrin-A5 reverse signaling when activated by Eph-A6 [2]. Ephrin-A5 is expressed differentially in VNO axons and required for their topographic projections. The difference in the expression level of ephrin-A5 appears to dictate onto which regions of the accessory olfactory bulb VNO axons are targeted: i.e., axons with higher level of ephrin-A5 are targeted to regions with higher level of Eph-A6 and vice versa.

#### Semaphorin Reverse Signaling in Neural Development in *Drosophila*

Several recent studies, including our own, suggest strongly that transmembrane semaphorin-1a-mediated reverse signaling plays an important role in regulating neural development in *Drosophila* [8–10]. While it has been shown that reverse signaling mediated by

transmembrane semaphorin-6D is required for the guidance of myocardial patterning in vertebrates [7], future studies are needed to determine if semaphorin reverse signaling is also involved in regulating the vertebrate neural development.

### **The Formation of Giant-fiber-motor Neuron Synapse in *Drosophila***

The ▶**giant fiber system** of *Drosophila* is involved in controlling the jump-and-flight response. During development, a giant interneuron in the giant fiber system of the brain projects an axon into the second thoracic segment where the axon forms synapses with a motor neuron, which in turn controls the activity of the jump muscle. Semaphorin-1a is required both pre- and postsynaptically for the formation of giant-fiber-motor neuron synapses, suggesting a role for semaphorin to mediate bi-directional signaling between pre- and postsynaptic partners [8]. Overexpression of wild-type semaphorin-1a, but not a truncated semaphorin-1a mutant protein lacking the cytoplasmic domain, causes a gain-of-function phenotype. These data suggest that the participation of semaphorin-1a in synapse formation involves the action of semaphorin-1a reverse signaling. It remains to be determined whether Plexin or other semaphorin-interacting proteins function as a ligand to activate semaphorin-1a in synapse formation.

### **Photoreceptor Axon Guidance in *Drosophila***

In the *Drosophila* adult visual system, R1-R6 photoreceptors project their axons from the retina to the superficial layer of the optic lobe, the lamina. During development, R1-R6 axons temporally stop at their intermediate target region in between two layers of glial cells prior to establishing synaptic connections with lamina neurons. We found recently that the transmembrane semaphorin-1a functions cell-autonomously in photoreceptor axons for the proper arrangement at the intermediate target region [9]. The function of semaphorin-1a in photoreceptor axons requires its cytoplasmic domain, consistent with a role for semaphorin-1a as a receptor to mediate reverse signaling. The identity of cell surface proteins that activate semaphorin-1a reverse signaling in photoreceptor axons remains to be determined.

### **Dendritic Targeting of Olfactory Projection Neurons in *Drosophila***

In the development of the *Drosophila* olfactory system, projection neurons project their dendrites onto discrete units called glomeruli in the ▶**antennal lobe**, the first olfactory information relay center equivalent to olfactory bulb in vertebrates. Different types of odorant receptor axons form one-to-one precise connections to dendrites projected from different types of projection neurons at glomeruli. Semaphorin-1a displays a differential

expression pattern on dendrites of projection neurons. Genetic analysis showed that semaphorin-1a is required differentially in projection neurons for the targeting of their dendrites onto discrete glomeruli in a cell-autonomous manner, indicating a role for semaphorin-1a as a receptor for dendritic targeting [10]. Consistently, the cytoplasmic domain of semaphorin-1a is shown to be indispensable for its function, which likely reflects its role in recruiting downstream signaling proteins within the dendrites of projection neurons. The guidance cue that activates semaphorin-1a reverse signaling in dendrites is unknown.

## **References**

1. Kullander K, Klein R (2002) Mechanisms and functions of Eph and ephrin signalling. *Nat Rev Mol Cell Biol* 3:475–486
2. Davy A, Soriano P (2005) Ephrin signaling in vivo: look both ways. *Dev Dyn* 232:1–10
3. Murai KK, Pasquale EB (2003) “Eph” ective signaling: forward, reverse and crosstalk. *J Cell Sci* 116:2823–2832
4. Cowan CA, Henkemeyer M (2001) The SH2/SH3 adaptor Grb4 transduces B-ephrin reverse signals. *Nature* 413:174–179
5. Murai KK, Nguyen LN, Irie F, Yamaguchi Y, Pasquale EB (2003) Control of hippocampal dendritic spine morphology through ephrin-A3/EphA4 signaling. *Nat Neurosci* 6:153–160
6. Davy A, Gale NW, Murray EW, Klinghoffer RA, Soriano P, Feuerstein C, Robbins SM (1999) Compartmentalized signaling by GPI-anchored ephrin-A5 requires the Fyn tyrosine kinase to regulate cellular adhesion. *Genes Dev* 13:3125–3135
7. Tran TS, Kolodkin AL, Bharadwaj R (2007) Semaphorin regulation of cellular morphology. *Annu Rev Cell Dev Biol* 23:263–292
8. Godenschwege TA, Hu H, Shan-Crofts X, Goodman CS, Murphey RK (2002) Bi-directional signaling by Semaphorin-1a during central synapse formation in *Drosophila*. *Nat Neurosci* 5:1294–1301
9. Cafferty P, Yu L, Long H, Rao Y (2006) Semaphorin-1a functions as a guidance receptor in the *Drosophila* visual system. *J Neurosci* 26:3999–4003
10. Komiyama T, Sweeney LB, Schuldiner O, Garcia KC, Luo L (2007) Graded expression of semaphorin-1a cell-autonomously directs dendritic targeting of olfactory projection neurons. *Cell* 128:399–410

## **Reward**

### **Definition**

A reward or positive reinforcer is any stimulus an animal will work to obtain. Often these stimuli have

biological significance to the animal such as food, shelter or sex, a class of stimuli sometimes referred to as primary or unlearned reinforcers. Other types of reward are initially affectively neutral but acquire value through being associated with a primary reinforcer.

An example of such a stimulus for humans is money which acquires value by virtue of its capacity to be exchanged for other kinds of primary reinforcers such as food or shelter.

- ▶ Reinforcer
- ▶ Value-based Learning

## Reward Signal in Neural Networks

### Definition

A scalar performance measure used for reinforcement learning of networks.

- ▶ Neural Networks for Control

## RFLP

### Definition

Restriction fragment length polymorphism. These are polymorphisms that change restriction sites. RFLPs with known chromosomal locations were used in linkage analysis, with Southern blotting, to map disease genes until the advent of microsatellite markers.

- ▶ Bioinformatics

## Rheobase

### Definition

Strength of a rectangular depolarizing direct current (DC) current necessary to elicit an action potential.

- ▶ Action Potential

## Rheological Models

MARCELO EPSTEIN

Schulich School of Engineering, University of Calgary, Calgary, AB, Canada

### Definition

A rheological model consists of an assembly of one-dimensional *rheological elements*, each of which can be seen as a black box with two protruding terminals.

### Description of the Theory

Each rheological element is characterized by a deterministic relationship between the (history of the) relative displacement (or *elongation*)  $u(t)$  between the terminals and the (history of the) applied force  $f(t)$ . In other words, knowing the displacement function  $u(t)$  for all past times  $t$  up to the present, the present value of the force can be uniquely determined by some mathematical operation or vice versa. The merit of this one-dimensional oversimplification of the complexity of a true continuum constitutive theory (q.v.) lies in the fact that, by combining a small number of rheological elements in series and in parallel, a wealth of mathematically tractable, surprisingly varied and suggestive force-elongation responses is obtained. Two rheological elements are said to be *connected in series* if one of the terminals of the first is connected to one of the terminals of the second, in such a way that the remaining two unconnected terminals are considered as the terminals of the new combined-element black box. Let  $[f_1(t), u_1(t)]$  and  $[f_2(t), u_2(t)]$  denote, respectively, the force-elongation pairs of the first and second elements connected in series. The main feature of a series combination is that both elements experience the same force, while the elongation of the combined black box is the sum of the elongations of the original elements. Denoting by  $[f(t), u(t)]$  the force-elongation pair of the combined series black box:

$$u(t) = u_1(t) + u_2(t) \quad f(t) = f_1(t) = f_2(t). \quad (1)$$

Two elements are said to be *connected in parallel* if each terminal of one element is connected to a counterpart in the other element. The two common terminals thus obtained are considered as the terminals of the combined black box. As a result, both elements experience necessarily the same elongation, while the forces are added to produce the response of the combined element. Using the same notation as before, for the ▶parallel arrangement:

$$u(t) = u_1(t) = u_2(t) \quad f(t) = f_1(t) + f_2(t). \quad (2)$$



Some of the most common elements in use are: the ► *linear spring*, the ► *linear damper* (or *linear dashpot*) and the ► *contractile element*. The linear spring is characterized by two material constants: the *rest length*  $L_0$  and the *stiffness constant*  $k$ . By convention, in the linear spring the elongation  $u$  is measured with respect to the rest length (in other words, when the elongation vanishes, the distance between the terminals is equal to the rest length). The force at time  $t$  is then proportional to the elongation at that time, namely:

$$f(t) = k u(t). \quad (3)$$

Thus, the linear spring provides a purely elastic response, whereby the past history of the ► *deformation* plays no role, except for the fact that the material always remembers its “original” rest length. The linear damper, on the other hand, is completely characterized by a single material constant  $c$  called the *viscous constant*. There is no rest length. The force-elongation relation is given by the equation:

$$f(t) = c \dot{u}(t). \quad (4)$$

In a linear damper the only fact that counts in determining the force between the terminals at a given time is the speed of elongation  $\dot{u}(t)$  at that time. In other words, the past history plays a role, albeit limited to the very immediate past. More sophisticated history elements can be defined. Finally, the contractile element is a useful device with important applications to muscle ► *mechanics*. It can be thought of as a frictionless slider that produces no force, whatever the value of the elongation may be. In muscle mechanics applications, however, it is usually assumed that this behavior is characteristic of the *inactive state* only and that the contractile element may be *activated*, so that in the *active state* the force-elongation response abides by an ad-hoc law (for example, a so-called *force-length relation*).

To illustrate the variety of material responses that can be obtained by means of rheological models, the *Maxwell model*, obtained by placing a linear spring and a linear dashpot in series is considered. It is not difficult to show that the response of the Maxwell model is completely contained in the following first-order ordinary differential equation:

$$\dot{u} = \frac{\dot{f}}{k} + \frac{f}{c}. \quad (5)$$

If a force  $f_0$  is suddenly applied, an instantaneous elongation of value  $u_\infty = \frac{f_0}{k}$  develops completely at the expense of the spring, while the dashpot does not have time to react. As time goes on, however, if the force is kept at a constant value, the elongation will keep growing steadily at the expense of the deformation of the damper. If the force is suddenly removed, the spring goes instantaneously back to its original length, while

the damper immediately stops deforming. At the end of the process, therefore, the Maxwell model retains a residual deformation. The response of a system to a suddenly applied load that remains constant in time is known as ► *creep*.

If a linear spring and a damper are combined in parallel, the result is the *Voigt model*. It is governed by the differential equation:

$$f = ku + c\dot{u}. \quad (6)$$

A sudden application of a force is met with no instantaneous response, since the damper cannot react immediately. As time goes on, however, an exponential growth of the elongation is observed which approaches asymptotically the value  $u_\infty = \frac{f}{k}$ . If the force is suddenly removed, the spring will slowly bring back the system to its original rest length. This is the type of behavior observed when sitting on a feather- or down-filled cushion. This effect is sometimes described as “delayed ► *elasticity*,” although the response is anything but elastic.

A more realistic description of the behavior of many materials is obtained by combining in parallel a Maxwell model with a linear spring. The result is known as the *Kelvin model* or the *standard linear solid*. Its creep response is similar to that of a Voigt model, except that, just like a Maxwell model, it also has an instantaneous elastic response, governed by the spring added in parallel.

If instead of subjecting the various models to a sudden force they are subjected to a sudden elongation, the response obtained in terms of the decay of the resulting force as time goes on is known as ► *relaxation*.

## References

1. Pipkin AC (1972) Lectures on viscoelasticity theory. In: Applied mathematics series, vol 7. Springer, Berlin
2. Fung YC (1981) Biomechanics. Springer, New York
3. Epstein M, Herzog W (1998) Theoretical models of skeletal muscle. Wiley, Chichester

## Rheostasis

### Definition

Regulation of the internal environment of an animal to a stable condition with a changing reference setpoint.

### ► Hibernation

## Rheumatoid Arthritis (RA)

### Definition

RA is traditionally considered a chronic, inflammatory autoimmune disorder that causes the immune system to attack the joints. It is a disabling and painful inflammatory condition, which can lead to substantial loss of mobility due to pain and joint destruction. RA is a systemic disease, often affecting extra-articular tissues throughout the body including the skin, blood vessels, heart, lungs, and muscles.

## Rhinencephalon

The olfactory bulb and those structures that receive afferents from the olfactory bulb are classified as being part of the rhinencephalon. They include primarily the olfactory tract and the basal olfactory area, parts of the amygdaloid body, septum verum and prepiriform cortex.

► General CNS

## Rhizotomy

### Definition

A surgical procedure in which spinal nerve roots are cut.

## Rho

### Definition

The Greek letter  $\rho$ , used to denote the rest phase of the circadian rest-activity cycle. Occurs at night in diurnal animals, and in the day in nocturnal animals.

- Alpha (Activity Phase) in Circadian Cycle
- Circadian Cycle
- Rho GTPases

## Rho Family of Small Guanosine Triphosphatases (Rho GTPases)

### Definition

Rho family of small guanosine triphosphatases (Rho GTPases) are important intracellular signaling proteins involved in various aspects of neuronal morphogenesis including migration, polarity, axon growth and guidance, dendrite arborization, spine plasticity, and synapse formation. Acting as intramolecular switches, the Rho GTPases transduce signals from various extracellular ligands to the cytoskeleton. They exist in two states: a GTP-bound active state, and a GDP-bound inactive state. Guanine nucleotide exchange factors turn on Rho GTPases by facilitating the exchange of GDP for GTP, and GTPase activating proteins increase their GTPase activity, helping to turn them off.

- Cytoskeleton
- Growth Cones
- Neural Development

## Rho GTPases

RYAN PETRIE, NATHALIE LAMARCHE-VANE  
Department of Anatomy and Cell Biology, McGill University, Montreal, Quebec, Canada

### Synonyms

Rho Family of Small GTP-Binding Proteins

### Definition

The Rho family of small GTP-binding proteins consists of 22 mammalian proteins related to each other based on the similarity of their amino acid sequence to the first family member to be identified, RhoA. These proteins are relatively small (less than 25 kDa) and all possess an intrinsic GTPase activity, which hydrolyzes the guanosine triphosphate (GTP) into guanosine diphosphate (GDP). The bound nucleotide regulates the activity of the GTPase, rendering it inactive or active in the case of GDP or GTP, respectively.

### Characteristics

The ► Rho GTPases are expressed in all cells from fertilization through adulthood and their activity is critical to many aspects of cell biology that are required for normal functioning of the organism [1]. When

active, the Rho GTPases can activate a diverse array of intracellular signaling pathways. RhoA, Rac1, and Cdc42, the best characterized members of the Rho family of small GTPases, regulate the assembly of the ►actin and ►microtubule cytoskeleton, a filamentous network of proteins within a cell that control cell shape, cell adhesion, cell polarity and cell migration. Specificity of Rho GTPase signaling is achieved by the coordinated regulation of the nucleotide bound state of the GTPase and the region of the cell to which the active form of the protein is targeted.

### The Cycling of GTP and GDP Regulates Rho GTPase Activity

Each of these monomeric GTPases acts as a molecular switch to control the downstream signaling pathways. The cycling of GDP-GTP binding to Rho GTPases is tightly regulated by three families of proteins. The GTPase is unable to exchange the bound GDP for free GTP in the cytosol without the help of proteins termed ►guanine nucleotide exchange factors (GEFs). In response to external stimuli, GEFs are activated and bind the GDP-bound conformation of Rho GTPases leading to the release of GDP. Then, the Rho GTPases in a free-nucleotide transition state are able to bind GTP in the cytosol and activate downstream effectors in their active GTP-bound conformation. The activity is terminated by ►GTPase-activating proteins (GAPs), which enhance the intrinsic GTPase activity, leading to the inactive state of the GTPase. Additionally, ►guanine nucleotide dissociation inhibitors (GDIs) can sequester Rho GTPases in their GDP-bound, inactive state (Fig. 1).

### Subcellular Localization of Rho GTPases

While inactive GTPases are usually restricted to the cytoplasm, the active forms are localized to the surface of membranes within the cell, such as plasma, golgi, or endosomal membranes. The correct intracellular localization of active GTPases is critical for their regulation and coupling to downstream signaling pathways. The targeting information is contained in the ►CAAX box present at the C-terminal end of the GTPase amino acid sequence [2]. This sequence is modified by the addition of an isoprenyl group on the side chain of the cysteine, which is then able to insert into membrane lipid bilayers. Additionally, there is a short stretch of basic residues upstream of the CAAX box that confers specificity to each Rho GTPase and influences into which membrane the isoprenyl chain inserts. The specificity in action is also achieved by the restricted subcellular distribution of GAPs and GEFs, which results in the inactivation/activation of the Rho GTPases being tightly coupled to specific regions of the cell.

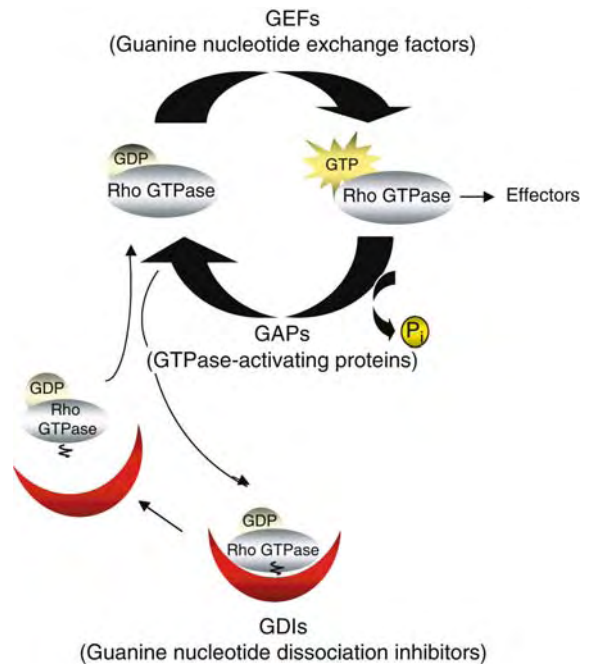

**Rho GTPases. Figure 1** *Cycling of Rho GTPases.* Rho GTPases exist in either an inactive, GDP-bound state or an active, GTP-bound state. Three families of proteins tightly regulate this GDP/GTP cycle. GEFs stimulate the exchange of GDP for GTP, thereby activating the GTPases. GAPs enhance the intrinsic GTPase activity, leading to the inactive GDP-bound form. GDIs bind to the GDP-bound GTPase and sequester the protein in the cytosol.

### Functions of Rho GTPases During Development of the Nervous System

#### Neuron Polarization and Axon Specification

During the initial stages of the development of the nervous system when neural precursors are generated by cell division, the cells lack features such as dendrites or axons and are non-polarized [3]. To begin the process of forming axons and dendrites the cells must specify which region of the plasma membrane will begin to extend away from the cell body in order to form elongated structures known as ►neurites. These structures will ultimately become the single axon and several dendrites of the nascent ►neuron, a process known as neuronal polarization. In vitro studies have revealed key roles for the Rho GTPases Cdc42 and Rac1 in the initial polarization of a neuron [4]. Cdc42 is targeted to a sub-region of the plasma membrane and recruits the polarity complex of Par3, Par6, and the atypical protein kinase C, a conserved multiprotein complex used throughout evolution to polarize different cell types. The polarity complex in turn recruits the GEFs Tiam1 and STEF, which catalyze the exchange of GDP for GTP on Rac1. The active Rac1 mediates the formation of filamentous actin and neurite formation ultimately polarizing the cell.

### Axon Guidance

As the nervous system develops, newborn neurons extend axons towards their cognate targets. The neuronal growth cone, located at the tip of the growing axon, is a highly motile structure acting as a sophisticated signal transduction device, capable of recognizing extracellular guidance cues and translating them into directed neurite outgrowth [5]. Over the past 15 years, a combination of cellular and genetic studies has led to the identification of highly conserved families of guidance molecules that can be either membrane-bound factors or secreted molecules, acting over short or long distances, respectively, to guide the growth of axons. They include the classical molecular cues: netrins, slits, ephrins, and semaphorins [6].

Cytoskeletal rearrangements are crucial during growth cone guidance. The growth cone is enriched in the cytoskeletal elements F-actin and microtubules that are rapidly remodeled in response to environmental cues and direct the migration of the growth cone [5]. There is now compelling evidence demonstrating a role for RhoA, Rac1, and Cdc42 as important signaling elements downstream of most, if not all, guidance cue receptors [7]. Indeed, Rho GTPases mediate a cascade of responses from receptors to actin remodeling within the neuronal growth cone. For instance, Rac1 interacts directly with the semaphorin receptor plexin-B1, suggesting that Rac1 plays a role in mediating the repulsive activities of semaphorins. On the other hand, the Rho-specific GEF, PDZ-RhoGEF LARG, interacts with plexin B to activate RhoA signaling, provoking growth cone repulsion and collapse. Ephexin, a GEF for RhoA and Cdc42, binds to Eph receptors to modulate Ephrin-induced growth cone collapse, whereas the slit receptors Robo mediate axon repulsion by interacting with srGAP that inhibits Cdc42. Finally, Rac1 and Cdc42 are important mediators of the signaling response of axons to the netrin-1 receptor DCC. Overall, it is clear that Rho GTPases are important regulators in axon pathfinding and guidance, and it is the correct balance of localized Rho GTPase activities through GEFs and GAPs that will determine the appropriate attractive and repulsive response of an axon to extracellular cues.

### Dendritogenesis and Structural Plasticity of the Dendritic Arbor

During the maturation of connectivity within the central nervous system (CNS), dendrites are highly dynamic. The branched structure of the dendrites is highly enriched in the cytoskeletal elements and it is the controlled remodeling of these structures that is responsible for the shape and complexity of the dendritic arbor. In many cases, dendritic spines are the location of the synaptic connections and their size and number correlate with their ability to transmit the correct information from

axon to dendrite. The ability of Rho GTPases to convert the upstream signals into cytoskeletal changes leads to remodeling of the dendrites [8]. For example, N-methyl D-aspartate (NMDA) receptors transmit excitatory transmissions mediated by L-glutamate. Activation of NMDA receptors increases the activity of Cdc42 and Rac1 while decreasing the activity of RhoA, leading to the stabilization of the dendritic spines [7]. The regulation of the growth and elaboration of the whole dendritic architecture represent an important mechanism of plasticity in the central nervous system.

### Axon Regeneration in the CNS

The activity of the Rho GTPase family member RhoA is known to induce actin-myosin contractility within the cell and to produce mechanical forces that can retract actin-dependent structures such as neurites [9]. Inhibition of RhoA in neuronal cells leads to neurite extension over substrates that would not normally be permissive for neurite outgrowth. Many reports are now suggesting that RhoA is highly activated following lesions in the CNS and mediates many of the signals associated with the growth suppressive environment of the CNS following injury. For example, myelin associated glycoprotein (MAG) is released from the damaged myelin sheath and binds to the Nogo receptor to activate RhoA, preventing regrowth of the damaged axons. This is accomplished because RhoA activates in turn Rho-kinase (ROCK), which is able to induce intracellular actin-myosin contractility that prevents axon outgrowth following injury. Therefore, RhoA is now a promising pharmacological target for therapy in an aim to promote [axon regeneration](#) in the CNS following injury.

### Implication of Rho GTPase Dysfunction as Being Causative for Mental Retardation

The importance of Rho GTPases in the nervous system development is further highlighted by research studies linking dysfunction in Rho GTPase signaling pathways and mental retardation in the adult. In this situation mutations in specific genes affect the developmental program such that the organism develops abnormally [7]. Malformed dendrites and dendritic spines are common in these conditions and are hypothesized to be important indicators of the mechanisms of impaired cognition in mental retardation. For example, in non-syndromic x-linked mental retardation, three genes out of a total of 13 have been pinpointed to be mutated and are encoding either regulators of Rho GTPases or downstream mediators of the pathways activated by Rho GTPases. In particular, the *OPHN-1* gene encodes the protein oligophrenin-1, which contains a RhoGAP domain shown to negatively regulate RhoA, Rac1, and Cdc42. It is specifically expressed at high levels in both axons and dendrites throughout the brain and a

mutation causing decreased levels of the oligophrenin-1 mRNA is associated with mental retardation. In addition, the *ARHGEF6* gene encodes a GEF that activates Rac1 and Cdc42 and a truncation mutant protein missing the first 28 amino acids is associated with mental retardation. Finally, the serine/threonine kinase activity of PAK3, a member of the p21-activated protein kinase family (PAK) family of proteins, acting downstream of Rac1 and Cdc42, has been found to be compromised in individuals with this neurological disorder.

### Concluding Remarks

RhoA, Rac1, and Cdc42 regulate a wide variety of intracellular signaling pathways to mediate many aspects of the development of the nervous system. The Rho family of GTPases includes 19 other members, the roles of which are relatively unknown. Future research will undoubtedly reveal many novel functions of this diverse family of proteins in the development of the nervous system.

### References

1. Jaffe AB, Hall A (2005) Rho GTPases: biochemistry and biology. *Annu Rev Cell Dev Biol* 21:247–269
2. Michaelson D, Silletti J, Murphy G, D'Eustachio P, Rush M, Philips MR (2001) Differential localization of Rho GTPases in live cells: regulation by hypervariable regions and RhoGDI binding. *J Cell Biol* 152:111–126
3. Arimura N, Kaibuchi K (2005) Key regulators in neuronal polarity. *Neuron* 48:881–884
4. Watabe-Uchida M, Govek EE, Van Aelst L (2006) Regulators of Rho GTPases in neuronal development. *J Neurosci* 26:10633–10635
5. Dent EW, Gertler FB (2003) Cytoskeletal dynamics and transport in growth cone motility and axon guidance. *Neuron* 40:209–227
6. Dickson BJ (2002) Molecular mechanisms of axon guidance. *Science* 298:1959–1964
7. Govek EE, Newey SE, Van Aelst L (2005) The role of Rho GTPases in neuronal development. *Genes Dev* 19:1–49
8. Schubert V, Dotti CG (2007) Transmitting on actin: synaptic control of dendritic architecture. *J Cell Sci* 120:205–212
9. Ellezam B, Dubreuil C, Winton M, Loy L, Dergham P, Selles-Navarro I, McKerracher L (2002) Inactivation of intracellular Rho to stimulate axon growth and regeneration. *Prog Brain Res* 137:371–380

## Rhodopsins

### ►Photopigments

## Rhombencephalon

### Definition

The rhombencephalon (Greek for rhombus-shaped brain) is the caudal part of the developing neural tube, the hindbrain, which is composed of the metencephalon (pons and cerebellum) and myelencephalon (medulla).

## Rhombomere

### ►Evolution of the Vestibular System

## RHT

### ►Retinohypothalamic Tract

## Rhynchocephalia

### Definition

Sister taxon to the Squamata (lizards, snakes, amphisbaenians) and incorporating the living Tuatara of New Zealand, *Sphenodon*. The term Sphenodontia refers to a subset of Rhynchocephalia that excludes the most basal forms.

### ►The Phylogeny and Evolution of Amniotes

## Rhythm

### Definition

Periodic change of an entity. In behavior, several rhythms are distinguished by their periods: circadian (about 24 h), circalunar (about 28 days), circannual (about 1 year).

### ►Hippocampus: Organization, Maturation, and Operation in Cognition and Pathological Conditions

## Rhythmic Jaw Movements

### ► Mastication

## Rhythmic Movements

OLE KIEHN

Mammalian Locomotor Laboratory, Department of Neuroscience, Karolinska, Stockholm, Sweden

### The Behavior

Rhythmic movements are motor acts that are characterized by the activation of groups of muscles in a recurring or cyclic pattern. Rhythmic movements are found in all animals ranging from invertebrates to man and include various behaviors that are continuously ongoing, like ► [respiration](#), are episodic, like ► [swimming](#), ► [mastication](#) and ► [walking](#), or brief like ► [scratching](#) and the ► [startle response](#). The rhythmic movements are generated by localized neuronal networks, called ► [central pattern generators](#), or CPGs. Activity in the CPGs directly controls the timing (rhythm) and phasing (pattern) of ► [motoneurons](#), whose activity in turn activates the ► [muscles](#) needed to generate the rhythmic movements; e.g., the limb muscles acting on the leg during walking or intercostals muscles and the diaphragm acting on the lungs during respiration. Thus, the term CPG alludes to the fact that these neuronal networks are restricted to specific regions of the central nervous system and, when appropriately activated, are capable of generating both the timing and phasing of rhythmic movements without receiving patterned ► [sensory information](#). The CPG for respiration or mastication in vertebrates is, for example, localized in the ► [brainstem](#) while the CPGs for swimming, scratching and walking are localized in the ► [spinal cord](#). The CPGs controlling rhythmic movements in invertebrates are typically localized to ganglionic structures, like to the ► [stomatogastric ganglion](#) that controls the foregut movements in Crustaceans or to the chain of midbody ganglia that control ► [leech swimming](#). Traditionally, rhythmic movements were studied in intact or semi-intact animals. Because of the distinct network localization, numerous preparations have been developed where the part of the central nervous system that contains the CPG network can be studied in isolation in vitro.

### External Control

Although CPGs are able to intrinsically generate the timing and phasing of rhythmic movements, they do not function in isolation. Rather, in most cases their activity is often turned on and off by an external command signal. For example, when a cat starts to walk or a fish starts to swim, the spinal CPGs are activated by activity in descending fiber tracts originating in the brainstem [1,2]. Initiating signals originating in the forebrain are funneled through the ► [basal ganglia](#) and conveyed to nuclei in the diencephalon (► [diencephalic locomotor region](#)) and mesencephalon (► [mesencephalic locomotor region](#)) and then to excitatory ► [reticulospinal neurons](#) in brainstem ► [locomotor regions in the midbrain and diencephalon](#). The reticulospinal neurons then project to the spinal locomotor network and provide the external ► [excitatory drive](#) needed to initiate and maintain the rhythmic activity. Similarly, descending inputs from “head ganglia” to CPGs in the stomatogastric ganglion or the swimming CPG in leech can turn specific rhythmic motor behaviors on and off [3]. Sensory inputs, like loud sound or sudden changes in light, might be the direct trigger for the descending signal leading to escape or startle responses [4], which is followed by more persistent rhythmic movements. Sensory inputs are also triggers for the scratching movements where the motor behavior is initiated by tactile stimulation applied to the skin [5].

### Sensory Information

Although rhythmic motor outputs can be generated in the absence of sensory information CPGs receive sensory feedback. Some of these sensory signals cause corrections of the rhythmic movements, as when a person is stumbling over an object. In this case ► [cutaneous sensory receptors](#) mediate the corrective signal to the CPG circuit [6]. Other sensory signals are involved in phase transitions and amplitude modulation of the rhythmic movements and are caused by ► [proprioceptive](#) feedback from the moving appendages. Examples of sensory inputs that are involved in phase transitions are feedback from ► [stretch receptors](#) in the lungs that regulate the transition from inspiration to expiration, joint receptors in the hip in mammals that regulate the transition from stance to swing and sensory receptors in the wing of the locust that influence the transition from wing depression to wing elevation [6,7]. Load receptors, like ► [tendon organs](#), or stretch receptors in muscles, like ► [muscle spindles](#), also provide proprioceptive cues for phase transitions and are actively involved in modulating the amplitude variation of rhythmic movements [7–9].

### Basic Network Features

The intrinsic function of rhythmic motor networks is defined by the synaptic interconnections between the

CPG neurons in the network and the membrane properties of the neurons. A minimal characterization of the network function therefore requires that CPG component neurons are identified, that the connectivity between individual neurons is established, and that the salient membrane properties are described. An analysis at this level of detail has only been obtained in a limited number of rhythmic motor systems both in invertebrates and in vertebrates.

Notable examples in invertebrates of CPGs that have been characterized in detail are the swim CPGs in the mollusks *Clione* [10], and *Tritonia* [11], the heart-beat network in leech [3,12], and the CPG circuits in the stomatogastric ganglion controlling foregut movements in Crustacea [13]. Because of the small number of cells (less than 30 neurons), the complete network connectivity has been worked out and the cellular properties of individual CPG neurons have been determined in great detail. From the analysis of these small CPG networks, it is clear that each CPG network has its specific characteristics and that none of them are alike. However, several basic network and cellular building blocks can be extracted from the analysis [11]. Network elements include extensive ▶reciprocal inhibition in a ▶half-center fashion, delayed ▶feed-forward excitation, ▶electrical coupling and ▶graded synaptic release. These network elements alone do not determine the timing and phasing that the CPG network produces but they interact with cellular properties that actively interpret the synaptic activity and contribute to timing and phasing. Such cellular elements are ▶bursting pagemaker properties that can provide sustained rhythmic drive, post-inhibitory rebound firing that helps escape inhibition and is generated ▶by h-channels (▶HCN) and ▶T-type calcium channels, ▶plateau potentials generated by ▶persistent calcium or sodium channels, ▶calcium-activated calcium channels (▶CAN channels) that amplify and prolong synaptic inputs, delayed activation generated by activation of potassium channels with slow kinetics (▶A-Type channels), and spike-frequency adaptation generated by ▶calcium-activated potassium channels [14].

In vertebrates, the CPG organizations for ▶swimming in lamprey and in ▶*Xenopus* tadpole have been revealed in great detail [15,16]. The core of these networks consists of ▶excitatory ▶CPG interneurons and ▶inhibitory glycinergic ▶interneurons. The glutamatergic interneurons project ipsilaterally and provide the excitatory drive to other CPG interneurons and motoneurons necessary to produce sustained rhythmic drive on one side of the cord. The glycinergic interneurons are ▶commissural interneurons projecting to the contralateral side where they connect to all CPG neurons and motor neurons and mediate reciprocal inhibition segmentally so that when one side is active the other side is inactive. This half center organization is

the basis for the side-to-side undulatory swimming. The rhythm itself is not dependent on inhibitory connections, but can be generated in a network of mutually coupled excitatory neurons. Each one of the about 100 spinal segments that makes up the lamprey spinal cord appear to contain such a basic CPG unit [17]. These units are coupled both in the ascending and descending directions. These connections provide the basis for the ▶intersegmental coordination of muscular activity along the length of the body that is required for the animal to swim. Similarly to invertebrate CPGs, a large number of intrinsic membrane properties influence the rhythmogenic capability of the swim CPG neurons and participate in patterning of the motor output [18,19].

The large number of neurons controlling any given behavior in mammals has made it difficult to reveal the detailed network organization of, for example, the CPGs controlling mammalian ▶walking [20], ▶mastication [21] or ▶respiration [22–24]. Knowledge about the functionality of these CPGs is, however, advancing rapidly. For the walking CPG, the key network functions are the rhythm generation, ipsilateral coordination of flexors and extensors across the same or different joints in a limb, and ▶left-right coordination [20]. The rhythm is generated by glutamatergic ipsilateral projecting interneurons [25]. The exact identity of these neurons has not been determined. The circuits underlying coordination of flexors and extensors segmentally and intersegmentally include inhibitory ▶Ia interneurons and ▶Renshaw cells, as well as a number of unidentified interneurons. Functional analysis of left-right circuitries in the mammals suggests that ▶intersegmental coordination provided by ▶commissural interneurons is involved in binding motor synergies along the cord, while inhibitory ▶intra-segmental commissural connections control segmental alternation and excitatory commissural connections control synchronous activity [20]. It thus appears that some basic characteristics of swimming CPG and walking CPG network structure are preserved. However, the commissural circuitries seem more complex in the walking CPG than what has been described for the swimming CPG. Additionally, while network elements in the swimming CPG appear to be composed of homogenous populations of neurons, similar network elements, such as the rhythm generation network in the walking CPG, appear to be composed of more heterogeneous populations of neurons. Thus, additional network layers are added when moving from a non-limbed to a limbed CPG. Similar to what is seen in invertebrate and lower vertebrate neurons, mammalian CPG neurons express to a variable degree rhythmogenic/pacemaker-like membrane properties or phase-regulating membrane properties [14,22–24,26].

A new addition to the CPG network analysis is methods for genetically dissecting the neuronal circuits.

Such methods include genetic silencing or activation of molecularly defined populations of neurons and have been applied to both invertebrate and vertebrate CPGs. In networks with many neurons, such manipulations can more directly link a population of CPG neurons to a specific network function than traditional electrophysiological methods are able to do [27].

### Neuromodulation of Rhythmic Movements

A lesson that has been learned from studies of CPGs in both invertebrates and vertebrates is that the overall network function is flexible and can be changed by ►neuromodulation that acts on individual CPG neurons and connectivity [28,29]. The neuromodulation may be the result of neurotransmitters and hormones released from sources outside the CPG circuits (►extrinsic neuromodulation) or the neuromodulation may be the result of neurotransmitters and signals released from active CPG neurons (►intrinsic neuromodulation). Examples of extrinsic ►neuromodulatory systems are the numerous ►amine and ►peptide containing systems that project to stomatogastric ganglion [28,30] and the descending 5-HT or dopamine systems in vertebrates [31]. Examples of intrinsic ►neuromodulatory systems are neurotransmitters released from swim CPG neurons in *Tritonia* [32], adenosine released from CPG neurons tadpole [18] and endocannabinoids from CPG neurons in the lamprey [33]. In all cases, the targets for neuromodulators are ligand-gated ion channels and/or chemical or electrical synaptic transmission. Because neuromodulators have these ubiquitous network targets, they can change timing, phasing or amplitude of the rhythmic movements separately or all of these parameters at once. Thus in some cases, the neuromodulation is a fine tuning of the rhythmic motor behavior, while in others the neuromodulation causes dramatic switching in the motor coordination.

### Disorders of Rhythmic Movements

Primary disorders of rhythmic movements are not common, although a number of respiratory dysfunctions involve defects in network function and/or its modulation [22]. Secondary disorders of rhythmic movements are due to injury of the external control systems, for example, damage to the spinal cord that leads to loss of ambulatory ability below the lesion. The ultimate way of restoring the rhythmic motor behavior after spinal cord injury is to promote re-growth or ►regeneration of the severed fibers across the injury. An alternative approach is ►neuro-rehabilitation. Experiments in animals with ►spinal cord injury have shown that sustained ►locomotor training on a treadmill in combination with drugs that activate the spinal locomotor CPG can lead to substantial recovery of the lost locomotor capability [34,35]. Clinical trials have shown that humans with partial spinal cord injury also can benefit from such ►locomotor rehabilitation therapy [34,35].

### References

1. Brocard F, Dubuc R (2003) Differential contribution of reticulospinal cells to the control of locomotion induced by the mesencephalic locomotor region. *J Neurophysiol* 90:1714–27
2. Jordan LM (1998) Initiation of locomotion in mammals. *Ann N Y Acad Sci* 860:83–93
3. Marder E, Calabrese RL (1996) Principles of rhythmic motor pattern generation. *Physiol Rev* 76:687–717
4. Fetcho JR (1991) Spinal network of the Mauthner cell. *Brain Behav Evol* 37:298–316
5. Stein PS (2005) Neuronal control of turtle hindlimb motor rhythms. *J Comp Physiol A Neuroethol Sens Neural Behav Physiol* 191:213–29
6. Grillner S (1981) Control of locomotion in bipeds, tetrapods, and fish. In Brooks V (ed) *Handbook of Physiology*, Bethesda, pp 1176–236
7. Pearson KG (1995) Proprioceptive regulation of locomotion. *Curr Opin Neurobiol* 5:786–91
8. Hultborn H (2001) State-dependent modulation of sensory feedback. *J Physiol* 533:5–13
9. McCrea DA (2001) Spinal circuitry of sensorimotor control of locomotion. *J Physiol* 533:41–50
10. Orlovsky GN, Deliagina TG, Grillner S (1999) *Neuronal control of locomotion. From mollusc to man*. Oxford University Press, Oxford
11. Getting P (1988) Comparative analysis of invertebrate spinal pattern generators. In Cohen A, Rossignol S, Grillner S (ed) *Neural control of rhythmic movements in vertebrates*, Wiley, New York, pp 101–28
12. Calabrese RL, Peterson E (1983) Neural control of heartbeat in the leech, *Hirido medicinalis*. In Roberts A, Roberts B (ed) *Neural origin of rhythmic movements*, Cambridge University Press, Cambridge, pp 195–221
13. Selverston A, Moulin M (1987) *The crustacean stomatogastric system*. Springer Berlin
14. Harris-Warrick RM (2002) Voltage-sensitive ion channels in rhythmic motor systems. *Curr Opin Neurobiol* 12:646–51
15. Grillner S, Wallen P, Brodin L, Lansner A (1991) Neuronal network generating locomotor behavior in lamprey: circuitry, transmitters, membrane properties, and simulation. *Annu Rev Neurosci* 14:169–99
16. Roberts A, Soffe SR, Wolf ES, Yoshida M, Zhao FY (1998) Central circuits controlling locomotion in young frog tadpoles. *Ann N Y Acad Sci* 860:19–34
17. Grillner S (2003) The motor infrastructure: from ion channels to neuronal networks. *Nat Rev Neurosci* 4:573–86
18. Dale N, Kuenzi FM (1997) Ion channels and the control of swimming in the *Xenopus* embryo. *Prog Neurobiol* 53:729–56
19. Grillner S (1997) Ion channels and locomotion. *Science* 278:1087–8
20. Kiehn O (2006) Locomotor circuits in the mammalian spinal cord. *Annu Rev Neurosci* 29:279–306
21. Lund J, Kolta A (2006) Generation of the central masticatory pattern and its modification by sensory feedback. *Dysphagia* 21(3):167–74
22. Feldman JL, Mitchell GS, Nattie EE (2003) Breathing: rhythmicity, plasticity, chemosensitivity. *Annu Rev Neurosci* 26:239–66
23. Ramirez JM, Tryba AK, Pena F (2004) Pacemaker neurons and neuronal networks: an integrative view. *Curr Opin Neurobiol* 14:665–74



24. Richter DW, Spyer KM (2001) Studying rhythmogenesis of breathing: comparison of in vivo and in vitro models. *Trends Neurosci* 24:464–72
25. Kiehn O, Quinlan KA, Restrepo CE, Lundfald L, Borgius L, et al. (2008) Excitatory components of the walking mammalian locomotor CPG. *Brain Res Rev* 57(1):56–63
26. Kiehn O, Kjaerulff O, Tresch MC, Harris-Warrick RM (2000) Contributions of intrinsic motor neuron properties to the production of rhythmic motor output in the mammalian spinal cord. *Brain Res Bull* 53:649–59
27. Kiehn O, Kullander K (2004) Central pattern generators deciphered by molecular genetics. *Neuron* 41:317–21
28. Harris-Warrick RM, Marder E (1991) Modulation of neural networks for behavior. *Annu Rev Neurosci* 14:39–57
29. Kiehn O, Katz P (1999) Making circuits dance: modulation of motor pattern generation. In Katz P (ed) *Beyond neurotransmission. neuromodulation and its importance for information processing*. Oxford University Press, Oxford, pp 275–317
30. Nusbaum M, Beenhakker M (2002) A small-systems approach to motor pattern generation. *Nature* 417 (6886):343–250
31. Schmidt BJ, Jordan LM (2000) The role of serotonin in reflex modulation and locomotor rhythm production in the mammalian spinal cord. *Brain Res Bull* 53:689–710
32. Katz P, Getting P, Frost W (1994) Dynamic neuromodulation of synaptic strength intrinsic to a central pattern generator circuit. *Nature* 367:729–31
33. El Manira A, Kyriakatos A, Nanou E, Mahmood R (2008) Endocannabinoid signaling in the spinal locomotor circuitry. *Brain Res Rev* 57(1):29–36
34. Edgerton VR, Kim SJ, Ichiyama RM, Gerasimenko YP, Roy RR (2006) Rehabilitative therapies after spinal cord injury. *J Neurotrauma* 23:560–70
35. Rossignol S, Drew T, Brustein E, Jiang W (1999) Locomotor performance and adaptation after partial or complete spinal cord lesions in the cat. *Prog Brain Res* 123:349–65

---

## Ribonuclease (RNase)

### Definition

An enzyme that catalyses the hydrolysis of an RNA resulting in either cleavage to smaller RNA units or by degradation to constituent nucleotides.

---

## Ribosome

### Definition

A ribosome is a non-membranous organelle that translates of a mRNA molecule into a polypeptide chain. It consists of 65% ribosomal RNA and 35% ribosomal proteins.

---

## Riddoch Phenomenon or Syndrome

### Definition

When visual cerebro-cortical area V5 is disconnected from area V1 (with which it is reciprocally connected and from which it normally receives its visual input) but has a secondary visual input that reaches it without passing through area V1, the subject can still experience visual motion consciously though crudely.

- ▶ [Blindsight](#)
- ▶ [Visual Perception](#)

---

## Rigidity

### Definition

An increased resistance to passive stretch that is nearly equal in both agonist and antagonist muscles and generally uniform throughout the range of motion of the joint being tested. It may be sustained (plastic or lead pipe) or intermittent and ratchetty (cogwheel). Although cogwheel rigidity is usually thought to be Parkinsonian rigidity complicated by Parkinsonian tremor, it may occur in the absence of tremor and the frequency felt by the examiner tends to be higher than that of the visible resting tremor.

- ▶ [Parkinson Disease](#)
- ▶ [Resting Tremor](#)

---

## Rigor Configuration

### Definition

The rigor configuration in the cross-bridge cycle is associated with the end-state of the power stroke with the nucleotide products (ADP and P) having been released. In order to advance from the rigor configuration, ATP is required to release the cross-bridge from actin.

- ▶ [Molecular and Cellular Biomechanics](#)
- ▶ [Power Stroke](#)
- ▶ [Sliding Filament Theory](#)

## RNA Interference

### Definition

RNA interference – this procedure is abbreviated RNAi. It consists of the down-regulation of gene expression by using specific double-stranded ribonucleic acids. The specific or chosen RNA base pairs with its complementary strand of mRNA resulting in the degradation of the latter.

► GAL4/UAS

## RNA Localization

► mRNA Targeting: Growth Cone Guidance

## RNA Synthesis

► DNA Transcription

## RNA Translation

ANDREW SIMMONDS

Department of Cell Biology, Faculty of Medicine and Dentistry, University of Alberta, Edmonton, AB, Canada

### Synonyms

Protein synthesis; Polypeptide synthesis

### Definition

RNA translation is the process whereby the genetic information encoded in messenger RNA (► mRNA) is translated by specialized cytoplasmic complexes (ribosomes) into a polypeptide. This process is essential for the function of all cell types, and each step of translation represents a highly regulated event.

### Characteristics

Eukaryotic mRNAs are initially transcribed from genetic information encoded in the nuclear DNA. After processing by various nuclear proteins (e.g., splicing factors), mRNAs are exported to, and subsequently translated within, the cytoplasm. The basic process translates the sequence of bases organized in three letter codons within the mRNA into a specific polypeptide string of linked amino acids. As more is learned about mRNA translation, it has become apparent that this process is a highly regulated event with several levels of control including storage of mRNAs in a non-translating state and restriction of translation to specific sub-domains within the cytoplasm. Many of these regulatory events are mediated by sequences encoded within the mRNA itself. Each mRNA can be functionally divided into several regions including the 5' cap, the 5' untranslated region (UTR), the ► open reading frame (ORF), the 3' UTR and a 3' domain consisting of repeated adenosine bases that are added post-transcriptionally (Fig. 1).

In a generalized model, the ORF is the most important region, with the information within encoding a specific protein, while the UTRs are thought to play roles in regulating localization, degradation and restrictions in the translation of the mRNA.

The core component of the cellular complex that reads the genetic information in the ORF and translates it into a specific protein is the ribosome. Several ribosomes can bind to a single mRNA to form a larger translation complex called a polysome. The genetic information in the ORF of the mRNA is read in three base segments by a collection of ► transfer RNA (tRNA) molecules that contain a complementary RNA code (anti-codon) that recognizes and binds a particular nucleotide triplet (codon) in the mRNA. A parallel cellular process specifically links each tRNA to the amino acid that corresponds to the codon (Fig. 2). The ribosomal complex processes along the mRNA and through the progressive recruitment of specific amino-acid linked tRNAs. The amino acids delivered by the tRNAs to the ribosome are covalently joined to produce the polypeptide encoded by the mRNA. This process is regulated at several levels. For example, proteins that will remain inside the cell are translated on free ribosomes in the cytoplasm while the ribosomes-mRNA-nascent polypeptide complexes translating exported or membrane bound proteins are trafficked to the endoplasmic reticulum. However, there are several other regulatory events during mRNA translation including: editing of the mRNA after it is transcribed (► RNA editing), sub-cellular localization of mRNAs, sub-cellular restriction of mRNA translation, sequestering multiple non-translating mRNAs in protein complexes and selective mRNA degradation.

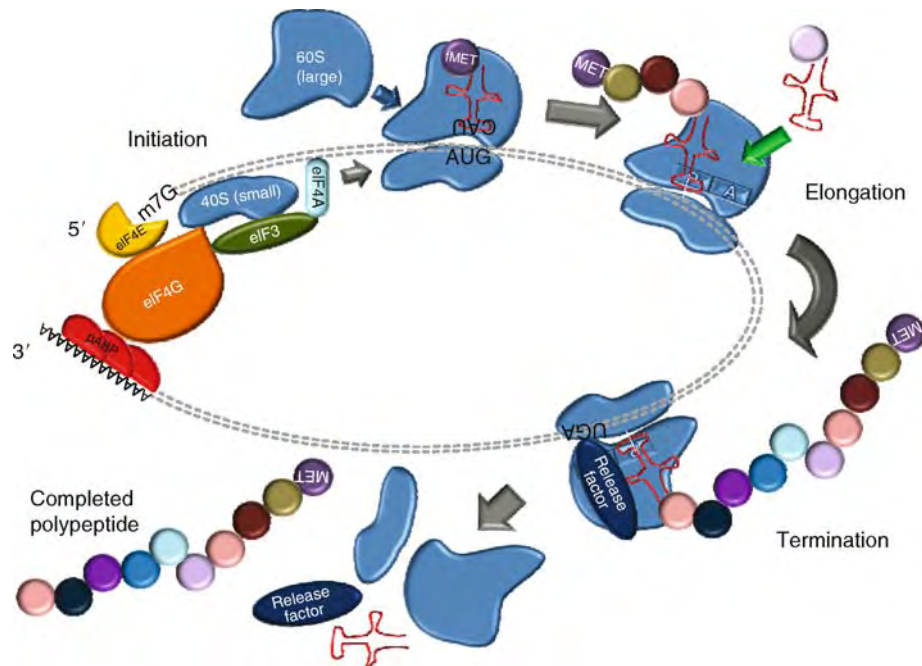

**RNA Translation. Figure 1** RNA translation: Initiation – RNA binding proteins that specifically interact with the 5' m7G cap and 3' UTR regions of mRNAs form the translation initiation complex. A complex of poly A binding protein (pABP, red) interacts with the 3' poly A tail, while eukaryotic Initiation Factors (eIFs) form a complex at the 5' end of the mRNA. The major proteins in this complex include the cap-binding protein eIF4E (yellow), and the eIF4G (orange), eIF3 (green) and eIF4A (pale blue). They serve to position the 40S (small) ribosomal subunit on the mRNA. In most cases of mRNA translation, the 40S subunit is thought to scan along the mRNA in a 5'-3' direction until it reaches an AUG codon where a specialized tRNA (fMET) brings in the first amino acid and the 60S (large) ribosomal subunit joins the complex to form a complete ribosome.

### Details of mRNA Translation

The translation process is often divided into three stages (Fig. 1): Initiation – where a complex of proteins (►eukaryotic initiation factors, eIFs) recruits ribosome(s) to the mRNA where they move to the beginning of the ORF, Elongation – which encompasses the processing of the ribosome along the coding region of the mRNA linking amino acids brought by specific transfer RNAs (tRNAs) into a growing polypeptide chain and Termination – which occurs at the end of the ORF characterized by the disassembly of the ribosomal complex and release of the full-length polypeptide.

### Initiation

Eukaryotic ribosomes contain a large and small subunit, each formed from a specific collection of ribosomal proteins and non-coding ribosomal RNAs (rRNAs). When an mRNA is to be translated, the small subunit of the ribosome first binds to a site “upstream” (on the 5' side) of the ORF. This activity is mediated by an initiation-complex consisting of ►eukaryotic initiation factor (eIF) proteins that bind to the 7 methylguanosine cap (m7G) [►RNA binding proteins Structures/Processes/Conditions] in the 5' and UTR. This also requires interaction with proteins that bind the polyA<sup>+</sup> sequence of the 3' UTR (Fig. 1). The small ribosome

subunit then proceeds along the 5' UTR region of mRNA in a 5' → 3' direction until it encounters an AUG-►start codon (Fig. 1). At this point it joins with a large ribosomal subunit to form a functional ribosome. Ribosomes contain two sites that contain tRNA molecules, the P-site which usually contains a peptidyl-tRNA molecule (i.e., a tRNA with the growing peptide attached) and an A-site which normally recruits aminoacylated –tRNAs which bring in additional amino acids for incorporation into the polypeptide (Fig. 1). Translation is initiated by an “initiator” tRNA, the only tRNA that can bind directly to an empty P-site of the ribosome. Most often in eukaryotes, this initiator tRNA encodes a methionine (Met) amino acid. At this point the ribosome is ready to recruit additional aminoacylated –tRNAs and proceed to synthesise a full length polypeptide. In special cases, other mechanisms can also initiate mRNA translation. This includes termination re-initiation, where ribosomes are re-directed to translate the same mRNA multiple times. Also, initiation can occur at an AUG codon other than the one nearest the m7G cap (leaky scanning), and ribosome shunting. Finally, there is an alternative to m7G cap-dependent translation initiation where internal ribosome entry sites (IRES) along the mRNA direct translation.

		2 <sup>nd</sup> position															
		U			C			A			G						
1 <sup>st</sup> position	U	UUU	Phenylalanine	Phe	F	UCU	Serine	Ser	S	UAU	Tyrosine	Tyr	Y	UGU	Cysteine	Cys	C
		UUC	Phenylalanine	Phe	F	UCC	Serine	Ser	S	UAC	Tyrosine	Tyr	Y	UGC	Cysteine	Cys	C
		UUA	Leucine	Leu	L	UCA	Serine	Ser	S	UAA	STOP			UGA	STOP		
		UUG	Leucine	Leu	L	UCG	Serine	Ser	S	UAG	STOP			UGG	Tryptophan	Trp	W
	C	CUU	Leucine	Leu	L	CCU	Proline	Pro	P	CAU	Histidine	His	H	CGU	Arginine	Arg	R
		CUC	Leucine	Leu	L	CCC	Proline	Pro	P	CAC	Histidine	His	H	CGC	Arginine	Arg	R
		CUA	Leucine	Leu	L	CCA	Proline	Pro	P	CAA	Glutamine	Gln	Q	CGA	Arginine	Arg	R
		CUG	Leucine	Leu	L	CCG	Proline	Pro	P	CAG	Glutamine	Gln	Q	CGG	Arginine	Arg	R
	A	AUU	Isoleucine	Ile	I	ACU	Threonine	Thr	T	AAU	Asparagine	Asn	N	AGU	Serine	Ser	S
		AUC	Isoleucine	Ile	I	ACC	Threonine	Thr	T	AAC	Asparagine	Asn	N	AGC	Serine	Ser	S
		AUA	Isoleucine	Ile	I	ACA	Threonine	Thr	T	AAA	Lysine	Lys	K	AGA	Arginine	Arg	R
		AUG	Methionine START Met M			ACG	Threonine	Thr	T	AAG	Lysine	Lys	K	AGG	Arginine	Arg	R
G	GUU	Valine	Val	V	GCU	Alanine	Ala	A	GAU	Aspartic acid	Asp	D	GGU	Glycine	Gly	G	
	GUC	Valine	Val	V	GCC	Alanine	Ala	A	GAC	Aspartic acid	Asp	D	GGC	Glycine	Gly	G	
	GUA	Valine	Val	V	GCA	Alanine	Ala	A	GAA	Glutamic acid	Glu	E	GGA	Glycine	Gly	G	
	GUG	Valine	Val	V	GCG	Alanine	Ala	A	GAG	Glutamic acid	Glu	E	GGG	Glycine	Gly	G	

**RNA Translation. Figure 2** Codon usage table: Codons are grouped by the first (*left*) and second (*top*) position. Note that in many cases the third position is redundant and that codons with a common first and second position base often encode the same amino acid.

## Elongation

In eukaryotic cells, there are 20 amino acids commonly used for protein synthesis. Each tRNA contains a region with three unpaired nucleotides (anti-codon) which binds the corresponding codon in the mRNA. The use of three bases to encode each amino acid means that there are actually ( $4^3$ ) different possibilities that can be used to uniquely encode them providing 64 unique identities. Thus, there are more codons than amino acids and therefore considerable redundancy in the code, with some amino acids encoded by four or more tRNAs with different anticodons. A separate process couples each specific amino acid to their representative encoding tRNA (s) via an activating enzyme (aminoacyl-tRNA synthetase). Also, some tRNAs can recognize more than one codon. This modified base pairing at the third nucleotide of a codon is called “wobble-pairing.” For example, the phenylalanine tRNA with the anticodon 3' AAG 5' recognizes UUC and UUU. Also, some codons are reserved for specialized functions. AUG signals for the beginning of each ORF and for the amino acid methionine (Fig. 2). As a result, there is usually a methionine at the amino terminal of the polypeptide synthesized from the mRNA. Any AUG codons after this point are interpreted for the insertion of an internal methionine.

Elongation of a nascent ribosome associated polypeptide is an iterative process in which a series of specific aminoacylated tRNAs, are recruited to their respective three-base codons within the A-site adjacent

to the P-site (Fig. 1). Once this occurs, elongation factors hydrolyze GTP (an energy source) to covalently link to the incoming amino acid to the existing polypeptide (Fig. 1). At this point the tRNA at the P site is released and the ribosome moves one codon (3 bases) downstream. The newly-arrived tRNA at the A-site, while still attached to the nascent polypeptide, shifts to the P site and opens the A site for recruitment of an aminoacyl-tRNA that carries an amino acid corresponding to the next codon. This occurs via another protein elongation factor and requires the energy of hydrolysis of another molecule of GTP. Once the ribosome complex clears the recruitment site, it is possible to recruit additional ribosome complexes to a single mRNA. Often a single mRNA molecule is translated simultaneously by many ribosomes. This multi-ribosome complex is called a polysome.

## Termination

Translation of a protein is normally finished when the ribosome reaches one or more ►STOP codons (UAA, UAG, UGA) (Fig. 2). Normally, there are no corresponding tRNA molecules with anti-codons for STOP codons. Instead, specific proteins (release factors) recognize these codons when they arrive at the A site of the ribosome and release the completed polypeptide (Fig. 1). During this process the ribosome complex is dissociated back into its corresponding subunits, which are then available for translation of additional mRNAs (Fig. 1).

### Regulation of mRNA Translation

Regulation of mRNA translation appears to be a much more common mechanism for regulating protein expression that was previously thought. There are several mechanisms that limit mRNA translation to specific cellular sub-domains. In addition, cytoplasmic mRNAs have a finite life and like mRNA transcription, degradation of mRNAs is also a regulated process. This includes the surveillance and destruction of aberrant mRNAs as the proteins translated from these mRNAs would potentially be detrimental to cell function. Also, there is an entire [▶RNA interference](#) [Structures/Processes/Conditions] regulatory system that employs small [▶non-coding RNA](#) molecules that also regulate translation and/or mRNA degradation (i.e., [▶RNAi](#)). These events are regulated through specific RNA binding proteins [Structures/Processes/Conditions] that interact with the RNA either before or after it is exported into the cytoplasm for translation. It is now thought that there is a dynamic balance between translation by ribosomes and cytoplasmic RNA regulatory complexes for access to mRNAs.

### RNA Transport Particles

In many cell types, mRNAs are transported to specific sub-domains to regulate protein expression. This process is important for establishing cellular asymmetry during cell division or directed cell migration. This process also appears critical for aspects of neuronal function, including axon guidance and nerve regeneration [1]. The RNA particles that contain these transported mRNAs also contain several of the proteins involved in translation including ribosomal subunits (Fig. 1). It is thought that translation is suppressed during mRNA transport.

### Processing-bodies

Processing bodies (P-bodies) are thought to be primarily sites of mRNA degradation although there are cases where they also sequester mRNAs away from the translational protein complexes to be released later. Degradation-specific P-bodies contain a complex that break down the mRNA by removing the 7mG cap and a 5'-3' exonuclease that subsequently breaks down the mRNA [2]. These structures also appear to be a destination for mRNAs that are being regulated by the RNAi pathway.

### Stress Granules

In mammalian cells, stress granules appear during events that seem to require a rapid shift in the translational events within a cell [3]. They are proposed to be sites where pools of translationally arrested mRNAs are stored as they contain several proteins also involved in mRNA translation such as the small ribosomal subunit. Functionally, these structures seem to have a role in sorting,

remodeling and exporting mRNAs either for subsequent translation or storage in complexes such as P-bodies.

### Preventing Translation of Mutated mRNAs

Eukaryotic cells possess several surveillance mechanisms to ensure the fidelity and appropriate translation of cytoplasmic mRNAs. Translation of aberrant mRNAs would obviously present a disadvantage to a cell. Defects in mRNA molecules can arise via mutations in the DNA of the encoding gene, or by errors that occur during transcription. Some of these errors would have no effect on translation, especially if they occur in the third (wobble) position of a codon due to codon redundancy (Fig. 2). However, mRNAs with incorrect amino acid codons or premature STOP codons would produce truncated proteins that would be ineffective or even harmful.

### Nonsense Mediated mRNA Decay

One process that removes non-sense mutations (premature stop codons) is the nonsense mediated decay (NMD) pathway [4]. Briefly, the complex of the RNA binding proteins that mediate joining of the last exons during nuclear RNA splicing remain associated with the mRNA as it is exported to the cytoplasm. During the first round of mRNA translation, these complexes are removed. If the ribosome complex dissociates from an mRNA via a premature termination codon, one or more of these complexes are not removed, and their retention marks the aberrant mRNA for selective destruction.

### Nonstop mRNA Decay and the Exosome

Nonstop transcripts contain no functional STOP codon. These mutations often occur during mRNA processing either by abnormal splicing or premature addition of the polyA<sup>+</sup> tail. During translation of these mRNAs, termination does not occur and the ribosome complex reaches the end of the poly(A) tail. If this occurs, the Ski7 protein binds to the empty A site overhanging the 3' end of the mRNA and recruits it to the exosome [5]. This exosome complex is the primary mediator of 3'-5' mRNA degradation that targets old mRNAs for degradation due to shortening of their 3' poly A<sup>+</sup> tail.

### References

1. Willis D, Li KW, Zheng JQ, Chang JH, Smit A, Kelly T, Merianda TT, Sylvester J, van Minnen J, Twiss JL (2005) Differential transport and local translation of cytoskeletal, injury-response, and neurodegeneration protein mRNAs in axons. *J Neurosci* 25:778–791
2. Sheth U, Parker R (2003) Decapping and decay of messenger RNA occur in cytoplasmic processing bodies. *Science* 300:805–808
3. Cheng J, Maquat LE (1993) Nonsense codons can reduce the abundance of nuclear mRNA without affecting the abundance of pre-mRNA or the half-life of cytoplasmic mRNA. *Mol Cell Biol* 13:1892–1902

4. Kedersha NL, Gupta M, Li W, Miller I, Anderson P (1999) RNA-binding proteins TIA-1 and TIAR link the phosphorylation of eIF-2 alpha to the assembly of mammalian stress granules. *J Cell Biol* 147:1431–1442
5. Frischmeyer PA, van Hoof A, O'Donnell K, Guerrierio AL, Parker R, Dietz HC (2002) An mRNA surveillance mechanism that eliminates transcripts lacking termination codons. *95:2258–2261*

## RNase H

### Definition

Ribonuclease is a general term for enzymes which catalyse the hydrolysis of RNA into smaller fragments. Ribonucleases are grouped into several sub-classes within Enzyme Class 2.7. (phosphorolytic enzymes) and Enzyme Class 3.1 (hydrolytic enzymes). RNase H cleaves the 3'-O-P-bond of RNA in a DNA/RNA duplex to produce 3'-hydroxyl and 5'-phosphate terminated products. Since RNase H hydrolyses RNA in a DNA:RNA duplex without degrading the DNA, it is commonly used to remove the RNA template after first strand cDNA synthesis.

► Serial Analysis of Gene Expression

## Rod and Frame, Rod and Disc

### Definition

Protocols to assess the impact of a static frame or a rotating disk on the visual perception of verticality (svv).

► Verticality Perception

## Rod Photoreceptor

### Definition

Rod-shaped photoreceptors in the vertebrate retina that mediate vision at low intensity light levels. Rods are far more numerous than cones in humans and are of only one type with peak spectral sensitivity ~500 nm.

► Photoreceptors

## Rod Spherule

### Definition

Synaptic terminal of a rod photoreceptor that provides output to rod bipolar and horizontal cells.

► Horizontal Cells  
 ► Photoreceptors  
 ► Retinal Bipolar Cells

## Roll Off

### Definition

The amount of attenuation of sound magnitude provided by a filter for waves outside of the filter's passband, usually expressed in dB/octave.

► Acoustics

## Romberg Sign

### Definition

Simply put, while standing and with the feet together, a positive Romberg sign is when the subject sways or steps out with the eyes closed but not with the eyes open. The amount of sway should make the examiner worried that the subject will fall since most people will sway a little with this test.

The interpretation of an abnormal Romberg test is not simple. A great deal of the nervous system is involved when performing the Romberg test and multiple small deficits in many systems could be present. In other words, the nervous system functions together. For instance, adequate strength in the legs is required. Proximal or distal weakness will prevent the subject from making corrections in stance. Significant cerebellar dysfunction will cause the subject to be unsteady with feet together and eyes open, while mild cerebellar dysfunction might only reveal itself with the eyes closed.

With intact cerebellar and motor function, one maintains balance using the visual, vestibular and proprioceptive systems. Since the Romberg test is performed with the eyes closed, abnormalities in either of the other two systems can cause an abnormal Romberg test. Classically,

the Romberg test assumes that the vestibular system is intact. That may not be a good assumption if dizziness is the primary complaint. In the classic situation, if the subject closes their eyes and significantly sways or steps out, the implication is that proprioception is impaired. If proprioceptive and vestibular functions were both intact, closing the eyes would not be a problem.

Proprioceptive function is transmitted through large diameter myelinated peripheral nerves and the dorsal columns of the spinal cord to nuclei in the brain stem. Peripheral neuropathy, vitamin B12 deficiency, multiple sclerosis and neurosyphilis are examples of diseases to consider when the Romberg sign is positive.

► Vestibular Tests: Romberg Test

## Root Neurons

### Definition

Special neurons unique to the rodent cochlear nucleus located in the auditory nerve root.

► Cochlear Nucleus

## Ror

### Definition

Nuclear orphan receptor related to the retinoic acid receptors. Binds to the consensus sequence ([A/T]A[A/T]NT[A/G]GGTCA termed RORE, in the promoter of target genes.

► Clock Genes

## Rostral Interstitial Nucleus of the MLF (riMLF)

### Definition

Located at the mesodiencephalic junction, this is the most rostral of the interstitial nuclei of the MLF.

► Eye Movements Field

## Rostral Ventrolateral Medulla (RVLM)

### Definition

The RVLM is part of the ventrolateral medulla and located just caudal to the facial nucleus. It is a vasomotor nucleus and contains (in addition to interneurons) sympathetic premotor neurons related to the sympathetic cardiomotor, cutaneous vasoconstrictor, muscle vasoconstrictor, renal vasoconstrictor, visceral (non-renal) vasoconstrictor pathways and to the adrenal medulla (probably cells secreting noradrenaline). These populations of sympathetic premotor neurons are viscerotopically organized.

► Autonomic Reflexes

► Blood Volume Regulation

## Rotation Vector

### Definition

Three dimensional eye positions can be expressed in rotation vector form, where the direction of the vector specifies the axis of rotation from primary position and its length specifies the rotation angle.

► Vestibulo-ocular Reflexes

## Rough Endoplasmic Reticulum (RER)

### Definition

The endoplasmic reticulum (ER) is an extensive membrane network of tubes and sac-like structures held together by the cytoskeleton. Some parts of the ER are covered with ribosomes on the surface, which give them a rough appearance at the level of the electron microscope. Ribosomes assemble amino acids into proteins based on instructions from the nucleus, and insert the freshly produced proteins directly into the ER, which processes them and then passes them on to the Golgi apparatus.

## Route Navigation (or Taxon Navigation)

### Definition

In route navigation the traveler is guided by a memorized set of turns and straight paths to reach a goal. Rule sets such as “at the big rock turn left; next, at the fallen tree bear right and proceed...” are examples of route learning. In animals route learning is based on operant conditioning. In humans it is usually accomplished by “following directions” generated by another (cultural transmission). Route learning can be effective but is inflexible.

- ▶ Operant Conditioning
- ▶ Spatial Learning/Memory

## Route Navigation Strategy

### Definition

Behavior relying on an egocentric reference frame and directed by chaining sequences of taxon and praxis strategies.

- ▶ Spatial Memory

## RTLLBs

- ▶ Reticulotectal Long-Lead Burst Neurons

## Rubrobulbar Tract

### Synonyms

Tractus rubrobulbaris

### Definition

Descending fibers of the rubrobulbar tract and rubrospinal tract terminate on the interneurons in the lateral reticular formation and the dorsolateral intermediate zone of the spinal cord and directly on motoneurons of

and rubrospinal tract have a somatotopic arrangement.

- ▶ Mesencephalon

## Rubrospinal Tract

### Synonyms

Tractus rubrospinalis

### Definition

Somatotopically arranged fiber bundles between the red nucleus and spinal cord. Runs in the lateral column of the spinal cord, originating in the magnocellular portion of the red nucleus, going to the spinal cord segments as far as the thoracic cord. Regulates the tone of important flexors.

- ▶ Mesencephalon

## RVOR (Rotational VOR)

- ▶ Vestibulo-Ocular Reflex



---

## S1

### Definition

Primary somatosensory cortex.

---

## S2

### Definition

Secondary somatosensory cortex.

---

## S-100

### Definition

S-100 protein is a dimer consisting of two 11-kDa subunits, alpha and beta, and is structurally related to the calcium-binding protein calmodulin, and to intestinal vitamin D-dependent calcium-binding protein. S-100 functions in calcium-dependent interactions with other proteins. S-100 is not found in Schwann cell precursors, but the protein is expressed in immature and mature Schwann cells. It is also expressed in mature astrocytes. S-100 can be used to distinguish between mature/immature Schwann cells and Schwann cell precursors or crest cells.

- ▶ Schwann Cell
- ▶ Schwann Cells in Nerve Regeneration

---

## Saccade

### Definition

- ▶ Saccade
- ▶ Saccadic Eye Movement

---

## Saccade – Delayed

### Definition

Saccades that are voluntarily withheld, after a targeting eccentric stimulus appears, until a central fixation stimulus is turned off. The temporal overlap between the time of target appearance and the turning off of the fixation point is called the delay period.

- ▶ Saccade
- ▶ Saccadic Eye Movement

---

## Saccade, Saccadic Eye Movement

### Definition

A rapid conjugate eye movement that shifts the line of sight (center of gaze) rapidly from one part of the visual field to another, mainly used for orienting towards an object of interest. It is characterized by stereotyped relationships between amplitude, duration, and peak velocity. In human subjects, peak velocity typically rises along with saccade amplitude up to a saturation level of  $400\text{--}500^\circ\text{ s}^{-1}$  which is reached when the amplitude exceeds  $10\text{--}30^\circ$ , whereas duration rises linearly at a rate of  $1.5\text{--}3\text{ ms per degree}$  starting from a minimum of  $20\text{--}30\text{ ms}$ . Saccades are the only type of eye movements that can be readily executed at will (as when scanning a picture), but are also intimately involved in reflexive and involuntary behaviors:

Suddenly occurring visual, but also auditory and tactile, stimuli elicit reflexive saccades toward the stimulus location (visual grasp reflex), and during seemingly quiet fixation the eyes are engaged in an ever continuing series of microsaccades which go unnoticed by the individual. Saccades are thought to be essentially preprogrammed according to visual information arising at latest about  $100\text{ ms}$  before movement onset although some possibility of “on-line” modification by concurrent sensory stimuli has been noted.

- ▶ Microsaccades

## Saccade Adaptation

CHARLES A. SCUDDER  
Portland, OR, USA

### Definition

Saccade adaptation is a process for maintaining saccade accuracy based on evaluating the accuracy of past saccades and appropriately correcting the motor commands for subsequent saccades. An adaptive process is required to maintain saccade accuracy because saccades have too short a duration relative to the long delays in the visual pathways to be corrected while in flight. It is a true adaptive process in that it is unconscious, accuracy improves gradually over repeated trials, and when complete, removal of the original error by experimental intervention produces a new saccadic error (dysmetria) in the opposite direction that can only be eliminated by a new process of adaptation.

The normally high accuracy of saccades is largely the product of continuous adaptation. Numerous components of the oculomotor system, such as the eye muscles, cranial nerves, and central pathways, gradually change during development and aging, and these changes would produce saccadic inaccuracy if uncorrected. Adaptation can sometimes maintain accuracy after pathological changes occurring in any of these components.

### Characteristics

#### Methods to Measure Adaptation

Saccade accuracy is quantified by measuring the endpoint of the saccade relative to the location of the target. In a typical experimental setup, subjects fixate a small stationary target spot, and after a delay, the target jumps to a new location. Subjects must quickly shift their gaze (make a saccade) to re-fixate the displaced target. Beginning at the initial fixation point, the target displacement and the saccade are expressed as vectors in polar coordinates. Adaptation can be expressed as a decrease in saccade error, which is the angular error (difference between the angles of the target and saccade vectors) together with the amplitude error (difference between the amplitudes of the target and saccade vectors). Alternatively, it can be expressed as the amplitude of the saccade relative to the amplitude of the target displacement, with 100% being perfect. This ratio is often called **gain**, but the term has mechanistic connotations that are inappropriate for saccade adaptation.

Although saccade adaptation is an everyday occurrence, an experimental intervention is usually invoked to reveal its power and features. The first experimental paradigm was modeled after human pathology. Patients

who develop a **paresis** of one or more muscles in one eye produce saccades that have different amplitudes in each eye. If the patient had been using the normal eye to view the world, the normal eye would make accurate saccades, but the eye with paresis (the “paretic eye”) would make saccades too short to land on the target (undershooting saccades). If an experimenter placed an opaque patch over the normal eye and forced the patient to use the paretic eye, saccades in the paretic eye would initially undershoot, but would also increase in size (adapt) over the period of about a day until they were nearly accurate [1]. Saccades in the normal eye would also increase in size so that they would overshoot the target. Of course, the normal eye is patched so that the CNS is unaware of the overshoot. Subsequently, if the patch is removed from the normal eye and placed over the paretic eye, the now viewing normal eye continues to overshoot the target. The overshoots gradually diminish until saccade metrics are restored to the state before the eye was ever patched. The paradigm has been adapted for use in animals by surgically weakening the medial and lateral rectus muscles of one eye to produce an artificial paresis [2], and an example of such adaptation is shown in Fig. 1.

In a second paradigm for producing saccadic adaptation, a target steps away from the fixation point, and while the saccade is in flight, the target is displaced again so that the otherwise accurate saccade will not land on the target [3,4]. The “intrasaccadic” target displacements can be backward relative to the first target step, forward, or to the side, and are typically 15–40% of the amplitude of the first target step. Repeated trials of the same type (e.g., all back-stepping) cause a consistent error that is gradually corrected by adaptation. Figure 2 illustrates this process for a human subject tracking a target where the initial target step of about 9° is followed by an intrasaccadic step of 3° backwards. In the space of 150 trials, the amplitude of the saccade decreases from overshooting the displaced target to essentially landing on the target. When the intrasaccadic step is discontinued at trial 375, saccade amplitude remains at its reduced value for some time even though the saccade now undershoots the target. In fact, a new gradual process of adaptation is required to increase saccade amplitude back to normal. A similar process of adaptation of saccade direction occurs if the intrasaccadic step is perpendicular to the initial target step.

### Characteristics of Saccade Adaptation

#### A True Adaptation?

Data indicate that the above changes in amplitude are the product of a true sensory-motor adaptation rather than the product of conscious effort or some covert “strategy.” First, the majority of human subjects are unaware of the intrasaccadic steps and therefore could

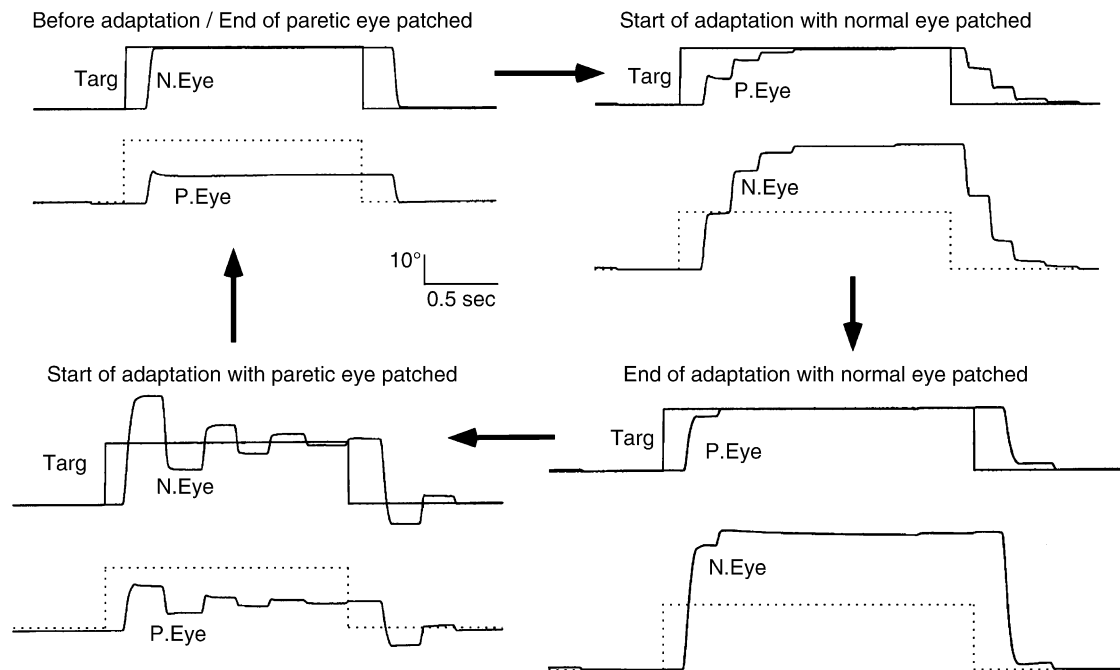

**Saccade Adaptation. Figure 1** Adaptation of saccade size produced by patching of either the normal or the parietic eye. The four stages of adaptation are shown for typical single trials, and are in clockwise order (*large arrows*). Horizontal position is illustrated for the visible target (Targ), normal eye (N.Eye), parietic eye (P.Eye), and the unseen target for the patched eye (*dotted lines*). Initially, the patch covered the parietic eye and the normal eye viewed the target (*top left*). Adaptation was initiated by switching the patch to cover the normal eye so that saccades in the viewing parietic eye were severely undershooting (*top right*). After viewing with the parietic eye for a day or more, saccade size increased in both eyes (*bottom right*). Finally, switching the patch back to cover the parietic eye resulted in severely overshooting saccades in the viewing normal eye (*bottom left*). Long-term adaptation to this situation produced decreases in saccade size and a return to normal-sized saccades in the normal eye (*top left*).

not form such a strategy. Second, discontinuation of the intrasaccadic steps (e.g., at trial 375, Fig. 1) does not produce an immediate reversal of the change in saccade size, even though the adapted size is now an encumbrance. Third, repeated sessions of adaptation and reversal do not result in any faster changes. Fourth, when examined under similar experimental conditions, the parietic-eye and intrasaccadic-step paradigms produce similar amounts of adaptation in similar amounts of time [2].

### Conjugate or Monocular?

Adapted saccades are conjugate by default, even in the parietic-eye paradigm where one eye is patched. However, if disparate visual stimuli are presented to each eye, a limited ability to adapt each eye disconjugately can be demonstrated.

### Time Course

The time course of adaptation varies tremendously depending on the details of the paradigm and the species. Adaptation in humans is approximately ten times faster than that in monkeys under comparable

experimental conditions. Adaptation is faster (as much as two times) when decreases in saccade size are required compared to when increases are required. Adaptation is also faster when there are few potential targets (e.g., subjects saccade back and forth between two targets) than when there are many (e.g., saccades are made to an array of targets with multiple rows and columns) [2,4].

The wide range in rates of adaptation might indicate that different sites and/or mechanisms of plastic changes are invoked with different paradigms or in different species. However, these apparent differences are probably more quantitative than qualitative. For instance, a very rapid form of adaptation has been identified in both monkeys [2] and humans [4], but in the former, it accounts for only a small part (<10%) of the total possible change, whereas in the latter it accounts for 20–85%. Consequently, many human experiments are terminated before a slower (monkey-like) form of adaptation could be revealed. Similarly, the parietic-muscle paradigm produces slow adaptation when subjects view the natural world outside the laboratory. However, the rate is the same as in the

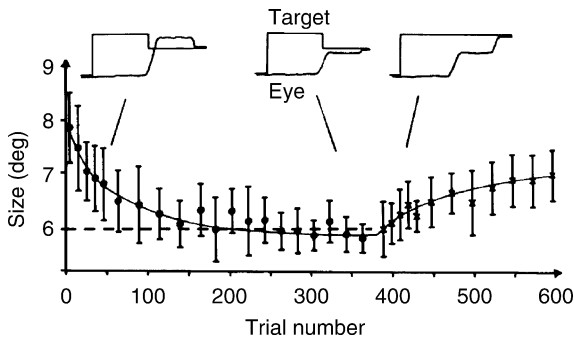

**Saccade Adaptation. Figure 2** Time course of adaptation of saccade size produced by using the intrasaccadic-step paradigm. Saccade size is plotted against the number of trials. To a target step about  $9^\circ$ , the monkey makes a slightly undershooting saccade (*left inset*), but the  $3^\circ$  backward step that occurs during the saccade makes it appear to the monkey that the saccade overshoots the target. After repeated trials with backward intrasaccadic steps, the saccade declines in size so that it slightly undershoots the displaced target (middle inset, and dotted line on plot). Elimination of the backward intrasaccadic steps at trial 375 renders the newly adapted saccade to seriously undershoot (*right inset*). The apparent **saccadic dysmetria** is slowly reversed (figure adapted from Deubel [3]).

intrasaccadic-step paradigm when the number of targets is the same, indicating that the paretic-muscle paradigm does not invoke a separate mechanism of adaptation [2].

### Adaptation Fields

If saccades are adapted using target steps of one size and direction, and the effects are tested using target steps of various sizes and directions, it is found that the induced change in saccade size decreases with increasing disparity between the test and adapted target step (reviewed in [5]). The range over which training transfers (generalizes) to steps of other sizes and directions is called the adaptation field. This finding explains the previous result that adaptation is slower with increasing numbers of potential targets. That is, adaptation of saccades to each target in the array occurs with incomplete benefit from adaptation to other targets in the array.

By default, adaptation fields are only weakly dependent on eye position *per se*. That is, adaptation to  $10^\circ$  rightward target steps at one location mostly transfers to  $10^\circ$  rightward target steps anywhere else in the visual field. However, adaptation can be rendered position dependent if training is position dependent [2,5]. For instance, training with backward intrasaccadic steps when looking left, and forward intrasaccadic steps when looking right, produces decreases in saccade size when looking left and increases in saccade size when looking right. Moreover, in humans with paresis

of one extraocular muscle, saccadic size in the paretic eye is eye-position dependent, and adaptation is correspondingly position dependent when the paretic eye is forced view the world [1].

### Transfer of Adaptation to Different Tasks

The situation in monkeys is simple; adaptation using one saccadic tracking task produces adapted saccades when measured in any other saccadic task. For instance, training using intrasaccadic steps and the simple “targeting” task described above produces comparable, or nearly comparable, adaptation of express saccades evoked in a **gap task** (very short latency reflexive saccades, see **Saccades-Express**), saccades measured in a **memory-guided saccade task** (saccades to a target flashed on and off 1 sec earlier), self-paced saccades to fixed targets, and catch-up saccades during smooth pursuit. In humans, transfer is more complicated. In general, transfer of adaptation from simpler paradigms (targeting task and gap task) to “higher-order” saccades (scanning and memory-guided) is weak, and *visa-versa* (reviewed in [5]). The data have been taken to mean that humans have more than one site of adaptation (see below).

### Upstream Conditions

Adaptation is a process of detecting errors and incrementally correcting them in subsequent movements. Obviously, the visual error produced when the line of sight does not fall on the target is the operational error that drives adaptation. However, after the dysmetric saccade, subjects immediately make a corrective saccade to remove the visual error. The nervous system could use either a neural representation of the visual error or a copy of the efferent command for the corrective saccade to serve as the error signal to induce the synaptic changes that underlie adaptation. Experimental tricks that produce visual error without corrective saccades show that the neural representation of visual error is used as the predominant signal that drives adaptation (reviewed in [5]).

### Involved Structures

*A priori*, any of the structures involved in generating saccades could potentially harbor the synapses that change to produce adaptation. These include the major cortical areas (**frontal eye fields**, **supplementary eye fields**, and **lateral intraparietal area**), the **superior colliculus**, the midline **cerebellum**, and the burst generator itself. The characteristics of adaptation constrain the choice. The existence of adaptation fields implicates a structure whose neurons have movement fields or a structure that receives input from one with movement fields. The existence of eye-position dependent adaptation implicates a structure that is at least potentially aware of current eye position. This would

appear to rule out the burst generator per se, the collicular synapses on burst-generator neurons, and arguably the superior colliculus itself, because all three areas are thought to encode only eye or gaze displacement. These conjectures have been tested by neurophysiological experiments in the superior colliculus. Experiments using saccades evoked by microstimulation of the colliculus either during the adapting or testing phase have been inconclusive (reviewed in [5]), perhaps because microstimulation does not evoke saccades in the same way as normal targeting saccades. On the other hand, measurements of the ►**movement fields** of neurons in the superior colliculus show that they change minimally as a result of adaptation, indicating that the adaptation takes place downstream of the colliculus [6].

The cerebellum is downstream of the superior colliculus (see ►**Cerebellum – role in eye movements**) and satisfies behavioral criteria noted above. In addition, it has been strongly implicated in adaptation in other motor systems and has a wealth of identified mechanisms of synaptic plasticity. Physiological experiments in monkeys strengthen the conjecture that it has a major role in saccade adaptation. Permanent lesions of the ►**oculomotor vermis** or fastigial nucleus severely impair or abolish the ability to adapt saccade size using intrasaccadic steps [7]. Temporary inactivation of the caudal fastigial nuclei using a GABA agonist produces dysmetria and prevents the expression of adaptation while the drug is active, but not after the drug has worn off [8]. Presumably, plastic changes had occurred upstream of the fastigial nucleus, e.g., in the vermis. Finally, the discharges of fastigial-nucleus neurons change as a result of adaptation of saccade size in a manner adequate to have produced the changes in size [9].

Adaptive changes in humans probably also involve the cerebellum [10], but the failure of changes to transfer to saccade tasks different from the training paradigm and the predominance of a very rapid form of adaptation indicates that another site might also be involved in some tasks. Functional MRI data do not implicate another structure [10], but the data are not definitive. There are other possibilities, including that most changes could occur in the cerebellum, but separate channels from different sources (the superior colliculus or frontal eye fields) are maintained and separately adapted.

## References

1. Optican LM (1985) Adaptive properties of the saccadic system. In: Berthoz A, Melvill Jones G (eds) *Adaptive mechanisms in gaze control*. Elsevier, New York, pp 71–79
2. Scudder CA, Batourina EY, Tunder GS (1998) Comparison of two methods of producing adaptation of saccade size and implications for the site of plasticity. *J Neurophysiol* 79:704–715

3. Deubel H (1989) Sensory and motor aspects of saccade control. *Eur Arch Psychiatr Neurol Sci* 239:17–22
4. Miller JM, Anstis T, Templeton WB (1981) Saccadic plasticity: Parametric adaptive control by retinal feedback. *J Exp Psychol Hum Percept Perform* 7:356–366
5. Hopp J, Fuchs AF (2004) The characteristics and neuronal substrate of saccadic eye movement plasticity. *Prog Neurobiol* 72:27–53
6. Frens MA, van Opstal AJ (1997) Monkey superior colliculus activity during short-term saccadic adaptation. *Brain Res Bull* 43:473–483
7. Barash S, Melikyan A, Sivakov A, Zhang MS, Glickstein M, Thier P (1999) Saccadic dysmetria and adaptation after lesions of the cerebellar cortex. *J Neurosci* 19:10931–10939
8. Robinson FR, Fuchs AF, Noto CT (2002) Cerebellar influences on saccade plasticity. *Ann NY Acad Sci* 956:155–163
9. Scudder CA, McGee DM (2003) Adaptive modification of saccade size produces correlated changes in the discharges of fastigial nucleus neurons. *J Neurophysiol* 90:1011–1026
10. Desmurget M, Pelisson D, Grethe JS, Alexander GE, Urquizar C, Prablanc C, Grafton ST (2000) Functional adaptation of reactive saccades in humans: a PET study. *Exp Brain Res* 132:243–259

## Saccade Remapping

### Definition

Saccade-related shift of visual target representation in The central nervous system (CNS). Conceivably due to processes subsumed under the rubric “Vector-subtraction hypothesis” (see Foveation Hypothesis) it is consistent with the well documented saccade-related shift of the receptive field of neurons sensitive to a direct or memorized visual stimulation (see Lateral intraparietal area (LIP) for a description of such visual receptive fields). This observed shift, which sometimes occurs in anticipation of the actual movement of the eyes, likely contributes to the neural processes suppressing the awareness of visual instabilities caused by saccadic eye movements.

Thus by extension, saccade remapping also refers to visual stability processes and to space constancy processes which allow us to encode our environment independently of eye movements.

- Eye-Hand Coordination**
- Foveation Hypothesis**
- Lateral Intraparietal Area (LIP)**
- Saccade**
- Saccadic Eye Movement**

## Saccade-Vergence Interactions

LAWRENCE MAYS

University of North Carolina at Charlotte, Charlotte, NC, USA

### Definition

► **Saccades** are very fast (up to  $700^\circ/\text{s}$ ) movements of the eyes which are generally employed to shift gaze from one object to another. In general, saccades are conjugate, in that the two eyes move in the same direction and by the same amount, even if only one eye is allowed to view the target. Saccades may be horizontal, vertical, or oblique. Horizontal ► **vergence** (**Disparity dependent vergence**, **Radial flow dependent vergence**) movements are very slow ( $5^\circ/\text{s}$  to  $50^\circ/\text{s}$ ) movements of the eyes in the opposite direction in the horizontal plane, and are used to transfer gaze between objects at different distances from the observer. Horizontal vergence movements are part of a near response, and are associated with ocular accommodation, which is the change in lens power needed to focus on a nearer or farther object (see ► **Accommodation-vergence interaction**). Saccade-vergence interaction refers to the increase in the speed of vergence observed when saccades occur during vergence movements, or alternatively, to the inequality of the sizes of horizontal saccades when they occur during vergence movements [1].

### Characteristics

#### Upstream Events/Conditions

Saccades may be voluntary or involuntary, and are usually directed toward visual targets in the environment, or they may be spontaneous or occur in response to other (e.g. auditory) cues. Saccades between targets that are equidistant from the observer do not involve vergence movements, aside from a small rapid divergence-convergence transient (► **Divergent eye movement**, ► **Convergent eye movement**), which may be due to mechanical factors. A horizontal saccade between two targets spaced  $8^\circ$  apart is shown in Fig. 1a. A saccade-free, or smooth, vergence movement between a far and a near target is shown in Fig. 1b. Vergence movements occur in response to shifts in gaze between visual targets at different distances. Vergence movements can occur in the absence of saccades, but this is rare in the natural environment; to do so, the far and near targets must be aligned with a point halfway between the eyes, as was the case for this example. Vergence movements have been extensively studied in the laboratory in this situation. There is evidence that the neuronal circuits for saccades and vergence movements are somewhat independent, although utilize the same ► **extraocular motoneurons** [2]. Lesions of the

pons and ► **medial longitudinal fasciculus (MLF)** may impair horizontal saccades without a major effect on vergence [3], while some midbrain lesions may impair vergence while leaving horizontal saccades relatively unaffected.

### Downstream Events/Conditions

If the vergence and saccadic subsystems were essentially independent, then one might expect the eye movements produced by each to sum linearly when a saccade occurs during a vergence movement. That this is not the case can be seen in Fig. 1c and d. This can be seen by noting the relative sizes of the horizontal saccades (Fig. 1c), or by comparing the vergence velocity profile for the saccade-vergence trace with that of the similar smooth vergence (saccade-free) case (Fig. 1d). There is a rapid acceleration of vergence during the saccade, which causes vergence movements during saccades to be completed more quickly than if

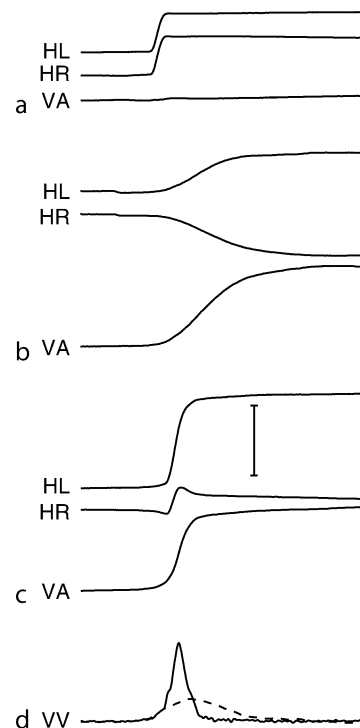

### Saccade-Vergence Interactions.

**Figure 1** Saccade-vergence interaction. This figure shows an  $8^\circ$  horizontal saccade (a), an  $11.5^\circ$  smooth horizontal vergence movement (b), and the interaction when a saccade of this size occurs during the vergence movement (c). (d) shows the vergence velocity profiles for the saccade + vergence (solid line) compared to the vergence only (dashed line) case. Abbreviations are: HL, horizontal left eye position; HR, horizontal right eye position; VA, vergence angle (i.e. HL-HR); VV, vergence velocity (first derivative of VA). The scale bar is  $10^\circ$ , and the time base is 500 ms.

there were no saccades. If the saccade and the vergence events summed linearly, the vergence velocity profiles in Fig. 1d would be identical. Not only do saccades speed vergence; it appears that vergence movements slow saccades.

### Involved Structures

The same extraocular motoneurons (►medial rectus for adduction, abducens for abduction) (►Ocular adduction, ►Ocular abduction) are utilized for both saccades and vergence movements, although not necessarily to the same extent. The pre-motor circuitry is quite different for the two types of eye movement. For vergence, some midbrain ►near response neurons appear to project to the medial rectus subdivisions of the oculomotor nucleus [4] and carry a signal related to vergence and accommodation but are unrelated to the conjugate movements characteristic of saccades. Most near response cells have precisely the vergence signal needed by medial rectus motoneurons, that is, they increase their firing rate linearly for convergence (convergent eye movements), and also have an appropriate vergence velocity signal. A small number of midbrain near response cells decrease their firing rate for convergence (divergence cells), and so have the appropriate signal for abducens motoneurons, but this connection has not been documented.

The pre-motor commands for horizontal saccades are organized in the pons. Two types of saccadic burst neurons (also called short- or medium-lead burst neurons) are found [5]. ►Excitatory burst neurons (EBNs) provide an excitatory burst to ipsilateral abducens neurons (motoneurons and internuclear neurons) and so provide the appropriate velocity command for the high-speed saccades. Inhibitory burst neurons show the same pattern of activity (i.e., burst for the horizontal component of an ipsilateral saccade) but inhibit the contralateral abducens nucleus during the saccade. Saccadic burst neurons are inhibited by pontine ►omnipause neurons, which are located in the nucleus raphé interpositus. Omnipause neurons are normally active during wakefulness, and must cease firing in order for a saccade to occur.

►Abducens internuclear neurons are located within the abducens nucleus but are not motoneurons. Their axons cross the brain at the level of the abducens nucleus and ascend the medial longitudinal fasciculus to provide excitatory input to the medial rectus motoneurons. To the extent that abducens internuclear neurons receive the same inputs as abducens motoneurons, the abducens internuclear pathway serves to ensure that the two eyes move conjugately in the horizontal plane. Abducens internuclear neurons do not provide a vergence signal to the medial rectus motoneurons, and damage to the internuclear pathway disrupts adduction for conjugate gaze shifts but not convergence [3]. Indeed, nearly all abducens internuclear neurons decrease their firing rate

for convergence (as do abducens motoneurons) and so they provide an inappropriate vergence signal to the medial rectus motoneurons, which must be overcome by the near response cell input to these motoneurons [6].

### Mechanism of the Interaction

Three mechanisms for this non-linear interaction between saccades and vergence have been proposed. The first explanation is that there is a non-linear interaction between saccadic and vergence commands at the level of the extraocular muscles, since the same extraocular muscles are used to execute both saccades and vergence movements. A strong argument against this explanation is that purely vertical saccades are about as effective at speeding vergence as horizontal saccades. This should not be the case if the interaction depended upon an interaction at the level of the extraocular muscles since different muscles are used for horizontal and vertical eye movements.

The second explanation notes that the sizes of the saccades in the two eyes are markedly different, and proposes that under the condition of shifting gaze between objects at different distances and directions, the normally conjugate saccadic system is allowed to operate in a disconjugate, or disjunctive mode (►Disjunctive eye movements), and produce different saccades for the two eyes [7]. One argument in favor of this explanation is the observation that, for unequal horizontal saccades occurring during vergence, some saccadic burst cells have activity associated with the movement of the right eye and some are associated with the left eye [8]. The possibility that saccadic pre-motor elements might command the eyes to move different distances suggests that the saccadic system is responsible for the speeding of vergence in this situation. On the other hand, there are strong arguments against this view. Studies of the activity of abducens motoneurons and internuclear neurons show that any separate right eye/left eye pre-motor signals are commingled and essentially lost at the level of the motoneurons [6]. Furthermore, it is clear that abducens internuclear neurons do not convey an appropriate vergence signal to the medial rectus motoneurons. Moreover, it is difficult to reconcile the idea that speeding of vergence is due to unequal horizontal saccades when it occurs with vertical saccades, which employ different motoneuron pools and different pre-motor circuitry.

A third view is that there is a mechanism that selectively speeds vergence during a saccade. According to this idea, the saccadic system generates equal saccades for the two eyes, but the occurrence of the saccade accelerates the vergence command, and the resulting rapid change in vergence angle, synchronized with the saccade, causes the saccade in one eye to be larger than that in the other. Indeed, it has been suggested that

pontine omnipause neurons, which inhibit saccadic burst neurons and must be turned off during saccades, also inhibit vergence burst neurons [9]. If so, then these vergence burst cells would be allowed to fire more vigorously during saccades, speeding vergence. Alternatively, some component of the saccadic burst signal could be combined with the vergence velocity signal to speed the vergence movement.

### Methods to Measure this Event/Condition

Saccade-vergence interactions require methods to measure eye movements with high temporal and spatial resolution. In general, faithful recording of saccades requires a sampling rate of at least 500 samples/s and small vergence movements should be recorded to nearest 0.1°. Non-contacting infrared techniques can be used if only horizontal movements are to be recorded. If vertical saccades are to be measured, scleral search (electromagnetic) coils should be considered.

### References

1. Ono H, Nakamizo S, Steinbach MJ (1978) Nonadditivity of vergence and saccadic eye movement. *Vision Res* 18:735–739
2. Mays LE, Porter JD (1984) Neural control of vergence eye movements: activity of abducens and oculomotor neurons. *J Neurophysiol* 52:743–761
3. Cogan DG (1970) Internuclear ophthalmoplegia, typical and atypical. *Arch Ophthalmol* 84:583–589
4. Zhang Y, Mays LE, Gamlin PDR (1992) Characteristics of near response cells projecting to the oculomotor nucleus. *J Neurophysiol* 67:944–960
5. Fuchs AF, Kaneko CRS, Scudder CA (1985) Brainstem control of saccadic eye movements. *Annu Rev Neurosci* 8:307–337
6. Gamlin PDR, Gnadt JW, Mays LE (1989) Abducens internuclear neurons carry an inappropriate signal for ocular convergence. *J Neurophysiol* 62:70–81
7. Enright JT (1984) Changes in vergence mediated by saccades. *J Physiol* 350:9–31
8. Zhou W, King WM (1998) Premotor commands encode monocular eye movements. *Nature* 393:692–695
9. Zee DS, Fitzgibbon EJ, Optican LM (1992) Saccade-vergence interactions in humans. *J Neurophysiol* 68:1642–1641

---

## Saccadic Burst Generator

### Definition

The saccadic burst generator is a neural network in the brain stem that converts saccadic-related signals from higher level sensorimotor structures into intense bursts

of activity that temporally drive the oculomotor neurons. The bursts of neural activity can be excitatory for agonist motoneurons and inhibitory for antagonists. The generator may also include gating circuits that help to control the onset and end of the bursts.

- ▶ Brainstem Burst Generator
- ▶ Saccade, Saccadic Eye Movement

---

## Saccadic Dysmetria

### Definition

Is a repeatable failure of saccadic eye movements to land on their intended target. The error can be one of saccade amplitude (either undershooting or overshooting) or one of saccade direction. Dysmetria can be produced by pathology within the orbital tissues, extraocular muscles, or in the brain. The brain has robust adaptive capabilities to make conjugate corrections for dysmetria, and limited capability to make monocular corrections.

These capabilities are thought to require the midline cerebellum, so enduring conjugate dysmetria is frequently due to pathology of the cerebellum.

- ▶ Dysmetria
- ▶ Saccade
- ▶ Saccadic Eye Movement

---

## Saccadic Eye Movement

### Definition

- ▶ Saccade
- ▶ Saccadic Eye Movement

---

## Saccular Test

- ▶ Vestibular Tests: Vestibular Evoked Myogenic Potentials Induced by High Level Sounds



## Sacculæ

### Definition

One of two otolith organs that sense gravity and linear acceleration such as from initiation of movement in a straight line. The sacculæ is oriented vertically in the head, and registers accelerations in the vertical or coronal plane.

► Peripheral Vestibular Apparatus

## Sacral Segment of the Spinal Cord

### Synonyms

Pars sacralis medullae spinalis; Sacral part of spinal cord

### Definition

Sacral cord. The segment of the spinal cord comprising the spinal nerves of the sacrum.

► Medulla Spinalis

## SAGE

► Serial Analysis of Gene Expression

## SAI and SAII Afferents

### Definition

Slowly adapting (SA) mechanoreceptive afferents thought to be related, respectively, to Merkel cells and Ruffini corpuscles. SAI afferents have small receptive fields, and a low threshold to mechanical stimulation.

SII afferents have larger receptive fields, appear to be absent from glabrous skin, and are especially sensitive to lateral skin stretch of the type that accompanies movement.

► Active Touch  
 ► Cutaneous Mechanoreceptors – Functional Behavior  
 ► Processing of Tactile Stimuli

## Salivary Secretion Control

GUNNAR TOBIN

Department of Pharmacology, The Sahlgrenska Academy at Göteborg University, Göteborg, Sweden

### Definition

The control of salivary secretion depends on reflex nerve impulses that involve afferent limbs, medullar salivary nuclei and an efferent limb consisting of the ►parasympathetic and sympathetic secretomotor and vascular nerves. Except for a scanty spontaneous secretion from minor salivary glands, the secretory process is elicited entirely by activity in the autonomic glandular innervation, albeit endocrine stimuli may modulate saliva composition. Also the glandular blood flow is principally controlled via the innervation with other influences, such as hormones having little effect. At rest, a small secretion normally occurs as a result of reflex glandular activation and the spontaneous secretion. Taste and mastication are important sensory inputs leading to activity in the two divisions of the ►autonomic nervous system, which act synergistically in the control of salivary secretion.

### Characteristics

#### Quantitative Description

Saliva is produced by three pairs of major glands and a number of minor glands (labial, buccal, lingual, palatal) [1]. The parotid (20–30 g) and submandibular glands (8–10 g) are conspicuously larger than the sublingual gland (3–5 g). The resting flow in healthy individuals usually amounts to 0.3–0.4 ml/min, which have the relative glandular contributions: submandibular 65%, parotid 20% and the sublingual and the minor glands 5–10% each. In stimulated flow of whole saliva, the parotid part may be as large as 50%.

### Higher Level Structures

#### Anatomy [1,2]

The parotid gland is located frontal and caudal to the auditory canal and surrounds the dorsal part of the mandible. On the masseter surface, close to the parotid duct, additional glandular tissue may occur (accessory parotid gland). The submandibular gland is located caudal to the parotid gland and medially to the body of the mandible, while the sublingual gland is located in the floor of the mouth cranial to the mylohyoid muscle. The minor salivary glands underlie most of the oral mucosa except the gingiva and the dorsum of the tongue, and in contrast to the major glands these glands may produce saliva spontaneously. The arterial blood flow supply is derived from various branches of the external carotid artery, and the venous drainage is provided by tributaries of the external and internal jugular veins.

### Autonomic Nerves

The parasympathetic preganglionic nerve fibers leave the central nervous system via the facial and the glossopharyngeal ►cranial nerves. The fibers in the facial nerve depart the nerve within the skull and run in the chorda tympani before fusing with the lingual nerve; some fibers of facial nerve reach palatal glands by other routes. The ►postganglionic fibers of ganglion submandibularis innervate the submandibular and the sublingual glands as well as minor lingual glands. The glossopharyngeal fibers enter the otic ganglion via n. petrosus minor, and the relatively long postganglionic nerve fibers reach the parotid gland and minor buccal glands via the auriculotemporal nerve. The postganglionic fibers of the sympathetic innervation originate in the superior cervical ganglion and follow the blood vessels to the glands.

### Central Connections

Figure 1 shows a schematic illustration of taste afferents, projections to areas of the ►limbic system and cortical level and efferent system [3]. Tentatively, ►limbic areas are associated with feeding- and drinking-related behavior and the cortex with discrimination of taste intensity and quality. The salivatory centers receive impulses from other brainstem nuclei and from the forebrain, and these impulses may be modulated by ►inhibitory or excitatory synapses. The precise location of the sympathetic salivary center is not identified, but the sympathetic impulses are outflows from the upper thoracic spinal cord. Vascular nerves are a separate set of efferent nerves than the secretomotor efferents, at least sympathetic, and while the parasympathetic vascular efferents are controlled by salivatory centers, the sympathetic are under central vasomotor control.

### Lower Level Components

#### Histology [4]

The glandular parenchyma consists of secretory endpieces (acini), often capped by cells in the form of demilunes, and of ducts. The endpieces consist of serous cells, producing a protein- and enzyme-rich secretion, of mucous cells, producing a secretion rich in glycoconjugates (e.g. mucin), and of seromucous cells, sharing features of each of the other two. The human parotid gland is a homocrine serous gland, the submandibular a heterocrine (mixed seromucous), while mucous cells dominate in the sublingual gland. Minor glands are heterocrine except the mucous palatal and the serous lingual von Ebner's glands. Contractile myoepithelial cells surround the secretory endpieces and the intercalated ducts into which the saliva produced by the endpieces drains. In the succeeding striated ducts, an active transport of electrolytes from the saliva to the bloodstream occurs. Eventually the striated ducts empty into the excretory ducts.

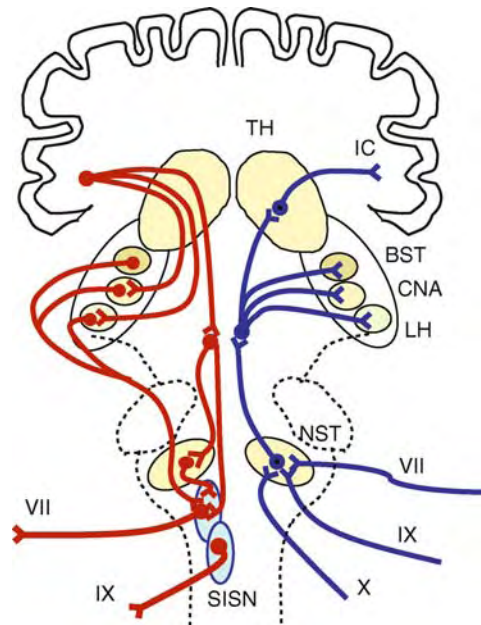

**Salivary Secretion Control. Figure 1** Schematic illustration based on studies in rats [3] of parasympathetic efferent system (facial nerve – submandibular/sublingual glands and glossopharyngeal nerve – parotid gland; to the left in illustration) and taste afferent system (facial, glossopharyngeal and ►vagal nerves; to the right). Taste information is relayed via neurons of the solitary nucleus (NST) to a second-order of neurons in the parabrachial nucleus. The dorsal ►thalamus (TH) projections of the nucleus terminate in the insular cortex (IC), while a ventral route to the limbic system terminates in the ►lateral hypothalamic area (LH), the central nucleus of the amygdala (►amygdala) (CNA) and the bed nucleus of the stria terminalis (BST). Direct and indirect descending projections reach the medullar parasympathetic superior ►salivatory center (the only one characterized). This salivatory center consists of the ►salivatory nuclei (superior and inferior salivatory nuclei) (SISN), the former connected to the submandibular and sublingual glands, and the latter to the parotid gland.

#### Innervation [4]

Generally, human salivary glands are densely innervated by ►cholinergic and ►adrenergic fibers, but the adrenergic innervation of sublingual and minor salivary glands is sparse or deficient. Fibers containing neuropeptides (►NANC transmitters; mainly ►vasoactive intestinal peptide (VIP) and ►neuropeptide Y (NPY)), also occur. The NANC transmitters often co-exist with a classical autonomic ►neurotransmitter in the same fiber. In animals, VIP and acetylcholine, and occasionally the enzyme ►nitric oxide synthase, may occur in the same parasympathetic postganglionic neuron, while NPY may co-exist with noradrenaline.

## Receptors

► **Muscarinic receptors**, alpha- and beta-► **adrenoceptors** as well as NANC transmitter receptors (VIP receptors) occur abundantly on parenchymal cells and in the glandular vasculature, and moreover, muscarinic receptors and  $\alpha_2$ -adrenoceptors occur on nerve terminals [5]. Glandular  $\alpha_1$ - and  $\beta_1$ -adrenoceptors have been described in human glands. While both muscarinic M1 and M3 receptors occur in human labial glands, all five subtypes exist in the rat submandibular gland but still with M3 subtype dominance. However, receptors for a number of transmitters, hormones and factors have been described in human salivary glands (e.g. epithelium growth factor (► **EGF**), androgen, progesterone, aldosterone and glucagons) and considering findings in animals, the list grows even longer and includes ► **tachykinin** (NK1), purine, ► **serotonin** and ► **GABA** receptors.

## Structural Regulation

### Ontogenesis and Neuronal Trophic Effects

Salivary glands arise in the embryo from the proliferation of epithelial cells into the mesoderm, forming a cord that becomes canalized, and postnatal the terminal cells are developed into the fully mature secretory endpieces. Parasympathetic responses occur already at birth, while sympathetic appear some days later. The autonomic innervation affects size and sensibility of salivary glands, and, as shown by animal studies, loss of the parasympathetic NANC drive causes a profound atrophy and ► **denervation supersensitivity** [4,6]. Acetylcholine seems to be of less significance for long-term regulations, but noradrenaline have structural effects; stimulation of the  $\beta$ -adrenoceptor induces increase in glandular size. In addition to the neuronal structural regulation, hormones (i.e. different steroid hormones including oestrogen, progesterone and androgens) may affect cell growth and gland size.

## Higher Level Processes

### Activation of Reflexes

During eating, increases in efferent outflows are attributed to stimulation of different ► **sensory receptors**; ► **gustatory receptors**, ► **mechanoreceptors**, ► **olfactory receptors** and nociceptors [2]. The gustatory-salivary reflex, activated by strong sour stimulus evokes a maximal secretory response, while other basic stimuli (salt, bitter, sweet) give smaller. However, secretion elicited by sweet and salt is richer in protein, suggesting quality-specific activation of parasympathetic and sympathetic fibers. Mastication activates mechanoreceptors in the periodontal ligament (► **Ruffini endings**) and in the mucosa, which results in greater ipsilateral responses than contralateral. Smell may evoke secretion by chemical irritation of free nerve endings and by odorants stimulating nasal olfactory receptor neurons

(olfactory-salivary reflex); the latter exists in the submandibular but not in the parotid gland. Noxious and non-noxious stimuli of oral tissues also activate salivary reflexes, while the existence of oesophageal, visual and psychic reflexes is a matter of debate. Hyposalivation during fear is, however, explained by central inhibition of salivatory centers reducing the efferent outflow.

## Sensory Inputs and Efferent Impulses

In animals, the efferent outflows from the salivatory centers depend on the sensory modality and on which confined oral area is being stimulated, and preganglionic parasympathetic and sympathetic neurons respond differently to taste, tactile and noxious mechanical stimulation [3]. The preganglionic parasympathetic neurons discharged spontaneously at a low firing rate, when examined in hamsters and rats, and fired to reflex stimulation by phasic-tonic or ► **tonic activity** (periodically up to 30 Hz). Neurons assumed to be a vasodilator type, tended to fire at a slightly higher frequency. Nevertheless, the ganglionic transmission from pre- to postganglionic neurons varies between species. Some species (e.g. rats) have ganglion cells that are innervated by a single preganglionic axon, while others have a multiple innervation yielding discharges in postganglionic neurons in short bursts, each at a very high frequency as seen in sheep. Also, sympathetic neurons may have a spontaneous and irregular discharge, in which the number of bursts increases by a sensory input.

## Lower Level Processes

### Receptor Pathways and the Cellular Secretory Mechanisms

Saliva, containing approximately 99% water and 1% of electrolytes and proteins, is produced in two steps – first formation of isotonic primary saliva by secretion from the secretory endpieces, and second reabsorption of sodium and chloride and some secretion of potassium and bicarbonate in the ducts [5]. Since the ducts are relatively impermeable for water the secondary saliva becomes hypotonic, but less so at increasing flow rates. Receptors being preferentially hydrokinetic (muscarinic ► **acetylcholine receptors** and  $\alpha_1$ -adrenoceptors (and tachykinin receptors in some species) activate the  $\text{Ca}^{2+}$ -dependent pathway, while the proteokinetic type ( $\beta$ -adrenoceptors and VIP receptors) activates the cAMP-pathway (Fig. 2) [4,7]).

The combined stimulation of both pathways results in ► **potentiation** of the responses, but responses are also modulated by prejunctional receptors that facilitate or inhibit transmitter release. The intracellular events leading to fluid secretion is elicited when  $\text{Ca}^{2+}$  rises, but how water moves is not fully clarified (Fig. 3 [7]).

Proteins are primarily secreted from acinar cells with the addition of a small proportion from ducts cells. Low

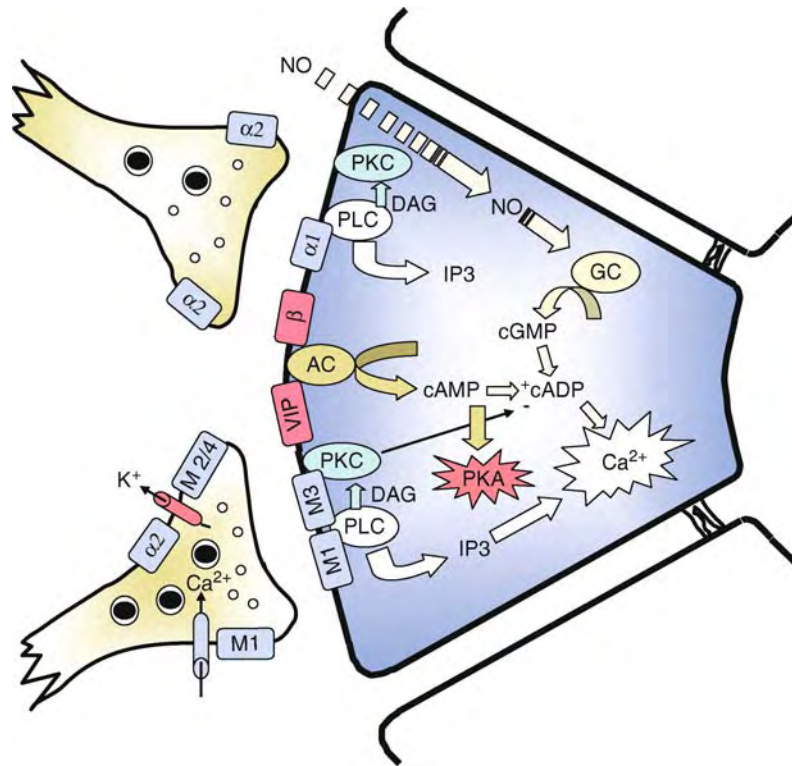

**Salivary Secretion Control. Figure 2** Schematic illustration of  $\blacktriangleright$ G-protein-coupled receptors for principal transmitters and key molecules of the intracellular pathways in a salivary secretory cell innervated by adrenergic and cholinergic/VIPergic neurons (modified from [3]). Transmitter binding to  $\alpha_1$ - $\blacktriangleright$ adrenoceptors, muscarinic M1 or M3 receptors induces via activation of phospholipase C phosphatidylinositol-4,5-bisphosphate to be hydrolyzed into inositol-1,4,5-trisphosphate ( $IP_3$ ) and diacylglycerol (DAG), leading to increase in the intracellular  $Ca^{2+}$  levels and to activation of  $\blacktriangleright$ protein kinase C (PKC). Transmitter binding to  $\beta$ -adrenoceptors activates  $\blacktriangleright$ adenylate cyclase that elevates [cAMP], thereby activating  $\blacktriangleright$ protein kinase A (PKA). Nitric oxide synthesized from L-arginine by nitric oxide synthase, passes through the cell membrane and activates soluble  $\blacktriangleright$ guanylate cyclase leading to the formation of cGMP. cGMP may activate ADP-ribosyl cyclase, leading to the formation of cADP ribose. cADP ribose and  $\blacktriangleright$  $IP_3$  receptors induce the release of stored  $Ca^{2+}$ . The activity of ADP-ribosyl cyclase is stimulated by cAMP, while protein kinase C seems to inhibit the enzyme. The connections provide possible ways for fluid and protein secretion by activation of any pathway.  $\blacktriangleright$ Presynaptic inhibition by muscarinic (M2 or M4) receptors and  $\alpha_2$ -adrenoceptors, hyperpolarizing (increased conductance of  $\blacktriangleright$  $K^+$  channels) the neuronal membrane, may restrain transmitter release. Presynaptic muscarinic M1 receptors may similarly affect  $\blacktriangleright$  $Ca^{2+}$  channels, thereby facilitating calcium influx and  $\blacktriangleright$ neurotransmitter release.

intensity of sympathetic and parasympathetic activity engage the  $\blacktriangleright$ regulatory and the  $\blacktriangleright$ constitutive route, respectively, while high parasympathetic intensity is necessary for activating the  $\blacktriangleright$ regulatory route [4].

## Process Regulation

### Fluid Responses

The autonomic impulses evoke secretion by releasing acetylcholine, noradrenaline and neuropeptides from glandular nerve terminals [4–6]. While parasympathetic activity evokes a copious secretion relatively poor in protein, activity within the sympathetic innervation evokes a sparse but protein-rich secretion. Although  $\alpha$ - or  $\beta$ -adrenoceptors evoke little fluid secretion, they are important for protein and enzyme secretion, in

particular  $\beta_1$ -adrenoceptors. Activation of the parasympathetic muscarinic receptors, predominantly of the M3 subtype, elicits most of the fluid secretion (Fig. 4). However, muscarinic M1 receptors also contribute to the salivary response as studies in animals indicate, in particular at low intensity of nerve activity (Fig. 5 [8]). The initiation of secretion is supported by parasympathetic and sympathetic ( $\alpha_1$ ) induced contraction of myoepithelial cells [4].

### Vascular Responses

Blood flow is not a secretion-limiting factor initially, since the interstitial fluid will preserve the response. However, in short, because of increase in interstitial oncotic pressure, salivation will cease unless the blood

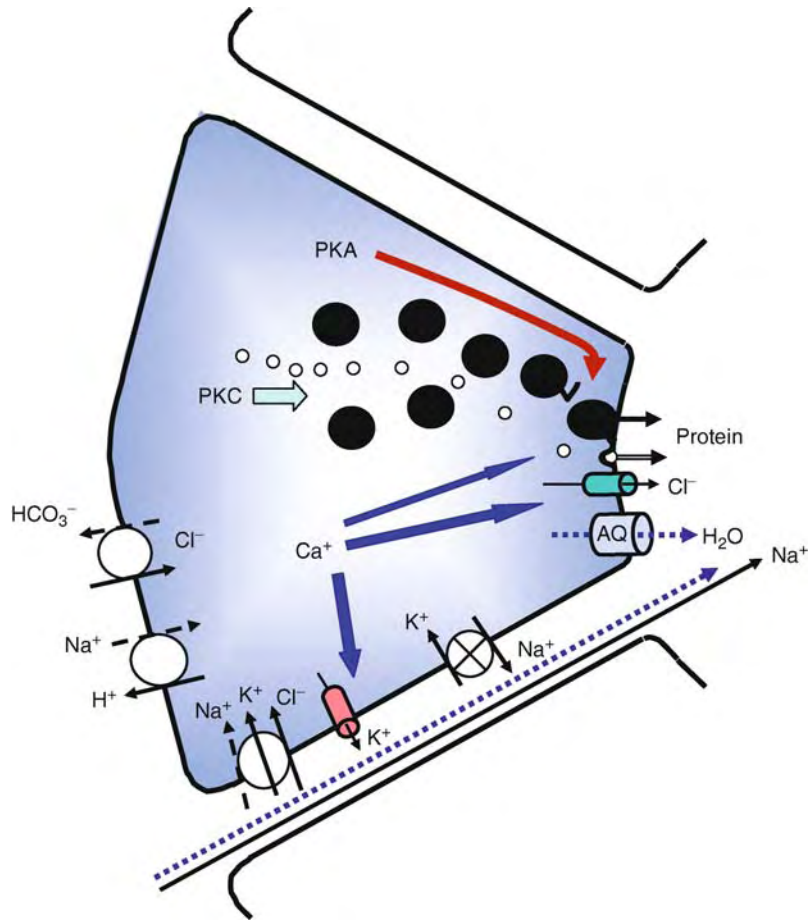

**Salivary Secretion Control. Figure 3** Schematic illustration of key molecular events leading to fluid and protein secretion in a secretory salivary cell (drawn from data from [4]). In the resting state, the intracellular  $\text{Ca}^{2+}$  concentration of the secretory cell is low, and the  $\text{Ca}^{2+}$  activated  $\text{K}^+$  and  $\text{Cl}^-$  channels are closed. When the  $\text{Ca}^{2+}$  concentration increases, the  $\text{K}^+$  and  $\text{Cl}^-$  channels open; effluxes of  $\text{Cl}^-$  and  $\text{K}^+$  occur via luminal and basolateral membrane channels, respectively. Chloride enters the secretory cell via a sodium-chloride co-transporter (NKCC1) in the basolateral membrane, for which energy is provided by the inwardly directed electrochemical gradient for  $\text{Na}^+$ . The increase in intracellular  $\text{Na}^+$  concentration stimulates  $\text{Na}^+/\text{K}^+$ ATPase ( $\text{Na}^+/\text{K}^+$  pump) to the expense of cellular  $\text{ATP}$ . The luminal secretion of  $\text{Na}^+$  seems to occur via the paracellular pathway driven by the electrochemical gradient across the epithelium. Water is transported by osmosis by the paracellular pathway and/or via aquaporin channels in the acinar cell membrane. Proteins, synthesized in the rough endoplasmic reticulum are transported in vesicles from the Golgi complex either to storage in granules (regulatory route) or directly to the plasma membrane (constitutive route). In the granular exocytosis, protein kinase A plays a key role by activating binding proteins ( $\text{Docking/priming}$ ;  $\text{VAMP2 to t-SNAREs}$ ), and  $\text{Ca}^{2+}$  seems to enhance membrane fusion. Protein kinase C has been connected to protein secretion, possibly by affecting binding proteins.

flow increases. While parasympathetic activity invariably increases it (Fig. 5), sympathetic activity exerts variable effects.

The parasympathetic-evoked increase is, as shown by animal experiments, largely mediated by neuropeptides (i.e. VIP [9]). In contrast to the cholinergic vasodilatation that occurs at low intensity of parasympathetic activity and which is partially un-dependent on nitric oxide synthesis, the atropine-resistant vasodilatation seems to be completely dependent. Also in man, VIP is a potent vasodilator and causes *in vitro* relaxation of

the submandibular artery. At rest, a tonic activity within the sympathetic innervation maintains a glandular vascular resistance by  $\alpha$ -adrenoceptor-mediated constriction, probably enhanced by NPY. However, during sympathetic activity, blood flow may still be preserved and thereby also the flow of saliva, as has been shown by animal studies [9]. Namely, after discontinuation of electrical stimulation of the sympathetic nerve, an adrenoceptor-mediated after-dilatation occurs that may be larger than the preceding vasoconstriction. Since sympathetic neurons fire in bursts during reflex-induced

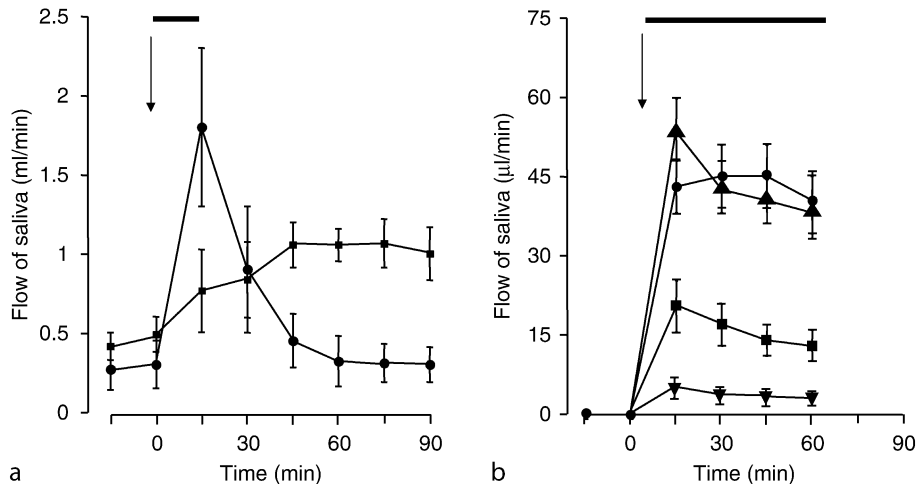

**Salivary Secretion Control. Figure 4** Fluid responses (means $\pm$ SEM) induced by different stimulation techniques in healthy adults (A;  $n = 5$ ) and in anaesthetized rats (B;  $n = 3-6$ ). A) Flow of saliva, without tongue movements or mastication in response to lozenges containing malic acid placed on the tongue (filled circle; dissolving period indicated by horizontal bar;) and to oral pilocarpine (filled square; 5 mg; administration indicated by arrow). B) Flow of saliva from rat parotid glands induced by application of one drop of citric acid (filled circle; 5%) on the tongue every 30 s (horizontal bar), by electrical stimulation of the auriculotemporal nerve (filled triangle; 40 Hz; horizontal bar), by electrical stimulation of the sympathetic nerve (filled inverted triangle; 50 Hz 1:10 s; horizontal bar) or by pilocarpine (filled square; 2 mg/kg IV; arrow). The diagrams in figure 4 are drawn from unpublished material and redrawn from data in Götrick et al. (2004) *J Dent Res* 83:393-397; Götrick, Tobin (2004) *Arch Oral Biol* 49:969-973).

activity, this is likely to occur repeatedly during physiological conditions.

### Transmitter Interactions

Simultaneous parasympathetic and sympathetic stimulations potentiate the responses as reflected by the fact that strong gustatory stimulations result in maximal flow rates of whole saliva (5-10 ml/min). In some species, administration of neuropeptides into the bloodstream evokes fluid and/or protein secretion; e.g.  $\blacktriangleright$  substance P (mainly fluid) and  $\blacktriangleright$  VIP (protein with or without a sparse fluid response), and when the parasympathetic nerve is stimulated electrically in these species, an atropine-resistant secretory response occurs [6]. *In vitro* examinations of the human submandibular glands do not indicate that these peptides induce any flow of saliva on their own, but VIP probably contributes by potentiating effects; muscarinic responses are potentiated by VIP (see Fig. 4 illustrating NANC + acetylcholine interaction; nerve response), and VIP elevates the content of  $\blacktriangleright$  cAMP in human submandibular glands. Co-localization of transmitters in single neurons implies that the relative amounts being released vary depending on the rate and pattern of the firing [9]. The release of VIP requires a high intensity of nerve activity (>10 Hz) and, as shown in animals, parasympathetic  $\blacktriangleright$  burst stimulation at high frequencies enhances vasodilatation and protein secretion, occasionally also salivation; *n.b.* maximal functional responses usually occur at 15-40 Hz (cf. preganglionic discharge). Furthermore, in burst

patterns, the long duration effects of neuropeptides improve the prerequisites for the classical transmitters acting thereupon, and additionally, the pattern takes advantage of transient facilitation by neuronal excitatory receptors and avoids the hold back at less neuronal activity by prejunctional inhibition [10].

### Function

The main functions of saliva are lubrication, protection and digestion [1]. Lubrication facilitates speaking and swallowing, the water of saliva moistens and the mucins bind food particles into bolus formation. Mucins lubricate and protect the mucosa, and salivary EGF benefits its repair. Protective roles are exerted by removing substances from the oral cavity (oral clearance), and by the buffer capacity by bicarbonate, phosphate and proteins in saliva. Salivary proteins may also protect against infections (e.g. IgA, peroxidase and lysozyme). The enzymes  $\alpha$ -amylase (parotid) and lipase (lingual von Ebner's glands) may initiate digestion of starch and triglycerides, respectively. Saliva also fulfils a taste-aiding function by dissolving flavor compounds, a necessity for taste receptor activation.

### Pathology

Salivary gland dysfunction, deleterious to oral health, could originate from primary glandular conditions (e.g. radiation, inflammatory diseases such as  $\blacktriangleright$  Sjögren's syndrome, duct stones, retention cysts and tumors) or could be secondary to systemic conditions (e.g.

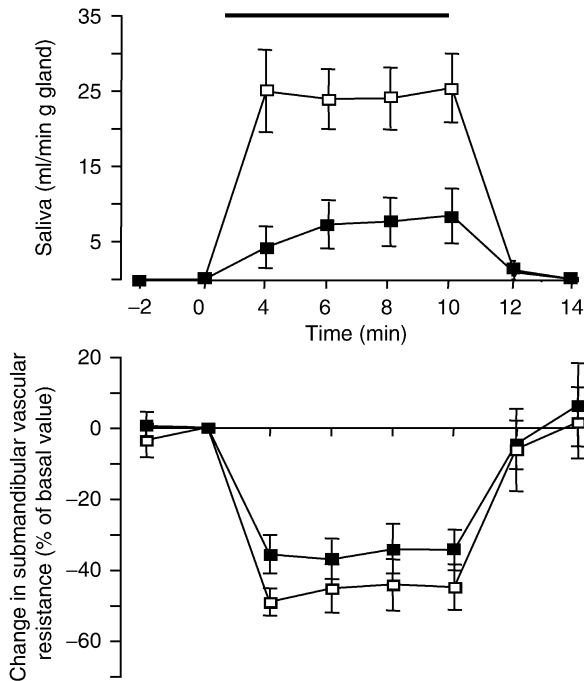

**Salivary Secretion Control. Figure 5** Flow of saliva (upper panel) and changes in submandibular vascular resistance (lower panel; perfusion pressure/blood flow; reflecting changes in glandular blood flow) in response to electrical stimulation of the chorda lingual nerve in anaesthetized sheep at 2 Hz for 10 min (indicated by horizontal bar) before (*open square*) and after (*filled square*) administration of pirenzepine (100 nmol/kg IV; “M1-selective” dose). Responses are mean $\pm$ SEM (n = 4). (Redrawn from material presented at the Physiological Society, Dec 2003; Tobin and Edwards, 2004, *J Physiol* 555P:C19).

medications, endocrine and autoimmune diseases, neurological disorders and infections [1,5]). The conditions often result in **xerostomia**, most commonly to medication, Sjögren’s syndrome and radiation towards the head and neck region. Due to the complexity of the reflexes involved in the control of salivary secretion, the targets for possible xerogenic effects are numerous, as also reflected by synergistic effects by multiple medications (polypharmacy). The principal mechanism of xerogenicity is by an anticholinergic action or by interference of central pathways.

### Therapy

Salivary enhancement therapies are either topical, local therapies or systemic therapies ([5], Fig. 4). Chewing gums and flavor lozenges as well as oral rinses are pills in the palliative therapy. Acupuncture is a suggested local therapy, assumed to cause relief of xerostomia by inducing release of neuropeptides. A number of drugs have the potential to intensify the flow of

saliva. Pilocarpine causes significant increases in most patients irrespective of the cause of xerostomia, but shows the typically adverse effects of a parasympathomimetic. In order to find secretagogues with less adverse effects, agents such as **acetylcholine esterase inhibitors**,  $\alpha_2$ -antagonists and agents up-regulating substance P have been evaluated in clinical trials.

### References

- Humphrey SP, Williamson RT (2001) A review of saliva: normal composition, flow, and function. *J Prosthet Dent* 85:162–169
- Linden RWA (1998) Taste. In: Harris M, Edgar M, Wright SM (eds) *Clinical Oral Science*, Oxford, pp 167–178
- Matsuo R, Morimoto T, Kang Y (1998) Neuronal activity of the superior salivatory nucleus in rats. *Eur J Morphol* 36:203–207
- Garrett JR, Kidd A (1993) The innervation of salivary glands as revealed by morphological methods. *Microsc Res Tech* 26:75–91
- Porter SR, Scully C, Hegarty AM (2004) An update of the etiology and management of xerostomia. *Oral Surg Oral Med Oral Pathol* 97:28–46
- Ekström J (1999) Role of nonadrenergic, noncholinergic autonomic transmitters in salivary glandular activities in vivo. In: Garrett JR, Ekstrom J, Anderson LC (eds) *Neuronal mechanisms of salivary secretion. Frontiers of oral biology*, vol 11. Karger, Basel, pp 94–130
- Turner RJ, Sugiya H (2002) Understanding salivary fluid and protein secretion. *Oral Dis* 8:3–11
- Tobin G, Giglio D, Götrick B (2002) Studies of muscarinic receptor subtypes in salivary gland function in anaesthetized rats. *Auton Neurosci* 100:1–9
- Edwards AV (1998) Autonomic control of salivary blood flow. In: Garrett JR, Ekström J, Anderson LC (eds) *Glandular mechanisms of salivary secretion. Frontiers of oral biology*, vol 10. Karger, Basel, pp 101–107
- Tobin G (2002) Presynaptic muscarinic receptor mechanisms and submandibular responses to stimulation of the parasympathetic innervation in bursts in rats. *Auton Neurosci* 99:111–118

## Salivatory Nuclei (Superior and Inferior Salivatory Nuclei)

### Definition

A pair of nuclei (superior and inferior salivatory nuclei) located rostral to the dorsal nucleus of the vagus from where the parasympathetic preganglionic neurons of the salivary gland innervation emerge.

### ► Salivary Secretion Control

## Salt Taste

### Definition

- ▶ Taste - Salt

higher than that of a megapixel digital camera (1,000 by 1,000 samples). Unlike the camera, which has constant sampling density across the photograph, the primate retina has higher density nearer the fovea. Each of the individual ganglion cell classes has its own sampling density, and most are substantially lower than a 1-megapixel camera.

- ▶ Retinal Ganglion Cells
- ▶ Visual Processing Streams in Primates

## Saltatory Conduction

### Definition

Conduction in myelinated axons depends upon a similar pattern of circular current flow. However, myelin is an effective insulator, and current flow through it is negligible. Instead, depolarization in myelinated axons jumps from one node of Ranvier to the next, with the current sink at the active node serving to electrotonically depolarize to the firing level the node ahead of the action potential. This jumping of depolarization from node to node is called saltatory conduction. It is a rapid process, and myelinated axons conduct up to 50 times faster than the fastest unmyelinated fibers.

- ▶ Action Potential Propagation

## Sampling

### Definition

The process of transforming a continuous signal into discrete units.

- ▶ Signals and Systems

## Sampling Density of Retinal Ganglion Cells

### Definition

The density of retinal ganglion cells across the retina. The total sampling by the human retina is slightly

## Sampling Frequency

### Definition

- ▶ Nyquist sampling theorem
- ▶ Signals and Systems

## Sapid Saporous, Saporific Stimulus

- ▶ Tastant

## Sarco(endo)plasmic Reticulum $\text{Ca}^{2+}$ -ATPase (SERCA)

### Definition

Integral membrane proteins that catalyze the ATP-dependent transport of  $\text{Ca}^{2+}$  from the cytosol to the lumen of the sarcoplasmic reticulum (SR). In conjunction with plasma membrane  $\text{Ca}^{2+}$ -ATPases, SERCAs are responsible for setting resting cytoplasmic  $\text{Ca}^{2+}$  concentrations, and during repetitive muscle contractions, they induce muscle relaxation through the rapid sequestration of large  $\text{Ca}^{2+}$  loads from the cytoplasm into the lumen of the SR.

- ▶ Excitation–Contraction Coupling



## Sarcolemma

### Definition

Sarcolemma is the cell membrane of skeletal muscle fibers.

► Skeletal Muscle Architecture

## Sarcomere

### Definition

A sarcomere is typically considered to be the basic contractile unit of muscle. It is defined as the structural repeat element that is bordered by two neighboring Z-plates.

It contains the contractile proteins actin and myosin, the regulatory proteins troponin and tropomyosin, and a host of structural proteins, most prominently titin, nebulin, and desmin.

- Actin
- Myosin
- Sarcomere Structural Proteins
- Skeletal Muscle Architecture
- Sliding Filament Theory
- Molecular and Cellular Biomechanics

## Sarcomere Structural Proteins

ELISABETH EHLER

The Randall Division of Cell and Molecular Biophysics & The Cardiovascular Division, King's College London, London, UK

### Synonyms

Cytoskeleton of the sarcomere

### Definition

Structural proteins are necessary to guarantee the correct assembly and maintenance of the ►sarcomere, the smallest unit of the ►myofibril. This multiprotein complex is essential for muscle contraction and mutations in structural proteins can lead to hereditary myopathies.

### Characteristics

The sarcomere is the smallest subunit of a myofibril, the contractile multiprotein complex in striated muscle cells (Fig. 1).

It is defined as the region between two Z-discs, which anchor the thin filaments, which are composed of actin and its associated proteins. Contraction is brought about by the interaction between actin and myosin, which is organized in a bipolar fashion to the thick filaments. These are anchored in the middle of the sarcomere in the M-band, which provides connection with the third filament system in muscle, the elastic filaments composed of titin. The thick filaments are equivalent to the A-bands (anisotropic), which are seen as dark broad bands in the polarization microscope and in electron micrographs. They alternate with the I-bands (isotropic), which have the darker contrasted Z-disc as a transverse structure in their middle. To provide maximum force output the contractile filaments in muscle are arranged to paracrystalline multiprotein complexes. Despite their extremely regular appearance, sarcomeres are constantly renewed with an approximal protein half-life of about 3 days. Increased physiological demand leads to the addition of sarcomeres in a process called ►hypertrophy. Also protein isoform composition can change, depending on developmental stage, muscle fiber type and mechanical stress, which is sensed in the sarcomere itself at transverse structures such as the Z-disc and the M-band [1]. A multitude of structural proteins are needed to bring about the regular arrangement of the sarcomere during embryonic development and to maintain it during lifetime. A key role seems to be played by the Z-disk protein alpha-actinin, the M-band protein myomesin and titin filaments stretching in between, which can be considered as the “backbone” of the sarcomere.

### Titin – Combining Scaffolding, Elasticity and Signaling

Titin (also called connectin) is regarded as the most important structural protein of the sarcomere since it spans throughout half a sarcomere and functions as a “molecular ruler” for the integration of most sarcomeric proteins, several signaling proteins and even metabolic enzymes [1]. Titin has a unique size with a molecular weight >3,000 kDa, leading to a single protein of about 1 µm length and lack of titin prevents the assembly of sarcomeres [1]. Titin is mainly composed of fibronectin type II and immunoglobulin modules. Its N-terminus is anchored at the Z-disk, where it interacts with actin filaments, alpha-actinin and telethonin and the protein stretches then throughout the sarcomere to the M-band, where its C-terminus overlaps with titin molecules coming from the other half sarcomere [2]. In addition to providing structural stability and functioning as a building plan, titin also contributes elasticity to the sarcomere due to the presence of inserted non-modular

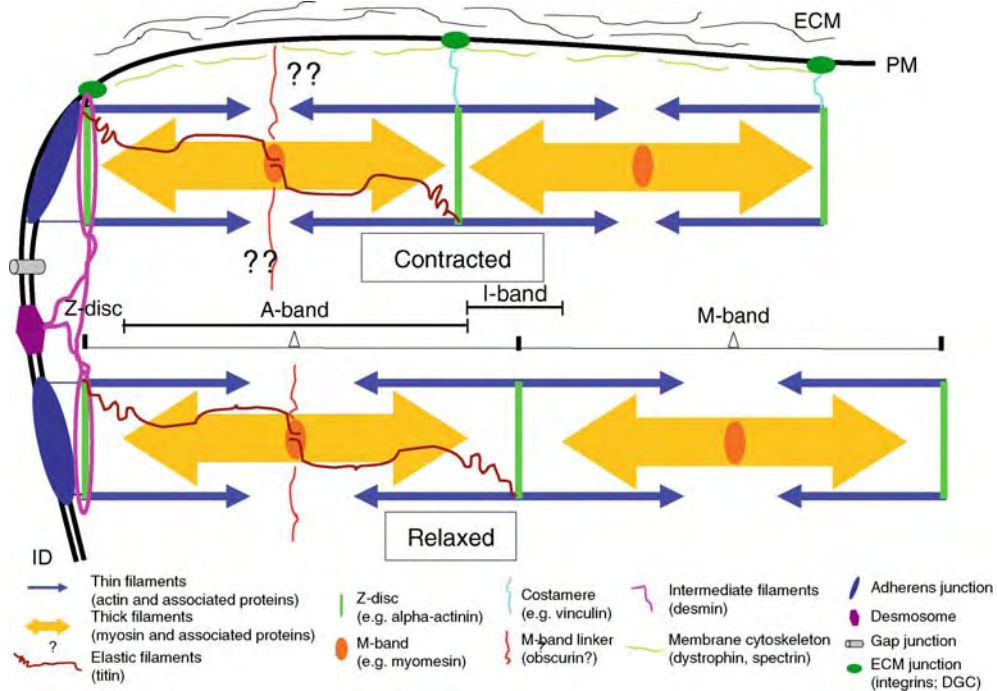

**Sarcomere Structural Proteins. Figure 1** Simplified schematic representation of sarcomeres and associated structural proteins. The thin (actin) and thick (myosin) filaments are represented as *solid blue* and *yellow arrows*, respectively to indicate their contractile behavior. Structural proteins can be classified according (i) to their location within sarcomeres (titin, actin-associated proteins in the thin filaments and Z-disc, myosin associated proteins in the thick filaments and M-band) (ii) by providing lateral or terminal links of the sarcomeres to contact structures at the plasma membrane (lateral: costameres; terminal: adherens junctions and desmosomes) and (iii) by integrating adjacent sarcomeres (intermediate filaments like desmin; obscurin?). Only one titin filament per half sarcomere is shown. The distance between two neighboring Z-discs is about two micrometers. *ECM* extracellular matrix; *PM* plasma membrane; *ID* intercalated disc; ▶ *DGC* dystrophin glycoprotein complex.

sequences mainly in the I-band region, whose length depends on muscle type and developmental stage [2]. This huge protein also possesses a kinase domain in its C-terminal region, whose activity is mechanically regulated and can trigger a signaling cascade to the nucleus [1].

### Sarcomere Structural Proteins of the Z-Disc and the Thin Filaments

Z-Discs are the terminal anchorage sites of the thin filaments and are characterized by the presence of sarcomeric alpha-actinin, which is a muscle-specific isoform of the actin cross-linking protein. In addition a plethora of other proteins has been identified at the Z-discs in recent years [3]. These play mainly a structural role (alpha-actinin, actin, titin N-terminus; nebulin C-terminus, CapZ), a signaling role (MLP, calcineurin) or potentially both (FATZ/myozenin/calsarcin2, ZASP/Cypher/Oracle, ALP, myotilin, telethonin/T-cap, gamma-filamin, myopalladin, enigma, myopodin, ArgBP2). The N-terminal region of titin binds both actin and alpha-actinin and is probably essential for the formation of the first complexes to be organized in a regular pattern during ▶ myofibrillogenesis [4]. In mature sarcomeres the two

most N-terminal domains of titin form a sandwich-like complex with telethonin to provide additional stabilization [2]. Neighboring Z-discs are linked by a cytoskeletal network that is composed of the muscle specific intermediate filament protein desmin (Fig. 1).

The thin filaments are constituted by two about one micrometer long filamentous chains composed of globular actin, which are entwined in a stretched helix. At the Z-disc end, which is also called the barbed end, they are capped by Cap-Z, at the end that stretches towards the middle of the sarcomere, the pointed end, they are capped by tropomodulin [5]. Tropomyosin dimers stretch along seven of these globular actins and interact with the troponin complex, which consists of troponin T, troponin I and troponin C. Calcium release by the sarcoplasmic reticulum triggers a conformational change in the troponin – tropomyosin complex, which makes actin more accessible for the myosin heads and eventually leads to muscle contraction.

Actin filaments have a precisely defined length that depends on the muscle fiber type. In skeletal muscle, the length regulation is mainly contributed by nebulin, a <900 kDa structural protein, whose C-terminus is

anchored at the Z-disc and which stretches through the internal groove of the helical actin filaments. Cardiac muscle expresses a shorter variant, nebulin, which is also anchored at the Z-disc, but which stretches only up to one third of the thin filament [3].

### Sarcomere Structural Proteins of the M-Band and the Thick Filaments

The transverse structure in the middle of the sarcomere is called the M-band. Depending on muscle fiber type, a different number of substructures can be defined by electron microscopy, the M-lines. The most important protein of the M-band appears to be myomesin, which is present in all vertebrate sarcomeres. Myomesin provides a structural link in the form of an antiparallel dimer between the tails of the myosin filaments and the C-termini of titin [6]. Due to its biophysical properties myomesin also contributes elasticity transverse to the direction of contraction in the sarcomere [6]. The elastic properties of the M-band are fiber-type specific and depend on the molecular composition of the M-band. Fast fibers express M-protein in addition to myomesin and show a rigid three-dimensional structure, while slow fibers or embryonic heart muscle express the EH-myomesin isoform in addition to myomesin and are more compliant [6]. Further evidence for the importance of the M-band region for sensing mechanical load comes from observations that the titin kinase domain, which is localized adjacent to the M-band, can be activated by stretch [1]. This induces a signaling cascade that eventually can lead to changes in gene expression via the transcription factor SRF (serum response factor) [1]. The M-band region also serves as anchorage site for several metabolic enzymes [7], for skeletal muscle calpain and for signaling proteins such as members of the MURF family, which bind either to titin itself or to adapter proteins [1].

The precise assembly of myosin to the thick filaments and their length is under tight control of the titin A-band region, which displays a super-repeat pattern of its modular domains and also interacts tightly with myosin. It is currently estimated that six titin filaments are associated with a half thick filament [2]. The super-repeat pattern also defines the association of MyBP-C to a subset of the A-band region. MyBP-C is probably important for the maintenance of thick filament structure, but may in addition also play a role for the fine-tuning of contraction, especially in cardiac muscle.

### Structural Connections Between the Sarcomere and the Plasma Membrane

Due to the considerable forces that are exerted during contraction it is absolutely essential that the sarcomeres are anchored properly to the plasma membrane and

that they are also integrated between each other. The terminal anchorage sites of the myofibrils are adherens junctions at the intercalated disk in cardiac muscle and focal contacts at the myotendinous junction in skeletal muscle and involve the anchorage of actin filaments emanating from the last Z-disc. A structural protein that seems to be important in these contact sites is N-RAP, a nebulin-related protein that is also known to interact with actin and several cell junction-type proteins [5].

In addition there are lateral connections between the sarcomeres and the plasma membrane. These are present at the level of the Z-disc, where they are called costameres and are mainly composed of vinculin and integrins, which mediate the contact to the extracellular matrix that surrounds muscle cells laterally [5]. By electron microscopy also filamentous connections between the M-band and the plasma membrane were observed, which may be based on obscurin, another high molecular weight modular protein of the sarcomere [6]. Additional structural stabilization is contributed by spectrin, which connects the edges of the Z-disks to membraneous compartments such as the sarcoplasmic reticulum as well as to the plasma membrane itself and by dystrophin, which via the dystrophin glycoprotein complex (►DGC) links the muscle cell cytoskeleton to extracellular laminin filaments [5].

Links between neighboring myofibrils are mainly mediated via the intermediate filament cytoskeleton, which is composed of desmin in muscle and which is concentrated at the level of the Z-disc. Currently it is unclear whether and how myofibrils are integrated at the level of the M-band. Among the currently identified proteins in this region, myomesin and obscurin are the most likely candidates for this role [6].

### Pathology

In the last decades mutations in structural sarcomeric proteins could be linked to different types of muscle disease [3], ranging from congenital myopathies (e.g. actin, tropomyosin, troponin T, gamma-filamin, myotilin, nebulin) and muscular dystrophies (e.g. titin, myotilin, telethonin, ZASP, desmin, nebulin, myosin heavy chain, dystrophin) to hereditary cardiomyopathies such as hypertrophic cardiomyopathy (titin, actin, MLP, troponin T, troponin I, troponin C, tropomyosin, myosin heavy chain, myosin light chain, MyBP-C) or dilated cardiomyopathy (titin, alpha-actinin, MLP, ZASP, actin, troponin T, tropomyosin, desmin, MyBP-C, myosin heavy chain, metavinculin, dystrophin). These myopathies can be clinically heterogeneous with a significant variability in severity and time of onset and a type of muscle disease is also not always strictly linked to a mutation in a particular protein. The position of the mutation in the respective molecule and its effect on protein stability and interaction with other proteins may define the final phenotype of the disease.

## References

1. Lange S, Ehler E, Gautel M (2006) From A to Z and back? Multicompartment proteins in the sarcomere. *Trends Cell Biol* 16:11–18
2. Linke WA (2007) Sense and stretchability: the role of titin and titin-associated proteins in myocardial stress-sensing and mechanical dysfunction. *Cardiovasc Res* 77:637–648
3. Frank D, Kuhn C, Katus HA, Frey N (2006) The sarcomeric Z-disc: a nodal point in signalling and disease. *J Mol Med* 84:446–468
4. Ehler E, Rothen BM, Hammerle SP, Komiyama M, Perriard JC (1999) Myofibrillogenesis in the developing chicken heart: assembly of Z-disk, M-line and the thick filaments. *J Cell Sci* 112:1529–1539
5. Clark KA, McElhinny AS, Beckerle MC, Gregorio CC (2002) Striated muscle cytoarchitecture: an intricate web of form and function. *Annu Rev Cell Dev Biol* 18:637–706
6. Agarkova I, Perriard JC (2005) The M-band: an elastic web that crosslinks thick filaments in the center of the sarcomere. *Trends Cell Biol* 15:477–485
7. Lange S, Auerbach D, McLoughlin P, Perriard E, Schaefer BW, Perriard JC, Ehler E (2002) Subcellular targeting of metabolic enzymes to titin in heart muscle may be mediated by DRAL/FHL-2. *J Cell Sci* 115:4925–4936

## Sarcopenia

- ▶ Muscle: Age-Related Changes

## Sarcoplasma

### Definition

Intracellular fluid within a muscle fiber.

- ▶ Membrane Potential: Basics

## Sarcopterygians

### Definition

Sistergroup of actinopterygians, include lobe-finned fishes, i.e., Latimeria (actinistians) and the lungfishes (dipnoi), and all land-vertebrates (tetrapods).

- ▶ Evolution of the Brain: In Fishes
- ▶ Evolution of the Telencephalon: In Anamniotes

## Satellite Cells in Muscle

### Definition

Satellite cells are located between the sarcolemma and the basal lamina of the muscle fiber, and remain in a non-proliferative quiescent state. They represent undifferentiated myogenic precursor cells, which have the ability to re-enter the cell cycle either in order to generate new muscle fibers or to provide new myonuclei to the parent fiber. Unlike myonuclei, satellite cells retain their ability to divide following myotrauma or exercise, and therefore have a unique role in the regeneration and growth of adult skeletal muscle that cannot be fulfilled by the post-mitotic myonuclei.

- ▶ Muscle – Age-Related Changes

## Sauropsids

### Definition

The diapsid radiation of amniote vertebrates, i.e., those with two bony fenestrae in the temporal region of the skull. Extant sauropsids include lizards, snakes, the tuatara *Sphenodon*, turtles, crocodiles, and birds.

- ▶ Evolution and the Concept of Homology
- ▶ The Phylogeny and Evolution of Amniotes

## Saxitoxin (STX)

### Definition

Saxitoxin (STX) is a paralytic toxin in marine dinoflagellates that, in some seasons, “bloom” and discolor the seawater (“red tide”). The shellfish feeding on them become contaminated and are highly dangerous to eat. Through the marine food chain, it can poison humans. The mechanism of toxicity is very similar to that of Tetrodotoxin (TTX). Saxitoxin binds from the outside of the cell membrane to various forms of Voltage-dependent Na<sup>+</sup> Channels and blocks the channel in an activation-state-independent manner.

- ▶ Action Potential
- ▶ Sodium Channels

## SC – Buildup Neurons

EDWARD L. KELLER  
Smith-Kettlewell Eye Research Institute,  
San Francisco, CA, USA

### Synonyms

Prelude neurons

### Definitions

► **Saccade-related neurons** in the superior colliculus (SC) that display extensive low frequency discharge, well before the onset of a saccade into the ► **movement field** (► **of a neuron**) of the cell have been called buildup [1] or prelude [2] neurons.

### Characteristics

#### History and Function

Saccade-related neurons in the superior colliculus (SC) in the alert monkey, which displayed a long buildup of low frequency discharge well before the onset of optimal saccades, were first described by Sparks et al. [3] and Mohler and Wurtz [4]. Sparks et al. [3] called cells that began a buildup of discharge approximately 80–100 ms before saccade onset in a ► **reaction time task**, class II neurons. They contrasted the gradual buildup of this type of SC neuron with another class of collicular neuron, which showed only a discrete high-frequency burst of activity that commenced about 20 ms before saccade onset. They argued that these two classes of collicular neurons formed separate classes. In contrast, Mohler and Wurtz [4] emphasized the earlier discharge of cells before saccade onset as a function of the depth of the neuron's location below the superficial layers of the SC. Deeper cells tended to have earlier discharge, but the amount of pre-saccadic lead varied gradually with depth into the SC. Based on their observations, the latter authors did not attempt to assign SC neurons into two separate classes, and did not assign a name to the deeper cells with longer pre-saccadic discharge. They also noted that deep cells tended to have larger movement fields.

Glimcher and Sparks [2] subsequently called a group of SC neurons with long-lead discharge before saccades into their movement field, prelude bursters. They distinguished this group of neurons in a cued, movement-selection task in which activity of prelude bursters began soon after a central visual cue indicated which of two potential eccentric targets was to be the goal of a delayed saccadic (► **Saccade – delayed**) response. This pre-saccadic activity was present when the cue required a saccade to the target located in the cell's movement field. They hypothesized that prelude bursters participate in the process of movement goal selection.

Munoz and Wurtz [1] identified delay-period activity in a group of SC neurons in a ► **delayed saccade** task and codified the name “buildup neurons” for these cells, which they argued formed a separate class of SC neurons that discharged (for movements into the center of the cell's movement field) at rates >30 spikes/s during the 100-ms period of time ending 100 ms before saccade onset. They showed further that neurons in this class tended to be located more ventrally in the intermediate and deep layers of the SC than the other class that they called “burst neurons”, neurons that began their discharge just before saccade onset. Finally, they stated that buildup cells displayed ► **open-field response** characteristics because they discharged for all saccades (in the preferred direction) larger than the center of the cell's response field. Based on this last characteristic and the timing of buildup cell discharge, they suggested that buildup neurons form a functional group of cells in which a rostrally spreading wave of activity codes the dynamic progression of a saccade, which ends when the wave of activity in buildup cells reaches the rostral pole of the SC. Figure 1 shows examples that contrast the difference of discharge patterns in SC buildup and burst neurons in a delayed saccade paradigm. In this paradigm, a monkey continued to fixate a centrally located visual spot when an

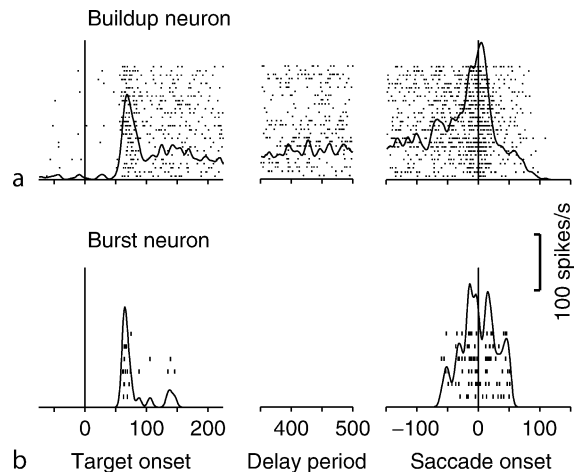

**SC – Buildup Neurons. Figure 1** Examples of the discharge patterns of a buildup and a burst cell recorded in the monkey SC during a delayed saccade paradigm. Each dot in the raster plots shows an individual discharge of a cell. Each row in the rasters shows a single trial. The curves in each plot show the average spike density of the cell's activity for the set of illustrated trials (Gaussian smoothing parameter = 4 ms). Plots on the left are aligned on the appearance of the target, those in the center are aligned on the end of the delay period when the fixation spot goes off (500 ms), and those on the right are aligned on saccade onset. (Modified by permission from [5]).

eccentric target appeared near the center of the cell's movement field. The two plots on the left, which are aligned on the appearance of the target, show that both cells have a brisk visual response that begins about 50 ms after target onset. The animal was required to maintain fixation at the central location after the appearance of the target until the fixation spot was extinguished. When the fixation spot was extinguished, the animal made a saccade to the location of the target. The two plots in the center show the activity in the two neurons aligned on the end of the delay period at 500 ms. Only the buildup cell shows activity in the delay period. The two plots on the right show the activity of the two cells aligned on the initiation of the saccade to the target. The buildup neuron shows a substantial amount of irregular activity in the period well before saccade onset, and exceeds the criterion used by Munoz and Wurtz [1] in the period of time ending 100 ms before saccade onset to be classified as a buildup neuron. The burst neuron shows a more discrete burst of activity that begins about 50 ms before saccade onset, and no activity in the period of time earlier than 100 ms before saccade onset.

Anderson et al. [6], using a delayed-saccade task, showed that SC saccade-related cells form a continuum in the level of their pre-saccadic discharge in a delayed-saccade task. They argued that cells like those shown in Fig. 1 formed the end points of such a continuum. In order to compare their cells sampled over a broader anatomical extent of the SC to those recorded by Munoz and Wurtz [1], they used a similar pre-saccadic level of discharge measure to arbitrarily define buildup cells. The later authors also provided evidence, using a two-dimensional estimation of the spatiotemporal population discharge in the SC, against the hypothesis that buildup cells participated in an organized, rostrally progressing wave of activity that controlled saccade duration during saccades. Instead, they hypothesized that buildup cells participated in saccade control in a similar fashion to burst cells, with population activity that peaked just before saccade onset and declined during saccades. However, neither burst cell or buildup cell discharge could command saccade end because considerable population activity remained at saccade end, particularly in buildup cells. Anderson et al. [6] confirmed the earlier observation [1] that SC cells with larger relative levels of pre-saccadic activity tended to be located more ventrally in the SC and to have open-field response characteristics. A subset of buildup cells have been reported to continue to discharge during the period of time when saccade trajectory was interrupted by electrical ▶microstimulation in the rostral SC or the ▶omnipause neuron area in the brain stem [7,8]. Since most SC neurons (both buildup and burst neurons) are silenced during the interrupted period, this subset of buildup cells may serve as the functional source that

rekindles SC discharge at the active site in the SC as the saccade resumes and ends on target.

Dorris et al. [9] also found that buildup and burst neurons overlapped in the level of their pre-saccadic buildup of discharge in a delayed saccade task. They proposed that two classes of neurons in the SC could better be distinguished based on the level of discharge present at the end of the gap period in a ▶gap-saccade paradigm. Cells with significant prelude activity in the gap period were defined as buildup neurons. As the prelude activity occurred in the gap period before the location of the target for the saccade was known, and was correlated with saccade latency and the occurrence of express saccades, these authors hypothesized that buildup cell activity was related to the function of motor preparation for saccades.

Basso and Wurtz [10] defined a group of SC cells they called buildup neurons that showed significant discharge in the delay period in a memory-guided, delayed-saccade task. In their definition, the criterion level of activity that distinguished buildup neurons was determined by a metric aligned to the end of the delay period, in contrast to most previous measures that were aligned on saccade onset. In additional experiments, they manipulated the number of potential targets present as the animal maintained fixation on a central visual target before signaling goal location by dimming one of the potential targets (a target pre-specification period). Based on their observation that the discharge of buildup cells in the pre-specification period showed an inverse level of activity in relation to the number of potential targets, they hypothesized that buildup cells signaled the establishment of a motor set before target selection was possible.

The rostral region of the SC has neurons that decrease their discharge during saccades rather than show a saccade-related increase. Cells located in this region of the SC that pause for most saccades have been called fixation neurons [11]. Anderson et al. [6] argued that these cells, although they paused for most saccades, showed a burst of activity for very small contralaterally directed saccades. Thus, they hypothesized that fixation cells formed a rostral extension of the caudal buildup cells, with movement fields that became smaller and smaller and ever closer to the fovea for more rostral locations on the SC. Krauzlis et al. [12] recorded from these rostral SC cells under a wider range of experimental conditions, including smooth pursuit movements, small saccades and fixation. They found that these cells displayed increased discharge during small saccades, for small fixation errors and during smooth pursuit, when small errors between the target and the eyes existed. They hypothesized that the discharge of these rostral cells best signified the existence of near foveal position errors between the target and eye position, regardless of the type of eye

movement (saccade or pursuit) or lack of an eye movement (fixation) that might be used to correct the error.

McPeck and Keller [5] found that SC saccade-related cells displayed activity that was consistent with a role in target selection in a reaction time, popout visual search task. They found no difference in the behavior of buildup neurons and burst neurons in this task. They identified buildup cells in a manner similar to that used by Basso and Wurtz [10]. McPeck et al. [13] also found, in a reaction time, popout visual search task, that the pre-saccadic discharge of SC cells located at the collicular image location of visual field distractors was correlated with the amount of curvature present in saccades. They found no difference in the behavior of buildup or burst neurons in their results. Buildup cells were identified in a manner similar to that used by Basso and Wurtz [10].

In conclusion, a wide ranging succession of experiments have consistently identified SC neurons called buildup or prelude neurons that show considerable amounts of low level, pre-saccade discharge that can lead saccade onset by 100 ms or more. It has not been conclusively established if the cells with buildup discharge form a discrete subset of SC saccade-related neurons or whether they are better described as one end of a continuum of cells with respect to pre-saccadic discharge behavior. The method of Basso and Wurtz [10], which defines cells as buildup cells based on significant delay-period discharge relative to resting discharge, suggests a subset of SC cells may be distinguishable statistically. Cells that display higher amounts of pre-saccadic discharge also tend to be located more ventrally in the SC and have larger movement fields than cells with less pre-saccadic discharge. In particular, the outer edge of the movement field of many of these buildup cells may extend beyond the limit of the oculomotor range. It is also not clear if buildup cells, as discriminated by the Basso and Wurtz [10] criterion, have a separate functional role in the saccadic system. Separate roles in motor set, target selection or motor preparation have been suggested as the functional role of buildup neurons. Reaction time tasks tend to show no difference in the functional role of buildup and burst cells.

### Higher Order Structures

Buildup neurons are found in the intermediate and deep layers of the superior colliculus. They form part of the descending oculomotor saccadic system.

### References

- Munoz DP, Wurtz RH (1995) Saccade-related activity in monkey superior colliculus. I. Characteristics of burst and buildup cells. *J Neurophysiol* 73:2313–2333
- Glimcher PW, Sparks DL (1992) Movement selection in advance of action in the superior colliculus. *Nature* 355:542–545
- Sparks DL, Holland R, Guthrie BL (1976) Size and distribution of movement fields in the monkey superior colliculus. *Brain Res* 113:21–34
- Mohler CW, Wurtz RH (1976) Organization of monkey superior colliculus: intermediate layer cells discharging before eye movements. *J Neurophysiol* 39:722–744
- McPeck RM, Keller EL (2002) Saccade target selection in the superior colliculus during a visual search task. *J Neurophysiol* 88:2019–2034
- Anderson RW, Keller EL, Gandhi NJ, Das S (1998) Two-dimensional saccade-related population activity in superior colliculus in monkey. *J Neurophysiol* 80:798–817
- Munoz DP, Waitzman DM, Wurtz RH (1996) Activity of neurons in monkey superior colliculus during interrupted saccades. *J Neurophysiol* 75:2562–2580
- Keller EL, Gandhi NJ, Sekaran SV (2000) Activity in deep intermediate layer collicular neurons during interrupted saccades. *Exp Brain Res* 130:227–237
- Dorris MC, Pare M, Munoz DP (1997) Neuronal activity in monkey superior colliculus related to the initiation of saccadic eye movements. *J Neurosci* 17:8566–8579
- Basso MA, Wurtz RH (1998) Modulation of neuronal activity in superior colliculus by changes in target probability. *J Neurosci* 18:7519–7534
- Munoz DP, Wurtz RH (1993) Fixation cells in monkey superior colliculus. I. Characteristics of cell discharge. *J Neurophysiol* 70:559–575
- Krauzlis RJ, Basso MA, Wurtz RH (2000) Discharge properties of neurons in the rostral superior colliculus of the monkey during smooth-pursuit eye movements. *J Neurophysiol* 84:876–891
- McPeck RM, Han JH, Keller EL (2003) Competition between saccade goals in the superior colliculus produces saccade curvature. *J Neurophysiol* 89:2577–2590

## SC – Interlayer Neurons

S

ADONIS MOSCHOVAKIS

Institute of Applied and Computational Mathematics, FO.R.T.H. and Department of Basic Sciences, University of Crete, Heraklion, Crete, Greece

### Definition

Neurons of the superficial SC layers *strata griseum superficiale* and *opticum* which project to the deeper SC layers.

### Characteristics

#### Higher Order Structure

Interlayer neurons are crucial components of the sensorimotor interface implemented inside the superior colliculus.

### Parts of the Structure

In primates, the projection from the superficial to the deeper SC layers largely originates from a particular class of neurons, designated L [1,2]. Fig. 1. provides two typical examples and illustrates the range of their morphological characteristics. Typical of such cells is the fact that one of them is located in the superficial gray layer (SGS) and the other in the stratum opticum (SO). Also typical of such cells is their somatodendritic morphology, which can be characterized as narrow field vertical in the case of cell I and wide field vertical in the case of cell II. Finally, typical of L cells is the fact that one of their axonal branches projects to the parabigeminal nucleus and even beyond it, presumably

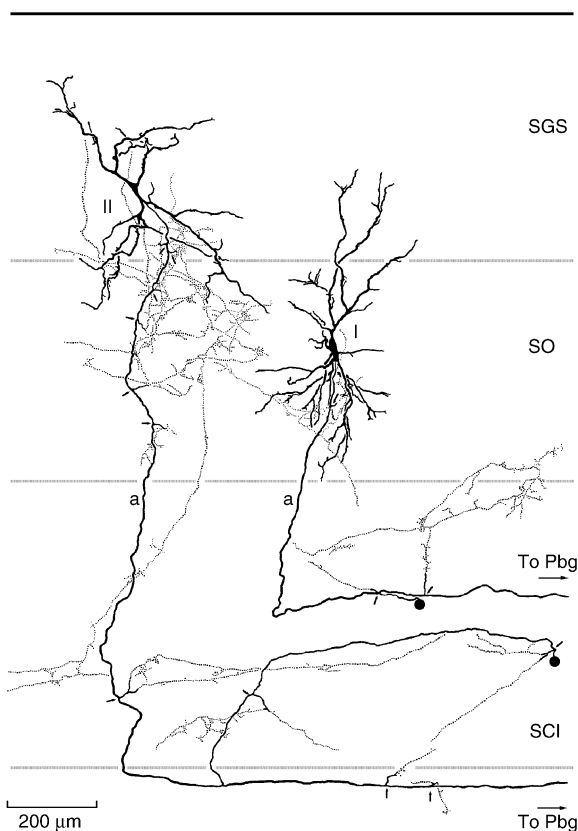

**SC – Interlayer Neurons. Figure 1** Complete camera lucida reconstruction of the dendritic (*solid*) and intratractal axonal termination patterns (*dotted*) of two primate L neurons in the frontal plane (modified from [2], with permission). The solid line indicates the surface of the superior colliculus and the stippled lines indicate borders between its layers. Small arrows point to the origin of intrinsic collaterals. Solid circles indicate the point where major axonal branches assume rostral trajectory. Abbreviations: *Pbg*, parabigeminal nucleus; *SGI*, stratum griseum intermediale; *SGS*, stratum griseum superficiale; *SO*, stratum opticum.

to the dorsolateral pontine gray. Fig. 1. also illustrates the considerable number of collaterals arising from the axons of L neurons. Some of them deploy terminal fields in the neighborhood of the soma they originate from in the SGS and SO, while others deploy terminal fields in the intermediate gray layer (SGI).

The origin of superficial to deeper collicular projections from cells displaying the somatodendritic features of L neurons (i.e. narrow and wide-field vertical cells) has been corroborated in other mammalian species. Narrow field vertical neurons of the SGS and SO of the rabbit were known to Cajal who was able to follow their axons to their bifurcation in the deeper tectal layers (Fig. 119 of [3]), but was unable to ascertain if they deployed any boutons. Examples of narrow and wide field vertical cells of the SGS and SO and their extensive axonal arborizations in the SGI have been documented in the hamster [4,5] and the rat [6]. However, L neurons are not the only ones to relay information from the superficial to the deeper SC layers. In both the monkey and the cat, the axons of tectotectal neurons of the SO (T neurons) also issue collaterals ramifying in the deeper tectal layers [7,2]. Additionally, axons of upper SGS neurons emit collaterals distributing terminals in the SGS, the SO, and the SGI in the neonate cat [8]. Unlike those originating from L or T neurons, the fairly long dendritic arbors of the feline neurons were seen to originate only from the dorsal pole of the soma and to branch profusely towards the surface of the SC. Axons of wide and narrow field vertical cells of the SGS and the SO, projecting to the nucleus lateralis posterior, have been also shown to deploy terminal fields in the deeper tectal layers of the hamster [9]. The axons of marginal, stellate, horizontal and unclassified cells of the superficial SC layers of this species have also been shown to deploy terminal fields in the deeper SC layers [5].

### Function of the Structure

In the rhesus monkey, the information carried from the superficial to the deeper SC layers can be surmised from the response properties of tectoparabigeminal cells; often these are directionally selective and respond with sustained discharges to stimuli crossing the center of their receptive field [10]. More varied information is conveyed from the superficial to the deeper SC layers in the hamster: the cells it originates from can respond to stationary flashed stimuli or not, they can be directionally selective or not and they can be sensitive to stimuli moving at high or low speeds [5]. Its importance is demonstrated by the fact that the visual responses of almost 90% of deeper SC neurons are reduced or abolished after injection of  $\text{CoCl}_2$ , which blocks synaptic transmission near the injection site in the superficial SC layers of the hamster [11]. The pattern of their projections to the deeper SC layers can have



important implications for the therein represented map of visual space. For example, in the hamster, visual receptive fields of deeper SC layer neurons are shifted laterally together, with the lateral shift of the projection from the superficial to the deeper tectal layers relative to projection lines normal to the SC surface [12].

Activation of the superficial layers (with brief electrical pulses) suffices to evoke excitatory postsynaptic potentials (EPSPs) in neurons of the deeper layers of frontally cut slices of the SC of young (8–28 old) tree shrews; their minimal latencies are monosynaptic but they can have multiple peaks and their duration, which can outlast the duration of the stimuli by 100-fold or more, is not related to the duration or the intensity of the stimulus [13]. Work in slices has been crucial in elucidating their pharmacology. Evoked EPSPs are glutamatergic [6,14,15] and are strongly enhanced when the target neurons are depolarized (either through activation of nicotinic ACh receptors or blockade of GABA<sub>A</sub> mediated inhibition).

The long bursts evoked in deeper SC neurons in response to electrical stimulation of the superficial SC, could be due to the reverberatory engagement of groups of deeper SC neurons mutually activated through their recurrent collaterals (described in the entry devoted to ►SC – tectal long-lead burst neurons). They could also be due to the reverberatory engagement of groups of superficial SC neurons contacted by the recurrent collaterals of their neighbors, which may or may not project directly to the deeper tectal layers. The density of the terminal fields deployed by axons of superficial SC neurons in the vicinity of the some they originate from can be appreciated from the examples shown in Fig. 1. Recurrent networks of similar complexity have been documented in several other mammalian species, i.e. cat [8,7], hamster [4,5], monkey [1,2] and the rat [6]. It is, therefore, hardly surprising that some of the deeper SC projecting superficial SC cells display similar long bursts of discharge in response to electrical stimulation of the superficial SC [14]. The multi-step projection of the superficial tectal layers to the deeper through several synapses may be the dominant path in some species. For example, small injections of biocytin in the SGS of the tree shrew (*Tupaia belangeri*) demonstrated the existence of a strong SGS projection to the SO, but not to the deeper layers [16].

### Higher Order Function

Relatively direct relay of visual signals from the superficial to the deeper SC is implicit in the ►foveation hypothesis proposed by Schiller and Koerner [17] (see the entry devoted to the foveation hypothesis for a discussion of this, at one time dominant, account of information flow through the SC). Despite early efforts to determine its existence [18], the projection from the superficial to the

deeper SC remained controversial until the mid-1980s. In a seminal review written in 1984, Chalupa [19] ranked this at the top of several questions that remained to be answered regarding the physiology of the SC. Soon after this review appeared, conclusive evidence of its existence began to appear, much in the manner that he had envisioned, i.e. with use of the intracellular HRP technique. This was accomplished first in the neonate [8] and adult [7] cat, and then in quick succession the adult hamster [4,5] and monkey [1,2]. Bulk tracer injections of an anterograde tracer generally thought not to be taken up and transported over significant distances by fibers of passage (*Phaseolus vulgaris* Leucoagglutinin, in short PHAL) were later employed to show that it exists on a larger scale in the hamster [12], and cat [20]. In ferrets, there is morphological evidence to suggest that its targets in the deeper tectal layers include cells of origin of the predorsal bundle [15].

The entry devoted to the foveation hypothesis also includes a summary of the reasons to doubt that transmission of visual information from the superficial to the deeper SC layers always suffices to accurately specify the metrics of saccades towards visual targets. Instead, relatively direct relay of visual signals from the superficial to the deeper SC could underlie the short latency of “express” saccades [2,21], as described in the entry SC-sensorimotor integration. Consistent with this notion, and the acetylcholinergic modulation of the efficacy of signal transmission along this route, injection of nicotine in the SC of the monkey increases the frequency of express saccades [22].

### Quantitative Measure for this Structure

About 40% of the neurons in the superficial SC have axons that deploy terminal fields in the deeper tectal layers [5]. Of the cell classes that participate in this projection, it is the primate L neurons whose appearance has been the object of detailed quantitative analysis [2]. Besides providing information about the range of values obtained by several morphological features (e.g. 3-D orientation of the dendritic tree, complexity of its branching pattern, etc.) this analysis allowed the formulation of canonical discriminant functions, which can objectively differentiate L neurons from other classes of SC cells. Moreover, given the manner in which visual space is represented in the superficial SC (along the mediolateral and rostrocaudal extent of the nucleus), the location and spatial distribution of the somatodendritic processes of L neurons on horizontal maps of the SC must have important implications for the size of their receptive fields, and thus the graininess with which they can represent the visible world. Examples of such horizontal rotations of camera lucida reconstructions of primate L neurons are shown in Fig. 2. The same figure also

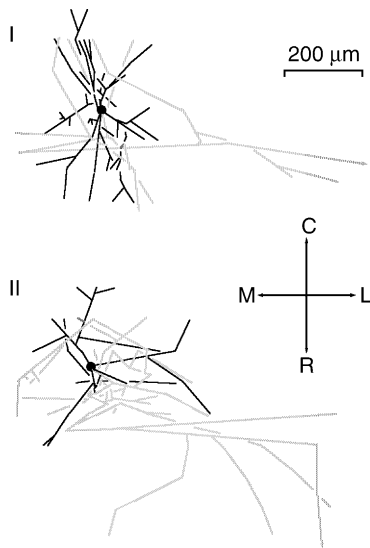

**SC – Interlayer Neurons. Figure 2** Reconstruction of the primate L neurons of Fig. 1 in the horizontal plane (modified from [2], with permission). Stippled lines indicate the neurons' axonal systems.

illustrates the region occupied by their axonal terminations in the deeper layers of the SC. Consistent with their columnar arrangement, the fairly large number of *boutons* they deploy (sometimes more than 3,000) is largely confined to a cylinder that measures somewhat less than 1 mm in diameter, underlies the territory occupied by the dendrites of the same neurons, and is oriented normally to the surface of the SC.

## References

- Karabelas AB, Moschovakis AK, Highstein SM (1986) Morphological classification of intracellularly HRP injected efferent neurons of the deeper layers of the primate superior colliculus. *Proc Soc Neurosci* 12:1185
- Moschovakis AK, Karabelas AB, Highstein SM (1988) Structure-function relationships in the primate superior colliculus. I. Morphological classification of efferent neurons. *J Neurophysiol* 60:232
- Cajal SRY (1911) *Histologie du Système Nerveux de l'Homme et des Vertébrés*. Maloine, Paris
- Mooney RD, Klein BG, Rhoades RW (1985) Correlations between the structural and functional characteristics of neurons in the superficial laminae and the hamster's superior colliculus. *J Neurosci* 5:2989
- Mooney RD, Nikolettseas MM, Hess PR, Allen Z, Lewin AC, Rhoades RW (1988) The projection from the superficial to the deep layers of the superior colliculus: an intracellular horseradish peroxidase injection study in the hamster. *J Neurosci* 8:1384
- Isa T, Endo T, Saito Y (1998) The visuo-motor pathway in the local circuit of the rat superior colliculus. *J Neurosci* 15:8496
- Moschovakis AK, Karabelas AB (1985) Observations on the somatodendritic morphology and axonal trajectory of intracellularly HRP-labeled efferent neurons located in the deeper layers of the superior colliculus of the cat. *J Comp Neurol* 239:276
- Grantyn R, Ludwig R, Eberhardt W (1984) Neurons of the superficial tectal gray: an intracellular HRP-study on the kitten superior colliculus in vitro. *Exp Brain Res* 55:172
- Mooney RD, Nikolettseas MM, Ruiz SA, Rhoades RW (1988) Receptive-field properties and morphological characteristics of the superior collicular neurons that project to the lateral posterior and dorsal lateral geniculate nuclei in the hamster. *J Neurophysiol* 59:1333
- Marrocco RT, McClurkin JW, Young RA (1981) Spatial properties of superior colliculus cells projecting to the inferior pulvinar and parabigeminal nucleus of the monkey. *Brain Res* 222:150
- Mooney RD, Huang X, Rhoades RW (1992) Functional influence of interlaminar connections in the hamster's superior colliculus. *J Neurosci* 12:2417
- Rhoades RW, Mooney RD, Rohrer WH, Nikolettseas MM, Fish SE (1989) Organization of the projection from the superficial to the deep layers of the hamster's superior colliculus as demonstrated by the anterograde transport of *Phaseolus vulgaris* leucoagglutinin. *J Comp Neurol* 283:54
- Lee PH, Helms MC, Augustine GJ, Hall WC (1997) Role of intrinsic synaptic circuitry in collicular sensorimotor integration. *Proc Natl Acad Sci USA* 94:13299
- Özen G, Augustine GJ, Hall WC (2000) Contribution of superficial layer neurons to premotor bursts in the superior colliculus. *J Neurophysiol* 84:460
- Doubell TP, Skalióra I, Baron J, King AJ (2003) Functional connectivity between the superficial and deeper layers of the superior colliculus: an anatomical substrate for sensorimotor integration. *J Neurosci* 23:6596
- Hall WC, Lee P (1993) Interlaminar connections of the superior colliculus in the tree shrew. I. The superficial gray layer. *J Comp Neurol* 332:213
- Schiller PH, Koerner F (1971) Discharge characteristics of single units in the superior colliculus of the alert rhesus monkey. *J Neurophysiol* 34:920
- Sprague JM (1975) Mammalian tectum. Intrinsic organization, afferent inputs, and integrative mechanisms: anatomical substrate. In: Ingle D, Sprague JM (eds) *Sensorimotor function of the midbrain tectum*, Neurosciences Research Program Bulletin, vol 13, MIT press, Cambridge, MA, pp 204
- Chalupa LM (1984) Visual physiology of the mammalian superior colliculus. In: Vanegas H (ed) *Comparative neurology of the optic tectum*, Plenum Press, New York, pp 775
- Behan M, Appell PP (1992) Intrinsic circuitry in the cat superior colliculus: projections from the superficial layers. *J Comp Neurol* 315:230
- Moschovakis AK, Scudder CA, Highstein SM (1996) The microscopic anatomy and physiology of the mammalian saccadic system. *Prog Neurobiol* 50:133
- Aizawa H, Kobayashi Y, Yamamoto M, Isa T (1999) Injection of nicotine into the superior colliculus facilitates occurrence of express saccades in monkeys. *J Neurophysiol* 82:1642

## SC – Local Feedback

EDWARD L. KELLER  
Smith-Kettlewell Eye Research Institute, San  
Francisco, CA, USA

### Synonyms

Efference copy; Corollary discharge feedback

### Definitions

► **Saccades** are rapid eye movements that normally are very accurate. Their accuracy under varying conditions suggests that this class of movements is controlled by feedback mechanisms in contrast to a preprogrammed control. However, feedback of afferent visual information about the progression of the movement that could be used to control and adjust saccade trajectory in flight is not possible, due to the short temporal duration of saccades and the long latencies required to process visual input. Following theoretical ideas derived from the study of other movement control systems [1], Robinson [1] proposed that saccades were controlled by feedback information derived from the ► **efferent motor commands**. Such internal or local signals, as opposed to afferent feedback from the visual system, could continuously encode the current eye position during saccades with only minimal delay (► **delayed saccade**), and thus, play a role in controlling their accuracy.

### Description of the Theory

In Robinson's theory [3], a copy of the efferent saccadic motor command was integrated to produce an eye position signal. This signal was directed centrally (the local feedback signal) and was compared to a neural representation of the goal or target of the saccade (Fig. 1). The difference between the local feedback signal, which represented current eye position during the saccade, and the desired goal was a dynamic motor error signal that in turn continuously updated the motor command until the error signal dropped to zero and the eyes arrived on target. Since the local feedback signal was derived from neural signals very close (in a synaptic sense) to the motor outflow, delays (in the feedback loop could be very short and performance, in terms of terminal accuracy, was optimized [2]. As evidence for the existence of a local feedback loop in the saccadic system, van Gisbergen et al. [2] cited the results of perturbation experiments in which the normal stereotyped trajectories of saccades were halted in mid-flight by electrical ► **microstimulation** of the omnipause neuron region (► **omnipause neuron area**) in the brainstem. Such interrupted saccades resumed their trajectory and ended on target [3,4], and thus, were compensated for the trajectory perturbation. Robinson

and his colleagues [2] hypothesized that the ► **comparator** that generated the dynamic motor error signal was located at the level of the ► **saccadic burst generator** in the brainstem, and further that the eye position local feedback signal used to close the feedback loop was generated by a ► **neural integrator** located in the brainstem close to the saccadic burst generator.

The concept of saccade control by local feedback remains a central hypothesis in all saccade system models, but the original model of Robinson has undergone considerable debate and modification since its promulgation. Jürgens et al. [5] argued that the desired saccade goal (desired target location) should be specified in retinotopic coordinates, not absolute position in head-centered coordinates as posited in the Robinson model. Implementation of this suggestion requires that the local feedback signal is displacement of eye position during the current saccade. An eye displacement signal could be generated by a separate neural integrator from the integrator that controlled the static, eye-position related discharge of oculomotor neurons. This second integrator would have to be reset after the end of each saccade. Scudder [6] proposed a model that posited that the superior colliculus was the source of the retinotopically coded desired target signal. In his model he integrated the difference between the SC input signal and a local feedback inhibitory signal from the saccadic burst generator that carried an instantaneous eye velocity signal in a group of brainstem neurons called long-lead bursters. Such an arrangement operated in displacement coordinates and avoided the specification of a resettable integrator by the incorporation of the inhibitory eye velocity signal. The output of the integrator in the Scudder model first increased in magnitude in the pre-saccadic period as the SC signal increased, but then declined in magnitude as the saccade progressed and returned to a zero level by saccade end under the influence of the inhibitory (negative sign in the model) eye velocity signal. No physical dynamic motor error signal exists in this model. Figure 1a shows a Robinson type local feedback model which specifically defines the signals discussed above: desired goal position ( $T_d$ ); local feedback of eye position ( $E(t)$ ); and dynamic motor error ( $me(t)$ ). The inclusion of the time variable ( $t$ ) in some model signals indicates that signal is updated continuously during a saccade. The schematic version shown here provides a lumped representation of the neural operations that are hypothesized to occur when saccades are generated. All the dynamic elements in the models described so far have single-input, single-output signals and well defined variables with exact physical meaning (e.g. motor error). These model elements (e.g. the comparator which computes the difference between the final goal and instantaneous eye position and outputs dynamic motor error) appear at discrete locations in the model topography, and

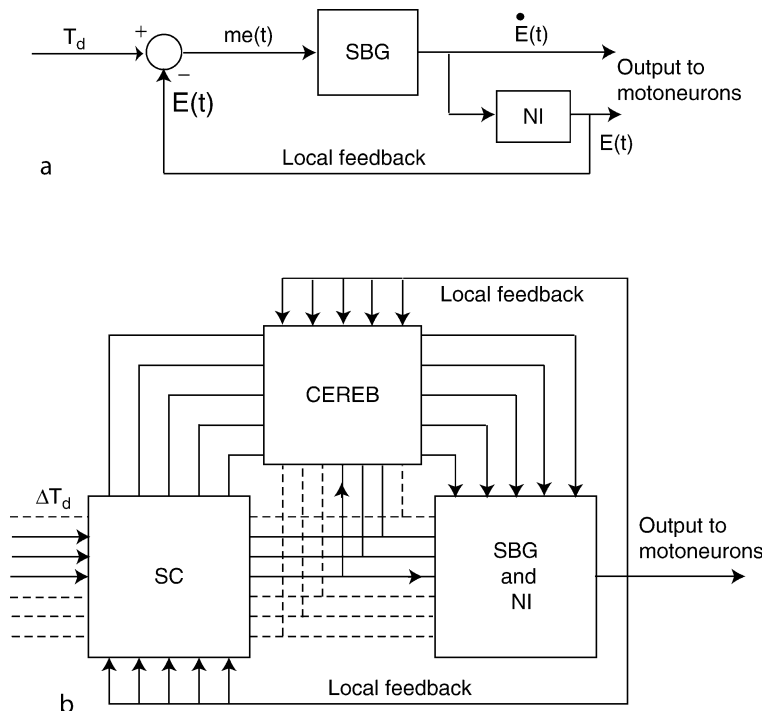

**SC – Local Feedback. Figure 1** Examples of models of saccade control that utilize local feedback to ensure movement accuracy. (a): Lumped model utilizing eye position feedback. A comparator continuously computes the difference between the saccade goal ( $T_d$ ) and the local feedback signal ( $E(t)$ ). The difference signal is dynamic motor error ( $me(t)$ ). Dynamic motor error controls the activity of burst neurons in the saccadic burst generator (SBG) which produce an eye velocity ( $\dot{E}(t)$ ) command signal to ocular motoneurons. The local feedback signal is current eye position that is computed by a neural integrator (NI) that also controls the eye-position related tonic discharge of ocular motoneurons. (b): A distributed model of saccade control. The boxes labeled SC and CEREB represent recurrent neural networks of the superior colliculus and the cerebellum, respectively. The box labeled SBG and NI represents the saccadic burst generator and a neural integrator. The saccade goal ( $\Delta T_d$ ) is represented with a space code by which input lines to the SC are active (shown by solid lines). Dashed lines indicate inactive input lines. Spatiotemporal discharge in SC and CEREB are produced by interconnected feedforward and feedback lines between the two structures and each structure's own pattern of recurrent connections (not shown). Both structures control the activity of the SBG in parallel through spatially weighted input lines. Local feedback is derived from the SBG and NI and may include both eye position and eye velocity signals. Combinations of these latter signals are fed back in a spatially weighted, distributed fashion to all the units in SC and CEREB. Dynamic motor error is represented in the distributed activity of the units in both SC and CEREB. Not all known connections are shown, e.g. CEREB may receive a spatially distributed input of  $\Delta T_d$  that is separate from that to SC.

hence the term “lumped model” that is used to classify this type of model. The single signal lines should not be confused to represent single neurons, rather they posit the existence of a group of neurons that carry a single physical signal with a temporal rate code.

More recently, several attempts have been made to represent the organization of the saccadic system and the local feedback concept with distributed models of signal processing (see [7] for a review). Biologically realistic models of this system require that at least the source of the desired goal, which originates in structures like the SC and the [cortical frontal eye fields \(FEF\)](#), be modeled in a distributed fashion. This is because these higher level sensorimotor structures primarily represent the desired target (saccade goal),

with a space code in which a target position is represented by the discharge of a population of cells centered at a specific location in the SC and the FEF. The temporal discharge pattern of the activated population of cells may be the same for very different saccade goals. Only the anatomical location of the activated population changes with target location.

[Figure 1b](#) is a schematic model which illustrates that most of the structures involved in the control of saccades are interconnected with multiple distributed feedback loops. Each of the structures shown by box elements: the SC, the cerebellum and the saccadic burst generator (SBG and NI) are themselves dynamic, recurrent neural networks. Saccade-related neurons in the SC and cerebellum display both place and temporal

coding. A local feedback signal still exists, but it may consist of both eye displacement and eye velocity signals, and it is distributed in a weighted fashion to all the spatially distributed neurons in the SC and the cerebellum. There is no single place in the model where a physical signal coding dynamic motor error exists. Instead, error is represented in a distributed fashion as a property of the whole network.

Specific implementations of distributed control have focused on the SC or the cerebellum.

Depending on the symmetry and the parameters used to model the lateral interconnections in either of these two structures, two quite different types of distributed control mechanisms may be generated. In one type of distributed model, eye velocity local feedback drives a moving wave of activity from an originally active site in the SC or the cerebellum [8]. This original locus of activity codes the desired saccade vector. When the spreading activity reaches the rostral pole of the colliculus (in the SC model) or the mirror symmetric location in the opposite cerebellum (in the cerebellar model), the movement ends. The rate of movement of the wave is controlled by the local distributed feedback of eye velocity, so that at any time during the saccade the distance from the wave front to the end-point location in either colliculus or cerebellum spatially codes motor error. In this form of local feedback control, the distributed structure performs a spatial integration of the eye velocity feedback and represents motor error in a distributed spatial location.

In the other type of control scheme, a distributed population of cells in the SC becomes activated by spatially coded visual input and recurrent, excitatory connections among SC cells themselves [9, 10]. In the Arai [10] model, and to a lesser extent in the Bozis and Moschovakis [9] model, feedback of eye velocity and/or eye displacement to the SC drives the discharge of SC cells originally active down at a rate coupled to the progression of the saccade. Additional local feedback to the brainstem SBG or the cerebellum is needed to make either model function in an accurate fashion.

In conclusion, some type of local feedback about the ongoing eye movement during saccades controls saccade trajectory, and hence the accuracy of these rapid movements. The feedback signal may involve instantaneous eye displacement or eye velocity variables or both. Both the superior colliculus and the cerebellum are involved in the control of saccades, and both receive extensive inputs from brainstem structures that carry eye velocity and position signals. Both structures are themselves recurrently connected, distributed dynamic neural networks. Therefore, control by local feedback is certain to involve highly distributed control processes. With present day neuroscience recording techniques it will be difficult to isolate the location of, and the precise mechanisms, underlying local feedback control in this distributed system.

Instead, local feedback and the motor error signals generated by local feedback are likely to be distributed properties of the entire network. Modern imaging techniques may be able to advance our knowledge of the mechanisms involved in the distributed control of saccades by local feedback.

## References

1. Robinson DA (1975) Oculomotor control signals. In: Lennerstrand G, Bach-Y-Rita P (eds) *Basic mechanisms of ocular motility and their clinical implications*. Pergamon Press, Oxford, pp 337–374
2. Van Gisbergen JAM, Robinson DA, Gielen S (1981) A quantitative analysis of generation of saccadic eye movements by burst neurons. *J Neurophysiol* 45:417–442
3. King WM, Fuchs AF (1977) Neuronal activity in the mesencephalon related to vertical eye movements. In: Baker R, Berthoz A (eds) *Control of gaze by brainstem neurons*. Elsevier, Amsterdam, pp 319–326
4. Keller EL (1977) Control of saccadic eye movements by midline brainstem neurons. In: Baker R, Berthoz A (eds) *Control of gaze by brainstem neurons*. Elsevier, Amsterdam, pp 327–336
5. Jürgens R, Becker W, Kornhuber HH (1981) Natural and drug-induced variations of velocity and duration of human saccadic eye movements: evidence for a control of the neural pulse generator by local feedback. *Biol Cybern* 39:87–96
6. Scudder CA (1988) A new local feedback model of the saccadic burst generator. *J Neurophysiol* 59:1455–1475
7. Keller EL (2004) Distributed neural processing in the saccadic system. In: Hall WC, Moschovakis AK (eds) *The superior colliculus: new approaches for studying sensorimotor integration*. CRC Press, Boca Raton, FL, pp 277–301
8. Lefèvre P, Galiana HL (1992) Dynamic feedback to the superior colliculus in a neural network model of the gaze control system. *Neural Netw* 5:871–890
9. Bozis A, Moschovakis AK (1998) Neural network simulations of the primate oculomotor system. III. A one-dimensional, one-directional model of the superior colliculus. *Biol Cybern* 79:215–231
10. Arai K, Das S, Keller EL, Aiyoshi E (1999) A distributed model of the saccade system: simulations of temporally perturbed saccades using position and velocity feedback. *Neural Netw* 12:1359–1375

## SC – Motor Map

EDWARD L. KELLER

Smith-Kettlewell Eye Research Institute,  
San Francisco, CA, USA

### Definition

The term motor map refers to a very general neuroscience concept in which movements with specific

spatial characteristics are represented topographically within a neural structure. The exposition here will be limited to gaze shifts (movements of the head and eyes) directed to targets presented in the visual surround of a subject. With this restriction, the topographical arrangement of movements on the map may be retinotopic or spatial. In a retinotopic motor map, the movements represented on the map are independent of the initial eye position in space, but vary smoothly in amplitude and direction as a function of the location of the target with respect to the fovea (the current line of sight). In a spatially coded motor map, specific locations in space are represented topographically in the neural structure. In this type of motor map, gaze comes to rest after a movement at a fixed location in space regardless of the initial position of gaze. For retinotopically coded motor maps, gaze shifts may be represented as movement vectors directed between the initial gaze position and the position of the target with respect to the fovea. Retinotopic movement vectors remain invariant for any initial position of gaze. In spatially coded maps, the movement is directed from any initial gaze position to an invariant point in the visual surround. Retinotopic motor maps in the SC are considered in detail below, but an example of a spatially coded map in SC in the cat is also described. Neurons in several gaze-related regions of the brain have a preferred movement vector for which they show the most vigorous peri-movement discharge. The level of their discharge declines systematically for movement vectors that are different in direction or amplitude from the preferred vector. Movement vectors are defined by the polar coordinates of movements to point targets in visual space, and therefore, can be alternately described as coordinates in a foveally centered visual space. If the movement-related neurons in a structure are organized in a topographical manner such that nearest neighbors anatomically also have nearest neighbor preferred vectors in the visual field, the structure contains a motor map. That is, neighboring points in the visual field (the movement vectors) are mapped to neighboring points in the motor map. In such motor maps, the amplitude and direction of the preferred movement vector in individual cells changes in a smooth manner as the anatomic locations of the cells being recorded are systematically altered within the neural structure. When the preferred movement vectors are plotted on an anatomical representation of the structure, a vector field emerges on which the preferred vector changes smoothly in direction and amplitude as a function of anatomic location.

### Description of the Theory

A variety of techniques have shown that several structures in the brain contain retinotopically coded motor maps for saccadic eye movements. The two most

thoroughly studied structures with ►saccade motor maps are the superior colliculus (SC) and the ►cortical frontal eye fields (FEF). The motor map in the SC will be described in detail in this exposition. The motor map in the SC has been well described because this mid-brain structure is approximately flat and is not located in a cortical sulcus, which has allowed recording and electrical ►microstimulation experiments to more precisely characterize the topographical arrangement of saccade vectors in this structure. In initial studies of the motor map in the SC, the animals' heads were mechanically restrained so that only eye and not combined eye and head (gaze) movements were recorded.

The saccadic eye movement fields of neurons in the intermediate and deep layers of the SC were determined by recording their discharge during a temporal window aligned on saccade onset. The activity of cells was determined for a succession of targets presented at different positions in the animal's visual field. In a manner similar to that found for the visual response of cells in visual structures of the brain, these response fields contained a central location (a saccade of a fixed amplitude and direction) which was associated with the most intense saccade-related discharge. The saccade vector with the largest discharge was called the preferred vector. By recording this preferred vector for cells encountered at different locations in the SC, a retinotopically organized map of the contralateral visual field was found [1]. The horizontal meridian of the contralateral field was represented by cells located along a rostral to caudal strip of the middle portion of one colliculus. Cells with preferred movement vectors with small amplitudes were located at rostral locations on this medial strip, and cells with large-amplitude preferred vectors were located caudally. Cells that coded movement vectors with down components were located laterally on the colliculus, and cells with up preferred vectors were located near the midline. The motor map found in the deeper layers of the SC is in spatial register with the sensory map of visual cell responses found in the upper layers of the SC.

A more precise specification of this collicular motor map of preferred saccade vectors was provided by an electrical microstimulation study [2]. In this study, the colliculus was sampled with sufficient density of stimulation sites to show that the motor map was logarithmically warped, so that the space allotted to the representation of small saccades in the rostral SC was greatly magnified with respect to that allotted to large saccades in caudal SC.

Ottes et al. [3] used Robinson's stimulation data [2] to construct a set of equations that converted saccade vectors in visual space into location in collicular space. The motor map defined by their equations is shown in Fig. 1. This motor map in SC space can be quantified by

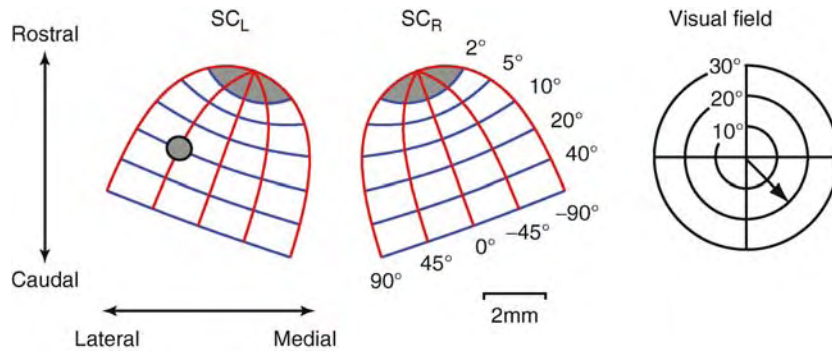

**SC – Motor Map. Figure 1** Motor map for saccadic eye movements in the monkey superior colliculus. The plot on the right shows a representation of the visual field in polar coordinates. An example of one saccade vector is shown by the arrow in this plot. The plot on the left shows the left superior colliculus ( $SC_L$ ) and the right superior colliculus ( $SC_R$ ) with inscribed saccadic isoamplitude curves (blue) and isodirectional curves (red). When the saccade vector shown in the visual field plot is made, the greatest activity will appear in the  $SC_L$  at the location of the small gray disk. The gray sectors at the most rostral extent of both colliculi show the location of a hypothesized fixation zone.

a logarithmic transformation of amplitude coordinates in visual space along rostral to caudal strips (blue curves in Fig. 1) in SC space, and by an inverse tangent transformation of directional coordinates in visual space along the medial to lateral strips (red curves in Fig. 1) in SC space. Figure 1 shows that the conformal transformation of the coordinates of the saccade vector in visual space into rostrocaudal and mediolateral coordinates of associated activity in collicular space is single valued. That is, each saccade vector in retinotopically centered visual space maps to a unique point in collicular space. One example of the mapping is shown by a vector in visual space (black arrow) which illustrates a desired saccade goal with an amplitude of  $20^\circ$ , and a direction to the right and down at  $45^\circ$ . This goal is represented in the motor map of the left SC at the location of the small gray disk where activity would be the greatest during this particular saccade. However, the motor map in one colliculus represents only contralateral visual space, so the map has discontinuities along its medial and lateral edges that represent saccades with pure up (medial edges) or down (lateral edges) directions. The exact pattern of discharge in the SC for nearly vertical saccades has never been studied quantitatively, but most likely pure vertical saccades are coded by activity in both colliculi.

Another irregularity has been reported to exist in the SC motor map. Instead of the map representing progressively ever smaller saccades as the most rostral region of the colliculus is traversed, a rostral region called the fixation zone is found that codes instead the suppression of saccades [4]. This zone, as defined by these investigators, is shown in Fig. 1 as the gray-shaded sectors at the rostral poles of both colliculi. Gandhi and Keller [5] stimulated this rostral region of the SC, and showed that progressively smaller

saccades could be evoked as the anatomic location of the stimulation site was moved further in the rostral direction. The direction of the small saccade evoked by stimulation at a particular rostral site with the animal fixating was first determined. They next stimulated with a short pulse train at the same site at the onset of large visually triggered saccades. If the direction of the small evoked saccade and the large visually guided saccade were the same, only a momentary interruption of the ongoing saccade occurred. This result would be expected if the site in the rostral SC were part of a fixation zone. In contrast, when the direction of the small evoked saccade was orthogonal to the direction of the large visual saccade, they found that, in addition to the slowing of the ongoing saccade, a spatial deviation of the two-dimensional trajectory of the ongoing saccade was produced. The direction of the deviation was consistent with the direction of the small saccade evoked by stimulation in the absence of an ongoing movement. The latter observation would be expected if the rostral region of the SC coded small saccade vectors that were averaged with the trajectory of the ongoing saccade during stimulation. Thus, although the rostral SC appears to play a role in maintaining gaze fixation (through the high level of tonic activity of cells located there and their connections to the omnipause cell region in the brain stem), it also plays a role in coding for smaller and smaller saccade vectors as location on the map is moved more rostral.

It is instructive to compare the single-valued transformation that characterizes the motor map in the SC with the motor map that exists in the FEF, in which the mapping from visual space to FEF space is not unique [6]. The precise form of this FEF map, which exists in the anterior bank of the arcuate sulcus, has not been quantified as well as that in the SC, but larger

amplitude saccades are represented dorsomedially and smaller saccades ventrolaterally. The representation of saccade direction changes systematically on radial penetrations down the anterior bank, but a given direction in visual space is often represented at multiple locations along the penetration.

Recently, movement mapping studies have been repeated in the SC of the monkey with its head unrestrained so that the possible representation of both head and eye movements could be ascertained. Both single-neuron recording studies [7] and microstimulation studies have demonstrated that the retinotopically organized motor map in the SC codes gaze (the sum of eye and head motion) instead of eye saccades. Based on their data from the head-unrestrained monkey, Freedman and his colleagues have suggested that the saccadic eye movement motor map shown in Fig. 1, which was obtained from recording and stimulation data in head-fixed animals, is badly distorted.

A motor map also exists in the SC of the cat as determined by electrical microstimulation experiments [8]. These investigators stimulated the deeper layers of the SC in the head-restrained cat, and reported that a map similar to that found in the monkey existed in the rostral half of the SC. Small saccades were presented rostrally and larger movement caudally, while saccades with a downward component were represented laterally and those with an up component were found medially. However, in contrast to the map found in the monkey, the map in the posterior half of the cat SC appeared to have a goal-directed (spatially coded) organization. Saccades evoked at a given site in this portion of the SC invariably ended at a fixed orientation in space, regardless of the initial position of the eyes at the start of the movement. Thus, the evoked saccade vector was highly dependent on the initial position of the eyes just before the saccade was initiated. The limited oculomotor range of the cat made the differentiation between goal-directed behavior and saturation effects near the limits of the oculomotor range difficult to make. Roucoux and Crommelinck [8] repeated the electrical stimulation study in the SC of the head-unrestrained cat and reported that a topologically organized gaze motor map existed throughout the structure. Small, eye only saccades were evoked from the rostral SC, while large gaze shifts that were composed of both eye and head movements were evoked from the caudal SC. The apparent goal-directed map found previously in the cat SC was apparently an artifact produced by restraining the head. A more recent study suggests that the rostral most portion of the cat SC contains a fixation zone [9] which codes for the suppression of saccades rather than smaller and smaller gaze vectors. Additional studies are required to check this suggestion against the conflicting results found in the monkey [5].

The movement fields of SC neurons can be quite large, i.e. these neurons discharge with the greatest intensity for a particular saccade vector, but also display significant activity over an extended range of neighboring saccade vectors. The result of this behavior in single cells is that a large population of cells in the SC will be active for any saccade. The location of this population of active cells shifts within the SC as a function of saccade vector [3,10]. The locus of population activity on the SC is an alternative way to describe the motor map for saccadic eye movements in the SC. Anderson et al. [10] estimated the two-dimensional loci of activity in the SC for a variety of saccades made to an extended region in contralateral visual space. The spatial extent of the population activity involved nearly 50% of the contralateral colliculus for any saccade. The spatial extent of the population activity was rather invariant with saccade size or direction, and the center of mass of this activity fit well with the motor map for saccades shown in Fig. 1, which was based on electrical microstimulation studies [2].

## References

- Schiller PH, Stryker MP (1972) Single-unit recording and stimulation in superior colliculus of the alert rhesus monkey. *J Neurophysiol* 35:915–924
- Robinson DA (1972) Eye movements evoked by collicular stimulation in the alert monkey. *Vision Res* 12:1795–1808
- Ottes FP, Van Gisbergen JAM, Eggermont JJ (1986) Visuomotor fields of the superior colliculus: a quantitative model. *Vision Res* 26:857–873
- Munoz DP, Wurtz RH (1992) Role of the rostral superior colliculus in active visual fixation and execution of express saccades. *J Neurophysiol* 67:1000–1002
- Gandhi NJ, Keller EL (1999) Comparison of saccades perturbed by stimulation of the rostral superior colliculus, the caudal superior colliculus, and the omnipause neuron region. *J Neurophysiol* 82:3236–3253
- Bruce CJ, Goldberg ME, Bushnell MC, Stanton GB (1985) Primate frontal eye fields. II. Physiological and anatomical correlates of electrically evoked eye movements. *J Neurophysiol* 54:714–734
- Freedman EG, Stanford TR, Sparks DL (1996) Combined eye-head shifts produced by electrical stimulation of the superior colliculus in rhesus monkey. *J Neurophysiol* 76:927–952
- Roucoux A, Crommelinck M (1976) Eye movements evoked by superior colliculus stimulation in the alert cat. *Brain Res* 106:349–363
- Paré M, Guitton D (1994) The fixation area of the cat superior colliculus: effects of electrical stimulation and direct connection with brainstem omnipause neurons. *Exp Brain Res* 101:109–122
- Anderson RW, Keller EL, Gandhi NJ, Das S (1998) Two-dimensional saccade-related population activity in superior colliculus in monkey. *J Neurophysiol* 80:798–817



## SC – Place Code

### Definition

A theoretical term used to refer to the fact that the SC specifies the metrics of saccades in terms of the anteroposterior and mediolateral location of the SC area activated when the nucleus is projected onto a horizontal plane.

► Eye Movements Field

## SC – Saccade Related Burst Neurons

XINTIAN HU<sup>1,2</sup>, DAVID L. SPARKS<sup>1</sup>

<sup>1</sup>Laboratory of Sensory Motor Integration, Kunming Institute of Zoology, The Chinese Academy of Sciences, Kunming, People's Republic of China

<sup>2</sup>Division of Neuroscience, Baylor College of Medicine, Houston, TX, USA

### Definition

► Saccade related burst neurons (SRBNs) of the ► superior colliculus (SC) are characterized by a high frequency burst that begins about 20 ms before ► saccades of appropriate amplitude and direction. In addition to the burst, some SRBNs have low frequency prelude activity preceding the burst. Although the onset of the burst is tightly coupled to the onset of the upcoming saccade (see below), the duration of the prelude activity varies from trial to trial and its onset is neither tightly coupled to the onset of the saccade nor to the onset of the target [1].

### Characteristics

#### Higher Order Structures

SRBNs are located in the deeper layers of SC and each of them has a movement field (each SRBN discharges optimally before saccades of a specific amplitude and direction, see below). They are organized topographically according to their movement fields. Neurons discharging before small saccades are found in the anterior part of SC, while those firing before large saccades are found in the posterior part of SC. Cells discharging before saccades with a downward component are located laterally in SC and those firing before saccades with an upward component are located medially [1]. In general, the distribution pattern

of SRBNs movement fields in SC corresponds to the motor map obtained by microstimulation studies [2].

### Parts of This Structure

The deeper layers of SC receive inputs from cortical and subcortical regions serving both sensory and motor functions. For example, the frontal eye fields (FEF), the posterior parietal cortex and inferior colliculus project extensively to this part of SC. These signals are processed and integrated into motor commands here and outputted downstream for the control of orienting behavior of the animal. Converging lines of evidence indicate that the axons of SRBNs are an important component of SC efferent pathway. Keller [3] reported that 10 out of 10 SRBNs recorded in SC could be antidromically activated by stimulation of the ► paramedian pontine reticular formation (PPRF) and the area that contains ► omnipause neurons (OPNs). Only 1 of 12 non-burst SC neurons, which displayed saccade related activity but lacked the high frequency burst, was activated. In another experiment, Moschovakis et al. [4] recorded from the SC of squirrel monkeys making spontaneous eye movements and grouped the recorded neurons into different functional classes. One class, named vectorial long-lead burst neurons, has properties that are very similar to those of the SRBNs. Those vectorial long-lead burst neurons have a motor field, display very little spontaneous activity and burst intensively before saccades made into their motor field. Like SRBNs, the burst preceded saccade onset by about 20 ms. The axons were filled with HRP after the recording, permitting their morphological identification. In addition to projecting to the contralateral SC, axons of those vectorial long-lead burst neurons bifurcate in the midbrain. One branch crosses the midline and joins the predorsal bundle, which terminates in, among other targets, PPRF, the horizontal burst generator. There is evidence indicating that these axons of the vectorial long-lead burst neurons actually make synaptic connections with neurons in PPRF [5]. The other branch joins the ventral ascending efferent bundle (AV). The vertical burst generator, the rostral interstitial nucleus of the median longitudinal fasciculus (riMLF), is one of the targets of the AV pathway [6].

### Functions of This Structure

As mentioned above, SRBNs have movement fields. The SRBN shown in Fig. 1 is an example. This cell discharges before a range of saccades (amplitude < 5°) aimed to the right and down region in the visual field. As the positions of the saccadic end points in the movement field varies, a systematic change of the discharge rate and duration can be observed. Saccades directed to the center of the field are preceded by

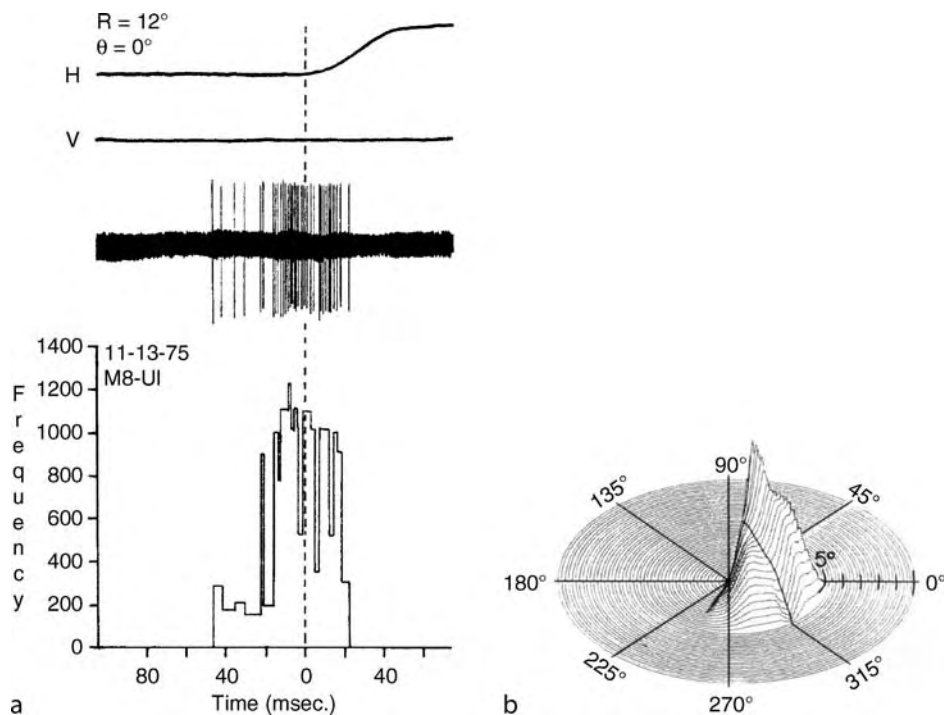

**SC – Saccade Related Burst Neurons. Figure 1** (a) Discharge pattern of a typical SC saccade related burst neuron (SRBN). Top graph: horizontal eye position (H) and vertical eye position (V) as a function of time. Middle graph: Action potentials of the cell. Bottom graph: instantaneous firing rate as a function of time. Vertical dotted line: the onset of the saccade. (b) A 3D plot of the movement field of this cell. The optimal amplitude is 1 degree at an angle of  $320^\circ$  (Courtesy of Sparks and Jay, 1986).

more vigorous discharges with longer durations, while saccades deviating from the optimal direction and amplitude are accompanied by less vigorous discharges with shorter durations. In addition to this spatial gradient, the movement field is also characterized by a temporal gradient. The time between the onset of the burst and the onset of the saccade is longer for those movements to the center of the field than those to the periphery. The size of SRBNs' movement fields tends to increase with eccentricity. That is, neurons that discharge before small saccades have small and sharply defined movement fields, while those firing before large saccades have large and coarsely tuned fields [1,7].

SRBNs discharge before saccades of specific directions and amplitudes regardless of initial eye position. Therefore, the collicular command is not to move the eye to a particular position in the orbit, but to displace the eye in a specific direction and amplitude [1]. Unlike the motor neurons and excitatory burst neurons (EBNs) in the brain stem, SRBNs do not code the direction and amplitude of an upcoming saccade by firing rate. Identical bursts may occur in association with

many saccades of different directions and amplitudes. Moreover, there is no distinguishable difference among the discharges of different SRBNs preferring different saccade sizes [7]. Thus, it is the location of the activated SRBNs in the SC motor map that determines saccade amplitude and direction. In other words, the direction and amplitude of a saccade are spatially coded in SC.

There is strong evidence indicating that the high frequency burst of SRBNs plays an important role in saccade initiation. First, the onset of the burst is tightly correlated to the saccade onset ( $r = 0.99$ ). Second, when the experimental parameters are setup in such a way that sometimes the visual target elicits a saccade and sometimes does not, the occurrence of the burst of a SRBN is almost perfectly correlated with the occurrence of the saccade. Although SRBNs sometimes discharge a few spikes in the absence of a saccade, this kind of activity is far less vigorous than the least vigorous ones that accompany appropriate saccades [8]. A more recent experiment, in which the monkey was required to cancel an on going visually guided saccade in one third of the trials, also showed that SC neurons

play an important role in the decision process regulating whether a saccade is to be made [9]. In addition to initiating the normal visually guided saccade mentioned in the above two experiments, the burst of SRBNs could also serve as the trigger signal in express saccades (saccades that have very short latency, ranging from 80 to 100 ms). Under the “gap” condition in which express saccades are often observed, the interval between the onset of the visual target and onset of the burst is shortened and, as a result, the saccadic latency is shortened [10].

### Higher Order Function

The deeper layers of SC in which the SRBNs are located are an important component in a circuit transforming signals from different sensory and motor areas into motor commands that initiate and guide the ►orienting responses of the eyes, head and pinnae.

### References

1. Sparks DL, Hartwich-Young R (1989) The deeper layers of the superior colliculus. In: Wurtz RH, Goldberg ME (eds) *Reviews of oculomotor research, the neurobiology of saccadic eye movements*. Elsevier Science, Amsterdam, pp 213–255
2. Robinson DA (1972) Eye movements evoked by collicular stimulation in the alert monkey. *Vision Res* 12(11):1795–1808
3. Keller EL (1979) Colliculoreticular organization in the oculomotor system. In: Granit R, Pompeiano O (eds) *Progress in brain research: reflex control of posture and movement*. Elsevier, Amsterdam, pp 725–743
4. Moschovakis AK, Karabelas AB, Highstein SM (1988) Structure-function relationships in the primate superior colliculus. II. Morphological identity of presaccadic neurons. *J Neurophysiol* 60(1):263–302
5. Scudder CA, Moschovakis AK, Karabelas AK, Highstein SM (1996) Anatomy and physiology of saccadic long-lead burst neurons recorded in the alert squirrel monkey. I. Descending projections from the mesencephalon. *J Neurophysiol* 76(1):332–352
6. Harting JK, Huerta MF, Frankfurter AJ, Strominger NL, Royce JG (1980) Ascending pathways from the monkey superior colliculus: an autoradiographic analysis. *J Comp Neurol* 192(4):853–882
7. Sparks DL, Mays LE (1980) Movement fields of saccade-related burst neurons in the monkey superior colliculus. *Brain Res* 190(1):39–50
8. Sparks DL (1978) Functional properties of neurons in the monkey superior colliculus: coupling of neuronal activity and saccade onset. *Brain Res* 156(1):1–16
9. Pare M, Hanes DP (2003) Controlled movement processing: superior colliculus activity associated with countermanded saccades. *J Neurosci* 23(16):6480–6489
10. Sparks DL, Rohrer WH, Zhang Y (2000) The role of the superior colliculus in saccade initiation: a study of express saccades and the gap effect. *Vision Res* 40(20):2763–2777

## SC – Sensorimotor Integration

ADONIS MOSCHOVAKIS<sup>1</sup>, ALEXEJ GRANTYN<sup>2</sup>

<sup>1</sup>Institute of Applied and Computational Mathematics, FO.R.T.H., and Department of Basic Sciences, University of Crete, Heraklion, Crete, Greece

<sup>2</sup>Laboratoire de Physiologie de la Perception et de l’Action, C.N.R.S – College de France, Paris, France

### Definition

The sequence of neural processes that enables the SC to use information about world events in order to issue motor commands guiding orienting responses to these events.

### Characteristics

#### Description of the Theory

The front stage of the sensorimotor interface contained in the SC devotes neural space to represent the location of sensory stimuli. The neural mechanisms employed to this end are considered in some length in the entry ►SC – sensory maps. Since the SC uses different frames of reference to encode the spatial location of stimuli of different modalities, the sensorimotor interface must use coordinate transformations to bring them in register to one another, as well as to the frame of reference used to encode movement metrics. Further, because sensory information reaches the SC from a multitude of stimuli while orienting movements can be executed one at a time, the sensorimotor interface must also include a mechanism to decide when to launch a movement and which of several targets to favor with it. Once the decision to launch the appropriate movement is reached, a command that specifies its amplitude and direction is issued in the form of presaccadic bursts of SC neuron discharges. As the SC uses a place code, and premotoneuronal interneurons use a time code to specify these parameters, the movement related commands must be decomposed and spatio-temporally transformed. The coordinate transformations used in the SC are briefly considered in the entry devoted to the ►foveation hypothesis, while the representation of movement metrics is considered in some length in the entries ►SC – motor map, ►SC – role in eye movements, ►SC – saccade related burst neurons (SRBNs) and ►SC – tectal long lead burst neurons (TLLBs). The present entry is devoted to the following issues: (i) Transmission of sensory information to movement related cells of the SC; (ii) Decision processes; (iii) Burst generation; and (iv) Vector decomposition and spatiotemporal transformation.

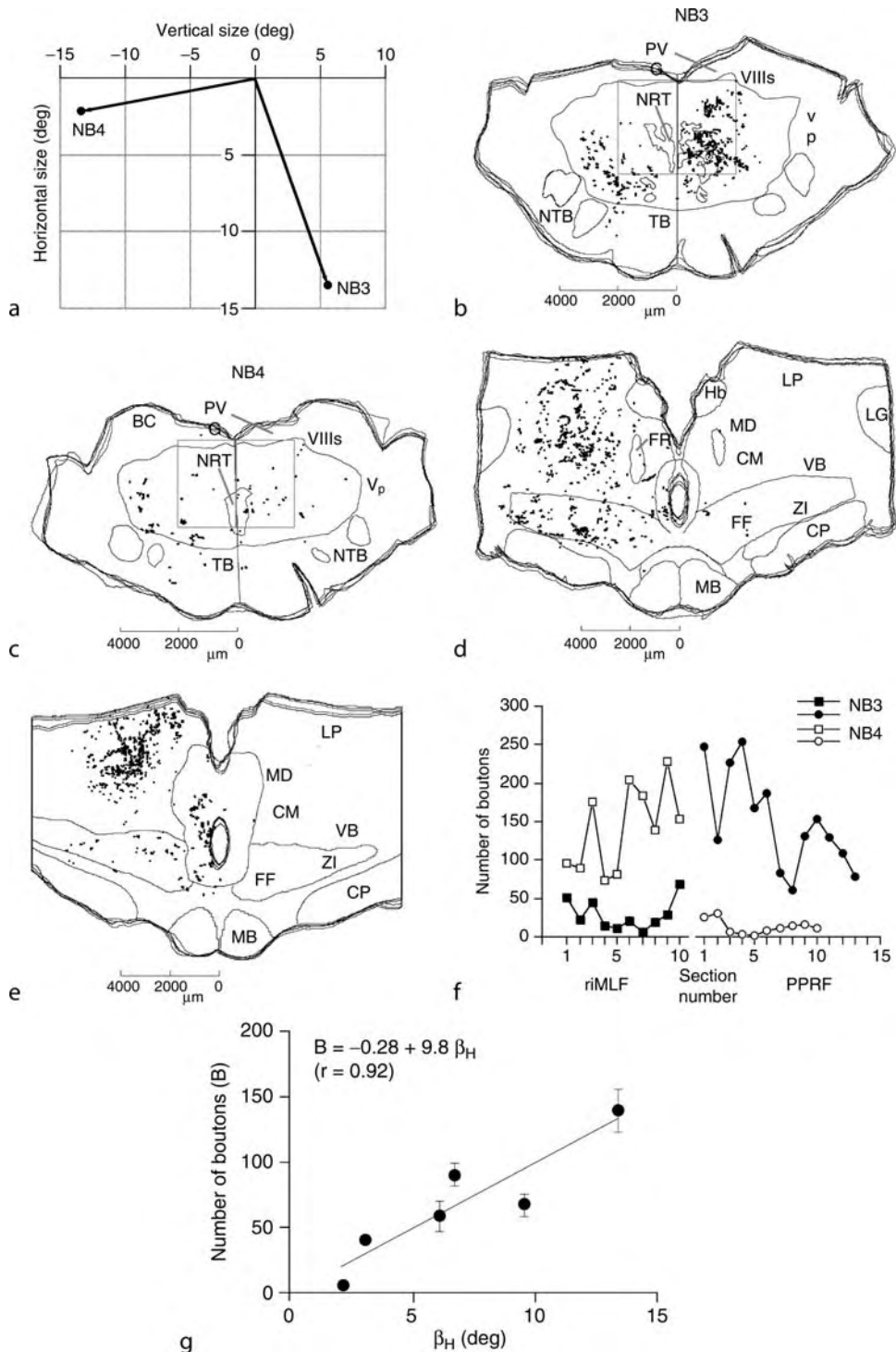

**SC – Sensorimotor Integration. Figure 1** (a) 2-D plot of the amplitude and direction of saccade vectors (abscissa: horizontal, ordinate: vertical) evoked from two SC sites in cats NB3 and NB4. Consistent with the motor map of the SC, the horizontal contraversive component was big (13.5 deg) in the case of NB3 and small (2.1 deg) in the case of NB4. Similarly, a conspicuous difference in the size and direction of the vertical components (5.6 deg upward in NB3 and 13.4 deg downward in NB4) agreed well with the location of the stimulus sites on the motor map. (b, c) Distribution of *boutons* in five consecutive sections, at the level of the rostral border of the nucleus reticularis pontis caudalis (NRPc), after biocytin injections in areas of the feline SC encoding saccades with a big horizontal and a small vertical component (NB3, b), or saccades with a small horizontal and a big vertical component (NB4, c). (d, e) Distribution of

### Transmission of Sensory Information to Movement Related Cells

The classes of cells that convey visual information from the superficial to the deeper SC layers and the role they play in generating bursts of discharge in deeper SC layer neurons are examined in the entry devoted to ►SC – interlayer neurons. The direct superficial to deeper visual information transfer is supplemented by a massive cortical projection of visual information to the deeper SC. Information of other modalities (e.g. auditory or somatosensory) is similarly funneled to the deeper SC layers, as described in the entry SC – sensory maps. The intensity of SC neuron discharge depends on the properties of the stimuli employed. For example, moving stimuli are particularly effective in driving SC cells [1]. Moreover, multimodal stimuli are more efficient in driving SC neurons than unimodal ones; the vast majority (84%) of deeper SC cells respond much more strongly to stimuli involving two or more sensory modalities than would be expected on the basis of their responses to unimodal stimuli [2]. It also depends on the context in which such discharges are emitted. For example, visual responses of primate superficial SC cells can be enhanced if stimuli in their receptive fields are used as targets for saccades [3], and the same is true of the visual responses of deeper SC movement related cells for rewarded movements [4].

The biological means that the SC employs to encode the location of visual targets and match it to the metrics of the saccade related motor commands it sends to its targets are examined in the entry devoted to the foveation hypothesis. As discussed there, use of raw sense data to represent stimulus location does not always suffice to accurately specify the discharge of presaccadic SC neurons, and therefore the metrics of ensuing saccades. Instead, stimulus location must sometimes be reevaluated through the use of coordinate transformations; subsumed under the heading “vector subtraction hypothesis” they are also described in the entry foveation hypothesis, while neurons crucially relevant for its implementation are described in the

entries devoted to the ►reticulotectal long-lead burst neurons and the ►SC – quasivisual neurons.

### Decision Processes

There is considerable evidence to suggest that the SC participates in processes which determine whether a saccade needs to be produced and if so when. Saccade reaction times offer a convenient means to assess the neural mechanisms leading to such a decision, in particular since their range can be readily influenced by experimental manipulation. For example, the latency of ►express saccades (often evoked with the use of the gap paradigm, in particular in trained subjects) is shorter than that of regular saccades [5]. Conversely, saccades to auditory [6] and somatosensory targets [7] and saccades away from targets (antisaccades [8]) take longer to initiate. Several parameters of the discharge of deeper SC neurons reflect these reaction time differences. For example, the number of deeper SC layer neurons bursting for saccades is larger [9], and the intensity of their discharge is greater [10], when saccade targets are visible rather than when they are not (such as in the case of antisaccades or spontaneous saccades). Also, the bursts of discharge of SC motor cells for longer latency saccades (e.g. to somatosensory targets) are delayed relative to those for saccades to visual targets [11].

It might be argued that the phasic sensory responses reaching the deeper SC layers are automatically translated into executable movement related phasic commands leading to quick decisions and early movements. This is probably not always the case, as indicated by the fact that ►tectoreticulospinal neurons (TRSNs) of the deeper SC of the cat emit short latency bursts of discharges for visual stimuli, yet these bursts do not accompany saccades [12]. Further, the motor responses of primate buildup neurons, which accompany correct anti-saccades of appropriate metrics, are weaker than their sensory responses to visual stimuli into their receptive field which are not followed by saccades (these would be erroneous prosaccades towards the stimulus rather than the correct anti-saccades away

*boutons* in five consecutive sections at the level of the rostral border of the Fields of Forel (FF) and, more precisely, their medial portion traversed by the retroflex bundle (homologous to the riMLF of the monkey) in the same cases (NB4, d; NB3, e). (f) Number of *boutons* that were recovered in the ipsilateral riMLF of NB3 (*solid squares*) and NB4 (*open squares*), and the contralateral PPRF of NB3 (*solid circles*) and NB4 (*open circles*) in several individual consecutive sections through these nuclei. (g) Plot of the average number of *boutons* deployed in the feline PPRF per 100 fibers per section (B; *ordinate*) from each one of several SC injection sites versus the size of the horizontal component of the characteristic vector (i.e. the saccade vector that would have been evoked had the eyes started from a straight ahead position) of the saccades evoked from the same site ( $\beta_H$ ; *abscissa*) after bulk injections of a tracer in collicular microzones of the cat. Error bars indicate the standard error of the mean. The solid line is the linear regression line through the data and obeys the equation displayed. Abbreviations: *Vp*, principal sensory nucleus of the trigeminal nerve; *VIII*s, superior vestibular nucleus; *BC*, brachium conjunctivum; *CM*, central median nucleus; *CP*, cerebral peduncle; *FF*, fields of Forel; *FR*, fasciculus retroflexus; *Hb*, habenula; *LG*, lateral geniculate nucleus; *LP*, lateral posterior complex; *MB*, mammillary bodies; *MD*, mediodorsal nucleus; *NRT*, nucleus reticularis tegmenti pontis; *NTB*, nucleus of the trapezoid body; *PVG*, periventricular gray; *TB*, trapezoid body; *ZI*, zona incerta.

from the stimulus which are actually executed [10]. Conceivably, the visual responses of omnipause neurons [13] transiently raise the threshold for initiating eye movements and thus bursts exiting the SC shortly after the appearance of salient stimuli are rendered ineffective. The notion that the visual bursts of deeper SC neurons could elicit saccades at least in some circumstances, such as those favoring express saccades (visuo-motor hypothesis [14]), has been explored, and shown to be unlikely in monkeys executing saccades of a particularly wide range of reaction times (engendered by interleaving trials in which target onset preceded -delayed saccade task, coincided with -step task, or followed -gap task, fixation target offset). Most SC cells emit only one burst which is tightly coupled either with the appearance of the target (visual cells) or with the onset of the saccade (movement cells). However, visuo-motor cells of the deeper SC generate two bursts of discharge, an early visual one and a second, motor one. The interval between the two decreased with the latency of the saccades until extremely short latencies were reached, in which case the motor burst fused with the visual one. The tight coupling between the onset of the motor burst and the onset of saccades extended into the express saccade range for both the visuo-motor and the motor cells, while no range of saccade reaction times was found in which visual rather than motor responses were tightly coupled to saccade onset [15].

A large range of reaction times can also be found in experiments employing a two choice discrimination task in which subject decision is declared by making a saccade in one of two directions. In such experiments, the latency of the movement varies almost continuously with task difficulty (a function of the separability of the cues employed to instruct movements in one or the other direction). Of the models proposed to account for the variability of saccade reaction times, diffusion models have been particularly useful in that they capture essential features of both subject performance and of cell discharge. Such models assume that to initiate a saccade, information starts from a baseline and drifts over time until it reaches a boundary [16]; reaction time (as well as the number of correct and erroneous responses) could in principle depend on the baseline, boundary and rate of the drift values. Indeed, the post-target presentation rate of rise of the firing of prelude neurons has been shown to reflect the dynamics of the decision process [16]. Moreover, there is some evidence to suggest that when the discharge of saccade related SC neurons exceeds a certain intensity (threshold), saccades in their movement field must be executed [17]. Finally, the intensity of discharge of prelude neurons, before target presentation (baseline), is influenced by the probability of reward [4] and of a target present in their receptive field [18], increases in the gap period [10], and is inversely correlated with the latency of

saccades [18]. It also determines whether a correct or erroneous movement will be executed in the anti-saccade task; high level prestimulus activity of prelude cells located near the SC site where visual stimuli are represented gives rise to reflexive saccades towards them [10]. Apparently, several factors can increase the excitability of deeper SC neurons; whenever this is the case, and depending on the strength and timing of superimposed sensory signals, SC cells can emit motor bursts leading to extremely short latency and maybe even inappropriate movements.

### **Burst Generation**

To some extent, the saccade related bursts of SC neurons are due to movement related signals they receive from the ►frontal and ►supplementary eye fields. However, since saccades can still be executed after lesions of the frontal lobes, the SC must be able to generate presaccadic bursts from signals which need not be either phasic or saccade related. Here, we consider two mechanisms: (i) synaptically modulated non-linear responses of deeper layer SC neurons, and (ii) the recurrent excitatory network deployed by TLLBs.

Under certain circumstances, the synaptic influence of fibers carrying sensory information to the deeper SC layers might evoke intense bursts in their targets. For example, application of the GABAergic antagonist bicuculline can evoke prolonged bursts of action potentials, which ride on top of large amplitude EPSPs produced in deeper SC neurons in response to electrical stimulation of the superficial layers of rat SC slices [19,20]. These are presumably due to NMDA receptor mediated regenerative processes switched on by the depolarization of the deeper SC cells due to the removal of synaptic inhibition. The source of GABA in such preparations is probably local interneurons [21], but the SC of intact animals has several additional ones. The best studied of these is the pars reticulata of the substantia nigra, and is examined in detail in the entry ►Substantia nigra – role in eye movements.

The recurrent plexus of TLLBs is described in the entry devoted to the ►SC – Tectal Long Lead Burst Neurons. The notion that it mediates excitatory synaptic influences between adjacent TLLBs is consistent with the fact that the main axon of such neurons joins the predorsal bundle [22] and the fact that predorsal bundle fibers are glutamatergic [23]. It is also consistent with the fact that brief inward currents superimposed on long-lasting ones can be recorded from SGI neurons in response to the photorelease of caged glutamate [24]. Similar bursting discharges of SGI neurons in rat slices could not be accounted for by the relationship between the firing rate and the intensity of the current injected into the neurons studied. Instead, consistent with the above described network of interacting TLLBs, they could be reproduced (abolished) by NMDA receptor activation (block) [25].

### Spatiotemporal Transformation and Vector Decomposition

As with other motor systems, the saccadic one is characterized by a profound transformation of its signals as they pass from higher order supranuclear structures to motoneurons. The “place” code used by the motor SC to specify saccade vectors is described in the entry devoted to ►SC – tectal long lead burst neurons. Its adoption makes eminent sense, as it allows the front end of the saccadic system (the motor SC) to use a code favored by sensory systems. However, because neural circuits interposed between the SC and the extraocular motoneurons use a time code to specify the same parameters (considered in the entries devoted to the ►horizontal and ►vertical medium lead burst neurons), this choice engenders two transformations of the movement related commands exiting the SC. Firstly, the vector of saccadic displacement represented in the SC must be “decomposed” into the vertical and horizontal saccadic components specified by the burst generators. Conceivably, this could be implemented by the Av and PDB branches of the axons of single TLLB neurons (described in the entry ►SC – tectal long lead burst neurons) which target the ipsilateral riMLF (the Av branch) and the contralateral PPRF (the PDB branch), respectively. The differential weighing of the simultaneous projections of single SC sites onto the vertical and horizontal burst generators could provide an anatomical substrate for “vector decomposition”. Consistent with this scheme, and as documented in Fig. 1b–f, collicular regions encoding saccades with a big horizontal and a small vertical component project strongly upon the horizontal burst generator and weakly upon the vertical burst generator, while regions encoding saccades with a small horizontal and a big vertical component give rise to the opposite pattern of projections [26].

Following vector decomposition, the spatial code employed by the SC must be further transformed to obtain a matching temporal code at the level of the burst generators. Such a “spatio-temporal” transformation could rely on the graded strength of anatomical projections of distinct SC sites onto the burst generators. Figure 1g illustrates experimental evidence consistent with this scheme [27]. As shown here, the number of *boutons* that tectal efferent fibers deploy within the confines of regions housing the horizontal burst generators (B) increases in proportion to the amplitude of the horizontal component of the saccade vector ( $\beta_H$ ) encoded by the collicular sites from which they originate. The relation between the two variables obeys the expression indicated on the figure. Its slope is equal to about ten *boutons* per degree of horizontal eye displacement per 100 fibers per section, while the high correlation coefficient ( $r = 0.92$ ) indicates that about 85% of the variance of the dependent variable (number of *boutons*) can be accounted for by the independent variable (saccade size).

### References

1. Chalupa LM (1984) Visual physiology of the mammalian superior colliculus. In: Vanegas H (ed) Comparative neurology of the optic tectum. Plenum Press, New York, pp 775
2. Meredith MA, Stein BE (1985) Descending efferents from the superior colliculus relay integrated multisensory information. *Science* 227:657
3. Goldberg ME, Wurtz RH (1972) Activity of superior colliculus in behaving monkey. II. Effect of attention on neuronal responses. *J Neurophysiol* 35:560
4. Ikeda T, Hikosaka O (2003) Reward-dependent gain and bias of visual responses in primate superior colliculus. *Neuron* 39:693
5. Fischer B, Boch R (1983) Saccadic eye movements after extremely short reaction times in the monkey. *Brain Res* 260:21
6. Zahn JR, Abel LA, Dell’Osso LF (1978) Audio-ocular response characteristics. *Sens Processes* 2:32
7. Groh JM, Sparks DL (1996) Saccades to somatosensory targets. I. Behavioral characteristics. *J Neurophysiol* 75:412
8. Fischer B, Weber H (1992) Characteristics of “anti” saccades in man. *Exp Brain Res* 89:415
9. Mohler CW, Wurtz RH (1976) Organization of monkey superior colliculus: intermediate layer cells discharging before eye movements. *J Neurophysiol* 39:722
10. Everling S, Dorris MC, Munoz DP (1998) Reflex suppression in the anti-saccade task is dependent on prestimulus neural processes. *J Neurophysiol* 80:1584
11. Groh JM, Sparks DL (1996) Saccades to somatosensory targets. II. Motor convergence in primate superior colliculus. *J Neurophysiol* 75:428
12. Grantyn A, Berthoz A (1985) Burst activity of identified tectoreticulo-spinal neurons in the alert cat. *Exp Brain Res* 57:417
13. Evinger C, Kaneko CRS, Fuchs AF (1982) The activity of omnipause neurons in alert cats during saccadic eye movements and visual stimuli. *J Neurophysiol* 47:827
14. Sommer MA (1994) Express saccades elicited during visual scan in the monkey. *Vis Res* 34:2023
15. Sparks D, Rohrer WH, Zhang Y (2000) The role of the superior colliculus in saccade initiation: a study of express saccades and the gap effect. *Vis Res* 40:2763
16. Ratcliff R, Cherian A, Segraves M (2003) A comparison of macaque behavior and superior colliculus neuronal activity to predictions from models of two-choice decisions. *J Neurophysiol* 90:1392
17. Paré M, Hanes DP (2003) Controlled movement processing: superior colliculus activity associated with countermanded saccades. *J Neurosci* 23:6480
18. Dorris MC, Munoz DP (1998) Saccadic probability influences motor preparation signals and time to saccadic initiation. *J Neurosci* 18:7015
19. Isa T, Endo T, Saito Y (1998) The visuo-motor pathway in the local circuit of the rat superior colliculus. *J Neurosci* 15:8496
20. Özen G, Augustine GJ, Hall WC (2000) Contribution of superficial layer neurons to premotor bursts in the superior colliculus. *J Neurophysiol* 84:460
21. Meredith MA, Ramoa AS (1998) Intrinsic circuitry of the superior colliculus: pharmacophysiological identification of horizontally oriented inhibitory interneurons. *J Neurophysiol* 79:1597

22. Moschovakis AK, Karabelas AB, Highstein SM (1988) Structure-function relationships in the primate superior colliculus. II. Morphological identity of presaccadic neurons. *J Neurophysiol* 60:263
23. Büttner-Ennever JA, Horn AKE (1994) Neuroanatomy of saccadic omnipause neurons in nucleus raphe interpositus. In: Fuchs AF, Brandt T, Büttner U, Zee DS (eds) *Contemporary ocular motor and vestibular research: a tribute to David A. Robinson*, Thieme Medical Publishers, New York, pp 489
24. Pettit DL, Helms MC, Lee P, Augustine GJ, Hall WC (1999) Local excitatory circuits in the intermediate gray layer of the superior colliculus. *J Neurophysiol* 81:1424
25. Saito Y, Isa T (2003) Local excitatory network and NMDA receptor activation generate a synchronous and bursting command from the superior colliculus. *J Neurosci* 23:5854
26. Grantyn AA, Dalezios Y, Kitama T, Moschovakis AK (1997) An anatomical basis for the spatio-temporal transformation in the saccadic system. *Soc Neurosci Abstr* 23:1295
27. Moschovakis AK, Kitama T, Dalezios Y, Petit J, Brandt AM, Grantyn AA (1998) An anatomical substrate for the spatiotemporal transformation. *J Neurosci* 18:10219

---

## SC – Sensory Maps

MARK M. G. WALTON<sup>1</sup>, DAVID L. SPARKS<sup>1</sup>,  
XINTIAN HU<sup>1,2</sup>

<sup>1</sup>Division of Neuroscience, Baylor College of Medicine, Houston, TX, USA

<sup>2</sup>Laboratory of Sensory Motor Integration, Kunming Institute of Zoology, The Chinese Academy of Sciences, Kunming, People's Republic of China

### Definition

A topographic arrangement of visual, somatosensory, and auditory signals can be found in the ►[superior colliculus](#). When the eyes are centered in the orbits, these maps lie approximately in spatial register with each other, and with saccade-related motor maps. When the eyes are not centered in the orbits, however, a map organized in body or head-centered coordinates will provide an inappropriate input to the oculomotor system, which requires that target position be specified in ►[motor coordinates](#) (i.e. the change in eye position required to look to the target). Consistent with this view, the spatial alignment of sensory maps in superior colliculus appears to shift with changes in the orientation of the eyes, head, and body.

### Characteristics

#### Higher Order Structures

The superior colliculus is a layered structure in the midbrain, consisting of three cellular layers, alternating

with four fibrous layers. Layer II contains the cell bodies of visual neurons, arranged in a topographic map of the contralateral visual hemifield. Multimodal sensory and motor signals are found in the intermediate and deep layers.

### Parts of This Structure

Topographic maps have been identified in the superior colliculus for several sensory modalities. Visual, somatosensory, and auditory maps lie approximately in register when the eyes are centered in the orbits.

### Functions of This Structure

#### Sensory Maps and Map Alignment

The ease with which we can reach out and grab our morning cup of coffee belies the complexity of the neural processing required to compute the location of the coffee cup in space. Cells in a specific region of the retina will be activated by light reflected from the cup, but there is not a one-to-one correspondence between which region of the retina is activated and the location of the cup in space. The positions of the eyes in the orbits, the position of the head, and the position of the body all affect the region of retinal activation. Thus, the location of a visual target cannot be computed using only signals that reach the brain through the optic nerve: localization requires that visual signals be combined with information about eye, head, and body positions. Localization of somatosensory and auditory stimuli also requires complex neural computations.

The superior colliculus (SC) provides an excellent model system for studying the neural processing involved in spatially-directed action. Signals from several sensory modalities converge in the deeper layers of SC, a region that also contains cells generating commands for orienting movements of the eyes, head, and pinnae. In mammals, many neurons residing in the deep division of SC are responsive to auditory, somatosensory and/or visual stimuli. Each sensory cell has a spatial receptive field and the sensory cells are organized according to the location of their receptive fields, thereby forming topographical sensory maps.

Visually responsive cells are activated by stimuli appearing in the contralateral visual field. Neurons with receptive fields in the upper visual field are located medially; those with receptive fields in the lower visual field are found laterally. Cells with receptive fields near the center of the visual field reside anteriorly; those responsive to peripheral stimuli are located posteriorly (Fig. 1). Tactile receptive fields are also organized topographically in the SC [1,2]. In each colliculus, representation of the contralateral forelimb and head is extensive, whereas only a small part of the colliculus is allocated to representation of the large cutaneous surface area of the trunk and hindlimb. The acoustic receptive fields of collicular neurons are large, but each



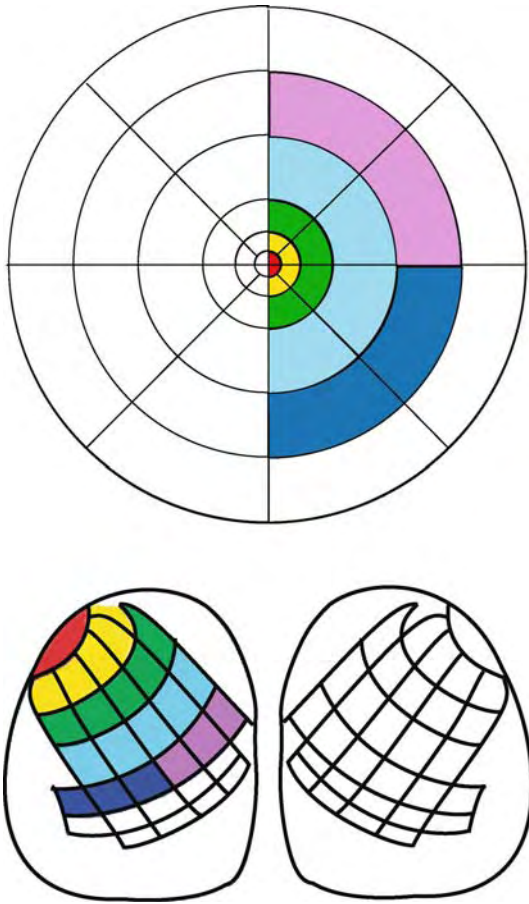

**SC – Sensory Maps. Figure 1** Top: color coded diagram of visual space. Bottom: schematic diagram of superior colliculus, showing the representation of the contralateral visual hemifield. Colors on the SC map correspond to the colors in the top panel. The area of visual space near the fovea is represented near the rostral end of superior colliculus; peripheral locations are represented caudally. Note that the area of visual space near the fovea is represented by a disproportionately large area of the SC map.

cell has a “best area,” defined as the range of stimulus locations which elicit responses greater than 75% of maximum. The best areas of cells vary systematically with cell location, forming a map of auditory space in the SC [3].

Thus, cells responsive to each modality are organized in an anatomical map and in anesthetized or paralyzed preparations; the visual, somatosensory, and auditory maps appear to be aligned. For example, in the paralyzed cat, collicular neurons responding to both auditory and visual stimuli have visual and auditory receptive fields that overlap spatially. For cells responding to auditory but not to visual stimuli, the location of the auditory receptive field is correlated with the spatial location of the receptive fields of

nearby visually responsive neurons. Observations such as these led to the assumption that the SC contains a general, modality independent map of the external environment. In such a map, stimuli originating from a particular region of the external world (regardless of sensory modality) would activate a particular subset of multimodal neurons (neurons that respond to visual, auditory, or tactile stimuli). The activation of these sensory neurons, in turn, could initiate ▶orienting responses by exciting adjacent cells with movement-related activity organized in a motor map aligned with the multimodal map of sensory space.

But what happens to the alignment of the visual and somatosensory maps in the unanesthetized, freely moving animal when the direction of ▶gaze and the position of the limbs in space do not maintain a fixed relationship, or to the alignment of the visual and auditory maps when the positions of the eyes change, with respect to the head? Jay and Sparks [4] noted that collicular neurons with saccade-related activity are organized topographically and it is the location of active neurons within the topographical map of movement fields that specifies the change in eye position required to direct gaze to the target location. They reasoned that the task of sensory systems is to specify the change in eye position required to look to a target, not merely the location of the target in head, body or ▶retinal coordinates. Consider, for example, a monkey with the head positioned “straight ahead” but with gaze directed  $24^\circ$  to the left of center. When an auditory stimulus is presented  $10^\circ$  to the right of center, interaural cues are used to localize the acoustic target in ▶head coordinates (“target is  $10^\circ$  right”). However, since the eyes are directed  $24^\circ$  left of center, a  $34^\circ$  rightward saccade is required to look to the target, and neurons in caudal regions of the left SC must be activated to produce this movement. If an auditory target is presented in the same location on another occasion with gaze directed  $24^\circ$  to the right of center, cells in the right SC must be activated to produce the  $14^\circ$  leftward saccade required to look to stimulus. Based upon these observations, they hypothesized that the maps of sensory space observed in the deeper layers of the SC were not static, and that the activity of the cells are encoded in motor, rather than sensory, coordinates.

To test this hypothesis, Jay and Sparks [4] plotted the receptive fields of neurons responsive to auditory and visual stimuli while the eye position of trained, alert monkeys was systematically varied. If auditory signals are organized in head coordinates, then in these experiments in which the head is fixed, the discharge of acoustically responsive neurons should be independent of initial fixation position and depend entirely upon the azimuth and elevation of the sound source. However, if auditory signals have been translated into motor coordinates, then the response of collicular

neurons to acoustic stimuli should be sensitive to both the position of the speaker in space and the position of the eyes in the orbits. They found that the auditory receptive fields shifted with changes in eye position and that, in the monkey, the map of auditory space in the deeper layers of the SC is not static. With each change in eye position, the site of neural activity induced by a fixed auditory stimulus shifts to a new location – a location that specifies the metrics of the movement that would direct gaze to the target location. A similar effect of eye position on the responses of collicular neurons to acoustic [5–7] and somatosensory [8] stimuli has been observed by other researchers.

### Multimodal Interactions

Many cells in the intermediate layers of SC respond to sensory stimuli of more than one modality. In anesthetized animals, dramatic enhancement and inhibitory effects on the responses of multimodal cells have been reported to occur when combinations of visual, somatic and auditory stimuli are presented to cat [2]. These interaction effects depend upon the spatial and temporal overlap of the multimodal stimuli. Enhancement usually occurs if each stimulus is in the center of its receptive field and if the two stimuli are temporally contiguous. Response depression occurs most commonly when one of the two stimuli is outside or on the fringe of the cell's receptive field, or if there is a large temporal disparity in the onset of the two stimuli [9]. A reasonable hypothesis is that ►multimodal enhancement, assumed to occur when two stimuli from the same region in external space appear simultaneously, facilitates orienting movements to that part of the environment. The physiological studies describing bimodal enhancement were performed in anesthetized animals. Populin and Yin [7] tested for bimodal enhancement in the superior colliculus of behaving cats trained to orient to acoustic, visual, and bimodal stimuli. They failed to observe the large enhanced responses reported in anesthetized animals, even when the time between presentation of the visual and acoustic stimuli was varied systematically and/or the relative intensity of the two stimuli was varied. They did, however, observe prominent depressive effects when the cats were required to fixate a visual target during presentation of an acoustic stimulus. Much remains to be learned about the role of multimodal cells in SC in the initiation and guidance of orienting movements of the eyes, head, and external ears.

### Higher Order Function

Although most neuroscientists studying sensory processing view the problem from the perspective of perception, perception is not the only end point of sensory processing. Movements are often initiated by and guided by sensory signals. Studies of the sensory

maps in SC have been influenced by the realization that the format of the motor command imposes constraints on the types of sensory processing that must occur. In the case of orienting movements of the eyes, the motor map in the SC is organized in relative coordinates – the signals specify the change in eye position required to look to a target. Thus, input signals that initiate a movement must also specify the location of the target with respect to the current gaze position, not the location of the target in body or head coordinates. According to this view, the sensory maps are dynamic and the receptive fields of collicular neurons shift with relative movements of the eyes, head, and body. A dynamic mapping of sensory space is required because of constraints imposed by the organization of the motor map. It seems likely that other motor systems will require specialized sensory processing to transform sensory signals into the format of the motor commands.

### Quantitative Measure for This Structure

Approximately 50% of neurons in the intermediate layers of SC are multisensory. Visual responses in superior colliculus occur at latencies of approximately 70 ms, and auditory responses occur at latencies of 20 ms or less [7]. In anesthetized cats, bimodal enhancement can exceed 300%; bimodal suppression can be nearly a complete suppression (99%) [2]. However, in the awake animal, Populin and Yin [7] reported that the responses to bimodal stimuli approximated, but generally did not exceed, the sum of the responses to the two single modality stimuli.

### References

1. Drager UC, Hubel DH (1975) Responses to visual stimulation and relationship between visual, auditory and somatosensory inputs in mouse superior colliculus. *J Neurophysiol* 38:690–713
2. Meredith MA, Stein BE (1986) Visual, auditory, and somatosensory convergence of cells in superior colliculus results in multisensory integration. *J Neurophysiol* 56:640–662
3. Middlebrooks JC, Knudsen EI (1984) A neural code for auditory space in the cat's superior colliculus. *J Neurosci* 4:2621–2634
4. Jay MF, Sparks DL (1987) Sensorimotor integration in the primate superior colliculus. II. Coordinates of auditory signals. *J Neurophysiol* 57:35–55
5. Hartline PH, Vilmal RL, King AJ, Kurylo DD, Northmore DP (1995) Effects of eye position on auditory localization and neural representation of space in superior colliculus of cats. *Exp Brain Res* 104:402–408
6. Peck CK, Baro JA, Warder SM (1995) Effects of eye position on saccadic eye movements and on the neuronal responses to auditory and visual stimuli in cat superior colliculus. *Exp Brain Res* 103:227–242
7. Populin LC, Yin TCT (2002) Bimodal interactions in the superior colliculus of the behaving cat. *J Neurosci* 22:2826–2834

8. Groh JM, Sparks DL (1996) Saccades to somatosensory targets. III. Eye-dependent somatosensory activity in primate superior colliculus. *J Neurophysiol* 75:439–453
9. Meredith MA, Stein BE (1986) Spatial factors determine the activity of multisensory neurons in cat superior colliculus. *Brain Res* 365:350–354
10. Populin LC, Tollin DJ, Yin TC (2004) Effect of eye position on saccades and neuronal responses to acoustic stimuli in the superior colliculus of the behaving cat. *J Neurophysiol* (in press)

## SC – Tectal Long-Lead Burst Neurons

ADONIS MOSCHOVAKIS

Institute of Applied and Computational Mathematics, F.O.R.T.H., and Department of Basic Sciences, University of Crete, Heraklion, Crete, Greece

### Synonyms

TLLBs

### Definition

The best studied saccade related efferent cells of the primate SC. They emit high frequency bursts for all saccades in their ►movement field (of saccade related neurons), including spontaneous ones. Their medium size somata occupy fairly superficial locations in the deeper layers of the SC, and give rise to vertically oriented dendritic fields of average complexity. Finally, their rather delicate axons deploy recurrent collaterals and participate in several tectofugal fiber bundles reaching a multitude of brainstem oculomotor related nuclei. Due to their pattern of discharge, TLLBs can be thought to correspond to the saccade related burst neurons (SRBNs), a subclass of SC movement cells described in detail by Sparks and his colleagues [1]. Also, due to their rather short lasting bursts, TLLBs cannot correspond to the ►SRBN type II neurons also first described by Sparks and his colleagues [2] and more recently by Wurtz and his colleagues [3] (the build-up neurons of these authors). The same is true for visually triggered movement cells, and ►fixation neurons.

### Characteristics

#### Higher Order Structure

The TLLBs are crucial components of the metric computer in the superior colliculus, the output of which they convey to the burst generators.

#### Parts of this Structure

The morphological features of TLLBs were elucidated after recording their discharges intraaxonally in alert

behaving monkeys and then injecting them with HRP [4]. A typical example is illustrated in Fig. 1. The shape and small or medium size of TLLB somata allows their assignment to the T class of tectal efferent neurons. This identification is consistent with their fairly superficial location in the SC, namely in the ventral stratum opticum and the dorsal stratum griseum intermediale. Further, it is consistent with the moderate complexity of their dendritic trees, which are oriented normally to the surface of the SC. Finally, it is consistent with the fact that their axons are rather thin (2.5–3.5 mm) and give rise to recurrent (Fig. 1, arrowhead) and commissural (Fig. 1, arrow) fibers. The axonal system of TLLBs participates in several efferent systems of the SC. As shown in Fig. 1, their main axon travels along the borders of the periaqueductal gray and crosses to the

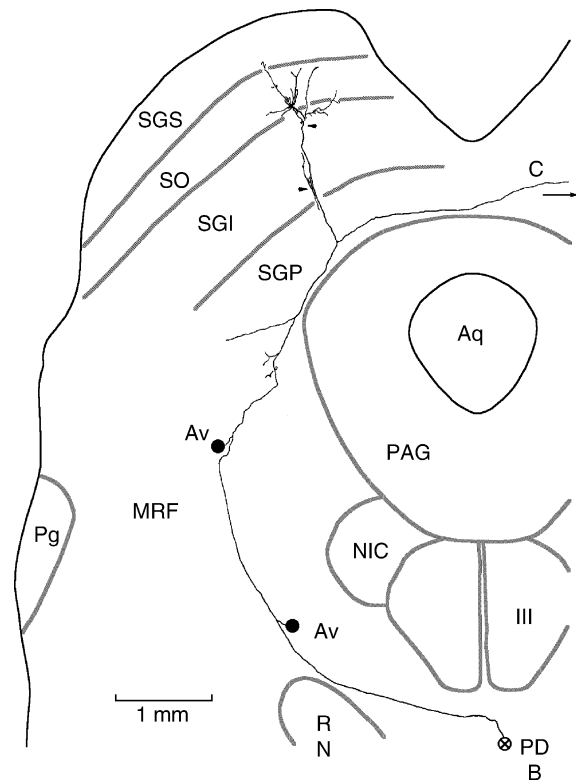

### SC – Tectal Long-Lead Burst Neurons.

**Figure 1** Camera lucida reconstruction of the somatodendritic and proximal axonal system of a TLLB (modified from [4], with permission). Arrowheads point to recurrent collaterals. Abbreviations: *III*, oculomotor nucleus; *Aq*, aqueduct of Sylvius; *Av*, ventral ascending fiber; *C*, commissural fiber; *MRF*, mesencephalic reticular formation; *NIC*, interstitial nucleus of Cajal; *PAG*, periaqueductal grey; *PDB*, predorsal bundle; *Pg*, parabigeminal nucleus; *RN*, red nucleus; *SGL*, stratum griseum intermediale; *SGP*, stratum griseum profundum; *SGS*, stratum griseum superficiale; *SO*, stratum opticum.

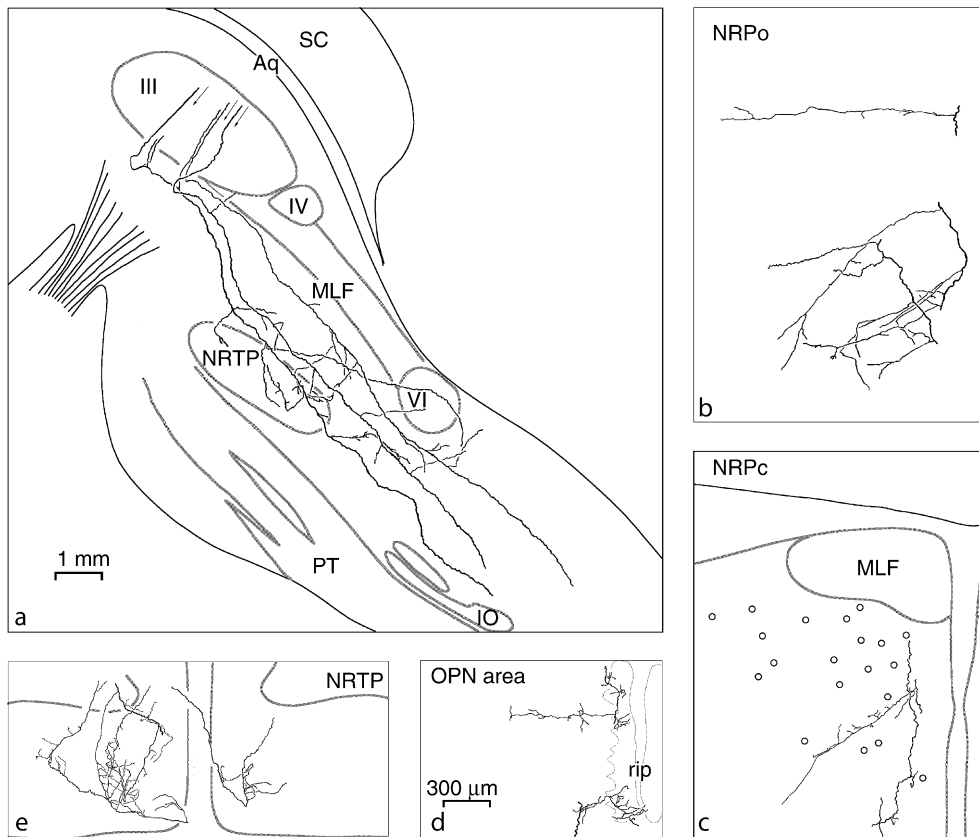

**SC – Tectal Long-Lead Burst Neurons. Figure 2** Distal pattern of axonal trajectory and projections of TLLBs (reproduced from [5], with permission). (a) Composite camera lucida reconstruction of the axonal system of three TLLBs in the sagittal plane. (b–e) Composite camera lucida reconstruction of the axonal system of two TLLBs in the frontal plane. Calibration bar in (d) applies to (b–e). Open circles in (c) indicate the location of functionally identified EBNs that were intracellularly injected with HRP by Strassman et al. [6]. Abbreviations: *IV*, trochlear nucleus; *VI*, abducens nucleus; *IO*, inferior olive; *MLF*, medial longitudinal fasciculus; *NRTP*, nucleus reticularis tegmenti pontis; *PT*, pyramidal tract; *rip*, nucleus raphe interpositus. Other abbreviations as in Fig. 1.

opposite side in the dorsal tegmental decussation of Meynert. Before crossing, it emits one or two major branches that follow the ventral ascending (Av) tectofugal fiber bundle on its way toward the riMLF. It also emits several thin collaterals which deploy terminal fields in the mesencephalic reticular formation. Fig. 2 illustrates the distal trajectory and patterns of termination of PDB branches of single identified TLLBs [5]. Their distal targets include the nucleus reticularis tegmenti pontis (NRTP), the nuclei reticularis pontis oralis (NRPo) and caudalis (NRPc), the nucleus paragigantocellularis dorsalis, and the nucleus raphe interpositus (rip).

### Functions of the Structure

TLLBs emit high frequency bursts for contraversive spontaneous saccades of the appropriate metrics (Fig. 3a). As the latency of their bursts is in the long lead range (21–46 ms on the average), such SC cells are called tectal long lead burst neurons (in short TLLBs). Saccades

preceded by TLLB discharges collectively define the cell's movement field; in the case of the neuron illustrated in Fig. 1, it encompasses small (about  $3^\circ$ ) right-up saccades (Fig. 3b). It is via their movement fields that TLLBs can encode the vector (amplitude and direction) of desired saccade displacement. As expected of cells causally relevant for saccades, TLLBs are generally silent both between saccades and for saccades outside their movement field (Fig. 1a). Nevertheless, the relationship between cell discharge and the execution of saccades is not as obligate as originally thought. For example, cell discharge does not reflect the actual displacement of the eyes during saccades that have been adapted, are executed toward remembered targets, or participate in gaze shifts accomplished through a combination of eye and head movements. In all these cases, TLLB discharge is better related to the distance between target and fovea (i.e. the metrics of saccades that would have foveated the target had they been executed) rather than to the metrics of the saccades that are in fact executed.

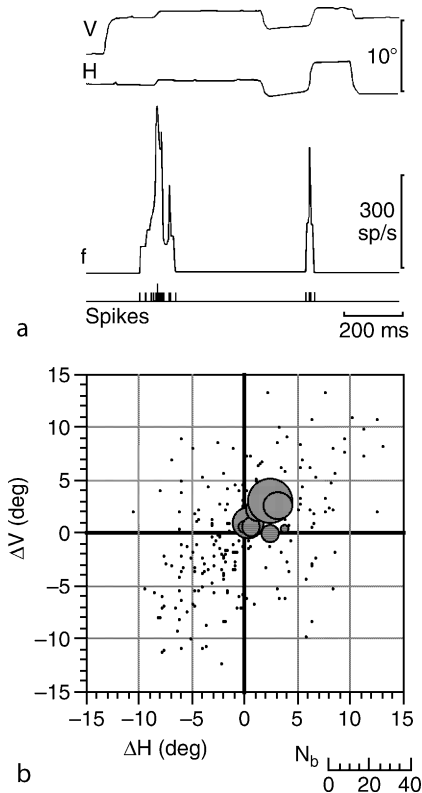

### SC – Tectal Long-Lead Burst Neurons.

**Figure 3** Salient physiological features of TLLBs (modified from [4], with permission). (a) Neuronal discharge pattern in relation to saccades. (b) Bubble diagram of the neuron's movement field. Circles are centered over the end points of saccades (in retinotopic coordinates) and their diameter is proportional to the number of spikes in the accompanying burst ( $N_b$ ). Dots indicate saccades not accompanied by spikes. Abbreviations:  $f$ , instantaneous firing rate;  $H$ ,  $V$ , instantaneous horizontal (H) and vertical (V) eye position.

The highly distributed axonal system of TLLBs is eminently suitable for conveying a saccade related command to targets of the SC. Firstly, the terminal fields they deploy in the central mesencephalic reticular formation occupy a region housing the somata of ►reticulo-tectal long-lead burst (RTLLB). Moreover, the nuclei targeted by Av and PDB fibers contain most of the premotoneuronal interneurons that comprise the burst generators: the Av branch supplies an area that houses ►vertical medium lead burst neurons (VMLBs), while the PDB branch supplies an area that houses ►horizontal ones (HMLBs). In this manner, each TLLB can simultaneously influence both the vertical and the horizontal burst generators. Also, the commissural collaterals of TLLBs could couple the two colliculi in a push-pull fashion so that saccades in opposite on-directions are not programmed simultaneously. This is

consistent with the observation that cells of the feline SC, which burst before saccades in one direction, are inhibited during saccades in the opposite direction [7]. Finally, as discussed in the entry ►SC – sensorimotor integration, the plexus of recurrent connections deployed by TLLBs could ensure the reciprocal excitation of neighboring TLLBs and give rise to their intense bursts.

### Higher Order Function

As different TLLBs encode different saccade vectors, the SC can be thought to implement a labeled line code. Moreover, TLLBs are topographically organized over the mediolateral and rostrocaudal extent of the SC, such that cells preferring small saccades are located in the rostral SC, while cells that prefer big saccades are located more caudally. Also, cells that discharge before upward saccades are located medially in the SC, whereas cells that discharge before downward saccades are located laterally [4]. It is for this reason that the SC is said to also use a place code to specify movement parameters. Adoption of a code generally preferred by sensory systems (the “place” code), provides an elegant biological solution to the problem of how to interface the front end of the saccadic system (the motor SC) with systems carrying sensory information about outside world events.

### Quantitative Measure for this Structure

The appearance of the class of primate collicular efferent neurons (T neurons) to which TLLBs belong has been the object of detailed quantitative analysis [8]. Besides providing information about the range of values obtained by several morphological features (e.g. 3-D orientation of their dendritic tree, complexity of its branching pattern, etc.), this analysis allowed the formulation of canonical discriminant functions that can objectively discriminate T neurons from other classes of collicular efferent cells. Moreover, there is some quantitative information regarding the differential strength of descending projections of intraaxonally labeled TLLBs to several of their target nuclei [5]. Due to the important role it could play in the generation of TLLB bursts, the spatial distribution of the boutons they deploy inside the SC has also attracted quantitative attention. Figure 4a illustrates the spatial distribution of the recurrent terminal field of one TLLB that was intraaxonally injected with HRP following its functional identification in an alert behaving squirrel monkey [9]. As shown here, TLLB recurrent projections (plotted in the inset of  $w_{(TLLBi \rightarrow TLLBj)}$  versus  $i-j$ ; Fig. 4b) cover a considerable proportion of the ipsilateral SC, and are spatially distributed in a bi-lobe fashion centered around the cell body they originate from. Such information has been used to generate a computational model of the SC, (schematically illustrated in Fig. 4b) that accounts for several counterintuitive results [9]. Firstly, it accounts

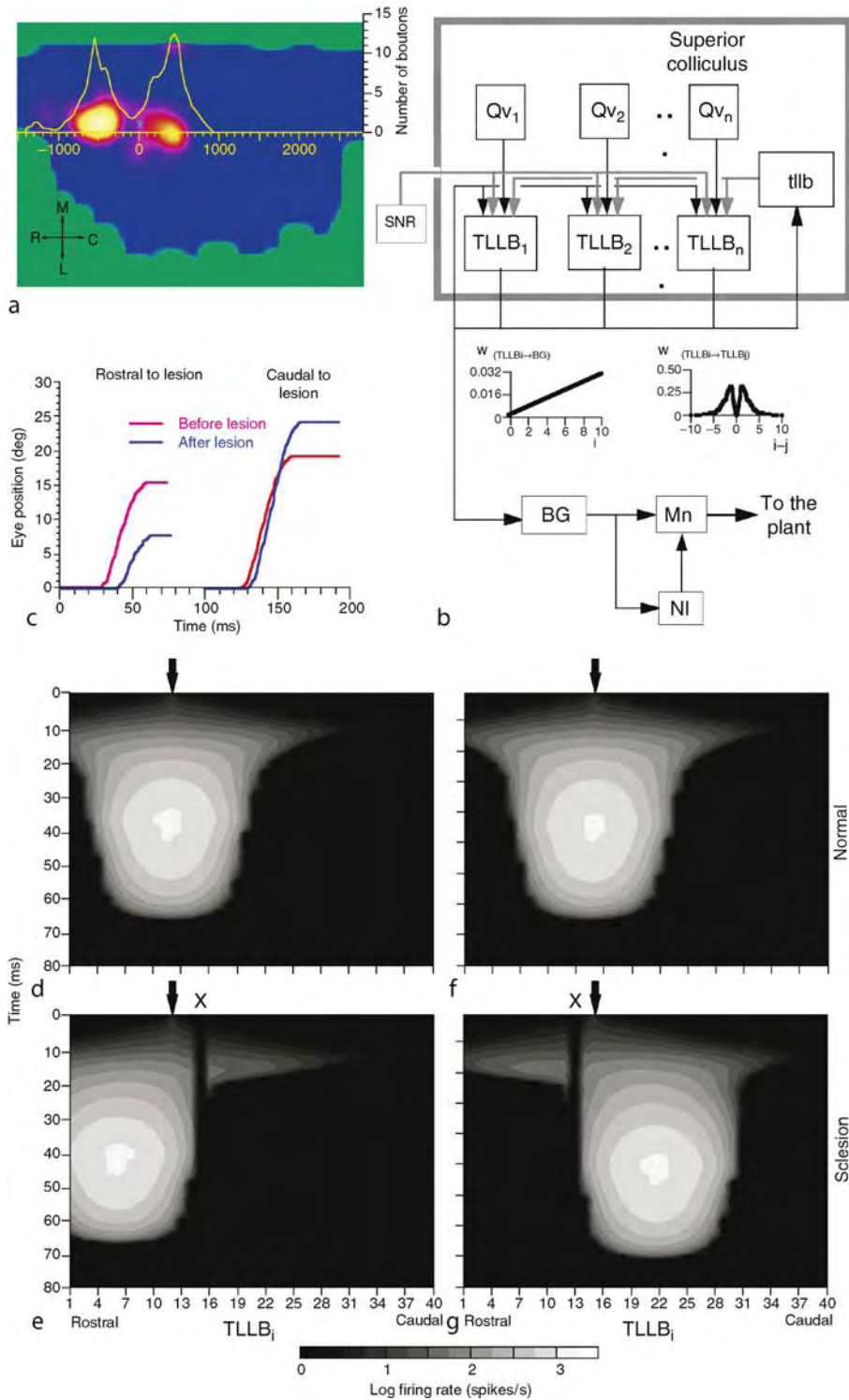

**SC – Tectal Long-Lead Burst Neurons. Figure 4** (a) Horizontal spatial distribution of terminals deployed in the deeper layers of the primate SC by a single functionally identified TLLB that was intraaxonally injected with HRP (reproduced from [9], with permission). Colors range from dark to light in proportion to the small or large number of boutons deployed in the corresponding point of the horizontal map of the SC. The yellow line is a plot of the number of boutons (*ordinate*) within 80  $\mu\text{m}$  of a plane through the soma and normal to the SC surface as a function of the rostrocaudal distance from the soma (*abscissa*). (b) Model of distributed population coding of saccade metrics in the motor layers of the SC (modified from [9], with permission). Solid lines indicate excitatory connections.

for the fact that simultaneous electrical stimulation of two collicular sites generates saccades equal to the average of the saccades that are generated when the two sites are stimulated separately, rather than to their sum. Further, it provides an intuitive understanding of why this is so, in that the spatial distribution of its engaged TLLB units shifts to a site intermediate between those activated when the two sites are stimulated separately. It also accounts for the fact that saccades can be hypermetric as well as hypometric after lesions of the superior colliculus (Fig. 4c), and demonstrates that the spatiotemporal profile of TLLB activation shifts in the requisite manner depending on the relative location of the stimulus and lesion sites (Fig. 4d–g). Finally, it accounts for the generation of staircases of saccades in response to long trains of constant stimulation, thus implying that the superior colliculus contains a biological oscillator. Evidence consistent with the involvement of a recurrent network of mutually excited TLLBs in burst generation is considered in the entry SC – sensorimotor integration. The same entry also includes a description of quantitative estimates of the spatial distribution of *boutons* deployed by efferent neurons of the SC in regions housing the burst generators and their implications for the “spatio-temporal transformation.”

## References

1. Sparks DL (1978) Functional properties of neurons in the monkey superior colliculus: coupling of neuronal activity and saccade onset. *Brain Res* 156:1
2. Sparks DL, Holland R, Guthrie BL (1976) Size and distribution of movement fields in the monkey superior colliculus. *Brain Res* 113:21
3. Munoz DP, Wurtz RH (1995) Saccade-related activity in monkey superior colliculus. I. Characteristics of burst and buildup cells. *J Neurophysiol* 73:2313
4. Moschovakis AK, Karabelas AB, Highstein SM (1988) Structure-function relationships in the primate superior colliculus. II. Morphological identity of presaccadic neurons. *J Neurophysiol* 60:263
5. Scudder CA, Moschovakis AK, Karabelas AB, Highstein SM (1996) Anatomy and physiology of saccadic long-lead burst neurons recorded in the alert squirrel monkey. I. Descending projections from the mesencephalon. *J Neurophysiol* 76:332
6. Strassman A, Highstein SM, McCrea RA (1986) Anatomy and physiology of saccadic burst neurons in the alert squirrel monkey. I. Excitatory burst neurons. *J Comp Neurol* 249:337
7. Infante C, Leiva J (1986) Simultaneous unitary neuronal activity in both superior colliculi and its relation to eye movements in the cat. *Brain Res* 381:390
8. Moschovakis AK, Karabelas AB, Highstein SM (1988) Structure-function relationships in the primate superior colliculus. I. Morphological classification of efferent neurons. *J Neurophysiol* 60:232
9. Boziz A, Moschovakis AK (1998) Neural network simulations of the primate oculomotor system. III. A one-dimensional one-directional model of the superior colliculus. *Biol Cybern* 79:215

## SC – Tectoreticulospinal Neurons

ALEXEJ GRANTYN

Laboratoire de Physiologie de la Perception et de l'Action (LPPA), CNRS – Collège de France, Paris, France

### Synonyms

X neurons, TRSNs

### Definition

“Tectoreticulospinal neurons (TRSNs)” are large or medium-size superior colliculus (SC) ►[projection neurons](#). Their long axons cross the midline in the dorsal tegmental decussation, descend in the ►[pre-dorsal bundle](#) (►[tectobulbospinal tract](#)) and make extensive connections with the midbrain, pontobulbar ►[tegmentum](#) (Midbrain, Pontobulbar) and the spinal cord by virtue of multiple axon collaterals. TRSNs are a subset of a larger class of the SC projection neurons, called “X neurons” [1] (Figs. 1 and 2).

### Characteristics

#### Higher Order Structures

##### The Superior Colliculus: An Overview

Cell bodies (somata) of TRSNs are located in the deep division of the SC, a laminated structure (Fig. 1)

All other connections are inhibitory. Numbers indicate connection strengths. Insets indicate spatially varying connection strengths ( $w$ ), plotted as a function of the location of source ( $i$ ), or the target ( $j$ ) neurons within their respective arrays, or in terms of the distance between them ( $i-j$ ). (c) Two examples of saccades produced before (blue) and after (red) simulated focal TLLB “lesion” experiments in response to activation of the same Qv unit. (d–g) Gray scale contour plot of the spatio-temporal profile of all TLLB units employed in the model as a function of their index (*abscissa*) and time (*ordinate*) for saccades evoked from a normal (d and f) or a “focally lesioned” (e and g) SC. Small index numbers correspond to rostral SC sites and big index numbers correspond to caudal SC sites. The gray scale is proportional to the Logarithm of the TLLB activation function. In (d) and (e), the stimulation point (*arrowheads*) is rostral to the lesion (x), while in (f) and (g), the stimulation point is caudal to the lesion. Abbreviations: BG, burst generator; C, caudal; L, lateral; M, medial; Mn, motoneuron; NI, neural integrator; R, rostral; SNR, neuron of the substantia nigra pars reticulata that pauses for saccades; Qv, quasivisual neuron; TLLB and *tlb*, excitatory and inhibitory tectal long-lead burst neurons.

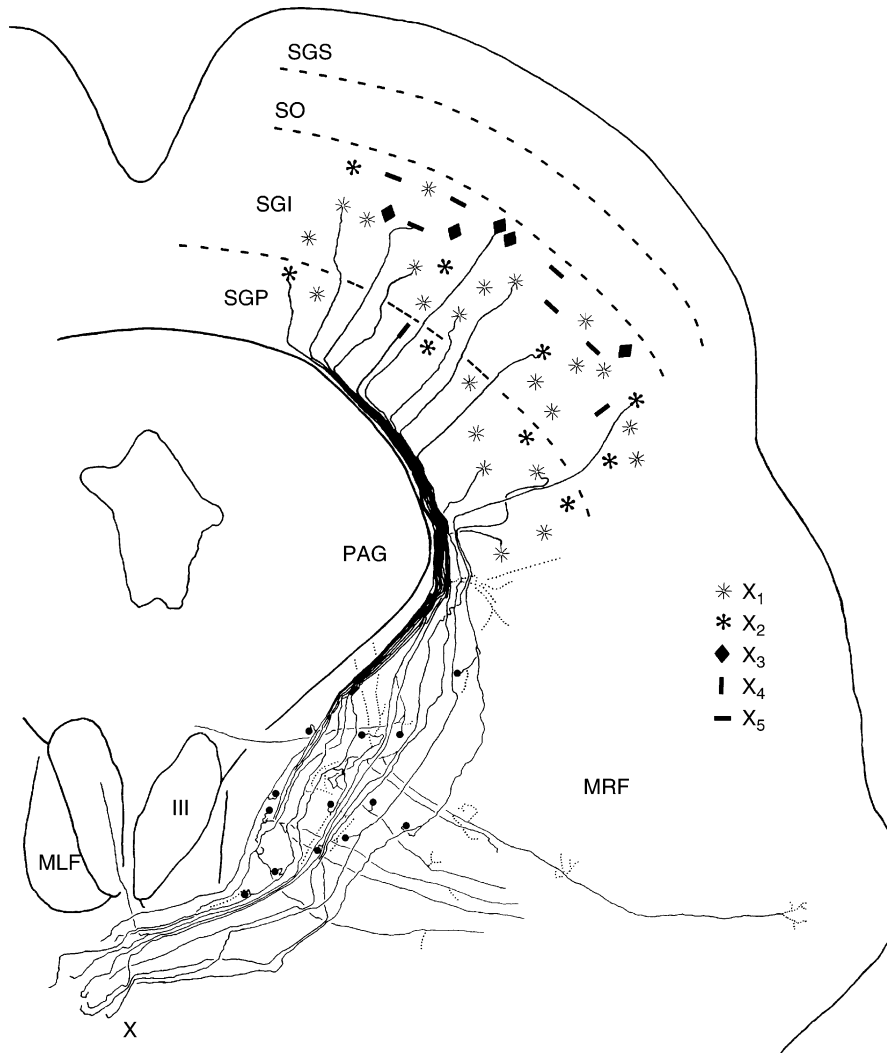

**SC – Tectoreticulospinal Neurons. Figure 1** Tracing of a representative coronal section through the midbrain to show the location of the superior colliculus, its principal layers, and the distribution of different subclasses of X neurons ( $X_1 - X_5$ , as indicated by symbols in the *inset*). Also shown are the initial axon trajectories till the decussation and proximal axon collaterals supplying the central mesencephalic reticular formation. (from [1], with permission of the Authors and Wiley & Sons, Inc.). Abbreviations: *MLF*, medial longitudinal fasciculus; *MRF*, mesencephalic reticular formation; *PAG*, periaqueductal gray substance; *SGS*, superficial gray layer; *SO*, optic layer; *SGI*, intermediate gray layer; *SGP*, deep gray layer; *X*, dorsal tegmental decussation; *III*, oculomotor nucleus. The fiber rich intermediate white layer in the lower SGI and the deep white layer in the lowermost SGP are not labeled. The latter can be recognized as the site of collection of outgoing X neuron axons on their course along the border of the periaqueductal gray.

occupying the anterior portion of the roof of the midbrain, the tectum. Its superficial layers (SGS, SO, Fig. 1) receive a direct pathway from the retina and contain a topographic map of the contralateral visual hemifield. The deeper SC is subdivided in the intermediate and deep layers (SGI, SGP, Fig. 1), which differ in their cell composition and afferent connections. Common to them is the convergence of afferent pathways from a great number of sources, including both higher order structures, such as the cerebral cortex and basal ganglia, and

ascending sensory pathways. Besides their well established role in the ►visuomotor transformation, the deeper layers are thus also the site of ►multisensory (convergence, integration). Besides neurons with local connections inside the SC, all layers contain projection neurons which form several pathways with different trajectories and different combinations of target regions. TRSNs are one of the classes of projection neurons. They send their axons in the predorsal bundle and establish the most extensive extrinsic connections.



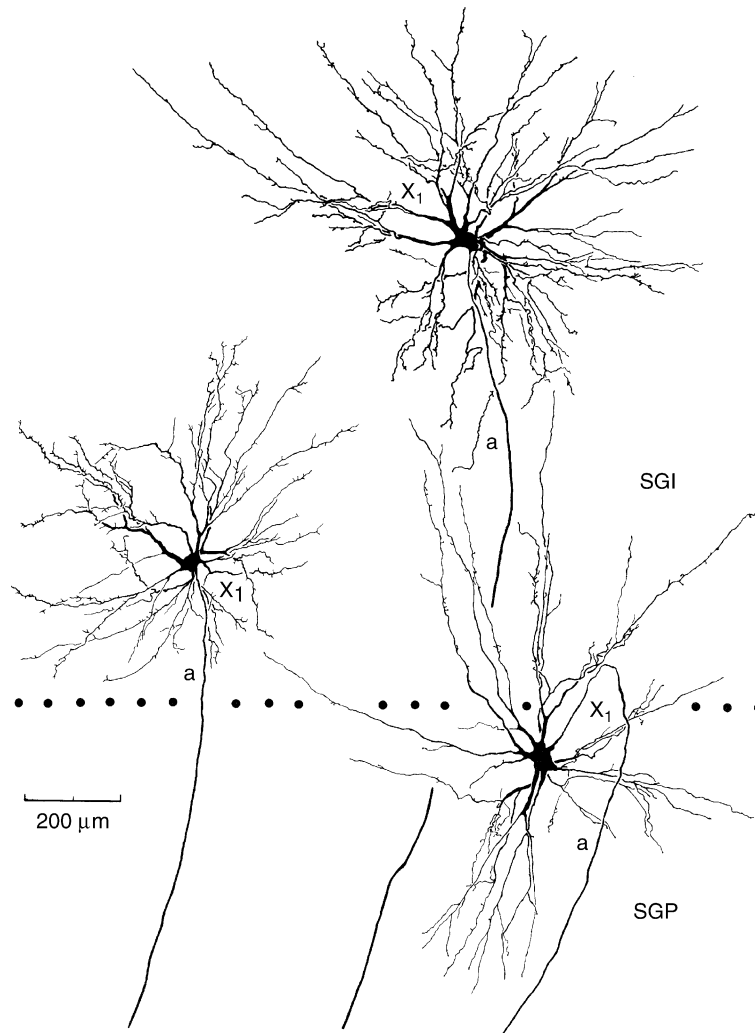

**SC – Tectoreticulospinal Neurons. Figure 2** Reconstruction of somatodendritic profiles of HRP-labeled  $X_1$  neurons. These exemplary neurons illustrate common features of  $X_1$  subclass (large dendritic extension, central position of the cell body with respect to radially oriented dendrites, approximately symmetrical dendritic field). Also the range of variation of soma size and dendritic extension can be readily recognized. See Table 1 for a summary of morphometric data. (from [1], with permission of the Authors and Wiley & Sons, Inc.).

### Morphology of TRSNs

#### Laminar Location

A majority (66% [2] to 73% [1]) of TRSN cell bodies are located in the intermediate gray layer of the SC (SGI), the remaining ones being found in the deeper layers (Fig. 1). They are distributed over the entire rostrocaudal and mediolateral extent of the SC, but their density is somewhat higher in the caudolateral quadrant. The complete ▶motor map of the SC can therefore gain access to the downstream areas contacted by TRSN axons, with some bias in favor of the representation of the lower half of the visual field.

#### Size and Dendritic Pattern

$X$  neurons (see Definition “Tectoreticulospinal Neurons (TRSNs)”) intracellularly labeled with ▶horseradish

peroxidase (HRP) have been subdivided in five subclasses ( $X_1$ – $X_5$ ), based on the size of cell bodies and the shape and orientation of the dendritic trees [1]. Some morphometric data underlying the classification are summarized in Table 1 (see ▶Quantitative measures). The first three subclasses ( $X_1$ – $X_3$ ) comprise medium-size and large cells, and correspond best to TRSNs identified by their crossed projection to the lower brainstem and to the spinal cord, and by their firing patterns during ▶orienting movements [2,3]. Smaller neurons ( $X_4$ ,  $X_5$ ) with vertically or horizontally oriented dendritic trees are unlikely to be present in the TRSN population. Judging from their spherical dendritic fields, a great majority of TRSNs belong to the  $X_1$  subclass (Fig. 2), characterized as “large multipolar wide field neurons” in preceding studies with

Golgi method in the cat. Typically, they have 5–10 stem dendrites arranged radially and occupying an approximately spherical space of considerable size (800–1,400  $\mu\text{m}$ ) (Table 1). Distal portions of dendrites often cross the borders of collicular layers, which explains the capacity of TRSNs to sample and integrate ascending, descending and interlaminar inputs to the deeper layers of the SC.

### Parts of this Structure

#### Main Axons, Axon Collaterals and Termination

Morphometric data on TRSN fiber system are summarized in Table 2 (see ►Quantitative measures). To-date, only a qualitative description of target areas is available for midbrain portions of TRSN axons [1,2]. In the pontobulbar tegmentum, the anatomical strength of connections could be evaluated for a few orienting-related TRSNs [3]. These data are collected in Table 3.

### Midbrain

Axons of TRSNs, at their exit from the SC, range 3–8  $\mu\text{m}$  in diameter but more than 90% are thicker than 4  $\mu\text{m}$ . They course along the border of the periaqueductal gray substance (PAG) (Fig. 1), cross the midline and join the contralateral predorsal bundle (PDB). Before crossing, all TRSNs emit a long “main ascending collateral” that goes rostrally and reaches the field of Forel (FF) and the rostral interstitial nucleus of the medial longitudinal fasciculus (riMLF). TRSNs have no recurrent collaterals terminating in the SC but they do issue several ipsilateral collaterals which supply with terminals the central mesencephalic reticular formation (cMRF) (Fig. 1). Other tegmental regions are “facultative” targets of TRSNs, supplied by some but not all TRSNs. The supraoculomotor region of the PAG receives projection from about one third of TRSNs, whereas collaterals terminating in the interstitial

**SC – Tectoreticulospinal Neurons. Table 1** Morphometric data of TRSN cell bodies and dendrites

	TRSN	X <sub>1</sub>	X <sub>2</sub>	X <sub>3</sub>	X <sub>4</sub>	X <sub>5</sub>
As	1,060–2,075	1,025–2,315	1,400–2,880	1,310–2,850	745–1,250	700–1,200
N-dd	7–10	5–7	4–7	5–7	4–6	5
D-dd	9–16	3–23	6–22	4–23	4–14	3.5–15
dd-shape	Spherical	Spherical	Vertical	Vertical	Vertical	Horizontal
Ext-dd M-L	800–1,400	640–1,200	750–1,000	500–800	400–500	1,000–1,250
Ext-dd A-P	<i>idem</i>	540–1,100	700–1,000	560–900	300–500	500–700
Ext-dd D-V	<i>idem</i>	630–1,400	820–1,300	1,150–1,400	1,100–1,500	600–750

As, soma surface area ( $\mu\text{m}^2$ ); N-dd, number of dendritic trunks; D-dd, diameter of dendritic trunks ( $\mu\text{m}$ ); dd-shape, shape and orientation bias of the dendritic field; Ext-dd, maximal extension of the dendritic field ( $\mu\text{m}$ ) in mediolateral (M-L), anteroposterior (A-P) and dorsoventral (D-V) cardinal directions of the stereotaxic coordinate system.

**SC – Tectoreticulospinal Neurons. Table 2** Morphometric data on TRSN axons and collaterals

	Midbrain	Pons-Medulla
Diametres of axons and collaterals ( $\mu\text{m}$ )		
Main axon (X1 neurons)	4.5–7.5 <sup>a</sup>	7.0–10.0 <sup>a</sup>
Main axon (visuomotor TRSNs)	–	4.6–9.3 <sup>b</sup>
Main ascending collaterals	1.0–3.5 <sup>a</sup>	<sup>c</sup>
Other first order collaterals	1.5–2.6 <sup>a</sup>	1.5–3.7 <sup>a</sup>
Intensity of collateral branching		
Number of first order collaterals	8–15 <sup>a</sup>	7–21 <sup>b</sup>
Distance between origins of collaterals ( $\mu\text{m}$ )	500–1,500 <sup>a</sup>	110–1,975 <sup>b</sup>
A-P extension of innervation domains <sup>d</sup> ( $\mu\text{m}$ )	–	350–3,500 <sup>b</sup>
Number of terminal boutons per collateral	–	11–2,180 <sup>b</sup>

<sup>a</sup>Data from TRSNs intracellularly labeled with HRP in acute experiments, without behavioral identification.

<sup>b</sup>Data from identified visuomotor TRSNs HRP-labeled in alert cats.

<sup>c</sup>Main ascending collaterals are present in the midbrain only; – quantitative data not available.

<sup>d</sup>Longitudinal space along the antero-posterior (A-P) axis of the brainstem occupied by second and higher order branches of individual collaterals and by terminals.

**SC – Tectoreticulospinal Neurons. Table 3** Quantitative data on the terminations of visuomotor (vm)-TRSNs in different regions of the pontobulbar reticular formation

		TRSN “S”		TRSN “A”		TRSN “K”	
Length of axon used for bouton counts (μm)		6,000		6,000		4,800	
Total number of boutons over analyzed axon length		3,270		6,261		924	
		nB	D	nB	D	nB	D
RPc Rostral half	Total innervation area	679	110	3078	208	118	85
	EBN area	352	160	980	371	72	112
RPc Caudal half	Total innervation area	833	252	1,858	215	650	108
	Abducens nucleus	145	207	331	473	108	154
RGc Rostral one third	Total innervation area	1561	295	1,325	270	156	143
	IBN area	442	224	460	383	173	98

Bouton numbers (nB) and bouton densities ( $D = nB \text{ mm}^{-3}$ ) from three TRSNs labeled with HRP in alert cats and identified as visuomotor by their firing patterns. Complete reconstruction of the axonal branching of TRSN “A” is shown in Fig. 3a. RPc, nucl. reticularis pontis caudalis; RGc, nucl. reticularis gigantocellularis; EBN, excitatory saccadic burst neurons; IBN, inhibitory saccadic burst neurons.

nucleus of Cajal (INC) are rare and no terminations have been traced in the oculomotor nucleus. Some fibers enter the nucleus of the posterior commissure (NPC) and other pretectal nuclei. From the functional point of view, it is important to note that all cells of this class project not only in the contralateral PDB but also to midbrain regions containing the vertical saccade generator (riMLF, INC, NPC), some intermediate circuits involved in horizontal saccades (cMRF, supraoculomotor PAG), and neurons projecting to the spinal cord and participating in the control of ▶head movements in the vertical plane (FF).

### Pons and Medulla

“Visuomotor TRSNs” (vm-TRSNs, see below) labeled by intra-axonal HRP injections [3,4] have axons of 4.6–9.3 μm in diameter. Collaterals are issued at all levels of the pons and medulla at variable inter-collateral distances, but their branching domains usually overlap along the longitudinal axis of the brainstem tegmentum (Table 2). The neuron illustrated in Fig. 3a is representative because the regions of its densest ramifications correspond to common terminal regions of all studied vm-TRSNs. The first of them (collateral 3 and 4) is in the rostral pole of the caudal pontine reticular nucleus (RPc), with a denser innervation of its central portion. The second (collaterals 5–8) is just rostral to the AbdN. The third one (collaterals 9, 10) corresponds to the caudal extremity of the dorsal RPc, where the terminations of vm-TRSNs become particularly dense near the border of the AbdN before entering in this nucleus as well. In the medulla, axons of vm-TRSNs ramify and terminate in the gigantocellular reticular nucleus (RGc) (e.g., Fig. 3a, collaterals 11–13). Superposition of terminal domains makes it clear that, taken together, vm-TRSNs make connections with the entire medial reticular formation in the pons and in the rostral medulla. Besides this termination domain in

common, individual neurons make selective connections with some but not other areas. Among such facultative targets are the precerebellar nucleus reticularis tegmenti pontis (NRT), nucleus prepositus hypoglossi (PH) and the motor nucleus of the facial nerve (VII). The strength of projections to the areas containing excitatory and inhibitory ▶burst neurons (Saccadic, Excitatory, Inhibitory) of the ▶horizontal saccade generator also differs between the vm-TRSNs (Table 3). Differences in local connection strengths between TRSNs may suggest that they fulfill specialized tasks in the selection of neural populations controlling different moving segments, e.g., eyes, head, spine and limbs, during complex orienting movements (synergies).

### Spinal Cord

Compared to pontobulbar axons of vm-TRSNs, spinal portions of axons, presumably originating from X neurons, have sparser collaterals and a smaller number of boutons per collateral in the spinal grey of C1 and C2 segments [6]. Although terminals in the motor nuclei of neck muscles have been previously reported, no terminations of X neurons have been found on retrogradely labeled motoneurons [6]. This latter study demonstrated an indirect connection through interneurons in the laminae V–VIII. Some electrophysiological studies affirmed, others denied, a direct SC connection with neck motoneurons, so that the question remains unresolved [5]. There is a general agreement, however, as to a powerful disynaptic tecto-reticulo-spinal connection through the caudal pontine (RPc) and rostral bulbar (RGc) reticular formations, as well as through spinal segmental interneurons.

### Summary

Connections of individual TRSNs in the brainstem are very extensive, suggesting, at a first glance, a fairly unspecific function. On the other hand, when regarded

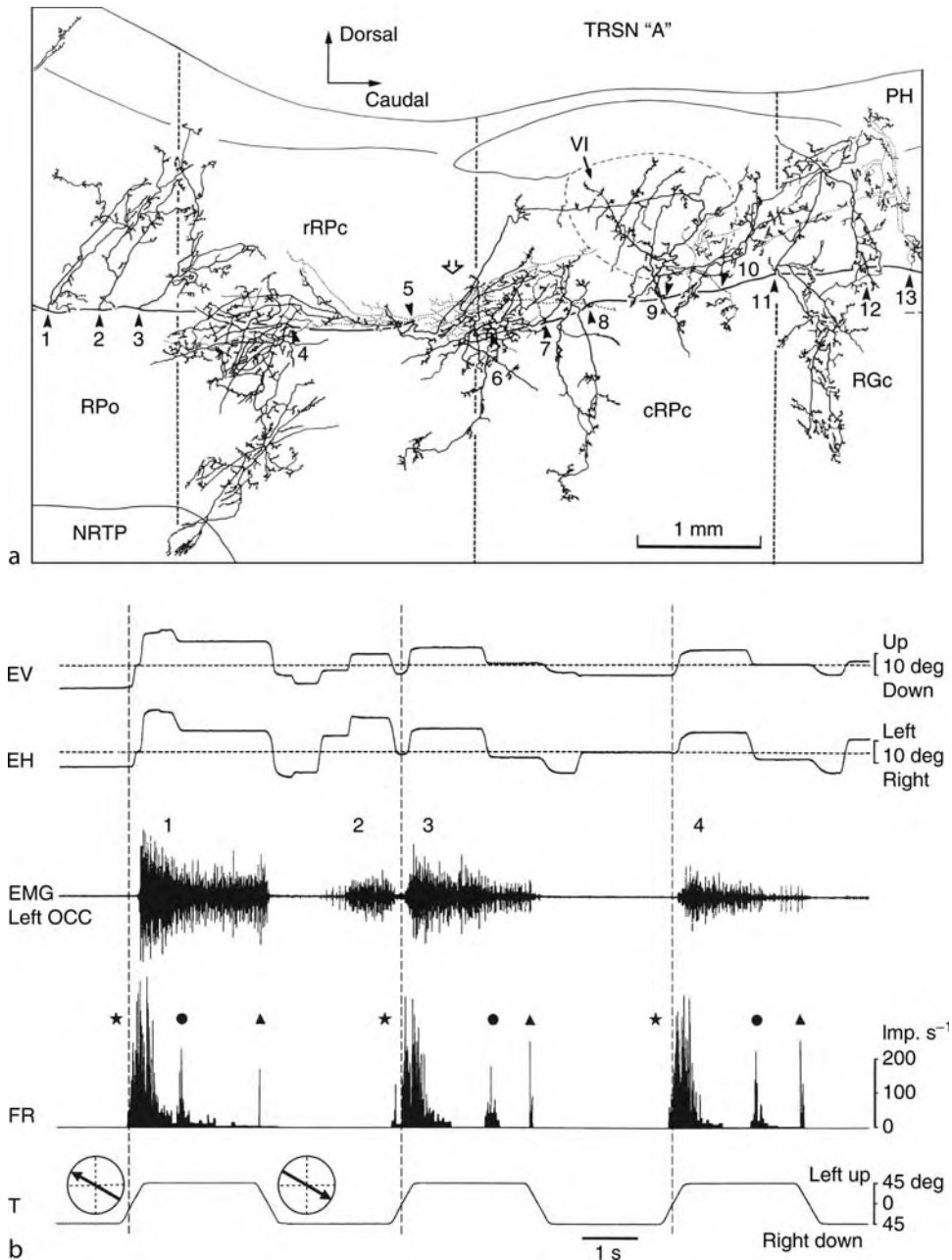

**SC – Tectoreticulospinal Neurons. Figure 3** Axonal morphology and discharge patterns of a “visuomotor” TRSN recorded and labeled in alert cat. **A**, Reconstruction in the parasagittal plane of axon collaterals in the pons and in the rostral medulla. Open arrow indicates the point of intraaxonal HRP injection. Quantitative data on terminations within three segments of the pontobulbar tegmentum (vertical interrupted lines) are presented in [Table 3](#) (TRSN “A”). Abbreviations: *NRTP*, nucl. reticularis tegmenti pontis; *RGc*, nucl. reticularis gigantocellularis; *RPc*, nucl. reticularis pontis caudalis (*r*, rostral; *c*, caudal halves); *RPo*, nucl. reticularis pontis oralis; *VI*, abducens nucleus. (modified from Grantyn et al. (1993), *Multisensory Control of Movement*, Oxford University Press, pp. 185–200, with permission). **B**, Discharge pattern of the same neuron during tracking of a moving target. From *top to bottom*: vertical (EV) and horizontal (EH) eye position, electromyogram (EMG) of the left m. obliquus capitis cranialis (OCC), instantaneous firing rate (FR) of the neuron and position of the target (T). *Insets* show the direction of target motion. Stars: “visuomotor” bursts during target motion in the neuron’s preferred direction, associated with tracking saccades, slow drifts (event 4) and neck muscle contractions. Vertical interrupted lines are drawn through the onset of high frequency firing before the saccades. Note weaker bursts of visual origin during return saccades (*circles*) and at the onset of target motion in the direction, opposite to the preferred one (*triangles*). Event 2 demonstrates the absence of discharge during spontaneous gaze shift in the preferred direction of the neuron. (Modified from [5], with permission).

as a population, they supply with terminals all areas known to harbor premotor neurons controlling eye and head movements toward the contralateral visual field. In the lower brainstem, terminals are distributed to the regions of long-lead and medium lead excitatory burst neurons of the horizontal saccade generator (RPs). Caudal RPs and RGc contain reticulospinal neurons (RSNs) controlling horizontal head movements, and strong monosynaptic connections of TRSNs to such cells have been proven by intracellular recordings (▶[intracellular labeling](#)). In the midbrain, TRSNs distribute terminals in the region of the vertical saccade generator (riMLF) and in the field of Forel, the site of location of RSNs controlling vertical components of head movements. TRSNs contact directly not only premotor areas but also motor nuclei participating in orienting movements. Monosynaptic excitatory effects of TRSNs on abducens (eye muscle), facial (ear muscles) and neck motoneurons are admittedly weak. Nevertheless, it is worth underscoring such a divergence to motor nuclei, all participating in complex orienting synergies, but very different according to biomechanical properties of moving organs (effectors) they control.

### Higher Order Function

#### *The Role of the Superior Colliculus in the Control of Gaze Shifts—An Overview*

The role of TRSNs is to transmit output signals of the SC to premotor structures of the brainstem tegmentum. The SC is commonly referred to as a subcortical “center” controlling orienting movements. Under orienting movements we understand rapid ▶[gaze shifts](#) toward novel or otherwise biologically significant events in the surroundings. Under natural conditions, such changes of gaze direction are achieved by coordinated saccadic movements of the eyes and rapid head movements. When large gaze displacements are required, movements of the trunk and of extremities do participate in orienting synergies. The most studied function of the SC consists of providing an output signal specifying the desired direction, amplitude and, to some extent, the speed of gaze shifts. These parameters are encoded in the location of the active population of SC output neurons with respect to coordinates of the motor map, as well as in the size and the level of excitation of the population. For a detailed description of neural processes underlying the control of gaze by the SC see ▶[SC – Role in eye movements](#), ▶[SC-Motor map](#), ▶[SC-Sensorimotor integration](#).

### Physiology of TRSNs

#### *Visuomotor Properties*

Typical activity pattern of a morphologically identified (Fig. 3a) visuomotor TRSN (vm-TRSN) [3–5] is shown

in Fig. 3b. This TRSN generated the strongest activity during ▶[tracking](#) of a target when it moved in the direction, opposite to the side of the cell’s location in the SC. Preferred directions of other TRSNs are usually within 50–60° from horizontal, but a few cells respond stronger to nearly vertical target motion. The earliest portions of the bursts (Fig. 3b, stars) are visual responses to the target, when it is close to entering the contralateral visual hemifield. Increments of the spike rate to 150–200 s<sup>-1</sup> precede first tracking saccades by about 100 ms but bursts continue beyond the saccade ends. They often coincide in time with sequences of saccades (Fig. 3b, event 1) or post-saccadic slow eye movements (e.g., Fig. 3b, event 4). Burst duration is similar to the duration of the dynamic component of the electromyogram (EMG) of neck muscles participating in an attempted head movement.

Discharge characteristics of vm-TRSNs, illustrated by an individual example of Fig. 3, vary in a broad range. Bursts start in advance of the onsets of gaze movement or EMG activation with lead times as short as 30 ms in some neurons and as long as 200 ms in others. Some cells generate bursts of relatively short duration (50–400 ms) and terminating before the end of eye saccades, others are able to generate sustained bursts in the range of 0.5–2.0 s. Temporal relationships of bursts with motor events of different duration (saccades, slow eye movements, activation of neck EMG) differ accordingly. Firing rate within the bursts is maximal in association with saccades in the neuron’s preferred direction and, particularly, when movements are very fast, as it happens when the level of the animal’s motivation for visual “capturing” of the target is high. However, the maximum firing rates vary considerably among vm-TRSNs (100–500 imp s<sup>-1</sup>), even when tested in neuron’s optimal behavioral conditions. The differences in burst durations, spike frequency during visuomotor bursts, and the probability of neuron’s recruitment during the movement can be explained by the differences in membrane excitability of TRSNs [7].

The above description, based on experiments on cats with immobilized heads, is in perfect agreement with the results obtained in head-free cats [8,9]. The study clearly demonstrated the contribution of TRSN discharges to the generation of eye and head components of the orienting synergy. In particular, there exists a tight temporal coupling between increments of the firing rate and accelerations of eye (delay 10–12 ms) and head (delay 24–32 ms) movements. Using stationary instead of moving targets for orienting, Munoz and coworkers [9] were able to further analyze spatial properties of movement-related TRSN discharges. They found that maximal firing rates are always associated with a particular vector of gaze shifts, corresponding to the optimal ▶[gaze motor error](#) (of a

neuron). However, all neurons will produce some firing for smaller or larger gaze displacements. Besides burst-like (phasic) movement-related discharges, about 75% of TRSNs generate sustained discharges during preparation of gaze shifts toward the location in space roughly corresponding to the location of neuron's visual receptive field. The size of the field is large (up to 70° horizontally and 40° vertically). The strongest preparatory firing is observed when target location corresponds to the optimal gaze motor error (► [Gaze Motor Error-Static](#)) of the neuron.

### **Multisensory Properties**

Practically all TRSNs tested in alert animals with visual, auditory and somesthetic stimuli display a multisensory convergence [8,10]. Visual responses to stationary targets have mean latencies of 50–95 ms, but the majority of neurons respond at less than 60 ms. Such responses usually consist of a few spikes, and they are weaker than responses to moving targets. Different sensory modalities interact on TRSNs in a complex way. Although the most consistent excitatory effects are provided by vision, via the retinotectal connections, auditory and somesthetic modalities can enhance or suppress visual responses, depending on the spatial coincidence or disparity of the stimulus sources in the surrounding space. Such interactions are considered as a part of the processes underlying the selection of targets for orienting movements [10].

### **Summary**

TRSNs identified both by morphological and by behavioral criteria in head-fixed cats have the following properties: (i) Broad spatial tuning of visual and movement-related discharges; (ii) Responsiveness to sensory stimuli of different modalities and a superposition of sensory (predominantly visual) and motor components in their bursts; (iii) Unequal capability to generate high frequency firing; (iv) Broad range burst durations, such that discharges of some neurons coincide in time with saccades only, while discharges of other neurons can contribute to all dynamic components of orienting synergies (saccades, slow eye drifts and contractions of neck muscles); (v) Nonobligatory association of vm-TRSN bursts with gaze shifts: they discharge only when the animal moves its gaze toward an object of its choice, but not during scanning gaze movements across a uniform visual background or in darkness. They also generate visual responses when a moving target is neglected and not tracked. By their location on the collicular motor map, TRSNs encode the gaze motor error and they also contribute to the control of dynamic parameters of both eye and head movements (► [eye-head tracking](#)). Considering the behavioral properties of individual TRSNs, their function should be defined as a fairly

generalized facilitation of premotor extracollicular circuits, whose activation is required to realign the head and the eyes to a relatively large albeit circumscribed area of the environment. This conclusion is well corroborated by the broad divergence of TRSN projections to the brainstem tegmentum. More specific functions of individual TRSNs are suggested by anatomical data, such as regional differences in the strength of connections and differences in patterns of multisensory integration. This aspect of “specificity” has, however, not been sufficiently studied.

### **Quantitative Measure for this Structure**

#### **Cell Bodies and Dendrites**

[Table 1](#) presents a selection of morphometric characteristics compiled from references [1,2]. TRSNs and X neurons have similar trajectory and branching patterns of axons in the midbrain, but the definition of TRSNs is further restricted by adding an identified descending projection to the lower medulla and to the spinal cord. According to their size (As) TRSNs are well comparable to X<sub>1</sub>–X<sub>3</sub> neurons. It should be noted that X<sub>2</sub> and X<sub>3</sub> neurons have a vertical orientation of dendritic fields, whereas radially symmetrical fields have only been reported for TRSNs. The available sample of completely reconstructed TRSNs is, however, smaller than that of X neurons, and it is premature to affirm that all of them belong to the X<sub>1</sub> subclass. On the other hand, all X neurons, including TRSNs, can be clearly distinguished from another class of SC neurons projecting in the PDB, the T neurons [1]. Firstly, T neurons are of consistently smaller size and, secondly, they emit recurrent collaterals passing to the opposite SC in the collicular commissure. Such collaterals have not been observed, either on X neurons or on TRSNs.

#### **Axons and Axon Collaterals**

[Table 2](#) summarizes quantitative data on axons and collaterals of TRSNs [2,3]. A broader range (3.0–8.0 μm) has been reported for the whole population of X neurons [1], but the thinnest axons (3.0–4.5 μm) were not observed among TRSNs. An HRP study of TRSN axons in the pontomedullary region of anesthetized cats suggested an increase of axon diameters on their descending course to the spinal cord [2]. The range of behaviorally identified visuomotor TRSNs also includes, however, smaller diameters. Conduction velocities of TRSN axons between the SC and the pons are in the range of 35.7–57.2 m s<sup>-1</sup> whereas the range of ponto-spinal portions of axons is broader (39.0–80 m s<sup>-1</sup>). Axon diameters and the related parameter, conduction velocities, are appropriate for a rapid and fairly synchronous transmission of spike volleys to target areas separated by long distances. Intracellular recordings have indeed demonstrated that minimal latencies of synaptic responses to SC stimulation are

0.5–1.0 ms in the pontine reticular formation neurons, 0.8–1.0 ms in abducens motoneurons and 1.4–1.6 ms in motoneurons of neck muscles in the upper spinal segments.

The presence of axon collaterals along the total length of main axons is common to all TRSNs. The richness of the collateralization varies between individual neurons, as shown in Table 2 by the numbers of collaterals issued over axon segments of a comparable length. Although some inter-collateral distances are quite long, termination domains of successive individual collaterals show practically no gaps. This is due to a great antero-posterior extension of collateral trees formed by second and higher order branches. The number of terminals issued by each collateral is variable and depends on the profuseness of branching which, in turn, is related to the diameter of collaterals at their origin.

### Topographic Distribution of Terminal Boutons in the Pontobulbar Tegmentum

The numbers of terminals and, in particular, their regional densities serve as a measure of the anatomical strength of connections. To obtain reliable data, the labeling of collaterals must be complete, i.e., one should be able to identify terminal boutons on all preterminal fibers. Table 3 shows bouton counts from three behaviorally identified vm-TRSNs [3]. To satisfy the above criterion of labeling quality, only a limited length of axons has been used for counts. Similar data are not available for the midbrain portion of TRSN axons.

Table 3 includes three well known areas involved in the control of saccadic eye movements which represent common targets of TRSNs. It can be seen that, in spite of considerable differences in local bouton numbers, their densities in the area of excitatory saccadic burst neurons are consistently higher than over the total innervation domain at the same brainstem level. It is not so in the case of the Abducens nucleus for which only TRSN “A” shows a high selectivity while it is small for TRSN “K”, and absent for TRSN “S”. Finally, TRSN “S” is the only one showing an over-proportional density of terminations in the region of inhibitory saccadic burst neurons.

### References

1. Moschovakis AK, Karabelas AB (1985) Observations on the somatodendritic morphology and axonal trajectory of intracellularly HRP-labeled efferent neurons located in the deeper layers of the superior colliculus of the cat. *J Comp Neurol* 239:276–308
2. Grantyn A, Grantyn R (1982) Axonal patterns and sites of termination of cat superior colliculus neurons projecting in the tecto-bulbo-spinal tract. *Exp Brain Res* 46:243–256
3. Olivier E, Grantyn A, Chat M, Berthoz A (1993) The control of slow orienting movements by tectoreticulospinal neurons in the cat: behavior, discharge patterns and underlying connections. *Exp Brain Res* 93:435–449

4. Grantyn A, Berthoz A (1985) Burst activity of identified tecto-reticulo-spinal neurons in the alert cat. *Exp Brain Res* 57:417–421
5. Olivier E, Grantyn A, Kitama T, Berthoz A (1995) Post-spike facilitation of neck EMG by cat tectoreticulospinal neurones during orienting movements. *J Physiol (London)* 482:455–466
6. Muto N, Kakei S, Shinoda Y (1996) Morphology of single axons of tectospinal neurons in the upper cervical spinal cord. *J Comp Neurol* 372:9–26
7. Grantyn R, Grantyn A, Schierwagen A (1983) Passive membrane properties, afterpotentials and repetitive firing of cat superior colliculus neurons studied in the anesthetized cat. *Exp Brain Res* 50:377–391
8. Guitton D, Munoz DP (1991) Control of orienting gaze shifts by the tectoreticulospinal system in the head-free cat. I. Identification, localization, and effects of behavior on sensory responses. *J Neurophysiol* 66:1605–1623
9. Munoz DP, Guitton D, Pélisson D (1991) Control of orienting gaze shifts by the tectoreticulospinal system in the head-free cat. III. Spatiotemporal characteristics of phasic motor discharges. *J Neurophysiol* 66:1642–1666
10. Meredith MA, Wallace MT, Stein BE (1992) Visual, auditory and somatosensory convergence in output neurons of the cat superior colliculus: multisensory properties of the tect-reticulo-spinal projection. *Exp Brain Res* 88:181–186

## SC – Visually Triggered Movement Cells

ROBERT H. WURTZ

Laboratory of Sensorimotor Research, National Eye Institute, National Institutes of Health, Bethesda, MD, USA

### Definition

Visually guided saccades (►saccade, ►saccadic eye movement) are those rapid eye movements that direct the eye to a visual target. This is in contrast to saccades occurring under other conditions, such as those made without any overt target termed spontaneous saccades or those made to targets that are no longer present, which are referred to as memory guided saccades. Neurons in the brain of a monkey that are active *only* when the saccade is made to a visual target that is present in the field of view are visually triggered movement cells. Neurons of this type were first identified in the ►superior colliculus (SC) and study of them has concentrated on that structure.

### Characteristics Higher Order Structures

The inputs to the superior colliculus that could contribute to the activity of the visually triggered

movement cells include large regions of cerebral cortex, but several areas in particular have neuronal responses to visual stimuli and increased activity before saccadic eye movements [1]. Neurons in the lateral intraparietal area of parietal cortex have strong responses to visual targets for saccades and are modestly active before saccades, while neurons in the frontal eye field area of frontal cortex have both visual responses to targets and clear bursts of activity before saccades. For the visually triggered movement cells in the superior colliculus, it may well be the nature of the visual activity in the cortex that is most important for understanding their function. Both cortical areas have strong direct projections to the superior colliculus, and the frontal eye field has an indirect pathway through the basal ganglia.

### Parts of This Structure

The superior colliculus has multiple layers including the superficial layers in which all of the neurons have visual responses, and the intermediate layers in which the neurons have not only visual responses but many also have a burst of activity preceding the saccadic eye movement [2]. The visually triggered movement cells lie in the intermediate layers and generally have both increased activity in response to the stimulus and the burst of activity before the onset of the saccade.

### Functions of This Structure

The visually triggered movement cells were first identified by comparing their activity when the monkey made a saccade to a visual target, with the activity before a saccade of the same amplitude and direction made in total darkness [3]. The visual response was of course absent in the dark, but the burst before the saccade was also absent even though the saccade in the dark and the saccade to a visual target were nearly identical. Such an absence of presaccadic bursts of activity were subsequently seen in experiments in which the monkey made a series of two saccades [4], or in which it made an anti-saccade away from a visual target [5]. More recently, the role of the visual target has been investigated systematically, and the presence of a visual target was found to alter the presaccadic burst of many collicular neurons [6]. In these tasks, monkeys made saccades to visual targets, to the location of remembered visual targets, and to locations where the targets had not appeared at all (a task referred to as the anti-saccade task). What these experiments showed was that the collicular neurons fell along a continuum, from those at one end that only showed the burst of activity before saccades to visual targets to those at the other end where the burst was the same whether or not the saccade was to a visual target. The visually triggered movement cells were simply those lying at one end of a continuum, not a unique class of neurons. It should be emphasized that this effect of the visual target was independent of

the intensity of the visual response of the neuron; weak visual responses could be followed by strong potentiation of the burst before the saccade. The strength of the visual effect on the presaccadic burst tended to decrease over several hundred milliseconds after the visual target had disappeared. Even though the velocity of the saccades in the absence of a visual target is lower, this variable did not fully account for the reduced presaccadic burst in the absence of the visual target. In net, the presence of the visual target seemed to have an effect on the vigor of the presaccadic burst that was second only to the effect of the amplitude and direction of the saccade to be made. Furthermore, at the same time as the presence of a visual target increased the presaccadic bursts, the presence of the target also reduced the scatter in the saccadic end points around the target, which is consistent with a contribution of the increased bursts to the greater precision of the saccades to visual targets.

### Higher Order Function

The superior colliculus is a homologue of the optic tectum found in other vertebrate animals, and across species these structures are clearly related to the control of eye and head movements. As the eyes are shifted to more frontal positions in the head and the high resolution fovea develops in the retina, the need for greater precision in directing saccades to visual targets becomes more critical for the animal's survival. It has been suggested [6] that the enhanced burst of activity in the superior colliculus that accompanies saccades to visual targets is part of this adaptation for greater precision in the visual guidance of saccades.

### Quantitative Measure for This Structure

Progress on the nature of the effect of the visual stimulus on neuronal activity has been made possible by the use of tasks that separate out the variables that alter the neuronal activity. A second critical factor in studying the awake monkeys results from the accurate recording of movements using the magnetic search coil method, which gives precise indication of eye position, velocity, and acceleration. The entire experiment is controlled by online computer systems that also collect and store all the data from the experiments.

### References

1. Krauzlis RJ (2004) Recasting the smooth pursuit eye movement system. *J Neurophysiol* 91:591–603
2. Sparks DL, Hartwich-Young R (1989) The neurobiology of saccadic eye movements. The deep layers of the superior colliculus. *Rev Oculomot Res* 3:213–256
3. Mohler CW, Wurtz RH (1976) Organization of monkey superior colliculus: intermediate layer cells discharging before eye movements. *J Neurophysiol* 39:722–744



4. Mays LE, Sparks DL (1980) Dissociation of visual and saccade-related responses in superior colliculus neurons. *J Neurophysiol* 43:207–232
5. Everling S, Dorris MC, Klein RM, Munoz DP (1999) Role of primate superior colliculus in preparation and execution of anti-saccades and pro-saccades. *J Neurosci* 19:2740–2754
6. Edelman JA, Goldberg ME (2001) Dependence of saccade-related activity in the primate superior colliculus on visual target presence. *J Neurophysiol* 86:676–691

## Scaffold Protein

YUTAKA HATA, JUNKO IIDA

Department of Medical Biochemistry, Graduate School of Medicine, Tokyo Medical and Dental University, Tokyo, Japan

### Synonyms

The words “adaptor” and “linker” are sometimes used to mean a scaffold protein; Although scaffold proteins have more varied functions than adaptor and linker

### Definition

Scaffold proteins are proteins that simultaneously bind two or more other proteins, and organize binding partners into a functional unit to enhance signaling efficiency and fidelity.

Signaling molecules interact with each other to form large complexes, and most of those complexes do not diffuse in the cytoplasm, but rather are attached to cell membranes. The complex is called *signalsome* or *transducisome*. Among components of a *signalsome*, a protein that binds to more than one protein and has no enzymatic activity is defined as a scaffold protein, because the primary function of such a molecule is to provide other components with a framework on which they efficiently work.

### Characteristics

#### Higher Level Structures

As biological signals come from outside a cell, many *signalsomes* are localized under the plasma membranes with receptors for the external signals. In the field of neurobiology, scaffold proteins at synapses are the most extensively studied. However, scaffold proteins can also form *signalsomes* in other subcellular structures including the nucleus, the Golgi apparatus, mitochondria, and centrosome.

#### Lower Level Components

Scaffold proteins are composed of multiple protein modules. Modules are compact folded portions of

proteins with 30–200 amino acids that recognize short continuous peptide sequences in their binding partners. ▶ **PSD-95/Discs large-A/ZO-1 (PDZ)**, Src-homology (SH) 2, SH3, WW, and phosphotyrosine binding, and guanylate kinase homologue domains are frequently recognized in scaffold proteins. Sterile alpha motif (SAM), WASP homology 1, ARM, and LIM domains are also detected in scaffold proteins. L27 and protein kinase A anchor domains are present in scaffold proteins binding to Lin-2/Lin-7 and protein kinase A, respectively. Scaffold proteins often have sequences involved in multimerization such as a coiled-coil domain and leucine-rich repeats. Furthermore, some scaffold proteins have short target motifs that bind to modules of other scaffold proteins.

### Structural Regulation

Alternative splicing is a source of diversity of scaffold proteins. Variants with different combinations of modules and motifs mediate distinct protein–protein interactions. Synapse-associated protein 97 (SAP97) has alternatively spliced insertions in the N-terminal domain, and in the region (HOOK domain) between the SH3 and the GK domains. The N-terminal insertions determine the ability of SAP97 to cluster potassium channels. The interaction of human Discs large (hDLG; human homologue of SAP97) with protein 4.1 depends on the insertion in the HOOK domain, and is involved in the localization of hDLG at cell junctions in epithelial cells. SAP97 with the same insertion is targeted to synapses in neurons, and delivers AMPA receptor subunit GluR1 to the cell surface. Posttranslational modifications also contribute to diversity and regulation of scaffold proteins. Phosphorylation regulates the interaction of the AMPA receptor subunit GluR2 with ▶ **Glutamate Receptor Interacting Protein (GRIP)** and PICK1. Phosphorylation by cyclin-dependent kinase 5 regulates the clustering (▶ **receptor regulation, clustering**) of PSD-95. Phosphorylation by calcium/calmodulin-dependent kinase II (CaMKII) induces synaptic targeting of SAP97. Palmitoylation is involved in synaptic targeting and interaction with ion channels of PSD-95 and localization at spine heads of GRIP. Axin needs sumoylation to activate c-Jun N-terminal kinase. Finally, activity-dependent poly-ubiquitination regulates the amount of scaffold proteins in neurons.

### Higher Level Processes

Scaffold proteins function in a wide variety of receptor, channel, and cell adhesion molecule signalings. Major research efforts by neurobiologists have been made to demonstrate that synaptic activity modulates protein–protein interactions mediated by synaptic scaffold proteins. For instance, activity-dependent phosphorylation of NMDA receptor subunit 2B disrupts the interaction with PSD-95. Activation of NMDA receptors induces

redistribution of A kinase-anchoring protein (AKAP) 79/150 through calcium signaling and F-actin organization. Studies on PSD-95 suggest that higher level processes may regulate the amount of scaffold proteins at translation and transcription levels. Estrogen stimulates translation of PSD-95. Activation of type I metabotropic glutamate receptors induces translation of PSD-95. Neuronal depolarization of spiral ganglion cells upregulates transcription of PSD-95 through neuregulin-1. Activity-dependent protein degradation also regulates the amount of synaptic scaffold proteins.

### Lower Level Processes

Scaffold proteins are involved in many biological processes including cell proliferation, apoptosis, endocytosis, and regulation of cytoskeletons. In neurons, scaffold proteins are involved in membrane traffic and endocytosis of neurotransmitter receptors, accumulation of synaptic components, and regulation of actin cytoskeleton. Researchers consider that scaffold proteins play roles through these processes in synaptogenesis and synaptic plasticity.

### Function

#### Function of Scaffold Proteins in Signaling

Scaffold proteins form signalsome to enhance signaling efficiency, ensure signaling fidelity, increase signaling sensitivity, and coordinate different signaling pathways. These biological advantages of signalsome were first delineated for *Drosophila* INAD. INAD is a multivalent PDZ protein that functions as a scaffold in the photo-transduction pathway. It assembles TRP, protein kinase C, and phospholipase C, and promotes signaling specificity and speed. The importance of scaffold proteins in mitogen activated protein kinase (MAPK) and cyclic AMP-dependent signalings is well documented.

#### Scaffold Proteins in MAPK Pathway

In yeast, Ste5 assembles components of MAPK including Ste11 (MAPK kinase), Ste7 (MAPK kinase), and Fus3 (MAPK) so that the kinases are efficiently activated. Another MAPK, Kss1, is also activated by Ste11 and Ste7. However, Ste5 only weakly binds Kss1, so that Fus3 is preferentially activated in response to pheromone. In other animals, Kinase suppressor of Ras (KSR) is a well-characterized scaffold in MAPK cascade. KSR has a multiple modular structure and binds many proteins, for example, Raf, MEK, ERK, and others. Although KSR has no kinase activity, loss-of-function studies in *Drosophila* and nematode indicate that KSR is a positive component of Ras/MAPK pathway. Gene targeting in mice supports that KSR is a requirement of the MAPK pathway in mammals. The connector enhancer of KSR (CNK) is a potential scaffold in MAPK pathway, and has SAM, PDZ, and pleckstrin homology domains and

interacts with Ras, Raf, and Rassf1. Synapses have a neuronal isoform of CNK named MAGUIN/CNK2. MAGUIN/CNK2 interacts with Raf and is necessary for NGF-mediated MAPK signaling. Jun-N terminal kinase (JNK)-interacting proteins (JIPs) are scaffold proteins for JNK and bind JNK, MKK7 (MAPK kinase), and MLK (MAPK kinase) [1].

#### Scaffold Proteins in cAMP Signaling

As its name implies, AKAP family proteins anchor PKA at specific subcellular structures, and regulate the temporal and spatial organization of signalings mediated by PKA. AKAP79/150 directly binds to PSD-95 and SAP97 in neurons, and forms a PKA-containing macromolecular complex that is associated with NMDA and AMPA receptors. Moreover, AKAP79/150 binds PKA, PKC, and calcium/calmodulin-dependent phosphatase, and provides a platform on which different signaling pathways cross-talk [2].

#### Scaffold Proteins Associated with Membrane Receptors

Scaffold proteins modulate receptor-dependent signaling in two ways: by clustering of receptors and through the assembly of signalsome physically associated to receptors. Scaffold proteins often cluster different categories of membrane proteins such as receptors, channels, and transporters. Na<sup>+</sup>/H<sup>+</sup> exchanger regulatory factor (NHERF) binds to  $\beta_2$ -adrenergic receptor in an agonist-dependent manner and mediates the change of cellular pH after stimulation of adrenergic receptor. Likewise, synaptic scaffold proteins link different receptors. PSD-95 directly binds to NMDA receptors, and indirectly associates with AMPA receptors through its interaction with stargazin. NMDA receptors are also linked to metabotropic glutamate receptors by sequential interactions of PSD-95, GKAP/SAPAP, Shank, and Homer/Vesl. PSD-95 also links  $\beta_1$ -adrenergic receptor to NMDA receptors. GRIP binds AMPA receptors and Eph receptor kinases by different PDZ domains. Moreover, GRIP binds EphrinB, a transmembrane ligand for Eph, and LAR family of receptor tyrosine phosphatase *via* liprin- $\alpha$  proteins. Tamalin interacts with metabotropic glutamate receptors and GABA<sub>B2</sub> receptor. As tamalin was also identified as a GRIP-associated protein, it may interact indirectly with AMPA receptors. In Purkinje cells, Shank that is associated with metabotropic glutamate receptors through Homer/Vesl directly binds glutamate receptor delta2. Although it needs to be determined which interactions can occur simultaneously, synaptic scaffold proteins may form a functional unit composed of various membrane proteins on specific cell surface domains.

As receptor density affects receptor properties, scaffold proteins can directly modulate receptor functions by cluster formation. For instance, NHERF and cystic fibrosis transmembrane conductance regulator (CFTR)-associated protein 70 both interact with CFTR, and

directly affect CFTR gating using tandem PDZ domains. In contrast, precise details of synaptic scaffold proteins on neurotransmitter receptors are not clear enough. NHERF binds platelet-derived growth factor receptor (PDGFR) and potentiates autophosphorylation of the receptor by oligomerization. PSD-95 induces clustering of ErbB4 and enhances ErbB4-mediated ERK signaling, although it is not shown whether PSD-95 affects autophosphorylation of ErbB4.

In addition to receptor-level regulation, scaffold proteins facilitate signal transduction through tethering signal molecules to physical proximity of receptors.  $\beta$ -Arrestin is a scaffold protein in G protein-coupled receptor (GPCR) signaling. The list of  $\beta$ -arrestin-interacting molecules includes JNK signaling molecules, tyrosine kinase, and components involved in endocytosis.  $\beta$ -Arrestin binds to GPCR phosphorylated by GPCR kinase and recruits interacting molecules to activated receptors. Recent intense studies have revealed that PSD-95 and other synaptic scaffold proteins bind various signaling proteins implicated in synaptic plasticity. PSD-95 interacts with GTPase-activating protein for Rap1 (synGAP- $\alpha$ ), GDP/GTP exchange factors for Rap1 (SPAR) and Rac (Kalirin-7), tyrosine kinase fyn, and Rho target protein (Citron kinase). GRIP, tamalin, and **gephyrin** bind GDP/GTP exchange factors for Ras (GRASP-1), ARF (ARNO), and CDC42 (collybistin), respectively. GRIP also interacts with GAP for ARF (GIT1) through liprin- $\alpha$ . Studies using mutant mice support that synaptic scaffold proteins are crucial for signaling of synaptic plasticity. Collectively, the data suggest that signaling molecules, only when assembled by scaffold proteins, can respond quickly to receptor activation, interact with each other efficiently to produce down-stream signals, and modulate receptor functions through the regulation of cytoskeleton and phosphorylation of receptors. A recent study has demonstrated that MUPP1 directly binds synGAP- $\alpha$  and CaMKII, and that CaMKII phosphorylates synGAP and suppresses its activity. Upon NMDAR stimulation, the elevation of calcium ions induces dephosphorylation of synGAP and dissociation of CaMKII from MUPP1. synGAP is then activated and inhibits p38 MAP kinase by inactivation of Rap1. The authors have demonstrated that synGAP- $\alpha$  phosphorylation requires the binding to MUPP1. Although how CaMKII regulates the activity of synGAP is not free of controversy, this report depicts the function of a scaffold protein in signaling well [3,4].

### **Function of Scaffold Proteins to Organize the Molecular Architectures in Cells**

#### **Scaffold Proteins and Cell Polarity**

Scaffold proteins are important to establish, maintain, and remodel the molecular architecture of specific membrane

domains. Three complexes composed of scaffold proteins and their binding partners are essential for cell polarity in epithelial cells. The first complex is Par3/Par6/aPKC. The second and the third complexes are Crumb/Pals1/PATJ and Scrib/Dlg/Lgl. Par3 have three PDZ domains, whereas Par6 has one PDZ domain and a CRIB motif to bind CDC42. PATJ is similar to MUPP1 and has L27 and thirteen PDZ domains. Dlg is SAP97 orthologue. Pals1 has L27, SH3, PDZ, and guanylate kinase domains. Scrib has a leucine-rich repeat and one PDZ domain. All these proteins function as scaffold proteins. The first and the second complexes are essential for proper formation of tight junctions in epithelial cells. The third complex is involved in the establishment of basolateral membranes. These polarity complexes link to each other. Par6 directly binds to Pals1. aPKC phosphorylates Lgl. In neurons, Par complex is involved in axon specification. The complex is localized at the tip of a newly formed axon depending on PI3-kinase, Rap1B, and CDC42, and interacts with kinesin [5].

#### **Scaffold Proteins and Receptor Localization**

Scaffold proteins regulate receptor localization on the cell surface. Receptor trafficking has been investigated most extensively for AMPA receptors. Newly synthesized AMPA receptors interact with scaffold proteins when they are still present at the ER. GluR2 interacts with PICK1, and this interaction is necessary for the export of GluR2 from the ER to the Golgi apparatus. Trafficking from cell bodies to dendrites is also regulated by scaffold proteins. GRIP binds to kinesin heavy chain and KIF5 transports GluR2 to dendrites. Although the precise details are unknown, SAP97 binds GluR1 and regulates the synaptic delivery. Stargazin and its isoforms are tetraspanins and bind all AMPA receptors. Stargazer mice, which do not have AMPA receptors on the cell surface in cerebellar granule neurons, support the essential role of stargazin in AMPA receptor trafficking. Furthermore, stargazin mediates synaptic targeting of AMPA receptors through binding to PSD-95. Additional factors that regulate synaptic targeting and clustering of AMPA receptors are cytoskeletal protein 4.1N, nPIST, and RIL. Among them, nPIST and RIL are regarded as scaffold proteins. nPIST binds to NMDA receptor subunit 2A by a PDZ domain and to stargazin by a different region. RIL binds to  $\alpha$ -actinin by a PDZ domain and GluR1 by a LIM domain. LTP correlates with the insertion of AMPA receptors into the cell surface membranes, while LTD involves the retrieval of receptors by endocytosis. The phosphorylation state of GluR1 is important for LTP and LTD, but the effect of phosphorylation and dephosphorylation of GluR1 on the interaction with SAP97 is not well characterized. In terms of GluR2, it is proposed that dephosphorylation following the modest elevation of calcium ion triggers dissociation of GRIP

from GluR2, so that GluR2 binds to PICK1 and is removed from the cell surface. Recent studies have shed light on NMDA receptor trafficking. NMDA receptor subunit 2B is transported to dendrites by a cargo composed of CASK/Lin-7/Lin-10 that binds to KIF17. The complex of Sec8 and SAP102 is important for NMDA receptor trafficking. NMDA receptors are internalized by clathrin-coated pits. This internalization is inhibited by PSD-95 and its isoforms. Activity-dependent serine phosphorylation of NMDA receptor subunit 2B by casein kinase II inhibits the interaction with PSD-95 and SAP102, and decreases the number of receptors on the cell's surface. Tyrosine dephosphorylation is also reported to regulate the endocytosis of NMDA receptors. At inhibitory postsynaptic sites, gephyrin plays a key role in the localization of glycine and GABA<sub>A</sub> receptors. Deletion of gephyrin reduces clusters of both receptors. Gephyrin interacts with tubulin and GABA<sub>A</sub> receptor-associated protein (GABARAP) that binds to  $\gamma 2$  subunit. The later protein is small and does not fit the criteria of a scaffold protein, but is involved in the intracellular transport of the receptor [6–8].

### Scaffold Proteins and Membrane Transport

Scaffold proteins are implicated in the transport of other proteins besides receptors. The presynaptic active zone is the membrane domain specialized for vesicle release. The active zone is composed of the matrix proteins (Bassoon, Piccolo, CAST/ERC) and functional units implicated in exocytosis (RIM, Munc13, Munc18). Most of them have modular structures and interact with each other in multiple ways. For instance, Piccolo has a PDZ domain and C2 domains, and interacts with signaling molecules (GAP for ARF (GIT1), and cAMP-GEF), a cytoskeleton-related protein (profilin and Abp), and other scaffold proteins (liprin- $\alpha$ , RIM, and CAST/ERC). In the synapse formation, vesicles containing scaffold proteins like Bassoon and Piccolo transport components of the active zone as packets to a nascent synapse. Furthermore, some scaffold proteins interact with motor proteins. Liprin- $\alpha$  has coiled-coil and SAM domains and interacts with LAR, Piccolo, RIM, CAST, GIT1, and GRIP. It also interacts with KIF1A that transports synaptic vesicles. JIPs bind to kinesin light chain and link amyloid precursor protein and ApoER2 to KIF5. Thereby, scaffold proteins may be important to ensure that distinct combinations of proteins are delivered efficiently to a specific membrane domain [9,10].

### Scaffold Proteins and the Cytoskeleton

One of the major outputs of signal transduction is the morphological change of cells. As mentioned above, synaptic scaffold proteins assemble various regulator proteins for the actin cytoskeleton, and are directly or

indirectly associated with the cytoskeleton. For instance, AKAP79/150 directly binds F-actin. Shank binds  $\alpha$ -fodrin,  $\beta$ PIX (GEF for Rac and CDC42), and cortactin (regulator for the cortical actin cytoskeleton). RIL binds  $\alpha$ -actinin. Cupid, an isoform of Homer/Vesl, directly interacts with F-actin and CDC42. These scaffold proteins are positioned to transmit signals from receptors to the cytoskeleton and modify the receptor activity through the remodeling of the cytoskeleton.

### Pathology

As scaffold proteins have various functions in neurons, they should be implicated in the pathophysiology of many neuronal diseases. However, to date, the number of reports is still limited. Human DLG3 encoding SAP102 was recently identified as a nonsyndromic X-linked mental retardation gene. Filamin is a scaffold protein associated with cortical actin and interacts with a large number of proteins including receptors and kinases. Filamin comprises of three members. One of the filamin genes, *FLNA*, is X-linked and its mutations cause brain malformation. Several mutant mice generated by gene targeting show phenotypes similar to human congenital diseases. The mutation of GRIP1 alters the localization of ECM protein, Fras, in keratinocytes, and leads to a phenotype that is reminiscent of Fraser syndrome with the blistered skin. Future studies may uncover mutations of scaffold protein genes in human diseases.

### References

- Morrison DK, Davis RJ (2003) Regulation of MAP kinase signaling modules by scaffold proteins in mammals. *Annu Rev Cell Dev Biol* 19:91–118
- Wong W, Scott JD (2004) AKAP signaling complexes: focal points in space and time. *Nat Rev Mol Cell Biol* 12:959–970
- Kim E, Sheng M (2004) PDZ domain proteins of synapses. *Nat rev Neurosci* 10:771–781
- McGee AW, Bredt DS (2003) Assembly and plasticity glutamatergic postsynaptic specialization. *Curr Opin Neurobiol* 13:111–118
- Roh MH, Margolis B (2003) Composition and function of PDZ protein complexes during cell polarization. *Am J Physiol Renal Physiol* 285:F377–F387
- Song I, Huganir RL (2002) Regulation of AMPA receptors during synaptic plasticity. *Trends Neurosci* 25:578–588
- Nong Y, Huang Y-Q, Salter MW (2004) NMDA receptors are movin' in. *Curr Opin Neurobiol* 14:353–361
- Moss SJ, Smart TG (2001) Constructing inhibitory synapses. *Nat rev Neurosci* 2:240–250
- Hirokawa N, Takemura R (2004) Kinesin superfamily proteins and their various functions and dynamics. *Exp Cell Res* 301:50–59
- Rosenmund C, Rettig J, Brose N (2003) Molecular mechanisms of active zone function. *Curr Opin Neurobiol* 13:509–519

## Scalar

### Definition

A quantity described by a single number.

► Neural Networks for Control

## Scale of Nature

► Evolution and the Scala Naturae

## Scent, Aroma

► Odor

## Schizophrenia

BERNHARD BOGERTS

Universitätsklinik für Psychiatrie, Psychotherapie und Psychosomatische Medizin, Otto-von-Guericke Universität Magdeburg, Magdeburg, Germany

### Synonyms

Schizophrenic psychosis; Morbus Bleuler

### Definition

The term “schizophrenia” was introduced in 1911 by E. Bleuler meaning a splitting of emotional and cognitive functions in the affected patients. Today the international classification systems ICD-10 and DSM IV-R provide consensus criteria on symptom constellations required for this diagnosis. Leading symptoms in the acute periods of the disease are

1. Reality distortions such as hallucinations (mainly auditory and somatosensory)
2. Delusions and paranoid symptoms such as feelings of being observed or persecuted often associated with anxiety
3. Disorganization of thinking and behaviour

These symptoms are summarized as so-called ► **positive schizophrenic symptoms**.

Patients can also suffer from ► **negative schizophrenic symptoms** such as

1. Emotional flattening
2. Loss of drive and initiative
3. Social withdrawal
4. Depression

as well as from psychomotor alterations such as stupor and mutism (inability to move or to speak). Positive and negative symptoms can occur alternatively during the course of the disease or simultaneously in acute stages. Symptom constellation and the long term course of the illness vary considerably. If hallucinations and delusions prevail, the paranoid-hallucinatory subtype (reality distortion subtype) of schizophrenia has to be diagnosed, if psychomotor symptoms (often combined with anxiety) dominate, the catatonic subtype (► **catatonia**), if affective flattening and avolition are the leading syndrome, the hebephrenic subtype (► **hebephrenia**), if disorganization of thinking and behaviour are the prominent clinical signs the disorganized subtype has to be diagnosed.

There are persons – often close relatives of schizophrenics – with eccentric behaviour and anomalies of thinking and emotions that have some similarities with schizophrenia but do not reach the extent of a real schizophrenic psychosis. Such very weak forms of positive or negative symptoms are usually diagnosed as ► **schizotypal personality disorder**.

The typical “positive” symptoms usually start in young adulthood or late adolescence, males in general earlier and more severely affected than females. Hebephrenia often becomes obvious during or shortly after puberty. With regard to the long term course, about one third of the patients show a rather benign outcome, i.e., symptoms disappear after one or two episodes; one third has an unfavourable outcome with progressive impairment of psychotic or residual symptoms (worsening of cognitive and emotional functions) and one third has a fluctuating course with exacerbations and remissions.

It should be emphasized that the enormous variety of psychopathological alterations summarized under the term “schizophrenia” do not represent a disease entity, but rather a hypothetical construct that was created many decades ago by leading authorities in the field and is now defined by international classifications committees, whose inclusion criteria changed from issue to issue, there are moreover differences between schizophrenia definitions in ICD and DSM criteria.

### Characteristics

#### Epidemiology and Genetics, Risk Factors

About one percent of the world’s population has a lifetime prevalence of schizophrenia, this is independent from the cultural or geographical background.

Schizophrenia very seldom begins during childhood on beyond the fourth decade of life. The disease has a strong genetic component. Monozygotic twins have a concordance rate of about 50%, even if they grow up in different families, first degree relatives have a concordance rate of 10–20%. This indicates that genetic and non-genetic components play an essential role in pathogenesis of schizophrenia.

Several research groups recently demonstrated that polymorphisms in the neuregulin-1 gene (chromosome 8p12) and dysbindin (DPNBP, chromosome 6p23.3) predispose to the disease. Because of the clinical complexity of psychotic symptoms, other genes might also have a pathogenetic significance. Neuregulin is important for neurodevelopmental processes, myelination and for NMDA-neurotransmission, Dysbindin is localized in the postsynaptic membranes and plays a role in neuronal signal transduction. All of these functions are believed to be disturbed in schizophrenia [1,2].

The following risk factors for later development of schizophrenia are now well established:

1. Genetic disposition (50% concordance in monozygotic twins)
2. Prenatal neurodevelopmental disorder (as indicated by, abnormal cytoarchitecture in frontal and temporal cortex) [3]
3. Birth complications (obstetric complications, hypoxia during birth)
4. Winter birth (increased risk of viral infections)
5. Chronic cannabis consumption
6. Migration (increased frequency in first and second generation Afro-Caribbean immigrants) [3]

In contrast to earlier psychodynamic oriented opinions, parental influences during childhood or educational styles do not predispose to later development of schizophrenic psychoses.

### Changes in Brain Structure of Schizophrenics

Numerous structural imaging studies by computed tomography (CT) or magnetic resonance imaging (MRI) reported a broad variety of subtle structural alterations in the brains of schizophrenics. The most consistent statistical findings are [4,5]:

1. Lateral ventricular enlargement (by about 20%)
2. Enlargement of frontal, temporal and parietal sulci
3. Smaller volume of hippocampus and parahippocampal gyrus (by about 10%)
4. Decreased thickness of frontal, temporal and parietal association cortex (by 5%)
5. Reduced asymmetry between right and left hemisphere

Post mortem studies also found changes at the microscopical level [4]:

1. Cellular disarray and abnormally positioned neurons in entorhinal cortex, hippocampus and prefrontal

brain, as an indicator of a prenatal disorder of neurodevelopment

2. Reduced neuropil and synaptic markers, while the number of nerve cells is unchanged
3. Alterations in myelin and oligodendroglia components [6]
4. Reduction of inhibitory interneuron terminals [7]

While cellular disarray in limbic mesiotemporal structures and frontal cortex as well as reduced cortical asymmetry are a strong argument for a prenatal developmental disorder, several MRI-studies could demonstrate a progressive loss of cortical tissue in the first years after the onset of clinical symptoms. This points to an additional degenerative component that adds to a primary neurodevelopmental disorder [3].

### Neurotransmitter Theories

#### Dopamine

The most prominent theory on neurotransmitter dysfunctions causing schizophrenic symptoms is the dopamine theory, according to which dopaminergic functions are in some way overactive in the schizophrenic brain. This theory is essentially based on the observation that antagonists on the D2-receptor have antipsychotic properties and that dopaminergic substances like amphetamine, cocaine or L-DOPA can induce a schizophrenia-like psychosis. However, earlier reports of increased concentration of dopamine receptors in the schizophrenic brain proved to be an artefact of antipsychotic treatment. On the other hand there are reports that schizophrenics have increased dopamine release after application of amphetamine and animal models after lesions in prefrontal and limbic structures show changes in dopamine turnover similar to those observed in psychotic patients [8,9].

#### Glutamat

The best drug induced model for schizophrenic symptoms is the phencyclidin-(PCP)-psychosis. After PCP consumption, the full spectrum of schizophrenic symptoms (hallucinations, paranoid ideas, catatonia, disorganized behaviour) can occur. PCP, like ketamine, is an antagonist of the NMDA-subtype of glutamate receptors. Several postmortem studies found a decreased concentration of the NMDA-subreceptor NR1 in temporal cortex or thalamus. Thus, a hypofunction of NMDA-linked neurotransmission can be postulated. The glutamate agonists Glycin and D-Serine are reported to have moderate antipsychotic effects [9].

#### GABA

Inhibitory interneurons containing GABA as neurotransmitter are another important candidate in current neurotransmitter theories of schizophrenia. GABA-cells are responsible for the bulk of neuronal inhibition in all cortical and subcortical structures. There are

several clinical indicators of disturbed neuronal inhibition in schizophrenic patients; these are:

1. Deficits in sensory gating
2. Hallucinations (explainable as dysinhibition of sensory cortical areas)
3. Reduced latent inhibition
4. Reduced prepulse inhibition

Some studies showed decreased mRNA for the GABA-synthesizing enzymes GAD65 and GAD67 in hippocampus and frontal cortex and of the GABA-transporter GAT in inhibitory cortical synapses. The peptides parvalbumin and reelin, that are co-localized in special subclasses of GABA-interneurons, are also diminished in frontal and temporal cortex [7].

### Therapy

After treatment with ►**antischizophrenic drugs** (synonyms: antipsychotic drugs, neuroleptics), acute symptoms usually improve within a few weeks. In many patients, prophylactic long term treatment with these drugs over years is necessary to prevent relapses.

Antipsychotic drugs or neuroleptics are dopamine antagonists whose therapeutic efficacy correlates essentially with their affinity to the Dopamine-2 (D2) receptor.

Antipsychotics can be divided into first generation or typical neuroleptics (prototype: haloperidol) and second generation or atypical neuroleptics (prototype: clozapine). The first generation neuroleptics block D2 receptors in all dopaminergic brain systems. By D2-receptor antagonism in the nigrostriatal system they often cause their “typical” extrapyramidal side effects like Parkinson symptoms and other forms of abnormal movements (dyskinesias), while their action in the mesolimbic and mesocortical dopamine system is believed to be responsible for the antischizophrenic properties. The second generation (atypical) neuroleptics have a higher affinity to the mesolimbic than to the nigrostriatal dopamine system, therefore they have much weaker or no extrapyramidal side effects, but they have antipsychotic actions that are comparable to that of the typical antipsychotics [8]. However, some of the second generation antipsychotics have other unfavourable side effects such as weight gain and other signs of a metabolic syndrome. This could be due to their affinity to multiple receptors including the histamine and serotonin receptors

Beside pharmacological treatment and after remission from acute psychosis, additional psychotherapeutic and psycho/socioeducational treatment strategies are helpful.

### References

1. Harrison PJ, Weinberger DR (2005) Schizophrenia genes, gene expression, and neuropathology: on the matter of their convergence. *Mol Psychiatry* 10:40–68
2. Weickert CS, Straub RE, McClintock BW, Matsumoto M, Hashimoto R, Hyde TM, Herman MM, Weinberger DR, Kleinman JE (2004) Human dysbindin (DTNBP1) gene expression in normal brain and in schizophrenic prefrontal cortex and midbrain. *Arch Gen Psychiatry* 61:544–55
3. Allin M, Murray R (2002) Schizophrenia: a neurodevelopmental or neurodegenerative disorder. *Curr Opin Psychiatry* 15:9–15
4. Bogerts B (1999) The neuropathology of schizophrenic diseases: historical aspects and present knowledge. *Eur Arch Psychiatry Clin Neurosci* 249(Suppl):2–13
5. Steen RG, Mull C, McClure R, Hamer RM, Lieberman JA (2006) Brain volume in first-episode schizophrenia. Systematic review and meta-analysis of magnetic resonance imaging studies. *Brit J Psychiat* 188:510–518
6. Cotter DR, Pariante CM, Everall IP (2001) Glial cell abnormalities in major psychiatric disorders: the evidence and implications. *Brain Res Bull* 55:585–95
7. Lewis DA, Hashimoto T, Volk DW (2005) Cortical inhibitory neurons and schizophrenia. *Nat Rev* 6:312–324
8. Gründer G, Landvogt C, Vernalen I et al. (2006) The striatal and extrastriatal D2/D3 receptor binding profile of clozapine in patients with schizophrenia. *Neuropsychopharmacol* 31:1027–1035
9. Moghaddam G, Krystal JH (2002) The neurochemistry of schizophrenia. In: Hirsch RS, Weinberger DR (Hrsg.): *Schizophrenia*. Oxford, Blackwell Science, pp 349–364

## Schizophrenic Psychosis

### ► Schizophrenia

## Schizotypal Personality Disorder

### Definition

Behavioural abnormalities in thinking and emotions that resemble very weak schizophrenic symptoms but do not reach an extent to be diagnosed as schizophrenia.

### ► Schizophrenia

## Schwann Cell

### Definition

Schwann cells are a type of peripheral nerve glial cell that surround axons. A Schwann cell can enclose a

number of individual axons (ensheathment), or surround a single axon with a compact spiraled sheet of its own plasma membrane (myelination). Myelination enables saltatory action potential propagation.

- ▶ Action Potential Propagation
- ▶ Myelin

---

## Schwann Cell Column

### Definition

- ▶ Schwann Cell
- ▶ Regeneration

---

## Schwann Cell Precursor

### Definition

Schwann cell precursors differentiate from migrating crest cells to become immature Schwann cells. They display a large number of phenotypic differences from both migrating crest cells and immature Schwann cells.

The majority of the cells in the embryonic day (E-)14 and E15 rat (mouse E12 and E 13) are Schwann cell precursors, and by E17 nearly all cells present in the peripheral nerve have differentiated into Schwann cells.

The survival of the precursors depends on axonal survival signal, neuregulin-1.

- ▶ Schwann Cell
- ▶ Schwann Cells in Nerve Regeneration

---

## Schwann Cells in Nerve Regeneration

HIDENORI HORIE

Advanced Research Institute for Biological Science,  
Waseda University, Nishitokyo, Tokyo, Japan

### Definition

The Schwann cell is a type of peripheral nerve glial cell that surrounds and interacts with axons. There are two types of Schwann cells: myelinating and

non-myelinating. Whereas myelinating Schwann cells form myelin around fast-conducting, large-diameter axons, non-myelinating Schwann cells surround smaller-diameter axons without forming a myelin sheath.

### Characteristics

#### Development and Classification of Schwann Cells

Studies in rats and mice have led to an understanding of the process of Schwann cell maturation. Most Schwann cells develop from cells derived from the ▶neural crest. The neural crest is a transient group of cells that delaminates from the dorsal part of the neural tube during embryonic development. In the trunk region, cells of the neural crest give rise to glial cells, neurons of sensory, sympathetic, and parasympathetic ganglia, chromaffin cells, and melanocytes. Between undifferentiated migrating crest cells and mature Schwann cells lie three main developmental transitions: first, the formation of ▶Schwann cell precursors; second, the formation of immature Schwann cells; and lastly, the reversible generation of myelinating and non-myelinating cells (Fig. 1).

Schwann cell precursors are the most prevalent cell type in peripheral nerves at embryonic day (E-) 14/15 in rats (E12/13 in mice), and by E17/18 in rats (E15/16 in mice), nearly all cells resident in peripheral nerves are Schwann cells or their precursors. Immature Schwann cells differentiate into myelinating Schwann cells initially, and form mature non-myelinating cells as development progresses. These Schwann cells regulate the development of the three main components of peripheral nerves – the neurons, connective tissue cells, and the Schwann cells themselves – to construct the peripheral nervous system (PNS).

Various proteins are markers of Schwann cell differentiation during embryonic development [2]. Use of these markers has been crucial for the characterization of the differentiation of Schwann cells from precursors to mature myelinating or non-myelinating cells, and for defining the roles of Schwann cells in the developing and adult PNS. The markers can be classified into four categories. The first category consists of markers that are found on embryonic PNS glia, but do not differentiate between developmental stages as these proteins are also expressed at later stages of Schwann cell development. An example of this type of marker is the cell adhesion molecule ▶L1. A second class of markers are those that are found on crest cells and Schwann cell precursors but at very low levels on immature Schwann cells, including N-cadherin and the transcription factor ▶AP2α. The third class of markers includes proteins that allow for the differentiation of Schwann cell precursors and immature Schwann cells from crest cells. This class is comprised of fatty acid binding protein ▶B-FABP, ▶protein zero (P0) and desert hedgehog (▶Dhh), which are also not found on



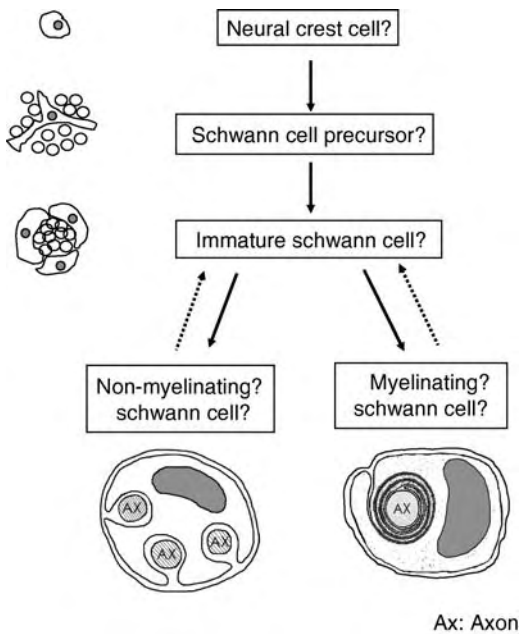

**Schwann Cells in Nerve Regeneration. Figure 1** The Schwann cell lineage in the rat and mouse.

Most Schwann cells develop from cells derived from the neural crest. Between migrating crest cells and mature Schwann cells lie three main developmental transitions: first, the formation of Schwann cell precursors; second, the formation of immature Schwann cells; and last, the reversible generation of myelinating and non-myelinating cells [1]. The Schwann cell precursors are always in close apposition to axons that are of similar size. They possess extensive sheet-like processes that contact and form junctions with processes from neighboring cells, thereby surrounding large groups of axons. These precursors differentiate into immature Schwann cells which display a large number of phenotypic differences from the precursor cells. The immature cells subsequently differentiate into two kinds of mature Schwann cells, myelinating and non-myelinating. Whereas myelinating Schwann cells associate with large diameter axons (Ax) in a 1:1 ratio, non-myelinating Schwann cells loosely ensheath numerous small diameter axons. Since Schwann cells are labile throughout their life cycle, differentiation into myelinating Schwann cells and non-myelinating Schwann cells is reversible [1].

early developing neurons and therefore provide a distinction between the neuronal and glial lineage at an early stage. The fourth group of markers consists of those that are found exclusively on immature and mature Schwann cells, and can therefore be used to distinguish these cells from Schwann cell precursors or crest cells. Markers in this class include calcium binding protein  $\blacktriangleright$ S-100 and glial fibrillary acidic protein (GFAP). Studies on the expression patterns of the aforementioned markers have led to the conclusion that immature

Schwann cells reversibly differentiate into two types of cells, myelinating Schwann cells and non-myelinating Schwann cells. Both of these cell types closely associate with axons in mature PNS, and they have essential roles in maintaining the appropriate structure and function of the PNS. They are also critical players in the processes of degeneration and regeneration following nerve injury.

**Function**

Schwann cells have been implicated in the development of various components of the peripheral nerve. Factors secreted by Schwann cells are important in the survival of immature neurons, and in the development of the connective tissues that provide protection and mechanical support for peripheral nerves (Fig. 2a). Schwann cells and their precursors regulate nerve development actively through their interactions with axons. Likewise, axons release factors that have effects on the survival and development of immature Schwann cells. One example of this reciprocal interaction is provided by mice that lack the neuregulin-1 receptor. Neuregulin-1 is the major axonally derived Schwann cell mitogen and survival factor, and it supports the survival of Schwann cell precursors [3]. Schwann cells and their precursors are severely depleted in peripheral nerves of mice lacking the receptor for neuregulin-1. Another phenotypic abnormality is also apparent in these mice: most sensory neurons and cervical and lumbar motoneurons are lost during the second half of embryonic development [4]. This suggests that Schwann cells and their precursors act as a source of developmental signals that are crucial for the survival of peripherally projecting neurons and the generation of peripheral nerves. Recent research has also implicated Schwann cells in the formation of the connective tissue structure of the nerve, which includes the endoneurium, perineurium, and epineurium. These act as protective diffusion barriers [5]. Thus, Schwann cells and their precursors have key roles both in the survival of developing neurons, and in the production of the connective tissue sheaths of peripheral nerves (Fig. 2a).

As mentioned above, myelinating and non-myelinating Schwann cells represent the terminal step of Schwann cell differentiation. These cells express distinct sets of proteins involved in cytoskeletal dynamics, associate with different sizes and numbers of axons, and have some disparate effects on the axons that they ensheath. Non-myelinating Schwann cells express high levels of the neural cell adhesion molecule (NCAM) and L1, modest levels of the neurotrophin receptor  $\blacktriangleright$ p75<sup>NTR</sup> and the growth-associated protein-43 kDa (GAP-43), and contain a distinct set of cytoskeletal proteins including glial GFAP. These cells do not express myelin-related proteins. In contrast, myelinating Schwann cells express little or no NCAM, L1, p75<sup>NTR</sup>, GAP-43, and GFAP. Instead, these cells express high levels of the structural components

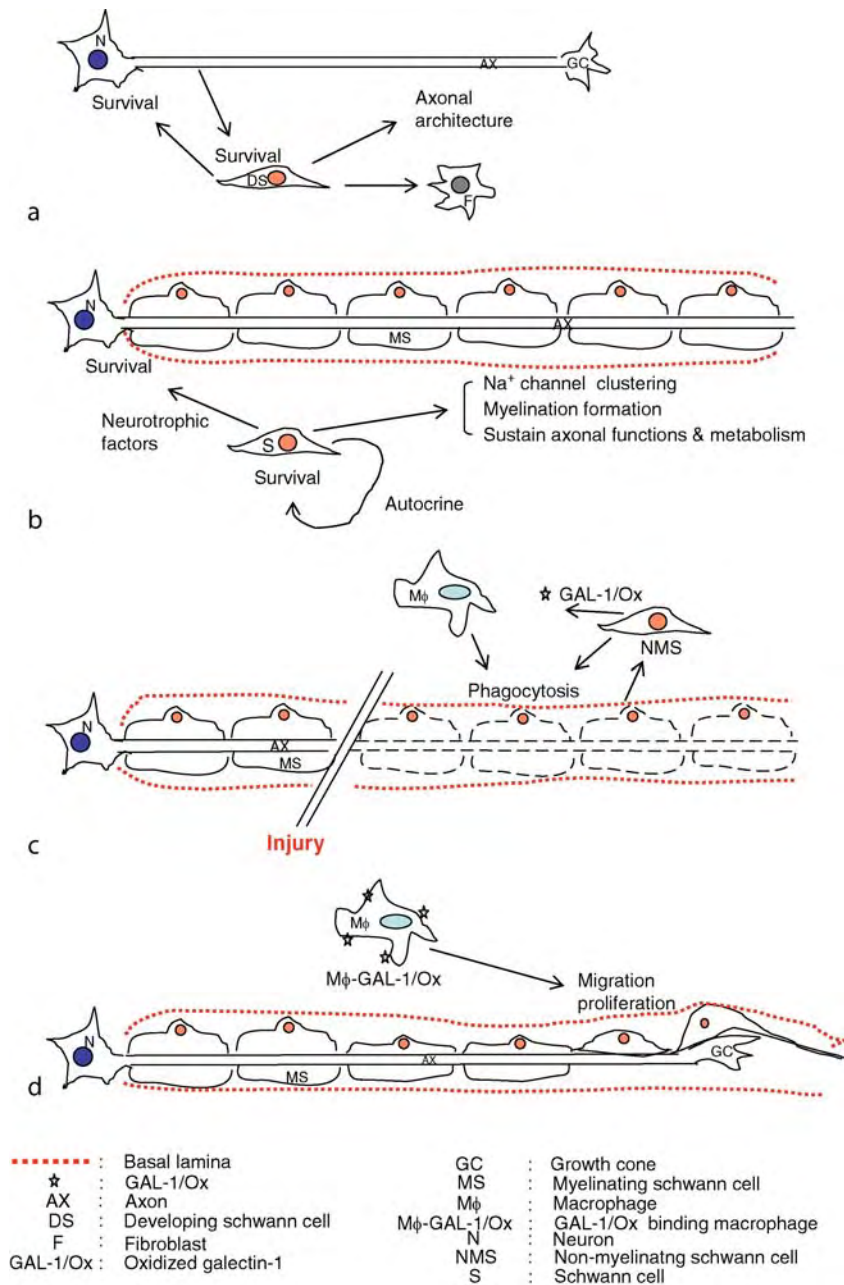

**Schwann Cells in Nerve Regeneration. Figure 2** Roles of Schwann cells in peripheral nerve during development, in the adult animal, and following nerve injury (Wallerian degeneration and subsequent axonal regeneration). (a) Developmental stage; (b) Mature stage; (c) Degeneration; (d) Regeneration. During developmental stages (a), Schwann cells and their precursors provide survival signals to neurons, and contribute to constructing the connective tissue sheaths of the nerves. Their survival is supported by axons via neuregulin-1. Upon maturation of the nerve and its cells (b), Schwann cells can survive by themselves and support neurons via neurotrophic factors. At this stage, Schwann cells have also formed myelin sheath around axons to propagate action potentials more quickly via saltatory conduction. After nerve injury, Wallerian degeneration (c) occurs distal to the site of axotomy. Axons and myelin sheaths are fragmented into debris and are phagocytosed by cells in the local microenvironment. Denervated myelin-forming Schwann cells de-differentiate into immature Schwann cells. The debris is phagocytosed in part by Schwann cells, but mainly by invading hematogenous macrophages. The Schwann cells secrete GAL-1/Ox. During the regeneration phase (d), the secreted GAL-1/Ox binds to macrophages and induces the release an unidentified factor that promotes Schwann cell migration. Regrowing axons from proximal stumps can then extend their processes along migrating Schwann cells towards their peripheral targets.

of the myelin sheath, including P0, myelin basic protein (MBP), peripheral myelin protein 22kDa (PMP22), connexin32, myelin-associated glycoprotein (MAG), and ▶*periaxin* [2]. Both types of Schwann cells surround axons to support neuronal survival by supplying trophic factors; however, unlike developing Schwann cells, mature Schwann cells can survive without support provided by axons (Fig. 2b).

Whereas non-myelinating Schwann cells loosely ensheath and support numerous small-diameter axons, myelinating Schwann cells surround large-diameter axons to furnish the myelin sheaths that insulate specific axonal populations in the PNS. Each individual myelinating Schwann cell forms a segment of myelin sheath about 1mm long on a single axon. The sheath assumes its form as the inner tongue of the Schwann cell and turns around the axon several times, wrapping it in concentric layers of membrane (Fig. 1). The intervals between segments of myelin are known as nodes of Ranvier. Myelination increases the diameter of axons and helps to direct  $\text{Na}^+$  channels to the ▶*node* of Ranvier [6].  $\text{Na}^+$  channels, which homogeneously distribute in the axonal membrane of unmyelinated axons (Fig. 3a), accumulate at these nodes. This accumulation essentially enables action potentials to “jump” from one node of Ranvier to the next (Fig. 3b). This jumping of action potential from node to node is called ▶*saltatory conduction*. It is a rapid process, as it allows myelinated axons to conduct up to 50 times faster than the fastest unmyelinated fibers. Myelination results in significant increases in the total number of neurofilaments and the proportion of phosphorylated neurofilaments, which comprise the majority of the axonal cytoskeleton [7].

### Pathology

Two basic pathologies can occur in the PNS: Wallerian degeneration resulting from nerve injury and segmental demyelination caused by autoimmunity to peripheral nerve myelin. Wallerian degeneration refers to all of the events that occur distal to the site of axotomy, and is a feature of any insult that causes axonal degeneration. During the first week post-axotomy, axons fragment and disappear, and the myelin sheaths separate at incisures, breaking up into debris. Both myelinating and non-myelinating Schwann cells are denervated and are affected significantly by nerve injury. Denervated myelinating Schwann cells are plastic and change to become immature Schwann cells (Fig. 2c). Over the next few weeks, this myelin debris is phagocytosed in part by Schwann cells but mainly by macrophages that invade the degenerating nerve from blood vessels. The clearance of myelin debris, which contains proteins that inhibit axonal regeneration, is required for regenerating axons to enter and grow into the degenerated nerve. Schwann cells undergo extensive

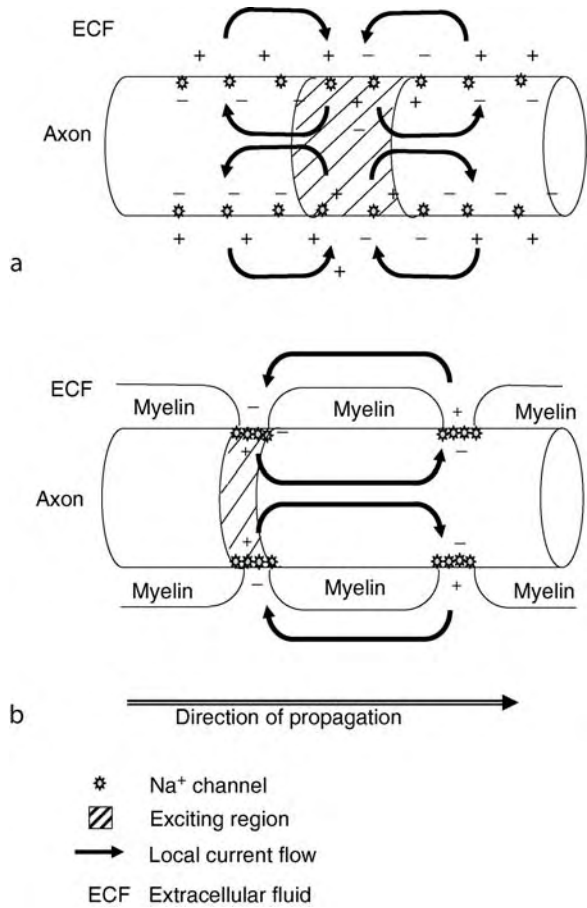

### Schwann Cells in Nerve Regeneration. Figure 3

Local current flow (movement of positive charges) around an impulse in unmyelinated and myelinated axons. (a) Unmyelinated axon, (b) myelinated axon.  $\text{Na}^+$  channels, which distribute homogeneously in the membranes of unmyelinated axons, cluster at nodes of Ranvier in myelinated axons. Action potentials are transmitted differently in the two axons. Unmyelinated axons propagate action potentials by electronically depolarizing the membrane directly ahead of the charge. In contrast, myelinated axons propagate the signal by depolarizing the membrane present in the next node of Ranvier, effectively allowing the charge to “jump” down the axon at high velocity (saltatory conduction).

proliferation between 3 and 5 days post-axotomy, and those that phagocytose myelin are activated to produce factors that promote axonal extension. The basal lamina persists and surrounds the column of denervated Schwann cells. Denervated, previously myelinating Schwann cells express many of the proteins that are characteristic of non-myelinating Schwann cells such as NCAM, L1,  $\text{p75}^{\text{NTR}}$ , and GAP-43, and dramatically decrease their synthesis of myelin-related proteins and glycolipids. These observations indicate that axonal signals are required to maintain the phenotype of mature Schwann cells.

Autoimmune demyelinating peripheral neuropathies, like ►Guillain-Barre syndrome (GBS) and chronic inflammatory demyelinating polyneuropathy (CIDP), are characterized by local inflammation and demyelination of peripheral nerves. Both sensory and motor axons are often affected, resulting in acute motor weakness affecting at least one limb associated with areflexia. Since most patients respond well to treatment with high dose intravenous immunoglobulin G or to plasma exchange [8], circulating self-recognizing antibodies are presumably involved in these disorders.

### Therapy

Schwann cells play essential roles in the regeneration of peripheral nerves, and have been used as a cellular source for factors that promote the regeneration and remyelination of injured axons in the central nervous system (CNS) [9]. Successful peripheral nerve regeneration requires the concerted interplay of non-neuronal cells, growth factors, cell adhesion molecules, extracellular matrix components, regenerating axons, and recruited macrophages [10]. In the past, initiation of axonal outgrowth after axotomy was thought to be regulated mainly by neurotrophic factors; however, more recent studies have identified another factor that is important in this process. This factor is the oxidized form of ►galectin-1 (GAL-1/Ox), which has been shown to increase the rate of initial axonal regrowth by facilitating the interaction of neuronal and non-neuronal cells after injury [11].

The pattern of expression of GAL-1 in cells of the peripheral nerve is consistent with its potential role in enhancing axonal regrowth following insult. A common model for peripheral axotomy involves injury to the sciatic nerve, which contains axons projecting from dorsal root ganglion neurons and motoneurons. These axons, along with Schwann cells, express the reduced form of GAL-1 (GAL-1/Red) and subsequently release these molecules into the extracellular space via a non-classical pathway. After sciatic nerve injury, axons are damaged and Schwann cells become reactive. Axons in the proximal nerve stump are sealed at the injury site. The secretion of GAL-1/Red is increased by these injured axons, especially from their growth cones. Reactive Schwann cells likely secrete GAL-1/Red in the same manner following axotomy. The GAL-1 molecules that are released into the extracellular milieu have two potential fates. First, some GAL-1/Red will bind to  $\beta$ -galactosides located on cell surfaces. A second event may also occur: some GAL-1/Red molecules may not interact with carbohydrate moieties and can enter the extracellular space, where they could be oxidized in the presence of agents such as NO that are induced by injury. Oxidation of GAL-1 involves the formation of three disulfide bonds and the loss

of lectin (carbohydrate-binding) activity. It is this form of GAL-1 that has been shown to enhance initial axonal outgrowth following peripheral nerve injury.

The major cellular target of GAL-1/Ox appears to be macrophages, and it is through events downstream of this interaction that axonal regrowth is accelerated. Target macrophages include those endogenous to the nerve itself, and those that are recruited from the blood in response to injury. The binding of GAL-1/Ox to a specific receptor on the plasma membrane of macrophages initiates a signal transduction cascade that leads to the secretion of an unidentified factor, which has been shown to promote axonal regrowth and Schwann cell migration after nerve injury. Migration of Schwann cells and fibroblasts from both proximal and distal stumps is important for the formation of cellular scaffolds that support regenerating axons. Treatment with GAL-1/Ox promotes Schwann cell migration from both stumps and accelerates axonal extension following injury, resulting in the promotion of functional recovery (Fig. 2d) [12]. Thus, GAL-1/Ox promotes the initiation of axonal regeneration in the PNS in animal models of neuropathy, suggesting that the factor may be useful therapeutically to enhance peripheral nerve regeneration.

The interaction between injured axons and cells in their microenvironment, including denervated Schwann cells, is critical for the successful regeneration of these axons. After injury and axonal sealing, growth cones are produced at the node of Ranvier located close to the proximal stump of the lesion. They must reach the distal nerve stump, which is possible even if there is a small gap between the proximal and distal nerve stumps. Upon arrival at the distal nerve stump, growth cones enter "Schwann tubes" (bands of Büngner), which consist of ordered columns of Schwann cells and their basal laminae. These bands provide the sole pathway for growth of regenerating axons in the distal nerve stump. Subsequent axon-Schwann cell interactions during nerve regeneration are fundamentally similar to those that occur during development. During early stages of regrowth, Schwann cells surround bundles of regenerating axons. As regeneration progresses, myelinating Schwann cells segregate with larger fibers into a 1:1 relationship, elaborate new basal laminae, and form new myelin sheaths. Much of the cholesterol and even a portion of the phospholipids of the original myelin sheaths are reincorporated into these new myelin sheaths. Macrophages and endoneurial fibroblasts are the key to this process, as they secrete lipoproteins that contain the recycled cholesterol and fatty acids, which are taken up by Schwann cells via low-density lipoprotein receptors [13]. With time, remyelinated axons may enlarge to nearly normal diameter, but the thickness of myelin sheaths and length of the myelin internodes do not recover to their uninjured sizes [14].

The pathway taken by regenerating axons to the targets depends largely on the nature of the lesion. After crush or freeze injury, the basal laminae of the Schwann cells remains intact at the site of injury. Growth cones usually remain within their basal lamina tubes, which guide them to their original targets. In contrast, nerve transection disrupts the continuity of the basal laminae. In this situation, axons usually do not enter their original Schwann tubes, and therefore do not reinnervate their original targets selectively. During the final stage of axonal regeneration, growth cones of regenerating axons passing through the distal nerve are guided to their targets by Schwann cells, resulting in the formation of functional neural networks.

## References

- Mirsky R, Jessen KR (2003) Embryonic and early postnatal development of Schwann cells. In: Jessen KR, Richardson WD (eds) *Glial cell development – basic principles and clinical relevance*. Oxford University Press, Oxford, pp 1–20
- Jessen KR, Mirsky R (2004) Schwann cell development. In: Lazzarini RA (ed) *Myelin biology and disorders 1*. Academic Press, Amsterdam, pp 329–370
- Adlkofer K, Lai C (2000) Role of neuroregulins in glial cell development. *Glia* 29:104–111
- Riethmacher D, Sonnenberg-Riethmacher E, Brinkmann V, Yamaai T, Lewin GR, Birchmeier C (1997) Severe neuropathies in mice with targeted mutations in the ErbB3 receptor. *Nature* 389:725–730
- Parmantier E, Lynn B, Lawson D, Turmaine M, Namini SS, Chakrabarti L, McMahon AP, Jessen KR (1999) Schwann cell-derived Desert hedgehog controls the development of peripheral nerve sheaths. *Neuron* 23:713–724
- Pedraza L, Huang JK, Colman DR (2001) Organizing principles of the axoglial apparatus. *Neuron* 30:335–344
- de Waegh SM, Lee VM, Brady ST (1992) Local modulation of neurofilament phosphorylation, axonal caliber, and slow axonal transport by myelinating Schwann cells. *Cell* 68:451–463
- Kwa MS, van Schaik IN, De Jonge RR, Brand A, Kalaydjewa L, van Velzen N, Vermeulen M, Baas F (2003) Autoimmunoreactivity to Schwann cells in patients with inflammatory neuropathies. *Brain* 126:361–375
- Keirstead SA, Rasminsky M, Fukuda Y, Carter DA, Aguayo AJ, Vidal-Sanz M (1989) Electrophysiologic responses in hamster superior colliculus evoked by regenerating retinal axons. *Science* 246:255–257
- Ide C (1996) Peripheral nerve regeneration. *Neurosci Res* 25:101–121
- Horie H, Inagaki Y, Sohma Y, Nozawa R, Okawa K, Hasegawa M, Muramatsu N, Kawano H, Horie M, Koyama H, Sakai I, Takeshita K, Kowada Y, Takano M, Kadota T (1999) Galectin-1 regulates initial axonal growth in peripheral nerves after axotomy. *J Neurosci* 19:9964–9974
- Horie H, Kadota T (2005) Oxidized galectin-1 is an essential factor for peripheral nerve regeneration. *Curr Drug Targets* 6:385–394
- Goodrum JF, Bouldin TW (1996) The cell biology of myelin degeneration and regeneration in the peripheral nervous system. *J Neuropathol Exp Neurol* 55:943–953
- Hoffman PN, Griffin JW (1993) The control of axonal caliber. In: Dyck PJ, Thomas PK, Low PA, Podusho JF (eds) *Peripheral neuropathy*. W.B. Saunders, Philadelphia, PA, pp 389–402

## Schwannoma

### Definition

Tumor of the ► myelin sheath built by ► Schwann cells.

► Myelin

► Schwann Cell

## Sciatic Neuritis

► Neural-Immune Interactions: Implications for Pain Management in Patient with Low-Back Pain and Sciatica

## Sciatica: Radiculopathy

► Neural-Immune Interactions: Implications for Pain Management in Patient with Low-Back Pain and Sciatica

## SCN

► Suprachiasmatic Nucleus

## SCN9A

### Definition

Na<sup>+</sup> channel gene that encodes Nav1.7, in patients with inherited erythromelalgia (IEM).

- ▶ Sodium Channels
- ▶ Voltage-gated Sodium Channels: Multiple Roles in the Pathophysiology of Pain

## Scolopidium

### Definition

The individual mechanosensory receptor unit of an insect auditory organ that consists of a linear chain of four cell types: (i) one or more bipolar neurons, (ii) a scolopale cell that forms a lumen around the cilium of the neuronal dendrite and whose cytoplasm contains electron dense scolopale rods, (iii) attachment cells that mechanically anchor and support the scolopale cell, and (iv) accessory cells that envelop and provide nutritive and mechanical support to the neuronal soma.

- ▶ Invertebrate Ears and Hearing

## Scotoma

### Definition

A scotoma is an area within the visual field in which a person is blind. Scotomata may be caused by damage to the retina or damage to visual areas within the brain.

When a scotoma is relatively small patients may not even notice that they have a visual defect (just as we do not typically notice that we have a blindspot in the region of the retina where the optic nerve leaves the eye).

- ▶ Blindsight
- ▶ Vision

## Scotopic

### Definition

Night condition or vision.

## Scratch Reflex

- ▶ Scratching

## Scratching

PAUL S. G. STEIN

Department of Biology, Washington University,  
St. Louis, MO, USA

### Synonyms

Scratch reflex; Wiping reflex

### Definition

Scratching is a motor behavior elicited by tactile stimulation of a site on the body surface [1–10]. During a scratch, a nearby limb reaches towards and rubs against the stimulated site.

An organism can scratch using a variety of strategies, or forms, according to the biomechanical demands of the task [10]. A human can use an elbow-over-the-shoulder strategy to scratch a site on the person's upper back and an elbow-under-the-shoulder strategy to scratch a site on the person's lower back. While only one strategy may be used to scratch each site on the back, a site located elsewhere may be scratched using more than one strategy. Either the hand or the elbow can successfully rub against a lateral site on a person's thorax. This is an example of motor equivalence.

A vertebrate with a complete transection of the spinal cord, termed a ▶spinal vertebrate, may produce successful scratching [7]. Supraspinal neuronal structures are not required for the generation of scratching behavior in these spinal vertebrates. Scratching has been studied in several spinal organisms: frog, turtle, cat, and dog. The spinal cord can select the appropriate strategy or form required to rub against a specific site.

For hindlimb scratching in frog [3] and in turtle [5,10], rostral scratching is used to rub against sites anterior to the hip in the midbody, lateral or pocket scratching is used to rub against sites near the hip, and caudal scratching is used to rub sites posterior to the hip near the anus.

A ►motor pattern is a specific sequence of motor neuron and/or muscle activations that occur during a behavior. In response to tactile stimulation of a site on the body surface, scratch motor patterns have been obtained with ►electromyographic recordings (EMGs) of muscle action potentials from specific muscles [5], as well as with ►electroneurographic recordings (ENGs) from nerves innervating these muscles [4,6,8]. For each scratch form, there is a specific motor pattern [4–6].

Movement-related sensory feedback can strongly modulate the characteristics of scratch motor patterns; such feedback is not required for the production of a scratch motor pattern, however. In an immobilized spinal vertebrate with all movement-related sensory feedback removed following blockade of neuromuscular synapses with a nicotinic acetylcholine receptor antagonist such as curare or gallamine, tactile stimulation evokes an excellent scratch motor pattern of ENG activation [4,6,8]. In response to stimulation of a specific site, the ENG motor pattern in the immobilized spinal preparation is an excellent replica of the EMG motor pattern in the spinal preparation with movement.

The neuronal networks in the spinal cord that produce scratch motor patterns in the absence of movement-related sensory feedback are termed ►central pattern generators (CPGs). Since these ENG motor patterns are produced in the absence of actual movements, they are termed “►fictive” motor patterns.

## Characteristics

### Quantitative Description

Scratching is often rhythmic. The rhythmic scratch motor pattern can be generated by a spinal CPG without movement-related sensory feedback; this establishes that the spinal CPG network is a neuronal oscillator.

The specific phase of the rhythmic scratch cycle during which a portion of the limb rubs against the stimulated site is a key feature of the scratch cycle [10]. The position of a toe in space as a function of time can be used to measure the scratch rhythm. The angles of several joints, e.g. hip and knee, are additional measures of the rhythm. The relative timing of knee angle in the cycle of movement of hip angle is a sensitive measure of the specific form of the scratch. In the turtle, the timing of the knee angle in the cycle of the hip is distinct for each form. The hip motor rhythm, the timing of activation of hip flexors and hip extensors as measured

with EMGs or ENGs, is an important measure. The relative timing of knee extensor activity in the hip motor rhythm is distinct for each form of the scratch in the turtle [4–6].

### Higher Level Structures

Scratch motor patterns are produced by CPGs. CPG neuronal networks are found in many organisms and produce a wide variety of rhythmic behaviors such as breathing, ►scratching, stepping, and swimming [9]. Current research programs in many laboratories include studies designed to reveal characteristics of these neuronal networks.

### Lower Level components

Tactile stimulation of a site on the body surface activates cutaneous afferent neurons whose axons enter the spinal cord via dorsal roots. Cutaneous afferents activate cutaneous interneurons. The scratch CPG includes the spinal cord interneurons that generate the scratch motor pattern. CPG interneurons are activated by cutaneous afferents and cutaneous interneurons. Some CPG interneurons have outputs that synapse upon limb motor neurons. These limb motor neurons synapse in turn upon the specific muscles of the limb that are activated during a scratch.

### Structural Regulation

Stimulation of a distinct set of cutaneous afferents activates the scratch CPG to generate a specific scratch motor pattern. The dynamic physiological structure of the scratch CPG is regulated by the activation pattern of tactile afferent inputs.

During the normal pattern of scratching, each agonist at a joint rhythmically alternates between activation and quiescence. During a normal scratch, each antagonist at a joint is active during agonist quiescence. During an antagonist deletion variation of scratching, the antagonist is quiet and there is no quiescence between successive bursts of agonist activation. The best-studied deletion is the hip-extensor deletion variation of rostral scratching in the turtle [6,8]. Knee-related deletions have also been described in the turtle. The occurrence of deletions demonstrates considerable flexibility in the dynamic structure of the scratch CPG.

### Higher Level Processes

CPGs for rhythmic scratching have properties shared with CPGs for other rhythmic behaviors, e.g. breathing, stepping, or swimming. What the neuronal mechanisms are that are responsible for generation of the motor rhythm and the specific sets of motor patterns is a fundamental issue for all CPGs.

### Lower Level Processes

Intracellular recordings from motor neurons and extracellular single-unit recordings from spinal interneurons during fictive scratching have provided important insights into the processes responsible for the production of the scratch motor pattern [1,2,4,6,8]. These recordings provide support for a modular organization of the scratch CPG.

Some studies of CPGs have focused upon evidence for a half-center modular organization; other studies of CPGs have focused upon evidence for a unit-burst-generator modular organization [6,8,9]. In the hypothesis of a half-center organization of a CPG, all the flexors of a limb are active at one phase of the cycle and all the extensors of a limb are active at a different phase of the cycle. Reciprocal inhibition between the flexor half-center and the extensor half-center is postulated to be the sole basis for CPG rhythmicity. This half-center organization does not apply to the rostral scratch in the turtle, since monoarticular knee-extensor motor activity is active during the latter portion of hip-flexor motor activity.

In the hypothesis of a unit-burst-generator organization of a turtle rostral scratch CPG, there is a hip-flexor ►module, a hip-extensor module, a knee-flexor module, and a knee-extensor module, etc. Reciprocal inhibition between agonist and antagonist modules at the hip joint is postulated to be one of the bases for CPG rhythmicity. Additional bases for CPG rhythmicity are reciprocal inhibition between agonist and antagonist modules at each other joint of the limb. Still other bases for rhythmicity are the intrinsic oscillations of each module (=“unit-burst-generator”), e.g. the hip-flexor module is postulated to be rhythmogenic even when the hip-extensor module is quiet.

Studies of normal rostral scratching as well as deletion variations of rostral scratching provide support for the unit-burst-generator hypothesis of CPG organization [6,8,9]. During normal rostral scratching, hip-extensor interneurons are active during hip-flexor motor neuron quiescence. During the hip-extensor deletion variation of rostral scratching, hip-extensor interneurons as well as hip-extensor motor neurons are quiet [8]. This supports the concept that hip-extensor interneurons belong to a hip-extensor module that acts in concert. These interneurons are active during hip-flexor quiescence of normal rostral scratching, and these interneurons are quiet during the hip-extensor deletion variation of rostral scratching. In addition, these results provide support for the idea that the hip-flexor module is rhythmogenic and its rhythmicity does not depend upon interneuronal activity in the hip-extensor module. Further support for the unit-burst-generator concept of the scratch CPG has been obtained with intracellular recordings from hip motor neurons during normal rostral scratching and during the hip-extensor deletion variation

of rostral scratching [6]. There is also support for rhythmogenic knee-flexor and knee-extensor modules.

### Process Regulation

Scratch CPG interneurons are broadly tuned [4,9]. They fire with maximal frequency in response to stimulation of a specific site on the body surface. For example, a rostral-tuned interneuron fires with maximal frequency in response to stimulation of a site in the rostral scratch receptive field. The interneuron responds with lower frequencies in response to stimulation of other sites on the body surface. Many scratch CPG interneurons are active during more than one form of the scratch. For example, many rostral-tuned interneurons are also activated in response to stimulation of a site in the pocket scratch receptive field. This suggests that the CPG interneurons for one form of scratch are also members of the CPG for other forms of scratch. Selective output of broadly tuned interneurons has been proposed as a mechanism that contributes to the production of specific scratch forms. In this hypothesis, the outputs of rostral-tuned interneurons support the co-activation of knee extensors and hip flexors that occurs during rostral scratching.

There are multisecond excitability changes that occur in the scratch CPG in response to tactile stimulation of a site on the body surface. In response to a brief stimulus, there is often a motor after discharge that outlasts the stimulus by several seconds [1]. After the motor after discharge has ended, there may also be activation of long afterdischarge interneurons in the spinal cord that fire for many seconds after the motor afterdischarge has ended. The firing of these interneurons may be a basis for a multisecond “memory” of cutaneous activation in the spinal cord. Intrinsic modulation of voltage-gated calcium channels in spinal circuitry may also occur following the activation of metabotropic glutamate receptors in response to a tactile stimulus [1]. Future experiments are needed to understand the roles of this intrinsic modulation in the production of scratch motor patterns.

### Function

Scratching serves to generate force against a site on the body surface that has received a tactile stimulus. One function of a scratch is to remove the object that has generated the tactile stimulus. For scratching to be successful, the nervous system must be able to calculate the location in space of the stimulated site on the body surface, and control the musculature of a limb so that a portion of the limb is moved to that same location in space. Scratching is an example of a ►sensorimotor transformation. Since scratching can be produced in animals with a complete transection of the spinal cord, spinal structures can perform sensorimotor transformations without neuronal interactions with supraspinal structures.



## Therapy

Studies of scratching provide support for the concept that spinal cord CPGs have considerable complexity. Rehabilitation strategies for spinal-injured humans based upon the assumption of spinal CPGs show considerable promise.

## References

1. Alaburda A, Hounsgaard J (2003) Metabotropic modulation of motoneurons by scratch-like spinal network activity. *J Neurosci* 23:8625–8629
2. Arshavsky YI, Gelfand IM, Orlovsky GN (1986) Cerebellum and rhythmical movements. Springer-Verlag, Berlin
3. Berkinblit MB, Feldman AG, Fukson OI (1989) Wiping reflex in the frog: movement patterns, receptive fields, and blends. In: Ewert JP, Arbib MA (eds) *Visuomotor coordination*. Plenum Press, NY, pp 615–629
4. Berkowitz A (2002) Both shared and specialized spinal circuitry for scratching and swimming in turtles. *J Comp Physiol* 188:225–234
5. Earhart GM, Stein PSG (2000) Step, swim, and scratch motor patterns in the turtle. *J Neurophysiol* 84:2181–2190
6. Robertson GA, Stein PSG (1988) Synaptic control of hindlimb motoneurons during three forms of the fictive scratch reflex in the turtle. *J Physiol (Lond)* 404:101–128
7. Stein PSG (1983) The vertebrate scratch reflex. *Symp Soc Exp Biol* 37:383–403
8. Stein PSG, Daniels-McQueen S (2002) Modular organization of turtle spinal interneurons during normal and deletion fictive rostral scratching. *J Neurosci* 22:6800–6809
9. Stein PSG, Smith JL (1997) Neural and biomechanical control strategies for different forms of vertebrate hindlimb motor tasks. In: Stein PSG, Grillner S, Selverston AI, Stuart DG (eds) *Neurons, networks, and motor behavior*. MIT Press, Cambridge, MA, pp 61–73
10. Stein PSG, Mortin LI, Robertson GA (1986) The forms of a task and their blends. In: Grillner S, Stein PSG, Stuart DG, Forssberg H, Herman RM (eds) *Neurobiology of vertebrate locomotion*. Macmillan Press, London, pp 201–216

SAD is the most common affective disorder unremittably experienced year after year in women of childbearing age living at temperate latitudes.

- ▶ Circannual Rhythm
- ▶ Circadian Sleep Phase Syndromes
- ▶ Melatonin

## Seasonality

ANTONIO A. NUNEZ, LAURA SMALE

Department of Psychology and Neuroscience Program, Michigan State University, East Lansing, MI, USA

### Definition

Seasonal changes that animals undergo in order to adapt to environmental circumstances as they vary across the year.

### Characteristics

Species from temperate zones experience considerable seasonal variation in their environments and many have developed complex adaptations to match their physiology and behavior to particular seasonal demands and opportunities. In mammals, the most prominent seasonal changes are seen in systems devoted to the control of energy balance and reproduction, but some species also show seasonality in non-reproductive social behaviors [e.g., aggression [1]] and immune competency [2], among other traits. There are many cues that animals can use to synchronize their seasonal cycles to environmental changes; fluctuations in average ambient temperature, rain fall and food availability are all possible candidates, but none of these is as reliable as progressive changes in daylength in predicting the flow of the seasons. Given this fact, it is perhaps not surprising to find that many species use daylength (▶ photoperiod) to phase their seasonal rhythms.

### Photoperiodism

The term ▶ photoperiodism has been adopted to refer to the use of daylength by a species to orchestrate seasonal cycles in physiology and behavior. Although the vast majority of the mechanistic studies on mammalian seasonality has focused on photoperiodic species such as hamsters, sheep and ferrets, there are examples of seasonal rhythms that are independent of photoperiod and which continue with a period close to a year under constant laboratory conditions. The annual cycle of body weight and body adiposity displayed by ground

## Seasonal Affective Disorder (SAD)

### Definition

Seasonal affective disorder (SAD) is another term for winter depression. SAD occurs in the same person every fall/winter and remits every spring. The treatment of choice is bright light exposure scheduled in the morning. However, low-dose melatonin administration in the afternoon/evening may also be effective. For some patients, bright light should be scheduled in the evening and melatonin should be taken in the morning.

squirrels is an example of an endogenous, ▶circannual rhythm that does not depend upon photoperiod [3].

Among the traits that show photoperiod-dependent seasonal cycles, reproductive physiology has received preferential attention. Work with a variety of animal models show how the shortening of the photoperiod, which signals that winter is approaching, and its lengthening in early spring can suppress gonadal function in spring and autumn breeders, respectively. Interestingly, this suppression is not maintained indefinitely, even if the animals are kept under the same daylength; after several weeks gonadal function returns to the level seen before the exposure to the non-stimulatory photoperiod. This rebound of reproductive competence is known as spontaneous recrudescence. That label implies that the recrudescence depends upon an endogenous mechanism but it also reflects our current lack of a mechanistic explanation for this phenomenon. The fact that there is a relatively fixed amount of time between gonadal regression and spontaneous recrudescence points to the existence of an ▶internal interval timer that is set by exposure to a non-stimulatory photoperiod (i.e., short days for spring breeders) or by a physiological change triggered by such photoperiod (e.g., a drop in the levels of gonadal or pituitary hormones).

### Photoperiodic Time Measurement and Melatonin

Pineal ▶melatonin has been shown to play a central role in the transduction of photoperiod into a physiological signal. Regardless of the species-specific distribution of sleep and wakefulness across the day–night cycle, the secretion of melatonin shows a nocturnal elevation that matches the length of the dark period. The duration of this nocturnal melatonin pulse is used by photoperiodic species to measure daylength and with very rare exceptions, ▶pinealectomy renders these animals insensitive to changes in photoperiod. The data from experiments with timed infusions of melatonin delivered to pinealectomized animals provide compelling evidence that the duration of the melatonin pulse drives the photoperiodic responses of the reproductive system. In hamsters relatively long-duration melatonin infusions result in gonadal regression regardless of the length of the prevailing photoperiod or the phase of the timed infusion with respect to the light dark cycle [4].

Light has two separate effects on the ▶pineal gland. It ▶entrains the ▶circadian rhythm of melatonin secretion to the light dark cycle and it can acutely suppress melatonin production during the night. The mammalian pineal gland is not itself photosensitive. It depends upon neural inputs for its responsiveness to light. The pathway that conveys both circadian and photic information to the pineal has been described in detail in several species. It starts in the retina where

a set of retinal ganglion cells that express the ▶photopigment melatonin give rise to the ▶retino-hypothalamic tract, which projects preferentially to the ▶suprachiasmatic nucleus (▶SCN). The SCN is the main ▶circadian pacemaker in mammals and it influences the pineal via a multisynaptic pathway that includes the hypothalamic ▶paraventricular nucleus and its long descending projections to pre-ganglionic sympathetic neurons of the spinal cord, which in turn contact the sympathetic units of the ▶superior cervical ganglia (▶SCG). Axons from the SCG reach the pineal and via the release of ▶norepinephrine regulate the synthesis and secretion of melatonin. Removing the eyes or transecting the optic nerve is equivalent to placing animals in short photoperiods or constant darkness. However, just like a pinealectomy, interruption of the pathway from the SCN to the pineal abolishes photoperiodic responses of most photoperiodic traits [2]. Notable exceptions are the short-day reduction in sexual behavior [5] and prolactin secretion [6] in female hamsters. These responses continue to be seen after the interruption of projections from the SCN to the paraventricular nucleus of the hypothalamus and may represent pineal-independent effects of photoperiod.

### Reading and Responding to the Melatonin Signal

Even though there is universal agreement that the length of the melatonin pulse serves to encode information about daylength in photoperiodic species, there is no consensus about where in the brain this signal is read and interpreted to induce remarkable changes in multiple systems. Brain lesions in several hypothalamic sites and central infusions of melatonin directed at specific targets have identified possible candidate sites for melatonin action. However, that literature features many species differences and contradictory results even within the same species. Often the effects of central melatonin infusions are specific to a particular trait, which indicates that there may be multiple sites that respond to melatonin in parallel for the photoperiodic control of specific systems. That the critical amount of daylength necessary to support summer like features differs for different traits in the same individual [7], also argues for multiple melatonin sensitive substrates with different thresholds.

Although there is no consensus about where melatonin acts in the brain to induce gonadal regression in spring breeders such as hamsters, it is clear that part of the cause for the collapse of the reproductive system is an increase in the effectiveness of gonadal hormone inhibition of ▶gonadotropin release from the anterior pituitary. This increased sensitivity to the negative feedback of gonadal steroids is a central effect, which results in diminished stimulation of the pituitary by ▶gonadotropin releasing hormone (GnRH). In short

days, the pituitary remains sensitive to GnRH stimulation as shown by the activation of gonadotropin release when gonadally regressed animals receive injections of the peptide. The recently discovered brain peptide kisspeptin, which directly stimulates GnRH neurons, may also play a role in the photoperiodic regulation of the reproductive system. In hamsters seasonal gonadal regression is correlated with a reduction of kisspeptin content in the anteroventral periventricular nucleus [8].

While the central sensitivity to the negative feedback of gonadal hormones increases in short days, male and female hamsters show a partial refractoriness to the activational effects of testicular and ovarian hormones on reproductive behavior. Thus, gonadectomized male hamsters treated with identical doses of exogenous testosterone only show full activation of the male copulatory pattern when exposed to long days [9]. Similarly, ovariectomized female hamsters treated with estradiol and tested with sexually active male hamsters rarely show ▶lordosis if they are kept in short days [10]. Therefore, in at least this species, seasonal infertility is achieved by suppressing the hormones of reproduction and by reducing the behavioral responsiveness to hormones that stimulate sexual behavior.

### Summary and Significance for Humans

The study of seasonality and particularly photoperiodic seasonality has identified a system that extends from the ▶retina to the pineal and that appears to serve as a transducer of information about daylength. This information, in the form of a nocturnal melatonin pulse, is used in a multitude of ways to produce seasonally appropriate adaptations, which increase survival and reproductive efficacy. All the components of this system have been conserved in humans, and there is evidence that humans show seasonality on a variety of traits and that these seasonal changes are driven by photoperiod. Some of us show seasonal changes in physiology and behavior, but for a few individuals these changes are extreme enough as to be considered a form of seasonal depression or ▶seasonal affective disorder (▶SAD). Knowledge derived from work with photoperiodic animal models is informing therapeutic interventions for SAD patients and is providing insights about milder forms of seasonal cycles in our species.

### References

1. Jasnow AM, Huhman KL, Bartnes TJ, Demas GE (2002) Short days and exogenous melatonin increases aggression of male Syrian hamsters (*Mesocricetus auratus*) *Horm Behav* 42:13–20
2. Nelson RJ, Demas GE (1996) Seasonal changes in immune function. *Q Rev Biol* 71:511–548

3. Zucker I, Boshes M (1982) Circannual body-weight rhythms of ground squirrels: role of gonadal hormones. *Am J Physiol* 243:R546–R551
4. Bartnes TJ, Powers JB, Hastings MH, Bittman EL, Goldman BD (1993) The timed infusion paradigm for melatonin delivery: what has it taught us about the melatonin signal, its reception and the photoperiodic control of seasonal responses? *J Pineal Res* 15:161–190
5. Badura LL, Sisk CL, Nunez AA (1987) Neural pathways involved in the photoperiodic control of reproductive physiology and behavior in female hamsters (*Mesocricetus auratus*). *Neuroendocrinology* 46:339–344
6. Badura LL, Goldman BD (1994) Prolactin secretion in female Siberian hamsters following hypothalamic deafferentation: role of photoperiod and dopamine. *Neuroendocrinology* 59:49–56
7. Duncan MJ, Goldman BD, DiPinto MN, Stetson MH (1985) Testicular function and pelage color have different critical daylengths in the Djungarian hamster, *Phodopus sungorus sungorus*. *Endocrinology* 116:424–430
8. Greives TJ, Mason AO, Scotti M-LL, Levine J, Ketterson ED, Kriegsfeld LJ, Demas GE (2007) Environmental control of kisspeptin: implications for seasonal reproduction. *Endocrinology* 148:1158–1166
9. Morin LP, Zucker I (1978) Photoperiodic regulation of copulatory behaviour in the male hamster. *Journal of Endocrinol* 77:244–258
10. Badura LL, Nunez AA (1989) Photoperiodic modulation of sexual and aggressive behavior in female golden hamsters (*Mesocricetus auratus*): role of the pineal gland. *Horm Behav* 23:27–42

## Second Messenger

### Definition

When a signal (protein hormones, growth factors, etc.) is received at the cell surface, second messengers are molecules that relay signals to target molecules inside the cell.

## Second Messenger Cascade

### Definition

Cascade of biochemical reaction activated by membrane receptors via trimeric G-protein leading to the generation of intracellular messengers, which in turn activate effector systems. Often mediate a considerable signal amplification.

## Second Messenger Pathway

### Definition

A general term indicating any of a number of intracellular signaling pathways activated by G protein-coupled receptors.

- ▶ G Protein-Coupled Receptor (Metabotropic Receptor)
- ▶ G-Protein Coupled Receptors (GPCRs) in Sensory Neuron Function and Pain
- ▶ G-protein Coupled Receptors (GPCRs): Key Players in the Detection of Sensory and Cell-Cell Communication Messages

## Second Somatosensory Cortex

- ▶ Somatosensory Cortex II

## Secondary Hyperalgesia

### Definition

Hyperalgesia at sites surrounding injured or inflamed areas.

- ▶ Hyperalgesia and Allodynia

## Secondary Motor Areas

### Definition

Motor areas of the cerebral cortex, other than primary motor cortex, located in the frontal lobe. These areas all contain corticospinal neurons and make synaptic connections with primary motor cortex. Six areas have been identified in primates including two areas on the lateral surface of hemisphere (dorsal premotor area, PMd and ventral premotor area, PMv) and four areas on the medial wall of the frontal lobe including supplementary motor area (SMA) and three cingulate motor areas (CMAr, CMAAd, CMAv).

- ▶ Corticospinal Neurons
- ▶ Motor Cortex: Output Properties and Organization

- ▶ Primary Motor Cortex (M1)
- ▶ Visual Space Representation for Reaching

## Secondary Neurodegeneration

### Definition

Progressive post-injury degenerative damage or death of neural tissue that escaped primary damage. It is mediated by many compounds and processes: for example, increased content of excitatory amino acids in the extracellular milieu; deprivation of growth factors; impairment of blood supply; increase in reactive oxygen species; and general ionic imbalance. The process is common to many neurodegenerative disorders and acute injuries of the central nervous system (CNS).

## Secondary Neurogenesis

- ▶ Adult Neurogenesis

## Secondary Prosencephalon

### Definition

Rostral subdivision of the embryonic forebrain that gives rise to the hypothalamus (ventrally), the telencephalon (dorsally) and the eye vesicle (laterally).

- ▶ Evolution and Embryological Development of the Forebrain

## Secondary Receptor Cell

### Definition

Specialized, non-neural sensory cell.

- ▶ Electroreceptor Organs

## Secondary Reinforcer

### Definition

Initially neutral sensory stimulus that obtained rewarding properties by previous association with a primary reinforcer.

- ▶ Operant Conditioning

## Secondary Sensory System

### Definition

- ▶ Sensory Systems

## Secondary Somatosensory Cortex (S2)

### Definition

A higher order sensory area, located within the depths of the lateral sulcus. Its inputs arise from a variety of sources, including S1 cortex and regions of the posterior parietal cortex. Receptive fields are often bilateral; inputs can be cutaneous or deep. There appear to be two body representations here: S2 proper is located caudally, while PV (parietal ventral area) is located rostrally.

- ▶ Primary Somatosensory Cortex (S1)
- ▶ Somatosensory Cortex, Plasticity

## Secondary Structure of Proteins

### Definition

The tendency of certain amino acid sequences to form ordered structures such as alpha helices or beta sheets. The amino acid sequence of an entire protein may be analyzed to determine those segments having a high probability of forming such structures (e.g. using the method of Chou and Fasman). For transmembrane proteins such as transmitter receptors or ion channels,

these predictions may be combined with those of hydropathy analysis to identify regions that might form transmembrane pores or gating structures.

## Secondary Vestibular Circuitry

- ▶ Vestibular Secondary Afferent Pathways

## Secretomotor Neuron

### Definition

Motor neurons of the enteric nervous system that innervate and evoke activity in the secretory glands of the digestive tract.

- ▶ Autonomic/Enteric Reflexes

## Seeing

- ▶ Vision

## Segment in Body Structure

### Definition

Many animals are organized with repeated body units called segments. In annelid worms, like the leech, each segment is much like the next, both in its external features, musculature, and internal organs. In vertebrate animals, the segments are not so recognizable externally or in visceral organs, but are easily seen in the organization of the musculature, in the spinal cord and its peripheral nerves, and in the pattern of their sensory and motor innervation. In fishes, the chevron-shaped bands of axial muscle that flake when we cook their flesh are called myotomes and correspond to segments.

Each myotome receives its motor (and sensory) innervation from a different spinal segment via its associated segmental nerves.

---

## Segmental Reflexes

### Definition

A short-latency electromyogram (EMG) response to muscle stretch or cutaneous stimulation that depends on rapid transmission of the sensory volley and evoked motor volley and involves monosynaptic or oligosynaptic pathways within the spinal cord. Also known as spinal reflexes.

- ▶ Electromyography
- ▶ Electric Fish

---

## Segmentation

### Definition

Segmentation is characterized by closely spaced contractions of the circular muscle layer, dividing the small bowel into small segments adjacent each other. Since these movements rhythmically alternate the sites of contractions (alternating contraction), the segmentation effectively mixes and circulates chyme.

---

## Segmentation of the Small Bowel

### Definition

Segmentation is characterized by closely spaced contractions of the circular muscle layer, dividing the small bowel into small segments adjacent each other. Since these movements rhythmically alternate the sites of contractions (alternating contraction), the segmentation effectively mixes and circulates chyme.

- ▶ Bowel Disorders

---

## Seizure

### Definition

Paroxysmal, abnormal, often excessive, repetitive, stereotypical pattern of brainwave activity. Can be provoked by fever, infection or other metabolic derangement or happen spontaneously as in epilepsy.

- ▶ Anticonvulsants
- ▶ Epilepsy

---

## Selective Feature Enhancement

- ▶ Contrast Enhancement

---

## Selective Vulnerability

### Definition

Selective vulnerability refers to the susceptibility of particular groups of neurons in the central and peripheral nervous system to age-associated neurodegeneration and death.

---

## Selective Working Memory

### Definition

Allows the formation of working memory, where task-relevant information is maintained in mind over a delay period while task-irrelevant information is filtered out through an attentional mechanism.

- ▶ Vision – Computational Approaches

---

## Selectivity

- ▶ Ion Channels from Development to Disease

## Self

ALBERT NEWEN

Institut für Philosophie, Ruhr Universität Bodium,  
Bodium, Germany

### Synonyms

The term 'self' is often used interchangeably with the term 'I' and 'person' to refer to human beings by characterizing the special epistemic or normative status of human beings.

### Definition

The self can be defined as the bearer of self-conscious states. From a naturalistic view the self is a cognitive system that enjoys some form of self-consciousness. Self-consciousness can be defined as the ability to consciously represent one's own states, especially (but not only) mental states, *as one's own* (Newen & Vogeley 2003). In the case of competent speakers this involves an indexical representation typically expressed by the word "I". If the relevant representation of my own states does involve neither language competence nor consciousness then we still have to presuppose a characteristic immediate self-representation. While "self" is mainly used to characterize the epistemic dimension of self-consciousness, i.e. the capacity to grasp first-person thoughts, "person" is used in debates searching for criteria of being a person which could serve as a basis for having rights and duties in society. From a linguistic point of view the term "self" is an artificial term which was constructed by nominalization of variants of the first-person pronoun "I" in natural language. We use expressions like "It's me," "myself," "she herself/he himself." "Self" was introduced to denote the bearer of the mental states of a self-conscious human being.

### Description of the Theory

We can distinguish four central questions concerning self-consciousness:

*The epistemological question:* Do we have a privileged access to our own mental phenomena such that only we can know with certainty which mental phenomena we have?

*The ontological question:* Is there a self as an ontologically nonreducible entity or can we explain all phenomena of self-consciousness without presupposing a self as a nonreducible entity?

*The Cognitive question:* How can we investigate the natural basis of self-consciousness with the methods of empirical psychology and cognitive neuroscience?

*The question about personal identity:* What is the criterion of being a person and of remaining the same person?

Philosophical thinking about self-consciousness was not invented by Descartes – as often stated or implicitly presupposed – but is already present in ancient philosophy. The first book discussing important aspects of a theory of self-consciousness is Plato's early dialogue *Charmides*. Since the history of self-consciousness is already presented in other overviews, let me illustrate these three dimensions of self-consciousness while concentrating mainly on the modern discussions:

1. The epistemological dimension: Do we have self-knowledge on the basis of a privileged access? The philosophers of the period from Descartes to Kant took two claims to be evident: the transparency and the infallibility of the mind. If someone is in the mental state M then he/she knows that he/she has that state (transparency). If someone believes that he himself/she herself is in the mental state M then he/she knows that this is so (infallibility). Both claims are no longer acceptable as general claims. Given that mental phenomena can be divided into mental dispositions, (mental traits like being jealous, being anxious etc.) on the one hand and mental events (occurrences of thinking, feeling or perception) on the other, the transparency of the mind is undermined by several systematic observations. It is obvious that my mental dispositions can often be more reliably evaluated by other persons observing me than by myself. Furthermore, there is evidence that the same is also true for certain occurrences of my beliefs and desires, namely unconscious ones (as e.g. presupposed in Freud's psychoanalysis). Unconscious occurrences of feeling and perception are presupposed in modern theories of selective attention. But not only the transparency thesis, also the infallibility thesis has to go: There are cases in which we consciously think that we are in a certain mental state M1 when in fact we are in a different state M2. Concerning feelings psychological studies show that we can characterize a special class of people (repressors) who systematically misclassify their own feelings when they are in situations which make them feel personally concerned (Weinberger & Davidson 1994). In such situations repressors report being perfectly calm even though their palms are sweating, their hearts are racing at 180 beats per minute etc. This demonstrates that one can have a basic emotion while lacking a conscious representation of it. Furthermore, there is a general argument against the infallibility of self-knowledge, which shows that even basic perceptual impressions can be misclassified and that we therefore do not always enjoy self-knowledge of these impressions: In order to have self-knowledge we must classify our mental states on the basis of concepts. If

there are circumstances in which I have partially inadequate concepts or in which I may misuse my correct concepts due to psychological disorders or mental traits, I will misclassify my own mental events. Self-knowledge of our own mental states presupposes a correct classification on the basis of our concepts and this is not infallible but only *de facto* often given under normal circumstances. By the way, it should have become clear that we do not enjoy any privileged access such that only we know with certainty which mental state we have. The only privilege we enjoy concerning our mental states is called familiarity (Ryle 1949): We have much more information about ourselves than other people because we recognize a lot of our mental states during our life while other people only share a part of it. But such a situation of familiarity has to be learned: Parents often are more familiar with their children's mental states than the children themselves. Presupposing that we have standard conceptual competence and psychological conditions, there is one further principal challenge to the possibility of self-knowledge. This challenge is mainly based on the claim that the content of our thought is partly dependent on the environment. Putnam's famous thought-experiment distinguishes Tom who lives on earth and Twin-Tom, a psychophysical *Doppelgänger* living on Twin-earth. The only difference between earth and Twin-earth is that in using the word "water" on earth we refer to the well-known substance H<sub>2</sub>O while Twin-Tom using the word "water" on Twin-earth refers to a substance which has the same superficial properties but nevertheless is chemically based on molecules XYZ. Independent of the question whether this difference in the essential properties is known to the speakers, the reference of "water" is a different substance. Therefore, if Tom utters "Water is a tasteless liquid" he is expressing a thought about H<sub>2</sub>O while Twin-Tom using the same words expresses a thought about XYZ. The conclusion of this thought experiment is that the content of thoughts is dependent on the environment. This is called externalism of thought. The challenge to self-knowledge is produced by the following claims: (a1) Self-knowledge about the content of our thoughts is only based on introspection and therefore is independent of the environment. (a2) The content of our thoughts is dependent on the environment (externalism).

The conclusion is: Either self-knowledge is impossible or externalism is wrong. Which part of the conclusion is the correct one is still part of the recent debate, but, the problematic preise is the externalism of thoughts while the externalism of utterances is widely accepted (Newen & Vogeley 2007).

2. The ontological dimension: Is there a self as an ontologically nonreducible entity? The *locus classicus* for a positive answer is the work of Rene Descartes. He claims that a person is constituted by a self as a purely

mental entity (*res cogitans*) and a distinct body as a purely material entity (*res extensa*). An alternative traditional view was developed by David Hume. According to his view the self is nothing but a bundle of impressions (or ideas) such that there is no nonreducible entity in addition to the impressions which are the basic entities in his framework. A third important traditional view is that of Immanuel Kant. He claims that the self is not an entity at all but only a condition of the possibility of experience, i.e. the self is something that has an important status, but it can only be characterized negatively and as a consequence of conceptual considerations: There has to be a self as a precondition of experience, because otherwise we do not have an explanation for the unity of our experiences.

We have thereby already outlined the three vivid options which still dominate the recent debate in the twentieth century. Thomas Nagel argued for the Cartesian view that any person has an objective self as a nonreducible entity, because he claims that without such a presupposition we could not account for the first-person-perspective which is characteristic for our experiences. Dennett, in the spirit of the Kantian strategy, developed the view that the self is a special abstract entity: It is the centre of gravity of the stories which a person tells about herself, because we have to account for the self-ascription of beliefs and desires in our autobiographical memory. The special status of the self is then parallel to the special status of the centre of gravity which a bike has: It is a theoretical abstract entity which is a consequence of physical theory in the case of the bike and theory of mind in the case of the self. Since this analogy is rather unspecific it remains unclear what status the self has in more detail.

Furthermore, there is a modern radicalization of the Humean view, the claim that the self is not an entity at all: According to Wittgenstein and Anscombe the self is nothing but a fiction we introduced because of grammatical fallacies: In natural language we use sentences like "I am in pain" which express the fact that we are suffering from pain. Wittgenstein insisted that we would express exactly the same just by uttering the vowel "AUA!". Since it does not even make sense to ask what the reference of such vowels is, Wittgenstein concludes that the impression that there is a reference of "I" is just a consequence of drawing wrong conclusions from the grammatical surface structure of natural language to the ontological structure of the world. Although this argument – relying on the synonymy of vowels and normal utterances – is very weak (because such a synonymy exists only in some special cases), the general position that the self is only a fiction has become supported by new arguments. Metzinger (2003) presented the self-model theory of self-consciousness, claiming that the human being is a neural machine which is able to construct a self-model.



The self-model is nothing but all the contents of the stream of consciousness a human being experiences at one moment. Since the self is identified with a *content*, i.e. the content of our phenomenal consciousness, it is just a fiction, an epiphenomenal product of our neural machinery. Theories which claim that the self is a content cannot account for the basic fact that we use the word “I” to talk about persons as human beings. Therefore, there is still the option of identifying the self with the person as human being. According to Peter Strawson the self is nothing but a person, i.e. a primitive natural entity which has both mental and physical properties. In this framework self-consciousness is not explained away as a fiction but treated as a special property of human beings. According to the philosophy of language we know that uttering I-sentences is a standard way of expressing self-conscious thoughts. The property of expressing self-conscious thoughts is closely connected to the so-called essential indexicality of the first-person pronoun “I” (Perry 1979): The thought expressed by uttering an “I”-sentence (e.g. “I am hungry” uttered by Ernst Mach) is different from the thoughts expressed by utterances in which only the word “I” is substituted by a term having the same reference (e.g. “Ernst Mach is hungry”) because only I-thoughts can have special motivational role. I will start to search for food only if I think that I am hungry. “I”-sentences have the feature of essential indexicality which is based on a property of self-conscious thoughts, namely the property of an immediate self-representation. The challenge for this common sense view is to explain the property of having an immediate self-representation.

3. The cognitive divison: There are at least two ways of investigating this core property, taking an ontogenetic perspective, on the one hand, and measuring neural correlates, on the other. Developmental psychologists started to investigate the development of human self-consciousness (Neisser 1998). This led to different models of distinguishing types of self-consciousness (e.g. Bermúdez, 1998). The challenge is that there are several intuition-based distinctions on the market, but what we need is a systematically founded typology (Newen & Vogeley, 2003). The general line of this research is to understand full-fledged self-consciousness by understanding the way it is developed in human ontogenesis and in principle also in evolution. A presupposition of these investigations is an analysis of the complex phenomenon self-consciousness into several cognitive competences which are necessary to have self-conscious thoughts. We can distinguish (i) perspectivity, (ii) agency, and (iii) mineness. Perspectivity includes the first-person-perspective we have in human perception but also in the case of self-ascribing beliefs. Agency means the feeling that we are causing an action, the feeling that the action is performed because

we want to perform it. Mineness can be characterized as the feeling that a bodily part (an arm, a leg) belongs to me, but also the feeling that a thought is *my* thought. The aim is to understand these fundamental cognitive capacities by investigating their development and explaining cases of malfunction in the case of mental diseases.

The second line of research aims at discovering the neural correlates of human self-consciousness. To measure neural correlates the general strategy runs as follows: On the basis of the conceptual analysis distinguishing perspectivity, agency and mineness, experimental paradigms to investigate different types of each capacity have to be developed. If an experimental design is validated then it can be used to measure the neural correlates. The first measurement of cognitive first-person-perspective was done by Vogeley, Bussfeld, Newen et al. (2001) measuring the neural correlates of the capacity to self-ascribing beliefs. There are further measurements of neural correlates of first-person-perspectives (Newen & Vogeley 2003, Ruby & Decety 2001 & 2003, Vogeley & Fink 2003).

Concerning the general strategy to naturalize human self-consciousness there is one basic argument which shows that we have to account for nonconceptual self-consciousness as a form of basic self-consciousness which is independent of and prior to linguistic competence. The argument is called the paradox of self-consciousness. It consists in the following incompatible propositions (Bermúdez 1998):

1. The only way to analyze the capacity to think a particular range of thoughts is by analyzing the capacity for the canonical linguistic expression of those thoughts (the Thought-Language-Principle).
2. The key to analyzing self-consciousness is to analyze the capacity to think “I”-thoughts.
3. “I”-thoughts are canonically expressed by means of the first-person pronoun and mastery of the first-person pronoun requires the capacity to think “I”-thoughts.
4. A noncircular account of self-consciousness is possible.

There is the additional background assumption that the capacity to think “I”-thoughts meets the Acquisition Constraint which says that if a given cognitive capacity is psychologically real, then there must be an explanation of how it is possible for an individual in the normal course of human development to acquire that capacity. If we accept that self-consciousness is independent from language competence (by denying 1) then we have to account for nonconceptual as well as conceptual forms of self-representation (Newen/ Vogeley 2003).

4. Personal identity: Self-consciousness is closely related to the debates on personal identity. The question

“What are the criteria of individuating a person?” was introduced by John Locke and he claimed that the person, which he identifies with the self, is defined by the continuation of the content of the memory the human being ascribes to itself. This criterion can be called the demand of psychological continuation. It means that if a human being loses his memory then he no longer remains the same person. Modern thought experiments can illustrate another consequence of this criterion (Parfit 1984): If the content of the memory is represented in the brain and the brain of Peter is transplanted into the body of Karl, then the body of Karl including the brain of Peter will be the person Peter. Psychological continuation only demands a partial overlap of the memories to individuate a person. One problematic consequence of this criterion is that it can easily be imagined that there are several human beings fulfilling the criterion of partial overlap of memories with the content of the self-ascribed memories of Peter at the time  $t_0$ . Presupposing that the memories of Peter at  $t_0$  are represented in his brain, we can make the following thought experiment: One half of Peter’s brain is transplanted into the body of Jo and the other half of Peter’s brain is transplanted into the body of Sam. It is presupposed that in both cases a significant part of Peter’s memories was transferred to Jo as well as to Sam. If this scenario seems too unrealistic then think of the brain as a piece of hardware. Then the same result of having a significant overlap with Peter’s memories at  $t_0$  can be produced by whatever method leads to copying or transferring a large part of Peter’s memories to Sam’s brain and to Jo’s brain. In both varieties of thought transfer the intuitive result is that Sam and Jo both have a significant overlap with Peter’s memories at  $t_0$ . Who then is the person Peter at  $t_1$ , after the transplantation of his brain partly into Sam and partly into Jo? The criterion says that there cannot be two persons which are both Peter and in the scenario of copying the memories of Peter into another brain, provided it happens without harming Peter, we would even have three persons Peter, the original one being identical with Sam and Jo. This leads us to an unacceptable violation of our intuitions concerning the principle of identity: Because of the normal change of a human being over time we have to accept that human beings differing in their material constitution can be the same person at different times. We cannot however accept that different human beings are the same person at the same time. Modern views of personal identity try to combine a criterion of space-time continuation with the demand of psychological continuation.

The modern debates in philosophy and cognitive science about the self are characterized by a lot of different scientific approaches – partly mentioned above – which aim at naturalizing the self and self-consciousness in all its facets, on the one hand, and

some new considerations which try to present principle reasons for the thesis that this aim can never be reached (Baker 1998, Bealer 1997), on the other.

## References

1. Newen A, Vogeley K (2003) Self-representation: the neural signature of self-consciousness. *Consciousness & Cognition* 12:529–543
2. Weinberger DA, Davidson MN (1994) Styles of inhibiting emotional expression: distinguishing repressive coping from impression management. *Journal of Personality* 62:587–613
3. Ryle G (1949) *The concept of mind*. Hutchinson, London
4. Newen A, Vosgerau G (2007) A representational account of self-knowledge. *Erkenntnis* 67:337–353
5. Metzinger T (2003) *Being no one*. MIT Press, Cambridge
6. Perry J (1979) The problem of the essential indexical. *Nous* 13:3–21
7. Neisser U (1998) Five kinds of self-knowledge. *Philosophical Psychology* 1:37–59
8. Bermudez JL (1998) *The paradox of self-consciousness*. MIT Press, Cambridge
9. Vogeley K, Bussfeld P, Newen A, Herrmann S, Happe F, Falkai P, Maier W, Shah NJ, Fink GR, Zilles K (2001) Mind reading: neural mechanisms of theory of mind and self-perspective. *Neuroimage* 14:170–181
10. Newen A, Vogeley K (2003) Self-representation: the neural signature of self-consciousness. *Consciousness & Cognition* 12:529–543
11. Ruby P, Decety J (2001) Effect of subjective perspective taking during simulation of action: a PET investigation of agency. *Nature Neuroscience* 4:546–550
12. Ruby P, Decety J (2003) What you believe versus what you think they believe: a neuroimaging study of conceptual perspective-taking. *European Journal of Neuroscience* 17:2475–2480
13. Vogeley K, Fink GR (2003) Neural correlates of first-person-perspective. *Trends in Cognitive Science* 7:38–42
14. Parfit D (1984) *Reasons and persons*. Clarendon Press, Oxford
15. Baker, LR (1998) The first person perspective: A test for naturalism. *American Philosophical Quarterly* 35:327–348
16. Bealer G (1997) Self-consciousness. *The Philosophical Review* 106:69–117

## Self-administration

### Definition

In a behavioral experiment the animal may be awarded. If the animal is allowed to administer the award by itself, we speak of self-administration. This way of award is often used to study the addictive potency of a drug.

## Self-antigen

► Anti-DNA Antibodies against Microbial and Non-Nucleic Acid Self-Antigens

## Self-appraisal

### Definition

Self-appraisal refers to the process of self-reflecting on and evaluating own meta-cognitive knowledge and strategies (i.e., declarative) (e.g., what strategies are relevant), procedural (e.g., how to apply them), and conditional (e.g., why they are effective and when they should be applied).

► Metacognition

## Self-consciousness

### Definition

A person has self-consciousness when she has a thought that she can express in the first person singular. In a supermarket, one may be well aware that the person with the torn sugar bag is making a mess without realizing that it is oneself who is making a mess.

Realizing this, one lives through an episode of self-consciousness expressible by “I am making a mess.” Sometimes only an introspective awareness of one’s own consciousness is called “self-consciousness.”

► Argument  
► Logic

## Self-management

### Definition

Self-management refers to the dynamic process of translating metacognitive knowledge adaptively to the task performance, and can be described as metacognition in action. It includes at least the three processes for actions: Planning, on-going evaluation by monitoring,

and regulation by modifying plans and changing/adjusting strategies, and these three processes recur repeatedly depending upon situations.

► Metacognition

## Self-motion Cues

### Definition

Self motion cues are derived directly from locomotion and provide feedback information about speed and direction of motion. Self motion cues are egocentric.

Therefore, in order to provide information to update a location on a map, self motion cues must be accompanied by a sighting, which positions and orients the traveler on the map. Self-motion cues include proprioception (sensations from the body), optic flow, and feedback from motor commands – also called an efference copy. A synonym for self motion is idiothetic.

► Navigation

## Self-perception

### Definition

A concept in spatial cognition that involves mentally representing one’s own action, other’s action, and observation of action. Representations between self and others are shared, but not identical, influencing processes of empathy and social interaction.

► Spatial Cognition

## Self-renewal

### Definition

Ability to go through numerous (virtually-indefinite) cycles of cell division while maintaining the undifferentiated state. To ensure self-renewal, stem cells undergo two types of cell division: symmetric cell division gives rise to two identical daughter cells both endowed with stem cell properties, while asymmetric

cell division produces only one daughter stem cell and one progenitor cell with limited self-renewal potential.

One theory claims that the molecular distinction between symmetric and asymmetric cell division in neural stem cells lies in differential segregation of certain cell membrane proteins (such as receptors) between the daughter cells. An alternative theory – the cell non-autonomic regulation of stemness during adulthood - is that stem cells remain undifferentiated from environmental cues in their particular germinal niche. Stem cells eventually differentiate once they leave that germinal niche or no longer receive those environmental regulators.

► Autoimmune Demyelinating Disorders: Stem Cell Therapy

---

## Self-sustaining Oscillation

### Definition

One can imagine at least two starkly different mechanisms for keeping track of the passage of time. On the one hand are timekeeping mechanisms like hourglasses, which only encode the passage of time relative to an external triggering event, and can only keep time continuously if that external triggering event repeatedly occurs. On the other hand are self-sustaining oscillators like pendulum clocks, which encode the passage of time relative to an internally determined repeating interval of time, in this case the 12-h half-day, and keep time over multiple intervals without requiring external triggers.

Circadian clocks are all self-sustained oscillators, as demonstrated by the continuation of circadian rhythms of various biological functions when organisms are maintained in environments that are devoid of any external cues to the passage of time.

- Cellular Clock
- Circadian Rhythm
- Morning/Evening Oscillators
- Oscillator Versus Hourglass Timers

---

## Self-synapse, Recurrent Synapse

- Autapse

---

## Semantic Memory

### Definition

Semantic memory refers to knowledge of the world. This system processes, stores and retrieves information about the meaning of words, thoughts, concepts, objects, actions, and facts.

- Amnesia
- Long-Term Memory
- Memory and Dementia

---

## Semantic Priming

### Definition

A form of priming in which the prime is semantically related to a subsequent test word.

- Latent Learning

---

## Semantical Behaviorism

- Behaviorism, Logical

---

## Semantical Physicalism

### Definition

The view that every mental sentence (or predicate) can be translated without loss of meaning into a non-mental sentence (or predicate).

- Behaviorism
- Logic

## Semantics (Two-Dimensional)

CHRISTIAN NIMTZ

Department of Philosophy, University of Bielefeld,  
Bielefeld, Germany

### Definition

“Two-dimensional semantics” denotes a family of semantic theories rooted in intensional semantics, held together by shared general ideas, yet divided by deep divergences in semantic aims and philosophical aspiration. Two-dimensional theorists agree that our sentence’s truth-values vary with what the facts are, as well as with what the sentences mean. To model this twofold dependence of truth on fact and meaning, 2D semantics assigns our expressions intensions of more than one kind. The resulting formal framework, common to all 2D semantics, distinguishes one dimension of actual worlds and primary intensions from a second dimension of counterfactual worlds and secondary intensions (hence, two-dimensionalism). These formal similarities often obscure the deep conceptual rifts between different interpretations of the 2D framework. Kaplan interprets it to capture context-dependence; Stalnaker understands it to model meta-semantic facts, and Chalmers construes it to display the epistemic roots of meaning.

### Description of the Theory

#### Fundamental Ideas of Two-Dimensional Semantics

Traditional intensional semantics assigns a sentence a single intension. This intension captures how the truth of the sentence depends on, and varies with, the respective facts. Two-dimensional semanticists draw our attention to another dependence. A sentence’s truth-value also depends on, and varies with, what the sentence means. Two-dimensional semanticists agree that our semantics has to account for this twofold dependence of truth-value on meaning and fact, and they agree that we can capture both dependencies relying on the apparatus of possible worlds and intensions familiar from intensional semantics. We just need to add the distinction between counterfactual and actual worlds, and we have to make use of the threefold distinction of kinds of intension this effects.

The twofold dependence noted is most pronounced in sentences containing indexicals. Whether “I am in *Milano*” is true in some possible world depends on the facts in that world, and it depends on who utters this sentence in the first place. If Pavarotti utters it, the sentence is true in a possible world if in that world, Pavarotti is in Milan. If someone else utters it, the sentence has different truth-conditions. Put generally,

the truth of an indexical sentence in some counterfactual world depends on what is the case in that world, and it depends on what is the case in the actual world it is uttered in. This inspires a general way to analyze the twofold dependence noted. We can hold that whether a sentence is true in some counterfactual world depends on the facts, depicted by what is the case in that world, and it depends on what the sentence means, determined by what is the case in the actual world. The counterfactual and actual worlds set apart here are not different entities. What gets discriminated are two different roles the very same possible worlds can play (assuming that we specify for worlds considered as actual a center consisting of a speaker, a place, and a time).

The distinction between counterfactual and actual worlds allows 2D semanticists to distinguish three different kinds of intensions. An expression’s *primary intension* assigns it an extension in every *actual* world, determining a function  $f: W_A \rightarrow E$  from actual worlds to extensions. An expression’s *secondary intension* assigns it an extension in every *counterfactual* world, determining a function  $f: W_C \rightarrow E$  from counterfactual worlds to extensions. An expression’s *two-dimensional intension* assigns it for any actual world a secondary intension, determining a function  $f: W_A \rightarrow (W_C \rightarrow E)$  from actual worlds to secondary extensions that portray how the expression’s primary and secondary intensions interlock.

Assigning these different intensions to a sentence allows 2D semantics to capture the way its truth-value varies with the actual and counterfactual world and, hence, depends on fact and meaning. A plausible assignment of intensions to “I am in *Milano*” is this: the primary intension of “I am in *Milano*” yields varying extensions across actual worlds depending on who utters the sentence. The secondary intension yields varying extensions across counterfactual worlds, depending on whether or not the one having uttered “I” is in these counterfactual circumstances in Milan. The 2D intension combines these two, capturing for each actual world which secondary intension an utterance of “I am in *Milano*” in this actual world effects.

The resulting formal structure (see Fig. 1), comprising two dimensions of worlds and three kinds of intensions, is common to all 2D semantics. Two-dimensional semanticists agree that we can model all representational properties of our language by assigning primary, secondary, and/or two-dimensional intensions to our terms and sentences. This consensus extends to the dimension of counterfactual worlds and secondary intensions. Two-dimensional semanticists agree that this dimension captures how an expression’s extension depends on the facts, and they take these worlds and intensions to be the possible worlds and

		Dimension 2 counterfactual worlds →		
		W1	W2	W3
Dimension 1 actual worlds →	W1*	W	W	f
	W2*	f	W	W
	W3*	W	W	f

**Semantics (Two-Dimensional).** Figure 1 A 2D matrix displaying a sentence's intensions for a small sample of worlds. The diagonal displays a single primary intension. Each row displays a secondary intension. The whole matrix displays a single two-dimensional intension.

standard intensions familiar from traditional intensional semantics. There is no consensus on the understanding of actual worlds and primary intensions. Two-dimensional theorists agree that this dimension captures how an expression's extension depends on what it means. This claim is open to interpretation, and the paradigmatic interpretations put forth by Kaplan, Stalnaker, and Chalmers exhibit deep divergences in semantic aim and philosophical aspiration. They even yield different answers to the questions (i) "What are actual worlds?" and (ii) "What precisely do we need actual worlds and primary intensions for?"

#### Kaplan: Actual Worlds as Contexts of Use

Kaplan [1,2] propounds a semantic interpretation of the 2D framework. He holds that (i) actual worlds are contexts, or possible occasions expressions can be used in, and he (ii) maintains that we need actual worlds and primary intensions to model the context dependence of language.

Kaplan detects an asymmetry between indexical tokens and indexical types. Indexical tokens have reference but no descriptive meaning. An utterance of "I" in a context refers to an individual. This fact exhausts its meaning. Pavarotti's utterance "I am in *Milano*" thus expresses a proposition about *him*, i.e., Pavarotti. Indexical types, on the other hand, have descriptive meaning but no reference. The type "I" does not refer. It still has a descriptive meaning any competent speaker must know. This meaning consists in a conventionally assigned rule dictating that any utterance of "I" refers to whoever produces the token in the respective context. Thus, the sentence type "I am in *Milano*" does not express a proposition, but any

competent speaker will know which proposition a token of this type expresses *if* it is uttered in a context.

Kaplan concludes that we must distinguish two kinds of meaning. Linguistic tokens have *contents*. The content of a term captures what it refers to, and the content of a sentence is the proposition it expresses. Linguistic types have *characters*. The character of an expression is a conventionally determined rule dictating which content a token of that expression expresses if it is uttered in a context. The characters of terms like "grandmother" will assign all tokens the very same content. By contrast, the characters of indexicals and demonstratives will assign their tokens varying contents, depending on the respective contexts.

It is this dependence of token meaning (or content) on type meaning (or character) cum context that Kaplan captures by means of a 2D framework. He models contents as secondary intensions. He models characters as two-dimensional intensions. The character of a sentence type specifies a secondary intension for each actual world, and thus captures how the proposition expressed by a token of that sentence varies with the context the token occurs in.

#### Stalnaker: Actual Worlds as Means for Reinterpretation

Stalnaker [3,4] offers a meta-semantic interpretation of the 2D framework. Stalnaker's holds (i) that actual worlds are possible alternative environments we might have introduced our terms in, and he (ii) distinguishes the subject matter of the 2D framework from its application: we need the apparatus of actual worlds and primary intensions to describe meta-semantic facts, but we put it to a pragmatic use.

Endorsing (i)–(iii), Stalnaker finds himself in a quandary: (i) Being necessarily true, the proposition expressed by "Hesperus = Phosphorus" does not exclude any possibility. (ii) A sentence can be used to communicate contingent information about the world only if the proposition it conveys excludes some possibility. (iii) "Hesperus = Phosphorus" can be used to communicate contingent information about the world. To resolve the puzzle, Stalnaker distinguishes the proposition *conveyed* with an informative use of "Hesperus = Phosphorus" from the proposition *expressed* in that use. The latter is determined by the standard semantic rules for the sentence, and it is necessarily true. The former is inferred from the speaker's pragmatic communicative intentions, and it is contingent. Reinterpreting the speaker's utterance to convey this contingent proposition allows the hearer to make sense of his utterance.

Reinterpretation is a familiar pragmatic procedure. If the standard semantic content of an utterance manifestly violates a conversational maxim, we assign it a different content by drawing on the speaker's communicative intentions. This is what the hearer of "Hesperus =

Phosphorus” does, noticing that the standard proposition expressed is ill-fit to convey information. The hearer reasons thus: (i) “Hesperus” has been introduced as a name for the brightest star in the evening, and “Phosphorus” has been introduced as a name for the brightest star in the morning. (ii) Which objects these introductions did yield depended on astronomical facts in our actual world. If the astronomical facts in the actual world had been relevantly different, “Hesperus” and “Phosphorus” would name two different objects. (iii) What the speaker intends to convey is that our world is one where this is not so. He wants to convey that our world conforms to the proposition *that the brightest star in the evening = the brightest star in the morning*.

It is this dependence of semantic meaning on introductory procedure cum actual world that Stalnaker captures by a 2D framework. He models standard semantic meanings as secondary intensions. Stalnaker models the propositions assigned in reinterpretation as primary intensions (which he calls, in line with Fig. 1, *diagonal propositions*). By displaying how an expression’s extension varies with the respective actual world, a primary intension captures how a term’s standard semantic meaning varies with the circumstances under which it is introduced.

### Chalmers: Actual Worlds as Epistemic Possibilities

Chalmers [5–8] offers an *epistemic* interpretation of the 2D framework. Chalmers (i) maintains that actual worlds are epistemic possibilities, and he (ii) holds that we need actual worlds and primary intensions to capture the epistemic dependence of meaning.

Chalmers draws on two ideas. His one idea is that reference and truth are *scrutable*. Given a description of our world cast in neutral terms, a speaker can (in principle) *a priori* infer what her expressions refer to, and which of her sentences are true. From a description of the appearance, make-up, and behavior of chemical substances that makes no use of the term “gold,” she can *a priori* infer the truth of “Gold is the chemical element with atomic number 79.” Chalmers’ other idea is that of epistemic modality. Epistemically possible hypotheses depict ways our world might be for all we can (in principle) *a priori* know, and a complete epistemic possibility depicts an epistemically possible world. For all we can know *a priori*, gold could be the chemical element with atomic number 55. A world in which this is true, hence, is an epistemic possibility. Chalmers merges these ideas in his thesis of *generalized scrutability*. Given a description of any epistemically possible world phrased in neutral terms, a competent speaker can (in principle) *a priori* infer what her terms refer to in that world, and which of her sentences are true in that world. This ability reveals that speakers associate epistemic intensions – i.e., functions from epistemically possible worlds to extensions – with their terms and sentences. The epistemic

intension associated with an expression is fundamental to the expression’s significance. For one thing, it captures cognitive significance. If a term plays a cognitive role for a speaker at all, she associates an epistemic intension with it that reveals what the term means for her. Secondly, the epistemic intension determines an extension in the actual world. For the actual world simply is the actualized epistemic possibility. Thirdly, the epistemic intension will ground the counterfactual intensions of all terms whose counterfactual intension depends on actual world extension.

It is this dependence of truth and reference on our ability to determine *a priori* extensions in epistemically possible worlds that Chalmers captures by means of a 2D framework. He identifies secondary intensions with standard truth-conditional meanings, and he employs two-dimensional intensions to model the dependence of secondary intensions on primary ones. Chalmers identifies primary intensions with epistemic intensions. By displaying how an expression’s extension varies with the respective actual world, a primary intension captures how a term’s actual extension varies with the respective epistemic possibility that is realized in our world.

### References

1. Kaplan D (1977/1989) Demonstratives. In: Almog J (ed) Themes from Kaplan. Oxford University Press, Oxford, pp 481–563
2. Kaplan D (1989) Afterthoughts. In: Almog J (ed) Themes from Kaplan. Oxford University Press, Oxford, pp 565–614
3. Stalnaker R (1978) Assertion. *Syntax Semant* 9:315–332
4. Stalnaker R (2004) Assertion revisited: on the interpretation of two-dimensional modal semantics. *Philos Stud* 118:299–322
5. Chalmers D (2002) On sense and intension. *Philos Perspect* 16:135–182
6. Chalmers D (2004) Epistemic two-dimensional semantics. *Philos Stud* 118:153–226
7. Chalmers D (2004) The foundations of two-dimensional semantics. In: Garcia-Carpintero M, Macia J (eds) Two-dimensional semantics: foundations and applications. Oxford University Press, Oxford
8. Chalmers D, Jackson F (2001) Conceptual analysis and reductive explanation. *Philos Rev* 110:315–360

## Semaphorin

### Definition

Family of secreted or cell surface-bound guidance molecules with attractive and repulsive actions mediated by receptors comprising plexin proteins and,

in certain cases, neuropilin. Semaphorins mainly act as short-range signals (semaphor is the Greek word for signal) to deflect growing axons from innervating inappropriate regions.

► Growth Inhibitory Molecules in Nervous System Development and Regeneration

---

## Semaphorin-3A

### Definition

Semaphorins constitute a family of secreted and transmembrane signaling proteins. In the nervous system, members of this family have been shown to play a role in axon pathfinding, branching and targeting. Some members of this family, including semaphorin-3A, function as chemorepellents of specific growth cones.

- Axon Pathfinding
- Growth Cone
- Semaphorin

---

## Semicircular Canals

### Definition

Parts of the membranous labyrinth in the form of semicircular ducts that stem from a structure of larger diameter (utricle). There are three for each side, oriented along three different, roughly orthogonal planes and contain labyrinthine (ampullar) receptors located in an enlargement at the base of each canal (ampulla). Angular acceleration in space induces motion of endolymph within the canals, which is maximal when the plane of rotation corresponds to that of the canal and absent when the two planes are perpendicular. The central axons of the primary afferents from the vestibular system (vestibular nerve) run with the VIIIth cranial nerve and terminate in the vestibular nuclei.

- Peripheral Vestibular Apparatus
- Utriculus
- Vestibular Nuclei
- Vestibular Primary Afferent Pathways in Mammals
- Evolution of the Vestibular System

---

## Semicompatibilism

### Definition

The thesis that free action is compatible with the truth of determinism even if the ability to have acted otherwise than one in fact acted is incompatible with the truth of determinism.

- Freedom of Will

---

## Semi-intact Preparations

### Definition

Typically refers to in-vitro preparations in which some part of the body is kept intact in addition to the nervous system. For example, semi-intact preparations of spinal cord along with attached hindlimbs can be used to record muscular contractions in response to stimulation of the spinal cord tissue. These preparations provide opportunities to better approximate in vivo conditions while retaining the ability to control the external environment.

---

## Sender

### Definition

In communication theory the partner that emits a signal.

---

## Senescence

- Olfaction and Gustation Aging

---

## Senile Dementia

- Alzheimer's Disease – Oxidative Injury and Cytokines



## Senile Dementia of the Alzheimer's Type

► Alzheimer's Disease – Oxidative Injury and Cytokines

## Senile Plaque

### Definition

A characteristic feature of the brains of Alzheimer's patients. It consists of a core of amyloid fibrils surrounded by dystrophic neuritis and is accumulated in the extracellular region. A principal component in senile plaques is amyloid fibrils, which are derived from the amyloid precursor protein (APP).

► Alzheimer's Disease  
 ► Neuroinflammation: Chronic Neuroinflammation and Memory Impairments

## Sensation Level (SL)

### Definition

The decibel level expressed relative to some other level measured in an experiment.

► Acoustics

## Sense Data (Singular: Sense Datum)

ALEXANDER STAUDACHER  
 Institut für Philosophie, Otto-von-Guericke-  
 Universität Magdeburg, Magdeburg, Germany

### Synonyms

Sensa (singular: sensum)

### Definition

One of the central debates in the philosophy of perception deals with the question of what we are immediately aware of in perception. According to sense-datum-theories the

objects of this immediate awareness are sense data. A typical example for a sense datum is the more or less round, red, bulgy expanse you are immediately aware of when you see a ripe tomato during normal daylight. At first, one might think that sense data are identical to those surfaces of physical objects facing us in a perceptual situation. In this case the claim that, in perception, we are immediately aware of sense data would just spell out our common sense assumption that, in perception, we are immediately aware of the facing surfaces of physical objects. But sense data should be distinguished from these surfaces for the following four reasons: (i) certain changes in the perceptual situation lead to changes in our sense data, whereas the features of the surfaces of the perceived physical objects are not affected by these changes: if you change your perspective on the tomato in the right way you will become aware of a new sense datum which is not round but elliptical; the surface of the physical object, however, won't undergo any such change. Likewise, with a change of the lighting-conditions you might become aware of a sense datum showing a different color, whereas the surface doesn't change. Finally, drugs, impairments of sense organs or psychological factors like expectations or prejudices concerning the object of perception may influence what kind of sense data we will have without any change in the perceived physical objects. (ii) Sense data are generally taken to be private, that is, they are accessible only to one perceiving subject and not to other subjects. Physical objects, on the other hand, are taken to be publicly accessible to many perceiving subjects. (iii) Most defenders of sense data take them to exist only when we are aware of them. Physical objects are generally supposed to continue to exist when nobody is aware of them. (iv) In cases of hallucination where no physical object is present at all (think of the rats hallucinated by the delirious drinker or the dagger that appears to Macbeth in Shakespeare's play), there is nevertheless a sense datum present which we are aware of. The same holds in cases of illusions where we are aware of a sense datum with properties differing from those of the physical object present in that perceptual situation (when you immerse a straight oar into water you will be aware of a sense datum which is bent).

These four points lead on the one hand to the question of how sense data are related to the physical objects of our environment and on the other hand to the question of how they are related to our perceptual awareness. To the first question the two main sense datum theories, ►phenomenalism and ►indirect or representative realism, give radically different answers explored in the next section. To the second question a certain version of the so called "act-object analysis" of perceptual awareness has been customarily presented as an answer. According to this analysis, perceptual states consist of two parts which have to be distinguished:

an act of awareness (sometimes called the “act of sensing” or just the “sensation”) and a sense datum which is the object this act is directed upon [1]. Since sense data form a part of a mental state, they have to be seen as something mental and therefore cannot exist unperceived.

### Description of the Theory

Sense data have been given two roles in the literature: (i) they have been taken as necessary for an adequate account of what we are immediately aware of in perception. (ii) They have been seen as the secure base of our empirical knowledge because it has been held that we cannot err with respect to their character: if a sense datum appears to you red it has to be red. You might mistake a white plate during sunset to be pink but you cannot mistake the pink expanse you experience in this situation for something else. It is important to note that one can give sense data the first role without putting any weight on the second role. The motivating idea behind the second role is the claim that empirical knowledge needs a secure fundament. One might refuse this idea, however, without giving up the claim that sense data play an indispensable role as immediate objects of perceptual awareness, because physical objects, as they are conceived by common sense, cannot play this role. Most of the more recent defenses of sense data theories lay their emphasis only on the first role. Therefore, this essay will concentrate on this point.

Historically, sense data can be seen as the heirs of the “ideas” or “impressions” of the epistemology of the seventeenth and eighteenth century, since the latter also had to play the two mentioned roles. The heyday of sense-datum-theories was the first half of the twentieth century [2–5]. For more recent defenses see [1,6–8].

According to common sense we are in perception immediately aware of the physical objects we perceive and these objects share the characteristics given in the four distinctive features above. Therefore, a defender of sense data has to give up either the claim that we are in perception immediately aware of physical objects or the claim that they share all of these features. Indirect realism follows the first route and phenomenalism the second one.

According to indirect realism, our perception of physical objects is only indirect because it is mediated by the immediate awareness of sense data in the following way: in the case of veridical perception a physical object will initiate a causal chain which leads via an affection of our sense organs and respective processes in the brain to the appearance of a sense datum (or a collection of sense data, for that matter). Such a sense datum serves the perceiver as a representation or sign of the physical object. In cases of illusion and hallucination the causal chain leading to the appearance of the sense datum doesn’t start with the same kind of object as in the case of

veridical perceptions. In the case of hallucinations it starts in the brain, because no external object is present. In the case of illusions it starts with an object that has properties which are different from those the object of your immediate awareness has. Indirect realism can admit that we perceive physical objects, but it claims that we have to distinguish between the objects of our immediate perceptual awareness (sense data) and the objects of perception (physical objects). Phenomenalism, on the other hand, does not distinguish between sense data and physical objects in that way. According to this theory physical objects are nothing but complex sequences of actual and possible sense data. A tomato is then nothing but the complex sequence of actual sense data I have at the time of seeing and touching it now and the sequence of possible sense data I would have if I changed my perspective relative to it, cut it into pieces and so on. If sense data exist only when we are aware of them, this leads to the consequence that physical objects cannot exist independently of the fact that we are aware of them. The common sense assumption that a rock in the desert also exists when no one perceives it becomes, in the hands of phenomenalism, the claim that one would be aware of the required rock-like sense data if one went to the relevant place in the desert. (For more on phenomenalism and indirect realism see the essay “perception.”)

But why adopt any sense-datum-theory at all? Several arguments in favor of the existence of sense data have been put forward. The general idea behind these arguments is always the same: First it is argued that there is a certain class of cases where it is impossible that we are immediately aware of physical objects, so that at least in these cases we have to be aware of something different. Then it is claimed that only by supposing our immediate awareness of certain objects of another kind, namely sense data. Can we do justice to these cases in the next step it is claimed that there is no sensible argument which allows us to restrict the result to these special cases, so we finally have to admit that we are in all cases of perception immediately aware of sense data.

The most famous of these arguments is probably the ► **Argument from illusion**. The conclusion that we are in perception always immediately aware of sense data is reached here in four steps. The first step consists of the observation that in perception things sometimes appear to possess sensory qualities (colors, forms, felt temperatures etc.) then they don’t possess. The second step is the claim that in all cases where something appears to a subject to possess a sensory quality, there is something of which the subject is aware which does possess that quality. The third step, an application of a logical principle known as Leibniz’ law, holds that if an object *a* possesses a sensory quality that an object *b* lacks, then *a* is not identical to *b*. According to the fourth step there is such continuity between those cases

in which objects appear other than they actually are and cases of veridical perception that the same analysis of perception must apply to both. An example may be helpful for illustration: A straight oar immersed in water will appear bent. Therefore, what we are immediately aware of can't be the straight oar, but must be a sense datum which is bent. And because of the continuity of the perceptual situation we will also be aware of a sense datum when we remove the oar from the water. But then we may conclude that we are always immediately aware of sense data.

Well known arguments coming to the same conclusion as the Argument from Illusion by more or less similar routes include the following: The ► **Argument from perspectival variation**: Objects appear different to us from different perspectives although the objects themselves don't change. Therefore, we have to be aware of different sense data in order to explain these changes. The ► **Argument from hallucination**: In cases of hallucinations where no object is present at all we are nevertheless aware of something which has certain sensory qualities, and therefore we are aware in these cases of certain sense data which are the bearers of these qualities. Since hallucinations and veridical perceptions are indistinguishable for the perceiving subject we can conclude that we are also aware of sense data in the latter case. The ► **Argument from science**: Science tells us that nothing has the properties it appears to have in perception. For example, nothing is colored in the way it appears colored to our eyes and what appears a grainless solid structure may in reality be a swarm of molecules. Therefore, perception we have to be aware in of something other than physical objects, namely sense data which are literally colored and appear grainless and solid. The ► **Time gap argument**: Our perceptual awareness is restricted to the present, we can't be immediately aware of things existing at earlier or future times, and all perception requires the transmission of information from the perceived object. These processes need time (as is most obviously the case when light from long ago extinct stars reaches our eyes), therefore, what we are immediately aware of in these cases can't be the physical object but has to be a sense datum. For a detailed critical discussion of these and related arguments compare [8,9].

Criticisms of sense-datum-theories take generally the following forms: (i) the validity or soundness of the aforementioned arguments is questioned. (ii) It is argued that a conception of sense data as special kinds of mental objects leads to difficulties better of avoided. (iii) Phenomenalism and indirect realism being, It being the relevant theories are supposed to have general implications which are utterly implausible or even disastrous. (For a discussion of this point see the essay on ► **perception**).

Concerning (i) only two prominent criticisms concerning the refusal of the second premise of the Argument

from Illusion can be briefly noted here. This premise has been criticized as fallacious in a variety of ways but the most common strategy is just to deny that in cases of illusory perception there has to be something which possesses the sensory qualities the physical object lacks. If we erroneously believe that our neighbor has got a new car, the possibility of this false belief doesn't presuppose that we are aware in this case of someone else, possibly existing only in our mind, who has a new car. Indeed, such a supposition would be a mistake, because then our belief wouldn't be about our neighbor but about this other person. If this is true in the case of belief why should we invoke special objects as bearers of sensory qualities in the case of perception? Defenders of the Argument from Illusion typically retort that perception forms a special case here, because the apparent features of objects we are presented with in perception are present in one specially vivid way lacking in the cases referred to in this criticism. In the case of illusions we not only take the physical object to be different from the way it actually is, the illusory feature (e.g. a color the physical object lacks) is vividly present in perceptual consciousness as a property of the object of awareness [8].

In order to avoid the introduction of sense data at this point the so-called adverbial theory of experience has held that the phenomenal aspect of our sense experiences can be analyzed in the following way: a vivid conscious experience of something red (be it veridical or not) can be understood as a certain way of perceiving; that is, we are not conscious of something instantiating the property which is responsible for the character of our conscious experience (a sense datum), but our perceptual state itself is characterized by that property, in the case of a experience as of something red we "sense in a redly manner" as it has been put [10]. It has been claimed, however, that this account cannot deal adequately with situations where we have an awareness of a manifold of different items with different colors and forms because this seems to require being aware of different items instantiating these properties [1].

Concerning (II) the following problems have been prominent in the debates: if sense data are something mental how can their existence be accommodated within the most widely shared metaphysical position of today, physicalism, which holds that everything is physical? Defenders of sense data can try here to refute physicalism [8], or they can try to reduce the data to physical phenomena along the lines of an identity of theory [7]. A related difficulty concerns the question where sense data have to be located, if they are to be distinguished from physical phenomena. Sense data possess extension (an expanse is at least two-dimensionally extended; there is no unanimity among the defenders of sense data whether they are three-dimensional or not), which seems to require that they are located in space. But can we locate them in physical space? They are private in the sense that

only the person who experiences them has access to them. Objects in physical space are not private in that way, however. One might introduce here private spaces but such a proposal leads to further difficulties, in particular of the question how these private spaces are related to each other and how they are related to public physical space. And this is not the only problem with respect to the claim that sense data are private: The claim also seems to be at odds with the common sense claim that different persons can be, in perception, immediately aware of the same object. This seems to be a presupposition of the idea that it makes sense at all to dispute the way things appear to us in perception. Furthermore, it has been contested whether the conception of a private object makes any sense at all.

Generally, sense data have been taken to be the way they appear to the perceiver. This was why they were introduced them in cases of illusion etc. While the straight oar immersed in water isn't bent there is another object which really is as it appears: the bent sense datum. But this claim leads to the following difficulty: sometimes the features of objects we are aware of will appear indeterminate; e.g. when we see a speckled hen the number of its speckles will appear indeterminate. If we are aware of a sense datum in this situation, and sense data are exactly as they appear, the sense datum in question would have an indeterminate number of speckles. But this is a logical impossibility. At least one defender of sense data has simply contested the applicability of this logical principle to sense data [2]. But defenders of sense data might try to solve the problem by claiming that the number of speckles is only indeterminate in the sense that we are unable to determine it by counting the speckles in the given amount of time. This is compatible with the idea that the sense datum has a determinate number of speckles we are all perceptually aware of.

## References

1. Jackson F (1976) Perception. A representative theory. Cambridge University Press, Cambridge
2. Ayer AJ (1940) The foundations of empirical knowledge. Macmillan and Co., London
3. Broad CD (1965) The theory of sensa. In: Swartz RJ (ed) Perceiving, sensing and knowing. Anchor Books, Garden City
4. Price HH (1954) Perception. Methuen, London.
5. Russell B (1912) The problems of philosophy. Home University Library, New York
6. Maund B (2003) Perception. McGill-Queen's University Press, Montreal
7. Perkins M (1983) Sensing the world. Hackett, Indianapolis
8. Robinson H (1994) Perception. Routledge, London
9. Pitcher G (1971) A theory of perception. Princeton University Press, Princeton
10. Chisholm R (1957) Perceiving: a philosophical study. Cornell University Press, Ithaca/NY

---

## Sense of Agency

### Definition

The sense of being the owner of one's own actions.

- ▶ Action Representation

---

## Sense of Balance

- ▶ Evolution of the Vestibular System

---

## Sense of Effort

### Definition

This sense refers to the perceived motor command associated with voluntary movements and muscle contractions. It is generated by sensory signals from muscles and by central signals related to the motor command required for the movements or muscle contraction.

---

## Sense of Equilibrium

- ▶ Evolution of the Vestibular System

---

## Sense of Smell

- ▶ Olfactory Sense

---

## Sense of Uprightness

- ▶ Verticality Perception

## Sensitive Period

### Definition

In the life span of an animal, the ability to react to environmental changes is not constant. There is a period during which exposure to abnormal conditions leads to abnormal function. This period is called sensitive period. The sensitive period has to be discriminated from the critical period. The latter describes the time during which an organism acquires normal function if it is exposed to normal conditions (see also Critical Period).

## Sensitivity of Sensory Receptors

### Definition

In regard to the physiological characteristics of a sensory receptor cell, sensitivity is defined in relation to two variables: threshold and steepness (gain) of the relationship between stimulus intensity and receptor response. The detection sensitivity is inversely related to the detection threshold, while the gain sensitivity is related to the steepness in a static or dynamic gain curve. Corresponding Definitions hold for central neurons.

- ▶ Sensory Systems

## Sensitization

### Definition

Sensitization is a type of non-associative learning that results in an increase in responses in general (increase in arousal and enhancement of all reflexes) or responses once habituated. Sensitization typically occurs when noxious or fearful stimuli are presented to an animal.

- ▶ Learning
- ▶ Sensory Plasticity and Perceptual Learning
- ▶ Startle Response
- ▶ Learning and Motivation

## Sensitization in Nociception

### Definition

- ▶ Hyperalgesia and Allodynia
- ▶ Pain

## Sensor

### Definition

A sensor is a device with the capability of transforming one type of energy into another. Sensor differs from actuator in the way it is used. The sensor is used to transform physical system variables into signals readable by the user.

- ▶ Control

## Sensor Fusion

- ▶ Posture – Sensory Integration

## Sensorimotor

### Definition

Animals register external events by their sensors and they act by their motor system. In general, the sensory information is represented in a different coordinate system than that of the motor system. Thus, the information has to be transformed from one code in the other. The processes underlying this transformation happen in sensorimotor areas and may be called sensorimotor transformations.

## Sensorimotor Integration

### Definition

The process of generating appropriate motor outputs, based on sensory inputs. In order to efficiently move in the world, we must integrate incoming sensory signals with each other and with motor commands. For example, to reach for a visual object, one must integrate visual representations of the object and its location with proprioception from the moving arm and hand, together with motor commands that appropriately project the arm in space. For many behaviors, motor actions and sensory processing are so tightly woven together that the two processes become inseparable.

## Sensorimotor Learning and the Basal Ganglia

MINORU KIMURA, YASUMASA UEDA  
Kyoto Prefectural University of Medicine,  
Kawaramachi-Hirokoji, Kamigyo-ku, Kyoto, Japan

### Synonyms

Value, actions and reinforcement learning in the basal ganglia

### Definition

Sensorimotor learning in the basal ganglia refers to the learning in which neurons in the striatum learn to encode and update the reward values of external stimuli and actions based on the reward prediction error signals from dopamine neurons.

### Characteristics

#### Dopamine-Dependent Plasticity of Cortico-Striatal Synaptic Transmission

The striatum is a rostro-caudally elongated subcortical structure, and is composed of laterally located putamen and medio-dorsally located caudate nucleus. It is the input stage of the basal ganglia receiving major signals from almost all parts of the cerebral cortical areas and centro-median parafascicular nuclei of the thalamus in a topographically organized manner. These projections use glutamate as a transmitter. In addition, dopamine neurons in the substantia nigra pars compacta, serotonergic neurons in the dorsal raphe and noradrenergic neurons in the locus ceruleus project to both the putamen and caudate nucleus. Motor cortical areas in

the frontal cortex and post-central somatosensory cortex project to the putamen, while the prefrontal, parietal and temporal cortical areas project to the caudate nucleus.

The axon terminals of cortical pyramidal neurons end and synapse on the spine of dendrite, while those of the thalamus end on the shaft of proximal dendrite of medium-spiny neurons of the striatum. The axons of single cortical neurons make as many as 2,900 (average 879) synapses on the striate neurons [1]. Varicosities of dopamine neurons make synapses on the neck of the dendritic spine (Fig. 1).

For single medium-spiny neurons in the striatum, about 10,000 terminals of pyramidal neurons in the cortex and 1,000 dopamine varicosities are estimated to make synapses on their dendrite [2]. This characteristic arrangement of synapses of cortical and dopaminergic origins makes an ideal framework for modification of cortico-striatal signal transmission by dopamine inputs. Indeed, long-term potentiation of cortico-striatal EPSP occurs in a dopamine D1 receptor-dependent manner [3].

### Striatal Neurons Learn to Encode Action-Specific Reward Value

As mentioned above, the striatum is the locus of converging cortical and subcortical signals on actions, external sensory events, motivation or reward value and others in a variety of combinations. This makes the striatal neuron activity so variable. A subset of neurons is selectively activated during limb movement or eye movement, another subset of neurons are activated by external stimuli and appear when the subjects are performing behavioral tasks. Still another subset of

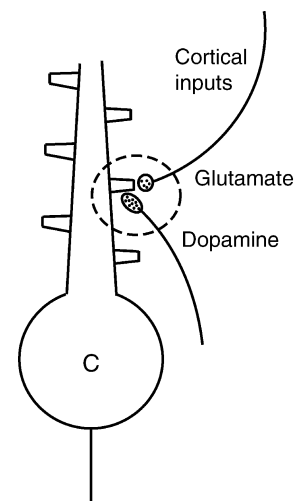

### Sensorimotor Learning and the Basal Ganglia.

**Figure 1** Schema of synaptic arrangement on the dendrite of striate projection neurons. Cortical terminals synapse on the spine, while dopamine varicosities contact with its neck.

neurons is activated when the outcomes of behavioral responses have occurred. While the **basal ganglia** receive signals of action, sensory events, motivation or reward value in the striatum, their outputs are directed mainly to the cerebral cortex through the cortico-basal ganglia loops [4] and partly to the superior colliculus and brain stem. A key question about the basal ganglia functions is: How are the variety of neural signals represented in the striatum different from those in the cerebral cortex? Limb or eye movement-related neurons are found in both the striatum and cerebral cortex. Similarly, neurons encoding reward value of external events are found in both structures.

Recent studies revealed an important aspect of representation and processing of sensorimotor signals in the striatum. For instance, through T-maze learning of rats, Graybiel and her group found that striatal neurons learn to encode automatized procedures of behavioral acts [5], suggesting involvement of the basal ganglia in habit learning. Caudate nucleus neurons of monkeys respond to visual cues for the directions of saccadic eye movements after which a reward is delivered. The magnitude of the responses is broadly tuned to the contralateral visual field. But if a reward is given only after the saccade to one of eight directions, neuronal responses are strongly biased towards the reward direction [6].

In another study by Samejima et al., monkeys performed a reward-based free choice task of turning a handle to the left or right [7]. They held a handle in the center position for 1 s, and turned the handle in either the left (L) or right (R) direction. The handle-turn was followed by either a large reward or a small reward. The probabilities of a large reward after left- and right-turns were fixed during a block of 30–150 trials, and varied between five types of trial blocks. In the “90–50” block, for example, the probability of a large-reward for the left-turn was 90%, and for the right-turn, 50%. In this case, by taking the small reward as one hundred ( $r = 100$ ), the value for the left-turn  $Q_L$  was 90 and the value for the right-turn  $Q_R$  was 50. There are four asymmetrically rewarded blocks, “90–50,” “50–90,” “50–10,” and “10–50,” and one symmetrically rewarded block, “50–50.” The neuronal activity related to reward expectation could be dissociated from that related to action selection. Although the monkeys should prefer the left-turn in both the 90–50 and 50–10 blocks, the reward values are different. Conversely, in the 90–50 and 10–50 blocks, although the monkey’s choice behavior should be the opposite, the action value for the right-turn  $Q_R$  remains at 50. **Figure 2** shows a representative neuron in which the delay period

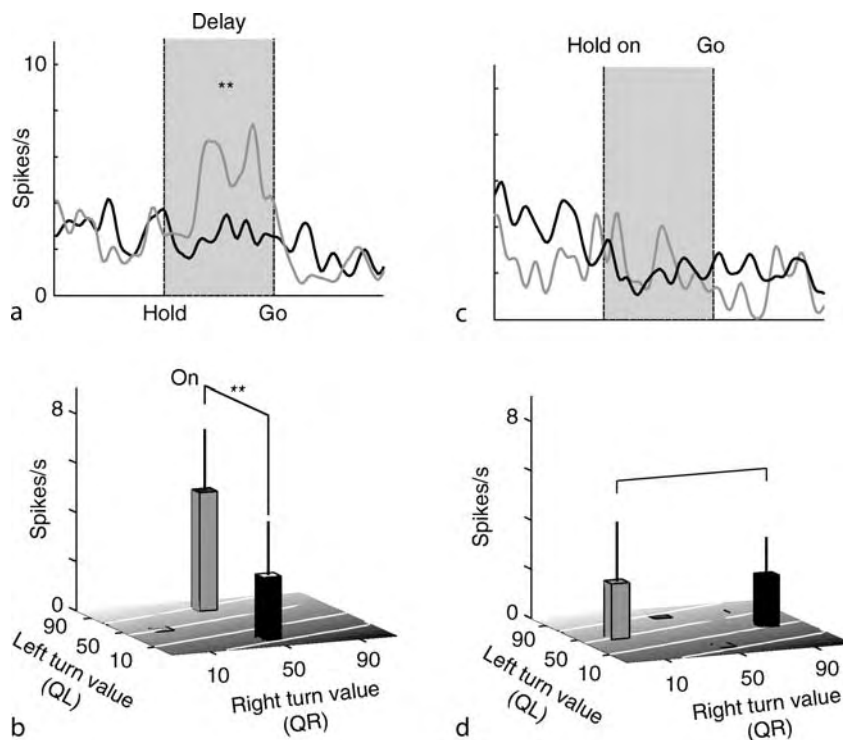

**Sensorimotor Learning and the Basal Ganglia. Figure 2** A “left-turn value neuron” Firing rates in 90–50 (grey) are higher than 10–50 (dark) block (a,b), but weak in both 50–10 (grey) and 50–90 (dark) blocks (c,d). Adapted from [7].

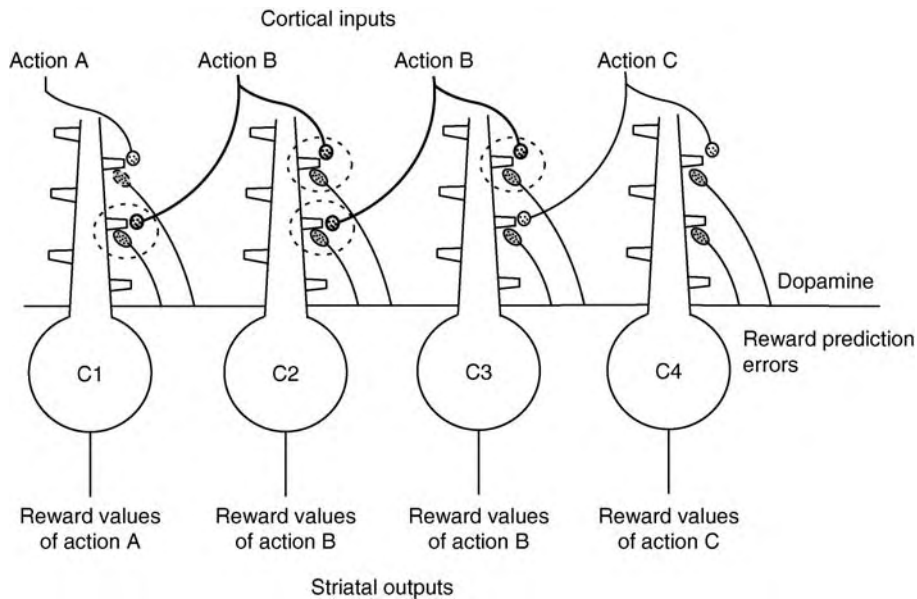

**Sensorimotor Learning and the Basal Ganglia. Figure 3** Hypothetical schema of how the striatal neurons encode reward values of actions. The cortical signal of action B is reinforced and updated by dopamine's reinforcement signals.

discharge rate was significantly higher in the 90–50 block (grey) than in the 10–50 block (dark).

This suggests that the neuron is selective to either left-turn action because monkeys turn the handle to the left in most trials of 90–50 block or left-turn value. But, because the neuron is only weakly activated during both 50–10 and 50–90 blocks (Fig. 2c and d), this neuron is regarded as a “left-turn value neuron.” There was a similar number of “right-turn value neurons.” The observation revealed that action-specific reward values are represented in the activity of the striate neurons rather than in the preparation for particular actions or relative values between the two alternative actions.

### Reinforcement Learning in the Basal Ganglia

How are the signals of action-specific reward values represented in the striatum processed for action and cognition, specifically for action selection? An important answer to the question was obtained by examining whether the monkey's action choice could be predicted by action values, which are estimated by previously chosen actions and their outcomes, and updated by reward prediction errors using a standard reinforcement learning model [8]. Samejima et al. [7] showed that the action values thus estimated successfully predicted individual action choices of monkeys. Furthermore, the discharge rates of “left-turn value neurons” and “right-turn value neurons” was correlated with the action values on a trial-by-trial basis [7]. Figure 3 illustrates schematically how the striatal neurons encode and update action-specific reward values based on the

action signals from the cerebral cortex and reward prediction error signals from the dopamine neurons.

This suggests that the action values are used for selection among alternative actions, and supports the proposed reinforcement learning model of basal ganglia [9]. On the other hand, it is still to be studied where and how the action value-based selection of action occurs. Does it occur in the striatum or its downstream? Intriguingly, while action value coding neurons are dominant in the striatum, neurons in the internal segment of globus pallidus, output nucleus of the basal ganglia, preferentially encode reward values of chosen actions [10]. This suggests the selection mechanisms are downstream of the striatum. Further research is necessary to answer the key question of how the reward values of behavioral cues and actions are encoded, stored and updated by dopamine signals for pursuing a multi-step action plan towards specific distant goals.

### References

1. Kincaid AE, Zheng T, Wilson CJ (1998) Connectivity and convergence of single corticostriatal axons. *J Neurosci* 18:4722–4731
2. Doucet G, Descarries L, Garcia S (1986) Quantification of the dopamine innervation in adult rat neostriatum. *Neuroscience* 19:427–445
3. Reynolds JN, Hyland BI, Wickens JR (2001) A cellular mechanism of reward-related learning. *Nature* 413:67–70
4. Hoover JE, Strick PL (1993) Multiple output channels in the basal ganglia. *Science* 259:819–821
5. Jog MS, Kubota Y, Connolly CI, Hillegaart V, Graybiel AM (1999) Building neural representations of habits. *Science* 286:1745–1749



6. Kawagoe R, Takikawa Y, Hikosaka O (1998) Expectation of reward modulates cognitive signals in the basal ganglia. *Nat Neurosci* 1:411–416
7. Samejima K, Ueda Y, Doya K, Kimura M (2005) Representation of action-specific reward values in the striatum. *Science* 310:1337–1340
8. Sutton RS, Barto AG (1998) *Reinforcement Learning*. The MIT Press, Cambridge
9. Doya K (2000) Complementary roles of basal ganglia and cerebellum in learning and motor control. *Curr Opin Neurobiol* 10:732–739
10. Pasquereau B et al. (2007) Shaping of motor responses by incentive values through the basal ganglia. *J Neurosci* 27:1176–83

## Sensorimotor Transformation

### Definition

The processes in a neuronal network involved in the production of a specific motor output in response to a distinct pattern of sensory inputs.

## Sensorineural Hearing Loss

### Definition

Hearing loss due to pathology of the inner ear and/or neural pathways.

►Hearing Aids

## Sensory Adaptation

### Definition

Adaptation to sensory stimuli may involve changes in receptor sensitivity (peripheral adaptation) or inhibition along the sensory pathways (central adaptation).

Sensory cells respond strongly to acute changes in their environment but cease responding when stimuli become constant. A decrease in responsiveness of sensory cells due to continual stimulation.

►Sensory Systems

## Sensory Aphasia

### Definition

Aphasia resulting from lesion to ►Wernicke's area (posterior part of the temporal lobe adjacent to the occipital and parietal lobes).

## Sensory Ataxia

### Definition

A►**ataxia** resulting from loss of sensory nerve fibers (►**sensory neuropathy**), which may be due to a number of diseases. The ensuing loss of ►**proprioception** (position and movement sense) creates difficulties in standing and walking. Patients stand with feet apart and show the ►**Romberg sign** with feet together and eyes closed or in the dark. Patients walk with feet widely apart, lifting them more than necessary and flinging the legs forward and outward in abrupt motions. Sensory neuropathy also leads to severe disturbances of voluntary arm and precision movements.

►Romberg's Sign

►Sensory Neuropathies

►Proprioception: Effect of Neurological Disease

## Sensory Conflict

### Definition

►Central Vestibular Disorders

## Sensory Control of Locomotion

►Locomotor Reflexes

## Sensory Dimension

### Definition

The way an individual perceives awareness or intensity of a particular setting, process, characteristic, attitude, or sensation. A full description of a particular item would usually include the sensory dimension of the item, along with its affective, cognitive, and behavioral dimensions.

senses; e.g., vision (light), hearing and touch (mechanical), temperature (thermal), olfaction (chemical).

► Sensory Systems

## Sensory-evoked Activity

Action potential electrical discharges recorded in the central nervous system following stimulation of sense organs or (tactile or electrical) stimulation of a sensory or mixed nerve in the periphery.

► Peripheral Feedback and Rhythm Generation

## Sensory Input

### Definition

A neural signal which encodes information which has been transduced via a sensory organ or fiber. These neural signals provide afferent information or “input” to neural centers which regulate reflexes, behaviors or homeostatic functions.

► Sensory Systems

## Sensory Integration

► Hippocampus: Organization, Maturation, and Operation in Cognition and Pathological Conditions

## Sensory Modality

### Definition

Is the type of physical phenomena that can be distinguished as a perception associated with the human

## Sensory Modulation of Central Pattern Generators

## Sensory Motor Learning/Memory and Cerebellum

TOMOO HIRANO

Department of Biophysics, Graduate School of Science, Kyoto University, Kyoto, Japan

### Definition

All animals including human beings obtain information about the external world through sensory organs such as eyes, ears, a nose, a tongue, skin etc., and respond to the stimuli by executing some actions with muscular movements in some cases. The sensory information is processed and integrated in the central nervous system, and the action is coordinated. The cerebellum plays a critical role in the motor control utilizing sensory information. The efficacy or smoothness of action in a particular condition improves with practice. Such improvement is the sensory motor learning. The cerebellum is also implicated in this type of learning, which is classified into the procedural learning (► Procedural memory).

### Characteristics

The cerebellum plays roles in the motor control and in the sensory motor learning. Familiar examples of the latter are improvement of skills in sports or riding bicycles with practice. However, the characteristics and mechanisms of sensory motor learning have been studied utilizing simple model tasks such as ► adaptation of vestibulo-ocular reflex or saccadic eye movement, ► prism adaptation, and classical conditioning.

### Adaptation of Vestibulo-Ocular Reflex

A head position of animal does not stay still during execution of an action. Thus, the visual scene captured

by an eye would move or drift (retinal slip, image motion on the retina), possibly causing blur of the image. You can experience such blur by watching the replay of video recorded with a camera held by someone's hands that would sometimes make you feel like seasick. However, we can usually get clear vision of the external world even if we are moving, and do not suffer from seasick in daily life. We owe this to two reflex mechanisms that compensate the eye position during the head movement. One is the vestibulo-ocular reflex and the other is the optokinetic response [1]. In the vestibulo-ocular reflex, the inner ears (semicircular canals and otolith organs) sense the head motion and send information to vestibular nuclei, and then to motor neurons controlling extraocular muscles. This reflex pathway enables eyeballs to move in the opposite direction of head motion. In the optokinetic eye movement, the movement of whole visual field is detected and the eyeballs move in the same direction of the visual field movement.

For the best performance of vestibulo-ocular reflex, the eyeball has to turn the same amount as the head turn in the opposite direction without delay. However, this is not an easy job. The sensory input that drives the vestibulo-ocular reflex is not visual signal but the information about the angular acceleration of head turn. Thus, the input sensory system has no way to know how well the retinal slip is suppressed by the reflex. Integration of visual and head rotation information is necessary for the good performance of reflex. The cerebellum adjusts the amplitude and timing of reflex by combining vestibular, visual, and eye movement information. The neuronal circuit controlling the vestibulo-ocular reflex is schematically presented in Fig. 1.

►Purkinje neurons, sole output neurons of the cerebellar cortex, send inhibitory outputs on neurons in the vestibular nuclei. The excitability of vestibular nuclei neurons is controlled by these inputs. Thus, the information transmission through the brainstem reflex

pathway is regulated by the cerebellum. A mismatch of the visual and the vestibular inputs alters the vestibulo-ocular reflex so that the retinal slip is reduced. This phenomenon is the adaptation of vestibulo-ocular reflex. The mismatch occurs when a man wear glasses or an extraocular muscle is injured etc. In experiments, the mismatch can be brought about by rotating an animal placed in front of a dotted or striped screen that is moving either in the same or opposite direction to the animal rotation. The activities of Purkinje neurons change gradually when such a mismatch is given to the animal. A cause of the alteration in ►Purkinje neuron activities has been considered the long-term depression, a type of long-lasting modulation of synaptic transmission (synaptic plasticity) occurring in Purkinje neurons. Detailed explanation about the long-term depression is described below. The long-term depression and the resultant alteration of Purkinje neuron activities have been considered to contribute to the adaptive modification of vestibulo-ocular reflex, although implication of additional mechanisms such as alteration in vestibular nuclei neurons has been suggested [2,3].

Optokinetic response also undergoes adaptation in some animal species, in which the amplitude of eye movement is less than that of the external scenery, resulting in a certain retinal slip. Continuous presentation of sinusoidally oscillating scene to an animal gradually increases the amplitude of eye movement so that the retinal slip is reduced. Long-term depression is also implicated in this adaptation.

### Eye Blink Conditioning

►Eye blink conditioning is one type of classical conditioning. Application of air puff to an eye or electrical stimulation around an eye makes the eyelid close. This is a simple defensive reflex to prevent injury of an eyeball, and the air puff or electrical stimulation that always induces the response is called an unconditioned stimulus (US), and the response induced

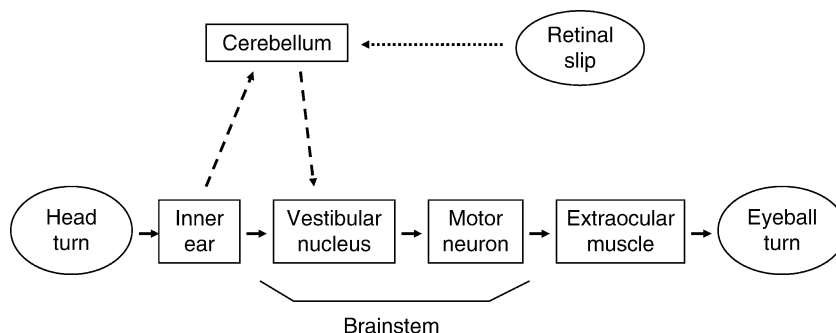

**Sensory Motor Learning/Memory and Cerebellum. Figure 1** Neuronal pathways controlling the vestibulo-ocular reflex.

by an unconditioned stimulus is called an unconditioned response (UR). When some sound is presented before application of the air puff repeatedly, the animal learns to close the eye just hearing the sound. This phenomenon is the eye blink conditioning [4], and the sound is called a conditioned stimulus (CS) and the response induced by the conditioned stimulus is called a conditioned response (CR). The eye blink conditioning is similar to Pavlov's conditioned reflex.

The cerebellum is involved in this eye blink conditioning. The lesion of cerebellum impaired the conditioning. Implication of the long-term depression has been reported. The information about CS is transmitted to a cerebellar nucleus and also to Purkinje neurons through parallel fibers and that about US is transmitted to Purkinje neurons through climbing fibers (Fig. 2).

Mossy fibers and climbing fibers are the major inputs to the cerebellar cortex. A climbing fiber forms large number of excitatory glutamatergic synapses on a Purkinje neuron. On the other hand a mossy fiber forms glutamatergic synapses on granule neurons. More than 100,000 granule neurons form glutamatergic synapses on a Purkinje neuron through parallel fibers (axons of granule neurons). Coupling of CS and US induces the long-term depression at parallel fiber-Purkinje neuron synapses, decreasing Purkinje neuron activities and hence inhibition on neurons in the cerebellar nucleus. Thus, neuronal activities in the cerebellar nucleus are upregulated, facilitating the information flow through the CS pathway including the cerebellar nucleus. Involvement of the central nervous system other

than the cerebellum such as the hippocampus in the eye blink conditioning has also been known.

### Long-Term Depression

Long-term depression is a type of synaptic plasticity accompanied with the long-lasting decrease in the efficacy of synaptic transmission [5]. In a cerebellar Purkinje neuron, the repetitive coupled activation of parallel fibers and a climbing fiber induces the long-lasting depression at the parallel fiber synapses. It has been proposed that the climbing fiber conveys the information regarding the motor error, and that the long-term depression works to reduce the information flow through the parallel fibers that have been involved in the error production (Fig. 2).

The cellular and molecular mechanism of long-term depression has been studied in vitro preparations such as brain slices and neuronal culture. A climbing fiber forms large numbers of glutamatergic synapses on dendrites of a Purkinje neuron providing exceptionally strong excitatory synaptic drive. Thus, when a climbing fiber is activated, a large increase in the intracellular  $Ca^{2+}$  concentration is induced in the postsynaptic Purkinje neuron. In contrast, each parallel fiber forms only one or two glutamatergic synapses on dendritic spines of a Purkinje neuron. The excitatory postsynaptic potential induced by a parallel fiber activation is far smaller than that by a climbing fiber. On the postsynaptic membrane of a Purkinje neuron at parallel fiber synapses, both ionotropic AMPA ( $\alpha$ -amino-3-hydroxy-5-methyl-4-isoxazole propionic acid) type glutamate receptor and metabotropic glutamate receptor (mGluR1) are located.

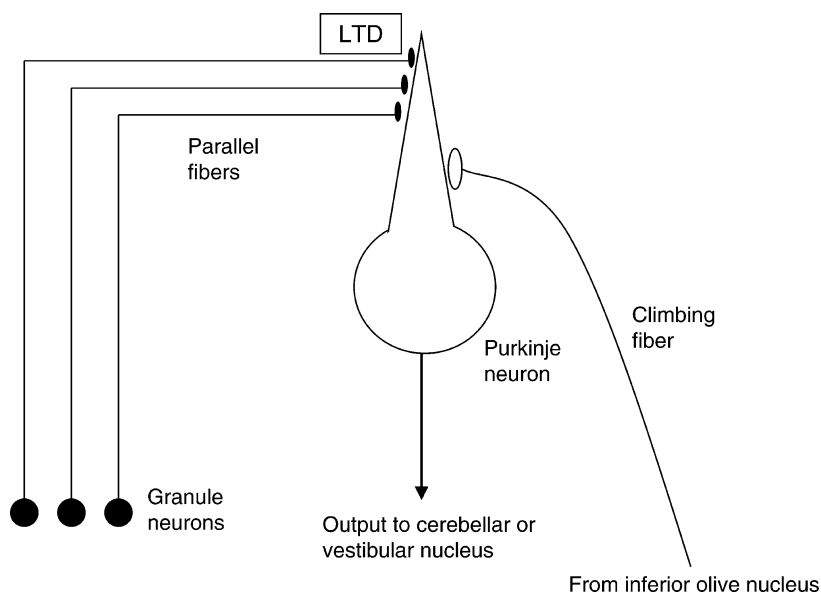

**Sensory Motor Learning/Memory and Cerebellum. Figure 2** Synaptic inputs to a cerebellar Purkinje neuron and the long-term depression (LTD).

Glutamate released from a parallel fiber activates both receptors. Activation of AMPA receptors causes the excitatory postsynaptic potential, and that of mGluR1 activates an enzyme called phospholipase C, which produces diacylglycerol and inositoltrisphosphate. The latter contributes to the increase in the cytoplasmic  $\text{Ca}^{2+}$  concentration through  $\text{Ca}^{2+}$  release from the intracellular stores, and the former contributes to activation of an enzyme called protein kinase C together with the intracellular  $\text{Ca}^{2+}$ . Activated protein kinase C phosphorylates the AMPA type glutamate receptor on the postsynaptic membrane. The phosphorylated AMPA receptor is then internalized to the cytoplasm and becomes nonresponsive to extracellular glutamate. This is the current simplified model of induction of long-term depression [5]. Implication of numbers of additional molecules including glutamate receptor  $\delta 2$  receptor, specifically expressed at parallel fiber-Purkinje neuron synapses, has been reported [6].

Roles of long-term depression in the sensory motor learning have been studied using mutant mice with the impaired long-term depression. These studies have shown the correlation between the long-term depression and the sensory motor learning. However, some sensory motor learning occurs in animals with impaired long-term depression. Thus, the ►cerebellar long-term depression seems not to be the sole mechanism for the sensory motor learning.

### Synaptic Plasticity Other than Long-Term Depression

Long-term potentiation, long-lasting increase in the efficacy of synaptic transmission, is also reported to occur at parallel fiber and Purkinje neuron synapses by repeated activation of parallel fibers alone. There are two types in the long-term potentiation. One is accompanied with the increased postsynaptic sensitivity to glutamate, and the other is caused by the enhanced release of glutamate from the presynaptic terminals of parallel fibers. The former long-term potentiation is the counterpart of the long-term depression. Implication of the long-term potentiation in the sensory motor learning has been suggested. The long-term potentiation and the long-term depression seem to play distinct roles in the sensory motor learning [7].

Synaptic plasticity has been reported at other synapses in the cerebellar cortex [8]. The long-term depression occurs also at climbing fiber-Purkinje neuron synapses. The efficacy of inhibitory synaptic transmission on a Purkinje neuron is potentiated for long-term by postsynaptic depolarization. The glutamatergic synapses between mossy fiber and a granule neuron also show long-term potentiation. Further, the synapses between parallel fibers and inhibitory interneurons (stellate or basket cells) also show synaptic plasticity. The respective role of each type of synaptic plasticity is unclear at present.

They might contribute to the sensory motor learning in concert with the long-term depression at parallel fiber-Purkinje neuron synapses.

### References

1. Robinson DA (1981) The use of control systems analysis in the neurophysiology of eye movements. *Annu Rev Neurosci* 4:463–503
2. Ito M (1982) Cerebellar control of the vestibulo-ocular reflex – around the flocculus hypothesis. *Annu Rev Neurosci* 5:275–296
3. du Lac S, Raymond JL, Sejnowski TJ, Lisberger SG (1995) Learning and memory in the vestibulo-ocular reflex. *Annu Rev Neurosci* 18:409–441
4. Thompson RF (2005) In search of memory traces. *Annu Rev Psychol* 56:1–23
5. Ito M (2002) The molecular organization of cerebellar long-term depression. *Nat Rev Neurosci* 3:896–902
6. Hirano T (2006) Cerebellar regulation mechanisms learned from studies on GluR $\delta 2$ . *Mol Neurobiol* 33:1–16
7. Boyden ES, Katoh A, Raymond JL (2004) Cerebellum-dependent learning: the role of multiple plasticity mechanisms. *Annu Rev Neurosci* 27:581–609
8. Hansel C, Linden DJ, D'Angelo E (2001) Beyond parallel fiber LTD: the diversity of synaptic and non-synaptic plasticity in the cerebellum. *Nat Neurosci* 4:467–475

## Sensory Mucous Gland

### ►Electroreceptor Organs

## Sensory Neuropathies

S

### Definition

Diseases of peripheral sensory nerve fibers, either in combination with motor nerve fibers or alone (pure sensory neuropathies). The latter may manifest as (i) pan-sensory (involving all types of sensory fibers), (ii) ►large-fiber sensory neuropathies (with deficits of tactile and vibration sense, ►proprioception, ►areflexia, ►sensory ataxia); (iii) small-fiber sensory neuropathies (numbness, cutaneous hypesthesia to pin-prick and temperature, burning dysesthesias).

- Peripheral Neuropathies
- Sensory Ataxia

## Sensory Placodes

### Definition

Ectodermal and neurectodermal thickenings at the anterior end of the neural plate giving rise to the major sensory organs of the head e.g., lens of the eye (ectodermal) and olfactory placode (neurectodermal).

► Evolution of the Terminal Nerve

## Sensory Plasticity and Perceptual Learning

MANFRED FAHLE

Bremen University, Department of Human Neurobiology, Bremen, Germany  
The Henry Wellcome Laboratories for Vision Sciences, London, England, UK

### Definition

Perceptual learning, a type of sensory plasticity, enhances perceptual performance based on changes in brain physiology and adjusts the cortical representation of the world. *Sensory Plasticity* in general includes both behavioral and physiological changes in perceptual learning, sensori-motor enhancement and long-term adaptation resulting from ► *experience*.

### Characteristics

#### Improved Perceptual Performance as a Result of Training

Lasting improvement in detecting, discriminating or categorizing sensory stimuli based on preceding experience is usually based on perceptual learning [1–3]. *Perceptual Learning* (PL) improves the representation and analysis of sensory information and reduces ► *noise* in sensory signals. Perceptual learning and plasticity of behavior are essential for humans to cope with changing environments. Better representation of a stimulus in the brain through learning improves its ► *detection*. Sharper ► *discrimination* from other stimuli – a more elaborate feat – is often task-specific and depends on attention being focused on specific feature(s) of the stimulus, thus restricting the learning to features important for the assigned task. A further aspect of plasticity and learning is the adjustment to the *situation* in general, especially under the usually somewhat artificial conditions of an experiment.

The improvement achieved through PL persists over extended time-spans, thus distinguishing PL from other changes in sensory processing such as short-term adaptation, ► *sensitization*, ► *habituation*, attention, and priming. These other processes all produce more transient changes of performance. PL clearly is of the procedural type, produces ► *implicit memory* traces and cannot be communicated to others, unlike declarative forms of memory such as ► *declarative (explicit) memory*. Another important characteristic of PL is that it appears to directly modify the neuronal mechanisms processing the task required [4]. Declarative forms of learning, on the other hand, lead to memory traces that are stored at least partly in specialized brain regions such as the ► *hippocampus*. To detect, discriminate, and extract the most relevant features from the multitude of signals supplied by the sense organs requires extensive PL during especially infancy and childhood. This plasticity of sensory processing continues throughout life even if with decreasing velocity and ease.

#### Interaction of Different Cortical Levels in Perceptual Learning and the Role of Attention

Sensory plasticity and PL take place on a number of ► *cortical levels*, including even highly specialized ► *early sensory cortices*, while, of course, also on higher, more cognitive ones [5]. Hence, an important distinction between different types of PL is whether the improvement achieved through ► *training* generalizes to other stimuli or tasks, indicating involvement of higher cortical areas, or else is highly stimulus-specific, indicating involvement of early levels.

Psychophysical, imaging and electrophysiological studies all indicate that early sensory cortices are involved in at least some forms of Perceptual Learning while these sensory cortices used to be considered as “hardwired” in adults.

The task required of the subject may be quite different for identical stimuli – the more complex a stimulus is, the higher is the number of different discrimination tasks that can be defined for this stimulus, such as searching for a specific geometrical configuration or color. Therefore, feedback from “higher” to “lower” levels of processing is required for the “early” cortices to be tuned to the task at hand – purely bottom-up information extracted from the stimulus does not suffice to define the task.

The effects of PL are similar to those of attention both behaviorally and regarding enhanced activity of cortical neurons. In both cases, processing of sensory stimuli improves even in “early” cortical areas as demonstrated by ► *single-cell recordings* in animals. However, while the effects of attention are similar to those of adaptation in that they do not leave any permanent traces, PL *does* leave long lasting traces. The extreme stimulus specificity of some forms of PL sets it further apart from the more general and transitory effects of attention.

### Stimulus Specificity in “Early” Perceptual Learning: “Early Selection” in Visual Perception

Training in many ▶perceptual tasks enhances performance within about 10–20 min of training to slow down thereafter. But often, the improvement achieved with one stimulus is quite specific for this stimulus and does not transfer to a stimulus rotated by even a few degrees. Improvement is similarly specific for the eye trained (under monocular conditions), for position in the visual field, as well as for motion speed, motion direction, and the exact task trained (Fig. 1).

The enhancement is specific for stimulus orientation for some tasks, for example for vernier discriminations, as outlined above, while not for other perceptual tasks. Learning usually generalizes more on later (cortical) levels than on lower ones since there ▶receptive field characteristics are less position specific. Hence, high position specificity indicates changes on early processing levels that select important information as soon as possible [6].

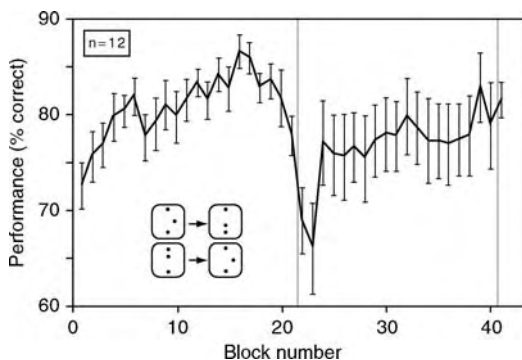

### Sensory Plasticity and Perceptual Learning.

**Figure 1** Specificity of improvement in Perceptual Learning. One group of observers started with a three dot bisection task, indicating whether the middle one of the dots was closer to the upper or else to the lower end point. The second group started with training a three dot vernier task, indicating whether the middle point was offset to the left or to the right relative to an imaginary line through the end points. Mean performance of both groups improved markedly within an 1-h training session (blocks 1–21). But when the tasks were switched between groups of observers (*left vertical line*), performance dropped even below baseline levels. Hence, improvement through training was highly specific for the task trained, even though the stimulus in both tasks differed by less than a photoreceptor diameter. Re-testing the first task at the very end of the second session (*right of right red line*) revealed good performance (from Fahle, M. & Morgan, M.; No transfer of perceptual learning between similar stimuli in the same retinal position. *Current Biology* 6:292–297, 1996).

### Generalization of Improvement in Late Visual Perceptual Learning, “Late Selection,” and Further Sense Modalities

PL can enhance discrimination between complex classes of stimuli such as different wines, in addition to the improvement in discrimination between simple stimuli. More complex tasks and more noisy stimuli tend to generalize more than simpler ones do, hence enhancement seems to be achieved at a relatively late stage for these forms of PL.

Training *auditory* tasks such as discriminating tone frequencies embetters [▶improves] performance and is accompanied by ▶reorganization of primary auditory cortex and other brain regions after some forms of PL while not after others. Similarly, training can improve discrimination in the realms of both taste and olfaction, and the representations in motor and somato-sensory cortex often increase in size for those body parts used during motor training, accompanied, for example, by improved two-point tactile resolution [7].

### Models of Perceptual Learning

Recent models of PL incorporate both aspects of PL, specificity and ▶generalization of learning. These models take into account both internal and external noise, implement recurrent (feedback) connections, and assess the change of internal templates. It turns out that sharper orientation tuning curves may account for the psychophysical results and that training seems to better eliminate external noise, possibly by retuning internal templates.

PL is based on at least two different mechanisms, one fast, the other slower. The first mechanism, as outlined in the Reverse Hierarchy model, starts fast and generalizes improvement at high cortical areas, adding the second mechanism if necessary. This second mechanism involves lower cortical levels leading to slower and more specific enhancement (Fig. 2).

These two mechanisms lead to either an early or a ▶late selection of relevant signals in analogy to theories on attention [6]. The slower and more specific mechanism of PL is highly specific for stimulus features—indicating an involvement of “early” stages of cortical information processing. On these early cortical stages, such as the primary visual cortex V1, neurons are specific for the eye and the visual field position stimulated. Therefore, this mechanism apparently involves changes in functional connectivity between neurons already on the level of V1. Such tuning of signal processing on an early level removes irrelevant noise early on. However, the adaptation of processing at peripheral levels modifies the neuronal front end for all possible stimuli and may therefore deteriorate detection for stimuli differing from the recently learned ones by interfering with processing optimized for other tasks. For example,

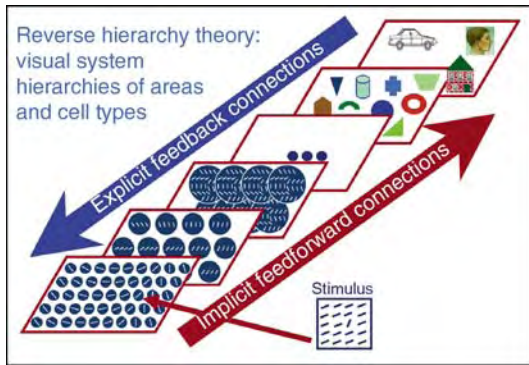

### Sensory Plasticity and Perceptual Learning.

**Figure 2** The Reverse Hierarchy Model of Ahissar and Hochstein conjectures that Perceptual Learning for easy tasks takes place on a “high” level of cortical information processing, improves performance fast, and generalizes to similar stimuli. If necessary, PL also involves lower levels where it is slower and highly stimulus specific (from Ahissar, M. & Hochstein, S.; The reverse hierarchy theory of visual perceptual learning. *Trends in Cognitive Sciences*, 8:457–464, 2004).

shallow luminance gradients are best detected by large receptive fields, which in turn are unable to detect fine gratings. Training to detect fine gratings would therefore improve their detection by decreasing receptive field size, but deteriorate detection of shallow gradients. Task-dependent switching between different “modes” of early cortical signal processing governed by top-down influence could solve this dilemma. Top-down control would select the most appropriate type of processing for the task at hand from a repertoire of (previously learned) alternatives, for example, by adjusting the neuronal gain of a defined population of neurons, or by modifying the amount of lateral inhibition on an early cortical stage.

The fast mechanism of PL resembles and may be identical with “conventional” forms of learning. It generalizes and is probably implemented in more central sensory cortices, located in the temporal and parietal lobes. Some forms of Perceptual Learning, especially the one generalizing over different stimulus types may take place exclusively on these higher processing levels.

### Possible Mechanisms and Electrophysiological Correlates of Sensory Plasticity

To indicate the level of neuronal plasticity is almost impossible on the basis of psychophysical results. But both sum-potential recording and single-cell recording detect plasticity on early stages of sensory cortices in visual, auditory and somato-sensory cortices, indicating some plasticity even in the lateral geniculate nucleus and primary visual cortex of adult animals

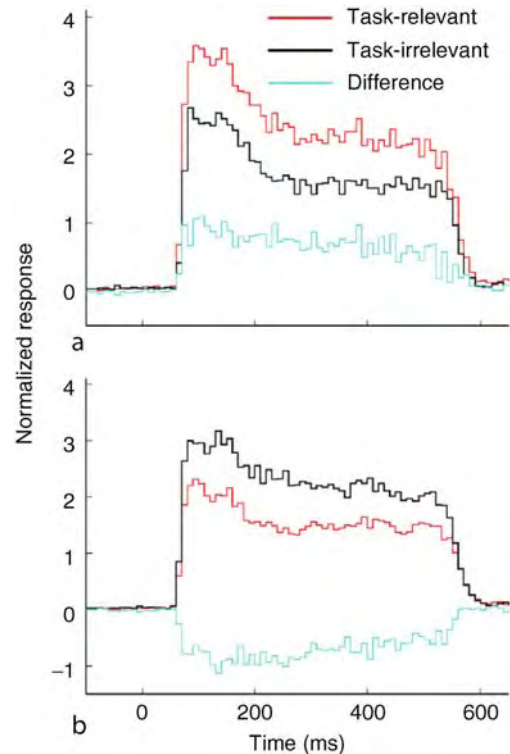

### Sensory Plasticity and Perceptual Learning.

**Figure 3** The characteristics of receptive fields in the visual cortex of an adult macaque monkey changed significantly as a result of training, though the exact mechanisms are still under debate. In any case, the changes depended on whether or not the stimulus was task relevant with both increase (a) and decrease (b) of responses after training (from Li, W., Piëch, V. & Gilbert, C.D.; Perceptual learning and top-down influences in primary visual cortex. *Nature Neuroscience*, 7:651–657, 2004).

including man (Fig. 3; [8,9]). Plasticity in the somato-sensory system may be especially pronounced [7]. Some of the transmitter substances involved are known (Fig. 4).

Sum potentials in humans change as a result of PL, even at latencies below 100 ms, and most pronounced over the occipital pole. The number of neurons in primary visual cortex representing a given orientation surprisingly decreased in monkeys who trained orientation discrimination for this orientation. This decrease was not associated with any evident changes in permanent receptive field properties, neither in V1 nor in inferior temporal cortex [10].

To sum up, PL changes perception as well as sum potentials and single cell responses and increases activity in the stimulus representation of V1 as demonstrated by fMRI. All these findings point to an involvement of early sensory cortices in Perceptual Learning.



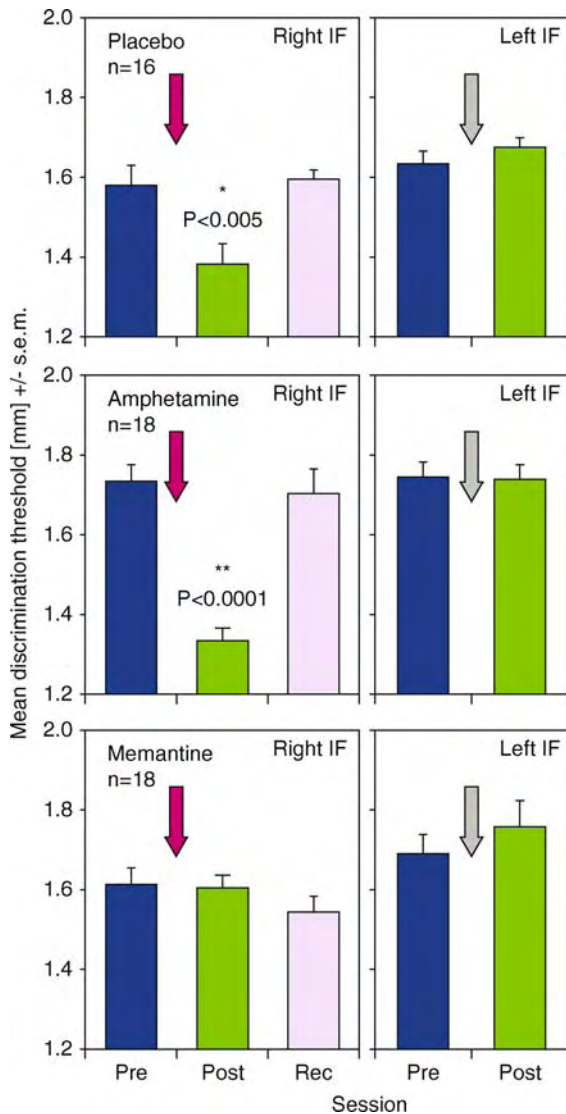

### Sensory Plasticity and Perceptual Learning.

**Figure 4** Pharmacological influences on Perceptual Learning. The amount and speed of Perceptual Learning can be influenced by different pharmacological agents. (a) Memantine, an antagonist of NMDA receptors, abolishes PL (as does GABA receptor blockade), (b) Amphetamine, on the other hand, speeds up the improvement through PL; (c) Under the influence of an placebo, PL is far more pronounced than in (a), but less pronounced than in (b) (from Dinse, H.R., Ragert, P., Pleger, B., Schwenkreis, P. & Tegenthoff, M.; Pharmacological suppression of perceptual learning and associated cortical reorganization. *Science*, 301:91–94, 2003).

### Conditions for Consolidation of Learning and Visual Rehabilitation of Patients

Consolidation of perceptual improvement achieved through training requires *sleep* or at least restful waking in both visual and auditory learning. In the realm of

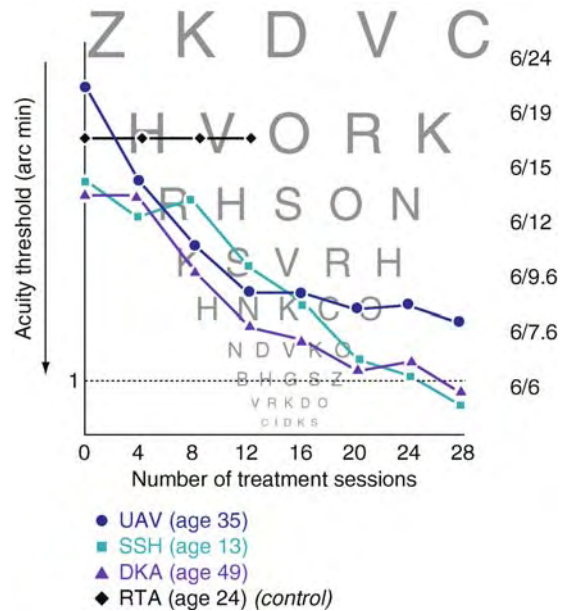

### Sensory Plasticity and Perceptual Learning.

**Figure 5** Improvement of amblyopic patients. The classic view is that amblyopia, a functional decrease of visual acuity, due to strabism or optical factors, cannot be cured in adults. However, using a specific type of training, Polat and co-workers (Polat, U., Ma-Naim, T. Belkin, M. & Sagi, D.; Improving vision in adult amblyopes by perceptual learning. *Proc. Nat. Acad. Sci. USA*, 101, 6692–6697, 2004) were able to improve visual acuity in about half of their patients, sometimes dramatically, while those in the control group did not improve.

sensory rehabilitation, patients wearing a [▶ cochlear implant](#) learn to make better use of the signals stemming from the implant, often up to the point of eventually being able to understand speech. Similar approaches are under way for the visual input. Especially amblyopic patients can benefit from PL, since visual training may double contrast sensitivity and significantly increase visual acuity (Fig. 5).

### Conclusions and Outlook

Perceptual learning can significantly improve both the detection and discrimination of stimuli after a short training. PL relies on at least two mechanisms, probably represented on different levels of cortical processing. Modifications on early cortical levels require long training and produce stronger improvements, that do not transfer to similar tasks or similar stimuli, such as a slightly rotated stimulus, while the faster mechanism generalizes. No perceptual learning seems to take place without some form of attention. Irrelevant signals including noise must be eliminated as early as possible during processing to achieve optimal performance. Top-down signals may be able to activate modifications

in neuronal processing achieved on early levels in a task-dependent way to prevent interference of learning one task with performance in other tasks. Learning easy perceptual tasks may not modify early sensory cortices, but only higher ones, allowing generalization of improvement to similar tasks. In summary, Perceptual Learning enables humans to sharpen up the detection, discrimination and classification (► [Categorization or Classification](#)) of stimuli, to cope with varying sensorimotor requirements and to adjust rather fast to changing environments.

### Acknowledgment

This article draws strongly on earlier articles of the same author on the same topic [4,6].

### References

1. Gibson E (1969) Principles of perceptual learning and development. Appleton-Century-Crofts, New York
2. Poggio T, Fahle M, Edelman S (1992) Fast perceptual learning in visual hyperacuity. *Science* 256:1018–1021
3. Sagi D, Tanne D (1994) Perceptual learning: learning to see. *Curr Opin Neurobiol* 4:195–199
4. Fahle M, Poggio T (eds) (2002) Perceptual learning. MIT, Cambridge
5. Calford MB, Chino YM, Das A, Gilbert CD, Heinen SJ, Kaas JH, Ullman S (2005) Neuroscience: rewiring the adult brain. *Nature* 438:300–307
6. Fahle M (2005a) Perceptual learning: specificity versus generalization. *Curr Opin Neurobiol* 15:154–160
7. Recanzone GH, Merzenich MM, Dinse HR (1992) Expansion of the cortical representation of a specific skin field in primary somatosensory cortex by intracortical micro stimulation. *Cereb Cortex* 2:181–196
8. Kaas JH, Krubitzer LA, Chino YM, Langston AL, Polley EH, Blair N (1990) Reorganization of cortical maps in adult mammals after lesions of the retina. *Science* 248:229–321
9. Gilbert CD, Sigman M, Crist R (2001) The neural basis of perceptual learning. *Neuron* 31:681–697
10. Ghose GM (2004) Learning in mammalian sensory cortex. *Curr Opin Neurobiol* 14:513–518

---

## Sensory Receptor

### Definition

Sensory receptors (in physiology) is any structure which, on receiving environmental stimuli, produces an informative nerve impulse. The receptor recognizes a stimulus in the external or internal environment, initiates a transduction process by producing graded potentials (receptor potentials), from which all-or-none action potentials are elicited, that are conducted

along afferent fibers originating in the same or adjacent cells.

- [Action Potential](#)
- [Receptor Potential](#)
- [Sensory Systems](#)

---

## Sensory Re-education

### Definition

A re-learning process, applied after nerve repair, aiming at a central nervous adaptation to the new pattern of sensory impulses transmitted by misdirected regenerated axons.

- [Regeneration: Clinical Aspects](#)

---

## Sensory Responsiveness

- [Sleep – Sensory Changes](#)

---

## Sensory Re-weighting

### Definition

A mechanism for regulating a sensory integration process by changing the relative contributions made by different sensory systems to a neural representation of a percept or to a neural signal used for motor action.

---

## Sensory Stroke

- [Proprioception: Effect of Neurological Disease](#)

## Sensory Substitution

### Definition

A mechanism whereby information from one sensory modality is replaced by or substituted for information from another sensory modality. This term often refers to prosthetic devices that are meant to convey one form of sensory information through a sensory system that is typically not used for that form of information. An example would be an array of tactile vibrators that represent a visual scene.

## Sensory Systems

UWE WINDHORST  
Göttingen, Germany

### Introduction

In order for organisms to survive and reproduce, they need an appropriate habitat. A habitat may be appropriate in terms of chemical constitution, ambient temperature, light conditions, food supply, availability of potential mates, and/or optimal conditions for their offspring. To continuously check for this appropriateness, organisms need information about the environment and the internal state of their body. An essential primary requirement is therefore the capacity to select, acquire and handle suitable information.

### Functions of Sensory Systems

Environmental and internal-state signals of importance to the animal (or plant) must be received. This in turn requires specialized ▶**sensory receptors**. The information delivered by receptors must then be processed for particular purposes. Sensory systems usually have multiple functions. On the one hand, they provide signals for regulatory systems. At higher levels, they serve to generate sensations and ▶**perceptions**. Perception requires ▶**consciousness**. In multi-cellular organisms (metazoa), information acquisition, transmission and processing are performed by a more or less complex nervous system. From the viewpoint of the central nervous system (CNS), there are two environments: its own body as an internal environment and the body's external environment.

The general functions of sensory systems can be briefly summarized as follows:

1. Selected representation of aspects of the body's external world in space and time. This in turn requires:
  - (a) Selectivity in focusing on world aspects of survival value for the organism.
  - (b) Detection, localization, and identification of stimuli from the external and internal environments.
  - (c) ▶**Figure-ground perception** discrimination, i.e. isolation, identification and recognition (for perception) of important objects and events (figure) against the background of all existing objects and events (ground).
  - (d) Discrimination of invariant and changeable properties of world aspects.
  - (e) Memory. Recognition requires current sensory data to be compared with records of past experiences.
2. Selected representation of aspects of the body's internal world in space and time, including:
  - (a) Body schema.
3. Provision of inputs for evaluation and decision systems that steer ▶**behavior**.
4. Provision of inputs for fast motor responses, such as escape ▶**reflexes**.

### Classification of Senses

Senses can be classified according to several criteria.

#### Nature of Stimuli

One classification is according to the physico-chemical nature of the stimuli activating peripheral sensory receptors (Table 1). Except in a few cases (e.g. ▶**vision**), the ensuing classes may encompass diverse senses and therefore not be very useful. For example, the "mechanical" category includes hearing (▶**Auditory neuroscience - Introduction**), the ▶**vestibular system**, cutaneous mechano-reception (▶**Tactile senses-touch**) and deep mechano-reception (▶**Proprioception**), sensations arising from visceral receptors etc.

#### Origin of Specific Stimuli

Senses can be grouped according to the site of origin of the specific stimuli:

1. ▶**Exteroceptive** senses receive stimuli from the world external to the body and comprise ▶**vision**, ▶**magnetic and electric senses**, hearing (audition), ▶**taste** and ▶**olfaction** (▶**Sensing chemical stimuli**).
2. ▶**Enteroceptive** senses receive stimuli arising within the body and comprise proprioception, and various other senses, such as deep thermosensibility and nociception (▶**Pain**).

This division is not unequivocal because some senses bridge the border. For instance, cutaneous mechanoreceptors can be excited by stimuli from both

**Sensory Systems. Table 1** Sensory modalities, qualities, receptors and adequate stimuli

Modality	Quality	Receptors	Adequate Stimuli
<i>Vision</i>	Brightness	Rods	Electromagnetic radiation
	Green	Cones	
	Red		
	Blue		
<i>Hearing (audition)</i>	Tone frequencies	Hair cells	Air pressure fluctuations
<i>Tactile sense</i>	Touch	Meissner	Mechanical deformation
	Pressure	Merkel	
	Vibration	Pacini etc.	
<i>Statokinetic sense</i>	Equilibrium	Hair cells	Absolute head position and acceleration
<i>Proprioception</i>	Body position and motion	Joint and ligamentous receptors	Joint position and motion
		Muscle spindles	Muscle length
		Golgi tendon organs	Muscle force
		Skin mechano-receptors	Joint position/motion
<i>Temperature</i>	Cold	Cold receptors	Electromagnetic radiation 700–900 nm
	Hot (warm)	Warm receptors	
<i>Pain</i>	Fast (first) pain	Nociceptors	Injuries, inflammation etc.
	Slow (second) pain		
<i>Taste (gustation)</i>	Sweet	Chemo-receptors	Chemical substances and ions
	Salty		
	Sour		
	Bitter		
	Umami		
<i>Smell (olfaction)</i>	Odors	Chemo-receptors	Odorants (pheromones)
Internal mechano-reception	Stomach extension	Extension receptors, pressoreceptors	Extension and pull
	Lung extension		
	Blood pressure		
Internal chemoreception	Osmotic pressure	Chemoreceptors	Osmolarity of body fluids
	CO <sub>2</sub> pressure		pH and pCO <sub>2</sub>
	O <sub>2</sub> pressure		pO <sub>2</sub>

In some animals: *electric or magnetic senses*.

the exterior and interior world, thus being exteroceptors and proprioceptors. The vestibular system monitors the spatial relation and its changes between the head and external space and thus belongs to both proprioception (with active head movement) and exteroception (with passive head movement). Finally, nociception and temperature senses go under both rubrics of entero- and exteroceptive senses.

### Modalities and Qualities (Sub-Modalities)

Using a number of different mechanisms, receptors are specialized to sense specific aspects of external and internal stimuli. These aspects define their ►adequate stimuli, which are those that excite the receptors most easily and at lowest energy levels. Specialization of this

sort is the basis of the “law of specific sense energies” propounded by Johannes Müller in 1826 [1]. It states that the quality of a sensation is not due to the stimulus but to the special sensory organ stimulated. Subjective sensory physiology further splits senses into modalities and qualities (or sub-modalities), which in turn are based on specific receptor systems, with some qualification [2]. Modalities refer to large classes of senses and the related receptors, e.g. visual, auditory, olfactory, gustatory and tactile (the five classic senses). Qualities refer to subclasses such as, in the ►visual system, perception of shades of grey from black to white and of different colors, or in the tactile domain, differentiation of pressure, touch and vibration sensations. An overview is given in Table 1.

## Proprioception

Proprioception is classically defined as being activated by mechanical stimuli arising from the body's self-generated motor actions [3]. Proprioceptors thus monitor the positions and movements of the body and its parts and include all receptors that carry signals related to these variables, irrespective of whether the signals reach consciousness or contribute to unconscious movement control [4]. Proprioceptors therefore comprise a fairly wide group of different mechanoreceptors, from muscle receptors (► [muscle spindles](#), ► [Golgi tendon organs](#), arguably free nerve endings), joint receptors, ligament receptors, to cutaneous mechano-receptors.

## Psychophysics

Before the development of objective recording techniques, the study of sensory processes had to rely on observations of subjective phenomena and their relations to the underlying external events (stimuli). A basic question in ► [Psychophysics](#) is to what extent attributes of subjective perceptions are linked to properties of stimuli. This approach may diversify into detection, identification, discrimination (from background) and scaling of stimuli.

## Sensitivities

An organism should be interested in a great sensitivity to any stimulus that has an important survival value. Sensitivity means a number of things. The detection sensitivity is inversely related to the detection threshold, while the gain sensitivity is related to the steepness of a plot of response vs. stimulus intensity.

## Thresholds

Thresholds may be distinguished into absolute threshold and difference threshold, and so are the respective sensitivities.

The *absolute threshold* ( $S_0$ ) is defined as the minimum stimulus intensity evoking a recognizable response in the receptor cell or perception. However, the peripheral (receptor) threshold and the central (sensation) threshold need not coincide because the latter is influenced by processes such as context, attention etc. (see below). Many receptor systems are exquisitely sensitive to their adequate stimulus. For example, a ► [photoreceptor](#) of the visual system can be excited by a single photon; the inner ear of some vertebrates reacts to very weak sounds barely above the mechanical noise level; and the bacterium *Escherichia coli* reacts to a few molecules of a chemical agent of interest, such as the amino acid aspartate [5]. Mechanical systems are often much less sensitive.

The *relative threshold* is defined as the minimum *just-noticeable difference* ( $\Delta S$ ) in a stimulus variable. For intensity, this difference,  $\Delta S$ , is taken relative to the

starting intensity,  $S$ . For example,  $\Delta S/S$  is about 1–2% for vision, 3% for pressure and between 10 and 20% for other senses. Relative thresholds can also be defined and measured for other stimulus dimensions like quality, time and space. For instance, in vision, relative thresholds exist for brightness (intensity) and color (frequency resolution). In hearing, relative thresholds determine the frequency resolution of different sounds; and differences in the times of arrival in both ears are important for the location of a sound source (► [Inter-aural time difference \(ITD\)](#)). Finally, the spatial resolution is important for stimulus localization and distinction (below).

## Psychophysical Functions

Of prominent interest in supra-threshold psychophysics is the relationship between the stimulus intensity, which can be measured objectively, and the subjective intensity of sensation, which needs to be measured in some indirect way using scales. This relationship has been studied using various methods, leading to different quantitative descriptions (► [Psychophysics](#)).

## Spatial Discrimination

Of major importance for organisms is the localization of stimuli (topognosis). The spatial localization and discrimination capacities vary widely between different senses, being very good in vision and audition, modest to good in cutaneous mechano-sensation, (► [Tactile senses-touch](#)) and almost nil in taste and ► [smell](#). In vision, the relative threshold in the fovea centralis is ca. 1' under favorable conditions, but in touch, the relative threshold (as determined by ► [two-point discrimination](#)) is much worse and varies considerably across the body surface, being greatest at the fingertips and on the lips (1–4 mm).

## Information, Signals and Carriers

Information is an abstract entity that needs to be encoded in a signal to be transmitted. Signals in turn are generated by some material substrate or carrier, which uses some mechanism to produce the signal. In the nervous system, there are essentially only two broad classes of signals: membrane potential changes (► [Membrane potential-basics](#)) and concentrations of chemical substances (although at many chemical ► [synapses](#), the concentrations of released ► [neurotransmitters](#) may be immaterial because they are so high as to saturate the available postsynaptic receptors). Membrane potential changes occur in two forms: continuous, ► [graded potentials](#) (depolarizations or hyperpolarizations), and ► [action potentials](#) (► [spikes](#)). These signals are essentially produced by and at membranes as carriers, and the mechanisms used are manifold. The existence of two forms of signal suggests that they need to be transformed into each other (see below).

## Principles of Receptor Systems

The limited set of signal types used by the nervous system contrasts with the abundance of physiologically important world aspects. This requires that the receptor cells convert these diverse forms into one common primary nervous language. For this purpose, sensory receptors have evolved specialized ▶**sensory transduction** and accessory structures.

### Receptor Cells

Sensory receptor cells may be of neural or epithelial origin. Due to their limited expansion, each receptor can sample stimuli from only a limited body region called ▶**receptive field (RF)**. Sensory receptors may produce the first-order sensory axon as part of the cell or make synaptic contact with another neuron. Primary sensory axons may travel considerable distances (more than a meter) to reach their first postsynaptic neurons at the next processing stage (e.g. in the spinal cord).

### Stimulus Transformation

Conversion of a stimulus into a form suitable for excitation of the receptor membrane is called sensory transformation. Important factors in this process are:

1. Location of receptors. For example, different types of ▶**cutaneous mechano-receptors**, (▶**Cutaneous mechanoreceptors**, **anatomical characteristics**) giving rise to tactile sensation lie in different regions and strata of the skin; and it is the different spatial relation and mechanical coupling to skeletal muscle fibers that makes sensory endings of ▶**muscle spindles** and ▶**Golgi tendon organs** respond to different mechanical variables of muscle performance (▶**Proprioception: Role of muscle receptors**).
2. “Auxiliary” or “accessory” structures. For instance, cutaneous mechano-receptors display specific sensitivity to particular temporal aspects of mechanical stimuli because of the filtering properties of the special anatomical structures associated with their sensory endings; in the auditory system, the complete mechanical apparatus from the tympanic membrane to the ▶**basilar membrane** transforms and filters the frequency content of the mechanical stimulus before reaching the ▶**hair cells** in the inner ear; and in the ▶**visual system**, light refraction and focus are performed by accessory structures (cornea, lens, etc.).

### Sensory Transduction

The transformed stimulus then strikes the receptor cell. By the process of transduction, the transformed stimulus causes the opening or closing of ▶**ion channels** in a local membrane region and produces a ▶**receptor current**, which in turn gives rise to a ▶**receptor potential**. In most receptors, the receptor

potential is in depolarizing direction, while in photoreceptors it is hyperpolarizing. The ions involved in the production of receptor potentials depend on the specific receptors. The receptor potential encodes various stimulus properties in a continuous amplitude-modulated way.

### Encoder

Since receptor potentials usually are graded local events in neurons (graded potentials) and thus undergo the typical electrotonic decrement in amplitude and slowing of their temporal transients when spreading electrotonically (▶**Electrotonic spread**), action potentials are needed to carry information over long distances. Thus, there must be a neuronal site, where the receptor potential is translated (encoded) into a train of action potentials. This site may be in the receptor cell itself or in a following nerve cell, depending on the organization of a particular sensory system.

In so-called primary receptor systems, the receptor cell itself has an axon to propagate action potentials to central nervous structures. The receptor cell proper thus contains the ▶**encoder**. In this case, ▶**receptor current** and potential are also called ▶**generator current** and ▶**generator potential** because they generate action potentials.

In so-called secondary sensory systems or tertiary sensory systems, such as the ▶**inner ear** or ▶**retina**, the receptor potential of the primary receptor cell is, via intermediate steps involving synapses, converted into membrane potential changes in secondary or tertiary cells, which then encode these changes into action potential sequences.

### Coding of Modality and Quality

Many sensory receptors are most sensitive to selected stimulus energies (receptor specificity). Their excitation thus defines the stimulus modality or quality in a ▶**labeled-line code** [6]. However, there are many ▶**polymodal receptors**, many of which are associated with small-diameter axons. In particular, ▶**chemoreceptors** for ▶**taste** and ▶**smell** often respond to several chemical agents, any one of which cannot, therefore, be coded in the discharge of individual receptor types, but only in the activity patterns of populations of receptor afferents (▶**across-neuron pattern code** [6]). This may also apply to other modalities. For example, in ▶**vision**, any particular wavelength is sensed by more than one retinal cone ▶**receptor type** (▶**Photoreceptors**; ▶**Retinal color vision in primates**; ▶**Color processing**) and in cutaneous mechano-sensation, natural stimuli usually excite more than one type of mechano-receptor (although the excitation of individual mechano-receptors may lead to defined sensations) (▶**Processing of tactile stimuli**).

### Coding of Stimulus Intensity

The quantitative relationships between the intensity of a stimulus and the discharge rate of an afferent sensory nerve fiber may take different forms in different sensory systems. In many mechano-sensory systems, it is close to linear, while in the visual and auditory systems it can be approximated by logarithmic or power-law functions with exponents  $<1$ . This diversity is related to the range of stimulus intensities encountered in these systems. As a gross rule, linear relationships prevail where stimulus range is relatively limited, and nonlinear mappings occur in systems where stimulus intensity can vary over many orders of magnitude, such as in the visual and auditory systems.

Another factor important for intensity coding is a spatial characteristic, especially in higher metazoa: recruitment. As the intensity of a stimulus increases, increasingly more sensory receptors and axons are excited and contribute to the flow of information in parallel channels. This is a [▶population code](#).

### Coding of Stimulus Time Course

The filtering characteristics of sensory receptors vary. Based on their temporal response profile to stimuli, receptors are traditionally classified grossly into rapidly adapting or slowly adapting. Rapidly adapting receptors, such as cutaneous hair-follicle endings ([▶Cutaneous mechanoreceptors, functional behavior](#)), which produce only one or little more action potentials to sudden and then maintained deflection of a skin hair, are also called phasic types. Slowly adapting receptors, such as the [▶muscle spindle](#), are also referred to as tonic types. Usually, however, most of them show an initial firing-rate overshoot in response to a step increase in stimulus intensity. They only differ in the relative amplitude of overshoot and the rate of firing decay (adaptation) from the overshoot. Thus, even tonic receptors often display a marked initial overshoot, which is an expression of sensitivity to change in the adequate stimulus. Adaptation may occur in all the processes important for sensory reception: transformation, transduction and encoding. An example for the filtering effects of the accessory apparatus is the [▶Pacian corpuscle](#), ([▶Vibration sense](#)) in which the onion-like sheath surrounding the sensory nerve ending filters out maintained stimulus components and makes the receptor a [▶high-pass filter](#). The next site of adaptation is the transducer. That is, even though a stimulus may be maintained, the receptor potential adapts. Finally, the encoder translating the receptor or generator potential into a train of action potentials may also adapt. Spike-frequency adaptation also occurs in central neurons, such as [▶motoneurons](#), in response to supra-threshold, step-like, maintained depolarization and is the result of several underlying processes. One is the inactivation of

transient voltage-gated  $\text{Na}^+$  channels ([▶Action potential](#)), this process being specifically referred to as accommodation [7].

### Principles of Central Processing

In general, processing of sensory signals occurs through a succession of hierarchically organized stages from the periphery to the cerebral cortex, with many descending feedback and cross-connections. A few general principles are as follows.

#### Modularity

One of the leading concepts in sensory physiology is the existence of parallel processing in various subsystems, here of signal flow from the periphery to the cerebral cortex [2]. Parallel processing is evident in various forms. First, individual receptor cells and their receptive fields need to be small for adequate spatial resolution and cannot therefore cover the whole area to be monitored, which instead requires a multitude of receptors. In several sensory systems (e.g. cutaneous senses, retina), receptor cells are arranged in two-dimensional sensory surfaces, which are tessellated by the receptor cells. The spatial order of this tessellation is maintained up to the cerebral cortex (topography), albeit in distorted form. Second, in some cases, the different modalities and sub-modalities are processed in functionally specialized systems, as, for example, in vision ([▶Visual Processing Stream in Primates](#); [▶Extrastriate visual Cortex](#)). However, at some stage, the pieces of information transmitted through, and processed within, spatial and functional channels must be integrated into unified representations (see below).

#### Topography

In several sensory systems, the pattern of neighborhood relationships among receptor cells is preserved throughout their central projections to higher stages, thus giving rise to topographic projections and topographic maps. Thus, the retina is mapped retinotopically onto several visual cortex areas ([▶Vision](#)); the cochlea is mapped cochleotopically or tonotopically onto the auditory cortex; and the skin surface is mapped somatotopically onto somatosensory cortex areas ([▶Somatotopic organization](#); [▶Primary somatosensory Cortex \(s1\)](#); [▶Somato-sensory Cortex, plasticity](#)). Similar maps exist in subcortical structures such as [▶thalamus](#), [▶colliculus superior](#) and cerebellum.

#### Functions of Maps

In considering the functional role of orderly maps, one has to take into account that there are different kinds of maps, which most likely have different functions [8]. Topographic maps allow for spatially close stimuli impinging on the receptor surface to be processed by

computations in local networks of neurons or modules that need not be connected via metabolically costly and space-consuming long-range connections. Also, local continuity on the map might serve as a metric for similarity in the space of the represented variables. For example, in the cochleotopic map of the auditory system, neighboring frequencies are represented such that they can interact over fixed distances [8]. Furthermore, cross-correlated activity in adjacent cell groups may serve to detect combinations and associations of the variables represented by any single group. Since most cortical connections are of short range, this mechanism would most readily work between adjacent cell groups. It may be assisted by the fact that gross topographic maps are often split into interdigitated reiterated slices representing different variables (features) and leading to multiple mappings within each small representational area. This pattern appears to make good sense in that a multi-dimensional variable or feature space (as in vision) is represented on a virtually two-dimensional surface. These additional variables (e.g. modalities or sub-modalities) can thus be labeled with a common spatial sign before being assembled into more complex higher-level entities.

### Integration of Senses

Events or objects in external space manifest themselves by emanating different kinds of energy, which are picked up by different senses, e.g. vision, audition, somato-sensation, smell. Despite this analysis in parallel sensory systems and sub-systems, the nervous system must ultimately come up with a unified ▶**percept** of the event or object, which requires that the different aspects and features supplied by the sensory systems be integrated (▶**Multimodal integration**). This integration must even be accomplished within individual sensory systems that often analyze objects according to different sub-modalities in different brain areas (e.g. in vision: form, color, depth and motion in space etc.). But integration must also be achieved intermodally. How and at what neural stage this integration is performed is referred to as the ▶**binding problem** (e.g. [9]).

Psychophysical, neurophysiological and brain-imaging studies have provided increasing evidence of vigorous interactions between sensory modalities. For example, vision and audition heavily interact, as already evidenced by the “▶**ventriloquist effect**,” but there are many other examples of cross-modal influences. Many of these interactions appear to take place at cerebro-cortical level, but at stages before the elaboration of conscious percepts [10].

### Multimodal Integration

There have been several hypotheses as to how the nervous system might handle the binding problem. One

hypothesis is based on the convergence of pathways from different receptor systems onto multimodal neurons [11–13]. Such multimodal convergence occurs throughout the neuraxis. Already in the spinal cord, different afferent nerve fibers carrying sensory information from different types of sensory receptors converge on central neurons [14,15]. The best investigated structure for multimodal convergence is the ▶**superior colliculus** of the midbrain, which integrates sensory signals from vision, hearing, somato-sensation and pain for attentive and orientation behaviors [11–13]. Multisensory convergence also takes place at cerebro-cortical levels. For example, areas in the posterior parietal cortex contribute to the multisensory construction of spatial frames of reference (see Sect. 8.1) for planning eye, arm and hand movements [16,17]. And the human lateral occipital complex contains a sub-region, which is activated by objects when either seen or touched. This convergence of visual and somato-sensory signals appears to enable the precise recovery of object shape [18].

Another hypothesis posits that separate cell groups representing different object features are temporarily linked by dynamic connections that entail, and are maintained by, synchronization between their discharges. If synchronization is understood in a loose way, it is easily seen that an object will elicit nearly simultaneous activity in different regions of the brain, all of which may be concerned with one or the other aspect of it. But it has been hypothesized that synchronization on a millisecond time base may couple many neurons into assemblies representing objects [9]. On a gross scale, these synchronizations often appear in the form of oscillations in the high-frequency  $\gamma$ -range (20–80 Hz), which may be widespread over the cerebro-cortical surface. In the locust olfactory system, higher-order cells appear to be able to read out input synchronization and use it to fine-tune their sensory properties [19].

An exaggerated form of multimodal integration may be ▶**synesthesia**, which is a condition in which otherwise normal persons experience sensations in a non-stimulated sensory modality by a stimulus applied to another sensory modality or ▶**sub-modality** (also quality).

### Memory

In order for organisms to properly appreciate objects and events, they should compare them with previous experiences, that is, stored information about themselves and the environments. This “knowledge” (not necessarily conscious, of course) is diverse, ranging from genetic information via internalized standards (e.g. sustainable substance concentrations) to fairly intricate internal representations or ▶**internal models** (▶**hearing and memory**).



## Representation of Space

A basic requirement for perception, orientation, movement and object manipulation is the representation of space and spatial relationships between objects, including the own body. Although theoretically this representation need not be based on frames of reference and coordinate systems as used in physics and engineering, there is much experimental evidence for the existence of such frames [20].

### Frames of Reference

Perceptual determination of an object's location, orientation and three-dimensional shape could make use of clues from several senses, e.g. vision, audition, proprioception and touch, not all of which may be available all the time. The sense receptors involved have different orientations to internal (body) and external space. For example, when an invisible object is localized by the position of the fingers touching it, finger position relative to the body can be determined making use of proprioception, which heavily involves muscle spindles. Since muscle spindles measure muscle lengths, their signals vary along dimensions of an *intrinsic frame of reference*. By contrast, when vision is primarily used for object localization, the object is projected onto the eye-fixed retinas, in an *extrinsic eye-centered* coordinate system. Already at this stage, three points are clear. (i) There is a difference between proprioception and vision in that the former can be used only in *peripersonal space*, whereas the latter covers far space as well, which imposes functionally differentiated roles on different senses. (ii) The spatial representations based on data from different senses operating with different reference frames must be brought in register with each other, involving *coordinate transformations* and *calibrations*. (iii) As a corollary, this process requires multimodal integration (see above).

The concepts of reference frames and coordinate transformations are extended when skilled movements guided by sensory feedback and thus involving sensorimotor transformations are considered. For example, consider a goal-directed movement such as pointing to a visible target. This task involves localization of the target and of initial hand position and collapsing hand with target position. As outlined above, the target is first projected onto the eye-fixed retinas, in an *extrinsic eye-centered* coordinate system. Since the eyes can move within the head, the eye-centered representation must be transformed into a head-centered representation, and, if the head is movable on the trunk, the head-centered representation must be transformed into a body-centered representation. When hearing is used for object localization, a head-centered auditory representation is the first step. Finally, the position of the arm/hand must be represented. The hand position can be given in terms of an intrinsic, rectangular Cartesian

coordinate system, where the  $x$ -axis is in a parafrontal and the  $y$ -axis in a parasagittal plane through the shoulder. Alternatively, the hand position can be described in terms of joint angles, thus establishing an intrinsic system based on body geometry. Both systems are used by the nervous system, with their relative weight often depending on conditions. Note that motor actions are ultimately expressed in the latter system, that is, as changes in joint angles. The organization of goal-directed movements must therefore include transformations of all needed sensory signals in different reference frames into the intrinsic frame of joint angles, which involves a cascade of processes. All these systems are egocentric coordinate systems related to the organism. There is evidence that monkeys and humans are able to build **▶allocentric** (world-based, e.g. object-centered) **▶reference frame**, for example in the **▶supplementary eye field**. As mentioned and emphasized again, object locations are often determined from contributions of several senses (vision, hearing, vestibular, tactile, proprioceptive systems), whose different representations must be unified into one multimodal representation, requiring that the different coordinate systems be aligned [16,20–22].

### Body Schema

In order to perceive and act, the nervous system must be able to relate the positions of the body and its parts to each other and to a representation of the external world. This complex representation is called the **▶body schema**. Humans normally are consciously aware of their body configuration, but often do not pay much attention to it. There are many pathological conditions, however, in which the existence of a body schema becomes strikingly apparent:

1. Phantom limb. When a limb is amputated or otherwise lost, the patient often feels the missing limb as if still existing. The configuration can change over time, however.
2. Hemispatial neglect arises in some forms of brain damage and may entail that the patients neglect entire parts of the external world or do not accept parts of their own body and associated extracorporeal objects (such as rings etc.) as belonging to them.
3. Paranoid **▶schizophrenia** may lead the patients to over- or underestimate the size or their limbs.

The body schema incorporates a representation of verticality based on signals from visual, vestibular, proprioceptive and several gravity receptors in the trunk [23], as well as a representation of the shape of the body and its dynamic changes. The sensation of shape depends on sensory signals carried by group Ia afferent fibers from muscle spindles [24] and conveying the positions of body parts relative to each other [25]. The sensory origin of the dynamic

movement information is not quite clear yet. How the body schema is generated centrally is largely unknown.

### Modulation of Sensory Processing

Potentially, the many sensory systems could deliver immense amounts of information, which, if processed unsifted, would swamp the processing capacities of the nervous system. Moreover, much of the sensory information impinging on the nervous system is not immediately relevant behaviorally. Thus, extensive processing of sensory signals can, and needs, only be done on selected aspects.

The consequence is that, as best investigated in ► [vision](#), the many objects in a visual scene compete for neural representation ([26] ► [Visual attention](#)). Resolution of this competition requires mechanisms ensuring

1. Selection of relevant pieces of information, involving
  - (a) Suppression of unneeded information
  - (b) Facilitation of needed information
2. Localization of the relevant information and directional processes toward this locus
3. Eye movements toward selected objects (if needed) to focus and observe them at high spatial resolution

The competition can be resolved by means of various processes steering ► [attention](#) [26]:

1. Bottom-up modulation by stimulus-driven processes
2. Top-down modulation, involving directed selective attention

Descending modulation of sensory processing can occur all the way from the cerebral cortex to the peripheral receptors, in the latter case by efferent control of receptor sensitivity (e.g. of auditory and vestibular ► [hair cells](#), ► [muscle spindles](#)).

### Bottom-Up Mechanisms: Saliency

Stimulus-driven processes are based on the saliency and “pop-out” of stimuli. Bottom-up means that attention is captured more easily by stimuli that are stronger, more extensive and/or move faster than others. Salient stimuli are easily detected among a number of distractors.

### Top-Down Mechanisms

Top-down refers to attention-shifting processes controlled by the brain.

### Selective Attention

Generally speaking, attention is the mental capability to select stimuli, responses, memories or thoughts, which are behaviorally relevant, from among those that are not [27]. Selection is achieved, at any time, by funneling the information flow through a small window of attention that may be shifted appropriately to interesting things

currently relevant to behavior. If relevant information is to be selected from non-important one, neuronal activities must be facilitated and/or suppressed appropriately. This implies that neuronal activities must be susceptible to attention. Directing attention like a searchlight again requires the multimodal integration of senses to construct a common spatial frame [17].

### Enhancement of Neuronal Response and Sensitivity

Neuronal responses and sensitivities to a stimulus are enhanced when attention is directed to the receptive field as compared to attention directed outside the receptive field. In vision, such attentional effects have been demonstrated in various visual areas (► [Visual attention](#)). Compatible results have been obtained in humans using functional brain imaging and event-related potentials. Response enhancement also occurs when attention is directed to a specific stimulus attribute, such as luminance, orientation, shape, color, and direction or speed of motion [26].

### Sources of Attentional Top-Down Influences

The top-down attentional modulations probably originate in a distributed network of higher-order areas in parietal and frontal cortex. For spatially directed attention, these areas include the superior parietal lobule (SPL), frontal eye field (FEF), supplementary (frontal) eye field (SEF) and perhaps inferior parietal lobule (IPL), middle frontal gyrus (MPF) and anterior cingulate cortex [26].

### Plasticity of Sensory Systems

The nervous system must be able to adapt to changing circumstances, at time scales from seconds to years. In ontogeny, this involves the dynamic establishment and maintenance of appropriate connections, including topographic representations of sensory surfaces and the peripheral motor apparatus [28]. However, such representations in sensory and motor cortices (and related subcortical structures) are alterable throughout life, in response to environmental and internal changes, e.g. frequent types of stimulation and lesions [29–35]. For example, consequent to loss of a digit, the somatotopic maps along the mechano-sensitive route to the cortex can be reorganized at all the intermediate processing levels, e.g. spinal cord, ► [dorsal column nuclei](#), thalamus and cerebral cortex [35] (► [Somatosensory Cortex, plasticity](#)).

### Mechanisms of Map Plasticity

A number of different processes and mechanisms contribute to the plasticity of topographic maps, from the influence of inhibitory interneurons to structural changes of axons and dendrites to synaptic plasticity. Structural changes, such as axon sprouting, synapse creation, retraction or elimination, occur in the initial

build-up of appropriate connections and have also been implicated in long-range reorganizations. Changes in dendritic arborization following prolonged exposure to complex environments or to specific motor tasks may be involved as well. Some mechanisms commonly shared with long-term synaptic plasticity may be at play here as well.

### Information Transfer and Neural Codes

Each stage of neural processing converts the input into an output, and each of these conversion processes distorts the signals to some extent. There are several reasons, among which three pop out:

1. **Dynamic range.** A neuron's response range is limited.
2. **▶Bandwidth.** Each neural channel is bandwidth-limited, limiting its speed of response and temporal resolution.
3. **▶Noise.** Each channel is corrupted by noise.

### Statistical Nature of Information Transfer

Noise implies that the coding and transfer of information are not completely reliable. Neuronal input-output relations are therefore of probabilistic nature. For instance, peripheral sensory systems encode stimuli into sequences of action potentials. Noise or uncontrolled variables in the encoding process entail that any particular stimulus may evoke several different sequences of action potentials and, conversely, any particular action potential sequence may be related to different stimuli. The same applies to synaptic inputs to neurons. Synapses may be fairly unreliable because transmitter release is a stochastic process with occasional failures.

### Neural Encoding

Noise, and dynamic-range and bandwidth limitations, co-determine the efficiency of any code used to encode and transmit information. Inefficiency would be expensive because it would imply more storage space, more expenditure of transmission energy, longer transmission times or larger bandwidths or dynamic ranges to store or transmit the same information [36]. The **▶efficient coding hypothesis** posits that sensory receptors and neurons have adapted so as to minimize the costs and get the job “done just right-enough” [37].

How efficiently do sensory systems code sensory signals into action potential trains?

### Sources of Inefficiency

One problem to be dealt with by sensory systems is natural stimulus statistics, i.e. the non-random statistical properties of environmental stimuli impinging onto sensory surfaces [38]. There are two main sources of redundancy:

1. Unequal probabilities of stimulus elements
2. Correlations between stimulus elements:
  - (a) Spatial correlations between parallel stimulus elements
  - (b) Temporal correlations between sequential stimulus elements

### Unequal Probabilities of Stimulus Elements

Consider primate vision. The image is cast on the retina and sampled by photoreceptors (and can thus be regarded as a two-dimensional array of picture elements: pixels). Natural images contain an abundance of statistical regularities that may in fact be important for survival [39]. For example, in indoor, outdoor and natural environments, the orientations of contour segments defining objects occur at different frequencies, with vertical and horizontal orientations occurring more frequently than oblique ones [40,41].

### Spatial Correlations between Parallel Stimulus Elements

Stimulus attributes at different pixels are correlated with each other [42] (see also [41]). This implies that “knowledge” of some section of an image can be used to predict other sections. In line with the above results, different contour segments of natural objects show orderly patterns, explaining the existence of long-range correlations in the distribution of oriented line segments over the visual field [43].

### Temporal Correlations between Sequential Signal Elements

The time courses of natural signals differ from white noise, in which successive values vary randomly. Stimuli vary smoothly and continuously in time, making any value at any time instant dependent on the previous history. This also applies for neural signals and is readily apparent in receptor and synaptic potentials, but often holds true also for spike trains, where the probability of a spike depends on the occurrence of previous spikes.

### Code Optimization

Because of its limited resources, the nervous system should try and reduce any coding inefficiency. Whether it does so, and if so what mechanisms it uses, is only partially known and may depend on the specifics of particular channels (see, e.g. [39]). There may be channels with limited capacities, in which coding efficiency may be pressing (for example, the optic nerve in mammals). By contrast, at other places (e.g. the cortical visual areas), redundancy might be of advantage; after all, the regularities in the environment allow the nervous system to make predictions [39].

An example for how to construct an optimal code is presented by the fly compound eye with possible extensions to the mammalian visual system [44]. Pictorial information is derived from the two-dimensional

spatial array of light intensities and their changes in time. The intensities in ambient daylight may vary over several orders of magnitude. If this range were transduced linearly into photoreceptor potentials, the gain would be uniformly low. Moreover, of prime importance in an image are changes, spatial contrasts and temporal variations, which delineate objects from others. Thus, some other form of coding is required.

► **Contrast** is a measure of relative intensity at some point in relation to the average (background) intensity level,  $I$ , in its surroundings, usually expressed as  $\Delta I/I$ .

The background intensity  $I$  can be estimated as a weighted average of the signals from surrounding photoreceptors. Such weighting functions have been computed for pictures of different statistical properties and intensities and different ► **signal-to-noise ratios**, and compared with measured data. To remove temporal correlations requires a biphasic response to an instantaneous flash (► **impulse response**). Thus, the weighting functions necessary for this computation are functions of space and time, over which the local means should be determined. This coding scheme has some essential features:

1. ► **Center-surround antagonism** in the receptive field (RF). Here the center is excitatory and the surround inhibitory. This receptive field organization is often found in sensory systems.
2. Reduction of redundancy resulting from spatio-temporal correlations. These correlations can be captured by properly designed weighting functions, and subtraction of the predictive signal thus removes or at least reduces the correlation-based redundancy from the center signal.

In summary, center-surround antagonism in receptive fields is capable of enhancing spatial contrasts, and this in turn reduces spatial redundancy that would otherwise be present in the signals of parallel neuronal elements due to spatial correlations in the sensory signals. Similar principles apply in the temporal domain, where properly chosen impulse functions may reduce temporal redundancy.

### Acknowledgment

*Dedicated to the outstanding scientist, academic teacher and friend Rainer F. Greger (3.1.1946-16.12.2007)*

I am grateful for encouragement and suggestions for improvement to Marc D. Binder and Douglas G. Stuart.”

### References

1. Müller J (1833–1840) Handbuch der physiologie des menschen für vorlesungen, 2 Hölscher, Coblenz
2. Mountcastle VB (1984) Central nervous mechanisms in mechanoreceptive sensibility. In: Darian-Smith I (ed) Handbook of physiology, the nervous system, vol III. Sensory processes, part 2. Amer Physiol Soc, Bethesda, pp 789–878
3. Sherrington CS (1906) On the proprioceptive system, especially in its reflex aspect. Brain 29:467–482
4. Prochazka A (1996) Proprioceptive feedback and movement regulation. In: Rowell L, Sheperd JT (eds) Handbook of physiology, Sect. 12: Exercise: Regulation and integration of multiple systems. Amer Physiol Soc, New York, pp 89–127
5. Brookes M (1998) Get the message. New Scientist, 15 August, 40–43
6. Doetsch GS (2000) Patterns in the brain: Neuronal population coding in the somatosensory system. Physiol Behav 69:187–201
7. Powers RK, Sawczuk A, Musick JR, Binder MD (1999) Multiple mechanisms of spike-frequency adaptation in motoneurons. J Physiol (Paris) 93:101–114
8. Stryker MP (Rapporteur), Allman J, Blakemore C, Greuel JM, Kaas JH, Merzenich MM, Rakic P, Singer W, Stent GS, van der Loos H, Wiesel TN (1988) Principles of cortical self-organization. In: Rakic P, Singer W (eds) Neurobiology of cortex. Wiley, Chichester New York Brisbane Toronto Singapore, pp 115–136
9. Singer W, Gray CM (1995) Visual feature integration and the temporal correlation hypothesis. Annu Rev Neurosci 18:555–586
10. Shimojo S, Shams L (2001) Sensory modalities are not separate modalities: plasticity and interactions. Curr Opin Neurobiol 11:505–509
11. Meredith MA (2002) On the neuronal basis for multisensory convergence: brief overview. Cogn Brain Res 14:31–40
12. Stein BE (1998) Neural mechanisms for synthesizing sensory information and producing adaptive behaviors. Exp Brain Res 123:124–135
13. Stein BE, Meredith MA (1993) The merging of the senses. MIT, Cambridge (Mass)
14. Jankowska E (1992) Interneuronal relay in spinal pathways from proprioceptors. Prog Neurobiol 38: 335–378
15. Windhorst U (2007) Muscle proprioceptive feedback and spinal networks. Brain Res Bull 73:155–202
16. Andersen RA, Snyder LH, Bradley DC, Xing J (1997) Multimodal representation of space in the posterior parietal cortex and its use in planning movements. Annu Rev Neurosci 20:303–330
17. Driver J, Spence C (1998) Attention and the crossmodal construction of space. Trends Cogn Sci 2:254–262
18. Amedi A, Jacobson G, Hendler T, Malach R, Zohary E (2002) Convergence of visual and tactile shape processing in the human lateral occipital complex. Cereb Cortex 12:1202–1212
19. Laurent G, Stopfer M, Friedrich RW, Rabinovich MI, Volkovskii A, Abarbanel HDI (2001) Odor encoding as an active, dynamical process: experiments, computation, and theory. Annu Rev Neurosci 24:263–297
20. Lacquaniti F (1997) Frames of reference in sensorimotor coordination. In: Jeannerod M, Grafman J (eds) Handbook of neuropsychology, vol 11. Elsevier, Amsterdam Lausanne New York Oxford Shannon Tokyo, pp 27–64
21. Knudsen EI, Brainard MS (1995) Creating a unified representation of visual and auditory space in the brain. Annu Rev Neurosci 18:19–43

22. Olson CR (2003) Brain representation of object-centered space in monkeys and humans. *Annu Rev Neurosci* 26:331–354
23. Mittelstaedt H (1998) Origin and processing of postural information. *Neurosci Biobehav Rev* 22:473–478
24. Matthews PBC (1988) Proprioceptors and their contribution to somatosensory mapping: Complex messages require complex processing. *Can J Physiol Pharmacol* 66:430–438
25. Massion J (1992) Movement, posture and equilibrium: Interaction and coordination. *Prog Neurobiol* 38:35–56
26. Kastner S, Ungerleider LG (2000) Mechanisms of visual attention in the human cortex. *Annu Rev Neurosci* 23:315–341
27. Corbetta M (1998) Frontoparietal cortical networks for directing attention and the eye to visual locations: Identical, independent, or overlapping neural systems? *Proc Natl Acad Sci USA* 95:831–838
28. Udin SB, Fawcett JW (1988) Formation of topographic maps. *Annu Rev Neurosci* 11:289–327
29. Buonomano DV, Merzenich MM (1998) Cortical plasticity: From synapses to maps. *Annu Rev Neurosci* 21:149–186
30. Jones EG (2000) Cortical and subcortical contributions to activity-dependent plasticity in primate somatosensory cortex. *Annu Rev Neurosci* 23:1–37
31. Kaas JH (1991) Plasticity of sensory and motor maps in adult mammals. *Annu Rev Neurosci* 14:137–167
32. Keuroghlian AS, Knudsen EI (2007) Adaptive auditory plasticity in developing and adult animals. *Prog Neurobiol* 82:109–121
33. Sanes JN, Donoghue JP (2000) Plasticity and primary motor cortex. *Annu Rev Neurosci* 23:393–415
34. Wall JT, Xu J, Wang X (2002) Human brain plasticity: An emerging view of the multiple substrates and mechanisms that cause cortical changes and related sensory dysfunctions after injuries of sensory inputs from the body. *Brain Res Rev* 39:181–215
35. Weinberger NM (1995) Dynamic regulation of receptive fields and maps in the adult sensory cortex. *Annu Rev Neurosci* 18:129–158
36. Atick JJ (1992) Could information theory provide an ecological theory of sensory processing? *Network* 3:213–251
37. Laughlin SB (2001) Energy as a constraint on the coding and processing of sensory information. *Curr Opin Neurobiol* 11:475–480
38. Simoncelli EP, Olshausen BA (2001) Natural image statistics and neural representation. *Annu Rev Neurosci* 24:1193–1216
39. Barlow HB (2001) The exploitation of regularities in the environment by the brain. *Behav Brain Sci* 24:602–607
40. Coppola DM, Purves HR, McCoy AN, Dale Purves D (1998) The distribution of oriented contours in the real world. *Proc Natl Acad Sci USA* 95:4002–4006
41. Van der Schaaf A, van Hateren JH (1996) Modelling the power spectra of natural images: Statistics and information. *Vision Res* 36:2759–2770
42. Ruderman DL (1994) The statistics of natural images. *Network: Comp Neural Syst* 5:517–548
43. Sigman M, Cecchi GA, Gilbert CD, Magnasco MO (2001) On a common circle: Natural scenes and Gestalt rules. *Proc Natl Acad Sci USA* 98:1935–1940
44. Laughlin SB (1987) Form and function in retinal processing. *Trends Neurosci* 10:478–483

## Sensory Transduction

### Definition

Sensory transduction denotes the process by which, in a sensory receptor cell, a physico-chemical stimulus is converted, by the opening or closing of ion channels in a local membrane region, into a receptor current, which in turn gives rise to a receptor potential.

- ▶ Receptor Potential
- ▶ Sensory Systems

## Septal Complex

- ▶ Evolution of Septal Nuclei

## Septal Nuclei

### Synonyms

- ▶ Nuclei septales

### Definition

The nuclei located in the septum verum (lateral septal nuclei, medial septal nuclei, nucleus of diagonal band) are involved in complex function circuits between hypothalamus and hippocampus. Lesions and stimulation show that the nuclei are involved in autonomic behavioral processes such as eating, drinking, micturition, defecation, sexual, reproduction and aggression behavior.

- ▶ Telencephalon

## Septal Organ

### Definition

“Organ of Masera,” bilaterally, isolated small patch of olfactory epithelium in several mammalian species at the nasal septal wall with axonal projections of specific

glomeruli in the olfactory bulb. Discovered 1921 by Broman, function yet unknown.

- ▶ Chemical Senses
- ▶ Olfactory Perception

## Septal Region

### Definition

The septal region (area septalis) lies medial and dorsal to the nucleus accumbens, and terminates dorsally in the septum pellucidum. The septal regions contains the septal nuclei and the diagonal band of Broca.

- ▶ Evolution of Septal Nuclei

## Septum, Lateral

### Definition

Part of the septal complex, comprising mostly GABAergic medium sized, spiny neurons, that receives massive inputs from the hippocampus and projects strongly to the preoptic region and medial septumdiagonal band complex, which is rich in cortically projecting cholinergic and GABAergic neurons.

## Septum Medullae

- ▶ Floor Plate

## Septum Pellucidum

### Definition

The septum pellucidum is part of the medial border of the cerebral hemisphere and third ventricle. It consists of a thin layer of glial tissue almost void of neurons. The septum pellucidum spans between corpus callosum, fornix, and septal region. The septa pellucida of both hemispheres are partially adherent but may contain the cavum septi pellucidi, a cavity filled with fluid.

## Sequence Learning

### Definition

Sequence learning is of behavioral procedures or “how to,” which is similar to skill learning. But it is learning of a series of multiple discrete movements towards a goal, like learning to play a musical instrument or learning to play tennis. It can reflect acquisition of processes of simple stimulus-response association or more extensive, sequential patterns of discrete movements.

In this learning, cortical motor areas, prefrontal cortex and subcortical areas especially the basal ganglia play major roles. Basal ganglia with dopamine system and prefrontal cortex are responsible for acquisition of a series of movements or actions towards a goal, favorable condition.

- ▶ Sensorimotor Learning and the Basal Ganglia

## Sequence of Pulse Intervals (SPI)

### Definition

A measure of the temporal patterning of electric organ discharge (EOD) production. Refers to the intervals between adjacent EODs over time.

- ▶ Reafferent Control in Electric Communication

## Serial Analysis of Gene Expression

ANTHONY BERNDT, CAIRINE LOGAN  
Institute of Maternal and Child Health, Genes and Development Research Group, Department of Cell Biology and Anatomy, Faculty of Medicine, University of Calgary, Calgary, AB, Canada

### Synonyms

SAGE; LongSAGE; SuperSAGE

### Definition

Serial Analysis of Gene Expression (SAGE) is a sequence-based approach that allows for global analysis of ▶mRNA transcripts, without the requirement of

*a priori* knowledge of an organism's ►transcriptome. SAGE produces a large library of short sequence tags that originate from mRNA extracted from a tissue or purified cell sample [1]. The frequency of each tag directly reflects transcript abundance while the sequence is sufficient to identify known transcripts in database searches. SAGE can be utilized to discover previously uncharacterized transcripts, unlike some types of ►microarray analysis, but currently costs several fold more than microarrays to implement.

## Characteristics

### Overview

Diverse interactions of many neuronal and glial cell types allows for intricate wiring and organization of the nervous system, making it one of the most complex tissues in animals. Although each cell in the nervous system contains an identical copy of the organism's genome, distinct gene expression profiles allows for variegated cellular and functional diversity. In the past, global differences in gene expression profiles have been examined by Northern Blotting, subtractive hybridization, comparative ►expressed sequence tag (EST) analysis and differential gene display [2]. However, these methods are capable of analyzing only a limited number of highly expressed transcript species and do not provide quantitative data on expression levels. Therefore, an approach to quantitatively and qualitatively examine the expression of large numbers of genes expressed at both low and high levels was needed to yield more detailed information on transcript expression profiles. SAGE, originally developed by Velculescu et al. (1995) [1], fulfilled this requirement and was readily adopted by investigators in many fields of biology in subsequent years. While genomics has been extremely successful in cataloguing protein coding gene sequences, it has provided less information on how these genes work in concert to maintain homeostasis by responding to environmental and internal cues, SAGE, therefore, offers an opportunity to increase our understanding of how large numbers of genes operate in a global manner.

### Purpose

SAGE data is utilized to determine the qualitative and quantitative expression distribution of thousands of transcripts simultaneously from a single RNA sample through the generation and sequencing of oligonucleotide tags derived from RNA transcripts [1]. These data can be used to describe the gene expression profile of a single cell or tissue type, or be used to compare different gene expression profiles of two or more samples [3–6]. SAGE tags without a match to known transcripts can also act as a starting point for the investigation of previously unknown genes. Further, SAGE libraries are

digital and are thus easily stored in publicly accessible databases for future comparison and analysis.

### Principles

Firstly, sufficient information is contained in a short nucleotide sequence, termed a “tag,” to accurately identify the transcript [1]. Standard SAGE tags are 10 nucleotides long, while the currently more favored LongSAGE tags are 17 nucleotides long [7]. (Note: these SAGE tags are actually 14 or 21 nucleotides long, respectively, but all tags contain a common nucleotide restriction enzyme recognition site at the 5' end meaning that only 10 or 17 nucleotides are unique to each tag.) Thus,  $4^{10}$  or  $4^{17}$  ( $1.04 \times 10^6$  or  $1.72 \times 10^{10}$ ) unique permutations can be represented using this short sequence. For comparison, the human genome contains a total of  $\sim 3 \times 10^9$  nucleotides, not all of which are transcribed. Secondly, from 25 to 50 concatamerized tags can be cloned into a single vector, allowing for serial analysis of multiple tags in a single sequencing run. Thirdly, each unique SAGE tag provides information on the genes contributing transcripts to the RNA population, as well as the frequency of occurrence when compared to the total populations of transcripts in the SAGE library.

### Method

#### Biochemistry

A standardized protocol for SAGE based on the original method developed by Velculescu et al. (1995) [1] is available to researchers and can be accessed at <http://www.sagenet.org>. LongSAGE [7] and SuperSAGE [8] are performed in a similar manner but utilize different tagging enzymes to generate longer tag lengths. Briefly, RNA is separated from proteins and cellular debris. One strand of cDNA is produced from mRNA by using reverse transcriptase and 5'-biotinylated oligo(dT) primers. Double stranded ►cDNA is then produced by digesting the original mRNA template with ►RNase H followed by DNA synthesis with DNA polymerase and DNA ligase. A type II ►restriction endonuclease, *Nla*III, called the anchoring enzyme (AE) in this context, cleaves the resulting double stranded cDNA. The product of the anchoring enzyme step is washed over ►streptavidin coated magnetic beads, capturing the biotinylated double-stranded cDNA fragments while the remaining cDNA is washed away. The anchored tags are then divided into two pools. Different linker sequences are ligated to each pool of anchored tags. The linkers contain a recognition motif for a type II restriction endonuclease, such as BsmFI, which cleaves DNA at a set distance from the recognition site. Blunt ends are generated by use of ►Klenow fragment. Mixing of the two populations of tags is followed by the ligation of these tags with DNA ligase to form ditags. PCR

amplification of the ditags is performed followed by purification of the PCR products by gel electrophoresis and extraction. The linker portions of the ditags are released with digestion by the anchoring enzyme (*Nla*III). The ditags are concatenated with DNA ligase and inserted into a ►plasmid vector for sequencing.

### Sequence Analysis and Tag Identification

High throughput sequencing methods produce digital datafiles of the concatamers. The beginning and end of each tag in the concatamer are identified by searching for the restriction site of the anchoring enzyme contained in each tag (CATG in the case of *Nla*III.) The sequence of each tag is then logged in a data file for further analysis. A conventional SAGE library will contain 50,000 to 100,000 total tags [3,4,6].

Virtual tag libraries have been generated *in silico* from cDNA sequences archived in the GenBank databases. These cDNA sequences are both cDNAs of described genes and ESTs. Software programs are used to compare the experimentally generated SAGE library with the *in silico* library. When an experimentally generated SAGE tag matches a virtual tag, the identity of the transcript or the gene from which the virtual tag was extracted is assigned to the experimentally generated SAGE tag.

### Data Analysis and Presentation

A common pattern of SAGE data presentation has evolved. The fraction of total tags is often plotted against the frequency with which the tags appear in the population. This relationship often assumes a power law distribution in which a small number of the tags found in the library is present at a very high frequency, while many different types of low copy number tags make up the bulk of the tag population. Tag frequency, sequence, and identity are presented in tables. Tags are often grouped into functional classes based upon Unigene Gene Ontology nomenclature. When two or more samples are compared, tags are presented in tables with the greatest differences between samples listed in descending order. Difference in gene expression level is evaluated based on the result from a statistical test rather than simple fold-difference in tag count between the groups being compared. These methods include a Poisson approximation developed by Audic and Claverie [4], Bayesian method, Monte Carlo Simulation or Fisher's Exact test [6]. Each technique has its own strengths and weaknesses; however, in each case a probability value (*p*-value) is generated that represents the probability of obtaining a result as extreme as the given case, assuming the case was generated by probability alone. When the *p*-value is less than an *a priori* chosen significance level ( $\alpha$ ), usually  $\alpha = 0.05$  or  $0.01$ , the null-hypothesis of no difference between gene expression levels is rejected.

## Advantages and Disadvantages

### Advantages

Techniques such as reverse real-time quantitative PCR (►RT-qPCR) and northern blotting are useful for studying the expression levels of one or a limited number of known genes [6]. Larger scale screening methods such as cDNA subtraction utilize hybridization to uncover differential expression of unknown genes on a small to medium scale, but provide little information on transcript abundance [2]. Conventional microarray analysis is usually used to study known transcript expression. However, recently developed tiling microarrays employ probes representing large stretches of a genome and can detect previously uncharacterized transcripts [9]. In contrast, SAGE provides exact counts of transcript frequency and identity within a library. SAGE can be considered an open experimental format where prior knowledge of the subject's genome is not required, and previously uncharacterized transcripts can be identified. Nevertheless, the true power and utility of SAGE is only fully actualized when a well annotated genome is available to match tags to known genes. Further, the number of SAGE tags collected in an experiment can easily be increased so that even very rare transcripts can be identified with a high probability that these rare transcripts will be previously uncharacterized.

### Disadvantages

Tag sequence specificity has been cited as a weakness in SAGE. Transcripts from two or more different genes can share the same tag sequence [7,8]. This weakness has been addressed by the development of LongSAGE [7] and SuperSAGE [8] approaches that expand SAGE tags from 10 to 17 or 26 nucleotide long tags, respectively, greatly increasing tag specificity.

In many studies, from 30 to 50% of SAGE tags do not map to known transcripts or genes [4,6]. Many of these unmapped tags appear as ►singletons. These unmapped transcripts could originate from introduction of base changes or sequencing errors since multiple steps are involved in SAGE tag collection and single pass sequencing can contain base errors. However, recent work utilizing tiling microarrays has shown that much of the genome may actually be transcribed at low levels suggesting that these unmapped tags may indeed represent unknown low abundance transcripts [9]. In many studies, singleton transcripts are excluded from further data analysis. Obviously, this approach, while simplifying interpretation of the data, detracts from the experimental power of SAGE to discover uncharacterized low copy number transcripts.

### Uses of SAGE in Neuroscience

The use of SAGE in neuroscience spans the genetic and neural complexity of organisms from the nematode *C. elegans* to mouse and human. The following



summaries of studies utilizing SAGE libraries have been chosen to highlight the diverse applicability of SAGE in neuroscience, but in no way acts as a comprehensive catalogue of the research done to date.

#### A. Effects of signaling molecules on the central nervous system

Datson et al. (2001) [3] utilized SAGE to identify corticosterone responsive genes in the ►hippocampus of the rat. Stress causes an increase in the release of corticosterone in rats by increasing the activity of the hypothalamic-pituitary-adrenal axis. Response to glucocorticoids occurs via binding of corticosterone to intracellular mineralocorticoid (MR) and glucocorticoid receptors (GR) which in turn activate or repress target genes. MRs are approximately 10 times more responsive to corticosterone than GRs. Exposing adrenalectomized animals to low or high corticosterone levels resulted in differential gene expression. Furthermore, comparison of MR- and GR-dependent expression profiles revealed that the majority of the corticosterone-responsive genes were regulated either by activated MR or by activated GR, while only a few genes were responsive to both. These differentially expressed genes were grouped into classes such as: energy expenditure and cellular metabolism; protein synthesis and turnover; signal transduction and neuronal connectivity; and neurotransmission. Although some genes were already known to be corticosterone responsive, such as GAP-43 and metallothionein-I, many were novel. Differential expression of six randomly chosen, previously identified genes was examined by *in situ* hybridization and found to correlate strongly with the SAGE data.

#### B. Development and differentiation of neuronal types

Etchberger et al. (2007) [4] utilized SAGE to compare the expression profile of gustatory neurons (ASE neurons) with thermosensory neurons (AFD neurons) of *C. elegans* and were able to identify >1,302 differentially expressed genes. These genes included transcription factors, ion channels, neurotransmitters, and receptors, as well as seven-transmembrane receptor-type putative gustatory receptor genes. Examination of the *cis*-regulatory sequences, through consecutive deletions of the promoter region of multiple differentially expressed genes, followed by sequence alignment and site-directed mutagenesis revealed a previously uncharacterized "ASE motif" required for the expression of many ASE-expressed genes. The ASE motif was identified as a binding site for the C2H2 zinc finger transcription factor CHE-1, which is essential for proper differentiation of the ASE cell type. This study highlights the usefulness of SAGE when combined with other more conventional approaches to interrogating the genome.

#### C. Molecular profile of pathophysiological processes

Focal Brain Ischemia Reperfusion injury (stroke) has been characterized as having acute and delayed phases. During the acute phase, hypoxia and energy failure cause cell necrosis, while delayed events, involving altered gene expression after blood flow has been re-established, are involved in subsequent inflammation and apoptosis. Trendelenburg et al. (2002) [6] utilized SAGE to identify candidate up-regulated and down-regulated genes involved in the delayed response. Metallothionein-II (MT-II) was the transcript most significantly increased 14 h after ischemia as compared to controls. However, the expression of the closely related gene Metallothionein-I (MT-I) could not be analysed using SAGE as it did not contain a NlaIII anchoring restriction site. Northern Blotting and semi-quantitative Western Blotting was utilized to confirm MT-II up-regulation. Immunohistochemistry revealed that both MT-I and MT-II were expressed in reactive astrocytes around the infarct core. MT-I and MT-II deficient knock-out mice were shown to have an infarct volume three times that of wild-type animals. This study demonstrates how SAGE data can be linked to functional relevance. Taken together, these findings suggest a protective role of metallothioneins in a model of stroke.

#### D. Comparative Gene Profiles of Developing Brain Regions

The two cerebral hemispheres of the human brain are specialized for distinct cognitive and behavioral functions. For example, language function is predominantly localized to a distributed network in the left cortex surrounding the lateral sulcus, called the perisylvian cortex, in ~97% of right-handers and ~60% of left-handers. Sun et al. (2005) generated SAGE libraries from the left and right perisylvian regions of human fetal brains at 12, 14 and 19 weeks of development. In all, 49 differentially expressed genes were found between the left and right regions in the 12 week old brain and 68 in the 14 week old brain. Factors known to play a role in cortical development, such as ID2, NEUROD6 and Lim Domain Only 4 (LMO4) were found to be asymmetrically expressed. LMO4 was further investigated with RT-qPCR and shown to be expressed at a higher level in the right cortex compared to the left at 12 weeks and 14 weeks, but not 19 weeks. *In situ* hybridization performed on brains at several different stages from 12 to 19 weeks of development also demonstrated that LMO4 expression is found to a greater extent over the right perisylvian cortex than the left, with diminishing asymmetry over the same period of development. LMO4 expression was also profiled in embryonic mice and exhibited a similar temporal pattern of lateral asymmetry but was not consistently lateralized to the right or left side. This may

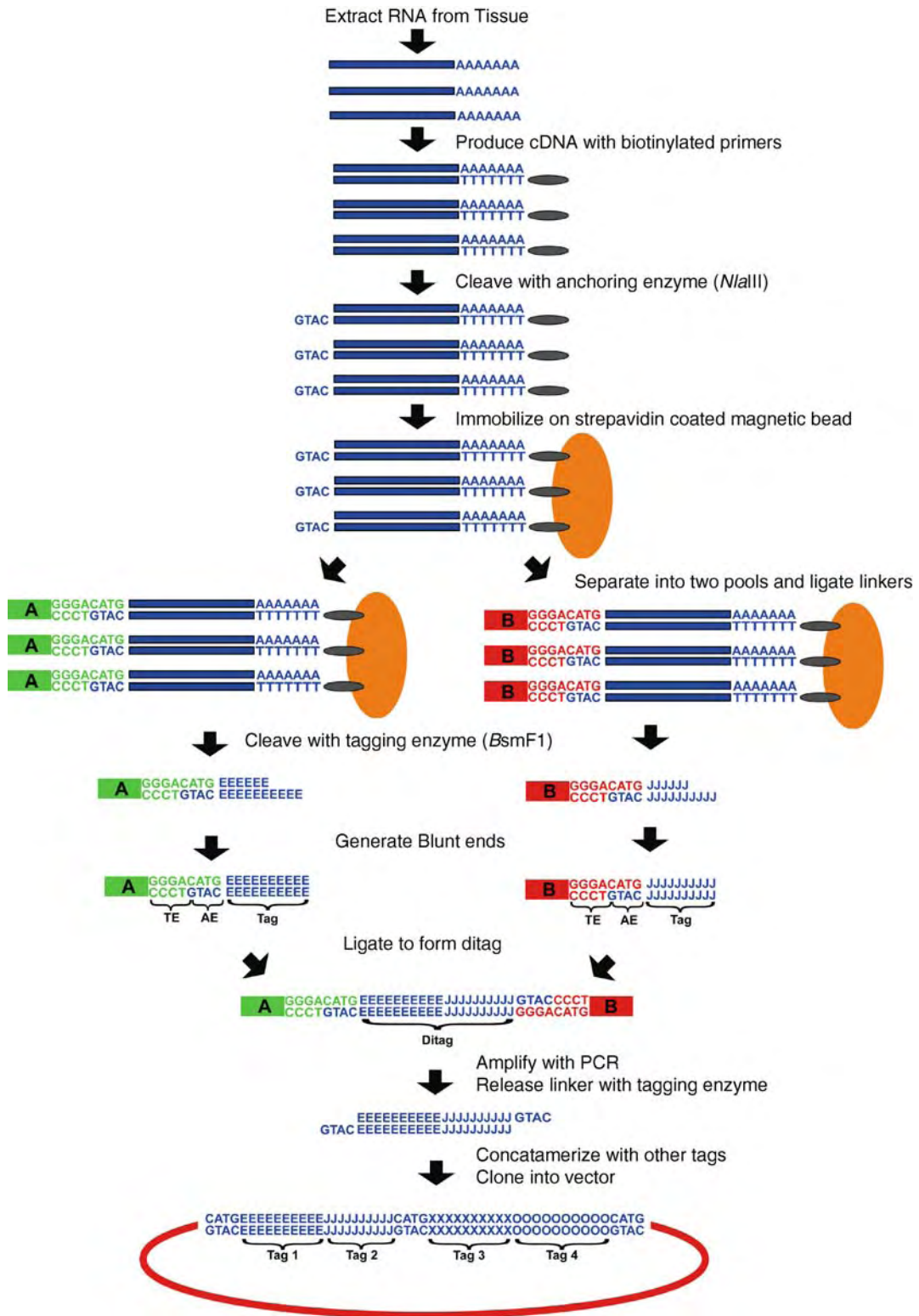

**Serial Analysis of Gene Expression. Figure 1** Schematic of SAGE Library Construction. Double stranded cDNA is produced from polyadenylated RNA transcripts. The anchoring enzyme defines the 5' end of the tag. After ligation to linkers, the tagging enzyme defines the 3' end of the tag. The anchoring enzyme is used to free the tags of the linkers before they are blunt-ended and ligated together to form ditags. The ditags are then concatenated and inserted into a plasmid for sequencing.

relate to motor asymmetries which are observed in individual mice, like paw preference, but are not biased on a population level as they are in humans where 90% of the human population has naturally greater dexterity with their right hand. The left-right differences in LMO4 expression in humans could potentially represent either a differing topographic mapping in the two hemispheres or alternatively a difference in the rate of cortical development, with the right hemisphere's development occurring more rapidly than the left.

### Future of SAGE

Currently, the sensitivity of SAGE to detect low copy number tags, many of which may represent real transcripts, is limited by cost-efficiency due to the current expense of DNA sequencing on conventional systems. New sequencing technologies are becoming available that should allow sequencing of millions of base pairs for a few hundred to a few thousand dollars with much higher throughput [10]. Furthermore, massively parallel sequencing-by-synthesis approaches like the Solexa 1G system or the 454 system that allow simultaneous sequencing of thousands of short nucleotide sequences at once should theoretically negate the need for cloning or concatamerization; instead, allowing a modified form of ditags to be directly sequenced [10]. Therefore, SAGE, or variations thereof, has the potential to play an increasing role in transcriptome and genome studies for the foreseeable future.

### References

1. Velculescu VE, Zhang L, Vogelstein B, Kinzler KW (1995) Serial analysis of gene expression. *Science* 270:484–487
2. Datson NA, van der Perk-de Jong J, van den Berg MP, de Kloet ER, Vreugdenhil E (1999) MicroSAGE: a modified procedure for serial analysis of gene expression in limited amounts of tissue. *Nucleic Acids Res* 27:1300–1307
3. Datson NA, van der Perk J, de Kloet ER, Vreugdenhil E (2001) Identification of corticosteroid-responsive genes in rat hippocampus using serial analysis of gene expression. *Eur J Neurosci* 14:675–689
4. Etchberger JF, Lorch A, Sleumer MC, Zapf R, Jones SJ, Marra MA, Holt RA, Moerman DG, Hobert O (2007) The molecular signature and cis-regulatory architecture of a *C. elegans* gustatory neuron. *Genes Dev* 21:1653–1674
5. Sun T, Patoine C, Abu-Khalil A, Visvader J, Sum E, Cherry TJ, Orkin SH, Geschwind DH, Walsh CA (2005) Early asymmetry of gene transcription in embryonic human left and right cerebral cortex. *Science* 308:1794–1798
6. Trendelenburg G, Prass K, Priller J, Kapinya K, Polley A, Muselmann C, Ruscher K, Kannbley U, Schmitt AO, Castell S, Wiegand F, Meisel A, Rosenthal A, Dirnagl U (2002) Serial analysis of gene expression identifies metallothionein-II as major neuroprotective gene in mouse focal cerebral ischemia. *J Neurosci* 22:5879–5888
7. Saha S, Sparks AB, Rago C, Akmaev V, Wang CJ, Vogelstein B, Kinzler KW, Velculescu VE (2002) Using the transcriptome to annotate the genome. *Nat Biotechnol* 20:508–512
8. Matsumura H, Reich S, Ito A, Saitoh H, Kamoun S, Winter P, Kahl G, Reuter M, Kruger DH, Terauchi R (2003) Gene expression analysis of plant host-pathogen interactions by SuperSAGE. *Proc Natl Acad Sci USA* 100:15718–15723
9. Birney E et al. (2007) Identification and analysis of functional elements in 1% of the human genome by the ENCODE pilot project. *Nature* 447:799–816
10. Bentley DR (2006) Whole-genome re-sequencing. *Curr Opin Genet Dev* 16:545–552

## Serial Learning

### Definition

Serial learning is learning to make a series of responses in exact order. In other words, it is a procedure of learning where the learner is exposed to stimuli to be remembered and later recalls those stimuli in the same order in which they initially appeared. Memory for words is a representative type of serial learning.

## Series Arrangement

### Definition

A combination of two rheological elements, such that the force is common to both and the elongations are to be added to obtain the elongation of the combined element.

► **Mechanics**

## Series Elasticity

► **Tendon**

## Serotonin Actions on Suprachiasmatic Nucleus

### Definition

One of the major transmitters in the nervous system. Serotonergic neurons from the raphe region densely innervate the suprachiasmatic nucleus (SCN). Raphe

neurons typically generate action potentials and release 5HT during the phases of the daily cycle in which the animals are awake. A diverse array of 5HT receptors have been reported in the SCN including the 5HT1A, 5HT1B, 5HT2A, 5HT2C, 5HT5A and 5HT7 receptor types. These G-protein linked receptors are coupled to adenylyl cyclase or phospholipase C. Activation of these signaling pathways could produce a variety of cellular effects in SCN neurons. The modulations of potassium and calcium channels most commonly mediate the ionic actions of 5HT in other brain regions although the specific ionic mechanisms that underlie 5HT's actions in the SCN are unknown.

Functionally, 5HT receptor agonists cause phase shifts of the SCN circadian oscillator when administered at times in the circadian cycle during which light does not cause phase shifts both in vitro and in vivo.

Evidence suggests that this pathway may mediate nonphotic activity induced phase shifts of the circadian system. In addition, a variety of evidence suggests that 5HT can also modulate photic input to the SCN. Neurotoxic destruction of the serotonergic input to the SCN alters the relationship between the light-dark cycle and locomotor activity and increases in 5HT levels alter the effects of light on the circadian system. Administration of 5HT can inhibit optic nerve induced field potentials in the SCN brain slice preparation, light-induced Fos expression and phase shifts of the circadian rhythm of wheel-running activity. Interestingly, 5HT receptor antagonists have been reported to enhance light-induced increases in the firing rates of SCN neurons and light-induced phase shifts. These results raise the possibility that 5HT may be involved in a tonic inhibition of the light-input pathway to the SCN. These studies are all consistent with the hypothesis that the serotonergic innervation of the SCN serves to modulate light input as well as mediate non-photic activity-induced phase shifts of the circadian system.

- ▶ Circadian Rhythm
- ▶ Slice Preparation
- ▶ Suprachiasmatic Nucleus

---

## Serotonin (5-hydroxytryptamine; 5-HT)

### Definition

Serotonin (5-hydroxytryptamine; 5-HT) is synthesized from L-tryptophan and can be converted to melatonin. It is a monoaminergic neurochemical that is common to the nervous and immune systems. Neurons containing

serotonin are located near the midline or raphé regions of the brainstem. Serotonergic fibers project widely throughout the central nervous system (CNS) and exert complex neuromodulatory effects mediated through 15 receptor subtypes. 5-HT contributes to functions such as endocrine and circadian rhythms, sleep, body temperature regulation, appetite, food intake, sexual and reproductive activity, aggression, motor functions, cognition, mood, anxiety, learning and memory. Outside the central nervous system, 5-HT is present in immune cells such as platelets, lymphocytes, monocytes and macrophages.

- ▶ Circadian Rhythm
- ▶ Melatonin
- ▶ Raphé Nuclei

---

## Servo Control

### Definition

The operation of a proportional feedback controller whereby the feedback loop serves to minimize the error between the desired and actual values of the controlled variable.

- ▶ Feedback Control of Movement

---

## Servomotor

### Definition

A motor that automatically controls the action of a mechanical device in a feedback system consisting of a sensing element and an amplifier.

---

## Set-point

### Definition

In the body, certain variables must be kept within a narrow limit for survival. This desired or reference point is called set point.

- ▶ Homeostasis

## Set-point in Temperature Regulation

### Definition

The value of a regulated variable that is stabilized by the processes of regulation. In temperature regulation, this variable is the core temperature ( $T_c$ ). In fever, its value shifts due to pyrogen-induced changes in the characteristics of the thermal controller such that the properties of the various feedback, feedforward and open-loop components that together contribute to thermal balance cause this balance to occur at a higher than “normal”  $T_c$ .

► Endotoxic Fever

## Seven Transmembrane Receptors

► G-protein Coupled Receptors (GPCRs): Key Players in the Detection of Sensory and Cell-Cell Communication Messages

## Severe Myoclonic Epilepsy of Infancy (SMEI)

### Definition

SMEI is a rare form of childhood epilepsy. The symptoms of this disorder begin with tonic/clonic seizure during the first 6 months of life and accompanied by elevated body temperatures. As time progresses, increasingly worse symptoms develop, such as myoclonic seizures, ataxia and photosensitive seizures. In 70% of children with SMEI bear a missense, frameshift and nonsense mutations in the SCN1A sodium channel gene that results in nonfunctional and truncated proteins.

► Epilepsy

## Sex

### Definition

Biological construct used to divide members of a species into reproductively distinct and often

complementary groups. A term used to classify organisms as male or female according to genetic composition and consequent anatomic structures and functions. The term sex can be used in reference to human or non-human animals.

► Gender/Sex Differences in Pain

## Sex Differences in Pain

► Gender/Sex Differences in Pain

## Sexual Behavior

### Definition

Behavior that is directed towards a sexual partner, includes courtship and copulation.

## Sex Lethal

### Definition

A name of a gene in *Drosophila* that undergoes sexspecific splicing to form an active Sex lethal protein in females, and non-active Sex lethal protein in males. The active form of Sex lethal initiates the female-specific development.

## Sexual Neurophysiology

► Neurophysiology of Sexual Spinal Reflexes

## Sexual Reflexes

LESLEY MARSON

Division of Urology, University of North Carolina at Chapel Hill, Chapel Hill, NC, USA

### Definition

Sexual reflexes in males and females comprise of complex integrated systems that are influenced by hormonal levels and sensory signals that are regulated by the central and peripheral nervous systems. Genital reflexes in males and females, such as genital arousal, erection and climax arise from spinal cord reflex mechanisms that are modulated by brain inputs. Other pathways, such as sexual desire and arousal may be regulated by higher central nervous system mechanisms, yet to be determined.

The structural components and mechanisms that lead to Sexual Reflexes, in particular genital reflexes, are outlined in this essay.

### Characteristics

#### Higher Level Structures

**Major Components: Peripheral Nerves, Spinal Cord and Brain (see Fig. 1)**

Sexual reflexes such as clitoral and vaginal **vasocongestion**, erection, ejaculation and sexual climax are organized at the spinal level. This conclusion is based

on experimental studies in animals with transected spinal cords and in human patients with spinal cord injury. Sensory stimulation from peripheral nerves increases activity in the spinal cord, which results in increased sexual motor output. For the most part the organization of the neural structures mediating sexual reflexes are similar in males and females.

Sexual responses require the complex coordination of sympathetic, parasympathetic and somatic efferents that are distributed over several spinal segments. These efferents must be coordinated by an interneuronal system that traverses multiple spinal segments. These spinal circuits are regulated by peripheral sensory inputs and descending inputs from the brain. The major supraspinal input is inhibitory and neurons in the caudal ventral hindbrain, in a region known as the nucleus paragigantocellularis, mediate the inhibition in both males and females. Forebrain sites can also facilitate activity of the spinal circuits.

The medial preoptic area is essential for male copulatory behavior (erections and ejaculation) in every species tested [1], and stimulation of this site evokes sexual reflexes in male rats [2]. In females, the brain sites facilitating sexual reflexes are less clear. The medial preoptic region in rats inhibits the display of **lordosis**, but may facilitate genital reflexes. The ventromedial nucleus of the hypothalamus is critical for the expression of lordosis [3], but lordosis is not seen in all species.

Other forebrain regions involved in sexual function have largely been identified on the basis of visualization

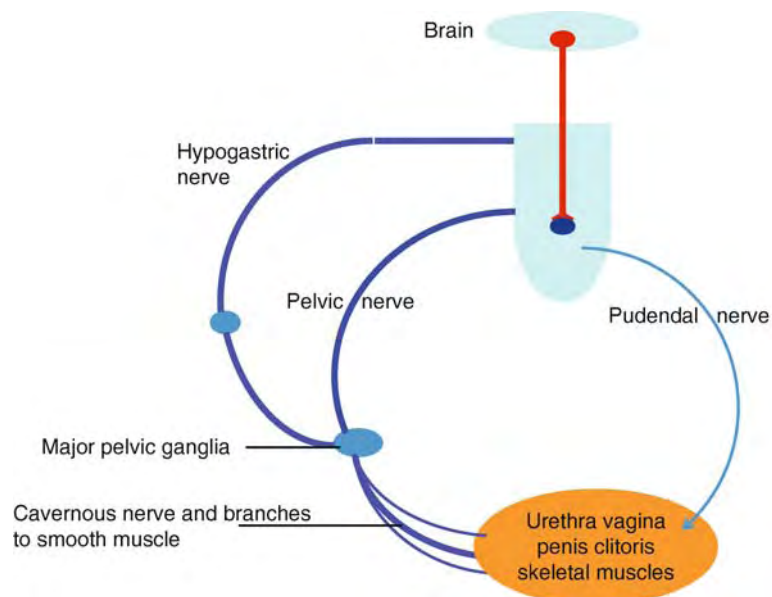

**Sexual Reflexes. Figure 1** Diagrammatic representation of the major components involved in sexual reflexes. Peripheral sympathetic (hypogastric), parasympathetic (pelvic) and somatic (pudendal) nerves regulate sexual reflexes. The spinal cord inputs (afferents) and outputs (efferents) are located on the lumbar and sacral cord. The brain modulates the activity of the spinal circuits, mainly by descending inhibition.

of activated neurons in association with particular events, for example, ejaculation or vaginocervical stimulation. The medial amygdala, bed nucleus of the stria terminalis, medial preoptic area, paraventricular nucleus, ventromedial hypothalamus, lateral hypothalamus and central gray are most consistently activated in response to sexual reflexes [4]. These areas may be part of the sensory, motivational or reward circuits that are associated with sexual satisfaction, in addition to regions processing sexual reflexes. Imaging studies in humans have identified areas in the cortex (inferior frontal cortex and insular cortex), midbrain and cerebellum that are activated with visually-evoked sexual stimulation or climax [5].

### Lower Level Components

#### Peripheral Nerves and Spinal Circuits

The peripheral innervation of the pelvic organs involved in sexual reflexes comprise of the autonomic (pelvic and hypogastric) and somatic (pudendal) nerves. Spinal afferents and efferents that regulate sexual function are located in the lower thoracic lumbar region (T11-L2 in humans, sympathetic) and sacral cord (parasympathetic and somatic). Sensory information from the genital areas travel in the afferent fibers of the pudendal nerve, which enter the spinal cord through the superficial dorsal horn and project to the dorsal gray commissure, which is located in the medial cord, where they terminate. The afferent neurons then synapse on spinal interneurons, which eventually send signals to the efferent spinal neurons that control the pelvic organs. The sensory information is also sent to other spinal segments and to the brain. The sensory afferents of the pelvic (parasympathetic) and hypogastric (sympathetic) nerves may also contribute to sexual reflexes; these fibers enter the dorsal horn and terminate in the lateral and medial gray matter. The efferent fibers of the pudendal nerve provide innervation of the pelvic floor, anal and urethral sphincters. The pudendal motor neurons are located in the ventral horn of the spinal cord (Onuf's nucleus). The efferent sympathetic and parasympathetic fibers relay through the major pelvic ganglion and the hypogastric plexus to form the ►postganglionic nerves (cavernous nerve, dorsal nerve of the penis and clitoris).

#### Ascending and Descending Spinal Pathways

The ►spinothalamic and ►spinoreticular pathways relay sensory information to the brain. These pathways travel in the dorsal region of the spinal cord and terminate in the thalamus. Most of the spinoreticular fibers travel in the lateral columns that terminate in the brainstem reticular formation. Descending information from the brain also passes through the dorsal spinal cord. The majority of these pathways cross over to the opposite side.

### Brain Sites

The nucleus paragigantocellularis projects directly to efferent neurons of the hypogastric, pelvic and pudendal nerves as well as interneurons in the spinal cord [2]. Lesions of this nucleus allow climactic-like responses to be evoked by peripheral stimulation [2]. Higher brain regions involved in sexual function, for example the medial preoptic area, paraventricular nucleus of the hypothalamus, ventromedial nucleus of the hypothalamus and amygdala, either project directly or indirectly to the nucleus paragigantocellularis and/or to the spinal cord. However, research from a number of laboratories has shown that the central gray is an important relay center for ascending and descending sexually relevant stimuli. Reciprocal connections between most of the brain regions involved in sexual reflexes have been identified.

### Structural Regulation

Spinal sexual reflexes are regulated by the amount of peripheral sensory stimulation received and by inhibition from brainstem regions. These spinal reflexes can function independently from inputs from the brain (as in the case of complete spinal cord injury). However, higher brain regions can evoke sexual reflexes, for example during nocturnal erections and ►psychogenic elicitation of climax.

The spinal and brainstem sites are relatively insensitive to the effects of gonadal steroid hormones (estrogen, progesterone, and testosterone). However, these hormones can modulate sexual reflexes in part by affecting the higher brain control of reflexive mechanisms, as well as altering the sensory threshold of the peripheral nerves.

### Higher Level Processes

Figure 2 summarizes the major processes.

The pelvic and hypogastric nerves mediate sensory information from the internal pelvic organs. Sensations to light touch, chemical stimuli and noxious stimuli of the vagina, cervix, penis and uterus are mediated via the pelvic nerve. Therefore, the pelvic nerve relays sensory information from genital manipulations during sexual behavior. The pelvic nerve is also crucial for the induction of pregnancy or pseudocyesis induced by mating or cervical stimulation. The hypogastric afferents that innervate the uterus, cervix and ovaries may be important in the transmission of noxious stimuli from the uterus. Both the pelvic and the hypogastric nerves are sensitive to circulating gonadal steroid hormones. These preganglionic nerves and their postganglionic nerves also control the contractile and blood flow changes that occur in the genital organs during sexual responses and regulate the secretion of seminal fluids into the urethra. The pudendal nerve mediates sensory

stimuli from the external genitals, the pelvic floor musculature, and surrounding areas including the perineum, clitoris, penis and urethra. The sensory signals that relay through the pudendal nerve are essential for lordosis and ►[urethrogenital reflexes](#).

Many brain sites receive genital sensory information, indicating that the descending control of spinal sexual function is itself strongly influenced by peripheral stimuli. For example, the nucleus paragigantocellularis, the paraventricular nucleus, the central gray and medial amygdala have all been shown to contain neurons whose activity is modulated by pelvic sensory input. These nuclei are involved in the modulation of spinal sexual reflexes and their activity is, in turn, modulated by genital sensory input.

Higher brain sites (midbrain, hypothalamus and amygdala) also receive cognitive sensory information and have estrogen and androgen receptors on the neurons. These structures are likely sites by which hormones regulate sexual behavior and motivation. However, lack of reward or increased inhibition of the CNS circuits may lead to disruption of the sex cycle and can terminate the occurrence of sexual reflexes.

## Lower Level Processes

### Peripheral Mechanisms

Noradrenaline and neuropeptide Y released by sympathetic nerves results in smooth muscle contractions of the penis and clitoris. Acetylcholine, vasoactive intestinal polypeptide and nitric oxide are released by the parasympathetic nerves. Acetylcholine release results

in contraction of the smooth muscle and stimulates release of endothelial nitric oxide. Vasoactive intestinal polypeptide and nitric oxide act to relax smooth muscles, which results in increased blood flow causing erection and vaginal and clitoral engorgement. Acetylcholine released from somatic nerves causes contractions of skeletal muscles.

### Spinal Mechanisms

Multiple neurotransmitters and their receptors are present in the spinal cord and may mediate the inhibition and/or facilitation of sexual reflexes. These include, but are not restricted to, adrenaline, dopamine, serotonin, oxytocin, substance P, melanocortin, nitric oxide, enkephalin, galanin, glutamate, and GABA.

A number of studies have shown that the descending inhibition of spinal sexual reflexes is mediated in part by serotonin [2]. Multiple serotonin receptors are present in the spinal cord, and serotonin receptor 1A and 1B are presently prime candidates for mediation of this inhibition. Peripherally evoked sexual reflexes are also altered by these classes of drugs; dopaminergic, adrenergic, peptides, steroids, hormones and cholinergic compounds. More information is needed as to the mechanisms of these drug effects.

Recent evidence from studies in male rats has demonstrated a group of galanin containing cells in the lumbar cord is essential for ejaculation, and may be part of a spinal ejaculatory generator in males [6]. These cells are also present in female rats but their function has not yet been determined.

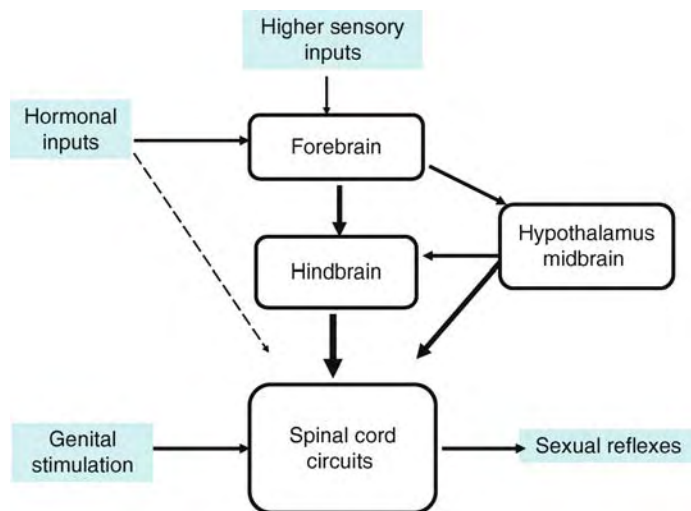

**Sexual Reflexes. Figure 2** Diagrammatic representation of the higher level processes regulating sexual reflexes. Genital sensory information enters the spinal cord; interneurons then relay messages through the spinal cord through multiple segments. These signals may also be sent to the brain. The efferent output then coordinates the appropriate sexual motor output, for example orgasm. Sensory and hormonal inputs also regulate the forebrain to activate sexual responses. Pathways relay through multiple sites including the hypothalamus and the nucleus paragigantocellularis in the hindbrain. The brain messages may also act on spinal cord circuits, either to inhibit or evoke sexual responses.



### Brain Mechanisms

Due to the complexity of neuronal connections in the brain and the multiple brain regions involved in sexual reflexes the brain mechanisms mediating sexual reflexes is still under study. However, a number of regulating mechanisms are known. Serotonin neurons in the nucleus paragigantocellularis are involved in the tonic inhibition of sexual reflexes [2]. Dopamine mechanisms in the forebrain appear to mediate the facilitation of sexual reflexes [7]. In addition, serotonin also acts in the forebrain and may alter dopamine release to decrease or increase sexual reflexes. During sexual arousal and orgasm, oxytocin from the paraventricular nucleus is secreted from the posterior pituitary into the blood stream in males and females [8–9].

### Process Regulation

Cognitive emotional desire may lead to arousal, which in turn may cause erection or genital vasocongestion (arousal), which may in turn lead to orgasm which terminates the sex cycle for some refractory period. Alternatively, genital stimulation may activate spinal pathways that lead to arousal and orgasm.

The spinal systems generating sexual responses can be excited or inhibited by peripheral sensory stimuli. A major afferent pathway travels in the pudendal nerve and is responsible for transmitting sexual stimuli from the external genitals and perineum. Visceral afferents in the pelvic and hypogastric nerve have been shown to transmit pain signals from the internal genitals and are probably inhibitory to sexual responses.

The spinal sexual reflex mechanisms are under descending excitatory and inhibitory control from the brainstem and hypothalamus. A major inhibitory site in the medulla has been shown to suppress sexual reflexes through serotonergic mechanisms. Hypothalamic stimulation can elicit sexual responses.

Many of the supraspinal sites influencing spinal sexual reflexes are interconnected and also receive genital sensory information.

Sensory and efferent information related to genital responses may also be relayed through the vagal nerve in addition to the spinal cord. The vagal pathway remains functional after spinal cord transection and may account for the menstrual cramping, analgesia, and orgasm reported in women with complete spinal cord transections [10]. However, further animal studies and verification of this hypothesis in clinical studies is required.

### Function

Sexual reflexes facilitate reproductive processes, male sperm transportation and induction of pregnancy. In addition sexual behavior is often rewarding.

A number of autonomic responses accompany sexual reflexes. Heart rate, blood pressure and respiration increase. In addition, swelling or vasodilatation of the

nipples, flushing, and sweating may occur. Reduced pelvic pain may also occur during sexual responses. Contractions of the anal sphincter, vagina, pelvic floor muscles and perineal muscles accompany climax. Prolactin, catecholamine and oxytocin are also released into the circulation with orgasm.

### Pathology

Erectile dysfunction in males may arise from inadequate vasodilatation, nerve degeneration, structural abnormalities such as Peyronie's disease, psychological disorders or as side effects of treatment for other disorders such as hypertension and depression. Premature ejaculation may arise due to hormonal imbalance in the CNS or hypersensitivity of the peripheral nerves.

► **Anorgasm** in males and females may occur if there has been peripheral nerve damage, lower spinal cord injury, or may be a result of psychological disorders including stress or as a result of treatment therapies for depression. Neurological disease that can cause sexual dysfunction include stroke, tumors, Parkinson's disease, dementia, epilepsy and diabetes, in addition to peripheral or central hormonal changes, like those present after giving birth and during and after menopause, or low testosterone levels. Dysparunia and vaginismus are common painful disorders in females that may be due to structural changes or psychological problems. Surgeries such as hysterectomy or removal of the prostate may result in nerve injury that leads to decreased sexual function.

### Therapy

The most common treatment for erectile dysfunction is PDE5 inhibitors e.g., sildenafil, vardenafil and tadalafil, which act on penile corpus cavernosal smooth muscle to aid relaxation by inhibiting the action of PDE5, which is an enzyme that degrades cGMP. The increased levels of cGMP lead to alterations in calcium concentrations that aid relaxation of the tissue; without penile stimulation the PDE5 inhibitors are not effective. Similar mechanisms are found in the clitoris. In addition, topical vasodilator substances, for example alprostadil or papavarine, may be used to increase blood flow to the genital organs and thus facilitate arousal-like responses. Vibratory and vacuum stimulatory devices can be used to facilitate genital arousal by increasing sensory inputs.

Structural abnormalities may be normalized with surgery or implants, but care is needed to avoid nerve damage.

A few drugs have gained some success in treating CNS disorders (yohimbine, apomorphine, bromocryptine, androgens). However, side effects do occur and the completeness of treatment is still unclear. Usually, psychotherapy and sex therapy is recommended prior to, or concomitant with, any drug therapy [11].

## References

1. Meisel RL, Sachs B (1994) The physiology of male sexual behavior In: Knobil E, Neill JD (eds) The physiology of reproduction, 2nd edn. Raven, New York, pp 3–105
2. McKenna KE, Marson L (1997) Spinal and brainstem control of sexual function. In: Jordan D (ed) Central control of autonomic function. Harwood Academic Publishers, pp 151–187
3. Pfaff DW, Schwartz-Giblin S, McCarthy MM, Kow LM (1994) Cellular and molecular mechanisms of female reproductive behaviors. In: Knobil E, Neil JD (eds) The physiology of reproduction. Raven, New York, pp 107–195
4. Coolen LM, Peters HJPW, Veening JG (1996) Fos immunoreactivity in the rat brain following consummatory elements of sexual behavior: a sex comparison. *Brain Res* 738:67–82
5. Holstege G, Georgiadis JR, Paans AMJ, Meiners LC, van der Graaf FHCE, Reinders AATS (2003) Brain activation during human male ejaculation. *J Neurosci* 23:9185–9193
6. Truitt WA, Coolen LM (2002) Identification of a potential ejaculation generator in the spinal cord. *Science* 297(5586):1566–1559
7. Hull EM, Muschamp JW, Sato S (2004) Dopamine and serotonin: influence on male sexual behavior *Physiol Behav* 83:291–307
8. Carmichael MS, Humbert R, Dixen J, Palmisano G, Greenleaf W, Davidson JM (1987) Plasma oxytocin increases in the human sexual response. *J Clin Endocrinol Metab* 64:27
9. Carmichael MS, Warburton VL, Dixen J, Davidson JM (1994) Relationships among cardiovascular, muscular and oxytocin responses during human sexual activity. *Arch Sex Bahav* 23:59
10. Whipple B, Gerdes CA, Komisaruk BR (1996) Sexual response to self stimulation in women with complete spinal cord injury. *J Sex Res* 33:231–240
11. Barnes T (1999) Integrated sex therapy: the interplay of behavioral cognitive and medical approaches. In: Carson CC, Kirby RS, Goldstein I (eds) *Textbook of erectile dysfunction*. Isis Medical Media, Oxford, pp 465–484

## Shaker-Channels

### Definition

Shaker-channels, eag (ether-á-go-go)-channels, slo (slow-poke)-channels were cloned from behavioral *Drosophila melanogaster* mutants. The channels were named according to the *Drosophila* mutant phenotype, Shaker, ether-go-go, slow-poke. Subsequently, eagcDNA was used to clone related voltage-gated potassium channel subunits erg (eag-related) and elk (eaglike). The human erg ortholog (HERG) mediates cardiac IKS.

## Shannon Theory

► Information Theory

## Shape Processing

### Definition

Shape refers to a distinctive combination of boundary and surface properties of a visual form. Shape processing refers to the brain's ability to combine many types of locally ambiguous visual signals, such as edges, texture, shading, depth, and color, to generate an emergent representation of an object's shape.

► Form Perception

► Visual Object Representation

## Sharpening

► Contrast Enhancement

## Shear Strain

### Definition

The components of strain associated with shear – e.g. one layer of tissue attempting to “slide” over another.

## Shear Stress

### Definition

The components of stress generated by the material shear strain.

► Shear Strain

## Shearing

### Definition

In any layer of tissue, a number of theoretical parallel planes can be distinguished. Shear is deformation of such a tissue layer in such a way that the parallel planes remain parallel but are shifted relative to each other along their original direction. If, for example, a square shape is sheared it turns into a parallelogram. Note that the legs of the parallelogram have changed length due to shearing.

► Intramuscular Myofascial Force Transmission

## Sherrington's Law of Reciprocal Innervation

### Definition

The contraction of a muscle is accompanied by simultaneous and proportional relaxation of its antagonist; also attributed to Descartes.

► Burst Cells – Medium Lead – Horizontal  
► Omnipause Neurons

## Shift Work

### Definition

Working outside the traditional 08:00 (8 A.M.) to 17:00 (5 P.M.) day shift. It is common to distinguish early morning shifts starting before 08:00 (8 A.M.), afternoon and evening shifts starting after 12:00 (noon), and night shifts typically starting at 23:00 h (11 P.M.). Working night shifts or morning shifts usually leads to sleep restriction, as one is forced to sleep during the day or early evening despite a high Alertness Level due to elevated wake drive in the circadian cycle. Working afternoon or evening shifts typically yields the most sleep of any of the possible shift work regimens including the normal day shift.

► Alertness Level  
► Internal Desynchrony

## Short Lead Burst Neurons, SLBNs

► Burst Cells – Medium Lead – Horizontal

## Short-Term Memory

YOSHIO SAKURAI

Department of Psychology, Graduate School of Letters, Kyoto University, Sakyo, Kyoto, Japan

### Definition

This is one of the three storage systems of memory, i.e., sensory store, short-term memory and long-term memory. Short-term memory (► [short term memory syndrome](#)) is a system for temporarily storing and managing information necessary to conduct learning and cognitive tasks. It acts as a scratch-pad for temporary recall of information under process and is involved in the selection, initiation, and termination of the information processing functions such as encoding, storing, and retrieval. Short-term memory is sometimes referred to as primary memory or active memory (► [active learning/memory](#)) and relationship to ► [working memory](#) is often discussed in psychology and neuroscience.

### Characteristics

#### Rapid Decay

Short-term memory decays rapidly. It retains information for a limited length of time only, no more than about 30 s, if no rehearsal of the information is carried out. Memory that exceeds short-term memory duration limits is known as long-term memory. In order to overcome the limitation of short-term memory, and retain information for longer periods, the information must be periodically rehearsed. During the rehearsal, the information re-enters the short-term store and be retained for a further period. The process of consolidation, i.e., transferring short-term memory to long term memory, is enhanced by the relationship of an item of short-term memory to an item in long-term memory.

#### Limited Capacity

Short-term memory has a limited amount of capacity. Human short-term memory has a forward memory span of approximately seven items plus or minus two [1], called “magical number seven”. Recent psychological researches have shown that this magical number seven is roughly accurate for college students recalling lists of

digits. Such length of recalled digits is sometime called “▶digit span.” Digit span is based on capacity of short-term memory, but the order of digits is required to be recalled. To test the auditory digit span, for instance, numbers are said slowly, then a person repeat it back. The average correctly recalled numbers are seven, the magical number seven.

However short-term memory span varies widely with populations tested and with material. For example, the ability to recall words in order depends on a number of characteristics of these words: Fewer words can be recalled when the words have longer spoken duration; this is known as the “word-length effect” [2]. Fewer words can be recalled when their speech sounds are similar to each other, this is called the “phonological similarity effect” [3]. More words can be recalled when the words are highly familiar and/or occur frequently in the language; recall performance is also better when all of the words in a list are taken from a single semantic category (such as sports) than when the words are taken from different categories.

### Chunking

Though the magical number seven, retaining about  $7 \pm 2$  different items in short-term memory is generally supported by experimental evidence, chunking of information can lead to an increase in the short term memory capacity and greatly increase amount of recalled items. Through putting each unit into a meaningful word or phrase, a person’s recall ability can improve through practice [4]. For example, in recalling a phone number, the person usually chunks the digits into three groups: first, the area code, then a three digit chunk and lastly a four digit chunk. This method of remembering phone numbers is far more effective than attempting to remember a string of ten digits.

### Separation From Long-Term Memory (Psychology)

An example of experimental psychology studies showed that some manipulations (e.g., a distracter task, such as repeatedly subtracting a single-digit number from a larger number following learning) impair memory for the 3–5 most recently learned words of a list (presumably still held in short-term memory), while leaving recall for words from earlier in the list (presumably stored in long-term memory) unaffected; other manipulations (e.g., semantic similarity of the words) affect only memory for earlier list words, but do not affect memory for the last few words in a list [5]. These results suggest that different factors affect short term recall (disruption of rehearsal) and long-term recall (semantic similarity). Together, these findings indicate that long-term memory and short-term memory can vary independently of each other. This is regarded as “double dissociation” and constitutes evidence for separate systems underlying short-term and long-term memory.

### Separation From Long-Term Memory (Neuropsychology)

One form of evidence in favor of the separate existence of short-term memory from long-term memory comes from anterograde amnesia, the inability to learn new facts and episodes. Patients with this form of amnesia, typically caused by damage to the medial part of temporal lobe, especially to the hippocampus have intact ability to retain small amounts of information over short time scales (up to 30 s) but are dramatically impaired in their ability to form long-term memories (a famous example is patient H.M.) [6]. This is interpreted as showing that the short-term memory is spared from amnesia.

### Related Brain Structures

Short-term memory is, as like the most types of memory, appear to be stored in the cerebral cortex. Different sensory areas of the cerebral cortex receive sensory information from eyes, ears, and other body parts and hold the information for a fraction of a few seconds in the sensory stores. Then only the attended information are encoded into short-term memory and not attended information will be lost. The short-term memory then is stored in the sensory areas of cortex and some of them are further transferred to the hippocampus and encoded into the long-term memory [6]. However, some neuroscience researchers suggest that short-term memory is further converged to the prefrontal cortex and then serve the information to working memory, speculated to be involved in the prefrontal cortex [7].

### Synaptic Mechanisms

Short-term memory is plastic and dynamic in nature and is still a matter of subject of various arguments not only about the related brain structures but also about underlying neural and synaptic mechanisms. It often describes synaptic events and refers particularly to the temporal sequence of events leading to stable and structural changes in synaptic efficacy [6]. Short-term memory may be formed by brief changes in synaptic transmissions. In the dynamic theory, it may arise out of a reverberating feedback circuit of neurons, where a memory is held electrically within a loop [8]. Thus, no physical changes are made, and synaptic connections are not modified. On the other hand, long-term memory, may be encoded by plastic changes of structures in existing synapses.

### Relationship to Working Memory

The relationship between short-term memory and working memory differently described by many theorists, but it is generally acknowledged that the two concepts are distinct. Working memory is a workspace or memory buffer in which information is maintained and

manipulated while it is being processed. It is a theoretical framework that refers to structures and processes used for temporarily storing and manipulating information. As such, working memory might also just as well be referred to as attention and processing. Short-term memory generally refers to just short-term storage of information. In other words, short-term memory may be passive memory and ►working memory is active memory. Thus while there are short-term memory components to working memory models, the concept of short-term memory is distinct from these more hypothetical concepts. Within one influential model of working memory [9] there are two short-term storage mechanisms: the phonological loop and the visuospatial sketchpad.

## References

1. Miller G (1956) The magical number seven, plus or minus two: some limits on our capacity for processing information. *Psychol Rev* 63:81–97
2. Baddeley AD, Thomson N, Buchanan M (1975) Word length and the structure of short term memory. *J Verbal Learn Verbal Behav* 14:575–589
3. Conrad R, Hull AJ (1964) Information, acoustic confusion and memory span. *Br J Psychol* 55:429–432
4. Ericsson KA, Chase WG, Faloan S (1980) Acquisition of a memory skill. *Science* 208:1181–1182
5. Davelaar EJ, Goshen-Gottstein YAA, Haarmann HJ, Usher M (2005) The demise of short-term memory revisited: empirical and computational investigation of recency effects. *Psychol Rev* 112:3–42
6. Squire L (1987) *Memory and brain*. Oxford University Press, New York
7. Funahashi S (2001) Neuronal mechanisms of executive control by the prefrontal cortex. *Neurosci Res* 39:147–165
8. Hebb DO (1949) *The organization of behavior – a neuropsychological theory*. Wiley, New York
9. Baddeley AD (1986) *Working memory*. Oxford University Press, New York

## Sicca Syndrome

### Definition

Sicca symptoms include dry eyes and mouth, difficulty to swallow, caries and reduced sense of taste and smell. The term sicca syndrome is used as a synonym for Sjögren's Syndrome.

- Central Nervous System Disease in Primary Sjögren's Syndrome
- Sjögren's Syndrome

## SIDS

### Definition

- Sudden Infant Death Syndrome.

## Sigma-1 Receptor Ligands

### Definition

Sigma receptors are widely distributed in the mammalian brain, and two subtypes exist, sigma-1 and sigma-2 receptors. Sigma-1 receptors have been cloned, and their distribution and physiological functions characterized. Thus, sigma-1 receptors are proposed to be involved in learning and memory as well as in certain neuropsychiatric disorders. Sigma-1 receptor ligands have been suggested to represent a new class of therapeutic agents for neuropsychiatric disorders.

- Memory Improvement

## Sign Stimuli

### Definition

Highly specific stimulus that symbolizes an object or event of biological importance (see also Key Stimulus).

## Signal Conversion

- Transduction

## Signal Detection Theory

### Definition

Signal detection theory (SDT) is a model of information processing that has been applied to the psychophysics of stimulus detection and discrimination.

- Psychophysics
- Pain Psychophysics

## Signal Peptide

### Definition

Signal peptide is a short peptide attached to the amino terminus of secreted or transmembrane proteins, which is bound by a signal recognition particle as soon as the protein leaves the ribosome, and results in targeting of the protein to the endoplasmic reticulum.

recognize sensory messages (photons, odorants, pheromones) or inter-cellular messages (hormones, neurotransmitters) and transduce them into biochemical and biophysical modifications in order to modify the cellular response: depolarisation, differentiation, movement, division, etc.

► [New Developments in G Protein-Coupled Receptor Theory](#)

## Signal-to-Noise Ratio (SNR)

### Definition

Physiological measurements record changes of light or electricity or other physical parameters. However, measurements always have a component of noise, be it from the technical apparatus, from the physical properties of the processes involved (e.g. the statistical nature of light), or from biological sources (e.g. the statistical nature of neuronal signaling). The signal-to-noise is the ratio between the power of the signal of interest and the noise accompanying it. The SNR is usually expressed in logarithms of this ratio, a unit known as Bell, or in units of one-tenth of a Bell, the decibel or dB.

► [Signals and Systems](#)

## Signal Transducers and Activator of Transcription 3 (STAT3)

### Definition

STATs belong to a transcription factor family activated by Janus Kinase (JAK). STATs have SH2 domains which bind phosphotyrosine residues on cytokine receptors and are themselves tyrosine-phosphorylated by JAKs. Following phosphorylation, STATs dissociate from the receptors and regulate gene expression.

## Signal Transduction

### Definition

Signal transduction includes an ensemble of mechanisms by which uni- and multi-cellular organisms

## Signal Transduction Cascade

### Definition

Signal transduction cascade is the pathway of sequentially activated or inhibited signaling molecules that leads from the activation of a receptor at the plasma membrane to a downstream effect within the cell.

## Signaling

► [BMP Signaling and Synaptic Development](#)

## Signaling Protein

### Definition

Secreted protein that have an effect on the fate of adjacent tissue in a concentration-dependent manner. Signaling proteins are often (but not only) produced in organizer centers are called "morphogens." Examples of signaling proteins are bone morphogenetic proteins (BMPs), Wnts, Sonic hedgehog (Shh) or fibroblastic growth factors (FGFs).

► [Evolution and Embryological Development of the Forebrain](#)

## Signals and Systems

ELAD YOM-TOV  
IBM Haifa Research Laboratory, Haifa University  
Campus, Haifa, Israel

### Definition

### Description of the Theory

#### Introduction

Biological systems are frequently analyzed using engineering tools. This can be done in several ways, two of which are through the investigation of the signals produced by the system and by modeling the system and its environment to predict their behavior under different conditions. These are closely related approaches, and many of the tools developed for one are applicable to the other. This essay gives a broad overview of these tools, known collectively as the field of signals and systems.

#### Signals

The human body generates a multitude of signals, many of which can be used to track its activity. However,

meaningful information can usually be gained only after these signals are recorded and processed. In this section, various methods of processing are described.

An important aspect of signal processing is the notion of the ►time domain and the ►frequency domain of signals. The time domain of the signals is a description of their progression through time. The frequency domain is a description of the signal as a sum of (a possibly infinite number of) sine waves at different frequencies and phases (the actual description is simply the phase and amplitude of each sine). This description, also known as the spectrum, is extremely useful in many applications, for example, ►filtering. One should note that processing in one of these dimensions directly affects the other.

The frequency content of a continuous signal can be computed using the ►Fourier Transform [1]. The output of this transform is the amplitude and phase of the sines at each frequency in the spectrum, which, if summed, will exactly match the signal in the time domain. Fig. 1 shows an example of a signal (the function  $\sin(x)/x$  in the time domain and its amplitude in the frequency domain).

The frequency-domain representation can be transformed back to the time domain using the Inverse Fourier Transform. Essentially, the Fourier transform is computed

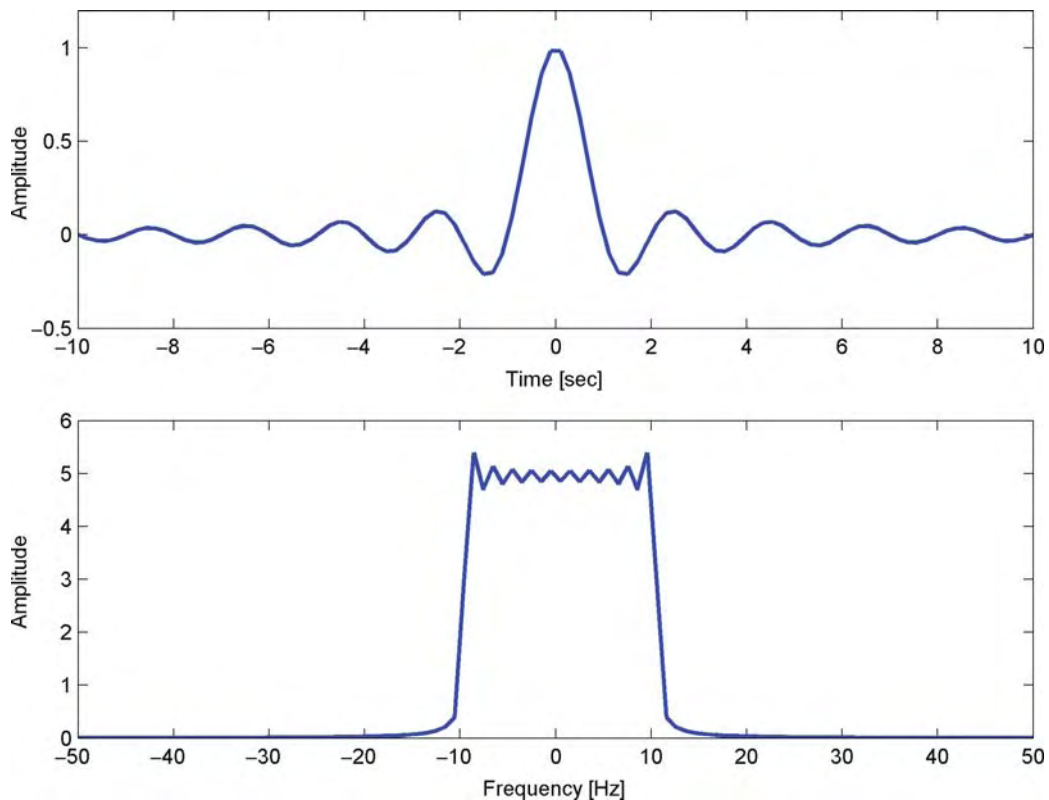

**Signals and Systems. Figure 1** A signal in the time domain and in the frequency domain. The top figure shows the progression of the signal  $\sin(x)/x$  through time. The bottom figure shows the amplitude of the frequency-domain representation of the same signal.

by finding the projection of the signal on sine functions (the kernel functions for this transform) at each frequency. There are special variants of this transform to deal with periodic signals and with discrete signals. If the signal is discrete, the relevant transform is the ► **Discrete Fourier Transform (DFT)**. The efficient algorithm for computing the Discrete Fourier Transform is known as the ► **Fast Fourier Transform (FFT)**.

Nowadays, most processing of signals is done digitally. Many of the methods we describe in this section can be performed on analog signals, but for the sake of clarity, they will be described in the digital domain.

The first stage in digital processing of a signal (after the appropriate sensor has acquired the signal) is to sample it. ► **Sampling** is the process of taking a continuous signal (i.e. one that has a value for each point in time) and recording its value in discrete points. The sampling rate needed in order to be able to reconstruct the signal back to its original (analog) form, without loss of information, should be at least twice as fast as the highest frequency component in the signal, as stated in ► **Nyquist's sampling theorem** [2]. Since most analog signals are not strictly band-limited, that is, they cannot be

said to have frequency components with a certain highest limit, most signals need to be filtered before sampling to comply with Nyquist's theorem. This is done using analog filters known as ► **anti-aliasing filters**, which allow only those components that have a frequency lower than a certain threshold to pass into the sampler.

After sampling, the signal is quantized and each sample given a discrete value. This discrete value depends on the range of the sampling device (e.g. in a 12 bit sampling device, the signal is given the closest of  $2^{12} = 4096$  values). A sampled, quantized, signal can then be stored on a computer or processed as needed. Fig. 2 shows a continuous signal and its sampled, quantized, representation.

There are a number of categories, by which signal processing systems are classified, among which the most important are linearity, time invariance, finite or infinite response, and causality. ► **Linear systems** are those that if two signals are passed through them, each multiplied by a constant, and summed, would give the same output if the signals were summed and only then passed through the system. An example of a linear system is an amplifier, which changes the gain of a

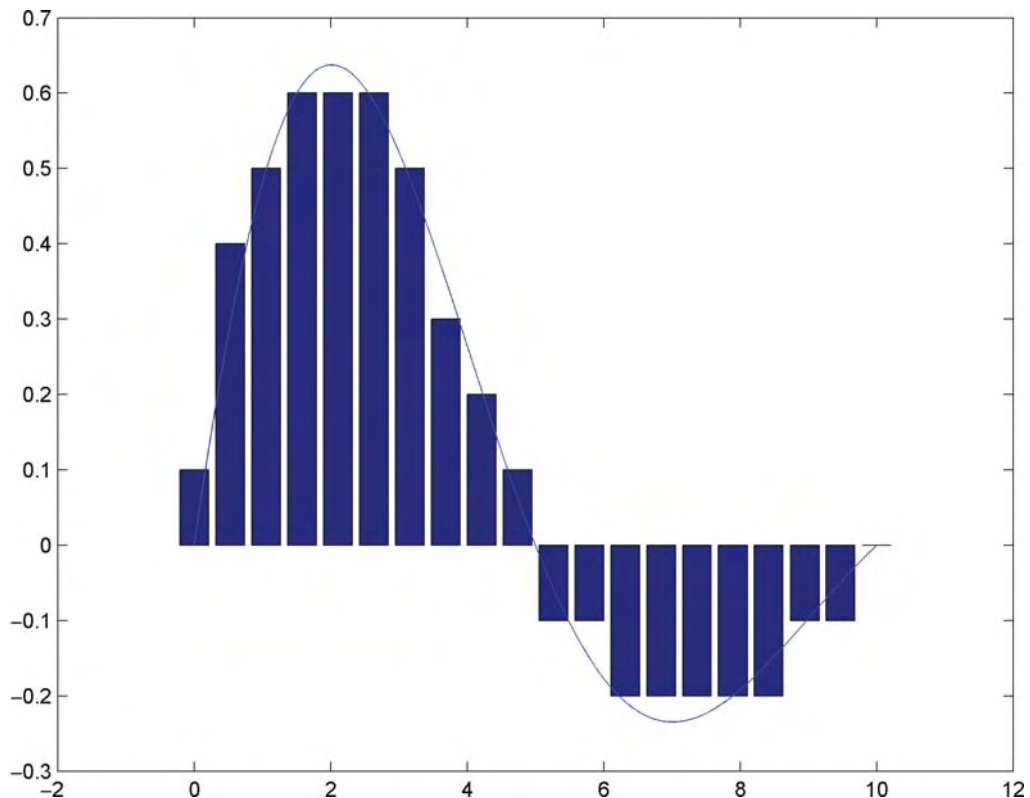

**Signals and Systems. Figure 2** A continuous and a sampled signal. This figure demonstrates the process of sampling and of quantization. The line is a continuous signal (i.e. one that has a value at each point in time). The bars show the same signal after it has been sampled and quantized. Sampling causes each time span to be represented by a single (usually average) value, while quantization rounds this value to the nearest value acceptable by the digital system.



signal by a constant factor. A time invariant system is one whose output behaves in a similar matter (albeit delayed) when the same signal is entered twice, with a delay between inputs.

Any digital computer can represent numbers up to a finite value. In finite response systems, it is guaranteed that any finite input will result in a finite output. An example of an infinite system is one that returns the reciprocal value of the inputs. Such a system, when presented with a zero input, will return an infinite value, which in practice means that the output will be distorted. Finally, it is usually desirable for a system to use data from the past and present, not from the future. Such systems are known as causal systems. Note that non-causal systems can still be implemented if a delay in the output is possible.

One of the basic operations, which can be performed on either an analog or a digital signal, is filtering. Filtering reshapes the signal, usually to give required frequency content. A (causal) digital filter operates on a signal by multiplying the filter coefficients by the inputs (current and previous), and possibly some of the previous outputs, and summing them. The most common filter types are the low-pass filter (►low-pass filtering), which passes only those frequency components at the low range of the spectrum; the high-pass filter (►High-pass filtering), which does the same for the high end of the spectrum; the ►band-pass filter; and

the notch filter, which removes a slim band of the spectrum, for example, the range occupied by the mains current. Fig. 3 shows an example of how filtering reshapes a signal. The left part of the Fig. 3 shows a signal comprised of the sum of two sines at different frequencies (as is evident from its spectrum in the lower left Fig. 3). This signal is passed through a low-pass filter, which removes the sine at the higher frequency so that the remaining signal is an almost pure sine.

Filters are categorized by the following parameters:

Their ►frequency response determines how the amplitude and phase at each frequency is modified by the filter. The ►bandwidth of a filter is the width of the effective frequency range passed by the filter.

The filter length describes the number of coefficients of the filter. A longer filter makes it possible to design filters with a sharper frequency response, at the cost of higher delays and poorer localization in the time domain due to the filter length.

The ►impulse response of the filter, explained below.

The impulse, known in the continuous domain as the ►Dirac delta, is a signal whose integral is unity, and its width approaches zero (which implies that its height approaches infinity). In the digital domain, it is a signal that is zero everywhere except for a single sample with a value of unity. The impulse is useful for typifying the

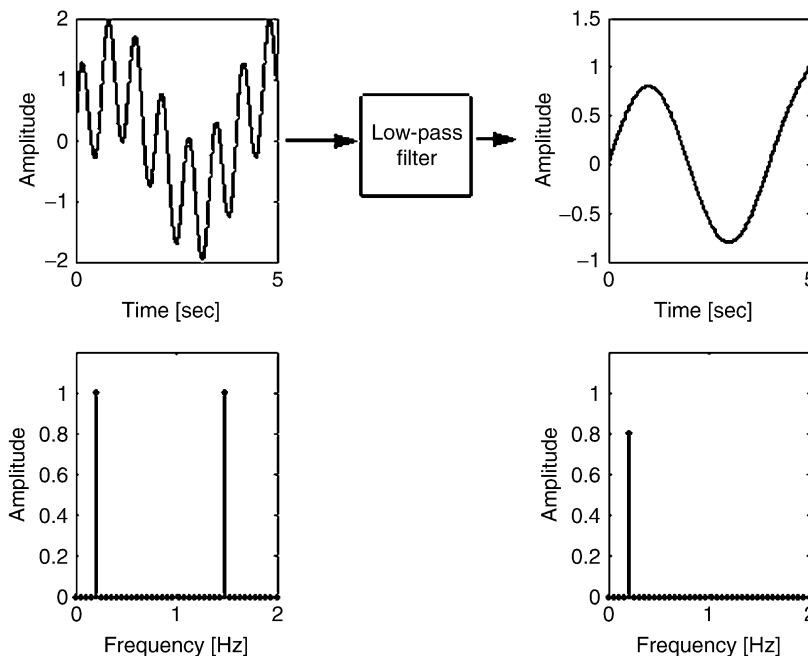

**Signals and Systems. Figure 3** Filtering a signal. This figure shows the effect of filtering on a signal. The leftmost figures show a signal comprised of the sum of two sines at different frequencies. The top left figure shows the signal in the time domain, while the bottom left figure shows the same signal in the frequency domain. The rightmost figures show the signal after it has passed through a low-pass filter, which removes one of the sine functions (the one of higher frequency). A by-product of this filter is a reduction in the amplitude of the remaining sine function.

time-domain behavior of a filter. Furthermore, filters are commonly classified as either having a finite or infinite impulse response. The former, when presented with an impulse as an input, will generate non-zero output for a finite time period, while the latter may continue to have a non-zero value indefinitely.

Although they are sometimes approximated as such, biological systems are never completely deterministic. The current state of the system, its environment, etc. affects processes. Thus, it is frequently useful to model the system and its signals as stochastic, or at least one to which random noise is added. Such signals require statistical tools for processing.

Arguably, the simplest parameters to estimate are the average and standard deviation of a signal, or its variance. In the case of several signals, we can instead measure the **cross-covariance** between these signals, and its normalized version, the cross-correlation (or simply the **correlation**). These latter parameters are used for measuring the linear dependency between signals. Higher-order correlations (or moments) can be useful in typifying systems, but these are rarely used in the processing of biological signals, except for cases where the object of the analysis is to discover **oscillator coupling** between signals (For example, [3]).

The correlation [1] can be computed at various time differences between signals (or between a signal and itself), yielding the cross-correlation function (or, similarly, the auto-correlation function). This yields information about the linear dependency between signals, assuming some delay between them.

The spectrum of a stochastic signal is computed by transforming the cross-correlation function instead of performing the Fourier transform on the signal itself. Such **cross-spectrum** (or, in the case of auto-correlation, the **autospectrum**) is useful, for example, in detecting frequencies where signals correlate. Similar functions are achieved by the **coherence** function, which is the cross-spectrum normalized by the square root of both auto-spectra.

Note that when the spectrum of a signal is estimated from a finite sample of data, the resulting auto-spectrum is only one of an infinite number of possible estimations of the spectrum, since the data itself is stochastic. There are two parameters of interest when assessing how close this estimation (like all other estimations based on stochastic data) is to the real spectrum. These are the **bias** and the **variance** of the estimate. The bias refers to how far the estimation would be from the real value, if an infinite number of signals were used to generate spectra estimations, and these would in turn be averaged. The variance is the variance of a finite number of spectra. In practice, one can usually minimize either the variance or the bias, but not both.

**Noise** is a signal that accompanies the signal of interest, but does not convey useful information. If, for

example, we were interested in a specific component of the **electroencephalogram (EEG)**, any other parts of the recorded signal, including other components of the EEG, would be considered noise. In most cases, it is assumed that the noise is added to the signal. The relation between the power of the signal of interest and that of the noise is measured by the **Signal-to-Noise ratio (SNR)**, expressed in decibels, that is:  $SNR = 10 \log(\text{Signal power/Noise power})$ .

The spectrum of the noise is also of interest. If the noise has a flat spectrum, which implies that it is completely uncorrelated in time, it is known as **white noise**. Similarly, a noise that has a non-flat spectrum is known as **colored noise**. If the noise is distinctly different from the signal in some way, it might be easily separated from the signal (for example, if its frequency range is different from that of the signal, it can be removed using an appropriate filter). Unfortunately, there are many cases where such separation does not exist. In such cases, more sophisticated processing methods are needed, for example, [4–7].

Fourier transform is limited by the fact that it implicitly assumes that the signal is infinite in time. Thus, when a limited number of samples are available, the estimation of the frequency components at low frequencies is problematic. Furthermore, the Fourier transform is limited in that one can either observe the time domain or the frequency domain, but not both. This limitation is slightly reduced by the Short Time Fourier Transform, essentially a division of the signal into short time sequences. In recent years, however, several methods, which enable simultaneous investigation of both the time and the frequency domain, have emerged. Essentially, instead of using a sine for a kernel function, as in the Fourier transform, a different function with a limited time span is used. Many families of such functions (known as wavelets) are known. Probably the most widely used are the Gabor, Daubechies, Mexican Hat, and Haar wavelets. The output of the wavelet transform for a one-dimensional signal is a two-dimensional representation of the time-frequency plane. Thus, local changes in both time and frequency can be observed.

## Systems

Modeling a complicated system is an extremely useful method for gaining understanding into its behavior, and for predicting its performance under various conditions. Modeling a system through the tools of system analysis is performed by identifying the inputs and outputs of the system, and representing its internal workings as a set of equations. A system can have single or multiple inputs, as well as single or several outputs.

Modeling biological systems has proved advantageous for diverse applications. Among them (to name only a few) are pacemaker design, **seizure prediction** based on EEG [8], as well as theoretic studies on **movement planning** [9].

Categories, similar to those used for typifying signal processing systems (outlined in the previous section), are used for classifying modeled systems. These include their linearity, stability, sensitivity to initial conditions, and time-invariance.

The set of equations used for modeling a system is frequently approximated as a linear set, so that the sum of outputs of two signals is equal to the output of the sums. This approximation is useful because there are many more tools for analysis of linear systems than for analysis of non-linear systems. Even when a system is known to be nonlinear, methods exist for ►linearization around a given area of its operational envelope. For example, time delay, which is a non-linear operator, can be approximated in the frequency plane using the Pade approximation.

An important parameter for systems is their stability. A stable system will have a finite output for every finite input value. Determining if a system is stable or not, based on its equations, has been an object of much research. Popular tools for ascertaining system stability examine the system equations in the frequency plane (importantly, both phase and amplitude), using diagrams known as Bode diagrams and Nichols charts. The result of this analysis is both the knowledge whether system is stable or not, as well as how far the system is from instability, as measured by the Phase Margin (PM) and Gain Margin (GM).

The full description from input to output of a system is known as the ►transfer function. Usually, the transfer function of linear systems is defined in the frequency plane or as a system of ►differential equations. When the frequency-plane description is used, instead of using the Fourier Transform for converting the system equations into the frequency plane, system engineers traditionally use the Laplace Transform for continuous systems and the Z-Transform for sampled systems. Both these transforms are identical to the Fourier Transform and the Discrete Fourier Transform, except for a change of variables. The roots of the transfer function polynomial (of linear systems) are useful for determining system stability. The roots of the nominator are known as ►zeros, while those of the denominator as ►poles. The Root-Locus method can be used for determining if the system is stable, and if so, under which conditions.

As noted above, a system can be modeled as a list of differential equations, where some of the equations describe the dependency between the internal variables of the system and previous inputs, while other equations describe the relation between internal and output variables. This description is known as the ►statespace description of a system. The states, in this description, are a particular combination of the internal variables.

An underlining assumption when analyzing a system in the frequency plane is that they are working in their

steady-state mode, that is, any changes in behavior resulting from initial conditions have disappeared for all practical purposes. However, the sensitivity of a system to its initial conditions can be highly important. Some systems exhibit chaotic behavior, defined as an extreme sensitivity to initial conditions. A chaotic system will reach vastly different steady states for slightly different initial conditions. In such systems, the behavior in state-space is one where, for some initial conditions, the system does not reach a final single state, but rather it hovers around a point (or several points) known as attractors.

It is possible to distinguish between random systems and systems that are chaotic (and thus contain a structure) by measuring their ►correlation dimension. This is a measure of the size of the attractors in the system. Note that this size can be a ►fractal, a term coined by Benoit Mandelbrot in 1975 [10] to describe objects built using recursion. Thus, while the dimension of a line is one, and of a rectangle two, fractal shapes have a non-integer dimension.

It is sometimes useful to model a system or a sub-system using only its statistical properties. This is useful, for example, in order to generate some stochastic behavior with parameters that are similar to those of a chosen system. Systems that can be modeled in this way, by generating white noise (the driving noise) and passing this noise through a differential equation that depends on previous outputs and the current value of the noise, are known as Auto-regressive (►Auto-regressive model) (AR) systems. Systems that can be modeled through a differential equation that operates on previous values of the noise are known as Moving-Average (►Moving-Average Model) (MA) systems, while those where the differential equation operates on both previous values of the noise and those of previous outputs are known as Auto-regressive Moving Average (►Auto-regressive Moving Average Model) (ARMA) systems. There are several methods for finding the coefficients of the differential equations given data recorded at the output of the system to be modeled. However, finding the coefficients of AR systems involves solving linear equations, while the coefficients of MA and ARMA systems are solved using non-linear equations. There is a useful extension to AR systems whereby, in addition to the driving noise, there is a deterministic input; these systems are known as Autoregressive with Exogeneous input (ARX) systems. One of the most popular applications of AR models is for compression of ►speech. The speech is cut into segments, each a few hundred milliseconds long. Each segment is modeled using its AR coefficients. Instead of transmitting the samples of the speech, only the AR coefficients are transmitted, and at the receiving end, the speech is regenerated using these coefficients and white noise.

## References

1. Therrien CW (1992) Discrete random signals and statistical signal processing. Prentice-Hall, Upper Saddle River, NJ, USA
2. Nyquist H (1928) Certain topics in telegraph transmission theory. *Trans AIEE* 47:617–644
3. Yom-Tov E, Yom-Tov S, Ur H (1999) A model of induced coupled movements in the human body - a case study. *Biol Cybern* 80:411–416
4. Mallat S, Zhang Z (1993) Matching pursuits with time-frequency dictionaries. *IEEE Trans Signal Process* 41 (12):3397–3415
5. Woody CD (1967) Characterization of an adaptive filter for the analysis of variable latency neuroelectronic signals. *Med Biol Eng Comput* 5:539–553
6. Haykin S (1996) Adaptive filter theory, 3rd edn. Prentice-Hall, Upper Saddle River, NJ, USA
7. Yom-Tov E, Inbar GF (2000) Movement-related potentials in the human spinal cord preceding toe movement. *Clin Neurophysiol* 111:350–361
8. van Drongelen W, Nayak S, Frim DM, Kohrman MH, Towle VL, Lee HC, McGee AB, Chico MS, Hecox KE (2003) Seizure anticipation in pediatric epilepsy: use of Kolmogorov entropy. *Pediatr Neurol* 29(3):207–213
9. Karniel A, Inbar GF (1997) A model for learning human reaching movements. *Biol Cybernetics* 77(3):173–183
10. Mandelbrot BB (1982) The fractal geometry of nature. WH Freeman and Company, New York, NY, USA

## Silent Nociceptor

### Definition

A group of nociceptive C fibers in human cutaneous nerves which are unresponsive to mechanical stimulation in intact skin. The term is misleading, since these nociceptive afferents respond to noxious heating and to chemical agents, e.g., capsaicin. A synonym “sleeping nociceptor” is derived from the observation that these units become sensitized (“awakened”) to mechanical stimulation in the course of inflammatory processes.

► [Nociceptors and Characteristics](#)

## Silent Period (SP)

### Definition

The period of electrical silence in the electromyographic recording during voluntary activation of

muscle(s), evoked by stimulation of the nervous system.

► [Transcranial Magnetic Stimulation](#)

## Silent Synapse

ANDRES BARRIA

Department of Physiology and Biophysics, University of Washington, Seattle, WA, USA

### Definition

The vast majority of excitatory neurotransmission in the brain is mediated by ► [glutamate](#) and its ► [ionotropic receptors](#), AMPA- and ► [NMDA-type glutamate receptors](#). In neuroscience, a silent synapse is an excitatory glutamatergic synapse whose postsynaptic membrane contains only NMDA-type glutamate receptors (► [NMDA-Rs](#)) and no AMPA-type glutamate receptors (► [AMPA-Rs](#)) ([Fig. 1](#)).

An action potential that invades the presynaptic terminal causes calcium entry into the terminal and fusion of neurotransmitter-filled synaptic vesicles releasing glutamate into the synaptic cleft. Presynaptically released glutamate binds to glutamate receptors present at the postsynaptic membrane briefly activating the conductance associated with them. Activation of AMPA-Rs leads to a fast inward current that depolarize the postsynaptic membrane. Activation of NMDA-Rs, however, does not cause an inward current because at the normal neuronal resting potential – around –60 mV – the receptor’s channel is blocked by physiological concentration of extracellular magnesium [1]. Thus, in normal synapses containing both, AMPA-Rs and NMDA-Rs, the inward current observed in response to glutamate release is mediated by the AMPA-R ([Fig. 1](#), left). Some synapses, however, contain only NMDA-type receptors. The blockade of the NMDA-R channel by magnesium renders these synapses inactive or “silent” to the release of presynaptic glutamate ([Fig. 1](#), right). It is important to note that if activation of a silent synapse occurs when the postsynaptic membrane is depolarized, the magnesium blockade is relieved and the NMDA-R will conduct current.

### Characteristics

#### Description of the Structure

Excitatory glutamatergic synapses in the central nervous system (CNS) consist of a presynaptic bouton with glutamate-filled vesicles and a postsynaptic

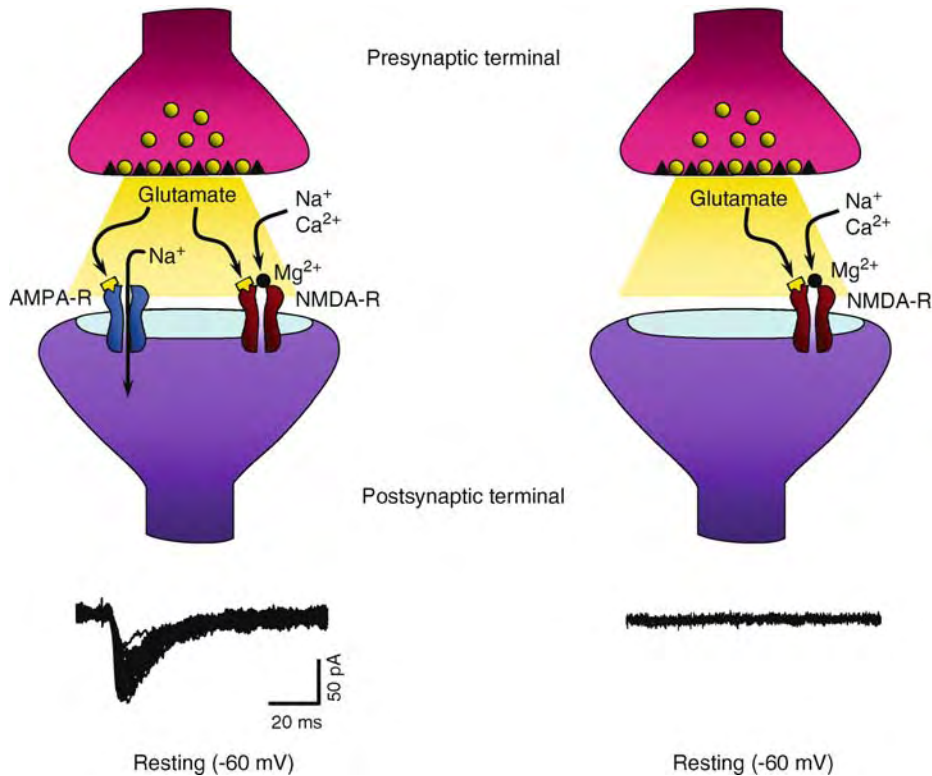

**Silent Synapse. Figure 1** The Glutamatergic Synapse. Left, synapse containing postsynaptic AMPA-Rs and NMDA-Rs at resting potential. Glutamate released from the presynaptic terminal binds to both receptors; however, the recorded excitatory post-synaptic current (EPSC) is due only to the activation of AMPA-Rs (lower traces). NMDA-Rs are blocked by physiological concentration of extracellular Mg<sup>2+</sup>. Right, silent synapse containing only NMDA-Rs at resting potential. Presynaptically released glutamate fails to activate NMDA-R responses due to the blockade by Mg<sup>2+</sup>; therefore no EPSC is recorded postsynaptically (lower traces).

structure containing glutamate receptors. Two types of glutamate receptors can be present at the postsynaptic membrane: (i) metabotropic receptors, associated to signal transduction mechanisms and second messenger cascades, and (ii) ionotropic receptors, directly coupled to ionic conductances. Glutamatergic ionotropic receptors can be further divided into non-NMDA receptors and NMDA receptors (NMDA-Rs) based on their affinity for the agonist NMDA. The most abundant and better understood non-NMDA receptors are the AMPA receptors (AMPA-Rs) [2].

At excitatory chemical synapses, synaptic transmission is mediated by activation of AMPA-Rs and NMDA-Rs. Activation of AMPA- or NMDA-receptors by presynaptically released glutamate results in the opening of an ionic channel which is non-selective to cations. This allows the flow of Na<sup>+</sup> and K<sup>+</sup> ions depending on the electrochemical gradient across the postsynaptic membrane. A significant fraction of the current flowing through NMDA-Rs is also carried by Ca<sup>2+</sup>. Calcium entry through postsynaptic NMDA-Rs is thought to play a critical role in synaptic plasticity, a

cellular mechanism for learning and memory, as well as in some neuropathologies. Certain AMPA-Rs are also permeable to Ca<sup>2+</sup>.

The conductance associated with the NMDA-R has slow rising and decay kinetics and – as mentioned – can be blocked by physiological concentrations of extracellular Mg<sup>2+</sup>. This blockade is strongly voltage-dependent and can be removed when the postsynaptic membrane is depolarized to around -40 mV (Fig. 2).

Thus, partial depolarization of the postsynaptic membrane relieves the magnesium block and allows the flow of ions through the channel when activated by glutamate. It is this property that allows the NMDA-receptor to be a coincidence detector of pre- and post-synaptic activity required in Hebbian models of plasticity [3].

In the hippocampus and other brain regions, the ratio of AMPA-R to NMDA-R mediated transmission is initially low and increases over development. Furthermore, many synaptic events, particularly early in development, are mediated by the activation of only NMDA-receptors. Such responses are proposed to

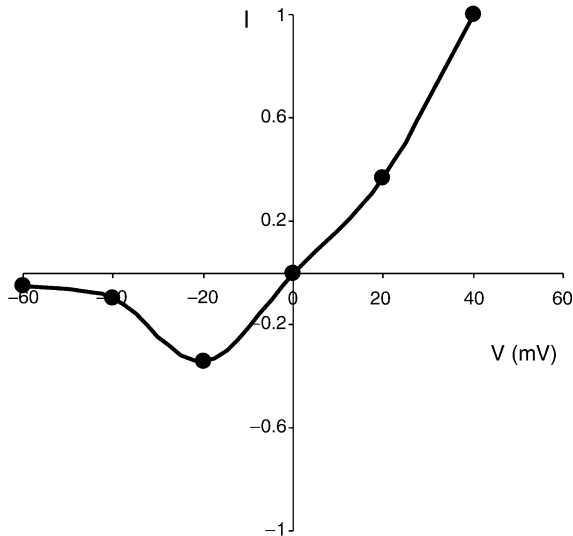

**Silent Synapse. Figure 2** Voltage dependency of  $Mg^{2+}$  blockade of the NMDA-R. Relationship of membrane voltage (V) and normalized current (I) flowing through the NMDA-R when activated by glutamate. The receptor is expressed in heterologous cells and glutamate is puffed onto the surface of a voltage-clamped cell in the presence of physiological concentration of  $Mg^{2+}$ . Notice that at  $-60$  mV there is practically no current.

occur at structures termed postsynaptically silent synapses, because transmission can only be detected if the postsynaptic membrane potential is raised above the resting level [4]. The prevalence of pure NMDA-R responses measured electrophysiologically decreases during development.

The presence of functionally silent synapses, that lack responses when presynaptic fibers are stimulated at resting potentials, can be explained by other mechanisms. Some scenarios consider the presence of both AMPA-Rs and NMDA-Rs at synapses, and they propose that early in development only low concentrations of glutamate reach synapses. NMDA-Rs exhibit higher affinity for glutamate than AMPA-Rs; therefore, low concentrations could activate primarily NMDA-Rs and not AMPA-Rs. Low concentration of glutamate could be achieved by a presynaptic vesicle that does not release all its content at once [5]. This could cause that glutamate concentration in the synaptic cleft increases slowly, activating only high affinity NMDA-Rs but not low affinity AMPA-Rs. A similar situation will occur if low concentrations of glutamate “spill over” from neighboring synapses [6]. Also, a synapse with a very low presynaptic probability of release will be rarely activated when its input is stimulated appearing to be silent [7]. These hypotheses are controversial and matter of discussion [8].

The existence of synapses lacking AMPA-Rs has been tested directly by immunogold labeling studies, which

have shown that the fraction of synapses containing NMDA-R but not AMPA-R immunoreactivity decreased from 84% at postnatal day 2 to 50% at 5 weeks with little changes in NMDA-R immunoreactivity [9].

Thus, silent synapses containing only NMDA-Rs are especially prevalent in development and have been found in many brain regions, including the hippocampus, cerebral cortex, and spinal cord. The molecular properties of NMDA-Rs explain why at resting potential there are no responses when presynaptic fibers are activated. The existence of such synapses has been corroborated with functional and anatomical studies.

### Regulation

Silent synapses stop being silent once they acquire AMPA-Rs and an inward current is produced postsynaptically in response to glutamate released from the presynaptic terminal. Conversion of silent synapses to functional synapses is a developmentally regulated process that requires synaptic activity or sensory experience. Also, silent synapses can acquire AMPA-Rs when cells are stimulated by protocols inducing long-term potentiation (LTP), a synaptic plasticity phenomenon thought to be the cellular correlate of learning and memory. In both cases, incorporation of AMPA-Rs into synapses is a tightly regulated process and requires synaptic activity and  $Ca^{2+}$  influx into the postsynaptic cell. AMPA-Rs with different subunit composition have different activity requirement to be incorporated into synapses. Trafficking of AMPA-Rs in and out of synapses involves the coordination of several kinases and phosphatases, as well as the interaction with several scaffolding proteins. Since the discovery of silent synapses, regulation of AMPA-R trafficking has been intensively studied and is currently a very dynamic field in neuroscience [10].

Over the past few years, a number of studies have tested the notion that silent synapses lack AMPA-Rs and that AMPA-Rs can be rapidly delivered to synapses during the induction of LTP. This model suggests that there must be a pool of non-synaptic AMPA-Rs near synapses available for delivery. Several studies have found ample amounts of non-synaptic AMPA-Rs on both surfaces and intracellular regions of dendrites that are delivered to synapses in response to LTP inducing protocols [10].

It is thought that rapid delivery of AMPA-Rs from non-synaptic sites to the synapse occurs via a mechanism analogous to the exocytosis of presynaptic vesicles during transmitter release. This rapid delivery of AMPA-Rs is thought to underlie the increase in synaptic transmission after LTP induction. Early studies in hippocampal slices showed that loading postsynaptic cells with toxins that specifically perturb membrane fusion could block LTP. Also, in dissociated

cultured neurons a form of dendritic exocytosis that was mediated by activation of CaMKII, a key enzyme in LTP induction, has been identified.

### Function

Several lines of evidence indicate that NMDA-receptors are present in synapses before AMPA-receptors and that during development AMPA-receptors are progressively added. Silent synapses are not a separate class of excitatory synapses that lack AMPA receptors, but rather an early stage in the ongoing maturation of the glutamatergic synapse. The fact that silent synapses generate no postsynaptic electrical signal when the postsynaptic cell is at its normal resting membrane potential, but can transmit robust postsynaptic electrical responses once the postsynaptic cell is depolarized, suggest an interesting and simple mechanism to modify neural circuitry. Activation of NMDA-Rs when the postsynaptic cell is depolarized will allow  $\text{Ca}^{2+}$  entry and the triggering of several calcium-dependent processes including the addition of AMPA-Rs to that specific synapse and activation of signaling pathways necessary for synapse stabilization, dendrite growth, and cell survival.

### References

1. Mayer ML, Westbrook GL, Guthrie PB (1984) Voltage-dependent block by  $\text{Mg}^{2+}$  of NMDA responses in spinal cord neurones. *Nature* 309:261–263
2. Dingledine R, Borges K, Bowie D, Traynelis SF (1999) The glutamate receptor ion channels. *Pharmacol Rev* 51:7–61
3. Malenka RC, Nicoll RA (1999) Long-term potentiation – a decade of progress? *Science* 285:1870–1874
4. Malenka RC, Nicoll RA (1997) Silent synapses speak up. *Neuron* 19:473–476
5. Choi S, Klingauf J, Tsien RW (2000) Postfusional regulation of cleft glutamate concentration during LTP at ‘silent synapses’. *Nat Neurosci* 3:330–336
6. Kullmann DM (2003) Silent synapses: what are they telling us about long-term potentiation? *Philos Trans R Soc Lond B Biol Sci* 358:727–733
7. Gasparini S, Saviane C, Voronin LL, Cherubini E (2000) Silent synapses in the developing hippocampus: lack of functional AMPA receptors or low probability of glutamate release? *Proc Natl Acad Sci USA* 97:9741–9746
8. Montgomery JM, Pavlidis P, Madison DV (2001) Pair recordings reveal all-silent synaptic connections and the postsynaptic expression of long-term potentiation. *Neuron* 29:691–701
9. Petralia RS et al. (1999) Selective acquisition of AMPA receptors over postnatal development suggests a molecular basis for silent synapses. *Nat Neurosci* 2:31–36
10. Malinow R, Malenka RC (2002) AMPA receptor trafficking and synaptic plasticity. *Annu Rev Neurosci* 25:103–126

## Silver Impregnation

### Definition

Nerve tissue has an affinity for silver (argyrophilia) and is easily impregnated by dilute silver solutions. Reducing the silver enables it to be deposited within the neuron's processes thus outlining the neuron (see below).

## Silver Staining

### Definition

Silver staining of nerve tissue is made possible by a variety of so-called reduced silver methods. The neurons appear as golden or dark brown against a yellow background.

## Simple Cell

### Definition

Simple cells are one of two main physiological types of cells in the primary visual cortex. They have receptive fields built of elongated, adjacent On and Off subregions that have a mutually suppressive influence.

The basis of this antagonism is a push-pull relationship between stimuli of opposite contrast in each subregion; e.g. where bright stimuli excite, dark stimuli inhibit. As a result of the geometry of the receptive field and the antagonism between neighboring subregions, simple cells are sensitive to stimulus orientation – they are good edge detectors. Cells with simple receptive fields were first discovered in the cat, where they are found only at the first, or thalamocortical, stage of processing.

► [Form Perception](#)

► [Geniculo-striate Pathway](#)

► [Striate Cortex Functions](#)

► [Visual Cortical and Subcortical Receptive Fields](#)

---

## Simple Lobule

### Synonyms

- ▶ Lobulus simplex

### Definition

The simple lobule belongs to the posterior lobe and is part of the cerebellar hemispheres. Apart from the areas in proximity to the vermis (intermediate part), the hemispheres belong to the phylogenetically young neocerebellum and receive their afferents via the mossy fibers of the pontocerebellar tract from the pontine nuclei. All hemisphere segments are hence also assigned to the pontocerebellum.

- ▶ Cerebellum

---

## Simple Receptive Fields

- ▶ Visual Cortical and Subcortical Receptive Fields

---

## Simple Sound

### Definition

A sound with one frequency component, or a sinusoidal sound, or a pure-tone sound.

- ▶ Acoustics

---

## Simulated Annealing

### Definition

A type of supervised learning algorithm based on ideas from statistical physics. It can be used in networks with arbitrary architectures.

- ▶ Neural Networks

---

## Simulated Microgravity

### Definition

Simulated microgravity encompasses ground-based conditions simulating changes in the internal environment of the living body such as changes in fluid distribution in space. For example, methods to induce headward fluid shift as seen in microgravity in space using head-out water immersion, lower body positive pressure, head-down bed rest, etc.

- ▶ Autonomic Function in Space

---

## Single-cell Recording

### Definition

Recording of the electrical activity of single neurons in the nervous system by means of electrodes introduced into the nervous tissue.

- ▶ Extracellular Recording

---

## Single-channel Activity

### Definition

Activity of a single ion channel viewed through the ion current passing through an open channel. Single-channel activity is measured in voltage-clamp conditions using the patch-clamp technique in cell-attached, outside-out and inside-out configuration. Single  $\text{Ca}^{2+}$  channels give rise to membrane currents in the order of picoamperes (pA) in high  $\text{Ba}^{2+}$  solutions.

- ▶ Calcium Channels – an Overview
- ▶ Intracellular Recording

---

## Single-fiber Action Potential

### Definition

Extracellular potential detected due to the propagation of the transmembrane action potential along a muscle fiber when stimulated.

- ▶ Electromyography



## Single-joint Movement

### Definition

Movement that involves rotations in a single joint.

► Motor Control Models

## Single-Photon Emission Computed Tomography (SPECT)

### Definition

Is a tomographic imaging technique based on the emission of gamma rays by a tracer that is absorbed by tissue (e.g., brain tissue) proportional to blood flow. The technique permits measurements of perfusion, which is coupled to metabolism.

## Singleton

### Definition

A set with exactly one element. A term used in SAGE studies to describe unique sequence tags appearing only once in a library.

► Serial Analysis of Gene Expression

## Single-unit Recording

### Definition

Recording from an individual nerve, glia or muscle cell (unit).

► Extracellular Recording

## Sinus Hair

### Definition

The sinus hair is a highly specialized hair follicle characterized by a well-developed venous sinus

associated with the hair follicle, and is usually located in the facial skin of mammals except humans. Vibrissae are examples of sinus hairs arranged in rows on the upper lips of cats, dogs, and rats. The sinus hair contains different kinds of sensory receptors including Merkel cell-neurite complexes, various kinds of palisade endings, and lamellated corpuscles.

► Merkel Cell-Neurite Complex Regeneration

## siRNA

### Definition

A small (or short) interfering RNA is a 20–25 nucleotide long double stranded RNA that shows complete complementary to the sequence of a mRNA and interferes with its expression by targeting it to the RNA interference pathway.

## Sister Groups/Sister Taxa

### Definition

In cladistic classification, any two taxa are sister groups if they are descended from the same node in a dichotomous branching tree

► The Phylogeny and Evolution of Amniotes

## Situational Factors in Pain

### Definition

Situational factors are contextual and psychological factors that can vary with the circumstances in which an individual experiences pain. These include: cognitive factors such as understanding of the pain problem, knowledge of effective therapies, and expectations for recovery; behavioral factors such as the specific distress behaviors during pain and the wider behaviors in response to a recurrent or chronic pain; and emotional factors such as fear, frustration, anxiety or depression.

► Pain in Children

## Sjögren's Syndrome

### Definition

Sjögren's syndrome is named after the Swedish ophthalmologist Henrik Sjögren who first described it in 1933. It is a chronic autoimmune disorder in which immune cells cause damage to salivary and lacrimal glands giving dry mouth and dry eyes. Sjögren's syndrome occurs in a primary and a secondary form. The secondary form is associated with rheumatic diseases such as rheumatoid arthritis, systemic lupus erythematosus ("lupus"), and polymyositis.

- ▶ Central Nervous System Disease in Primary Sjögren's Syndrome
- ▶ Rheumatoid Arthritis (RA)
- ▶ Salivary Secretion Control
- ▶ Systemic Lupus Erythematosus (SLE)

## SK Channels

### Definition

Small-conductance  $\text{Ca}^{2+}$ -activated  $\text{K}^+$  channels present in autonomic neurons and sometimes involved in after-hyperpolarization.

- ▶ Neuronal Potassium Channels
- ▶ Action Potential

## Skeletal Muscle Architecture

ROLAND R. ROY, VICTOR REGGIE EDGERTON  
Brain Research Institute and Department of  
Physiological Science, University of California,  
Los Angeles, CA, USA

### Definition

Muscle architecture is the structural design of a skeletal muscle in terms of the arrangement of the muscle fibers, muscle units, and connective tissue elements within and around which they are embedded. These design features define the axis of force and displacement generation of a muscle-tendon complex.

## Characteristics

### Muscle Fiber Architecture

Single skeletal muscle fibers are elongated, multinucleated cells that have variable lengths and shapes. A fiber is comprised of a number of myofibrils arranged in parallel and comprised of sarcomeres arranged in-series. A ▶sarcomere, in turn, is comprised of myofilaments, i.e. namely myosin and actin, and is the functional unit of muscle contraction. The basal lamina defines the anatomical boundary of a single fiber. A majority of muscle fibers have a single point of innervation identified as the ▶neuromuscular junction or motor endplate. Myonuclei are distributed along the length of the fiber, with a higher density usually observed at specialized regions, i.e. the neuromuscular junction and the ▶myotendinous junction. The anatomical length of an individual muscle fiber is highly variable, e.g. the range in humans is from a few mm to several cm. In many cases, short muscle fibers are arranged in-series and activated simultaneously such that the functional length of the muscle fiber is enhanced significantly. The shape of an individual fiber is also highly variable (Fig. 1).

The cross-sectional area of a fiber can be relatively homogeneous throughout its length, or the fiber can taper (show a decrease in fiber area) at one or both ends. The amount of tapering can vary from a partial tapering to a full taper where the cross-sectional area becomes a filamentous strand. The termination of a muscle fiber usually involves some connective tissue interface, i.e. at a tendon, aponeurosis, the end of another muscle fiber, or intrafascicularly. The muscle fiber: connective tissue interface of a non-tapering fiber is usually a blunt ending, i.e. an abrupt termination with complex infoldings between the ▶sarcolemma and connective tissue elements. The termination of tapering fibers is much more complex and variable, ranging from blunt-like endings between the sarcolemmal membranes of two fibers arranged in-series to interdigitating myomyonal junctions between the tapering ends of two adjacent fibers.

### Motor Unit and Muscle Unit Architecture

A single ▶motor unit is defined as an  $\alpha$ -motoneuron and all of the muscle fibers that it innervates. Using repetitive stimulation of a single motor axon or an individual motoneuron, the fibers belonging to a motor unit can be depleted of their glycogen and then identified on histological sections stained for glycogen content. All muscle fibers within a motor unit are, in general, of the same phenotype, i.e. have similar, although not identical, mechanical and metabolic properties. The architectural properties of the constituent fibers vary within a motor unit, although it appears that slow motor units have a higher percentage of non-tapering fibers than fast motor units. The spatial distribution of the fibers in any cross section of a muscle is nonrandom and

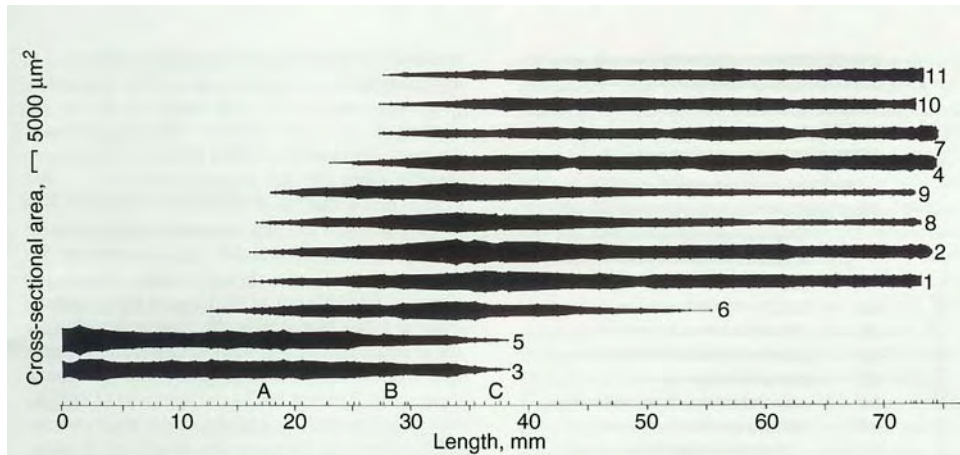

**Skeletal Muscle Architecture. Figure 1** Cross-sectional area of eleven fibers reconstructed from serial sections of a glycogen-depleted fast motor unit in the cat tibialis anterior muscle. All fibers are from one well-defined ►fascicle. The proximal end of the muscle is at 0 mm. Note the various shapes of the fibers to include full and partial tapering, and blunt and tapered fiber terminations. (Taken from [1], Fig. 5).

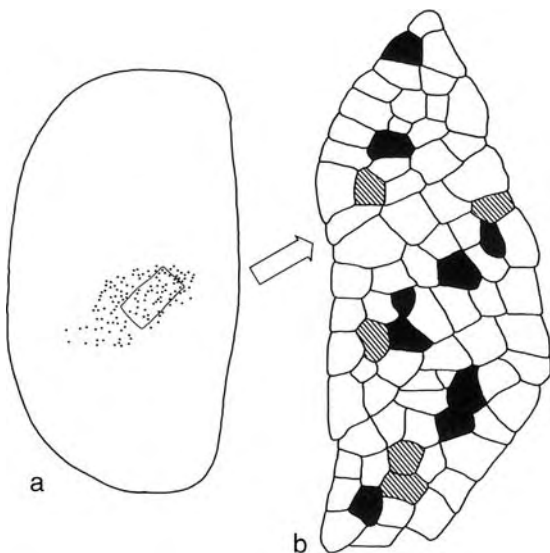

**Skeletal Muscle Architecture. Figure 2** (a) Distribution of glycogen-depleted muscle fibers (*black dots*) belonging to a single motor unit within a single cross section of a cat tibialis anterior muscle. The outlined region in the motor unit area was selected for analysis. (b) Schematic representation of a single fascicle from the area outlined in (a). All fibers in the fascicle were classified as being depleted of glycogen (motor unit fibers) or not depleted of glycogen (non-motor unit fibers) and as slow or fast based on myofibrillar ATPase staining. Muscle fibers are identified as fast, depleted motor unit fibers (*striped*), slow non-depleted fibers (*black*), or fast non-depleted fibers (*white*). (Taken from [2], Fig. 1).



**Skeletal Muscle Architecture. Figure 3** The territory of a fast fatigable motor unit (*white area*) along the proximodistal (*right to left*) axis of a cat tibialis anterior muscle is shown. Segments of the outline of the muscle are deleted to allow visualization of the motor unit territory. Note that the territory tapers and shifts from one surface to the other along the length of the muscle. (Taken from [3], Fig. 1).

is thought to reflect the axonal growth processes occurring during innervation at a developmental stage (Fig. 2). In most muscles, the muscle fibers of a single motor unit occupy only a portion of the cross section along the length of the muscle and the extent of this motor unit territory varies considerably. The 3-D shape of the motor unit territory reflects the distribution and length of the fibers comprising the motor unit (Fig. 3).

### Connective Tissue Framework

There is a highly specialized connective tissue framework that is distributed throughout a skeletal muscle [7]. As stated above, individual muscle fibers are enveloped by a basal lamina containing primarily type IV collagen, fibronectin, enactin, and laminin. The remainder of the extracellular matrix has been divided into three levels of organization based on its relation to the muscle fibers. The ►**endomysium** is a collagenous sheath that is contiguous with the basal lamina of the muscle cells. The ►**perimysium** is the thickened endomysium that circumscribes fascicles of muscle fibers. The ►**epimysium** surrounds the outer surface of the muscle. These levels of organization are distinguishable primarily by their morphology rather than differences in their composition. All three are composed primarily of types I and III collagen. The endomysium and perimysium are usually referred to collectively as the intramuscular

connective tissue. A dramatic illustration of the 3-D structure of the intramuscular connective tissue can be found in ►**Figure xx in Huijing et al. (Chapter xx in this book)**. If the reader imagines this honeycomb of connective tissue extending to each end of the muscle, it is possible to conceive the muscle as a continuous tendon with muscle fibers embedded within.

### Muscle Compartmentalization

A large number of mammalian skeletal muscles are compartmentalized, i.e. subdivided into anatomical sub-compartments each having a separate primary nerve branch and showing some sensory partitioning (Figs. 4 and 5).

The arrangement of the compartments within a muscle can be in series, in tandem, in parallel, etc. Many muscles and muscle compartments can also be subdivided by their fiber type composition. For example, many

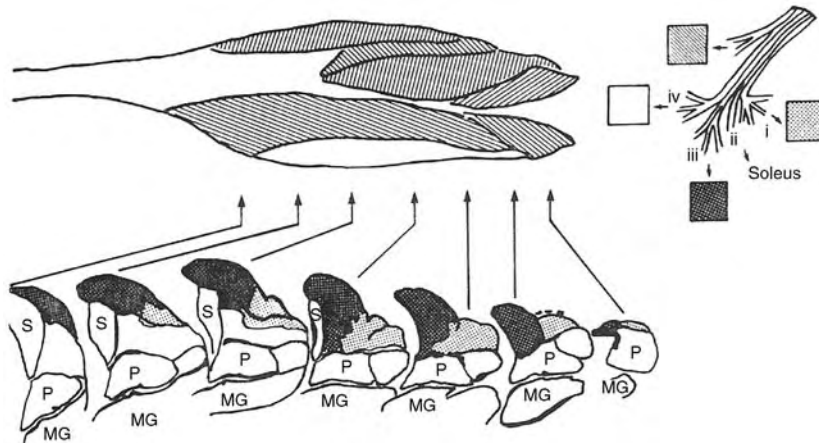

**Skeletal Muscle Architecture. Figure 4** Compartmentalization of the cat lateral gastrocnemius muscle is illustrated. Muscular subvolumes (compartments) supplied by primary nerve branches are identified. Shown are a compilation of serial sections from several glycogen-depletion experiments that describe the regions innervated by primary muscle nerve branches. Proximal end of the muscle is on the right side. (Taken from [5], Fig. 6).

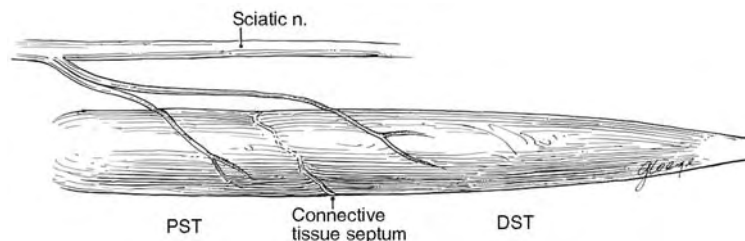

**Skeletal Muscle Architecture. Figure 5** Schematic drawing of the cat semitendinosus (ST) muscle. A dense connective tissue band divides the ST into a proximal (PST) and distal (DST) end. The muscle fibers of each end are arranged in parallel (angle of pinnation =  $\sim 0^\circ$ ) and are connected in series at the connective tissue band, with distal fibers being approximately twice as long as the proximal fibers. Each muscle compartment is innervated by a separate branch from the sciatic nerve. (Taken from [6], Fig. 1).

muscles and muscle compartments show a much higher percentage of slow fibers in the regions that are closer to the center of the limb or trunk, i.e. close to the bony elements, than regions that are more superficial, i.e. away from the bony elements. This type of compartmentalization is much less evident in the muscles of humans compared to most other animals. Compartmentalization has some functional implications [7]. For example, in many instances, the individual compartments can be recruited independently of each other during specific motor tasks. Similarly, a region of a muscle comprised of a relatively high proportion of slow fibers is normally recruited at lower force levels than a region having a lower proportion of slow fibers.

### Structure-Function Relationships

The arrangement of the fibers/fascicles within a muscle influences its mechanical properties. A muscle that has relatively long fibers or fascicles, i.e. a large number of sarcomeres in series, is optimally designed for producing long excursions and thus for speed of contraction. In contrast, a muscle with relatively short fibers or fascicles, i.e. a large number of fibers or fascicles in parallel, is optimally designed for force production. The muscle fibers/fascicles within a muscle can be arranged in parallel to or displaced from (pinnated) the axis of force- or displacement-generation. In pinnated muscles, the muscle fibers can be arranged in a unipinnate or multipinnate arrangement depending on the intramuscular connective tissue framework. The significance of the pinnation angle of the muscle fibers is that the transfer of force or displacement is theoretically compromised along the axis of the force- or displacement-generating axis, i.e. decreased by the cosine of the angle of pinnation. An advantage of fiber pinnation is the increase in the number of fibers that can be arranged in parallel, and thus an increase in force potential. The angle of pinnation in a rested state has been reported to be relatively small across most muscles. Although there are minimal data on sarcomere function in vivo, the fiber angle in some muscles appear to increase dramatically during dynamic contractions, i.e. the fibers are free to rotate during a contraction. This has been elegantly demonstrated in humans using ultrasound techniques. The ability of force to be transmitted laterally via interconnections among the individual fibers arranged in parallel and eventually to the site of insertion ensures the effectiveness of force transmission, even when there is a large angle of pinnation (►see Chapter xxx by Huijing in this book). A final point here is that, many of the relatively large muscles in humans have multiple compartments and complex tendons of insertion and origin, and we do not understand at all how these compartments interact to generate a given force and displacement.

### Plasticity of Muscle Architecture

The architectural properties of a muscle are highly plastic. Muscle and fiber size will increase (hypertrophy, e.g. with resistance training) or decrease (atrophy, e.g. with aging) with changes in the activation/loading conditions. Chronic stretching of a muscle fiber results in the addition of sarcomeres and thus a lengthening of the muscle fiber, whereas chronic shortening has the opposite effect. Hypertrophy of a muscle increases, whereas atrophy decreases, the angle of pinnation of the muscle fibers/fascicles. These considerations may become highly relevant under certain circumstances.

### Functional Implications

It is interesting to note that almost all of the variables measured to characterize muscle architecture are based on the muscle fibers themselves, i.e. the number of sarcomeres arranged in series and in parallel and the angular arrangement of these fibers with respect to the direction of pull of the muscle. There is no inclusion of any of the passive tissues of the musculo-tendinous complex in these measurements. In most experiments any potential contribution of the interfiber matrix, the connective tissue that forms fascicles, aponeuroses and tendons are omitted from the formula to calculate the force and velocity of shortening potential of a muscle. Furthermore, most experiments are specifically designed to eliminate elastic properties. This omission is practically universal, in spite of the fact that it is clear that one cannot predict these measures of function based on muscle fiber architecture and sarcomere dynamics derived from isolated single muscle fibers, in large animals as it can in the smaller animals such as the mouse, rat and guinea pig. The formula classically used to calculate physiological cross-sectional area of a muscle provides highly variable estimates of maximum force and velocity of shortening in human muscles. This limitation suggests that there are some novel fundamental design strategies that have been used in the evolution of larger animals. For example, the difference in body and muscle volumes in the human and the cat may differ 50-fold, whereas the lengths of the fibers in homologous muscles are approximately the same in many cases.

For the physiological cross-sectional area of a muscle to represent its maximum force potential, it must be assumed that the force generated by a single fiber is independent of its length, which in turn implies that all forces among the sarcomeres are transmitted in series and entirely to the end of the muscle fiber to the myotendinous junction, which then transmits the forces to the aponeurosis and/or tendon. It is quite clear now that this is not the case. Muscle forces are transmitted from sarcomeres along the entire length of muscle fibers laterally to the interfiber matrix, and the matrix in turn transmits these forces to connective tissues that form

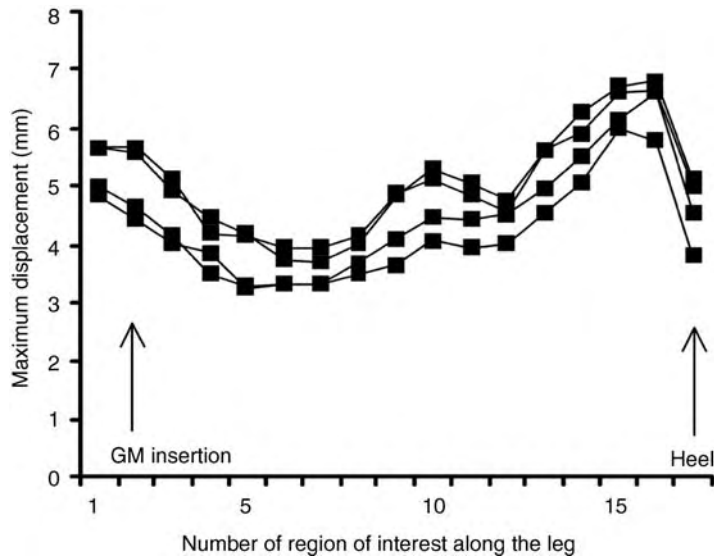

**Skeletal Muscle Architecture. Figure 6** Example of the maximum displacement at various regions of interest along the aponeurosis-tendon of the gastrocnemius muscle (GM) for one subject during four trials (contractions) in one session. Displacement was calculated using cine phase-contrast magnetic resonance images. Note the nonuniformity in the strain along the aponeurosis-tendon complex. (Taken from [9], Fig. 4).

fascicles, aponeuroses and eventually a tendon. In effect, in large muscles this lateral transmission of forces from sarcomeres along the length of fibers will require much more detailed and sophisticated models of force transmission than is represented by the simpler, traditional models which assume transmission of forces only from sarcomere to sarcomere along the length of the fibers and eventually only to the myotendinous junction. Other sections in this series have addressed some of these issues, demonstrating the potential importance of mechanical interactions from muscle to muscle via the connective tissue sheets that surround them, as well as the interactions of the connective tissues within the muscle, including the interfiber connective tissue matrix (►see Chapter xxx by Huijing in this book).

Obviously, the ability to monitor sarcomere dynamics, muscle fiber shortening and orientation and strains among and within the different levels of organization of the connective tissues that encase the muscle fibers to form a muscle is a technological challenge, even for small muscles in small animals. Some progress has been made in attempting to monitor *in vivo* sarcomere dynamics in a fish during swimming, in human muscles during normal voluntary isometric activation of selected muscle groups as well as during dynamic jumping movements using ultrasound and magnetic resonance imaging [8]. The initial examinations of the intramuscular dynamics during isometric contractions of the triceps surae in humans demonstrate a remarkable complexity and spatial heterogeneity in the strain of events that occur throughout the triceps surae and particularly the soleus

muscle. It is also evident that the strain that occurs within the aponeurosis of the Achilles tendon varies along its length during an isometric contraction (Fig. 6). These studies represent only a beginning of the efforts that are likely to reveal important new basic concepts in muscle design, which will enable us to more accurately predict the physiological potential of a given muscle-tendon complex. This information could also be important in efforts to design artificial muscles that can be used to assist or replace dysfunctional muscles.

### Therapeutic Interventions

The consideration of muscle architecture has become prominent in the area of tendon transfers in patients with a variety of musculoskeletal diseases [10]. In instances where a muscle or muscle group has become dysfunctional, it is a common procedure to transfer the tendon of a nearby muscle to compensate for the loss of specific movements. Lieber and colleagues have clearly shown that a crucial consideration in these procedures is the operating range of the musculoskeletal unit to be transferred, i.e. the architectural features of the unit should closely match the kinematics of the desired movements.

### References

1. Ounjian M, Roy RR, Eldred E, Garfinkel A, Payne JR, Armstrong A, Toga AW, Edgerton VR (1991) Physiological and developmental implications of motor unit anatomy. *J Neurobiol* 22:547–559
2. Bodine SC, Garfinkel A, Roy RR, Edgerton VR (1988) Spatial distribution of motor unit fibers in the cat

- soleus and tibialis anterior muscles: local interactions. *J Neurosci* 8:2142–2152
3. Roy RR, Garfinkel A, Ounjian M, Payne J, Hirahara A, Hsu E, Edgerton VR (1995) Three-dimensional structure of cat tibialis anterior motor units. *Muscle Nerve* 18:1187–1195
  4. Trotter JA, Richmond FJR, Purslow PP (1995) Functional morphology and motor control of series-fibered muscles. *Exerc Sports Sci Rev* 23:167–213
  5. English AW, Letbetter WD (1982) Anatomy and innervation patterns of cat lateral gastrocnemius and plantaris muscles. *Am J Anat* 164:67–77
  6. Bodine SC, Roy RR, Meadows DA, Zernicke RF, Sacks RD, Fournier M, Edgerton VR (1982) Architectural, histochemical, and contractile characteristics of a unique biarticular muscle: the cat semitendinosus. *J Neurophysiol* 48:192–201
  7. Edgerton VR, Bodine SC, Roy RR (1987) Muscle architecture and performance: Stress and strain relationships in a muscle with two compartments arranged in series. *Med Sport Sci* 26:12–23
  8. Muramatsu T, Muraoka T, Takeshita D, Kawakami Y, Hirano Y, Fukunaga T (2001) Mechanical properties of tendon and aponeurosis of human gastrocnemius muscle in vivo. *J Appl Physiol* 90:1671–1678
  9. Finni T, Hodgson JA, Lai AM, Edgerton VR, Sinha S (2003) Nonuniform strain of human soleus aponeurosis-tendon complex during submaximal voluntary contractions. *J Appl Physiol* 95:829–837
  10. Lieber RL, Friden J (2004) Implications of muscle design on surgical reconstruction of upper extremities. *Clin Orthop* 419:267–279

---

## Skew Deviation

- ▶ Vestibular Tests Ocular Tilt Reaction

---

## Skill

- ▶ Coordination

---

## Skill Learning

### Definition

Skill learning is learning of behavioral procedures or “how to.” Examples of skill learning are learning to ride a bike, learning to touch type, learning to play a musical

instrument or learning to swim. This learning proceeds implicitly and unconsciously by using feedback information. Skill learning can reflect acquisition of an “internal model” of an external object to control. For instance, in the cerebellum, movement trajectories of limb or eye directed to an object are computed by an “inverse model” which transforms from desired trajectory input to motor command output to skeletal muscles.

- ▶ Internal Models
- ▶ Sensorimotor Learning and the Basal Ganglia

---

## Skin Photoreceptor

### Definition

Photoreceptors in the skin (or dermal photoreceptors) in non-mammalian vertebrates that regulate some non-image forming photoresponses. An opsin-like molecule in photosensitive pigment cells known as melanophores of *Xenopus laevis* was named melanopsin. The photoreceptor(s) in the skin of fish exhibits several properties of the opsin family of photopigments, but is not yet identified.

- ▶ Photopigments

---

## Slave Oscillators

- ▶ Internal Desynchrony

---

## Sleep

### Definition

Sleep is a state of rest in animals that is characterized by behavioral quiescence and decreased responsiveness to environmental stimuli. The timing of sleep is controlled by an animal’s internal biological clock and sleep occurs mostly during the night (diurnal species) or during the day (nocturnal species). Other aspects of sleep behavior (e.g., daily sleep amounts, specific sleep

postures, preference to sleep in a protected environment such as a nest) vary considerably across species.

Common to all species is the expression of rebound increases in sleep amount when animals are deprived of sleep during all or part of their normal rest period.

#### ► Sleep Generating Mechanisms

## Sleep – Developmental Changes

DANIEL A. COHEN

Harvard Medical School, Beth Israel Deaconess Medical Center, Department of Neurology, Brigham and Women's Hospital, Division of Sleep Medicine, Boston, MA, USA

### Definition

Sleep undergoes characteristic changes across the developmental progression from birth to early adulthood, including total sleep time, the proportion and timing of rapid eye movement (REM) and non-rapid eye movement (NREM) sleep, and electrophysiological features of sleep. These features may serve as markers of nervous system development, and sleep itself may be critical for normal development.

### Characteristics

#### Introduction

Sleep is a complex, highly organized state associated with reversible changes in consciousness, neuronal network firing properties, cerebral blood flow, gene expression profiles, brain chemistry, and autonomic nervous system activity. The precise functions of sleep remain poorly understood, but it is likely that a prominent function of sleep is to promote neuronal repair and reorganization in the brain [1]. Therefore, “sleep is of the brain, by the brain, and for the brain” [2]. With this framework in mind, it is not surprising that the most rapid changes in the organization and physiology of sleep occur during development.

#### Total Sleep Time

In the neonatal period (first 28 days of life) in humans, total sleep time tends to occupy 16 or more hours per day, declining to roughly 13 h at 6 months, 10 h at 2 years, and 9 h by age five. Shortly after birth, a large proportion of sleep occurs during the daytime, and with age sleep gradually becomes primarily a nocturnal phenomenon.

This is likely due to maturation of the ►circadian pacemaker and the endogenous rhythm of ►rest-activity cycles [3].

### Sleep States: Rapid and Non-Rapid Eye Movement Sleep

Sleep is not a homogenous state and is generally divided between ►rapid eye movement (REM) sleep and stages of ►non-rapid eye movement (NREM) sleep. Sleep stages are defined by the patterns of electrical activity recorded over various scalp locations, changes in muscle tone or body movements, eye movements, and in infants the regularity of the respiratory pattern. Visual scoring has been used to characterize behavioral states in neonates into active and quiet sleep. Active sleep is characterized by: closed eyes, rapid eye movements, irregular respirations, and body twitches, and this is likely the precursor to REM sleep. Quiet sleep is characterized by: closed eyes, minimal eye and body movements, and regular respirations. This is likely the precursor to NREM sleep. In neonates, a substantial proportion of sleep may not be easily recognized as active or quiet sleep, and the term indeterminate sleep may be used.

During the first few months of life NREM sleep becomes divided into stages of lighter sleep, stage 1 and stage 2 sleep, as well as deeper stage 3 and stage 4 sleep (now generally combined as ►slow wave sleep). The depth of NREM sleep relates to the ease at which an environmental stimulus can cause an arousal from sleep to wakefulness. Sleep architecture, or the orderly progression of sleep stages across the night, changes significantly during development.

During early infancy, the oscillations between REM and NREM occur at roughly 60 min cycles, lengthening to about 90 min in the adult. Newborns and infants in the first month of life make the transition from wakefulness to sleep through REM or with only a few minutes of intervening NREM sleep prior to the first REM period [4]. After about 2–3 months of age, sleep is generally entered through NREM sleep through adulthood except under abnormal conditions such as: narcolepsy, the withdrawal of REM suppressing medications, or significant prior sleep restriction. The proportion of REM sleep is roughly 50% of sleep in the newborn, gradually declining to roughly 15–20% by the end of puberty [5]. The proportion of slow wave activity during NREM sleep declines sharply during adolescence.

### Electrophysiological Changes during Development

The electrophysiological patterns recorded by the electroencephalogram (EEG) undergo characteristic changes across gestational age, which is the time elapsed since the first day of the mother's last normal menstrual cycle. EEG patterns have been characterized in normal premature infants as early as 25–27 weeks



gestational age [6]. The EEG is initially discontinuous, with relatively long periods of electrical silence for periods of 30 s or more mixed with bursts of relatively high voltage activity lasting up to 20 s. It was previously felt that before 32 weeks, distinguishing ►waking and ►sleep states by EEG was not possible, but EEG differentiation may be possible as early as 28 weeks [6]. By 31–32 weeks, active sleep, quiet sleep, and wakefulness reliably show differential activity patterns. The EEG becomes more continuous, with general continuity in active sleep and wakefulness. During quiet sleep, the *trace alternant* pattern emerges with bursts of large slow frequency waves and relatively short periods of EEG quiescence. This generally disappears by 47 weeks development at which time the EEG becomes continuous in all behavioral states. ►Sleep spindles, which are short, high frequency bursts generally in the 12–14 cycles per second frequency range, begin to develop by 2–3 months post term. Sleep spindles are the hallmark of stage 2 NREM sleep. Spindles are initially asymmetric, but they become synchronous over both hemispheres during infancy. Generally by 3 months of age, the proportion of slow waves increases and starts to become similar to adult slow wave sleep [7]. Generally by 4 months of age, spindles and slow wave activity are present to a degree that allows confident segmentation of NREM sleep into its component stages. ►K complexes, another feature of Stage 2 NREM sleep, are present generally by 6 months of age. These are waves with a characteristic biphasic shape (negative then positive polarity). The posterior dominant rhythm of relaxed wakefulness gradually increases in frequency from 3 to 4 cycles per second at 3 months, 5–6 cycles per second at 6 months, 7–8 cycles per second by age three, and 8–10 cycles per second by age 15 [4]. Attenuation of the posterior dominant rhythm aids in the recognition of the transition from wake to sleep. Detailed descriptions of the electrophysiological changes of sleep across development have been documented elsewhere [4,7]. The key concept is that changes in the electrophysiological features of sleep are intimately coupled to gestational age and the level of maturation of the nervous system.

### Sleep and Developmental Milestones

The electrophysiological changes that occur during maturation reflect changes in network firing properties and patterns of depolarization and hyperpolarization of cortical neurons. The precise changes in the nervous system associated with the developmental progression of the sleep EEG are poorly understood. It has long been speculated that increasing myelination of the brain during development is a key factor in the timing and characteristics changes of the sleep EEG. Other

mechanisms are possible as well. For example, in developing neurons there may be a shift in the post-synaptic receptor profiles and responsiveness to various neurotransmitters [5]. The changes in sleep behavior and physiology across development may be considered milestones of brain maturation, similar to other milestones such as the disappearance of various reflexes, development of fine motor skills, or language development. As such, features of the sleep EEG may be associated with the brain's capacity for information processing. For example, the precise electrophysiological characteristics of sleep spindles may be markers of general cognitive ability [8].

### Sleep may influence the Development Process

Sleep may not only serve as a useful marker of the developmental state of the brain, but sleep may be a critical process to promote normal nervous system development. There is a growing body of literature for the role of sleep in the off-line processing of memories during a period of consolidation. This is an example of the role of sleep in plasticity, or the experience dependent changes that occur at the synaptic level. Changes in synaptic connections may increase or decrease the probability of activating particular neural networks, shaping the information processing capabilities of the brain.

The proportion of REM sleep is highest in the neonatal period, the phase of the life cycle associated with the most rapid re-organization of the brain. REM sleep deprivation experiments in animals have been used to determine the influence of this sleep stage on neural network connectivity. A particularly influential model for understanding development of neural connectivity has been monocular visual deprivation in developing animals. When one eye is deprived of visual input during a critical period of development, the brain undergoes reorganization so that cortical structures involved in visual processing become more heavily connected to the open eye. REM sleep deprivation during this critical period shifts the balance further, enhancing connections to the open eye at the expense of the visually deprived eye [9]. This has been interpreted to signify that normal REM sleep provides an opportunity for the deprived eye to compete for cortical connectivity despite the lack of external visual input. REM sleep is a state of high neuronal firing rates and brain metabolism that is similar to waking levels, and there is particular activation of visual processing areas such as occurs during ►dreams. Endogenous neuronal activity of visual pathways during REM sleep may enhance connectivity, so that maturation of the visual system may occur during sleep when there is no visual sensory input through closed eyes. Promoting use dependent plasticity in the visual system

during REM sleep is one example of how sleep processes can interact with the brain to promote normal connectivity. Slow wave sleep may also provide an opportunity for the brain to strengthen specific networks, for example, during the neuronal re-play of recently acquired memory traces during slow wave sleep.

### Clinical Implications

The sleeping brain reflects a highly organized pattern of neural activity, involving both cortical and sub-cortical structures. Changes in sleep behavior and physiology are intimately coupled with nervous system development. As an extension of the neurological examination, improved methodology to capture the physiological processes of sleep may provide sensitive markers of brain maturation. Therefore, sleep analysis may become a valuable tool for predicting neurological prognosis. Sleep is not only a window to the organization of the brain, but sleep may also be critical for its development. Cognitive and emotional difficulties later in life may result from abnormal sleep quantity or quality during development. For example, early REM deprivation may lead to mood disorders such as depression [10]. Sleep is important for the consolidation of memories and may have other benefits on cognitive function. Public health education to foster optimal sleep habits for children and effective screening tools for childhood sleep disorders may improve school performance, social functioning, and overall wellbeing.

### References

1. Savagè VM, West GB (2007) A quantitative, theoretical framework for understanding mammalian sleep. *Proc Natl Acad Sci* 104(3):1051–1056
2. Hobson AJ (2005) Sleep is of the brain, by the brain and for the brain. *Nature* 437(27):1254–1256
3. Rivkees SA (2003) Developing circadian rhythmicity in infants. *Pediatrics* 112:373–381
4. Grigg-Damberger M et al. (2007) The visual scoring of sleep and arousal in infants and children. *J Clin Sleep Med* 3(2):201–240
5. Kobayashi T et al. (2004) Development of REM sleep drive and clinical implications. *J Appl Physiol* 96:735–746
6. Selton D, Andre M, Hascoet J (2000) Normal EEG in very premature infants: reference criteria. *Clin Neurophysiol* 111:2116–2124
7. Dan B, Boyd S (2006) A neuropsychological perspective on sleep and its maturation. *Develop Med Child Neurol* 48:773–779
8. Schabus M et al. (2006) Sleep spindle-related activity in the human EEG and its relation to general cognitive and learning abilities. *Eur J Neurosci* 23:1738–1746
9. Siegel JM (2005) Functional implications of sleep development. *PLoS Biol* 3(5):756–758
10. Dang-Vu T et al. (2006) A role for sleep in brain plasticity. *Pediatr Rehabil* 9(2):98–118

## Sleep – Endocrine Changes

CLAUDE GRONFIER<sup>1</sup>, ELIZABETH B. KLERMAN<sup>2</sup>

<sup>1</sup>Department of Chronobiology, Stem Cell and Brain Research Institute, Institut National de la Santé et de la Recherche Médicale, France

<sup>2</sup>Division of Sleep Medicine, Department of Sleep Medicine, Brigham and Women's Hospital, Harvard Medical School, Boston, MA, USA

### Definition

The inter-relationships of hormone concentrations, sleep and circadian rhythms. The frequency and/or amplitude of pulsatile hormone release may be affected by sleep, specific sleep stages and/or circadian rhythms. In turn, hormone concentrations may affect sleep and the circadian timing system.

### Characteristics

#### Introduction

A hormone is a chemical messenger that carries its signal via the blood. Many hormones are rhythmically released. Their periodicity can be ►ultradian (i.e., with a period shorter than 24 h, e.g., ~90 min pulses of thyrotropin [TSH]), circadian (i.e., with a period close to 24 h, e.g., melatonin), or infradian (i.e., with a period longer than 24 h, e.g. sexual hormones such as Luteinizing Hormone or Follicle Stimulating Hormone) or combinations of these periodicities; one example is circadian variation in ultradian pulse frequency or amplitude.

Daily oscillations of endocrine activity are driven by mechanisms that can be endogenous (internal), exogenous (environmental), or by a combination. In addition to the conventionally considered biochemical regulatory mechanisms for each hormone's synthesis, release and clearance, other influences include the endogenous circadian biological clock, located in the ►suprachiasmatic nuclei (►SCN) of the ►hypothalamus, and endogenous sleep/wake-related processes) [1]. Environmental factors that are known to affect hormone release are: posture changes, physical activity, food intake, temperature, and light. In individuals living in real life conditions, endogenous and exogenous factors are usually confounded. For example, sleeping usually occurs a specific circadian phases and is not only a change in conscious state, but also is usually accompanied by a change in posture, feeding/fasting, light levels and social contacts, all of which may individually affect hormones. Only controlled laboratory studies allow for separation of those factors, and permit to infer controlling mechanisms of hormonal release.

The most thoroughly studied hormone-sleep interactions are those of the pituitary hormones. Early studies have described three categories of sleep-hormone

interactions: (i) hormones weakly influenced by sleep, such as adrenocorticotrophic hormone (ACTH), cortisol and ►melatonin, (ii) hormones strongly influenced by sleep as a whole, such as prolactin (PRL) and TSH; (iii) hormones influenced by a particular stage of sleep, such as growth hormone (GH) [2]. More recently, a variety of protocols have been used to investigate the relationships between hormones and sleep and circadian systems, including: complete and partial sleep deprivation, acute or chronic shifts of the sleep time, administration of pharmacological agents which disturb either sleep or hormone secretion, and the use of pathologies in which either endocrine or sleep disturbances are observed [1,3,4]. Using frequent blood sampling rates, sensitive hormonal assays, and controlled protocols, those studies have found that, most hormones are influenced, with different respective contributions, both by circadian and sleep-related processes.

### Specific Relationships between Sleep and Hormones

#### Prolactin (PRL)

Under baseline conditions, 24-h profiles of PRL show low levels during daytime and high levels during sleep. Studies using experimental strategies such as shifts of the sleep episode have shown a close association between sleep and the increase in PRL release. Figure 1a illustrates the effect of an 8-h shift in the sleep period on the 24-h PRL profiles in a group of young subjects. In order to differentiate circadian influences from sleep-related effects, day-active subjects were studied once under a normal 24-h ►sleep-wake cycle (sleep from 2300 or 23 to 0700 or 7 h), and once under a 24-h cycle where sleep was delayed by 8-h (sleep from 0700 or 7 to 1500 or 15 h). In both conditions, PRL is high during sleep time and low during waketime, showing the strong influence of sleep on PRL release. It is important to note that, a systematic PRL pulse was found in all subjects during the night of ►sleep deprivation, at the time of habitual sleep. This pulse, also observed in ►jet lag studies, is thought to reflect an influence of the circadian timing system on PRL release, independent of sleep [4].

The search for an association between the internal sleep structure and the episodic PRL pulses has led to conflicting reports. A relationship between the alternation of ►REM and ►NREM sleep episodes and the occurrence of nadirs and peaks, respectively, in plasma PRL levels has been described in some studies, but not in others. Using spectral analysis of the sleep EEG, however, a clear temporal link between PRL release and the ►electroencephalographic activity (►EEG) during sleep has been described. PRL secretory rates have been found to be positively correlated with delta wave activity (also called ►slow wave activity, ►SWA, 0.5–3.5 Hz), an indicator of sleep depth, and negatively correlated with alpha (8–12.5 Hz) and beta frequency

bands (13–35 Hz), indicators of relaxed wakefulness, and active wakefulness respectively (Fig. 1b) [3].

#### Growth Hormone (GH)

The 24-h profile of GH is characterized by a sleep-dependent rhythm, with a large secretory episode occurring just after sleep onset, temporally related to the first episode of ►slow-wave sleep (SWS). Other pulses may occur later during sleep and during wakefulness, especially in women. Figure 1a illustrates the mean GH profiles during a normal 24-h period, and during a 24-h period where sleep was delay shifted by 8-h. In both conditions, a large GH pulse is measured just after sleep onset. This hormone is therefore clearly controlled by sleep mechanisms. A weak circadian influence on GH release has been proposed, as GH pulses are usually observed during sleep deprivation at the habitual sleep time [4].

Despite the large number of studies, the underlying mechanisms coupling GH and SWS have not yet been clearly identified. Some authors have concluded that the temporal association observed between GH pulses and the first episode of SWS may be fortuitous. In more recent studies, however, a close temporal relationship has been found between SWS and GH secretory rates. In addition, a significant correlation has been described between the amount of GH secreted during SWS and the duration of the associated SWS episodes, under normal conditions, as well as after pharmacological enhancement of SWS with gamma-hydroxybutyrate [4]. This result has been confirmed by another study describing a quantitative relationship between the amount of GH secreted and the concomitant amount of delta wave activity (Fig. 1b). Interestingly, when sleep is enriched in SWS by ritanserin (a 5-HT<sub>2</sub> receptor antagonist), an equivalent increase in delta wave activity and GH secretion is found [5]. Taken together, these results suggest that the regulatory mechanisms involved in the control of delta wave activity and GH secretion share common pathways. In rodents, growth hormone releasing hormone (GHRH) neurons could be the common link between GH release by the pituitary and SWS generation.

#### Thyrotropin (TSH)

TSH exhibits a 24-h rhythm generated by amplitude and frequency modulation of secretory pulses. TSH has low daytime values which begin to increase in the late afternoon, reaching maximum levels around the time of sleep onset. Subsequently, a slow decline, generally attributed to an inhibitory influence of sleep, occurs during the night. Figure 1a illustrates 24-h profiles of TSH both during a normal 24-h period and a sleep shift. During sleep deprivation, TSH levels continue to rise, peaking later in the night. It is generally admitted that sleep exerts an inhibitory influence on TSH secretion,

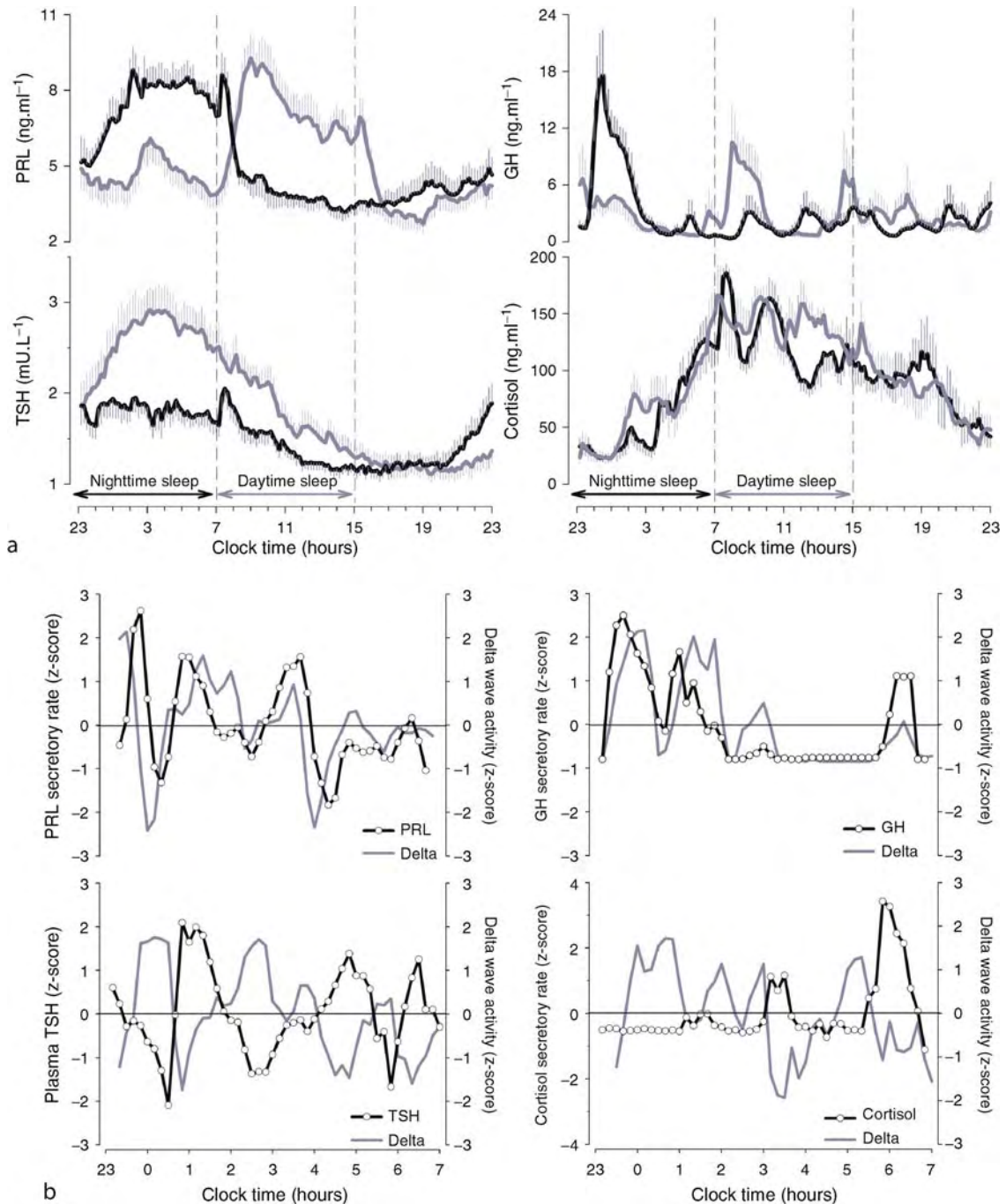

**Sleep – Endocrine Changes. Figure 1** (a) 24-h profiles of PRL, GH, TSH and cortisol in a group of eight healthy young subjects, measured once under a normal 24-h sleep-wake cycle (sleep from 23 to 7 h, dark line), and once under a 24-h cycle after a delay shift of the sleep episode by 8-h (sleep from 7 to 15 h, gray line). (b) Nocturnal hormonal profiles of PRL, GH, TSH, and cortisol (dark line with open circles) and concomitant with delta wave activity, as a marker of sleep depth (gray line). Adapted from [3].

and that sleep deprivation removes that inhibition. It is considered that the 24-h TSH profile results from an interaction between the endogenous circadian timing system and a sleep-related inhibitory effect. When the depth of sleep at the habitual time is enhanced by prior

sleep deprivation, the nocturnal TSH rise is markedly reduced, suggesting that SWS is probably the primary determinant of the sleep-associated fall [3,4].

A temporal association has been described between the internal sleep structure and TSH pulses, such that

SWS is associated with declining plasma TSH levels, and awakenings with rising levels. These relationships have been confirmed using spectral (frequency) analysis of the sleep EEG, which demonstrated that the nocturnal TSH profile was negatively correlated with the delta wave activity. Figure 1b shows that increases in TSH levels are linked to decreases in delta wave activity, and conversely, that decreases in TSH levels are associated with increases in delta wave activity. The nocturnal TSH profile closely reflects variations of sleep EEG activity. Whether EEG activity has a modulatory role on TSH levels, or inversely, whether TSH variations could influence sleep structure, remains to be clarified. However, the fact that sleep deprivation is associated with an increase in TSH release favors the hypothesis that it is SWS that inhibits TSH secretion [3].

#### **ACTH/Cortisol**

The 24-h cortisol rhythm is generally considered to be mainly under endogenous circadian control, and therefore to be relatively independent of sleep. Indeed, it is only slightly affected by short-term manipulations of sleep such as sleep reversal, selective and total sleep deprivation, and abrupt shift in the sleep period (Fig. 1a). However, temporal relationships between cortisol and sleep have been found, and sleep has been proposed to exert an inhibitory effect on cortisol release [6], particularly in the first few hours of the night. This finding has been challenged by other studies, which concluded that sleep does not inhibit cortisol since ►diurnal sleep does not suppress cortisol release [3].

Despite these discrepancies, temporal relationships between cortisol pulses and the internal sleep structure have been described. Awakenings or light sleep periods are associated with increasing plasma cortisol levels, whereas SWS is associated with low or decreasing cortisol levels. Using spectral analysis of the sleep-EEG and deconvolution procedures for estimation of cortisol secretory rates, an inverse relationship between cortisol secretory pulses and oscillations in delta wave activity during nocturnal sleep as well as during diurnal sleep was described. Increases in cortisol secretory rates were associated with decreases in delta wave activity, and conversely, peaks in delta wave activity occurred only during low cortisol secretion (Fig. 1b). It is possible that both sleep is inhibited by cortisol release and cortisol release is inhibited by sleep (SWS in particular). Cross-correlation analyses between delta wave activity and cortisol secretory rates revealed that cortisol oscillations precede the changes in EEG activity by about 10 min, suggesting that cortisol secretion or its secretory processes may modulate the EEG activity, rather than the inverse [3]. At the same time, this finding does not exclude that SWS exerts an inhibitory influences on cortisol release through delayed effects. Until new data is available, in particular from studies in which sleep

and circadian influences can be separated (such as in ►forced desynchrony protocols), the safest statement that can be made at this point, is that reciprocal negative interactions exist between SWS and cortisol secretion.

#### **Other Hormones and Neuropeptides**

Sleep is a strong modulator of glucose and insulin secretion, since high glucose and high insulin levels are seen during sleep, irrespective of sleep timing. Endogenous circadian rhythms of glucose and insulin secretion have been reported, but they are rather of low amplitude. The 24-h rhythm of satiety-sensing hormone leptin has a nocturnal increase that is under both circadian control (persisting during sleep deprivation) and sleep control (sleep deprivation dampens its amplitude) [4]. The appetite stimulant hormone ghrelin also shows a sleep-associated increase at night [4]. Recent studies have investigated the rhythmicity of ►orexin/hypocretin, a brain neuropeptide involved in sleep maintenance. Orexin levels increase during the day and decrease at night, under the dual control sleep/wake and circadian processes. Indeed, lesions of the SCN abolish the circadian rhythmicity of orexin, and sleep deprivation lead to subsequent increases in orexin levels [7].

#### **Sleep Debt and Hormones/Metabolic Syndrome**

Although the effects of inpatient short-term single episodes of sleep deprivation on brain functioning have been extensively studied, the consequences of chronic sleep restriction (insufficient sleep for multiple days) as experienced by millions of people, have received much less attention. During the past 5–6 years, however, a set of studies has demonstrated that the effects of sleep restriction is not limited to the executive performance and alertness functions of the brain, but also affects the entire body. Elegant studies have shown that sleep curtailment impacts the somatotrophic (GH), corticotrophic (cortisol) and thyrotrophic (TSH) axes [8]. Interestingly, they also showed under a sleep restriction protocol, that leptin is decreased and ghrelin is increased, reducing the feeling of satiety and increasing the feeling of hunger [9]. Another group of studies, showed that short sleep duration is associated with reduced leptin, increased ghrelin and increased body mass index (BMI, an index of obesity) [10]. Taken together, these results suggest a causal relationship between sleep debt and metabolism impairment that has large implications for the health of sleep restricted individuals in industrial societies, in which the rate of obesity and metabolic illnesses such as type II diabetes is increasing dramatically.

#### **Conclusions**

This chapter highlights the wide variety of relationships between sleep and hormonal activity. PRL and GH are increased during sleep (SWS in particular) and

mainly driven by sleep. In contrast, the circadian timing system is the main driving force of the 24-h rhythm of melatonin and cortisol, with, for the latter hormone an additional influence of the internal sleep structure on its pulsatile release. TSH lies on the boundary of these classes of hormones, as its 24-h rhythm is generated by the circadian system and by modulated (inhibited) by sleep (SWS).

Because of the intricate relationships among hormones, sleep, and the circadian timing system, alterations of hormonal release can impact sleep and its structure. Similarly, sleep loss and circadian misalignment, either due to pathologies (sleep apnea, ►insomnia, etc.) of real life situations (voluntary or socially induced sleep curtailment, jet lag, ►shift work) can have a detrimental impact of many endocrine systems. Further work is needed to detail the neuroanatomy and molecular mechanistic links between sleep and hormones that result in the observed interactions.

## References

1. Czeisler CA, Klerman EB (1999) Circadian and sleep-dependent regulation of hormone release in humans. *Recent Prog Horm Res* 54:97–130
2. Mullen PE (1983) Sleep and its interactions with endocrine rhythms. *Br J Psychiatry* 14:215–220
3. Gronfier C, Brandenberger G (1998) Ultradian rhythms in pituitary and adrenal hormones: their relations to sleep. *Sleep Med Rev* 2(1):17–29
4. Van Cauter E (2005) Endocrine physiology. In: Kryger (ed) *Principles and practice of sleep medicine*. Elsevier, Philadelphia, PA
5. Gronfier C, Luthringer R, Follenius M, Schaltenbrand N, Macher JP, Muzet A, Brandenberger G (1996) A quantitative evaluation of the relationships between growth hormone secretion and delta wave electroencephalographic activity during normal sleep and after enrichment in delta waves. *Sleep* 19:817–824
6. Weitzman ED, Zimmerman JC, Czeisler CA, Ronda J (1983) Cortisol secretion is inhibited during sleep in normal man. *J Clin Endocrinol Metab* 56:352–355
7. Zeitzer JM, Buckmaster CL, Lyons DM, Mignot E (2007) Increasing length of wakefulness and modulation of hypocretin-1 in the wake-consolidated squirrel monkey. *Am J Physiol Regul Integr Comp Physiol* 293(4):R1736–R1742
8. Van Cauter E, Holmback U, Knutson K, Leproult R, Miller A, Nedeltcheva A, Pannain S, Penev P, Tasali E, Spiegel K (2007) Impact of sleep and sleep loss on neuroendocrine and metabolic function. *Horm Res* 67:2–9
9. Spiegel K, Tasali E, Penev P, Van Cauter E (2004) Brief communication: Sleep curtailment in healthy young men is associated with decreased leptin levels, elevated ghrelin levels, and increased hunger and appetite. *Ann Intern Med* 141(11):846–850
10. Taheri S, Lin L, Austin D, Young T, Mignot E (2004) Short sleep duration is associated with reduced leptin, elevated ghrelin, and increased body mass index. *PLoS Med* 1(3):e62

## Sleep – Motor Changes

KENNETH P. WRIGHT JR

Sleep and Chronobiology Laboratory, Department of Integrative Physiology, University of Colorado at Boulder, Boulder, CO, USA

### Synonyms

Descending Drive to motoneuron pool; Motor responsiveness; Sleep Movement Disorders

### Definition

Sleep associated motor changes reflect neurophysiological alterations in descending excitatory and inhibitory drives to the alpha ►motoneuron pool. Integration of descending excitatory and inhibitory drives determines net motor output during sleep.

### Characteristics

Sleep is characterized by specific postural changes, reductions in muscle tone, and changes in excitatory and inhibitory inputs to ►motoneurons that influence the likelihood of an action potential and therefore motor output. Motor output characteristically changes across wakefulness and sleep states such that muscle activity is highest during active wakefulness, decreases during quiet wakefulness and ►Non-REM sleep (NREM) sleep, and is minimal or absent during ►rapid eye movement (REM). Thus, measurement of gross motor activity, i.e., inactivity, has often been used as a proxy to assess wakefulness-sleep timing [1].

### Changes in Descending Drive to Motor Neurons During Sleep

In most mammals, activities of alpha motoneurons that innervate skeletal and respiratory ►muscle fibers may or may not be reduced during NREM sleep relative to quiet wakefulness, whereas during REM sleep motoneuron activity is actively reduced or inhibited. However, compared to active wakefulness when the ►alpha motoneuron membrane potential is most easily raised above threshold for the generation of action potentials, the membrane potential of motor neurons are ►hyperpolarized during NREM sleep. Motoneuron membrane potential becomes even more hyperpolarized during REM sleep making it even less likely that an action potential will occur. Sleep related changes in membrane potential are thought to be caused at least in part by a reduction or removal of excitatory drive to the motoneuron pool (i.e., ►disfacilitation) and by increased inhibitory drive at the level of the ►postsynaptic membrane. Excitatory drive is reduced to the greatest extent during REM sleep. Reductions in ►monoaminergic neuronal activity emanating from ►brain stem raphe serotonergic neurons and ►locus

coeruleus noradrenergic neurons are hypothesized to contribute to reductions in the excitatory drive to the motoneuron pool during sleep compared to wakefulness [2]. REM state specific activation of brain stem ►cholinergic neuronal cell groups and reductions in brain stem serotonergic and noradrenergic activity are reported to contribute to ►muscle atonia during REM sleep [3,4]. Findings from lesion studies indicate that damage to cell in the peri locus coeruleus [4] or ►sublaterodorsal tegmental nucleus [5] of the brain-stem can result in a release from muscle atonia during REM sleep and as a result, animals appear to act out their dreams [6,7]. ►Glutamatergic cells within the sublaterodorsal tegmental nucleus of the brain stem are reported to project to ►spinal cord interneurons [5], and to actively inhibit alpha motor neuron action potentials through release of ►glycine and ►GABA [2,4,5]. In addition, during REM sleep there is an increase in small amplitude spontaneous as well as sensory stimulated ►inhibitory post synaptic potentials (IPSPs) in the motoneurons. These small amplitude IPSPs and REM state specific large amplitude IPSPs are reported to be associated with responses to sensory stimulation and ►pontine-geniculo-occipital (PGO) waves [8].

Although reduced, supraspinal excitatory drives to the motoneuron pool remain active even during REM sleep. Inhibitory drives generally predominate during REM sleep and thus muscle activation does not typically occur. However, twitches in skeletal muscle fibers take place during REM sleep and these brief increases in muscle activity are thought to be due to a temporary predominance of excitatory over inhibitory drives. Phasic muscle twitches that occur during REM sleep are reported to be associated with phasic activity in other systems such as rapid eye movements, PGO waves, and middle ear muscle activity. Some species, such as dogs and perhaps aquatic mammals like dolphins, appear to have less muscle inhibition during REM sleep.

### Behavioral Responses to Environmental Stimuli During Sleep

In humans, it has been demonstrated that behavioral responsiveness to stimuli can occur in all stages of sleep; however, the likelihood of a behavioral response is generally reported to be greatest in stages 1 and 2 sleep (reviewed in [9]). Behavioral responsiveness to stimuli during sleep is dependent on changes in sensory ►thresholds as well as the ability to perform and complete the behavioral response. For example, a button press in response to a tone is less likely to occur during the muscle atonia of REM sleep whereas taking a deep breath in response to an ►auditory tone can take place during REM sleep. In some cases, aborted attempts to respond with a button press can be observed in the ►electromyographic (EMG) activity of hand and forearm muscles during sleep. Findings from such

studies demonstrate that complex motor behaviors are possible during sleep.

### Sleep Movement Disorders and Motor Phenomena During Sleep in Humans

A number of sleep movement neurological disorders have been identified. Examples include, periodic limb movements of sleep (PLMS), sleep bruxism, REM sleep behavior disorder (RBD), sleep walking, sleep related eating disorder, and obstructive sleep apnea. Periodic limb movements during sleep are characterized by periodic (i.e., every ~20–90 s), rapid flexion of the foot or knee and hip, or the extension of the big toe. Although less common, movements of the arms can also occur during sleep. Sleep bruxism – grinding or clenching of the teeth during sleep – has been reported to occur during all sleep stages but most predominantly in stages 1 and 2 of NREM sleep. Patients with REM sleep behavior disorder exhibit episodes of REM sleep without muscle atonia and therefore these patients appear to act out their dreams. Often, REM sleep behavior disorder can be seen in patients with neurological disorders such as Parkinson’s disease. Sleep walking is an arousal out of deep NREM sleep and neurophysiologically the cortical EEG shows signs of wakefulness and sleep. Presumably, sleep related eating disorder is similar to sleep walking. Reductions in respiratory muscle activity during REM sleep also contribute to the cessation of breathing that is observed in the sleep disorder obstructive sleep apnea [10]. Sleep apnea is often worst during the muscle atonia of REM sleep. Many of the complex motor behaviors that take place during sleep are often unremembered because formation of “new” memories appears to be inactive during sleep. Effective treatments are available for patients with movement disorders during sleep. One last sleep related motor phenomena to be mentioned is the hypnagogic jerk, also referred to as a sleep start. The hypnagogic jerk is a sudden, non-periodic, involuntary contraction of the appendicular and/or axial muscles of the body during the transition (►transitions) from wakefulness to sleep. Hypnagogic jerks are usually considered to be benign motor behavior unless they occur multiple times per night and cause sleep onset insomnia. The common sensation of falling during a hypnagogic jerk may be the reason for the colloquialism “falling asleep.” The neurophysiology of hypnagogic jerks is not well understood but is likely to be related to changes in inhibitory and excitatory drive to the motoneuron pool.

In summary, motor activity during sleep is determined by the summation of excitatory and inhibitory inputs to ►motoneurons. Inhibitory influences generally predominate during sleep. Furthermore, muscle activity is actively inhibited during REM sleep. Odd motor behaviors during sleep may be related to neurological disorders.

## References

1. Morgenthaler T, Alessi C, Friedman L, Owens J, Kapur V, Boehlecke B, Brown T, Chesson A Jr, Coleman J, Lee-Chiong T, Pancer J, Swick TJ (2007) Practice parameters for the use of actigraphy in the assessment of sleep and sleep disorders: an update for 2007. *Sleep* 30:519–529
2. Lai YY, Kodama T, Siegel JM (2001) Changes in monoamine release in the ventral horn and hypoglossal nucleus linked to pontine inhibition of muscle tone: an in vivo microdialysis study. *J Neurosci* 21:7384–7391
3. Fenik VB, Davies RO, Kubin L (2005) Noradrenergic, serotonergic and GABAergic antagonists injected together into the XII nucleus abolish the REM sleep-like depression of hypoglossal motoneuronal activity. *J Sleep Res* 14:419–429
4. Chase MH, Morales FR (2005) Control of motoneurons during sleep. In: Kryger MH, Roth T, Dement WC (eds) *Principles and practice of sleep medicine*. Elsevier Saunders, Philadelphia, pp 154–168
5. Lu J, Sherman D, Devor M, Saper CB (2006) A putative flip-flop switch for control of REM sleep. *Nature* 441:589–594
6. Mouret J, Delorme F, Jouvet M (1967) Lesions of the pontine tegmentum and sleep in rats. *C R Seances Soc Biol Fil* 161:1603–1606
7. Henley K, Morrison AR (1974) A re-evaluation of the effects of lesions of the pontine tegmentum and locus coeruleus on phenomena of paradoxical sleep in the cat. *Acta Neurobiol Exp* 34:215–232
8. Kohlmeier KA, Lopez-Rodriguez F, Morales FR, Chase MH (1997) Relationship between sensory stimuli-elicited IPSPs in motoneurons and PGO waves during cholinergically induced muscle atonia. *J Neurophysiol* 78:2145–2155
9. Wright KP Jr (2005) Environmental influences on sleep and sleep deprivation. In: Kushida CA *Sleep deprivation: basic science, physiology, and behavior*. Marcel Dekker, New York, pp 121–155
10. Homer RL (2000) Impact of brainstem sleep mechanisms on pharyngeal motor control. *Respir Physiol* 119:113–121

---

## Sleep – Sensory Changes

KENNETH P. WRIGHT JR

Sleep and Chronobiology Laboratory, Department of Integrative Physiology, University of Colorado at Boulder, Boulder, CO, USA

### Synonyms

Sensory Information Processing; Sensory Responsiveness

### Definition

Sleep associated changes in sensory physiology reflect neurophysiological alterations in ascending arousal systems and activation of sleep promoting systems.

## Characteristics

Sleep was once thought to be caused by a lack of environmental stimulation and sensory systems were thought to be relatively inactive during sleep. We now know that sleep is actively promoted by the brain and that processing of sensory information remains active during sleep [1–3]. However, neurophysiological changes during sleep are associated with alterations in sensory information processing and reductions in responsiveness to external stimuli. For example, arousal thresholds are higher during sleep than wakefulness and sensory physiology is different between stages of non-REM (NREM) and rapid eye movement (REM) sleep. In general, arousal thresholds progressively increase from light stage N1 through deep stage N3 of NREM sleep whereas arousal thresholds during REM sleep have been reported to be similar to those observed during deep NREM sleep or lighter stage N2 sleep depending on the amount of prior deep NREM sleep, time of night and/or circadian time [4,5].

### Brain Sensory System Activity During Sleep

The vast majority of studies that have examined the activity of sensory systems during sleep have examined exposure to auditory stimuli. In the 1930s, Loomis and colleagues first described electroencephalographic (EEG) activation and the K-complex EEG response to environmental stimuli during sleep [6]. More recent studies have reported that a meaningful stimulus, such as the person's name, produces more K-complexes than do less important stimuli. Brain imaging studies indicate that activation of the auditory cortex, the thalamus and the caudate nucleus occurs in response to auditory stimuli during NREM sleep [7] suggesting that some level of cortical processing takes place during sleep. Exposure to most odors alters EEG activity during sleep even if the odor is below detection threshold during wakefulness. Exposure to painful stimuli such as electric shock, hot and cold water applied to the skin, and infusion of saline into muscle have been reported to result in EEG arousals and increased heart rate responses during sleep (reviewed in [2]). Behavioral button switch press responses to photic flash stimuli during stages 1 and 2 sleep and also REM sleep have been reported. To date, brain EEG arousals have been reported in response to auditory, olfactory, somatosensory, visual, and taste stimuli.

### Sensory Information Processing During Sleep

The finding that sensory information can be processed during sleep is also supported by findings from evoked or event related potential studies. Early components of the evoked potential are linked to the sensory processing of stimuli and later components are linked to cognitive processing of stimuli. In general, the early brain stem components of the evoked potential



are similar between sleep and wakefulness whereas the later cognitive components are altered by sleep [8]. The cognitive evoked potential referred to as the ►P300 is elicited during wakefulness when stimuli are both detected and attended. The P300 is present during sleep but the latency of the P300 is delayed and the amplitude is reduced [9]. Other auditory evoked components such as the ►N1 and ►P2 are altered during sleep compared to wakefulness [8]. Changes in evoked potentials measured by EEG and ►magnetoencephalography (MEG) [3] between wakefulness and sleep and among NREM and REM sleep stages have been reported in response to auditory, somatosensory and visual stimuli. Although sensory processing can occur during sleep the neurophysiology of sleep does not appear to be conducive to the formation of new memories, with the exception of ►classical conditioning [2].

### Synaptic Excitability During Sleep

Neurophysiologically, the intrinsic and ►synaptic excitability of cortical and thalamic neurons changes between wakefulness and sleep, and between NREM and REM sleep. Wakefulness and REM sleep are associated with EEG activation caused by brainstem and ►forebrain arousal systems, whereas during deep NREM sleep the EEG is characterized by ►slow oscillations and ►synchronization. Relatedly, the transmission of sensory information from the thalamus to the cortex is enhanced during wakefulness and REM sleep compared to NREM sleep [10]. ►Field potentials between the thalamus and cortex that are evoked by stimulation of sensory pathways are reduced during NREM sleep. In addition, when a ►sleep spindle is generated – spindles are a hallmark of NREM stage N2 sleep in humans – there is an inhibition of sensory information transfer from the thalamus to the cortex. Such blockade of sensory information transfer during NREM sleep appears to occur at the level of the thalamus and ►GABA is thought to be a primary neurotransmitter involved in this process.

### Inhibition of Ascending Arousal Systems During Sleep Influences Sensory Information Processing

Reductions in activity of a multitude of brain stem, ►midbrain and forebrain arousal systems critically involved in attention and memory processes, likely contribute to alterations in sensory processing during sleep. In general, sleep promoting regions of the brain actively inhibit activity of ascending arousal systems including ►locus coeruleus noradrenergic neurons, ►raphe serotonergic neurons, ►basal forebrain and brain stem ►cholinergic neurons and ►hypothalamic orexigenic and histaminergic neurons (►histamine). Activities of ►monoaminergic neurons are even further reduced, if not completely silent, during REM sleep, whereas ►REM on cells actively promote REM sleep.

In summary, all sensory systems studied to date show that sensory processing take place during sleep, yet information processing and behavioral responsiveness to external stimuli are altered during sleep. Information transfer from the thalamus to cortical areas is blocked during synchronizing events, such as the generation of sleep spindles, during NREM sleep. Furthermore, there exist differences in sensory processing among NREM and REM sleep states that are likely related to changes in modulatory neurotransmitter brain stem, forebrain and midbrain arousal systems, which widely innervate cortical and subcortical structures.

### References

1. Velluti RA (1997) Interactions between sleep and sensory physiology. *J Sleep Res* 6:61–77
2. Wright KP Jr (2005) Environmental influences on sleep and sleep deprivation. In: Kushida CA (ed) *Sleep deprivation: basic science, physiology, and behavior*. Marcel Dekker, New York, pp 121–155
3. Kakigi R, Naka D, Okusa T, Wang X, Inui K, Qiu Y, Tran TD, Miki K, Tamura Y, Nguyen TB, Watanabe S, Hoshiyama M (2003). Sensory perception during sleep in humans: a magnetoencephalographic study. *Sleep Med* 4:493–507
4. Lammers WJ, Badia P, Hughes R, Harsh J (1991) Temperature, time-of-night of testing, and responsiveness to stimuli presented while sleeping. *Psychophysiol* 28:463–467
5. Pivik RT, Joncas S, Busby KA (1999) Sleep spindles and arousal: the effects of age and sensory stimulation. *Sleep Res Online* 2:89–100
6. Davis H, Davis PA, Loomis AL, Harvey EN, Hobart G (1939) Electrical reactions of the human brain to auditory stimulation during sleep. *J Neurophysiol* 2:500–514
7. Portas CM, Krakow K, Allen P, Josephs O, Armony JL, Frith CD (2000) Auditory processing across the sleep-wake cycle: simultaneous EEG and fMRI monitoring in humans. *Neuron* 28:991–999
8. Campbell K, Bell I, Bastien C (1992) Evoked potential measures of information processing during natural sleep. In: Broughton RJ, Ogilvie RD (eds) *Sleep, arousal, and performance*. Birkhäuser, Boston, pp 88–116
9. Cote KA, Etienne L, Campbell KB (2001) Neurophysiological evidence for the detection of external stimuli during sleep. *Sleep* 24:791–803
10. Steriade M (2005) Brain electrical activity and sensory processing during waking and sleep states. In: Kryger MH, Roth T, Dement WC (eds) *Principles and practice of sleep medicine*, 4th edn. W. B. Saunders Company, Philadelphia, PA, pp 101–119

## Sleep Apnea

►Obstructive Sleep Apnea

## Sleep Brain Wave Activity

- ▶ EEG in Sleep States

## Sleep Cycle

### Definition

One sleep cycle lasts about 90 min and is comprised of one set each of non-rapid eye movement (NREM) sleep and rapid eye movement (REM) sleep. Most people repeat this cycle four times a night.

- ▶ Non-REM Sleep
- ▶ Rapid Eye Movement (REM) sleep
- ▶ Sleep States
- ▶ Sleep-wake Cycle

## Sleep Electroencephalography (EEG)

- ▶ EEG in Sleep States

## Sleep Generating Mechanisms

RONALD SZYMUSIAK<sup>1</sup>, DENNIS MCGINTY<sup>2</sup>

<sup>1</sup>Departments of Medicine and Neurobiology, School of Medicine, University of California, Los Angeles, CA, USA

<sup>2</sup>Department of Psychology, University of California, Los Angeles, CA, USA

### Synonyms

Sleep regulating mechanisms; Sleep onset mechanisms

### Definition

Neuronal and neurochemical mechanisms that actively promote sleep onset, function to maintain sleep continuity, and regulate sleep depth in response to homeostatic and circadian demands.

### Characteristics

#### Sleep as an Active Process

The prevailing view among physiologists during the first half of the twentieth century was that waking brain activity depended upon sensory stimulation. ▶ Sleep was believed to occur as a passive consequence of diminished sensory input that accompanied instinctual sleep preparatory behaviors (e.g., behavioral rest, eye closure, selection of a warm, quiet environment, etc.). Within this conceptual framework, then, the existence of brain mechanisms that actively generated sleep was not required [1].

This concept of sleep as a passive process was undermined by the following findings (i) sleep consists of an active cycling between ▶ nonREM and ▶ REM sleep, (ii) electrical stimulation of the midline thalamus or of the basal forebrain elicits sleep and (iii) brainstem transactions at the midpontine level or discrete lesions of the rostral hypothalamus cause chronic sleep suppression [2]. As will be described in this essay, the existence of neuronal mechanisms that function to actively generate and maintain sleep is now firmly established.

#### Sleep Generation Entails Coordinated Inhibition of Arousal Systems

During the past 50 years, researchers have focused on identifying specific neuronal groups and pathways in the brain that interact to generate arousal states. Multiple chemically-defined neuronal systems located in the brainstem and posterior hypothalamus function to promote both behavioral and electrographic aspects of arousal. These arousal systems include monoaminergic neurons in the rostral pons, midbrain and posterior hypothalamus, cholinergic neurons in the brainstem and basal forebrain, dopaminergic neurons in the ventral tegmentum and ▶ orexin - (hypocretin-) containing neurons in the lateral hypothalamus (Fig. 1) [3]. Most of these arousal systems are characterized by localized aggregations of cell bodies with long axonal projections that have widespread forebrain targets, including the thalamus, limbic system and neocortex (Fig. 1). Descending projections from the arousal systems (not all of which are shown in Fig. 1) regulate muscle tone and autonomic nervous system activity at the level of the brainstem and spinal cord.

The characterization of these neuronal groups as “arousal systems” is an over-simplification, as each regulates various aspects of waking brain function. However, the collective activity in these neuronal systems during waking imparts a tonic background level of arousal/activation that is reflected in low voltage, fast frequency cortical EEG patterns. Neuronal activity in these arousal systems is characterized by high levels of tonic or phasic discharge during ▶ waking behaviors, and comparative quiescence during sleep.

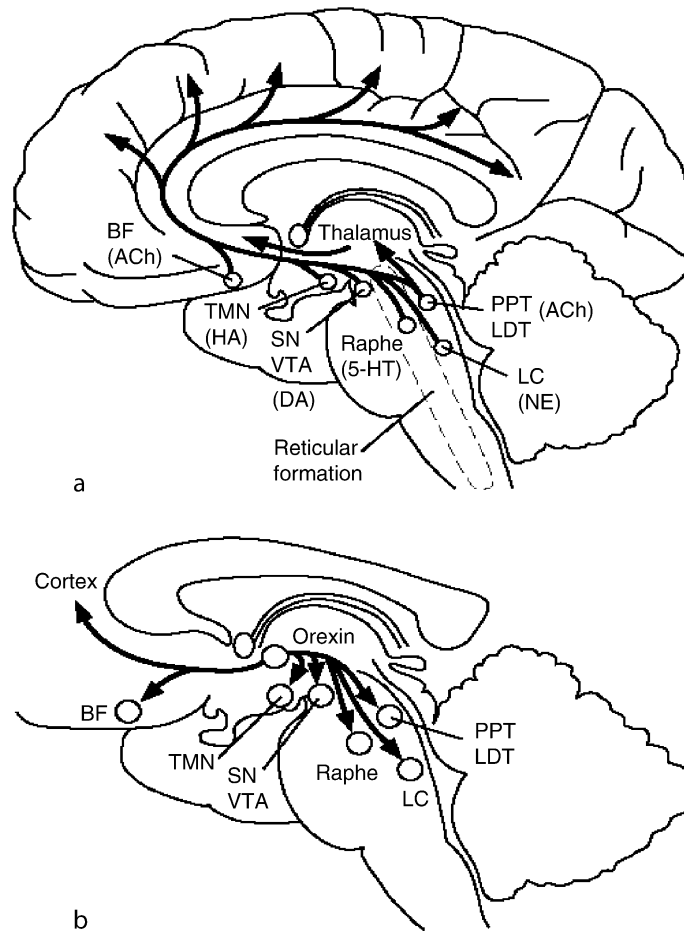

**Sleep Generating Mechanisms. Figure 1** Ascending arousal systems in the brainstem and posterior hypothalamus. (a) Schematically depicted are (i) acetylcholine (ACh) neurons in the pedunculopontine and laterodorsal tegmental areas (PPT/LDT) and the basal forebrain (BF); (ii) noradrenergic (NE) neurons in the locus coeruleus (LC); (iii) serotonergic (5-HT) neurons in the dorsal raphe nucleus; (iv) histamine (HA) neurons in the tuberomammillary nucleus (TMN); (v) dopamine (DA) neurons in the substantia nigra and ventral tegmental area (SN/VTA). (b) Localization and projections of orexin neurons in the perifornical lateral hypothalamus. From [3] with permission.

Some arousal systems (e.g., cholinergic) exhibit elevated discharge during waking and REM sleep and minimum activity during nonREM sleep. Others (e.g., the monoaminergic systems) display discharge rates during REM sleep that are as low or lower than that observed during nonREM sleep (so-called “▶REM-off” discharge pattern) [3,4]. What is common to nearly all of the arousal systems schematized in Fig. 1, is a rapid decline in neuronal activity just prior to, or at the time of sleep onset.

A critical task, therefore, for brain mechanisms that generate sleep is to achieve a coordinated inhibition and/or disfacilitation of these disparate arousal-regulatory neuronal groups. There are three interrelated cellular and neurochemical mechanisms that accomplish this. First, is a system of neurons located in the preoptic hypothalamus that is activated during sleep and that

exerts sleep-related inhibitory influences over several of the arousal systems through synaptic connectivity with these systems. Second, are endogenous sleep factors (e.g., adenosine) that exert inhibitory neuromodulatory effects on one or more arousal systems. Third, in all mammals, the timing of sleep and waking is controlled by the circadian clock in the brain. Thus, a third aspect of sleep generation involves regulation of the excitability of the arousal systems by the circadian clock in the ▶suprachiasmatic nucleus of the hypothalamus.

### Sleep Generating Neurons in the Preoptic Hypothalamus

The preoptic area of the hypothalamus was initially identified as a potential site of sleep generating mechanisms on the basis of stimulation and lesion studies. Electrical or chemical stimulation of this area can

acutely evoke sleep onset and experimental damage to the preoptic hypothalamus yields profound and persistent insomnia [4]. Recordings of neuronal activity during natural sleep and waking identify neurons in the preoptic area that display elevated discharge rates during nonREM and REM sleep compared to waking. The activity of these “sleep-active” neurons increases prior to sleep onset during waking to sleep transitions. The sleep-wake discharge pattern of these preoptic neurons is the reciprocal of the REM-off discharge pattern observed in several of the arousal systems [4].

In addition to single unit recordings, sleep-active neurons can be identified by immunostaining for the protein product of the *c-fos* gene. *c-fos* gene expression is a validated marker of neuronal activation. By comparing immunoreactivity for the c-Fos protein in the brains of animals that are predominately asleep or predominately awake during the 1–2 h prior to sacrifice, the anatomical distribution of sleep-active neurons in the brain can be determined. This approach identifies two subregions of the preoptic area in the rat that contain high densities of sleep-active neurons; the ►ventrolateral preoptic area (►VLPO) and the median preoptic nucleus (MnPN) [4,5]. Combined staining for sleep-related Fos protein and neurotransmitter makers reveals that most sleep-active neurons in the MnPN synthesize the inhibitory neurotransmitter GABA, and that sleep-active neurons in the VLPO contain both GABA and the inhibitory neuropeptide, galanin.

Mechanisms of sleep induction by preoptic area neurons entail GABA-mediated inhibition of multiple arousal systems. Anatomical studies demonstrate direct projections from the VLPO and MnPN to all of the ascending monoaminergic arousal systems and to the orexin neuronal system. Particularly dense are the projections from the VLPO to histaminergic neurons in the tuberomammillary nucleus of the posterior hypothalamus (Fig. 1) [5]. The functional importance of this pathway is demonstrated by the ability of electrical stimulation of the VLPO to evoke GABA-mediated inhibitory postsynaptic potentials in histamine neurons. Activation of sleep-active neurons in the preoptic area by local thermal stimulation suppresses waking activity in serotonergic neurons in the dorsal raphe nucleus. Evidence also supports functional inhibition of orexin neurons by sleep-regulatory cells in the preoptic area. MnPN and VLPO neurons projecting to the orexin neuronal field in the lateral hypothalamus exhibit sleep-related c-Fos expression. Electrical or chemical activation of the MnPN evokes suppression of waking neuronal discharge in the lateral hypothalamus [4]. Collectively, findings support the hypothesis that deactivation of several functionally important arousal systems during sleep is due to GABA-mediated inhibition originating in the preoptic hypothalamus.

A mechanism that may help stabilize sleep-waking transitions arises from mutually inhibitory interactions between VLPO neurons and the monoaminergic arousal systems. VLPO neurons are inhibited by ►serotonin and noradrenalin. Thus, waking-related monoaminergic activity prevents inappropriate activation of VLPO sleep-generating cells during the active phase of an animal’s day. At wake to sleep transitions during the rest phase, activation of VLPO neurons is reinforced by disinhibition as monoaminergic activity wanes. The mutual inhibitory interactions between sleep- and arousal-regulatory neurons function like a bi-stable switch (or flip-flop switch), and can help promote rapid and stable transitions between wakefulness and sleep [5].

GABAergic neurons in the preoptic area also participate in regulating homeostatic increases in sleep amount and sleep depth that occur as a consequence of sleep deprivation [4]. MnPN GABAergic neurons are progressively activated during a period of sleep deprivation, as sleep propensity (i.e., the tendency to fall asleep) increases. Activity of VLPO neurons is enhanced during recovery sleep following sleep deprivation.

### Endogenous Sleep Factors

Humoral theories of sleep generation have a long history, and are appealing because the cycling between waking and sleep seems consistent with the waxing and waning of an endogenous sleep-regulatory substance [1]. The search for, and characterization of endogenous sleep factors remains an active area of contemporary sleep neurobiology [6]. Most candidate sleep factors are implicated in a key feature of sleep regulation, namely the homeostatic control of sleep. A defining feature of sleep in mammals is that deprivation or restriction of sleep is followed by increased sleep drive (sleepiness) and, when sleep is permitted, rebound increases in sleep amount and sleep depth. There is evidence that putative sleep factors such as adenosine (see below) accumulate during sustained waking and dissipate during recovery sleep, thereby contributing to homeostatic aspects of sleep regulation.

A large body of evidence supports a role for adenosine as a sleep generating neurochemical [6,7]. Acting through the A<sub>1</sub> receptor, adenosine has inhibitory effects on multiple neuronal types in several brain regions. Adenosine is a by product of brain metabolism, and AD levels are elevated in response to intense brain activation (e.g., seizures) and as a consequence of sustained waking. Sleep deprivation is accompanied by elevated adenosine levels in the basal forebrain, followed by a decline in these levels during recovery sleep [7]. Administration of A<sub>1</sub> adenosine receptor agonists promotes sleep and enhances EEG slow-wave activity. The stimulant, caffeine, is an A<sub>1</sub> receptor antagonist. Collectively, these findings impli-

cate adenosine in homeostatic sleep regulation. Sleep generating effects of adenosine entail  $A_1$  receptor mediated inhibition of arousal systems, including basal forebrain cholinergic neurons and orexin neurons in the lateral hypothalamus. Adenosine may activate sleep regulatory neurons in the VLPO as well, due to  $A_1$  receptor mediated disinhibition and to excitatory actions mediated by  $A_{2A}$  receptors.

While adenosine is arguably the most completely characterized putative sleep factor, other candidate substances are being actively investigated. Several cytokines, including, interleukin- $1\beta$  and tumor necrosis factor- $\alpha$ , are sleep promoting and augment EEG slow-wave activity during sleep [6]. Antagonism of these cytokines can disrupt normal sleep and impair homeostatic responses to sleep deprivation. Cytokines are pivotal to the sleep enhancement that accompanies immune system activation and are implicated in normal sleep generation as well. Cellular mechanisms of cytokine-mediated sleep generation are not completely understood, but may involve a combination of arousal system inhibition and activation of preoptic sleep regulatory neurons. Additional candidate sleep factors include prostaglandin- $D_2$  and growth hormone releasing hormone [3,6].

### The Suprachiasmatic Nucleus and Sleep Generation

As Borbely articulated in his two-process model 25 years ago [8], the generation of sleep is under both circadian and homeostatic control. Homeostatic pressure for sleep increases in proportion to prior time awake, but the circadian system regulates the timing of sleep, such that it is largely confined to the species-appropriate time of day. The cellular and neurochemical details of how the mammalian suprachiasmatic nucleus (SCN) interacts with sleep generating mechanisms are far from completely understood. The SCN may regulate the timing of sleep primarily through modulation of activity in one or more arousal systems [9]. Ablation of the SCN in primates, while eliminating free running circadian rhythms in rest and activity, causes a significant increase in daily total sleep time, suggestive of an arousal deficit. The intact SCN has few direct efferent projections to hypothalamic or brainstem arousal systems. SCN modulation of arousal systems may involve neurohormones, since transplantation of SCN tissue can restore rest-activity rhythms in rats with SCN ablation. A multisynaptic pathway, involving the hypothalamic subparaventricular zone and the dorsomedial hypothalamic nucleus (DMH), links the SCN with the orexin arousal system [9]. The final link in this pathway is an excitatory glutamatergic projection from the DMH to the orexin neurons in the lateral hypothalamus [9]. SCN influences on sleep generation may also entail inhibition of preoptic area neurons. GABAergic projections from the DMH to the VLPO

could convey inhibitory effects from the SCN [9]. Direct SCN to VLPO pathways may also play a functional role. A recent finding in a horizontal hypothalamic slice preparation, demonstrates that electrical or chemical activation of the SCN evokes inhibition in VLPO neurons [10]. Thus, SCN control of the timing of sleep generation may involve a combination of excitatory modulation of the arousal systems and inhibition of VLPO neurons.

### References

1. Kleitman N (1963) Sleep and wakefulness. University of Chicago Press, Chicago, 552 pp
2. Moruzzi G (1972) The sleep-waking cycle. *Ergebnisse der Physiologie* 64:1–165
3. Espana RA, Scammell TE (2004) Sleep neurobiology for the clinician. *Sleep* 27:811–820
4. Szymusiak R, Gvilia I, McGinty D (2007) Hypothalamic control of sleep. *Sleep Med* 8:291–301
5. Saper CB, Chou TC, Scammell TE (2001) The sleep switch: hypothalamic control of sleep and wakefulness. *Trends Neurosci* 24:726–731
6. Obal F Jr, Krueger JM (2003) Biochemical regulation of non-rapid-eye-movement sleep. *Front Biosci* 8:d520–d550
7. Porkka-Heiskanen T, Strecker RE, Thakkar M, Bjorkum AA, Greene RW, McCarley RW (1997) Adenosine: a mediator of the sleep-inducing effects of prolonged wakefulness. *Science* 276:1265–1268
8. Borbely A (1982) A two process model of sleep regulation. *Hum Neurobiol* 3:195–204
9. Fuller P, Gooley J, Saper CB (2006) Neurobiology of the sleep-wake cycle: sleep architecture, circadian regulation and regulatory feedback. *J Biol Rhythms* 21(6):482–493
10. Saint-Mleux B, Bayer L, Eggermann E, Jones BE, Muhlethaler M, Serafin M (2007) Suprachiasmatic modulation of noradrenalin release in the ventrolateral preoptic nucleus. *J Neurosci* 27:6412–6416

## Sleep Homeostasis

S

PAUL FRANKEN

Center for Integrative Genomics, University of Lausanne, Lausanne-Dorigny, Switzerland

### Synonyms

Homeostatic regulation of sleep need; Pressure; Intensity; Debt; Propensity, or duration; Process S; Sleep recovery process

### Definition

Homeostatic regulatory processes strive to maintain physiological variables constant or within an acceptable range thereby ensuring optimal functioning of the

organism. Sleep is thought of as a behavior that subserves a homeostatic process; a need or pressure for sleep accumulates during wakefulness and this need can only be alleviated efficiently during sleep. When sleep need exceeds optimal levels, such as occurs under conditions of sleep loss or sleep restriction, it negatively impacts cognitive performance and ultimately will lead to diminished health and well-being. The effects of sleep loss or sleep restriction can be countered by sleeping longer and/or by intensifying sleep. In particular, the observations that sleep time and/or intensity increase after sleep loss led to the notion that sleep is homeostatically regulated.

### Characteristics

The concept of homeostasis was first formulated by the French physiologist Claude Bernard (1813–1878). He stated that the constancy of the internal environment (“*le milieu intérieur*”) is the condition for “a free and independent life.” The term homeostasis itself was later coined by the American physiologist Walter Cannon (1871–1945). Homeostatic regulation has been extensively documented for, e.g., blood glucose levels and body temperature. The physiology behind sensing and evaluating these variables, as well as how effector mechanisms are activated and act to counter deviations from “set-point,” is well understood. Its application to sleep-wake regulation is, however, problematic for several reasons: (i) When describing sleep phenomenology at least three main processes have to be considered that all interact and of which the respective contributions sleep are difficult to separate in normal, daily life conditions. Thus a ▶circadian process interacts with the homeostatic process enabling us to stay awake and alert throughout the day and to remain asleep through the night. A third regulatory process underlies the more or less rhythmic alternation between the two main sleep states [i.e., ▶rapid-eye-movement (REM) sleep and ▶non-REM (NREM) sleep] also known as the NREM-REM sleep cycle. (ii) Both sleep states can be said to be homeostatically regulated since deprivation of sleep leads to increases in the duration of both. However, the regulation of the duration of NREM sleep differs from that from of REM sleep. Furthermore, different aspects of one state, such as the duration and intensity of NREM sleep, are regulated differently. (iii) The regulated variable and the neuro-physiological function of sleep remain elusive which makes it difficult to study the homeostatic control circuitry of sleep. Consequently, most concepts of the homeostatic regulation of sleep have been based on behavioral and EEG studies. The search for the neuro-chemical, neuro-anatomical, and molecular-genetic substrates of sleep homeostasis is the focus of intense research in

various organisms. Homeostatic regulation of sleep also has been observed in invertebrates. The fruit fly, in particular, provides a powerful model system to dissect the molecular-genetic underpinnings of sleep function.

### The Homeostatic Regulation of NREM Sleep

In mammals, the homeostatic regulation of NREM sleep has been extensively studied and consists of changes in both duration and intensity. One widely used measure of NREM sleep intensity or depth that can be extracted from the electroencephalogram (EEG) is power in the delta frequency range (1–4 Hz). This measure is referred to as ▶slow-wave activity (SWA) or ▶EEG delta power and quantifies the prevalence and amplitude of slow waves that are characteristic of the NREM sleep EEG. When EEG slow waves are prevalent and SWA is high, arousal thresholds also are high (i.e., it is more difficult to awaken a subject) and sleep is more consolidated (i.e., less brief awakenings). SWA in NREM sleep typically declines over the course of the daily sleep period, increases as waking proceeds and is reduced after excess sleep. These changes in SWA are highly reliable and predictable and can be closely approximated through mathematical simulations. Because of this, much attention has been focused on this aspect of sleep and often the homeostatic regulation of sleep is equated with the sleep-wake dependent changes in SWA. These changes in SWA played a central role in the conceptualization of Alexander Borbély’s ▶two-process model of sleep regulation [1]. In this influential model a homeostatic process, “▶Process S,” reflected by SWA, in interaction with a circadian process, “▶Process C,” regulates the timing and intensity of NREM sleep. Many aspects of sleep regulation can be understood in the context of this model. Among those are the recovery from sleep deprivation, the dependence of sleep duration on circadian phase, sleep during shift work, sleep fragmentation during continuous bed rest, and ▶internal desynchronization in the absence of time cues. That SWA can be used to index sleep need has been demonstrated in most, if not all mammalian species investigated to date.

Initially, the state of Process S was monitored only during NREM sleep by quantifying SWA. This measure is interpreted and used to index sleep need. In addition, it is thought that changes in SWA determine the efficiency with which sleep need is recovered during the sleep period. The initial part of the night during which NREM sleep SWA is high and rapidly declines, is therefore considered especially recuperative in terms of reducing the need for sleep. Suppressing EEG slow waves during this part of the night by presenting

acoustic stimuli (that did not awaken the subjects) led to an intra-night SWA rebound in the second, undisturbed half of the night indicating that the recovery process can be delayed and that the expression of EEG slow waves are functionally relevant. Meanwhile, EEG measures reflecting changes in sleep need have also been identified in the waking EEG.

Also the duration of NREM sleep is considered to be homeostatically regulated because increases in time spent in this state are observed after sleep deprivation (provided the experimental protocol allows for sleep extension). These “▶rebounds” in NREM sleep duration are, however, usually less precise, depend on circadian phase at which sleep occurs, make up only a fraction of NREM sleep time lost, and can take place over a longer time span as compared to the immediate and highly predictable changes in SWA. Nevertheless, even small increases in NREM sleep duration can importantly affect SWA which poses the question of which aspect of sleep is homeostatically defended. Results of a sleep deprivation study in rats illustrate this issue. Twenty-four hours without sleep resulted in the expected and immediate increase in SWA that quickly subsided over the first 4 h of the recovery period. The duration of NREM sleep was also increased but this increase lasted for most of the 48 h for which recovery was monitored. As a result of the increase in NREM sleep time, SWA fell to values below those reached under baseline conditions (i.e., “▶negative rebound”). Although both the positive and negative rebound in SWA in this study could be explained based on the altered sleep-wake distribution, the following question presents itself: If SWA indeed reflects sleep need then why should animals continue to sleep more (compared to baseline) when SWA is below baseline? The issue of the homeostatic regulation of NREM sleep time versus NREM intensity (i.e., SWA) is also relevant in the context of development; rats younger than 24-days old seem not yet able to compensate for sleep time lost by intensifying sleep and, in contrast to older rats, they compensate almost all of the sleep lost by sleeping more.

### The Homeostatic Regulation of REM Sleep

Although EEG measures indicative of REMS intensity have been proposed, losses in REM sleep seem to be primarily compensated by increases in REM sleep time as has been observed after selective REM sleep deprivation or total sleep deprivation in a variety of mammalian species. In particular, several studies in rats, cats, and mice indicate that the REMS increase during recovery from REM sleep deprivation, varying in length from 1 to 24 h, is proportional to the loss incurred by that deprivation (for references see [2]).

This suggests that the daily amount of REM sleep is accurately regulated in these species. Strong evidence for a homeostatic regulation of REM sleep in humans is less well established as usually only small and/or delayed rebounds have been reported. Based, in part, on these discrepancies among species, James Horne argued that REM sleep is a “default” state and as such its duration is not homeostatically regulated [3]. On the other hand, based on data obtained in rats, Allan Rechtschaffen went so far as to suggest that REM sleep is the only sleep state that is homeostatically defended [4].

### The NREM-REM Sleep Cycle

Because both NREM and REM sleep seem homeostatically regulated, because their regulation differs, and because these two states greatly differ in many electro-physiological and neuro-chemical aspects, it is plausible to assume that they fulfill specific functions. During a sleep episode both NREM and REM sleep needs have to be fulfilled, an assumption supported by the observation that the two behaviors seem to compete for expression; i.e., a selective high pressure for one sleep state has repercussions for the expression of the other (reviewed in [2]). The alternation between NREM and REM sleep, i.e. the NREM–REMS cycle, can thus be viewed as a way “the system” ensures that the need for both behaviors is addressed efficiently within the circadian time frame allotted for sleep. The process underlying the more or less regular NREM–REMS alternation during sleep is thought to be a sleep-dependent oscillator; or, in other words, a homeostatic need to express REM sleep increases as a function of time spent in NREM sleep. Evidence for such need is based on the observation that the number of attempts to enter REM sleep increase as a function of the time-spent-asleep without REM sleep.

### Homeostatic versus Circadian Processes

Apart from the homeostatic process (“Process S”) that is activated by and counters the effects of sleep loss, an equally important, circadian process (“Process C”) determines the time-of-day sleep preferably occurs. Their interaction is described in the two-process model [1] and the fine-tuned, opposing influence between the two enables us to stay awake and alert throughout the day and to remain asleep at night [5]. Despite this close interrelationship it is widely believed that the two processes operate independently. This notion is based on observations in animals that lost circadian rhythmicity, sleep deprivation still elicits an intact homeostatic response in sleep time and intensity. Moreover, in humans it has been demonstrated that the daily, sleep-wake dependent variation in SWA is little affected by

circadian factors. More recent observations challenge this notion and suggest a direct cross-talk between the two regulatory systems. Thus, sleep deprivation was found to affect the phase of circadian rhythms and high levels of SWA seem to suppress neuronal activity in the ► **supra-chiasmatic nucleus** (► **SCN**), the hypothalamic structure that contains the circadian pacemaker. Finally, animals that lack circadian rhythms through genetic lesioning (i.e., “knock-outs”) of one or more core circadian clock genes, also have altered sleep homeostasis (reviewed in [6]).

### Functional Considerations

After having established that sleep is homeostatically regulated the next obvious question to ask is what is being regulated or what function does sleep subservise. Given the complexity of sleep and its regulation it is likely that sleep fulfills more than one function. Several functions have been proposed over the years. Most have in common that sleep fulfills a function specifically benefiting the brain (“*Sleep is of the brain, by the brain, and for the brain!*”). This assertion is based on a variety of observations. Prominent among those are the facts that brain electrical and metabolic activity dramatically differs between NREM sleep and wakefulness, that falling asleep is associated with a loss of consciousness, that loss of sleep affects first and foremost cognitive performance, vigilance, and alertness, and that the variable that most reliably indexes the time-spent-awake and -asleep (i.e., SWA) is of cortical and thalamo-cortical origin.

The analysis of SWA reveals that sleep need is a local and use-dependent process [7,8]. SWA exhibits a frontal predominance both under baseline conditions, as well as after sleep deprivation. Local changes in SWA can be induced by engaging volunteers in tasks that activate specific brain areas. Thus vibration of one hand, which stimulates the somato-sensory cortex during wakefulness, leads to an increase in SWA in the contra-lateral sensorimotor cortex. Similarly, in rodents, regional activation of the barrel-cortex by unilateral whisker stimulation is followed by an increase of SWA in the stimulated cortex, specifically. Perhaps the most striking example of SWA’s local and use-dependent aspects has been observed in the bottlenose dolphin. This mammal displays unilateral slow-wave sleep (NREM sleep with high SWA) and depriving one hemisphere of slow-wave sleep resulted in an increase in SWA in that hemisphere only. An extension of the use-dependent regulation of SWA is the association between local increases in SWA and the consolidation of particular forms of memory. The highly predictive sleep-wake dependent changes in SWA as observed in the EEG and its local and use-dependent nature gave rise to the notion that slow waves are closely linked to a recovery process that occur

during NREM sleep and that this recovery is linked to the neuronal activation during wakefulness.

Neuronal activation during wakefulness is associated with synaptic rearrangement or strengthening at the level of individual neurons and/or at the level of brain micro-circuitry [7,8]. Extended periods of wakefulness would result in levels of synaptic weight that cannot be sustained or allow for further plastic events. The regular hyperpolarizing-depolarizing membrane potentials that underlie slow waves and/or associated changes in growth factors may reverse the detrimental effects of wakefulness on synaptic weight and brain micro-circuitry. Through such mechanisms SWA could restore performance and plasticity for the subsequent wake episode. Such detailed account on the hypothetical restorative function of SWA are still lacking for the other homeostatically regulated aspects (i.e., duration of NREM sleep and of REM sleep).

### Molecular and Genetic Correlates

SWA and its regulation by the duration of wakefulness are under genetic control. The dynamics of the sleep homeostatic process in mice were found to differ with genetic background and a QTL (Quantitative-Trait Locus) region on chromosome 13 was identified that could explain 50% of the variance in this trait between two inbred strains of mice (reviewed in [9]). In humans, a polymorphism in the circadian ► **clock gene** *Period-3* has been shown to affect SWA and waking performance. Previously, studies in mice had demonstrated that the clock genes ► *Cryptochrome-1* and *-2*, ► *Bmal1*, ► *Clock*, and *Npas2* affect expression and regulation of SWA and NREM sleep (reviewed in [6]). The involvement of genes that play a key role in the generation of circadian rhythms in the regulation on SWA and NREM sleep seems at odds with the notion that the sleep homeostatic process and the circadian timing system are considered separate processes (see above). These results also demonstrate that genetic factors contribute to the considerable individual differences observed in the expression and regulation of SWA.

With the development of the techniques that allow for high-throughput assessment of gene expression; i.e., “microarrays,” (► **microarray**, **DNA Chip**) genome-wide expression profiling has been performed to investigate which genes change their expression with time-spent-awake or -asleep. Instead of focusing on individual genes such approach allows for the identification of pathways that are activated with sleep loss. Stress-induced transcripts such as heat-shock proteins, genes encoding molecules involved in synaptic plasticity, and, more general, genes coding for enzymes involved in biosynthesis were found to change expression with sleep and waking in the few available studies. Progress on high-throughput techniques to investigate changes in proteins levels is being made



and preliminary studies using these techniques in sleep research have been published (see [9] for review).

## References

1. Daan S, Beersma DG, Borbely AA (1984) Timing of human sleep: recovery process gated by a circadian pacemaker. *Am J Physiol* 246:R161–R183
2. Franken P (2002) Long-term vs. short-term processes regulating REM sleep [see comments.]. *J Sleep Res* 11:17–28
3. Horne JA (2000) REM sleep – by default? *Neurosci Biobehav Rev* 24:777–797
4. Rechtschaffen A, Bergmann BM, Gilliland MA, Bauer K (1999) Effects of method, duration, and sleep stage on rebounds from sleep deprivation in the rat. *Sleep* 22:11–13
5. Dijk DJ, Franken P (2005) Interaction of sleep homeostasis and circadian rhythmicity: dependent or independent systems? In: Meir H, Kryger MH, Roth T, Dement W (ed) *Principles and practice of sleep medicine*. Saunders/Elsevier
6. Franken P, Thomason R, Heller HC, O'Hara BF (2007) A non-circadian role for clock genes in sleep homeostasis. *BMC Neurosci* 8:87
7. Krueger JM, Obal FJR, Ferenc J (2003) Sleep function. *Front Biosci* 8:511–519
8. Tononi G, Cirelli C (2006) Sleep function and synaptic homeostasis. *Sleep Med Rev* 10:49–62
9. O'Hara BF, Ding J, Bernat RL, Franken P (2007) Genomic and proteomic approaches towards an understanding of sleep. *CNS Neurol Disord Drug Targets* 6:71–81

## Sleep Inertia

### Definition

Interval of reduced alertness, cognitive performance impairment, grogginess, and tendency to return to sleep, which occurs immediately after awakening. The impairment from sleep inertia is normally mild and short-lived (less than half an hour), and is believed to be affected by the structure of the prior sleep period (non-REM sleep and rapid eye movement (REM) sleep amounts), the sleep stage from which awakening occurs, and the timing of the awakening relative to the circadian cycle. The magnitude and duration of sleep inertia are enhanced by prior sleep loss, such that the effect may become as substantial as the cognitive impairment normally seen after a night of total sleep deprivation and may take up to 2 h to dissipate.

- ▶ Alertness Level
- ▶ Circadian Cycle
- ▶ Non-REM Sleep
- ▶ Rapid Eye Movement (REM) Sleep

## Sleep Movement Disorders

- ▶ Sleep – Motor Changes

## Sleep-onset Mechanisms

- ▶ Sleep Generating Mechanisms

## Sleep-onset REM Period

### Definition

Abnormally rapid transition from wakefulness to REM sleep, skipping the period of non-REM sleep that normally characterizes the beginning of the sleep period. Sleep-onset REM periods (SOREMs) are a symptom of narcolepsy and as such can be considered in the diagnosis of this disorder.

- ▶ Alertness Level
- ▶ Non-REM Sleep
- ▶ Rapid Eye Movement (REM) Sleep

## Sleep Paralysis

### Definition

Sleep Paralysis is an inability to move occurring either at sleep onset or upon awakening from sleep. Episodes last a few minutes and are usually accompanied by intense feelings of fear and/or anxiety. Isolated sleep paralysis can occur in up to 25% of healthy, normal individuals and may be precipitated by sleep deprivation. Sleep paralysis is more commonly found in patients with narcolepsy.

- ▶ Narcolepsy
- ▶ Sleep Generating Mechanisms

## Sleep Phylogeny

JEROME M. SIEGEL

Center for Sleep Research 151A3, Department of Psychiatry, UCLA School of Medicine, Veterans Administration Greater Los Angeles Health Care System, North Hills, CA, USA

### Definition

► **Sleep phylogeny** refers to the variation in the nature and amount of sleep across species.

### Characteristics

A primary motivation for the study of sleep in various animals is to gain some insight into the function(s) of sleep. What aspects of sleep, if any, are present in all mammals? What aspects of sleep differ between animals? Why are there two kinds of sleep, ► **REM sleep** and ► **nonREM sleep**?

The amount and nature of sleep are correlated with age, body size and ecological variables, including life in the terrestrial vs. aquatic environment, diet and the safety of the sleeping site. The sleep phylogeny literature suggests that sleep reduces activity to the amount needed for feeding and species reproduction, and maximizes energy conservation, thereby furthering genetic survival. Theories of REM sleep function have suggested that in addition to these functions, this state may have a role in periodic brain activation during sleep, in localized brain and body recuperative processes and in emotional regulation.

### Sleep Studies in Terrestrial Mammals

Daily sleep amounts vary substantially throughout the mammalian class. Some animals, such as bats and opossums, sleep for 18–20 h/day, whereas others, such as the elephant and giraffe, sleep as little as 3–4 h/day. One might expect that species in each mammalian order would have a similar pattern of sleep because of their defining genetic, behavioral, and anatomical similarities. However, this is not the case. Primates as a group (or carnivores as a group, or rodents as a group) do not have a characteristic sleep duration. Sleep time in these various orders overlaps extensively and any “order related” contribution to sleep duration must be small relative to other factors [1]. Human sleep does not appear to be quantitatively unique in its duration or in the proportion or absolute amount of REM sleep.

Daily sleep amounts are highest in carnivores, lower in omnivores, and lowest in herbivores. Sleep time is inversely correlated with body mass in herbivores. This correlation is responsible for a significant overall correlation between body mass and sleep time over all mammals studied to date [1].

Most studies of mammalian sleep have been performed on placental (eutherian) or marsupial mammals. The third subclass of mammals is the monotremes, found in Australia and New Guinea. These egg-laying mammals have more genetic and physiological similarities to reptiles and birds than do other mammals and are thought to have more characteristics of the common mammalian ancestor. Both the echidna and platypus show evidence of ► **brainstem** activation during sleep, with the platypus displaying intense rapid eye, limb, and bill movements periodically during sleep. However, the low voltage neocortical EEG typically seen in placental and marsupial mammals during REM sleep is not consistently present during sleep in either the echidna or platypus during these motor activities. Instead the neocortical EEG may resemble that of nonREM sleep [2,3]. Thus, these “primitive” mammals appear to have a form of REM sleep largely localized to the brainstem.

### Sleep in Marine Mammals

All terrestrial mammals show relatively high voltage low frequency (slow) neocortical electrical brain waves (EEG) bilaterally during the behavioral state that is recognized as nonREM sleep. In contrast, cetaceans (whales and dolphins) almost never have high voltage slow waves in both hemispheres at the same time. The eye contralateral to the hemisphere with slow waves is almost always closed while the other eye is almost always open. There have been no published reports documenting REM sleep in cetaceans, making them the only studied mammals in which this state has not been observed.

The bottlenose dolphin (*Tursiops truncatus*), when not floating or resting on the bottom, generally swims in a single direction (usually counterclockwise) even as the brain hemisphere with slow waves alternates. Some smaller cetacean species are rarely, if ever, immobile, moving and avoiding obstacles 24 h a day from birth until death, even during unihemispheric slow wave activity; these animals may never exhibit the immobility that is used in terrestrial mammals to define the state of sleep [4].

### Postpartum Sleep Behavior in Cetaceans

Further evidence for the unique properties of “sleep” in cetaceans are the phenomena of a near absence of sleep behavior in neonates and a postpartum reduction of sleep behavior in their mothers [5]. All studied terrestrial mammals have shown minimal activity and maximal total sleep and REM sleep amounts at birth, with sleep gradually decreasing and activity gradually increasing to adult levels as the animals grow to maturity. This is not the pattern in cetaceans. Killer whales (*Orcinus orca*) and dolphins have minimal amounts of sleep behavior (i.e., immobility or eye

closure) at birth, with sleep behavior slowly increasing to adult levels over a period of months. This minimal amount of sleep behavior occurs during the period of most rapid growth of body and brain for the newborn, during a period of bonding to the mother and learning how to nurse, find food, avoid predators, and swim efficiently. The continuous activity of cetaceans has adaptive value in allowing the neonate, which is much less insulated by body fat than the adults, to thermoregulate in cold ocean water. The suppression of sleep behavior also allows the neonate to swim with and be protected by its mother during development. As the animal gains mass and blubber and approaches adult size, adult-like “sleep” or rest behavior, including periods of immobility, emerges. Both mother and calf go without substantial amounts of immobility and without substantial amounts of the eye closure linked to unihemispheric slow waves during the postpartum period. Keeping rats awake for comparable periods is lethal. Neither cetacean mother nor calf show any rebound increase in the amount of sleep behavior following this period.

### Neocortical Activity and Sleep

Although neocortical EEG changes are the most easily observed electrical correlate of nonREM sleep, as they are recordable from scalp electrodes in humans and from electrodes placed on the surface of the cortex in other animals, sleep produces large changes in the rates and patterns of neuronal activity in nearly all brain regions. Cortical EEG phenomena are controlled by and reflect activity in thalamic, hypothalamic and brainstem reticular regions. The cellular activity changes underlying the changes in neocortical EEG include calcium fluxes into and hyperpolarization of neocortical and thalamic neurons that are synchronized in large populations, producing high voltage brain waves. But neocortical size does not correlate positively with sleep amount. Both total brain weight and encephalization correlate poorly and negatively with total nonREM and REM sleep amounts [1]. The elephant, which has the largest neocortex of any terrestrial mammal, has one of the smallest sleep amounts. Conversely, the rat and the platypus, which have smooth cortices with small total neocortical volumes, have extremely large amounts of nonREM and REM sleep, with the platypus having more REM sleep than any other animal studied to date [3].

Although neocortical size does not appear to be a major determinant of either nonREM or REM sleep amounts, recent work has indicated that neocortical activity during sleep may be altered by prior waking activity. Some such changes dissipate with continued ►waking, suggesting that localized recuperative processes may occur during either waking or sleep in systems projecting to, or within, the neocortex.

Sleep may be adaptive because it conserves energy and suppresses behavior across portions of the

►circadian cycle, just as ►hibernation does across certain seasons. Large herbivores may have evolved reduced sleep amounts because they are more vulnerable to predators than small herbivores. A second hypothesis is that these grazing animals may need to spend more time awake in order to eat, because of the low caloric density of their food. A complementary hypothesis is that small herbivores and other mammals may need to maximize sleep amounts in order to conserve energy, because their relatively high surface area to body mass ratio makes it costly to maintain their body temperature, but retreating to a warm, protected nest may minimize this cost. A striking feature of sleep in animals with small daily sleep amounts, such as many herbivores, is that sleep depth, as judged by EEG and sensory response threshold, appears to be less than that in animals requiring more sleep; i.e., animals with reduced sleep amounts do not appear to “make up” for reduced sleep by sleeping more “deeply.”

Energy conservation may be particularly important in newborns. Their high surface area to body mass ratio and need for rapid growth makes the energy conservation achieved by sleep highly adaptive. Furthermore, animals that are immature at birth benefit from the sleep-induced reduction in exposure to danger. When body size increases and sensory-motor systems mature, young animals derive greater benefits from waking activities and can begin to defend themselves, consistent with the developmental decrease in sleep time.

### Body Mass, Metabolism and Sleep Control

One of the best established relations in mammalian biology is the inverse relationship between body mass and mass specific metabolic rate. Small animals have high metabolic rates per gram of weight; large animals have low metabolic rates. Brain metabolic rate is correlated with body metabolic rate. Elevated metabolism is linked to a number of biochemical changes, several of which have been linked to sleep control.

Sleep time may be related to defense against oxidative stress. A high metabolic rate results in the generation of high levels of reactive oxygen species (ROS) by mitochondria. This ROS generation has been linked to normal aging. Sleep deprivation in the rat is accompanied by indications of increased oxidative stress and evidence of membrane disruption in the hippocampus, subcortical brain regions and peripheral tissues [6–8]. There appear to be no such changes in the neocortex [7,9]. Higher brain metabolic rates may require longer periods of sleep to interrupt ROS induced damage to brain cells, facilitate the synthesis and activities of molecules that protect brain cells from oxidative stress, allow sufficient time for the repair or replacement of essential cellular components in neurons and glia, and deal with other biochemical consequences of ►waking metabolic activity.

One may hypothesize that the “ratio” of the energy conservation benefit of sleep to the waking metabolic activity-derived need for sleep for brain recuperation varies across species. Carnivores and omnivores, which tend to have more sleep than predicted on the basis of body mass, may make more use of the energy conservation aspects of sleep; their generally safe sleep places and their ability to eat meals with high caloric density may make continuous activity unnecessary. In such a situation, genetic fitness might best be served by energy conservation, which would reduce the need for hunting, aid nurturing of the young, speed development and generally aid in reproductive success.

Protein synthesis in the brain is increased during **slow wave sleep**. New neurons are generated in adult animals in the olfactory bulb, the subventricular zone lining the lateral ventricles, and in the subgranular cell layer of the dentate gyrus of the hippocampus, in a process that produces functional neurons in 3–4 weeks. It has been shown that this neurogenesis is facilitated by exercise and blocked by stress. Short term (2–3 day) total sleep deprivation, even done when controlling for other forms of stress, also blocks subsequent neurogenesis in the dentate gyrus [10]. Thus, sleep may have a general role in allowing or facilitating neurogenesis.

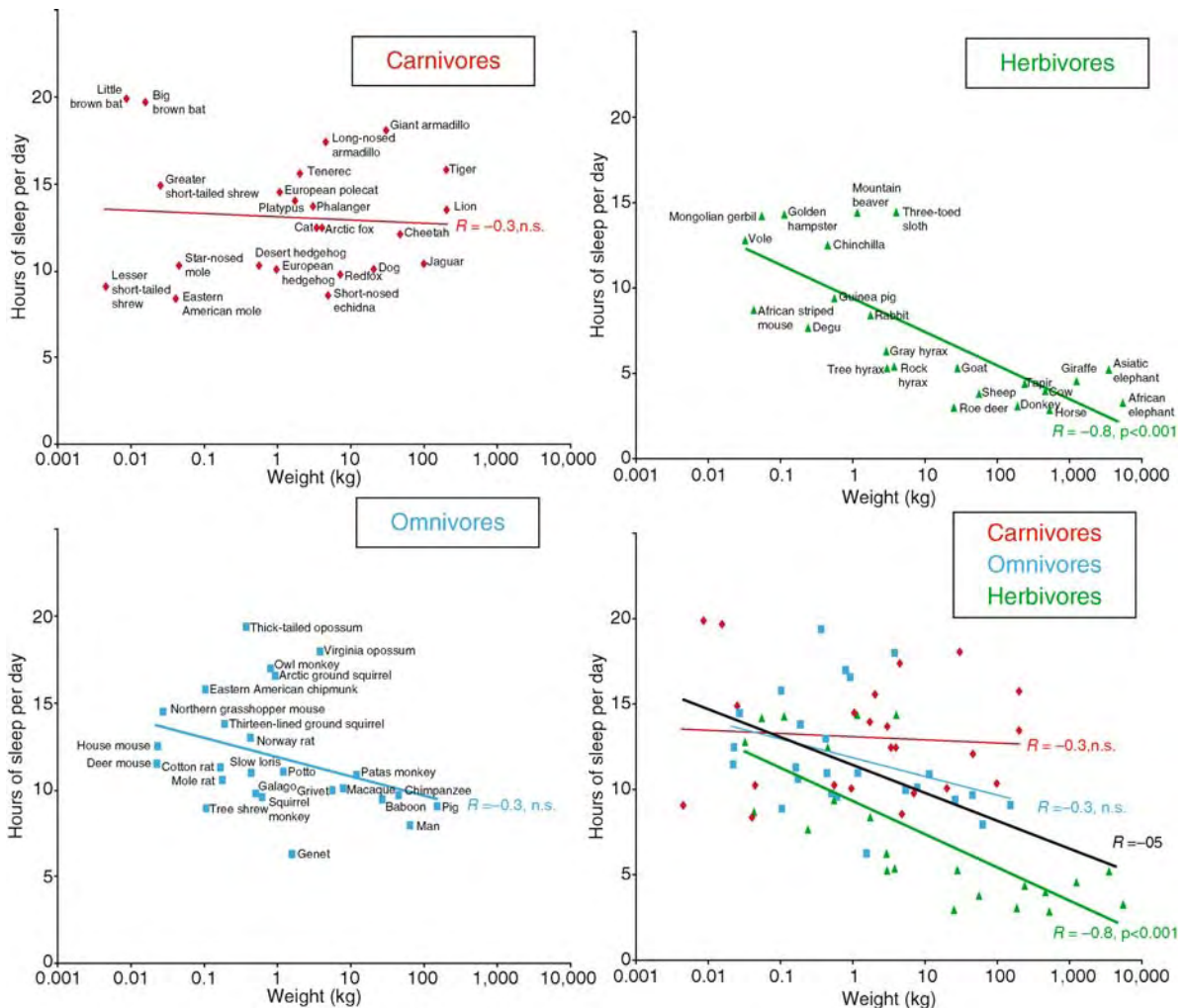

**Sleep Phylogeny. Figure 1** Sleep time in mammals: Carnivores are in red, herbivores in green and omnivores in blue. Sleep times in carnivores, omnivores and herbivores significantly differ ( $p < 0.0002$ ,  $F$  test,  $df$  2, 68), with carnivore sleep amounts significantly greater than those of herbivores ( $p < 0.001$ ,  $t$  test,  $df$  24, 22). Sleep amount is an inverse function of body mass over all terrestrial mammals (black line). This function accounts for approximately 25% of the interspecies variance in reported sleep amounts (Regression of log weight against sleep amount,  $R = -0.5$ ,  $p < 0.0001$ ,  $N = 71$ ). Herbivores are responsible for this relation, since body mass and sleep time were significantly and inversely correlated in herbivores ( $R = -0.77$ ,  $p < 0.001$ ,  $df$  24), but were not in carnivores ( $R = -0.28$ ,  $df$  24) or omnivores ( $R = -0.25$ ,  $df$  25).

## REM Sleep

REM sleep amount is positively correlated with total sleep amount and negatively correlated with body weight. However, if one statistically controls for body weight or brain weight, REM sleep amount is most strongly correlated with immaturity at birth [1]. Altricial animals, those that are immature at birth, tend to have more REM sleep than animals that are mature at birth, or precocial. This tendency is marked in the neonatal period. But perhaps more remarkable is that altricial mammals continue to have more REM sleep as adults. The platypus has 8 h of REM sleep per day as an adult. The platypus neonate cannot thermoregulate, locomote, acquire food or defend itself at birth, and lives attached to its mother. The ferret, likewise, is immature at birth and the adult has over 6 h of REM sleep per day. In contrast, the guinea pig has only 1 h of REM sleep per day as an adult. The guinea pig is born with teeth, claws, fur and eyes open; it thermoregulates at birth, locomotes within an hour of birth and eats solid food within a day of birth. Similarly, the sheep and giraffe are relatively mature at birth and have little REM sleep (less than one h/day) at maturity [1]. The extremely high levels of REM sleep seen at birth, followed by a slow decrease to adult levels in altricial terrestrial animals, must be an important clue to its function. This time course, combined with the observation that neuronal activity levels are high in REM sleep, led to the hypothesis that this sleep state is involved in the development of the brain.

Dolphins, which can be continuously mobile while having unihemispheric slow waves must have continuous brainstem activity to control this movement, since the brainstem is the final path for motor control. This contrasts with the situation in land mammals, all of which have bilateral slow waves and immobility during sleep and greatly reduced brainstem activity. The absence or reduction of REM sleep in marine mammals displaying unihemispheric slow waves supports the hypothesis that the stimulation of brainstem activating systems is an important function of REM sleep. Similarly, the manifestation of REM sleep in monotremes as a largely brainstem state, without marked neocortical activation, suggests that REM sleep may have evolved as a state of brainstem activation, with cortical stimulation functions added later in evolution. The cold-induced increase in REM-sleep amount in the isolated brainstem, the increased REM-sleep amount at the minimum of the circadian brain, and body temperature cycles and the increase in the temperatures of brain regions during REM sleep are consistent with this brainstem activation hypothesis.

## Concluding Paragraph

The nature and duration of sleep are important factors in determining genetic fitness. In sleep, animals realize

benefits from reducing energy expenditure, confining behaviors to periods when it is most efficient to find food, avoiding predators and tending to their young. The expression of sleep varies across animals with some being able to sleep deeply and for long durations and others who cannot sleep in safe places evolving to be somewhat responsive for 24 h aday (Fig. 1). Several species are able to greatly reduce sleep time during the postpartum period and during long migrations. Sleep is best viewed as an adaptive state, furthering survival. REM sleep appears to have originated as a brainstem state providing periodic activation of this vital region. In most placental mammals this activation also includes forebrain regions, with increased brain metabolism and neuronal activity. It has been suggested that REM sleep helps maintain neural function during sleep and prepares the brain for rapid awakening [11].

## References

1. Zepelin H, Siegel JM, Tobler I (2005) In: Kryger MH, Roth T, Dement WC (eds) Principles and practice of sleep medicine Elsevier Saunders, Philadelphia, pp 91–100
2. Siegel JM, Manger P, Nienhuis R, Fahringer HM, Pettigrew J (1996) *J Neurosci* 16:3500–3506
3. Siegel JM, Manger PR, Nienhuis R, Fahringer HM, Shalita T, Pettigrew JD (1999) *Neuroscience* 91:391–400
4. Mukhametov LM, Lyamin OI, Shpak OV, Manger P, Siegel JM (2002) Proceedings of the 14th Biennial Conference on the Biology of Marine Mammals, Vancouver, Nov 27–Dec 3, p 152
5. Lyamin O, Pryaslova J, Lance V, Siegel J (2005) *Nature* 435:1177
6. Eiland MM, Ramanathan L, Gulyani S, Gilliland M, Bergmann BM, Rechtschaffen A, Siegel JM (2002) *Brain Res* 945:1–8
7. Ramanathan L, Gulyani S, Nienhuis R, Siegel JM (2002) *Neuroreport* 13:1387–1390
8. Everson CA, Laatsch CD, Hogg N (2005) *Am J Physiol Regul Integr Comp Physiol* 288:R374–R383
9. Gopalakrishnan A, Ji LL, Cirelli C (2004) *Sleep* 27:27–35
10. Guzman-Marin R, Suntsova N, Stewart DR, Gong H, Szymusiak R, McGinty D (2003) *J Physiol* 549:563–571
11. Siegel JM (2008) *Trends Neurosci* 31:208–213

## Sleep Rebound

### Definition

Sleep rebound is a term used to describe the increase of a sleep variable above normal (or baseline) levels after a period of sleep restriction or deprivation. Rebounds have been observed for many aspects of sleep (e.g.

electroencephalographic (EEG) delta power, non-rapid eye movement (NREM) and rapid eye movement (REM) sleep duration) and are interpreted as an effort to compensate for the incurred loss of sleep and as proof that sleep is homeostatically regulated. Such initial (positive) rebounds can be followed by subsequent negative rebounds when variables reach below-baseline levels as has been documented for EEG delta power.

- ▶ Electroencephalography
- ▶ Non-REM Sleep
- ▶ Rapid Eye Movement (REM) Sleep

---

## Sleep Recovery Process

- ▶ Sleep Homeostasis

---

## Sleep-regulating Mechanisms

- ▶ Sleep Generating Mechanisms

---

## Sleep Spindles

### Definition

Sleep-related electroencephalographic (EEG) events characterized by 1–2 s burst of nearly sinusoidal 12–15 Hz activity. There is a waxing and waning of amplitude across the duration of the event, giving it a characteristic “spindle” shape. During transitions from waking to stable sleep, sleep spindles are among the first EEG events to appear that exhibit high intra- and inter-hemispheric coherence. Sleep spindles are a defining feature of Stage 2 nonREM sleep in humans.

- ▶ Electroencephalography
- ▶ Sleep Generating Mechanisms

---

## Sleep States

MARCOS G. FRANK

University of Pennsylvania, Department of Neuroscience, Philadelphia, PA, USA

### Synonyms

Vigilance states; Arousal states

### Definition

Sleep states refer to distinct constellations of physiological, behavioral and neurological variables that alternate with wakefulness and are periodically expressed during the 24-h day. The primary defining features of sleep across the animal kingdom include (i) an increase in arousal thresholds; (ii) stereotyped behaviors (e.g., sleep postures, sustained quiescence, avoidance of sensory stimulation); and (iii) homeostatic regulation. Subsidiary features of sleep that are found in some species include (i) changes in autonomic/endocrine function; (ii) alterations in brain rhythms; and (iii) strong circadian regulation [1,2].

### Characteristics

Sleep is one of several core behaviors that, like feeding, drinking and reproduction appears to be ubiquitous among higher organisms. It is considered an appetitive behavior vital for life because a need for sleep accumulates in its absence, and prolonged sleep loss is fatal in vertebrate and invertebrate species [3]. In placental mammals and birds, sleep is divided into two principal states of non-rapid-eye-movement (non-REM) and REM (or “▶paradoxical”) ▶sleep. ▶REM sleep, however, is not typically observed in reptiles and amphibians or invertebrates which instead display a single sleep state that behaviorally resembles mammalian ▶non-REM sleep [1,2]. In most species, sleep is regulated by distinct homeostatic and circadian mechanisms. The homeostat governs the accumulation and compensatory discharge of sleep need; a process commonly detected by increases in sleep time and intensity following extended wakefulness. In contrast, the biological clock provides signals that offset the accumulation of sleep need and influences sleep onset and arousal [4].

### Human Sleep

The mammalian states of non-REM and REM sleep can be further divided into sub-stages that are entered and exited in an orderly fashion across the major rest (or inactive) phase. In humans, sleep is entered through non-REM sleep which progresses from “light” to “deep” stages. Each stage is accompanied by a rise in arousal thresholds and characteristic changes in brain

rhythms that reflect increasing levels of neuronal hyperpolarization [5]. These include thalamocortical spindles, a slow neocortical wave, and delta waves. Non-REM sleep is also accompanied by a slowing of respiration and heart rate, a drop in core temperature and a peak in growth hormone secretion [3–5]. The descent into stage 4 sleep is followed by periodic ascents into REM sleep. REM sleep is characterized by several peculiar neurological and physiological changes including paralysis of skeletal muscles, REMs, a “waking”-like electroencephalogram (EEG), suppression of monoaminergic neurotransmission and irregular patterns of respiration and heart rate. REM sleep is sometimes further divided into sub-stages which refer to periods with or without phasic events (e.g. REMs). In healthy humans, approximately 4–5 NREM-REM cycles occur during the night [5].

### Phylogenetic Studies of Sleep States

The basic properties of sleep observed in humans are also observed in placental and marsupial mammals and birds [1,2]. There are however, important differences as the amounts of total sleep and/or REM sleep vary among different species and the distinct sub-stages of sleep typical of humans are not always observed. In addition, endocrine changes observed in humans are not always detected in other mammals and REM sleep is accompanied by certain types of brain activity (e.g., hippocampal theta rhythms and pontine-geniculate-occipital waves) that may not occur in humans [1,2]. Birds are also quite peculiar in that REM sleep amounts represent a much smaller fraction of total sleep time in comparison to mammals [1].

Sleep has also been studied in several non-mammalian vertebrates, including lizards, snakes, crocodiles, turtles, frogs and salamanders [1,2]. In these species, a state that exhibits the primary features of sleep has been observed, but no convincing signs of REM sleep have been reported. Moreover, the brain rhythms typical of mammalian sleep are absent and instead sleep is accompanied by bursts of neuronal activity that appear as a train of unitary spikes in the EEG. In other cases a slow oscillation is occasionally observed that bears some resemblance to the mammalian slow wave. Similar phenomena are reported during sleep in terrestrial invertebrates (insects and arachnids) [2,6]. Overall, however, neurophysiological changes in sleep in these species are not as distinct as those reported in mammals and birds. This may reflect the fact that these species lack the neurological structures necessary for the generation of mammalian brain rhythms.

### Ontogenetic Studies of Sleep States

There are dramatic changes in sleep expression and regulation across the lifespan [7]. These can be summarized as follows. First, recordings of EEG and

autonomic activities in very young, developing mammals do not reveal clear signs of REM and non-REM sleep, reflecting the extreme immaturity of the nervous system. Second, once sleep emerges its amounts are very high and then decline with subsequent development. In mammals, these changes are predominantly due to an initial abundance of REM sleep, which is progressively replaced by non-REM sleep. Sleep amounts eventually stabilize by early adult-hood at which time REM sleep and “deep” non-REM sleep begin to slowly decline, reaching their nadir in senescence [5]. A similar pattern has been reported in fruit flies, where newly hatched flies have much more sleep than adult flies [6]. Third, circadian regulation and homeostatic regulation are quite different in early life. Infant animals do not respond to sleep loss as adults do and circadian rhythms are absent until a certain stage of development [7].

### Sleep State Mechanisms

Non-REM and REM sleep are generated by distinct neural circuits and brain regions. Although the precise mechanisms have not been completely determined, there is consensus that non-REM sleep is generated by hypothalamic and forebrain regions whereas REM sleep is chiefly controlled by brainstem circuits [8]. The forebrain contains populations of neurons that secrete the inhibitory neurotransmitter GABA onto other neurons important in maintaining arousal. The hypothalamus contains several nuclei (e.g. the ►VLPO) that induce sleep when stimulated or in some cases, when warmed (i.e., are temperature sensitive) [9]. These nuclei secrete the inhibitory neuropeptide Galinin onto posterior hypothalamic structures also important in arousal [10]. Within the brainstem are regions that when stimulated produce REM sleep in its entirety, or separate components of REM sleep. These regions include cholinceptive neurons and glutamatergic and GABAergic circuits. Stable state expression appears to be controlled by the peptide hypocretin/►orexin because in its absence the normal alternation of sleep and wakefulness is highly disturbed (e.g., in ►narcolepsy) [9,10].

### References

1. Frank MG (1999) Phylogeny and evolution of rapid-eye-movement (REM) sleep. In: Mallick BN, Inoue S (eds) Rapid eye movement sleep. Narosa, New Delhi, pp 17–38
2. Tobler I (2005) Phylogeny of sleep regulation. In: Kryger MH, Roth T, Dement WC (eds) Principles and practice of sleep medicine, vol 4. Saunders, Philadelphia, pp 72–90
3. Frank MG (2006) The mystery of sleep function: current perspectives and future directions. *Rev Neurosci* 17:375–392
4. Borbely AA (1982) Sleep regulation: circadian rhythm and homeostasis. Current topics in neuroendocrinology. In: Ganten D, Pfaff D (eds) Sleep: clinical and experimental aspects. Springer-Verlag, Berlin, pp 82–103

5. Carskadon MA, Dement WC (2005) Normal human sleep: an overview. In: Kryger MH, Roth T, Dement WC (eds) Principles and practice of sleep medicine, vol 4. Saunders, Philadelphia, pp 13–23
6. Shaw PJ, Cirelli C, Greenspan RJ, Tononi G (2000) Correlates of sleep and waking in *Drosophila melanogaster*. *Science* 287:1834–1837
7. Davis FC, Frank MG, Heller HC (1999) Ontogeny of sleep and circadian rhythms. In: Zee PC, Turek FW (eds) Regulation of sleep and circadian rhythms, vol 133. Marcel Dekker, New York, pp 19–80
8. Jones BE (2005) Basic mechanisms of sleep-waking states. In: Kryger MH, Roth T, Dement WC (eds) Principles and practice of sleep medicine, vol 4. Saunders, Philadelphia, pp 136–153
9. Szymusiak R, Gvilia I, McGinty D (2007) Hypothalamic control of sleep. *Sleep Med* 8:291–301
10. Saper CB, Scammell TE, Lu J (2005) Hypothalamic regulation of sleep and circadian rhythms. *Nature* 437:1257–1263

## Sleep-Wake Autonomic Regulation

BARBARA E. JONES

Department of Neurology and Neurosurgery, McGill University, Montreal Neurological Institute, Montreal, QC, Canada

### Synonyms

Sleep-wake modulation of visceral function

### Definition

Across the ►sleep-wake cycle, functions of the viscera (internal organs) are modulated together with those of the soma (body) in an integral manner. Visceral functions (involving smooth muscles of blood vessels, bronchi, gastrointestinal tract and glands) are generally regulated in an automatic or involuntary manner by the autonomic nervous system. In contrast, somatic functions (involving the skeletal muscles) can be controlled in a voluntary manner through input from the brain to the somatic motor neurons. The autonomic nervous system serves to maintain ►homeostasis (constant state) of the internal milieu, including blood pressure, O<sub>2</sub>/CO<sub>2</sub> concentrations, osmolarity and sugar, while responding to metabolic needs for energy within the organism. In this process, it regulates the cardiovascular, respiratory, endocrine and digestive systems. These in turn also allow the maintenance of a relatively constant body temperature and associated basal metabolism in mammals and birds. The autonomic nervous system controls these systems through its two reciprocally functioning components: the sympathetic and the

parasympathetic. Generally, the sympathetic system supports action of the somatic system by catabolism and mobilization of energy stores to increase energy supply to the skeletal muscles for movement. In contrast, the parasympathetic system functions during rest of the somatic system and is responsible for anabolism and restoration of energy stores. Across sleep-wake states, the sympathetic and parasympathetic systems assume different levels of control and activity such that sleep-wake cycles, as well as their ►circadian organization, permit periods of maximal action during wake and periods of maximal rest during sleep for long term homeostasis of the organism.

There are three distinct states in mammals and birds: ►wake (W), ►slow wave sleep (SWS) and ►paradoxical sleep (PS) or ►rapid eye movement sleep (REMS). Through these states, homeostasis is maintained within an appropriate range of physiological parameters by afferent feedback from receptors and efferent adjustments through the sympathetic or parasympathetic systems. During W, autonomic regulation depends upon behavior, foraging, fighting, fleeing, breeding or eating and resting. During SWS, it is predominated by the parasympathetic division which supports rest and restoration. During PS or REMS, despite continued parasympathetic activity, storms of sympathetic activity occur. Moreover, whereas feedback control is generally robustly exerted during W and SWS, it is blocked or dampened during PS or REMS. This state is called “paradoxical,” since despite inactivity and maximal rest in the somatic postural muscles, phasic bursts of activity occur in the somatic eye, facial and distal flexor muscles in the form of twitches and in the cardiovascular system in the form of blood pressure surges. This phasic activity is similar to bursts of somatic and sympathetic activities which can occur during waking behaviors and thus could reflect ►dreaming activity.

### Characteristics

Autonomic regulation occurs in an integrated manner across multiple peripheral systems and in parallel with somatic systems across sleep-wake states due to coordination by the central nervous system [1–3]. Nonetheless, the regulation of those systems across states can be most easily considered for each system, including principally cardiovascular [4,5], respiratory [6,7], thermal [8], endocrine [9] and digestive [10] regulatory systems.

### Cardiovascular Regulation

Heart rate and blood pressure as well as circulation are regulated during waking by the autonomic nervous system, such that they respond to the demands of activity to be high, stimulated by adrenergic sympathetic input, during walking or running, for example, and attenuated to be low by cholinergic parasympathetic input, during



resting. These autonomic responses occur in parallel with voluntary commands to the somatic system in association with different behaviors. For running, for example, excitation of particular sympathetic ganglia and inhibition of parasympathetic ganglia would stimulate an increase in heart rate and blood pressure and be responsible for an increase in blood flow to the skeletal muscles and decrease in blood flow to the viscera. Adjustments also occur as a function of feedback, positive and negative, to the central nervous system. Thus, a drop in blood pressure upon standing stimulates a compensatory increase in blood pressure through the sympathetic outflow to the heart and major arteries. Excessive increases in blood pressure on the other hand can evoke negative feedback to decrease pressure by inhibiting the sympathetic and exciting the parasympathetic outflow. Cardiovascular regulation during waking is thus a function of behavior and feedback control mechanisms that allow a physiological range of values for action while maintaining healthy homeostasis. An active waking state is stimulated and maintained by ►arousal systems in the brain which in turn promote activity in both the somatic and sympathetic motor systems. Of these, central noradrenaline (NA)-containing ►locus coeruleus (LC) neurons and ►orexin/hypocretin (Orx/Hcrt)-containing hypothalamic neurons are known to excite somatic motor and sympathetic (preganglionic) motor neurons, such that movement and activity are supported by increased cardiovascular function and appropriate circulation.

During SWS, heart rate and blood pressure are on average lower than during waking. It is a state of rest for the body and brain. The sympathetic input to the heart and blood vessels is dampened or silent. The parasympathetic input predominates. Sleep is generated by neural systems in the brain which act to dampen central arousal systems and promote peripheral parasympathetic activity. Of these, neurons in the solitary tract nucleus and surrounding region of the medulla, where vagal afferent and efferent fibers arrive and emerge, have the capacity to promote SWS by central projections, while also evoking decreases in heart rate and blood pressure through peripheral vagus outflow. This circuit can be reflexively triggered by extreme increases in blood pressure that by baroreceptor feedback propagate a vagal-mediated drop in blood pressure and an associated loss of consciousness and muscle tone, or syncope. Neurons in the basal forebrain and ►preoptic area also promote sleep along with parasympathetic changes in heart rate and blood pressure, as evidenced by the effects of electrical stimulation of these regions.

During PS or REMS, heart rate and blood pressure are irregular and manifest sudden surges upon relatively low base levels continuing from SWS. These surges are caused by sudden increases in sympathetic nerve activity upon a background of more continuous

parasympathetic activity. Interestingly, blood vessels to skeletal postural muscles are constricted by sympathetic nerve activity, whereas blood vessels to the viscera and genitals are dilated by inhibition of sympathetic nerve activity, indicating differential sympathetic control and resulting circulation during this state. PS is promoted in the ►brainstem by discharge of cholinergic neurons in the pontomesencephalic tegmentum while other neurons of the arousal systems, importantly the NA and Orx/Hcrt neurons, are silent. The cessation of activity in the latter neurons results in a disfacilitation of sympathetic as well as somatic motor neurons. Particular GABAergic and glycinergic neurons are additionally responsible for tonic inhibition of the somatic postural motor neurons. At the same time, other glutamatergic reticulo-spinal neurons discharge in phasic bursts, stimulating rapid eye movements and twitches of facial and distal flexor somatic motor neurons. Such phasic excitation is presumably also transmitted in parallel to certain sympathetic (preganglionic) motor neurons in the spinal cord to stimulate blood pressure surges and tachycardia.

### Respiratory Regulation

During ►waking, respiration is regulated as a function of activity and the corresponding need for oxygen uptake and carbon dioxide dissipation. With increasing use of muscles stimulated by locomotion, for example, respiration is increased. This response involves both the somatic and visceral motor systems; the diaphragm and intercostal muscles are striate muscles and under voluntary control through somatic motor neurons for breathing, and the bronchial dilator muscles are smooth muscles and under involuntary control of the autonomic nervous system. There is also feedback control through the vagus which stimulates respiration in response to changes in oxygen or carbon dioxide. During active wakefulness, arousal systems in the brain facilitate respiratory motor neurons in the spinal cord for increased ventilation and excite preganglionic sympathetic neurons to dilate the bronchial muscles for greater gaseous exchange in the lungs. There is also a facilitatory influence upon the respiratory rhythmic pattern generator neurons in the medulla. On the other hand, some behaviors can be associated with voluntary breath control and holding that can override to a certain extent the rhythm pattern generator and feedback control.

During SWS, respiration is rhythmic and slow. Feedback mechanisms function to increase rate in response to changes in oxygen or carbon dioxide, although the threshold for this response is slightly higher.

During PS or REMS, respiration can be irregular, somewhat like it can be during waking, particularly during periods of phasic twitches and rapid eye movements. In parallel with the atonia of the postural

muscles, there is also a relative loss of tone in the muscles of the air passages. And there is a relative inhibition of sensory-motor reflexes in the visceral as in the somatic systems, such that the threshold for arousal and increased ventilation with decreasing oxygen and increasing carbon dioxide concentrations in the blood is greatly increased. For these reasons, PS can be associated with relative hypoxia and hypercapnia. In normal animals or humans on the other hand, this state is perhaps not entirely different from certain waking periods in association with particular behaviors and thus might reflect dreaming activity.

### Thermal Regulation

In most mammals and birds, body temperature is maintained in a fairly narrow range. For this purpose, energy is expended and thus metabolism increased for warming the body in cold ambient temperatures or for cooling the body in hot ambient temperatures. These regulatory changes are effected through the somatic and autonomic nervous systems which by integral adjustments stimulate changes in behavior and physiological processes. These include included adoption of heat conserving postures (curled), shivering, cutaneous vasoconstriction and shallow breathing for warming in cool environments or adoption of heat dissipating postures (outstretched), cutaneous vasodilatation, sweating and panting for cooling in warm environments. All of these mechanisms function through feedback control during waking behaviors. Generally, increases in somatic motor activity are associated with increases in metabolic rate and temperature up to a point at which cooling mechanisms are activated. The regulatory centers and neurons for temperature sensing and adjustment are in the ► **hypothalamus** and preoptic area where they overlap with sleep-wake promoting systems.

During SWS, body and brain temperature along with metabolism are lower than during waking due not simply to reduced activity, but also to a change in the thermostatic set point of the thermal regulatory system. A thermal regulatory posture is adopted in SWS which is thus dependent upon the ambient temperature, curled in cold or outstretched in hot environments. Other autonomic adjustments to changing temperatures also function as during waking, however at a lower body temperature. In fact with the onset of sleep, cutaneous vasodilatation occurs and is associated with cooling of the body and brain by  $\sim 1^\circ$  or so during SWS. These changes are promoted by warm-sensitive, sleep promoting neurons in the preoptic area.

During PS or REM sleep, thermal regulatory systems do not function in the same way they do in most periods of waking or SWS. The feedback circuits are closed and somatic along with many sympathetic motor neurons are inhibited, so that shivering or sweating cannot be induced during PS by changes in ambient temperature.

On the other hand, given surface and muscle vasoconstriction and visceral vasodilatation (above), core body temperature is well conserved during PS and brain temperature actually increases along with the increases in activity and metabolism that occur in the brain during this state.

### Endocrine Regulation

Through multiple endocrine systems, which release various hormones into blood and body fluids to act on target cells in different organs, metabolism and temperature along with many functions of the body and organism are kept within a healthy range. Collectively, they maintain the nutrient, mineral and water fluxes of the internal milieu and also serve special functions for growth and reproduction. These hormonal systems are in turn regulated by the autonomic and central nervous systems. Several important hormones show sleep-wake, as well as circadian, changes or regulation in their release. The corticosteroids, cortisol in humans, which mobilize energy stores for catabolism to support increased metabolism for activity, are maximal in association with or anticipation of waking periods, starting in the early morning for humans, and minimal during sleep, particularly SWS in the first part of the night for humans. Conversely, release of growth hormone and prolactin, which mobilize energy stores for restorative protein synthesis and growth, is maximal during SWS in the first part of the night for humans. In hydromineral regulatory systems, plasma renin which stimulates through angiotensin, retention of sodium and water by the kidney, increases during periods of SWS in response to SWS-associated decreases in blood pressure and volume. ► **Melatonin** is high throughout the night, but is absent in daytime.

### Digestive Regulation

Digestion is obviously a function of eating, which is done during waking, but the gastrointestinal system and associated endocrine systems are regulated across the sleep-wake cycle as well. Digestion is controlled by the enteric nervous system, which is influenced by the autonomic nervous system but can also function almost independently in the process of digestion, particularly digestive peristalsis. Nonetheless, the parasympathetic system is importantly involved in the secretion of digestive juices, including saliva and gastric acid, and in visceral motility. Selective and reciprocal changes in sympathetic and parasympathetic components are also responsible for diverting circulation from the skeletal muscles to the smooth muscles of the viscera to support gastrointestinal activity. Similarly, the parasympathetic system through ► **acetylcholine** stimulates insulin release from the beta cells, whereas the sympathetic through noradrenaline inhibits insulin release from the beta cells and stimulates glucagon release from the alpha

cells of the pancreas. Insulin promotes uptake of glucose and its storage as ►glycogen in liver and muscle cells. Glucagon prevents these and stimulates glycogenolysis for mobilization and use of glucose. Thus during waking, dependent upon consumption of a meal, the parasympathetic system stimulates digestion and an anabolic state of replenishing energy stores during periods of rest, whereas the sympathetic system inhibits digestion and promotes a catabolic state of energy mobilization and expenditure during motor activity.

During SWS as during rest, when the parasympathetic system predominates, digestion of food can continue. Generally, however, food is digested prior to sleep onset, and digestive activity is relatively quiescent during sleep. Nonetheless, gastric acid secretion continues. Insulin release is quite high during the night in humans. Insulin release is highest in the early part of the night during SWS when growth hormone release is also high, rendering this period and state of rest a maximal anabolic state, since the release of insulin together with growth hormone would stimulate uptake of amino acids and protein synthesis in multiple tissues.

Relatively little is known concerning changes in digestive or metabolic processes during PS or REMS, relative to SWS. However, given the storms of sympathetic activity that occur during PS, many digestive and hormonal processes can be differentially affected during this state.

### Summary of Physiological Regulation Across Sleep-Wake States

During waking, homeostatic processes involving positive and negative feedback maintain the body in a relatively balanced state while permitting activity to modulate various systems within a healthy range. Under conditions of high activity involving locomotion, fight or flight, central arousal systems activate both somatic and sympathetic motor systems. These systems are also activated by hunger and promotion of food seeking behaviors. Blood pressure, heart rate, blood supply to muscles, respiratory rate, temperature, cortisol and glucagon release are all increased for supply of energy in these catabolic states. At the same time, blood supply to the viscera, digestive processes, growth hormone, prolactin and insulin release are all decreased and energy storage thus prevented. Following consumption of a meal, an anabolic state of rest usually follows during which the sympathetic nervous system is inhibited and the parasympathetic nervous system activated. This condition allows for digestion by facilitation of gastrointestinal activity along with secretion of acid and digestive juices. Release of insulin is stimulated and promotes uptake of glucose and replenishment of fuel stores.

SWS also is a state of rest but one which allows maximal rest and restoration of fuel stores. This

anabolic state is characterized by somatic inactivity and a predominance of parasympathetic activity in the periphery, centrally promoted by sleep promoting systems in the brainstem and preoptic area. Blood pressure, heart rate, respiration, body temperature and basal metabolism along with corticosteroid release are all at their lowest levels. Digestive processes are relatively quiescent as digestion of food has usually been completed. On the other hand, insulin is high along with growth hormone and prolactin release which collectively stimulate amino acid uptake and protein synthesis for repair and growth along with replenishment of energy stores in multiple tissues. SWS is thus an anabolic state allowing for large homeostatic adjustments in all physiological systems for reestablishing and maintaining balance in energy stores and a healthy condition of tissue in adult organisms, as well as growth in immature organisms.

PS or REMS is truly a “paradoxical” state since it is also an anabolic state of sleep and continued rest for the antigravity skeletal muscles, yet is a catabolic state with high activity for the brain and some rapid or twitching muscles, along with the sympathetic nervous system through which surges in heart rate, blood pressure, and respiration occur. During this state, the feedback mechanisms which are fundamental to homeostasis are inhibited, such that cardiovascular, respiratory and thermal regulation are blunted. Such changes may reflect conditions which can also occur with active behaviors during waking and thus dream activity or processes during this “paradoxical” state.

### References

1. Parmeggiani PL (2005) Physiologic regulation in sleep. In: Kryger MH, Roth T, Dement WC (eds) Principles and practice of sleep medicine. Elsevier Saunders, Philadelphia, pp 185–191
2. Jones BE (2005) Basic mechanisms of sleep-wake states. In: Kryger MH, Roth T, Dement WC (eds) Principles and practice of sleep medicine. In: Elsevier Saunders, Philadelphia, pp 136–153
3. McGinty D, Szymusiak R (2005) Sleep-promoting mechanisms in mammals. In: Kryger MH, Roth T, Dement WC (eds) Principles and practice of sleep medicine. Elsevier Saunders, Philadelphia, pp 169–184
4. Verrier RL, Harper RM, Hobson JA (2005) Cardiovascular physiology: central and autonomic regulation. In: Kryger MH, Roth T, Dement WC (eds) Principles and practice of sleep medicine. Elsevier Saunders, Philadelphia, pp 192–202
5. Franzini C (2005) Cardiovascular physiology: the peripheral circulation. In: Kryger MH, Roth T, Dement WC (eds) Principles and practice of sleep medicine. Elsevier Saunders, Philadelphia, pp 203–212
6. Orem J, Kubin L (2005) Respiratory physiology: central neural control. In: Kryger MH, Roth T, Dement WC (eds) Principles and practice of sleep medicine. Elsevier Saunders, Philadelphia, pp 213–223

7. Douglas NJ (2005) Respiratory physiology: control of ventilation. In: Kryger MH, Roth T, Dement WC (eds) Principles and practice of sleep medicine. Elsevier Saunders, Philadelphia, pp 224–231
8. Heller HC (2005) Temperature, thermoregulation and sleep. In: Kryger MH, Roth T, Dement WC (eds) Principles and practice of sleep medicine. Elsevier Saunders, Philadelphia, pp 292–304
9. Van Cauter E (2005) Endocrine physiology. In: Kryger MH, Roth T, Dement WC (eds) Principles and practice of sleep medicine. Elsevier Saunders, Philadelphia, pp 266–282
10. Orr WC (2005) Gastrointestinal physiology. In: Kryger MH, Roth T, Dement WC (eds) Principles and practice of sleep medicine. Elsevier Saunders, Philadelphia, pp 283–291

## Sleep-Wake Cycle

DERK-JAN DIJK

Surrey Sleep Research Centre, University of Surrey,  
Guildford, Surrey, UK

### Synonyms

Sleep-wake rhythms; Wake-sleep cycle

### Definition

The rhythmic alternation between two behavioral states: sleep and wakefulness. The rhythmic regulation of the alternation between these two states usually refers to rhythms with a circadian period.

### Characteristics

#### Sleep and the Sleep-Wake Cycle

The defining behavioral characteristics of sleep that are used to identify sleep in many animals are: (i) a species-specific posture; (ii) reduced responsiveness to external stimuli; (iii) rebound after deprivation see [1].

The assessment of a species-specific posture requires around-the-clock behavioral observations. In most species, sleep will be accompanied by behavioral quiescence. In some species, such as dolphins, sleep verified by electrophysiological recordings has been observed while the animal is behaving.

Variation in responsiveness across putative sleep and wake states can be assessed by quantification of arousal thresholds for standardized tactile, auditory, or other stimuli. Animals can be deprived from sleep by continuous stimulation through handling or engagement of the animal in activities such as exploration or forced locomotor activity. A rebound of the putative sleep state after a period of deprivation is indicative of homeostatic

regulation of sleep and is considered a characteristic that differentiates between a simple circadian rhythm and a homeostatically regulated state.

### NREM and REM Sleep

In mammals and birds sleep can be subdivided in two very different sleep states: ►non-rapid-eye movement (NREM) sleep and ►rapid-eye movement sleep (REM) see [1,2]. The two states are identified by simultaneous recording of the ►electroencephalogram (EEG), the electroculogram (EOG) and muscle tone (►electromyogram, EMG). NREM sleep is characterized by low frequency, high amplitude EEG patterns and absence of rapid eye movements. In mammals, ►sleep spindles and slow waves (also referred to as ►slow-wave activity, SWA, or delta waves) are defining EEG characteristics of NREM sleep. In humans, NREM sleep is subdivided in stages 1–4 which contain progressively more SWA. During REM sleep, the EEG patterns resemble those of quiet wakefulness, while at the same time rapid eye movements and atonia in skeletal muscles are observed. The major neuromodulatory systems, including the noradrenergic, serotonergic, histaminergic, cholinergic, and orexinergic systems, are implicated in the alternation between the three vigilance states, NREM, REM and wakefulness. NREM and REM sleep alternate with an ►ultradian periodicity within the sleep episode. The period of this ultradian rhythm varies both within and between species and is proportional to brain size. The ultradian rhythm in REM sleep is generated by the reciprocal interaction of neuronal populations in the upper brain stem and hypothalamus.

### Homeostatic Regulation of Sleep and its Function

When animals are provided with *ad libitum* sleep opportunity following a period of enforced wakefulness, i.e., total ►sleep deprivation, an increase in sleep is observed see [3–5]. In mammals, total sleep deprivation leads to an increase in total sleep time, an increase in SWA in NREM sleep and an increase in REM sleep time. Selective deprivation of REM sleep is followed by an increase in REM sleep, and selective deprivation of ►slow-wave sleep (SWS) or SWA leads to a selective enhancement of SWA. SWA in NREM is under strict homeostatic control and mathematical models describing its dependence on the sleep-wake history are available for rats and humans. SWA is also affected by specific experiences during wakefulness, such as explorative behavior, intense somatosensory stimulation and learning. This accurate control of SWA has led to the hypothesis that slow waves are an important aspect of sleep and that they reverse non-specific detrimental effects of wakefulness on the central nervous system. Current hypotheses on the function of sleep for the central nervous system

emphasize the role of SWS in reversing the increase in synaptic strength and the role of both REM and NREM sleep in consolidation of procedural and declarative memories.

### Circadian Regulation of Sleep

In nocturnal species such as rats and mice, wakefulness predominates during the night and sleep during the day see [6–9]. In ►diurnal species, such as humans and fruit flies, wakefulness occurs primarily during the day and sleep at night. This association between the ►light-dark cycle and the predominance of sleep is, in itself, not sufficient to conclude that it is regulated by endogenous circadian rhythms. Involvement of circadian process in the regulation of sleep can be ascertained by quantifying its occurrence while the organism is studied under constant environmental conditions, i.e., in the absence of rhythmic variations in variables such as light and temperature. If sleep and wakefulness are not uniformly distributed but the probability of their occurrence varies with a periodicity in the circadian range, then it is safe to assume that circadian processes are involved.

In all species in which sleep has been identified, circadian processes play a role in its regulation. In mammals the role of circadian processes has been studied by ablation of the ►suprachiasmatic nuclei (SCN) of the hypothalamus, which are the locus of the ►pacemaker driving circadian rhythms in physiology and behavior. SCN lesions abolish neither the occurrence of sleep, nor its homeostatic regulation. Although specific aspects of sleep structure, such as REM sleep, and EEG phenomena, such as ►sleep spindles, are modulated by circadian processes, the circadian regulation of sleep primarily concerns its timing. Whereas in the intact animal the distribution of sleep and wakefulness is circadian, in the SCN-lesioned animals sleep and wakefulness are distributed uniformly across the 24 h period. The SCN exert its influence on sleep through indirect projections via the dorsal medial hypothalamus to areas involved in the generation of sleep and wakefulness which are located in the hypothalamus, the thalamus and the brainstem. The SCN also modulate sleep propensity through their influence on the circadian rhythms in other variables, such as body temperature and the pineal hormone ►melatonin.

Alterations of some of the core ►clock genes involved in the generation of circadian process do not abolish sleep or the homeostatic response to sleep loss but lead to modifications in total sleep time, sleep structure and the homeostatic regulation of sleep in animals and humans. For example, in mice devoid of the *Cry1* and *Cry2* genes, EEG SWA, which is a primary marker of sleep homeostasis, is enhanced and total sleep time is increased. In humans, a polymorphism in the *PER3* gene is associated with an enhancement of SWA in NREM

sleep, and theta and alpha activity in the EEG in wakefulness and REM sleep.

### Interaction of the Homeostatic and Circadian Regulation of Sleep-Wake Cycles in Humans

The interaction of sleep regulatory and circadian processes has been studied in detail in humans see [6,10]. Early experiments by Aschoff and Wever in Germany and Czeisler and Weitzman in the US established that the human sleep-wake cycle persists with a near 24-h period in the absence of an externally imposed light-dark or clock time cycles. These observations demonstrated the endogenous circadian nature of the ►sleep-wake cycle also in humans. Furthermore, both research groups reported that the sleep-wake cycle can dissociate from the endogenous circadian rhythms of other variables, such as core body temperature and urine volume. This phenomenon, which was called spontaneous ►desynchrony, demonstrates that the sleep-wake cycle is generated by the interaction of two oscillatory processes, which in the two-process model of sleep regulation are referred to as a circadian and a homeostatic ►oscillator.

According to this standard model, the circadian oscillator regulates the preferred timing of sleep and the homeostatic oscillator tracks sleep debt, which increases during wakefulness and dissipates during sleep. The deep circadian oscillator is synchronized to the 24-h geophysical cycles primarily through circadian variation in its sensitivity to ocular light exposure. The mechanisms underlying the synchronization between the homeostatic and circadian oscillator are not well understood. Under normal, entrained conditions, when we are active during the day, and sleep at night, the two oscillators are in synchrony.

Desynchrony between the two oscillators occurs during ►shift work and ►jet-lag and has been induced in the laboratory in forced-desynchrony experiments. Under these conditions the circadian oscillator can be tracked by the rhythm of melatonin, and has been shown to oscillate with a period of approximately 24.2 h. Circadian wake propensity, as assessed by the latency to sleep onset (Fig. 1b), or the intrusion of wakefulness in scheduled sleep episode (Fig. 1c), is greatest just prior to the onset of nocturnal melatonin secretion, which under entrained conditions occurs at approximately 22:00 h (Fig. 1d). Circadian sleep propensity is strongest at the nadir of the core body temperature rhythm, which in healthy individuals is located at approximately 06:00 h (Fig. 1e). The homeostatic oscillator can be tracked by slow EEG oscillations in the sleep and wake EEG. Homeostatic sleep pressure increases during the waking day (Fig. 1a), in parallel to the increase in the circadian drive for wakefulness and declines during the nocturnal sleep episode, in parallel to the increase in the circadian

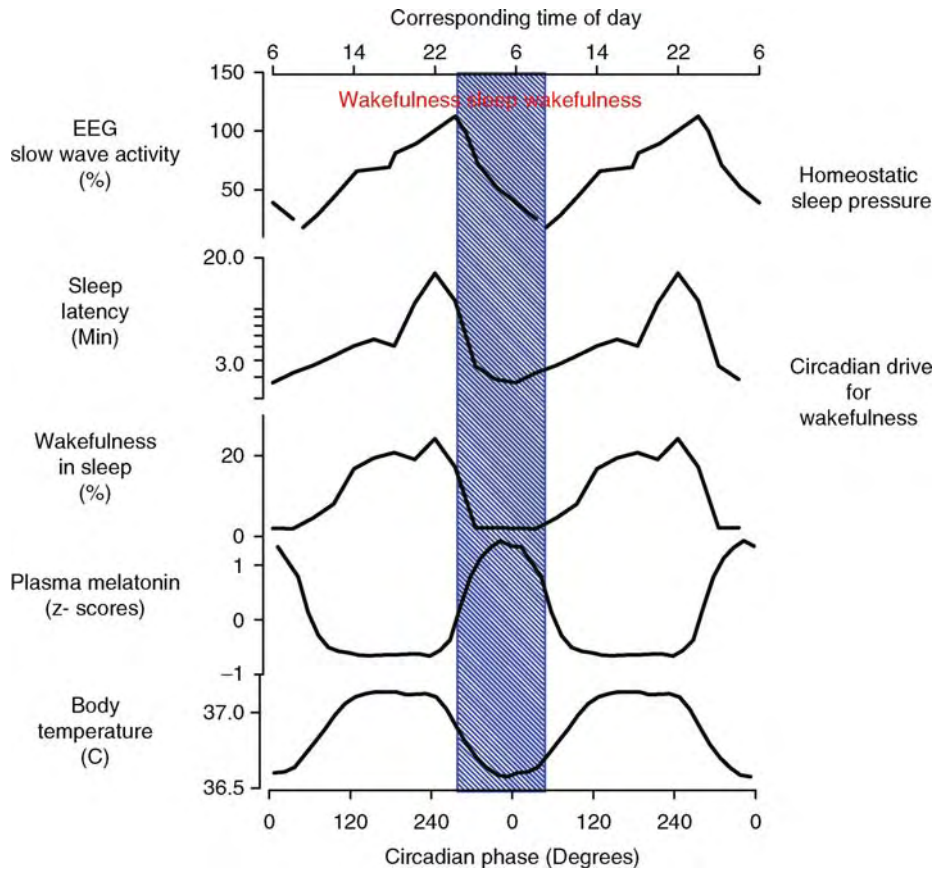

**Sleep-Wake Cycle. Figure 1** Circadian and homeostatic regulation of sleep and wakefulness in humans. Panel A: Increase of homeostatic sleep pressure during wakefulness and its dissipation during sleep as reflected in EEG SWA during daytime naps and nocturnal sleep. Circadian variation in wake/sleep propensity as reflected in the latency to sleep onset (Panel B) after 18 h:40 min of wakefulness and wakefulness (Panel C) in sleep opportunities, measured during forced desynchrony of the sleep-wake cycle and endogenous circadian rhythms of melatonin (Panel D) and core body temperature (Panel E).

drive for sleep. It is through these opposing homeostatic and circadian processes that the sleep-wake cycle remains consolidated when the two oscillators are synchronized during **▶entrainment**. During disruption of this desynchrony, as occurs during shift work, jet lag and in circadian sleep disorders, sleep consolidation and waking performance are compromised.

## References

1. Siegel JM (2005) Clues to the functions of mammalian sleep. *Nature* 437:1264–1271
2. Saper CB, Scammell TE, Lu J (2005) Hypothalamic regulation of sleep and circadian rhythms. *Nature* 437:1257–1263
3. Borbély AA, Dijk DJ, Achermann P, Tobler I (2001) Processes underlying the regulation of the sleep-wake cycle. In: Takahashi JS, Turek FW, Moore RY (eds) *Circadian clocks*. Kluwer Academic/Plenum Publishers, New York, pp 457–479
4. Maquet P (2001) The role of sleep in learning and memory. *Science* 294:1048–1052
5. Tononi G, Cirelli C (2006) Sleep function and synaptic homeostasis. *Sleep Med Rev* 10:49–62
6. Czeisler CA, Dijk DJ (2001) Human circadian physiology and sleep-wake regulation. In: Takahashi JS, Turek FW, Moore RY (eds) *Circadian clocks*. Kluwer Academic/Plenum Publishers, New York, pp 531–569
7. Mistlberger RE (2005) Circadian regulation of sleep in mammals: role of the suprachiasmatic nucleus. *Brain Res Brain Res Rev* 49:429–454
8. Dijk DJ, Franken P (2005) Interaction of sleep homeostasis and circadian rhythmicity: dependent or independent systems. In: Kryger MH, Roth T, Dement WC (eds) *Principles and practice of sleep medicine*. Elsevier Saunders, Philadelphia, pp 418–434
9. Viola AU, Archer SN, James LM, Groeger JA, Lo JC, Skene DJ, von Schantz M, Dijk DJ (2007) *PER3* polymorphism predicts sleep structure and waking performance. *Curr Biol* 17:613–618
10. Dijk D-J, Duffy JF, Riel E, Shanahan TL, Czeisler CA (1999) Ageing and the circadian and homeostatic regulation of human sleep during forced desynchrony of rest, melatonin and temperature rhythms. *J Physiol* 516 (pt 2):611–627

## Sleep-Wake Mechanisms

BARBARA E. JONES

Department of Neurology & Neurosurgery, McGill University, Montreal Neurological Institute, Montreal, QC, Canada

### Synonyms

Sleep-wake neurochemical substrates

### Definition

Mechanisms comprising the neural systems and their neurotransmitters which generate the three major states of mammals: wake (W), slow wave sleep (SWS) and paradoxical sleep (PS) or rapid eye movement sleep (REMS).

### Characteristics

The sleep-wake mechanisms comprise the neural systems and their neurotransmitters which generate the three major states of mammals: ►wake (W), ►slow wave sleep (SWS) and ►paradoxical sleep (PS) or ►rapid eye movement sleep (REMS) (see Fig. 1). W is a behaviorally active and responsive state with phasic and tonic activity on the electromyogram (EMG) recorded from the postural muscles, and fast activity (gamma, 30–60 Hz) on the electroencephalogram (EEG) recorded from the cerebral cortex. SWS is a behaviorally quiet state with low muscle tone on the EMG and large slow waves (delta, 0.5–4 Hz) on the EEG. PS or REMS is a “paradoxical” state because it is characterized by muscle atonia on the EMG of the axial postural muscles, yet by rapid eye movements and small twitches of the facial and distal flexor muscles. It is also characterized behaviorally by a lack of responsiveness, typical of sleep, yet by fast (gamma) activity on the EEG, typical of cortical activation and W.

The neural systems generating these states are located through the ►brainstem, hypothalamus and basal forebrain (BF) and give rise to either descending projections to the spinal cord, by which they influence movement and muscle tone (recorded on the EMG), or ascending projections to the cerebral cortex, by which they influence cortical activity (recorded on the EEG) (see Fig. 1).

The different neural systems utilize different chemical neurotransmitters, which include most importantly: ►glutamate (Glu), GABA, ►acetylcholine (ACh), noradrenaline (NA), ►histamine (HA) and ►orexin (►Orx or ►hypocretin, ►Hcrt) (see Fig. 1). Since except for Glu and GABA, these chemicals serve as neuromodulators upon specific receptors on specific cells, they can generate specific states or the specific EMG or EEG activities of those states.

Specific neural groups with particular projections and neurotransmitters discharge during particular states or in association with particular EMG or EEG activities of those states such as to exert their influence in a state selective and determining manner (see Fig. 1).

### Neural Systems and Their Neurochemical Substrates

#### Arousal Systems

##### *The Reticular Formation (RF) and Glutamate (Glu)*

Since the early studies of Moruzzi and Magoun, it has been known that the RF, which is a netlike web of cells and passing fibers in the brainstem, is essential for the ►maintenance of wakefulness, as its destruction by large lesions results in a comatose state [2]. Neurons of the RF give rise to descending projections into the spinal cord by which they influence movement and muscle tone or to ascending projections into the forebrain by which they influence through other relays, cortical activity (see Fig. 1). Through a dorsal pathway, the RF neurons project onto midline and intralaminar neurons in the thalamus, which project in turn in a widespread manner to the cerebral cortex, as the nonspecific thalamo-cortical projection system. Through a ventral pathway, the RF neurons project to and through the hypothalamus and up to the BF from where other neurons also project in turn in a widespread manner to the cerebral cortex, as the basalo-cortical projection system.

Most projection neurons in the RF likely utilize Glu as a neurotransmitter and would accordingly excite their target neurons in the spinal cord or forebrain (Fig. 1).

Neurons in the caudal pontine and medullary RF with predominantly descending projections discharge maximally during waking and in association with movement and muscle tone. Those more concentrated in the oral pontine and mesencephalic RF with predominantly ascending projections discharge maximally during waking and in association with cortical activation. Collectively, these RF neurons stimulate and maintain by their activity and release of Glu, behavioral ►arousal with muscle tone and cortical activation.

##### *Cortical Activation and Acetylcholine (ACh)*

From very early studies, ACh has been known to play a very important role in cortical activation [1–3]. Drugs which enhance or mimic cholinergic transmission, such as physostigmine and nicotine, enhance cortical activation, whereas those which block ACh receptors, such as atropine, diminish fast cortical activity, which is replaced by slow wave activity. Interestingly, however, blocking cortical activation with atropine does not prevent movement or behavioral arousal and so produces a dissociation between cortical activity and behavior. Moreover, ACh release from the cortex is high in association with cortical activation during both W and PS. And, injections of the cholinergic agonist,

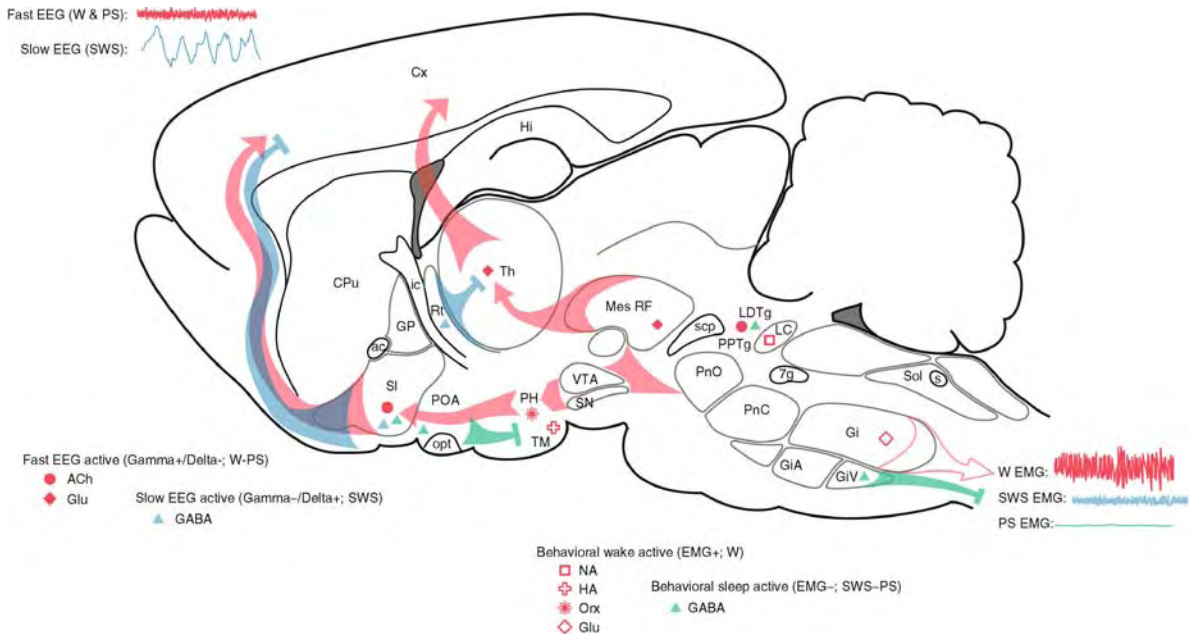

**Sleep-Wake Mechanisms. Figure 1** Sleep-wake state neurochemical substrates. Sagittal schematic view of the rat brain depicting neurons with their chemical neurotransmitters and pathways by which they influence cortical activity or behavior across the sleep/wake cycle. Wake (W) is characterized by fast gamma activity on the cortical EEG (upper left) and high postural muscle tone on the neck EMG (lower right); slow wave sleep (SWS) by slow delta EEG and low tone on the EMG; and paradoxical sleep (PS) by fast gamma EEG and atonia on the EMG. Neurons which are active during waking (red symbols) include cells with ascending projections toward the cortex which stimulate fast cortical activity and cells with descending projections toward the spinal cord which stimulate postural muscle tone and behavioral waking. Those with predominantly ascending projections discharge in association with fast EEG activity (gamma+) and cease firing with delta activity (delta-) to be active during both W and PS (filled red symbols); they include cholinergic (ACh) and glutamatergic (Glu) neurons. Those with more diffuse or descending projections discharge in association with behavioral arousal and EMG activity (EMG+) and cease firing with muscle atonia to be active during W and silent during PS (empty red symbols); they include noradrenergic (NA), histaminergic (HA), orexinergic (Orx) and some putative glutamatergic (Glu) neurons. Neurons which are active during sleep (blue and aqua symbols) include cells with ascending projections toward the cortex which dampen fast cortical activity and those with descending projections toward the brainstem and spinal cord which diminish behavioral arousal and muscle tone. Those with projections to the cortex discharge in association with slow EEG activity (gamma-/delta+) during SWS (blue triangles) and include certain GABAergic neurons in the basal forebrain (BF) and preoptic area. Also shown are GABAergic neurons of the nucleus reticularis in the thalamus that discharge in bursts with sleep spindles and slow waves to inhibit and pace thalamocortical relay neurons. In the BF and preoptic area, presumed GABAergic neurons with descending projections increase their firing as muscle tone progressively decreases (EMG-) during SWS and PS (aqua symbols). Also shown are GABAergic (and/or glycinergic) neurons in the ventral medulla that project directly to the spinal cord where they could inhibit neck and other motor neurons during sleep. Abbreviations: 7g, genu 7th nerve; ac, anterior commissure; ACh, acetylcholine; CPu, caudate putamen; Cx, cortex; EEG, electroencephalogram; EMG, electromyogram; Gi, gigantocellular RF; GiA, gigantocellular, alpha part RF; GiV, gigantocellular, ventral part RF; GP, globus pallidus; Hi, hippocampus; ic, internal capsule; LC, locus coeruleus; LDTg, laterodorsal tegmental nucleus; Mes RF, mesencephalic RF; NA, noradrenaline; opt, optic tract; PH, posterior hypothalamus; PnC, pontine, caudal part RF; PnO, pontine, oral part RF; POA, preoptic area; PPTg, pedunculopontine tegmental nucleus; PS, paradoxical sleep; RF, reticular formation; Rt, reticularis nucleus of the thalamus; s, solitary tract; scp, superior cerebellar peduncle; SI, substantia innominata; SN, substantia nigra; Sol, solitary tract nucleus; SWS, slow wave sleep; Th, thalamus; TM, tuberomammillary nucleus; VTA, ventral tegmental area (Modified from [1]).

carbachol into the brain and particularly into the oral pontine RF produce a state with cortical activation in association with muscle atonia or the state of PS. ACh and cholinergic neurons thus elicit cortical activation in the presence or absence of behavioral

arousal and thus likely stimulate cognitive processes during both W and PS. They may even elicit attenuation of movement or muscle tone along with attentive immobility during waking or with dreaming during PS.



Cholinergic neurons are located in the brainstem, where they are clustered in the dorsolateral pontomesencephalic tegmentum within the laterodorsal and pedunculopontine tegmental nuclei (LDT and PPT). The LDT and PPT neurons project locally into the brainstem RF and rostrally to the thalamus, hypothalamus and BF. ACh excites thalamo-cortical projection neurons to promote their tonic discharge and thus to promote through them, fast cortical activity or cortical activation [4]. Cholinergic neurons are also located in the BF, where they comprise the magnocellular basal nucleus of Meynert within the substantia innominata (SI, see Fig. 1). In the rat brain, they are distributed as well within the magnocellular preoptic nucleus (MCPO), nucleus of the diagonal band of Broca (DBB) and medial septum (MS). Collectively, the BF cholinergic neurons innervate all of the neocortex and hippocampus. ACh excites pyramidal cells in the cortex and thus promotes therein fast cortical activity while blocking slow wave activity [4].

Immunohistochemically identified cholinergic neurons have to date only been recorded in the BF. The BF ACh cells discharge in association with fast cortical activity ( $\gamma$ +/ $\delta$ -) during W and PS (as W-PS active cells) (see Fig. 1). Presumed cholinergic neurons in the LDT and PPT discharge in a similar manner. They can thus collectively stimulate cortical activation during both W and PS.

### **Behavioral Arousal, Noradrenaline (NA) and Dopamine (DA)**

The catecholamines, NA and DA have been known to stimulate arousal since early pharmacological studies [2,3,5]. Amphetamine, which releases both NA and DA, evokes prolonged wakefulness characterized by cortical activation and behavioral arousal.

NA-containing neurons are located in the brainstem and clustered in the **▶locus coeruleus (LC)** in the pons (see Fig. 1). The LC neurons give rise to highly diffuse projections. They project into the brainstem and spinal cord and directly innervate and excite motor neurons. They project into forebrain subcortical relay stations of the thalamus, hypothalamus and BF and also directly up to the cerebral cortex. In the thalamus, NA excites the thalamo-cortical projection neurons and in the BF, it excites the cholinergic basalo-cortical neurons. In the cortex, it also excites pyramidal cells to stimulate fast cortical activity [4]. When NA neurons discharge and NA is released, they would thus stimulate both behavioral arousal and cortical activation. LC neurons discharge selectively during waking and at highest rates during active waking. They decrease and cease firing during SWS and PS.

DA-containing neurons are located in the diencephalon and mesencephalon, being most numerous in the substantia nigra (SN) and ventral tegmental area (VTA).

The latter cell groups project into the forebrain, particularly the striatum, amygdala, BF and prefrontal cortex. Both through pharmacological studies and clinical studies of Parkinson's patients, suffering from degeneration of DA neurons, DA is known to play an important role in movement. However, their influence in this domain occurs through forebrain centers, including limbic structures and thus by promoting movement but not directly stimulating it through action upon motor neurons. Given its release by many addictive drugs, DA is also known to be positively rewarding. Upon recording, presumed DA neurons were surprisingly found to discharge during waking and sleep, although in different patterns. They discharge in bursts with rewarding stimuli during W and they do so during PS, perhaps underlying the emotional components of **▶dream** activity.

### **Behavioral Arousal and Histamine (HA)**

HA has been known to stimulate waking since anti-histaminergic drugs diminish cortical activation and produce sleepiness [2,5,6]. The HA neurons are located in the **▶tuberomammillary (TM) nucleus** of the hypothalamus (see Fig. 1). They give rise to highly diffuse projections into the forebrain and also though to a lesser extent the brainstem and spinal cord. HA excites neurons in the thalamus, BF and cortex, stimulating cortical activation. They discharge during waking and cease firing during sleep.

### **Behavioral Arousal and Orexin (Orx)/Hypocretin (Hcrt)**

Following its discovery ~10 years ago, Orx/Hcrt was found to be essential for the maintenance of waking and behavioral arousal, since in its absence or that of its receptor, **▶narcolepsy** with cataplexy occurs in mice, dogs and humans [1,5-7]. In humans, this condition is characterized by excessive daytime sleepiness, sleep onset REMS, paralysis and hallucinations. Cataplexy or sudden loss of muscle tone is often triggered by strong emotions and particularly laughter. Given the almost direct entry into REMS or loss of muscle tone accompanied by hallucinations, this disorder is thought to be a disorder of REMS. Its appearance in absence of Orx/Hcrt indicates that Orx/Hcrt neurons sustain behavioral arousal with postural muscle tone, particularly under conditions of strong emotion when other systems, perhaps cholinergic (above), precipitate a loss of muscle tone. The neurons which contain Orx/Hcrt are located in the posterior hypothalamus (see Fig. 1) and like NA LC neurons give rise to highly diffuse projections through the forebrain, brainstem and spinal cord. In the spinal cord, they innervate and excite motor neurons. In the brainstem and forebrain, they innervate and excite the neurons of the other arousal systems, including the ACh LDT/PPT and BF neurons, the NA LC neurons, and the HA TM neurons, together with neurons of the diffuse

thalamo-cortical projection system and deep layers of the cortex. They also directly excite somatic and sympathetic motor neurons. Their discharge would thus be associated with cortical activation and behavioral arousal with increased muscle tone and sympathetic activity. Immunohistochemically identified Orx/Hcrt neurons were indeed found to discharge during active waking, decrease firing during quiet waking and cease firing during sleep, including PS.

### Sleep Systems

#### GABA

GABA has long been known to be important in promoting sleep, since the major hypnotic drugs and many anesthetics act by enhancing GABAergic transmission [1,5,8]. GABAergic neurons are located through all regions of the brain and of course are critical for normal functioning during waking of all neural circuits. However, particular GABAergic neurons are responsible for inhibiting and/or shaping the discharge of neurons of the arousal and activating systems.

As learned in early studies, there are neurons concentrated in certain regions of the brainstem RF which through descending projections to the spinal cord inhibit movement and muscle tone (see Fig. 1). These RF neurons utilize the inhibitory neurotransmitters, GABA and glycine. These amino acids are responsible for inhibiting motor neurons in the spinal cord and brainstem during PS [9]. Such RF neurons discharge selectively during sleep and maximally during the muscle atonia of PS.

GABAergic neurons through the brainstem RF also become active with sleep and are likely responsible for inhibiting other RF projection neurons. GABAergic neurons in the oral pontine and mesencephalic RF can inhibit neighboring Glu forebrain projecting neurons to diminish their discharge with sleep. Such GABAergic neurons also inhibit the LC NA neurons to allow sleep and PS with muscle atonia to occur (Fig. 1).

In the thalamus, GABAergic neurons, located in what is called the thalamic reticular nucleus, surround and innervate the specific and nonspecific thalamo-cortical projection neurons (see Fig. 1). By their specific properties and pattern of discharge, they not only inhibit, but also shape the discharge pattern of the thalamo-cortical relay neurons [10]. When released from excitatory inputs from the RF, the GABAergic thalamic reticular neurons discharge in bursts to drive spindle and then delta activity in the thalamo-cortical neurons. This activity is transmitted through the thalamo-cortical-thalamic pathways to generate the slow wave patterns which characterize and define SWS.

Other GABAergic neurons are found in the BF and preoptic area (including the ventrolateral preoptic area), (POA) which also play important roles in generating

sleep (see Fig. 1) [1,7,8]. Among these, some GABAergic neurons discharge in association with cortical slow waves which they could accordingly promote during SWS. The discharge of these SWS-active cells is negatively correlated with gamma EEG activity and positively correlated with delta EEG activity (gamma-/delta+). Some may project directly to the cortex, others locally onto neighboring cholinergic BF neurons, which have a reciprocal profile of discharge (above). Other presumed GABAergic BF and POA neurons discharge at progressively higher rates through SWS into PS, as SWS/PS-active cells. Their discharge is negatively correlated with EMG. Such cells likely correspond in part to GABAergic neurons giving rise to descending projections to the posterior hypothalamus and innervating Orx/Hcrt neurons, which are inhibited by GABAergic inputs during sleep.

#### Adenosine

► Adenosine has long been thought to play a role in promoting sleep since one of the major stimulants, caffeine, acts as an antagonist of adenosine receptors [3]. It is potentially released from all nerve terminals, since it is a product of ATP, the major energy source contained in terminals and their synaptic vesicles. Its levels are progressively increased with sleep deprivation, presumably as more ATP would be utilized and metabolized by actively discharging neurons. Adenosine inhibits many neurons in the brain, including importantly the cholinergic BF neurons.

#### Orchestration of Neural Systems Generating Sleep-Wake States

The three states of mammals are generated by concerted or reciprocal discharge of homologous and chemically distinct cell groups through the brain. W is stimulated and maintained by spinally projecting and forebrain projecting Glu RF neurons, which are in turn facilitated and reinforced in their action by diffusely projecting NA, HA and Orx neurons. These systems collectively promote motor activity along with muscle tone for behavioral arousal with cortical activation. GABAergic neurons in the brainstem, preoptic area and BF inhibit the neurons of these arousal systems to shut them off during sleep and thus prevent behavioral arousal while diminishing muscle tone. Other GABAergic neurons in the thalamus and BF inhibit thalamo-cortical and cortical neurons respectively, while also pacing them to elicit spindle and slow wave activity in the cortex during SWS. Discharging during W and PS, cholinergic neurons in the brainstem and BF stimulate cortical activation along with attention during W and perhaps ► dreaming during PS, when in absence of the influence from other arousal systems, most importantly Orx/Hcrt neurons, they also provoke a loss of muscle tone.

## References

1. Jones BE (2005) From waking to sleeping: neuronal and chemical substrates. *Trends Pharmacol Sci* 26:578–586
2. Jones BE (2005) Basic mechanisms of sleep-wake states. In Kryger MH, Roth T, Dement WC (eds) *Principles and practice of sleep medicine*. Elsevier Saunders, Philadelphia, pp 136–153
3. McCarley RW (2007) Neurobiology of REM and NREM sleep. *Sleep Med* 8:302–330
4. McCormick DA (1992) Neurotransmitter actions in the thalamus and cerebral cortex and their role in neuromodulation of thalamocortical activity. *Prog Neurobiol* 39:337–388
5. Siegel JM (2004) The neurotransmitters of sleep. *J Clin Psychiat* 65 (Suppl 16):4–7
6. Mignot E, Taheri S, Nishino S (2002) Sleeping with the hypothalamus: emerging therapeutic targets for sleep disorders. *Nat Neurosci* 5 (Suppl):1071–1075
7. Saper CB, Chou TC, Scammell TE (2001) The sleep switch: hypothalamic control of sleep and wakefulness. *Trends Neurosci* 24:726–731
8. Szymusiak R, Gvilia I, McGinty D (2007) Hypothalamic control of sleep. *Sleep Med* 8:291–301
9. Chase MH, Morales FR (2005) The control of motoneurons during sleep. In Kryger MH, Roth T, Dement WC (eds) *Principles and practice of sleep medicine*. Saunders, Philadelphia, pp 154–168
10. Steriade M, McCormick DA, Sejnowski TJ (1993) Thalamocortical oscillations in the sleeping and aroused brain. *Science* 262:679–685

## Sleep-wake Modulation of Visceral Function

- ▶ Sleep-Wake Autonomic Regulation

## Sleep-wake Neurochemical Substrates

- ▶ Sleep-Wake Mechanisms

## Sleep-wake Rhythms

- ▶ Sleep-Wake Cycle

## Sleep Walking

### Definition

Sleep walking, also known as Somnambulism, consists of a series of complex behaviors that are initiated during sudden arousals from Non-REM sleep, and usually from slow-wave (delta) sleep, which culminate in walking around with an altered state of consciousness and impaired judgment, with absent or poor subsequent recall. In some adults there is associated dreaming.

- ▶ Non-REM Sleep

## Sleepiness

### Definition

The subjective report of the drive for sleep, or likelihood of falling asleep. Objectively it can be measured by the time it takes to fall asleep in a standardized test: the multiple sleep latency test.

- ▶ Alertness Level
- ▶ Sleep-wake Cycle

## Sleeping Sickness

### Definition

Infectious parasitic disease carried by tsetse flies and characterized by inflammation of the brain and the covering of the brain (meninges). An alternative name is African trypanosomiasis. Sleeping sickness is caused by two organisms, *T. brucei rhodesiense* and *T. brucei gambiense*.

## Slice Preparation

HARUYUKI KAMIYA

Department of Neurobiology, Department of Molecular Neuroanatomy, Hokkaido University School of Medicine, Sapporo, Japan

### Synonyms

Acute brain slice

## Definition

Thin sections ( $\sim 400\ \mu\text{m}$  thick) of part of the brain kept in oxygenated ►artificial cerebrospinal fluid.

## Purpose

In the mammalian central nervous system (CNS), pharmacological studies were seriously hampered by the presence of the blood brain barrier (BBB). Direct infusion of drugs into the small brain regions is technically difficult *in vivo*, and it is rather hard to estimate the actual concentration of the drug at the recording site. In order to develop alternative *in vitro* experimental systems enabling pharmacological studies in a quantitative manner, in the mid 1960s, Yamamoto and McIlwain, devised a novel way to keep intact neuronal networks in thin slices of anterior piriform cortex [1,2]. Afterwards, it was revealed that this method is applicable to many cortical areas including neocortex, cerebellum, hippocampus, *etc* (Figs. 1 and 2).

Slice preparation retains intact structures and functions of CNS synapses, and use-dependent synaptic plasticity such as LTP and LTD can also be induced in these experimental systems. Currently, slice preparation is one of the most widely-used techniques to study the mechanism of synaptic transmission and plasticity *in vitro*. It also provides useful experimental models for the study of the pathological mechanisms underlying epileptogenesis and generation of seizure discharges. Slices are also widely used for studies of ischemic cell damage following hypoxia and hypoglycemia.

## Principles

In principle, slice preparations can be made from any brain regions by cutting them into thin sections.

However, in practice there are several technical limitations to this method. Slices are usually continuously

perfused with artificial cerebrospinal fluid (at a rate of  $\sim 2\ \text{ml/min}$ ) bubbled with 95%  $\text{O}_2$  and 5%  $\text{CO}_2$ . Neurons in slice preparation are nourished with oxygen and glucose exclusively by penetration from the surface, and therefore the thickness of the slice is limited and must be thinner than  $\sim 400\ \mu\text{m}$ . In addition, several conditions are critical for preparing “healthy” slices. Generally, slices should be cut quickly following removal from the skull in order to avoid ischemic neuronal damage. Cooling of tissues before and during slicing improves viability of neurons and is practically essential. Using a ►cutting solution also improves the viability of neurons, especially when slices are prepared from older animals. Since cell damage is mainly due to an influx of  $\text{Ca}^{2+}$  from the cut end or by activation of  $\text{Ca}^{2+}$  channels and NMDA receptor channels, a low  $\text{Ca}^{2+}$  and/or  $\text{Na}^+$  solution remarkably reduces cell death during slicing. After cutting slices, it takes approximately one hour to recover metabolisms of neurons from cooling and subsequent depletion of ATP. Slices can be kept alive for up to 10 h, but their activity gradually diminishes due to the breakdown of important molecules such as proteins, nucleotides and lipids, because artificial cerebrospinal fluid does not supply sources for synthesis of those macromolecules.

## Advantages and Disadvantages

Slice preparation offers innovative experimental approaches for cellular and molecular neuroscientists. As discussed above, the most important advantage of this method is that quantitative pharmacological experiments of CNS neurons become feasible. In addition to pharmacological application, slice preparation is well suited for detailed cellular neurophysiological studies of CNS. Neurons are readily visible under the



**Slice Preparation. Figure 1** Hippocampal slice preparation. *Left panel:* Surface image of the slices. Transverse slices of mouse hippocampus ( $\sim 400\ \mu\text{m}$  thickness) were prepared using a ►vibrating slicer (see Fig. 2) and viewed under microscope with DIC optics. A photograph was taken from the boxed area shown in the schematic drawing (*right panel*). Note that some of the neuronal cell bodies can be seen in the cell layer (translucent layer). Hippocampal slice retains intact neuronal networks of tri-synaptic circuit, which are thought to be important for mnemonic function of the hippocampus.



### Slice Preparation. Figure 2 Vibrating slicer.

Conventional vibrating type slicers for fixed tissues can be used for cutting living brain slices. A block of brain tissue was glued to the bottom of some metal dishes, and continuously submerged in an ice-cooled artificial cerebrospinal fluid gassed with 95% O<sub>2</sub> and 5% CO<sub>2</sub>. After slicing using a horizontally oscillating razor blade, the metal dishes were lifted for the desired thickness (~400 μm) and cut another plane to obtain the slice.

microscope with DIC optics, and movement due to pulsation is absent. Therefore, slice preparation is adopted for many *in vitro* neurophysiological studies of ion channels, synaptic transmission, and local neuronal networks. Patch clamp recordings are also possible [3], even from fine cellular processes such as dendrite [4], axon [5], and presynaptic terminal [6] (►blind patch-clamp, slice patch-clamp). On the other hand, serious disadvantages of this method are that slices are short-lived and cannot be used for longer period than days. Therefore, acute slices are not usually suited for the molecular biological experiments using heterologous gene expression. In order to overcome this disadvantage, Gähwiler developed an ►organotypic slice culture that enables cultivation of slices for many weeks to months [7]. Thereafter, a much simpler method was revised for cultivating slices [8]. Currently, organotypic slice culture has been widely adopted for experiments requiring gene delivery either by using virus vector or by biolistic method. Combining GFP imaging with multiphoton laser microscopy, movement of glutamate receptors following high-frequency stimulation can be monitored in a real time manner [9]. Recently, activity-dependent changes in spine shape were also shown

using a similar experimental strategy [10]. Another inevitable limitation of slice preparation arises from the slicing procedure itself. Although slices retain cytoarchitecture of the tissue of origin, only a fraction of the neuronal networks is kept intact because of thickness limitation (~400 μm). Therefore, it should be noted that natural inputs from presynaptic neurons are largely diminished or abolished in slice preparation.

### References

1. Yamamoto C, McIlwain H (1966) Potentials evoked *in vitro* in preparations from the mammalian brain. *Nature* 210:1055–1056
2. Yamamoto C, McIlwain H (1966) Electrical activities in thin sections from the mammalian brain maintained in chemically-defined media *in vitro*. *J Neurochem* 13:1333–1343
3. Edwards F, Konnerth A, Sakmann B, Takahashi T (1989) A thin slice preparation for patch clamp recordings from neurones of the mammalian central nervous system. *Pflügers Arch* 414:600–612
4. Stuart G, Sakmann B (1994) Active propagation of somatic action potentials into neocortical pyramidal cell dendrites. *Nature* 367:69–72
5. Clark B, Monsivias P, London M, Hauser M (2005) The site of action potential initiation in cerebellar Purkinje neurons. *Nat Neurosci* 8: 137–139
6. Geiger J, Jonas P (2000) Dynamic control of presynaptic Ca<sup>2+</sup> inflow by fast-inactivating K<sup>+</sup> channels in hippocampal mossy fiber boutons. *Neuron* 28:927–939
7. Gähwiler B (1981) Organotypic monolayer cultures of nervous tissue. *J Neurosci Methods* 4:329–342
8. Stoppini L, Buchs P, Muller D (1991) A simple method for organotypic cultures of nervous tissue. *J Neurosci Methods* 37:173–182
9. Shi S, Hayashi Y, Petralia R, Zaman S, Wenthold R, Svoboda K, Malinow R (1999) Rapid spine delivery and redistribution of AMPA receptors after synaptic NMDA receptor activation. *Science* 284:1811–1816
10. Matsuzaki M, Honkura N, Ellis-Davies G, Kasai H (2004) Structural basis of long-term potentiation in single dendritic spines. *Nature* 429:761–766

## Sliding Filament Theory

WALTER HERZOG

Faculty of Kinesiology, University of Calgary,  
Calgary, Canada

### Definition

According to the sliding filament theory, muscle contraction occurs through the relative sliding of two sets of filaments (►actin and ►myosin). This sliding is produced by cyclic interactions of sidepieces from

the myosin filament (►cross-bridges) with specific sites on the actin filament. Each such interaction is associated with a cross-bridge ►power stroke whose energy is derived from the hydrolysis of adenosine-triphosphate (►ATP), one ATP per cross-bridge cycle.

### Characteristics

Prior to the 1950s, muscle contraction and force production was associated with the shortening of myosin filaments. Myosin filaments can be seen with microscopy as the dark bands (the so called A-bands) in the striation pattern typical for skeletal and cardiac muscle (Fig. 1).

However, in 1954, Andrew Huxley and Rolf Niedergerke [1] in single fibres and Hugh Huxley and Jean Hanson [2] in isolated myofibrils showed independently that the A-band was not shortening when their preparations were activated and contracted. They speculated that muscle contraction and shortening was not caused by A-band (or myosin) shortening, but rather by the sliding of actin filaments relative to the myosin filaments. This sliding was proposed to be powered by so called cross-bridges (sidepieces arising from the myosin filament) that attach cyclically to actin and pull the actin past the myosin filament.

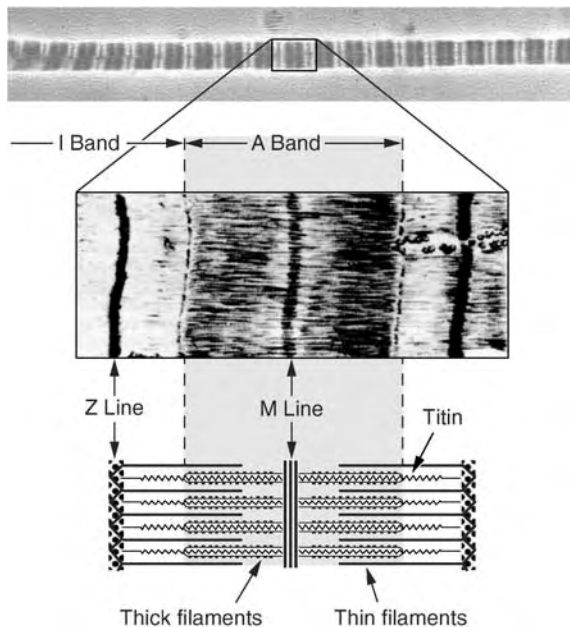

**Sliding Filament Theory. Figure 1** Micrograph of a series of sarcomeres from a single myofibril (*top panel*), an isolated sarcomere bordered by the z-lines and containing myosin (or thick filaments) in the A-band region and actin (or thin filaments) in the I-band region (*middle panel*), and schematic representation of an isolated sarcomere with z-lines, thick filaments, thin filaments and titin identified (*bottom panel*).

### The 1957 Cross-Bridge Theory

In 1957, Andrew Huxley [3] was the first to describe in precise mathematical terms how muscle contraction might occur and how the myosin and actin filaments might interact to cause muscle contraction. Huxley [3] proposed that cross-bridges were uniformly arranged along the myosin filament, and that there were uniformly arranged attachment sites for the cross-bridges on actin. Cross-bridges were assumed to be attached to myosin through a linearly elastic spring and they were moving around an equilibrium point through thermal agitation (Fig. 2).

Attachment and detachment of cross-bridges to actin was determined by a set of attachment and detachment rate functions that depended exclusively on the location of the cross-bridge equilibrium point relative to the nearest attachment site (“ $x$ ” in Fig. 2). The attachment and detachment functions were asymmetric with respect to the cross-bridge equilibrium point, thus enforcing that force production was unidirectional, muscles can pull and exert tension, but they cannot push (Fig. 2). The 1957 theory contains

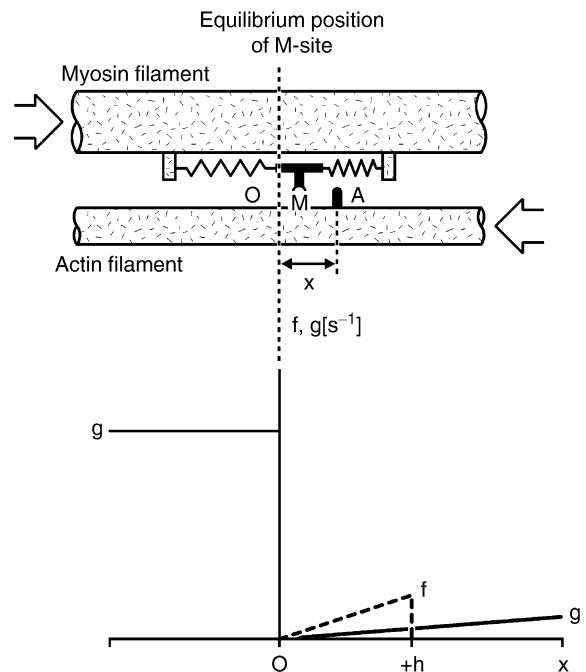

**Sliding Filament Theory. Figure 2** *Top*: Schematic illustration of the 1957 cross-bridge model with the cross-bridge head ( $M$ ) oscillating around its equilibrium position through thermal agitation until it may become attached to its nearest attachment site on actin ( $A$ ) *Bottom*: Rate functions of attachment ( $f$ ) and detachment ( $g$ ) as defined by Huxley [4]. Note that the rate functions are exclusive functions of  $x$ , the distance from the cross-bridge equilibrium position to the nearest actin attachment site. (Adapted from [3] with permission).

two cross-bridge states, an attached and a detached state. The action of each cross-bridge is independent of other cross-bridges and the force is given by the stretch of the elastic element that connects the cross-bridge to the myosin filament. Each cross-bridge cycle (attachment and detachment) was associated with the hydrolysis of one ATP.

### The 1969 Cross-Bridge Theory

Hugh Huxley [4] showed that the spacing between actin and myosin filaments behaves isovolumetrically, like that observed in whole muscle. Therefore, when sarcomeres are stretched from 2.0 to 2.8  $\mu\text{m}$ , myofilaments approach each other and the distance between them decreases by about 18%. Huxley [4] argued that this is too great a range for protein interactions that must produce specific conformational changes associated with the regulation of enzyme activities. Based on further structural evidence, Huxley [4] suggested that the light meromyosin (LMM) part of the cross-bridge was bonded to the backbone of the filament (Fig. 3). The linear portion of the heavy meromyosin S-2 component (S-2) was assumed to be attached to the LMM portion through a flexible joint. The cross-bridge head (heavy meromyosin S-1) was also assumed to be attached to the heavy meromyosin S-2 portion through a flexible joint (Fig. 3), thus cross-bridges can interact with actin through a great range of lattice spacings without changing their orientation. Huxley [4] provided further structural evidence suggesting that the cross-bridge head could rotate and

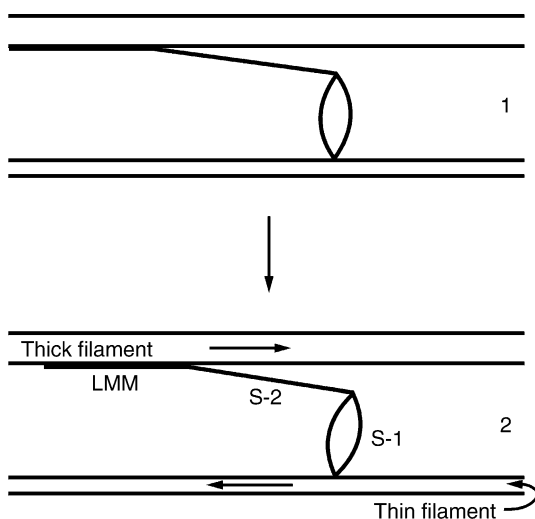

**Sliding Filament Theory. Figure 3** Schematic illustration of the mechanism of force generation according to Huxley [4]. Note that in the 1969 model, the cross-bridge head (S-1) can rotate around its attachment point on actin (thin filament).

so produce force and sliding of actin. Thus the swinging lever arm theory was born.

### The 1971 Cross-Bridge Theory

A characteristic of muscle contraction that could not be predicted adequately with existing models was the force transients following quick length changes. When a muscle fibre is shortened rapidly, force drops virtually simultaneously with the length change and then recovers quickly at first (1–2 ms) and more slowly later (Fig. 4).

In order to account for the force transients following stepwise length changes and to avoid losing the good predictive power of earlier cross-bridge models, Huxley and Simmons [5] introduced the concept of different attachment states for cross-bridges, thereby allowing the cross-bridges to perform work in a small number of steps. Going from one stable attachment configuration to the next was associated with progressively lower potential energy. Furthermore, Huxley and Simmons [5] assumed that there was an elastic element within each cross-bridge which allowed for cross-bridges to go from one stable attachment configuration to the next without a corresponding relative displacement of the actin and myosin filaments (Fig. 5).

The force transients during a quick release could now be explained as follows. The virtually instantaneous drop in force with a quick shortening step was associated with the elastic cross-bridge element. The quick force recovery was associated with a rotation of the cross-bridge head from a position of high to a position of low potential energy, thereby stretching the elastic link connecting the cross-bridge to the filament and increasing force. Finally, the slow recovery of force was associated with the normal attachment/detachment

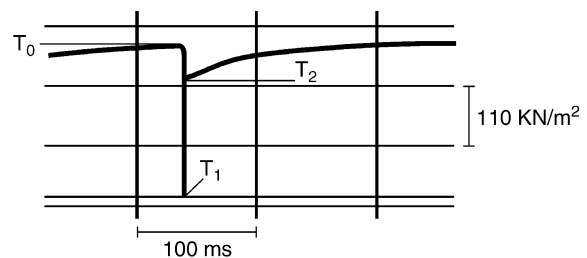

**Sliding Filament Theory. Figure 4** Force-time trace of an isolated muscle fibre preparation that is shortened rapidly by approximately 6 nm/half-sarcomere. When the fibre is shortened, force drops instantaneously because of the elastic attachment of the cross-bridge to the myosin backbone. Force then recovers, first rapidly because of a quick rotation of attached cross-bridge heads, then slowly in accordance with the normal attachment/detachment kinetics of cross-bridges (Adapted from Ford et al. (1977); with permission).

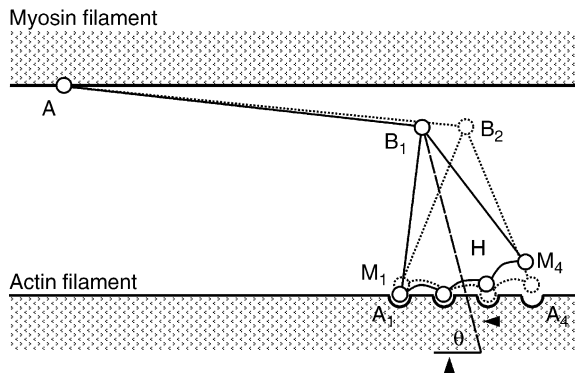

**Sliding Filament Theory. Figure 5** Schematic representation of the cross-bridge model according to Huxley and Simmons [5]. In this model, the cross-bridge head rotates about its attachment site on actin in several discrete steps (Adapted from [5] with permission).

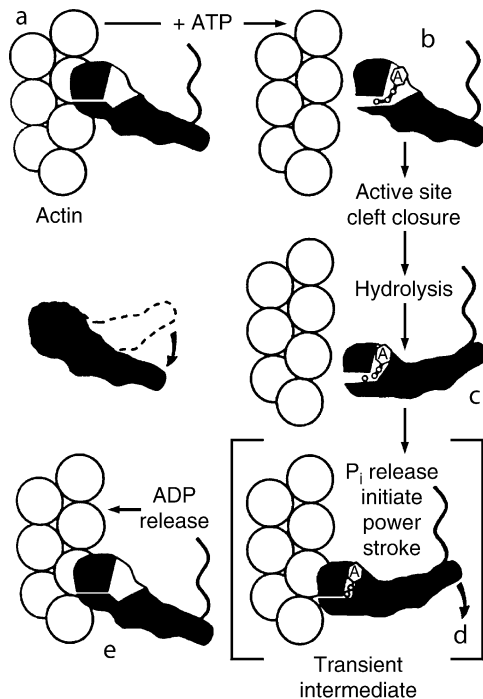

**Sliding Filament Theory. Figure 6** Schematic representation of the mechanism of contraction according to Rayment et al. [6, 7]. In this model, the part of the cross-bridge that attaches to actin remains fixed, while rotation of the “cross-bridge” is associated with a conformational change of the light chain binding domain around a hinge in the myosin head (Adapted from Rayment et al. [6] (1993); with permission).

kinetics of the cross-bridges. Thus, cross-bridge models went from two states (attached and detached) to multiple state models with at least one detached and at least two attached states.

### Current Thinking

One further step in the development of cross-bridge models deserves attention. In their 1971 explanation of multi-state cross-bridge models, Huxley and Simmons thought that rotation involved the entire cross-bridge head and occurred around the attachment sites on actin. However, based on structural studies of the cross-bridge head (HMM S-1) and the corresponding attachment site on actin, Rayment et al. [6,7] suggested that the attachment of the cross-bridge head on actin was fixed, while the actual “cross-bridge” rotation was associated with a conformational change of the light chain binding domain around a hinge in the myosin head (Fig. 6).

### References

1. Huxley AF, Niedergerke R (1954) Structural changes in muscle during contraction. Interference microscopy of living muscle fibres. *Nature* 173:971–973
2. Huxley HE, Hanson J (1954) Changes in cross-striations of muscle during contraction and stretch and their structural implications. *Nature* 173:973–976
3. Huxley AF (1957) Muscle structure and theories of contraction. *Prog Biophys Biophys Chem* 7:255–318
4. Huxley HE (1969) The mechanism of muscular contraction. *Science* 164:1356–1366
5. Huxley AF, Simmons RM (1971) Proposed mechanism of force generation in striated muscle. *Nature* 233:533–538
6. Rayment I, Holden HM, Whittaker M, Yohn CB, Lorenz M, Holmes KC, Milligan RA (1993) Structure of the actin-myosin complex and its implications for muscle contraction. *Science* 261:58–65
7. Rayment I, Rypniewski WR, Schmidt-Bäse K, Smith R, Tomchick DR, Benning MM, Winkelmann DA, Wesenberg G, Holden HM (1993) Three-dimensional structure of myosin subfragment-1: a molecular motor. *Science* 261:50–58
8. Ford LE, Huxley AF, Simmons RM (1977) Tension responses to sudden length change in stimulated frog muscle fibers near slack length. *J Physiol (London)* 269:441–515

## Sliding Mode Control

### Definition

An approach to the synthesis of feedback controllers for nonlinear control systems, where the system trajectories are forced to reach in finite time a certain desirable surface in the state space.

### ► Nonlinear Control Systems



## Slits

### Definition

Secreted proteins that exert attractive or repulsive effects via receptors of the Robo family. A prominent role of slits is the guidance of commissural axons at the ventral midline and in axon pathfinding at the optic chiasm.

- ▶ Growth Inhibitory Molecules in Nervous System
- ▶ Development and Regeneration

## Slow Oscillation in Non-REM Sleep

### Definition

Slow (<1 Hz) alternation between hyperpolarization and depolarization of cortical neurons during NREM sleep.

- ▶ Non-REM Sleep
- ▶ Sleep – Motor Changes
- ▶ Sleep – Sensory Changes

## Slow-wave Sleep (SWS)

### Definition

The component of mammalian non-REM sleep that is accompanied by maximal amounts of high-amplitude electroencephalogram (EEG) slow-wave activity in the 0.3–4 Hz frequency range (also known as delta waves). In humans, SWS is synonymous with Stage 3/4 sleep. SWS is regarded as the deepest and most restorative stage of nonREM sleep, and slow-wave activity in the EEG is an accepted measure of homeostatic sleep need.

- ▶ Electroencephalography
- ▶ Non-REM Sleep
- ▶ Sleep Generating Mechanisms

## Slowly Adapting Pulmonary Stretch Receptors

- ▶ Respiratory Reflexes

## Slowly Adapting Type I Mechanoreceptors

### Definition

A mechanically sensitive sensory ending in the skin that adapts slowly to a sustained indentation and therefore is sensitive to static events; it is also dynamically sensitive. It has small, well-defined receptive fields and the sensory terminal is believed to innervate the Merkel-cell neurite complex. Also known as SAI (slowly-adapting type I) afferents in humans and SA receptors in the cat and primate.

- ▶ Cutaneous Mechanoreceptors
- ▶ Functional Behavior
- ▶ Electric Fish

## Slowly Adapting Type II Mechanoreceptors

### Definition

A mechanically sensitive sensory ending in the skin that adapts slowly to a sustained indentation and therefore is sensitive to static events; it is also dynamically sensitive. It has large, poorly-defined receptive fields and the sensory terminal is believed to innervate the Ruffini ending. Also known as SAII (slowly-adapting type II) afferents in humans and other animals.

- ▶ Cutaneous Mechanoreceptors
- ▶ Functional Behavior
- ▶ Electric Fish

## SMA (Supplementary Motor Area)

### Definition

- ▶ Supplementray Motor Area

## SMAD Signaling

- ▶ BMP Signaling and Synaptic Development

## Small Pit Organ

### Definition

Electroreceptive sensory organ described in catfishes, and that is part of the octavolateral system. Functionally equivalent to the ampullary electroreceptor organ in sharks, sturgeons and some other non-teleost fish.

- ▶ Electric Fish

## “Smart”

- ▶ Nootropic Drugs

## Smell

- ▶ Odor

## Smell Disorders

BASILE NICOLAS LANDIS

Unité de Rhinologie-Olfactologie, Clinique de Oto-Rhinologie-Laryngologie et de Chirurgie cervico-faciale, Hopitaux Universitaires de Genève, Genève, Switzerland

### Synonyms

Olfactory disorders; Dysosmia

### Definition

Olfactory disorders are states where the normal human olfactory function is altered. This might happen physiologically with age, but is mainly the consequence of a pathological event. The most frequent causes of olfactory disorders are head trauma, upper respiratory tract infections or sinunasal diseases. Other causes, assessing methods and therapy options are discussed.

### Characteristics

#### Anatomy

Olfactory perception starts at the level of the olfactory epithelium in the roof of the nasal cavity. ▶ **Olfactory receptor neurons (ORN)** are embedded within the respiratory epithelium and send their axons through the cribriform plate towards the olfactory bulbs. From there, most fibers directly project to the piriform and entorhinal cortices as well as to the amygdalae (all structures formerly subsumed under the term “limbic system”) whereas a minority of fibers project through the thalamus towards the orbito-frontal cortex. Compared to other sensory modalities the olfactory system has some particularities. First, the majority of the olfactory fibers do not cross but project ipsilaterally in the brain. Second, most olfactory fibers bypass the thalamus and project very rapidly and directly in the pyriform cortex, amygdalae, and entorhinal cortex which are implicated in emotional and memory processing.

### Chemicals Senses

Although this essay focuses on the olfactory system, it is necessary to mention briefly, taste and ▶ **trigeminal function**. Together with olfaction, taste and trigeminal function are called the “chemical senses.” All three systems can be stimulated by chemicals, and they provide us with different information. The trigeminal system is the somato-sensory innervation of the nasal mucosa. The main modalities supplied by the trigeminal system are temperature, pain, touch, and irritation. Since most odorous compounds stimulate trigeminal nerve endings, at least at higher concentrations, this system is almost always co-activated in the perception of odors. With few exceptions almost all odorants have

been shown to exhibit trigeminal activation to some extent [1] (e.g., mint has a somewhat fruity odor, but also evokes a typical cooling effect which is mainly trigeminally mediated). The gustatory system provides the five basic tastes; sweet, sour, salty, bitter, and umami (glutamate). The latter, which resembles mainly the taste of chicken soup, has long been claimed in the Asian literature to be a basic taste quality, whereas the western scientific community considered umami mainly as a “taste enhancer.” This controversy was resolved when monosodium glutamate receptors were found on the tongue surface acting as specific taste receptors [2]. Taste receptors are located within the taste buds, which are situated on all papillae except the filiform type. The highest densities of taste buds are found on the tongue and palate but they are also found throughout the entire oral cavity, hypopharynx and larynx. The facial, glossopharyngeal, and vagal nerves provide neural supply for these cells. Like olfaction, taste fibers project ipsilaterally into the brain stem. All gustatory fibers (facial, glossopharyngeal and vagus) innervating the oral-pharyngeal cavity converge into the nucleus solitarius within the brain stem. In most situations of the daily life (e.g., eating) all three chemical senses are stimulated concomitantly.

### Retronasal Olfaction

“Retronasal olfaction” encompasses the perception of odors emanating from the oral cavity during eating and drinking. It is opposed to “orthonasal olfaction” which occurs during sniffing. The retronasal olfactory pathway, contributing to the flavor of foods or drinks, is commonly associated with “taste.” Clinically, most patients with olfactory dysfunction complain of both, loss of smell and taste. Furthermore, this “taste” loss has been reported to affect quality of life of most patients with olfactory disorders [3].

### Measurement

Olfactory function, like most other sensory systems can be measured by psychophysical or objective techniques. Since the subjects’ self assessment of olfactory function is unreliable, testing of olfactory function is necessary [3].

### Psychophysical Methods

The basic principle of psychophysical testing of olfaction is to expose a subject to an olfactory stimulus and to interpret the responses or reactions of the tested subject.

The most valuable advantage of psychophysical testing compared to objective testing methods is the rapidity which allows quick screening for olfactory dysfunction. More extensive testing sets, which can also be used for clinical research, allow graduation of the olfactory disorder. Fundamentally, every collection

of odors is a potential olfactory test. Whatever a clinical test consists of, it should reliably distinguish between anosmic, hyposmic, and normosmic subjects. Most tests are based on a forced choice paradigm. An odorant is presented at supra-threshold concentration and the subject has to identify the odor from a list of descriptions of odors (e.g., the subject gets rose odor to smell, and is asked whether the perceived odor was “banana,” “anis,” “rose,” or “lilac”). This forced-choice procedure controls the subjects’ response bias. It also (potentially) allows the detection of malingerers since even anosmic subjects will produce a few “correct” answers provided in a random selection of items. The result of the test corresponds to the sum of the correctly identified items. This test design is called a ► **smell identification test**, and is the most widely used way of testing [4]. Another widely used test design are ► **threshold tests**. The idea of threshold tests is to expose a subject repeatedly to ascending and descending concentrations of the same odorant and to identify the least detectable concentration for this individual odor.

Besides the solid body of literature and its clinical convenience, the psychophysical tests have one main limitation. As soon as the patient’s collaboration is not guaranteed, interpretation of test results becomes difficult or even impossible.

### Objective Methods

#### Electro-Olfactogram (EOG)

Electro-olfactograms (EOG) are electrical potentials of the olfactory epithelium that occur in response to olfactory stimulation. The EOG represents the sum of generator potentials of ORN.

#### Chemosensory Event-Related Potentials (CSERP)

Event-related potentials are EEG-derived poly-phasic signals. They are caused by the activation of cortical neurons which generate electro-magnetic fields. As the EEG is a noisy signal which contains activity from many cortical neurons, ERP need to be extracted from this background activity. The classical approach to this problem involves averaging of individual responses to olfactory stimuli such that random activity would cancel itself out while all non-random activation would remain. Olfactory ERP (i) are direct correlates of neuronal activation, unlike the signals that are seen, for example, in functional MR imaging, (ii) have an extremely high temporal resolution in the range of micro-seconds, (iii) allow the investigation of the sequential processing of olfactory information, and (iv) can be obtained independently of the subject’s response bias

### Symptoms

Although this distinction is a matter of debate, the discrimination between qualitative and quantitative

olfactory disorder have proven helpful in clinical practice. This distinction is mainly based on the patient's history and psychophysical test results.

### **Quantitative Olfactory Disorders**

#### **Normosmia/Hyposmia/Anosmia**

▶**Normosmia** (▶**Normosmia/Hyposmia/Anosmia**) is the subjectively perceived normal olfactory function, usually defined as the ability to detect the great majority of tested odors in a given olfactory test. ▶**Hyposmia** means the decrease of this olfactory function and ▶**anosmia** the total loss of any olfactory function. Beside total anosmia, specific anosmias have been described, where only certain odors are not perceived and most odors are smelt normally [5].

#### **Qualitative Olfactory Disorders**

The term “qualitative olfactory disorder” reflects the qualitatively changed perception of odorous sensation. They are frequently, but not necessarily, associated with quantitative olfactory disorders.

#### **Parosmia**

▶**Parosmia** describes the distorted perception of smells in presence of an odor source. In other words, parosmias are triggered by odors. This is a symptom occurring particularly often in post-URTI or posttraumatic olfactory disorders. Mostly odors are distorted into unpleasant odors. For example, to parosmic patients, coffee smells like burnt plastic. The exact explanation of the molecular modifications leading to parosmia is as yet unknown. Even the site of parosmia generation (olfactory epithelium, olfactory bulb, or other central-nervous olfactory structures) is not clear. Important clinically, is the observation that most parosmic impressions tend to diminish over months and finally disappear after years.

#### **Phantosmia**

▶**Phantosmia** describes the distorted perception of smells in the absence of an odor source. Most often, phantosmias occur after trauma or URTI and consist of unpleasant odors occurring without being elicited through environmental odor sources. Phantosmias also have a tendency to disappear over the course of years.

### **Causes/Etiologies**

Methodological progresses made in the assessment of olfactory function allowed epidemiological studies, which demonstrated that the occurrence of olfactory disturbances is largely underestimated. Almost 15% of the general population suffers from a mild or severe olfactory dysfunction [6].

### **Most Common Causes**

#### **Olfactory Loss Following Infections of the Upper Respiratory Tract (URTI)**

Apart from posttraumatic and ▶**sinunasal origin**, post-URTI olfactory loss is among the major causes of olfactory dysfunction. The patient's history typically starts with a cold, during which he loses his sense of smell. Not particularly bothered during the cold, the patient becomes suspicious about the smell loss when, one or two months after all sinunasal symptoms have abated, normal olfactory function does not return. Currently, no good data indicate which agent in such upper tract respiratory infections (URTI) leads to olfactory lesions. It is not even clear whether toxicity originates from a virus or bacteria, or from the immune response directed against olfactory neuroepithelium. In one third of those patients parosmia occurs two to three month after the URTI.

#### **Posttraumatic Olfactory Loss**

Posttraumatic olfactory disorders represent approximately 20% of the patients seen in “Smell and Taste Clinics” [7]. The current explanation is that “coup-contre-coup” lesions or tearing of the filae olfactoriae leads to anosmia or hyposmia. Olfactory loss seems to correlate with the severity of the trauma [8], although several authors pointed out the fact that there is considerable individual variability in terms of the vulnerability of olfactory structures. Thus, even minor trauma can lead to anosmia whereas severe brain injuries may not alter olfaction [8]. Probably, the injured parts of the olfactory system are most often the filae olfactoriae which cross the cribriform plate. Similar to post-URTI olfactory impairment, these patients are prone to develop parosmia and phantosmia several months after the trauma.

#### **Sinunasal Causes**

Approximately 20% of all patients in smell and taste consultations have lost or impaired olfactory function due to a nasal problem [7]. Chronic inflammatory processes within the nasal and paranasal cavities such as nasal polyposis probably lead to mechanical obstruction of nasal cavity restricting the airflow to the olfactory cleft. During the last two decades, as a result of better olfactory tests, mild olfactory impairments could also be identified in other groups of patients with sinunasal diseases such as allergic and uncomplicated chronic rhinosinusitis.

#### **Neurodegenerative Causes**

Olfactory loss is common in patients with idiopathic Parkinson's disease (IPD). This olfactory deficit is so reliable that it can be used as a marker of IPD [9]. In other words; if a patient with normal olfactory function presents

with IPD symptoms the diagnosis should be re-investigated [10]. It can also be assumed that olfactory loss precedes the onset of motor symptoms by 4–6 years so that IPD may be the reason for “idiopathic olfactory loss” in some patients. Olfactory loss is also observed regularly in Alzheimer’s disease, but at a much lower frequency and is less pronounced in multiple system atrophy, Huntington’s disease, and motor neuron disease. Little or no olfactory deficit is seen in cortico-basal degeneration, progressive supranuclear palsy, or essential tremor.

### **Idiopathic**

In almost 20% of the patients with olfactory disorders, no origin is identified even after extensive workup. These idiopathic (unknown) olfactory disorders seem simply to reflect the poor understanding of factors interfering with olfaction. With further insight and research this percentage should logically decrease.

### **Less Frequent Causes**

#### **Endocrine Diseases**

Diabetes has been shown in most studies to cause slight olfactory deficiencies especially at threshold levels. Several other endocrine diseases have been reported to cause olfactory disorders.

#### **Epilepsy**

The general findings in epileptic patients were that they perform similar to controls with regard to odor thresholds. In contrast, more centrally believed tasks such as odor identification, discrimination or memory tests revealed that epileptic patients have olfactory impairments predominating on the side of the epileptic focus. This indicates that decreased olfactory function in epileptic patients is primarily due to centrally altered olfactory structures whereby the temporal lobe is the main lesion site.

#### **General Pathologies**

Long lists of general pathologies causing olfactory disorders can be found in most reviews and textbooks of smell and taste disorders, whereas only few large studies investigated general disease and olfactory function. Especially kidney and liver affections have been associated with decreased olfactory function.

#### **Drug-Induced/Toxic**

Numerous toxins have been implicated as causes of olfactory disorders. Nevertheless, this information has been mainly accumulated on the basis of case reports.

#### **Congenital**

Congenital anosmia occurring as an isolated defect or occurring within the context of a syndrome are

distinguished. Isolated ►congenital anosmia seems to occur more often than previously believed. Apart from the typical patient history of no odor memories, only MR imaging leads to a more definitive diagnosis showing hypoplasia or aplasia of the olfactory bulbs. Among cases of congenital anosmia as part of a syndrome, the Kallmann-Syndrom is the disorder in which it is most frequently encountered. This is an anosmia associated with hypogonadotropic hypogonadism clinically characterized by infertility and anosmia. Congenital anosmia is typically discovered during early puberty.

### **Consequences**

Compared to deafness or blindness, anosmia is less disabling in terms of typical social functioning. However, beside the associated dangers like eating spoiled food or non recognition of fire and smoke, it considerably impairs quality of life. Recent studies underlined the potential alteration of quality of life consecutive to olfactory impairment [3]. In some patients olfactory dysfunction even leads to depression.

### **Treatment**

The treatments of olfactory disorders mainly depend of its origin. Neither treatment nor ►spontaneous recovery can be expected in age-related and congenital anosmia. Sinusnasal smell disorders are mostly treatable with antibiotic and anti-inflammatory drugs such as systemic and topical corticosteroids. In general, treating the underlying nasal disease, either surgically or with medical treatment, improves olfactory function. Toxic- and drug- induced smell disorders may recover once the drug intake is interrupted. For two of the most important causes (post-URTI and posttraumatic) of olfactory dysfunction, no curative treatment exists. However, in contrast to other sensory neurons, olfactory neurons regenerate regularly. Thus, spontaneous recovery after olfactory loss is often observed after posttraumatic and post-URTI olfactory dysfunction. Recovery rates are much better in post-URTI (in ca. 60% of the patients) than in posttraumatic (ca. 15%) patients. Usually the main recovery takes place within the two years after the event causing the olfactory disturbance. Spontaneous recovery often remains partial and rarely complete. Although olfactory neurons have the ability to regenerate, the exact mechanisms favoring such spontaneous recovery are not understood. It is currently impossible to predict an individual outcome with regard to recovery. In contrast to the quantitative olfactory disorders, the qualitative disorders have a far better prognosis of spontaneous disappearance. Parosmias tend to decrease to a bearable level after approximately one year. To summarize, the best current therapeutic attitude towards post-URTI and posttraumatic olfactory disorders is to correctly inform the patient, without removing all hope of recovery.

## References

1. Doty RL et al. (1978) Intranasal trigeminal stimulation from odorous volatiles: psychometric responses from anosmic and normal humans. *Physiol Behav* 20(2):175–185
2. Chaudhari N, Landin AM, Roper SD (2000) A metabotropic glutamate receptor variant functions as a taste receptor. *Nat Neurosci* 3(2):113–119
3. Hummel T, Nordin S (2005) Olfactory disorders and their consequences for quality of life. *Acta Otolaryngol* 125(2):116–121
4. Doty RL et al. (1984) University of Pennsylvania smell identification test: a rapid quantitative olfactory function test for the clinic. *Laryngoscope* 94(2 Pt 1):176–178
5. Amoore JE (1991) Specific anosmias. In: Getchell TV et al. (eds) *Smell and taste in health and disease*. Raven Press, New York, 655–664
6. Landis BN, Hummel T (2006) New evidence for high occurrence of olfactory dysfunctions within the population. *Am J Med* 119(1):91–92
7. Temmel AF et al. (2002) Characteristics of olfactory disorders in relation to major causes of olfactory loss. *Arch Otolaryngol Head Neck Surg* 128(6):635–641
8. Sumner D (1964) Post-traumatic anosmia. *Brain* 87:107–120
9. Meshulam RI et al. (1998) Olfaction in neurodegenerative disease: a meta-analysis of olfactory functioning in Alzheimer's and Parkinson's diseases. *Arch Neurol* 55(1):84–90
10. Hawkes CH, Shephard BC, Daniel SE (1999) Is Parkinson's disease a primary olfactory disorder? *QJM* 92(8):473–480

## Smell Identification Test

### Definition

Testing olfactory function can be done by different means. The most popular and widespread one is to use an identification test. The subject is exposed to an odorant in a concentration which is far over threshold concentrations. Then the subject has to identify this odor. In order to facilitate the task he is presented a list of possibilities (usually four) of which he has to decide for one. The number of correct answers is the score of the identification test.

► [Smell Disorders](#)

## Smooth Pursuit

### Definition

Continuous eye movements made to track a moving visual target.

## Smooth Pursuit Eye Movements

### Definition

Smooth pursuit eye movements are those where subjects intentionally track a smoothly moving object or target using their eyes. The smooth pursuit system attempts to match the velocity of subject's eye movements to that of the target so that the image of the target continuously falls on the fovea.

Because subjects rarely do this perfectly, accumulating position errors are corrected using saccadic eye movements, often called “catch-up saccades”. Although movement of the image of the target on the retina (retinal slip) is often a stimulus for smooth pursuit, it is not a necessary one. Subjects can track a target with negligible slip if the target motion is highly predictable, and subjects can correctly track the perception of movement created by object moving behind a narrow stationary slit oriented perpendicular to the motion (i.e., the visible edges of the object also move perpendicular to the actual motion).

Smooth pursuit is distinct from the optokinetic response, which is involuntary and responsive to image motion anywhere on the retina. Animals lacking a fovea exhibit little or no smooth pursuit, but do exhibit an optokinetic response.

► [Retinal Slip](#)

► [Saccade, Saccadic Eye Movement](#)

## Snapback Hairpin

### Definition

Snapback hairpin – A short hairpin RNA (shRNA) is a sequence of RNA that makes a tight hairpin turn that can be used to silence gene expression via RNA interference. This is when a single-stranded RNA folds back on itself by pairing with its own complementary strand. Snapback refers to this hairpin formation.

► [GAL4/UAS](#)

## Snapshot Memory

### Definition

The memory of the scene from a goal. Upon reaching a goal for the first time, a subject may make a survey of

the scene from the goal and store this in memory for subsequent use in returning to the goal. This snapshot may be used to mediate a form of navigation back to the goal. This involves moving to minimize the difference between the current snapshot and the one from memory.

A common form of insect navigation is based on snapshot memory, and there is also evidence that mammals use snapshot memory too.

► [Spatial Learning/Memory](#)

## SNARE Proteins

### Definition

Snare proteins are group of proteins located on the membrane of synaptic vesicles and the prejunctional nerve terminal that interact to mediate vesicle docking, fusion and exocytosis of neurotransmitters in a calcium-dependent manner. The proteins on vesicle membranes include synaptotagmin and synaptobrevin (v-SNAREs), with syntaxin and SNAP-25 located on the inner surface of the nerve terminal membrane (t-SNAREs).

► [Postganglionic Neurotransmitter](#)

## Sniff

### Definition

Sniffing is the drawing of air into the nasal cavity with the goal of odor detection. The flow rate observed during a sniff is usually higher than what is seen during quiet inspiration and the initial flow rate is very consistent from sniff to sniff. The higher flow is thought to direct more of the incoming air to the olfactory receptors and it facilitates olfaction by creating a more turbulent flow within the nasal cavity.

► [Nasal Passageways](#)

## Sniffing Behavior (Mammals)

► [Odor-Sampling Behavior](#)

## Snoring

### Definition

Sound produced by vibration of anatomic structures in the upper airway during sleep. Snoring can be caused by obstruction or narrowing of the upper airway (e.g., obesity, elongated soft palate, relaxation of tissues in the throat) and by sedative drugs (alcohol and some prescription medications including sleeping pills).

Snoring often disrupts the sleep of housemates more than that of the person snoring. However, loud snoring associated with pauses in breathing can be a sign of sleep breathing disorders referred to as sleep apnea and upper airway resistance syndrome. Snoring in children may be related to airway obstruction caused by large tonsils or adenoids.

► [Sleep – Motor Changes](#)

► [Sleep – Sensory Changes](#)

## SNP

### Definition

Single nucleotide polymorphism, one base pair sequence difference between alleles.

► [Bioinformatics](#)

## Social Behavior Network

### Definition

Set of interconnected brain areas implicated in the control of multiple forms of social behavior, such as communication and sexual behavior. Each one of these brain areas is a node of the network. These nodes are also characterized by containing receptors to sexual steroids.

► [Evolution of Septal Nuclei](#)

## Social Chemosignal

BENOIST SCHAAL

Centre Européen des Sciences du Goût, CNRS, Dijon, France

### Synonyms

Social odor [1]; Semiochemical [2]; Sociochemical [3]  
 Related terms: Social olfaction; Social chemosensation; Chemical communication; Semiochemistry [2]; Sociochemistry

### Definition

Social chemosignals encompass all types of stimulations exchanged among members of a given species and that are detected through the chemical senses (i.e., olfaction, vomerolfaction, taste, tarsal chemoreception). These are carried by chemicals derived from physiological processes and circumstantially learned as social cues, as well as by specialized signals, termed pheromones, which were evolutionarily selected for communicative purposes.

It should be noted that whereas all pheromones are social chemosignals, all social chemosignals are not pheromones. There is indeed a definitional confusion leading to the indiscriminate use of the pheromone concept to designate any communicative process involving odors. In fact, pheromones may be conceived more as regulating than as informative factors. Thus, the term pheromone should be kept separate to qualify *well-identified chemicals* that fulfill an operational set of functional criteria [4,5]. Pheromones have been proposed to belong to a subclass of (i) chemically simple compounds (single- or multiple-component pheromones made up with a limited set of active compounds in given ratio); (ii) that are exclusive in eliciting (iii) a well-defined and invariant behavioral/physiological response with obvious functional significance (iv) among individuals of the same species; finally, (v) the activity of these compounds should be minimally dependent on learning processes [4,5]. In sum, pheromones represent only a portion of social chemosignals; these latter include more or less additional compounds leading to mixtures that can be exceedingly complex in both chemical (sometimes composed by several hundreds of compounds) and semiotic terms. These social chemosignals elicit responses that can be highly variable as a function of the context or the interacting organisms' internal state, mingle individual as well as supra-individual (colony, caste, species, etc.) information, and depend on prior experience and cognitive processes.

### Characteristics

The chemical, physiological and behavioral principles of social olfaction mostly stem from studies in Insects

and Vertebrates, especially Mammals [2,6]. Accordingly, these principles may be revised with incoming new knowledge from other taxa. As in any communication system, social odors may be described in the context of the functional loop between an emitting individual carrying the source of the chemosignal that impinges on a recipient organism responding either by attentional mobilization, by an immediate overt behavior or by a covert physiological reaction.

### Sources

Social chemosignals are derived from multiple sources, which are either distributed over the tegumentary surface (sebaceous, eccrine and apocrines sweat glands) or collected in more or less specialized scent glands. They can also be emitted by the way of various excretory carriers, such as tears, breath, saliva, mucus, milk, the genital discharges, urine, or feces [2,6]. These biological substrates may transmit an intrinsic distinctive odor or may gain their characteristic odor through the action of bacteria dwelling on the skin surface or in glandular recesses. They are composed of volatile and involatile fractions the interaction of which modulates the temporal dynamics and properties of the final odor stimulus.

These multiple secretory or excretory sources, and hence the odor quality and intensity derived from them, are regulated by the organism's genetic and immunogenetic constitution, but can also be induced by a multiplicity of factors, including endocrine status (linked with age, sex, reproductive stage), metabolism (diet, pathology), and psychobiological state (age, stress, dominance, fitness). The combined action of all these causal pathways leads to the formation of a specific chemical image or of an individual's olfactory fingerprint or signature.

### Signals

The chemistry that any organism presents to its conspecifics can be exceedingly complex and versatile, and its total chemical understanding may be unattainable [2]. Many classes of biologically emitted chemical compounds are physically and biologically compatible with chemosensory function. In terrestrial animals, a first partition in this complexity is between volatile and involatile fractions of the chemosignals, leading to ►odor detection or ►odor tracking from a distance or to the need for direct contact with the stimulus.

In this way, involatile proteins, lipids or cuticular hydrocarbon can act as fixatives or precursors of volatile cues, as well as contact chemosignals. In aquatic species, chemosignals generally need to be hydrosoluble, and bind with receptors from the olfactory as well as the taste system [7]. A second divide in the complexity of chemosignals is between individual-specific and species-specific compounds in the stimulus. Depending on the behavioral tests used to assess the responses, an



organisms' ability to extract individual or supra-individual meanings can be evidenced in a same chemosignal. Thus, social chemosignals may be conceived as more or less complex stimuli in which multiple levels of information can be nested (Fig. 1).

Little is known on the rules by which information is ciphered in social chemosignals [4,7,8]. A same biological secretion may code for one information or for several, or different secretions may code for the same information. Within a complex secretion, only one or several compounds, or groups of compounds, may carry the signal, the remaining compounds constituting background noise. The term "mosaic signal" has been proposed for such complex signals in which most of the individual compounds do not bear an effect by themselves [8], but are part of a multidimensional chemical signal classified in a multidimensional perceptual space.

### Reception and Integration

Animal organisms have evolved several neural systems to detect, analyze, extract and store information from social chemosignals [8,9]. In higher vertebrates, an

array of different systems detects chemosignals depending on the volatility and concentration of ligand molecules. From the most to the least volatile stimuli, the main olfactory system, the accessory olfactory (or vomeronasal) system and taste system come into play. The trigeminal system may be drawn in the detection of higher intensity compounds. In these systems, recognition pathways can be narrowly or broadly tuned, leading to specialized versus generalist chemoreception [9]. It was long held in higher vertebrates that some of these neural pathways (e.g., the vomeronasal system) were dedicated to detect social chemosignals of the subclass pheromones. A strict functional exclusivity has been since questioned, and overlap and interactions between specialized and generalist systems of chemodetection now seems to be the rule.

The brain structures involved in higher level processing of social chemosignals remain poorly understood, and offer a promising ground for future advances in cognitive and behavioral neuroscience [9]. So far, we know in rodents some neural structures (e.g., medial area of the amygdala, hypothalamus) that react differentially to complex odors contrasted along sex or individuality,

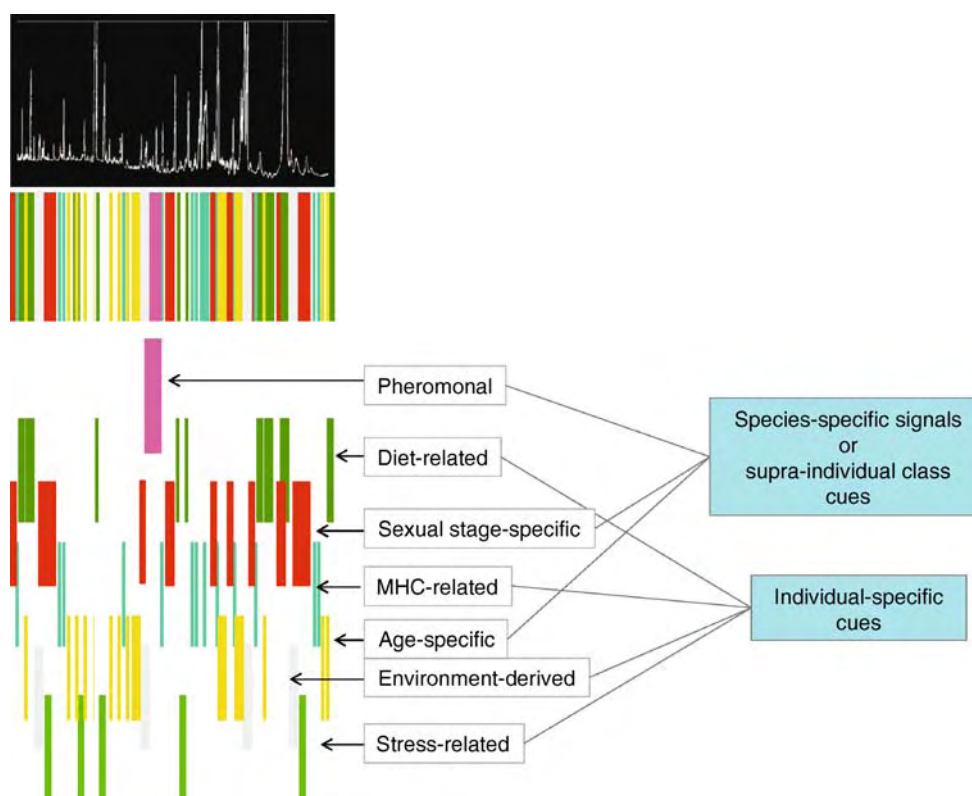

**Social Chemosignal. Figure 1** A bar-code metaphor to nested chemical sources of meanings within a social chemosignal. The complex chromatographic pattern is translated in color bars representing levels of meanings. The decomposed bundles of bars represent compounds that are correlated with a given meaning, and hence with a given communicative function. Note that a pheromone is inclusive to a social chemosignal.

linking social chemosensory inputs to the brain areas involved in neuroendocrine, affective and cognitive processes.

### Functions

The chemical senses being operative throughout the animal kingdom, their involvement in social processes is well conserved [1,5,7,10]. This functional ubiquity is reinforced by the fact that chemosignals have specific advantages over visual or auditory signals in terms of pervasiveness: they can operate in obscure (night-time, burrows, turbid water) or noisy (dense colonies) environments, are distributable in space and time (scent-marking) and can outlast for long periods the emitter's presence. Further, these chemosignals can rally attention in other modalities (alerting function) and they can be integrated with the entries from the other sensory systems, leading to the multimodal appraisal of conspecifics (cognitive function) and redundant regulation of behavior.

Social chemosignals can convey a wide range of psychobiological meanings actualized in the varying types and rates of behavioral and physiological responses measurable in appropriate experimental situations [6,7]. The basic requirement of social life being the recognition of particular individuals, or classes of individuals, it is seminal that chemoreceptive cues encode such categories. ► **Odor recognition** of individuality, or of classes of individuals, has been repeatedly shown in vertebrates and insects, making olfaction a basic organizing system of social life. The recently established role of peptides from the major histocompatibility complex in individuality signals reveals how genotypic information can be externalized and traced in vertebrates. Similar abilities lead to discriminate social categories such as age or gender, or to differentiate kin, family and colony members from out-groups, inducing within-group social selectivity and more or less between-group closure, and strategies to avoid consanguinity.

Social odors are also used as situational cues inscribing the individual in space and time. This is best observed in the frequent marking behaviors involved in the establishment and maintenance of a territory, or trails within it, in the labeling of conspecifics, foods or objects with own odor, or even in self-anointing. Social chemosignals are also involved in the coordination of social interactions. They can elicit recruitment and aggregative responses (as in foraging and reproductive parties), as well as avoidance and dissociative responses (warning signals, *Angstgeruch*, *Schreckstoff*). Finally, chemosensory correlates can be traced to decode indices related to psychological state (mood, stress), fitness (dominance, aggressiveness), and diet and health status (pathologies, parasite load) [1,7].

Social chemosignals have been investigated most extensively in the context of reproductive processes [5–8]. They guide the appraisal of mate quality, and

hence direct mate choice and recognition, provide mutual indications on male sexual state and female stage of receptivity, and in concert with the other senses orchestrate courtship and copulation. In species that take care from their young (social insects, mammals), females are sensitive to the odor cues emitted by their offspring. Brood, amniotic and neonatal chemosignals determine the rapid onset of selective responses of females directed toward the young [10]. Reciprocally, at least in mammals, newborns are attracted to odor cues from females, and rapidly develop selective attachment responses to their mother. Further, mammalian females emit odor signals near the mammary glands or in milk, which have the effect of boosting neonatal motivation and of providing guidance to the nipples. In addition to the orchestration of behavior, data from rodents, ungulates and primates also indicate that social chemosignals modulate the physiological coordination of reproduction within groups. For example, urinary volatiles of reproductively-active males accelerate the attainment of puberty in young females, or induce estrus, block pregnancy, or synchronize ovarian cycles in mature females [5,7,9].

Finally, it may be highlighted that social chemosignals remain active in species that have developed higher cognitive processes, ideation, and communication systems dominated by vision and audition. Although it has been proposed that improved visual abilities in primates made olfaction redundant, social chemosignals remain actively involved in inter-individual exchanges [10]. For example, men and women can distinguish gender and recognize their mates and genetic relatives. Likewise, infants single out the individual odor of their mother from that of other females; but, in addition, infants display general attraction to the breast odor of any lactating woman and to the odor of conspecific milk. This is a well documented situation where individual and supra-individual cues can be extracted from a same chemosignal. The fact that social chemosignals make a notable contribution to the perceptual world of humans is further underlined by their universal use of extraneous odorants, adding culturally shaped complexity to the odors produced by species-specific chemo-emission.

### Development: How Odors Become Social Signals?

The most obvious means by which odors become socially relevant is through acquisition processes, i.e., direct familiarization, associative learning, or conditioning [7,10]. Odor familiarization can be already set on in ovo or in utero, while embryos are exposed to genotype- or phenotype-related (dietary) compounds transmitted by the maternal organism. This explains how newly emerged insect larvae and vertebrate newborns can already be biased in their responses to maternal chemosignals against homologous signals from other conspecifics. Afterwards, the range of

stimuli that become salient in social contexts is rapidly, and sometimes lastingly, expanded through odor exposure during early sensitive periods. In this way, the females' constitutional odors, as well as circumstantial odorants from the environment associated with her, can be imprinted as chemical templates against which future allies or mates are selected. Further, indirect familiarization, by which familiar individuals (kin) can be used as standards against which others are compared, can also come into play in the discriminative value of chemosignals. In this case, individuals or categories of individuals are discriminated not because of previous contact, but as a function of phenotypic resemblance to relatives (or self) with whom one is acquainted (phenotype matching). Lifelong learning processes mediated by social interactions occur further in juveniles and adults, especially in emotion-primed contexts. Another recently-evidenced way to engage the learning of social chemosignals is through the intrinsic reinforcing impact of pheromones. In certain cases, these compounds promote the rapid learning of any odorant that is associated with them, rendering initially inactive odorants functionally similar to them, and thus engage circumstantial odorants into communicative actions. In this way, predisposed and plastic cognitive processes may cooperate in attuning individuals to the local conditions of their present and future social networks.

## References

1. Brown RE (1979) Mammalian social odors: a critical review. *Adv Study Behav* 10:103–162
2. Albone ES (1984) Mammalian semiochemistry. Wiley, Chichester
3. Bell WJ, Carde RT (eds) (1984) Chemical ecology of insects. Chapman & Hall, London
4. Beauchamp GK, Doty RL, Moulton DG, Mugford RA (1976) The pheromone concept in mammalian chemical communication: a critique. In: Doty RL (ed) Mammalian olfaction, reproductive processes, and behavior. Academic, New York, pp 143–160
5. Doty RL (2003) Mammalian pheromones: fact or fantasy? In: Doty RL (ed) Handbook of olfaction and gustation, 2nd edn, M Dekker, New York, pp 345–383
6. Brown RE, MacDonald DW (1985) Social odours in mammals, Clarendon, Oxford
7. Wyatt TD (2003) Pheromones and animal behaviour. Cambridge University Press, Cambridge
8. Johnston RE (2000) Chemical communication and pheromones: the types of chemical signals and the role of the vomeronasal system. In: Finger TE, Silver WL, Restrepo D (eds) The neurobiology of taste and smell. Wiley-Liss, New York
9. Brennan PA, Keverne EB (2004) Something in the air? New insights into mammalian pheromones. *Curr Biol* 14:81–89
10. Schaal B, Porter RH (2001) Microsmatic humans revisited: the generation and perception of chemical signals. *Adv Study Behav* 20:135–199

## Sodium Channels

SIMON ROCK LEVINSON

Department of Physiology and Biophysics, University of Colorado School of Medicine, Aurora, CO, USA

### Synonyms

Voltage-dependent sodium ( $\text{Na}^+$ ) channel; Voltage-gated  $\text{Na}^+$  channel; Voltage-sensitive  $\text{Na}^+$  channel; Voltage-activated  $\text{Na}^+$  channel

### Definition

Sodium ( $\text{Na}^+$ ) channels are ► **membrane glycoproteins** (► **Cell membrane – components and functions**) that form  $\text{Na}^+$ -selective voltage-gated pores across the plasma membranes of excitable cells, such as neurons and muscle fibers. When these pores are in an open configuration,  $\text{Na}^+$  cations flow through them. This flux is usually into the cell, and thus creates a voltage change across the cell membrane that is the basis of the propagating electrical signal known as the action potential (► **Action potential; Action potential propagation**). (Note: These voltage-gated channels are not to be confused with non-voltage-gated epithelial  $\text{Na}^+$  channels (ENaCs) that are found in a variety of epithelial tissues, such as kidney, colon, and lung.)

### Characteristics

Voltage-gated  $\text{Na}^+$  channels are the primary molecular entities that initiate the propagating action potential of nerve axons, the fundamental electrical signal that underlies communication in the nervous system. Due to their central role in the function of the nervous system, a variety of natural toxins have evolved that affect them, while several clinically important drug classes target  $\text{Na}^+$  channels, such as local anesthetics, chronic pain medications, and anti-seizure (► **Seizures**) drugs. Finally, genetically-based changes in the function of  $\text{Na}^+$  channels can give rise to a number of human diseases, e.g. certain forms of cardiac long Q-T syndrome and epilepsy (► **Epilepsy**), and the periodic paralyses of muscle (► **Familial periodic paralysis**). For these reasons,  $\text{Na}^+$  channels have been well studied in the past and will continue to be a focus of major investigative efforts for some time to come.

As with many other proteins, within a given organism  $\text{Na}^+$  channels are encoded by a number of genes, giving rise to channel ► **isoforms**. In addition, additional diversity in channel types may derive from variations in the RNA processing of any gene transcript, while posttranslational modifications can vary the functional properties of the expressed gene product itself [1,2]. Consideration of the biological significance

of such structural and functional variations among Na<sup>+</sup> channel isoforms is a major focus of current research.

### Basic Physiological Functions of Na<sup>+</sup> Channels Role in Generation of Propagating Action Potentials (►Action potential)

The study of the functional properties of Na<sup>+</sup> channels in generating action potentials has a long history and is described in detail in a number of texts (e.g. [3]). In its simplest terms, the action potential is a brief, propagating change in the transmembrane voltage across the neuron axon. As originally elucidated by the classic work of Hodgkin and Huxley (see [3]), this waveform is generated by the coordinated flux of Na<sup>+</sup> and K<sup>+</sup> ions across the cell membrane (Fig. 1). Subsequently it has been established that these ion fluxes are mediated by discrete molecular pores known as voltage-gated Na<sup>+</sup> and K<sup>+</sup> ►ion channels (Neuronal potassium channels). In particular, these channels are closed in the resting state, but are opened by any stimulus (e.g. by a ►postsynaptic potential at a ►synapse or a ►generator potential in a ►sensory receptor) that ►depolarizes the negative resting membrane potential (i.e. decreases it towards zero), past a characteristic threshold level.

Initially, this voltage change causes Na<sup>+</sup> channels to open or ►activate, allowing Na<sup>+</sup> ions to flow passively into the cell driven by their ►electrochemical gradient (►Membrane potential – basics). This influx of positive charge further depolarizes the transmembrane voltage, and causes the initial rising phase of the action potential (Fig. 1), which goes toward  $V_{Na}$  (i.e. the Na<sup>+</sup> ►equilibrium potential as approximated by the ►Nernst equation for Na<sup>+</sup>). In reality,  $V_{Na}$  is never quite reached because of two subsequent limiting processes: (i) Na<sup>+</sup> channels ►inactivate, thus shutting off the further influx of Na<sup>+</sup> ions; (ii) K<sup>+</sup> channels slowly open, which allows the outward flow of K<sup>+</sup> ions from the cell driven by their own electrochemical gradient, thus returning (►re-polarizing) the membrane potential to its original resting level. After a brief delay (the ►refractory period), during which Na<sup>+</sup> channels recover from inactivation and K<sup>+</sup> channels close, another action potential may be generated.

The basic description above allows one to explain certain fundamental properties of the action potential, namely the “all-or-none” nature of its amplitude and its propagation. Both phenomena are related to the fact that in excitable tissues the influx of Na<sup>+</sup> ions through the

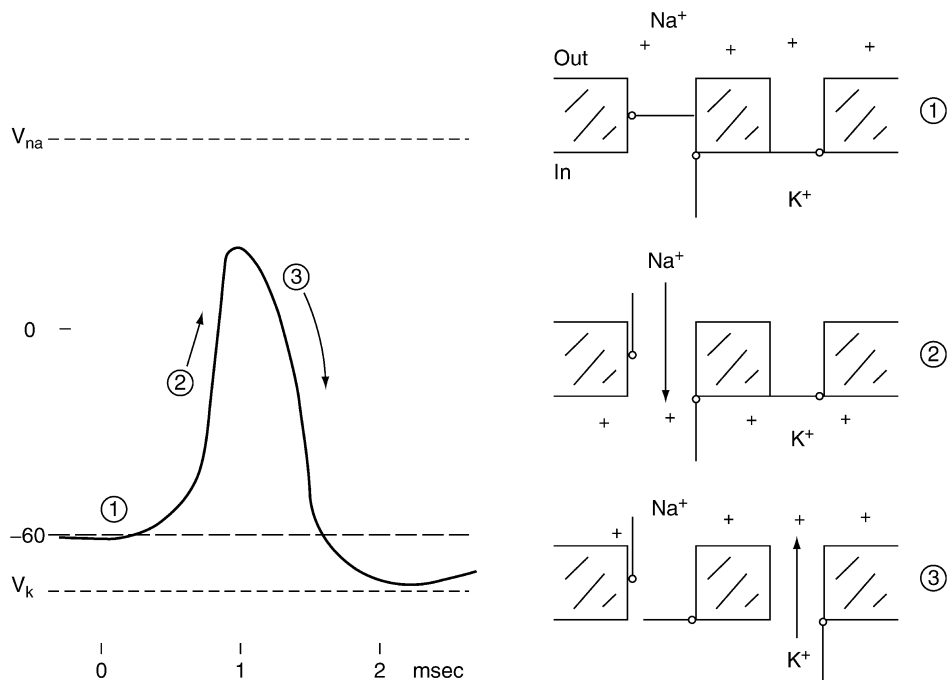

**Sodium Channels. Figure 1** Ionic flows involved in generation of the action potential. The left part of the panel shows the action potential waveform, while the right part shows the gating state changes in Na<sup>+</sup> and K<sup>+</sup> channels that shape the action potential. Thus in the resting state (i), both Na<sup>+</sup> and K<sup>+</sup> channels are in the closed, nonconducting states. In (ii), a suprathreshold voltage stimulus causes Na<sup>+</sup> channels to open rapidly (i.e. activate), and the resultant influx of positively charged Na<sup>+</sup> ions causes the positive-going “►depolarizing” phase of the action potential. In (iii), the upstroke of the action potential ceases due to the entry of Na<sup>+</sup> channels into their “►inactivated” state, while the delayed opening of K<sup>+</sup> channels allows the efflux of K<sup>+</sup> cations to return the membrane potential to its starting value.

first few opening  $\text{Na}^+$  channels causes an increased local depolarization that accelerates the opening of some of the surrounding channels; influx of  $\text{Na}^+$  through these channels in turn further depolarizes the membrane, thus increasing the opening rate of more  $\text{Na}^+$  channels, and so on. This “regenerative” effect quickly becomes the dominant stimulus for  $\text{Na}^+$  channel activation, hence overwhelming the influence of the original stimulus. As a result, all subsequent processes in the action potential (e.g.  $\text{Na}^+$  channel inactivation,  $\text{K}^+$  channel opening) are obligatorily entrained by the regenerative phenomenon, and thus the action potential amplitude and shape are independent of the initial depolarizing stimulus. This explosively regenerative upswing in the membrane potential also propagates in a domino-like fashion, as channels adjacent to this activation zone are recruited into a conducting state (► [Action potential propagation](#)). In addition to this the process of “continuous conduction” characteristic of unmyelinated nerve fibers found in most animals,  $\text{Na}^+$  channels also mediate the process of fast saltatory (“jumping”) conduction that is found in the ► [myelinated axons](#) of vertebrates through the formation of very high densities of channel clusters at nodes of Ranvier.

### **Role of $\text{Na}^+$ Channels in the Initiation of Action Potentials and in Integrating Multiple Synaptic Signals at Dendrites**

In addition to their classical role in generating action potentials, it has more recently been appreciated that  $\text{Na}^+$  channels also are involved in initiating action potentials and in responding to more graded signals such as stimuli transduced by sensory receptors or synaptic potentials in neuron dendrites.

One essential role of  $\text{Na}^+$  channels is to reinitiate the action potential on the postsynaptic side as a result of synaptic transmission. Thus in the motor endplate,  $\text{Na}^+$  channels are located in the folds of the postsynaptic membrane (► [Neuromuscular transmission](#)). Both the high density of channels and the geometry of the folds themselves allow endplate potentials to initiate reliably a propagating action potential in the postsynaptic membrane. In neurons,  $\text{Na}^+$  channels are present at high density in the ► [axon hillock](#) and ► [initial segment](#) of the axon. These channels initiate an action potential only when synaptic inputs at dendritic synapses summate sufficiently to depolarize the membrane potential in the peri-somatic axonal membrane. Clearly, in both of these cases the voltage-sensitivity of the  $\text{Na}^+$  channels will determine the strength of synaptic signal required to fire an action potential in the postsynaptic cell. In addition, a very low and non-uniform density of  $\text{Na}^+$  channels has been inferred to exist in the dendrites themselves. These channels are thought to be part of the mechanism by which dendrites perform signal processing of multiple synaptic inputs to produce an appropriate output at the

axon hillock. Finally,  $\text{Na}^+$  channels are found in certain sensory receptors, e.g. those for pain (► [Pain](#)), taste (► [Chemical senses](#)), and sound (► [Hearing](#)), where they are part of the transduction mechanisms that amplify weak sensory stimuli.

In summary, recent work shows that  $\text{Na}^+$  channels play a number of important yet different roles in neuronal communication and sensory transduction. The multiplicity of such functions suggests that functionally distinct  $\text{Na}^+$  channel types (i.e. isoforms) will serve in these different roles.

## **The Molecular Basis for $\text{Na}^+$ Channel Function**

### **Basic Functional Properties of $\text{Na}^+$ Channels**

The microscopic functional properties of individual  $\text{Na}^+$  ion channels that underlie its role in electrical signaling phenomena may be conveniently broken down as follows. First,  $\text{Na}^+$  channels must have a *transmembrane aqueous pore* that allows the passage of ions across the plasma membrane. Second, access to this pore pathway must be regulated by a mechanism for *ion selectivity* that allows the channel to choose  $\text{Na}^+$  over other ions in physiological solutions (e.g.  $\text{K}^+$ ,  $\text{Cl}^-$ ,  $\text{Ca}^{2+}$ ). Lastly, there must be *voltage-sensitive activation and inactivation gates* that allow channels to assume the various closed, open, and inactivated states that occur in response to changes in membrane voltage (Fig. 1).

### **Subunit Composition and Amino Acid Sequence of $\text{Na}^+$ Channels**

The basic molecular mechanisms of  $\text{Na}^+$  channel operation (i.e. that which forms voltage-gated, ion selective pores) are contained within a single large polypeptide (usually designated as an “ $\alpha$ ” subunit). These are very large proteins of approximately 2,000 amino acid residues in length whose amino acid sequences have been determined largely from cloned cDNAs (see [1] for a description of the strategies and methods used). Naturally, models of the secondary and higher order structure could then be constructed from a combination of ► [hydrophathy](#) and secondary structure prediction analysis.

Such a predictive model for the  $\text{Na}^+$  channel structure is shown in Fig. 2. First, hydrophathy and ► [secondary structure](#) constraints predict that  $\text{Na}^+$  channels consist of four transmembrane domains (I, II, III, IV), each of which consists of six hydrophobic  $\alpha$ -helices (S1–S6). Second, this architecture suggests that the four domains might contain segments (i.e. the  $\alpha$ -helices) of highly (but not completely) conserved sequence homology to one another. These “internal repeats” have been confirmed by homology analysis.

In addition to these primary  $\alpha$  subunits, many channels are associated with one or several “accessory”  $\beta$  subunits. While not directly part of the actual pore, selectivity or gating structures, there is increasing evidence that such

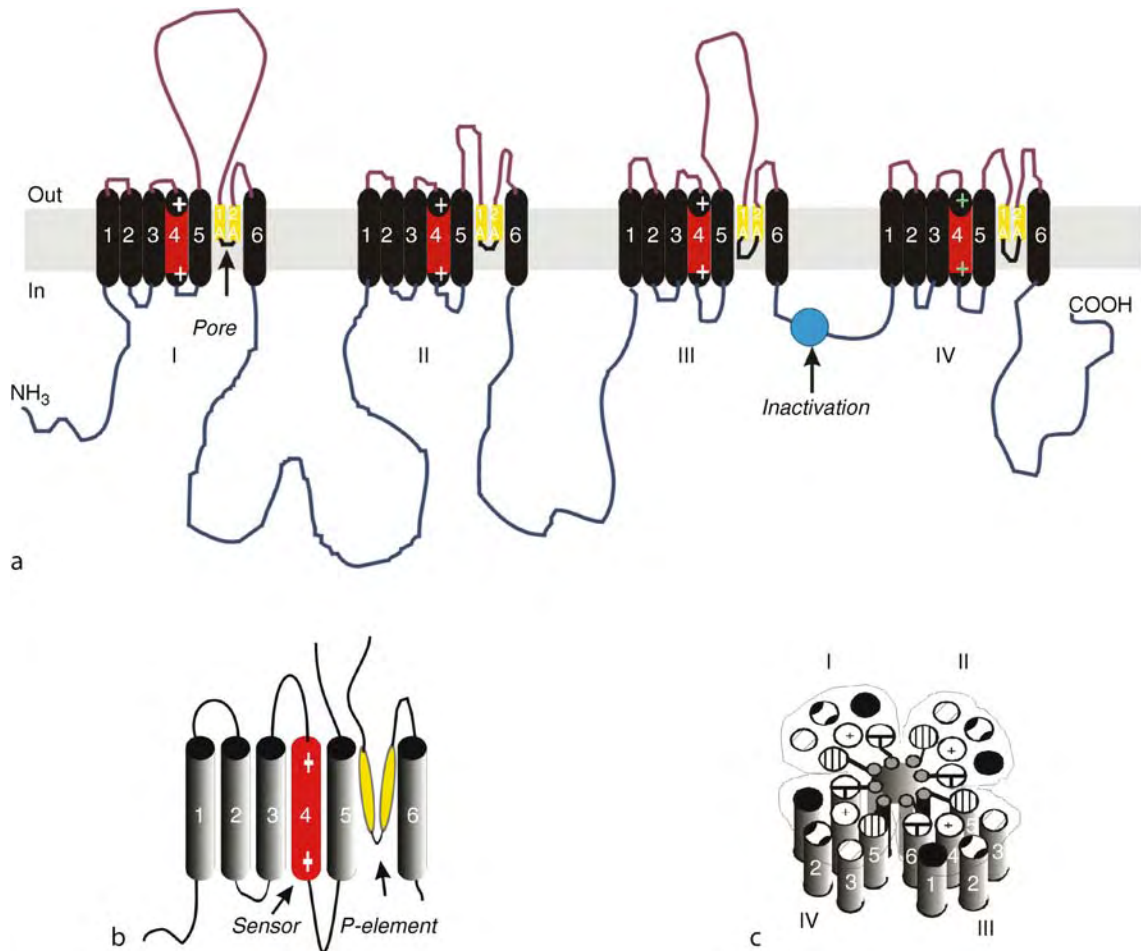

**Sodium Channels. Figure 2** (a) Predicted secondary structure of a typical Na<sup>+</sup> channel  $\alpha$  subunit. (b) Enlarged view of a transmembrane homology domain, showing segments postulated to comprise the voltage sensor and the selectivity filter in the pore lining ("p-element"). (c) Transmembrane "staves of a barrel" tertiary architecture involved in pore formation by  $\alpha$  subunit homology domains.

subunits play important roles in regulating channel numbers, localization, and gating [4].

### Sodium Channel Molecular Mechanisms

**Pore formation:** The four-fold pseudo-symmetry of Na<sup>+</sup> channel domains has been taken to imply that transmembrane pores are formed by an arrangement in which each internal repeat domain forms one quarter of the pore structure (Fig. 2). This architecture is highly similar to that of many other ion channels as described in other articles, e.g. K<sup>+</sup> channels that are formed by a four-fold association of individual subunits shown (► [Neuronal potassium channels](#)). A variety of ► [mutagenesis](#) studies have confirmed this "staves of a barrel" architecture.

**Ion Selectivity:** Classic biophysical studies provided evidence for thinking that the ion selectivity apparatus lay within the lining of the transmembrane pore itself, and consisted of a narrowing of the pore to form a "selectivity filter" (see [3]). It is currently thought that

fully hydrated ions are too large to pass through the filter by themselves, and that the role of the selectivity filter is to remove their associated water, thus the naked ion would then be small enough to move past the barrier. Selectivity among ions would thus occur through differences in their relative affinity for water-removing selectivity filter. Such a view has largely been confirmed for other ion channels, and such a mechanism is assumed to operate for Na<sup>+</sup> channels.

The amino acid sequences responsible have been identified in Na<sup>+</sup> and other voltage-gated channels, and reside in the sequences between helices S5 and S6 termed the "P-element" or "P-loop" (Fig. 2). Thus Na<sup>+</sup> channels are postulated to contain four such loops, each one of which forms a quarter-sector of the cylindrical pore lining, and mutagenesis of the four P-loop segments in Na<sup>+</sup> channels has identified the region as crucial to the selectivity properties. In particular, two negatively charged glutamate residues have been

localized in this region that are thought to be responsible for binding the  $\text{Na}^+$  cation, causing the  $\text{Na}^+$  water of hydration to dissociate and allowing the ion to pass the selectivity barrier [5].

**Voltage-sensitive gating** (► **Ion channel gating**): The transmembrane segment S4 contains a strikingly unusual motif that consists of a repeated triad of two very hydrophobic amino acids (usually leucine, isoleucine, or valine) followed by a positively charged amino acid (arginine or lysine) [1,3,6]. This structure is found in all voltage-gated cation channels, and it is highly suggestive of a ► **voltage sensor** lying within the transmembrane electrical field. The basic idea is that sufficient changes in transmembrane potential will cause motion of the S4 structure in the membrane, and it is this motion that is then mechanically coupled to other parts of the channel structure to open (i.e. activate) the pore. Thus mutagenic substitution of the positively charged amino acids for either neutral or negatively charged residues usually alters the voltage-dependence of channel opening. More recently, elegant biophysical experiments have been done in which fluorescent reporter probes have been introduced into these segments and surrounding structures [6]. These studies provide strong support for the identification of these S4 segments as voltage sensors in  $\text{Na}^+$  channel gating, while they illuminate the actual molecular movements that give rise to activation gating.

The mechanism of  $\text{Na}^+$  channel inactivation has also been successfully addressed in structure-function mutagenesis studies (see [6]). Evidence from a large number of classic electrophysiological studies suggested that inactivation for ion channels generally occurred through a mechanism in which the inactivation gate is a protein “ball” that enters and blocks the open channel from the inside of the membrane. For  $\text{Na}^+$  channels, this “ball” lies in a highly conserved cytoplasmic sequence between domains III and IV, and is thus tethered to the channel by a “chain” formed by amino acid residues at both ends. This model has been elegantly confirmed in a series of mutagenesis experiments that have identified the critical residues this “ball and chain” mechanism. Mutagenesis and biophysical experiments have also identified candidate sites within the channel to which the ball binds to occlude the pore.

### Molecular Diversity of $\text{Na}^+$ Channels: Isoforms

As described earlier,  $\text{Na}^+$  channels consist of a large polypeptide “ $\alpha$  subunit” that forms the pore and gating structures, along with a variable number of accessory  $\beta$  subunits. Nine genes that code for  $\text{Na}^+$  channel  $\alpha$  subunits and four  $\beta$  subunits have been identified in mammals. The nomenclature that evolved for the different  $\alpha$  isoforms was awkward and inconsistently used, thus a simpler nomenclature has been proposed that is now accepted in which individual  $\alpha$  polypeptides

are designated as  $\text{Na}_v1.x$ , where “x” ranges from 1 to 9. In addition, a rather mysterious  $\text{Na}^+$  channel-like protein has been identified from cDNA clones and has been termed an “atypical”  $\text{Na}^+$  channel, or  $\text{Na}_v2$  in the current nomenclature. Based on difficulties in studying its functional properties, it is still uncertain whether it is a functional  $\text{Na}^+$  channel in vivo. Lastly, the four  $\beta$  subunits, designated as  $\beta1$  through  $\beta4$ , have similar structures consisting of a single transmembrane domain with a short cytoplasmic tail and an extracellular domain that has ► **immunoglobulin-like motifs** [4].

Finally, although there has been no systematic study describing all the molecular isoforms generated by each  $\text{Na}^+$  channel gene, it is likely that each gene gives rise to a geometric increase in protein isoforms due to alternative splicing and editing of mRNA, to posttranslational modifications, and to different combinations of subunits. The physiological significance of such potentially great molecular diversity of  $\text{Na}^+$  channels has only recently started to become clearer.

### Physiological Significance of $\text{Na}^+$ Channel Diversity Functional Variations Among $\text{Na}^+$ Currents in Cells and Tissues in vivo

In addition to their central role in mediating the propagating action potential,  $\text{Na}^+$  channels have been recently recognized to play an increasing number of roles in sensory transduction and in signal processing events (see above). These different roles would seem to require different functional forms of  $\text{Na}^+$  channels to serve each one of them. However, it has been difficult to study the functional properties of different channel isoforms in actual nervous tissues because multiple isoforms are nearly always co-expressed in a given neuron. Thus such studies have often utilized ► **heterologous expression** systems in which cDNAs encoding a specific channel isoform are introduced into a cell line that has no (or nearly no)  $\text{Na}^+$  channels of its own.

In any case, significant functional differences in basic voltage gating behavior have been found among isoforms. For example, the  $\text{Na}_v1.6$  isoform generally displays very rapid kinetics, which is assumed to be adapted to its role as the primary isoform involved in fast *saltatory conduction* of frequency-encoded information over myelinated fibers (► **Action potential propagation**). On the other hand, peripheral nervous system isoforms such as  $\text{Na}_v1.7$  and  $\text{Na}_v1.8$  display slow kinetics of gating, which are thought to be somehow important to their role in the transmission of pain information from the site of injury [7] (► **Voltage-gated sodium channels: multiple roles in the pathophysiology of pain**).

In addition, when co-expressed with various  $\alpha$  isoforms,  $\beta$  subunits cause significant alterations to  $\text{Na}^+$  channel function to occur, the details of which depend on the specific combination of  $\alpha$  and accessory subunits in the complex [4]. For example, association of  $\beta4$  with

Na<sub>v</sub>1.6 results in a Na<sup>+</sup> channel with highly unusual inactivation properties that appear to be required for the spiking behavior of the ►Purkinje neurons in which it is expressed. Thus differential association of accessory subunits is a basis for generating additional functional diversity among Na<sup>+</sup> channel isoforms.

#### Sodium Channel Isoforms are Differently Modulated by Intracellular Signaling Cascades

Sodium channels are substrates for biochemical modification by protein kinases (i.e. PKC, PKA, RPTPβ), and such modifications result in significant changes to the functional properties of channels in vivo [2]. Such dynamic, cell signaling-related changes are known collectively as ►ion channel modulation. Recent work has established that modulation effects are isoform-specific. For example, PKA appears to reduce the number of Na<sup>+</sup>-conducting Na<sub>v</sub>1.2 channels while it otherwise specifically affects the gating kinetics of the Na<sub>v</sub>1.8 isoform. Overall, it appears that Na<sup>+</sup> channel isoforms may indeed be differentially modified by a variety of mechanisms, and this may serve as the basis for the specific regulation of Na<sup>+</sup> currents within individual cell types and tissues.

#### Differential Expression and Localization of Na<sup>+</sup> Channel Isoforms in Tissues: Targeting and Clustering

The above suggests that functional and regulatory differences among Na<sup>+</sup> channel isoforms allow the tissue-specific expression and modulation of electrical signaling properties. Thus it has been found that Na<sup>+</sup> channel isoforms are differentially expressed among excitable tissues. Figure 3 summarizes information derived from ►immunocytochemical studies

(►immunocytochemistry) regarding the selective localization of Na<sup>+</sup> channels in excitable tissues. It would seem that the expression of individual Na<sup>+</sup> channel isoforms is highly tissue/cell specific (see Fig. 4 for examples). Thus two isoforms are selectively expressed in muscle, while three appear to be peripheral nervous system specific. Nonetheless, there are a few recent reports of expression of these isoforms in the central nervous system, so the tissue-selective expression of some isoforms is still uncertain.

In addition, even within a given cell, different isoforms are usually selectively targeted to different specializations, such as dendrites or the axon hillock. For example, in retinal ganglion cells (►Retinal ganglion cells), the Na<sub>v</sub>1.2 isoform is expressed in the unmyelinated segment of the neuron axon within the retina itself, whereas Na<sub>v</sub>1.6 is selectively clustered at ►nodes of Ranvier in the ►optic nerve. Thus there must be cellular targeting mechanisms to achieve the differential distribution of these two isoforms in the same axon. At present the mechanisms behind the selective targeting of Na<sup>+</sup> channels are being actively investigated.

The formation of high-density clusters of Na<sup>+</sup> channels at nodes of Ranvier is one aspect of Na<sup>+</sup> channel targeting and clustering that is being actively studied by a number of laboratories. These clusters are essential to the mechanism of high-speed saltatory conduction in myelinated nerve axons (►Action potential propagation). Here the neuron must precisely target the Na<sub>v</sub>1.6 isoform to the minute domains of the nodal gaps, and it must do this for nodes that may be many thousands of cell diameters remote from the soma where the channels are synthesized. How might such a spectacular process of transport, targeting, and clustering be achieved?

Sodium channel isoforms

Na <sub>v</sub> 1.1 (Type I)	<i>Dendrites</i>
Na <sub>v</sub> 1.2 (Type II/IIA)	<i>Unmyelin. initial segments</i>
Na <sub>v</sub> 1.3 (Type III)	<i>Early neuronal development</i>
Na <sub>v</sub> 1.4 (SkM1, μ1)	<i>Skeletal muscle (mature)</i>
Na <sub>v</sub> 1.5 (H1, SkM2, μ2)	<i>Heart, Immature Skel. musc.</i>
Na <sub>v</sub> 1.6 (Cer3, PN4)	<i>Nodes, synapses, dendrites</i>
Na <sub>v</sub> 1.7 (PN1, hNE-Na, Nas)	<i>Unmyelinated PNS (pain)</i>
Na <sub>v</sub> 1.8 (SNS, PN3)	<i>Unmyelinated PNS (pain)</i>
Na <sub>v</sub> 1.9 (NaN, SNS2)	<i>PNS – free nerve endings</i>
Na <sub>v</sub> 2.x (ret1, NaG, atypical)	<i>Nonmyelinating Schwann c.</i>

**Sodium Channels. Figure 3** Sodium channel isoforms and their known distributions in excitable tissues. Also given are older alternative isoform protein designations: Genomic nomenclature is also sometimes used, but is not shown here.



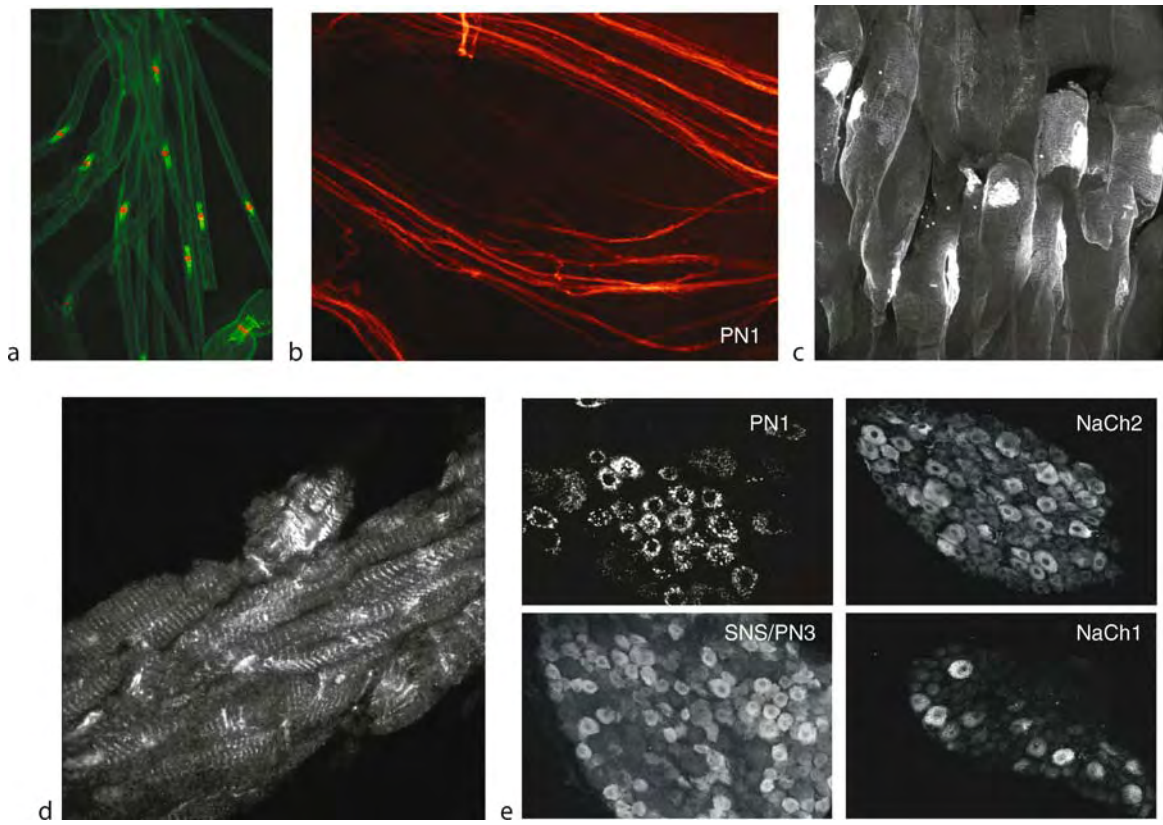

**Sodium Channels. Figure 4** Images of the subcellular localization of various  $\text{Na}^+$  channel isoforms as seen using isoform-specific immunofluorescence techniques. (a)  $\text{Na}_v1.6$  channels (red fluorescence) at nodes of Ranvier. These are mouse sciatic nerve axons co-labeled for caspr (green), a protein found in paranodal glia-axonal junctions. (b)  $\text{Na}_v1.7$  (a.k.a. PN1) isoform expression in unmyelinated fiber bundles of mouse sciatic nerve. (c)  $\text{Na}_v1.4$  expression in rat skeletal muscle. Note the intense labeling of postsynaptic  $\text{Na}^+$  channel clusters, while weaker labeling of t-tubules is also apparent (as seen in the z-line labeling pattern). (d)  $\text{Na}_v1.5$  expression in rat cardiac ventricular myocytes. Note intense staining of intercalated discs between myocytes and the t-tubule staining pattern. (e) Expression of isoforms in the dorsal root ganglion. Isoforms are identified by the older nomenclature. Note that expression of isoforms varies among different sized subpopulations of neurons, i.e. smaller neurons express PN1 and SNS ( $\text{Na}_v1.7$  and  $1.8$ ), while larger neurons express  $\text{Na}_v1.1$  and  $\text{Na}_v1.2$ .

Part of the answer to this question appears to be that myelinating glia (i.e. ►Schwann cells in the peripheral nervous system, ►oligodendrocytes in the central nervous system) assist the neuron by specifying where nodal clusters are to be formed. In particular, immunocytochemical studies show that when glia start to form compact myelin during development,  $\text{Na}^+$  channel clusters quickly form at the ends of the myelinating glial cell. Further, as the myelin sheath extends along the axon, these clusters appear to move with it at the edge of the growing glial processes. This motion continues until adjacent myelin sheaths come close to one another; at this point the adjoining clusters appear to fuse to form a stable nodal cluster [8].

At the other end of the nodal clustering process, a number of proteins have been described that define the nodal membrane domain, while others have been

identified as being part of the actual  $\text{Na}^+$  channel cluster complex (see [9]). In particular, ►ankyrinG is thought to be the link that joins  $\text{Na}^+$  channels to the axonal cytoskeleton, but this interaction seems to take place between ankyrinG and the  $\beta 1$  subunit.

#### Roles of $\text{Na}^+$ Channels in Human Disease: $\text{Na}^+$ Channelopathies

Finally, a growing number of human disorders have been identified with defects in  $\text{Na}^+$  channel function or expression [10] (see ►Channelopathies; ►Voltage-gated sodium channels: multiple roles in the pathophysiology of pain). Best characterized are the periodic paralyses (►Familial periodic paralysis) and certain myotonias (►Myotonia) of muscle and certain heritable forms of long Q-T syndrome of the heart; these involve  $\text{Na}_v1.4$  and  $\text{Na}_v1.5$  isoforms, respectively. In the

nervous system, several forms of ►epilepsy and pain disorders have been linked to genetic defects in the functional properties of Na<sup>+</sup> channel isoforms, particularly Na<sub>v</sub>1.1 and Na<sub>v</sub>1.7 (►Voltage-gated sodium channels: multiple roles in the pathophysiology of pain). In addition, a form of epilepsy has been associated with a defect in β1 expression. No doubt other human disorders will be identified as Na<sup>+</sup> channelopathies of other isoforms, especially since animal diseases have been associated with such defects (e.g. Na<sub>v</sub>1.6 channelopathies in mice).

## References

1. Levinson SR, Sather WA (2001) Structure and mechanism of voltage-gated ion channels. In: Sperelakis N (ed) *Cell Physiology Sourcebook*. Academic Press, San Diego, CA, pp 455–478
2. Catterall WA, Hulme JT, Jiang X, Few WP (2006) Regulation of sodium and calcium channels by signaling complexes. *J Recept Signal Transduct Res* 26:577–598
3. Hille B (2001) *Ion channels of excitable membranes*, 3rd edn. Sinauer Associates, Sunderland
4. Meadows LS, Isom LL (2005) Sodium channels as macromolecular complexes: implications for inherited arrhythmia syndromes. *Cardiovasc Res* 67:448–458
5. Heinemann SH, Terlau H, Stuhmer W, Imoto K, Numa S (1992) Calcium channel characteristics conferred on the sodium channel by single mutations. *Nature* 356:441–443
6. Bezanilla F (2000) The voltage sensor in voltage-dependent ion channels. *Physiol Rev* 80:555–592
7. Cummins TR, Sheets PL, Waxman SG (2007) The roles of sodium channels in nociception: implications for mechanisms of pain. *Pain* 131:243–257
8. Dugandzija-Novakovic S, Koszowski AG, Levinson SR, Shrager P (1995) Clustering of Na<sup>+</sup> channels and node of Ranvier formation in remyelinating axons. *J Neurosci* 15:492–503
9. Salzer JL (2003) Polarized domains of myelinated axons. *Neuron* 40:297–318
10. George AL Jr (2005) Inherited disorders of voltage-gated sodium channels. *J Clin Invest* 115:1990–1999

## Sodium (Na<sup>+</sup>) Channel Activation

### Definition

The transient opening of a Na<sup>+</sup> channel upon application of a depolarizing stimulus, which allows the selective inflow of Na<sup>+</sup> ions down the electrochemical gradient.

- Action Potential
- Sodium Channels

## Sodium (Na<sup>+</sup>) Channel Fast Inactivation

### Definition

Rapid inactivation (within milliseconds) of the channel which is accomplished by the structural rearrangement that cause blocking the cytoplasmic end of the channel's pore by the inactivation gate residues, thus terminating the inflow of Na<sup>+</sup> ions.

- Action Potential
- Sodium Channels

## Sodium (Na<sup>+</sup>) Channelopathies

### Definition

Pathologies linked to mutations in genes encoding voltage-gated Na<sup>+</sup> channels, or to dysregulation of these channels under pathological conditions.

- Voltage-gated Sodium Channels: Multiple Roles in the Pathophysiology of Pain

## Soft Determinism

### Definition

The thesis that determinism is true and is compatible with free action.

- Freedom of Will

## Solitary Nucleus

### Synonyms

- Nucl. solitarius

### Definition

Long cell column in the floor of the fourth ventricle, at the level of cranial nerves X, IX and VII. The nucleus has two parts:

- Solitary nucleus, gustatory part
- Here terminate relevant fibers of cranial nerves X, IX and VII.
- Solitary nucleus, cardiorespiratory part Here terminate mucosa-innervating sensory fibers from cranial nerves VII, IX, and X. Efferents go to the dorsal nucleus of the vagus nerve, medial parabrachial nucleus and to the dorsal tegmental nucleus. Direct fibers to the spinal cord course via the solitary spinal tract.

► Myelencephalon

## Solitary Tract

### Synonyms

► Tractus solitarius

### Definition

The solitary tract comprises afferent fibers of cranial nerves VII, IX and X, which after entering the brainstem embark on a rostrocaudal course to gradually terminate in the solitary nucleus.

► Myelencephalon

## Soluble NSF Attachment Protein Receptor (SNARE)

### Definition

A protein which facilitates the binding of NSF to the SNARE complex. Isoforms of this protein are identified by a Greek letter (e.g.  $\alpha$ -,  $\beta$ - or  $\gamma$ -) before the term. They can form a complex called the SNARE complex which is important for the process of exocytosis. In synaptic terminals the key SNAREs are: syntaxin, synaptobrevin and SNAP-25.

- Non-synaptic Release
- SNARE Proteins
- Soluble NSF Attachment Protein Receptor (SNARE)

## Soma

### Definition

Soma is the synonym of cell body.

## Soma-Soma Synapse

### Definition

Synapse formed between two neuronal cell bodies.

► Synaptic Transmission: Model Systems

## Somatic Features

### Definition

For a diagnosis of major depression with somatic features, the individual must display at least four of the following: marked loss of interest or pleasure in activities that are normally pleasurable; lack of emotional reaction to events or activities that normally produce an emotional response; waking in the morning 2 hours or more before the usual time; depression is worse in the morning; marked psychomotor retardation or agitation (observed by other people); marked loss of appetite; weight loss (5% or more of body weight in the past month); marked loss of libido.

► Major Depressive Disorder

## Somato-Autonomic Reflex

SAE UCHIDA, BRIAN BUDGELL  
Tokyo Metropolitan Institute of Gerontology,  
Tokyo, Japan

### Synonyms

Somato-visceral reflex

### Definition

A somato-autonomic reflex is a reflex elicited by stimulation of somatic tissue (strictly speaking, tissue of

the musculoskeletal system and the dermis of the skin), and manifesting as an alteration in autonomic nervous system function. Altered autonomic nervous system function may or may not subsequently lead to changes in the function of dependent organs, in which case one could properly refer to the phenomenon as a somato-visceral reflex. However, one should also keep in mind that somatic stimulation may evoke mechanisms external to the autonomic nervous system which, nonetheless, impact visceral function and would therefore constitute somato-visceral reflexes. Such mechanisms include humoral, immune and non-autonomic neurological processes. Thus, while the terms somato-autonomic and somato-visceral are often used interchangeably, there are differences in nuance.

## Characteristics

### Quantitative Description

A great variety of somato-autonomic reflexes has been described in the research literature, and a number of these reflexes have considerable clinical importance. In conscious subjects, somatic stimulation is likely to lead to somatic sensation and to emotional responses that add a further level of complexity to somato-autonomic interactions. Hence, it is extremely challenging to isolate somato-autonomic reflexes in conscious humans and animals. In anesthetized animal preparations, however, somatic stimulation has been clearly shown to elicit responses in autonomic efferent nerves and, thereby, in the functions of various organs. Indeed, a comprehensive review of the literature [1] has revealed somato-autonomic reflexes arising from noxious and innocuous thermal, mechanical and chemical stimulation of virtually all somatic structures investigated, and manifesting in, for example, the cardiovascular, digestive, urogenital and endocrine systems.

### Higher Level Structures

► [Central structures regulating autonomic function](#) [link to essay “Central Regulation of Autonomic Function” by Dr. Benarroch] have been described comprehensively elsewhere in this text. Important centers for autonomic output, such as the nucleus tractus solitarius (► [NTS](#) [link to glossary item “Nucleus of the Solitary tract” by Dr. Benarroch]) and rostromedullary nucleus (► [RVLM](#) [link to glossary item “Rostral Ventrolateral Nucleus (RVLM)” by Dr. Kannan]), receive inputs from higher centers and thus are influenced by, for example, emotional state. These same centres also receive visceral sensation which contributes to the generation of ► [viscero-visceral reflexes](#) [link to glossary item “viscero-visceral reflex” by Dr. Budgell] such as the ► [baroreceptor reflex](#) [link to glossary item “Baroreceptor reflex” by Dr. Dampney]. Additionally, autonomic nuclei in the brain stem receive relays from centres which receive noxious input,

including noxious input from somatic tissues. Thus, somatic pain influences central autonomic function indirectly, through emotional responses to pain, and also through less circuitous relays [2]. Important within the context of somato-autonomic reflexes, is the more recent demonstration of direct inputs from somatic afferents to central autonomic motor nuclei; see, for example [3].

### Lower Level Structures

The lower level structures contributing to somato-autonomic reflexes are somatic afferents, and sympathetic, parasympathetic and enteric motor neurons. The afferent limbs of somato-autonomic reflexes include group II, III and IV afferent fibers entering the spinal cord via the spinal nerves, and entering the brainstem via the trigeminal nerve. There is also emerging evidence to suggest that group Ia or Ib afferents (from muscle spindles and Golgi tendon organs) modulate some autonomic reflexes [4].

### Higher Level Processes

The importance of central regulation of autonomic function is brought into sharp focus by the distressing and even life-threatening manifestations of ► [disease effecting these structures](#) [link to essay “Autonomic Insufficiency” by Budgell]. Furthermore, while a simplified view would hold that noxious stimulation increases sympathetic output, while innocuous stimulation decreases it (with the inverse effects on parasympathetic output) [5], clinical observations and laboratory experiments demonstrate that the higher autonomic centres are much more discriminating. As mentioned above and described in detail elsewhere in this text [link to essay “Central Regulation of Autonomic Function” by Dr. Benarroch], ► [autonomic centres in the brain](#) receive divergent input allowing the integration of emotion, information concerning the internal environment, and somatic sensory information. This permits them to generate not simply stereotypical responses, such as ► [fight or flight response](#) [link to glossary item “fight-or-flight response” by Dr. Passatore], but rather responses which are specific to the immediate needs of the organism. Hence, by way of example, there will be occasions on which the higher level structures dampen what might otherwise be exuberant sympathetically-mediated hypertensive responses to pain. The adaptive importance of this discriminative potential becomes obvious in patients with high spinal cord injuries, and in laboratory animals subjected to experimental spinal cord lesions.

### Lower Level Processes

In subjects with an intact nervous system, autonomic reflex responses may include excitation or inhibition of motor neuron activity, depending, in part, on the somatic afferent modalities involved; see for example [6]. Classically, noxious somatic stimulation has been

thought to increase the activity of peripheral autonomic nerves, and any number of experimental studies support this generalization; see, for example [7]. However, in animals subjected to spinal lesions, one can observe the native reflex activity of peripheral autonomic nerves below the level of the lesion in the absence of modulating influences from autonomic centres in the brain. In such animals, the peripheral autonomic motor neurons seem to be capable of only excitatory responses to stimuli [6]. Furthermore, these reflexes exhibit a clear segmental organization [7,8]. That is to say the reflex output of an autonomic motor neuron is likely to be greatest when the stimulation is conveyed by a sensory nerve which enters the same spinal cord segment. By way of example, noxious pinching of upper thoracic skin may preferentially excite the cardiac sympathetic nerves which originate in the upper thoracic region, and this leads to reflex [tachycardia](#) [link to glossary item “tachycardia” by Budgett]. On the other hand, noxious pinching of abdominal skin may preferentially excite the renal sympathetic nerves which originate in the lower thoracic and upper lumbar spinal cord of the rat, and this leads to increased blood pressure.

### Process Regulation

It would appear that there are a number of parallels between somato-somatic and somato-autonomic reflexes. To use the patellar reflex as an example of a somato-somatic reflex, when one strikes the patellar ligament and stretches the quadriceps muscles, somatic information enters the spinal cord, synapses immediately with somatomotor neurons at the same level(s), producing an excitatory response – the leg jumps. Furthermore, it appears that this reflex is normally dampened by inhibitory influences descending from the brain, such that the reflex often becomes exuberant with brain or spinal cord injury. Similarly, it appears that somatic information entering the spinal cord may synapse with autonomic motor neurons originating in the same region of the cord, producing an excitatory response – for example, an increase in heart rate or blood pressure. As with the somato-somatic reflex, it appears that such somato-autonomic reflexes are often dampened by inhibitory influences descending from autonomic centres in the brain.

This model of somato-autonomic reflexes is both attractive and logical, but has been slow to emerge due to the complexity of autonomic anatomy and physiology. In particular, early experimentation into somato-autonomic reflexes often employed noxious stimulation of limb afferents; a model which obscures the segmental organization of autonomic function. This is because somatic sensory information from the forelimbs and hind limbs enters the spinal cord at the cervical and lumbar enlargements, respectively. In these regions of the spinal cord, there are many somatic motor neurons

to control limb movement, but relatively few autonomic motor neurons. Hence, autonomic reflex responses to limb stimulation are necessarily mediated primarily at the supraspinal level, and so are abolished by transection of the upper cervical spinal cord. It was only with systematic investigation of thoracolumbar stimulation that the segmental organization of somato-autonomic reflexes became apparent.

The thoracolumbar region of the spinal cord (exclusive of the lumbar enlargement) and the sacral region contain abundant [preganglionic autonomic motor neurons](#) [link to glossary item “preganglionic neurons” by Dr. Gabella]. In humans, preganglionic sympathetic neurons are concentrated in the intermediolateral and intermediomedial columns between, approximately, the first thoracic and the second or third lumbar segments. Preganglionic parasympathetic neurons form the intermediate columns in the second to fourth sacral segments. Hence, somatic afferents entering the spinal cord at these segmental levels have the potential to elicit local, spinally-mediated reflex responses, and may also synapse with projections to higher supraspinal centers (Fig. 1).

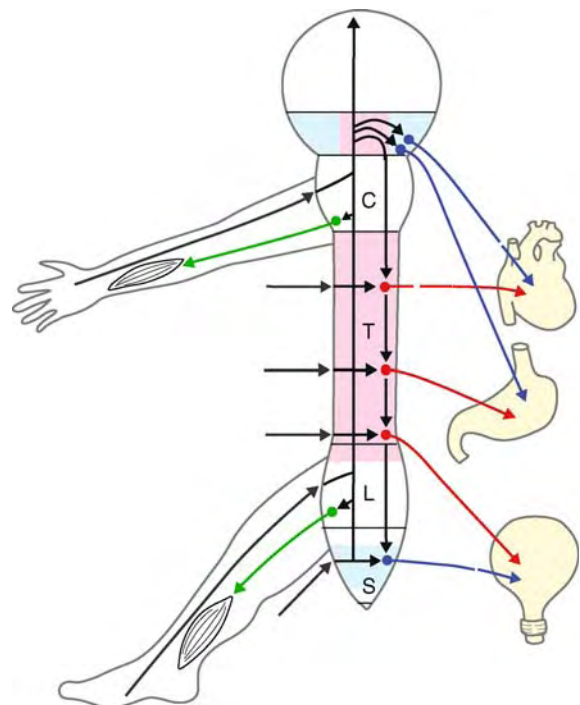

**Somato-Autonomic Reflex. Figure 1** Schematic diagram of the reflex pathways for the somato-somatic and somato-autonomic reflexes (from Sato A. et al. 1997 [1]). Somatic stimulation of limb tissues elicits reflexes mediated primarily at the supraspinal level (in the brain), whereas somatic stimulation within the distribution of the thoracolumbar spinal nerves (the trunk region) has the potential to elicit both spinally-mediated and supraspinally-mediated reflexes.

Thus, stimulation within the distribution of the thoracolumbar and second to fourth sacral spinal nerves may elicit “segmentally-organized” somato-autonomic reflexes. That is to say, the stimulation may preferentially elicit responses in visceral organs receiving autonomic efferent innervation from the same (or adjacent) segmental level(s) as the involved afferents. Moreover, the segmental organization of these reflexes is likely to manifest itself more clearly when released from descending inhibitory influences, as for example when the cervical spinal cord is transected.

### Clinical Implications

A number of somato-autonomic reflexes have well established roles in clinical practice. For example, ►paralytic ileus [link to glossary item “Paralytic Ileus” by H. Katayama] may be an important clue to the presence of local disease such as an occult fracture of the lumbar spine. Similarly, the ciliospinal reflex may be used to assess the extent of injury to the cervical sympathetic trunk. More recently, ►autonomic dysreflexia, [link to glossary item “autonomic/enteric dysreflexia” by Budgell] exuberant autonomic reflex activity in patients with spinal injury, has emerged as an important clinical challenge. Historically, somatic stimulation has also been used in a variety of health care practices, including acupuncture and spinal manipulation, to manage visceral disease. Clinical and basic scientific studies suggest that somato-autonomic reflexes may account for at least some of the therapeutic effects achieved with these therapies [9].

### References

1. Sato A, Sato Y, Schmidt RF (1997) The impact of somatosensory input on autonomic functions. *Rev Physiol Biochem Pharmacol* 130:1–328
2. Keya KA, Li QF, Bandler R (2000) Muscle pain activates a direct projection from ventrolateral periaqueductal gray to rostral ventrolateral medulla in rats. *Neurosci Lett* 290:157–160
3. Degtyarenko AM, Kaufman MP (2006) Barosensory cells in the nucleus tractus solitarius receive convergent input from group III muscle afferents and central command. *Neuroscience* 140(3):1041–1050
4. Bolton PS, Ray C (2000) Neck afferent involvement in cardiovascular control during movement. *Brain Res Bull* 53:45–49
5. Malliani A (1997) The autonomic nervous system: a Sherringtonian revision of its integrated properties in the control of circulation. *J Auton Nerv Syst* 64:158–161
6. Morrison JFB, Sato A, Sato Y, Suzuki A (1996) Excitatory and inhibitory A- and C-reflexes in pelvic parasympathetic efferent nerves elicited by single shock to A and C afferent fibers of perineal and limb somatic nerves in anesthetized rats. *Neurosci Lett* 212(1):25–28
7. Kimura A, Ohsawa H, Sato A, Sato Y (1995) Somato-cardiovascular reflexes in anesthetized rats with the central nervous system intact or acutely spinalized at the cervical level. *Neurosci Res* 22:297–305
8. Kimura A, Sato A, Sato Y, Suzuki H (1996) A- and C-reflexes elicited in cardiac sympathetic nerves by single shock to a somatic afferent nerve include spinal and supraspinal components in anesthetized rats. *Neurosci Res* 25:91–96
9. Sakai S, Hori E, Umeno K, Kitabayashi N, Ono T, Nishijo H (2007) Specific acupuncture sensation correlates with EEGs and autonomic changes in human subjects. *Auton Neurosci* 133(2):158–169

## Somato-cardiovascular Reflexes

### ► Cardiovascular Reflexes

## Somatosensory Cortex, Plasticity

JON H. KAAS

Department of Psychology, Vanderbilt University, Nashville, TN, USA

### Definition

Somatosensory ►cortex is the part of neocortex of the forebrains of mammals that is activated exclusively or mainly by somatosensory stimuli. Somatosensory cortex is plastic in the sense that it can change in internal organization so that the response properties of neurons in the cortex are altered. Most notably, neurons that lose their major source of somatosensory activation following nerve or nervous system injury typically become responsive to remaining sources of activation.

### Characteristics

Somatosensory cortex is divided into a number of functionally distinct regions called areas. Typically, each area represents cutaneous or (and) deep tissue (muscle and joints) receptors of the contralateral body in a systematic (somatotopic) pattern. Areas depend on inputs from the somatosensory ►thalamus and other somatosensory areas for activation. The loss of a source of activation, such as afferents from the hand, is typically followed by neurons developing responsiveness to remaining inputs, such as those from the face or arm. Sensory experiences can also alter the response properties of neurons, often in ways that they become more selective for the experienced stimuli. These plastic changes in somatosensory cortex are mediated by the growth of axons and the formation of new synapses

in the somatosensory system, as well as by cellular changes that influence the sensitivities of neurons to neurotransmitters.

### Plasticity in the Somatosensory System

Neural **▶plasticity** has often been observed during the development of the nervous system, in that the early loss of some input, such as that from the whiskers of the face in rats, will alter the course of development so that parts of somatosensory cortex that represent the whiskers fail to develop properly. Thus, sensory experience is essential for the normal development of the somatosensory system and somatosensory cortex.

The somatosensory systems of mature mammals are also plastic, but the mature system responds somewhat differently. In adult mammals, the response properties of cortical neurons are reversibly altered by sensory experience, often in ways that makes them more sensitive to relevant stimuli. Such changes in neuron response characteristics appear to mediate long-lasting improvements in sensory and perceptual abilities that are called **▶perceptual learning**. In addition, damage to the mature nervous system usually results in some

reorganization of the system so that remaining neurons partially compensate for the loss, allowing some behavioral recovery. However, a major loss of sensory inputs results in an extensive reactivation of deactivated portions of somatosensory cortex by remaining somatosensory inputs in ways that result in misperceptions, such as feeling **▶touch** or pain in a missing (phantom) limb. Researchers are trying to understand the mechanisms of neural plasticity so that useful forms of plasticity can be promoted, and harmful types of plasticity can be prevented.

### The Organization of the Somatosensory System and Somatosensory Cortex

While the somatosensory system is complex, and involves several afferent pathways [1] nearly all of the studies of plasticity in the somatosensory system have focused on the major pathway that starts with encapsulated, low-threshold mechanoreceptors in the skin and reaches primary somatosensory cortex via the dorsal column-trigeminal nuclear complex in the **▶brainstem** and the ventroposterior **▶nucleus** in the thalamus (Fig. 1).

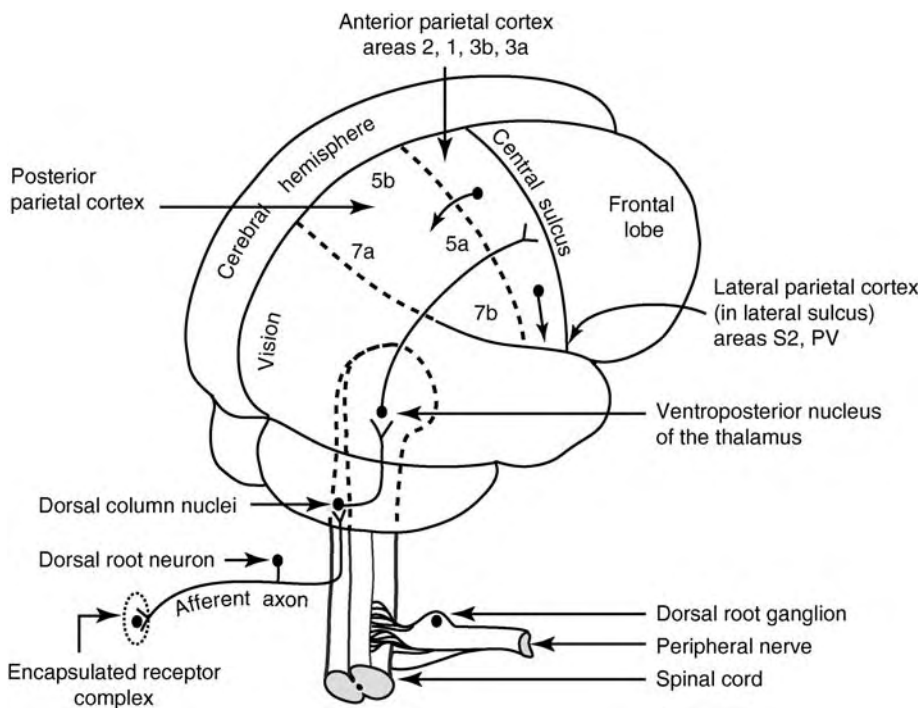

**Somatosensory Cortex, Plasticity. Figure 1** The somatosensory system for tactile discriminations in humans. Afferents in peripheral nerves enter the spinal cord or brain stem and send branches to the dorsal column-trigeminal nuclear complex where the contralateral body surface is represented somatotopically. Neurons in these nuclei project to the ventroposterior nucleus of the thalamus of the contralateral cerebral hemisphere, where neurons project to primary somatosensory cortex (area 3b). Information is then relayed to other somatosensory areas. Cortical regions are numbered according to current use of the numbering system of Brodmann. S2, the second somatosensory area; PV, the parietal ventral area.

Much of the research in the plasticity of the mature somatosensory system after injury has involved alterations of the representation of the glabrous hand in area 3b (primary somatosensory cortex) of anterior parietal cortex. According to Bolanowski and coworkers [2], tactile experience in humans depends on combinations of neural activity in four peripheral nerve channels that appear to correspond to the two slowly adapting and two rapidly adapting classes of low-threshold mechanoreceptor afferents. These afferents enter the spinal cord and course rostrally in the dorsal columns to the dorsal column nuclei, including the cuneate nucleus for afferents from the upper limb, the gracile nucleus column nuclei for the lower body, and the trigeminal nucleus for the head. These nuclei of the lower brainstem project to the ventroposterior nucleus (VP) in the contralateral thalamus. The ventroposterior nucleus, in turn, projects densely to layer 4 of area 3b, and to layer 3 of area 1 in

anterior parietal cortex. Area 3b distributes tactile information to areas 1, 2, and 3a of anterior parietal cortex, and to the second somatosensory area, S2, and the parietal ventral area, PV, of lateral parietal cortex in the lateral sulcus. These areas distribute tactile information to additional areas in lateral parietal and posterior parietal cortex, as well as to motor cortex. The subcortical nuclei and most of the cortical areas of the somatosensory system contain systematic, topographic (somatotopic) representations of the body, including the glabrous hand. Thus, at least the early stages of the ascending somatosensory processing hierarchy of nuclei and areas can be portrayed schematically as a series of surfaces where the order of the distribution of receptors in the skin is preserved in representations of the skin at each level (Fig. 2).

While the representation of the fine grain of the receptor array is degraded somewhat from level to

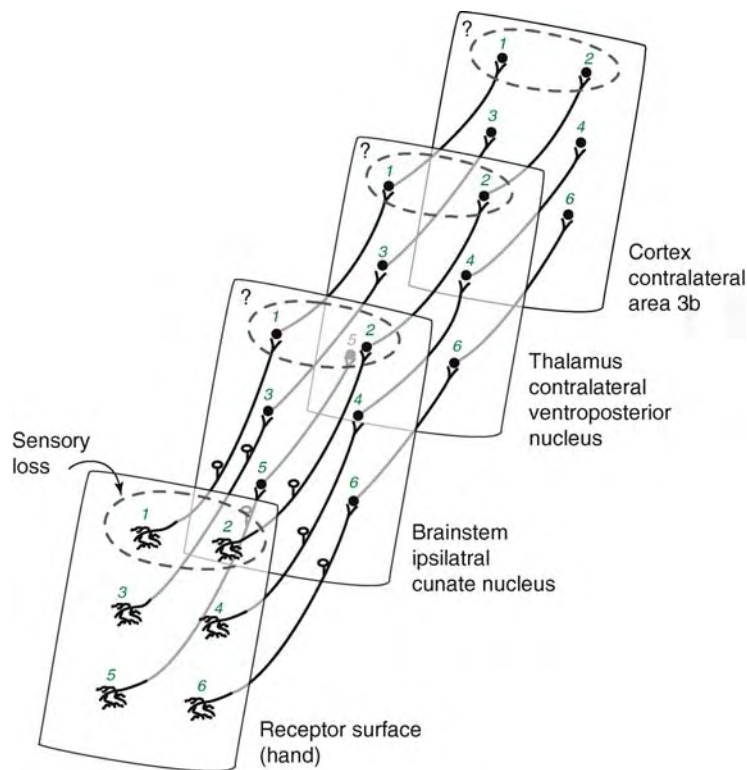

**Somatosensory Cortex, Plasticity. Figure 2** A schematic of the early stages of the portion of the somatosensory system that processes tactile information from the mechanoreceptor of the skin. In this schematic, the surface of the hand is portrayed as a simple sheet, with subsequent targets in the nervous system as similar sheets. The important point is that the order of afferents subserving receptors of the hand is preserved as they terminate in the cuneate nucleus of the brainstem, and the order is further preserved as neurons project successively to the thalamus and cortex. Thus, removing some of the afferents, such as those from positions 1 and 2 (dashed lines) immediately deprives neurons at the 1 and 2 positions at subsequent levels of their sources of tactile activation. Plasticity is demonstrated when any of these deprived zones of nuclei or cortical areas recover responsiveness to any of the preserved inputs.



level, as receptive fields for neurons become larger, orderly ►**somatotopic** representations are found at each stage up to and beyond area 3b to also include the representations in areas 3a, 1, 2, S2, PV and elsewhere. In rats, and many other mammals, similar processing hierarchies exist, but they are less elaborate at the cortical level. In rats and other mammals, primary somatosensory cortex, S1, corresponds to area 3b of primates.

### The Immediate Consequences of Sensory Loss

In either monkeys [3] or rats [4], the immediate consequence of removing a portion of the tactile afferents from the body is to completely deactivate the corresponding portions of each successive representation in the hierarchy. Thus, if afferents from skin locations 1 and 2 in Fig. 2 are eliminated by sectioning them in the dorsal columns of the spinal cord, neurons in locations 1 and 2 in the brainstem, thalamus, and primary somatosensory cortex will no longer respond to tactile stimulation on skin locations 1 and 2, or any other place on the body. In some higher order representations such as S2, where the convergence of inputs creates larger receptive fields that include locations 3 and 4 as well as 1 and 2, neurons in partially deprived cortex will respond only to touch on locations 3 and 4 and not 1 and 2, thereby having smaller receptive fields. This complete or partial deactivation of neurons is exactly what one would expect from the diagram in Fig. 2, but the brain is not stable like the diagram, and the somatosensory system immediately starts to recover from the damage. What occurs depends in part on the species (rat or monkey) and the age of the animal at the time of injury. Also, the type of recovery is more dependent on the magnitude of the sensory loss rather than the way the loss occurred. Thus, similar recoveries can occur after damage to peripheral sensory nerves, the section of the dorsal roots of sensory nerves as they enter the spinal cord, section of ascending branches of afferents in the dorsal columns of the spinal cord, or even the loss of a limb via therapeutic amputation.

### Plasticity after Sensory Loss in Mature Primates

After a sensory loss in primates, a process begins that starts to reactivate the deactivated neurons via remaining afferents [5]. If the loss is limited, such as the loss of afferents from part of the glabrous hand via section of the median nerve, reactivation proceeds rapidly over the course of 2–3 weeks, with most of the deprived neurons acquiring new receptive fields on the dorsal, hairy surface of the hand and digits. The reactivation is complete or nearly complete at the level of the cortex, nearly complete at the level of the thalamus, and partial, but extensive, at the level of the cuneate nucleus in the

brainstem. As afferents from the back of the hand terminate in the cuneate nucleus very close to those from the glabrous hand, the critical mechanism of reactivation is likely to be the local sprouting of preserved afferents in the cuneate nucleus to synapse on and activate denervated neurons. Although the reactivation of neurons in the cuneate nucleus is incomplete, these reactivated neurons project to the ventroposterior nucleus of the thalamus where the activity is amplified to include more neurons at the thalamic and cortical levels via the divergence of projections in each relay, and the lateral (horizontal) connections in cortex. In addition, there is likely to be some axon sprouting and the formation of new connections at the thalamic and cortical levels to further promote reactivation. Reactivation is also promoted by self-regulatory cellular mechanisms such that deprived neurons produce less inhibitory neurotransmitters and fewer receptors for inhibitory neurotransmitters, thereby making them more sensitive to remaining inputs.

If the sensory loss is such that all inputs are sectioned from some digits, but at least a few inputs remain from other digits, deprived cortex becomes completely or nearly completely reactivated by preserved inputs from the hand, including those that were so sparse that initially they failed to activate any cortical neurons [3,6]. This reactivation results in a considerable recovery of hand use in skilled behavior, such as in retrieving food. Thus, the cortical reactivation is clearly useful. This recovery of cortical activation and behavior occurs over a period of weeks to several months, and again it depends on the growth of new connections in the dorsal column cuneate nucleus, and possibly in the thalamus and cortex.

A greater sensory loss, such as the loss of all the afferents from an arm after an injury and therapeutic amputation, or after extensive damage to the dorsal roots of nerves subserving the arm, is followed after months of recovery in the reactivation of the deprived parts of somatosensory cortex. Cortex that is normally devoted to the hand can be reactivated by inputs from the stump of the amputated limb or from the face [7,8]. Similar, but possibly less complete reactivations of the deactivated portions of the ventroposterior nucleus of the thalamus have been observed in both monkeys and humans. As with more limited sensory losses, the growth of new connections at the level of the brainstem, and the amplification of those effects at higher levels, seems to be critical to the cortical reactivation. Such extensive reactivations appear to be largely maladaptive, as patients with arm amputations report feeling touch on the fingers of the missing hand after being touched on the face or arm stump. A similar reorganization of the pain system could account for the feeling of pain in missing limbs of patients after amputations (phantom pain). Thus, not all outcomes of brain plasticity are good, and

we need to learn how to promote types of plasticity that restore lost abilities while preventing types of plasticity that lead to misperceptions and pain.

### Plasticity of the Somatosensory System in the Developing Brain

The effects of sensory loss can be quite different in developing and mature brains. The section of somatosensory afferents of the forelimb in the spinal cord of the developing brain of rats around the time of birth can cause a rapid degeneration of the relay neurons in the cuneate nucleus of the brainstem and a loss of the normal modular organization of the nucleus that reflects the normal somatotopy [9]. Most of the deprived neurons in the brainstem apparently die before they are reinnervated by the sprouting of preserved tactile inputs. As a result, the deprived portion of the ventroposterior nucleus fails to develop, and even much of deprived primary somatosensory cortex (S1) fails to histologically develop or acquire a source of somatosensory activation. However, preserved afferents from the anterior upper arm may activate forelimb cortex, and these afferents typically activate a larger than normal portion of S1, including some of the deprived forepaw region, demonstrating that preserved afferents also enlarge their cortical territory in the developing somatosensory system. Similar results have been obtained after forelimb amputation in neonatal rats. In addition, after forelimb amputation, some hind limb afferents grow into the cuneate nucleus to activate and preserve neurons.

Presently, little is known about what happens to the somatosensory system after sensory loss in newborn primates. However, the degeneration of the deprived portions of the brainstem relay nuclei would remove one site that is important in the reactivation of cortex in adults.

### Plasticity Following Somatosensory Experience

Sensory experience and learning produce changes in somatosensory cortex that are often called “use-dependent plasticity.” During development, the extensive use of a part of the sensory surface can lead to an over-representation of that surface, while the disuse of a surface can result in an under-representation of that part. Such sensory experience, or lack of experience, can alter the course of development so that changes in representation are difficult or impossible to reverse after the brain matures.

Sensory experience also changes the organization of the somatosensory system in mature mammals. In contrast to the usual outcome of developmental plasticity, changes induced by experience in the mature somatosensory system can be rapidly reversed. The changes are largely at the level of single neurons and

small groups of neurons, and therefore they are not expressed as large changes in somatotopy. For example, neurons in somatosensory cortex of rats that respond mainly to the movement of a single whisker on the face typically increase their responsiveness to an adjoining whisker, if the two whiskers are repeatedly stimulated together (called whisker pairing). Similar changes in the response properties of neurons in somatosensory cortex of monkeys have been shown to follow training and sensory experience. Over periods of disuse or altered use, the changed properties of cortical neurons typically reverse. The ability of neurons to change how they respond to stimuli apparently depends cellular mechanisms that alter synaptic strengths, and they often depend on co-activations of neurons by sensory inputs and by neurotransmitter systems that modulate neural activity [10]. As perceptual skills improve with training, and training changes the properties of cortical neurons in ways that would enhance the detection of the stimuli rewarded during training, such perceptual learning is often attributed to local regions of experience induced plasticity in somatotopic cortical representations.

### References

1. Kaas JH (2004) Somatosensory System. In: Paxinos G, Mai JK (eds) *The Human Nervous System*, 2nd edn. Academic, New York, pp 1059–1092
2. Bolanowski SJ, Gescheider GA, Verrillo RT (1994) Hairy skin: psychophysical channels and their physiological substrates. *Somatosens Mot Res* 11:279–290
3. Jain N, Catania KC, Kaas JH (1997) Deactivation and reactivation of somatosensory cortex after dorsal spinal cord injury. *Nature* 386:495–498
4. Jain N, Florence SL, Kaas JH (1995) Limits on plasticity in somatosensory cortex of adult rats: hindlimb cortex is not reactivated after dorsal column section. *J Neurophysiol* 73:1537–1546
5. Kaas JH, Florence SL (2001) Reorganization of sensory and motor systems in adult mammals after injury. In: Kaas JH (ed) *The mutable brain*. Harwood Academic Publishers, Amsterdam
6. Darian-Smith C, Cifferri MM (2005) Loss and recovery of voluntary hand movements in the macaque following a cervical dorsal rhizotomy. *J Comp Neurol* 491:27–45
7. Pons TP, Garraghty PE, Ommaya AK, Kaas JH, Taub E, Mishkin M (1991) Massive cortical reorganization after sensory deafferentation in adult macaques. *Science* 252:1857–1860
8. Florence SL, Kaas JH (1995) Large-scale reorganization at multiple levels of the somatosensory pathway follows therapeutic amputation of the hand in monkeys. *J Neurosci* 15:8083–8095
9. Jain N, Diener PS, Coq JO, Kaas JH (2003) Patterned activity via spinal dorsal quadrant inputs is necessary for the formation of organized somatosensory maps. *J Neurosci* 23:10321–10330
10. Buonomano DV, Merzenich MM (1998) Cortical plasticity: from synapses to maps. *Annu Rev Neurosci* 21:149–186

## Somatosensory Cortex I

YOSHIKI IWAMURA

Department of Sensory Science, Kawasaki University of Medical Welfare, Kurashiki, Okayama, Japan

### Synonyms

Primary somatosensory cortex; First somatosensory cortex, SI

### Definition

The cortical area first found to be specifically involved in somatosensory processing. It is in the postcentral gyrus in primates and in the postcruciate gyrus in cats. The human somatosensory cortex was defined earlier as the regions where electrical stimulation provoked subjective somatosensory experiences. In animals, cortical evoked potentials were recorded by electrical stimulation of the body surface to determine the location of the somatosensory cortex.

### Characteristics

The somatosensory cortex I (SI) was located in the postcentral gyrus in primates. In humans, electrical stimulation of the postcentral gyrus evoked subjective somatic sensation and the somatotopic maps of the body representation over the cortical surface were drawn. In monkeys, cortical evoked potentials were recorded with shortest latency after stimulation of the periphery, either skin or nerves. Analogous somatotopic maps of the body representation were also drawn in various other mammals [1].

### Cytoarchitectonic Subdivisions of SI

Brodman assigned three different cytoarchitectonic areas in the postcentral gyrus of primates, areas 3, 1 and 2. Later area 3 was subdivided into areas 3a and 3b.

### Thalamic Inputs to SI

SI receives direct projections from the thalamic ventrobasal complex, the specific somatosensory relay nuclei that mainly convey somatosensory signals from the periphery through the dorsal column-lemniscal system, and some through the spinothalamic tract. Sensory signals from deep tissues, muscles or joints project mainly to area 3a, while those from the skin or intra-oral mucous membrane, project mainly to area 3b. The projections from the ventrobasal complex also go to areas 1 and 2, but less heavily than to area 3. Area 2 receives some additional projections from the thalamic association nuclei such as the posterior nuclei.

### Cortico-Cortical Association Connections of SI

The gray matter of the neocortex is composed of six layers. Axons of neurons in layer III project to other

cortical areas as cortico-cortical association fibers. In SI, areas 3a and 3b project to areas 1 and 2, and area 1 to area 2. Areas 3a, 1 and 2 project anteriorly to the motor cortices. Areas 1 and 2 project posteriorly to areas 5 and 7. Areas 3b, 1 and 2 project to the second somatosensory cortex (SII) [2].

### Callosal Connections of SI

Among neurons in layer III, some neurons send axons to the other hemisphere through the corpus callosum. Through these callosal fibers homotopic cortical regions of two hemispheres are connected. Generally speaking, the callosal fibers are scarce in the primary sensory areas. In SI, it is in 50 area 3b, the hand or foot region, in particular. They are seen only in the face or trunk region in area 3b. The callosal connections are denser in area 2 and more posterior in area 5, seen even in the hand or foot region [2].

### Corticofugal Connections from SI

Neurons in the cortical layers V and VI send axons down to subcortical structures. Neurons in layer V send axons to the brain stem and spinal cord while those in layer VI send axons to the thalamus [2].

### Somatotopic Representation of the Body Surface

SI is characterized by a topological (somatotopic) representation of the body over the cortical surface. In SI of the primate, the oral cavity, face, hand, arm, trunk, leg, and foot are represented orderly in the lateral-medial direction over the postcentral gyrus. Penfield and Boldrey (1937) invented a homunculus to describe such an arrangement. Maps of somatotopic representation of the body over the cortical surface were demonstrated in various other mammals by recording evoked potentials. The cortical tissue devoted to each body-part representation is not equal. The part of the body which is most exaggerated in the somatotopic map differs among animals. In primates, the cortical region for the oral cavity, face, hand, or foot is much larger compared to that of the trunk or the proximal part of the arms or legs.

### Plastic Changes in the Somatotomy

It has been reported that amputation of a digit in macaques resulted in modification of the cortical representation map in a way to cover the representation area of the lost digit by that of adjacent digits. After extensive training to use certain digits this resulted in the enlargement of the representation of adjacent digits. Furthermore, in owl monkeys after extensive use of three digits together, neurons emerged with multidigit receptive fields, which were never seen in untrained animals in area 3b [3].

Blind persons who use three fingers together to read Braille frequently misperceive which of the fingers

actually touches the text. In these subjects an expansion and dislocation of SI hand representation were found by magnetic source imaging techniques [4]. The representation area of fingers measured by magnetic source imaging increased in the left hand in string players possibly as the result of extensive training [5].

### **Columnar Structures of SI and Diversity of Neuronal Receptive Field along a Perpendicular Array**

There has been a hypothesis that the neocortex is columnar in its structure. The idea of columnar organization of the cortex in a physiological sense was first proposed in the cat somatosensory cortex by Mountcastle (1957). He described that neuronal receptive field locations tended to be similar among neurons recorded along an electrode track perpendicular to the cortical surface. He thought the phenomenon reflected the anatomical structure of vertical neuronal arrays in the cortex proposed by Lorente de No (1949). The columns were thought to be basic and elementary structures for the localization of functions in the neocortex.

The columnar structure in its original proposal was based on the assumption that a cortical locus represents a locus in the periphery faithfully, that is, the cortex is somatotopic. Receptive field characteristics of neurons in a single column could share a common thalamocortical input. It was thought that the barrel cortex in the rodent is a typical example: each barrel represents a single whisker hair there. However, recent studies show that it is not so simple in the barrel field (ref to Essay by Ebner). In other cortical areas in SI of monkeys that are more associative, such as areas 2 or 5, what is represented in the putative unitary structure is not clear-cut, because receptive field characteristics are not necessarily the same nor are they similar among neurons in a vertical array. Neurons in deep layers tend to have larger and more complex receptive fields [6,7].

Receptive fields of neighboring neurons diversify in conjunction with an increase in receptive field size and the complexity of neuronal properties in the crown of the postcentral gyrus, areas 1 and 2. In that sense, some investigators doubt that the cortex is modular. There are synonyms of column: mini-columns, modules, slabs, stripes, bands, barrels, beads, blobs, patches, puffs, lattices etc.

### **Hierarchical Processing in the Hand Region**

Modern microelectrode techniques to record single neuronal activity in waking animals enabled scientists to analyze detailed organization of the enlarged cortical finger representation in the monkey [1]. The most important principle of information processing in SI is a hierarchical processing, that is, information each neuron bears becomes progressively more complex along the rostral-caudal axis of the postcentral gyrus [6]. In the

finger region of area 3b in the monkey, the neuronal receptive field is small, often representing only a part of a phalange of a single finger. Functionally unique parts of fingers (i.e. tips, ventral glabrous surfaces, and dorsal surfaces) are represented separately, forming different subdivisions of area 3b. These subdivisions provide a basis for inter-digital integration of information in the more caudal regions of SI, areas 1, 2 and 5.

In areas 1 and 2, progressive inter-phalangeal or inter-digital integration takes place, and receptive fields of neurons become larger, covering more than one phalange of a finger, or more than one finger. The inter-digital integration is more remarkable in the ulnar fingers than in the radial ones. There are unique types of neurons in areas 1 and 2 with selectivity to specific features of stimulus, such as the direction of a moving stimulus; the presence of an edge or rough surface; those that are activated better or solely by the monkey's active hand movements, including reaching; or those facilitated or inhibited by attention.

### **Vertical Neuronal Arrays Representing Active Touch**

Diversity in the receptive field of cortical neurons was also pointed out in conjunction with a perpendicular array of neurons [7]. Receptive fields of neurons recorded along a perpendicular penetration were often variable, but the largest receptive fields usually covered the others, and were found mostly in the infragranular layers. Often they included inhibitory receptive fields that were arranged side-by-side to the excitatory ones, and also some of them responded to both skin stimulation and joint manipulation. The key stimulus common to neurons in a perpendicular penetration was the contact of an object to the receptive field achieved during an animal's active behavior to manipulate objects. Thus the largest receptive field was designated as functional surfaces. They could be regarded as a functional assemblage that deals with a set of information concerning one of various aspects of active touch.

### **Bilateral Representation of the Body in SI**

The hierarchical integration proceeds to combine information from the bilateral sides in the higher stages of hierarchical processing: a substantial number of neurons with bilateral or ipsilateral receptive fields are found in the caudalmost part (areas 2 and 5) of the postcentral finger region, and also in other body parts.

Neurons in SI usually have receptive fields on the contralateral body. Several studies reported the presence of neurons with bilateral receptive fields (Manzoni et al. 1989). According to these studies, these exceptional bilateral activities were limited to the body midline including the dorsal or ventral trunk, occiput, perioral face, or oral cavity. The midline structures are activated bilaterally in normal body use and thus have good reason to be represented bilaterally. From the

same functional standpoint however, even the distal and other body parts such as hands, shoulders, or feet should also be represented bilaterally. It had been generally thought such bilateral integrations were postponed to SII and the parietal association cortices.

Indeed, such bilateral activities have been found in the postcentral gyrus of macaque monkeys (Iwamura et al. 1994, 2001) [8]: bilateral hands, arms/shoulders and trunk, girdles, and feet neurons have been found in the caudalmost part of the postcentral gyrus (areas 2 and 5) in the dorsal bank of the intraparietal sulcus. These neurons were found systematically and nearly somatotopically. The bilateral receptive fields are large and the most complex types found in this gyrus. The distribution of the bilateral receptive field neurons roughly corresponds to that of callosal connections in this gyrus.

### Hierarchical Processing in the Hand Region of Human Somatosensory Cortex

Recent progress in technology of investigating human brain activity such as MEG, PET, fMRI, TMS etc. enabled the confirmation that the organization of the human somatosensory cortex (SI) is based on the same principles as those found in macaque as described in the previous section. Precise cytoarchitectonic structures of the human SI have been described. Representation of single finger in multiple sites of the hand region, overlapping representation of different fingers, the increasing rostral to caudal convergence of finger representation, integration of cutaneous and kinesthetic information in the caudal region were described, and thus the presence of hierarchical processing of information was confirmed in the hand region of the human somatosensory cortex [9]. Inui et al. (2004) compared the latency of SEF potential and found that it becomes progressively longer as the recording site moves caudally in the postcentral gyrus, from area 3b to 1 and 2, and areas 5 and 7.

### Attributes of Tactile Perception Represented in Cortical Activity

Cortical activities representing spatio-temporal patterns of tactile skin stimulation such as flutter-vibration, motion, direction, length, velocity of tactile stimulus, surface texture, spatial form, and so on, have been studied [1]. Studies of single cells in the somatosensory cortex SI have shown that responses reproduce essential object features presented to the skin and show response patterns similar in many cases to the primary afferent input signals. For example, the configuration of embossed dot ensembles is clearly evident in the response patterns across arrays of single cortical units. Some single cortical units have characteristics that appear to combine response characteristics of more than one afferent type, e.g. SAI and FAI afferents, providing

an additional layer of information. DiCarlo et al. (1998) indicated that area 3b neurons act as local spatio-temporal filters and may contribute to form and texture perception.

Lesions placed in the caudal postcentral region cause disturbances in the discrimination of size, form and roughness of tactile objects. Neurons were found in the caudal part of the SI of monkeys that were activated by the contact of either round or elongated objects with edges (Iwamura & Tanaka 1978). These neurons were considered as neuronal correlates of stereognosis.

In human brain the presence of systematic and hierarchical organization to discriminate texture or object shape was shown [9].

### Representation of Pain in SI (See Pain Section)

Single-neuronal recordings in the monkey established that nociceptive pathways project to area 3b and 1 of the somatosensory cortex SI. SI may be involved in the sensory-discriminative aspect of pain, especially stimulus localization. Intensity may be coded in other somatosensory cortical areas as well [10]. Pain has a strong emotional component, in addition to the sensory component, and is therefore processed by further distributed multiple cortical loci.

### Pathology

Lesions of SI produce deficits in somaesthesia, including simple light touch, two-point discrimination, position sense, vibration sense and complex perceptual abilities such as tactile object recognition and visuo-tactile matching. In contrast, patients with lesions of the posterior parietal cortex (posterior S1 and areas 5 and 7) are particularly impaired on complex tasks. Some of these patients also show difficulties in generating exploratory and manipulative finger movements within the context of active touch, called limb kinetic apraxia (Liepmann 1910). Such observations suggest that the posterior parietal cortex is a key station in generating and executing exploratory movements utilizing both efference copy and sensory feedback.

### References

1. Burton H, Sinclair R (1996) Somatosensory cortex and tactile perceptions. In: Kruger L (ed) Touch and pain. Academic, London, pp 105–177
2. Jones EG (1986) Connectivity of the primary sensory-motor cortex. In: Jones EG, Peters A (eds) Cerebral cortex, sensory-motor areas and aspects of cortical connectivity, vol. 5. Plenum New York, pp 113–183
3. Wang X, Merzenich MM, Sameshima K, Jenkins WM (1995) Remodelling of hand representation in adult cortex determined by timing of tactile stimulation. *Nature* 378:71–75
4. Sterr A, Muller MM, Elbert T, Rockstroh B, Pantev C, Taub E (1998) Changed perceptions in Braille readers. *Nature* 391:134–135

5. Elbert T, Pantev C, Wienbruch C, Rockstroh B, Taub E (1995) Increased cortical representation of the fingers of the left hand in string players. *Science* 270:305–307
6. Iwamura Y (1998) Hierarchical somatosensory processing. *Curr Opin Neurobiol* 8:522–528
7. Iwamura Y, Tanaka M, Sakamoto M, Hikosaka O (1985) Vertical neuronal arrays in the postcentral gyrus signaling active touch; a receptive field study in the conscious monkey. *Exp Brain Res* 58:412–420
8. Iwamura Y, Taoka M, Iriki A (2001) Bilateral activity and callosal connections in the somatosensory cortex. *Neuroscientist*, 7:419–429
9. Bodegard A, Geyer S, Grefkes C, Zilles K, Roland PE (2001) Hierarchical processing of tactile shape in the human brain. *Neuron* 31:317–328
10. Treede RD, Kenshalo DR, Gracely RH, Jones AKP (1999) The cortical representation of pain. *Pain* 79:105–111

## Somatosensory Cortex II

YOSHIAKI IWAMURA

Department of Sensory Science, Kawasaki University of Medical Welfare, Kurashiki, Okayama, Japan

### Synonyms

Secondary somatosensory cortex; The second somatosensory cortex; SII

### Definition

The cortical area involved in the somatosensory processing in the parietal operculum in primates and in the lateral cortical region in the cat. It has been defined as a separate cortical region from SI based on the presence of an independent somatotopic representation of the body. The extent of SII and its functional role are still in debate.

### Characteristics

Adrian (1940, 1941) found the second representations of the contralateral paw and toe being close to each other in a small portion of the lateral cortex of the cat. Penfield suggested the presence of the second somatosensory cortex (SII) in the human in the parietal operculum, in the Sylvian fissure (Rasmussen & Penfield 1947, Penfield & Rasmussen 1950): somatic sensations referred to the limbs or other body parts of either side (though more often the contralateral side) were obtained by electrical stimulation of the cortex. Woolsey (1958) later confirmed the presence of SII in various mammals [1].

### Location of SII in Terms of Brodman's Cytoarchitectonic Areas

SII can be included in Brodman's area 43, but they do not correspond to each other since the area 43 encompasses the postcentral face region of areas 3 and 1, and reaches the insula. Posterior to area 43, Brodman identified area 40. Area 40, known as the posterior parietal association cortex, could include a part of SII [1].

### Thalamic Projections to SII

Major thalamic nuclei projecting to SII are VPI (nucleus ventralis postero-inferior in the ventrobasal complex), PO (the posterior nuclei), and CL (nucleus centralis lateralis in the intralaminar nuclei). Sensory modalities reaching to the SII region are innocuous cutaneous, proprioceptive, and nociceptive.

### Cortico-cortical Inputs to SII

SII in the primate receives ipsilateral cortico-cortical projections from each of the three cytoarchitectonic subdivisions of SI, areas 3b, 1 and 2, and areas 5 and 7 in the parietal cortex [1]. SII receives callosal inputs from the contralateral SI and SII.

### Subdividing of SII Region

#### Monkey Studies

Based on single neuronal recording in monkeys (after halothene administration was discontinued), Whitsel et al. (1969) divided the second somatosensory area into two parts, rostral and caudal. They defined the rostral area as a true SII (SII/r) where neurons were activated solely by one modality of somatic stimuli from the contralateral side (thus the body representation was somatotopic), while in the caudal area the neuronal receptive fields were large (thus the body representation was not somatotopic) and some neurons were activated by visual or auditory stimuli. Robinson & Burton (1980) did more extensive microelectrode mapping in unanesthetized monkeys in SII and the surrounding areas. They found a rather complex somatotopic representation of the contralateral body in SII. Burton et al. (1995) divided SII into two parts, based on the labeled corticocortical connections from area 3b and 1 to the SII region: two somatotopic maps were in mirror image. Krubitzer et al. (1995) recorded multi-units in anesthetized monkeys and proposed that the lateral somatosensory cortex should be divided into two parts, SII and PV (parietal ventral area). One of the common findings in these mapping studies was that the distal limbs occupy the central and largest part of the SII region [1].

Recently, Fitzgerald et al. (2004) reported that the SII hand region comprises of three adjoining fields: posterior, central and anterior, by receptive field

analysis of single units recorded from unanesthetized macaque brain [2]. The central field receives cutaneous inputs only while the other two fields receive both cutaneous and proprioceptive inputs. The authors speculate that the three fields play different roles in tactile perception.

### Human Studies

Disbrow et al. (2000) based on fMRI data proposed that the subdividing of SII cortex with the nomenclature of SII and PV proposed by Krubitzer et al. (1995) for monkeys was applicable to the human SII region. Mima et al. (1997) demonstrated two representations of the hand by recording SEPS and SEFS directly from the cortical surface of the human perisylvian cortex (SII).

Eickhoff et al. (2006) histologically mapped the SII cortex of human postmortem brains and identified four cytoarchitectonic areas: OP1–4 (for Operculum, 1–4 in caudal to rostral sequence) [3]. The authors claim that this cytoarchitectonic heterogeneity corresponds to results of fMRI studies on the human SII cortex.

### Bilateral Body Representation

Earlier studies in monkeys pointed out the presence of neurons with bilateral receptive fields (Burton 1986, Manzoni et al. 1986, Whitsel et al. 1969), but survey for the bilateral representation have not been extensive. More recent studies in human using magnetoencephalography or neuroimaging techniques confirmed that the representation is bilateral in SII [4].

### SII is a Higher Stage of Serial Information Processing Monkey Studies

The notion that SII is hierarchically higher than SI in the information processing network was proposed on the basis of their anatomical relationships: SI sends projections to SII, while SII projects back to the superficial layers of SI (Burton et al. 1995, Caulier et al. 1998) [1]. Physiological studies have shown that SII neurons tend to have larger and more complex receptive fields, including bilateral ones [1]. SII has been viewed as being composed of at least two parts, with area 3b having greater connections to the anterior part (Burton et al. 1995). It was proposed that there is a hierarchical relationship between the two parts of SII with regard to the receptive field properties of their neurons. Jiang et al. (1997) have shown that neurons in SII signal a change in texture but not its magnitude; thus, SII neurons are of a higher-order than SI neurons, which show a graded change in discharge when the spatial periods of test gratings are increased [5].

On the other hand, neural activity in SII of the marmoset monkey and cat is not completely abolished by reversible inactivation of SI (Zhang et al. 1996, Rowe et al. 1996), leading to the suggestion that the strict serial processing scheme might be in need of

revision. Zhang et al. (2001) concluded that SI and SII occupy a hierarchically equivalent network for tactile processing [6].

### Human Studies

Inui et al. (2004) compared the latency of SEFs evoked by transcutaneous electrical stimulations applied to the dorsum of the left hand, just on the first metacarpal bone, and found that it becomes progressively longer as the recording site moves caudally in the postcentral gyrus, from area 3b to 1 and 2, and areas 5 and 7. The latency was even longer further in SII, indicating the presence of serial hierarchical processing from SI to SII [7].

SEFS evoked by median nerve stimulation have been recorded in SI, posterior parietal, parietal opercular (SII), and frontal regions (Mauguiere et al. 1997). On the basis of latency differences, it was assumed that the higher-order areas receive signals from SI through serial feedforward projections.

Huttunen et al. (1996) recorded SEFs in response to median nerve stimulation so as to measure changes in responsiveness during finger movements. The changes did not parallel those in SI, suggesting that the changes depended on additional modulatory inputs to SII rather than those from SI. The long latency component of SEF in response to stimulation of the posterior tibial nerve is affected by movement imagery of a toe in bilateral SII. Painful stimulation first activates contralateral SI and then bilateral SII, although it is not clear whether SII receives signals through SI or directly from the thalamus. SEFS in response to median nerve stimulation in SII are enhanced during thenar muscle contraction, possibly by decreasing inhibition from SI. Enhanced SII activation might be related to the tuning of SII neurons towards the relevant tactile input arising from the muscle.

Young et al. (2004) found that separation of hand and foot representation was clear in SI but less and less clear in SII in the order of OP4, OP2 and OP1. Instead, the rostralmost area (OP4) showed task-related enhancement [8].

### Attention to Tactile Objects Alters Responsiveness of SII

Recent studies have identified neurons in the monkey somatosensory cortex with enhanced sensitivity and selectivity for stimuli to which an animal is directing its attention (Sinclare & Burton 1993, Hsiao et al. 1993, Burton et al. 1997). The authors argue that SII, rather than SI, plays a role in tactile attention because a larger number of neurons in SII is related to attention. Burton et al. (1997) found that tactile and auditory cues correlate with enhanced or suppressed average firing rates of SII or area 7b neurons (45–50% of neurons) in response to vibrotactile stimuli. These modulations are consistent with a model of possible neural mechanisms associated

with selective attention and confirm earlier suggestions that SII plays a role in tactile attention. The authors also suggest that area 7b might play a similar role.

Nelson et al. (2004) confirmed in a human fMRI study that SII was activated more often during an attention demanding tracking task compared with passive vibration.

Chapman et al. (2005) in the study to record neurons in monkeys that were activated by a texture discrimination task, concluded that the attentional mechanisms were dual, one involved both SI and SII, while the other was more specific to SII [9].

### SII Neurons Activated by Decision-Making

Romo et al. (2002) found that some SII neurons were activated specifically at decision-making. They trained monkeys to compare two mechanical vibrations applied sequentially to the fingertips and to report which of the two had the higher frequency.

Activity of some SII neurons were correlated with monkey's decision-making to judge which of two stimuli (remembered and current) is higher in their vibration frequency [10].

### SII for Proprioception

Fitzgerald et al. (2004) [2] reported by receptive field analysis of single units recorded from unanesthetized macaque brain, that the central field receives cutaneous inputs only while the other two, the anterior and posterior fields, receive both cutaneous and proprioceptive inputs. The authors speculate that three fields play different roles in tactile perception. Alary et al. (2001) in a human SEF study suggested that human left SII plays a predominant role in proprioceptive processing.

### Projection of Pain in Human SII

Feretti et al. (2003) found in an fMRI study that the activity for the painful stimulation was localized more posteriorly compared to that for the nonpainful stimulation. Bingel et al. (2004) in an fMRI study showed that both SI and SII encode spatial information of nociceptive stimuli independent of tactile ones, and proposed the concept of a redundant representation of discriminative stimulus in somatosensory cortices. Marthofner et al. (2006) in an fMRI study concluded that SII plays an important role in the discrimination dimension of pain rather than the affective-motivational ones.

## References

- Burton H, Sinclair R (1996) Somatosensory cortex and tactile perceptions. In: Kruger L (ed) Touch and pain. Academic, London, pp 105–177
- Fitzgerald PJ, Lane JW, Thankur PH, Hsiao SS (2004) Receptive field properties of the macaque second somatosensory cortex: evidence for multiple functional representations. *J Neurosci* 24:11193–11204
- Eickhoff SB, Schleicher A, Zilles K, Amunts K (2006) The human parietal operculum. I. Cytoarchitectonic mapping of subdivision. *Cereb Cortex* 16:254–267
- Iwamura Y (1998) Hierarchical somatosensory processing. *Curr Opin Neurobiol* 8:522–528
- Jiang W, Tremblay E, Chapman CE (1997) Neuronal encoding of texture changes in the primary and the secondary somatosensory cortical areas of monkeys during passive texture discrimination. *J Neurophysiol* 77:1656–1662
- Zhang HQ, Murray GM, Coleman GT, Turman AB, Zhang SP, Rowe MJ (2001) Functional characteristics of the parallel SI- and SII-projecting neurons of the thalamic ventral posterior nucleus in the marmoset. *J Neurophysiol* 85:1805–1822
- Inui K, Wang X, Tamura Y, Kaneoke Y, Kakigi R (2004) Serial processing in the human somatosensory system. *Cereb Cortex* 14:851–857
- Young JP, Herath P, Eickhoff S, Choi J, Grefkes C, Roland PE (2004) Somatotopy and attentional modulation of the human parietal and opercular regions. *J Neurosci* 24:5391–5399
- Chapman CE, Meftah E-M (2005) Independent controls of attentional influences in primary and secondary somatosensory cortex. *J Neurophysiol* 94:4094–4107
- Romo R, Hernandez A, Zainos A, Lemus L, Brody CD (2002) Neuronal correlates of decision-making in secondary somatosensory cortex. *Nat Neurosci* 5:1217–1225

## Somatosensory Projections to the Central Nervous System

MARK J. ROWE

Department of Physiology and Pharmacology, School of Medical Sciences, The University of New South Wales, Sydney, NSW, Australia

### Synonyms

Somatic Sensory Projections to the Central Nervous System

### Definition

► Somatosensory projections arise from ► sensory receptors and nerve fibers distributed throughout the body as a whole, as distinct from those arising from the highly specialized sense organs for vision, hearing, balance, taste and olfaction. They are therefore concerned with the sensory modalities of touch, pain and thermal sensation, and the kinaesthetic sense which is the sense of body position and movement.

### Characteristics

#### The Sources of Somatosensory Information

Much of the information contributing to the different modalities of somatic sensation is derived from sensory



receptors or nerve endings in the skin, in particular, for touch and thermal sensations. However, for kinaesthesia, the information is derived from receptors in muscles and joints, and to some extent, from those within the skin because, as fingers or limbs are moved, the cutaneous mechanoreceptors are subject to perturbation in association with the stretch or compression of the skin in the vicinity of the joints being moved. In the case of pain sensations, the input may be derived from almost any site in the body, including, of course, the skin, but also from muscles and joints, for example, in association with muscle injury or inflammatory diseases of joints. Inputs for pain sensation may also arise from pathophysiological disturbances in our internal organs and give rise to ►referred pain in which the pain is associated with an external body part, such as the left shoulder or arm, in the case of coronary-induced cardiac pain. The pattern of pain referral is crucial for differential diagnosis at a clinical level, and, in terms of its explanation, is thought to reflect convergence or overlap within the central nervous system (CNS) projections of nociceptive afferent nerve fibers arising from the affected visceral organ and from the somatic site to which the pain is referred.

### The Nature of Somatosensory Receptors and Associated Afferent Nerve Fibers

The receptors and sensory nerve fibers responsible for the four modalities of somatic sensation fall into two broad groupings. First, the mechanoreceptors for tactile and kinaesthetic sensation are specialized transducer structures in which the sensory nerve ending has a complex association with non-neural cells. In contrast, thermal and pain information appears to be derived from naked sensory nerve endings in which the peripheral endings of the sensory nerve fibers, whether in the skin, muscles, joints or viscera, have some physicochemical specialization that enables them to act as transducers that convert the thermal or a variety of noxious stimuli into the electrical signals that are conveyed over the sensory nerve fibers to the CNS. A further distinction among these four modalities of somatic sensation exists over the diameter and conduction velocity of the sensory nerve fibers responsible for each modality of somatic sensation. These somatic sensory nerve fibers are usually classified into four major groups on the criterion of the cross-sectional diameter of the nerve fiber (or axon) and range from as fine as <1  $\mu\text{m}$  in diameter (the group IV fibers, or C fibers as they are also known, that lack a fatty-insulating layer of ►myelin around the conducting cable of the nerve fiber) up to diameters of  $\sim 20 \mu\text{m}$  (the Group I fibers, which, like the Group II and III fibers, are said to be myelinated, because the nerve axon is ensheathed by a myelin layer that helps confer a faster signaling speed on the fiber. The largest and fastest

conducting fibers (Gr. I and II) carry kinaesthetic and tactile information, whereas the Gr. III and IV fibers carry information for pain and thermal sensations. Fiber diameter correlates with the conduction velocity at which impulses are propagated along these somatic sensory nerve fibers, with velocities exceeding 100 m/s in Gr. I fibers, and ranging from  $\sim 40$ – $70$  m/s in Gr. II fibers,  $\sim 10$ – $30$  m/s in Gr. III fibers, and  $\sim 0.5$ – $2$  m/s in Gr. IV fibers. It should be emphasized that a peripheral somatic nerve such as the ulnar nerve (which is the one that passes close to the humerus bone near the elbow, and which, if bumped, generates pain and the pins-and-needles sensation) contains thousands of individual nerve fibers and includes not just the sensory, or afferent fibers, but also nerve fibers that convey signals outwards from the CNS to bring about muscle contraction, and others, the autonomic efferent fibers, that control blood vessel diameter and sweat gland activity.

### The Projection of Somatosensory Information From the Periphery to the CNS

Somatosensory information for touch, kinaesthesia, pain and thermal sensations is carried from all parts of the body to the CNS via vast numbers of nerves that finally enter either the spinal cord or the brainstem, depending on their source in the body. Those arising below the head enter the spinal cord via a series of paired posterior nerve roots that extend all the way from the upper cervical levels of the cord down through thoracic, lumbar and sacral levels. Each pair of spinal nerves supplies a particular band of skin, known as a ►dermatome, and associated subcutaneous somatic or visceral structures. Inputs from the feet and legs enter at lumbo-sacral levels while those from the trunk, arms and hand enter at progressively higher levels of the spinal cord. Somatosensory information from craniofacial regions enters the brainstem directly via the fifth cranial nerve, known as the trigeminal nerve, and therefore mediates tactile and kinaesthetic sensations upon which we rely for the complex sensori-motor mechanisms involved in facial expression, speech and eating, together with pathophysiological ones associated with toothache and headache.

### Projection of Somatosensory Information Within the CNS

Upon entering the CNS, somatosensory nerve fibers may project, as a result of branching in their axons, into more than one target site at which they make synaptic connections with neurones of the CNS. In this way, incoming signals may be distributed in parallel for different processing purposes, supplying, first, intraspinal nerve networks for the reflex regulation of posture and movement; second, central structures, such as the cerebellum, for the regulation of voluntary movements; and third, ascending pathways, crucial for conscious

sensory and perceptual experience, that convey the information to somatosensory areas of the cerebral cortex, in particular, the primary and secondary somatosensory areas of cortex (SI and SII respectively) located in the postcentral gyrus and the Sylvian fissure of the human cerebral cortex. In each of these cortical areas, the somatic inputs are projected in a so-called ►**somatotopic** pattern that retains the spatial relations of the body parts, but with the area of representation of those body regions being proportional to the density of somatosensory innervation of the region.

### **CNS Pathways for Ascending Projections of Somatosensory Information**

There appear to be at least three major pathways within the spinal cord for conveying somatosensory information to higher centers of the brain for somatic sensation and perception. The first of these is the Dorsal Column (DC) system, made up, to a great extent, of Gr. I and II tactile and kinaesthetic sensory axons that project directly up the spinal dorsal columns before synapsing with neurones in the ►**dorsal column nuclei** (DCN) at the junction of the spinal cord and brainstem. Although inputs from the upper body, including the hand, project directly to the cuneate nucleus division of the DCN, those from the leg are conveyed over both direct and indirect paths to the gracile nucleus division of the DCN and a further division, known as nucleus Z, located just in front of the gracile nucleus [1]. Output from the DCN is projected across the midline of the brain and ascends via the medial lemniscus to the level of the ►**thalamus**, in particular, the ventralposterior (VP) nucleus, for further synaptic processing before the next stage of projection takes place to the SI and SII areas of the cerebral cortex.

The second principal ascending spinal cord pathway for ascending somatosensory information is the ►**spinothalamic tract** (STT) which arises from neurones of the spinal dorsal horn, and which, in contrast to the DCN, receives direct input from Gr. III and IV afferent nerve fibers responsible for signaling pain and thermal information [2]. However, there are also substantial inputs to this STT system from collateral branches of larger tactile afferent fibers. STT axons project from the dorsal horn across the midline of the spinal cord, ascending in the anterolateral columns of the cord, and project to a number of different nuclei of the thalamus.

The third of the major ascending somatosensory pathways at the spinal level is the ►**spinocervical tract** (SCT) system which, like the STT, arises from dorsal horn neurones [3]. However, the SCT axons project into the ipsilateral dorsolateral columns to the upper cervical cord where they synapse with neurones of the lateral cervical nucleus whose axons, in turn, project

across the midline to ascend in association with the dorsal column-lemniscal pathway to the thalamus. The SCT system, whose input comes predominantly from tactile and nociceptive sources, is most prominent in carnivores, but is present in primates, including human beings [1,3].

Somatosensory information may also be conveyed to higher centers of the brain over less direct pathways, in particular, involving spino-reticular pathways (►**spinoreticular tracts**) whose functions are not entirely clear, but are probably not of major importance for the signaling of detailed discriminative information for sensory experience.

### **Role of Ascending Somatosensory Pathways Based Upon Experimental Surgical or Clinical Evidence**

Lesions, whether in experimental animals, or in human patients, do not provide an unequivocal account of the functional role of each of the major ascending somatosensory pathways, principally because of the difficulty of confining the disruption selectively to the intended ascending pathway. Nevertheless, observations of this type, coupled with a knowledge of the inputs reaching each of these systems, have identified the DC system as the principal ascending pathway for tactile and kinaesthetic information, while the STT appears to be the principal path for pain and thermal signaling. This knowledge has been utilized at times for the alleviation of intractable pain in patients, by means of surgical interruption of the spinal anterolateral tracts [2]. Inferences about the function of the SCT system are especially difficult to derive from lesion data as the dorsolateral columns of the cord contain a mixture of different fiber tracts.

### **Function of Ascending Somatosensory Pathways Revealed by Electrophysiological Studies**

Electrophysiological recordings from STT neurones, in particular, by Willis' group in Texas [2], have demonstrated that a great many are involved in nociceptive processing. However, some are responsive to gentle touch and may therefore contribute to the residual tactile sensory capacities that can survive if the DC pathway is damaged [4]. However, as the SCT is also involved in processing innocuous tactile information [3,5], it also remains a candidate for this role.

### **Differential Representation of Different Body Regions Within Ascending Somatosensory Projection Pathways**

Recent detailed analysis of the function of these ascending tactile systems has clarified to a great extent the differential capacities of these pathways and why such marked differences exist among them in their contributions to tactile sensibility. *First*, it is now

recognized that there are important differences in the regional representation of the body within the different ascending systems. For example, there is a restricted representation of glabrous skin inputs from the limb extremities in both the SCT [3] and STT systems [2], in contrast to the DC system which clearly serves as the pre-eminent pathway for tactile information from these crucial prehensile regions of the limb extremities [6–8]. However, for tactile inputs from the more proximal, hairy regions of skin on the limbs and trunk, there is a prominent representation within all three of these ascending pathways [2,3,5,8–10]. One might therefore ask whether there are differences in the signaling of tactile information from these sources over the three parallel pathways. In order to evaluate this issue in a quantitative way it has been necessary to employ reproducible forms of cutaneous stimulation, for the most part involving precise step indentations or sinusoidal vibrotactile stimuli delivered to the skin by means of feedback-controlled mechanical stimulators (Fig. 1).

### Quantitative Analysis of Tactile Coding Capacities for Neurons of the DC Ascending Somatosensory Pathway

In the case of the DC system, the individual neurons display a striking capacity to code reliably for the various parameters of tactile stimuli whether these are applied to the glabrous skin [6,7] or to hairy regions of skin [9,10] (Fig. 1b and c). These DCN neurons display sensitively graded stimulus-response relations as a function of changes in the intensity of both vibrotactile stimuli and static forms of skin indentation, and, in addition, retain a tightly phaselocked pattern of response to vibrotactile stimuli over a broad bandwidth of vibration frequencies extending up to ~400 Hz [6–8,10] (Fig. 1c). The high security of synaptic transmission between tactile afferent fibers and their DCN target neurons [7,10] enables the DCN neurons to retain, in their rates and patterns of impulse activity, a reliable signal of the intensity and periodicity parameters of vibrotactile perturbations encountered in either the glabrous or hairy skin.

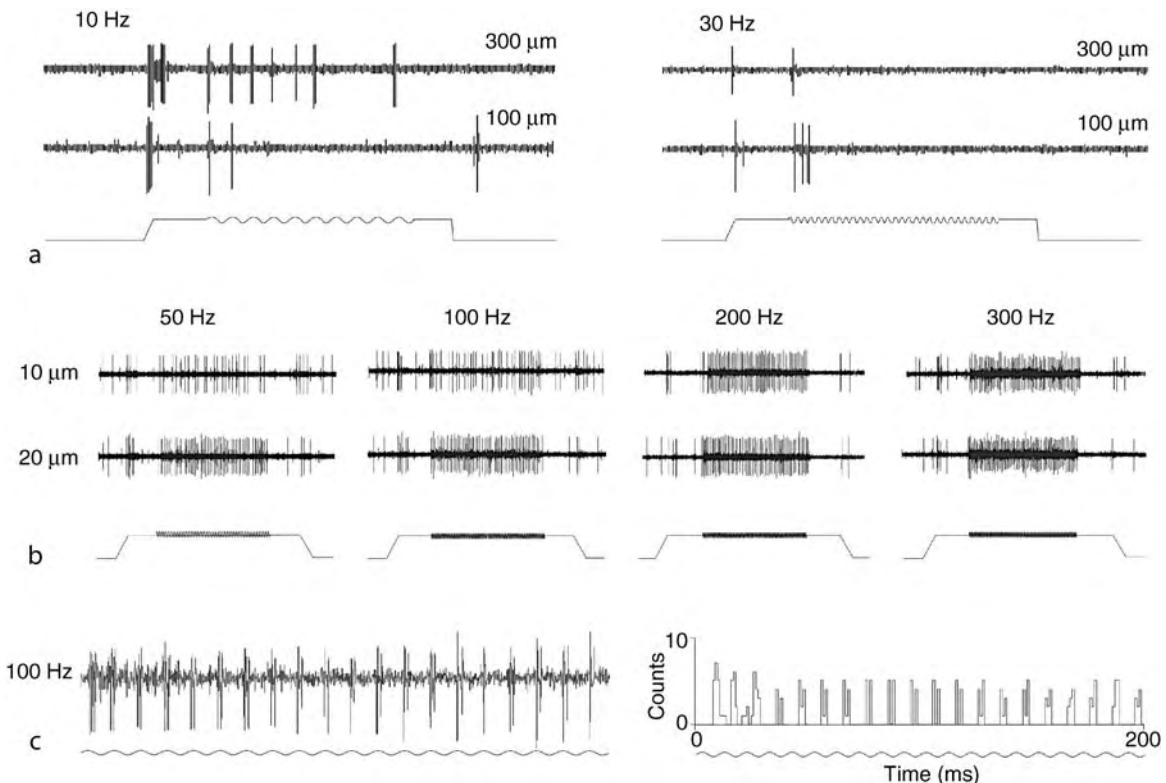

**Somatosensory Projections to the Central Nervous System. Figure 1** Vibrotactile responsiveness of representative neurons of the SCT system (a) and DCN-lemniscal system (b and c). (a) the paired impulse traces show the limited responsiveness of a typical SCT neuron to 1s-long trains of skin vibration at 10 and 30 Hz, at the indicated amplitudes. (b) paired impulse traces show the response behavior of a DCN neuron to 1s trains of skin vibration at 50, 100, 200, and 300 Hz, at the two indicated amplitudes. (c) the expanded impulse trace (on the left hand side) and response histogram of accumulated impulse counts (on the right) show the precise phaselocking of DCN responses to the waveform of a 100 Hz train of skin vibration. (Figure modified from Fig. 1 in [9], and Figs. 5 and 9 in [8]).

### Quantitative Analysis of Tactile Coding Capacities for Neurones of Somatosensory Pathways Arising in the Spinal Dorsal Horn

Within the parallel ascending projection systems arising in the spinal dorsal horn, such as the spinocervical tract (SCT) pathway, there have also been reports of secure transmission between tactile afferent fibers and the post-synaptic neurons [3,5]. However, these studies of transmission characteristics were based upon very brief input signals. With recent study using vibration stimulus trains that generate a sustained input, it has become clear that SCT and other dorsal horn projection neurons are fundamentally limited in their capacity to sustain a response beyond the transient, onset component (Fig. 1a), in contrast to the neurones of the DCN [8,9]. Furthermore, as a consequence, the response levels of these dorsal horn neurones are very low and stimulus-response relations display only a very coarse and poorly-graded signal of vibrotactile stimulus intensity, in contrast to DCN neurones [8,9], demonstrating that their capacity to signal intensive changes in vibrotactile disturbances is vastly poorer than that of individual neurones of the DCN-lemniscal pathway. As spinal dorsal horn neurones are limited in their bandwidth of vibrotactile responsiveness to no more than 5–10 Hz [9] (Fig. 1a) there is a dramatic difference in functional properties, with DCN neurones displaying a vibrotactile bandwidth effectively 40 times broader than that of dorsal horn neurones in systems such as the SCT and STT [2,6,7–10] (Fig. 1). In addition, DCN neurones retain great precision in the temporal patterning of their impulse activity in a way that enables them to reliably signal information about the periodicity inherent in vibrotactile stimuli, at least up to frequencies of several hundred Hertz [6–8,10] (Fig. 1c). In contrast, even at very low vibration frequencies (up to 5–10 Hz) that SCT and other dorsal horn neurones can follow, the phaselocking of responses is poorer than in DCN neurones [9]. The limitations revealed by these quantitative measures suggest that ascending pathways from the dorsal horn, such as the SCT system, could, in contrast to the DCN system, serve as little more than coarse *event detectors* for tactile sensory experience [9].

### Evolutionary and Comparative Roles of Dorsal Horn and DC Tactile Projection Systems

The limited capacities of SCT and other dorsal horn neurones in tactile signaling raises the question of why these ascending systems should operate in parallel with the far more discriminative DC system. From an evolutionary perspective, one finds that both systems appear to be present in amphibians, reptiles and birds, as well as in mammals. However, it is unclear whether the tactile signaling capacities of the dorsal horn somatosensory projection systems and those of the DC-lemniscal systems have remained consistently different across generic and species borders. Perhaps

the existence of both these major systems represents, at least in the tactile signaling capacities of the dorsal horn outflow projection system, a form of redundancy in the evolution of sensory systems. Alternatively, subtle differences in projection targets of each system at higher levels of the nervous system may confer some differential and unique role in tactile sensibility upon the two systems.

### References

1. Brown AG, Gordon G (1977) Subcortical mechanisms concerned in somatic sensation. *Brit Med Bull* 33:121–128
2. Willis WD, Coggeshall RE (1991) Sensory mechanisms of the spinal cord, 2nd edn. Plenum Press, New York
3. Brown AG (1981) The spinocervical tract. *Prog Neurobiol* 17:59–96
4. Vierck CJ (1998) Impaired detection of repetitive stimulation following interruption of the spinal dorsal column in primates. *Somatosens Mot Res* 15:157–163
5. Brown AG, Koerber HR, Noble R (1987) Excitatory actions of single impulses in single hair follicle afferent fibres on spinocervical tract neurones in the cat. *J Physiol* 382:291–312
6. Douglas PR, Ferrington DG, Rowe MJ (1978) Coding of information about tactile stimuli by neurones of the cuneate nucleus. *J Physiol* 285:493–513
7. Rowe MJ (2002) Synaptic transmission between single tactile and kinaesthetic sensory nerve fibres and their central target neurones. *Behav Brain Res* 135:197–212
8. Sahai V, Mahns DA, Robinson L, Perkins N, Coleman GT, Rowe MJ (2006) Processing of vibrotactile inputs from hairy skin by neurons of the dorsal column nuclei in the cat. *J Neurophysiol* 95:1451–1464
9. Sahai V, Mahns DA, Perkins N, Robinson L, Rowe MJ (2006) Vibrotactile coding capacities of spinocervical tract neurons in the cat. *J Neurophysiol* 95:1465–1477
10. Zachariah MK, Coleman GT, Mahns DA, Zhang HQ, Rowe MJ (2001) Transmission security for single, hair follicle-associated tactile afferent fibres and their target cuneate neurons in the cat. *J Neurophysiol* 86:900–911

## Somatosensory Reorganization

BEN GODDE

Jacobs Center on Lifelong Learning and Institutional Development, Jacobs University Bremen, Bremen, Germany

### Synonyms

Somatosensory representational plasticity; somatosensory remodelling

### Definition

Tactile inputs from the body surface are sequentially processed at various subcortical stages (spinal cord,

brain stem, thalamus) before this information reaches the primary somatosensory cortex (SI) and the following other cortical areas.

Each of these processing levels is characterized by a topographic representation of their respective sensory epithelial surfaces. The result is a somatotopic map of the body surface (called ▶**homunculus**), where neighbouring neurons respond to tactile stimuli at neighbouring skin sites. The size of the representations of different body parts within these maps is related to their behavioural relevance, the receptor density, and the amount of tactile sensations within these body parts. Consequently, certain body parts, like the tongue and single fingers, are over represented relative to much larger body parts like the abdomen.

However, cortical representations are not fixed but continuously modified throughout life in response to use, learning, skill acquisition, or lesions. Thus, somatosensory reorganization describes lasting changes in the layout of topographic representations of the body surface, allowing developmental and adult adaptation to individual and dynamically changing sensory input patterns that are not specified by genetic constraints.

Although somatosensory reorganization is best described for the ▶**primary somatosensory cortex (SI)**, which is located in the postcentral gyrus, it occurs at all afferent subcortical levels and is not restricted to cortical areas.

## Characteristics

### Higher Level Structures

The classical experiments in monkey somatosensory cortex, performed by Merzenich and colleagues, demonstrated that immediately after peripheral nerve section or digit amputation a large portion of the respective cortical representation was unresponsive to any stimulation, but over the course of a few weeks, this unresponsive area came to be excited by inputs from neighbouring skin surfaces. The recent development of ▶**non-invasive imaging techniques** made it possible to perform similar studies in humans. These studies consistently revealed that neurons in the SI hand or forelimb representation, having lost their inputs due to amputation, became reactivated by inputs from the stump or the face [1].

Other experiments demonstrated that the somatosensory cortex could dynamically allocate areas in a use-dependent manner. In monkeys, extensive training in a tactile discrimination task resulted in an expansion of the respective cortical representation of the trained skin surface [2]. In professional string players, the cortical representation of the left string-fingers are substantially enlarged as compared to the fingers of the right hand. Similarly, blind Braille readers have increased representations of their reading fingers, which are accompanied by superior tactile spatial acuity with these fingers [3].

Moreover, it is also possible to induce lasting changes in sensory performance by passive induction of cortical reorganization without conscious attention and feedback. For example, in humans, a few hours of synchronous tactile stimulation of separated ▶**receptive fields** on single fingers also leads to an increase of the related representational areas and their overlap in primary somatosensory cortex, paralleled by improvement in spatial two-point discrimination [4]. However, the improvement is completely reversible within hours after termination of the stimulation protocol. Therefore, stability of the reorganization is closely related to the time course of induction, and original representations reoccur after exposure to the original sensory input statistics.

### Lower Level Components

Topographic changes as well as changes in single neuron response characteristics, synaptic properties, and biochemical processes can be found months or years after peripheral deafferentation at all subcortical afferent stages [1]. However, it seems to be most pronounced at the somatosensory cortex. One reason for that might be the system of divergent and convergent afferents, leading to increasing ▶**magnification factors** from the periphery to the cortex. Thus, small changes at the brain stem level would induce much larger changes in the cortex. However, the extent of cortical reorganization goes far beyond the boundaries of thalamocortical afferents favouring far-reaching intracortical horizontal connections in being the substrate for these effects. Moreover, tactile training experiments in monkeys revealed cortical receptive field changes, which were not paralleled by similar changes in the thalamus [1]. Using microstimulation to induce short-term plasticity in the SI cortex and thalamus, without involving more peripheral levels of sensory processing could demonstrate that reorganization in the thalamus can be induced by stimulating the cortex, but in contrast, no thalamocortical transfer was found. What is more, the largest map changes were observed in the cortex after ▶**intracortical microstimulation**. These results direct to the cortex as main substrate for somatosensory reorganization.

### Higher Level Processes

▶**Hebbian-based learning rules** relate to the detection of temporally correlated inputs and are often used to explain the formation and plasticity of representational maps. In the case of topographic representations of sensory epithelia, peripheral inputs that fire in close temporal proximity are more likely to represent neighbouring points on the peripheral sensory sheets.

Animal and human data have always pointed to the behavioural significance of input timing [1]. In monkeys, artificially induced ▶**syndactyly**, aimed to

enhance indirectly the degree of synchronicity of inputs across two merged fingers, led to a fusion of the respective cortical representations. In human subjects, after surgical reversal of congenital syndactyly, and therefore reduction in synchronous tactile inputs, cortical representations of the respective fingers that had been strongly overlapping before surgery, became rapidly separated.

Even enhancement of synchronous usage of different fingers in monkeys during training in a tactile discrimination task, resulted in an integration of the representations of those parts of the fingers that received temporally coincident inputs [1]. In humans, examination of the cortical hand representations of blind Braille readers who use three fingers of each hand in synchrony for reading [3], revealed a distortion of the normal cortical topography due to an increase of overlap of the respective finger representations.

On the neuronal level, in freely moving rats, clipping and pairing whiskers for several days led to increased neuronal responses to the paired surround receptive field whiskers which had experienced temporally correlated activity, and decreased responses to the clipped whiskers in which activity was temporally de-correlated to the neuron's principle whisker [5].

More recently, imaging experiments in humans [4] revealed consistent effects of synchronous coactivation characterized by an enlargement of the respective somatosensory cortical representations and their overlap. On the other hand, segregation of cortical representations could be induced by asynchronous coactivation [6].

Interestingly, coactivation-induced somatosensory reorganization was accompanied by alterations in perceptual capacities: after synchronous coactivation, two-point discrimination performance was improved, while frequency discrimination and localization became impaired. On the other hand, segregation of cortical representations induced by asynchronous coactivation was paralleled by an impairment of two-point discrimination, but an improvement of localization abilities on the stimulated skin sites.

### Lower Level Processes

Reorganization can be observed on different time scales from minutes and hours to days, weeks, months, and even years, indicating different mechanisms being involved. After extensive remodelling of sensory afferents and cortical representational areas during maturation, only very few changes in the anatomical connections can be observed in the adult individual. Local growth of axons and dendrites, as found months or years after severe central or peripheral lesions, cover only very short distances (several micrometers) and cannot account for far reaching map reorganization of several millimetres to centimetres. Possible other mechanisms

are the unmasking of previous silent, subthreshold, or actively inhibited synaptic connections. Increased numbers of GABA<sub>A</sub>-receptors after chronic injury might be interpreted as response to immediately decreasing levels of the inhibitory neurotransmitter ►GABA, leading to disinhibition and hyperexcitability extending over several millimetres within minutes after deafferentation [1].

Changes within the existing network based on cellular and synaptic mechanisms may play a crucial role, also underlying short-term somatosensory cortical reorganization after training or extensive tactile stimulation. This might be alterations in synaptic strengths and efficacy, changes in the balance of excitatory and inhibitory intracortical connections, as well as structural processes resulting in the formation of new synapses and an increase in spine density. In a Hebbian sense, the importance of stimulus timing and the amount of synchronicity of different stimuli point to the relevance of spike timing-dependent processes like ►long-term potentiation (LTP) and ►long-term depression (LTD) [7]. This view is supported by the finding that input-dependent plasticity can be facilitated or blocked by either ►NMDA-agonists or antagonists, respectively [7].

### Process Regulation

Cortical plasticity allows adaptation to changing sensory environments and demands. However, sensory reorganization influences perception and may interfere with the need for stable percepts of the outer world. Thus, it is important that changes in the amount of sensory inputs causing reorganization are behaviourally relevant. Interestingly, Recanzone and co-workers found changes in the somatosensory hand representation of monkeys after extensive tactile finger stimulation only when the monkey had to attend the stimuli to get a reward but not with passive stimulation [2]. The ►nucleus basalis (NB), a subcortical structure receiving inputs from limbic and paralimbic regions and sending excitatory projections to the entire brain, seems to play a key role in estimating the behavioural relevance of particular stimuli and the control of selective attention [8]. Nevertheless, as shown above, cortical plasticity is controlled not only by top-down directed processes like attention or reinforcement, but somatosensory reorganization can also be induced in a bottom-up fashion purely by the statistics of the sensory inputs. The application of tactile stimuli with high frequency for several hours, resulting in a total number of stimuli that is much larger than that used in most training experiments, might yield an intrinsic behavioural significance of these stimuli relative to others.

### Function

Functional recovery after damage seems to be one major role of somatosensory reorganization. However,

since processes of axonal and dendritic sprouting, as occurring after deafferentation, are very slow and would not have direct evolutionary advantages, the main role of somatosensory reorganization might be founded on its strong relationship to tactile learning processes. Further, whereas physical growth during maturation establishes the gross layout of the somatosensory map, adult plasticity allows the ongoing adjustment of cortical information processing to changing demands.

### Pathology

Somatosensory reorganization not only takes part in tactile learning or rehabilitation after lesions. It may also be related to maladaptive phenomena like ►phantom limb pain (PLP) or ►focal dystonia [3].

In upper arm amputees, the neighbouring representations of the face and shoulder invade the representational area of the lost arm. A significant relationship was found between the amount of reorganization in the primary somatosensory cortex, and the occurrence of phantom sensations and even phantom limb pain that were perceived to be emanating from the now missing extremity.

Focal dystonia – a motor disorder often leading to loss of motor control of one or more fingers – is frequently observed in musicians like pianists or string players who extensively do repetitive, synchronous movements of their fingers. Motor impairment is associated with somatosensory cortical reorganization: Assumable as a consequence of synchronous inputs from multiple skin sites at unusually high rates, topographic order is disturbed and cortical representations of the fingers are more overlapping than in controls.

### Therapy

One kind of therapy for patients suffering from PLP as well as from focal dystonia is to reverse cortical reorganization. Huse and colleagues treated upper arm amputees suffering from PLP with asynchronous tactile stimulation of the stump and the face for several months, and found a decrease in PLP accompanied by a disintegration of the face and stump representations [9]. Tactile discrimination training had a similarly beneficial effect on both the cortical topography and PLP [10].

Whereas some researchers also suggested sensory discrimination training for the treatment of patients suffering from focal dystonia, Elbert and co-workers used a different approach: they fixed single fingers with a splint so that the other fingers could be moved independently. After both kinds of therapy, a normalization of the map layout and a decrease of dystonic symptoms occurred [3].

## References

1. Buonomano DV, Merzenich MM (1998) Cortical plasticity: from synapses to maps. *Annu Rev Neurosci* 21:149–186
2. Recanzone GH (2000) Cerebral cortex plasticity: perception and skill acquisition. In: Gazzaniga MS (ed) *The new cognitive neurosciences*. MIT, Boston, pp 237–250
3. Sterr A, Elbert T, Rockstroh B (2002) Functional reorganization of human cerebral cortex. In: Fahle M et al. (eds) *Perceptual learning*, MIT, Boston
4. Dinse HR, Merzenich MM (2002) Adaptation of inputs in the somatosensory system. In: Fahle M et al. (eds) *Perceptual learning*, MIT, Boston
5. Diamond ME, Armstrong-James M, Ebner FF (1993) Experience-dependent plasticity in adult rat barrel cortex. *Proc Natl Acad Sci USA* 90:2082–2086
6. Pilz K, Veit R, Braun C, Godde B (2004) Effects of co-activation on cortical organization and discrimination performance. *Neuroreport* 15:2669–2672
7. Dinse HR, Ragert P, Pleger B, Schwenkreis P, Tegenthoff M (2003) Pharmacological modulation of perceptual learning and associated cortical reorganization. *Science* 301:91–94
8. Kilgard MP, Merzenich MM (1998) Cortical map reorganization enabled by nucleus basalis activity. *Science* 279:1714–1718
9. Huse E, Preissl H, Larbig W, Birbaumer N (2001) Phantom limb pain. *Lancet* 358:1015
10. Flor H, Denke C, Schaefer M, Grusser S (2001) Effect of sensory discrimination training on cortical reorganization and phantom limb pain. *Lancet*, 357:1763–1764

## Somatosensory Representation

### Definition

A cortical area or a subcortical nucleus where neurons are activated, when receptors of the body (skin and deep tissues) are stimulated, in a spatial pattern that reflects (represents) the locations of the receptors in the body.

- Somatosensory Cortex I (SI)
- Somatosensory Cortex II (SII)
- Somatosensory Cortex, Plasticity
- Somatosensory Reorganization

## Somatosensory Representational Plasticity

- Somatosensory Reorganization

## Somatosensory Senses

### Definition

Body senses of pain, touch, temperature and the position of muscles and joints.

- ▶ Sensory Systems

## Somatosensory Trigeminal System

- ▶ Evolution of the Trigeminal Sensory System and its Specializations

## Somatostatin

### Definition

A peptide hormone that inhibits growth hormone release from the pituitary and affects neurotransmission and cell proliferation.

- ▶ Neuroendocrinology of Psychiatric Disorders

## Somatotopic Map

The ordered projection of a sensory surface to one or more structures of the central nervous system.

## Somatotopic Organization

### Definition

The localization of function for different body parts to separate regions of the cerebral cortex or brain area. Somatotopic organization exists for both motor output

from the brain in the form of movements as well as sensory input to the brain from the body surface.

- ▶ Motor Cortex: Output Properties and Organization
- ▶ Somatosensory Projections to the Central Nervous System
- ▶ Somatosensory Reorganization

## Somato-visceral Reflex

- ▶ Somato-Autonomic Reflex

## Somniloquy

### Definition

Somniloquy, also known as Sleepwalking, consists of expressing speech during any stage of Non-REM or REM sleep. The speech can be fragmented and unintelligible, or it can be clear, coherent, and lengthy and mimic an actual conversation, including emotional tone. The content of the talking can be meaningful or random.

- ▶ Non-REM Sleep
- ▶ Rapid Eye Movement (REM) sleep

## Somnogens

### Definition

Endogenous substances that increase sleepiness or promote sleep. Examples of somnogens in the sleep research literature include prostaglandin D2 (PGD2), Interleukin-1 (IL-1), Muramyl peptides, and adenosine.

Various substances classified as somnogens may have different effects on NREM and REM sleep stages and thus they may be best characterized by indicating their affects on wakefulness, NREM and REM states.

- ▶ Non-REM Sleep
- ▶ Rapid Eye Movement (REM) sleep
- ▶ Sleep – Motor Changes
- ▶ Sleep – Sensory Changes



## Song Control System

### Definition

An interconnected chain of brain areas that controls song production and sensory-motor learning.

► Song Learning of Songbirds

## Song Learning

### Definition

Bird calls are, in general, acquired by inheritance. However, two orders of birds are able to learn vocalizations: parrots and passerines. These birds inherit only a very general motor program. They modify this program in two steps: first they hear their father singing. They store this information in a template. When they start to sing by themselves they compare their own singing with the stored template.

## Song Learning of Songbirds

MANFRED GAHR

Department of Behavioural Neurobiology, Max Planck Institute for Ornithology, Germany

### Definition

Songs of songbirds (order Passeriformes, suborder oscines) are sequences of frequency-amplitude-modulated sounds and intervening silent intervals. First, songs can be characterized by the phonology of the sounds, which are named elements. Second, songs can be characterized by its syntax, the rules with which elements and silent intervals are combined to form longer temporal sequences. For example, in some species such as the great tit the songs of a male can be classified into distinct song types, characterized by unique sequences of elements. In other species such as the sedge warbler songs consist of sequences of randomly assembled elements, rarely repeated in the same order. Intra- and interspecies differences in song phonology and syntax are in part due to auditory-motor learning, i.e., songs are cultural trades much like human language.

### Characteristics

#### Song Learning: Consideration from Behavioral Experiments

During development young birds first listen, guided by innate auditory preferences for conspecific song, and memorize the song of an adult tutor during the ► **sensory phase**. The overlapping or subsequent sensory-motor phase starts with the onset of singing at a species typical age. In the sensory-motor phase, the juveniles first produce immature vocalizations that they gradually refine and approach towards the memorized tutor song. Konishi [1] developed the concept of an acquired auditory ► **template** or memory as the basis of song learning in songbirds. He showed that deafening of non-learning species (e.g., chicken) shortly after hatching had no effect on their vocal development. In contrast, deafening in songbirds such as the white-crowned sparrow disturbed song development dramatically depending on the age at which the surgery took place. Males that were operated upon before onset of singing developed highly abnormal songs, while those deafened after establishing of a stable (crystallized) song pattern maintained their songs. This pioneering and subsequent works [1,2,3] suggest that: (i) innate motor programs are only sufficient for the development of parts of the song, (ii) a combination of innate and acquired auditory templates guides song development, and (iii) self-generated auditory feedback is essential for the conversion of innate and acquired templates into songs. Although the timing and the amount of learning from external models might vary considerably between species, vocal learning appears a general feature of songbirds while the song features (e.g., the phonology, the syntax) to be learned are species-typical.

These behavioral studies suggest neural circuits for the following processes [3–5]: (i) the generation of the motor commands that give rise to the songs, (ii) the sensory learning of sounds, and (iii) the comparison of self-generated sounds and auditory memories and subsequent error correction mechanisms during sensory-motor learning. Despite the large diversity of song pattern among songbirds, the neurobiological mechanisms of vocal learning detailed below are derived, mainly for technical reasons, from a few species, primarily the zebra finch.

#### The Song Control System Produces Learned Vocalization

In songbirds, neural vocal control is achieved by a chain of anatomically discrete, interconnected brain areas in the fore-, mid-, and hind-brain [6] (Fig. 1).

These areas can be subdivided in the descending motor pathway (HVC, RA, nXIIIs) and the anterior forebrain pathway (AFP). The AFP is a forebrain-basal-ganglia loop that connects HVC with RA via three intervening areas (LMAN, DLM, Area X). Besides

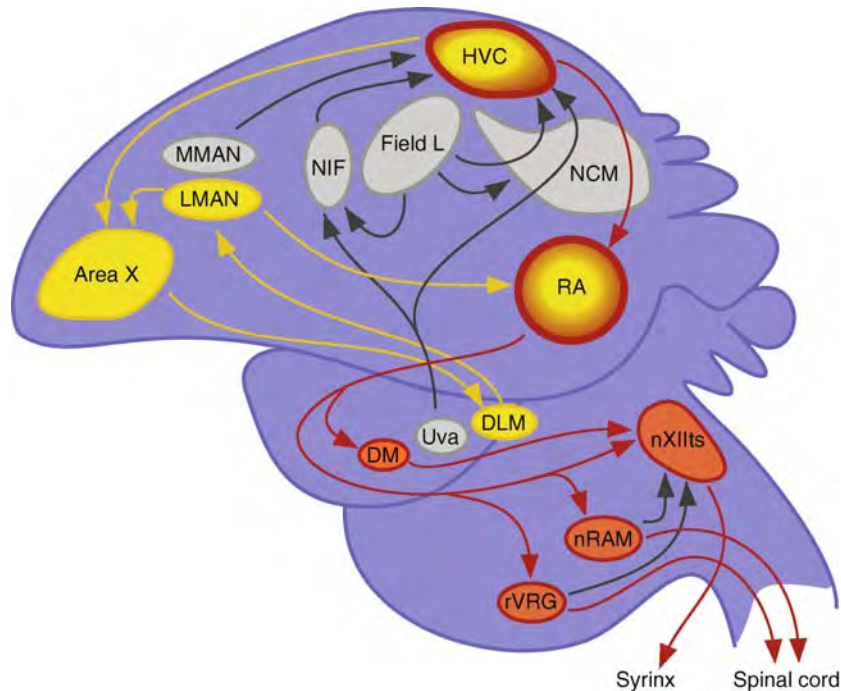

**Song Learning of Songbirds. Figure 1** A schematic parasagittal view of the song system of songbirds indicating the major projections (arrows). The descending motor control pathway (red) includes the HVC, RA and syringeal motonucleus nXIIIts as well as respiratory premotor areas. HVC and RA are further the beginning, respectively, and the end of the anterior forebrain pathway (AFP) (including Area X, LMAN, DLM) (yellow) that is likely involved in sensory-motor learning. Thus, HVC and RA (red + yellow) might be involved in motor control and sensory-motor learning. Sensory input (grey) comes via the UVA (somatosensory) and via the Field-L complex and NIF (auditory) into the HVC. Song perceptual learning might first take place in the Field-L complex and NCM. The role of MMAN is not studied in detail. Abbreviations: DLM, nucleus dorsolateralis thalamus, pars medialis; DM, nucleus dorsomedialis; HVC, Nucleus HVC of the nidopallium; LMAN, Lateral magnocellular nucleus of anterior nidopallium; L, Field L; MMAN, Medial magnocellular nucleus of anterior nidopallium; NCM, Caudal medial nidopallium; NIF, Nucleus interface of the nidopallium; nRAM, nucleus retroambigualis; nXIIIts, pars tracheosyringealis of hypoglossal nucleus; RA, Robust nucleus of arcopallium; rVRG, rostroventral respiratory group; UVA, nucleus uvaeformis.

the AFP, there are further recursive loops between song areas and sensory input comes from the somatosensory and the auditory system. Although the flow of auditory information into the vocal areas is not entirely worked out, the avian primary auditory cortex (Field L-complex) appears to connect with NIF and HVC (Fig. 1) [4,6].

The production of learned vocalizations correlates with the differentiation of forebrain vocal control areas [6] (Fig. 1). These forebrain areas are rudimentary in females of those songbird species such as the zebra finch, in which females produce only innate vocalizations (calls). In suboscine passerines such as the tyrannid flycatchers and in those non-passerine species that do not learn its vocalizations, these forebrain areas are missing entirely. Interestingly, in parrots (order Psittaciformes) and hummingbirds (family Trochilidae, order Apodiformes), the other two avian taxa with vocal learning, the vocal control system too comprises

multiple forebrain areas. Since the three groups of song learning birds (songbirds, parrots and hummingbirds) are not closely related, vocal learning evolved independently at least three times among birds.

#### **The Descending Motor Pathway Generates the Motor Commands of Song**

Singing involves inspiratory airflow (silent intervals) and expiratory airflow, during which the frequency-modulated sounds are produced involving activity of the syrinx and of suprasyringeal structures such as the trachea, tongue, and beak. The descending motor pathway consists of the HVC, RA and hindbrain areas that innervate the syringeal muscles (nXIIIts) and expiratory and inspiratory motoneurons of the spinal cord (Fig. 1) [6]. This pathway generates the motor commands of the song with a hierarchical organization. The premotor activity of HVC correlates with larger vocal sequences and that of RA with the motoric details.

### ***Is the Template Memorized in the Auditory or the Song System?***

Despite the comparative evidence that implicates forebrain areas in the production of learned vocalizations, the location of the template, probably a distributed function, is unclear. Since auditory learning is a general characteristic of birds and not linked to the production of learned vocalizations, template formation might occur in the auditory system and/or in the ►song control system. The best experimental attempt to involve the song system, in particular the AFP, in sensory learning has been to reversibly inactivate the LMAN by infusing a NMDA-receptor antagonist during tutoring periods but not during periods of active singing of young zebra finches. Although song learning is somewhat reduced in these males, template formation was not prevented [4,5]. A recent study employing markers of neuronal activity suggests that some auditory responses in the caudomedial nidopallium reflect the song learning experience of individual male zebra finches (Fig. 1). This finding and the lack of song control neurons that are tuned to the ►tutor song before the onset of sensory-motor learning indicates that sensory learning of song occurs first in the auditory cortex rather than in the song system [4,5].

### ***Where does Sensory-Motor Learning Take Place?***

During sensory-motor learning, motor circuits need to be gradually shaped by singing-based feedback in order to transform an auditory map into a muscle map. The electrophysiological finding of auditory neurons that become tuned to features of the tutor song, or of the ►birds-own-song, or of both in vocal areas gives anatomical grounds for sensory-motor learning in the song system [4,5]. Such neurons are found in the descending motor pathway (HVC, RA) and in the AFP. Lesion experiments of the AFP suggest that the integrity of this loop is necessary for sensory-motor learning. Although lesions do not locate function and AFP-lesions affect the differentiation of the descending motor pathway, such lesions inhibit the development of aberrant songs that can be induced through certain experimental conditions [5]. This suggests the AFP as part of a comparator that generates a correction signal. Another candidate for sensory-motor learning is the HVC [4]. The auditory properties of HVC (neurons tuned to birds-own-song and tutor song), the separate projections of HVC into the descending motor pathway and into the AFP, and the properties of the local HVC-circuitry put this area in a central position for sensory-motor integration. Thus, we need to consider that sensory-motor learning is a distributed function with various tasks located in various brain areas or neural assemblies.

### ***Hormone-Dependent Differentiation of the Song Control System and Song Learning***

The evolution of forebrain song control areas in songbirds is paralleled by the evolution of estrogen (only HVC) and androgen receptor (all song areas) expression [7,8]. During ontogeny, expression of these hormone receptors is one of first neurochemical features of song areas to emerge, i.e., the song system is sensitive to gonadal hormones during periods of sensory and sensory-motor learning.

Androgens and estrogens specify the sexual differentiation of brain and behavior upon brain-intrinsic genetic mechanisms. In this process, the hormones first specify the global development of the song control system, which provides the crude substrate for song development. Some of these hormone-sensitive global anatomical features, in particular the size of the vocal areas and its neuron numbers, are proposed to relate to the amount of song motor memories, i.e., to the amount of ►sensory motor learning [7,8]. However, since the overt motor memories do not in all cases represent the total learned repertoire such correlations are controversial. For example, adult male canaries sing some of their song elements in certain seasons while others are produced year-round. Similarly, the selective production of song units after initial overproduction due to socio-sexual interactions, coined action-based-learning by Marler [2], does not mean that unused motor memories are deleted.

Next to the overall differentiation of a functional song system, androgens and estrogens modify many neural phenotypes (synapse density, synaptic proteins, neurotrophins, neurotransmitter receptors) that are potentially involved in the formation of neural circuits during song learning. In relation, circumstantial evidence suggests hormonal modification of sensory-motor learning: High levels of testosterone induces premature crystallization, i.e., ends sensory-motor learning, while depletion of testosterone delays the closure of sensory-motor learning. Similarly, seasonal periods of sensory-motor learning in adult canaries coincide somewhat with periods of low testosterone production. These findings need, however, to consider that testosterone increases singing activity. Thus, it remains to be seen if sex hormones affect the production of motor commands, or auditory properties or the comparison between birds-own-song and the song template. The presence of further types of hormone receptors (e.g., melatonin) in the song system as well as the expression of receptors of the ascending monoaminergic systems (e.g., dopamine receptors) suggest that song learning is modulated by a number of signaling systems that reflect environmental conditions. Such modulatory action is to be expected since learned songs are under sexual selection pressure [7,8].

### Sensory and Sensory-Motor Learning at the Circuit Level

After the onset of singing, i.e., during the period of sensory-motor learning, neurons that are tuned to birds-own-song or to the tutor song or to both emerge in various parts of the song control system. Thus, it is likely that the template is first formed outside the song control system and subsequently shifted to (multiple) sites of the vocal system during the sensory-motor period of song learning, a process reminiscent of memory translocation in visual imprinting. Syringeal deafferentiation that hampers the birds to gradually copy the tutor model indicates that the neural representation of the tutor song in vocal areas requires the process of sensory-motor learning [5].

The transformation of the auditory template into a motor representation in the song system requires comparison. The comparator circuit would evaluate auditory feedback of the birds-own-song in the context of the template. Differences between the actual song and the model would result in an error signal that modifies the song control system so that subsequent song better matches the template. One scenario is that premotor-linked inhibition and auditory-evoked excitation of Area X-projecting HVC neurons might constitute an estimate of the error signal. The inhibition is through inhibitory HVC interneurons, which are activated by RA-projecting HVC neurons. In relation, Area X-projecting HVC neurons can respond to various sounds including birds-own-song, but are silent during the singing of adult males, i.e., these neurons might only be active in the case of non-matching auditory feedback but otherwise cancel out auditory feedback. Such error estimates could also be produced in the AFP, since the AFP also contains neurons tuned to the birds-own song and/or the tutor song and is active during singing. The song related activity of the AFP might constitute an efference copy of premotor activity, which results (as detailed above) from the patterned inhibition of X-projecting HVC neurons during singing. This inhibition of the input to Area X could activate LMAN circuits through disinhibition of a thalamic relay (DLM), similar to mammalian cortex-basal-ganglia circuitry. Although there is much progress in understanding the properties of the vocal circuitry in relation to song learning, the central problem of how an error signal modifies the motor network is unsolved [4,5]. However, since the AFP and the HVC excite the same RA neurons with a time difference of about 60 msec, delayed excitation could be used as a reinforcement signal to the descending motor pathway. Lastly, since song areas of sleeping animals show discharge patterns that are remarkably similar to patterns generated during singing, off-line rehearsal might play a role in sensory-motor learning or maintenance of motor memories [3–5]. This would solve some problems of the above scenarios resulting from fast sound production.

### Cellular Mechanisms of Sensory and Sensory-Motor Learning

In general, we don't need to expect any "songbird-special" cellular mechanisms of learning, seen in the similarities of song learning to other types of sensory-motor learning [9]. Thus, the songbird-specific feature is grounded in the anatomy and connectivity of the vocal system itself. One speciality of song learning might, however, be seen in the ample recruitment of new neurons into certain song areas (see below) [10].

Changes of the vocal system during sensory-motor learning have been best studied in the AFP. Refinements of topographic projections between LMAN and RA, elimination of synaptic contacts in LMAN, faster NMDA currents at the DLM to LMAN synapse, and loss of activity-dependent synaptic potentiation and depression in LMAN have been reported. It is difficult to establish if such regression and refinement underlie sensory-motor learning, since the song system still undergoes maturation during the sensory-motor period that is independent of learning. To separate maturation from learning related events, zebra finches are raised under special conditions, e.g., without tutor. Although this approach indicates that certain developmental observations such as synapse elimination in LMAN are linked to song learning, the findings might rather reflect the social isolation than the lack of learning [9].

An unusual type of mechanism involved in sensory-motor learning might be the recruitment of new neurons during both development and adulthood [10]. Various factors including testosterone, auditory input, or singing are thought to affect the addition of new neurons in HVC. Although, fascinatingly, these new neurons are integrated into neural circuits, clear evidence that they are required for song learning is missing. In female canaries, the number of new neurons can be increased by testosterone treatment, which is otherwise known to induce song crystallization. If the new neurons indeed play a role in this behavioral process needs to be seen since neuron recruitment is subsequent to testosterone-induced angiogenesis in HVC. The latter certainly has a number of consequences next to facilitating neuronal recruitment that could underlie song development [10].

### Function of Song Learning

Song learning might facilitate the adjustment of vocal development to local ecological demands or socio-sexual experiences. However, evolutionary related groups of birds (the ►suboscines) are successful without the evolution of song learning. Among ►songbirds, song learning is an additional criterion upon which sexual selection works, seen in the function of learned song in the realm of reproduction (mate choice, territorial defence). Mate choice based on singing not only considers the actual physiology such as high levels

of sex hormones of the advertiser, but also considers the life history of the singer, i.e., its physiological conditions during song learning periods [7].

## References

1. Konishi M (1965) The role of auditory feedback in the control of vocalization in the white-crowned sparrow. *Z Tierpsychol* 22:770–783
2. Marler P (1997) Three models of song learning: evidence from behavior. *J Neurobiol* 33:501–516
3. Margoliash D (2002) evaluating theories of bird song learning: implications for future directions. *J Comp Physiol A* 188:851–866
4. Mooney R (2004) Synaptic mechanisms for auditory-vocal integration and the correction of vocal errors. *Ann N Y Acad Sci* 1016:476–494
5. Doupe AJ, Solis MM, Kimpo R, Boettinger CA (2004) Cellular, circuit, and synaptic mechanisms in learning. *Ann N Y Acad Sci* 1016:495–523
6. Wild JM (2004) Functional neuroanatomy of the sensorimotor control of singing. *Ann N Y Acad Sci* 1016:438–462
7. Gil D, Gahr M (2002) The honesty of bird song: multiple constraints for multiple traits. *Trends Ecol Evol* 17:133–140
8. Ball GF, Riters LV, Balthazart J (2002) Neuroendocrinology of song behavior and avian brain plasticity: multiple sites of action of sex steroid hormones. *Front Neuroendocrinol* 23:137–178
9. Nordeen KW, Nordeen EJ (2004) Synaptic and molecular mechanisms regulating plasticity during early learning. *Ann N Y Acad Sci* 1016:416–437
10. Gahr M, Leitner S, Fusani L, Rybak F (2002) What is the adaptive role of neurogenesis in adult birds? *Prog Brain Res* 138:233–254

## Sonomicrometry

- Measurement Techniques

## Sound

### Definition

Sound is an oscillation in pressure, stress, particle displacement, particle velocity in a medium with mass and inertia.

- Acoustics

## Sound Intensity (I)

### Definition

The average rate of sound energy transmitted in the specified direction through a unit area normal to this direction at the point considered. For cases in air,  $I = \frac{1}{2} p^2 / \rho_0 c$ , where  $p$  is pressure,  $\rho_0$  is the density of the medium, and  $c$  is speed of sound in the medium.

- Acoustics

## Sound Localisation Pathways

- Binaural Pathways and Processing

## Sound Pressure Level (SPL)

### Definition

The decibel level expressed relative to 20  $\mu\text{Pa}$  (micropascal), which is approximately the lowest sound pressure that humans with normal hearing can detect.

- Acoustics

## Sound Representation

- Tonotopic Organization (Maps)

## Sour Taste

### Definition

- Taste - Sour

---

## Source Amnesia

### Definition

When one can recall a fact or an idea, but cannot recall the source of the information. In other words, the person can recall the fact, but cannot remember where or when the fact was learned. It has been linked to frontal lobe dysfunction.

- ▶ Amnesia

---

## Source Monitoring

### Definition

Source monitoring refers to the process of identifying the origin of memories and knowledge, such as when, where, or from whom they were obtained, independent of the knowledge on what information and knowledge one has in own memory storage.

- ▶ Metacognition

---

## Southern Blot

### Definition

Southern Blot is used to identify a particular DNA in a sample. Genomic DNA is isolated from a population of cells, separated on the basis of size by gel electrophoresis, and the DNA transferred to a membrane. A radioactive (or fluorescent/chromogenic) complementary DNA or RNA probe is then used to detect the DNA.

---

## Space Adaptation Syndrome Drugs

- ▶ Anti-Motion Sickness Drugs

---

## Space Motion Sickness

### Definition

Space motion sickness is a condition resembling motion sickness on Earth but encountered during early exposure of astronauts to microgravity in space. Symptoms consist of nausea, vomiting, headache, vertiginous sensation etc.

- ▶ Autonomic Function in Space
- ▶ Motion Sickness
- ▶ Anti-Motion Sickness Drugs

---

## Sparse Coding

- ▶ Combinatorial Coding

---

## Spasm

### Definition

Brief, non-sustained contraction of one or more muscles.

---

## Spasm-like Electromyographic (EMG) Activities

### Definition

The generation of single unit potentials and compound motor action potentials that were evoked by noxious chemical stimulation of visceral afferent fibers.

- ▶ Electromyography
- ▶ Viscero-Somatic Reflex

## Spasmodic Torticollis

### Definition

Also known as cervical dystonia, is characterized by abnormal sustained muscle contraction causing twisting, turning, and abnormal posturing of the neck. Botulinum toxin injections are the first line of therapy for most focal dystonias such as torticollis.

## Spasmophilia

### Definition

Idiopathic normocalcemic ▶tetany, which may be hereditary or acquired.

## Spastic Ileus

▶Bowel Disorders

## Spasticity

### Definition

Spasticity results from damage to motor nerve fiber systems descending from supraspinal to brainstem and spinal structures. However, lesions limited to the pyramidal tract (e.g., the pyramids in the medulla oblongata) entail a Babinski reflex and paresis (i.e., temporary weakness and loss of dexterity), but neither spastic dystonia nor permanent weakness. The pathophysiology is complicated, therefore, also due to the fact that (i) depending on damage site, there are several clinical syndromes with potentially different pathogenic

mechanisms (cerebral spasticity vs. spinal spasticity, which can be symmetric or asymmetric), (ii) descending fibers and afferent sensory fibers show a complex convergence onto motoneurons and interneurons in brainstem and spinal cord. In varying combinations, symptoms include *positive symptoms* such as *hypertonia* (velocity-dependent resistance of skeletal muscle to stretch); *hyperreflexia* (enhanced tendon reflexes and clonus); *enhanced cutaneous reflexes*; *contractures*; *autonomic hyperreflexia*; and *negative symptoms* including *paresis*; *synkinesia*; *lack of dexterity and enhanced fatiguability*. *Hypertonia* probably has several intertwined causes. First, muscle compliance may change due to changes in collagen tissue, tendons and joint capsules, thus entailing a higher passive stiffness. Second, the histochemistry and morphometry of spastic muscle may change. *Hyperreflexia*: The tendon reflexes and the fast dynamic reflex responses to maintained muscle stretches, as well as the H-reflex (Hoffmann reflex), are enhanced. *Clonus* is thought to result from increased stretch reflex excitability and consequent tendency towards oscillation. The *enhanced tendon jerk* can probably not be accounted for by augmented  $\gamma$ -motoneuron activity.  $\alpha$ -Motoneurons might become hyperexcitable due to changes in biophysical properties or synaptic inputs. Recurrent inhibition has been found changed in spastic patients, but in different ways, partially dependent on disease state. Reciprocal inhibition is often disrupted and mostly reduced in spastic patients, which might disrupt the orderly alternation of agonist/antagonist activity during rhythmic movements such as locomotion. Changes in reflex pathways from Golgi tendon organs could alter reflex excitability. The presynaptic inhibition of group Ia fibers from muscle spindles appears reduced in amyotrophic lateral sclerosis, multiple sclerosis and patients with spinal cord injury. *Spinal reorganization*: Short- to long-term plastic changes may re-organize spinal operations so as to increase the cord's excitability. Mechanisms might include the unmasking of existing but hitherto ineffective synapses, collateral sprouting, reductions in pre- and postsynaptic inhibition, and changes in postsynaptic sensitivity ("denervation hypersensitivity"). *Flexor spasms*: Flexor spasms are another facultative sign that occurs especially in spinal cord-injured patients. They probably represent the augmented form of normal flexion reflexes as they are used during locomotion and the withdrawal reflex. They may be elicited by excitation of small-diameter, mechanically sensitive muscle afferents (maybe including group II muscle spindle afferents), joint and cutaneous afferents. In cerebral spasticity, short-latency cutaneous reflexes may be suppressed, while spinal spasticity often goes along with a particularly prominent enhancement of the

long-latency flexor withdrawal reflexes, with a reduced threshold, prolonged duration and irradiation. *Spastic Gait*: The traditional concept of spastic gait disorders envisages exaggerated reflexes as the primary change underlying spastic movement disorders and thus promotes anti-spastic drugs as means to reduce the reflex activity. The new concept emphasizes the loss of functionally more important long-latency reflexes (leading to reduced muscle activity during movements despite increased short-latency stretch reflexes) and changes in non-neural factors that compensate for the loss of supraspinal drive, which would argue against anti-spastic drugs in mobile patients. In children with early supraspinal motor lesions, e.g., in *cerebral palsy* children, the usual maturation of gait does not take place so that the co-activation of antagonist leg muscles persists. In adults with spasticity acquired after the age of four years, the reciprocal pattern is developed, but temporal overlap of antagonist muscle activities is pronounced. Functionally important polysynaptic and long-latency reflexes are diminished, leading to reduced proprioceptive contributions to the leg muscle activations, which are less well modulated and less well adapted to the ground conditions. One problem in making spastic patients walk more easily is to overcome the destructive flexor spasms. Modern treatment strategies rest on combinations of physiotherapy, locomotor training, electrical stimulation (e.g. of spinal cord and peripheral afferents), and drug therapy (e.g., with  $\alpha_2$ -agonist clonidine) to support rhythmic spinal activity generation, provided by spinal central pattern generators (CPGs), while attempts at repairing the spinal lesions are in the experimental phase.

- ▶ Amyotrophic Lateral Sclerosis (ALS)
- ▶ Babinski Reflex
- ▶ Central Pattern Generator
- ▶ Clonus
- ▶ Golgi Tendon Organ
- ▶ H-reflex (Hoffmann Reflex)
- ▶ Multiple Sclerosis
- ▶ Muscle Spindle
- ▶ Presynaptic Inhibition
- ▶ Reciprocal Inhibition
- ▶ Regeneration

---

## Spatial Abilities

- ▶ Spatial Memory

---

## Spatial Attention

### Definition

The process of selecting stimuli on the basis of spatial location. Items in the selected region then receive further cognitive processing.

- ▶ Spatial Cognition
- ▶ Visual Attention

---

## Spatial Coding

- ▶ Combinatorial Coding

---

## Spatial Cognition (Category: Others)

SARAH H. CREEM-REGEHR

Department of Psychology, University of Utah, Salt Lake City, UT, USA

### Definition

The representation of location, orientation, and action with respect to the self, others, objects, or the environment. Spatial cognition may be studied in the context of sensory information, motor control, frames of reference, scale, maps, imagery, attention, language, and memory. Approaches include developmental, neural, cognitive, and cognitive neuroscience investigations of both humans and nonhuman animals. The study of spatial cognition crosses disciplines of psychology, ethology, geography, information science, and computer science.

### Characteristics

#### Multiple Sources of Spatial Information and Integration

There are multiple sources of information for spatial orientation. External, or allothetic, information includes visual, auditory, olfactory, or tactile cues for position. Internal, or idiothetic, information includes proprioceptive and vestibular sources that change as a result of self-movement. Research has addressed the relative contribution and integration of sensory information for



the perception of self-motion and spatial localization within one's environment. Nonhuman animals have been shown to integrate allothetic and idiothetic cues in a flexible manner, using both route-based and landmark-based references. For example, given an environment with visual, olfactory, and internal motion cues, rodents will rely first on vision, next on olfaction, and third on motion-based path integration (see below). However, given unreliable or the lack of visual and olfactory cues, the animals will navigate through path integration alone [1]. Humans have been shown to dynamically calibrate perceptual and motor information. There is consistent covariation between action and perception as an observer navigates through space. For example, when a person walks along a straight path (translation), visual perspective translates as well. Rieser and colleagues [2] demonstrated that changing this perception-action coupling will lead to systematic recalibration of representation-action coupling, or how one dynamically updates spatial orientation without vision.

### Action, Path Integration, and Spatial Updating

A common goal for all organisms is to act in their environment, making action critical to defining spatial cognition. Moving in space provides information about spatial location through efferent feedback of the motor system, afferent proprioceptive cues linked to limb movement, and vestibular cues of linear acceleration and rotation. ▶**Spatial updating** is the process of updating representations of the locations in the environment with respect to the self and others. It potentially involves two broad sources of information. The first is path integration, in which velocity- or acceleration-based self-motion information from the visual, vestibular, and proprioceptive systems is used to update one's spatial displacement. The second is the recognition and use of landmarks within the environment. Path integration is typically tested in both human and nonhuman animals with a return-to-origin or path completion task in which the observer follows an outbound path and then travels back (or points or turns) to the origin of the path without the use of positional landmarks. Although organisms such as the desert ant and rodents are quite skilled at path integration, it has been suggested that humans are imprecise when navigating by path integration alone. In contrast, tasks referred to as visually directed actions, in which an observer typically walks without vision to a previously viewed target, are performed on average, quite accurately up to approximately 20 m.

It has also been proposed that transient action-based responses (necessarily egocentric, see next characteristic) involve a distinct representation of space as opposed to longer-lasting spatial representations that

use other spatial frames of reference (▶**spatial frame of reference**) [3]. This “two visual systems approach” suggests that spatial characteristics may be processed independently depending on the goal of the observer, defining a long-term conscious system for “what” or identification versus an immediate unconscious system for “how” or guiding actions. However, other research supports the claim that some visually directed actions and cognitive response measures are informed by the same spatial representations.

### Frames of Reference and Structure of Space

Spatial frames of reference are a means of representing spatial locations relative to some spatial framework. Generally, frames of reference are defined relative to the viewer, *egocentric*, or relative to something other than the viewer, *allocentric*. More specifically, the egocentric frame of reference involves a ▶**first person perspective** and may be subdivided into spatial relations to body-parts, such as oculocentric, headcentric, and bodycentric, specifying spatial locations relative to the eye, head, and body, respectively. Allocentric representations include the object-relative frame which defines space relative to two or more objects and the environmental frame which defines space relative to cardinal directions of north, south, east, and west. The gravitational frame of reference specifies up and down relative to gravity.

Regions of space defined relative to the observer have been characterized in the context of the utility of information for space perception and action-relevant goals. In the context of space perception, Cutting and Vishton [4] defined *personal space*, which extends slightly beyond an arm's reach from the observer, *action space*, within which we can rapidly locomote and extending from the boundaries of personal space to approximately 30 m from the observer, and *vista space* beyond 30 m from the observer. In a somewhat different context of how people think about space, Tversky [5] categorized *space of the body* as the understanding of positions and relations of body-parts, *space around the body* as the space within which one can immediately see and reach to things, and *space of navigation* as space that is explored and too large to see all at once.

### Imagery and Spatial Transformations

The human ability to imagine spatial transformations is important for accomplishing many daily goals such as action planning, object recognition, spatial navigation, and problem solving. Much of the early work on ▶**spatial imagery** and mental rotation focused on the human ability to make a decision about the congruency of one rotated object with respect to another. Shepard

and Metzler [6] found that the time required to make a decision about the similarity of the structure of two rotated objects was a function of the angular disparity between the two objects. This monotonic rotation function was upheld for rotations in the picture plane and in depth. Much mental rotation work has focused on 2D or 3D objects but other related research has involved imagined transformations of hands and bodies using both cognitive and neuroimaging approaches.

Mental transformations of bodies and body-parts may serve to facilitate planning of actions, predicting or understanding other's behavior, or other complex tasks of spatial reasoning. Parsons' [7] work with imagined spatial transformations of biological objects such as hands, feet, and bodies indicated that the response time to make a left-right decision about the hands or feet (given no explicit instructions on a strategy to use) was highly correlated with the time required to imagine a limb movement (without the left-right decision). Both types of judgments were also highly correlated with participant's ratings of the awkwardness of moving into a given limb orientation. This work relates to the concept of body schema, knowledge of the spatial relations among the parts of the body that can be used to represent oneself and others, as well as ►self perception.

A related paradigm has compared object- and perspective-based transformations in the context of spatially updating external objects. Several studies have directly compared both cognitive and neural mechanisms involved in mental transformations of objects versus egocentric (or viewer) perspective [8]. When participants are given a spatial updating task to name an object in a given location after a specified imagined transformation, a large systematic performance advantage has been found for viewer versus object/array transformations.

### Spatial Attention

►Spatial attention is the process of selecting stimuli on the basis of spatial location. Often this process relies on visual stimuli and is referred to as ►visuospatial attention. Items in the selected region then receive further cognitive processing. Attentional mechanisms may operate early or late in processing. In a spatial cuing paradigm, a "cue" preceding a target either predicts (valid trial) or does not predict (invalid) the target's spatial location. Typically, valid trials lead to facilitation of responses to the target, although this effect can be reversed when the time interval between the cue and the target is increased. Neglect is a disorder of spatial attention typically a result of damage to the right posterior parietal lobe. Patients with neglect fail to attend to the side of space opposite the brain lesion are typically unaware of

stimuli falling on the left side of egocentric or object-centered space.

### Spatial Language

►Spatial language uses verbal description to represent objects and locations with respect to multiple coordinate systems or frames of reference. Both the scene characteristics and the speaker's perspective and goals influence schematization of spatial relations in language. Spatial language can be used effectively to communicate spatial layout and directions. Furthermore, mental representations of space based on verbal descriptions have been shown to be functionally similar, and accessed and updated as those based on visual information [9]. However, some recent work has shown that language-based responses of direction lead to different spatial updating performance than body-based responses such as turning or pointing.

### Cognitive Maps, Place Cells, and Spatial Knowledge

Historically, the term ►cognitive map has been used to refer to a mental map of space represented in an allocentric framework. The hippocampus is one brain region which has been defined as integral to spatial memory and a cognitive map theory in animals. Identified within the hippocampus were place cells, neurons that fire in response to specific locations in an environment regardless of the animal's movement or perspective. This pattern of neural activity specific to spatial positions led to the proposal of the hippocampus as supporting an allocentric environmental map, distinguished from other brain regions that might support more egocentric representations of space. Recent data shows that in addition to place cells, neurons throughout the limbic system encode nonspatial experiences and viewing orientation (head direction cells), suggesting a more general navigation system. This conjecture is also supported by human lesion research in which patients with hippocampal damage are impaired in path integration. More generally, human cognitive mapping defined from cognitive psychology and geography involves extracting information from large-scale environments to store in some type of mental representation of space [10].

A distinction between route and survey perspectives has been made both in spatial learning and memory. Route-based perspectives involve egocentric representations from the viewpoint of the observer navigating in an environment. Survey-based perspectives involve map-like or global "birds-eye" spatial representations without a specific viewer orientation. Although these types of representations may be distinguished clearly in spatial cognition, human neuroimaging data suggests that the neural substrates supporting these representations overlap.

## Neural Representations of Space

Two dominant regions of the brain that are implicated in spatial cognition are the parietal cortex and the hippocampus. Evidence for the strong role of the parietal cortex in spatial cognition comes from a variety of domains such as single-unit recording of neurons in the monkey for different spatial frames of reference, lesions in humans associated with neglect and other spatial deficits, and functional neuroimaging of spatial decisions, imagery, and navigation with healthy humans. The hippocampus has been implicated in large-scale spatial navigation, allocentric representations and spatial memory for the configuration of objects. Hypotheses differ in how the parietal cortex and hippocampus interact.

## References

1. Etienne AS (2003) How does path integration interact with olfaction, vision, and the representation of space? In: Jeffery KJ (ed) *The neurobiology of spatial behavior*. Oxford University Press, Oxford, pp 48–66
2. Rieser JJ, Pick HLJ, Ashmead DH, Garing AE (1995) Calibration of human locomotion and models of perceptual-motor organization. *J Exp Psychol Hum Percept Perform* 21:480–497
3. Milner AD, Goodale MA (1995) *The visual brain in action*. Oxford University Press, Oxford
4. Cutting JE, Vishton PM (1995) Perceiving layout and knowing distances: the integration, relative potency, and contextual use of different information about depth. In: Epstein W, Rogers W (eds) *Perception of space and motion*. Academic Press, New York, pp 69–1175
5. Tversky B (2003) Structures of mental spaces: how people think about space. *Environ Behav* 35:66–90
6. Shepard RN, Metzler J (1971) Mental rotation of three-dimensional objects. *Science* 171:701–703
7. Parsons LM (1987) Imagined spatial transformations of one's hands and feet. *Cogn Psychol* 19:178–241
8. Presson CC (1982) Strategies in spatial reasoning. *J Exp Psychol Learn Mem Cogn* 8:243–251
9. Tversky B, Kim J, Cohen A (1999) Mental models of spatial relations and transformations from language. In: Rickheit G, Habel C (eds) *Mental models in discourse processing and reasoning*. Elsevier, Amsterdam, pp 239–258
10. Golledge RG (1999) Human wayfinding and cognitive maps. In: Golledge RG (ed) *Wayfinding behavior*. Johns Hopkins University Press, Baltimore, MD, pp 5–45

## Spatial Cueing Paradigm

### Definition

► Visual Attention

## Spatial Frame of Reference

### Definition

A means of representing spatial locations relative to some spatial framework. Broadly, frames of reference are defined relative to the viewer, egocentric, or relative to something other than the viewer, allocentric. Specifically, the viewer-centered reference frame can be sub-divided into head, limb, or body reference frames. The allocentric reference frame includes objector environment-relative frameworks.

► Spatial Cognition

## Spatial Hearing

► Neuroethology of Sound Localization in Barn Owls

## Spatial Imagery

### Definition

A quasi-pictorial representation of spatial knowledge in the absence of immediate sensory input that emphasizes the location and orientation of objects or parts of objects.

► Spatial Cognition

## Spatial Language

### Definition

A means of representing objects and locations through verbal description with respect to multiple coordinate systems or frames of reference.

► Spatial Cognition

## Spatial Learning/Memory

JOHN L. KUBIE<sup>1</sup>, ANDRÉ A. FENTON<sup>2</sup>

<sup>1</sup>Department of Anatomy and Cell Biology, State University of New York, Downstate Medical Center, Brooklyn, NY, USA

<sup>2</sup>Department of Physiology and Pharmacology, The Robert F. Furchgott Center for Neural and Behavioral Science, State University of New York, Downstate Medical Center, Brooklyn, NY, USA

### Synonyms

Navigation

### Definition

Spatial learning and memory refers to the set of behaviors and processes through which information about external environmental space is acquired, stored, organized, and used. These phenomena provide a paradigm to systematically study the neural basis of cognition.

### Characteristics

#### Background

While gathering nuts, a squirrel spots a threatening hawk overhead. Quickly, it runs at top speed in a direct path towards the safety of the nest. How is this done? How does the squirrel process its current sensory information, combine that with memory, and rapidly choose the best path for survival?

Animal **▶navigation** has been studied for over 100 years in the laboratory. For several decades in the early twentieth century, animal psychologists argued about whether rats solved complex maze (**▶maze learning**) tasks by means of “place” or “response” strategies. Tolman, the leader of the “place” group argued that the maze behavior of rats could only be explained if a rat possessed a “cognitive map” of the maze. Such a map would describe the spatial relations among major **▶landmarks**.

The brain has two types of representations of space: egocentric and allocentric. An egocentric spatial representation refers to a representation using body-centered coordinates (the ego or self). Examples of egocentric neural maps are **▶retinocentric** (retina-centered) maps in the **▶visual** and **▶parietal** cortices, and **▶somatotopic** (body-centered) maps in the **▶somatosensory** or **▶motor cortex**.

Allocentric representations have coordinate frames that are not centered on the body. The simplest example is a road map. Significantly, Tolman’s cognitive map is allocentric. Later in this article we will describe several examples of neuronal representations that are allocentric. Since the data the brain uses to construct these

maps enters via body-centered sensory channels, allocentric representations seem complex in that they involve transforms to-and-from egocentric frames. Although allocentric representations are difficult to construct, they permit important efficiencies.

### Spatial Navigation Strategies

Navigation is the process of planning and going to a specific location. Its function is to make efficient use of scattered resources. There are four principal mechanisms: (i) **▶Beaconing** is taxic movement towards a landmark. Animals may use a wide variety of strategies to reach a beacon, ranging from simple **▶chemotaxis** to complex processes such as **▶echolocation**. One form of beaconing may involve moving to minimize the difference between the current visual snapshot and a previously memorized snapshot taken from the goal. (ii) **Homing** is the process of returning to a place by reverse summation of the outbound movement vectors. (iii) **Route learning** is a memorized series of **▶local cue** response rules. An example might be “at the big rock, turn left; next, at the fallen tree bear right...”. Route learning is also called “response chaining” and in animals is typically acquired through operant conditioning. Route learning can work effectively in a static environment, but is inflexible. (iv) **Cognitive mapping** is a navigational strategy where behavior is optimized by using a two- or three-dimensional representation of the environment.

A cognitive map can be thought of as a bird’s-eye representation. These are economical representations of the many relationships among environmental features. Importantly, unless we are referring to birds, these global representations of relationships among landmarks have never been seen; that is, they are transformations of sensory data. Using a cognitive map permits taking direct paths from any location to any other location on the map. Start and stop points may or may not be the locations of important landmarks. The gold-standard test of whether an animal is using a mapping strategy has been to see whether it can take a novel route to an unmarked goal. Such a route would rarely occur if the animal is navigating with other strategies.

This article will focus on neural mechanisms that contribute to map-based navigation. The mapping strategy is sometimes referred to as the locale navigation strategy in contrast to a **▶route navigation** (**▶or taxon navigation**) strategy. We will be focusing on the mechanisms that have been studied in the laboratory over the past 30 years, chiefly in the hippocampus and chiefly in rats. There are other well-studied aspects of animal navigation whose neural substrate is being explored. These include trail following in a variety of animals, **▶chemotaxis**, **▶path integration** and snapshot navigation in insects, migration in birds and other animals, **▶magnetic sensation**, food caching, and flocking. These will not be covered.

There are two parts to the cognitive mapping process: creating the map and using the map. The process of map creation is associated with ►exploratory behavior. At the neuronal level, this is the plastic stage when the map is created, filled out and stabilized. Usage is when an animal can take an efficient route or exhibit other behavioral efficiencies. Presumably, during usage the brain map is read-out and utilized.

It is important to note that the hippocampus, the focus of this article, is commonly associated with the plasticity during the storage of ►declarative (generic) memories. Although it seems likely that map learning and ►declarative learning have much in common, the relationship remains problematic. Nonetheless, it is clear that modification of hippocampal circuits is involved in both declarative learning and spatial learning. In addition, long-term potentiation (►LTP), the favored model for memory, is a prominent feature of hippocampal circuits and is involved in both declarative learning and acquiring spatial maps.

### Measuring Spatial Learning and Memory in the Laboratory

Three sets of techniques comprise the great majority of laboratory approaches to navigational behavior. For the first half of the twentieth century, studies of rat cognition employed a wide variety of alleyway mazes. Some of the most familiar are the Hebb-Williams maze set, the sunburst maze, the T maze and the plus maze. Famously, Tolman and Hull used a variety of these to demonstrate that rats either did or did not use a cognitive map in navigation. In 1976 Olton and Samuelson introduced the ►radial-arm maze. In this, apparatus arms are baited at the ends, and a rat or mouse will forage using an innate win-shift strategy to visit each arm only once. Although a number of effective strategies are possible, such as a rat avoiding its own odor trace, rats spontaneously use an apparent mapping strategy, avoiding a previously-visited arm because of its association with the spatial arrangement of distal landmark cues. Although an inherent problem with the radial-arm maze is that it can be solved by a variety of strategies, it remains popular due to ease of use and the relative ease of combining navigational problem solving with electrophysiological recordings. The water maze, introduced by Morris in 1981, is a circular swimming pool with a stationary slightly-submerged escape platform [1]. On initial trials a rat is introduced near a wall and swims until it bumps into the submerged platform. On subsequent trials when the rat is introduced from various start locations it will take shorter times and more direct routes to the platform. After a few dozen trials a typical rat will take direct escape paths from any start location. The water maze provides the clearest example that a rat can take a novel route to an unmarked goal.

In ship navigation, two strategies are commonly used to determine a vessel's location: The first is "►fixing a position by sighting", where the navigator records angles and distances to distal objects (stars, landmarks), and, with the aid of a map, determines the ship's position. The second is "►dead reckoning" where the navigator uses knowledge of the ship's motion (speed, direction, time) to update position on the map. Although sightings are critical, in certain situations, such as fog, navigators rely completely on dead reckoning. Rodents appear to use both types of strategy for navigation. In rats ►self-motion cues (►idiothetic cues) are generated from motor commands and sensory cues generated from self motion, such as vestibular activity, optic flow and proprioception. Sighting cues (allothetic cues) are not exclusively visual, as rodents also rely heavily on their auditory, tactile and olfactory senses.

### The Spatial Theory of the Hippocampus

A salient clue that the hippocampus might be involved in navigation was provided by the ►theta rhythm, a highly regular 6–10 Hz EEG oscillation generated in the ►hippocampus. In rats, theta is present whenever the animal walks or interacts with external objects [2]. Both hippocampal principal cells and interneurons fire in register with the theta rhythm, with the firing of certain interneurons (►theta cells) dramatically entrained. Several theories have suggested that the theta rhythm plays a role in navigational behavior, but all are speculative. It was the subsequent observation of place cells in the hippocampus [3] and the ►cognitive map theory that followed, which first convincingly linked the hippocampus to navigation.

In 1978 O'Keefe and Nadel published the cognitive map theory as a book ►The Hippocampus as a Cognitive Map [4]. The book was the birthing event in the neuroscientific approach to navigation. This book contained five important features. First, it summarized O'Keefe's discovery of hippocampal ►place cells. Place cells initiated the notion that the hippocampus was part of navigational machinery. Second, it placed navigational problem solving in a historical/philosophical context, notably invoking Kant and Tolman as the sources for the idea that the brain had an inborn, map-like representation of the world. Third, most remarkably, it reviewed the rat hippocampal lesion literature and made a convincing argument that the deficits reported in virtually all studies could be attributed to failures of a brain map. Fourth, it established the first of many computational models for how hippocampal place cells are formed and how they might aid in route finding. And, finally, it speculated on the relationship of the hippocampal map to learning. Although there remains intense debate over the degree to which the rat or human hippocampus is devoted to spatial problem solving, this book,

and the questions it raised, remains the touchstone of these key issues.

Hippocampal lesions have been the principal tool of establishing a causal relationship between this structure and navigation. In the 1970s and 80s it was repeatedly established that hippocampal lesions eliminated use of locale (mapping) strategies on the plus maze, the radial arm maze and the water maze. After hippocampal damage rats either relied on cue strategies, response strategies or apparently random goal selection. Particularly stark, early results were obtained with the water maze. After several training sessions an intact rat will swim directly towards the goal from any start location. A rat given hippocampal lesions and similar training is more likely to swim in circles [5]. It is important to realize that lesions to several other parts of the brain, including the ►subiculum, and the ►entorhinal, ►medial prefrontal, ►parietal, and ►cingulate cortices also impair navigation in the water maze, suggesting a network of structures mediate navigation by mapping. Lesion studies have provided additional insights. For example, when rats are trained in a plus maze, they will initially use hippocampus-dependent locale strategies (e.g. go to a particular part of the room). After more extensive training, rats will switch to a hippocampus-independent response strategy (e.g. turn right). Another important line of work involves ►acoustic fear conditioning. Several labs have demonstrated that a rat requires an intact ►amygdala to form a tone-shock association. On the other hand, a rat must have an intact hippocampus for the global environment (►context) to influence the tone-shock association or for the rat to learn a direct relationship between context and shock. Although these fear-conditioning studies do not involve navigation directly, there is a fascinating connection. If we view the enclosure that a rat is tested in as a large “place”, rats with hippocampal damage are exhibiting a form of spatial deficit. These studies suggest a continuity between place and context.

Pharmacological, genetic, and molecular imaging studies also implicate the hippocampus in navigation.

Anticholinergic drugs like atropine disrupt the theta rhythm. Like other manipulations that disrupt theta, such drugs also impair spatial navigation in the water maze. Similarly, specific forms and phases of spatial learning are impaired by drugs and genetic manipulations that interfere with the induction of ►LTP such as treatments that impair *N*-methyl-D-aspartate (►NMDA) glutamate receptor function. The imaging of memory-related and activity-related molecules like immediate early genes also suggest the hippocampus is a key structure in spatial learning and memory. However, it is important to keep in mind that to-date essentially all pharmacological and genetic treatments that impair spatial behavior also interfere with both the information processing and storage functions of the brain, and thus far, molecular imaging has not distinguished between the potentially distinct processing and storage functions of a brain area.

### The Neurophysiology of Allocentric Spatial Information

The specific information processed by a part of the brain can be discovered by recording the action potential discharge of individual neurons from a freely-behaving subject and then by correlating the neural activity with well-defined sensory, motor, and cognitive variables. Projecting neural discharge onto representations of a freely-moving subject’s position and direction revealed that the activity of individual neurons in three connected mammalian brain networks contain allocentric positional and directional information that may be the basis of the cognitive map.

### Place Cells

Place cells are hippocampal ►pyramidal neurons with strong location-specific firing. An individual place cell fires rapidly almost only when the animal is in discrete regions of the environment termed “►firing fields”. Typically, a place cell will have zero, one or a few firing fields in a few scattered locations (Fig. 1). An animal’s location can be predicted, within a few centimeters, from the activity of an ensemble of a few hundred place cells [6].

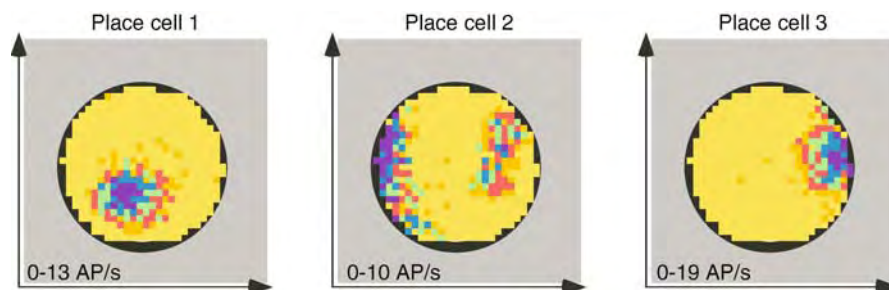

**Spatial Learning/Memory. Figure 1** Firing rate maps from three simultaneously recorded place cells. The recording was made while the rat was foraging for food on a 82-cm disk. The maps are depicted in real-world space; thus, they are allocentric. The color code is that yellow codes regions of zero firing rate, while the colors orange, red, green, blue and purple represent higher rates. The range of rates is given for each cell in units of action potentials/sec.

### Grid Cells

Grid cells, discovered by the Moser lab in Norway, are cells that show intense location-specific firing. Unlike the firing patterns of place cells, however, grid cells

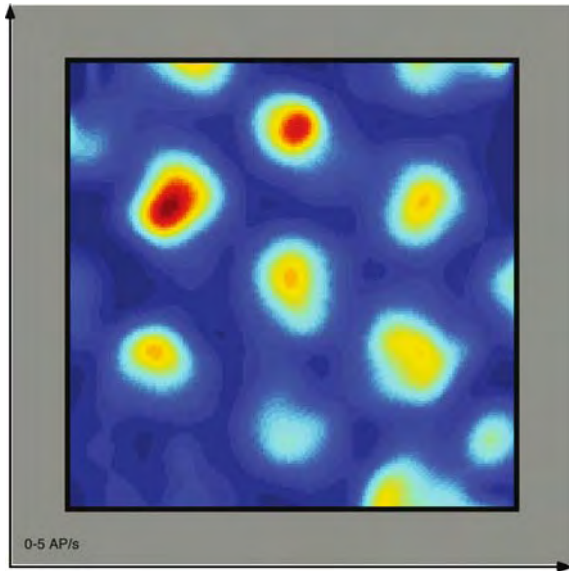

**Spatial Learning/Memory. Figure 2** The firing rate map from a grid cell recorded from a rat foraging in a 1.5 m square black box with a white card on one wall. Again, the map coordinates are in real-world, allocentric space. The color code is blue for 0 AP/s and red for 5 AP/s. Figure courtesy of Jonathan Whitlock, May-Britt Moser and Edvard Moser.

firing patterns are spread over an environment [7]. The pattern appears as a regular, hexagonal grid (Fig. 2). Grid cells are found in the dorso-caudal part of the medial **▶entorhinal cortex**.

### Head-direction Cells

Head-direction cells are neurons that fire when the rat's head is pointed in a particular direction with different cells tuned to different directions (Fig. 3). The directional tuning is independent of a rat's location. (Therefore, if mapped on a floor projection, the tuning of a head-direction cell is a set of parallel vectors). Originally discovered by Ranck [8] during recordings of the post-subiculum (part of the hippocampal formation), head-direction cells can be recorded in several areas including the anterior and lateral dorsal thalamus and mammillary bodies. These regions, which resemble the Papez circuit, have interconnections with various parts of the hippocampal formation.

Place cells, grid cells and head-direction cells have important similarities. The best spatial discharge correlate of each cell class is a map-like feature of allocentric space. Activity within each class of representation tends to be internally coherent so that the firing of individual neurons is constrained to remain in register with the discharge of other neurons in the representation. The spatial discharge of each cell class also tends to stay in register with external sensory orientation cues, but firing is also controlled, at least in part, by other inputs like self-motion. Several models describe how these three neuron classes together represent an animal's location and orientation in allocentric space [9].

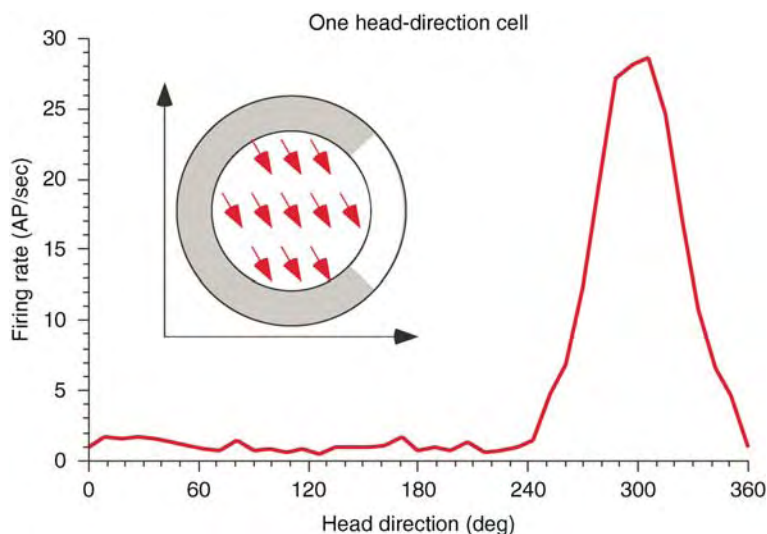

**Spatial Learning/Memory. Figure 3** This plot of data from a head-direction cell depicts firing rate as a function of head angle. Data were collected while the rat collected food pellets in a 76-cm gray cylinder with a white card on the wall. Head angle is with respect to east, and is therefore allocentric. The inset is an idealized representation of the preferred head angle at different regions of the cylinder.

### Local and Global Space

We've described the fundamental local spatial discharge correlates of place cells, grid cells, and head-direction cells, as animals move within a single environment, but additional features of these networks can be revealed by comparing their discharge in distinct environments. The across-cell pattern of place cells and grid cells in two distinct environments can “remap”, meaning the spatial relations amongst place fields and grid peaks is scrambled, as if reset between environments [10]. ▶**Remapping** radically changes which principal cells can be simultaneously active. In contrast, conditions that trigger remapping typically cause all head-direction cells to reorient as a cohesive unit, perpetually preserving which cells do and do not discharge together. As a rat moves within a single environment, the rat's local position and direction is signaled by a unique across-cell, ensemble discharge pattern that changes smoothly within the place cell, grid cell, and head-direction cell networks. Remapping implies that the ensemble activity of each cell class can switch abruptly when a rat is moved between two environments. Under special conditions this switch may also occur within a single environment, suggesting these networks may signal global space or context as well as local space.

### Conclusion

Returning to our initial question, how does the squirrel know the best path? How does the map work? We still do not know. Over the past three decades scientists have used ingenious methods and advanced tools to observe the map in action. We now have a good description of the brain map and how it is formed. We see a rich ever-changing array of spatial data. But we don't know how brain networks use these data to calculate an optimal path and organize behavior. A few simple models have been developed, but they need extensive work. Understanding how the brain solves spatial challenges like the squirrel's appears to be a tractable cognitive problem. Understanding the operation of the cognitive map is a challenge for the next decade.

### References

1. Morris RGM (1981) Spatial localization does not require the presence of local cues. *Learn Motiv* 12:239–260
2. Vanderwolf CH (1969) Hippocampal electrical activity and voluntary movement in the rat. *Electroencephalogr Clin Neurophysiol* 26:407–418
3. O'Keefe J, Dostrovsky J (1971) The hippocampus as a spatial map. Preliminary evidence from unit activity in the freely moving rat. *Brain Res* 34:171–175
4. O'Keefe J, Nadel L (1978) *The Hippocampus as a cognitive map*, Clarendon Press, Oxford
5. Morris RGM, Garrud P, Rawlins JNP, O'Keefe J (1982) Place navigation in rats with hippocampal lesions. *Nature* 297:681–683

6. Wilson MA, McNaughton BL (1993) Dynamics of the hippocampal ensemble code for space. *Science* 261:1055–1058
7. Hafting T, Fyhn M, Molden S, Moser MB, Moser EI (2005) Microstructure of a spatial map in the entorhinal cortex. *Nature* 436:801–806
8. Ranck JB Jr (1985) Head direction cells in the deep cell layer of dorsal presubiculum in freely moving rats. In: Buzsáki G and Vanderwolf CH (eds), *Electrical activity of the archicortex*. Akadémiai Kiado, Budapest, pp 217–220
9. McNaughton BL, Battaglia FP, Jensen O, Moser EI, Moser MB (2006) Path integration and the neural basis of the “cognitive map”. *Nat Rev Neurosci* 7:663–667
10. Muller RU, Kubie JL (1987) The effects of changes in the environment on the spatial firing of hippocampal complex-spike cells. *J Neurosci* 7:1951–1968

## Spatial Memory

CATHERINE BRANDNER

Université de Lausanne, Institut de Psychologie,  
Lausanne, Switzerland

### Synonyms

Spatial cognition; Spatial abilities; Spatial navigation; Cognitive map; Way finding

### Definition

From an evolutionary perspective, spatial memory is crucial to foraging and reproduction but, at the same time, multiplies the risks of getting lost, being killed or consumed by other animals (predation). Thus, survival of mobile species depends on their ability to reach a feeding location, return home quickly and safely, find shortcuts and avoid dangerous places. These basic behaviors are crucial for successful interactions with the environment and call upon effective spatial navigation skills.

The capacity to move through space may appear to be a very simple behavior consisting in maintaining a body trajectory from a place to another. However, getting from place to place is more than a body displacement. Indeed, ▶**navigation** is an action oriented by a goal that at least involves knowing where I am and where I go. Such knowledge requires the encoding and the gathering of multimodal information concerning our body position relative to the position of other objects. This ability – called spatial memory – is now considered as analogous to human ▶**episodic memory** (memory of personal, experiential events) since both rely on the coding, storing and retrieving of events in a spatio-temporal context (e.g. [1]).



Characterizing spatial orientation and spatial memory skills requires an understanding of how cognitive and neural mechanisms underlie adaptive behavior to environmental requirements. The following section summarizes the basic concepts and findings issued from this research effort.

## Characteristics

### Reference Frames

Fixing and maintaining a trajectory from place to place is done through the establishment of a relationship between subject and object. This relationship is commonly categorized in egocentric and **▶allocentric reference frames**.

Frameworks centered on the subject (e.g. body parts such as head, trunk, arm, or receptor surfaces such as retina) are called **▶egocentric reference frames**. Such **▶reference frames** allow the subject to directly estimate the position of an object relative to their own body. However, the egocentric bearing is not invariant with respect to the subject's orientation and position. Frameworks centered outside of the body, on a fixed point in the environment (e.g. mountain, corner of a room or individual object), are allocentric reference frames. Such reference frames provide two main advantages: (i) to be invariant with respect to the subject's position and orientation in the environment, and (ii) to represent the relative location of objects independently from the subject's viewpoint.

Although these two systems of knowledge allow navigation, their respective weight depends on learning. Indeed, if a local or egocentric frame is immediately available even for naive subjects, a relational or allocentric frame depends on the development of spatial skills.

### Spatial Navigation Strategies

Spatial cognition is assumed to be a hierarchical set of reference frameworks -or maps- containing landmarks, routes, locations, and configurations that integrate relative information about landmarks, routes and locations in a coherent structure. It is based on what information is perceived, represented and processed by the subject to solve navigation tasks. Adaptive spatial behavior relies on the flexibility in the use of reference frames depending on the problem to be solved. This involves the capability to choose among different cognitive possibilities that are referred to as spatial strategies.

A four-level hierarchy of **▶spatial navigation strategies** based on a large range of researches [e.g. 2–4] can be resumed as following (fig. 1):

- ▶ **Taxon navigation strategy** (level 1) is used when a location coincides with a conspicuous cue. In such case, approaching a goal location is easy if the latter is either directly visible or identified by a visible cue. Such behavior does not require spatial

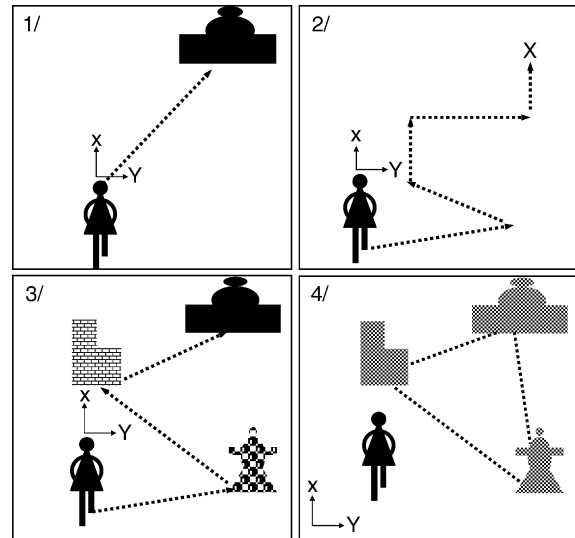

**Spatial Memory. Figure 1** Egocentric and allocentric reference frames. The egocentric reference frame (1 taxon, 2 praxis and 3 route navigation strategies) is centered on the subject (x and y arrows) whereas the allocentric reference frame is centered outside the body (4 relational or configural strategy).

memory per se, but rather an association between the cue and the goal to initiate a guided movement.

- ▶ **Praxis navigation strategy** (level 2) is used when a subject can navigate towards a hidden goal by executing a specific motor sequence acquired by extensive training. For example, if the goal is never moved and the individual always starts at the same location and with the same orientation, it can easily learn the appropriate of taxon and sequence of movements leading to that goal.
- ▶ **Route navigation strategy** (level 3) is a more complex strategy where the subject has learnt to associate a direction of movement to each sensory view. This strategy is appropriate, when a goal is identified by a sequence of specific sensory cues. Then, instead of single cue guidance, the subject can use more elaborate chaining sequences of taxon and praxis strategies.

Relational or configural strategy (▶ **Relational or configural navigation strategy**) (level 4) is based on the coding of relations between attributes of the environment into an internal **▶spatial representation**. An important property of this representation is that it offers a flexible spatial behavior adapted to each situation. In a familiar environment for example, subjects can get to a place from different starting points, as well as choose a novel path when the usual one is unavailable.

To summarize, taxon, praxis and route navigation strategies are based on an egocentric frame of reference

depending on sensory-action associations where the position of the goal is directly estimated with respect of body-based references. They are inflexible in the sense that they prevent the taking into account that different paths may join the same place. Relational or configural strategy is based on an allocentric reference frame (a spatial representation of the environment) where the relationships between stimuli are maintained invariant with respect to the subject's position.

### Multimodal Sensory Information

The establishment of an efficient spatial representation relies on the integration of multimodal sensory information that has been divided into allothetic (▶allothetic information) and idiothetic (▶idiothetic information) categories.

Stimuli provided by environment-like visual, olfactory, sound, tactile stimuli- are allothetic signals providing spatial information to the subject. Orientation based on allothetic stimuli allows, for example, identifying a place through visual features of a particular object.

Stimuli provided by the body-like vestibular, proprioceptive and motor command efferent copies are idiothetic signals providing information about continuous changes of the subject position and orientation. Orientation based on idiothetic stimuli allows deriving the subject's current position in relation to a starting position by the integration of its angular and linear displacements. This ability to keep track of spatial location relying on self-motion information is referred to as ▶path integration (e.g. [5]). Although path integration is available in all types of environments (unknown, absence of landmarks, darkness), its use is limited by its vulnerability to cumulative non-systematic errors over distance. However, when allothetic landmarks are available, path integration can be reset in order to maintain orientation.

Therefore, prevention of ambiguous information relies on the combination of different sensory information that is encoded within different reference frames. Thus, multisensory integration requires the integration of different reference frames into a unified spatial framework, and the hippocampus appears to be the brain region in charge of such process.

### Spatial Coding and Hippocampal Brain Area

Studies of the hippocampal formation occupy a central position in the advance of theories concerning episodic and spatial memory. Early experimental evidences for location-sensitive neurons in the rat hippocampus called "place cells," and the "▶cognitive map theory" promoted by O'Keefe and Nadel [6] make out the hippocampus as the brain area that mediates allocentric spatial coding. Hippocampal function appears to be required in spatial representation, path integration and exploration (e.g. [7]) concerning the encoding of trajectories, single cell recording data suggests that

the hippocampus represents the animal's position in the context of a trajectory through space while the entorhinal cortex represents regularities across different trajectories that could allow for generalization across experiences. Apart from the hippocampal area, the posterior parietal cortex seems to be in charge of egocentric spatial coding that represents body location related to subject's environment. It has been hypothesized that the multiple egocentric representations from sensory receptors and motor effectors converge from the parietal cortex onto the hippocampal formation where they are translated into an allocentric spatial reference frame. This postulate is based on findings showing strong neuronal connections between the posterior parietal cortex and the hippocampal formation, and between the hippocampal formation and the parahippocampal region. Thus, it could be postulated that spatial memory and flexible navigation requires the combination of both egocentric and allocentric components of the task, which is based on the cooperation of parietal cortex and the hippocampus respectively. This hypothesis is supported by a large convergence of data from experimental psychology, comparative anatomy and field research (for reviews see for example [8–10]).

### References

1. Burgess N, Maguire EA, O'Keefe J (2002) The human hippocampus and spatial and episodic memory. *Neuron* 35:625–641
2. Kuipers BJ (2000) The spatial semantic hierarchy. *Artif Intell* 119:191–233
3. Redish AD (1999) Beyond the cognitive map, from place cells to episodic memory. MIT Press-Bradford Books, London
4. Trullier O, Wiener SI, Berthoz A, Meyer J-A (1997) Biologically-based artificial navigation systems: review and prospects. *Prog Neurobiol* 51:483–544
5. Etienne AS (1987) The control of short-distance homing in the golden hamster. In: Ellen P, Thinus-Blanc C (eds) *Cognitive processes and spatial orientation in animal and man*, vol 1. Experimental animal Psychology and ethology. NATO TS (Series no 36), pp 233–251
6. O'Keefe L, Nadel L (1979) *The hippocampus as a cognitive map*. Clarendon press, Oxford
7. Olton DS, Becker JT, Handelmann GE (1979) Hippocampus, space, and memory. *Behav Brain Sci* 2:313–365
8. Burgess N, Jeffery KJ, O'Keefe J (1999) Integrating hippocampal and parietal functions: a spatial point of view. In: Burgess KJJ, O'Keefe J (eds) *The hippocampal and parietal foundations of spatial cognition*. Oxford University Press, Oxford, pp 3–29
9. Thier P, Andersen RA (1996) Electrical microstimulation suggests two different kinds of representation of head-centered space in the intraparietal sulcus of rhesus monkeys. *Proc Natl Acad Sci USA* 93:4962–4967
10. VanElzakker M, O'Reilly RC, Rudy JW (2003) Transitivity, flexibility, conjunctive representations and the hippocampus. I. An empirical analysis. *Hippocampus* 13:334–340

## Spatial Navigation

- ▶ Spatial Memory

## Spatial Orientation

### Definition

Orientation of the head and body in space. Inputs from the vestibular, visual and somatosensory systems provide critical information about the spatial orientation. Once information from two sensory inputs conflicts, disorientation and vertigo are brought about.

- ▶ Anti-Motion Sickness Drugs
- ▶ Vertigo

## Spatial Receptive Field (SRF)

### Definition

The region of space from which a sound can evoke a response in auditory neurons.

- ▶ Neuroethology of Sound Localization in Barn Owls

## Spatial Representation

### Definition

Synonym of cognitive map, internal representation where the coding of relations between attributes of the environment are maintained invariant with respect to the subject's position.

- ▶ Spatial Memory

## Spatial Resolving Power

### Definition

The detection of light energy by the eye based on the spacing of the detector elements i.e. photoreceptors, retinal ganglion cells. Typically expressed in either cycles per degree or minutes and seconds of arc, spatial resolving power may be partly dependent on the optical resolution of the lens.

- ▶ Photoreceptors
- ▶ Retinal Ganglion Cells

## Spatial Rule of Multisensory Integration

### Definition

The principle that multisensory stimuli from will be integrated depending on their relative spatial locations. Typically, stimuli presented from the same spatial location will result in enhanced multisensory integration, while stimuli presented from different spatial locations result in decreased multisensory integration, or multisensory inhibition.

- ▶ Multimodal Integration

## Spatial-temporal Transformation

### Definition

Many sensory regions of the cerebral cortex and brain stem receive information from the outside world via a topographic and in many cases a point-to-point relationship between the physical stimulus (e.g., visual, auditory, somatosensory, etc) and the target neural structure. However, the actions of the organism are carried out by effectors (e.g., muscle) that require temporal signals to control the rate and amplitude of the movement as well as maintain its final position. Exactly how the brain performs the conversion from topographic maps into the appropriately timed neural signals is under intensive investigation. This transformation from spatial coordinates (i.e., topographic maps) to temporal

activity (e.g., muscle contraction) is called the spatial to temporal transformation. It has been studied extensively in the oculomotor system.

## Spatial Updating

### Definition

The process of updating representations of the locations in the environment with respect to the self and others after the observer or objects have moved.

- ▶ Spatial Cognition

## Spatial Vision

### Definition

Information about the structure of the visual scene as opposed to unstructured information like overall light levels.

- ▶ Blindsight
- ▶ Visual Space Representation for Action
- ▶ Visual Space Representation for Reaching
- ▶ Vision

## Spatiotemporal Learning Rule LTP STLR

- ▶ Synaptic Plasticity

## Spatiotopic

### Definition

It makes reference to topographic arrangements of sensory pathways that reflect the spatial localization of sensory stimuli.

- ▶ Evolution of the Optic Tectum: In Amniotes

## Species-specific Defense Reaction (SSDR)

### Definition

Bolles (1970) first characterized SSDRs as innate defensive reactions in response to aversive stimuli. Bolles stated that animals undergoing aversive conditioning are more likely to learn reinforced responses related to their innate SSDRs than other behaviors (e.g., freezing vs. lever pressing). The Blanchards experimentally validated the SSDR theory, broadening the spectrum of known defense reactions and redefining the term as “species-typical defense reactions,” due to a cross-species generality of defensive behaviors.

- ▶ Aversive Learning

## Specific Anosmia

### Definition

Specific anosmia is selective inability to smell one particular odor. This anosmia may be genetically based.

- ▶ Smell Disorders

## Specificity of Learning

### Definition

The improvement of discrimination, classification, or discrimination achieved through training does not transfer to similar (classes of) stimuli.

- ▶ Sensory Plasticity and Perceptual Learning

## Spectral

### Definition

Refers to the frequency (pitch) aspects of the speech signal.

- ▶ Hearing Aids

## Spectral Reflectance

### Definition

In vision, the proportion of photons at different wavelengths in the visible spectrum which are reflected by a given object in the visual field. Spectral reflectance is the inverse of spectral absorption.

- ▶ Color Processing
- ▶ Retinal Color Vision in Primates

## Spectral-shape Cues in Hearing

### Definition

In the ear canals of humans and other mammals, certain frequencies are attenuated or boosted in a manner that is highly characteristic of the position of the source along the midsagittal plane. For instance, when a sound with a flat spectrum at the speaker is placed overhead, the 8 kHz band is found to have been boosted in the ear canal, due to the shape of the human head and ear. Humans appear to use these bands, collectively called spectral shape cues, for vertical sound localization. (Humans use interaural differences in time and level to localize sounds in the horizontal plane).

## Spectrin

### Definition

A membrane-associated protein that interacts with a number of other proteins, including actin and ankyrin, to form and maintain the cytoskeletal network or “mesh” found near intracellular membrane surfaces.

- ▶ Synaptic Proteins and Regulated Exocytosis

## Spectrogram

### Definition

A pattern for sound analysis that provides a three-dimensional display of time on the horizontal axis,

frequency on the vertical axis and intensity on a color or gray scale.

- ▶ Speech Perception

## Spectrum in Acoustics

### Definition

A description of the relationship between magnitude (pressure or sound intensity), frequency and starting phase of the sinusoidal components of a complex sound wave.

- ▶ Acoustics

## Speech Perception

KEITH R. KLUENDER

Department of Psychology, University of Wisconsin, Madison, WI, USA

### Synonyms

Human speech recognition; Human speech understanding

### Definition

Speech perception encompasses an array of sensory and perceptual processes through which listeners can recognize words using sensory signals from the ears and sometimes the eyes.

### Characteristics

#### Speech Production

In many ways, perception of speech is much like other perceptual tasks. However, there is one aspect of speech communication that is not typical of most perception. A tree does not strike a pose that deliberately conveys strength and longevity, but talkers do speak so that they can be understood. Speech sounds are created especially for listeners.

Owing primarily to unique characteristics of supralaryngeal anatomy, the adult human’s sound-producing abilities are unrivaled among other organisms. This capacity is revealed in a grand assortment of over 850 different speech sounds used contrastively by the more than 5,000 distinct languages around the world. In contrast to this diversity, collections of consonants

and vowels used by individual languages are anything but random. One factor that may help determine what combinations of vowels and consonants are commonly used is the ease with which the sounds are produced either in isolation or in sequence with other sounds. Most important for perception is the fact that speech sound repertoires of all languages have developed over generations toward greater communicative effectiveness, with inventories of sounds optimized for acoustic and auditory distinctiveness [1].

Another factor that makes differences between speech sounds perceptually dependable is the complexity and consequent redundancy of the speech signal. Speech ► **articulation** has multiple acoustic consequences. Often, multiple acoustic attributes are effortless consequences of passive interactions between articulators and/or airflow. Talkers also systematically vary relatively independent articulatory maneuvers to enhance auditory distinctiveness.

### Speech Perception

Performances of listeners detecting tones in quiet and detecting small differences in pitch are poor predictors of ability to understand speech. Perceiving distinctions between speech sounds does not rely upon the ability to make fine-grained discriminations bordering on sensory or perceptual thresholds of auditory systems. Differences between even relatively similar vowels, such as [æ] (as in “bat”) and [ɛ] (as in “bet”), are easy to detect on the basis of gross spectral and temporal differences. Hence, speech recognition shares little in common with the types of discriminations presented in psychoacoustic studies that demonstrate humans’ ability to detect tiny changes between simple signals. Listeners who suffer significant hearing loss can, nonetheless, manage to understand speech until the level of impairment becomes severe. The ability of normal hearing listeners to understand severely degraded speech is particularly impressive.

Because talkers exploit auditory capacities, several observations follow. First, human infants are quite proficient at discriminating differences between speech sounds from a very early age. Three decades of studies document impressive abilities of human infants, some less than one week old, to discriminate a wide variety of consonants and vowels from across many languages. Second, discrimination of speech contrasts by nonhuman animals is quite good, with multiple demonstrations that animals can distinguish human speech sounds with facility. These findings for human infants and for nonhuman animals can be expected, based on the tendency of languages to use acoustically and perceptually robust distinctions [2].

Because nonhuman animals appear to provide an adequate model for simpler aspects of speech perception, many neurophysiological studies have been conducted in the interest of describing neural representation

of speech sounds. Most of this work has focused upon neural responses in the auditory (VIIIth) nerve, but there have been a number of studies concerning successive stages of the auditory system such as ventral cochlear nucleus, inferior colliculus, medial geniculate and auditory cortex.

Enough is known about the ability of humans and animals to use the acoustic information necessary for speech perception to make it clear that apparent limitations on the separate contributions of individual neurons, especially at the periphery, do not present obstacles to understanding speech. In part, this is because ample information is conveyed across 15,000 auditory nerve fibers and increasing numbers of neurons at successive levels of the auditory system. In addition, high fidelity representations are unnecessary to convey acoustically robust distinctions between sounds. Subsequent research should better illuminate the contributions of populations of neurons at low and at higher levels in processing the information contained in speech sounds.

Producing and perceiving differences between speech sounds is only a part of understanding how speech is perceived. Speech production gives rise to a host of acoustic attributes; however, matters are complicated by the fact that no single acoustic attribute by itself dependably signals any given consonant or vowel. This is referred to as the classic problem of “lack of invariance,” the fact that there are no individually necessary and sufficient cues that uniquely identify speech sounds. Multiple acoustic attributes of the speech signal must be combined to identify speech sounds.

The ability to discriminate speech sounds on the basis of one or more acoustic attributes is *not* synonymous with the functional use of speech sounds. Speech perception requires treating acoustically different complex sounds as linguistically equivalent. Among the many variations in the speech signal, some are relevant to the linguistic message, but many are not. Speech perception requires ignoring irrelevant variation and focusing on linguistically relevant changes. For example, listeners must identify sequences of consonants and vowels despite substantial changes to the speech signal owing to differences in talkers. Other sources of variability that do not affect the linguistic content of speech include acoustic consequences of distance, room reverberation or competing sounds in the environment including the voices of other talkers.

Because so very many speech sounds are used across the languages of the world, perceiving distinctions in one’s own language requires becoming tuned to the important distinctions in that language. Acoustic differences that matter critically for one language may be irrelevant or even distracting in another language. Perception must become tuned in such a way that most of the many possible differences between speech

sounds are relatively ignored, while at the same time the relatively few important distinctions between speech sounds that are used by a specific language are preserved or even enhanced.

Even for utterances by the same speaker, acoustic qualities of consonants and vowels vary. Production of consonants and vowels is altered by articulation of consonants or vowels that precede and follow. This process, known as ►**coarticulation**, results in temporal and spatial overlap in production of successive sounds. One example is the pattern of spectral peaks (►**formants**  $F_1$ ,  $F_2$ ,  $F_3$ ) for the stop consonant [d] following the vowel [o] (“oh”) and preceding [a] (“ah”, left) and following [a] and preceding [i] (“ee”, right) as depicted schematically in Fig. 1. Due to overlapping production of vowels and consonants, there is no single acoustic quality that signals [d] in both [oda] and [adi].

Explaining perception in the face of context sensitivity and lack of invariance is central to understanding speech perception. It has been shown that auditory processes that increase spectral contrast between successive speech and nonspeech sounds contribute to reversing the assimilative effects of coarticulation [3]. Also, in a way that bears a striking resemblance to visual perceptual constancies, multiple aspects of the speech signal come to be used together through experience with systematic covariation among attributes. One of the things that neural systems do best is to exploit multiple sources of modestly reliable information to reach a highly reliable conclusion. Simulations of neural connectivity and activity in artificial neural networks or connectionist models are designed to mimic the use of multiple attributes and associations between attributes as a function of experience with natural covariation [4]. Some of the most interesting findings to come out of computer simulations of vision have been demonstrations that performance can remain very robust across severe degradations of the signal such as

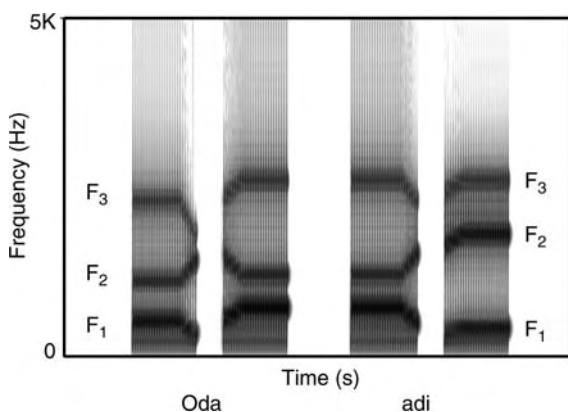

**Speech Perception. Figure 1** Pattern of spectral peaks.

adding noise, spectral filtering or deleting portions of the signal – a close analogy to the robustness of speech perception.

### Effects of Experience

Studies on development of speech perception address some of the same issues. Infants’ perception of individual speech sounds and words is shaped by statistical regularities across speech sounds heard within even a single listening session. In addition, there have been a small number of studies in which animals, instead of infants or computers, have served as surrogates to reveal how experience with natural covariation between acoustic attributes of speech help to maintain perceptual constancy for speech sounds. In each case, perceptual performance reveals sensitivity to experience with the frequency with which particular sounds occur and with the ways acoustic properties co-occur.

During the first year of life before infants produce much speech, they become increasingly attuned to the differences between vowels and consonants that are functionally appropriate to their language environment [5]. They begin to respond only to acoustic differences that distinguish two sounds in their native language, but not to acoustically equivalent differences that do not distinguish sounds in their language even when those differences are used by other languages. Adult difficulties perceiving differences between sounds in a non-native language develop early. There have been many studies of adult perception and production of contrasts when learning a second language and these show that ease of perception can be predicted on the basis of similarity or dissimilarity with sounds experienced in the native language.

Among experimental phenomena related to speech perception, perhaps none is more widely known than categorical perception. This classic perceptual process is studied using a series of stimuli that vary systematically in one or more acoustic attributes that distinguish between two speech sounds. Listeners label each stimulus as one or the other speech sound, and they discriminate between pairs of speech sounds drawn from different points along the series. Three features define categorical perception, a labeling (identification) function with an abrupt transition between the two categories, discontinuous discrimination performance (near perfect across the identification boundary and near chance when both stimuli are from the same side) and the ability to predict discrimination performance on the basis of labeling data (Fig. 2).

These patterns of data stand in contrast to perception of simple stimuli continuously varying along dimensions such as frequency, intensity, etc. Many additional findings indicate that categorical perception is not unique to humans’ perception of speech. As might be expected given the major role of experience in

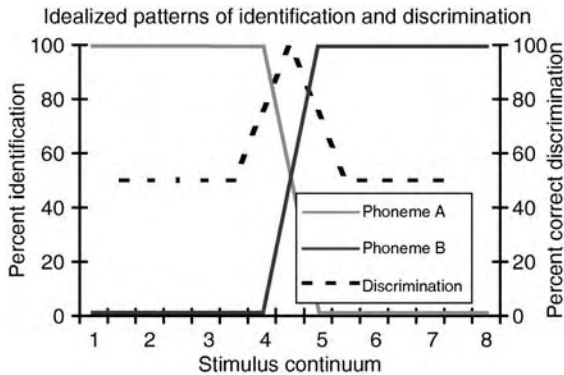

**Speech Perception. Figure 2** Idealized Patterns of Identification and Discrimination.

perception of speech, when experience is simulated using artificial neural network models, signature response patterns for categorical perception are emergent properties of learning following exposure to distributions of speech sounds [6]. Consistent with this conclusion, categorical perception has been observed with a number of visual and nonspeech auditory stimuli with which observers and listeners have much experience.

### Cortical Processing of Speech

Modern methods of electroencephalography (EEG), magnetoencephalography (MEG), positron emission tomography (PET) and functional magnetic resonance imaging (fMRI) are contributing to a greater understanding of cortical functions related to speech perception.

Presentation of sounds of any kind results in activation of primary auditory cortex (AI). Beyond AI, ventral, anterior and posterior, there is a belt of cortex that is activated by more complex sounds (Fig. 3). Ventrally, a second belt, sometimes referred to as a parabelt, can be described. For these belt areas, often referred to as “secondary” or “associational” areas, there is decreasing activation in response to very simple sounds such as sine waves and white noise, particularly when stimuli do not change much over time. In addition to responding to more complex acoustic structure, there is greater evidence of cross-modal encoding (e.g. auditory and visual), particularly in parabelt areas. Activation in response to speech in core, belt and parabelt areas of auditory cortex has most often been found to be relatively balanced bilaterally in the absence of higher-level linguistic effects [7].

Some very recent research suggests that, when listeners discriminate speech sounds such as “ba” and “da”, brain areas anterior and ventral to parabelt areas on the superior temporal lobe are more activated relative to very similar nonspeech sounds and this activation is relatively stronger in the left hemisphere [8]. When listeners understand whole meaningful sentences, activation is more clearly lateralized to the left

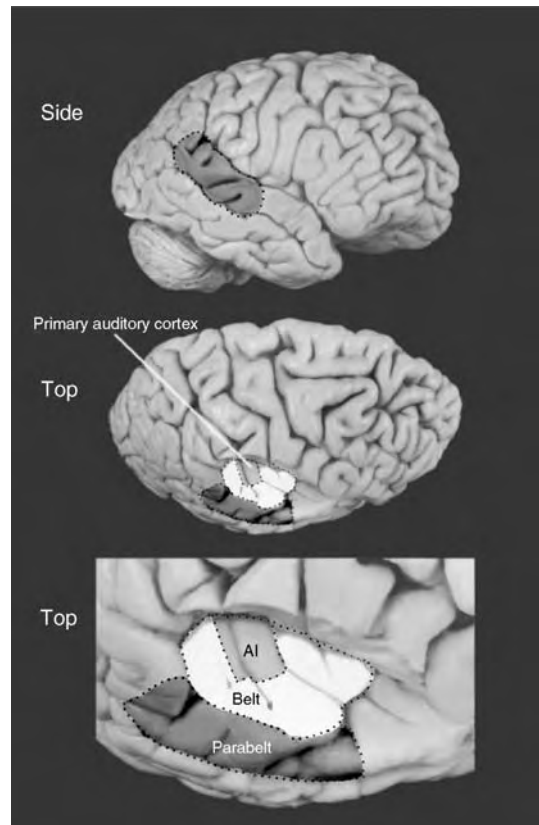

**Speech Perception. Figure 3** Cortical processing of speech.

hemisphere in regions yet further anterior and ventral in the temporal lobe [9].

Although evidence for strong lateralization of cortical speech processing – absent higher linguistic content – is relatively limited, this does not imply that there is nothing special about processing of speech in the human cortex. There are other ways in which processing of speech can be distinguished from perception of other sounds. Cortical organization is critically linked to the amount and nature of experience and there are no acoustic signals with which humans have more experience than speech. One may well expect that, as more becomes known about cortical processing of complex sounds, cortical areas that appear more exclusively dedicated to speech sounds may be revealed.

Evidence for two types of cross-modal organization might also be expected in cortex. First, owing to a wealth of experience simultaneously hearing speech and viewing talkers’ faces, one may expect substantial interaction between auditory and visual speech. The so-called McGurk effect, achieved by placing auditory and visual speech information in conflict, provides a powerful behavioral demonstration of this interaction, and there is some brain imaging evidence for cortical areas related to these perceptual effects [10]. Second,



there is some reason to expect evidence of interactions between speech production and perception. In addition to the more dorsal route between posterior temporal and motor cortex via the arcuate fasciculus, there is another connection between temporal and frontal areas of cortex via the uncinate fasciculus, which extends from anterior temporal cortex to inferior frontal gyrus. Thus, anatomical connections are in place to support associations between areas involved in perception of speech with areas involved with production. Given that speech provides an unusual case for which, at least when one is talking, there are simultaneous activities for producing and perceiving one's own speech, the potential for such as an association existing and being significant for speech perception is substantial.

## References

1. Kluender KR (1994) Speech perception as a tractable problem in cognitive science. In: Gernsbacher MA (ed) *Handbook of psycholinguistics*. Academic Press, San Diego, CA 173–217
2. Kluender KR, Lotto AJ, Holt LL (2005) Contributions of nonhuman animal models to understanding human speech perception. In: Greenberg S, Ainsworth W (eds) *Listening to speech: an auditory perspective*. Lawrence Erlbaum, Manwah, NJ pp203–220
3. Holt LL, Kluender KR (2000) General auditory processes contribute to perceptual accommodation of coarticulation. *Phonetica* 57:170–180
4. Anderson JA, Silverstein JW, Ritz SA, Jones RS (1977) Distinctive features, categorical perception, and probability learning: some applications of a neural model. *Psychol Rev* 84:413–451
5. Werker JF, Tees RC (1984) Phonemic and phonetic factors in adult cross-language speech perception. *J Acous Soc Am* 75:1866–1878
6. Damper RI, Harnad SR (2000) Neural network models of categorical perception. *Percept Psychophys* 62:843–867
7. Binder JR (2000) The new neuroanatomy of speech perception. *Brain* 123:2371–2372
8. Liebenthal E, Binder JR, Spitzer SM, Possing ET, Medler DA (2005) Neural substrates of phonemic perception. *Cereb Cortex* 15:1621–1631
9. Scott SK, Blank CC, Rosen S, Wise RJS (2000) Identification of a pathway for intelligible speech in the left temporal lobe. *Brain* 123:2400–2406
10. Calvert GA et al. (1997) Activation of auditory cortex during silent lipreading. *Science* 276:593–596

## Speed-accuracy Trade-off

### Definition

The rule that the accuracy of a target-directed movement is inversely related to its speed. To increase accuracy, reduce speed.

## Speed Profile

### Definition

Temporal aspects of the motion along a path, as they are manifested in the profile of the speed as a function of time. The path together with the speed profile over it, define the trajectory.

► [Arm Trajectory Formation](#)

## Sphingolipids (SLs)

### Definition

Ubiquitous, cell- and species-specific components of cell membranes, and together with their metabolites act as signaling molecules involved in cell-to-cell and cell-to-matrix interactions, cell adhesion, differentiation and death, modulation of membrane receptors, signal transduction, and stress responses. Genetic diseases of both the synthesis and degradation of SLs are known. Disease of SL biosynthesis may lead to infantile-onset symptomatic ► [epilepsy](#) (► [seizures](#) within the first year of life). Defective degradation of SLs and other lipids leads to accumulation of non-degradable material in lysosomes (lysosomal storage disorders). At present, more than 40 lysosomal storage disorders are known, of which 9-10 are due to defective degradation of SLs, among them Fabry disease, ► [Gaucher disease](#) and ► [Tay-Sachs disease](#).

► [Membrane Components](#)

► [Gaucher's Disease](#)

► [Tay-Sachs Disease](#)

## Spike

### Definition

Spike – (also discharge, impulse): another term for the most rapidly changing portion of the action potential.

► [Action Potential](#)

► [Sensory Systems](#)

---

## Spike Sorting

### Definition

Class of techniques and algorithms that use the shape of waveforms collected by one or more electrodes in a neural preparation to distinguish the activity of one or more neurons from background electrical noise – this is also known as “spike detection” – and to assign spikes to different neurons. Extra-cellular electrodes often detect action potentials generated by several neurons in their vicinity. Since the spike shapes are unique and quite reproducible for each neuron, classification of these shapes can be used to distinguish spikes produced by different neurons.

► Computer-Neural Hybrids

---

## Spike Train

### Definition

Series of action potentials (or spikes).

► Action Potential  
► Sensory Systems

---

## Spin Tensor

### Definition

The skew symmetric part of the velocity gradient. Also called vorticity tensor.

► Mechanics

---

## Spina Bifida

### Definition

Developmental abnormality resulting from the failure of the caudal ►neural tube to close, which in turn results

in disruption of the functions of the lumbar and sacral spinal segments.

► Neural Tube

---

## Spinal Animals

### Definition

“Acute Spinal” refers to an animal whose spinal cord is surgically cut with a scalpel on the day of an experiment and is used to record electrophysiological data from muscles, nerves or spinal neurons “Chronic Spinal” refers to spinal animals whose spinal cord is cut at various levels (usually T13 in cats and T8 in rodents) and the animal is kept for a varying number of days, weeks and months to record kinematics, kinetics or EMGs.

► Locomotor Training

---

## Spinal Autonomic Circuit

### Definition

Segmental or propriospinal reflex circuit consisting of primary afferent neurons (mostly with small-diameter A $\delta$ - or C-fibers), interneurons and preganglionic neurons. These spinal autonomic circuits are functionally defined by the function of the final autonomic (sympathetic or parasympathetic) pathway (e.g. muscle vasoconstrictor, urinary bladder etc) and the functional type of primary afferent neuron.

► Complex Regional Pain Syndromes: Pathophysiological Mechanisms

---

## Spinal Border Cells

### Definition

Spinal border cells are a group of large neurons. similar in appearance to motoneurons, near the lateral border of the ventral horn of lumbar spinal cord segments. They relay proprioceptive information to the ipsilateral side of the anterior lobe of the cerebellum.

## Spinal Column

### Definition

The longitudinal column of bony rings that surrounds the spinal cord. Also known as the vertebral column or backbone.

- ▶ Evolution of the Spinal Cord
- ▶ Transplantation of Olfactory Ensheathing Cells

## Spinal Cord

### Synonyms

- ▶ Medulla spinalis

### Definition

Spinal cord is surrounded by the spinal meninges, enclosed in the vertebral canal and extends in adults to about the second lumbar vertebra. Here are found primarily conduction pathways, synaptic centers but also motor programs (simple and complex reflexes, movement programs, inter alia).

- ▶ Development of Nociception
- ▶ Medulla spinalis
- ▶ Transplantation of Olfactory Ensheathing Cells

## Spinal Cord Stimulation

### Definition

Electrical stimulation of the dorsal column with high frequency, low intensity, short duration pulses activate large fibers of the dorsal column. These large fibers excite inhibitory interneurons and modulate the processing of spinothalamic tract cells receiving afferent information that was generated by applying a noxious chemical stimulus to the heart.

- ▶ Ascending Nociceptive Pathways
- ▶ Somatosensory Projections to the Central Nervous System
- ▶ Viscero-Somatic Reflex

## Spinal Cord, Cervical Part

### Synonyms

- ▶ Medulla spinalis; Pars cervicalis

### Definition

Cervical cord. The part of the spinal cord comprising the spinal nerves of the cervical vertebral column.

- ▶ Medulla Spinalis

## Spinal Cord, Gray Matter

### Synonyms

- ▶ Medulla spinalis; Subst. grisea

### Definition

Here are found nuclear regions in which the fibers synapse. Three areas are distinguished:

- Posterior horn
- Intermediate substance
- Anterior horn

- ▶ Medulla spinalis

## Spinal Cord, Lumbar Part

### Synonyms

- ▶ Medulla spinalis; Pars lumbalis

### Definition

Lumbar cord. The part of the spinal cord comprising the spinal nerves of the lumbar vertebral column, epidural cavity, which spreads across the entire length of the vertebral column. Cervical, thoracic and lumbar epidural cavities are also called peridural cavity. The peridural cavity plays a decisive role in epidural anesthesia.

- ▶ Medulla spinalis

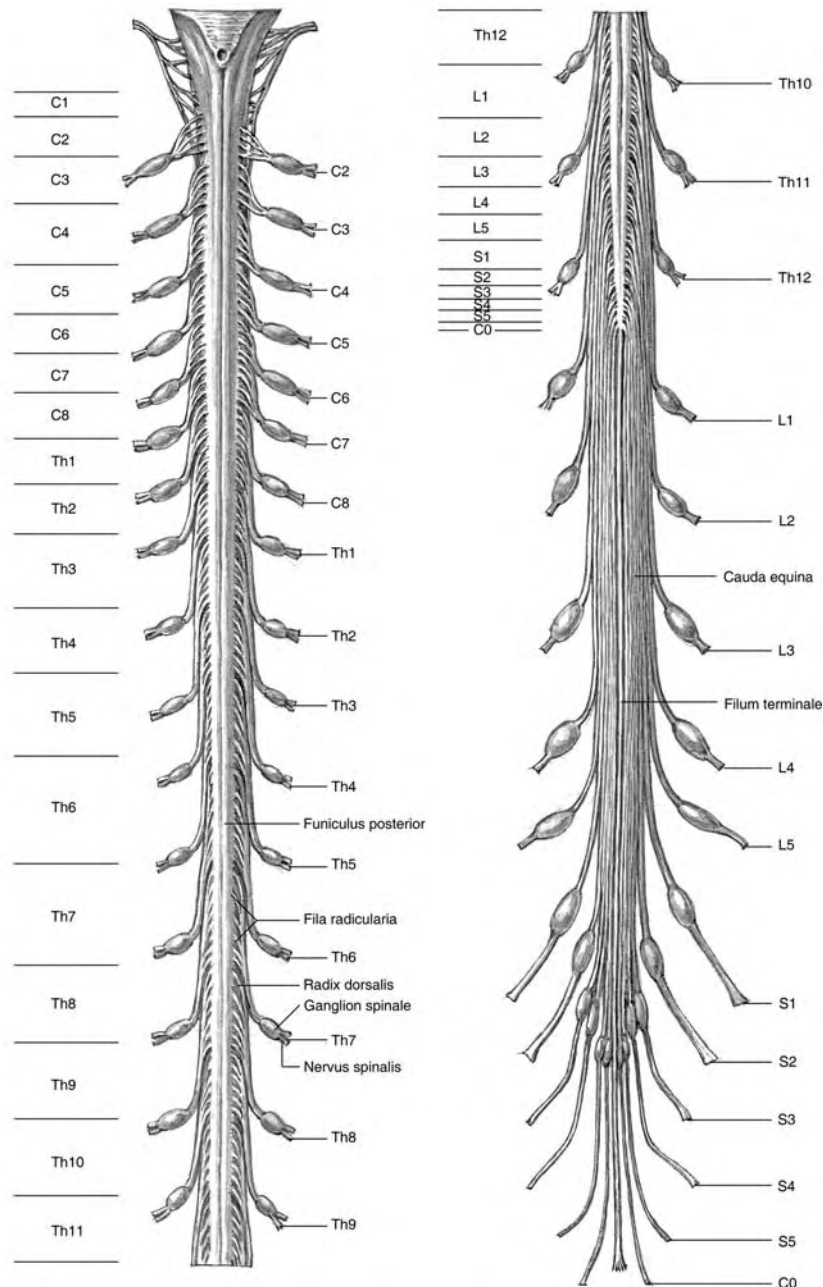

**Spinal Cord. Figure 1** Dorsal view of the spinal cord showing attached dorsal root filaments and spinal ganglia. The cervical (C), thoracic (T), lumbar (L), sacral (S) and coccygeal (Co) spinal nerves have been transected at their site of exit from the intervertebral foramina. The position of the spinal segments is indicated on the *left* side of the cord (2/3 $\times$ ). Original figure 03.14 taken from Nieuwenhuys, R; Voogd, J; van Huijzen, C. (Eds) 2008 "The Human Central Nervous System". Fourth Edition. Springer, Berlin. page 83 with permission.

## Spinal Cord, Thoracic Part

### Synonyms

► Medulla spinalis; Pars thoracica

### Definition

Thoracic cord. The part of the spinal cord comprising the spinal nerves of the thoracic vertebral column.

► Medulla Spinalis

## Spinal Ganglion

### Synonyms

►Ganglion spinale

### Definition

Spinal ganglion is formed by the cell nuclei of viscerosensory, bi- or multipolar neurons, which project across the dorsal root into the spinal cord, where they mostly synapse directly on visceromotor efferent fibers, thus creating the basis for autonomic reflex arcs.

(S1–S5), and 1 coccygeal. Each segment pair provides sensory innervation for a clearly delineated skin area (= dermatome). Close to the spinal cord, the spinal nerve divides into a sensory dorsal root and a motor ventral root. External to the intervertebral foramen it divides again into a ventral branch and a dorsal branch.

►Medulla Spinalis

## Spinal Hyperexcitability

### Definition

Sensitization of spinal cord neurons for peripheral input.

►Hyperalgesia and Allodynia

## Spinal Muscular Atrophy

### Definition

Disease of spinal ►motoneurons (with some ►demyelination of the ►corticospinal tracts) presenting with wasting and weakness of skeletal muscles, loss of reflexes and ►fasciculations; may be the same disease as ►amyotrophic lateral sclerosis.

►Amyotrophic Lateral Sclerosis  
 ►Corticospinal Tract  
 ►Fasciculations

## Spinal Nerve

### Synonyms

►N spinalis

### Definition

A spinal nerve originates in the spinal cord, unlike the cranial nerve which arises from the cerebrum. A distinction is made between 31 pairs: 8 cervical (C1–C8), 12 thoracic (Th1–Th12), 5 lumbar (L1–L5), 5 sacral

## Spinal Nucleus of the Trigeminal Nerve

### Synonyms

►Nucl. spinalis n. trigemini

### Definition

This nucleus extends from the principal nucleus of the trigeminal nerve to the dorsal column of the cervical cord, which it enters. Afferents are the axons from the trigeminal ganglion, which convey somatotopically organized impulses from the face via the spinal tract of the trigeminal nerve. Efferents come from the caudal nuclear region, decussate to the contralateral side and pass as the lateral trigeminothalamic tract to the ventral posteromedial thalamic nucleus.

►Myelencephalon

## Spinal Reflex

### Definition

A reflex mediated via neuronal pathways located entirely within the spinal cord.

## Spinal Respiratory Neurons and Respiratory Control

JOHN J. GREER

Department of Physiology, Centre for Neuroscience, University of Alberta, Edmonton, AB, Canada

### Definition

Air flow in and out of the lungs is regulated by mechanical action of the ribcage moving in axial and radial directions. Inspiration is an active phase controlled by the

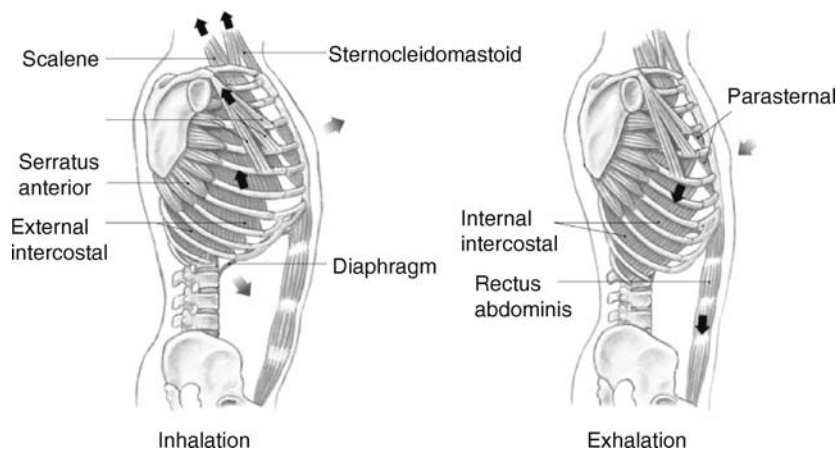

**Spinal Respiratory Neurons and Respiratory Control. Figure 1** Respiratory muscles innervated by spinal respiratory motoneurons that are recruited during inhalation and exhalation. Levator costae (occupying most rostral regions of each intercostal space), triangularis sterni (underlie parasternal muscles) and other abdominal muscles besides rectus abdominis not shown.

contraction of the diaphragm, levator costae, scalene, parasternal and external intercostals muscles. In addition, the sternocleidomastoid, pectoralis, serratus anterior and trapezius muscles are recruited during forceful inspiration. Expiration is largely passive, except for the recruitment of levator costae muscles. During forced expiration, rib cage movements are also controlled by abdominal and internal intercostal muscles (Fig. 1). Further, the thoracoabdominal muscles play a role in vocalization, various gastrointestinal activities, as well as ribcage stabilization and postural adjustments, particularly during locomotor activities and exercise. Thus, their contribution to airflow generation will vary from breath to breath as it is adjusted to best meet these multiple demands. The motoneurons innervating and controlling these muscles are located within the ventral horn of the spinal cord. This section will provide an overview of the anatomical and physiological properties of spinal respiratory motoneurons. The primary focus will be on **alpha motoneurons**, those that innervate extrafusal muscle fibers. A brief discussion of **gamma motoneurons** which innervate intrafusal fibers of muscle spindles will appear at the end. There a number of excellent reviews that provide more in depth discussions of spinal respiratory motoneurons and the muscles they innervate [1–4].

## Characteristics Phrenic Motoneurons

Phrenic motoneurons (PMNs) are the sole source of efferent innervation of the diaphragm muscle, the primary inspiratory muscle controlling thoracic expansion. PMNs have been studied in much more detail compared to other spinal respiratory motoneurons.

*Anatomy:* PMNs are located in the ventral horn of cervical (C)3–C5 segments of the human and rodent spinal

cord. The relative proportion of PMNs residing within each cervical segment varies with species. The PMN nucleus is readily recognizable by its medial position in the ventral horn and the extensive rostrocaudally-oriented dendritic branches (Fig. 2). It has been suggested that these dendritic bundles assist in coordinating respiratory movements by synchronizing the activity of groups of motoneurons. The diaphragm originates from a single embryological structure but is functionally compartmentalized into costal and crural regions via selective recruitment of motor units. PMNs innervating the costal diaphragm are located rostral relative to those innervating the crural diaphragm.

*Synaptic input and discharge characteristics:* PMNs receive inspiratory drive from bulbospinal neurons located in the ventral nucleus of the solitary tract, referred to as the **DRG (dorsal respiratory group)**, and rostral region of the ventrolateral column of respiratory neurons called the rostral ventral respiratory group (rVRG). In the rat, however, the DRG contribution is minor. The connections from the medulla to PMNs are both mono- and poly-synaptic, but monosynaptic connections predominate.

Glutamate is the main neurotransmitter mediating transmission of synaptic inspiratory drive to PMNs. The majority of the glutamate-mediated action is via non- **NMDA (N-methyl-D-aspartic acid)** receptors. However, there is an NMDA-receptor mediated component that accounts for ~10% of the baseline drive and that component may be further enhanced via reflex-mediated synaptic input. PMNs are silent during the expiratory phase due to the combined withdrawal of inspiratory drive and the activation of GABAergic inhibitory synaptic drive. The primary source of inhibitory drive to PMNs arises from expiratory bulbospinal neurons located in the caudal VRG and **Böttinger**

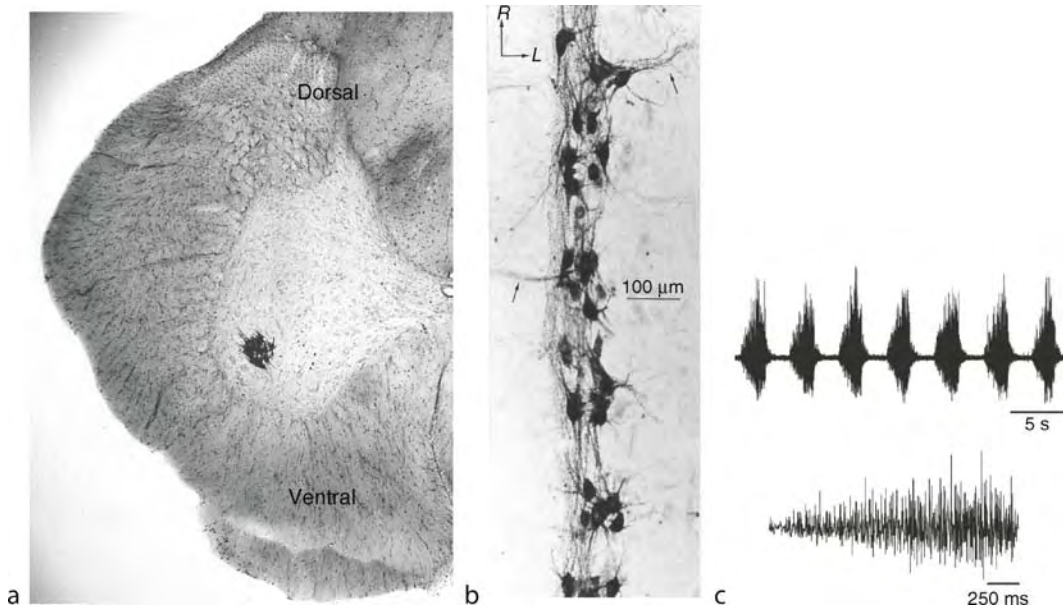

**Spinal Respiratory Neurons and Respiratory Control. Figure 2** (a) HRP labeled PMNs showing distinct clustering and bundling of rostrocaudal projecting neurites. Figures provided by Dr. H. Goshgarian, Wayne State U. (b) Cat phrenic nerve recording showing characteristic ramp-like burst pattern. Figures provided by Irene Solomon, University of New York at Stony Brook.

complex (BötC) located at the rostral end of the ventral respiratory column. Further, PMNs receive GABAergic inhibitory drive concomitant with excitatory glutamatergic inspiratory drive; the balance of each being adjusted to shape PMN discharge pattern and subsequent drive to the diaphragm muscle.

In addition to the fast excitatory and inhibitory inspiratory drives mediated, respectively by the amino acid transmitters glutamate and GABA, a dense plexus of synaptic varicosities converge onto the PMN pool that contain a multitude of neurotransmitters, including serotonin, thyrotropin releasing hormone, noradrenaline, Substance P, metenkephalin, cholecystokinin, galanin, neuropeptide Y and adenosine. The neuromodulators regulate PMN excitability on a slower time scale relative to the amino acid transmitters. In addition, the activity of these modulatory neurons often varies between states (e.g., sleep-wake cycling).

The pattern of phrenic discharge increases in a ramp-shaped pattern during each inspiratory burst (Fig. 2). The increasing discharge is due to the increase in discharge frequency of individual PMNs and recruitment of previously silent PMNs. There is also post-inspiratory discharge amongst a sub-population of PMNs that works in concert with activation of laryngeal expiratory motoneurons to provide a smooth transition from inspiration to expiration by limiting early expiratory airflow. In addition, PMNs receive endogenous rhythmic inspiratory currents with prominent oscillations in the 20–50 Hz and 80–150 Hz

ranges. It has been hypothesized that these oscillations control the precise timing of action potentials, helping to maximize synaptic drive efficiency by constraining MN firing frequencies to those optimal for muscle contraction [5].

Details of how PMN output in the form of action potentials are determined by the complex interaction of intrinsic and synaptic properties is largely unknown. This requires specific knowledge of several factors including neuronal morphology, type and distribution of multiple types of voltage- and ligand-gated channels, second messenger systems and their actions, associated endogenous neurotransmitters and their location on the somatodendritic and presynaptic membranes, and the interactions between various neuromodulators and ionic channels (see [3,10] for review).

*Development:* Most mammalian motor systems do not become fully functional until they undergo significant postnatal development. While the neuronal and muscular components of the respiratory system mature postnatally, they must be developmentally advanced and functional by birth to generate a rhythm and motor behavior that is sufficient for gas exchange in a highly compliant chest wall but can also to integrate swallowing and other behaviors with breathing. The development of rat PMNs during the perinatal period has been systematically examined (see [7] for review).

PMNs differentiate and proliferate within the ventricular zone of the neural tube. They are organized into

tightly packed clusters, linked by gap junctions, as they migrate to reach their final position in the ventral horn. During these early stages, the PMN somata and their simple mediolateral neurites align along the processes of radial glia that provide a guiding substrate. The specification of motoneuron identity is thought to be controlled, in part, by the combinatorial actions of transcription factors. The detail of how these operate to specifically define phrenic versus brachial phenotype has not been examined. The axons of phrenic and brachial motoneurons exit via cervical ventral roots and migrate together toward the primordial diaphragm. Under the influence of currently unidentified guidance cues, the two populations, led by pioneer axons, diverge. Phrenic axons continue to grow ventrally toward the diaphragmatic primordium; brachial axons turn laterally to grow into the limb bud. The phrenic nerve initiates branching within the diaphragm when myoblasts in the region of contact with the phrenic nerve begin to fuse and form distinct primary myotubes. As the nerve migrates through the various sectors of the diaphragm, myoblasts along the nerve's path begin to fuse and form additional myotubes.

During these early stages of development from the time of initial axon outgrowth until the diaphragm is

fully formed, PMNs are recruited as part of a robust, regular rhythmic motor pattern that is generated along the entire developing spinal cord and brainstem. It has been hypothesized that the spontaneous embryonic rhythmic activity plays a key role in regulating the early development of neuronal circuits and motoneuronal phenotype.

The phrenic nerve intramuscular branching and concomitant diaphragmatic myotube formation is largely complete by embryonic day 17 in the rat and the 10th week of gestation in the human. This is also the time of the commencement of inspiratory drive transmission to PMNs, the inception of fetal breathing movements (FBMs) and the arrival of phrenic afferents to the motoneuron pool.

During the period spanning the inception of FBMs to birth there is dramatic change in PMN morphology, passive membrane properties, action potential characteristics and firing properties (Fig. 3). Changes include the following. (i) PMN dendritic branching is rearranged into the rostrocaudal bundling characteristic of mature PMNs, and gap junctions between PMNs decrease. (ii) PMN  $\blacktriangleright$ resting membrane potential becomes significantly more hyperpolarized ( $\sim 10$  mV) without a significant change in action potential threshold, whereas

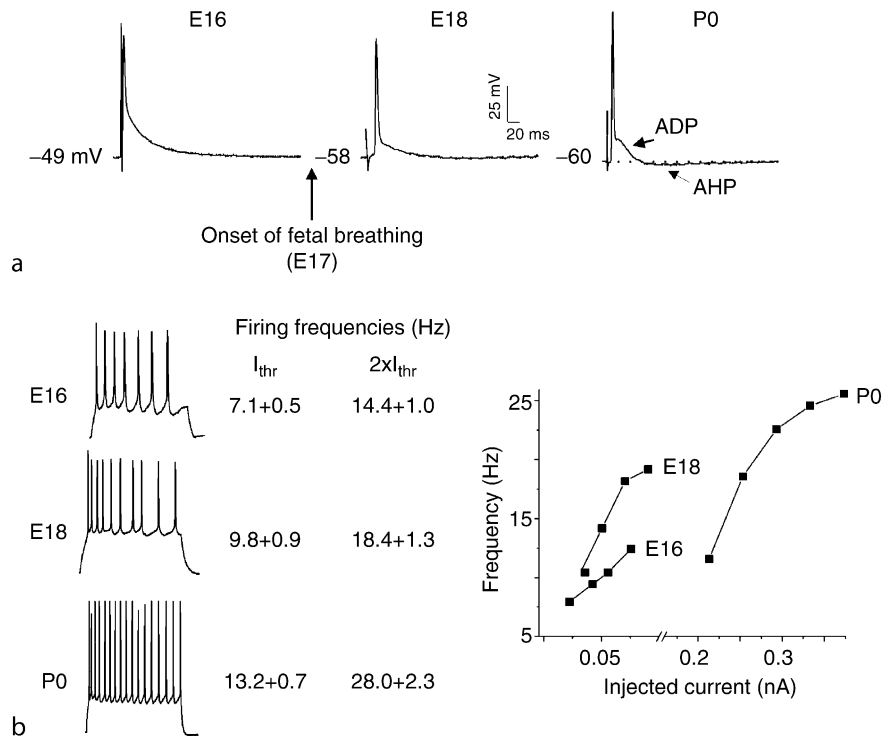

**Spinal Respiratory Neurons and Respiratory Control. Figure 3** (a) Typical action potentials recorded from embryonic day (E16), E18 and postnatal (P)0 rat PMNs. (b) *Left panel* shows examples of repetitive firing patterns generated following injection of a depolarizing square pulse. *Right panel* shows representative current frequency plot for PMNs at various ages studied. Adapted from [7].



there are significant decreases in the input resistance (▶ **membrane resistance**) (~three times lower) and ▶ **time constant** (~1.4 times shorter). Thus, PMNs require significantly less depolarizing current to reach threshold at the inception of inspiratory drive compared with more mature states (i.e., rheobase current is ~2.5 times less at E17 than at birth). Functionally, the increased propensity for reaching firing threshold will compensate for a relatively weak descending inspiratory drive at this age, and thus facilitate the production of fetal breathing movements. (iii) Action potential characteristics change markedly. The amplitude increases by ~12 mV and the duration decreases by ~50%. Calcium conductances emerge which play a large role in the development of after-depolarizing and -hyperpolarizing potentials. (iv) Concomitant with changes in the duration and shape of action potentials, there is a marked change in the repetitive firing properties of PMNs. By birth, PMNs fire at ~ two times the maximum discharge frequency achieved at the onset of FBMs. The net results of the changes in the passive and action potential properties are that by birth, PMNs, while requiring a stronger synaptic drive to initiate firing, are capable of driving the diaphragm musculature to produce greater contractile forces in comparison to those generated in utero.

### Respiratory Motoneurons Innervating Thoracic Muscles

Motoneurons innervating thoracic muscles are phasically active during inspiratory or expiratory phases to control ribcage expansion. Further, they regulate ribcage stability and therefore improve the efficiency of the diaphragm muscle.

**Anatomy:** Internal and external intercostal, as well as triangularis sterni and parasternal motoneurons are located in the ventromedial region that corresponds to the intercostal space in which the muscle is located. In the transverse plane, levator costae motoneurons are located in the ventromedial region of the ventral horn, while the parasternal and triangularis sterni motoneurons are located primarily along the lateral edge of the ventral horn. Internal and external intercostal motoneurons are located between these motoneuron groups with external intercostals motoneurons generally being more medial than internal intercostals motoneurons.

**Synaptic input and discharge characteristics:** Inspiratory drive transmission to thoracic respiratory motoneurons arises from the rVRG and ▶ **DRG**. Expiratory drive arises from the cVRG, but likely not the BötC which does not project beyond the cervical spinal cord. Unlike PMNs, there seems to be very little monosynaptic input to thoracic respiratory motoneurons from the medulla. Rather, there is a segmental interneuronal network transmitting reciprocal inhibition between inspiratory and expiratory intercostals motoneurons that provides spinal integration of supraspinal and

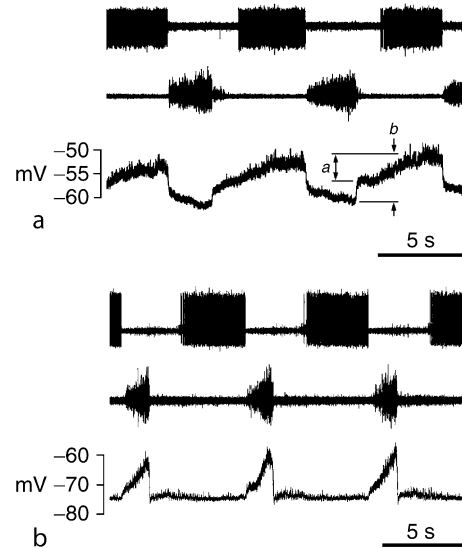

**Spinal Respiratory Neurons and Respiratory Control. Figure 4** Examples of central respiratory drive potentials (CRDPs) in intercostal motoneurons. Records from the top panel, from the top: extracellular discharge from an expiratory bulbospinal neuron; efferent discharge in an external intercostal nerve, used to define inspiration; intracellular recording from a motoneuron. (a) expiratory motoneuron, (b) inspiratory motoneuron. Adapted from [6].

segmental synaptic inputs (Fig. 4). The neurochemical control of respiratory motoneurons controlling thoracic musculature has not been studied in detail. However, it would appear that the primary inspiratory drive is via glutamatergic synaptic input.

Parasternal, external intercostal and levator costae motoneurons are activated during the inspiratory phase. There is a rostrocaudal gradient of the strength of inspiratory activity in external intercostals muscles. In contrast, there is a tendency for the levator costae motoneurons innervating caudally located muscle to be recruited strongly during inspiration.

Internal intercostal and triangularis sterni motoneurons are activated during the expiratory phase. The majority of triangularis sterni motoneurons commence firing mid-expiration. There is a caudorostral gradient of the strength of expiratory activity in internal intercostals muscles.

Motoneurons innervating muscles in the neck, shoulder and chest region can also contribute to movements of the thorax during respiration. Scaleni motoneurons, located in segments C2-C7, are activated during inspiration. Scalene muscle activity assists with the lifting of the upper ribcage. The sternocleidomastoid, pectoralis, trapezius and serratus anterior motoneurons are not rhythmically active at rest but can be recruited during forced inspiration. Sternocleidomastoid motoneurons are located in segments C1-C3 and trapezius motoneurons extend from C2-C6; both send axons via the spinal

accessory nerve. Notably, there is overlap in the location of caudally located trapezius and PMNs. Pectoralis motoneurons are located within the medial to ventromedial tip of the ventral gray matter of C6-C7. The majority of serratus anterior motoneurons are from C6, with a smaller component located at C7.

### Abdominal Motoneurons

The respiratory abdominal muscles comprise two outer (external oblique, EO, and rectus abdominis, RA) and two inner (internal oblique, IO, and transversus abdominis, TA) muscles. Abdominal muscles are primarily innervated by motoneurons located in the lower thoracic and upper lumbar spinal cord; external oblique (T6-L3), internal oblique (T13-L3), transverse abdominis (T9-L3) and rectus abdominis (T4-L3). There is considerable overlap in the positioning of those motoneurons within the ventrolateral region of the ventral horn. Abdominal motoneurons are recruited during forced expirations. Premotoneurons supplying abdominal motoneurons are localized in the caudal part of the ►VRG (ventral respiratory group), within or close to the nucleus retroambiguus. It has been recently hypothesized that preinspiratory neurons located in the rostral ventrolateral medulla close to the ventral surface at the level of the rostral half of the nucleus retrofacialis provide rhythmic drive to those premotoneurons (Fig. 5).

### Gamma Motoneurons

Muscle spindles respond to changes in muscle length. The sensitivity and firing rate of muscle spindles is modulated by fusimotor axons. Most fusimotor axons derive from  $\gamma$ -motoneurons that exclusively innervate spindles, but a minority are  $\beta$ -fibers ( $\alpha$ -motoneurons that innervate spindle intrafusal muscle fibers and skeletal muscle fibers). Intercostal muscles have a rich complement of muscle spindles and gamma motoneuron innervation (reviewed in [9]). Inspiratory activity of external intercostals is markedly reduced in the absence of feedback onto intercostal motoneurons from muscle spindle afferents. In contrast, the diaphragm and triangularis sterni muscle have very few muscle spindles and consequently a low number of gamma motoneurons in their motoneuron pools. Perhaps reflex activity mediated via muscle spindles would be functionally inappropriate for the diaphragm, the major muscle controlling inspiration. For instance, reflex activation of PMNs by spindle afferents could occur when the diaphragm is passively lengthened either due to trunk rotation or pressure applied by adjacent abdominal organs. Likewise, heightened fusimotor activity that can occur in association with certain states of alertness, would result in increased muscle spindle afferent discharge and reflex activation of PMNs. These occurrences could theoretically lead to disturbances in diaphragm function and breathing pattern.

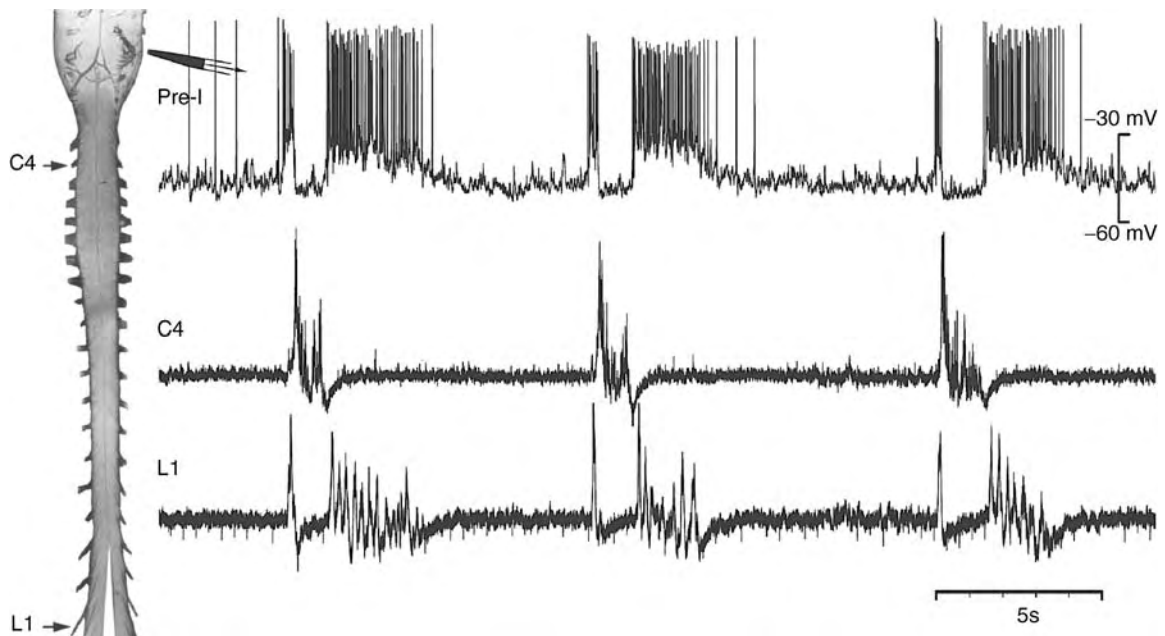

**Spinal Respiratory Neurons and Respiratory Control. Figure 5** Expiratory activity of lumbar motoneurons. Activity of the preinspiratory neuron located in the parafacial nucleus region projecting to the nucleus retroambiguus and traces of C4 and L1 root activity generated in an *in vitro* neonatal rat brainstem-spinal cord preparation. The firing pattern of the preinspiratory neurons and L1 root *in vitro* consisted of two distinct bursts bracketing C4 root activity. Adapted from [8].

## References

- Berger AJ, Bellingham MC (1995) Mechanisms of Respiratory Motor Output. In: Dempsey JA, Pack AI (eds) Regulation of breathing. Marcel Dekker Inc, New York, pp 71–150
- De Troyer A, Kirkwood PA, Wilson TA (2005) Respiratory action of the intercostal muscles. *Physiol Rev* 85 (2):717–756
- Feldman JL, Smith JC (1995) Neural control of respiratory pattern in mammals: an overview. In: Dempsey JA, Pack AI (eds) Regulation of breathing. Marcel Dekker Inc, New York, pp 39–70
- Monteau R, Hilaire G (1991) Spinal respiratory motoneurons. *Prog Neurobiol* 37(2):83–144
- Parkis MA, Feldman JL, Robinson DM, Funk GD (2003) Oscillations in endogenous inputs to neurons affect excitability and signal processing. *J Neurosci* 23 (22):8152–8158
- Saywell SA, Anissimova NP, Ford TW, Meehan CF, Kirkwood PA (2007) The respiratory drive to thoracic motoneurons in the cat and its relation to the connections from expiratory bulbospinal neurones. *J Physiol* 579:765–782
- Greer JJ, Funk GD (2005) Development of respiratory motoneuron properties during the perinatal period. *Respir Physiol Neurobiol* 149(1–3):43–61
- Janczewski WA, Onimaru H, Homma I, Feldman JL (2002) Opioid-resistant respiratory pathway from the preinspiratory neurones to abdominal muscles: in vivo and in vitro study in the newborn rat. *J Physiol* 545:1017–1026
- Duron B (1981) Intercostal and diaphragmatic muscle endings and afferents. In: Hornbein TF (ed) Regulation of breathing, Part I. Marcel Dekker Inc, New York, pp 473–540
- Rekling JC, Funk GD, Bayliss DA, Dong XW, Feldman JL (2000) Synaptic control of motoneuronal excitability. *Physiol Rev* 80(2):767–852

## Spinal Shock

### Definition

Spinal shock results from a complete transection of the spinal cord and denotes a state of reduced or absent spinal reflexes, which gradually recover within weeks and months and then often are enhanced.

## Spinal Trigeminal Nucleus

### Definition

The spinal trigeminal nucleus receives input from the pain and temperature (and some tactile) afferents in the

trigeminal nerve (Vth cranial nerve). This nucleus is in the lateral brainstem and extends from the pons through the medulla to the spinal cord where it is continuous with the substantia gelatinosa region of the dorsal gray.

## Spinal Trigeminal Tract

### Definition

The spinal trigeminal tract is made of primary afferent fibers of the trigeminal nerve (Vth cranial nerve) that carry pain and temperature (and some tactile) information. The cell bodies of these fibers are in the trigeminal ganglion. The tract begins at the Vth nerve entry in the pons and courses lateral to the spinal Vth nucleus in its descent to the spinal cord where it is continuous with the tract of Lissauer.

## Spinal Vertebrate

### Definition

A vertebrate with a complete transection of the spinal cord.

## Spine, Morphological Change

HARUO KASAI

Laboratory of structured Physiology, Center for Disease Biology and Integrative Medicine, University of Tokyo, Tokyo, Japan

### Definition

#### Dendritic Spines and Filopodia

Spiny protrusions of dendrites that receive excitatory synaptic inputs. Dendritic spines possess a bulbous head, at which stable synaptic contact with a presynaptic terminal is formed. Dendritic **filopodia** do not manifest a bulbous head and are often longer than spines as well as highly motile and unstable. Filopodia are numerous in neurons of young animals but are sparse in those of adults. It is often difficult to distinguish filopodia from thin spines. Filamentous (F) actin is highly enriched in spines

and filopodia, whereas microtubules are absent; in contrast, F-actin is less abundant and microtubules are present in the parental dendritic shaft.

## Characteristics

### Quantitative Description

Spines are present on a variety of neurons, but they are especially numerous (1–15 spines per micrometer) and prominent in the major projection neurons of the vertebrate brain, including cerebellar Purkinje cells, ►pyramidal neurons in the cerebral cortex, and medium spiny neurons in the basal ganglia. In pyramidal neurons, the morphology of spines is highly variable; spine–head volume varies from  $0.005 \mu\text{m}^3$  to  $0.5 \mu\text{m}^3$  (head diameter of  $0.2\text{--}1 \mu\text{m}$ ), spine–neck length from  $0 \mu\text{m}$  to  $1.1 \mu\text{m}$ , and spine–neck diameter from  $0.04 \mu\text{m}$  to  $0.26 \mu\text{m}$ . Spine structure is less variable in Purkinje neurons, with head volume ranging between only  $0.06 \mu\text{m}^3$  and  $0.18 \mu\text{m}^3$  [1]. The structure of spines, especially that of the neck, is difficult to study, even with serial reconstruction by electron microscopy, because the thickness of tissue sections ( $\sim 0.06 \mu\text{m}$ ) is similar to the diameter of spine necks. High-voltage electron microscopy allows examination of a large number of spines without serial sectioning (Fig. 1), and may prove useful for detailed quantitation.

Direct imaging of spines in living brain tissue is possible by ►two-photon excitation microscopy. With this fluorescence imaging technique, spine–head volume ( $V_H$ ) can be determined by measurement of the total

fluorescence intensity of the spine head. Spine–neck geometry can be similarly quantified from fluorescence images or can be determined by quantitative  $\text{Ca}^{2+}$  imaging [2], and expressed as a parameter, spine–neck  $\text{Ca}^{2+}$  conductance ( $g_N$ ) (Fig. 2).

Spine–neck  $\text{Ca}^{2+}$  conductance varies by a factor of up to 1,000, and is approximately proportional to the second power of spine–head volume in hippocampal pyramidal neurons. This nonlinear relation may be essential for the plasticity of small spines and the stability of large spines [2]. Similar head–neck relations are also apparent by electron microscopy (Fig. 1). Three typical types of spine – thin, stubby, and mushroom – have been distinguished (Fig. 2), but these types reflect three extremes of one continuous population of spines.

### Higher Level Structures

Spines are components of dendrites and of excitatory synapses. They are also one of the major constituents of the ►neuropile.

### Lower Level Components

Synaptic contact is made at the region of a spine at which a ►postsynaptic density (PSD) is identifiable by electron microscopy, at the cytoplasmic face of the plasma membrane. Most spines also contain a ►spine apparatus, a structure thought both to function as a  $\text{Ca}^{2+}$  store and to house the machinery for protein synthesis. The spine apparatus is more prevalent in larger spines. Polyribosomes are also present in spine heads, where they are

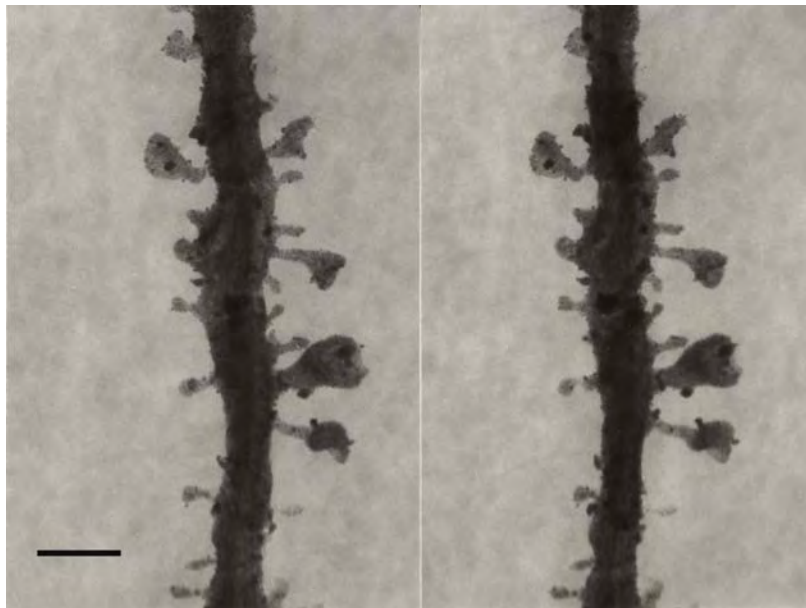

**Spine, Morphological Change. Figure 1** High-voltage electron microscopic stereo image of a dendrite of a rat hippocampal granule cell. Many partially hidden spines are apparent on the dendritic shaft. Golgi preparation with a thickness of  $5 \mu\text{m}$ ; scale bar,  $1 \mu\text{m}$ . Courtesy of K. Hama. Methodology is described in *Microscopy Research and Technique* 29(1994) 357–367.

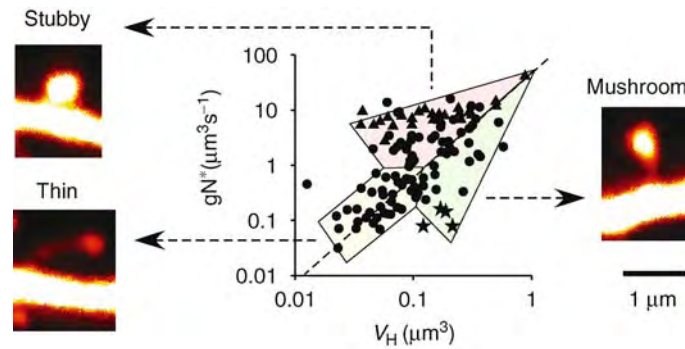

**Spine, Morphological Change. Figure 2** Distribution of spine–head volume ( $V_H$ ) and spine–neck  $\text{Ca}^{2+}$  conductance ( $g_N^*$ ) for 115 spines, in four dendrites, in slice-culture preparations of rat hippocampal CA1 pyramidal cells. Values of  $g_N^*$  were obtained from fluorescence images as described in [2]. The yellow, green, and red regions contain thin, mushroom, and stubby spines, respectively. Stars represent typical mushroom spines with long narrow necks and relatively large heads, and triangles typical stubby spines without a neck. Modified with permission from [2].

thought to participate in protein synthesis, and their prevalence is increased after tetanic stimulation.

### Structural Regulation

Spines are either formed from dendritic filopodia after establishment of a stable synapse or emerge directly from a dendritic shaft. The dynamics of transitions among spines with different structures has been partly understood. Rapid enlargement of spines with a small head is induced by tetanic stimulation of presynaptic fibers, and gives rise to long-term potentiation (LTP) [3]. Spine enlargement and LTP can be induced at the level of a single spine by direct stimulation of the spine, indicating that individual spines are able to serve as memory elements at the cellular level. In addition, large spines ( $V_H$  of  $>0.1 \mu\text{m}^3$ ) are resistant to long-lasting enlargement and LTP [3], and they can stably exist in living animals for months or more than a year [4,5], suggesting that large spines might represent physical traces of long-term memory.

Spines also change their shape sporadically with a time constant of minutes to hours, a process that can be detected as fluctuations in spine–head fluorescence and which possibly reflects treadmilling of actin. Indeed, many molecules that regulate the actin cytoskeleton affect spine structure [6]. Abnormal spine shape, or spine dysgenesis, is associated with various forms of mental retardation [7]. Spines are thus unusually numerous and tortuous in individuals with fragile X syndrome, the most frequent form of hereditary mental retardation. Many hormones, especially sex steroids, alter spine density.

### Higher Level Processes

Spines are basic functional units of higher order brain activities, such as learning and memory as well as cognitive and executive processes. Spines are thus more prominent in higher animals and are absent from

most invertebrate neurons. Spines are also present at extremely high density on the major projection neurons, which play a central role in mental functions, and are postsynaptic to most excitatory synaptic inputs. In addition, spine density and shape are affected by various environmental factors and are abnormal in individuals with various mental disorders. Spines also undergo extensive reorganization during the critical period of ocular dominance plasticity. Finally, spines detect coincidence of pre- and postsynaptic neuronal activities and respond with rapid structural and functional plasticity [3].

### Lower Level Processes

Spine structure underlies the major spine function, the sensing of glutamate released from presynaptic terminals. It is now possible to measure the function of individual spines by two-photon uncaging of a caged-glutamate compound [2, 3, 8]. This approach has revealed that expression of glutamate receptors sensitive to  $\alpha$ -amino-3-hydroxy-5-methyl-4-isoxazolepropionic acid (AMPA) in spines is approximately proportional to spine–head volume [8] and that these receptors are absent from filopodia (Fig. 3).

The abundance of glutamate receptors sensitive to *N*-methyl-D-aspartate (NMDA) is also greater in larger spines than in smaller ones. Whereas expression of NMDA receptors is significant even in small spines, however, that of AMPA receptors is not, suggesting that small spines form silent synapses [2]. Small spines are also preferential sites for LTP [3]. The differential distribution of NMDA and AMPA receptors in small spines may reflect the abundance of binding partners for NMDA receptors in PSDs and the dependence of AMPA receptor function on F-actin [6].

The spine neck is a critical determinant of  $\text{Ca}^{2+}$  diffusion from the spine head into the dendritic shaft

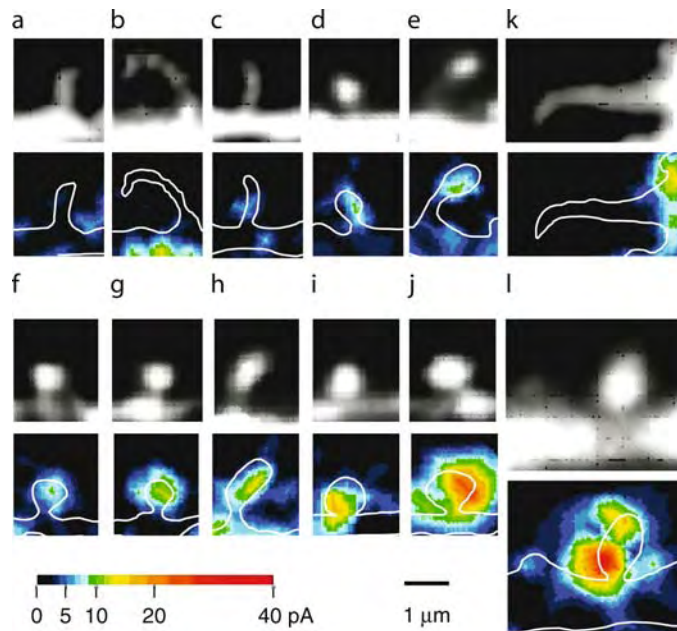

**Spine, Morphological Change. Figure 3** Spine geometry and expression of functional AMPA receptors. Fluorescence images (*upper panels*) and glutamate-sensitivity maps (*lower panels*) are shown for various dendritic spines of CA1 pyramidal neurons in fresh hippocampal slices prepared from adult (a–k) or 9-day-old (l) rats. The fluorescence profiles were obtained from stacked images containing the respective spine. The glutamate-sensitivity maps are based on AMPA receptor-mediated current, the amplitude of which is pseudocolor coded as indicated. The maps were smoothed by linear interpolation. White lines indicate the contours of dendritic structures. Representative data from thin spines (a–e), mushroom spines (f–j), and filopodia (k) are shown. Reproduced with permission from [8].

during NMDA receptor-mediated responses [2]. Furthermore, increases in the concentration of  $\text{Ca}^{2+}$  within spines are greater and more confined in those with a narrow neck. Given that the spine neck tends to be narrower in smaller spines (Fig. 2), increases in cytosolic  $\text{Ca}^{2+}$  concentration are larger and more confined in such spines, whereas they are smaller and spread into the parental dendritic shaft in large spines. The spine neck may also restrict the movement of large structures such as the spine apparatus and polyribosomes. In contrast, the diameter of even the smallest spine necks is not sufficiently small to substantially affect the propagation of excitatory postsynaptic currents.

NMDA receptor-dependent  $\text{Ca}^{2+}$  influx into the spine head induces enlargement of the head in a manner dependent on calmodulin and on actin polymerization [3]. The long-lasting phase of spine enlargement further requires the action of  $\text{Ca}^{2+}$ - and calmodulin-dependent protein kinase II. Spines also express metabotropic glutamate receptors and receptors for brain-derived neurotrophic factor (BDNF), which trigger the activation of various protein and lipid kinases (such as cyclic AMP-dependent protein kinase, protein kinase C, mitogen-activated protein kinase, phosphoinositide 3-kinase, and

Src), protein phosphatases (such as calcineurin), and small GTPases (Ras, Rap, Rac, Rho) as well as stimulate protein synthesis. Such intracellular signaling is thought to alter spine morphology through regulation of the actin cytoskeleton as well as exo- and endocytosis. Spine molecules thus regulate spine structures and vice versa. The reciprocal relationships between spine molecules and structures may underlie the high stability of spines in the brain, and their characterization is important for an understanding of spine function at the molecular level.

### Process Regulation

#### LTP and Dendritic Spines

LTP is induced at glutamatergic synapses on spines in an input-specific manner. In aspiny interneurons, however, LTP is either absent or spreads along dendrites [9]. Spines thus appear to support the induction and input specificity of LTP. Induction of LTP is input specific even at the level of the individual spine [3] as a result of the confined increase in cytosolic  $\text{Ca}^{2+}$  concentration within the spine head. LTP is associated with spine enlargement and actin polymerization, which results in accumulation of scaffold proteins and AMPA receptors through lateral diffusion and exocytotic insertion into the spine membrane.

Given that spine–head volume is correlated with AMPA receptor expression in the steady state [8], long-lasting plasticity would be expected to lead to an alteration of spine structure. The extent of immediate structural change, however, may be variable, depending on the specific synapse and experimental conditions. Structural plasticities of spines include phenomena other than LTP, since LTP is mainly associated with enlargement of small spines into medium-sized spines [3]. Such plasticities include the emergence of new filopodia or spines, reflecting the generation of new connections, and the maturation of large spines, reflecting the formation of highly stable connections.

### Function

The reason why spines are necessary for the function and plasticity of synapses in the brain awaits further investigation. It has long been thought that the persistence of memory traces in a biological system requires their storage in a structural form [10]. If this is the case, then the structure and density of spines appear well suited for the rapid induction and maintenance of memory at the highest density, in a manner that satisfies Hebb's learning principle.

### Pathology

Abnormalities in spine density or morphology, which are associated with various mental disorders, may partly reflect abnormal neuronal activities [7]. Dendritic spines, however, may be the primary sites of diseases, since mutations in proteins expressed in spines are identified in certain types of mental retardation [7]. Spine dysfunction likely underlies a broader range of mental disorders, given that glutamatergic synaptic transmission is impaired in many such conditions, including schizophrenia.

### References

- Harris KM, Stevens JK (1989) Dendritic spines of CA 1 pyramidal cells in the rat hippocampus: serial electron microscopy with reference to their biophysical characteristics. *J Neurosci* 9:2982–2997
- Noguchi J, Matsuzaki M, Ellis-Davies GCR, Kasai H (2005) Spine–neck geometry determines NMDA receptor-dependent  $Ca^{2+}$  signaling in dendrites. *Neuron* 46:609–622
- Matsuzaki M, Honkura N, Ellis-Davies GC, Kasai H (2004) Structural basis of long-term potentiation in single dendritic spines. *Nature* 429:761–766
- Trachtenberg JT, Chen BE, Knott GW, Feng G, Sanes JR, Welker E, Svoboda K (2002) Long-term in vivo imaging of experience-dependent synaptic plasticity in adult cortex. *Nature* 420:788–794
- Grutzendler J, Kasthuri N, Gan WB (2002) Long-term dendritic spine stability in the adult cortex. *Nature* 420:812–816
- Kasai H, Matsuzaki M, Noguchi J, Yasumatsu N, Nakahara H (2003) Structure–stability–function relationships of dendritic spines. *Trends Neurosci* 26:360–368

- Fiala JC, Spacek J, Harris KM (2002) Dendritic spine pathology: cause or consequence of neurological disorders? *Brain Res Rev* 39:29–54
- Matsuzaki M, Ellis-Davies GCR, Nemoto T, Miyashita Y, Iino M, Kasai H (2001) Dendritic spine geometry is critical for AMPA receptor expression in hippocampal CA1 pyramidal neurons. *Nat Neurosci* 4:1086–1092
- McBain CJ, Freund TF, Mody I (1999) Glutamatergic synapses onto hippocampal interneurons: precision timing without lasting plasticity. *Trends Neurosci* 22:228–235
- Hebb DO (1949) *The organization of behavior*. Wiley, New York

## Spines (Dendritic)

### Definition

Small protrusions of the dendrite with which an axon terminal forms a synapse.

- ▶ Spine
- ▶ Morphological Change

## Spinocerebellum

### Definition

Several classifications are used to subdivide the cerebellum based on anatomical, phylogenetic and functional (i. e. termination of cerebellar afferents and efferents) findings. The anterior and posterior parts of the vermis and paravermal parts of the cerebellar hemispheres were called spinocerebellum because of their spinal afferents. The spinocerebellum corresponds to the paleocerebellum based on phylogenetic and embryological studies.

- ▶ Cerebellum
- ▶ Cerebellar Functions
- ▶ Posture Role of Cerebellum

## Spinocervical Tract

### Definition

An ascending pathway that arises from neurons of the spinal dorsal horn and projects via the ipsilateral

dorsolateral columns to the lateral cervical nucleus located at the C1-C3 level of the spinal cord.

- ▶ Ascending Nociceptive Pathways
- ▶ Somatosensory Projections to the Central Nervous System

---

## Spinoreticular Tract

### Definition

Ascending somatosensory pathways that project and make synaptic connections within the reticular formation of the brainstem.

- ▶ Somatosensory Projections to the Central Nervous System

---

## Spinothalamic Tract

### Definition

The spinothalamic tract is a pathway that originates from neurons whose cell bodies are found in the dorsal horn, and their axons cross over within one or two segments and ascend within the ventrolateral white matter to the ventral posterior lateral nucleus of the thalamus. This is the classical pathway for transmission of nociceptive stimuli from visceral and somatic structures to areas of the brain via the thalamus that are involved with pain sensation.

- ▶ Ascending Nociceptive Pathways
- ▶ Thalamus

---

## SPL – Superior Parietal Lobule

### Definition

- ▶ Visual Space Representation for Reaching

---

## Splanchnic Afferents

- ▶ Visceral Afferents

---

## Spliceosome

### Definition

A protein complex of proteins that mediate the splicing reaction.

- ▶ Alternative Splicing and Glial Maturation

---

## Split Brain

### Definition

Neurological state of separated left and right ▶ hemispheres effected surgically by sectioning the ▶ corpus callosum and ▶ anterior commissure, often in patients with otherwise untreatable epilepsy. Split-brain patients present with neurological peculiarities yielding insights into the functional asymmetries between the two hemispheres.

- ▶ Corpus Callosum

---

## Split Rhythms

### Definition

A dissociation of circadian components induced by appropriate environmental conditions. In some species, exposure to constant light causes the usual 24 h activity/rest cycle to dissociate into two components. These “morning” (M) and “evening” (E) components run at slightly different periods before coupling in a stable (antiphase) relationship. In hamsters induced to split, clock gene expression in the left and right Suprachiasmatic nucleus (SCN) assume an antiphase relationship as well. Related dissociations, which may not be mechanistically similar, may be induced by exposure to ultradian (much shorter than 24 h) light-dark cycles or to light-dark cycles with periods at the limits of entrainment for the organism. This latter type of dissociation may involve one oscillator that entrains to the light-dark cycle and another that is unable to entrain and therefore essentially free-runs.

- ▶ Circadian Rhythm
- ▶ Clock Genes
- ▶ Suprachiasmatic Nucleus



## Spontaneous Activity

Barrages of action potential electrical discharges that do not bear any obvious relationship to brain activities such as sensory information processing or movement generation.

## Spontaneous Internal Desynchronization

### Definition

Loss of synchrony between two or more endogenous circadian rhythms, originally defined to describe dissociation between the sleep-wake cycle and the body temperature cycle in humans maintained in temporal isolation.

- ▶ Circadian Rhythm
- ▶ Internal Desynchrony
- ▶ Sleep-wake Cycle

## Spontaneous Recovery

### Definition

The re-emergence of conditioned responses after the passage of time following extinction training.

- ▶ Learning and Extinction

## Spontaneous Saccades

### Definition

Saccadic eye movements that are made with no apparent incentive and with no obvious external stimuli.

- ▶ Saccade, Saccadic Eye Movement

## Sprouting

### Definition

Growth of nerve fiber to form new synaptic connections. One trigger for sprouting at the neuromuscular junction is loss of synaptic activity.

- ▶ Neuromuscular Junction

## SRBN Type II

### Definition

Superior colliculus (SC) neurons characterized by activity which increases about 80–100 ms before the onset of the saccade, reaches a peak value that precedes saccade onset by 10–20 ms, and then wanes. They correspond to the more recently described build-up neurons (BUNs).

- ▶ Saccade, Saccadic Eye Movement
- ▶ Superior Colliculus
- ▶ SC – Tectal Long-Lead Burst Neurons

## Src

### Definition

A non-receptor tyrosine cytoplasmic kinase that can transfer a phosphate group from ATP to tyrosine residues of target proteins.

## Src Homology Domain

### Definition

A protein domain first identified as a conserved sequence in Src. This domain in a protein allows it to interact with phosphorylated tyrosine residues of other proteins.

## SSDR

### Definition

► Species-specific Defense Reaction

## SSP

### Definition

► Subacute Sclerosing Panencephalitis

## Stability

### Definition

A system is said to be stable if it returns to some equilibrium condition after it is perturbed.

► Control

## Stabilography

► Stabilometry

## Stabilometry

LORENZO CHIARI

Dipartimento di Elettronica, Informatica e Sistemistica,  
Alma Mater Studiorum – Università di Bologna,  
Bologna, Italia

### Synonyms

Static posturography; Stabilography; Computerized stabilometry

### Definition

Stabilometry is the objective study of body sway during quiet standing, i.e., stance in the absence of any

voluntary movements or external perturbations. Conventionally, the study focuses on the properties of body sway during upright standing, thus far primarily measured by means of force plates. Sometimes, upper body sway is studied in sitting postures.

### Purpose

Stabilometry aims at collecting information indicative of the steady-state functioning of the postural control system, and of its success in stabilizing the body against gravity, by examining the properties of measures, directly or indirectly related with ►postural sway.

### Principles

Stabilometry is a valid, objective and functional evaluation of the postural control system in its steady-state behavior [1]. Quiet, upright stance is the basic, representative posture that is traditionally investigated in stabilometry although a few studies concentrate on sitting postures.

During the test, the subject is asked to stand upright in a stationary environment where, depending on the protocol, one or more sensory afferences can be made unavailable or manipulated. Upright stance is inherently unstable. Small deviations from an upright body position result in a gravity-induced torque acting on the body, causing it to accelerate further away from the upright position. Many muscles become tonically and phasically active, in a largely automatic way, to generate appropriate, corrective torques to oppose the destabilizing torque due to gravity. As a result of such an active process, even when visual, somatosensory, and vestibular systems are all active, a standing individual will sway slightly. This sway will increase, as sensory input is distorted or removed, as it may happen, e.g., (i) when vision is not available or is sway-referenced, (ii) when the support surface is compliant or sway-referenced, and (iii) when vestibular information is distorted. Similarly, this sway will decrease, when (i) sensory input is augmented or reinforced, (ii) by repetitive balance training, (iii) by an artificial biofeedback device, or (iv) by threat of a fall.

Postural sway during quiet standing reflects this interplay between gravity destabilizing the body and actions by the postural control system to prevent a loss of balance, and can be modeled with an inverted pendulum model of the body [2]. The regulatory mechanisms underlying postural sway are not fully understood yet, and controversy remains regarding the organization of sensory and motor systems contributing to spontaneous sway.

Balance impairments caused by altered sensory, motor, or central nervous function related to such factors such as older age and pathology (e.g., cerebellar ataxia, peripheral neuropathy, Parkinson's disease) will be reflected in characteristic, altered characteristics of postural sway [3–4]. The influence of different factors on postural sway

during quiet standing has been the focus of much clinical and basic scientific study.

Due to its complexity, the postural control system is challenging to measure with simple methods, although simple methods are needed, especially in clinical practice. Since a direct, multisegmental analysis of postural sway during stance may require complex kinematic trackers such as motion analysis systems, postural sway is most often described indirectly by the fluctuations of the **center of pressure (COP)** on the ground, measured with a force platform. By means of a set of mechano-electrical force transducers (strain gages or piezoelectric crystals), force platforms act as dynamometers and record the interaction between the feet and the ground, i.e., the ground-reaction, and the COP. Ground-reaction force and COP are related to postural sway, more precisely, to the motion of the body **center of mass (COM)**, and consequently provide important insights into the process of controlling balance [2]. In the future, portable systems, based on miniaturized, inertial sensors (accelerometers, gyroscopes), may allow a direct, multisegmental analysis of body sway. Several studies are in progress to determine procedures to make measurement of sway with portable inertial sensors robust and valid [5].

The vast majority of studies in stabilometry have been limited to force plate studies using only one force platform. In that case, the COP reflects the net effect of the ankle muscles and the loading/unloading of each limb [2] as well as the movement of the COM of the entire body, and displays as a random-looking pattern when its antero-posterior (AP) coordinates are plotted against its medio-lateral (ML) coordinates. This plot is commonly referred to as statokinesigram

(Fig. 1a). Alternatively, each COP coordinate can be represented as a function of time, to obtain the so-called stabilograms (Fig. 1b) [1].

If two force platforms are available, one for each foot, distinct left and right COP displacements can be measured (Fig. 1a) [2]. Since the ankle muscles are important controllers of the COP, the location of the COP under each foot is an outcome from concerted efforts of the ipsilateral, individual ankle muscles. Increasing plantarflexor activity (e.g., triceps surae, peroneii) moves the COP anteriorly; increasing dorsiflexor activity (e.g., tibialis anterior) moves the COP posteriorly. Increasing invertors' activity (e.g., triceps surae, tibialis anterior and posterior) moves the COP laterally; increasing evertors' activity (e.g., peroneii) moves the COP medially. Individual ankle muscle actions on the COP can be investigated through in-vitro studies [6] that demonstrated that the calf (plantarflexor group) is the most efficient COP controller in the anterior direction, while the tibialis anterior muscle and dorsiflexor group are the major COP controllers in the posterior direction. Two force platforms also disclose the lateral loading and unloading mechanism, and the consequent pressure modulation under each foot, controlled by the activity of the hip abductor/adductor muscles (e.g., tensor fascia latae, gluteus maximus, semimembranosus). In this case, the location of the total body COP either in the AP or ML directions can be computed by using Varignon's theorem that states that in equivalent force systems the sum of moments equals the moment of the resultant.

Several methods exist to describe postural sway using the COP statokinesigram and/or stabilograms. In general, measures that are most commonly used are

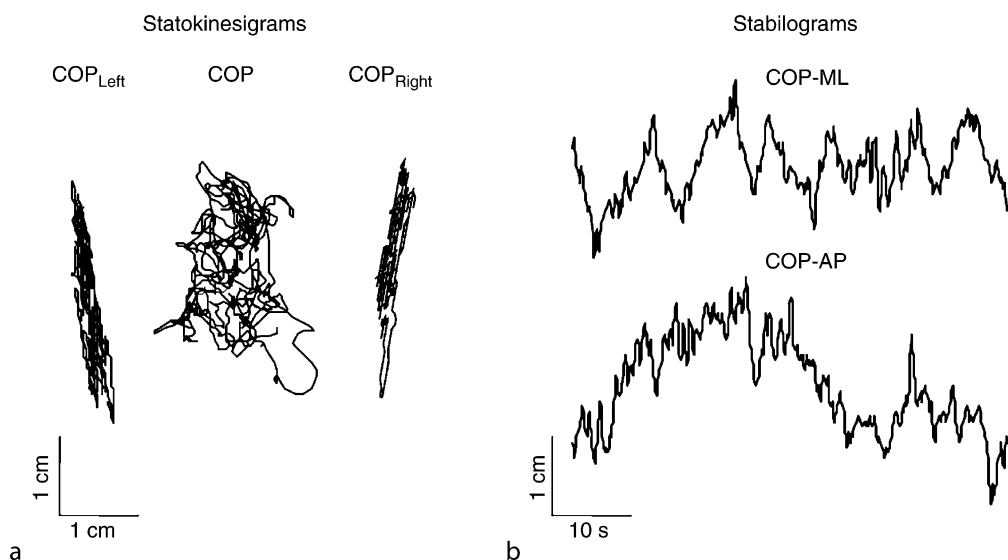

**Stabilometry. Figure 1** Representative quiet stance recordings through a force platform. (a) AP vs ML coordinates of the COP in presence of a two force platform set-up (COP<sub>Left</sub>, COP<sub>Right</sub>) and resultant, whole-body COP. (b) Time series of ML and AP coordinates of whole-body COP.

those that describe statistical properties of the COP, treated as a stationary signal, in the time and frequency domain [7]. Time domain measures estimate a parameter associated with either the displacement (expressed in mm) or the velocity of the COP trace, and include parameters such as: mean distance from average COP position (mm), root mean square distance from average COP position (mm), total distance traveled by the COP (mm), peak-to-peak COP displacement (mm), mean velocity of the COP (mm/s), area of the 95% confidence circle or ellipse (mm<sup>2</sup>), swept area (mm<sup>2</sup>/s).

Frequency domain measures characterize the power spectral density of the COP, and include parameters as: total power (mm<sup>2</sup>), power in selected bandwidths (mm<sup>2</sup>), median frequency (Hz), 95% power frequency (Hz), centroidal frequency (Hz), frequency dispersion (dimensionless).

Many studies in force platform stabilometry characterized postural sway based on a single COP-based measure, but more recent studies usually include multiple measures [4,7]. Depending on the cause of the postural instability, velocity-related measures were often reported to separate stable postural control from reduced stability better than displacement-related measures [4,8]. No general rule of thumb is available, however, to select the best subset of measures needed in force platform stabilometry. Since many and varied sway measures exist, feature selection has to be preliminary performed to keep only independent measures and avoid redundancy, make statistical analyses stronger, and facilitate interpretation of the results.

The ideal set of measures to recommend for practical use should be minimally influenced by spurious sources of within- (e.g., non-stationarity, fatigue) and between-subject variability (e.g., anthropometry) that may peculiarly influence the characteristics of the COP. In addition, selected measures should be sufficiently sensitive to changes in hypothesized physiological determinants of postural sway and hence able to identify actual, significant changes in posture control across patients' or treatments' groups or across experimental conditions [9]. Several recent studies, using different methodologies, have recommended and justify different subsets of three to four COP-based measures, e.g., see [8].

Interestingly, COP displacements during quiet stance display a fractal behavior. This important property, common to many physiological processes, can be expressed in terms of statistical self-similarity. Such self-similarity implies that there is a scaling relationship describing how the measured value of a statistical property depends on the scale in which it is measured. The simplest scaling relationship determined by self-similarity has a power law form, leading to a straight line on log-log plots.

In the analysis of COP experimental data, the existence of scaling comes to light, for example, if the

variance of the displacements (i.e., the distances between consecutive points of the statokinesigram) is examined over different time scales. One main implication of fractality is that scaling functions that describe how the values change with the resolution tells more about the data than the value of the measurement at any one resolution (in particular, at the higher resolution as it is commonly done by the summary statistic scores, working with the original sampled time series). For this reason, to obtain more significant parameters about the postural control system, techniques postulating the time-scale dependence of COP statistical properties have been proposed [10]. These techniques show that COP fluctuations have a structure that is dependent upon the time-scale of observation and not simply random. This result was interpreted by proposing different modes of postural control taking place over different periods of time and opened the way to more sophisticated tools in postural sway analysis.

### Advantages and Disadvantages

Platform stabilometry is a simple and easy tool to objectively investigate the function of the postural control system in its steady-state behavior. To date, stabilometry undoubtedly suffers, however, from several limiting factors including (i) the absence of a definite "normal pattern"; (ii) the lack of standardization in the measurement protocols; (iii) the large number of highly coupled variables that are computed from the force platform recordings.

Most COP-based measures have in common a medium to large variability, both between- and within-subjects, and this may be a limiting factor when wishing to determine whether a postural performance is abnormal or whether it is sensitive to change from a treatment or a therapy [1,9]. The inherent variability of such measures in normal subjects has been the object of several studies. Within-subject variability has been partially explained by a learning effect that leads to an optimization of the energy expenditure by means of a progressive reduction in body sway over repeated trials. The large between-subject differences prevents defining normative values for stabilometric parameters [1]. This is a major restriction of stabilometry, which limits its routine use in clinical practice or as a first-level examination of postural control. For this reason, it is important to cope with all the potential sources of spurious variability that may mask or overwhelm control-related information. To this aim, first, a significant role can be ascribed to inconsistencies in the measurement procedure (between experimental sessions within the same lab and, more so, between different laboratories) including, e.g., reproducibility of the experimental protocol such as foot placement and duration of testing, environmental conditions, random errors, and signal processing. A second source of

variability is related to the intrinsic differences between subjects in terms of their biomechanics. Subject morphology, together with joints and muscle function, has been identified, in a systems approach, as the main biomechanical factors involved in balance control. Body size and foot placement are known to influence postural stability and their impact on COP-based measures can be at least partly removed through normalization [9].

## References

1. Kapteyn TS, Bles W, Njikiktjien CJ, Kodde L, Massen CH, Mol JM (1983) Standardization in platform stabilometry being a part of posturography. *Agressologie* 24:321–326
2. Winter DA (1995) Human balance and posture control during standing and walking. *Gait Posture* 3:193–214
3. Diener HC, Dichgans J, Bacher M, Gompf B (1984) Quantification of postural sway in normals and patients with cerebellar diseases. *Electroencephalogr Clin Neurophysiol* 57:134–142
4. Rocchi L, Chiari L, Horak FB (2002) Effects of deep brain stimulation and levodopa on postural sway in Parkinson's disease. *J Neurol Neurosurg Psychiatr* 73:267–274
5. Mayagoitia RE, Lotters JC, Veltink PH, Hermens H (2002) Standing balance evaluation using a triaxial accelerometer. *Gait Posture* 16:55–59
6. Kim K, Uchiyama E, Kitaoka HB, An K (2003) An in vitro study of individual ankle muscle actions on the center of pressure. *Gait Posture* 17:125–131
7. Prieto TE, Myklebust JB, Hoffman RG, Lovett EG, Myklebust BM (1996) Measures of postural steadiness: differences between healthy young and elderly adults. *IEEE Trans Biomed Eng* 43:956–966
8. Maurer C, Peterka RJ (2005) A new interpretation of spontaneous sway measures based on a simple model of human postural control. *J Neurophysiol* 93:189–200
9. Chiari L, Rocchi L, Cappello A (2002) Stabilometric parameters are affected by anthropometry and foot placement. *Clin Biomech* 17:666–677
10. Collins JJ, De Luca CJ (1993) Open-loop and closed-loop control of posture: a random-walk analysis of center-of-pressure trajectories. *Exp Brain Res* 95:308–318

## Stain

### Definition

A stain is any number of chemical compounds which when applied to tissue appropriately will color cellular components. Thus details of particular cellular structure can be studied under a microscope. A variety of stains are used to study nerve tissue. Some, such as Nissl stains, mark cytoplasmic detail and show cell bodies. Others, such as the Weigert stains, mark the myelin and

show myelinated axons. Still others, such as Nauta silver stains, show axons and their terminals, while Golgi stains show a few neurons in their entirety.

## Staircase Method

### Definition

A psychophysical procedure by which the stimulus intensity is changed according to an observer's response to bracket the threshold; an interactive variant of the method of limits.

### ► Psychophysics

## Standing Wave

### Definition

A periodic wave having a fixed distribution in space that is the result of interference. Such waves are characterized by the existence of nodes and antinodes that are fixed in space.

### ► Acoustics

## Stapedius Muscle

### Definition

One of two muscles in the middle ear of mammals that is involved in the middle ear muscle reflex. (The other middle ear muscle is the tensor tympani muscle.) The stapedius muscle arises from the auditory tube and inserts onto the stapes, or stirrup, which is the middle ear bone directly connected to the round window of the inner ear. The stapedius muscle is innervated by the facial nerve. Its contractions dampen sound-induced oscillations of middle ear bones and reduce sound amplitude, thus protecting the ear from intense sound signals.

### ► Auditory-Motor Interactions

## Starburst Amacrine Cell

### Definition

Retinal interneuron with a characteristic, radially symmetrical dendritic morphology that functionally participates in the propagation of  $\text{Ca}^{2+}$  waves in the developing retina and in the generation of direction selectivity in the adult.

► [Retinal Direction Selectivity: Role of Starburst Amacrine Cells](#)

## Start Codon

### Definition

A trinucleotide sequence within the mRNA that initiates RNA translation. The usual start codon is ATG in DNA.

## Starting Phase

### Definition

The point in time at which a sound wave starts relative to the period of the sound wave, expressed in degrees or radians.

► [Acoustics](#)

## Startle Response

JOSEPH R. FETCHO

Department of Neurobiology and Behavior, Cornell University, Ithaca, NY, USA

### Synonyms

Escape behavior

### Definition

Startle responses are rapid movements that occur very quickly following an abrupt, unexpected, strong

sensory stimulus, such as a loud sound produced by a slamming door. Startle or escape responses are shared by almost all animals, including both invertebrates and vertebrates [1]. In many cases, they are thought to serve protective functions such as avoiding the attack of predators. The form of the response varies across species. In humans, it usually consists of closing of the eyes and a hunching of the head and body. Extension of the legs in some mammals can lead to a jumping movement that might serve to move the animal away from an attacking predator. In fish, the startle (escape) response involves a rapid bend of the body that turns the fish away from the stimulus. This is usually followed by rapid swimming to avoid capture by a potential predator. In invertebrates, startle might consist of a rapid jump followed by flight in a fly, or a tail flip in a crayfish.

### Characteristics

#### Quantitative Description

Perhaps the most characteristic feature of a startle response is the very short time between the stimulus and the start of the movement. This occurs in about 14 milliseconds (ms) in humans, 10 ms in rats and as little as 5 ms in larval fish [1]. Typically, the magnitude of the response is measured as the force or amplitude of the movement. In mammals, such as rats, this is accomplished by measuring the force generated by limb movements in specialized cages fitted with accelerometers. In fish, the angular velocity and magnitude of the bending of the body are measured using high-speed imaging because the movements are very fast. Startle responses can vary in magnitude depending upon the strength of the stimulus and its source, as well as the history of exposure to other stimuli. For example, responses are increased following induction of fearful states and are reduced in amplitude following prior exposure to a weak stimulus that does not elicit a startle response [2].

### Higher Level Structures

Startle responses are typically produced by relatively large, fast conducting neurons. These are the giant neurons in invertebrate systems such as flies, crayfish, and squid. In vertebrates, the cell bodies of the giant neurons are in the hindbrain ► [reticular formation](#) and their axons have outputs in the brain and spinal cord. There are relatively few of these neurons in fishes and amphibians, where they include the well-studied giant ► [Mauthner cells](#) [3]. A larger number of neurons located in the ► [caudal pontine reticular nucleus](#) in the hindbrain mediates the startle response in mammals [4]. Among vertebrates, the pathways for sound elicited startle responses are strikingly similar, with very short pathways from the ear to giant neurons in the hindbrain,

and direct pathways from hindbrain to motoneurons and interneurons in the spinal cord.

### Lower Level Components

Startle or escape responses typically engage local circuits controlling a variety of muscle groups, including muscles in the head responsible for eye blinks and jaw clenching, as well as axial (trunk) and limb muscles. Some of the networks for these circuits have been well described in fishes and invertebrates where the giant neurons connect directly to motoneurons, as well as to excitatory interneurons that drive motoneurons and inhibitory interneurons that control antagonistic muscle groups [5,6]. Evidence from mammals indicates similar patterns of output to local motor circuits in the head and spinal cord [4].

### Structural Regulation

The patterns of recruitment of the giant hindbrain neurons vary in conjunction with variation of the behavior. This is best documented in fishes, where the form of the escape response varies depending upon the source of the sensory stimulus that elicits it [7]. This variation is associated with different patterns of activation of the giant neurons in the hindbrain [8]. The gradations of the magnitude of escape responses in mammals are also likely to be a consequence of changing patterns of recruitment of hindbrain neurons, because reductions of the number of neurons in lesioning experiments is associated with a reduction in response amplitude [9].

### Higher Level Processes

The rapid nature of the startle response is reflected in a circuit designed for speed. There are only a few neurons in the path from sensory input to initial motor output – four in the pathway for auditory startle in fish and five in mammals. These pathways generally contain ►**electrical synapses**, which are associated with speed and synchronous activation of circuits. The giant neurons in the hindbrain of vertebrates also have some of the largest and fastest conducting axons in the central nervous system, designed to quickly relay the sensory signals to the spinal cord to produce a motor response.

### Lower Level Processes

The rapid, powerful drive to the spinal cord is associated with a large pulse of activation in muscles that results from a synchronous activation of motoneurons. This may be important for overwhelming any ongoing muscle activity that might interfere with initiation of the startle or escape response.

### Process Regulation

The magnitude of the startle/escape responses changes in conjunction with prior experience. Most notably, the

response shows simple forms of learning such as ►**habituation** and ►**sensitization** [2]. Cellular data indicate that there is plasticity of synaptic connections onto the giant neurons in the form of ►**long term potentiation** and ►**long term depression**, which might underlie the simple forms of learning associated with the response [3]. Innervation of giant neurons by ►**serotonergic and dopaminergic systems** is consistent with evidence that changing levels of serotonin and dopamine can alter the startle response, with serotonin usually attenuating responses and dopamine elevating them [2]. Importantly, the startle response shows ►**prepulse inhibition**, with a reduced startle response to a strong stimulus when it follows a stimulus too weak to elicit a startle. Prepulse inhibition occurs broadly among species. In invertebrates, a neuron that produces it by ►**presynaptic inhibition** of sensory neurons has recently been identified [10]. As many neuropsychiatric diseases are associated with disruption of serotonergic and dopaminergic modulatory systems or with changes in prepulse inhibition, the startle system is becoming a model for identifying genes that might underlie diseases of the brain [11].

### Function

Startle or escape responses appear to serve a protective function that is most obvious in invertebrate animals and aquatic vertebrates, where the circuits are recruited in response to predatory attacks. A similar anti-predatory role might occur in quadrupedal mammals. In humans, the function is less obvious, although the tensing of the body and the closing of the eyes in response to a loud sound might serve to protect the body from possible injury, as these sounds might naturally occur in hazardous situations produced by breaking or falling objects such as rocks and branches.

### Pathology

Abnormal prepulse inhibition of the startle response is associated with neurological disorders including ►**schizophrenia**, obsessive-compulsive disorder, and ►**Huntington's disease** [11]. Some of these deficits are thought to result from problems in the control of the flow of sensory information through central circuits to motor output – a process called sensorimotor gating. This has led to studies of deficits in prepulse inhibition of startle in genetic models such as mice, as a tool to identify the genetic basis of neuropsychiatric diseases [11]. Mutations in receptors and transporters involved in serotonergic and dopaminergic transmission alter prepulse inhibition of the startle response and also contribute to psychiatric disorders. Exaggerated startle responses and a lack of habituation are associated with a disorder called hyperekplexia, or familial startle disease, which occurs as a consequence of a mutation

in the alpha subunit of the glycine receptor [12]. This is consistent with the known important role of inhibitory pathways in controlling startle responses and in sensorimotor gating more generally.

### Therapy

Drugs that are known to alter serotonergic and dopaminergic transmission also have effects on startle behavior. The known circuitry and reproducible responses of the startle behavior, make it a good system for testing the effects of drugs that might serve to alleviate the neuropsychiatric disorders associated with changes in startle pathways [13]. Drugs that improve deficits in startle responses in animals or humans might also alleviate the more severe neuropsychiatric symptoms associated with these deficits.

### References

1. Eaton RC (ed) (1984) Neural mechanisms of startle behavior. Plenum, New York, p 377
2. Davis M (1984) The mammalian startle response, in Neural Mechanisms of Startle Behavior. In: Eaton RC (ed) Plenum, New York, pp 287–351
3. Zottoli SJ, Faber DS (2000) The mauthner cell: what has it taught us? *Neuroscientist* 6(1):25–37
4. Lingenhohl K, Friauf E (1994) Giant neurons in the rat reticular formation: A sensorimotor interface in the elementary acoustic startle circuit. *J Neurosci* 14:1176–1194
5. Edwards DH, Heitler WJ, Krasne FB (1999) Fifty years of a command neuron: the neurobiology of escape behavior in the crayfish. *Trends Neurosci* 22(4):153–161
6. Fetcho JR, Faber DS (1988) Identification of motoneurons and interneurons in the spinal network for escapes initiated by the Mauthner cell in goldfish. *J Neurosci* 8:4192–4213
7. Eaton RC, Emberley DS (1991) DS How stimulus direction determines the trajectory of the Mauthner initiated escape response. *J Exp Biol* 161:469–487
8. O'Malley DM, Kao YH, Fetcho JR (1996) Imaging the functional organization of zebrafish hindbrain segments during escape behaviors. *Neuron* 17:1145–1155
9. Koch M, Lingenhohl K, Pilz PKD (1992) Loss of the acoustic startle response following neurotoxic lesions of the caudal pontine reticular formation: possible role of giant neurons. *Neuroscience* 49:617–625
10. Frost WN et al. (2003) A cellular mechanism for prepulse inhibition. *Neuron* 40(5):991–1001
11. Geyer MA, McIlwain KL, Paylor R (2002) Mouse genetic models for prepulse inhibition: an early review. *Mol Psychiatry* 7(10):1039–1053
12. Shiang R et al. (1993) Mutations in the alpha 1 subunit of the inhibitory glycine receptor cause the dominant neurologic disorder, hyperekplexia. *Nat Genet* 5(4):351–358
13. Kumari V, Sharma T (2002) Effects of typical and atypical antipsychotics on prepulse inhibition in schizophrenia: a critical evaluation of current evidence and directions for future research. *Psychopharmacology (Berl)* 162(2):97–101

## State

### Definition

Particulars can be in different states. “State” can mean a state token, e.g. a concrete occurrence of molecular motion in a body or of a neural activity in a person’s brain. Alternatively, “state” can mean a state type. This is either a property that can be shared by several things or persons, such as being hot or being in pain, or a kind of state tokens, such as a certain kind of molecular motion or neural activity. In control theory, a state is defined by a collection of variables that describes system behavior. Present state, together with the future inputs to the system, uniquely determines future states.

- ▶ Argument
- ▶ Control
- ▶ Logic

## State, Functional

### Definition

A functional state is a higher-order property of a particular system: the property of being in some inner state or other that plays a certain functional role, i.e. that bears certain (causal) relations to outer affections of the system (inputs), its outer behavior (outputs), and to other inner states. Different systems can be in the same functional state, although the inner states that play the functional role in question radically differ in nature.

- ▶ Argument
- ▶ Logic

## State, Mental

### Definition

A mental state is a state of the kind that is typically attributed by mental predicates such as “is in pain” or “believes that it is raining.” In a narrow sense, only



long-term mental attitudes like beliefs (Belief) or desires are states. But mental events (sensations, feelings, thoughts) (Consciousness) are called states, too. Mental states may be physical states (identity theory), functional states (ontological functionalism), or sui generis (dualism).

- ▶ Argument
- ▶ Logic

---

## State, Physical

### Definition

States that can be attributed by a detailed description in the language of the physical sciences are physical states. If a state is of the same kind as these, it counts as physical even if that particular state cannot be described by current science. In a very narrow sense, only states describable by physics are physical. When contrasted with mental states, “physical state” often means “a state that is either physical or functional or a mixture thereof.

- ▶ Argument
- ▶ Logic
- ▶ State, Functional

---

## State, Representational

### Definition

Postulating representational states in order to account for a certain psychological achievement carries two main commitments: different representational states can occur independently of each other, and only their contents and functional roles, but not their intrinsic natures are of mental significance. It is often further assumed that such states form sentencelike or image-like complexes and that they are related to their contents one by one rather than holistically.

- ▶ Argument
- ▶ Logic
- ▶ State, Functional

---

## State Estimation

### Definition

The process of estimating the plant state from sensory feedback and knowledge of the plant dynamics and effector activations.

- ▶ Neural Networks for Control

---

## State of Activation

### Definition

Theory that states that the modulation of GABAergic synaptic connections between nucleus tractus solitarii (NTS) and dorsal motor nucleus of the vagus (DMV) is controlled by the levels of cAMP (cyclic AMP) in the NTS terminals. In “resting” conditions, the GABAergic synapse is unresponsive to neuromodulators, when the levels of cAMP are increased by hormones released following a meal, the synaptic connection is “primed” and available to modulation.

- ▶ Cyclic AMP
- ▶ Nucleus Tractus Solitarii
- ▶ Dorsal Motor Nucleus of the Vagus (DMV)
- ▶ GABA

---

## State of Affairs

### Definition

A situation, something that might be the case, if a state of affairs obtains it becomes a fact.

- ▶ Possible World

---

## State Space

### Definition

The space, which contains all the possible states of a system, e.g. all the possible values of its variables.

- ▶ Signals and Systems

## State Variables (SVs)

### Definition

Express relationships inherent in natural laws (e.g., forces and kinematic variables in Newton's laws of motion); any variables that cannot be changed independently of SVs (e.g., in the intact neuromuscular system, stiffness, damping, and the magnitude of muscle activation since they are coupled to changes in muscle force, a SV); constrained by natural laws, can only be changed indirectly by neural control levels, by regulating control variables.

► Equilibrium Point Control

for the receptor to signal the persistence of a (constant) stimulus, for some time after stimulus onset. Dynamic sensitivity describes the capacity for the receptor to signal when the stimulus intensity changes over time.

► Autonomic Control of Sensory Receptors  
► Sensory Systems

## Static

### Definition

Static implies that there are no changes over time (*i.e.*, a steady-state has been reached). For skeletal muscle, static refers to the state when no length or force changes are occurring.

## Static Posturography

► Stabilometry

## Static (Steady-State) Stiffness

### Definition

The proportionality constant that relates the change in force (or torque), produced by displacement from an initial stationary position to a final stationary position, to the displacement.

► Impedance Control

## Static Air Pressure

### Definition

The air pressure at a point in space that would exist in the absence of sound waves.

► Acoustics

## Statics

MARCELO EPSTEIN

Schulich School of Engineering, University of Calgary, Calgary, AB, Canada

### Definition

Statics is the science of equilibrium.

## Static and Dynamic Sensitivity of Sensory Receptors

### Definition

Static and dynamic sensitivity are qualitative terms aimed to characterize the sensory receptor response to external stimuli. Static sensitivity describes the capacity

### Description of the Theory

The fundamental equations of ►mechanics (q.v.) are differential equations, whose solution determines the motion of a mechanical system. A mechanical system is said to be in *equilibrium* if there exists an inertial frame for which the motion vanishes identically. In all other inertial frames, therefore, the motion can at most consist of a uniform translation, namely, each and every particle of the system moves with a constant ►velocity, equal

for all particles. A useful subdivision of classical mechanics from this point of view is into *statics* (the science of equilibrium) and *dynamics* (the science of motion). Although the first is clearly a particular case of the second, it is useful sometimes to regard it as an independent discipline. This point of view not only facilitates the treatment for those many applications in which motion is not of interest, but it also provides an intuitive basis to regard, somewhat paradoxically, dynamics as a particular case of statics, whereby the so-called *forces of inertia* are brought to bear.

The concept of equilibrium applies equally well to classical mechanics (q.v.) and to continuum mechanics (q.v.). This article will however, concentrate on the statics of a rigid body, leaving for the article on the [▶principle of virtual work](#) (q.v.) a re-consideration of statics from a more general point of view. The first task is to obtain a set of necessary conditions for the equilibrium of a rigid body. Since, by definition, equilibrium can be regarded as the absence of motion (in an inertial frame), a direct application of Eqs. 6 and 7 of [▶Newtonian mechanics](#) (q.v.) yields the following two vectorial *equilibrium equations*:

$$\mathbf{F}^{ext} = \mathbf{0}, \tag{1}$$

and

$$\mathbf{M}_0^{ext} = \mathbf{0}. \tag{2}$$

In words, a necessary condition for the equilibrium of a rigid body is that the sum of all the external forces and the sum of all the moments of the external forces with respect to a fixed point be equal to zero. Notice that, while [Eq. 1](#) guarantees that the center of mass of the system will move at a constant velocity, the satisfaction of [Eq. 2](#) is not sufficient to guarantee that the rigid body will be at rest from the rotational point of view. It is only for this reason that these equations are not also sufficient for equilibrium. To guarantee equilibrium, at some instant of time the angular velocity vector must vanish. From the point of view of statics as an independent discipline, however, these two vectorial equations are considered as the very definition of equilibrium.

Considering a system of rigid bodies interconnected perhaps by means of joints (such as the skeletal system), it is possible to mentally split this system into its component members (each bone, say) and to draw a *free-body diagram* of each member. This diagram must include not only the external forces directly applied to the member (such as weight, ground reaction, etc.), but also the forces transmitted by the other members from which it has been detached (joint forces and muscle forces transmitted through tendons and ligaments, for example). It is to the totality of these forces that [Eqs. 1](#) and [2](#) are to be applied, resulting in a system of six *algebraic* equations for each member, involving just the forces and the geometry of the system. A system is called *statically determinate* if the

number of equations obtained in this way is exactly equal to the number of the statical unknown quantities of the problem. These statical unknowns usually represent the forces of interaction (such as muscle and joint forces and ground reaction forces). If the number of statical unknown quantities is larger than the number of equations of statics, the system is said to be *statically indeterminate* and its solution will in general fall into the domain of continuum mechanics (q.v.) or require the incorporation of extra information (conveying, for example, the assumed *force sharing* conditions of agonistic muscles). Cases in which the number of equations of statics is larger than the number of statical unknown quantities (*statical under-determinacy*) may also occur, indicating that there are extra conditions to be satisfied between the geometry and the applied forces. To illustrate the various situations just described, the simple example of a two-bone planar system may suffice (e.g., the femur and the tibia). The planarity of the system manifests itself in the assumption that all forces involved belong to the plane in which the system is assumed to be constrained to move. Assume that the bones are rigid and that they are connected by an ideal frictionless hinge (the knee, say). Assume, moreover, that one of the bones is hinged at the other end to a fixed joint (e.g., a fixed hip). Assuming the plane of the system to be identified with an *x-y* coordinate plane, [Eq. 1](#) reduces, for each bone, to two scalar equations (the sum of the *x*- and *y*- components of the external forces, respectively, equal to zero), while [Eq. 2](#) becomes a single scalar equation (the sum of the *z*-components of the moments equal to zero), the other component equations vanishing trivially by the assumed planarity of the system. There is thus a total of six equations of statics, three for each member. Considering first the case in which there are no muscles involved and the system is subjected just to its own weight (hanging, as it were, as a skeleton in the closet), the unknown quantities are: the angular deviations of each bone from the vertical position (two quantities), the reaction force at the hip (two quantities) and the interaction force at the knee (two quantities). When drawing the free-body diagrams, the interaction force at the knee will appear in each of the diagrams, with opposite senses, as required by Newton's third law, the so-called principle of action and reaction (see the article on Newtonian mechanics). The system is, therefore, statically under-determinate, indicating that the geometry of the system is to be determined as part of the solution. It has, in fact, two solutions, only one of which (the one corresponding to the bones lying vertically directly *under* the hip) is stable. Assume now that the bones are connected by a single muscle, which is assumed to be perfectly articulated at the points of insertion. For simplicity, also assume that the muscle is of a known length (say, when fully activated). There is now a situation in which the bone-muscle system forms roughly the shape of the letter *A*, hanging from the hip. Again, the



system is statically under-determined, although less so than before. The number of static unknowns has increased by one (the internal force in the muscle), while the number of geometrical unknowns has decreased by one. Suppose now that the free end of the tibia rests, in a frictionless manner, on the ground, thus eliciting a vertical reaction (assuming the ground to be below the hip at a distance strictly smaller than the sum of the lengths of the bones). The system becomes statically determined, its geometry being completely prescribed by the data. (There are actually four geometric ►[configurations](#) compatible with the given data). Suppose now that the free end of the tibia is anchored to the ground, by means of an ideal hinge, thus requiring both a horizontal and a vertical component of the ground reaction. The system becomes statically indeterminate. The static indeterminacy can be exacerbated by adding more muscles in parallel with the one already in place.

As mentioned above, the idea of free-body diagram can be also applied beyond the domain of statics to derive the equations of motion of a system by incorporating the forces of inertia. This point of view, sometimes called ►[D'Alembert's principle](#), requires that the right-hand sides of Eqs. 6 and 7 of Newtonian mechanics (q.v.) be regarded as some kind of negative external forces and moments. Defining, therefore,  $\mathbf{F}_{inertia}^{ext} = -\dot{\mathbf{P}}$  and  $\mathbf{M}_{0,inertia}^{ext} = -\dot{\mathbf{H}}_0$ , and incorporating these new "external" forces into our free-body diagrams, statics [Eqs. 1 and 2](#) may be applied to the formulation of the dynamical problem.

In the case of continuum mechanics (q.v.), the problem of continuum statics consists of solving the system of partial differential equations obtained from the ►[balance laws](#) (q.v.) when all the time-derivatives are regarded as zero. In a more restricted sense, however, continuum statics applies mainly to the purely mechanical aspects, leaving thermodynamic considerations aside. Thus, a problem of continuum statics will usually involve only the balances of momentum and of ►[angular momentum](#) and a constitutive equation for the ►[stress](#) in terms of kinematical quantities only (see the articles ►[Kinematics of Deformation](#) and ►[Constitutive Theory](#)), while temperature, ►[heat flux](#) and ►[internal energy](#) are not taken into consideration.

An alternative formulation of statics can be obtained by means of the principle of virtual work (q.v.).

---

## Statistical Inference

►[Bayesian Statistics \(with Particular Focus on the Motor System\)](#)

---

## Statistical Mechanics

### Definition

An extension of Newtonian mechanics in the later years of the nineteenth century, which explained the behavior of aggregates of molecules (gases) statistically; it resulted in a definitive formulation of the second law of thermodynamics by Boltzmann.

---

## Statocyst

### Definition

The balance organ of an invertebrate.

►[Evolution of the Vestibular System](#)

---

## Status Epilepticus (SE)

### Definition

Serious condition of prolonged and repetitive ►[seizures](#) that tend to be self-sustaining. The definition of prolonged has varied from 5 to 30 min. There are various clinical forms: subtle SE, impending SE, established SE, non-convulsive SE, and generalized convulsive SE. The transition from isolated seizures to SE probably involves changes in ►[GABA<sub>A</sub>](#) (►[γ-aminobutyric acid](#)) receptors, ►[AMPA](#) (►[α-amino-3-hydroxy-5-methyl-4-isoxazolepropionic acid](#)) and ►[NMDA](#) (N-methyl-D-aspartic acid) receptors, as well as changes in neuropeptides. These changes may explain the hyperexcitability of cortical neurons, the tendency of seizures to become self-sustaining, and the development of resistance to antiepileptic drugs.

►[Anticonvulsants](#)

---

## Steady (also Equilibrium) State

### Definition

State of the system comprised of the organism and the environment, when neurons influencing the motor

outcome generate stationary (tonic) activity or remain silent, all torques and forces including those resulting from the interaction of the organism with the environment are balanced and do not change, and the body and its segments cease to move; may be changed by external forces or control variables causing motor actions.

► [Equilibrium Point Control](#)

## Stellate Cell

### Definition

Multipolar neuron whose dendrites project in all directions. Also used to describe multipolar neurons with less uniform dendritic fields.

## Stellate Cell in Cochlear Nucleus

### Definition

Neurons that occupy all parts the ventral cochlear nucleus, receive auditory nerve terminals in their dendrites, and project to the inferior colliculus or to the cochlear nucleus on the other side. They may have different functional roles depending on their targets.

► [Cochlear Nucleus](#)

## Stem Cell

### Definition

Immature undifferentiated cell endowed with endless capacities of self-renewal, i.e., to reproduce itself identically, and the ability to generate multiple mature cell types. It can be produced both during the embryonic development and in the adult age. Whereas embryonic stem cells can give rise to virtually all the cell types in the body, adult stem cells only generate a limited number of cell types depending on the tissue from which they are originated.

For instance, stem cells residing in the subventricular zone of the mammalian brain can be isolated and cultured. One single stem cell can proliferate to form a spherical aggregate of cells called a neurosphere containing both stem and progenitor cells. Plated onto an adherent support, cells differentiate into neurons, astrocytes and oligodendrocytes. Stem cells are, therein, multipotent cells as they produce a wide range of cell type.

Moreover, the stock of multipotent stem cells is maintained during the lifespan of the organism. According to their capacities, stem cell therapies are under investigation as they could replace dead cells and may provide successful cures for neurodegenerative and demyelinating diseases, heart failure, spinal cord injuries, among others.

- [Adult Neurogenesis](#)
- [Neural Development](#)
- [Neurogenesis and Inflammation](#)

## Stem Cell Transplantation

### Definition

Medical procedure in the field of hematology, oncology or regenerative medicine that involves transplantation of stem cells of different origins (e.g., neural stem cells, hematopoietic stem cells, mesenchymal stem cells, cord blood stem cells, etc.). It is most often performed on people with diseases of the blood or bone marrow, certain types of cancer or diseases of the central nervous system [e.g., multiple sclerosis (MS), Parkinson disease (PD), Huntington's disease (HD), etc.]. Transplanted stem cells are usually administered either locally (e.g., intraparenchymally), intravenously or intrathecally (e.g., through the cerebrospinal fluid circulation). The main aims of the procedure are either the repopulation of the host bone marrow and the production of new blood cells (e.g., in the case of hematopoietic vs. cord blood stem cell transplantation), the replacement of lost vs. injured neural cells (e.g., in the case of neural stem cell transplantation) or the induction of peripheral immune tolerance (e.g., in the case of mesenchymal and neural stem cell transplantation).

- [Autoimmune Demyelinating Disorders: Stem Cell Therapy](#)
- [Huntington's Disease](#)
- [Multiple Sclerosis](#)
- [Parkinson Disease](#)

## Stem Taxon

### Definition

A stem taxon is one that shares some but not all derived characters with a well-defined clade.

- ▶ The Phylogeny and Evolution of Amniotes

## Stepping Strategy

### Definition

A change in support reaction to postural perturbation in which one or more rapid stepping movements are used to restore equilibrium.

- ▶ Postural Strategies

## Step Response

### Definition

The output of a system when a Heaviside (step) function is input into it.

- ▶ Signals and Systems

## Stereocilia of Vestibular Hair Cell

### Definition

Cilia projecting from the apical surface of the receptor hair cell. The cilia are connected to each other by small actin filaments and vary in stiffness. Stereocilia deflection leads to mechano-electrical transduction in the kinocilium.

- ▶ Peripheral Vestibular Apparatus

## Stereognosis

### Definition

The ability to perceive the properties of an object by touch.

- ▶ Active Touch
- ▶ Haptics
- ▶ Processing of Tactile Stimuli

## Stereogram

### Definition

A set of objects seen by both eyes such that their fusion results in binocular disparity detection and stereoscopic vision.

- ▶ Binocular Vision

## Stereopsis

### Definition

The combination of image information from left and right eyes via binocular disparity provides the basis for stereoscopic depth perception.

- ▶ Binocular Vision

## Stereoscopic Acuity

### Definition

- ▶ Binocular Vision

## Stereotaxy

### Definition

Stereotaxy is a method for locating deep brain structures that can be reached from the surface with the use of electrodes or other probes. The probes can then lesion or electrically stimulate the target region or inject a drug or tracer. Usually a stereotaxic instrument is attached to the skull and deep structures are reached with the use of stereotaxic brain atlases prepared with standard coordinates based on skull landmarks and deep midline structures seen in scans of different types (e.g., X-ray or Magnetic Resonance Images).

## Steroid Hormones

► Neuroendocrinological Drugs

## STG

► Stomatogastric Ganglion

## Stiff-man Syndrome

### Definition

Uncommon disease consisting of several forms, with the severity of evolution differing in each individual case. It is characterized by symmetrical muscle ► rigidity and painful ► spasms of the lumbar paraspinal, abdominal, and occasionally proximal leg muscles, which often lead to skeletal deformity (e.g., lumbar hyperlordosis). There is continuous motor unit activity with abnormal exteroceptive reflexes. Variants may involve one limb only (stiff leg syndrome), and other symptoms and signs such as eye movement disturbances, ► ataxia, or ► Babinski sign, or concur with malignant disease. Antineuronal autoimmunity (against glutamic acid decarboxylase, GAD) and

accompanying autoimmune diseases are characteristic features. Patients remain ambulant.

► Babinski Sign

## Stiffness

### Definition

The strict definition in physics is: change of force per unit change of length, or the slope of the force-length curve of a structure ( $df/dl$ ). In motor control, the term characterizes the ability of the neuromuscular system to resist deviations from an equilibrium or current position elicited by external perturbations; required, together with damping, for stability of posture and movement; the ratio of the change in the static values of forces (torques) to a small (“infinitesimal”) change in position elicited by an external load provided that control variables remain the same; measurements are comparatively easy for steady states of the system but are unreliable for transitional states (e.g. during movements) because of the necessity to extrapolate dynamic muscle forces and torques to static values, delays in the position-dependent muscle force regulation, and changes in control variables underlying active movements.

► Equilibrium Point Control

## Stimulant Drugs

► Stimulants

## Stimulants

STEPHEN J. KISH

Human Neurochemical Pathology Laboratory, Centre for Addiction and Mental Health, Toronto, ON, Canada

### Synonyms

Psychostimulants; Stimulant drugs; Analeptics; Excitants; Activators; Energizers; Awakening agents; Tonics

## Definition

Stimulants are chemical substances that temporarily activate the nervous system. In common usage, stimulants are generally understood as chemicals that increase activity of the ▶[central nervous system](#) (i.e. psychostimulants) although such substances may also activate the ▶[sympathetic nervous system](#). The temporary effects of stimulants can include increased ▶[alertness](#), wakefulness, a feeling of well-being, euphoria, and increased ▶[heart rate](#) and ▶[blood pressure](#). The substances may be derived from natural products (e.g. caffeine from the coffee plant) or can be synthesized (▶[methamphetamine](#)). Stimulants are used both for therapeutic and recreational purposes.

## Characteristics

### Examples of Stimulants

The [Table 1](#) provides representative examples of common stimulants used by humans.

### Overview: What We Know and Do Not Know About Stimulants

This essay focuses to the extent possible on stimulant actions in the human, as it is the human stimulant user, rather than the experimental animal, that can best report on many of the key effects of the drugs. Good

**Stimulants. Table 1** Examples of stimulant drugs used by humans

Classical stimulant drugs	“Atypical” stimulant drugs
Amphetamine and structurally related compounds	Caffeine
D-amphetamine	Modafinil
methamphetamine	
methylenedioxymethamphetamine (mdma, ecstasy)	
methylenedioxyamphetamine (mda, “love drug”)	
phentermine	
ephedrine	
cathionine	
Fenfluramine	
Nicotine	
Cocaine	
Methylphenidate (Ritalin)	

Stimulant drugs known or suspected to have a major action as monoamine neurotransmitter releasers are **boldened**. Stimulants having a major action as monoamine neurotransmitter transporter inhibitors are *italicized*. Caffeine and modafinil are listed as “atypical” stimulants as the primary mechanism of action of some of the key acute effects of the drugs is probably different from that of the classical stimulants (caffeine: adenosine receptor antagonism) or is unknown (modafinil).

information is available on the acute (temporary) behavioural effects of stimulants in humans. However, there is much uncertainty regarding mechanisms that explain their behavioural effects.

### Acute Behavioural Effects

The typical acute (minutes to hours) effects of a low to moderate dose of a stimulant drug in a normal human include feelings of ▶[alertness](#), wakefulness, energy, well-being (euphoria at higher doses), and suppression of appetite. As a consequence, stimulants have been used to improve concentration and attention, counteract fatigue and excessive sleepiness (e.g. in ▶[narcolepsy](#)), cause feelings of pleasure, and induce weight loss. Many stimulants also activate the cardiovascular system (cause increased ▶[heart rate](#) and ▶[blood pressure](#)).

The ▶[central](#) and ▶[sympathetic nervous system](#) effects are typically observed to some degree with all of the classical stimulant drugs with the differences in drug intensity and duration explained by drug pharmacokinetic properties, route of administration characteristic of the drug (e.g. oral vs. inhalation), and probably, drug maximal response. Unlike the classical stimulants (e.g. ▶[methamphetamine](#)), the atypical stimulant modafinil can induce wakefulness with no or little accompanying activation of the cardiovascular system (▶[Nootropic Drugs](#)).

In addition to the acute stimulant effects described above, one of the amphetamine derivatives, mdma (▶[ecstasy](#)), is claimed by many stimulant users to promote feelings of openness, sociability, and talkativeness (and possibly empathy) to a greater extent than that caused by the parent drug ▶[methamphetamine](#), although this has yet to be verified.

### Chronic Behavioural Effects Following Repeated Exposure

It is generally assumed from animal findings that partial ▶[tolerance](#) will develop in the human to some or perhaps all of the acute behavioural effects of stimulant drugs following repeated exposure – but this has been somewhat difficult to prove in humans (▶[Tolerance and Dependence](#)). The question of ▶[tolerance](#) is best addressed by prospective studies of chronic drug exposure in previously drug-naïve humans. However, for many of the representative stimulants (e.g. ▶[methamphetamine](#), ▶[cocaine](#)), data from such prospective studies are still too limited [1] because of the ethical problem of exposing humans repeatedly to drugs that might cause harm.

Findings from chronic stimulant users suggest that partial ▶[tolerance](#) to some of the effects of stimulant drugs (e.g. drug liking, cardiovascular activation) most likely develops following repeated exposure to moderate to heavy stimulant doses, especially during a drug “binge” characterized by rapid dose escalation.



However, the extent to which such ▶tolerance carries over to the next drug use that might occur a week or two later is still unclear. In the case of ▶ecstasy, many users report some persistent (weeks to months or longer after last use) tolerance to the pleasurable effects of the drug with repeated drug use. This probably represents a combination of a true ▶tolerance and some decrease in novelty of the drug experience.

Animal findings indicate convincingly that repeated intermittent doses of stimulant drugs can induce an increase in ▶locomotion as compared with that produced by the first exposure to the drug. However, it is still quite uncertain [2] whether ▶sensitization (reverse ▶tolerance) to any of the behavioural effects of stimulant drugs reliably occurs in the human (possible examples being emerging ▶psychosis and stereotyped movements in ▶methamphetamine users) and the specific counterpart in humans to the motor sensitization reported in experimental animals is unknown.

A ▶withdrawal syndrome, which can include ▶depression, ▶anhedonia, and ▶anxiety, can develop within hours or days following drug cessation after repeated exposure to moderate to heavy doses of stimulant drugs, or to a single high dose of the drug. Typically, ▶withdrawal features are the opposite of some of the acute effects of the drug (e.g. unpleasant vs. pleasant feelings; increased vs. decreased appetite) and can last a few hours to days or even weeks (see ▶Tolerance and Dependence).

In some individuals, chronic exposure to stimulants leads to a state of drug ▶addiction characterized by a ▶compulsive wanting or ▶craving for the stimulant drug and a loss of control. ▶Addiction is not an obligatory component of a ▶withdrawal syndrome.

### Mechanism of Action of Some of the Acute Behavioural Effects of Classical Stimulants

Stimulant drug targets. Brain neuronal systems have been identified that are acted upon by stimulant drugs. However, not yet established is the extent to which these drug targets are critically involved in stimulant actions.

In brain, stimulant drugs act *inter alia* on neurones that utilize ▶dopamine, ▶noradrenaline, and ▶serotonin as ▶neurotransmitters. Studies of patients with the dopamine deficiency condition ▶Parkinson's disease show that ▶dopamine in the ▶putamen and ▶caudate subdivisions of the ▶striatum is involved in ▶motor control and probably in aspects of ▶cognition [3] (▶Drug Treatment for Motor Disorders and Antipsychotics). Dopamine, localized to the ▶ventral striatum/▶nucleus accumbens portion of the ▶striatum has often been considered to mediate feelings of pleasure. However, this is likely an oversimplification and debate continues on re-defining this aspect of the role of ▶dopamine from such possibilities (all related) as "liking," "wanting," and "▶incentive salience" [4].

The precise roles of brain noradrenaline and ▶serotonin are less certain as there does not exist any human conditions characterized by selective loss of either of the ▶neurotransmitters. However, the ▶antidepressant actions of fairly selective serotonin and noradrenaline ▶transporter inhibitors suggest involvement of both ▶neurotransmitters in ▶mood and an extensive animal literature suggests an involvement of noradrenaline in arousal and ▶attention [5] (▶Antidepressants).

▶Classical stimulants activate monoamine neurotransmitter systems. A primary action of the "▶amphetamine-like" stimulants (see Table 1) is to elevate brain extracellular ▶monoamine neurotransmitter (▶dopamine, ▶serotonin, noradrenaline) levels by enhancing ▶neurotransmitter release from the nerve endings [6]. Although the mechanism by which ▶amphetamine stimulants cause release is still under investigation, it likely involves (i) redistribution of the neurotransmitters from the synaptic vesicle (via the ▶vesicular monoamine transporter [VMAT2]) to the neuronal cytoplasm and (ii) reverse transport of the ▶neurotransmitter through the plasma membrane transporter into the extracellular space [7]. A primary action of "cocaine-like" stimulants is to increase extracellular ▶monoamine neurotransmitter concentrations by binding to plasma membrane ▶transporter proteins (▶dopamine transporter, ▶serotonin transporter, ▶noradrenaline transporter) and thereby blocking reuptake of the ▶neurotransmitter from the ▶synapse into the nerve ending [6]. Some (but not all) data in the human suggest that cigarette smoking can cause a slight increase in release of ▶dopamine in the ▶striatum – an action attributed to ▶nicotine. The ▶dopamine-releasing action of ▶nicotine is considered to be mediated, at least in part, by activation of ▶nicotinic receptors of the  $\alpha_4$  and  $\beta_2$  subtypes [8].

Since the stimulant drugs act, to a varying degree, depending on the stimulant, on all three ▶monoamine neurotransmitter systems [6], it is difficult to ascribe specific behavioural effects of the drug to involvement of a single ▶neurotransmitter. Speculations, mentioned below, on mechanism are primarily based on animal findings.

▶Cardiovascular activation. Activation of ▶heart rate and blood pressure caused by some stimulants (e.g. ▶methamphetamine) has been commonly explained by a drug-induced release of noradrenaline from ▶sympathetic nerve endings and subsequent activation of ▶adrenergic receptors. However, the situation is probably much more complicated with some data suggesting involvement of ▶monoamine neurotransmitters (▶dopamine and/or noradrenaline) in brain as well as in the ▶sympathetic nervous system.

▶Alerting and attention. Animal data suggest that the ▶alerting and improved ▶attentional effects of

the prototype ▶monoamine neurotransmitter releaser (▶amphetamine) and uptake blocker (▶methylphenidate) could be explained in large part by enhancement of brain noradrenergic function. This is also suggested by the efficacy of ▶atomoxetine, reputedly a selective ▶noradrenaline transporter blocker, in treatment of patients with ▶attention deficit/hyperactivity disorder (▶ADHD) (explained as a disorder of ▶attentional control). Comparison of the maximal clinical response of ▶amphetamine and methylphenidate (activate both ▶dopamine and noradrenaline systems) vs. atomoxetine in treatment of ▶ADHD may help to establish extent of involvement of ▶dopamine.

▶Liking. It is commonly assumed that “all roads lead to ▶dopamine” when explaining the feelings of well-being and euphoria associated with a moderate stimulant dose.

This is supported by brain imaging findings in the human strongly suggesting that administration of a variety of stimulants (▶amphetamine, ▶nicotine, cocaine, methylphenidate) cause increased synaptic levels of ▶striatal dopamine and that, in some studies, the extent of increase in ▶dopamine correlates with subjective measures of ▶mood [9].

At odds with the ▶dopamine hypothesis, however, is the simple observation that the positive effects of stimulants in humans are not antagonized by dopamine receptor blocking agents. In contrast, preliminary data (requiring confirmation) indicate that the “positive” effects of at least three stimulant drugs (amphetamine, cocaine, ▶nicotine [cigarette smoking]) are partially antagonized by non-selective ▶opioid receptor antagonists (naloxone or naltrexone). This suggests that the “liking” effect of some stimulants might be mediated through a process involving activation of an endogenous ▶opioid.

▶Increased sociability with ecstasy vs. amphetamine. The mechanism explaining this reputed drug effect is unknown but likely involves the ability of ▶ecstasy to preferentially release the ▶neurotransmitter serotonin as compared to ▶dopamine, whereas ▶dopamine (vs. ▶serotonin) is preferentially released by ▶amphetamine.

### Mechanism of Acute Effects of Some Atypical Stimulants

▶Adenosine is considered to be an inhibitory neuro-modulator involved in regulation of the ▶sleep-wake cycle. The mechanism of the modest stimulant action in humans of caffeine, an “atypical” stimulant found in coffee, tea, and cola, is likely related to its ability to block the action of ▶adenosine at its adenosine A<sub>2A</sub> receptor as suggested by the lack of stimulant effect of caffeine in mice lacking this receptor.

Modafinil is an atypical stimulant, structurally unrelated to the ▶amphetamines, currently used clinically for the treatment of excessive ▶sleepiness. This is an

example of a stimulant in which animal data implicate many different drug targets, but insufficient information is presently available to identify those targets likely to be critically involved in its stimulant action.

### Mechanism of Action of Some Chronic Behavioural Effects

▶Withdrawal. Some of the unpleasant behavioural features of ▶withdrawal to repeated exposure to stimulants are likely related to a “deficiency state” for those ▶monoamine neurotransmitter systems that are activated acutely by the stimulants [6]. In the case of ▶ecstasy, for example, the ▶depression-like features during drug ▶withdrawal are most likely due in part to an actual deficiency of brain ▶serotonin. Similarly, the postmortem ▶brain finding of low ▶striatal dopamine in chronic ▶methamphetamine users suggests that some features of ▶methamphetamine withdrawal, including ▶anhedonia and problems with ▶cognition, can be explained by loss of this ▶neurotransmitter [10]. It is also highly likely that diverse ▶adaptations downstream from the ▶monoamine neurotransmitter receptors underlie the ▶withdrawal syndrome associated with stimulant drug taking.

▶Addiction. Speculations on possible mechanisms explaining stimulant-induced ▶addiction can be found in the Chapter on Tolerance and Dependence. This reviewer finds attractive the model proposing that ▶addiction is a form of “pathological ▶learning” for which ▶dopamine (perhaps critically) helps facilitate the ▶learning process and in which ▶memories, once formed, are rather resistant to change [2].

No single neuronal system in brain has yet been identified which is critical in explaining the transition from stimulant “liking” to “wanting” or “▶craving” in the human, including ▶dopamine. Certainly, ▶dopamine is somehow involved, at least initially, as stimulants that (rapidly) elevate extracellular levels of this ▶neurotransmitter in human ▶brain can be abused. However, the evidence for ▶dopamine receptor blocking drugs influencing drug ▶craving and ▶relapse in humans is not compelling. Those stimulants that have a preferential action on the ▶serotonin (vs. dopamine) system (▶fenfluramine, ecstasy) appear to have a lower risk of ▶addiction.

Clinical pharmacological studies testing potential anti-addiction medications in humans are key to identification of neuronal targets likely involved in stimulant addiction. Although such data are still preliminary, not always consistent, and no “magic bullet” has yet been discovered, some interesting findings have emerged:

In the case of ▶nicotine addiction (as an example), emerging pharmacological data show that drugs blocking ▶opioid and CB1 ▶cannabinoid receptors help some tobacco smokers quit the drug, suggesting possible involvement of ▶endogenous opioids and

►cannabinoids in ►craving and ►relapse in humans. Using also the example of ►nicotine, a rational approach in development of a drug to block relapse incorporates a “drug substitution” strategy in which the drug therapeutic is a “dual action” ►partial agonist drug that acts as an agonist at the ►nicotine  $\alpha_4\beta_2$  ►receptor, but has lower (e.g. 30–70%) maximal response than ►nicotine (but still sufficient to reduce ►craving during drug ►withdrawal) and also acts as an antagonist in the presence of ►nicotine. Preliminary data suggest that such a ►nicotine partial agonist drug improve smoking quit rates in humans [8].

### Do Stimulants Cause Persistent Brain Damage?

A variety of structural brain abnormalities have been reported in some chronic users of ►methamphetamine, ►ecstasy, and cocaine; however, to date the findings are too inconsistent and anecdotal to provide a definitive conclusion.

Good evidence exists in the animal literature that neurochemical markers of brain ►dopamine nerve terminals (►dopamine, ►dopamine transporter, ►VMAT2) are persistently decreased in experimental animals given high doses of ►methamphetamine (see [10]) whereas markers for ►serotonin neurones (►serotonin, ►serotonin transporter) are decreased in nerve terminal regions following high dose exposure to ►ecstasy. Oxidative damage due to formation of oxy-radicals derived from ►dopamine and ►serotonin is a plausible mechanism for the toxicity.

In the human literature decreased ►striatal concentration of the ►dopamine transporter in some abstinent (months to years) ►methamphetamine users has been reported (see [10]). Although low ►dopamine transporter does not necessarily equal actual loss of ►dopamine nerve terminals, the human data do suggest that some (likely dose-dependent) “damage” could occur to dopamine neurones in ►methamphetamine users that persists some months or longer after the last exposure to the drug. Similarly, emerging, though still preliminary, data describe a brain serotonin transporter decrease in the cerebral cortex of abstinent ►ecstasy users. The question whether these changes are associated with any functional impairment is still debated.

### References

1. Comer SD, Hart CL, Ward AS, Haney M, Foltin RW, Fischman MW (2001) Effects of repeated oral methamphetamine administration in humans. *Psychopharmacology (Berl)* 155(4):397–404
2. Hyman SE (2005) Addiction: a disease of learning and memory. *Am J Psychiatr* 162:1414–1422
3. Kish SJ, Shannak K, Hornykiewicz O (1988) Uneven pattern of dopamine loss in the striatum of patients with idiopathic Parkinson’s disease. Pathophysiologic and clinical implications. *N Engl J Med* 318(14):876–880

4. Salamone JD, Correa M, Farrar A, Mingote SM (2007) Effort-related functions of nucleus accumbens dopamine and associated forebrain circuits. *Psychopharmacology (Berl)* 191:461–482
5. Berridge CW (2006) Neural substrates of psychostimulant-induced arousal. *Neuropsychopharmacology* 31:2332–2340
6. Rothman RB, Baumann MH (2003) Monoamine transporters and psychostimulant drugs. *Eur J Pharmacol* 479:23–40
7. Sulzer D, Sonders MS, Poulsen NW, Galli (2005) A mechanisms of neurotransmitter release by amphetamines: a review. *Prog Neurobiol* 75:406–433
8. Rollema H, Coe JW, Chambers LK, Hurst RS, Stahl SM, Williams KE (2007) Rationale, pharmacology and clinical efficacy of partial agonists of alpha4beta2 nACh receptors for smoking cessation. *Trends Pharmacol Sci* 28:316–325
9. Leyton M (2007) Conditioned and sensitized responses to stimulant drugs in humans. *Prog Neuropsychopharmacol Biol Psychiatry* 31:1601–1613
10. Moszczynska A, Fitzmaurice P, Ang L, Kalasinsky KS, Schmunk GA, Peretti FJ, Aiken SS, Wickham DJ, Kish SJ (2004) Why is parkinsonism not a feature of human methamphetamine users? *Brain* 127:363–3670

## Stimulus

### Definition

The pattern of physical energy change set up by an object or event in the environment (distal stimulus) which excites the receptors of a sense organ (proximal stimulus).

►Psychophysics

## Stimulus Translation

►Transduction

## Stochastic Process

### Definition

A process in which the characteristic variables undergo random fluctuations.

►Brownian Motions

## Stochastic Resonance

### Definition

Stochastic resonance refers to a nonlinear dynamical interaction of a periodic signal and noise appearing in multistable systems (e.g. a neuron) near a bifurcation. The noise can be either random or fractal and exist internal to the system or be externally applied. Information flow (the periodic signal) through the system is optimized by a particular noise intensity, thereby actually increasing the signal-to-noise ratio. Stochastic resonance is a strictly nonlinear effect, not accessible within the framework of linear signal processing theories.

## Stomatogastric Ganglion

RONALD M. HARRIS-WARRICK,  
BRUCE R. JOHNSON  
Department of Neurobiology and Behavior, Cornell  
University, Ithaca, NY, USA

### Synonyms

STG

### Definition

The stomatogastric ►ganglion (STG) in lobsters, crabs and other crustaceans is one of the premier systems for studying how neural networks generate rhythmic motor patterns [1]. It is an important model system for more complex behaviors such as respiration, locomotion, rhythmic scratching, and mastication, and has given insights into the mechanisms underlying behavioral flexibility. The STG is part of the stomatogastric nervous system (STNS), which controls movements of the crustacean foregut (Fig. 1a). The STNS includes the STG, the oesophageal ganglion, and the paired commissural ganglia.

### Characteristics

The STG is a small ganglion of about 30 neurons (Fig. 1b), all individually identifiable (Fig. 1c). It contains two complete ►Central Pattern Generator (CPG) networks that drive rhythmic movements of the foregut: the gastric mill and the pyloric networks. In the spiny lobster, *Panulirus interruptus*, the gastric mill network contains eleven identified neurons: one interneuron and ten neurons that act both as CPG

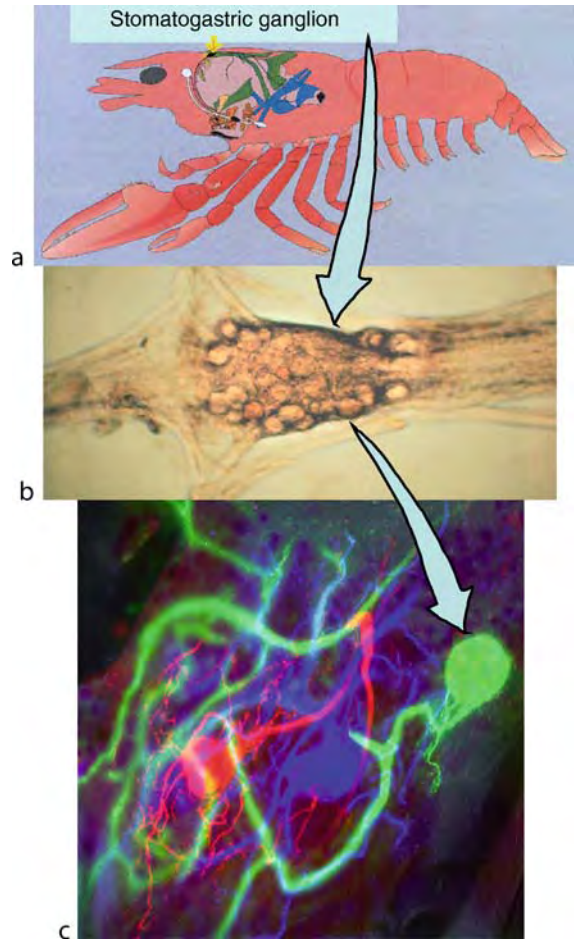

**Stomatogastric Ganglion. Figure 1** The stomatogastric ganglion (STG) of crustaceans, its neurons and gastric and pyloric networks. (a) Schematic of the lobster digestive system highlighting the position of the stomatogastric ganglion and the muscles the gastric (green) and pyloric (blue) networks control (from Simmers et al. (1995) *Am Sci* 83:262–268). (b) Photomicrograph of the STG showing individual neuron cell bodies. The largest cell bodies are approximately 100  $\mu\text{m}$  in diameter. (c) Individual STG neurons stained with fluorescent dextran amines: Pyloric dilator (*PD*, red), Lateral Pyloric (*LP*, green) and Pyloric Constrictor (*PY*, blue). Photograph taken by Peter Kloppenburg.

neurons and as motoneurons. The gastric mill network generates slow rhythmic movements of the three internal teeth that masticate food inside the foregut (Fig. 2a).

The pyloric network contains fourteen identifiable neurons in six major classes (Fig. 2b). One is an interneuron while thirteen are dual function CPG/motoneurons. This network organizes more rapid rhythmic pumping, mixing and filtering movement in the pylorus, or posterior region of the foregut. These

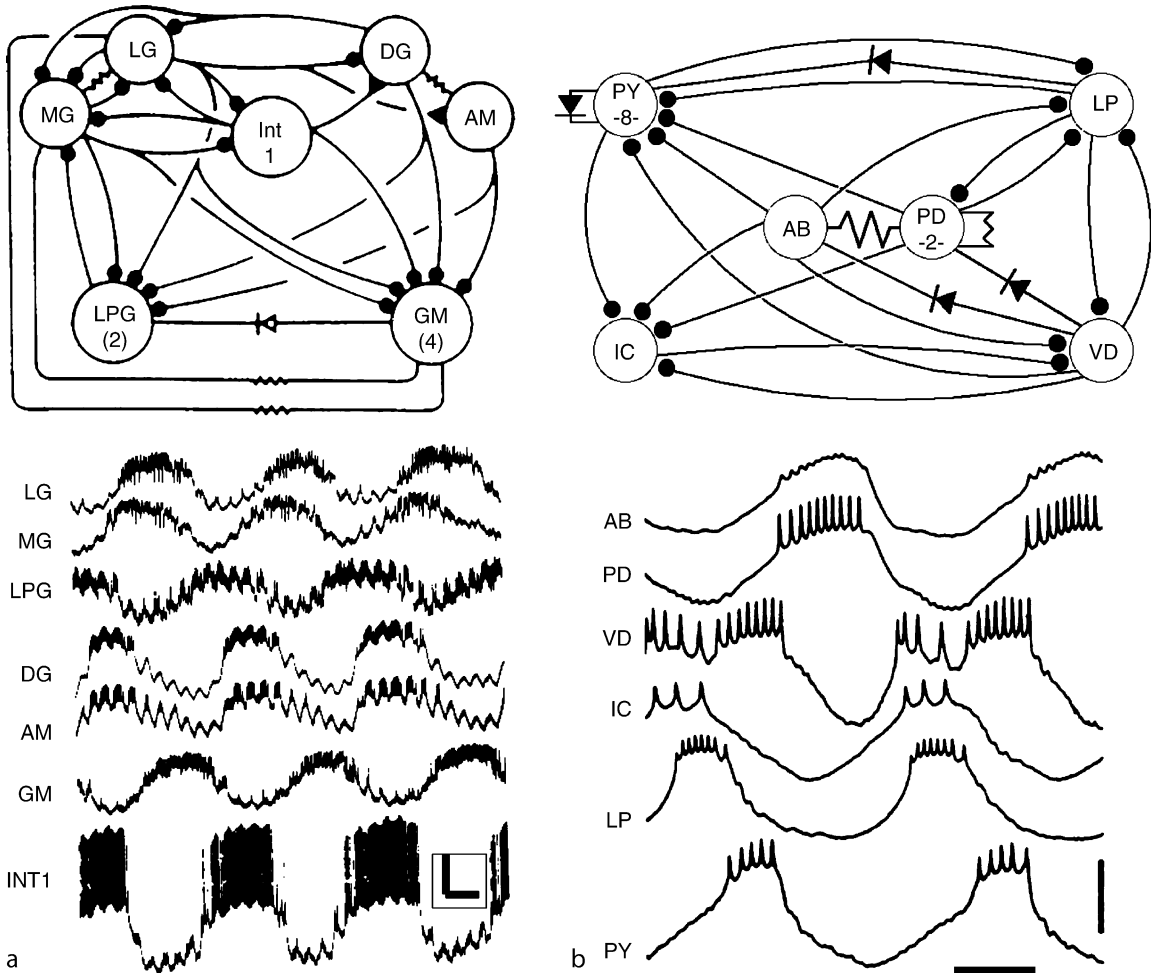

**Stomatogastric Ganglion. Figure 2** Networks and activity of the gastric mill and pyloric motor patterns. (a) Top: connectivity diagram of the gastric mill network, and bottom: intracellular recordings of from the different cell types during gastric network activity. Calibrations: 1 s and 10 mV. Neurons: LG Lateral Gastric, MG Medial Gastric, LPG Lateral Posterior Gastric, DG Dorsal Gastric, AM Anterior Median, GM Gastric Mill, INT1 Interneuron 1. (b) Top: connectivity diagram of the pyloric network, and bottom: intracellular recordings from the different cell types during pyloric network activity. Calibrations: 300 ms and 20 mV. Neurons: PD Pyloric Dilator, LP Lateral Pyloric, AB Anterior Burster, VD Ventricular Dilator, IC Inferior Cardiac, PY Pyloric Constrictor. In (a) and (b), Top, the filled circles indicate chemical inhibitory synapses, resistor symbols indicate non-rectifying electrical synapses and diode symbols indicate rectifying electrical synapses. From ref. [1].

networks vary only slightly between different crustaceans, showing their evolutionary conservation.

### Upstream Events/Conditions

When isolated from the rest of the nervous system, both of the CPGs in the STG cease to function. Descending modulatory inputs from the commissural, oesophageal and other ganglia are essential to activate the motor patterns. In the lobster, there are about 120 central neurons as well as a number of sensory/modulatory neurons that affect the ganglion [2]. The CPG motor patterns vary markedly, depending on which modulatory inputs are active. A number of these modulatory neurons have been identified; when selectively stimulated, each

can elicit a distinct variant of the gastric and/or pyloric motor patterns. Most of these modulatory neurons release two or more co-transmitters; often one is a fast-acting neurotransmitter like glutamate, while the others are slower acting neuromodulators including peptides (such as proctolin) or amines (such as dopamine) [3]. In addition, a number of circulating neurohormones (such as serotonin) act on the STG over longer times and at lower concentrations. More than 20 modulatory substances have been identified that affect the STG networks.

Modulatory inputs reconfigure the CPGs in several ways. First, they determine which cells are actively firing in the network. Second, they alter the cycle

frequency, intensity of firing and phasing of the component neurons. Third, they can shift the allegiance of neurons to fire with a different CPG for an entirely different behavior. Finally, they can fuse two or three networks into a new motor network for a novel behavior.

### Downstream Events/Conditions

Much work has gone into understanding how the pyloric network, and to a lesser extent the gastric mill network, generates its rhythmic output. In brief, the motor pattern is shaped by the interaction between two complementary processes: the intrinsic firing properties of the different neurons, and the pattern and kinetics of their synaptic interactions. Due to space considerations, in this paper we discuss how these processes interact to generate the pyloric rhythm. The gastric mill rhythm is more complex and more integrated with other STNS networks than the relatively independent pyloric network.

### Intrinsic Properties of Pyloric Neurons

The six classes of neurons in the pyloric network each have a unique firing pattern during the pyloric rhythm. Each neuron can be studied in isolation from all synaptic input by a combination of photoablation of synaptically connected neurons and pharmacological blockade of pre-synaptic inputs. A number of distinct intrinsic electrophysiological properties shape the neurons' firing patterns [1].

With intact modulatory inputs, all of the neurons are capable of rhythmic **▶bursting** of different kinds and at different rates. However, this is lost when modulatory inputs from other ganglia are blocked: all of the neurons fall silent or fire slowly. Thus, these neurons are **▶conditional bursters** which oscillate only in the appropriate modulatory environment. The Anterior Burster (AB) typically oscillates at the highest frequency and thus acts as the primary pyloric **▶pacemaker** (Fig. 2b). The AB neuron is electrically coupled to the two Pyloric Dilator (PD) neurons, which oscillate more slowly and constrain the AB oscillatory frequency. These three neurons form the pacemaker group and play the major role in setting the cycle frequency.

The remaining follower neurons are all inhibited by the pacemaker group. All the follower neurons possess **▶post-inhibitory rebound**, where after synaptic inhibition they rebound to fire a burst of action potentials. Some of the neurons also show **▶delayed excitation**, such that they rebound more slowly after inhibition, and begin firing only after a delay. This delay is due to the activation of a subthreshold transient potassium current,  $I_A$ , which competes with a slow hyperpolarization-activated inward current,  $I_h$ , to set the rate of post-inhibitory rebound. Many of the neurons

also express **▶plateau potentials**, where a short depolarizing input, or post-inhibitory rebound, can trigger prolonged action potential firing that lasts until synaptic inhibition or the slow development of outward currents repolarizes the neuron.

### Synaptic Interactions

The pyloric network is highly interconnected (Fig. 2b) top. All the neurons make chemical inhibitory synapses, using either acetylcholine or glutamate which, unlike vertebrate systems, act as fast inhibitory transmitters. Release of transmitter is not only spike-evoked but also graded, with continuous release as a function of membrane potential during the neurons' oscillations. These synapses are highly susceptible to depression during normal oscillations: the synapses weaken as the cycle frequency accelerates [4]. In addition, several of the neurons make rectifying or non-rectifying **▶electrical synapses** with partner neurons, which help to synchronize or initiate activity.

### Generating the Pyloric Rhythm

With modulatory inputs intact, the 14 neurons in the pyloric network fire rhythmic bursts of action potentials in a characteristic triphasic pattern (Fig. 2b). The major pacemaker, AB, and the electrically coupled PD neurons, burst synchronously in the first **▶phase**. This pacemaker kernel inhibits all the follower neurons. As the endogenous burst terminates, the follower cells repolarize by **▶post-inhibitory rebound** to resume firing, but at different rates, due to different amounts of subthreshold outward currents that cause delayed excitation. The IC (Inferior Cardiac) and VD (Ventricular Dilator) neurons rebound most quickly. However, the LP (Lateral Pyloric) neuron is not far behind, and it silences the VD due to a very strong synaptic inhibition, and inhibits PD. The LP then fires tonically, while the PY (Pyloric Constrictor) neurons depolarize more slowly by post-inhibitory rebound from their pacemaker inhibition and begin firing. In turn the PY neurons inhibit the LP and IC neurons, disinhibiting the VD neurons, which fire a second burst. These neurons fire until they are inhibited by the next pacemaker kernel burst, and the cycle repeats. The rebound burst of action potentials in follower cells is supported by their plateau properties.

The pyloric rhythm shows **▶phase constancy**, a general feature of rhythmic behaviors: while the cycle frequency can vary over time, the neurons adjust their burst durations to retain a constant phase relationship with one another. The neural mechanisms underlying phase constancy remain unclear, but frequency-dependent synaptic depression as well as the kinetics of activation, inactivation and deinactivation of voltage-sensitive ion channels play important roles [4]. The phase relations do change when the modulatory milieu is altered.

## Nonlinear Muscle Responses to the Neuronal Motor Pattern

The muscles driven by the pyloric network have different kinetics of contraction: many of them are very slow, and exhibit a large tonic contracture with only small superimposed oscillations in response to the rhythmic pyloric neural drive. Subtle changes in the numbers of spikes per burst, however, can alter this resting contracture. The pyloric network receives inputs from the slower gastric mill CPG and the cardiac sac CPG, another network that causes slow rhythmic contractions of the foregut sac. These minor inputs cause subtle changes in cycle frequency and spikes per burst in some of the pyloric neurons. These small changes are magnified at the muscle level, so when both gastric and cardiac sac rhythms are simultaneously active, the major pyloric muscle contractions are in time with the much slower gastric mill and cardiac sac rhythms, despite the fact that only pyloric motoneurons innervate these muscles [5]. In addition, some pyloric muscles are themselves conditional oscillators whose intrinsic contractions interact with the oscillatory neural input; the motoneuronal drive entrains the muscle's rhythmic oscillations but does not affect their amplitude.

## Neuromodulation

A large number of modulatory neurons act to reconfigure the STG networks over the short term, and the actions of applied neuromodulators such as amines and peptides has been studied in detail [1,2,6] (Fig. 3a).

These modulators alter the pyloric motor pattern by three mechanisms:

1. Alter the intrinsic firing properties of neurons. Modulators can shape the conditional oscillations, plateau properties, post-inhibitory rebound and delayed excitation of the different pyloric neurons. For example, DA enhances bursting in the AB neuron, enhances post-inhibitory rebound and plateau properties in the LP, IC and many of the PY neurons, and inhibits the PD and VD neurons [6]. As a result, the PD and VD neurons are phase-delayed or fall silent, while the other followers are phase-advanced and fire vigorous bursts of action potentials (Figs. 3b, c).
2. Change which neurons are active in the motor pattern. Modulators can excite some neurons while inhibiting others, changing the active components in the network (Fig. 3c). However, silent neurons can still affect the motor pattern when they are electrically coupled to active neurons, by exerting a functionally inhibitory electrotonic drag.
3. Alter the strengths of synapses in the network (Figs. 3d, 4) [6,7]. A single neuromodulator can strengthen some synapses while weakening others.

These changes occur by both pre-synaptic increases or decreases in transmitter release, which is in part due to modulation of calcium currents in nerve terminals, and in part to post-synaptic alterations in transmitter responsiveness. Amines also modify electrical coupling, either directly or indirectly via changes in input resistance. At several synapses, which combine electrical and chemical inhibitory components, dopamine can invert the net sign of the synaptic interaction via opposite effects on the electrical and chemical components (Figs. 3d, 4). Not all of the observed synaptic modulation may have functional consequences for pyloric network function. The magnitude of synaptic strength changes that are sufficient to evoke changes in network activity is still not clear.

The complexity of these effects on the pyloric neurons' ionic currents and synaptic strength is illustrated for one neuromodulator, dopamine, in Fig. 4. In many cases, DA exerts conflicting effects on a target [6]. At several synapses it enhances pre-synaptic release while weakening post-synaptic responsiveness. In some neurons, DA alters complementary sets of ionic currents that by themselves would lead to either increases or decreases in a neuron's excitability. These opposing effects could act as brakes to constrain the neuronal activity within a certain window, and to prevent the neurons from being "over-modulated" and dysfunctional. Alternatively, opposing modulatory effects could themselves be subject to differential metamodulation by other transmitters, which could change the net sign of the DA effect.

DA is an example of a neuromodulator with widespread and divergent actions on the different synapses and neurons in a neural network. In contrast, a number of peptides act through independent receptors but converge on a single ionic current to activate multiple pyloric neurons by a common mechanism [2]. The different peptides target distinct populations of neurons (due to differential expression of their receptors), leading to different motor patterns despite their common ionic targets.

## Involved Structures

The variability in STG neuron firing properties arises from neuron-specific patterns of expression of genes that encode ion channels, receptors and enzymes. Currents that have been studied in detail include the typical inward currents such as the voltage-sensitive sodium ( $I_{Na(V)}$ ), calcium ( $I_{Ca}$ ), hyperpolarization-activated inward ( $I_h$ ) and persistent sodium ( $I_{Na(P)}$ ) currents, and the non-selective cation current ( $I_{CAN}$ ). In addition, these neurons express outward currents including the transient potassium ( $I_A$ ), delayed rectifier ( $I_{K(V)}$ ), and calcium-activated ( $I_{K(Ca)}$ ) currents. As described above,

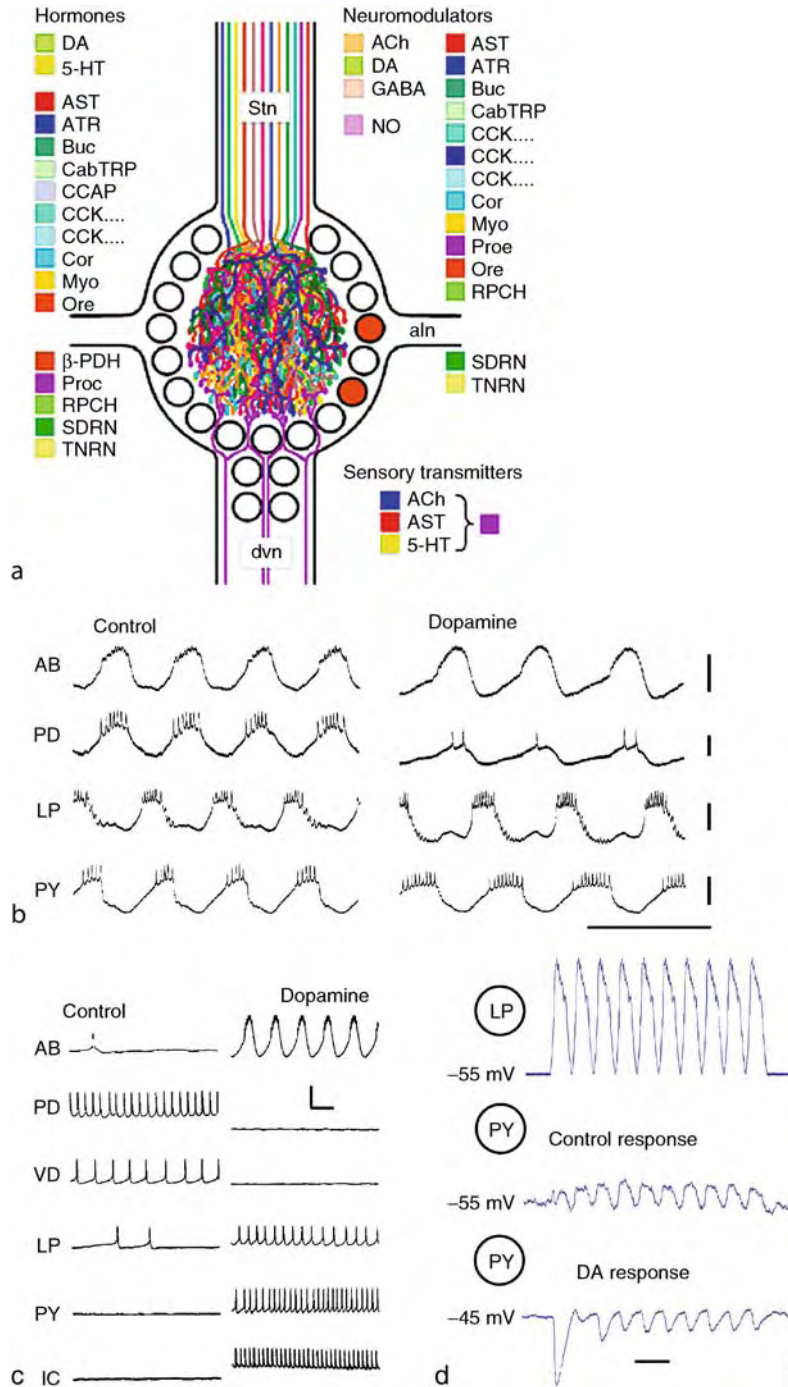

**Stomatogastric Ganglion. Figure 3** ▶ Neuromodulation of STG networks. (a) Diagrammatic summary of known neuromodulatory inputs into the STG (Figure from Eve Marder). (b) Pyloric activity recorded intracellularly from four pyloric neurons under control and dopamine conditions. Calibrations: 1 s and 10 mV (From Kloppenburg et al. (1999) *J Neurophysiol.* 81:29–38) (c) Dopamine effects on the excitability of synaptically isolated pyloric neurons. Calibrations: 1 s and 5 mV IC; 10 mV AB, PD, VD, LP, PY. (From Flamm and Harris-Warrick (1986) *J Neurophysiol* 55:866–881) (d) Dopamine reversal of synaptic sign at a mixed electrical/chemical inhibitory synapse. Realistic waveforms (30 mV) were used as voltage clamp stimuli in the presynaptic LP neuron while recording the responses in the post-synaptic PY neuron. Under control conditions, the PY neuron depolarizes in phase with the LP depolarizations. During application of dopamine, the PY neuron hyperpolarizes in phase with the LP depolarizations. Calibrations: 1 s and 1 mV Control, 10 mV DA response. (From Johnson et al. (2005) *J Neurophysiol* 94:3101–3111).



these currents are major targets of neuromodulators which alter the firing properties of neurons and the strengths of their synapses. Within a single neuron, modulators such as dopamine affect multiple ionic currents to alter its intrinsic firing properties (Fig. 4).

Interestingly, experimental and modeling studies have shown that many different combinations of ionic currents

can generate the same basic firing pattern. For example, in different Inferior Cardiac neurons, the amounts of three outward currents varied over a wide range even though the neurons had very similar firing properties; modeling studies support this result, showing that many different combinations of ionic currents could generate the same bursting firing pattern. Similarly, when model pyloric

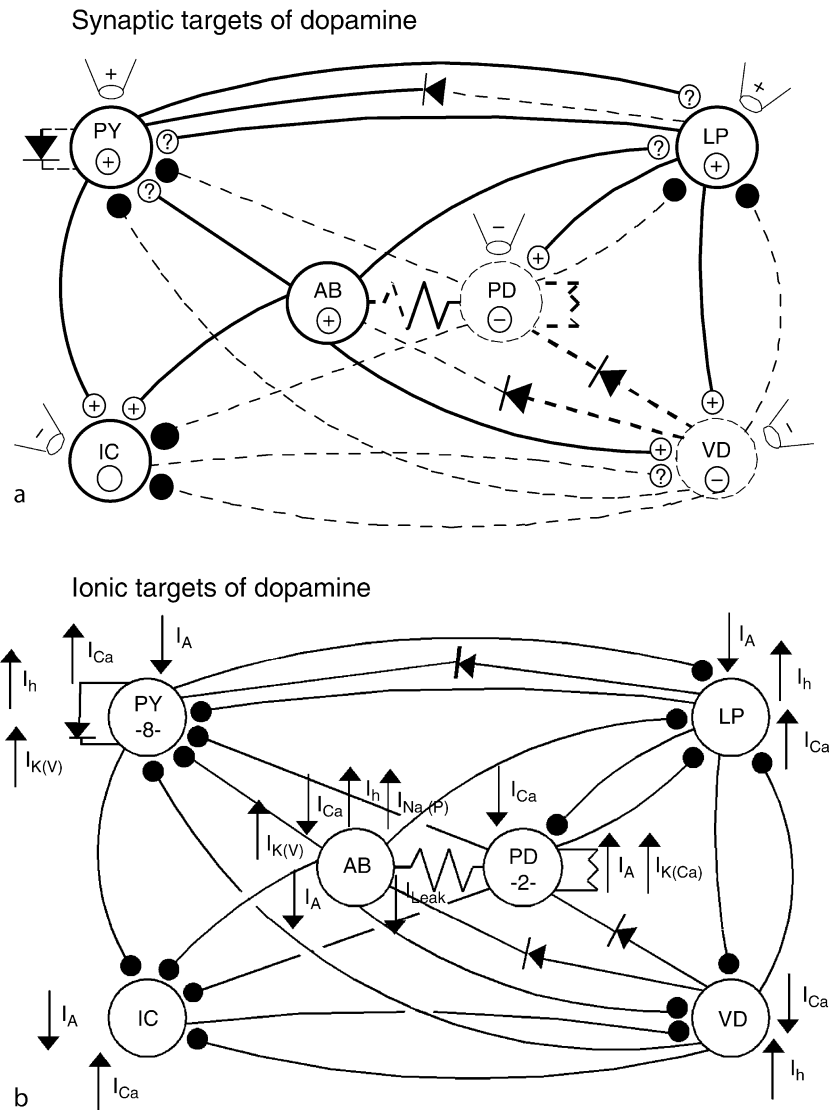

**Stomatogastric Ganglion. Figure 4** Summary of dopamine (DA) effects on the intrinsic and synaptic properties of pyloric neurons in the STG. (a) Synaptic targets of DA. Dopamine alters the strength of every chemical and electrical synapse in the pyloric network. Bold lines indicate synapse strengthening and dashed lines indicate weakening. Electrode tips with (-) and (+) signs indicate reduced and enhanced responses to applied glutamate during dopamine application; (+) signs inside nerve terminals indicate DA enhancement of transmitter release; (+) and (-) signs inside neuron cell bodies indicate effects of DA on cell input resistance. (b) Ionic targets of DA. Currents affected:  $I_{Na(P)}$ : Persistent sodium current;  $I_{Ca}$ : Voltage-sensitive calcium current;  $I_A$ : transient potassium current;  $I_{K(V)}$ : delayed rectifier potassium current;  $I_{K(Ca)}$ : calcium-activated potassium current;  $I_h$ : hyperpolarization-activated inward current;  $I_{Leak}$ : voltage-insensitive leak current. Upward and downward pointed arrows indicate DA's effects on different ionic current magnitudes in each neuron.

neurons were coupled via variable strength synapses to form more than 20 million versions of a simple three-neuron network, the same motor pattern could be generated by many different combinations of ionic and synaptic parameters [8] (Fig. 5).

Additional evidence for multiple ionic solutions to a neuron's firing properties comes from studies of ▶homeostatic regulation, the slow compensatory changes the neurons make when their normal activity pattern is altered. The CPG motor patterns are normally completely dependent on modulatory inputs from other ganglia; when these are blocked the neurons lose their conditional bursting properties. However, if an isolated ▶ganglion or neuron is maintained for several days in culture, the neurons restore their bursting properties which are now not dependent on modulatory inputs, and the pyloric rhythm is reactivated. The

underlying mechanisms for this include a transcription-dependent increase in sodium and calcium currents and a decrease in potassium currents [9]. In other studies, artificial up-regulation of the transient potassium current,  $I_A$ , by RNA injection in single pyloric neurons leads to a proportional up-regulation of  $I_h$  [10]. Since the increased  $I_h$  counteracts the effects of the increased  $I_A$ , the firing properties of the neurons were essentially unchanged.

This work has led to the general conclusion that the firing properties of a neuron are not rigidly determined by the expression of a fixed ratio of ionic currents, but that there are multiple and redundant solutions for each neuron. It will be a challenge to identify the developmental mechanisms that allow this flexibility while reliably generating neurons with appropriate firing properties.

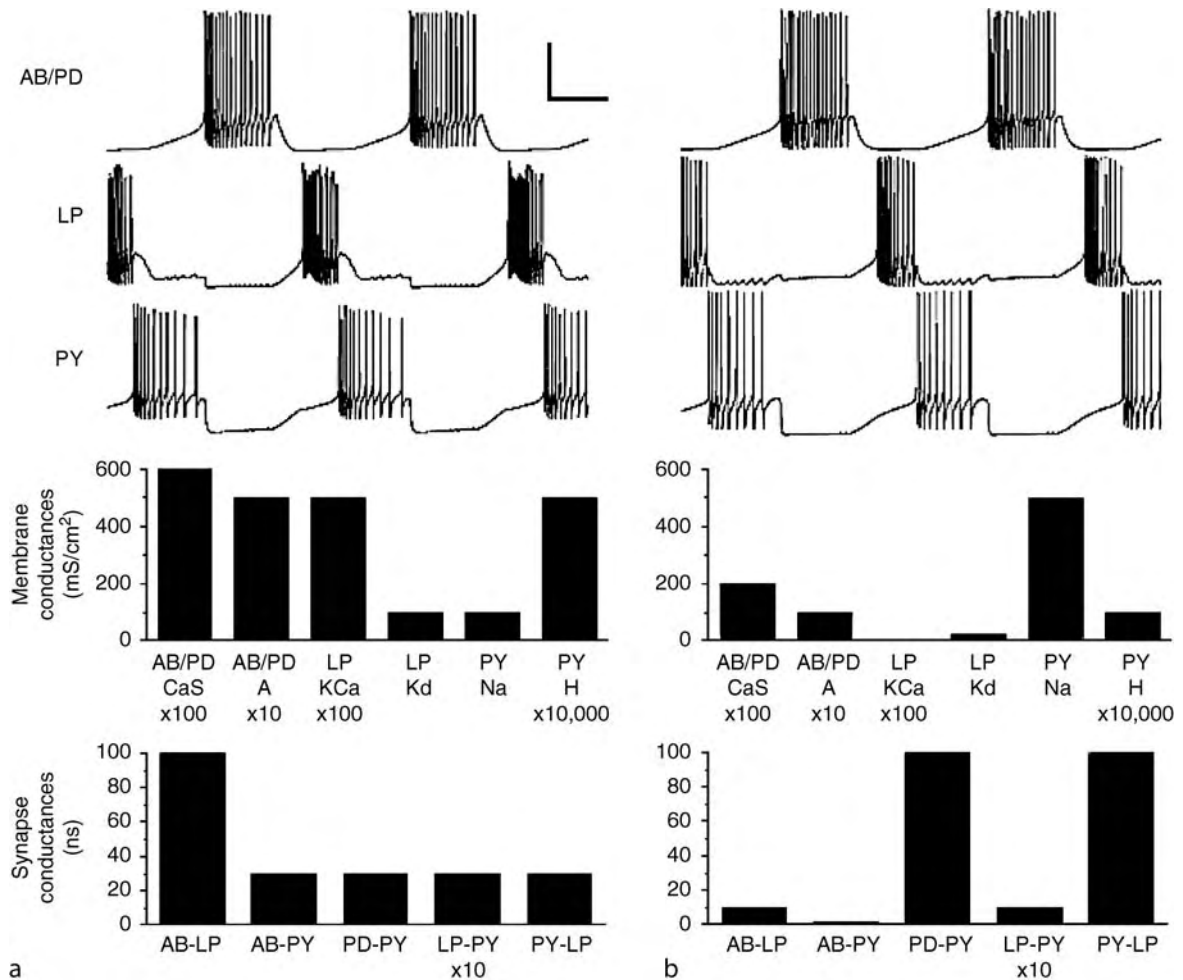

**Stomatogastric Ganglion. Figure 5** Different synaptic and ionic current magnitudes can create similar pyloric activity patterns. (a) *Top*: Model network activity in three cells created by the specific model membrane and synaptic conductances shown in bottom. (b) *Top*: Similar model network activity created by very different ionic and synaptic conductances shown in bottom. Calibrations: 0.5 s, 50 mV. (From ref. [8]).

### Methods to Measure This System

Studies of the STG have benefited from the convergence of a number of different but complementary experimental approaches:

1. Electrophysiology: Combined intracellular and extracellular recordings allow the complete pyloric or gastric mill motor pattern to be monitored simultaneously. The properties of single neurons can be studied in isolation after removing all synaptic input by fluorescent dye-induced killing of connected neurons and pharmacological blockade of synaptic inputs. Voltage clamp studies allow analysis of individual currents underlying neuronal firing properties.
2. Anatomy: Each identified neuron can be dye-injected, allowing its structure to be carefully mapped, and combined with immunocytochemical mapping of neuromodulator inputs.
3. Imaging studies: intracellular calcium levels can be monitored in single nerve terminals using calcium-sensitive dyes such as calcium green. Intracellular second messenger systems can also be monitored optically using fluorescence resonance energy transfer (FRET) signaling molecules.
4. Molecular biology: A number of ion channel genes have been cloned from lobster and their distribution in the STG mapped by immunocytochemistry. Some have been over-expressed in identified neurons and their effects on neuronal activity determined. Recently, a set of monoamine receptor genes has been identified, and a single cell microarray analysis of multiple genes is being developed.
5. Modeling: Models are a critical adjunct to all the work in the STG. These models have allowed a quantitative analysis of the roles of different synapses and ionic currents in shaping network function, and have demonstrated redundancy in ionic solutions to the firing properties of neurons.

### References

1. Harris-Warrick RM, Marder E, Selverston AI, Moulins M (eds) (1992) The stomatogastric nervous system: a model biological neural network, MIT Press, Boston, 328 pp
2. Marder E, Thirumalai V (2002) Cellular, synaptic and network effects of neuromodulation. *Neural Netw* 15:479–493
3. Nusbaum MP, Blitz DM, Swensen AM, Wood D, Marder E (2001) The roles of co-transmission in neural network modulation. *Trends Neurosci* 24:146–154
4. Manor Y, Bose A, Booth V, Nadim F (2003) Contribution of synaptic depression to phase maintenance in a model rhythmic network. *J Neurophysiol* 90:3513–3528
5. Thuma JB, Morris LG, Weaver AL, Hooper SL (2003) Lobster (*Panulirus interruptus*) pyloric muscles express the motor patterns of three neural networks, only one of which innervates the muscles. *J Neurosci* 23:8911–8920

6. Harris-Warrick RM, Johnson BR, Peck JH, Kloppenburg P, Ayali A, Skarbinski J (1998) Distributed effects of dopamine modulation in the crustacean pyloric network. *Ann New York Acad Sci*, 860:155–167
7. Johnson BR, Peck JH, Harris-Warrick RM (1995) Distributed amine modulation of graded chemical transmission in the pyloric network of the lobster stomatogastric ganglion. *J Neurophysiol* 74:437–452
8. Prinz AA, Bucher D, Marder E (2004) Similar network activity from disparate circuit parameters. *Nat Neurosci* 7:1345–1352
9. Turrigiano G, LeMasson G, Marder E (1995) Selective regulation of current densities underlies spontaneous changes in the activity of cultured neurons. *J Neurosci* 15:3640–3652
10. MacLean JN, Zhang Y, Johnson BR, Harris-Warrick RM (2003) Activity-independent homeostasis in rhythmically active neurons. *Neuron* 37:109–120

## Stop Codon

### Definition

A trinucleotide sequence within the mRNA that halts RNA translation. The three most common stop codons are UAG, UAA, and UGA.

## Strain

### Definition

A generic name for a variety of measures of the “change of shape and size” of a “small neighborhood” of a body point. In essence, all measures of strain are related to the positive-definite symmetric part in the polar decomposition of the deformation gradient.

- ▶ Mechanics
- ▶ Measurement Techniques

## Strain-hardening

### Definition

Most soft tissues become stiffer as the stretch or strain is increased – often associated with increasing recruitment

of previously slack collagen fibers. This material behavior is called “strain-hardening.”

► Cardiovascular Mechanics

## Streptavidin

### Definition

Streptavidin is a 60 kDa tetrameric protein purified from the bacterium *Streptomyces avidini*. A recombinant 53 kDa form is also commercially available. Like the avidin protein found in eukaryotic sources, streptavidin has a very high affinity for biotin ( $K_d=10^{-13}$  to  $10^{-15}$ ) but lacks the extensive glycosylation found in avidin. The lack of extensive glycosylation means that streptavidin has the advantage of much lower non-specific binding than avidin and; is therefore, more useful in laboratory applications.

► Serial Analysis of Gene Expression

## Stress

### Definition

Is defined as a constellation of events, comprised of a stimulus (stressor), that precipitates a reaction in the brain (stress perception), which subsequently activates physiological fight or flight systems in the body (stress response). The stress response results in the release of neurotransmitters and hormones that serve as the brain’s messengers to the body. An important distinguishing characteristic of stress is its duration. Acute stress is defined as stress that lasts for a period of minutes to hours, and chronic stress as stress that persists for several hours a day or weeks or months. An important marker for deleterious amounts of chronic stress may be a breakdown in the rhythmicity of the circadian cortisol cycle. Stress has long been suspected to play a role in the etiology of many diseases, and numerous studies have shown that stress can be immunosuppressive and hence may be detrimental to health.

► Stress Response

► Measurement Techniques (Pressure)

## Stress Effects During Intense Training on Cellular Immunity, Hormones and Respiratory Infections

GOMEZ-MERINO DANIELLE

Department of Physiology, Institut de Médecine Aérospatiale du Service de Santé des Armées, BP 73, Brétigny-sur-Orge, France

### Synonyms

Heavy Exertion; Physical Exercise

### Definition

In this essay on the influence of combined ►stress during intense training on ►cellular immunity, hormones and respiratory infections, we have argued that athletes and soldiers who engaged in intense and repeated ►exercise training programs and experienced combined stressors such as energy and/or sleep deprivation, and/or psychological restraint, are at risk of respiratory tract infections.

The two parts are distinguished as: (i) intense exercise and alteration of immune responses focusing on cellular immunity and the role played by cytokines. The relationship to the risk of ►upper respiratory tract infections (URTIs) is overviewed [1–4], and (ii) The ►Overtraining Syndrome (OTS) and ►neuroimmunomodulation [5,6]. OTS has been diagnosed in athletes and is characterized by a sports-specific decrease in performance despite periods of recovery together with disturbances in mood state. Signs/symptoms have been categorized according to physiological performance, psychological/information processing, immunological, and biochemical parameters. It is also probable that other signs/symptoms typically associated with overtraining, excluding organic diseases, are evident before deterioration in performance. These might include generalized fatigue, depression, loss of appetite, muscle and joint pain, and an increased incidence of illness. Thus, the relevance of implication of cytokines and the neurotransmitter serotonin in OTS are presented because they play a role in the regulation of immunity.

### Characteristics

Hans Selye first popularized the concept of ►stress in the 1950s. Selye theorized that all individuals respond to all types of threatening situations in the same manner, and he called this the General Adaptation Syndrome (GAS). He claimed that, in addition to the sympathetic nervous system (SNS) arousal, other bodily systems such as the adrenal cortex and pituitary gland may be

involved in the response to threat. As the threat wanes, Selye suggested, body functions return to normal, thereby allowing the body to focus on healing and growth again. But if the threat is prolonged and sustained (chronic), the SNS arousal never gets “turned off,” and health can be impaired. With a continuously suppressed immune system, for example, a person would be more vulnerable than usual to infection – which is one explanation of why some individuals get sick so often.

Soldiers or athletes are two populations that experience combined stressors during repeated military field operations or intense training such as intense physical exercise, sleep and energy deficiency, environmental conditions (cold, heat), and psychological pressure. The effects of these various stressors on the health are complex, but could be deleterious as it has been shown that chronic stress leads to immunosuppression. Several exercise researchers have elaborated on the “open window” model, proposing that the athlete who trains excessively, without sufficient recovery time, shows a cumulative effect of the vulnerable “open window” period lasting between 3 and 72 h, and thus may encounter the risk of developing transient immunosuppression and an increased risk of infections, particularly ▶upper respiratory tract infections (URTIs) (Fig. 1) [3]. Other infections may occur via the eye, ear or skin. There have also been reports of intestinal upsets such as diarrhea, slow wound healing, and increased susceptibility to environmental and food allergens.

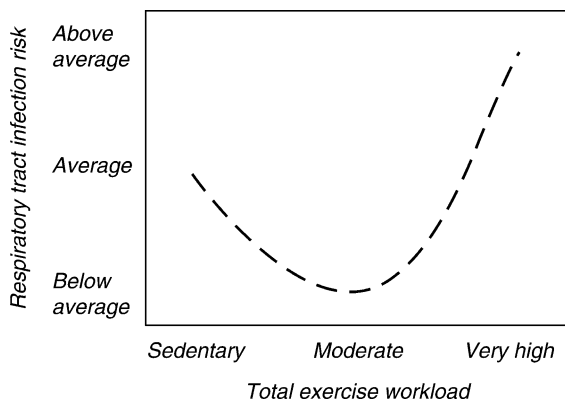

### Stress Effects During Intense Training on Cellular Immunity, Hormones and Respiratory Infections.

**Figure 1** Exercise and risk of upper respiratory tract infections (URTIs) (from Nieman 2000 [3], with permission of The American College of Sports Medicine). “J”-shaped model of relationship between varying amounts of exercise and risk of upper respiratory tract infections. This model suggests that moderate exercise may lower risk of URTI while excessive amounts may increase the risk.

### Exercise, Alteration of Immune Responses and Risk of Upper Respiratory Tract Infections (URTIs): the Role of Cytokines

The notion has emerged that tissue damage associated with physical exercise, such as muscle and/or connective tissue and/or bone, may alter immune function [6]. Mild tissue damage, followed by recovery, is an integral part of adaptation associated with exercise, but if an athlete increases training loads with additional stress factors, it is possible that a more chronic form of tissue trauma appears. The inflammatory response to injury is characterized by an initial phase of acute neutrophil accumulation, and a later phase of mononuclear cell accumulation. Then, there is a cessation of inflammatory cell influx, and processes of injured tissue repair occur. An important aspect of an inflammation/immune response is the upregulation of cytokines produced by, and mediating communication between and within, immune and non-immune cells, organs and organ systems throughout the body including the central nervous system (CNS). ▶Cytokines coordinate infiltration of white blood cells into injured tissue. During the course of inflammation, cells intrinsic to the injured tissue as well as immune cells recruited to the area release chemical attractants (chemokines) that cause leucocyte adhesion to vascular endothelium and migration into the tissue spaces. Chemokines are divided into two families, the CC and the CXC (conserved cysteine residues are separated by no other residue, CC, or by one other residue, CXC), and, like cytokines, display synergy, antagonism, redundancy and pleiotropy in chemotaxis.

When produced in large quantities, there is a spillover of cytokines into the circulation rendering possible the CNS assessment through several mechanisms. They represent a powerful mediator of the stress response in the CNS because they link the CNS, the neuroendocrine and the immune systems [7]. Cytokines are either pro-inflammatory (TNF- $\alpha$ , IFN $\gamma$ , IL-2) and stimulate both the hypothalamo-pituitary adrenal axis (HPA) and neurotransmitters synthesis (serotonin and norepinephrine) or anti-inflammatory (IL-10, IL-4). Other cytokines such as IL-6 function as pro- and anti-inflammatory. Another anti-inflammatory mediator is the IL-1 receptor antagonist (IL-1ra) that blocks the IL-1 action. There is cytokine synthesis in the CNS, by the glia, microglia, astrocytes and neurons. Also, several tissues at the periphery are able to synthesize cytokines such as skeletal muscles, adipose tissue, epithelial tissue, and adrenals. Cytokine receptors are present in the CNS (to IL-1 in hypothalamus and hippocampus, to IL-6 in hippocampus) and in the periphery (to IL-6 in skeletal muscles, adipose tissue, and adrenals). They represent neuromodulators as they are involved in memory and sleep processes.

Numerous studies are related to the role of cytokines on immune response, particularly the specific and acquired immunity. This specific aspect is triggered by T and B lymphocytes that are respectively involved in the intracellular pathogens destruction (virus, bacteria) and production of specific antibodies to antigens. T lymphocytes are divided into two distinct subsets, named as Th1 and Th2 cells, which are respectively associated with cell-mediated immunity and humoral immunity. Although the two subsets play a role in homeostasis defense of the body, it appears that in response to trauma or infection the balance is in favor of one or the other. The Th1 response induces cell-mediated immunity (monocytes/macrophages) and is present in autoimmune diseases, while the Th2 response induces humoral immunity (differentiation of B cells in antibody-secreting plasma cells, synthesis of antibodies such as IgE, grow and activation of mast cells and eosinophils) and is present in allergy diseases. Regulation of the balance lies on their respective associated cytokines: Th1 includes IL-2, IL-12, IFN $\gamma$ , while Th2 includes IL-4, IL-6, IL-10, IL-13, and TNF- $\alpha$ . It has been shown that acute and chronic stress can decrease the Th1 response and increase the Th2 response under influence of stress hormones, glucocorticoides (GC) and catecholamines [7]. Acting through their receptors, GCs decrease the cytokine production associated to Th1. Catecholamines triggered similar effects particularly via  $\beta$ -adrenergic receptors.

During strenuous exertion, the relationship between the defined parameters of immunosuppression in the “open window theory” and the incidence of URTIs is a matter of current debate. Many alterations have been noted on **cellular and humoral immunity**. These include suppressed neutrophil function, suppressed lymphocyte count and proliferation, suppressed natural killer (NK) cell count and activity, changes in

polymorphonuclear cell priming potential, and decreased serum, nasal and salivary immunoglobulins (Igs) (Table 1) [2,3]. Several studies have explored the relationship between URTIs and two main immune parameters that are decreased during heavy exertion, salivary immunoglobulin A (sIgA) and blood NK cell counts and/or NK activity. At present it is mainly the fall in blood NK cell count and/or activity that have been shown to be associated with an increased risk of URTIs during intense training for soldiers or athletes [2]. Changes in other immune-related factors suggestive of immunosuppression have also been noted after heavy exertion. These include changes in hormones and cytokines favoring a shift from the Th1 to the Th2 cytokine pattern. During intense military training, a relationship between URTIs and NK cell counts concomitantly to hormonal and cytokine responses has been shown, suggesting induction of a Th2 immune response (i.e., decreases in immunostimulatory hormones such as leptin and prolactin and increase in IL-6) [2].

It is well documented that exercise affects local and systemic cytokine production, with similarities to the cytokine response to infection. In sepsis, the cytokine cascades are TNF- $\alpha$ , IL-1 $\beta$ , IL-6, IL-1ra, sTNF-R (soluble receptor to TNF), and IL-10. The cytokine response to prolonged endurance exercise differs from that of infection in the fact that TNF- $\alpha$  and IL-1 $\beta$  were not reportedly increased. Typically, IL-6 is the first cytokine present in the circulation after exercise followed by IL-1ra (IL-1 receptor antagonist), IL-10, and the chemokine IL-8 [4]. The Pedersen group has demonstrated that (i) the major source of circulating IL-6 during prolonged exercise is skeletal muscle, but there is also adipose tissue production, (ii) the muscle production is sensitive to muscle glycogen content, and (iii) during prolonged exercise IL-6 plays a role in glucose homeostasis and lipid metabolism [8].

**Stress Effects During Intense Training on Cellular Immunity, Hormones and Respiratory Infections. Table 1**  
Changes in immune system components after prolonged heavy exertion (from [3])

• Neutrocytosis and lymphopenia, induced by high plasma cortisol
• Increase in blood granulocyte and monocyte phagocytosis, but a decrease in nasal neutrophil phagocytosis
• Decrease in granulocyte oxidative burst activity
• Decrease in nasal mucociliary clearance
• Decrease in natural killer cell cytotoxic activity
• Decrease in mitogen-induced lymphocyte proliferation (a measure of T cell function)
• Decrease in the delayed-type hypersensitivity response
• Increase in plasma levels of pro- and anti-inflammatory cytokines (e.g., interleukin-6 and interleukin-1 receptor antagonist)
• Decrease in ex vivo production of cytokines (interferon-g, interleukin-1 and interleukin-6) in response to mitogens and endotoxin
• Decrease in nasal and salivary IgA level
• Blunted major histocompatibility complex II expression in macrophages

### The Overtraining Syndrome (OTS) and Neuroimmunomodulation

For the athlete, the increased susceptibility to infectious illness has been associated with the condition of overtraining syndrome (OTS), also referred to as “staleness” or burnout’ syndrome. It is often suggested that OTS is the result of an accumulation of stressors that exceed an athlete’s finite resistance capacity, similar to that which Selye observed. It is characterized by a sports-specific decrease in performance despite periods of recovery together with disturbances in mood state. Fry and colleagues [9] have categorized signs/symptoms of OTS according to physiological performance, psychological/information processing, immunological, and biochemical parameters. It is also probable that other signs/symptoms typically associated with overtraining, excluding organic diseases, are evident before deterioration in performance. These might include generalized fatigue, depression, muscle and joint pain, and loss of appetite (Table 2). At present, the definitive diagnostic criteria and the biochemical/metabolic mechanism for OTS are unknown. However, exercise scientists have suggested considering the endocrine, immune and nervous systems as a large system serving integrated functions. Thus, the “cytokine” and “IL-6” hypotheses of the OTS have been proposed.

Cytokines play a function as neuromodulators and immune mediators, and represent the systemic aspect of an immune/inflammatory response, which coordinates the whole body response by simultaneously acting on different organ systems including the central nervous system (CNS). Smith [6] hypothesizes that exercise-related immunosuppression is due to tissue trauma sustained during intense exercise, producing cytokines, which drive the development of a Th2 lymphocyte profile. A Th2 cell response results in simultaneous suppression of cell-mediated immunity, rendering the athlete susceptible to infection. Robson [5] explores the cytokine hypothesis of OTS with a direct focus on IL-6 and thus hypothesizes that the principal abnormal factors in OTS are an increased production of and/or intolerance to IL-6 during exercise.

The cytokine hypothesis of OTS relies on the fact that they can access the CNS and may induce brain-mediated signs of illness by acting at central, rather than peripheral, sites. They may directly access brain structures, either using a transport system to cross the blood brain-barrier (BBB), or acting at the level of circumventricular organs (CVO), where this barrier does not exist [6,7]. They may also inform the CNS indirectly via activation of afferent neurons of the vagus nerve; neural afferents may activate transcription and translation of cytokines within the CNS. In the brain, there are specific receptors for IL-1, IL-6, and TNF that have a discrete distribution. Blocking IL-1 receptors in

### Stress Effects During Intense Training on Cellular Immunity, Hormones and Respiratory

**Infections. Table 2** Signs and symptoms associated with overtraining syndrome (from [9])

<i>A. Physiological performance</i>
• Decreased performance
• Inability to meet previously attained performance
• Recovery prolonged
• Decreased muscular strength
• Decreased maximum work capacity
• Loss of coordination
• Reappearance of mistakes already corrected
• Chronic fatigue
• Insomnia with and without night sweats
• Muscle soreness or tenderness
• Loss of appetite
<i>B. Psychological/information processing</i>
• Feelings of depression
• General apathy
• Emotional instability
• Difficulty in concentrating at work and training
• Fear of competition
<i>C. Immunological</i>
• Increased susceptibility to and severity of illnesses, colds, and allergies
• Flu-like illness
• Minor scratches heal slowly
• Bacterial infection
<i>D. Biochemical</i>
• Negative nitrogen balance
• Depressed muscle glycogen concentration
• Mineral depletion (e.g., zinc, cobalt, aluminium, selenium, copper)
• Elevated cortisol
• Low free testosterone

the brain can prevent some of the sickness responses to peripheral administration of cytokines. Furthermore, administration of certain cytokines directly into the brain produces many or all of the sickness responses. IL-1 and IL-6 receptors in the brain are abundant in the area of the hypothalamus. The binding of cytokines in the hypothalamus results in activation of the hypothalamic-pituitary-adrenal axis (HPA-axis) and sympathetic nuclei, resulting in increased levels of circulating catecholamines, and cortisol, the traditional stress hormones. Robson [5] focuses on the IL-6 hypothesis of OTS because it has been shown that intracerebroventricular administration of IL-6 to rats stimulates the HPA axis, increases tryptophan and serotonin metabolism, induces fever, and decreases appetite and

locomotor activity. In addition, the exercise endurance is reduced in IL-6-deficient mice. For the athlete, several risk factors considered either individually or in combination but experienced chronically can weaken the BBB and permit the cytokine access to the CNS: the exercise workload, exposition to infectious agents, hyperthermia, hypoglycemia, and depression. The Nybo researcher group [10] has particularly evidenced the link between prolonged exercise-induced hyperthermia or hypoglycemia and central fatigue.

Examination of neuroendocrine and immune responses that exist during depression has offered insights into the mechanism and treatment of OTS. Similarly, the relevance of implication of neurotransmitters such as ►serotonin (5-HT: 5-hydroxytryptamine) and noradrenaline has been introduced. The 5-HT system is the largest brain system playing a role in the regulation of mood state, sleep, appetite, cognitive function, memory, circadian rhythms, motor function and sexual activity, neuroendocrine and immune responses. A recent study reports in one case of a severe OTS state a decrease in serotonin transmission in certain parts of the brain, using single-photon emission computed tomography (SPECT). Moreover, serotonergic neurotransmission is thought to be a neuromodulatory system exerting its activity in the CNS and in the periphery. Serotonin can affect immune functions and several findings suggest that modulation of the immune system by serotonin occurs at the lymphocytes level. Presence of 5-HT<sub>1B</sub> receptors has been evidenced in rodent lymphocytes and splenocytes and a human T lymphoblastoid cell line. While there is no report on OTS and change in 5-HT in the immune system, it has been shown that 5-HT<sub>1B</sub> receptors in lymphocytes are desensitized after intense military training [1].

### Conclusion

In conclusion, populations such as soldiers or athletes submitted to combined stress exceeding stress tolerance [i.e., prolonged and repeated exercises, lack of sleep and energy intake, psychological stress, environmental conditions (heat, cold)] are at risk of immunosuppression and exposed to infections, particularly those of the upper respiratory tract.

### References

1. Chennaoui M, Drogou C, Gomez-Merino D, Guezennec CY (2005) Effects of an intense training on functional activity of 5-HT<sub>1B</sub> receptors in human peripheral blood lymphocytes. *Neurosci Lett* 382:1–4
2. Gomez-Merino D, Drogou C, Chennaoui M, Mathieu J, Tiollier E, Guezennec CY (2005) Effects of combined stress during intense training on cellular immunity, hormones and respiratory infections. *Neuroimmunomodulation* 12(3):164–172

3. Nieman DC (2000) Is infection risk linked to exercise workload? *Med Sci Sports Exerc* 32(7):S406–S411
4. Suzuki K, Nakaji S, Yamada M, Totsuka M, Sato K, Sugawara K (2002) Systemic inflammatory response to exhaustive exercise. Cytokine kinetics. *Exerc Immunol Rev* 8:6–48
5. Robson PJ (2003) Elucidating the unexplained underperformance syndrome in endurance athletes. *Sports Med* 33(10):771–781
6. Smith LL (2003) Overtraining, excessive exercise, and altered immunity. Is this a T Helper-1 versus T Helper-2 lymphocyte response? *Sports Med* 33(5):347–364
7. Elenkov IJ, Chrousos GP (1999) Stress hormones, Th1/Th2 patterns, pro/anti inflammatory cytokines and susceptibility to disease. *Trends Endocrinol Metab* 10(9):359–368
8. Febbraio MA, Pedersen BK (2002) Muscle-derived interleukin-6: mechanisms for activation and possible biological roles. *FASEB J* 16:1335–1347
9. Fry RW, Morton AR, Keast D (1991) Overtraining in athletes: an update. *Sports Med* 12:32–65
10. Nybo L, Secher NH (2004) Cerebral perturbations provoked by prolonged exercise. *Prog Neurobiol* 72:223–261

## Stress in Mechanics

### Definition

A generic name for a variety of measures of “the forces per unit area” at a point of a body. In essence, all measures of stress are related to the flux tensor associated with the flux of linear momentum. Specific examples are the first Piola-Kirchhoff stress and the Cauchy stress.

### ►Mechanics

## Stress-induced Analgesia (SIA)

### Definition

Pain reduction occurring in response to a physically taxing or stressful event, such as a forced cold-water swim. Presumed to involve both opioid and non-opioid systems.

- Descending Modulation of Nociception
- Gender/sex Differences in Pain



## Stress/Pressure

### Definition

The force per unit area exerted on a material. The SI unit for stress/pressure is newtons per meter squared (N/m<sup>2</sup>) which is given the name pascal (Pa).

### ► Measurement Techniques (Pressure)

## Stress Response

WILLIAM E. CULLINAN

Department of Biomedical Sciences and Integrative Neuroscience Research Center, Marquette University, Milwaukee, WI, USA

Department of Neurosurgery, Medical College of Wisconsin, Milwaukee, WI, USA

### Definition

The stress response is a complex set of coordinated changes involving neuroendocrine, autonomic, and behavioral components. At the neuroendocrine level, a complex cascade of events is initiated in the brain and pituitary, culminating in the ACTH-induced synthesis and release of glucocorticoids from the adrenal glands. Autonomic activation is simultaneously induced, involving widespread and divergent outflow through the sympathetic nervous system and secretion of adrenal catecholamines, resulting in increases in heart rate, respiration, and blood pressure, as well as mobilization of energy resources. Behavioral changes are induced that promote increased attention and arousal, while inhibiting other non-essential activities (e.g. feeding, gastric motility, sexual behavior). The term *stress*, initially coined by in 1936 by Selye [1], described a pathophysiological state induced by physical or psychological stimuli, the persistence of which may lead to disease or death. Such challenges may be real or interpreted threats to homeostatic balance, and can result in an array of responses that may be adaptive or maladaptive.

### Characteristics

#### Stress Classes and Consequences

Numerous attempts have been made to subdivide stressors according to class. Most authors have delineated stressors of a psychological or psychogenic origin versus those of a physical nature. Stressors within the former category (e.g. novelty, social defeat) have more

recently been termed *processive* or *anticipatory* to emphasize extensive neural processing occurring largely within limbic brain structures prior to transmission to the PVN. Stressors in the latter category (e.g. cardiovascular) have been termed “systemic” or “direct” to underscore a more immediate challenge to homeostasis, as well as an uninterrupted access to the PVN from key afferent sites, particularly in the brainstem. It is the case, however, that overlap exists among both stress classes and the neuronal circuits that mediate them. Remarkably, these circuitries are organized in a hierarchical fashion that enables an appropriate assessment or weighing of the significance of an internal or external threat, with subsequent translation into neuroendocrine, autonomic, and behavioral responses [2]. It is also evident that exposure to stress can produce long-term changes in neuronal function through mechanisms at multiple levels, including synaptic neurotransmission, intracellular signaling, gene regulation, and even morphological changes within key structures. Many of these changes may be considered normal adaptations, even in cases of prolonged or chronic stress. However, when the capacity of the brain’s stress circuitry to maintain normal responsiveness is exceeded in the face of ongoing challenge, stress may be considered maladaptive, and ultimately deleterious to health.

### The Hypothalamic-Pituitary-Adrenocortical (HPA) Axis

The origin of the final common pathway of a major neuroendocrine response to stress is the hypothalamic paraventricular nucleus (PVN); neurons in the medial parvocellular division of this nucleus synthesize and release corticotropin-releasing hormone (CRH) and project to the median eminence, where CRH is released into the portal vasculature. CRH stimulates anterior pituitary cells to secrete adrenocorticotrophic hormone (ACTH, and additional products cleaved from a common precursor, pro-opiomelanocortin; POMC). ACTH is (Fig. 1) carried through the systemic circulation to the adrenal cortex, where it induces the synthesis and release of glucocorticoids (primarily cortisol in humans, corticosterone in rodents) from the zona fasciculata of the adrenal glands. The hypothalamic CRH neurons of the PVN are therefore the primary integrators of the HPA axis, processing stress-related information carried over multiple afferent pathways that differ according to the nature or class of the stressor. The PVN also contains populations of neurons with projections to the brainstem and spinal cord. These neurons, together with cells from adjacent hypothalamic nuclei, regulate outflow to the preganglionic neurons of the autonomic nervous system, including those governing the sympatho-adrenal-medullary response. In addition, arginine vasopressin (AVP), a neuropeptide highly expressed in neurons of the adjacent magnocellular division of the PVN and principally involved in osmotic regulation, is

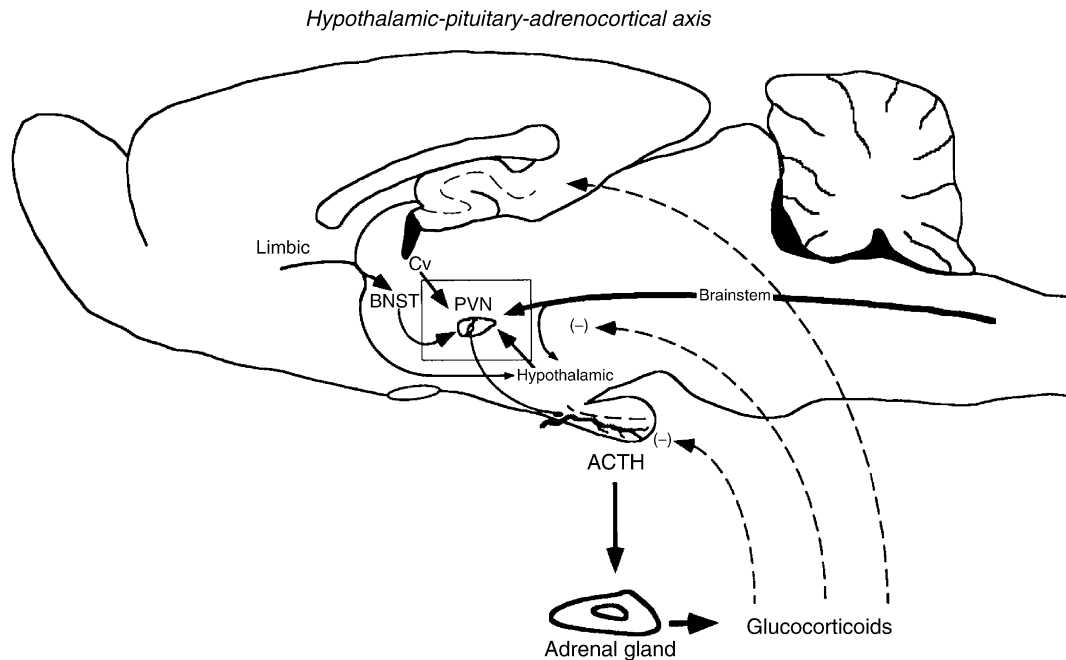

**Stress Response. Figure 1** Diagram illustrating the major components of the Hypothalamic-Pituitary-Adrenocortical (HPA) Axis. Solid arrows indicate sources of regulatory afferents from the brainstem, limbic forebrain, hypothalamus, and circumventricular organs. Dashed lines denote major sites of glucocorticoid negative feedback. Abbreviations: *ACTH* adrenocorticotropic hormone; *BNST* bed nucleus of the stria terminalis; *Cv* circumventricular organs; *PVN* hypothalamic paraventricular nucleus.

co-expressed within hypophysiotropic CRH neurons. AVP is capable of potentiating the effects of CRH on pituitary ACTH release. While CRH is clearly the most potent ACTH secretagogue, hypophysiotropic CRH neurons are also capable of co-expressing a number of peptides in addition to AVP. Recruitment of these transmitters appears to be condition-dependent, affording a wide range of responsiveness to the glucocorticoid stress response.

Glucocorticoids have powerful actions throughout the body, targeting a diverse array of tissues including muscle, fat, skin, bone, kidney and liver. These steroid hormones also have direct effects on immune cells, on the production of inflammatory cytokines, as well as within the CNS itself. Dysregulation of glucocorticoid secretion contributes to numerous disease states including cardiovascular, autoimmune, metabolic, and neuropsychiatric disorders. For example, oversecretion of glucocorticoids can suppress immune function, increasing susceptibility to infection [3], and HPA axis overactivity is a common feature in many patients with depressive illness [4]. Conversely, under-activity of the HPA axis increases susceptibility to autoimmune and inflammatory conditions. Regulation of glucocorticoid levels within a normal range is therefore critical to health. Glucocorticoids also play an important role in cognitive processes such as learning, memory and attention, all of which are affected by dysregulation of

the glucocorticoid stress response as well as stress-induced changes in levels of circulating catecholamines.

#### Afferent Regulation of the PVN

CRH neurons of the PVN are under complex afferent regulation from numerous brain areas. These inputs can be divided into several major classes: brainstem nuclei, local hypothalamic regions, limbic-associated forebrain structures, and circumventricular organs [5]. Major sources of stimulatory input to the PVN emanate from caudal brainstem regions containing the neurotransmitters norepinephrine and epinephrine. Most prominent among them are the A2 region of the nucleus of the tractus solitarius (NTS) and the A1/C1 area of the ventrolateral medulla, which have direct lines of input to the medial parvocellular PVN rich in CRH neurons. The noradrenergic input to CRH neurons is particularly dense, and pharmacological effects here are mediated via  $\alpha$ -1 adrenergic receptors. These brainstem regions receive visceral afferent information carried (Fig. 2) via the ninth and tenth cranial nerves, and relay information to the HPA axis concerning the state of the internal milieu. They are also interconnected with brainstem cardiovascular and respiratory centers. More recent data have indicated that ascending projections from the NTS also include non-catecholaminergic elements. Moreover, numerous additional brainstem regions send projections to the PVN either directly, or via

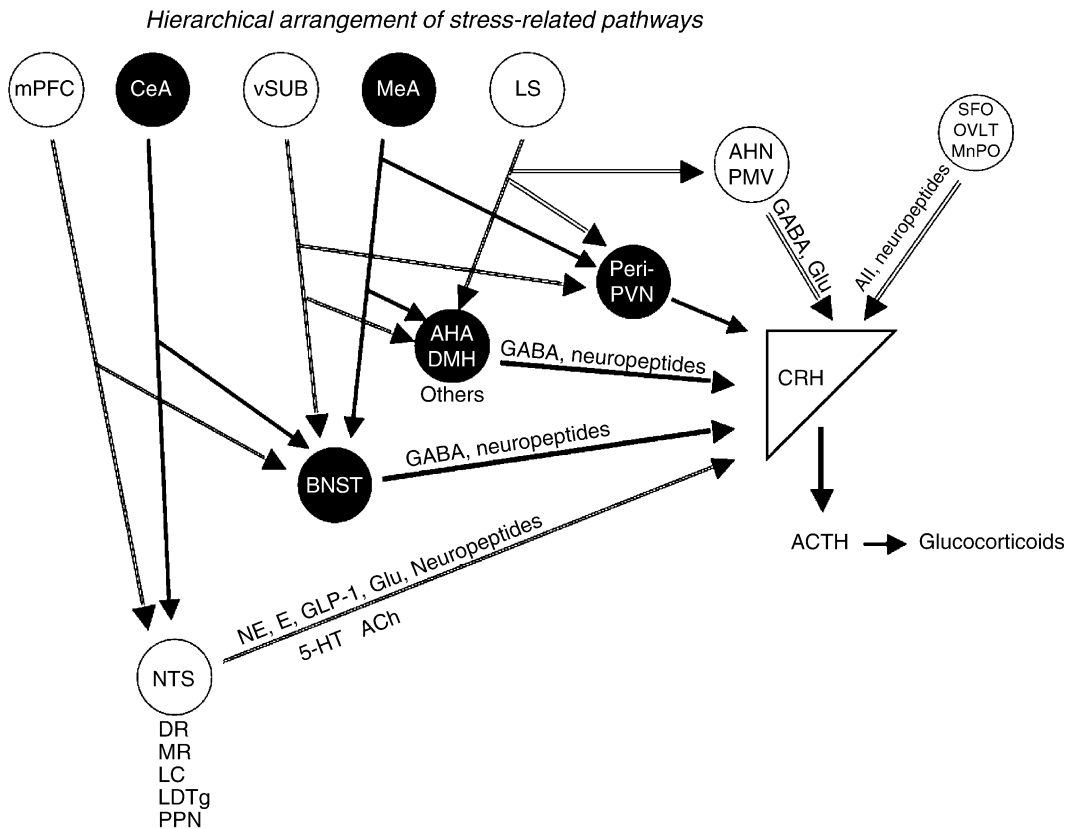

**Stress Response. Figure 2** Schematic diagram illustrating complex, hierarchically organized afferent regulation of hypophysiotropic CRH neurons of the HPA axis. White circles denote brain regions with excitatory outflow; black circles indicate areas thought to have inhibitory outflow. Abbreviations: *5-HT* 5-hydroxytryptamine (serotonin); *All* angiotensin II; *ACTH* adrenocorticotrophic hormone; *AHA* anterior hypothalamic area; *BNST* bed nucleus of stria terminalis; *CeA* central amygdaloid nucleus; *CRH* corticotropin-releasing hormone; *DMH* dorsomedial hypothalamic nucleus; *DR* dorsal raphe nucleus; *GLP-1* glucagon-like peptide I; *Glu* glutamate; *LC* locus coeruleus; *LDTg* laterodorsal tegmental nucleus; *LS* lateral septal nucleus; *MeA* medial amygdaloid nucleus; *MR* median raphe nucleus; *OVLT* organum vasculosum of lamina terminalis; *MnPO* medial preoptic nucleus; *NTS* nucleus tractus solitarius; *PPN* pedunculo pontine nucleus; *SFO* subfornical organ; *vSUB*, ventral subiculum of hippocampus; *PMV* ventral premammillary nucleus.

forebrain relays. Included are serotonergic fibers emanating from the dorsal and median raphe nuclei, cholinergic fibers from the pedunculo pontine and lateral dorsal tegmental nuclei, noradrenergic projections from the locus coeruleus, as well as inputs from the lateral parabrachial nucleus and periaqueductal gray regions. The majority of these inputs are stimulatory in nature, and many transmit somatic and special sensory information to the PVN. In contrast, a series of local forebrain (including intrahypothalamic) regions are known to distribute GABA-mediated inhibitory projections to the PVN. These include the medial preoptic area, bed nucleus of the stria terminalis, dorsomedial hypothalamic nucleus, and anterior hypothalamic area immediately surrounding the PVN. Interestingly, limbic system associated inputs to the HPA axis (medial prefrontal cortex, hippocampus, amygdala) lack direct

projections to the PVN, and influence CRH neurons via relays with neurons located within these local territories [6]. Beyond the aforementioned pathways, research over the past decade has focused on extrahypothalamic CRH and the urocortins—centrally expressed neuropeptides sharing a family resemblance to CRH and acting at its receptors [7]. In addition to these strictly neuronally mediated inputs, blood-borne chemosensory signals reach the PVN either directly via the intrinsic vasculature, or by circumventricular organs (subfornical organ, organum vasculosum of the lamina terminalis) that send neuronal relays to the PVN.

### Glucocorticoid Regulation

Termination of glucocorticoid secretion following stressful episodes is accomplished by negative feedback occurring within different time domains and at multiple

levels of the HPA axis [8]. For example, glucocorticoids inhibit POMC expression and ACTH release at the level of the anterior pituitary, and inhibit hypophysiotropic CRH neurons at the level of the PVN through both genomic and non-genomic mechanisms. Glucocorticoids also act centrally at higher centers; glucocorticoid receptors are found at multiple central sites including the cerebral cortex, hippocampus, septum, amygdala, cerebellum, and brainstem. Two types of the receptor exist. The type II or GR (glucocorticoid receptor) has a widespread distribution in the CNS. The type I, or MR (mineralocorticoid receptor) receptor is more limited in expression, but has a 10-fold higher affinity for glucocorticoids than GR. Both are members of the steroid hormone superfamily, existing in an unbound state within the cytoplasm, but when bound by ligand are translocated to the nucleus where they bind to the promoter regions of responsive genes. Several lines of evidence have suggested that MR may be primarily important in maintaining basal expression of ACTH secretagogues (particularly at the circadian nadir), whereas GR may function principally at the circadian peak and following stressful stimuli. In addition, evidence suggests that glucocorticoid-independent neuronal inhibitory mechanisms are in operation during stressful conditions. For example, inhibition of ACTH release can occur in the absence of glucocorticoid negative feedback [9], implicating additional inhibitory mechanisms involved in restraining HPA-axis activation.

### Limbic Control of Stress Responsiveness

A number of constituent elements of the limbic system have been heavily implicated in the responsiveness of the HPA axis. These regions share the common feature that they lack direct PVN projections. The hippocampus plays a prominent role in inhibition of the glucocorticoid stress response, consistent with its high levels of expression of glucocorticoid receptors (see above). Moreover, functional studies have demonstrated a deficit in negative feedback following lesions of this structure, as well as with receptor inactivation or with gene deletion. Anatomical data are consistent with this picture: the ventral subiculum, the major output structure of the hippocampus, sends an impressive excitatory (glutamatergic) projection to the basal forebrain, but does not contact PVN neurons directly. These signals are converted to an inhibitory signal at the PVN by way of relays among populations of GABAergic neurons in the hypothalamus and BNST.

The amygdala, in contrast to the hippocampus, appears to stimulate the PVN. A major distinction lies in the class of stressors in which these limbic nuclei play a vital role. The medial amygdaloid nucleus stimulates the HPA axis in response to anticipatory but not systemic stressors, whereas the reverse is the case for the central amygdaloid nucleus. Interestingly,

projection neurons from both the medial and central amygdaloid nuclei are GABAergic, and like hippocampal projections, do not directly innervate the PVN. Rather, both medial and central amygdaloid regions are also thought to target local inhibitory relay neurons, and thereby function through a disinhibitory mechanism.

Numerous studies have implicated the medial prefrontal cortex in HPA axis regulation. An increasing body of literature has indicated that dorsal components of this region are inhibitory to the PVN, whereas more ventral territories appear to stimulate HPA output [10]. In both cases this limbic cortical output is mediated via multiple relays in forebrain (e.g. BNST), or in the case of ventral prefrontal areas (infralimbic cortex), brainstem regions such as the NTS.

Several additional forebrain regions considered part of the limbic system are known to affect HPA activity. These include the lateral septal nucleus, which inhibits the stress response, as well as limbic components of the thalamus (e.g. paraventricular nucleus of the thalamus) that mediate habituation of the stress response. Finally, several loci within the hypothalamus intersect with classical limbic circuitries, and relays through these regions permit limbic information to be processed with regard to ongoing physiological status. The net effect is that stressor salience is fine-tuned within these local circuits to account for caloric requirements, thermoregulatory status, osmotic balance, and diurnal rhythmicity prior to being translated to the PVN.

### References

1. Selye H (1936) A syndrome produced by diverse noxious agents. *Nature* 38:32
2. Herman JP, Figueiredo HF, Mueller NK, Ulrich-Lai Y, Ostrander MM, Choi DC, Cullinan WE (2003) Central mechanisms of stress integration: hierarchical circuitry controlling hypothalamo-pituitary-adrenocortical responsiveness. *Front Neuroendocrinol* 24:151–180
3. O'Connor TM, O'Halloran DJ, Shanahan F (2000) The stress response of the hypothalamic-pituitary-adrenocortical axis: from molecules to melancholia. *Q J Med* 93:323–333
4. DeKloet ER, Holsboer F (2005) Stress and the brain: From adaptation to disease. *Nat Rev* 6:463–475
5. Sawchenko PE, Brown ER, Chan RK, Ericsson A, Li HY, Roland BL, Kovacs KJ (1996) The paraventricular nucleus of the hypothalamus and the functional neuroanatomy of visceromotor responses to stress. *Prog Brain Res* 107:201–222
6. Herman JP, Cullinan WE (1997) Neurocircuitry of stress: central control of the hypothalamo-pituitary-adrenocortical axis. *Trends Neurosci* 20:78–84
7. Zorilla EP, Koob GF (2005) The roles of urocortins 1, 2, and 3 in the brain. In: Steckler T, Kalin NH, Reul JM (eds) *Handbook of stress and the brain*, vol 15. Elsevier, Amsterdam, pp 179–203
8. Keller-Wood M, Dallman MF (1984) Corticosteroid inhibition of ACTH secretion. *Endocrine Rev* 5:1–24

9. Jacobson L, Akana S, Cascio CS, Shinsako J, Dallman MF (1988) Circadian variations in plasma corticosterone permit normal termination of adrenocorticotropin responses to stress. *Endocrinology* 122:1343–1348
10. Radley JJ, Arias CM, Sawchenko PE (2006) Regional differentiation of the medial prefrontal cortex in regulating adaptive responses to acute emotional stress. *J Neurosci* 26(50):12967–12976

## Stress Response (Heat Shock) Protein

### Definition

Protein that is synthesized in response to mechanical, chemical or thermal (heat shock) injury (stress), and which usually promotes survival of the cell.

## Stretch-inactivated Cation Channel (SIC)

### Definition

Stretch-inactivated cation channels underlie the hyperosmotic depolarization which is associated with an increase in membrane conductance. This response is due to the bi-directional, cell-volume-dependent modulation of a non-selective cation conductance. Cells shrinking in the presence of hypertonic solution disinhibit channel activity, which leads to depolarization.

Conversely, cell swelling induced by a hypoosmotic solution inhibits basal channel activity and leads to hyperpolarization.

- ▶ Blood Volume Regulation

## Stretch Receptor

### Definition

In many animals, muscles contain specialized sensory end organs that are activated when the muscle in which they are contained is lengthened or stretched. These sensory receptors signal the length of the muscle to the central nervous system (CNS) and can also signal the velocity of a change in length. In the lamprey, these

receptors are located in the spinal cord itself and respond when the cord bends during body undulations.

- ▶ Intersegmental Coordination
- ▶ Sensory Systems

## Stretch Reflex

### Definition

The stretch reflex is a reflex that causes a muscle to contract and shorten after it is stretched. The elongation of a muscle, usually by an external perturbation is encoded by the firing of muscle spindle receptors within the muscle. The Ia muscle spindle afferents synapse on motoneurons of the same muscle, causing the muscle to contract in response to muscle stretch.

- ▶ Postural Synergies

## Stretch Resistance

- ▶ Muscular Stiffness

## Stretching Tensor

### Definition

The symmetric part of the velocity gradient. Also called rate of deformation tensor.

- ▶ Mechanics

## Stria Terminalis

### Definition

The stria terminalis is the most important efferent of the amygdaloid body. It is a bundle of myelinated fibers

coursing in the lateral ventricle, in the groove between thalamus and caudate nucleus and dividing at the anterior commissure. Target areas are: preoptic area, anterior hypothalamic area, hypothalamic nuclei, interstitial nucleus of stria terminalis. It marks the border between diencephalon and telencephalon.

- ▶ Amygdala
- ▶ Evolution of the Amygdala: Tetrapods
- ▶ Diencephalon

---

## Striate Cortex

### Definition

The striate cortex (also called Brodmann's area 17, V1, and primary visual cortex) is the first cortical visual area. It lies in the calcarine sulcus of the occipital lobe and receives signals relayed from the retina via the lateral geniculate nucleus of the thalamus.

- ▶ Striate Cortex Functions
- ▶ Geniculo-striate Pathway

---

## Striate Cortex Functions

DANIEL L. ADAMS, JONATHAN C. HORTON  
Koret Vision Research Laboratory, Department of  
Ophthalmology, UCSF, San Francisco, CA, USA

### Synonyms

Area V1; Primary visual cortex; Brodmann area 17

### Definition

Striate cortex is the primary sensory cortical area for vision. Damage to striate cortex causes blind regions, called scotomas, in the field of vision. Striate cortex derives its name from the stria of ▶Gennari, a prominent band of ▶myelin in layer 4, visible to the naked eye. In histological sections, striate cortex has a characteristic laminar cell structure (Fig. 1). Striate cortex is located within the calcarine sulcus on the medial face of each ▶occipital lobe. It occupies about 10% of the whole cerebral cortex. Each neuron in striate cortex responds to visual stimuli presented within a small portion of the visual field, known as the ▶receptive field (▶Visual cortical and subcortical

receptive fields). The properties of a visual cell can be ascertained by analyzing the response to different types of visual stimuli falling within the receptive field. Thus, the functions of striate cortex can be defined by identifying the cardinal properties of its constituent cells, such as selectivity for stimulus orientation, direction of motion and stereoscopic depth (▶Binocular Vision). These properties must be synthesized within striate cortex, because they are not present in the cells that provide ascending input. Another way to define the functions of striate cortex is to examine how the properties of single cells are related to anatomical structures, commonly revealed by the presence of functional maps. Neurons with similar properties tend to be grouped together, and there is a continuous and gradual change in physiological characteristics across the cortical sheet. Numerous superimposed maps are present within area V1 that together provide full coverage of the visual field for multiple visual modalities.

### Characteristics

#### Overview

The neural processing of visual signals begins with the capture of light images by photoreceptor cells (▶photoreceptors). After some internal retinal processing, visual information exits the eye in the form of action potentials propagated along the axons of ganglion cells (▶retinal ganglion cells). These axons are grouped into bundles that form the ▶optic nerves. The two optic nerves meet and decussate partially at the ▶optic chiasm, to form the ▶optic tracts. In the optic tracts, crossed fibers from the nasal half of each retina run alongside uncrossed fibers from the temporal half of each retina. The axons synapse on cells in the ▶lateral geniculate nucleus (LGN) of the ▶thalamus. The LGN provides the major ascending input to striate cortex, via the ▶optic radiations, to layer 4. The main cortical output is derived from layers 2, 3, 5, and 6. Between the input and output layers, intracortical circuitry combines and elaborates visual signals to generate novel receptive field properties. The visual system includes a network of multiple cortical areas, each receiving input from and sending connections to other areas. Each area in the network acts as a specialized processing module, extracting specific types of visual information. Striate cortex can be thought of as the foundation of this network. It distributes and receives information from many different interconnected areas. Striate cortex also sends a major feedback projection to the LGN. The function of this pathway is contentious; it may modulate the flow of information into striate cortex.

#### Input

Cells within each layer of striate cortex have characteristic morphologies and patterns of connectivity (▶Visual cortex – neurons and local circuits). The input from

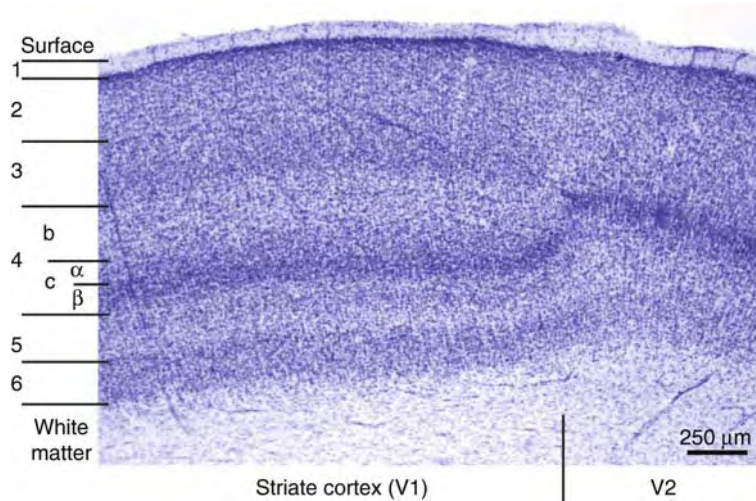

**Striate Cortex Functions. Figure 1** Cross section through striate cortex stained with cresyl violet to show neuronal cell bodies. The multi-layered structure of the cortical sheet is evident, as well as the transition between striate cortex and the second visual area, V2. Layer 4 is a conspicuous feature of striate cortex, containing two cell-dense input sublayers (4c $\beta$  and 4c $\alpha$ ), as well as a cell sparse sublayer (4b) containing the stria of Gennari.

the LGN to striate cortex abides by a laminar organization, such that three categories of LGN cells project to three separate laminar divisions (Fig. 2), also see ►[geniculo-striate pathways](#)). Thus, the functional division in the LGN is maintained in the input layers of striate cortex. To generate more specialized functional properties, the signals from multiple LGN inputs converge onto single cortical cells. This convergent processing of visual information in striate cortex is achieved by complex circuits that operate between the input and the output cells.

#### **Intracortical Circuitry**

Intracortical circuitry forms the anatomical basis of neural processing of visual information (►[Visual cortex – neurons and local circuits](#)). Intracortical projections connect cells that are separated horizontally in the same layer or vertically in separate layers. These connections allow visual signals from many cells to combine and influence each other. In the case of striate cortex (Fig. 3), the dense internal circuitry provides ample opportunity for the integration of functional properties that remain segregated at the level of the LGN. The intracortical circuitry of striate cortex is responsible for the elaboration of the elementary properties of LGN cells into novel, more specialized attributes, such as orientation, direction and binocular disparity tuning.

#### **Retinotopy**

Neighboring cells in striate cortex represent adjacent points in the visual field. This organizing principle is called ►[retinotopy](#) (Fig. 4). A consequence of retinotopic organization is the formation of a map of the

visual scene on the cortex. The fovea in each retina corresponds to the ►[fixation point](#). The fovea represented posteriorly near the occipital pole. A vertical line running through the fixation point divides the visual scene into left and right hemifields. Each hemifield is represented in striate cortex of the contralateral hemisphere. Thus if striate cortex on one side is destroyed, vision is lost from the visual field on the opposite (contralateral) side. In this case, the damage is said to have caused a ►[homonymous hemianopia](#) – loss of vision from both eyes resulting in complete blindness on one full side of the visual field.

When we examine something closely, like the printed words on a page, we move our eyes so that light reflected from the point of interest is focused onto the fovea of each retina. The ►[eye movements](#) (►[Saccades](#)) that control this behavior allow us to take full advantage of the fovea by placing it serially on regions of interest. Numerous specializations in the retina (including a high density of ones) endow the fovea with maximum resolution. As a result, more information emanates from the fovea than from the peripheral retina. To serve the fovea, a far greater amount of cortical tissue is allotted to central versus peripheral retina. In fact, the surface area of striate cortex devoted to 1° is about 10,000 times greater at the fovea than in the periphery. This results in distortion of the visual scene by the retinotopic map in striate cortex (Fig. 5).

#### **Ocular Dominance**

Cells in the LGN are monocular; they respond to stimuli presented to one eye but not to the other. Likewise, the

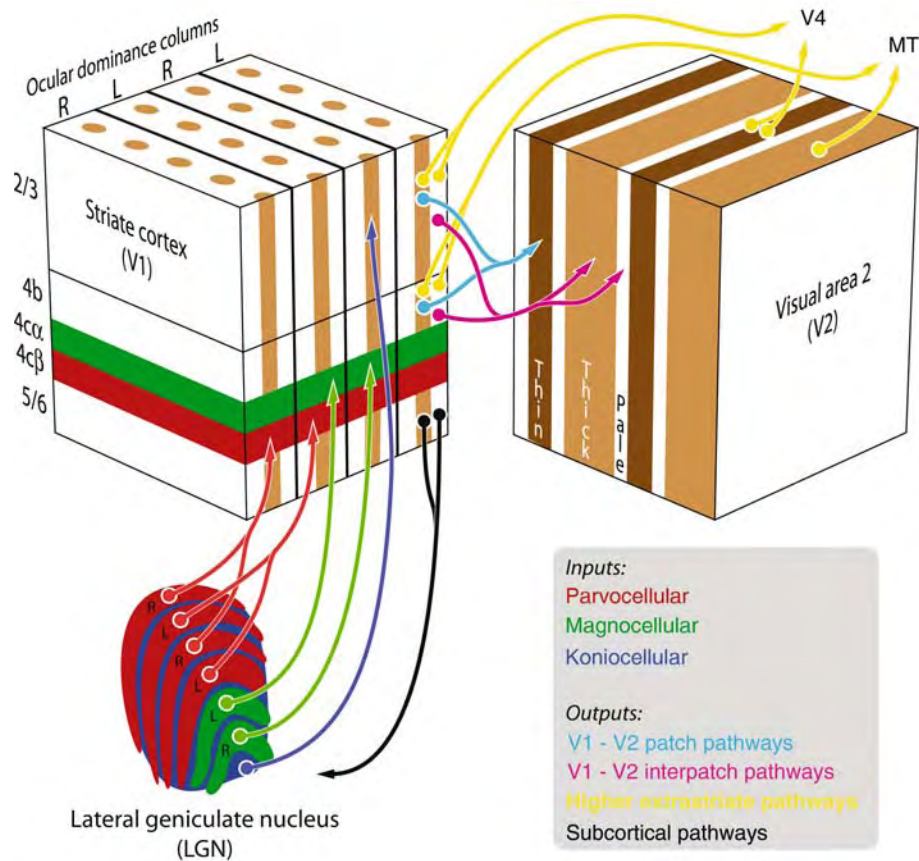

**Striate Cortex Functions. Figure 2** Inputs and outputs of striate cortex. Cells in the LGN provide the major ascending input to striate cortex. Their axon terminals segregate both by eye (R, L) and by layer. Recipient cells in layer 4c $\beta$  (parvo), 4c $\alpha$  (magn) and 2,3 (konio) make extensive intracortical connections, partially merging inputs from the three functional LGN channels. The output from striate cortex to area V2 is organized by cytochrome oxidase compartment. The patches (vertical brown cylinders) project to thin stripes, and the interpatches project to thick and pale stripes. The output of V2 also respects cytochrome oxidase divisions: thick stripes project to the middle temporal area (MT), while thin and pale stripes supply area V4.

cells in layer 4c of striate cortex are monocular, because they are targeted selectively by LGN inputs. Layer 4c is segregated into regions dominated by the left eye or the right eye. These two domains interdigitate to form a labyrinthine pattern tangential to the cortical sheet-called “▶ocular dominance columns”. The pattern formed by ocular dominance columns is distinctive and robust [2]. It is best appreciated when the cortex has been removed from the rest of the brain, unfolded and flattened before histological sections are cut tangential to the surface [3] (Fig. 4b). Rather like a fingerprint, the ocular dominance pattern is unique and highly variable between individuals and species. Columns are found in most carnivores and primates, including humans. In animals that lack columns, monocular cells persist, but they are mixed homogenously in layer 4c. Ocular dominance columns are intriguing, but their function is unknown.

### Disparity Selectivity

Most cortical cells in layer 4c are monocular, i.e. they respond to stimulation of only one eye. Binocular integration (▶Binocular vision) occurs by the convergence of intrinsic projections from monocular cells in layer 4c onto single cells in the upper and lower layers of the cortex. Most binocular cells are sensitive to small differences in the spatial location of images falling on each retina. This endows them with the capacity to extract information about the depth of stimuli relative to the fixation point: a property known as ▶disparity selectivity. Some binocular cells are tuned to respond maximally to stimuli placed on the fixation plane, whereas others prefer stimuli in front of or behind it. As a population, disparity-tuned neurons encode accurate information about depth, and therefore provide the cellular basis for the perceptual phenomenon of ▶stereopsis. They also provide signals to the



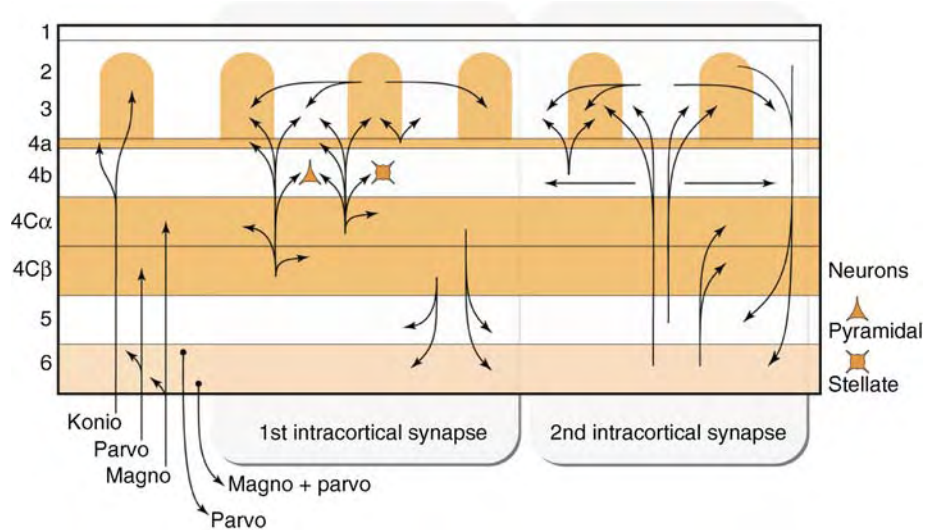

**Striate Cortex Functions. Figure 3** Intracortical circuitry within striate cortex. (Left) V1 is innervated by parvocellular, magnocellular, and koniocellular laminae of the LGN, which segregate in layers 4c $\beta$ , 4c $\alpha$ , and 4a 2/3 respectively. Even by the first intracortical synapse, these functional streams intermingle extensively. At the second intracortical synapse, increasing emphasis on horizontal projections further blends V1 signals. The relative strength of projections is not shown in this schematic diagram, nor is the diversity of cell types and classes comprising the intracortical wiring (Figure from [1]).

►brainstem for the ►oculomotor system to drive reflexive, ►disparity dependent►vergence movements that bring both foveas onto a common target in depth.

Specialized stimuli called random dot stereograms are often used to study stereopsis because they contain no depth cues except disparity. Random dot stereograms whose elements have opposite contrast in the two eyes (anticorrelated) do not give rise to a sensation of depth. However, cells in striate cortex are selective for the disparity in anticorrelated random dot stereograms. The difference between the responses of a striate cortex cell to correlated versus anticorrelated stereograms is an inversion of the disparity tuning curve. Thus, cells in striate cortex can exhibit disparity-tuned responses that do not lead to a perception of depth [4]. That the activity of cells in striate cortex does not necessarily correlate with perception is an interesting insight into striate cortex function. It is likely that networks of neurons from striate cortex to ►extrastriate areas (►extrastriate visual cortex) must also be activated to produce a conscious visual experience of depth.

### Orientation Selectivity

Unlike cells in the LGN, which fire best to small spots of light, most cortical cells outside of layer 4c $\beta$  display ►orientation selectivity (Fig. 6). These cells respond optimally when the stimulus is presented at a specific orientation within the ►receptive field [5] (►Geniculostriate pathway; ►Visual cortical and subcortical receptive fields). Since they respond to ►contours,

orientation-tuned cells comprise the elementary units necessary for form vision (►form perception). In striate cortex, orientation-tuned cells have a distinct functional organization: orientation tuning rotates gradually as the cortical sheet is traversed in a tangential direction. Optical imaging produces a strikingly ordered ►orientation map, containing singularities (as referred to as pin-wheels) where neurons with different orientation preferences converge and saddle zones where transitions are more gradual (Fig. 7) [6]. Recent experiments have shown that neuronal maps can be described more accurately by invoking Fourier energy models, rather than simply orientation tuning [7].

### Direction selectivity

The detection of movement is a fundamental function of the visual system. Even animals with rudimentary vision are able to sense motion. In primates, motion vision is thought to be mediated by populations of cells whose responses are tuned to particular directions of stimulus movement. Such cells are less concerned with the orientation, form or color of the stimulus, but are often tuned to its speed. In some cases, the responses of direction selective cells are inhibited when the stimulus moves 180° opposite to the preferred direction. Since LGN cells do not exhibit direction selectivity, it must be generated within striate cortex by projections between multiple non-directional cells in specialized circuits. Direction selective cells are most prominent in layers 4b and 5/6 of striate cortex.

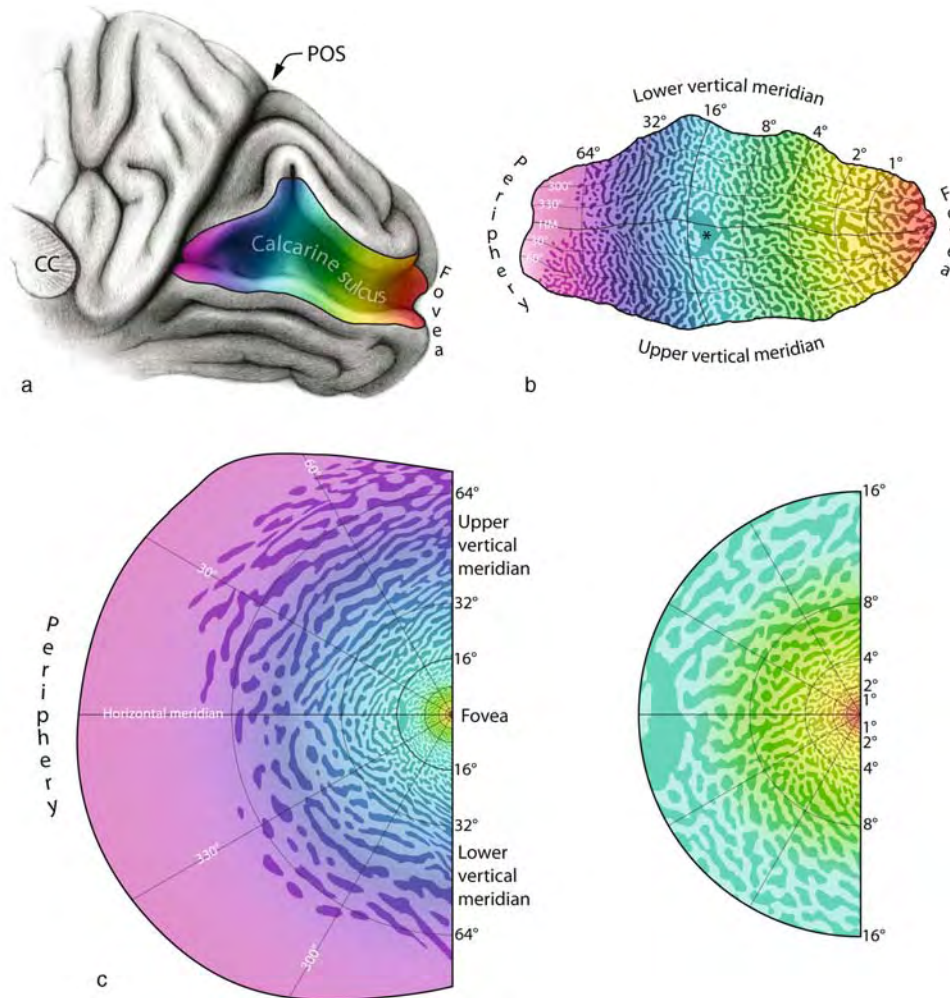

**Striate Cortex Functions. Figure 4** The retinotopic map and ocular dominance column pattern in human striate cortex. (a) Medial face of the right hemisphere with the calcarine sulcus opened to expose striate cortex. Visual eccentricity is color-coded: the representation of the fovea is red and the far periphery is violet. cc = corpus callosum. (b) Unfolded striate cortex, showing retinotopic coordinates. The left eye's columns correspond to the pale regions. The blind spot appears as a solid oval (\*). The representation of the monocular crescent also lacks columns, because the extreme temporal visual field is supplied by the contralateral eye alone. (c) Projection of striate cortex back onto the visual hemifield, demonstrating the magnification of central vision in the cortex. The central 16° are shown at higher magnification on the right. Since ocular dominance columns are relatively constant in size, their projection onto the visual field is greatly distorted by cortical magnification.

The direction-selective cells of striate cortex form the building blocks for motion vision (► [Visual processing of motion](#)). However, taken in isolation, their responses are not sufficient to describe completely the direction of motion of an object in the visual world. The receptive fields of direction-selective cells in striate cortex are small. Consequently, each cell can respond only to individual components of a moving object. Since the global direction of movement of an object is a sum of all of its component vectors, the responses of many striate cortex cells must be considered to gain an accurate

measure of the object's direction; single cells in striate cortex are not equipped to provide this information. This is known as the ► [aperture problem](#), because it arises when one observes the motion of an oriented contour through a small aperture that blocks the view of the ends of the line (Fig. 8). Direction-selective cells in layer 4b of striate cortex project directly to an extrastriate visual area, the medial temporal area (MT), also known as V5. MT cells are also direction-selective, but their receptive fields are larger than those of striate cortical neurons. Single MT cells receive input from multiple

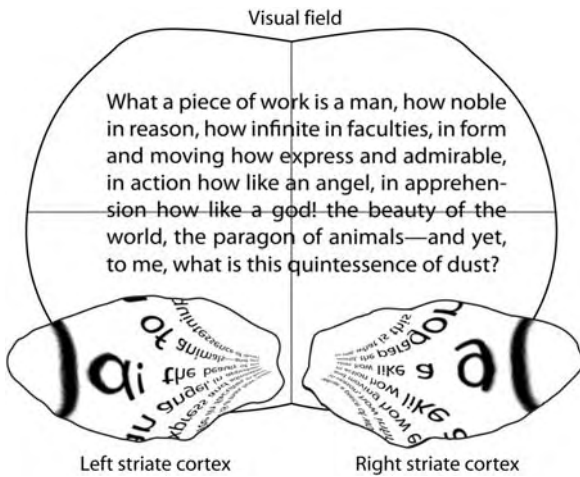

**Striate Cortex Functions. Figure 5** Projection of a visual image onto striate cortex. A greater amount of tissue is allocated to the representation of the central portion of the visual field in striate cortex, resulting in distortion of the text. The crosshair represents the center of gaze, which corresponds to the fovea in each eye. The left side of the visual field is reflected about a horizontal axis and projected onto the right hemisphere (and *visa-versa*). The increase in magnification from peripheral to central visual field in the cortical transformation of the image is logarithmic.

direction-selective cells in striate cortex, enabling them to be selective for the global direction of motion of an object in the visual world [8].

**Color Selectivity**

Cells influenced by the wavelength composition of stimuli are said to be color-selective, and provide information necessary for color perception (Color processing). Many cells in striate cortex have a color-opponent, center-surround structure to their receptive fields. This organization reflects an imbalance in the spatial composition of inputs from different cone photoreceptors (Photoreceptors) in the retina. Other cells display the property of double color opponency, i.e. their center and surround are maximally inhibited or excited by pairs of different wavelengths. Such cells are ideal for detecting chromatic borders. Some cortical cells are tuned to both the color and the orientation of stimuli.

There is a diverse range of wavelength combinations present in natural illumination. The visual system must take into account the wavelength composition of the illuminating light to perceive accurately the color of objects. The process of discounting the influence of the illuminant is called color constancy. Cells in striate cortex respond only to the wavelength composition of reflected light rather than the perceived color of the surface [9], i.e. they do not exhibit color constancy.

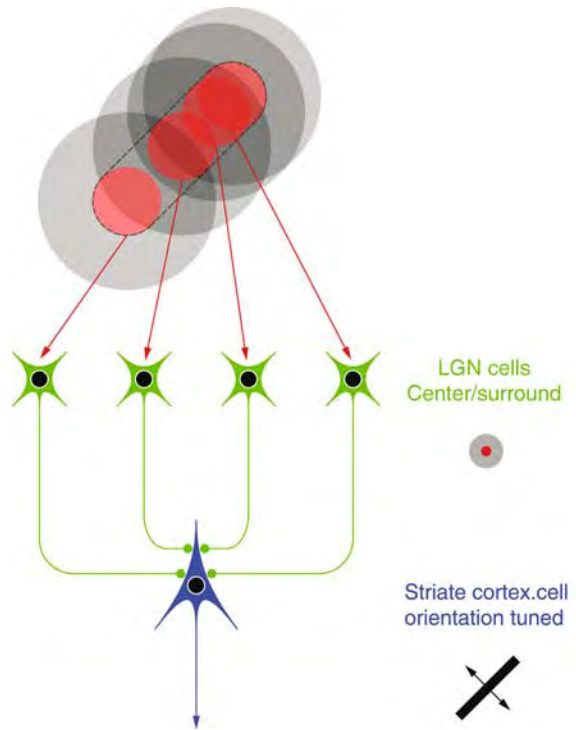

**Striate Cortex Functions. Figure 6** The generation of orientation selectivity in striate cortex. The receptive fields of LGN cells have a center-surround structure. They each respond best to spots of light appearing at the center of the receptive field (red). Stimulation of each cell. Here a population of center-surround cells (green) is shown, forming excitatory synapses onto a single cortical cell (blue). If a light impinges on the centers of the LGN cells simultaneously, the cortical cell will be activated maximally. The property of orientation selectivity may be derived from selective connections between such geniculate cells and cortical cells.

Consequently, “color” cells in striate cortex are more accurately referred to as wavelength-selective. The calculations necessary to provide color constancy must therefore be made in a higher visual area, such as V4. Just as for disparity and direction selective cells in striate cortex, wavelength selective cells encode a physical property of the world that does not necessarily correlate with perception.

**Cytochrome Oxidase Architecture**

Cytochrome oxidase is a metabolic enzyme present in mitochondria. The level of cytochrome oxidase is regulated by cell activity over a time scale of hours. In cortical tissue, the density of cytochrome oxidase is heterogeneous. In striate cortex, the input layers stain most richly, indicating that they have the highest rate of

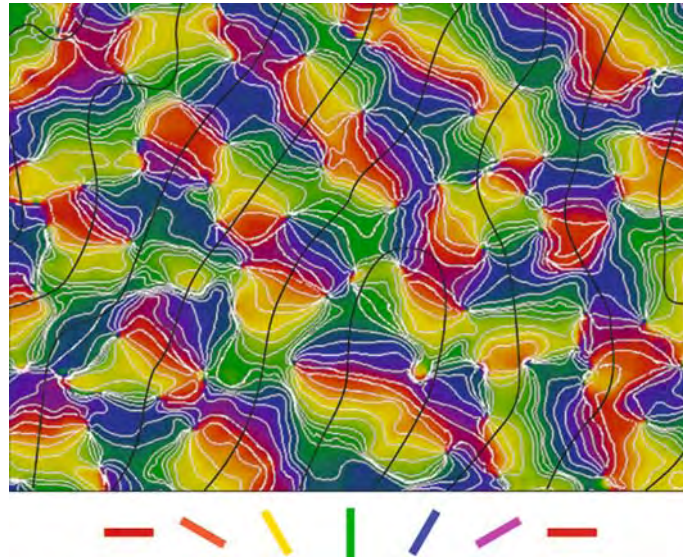

**Striate Cortex Functions. Figure 7** Map of orientation preference in macaque striate cortex. Orientation selectivity is measured by optically imaging the cortical surface in the presence of a voltage-sensitive dye. Physiological response is color coded according to the orientation of the bar stimulus that generates the strongest signal. White lines are iso-orientation contours. Black lines represent the borders of ocular dominance columns. The iso-orientation lines converge at pinwheel centers which tend to be centered within ocular dominance columns (Data from [5]).

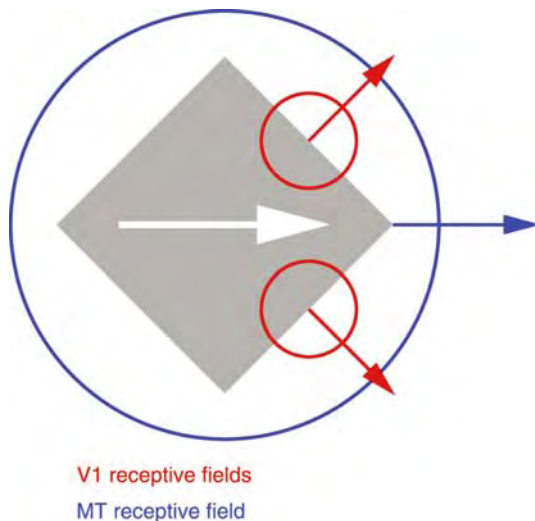

**Striate Cortex Functions. Figure 8** The aperture problem. The direction of motion of an object (*the gray square*) cannot be determined by observing the direction of motion of individual local components. The global direction of motion of the object can be determined only from the sum of all the component vectors. Cells in striate cortex are able to signal the direction only of local contours because their receptive fields (*red*) are too small to sum vectors from the whole object. Cells in MT, however, have large receptive fields (*blue*) that are formed by combining the output from many cells in striate cortex. They are better equipped to solve the aperture problem and to encode the true direction of motion (*white arrow*) of the object.

physiological activity. In the tangential plane, cytochrome oxidase histochemistry reveals a regular array of patches, most prominently in layers 2 and 3 (Fig. 9). Also known as puffs or ►blobs, these patches span the full thickness of the cortex, except for layers 1, 4a and 4c. Patches are thought to constitute functional units within striate cortex, because their anatomical connections are distinct. In layers 2 and 3 they receive a direct projection from konio cells in the LGN (Fig. 2) (►Geniculo-striate pathway). Because this projection is monocular, and patches are located within the middle of ocular dominance columns, their cells usually show a strong response bias for one eye. Other physiological properties may correlate with cytochrome oxidase patches in striate cortex. For example, there is weak evidence that unoriented, color-selective cells are clustered within patches. Patches may also be aligned with pinwheel centers in the orientation map [6].

Visual area 2 (►area V2) also has a characteristic cytochrome oxidase architecture (Fig. 9), consisting of parallel stripes (see also ►Extrastriate visual cortex). Three distinct types of cytochrome oxidase stripes are present in the monkey, forming an alternating pattern orthogonal to the area V2 border. There are two classes of dark stripes – thick and thin – separated by pale stripes. The stripes in area V2 extend through the full thickness of the cortex. Each stripe class in area V2 has distinct functional properties, as shown by physiological recording. Moreover, the input and output connections of area V2 are organized by stripe type (Fig. 2).

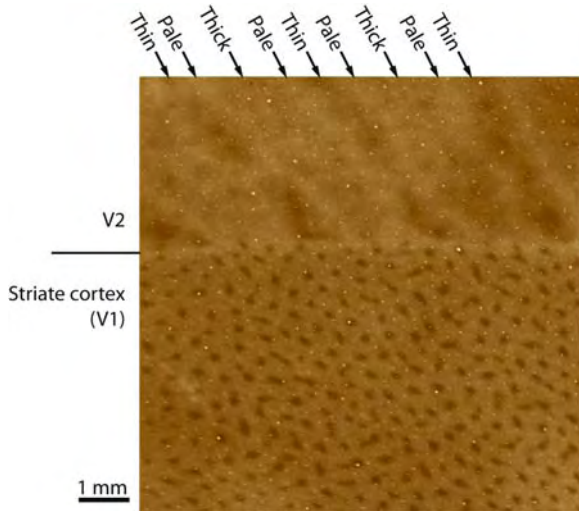

**Striate Cortex Functions. Figure 9** Functional compartments in V1 and V2 are interconnected. This tangential section was stained for cytochrome oxidase, revealing a regular array of patches in striate cortex and repeating cycles of thick-pale-thin-pale stripes in V2. Patches connect to thin stripes; interpatches supply thick and pale stripes.

### Output

The main cortical projection target of striate cortex is V2. V1 cells in patches project to V2 cells in thin stripes (Fig. 2). This projection may be specialized for ►color processing, through a pathway that combines LGN ►parvocellular and ►koniocellular inputs in patches, and then proceeds via area V2 thin stripes to area V4. Cells located in the area V1 interpatch regions project to thick or pale stripes. A substantial proportion of interpatch cells have axons that bifurcate to terminate in both a thick and a pale stripe [1].

Cells in striate cortex also give rise to axons that project to extrastriate areas beyond area V2. Some ►direction-selective cells in layer 4b project directly to MT. Patch and interpatch cells in layers 2 and 3 project directly to area V4, an area thought to process color and form information that also receives input from V2's thin stripes and pale stripes. Thus, the outputs of striate cortex provide the origin for multiple cortical ►visual processing streams, each dividing further to become more specialized for specific visual modalities. Ultimately, these pathways result in a division of labor among multiple, functionally specialized regions of the brain.

### Summary

Striate cortex contains cells that encode basic information about many visual modalities. However, the responses of these cells do not correlate directly with perception. Information must be passed from striate cortex to higher visual areas, where the activity of single

cells provides a precise readout of sensory experience. Because signals pass through striate cortex *en-route* to these higher areas, lesions of striate cortex block the flow of information to the whole cortical visual system. Thus, while it may not signal perception *per se*, an intact striate cortex is necessary for conscious vision. Humans with lesions of striate cortex are capable of making only coarse visual discriminations in their blind fields. This preserved visual ability sometimes goes unnoticed by the subject until explicitly tested under laboratory conditions, prompting some investigators to call it “blindsight” (►Blindsight). The existence of such residual vision means that there must be an alternate route to higher cortical visual areas that bypasses striate cortex. Recently a neural pathway that could fulfill such a role was found in the macaque [10]. Small numbers of cells in the LGN were found to project directly to the extrastriate motion processing area MT. This pathway may be responsible for the rudimentary visual capacity to sense motion that persists in the absence of striate cortex.

Compared to more specialized extrastriate visual areas like MT, the functions of striate cortex are manifold. Perhaps it is best thought of as a refinery and distribution station, first extracting and purifying components of visual information, then routing them to appropriate specialized areas of the extrastriate visual system for more detailed analysis.

### References

1. Sincich LC, Horton JC (2005) The circuitry of V1 and V2: integration of color, form, and motion. *Annu Rev Neurosci* 28:303–326
2. Hubel DH, Wiesel TN (1969) Anatomical demonstration of columns in the monkey striate cortex. *Nature* 221 (182):747–750
3. Adams DL, Sincich LC, Horton JC (2007) Complete pattern of ocular dominance columns in human primary visual cortex. *J Neurosci* 27(39):10391–10403
4. Cumming BG, Parker AJ (1997) Responses of primary visual cortical neurons to binocular disparity without depth perception. *Nature* 389(6648):280–283
5. Hubel DH, Wiesel TN (1977) The Ferrier lecture: functional architecture of macaque monkey visual cortex. *Proc Royal Soc Lond B* 198:1–59
6. Blasdel GG, Salama G (1986) Voltage-sensitive dyes reveal a modular organization in monkey striate cortex. *Nature* 321(6070):579–585
7. Basole A, White LE, Fitzpatrick D (2003) Mapping multiple features in the population response of visual cortex. *Nature* 423(6943):986–990
8. Rust NC et al. (2006) How MT cells analyze the motion of visual patterns. *Nat Neurosci* 9(11):1421–1431
9. Zeki S (1983) Colour coding in the cerebral cortex: the reaction of cells in monkey visual cortex to wavelengths and colours. *Neuroscience* 9(4):741–765
10. Sincich LC et al. (2004) Bypassing V1: a direct geniculate input to area MT. *Nat Neurosci* 7(10):1123–1128

## Striatopallidum

DANIEL S. ZAHM

Department of Pharmacological and Physiological Science, Saint Louis University School of Medicine, Grand Blvd., Saint Louis, MO, USA

### Synonyms

Basal ganglia; Cortico-subcortical reentrant circuit; Cortico-basal ganglia-thalamocortical circuit; Forebrain functional-anatomical system; Forebrain macrosystem

### Definition

Striatopallidum refers to a general pattern of neural connectivity, originally limited to the basal ganglia (see essay on ►[Basal Ganglia](#)), relating the cerebral cortex to certain ►[deep telencephalic nuclei](#), such as the ►[caudate nucleus](#) and ►[putamen](#), which receive massive cortical ►[projections](#) and the ►[globus pallidus](#), to which the caudate nucleus and putamen project. The globus pallidus in turn gives rise to outputs that (1) return to motor planning related parts of the cortex via relays traversing the thalamus (see essay on ►[Thalamus](#)) or (2) descend into the brainstem to terminate largely in the vicinity of motor related structures associated with the reticular formation of the brain (see essay on ►[Reticular Formation](#)). During the past 30 years the meaning of the term striatopallidum has broadened, as cortico-subcortical relationships resembling those of basal ganglia have been described in association with a number of structures classically grouped with the ►[limbic system](#) (see also ►[Limbic System](#)), including the ►[nucleus accumbens](#), ►[olfactory tubercle](#), ►[amygdala](#) and ►[bed nucleus of the stria terminalis](#) and some additional territories in the ►[basal forebrain](#).

### Characteristics

The prototypic pattern of neural connections in the striatopallidum, as alluded to in the definition given above, is classically associated with the ►[corpus striatum](#), as in e.g., Nauta and Mehler's classic description of the connections of the ►[lentiform nucleus](#) in the monkey [1]. The term striatum refers to visible striations caused by axon fascicles fanning through the corpus striatum, which comprises the caudate and lentiform nuclei. The lentiform nucleus in turn consists of the putamen and globus pallidus. The cerebral cortex of projects massively to the caudate nucleus and putamen, which both comprise mostly medium size, densely spiny, inhibitory neurons, are structurally and physiologically similar and project massively to the globus pallidus. The globus pallidus differs from the caudate nucleus and putamen structurally and

functionally and gives rise to the trans-thalamic and descending outputs from the complex. For unknown reasons, the term striatum came to be reserved for the caudate and putamen, distinguishing them from the globus pallidus, or pallidum. Although the deep telencephalic nuclei or basal ganglia, correctly also include the amygdala (also called the amygdaloid complex) and septal nuclei, common usage of the term basal ganglia became limited to the corpus striatum. Hence, the meaning of the term striatopallidum came to approximate that of the term basal ganglia.

A number of more or less epic conceptual developments during the past 30 years have served to broaden the definition of the basal ganglia, resulting in a gradually increasing usage of the term striatopallidum and generalization of its meaning. The first of these occurred during the early 1970's with the discovery that the olfactory tubercle in the rodent is occupied by neural tissue that, in terms of intrinsic character and extrinsic connections, is striatal [2]. The striatum in the olfactory tubercle, which came to be called ►[ventral striatum](#), was observed to interdigitate with another distinct district in the tubercle containing neural tissue of pallidal character representing a rostroventral extension of the globus pallidus protruding into the basal forebrain and deep parts of the tubercle. Cortical inputs to the striatal district of the tubercle, which occupies its superficial and intermediate parts, arise in the primary olfactory (piriform) cortex. The striatal district of the tubercle projects to the overlying so-called ►[ventral pallidum](#), which in turn projects to the ►[mediodorsal nucleus of the thalamus](#) [3]. These relationships, combined with the observation that the nucleus accumbens gives rise to a striatopallidal projection to an adjacent part of the ventral pallidum [4], served to confirm the longstanding, tentative characterization of the nucleus accumbens as part of basal ganglia [5].

These findings broadened the concept of basal ganglia. Now the entire cerebral cortex, including the olfactory cortex and hippocampus would be regarded as utilizing mechanisms provided by basal ganglia circuitry. The previously held concept that the cortico-subcortical relationships in brain can be split into distinct limbic (see also synopsis on ►[Limbic System](#)) and ►[extrapyramidal](#) (basal ganglia) sectors was no longer tenable. On the contrary, the parallel disposition of the newly discovered cortico-basal ganglia-thalamocortical circuit traversing ventral striatum, ventral pallidum and the ►[thalamic mediodorsal nucleus](#) and the "classical" basal ganglia circuit involving, e.g., the caudate nucleus and putamen, globus pallidus and anterior ►[ventral tier thalamic nuclei](#) (VA-VL), eventually led to a more refined appreciation of parallel, segregated basal ganglia-thalamocortical circuits ([6], see also essays on ►[Basal Ganglia](#) and ►[Cortico-Subcortical Reentrant Circuits](#)), an appreciation laden with implications for the

diagnosis and treatment of neuropsychiatric illness [7]. Furthermore, the continuity across dorsal and ventral striatopallidum of the massive terminations of the ventral mesencephalic dopaminergic projections energized fields of inquiry concerned with dopamine and its receptors, including neuropsychiatry (in particular as related to schizophrenia) and drug abuse research.

A second major conceptual “advance” was described in a paper that became quite influential essentially by reasserting the validity of some neglected concepts from the classical literature ([8] and references therein). These authors recapitulated the venerable, but largely forgotten, concept that the amygdaloid complex comprises two distinct sectors (see essay on Amygdala). One is a cortical-laterobasal part of the amygdala that is cortex-like in terms of its intrinsic cellular and neurochemical composition and extrinsic connections. The second is a centromedial part that includes the ►central (CeA) and ►medial nuclei (MeA) of the amygdala. Some additional structures exhibiting strikingly similar tissue composition and continuity with the CeA and MeA include the bed nucleus of the stria terminalis (BST), similarly differentiated and organized neuronal groups dispersed within the ►stria terminalis and certain basal forebrain territories extending between the centromedial amygdala and BST, all of which together came to be called ►extended amygdala. A central division of the extended amygdala gets its major descending inputs largely from the cortical-like laterobasal complex of the amygdala and gives rise to outputs to the ►lateral hypothalamus and brainstem somatic and autonomic motor effectors. A medial division of the extended amygdala gets descending inputs largely from the cortical nucleus of the amygdala and projects mostly to neuroendocrine effectors in the medial hypothalamus (see essay on ►Hypothalamus). While acknowledging that the extended amygdala exhibits features that strikingly resemble the intrinsic organization and extrinsic connections of striatopallidum, Alheid and Heimer [8] opted to emphasize those aspects of tissue composition and function that distinguish extended amygdala from striatopallidum and conceived of the two as distinct ►basal forebrain functional-anatomical systems. They also mentioned that additional evaluation would probably reveal the ►lateral septum to be an input (striatal) structure of yet another distinct striatopallidal-like basal forebrain functional-anatomical system receiving massive hippocampal inputs.

A couple of investigators subsequently adopted the fundamental tenets articulated by Heimer and Alheid so completely as to vigorously advocate that the cortico-subcortical relationships of the extended amygdala be regarded without qualification as striatopallidal [9,10]. One effect of these papers has been to further increase the currency of the term striatopallidum in contemporary neuroscience intercourse.

## References

1. Nauta WJH, Mehler WR (1966) Projections of the lentiform nucleus in the monkey. *Brain Res* 1:3–42
2. Heimer L (1972) The olfactory connections of the diencephalon in the rat. An experimental light- and electron-microscopic study with special emphasis on the problem of terminal degeneration. *Brain Behav Evol* 6:484–523
3. Young WS III, Alheid GF, Heimer L (1984) The ventral pallidal projection to the mediodorsal thalamus: a study with fluorescent retrograde tracers and immunohisto-fluorescence. *J Neurosci* 4:1626–1638
4. Heimer L, Wilson RD (1975) The subcortical projections of allocortex: similarities in the neuronal associations of the hippocampus, the piriform cortex and the neocortex. In: Santini M (ed) *Golgi centennial symposium proceedings*. Raven, New York, pp 173–193
5. Chronister RB, DeFrance JF (1980) Nucleus accumbens in historical perspective. In: Chronister RB, DeFrance JF (eds) *The neurobiology of the nucleus accumbens*. Hair Institute for Electrophysiological Research, pp 1–6
6. Alexander GE, DeLong MR, Strick PL (1986) Parallel organization of functionally segregated circuits linking basal ganglia and cortex. *Annu Rev Neurosci* 9:357–381
7. Lichter DG, Cummings JL (2001) *Frontal-subcortical circuits in psychiatric and neurological disorders*. Guilford, New York
8. Alheid GF, Heimer L (1988) New perspectives in basal forebrain organization of special relevance for neuropsychiatric disorders: the striatopallidal, amygdaloid, and corticopetal components of substantia innominata. *Neuroscience* 27:1–39
9. Cassell MD (1998) The amygdala: myth or monolith? *TINS* 21:200–201
10. Swanson LW, Petrovich GD (1998) What is the amygdala? *Trends Neurosci* 21:323–331

## Striatum

### Definition

The striatal components of the striatopallidal complexes. In mammalian terminology, the dorsal striatum is also known as the caudate nucleus and putamen. It receives glutamatergic cortical inputs and dopaminergic inputs from the substantia nigra, and it projects to the globus pallidus. The ventral striatum consists of the nucleus accumbens and the olfactory tubercle. It projects to the ventral pallidum. The striatopallidal complexes are involved in circuits that control the suppression and/or initiation of movements.

- Evolution of the Diencephalon
- Evolution of the Dorsal Thalamus
- Striatopallidum

## Striatum, Dorsal

### Definition

Caudate nucleus and putamen as part of the basal ganglia.

- ▶ Basal Ganglia
- ▶ Striatopallidum

## Striatum, Ventral

### Definition

Part of the striatal complex comprising the ventral parts of the caudate nucleus and putamen, the accumbens and striatal districts in the olfactory tubercle, i.e. containing a dense accumulation of medium-sized, densely spiny GABAergic neurons.

- ▶ Basal Ganglia
- ▶ Striatopallidum

## Striola

### Definition

A central specialized region of otoconia and receptor cells that lies centrally in the otolith maculae. Within the striola lies the imaginary reversal line, where hair cells of opposing polarity reside.

- ▶ Peripheral Vestibular Apparatus

## Stroke

CLAIRE CREUTZFELD, DAVID TIRSCHWELL  
Harborview Neurology - Comprehensive Stroke Center  
University of Washington School of Medicine, Seattle,  
WA, USA

### Synonyms

Cerebrovascular disease; Cerebrovascular accident; CVA, Brain attack

### Definition

Stroke is defined as rapidly developed clinical signs of focal (or global<sup>1</sup>) disturbance of cerebral function lasting more than 24 h (unless interrupted by surgery or death), with no apparent cause other than a vascular origin: it includes patients presenting with clinical signs and symptoms suggestive of subarachnoid haemorrhage, intracerebral haemorrhage or cerebral ischaemic necrosis [1].

### Characteristics

#### Epidemiology

Stroke is the second leading cause of lost disability-adjusted life years in high-income countries and of death worldwide, after ischemic heart disease; in 2001, an estimated 5.4 million people died from stroke worldwide [2]. In the USA, there are approximately 700,000 strokes each year, killing over 150,000 people; almost a third of stroke victims are younger than 65 years of age [3]. In Western societies, 80% of strokes are ischemic, and the remaining 20% are caused by hemorrhages. One-month case fatality rate for stroke ranges between 8 and 40%, with mortality highest for hemorrhagic strokes and in developing countries [3].

#### Etiology/Subtypes

A stroke is caused by disruption of blood supply to a part of the brain. Brain tissue that no longer receives its blood supply can die within a few hours unless something is done to stop the damage. Blockage of an artery leads to *ischemic stroke*. If this blockage lasts less than 24 h, with complete resolution of symptoms, it is called a transient ischemic attack (▶TIA). Strokes due to bursting of an artery are called hemorrhagic strokes. In *intracerebral (or intraparenchymal) hemorrhages*, the blood clot forms in the brain itself, while *subarachnoid hemorrhages* are due to bleeding within the membranes surrounding the brain, usually around the base of the brain. Another, rarer form of stroke can occur when a vein (that drains blood out of the brain) is blocked. This is called a *venous stroke*. ▶Hypertension is probably the most important modifiable risk factor for stroke: continuous high pressure in vessels results in atherosclerotic plaque formation and endothelial damage.

- *Ischemic Stroke (IS)* represents about 80% of all strokes and is caused by occlusion of an artery supplying the brain. This can be one of the large arteries in the neck or the base of the brain or in small arteries inside the brain itself. The artery occludes either locally or by a blood clot that formed elsewhere in the body and traveled to the brain

<sup>1</sup> Global: this applies to patients with subarachnoid haemorrhage or deep coma but excluding coma of systemic vascular origin such as shock, Stokes-dams syndrome or hypertensive encephalopathy.



through the artery (► **embolic infarct**, see ► **ischemic stroke**). The main modifiable risk factors for ischemic stroke include arterial hypertension, ► **atrial fibrillation**, cigarette smoking, ► **hyperlipidemia**, ► **diabetes mellitus**, and a previous stroke or transient ischemic attack (TIA).

- **Intracerebral hemorrhage (ICH)** is caused by bleeding of a blood vessel inside the brain parenchyma and accounts for approximately 15% of strokes. Damage is caused both by the impaired blood supply and by the pressure on the brain from the hematoma. The most common cause of intracerebral hemorrhage is high blood pressure. Abnormally formed blood vessels in the brain can be another cause, especially in younger people.
- **Subarachnoid hemorrhage (SAH)** results from bleeding of an artery into the membranes surrounding the brain, usually around the base of the brain. Less than 5% of all strokes are SAH. The most frequent cause of subarachnoid hemorrhage is bleeding from an aneurysm. An aneurysm is a bulge of an artery caused by weakening and ballooning of a short portion of the vessel wall. High blood pressure, smoking, excessive alcohol-intake and a family history of burst aneurysms can increase a person's risk of subarachnoid hemorrhage [4].
- **Venous stroke** is caused by a blockage of the veins that allow blood to drain out of the brain (cerebral vein or venous sinus thrombosis). This causes a backpressure that can result in either ► **ischemia** or hemorrhage. Venous stroke most commonly occurs in the setting of a medical or genetic condition that increases a person's tendency to form blood clots (► **hypercoagulable state**). Severe dehydration or infection of the sinuses of the head can also predispose to venous stroke. Less than 1% of strokes are venous.

### Signs and Symptoms

The symptoms of stroke depend on the type of stroke and the area of the brain affected. They are usually

unilateral, occurring on the side of the body opposite to the affected side of the brain. As is implied in the word “stroke,” symptoms typically develop suddenly and rapidly.

Common symptoms include weakness or numbness; confusion, trouble speaking or understanding; loss of vision in all or part of the visual field; loss of balance or coordination, trouble walking or dizziness. Loss of consciousness, headache, and vomiting at the onset occur more often in hemorrhagic stroke and venous stroke because of increased intracranial pressure (ICP).

Seizures may occur in up to 20% of ischemic, 30% of hemorrhagic, and in 40% of patients with venous stroke [5,6,7].

A combination of symptoms caused by impairment of one arterial territory is termed *vascular syndrome*, for example a posterior cerebral artery (PCA) syndrome includes visual problems, as the PCA supplies the visual ► **cortex** (see “ischemic stroke, vascular syndromes”).

### Differential Diagnosis

See: [Table 1](#)

### Diagnosis

- Deficits are identified by a careful ► **neurological examination**, and the severity assessed using one of the standardized stroke scales, i.e., the National Institute of Health Stroke Scale ([http://www.ninds.nih.gov/doctors/NIH\\_Stroke\\_Scale\\_Booklet.pdf](http://www.ninds.nih.gov/doctors/NIH_Stroke_Scale_Booklet.pdf)).
- ► **Laboratory workup** should include basic metabolic panel with glucose, complete blood count, coagulation parameters and an EKG to identify arrhythmias and/or signs of acute or previous myocardial infarction. If this is abnormal, markers of cardiac ischemia should be checked. In the appropriate setting, hypercoagulable workup and vasculitis testing may be indicated, as well as hepatic function tests, toxicology screen, blood alcohol level, pregnancy test, arterial blood gas. If subarachnoid hemorrhage is suspected and CT scan shows no blood, a lumbar puncture is required.

**Stroke. Table 1** Differential diagnosis of acute stroke presentation

• TIA	• CNS Infection
• Ischemic Stroke	• Tumor (with sz)
• Intracerebral Hemorrhage	• Peripheral nerve lesions
• Subdural Hematoma (small)	• Metabolic abnormalities
• Focal seizure	• Hyper/hypoglycemia
• Post-ictal Todd's paralysis	• Anamnestic deficit
• Syncope/Presyncope	• Esp. infected elderly
• Complicated migraine	• Toxic States
• Transient confusion in the elderly and/or demented	• Hypertensive Encephalopathy
• Vertigo of peripheral origin	• Conversion disorder

- **▶Imaging:** Non-contrast head CT remains the most commonly used imaging modality in the acute setting, because it is fast, easy, widely available and less expensive than MRI. MRI is more sensitive for detection of acute ischemic stroke and is better at identifying acute, small cortical, small deep, and posterior fossa infarcts, and at distinguishing acute from chronic stroke [5]. CT- or MR-Angiography is a helpful noninvasive method to identify any cervical or intracranial stenoses and can detect aneurysms in 95% of the cases [4]. Venous sinus thrombosis can usually be detected on MRI, but if there is clinical suspicion for it, CT- or MR-Venogram should be obtained.
- **▶Ancillary tests**
  - Cardiac monitoring for at least 24h after the event, to identify arrhythmias.
  - Echocardiogram is an ultrasound study of the heart that can look for any source of cardioembolism, for example wall motion, valvular abnormalities, or a clot inside the heart. “Bubble studies” can identify a **▶cardiac shunt** as a cause of **▶paradoxical embolism**.
  - Ultrasound of the arteries in the neck and brain (carotid ultrasound, transcranial ultrasound) evaluates the presence and degree of vessel narrowing and may identify clots traveling through that vessel.
  - With conventional angiography, the arteries and veins of the brain are best visualized and most vascular abnormalities can be detected. At the same time, it can be used for interventions such as closure of an aneurysm or opening of a blocked artery. Being an interventional procedure, it does have its own risks, which should be weighed against the potential benefit.
- Life style/diet: people with any vascular risk factors or a history of a stroke or a heart attack should limit their daily alcohol use, try to maintain their ideal body weight, exercise daily and stop smoking [8].
- Blood pressure (BP): hypertension, defined as a BP of 140/90mmHg or higher for an extended period of time, is the most important modifiable risk factor for stroke, and reduction of BP reduces this risk. Choice of BP-lowering agent is still uncertain but diuretics and/or ACE-inhibitors are recommended [8].
- **▶Diabetes mellitus:** The risk for stroke (especially ischemic stroke) in people with diabetes can be substantially reduced with tight control of blood glucose. People with diabetes should also be particularly weary of other risk factors, such as hypertension and hyperlipidemia.
- **▶Hyperlipidemia:** In patients with vascular disease or a history of an ischemic stroke, life style modification, diet and medications are recommended to lower cholesterol levels. Statins have been shown to reduce the risk of ischemic stroke but slightly increase that for hemorrhagic stroke [9].
- Antiplatelet therapy: Patients, who have had a non-**▶cardioembolic** ischemic stroke, should take ASA to prevent stroke recurrence or any other vascular event. The use of other antiplatelet agents (dipyridamole, clopidogrel) may be considered as additional or alternative therapy.
- Anticoagulation is indicated in patients with atrial fibrillation (usually indefinitely), in those where a clear tendency for forming blood clots was found (indefinitely), and in patients with venous thrombosis (for six months, or longer if a predisposing factor has been identified) [7]. Anticoagulation is relatively contra-indicated after intracerebral hemorrhage.
- After a hemorrhagic stroke, the use of blood thinning medication of any kind (antiplatelet or anticoagulation agents) is associated with a risk of another hemorrhage, but needs to be weighed against the risk of a thrombotic event on an individual basis.

### Acute Management

The sooner a stroke is treated, the better the chance of recovery. Patients treated in hospitals with a dedicated Stroke Team or Stroke Unit and a specialized care program for stroke patients have improved odds of recovery. Thus, if a stroke is suspected, emergency medical services should be activated immediately [5]. The treatment of stroke is a rapidly evolving discipline and there are a number of modalities both proven and experimental that are effective in minimizing the damage and improving the outcome from stroke. The details of the treatment of stroke are outside of the intended scope of this encyclopedia.

### Stroke Prevention

Almost a third of all strokes are recurrent attacks [3]. Thus, careful attention needs to be paid to all vascular risk factors. The ways to reduce the risk of a recurrent stroke are very similar to those that can prevent a stroke in the first place.

### Prognosis

Prognosis depends on the patient’s age, type of stroke and how severe the stroke is at the onset. 20% of victims die within one month of having an ischemic stroke, 40% after an intracerebral hemorrhage and 30% after subarachnoid hemorrhage. The majority of survivors have some long-term disability; 50–70% of stroke survivors do become independent, 15–30% are permanently disabled and 20% live in a nursing home at three months after onset [3].

### Stroke Rehabilitation

Early stroke rehabilitation services are very effective in reducing long-term disability and improving quality of life as well as reducing overall health care costs [10].

Rehabilitation doctors, Speech and Language therapists, Physical and Occupational therapists should be involved early on in the care of a stroke patient.

## References

1. WHO (1999) <http://www.ktl.fi/publications/monica/manual/part4/iv-2.htm#Introduction>
2. Lopez AD et al. (2006) Global and regional burden of disease and risk factors, 2001: systematic analysis of population health data. *Lancet* 367(9524):1747–1757
3. Rosamond W et al. (2007) Heart disease and stroke statistics – 2007 update: a report from the American Heart Association Statistics Committee and Stroke Statistics Subcommittee. *Circulation* 115(5):e69–e171
4. van Gijn J, Kerr RS, Rinkel GJ (2007) Subarachnoid haemorrhage. *Lancet* 369(9558):306–318
5. Adams HP Jr et al. (2007) Guidelines for the early management of adults with ischemic stroke: a guideline from the American Heart Association/American Stroke Association Stroke Council, Clinical Cardiology Council, Cardiovascular Radiology and Intervention Council, and the Atherosclerotic Peripheral Vascular Disease and Quality of Care Outcomes in Research Interdisciplinary Working Groups: the American Academy of Neurology affirms the value of this guideline as an educational tool for neurologists. *Stroke* 38(5):1655–1711
6. Claassen J et al. (2007) Electrographic seizures and periodic discharges after intracerebral hemorrhage. *Neurology* 69(13):1356–1365
7. Stam J (2005) Thrombosis of the cerebral veins and sinuses. *N Engl J Med* 352(17):1791–1798
8. Sacco RL et al. (2006) Guidelines for prevention of stroke in patients with ischemic stroke or transient ischemic attack: a statement for healthcare professionals from the American Heart Association/American Stroke Association Council on Stroke: co-sponsored by the Council on Cardiovascular Radiology and Intervention: the American Academy of Neurology affirms the value of this guideline. *Circulation* 113(10):e409–e449
9. Amarenco P et al. (2006) High-dose atorvastatin after stroke or transient ischemic attack. *N Engl J Med* 355(6):549–559
10. Walker MF (2007) Stroke rehabilitation: evidence-based or evidence-tinged? *J Rehabil Med* 39(3):193–197

## Stroma

### Definition

The connective tissue network (of endomysium, perimysium and epimysium) within a muscle. The word of Greek origin actually refers to a supporting function.

► **Intramuscular Myofascial Force Transmission**

## Structure-from-Motion

### Definition

The perception of three-dimensional structure from motion occurs when, for example, a two-dimensional pattern of dots moves in such a way that the dot trajectories are consistent with the retinal image projected by rotation of a three-dimensional object.

► **Visual Motion Processing**

## Stumbling-corrective Reaction

### Definition

A reflex initiated in walking mammals to lift the leg over an obstacle when the leg contacts the obstacle.

► **Locomotor Reflexes**

## Stupor

### Definition

Stupor denotes a state, from which the patient can be aroused by very strong stimuli, but he/she tries to avoid uncomfortable stimuli, and the verbal responses are absent or slow.

## Subacute Sclerosing Panencephalitis (SSP)

### Definition

SSP is a progressive, debilitating, and fatal brain disorder caused by infection with a mutant measles (rubeola) virus. A mutant virus is one that has undergone genetic changes (mutations).

## Subcortical Infarction

### Definition

Subcortical infarcts are located in the basal ganglia, internal capsule, or corona radiata and are thought more commonly to be caused by hypertension and diabetes and less commonly by cardiac or artery-to-artery embolism.

- ▶ Ischemic Stroke
- ▶ Stroke

## Subcortical Visual Shell

### Definition

Twelve contiguous retinorecipient nuclei of the thalamus and midbrain, not including the terminal nuclei of the accessory optic system. In order from ventrolateral to dorsomedial they are the ventral lateral geniculate n., intergeniculate leaflet, dorsal lateral geniculate n., lateral posterior n., posterior limitans n., nucleus of the optic tract, anterior pretectal n., posterior pretectal n., medial pretectal n., commissural pretectal n. and, positioned dorsocaudally, the superior colliculus.

- ▶ Intergeniculate Leaflet

## Subgranular Layer of Hippocampus

### Definition

The subgranular layer of the hippocampus is the region of the dentate gyrus between the granular cell layer and the hilus. Neural stem or progenitor cells (NSPCs) reside in this region. Neuronal progeny of these NSPCs migrate varying distances into the granular cell layer, extending their dendrites and axons into the molecular layer and CA3, respectively.

## Subiculum

### Definition

The subiculum is a band of cells that deep in the hippocampal sulcus continues the CA1 cell layer of

Ammon's horn and, for its part, joins the cell band of the presubkulum. It thus marks the transition from hippocampus to the area surrounding hippocampus. In the subiculum most efferents arise from the hippocampus (-> fornix), afferents come from the entorhinal area primarily.

- ▶ Telencephalon

## Subjective Contour

### Definition

- ▶ Illusory Contour
- ▶ Perceptual Filling-In

## Subjective Day/Night

### Definition

Used in circadian biology when a test subject is housed in constant conditions where circadian rhythms adopt their endogenous, free-running period. Subjective day defines the portion of the endogenous circadian rhythm that would normally be associated with the light phase (daytime). Subjective night defines the portion of the endogenous circadian rhythm normally associated with the dark phase (nighttime). The behaviorally active phase of diurnal organisms occurs during the subjective day whereas it occurs during the subjective night for nocturnal organisms.

- ▶ Chronobiology
- ▶ Circadian Rhythm

## Subjectivity

### Definition

Subjectivity may be attributed to (i) a particular mental event, because it is experienced by just one person, who has a privileged access to it; (ii) types of [→] phenomenal consciousness (qualia), because only if one has had such experiences does one know what it is

like to have them; (iii) the entity (subject) that is in mental states, esp. if one takes it to differ in kind from physical objects; (iv) [->] self-consciousness because it is the awareness a person has of herself as herself.

- ▶ Argument
- ▶ Logic

## Sub-Modality (also Quality)

### Definition

Sub-modalities (qualities) refer to subclasses of modalities, such as, in the visual system, perception of shades of grey from black to white and of different colors, or in the tactile domain, differentiation of pressure, touch and vibration sensations.

- ▶ Sensory Systems

## Submucosal Plexus

### Definition

The submucosal plexus is a division of the enteric nervous system, a plexus of small ganglia and connecting nerve fiber bundles that lies within the submucosal layer, between the external musculature and the mucosa of the small and large intestines, forming a continuous network from the duodenum to the internal anal sphincter.

- ▶ Autonomic/Enteric Reflexes
- ▶ Enteric Nervous System

## Subpallial Amygdala

### Definition

Part of the amygdala that derives from the subpallium, i.e., the ventral part of the telencephalon. It is composed by nuclei of striatal and pallidal origin in all tetrapods.

- ▶ Evolution of the Amygdala: Tetrapods

## Subparaventricular Zone

### Definition

A loosely defined population of neurons that resides directly ventral to the paraventricular nucleus (PVN) in the anterior hypothalamus. Neurons in this region receive dense projections from the suprachiasmatic nucleus, the brain's circadian pacemaker, as well as projections from other hypothalamic nuclei. It is hypothesized that these neurons integrate circadian and metabolic information.

- ▶ Circadian Pacemaker
- ▶ Paraventricular Nucleus (PVN)
- ▶ Suprachiasmatic Nucleus
- ▶ Ventrolateral Preoptic Nucleus (VLPO)

## Substance P

### Definition

Substance P is a member of a group of polypeptides known as neurokinins or tachykinins. Substance P as well as neurokinin NK1 receptors have been detected in vagal afferent neurons in the area postrema, nucleus tractus solitarii and dorsal motor nucleus of the vagus. Substance P has been shown to increase the firing rate of neurons in the area postrema and nucleus tractus solitarii and to produce retching when applied directly to these areas in animal studies. Substance P is also a co-transmitter in nociceptive group C afferent fibers and is crucially involved in central sensitization.

- ▶ Area Postrema (AP)
- ▶ Hyperalgesia and Allodynia
- ▶ Nucleus of the Solitary Tract

## Substantia Gelatinosa (of Roland)

### Synonyms

- ▶ Gelatinous substance

### Definition

A small-celled area in the posterior horn of the spinal cord. Pain fibers synapse here.

- ▶ Medulla Spinalis

## Substantia Gelatinosa of the Spinal Nucleus of the Trigeminal Nerve, Caudal Part

### Definition

Substantia gelatinosa (of Roland) at the level of the spinal nucleus of the trigeminal nerve, caudal part. Pain fibers synapse here.

► Medulla Spinalis

## Substantia Innominata

### Definition

The broad expanse of ventral forebrain territory situated beneath the globus pallidus (sublenticular substantia innominata) and anterior commissure (sublenticular substantia innominata) lateral to the lateral preoptic and lateral hypothalamic areas. Rostrally, it tapers into the deep layers of the olfactory tubercle and caudally it merges into the anterior amygdaloid area, ending where the internal capsule reaches the ventral surface of the brain to form the cerebral peduncle. The term, which implies an indeterminate neural organization, has lost some currency with the descriptions of the ventral striatopallidum, extended amygdala and magnocellular basal forebrain system, which occupy territory within the so-called substantia innominata.

► Striatopallidum  
► Ventral

## Substantia Nigra

### Definition

The substantia nigra is the largest nucleus of the  
► Mesencephalon. A distinction is made between:

- Substantia nigra, pars compacta
- Substantia nigra, pars reticulata

There is a very close, possibly even reciprocal point-to-point, connection between corpus striatum and substantia nigra. The substantia nigra, pars compacta, plays an important role in Parkinson's disease.

► Mesencephalon

## Substantia Nigra, Pars Compacta

### Definition

The dorsal, large-celled segments of the substantia nigra are globally known as pars compacta. The large, polygonal and dopamine-producing cells lie close together. Their very fine dopaminergic efferents form direct synaptic contacts with striatonigral projection neurons. This projection plays an important role in the initiation of voluntary, motor programs.

Parkinson's disease is characterized by progressive loss of neurons in the substantia nigra, pars compacta, degeneration of their ascending projections and reduction of the dopamine content in the corpus striatum. Symptoms include rigor, tremor, akinesia.

► Mesencephalon

## Substantia Nigra, Pars Reticulata

### Definition

The ventral, small-celled sections of the substantia nigra are called the pars reticulata. The cells (cell group A9) are less densely packed, and have a structure similar to that of the inner segment of the globus pallidus. They receive topically organized afferents from the caudate nucleus and globus pallidus (GABA, substance P, dynorphin, enkephalin). Efferents pass to the substantia nigra, globus pallidus, caudate nucleus, and putamen.

► Mesencephalon

## Substantia Nigra: Role in Eye Movements

OKIHIDE HIKOSAKA

Laboratory of Sensorimotor Research, National Eye Institute, National Institute of Health, Bethesda, MD, USA

### Definition

The substantia nigra (SN), which is located in the ventral part of the midbrain, is either a part of the basal ganglia or closely associated with the basal ganglia.

Its contribution to eye movements is mentioned in the section “►Basal ganglia – Role in eye movements”.

## Characteristics

### Lower Level Components

The substantia nigra (SN) is composed of two parts: pars reticulata (SNr), which contains GABAergic neurons, and pars compacta (SNc), which contains dopaminergic (DA) neurons. The relation of the SN to eye movements was first suggested by anatomical studies showing that some neurons in the SNr project to the ►intermediate layer of the superior colliculus (SC) [1] (Fig. 1). The SC in mammals is known to be crucial for orienting of the eyes and head toward an object of interest. An equivalent structure, which is called the optic tectum, is universally present in other vertebrates and is under the control of the homologue of the basal ganglia [2]. Thus, the role of the SN (or the basal ganglia) in eye movements should be considered in a larger framework of animal behavior in which orienting is crucial for survival.

### Higher Level Processes

Neurons in the SNr are characterized by their rapid and tonic firing. Their firing frequency is usually between 40 and 100 spikes/sec in monkeys [3]. Neurons in the internal segment of the ►globus pallidus, many of which are related to skeletal movements, also fire rapidly and tonically. Thus, the high background activity is common to virtually all output neurons of the

basal ganglia. Furthermore, virtually all of them are GABAergic. These facts indicate that neurons that receive outputs of the basal ganglia should be kept inhibited by them. The functional importance of the basal ganglia-induced inhibition can be demonstrated experimentally [3]. The inhibition can be reduced or eliminated by injecting a small amount of a GABA agonist (muscimol) into the SNr, because SNr neurons have a high density of GABA receptors and therefore muscimol would inhibit their firing. After muscimol injection in the SNr, animals can no longer maintain stable eye position and make saccades continually and probably involuntarily. This happens to all animals tested: monkeys, cats, and rats. Rats, compared with monkeys, exhibit a wider range of involuntary movements in addition to eye movements. A similar phenomenon occurs for skeletal movements when muscimol is injected in the globus pallidus internal segment. These findings may be relevant to the fact that patients with basal ganglia dysfunction usually exhibit some type of involuntary movements, such as tremor, dyskinesia, dystonia, ballism, and chorea. These involuntary movements may be caused by a reduction of the basal ganglia-induced inhibition. The reduction of inhibition could be sustained or phasic (possibly with rhythms).

However, the sustained inhibition alone can hardly be a motor control mechanism. Neurons in the SNr actually change (usually decrease) their firing rates in preparation for ►saccadic eye movement [3]. Many SNr neurons stop firing in response to a visual stimulus

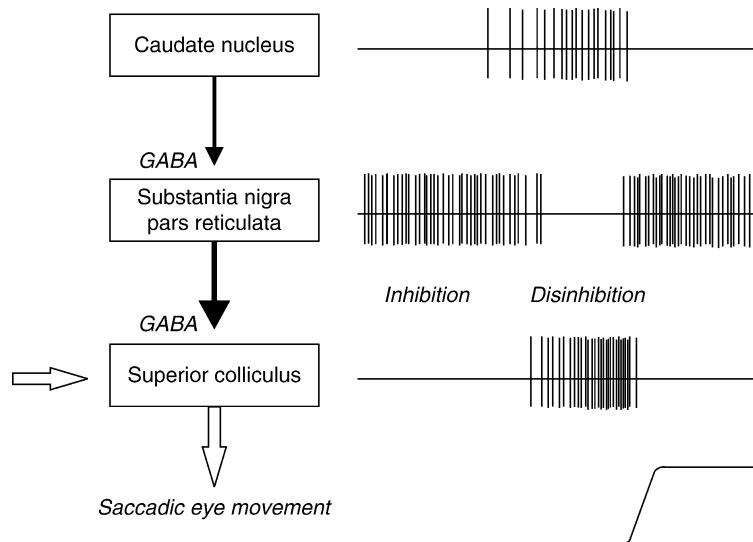

**Substantia Nigra: Role in Eye Movements. Figure 1** Tonic inhibition and disinhibition of superior colliculus neurons by the basal ganglia. The tonic inhibition of the superior colliculus (SC) by the substantia nigra pars reticulata (SNr) can be reduced by another inhibition from the caudate nucleus (CD) to the SNr. Both CD-SNr and SNr-SC connections are GABAergic. The level of the SNr-SC inhibition determines the likelihood of the occurrence of saccade which is triggered by excitatory inputs from saccade-related areas in the cerebral cortex (not shown).

if the animal is ready to make a saccade to it (Fig. 1). Other neurons do so just before the saccade. Many of these SNr neurons project to the intermediate layer of the SC [3] and have inhibitory synaptic contacts with saccadic burst neurons [4]. This means that the SNr-induced tonic inhibition on SC neurons is removed or reduced before saccade. Note that saccadic neurons in the SC receive excitatory inputs from many brain areas, especially saccade-related cortical areas: the ►frontal eye field (FEF), ►supplementary eye field (SEF), and ►lateral intra-parietal area (LIP). These excitatory cortical inputs, together with the SNr-induced disinhibition, would make SC neurons fire in a burst and the signal is sent to the ►brainstem saccade generators. Note, however, SNr neurons may increase their activity before saccade. In such a case, the SC would be less likely to generate a signal to induce saccades.

In short, the SNr-induced inhibition on SC neurons acts as a gate for saccade generation (Fig. 1). SC neurons are constantly bombarded by excitatory inputs from many brain areas because there are so many objects that can attract our attention and gaze. However, these inputs are often incapable of inducing a burst of spikes in SC neurons due to the SNr-induced tonic inhibition. Only when the SNr-induced inhibition is reduced, SC neurons would exhibit a burst of spikes reliably. This is probably a very efficient mechanism to select an appropriate action in a particular context.

Selection of action is meaningful only if the criteria of selection are identified. There are at least three criteria for the selection of information by the SNr. First, SNr neurons select the spatial vector of saccade by reducing their activity only before saccades that have a certain range of direction and amplitude. However, this selection is common to the excitatory inputs from cortical eye fields, and is unlikely to add a new feature to the signals carried by SC neurons. Second, SNr neurons may select saccades directed to the remembered location of a visual stimulus (►memory-guided saccades) rather than saccades directed to a visual stimulus (►visually guided saccades). This is based on the experimental observation, indicating that some SNr neurons reduce their activity selectively before memory-guided saccades [5]. Third, SNr neurons may select saccades that are directed to a spatial location where a larger ►reward is expected [6]. This is shown by the experiment in which the amount of reward is associated unequally among possible target positions. Many SNr neurons reduce their activity more strongly before a saccade to the location where a larger reward is associated. It is unknown how unique the second and third criteria are to the SNr, compared with other areas that provide the SC with inputs. This is a very important question on the function of the SNr and consequently the basal ganglia in general.

### Lower Level Processes

How is the activity of SNr neurons generated? First, the rapid and tonic firing is thought to be caused by two factors: the intrinsic membrane properties of SNr neurons and the excitatory input from the ►subthalamic nucleus (STN). Second, the decrease in firing rate of SNr neurons is caused by GABAergic inhibitory inputs from the caudate nucleus (CD) [7] (Fig. 1). While the CD-SNr inhibitory connection is known anatomically, its function is confirmed physiologically by the presence of neurons in the CD that increase in firing rate before saccade, and the inhibition of SNr neurons in response to electrical stimulation of the saccade-related region in the CD (see section ►Caudate – Role in eye movements). Third, the cause of the increase in firing of SNr neurons is less certain. Two likely causes, based on anatomy, are the excitatory input from the STN and the reduction of the inhibition from the external segment of the globus pallidus.

As mentioned at the beginning, another part of the substantia nigra (SN) is pars compacta (SNc). While neurons in the SNr are GABAergic, neurons in the SNc are dopaminergic [8]. Neurons in the SNc are a significant constituent of midbrain dopaminergic neurons; others include the ventral tegmental area and the area dorsal to the SNc. A majority of SNc neurons project to the striatum, CD and putamen, and make synapses on projection neurons and interneurons. The importance of midbrain dopaminergic neurons in motor control is highlighted by Parkinson's disease, in which most of these dopaminergic neurons degenerate. Eye movements are also impaired in human Parkinson's disease and its animal models [3]. This seems largely due to a lack of dopaminergic effects on CD projection neurons because local degeneration of dopaminergic axons in the CD leads to severe deficits in saccadic eye movements.

### Process Regulation

How then do dopaminergic neurons in the SNc contribute to saccadic motor control? Unlike SNr or CD neurons, SNc dopaminergic neurons neither fire before or after saccades, nor respond to a visual stimulus that guides saccades. Instead, they respond to reward if it is given unexpectedly [9]. Further, if different visual stimuli are presented to induce different saccades, and if one of the visual stimuli is consistently followed by a larger reward, then SNc dopaminergic neurons respond to it with a short burst of spikes and respond to the other stimuli with suppression of firing [10]. This dependency on expected reward value is common to SNr neurons, although the polarity of response is opposite (i.e., stronger inhibition in SNr neurons). It has been hypothesized that SNr neurons acquire the reward dependency from SNc dopaminergic neurons through



their connections to CD projection neurons. However, unlike SNr neurons, SNc neurons have no spatial selectivity: the reward value associated with the stimulus, but not its spatial location, matters. SNr neurons should then acquire spatial selectivity from non-dopaminergic mechanism, which presumably originates from cerebral cortical areas (including FEF, SEF, and LIP) and is mediated by the CD. To summarize, the CD is an important area where spatial information originates from the cerebral cortex and reward-related information originated from SNc dopaminergic neurons are integrated.

## References

1. Graybiel AM, Ragsdale CW (1979) Fiber connections of the basal ganglia. In: Cuenod M, Kreutzberg GW, Bloom FE (eds) Development of chemical specificity of neurons. Elsevier, Amsterdam, pp 239–283
2. Marin O, Smeets WJAJ, González A (1998) Evolution of the basal ganglia in tetrapods: a new perspective based on recent studies in amphibians. *Trends Neurosci* 21:487–494
3. Hikosaka O, Takikawa Y, Kawagoe R (2000) Role of the basal ganglia in the control of purposive saccadic eye movements. *Physiol Rev* 80:953–978
4. Karabelas AB, Moschovakis AK (1985) Nigral inhibitory termination on efferent neurons of the superior colliculus: an intracellular horseradish peroxidase study in the cat. *J Comp Neurol* 239:309–329
5. Hikosaka O, Wurtz RH (1983) Visual and oculomotor functions of monkey substantia nigra pars reticulata. III. Memory-contingent visual and saccade responses. *J Neurophysiol* 49:1268–1284
6. Sato M, Hikosaka O (2002) Role of primate substantia nigra pars reticulata in reward-oriented saccadic eye movement. *J Neurosci* 22:2363–2373
7. Hikosaka O, Sakamoto M, Miyashita N (1993) Effects of caudate nucleus stimulation on substantia nigra cell activity in monkey. *Exp Brain Res* 95:457–472
8. Andén NE, Carlsson A, Dahlström A, Fuxe K, Hillarp NA, Larsson K (1964) Demonstration and mapping out of nigro-neostriatal dopamine neurons. *Life Sci* 3:523–530
9. Schultz W (1998) Predictive reward signal of dopamine neurons. *J Neurophysiol* 80:1–27
10. Kawagoe R, Takikawa Y, Hikosaka O (2004) Reward-predicting activity of dopamine and caudate neurons – a possible mechanism of motivational control of saccadic eye movement. *J Neurophysiol* 91:1013–1024

## Substantia Reticularis

► Reticular Formation

## Substrate Adhesion Molecules

### Definition

SAMs Molecules of the extracellular matrix with which cells can interact through membrane receptors. Collagen, laminin and fibronectin are examples of such molecules.

## Subtetanic Contraction

### Definition

Subtetanic contraction is the most common working mode of skeletal muscles: the muscle fibers are activated at a “sufficiently high” frequency such that the single twitch responses merge together, i.e. giving rise to temporal summation. The developed muscle force increases with increasing frequency of activation, due to the increasing temporal summation of single twitches, up to a maximum. The maximal force is achieved with the tetanic contraction, i.e. the condition in which maximal summation (fusion) of twitch responses is reached. Increasing the frequency of stimulation of muscle fibers beyond the tetanic stimulation frequency will not produce further increase in force.

- Force-frequency Relation of Skeletal Muscle
- Tetanus in Muscle Contraction
- Twitch (Muscle)

## Subthalamic Nucleus (Luys)

### Synonyms

- Nucl. subthalamicus (Luys)

### Definition

A well-circumscribed, large-celled nucleus in the caudalmost region of the diencephalon. It belongs with the globus pallidus, inter alia, to the subthalamus.

The lateral globus pallidus projects strictly topographically to the subthalamic nucleus, which in turn projects with inhibitory effects to all parts of the globus pallidus. Efferents also to the caudate nucleus, putamen and substantia nigra. GABA is the transmitter for both projections.

- Basal Ganglia
- Diencephalon

## Subventricular Zone (SVZ)

### Definition

The subventricular zone (SVZ) is the region adjacent to the ventricular zone (VZ), which constitutes the wall of the lateral ventricle. It is most prominent in the medial and lateral ganglionic eminences of the embryonic brain. It is one of the few germinal zones in the adult brain and new neurons are continuously generated in the SVZ. In this region, there are at least four types of cells with distinct functions: Ependymal cells (Type E cells) line the wall of the ventricle. Type B cells are a special form of astrocytes that act as neural stem cells, and are slowly dividing. Type B cells most rapidly generate proliferating Type C transit amplifying precursors. Type C cells then differentiate into Type A cells, migrating neuroblasts. Type A cells migrate anteriorly and then enter the rostral migratory stream (RMS) leading to the olfactory bulb, where they differentiate into interneurons.

## Succinylcholine (Suxamethonium)

### Definition

Depolarizing blocker of the neuromuscular junction; like acetylcholine, it binds to acetylcholine receptors but longer, thereby preventing acetylcholine from docking onto its receptors; since it has the intrinsic capacity of acetylcholine of opening the receptor-related ion channels, it depolarizes the muscle membrane over a prolonged period and causes a depolarization block.

► [Neuromuscular Junction](#)

## Sudden Infant Death Syndrome (SIDS)

### Definition

Sudden death of an infant under 1 year of age that remains unexplained after a thorough case investigation, including performance of a complete autopsy, examination of the death scene, and review of the clinical history. Leading cause of postneonatal infant

mortality in the United States, Canada and European Countries.

Affected children typically die during the night and early morning hours. One of the leading hypotheses is that SIDS is caused by defects in brainstem neuronal networks that control respiration and/or cardiac stability during sleep. These defects result in a failure of protective responses to life-threatening stressors (e.g. hypoxia) during a critical period in the postnatal development of the child.

► [Laryngeal Chemoreflexes](#)

## Sufficiently Exciting

### Definition

Sufficiently Exciting refers to actions taken on (inputs to) a physical system. It is used in conjunction with a model estimator – one would like to “excite” the physical system with the purpose of creating data that reflects the behavior of this system as much as possible.

► [Adaptive Control](#)

## Sulcus Lateralis (Sylvii)

### Definition

Major fissure on the lateral side of the hemisphere between temporal and parietal lobes.

## Sulcus Limitans

### Definition

The sulcus limitans appears in the developing neural tube. The central canal of the tube forms a small sulcus at its midlateral point on each side. This sulcus defines the boundary between the dorsally developing sensory and the ventrally developing motor regions.

## Summation by Retinal Ganglion Cells

### Definition

Although retinal ganglion cells are the retinal sampling element, each ganglion cell may sum input from numerous photoreceptors. More numerous ganglion cells (e.g. midget cells) summate from fewer receptors than sparser cell types such as P giant cells. Also, all ganglion cell types summate over larger groups of photoreceptors in peripheral than in central (foveal) retina.

- ▶ Photoreceptors
- ▶ Retinal Ganglion Cells
- ▶ Visual Processing Streams in Primates

## Summation Tones

### Definition

Tonal components at the output of a nonlinear system with frequencies equal to the sum of the frequencies of the input tonal components.

- ▶ Acoustics

## Sumo

### Definition

Small Ubiquitin-related Modifier (SUMO) proteins are a family of 4 proteins that are similar to ubiquitin in that they can be covalently attached (sumoylation) to other proteins through a process analogous to ubiquitination.

Unlike ubiquitination, sumoylation is a post-translational modification that is not used primarily to tag proteins for degradation but rather is utilized in other cellular processes, such as nuclear-cytosolic transport, transcriptional regulation, apoptosis, protein stability, response to stress, and progression through the cell cycle.

- ▶ Receptor Trafficking

## Sumoylation

### Definition

SUMO conjugation to its target is analogous to that of ubiquitination in that it involves an enzymatic cascade. In the first step, an ATP dependent protease (the SENP proteases) cleaves a C-terminal peptide (the last four amino acids). SUMO then becomes bound to an E1 enzyme (SUMO Activating Enzyme (SAE)) and then passed to an E2 conjugating enzyme (Ubc9). Sumoylation then occurs on a protein with a consensus SUMO attachment sequence, with the help of an E3 ligase. The SUMO attachment sequence is the B-K-x-D/E motif. In the absence of this consensus sequence, the E3 ligase facilitates attachment. Several Sumo-E3 ligases exist and the most common are the PIAS proteins, which belong to the zinc-RING finger superfamily of proteins. Sumoylation, like ubiquitination, is reversible and SUMO can be removed by a protease (e.g. Ulp2) in an ATP dependent manner. SUMO, like ubiquitin, can form chains, but unlike ubiquitin, SUMO chains are likely to be preassembled prior to conjugation onto the target protein.

- ▶ Receptor Trafficking

## SUNA

### Definition

Short-lasting Unilateral Neuralgiform Headache Attacks with Cranial Autonomic Symptoms.

- ▶ Trigeminal Autonomic Cephalalgias
- ▶ Headache

## SUNCT

### Definition

Short-lasting Unilateral Neuralgiform Headache Attacks with Conjunctival Injection and Tearing.

- ▶ Trigeminal Autonomic Cephalalgias
- ▶ Headache

## Superior Cerebellar Peduncle

### Synonyms

► *Pedunculus cerebellaris sup.*

### Definition

The major cerebellar efferents pass through this peduncle: cerebellothalamic tract and cerebellorubral tract. Since they cannot be easily distinguished from each other they are collectively known as the “superior cerebellar peduncle.”

The only afferent tract is the anterior spinocerebellar tract, conducting proprioceptive information from the spinal cord to the spinocerebellum.

► *Cerebellum*

## Superior Cervical Ganglion

### Synonyms

► *Ganglion cervicale sup.*

### Definition

Sympathetic ganglion. The associated neurons are situated in the upper thoracic cord (the cervical cord has no sympathetic neurons).

## Superior Colliculus

### Synonyms

► *Colliculus sup.*

### Definition

Upper hill of the quadrigeminal lamina. Involved in fast eye movements, synaptic center for optokinetic reflexes (saccades). Afferents from the retina and visual cortex (optofacial winking reflex), inferior colliculus and auditory cortex (reflex movement in direction of source of noise). Involved in accommodation reflex. Efferents to oculomotor cranial nerve nuclei and spinal cord.

Damage to the superior colliculi results in interruption of reflex eye movements, but not in impairment of cognitive perceptivity (e.g. image recognition).

► *Mesencephalon*

## Superior Colliculus and Hearing

ANDREW J. KING

Department of Physiology, Anatomy and Genetics, Sherrington Building, University of Oxford, Oxford, UK

### Synonyms

Auditory space map

### Definition

The map of auditory space in the ► *superior colliculus*, which is superimposed upon and integrated with the representations of other sensory modalities, thereby allowing different sensory cues to guide orienting movements of the eyes, head and body.

### Characteristics

One of the key functions of the central nervous system is to obtain information about the external environment and to control movement of the body within it. Critical to this is an ability to determine the whereabouts of specific events, such as potential prey or predators, so that they can be attended to, approached or avoided as the need arises. In order that they can trigger movement, sensory signals must be integrated with motor-related activity. This is actually a common feature of neurons in both cortical and subcortical areas that contribute to the control of movement. One brain region involved in sensorimotor processing that has received particular attention is the superior colliculus, which forms part of the roof of the ► *midbrain* (Fig. 1a).

This nucleus contains overlapping sensory and motor maps, which provides an efficient means by which activation by a stimulus from a particular location in space can be transformed into motor commands that specify the movements required to orient toward that stimulus [1].

### Sensory Maps in the Superior Colliculus

While a role for the superior colliculus in the visual control of ► *saccadic eye movements* – rapid changes in eye position that redirect gaze toward objects of interest so that they can be seen with better resolution – has long been recognized, it is now known that this nucleus plays a more general function in mediating sensory-evoked orienting movements as well as certain other behaviors. The dorsally located superficial layers of the superior colliculus receive almost exclusively visual inputs that arise directly from the ► *retina* and indirectly from the visual cortex, whereas the more ventral intermediate and deep layers are innervated by auditory and somatosensory as well as visual structures. Consequently, these layers should be viewed as a

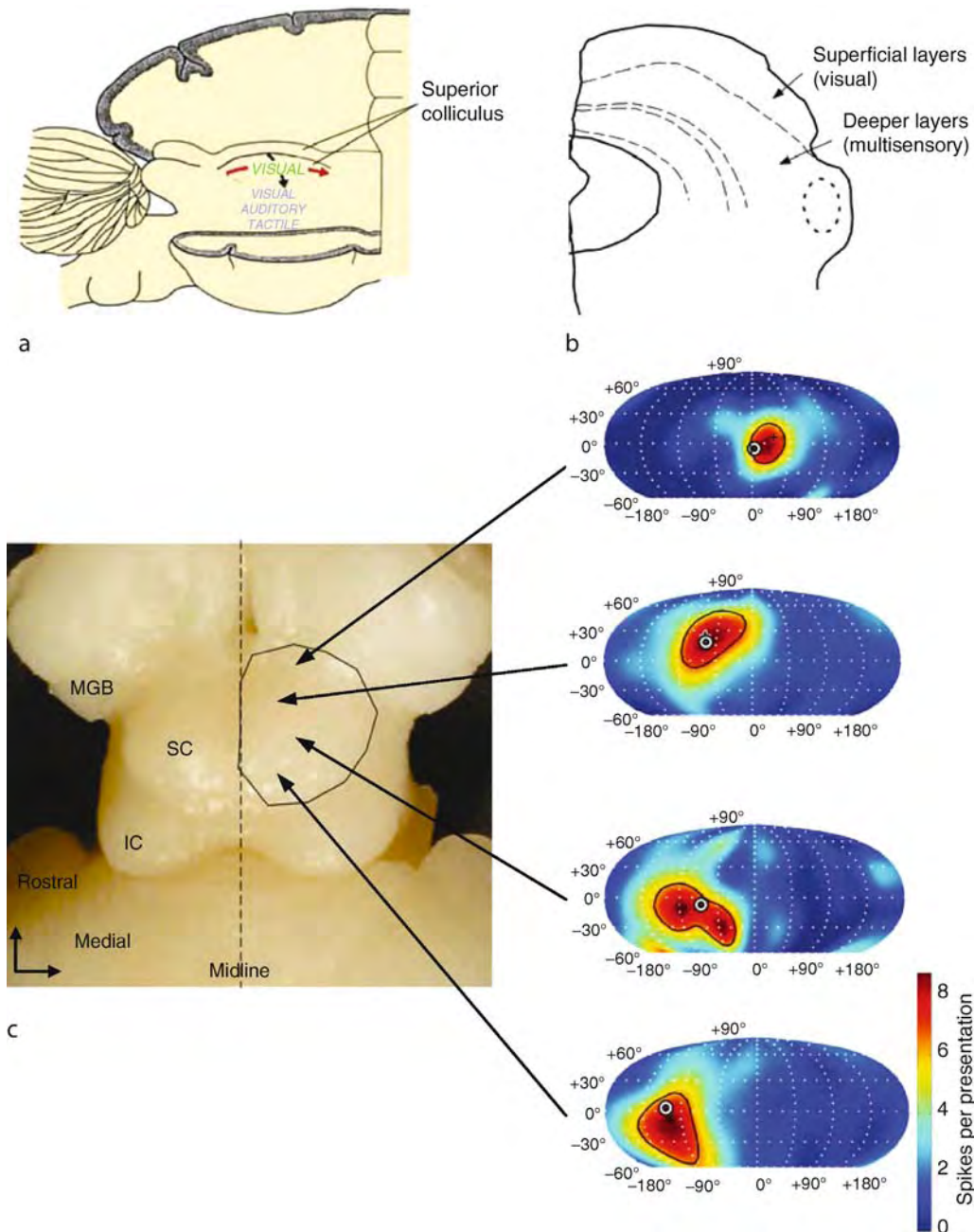

**Superior Colliculus and Hearing. Figure 1** Representation of auditory space in the superior colliculus. (a) This schematic depicts the brain of a ferret, which is representative of other mammals, in which the posterior part of the cortex has been removed so that the left and right superior colliculi can be visualized. The sensory inputs to different regions of this midbrain nucleus are indicated. (b) Outline of a coronal section of the superior colliculus. The location of different layers is depicted by the dashed lines. The most dorsal superficial layers are exclusively visual, whereas the deeper layers contain neurons that are responsive to visual, auditory and/or somatosensory stimuli. Many neurons in the deeper collicular layers also discharge prior to eye and head movements toward these sensory targets. (c) Auditory spatial receptive fields of four deeper layer neurons recorded in the right superior colliculus at the positions shown on a dorsal view of the midbrain. Color scale indicates the mean number of action potentials evoked per stimulus presentation, with the maximum response indicated by the red regions. The black cross shows the direction of the centroid vector, which indicates the preferred sound direction for each neuron, while the white circle represents the location of a visual stimulus that evoked the strongest response from neurons recorded in the overlying superficial layers. Note that the visual and auditory receptive fields covary within the superior colliculus.

multisensory region, in which many of the neurons receive converging inputs from different sensory modalities (Fig. 1b).

Each of these sensory representations is organized into a map of space. This is based on individual neurons responding to the appropriate stimulus when it falls within a restricted region of space known as the ►receptive field. The locations of these receptive fields vary systematically with the locations of the neurons within the superior colliculus (Fig. 1c). Moreover, the visual, auditory and somatosensory maps are topographically aligned with each other. Thus, visual and auditory stimuli located in front of the animal or objects touching the face are represented in the most anterior or rostral part of the nucleus, whereas stimuli located behind the animal will activate the most posterior or caudal part. Similarly, neurons in the medial part of the superior colliculus respond most strongly to visual or auditory targets above the animal or to stimulation of the upper part of the body, while neurons on the lateral side respond best to stimuli coming from below.

The registration of the sensory maps across the different layers of the superior colliculus is also observed at the level of individual multisensory neurons, which have overlapping spatial receptive fields in each of the sensory modalities to which they respond. When different types of stimuli are presented together at approximately the same time and from the same region of space, these neurons typically respond more strongly than they do to each individual stimulus [2]. Indeed, the responses to multisensory stimulation sometimes exceed the sum of the responses to the individual stimuli. By contrast, if the different stimuli to which the neurons respond are widely separated in space or time, inhibitory interactions tend to be observed, resulting in weaker responses to multisensory stimulation.

In addition to having sensory responses, deeper layer superior colliculus neurons can exhibit premotor activity. In other words, they discharge prior to and during orienting movements of the eyes, head and, in species where they are mobile, the ears [3]. This motor-related activity is also organized into a map, which can be demonstrated by observing the amplitude and direction of the orienting movements produced by focal electrical stimulation of different regions of the colliculus. Because the sensory and motor maps are in register, neurons responsive to stimuli from a particular direction in space may also be active prior to movements that shift the direction of gaze to that location in space.

Direct evidence for a role for the individual sensory representations in the control of orienting movements has come from studies in which different regions of the superior colliculus have been inactivated. Cooling of the superficial layers of the colliculus on one side only degrades the accuracy of orienting responses to visual

stimuli presented in the opposite hemifield, whereas additional inactivation of the intermediate layers results in auditory orienting deficits too [4]. Partial unilateral lesions of the deeper layers have also been shown to eliminate the improvement in the accuracy of localization responses that is normally observed when visual and auditory stimuli are paired at the same location in space [5], further establishing a link between the sensory response properties of superior colliculus neurons and orientation behavior.

### Representing Auditory Space in the Brain

Maps of visual space and of the body surface in the brain have their origin in the way in which these sensory signals are represented at the receptor surface. The optical properties of the eye allow each part of the retina to sample a different region of the visual world, collectively giving rise to a neural map of visual space. Similarly, each region of the body surface is represented by the activity of ►mechanoreceptors in that part of the skin. The visual and somatosensory maps found in the superior colliculus and elsewhere in the brain therefore arise from spatially ordered projections that begin with the output from their respective sense organs.

The formation of a map of the auditory world in the brain presents a different challenge, however, as the auditory receptor cells in the ►cochlea are tuned to different sound frequencies rather than positions in space. The direction of a sound source is determined by comparing the amplitude level and timing of the sounds reaching the two ears. In addition to these “►binaural” cues, the external ear – the visible part of the ear – filters the incoming sound, changing its spectral composition in ways that depend on the direction of sound incidence. In humans and other mammals, binaural cues provide the principal basis by which sound sources in the horizontal plane are localized, whereas spectral cues are utilized for distinguishing between sounds in front of and behind the head and for localization in the vertical plane.

Neuronal sensitivity to each of these localization cues is first established in a different region of the ►brainstem. These pathways converge in the ►inferior colliculus, where a topographic representation of space first emerges, which is then transmitted to the deeper layers of the superior colliculus. The steps leading to the synthesis of the auditory space map have been studied in most detail in barn owls, a species with particularly good directional hearing [6]. Because of an unusual asymmetry in its ears, barn owls actually use one of the binaural cues – interaural level differences – to determine the vertical angle of their prey, such as a mouse on the ground, whereas interaural time differences are used for pinpointing its horizontal location. Although interaural time differences are the primary

cues for localizing low frequency sounds in mammals, they do not contribute to the spatial selectivity of superior colliculus neurons, which tend to be broadly tuned to high frequency sounds. Instead, the map of auditory space is based on a combination of interaural level differences and spectral cues [7].

Most studies have focused on how the direction of a sound source is represented in the superior colliculus. In echolocating bats, some neurons can specify target distance, as a result of being tuned to the delay between the animals' ultrasonic vocal signals and the returning echoes produced by reflections from objects in the flight path. The importance of the superior colliculus in acoustic orienting of echolocating bats in three-dimensional space is further highlighted by the finding that neurons in this nucleus discharge just before the animals produce biosonar pulses but not when they emit communication calls [8].

### What Happens When the Eyes (or Ears) Move?

An important consequence of the differences in the way in which the visual, auditory and somatosensory maps in the superior colliculus are constructed is that independent movements of the sense organs – such as the eyes or the ears – should result in the sensory representations becoming misaligned. This is not a problem for the barn owl because its eyes and external ear structures are effectively immobile. But in mammals, changes in the direction of gaze are accompanied by shifts in the location of auditory and somatosensory receptive fields, indicating that these sensory signals are transformed into coordinates that take into account the current position of the eyes [3]. This presumably allows accurate orienting movements to be maintained irrespective of initial eye position.

### Sensory Experience and the Development of the Auditory Space Map

In addition to being continually updated by eye-position signals, the auditory space map is shaped by sensory experience as it emerges during development [9]. This is necessary because the values of the auditory localization cues corresponding to a particular sound direction depend on the size and shape of the head and external ears, which can vary markedly between and within individuals. In particular, vision plays a key role in aligning the different sensory maps, as revealed by the dramatic changes produced in the auditory responses when visual inputs are altered. This has been demonstrated most clearly by mounting prisms in front of the eyes of young barn owls in order to shift their visual world to one side. The resulting misalignment between the visual and auditory maps is overcome by a corresponding shift in auditory spatial tuning. Similar findings have also been obtained in mammals [9],

suggesting that establishing and maintaining the registration of the maps is critical for synthesizing the different sensory cues associated with targets that can be both seen and heard. As a result these cues can be used to specify the orienting movements that bring about a change in the direction of gaze.

### The Superior Colliculus and Auditory Localization

Although a close relationship between the sensory representations in the superior colliculus and reflexive orienting behaviors has been established in a range of species, it is important to appreciate that a map of auditory space is not a prerequisite for localizing sound. In higher mammals (carnivores and primates), lesions of the auditory cortex result in deficits in sound localization, yet there is no evidence for a space map in the cortex. Instead, cortical neurons seem to carry information about sound source location in both the number and timing of their action potentials [10]. Nevertheless, it is likely that interactions between the cortex and midbrain, possibly mediated by descending [corticothalamic](#) projections, contribute to behaviors that require sound localization.

### References

1. King AJ (2006) The superior colliculus. *Curr Biol* 14: R335–R338
2. Stein BE (1998) Neural mechanisms for synthesizing sensory information and producing adaptive behaviors. *Exp Brain Res* 123:124–135
3. Sparks DL, Groh JM (1995) The superior colliculus: a window for viewing issues in integrative neuroscience. In: Gazzaniga MS (ed) *The cognitive neurosciences*. MIT Press, Cambridge MA, pp 565–584
4. Lomber SG, Payne BR, Cornwell P (2001) Role of the superior colliculus in analyses of space: superficial and intermediate layer contributions to visual orienting, auditory orienting, and visuospatial discriminations during unilateral and bilateral deactivations. *J Comp Neurol* 441:44–57
5. Burnett LR, Stein BE, Chaponis D, Wallace MT (2004) Superior colliculus lesions preferentially disrupt multi-sensory orientation. *Neuroscience* 124:535–547
6. Konishi M (1995) Neural mechanisms of auditory image formation. In: Gazzaniga MS (ed) *The cognitive neurosciences*. MIT Press, Cambridge MA, pp 269–277
7. Campbell RAA, Doubell TP, Nodal FR, Schnupp JWH, King AJ (2006) Interaural timing cues do not contribute to the map of space in the ferret superior colliculus: a virtual acoustic space study. *J Neurophysiol* 95:242–254
8. Sinha SR, Moss CF (2007) Vocal premotor activity in the superior colliculus. *J Neurosci* 27:98–110
9. King AJ (1999) Sensory experience and the formation of a computational map of auditory space in the brain. *BioEssays* 21:900–911
10. Middlebrooks JC (2000) Cortical representations of auditory space. In: Gazzaniga MS (ed) *The new cognitive neurosciences*, 2nd edn. MIT Press, Cambridge MA, pp 425–436

## Superior Colliculus-Fixation Neurons

### Definition

Neurons that have a steady discharge when a subject is attentively fixating a spot of light, even when the spot disappears and the subject fixates the same, though invisible, location in the dark. These cells are located in a restricted zone of the rostral superior colliculus encompassing the foveal representation of the visual field.

### ► Fixation System

## Superior Colliculus – Quasi-Visual Neurons

MARK M. G. WALTON, DAVID L. SPARKS,  
XINTIAN HU  
Division of Neuroscience, Baylor College of Medicine,  
Houston, TX, USA

### Definitions

Quasi-visual neurons – ► **Superior colliculus** neurons that exhibit a tonic discharge that begins ~70 ms after the onset of a visual target and continues until saccade onset, but that have response fields that are predictive of the vector of the saccade, rather than the retinotopic location of the visual target.

### Characteristics

#### Higher Order Structures

Quasi-visual (QV) neurons are found in the intermediate gray layer of the superior colliculus (SC). The SC is a seven layered structure in the midbrain involved in ► **sensorimotor integration** and orienting behavior.

#### Parts of This Structure

Currently, very little is known about the morphological characteristics of QV neurons or their afferent and efferent projections. It seems likely, however, that these neurons receive direct projections from FEF. Neurons with similar properties have been described in frontal eye fields [1], and saccade related neurons in SC are known to receive direct projections from FEF. However, it should be pointed out that these authors believe that QV neurons in FEF are best thought of as visual neurons that would send signals to SC only indirectly.

#### Functions of This Structure

Quasi-visual neurons are one of several functional classes of neuron in primate superior colliculus originally

described by Mays and Sparks [2]. On a simple, target-step saccade task, QV neurons resembled visual cells, with no alteration of firing rate associated with saccade onset. On these trials, they exhibited a sustained discharge that began ~70 ms after target onset and continued until the saccade occurred. Sustained responses occurred even if the target was flashed for only 20–80 ms.

The unique characteristics of these neurons could be seen using a ► **double saccade task**. On these trials, the vector of the saccade associated with the most vigorous discharge was found to be the same as that associated with the most vigorous discharge in the target step task (Fig. 1). This was true even though, for the double saccade task, no visual target ever appeared at the retinotopic location corresponding to the endpoint of the second saccade. That is, when a dissociation exists between the retinotopic location of the visual target and the saccade vector, the response fields of QV neurons appear to be associated with the latter. The timing of neuronal discharge was not tightly linked to either visual target onset or saccade onset.

On ► **visual probe trials**, a peripheral visual target was briefly flashed while the monkeys fixated a central fixation target. On these trials, QV cells exhibited a sustained discharge that persisted until ~200 ms after target offset. These authors also tried a variant of the double saccade task in which the second target was within the classical receptive field of the neuron. In this case, QV neurons discharged 110–120 ms after the onset of the second target, despite the fact that the first saccade was directed to a different location. Thus, these neurons are visually responsive, and can respond vigorously even when the saccade being planned is to a location outside their response fields. These results show that quasi-visual cells are neither completely visual nor completely motor, at least not in the usual sense. Instead, they seem to have elements of both visual and motor responses. These authors suggested that these cells might encode static eye position error (the difference between current and desired eye position).

Since Mays and Sparks first described QV neurons, several studies have suggested potential roles for these cells. Amador et al. [4] suggested that QV neurons might play an important role in the generation of anti-saccades. On ► **anti-saccade tasks**, these authors observed that monkeys occasionally made erroneous saccades to the target followed by extremely short latency “turnaround saccades” to the correct location. It was suggested that QV neurons may play a role in generating these very short latency turnaround saccades.

Very short ► **intersaccadic intervals** are sometimes observed when the task calls for a sequence of saccades [5]. These short intersaccadic intervals seem to require that the brain begin some of the computations



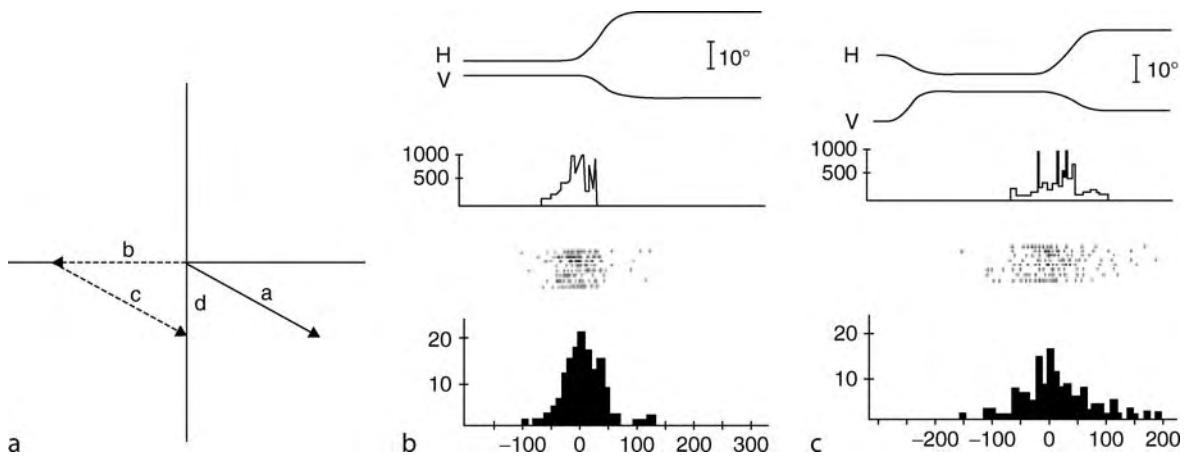

**Superior Colliculus – Quasi-Visual Neurons.** **Figure 1** (a) The initial eye position is at the origin. The vector labeled *a* indicates a saccade in the **target step saccade task**, to the location marked with the arrow. In the double saccade task, the first saccade is labeled *b* and the second is labeled *c*. Note that the vector of the second saccade of the double saccade task matches the vector of the saccade in the target step task. (b) Response of a quasivisual neuron associated with the saccade labeled *a* in panel (a). (c) Response of the same neuron during the double saccade task. Note that the cell responds vigorously for saccade *c* even though no visual target ever appears at that retinotopic location. On visual probe trials, the cell would respond to the appearance of a visual target at the location indicated by *a*, even if the animal is not required to make a saccade to this location (data not shown) (Adapted from [3]).

necessary for the second saccade even before the first saccade is executed. Tian et al. [2] described neurons (also referred to as QV neurons) with very similar properties in monkey frontal eye fields. These authors reported evidence that these neurons form a map of the spatial locations of potential saccade targets. Such a map would allow sequences of saccades to be programmed, and spatially accurate saccades executed, even if the visual targets are all extinguished prior to the first saccade. Thus, it may be that QV neurons in SC play an important role in the generation of sequences of saccades by helping the brain to maintain a spatially invariant representation of possible saccade target locations, even though each saccade alters the retinotopic location of those potential targets.

However, it must be pointed out that, to date, no subsequent studies have used the double saccade task while recording from QV neurons in SC. Therefore, the original Mays and Sparks paper remains the only study to provide data regarding cells that can be confidently classified as QV neurons in SC.

### Higher Order Function

QV neurons seem to be part of a spatial memory system that also encompasses the Frontal Eye Fields, and possibly the Lateral Intraparietal area and area 46.

### Quantitative Measure for This Structure

Currently, the only quantitative measurements available for QV neurons are those related to the discharge properties of these neurons, discussed above.

### References

1. Tian J, Schlag J, Schlag-Rey M (2000) Testing quasi-visual neurons in the monkey's frontal eye field with triple-step paradigm. *Exp Brain Res* 130:433–440
2. Mays LE, Sparks DL (1980) Dissociation of visual and saccade-related responses in superior colliculus neurons. *J Neurophysiol* 43:207–232
3. Sparks DL, Porter JD (1983) Spatial localization of saccade targets. II. Activity of superior colliculus neurons preceding compensatory saccades. *J Neurophysiol* 49:64–74
4. Amador N, Schlag-Rey M, Schlag J (1998) Primate antisaccades. I. Behavioral characteristics. *J Neurophysiol* 80:1775–1786
5. Becker W, Jergens R (1979) An analysis of the saccadic system by means of double step stimuli. *Vision Res* 19:967–983

## Superior Colliculus – Role in Eye Movements

MARK M. G. WALTON, DAVID L. SPARKS,  
XINTIAN HU  
Division of Neuroscience, Baylor College of Medicine,  
Houston, TX, USA

### Definitions

► **Gaze** – The direction of the line of sight with respect to external space.

Oculocentric reference frame – A coordinate system specifying the location of a target with respect to the current direction of fixation.

► **Superior colliculus** – A seven layered structure in the midbrain, involved in ► **sensorimotor integration** and the control of orienting behaviors.

## Characteristics

### Higher Order Structures

The superior colliculus occupies an important central role in the circuitry controlling orienting movements (► **Orienting responses**) and sensorimotor integration. Consistent with these functions, this structure receives both sensory and motor inputs from a large number of cortical and subcortical areas.

### Parts of this Structure

The superior colliculus is a seven-layered structure in the midbrain involved in orienting behavior and sensorimotor integration. The most dorsal of the three cellular layers and the surrounding two fibrous layers are generally referred to as the superficial layers [1]. The four ventralmost layers (two cellular and two fibrous) are typically referred to as the deep layers (or, alternatively, the intermediate and deep layers).

### Functions of this Structure

The role of the superior colliculus in the control of eye movements is part of its more general role in the control of gaze, including combined movements of the eyes and head [1]. In the intermediate and deep layers, several classes of neuron modulate activity in association with saccades. Saccade related burst neurons (SRBN) are characterized by a high frequency burst of spikes, beginning ~20 ms before the onset of saccades of a particular vector [2]. The movement fields of these neurons are arranged in a topographic map that lies approximately in register with the receptive fields of visual neurons in the superficial layers. Thus, the vector of the saccade is encoded by the location of activity within the collicular map. Some burst neurons (referred to as visuomotor burst neurons) also exhibit a visually evoked burst of spikes that begins ~70 ms after target onset. These cells are sometimes regarded as a separate class, although a continuum exists between exclusively motor bursters and those with strong bursts for both target onset and saccade onset. Saccade-related activity is also, to varying degrees, often dependent on the presence of a visual target [3]. Some cells respond equally vigorously regardless of whether or not the visual target is extinguished before the saccade, while others do not respond at all if the saccade is directed to the remembered location of a target that has been extinguished. Again a continuum exists, with most cells responding more vigorously if the visual target is still

present at the time of the saccade. On ► **delayed saccade tasks**, some neurons, usually referred to as prelude or buildup cells, display tonic activity during the interval, beginning roughly 70 ms after target onset and ending at saccade onset, often culminating in a burst of spikes that is time-locked to saccade onset. These cells have been described as having open movement fields, meaning that they respond to any saccade that is in the optimal direction and that is equal to, or larger than, a particular value [4]. Quasivisual neurons are another class of cell described by Mays and Sparks [2]. These cells appear to be encoding ► **motor error**, and are best thought of as being neither completely visual nor completely motor. Fixation neurons are found near the rostral end of SC. These cells fire tonically during periods of steady fixation and pause for most saccades in all directions. Injection of muscimol into the rostral SC interferes with the monkey's ability to suppress unwanted saccades to peripheral visual targets [5]. On the basis of these observations, it was proposed that fixation cells are involved in the maintenance of active fixation. As shown by Krauzlis et al. [6]; however, many of these cells also burst for small contraversive saccades. These authors concluded that these cells encode motor error. Thus, the exact role of fixation cells in the control of saccades remains controversial.

In most current models of the saccadic system, a corollary discharge of the premotor burst is fed back to a comparator, which compares actual eye displacement to desired eye displacement. When this value reaches zero, the saccade ends. According to one view, SC is kept up to date about the progress of the ongoing saccade through feedback signals from the brainstem saccade generator. Evidence to support this notion has come from studies in which saccades were interrupted mid-flight by stimulating the omnipause (OPN) region. Keller, Gandhi, and Vijay Sekaran [7], for example, reported that the saccade resumes after the end of the stimulation and reaches the target correctly. These authors found that the same region of SC that was active before the saccade becomes re-activated for the resumed movement, which seems to indicate that the SC must have received feedback regarding the interruption.

On the other hand, the SC might be upstream from the local feedback loop. According to this idea, the SC generates a saccadic command that is sent to the brainstem saccade generator, but receives no feedback related to the progress of the saccade. These models, however, have difficulty explaining results such as those described above [7].

Lefevre et al. [8] proposed a model of saccadic control in which the superior colliculus is seen as less important than the cerebellum. More specifically, these authors proposed that the superior colliculus determines the timing of saccade onset and provides a general drive

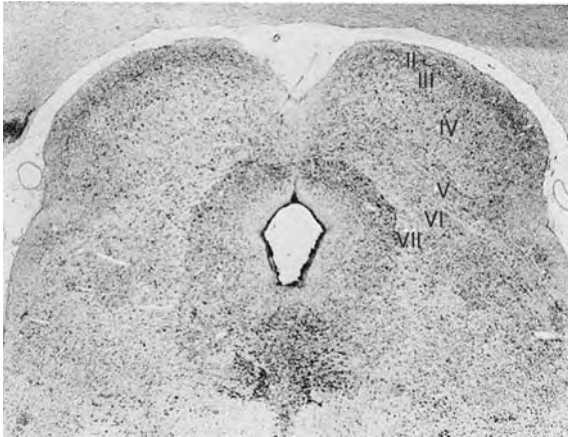

**Superior Colliculus – Quasi-Visual Neurons.**  
**Figure 1** Coronal section showing the superior colliculus. Layers are labeled with roman numerals (Adapted from [10]).

that moves the eyes approximately in the right direction. According to this view, activation of the superior colliculus is neither necessary nor sufficient for saccades to occur. In support of this idea, the authors pointed out that lesions of the cerebellum severely impair saccadic eye movements. In contrast, primates still make reasonably accurate saccades even when the superior colliculus is ablated. As post-lesion plastic changes in alternative saccadic pathways can potentially mitigate the effects of permanent lesions, several studies have examined saccade metrics and accuracy following reversible inactivation of SC (for example, see [9]). While these studies reported a noticeable tendency for the post-injection saccades to be slower, of longer duration, and hypometric, reversible inactivation of SC does not prevent monkeys from making saccades to visual targets.

### Higher Order Function

As can be seen from the above discussion of cell types, there is good evidence that the SC is involved in the transformation of sensory signals into eye movement commands. The intermediate layers of SC receive visual, somatosensory, and auditory input from a large number of brain areas, as well as input from other saccade-related structures such as frontal eye fields, supplementary eye fields, and the lateral intraparietal area. As discussed above, a number of studies have described neurons in SC that are difficult to classify as clearly sensory or clearly motor [2].

In many species, the superior colliculus is involved in generating movements that orient the eyes and ears to visual and auditory stimuli of interest. In mammals, for example, the intermediate and deep layers carry signals related to movements of the eyes, head, and pinnae.

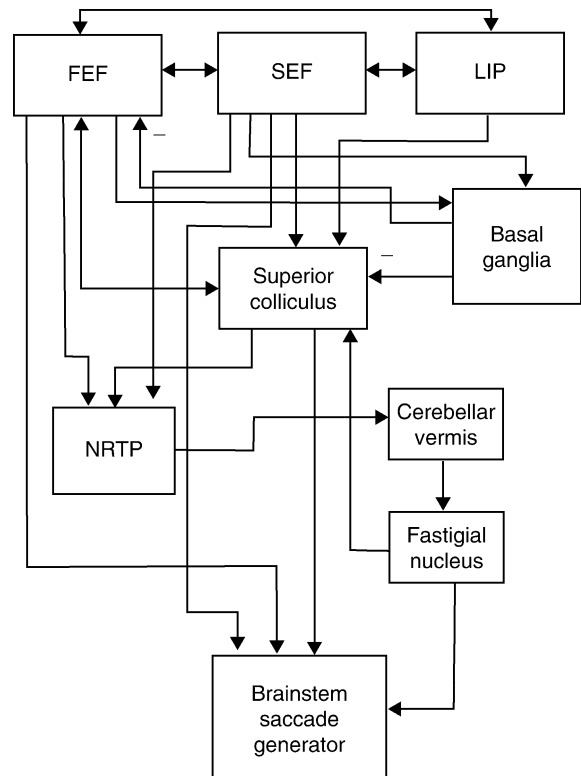

**Superior Colliculus – Quasi-Visual Neurons.**  
**Figure 2** Simplified wiring diagram of the saccadic system. The superior colliculus occupies a central role in the saccadic system circuitry.

### Quantitative Measure for this Structure

Studies investigating the role of the SC in eye movement control typically attempt to quantify neuronal behavior by measuring the firing rate of individual neurons in the deeper layers. Most commonly, this involves measures such as firing rate, the number of spikes in the burst, and the timing of the burst with respect to visual target onset and/or saccade onset. For example, peak spike frequency is correlated with peak saccade velocity.

### References

1. Freedman EG, Stanford TR, Sparks DL (1996) Combined eye-head gaze shifts produced by electrical stimulation of the superior colliculus in rhesus monkeys. *J Neurophysiol* 76:927–952
2. Mays LE, Sparks DL (1980) Dissociation of visual and saccade-related responses in superior colliculus neurons. *J Neurophysiol* 43:207–232
3. Edelman JA, Goldberg ME (2001) Dependence of saccade-related activity in the primate superior colliculus on visual target presence. *J Neurophysiol* 86:676–691
4. Munoz DP, Wurtz RH (1995) Saccade-related activity in monkey superior colliculus. I. Characteristics of burst and buildup cells. *J Neurophysiol* 6:2313–2333

5. Munoz DP, Wurtz RH (1992) Role of the rostral superior colliculus in active visual fixation and execution of express saccades. *J Neurophysiol* 67:1000–1002
6. Krauzlis RJ, Basso MA, Wurtz RH (1997) Shared motor error for multiple eye movements. *Science* 276:1693–1695
7. Keller EL, Gandhi NJ, Vijay Sekaran S (2000) Activity in deep intermediate layer collicular neurons during interrupted saccades. *Exp Brain Res* 130:227–237
8. Lefevre P, Quaia C, Optican LM (1998) Distributed model of control of saccades by superior colliculus and cerebellum. *Neural Netw* 11:1175–1190
9. Aizawa H, Wurtz RH (1998) Reversible inactivation of monkey superior colliculus. I. Curvature of saccade trajectory. *J Neurophysiol* 79:2082–2096
10. Huerta MF, Harting JK (1984) The mammalian superior colliculus: studies of its morphology and connections. In: Vanegas H (ed) *Comparative neurology of the optic tectum*. Plenum, New York, pp 687–773

The part of the fasciculus connecting the motor (Broca's) speech center with the sensory (Wernicke's) speech center is called the arcuate fasciculus.

#### ► Pathways

---

## Superior Frontal Gyrus

### Synonyms

► Gyrus front. sup.

### Definition

In the area of the frontal gyrus close to the precentral gyrus is situated the premotor cortex, which plays an important role in planning effector voluntary movements and has close interaction with the cerebellum, thalamic nuclei and basal ganglia.

At the level of the superior frontal gyrus is situated the frontal eye field, which is involved in planning voluntary eye movements. Hyperactivity of these neurons due to hemorrhage or tumors causes conjugate movements of both eyeballs (deviation conjugee). Conversely, destruction of tissue causes ipsilateral deviation conjugee, since now the activity of the contralateral eye field no longer has an antagonist.

► Telencephalon

---

## Superior Longitudinal Fasciculus

### Synonyms

► Fasciculus longitudinalis sup.

### Definition

With its two branches (anterior brachium and posterior brachium), the superior longitudinal fasciculus establishes connections between virtually all cortical areas.

---

## Superior Oblique Muscle

### Definition

Superior oblique is one of the six eye muscles.

► Eye Orbital Mechanics

---

## Superior Olivary Nuclei

TOM C. T. YIN

Department of Physiology and Neuroscience Training Program, University of Wisconsin-Madison, Madison, WI, USA

### Synonyms

Nuclei of the superior olive; Superior olivary complex; SOC

### Definition

The superior olivary nuclei are a group of nuclei located in the brainstem near the junction of the pons and medulla. It is the first auditory relay after the cochlear nucleus on the way to the auditory cortex and is the major point at which information from the two ears is integrated.

### Characteristics

#### Introduction

The superior olivary nuclei or complex (SOC), as they are more commonly called, occupy an important and unique position in the ascending auditory pathway. The SOC lies at the ponto-medullary border. Acoustic information is conducted from the outer ear into the inner ear where the cochlea transduces the mechanical energy into neural impulses that are conveyed by the auditory nerve fibers, which compose one component of the VIII cranial nerve, into the central nervous system. The other component of cranial nerve VIII is the vestibular nerve which originates from the vestibular apparatus of the inner ear. All auditory nerve fibers

synapse in the cochlear nuclei where there is some initial processing of the afferent information. Cells in the cochlear nuclei then project to the SOC of both sides so that the SOC represents the first major point at which cells combine the inputs from the two ears. Therefore the SOC is a critical point for processing of binaural information which is essential for accurate sound localization. To understand the neural processing, we must first consider what cues are needed for sound localization.

Imagine walking down the street of a town late at night and suddenly hearing a strange sound. In this situation, there are two important tasks that our auditory system must do. It has to identify the sound (a cat meowing or the footsteps of a possible mugger) and it has to tell us where the sound comes from. We understand very little about how the auditory system can identify sounds but considerably more about the neural processes that underlie the ability to establish where a sound originates.

Note that the problem of localizing a stimulus is quite different for the auditory system than it is for the other two major sensory systems, vision and somatosensation. In both of the latter systems the location of a stimulus is naturally encoded in the location of the sensory receptor since there is a map of the space in the sensory epithelium, in the retina for the visual system and on the body surface for the somatosensory system. By contrast, the inner ear contains a map of the frequency, not location, of the sound. The location of the sound must then be computed by the nervous system by analyzing the small differences between the sounds at the two ears, ► **interaural time differences** (ITDs) and ► **interaural level differences** (ILDs, also called interaural intensity differences, IIDs). A remarkable feature of the auditory system is its sensitivity to these interaural disparities: the maximum ITD for the human head when a sound is opposite one ear is about 800  $\mu$ s while human subjects can detect ITDs as small as 10  $\mu$ s.

The maximum ILD is heavily dependent upon the frequency of the sound since the head acts as an effective acoustic shadow only for sounds with wavelengths that are shorter than the dimensions of the head, i.e. for high frequency sounds. Thus maximal ILDs are on the order of 20–30 dB at 15–20 kHz at the upper end of human hearing and only a few dB at the lower end of human hearing. Therefore, we would expect ILDs to be an effective cue only at high frequencies. The width of an average human head is around 15 cm which corresponds to the wavelength of a 2,000 Hz tone. Therefore ILDs should be effective for frequencies above 2 kHz and ineffective for lower frequencies. On the other hand the phase-locking that encodes temporal patterns in the cochlea is also frequency dependent: in mammals auditory nerve fibers will only phase-lock to tones below about 2–3 kHz.

Therefore timing information about the fine structure of sounds is only preserved at low frequencies and ITDs would only be effective at those frequencies. The frequency dependence of ITDs and ILDs is the basis for the classical duplex theory of sound localization [1].

Where in the nervous system are these cues encoded? The most likely candidates are the nuclei in the superior olivary complex (SOC) which occupy a unique position in the ascending auditory pathway: they represent the first major point at which cells in the auditory system combine the inputs from the two ears. These inputs arrive from the anteroventral cochlear nucleus of both sides and they are shown in Fig 1 from a classical drawing of the left SOC [2] from Golgi stained sections of the neonatal cat. In Fig. 1 the midline is to the right and the three major nuclei can be discerned from lateral (left) to medial (right): ► **lateral superior olive** the (LSO), ► **medial superior olive** (MSO) and the ► **medial nucleus of the trapezoid body** (MNTB). In the cat in coronal sections the LSO takes the appearance of a prominent S-shape while the MSO is a narrow nucleus. The LSO and MSO are the key players in the encoding of the two interaural cues of ITDs and ILDs.

### Processing of Interaural Time Differences

Fig. 2 shows simplified versions of the circuits that are believed to be important for encoding the interaural cues of ITDs and ILDs. ITDs are believed to be encoded by cells in the medial superior olive (MSO). Anatomically, cells in the MSO receive excitatory inputs from the spherical bushy cells of the anteroventral cochlear

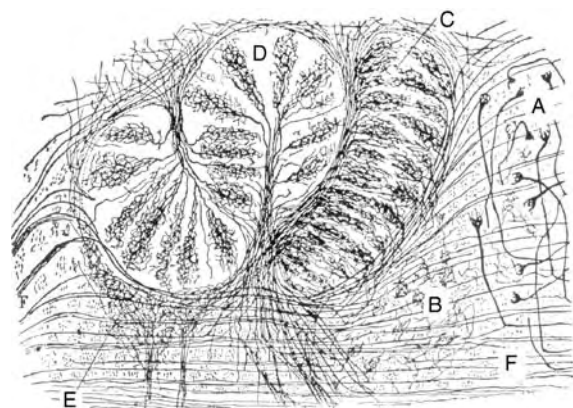

**Superior Olivary Nuclei. Figure 1** Drawings of the terminal arborizations from Golgi stains of afferents to the superior olivary nuclei of the neonatal cat. The three major nuclei are labeled: (A) medial nucleus of the trapezoid body, (C) medial superior olive, and (D) lateral superior olive. In addition two periolivary nuclei are also shown: (B) ventromedial periolivary nucleus and (E) lateral periolivary nucleus. The fibers of the trapezoid body (F) are also labeled.

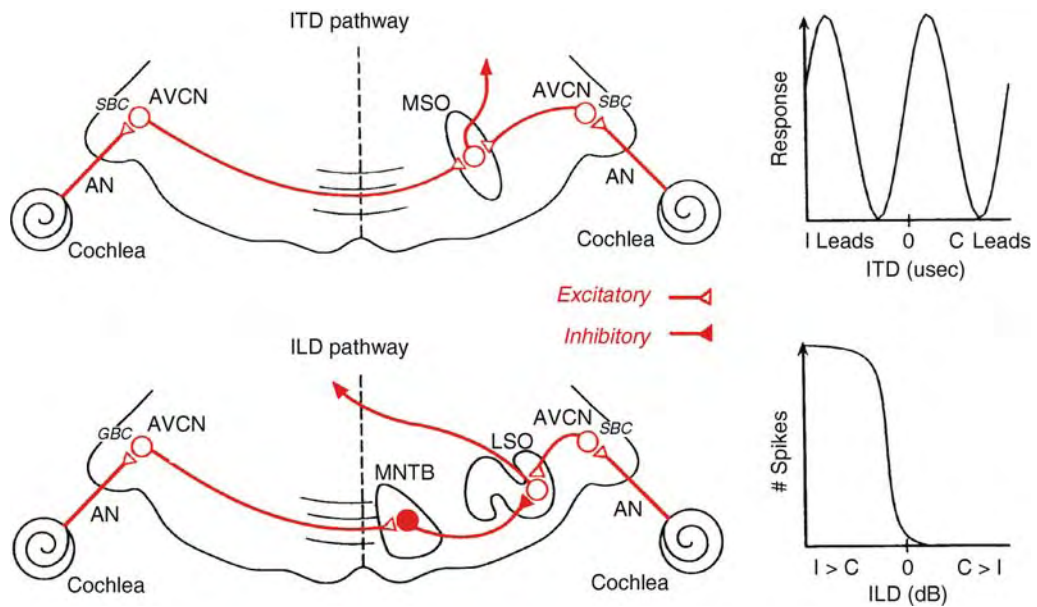

**Superior Olivary Nuclei. Figure 2** Schematic drawings of the two circuits in the superior olivary complex that encode interaural time differences (ITDs) (*above*) and interaural level differences (ILDs) (*below*). Abbreviations: AN, auditory nerve fibers; AVCN, anteroventral cochlear nucleus; MSO, medial superior olive; LSO, lateral superior olive; MNTB, medial nucleus of the trapezoid body; SBC, spherical bushy cell; GBC globular bushy cell. To the right are drawings of typical responses of a cell in the MSO (*top right*) to variations in ITDs of pure tones and responses of a cell in the LSO (*bottom right*) as a function of the ILD in dB. The response to ITDs is periodic at the period of the stimulus tone and reflects the fact that the cells in the MSO are sensitive to interaural phase differences.

nucleus of each side. MSO cells are unusual cytoarchitecturally in having prominent dendrites that extend to the lateral and medial side where they meet the afferents from the left and right side (Fig. 1). The afferents from the ipsilateral cochlear nucleus synapse on the lateral dendrites while those from the contralateral side synapse on the medial dendrites. Physiologically, the cells in the MSO have been shown to be binaurally excited and exquisitely sensitive to the time of arrival of sounds to the two ears [3,4]. MSO cells behave like coincidence detectors with very sharp temporal windows so that they respond only when the inputs from the two sides arrive coincidentally or nearly so. A widely accepted model of this circuit was first proposed by Jeffress [5] who hypothesized that the timing of the arrival of inputs from each side is governed by the delays associated with differences in axonal length and that there is a systematic change in axonal delays from one end of the MSO to the other, which would result in a map of ITDs across one axis of the MSO. Since the pathlength to the MSO is naturally longer from the contralateral ear, then a natural consequence of the coincidence mechanism is that MSO cells respond best when the sound source is in the contralateral sound field where the sound can reach the contralateral ear before the ipsilateral ear and thus compensate for the longer axonal path from the contralateral side.

Recent studies of the anatomy [6] and physiology [7] of the MSO have shown the existence of inhibitory inputs which originate from the medial nucleus of the trapezoid body (MNTB) and lateral nucleus of the trapezoid body (LNTB). The MNTB receives input from the spherical bushy cells of the anteroventral cochlear nucleus of the contralateral side while the LNTB receives input from the same cells on the ipsilateral side. The function of these inhibitory circuits is still controversial [8].

### Processing of Interaural Level Differences

A parallel circuit in the superior olivary complex is believed to be responsible for encoding interaural level differences (ILDs) (Fig. 2, bottom). Cells in the lateral superior olive (LSO) receive excitatory input from the spherical bushy cells of the ipsilateral side and inhibitory input from the contralateral side that is relayed via an inhibitory interneuron in the medial nucleus of the trapezoid body (MNTB) [9]. The MNTB cells received input from the globular bushy cells of the contralateral side by way of a very specialized synaptic ending, the calyx of Held. In accordance with this circuit, cells in the LSO are excited by stimulation of the ipsilateral ear and inhibited by stimulation of the contralateral ear.

For binaural stimuli, LSO cells respond to the difference in intensity (ipsilateral intensity – contralateral

intensity) of the sounds to the two ears. Thus for free-field sounds, LSO cells respond well to stimuli presented in the ipsilateral sound field where the level of the sound is greater in the ipsilateral than the contralateral ear and poorly when the sound is in the contralateral sound field.

The large calyceal synapses between the globular bushy axons and the MNTB cells are very unusual one and can be seen prominently in Fig. 1. It is often said to be the largest synapse in the brain. The presynaptic element is so large that recordings can be made from both the pre- and post-synaptic neurons so that this synapse has become a model for biophysical studies of synaptic transmission.

It is well-known that there is a systematic crossed relationship between the representation in the cerebral cortex and body part or sensory field in all sensory and motor systems. The right motor cortex controls muscles on the left side of the body, cells in the left visual cortex have receptive fields in the right visual field, and cells in the left somatosensory cortex respond to touch or pain to the right side of the body. Note that cells in the MSO respond preferentially to sounds in the contralateral sound field whereas cells in the LSO respond to sounds in the ipsilateral sound field. This apparent paradox is resolved by having MSO project to the ipsilateral inferior colliculus while most LSO cells project to the contralateral inferior colliculus (Fig. 2). The subsequent projections of the inferior colliculus to the medial geniculate and then onto the cortex are all predominantly uncrossed which then makes cells in the auditory cortex respond to sounds in the contralateral sound field, as with the other sensory systems.

All of the nuclei in the superior olivary complex, like those of other ascending auditory nuclei are tonotopically organized, i.e. there is a systematic map of frequency along one axis of the nucleus. In accordance with the expectations of the classical duplex theory, both the MNTB and LSO have a disproportionate representation of high frequencies, which are associated with ILDs, while the MSO is biased toward low frequencies, which are useful for encoding ITDs. In animals with different head sizes, the ability to localize low frequency tones appears to be correlated to the size of the MSO. Interestingly, humans have a very prominent MSO, which is correlated with the importance of ITDs for sound localization but a very small LSO, even though we are clearly able to encode ILDs.

### The Periolivary Nuclei

In addition to the major nuclei of the SOC, the MSO, LSO and MNTB, there are also some smaller nuclei that collectively are usually referred to as the periolivary nuclei. The size and prominence of the periolivary nuclei vary somewhat from one species to another and the identification of individual nuclei vary from one investigator to another. An interesting aspect of these nuclei is that in

some animals they are the source of the olivo-cochlear efferents [10]. These efferent fibers project from to the cochlea and innervate primarily the outer hair cells, though there are also fibers that end on the inner hair cells. Since 90% of the auditory nerve fibers innervate a single inner hair cells, the action of the olivo-cochlear efferents must be indirect. Current theories center on the fact that the outer hair cells are motile and can contract which could affect the micromechanics of the basilar membrane motion and consequently modulate the inner hair cell response. In rodents the olivo-cochlear efferents originate from cells that are located within the lateral superior olive.

## References

1. Rayleigh LJS (1907) On our perception of sound direction. *Philos Mag* 6 Ser:214–232
2. Ramon y Cajal S (1909) *Histologie du Systeme Nerveux de l'Homme et des Vertebrates*, vol 1. Instituto Ramon y Cajal, Madrid, pp 754–838
3. Goldberg JM, Brown PB (1969) Response of binaural neurons of dog superior olivary complex to dichotic tonal stimuli: some physiological mechanisms of sound localization. *J Neurophysiol* 32:613–636
4. Yin TCT, Chan JC (1990) Interaural time sensitivity in medial superior olive of cat. *J Neurophysiol* 64:465–88
5. Jeffress LA (1948) A place theory of sound localization. *J Comp Physiol Psychol* 41:35–39
6. Cant NB, Hyson RL (1992) Projections from the lateral nucleus of the trapezoid body to the medial superior olivary nucleus in the gerbil. *Hear Res* 58:26–34
7. Grothe B, Sanes DH (1993) Bilateral inhibition by glycinergic afferents in the medial superior olive. *J Neurophysiol* 69:1192–1196
8. Joris PX, Yin TCT (2007) A matter of time: internal delays in binaural processing. *Trends Neurosci* 30:70–78
9. Boudreau JC, Tsuchitani C (1968) Binaural interaction in the cat superior olive S segment. *J Neurophysiol* 31:442–454
10. Warr WB (1992) Organization of olivocochlear efferent systems in mammals. In: Fay RR, Popper A (eds) *The mammalian auditory pathway: neuroanatomy*. Springer, New York, pp 410–448

## Superior Olive

### Synonyms

► *Nucl. olivaris sup.*; ► Superior olivary nucleus

### Definition

The superior olivary complex comprises the nuclei:

- Nucleus of the trapezoid body
- Nucleus of the superior lateral olive

- Medial nucleus of the superior olive

and is thus a vital synaptic center in the auditory tract, playing an important role in acoustic reflexes (reflex eye movements towards the source of noise, fright movements).

- ▶ Mesencephalon

---

## Superior Parietal Lobule

### Synonyms

- ▶ Lobulus parietalis sup.

### Definition

In the direction of the occipital pole, the inferior and superior lobules unite at the postcentral gyrus.

Analogous to the secondary motor cortex there is also a secondary sensory cortex for the somatosensory control; this is believed to stretch across both lobules and to be responsible for analysis, recognition and assessment of tactile information.

- ▶ Telencephalon
- ▶ Visual Space Representation for Reaching

---

## Superior Prefrontal Gyrus

### Definition

Part of the frontal lobe; involved in orchestrating executive function.

---

## Superior Rectus Muscle

### Definition

Superior rectus is one of the six eye muscles.

- ▶ Eye Orbital Mechanics

---

## Superior Semicircular Canal Dehiscence Syndrome

### Definition

Disorder of the labyrinth caused by a dehiscence (opening) in the bone that covers the superior canal. Patients can develop vestibular and/or auditory symptoms and signs. The effect of the dehiscence is to create a third mobile window into the inner ear.

- ▶ Disorders of the Vestibular Periphery

---

## Superior Temporal Gyrus

### Definition

The superior temporal gyrus is the cerebral cortical fold immediately ventral to the lateral fissure. Its posterior portion is part of the language cortex.

---

## Superior Vestibular Nucleus

### Synonyms

- ▶ Nucl vestibularis sup.

- ▶ Vestibular Nuclei
- ▶ Pons

---

## Supernormal Stimulus

### Definition

Stimulus with a releasing value that is higher than the releasing value of the natural key stimulus.

---

## SuperSAGE

- ▶ Serial Analysis of Gene Expression



## Supersensitivity of Blood Vessels

### Definition

Increased response (constriction) of blood vessels to circulating or neurally released noradrenaline (and other vasoactive agents) following partial or complete denervation, decentralization or decrease of activity in postganglionic vasoconstrictor neurons. The increased response to noradrenaline is primary due to a decrease of neural uptake of noradrenaline by the postganglionic terminals.

► [Complex Regional Pain Syndromes: Pathophysiological Mechanisms](#)

## Supervenience

JOHN SYMONS

Department of Philosophy, The University of Texas at El Paso, El Paso, TX, USA

### Definition

Supervenience is a philosophical term of art that refers to the determination relation between lower and higher-level ontological phenomena. For example, physicalists believe that psychological facts supervene on neural facts.

### Description of the Theory

In the 1970's and 1980's the concept of supervenience figured in philosophical debates as a promising way to shed light on the mind-body problem. According to the standard view in metaphysics and philosophy of mind, supervenience is a relation between two sets of properties such that:

1. They vary together in a regular way.
2. One set somehow determines the other.
3. That the two sets are different in kind.

For example, mental properties can be said to supervene on physical properties if they are covariant and if physical properties are more basic than mental properties. Likewise, baldness supervenes on the distribution of hair, computer operating systems supervene on computer hardware, ethical actions supervene on the movements of bodies, etc.

Supervenience is not an exotic or purely philosophical notion. The basic idea arises quite naturally out of our belief that some features of reality depend on others.

In the philosophy of mind, the supervenience thesis rests on the belief that mental life depends on the activity of the brain (or on the brain plus some aspects of the environment). If one believes that any change at the psychological level can only happen by virtue of a change at the neural level then one holds a version of the supervenience thesis for mental life. While supervenience has some intuitively appealing features, the challenge is to get clear on the notions of fundamentality and determination that are central to the supervenience thesis.

The precise nature of the determination involved in the supervenience thesis depends, among other things on modal considerations; on what is meant by necessity and possibility. For instance, when one says that no higher-level change in the properties of an object is possible without a change in its lower-level properties, a variety of things can be meant depending on the force of "is possible." If one believes that the determination relation holds across all possible worlds then one is arguing for a stronger version of supervenience than if one contends that the determination relation holds only for our world, as it actually is, with its physical laws as they happen to be. Additionally, the supervenience thesis will have different implications depending on what one means by the object in question. Global, regional and local supervenience relations can be distinguished, depending on where one sets the parameters of the object in question. Global supervenience takes as its object, the entire universe, for regional and local supervenience the object is some subset of the universe.

### Metaphysical Assumptions

Discussions of the notion of supervenience begin with some familiar and widely shared metaphysical assumptions. It is assumed, for example that facts about the natural world can be understood as falling into distinct levels. Chemical, biological, psychological and economic facts fall into distinct levels, hierarchically arranged from the more basic and general, or "lower," to the more specific and "higher." In this picture, physics is the most fundamental science and physical facts and laws have maximal generality, insofar as they apply to all of nature. With this stratified picture of nature comes the notion that each of the higher-levels depends on the lower levels in some sense. In this spirit, contemporary neuroscientists and philosophers of mind generally assume that psychological facts are determined by neuroscientific facts which are, in turn, determined by bio-chemical facts.

While supervenience is completely compatible with reductionism, supervenience theorists generally assume that the relationship between levels is non-reductive. Many philosophers who accepted non-reductive physicalism were drawn to supervenience as a way of embracing a respectable physicalist metaphysics while at

the same time maintaining a form of irreducibility for mental level facts.

Having a belief, a feeling or a desire is not simply a matter of possessing one or more of a defined set of physical properties. For instance, the dog, the octopus and the Martian might all be in pain while possessing differently structured brains, or even – at least in the case of the Martian – no brain at all. One can imagine different structures realizing precisely the kinds of behaviors or functions that we associate with any mental term. Considerations of this kind, so-called multiple realizability arguments, encouraged most contemporary philosophers of mind to abandon classical reductionism for some version of non-reductive physicalism. This means that they reject claims that the mind simply is the brain (the identity theory) as well as claims that the micro-physical description of reality is the only description we need (strong reductionism).

While multiple realizability arguments led many philosophers to reject straightforward reductionism, it seems unscientific to deny that mental life is dependent on the physical stuff in which mental life is realized. If one wishes to maintain a commitment to physicalism while rejecting reductionism one faces the problem of understanding the nature of the dependence between higher and lower-level facts about organisms. The mind-body problem in its contemporary form is the problem of reconciling physicalism and anti-reductionism. This is quite different from the mind-body problem we inherited from Descartes, which involved accounting for the interaction between spatial and non-spatial substances.

Philosophers noticed that this modern version of the mind-body problem could be understood in terms of the relationship between properties. For example, an object can have properties related to its shape, velocity, mass, position, color and the like without the problem of their compatibility or causal relations ever arising. Some of an object's properties clearly determine others. For instance, the characteristics of an object's surface will determine its colors. In other cases, properties may have no obvious connection or determinative relationship. Consider the relationship between the mass of a vase and its distance from Paris. The analysis of notions like mentality in terms of properties opened the possibility that an object can have both physical and psychological properties without encountering Cartesian-style problems about the relationship between spatial and non-spatial substances. Properties-based metaphysical analyses were attractive to non-reductive physicalists precisely because they permit us to talk about objects, events and states of affairs as having both physical and psychological properties.

Donald Davidson's anomalous monism is an example of this kind of properties-based metaphysics. Davidson accepted a physicalistic metaphysics while denying that science will generate a straightforward

reduction of mental types to physical types. And yet, Davidson did not believe that mental life somehow floated free of the physical world. Rather, as a scientifically inclined philosopher, he was committed to the idea that there are no events that have only mental properties [1]. However, saying that an object that has mental properties must also have physical properties is not necessarily any comfort to the reductionist. After all, as Jaegwon Kim points out, while it is true that if an object has a color, it must have a shape, there is no necessary relationship between for example, the squareness of an object and its redness [2].

Anomalous monism, by itself, does not offer much of a theory of the relationship between mental and physical properties. And yet there seems to be more of a connection between minds and bodies than exists between shapes and colors. In his classic paper "Mental Events" Davidson attempts to reconcile his commitment to physicalism with his anti-reductionism using the concept of supervenience. Davidson is widely credited as introducing the term "supervenience" in its contemporary form in that paper. In a frequently cited passage he defines supervenience as meaning "that there cannot be two events alike in all physical respects but differing in some mental respect, or that an object cannot alter in some mental respect without altering in some physical respect" [1,3]. According to advocates of supervenience in the philosophy of mind, this definition has far more substance than something like the mere necessary dependence of color properties on shape properties. To say that minds supervene on brain states for example, is to suggest that one can only have a mental property by virtue of having some neural property, and that understanding this dependence relation will allow us to understand the nature of the relationship between mental life and embodiment. The implicit claim is that supervenience will give us more than the simple acknowledgement *that* there is some relationship between the two.

### Kinds of Supervenience

In addition to assuming that facts about more fundamental levels of reality must determine facts at higher ontological levels, there are two additional assumptions that are related to the first:

1. Changes at the higher level depend on changes at the lower level.
2. Identical states of affairs at the lower level necessitate identical states of affairs at the higher level.

In the case of the relationship between mental and physical phenomena these two assumptions are exemplified in the following way:

- 1a. Changes at the psychological or mental level are only possible via changes at the neural level.

- 2a. It is impossible for organisms to be in identical brain states without also sharing the same psychological states.

For neuroscientists, these are fundamental assumptions. After all, neuroscience would of little general interest if psychological differences were not determined in some law-like way by neural differences. Of these two assumptions, 2 can be understood as the minimal requirement for a physicalist metaphysics. Of course 2a is debatable and might be made compatible with physicalism given some fancy philosophical footwork. We can rephrase 2 so as to bring out its modal character:

- 2m. It is not possible for two things to be identical at the lowest level and not identical at higher-levels.

In this form we can see that the strength of the modal component is very important to the meaning of the overall claim. If it is merely a claim about the way things happen to be in this world, then one is only committed to “weak supervenience.” If it is a claim about the relationship between the two levels in all worlds that we can properly describe, then it is an example of a “strong supervenience” claim.

Debates over the nature of the determination relation itself have also distinguished between conceptual, metaphysical and nomological supervenience. To say that  $m$  nomologically supervenes on  $p$  is simply to say that there happens to be a lawlike connection between the two. For example  $m$  might supervene on  $p$  because of the ways that the laws of physics happen to stand in some world. This, of course, would be to claim that  $m$  weakly supervened on  $p$ .

Metaphysical supervenience involves the assertion that a determination relation holds across all possible worlds. If  $m$  metaphysically supervenes on  $p$  then in all possible worlds  $m$  will appear every time  $p$  appears. Finally, to claim that  $m$  conceptually supervenes on  $p$  is to suggest that anyone who understands the concepts  $p$  and  $m$  will recognize that they are related. Certain conceptual truths, for instance, that unmarried males are bachelors, or that  $2 + 2 = 4$  hold across all possible worlds. Conceptual truths of this kind sometimes entail supervenience relations. For example, as discussed previously, baldness, supervenes on hair distribution. Or, to put it another way, one’s hair distribution properties determine whether one has the property of being bald. Since being bald, is, by definition connected to having an unacceptably meager distribution of hair, one can see hair distribution as determining baldness across all possible states of affairs. Both metaphysical and conceptual supervenience are cases of strong supervenience.

While it is illuminating to examine the consequences of altering the modal strength of claims about determination relations, such analyses do not provide

significant insight into the nature of determination itself. Supervenience claims entail the existence of a determination relation, are governed in large part by one’s modal commitments, however, bracketing the modal component of the claim, it seems that the supervenience claim itself does not do very much more than point to precisely the phenomenon we had hoped to understand, namely the covariation of mental and biological properties.

By saying that mental facts supervene on neuroscientific facts, philosophers promised some understanding of how higher-level facts about mental life are determined by lower-level facts about neuroscience. After three decades of debate, supervenience has not lived up to the hopes of its advocates. As Jaegwon Kim, one of the most important proponents of supervenience, puts it: “We must conclude then that mind-body supervenience is not an explanatory theory; it merely states a pattern of property covariation between the mental and the physical and points to the existence of a dependency relation between the two.” (1998, 14) Property covariation is the problem to be explained, and can be accounted for in a variety of ways. Unfortunately, supervenience is not one of them. Perhaps one reason for increased interest in emergence and reduction in recent philosophy of mind may be the realization that these approaches hold out the possibility of the kind of explanatory account of the relationship between mind and body that supervenience failed to provide.

While even its most ardent advocates concede that supervenience did not live up to their expectations, it is nonetheless clear that analyses of the nature of supervenience have helped us to understand what counts as an acceptable explanation of the mind’s place in nature given our basic commitments to physicalist metaphysics.

## References

1. Davidson D (1970) Mental Events. In: Foster L, Swanson JW (eds) Experience and theory. University of Massachusetts Press, Amherst.
2. Kim J (1998) Mind in a physical world. MIT Press, Cambridge MA
3. Davidson D (1980) Essays on actions and events. Clarendon Press, Oxford

## Supervised Learning

### Definition

Supervised learning is a form of learning in computational models such as artificial neural networks. The network is trained by computing the difference between its output and a teaching signal, which has to be

provided externally. This difference, the net error, is used in order to estimate by how much, and in which direction, to adjust connection weights in the network.

A disadvantage of supervised learning is that in many cases the existence of a teaching signal is not justified by the context of the application. It has been proposed that supervised learning occurs in the cerebellum.

- ▶ Cerebellum
- ▶ Connectionism
- ▶ Neural Networks

## Supplementary Eye Field

JEFFREY D. SCHALL

Center for Integrative and Cognitive Neuroscience,  
Vanderbilt Vision Research Center, Department  
of Psychology, Vanderbilt University, Nashville,  
TN, USA

### Definition

The supplementary eye field (SEF) is an area in the dorsal medial frontal lobe of the cerebral cortex that contributes indirectly to the control of movements of the eyes.

### Characteristics

#### Higher Level Structures

SEF is located at the rostral end of the supplementary motor area, contiguous with the representation of oro-facial, pinna and forelimb movements. SEF is located in Brodman's area 6 and corresponds to area F7 [1]. The human SEF is located on the medial surface of the superior frontal gyrus in the upper part of the paracentral sulcus (Fig. 1).

#### Lower Level Components

The connectivity of SEF is distinct from that of the skeletal motor cortex surrounding it, and SEF shares many but not all efferent targets and afferent sources with the frontal eye field (FEF) [2,3]. The major thalamic inputs to SEF arise mainly from the medial ventroanterior nucleus and the lateral segment of the mediodorsal nucleus as well as the intralaminar thalamic nuclei. These thalamic inputs convey signals mainly from the visuomotor zone of the substantia nigra pars reticulata, the intermediate layers of the superior colliculus and the face representation of the deep cerebellar nuclei. SEF projects to the caudate nucleus in a zone largely but not completely overlapping afferents from FEF, to the superior colliculus in a more

diffuse pattern than the FEF counterpart, to specific brainstem oculomotor regions such as the nucleus raphe interpositus, the nucleus reticularis tegmenti pontis, the nucleus prepositus hypoglossi, the mesencephalic reticular formation, the interstitial nucleus of Cajal and the pontine reticular formation as well as the dorsomedial pontine nuclei.

SEF is reciprocally connected with several cortical areas, although fewer visual areas than is FEF. SEF interacts directly with area MST, the superior temporal polysensory area, area LIP, with anterior and posterior cingulate cortex and with the postarcuate premotor areas as well as the supplementary motor area and with prefrontal cortex in areas 12 and 46. SEF is also heavily connected with FEF in a spatial pattern that departs from the typical topography observed between other cortical areas.

### Higher Level Processes and Lower Level Processes

#### Sensory Processes

Neurons in SEF respond to visual and auditory stimuli [2,3]. However, visual responses are later and less vigorous than those observed in FEF. SEF neurons exhibit various kinds of extraretinal modulation including anticipatory activity and responses conditional on stimulus-response mapping rules [4]. Thus, SEF visual responses reflect less about the properties of the image and more about the stimulus in the context of the ongoing behavior.

#### Gaze Control

A great deal of evidence demonstrates that the SEF plays some role in the production of movements of the eyes [2,3]. In his pioneering electrical stimulation studies in humans, Penfield noted gaze shifts evoked by stimulation of the rostral part of the supplementary motor area (SMA). This finding has been confirmed using subdural electrode arrays to stimulate and record in humans. Schlag and Schlag-Rey first identified SEF as an area in which low intensity microstimulation evokes saccades and neurons discharge in relation to saccade production [5]. SEF neurons are also active in relation to the production of pursuit eye movements [6].

Numerous functional brain imaging studies using PET and fMRI have described activation in and around SEF of humans producing saccades [7]. Common findings include greater activation in SEF associated with antisaccades or memory-guided saccades relative to simple visually guided saccades.

Several other characteristics of SEF distinguish it from FEF. Electrical stimulation of many sites in SEF evokes saccades with dimension and direction dependent on the position of the eyes in the orbit, unlike what is observed in FEF or superior colliculus. Also, the saccade-related activity of many SEF neurons is contingent on the context in which the saccade is produced.

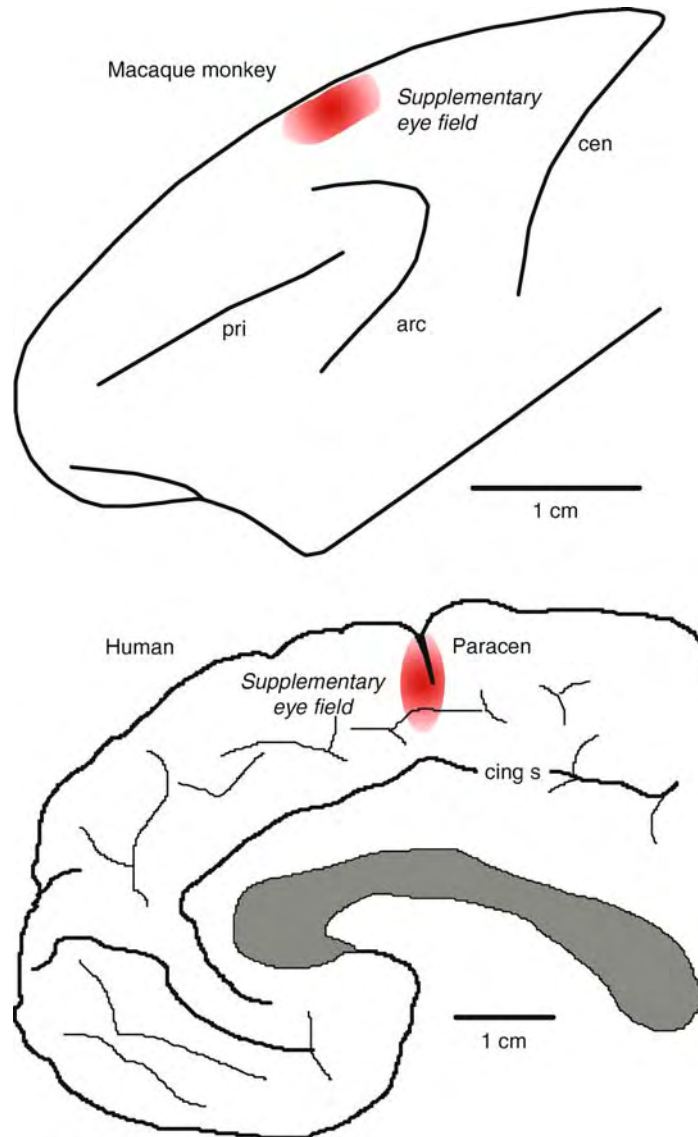

**Supplementary Eye Field. Figure 1** Location of supplementary eye field in lateral view of frontal lobe of macaque monkey (*top*) and medial view of frontal lobe of human (*bottom*). In macaque monkeys, SEF is located on the dorsomedial convexity, medial to the upper limb of the arcuate sulcus. In humans, SEF is located dorsally on the medial surface around the paracentral sulcus. Abbreviations: *arc*, arcuate sulcus; *cen*, central sulcus; *cing s*, cingulate sulcus; *pri*, principal sulcus.

Finally, despite the apparent relation of SEF to saccade production, when tested in a task requiring control of saccade initiation, few neurons in SEF generate signals that are sufficient to control gaze. Thus, although anatomically and physiologically SEF seems to parallel FEF in many respects, SEF seems to play a less essential or potent role in saccade production.

#### **Supervisory Control**

Diverse more complex functional properties of SEF neurons have been described including conditional motor learning, object-centered representation,

production of anti-saccades and sequences of saccades and eye-hand coordination. Theories of executive control cite five types of behavior that require supervisory control – planning or decision making, error correction, producing responses that are not well-learned, dealing with difficult or risky conditions and overcoming habitual responses. These categories include the conditions under which various investigators have reported neural activity in supplementary eye field. Therefore, these diverse findings can be organized under the hypothesis that SEF is part of a supervisory control network that is called into action when alternative

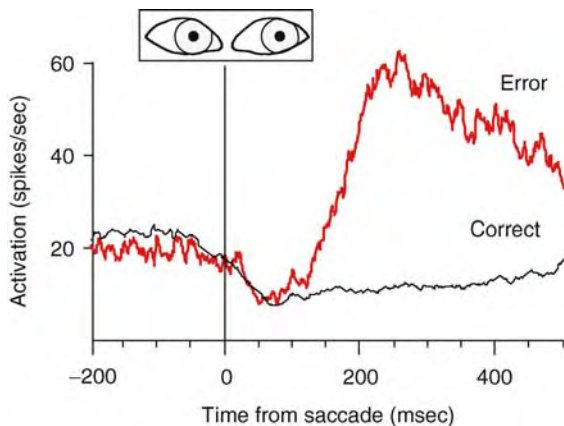

**Supplementary Eye Field. Figure 2** Activity of a representative SEF neuron aligned on the initiation of a saccade that was correct (black) and an error (red). This neuron signaled the production of errors.

responses are difficult to distinguish, habitual responses must be overcome, consequences are uncertain, and deliberation is necessary [8,9]. The supervisory system exerts control over the processes that produce sensory-guided movements. Physiological evidence for a supervisory system in humans includes a scalp potential referred to as the error-related negativity that occurs when subjects produce errors. In macaque monkey SEF, certain neurons exhibit modulation specifically following a saccade that is an error (Fig. 2). Other neurons in SEF signal the anticipation and receipt of reinforcement. Still other neurons in SEF seem to signal the amount of mutually incompatible co-activation occurring. Error, reward and conflict signals form the basis of current models of executive control. Therefore, the most plausible current hypothesis about the function of SEF proposes that it provides executive control when saccades are produced under complex conditions.

### Function

SEF contributes to the executive control of eye movements.

### Pathology

Damage to SEF in humans or monkeys results in symptoms that are relatively mild and difficult to discern. Experimental ablation or inactivation of the SEF in macaque monkeys does not impair accurate fixation of eccentric visual targets or execution of saccadic eye movements to single visible or to remembered target locations. Modest impairment in production of sequences of saccades is observed. Transcranial magnetic stimulation that transiently inactivates SEF in humans also impairs production of a memorized sequence of eye movements. It should be noted that combined ablation of the FEF and the superior colliculus, leaving the

SEF intact, produces effective gaze paralysis. These observations reinforce the conclusion that SEF plays an indirect role in gaze control. A recent report of one patient with a lesion restricted to SEF in one hemisphere described impaired self-control but intact error monitoring during a saccade task.

### References

1. Matelli M, Luppino G, Rizzolatti G (1991) Architecture of superior and mesial area 6 and the adjacent cingulate cortex in the macaque monkey. *J Comp Neurol* 311:445–462
2. Schall JD (1997) Visuomotor areas of the frontal lobe. In: Rockland K, Peters A, Kaas J (eds) *Extrastriate cortex of primates. Cerebral cortex*, vol 12. Plenum Press, New York, pp 527–638
3. Tehovnik EJ, Sommer MA, Chou IH, Slocum WM, Schiller PH (2000) Eye fields in the frontal lobes of primates. *Brain Res Brain Res Rev* 32:413–448
4. Coe B, Tomihara K, Matsusawa M, Hikosaka O (2002) Visual and anticipatory bias in three cortical eye fields of the monkey during an adaptive decision-making task. *J Neurosci* 22:5081–5090
5. Schlag J, Schlag-Rey M (1987) Evidence for a supplementary eye field. *J Neurophysiol* 57:179–200
6. Heinen SJ, Liu M (1997) Single-neuron activity in the dorsomedial frontal cortex during smooth-pursuit eye movements to predictable target motion. *Vis Neurosci* 14:853–865
7. Brown MR, DeSouza JF, Goltz HC, Ford K, Menon RS, Goodale MA, Everling S (2004) Comparison of memory- and visually guided saccades using event-related fMRI. *J Neurophysiol* 91:873–889
8. Olson CR, Gettner SN (2002) Neuronal activity related to rule and conflict in macaque supplementary eye field. *Physiol Behav* 77:663–670
9. Schall JD, Stuphorn V, Brown JW (2002) Monitoring and control of action by the frontal lobes. *Neuron* 36:309–322

## Supplementary Motor Area (SMA, F3)

### Definition

A secondary motor area located on the medial wall of the frontal lobe anterior to the hindlimb representation of primary motor cortex. This area has projections to primary motor cortex and is also contains large numbers of corticospinal neurons. SMA is important for producing bilateral movements and sequences of movements.

- ▶ Motor Cortex: Output Properties and Organization
- ▶ Primary Motor Cortex (M1)
- ▶ Visual Space Representation for Reaching

## Suprachiasmatic Nucleus

RAE SILVER<sup>1</sup>, HUGH PIGGINS<sup>2</sup>

<sup>1</sup>Kaplan Professor of Natural and Physical Sciences, Departments of Psychology at Barnard College and at Columbia University, Department of Pathology and Cell Biology, Columbia Health Sciences, New York, NY, USA

<sup>2</sup>Professor of Life Sciences, University of Manchester, Manchester, England, UK

### Synonyms

SCN

### Definition

A hypothalamic nucleus lying above the optic chiasm and functioning as a master clock by setting the phase of activity of responses throughout the body.

### Characteristics

**There is a clock in the brain.** If one were placed in an environment such as a cave, where there are no time cues at all, then cycles of sleep and wake would persist with a period of approximately 24 h. It was once considered possible that this ~24 h periodicity was the result of the earth's rotation around the sun. It is now well established however, that this rhythm is the achievement of a brain clock, located in the suprachiasmatic nucleus (SCN) of the hypothalamus. The experimental evidence that the SCN is the locus of a master clock in the brain that organizes the daily activities of the body is very robust, as it comes from many types of studies in many different labs, all of which converge on this conclusion. Thus, lesions of the SCN abolish all daily rhythms, transplants of the nucleus restore rhythmicity to an SCN-lesioned host animal, with the period of the donor, and ►rhythmicity of the SCN is sustained *in vitro* and *in vivo*, in the absence of input from the rest of the brain. In summary, the SCN is the locus of a brain clock that signals time of day to the body, findings that have been amply reviewed[1–4]. The SCN is necessary for these functions, and they can not be taken over by any other brain region.

**The SCN is made up of individual cells that are themselves circadian clocks.** The SCN contains ~10,000–20,000 neurons and about a third as many astroglia. For many years, it was unclear whether circadian rhythmicity was an emergent property of a network of ►oscillators working together, or a property of individual cells. The cellular basis of circadian rhythmicity was first seen in daily changes in spontaneous electrical activity of neurons. This discovery

made it logical to seek the intracellular mechanism of rhythmicity. One of the most important discoveries of the past decade has been the identification of clock genes. These clock genes occur in a wide variety of organisms, ranging from prokaryotic bacteria, to plants, flies and mammals. Importantly, there is striking homology between clock genes among animals, enabling rapid discovery in research.

Within individual cells, the clock mechanism involves multiple core ►feedback loops consisting of positive and negative regulatory elements of transcription/translation which mediate the expression of a large number of genes at distinct circadian phases [4,5]. Briefly, the elements of the feedback loop include the transcriptional activators ►BMAL1 and ►CLOCK and the negative regulators PER and CRY which act on circadian ►E-box promoter elements. Post-translational modifications involving protein phosphorylation and ubiquitination temporally separate the turnover of the key positive and negative components of the clock, thereby producing a period length for the entire cycle of changes of approximately 24 h. Additional interlocking loops are produced by E-box-mediated regulation involving the ROR/►REV-ERB binding element (RORE) and the DBP/E4BP4 binding element (D-box). By assessing the expression level of key-clock genes and or their protein products, we can assess the time of day encoded in the cell.

**Coordination of bodily rhythms and function of timing information.** In orchestrating the timing of daily rhythms in physiology and behavior, the SCN prepares the body for the transitions between day and night. Daily rhythms can be seen not only in the salient behaviors of sleep and wake, but in virtually all behavioral and physiological responses that can be measured. For example, there are rhythmic oscillations in speed of responding in timed tasks, in the secretion of hormones, in concentrations of urinary metabolites, and in hunger and eating. Many of these responses enable the anticipation of changes that will soon occur. The optimal timing of each of these functions ensures their occurrence in the appropriate temporal niche: correct timing is a form of resource partitioning.

**Light provides the most salient and reliable synchronizing or entraining signal from the environment,** and functions to set the phase of SCN oscillators. The ►retina is the only light sensitive tissue in mammals, and the SCN receives direct input from the retina via the ►retinohypothalamic tract. (In contrast, non-mammalian vertebrates have a photosensitive ►pineal gland and/or ►photoreceptors within the brain itself and many organisms have light sensitive cells in various parts of the body). The SCN gets photic information from both rod/cone photoreceptors and from ►intrinsically photosensitive retinal ganglion cells (RCGs) [6]. The ►rods and ►cones, containing the photopigments rhodopsin

and iodopsin, are the classical photoreceptors in the outer retina of the eye. Rods and cones send their signals to neurons in the inner retina, the RGCs. Most RGCs project their axons via the optic nerve to brain areas involved in (conscious) vision. On the other hand, a small proportion (~1%) of RGCs expresses the photopigment ►melanopsin, is intrinsically photosensitive and project via the retinohypothalamic tract to the SCN among other brain regions. Projections of these intrinsically photosensitive RGC's make up about 80% of the retinal input to the SCN and regulate (not conscious) detection of light and dark, or nonvisual photoreception.

**Intercellular communication in the SCN.** One might imagine that SCN oscillators acts as a coherent unit, producing one synchronized rhythm throughout the nucleus. This is not at all the case. SCN neurons have a topographically and functionally structured arrangement, with distinct populations of neurons that are heterogeneous in morphology, physiology and neurotransmitter content [2]. Some neurons receive information about light via the retina, others mediate intercellular communication within the nucleus. Each of these functional cell types transfers photic or circadian signals to other brain regions. Synchronization of neurons within the SCN is achieved via multiple mechanisms including synaptic transmission, gap junctions, and possibly by diffusible signals, ensuring robust responses in the face of genetic or environmental perturbations. An orderly sequence of activation of cells occurs, and this has been studied by exploring the circuitry of the SCN.

**The SCN has two main communicating compartments: ventral core and dorsal shell.** Within the nucleus, the neurons located in a ventral “►core” subdivision receive light input from the retina and communicate that information to neurons of the dorsal “►shell.” Core neurons express the neuropeptides, ►vasoactive intestinal peptide (VIP) and ►gastrin-releasing peptide (GRP). Core neurons are not detectably rhythmic or show very low levels of rhythmicity, measured by either electrical activity or clock gene expression. In a sense, core SCN neurons behave as “gates,” sometimes open and sometimes closed to environmental input, and they function to narrow the phase dispersion of individual oscillating cells in the shell SCN [3]. Core cells express immediate early genes such as *cfos* and the core clock genes ►*Period1* (*Per1*) and ►*Period2* (*Per2*), during the night or subjective night, but not during the day or subjective day. Furthermore, the expression of immediate early genes and proteins is highly correlated with the behavioral ►phase shifting effects of light. In contrast to the core, neurons of the dorsal shell contain ►vasopressin (►VP) and rhythmically express *Per1* and *Per2* [2] and have daily electrical activity rhythms, with higher firing rates during the day than at night. That rhythmic electrical activity is important in producing synchrony among SCN neurons has been

shown in studies using tetrodotoxin, which prevents action potentials by blocking voltage-dependent Na<sup>+</sup> channels. Application of tetrodotoxin to SCN slices, results in the loss of synchrony among SCN neurons.

The orderly expression of circadian rhythmicity dependent on networks of cells between core and shell and within shell networks has been confirmed by work both *in vivo* and *in vitro*. Lesions of the core SCN result in loss of behavioral and physiological rhythmicity, even when cells of the shell SCN survive ablation. If the dorsal and ventral SCN in a brain slice are separated by a cut, neurons in the dorsal shell become desynchronized, while those in the ventral core remain synchronized. In a slice preparation that lacks an ►SCN core, ►rhythmicity is unstable and of low amplitude, measured by bioluminescence of luciferase reporter for *Per2* [3]. In contrast, if a slice contains both core and shell neurons, a high amplitude, stereotyped spatio-temporal pattern of changes in gene expression occurs, with a complex wave of activation in a series of steps, beginning at the dorsomedial SCN, spreading ventrally in the outer shell and then centrally to the inner shell and a simpler pattern of deactivation involving a contraction of expression towards the central inner shell. A similar slow spread of signal is seen in SCN from animals sampled at different times. Taken together, these findings consistently indicate that core neurons are necessary for rhythmicity in SCN tissue and in the behavior and physiology of the animal, and that a temporally organized sequence of activation occurs on a daily basis in the SCN. The major neurotransmitters and chemical synapses in the SCN that comprise its circuits include GABA, VIP and GRP. GABA and its receptors are expressed throughout the SCN. GABAergic transmission shows a circadian rhythm, and GABA treatment both phase shifts and synchronizes firing rate rhythms among SCN neurons [7]. In the SCN, both VIP and GRP occur in the core retinorecipient region and these peptides have daily rhythms, with GRP peaking in the day and VIP peaking in the night. VIP- and GRP-containing neurons have extensive intra- and extra-SCN projections and their respective targets, VPAC<sub>2</sub> receptor (encoded by the *Vipr2* gene) and the GRP receptor (BB<sub>2</sub>) are both more heavily expressed in dorsal SCN. Mice lacking BB<sub>2</sub> receptor expression maintain molecular and behavioral rhythmicity albeit with subtle alterations, indicating that GRP-BB<sub>2</sub> signaling functions to amplify endogenous circadian rhythmicity. By contrast, mice deficient in VIP (*Vip*<sup>-/-</sup>) and mice lacking VPAC<sub>2</sub> expression (*Vipr2*<sup>-/-</sup>) are both incapable of sustaining normal circadian locomotor rhythms suggesting that this signaling system is necessary for sustaining circadian clock function. Indeed, molecular rhythms of clock genes and *c-Fos* are severely attenuated in the SCN of *Vipr2*<sup>-/-</sup> mice while the firing rate rhythms of VIP<sup>-/-</sup> and *Vipr2*<sup>-/-</sup> SCN cells are blunted or absent and show disrupted synchronization.



*GRP administration leads to induction of Per1 and Per2 mRNA as well as c-Fos protein in the dorsal SCN, and produces phase shifts in firing rate rhythms in SCN slices and in locomotor behavior. GRP administration restores neuronal rhythms in Vipr<sup>2-/-</sup> SCN slices.*

**Output signals of the SCN.** Information from the SCN is transmitted directly, by neuronal projections to other brain regions and indirectly, via intermediate neurons to peripheral organs such as the pineal gland and liver via intermediate neurons [8]. Hypothalamic intermediate neurons in the ►subparaventricular zone and the paraventricular nucleus are important in this process. In addition, diffusible signals from the SCN are also sufficient to restore and sustain circadian behavioral rhythms in SCN-ablated animals. Consistent with this finding, transplanted fibroblasts assume the rhythmic phenotype of their host animal. Several prohormones and peptides are rhythmically produced in the SCN, and are candidate signaling molecules. Several diffusible signals have also been identified as output factors of the SCN, including ►transforming growth factor-alpha, ►prokineticin-2 and cardiotropin-like cytokine. Neural targets of SCN efferents such as the subparaventricular zone and ►paraventricular nucleus of the thalamus, express receptors for many of these molecules.

**The brain clock is one part of the circadian system in the body.** In regulating rhythmicity throughout the body, the SCN is part of a circadian system that involves a body-wide, hierarchically organized network of oscillators. The output from the SCN synchronizes the activity of ►peripheral oscillators, found in most tissues. These peripheral oscillators express autonomous rhythms, independent of the brain clock, but the SCN is required to synchronize the phase of peripheral oscillators within and between tissues.

The molecular oscillations of clock cells occur in virtually all tissues including the eyes, liver, kidneys, skin and muscles in mammals [9]. These oscillators in peripheral tissues can not maintain rhythmicity for a prolonged time, and dampen rapidly if they do not receive time cues from the SCN or the environment. The master clock in the SCN controls the peripheral oscillators by means of neuronal and/or humoral signals. When the SCN is lesioned, the circadian gene expression dampens in the peripheral tissues, probably because peripheral oscillators are desynchronized from each other. Understanding the actions of factors downstream of the SCN is will be a key to understanding how coordinated circadian rhythmicity is achieved in the brain and the rest of the body. Disruption of normal circadian patterns occurs in diverse disease symptoms including metabolism, cancer, and sleep [10], and the development of therapeutic interventions to treat circadian-related disorders depends on understanding the basic biology of rhythmicity and clocks.

## References

1. Klein DC, Moore RY, Reppert SM (eds) (1991) Suprachiasmatic Nucleus. The Mind's Clock. Oxford University Press, New York, p 467
2. Antle MC, Silver R (2005) Orchestrating time: arrangements of the brain circadian clock. Trends Neurosci 28:145–151
3. Yan L, Karatsoreos I, LeSauter J, Welsh DK, Kay SA, Foley DK, Silver R (2008) Exploring spatiotemporal edited by Stillman B & D. Stewart organization of the SCN circuits, in *clocks and rhythms*. Cold Spring Harbor Symposia on Quantitative Biology Symposium 72, Cold Spring Harbor Laboratory Press
4. Journal of Biological Rhythms. December 2006, Volume 21, No. 6
5. Reppert SM, Weaver DR (2001) Molecular analysis of mammalian circadian rhythms. Annu Rev Physiol 63:647–676
6. Berson DM (2003) Strange vision: ganglion cells as circadian photoreceptors. Trends Neurosci 26:314–320
7. Brown TM, Piggins HD (2007) Electrophysiology of the suprachiasmatic circadian clock. Prog Neurobiol 82:229–255
8. Kalsbeek A, Palm IF, La Fleur SE, Scheer FA, Perreault Lenz S, Ruiters M, Kreier F, Cailotto C, Buijs RM (2006) SCN outputs and the hypothalamic balance of life. J Biol Rhythms 21:458–469
9. Stratmann M, Schibler U (2006) Properties, entrainment, and physiological functions of mammalian peripheral oscillators. J Biol Rhythms 21:494–506
10. Levi F, Schibler U (2007) Circadian rhythms: mechanisms and therapeutic implications. Annu Rev Pharmacol Toxicol 47:593–628

## Suprachiasmatic Nucleus Core

### Definition

One of two major anatomical and functional compartments of the suprachiasmatic nucleus (SCN). The core is more densely innervated by retina, visual thalamus, and brainstem than the other compartment, but contains fewer intrinsically rhythmic neurons or “clock” cells. Neurochemically, the core is typically demarcated by vasoactive intestinal polypeptide-containing neurons that densely innervate cells of the shell SCN. It is thought that the core SCN acts to integrate internal physiological and neural states with extrinsic environmental time cues and conveys these to the main oscillator in shell SCN. Reciprocally, circadian phase information from the shell SCN is relayed to the core SCN neurons via inhibitory synaptic transmission to ensure that core SCN neurons respond to extrinsic signals are appropriately phased.

► Suprachiasmatic Nucleus

► Suprachiasmatic Nucleus Shell

## Suprachiasmatic Nucleus Gating

### Definition

The notion of gating alludes to the function served by a “gate” in ordinary English usage. Thus, gating is the process in which a signal passes through when the gate is open, and fails to pass through when the gate is closed. The suprachiasmatic nucleus response to light is gated, in that a light pulse during the nocturnal animal’s subjective night produces a change in gene expression in the nucleus along with a resetting of rhythmic behavior, while a light pulse during the animal’s day produces no response. This is true even when the organism is housed in complete darkness, and the physical conditions at the time of exposure to light is identical at both times points.

- ▶ Clock Genes
- ▶ Suprachiasmatic Nucleus

## Suprachiasmatic Nucleus Shell

### Definition

One of two major anatomical and functional compartments of the suprachiasmatic nucleus (SCN). The shell is less densely innervated by retina, visual thalamus, and brainstem than the other compartment, but contains more intrinsically rhythmic neurons or “clock” cells. Neurochemically, the shell is typically demarcated by arginine vasopressin-containing and somatostatin-containing neurons. The precise distribution of these varies across the rostrocaudal axis of the SCN as well as between species. However, dense innervation of the shell SCN cells with fibers and terminals from neurons in core SCN is relatively invariant across most rodent species.

Currently, the shell is believed to function as the main oscillator of the SCN and regulates via inhibitory neurotransmission neural activity in the core SCN. Potential resetting information is in turn relayed to the shell SCN by core SCN neurons.

- ▶ Suprachiasmatic Nucleus
- ▶ Suprachiasmatic Nucleus Core

## Supramarginal Gyrus

### Definition

The supramarginal gyrus is the convolution of the inferior parietal lobule that arches around the terminal part of the ascending ramus of the lateral fissure. It is a part of the association cortex, which when damaged, can result in an agnosia, a failure to recognize. For example, in tactile agnosia there is a failure to recognize an object by tactile and kinesthetic sense (stereognosis) even though the sensory pathways and primary somatosensory cortex are intact.

## Supramodal

- ▶ Multimodal Integration

## Supraoptic Nucleus

### Synonyms

- ▶ Nucl. supraopticus; ▶ supra-optic nucleus

### Definition

Situated directly above the optic nerve, this nucleus together with the paraventricular nucleus forms the neuroendocrine system of the posterior lobe of the hypophysis. Efferents go to the neurohypophysis where they release into the blood ADH (vasopressin) and oxytocin. ADH (antidiuretic hormone) inhibits the permeability of renal epithelia to water. Oxytocin effects contraction of the uterus when giving birth and controls the release of milk during the lactation phase.

Dysfunction of this nuclear region induces the clinical manifestations of diabetes insipidus with severe polyuria (more than 20 l per day), since the lack of ADH results in a more or less unimpeded efflux of water from the renal epithelium.

- ▶ Diencephalon

## Surface Perception

### Definition

- ▶ Form Perception

## Surface Processing

### Definition

- ▶ Form Perception

## Surface Traction

### Definition

External force applied at the boundary per unit area. It represents the flux term associated with the linear momentum.

- ▶ Mechanics

## Surrogate Outcome

### Definition

A biomarker that is used as an outcome measure in, e.g. a clinical trial. Surrogate outcomes are powerful tools increasingly used in large, multi-center trials.

## Surround Influence

- ▶ Contextual Influences in Visual Processing

## Suture

### Definition

The narrow, tight fibrous junction between two bony plates of the skull.

- ▶ Joints

## Sweat Gland Control

TOSHIO OHHASHI, YOSHIKO KAWAI

Department of Physiology, Shinshu University School of Medicine, Matsumoto, Japan

### Definition

Thermal sweating plays an important role in keeping the body temperature constant. It appears over the whole body surface. In contrast, mental or emotional sweating is usually produced by emotion, mental stress and sensory stimulation. The active sweating appears on the palms and soles.

### Characteristics

#### Quantitative Description

Human perspiration is classified into two types: insensible perspiration and active sweating. Insensible perspiration usually means the insensible loss of body weight. Water loss from the respiratory passages, the skin, and gaseous exchanges in the lungs contribute to the insensible loss of body weight. In the skin, the epidermis may be supplied with water originating from blood in the skin microcirculation and interstitial spaces so that water can evaporate from its dry surface. Thus, the evaporation of water from the skin seems to depend on several environmental factors such as ambient temperature and ambient humidity.

Heat, mental stimuli, muscular exercise and carbon dioxide are well known to induce active sweating in human beings. From the physiological point of view, such active sweating may be classified into two types: thermal and mental or emotional. Thermal sweating plays an important role in keeping the body temperature constant. It appears over the whole body surface. Emotion, mental stress and sensory stimulation are the other causal agents of active sweating. Mental or emotional sweating usually appears on the palms and soles. The physiological

features of mental sweating differ considerably from those of thermal sweating. Mental sweating has a shorter latent period for its onset. It immediately attains a certain rate of secretion that corresponds to the intensity of stimulation, remains as long as the stimulation lasts and subsides quickly after it ends.

Eccrine glands contribute to both types of sweating. The eccrine gland is tubular, the secretory part forming a closed coil. The duct begins in this coil and is partly embraced by it. It opens on the skin surface through a corkscrew-like channel that pierces the epidermis. The active sweat glands are present most densely on the sole, forehead and palm, somewhat less on the back of the hand, still less on the lumber region, and the lateral and extensor surfaces of the extremities, and least on the trunk and the flexor and medial surfaces of the extremities [1]. The secretory nerve fibers innervated in human sweat glands are sympathetic, which seem to be cholinergic in character as sweating is produced by pilocarpine and stopped by atropine [2]. Recently vasoactive intestinal peptide (VIP) coexisting in the cholinergic nerve fibers has been suggested as a candidate neurotransmitter that may control the blood circulation of the sweat glands [3]. The sudorific nervous system is also separated into parts for thermal and emotional sweating, each being controlled by its own regulatory centre in the brain that is associated with the sweat glands in its respective region of the skin.

Kuno (1956) [1] postulates that sweat glands of the general body surface are under the control of the center for thermal sweating which is a part of, or is closely associated with, the hypothalamic temperature regulation center. Whereas the center for mental sweating is located in the cerebral cortex and not only controls directly the sweat glands of the confined areas, such as palms and soles, but also affects sweating of the general body surface through exciting the center of thermal sweating. The presence of a cortical sweat-inhibitory center has also been suggested. Thus, sweat response to mental stimulation may appear body surface only when close to or above the threshold of thermal sweating. Even in a temperature environment, however, neural impulses for thermal sweating still reach the sweat glands and mental effects can be visualized on a focal area where local sweating has been provoked by a sudorific agent [4]. Thus, the findings imply that the differences in nature between palmar and non-palmar sweating may possibly be relative ones, especially in the periphery, as suggested by Nakayama (1969) [5]. On the other hand, the other studies suggest that the palmar and non-palmar sweatings are under the control of essentially different central mechanisms as mentioned by Kuno (1956) [1]. It has been demonstrated that a single stimulus can cause inhibition of non-palmar sweating simultaneously with facilitation of palmar sweating [6]. Thus, various non-thermal

stimuli appear to exert two ways of effects on non-palmar sweating, excitation and inhibition, while they equally bring about facilitation of palmar sweating. The stimuli that provoke emotional excitation or protopathic sensation are considered to produce facilitation of non-palmar sweating. Consequently, there appears to be a higher central mechanism that is closely associated with such mental functions and exerts an excitatory effect on the center for thermal sweating. The limbic cortex that is considered to be the structure closely related to emotion, protopathic sensation and also to autonomic functions may likely be involved in this mechanism. The sweat-suppressive response on the general body surface appears to be provoked by stimuli that act as mental stress involving thought and memory, and by efforts for physical tasks. It is assumed therefore that the activity of regions in the neocortex may be concerned with this sweat-suppressive mechanism, possibly by exerting an inhibitory effect on the center for thermal sweating. In contrast, palmar sweating responds to any non-thermal sweating [6].

Regarding central mechanisms of active palmar sweating responses, a very impressive paper by using the newly developed ratemeter [7] was reported that the average electroencephalographs (EEGs) contained slow wave fluctuations, which occurred 5 s prior to the onset of mental calculation-mediated palmar sweating response (MSR). The central source locations of the MSR-related potentials were analyzed by the EEG dipole tracing method. In conclusion, the mental stimulation activated the medial part of the amygdala 5 s prior to the MSR in one subject or the lateral part of the hippocampus 5 s prior to the MSR in another subject. Thus, it seems reliable to assume that the mental stimulation such as arithmetic calculations elicits electrical activity in the limbic system including the amygdala and hippocampus. This activation of limbic system was confirmed to increase the sympathetic sudomotor activity 3 s prior to the onset of MSR [7].

The amygdala has long been thought to be involved in emotional behavior, and its role in anxiety and conditioned fear has been highlighted [8]. Thus, emotional expression may be mediated by neural connections from the lateral to the central nucleus of the amygdala, which, through its projections to hypothalamus and brainstem areas, is thereby able to coordinate the behavioral, endocrine and autonomic responses that form an integrated emotional response [9]. In a clinical case, a complete reduction of active palmar sweating responses was reported in a young female patient with viral encephalitis that elicited inflammatory damage to the bilateral amygdala. The damage was confirmed through functional neuroimaging techniques such as functional magnetic resonance imaging (fMRI) (Asahina M (2001) Personal communication). On the other hand, no functional change in noradrenergic sympathetic nerve fibers

innervated in microcirculation of the palmar skin was, however, observed in the same patient.

### Measurements for Palmar Active Sweating

We measured the responses of active sweating by using the newly developed ratemeter (SKD-2000, Skinos, Nagoya, Japan) attached to the palmar side of the left thumb (attached area 1 cm<sup>2</sup>). In brief, the ratemeter consists of three parts: (i) a specialized chamber equipped with a capacitance-typed humidity sensor and an electrical circuit to compensate changes in ambient temperature, (ii) a supply element for dehumidified air, and (iii) an electrical signal processing circuit. The ventilated chamber has two compartments. The first compartment is formed for mixing both the water perspired from skin and the dehumidified air supplied from the air supply unit. The second compartment is formed on top of the first one and connected with the first compartment through a communicating hole. The humidity sensor and a small thermistor are set on the roof of the second compartment. The dehumidified air passed through a tube filled with silica gel for drying was circulated through the two compartments (flow rate 300 ml/min). Thus, the ratemeter is handy and suitable to use clinically at the bed-side because of no usage of huge cylinder system. The absolute amount of palmar perspiration including active sweating responses is calculated electrically through three parameters: (i) relative humidity recorded with the capacitance-typed thin-film humidity sensor, (ii) temperature of air circulated through the ventilated chamber, and (iii) the saturated vapor pressure calculated theoretically with the air-temperature. These parameters are subjected to calculation in analogue of the absolute amount of the palmar perspiration, and then, after A/D conversion, to microcomputation. Ultimately, the absolute amount

of the loss of water per a constant area of the palmar skin and a constant time is recorded on a chart recorder and stored into a personal computer. The data stored were analyzed with a commercial software program (Hyper Wave, Kissei Komtec, Matsumoto, Japan).

Figure 1 demonstrates representative recordings of mental and physical stimuli such as performance of mental arithmetic, talking with a friend, deep respiratory movement and hand grasping on palmar perspiration and on the R-R intervals determined by continuous recordings of a surface electrocardiogram. Palmar perspiration including active sweating was recorded by the home-made ratemeter with the capacitance humidity sensor. The insensible perspiration and active sweating were evaluated on the thumb of the left hand of a healthy man aged 48. Three cycles of deep inspiration with deep respiratory movement caused a marked decrease in the R-R interval followed by three spikes of the active sweating with a short time lag. Performance of mental arithmetic, such as repetitive subtraction of 7 from 1,000, also produced a significant increase in active sweating on the palm. The stimulation simultaneously produced a decrease in the R-R intervals with phasic oscillations, which returned to the control level with an overshoot after the stimulation. When a friend entered the examination room, a marked increase in the active sweating with many oscillations was observed without a significant change in the R-R intervals. When the subject started to talk with his friend a significant increase in the active sweating was found with a tentative decrease of the R-R intervals. Grasping of a 25 kg weight with the right hand for 20 s caused a cessation of respiratory movement followed by a marked increase in active sweating with oscillations and a sustained decrease in R-R intervals. These findings suggest that the new home-made ratemeter is

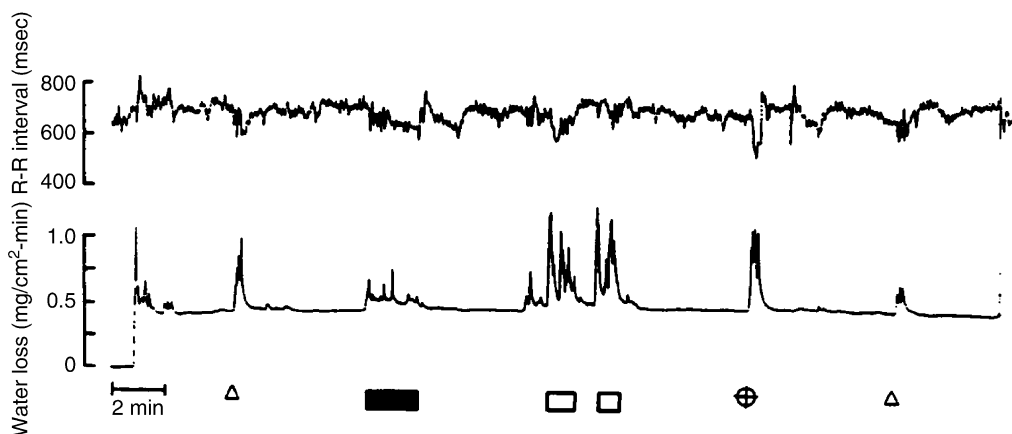

**Sweat Gland Control.** Figure 1 Representative recordings of palmar active sweating. The effects of mental and physical stimuli such as deep respiratory movement ( $\Delta$ ), performance of mental arithmetic ( $\blacksquare$ ), talking with a friend ( $\square$ ), and hand grasping ( $\oplus$ ) on palmar perspiration recorded by the ratemeter (lower panel) and on changes in the R-R intervals (upper panel) in a healthy male subject aged 48. [10].

suitable for detecting phasic changes in active sweating on the palmar skin and that the changes in sweating do not always agree with oscillatory changes in the R-R intervals in humans. In addition, grasping of the hand is confirmed to be one of best stimuli to selectively activate eccrine sweat glands in human palms.

## References

1. Kuno Y (1956) Human perspiration. Thomas, Springfield
2. Hurley HJ, Shelley WB, Koelle GB (1953) The distribution of cholinesterase in human skin, with special reference to eccrine and apocrine glands. *J Invest Dermatol* 21:139–147
3. Lundberg JM, Ånggard A, Fahrenkrug J, Hökfelt T, Mutt V (1980) Vasoactive intestinal polypeptides in cholinergic neurons of exocrine glands: functional significance of coexisting transmitters for vasodilation and secretion. *Proc Natl Acad Sci USA* 77:1651
4. Kennard DW (1963) The nervous regulation of the sweating apparatus of human skin, and emotive sweating in thermal sweating areas. *J Physiol* 165:457–467
5. Nakayama T (1969) A further investigation on the nature of sweat discharge in man. *Tohoku J Exp Med* 98:265–272
6. Ogawa T (1975) Thermal influence on palmar sweating and mental influence on generalized sweating in man. *Jpn J Physiol* 25:525–536
7. Homma S, Matsunami K, Han XY, Deguchi K (2001) Hippocampus in relation to mental sweating response evoked by memory recall and mental calculation: a human electroencephalography study with dipole tracing. *Neurosci Lett* 305:1–4
8. Davis M (1992) The role of the amygdala in fear and anxiety. *Annu Rev Neurosci* 15:353–375
9. Gallagher M, Chiba CC (1996) The amygdala and emotion. *Curr Opin Neurobiol* 6:221–227
10. Ohhashi T, Sakaguchi M, Tsuda T (1998) Human perspiration measurement. *Physiol Meas* 19:449–461

## Sweating Disorders

### Definition

The sweating disorders are classified into anhidrosis and hyperhidrosis. An anhidrosis disorder is defined as the inability of the body to produce and/or deliver sweat onto the skin surface. Hyperhidrosis over the whole body surface may be seen as a component of various diseases, e.g. night sweat, inphthisis. More marked hyperhidrosis appears restricted to certain parts of the body surface, and the following patterns seem to appear frequently, (i) Hyperhidrosis of the palms and soles, (ii) Hyperhidrosis of the axillae, (iii) Hyperhidrosis on the face, and (iv) other varied patterns of hyperhidrosis.

► Sweat Gland Control

## Sweet Taste

### Definition

► Taste – Sweet

## Sydenham Chorea

### Definition

Also known as Saint Vitus' dance. Sydenham chorea (SC) is the most common acquired ►chorea in children and presents as choreiform movements, obsessive-compulsive symptoms very similar to those in traditional obsessive-compulsive disorders, and behavioral and psychiatric changes. It occurs in association with rheumatic fever, which is an immunologically mediated disease following infection by group A beta-hemolytic Streptococcus (GABHS). Antibodies against GABHS cross-react autoaggressively with the heart, joints, skin, and brain tissues including the ►basal ganglia, which causes the motor and psychiatric changes.

► Basal Ganglia

► Basal Ganglia – Motor Function of

## Sylvian Fissure

### Definition

A deep sulcus found by F. Sylvius (1663), separating the temporal lobe from the frontal and parietal lobes. It is called also as the lateral sulcus.

► Somatosensory Cortex II (SII)

## Sympathetic

► Central Integration of Cardiovascular and Respiratory Activity Studied In?Situ

## Sympathetic Apraxia

### Definition

Lesions of the ▶ **premotor cortex** in the dominant hemisphere may entail impairment of movements of the ipsilateral limbs.

▶ **Limb Kinetic Apraxia**

The effects of specific antagonists depend on subunit composition, but will also depend on the size of the underlying synaptic current.

- ▶ **Acetylcholine**
- ▶ **Autonomic Ganglia**
- ▶ **Sympathetic Pathways**

## Sympathetic Block

### Definition

Blockade of the activity in the sympathetic outflow to an extremity by a local anesthetic applied to the appropriate ganglion (ganglia) of the sympathetic chain. A measure of a complete block is an increase of skin temperature at a finger or toe tip to about 36°C.

▶ **Complex Regional Pain Syndromes: Pathophysiological Mechanisms**

### Definition

Division of the autonomic nervous system that is concerned with catabolic activity by such actions as augmenting cardiac output, promoting blood supply to skeletal muscles and inhibiting the digestive system. This system arises from the thoracolumbar segments of the spinal cord in mammals. This system innervates the vasculature throughout the body as well as specific targets such as the dilator pupillae, the cardiac pacemaker, lymphoid tissues, the male internal reproductive organs, etc. It is excitatory to sphincters in the gastrointestinal tract and inhibitory to the rest of the gut.

- ▶ **Ageing of Autonomic/Enteric Function**
- ▶ **Autonomic Ganglia**
- ▶ **Sympathetic Pathways**

## Sympathetic Ganglia

▶ **Autonomic Ganglia**

## Sympathetic Pathways

### Definition

The sympathetic pathways form one of the major subdivisions of the autonomic nervous system (there are also parasympathetic pathways and enteric pathways, and an afferent or sensory component). They extend from the thoraco-lumbar spinal cord to the peripheral organs, including the adrenal gland, heart and all the blood vessels of the body, and represent the autonomic thoraco-lumbar outflow.

The axons of the preganglionic neurons of the sympathetic pathways (preganglionic fibers) reach the corresponding ventral roots, they emerge as separate nerve (called white rami communicantes) which in turn reach the paravertebral sympathetic chain (or trunk).

The chain, a symmetrical structure on each side of the body, is made of ganglia and connecting nerve strands, and extends from the base of the skull to the sacral region; within the chain the preganglionic fibers spread out cranially and caudally and reach all ganglia. The

## Sympathetic Ganglion Block

### Definition

Normally in the paravertebral chain, the discharge of only one preganglionic axon is responsible for transmission to each postganglionic cell, as the only effective inputs are suprathreshold with a very high safety factor, as at the neuromuscular junction. Acetylcholine (ACh) released from preganglionic terminals activates subsynaptic nicotinic receptor-channels (nAChRs). Ganglionic nAChRs in sympathetic ganglia differ from nicotinic receptors elsewhere, with the  $\alpha 3/\beta 4$  subunit predominating.

largest ganglia are the superior cervical ganglion, which provides sympathetic innervation to organs of the head, including cerebral blood vessels and skin, and the stellate ganglion, the main target of which is the heart.

Some preganglionic fibers reach the adrenal gland; others travel further away from the spinal cord, form the splanchnic nerves and reach sympathetic ganglia located in front of the abdominal aorta, the prevertebral ganglia. The preganglionic sympathetic neurons are cholinergic while the ganglion neurons and their postganglionic fibers are in the great majority adrenergic.

These secrete noradrenaline that stimulate the heart to beat faster and more strongly and blood vessels to constrict and to increase blood pressure (but to dilate pulmonary and coronary vessels).

## Sympathetically Maintained Pain (SMP)

### Definition

Sympathetically-Maintained Pain (SMP) is a pain that is maintained by sympathetic afferent innervation or by circulating catecholamines. It may occur in several conditions, such as Complex Regional Pain Syndromes (CRPS I and II), inflammatory pains, phantom pain, metabolic neuropathies, neuralgias. Blockade of the sympathetic outflow to the affected extremity by a local anesthetic injected close to the appropriate paravertebral ganglion/ganglia (stellate ganglion for forearm, lumbar ganglia L4/L5 for the hindlimb) significantly reduces the for  $\geq 6$  hours.

- ▶ Autonomic Control of Sensory Receptors
- ▶ Complex Regional Pain Syndromes – Pathophysiological Mechanisms

## Sympatho-adrenal System

### Definition

The sympatho-adrenal system is the adrenal medulla and its innervation by sympathetic preganglionic neurons. The adrenal medulla consists of cells that release either adrenaline or noradrenaline upon impulses in the preganglionic neurons. The sympatho-adrenal system is

functionally distinct from the various types of sympatho-neural systems.

- ▶ Complex Regional Pain Syndromes: Pathophysiological Mechanisms

## Sympathomimetics

### Definition

Sympathomimetics are pharmacological agents mimicking the effects of stimulation of the sympathetic nervous system.

- ▶ Sympathetic Nervous System
- ▶ Sympathetic Pathways

## Symporter

### Definition

- ▶ Ion Transport

## Synapomorphy

### Definition

A shared derived trait. A trait present in all members of a phylogenetic group that are derived from a common ancestor, and not present in the sister group.

- ▶ Electric Fish
- ▶ Evolution and the Concept of Homology

## Synapse

MASAMI TAKAHASHI

Department of Biochemistry, Kitasato University  
School of Medicine, Sagami-hara-shi, Kanagawa, Japan

### Synapse

There are more than 100 billion neurons and many more glial cells in the human brain. Neurons extend long



neurites and form neuronal networks whilst having functional contact through a specialized structure called the synapse, and various brain functions are conducted by this neuronal network. Neurons have two types of neurite, one is dendrite and another is axon. Neurons receive signals through many synapses formed on dendrite and cell soma. These signals are processed by summation or integration (►synaptic integration), and finally generate action potentials at the hillock of axon. Action potential propagates along the long axon and communicates a message to other neurons through synapses made along axons and/or axonal terminals.

There is a special gap between two neurons at the synapse, thus the electrical signal, the action potential, cannot propagate beyond the synapse. In many cases, synaptic transmission is mediated by a chemical substance called ►neurotransmitter. Since the electrical signal cannot spread over synapses without restriction, and signals propagate after conversion to chemical signals, it becomes possible for data processing to occur for the expression of higher brain functions. It may be possible to say that there are numerous numbers of biological switches, they are synapses, in the neuronal network, and multiple brain functions are achieved by controlling the neuronal network with these switches. More importantly, the properties of synapses are changing in the short-term as well as in the long-term in a neuronal activity-dependent manner, and sometimes, formation and disappearance of synapses occurs in some cases. This characteristic property of synapses called synaptic plasticity enables us to survive after

a struggle for existence by acquiring and storing information from the environment, and using this information to properly modify the property of the neuronal network to make proper responses. More importantly, memories stored in the neuronal network are absolutely essential for human personality, and it has now become a very important problem to overcome memory disorders in an aging society.

## Basic Structure and Functions of Chemical Synapse

### Structure of Chemical Synapse

Usually, synaptic transmission is conducted unidirectionally from a presynaptic neuron to a postsynaptic neuron. As a consequence, a synaptic structure is composed of presynaptic and postsynaptic elements separated by a 20–50 nm space called the synaptic cleft (Fig. 1). In the presynaptic nerve terminal, many small clear vesicles called synaptic vesicles, which have a diameter of around 40–50 nm, are accumulated. There are also some large dense-cored synaptic vesicles that have a diameter of 70–200 nm. Presynaptic cytoplasm also contains mitochondria that are usually positioned some distance away from the synaptic vesicles. Mitochondria provide ATP, necessary for the accumulation of chemical neurotransmitters into the synaptic vesicles by active transport, and perhaps, are involved in the regulation of intracellular  $\text{Ca}^{2+}$  homeostasis. In the presynaptic plasma membrane face to postsynaptic membrane, there is a specialized region called the active zone, where neurotransmitter release occurs (►active

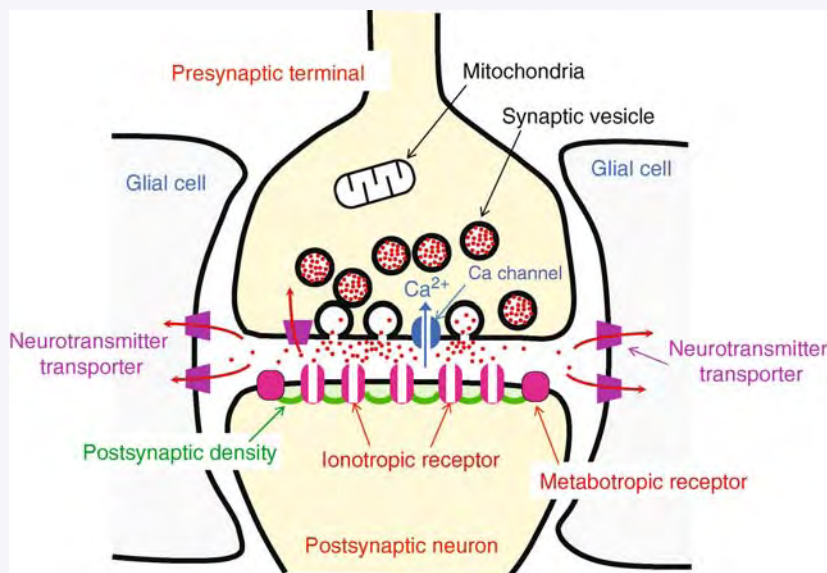

**Synapse. Figure 1** Basic structure of chemical synapse. Neurotransmitters are stored in synaptic vesicles and are released from presynaptic nerve terminals by a  $\text{Ca}^{2+}$ -dependent exocytosis. Neurotransmitters activate both ionotropic and metabotropic receptors in the postsynaptic plasmamembrane. Neurotransmitters in the synaptic cleft are recovered for reuse to neurons and glial cells by membrane neurotransmitter transporters.

zone). The synaptic cleft is filled with extracellular matrix, which contains a number of extracellular proteins thought to be important in synapse formation and stabilization, such as laminin and cell adhesion molecules (▶**synaptic adhesion molecule**). Many ▶**ionotropic** and (▶**G protein-coupled receptor (Metabotropic receptor)**) metabotropic receptors are accumulated at the portion of postsynaptic membrane directly opposed to the presynaptic terminal. The region just beneath the receptor-laden postsynaptic membrane often has a characteristic protein-rich structure called postsynaptic density (PSD). In addition to the receptors, many proteins for signal transduction are functionally organized into a huge multi protein complex in PSD through bindings to several ▶**scaffold proteins**. Some receptors also exist in the presynaptic plasma membrane, which are important for feedback regulation of neurotransmitter release. Except for the synaptic contact between the pre and post synaptic membrane, the synaptic structure is entirely covered with astroglial cells. Recent studies revealed that several neurotransmitter receptors are also expressed in glial membrane, and the glial cells may play active roles in the regulation of synaptic function.

### Mechanisms of Chemical Synaptic Transmission

By an invasion of action potential into presynaptic nerve terminals, a voltage-dependent Ca channel is activated and  $\text{Ca}^{2+}$  ions are introduced into the nerve terminal, which triggers neurotransmitter release into the synaptic cleft by an ▶**exocytosis** of synaptic vesicles involving docking and fusion of the synaptic vesicle membrane with the presynaptic plasma membrane. Neurotransmitters spread in the synaptic cleft by diffusion and bind to receptors in postsynaptic membranes for activation. ▶**Ionotropic receptors** activation causes a rapid change in membrane potential and the probability of action potential generation. Activation of metabotropic receptors ▶(**G protein-coupled receptor (Metabotropic receptor)**) slowly induces the generation of second messengers and/or a change in membrane potential through a modulation of ion channel function. All of these changes cause a change in responsibility to other synaptic input. After activation of these receptors, neurotransmitters in the synaptic cleft are removed by membrane transporters and/or neurotransmitter degradation enzymes in the neuronal and glial plasma membranes or the extracellular matrix to terminate synaptic transmission.

### Presynaptic Mechanisms Neurotransmitters

Two groups of substances are used as chemical ▶**neurotransmitters**. One is a group of relatively small molecular size, which are some amino acids, monoamines, acetylcholine, and ATP, and another is a group

of neuropeptides. Many nonpeptidic neurotransmitters are stored in small clear synaptic vesicles, whereas the peptidic neurotransmitters are stored in the large dense-core vesicles.

It is not so easy to classify a substance as a neurotransmitter, and even for glutamate, which is established as a major neurotransmitter in the vertebrate brain, it took a long time to be approved as a neurotransmitter. At least the following five conditions should be satisfied for classification as a neurotransmitter: (i) The substance is synthesized in neurons. (ii) The substance is stored in presynaptic terminals. (iii) The substance is released after stimulation of neurons. (iv) An equivalent effect is observed by the substance exogenously applied. (v) A removing mechanism exists.

### Properties of Neurotransmitters

#### Dale's Law

Usually, every neuron has only one kind of small neurotransmitter (Dale's law). Thus, neurons can be characterized by the neurotransmitter that they have. For example, neurons having glutamate,  $\gamma$ -aminobutyric acid (GABA), adrenalin (epinephrine), and acetylcholine as neurotransmitters are called glutamatergic, GABAergic, adrenergic, and cholinergic neurons, respectively. However, ATP coexists with acetylcholine and catecholamine in some synaptic vesicles and in secretory vesicles. There is also a report showing that GABA and glycine are used as neurotransmitters in one neuron. Thus, it is not clear how Dale's law is strictly approvable. It is obvious that most of the neurons have both small clear synaptic vesicles and large dense-cored vesicles, and thus, most of the neurons have at least two types of neurotransmitter, one is nonpeptidic and another is peptidic.

#### Glutamate and Aspartate

In vertebrate brain, glutamatergic neurons are distributed throughout the central nervous system and glutamate is used as a major excitatory neurotransmitter in the brain. Glutamate is synthesized from 2-oxoglutarate, an intermediate product of tricarboxylic acid cycle, by transaminase. Glutamate binds and activates both ionotropic receptors such as NMDA receptors and non-NMDA receptors, as well as various metabotropic glutamate receptors. Glutamate is recovered from synaptic cleft by membrane glutamate transporters present in neuronal and glial plasma membranes. Aspartate is also used as a neurotransmitter in some kinds of neurons.

#### Gamma-Aminobutyric Acid (GABA) and Glycine

GABA and glycine are used as major inhibitory neurotransmitters in the mammalian central nervous system (CNS). GABA is synthesized from glutamic acid by glutamic acid decarboxylase (GAD). GABA activates ionotropic  $\text{GABA}_A$  receptor and metabotropic

GABA<sub>B</sub> receptor. Glycine is mainly used in the spinal cord. Only the ionotropic receptor is known as a glycine receptor.

### Monoamines

Non-amino acid compounds that have an amino residue such as catecholamine and indoleamine are generally known as monoamines. In the nervous system, dopamine, noradrenalin (norepinephrine), and adrenalin (epinephrine) are used as neurotransmitters, and are synthesized from tyrosine by tyrosine hydroxylase and following several other enzymes. As for indoleamine, serotonin is used as a neurotransmitter, which is synthesized from tryptophan by enzymes including tryptophan hydroxylase.

Most of the cell bodies of monoaminergic neurons are accumulated in the brain stem and their neurites are innervate to a broad range of brain regions. The axons of these neurons are highly branched and often have varicosities, and the monoamines are released from these structures diffusely around the releasing site. All of the receptors for monoamine neurotransmitters are metabotropic, and no ionotropic receptor is known so far. Thus, the major roles of monoamine neurotransmitters are not regular synaptic transmission conducted by glutamate and GABA, but are regulatory roles to alter the responsibility of postsynaptic neurons to other synaptic input.

Cell bodies of dopaminergic neurons are enriched in the substantia nigra and ventral tegmental areas in the mid brain, and participate in emotional control and complex motor activities. Serotonergic neurons are mainly located in the raphe nucleus in pons, and are related to mode and anxiety. Noradrenergic neurons are enriched in locus ceruleus in pons, and have responsibility for emotional excitement, judging for a decision, sleep and mood. In the mammalian peripheral nervous system noradrenalin is used as a neurotransmitter of postganglionic neurons.

### Acetylcholine

Acetylcholine is a neurotransmitter of motor neurons in vertebrate neuromuscular junctions and induces very fast contraction of skeletal muscles. In mammalian CSN, cholinergic neurons are enriched in basal ganglia, such as nucleus basalis Meynert and septal nucleus, and pons, and these cholinergic neurons send their neurites to a broad range of brain areas. In the peripheral nervous system, acetylcholine is a neurotransmitter of preganglionic neurons and postganglionic neurons of the parasympathetic nervous system. Acetylcholine is synthesized in nerve terminals from acetyl-coenzyme A and choline by choline acetyltransferase. Acetylcholine activates the nicotinic acetylcholine receptor, an ionotropic receptor, and muscarinic acetylcholine receptor, a metabotropic receptor. Acetylcholine is

released in the synaptic cleft and is hydrolyzed by acetylcholinesterase located in cell membranes as well as in the extracellular matrix. The resulting choline is used for acetylcholine synthesis after reuptake by membrane choline transporter.

### ATP

ATP is a universal energy currency, but is also used as a neurotransmitter in neurons. ATP is shown to be stored in synaptic vesicles of *Torpedo* electric organs and secretory vesicles of adrenal chromaffin cells, however, the transport mechanism into synaptic vesicles is not yet known. ATP activates ionotropic P2X receptors and metabotropic P2Y receptors. ATP also activates metabotropic adenosine receptors after conversion to adenosine.

### Peptidic Neurotransmitters

More than 50 neuropeptides are found in the mammalian brain and many of these peptides are likely to be used as neurotransmitters. After being synthesized in endoplasmic reticulum in neuronal cell soma, neuropeptides are packed in vesicles and transported along long axons to presynaptic terminals. All of the neuropeptide receptors are metabotropic, and induce slowly activated and prolonged responses in their target neurons. Neuropeptides released into the synaptic cleft is degraded by extracellular peptidases without reuse. Conventional neuronal excitation does not induce exocytosis of large dense-cored vesicles, and neuropeptides are released only after high frequency stimulation. Thus, neurons change a property of synaptic transmission in a frequency-dependent manner.

Neurotrophins, such as nerve growth factor and brain-derived neurotrophic factor, are polypeptides essential for the survival and maturation of neurons in the developing stage. These neurotrophins are also expressed in adult brain and participate in the regulation of neuronal and synaptic activities [1]. At least some portion of neurotrophins are released from neurons by exocytosis in an activity-dependent manner. Neurotrophins exert their action through the activation of Trk receptors, which are members of the receptor tyrosine kinase super family.

### Storage of Neurotransmitter into Synaptic Vesicles

Various [vesicular neurotransmitter transporters](#) for nonpeptidic neurotransmitters are expressed in small synaptic vesicles and specifically accumulate neurotransmitters in a type-dependent manner. H<sup>+</sup>-ATPase is also expressed in synaptic vesicle membranes, and creates a proton gradient across the membrane by the hydrolysis of ATP. All of the vesicular neurotransmitter transporters used this proton gradient to actively transport neurotransmitters into vesicles. Glutamate and glycine are very common amino acids, and thus the

expression of vesicular transporters of glutamate and glycine characterize glutamatergic and glycinergic neurons.

### Exocytotic Release of Neurotransmitters

#### Exocytosis

Neurotransmitters stored in synaptic vesicles are released into the synaptic cleft by ►**exocytosis**, which involves the docking and fusion of the synaptic vesicle membrane with the presynaptic plasma membrane. The idea that neurotransmitters are released not by simple diffusion but by a package of elementary unit (►**quantal transmission**) was initially postulated by Kats and Miledi from a quantal analysis of synaptic transmission of frog neuromuscular junctions. This hypothesis is further supported by the discovery of synaptic vesicles using electron microscopy. Although it has been hypothesized that neurotransmitters are released by an exocytosis of synaptic vesicles, it is only recently that direct experimental evidence supporting this idea was obtained. Early experiments of freeze-fracture electron microscopic techniques revealed that small holes appeared along ►**active zones** and possible synaptic vesicle proteins appeared in the presynaptic membrane after electric stimulation of presynaptic fibers. The appearance of synaptic vesicle proteins in plasma membranes after stimulation was also observed in cultured neurons by immunocytochemistry, using antibodies that recognize epitopes located in the luminal site of synaptic vesicles. However, all of these results were obtained by using fixed preparations, and real-time process of exocytosis was not observed in these experiments.

The area of cell surface membrane is expected to be increased after the fusion of synaptic vesicle membrane, and cell surface area can be measured by observing membrane capacitance by an electrophysiological technique (►**Capacitance measurement**). Increment of cell surface area after stimulation is successfully observed in real time with good time resolution using adrenal chromaffin cells and Calyx of Held, a neuronal preparation having a giant presynaptic terminal. Furthermore, the process of exocytosis was visually observed in real-time in adrenal chromaffin cells and hair cells of the inner ear by using video-enhanced microscopy and total-reflection fluorescence microscopy (►**evanescent field fluorescence microscopy**). The exocytotic process was also monitored in various neuronal preparations, including neuromuscular junction, brain slice, and cultured neurons by using a fluorescence dye, ►**FM1-43**, and pH-sensitive fluorescence proteins.

#### Merit of Exocytosis

Neurotransmitters released into the synaptic cleft bind reversibly to their receptors in the postsynaptic membrane, and the binding speed is dependent on their

concentration. Thus, to achieve rapid activation of the receptor, it is necessary to increase neurotransmitter concentration very rapidly after action potential propagation to the nerve terminals. Various problems will arise for cellular metabolisms and function if any particular substance accumulates in the cytoplasm at a very high concentration. By using vesicles that have a lipid bilayer membrane, it becomes possible to accumulate neurotransmitters of very high concentration without any effect on cellular metabolism. The extracellular concentration can be increased very rapidly by releasing all of the content in a single process. It is also possible to regulate the efficiency of neurotransmitter release by changing the distribution and location of synaptic vesicles in presynaptic terminals.

#### SNARE Proteins

Both the plasma membrane and the synaptic vesicle membrane is composed of phospholipid bilayers, and it is necessary to fuse these two membranes for exocytosis. However, the hydrophilic head group of phospholipids are hydrated, and as two lipid membranes are difficult to bring close to each other within 2 nm, the assistance of proteins is necessary to promote membrane fusion. So called SNARE proteins play an essential role in bringing membranes close enough to induce membrane fusion (►**Presynaptic proteins**).

In neurons, three SNARE proteins, VAMP-2/syntaxin-2 in synaptic vesicle membranes, and syntaxin and SNAP-25 in plasma membranes, are involved in the exocytosis of synaptic vesicles. It is now believed that membrane fusion is induced by a complex formation of these SNARE proteins. It is possible to regulate exocytosis and ►**synaptic vesicle recycling** by modifying the formation or dissociation of the SNARE complex. Many SNARE binding proteins are expressed in presynaptic terminals and are likely to be involved in the regulation of presynaptic functions.

#### Ca<sup>2+</sup>-Sensitivity

Exocytotic secretion is a cellular function generally observed in eukaryotic cells. There are two pathways for secretion, one is an unregulated constitutive pathway and another is a regulated pathway. Neurotransmitter release is one of the regulated pathways and is triggered by Ca<sup>2+</sup>. Various ►**calcium binding proteins** that have different affinities to Ca<sup>2+</sup> are expressed in the brain, and it is widely accepted that the Ca<sup>2+</sup>-binding protein which regulates neurotransmitter release is a synaptotagmin, a synaptic vesicle protein that has C2 domains. The affinity of Ca<sup>2+</sup> to C2 domain is not very high, but this property is quite important for the Ca<sup>2+</sup> binding of neurotransmitter release. Action potential invasion to presynaptic terminals activates a voltage-dependent Ca channel near the ►**active zone**, and Ca<sup>2+</sup> influx into

the terminal triggers exocytosis. Intracellular  $\text{Ca}^{2+}$  will return to the basal level by  $\text{Ca}^{2+}$  excretion mechanisms, but it takes some time to return to the basal level. If the  $\text{Ca}^{2+}$  binding protein has a high  $\text{Ca}^{2+}$  sensitivity, neurotransmitter release will continue by this residual  $\text{Ca}^{2+}$ . Since neurons send different kinds of messages along axons by changing the pattern and frequency of action potentials, the resolution of signal will decrease if the neurotransmitter release is not terminated quickly after invasion of action potential. Many  $\text{Ca}^{2+}$  binding proteins of high  $\text{Ca}^{2+}$  affinity are also expressed, but their functional roles are not well defined.

### Elementary Steps of Exocytosis

Prior to  $\text{Ca}^{2+}$ -induced membrane fusion, there are several elementary steps necessary for exocytosis, which are tethering, docking and ►priming of synaptic vesicles. Several ►presynaptic proteins are involved in each step, and neurotransmitter release is regulated by modifying the functions and properties of these regulatory proteins.

There are several different synaptic vesicle pools that have different exocytotic properties, such as readily releasable pools, releasable pools, and storage pools. In *Drosophila* neuro-muscular junction, these pools are specially refined by an imaging analysis (►synaptic vesicle recycling). Some synaptic vesicles are anchored to the actin cytoskeleton in presynaptic terminals through a phosphoprotein, synapsin, and their association is regulated by protein kinases. Some synaptic vesicles are believed to be preset in the vicinity of a Ca channel in the active zone to achieve very fast release of neurotransmitter within 0.2 ms after activation of Ca channel. The efficiency of neurotransmitter release could be regulated by changing the size of vesicle pools and location of the vesicles.

### Synaptic Vesicle Recycling

After their synthesis in the cell body, synaptic proteins are transported to the presynaptic nerve terminals along axons by an axonal flow, and it takes time to reach the nerve terminals. Normal synaptic transmission is conducted by an exocytosis of small synaptic vesicles. If all of these vesicles are used only once without recycling, the synaptic vesicle is easily depleted after high frequency stimulation. To avoid such a situation, synaptic vesicles are locally recycled and reused (►synaptic vesicle recycling). After exocytosis, synaptic vesicle proteins are selectively recovered from the plasma membrane by clathrin-mediated endocytosis. The synaptic vesicles are reformed either directly or after being incorporated into an endosome-like structure. In some cases, neurotransmitters are released from synaptic vesicles by a kiss and run mechanism without full fusion. Neurotransmitters are released through a fusion pore, which is formed transiently by the docked vesicles and the plasma membrane. After detaching, the

neurotransmitter is refilled and reused for the next stimulation.

## Postsynaptic Mechanisms

Neurotransmitters bind to receptors in the postsynaptic membrane. Two types of receptors, the ►ionotropic receptor and the metabotropic receptor (►G protein-coupled receptor), are used for synaptic transmission and they induce postsynaptic responses in different mechanisms. Many different subtypes of receptors are usually expressed in the brain, and thus each neurotransmitter is able to induce different kinds of responses in different neurons and brain regions.

### Ionotropic Receptors

#### Structure of Ionotropic Receptors

►Ionotropic receptors are ligand-gated ion channels, and their opening and closing is regulated by neurotransmitter binding. Ionotropic receptors are composed of several subunits, and an ion channel pore is formed in the center of the complex. The structure and numbers of subunits are varied among different receptors. Nicotinic acetylcholine receptor,  $\text{GABA}_A$  receptor, glycine receptor and serotonin  $5\text{-HT}_3$  receptor have five subunits, and each subunit has four transmembrane segments with extracellular orientation of both amino- and carboxy-terminals. Glutamate receptors are composed of four subunits, and each subunit has two fully transmembrane segments and one loop structure arriving ion channel pore. The amino- and carboxy-terminal of each subunit are exposed to extracellular and cytoplasmic face, respectively. Glutamate receptors are further classified into NMDA receptor and nonNMDA receptor (AMPA-type and kainate-type) according to their pharmacological properties. The ATP receptor is composed of three subunits that have two transmembrane segments. Both amino- and carboxy-terminals are located in the cytoplasm.

#### Roles of Various Ionotropic Receptors

Ionotropic receptors can be classified into two types depending on the difference in ion permeabilities. Excitatory receptors permeate monovalent cations, such as  $\text{Na}^+$  and  $\text{K}^+$ , and the activation of the excitatory receptor induced membrane depolarization called excitatory ►postsynaptic potential (epsp), which increases the probability to generate action potential in postsynaptic neurons. Some excitatory receptors, including NMDA receptors, also permeate  $\text{Ca}^{2+}$  that plays important roles for regulation of synaptic function and for synaptic plasticity. Glutamate, serotonin, acetylcholine, and ATP are neurotransmitters acting on excitatory receptors.

In contrast, inhibitory receptors have permeability to anions, typically chloride in many cells. Hyperpolarization of membrane potential called inhibitory

►postsynaptic potential (ipsp) is generated by the activation, which reduces the probability of action potential generation in postsynaptic neurons. The neurotransmitters of these receptors are GABA and glycine. It is noteworthy that GABA and glycine receptors do not always behave as inhibitory receptors. In immature neurons, the intracellular  $\text{Cl}^-$  concentration is higher than that in matured neurons, and thus activation of GABA<sub>A</sub> and glycine receptors induce an efflux of  $\text{Cl}^-$ , and depolarize membrane potential sometimes leading to action potentials.

### Signal Processing by Ionotropic Receptors

In the neuromuscular junction, an action potential invaded in the endplate generates an action potential in skeletal muscles without failure, to assure rapid and smooth contraction of the skeletal muscle. In a marked contrast, the size of epsp in most of the central synapses is much smaller than that generate action potential, and single synaptic input will never generate action potentials. Every neuron has multiple innervations and an action potential is generated after the summation of individual epsps. There are two types of summation, special summation and temporal summation. Spatial summation is a way of achieving an action potential in a neuron which involves input from multiple cells. Because the potential produced by a brief synaptic current falls off relatively slowly, it is possible to get summation of the effects by repeated stimulation of a single ending if the frequency of firing of the presynaptic fiber is high enough. This type of summation is called temporal summation. Neurons receive both excitatory and inhibitory input, and a summation of epsps and ipsp, which is called integration (►synaptic integration), determines the probability of action potential firing.

### Metabotropic Receptor

#### Roles of Metabotropic Receptors

Synaptic transmission mediated by ionotropic receptors induces a rapid change in membrane potential of postsynaptic neurons and is called an ordinary transmission. On the other hand, synaptic transmission mediated by metabotropic receptors (►G protein-coupled receptor (metabotropic receptor) is characterized as a slow and prolonged response to alter the responsibility to the following synaptic input, and is called a neuromodulatory transmission. Sometimes neurotransmitters for metabotropic receptors are called neuromodulators. Membrane potentials may change after activation of a metabotropic receptor, however, the change is small and slow compared to that caused by an ionotropic receptor.

The importance of neuromodulatory transmission is a long-lasting effect ranging from several hundred milliseconds to several hours. These sustained effects are

essential for various long-lasting brain functions such as learning, memory, and adaptation. Gene expression may be changed after activation of a metabotropic receptor, which induces very stable and sustained changes in neuronal properties.

Many more kinds of metabotropic receptors are expressed in brain compared to ionotropic receptors. Glycine is an exceptional neurotransmitter having no metabotropic receptor. All of the receptors for monoamines and neuropeptides are metabotropic, and only one type is ionotropic among six serotonin receptors.

### Structure of Metabotropic Receptors

Metabotropic receptors are members of the ►G protein-coupled receptors (metabotropic receptors) (GPCR) and have seven transmembrane segments with an extracellular amino-terminal domain and an intracellular carboxy-terminal domain. The ligand binding site is varied among different types of receptors. Glutamate binds to the amino-terminal domain and catecholamine binds to a site in the transmembrane domain. Metabotropic receptors bind to tetrameric G proteins through the cytoplasmic region. The functional role of the metabotropic receptor is to activate G proteins. Tetrameric G protein is composed of three subunits,  $\alpha$ ,  $\beta$ , and  $\gamma$ , and 20, 5, and 7 different kinds of isoforms are expressed, respectively. The cellular response is varied depending on which type of G protein is coupled to the receptor. Activation of the receptors coupled to the G<sub>s</sub> subfamily elevates intracellular cAMP concentration by activating adenylate cyclase, whereas that coupled to the G<sub>i/o</sub> subfamily suppresses cAMP production. The receptors coupled to the G<sub>q</sub> subfamily activate phospholipase C $\beta$  and induce production of second messengers, diacylglycerol and IP<sub>3</sub>. These second messengers can activate various protein kinases, and in turn phosphorylate various synaptic proteins to modulate synaptic functions. Gene expression is also induced by the receptor activation. Activated  $\alpha$  and  $\beta\gamma$  subunits of G protein also bind to ion channels, and sometimes generate epsp and ipsp in postsynaptic neurons.

### Receptor Ion Channel Complex Formation

►Scaffold proteins are proteins which have various protein binding domains in their structure, such as PDZ domain, SH3 domain GK domain. Many kinds of proteins including receptors, ion channels, and proteins for signal transduction, bind to the scaffold protein through specific binding motifs. Several scaffold proteins can be cross-linked with adaptor proteins. Thus, a fudge multiprotein complex is formed in the synaptic site. Presynaptic and postsynaptic protein complexes are cross-linked through cell ►adhesion proteins bound to the scaffold proteins, and these multi protein complexes play very important roles to properly arrange the many synaptic proteins at the synaptic site.

The binding of membrane proteins to the scaffold proteins could be regulated by protein phosphorylation, and these regulations may be important for the regulation of the synaptic function. Scaffold proteins are also important for the axonal transport of neurotransmitter receptors to the synaptic site. Cargo vesicles having a glutamate receptor are linked to microtubule-dependent motor proteins via scaffold protein complexes.

### Removal of Neurotransmitter from Synaptic Site

Neurotransmitters must be removed quickly after activation of the neurotransmitter receptor. A prolonged exposure of neurotransmitters to their receptors results in various unfavorable phenomenon. Receptors will be desensitized, and the resolution of signals made by repetitive action potentials will be weakened. In addition to simple diffusion, membrane transporter and degradation enzymes mediate the removal of neurotransmitters from the synaptic cleft. The importance of the clearing system could dreadfully be visualized by a terrible criminal event by Japanese terrorists, who spread salin, an inhibitor of acetylcholine degradation enzyme, in the subway station and killed many people in Japan. It is also noteworthy, that huge numbers of people take a blocker of serotonin transporter to reduce anxiety.

### Neurotransmitter Transporter

Most small neurotransmitters are recovered to presynaptic nerve terminals by membrane transporters (►neurotransmitter transporter) and further accumulated into synaptic vesicles by ►vesicular neurotransmitter transporters for reuse. So far, transporters specific for glutamate, GABA, glycine, dopamine, noradrenalin, serotonin, and choline have been identified. Membrane transporters actively transport neurotransmitters by using  $\text{Na}^+$  gradients across plasma membranes, which are generated by  $\text{Na}^+/\text{K}^+$ -ATPase using hydrolyzing energy of ATP. Membrane transporters are also present in glial membranes. Glutamate incorporated into glial cells is converted into glutamine and sent to the neuron. Glutamine is again converted into glutamate in neurons and used again as a neurotransmitter.

### Degradation Enzymes

Acetylcholine is hydrolyzed by acetylcholinesterase into choline and acetic acid. Acetylcholinesterase is localized in the plasma membranes of the CNS, but it also exists in the extracellular matrix in the neuromuscular junction. After hydrolysis, the resulting choline is reuptaken by membrane choline transporters and is used for acetylcholine synthesis. A part of the monoamines released into the synaptic cleft is metabolized by catechol-*O*-methyl transferase (COMT) and monoamine oxidase (MAO). Peptidic neurotransmitters are degraded by peptidase.

### Retrograde Messenger

Most neurotransmitters send information from presynaptic neurons to postsynaptic neurons, however, some information transmits in a retrograde manner. All ►retrograde messengers are labile and membrane permeable, and thus not stored in vesicles. They are generated by synaptic activation and act on presynaptic cells instantly by diffusion.

Nitric oxide (NO) is a messenger molecule of gas generated from arginine by nitric-oxide synthase (NOS). The life time of NO is only a few seconds.  $\text{Ca}^{2+}$  influx into postsynaptic cells via NMDA receptor and Ca channels activate  $\text{Ca}^{2+}$ -dependent NOS [2]. NO is diffused through plasma membranes and activates guanylate cyclase in the presynaptic terminal, resulting in a generation of cGMP, which in turn activates cGMP-dependent protein kinase. The presynaptic function could be regulated through the phosphorylation of some presynaptic proteins.

Cannabinoid is a chemical giving euphoria and found in hashish. It induces a neuronal action through the binding to cannabinoid receptors. Endogenous cannabinoid is generated in postsynaptic cells after synaptic activation, and the generated cannabinoid modulates presynaptic function through binding to a presynaptic cannabinoid receptor.

### Variation of Synapse

Basic mechanisms of synaptic transmission are common among many chemical synapses, however, there are many variations in the structure of chemical synapses. In addition, there are also electrical synapses in the brain (Fig. 2).

### Morphological Variations

There are two common morphological types of synaptic connections in the brain, Gray type I and type II. Type I synapses are often glutamatergic and therefore excitatory, whereas type II synapses are often GABAergic and therefore inhibitory. In type I synapses the synaptic cleft is slightly widened to approximately 30 nm, and the active zone is larger. The synaptic vesicles have a characteristic round shape in electronmicroscopy. The PSD is very thick, and amorphous dense basement-membrane material appears in the synaptic cleft. In type II synapses, the synaptic cleft is 20 nm across and the active zone is smaller. PSD is less obvious and there is little or no basement membrane in the synaptic cleft. The synaptic vesicles tend to be oval or flattened.

Ribbon synapses are found in certain primary sensory cells, such as photoreceptors and mechanoreceptors. These synapses are identified by the presence of proteinaceous ribbon within their presynaptic terminals. Spine synapses are a synapses formed on the dendritic spine. The spine is connected to the dendritic shaft by a thin neck which restricts the rise in

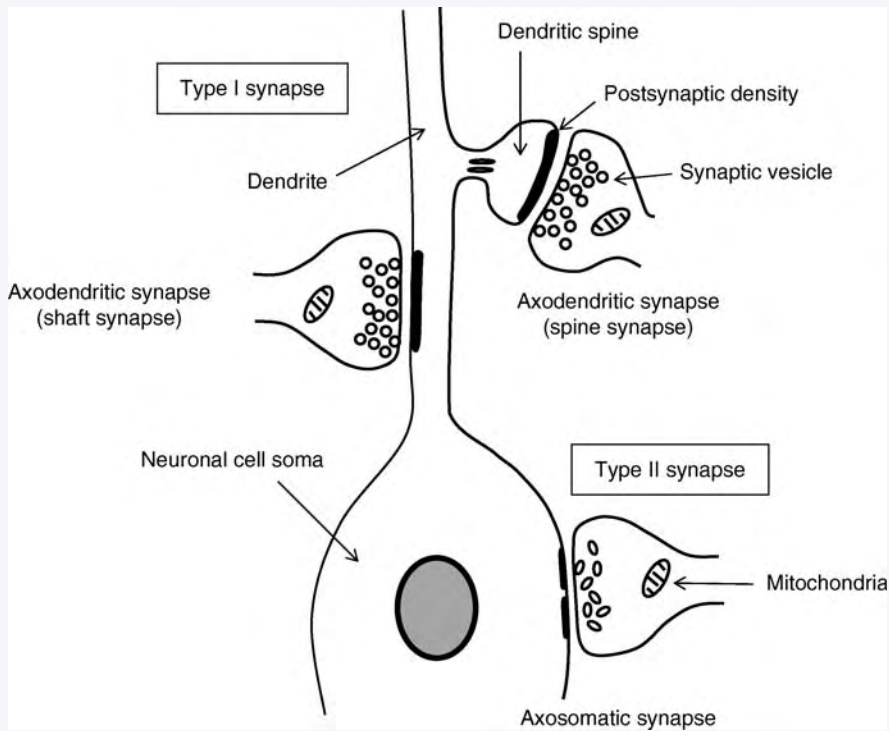

**Synapse. Figure 2** Variations of chemical synapses in the central nervous system. Chemical synapses are classified by their mode of innervations and by the structure of postsynaptic density.

$Ca^{2+}$  concentration in the spine. Thus, each spine represents a distinct biochemical component. The morphology and properties of spine synapses change dramatically in a synaptic activity-dependent manner, which is quite important for synaptic plasticity and possibly in memory storage.

#### Variation in Mode of Innervation

Neurons of the CNS have several thousand synaptic inputs on average, and synapses are formed in various regions of the neuron. The synapse made on dendrite and cell soma is called axodendritic synapse and axosomatic synapse, respectively. Many axodendritic synapses are excitatory, and axosomatic synapses are inhibitory. Dendrodendritic synapses are synapses formed between dendrites, and are characteristic for their bidirectional transmission. An axoaxonal synapse is a synapse formed at presynaptic terminals, and is responsible for presynaptic regulation.

#### Synapses in Peripheral Tissues

Synapses can also be found in peripheral tissues. The basic structure is the same as those of central synapses, however, there are marked variations in their structure to optimize their functional roles [3].

#### Neuromuscular Junction

The neuromuscular junction is a synapse formed between motor neurons and skeletal muscle cells. This

synapse is specialized to provide transient, fail-safe excitation of the postsynaptic muscle cells, ensuring muscle contraction whenever the motor neuron is active. The speed of transmission is quite fast to induce rapid contraction of skeletal muscle. To achieve these characteristic properties, the neuromuscular synapse is optimized for releasing large quantities of acetylcholine very rapidly. The synaptic structure shows a characteristic structure called end plate. Thus, the epp (▶postsynaptic potential) of the neuromuscular junction is often referred to as endplate potential. A neuromuscular synapse consists of a highly branched presynaptic termination of the motor neuron that innervates long, cylindrical muscle cells. A single synapse has several hundred active zones, where a large cluster of synaptic vesicles is accumulated. The postsynaptic component apposed to the presynaptic active zone is characterized by a postjunctional fold, a tremendous number of nicotinic acetylcholine receptors are clustered at the peak of this fold. This arrangement allows the receptor to detect the release of acetylcholine quickly and efficiently. Acetylcholinesterase is found in the extracellular matrix of the synaptic cleft and postjunctional fold.

#### Autonomic Neuronal Synapse

Autonomic neurons regulate smooth muscle contraction and secretion from various endocrine and exocrine cells. The synapses of autonomic neurons act over a



slower time scale, and thus the synaptic structure is quite different from that of fast-acting synapses. Presynaptic terminals at these synapses are varicose in structure and filled with dense-core vesicles containing various neurotransmitters, including acetylcholine, catecholamines, ATP, and peptides. These vesicles are dispersed throughout the presynaptic cytoplasm, and there are no indications of the active zones. The synaptic cleft is larger than the one of other types of synapses and can be as great as 2  $\mu\text{m}$ . The postsynaptic cell also lacks a postsynaptic density and receptor clustering.

### Electrical Synapse

Although they are a distinct minority, electrical synapses are found in all nervous systems [4]. The extracellular space between pre- and postsynaptic neurons at an electrical synapse is 3–3.5 nm, which is much smaller than the synaptic cleft of general chemical synapses (about 20–50 nm). The narrow space between these neurons is bridged by a gap junction channel, and the intracellular current flow is through the gap junction. In the mammalian nervous system, most electrical synapses are bidirectional and the current can flow in either direction across the gap junction. These channels are formed by two hemichannels, one in the presynaptic neuron and the other in the postsynaptic neuron. Each hemichannel is called connexon, which is composed of six subunits of an identical protein called connexin, arranged in a hexagonal pattern with a 2 nm diameter central hole. At electrical synapses, the current generated by voltage-gated channels at the presynaptic neuron flows directly into the postsynaptic neuron, and thus, the transmission at such a synapse is very rapid (<0.1 msec) compared to a chemical synapse. Electrical synapses are present where the activity of neighboring neurons are to be highly synchronized. On the other hand, plastic regulation of transmission is difficult in electrical synapses.

### Preparation for the Study of Synaptic Functions

Since a synapse is a very small fine structure containing a large number of proteins, it is not easy to study the synapse functions in the brain. Many unique preparations have been used for the study of synaptic functions.

#### Giant Synapse Preparation

In electrophysiological experiments, the synaptic current is recorded only from postsynaptic neurons, since the size of the presynaptic nerve terminal is too small to insert a microelectrode. To measure the membrane potential and capacitance, preparations having large presynaptic terminals, such as neuromuscular junctions and giant synapse of squid have been used. In the mammalian central nervous system, the

Calyx of Held, a particularly large synapse in the auditory central nervous system, is used.

#### Slice Preparation

It is possible to keep brain thin slice (200–500  $\mu\text{m}$  thickness) in artificial cerebro-spinal fluid saturated with 95%  $\text{O}_2$ /5%  $\text{CO}_2$ , pH 7.4 for several hours to several days, and the electric response can be monitored without disturbance of respiratory and cardiac vibrations. Since neuronal networks are retained in the **▶slice preparation**, it is possible to study the properties of the neuronal network. It is also easy to change extracellular conditions, and many imaging techniques using various dyes sensitive to membrane potential,  $\text{Ca}^{2+}$ , and pH, as well as FM dye such as **▶FM1-43** are applicable.

It is also possible to keep brain slices on membranes for longer periods in a cell culture media, preserving the neural network in these preparations. However, most of the synaptic contacts may be lost after preparation and are regenerated after cultivation. Proliferation of nonneuronal cells is also remarkable in this preparation, and the structural differences between the culture and the brain become larger with time.

#### Dissociation Culture of Neurons

Enzymatically dissociated neurons from embryonic and neonatal rodent brain are able to be kept in culture for long periods. Synaptic formation and neuronal maturation advances in culture. Many experimental techniques including electrophysiology, imaging, and biochemical measurement are easily applicable. Activity of the postsynaptic cell body could be monitored by electrophysiological methods as well as imaging techniques using voltage-sensitive dyes and  $\text{Ca}^{2+}$ -sensitive dyes. Presynaptic activity is monitored using FM dye (**▶FM1-43**). Some caution should be kept in mind, that is, neuronal maturation may be advanced in culture, however, it is not certain how the maturation is completed. Except for cerebellar granule cells in culture, where >90% cells are glutamatergic neurons, it is also a problem that many kinds of neurons coexist in culture. Since many neurons extend many neurites and form numerous synapses randomly, it is difficult to get a record from pre- and postsynaptic neurons at the same time. To overcome this difficulty, an elegant method of culture called **▶autapse** has been developed. In this method, a single neuron is cultured on a small glial island of 200–700  $\mu\text{m}$  diameter. The neuron makes synaptic contact on its cell body. It is possible to stimulate and record postsynaptic responses with the same single electrode. It is also possible to inject various substances and antibodies into the cell body to see the effect on both pre- and postsynaptic functions, since these substances easily diffuse to presynaptic terminals.

### Adrenal Chromaffin Cell

Since the presynaptic terminal is a very small structure, it is difficult to quantically measure the process of neurotransmitter release in real time. Adrenal medullary chromaffin cells are derived from the same precursor cells as those of autonomic neurons and share many common properties with neurons. In fact, chromaffin cells from neonatal rat adrenal are still able to differentiate into neurons in the presence of nerve growth factor. It is easy to prepare a fairly homogeneous cell preparation, enough even for biochemical studies from bovine adrenal medulla. Chromaffin cells have about 30,000 dense-core vesicles containing either noradrenalin or adrenalin of around 280 nm in diameter, and release these catecholamines by a  $\text{Ca}^{2+}$ -dependent exocytosis. It is easy to keep in culture for a long period, enough to do multiple types of experiment including a transient gene expression using virus vector. The exocytotic process of the dense-cored vesicles is monitored by a membrane ►[capacitance measurement](#), electrophysiological measurement with carbon fiber electrode, video-enhanced microscopy, and total reflection fluorescence microscopy (►[evanescent field fluorescence microscopy](#)). For biochemical analysis, membrane permeabilized model cells are used successfully. Clonal PC12 cells derived from rat adrenal tumor have also been used extensively.

### Synaptosome

When brain is homogenized in an isotonic sucrose solution, nerve terminals are pinched-off and resealed to a round structure called a ►[synaptosome](#) of 0.5–1  $\mu\text{m}$  in diameter. Synaptosomes are enriched in postmitochondrial P2 fraction of brain homogenate and further purified by a density gradient ultracentrifugation. Synaptosomes contain one to several mitochondria and regenerate membrane potential by the action of  $\text{Na}^+/\text{K}^+$ -ATPase when they are incubated in the presence of glucose and oxygen. They can be kept alive for several hours. PSD structures are tightly attached to most synaptosomes. Synaptosomes have been used for the biochemical assay of neurotransmitter synthesis, release and reuptake. By modifying the preparation, synaptoneuroosomes and synaptodendrosomes in which both presynaptic terminal and dendritic spine are resealed, have been obtained.

A recent study revealed that glial cells release glutamate and various peptides by a  $\text{Ca}^{2+}$ -dependent exocytotic mechanism. A resealed cellular fragment of glial cells called gliosome is prepared from brain homogenate by a Percoll gradient ultracentrifugation. Gliosomes are different from synaptosomes in density and ultrastructural morphology. Glutamate is released from gliosomes in a  $\text{Ca}^{2+}$ -dependent manner.

### Mutant Mouse

Many knock-out mice of synaptic proteins have been generated and successfully used for the study of these proteins in synaptic function.

### Synapse Formation and Plasticity in Development

#### Synaptogenesis

During development, neurons extend neurites and make synaptic contacts after finding a proper target neuron. The tip of a growing neurite represents a characteristic structure called a growth cone, which is completely different from the presynaptic terminal in structure. A growth cone is enriched in actin and is a very active structure with extending and retracting filopodia to find a proper target cell. The extension of a neurite is controlled by various guidance molecules and growth factors.

The process of ►[synaptogenesis](#) was extensively studied in the neuromuscular junction [5]. On attaching to a target cell, the growth cone stops moving and shows morphological changes. The nerve terminal is bloated and synaptic vesicles appear inside. CAZ (cytomatrix assembled at active zone) becomes visible with maturation to form an active zone. In response to the presynaptic differentiation, postsynaptic differentiation also proceeds. Postsynaptic density and synaptic folding are formed beneath the active zone. Nicotinic acetylcholine receptor clusters are formed on the edge of synaptic folding, and acetylcholine esterase is enriched in the extracellular matrix in the synaptic folding. Several soluble factors including agrin play crucial roles in this coordinated differentiation. Morphological changes in synaptic structure during maturation are also observed in neurons of CSN.

### Synaptic Plasticity in Development

A basic design of the neuronal network is genetically determined, however, activity-dependent fine tuning is necessary to complete the formation of the neural network. Most of the neurite extensions occur in an activity-independent manner, plasticity of the neuronal network is obvious in the stage of synaptogenesis. Synaptogenesis starts in the brain from late embryonic to early postnatal stages. In many brain regions, extra synapses are transiently formed during the early postnatal period, and are then decreased to adult level in an activity-dependent manner. In other words, multiple innervation occur first, followed by a selective ►[synaptic elimination](#) of extra synapses, with synaptic activity playing a crucial role in the selection.

Synaptic plasticity in development has been extensively studied in sensory systems. Retinal ganglion neurons send a projection to the visual cortex in the brain via monosynaptic transmission. In the adult brain, the projections from the left eye are spatially separated

from those from the right eye. In contrast, most neurons of the visual cortex have dual innervations from both the right and left eye at birth. In a particular period called the critical period during the early postnatal period, selective elimination of extra synapses occur to shift to a unitary innervation. Multiple innervated neurons compete with each other to occupy the synaptic site, and neuronal activity during the critical period has a definite effect on the competition. If one eye is closed during the critical period, synaptic connection from the closed eye fails in the competition and the modified innervation map is fixed through the whole of life. A similar phenomenon is also observed in the sensory cortex for face fungus in rat, and in the phenomena called ▶ **imprinting** in birds. Activity-dependent synaptic elimination (▶ **synapse formation and elimination: competition and the role of activity**) is also observed in climbing fiber synapse in cerebellum, and in neuromuscular junctions.

The critical period is different among different species. In the human cerebral cortex, the number of synapses increases markedly after birth and attains a maximal level around four months after birth. It declines thereafter to adult level in early childhood. The visual projection area is smaller and the auditory projection area is larger in a patient with a congenital visual defect than those of a normal person. If one eye is temporally closed with an eye bandage to cure cockeye during the critical period, the patient will have a visual defect throughout the whole of his life. On the other hand, if a person starts practicing the violin in the critical period, the person will have a more exhaustive movement of fingers since his motor area for fingers increased throughout life.

### Synaptogenesis in Adult Brain

If new synaptic formation is an event in development, we can say that the brain continues to develop throughout the whole of life. Many synapses are forming, losing and change their property to change the function of the neuronal network, and these characteristic features are an origin of many remarkable functions, including, learning, memory, thinking and creativity, those that are not determined by genetic information.

Neurogenesis still occurs in some regions of the adult brain including the dentate gyrus of hippocampal formation [6]. Newly formed neurites of granular cells forms many new synapses in the dendrite of CA3 pyramidal cells. There is good evidence to show that synaptogenesis also occurs in the adult brain. The number of dendrites, branching point of dendrites, and synapses increase in a rat brain cortex which is kept in a complex environment. A partial rearrangement of sensory cortex has been observed in some adult animals

after inhibiting sensory neurons from the finger in prosimian and bat.

## Synaptic Plasticity

### Importance of Synaptic Plasticity

Signal processing by ionotropic receptor-mediated summation and integration (▶ **synaptic integration**) determine the output without changing the individual synaptic response. If a neuronal network only has such a system for signal processing, it is not possible to store information acquired by external inputs, or to use this information to change the property and function of the neuronal network in response to environmental change in the battle for survival.

A characteristic feature of synapses is to change the size of epsp dynamically in response to previous activity. In other words, the strength of synaptic transmission is continuously changing in an activity-dependent manner whilst retaining a history of prior activity. What kind of information is stored in the neuronal network as a memory is not determined by genetic information. Synaptic plasticity is believed to be a molecular and cellular basis of learning and memory. Identity is one of the most important properties for human beings, and is established on memories. Memory defect by aging is now becoming a serious problem for the aged society, since the identity of the aged person disappears with the loss of their memory. It is also necessary to rearrange neuronal networks to change the response for adaptation to environmental change. These properties are also dependent on the characteristic property of the neuronal network. There are multiple mechanisms of variety of time scale in synaptic plasticity. In some cases, reconstruction of neuronal networks by losing or forming synaptic contact occurs.

### Plasticity of Various Time Constant

#### Facilitation

At most synapses, repetitive high-frequency stimulation (called a tetanus) is initially dominated by a growth in successive epsp amplitude, called synaptic facilitation. This process builds to a steady state within about 1 s and decays equally rapidly when stimulation stops. When a pair of stimuli is given to some synapses with several ten second intervals, the amplitude of the second response either increases, called paired-pulse facilitation, or decreases, called paired-pulse depression, compared to the first response. These properties are often used as a parameter of presynaptic activity.

#### Potentiation

Some synapses display a growth in epsp amplitude that lasts minutes and is called potentiation. The potentiation that appears after moderate (50–100 per sec) tetanic

stimulation is called posttetanic potentiation (PTP), which is observed in many synapses including the neuromuscular junction.

### Long-Term Potentiation

In some synapses, a brief high-frequency tetanic stimulation induces a long-lasting increase in the amplitude of epsp, called ▶long-term potentiation (LTP). Whereas PTP decays within a few minutes, LTP decays over the course of several hours or, under certain conditions, up to a month or more. Low-frequency stimulation sometimes results in long-lasting depression of epsp, called long-term depression (LTD). It is also possible to cancel LTP and LTD by applying proper stimulation after a while, and these phenomenon are called depotentiation and dedepression, respectively. The expression and maintenance of LTP and LTD are not derived from a single mechanism, but are generated by multiple mechanisms, from short-time mechanisms without new gene expression to long-term mechanisms involving gene expression and protein synthesis.

### Typical Studies of Synaptic Plasticity

Synaptic plasticity is quite an important phenomenon in brain functions, and extensive studies have been successfully conducted in invertebrate and vertebrate nervous system.

### *Aplysia* Neuron

*Aplysia* is a marine mollusk and has a relatively simple nervous system. Eric Kandel and his colleagues found that *Aplysia* showed activities of primitive learning and memory, and extensively studied the mechanisms in cellular and molecular levels [7].

Some neurons have very large cell bodies and are easy to identify in ganglion. Major neurons are numbered and characterized. The identified neurons reconstruct a neuronal circuit in culture and show synaptic plasticity that is observed in the neuronal network of living animals. Thus, it is easy to study synaptic function for a long period (several hours to several days) with multiple techniques.

*Aplysia* uses gills for respiration that show a withdraw reflex when some stimuli is applied on their bodies to protect them. When animals were repeatedly stimulated with water puffing every three minutes for four hours, the withdrawal response decreased with time and finally showed no response. This phenomenon is called habituation, and is also popular in our life. This habituation originates from a change in synaptic property between the sensory neuron and the motor neuron. Inactivation of Ca channel responsible for neurotransmitter release, as well as a decrement of releasable synaptic vesicles is a major mechanism of this phenomenon.

When noxious stimuli are applied to a habituated *Aplysia*, the animal again shows a withdrawal response even to a weak stimulus that does not induce any response under normal conditions. This phenomenon, called sensitization, results from the stimulation of neurotransmitter release from the sensory neurons. A noxious stimulus activates interneuron innervated at the presynaptic nerve terminal of the sensory neuron. Serotonin released from the interneuron activates a presynaptic serotonin receptor of the sensory neuron. Activation of presynaptic serotonin receptor coupled with Gs results in an elevation of intracellular cAMP level, which in turn activates PKA. PKA suppresses K channel activity by phosphorylation, which in turn prolongs Ca<sup>2+</sup> influx through Ca channels. The stimulation of neurotransmitter release from the sensory neuron is also induced by increasing the size of the releasable pool of synaptic vesicles in PKA- and PKC-dependent mechanisms.

Sensitization is usually retained for less than a day, however, when the noxious stimuli are repeatedly applied everyday for several days, the effect of sensitization sustains over one week. The important finding is that mechanisms are quite different between the short-term sensitization and the long-term sensitization, and new gene expression and protein synthesis are essential for the expression of the long-term sensitization. Prolonged and repeated activation of serotonin receptors results in continuous activation of PKA, and the catalytic subunit of PKA translocates to the nucleus and activates cAMP-dependent gene expression by activating CREB by phosphorylation.

### LTP and LTD in Hippocampus

Memory formation and special learning are impaired when the hippocampus is injured in humans and rat, indicating that the hippocampus plays a critical role in memory. A lot of attention has focused on the hippocampus since LTP was found there. There are three synapses in the major neuronal circuit in the hippocampus, and LTP is observed in all of these synapses. The mechanisms of LTP induction are different among these three synapses, and the mechanism of the CA1 synapse has been most extensively studied. In brief, LTP is induced in a CA1 synapse according to the following mechanism. Synaptic transmission of the CA1 synapse is mediated by glutamate and two types of glutamate receptors, NMDA and AMPA, both being expressed at the post synaptic site. Under normal conditions, the NMDA receptor is blocked by Mg<sup>2+</sup> ions, and the AMPA receptor plays a predominant role in synaptic transmission. High frequency stimulation activates many AMPA receptors and a resulting large depolarization of postsynaptic membrane cancels the Mg<sup>2+</sup> block of NMDA receptors. In addition to Na<sup>+</sup>, Ca<sup>2+</sup> ions influxes into the

postsynaptic site, and induce a  $\text{Ca}^{2+}$ -dependent process that leads to LTP. CaMKII plays a critical role in the  $\text{Ca}^{2+}$ -dependent induction of LTP.

Several important ideas have been obtained from studies of hippocampal LTP, one of the most important ones being gene-expression-dependency. Just like short-term sensitization in *Aplysia*, expression of short-term LTP is not dependent on new gene expression and protein synthesis, and posttranslational modification including protein phosphorylation of preexisting proteins play major roles. On the other hand, gene expression and new protein synthesis are indispensable for the expression of LTP. Many genes changing expression patterns in the induction of LTP have been identified, however, the precise consequences of these gene expressions and LTP induction has not yet been clarified.

LTP in CA1 is associative (▶**associative long-term potentiation (LTP)**) and both pre- and postsynaptic activities are necessary for their induction. In contrast, CA3 synapse shows no association, and it occurs by a presynaptic mechanisms. Cyclic AMP-dependent protein phosphorylation may play a critical role in the induction of CA3 LTP.

### Cellular and Molecular Mechanisms of Synaptic Plasticity

There are many possible mechanisms for inducing a long-lasting change in synaptic properties and function.

#### Protein Phosphorylation

Gene expression is not required for the expression of short-term synaptic plasticity, and posttranslational modification of preexisting protein plays a crucial role in this mechanism. Activation of metabotropic receptors and  $\text{Ca}^{2+}$  mobilization activate various kinds of protein kinases and phosphatase, which in turn change the state of phosphorylation of many synaptic proteins. These mechanisms are present in both presynapse and postsynapse. In presynaptic terminals, protein phosphorylation modifies the presynaptic function by phosphorylating neurotransmitter synthesizing enzymes, such as cAMP-dependent phosphorylation of tyrosine hydroxylase, various proteins involved in neurotransmitter release (▶**regulation of neurotransmitter release by protein phosphorylation**), and ▶**vesicular neurotransmitter transporter**. In the postsynapse, phosphorylation of neurotransmitter receptors are predominant in its regulation [8].

#### Translocation of Receptors

In developing neurons, there appear many ▶**silent synapses** in which are devoid of AMPA receptors and only NMDA receptors are expressed in the synaptic membrane. Since the NMDA receptor is blocked by  $\text{Mg}^{2+}$  at normal membrane potential, no synaptic

current is induced by glutamate. With maturation of the brain, these silent synapses become activated, and the number of silent synapses decreases with maturation. However, some silent synapses are still present in the adult brain, and participate in the synaptic plasticity such as LTP.

In early studies, phosphorylation of the AMPA receptor was believed to be primarily important for the activation, however, recent studies revealed that translocation of the AMPA receptor from the intracellular store site to the plasma membrane is predominant in its activation. The expression of the AMPA receptor in the synaptic plasma membrane is likely to occur by an ▶**exocytosis** of intracellular vesicles carrying AMPA receptors.  $\text{Ca}^{2+}$  is necessary to induce LTP in CA1 synapses. CaMKII is likely to be involved in triggering exocytosis.

#### Adhesion Molecules

Synaptic connection is retained by cell adhesion molecules in the presynaptic and postsynaptic membrane (▶**synaptic adhesion molecule**). To alter the synaptic connection, the regulation of adhesion molecules is important. Cadherin-mediated regulation is important for the change in spine structure. Degradation of adhesion molecules is necessary for the rearrangement of synaptic connections. Many ▶**extracellular proteases** are expressed in the synaptic area and play important roles in LTP formation.

#### Spine, Morphological Change

Actin cytoskeleton is abundant in the dendritic spine, and the spine changes their morphology dynamically in a synaptic activity-dependent manner (▶**spine, morphological change**). There is a dramatic change in spine morphology several tens of minutes after induction of LTP. The dynamics of the actin cytoskeleton is regulated by  $\text{Ca}^{2+}$  and by multiple signal transduction mechanisms downstream of the metabotropic receptor and neurotrophin receptors. There are at least two types of spines. One is filopodia-like and has no AMPA receptor. Another is mushroom-like in shape and expresses AMPA receptor. After induction of LTP in the filopodia-like spine, it changes to the mushroom-like spine and acquires AMPA receptor.

In electronmicroscopic observations, two types of spine synapse are also observed, one is a nonperforated and another is a ▶**perforated synapse**, in which PSD is discontinuous. The number of perforated synapses increases after LTP induction, and attains a maximal level 15–60 min after induction. Since some nonperforated synapses have no AMPA receptor, these morphological changes may be accompanied by the activation of ▶**silent synapses**.

Many synaptic terminals are formed in the cell soma. Since the postsynaptic compartments are not separated

from each other, the effect of synaptic input spreads over the entire cell surface, no input specificity is achieved. On the contrary, the postsynaptic components of spine synapse are separated one by one, and the diffusion of various substances is restricted by the narrow spine neck. Thus, most changes in the postsynaptic site are restricted to the synapse, and input-specificity of plasticity appears.

In the memory circuit of an electrical computer, there are fudge numbers of condensers that are used for memory storage and calculation by changing the condenser into two states, charged and uncharged. In addition, each condenser is accompanied by a transistor switch to charge or discharge condensers. In the brain, there are numerous numbers of spines, which can change their state and shape reversibly. Each spine has an input of glutamatergic neurons, and the glutamate released from each presynaptic site can induce a change of spine structure and state. This analogy suggests a possibility that the spine might be an element for memory storage. There are fudge numbers of spines in the brain, enough to store fudge numbers of memories. Furthermore, since the structure of large spines is very stable, long-term storage of memory could be stored in the spine. In future, we might be able to read memory stored in the brain by analyzing spine structure.

### **Gene Expression and Protein Synthesis**

New gene expression and protein synthesis is essential for the expression of long-term plasticity. Many genes whose expressions are changed in LTP have been identified and characterized. It is not so clear how these gene products participate in the changes of synaptic structure and functions in the brain.

Synaptic signals should be delivered to the nucleus where gene expression takes place. In CA1 synapses, synaptic activity is thought to be delivered by  $\text{Ca}^{2+}$  and/or  $\text{Ca}^{2+}$ -dependent protein kinases. In *Aplysia* neurons, it has been shown that MAP kinase and PKA translocate to the nucleus after stimulation and activate gene expression by phosphorylating CREB. The importance of CREB in long-term memory is also shown in the mammalian brain [9,10].

One of the characteristic features of synaptic plasticity is input specificity. Since proteins are usually synthesized in the cell body, the synthesized proteins should be transported selectively to synapses, where the synaptic activity for plasticity occurs. There are at least two possibilities to achieve this input specificity. One is a hypothetical idea of a synaptic tag [11,12]. Synaptic activity results a trace in synapse, and the newly synthesized protein accumulates at the specific synapse according to the tag.

The second idea is a local protein synthesis at the synaptic site [13,14]. It has now been established that some mRNAs are present in the dendrite, and a

noncoding region of mRNA is essential for dendritic delivery of the mRNA. Several mRNA binding proteins have been identified. Many membrane proteins are glycosylated in the Golgi complex in the cell body, but the mechanisms of glycosylation of locally synthesized protein is not yet known.

### **Neuronal Defect Related to Synaptic Functions Neuronal Defects in Development**

Since synaptogenesis starts in the late stage of pregnancy, deficiency of synaptic function is not assumed to make severe effects on brain development during embryonic age. In fact, many knock-out mice of synaptic proteins died after birth. The severe effects are derived by disorders that occur during the critical period as described above.

### **Plasticity-Related Neuronal Defects**

Plasticity of the dendritic spine structure and functions are quite important for the expression of various brain functions including learning and memory. Abnormal spine shape, or spine dysgenesis, is associated with various forms of mental retardation [15]. Reduction of hippocampal volume is observed in patients with major depression, possibly due to a retraction of dendrites and a reduction of neuronal connectivity. Antidepressant treatments appear to protect against hippocampal volume loss and also increases adult neurogenesis in hippocampus [16].

The secretion of glucocorticoids from the adrenal cortex is one of the major responses to stress. Strong and prolonged stress makes various severe effects on the structure and functions of the hippocampus, since its expression level of the glucocorticoid receptor is quite high. Repeated stress causes atrophy of dendrites in the CA3 region, and both acute and chronic stress suppresses neurogenesis of dentate gyrus granule neurons [17]. Maternal behavior in the rat permanently alters the development of stress response by altering glucocorticoid receptor expression in the hippocampus by an epigenetic mechanism. Pups which do not have enough maternal care during the first 10 days of life, showed stress vulnerability and increased anxiety throughout their whole life [18].

### **Psychoactive Drugs**

Defects in synaptic function result in various problems in the brain, and many compounds that act on synaptic proteins are widely used for clinical use as physiological drugs. Tricyclic antidepressive agents like imipramine, and a selective serotonin reuptake inhibitor (SSRI) like fluoxetine, are widely used for the treatment of depression, bipolar disorder, and anxiety disorder by inhibiting serotonin transporter. Barbiturate and benzodiazepine are used as an antianxiety drug, which binds to the  $\text{GABA}_A$  receptor and enhances GABA action by

increasing affinity of GABA to the receptor. Benzodiazepines are also used as a sedative and anticonvulsant drug. Positive and negative symptoms appeared in patient with schizophrenia, and antagonists of the dopamine receptor like haloperidol and that of the NMDA receptor are used for the treatment, respectively.

### Drug Dependence

In many countries, street drugs are illegal since most of these compounds induce drug dependence. Many of these drugs exert their action by acting on synaptic proteins. Amphetamine and cocaine are stimulant drugs. They induce releases of dopamine and noradrenalin and suppress reuptakes of these neurotransmitters. On the other hand, morphine acts as an agonist of the opiate receptor. Marijuana is a psychoactive drug and an agonist of the metabotropic cannabinoid receptor.

### Toxins

Many toxins exert their action by blocking the functions of synaptic proteins [19]. Tetanus toxin and botulinum neurotoxin are protein neurotoxins produced by an anaerobic bacterium, *Clostridium tetani* and *Clostridium botulinu*, respectively [20,21]. Several immunologically distinguishable forms of botulinum neurotoxin, designated as types A, B, C, D, E, F, and G, are produced by different strains of *Clostridium botulinum*. All of these neurotoxins act primarily on neurons and inhibit neurotransmitter release from presynaptic nerve terminals. These neurotoxins are composed of a heavy chain and a light chain held together by a disulfide bond. The heavy chain is responsible for the specific binding to their neuronal receptors in axonal terminals. As for type A and type B botulinum neurotoxins, neuronal receptors are identified as synaptic vesicle proteins SV2 and synaptotagmin, respectively. Following the attachment on the surface of axon terminals, the toxin can be taken into neurons by endocytosis, and then the light chain enters into the cytoplasm. The light chain is a  $Zn^{2+}$ -dependent protease and exclusively hydrolyzes peptide bonds within SNARE proteins in a type-specific manner, and inhibits neurotransmitter release by disturbing SNARE complex formation. Botulinum toxins are successfully used for the treatment of crossed eyes, migraine headaches, dystonia, and many other defects [22].

Tubocurarine chloride is a toxin obtained from the arrow poison curare. It binds to nicotinic acetylcholine receptor and blocks its function. Both  $\alpha$ -bungarotoxin obtained in snake venom, and  $\alpha$ -conotoxin obtained from the venom of the marine cone snail also inhibit the nicotinic acetylcholine receptor. Omega-conotoxins from the cone snail and  $\omega$ -agatoxin isolated from the venom of spider inhibit neuronal Ca channels and suppress neurotransmitter release from presynaptic terminals.

Sarin (O-Isopropyl methylphosphonofluoridate) is an extremely toxic substance used as a chemical weapon. It is a very potent inhibitor of acetylcholinesterase. Acetylcholine is one of the most important neurotransmitters of the respiratory center in the brain stem, and disturbance of the cholinergic system in the center results in a blockage of the diaphragm. In the peripheral nervous system, the nicotinic acetylcholine receptor is desensitized, and thus sarin induces a paralysis of the muscles. Interestingly, donepezil, another inhibitor of acetylcholinesterase marketed under the trade name Aricept, is used in the treatment of Alzheimer's disease, where it is applied to increase cortical acetylcholine.

### Autoimmundiseases

Some patients of autoimmune diseases have autoantibodies to synaptic proteins. ►**Myasthenia gravis** is a neuromuscular disease leading to fluctuating muscle weakness and fatigability. The weakness is caused by circulating antibodies that block acetylcholine receptors at the post-synaptic neuromuscular junction. ►**Lambert-Eaton myasthenic syndrome** is also an autoimmune disease accompanied by progressed muscle weakness. The autoantibodies to Ca-channels and synaptotagmin, a synaptic vesicle protein, are generated in the blood of patients.

### References

1. Bramham CR, Messaoudi E (2005) BDNF function in adult synaptic plasticity: the synaptic consolidation hypothesis. *Prog Neurobiol* 76(2):99–125
2. Hawkins RD, Son H, Arancio O (1998) Nitric oxide as a retrograde messenger during long-term potentiation in hippocampus. *Prog Brain Res* 118:155–172
3. Burns ME, Augustine GJ (1995) Synaptic structure and function: dynamic organization yields architectural precision. *Cell* 83:187–194
4. Bennett MV, Zukin RS (2004) Electrical coupling and neuronal synchronization in the mammalian brain. *Neuron* 41:495–511
5. Sanes JR, Lichtman JW (1999) Development of the vertebrate neuromuscular junction. *Ann Rev Neurosci* 22:389–442
6. Gross CG (2000) Neurogenesis in the adult brain: death of a dogma. *Nat Rev Neurosci* 1:67–73
7. Hawkins RD, Kandel ER, Bailey CH (2006) Molecular mechanisms of memory storage in *Aplysia*. *Biol Bull* 210:174–191
8. Soderling TR, Derkach VA (2000) Postsynaptic protein phosphorylation and LTP. *Trends Neurosci* 23:75–80
9. Wang H, Hu Y, Tsien JZ (2006) Molecular and systems mechanisms of memory consolidation and storage. *Prog Neurobiol* 79:123–135
10. Wu H, Zhou Y, Xiong ZQ (2007) Transducer of regulated CREB and late phase long-term synaptic potentiation. *FEBS J* 274:3218–3223

11. Frey U, Morris RG (1998) Synaptic tagging: implications for late maintenance of hippocampal long-term potentiation. *Trends Neurosci* 21:181–188
12. Reymann KG, Frey JU (2007) The late maintenance of hippocampal LTP: requirements, phases, “synaptic tagging,” “late-associativity” and implications. *Neuropharmacology* 52:24–40
13. Pfeiffer BE, Huber KM (2006) Current advances in local protein synthesis and synaptic plasticity. *J Neurosci* 26:7147–7150
14. Schuman EM, Dynes JL, Steward O (2006) Synaptic regulation of translation of dendritic mRNAs. *J Neurosci* 26:7143–7146
15. Fiala JC, Spacek J, Harris KM (2002) Dendritic spine pathology: cause or consequence of neurological disorders? *Brain Res Brain Res Rev* 39:29–54
16. Castrén E (2004) Neurotrophic effects of antidepressant drugs. *Curr Opin Pharmacol* 4:58–64
17. McEwen BS (1999) Stress and hippocampal plasticity. *Annu Rev Neurosci* 22:105–122
18. Diorio J, Meaney MJ (2007) Maternal programming of defensive responses through sustained effects on gene expression. *J Psychiatry Neurosci* 32:275–284
19. Conn PM (1992) Neurotoxins. In: *Methods in neuroscience*. Academic Press, San Diego
20. Rossetto O, Seveso M, Caccin P, Schiavo G, Montecucco C (2001) Tetanus and botulinum neurotoxins: turning bad guys into good by research. *Toxicon* 39:27–41
21. Montecucco C, Schiavo G, Pantano S (2005) SNARE complexes and neuroexocytosis: how many, how close? *Trends Biochem Sci* 30:367–372
22. Jankovic J (2004) Botulinum toxin in clinical practice. *J Neurol Neurosurg Psychiatry* 75:951–957

followed by recruitment of pre- and postsynaptic molecules important for synapse function.

- ▶ Synapse Formation and Elimination: Competition and the Role of Activity
- ▶ Synapse Formation: Neuromuscular Junction Versus Central Nervous System
- ▶ Synaptogenesis

## Synapse Formation and Elimination: Competition and the Role of Activity

LAURA CANCEDDA<sup>1</sup>, MU-MING POO<sup>2</sup>

<sup>1</sup>Department of Neuroscience and Brain Technologies, The Italian Institute of Technology, Genoa, Italy

<sup>2</sup>Division of Neurobiology, Department of Molecular and Cell Biology, Helen Wills Neuroscience Institute, University of California at Berkeley, Berkeley, CA, USA

### Definition

Synaptic **competition** is a cellular process by which the presence of one synapse affects the stability or survival of other synapses on the same postsynaptic cell. Synapse elimination refers to synapse loss due to either a low “intrinsic merit” of the synapse for survival or to its failure in winning synaptic competition with other synapses on the same cell [1]. Such competition and elimination can be driven by either neuronal/synaptic activity or other activity-independent processes [2]. We here summarize the evidence of activity-dependent synaptic competition and elimination in various brain regions, together with potential underlying cellular mechanisms.

### Characteristics

#### Introduction

Synaptic competition is a cellular process by which the presence of one synapse affects the stability or survival of other synapses on the same postsynaptic cell. Synapse elimination refers to synapse loss due to either a low “intrinsic merit” of the synapse for survival or to its failure in winning synaptic competition with other synapses on the same cell. Such competition and elimination can be driven by either neuronal/synaptic activity or other activity-independent processes. The idea that the strength of synaptic connections between neurons may be modified can be traced back to Ramon y Cajal, who proposed that such modification serves as a cellular mechanism for learning and memory. That memory formation involves making and breaking

## Synapse Elimination

### Definition

The removal of redundant connections formed during development or plasticity, also called pruning.

- ▶ Activity-Dependent Synaptic Plasticity
- ▶ Synapse Formation and Elimination: Competition and the Role of Activity
- ▶ Synaptic Elimination

## Synapse Formation

### Definition

Synapse formation is a multi-step process that occurs after the first contact of an axon and dendrite are made



existing synaptic connections has been a popular idea over the past century, but solid experimental evidence in support of this idea has been elusive. Recent morphological studies of synapse stability in the adult rodent brain have revealed rather limited synaptic remodeling under normal conditions. In contrast, initial synaptic connections established early in the developing nervous system undergo substantial remodeling, with some connections stabilized and others eliminated, as a result of experience. This developmental remodeling of connectivity often involves cooperative and competitive interactions between converging synapses on the postsynaptic cell and in many cases depends on the pattern of electrical activity. We here summarize the evidence of activity-dependent synaptic competition and elimination in various brain regions, together with potential underlying cellular mechanisms.

### Visual System

Activity-dependent synaptic competition and elimination in the central nervous system was first indicated by work of Hubel and Wiesel on the development of ocular dominance columns (ODCs) in the visual cortex. Cortical neurons preferentially responding to one eye or the other are normally found to be segregated into alternating columns in the primary visual cortex, representing sorting of geniculocortical projections serving two eyes during postnatal development. The sorting process occurs prior to eye opening and is highly sensitive to visual experience. Depriving visual input to one eye of a newborn cat or monkey by suturing the eyelid during a critical period after birth leads to retraction of geniculocortical projections serving that eye. Interestingly, the consequences of visual deprivation during early postnatal period are much more severe in cats subjected to monocular deprivation than binocular deprivation, suggesting that competition driven by activity between two eyes, rather than the reduced activity in one eye, is responsible for sorting geniculocortical projections. The ODCs develop by a progressive segregation of initially overlapping geniculocortical projections serving two eyes. While the initial alternating pattern of projections is established by mechanisms independent of the retina activity, pruning of extensive overlapping projections is likely to be driven by activity, including spontaneous or visually evoked retinal activity, because blocking the firing of retinal ganglion cells (RGCs) in both eyes prevents complete ODC formation.

Early in development there is also substantial overlap of retinogeniculate projections from the two eyes in the lateral geniculate nucleus (LGN). Segregation of these projections into eye-specific layers occurs before the onset of vision, but at a time when ►spontaneous activity waves are prominent in the retina. Blocking all activity in both eyes prevents segregation of

retinogeniculate projections and can desegregate already existing eye-specific projections later in development, although it is unclear whether the specific pattern of the waves is required for eye-specific segregation. When the activity is altered in one eye, the more active eye acquires more synaptic territory than the less active eye, suggesting activity-mediated competition. Furthermore, even after eye-specific segregation is completed, activity in one eye can further prune retinogeniculate projections by reducing the convergence of RGC inputs onto a single LGN neuron from 12 to 20 to one. This within-eye pruning based on activity-dependent competition among RGCs facilitates sharpening of the receptive field of LGN neurons. Such activity-dependent competition may be attributed to the competition in the growth or stability of RGC axonal arbors. In the developing optic tectum of zebrafish, reducing neuronal and synaptic activity in a subset of RGCs leads to suppression of their axon growth and branching and this suppression is relieved by blocking the activity of nearby RGC axons as well [3].

The successive levels of the mammalian visual system are organized into retinotopic maps that preserve an orderly representation of visual inputs at the retina, through topographically precise retinogeniculate, retinocollicular and geniculocortical projections. Formation of these maps requires specific patterns of spontaneous activity in the retina because disrupting these waves affects map formation at all levels. While the initial projections may establish a crude retinotopic map via axon guidance based on ►molecular cues, interfering with both axon guidance cues and spontaneous wave activity in the same animal results in a dramatic cumulative effect in disrupting the map in the superior colliculus. Finally, the development of retina circuitry itself also depends on activity. Depriving the retinal activity by blocking spontaneous activity or dark rearing blocks both the normal maturational loss of ON-OFF responsive RGCs and the pruning of dendrites at the stratified ON and OFF layers of the inner plexiform layer, although it is unclear whether dendritic pruning in this layer results from competitive interaction among bipolar inputs.

### Somatosensory System

Somatosensory projections in the brain exhibit a ►somatotopic map, with axons of peripheral receptor sheets projecting in an orderly manner onto central brain structures. The most intensively studied system is the rodent trigeminal pathway where the patterned array of the whisker is replicated in the patchy distribution of afferents and the modular organization of their postsynaptic counterparts along the pathway from the periphery to the primary somatosensory cortex. The whisker-related patterns are first established in the brainstem nuclei, then in the ventro posteromedial

nucleus of the thalamus, and finally in the somatosensory cortex (“barrels”), where neurons respond best or exclusively to deflection of the corresponding facial whisker. These somatotopic maps emerge during early development in ascending order along the neuroaxis, with a sequence that includes afferent fibers segregation before rearrangement of their target neurons in discrete zones along the pathway. It is generally believed that the initial crude topographic projection of the afferent fibers is independent of sensory experience, but the presence of segregated afferent fibers and postsynaptic glutamate receptor activities are required for the subsequent parcellation of their postsynaptic targets [4].

That cortical map formation depends on a competitive process is suggested by the finding that damage of the branch of the trigeminal nerve supplying the whisker pad prior to birth results in a reduction of the cortical representation of the whiskers and a concomitant increase in the representation of other peripheral receptor surfaces. Whether and how such competition occurs through synaptic competition and elimination are unknown. ►**Synapse elimination** has been observed in the ventral posteromedial thalamic nucleus of young animals, where multiple afferents on each neuron are reduced to one or two afferents as the animal matures. However, this synapse elimination and remodeling occurs even in animals deprived of sensory experience from birth, indicating that the process is independent of sensory experience, although spontaneous neuronal activity may still be required.

Morphological organization of somatosensory cortical neurons into barrels during development depends on signals conveyed by invading thalamic axons and sensory activity. Indeed, primordial visual cortex transplanted into the neonatal somatosensory cortex form barrels when invaded by axons from somatosensory thalamic nuclei, and genetic manipulations that interfere with the appropriate segregation of these axons disrupt barrel formation. Moreover, that sensory peripheral sensory signals may be instructive in sculpting the somatosensory cortical map is also evidenced by lesion or genetic studies showing that altering the number of functioning whiskers leads to shrinkage, expansion or addition of barrels. However, such aberrant barrel formation may result from sprouting and retraction of afferents and dendrites due to neuronal degeneration and alteration in the number of afferents, involving competitive ►**synapse formation**, rather than activity-dependent synaptic competition. Notably, changes in whisker use drive functional changes in the barrel neurons without affect anatomical appearance of barrels, suggesting no gross reorganization of synaptic connections. Nevertheless, sensory deprivation results in a specific loss of GABAergic synapses and impairment of secondary dendritic branches in the barrel cortex. Thus, activity may lead to synapse elimination

of at least a subset of synapses in the somatosensory cortex, presumably through a competitive process.

### **Auditory System**

Sound entering the ear stimulates cochlea hair cells, which make synaptic connection with spiral ganglion cells that give rise to the primary auditory nerve for carrying auditory information into the brainstem. From there the signals converge in the inferior colliculus that sends projections to the thalamus, which further relays auditory signals to the auditory cortex. In these relay areas neurons are arranged in a topographic manner according to the sound frequencies to which they are most sensitive. Although the topography of these connections is apparent early in development, the precision of the map is refined later in development through an activity-dependent process [5]. Developmental pruning of both axonal arbors and dendritic branches has been widely observed in the auditory system. Cochlear nerve axons and their target neurons in nucleus magnocellularis (NM) undergo extensive parallel structural transformations involving pruning of cochlear axonal arbor, massive reduction of dendrites in NM neurons, and elimination of poly-neuronal innervation. Since otocyst removal has no effect on the extent, timing, and pattern of dendritic loss, this extensive synapse elimination is independent of the sensory activity. Interestingly, after this early massive remodeling, NM neurons undergo further dendritic growth before maturation in a sensory activity-dependent manner.

In contrast to that in the NM, developmental remodeling of axons and dendrites in the nucleus laminaris and superior olivary nucleus (SON) after the onset of hearing appears to be activity-dependent. Cochlea removal or blockade of glycinergic transmission impairs remodeling of axonal and dendritic morphology in SON. Since most of the remodeling occurs after the onset of hearing, acoustically evoked activity is likely to be involved, although spontaneous activity may also contribute. Indeed, correlated spontaneous activity is present in the embryonic brainstem and auditory nerve. The spatiotemporal pattern of spontaneous firing could provide developmental cues for the spatial ordering of auditory projections, as suggested by the presence of a systematic relationship between the rate of rhythmic bursting and the tonotopic location in the chick. Such activity-dependent remodeling of connectivity may contribute to the tonotopic map refinement at many different levels in the auditory system.

After the onset of hearing, the auditory cortex undergoes a transition from a tonotopic map dominated by broadly tuned, high frequency-selective neurons to the adult tonotopic map consisting of neurons that represent the full spectrum of acoustic inputs. ►**Sensory-evoked activity** is responsible for this transition. Early

acoustic environment is critical for the maturation of tonotopic maps, because exposing rat pups to pulsed white noise or rearing them in continuous moderate-level noise impairs the emergence of adult-like tonotopic map, whereas exposure to pulsed tones of specific frequencies results in accelerated emergence and expansion of auditory cortex representations of those frequencies. This activity-dependent remodeling of cortical maps are likely to involve synaptic competition and elimination, although whether functional refinement of the map directly reflects structural reorganization of synaptic connectivity remains to be determined.

### Olfactory System

The olfactory sensory neurons in mammals express only one of about 1000 odorant receptor genes and neurons expressing a given receptor are randomly dispersed within one of four broad zones in the olfactory epithelium. The axons of these sensory neurons converge upon spatially conserved glomerulus within the olfactory bulb. The topographic mapping between sensory neurons and specific glomeruli may depend on the expression of specific molecules along their projection pathways or in themselves. There is evidence, however, that activity in these olfactory neurons may also play a role. Although the patterns of axon convergence in the bulb is largely intact in mice lacking functional olfactory cyclic nucleotide-gated channels, hence no odorant-evoked activity occurs in these neurons, non-correlated spontaneous activity may still be required for the correct mapping process. Indeed, sensory map is not affected when conditional expression of tetanus toxin light chain inhibits synaptic transmission in the majority of olfactory sensory neurons. However, inhibition of synaptic release in a small subpopulation of neurons expressing the P2 receptor results in correct targeting of the sensory axons initially, but the P2 glomerulus is not maintained and P2 neurons ultimately diminish. Preventing excitation of the neuron has a similar effect on the formation of the olfactory map. Thus, spontaneous neuronal activity may play a role in pruning or stabilization of axon terminals of olfactory neurons on their glomerular target cells, but there is little evidence that synaptic competition is involved in olfactory map formation.

### Cerebellum

The two main afferent systems in the cerebellar cortex are the climbing fibers (CF) originated from the inferior olivary nucleus and the mossy fibers (MF) from various nuclei in the spinal cord, brain stem, and deep cerebellar nuclei. Each CF directly contacts the proximal dendritic compartment of a single Purkinje cell, whereas the MFs influence Purkinje cells indirectly through granule cells, whose axons form the parallel fibers (PFs) that synapse onto the dendrites of many PCs. There is evidence for a

complex ►**topographic map** of these afferents fibers. For example, cutaneous inputs carried by CFs are topographically organized to form a map of peripheral body, with CF axonal arbors in register with cortical parasagittal bands of chemically heterogeneous PCs. The formation of these precise topographic maps involves both activity independent and dependent steps. First, positional information shared between CFs and PCs during embryonic development provides the molecular code for the formation of coarse-grained maps independent of neuronal activity. Activity-dependent mechanisms are later required for the transition to a fine-grained map, by pruning CF terminal arbors on each PC from multiple to single CF innervation [6]. This pruning involves strengthening one CF while weakening all other CFs during the first postnatal week, leading to the elimination of the latter. Moreover, alteration of the temporal pattern of CF activities specifically during development impairs such CF elimination *in vivo*, suggesting an activity pattern-dependent synaptic competition.

In addition to potential competition among homologous CFs, there is also heterologous competition between CFs and PFs that results in their segregation into different dendritic domains of each PC. Weakening of the CF input leads to the reduction of its dendritic territory and concomitant strengthening and expansion of the PF input, and vice versa. Furthermore, elimination of CFs depends on the activity of developing PF-PC synapses, because CF elimination is affected by reducing PF inputs, through granule cell degeneration, impairment of granule cell function, or genetic manipulation of PF-PC synapse formation or efficacy. The similarity in the consequence of reducing CF and PF activities in CF elimination suggests that similar mechanisms may underlie synaptic competition/elimination among homologous vs. heterologous inputs.

### Autonomic Ganglia

Ganglionic cells in the autonomic nervous system are innervated by preganglionic neurons of the spinal cord or brainstem and send projections to target tissues via spinal nerves to control involuntary functions of the body. In mammals, characteristic patterns of sympathetic and organ responses elicited by the activity of individual spinal axons are due to mapping between specific spinal segments and peripheral targets. This mapping requires a stereotyped and selective innervation of ganglion cells by preganglionic axons, with each ganglion cell innervated by one or few axons from specific contiguous spinal cord segments. During development there is a transition from initially exuberant innervation of each ganglion cell by many preganglionic axons to innervation by only one or a few axons. Since the spinal segment responsible for activating the mature and neonatal ganglion cell is the

same, developmental synapse elimination involves reduction of preganglionic axons from the same spinal segment, suggesting competition occurs among axons of nearby spinal neurons. Furthermore, transection of a portion of preganglionic nerve innervating a developing ganglion leads to sprouting of residual preganglionic axons and partial restoration of original multiplicity of innervation. These results are all consistent with the idea that synaptic elimination is not simply due to the intrinsic merit of the input, but involves competition among inputs, presumably for a postsynaptic factor of limited supply, e.g., locally secreted trophic factor (see Mechanisms).

The competitive interaction that determines the final number of preganglionic axons converging upon a single ganglion cell depends on the proximity of competing synapses, with each surviving synaptic terminal claiming a certain territory on the dendritic or somatic surface and neurons with more extensive dendritic arbors receiving more axons. This distance-dependent synapse competition can be explained by a limited amount of available postsynaptic factors. This synapse competition appears to be activity-dependent, because among converging inputs to a single ganglion neuron, strong synapses become further strengthened and weak synapses further weakened during synapse elimination. Moreover, the synaptic strength for each synaptic input of a multiply innervated cell is, on average, weaker than that of a singly innervated cell, suggesting that the total synaptic strength of a postsynaptic ganglion cell is conserved, due to a limited amount of a synapse-related factor.

### Neuromuscular Junction

Each muscle fiber in the neonatal animal is multiply-innervated by axon collaterals of several motoneurons, but becomes singly-innervated during early postnatal life [7]. This process depends on synapse elimination involving withdrawal of a subset of nerve terminals of each motoneuron innervating a given muscle (i.e., reduction of the size of motor units) rather than reduction in the number of motoneurons innervating a muscle. Partial denervation of the muscle at birth results in the retention of the large motor unit size without substantial collateral motor axon sprouting. Synapse elimination is competitive rather than a random process of withdrawal, since muscle fiber without a single axon is never observed. The elimination is also activity-dependent. Blocking motoneuronal activity prevents elimination, while elevating activity accelerates it. Importantly, when the relative synaptic efficacy of two competing axons at a single neuromuscular junction is impaired by genetic deletion of acetylcholine in one axon, the latter loses the competition, suggesting that the strength of the synapse is predictive of the outcome of the competition [8].

### Mechanisms of Activity-Driven Synapse Competition The Hebb's Rule for Synapse Competition

Hebb postulated that strengthening of a synapse might be achieved by repetitive presynaptic activation that leads to postsynaptic firing. This postulate was later transformed into a simple rule – coincident pre- and postsynaptic activity leads to synapse strengthening and stabilization. To account for the finding of Hubel and Wiesel on activity-dependent remodeling of connectivity in the developing visual system, Stent further extended the ►Hebb's rule by assuming that noncoincident pre- and postsynaptic activity leads to synapse weakening and elimination. Modeling studies showed that such correlation-based Hebb's rule could explain activity-dependent refinement of developing visual circuits. In the past decade, a temporally specific form of Hebb's rule has been proposed, based on findings of spike timing dependent synaptic plasticity in a variety of systems [9]. The temporal order in the spiking of pre- and postsynaptic neurons was shown to be critical for synaptic modification, in addition to the extent of coincidence in spiking: "Pre-before-post" results in strengthening and "post-before-pre" leads to weakening of the synapse. This spike-timing dependent plasticity offers an element of causality in the activity-induced synaptic competition: Inputs that contribute to (and cause) the postsynaptic spiking are advantageous in synaptic competition over those inputs arriving after postsynaptic spiking has just occurred. Importantly, experimental evidence for the validity of various forms of the Hebb's rule mainly came from studies of activity-induced functional changes of synaptic efficacy, e.g., long-term potentiation (LTP) or long-term depression (►LTD), rather than changes in the morphological connectivity.

### Importance of Temporal Pattern of Activity

The importance of the pattern of activity in synapse competition has been demonstrated mainly in the development of ocular dominance and orientation selectivity of the primary visual cortex. Rearing kittens with induced squint (strabismus), which alters the pattern but not the absolute level of activity, results in striking changes in the binocular property of cortical cells, reflecting altered synapse competition of geniculocortical inputs. Artificially imposing synchronous activity on optic nerves from the two eyes prevents segregation of thalamocortical projections into ocular dominance columns, whereas asynchronous activity allows segregation. Similarly, synchronous activation of optic nerves blocks the development of topographic maps in the optic tectum and reduces orientation selectivity in the cortex. Spike-timing-dependent synaptic modification provides a natural basis for such pattern dependent competition. In the developing *Xenopus* visual system, spike timing-dependent induction of ►LTP and LTD has been demonstrated, but whether such persistent changes in

functional efficacy of synapse is causally related to structural changes in connectivity remains unknown.

### **Contribution by GABAergic Inhibition**

Activity in the brain depends on a proper balance of excitation and inhibition. It is thus not surprising that GABAergic activity plays a regulatory role in the refinement of developing circuits. In mice lacking one form of the enzyme (GAD65) responsible for GABA synthesis, the ocular dominance plasticity resulting from monocular deprivation is absent, and increasing GABA inhibition in diazepam-treated mutant mice allows the appearance of ocular dominance plasticity. In the developing retinotectal system, a proper level of GABAergic inhibition is required for normal refinement of the retinotopic map in the tectum, both the increase and decrease of inhibition impede **map refinement**. Interestingly, the role of GABAergic inhibition appears not only to reduce the overall neuronal excitation, but also to sharpen the temporal pattern of the neuronal activity by shortening stimulus-evoked discharges, potentially facilitating spike timing-dependent refinement of neural circuits. Shunting of specific excitatory inputs may also be achieved by selective distribution of inhibitory synapses on the dendrite. Finally, inhibitory synapses may also undergo competition and refinement as well, because they are integral part of the neural circuit. At present, it is unknown how nascent inhibitory connections, while playing important regulatory roles in refining excitatory connections, can themselves undergo activity-driven refinement and be properly consolidated into the mature circuit.

### **Causal Link Between LTP/LTD and Synapse Competition**

At some synapses repetitive co-activation of the pre- and postsynaptic cell leads to not only homosynaptic LTP, but also heterosynaptic LTD of non-coactive converging synapses onto the postsynaptic cell, thus providing a potential competitive mechanism for synaptic elimination. The hypothesis that synapse stabilization and elimination are mechanistically linked to or even result from activity-induced LTP and LTD, respectively, remains to be fully tested. Many lines of correlative evidence support this hypothesis. Blocking NMDA receptor activation, which abolishes many forms of LTP/LTD, impedes refinement of developmental circuits. Repetitive visual stimuli that modify developing visual circuits can induce NMDA receptor-dependent LTP/LTD of retinotectal synapses. During the postnatal critical period, the composition of **NMDA receptors** undergoes experience-dependent developmental regulation in the visual system, and there is a correlation between the susceptibility for LTP/LTD induction and for circuit refinement. However, whether LTP/LTD is relevant or a prelude to structural refinement in the visual system remains unknown. Synapse elimination

(structurally) will certainly eliminate the synaptic function, but whether LTD will lead to synapse elimination is unclear. Recent studies in hippocampal slices has provided evidence that LTP/LTD induction is followed by a swelling/shrinkage of dendritic spines, supporting the linkage between synaptic efficacy and synaptic structure.

### **The Trophic Factor Hypothesis**

Purves and Lichtman have proposed that synaptic competition involves the competition between co-innervating presynaptic terminals for a limited amount of “trophic factors” derived from the postsynaptic cell. This hypothesis can be extended to factors in the postsynaptic cytoplasm or plasmalemma, together with a localized retrograde signaling to the presynaptic nerve terminal. Competition for the trophic factor can be regulated by activity. The activity can serve a permissive role for synapse competition by regulating the synthesis and release of trophic factors/retrograde signals, whereas other activity-independent mechanisms determine the competitive advantage of a synapse. For activity to serve an instructive role, the pattern of activity in the co-innervating nerve terminals may determine the outcome of competition by controlling the uptake or the efficacy of the trophic factor at the nerve terminal. The local release of trophic factors may also depend on local synaptic activation, which is in turn driven by the pattern of activity, including the timing of pre- and postsynaptic spiking. The **neurotrophin** family of proteins, which are known to regulate synaptic function and axon/dendrite morphology, are attractive candidates for the trophic factor in synapse competition [10]. The expression and secretion of neurotrophins, and their potentiating actions on the synapse, are all activity-dependent. Neurotrophins are required for the development of ocular dominance column and for the induction of activity-induced LTP in several systems. Furthermore, neurotrophin secretion is activity-pattern dependent, and the secreted neurotrophins are likely to act locally by its binding to cell surfaces at the synapse, allowing them to serve as local synaptic modulators. Activity-dependent depletion of available neurotrophins in the local environment of the synapse may lead to the functional and structural modification underlying synapse elimination.

### **Concluding Remarks**

Studies of synapse competition and elimination in the near future are likely to be facilitated greatly by the availability of many new technologies for selective neuronal labeling and optical imaging in the living animal. Transgenic animals with selective populations of fluorescence-tagged neurons, together with *in vivo* multiphoton imaging, will allow us to directly monitor changes in the morphology of axons and dendrites during the process of synapse competition and refinement over

prolonged period in the intact brain. Fluorescent  $\text{Ca}^{2+}$  or membrane-voltage sensors will allow us to monitor neuronal activities, and photo-activated probes expressed in selective neuronal populations will allow us to directly manipulate neuronal activity and to examine how activity drives synapse competition and elimination.

## References

1. Purves D, Lichtman JW (1980) Elimination of synapses in the developing nervous system. *Science* 210:153–157
2. Katz LC, Shatz CJ (1996) Synaptic activity and the construction of cortical circuits. *Science* 274:1133–1138
3. Hua JY, Smear MC, Baier H, Stephen J, Smith SJ (2005) Regulation of axon growth in vivo by activity-based competition. *Nature* 434:1022–1026
4. Feldman DE, Brecht M (2005) Map plasticity in somatosensory cortex. *Science* 310:810–815
5. Rubel EW, Fritsch B (2002) Auditory system development: primary auditory neurons and their targets. *Annu Rev Neurosci* 25:51–101
6. Lohof AM, Delhaye-Bouchaud N, Mariani J (1996) Synapse elimination in the central nervous system: functional significance and cellular mechanisms. *Rev Neurosci* 7:85–101
7. Sanes JR, Lichtman JW (1999) Development of the vertebrate neuromuscular junction. *Annu Rev Neurosci* 22:389–442
8. Buffelli M, Burgess RW, Feng G, Lobe CG, Lichtman JW, Sanes JR (2003) Genetic evidence that relative synaptic efficacy biases the outcome of synaptic competition. *Nature* 424:430–434
9. Bi G, Poo M-m (2001) Synaptic modification by correlated activity: Hebb's postulate revisited. *Annu Rev Neurosci* 24:139–166
10. Poo M-m (2001) Neurotrophins as synaptic modulators. *Nat Rev Neurosci* 2:24–32

## Synapse Formation: Neuromuscular Junction Versus Central Nervous System

PAMELA ARSTIKAITIS, ALAA EL-HUSSEINI  
Department of Psychiatry and the Brain Research Centre, University of British Columbia, Vancouver, BC, Canada

### Synonyms

Synaptogenesis; Establishing stable neuronal contacts; Neuron-to-neuron communication

### Definition

Synapses are the structural basis of communication between neurons in the ►central nervous system (CNS) and between neurons and muscle cells in the

►peripheral nervous system (PNS). Synapse development involves the formation of a contact between axon terminals and specific sites on the appropriate target. This is followed by contact stabilization and maturation which involves the recruitment of the appropriate protein machinery at pre- and postsynaptic sites.

## Characteristics

### Formation of the Vertebrate Neuromuscular Junction (NMJ)

Formation of a NMJ synapse involves the establishment of a connection between a presynaptic terminal of a ►motoneuron and a postsynaptic skeletal muscle cell. The NMJ is a large and accessible structure that develops in a stereotypical manner as each muscle fiber receives input from a single motoneuron axon. As a result, the molecular, cellular and physiological properties of this synapse have been well characterized. In the stereotypical NMJ, numerous presynaptic ►active zones are directly aligned with a postsynaptic specialization called a junctional fold.

The folds are introversions into the muscle plasma membrane, with cationic ligand-gated ►acetylcholine receptors localized to the top and voltage gated sodium channels deeper within these folds [1]. In response to an action potential, the multiple release sites of the presynaptic terminal have a high probability of vesicular release and the amount of ►acetylcholine released saturates the ►postsynaptic receptors. To control the efficacy of transmission, an enzyme called acetylcholinesterase (AChE) present at the synaptic cleft, acts to degrade the released transmitter, terminating the signal. Another important structural component of the NMJ is the thick basal lamina of the ►extracellular matrix (ECM) that runs through the cleft. During formation and maturation of the synapse, components of the ECM at the NMJ serve critical signaling and structural roles as a diffusion barrier for AChE.

NMJ formation is directed by reciprocal interactions between motor neurons and muscle fibers. ►Laminins, a component of the NMJ basal lamina, have come forward as a muscle derived signal involved in the development of the presynaptic terminal [1]. Specifically, ►laminin  $\beta 2$  has been shown to act as a stop signal for incoming axons *in vitro*. Mice lacking laminin  $\beta 2$  form few active zones and fail to align vesicles apposed to receptors on the muscle fiber [1]. These results highlight the importance of muscle-derived signals in proper NMJ development.

At the postsynaptic side, high concentrations of acetylcholine receptors (AChRs) are clustered at central regions of the myofibers following muscle production. This occurs before the arrival of the motoneuron axonal ►growth cone, and is termed pre-patterning [2].

Recent *in vivo* studies demonstrate that AChRs are preferentially formed at the endplate band where

innervation occurs, suggesting that the site where the motoneuron contacts the muscle may not be the only factor determining synapse location. As the motoneuron axon approaches the muscle fiber, secreted factors such

as **▶ agrin** and **▶ neuregulin**, are released from the axon that results in further clustering of AChR and maturation of postsynaptic specializations [1] (Fig. 1). Agrin is secreted by motor neurons and by muscle, which binds

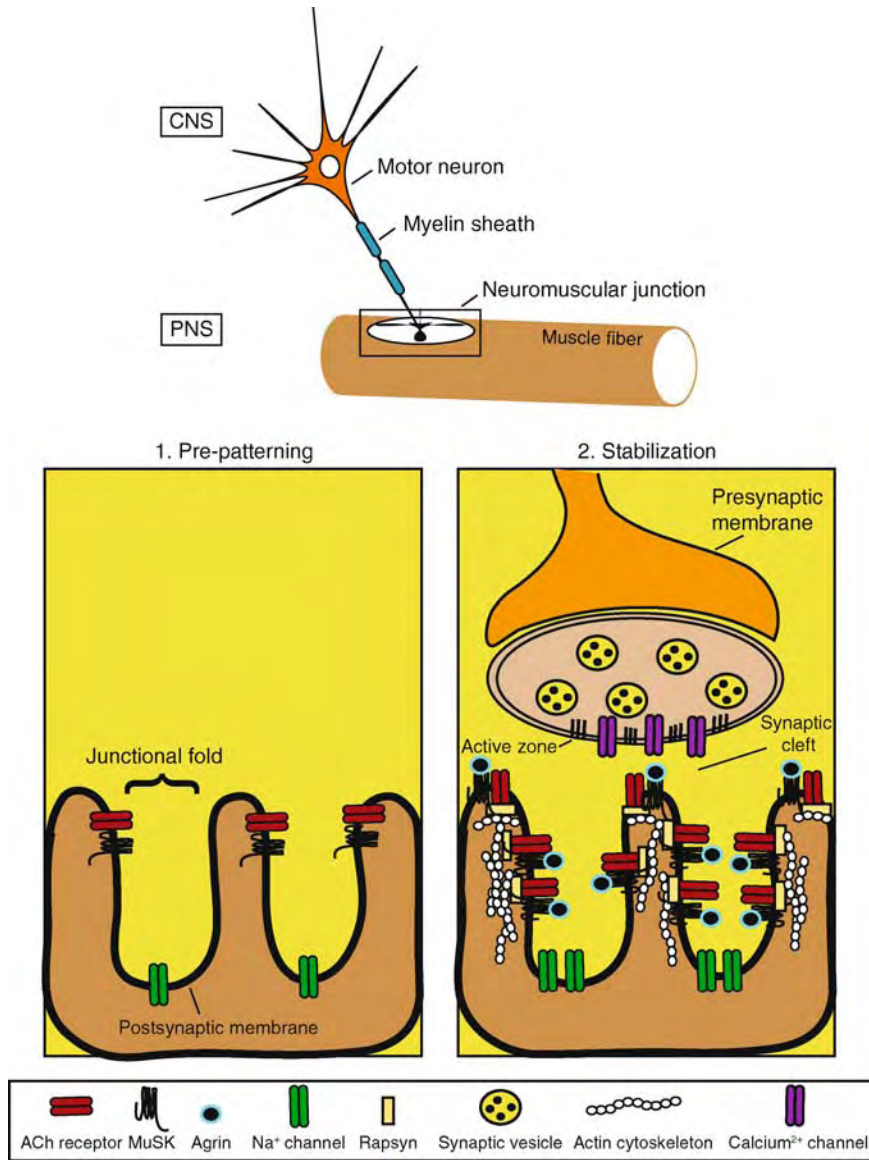

**Synapse Formation: Neuromuscular Junction Versus Central Nervous System. Figure 1** Sequence of events that underlie synapse formation at the neuromuscular junction. Motor neurons from the motor cortex located in the CNS send axons ensheathed in myelin to target muscle cells. A contact between a motoneuron axon and muscle fiber constitutes the neuromuscular junction (NMJ; left panel). At NMJ, acetylcholine receptors (AChRs) are positioned at the postsynaptic membrane opposite to the presynaptic nerve terminal **▶ active zone** containing the neurotransmitter acetylcholine (Ach). An early step of NMJ synapse formation is pre-patterning of AChRs in the endplate region. This is thought to be a muscle-specific program as initial clustering of AChRs occurs in the absence of input from the motor neuron. It is thought that MuSK activation occurs independently of agrin to induce AChR clustering during pre-patterning. Synapse stabilization and maturation involves enhanced clustering of AChRs and this process is thought to require agrin and MuSK. Furthermore, rapsyn, a scaffolding molecule bound to the actin cytoskeleton, also modulates anchoring of AChRs. Based on findings reviewed in [1].

to ►muscle-specific receptor tyrosine kinase (MuSK). Activation of ►MuSK causes enhanced AChR clustering and the production of more AChRs [3] (Fig. 1).

In mice lacking agrin, AChRs are reduced in number with a wider distribution and show incomplete motoneuron terminal differentiation, suggesting that postsynaptic differentiation is necessary for additional presynaptic development [1]. AChR-inducing activity (ARIA) or ►neuregulin-1 increases AChR expression through activation of its receptor, membrane associated tyrosine kinases related to EGF receptors (►erbB receptors) [1]. Unlike agrin, neuregulin/erbB signaling is dispensable to NMJ function, and thus may play a modulatory role in NMJ development [1]. Another protein important for pre-patterning of AChR clustering is the scaffolding molecule ►rapsyn, which directly binds to and stabilizes AChRs on the surface of the developing muscle. Interestingly, since rapsyn-deficient mice lack receptor clusters [2] (Fig. 1). Studies on mice deficient in the enzyme required for neurotransmitter synthesis, ChAT [1] revealed that motoneuron activity is important for the refinement and maintenance of NMJs [1]. In summary, recent studies revealed several signals from both the pre- and postsynaptic sites are needed to establish stable contacts between ►motoneurons and muscle cells and to induce receptor clustering and maturation of the NMJ.

### Formation of Central Nervous System (CNS) Synapses Synapse Heterogeneity

Mechanisms involved in central nervous system (►CNS) synapse development are far less understood due to multifarious neuronal types and the neurotransmitter they release. In addition, there are differences in their temporal development [2]. Neurotransmitter released from pre►synaptic vesicles bind to postsynaptic receptors eliciting a specific effect that depends on the (i) type and number of postsynaptic receptors, (ii) developmental stage of the neuron, (iii) type of neurotransmitter released, and (iv) neuronal activity [2]. Despite the complexity of CNS synapses, the basic principles of NMJ formation still hold true, such as the cooperation of axonal and target-derived signals and modulation by activity. Several classes of molecules including ►cell adhesion molecules, secreted factors, and scaffolding proteins have emerged as important proponents for the formation and maintenance of CNS synapses (Fig. 2).

### Overview of Synaptogenesis: Carefully Choreographed Steps

The formation of a CNS synapse involves several key steps, which include: neuronal contact establishment, recruitment of pre- and postsynaptic proteins, contact stabilization and maturation [2] (Fig. 2). Each of the steps of ►synaptogenesis outlined above requires

cross-talk between two neurons. Developmental regulation of protein expression, as well as mechanisms that govern localization of neurotransmitter receptors and associated proteins to particular contact sites, are key processes that control synaptic contact maturation and function.

Correct connectivity is essential for a functional neuronal network thus, target regulation must be specific [2]. To achieve this, axons often travel long paths before reaching the appropriate target cell (Fig. 2). This has been described in terms of axonal ►growth cones that extend ►filopodia searching for the proper target. Dendrites also extend growth cones and are decorated with filopodia which are thought to be important for contact initiation [2] (Fig. 2). Axon guidance is aided by cues in their environment that act as attractive and repulsive cues. Secreted factors, for example, Wnt and fibroblast growth factor (FGF) function as retrograde signals to regulate axon arborization and synaptic differentiation. Specifically, Wnt is released from postsynaptic neurons, resulting in a decrease in axon extension and an increase in growth cone size. This effectively “slows” down the axon once it reaches the appropriate target and enhances the possibility of contact initiation.

A successful contact formation requires cross-talk between the axon and target cell to recruit the appropriate neurotransmitter release machinery and their receptors at contact sites [3]. Cell adhesion complexes are also attractive candidates for the regulation of synaptogenesis as they can function to bi-directionally regulate molecular and morphological changes in ►synapse formation [3]. Due to the large number and diversity of neuronal contacts formed during synaptogenesis, multiple adhesion systems must exist to offer sufficient possible combinations to ensure formation and stabilization of proper contacts between neurons. A prime example includes ►cadherins, homomeric adhesion molecules, thought to regulate target recognition in the CNS. The cadherin superfamily is comprised of more than 100 members, including classical cadherins, cadherin-related proteins and ►protocadherins, many of which are expressed in the brain [3]. Thus, matching cadherins in axons and dendrites is believed to promote selective adhesion between appropriate partners in a “lock and key” fashion. Because of their adhesive properties, adhesion molecules are thought to serve four major functions: (i) Synaptic contact initiation, (ii) contact stabilization and recruitment of other molecules that regulate synapse maturation, specificity and function, (iii) maintenance of mature synapses, and (iv) trans-synaptic signaling which allows communication between the pre- and postsynaptic compartments to synchronize neurotransmitter release and postsynaptic neurotransmitter activity and signaling [3]. Importantly, recent studies revealed that many



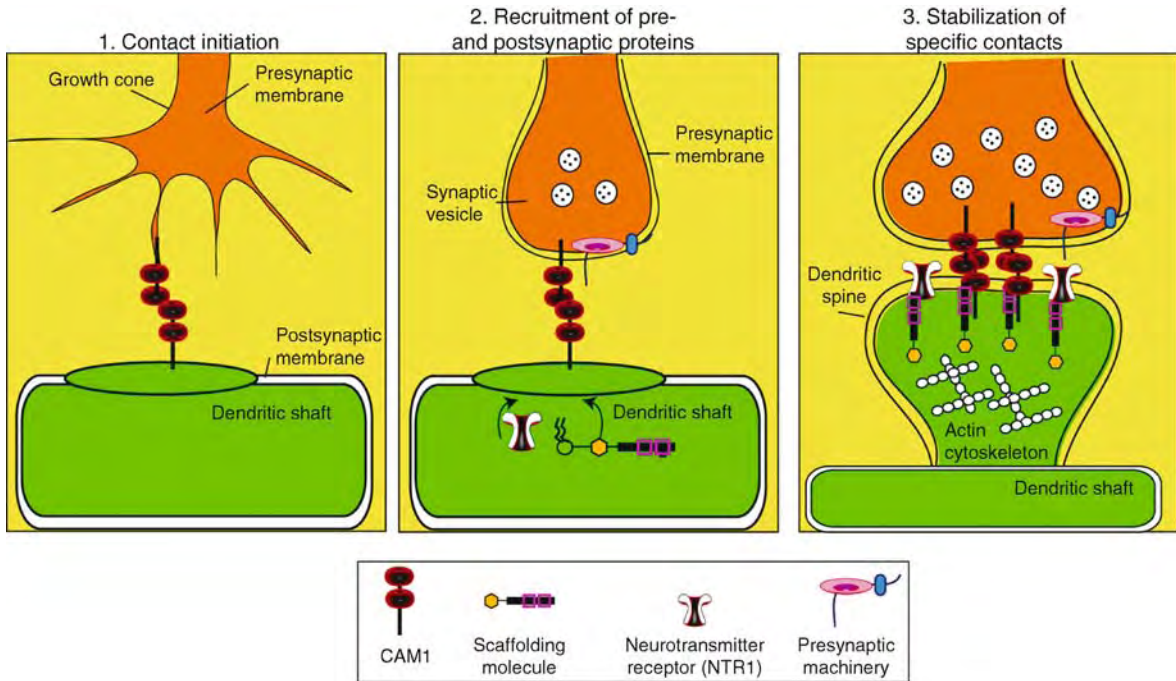

**Synapse Formation: Neuromuscular Junction Versus Central Nervous System. Figure 2** Proposed role of cell adhesion and scaffolding molecules in the formation and stabilization of glutamatergic CNS synapses. (left panel) Specific cell adhesion molecules (CAMs) are thought to control contact specificity. At this early stage, axonal growth cones are thought to contact the dendritic shaft of postsynaptic cells to establish a contact. Dendritic filopodia are also thought to participate in initial contact initiation and formation of bulbous protrusions known as dendritic spines. Initial contact can also occur by axons contacting dendrites in passing. Another key step in synapse formation is contact maturation at which recruitment of pre- and postsynaptic proteins takes place. (middle panel) During synapse maturation, presynaptic neurotransmitter synthesis and release machinery are recruited to the presynaptic terminal (referred to as presynaptic machinery in legend). At the postsynaptic side, cell adhesion molecules, scaffolding proteins and neurotransmitter receptors are recruited. (right panel) Some of the key neurotransmitter receptors and associated adhesion and scaffolding proteins recruited to mature glutamatergic excitatory synapses are indicated. The recruitment of these proteins is thought to regulate both contact stabilization and neurotransmitter receptor clustering, as well as changes in synapse morphology such as spine formation. The dynamic addition and removal of these molecules at mature synapses controls synaptic strength and plasticity.

aspects of memory formation and animal behavior can be affected when adhesion molecules are disrupted or eliminated. Thus, delineating the role of the various adhesion systems in synapse formation will help not only understanding the intricate mechanisms involved in neuronal contact formation and maturation, but also in establishing the specific neuronal circuits that regulate neuronal communication and ultimately brain function. However, numerous adhesive complexes have been discovered and this makes them both interesting and difficult to study.

A family of cell adhesion molecules that are emerging as critical modulators of synapse induction and maturation are postsynaptic ►neuroligins and their presynaptic binding partners, ►neurexins [3,4] (Figs. 2 and 3).

One thousand isoforms of neurexins potentially can be generated by alternative splicing and this suggested a role for these molecules in controlling synapse type and

specificity. The intracellular domains of both neuroigin and neurexin are short and terminate in PDZ (PSD-95, discs large and zona occludens1)-domain binding sites, which aid in connecting them to other synaptic proteins [3,4]. For instance, association of ►neuroigin-1 with scaffolding molecules such as PSD-95 can modulate synapse size and number (Fig. 2). Surprisingly, recent studies illustrate that neuroligins and neurexins can regulate formation of glutamatergic (excitatory) synapses and GABAergic (inhibitory) contacts, where neuroigin-1 is localized primarily to ►excitatory synapses and ►neuroigin-2 is localized to ►inhibitory synapses [3,4] (Fig. 3). Manipulation of the levels of these proteins can influence the excitatory/inhibitory synaptic ratio, leading to the proposal that neuroligins may play a role in maintaining the balance of synaptic input. Other adhesion molecules including SynCAMs, ephrins, and SALMs also play a role in synapse induction and maturation (Fig. 2). This highlights the

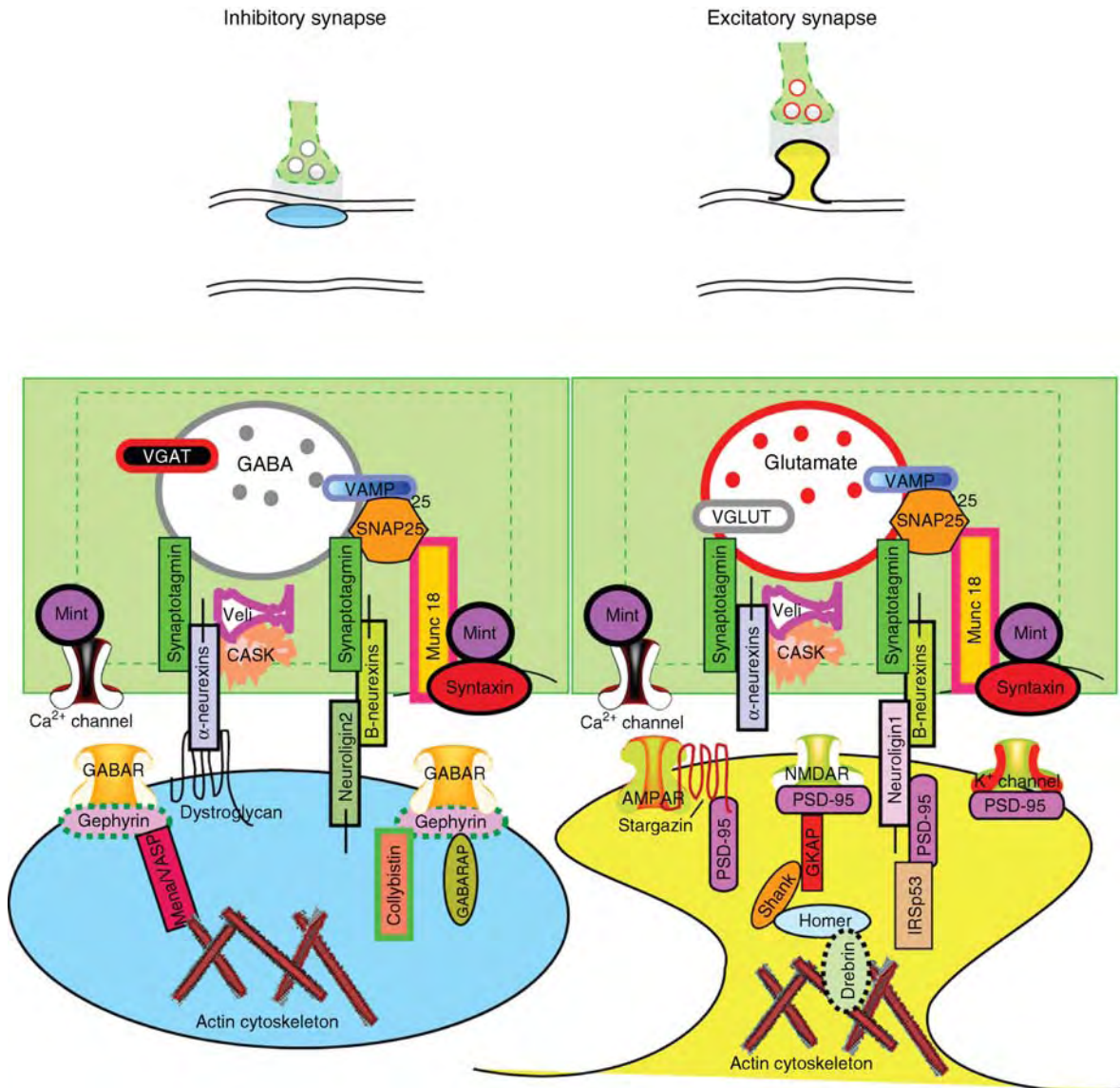

**Synapse Formation: Neuromuscular Junction Versus Central Nervous System. Figure 3** Differential recruitment of adhesion and scaffolding molecules to excitatory and inhibitory synapses. Excitatory and inhibitory synapses are distinguished based on their morphology and molecular composition. (left panel) The majority of inhibitory transmission in the mammalian CNS is mediated by GABA and these inhibitory synapses are mainly formed on dendritic shafts. (right panel) In contrast, glutamatergic synapses are the major excitatory synapses in the CNS, which are mainly formed on dendritic protrusions known as spines. Inhibitory and excitatory synapses share the majority of proteins involved in presynaptic release however, their terminals contain specific enzymes that synthesize and transport neurotransmitters into presynaptic vesicles. At the postsynaptic membrane, distinct neurotransmitter receptors, adhesion and scaffolding proteins are localized. Excitatory synapses also contain an electron dense organelle called the postsynaptic density (PSD). The differential sorting of adhesion and scaffolding molecules to particular neuronal contacts is thought to modulate synaptic signaling. For instance, the adhesion molecule neuroligin1 is enriched at excitatory sites where it regulates recruitment of PSD-95, a major scaffolding molecule localized to excitatory synapses. In contrast neuroligin2, is enriched at inhibitory synapses and induces recruitment of gephyrin. This differential recruitment of proteins at particular synaptic sites is thought to gauge retrograde signaling at the synapse as well as clustering of neurotransmitter receptors and associated proteins. Coupling of adhesion and scaffolding molecules also provides an anchor to the cytoskeleton and controls synapse morphology. Based on findings reviewed in [4].

redundancy of signals present in the CNS for contact initiation and synapse maturation.

### **Morphological and Structural Changes Associated with Synapse Maturation**

During the recruitment of pre- and postsynaptic proteins to initial sites of contact, the content and morphology of pre- and postsynaptic membranes develop in a coordinated manner. Maturation of glutamatergic synaptic contacts, the most characterized synapses in the brain, involves the formation of spines, ►actin rich dendritic protrusions with a bulbous head [4]. Spines are thought to emerge from dendritic filopodia, long and thin protrusions which have been proposed to initiate contacts by actively seeking nearby axons [5]. Mature spines contain an electron dense organelle called the ►postsynaptic density (PSD) which contains receptors and associated scaffolding and signaling molecules which are thought to regulate ►glutamate receptor clustering and function at the synapse [5]. Several adhesion and scaffolding molecules that regulate spine morphology have been identified (Fig. 2). Adhesion complexes affecting spine morphology include: neuroligins, cadherins, integrin ligands (laminin and reelin), Eph receptors and syndecans as well as members of the immunoglobulin superfamily [6]. Scaffolding proteins affecting spine morphology include PSD-95, shank/homer complex and IRSp53. Overexpression studies in cultured neurons of PSD-95, neuroligin and IRSp53, two proteins that bind to PSD-95, increases the density of ►dendritic spines [6]. Another key molecule involved in spine morphogenesis is drebrin A as it promotes actin assembly and the synaptic clustering of PSD-95 in the ►PSD [7]. Interestingly, overexpression of drebrin A, shank/homer complex or syndecan can accelerate the maturation of filopodia-like protrusions into mature spines [6]. Furthermore, blocking N-cadherin function results in loss of spines and appearance of filopodia-like protrusions. Finally, integrin ligands have been shown to affect dendritic spines: laminin increases spine density whereas reelin promotes spine stability [2].

Clustering of neurotransmitter receptors and associated proteins at newly formed contact sites is critical for synapse maturation. Most of our knowledge of the importance of molecules in the control of receptor clustering and function has emerged from the discovery of scaffolding proteins associated with ►glutamate receptors. These studies revealed that scaffold proteins function to bind and recruit other proteins that regulate actin cytoskeleton remodeling and signal transduction. This links neurotransmitter receptor activation to intracellular cytoskeletal and signaling modification. An important family of molecules that participates in this process is the scaffolding proteins that regulate

clustering and assembly of neurotransmitter receptors as well as proteins that regulate actin cytoskeleton remodeling and signal transduction [6]. The membrane-associated guanylate kinase (MAGUK) family of scaffolding proteins is of central importance in regulation of protein clustering at the synapse. Many MAGUKS contain PDZ domains which function in protein-protein interactions. The prototypical MAGUK is PSD-95 which binds directly to N-methyl-D-aspartate-type (►NMDA) glutamate receptor subunits and voltage-gated potassium channels and indirectly to  $\alpha$ -amino-3-hydroxy-5-methyl-4-isoxazole propionate (►AMPA) type glutamate receptors [8] (Figs. 2 and 3). Overexpression of PSD-95 enhances maturation of presynaptic terminals and increases spine size. Consistent with this, knockdown of PSD-95 results in reduced clustering of AMPA receptors (AMPA receptors), GKAP and Shank and an overall decrease in the number of excitatory contacts [9]. Despite the striking effects of PSD-95 on synapse maturation of cultured neurons, the majority of excitatory synapses in PSD-95 knockout animals display normal synapse number and size [9]. This result could be explained by a redundancy in the function of the numerous PDZ proteins located at the synapse. AMPARs are directly linked to two other scaffolding proteins glutamate-receptor-interacting protein/AMPA-binding protein (►GRIP/ABP) and protein interacting with C kinase 1 (PICK1) and these interactions may regulate synaptic targeting and trafficking of AMPARs [8] (Fig. 2). GRIP is localized to both axons and dendrites in neurons and functions to stabilize AMPARs and other interacting proteins at synaptic sites. PICK1 is present at synaptic and non-synaptic sites in neurons and may function to direct AMPARs to endocytic or exocytic buds through BAR domain binding, which is a sensor for lipid membrane curvature (Fig. 2). Phosphorylation of the C terminus of GluR2 alters its binding specificity for GRIP and PICK1, and contributes to synaptic plasticity by altering AMPAR trafficking [8].

In contrast, the majority of inhibitory transmission in the mammalian CNS is mediated by ►GABA, a neurotransmitter responsible for modulation of neuronal excitability and function [2]. GABAergic synapses are not associated with a clear PSD and are usually found on the dendritic shaft [4,5]. Thus, excitatory and inhibitory synapses can be distinguished based on morphology and molecular composition of the postsynaptic component [2] (Fig. 3).

The last step in synapse development involves fine-tuning of neuronal circuits such that the formed synapses may be stabilized or lost [2]. Recent studies suggest that neuronal activity plays a role in fine-tuning the number of contacts formed, ultimately leading to

stabilization of a particular subset of contacts which persists in the adult nervous system [3]. In the adult brain, changes in synaptic content, shape and their adhesive properties are thought to be the key mechanisms that control synaptic strength and plasticity, processes implicated in the regulation of information storage and transfer between neuronal cells. Thus, the continual formation and remodeling of synaptic contacts in early development and adulthood, respectively, play a key role in refining neuronal circuitry and communication between neuronal cells.

### Abnormalities in Synapse Development Associated with Neurodevelopmental Disorders

Recent studies indicate that improper synapse formation may be a leading cause of neurodevelopmental disorders such as ►autism, mental retardation, and schizophrenia [10]. Autism is the most genetically determined disorder manifested at early stages of postnatal development [10]. Thus, the behavioral and cognitive deficits exhibited in autistic patients are thought to result from improper development of neuronal circuitry implicated in sensory, mnemonic, social and emotional information processing [10]. Interestingly, neuroimaging studies of aberrant circuitry in autistic patients has lead to a model whereby altered excitation (E)/inhibition (I) ratio involved in information processing may underlie the dysfunctions in patients with autism [3]. During brain development, alteration in the E/I ratio can lead to abnormal synaptic connectivity and function, resulting in severe neurological impairments. As mentioned earlier, neuroligins are important proteins for controlling the function of excitatory and inhibitory synapses, making them good candidate genes affected in autism. Indeed, rearrangement of chromosomal regions of neuroligins and PSD-95 genes and mutations in neuroligins and neurexins have been associated with autism [10]. In addition, mutations in the adhesion molecule NrCam and the scaffolding protein Shank3 have been linked to autism, however, the underlying biological mechanism(s) associated with altered expression of these proteins remains unclear [6]. Many forms of mental retardation and memory impairment also have been also linked to defects in spine maturation [5]. Thus, emerging evidence indicates that defects in synapse formation/maturation may be a common defect associated with several neurodevelopmental disorders.

### Acknowledgments

The author, Pamela Arstikaitis, would like to dedicate this article to the memory of the supervisor, Dr. Alaa El-Husseini who recently passed away. Alaa was a brilliant scientist whose love and passion for science was contagious as he touched numerous people with his energy and aspirations.

## References

1. Burgess RW (2006) The formation of the vertebrate neuromuscular junction: roles for the extracellular matrix in synaptogenesis. In: Dityatev A, El-Husseini A (eds) *Molecular mechanisms of synaptogenesis*. Springer Science/Business Media LLC, New York, pp 1–9
2. Gerrow K, El-Husseini A (2006) Cell adhesion molecules at the synapse. *Front Biosci* 11:2400–2419. doi:1978 [pii]
3. Dalva MB, McClelland AC, Kayser MS (2007) Cell adhesion molecules: signalling functions at the synapse. *Nat Rev Neurosci* 8(3):206–220. doi:nrm2075 [pii] 10.1038/nrm2075
4. Craig AM, Kang Y (2007) Neurexin-Neuroigin signaling in synapse development. *Curr Opin Neurobiol* 17:43–52
5. Sheng M, Hoogenraad CC (2007) The postsynaptic architecture of excitatory synapses: a more quantitative view. *Annu Rev Biochem* 76:823–847
6. Romorini S, Piccoli G, Sala C (2006) Regulation of dendritic spine morphology and synaptic function by scaffolding proteins. In: Dityatev A, El-Husseini A (eds) *Molecular mechanisms of synaptogenesis*. Springer Science/Business Media LLC, New York, pp 1–9
7. Sekino Y, Kojima N, Shirao T (2007). Role of actin cytoskeleton in dendritic spine morphogenesis. *Neurochem Int* 51:92–104
8. Brecht DS, Nicoll RA (2003) AMPA receptor trafficking at excitatory synapses. *Neuron* 40:361–379
9. Lise MF, El-Husseini A (2006) The neuroligin and neurexin families: from structure to function at the synapse. *Cell Mol Life Sci* 63:1833–1849
10. Talebizadeh Z, Bittel DC, Veatch OJ, Butler MG, Takahashi TN, Miles JH (2004) Do known mutations in neuroligin genes (NLGN3 and NLGN4) cause autism? *J Autism Dev Disord* 34:735–736

## Synapse Loss

### ► Synaptic Elimination

## Synapse Maturation

### Definition

During the process of synaptogenesis, multiple molecular components are required for a fully functional synapse. The final assembly and activation of these components is referred to as synapse maturation.

### ► Synaptogenesis

## Synapse Refinement

### Definition

Similar to synapse elimination, refinement refers to the fine tuning of neuronal connections, often occurring after and in response to activity patterns.

- ▶ Activity-Dependent Synaptic Plasticity

## Synapsida

### Definition

A clade of amniotes incorporating mammals and those amniotes more closely related to mammals than to true reptiles. In the past, non-mammalian synapsids were often referred to as “mammal-like reptiles,” but this term is inaccurate. These animals were not reptiles.

- ▶ The Phylogeny and Evolution of Amniotes

## Synapsin

### Definition

Synapsins are protein molecules that bind vesicles to the presynaptic membrane.

- ▶ Membrane Components
- ▶ Synaptic Transmission

## Synaptic Adhesion Molecule

MASAHITO YAMAGATA

Department of Molecular and Cellular Biology,  
Harvard University, Cambridge, MA, USA

### Definition

Synaptic adhesion molecules are a diverse family of cell adhesion molecules involved in the development and maintenance of synapses [1–4].

Synaptic adhesion molecules are localized transiently or permanently at mature synapses and/or developing precursors, and in most cases, they are highly enriched in the synaptic membranes. They may directly participate in adhesion by connecting pre- and postsynaptic membranes together, or adhesion may not be their primary function, but the specific ligand-receptor recognitions transmit signals to the cytoplasm. They may be involved in one or multiple steps in synapse development and maintenance: specific target recognition, synaptic differentiation, and stabilization and modulation of synaptic structure (see Function). As brain function relies on specificity of synaptic connectivity among different classes of neurons as well as regulation of synaptic connections, these molecules must play pivotal roles in the development and maintenance of lower and higher brain functions. Impairment of synaptic adhesion molecules is likely to affect brain functions (see Pathology).

### Characteristics

#### Higher Level Structures

The term “synapse (synaptein),” first coined in 1897 by Charles Sherrington, comes from the Greek: “syn” meaning “together,” and “haptain” meaning “to fasten or bind.” As this etymology indicates, two neuronal membranes at synapses close together with a narrow space (~20 nm) between them: synapses are specialized forms of cell-cell junctions. A principal difference between synapses and other junctions is that synapses are asymmetric between presynaptic and postsynaptic structures. The presynaptic specialization, usually on the axon, has an apparatus for neurotransmitter storage and release (the synaptic vesicle and active zone). The postsynaptic specialization, usually on dendrites, has neurotransmitter receptors, and associated scaffolding and signaling proteins (the postsynaptic density).

There are two types of adhesive structures at synapses: puncta adherentia and synaptic junctions [5]. Synaptic junctions are the sites of neurotransmission, whereas puncta adherentia are formed at the surrounding area outside of the active zone. The puncta adherentia are a neuronal form of ▶adherence junctions that are maintained by cadherins. The occurrence of these adhesive structures and synaptic adhesion molecules varies depending on which synapse or stage of development is observed.

#### Lower Level Components

Many of the synaptic adhesion molecules are members of the cadherin and immunoglobulin superfamilies [2,3] (Fig. 1).

Another major family of adhesion molecules, the integrins, is also present at synapses, together with members of families that are adhesive but are not generally considered as adhesion molecules- e.g. the Eph receptor

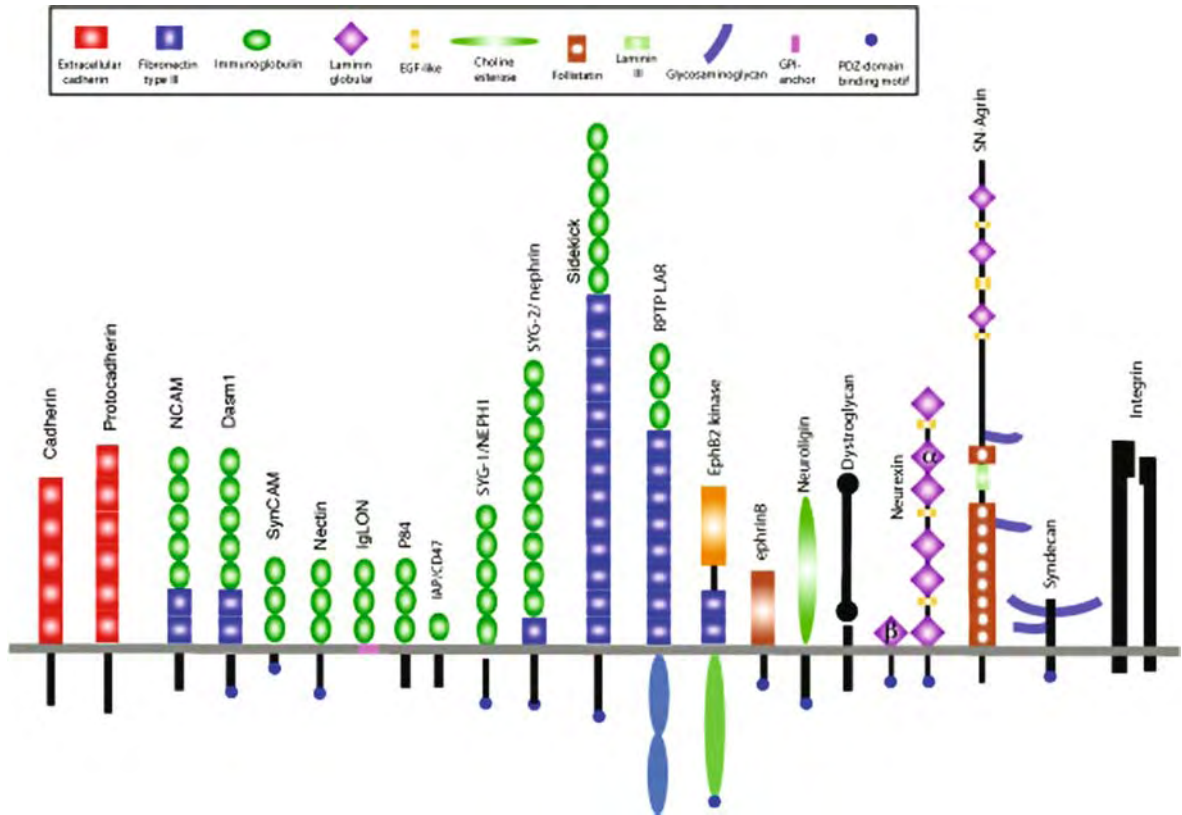

**Synaptic Adhesion Molecule. Figure 1** Synaptic adhesion molecules.

kinases and their ephrin ligands, and neurexins and their partners, the neuroligins.

Classic cadherins are  $\text{Ca}^{2+}$ -dependent, single-pass transmembrane molecules with five extracellular cadherin (EC) repeats, which mediate primarily homophilic (more rarely heterophilic) adhesion. N-cadherin was one of the first adhesion molecules shown to be localized at the synaptic cleft. Cadherins directly couple to cytoskeletons via intracellular proteins called catenins, and generate puncta adherentia at synapses.

The protocadherins bear varying numbers of EC repeats in their ectodomains. The vertebrate protocadherin genes have a genomic organization that is similar to that of the immunoglobulin gene, and which consists of “variable” and “constant” exons orientated in a tandem array on a single chromosome. This striking genomic organization led to (as yet unproven) postulation that protocadherin diversity underlies synaptic specificity. Indeed, some members are concentrated at synapses, albeit not confined to them.

The immunoglobulin (Ig) superfamily represents a highly diversified group of cell surface molecules responsible for a wide range of molecular and cellular recognition functions. They contain varying numbers of extracellular cysteine-looped domains that are characteristic of antibody molecules. Many have one

or more fibronectin type III (FNIII) repeats between the Ig domains and the membrane. This superfamily can be further classified according to occurrence of other domains. Synaptic adhesion molecules belonging to this superfamily are N-CAM, Dasm1, nectins, SynCAMs, IgLONs, Syg-1, Syg-2, sidekicks, and LAR. A striking feature of most, if not all, synaptic adhesion molecules of this family is that they possess a C-terminus motif for binding PDZ scaffolding proteins that likely contribute to their synaptic localization.

Integrins are heterodimers of  $\alpha$  and  $\beta$  subunits, and mediate adhesion of cells to the extracellular matrix and to other cells. Integrins are present at the vertebrate neuromuscular junction, where they presumably interact with the basal lamina. Several integrins have also been observed at vertebrate central nervous system synapses.

Eph receptor tyrosine kinases and their ephrin ligands can be grouped into two families: ephrinA ligands are attached to the membrane by a glycosylphosphatidylinositol-anchor and bind to EphA receptors, while ephrinB ligands are transmembrane proteins that bind to EphB receptors. EphB receptors have been localized to the synapse.

Neuroligins constitute of a family of neuronal cell-surface proteins with a cholinesterase domain that lacks enzymatic activity. Neuroligins bind to  $\beta$ -neurexins,

another class of neuronal cell-surface proteins that contain laminin globular domains. There are three neuroligins, which undergo extensive alternative splicing to potentially express a bewildering number of isoforms. Both neuroligins and neuroligins have a motif for binding to PDZ scaffolding proteins, and are enriched at the synapse.

In addition to these adhesion molecules, several transmembrane molecules have been reported to be localized at synapses. These include syndecans, dystroglycan, and membrane-tethered agrin. Leucine-rich repeats-containing transmembrane molecules including the *capricious* protein were accumulated at some *Drosophila* neuromuscular junctions.

## Function

### Specific Target Recognition

Specific connectivity among a myriad of neurons is the hallmark of the nervous system. Following differentiation and migration, a developing neuron reaches its final destination in the nervous system. To establish neuronal connections with its target, a neuron must extend axonal and dendritic processes towards the proximity of targets located significant distances away, and finally select the choice of proper partner neurons with which to form specific synapses in a jungle of neuronal processes. Presynaptic inputs from defined neurons are not only connected to specific types of postsynaptic neurons, but are often synapsed to restricted subcellular compartments such as spines vs. shafts or dendrites vs. soma. To explain the mechanism that underlies synaptic specificity in neural circuit formation, Roger Sperry formulated the “chemoaffinity theory,” in which adhesion molecules determine wiring specificity of the “lock and key” sort. Many examples of receptor-ligand partners are known that guide growth of axons towards their approximate target areas. However, there must also be molecular and cellular mechanisms that mediate the interaction between direct synaptic partners and initiate synapse formation.

Recent studies on an array of Ig superfamily molecules have shown that this group of adhesion molecules is important for the synaptic specificity. For example, SYG-1 and SYG-2 were isolated in a genetic screen for *C. elegans* mutants with altered synaptic positions. SYG-1 and SYG-2 belong to a subgroup of the Ig protein family that is conserved from *C. elegans* to human [6]. Sidekicks have been implicated in selective synapse formation in the chick retina. A shared feature of SYG-1, SYG-2, and sidekicks is a motif for binding to PDZ-scaffolding proteins, suggesting a model in which adhesion-triggered recruiting of key PDZ proteins is a first step in precise synaptic wiring. Neurofascin is an L1-related Ig superfamily molecule, and its ankyrin-dependent subcellular localization determines subcellular localization of GABAergic synapses in the cerebellum.

### Synaptic Differentiation

Synapse formation involves stabilization of initial sites of weak adhesion between axons and targets, followed by recruitment of specific protein complexes to newly formed presynaptic and postsynaptic structures [4,7,8]. Axons can usually release small amounts of neurotransmitter even before they contact a postsynaptic partner, and many postsynaptic cells express neurotransmitter receptors before they are innervated. Once pre- and postsynaptic processes establish contact, the machineries for release of and response to neurotransmitter are concentrated at sites of contact, and placed in precise apposition to each other. Important features of presynaptic differentiation include aggregation of appropriate synaptic vesicles and association with active zones; critical features of postsynaptic differentiation include clustering of specific postsynaptic receptors and association with signaling and scaffolding proteins. There is also a high degree of variation in synaptic neurochemistry and morphology- e.g. excitatory, inhibitory, asymmetric, symmetric, ribbon, en passant, and terminal. The fact that these specializations develop specifically at contact sites, and that they develop in exact apposition, demonstrate that adhesion-mediated local signaling must provide the coordination between the target neuron and the innervating axon.

The synaptic adhesion molecule neuroligin-1 was the first target-derived signal shown to induce presynaptic differentiation of excitatory synapses in hippocampal axons [2]. This differentiation is mediated by neuroligin interaction with  $\beta$ -neuroligin. More recently, it has been revealed that this interaction mediates both glutamatergic and GABAergic synapse formation in hippocampal neurons, and differences in neuroligin isoform and binding specificity may control the formation and functional balance of excitatory and inhibitory synapses. SynCAM1 is the other membrane protein shown to provide a target-derived signal during synaptic differentiation [8]. SynCAM1 belongs to a family of proteins characterized by three extracellular immunoglobulin-like domains and a cytosolic tail with a PDZ-binding motif. SynCAM and neuroligin-1-induced artificial synapses were essentially identical, but it appears that neuroligin-1 contributes to more morphological aspect of synapse induction.

A panoply of synaptic adhesion molecules were also shown to control localization and function of postsynaptic neurotransmitter receptors. The EphB receptor tyrosine kinases and their ligands, the ephrinsB regulate function of a NMDA type glutamate receptor. The receptor-type protein tyrosine phosphatase LAR is an Ig superfamily that is important for the surface expression and clustering of AMPA-type glutamate receptors at synaptic sites. In the developing brain, excitatory synapses initially contain only NMDA receptor and therefore are “silent” at the resting membrane potential.

However, later, synapses acquire AMPA receptors. Dendrite arborization and synapse maturation 1 (Dasm1), the Ig superfamily member, appears to control this excitatory synapse maturation [9].

### Stabilization and Regulation of Synaptic Structure

At all the intracellular junctions, adhesion molecules connect two membranes, and stabilize the architecture of the junction. Likewise, synaptic adhesion molecules protect synapses by adhering pre- and postsynaptic membranes. Stability of interneuronal synaptic membranes from mechanical force is obvious from the ability to isolate intact synaptosomes. The fact that synaptic adhesion molecules stabilize synaptic structure indicates that strengthening and weakening of adhesion could regulate synaptic structure. Such a function would be of importance to synaptic plasticity, which is believed to involve changes in synaptic density and size, to synapse maturation, which requires the organized enlargement of presynaptic boutons and postsynaptic structures, and to synapse elimination, which is de-adhesion of two synaptic membranes. These synaptic remodeling events are likely to contribute to one of the mechanisms that underlie learning and memory.

The majority of excitatory synapses in the brain are made onto dendritic spines, knobby protrusions of the dendritic shaft. Dendritic spines are highly dynamic, and undergo a variety of actin cytoskeleton-based morphological changes both during synapse formation, and in response to activity changes. It is believed that changes in dendritic spine number and morphology reflect synaptic plasticity, particularly changes in synaptic connections between neurons. Several studies have shown that a cadherin-catenin adhesion system controls spine structure in cultured hippocampal neurons [10]. N-cadherin localization and adhesive strength change in response to neural activity. These observations suggest that synaptic activity dynamically regulates both the strength and the localization of cadherin-based adhesions, changes that may be important for regulating synaptic plasticity.

### Pathology

As synaptic adhesion molecules regulate synaptic development and maintenance, their dysfunction may cause synaptic deficits that ultimately underlie disorders ranging from neurodevelopmental syndromes to neurodegenerative disorders. Autism is a neurodevelopmental syndrome that affects an estimated 2–6 per 1,000 individuals. It has been hypothesized that changes in neuronal circuitry and synaptic signaling are responsible for the behavioral and cognitive aberrations in autistic patients. Point mutations in neuroligins have been linked to a small subset of patients with autism-spectrum disorders. Cognitive decline characterizes mental retardation syndromes such as

Cri-du-Chat and neurodegenerative disorders, such as Alzheimer's disease. Involvement of cadherin-mediated adhesion in cognitive decline has been suggested by cognitive dysfunction in  $\delta$ -catenin-deficient mice, and cleavage of N-cadherin by presenilin 1-dependent  $\gamma$ -secretase protease. Mutations in the nectin-1 gene cause cleft lip/palate ectodermal dysplasia, frequently associated with mental retardation.

Impaired development and plasticity of synapses could also underlie the synaptic pathology of schizophrenia. However, more research is needed on which and how synaptic adhesion molecules contribute to etiology of this psychiatric disease.

### References

1. Sudhof TC (2001) The synaptic cleft and synaptic cell adhesion. In: Stevens CF, Cowan WM, Sudhof TC (eds) Synapses. Johns Hopkins University Press, Baltimore, pp 275–313
2. Scheiffele P (2003) Cell-cell signaling during synapse formation in the CNS. *Annu Rev Neurosci* 26:485–508
3. Yamagata M, Sanes JR, Weiner JA (2003) Synaptic adhesion molecules. *Curr Opin Cell Biol* 15:621–632
4. Washbourne P, Dityatev A, Scheiffele P, Biederer T, Weiner JA, Christopherson KS, El-Husseini A (2004) Cell adhesion molecules in synapse formation. *J Neurosci* 24:9244–9249
5. Vaughn JE (1989) Fine structure of synaptogenesis in the vertebrate central nervous system. *Synapse* 3:255–285
6. Shen K (2004) Molecular mechanisms of target specificity during synapse formation. *Curr Opin Neurobiol* 14:83–88
7. Sanes JR, Lichtman JW (1999) Development of the vertebrate neuromuscular junction. *Annu Rev Neurosci* 22:389–442
8. Garner CC, Zhai RG, Gundelfinger ED, Ziv NE (2002) Molecular mechanisms of CNS synaptogenesis. *Trends Neurosci* 25:243–251
9. Shi SH, Cheng T, Jan LY, Jan YN (2004) The immunoglobulin family member dendrite arborization and synapse maturation 1 (Dasm1) controls excitatory synapse maturation. *Proc Natl Acad Sci USA* 101:13346–13351
10. Takeichi M, Abe K (2005) Synaptic contact dynamics controlled by cadherin and catenins. *Trends Cell Biol* 15:216–221

## Synaptic Competition

### Definition

A mechanism for synaptic refinement, in which less heavily used synapses are eliminated.

► Activity-Dependent Synaptic Plasticity



## Synaptic Convergence

### Definition

The projection of multiple neurons onto a single target neuron. Synaptic convergence makes it possible for the target neuron to integrate across many synaptic inputs.

## Synaptic Depression

### Definition

The reduction in postsynaptic response to presynaptic release of neurotransmitter that occurs during trains of stimuli. At the neuromuscular junction, the cause of synaptic depression is thought to be a reduction in release of acetylcholine following each stimulus. At other synapses, there may also be a postsynaptic contribution.

- ▶ Acetylcholine
- ▶ Neuromuscular Junction

## Synaptic Elimination

YOSHIO HATA

Division of Integrative Bioscience, Tottori University Graduate School of Medical Sciences, Yonago, Japan

### Synonyms

Synapse loss

### Definition

Synaptic elimination is a process of brain development that reduces the number of synaptic contacts. The process is important for the formation of precise neural circuitry, which is necessary for proper brain functions. Synaptic contacts are generated in excess during the early phase of development. In subsequent stages, the redundant synapses are eliminated while the proper ones are strengthened to construct specific neural connections. Synapse elimination takes place in various neural tissues including cerebral cortex, cerebellum and ▶ neuromuscular junctions, and is supposed to be

a general mechanism of the development of neural circuitry. The process of elimination is often regulated by neural activity so that active synapses are strengthened, whereas the inactive ones are weakened and ultimately eliminated.

### Characteristics

#### Quantitative Description

The brain is not mature at birth and significant developmental events take place postnatally. During postnatal development, there is a period (▶ critical period) of exuberant synapse formation followed by a period of synaptic “pruning” in the brain. The developmental profile of synapse number and density (number of synapses per unit volume) has been examined in various mammalian species including human.

In the primary visual cortex of monkey, synapse density increases rapidly around birth [1]. This period of ▶ synaptogenesis begins two months before birth, and the synaptic density reaches approximately the same level as that in adults. The rapid synaptogenesis continues for another two to three months after birth when the synaptic density reaches its maximum (about 90 synapses/100  $\mu\text{m}^3$ ). The synapse density is maintained at this high level during the next two years. At puberty, however, synapse elimination begins and the synapse density rapidly decreases to the adult level (40–50 synapses/100  $\mu\text{m}^3$ ) by five postnatal years. The postnatal development of synapse density reveals a similar profile, high synapse density during adolescence and lower density in maturity, in other cortical areas such as somatosensory, motor and limbic areas [2]. While the rapid synaptogenesis takes place concurrently in different cortical areas, the synapse elimination appears to begin earlier in the visual and somatosensory cortex than in the prefrontal cortex. However, the period of synapse elimination largely overlap with each other among cortical areas, and reach the adult level at the time of sexual maturity.

The development of cortical synapses follows a similar time course in the human brain. In human visual cortex, the synapse density shows a rapid increase at around two months of age and reaches the maximum at 8–10 months [3]. The synapse density then declines to the adult level at around ten years of age. In the frontal cortex, however, the beginning of synapse formation is delayed, and the synapse density gets to the maximum value at around two years of age. The high synapse density remains until eight years of age, and then slowly declines to the adult level at around 16 years. Thus, the rapid synaptogenesis and the following synapse elimination might take place at different times in different cortical areas in human [4].

The synapse elimination is regulated by experience-dependent mechanisms. If monkeys are raised without visual inputs by removing both eyes in utero, the

decrease of a class of synapses in the visual cortex does not take place [5]. Furthermore, visual deprivation in one eye of developing animals leads to a strong suppression of cortical response to the deprived eye, and ultimately to the selective pruning of the input axons carrying information from the deprived eye [6].

### Higher Level Processes

The elimination of redundant synapses is an important step for the construction of specific neural circuitry in the mature brain. Early formed neural connections tend to include aberrant projections. During development, the synapses made by such aberrant axons should be eliminated and the axon should finally retract. For example, refinement of neural connections by elimination of redundant synapses is well documented in skeletal muscles and autonomic ganglia [7]. Early in development, each muscle fiber and ganglionic neuron is innervated by multiple input axons from motor neurons and preganglionic neurons, respectively (Fig. 1, right).

Thereafter, all but one input axon innervating the same target lose their synaptic contacts and retract, so that

each muscle fiber and ganglionic neuron is innervated by a single axon in the adult. Although the synapses made with the inappropriate axons would disappear, the appropriate axons that will innervate the target in maturity grow in size and complexity to make more synaptic contacts. Thus, the development of neural networks is not a simple formation or elimination of synapses, but the redistribution of synapses so that each axon can focus its contacts to the appropriate targets.

A similar process also operates in the central nervous system. Input axons carrying information from each eye distribute separately in the primary visual cortex of higher mammals including cats, monkeys and humans [8] (Fig. 1, left). In young animals, however, the input axons from two eyes widely spread over the visual cortex and overlap with each other. The input axons gradually retract from inappropriate cortical territory and obtain the adult-like segregated distribution. In the cerebellum of newborn animals, the Purkinje cells are innervated by multiple climbing fibers that originate in the inferior olive [9]. During development, redundant climbing fibers are eliminated and single fibers innervate each Purkinje cell.

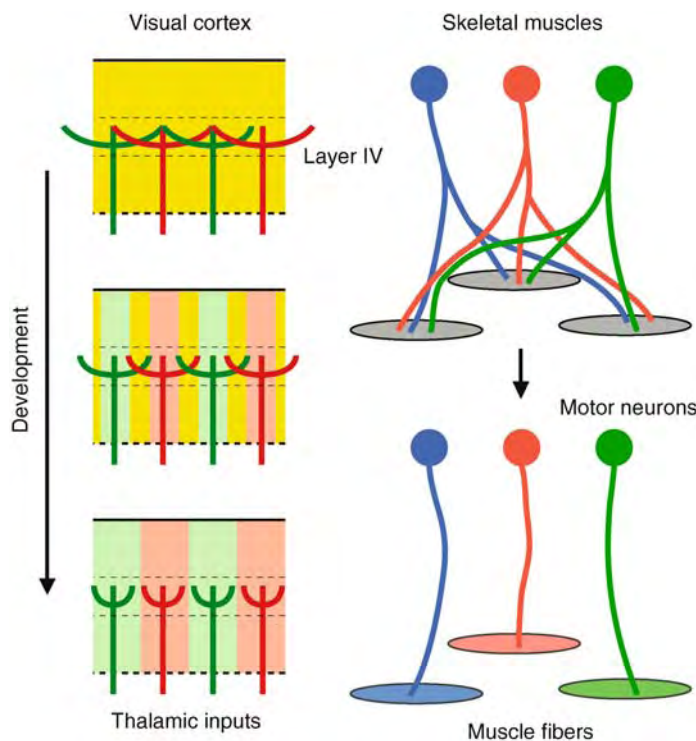

**Synaptic Elimination. Figure 1** Schematic representation of the rearrangement of neural connections during postnatal development. In the primary visual cortex (*left*), the ascending axons from the lateral geniculate nucleus provide inputs to cortical layer IV. The axons from two eyes (red and green, respectively) initially overlap and gradually segregate to occupy different cortical regions. The muscle fibers are innervated by multiple motor neurons at birth (*right*). The input axons lose their synaptic contacts to the inappropriate targets and project to single muscle fibers in the adult.

## Process Regulation

The synapse elimination is largely regulated by mechanisms depending on neural activity. The developmental refinements of neural circuitry in various brain areas show that the competition between inputs plays an important role in determining which synapse should be eliminated (► **activity-dependent synaptic competition**).

The direct observation of the process of synapse elimination in neuromuscular junctions offers a great deal of insight into the mechanisms of the process [7]. In the mouse neck, each muscle fiber receives axonal innervations from several motor neurons at birth. The number of innervations reduces in the following two weeks and each muscle fiber begins to receive single input. Before the withdrawal of redundant axon terminals, synapses on them reveal a functional weakening. Synaptic potentials recorded in the developing muscle fibers show that each of the multiple inputs has strong synaptic effects, enough to cause muscle contraction at birth, and the strength of each synaptic input is often indistinguishable from each other. Therefore, it is difficult to predict which input would subsequently monopolize the fiber. The input that is going to be eliminated ultimately becomes gradually weaker before any sign of retraction could be observed in the presynaptic terminals. The weakening of synaptic potentials is caused by a reduction in neurotransmitter release and by a reduction in postsynaptic receptor density. The physiological synapse elimination is followed by axonal withdrawal of weak inputs.

Synaptic interactions play a key role in determining which input should be eliminated. If neural activity of motor neuron axons is blocked pharmacologically, redundant axons do not retract and ► **multiple innervations** persist. Suppression of synaptic interactions at the neuromuscular junctions by blocking acetylcholine (ACh) receptors also prevents the input elimination. Thus, neural activity and the following synaptic interactions are necessary for the synapse rearrangements (► **activity-dependent synaptic rearrangement**). In addition, if a small part of a single neuromuscular junction, which is innervated by one axon, is functionally blocked by applying an irreversible blocker of the postsynaptic ACh receptors, the ACh receptors gradually disappear only in the blocked region. Subsequently, the axon terminals innervating the blocked region withdraw as observed in natural development. On the other hand, blocking ACh receptors in the entire area of a single neuromuscular junction does not induce synapse elimination. Thus, synapse inactivation can lead to elimination of the synapse only when the other synapses are active, suggesting that local imbalance of input strength is an important factor to initiate synapse elimination. The synaptic interactions at active synapses might generate suppressive signals in the postsynaptic cells that can destabilize inactive

synapses in the surrounding region, together with supportive signals that maintain the activated synapse. Although the molecular machinery of such intercellular signaling is yet to be characterized, several protein kinases and phosphatases might be involved in the process. For example, in mutant mice in which protein kinase C (PKC)-gamma is genetically inactivated, the elimination of multiple innervations of cerebellar Purkinje cells by climbing fibers, as mentioned above, is markedly prevented [10]. Thus, the activity of PKC is essential for normal elimination of redundant climbing fibers.

The relative strength of inputs also guides the rearrangement of input axons in the visual system [8]. Blocking visual inputs from one eye induces a strong suppression of the cortical responses to the eye, followed by a significant retraction of input axons serving the eye. If the visual inputs from both eyes are blocked, however, the suppression of cortical responses is limited and the input axons are maintained.

## Pathology

Abnormal synapse elimination prevents the construction of normal neural circuitry and is supposed to underlie various psychiatric disorders, such as fragile X syndrome and schizophrenia.

## References

1. Bourgeois JP, Rakic P (1993) Changes of synaptic density in the primary visual cortex of the macaque monkey from fetal to adult stage. *J Neurosci* 13:2801–2820
2. Rakic P, Bourgeois JP, Goldman-Rakic PS (1994) Synaptic development of the cerebral cortex: implications for learning, memory, and mental illness. *Prog Brain Res* 102:227–243
3. Huttenlocher PR, de Courten C (1987) The development of synapses in striate cortex of man. *Hum Neurobiol* 6:1–9
4. Huttenlocher PR, Dabholkar AS (1997) Regional differences in synaptogenesis in human cerebral cortex. *J Comp Neurol* 387:167–178
5. Bourgeois JP, Rakic P (1996) Synaptogenesis in the occipital cortex of macaque monkey devoid of retinal input from early embryonic stages. *Eur J Neurosci* 8:942–950
6. Antonini A, Stryker MP (1993) Rapid remodeling of axonal arbors in the visual cortex. *Science* 260:1819–1821
7. Lichtman JW, Colman H (2000) Synapse elimination and indelible memory. *Neuron* 25:269–278
8. Katz LC, Shatz CJ (1996) Synaptic activity and the construction of cortical circuits. *Science* 274:1133–1138
9. Lohof AM, Delhaye-Bouchaud N, Mariani J (1996) Synapse elimination in the central nervous system: functional significance and cellular mechanisms. *Rev Neurosci* 7:85–101
10. Kano M, Hashimoto K, Chen C, Abeliovich A, Aiba A, Kurihara H, Watanabe M, Inoue Y, Tonegawa S (1995) Impaired synapse elimination during cerebellar development in PKC gamma mutant mice. *Cell* 83:1223–1231

## Synaptic Excitability

### Definition

Related to the responsiveness of a neuron to excitatory input.

## Synaptic Inputs

### Definition

The contacts between neurons are called synapses. Any given neuron can receive input from just a few to over 100,000 other neurons. The synaptic inputs can be excitatory, meaning that they are likely to make the cell produce action potentials, or they can be inhibitory, meaning that they are likely to stop the cell from producing action potentials. Synaptic inputs interact with the electrical excitability of neurons to process neural information and generate output action potentials.

## Synaptic Integration

MIYAKAWA HIROYOSHI

Laboratory of cellular Neurobiology, School of Life Sciences, Tokyo University of Pharmacy and Life Sciences, Tokyo, Japan

### Synonyms

Dendritic integration; Single neuron computation

### Definition

Neurons in the central nervous system receive many thousands of synaptic inputs, integrate them, and give off outputs in the form of nerve impulses. The process of determining outputs from the inputs is called **synaptic integration**. Since most of the synaptic contacts are made on the dendritic arborization, and the nerve impulses are generated at the initial segment of the axon near the cell body, the most important part of the integration takes place at the dendrites, and hence is referred to as **dendritic integration** [1]. Some of the integration takes place at **presynaptic terminals** where transmitter release is regulated by inputs from other sources. In addition to synaptic interactions, neurons

and glial cells interact with each other via non-synaptic mechanisms such as **volume transmission** [2] or **ephaptic interaction**. All of these processes and mechanisms are involved in the integration of information in the neural cell assembly. Further, the process of synaptic integration is not stereotypical but, over various lengths of time, undergoes plastic changes that are referred to as **synaptic plasticity**. Some forms of synaptic plasticity, the short-term plasticity, such as **paired pulse facilitation**, take place while incoming information is being processed, and thus can be regarded as part of the integration processes.

### Characteristics

#### Dendritic Integration

Most of the synaptic contacts are made on dendritic processes, where there are special structures called postsynaptic density apposing presynaptic terminals. Binding of transmitters released from the presynaptic terminals to the receptors located at the postsynaptic density generates postsynaptic potentials. The postsynaptic potentials spread along the dendrites to the cell body and to the initial segment of the axon. In the course of the spread, the potentials are distorted depending upon the electrical properties of the dendrites. If the **summation** of the distorted postsynaptic potentials provides sufficient depolarization, nerve impulses are generated at spike initiation zones somewhere along the dendrite-soma-axon axis, most probably near the initial segment, and will be sent out as outputs.

#### Synaptic Summation: Spatial and Temporal Summation

There are two basic modes of summation, **temporal summation** and **spatial summation**. Summation of postsynaptic potentials with a fast decay time can be significant only when the inputs coincide in time. This kind of summation happens when synaptic inputs arrive at spatially separate synaptic sites, and is called spatial summation. Neurons that summate inputs with this manner are called coincidence-detectors. Postsynaptic potentials with a slow decay time can summate over time, even when inputs arrive with some delay. This kind of summation is called temporal summation, and the neurons that show temporal summation are called integrate-and-fire units (Fig. 1).

#### Synaptic Summation: Non-linear Summation

Summation of postsynaptic potential is generally non-linear for several reasons. One reason is that a large change in membrane potential induced by one input can reduce the driving force for the synaptic current for the second input. Another reason is that an increase of membrane conductance induced by one input can shunt the postsynaptic current of the second input. For instance, GABA mediated transmissions usually result

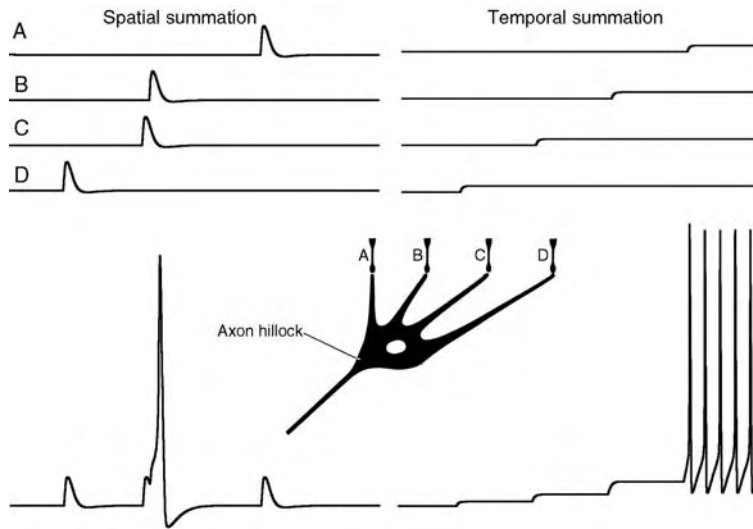

**Synaptic Integration. Figure 1** Spatial summation and temporal summation. Two modes of synaptic summation, when four synaptic inputs (A–D) arrive at four separate locations of a neuron with brief intervals. Spatial summation (left): Summation of postsynaptic potentials with a fast decay time can be significant only when they coincide in time. Temporal summation (right): Postsynaptic potentials with a slow decay time can be summated overtime.

in a small change in membrane potential, usually hyperpolarizing, but can inhibit the response for the second input because the postsynaptic current due to the second input flow through the GABA receptor channel without charging the membrane. This type of inhibition is called **shunting inhibition**.

#### **Spread of Postsynaptic Potential in Passive Dendrites**

One of the characteristic features of neurons is that they have rich dendritic arborizations. Due to this, the neurons are not isopotential, and postsynaptic potentials will be distorted as they spread from the input location to other locations along the dendrites. The conceptual basis of our understanding, concerning the manner by which postsynaptic potential spreads along the dendrite, was established by W. Rall and his colleagues through theoretical and modeling studies [3]. According to their pioneering works, in which cable theory was applied by assuming that the dendrites can be lumped to a simple cable, the important factors that determine the spread of potential are the passive properties of the dendrites, such as the diameter, membrane resistivity and cytoplasmic resistivity. They predicted that the amplitude of postsynaptic potentials decay significantly as they spread from the input site towards the cell body or the initial segment. The longer the dendrites, the greater the decay. They also predicted that the dendrites behave as frequency filters that curtail fast component. These predictions have been shown to be the case experimentally by performing multiple electrical recordings from single neurons [4] (Fig. 2).

The extent of shunting inhibition depends on the locations of synaptic contacts. For instance, a GABA

mediated inhibitory input made on the distal end of a dendrite would not strongly inhibit a glutamate mediated excitatory input made near the cell body, whereas a GABA mediated input made on the cell body or on the initial segment can prevent the cell from generating an outgoing impulse, no matter how many excitatory inputs the cell receives (Fig. 3).

#### **Roles of Active Membrane Properties on Dendritic Integration**

Despite early studies showing active properties of dendrites, it has long been the common understanding that the dendrites are electrically passive structures providing nothing but an area for synaptic contacts. Recently, however, it has become well recognized that various types of voltage-gated ion channels with different ion selectivities, voltage sensitivities, kinetics and density distributions are distributed along the dendritic membrane [5]. These channels endow the dendritic membrane with complex characteristic features that may have strong impacts on dendritic integration.

#### **Low Voltage-Activated Ion Channels**

Some types of ion channels distributed along the dendrites, such as A-type K channels and T-type Ca channels are low-voltage activated, show rapid inactivation, and can be activated or inactivated by small changes in membrane potential near the resting potential. There are some other types of ion channels, such as I<sub>h</sub> channels, that can be activated by hyperpolarizing the membrane potential below resting potential. These low voltage activated channels may

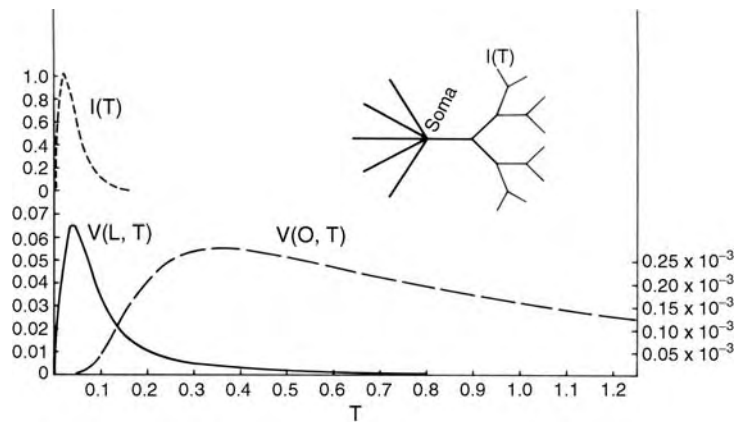

**Synaptic Integration. Figure 2** Distortion of postsynaptic potentials computed voltage time course at the input receiving branch terminal (solid curve) and at the soma (lower dashed curve) for an injected current  $I(T)$  (upper dashed curve) are shown. The soma response  $V(O, T)$  (scale at left) is much smaller and slower than the response at the input site  $V(L, T)$  (scale at the right). The neuron model is shown on the upper right (adapted from Rall W, Rinzel J (1973) *Biophys J* 13:648–688).

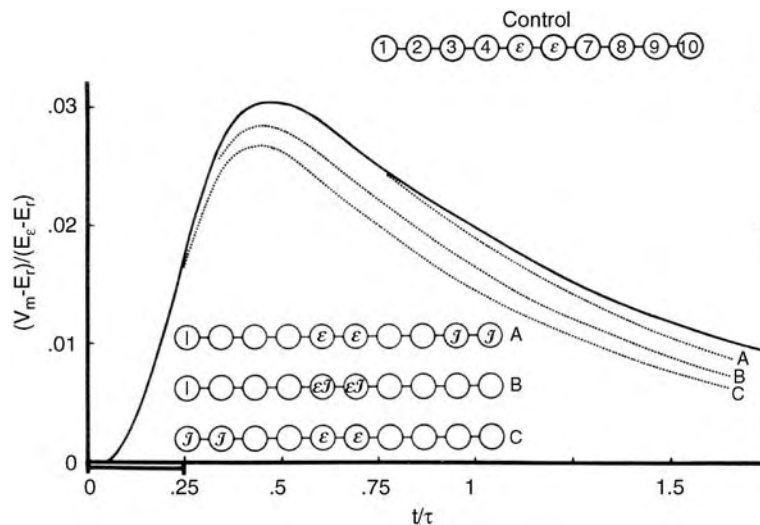

**Synaptic Integration. Figure 3** Effect of inhibitory-conductance location upon transient soma-membrane depolarization. The continuous curve represents the uninhibited “control” transient in compartment 1 for an excitatory input ( $\mathcal{E}$ ) at compartments 5 and 6. The dotted curves show the inhibitory effect of having  $\mathcal{J}$  in compartments throughout the time (adapted from Rall W (1964) In: Reiss RF (ed) *Neural theory and modeling*. Stanford University Press, Stanford, CA).

distort postsynaptic potential by boosting or dampening membrane potential changes.

### Dendritic Action Potentials

Dendritic membranes of many types of neurons in the central nervous system are excitable. Cortical and hippocampal pyramidal neurons generate Na dependent fast action potential, which can propagate along the dendrites. The direction could be either forward (from the dendrites toward the cell body) or backward (from the soma toward dendrites) depending on the

situations [6]. Pyramidal neurons and cerebellar Purkinje neurons generate Ca dependent slow action potential in their dendrites. Although it has been shown that these dendritic action potentials can be triggered by synaptic inputs, their functional roles are not yet well understood. One possible role is that these potentials may be important in determining the pattern of the output in the form of axonal impulses. Postsynaptic potentials generated by local synaptic inputs, which are not large enough to initiate action potentials at the initial segment, might trigger dendritic action potentials that

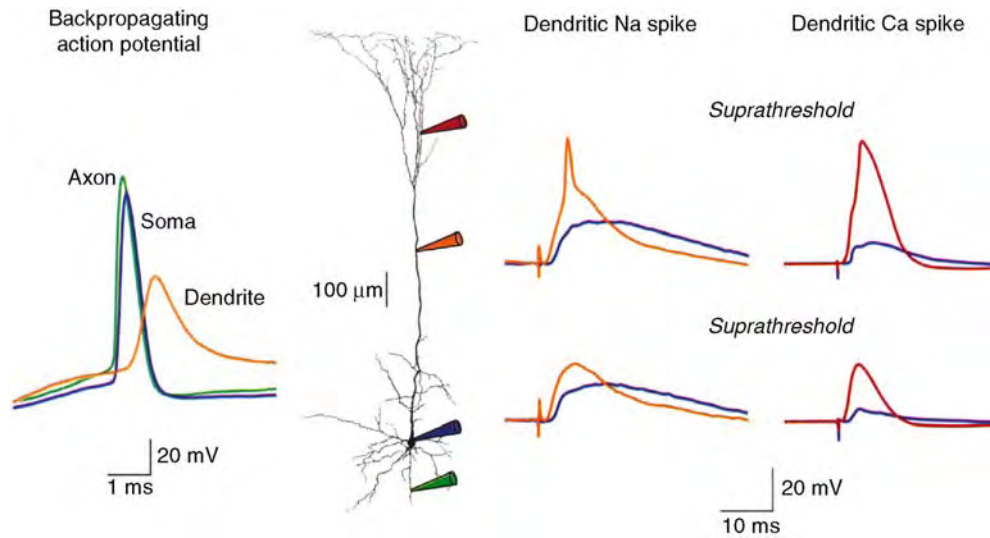

**Synaptic Integration. Figure 4** Dendritic Excitability. Recordings are from neocortical layer 5 pyramidal neurons. Left: An action potential evoked by distal synaptic input recorded simultaneously from the axon, soma, and the apical dendrite 300  $\mu\text{m}$  from the soma. Right: Generation of dendritic Na and Ca spikes. Recordings are made simultaneously from the soma and the dendrite (adapted from Hausser M, Spruston N, Stuart GJ (2000) Diversity and dynamics of dendritic signaling. *Science* 290:739–744).

convey information to the initial segment and initiate impulses that can travel down the axon. Another possibility is that the dendritic action potential may be important in inducing a transient increase of intracellular Ca concentration (Fig. 4).

#### Transient Increase of Intracellular Ca and Dendritic Integration

Transient increase of intracellular Ca accompanies various neuronal activities [7]. There are several sources for the Ca. Firstly, activation of Ca-permeating ligand gated channels, such as NMDA-type glutamate receptor or nicotinic acetylcholine receptors  $\alpha 7$  subunits, allow Ca to enter from the extracellular space. Secondly, Ca enters through voltage gated Ca channels, activated during Ca-dependent action potentials or during depolarization due to any mechanism. Thirdly, activation of intracellular signaling pathways induces Ca release from intracellular stores.

Elevated Ca modulates synaptic integration by various mechanisms. Some of these mechanisms are by directly gating ion channels such as Ca-dependent K channels, by modulating ion channels through Ca-dependent phosphorylation, or by triggering synthesis of proteins involved in synaptic responses such as transmitter receptors.

#### Synaptic Integration at Presynaptic Sites

The presynaptic terminals are also postsynaptic sites at many synapses, in that various types of receptors on the

membrane receive ligands from various sources. Firstly, axons of some neurons, such as GABAergic interneurons, make synaptic contacts on presynaptic terminals and inhibit transmitter release [8]. This type of inhibition is called **presynaptic inhibition**. Secondly, transmitters released from the terminal can diffuse in the synaptic cleft to bind to receptors on the synaptic terminals and inhibit transmitter release. This type of action is called **autoreception**. The transmitter can also diffuse at longer distances (**spill over**), and act on the presynaptic terminals of nearby neurons as well as on the postsynaptic neurons. Interaction by these mechanisms is called volume transmission.

In addition, molecules that can diffuse across membrane, such as nitric oxide, carbon mono-oxide, arachidonic acids, and endocannabinoids that are generated in the postsynaptic neurons, diffuse back to the presynaptic terminals and modulate synaptic transmission. This type of mechanism provides additional pathway of volume transmission, and is called **retrograde transmission** [9].

At the presynaptic terminals, the probability of transmitter release can vary from time to time as nerve impulses arrive at the terminals. This phenomenon can be demonstrated by activating the presynaptic fibers at short intervals, typically few tens of milliseconds. The release probability for the second impulse may be either higher or lower compared to that for the first impulse. These types of short-term plasticities are called paired pulse facilitation or **paired pulse depression**, respectively.

The details of integration in presynaptic terminals are not well understood. Since transmitter release is a rather complex phenomenon involving large varieties of molecules and mechanisms, the mechanisms for the integration in the presynaptic terminals are likely to be diverse.

### Higher Level Processes

Integration of information is the most important task the brain or nervous system performs. To execute this task, assembly of neurons and neuroglia form networks at local and global levels. Synaptic integration is an cellular-level elementary process for this task. At the local and global network level, information is integrated by processes that have principles of their own.

### Lower Level Processes

The following is a list of the important lower level processes involved in synaptic integration:

1. Gating of ion channels
2. Synaptic activation of intracellular signaling pathways
3. Dynamics of Ca ion
4. Diffusion of molecules in and out of the cells
5. Release of transmitters

### Process Regulation

Process of synaptic integration is regulated both extrinsically and intrinsically. Depending on mental or physical situations, various neuromodulators such as catecholamines or peptides, activate receptors on neurons, modulate functional proteins and lipids, control gene expressions, and regulate synaptic integration. Activities of neurons give rise to activation of similar intracellular mechanisms that can be activated by neuromodulators, and regulate synaptic integration.

### Function

Synaptic integration is the basis for any kind of information processing taking place in the central nervous system.

### References

1. Stuart G, Spruston N, Häusser M (eds) (1999) *Dendrites*. Oxford University Press, Oxford
2. Agnati IF, Fuxe K, Nicholson C, Sykova E (eds) (2000) Volume transmission revisited. *Progress in brain research*, vol 125. Elsevier, Amsterdam
3. Segev I, Rinzel J, Shepherd GM (eds) (1995) *The theoretical foundation of dendritic function: selected papers of Wilfrid Rall with commentaries*. MIT Press, Cambridge, MA
4. Stuart G, Spruston N (1998) Determinants of voltage attenuation in neocortical pyramidal neuron dendrites. *Journal of Neuroscience* 18:3501–3510
5. Johnston D, Magee JC, Colbert C, Christie BR (1996) Active properties of neuronal dendrites. *Annual Review of Neuroscience* 19:165–186

6. Larkum ME, Zhu JJ, Sakmann B (2001) Dendritic mechanisms underlying the coupling of the dendritic with the axonal action potential initiation zone of adult rat layer 5 pyramidal neurons. *Journal of Physiology* 533:447–466
7. Augustine GJ, Santamaria F (2001) Local calcium signaling in neurons. *Neuron* 40:331–346
8. Vizi ES (2000) Role of high-affinity receptors and membrane transporters in nonsynaptic communication and drug action in the central nervous system. *Pharmacological Reviews* 52:63–89
9. Fitzsimonds RM, Poo MM (1998) Retrograde signaling in the development and modification of synapses. *Physiological Reviews* 78:143–170

## Synaptic Long-Term Potentiation in Pain Pathways

JÜRGEN SANDKÜHLER

Department of Neurophysiology, Center for Brain Research, Medical University of Vienna, Vienna, Austria

### Synonyms

LTP

### Definition

► LTP is an intensively studied model of synaptic plasticity. LTP is defined as a long-lasting (but not necessarily irreversible) increase in synaptic strength. Early phase LTP is independent of *de-novo* protein synthesis and lasts for up to three hours. Late phase LTP involves protein synthesis and lasts longer than three hours. Synaptic strength is the magnitude of the post-synaptic response (i.e., the post-synaptic potential or the post-synaptic current, but not action potential firing, see below) in response to a pre-synaptic action potential. LTP can be expressed pre- and/or post-synaptically. Synaptic strength can increase if the release of neurotransmitter(s) is enhanced and/or if the postsynaptic effects of the neurotransmitter(s) become stronger. LTP at synapses in hippocampus is the prime model for learning and memory formation. Recent studies have shown that LTP can also be induced in pain pathways and likely contribute to hyperalgesia caused by inflammation, trauma or neuropathy.

### Characteristics

#### How to (and how not to) Measure LTP

When studying LTP it is essential to measure the changes of mono-synaptically-evoked post-synaptic



currents or potentials in response to a single pre-synaptic action potential. Whole-cell patch-clamp recording is now the most often used technique. To evaluate LTP at the first synapses in nociceptive pathways, transverse slices from lumbar spinal cord of rats or mice with long dorsal roots attached can be prepared to study mono-synaptic, A $\delta$ -fiber or C-fiber evoked excitatory postsynaptic potentials or currents in identified dorsal horn neurons [1].

Some aspects of LTP can only be studied in the entire animal. *In vivo* C-fiber-evoked field potentials can be measured in superficial spinal dorsal horn, for example in response to high intensity electrical stimulation of the sciatic nerve for up to 24 h [2]. These extracellular recorded field potentials reflect summation of post-synaptic, mainly mono-synaptically-evoked currents but not action potential firing [2].

LTP can not be directly investigated by recording action potential discharges of post-synaptic neurons because action potential firing not only depends upon synaptic strength, but also on membrane excitability and the balance between excitatory and inhibitory input to the neuron. For the same reasons poly-synaptically-evoked responses can generally not be used to study synaptic strength and changes thereof.

## Induction Protocols

### High Frequency Electrical Nerve Stimulation

LTP at spinal synapses of small diameter primary afferents has most often been induced by high intensity, high frequency burst-like stimulation (typically 100 Hz bursts given several times for 1 s at C-fiber strength) both, *in vitro* and *in vivo*. In spinal cord slice preparations, both, A $\delta$ -fiber and C-fiber [2,4]-evoked responses are potentiated by high frequency stimulation (HFS) when post-synaptic neurons are mildly depolarized to  $-70$  to  $-50$  mV. The same HFS induces, however, long-term depression (LTD) of A $\delta$ -fiber-evoked responses if cells are hyperpolarized to  $-85$  mV, suggesting that the polarity of synaptic plasticity is voltage-dependent.

The role of most spinal dorsal horn neurons in nociception is uncertain with one notable exception. Lamina I neurons that express the NK1 receptor play a pivotal role in development of hyperalgesia in behaving animals. Interestingly, HFS induces LTP selectively at C-fiber synapses with lamina I neurons that express the NK1 receptor and send a projection to the parabrachial area (Fig. 1). In contrast, HFS fails to induce LTP at synapses with neurons that express the NK1 receptor and send a projection to the periaqueductal grey or at synapses with neurons which do not express the NK1 receptor and have no identified supraspinal projection (Fig. 1) [1,3].

Conditioning HFS at C-fiber intensity of sciatic nerve afferents induces LTP of C-fiber, but not A $\beta$ -

fiber-evoked field potentials in superficial spinal dorsal horn of deeply anaesthetized rats [2,4]. In contrast, conditioning HFS at A-fiber intensity fails to induce LTP of either A- or C-fiber-evoked field potentials in intact animals. In spinalized animals, conditioning HFS at A $\delta$ -fiber intensity induces, however, LTP of C-fiber-evoked field potentials.

### Low Frequency Electrical Nerve Stimulation

Some C-fibers may discharge at rates as high as  $100 \text{ imp s}^{-1}$  for short periods of time (e.g., at the beginning of a noxious mechanical stimulus). Most C-fibers discharge, however, at considerably lower rates, around  $1\text{--}10 \text{ imp s}^{-1}$  (e.g., in response to an inflammation or an injury). Conditioning stimulation within this lower frequency range is also successfully used to induce LTP at C-fiber synapses. In a spinal cord-dorsal root slice preparation, conditioning electrical low frequency stimulation (LFS 2 Hz for 2–3 min, C-fiber strength) of dorsal root afferents induces LTP selectively at C-fiber synapses with lamina I neurons that express the NK1 receptor and project to the periaqueductal grey (Fig. 1) [3]. C-fiber synapses with lamina I neurons that express the NK1 receptor and project to the parabrachial area or with no identified supraspinal projection are, in contrast, not potentiated by LFS (Fig. 1) [3]. Thus, the pattern and the frequency of discharges in C-fibers determine which synapses at the origin of different ascending pain pathways are potentiated.

In spinal cord slices from neonatal rats, field potentials evoked by electrical stimulation in the tract of Lissauer are potentiated by repetitive burst-like stimulation at 10 Hz.

In deeply anaesthetized adult rats with their spinal cords intact, LFS (at 2 Hz for 2–3 min) of sciatic nerve at C-fiber intensity but not at A $\delta$ -fiber intensity also triggers LTP of C-fiber-evoked potentials (Fig. 1) [3].

In conclusion, HFS and LFS have divergent effects on the strength of different C-fiber synapses. This finding is in line with previous reports illustrating that the frequency of the afferent barrage in C-fiber may have qualitatively different effects in spinal cord. For example, brain-derived neurotrophic factor is released from primary afferents in spinal cord slices in an activity-dependent manner by HFS at 100 Hz, but not by 1 Hz LFS of primary afferent nerve fibers. Furthermore, in spinal cord slices from mice, HFS (100 Hz) of primary afferent nerves at C-fiber intensity, but not LFS (900 pulses at 1 Hz) selectively induces phosphorylation of extracellular receptor-activated MAP Kinases (ERK1/2) in spinal dorsal horn lamina I.

### Natural Noxious Stimulation

In the brain, LTP induction requires synchronous, high-frequency pre-synaptic activity or pairing of low-level

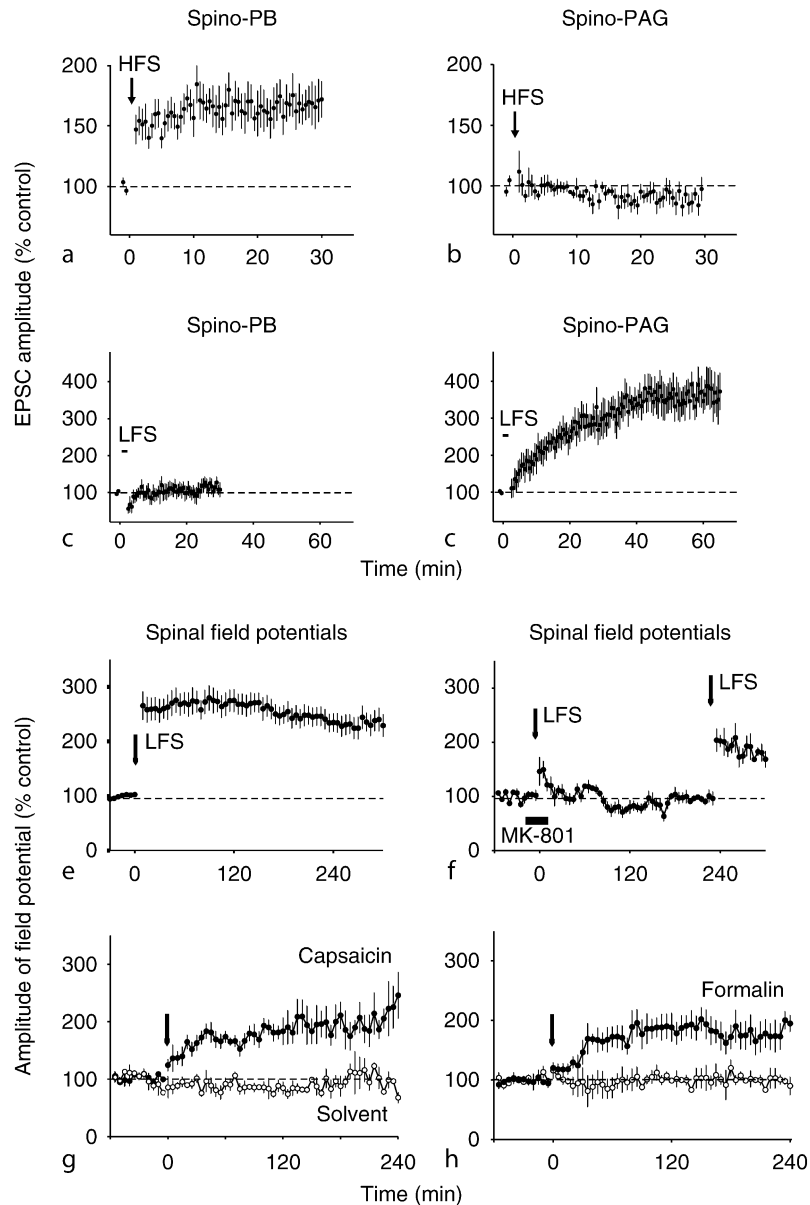

**Synaptic Long-Term Potentiation in Pain Pathways.** **Figure 1** A–D show contrasting forms of LTP expressed in distinct groups of spinal lamina I projection neurons *in vitro*. A, B Time courses of mean amplitudes ( $\pm$ SEM) of C-fiber-evoked EPSCs in lamina I neurons with a projection to the parabrachial area (PB,  $n = 8$ ) or the periaqueductal grey (PAG,  $n = 7$ ). Conditioning HFS induced LTP in all spino-PB neurons tested but was ineffective in spino-PAG neurons. C, D Conditioning LFS induced LTP in all 18 spino-PAG neurons tested but was never effective in seven spino-PB neurons. E–H LTP can be induced by natural, low frequency afferent barrage evoked by inflammation of peripheral tissue *in vivo*. Mean time courses of C-fiber-evoked field potentials recorded extracellularly in superficial spinal dorsal horn in response to electrical stimulation of left sciatic nerve of deeply anaesthetized adult rats with spinal cords and afferent nerves intact. Conditioning electrical LFS (2 Hz, 2 min at C-fiber intensity) of sciatic nerve at time zero (arrow) induced LTP ( $n = 28$ , E) which was prevented by NMDA receptor antagonist MK-801 ( $3 \text{ mg kg}^{-1}$ , i.v.-infusion over 30 min: horizontal bar,  $n = 5$ , F). A second conditioning LFS four hours later (arrow) was partially effective in inducing LTP. Subcutaneous injections of transient receptor potential vanilloid 1 channel agonist capsaicin (1%, 100  $\mu\text{l}$ ,  $n = 5$ , G) or formalin (5%, 100  $\mu\text{l}$ ,  $n = 6$ , H) into the glabrous skin at the ipsilateral hind paw, within the innervation territory of the sciatic nerve at time zero (arrows) induced LTP (closed circles), while injections of the respective solvents (open circles) had no effects ( $n = 3$  in each group). Modified from [4].

pre-synaptic activity with strong post-synaptic depolarization. At least some of the C-fiber synapses in superficial spinal dorsal horn are apparently unique in that LTP can be induced by LFS and by natural, low or high frequency, asynchronous and irregular discharge patterns in sensory nerve fibers. In animals with spinal cord and descending pathways intact, intraplantar subcutaneous injections of capsaicin (100  $\mu$ l, 1%) or formalin (100  $\mu$ l, 5%) induce slowly rising LTP (Fig. 1) [3].

Some forms of low level afferent input lead to LTP only if descending, presumably inhibitory pathways are interrupted or weakened. Noxious radiant heating of hindpaw skin induces LTP in spinalized animals but not in animals with spinal cord intact. Likewise, repetitive, noxious squeezing of the skin or the sciatic nerve induces LTP of C-fiber-evoked field potentials only in spinalized rats. These findings demonstrate that endogenous antinociceptive systems not only raise thresholds for nociception, but also those for the induction of LTP.

#### Pharmacological Induction

LTP can also be induced at C-fiber synapses in the absence of any pre-synaptic activity. Spinal application of a dopamine 1/dopamine 5 receptor agonist *in vivo* induces a slowly developing LTP of C-fiber-evoked field potentials that lasts for at least 10 h and which is blocked by a dopamine 1/dopamine 5 receptor antagonist. In spinalized, deeply anaesthetized, adult rats, superfusions of spinal cord segments with NMDA (10  $\mu$ M), substance P (10  $\mu$ M) or neurokinin A (1  $\mu$ M) are all sufficient to induce LTP of C-fiber-evoked field potentials. With spinal cord and descending (inhibitory) pathways intact, spinal applications of NMDA (1–100  $\mu$ M), substance P (1–100  $\mu$ M) or neurokinin A (1 or 10  $\mu$ M) fail, however, to induce LTP of C-fiber-evoked field potentials.

#### LTP of A-Fiber-Evoked Responses

Spinal field potentials evoked by excitation of primary afferent A-fibers are depressed by conditioning 50 Hz stimulation of the sciatic nerve. After systemic application of the GABA<sub>A</sub> receptor antagonist bicuculline, the same conditioning stimulus now produces LTP rather than LTD [5]. Similarly, 50 Hz conditioning stimulation produces short lasting potentiation followed by LTD in control animals, but LTP in animals with a chronic constriction injury (CCI) of the sciatic nerve. Topical application of muscimol (10  $\mu$ g), a GABA<sub>A</sub> receptor agonist, to spinal cord prevents tetanus-induced LTP of A-fiber-evoked field potentials in animals with a CCI. This also suggests that the polarity of synaptic plasticity is context-sensitive and not solely dominated by the type of afferent input.

#### Signal Transduction Pathways of LTP Induction and Maintenance

LTP can, in principle, be induced and expressed by pre-synaptic or by post-synaptic mechanisms or by any combination thereof. At present, there is clear evidence for a post-synaptic, Ca<sup>2+</sup>-dependent form of LTP induction in spinal cord lamina I neurons. Induction of LTP at C-fiber synapses requires co-activation of NK1 and NK2 receptors, opening of ionotropic glutamate receptors of the NMDA type, opening of T-type voltage-gated calcium channels, and activation of group I but not group II or III metabotropic glutamate receptors. Activation of NK1 receptors by substance P may directly enhance single NMDA channel opening and NMDA receptor-mediated currents in lamina I neurons. All this may lead to a substantial rise in post-synaptic [Ca<sup>2+</sup>]<sub>i</sub>.

A rise in post-synaptic [Ca<sup>2+</sup>]<sub>i</sub> is essential for LTP induction, and the magnitude in [Ca<sup>2+</sup>]<sub>i</sub> rise is linearly correlated with the magnitude of LTP *in vitro* [1]. Recent data demonstrate that LTP-inducing stimuli cause a substantial rise in [Ca<sup>2+</sup>]<sub>i</sub> in lamina I neurons not only in slice preparations, but also in intact animals [3]. Not surprisingly therefore, signal transduction involves Ca<sup>2+</sup>-dependent pathways including activation of protein kinase C, calcium-calmodulin-dependent protein kinase II (CaMKII), protein kinase A (PKA) phospholipase C (PLC), inositoltriphosphate-3 (IP<sub>3</sub>) receptors, mitogen-activated protein kinase (MAPK) and nitric oxide synthase (NOS).

Inhibition of protein synthesis in spinal cord by either cycloheximide or anisomycin selectively inhibits the maintenance of the late-phase of spinal LTP, but does not affect either LTP induction or baseline responses of C-fiber-evoked field potentials [6].

Importantly, the very same signal transduction pathways are required for full expression of hyperalgesia in animal models of inflammatory and neuropathic pain.

#### LTP Induction can be Prevented

In mature rats, a deep (surgical) level of anesthesia with either urethane, isoflurane or sevoflurane is insufficient to pre-empt LTP induction of C-fiber-evoked field potentials [7]. LTP is, however, prevented by low dose intravenous infusion of the  $\mu$ -opioid receptor agonist fentanyl [7]. Similarly, LTP of spinal field potentials elicited by stimulation in the tract of Lissauer in spinal cord slices is blocked by DAMGO, a more specific agonist at the  $\mu$ -opioid receptor. Activation of spinal  $\alpha_2$ -adrenoreceptors by clonidine or spinal application of the benzodiazepine diazepam also prevents LTP induction *in vivo*.

Functional blockade of glial cells by intrathecal administration of fluorocitrate changes the polarity of HFS-induced synaptic plasticity. When HFS is given

1 hr, but not 3 hr after fluorocitrate, LTD but not LTP of C-fiber-evoked field potentials is induced.

### Reversal of LTP

After LTP induction of C-fiber-evoked field potentials, synaptic strength can be normalized by brief, high frequency conditioning electrical stimulation of sciatic nerve fibers at A $\delta$ -fiber intensity. Reversal of LTP by A $\delta$ -fiber stimulation is time-dependent and effective only when applied 15 or 60 min but not 3 h after LTP induction.

Spinal application of either NK1 or NK2 receptor antagonists one to three hours after HFS (i.e., after LTP is established) does not affect maintenance of LTP [2], suggesting that activation of these receptors, which are required for the induction of LTP, are not essential for its maintenance.

### Functional Consequences of LTP in Pain Pathways

Changes of synaptic strength may have a powerful impact on signal flow in selected pathways. A typical consequence of LTP at excitatory synapses would be an increase in action potential firing of the same and perhaps also downstream neurons in response to a given stimulus. Indeed, LTP-inducing conditioning stimuli have been found to facilitate action potential firing of multireceptive neurons in deep dorsal horn [8]. This is likely due to LTP at the first synapse in the nociceptive pathway, but other mechanisms of facilitation should not be excluded. Action potential firing would also be enhanced if membrane excitability is increased (i.e., the threshold for action potential firing is lowered), if inhibition is less effective or if inhibition is even reversed and becomes excitatory (e.g., due to a reversal of the anion gradient in the post-synaptic neuron).

Conditioning HFS of the sciatic nerve fibers that induces LTP at synapses of C-fibers in spinal cord has behavioral consequences in rats and causes thermal hyperalgesia of the ipsilateral hind paw for six days. This suggests that LTP at C-fiber synapses has an impact on nociceptive behavior.

### Perceptual Correlates of LTP in Pain Pathways

In human subjects, conditioning HFS of cutaneous peptidergic afferents causes increased pain perception in response to electrical test stimuli applied through the same stimulation electrode [9]. Noxious stimulation with punctate mechanical probes in skin adjacent to the site of HFS conditioning uncovers a marked (2–3 fold) increase in pain sensitivity (i.e., secondary hyperalgesia [9]). Touching the skin around the conditioning stimulation electrode with a soft cotton wisp evokes pain only after HFS. Thus, HFS also induces secondary mechanical allodynia. Hyperalgesia at the conditioning site but not secondary hyperalgesia or allodynia at adjacent skin areas is prevented by pre-treatment with ketamine,

a clinically used drug which, among other effects, also blocks NMDA receptors.

All thermal modalities comprising cold and warm detection thresholds, cold and heat pain thresholds as well as pain summation (perceptual “wind-up”) remain unaltered after conditioning HFS of peptidergic skin nerve fibers.

When verbal pain descriptors are used to evaluate pain in addition to its perceived intensity after HFS, a significant long-term increase in scores for sensory but not for affective descriptors of pain is detected [10]. Within the list of sensory descriptors, those describing superficial pain, those for heat pain and those for sharp mechanical pain are all potentiated. The authors conclude that brief painful stimuli rarely have a strong affective component and that perceived pain after HFS exhibits predominantly a potentiation of the C-fiber-mediated percepts hot and burning [10].

In humans subjects, conditioning LFS also causes increased pain sensitivity in the area around the LFS conditioning skin site, but a depression of pain evoked by stimulation through the same electrode [9].

### Conclusions

LTP at synapses between primary afferent C-fibers and a group of nociceptive neurons in spinal cord lamina I that express the NK1 receptor for substance P is a potential mechanism underlying some forms of pain amplification in behaving animals and perhaps human subjects. Both LTP and hyperalgesia involve the same essential elements (i.e., primary afferent C-fibers and lamina I neurons that express the NK1 receptor). Further, the induction protocols, pharmacological profile and signal transduction pathways are virtually identical.

### References

- Ikeda H, Heinke B, Ruscheweyh R, Sandkühler J (2003) Synaptic plasticity in spinal lamina I projection neurons that mediate hyperalgesia. *Science* 299:1237–1240
- Liu XG, Sandkühler J (1997) Characterization of long-term potentiation of C-fiber-evoked potentials in spinal dorsal horn of adult rat: essential role of NK1 and NK2 receptors. *J Neurophysiol* 78:1973–1982
- Ikeda H, Stark J, Fischer H, Wagner M, Drdla R, Jäger T, Sandkühler J (2006) Synaptic amplifier of inflammatory pain in the spinal dorsal horn. *Science* 312:1659–1662
- Liu XG, Sandkühler J (1995) Long-term potentiation of C-fiber-evoked potentials in the rat spinal dorsal horn is prevented by spinal *N*-methyl-D-aspartic acid receptor blockade. *Neurosci Lett* 191:43–46
- Miletic G, Miletic V (2001) Contribution of GABA-A receptors to metaplasticity in the spinal dorsal horn. *Pain* 90:157–162
- Hu N-W, Zhang H-M, Hu X-D, Li M-T, Zhang T, Zhou L-J, Liu X-G (2003) Protein synthesis inhibition blocks the late-phase LTP of C-fiber evoked field potentials in rat spinal dorsal horn. *J Neurophysiol* 89:2354–2359

7. Benrath J, Brechtel C, Martin E, Sandkühler J (2004) Low doses of fentanyl block central sensitization in the rat spinal cord *in vivo*. *Anesthesiology* 100:1545–1551
8. Afrah AW, Fiskå A, Gjerstad J, Gustafsson H, Tjølsen A, Olgart L, Stiller C-O, Hole K, Brodin E (2002) Spinal substance P release *in vivo*. during the induction of long-term potentiation in dorsal horn neurons. *Pain* 96:49–55
9. Klein T, Magerl W, Hopf H-C, Sandkühler J, Treede R-D (2004) Perceptual correlates of nociceptive long-term potentiation and long-term depression in humans. *J Neurosci* 24:964–971
10. Hansen N, Klein T, Magerl W, Treede R-D (2007) Psychophysical evidence for long-term potentiation of C-fiber and A $\delta$ -fiber pathways in humans by analysis of pain descriptors. *J Neurophysiol.* 97:2559–2563

## Synaptic Modification

### ► Synaptic Plasticity

## Synaptic Plasticity

MINORU TSUKADA  
Brain Science Institute, Tamagawa University,  
Tamagawa-gakuen, Machida, Tokyo, Japan

### Synonyms

Synaptic modification; Long term potentiation; Hebb-like learning rules; Spatiotemporal learning rule LTP STLR

### Definition

#### Long term Potentiation (LTP) and Hebb-like Learning Rules

Long term potentiation (LTP) is a long-lasting increase in the amplitude of a synaptic response following brief, high-frequency activity of a synapse and is loosely defined as an enduring, activity-dependent increase in synaptic efficacy.

Hebb-like synaptic plasticity is the assumption that synaptic modification is strengthened only if the pre- and post-synaptic elements are activated simultaneously.

LTP that requires coincident pre- and post-synaptic activity is a plausibly biological correlate for the Hebbian synaptic modification.

## Characteristics

### Hebb and the Spatiotemporal Learning Rule (non-Hebb)

Synaptic plasticity is considered to be a fundamental mechanism of learning and memory. Hebb [1] proposed the idea that synaptic modification is strengthened only if the pre- and post-synaptic elements are activated simultaneously. Experimentally, long term potentiation (LTP) and long term depression (LTD) are generally considered to be the cellular basis of learning and memory. Recently, a series of experiments provided direct empirical evidence of Hebb's proposal. These reports indicated that synaptic modification can be induced by repetitive pairing of EPSP and back-propagating action potentials (BAPs) [2]. Pre-synaptic spiking within tens of milliseconds [ms] before post-synaptic spiking induced LTP whereas the reverse order resulted in LTD. This spike timing dependent LTP/LTD has been confirmed by using pyramidal cell pairs in hippocampal cultures, in which they found an asymmetric profile of LTP and LTD in relation to the relative timing between EPSPs and BAPs [3]. On the other hand, the spatiotemporal learning rule (STLR), proposed as a non-Hebb type by Tsukada et al. [4,5] (Fig. 1), consists of two distinctive factors; “cooperative plasticity without a cell spike,” and “its temporal summation.”

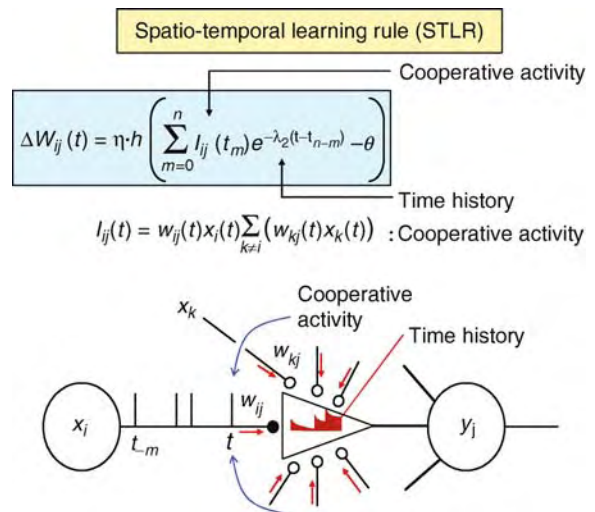

**Synaptic Plasticity. Figure 1** The spatiotemporal learning rule (STLR). Where  $w_{ij}(t)$ ; the value of a weight from neuron  $j$  to neuron  $i$  prior to adjustment,  $\Delta w_{ij}(t) = w_{ij}(t+1) - w_{ij}(t)$ ,  $\eta$ ; the learning rate coefficient,  $x_j(t)$ ; the level of excitation of input to neuron  $j$ ,  $y_i(t)$ ; the output of neuron  $i$ ,  $I_{ij}(t)$ ; the value of cooperative activity from neuron  $j$  to neuron  $i$ ,  $h(u)$ ; a sigmoid function of the potentiation force,  $\theta$  is the thresholds, and  $\lambda_2$  is the decay constant of temporal summation which is a slow dynamic process ( $\lambda_2 = 223\text{ms}$ ) (Aihara, et. al. 2000).

### Experimental Support for STLR (non-Hebb)

The STLR consisted of two defining factors: (i) cooperative plasticity without a post-synaptic spike and (ii) temporal summation. We have obtained evidence for temporal summation from neurophysiological experiments by applying temporal stimuli to Schaffer collaterals of CA3 [4,6]. The coincidence of spike timing of Schaffer collateral paired stimuli of CA3 played a crucial role in inducing associative LTP [7]. The ▶**homosynaptic** and ▶**heterosynaptic** associative LTP could be induced under conditions which inhibited the activation of dendritic Na<sup>+</sup> channels. Our results show that LTP can indeed occur at dendritic synapses of hippocampal CA1 pyramidal neurons even in the absence of a post-synaptic somatic spike. These results suggest that if the two inputs synchronize at the dendritic synapse of CA1 pyramidal cells then the synapse is strengthened and the functional connection is organized on the dendrite. If the two inputs are asynchronous then the connection is weakened. The functional connection/disconnection depends on the input-input timing dependent LTP (Fig. 2).

This differs from the Hebbian learning rule that requires coactivity of pre-synaptic and post-synaptic neurons. The STLR incorporated two dynamic processes: fast (10–30 ms) and slow (150–250 ms) processes. The fast process works as a time window to detect a spatial coincidence among various inputs projected to a weight space of the dendrites of hippocampal CA1 pyramidal neurons, while the slow process works as a temporal integrator of a sequence of events. By fitting parameters to the physiological data of the LTP time scale, we determined the decay constant of fast dynamics to be 17 ms, which corresponds to the period of hippocampal ▶**gamma oscillations** [8]. In contrast, the decay constant of the slow dynamics is 169 ms, which corresponds to a ▶**theta rhythm**. In combination, these findings suggest that cell assemblies are synchronized at two time scales in the hippocampal-cortical memory system. This phenomenon appears to

correlate with the memory formation in the spatio-temporal context.

### The Functional Differences Between STLR and Hebb

We applied two rules to a single-layered artificial neural network and compared its ability to separate spatiotemporal patterns with that of other rules, including the Hebbian learning rule and its extended rules. The simulation results [5] showed that the STLR rather than the Hebbian learning rule or its extensions had the highest efficiency in discriminating spatiotemporal pattern sequences. The novel features of this learning rule were induction of cooperative plasticity without a post-synaptic spike and the time history of its input sequences.

According to the Hebbian rule, connections strengthen only if the pre- and post-synaptic elements are activated simultaneously, and thus, the Hebbian rule tends to map all of the spatio-temporal input patterns with identical firing rates into one output pattern. Hebbian rule has a natural tendency to attract analogous firing patterns into a representative one, so called “pattern completion.” In contrast, the STLR produces different output patterns depending on individual input patterns. Thus, the STLR has a high ability in pattern separation, while the Hebbian rule has a high ability in pattern completion.

The extension of the theoretical simulation results imply that this phenomenon occurs in a dendrites-soma system of a single pyramidal cell. This system includes a spine structure, ▶**NMDA receptors**, and Na<sup>+</sup> and Ca<sup>+</sup> channels. The pyramidal cell integrates all of these local dendrite functions. Our previous research revealed that the STLR and the Hebbian rule coexist in single pyramidal neurons of the hippocampal CA1 area. The Hebbian rule leads to the pattern completion (Fig. 3a) and the STLR leads to the pattern separation (Fig. 3b).

In the STLR, synaptic weight changes are determined by the “synchrony” level of input neurons (bottom-up), whereas in the Hebbian rule, the soma

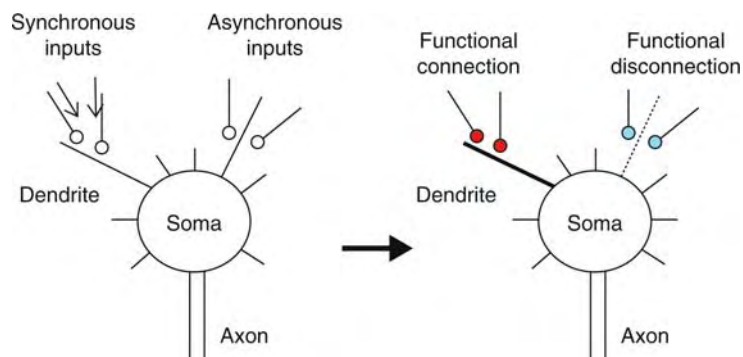

**Synaptic Plasticity. Figure 2** A schematic representation of functional connection/disconnection by cooperative activity dependent LTP/LTD.

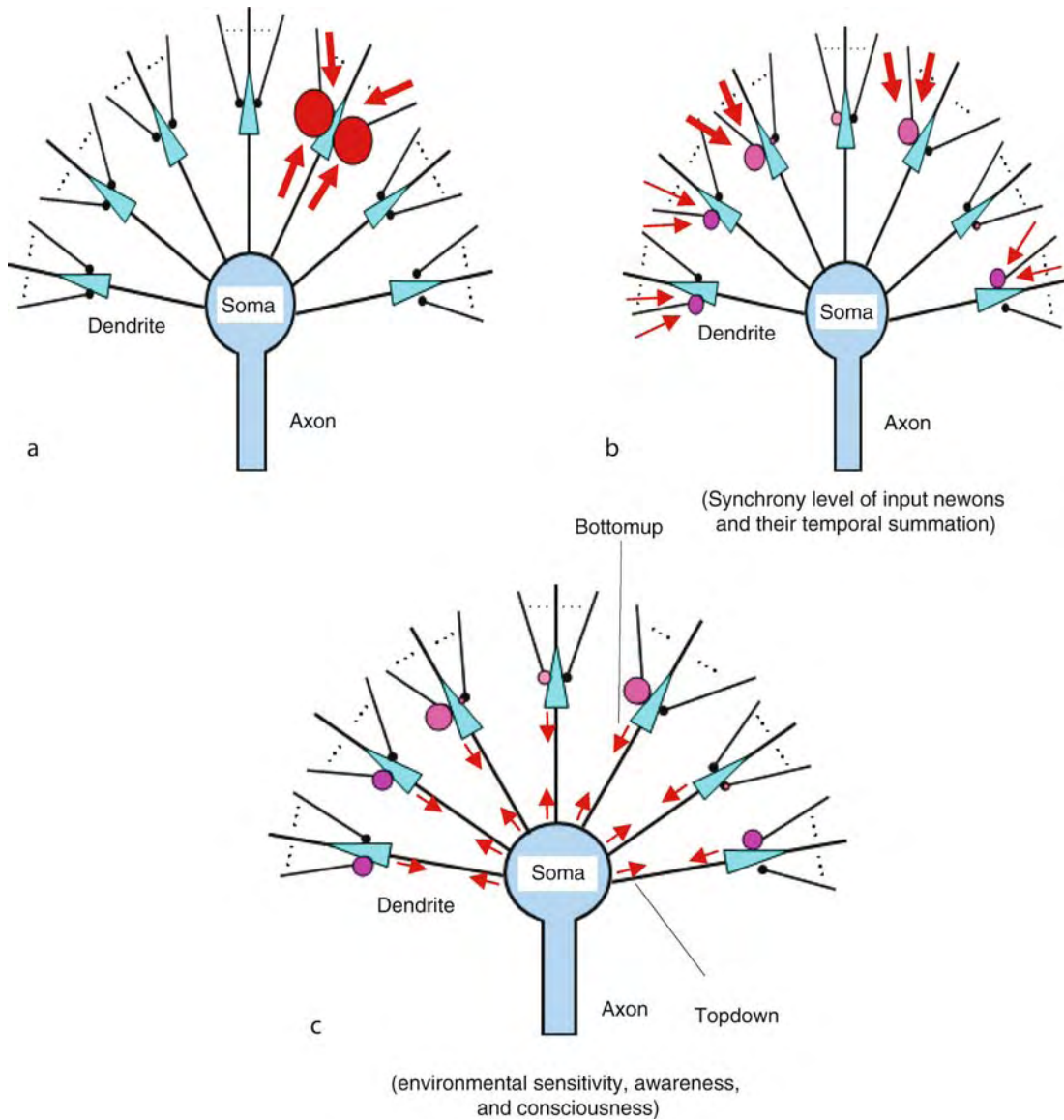

**Synaptic Plasticity. Figure 3** Functional differences between Hebb (a), and STLR (b), and their interaction (c) in a dendrite(local)-soma(global) system of single pyramidal cells of the CA1.

S

fires by integrating dendritic local potentials or by top-down information such as environmental sensitivity, awareness, and consciousness (top-down) (see Fig. 3c and its legend). The coexistence of the STLR (local information) and the Hebbian rule (global information) on the neuronal level may support this dynamic process that repeats itself until the internal model fits the external environment. The dendrite-soma interaction in pyramidal neurons of the hippocampal CA1 area can play an important role in the context formation of policy, reward, and value in [reinforcement learning](#).

The role of soma spiking as top-down information raise a number of interesting computational predictions. First, hippocampal theta is one of candidates of

top-down information which is driven by the medial septum [9]. The theta stimulation in the adult rat hippocampus can induce LTP [10]. Second, extrinsic modulators, such as acetylcholine, serotonin, norepinephrine and dopamine, can alter neuronal throughput and BAPs (so-called “meta-plasticity”) in such way that these transmitters diffuse broadly.

When you are confronted by certain situations, you naturally compare it to your previous experiences and attempt to predict what may happen and plan your actions in respect to predicted outcomes that we found favorable. In this way, your past, present, and pre-future memory work together and determine your actions. If these actions do not fit, then a new hypothesis is

formulated, new data is reasoned, and the previous model is amended. The coexistence of the STLR and the Hebbian rule may support this dynamic process, which repeats itself until the internal model fits the outer environment. In reinforcement learning, the dendritic-soma interaction in single pyramidal neurons of the hippocampal CA1 area can play an important role in the context formation of policy, reward, and value.

► **Hippocampus: Organization, Maturation, and Operation in Cognition and Pathological Conditions**

## References

1. Hebb DO (1949) The organization of behavior. Wiley, New York
2. Markram H, Lubke J, Frotscher M, Sakmann B (1997) Regulation of synaptic efficacy by coincidence of postsynaptic Aps and EPSPs. *Science* 275:213–215
3. Bi G, Poo M (1998) Synaptic modifications in cultured hippocampal neurons; dependence on spike timing, synaptic strength, and postsynaptic type. *J Neurosci* 18:10464–10472
4. Tsukada M, Aihara T, Saito H, Kato H (1996) Hippocampal LTP depends on spatial and temporal correlation of inputs. *Neural Netw* 9:1357–1365
5. Tsukada M, Pan X (2005) The spatiotemporal learning rule and its efficiency in separating spatiotemporal patterns. *Biol Cybern* 92:139–146
6. Tsukada M, Aihara T, Mizuro M, Kato H, Ito K (1994) Temporal pattern sensitivity of long-term potentiation in hippocampal CA1 neurons. *Biol Cybern* 70:495–503
7. Tsukada M, Yamazaki, Kojima H (in press) Interaction between the spatiotemporal learning rule (STLR) and Hebb type (HEBB) in single pyramidal cells in the hippocampal CA1 area. *Cogn Neurodyn* (in press)
8. Aihara T, Tsukada M, Matsda H (2000) Two dynamic processes for the induction of long-term potentiation in hippocampal CA1 neurons. *Biol Cybern* 82:189–195
9. Buzsaki G, Leung L, Vanderwolf CH (1983) Cellular bases of hippocampal EEG in the behaving rat. *Brain Res Rev* 6:169–171
10. Thomas MJ, Watabe AM, Moody TD, Makhinson M, O'Dell TJ (1998) Postsynaptic complex spike bursting enables the induction of LTP by theta frequency synaptic stimulation. *J Neurosci* 18:7118–126

## Synaptic Plasticity, Selectivity

### Definition

When high-frequency stimulation is applied to one of the two independent pathways innervating the same postsynaptic cells, LTP is usually induced selectively in the tetanized pathway and is not induced in the other

independent pathway. This characteristic of LTP is called “selectivity” or “specificity.”

- **Memory, ► Molecular Mechanisms**
- **Associative Long-Term Potentiation (LTP)**
- **Long-Term Potentiation (LTP)**

## Synaptic Properties

### Definition

The strength of synaptic connections and whether they are inhibitory or excitatory are all properties which affect the network behavior. Synaptic transmission can be modulated in diverse ways both pre and postsynaptically. Also critical is temporal summation of postsynaptic potentials, which can lead to short term potentiation of synaptic properties.

## Synaptic Proteins and Regulated Exocytosis

JENS R. COORSEN<sup>1,2</sup>

<sup>1</sup>Hotchkiss Brain Institute, Faculty of Medicine, University of Calgary, Calgary, AB, Canada

<sup>2</sup>Chair of Molecular Physiology, School of Medicine, University of Western Sydney, Campbelltown, NSW, Australia

### Synonyms

Exocytotic cycle; Synaptic release mechanism; Machinery of the neuronal secretory pathway

### Definition

As one of the most highly differentiated and thus specialized secretory cells, neuronal functions are in many ways directly or indirectly defined by the specificity, efficiency, and speed of the synaptic release process. From the instant that a depolarizing waveform invades the terminal of a chemical synapse to detection of a post-synaptic response can be as fast as ~150 μs; the lag between calcium influx and fusion is estimated to be as little as 60 μs. Despite hundreds of synaptic vesicles (SV) in a given neuron, the supply is not inexhaustible, necessitating that neurons also have fast



and efficient mechanisms to retrieve, refill and recycle SV, in particular to compensate for high frequency release under strong (e.g. highly repetitive) stimulus conditions. This dynamic cyclic pathway, coupling the release and retrieval processes, together with preceding steps that efficiently direct and move nascent SV from the trans-Golgi toward the synapse and then onto specialized sites on the plasma membrane (PM), is generally referred to as the regulated exocytotic pathway. Localized transient increases in cytoplasmic free calcium concentrations ( $[Ca^{2+}]_{free}$ ) in the vicinity of open voltage-gated  $\text{Ca}^{2+}$  channels act as focal sources of  $[Ca^{2+}]_{free}$  that may reach 10–100  $\mu\text{M}$  (relative to  $\sim 200\text{--}300$  nM resting  $[Ca^{2+}]_{free}$ ). These transient  $\text{Ca}^{2+}$  microdomains are the primary trigger (e.g. “regulator”) for the defining step of exocytosis: fusion of the SV and PM. This regulated membrane fusion (e.g. merger of the apposed bilayer membranes) results in an opening (the fusion pore) that enables release of the SV luminal content into the synaptic cleft; the released neurotransmitters then interact with receptors on the post-synaptic membrane, resulting in the depolarization of that cell and thus propagation of the original electrical signal to the next component(s) of the neural circuit.

The regulated exocytotic pathway thus consists of a series of concomitant and inter-connected stages that overlap temporally and also at the molecular level. Being highly conserved across eukaryotes, much has been learned over the last three decades using other secretory cell types and even cell fractions as model systems; despite access even to synaptosomes, the extremely small size and accessibility issues inherent to most synapses, and the fast kinetics of the release process, severely limited or obviated the coupled functional–molecular analyses necessary to effectively dissect underlying molecular mechanisms. The inability to “cleanly” separate certain functions still limits our understanding of specific molecular mechanisms. This is slowly changing, with many research groups bringing different combinations of refined and advanced techniques to bear on questions of the specific roles that particular proteins, or protein interactions, play at defined stages of the exocytotic pathway. The integrated work from a tremendous range of research teams – combining electrophysiological (e.g. patch clamp), imaging (e.g.  $\text{Total internal reflection microscopy}$  and confocal microscopy), ultrastructural (e.g.  $\text{Electron microscopic tomography}$  and rapid freeze), molecular biological, proteomic, and other research techniques, in a range of fast secretory cell types (albeit perhaps not all as fast as the “fastest” of neurons, e.g. neuroendocrine cells, oocytes, paramecium, and so forth) – makes this area one of the most fruitful inter- and multi-disciplinary junctions in modern Cell Physiology. In the last 15 years alone the field has gone from having virtually no known

key proteins, to having identified dozens or more proteins critical to the exocytotic pathway, with some even known to function at reasonably well-defined stages and with certain partners. There is little doubt that the interdisciplinary and cooperative interactions that have fuelled this area of research will continue to drive a fuller and more thorough molecular understanding of the different stages in the exocytotic pathway, their transition points, and what specific adaptations and mechanisms may (or may not) be neuron-specific.

### Characteristics

Based originally on the convergence of results from a range of different functional assays in a variety of different cellular model systems, the exocytotic pathway is now generally thought of as constituting a series of stages [1]. The actual proteins functioning at a specific stage, or indeed the specific molecular function of a given protein (or its interactions) in one or more stages, is often not yet so well understood. This is however rapidly changing with the continued growth and application of cutting-edge technologies in Neuroscience research. The exocytotic pathway (or more specifically the path of an SV in this cycle) is thus generally said to proceed via the following stages: trafficking, targeting, tethering, docking, priming, triggering, fusion, and retrieval. To specifically delineate it from the release portion of the exocytotic pathway, the retrieval stage is commonly referred to as endocytosis. Short descriptions of each stage follow and include mention of at least some of the proteins that are more commonly agreed to (likely) function in the associated molecular mechanisms. It is important to note that despite often being cartooned as specific steps, there are no clear-cut delineations between many of the stages, and indeed molecular mechanisms contributing to a given stage may already initiate their functions in preceding stages. For example, while some representations suggest that priming occurs after docking, considering the myriad of molecular alterations that may underlie this stage it is possible that some occur before, during, or after tethering and docking. Potential confusion is further compounded by the aforementioned speed of exocytosis in neurons, in many instances making the timing of specific molecular events difficult to clearly define.

### Trafficking

Newly synthesized SV leave the soma and undergo anterograde transport to the synapses via well-characterized mechanisms. This energy-dependent axonal transport utilizes microtubules as cytoskeletal tracks and is mediated by the motor protein kinesin (an ATPase with a microtubule binding domain). At the synaptic terminal, other transport or translocation machinery appears to take over, not only for further SV trafficking

but, importantly, to aid in segregating SV into functionally-defined sub-populations or pools. Defined largely based on the results of secretion assays and time-resolved electrophysiological measurements (e.g. membrane capacitance changes assessed by patch clamp recording) these pools are defined not only physically but in most cases also molecularly, generally corresponding to the different stages of exocytosis [1]. Moving from the axon-terminal interface toward the release sites of the synaptic terminal, three sequentially arranged pools of SV are broadly described as:

1. Unprimed (UPP) – a large population of SV mostly located deeper within the terminal that, upon passing through preparatory steps, can refill the Reserve pool. Also known as the resting or depot pool, these SV can be recruited during periods of massive stimulation and/or disruption of SV retrieval and recycling.
2. Reserve (RP; a.k.a. slowly releasable) – a population of SV that are not fully release-ready but can be rapidly recruited to that terminal pool.
3. Readily releasable (the RRP) – those SV fully docked at the PM and competent for fast,  $\text{Ca}^{2+}$ -triggered release; a sub-population of only a few vesicles has been identified as an Immediately releasable pool (IRP).

In the terminals it appears that the myosin motor proteins mediate translocation between these pools, utilizing actin clusters as tracks; myosin is known to interact with the SV proteins synaptobrevin (a.k.a. VAMP) and synaptophysin. Actin clusters also likely serve in some capacity to delimit SV movement between pools.

### Targeting

The next stage or process is intimately linked with trafficking and tethering (see below) as there must be a control mechanism to ensure that SV are targeted to appropriate synapses and subsequently, within the terminal, to proper/effective release sites. Concerning the latter, there is little direct evidence for specific protein functions although small G-proteins of the rab family have been suggested to have a role, as has the ►exocyst complex.

### Tethering

Those SV destined to fuse with the PM must of course be positioned at it. The localization near and initial loose or reversible attachment of SV to the PM is termed tethering and may in part involve cytoskeletal elements and rab proteins. At the ultrastructural level, tethering generally refers to those SV-PM attachments at distances that are greater than half an SV diameter (e.g., >25 nm). Due to their roles in linking the SV and

cytoskeletal elements, and in promoting SV clustering at active zones (see below), the synapsins have also been implicated as tethering elements.

### Docking

Proceeding from the tethered state, a more stable and intimate contact of the SV and PM is required to ensure the efficiency of triggered fusion and reduce the associated energy barriers. This likely represents a continuum of molecular states, from tethering through to the loose formation of inter-membrane SNARE complexes. Physically, a fully docked SV is generally regarded as being held within ~5–10 nm of the PM.

In nerve terminals, tethering, docking, and in particular fusion, are restricted to a specialized area of the presynaptic PM known as the active zone (AZ). This is a region of clustering of voltage-gated calcium channels that are close to, or constitute part of, SV docking sites. In electron micrographs, the AZ appears as an electron dense region of the PM, with an associated cytomatrix complex, and these are located directly across the synaptic cleft from the postsynaptic density; this tight alignment ensures the speed and fidelity of synaptic transmission [2]. Thus, proteins enriched in the AZ and its cytomatrix have been implicated in tethering and docking [1–3]. These include the rab-interacting RIM, as well as Piccolo, Bassoon, Munc13, ►Liprin- $\alpha$ , and ►ELKS that have been shown to interact with each other as well as with other accessory proteins including synaptotagmin, ►spectrin, calmodulin, ►DOC2, ►14-3-3, Munc18, and elements of the cytoskeleton, as well as with the voltage-gated calcium channels (that bind syntaxin, SNAP-25, synaptotagmin, and ►CSP via a specific protein interaction, or ►synprint, domain). Scaffold/ ►adaptor proteins including ►CASK, ►Mint, and ►Velis have also been identified as binding partners of some of these potential docking elements. In addition, syntaxin, that binds Munc13, is recognized to be required in docking. It seems likely that this is due to its role in the so-called inter-membrane SNARE complex that bridges the SV and PM. Specifically, syntaxin and SNAP-25 form dimers at the AZ, and these then bind with synaptobrevin on the vesicle membrane; together, these form extended coil-coil structures that are said to “zipper-up” from their N-terminal ends toward the C-terminal ends (containing the membrane anchoring regions) and thus bring the membranes into close apposition. This complex (likely in multiple copies at a docking site) is also thought to ensure the specificity of SV targeting. As the initial complex is in only a loose interaction, this and intermediate states (preceding the final tightly coiled complex), may represent increasingly stabilized interactions involved in tethering and docking.

## Priming

At the different stages described, and upon docking to the membrane, SV also undergo a series of molecular alterations that imbue them with full  $\text{Ca}^{2+}$  sensitivity and fusion competence. Simply, the SV become part of the RRP (or even IRP) and are capable of fast,  $\text{Ca}^{2+}$ -triggered release. Priming is thus another broad term, describing all functional molecular modifications, specifically including any ATP-dependent processes that facilitate and enable subsequent fast SV fusion. A number of proteins have been identified as critical to priming, including phosphatidylinositol kinases and the phosphatidylinositol transfer protein. As priming is sensitive to the levels of  $[\text{Ca}^{2+}]_{\text{free}}$ , and requires ATP, protein kinase activities have also been found to be critical. Specifically, the activities of the cAMP-dependent protein kinase and of protein kinase C have been linked to the replenishment or maintenance of the RRP; this could in part be due to stabilization of the inter-membrane SNARE complex [1]. Although it may occur rapidly and exist only transiently, many now consider the fully zippered SNARE complex to be the final step of priming; at this point the SV and PM are in close apposition as required to efficient fusion, the tight coiling of the SNARE complex likely having reduced part of the high energy barrier to subsequent membrane merger [4 and references therein].

## Triggering

After priming, the ensuing molecular steps, up to and including fusion, do not require ATP. This has been interpreted to indicate that the localized fusion site has been set-up (e.g. much like a “loaded-spring”) to respond with virtually unflinching efficiency. As the trigger,  $\text{Ca}^{2+}$  is thus thought to release the mechanism. The best evidence for this is the fact that the lipidic steps of membrane merger can be blocked with certain molecules (e.g. lysophosphatidylcholine) despite triggering of the associated upstream machinery by  $\text{Ca}^{2+}$ ; washout of the LPC then results in the rapid completion of fusion despite the absence of the trigger. Currently, the best candidate for a  $\text{Ca}^{2+}$  “sensor” is the protein synaptotagmin that is associated with the SNARE complex and also with specific membrane lipids. It is thought that  $\text{Ca}^{2+}$ -triggered interactions of specific domains in the synaptotagmin molecule with lipids may promote some of the membrane rearrangements that then initiate membrane fusion [5]. Certainly this would explain the association of synaptotagmin with the synchronous SV release that occurs with the opening of voltage-gated  $\text{Ca}^{2+}$  channels. The existence of additional sensors is also postulated based on the estimated numbers of  $\text{Ca}^{2+}$  ions that are thought to effect the release reaction; these estimates currently remain somewhat model-dependent.

## Fusion

The triggered fusion of the SV and the PM is the defining step of regulated exocytosis. Specifically, this requires the triggered focal merger of the SV bilayer membrane with that of the PM, at a highly restricted and specialized domain within the AZ. Without this, there is no release of neurotransmitters, no signaling between neurons, and thus no effective neural circuitry. The actual molecular mechanism mediating bilayer merger has been studied for decades and has relied heavily on biophysical analyses of membrane properties and associated mathematical modeling to reach our current understanding of the process. It is now reasonably clear that the inter-membrane SNARE complex itself does not drive membrane fusion [4,6], nor does it seem do other protein components, despite their contributions to delimiting the site, controlling the timing, and facilitating the outcome. It is currently most widely accepted that the fusion pore itself is likely to be lipidic. The stalk-pore hypothesis describes a series of transient, high curvature membrane intermediates that yield the lowest energy molecular pathway to fusion pore opening and full expansion [7,8]. At this stage of terminal fusion (e.g. full vesicle collapse), the vesicle and plasma membranes are continuous and only an active retrieval mechanism can reform the vesicle and recycle it for another round of exocytosis (see below).

Yet there is accumulating evidence to suggest another form of tightly coupled fusion and recycling that does not utilize full fusion [9]. “Kiss & Run” has been identified as a transient fusion event that results in only a partial release of vesicle content prior to the reversal or resealing of the fusion pore (sometimes referred to as a “flickering” pore). This is perhaps best thought of as a tight, focal interface between fusion and retrieval in which the SV never loses its identity. Variations on this theme suggest the continued docking or the undocking of the SV following the transient fusion event. There is evidence indicating that kiss & run is a specific response to certain modes of synaptic stimulation. If this is the case, a single synapse is even more versatile and complex in its responses than had been previously imagined, and modulation of the fusion pore may be a key step in signal integration.

## Endocytosis

The classical pathway of SV recycling involves the formation of clathrin-coated vesicles near previous release sites, with a ►fission reaction mediated by dynamin and associated proteins actually severing the new vesicle from the PM [10]. These vesicles are processed through endosomal intermediates before being refilled with transmitter (via specific transporters) and re-entering the RP or RRP as new SV. Recycling of the SNARE complex components, in part through the

concerted actions of NSF and  $\alpha$ -SNAP, is particularly important in this process. Another, faster, non-clathrin based mechanism of SV retrieval is also recognized that does not require subsequent passage through intermediate compartments; SV are quickly refilled and thus rapidly re-enter the RRP. Kiss & Run may be a highly specialized form of this latter recycling mechanism.

## References

1. Becherer U, Rettig J (2006) Vesicle pools, docking, priming, and release. *Cell Tissue Res* 326:393–407
2. Schoch S, Gundelfinger ED (2006) Molecular organization of the presynaptic active zone. *Cell Tissue Res* 326:379–391
3. Khanna R, Zougman A, Stanley EF (2007) A proteomic screen for presynaptic terminal N-type calcium channel (CaV2.2) binding partners. *J Biochem Mol Biol* 40:302–314
4. Szule JA, Coorssen JR (2003) Revisiting the role of SNAREs in exocytosis and membrane fusion. *Biochim Biophys Acta* 1641:1185–1196
5. Araç D, Chen X, Khant HA, Ubach J, Ludtke SJ, Kikkawa M, Johnson AE, Chiu W, Südhof TC, Rizo J (2006) Close membrane-membrane proximity induced by Ca<sup>2+</sup>-dependent multivalent binding of synaptotagmin-1 to phospholipids. *Nat Struct Mol Biol* 13:209–217
6. Chen X, Araç D, Wang T-M, Gilpin CJ, Zimmerberg J, Rizo J (2006) SNARE-mediated lipid mixing depends on the physical state of the vesicles. *Biophys J* 90:2062–2074
7. Chernomordik LV, Zimmerberg J, Kozlov MM (2006) Membranes of the world unit! *J Cell Biol* 175:201–207
8. Churchward MA, Rogasevskaia T, Höfgen J, Bau J, Coorssen JR (2005) Cholesterol facilitates the native mechanism of Ca<sup>2+</sup>-triggered membrane fusion. *J Cell Sci* 118:4833–4848
9. Harata NC, Aravanis AM, Tsien RW (2006) Kiss-and-run and full-collapse fusion as modes of exo-endocytosis. *J Neurochem* 97:1546–1570
10. Ferguson SM, Brasnjo G, Hayashi M, Wölfel M, Collesi C, Giovedi S, Raimondi A, Gong L-W, Ariel P, Paradise S, O'Toole E, Flavell R, Cremona O, Miesenböck G, Ryan TA, De Camilli P (2007) A selective activity-dependent requirement for Dynamin 1 in synaptic vesicle endocytosis. *Science* 316:570–574

## Synaptic Regeneration

### Definition

Generation of new synaptic contacts after losing synapses by nerve damage such as disease or injury.

- ▶ Regeneration
- ▶ Synaptic Elimination

## Synaptic Release

### Definition

Synaptic vesicles release their contents in response to depolarization of the presynaptic membrane.

- ▶ Synaptic Transmission: Model Systems

## Synaptic Scaling

### Definition

The differential modulation of the individual synaptic gains in a population of synapses. This process occurs to stabilize the neuronal network.

- ▶ Activity-Dependent Synaptic Plasticity

## Synaptic Specificity

AKINAO NOSE

Department of Complexity Science and Engineering, Graduate School of Frontier Sciences, University of Tokyo, Tokyo, Japan

### Synonyms

Target specificity

### Definition

Specificity of synaptic connections between neurons and their target cells. In a narrower definition, it refers to the formation of synaptic structures between neurons and their specific cellular or subcellular targets.

### Characteristics

#### Description of the Process

The proper functioning of the nervous system depends on precise interconnections between distinct types of neurons. Therefore, understanding the molecular mechanisms of synaptic specificity – the specificity with which connections form between neurons – is a central issue in modern neuroscience. The magnitude of the complexity involved in this process is daunting. In the human brain, each of the roughly 10<sup>11</sup> neurons establishes connections with, on average, over a thousand target cells in a highly characteristic manner. Remarkably, much

of the intricate patterning of these synaptic connections can be generated in the absence of activity or experience; thus the information necessary for this precise wiring must be largely encoded by the genetic program. It was Roger Sperry who first showed that synaptic specificity could be generated in a predetermined manner, independent of the experience of the animal [1]. After a series of experiments on the retinotectal projection in frogs, he proposed the highly influential “▶chemoaffinity hypothesis” [see Glossary]. The theory posits that individual target cells and their innervating nerves must carry matching sets of molecular markers or have “chemoaffinity” to establish specific connections between them. This idea motivated subsequent studies on the molecular mechanisms of synaptic specificity.

Synaptic specificity is generated in a stepwise fashion through three major stages of neuronal recognition (Fig. 1) [2,3].

Neurons first extend axons over long distances along stereotyped pathways toward their target region (axon pathfinding). Some neurons then search for a specific location or position within a field of target cells that represents a map of sensory information (topographic mapping).

Finally, neurons select individual target cells with which to make synaptic connections (cellular targeting). In many cases, presynaptic axons not only distinguish potential target cells but also recognize the appropriate subcellular region of the target cell (for

example, the cell body versus dendrites; subcellular targeting).

The focus of this essay is mainly on the third step—cellular and subcellular targeting—addressing the topic of synaptic specificity in its narrower sense. Please refer to other essays for detailed accounts of the first two steps of the generation of synaptic specificity. Also see the essay on “target selection”.

### Regulation of the Process

Axons extend toward their targets by attractive and repulsive guidance cues expressed along the pathway, as well as by cues from the target cells themselves [2]. Axons recognize and respond to these cues with a specialized terminal structure, the growth cone. The growth cone bears receptors that bind to the guidance cues and elicit signal transduction cascades that regulate growth cone steering. The guidance cues expressed by target cells, together with their receptors on the presynaptic cells, determine target specificity and are collectively called target recognition molecules. Compared to the wealth of information on the molecules and signaling that regulate axon pathfinding and topographic mapping, relatively little is known about molecules involved in selection of discrete target cells. However, functional analysis of several candidate molecules begins to illuminate the molecular mechanisms of target recognition (as described below in more detail). As initially postulated by Sperry, target specificity indeed appears to be regulated by the action of the molecular labels on the target (or nearby) cells and their receptors on specific presynaptic cells. Some of such labels are cell adhesion molecules that promote interaction between specific pre- and postsynaptic cells.

How the tremendous diversity of synaptic connections is coded by such cellular labels on neurons and targets is an important but unsolved problem. Is it coded by differential and/or combinatorial use of a relatively small number of molecules? Or are there diverse sets of complementary molecules expressed on individual cells? Several large families of cell surface proteins have been implicated in synaptic specificity, including the cadherin-related neuronal receptors (CNRs), neu-exins/neuroigins, odorant receptors and *Drosophila* Dscams. For example, alternative splicing of the *Drosophila* cell adhesion molecule Dscam potentially generates 38,016 isoforms [4]. However, whether these large gene families indeed mediate synaptic specificity remains to be determined. On the other hand, there is evidence that molecules without such immense diversity can function as target recognition molecules (as described below in more detail).

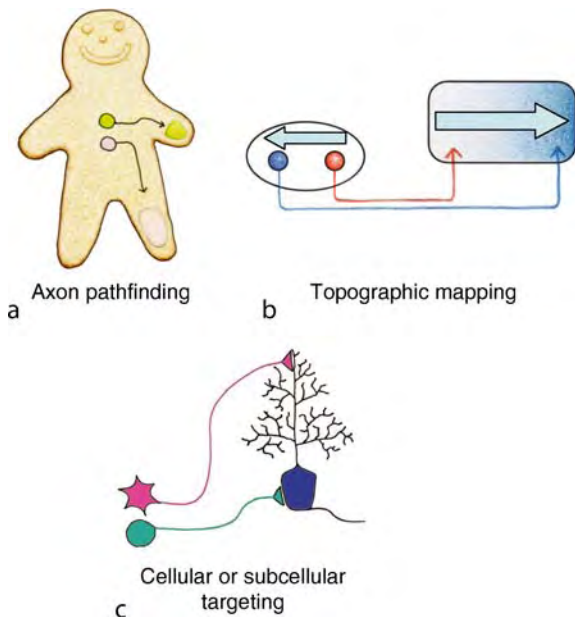

**Synaptic Specificity. Figure 1** Generation of synaptic specificity. Synaptic specificity is generated in a stepwise fashion through three major stages: axon pathfinding (a), topographic mapping (b) and cellular and subcellular targeting (c).

### Higher-Level Processes

For proper neural wiring to occur, the guidance cues expressed along axon pathways and targets and their

receptors in the presynaptic cells, have to be expressed at the right place at the right time. This process is regulated in part by the action of transcription factors as they specify the fate of individual neurons. For example, combinatorial expression of LIM-homeodomain transcription factors, the LIM code, determines the axon pathways of motor neurons toward their distinct muscle targets in vertebrates as well as in *Drosophila*. However, the specific downstream axon-guidance molecules that are regulated by these transcription factors are not yet defined.

### Examples of Synaptic Specificity: Selecting Discrete Targets

#### Cell-to-Cell Targeting

Upon reaching the target region, neurons must choose specific synaptic partners from among a number of potential targets in the vicinity. In the cerebral cortex, for example, chandelier cell interneurons form synapses only with pyramidal neurons and in the cerebellum, ascending fibers connect only with Purkinje cells. The molecular mechanisms of cell-to-cell targeting are currently best characterized in the *Drosophila* neuromuscular system (Fig. 2a) [5].

In each segment of *Drosophila* larvae, ~40 motor neurons specifically innervate 30 muscle cells. Each

motor neuron contacts many different muscles in the target region before forming synapses with only one or a few targets, suggesting the presence of specific cues present on individual target cells. Molecular and genetic studies have indeed identified several cell-surface or secreted proteins that are expressed in different subsets of muscles and can either attract or repel specific motor neurons. These include cell adhesion molecules with leucine-rich repeats (LRR), connectin, toll and capricious, a cell adhesion molecule of the immunoglobulin superfamily fasciclin3 (Fas3) and the attractive and/or repulsive secreted guidance molecules known as netrins and semaphorins. Connectin, Fas3 and capricious are also expressed on the presynaptic axons that innervate the muscles that express the same molecule and appear to mediate homophilic and attractive interaction between the synaptic partners. On the other hand, netrins, semaphorins and toll are expressed only on the target cells; they promote or inhibit synapse formation by binding to heterophilic receptors on the growth cone. These candidate target recognition molecules appear to function in a partially redundant manner to determine synaptic specificity; although gain-of-function mutations or ectopic expression of these molecules dramatically affects target specificity, loss-of-function mutations generally lead to only minor defects. Consistent with this idea, presynaptic motor neurons are able to integrate the information provided by multiple attractive and repulsive muscle cues.

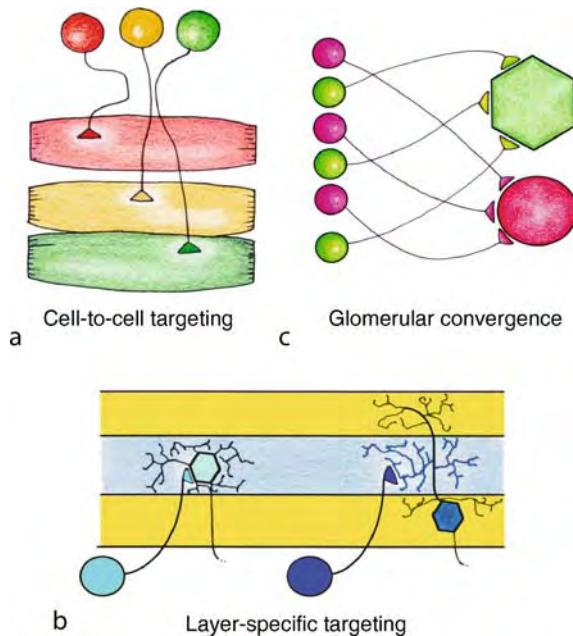

**Synaptic Specificity. Figure 2** Examples of discrete targeting. Synaptic specificity can be generated by different forms of neuronal targeting. (a) Cell-to-cell targeting as in the case of a *Drosophila* neuromuscular connection. (b) Layer-specific targeting as found in the tectum and the cerebral cortex. (c) Glomerular convergence in the olfactory system.

#### Layer-Specific Targeting

Layer-specific (also called lamina-specific) innervation is a common form of neuronal targeting, since many targets in the central nervous system, such as the tectum and the cerebral cortex are divided into multiple layers [6]. Arriving axons thus form specific synaptic connections by selecting the right layer(s). In some cases, the postsynaptic cells and their dendrites are themselves confined to a particular layer (Fig. 2b, left). In other cases, postsynaptic cells have dendritic branches that extend through multiple layers (Fig. 2b, right). In the latter case, presynaptic cells must recognize not only the specific target cell but also its correct dendritic segments for synapse formation (subcellular specificity). Several candidate target recognition molecules that are expressed in a layer-specific manner in vertebrates have been reported, including N-cadherin, sidekicks (Sdks) and ephrins. Of these, the best characterized are Sdk1 and Sdk2, which are homologous immunoglobulin superfamily cell adhesion molecules that are expressed in different subsets of retinal cells [7]. Sidekick proteins are concentrated at synapses that form between Sdk-expressing pre- and post-synaptic cells. Ectopic expression of Sdks in normally Sdk-negative presynaptic cells redirects their terminals to Sdk-positive layers.

A good model system for layer-specific targeting is photoreceptor targeting in the *Drosophila* visual system [4]. Eight photoreceptors (R cells; R1–8) that comprise the simple eye project to distinct layers of the optic lobe; R1–R6 project to the first optic ganglion (the lamina) and R7 and R8 project to distinct layers in the second optic ganglion (the medulla). Large-scale genetic screening has been used to identify several receptors and cell adhesion molecules that are involved in this targeting process, including the cadherins N-cadherin and flamingo and the receptor protein tyrosine phosphatases LAR and PTP69D [4]. Although the expression of these molecules is not restricted to particular R cells or target layers, the mutant phenotypes indicate that they function in specific aspects of R cell targeting. On the other hand, the LRR cell adhesion molecule capricious, which was originally identified for its role in neuromuscular specificity (as described above), is specifically expressed in R8 cells and their target cells in the medulla [8]. Both loss-of-function and gain-of-function analyses suggest that capricious regulates layer-specific targeting by mediating specific axon-target interaction.

#### **Glomerular Convergence: Targeting in the Olfactory System**

The odorant receptors constitute a large receptor family (~1,000 in mammals). Olfactory neurons that express a particular receptor are scattered in a large area of the nasal epithelium. Yet, their axons converge onto specific target glomeruli in the olfactory bulb (Fig. 2c). The odorant receptor itself has been implicated in this targeting process [9]. When a single odorant receptor is deleted, the neurons that normally express it fail to converge on their target glomerulus. On the other hand, replacing a normal olfactory receptor with an ectopic one causes olfactory neurons to target neither the normal glomerulus nor the one expected for the new receptor. Instead, they map to an ectopic glomerulus located in between. These results suggest that while odorant receptors are important in glomerulus targeting, they are not the sole determinants.

#### **Targeting Mediated by “Guidepost Cells”**

In some cases, synaptic specificity between two neurons is determined by the function of a third cell. The HSNL motor neurons in *C. elegans* form synaptic connections with VC4 and VC5 neurons and the vulval muscle vm2, in the vicinity of the vulval epithelial cells [10]. The vulval epithelial cells, but not the target cells themselves, are important in synaptic positioning. Thus, the epithelial cells serve as guidepost cells that induce the formation of specific synaptic sites. SYG-1 and SYG-2, a pair of transmembrane proteins of the immunoglobulin superfamily that heterophilically bind to each other, have been

implicated in this process. SYG-1 is expressed in presynaptic HSNL motor neurons and SYG-2 in the guidepost epithelial cells. Both are necessary for normal synapse formation by the HSNL neurons. Ectopic expression of SYG-2 induces the accumulation of SYG-1 and presynaptic markers in HSNL adjacent to that region.

#### **References**

1. Sperry RW (1963) Chemoaffinity in the orderly growth of nerve fiber patterns and connections. *Proc Natl Acad Sci USA* 50:703–710
2. Tessier-Lavigne M, Goodman CS (1996) The molecular biology of axon guidance. *Science* 274:1123–1133
3. Benson DL, Colman DR, Huntley GW (2001) Molecules, maps and synapse specificity. *Nat Rev Neurosci* 2:899–909
4. Clandinin TR, Zipursky SL (2002) Making connections in the fly visual system. *Neuron* 35:827–841
5. Rose D, Chiba A (2000) Synaptic target recognition at *Drosophila* neuromuscular junctions. *Microsc Res Tech* 49:3–13
6. Yamagata M, Weiner JA, Sanes JR (2002) Sidekicks: synaptic adhesion molecules that promote lamina-specific connectivity in the retina. *Cell* 110:649–660
7. Sanes JR, Yamagata M (1999) Formation of lamina-specific synaptic connections. *Curr Opin Neurobiol* 9:79–87
8. Shinza-Kameda M, Takasu E, Sakurai K, Hayashi S, Nose A (2006) Regulation of layer-specific targeting by reciprocal expression of a cell adhesion molecule, capricious. *Neuron* 49:205–213
9. Feinstein P, Mombaerts P (2004) A contextual model for axonal sorting into glomeruli in the mouse olfactory system. *Cell* 117:817–831
10. Shen K, Fetter RD, Bargmann CI (2004) Synaptic specificity is generated by the synaptic guidepost protein SYG-2 and its receptor, SYG-1. *Cell* 116:869–881

## **Synaptic Transmission: Model Systems**

S

ZHONG-PING FENG

Department of Physiology, University of Toronto,  
Toronto, ON, Canada

#### **Synonyms**

Model presynaptic release sites

#### **Definition**

Model systems are being used to define the structural and functional attributes of synapses, which are specialized points of physical and functional contact between two communicating neuronal elements.

## Characteristics

Cell-cell communication is essential to all nervous system functions. Synapses allow signals to be transmitted from neurons to their targets, providing the minimal building blocks necessary for neural integration. ► **Chemical synapses**, which consist of presynaptic and postsynaptic compartments separated by a synaptic cleft, are highly specialized structures that mediate the transmission of signals from presynaptic termini to postsynaptic targets via chemicals known as ► **neurotransmitters**. The structural and functional features of synapses are conserved in vertebrates and invertebrates.

At most chemical synapses, an action potential that invades a presynaptic terminal leads to a depolarization that causes voltage-activated calcium channels to open. A calcium influx increases the intracellular calcium concentration, resulting in the generation of calcium microdomains or nanodomains, which facilitate the fusion of transmitter-containing synaptic vesicles to the presynaptic membrane. After fusing to the membrane, the synaptic vesicles release their contents (neurotransmitters) into the synaptic cleft via exocytosis. The transmitters released by exocytosis diffuse to the postsynaptic membrane where they bind to ► **postsynaptic receptors**; thus, directly or indirectly, alters the excitability of the postsynaptic cells. At ► **excitatory synapses**, transmitter binding to postsynaptic receptors allows a net inward current, which depolarizes the membrane toward the action potential threshold (► **Excitatory postsynaptic potential (EPSP)**); whereas at ► **inhibitory synapses**, transmitter binding to postsynaptic receptors allows a net outward current, which drives the membrane potential away from threshold and maintains a membrane potential that is negative relative to the threshold value (► **Inhibitory postsynaptic potential (IPSP)**). Thus, the synapse mediates communication between the presynaptic and postsynaptic cells.

A variety of forms of the synapse have been identified. Depending on the nature of the postsynaptic cell, the synapse can be divided into two major categories: the ► **neuro-muscular synapse (Neuromuscular junction, NMJ)**, which refers to a synapse formed between a presynaptic neuron and a postsynaptic muscle cell, and the ► **neuronal synapse (► Central synapse)**, which refers to a synapse formed between two neurons.

Much of our understanding of the basic properties of synaptic transmission is the result of a large body of work done on neuromuscular junctions, largely due to its anatomical simplicity and accessibility. Using these models, the principle structures of presynaptic features, release mechanisms of acetylcholine, and synaptic efficacy of transmission have been determined. For instance, studies on frog neuromuscular junctions demonstrated the quantal release of synaptic vesicles by Del Castillo and Katz in 1954, vesicle fusion

to cytoplasmic membrane by Heuser and Reese in 1973, acetylcholine-dependent single-channel activity by Neher and Sakmann in 1976, the calcium requirement for release by Katz and Miledi in 1967, and the colocalization between the presynaptic calcium channels and postsynaptic acetylcholine receptors by Robitaille and colleagues in 1990. In addition to principle studies of neurotransmission, NMJs with specific features have also been used to investigate modulatory mechanism of synaptic transmission. For instance, Atwood and colleagues in 1967 showed that crustacean phasic and tonic glutamatergic motor neurons are innervated to a common muscle cell, but evoke different postsynaptic excitatory responses. The phasic EPSPs are large and often exhibit synaptic facilitation, whereas the tonic EPSPs are small and usually exhibit synaptic depression. These distinct properties have made crustacean NMJ models useful to study synaptic specialization. A number of genetic models of invertebrates have been used to identify molecules that are involved in regulating and mediating neurotransmission at neuromuscular junctions. For instance, the role of synaptotagmin in the NMJ transmission were investigated in *Drosophila* by Littleton and Colleagues in 1993, and Schwarz's group in 1994, and in *C. elegans* by Nonet and colleagues in 1993 and Jorgensen and colleagues in 1995.

Many of the principle properties that have been established for synaptic transmission at neuromuscular junctions are shared by central synapses. However, recent studies have shown that certain features of central synapses are distinct from those of neuromuscular junctions. For instance, Ceccarelli and colleagues in 1973 showed that presynaptic vesicles in neuromuscular junctions are locally reused at the synapse at which they are recycled. Work by Krueger and colleagues in 2003 indicated that functional synaptic vesicles in hippocampal neurons exhibit considerable mobility and can transit from the stable ► **synaptic release sites** along axons to other sites. Presynaptic proteins associated with neurotransmission are also shared amongst the neighboring terminals. Another example is the size of the quantal response, an elementary unit of synaptic transmission. The variability of the quantal size in the NMJs is low (the coefficient of variation is  $\sim 0.3$ ), whereas that in the central synapses is ranged widely (the coefficients of variation are from 0.23 to 0.6), dependent on the preparation used. In addition, certain molecules that are critical to synapse formation in neuromuscular junctions play different roles in central synapses. For instance, agrin is essential to neuromuscular junction formation as showed by McMahan in 1990. Serpinsky and colleagues in 1999 reported that central synapses, however, form in the absence of agrin.

Our limited understanding of the presynaptic mechanisms of neuronal (central) synapses can be



attributed to the complex anatomical structures and small size of most of neuronal synapses, which makes the synapses less accessible to electrophysiological recordings. Unlike the situation in neuromuscular junctions, in neuronal synapses the structures of both the presynaptic and postsynaptic neurons are highly variable. A stereotypical presynaptic element is the nerve terminal of axon, which forms synapse with a postsynaptic dendrite (axonal-dendrite synapse), a postsynaptic soma (▶**Axonal-soma synapse**), or a postsynaptic axon (▶**Axo-axonal synapse**). However, atypical synapses can form between a presynaptic dendrite and a postsynaptic axon (▶**Dendro-axonal synapse**), or between cell somata (▶**Soma-soma synapse**). Although afferent axons are only rarely postsynaptic to dendrites, the ultrastructures of dendro-axonal synapse have been described in dorsal horn of cats and monkeys by Ralton III's group in 1984, and of rats by Cruz and colleagues in early 1990s. *In vivo* axo-axonal synapses have been described in both invertebrates and vertebrates. For instance, ultrastructures of synaptic vesicle clustering in crayfish and in spider crabs have been shown at both axonal sites by Atwood's group in 1970s. Depolarization of an inhibitory efferent axon projection to the excitatory terminals results in modulation of excitatory transmitter release. Ralton III's group detailed the axo-axonal structures in rats, monkeys, and cats. The same group in early 1980s also reported multiple forms of synaptic connections in the macaque spinal cord, including axo-dendritic, axo-axonal, axo-somatic, and dendro-axonal synapses. One of the short-comes of these native synapse preparations in higher animals is to determine the presynaptic release properties due to the small size of the synapses and the complex anatomy, which does not permit direct access to the synaptic sites for functional analysis.

Our understanding of synaptic transmission in neuronal synapses largely relies on the availability of synapse models in which functional properties of synaptic transmission can be detected by direct electrophysiological recordings at the presynaptic release sites. This entry will focus on the major neuronal synapse models used to study the mechanisms and control of transmitter release in the neuronal synapse.

## Native Neuronal Synapse Models

### Squid Giant Synapse

The squid giant synapse forms between a presynaptic second-order giant fiber and a postsynaptic third-order giant nerve. These synapses are particularly large (100s  $\mu\text{m}$ ). Synaptic transmission in the squid giant synapse was first recorded by Bullock and Hagiwara in 1957. Later studies using this synapse model demonstrated the correlation between the presynaptic depolarization, presynaptic calcium concentration and postsynaptic potential. For example, Llinas' group

in early 1980s showed that calcium entry is directly related to the release of transmitter and confirmed the power relationship between calcium concentration and transmitter release by Katz and Miledi in 1970.

### Calyceal Synapses

Giant calyceal synapses were first described in the nucleus magnocellularis of the avian auditory system. A classical example is the chick ciliary synapse as described by Marin and Pilar in 1964 and by Stanley and Goping in 1991. In this giant chick synapse, the presynaptic element envelops the postsynaptic ciliary neuron and contains a typical fast-transmitting cholinergic nerve terminal. Glutamatergic synapses are also observed in neurons of the chick nucleus magnocellularis (nMAG), one of the avian cochlear nuclei that receives somatic, calyceal innervation from the auditory nerve fibers as reported by Zhang and Trussell in 1994.

Hans Held (1894) first described calyceal synapses in the mammalian auditory brainstem, and these giant synapses were further characterized by Lorente de No in 1980, and Spirou and colleagues in 1990. The "endbulb of Held" synapses form between auditory fibers (presynaptic) from the spiral ganglion in the inner ear and the bushy cell soma (postsynaptic) of the ventral cochlear nucleus, and ▶**calyx of Held synapses** form between a projection of globular bushy cells (presynaptic) in the anterior ventral cochlear nucleus and the cell soma of a principal neuron (postsynaptic) in the medial nucleus of the trapezoid body (MNTB) (Fig. 1).

The calyx of Held is a typical example of an axonal-soma synapse, from which Forsythe (1994) pioneered the first patch clamp recordings from nerve terminals. The globular bushy nerve terminals in this synapse release glutamate, resulting in fast AMPA and slow NMDA excitatory postsynaptic currents.

One of the major advantages of the calyx of Held as a model for the study of synaptic transmission is the accessibility of its large presynaptic terminal (10–15  $\mu\text{m}$ ), which permits patch-clamp recordings, capacitance measurements of exocytosis in combined with calcium imaging, and uncaging studies. These features have made the calyx of Held a popular synapse model of central synaptic transmission in the last decade. For instance, this model system has been used to study the quantal properties of transmission by Schneggenburger and colleagues in 1999, the calcium sensitivity of transmitter release by Bollmann and colleagues in 2000, the regulation of presynaptic calcium level and vesicle release by Takahashi's group in 1996, and the presynaptic mechanisms of short-term synaptic plasticity by a number of groups including Barnes-Davies and Forsythe in 1995, Turecek and Trussell in 2001, and Xu and Wu in 2005. The calyx of Held has also been used to study the developmental and

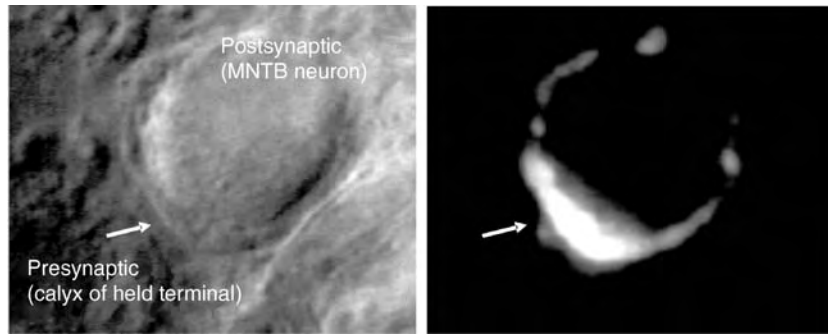

**Synaptic Transmission: Model Systems. Figure 1** The calyx of Held synapses in the auditory brainstem slice. Left: DIC image; Middle: epifluorescence image of the same synapse with presynaptic terminal loaded with Lucifer Yellow. Arrow: the presynaptic calyx of Held nerve terminal enveloping the postsynaptic MNTB neuron. The cell diameter:  $\sim 15$   $\mu\text{m}$  (Courtesy of Lu-Yang Wang).

maturational changes that occur in presynaptic function as reported by Taschenberger and von Gersdorff in 2000, and Joshi and Wang in 2002. Manipulation of the presynaptic release mechanism at the molecular level is the major challenge in using this model system.

#### Retinal Bipolar Cells

The retinal bipolar cells of goldfish have a single, large and bulbous synaptic terminal, 8–12  $\mu\text{m}$  in diameter, allowing patch-clamp recordings to be made on either dissociated bipolar cells or detached terminals as reported by Matthews' group in 1994. The ribbon-type terminals of the retinal bipolar cells, which secrete glutamate via the fusion of small, clear-core vesicles to the presynaptic membrane, have been used to study the mechanisms of calcium-dependent exocytosis and synaptic vesicle recycling.

#### Neurohypophysial Nerve Terminals

The nerve terminals of neurohypophysis (the posterior pituitary gland) extending from supraoptic and paraventricular nuclei release peptide neurohormones into the capillaries of the hypophyseal circulation. Arginine-vasopressin and oxytocin are the two major peptides found in neurohypophysial secretory granules. Some neurohypophysial nerve terminals have endings as large as 8–10  $\mu\text{m}$  in diameter. Neurohypophysial synapse preparations have been used to study the calcium-dependent release mechanisms of peptide hormones in the work by Lemos and Nordmann in 1986 and Jackson and colleagues in 1991.

#### Hippocampal Brain Slices

Hippocampal brain slices have been used to study the presynaptic mechanisms involved in synaptic plasticity in the CA1 region since the work by Creager and colleagues in 1980. Direct patch-clamp recordings have been achieved on the mossy fiber terminal in the hippocampal CA3 region by Geiger and Jonas in 2000. This study demonstrated that slow recovery from

inactivation of presynaptic  $\text{K}^+$  channels regulates presynaptic strength by enhancing presynaptic calcium influx. The major limitation of this model is again the small presynaptic site.

#### Synapse Models in Primary Cell Culture

##### Neurite-Neurite Synapses

Synaptic connectivity has been extensively studied in synapses formed in primary dissociated neuronal cell culture. Rotten hippocampal neuronal cultures are commonly used to study synapse function and structure *in vitro*. Unfortunately, the identities of the synapses in these cultures are usually unknown until the recording is completed. In addition, glial cells are required to establish these cell cultures, and functional synapses take up to weeks to form, increasing the variation and complexity found in these preparations. Simpler invertebrate neuronal cell culture models, such as those derived from mollusks, are also used to study synaptic function and synapse formation. Invertebrate *in vitro* systems offer some major advantages, including neurons that are usually individually identifiable, synapses that form in the absence of glial cells, and neurites that proceed with large growth cones. However, even in simple mollusk model systems, the neurite-neurite synapses are small, and electrophysiological recordings are often performed at cell somata that lie some distance from the synapse. The number of synapses in these cultures and the time it takes for the synapses to form between neurites varies between preparations. The formation of synapses depends primarily on neurite outgrowth. The temporal and spatial sequences of synaptic dynamics are difficult to observe directly. Thus, in an ideal model, the synapse would form between the cell bodies of identified neurons in the absence of neurites, namely a soma-soma synapse.

##### Soma-Soma Synapses

In culture, synapses form between neuronal somata in the absence of neurites. The major advantage of

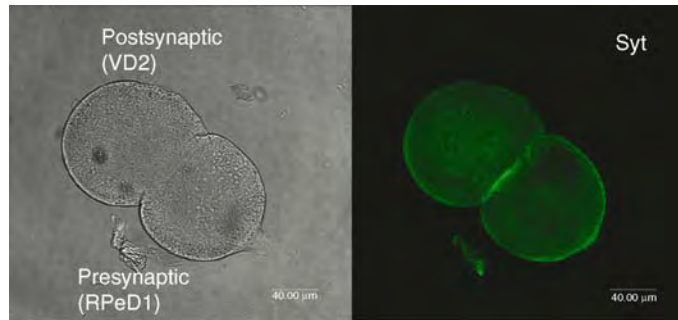

**Synaptic Transmission: Model Systems. Figure 2** A soma-soma synapse between identified *Lymnaea stagnalis* neurons in culture. Left: light image; Right: confocal image showing synaptotagmin clustering at the presynaptic site. Scale bar: 40 mm (Courtesy of Peter Gardzinski and Zhong-Ping Feng).

this model is that the synapses are large and relatively easily accessible for electrophysiological recordings and calcium imaging. The soma-soma synapse model, which most often employs neurons derived from molluscs, was pioneered in leech [1] and subsequently refined in the snails *Helisoma* [2] and *Aplysia* [3]. Feng et al. [4] adapted the soma-soma synapse approach to *Lymnaea stagnalis*. Functionally well-defined presynaptic and postsynaptic neurons can be individually isolated and paired in a soma-soma configuration in cell culture (Fig. 2).

Simultaneous electrophysiological recordings can be directly performed on the pre- and postsynaptic sites. Specific synaptic connections, similar to those observed *in vivo* and *in vitro* between neurites reported by Syed's group in early 1990s, have been detected between the identified neurons. In addition, voltage-induced calcium hotspots [5] and synaptic vesicle aggregation, labeled by FM1-43 signaling [6] or synaptotagmin [7], have been observed at the presynaptic sites. Formation of inhibitory and excitatory synapses has been showed to require distinct trophic factors [4,8]. The synaptic efficacy of *Lymnaea* soma-soma synapses is regulated by the cAMP-PKA signal transduction pathway [9] and glial cells [10]. Our recent study showed that the C2A and C2B calcium binding loops of synaptotagmin play different roles in synapse formation and synaptic transmission between soma-soma synapses [7]. The *Lymnaea* soma-soma synapse provides an unrivaled functional model for investigating the molecular mechanisms underlying synapse function.

### Isolated Synapse Preparation

#### Synaptosome

Synaptosomal preparations are made from isolated nerve terminals and axonal varicosities *in vitro*. The well-sealed synaptosomes contain 70–100% of presynaptic boutons and terminals, and closely resemble the nerve terminal or varicosity from which they were derived. This model system has been used to identify proteins and mechanisms involved in

exocytosis since the work of Whittaker's group in 1964. Direct patch clamp recording was first made by Nicholls and Sihra in 1986. Synaptosomes are derived from non-uniform sources of nerve terminals and varicosities and contain a mixture of multiple-types of synapses and transmitters; these features limit its usefulness in studies on the specificity of synaptic release mechanisms.

In summary, every model has its own particular strengths and limitations. The major advantage of the *in vitro* soma-soma synapse model between *Lymnaea* neurons is that the giant synapse forms between individually identifiable cells. In contrast to native giant synapses, the soma-soma synapse model allows direct assessment of the timing of synapse development, thus offering an ideal model not only for studying the cellular and molecular mechanisms of synaptic function, but also allowing investigations of the maturation of synapses formed between adult neurons.

### References

1. Fuchs PA, Henderson LP, Nicholls JG (1982) Chemical transmission between individual Retzius and sensory neurones of the leech in culture. *J Physiol* 323:195–210
2. Haydon PG (1988) The formation of chemical synapses between cell-cultured neuronal somata. *J Neurosci* 8:1032–1038
3. Klein M (1994) Synaptic augmentation by 5-HT at rested *Aplysia* sensorimotor synapses: independence of action potential prolongation. *Neuron* 13:159–166
4. Feng ZP, Klumperman J, Lukowiak K, Syed NI (1997) *In vitro* synaptogenesis between the somata of identified *Lymnaea* neurons requires protein synthesis but not extrinsic growth factors or substrate adhesion molecules. *J Neurosci* 17:7839–7849
5. Feng ZP, Grigoriev N, Munno D, Lukowiak K, MacVicar BA, Goldberg JL, Syed NI (2002) Development of Ca<sup>2+</sup> hotspots between *Lymnaea* neurons during synaptogenesis. *J Physiol* 539:53–65
6. Woodall AJ, Naruo H, Prince DJ, Feng ZP, Winlow W, Takasaki M, Syed NI (2003) Anesthetic treatment blocks synaptogenesis but not neuronal regeneration of cultured *Lymnaea* neurons. *J Neurophysiol* 90:2232–2239

7. Gardzinski P, Lee DW, Fei GH, Hui K, Huang GJ, Sun HS, Feng ZP (2007) The role of synaptotagmin I C2A calcium-binding domain in synaptic vesicle clustering during synapse formation. *J Physiol* 581:75–90
8. Woodin MA, Hamakawa T, Takasaki M, Lukowiak K, Syed NI (1999) Trophic factor-induced plasticity of synaptic connections between identified *Lymnaea* neurons. *Learn Mem* 6:307–316
9. Munno DW, Prince DJ, Syed NI (2003) Synapse number and synaptic efficacy are regulated by presynaptic cAMP and protein kinase A. *J Neurosci* 23:4146–4155
10. Smit AB, Syed NI, Schaap D, van Minnen J, Klumperman J, Kits KS, Lodder H, van der Schors RC, van Elk R, Sorgedraeger B, Breje K, Sixma TK, Geraerts WP (2001) A glia-derived acetylcholine-binding protein that modulates synaptic transmission. *Nature* 411:261–268

## Synaptic Vesicle

### Definition

Synaptic vesicles are membrane-bound organelles found in presynaptic terminals. They accumulate neurotransmitters and neuromodulators, and release these substances into synaptic cleft by a  $\text{Ca}^{2+}$ -dependent exocytosis.

### ► Synaptic Vesicle Recycling

## Synaptic Vesicle Recycling

HIROSHI KUROMI

Institute for Behavioral Sciences, Gunma University  
Graduate School of Medicine, Maebashi, Japan

### Definition

Proteins of Synaptic Vesicle (SV) component are synthesized in the neuronal cell body and transported to the terminal by axonal transport. In addition, SVs are reformed by recycling of SVs after exocytosis at the nerve terminal. The recycling process includes endocytosis of SVs, refilling with neurotransmitter, translocation to release sites, and reformation of pools of SVs.

### Characteristics

#### Quantitative Description

##### Time Course of SV Recycling

The time course of SV recycling varies depending on the type of synapses, or on the intensity and duration of the

stimulus. In optical measurements by using fluorescence dye, the time required for a SV to be endocytosed, transported, and prepared for a new round of release was estimated to be shorter than 40 s at the frog neuromuscular junction, and in cultured rat hippocampal neurons [1], rapid recycling (few sec) was also detected in cultured hippocampal neurons. The time for recycling becomes much longer at prolonged stimulation. The first step of SV recycling is the endocytosis at the plasma membrane of nerve terminals. The half time of endocytosis after a brief burst of exocytosis is approximately 20 s or a few seconds [2]. With capacitance measurement at the giant terminal of goldfish bipolar neurons and at saccular hair cells, the time constant of the endocytosis following exocytosis was estimated as brief as 2 s. For SV attachment to the plasma membrane and pre-fusion may be required approximately 10–20 ms and for  $\text{Ca}^{2+}$ -triggered fusion less than 1 ms, most of SV recycling consists of reformation of release-ready SVs and neurotransmitter uptake.

### SV Pools

The active zones of nerve terminals are considered as release sites for neurotransmitter. Few SVs (5–10) are attached to the active zone and considered as release-ready SVs. There are clusters of some 200–500 SVs that are situated next to the active zone. The majority of SVs are located in the cytosol of the nerve terminals. From functional determinations, SVs are divided into three groups (pools), the Immediately Releasable (a few percent of the total), the Readily Releasable (10–20%), and the Reserve pools (all the rest) in nerve terminals of fly and frog neuromuscular junctions, goldfish retina, and mammalian hippocampal and calyx of Held synapses [3].

### Higher Level Structures

Neurons release neurotransmitters only at nerve endings, which are situated far from the cell body. The supply of SVs by transportation from the cell body to nerve endings is not enough to maintain continuous release of neurotransmitters for a long time. How can nerve endings sustain a high rate of release of transmitters for a prolonged period without exhausting their supply of SVs? Some forms of local recycling of SVs must occur at the nerve ending.

### Lower Level Components

According to the vesicle hypothesis, neurotransmitter is contained in SVs and transmitter release occurs by exocytosis of SVs. After exocytosis, SVs are slowly retrieved from the plasma membrane, mainly by formation of clathrin-coated pits. The retrieved SVs are processed in the terminal to generate new SVs, either by direct uncoating of clathrin-coated SVs or via intermediate ►endosomes (cisternae) that later give rise

to new SVs [4]. In addition, a faster clathrin-independent retrieval mechanism, including “▶kiss-and-run,” where SVs fuse only temporarily with the presynaptic membrane before retrieval has also been suggested [5] (Fig. 1). The frequency of stimulation may determine vesicle endocytosis through two different recycling routes. Ceccarelli et al. [5] used low frequency stimulation, and found no requirement for endocytic intermediates. Heuser and Reese [4] used high frequency stimulation, and found that vesicle reformation was required for endocytic intermediates. Electron microscopic observations revealed that two endocytic pathways exist in single presynaptic boutons of *Drosophila*. During recovery, after blockade of endocytosis in a temperature-sensitive dynamin mutant, *shibire*, one pathway of endocytosis was found to be fast, did not rely on endosomal intermediates, and refilled a pool of vesicles near the active zone. A slower pathway refilled a vesicle pool distal to the active zones, through cisterna-like intermediates [6]. The pool recovered via the fast pathway supplied SVs for evoked release (at low frequency, and may constitute a ▶readily releasable pool). The second pool may constitute the ▶reserve pool of SVs for transmitter release at a high frequency.

### Higher Level Processes

The recycling of SVs in presynaptic terminals is regulated by retrograde signals from postsynaptic cells. Fluorescence imaging and pharmacological analysis showed that a nitric oxide (NO) signal generated

postsynaptically regulates endocytosis, and at least one later step in SV recycling in rat hippocampal neurons in culture. In goldfish retinal slices, fast endocytosis of SVs in presynaptic terminals is inhibited by postsynaptically released GABA-mediated chloride influx.

### Lower Level Processes

In the kiss-and-run cycling of SVs [5], no endocytic process is necessary. During kiss-and-run cycling, SVs transiently release transmitter through a narrow pore, and the empty vesicle either detaches from the active zone or remains in place and is refilled with transmitter. Recently recycled SVs occupy a privileged location near the active zone, which would neatly explain their preferential reuse. The importance of clathrin-mediated endocytosis in recycling of SVs is well established. Assembly of endocytotic machinery proteins including clathrin, adaptor proteins (AP-2), endophilins and formation of clathrin-coated pits are necessary for retrieval of SVs from the plasma membrane by dynamin. For further steps of recycling of SVs after retrieval of clathrin-coated SVs, the clathrin-coated SVs are processed for uncoating. An interaction between Hsc70 and auxilin are suggested to be required for uncoating. Genetically induced disruption of genes encoding these proteins in *Drosophila* resulted in severe impairment of SV recycling. In either case of clathrin-mediated or kiss-and-run cycled retrieval of SVs, after fission of SVs by dynamin, empty SVs acidify via proton pump activity (vacuolar ATPase) to generate an electrochemical gradient across the SV membrane. SVs are then filled

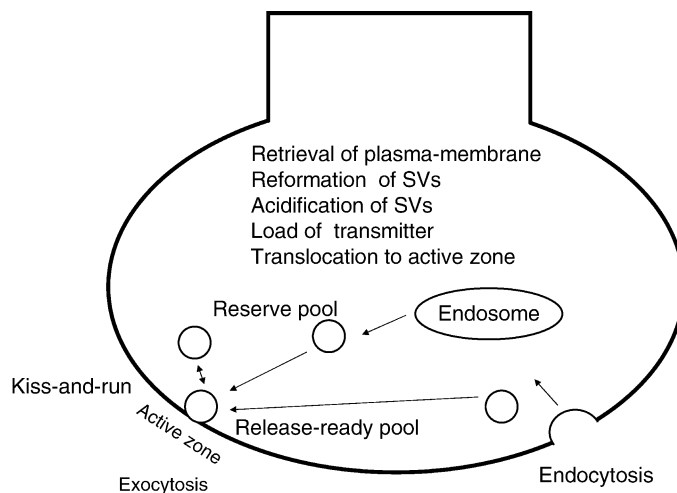

**Synaptic Vesicle Recycling. Figure 1** Synaptic Vesicle Recycling. There are alternative pathways for SV recycling; kiss-and-run cycling and full fusion followed by endocytosis. During kiss-and-run cycling, SVs transiently release transmitter through a narrow pore, and the empty vesicle either detaches from the active zone or it remains in place and refills with transmitter. Kiss-and-run cycling occurs at the active zone, is dependent on dynamin, but does not require clathrin assembly. After exocytosis, SVs are slowly retrieved from plasma membrane, mainly by formation of clathrin-coated pits. The retrieved SVs are processed in the terminals to generate new SVs, either by direct uncoating of clathrin-coated SVs or via intermediate endosomes (cisternae) that later give rise to new SVs.

with neurotransmitters by active transport, which is mediated by transporters specialized for individual transmitter, utilizing energy of  $H^+$  gradient. There are specific transporters for glutamate (GLUT 1, 2 and 3), ATP, and acetylcholine, a common transporter for glycine and GABA, and one for all catecholamines. SVs filled with neurotransmitters are translocated to the area near to active zones. Although participation of cytoskeleton and motor proteins in this active transport process has been suggested, direct evidence has not yet been obtained.

### Process Regulation

Following incorporation of the SV membrane into the plasma membrane by exocytosis, the endocytic process could be blocked by removing extracellular  $Ca^{2+}$ . The block could then be released by re-adding low concentrations of extracellular  $Ca^{2+}$  [7]. One of the roles of  $Ca^{2+}$  influx in endocytosis of SVs is in assembly of endocytotic machinery proteins at the plasma membrane. When  $Ca^{2+}$  influx linked to endocytosis was selectively blocked at the *Drosophila* neuromuscular junction, components of SV were incorporated into the plasma membrane but no clathrin clusters were formed [8].  $Ca^{2+}$  influx accelerates endocytosis at rat cultured hippocampal neurons. However, elevation of the intracellular  $Ca^{2+}$  level to a few hundred nM inhibits endocytosis in goldfish bipolar terminals.

### Function

The most striking demonstration of the importance of recycling of SVs in animal behaviors came from the phenotypic characterization of temperature-sensitive *Drosophila shibire* mutants (*shits*) [9]. *Shits* flies are normal at a permissive temperature of 19°C, but become rapidly paralyzed at the non-permissive temperature of 29°C. Exocytosis occurs normally at 29°C, but endocytosis is impaired, leading to a rapid depletion of SVs. The roles of clathrin-mediated endocytosis of SVs and kiss-and-run cycling of SVs in synaptic transmission are clearly demonstrated in *endophilin* mutants. Endophilin is a key molecule for clathrin-mediated-endocytosis. Electrophysiological recordings at the neuromuscular junction in *endophilin* mutants demonstrated that a lack of clathrin-mediated endocytosis does not affect neurotransmitter release at low levels of synaptic activity. However, when stimulated at a high frequency, *endophilin*-null neuromuscular junctions undergo a strong synaptic depression, highlighting the importance of clathrin-mediated recycling. However, neurotransmitter-release is not completely abolished (► neurotransmitter release, elementary step). Neurotransmission remained at the 15–20% level throughout the stimulus. In contrast, at restricted temperatures in *shibire*, neurotransmission is completely abolished after intense-stimulation [10] (Fig. 2).

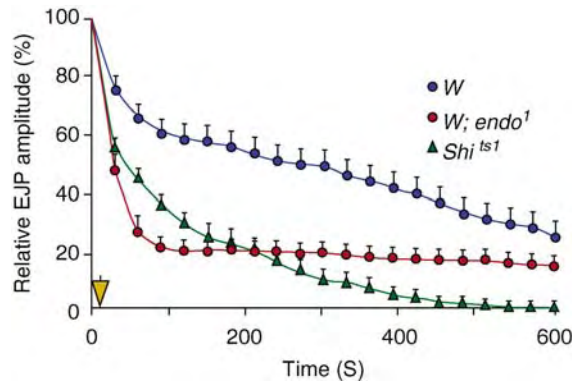

**Synaptic Vesicle Recycling. Figure 2** Roles of Endocytosis of SVs, Kiss-and-Run Cycling and Clathrin-Mediated Endocytosis, in Synaptic Transmission. Amplitude of the excitatory junctional potential (EJP) evoked by nerve stimulation at 10 Hz. Values are relative to the EJP amplitude measured at 1 Hz before applying the tetanus. Blue circles, *w*; red circles, *endo<sup>1</sup>*; green triangles, *shits<sup>1</sup>*, recorded at the non-permissive temperature. The yellow arrow indicates the approximate time at which full depletion of the total vesicle pool in *endo<sup>1</sup>* mutant terminals would occur at 10 Hz stimulation in the absence of vesicle retrieval by using *shits<sup>1</sup>*; *endo1* animals [10].

### References

- Ryan TA, Smith SJ (1995) Vesicle pool mobilization during action potential firing at hippocampal synapses. *Neuron* 14:983–989
- Klingauf J, Kavalali ET, Tsien RW (1998) Kinetics and regulation of fast endocytosis at hippocampal synapses. *Nature* 394:581–585
- Rizzoli SO, Betz WJ (2005) Synaptic vesicle pools. *Nat Rev Neurosci* 6:57–69
- Heuser JE, Reese TS (1973) Evidence for recycling of synaptic vesicle membrane during transmitter release at the frog neuromuscular junction. *J Cell Biol* 57:315–344
- Ceccarelli B, Hurlbut WP, Mauro A (1973) Turnover of transmitter and synaptic vesicles at the frog neuromuscular junction. *J Cell Biol* 57:499–524
- Koenig JH, Ikeda K (1996) Synaptic vesicles have two distinct recycling pathways. *J Cell Biol* 135:797–808
- Gad H, Low P, Zotova E, Brodin L, Shupliakov O (1998) Dissociation between  $Ca^{2+}$ -triggered synaptic vesicle exocytosis and clathrin-mediated endocytosis at a central synapse. *Neuron* 21:607–616
- Kuromi H, Honda A, Kidokoro Y (2004)  $Ca^{2+}$  influx through distinct routes controls exocytosis and endocytosis at *Drosophila* presynaptic terminals. *Neuron* 41:101–111
- Grigliatti T, Suzuki DT (1971) Temperature-sensitive mutations in *Drosophila melanogaster*. 8. The homeotic mutant, *ss a40a*. *Proc Natl Acad Sci USA* 68:1307–1311
- Verstreken P, Kjaerulff O, Eloyd TE, Atkinson A, Zhou Yi, Meinertzhagen IA, Bellen H (2002) *Endophilin* mutations block clathrin-mediated endocytosis but not neurotransmitter release. *Cell* 109:101–112

## Synaptodendrosome

► Synaptosome

## Synaptogenesis

MASUMI ICHIKAWA  
Tokyo Metropolitan Institute for Neuroscience,  
Tokyo, Japan

### Synonyms

Synapse formation

### Definition

Formation and maturation of synaptic contacts during development in the central and peripheral nervous system.

Synapse is the specialized contact between neurons through which they communicate. Synaptogenesis is a process in which synaptic contacts form and mature. The formation of synaptic contact is a complex process requiring the coordinated assembly of components on either side of the ► **synaptic cleft**. Synapse assembly begins when the immature presynaptic process contacts the postsynaptic neurons, leading to formation of an active zone where ► **neurotransmitters** are released into the synaptic cleft. During the postsynaptic process, receptors and signaling molecules are induced and localized, conferring the capacity to transduce the given signal into a postsynaptic response. The morphological rearrangements take place once synaptic targets establish their initial contact. During these maturational changes, functional molecules are also rearranged in synapses.

### Characteristics

Following proliferation, migration and differentiation, a developing neuron reaches its final destination in the nervous system. To establish contact with its synaptic partners, a neuron must extend axonal (presynaptic) and dendritic (postsynaptic) processes towards targets located significant distances away. Extending axons and ► **dendrites** are guided towards their targets. The journey of both ► **axons** and dendrites towards its synaptic partner is regulated by a series of intermediate targets by cell–cell interaction and gradients of diffusible chemotrophic factors, which can be attractive or repulsive in nature [1–3]. Synaptogenesis involves a series of vary gradual structural, functional, and molecular changes in differentiation and maturational processes.

### Cell-Cell Interaction during Synapse Formation

The formation of synapses involves an interaction between the presynaptic and the postsynaptic elements. Postsynaptic densities without presynaptic processes, and free presynaptic processes with associated ► **synaptic vesicles**, have been observed ultrastructurally in the developing brain. Prior to synaptic contact, receptor molecules of neurotransmitter are present on the surface of postsynaptic processes, and synaptic vesicles in the isolated presynaptic processes release synaptic transmitters before synapse formation. Transmitter-receptor interaction attracts appropriate target processes by binding to and stimulating postsynaptic processes. These two pre- and postsynaptic elements must first come into close proximity. Both pre- and postsynaptic processes play active roles in identifying and attracting their potential synaptic partners through a series of cell-cell interactions, either diffusible (neurotransmitter, ► **neurotrophic factor**) or ► **cell adhesion molecules** (N-CAM, cadherin, SyCAM, neurexin, neuroligin) [1] (Fig. 1). Whilst making contact, these molecules stabilize pre- and postsynaptic scaffolding proteins such as CASK and PSD-95M. Subsequent formations of synaptic contacts and interactions between neurotrophic factors and receptors leads to clustering of specific (non-L type) ► **Ca channels** and synaptic vesicles in presynaptic processes and transmitter receptors in postsynaptic processes [4]. Other molecules localize in pre and postsynaptic elements during cell–cell interactions (Fig. 1).

1. Pre- and postsynaptic growth processes approach each other. Transmitter-receptor interaction attracts appropriate target processes by binding and stimulating postsynaptic processes. Various components of pre- and postsynaptic specialization, including presynaptic packets containing synaptic machinery and channels, and postsynaptic proteins are mobile prior to contact.
2. As extending growth processes contact, the processes smooth, and asymmetric interactions between cell adhesion molecules mark the synaptic sites and stabilize pre- and postsynaptic scaffolding proteins.
3. Subsequent formation of synaptic contacts and interactions between neurotrophic factors and receptors lead to clustering of specific (non L type) Ca channels and synaptic vesicles in presynaptic processes and transmitter receptors at the postsynaptic processes.

### Differentiation and Maturation of Synapse

There is no general rule about the order of maturation of the pre- and postsynaptic structures, but in each case, the order is apparently invariant. A number of factors may have to act in combination to result in the functional maturation of the synapses (Fig. 2).

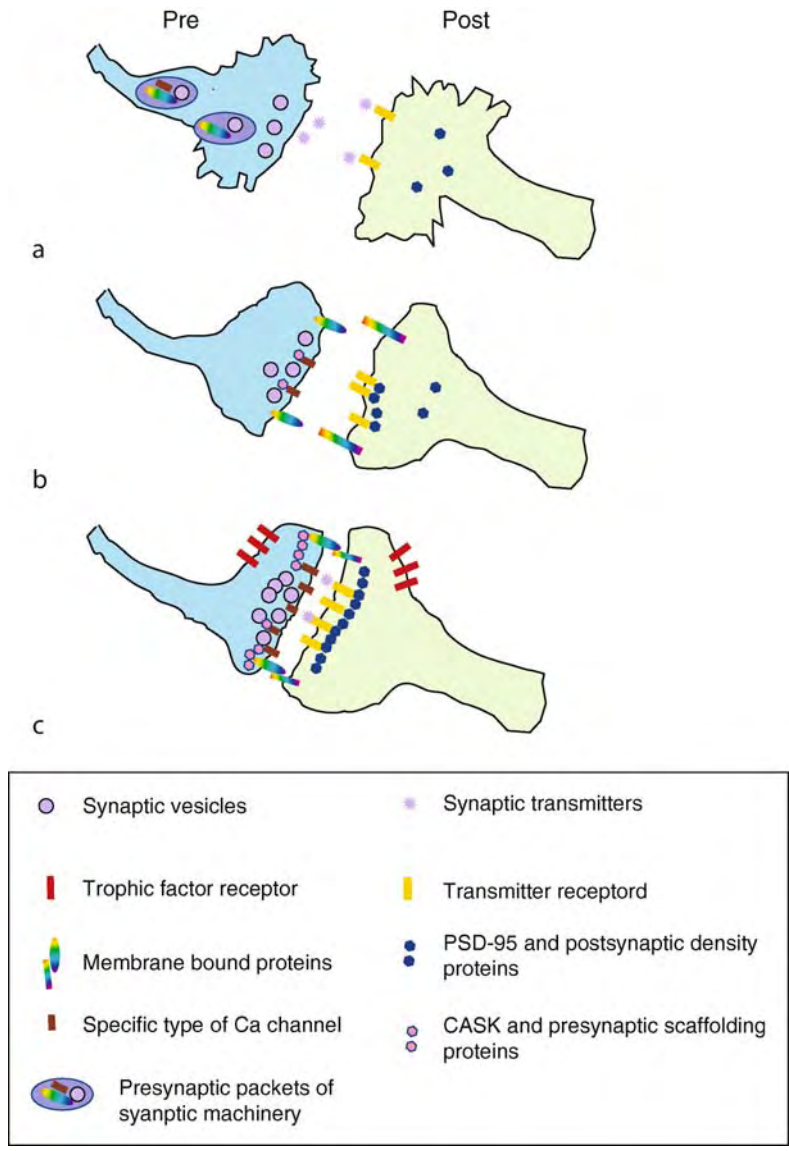

**Synaptogenesis. Figure 1** Steps of synaptic contact formation.

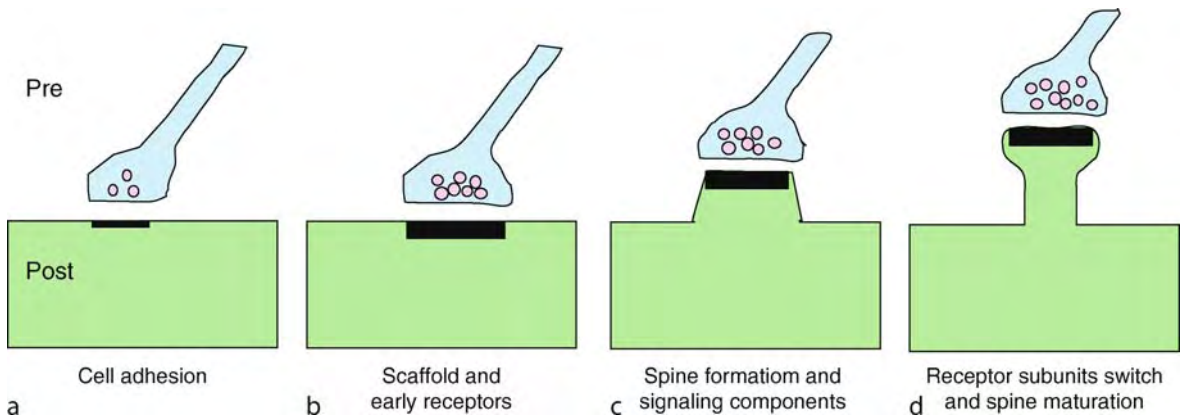

**Synaptogenesis. Figure 2** Maturation of spine synapses.



An approximate sequence of assembly of postsynaptic components is related to maturational changes in synaptic structure. (i) Pre- and postsynaptic processes form morphologically unspecialized but functioned contact. The earliest synapses recognized ultrastructurally contain only few synaptic vesicles. (ii) Putative scaffolding proteins such as PSD-95, GKAP/SAPAP, and Shank families localize to synapse early with an increase of size of PSD. Synaptic vesicles begin to accumulate at presynaptic processes. (iii) Many spine associated components such as actinin, drebrin, and CaMKII cluster at synapses late in development, concurrent with the outgrowth of spines. (iv) Rapid neurotransmitter receptor accumulation occurs in the spines. NMDA type glutamate receptors undergo a subunit switch from NR2B to NR2A associated with maturation of spines.

Functional activity may be necessary to ensure full maturation and permanent stability of the synapses.

### Morphological Maturation

1. The number of synaptic vesicles increases in development and differentiation.

The earliest synapses recognized ultrastructurally contain only a few synaptic vesicles. The number of synaptic vesicles increases with development. In the rat cerebral cortex, a fourfold increase in the number of vesicles per terminal has been observed [5,6].

2. The size of pre- and postsynaptic density increases in maturation [6].
3. The outgrowth of dendritic spines occurs in the late stage of development.

Dendritic spines develop gradually following initial synapse formation. Quantitative electron microscopic studies show that spine synapses develop from shaft synapses by outgrowth through a stage of stubby spine [7].

4. The shape of spine changes dependent on the activity of stimulation.

Activity can regulate the pre- and postsynaptic structure and synapse formation. However, there is not yet a consensus on how activity influences synaptic constituents. The variation may reflect differences in cell type, developmental state, experimental preparation, time course, and mode of activity manipulation [8,9].

### Molecular Differentiation

1. Changes in cell adhesion molecules occur. The actions of cell adhesion molecules is not limited to initial contact formation, but is also involved in specific target recognition and regulation of synaptic size and strength [5].
2. Maturational changes in structural proteins occur. Scaffolding protein (PSD-95, GKAP/SAPAP, Shank

families) localize to synapses early, functional protein (CaMKIIa and syndecan-2) cluster at synapses late in development, concurrent with maturation of dendritic spines [1].

3. Receptor subunits switch in association with the changes of the presynaptic terminal. Many spine associated components such as actinin, drebrin, and CaMKII cluster at synapses late in development, concurrent with the outgrowth or maturation of dendritic spines. NMDA type glutamate receptors also undergo a subunit switch from NR2B to NR2A [2].
4. Neurotrophins (NGF, BDNF, NT3, 4/5) have been implicated in multiple aspects of synaptic development. BDNF induces axonal and dendritic branching and remodeling, increases the efficacy of synaptic transmission, and modulates the functional maturation of synapses [10].

### Critical Period of Synaptogenesis in Developing Brain

The onset of synaptogenesis occurs according to a remarkably invariant timetable. In each region of the mammalian brain, there is usually a difference of less than a few days between individuals of the same species in the appearance of the first synapses on any particular type of neurons. Synapses appear suddenly and increase rapidly in numbers. Excessive production of synapses, followed by elimination of redundant synapses, occurs in many regions.

Dramatic increases in synaptogenesis of mammalian cerebral cortex occur during the early postnatal period of development. The critical period of synaptogenesis is postnatal 2 weeks in rodent cerebral cortex and the first year after birth in human visual cortex [11,12].

### Activity-Dependent Synaptogenesis in Adult Brain

Recent developments in real time imaging techniques have revealed not only that synaptic structures are motile, but also that a fraction of synapses undergo a continuous elimination and formation process in adult CNS. Activation of neuronal networks enhances dynamic mechanisms at both the presynaptic (remodeling of axonal branching) and postsynaptic (turnover of dendritic spines) level. Structural changes of synapses can occur rapidly within 24 h of sensory stimulation [8,12]. Activity dependent synaptogenesis takes place in adult CNS.

### References

1. Craig AM, Lichtman JW (2001) Synapse formation and maturation. In: Cowan WM, Sudhof TC, Stevens CF (eds) Synapses. The John Hopkins University press, Baltimore, MD, pp 571–612
2. Cohen-Cory S (2002) The developing synapse: construction and modulation of synaptic structures and circuits. *Science* 298:770–776
3. Ferreira A, Paganoni S (2002) The formation of synapses in the central nervous system. *Mol Neurobiol* 26:69–79

4. Munno DW, Syed NI (2003) Synaptogenesis in the CNS: an odyssey from wiring together to firing together. *J Physiol* 552:1–11
5. Abbas L (2003) Synapse formation: lets stick together. *Curr Biol* 13:25–27
6. Ichikawa M, Muramoto K, Kobayashi K, Kawahara M, Kuroda Y (1993) Formation and maturation of synapses in primary cultures of rat cerebral cortical cells: An electron microscopic study. *Neurosci Res* 16:95–103
7. Miller M, Peter A (1981) Maturation of rat visual cortex. II. A combined Golgi-electron microscopic study of pyramidal neurons. *J Comp Neurol* 203:555–573
8. Muller D, Nikonenko I (2003) Dynamic presynaptic varicosities a role in activity-dependent synaptogenesis. *Trends Neurosci* 26:573–575
9. Zito K, Svoboda K (2002) Activity-dependent synaptogenesis in the adult mammalian cortex. *Neuron* 35:1015–1017
10. Goda Y, Davis GW (2003) mechanisms of synapse assembly and disassembly. *Neuron* 40:243–264
11. Blue ME, Parnavelas JG (1983) The formation and maturation of synapses in the visual cortex of rat. II. Quantitative analysis. *J Comp Neurol* 12:697–712
12. Ramakers GJ (2004) Neuronal network formation in human cerebral cortex. *Prog Brain Res* 147:3–14

---

## Synaptoneurosoma

► Synaptosome

---

## Synaptosome

SILVIA DE RUBEIS<sup>1</sup>, CLAUDIA BAGNI<sup>2,3</sup>

<sup>1</sup>Department of Biology, University “Tor Vergata”, Rome Department of Molecular and Developmental Genetics/VIB11, Catholic University of Leuven, Leuven, Belgium

<sup>2</sup>Department of Experimental Medicine and Biochemical Sciences, University “Tor Vergata”, Rome, Italy

<sup>3</sup>Department of Molecular and Developmental Genetics/VIB11 Catholic University of Leuven, Leuven, Belgium

### Synonyms

Synaptoneurosoma; Synaptodendrosoma; Neurosecretosome

### Definition

The ► **synaptosome** is a subcellular particle deriving from the interruption of the axonal termini (see ► **Axon**)

after the brain tissue has been homogenized in a buffer isoosmotic with the plasma. It represents mainly the presynaptic compartment or presynaptic spine but often retains part of the postsynaptic components according to the experimental condition used.

The ► **synaptoneurosoma** is a composite particle containing one or more presynaptic compartments (synaptosome) attached to a postsynaptic element (neurosoma) [1]. In the ► **synaptodendrosoma**, the axon terminal adheres to a larger portion of the postsynaptic compartment (dendrite) (see ► **Dendrite**) [2]. Finally, the ► **neurosecretosomes** are a subtype of synaptosomes isolated from neurosecretory neurons such as neurons from the neurohypophysis [3].

## Characteristics

### Quantitative Description

The synaptosomal particles have a variable size according to their composition. The simplest synaptosomes are small bodies with a mean diameter of 0.6 µm or up to 1 µm for the neurosecretosomes [1,3]. As the neurosoma vesicle measures around 1 µm, the complete synaptoneurosoma has a mean diameter of 1.6 µm [1].

### Pre and Postsynaptic Compartment Purification

The quality and composition of the synaptosomal fraction depends on the purification method used. The use of one or multiple step gradients as well as the homogenization of the brain, performed manually or mechanically, leads to a different population of synaptosomes with variable intact postsynaptic compartments.

The traditional procedure utilizes the separation of particles deriving from brain tissue homogenate, through an isoosmotic density gradient [4]. The homogenate is loaded on a sucrose gradient that is then centrifuged at high speed. During the centrifugation, each particle sediments at a specific location along the gradient according to the size and weight leading to the separation of four major subcellular fractions. The bottom fraction (P1) contains mainly nuclei and cell debris, whereas the middle fraction (P2) is a heterogeneous population including myelin fragments, synaptosomes and free mitochondria. At the top, the microsomes, ribosomes and smaller entities form two distinct fractions (P3 and P4). The further separation of the middle fraction (P2) leads to the isolation of synaptosomes.

To improve the quality of synaptoneurosomes fractions, recently, a second density gradient has been employed that makes use of chemicals based on the iodixanol [5]. While the purity of the preparation is very high, the synaptoneurosoma recovery is quite low. An alternative method, frequently used for the isolation of synaptoneurosomes, makes use of subsequent filtration steps in isoosmotic buffer. The brain homogenate is passed first through a 100 µm nylon mesh filter and then through a 5 µm filter [1].

## Higher Level Structures

The synaptosomes appear as spherical or elongated particles containing the nerve terminal often joined to a partial or complete postsynaptic compartment [4,5]. The particle is coated by a membrane, which seals off at the point where the axon is fractured. This continuous envelope preserves the integrity of synaptoneurosome and thus both the presynaptic and postsynaptic compartments retain their main structural features [4].

The presynaptic element (see ►Chemical synapse, ►presynaptic structure) contains a pool of synaptic vesicles (see ►Synaptic vesicle) that are organized in the active zone (see ►Active zone) close to the presynaptic membrane [1,4].

As mentioned, although in the synaptosome preparation the postsynapse is often not well preserved, the sealed presynaptic compartment is frequently attached to a residual of postsynaptic membrane. In the intact synaptoneurosome the postsynaptic element is well conserved as shown by a sealed membrane containing a dense structure beneath the membrane, known as postsynaptic density (PSD) (see ►Postsynaptic density) [1]. Figure 1 shows: (i) a drawing of a synaptic contact (pre and postsynaptic compartments) that is picked off during the isolation of synaptoneurosome, (ii) an image, acquired at the electron microscope, of a synaptoneurosome obtained with a protocol previously described [5] and (iii) a colored drawing of the same electron microscopy image.

## Lower Level Components

At the ultrastructural level, the synaptosomal particles retain the cytoplasmic components and organelles.

*In vivo*, the presynaptic element presents an active zone (see ►Active zone) containing numerous synaptic vesicles 40–250 nm in diameter: a storage of releasable neurotransmitters (see ►Neurotransmitter). Generally, the synaptosomes contain small vesicles (40–60 nm in

diameter), both clear-core vesicles with acetylcholine or amino acid transmitters, and dense-core vesicles (see ►Dense core vesicles) with catecholamines [6,7]. Sometimes larger dense-core vesicles (see ►Large dense core vesicles) have been observed containing neuropeptides (up to 250 nm in diameter) or biogenic amines [6,7]. In the neurosecretosomes the hormones are packaged in large neurosecretory granules (around 150 nm in diameter), with a dense core surrounded by a clear zone [3].

The presynaptic element preserves also the molecular machinery for exocytosis of synaptic vesicles (see ►Presynaptic exocytosis) [7] and the synaptophysin fractions are highly enriched in proteins, involved in neurotransmitter release, such as synaptophysin (see ►Synaptophysin) [5]. In intact synaptophysin, the exocytosis apparatus can maintain its functionality (see below). Within the presynaptic compartment one or more mitochondria are found and supply the energy for the local metabolism [4,7].

The pre and postsynaptic elements in the synaptoneurosome are joined together, as expected in a chemical synapse (see ►Chemical synapse). As mentioned, the Postsynaptic membrane shows a local thickening, the postsynaptic density (PSD), which links the neurotransmitters receptors to signaling protein and cytoskeleton. In fact, the key component of this machinery, known as postsynaptic density protein 95 (PSD-95), (see ►PSD-95) is highly enriched in synaptosomal fractions [5].

In polarized cells, the mRNAs are delivered to specific subcellular compartments to be locally translated. In neurons, mRNAs as well as the translational machinery have been found in dendrites and in axons, especially in growth cone (see ►Dendritic protein synthesis) [8 and references therein]. In synaptoneurosome, ►dendritic mRNAs, polyribosomes [8 and references therein] and translational factors [9] have been detected and messenger RNAs can be locally

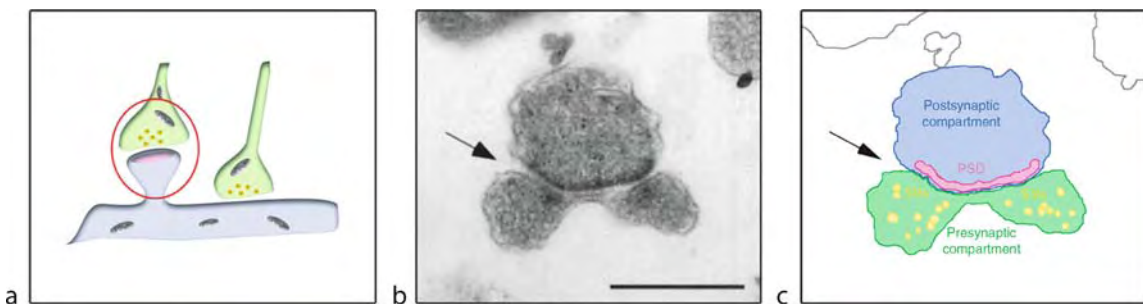

**Synaptosome. Figure 1** (a) Drawing of a synaptic contact. The red circle indicates the point of rupture of the axon-dendrite contact. The postsynaptic compartment is shown in light blue with a visible postsynaptic density (PSD) in pink; the presynapse is shown in green and contains synaptic vesicles in yellow. (b) Electron micrograph of a synaptoneurosome from Bagni et al. (2000) J Neurosci. Copyright 2000 Society for Neuroscience (c) Colored drawing of the previous micrograph. Postsynapse (light blue), PSD (pink), presynaptic terminal (green), synaptic vesicles (SVs) (yellow). Scale bar is 0.5  $\mu$ m.

translated upon synaptic stimulation (see below) [5,8 and references therein]. Lately, small non-coding RNAs such as microRNAs and the Brain Cytoplasmic RNA 1, *BCI*, have also been detected at synapses [2,10].

### Higher Level Processes

The synaptosomes maintain their viability and metabolic activity, in media isotonic to plasma, for some hours after isolation [6]. The high membrane potential and the low intracellular calcium concentration indicate the integrity of synaptosomal particles [7].

Importantly, the synaptosomes include mitochondria that supply the energy needed for the metabolic activities of presynaptic terminals. In fact the synaptosomal mitochondria possess a stable membrane potential which sustains the ATP production for the bioenergetic metabolism [7]. As the synaptosomal particles are vulnerable to osmotic shock, the suspension in hypo-osmotic media leads to bursting of synaptosomes and release of intact synaptic vesicles and mitochondria [6].

In conclusion, the viable synaptosome behaves similarly to the synaptic compartment *in vivo* and can react to physiological and not physiological stimulations modulating its own functions (see below).

### Lower Level Processes

The synaptosomes retain the ability to release the neurotransmitters by calcium-dependent exocytosis (see ►[Exocytosis](#)) as it occurs at synapses [7]. After stimulation, the synaptic vesicles move toward the active zone and, occasionally, the fusion of the vesicles with the membrane can also be observed. The endocytotic recycling of membranes provides the replenishment of vesicles pool (see ►[Synaptic vesicle recycling](#)). The synaptosomes release different class of neurotransmitters – catecholamines, neuropeptides and amino acid transmitters, mainly glutamate [7 and references therein].

As previously mentioned, the synaptoneuroosomes retain the majority of cytoplasmic components, including the synaptic mRNAs and the protein synthesis apparatus. Active translation in these particles has been shown by the incorporation of radiolabeled amido acids into proteins [5,8 and references therein]. Interestingly, protein synthesis within synaptoneuroosomes is activity-regulated. After stimulation, the translation of subset of synaptic mRNAs encoding for key synaptic proteins increases. Last, but not least, the intact synaptoneuroosomes possess functional neurotransmitter receptors and relative signaling complex. As a consequence, they retain the ability to trigger events and processes occurring in the intact neuronal cell (see below).

### Process Regulation

Although the synaptosome maintains the metabolic machinery of synaptic terminals, it has lost the axonal input and thus it cannot receive physiological stimuli.

Nevertheless, the intact synaptosome possesses functional neurotransmitters receptors that are up to respond to pharmacological drugs. In fact, the synaptosomal membrane has a negative membrane potential whose polarity changes after receptors activation as it happens in the whole neuron [7].

The stimulation can be obtained by alteration of ionic environment increasing potassium ion, by pharmacological inhibition of ion channels such as potassium channel [7] or by administration of physiological or pharmacological receptors agonists. In particular, treatment of synaptoneuroosomes with metabotropic glutamate receptor (mGluR) agonists increases the amount of ribosomes associated with mRNAs, i.e. increases general local protein synthesis [8 and references therein]. Moreover, the administration of glutamate activates the translation of specific synaptic mRNAs [5]. At last, synaptoneuroosomes maintain also the ability to respond to neurotrophic factors such as brain-derived neurotrophic factor (BDNF) which activates the protein synthesis machinery [9] enhancing the translation of specific mRNAs [10].

### Function (Purpose)

The synaptosomes provide a versatile model to study the ultrastructure and the physiological features of the synapses.

The synaptosomal preparations can be used as starting material to isolate synaptic elements such as synaptic vesicles, synaptic mitochondria, purified postsynaptic density and synaptic mRNAs.

The synaptosomes have been used as a model to study synaptic processes. First, the synaptosomes have been extensively exploited to investigate neurotransmitter release, especially the glutamate release, and the regulation of this process [7]. In this context, the synaptosomes also enabled the study of the molecular basis of both endocytosis and exocytosis as the synaptosome is the simplest compartment containing the endocytotic and exocytotic apparatus [7]. Second, the synaptoneuroosomes and the synaptodendrosomes have been exploited to identify the synaptically localized mRNAs and to study the regulated local protein synthesis [2,5,8 and references therein]. As the neurotransmitters receptors and the membrane maintain their functionality, the synaptosomal preparations have also been used to investigate the physiological regulation of above-mentioned processes after receptors stimulation or ion channel blockade.

### References

1. Hollingsworth EB, McNeal ET, Burton JL, Williams RJ, Daly JW et al. (1985) Biochemical characterization of a filtered synaptoneurosome preparation from guinea pig cerebral cortex: cyclic adenosine 3': 5'-monophosphate-generating systems, receptors, and enzymes. *J Neurosci* 5:2240–2253

2. Rao A, Steward O (1993) Evaluation of RNAs present in synaptodendrosomes: dendritic, glial, and neuronal cell body contribution. *J Neurochem* 61:835–844
3. Toescu EC, Morris JF (1990) Morphometric analysis of nerve endings isolated from bovine and rat neurohypophysis. *J Anat* 173:1–17
4. Gray EG, Whittaker VP (1962) The isolation of nerve endings from brain: an electron-microscopic study of cell fragments derived by homogenization and centrifugation. *J Anat* 96:79–88
5. Bagni C, Mannucci L, Dotti CG, Amaldi F (2000) Chemical stimulation of synaptosomes modulates alpha-Ca<sup>2+</sup>/calmodulin-dependent protein kinase II mRNA association to polysomes. *J Neurosci* 20:RC76
6. Whittaker VP, Michaelson IA, Kirkland RJ (1964) The separation of synaptic vesicles from nerve-ending particles (“synaptosomes”). *Biochem J* 90:293–303
7. Nicholls DG (2003) Bioenergetics and transmitter release in the isolated nerve terminal. *Neurochem Res* 28:1433–1441
8. Steward O, Schuman EM (2003) Compartmentalized synthesis and degradation of proteins in neurons. *Neuron* 40:347–359
9. Takei N, Inamura N, Kawamura M, Namba H, Hara K et al. (2004) Brain-derived neurotrophic factor induces mammalian target of rapamycin-dependent local activation of translation machinery and protein synthesis in neuronal dendrites. *J Neurosci* 24:9760–9769
10. Schratt GM, Tuebing F, Nigh EA, Kane CG, Sabatini ME et al. (2006) A brain-specific microRNA regulates dendritic spine development. *Nature* 439:283–289

## Synaptosome-associated Protein of 25 kDa (SNAP-25)

### Definition

A protein in the SNARE complex. Isoforms of this protein are identified by a number (e.g. 25 or 23) after the term which refers to the molecular weight of the protein in units of kDa.

- ▶ Non-synaptic Release
- ▶ SNARE Proteins
- ▶ Soluble NSF Attachment Protein Receptor (SNARE)
- ▶ Synaptosome

## Synchronization

- ▶ Temporal Coding

## Synchronized, Desynchronized Brain Activity

- ▶ Brain Rhythms

## Syncope

### Definition

Acute, brief and transient loss of consciousness and postural tone (general muscle weakness and inability to stand upright) with spontaneous and complete recovery. A syncope is often preceded by faintness which denotes a lack of strength with a feeling of giddiness, swaying ground or surrounding objects, and impending loss of consciousness (presyncope). There are many possible causes of syncope, in particular cardiovascular changes and changes in blood state (e.g., hypoxia, anemia etc.) with a reduced supply of oxygen to the brain. Syncope may thus be classified as vasodepressor (vasovagal) or neurocardiogenic syncope, postural hypotension with a defect in vasomotor reflexes, cardiac syncope, carotid sinus syncope, and others.

## Syndactyly

### Definition

Syndactyly describes the congenital or artificial webbing of adjacent fingers. As a consequence, webbed fingers cannot be used independently resulting in temporal coincidence of tactile inputs to these fingers.

- ▶ Somatosensory Reorganization

## Syndrome of Inappropriate ADH Secretion (SIADH)

### Definition

SIADH is characterized by plasma antidiuretic hormone (ADH) levels that are elevated above those

expected on the basis of body fluid osmolality and blood volume or arterial pressure.

- ▶ Blood Volume Regulation
- ▶ Vasopressin (VP) or Antidiuretic Hormone (ADH)

---

## Synergist Muscles

### Definition

Muscles acting to produce the same motion or torque at a joint.

- ▶ Impedance Control

---

## Synergy

- ▶ Coordination

---

## Synesthesia

### Definition

Synesthesia is a condition, in which otherwise normal persons experience sensations in a non-stimulated sensory modality when stimulated by stimuli in another sensory modality or sub-modality. It runs in families, prevails among women and non-right-handers. These synesthetes may see letters or numbers colored (e.g. 5 as green and 6 as red: grapheme-color synesthesia or lexical synesthesia; blind people may have colored impressions of Braille signs), “see” tones as colors (e.g. C-sharp as blue: color-hearing), “hear” colors, “taste” shapes, “smell” the color red, describe music as movements of colored forms in visual space. The most common synesthetic experiences are color-hearing (with clear associations of particular colors with particular sounds) and grapheme-color synesthesia. In synesthetes who clearly associate specific graphemes with specific colors (e.g. “R” is blue), display of the

grapheme in another color (e.g. red) may evoke affective reactions (e.g. uneasiness). Evidence is accumulating to indicate that these synesthetic sensations are real perceptions and may be due to hyperactivity of color-sensitive cortical areas or “cross-activation” of brain areas concerned with the associated percepts, thus extending normal processes in multisensory integration by hyperconnectivity between different cerebro-cortical areas. Many well-known artists are known to have been synesthetes, e.g. Alexander Scriabin, Olivier Messiaen, Arthur Rimbaud, Charles Baudelaire, Vladimir Nabokov, Vasily Kandinsky, David Hockney.

- ▶ Sensory Systems

---

## Synesthete

### Definition

A person with developmental or inherited synesthesia.

- ▶ Lexical-Gustatory Synesthesia
- ▶ Synesthesia

---

## Synkinesias

### Definition

Co-contractions of normally independently controlled muscles. For example, in *jaw winking*, voluntary movements of the lower face coincide with, e.g., eye closure.

---

## Synovial Fluid

### Definition

Synovial fluid is the fluid found on the articulating surface of joints. It is closely associated with the

cartilage fluid and is essential for the virtually frictionless movement of joints.

► [Articular Cartilage](#)

## Synovium

### Definition

Thin membranous layer lining synovial joints that secretes synovial fluid and contains nerves and vessels (both blood and lymphatics).

► [Joints](#)

## Synprint

### Definition

A synaptic protein interaction site localized to the large intracellular loop between domains II and III of the  $\alpha 1$  subunits of N- and P/Q-type  $\text{Ca}^{2+}$  channels. Enables binding of syntaxin, SNAP-25 and synaptotagmin to the  $\text{Ca}^{2+}$  channels, affecting the efficiency of  $\text{Ca}^{2+}$  entry vesicle release coupling.

► [Calcium Channels – an Overview](#)  
 ► [Synaptic Proteins and Regulated Exocytosis](#)

## Synprint Motif

### Definition

Acronym of synaptic protein interaction region: an approximately 225 amino acid stretch in the intracellular domain II-III linker region of the  $\alpha 1$ -subunit of mammalian Cav2.1 and Cav2.2 channels which binds SNARE proteins. The site is considered unique to vertebrate N-type  $\text{Ca}^{2+}$  channels and P/Q-type  $\text{Ca}^{2+}$  channels and seems to be at the origin or the tight coupling between these channels and presynaptic vesicles.

► [Calcium Channels – an Overview](#)

## Synthetic Quality in Olfaction

### Definition

In odor-mixture psychophysics, a synthetic quality occurs when a mixture of odorants smells like something different than the component odorants.

► [Olfactory Information](#)

## Syphilitic Meningitis

### Definition

Syphilitic meningitis mostly occurs within two years of the primary infection and is characterized by nocturnal headache, malaise, fever, stiff neck, and cranial nerve palsies.

## Syringomyelia

### Definition

An abnormal cystic structure within the center of the spinal cord resulting from the cerebro-spinal fluid (CSF) build-up. It most commonly occurs in the cervical spine. It can be primary or secondary (develops as a result of blockage of the CSF flow). The most common causes include birth defects, tumors and trauma. This condition is associated with Chiari I and II malformations. Typical symptoms include segmental muscular weakness and atrophy with associated specific sensory loss (loss of pain and temperature sensation with preservation of the sense of touch).

Surgical intervention may be needed to alleviate the symptoms and the indications usually depend on the primary cause.

► [Gliomas](#)

## Syrinx

### Definition

A special secondary vocal organ of birds, a modification of the lower part of the trachea, a “lower larynx.”

► [Evolution of the Brain: At the Reptile-Bird Transition](#)

## System – Nonlinear

### Definition

The general class of systems for which the relation between the input variables (initial conditions or external inputs) and output or state variables is not linear.

Common descriptions are by (nonlinear) state equations, differential equations, or difference equations.

► Nonlinear Control Systems

---

## Systemic Lupus Erythematosus (SLE)

### Definition

A disease of immune dysregulation characterized by inflammation in several organs and associated with the production of autoantibodies, especially anti-nuclear antibodies.

► Anti-DNA Antibodies against Microbial and Non-Nucleic Acid Self-Antigens

---

## Systems Biology

### Definition

Systems biology describes attempts to collate the individual insights obtained from disparate experimental systems with the high throughput datasets obtained from genomics, proteomics, imaging and studies of mutation, and to develop ways of mathematically modeling these data in order to make predictions about the behavior of cells and organs.

► Bioinformatics

---

## Syt

► Calcium Binding Proteins



---

## T Cells

### Definition

Major cellular players of the immune system's adaptive arm.

---

## T Helper 1 & T Helper 2 Phenotype

### Definition

T helper lymphocytes are CD4+ T lymphocytes that mature upon interaction with an antigen presenting cell presenting an antigen to antigen specific T cells that mainly produce interferon-gamma and IL-2 (T helper 1 cells) or mainly IL-4 and IL-10 (T helper 2 cells). Multiple Sclerosis (MS) is considered to be a T helper 1 type of (auto) immune response.

- ▶ Multiple Sclerosis
- ▶ Neuroendocrinology of Multiple Sclerosis

---

## L-T

- ▶ Length-Tension

---

## Tabes Dorsalis

### Definition

Late consequence (5 to 15 years after the primary infection) of the chronic inflammation initiated by

*Treponema pallidum* (syphilis or lues), leading to degenerative and sclerotic changes in posterior spinal nerve roots, large-diameter neurons in the dorsal-root ganglia, long thick myelinated fibers in the dorsal columns, optic nerves and oculomotor nuclei. Tabetic patients suffer from lightning root pains, severe deficits in touch and position sense without serious impairment of temperature and pain sensation, spastic gait, failing vision, small and irregular pupils, gastric crisis, urinary and sexual disturbances.

---

## Tachycardia

### Definition

Tachycardia refers to an abnormally rapid heart rate, and in clinical practice this is often taken to be a resting heart rate in excess of 100 beats per minute. Tachycardia may be seen with fever and sympatho-excitation. It also results from specific disorders affecting the generation and transmission of impulses in the electrical conduction system of the heart. With extreme tachycardia cardiac output declines because the high rate of ventricular contraction does not permit adequate flow of blood into the ventricles. Hence, rates in the range of 250–300 beats per minute are unsustainable and carry a high risk of ventricular fibrillation followed by cardiac arrest.

---

## Tachykinins

### Definition

Tachykinins are a group of related endogenous peptides, substance P, neurokinin A and neurokinin B, which are widely distributed within the nervous system. Substance P and neurokinin A are formed by cleavage of a larger protein precursor, pre-pro-tachykinin.

Nociceptive sensory neurons express substance P and neurokinin A and release these mediators in the periphery as well as in the dorsal horn of the spinal cord. Inflammation increases substance P expression. Activation of nociceptors results in the release of substance P in the periphery, which contributes to neurogenic inflammation. Substance P release in the dorsal horn contributes to the development of chronic pain. The effects of tachykinins are mediated by a group of G-protein coupled receptors called NK1, NK2 and NK3, which bind substance P, neurokinin A and neurokinin B, respectively.

- ▶ Neurogenic Inflammation
- ▶ Nociceptors and Characteristics
- ▶ Pain
- ▶ Substance P

---

## Tactile Acuity

### Definition

The extent to which one can discern small structural details in objects that touch the skin.

- ▶ Processing of Tactile Stimuli

---

## Tactile Afferents

- ▶ Cutaneous Mechanoreceptors, Functional Behavior

---

## Tactile Apraxia

### Definition

Neurological disorder characterized by a specific disturbance in the use of hand movements when interacting with objects in the presence of relatively normal hand movements when objects are not involved (e.g., gestures).

- ▶ Haptics

---

## Tactile Attention

CHRISTINE ELAINE CHAPMAN

Group de recherche sur le système nerveux central,  
Département de Physiologie & École de Réadaptation,  
Faculté de Médecine, Université de Montréal,  
Montréal, QC, Canada

### Definition

Attention allows one to focus awareness and the processing capacities of the brain on objects and events relevant to one's immediate, behavioural goals, and this within the context of a central nervous system (CNS) that is constantly bombarded by a steady stream of sensory inputs. Tactile attention specifically refers to attention to somatic sensory stimuli. While this term can encompass all of the submodalities that contribute to somatic sensation (touch/pressure, position/movement, temperature, pain), most experimental studies have concentrated on characterizing sensory responsiveness to touch during manipulations of attention, and this is the focus of this essay.

### Characteristics

#### Quantitative Description

Attention can be directed either voluntarily (top-down, endogenous) or involuntarily (bottom-up, exogenous) towards a specific stimulus. Typical examples would be, respectively, searching through a hand bag to find a pen versus the attention-grabbing elicited by the onset of vibration from a cell phone in one's pocket. Attention can be focused on any number of attributes of the stimulus, including its spatial location, features (texture, shape, size, consistency etc) and/or modality. Attention can be directed to a single stimulus (selective attention), or can be shared across multiple stimuli (divided attention). Finally, attention can be directed towards a stimulus either covertly or overtly (respectively, with or without orienting the receptors towards the stimulus). Overt orientation can include orienting the head and eyes towards an object of interest, so as to facilitate interactions. For example, an insect might land on one's arm, but the eventual motor response would depend on whether the insect might potentially bite (wasp) or not (housefly). For touch, the hand is appropriately shaped and positioned during the transport phase of a reach-to-grasp movement, thereby ensuring that the object will be secured in an efficient manner. Vision of the object is not essential for orienting to occur. Examples include the coordinated tongue and jaw movements that accompany chewing of a food morsel, or the adjustments in hand and finger posture that occur when grasping an object in the dark. Finally, orienting behaviour can be aversive, in the case of, for example, a painful tactile stimulus.

## Description of the Process

In comparison with the visual system, there is much less information available about the effects of attention on the perception of tactile stimuli. For all modalities, attentional effects are inferred by measuring the time taken to evaluate the stimulus (reaction time), response accuracy and also measures of sensory sensitivity (detection or discrimination thresholds). Faster reaction times are presumed to reflect speeded up processing and decision making, although the measures can also reflect increased readiness to move. Improved accuracy and reductions in sensory thresholds are likewise considered to reflect enhanced processing of sensory inputs. Some caution is necessary, however, because such changes can also reflect a change in response criterion or bias (willingness to report the presence of a stimulus when measuring detection threshold, for example).

## Spatial Attention

When attention is directed with spatial cues to different fingers of the hands, then the ability to discriminate surface texture and also vibrotactile stimulation shows a modest improvement with cueing (attention towards or away from the location of the stimulus). The effects are, however, dependent on the task design only being obvious when the task is more difficult, detecting the absence rather than the presence of a change in stimulus intensity [1]. Using reaction time measures, more robust attentional enhancements are seen in simpler tasks in which subjects discriminate the spatial location of vibrotactile stimuli applied to the fingers of each hand (thumb and index finger), in this case within the context of a cross-modal manipulation of attention (tactile and visual). Reaction times to vibrotactile stimuli are faster when attention is correctly directed to the general location of the stimulation (right or left hand) as compared to when attention is misdirected to the unstimulated side [2]. Interestingly, an asymmetry is observed for targets located on the left as compared to the right, with cueing having larger effects for the former, potentially reflecting a default rightward attentional bias.

## Cross-Modal Attention

To what extent are attentional controls similar across different modalities? This question can be approached by measuring the ability of subjects to perform similar sensory tasks under different attentional states: attention directed towards or away from each modality, or divided across modalities. Figure 1a shows typical results obtained in a cross-modal manipulation of attention across touch (vibrotactile stimuli to the fingertip) and vision (illumination of a central light), based on simple reaction time measures [3].

Subject attention was redirected on a trial-by-trial basis with instruction lights: directed attention (valid

cue) versus divided attention (neutral cue). The subject's task was to respond as quickly as possible to the presentation of the stimulus (tactile or visual). The design included a small number of invalid cues (attention misdirected). Typically, reaction times are shortest with directed attention, intermediate for divided attention, and longest when attention is misdirected. Interestingly, attention has proportionally similar effects on the detection of weak and stronger vibrotactile stimuli, as well as on detection of the visual stimulus (Fig. 1b), suggesting that attention may exert a generalized effect on perceptual abilities across touch and vision. Although the experimental design could be criticized since the visual and tactile stimuli did not come from the same spatial location, an advantage for directed attention over divided attention is also seen when the spatial confound is controlled, in this case in the context of experiments contrasting attentional influences across three modalities, touch, vision and audition [2]. In a task involving spatial discrimination, attention has proportionally larger effects on tactile than visual or auditory stimuli. While this observation might reflect different mechanisms when attention is divided across multiple modalities (versus two modalities), it should be stressed that touch requires physical contact between the surround and the receptors, and that this contact may serve as a reference point for interpreting incoming inputs. In contrast, audition and vision have no such reference.

## Orienting

An involuntary or reflexive shift of attention to a tactile cue is referred to as orienting. There is evidence that a preceding vibration can shorten reaction times to vibrotactile stimuli, even though the subjects had been instructed that the vibration had no relation to the target location (right or left hand) and that it should be ignored. Whether such effects are reflexive in nature is, however, not clear: for example, shortened reaction times have been shown using relatively long delays between the alerting cue and the stimulus to discriminate (200–400 ms), but such delays fall well within the time required for voluntary movement in response to a stimulus. Another approach, somewhat akin to studies of cross-modal attention, has been to show that vision of the stimulated body part (non informative since the subjects can not see the actual stimulus application), accompanied or not by orienting the head and eyes, improves the ability of subjects to perform tactile discrimination tasks. These results have been challenged since changes in response bias (willingness to report stimuli as being present) might have occurred, and contributed to the apparent enhancement of tactile sensitivity [4]. The underlying mechanisms are likely complex since performance on other somatic sensory tasks, specifically haptic shape and orientation, are

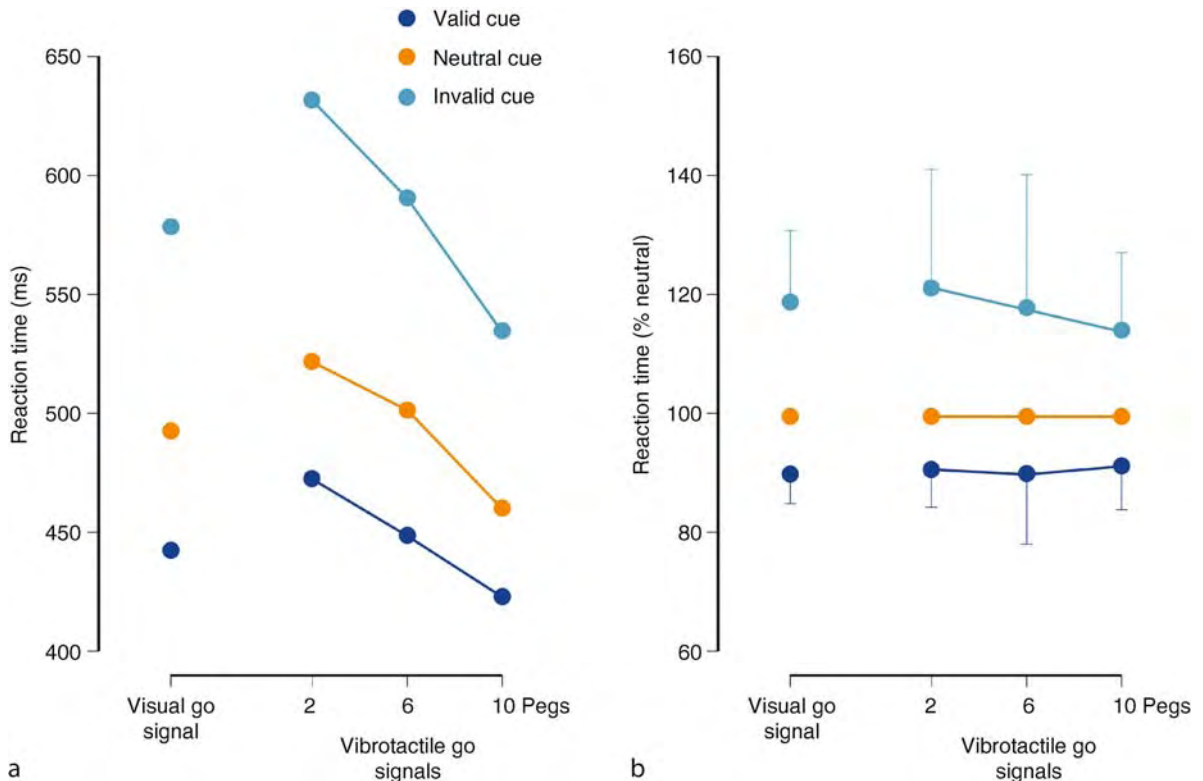

**Tactile Attention. Figure 1** (a) Mean reaction times for detecting visual and vibrotactile stimuli as a function of the cue condition ( $n = 12$ ): valid (attention directed to the correct modality); neutral (attention divided); and invalid (attention misdirected). Attention was directed on a trial-by-trial basis. The vibrotactile stimulus intensity was systematically varied by increasing the number of active pins in the vibrotactile array presented to the right index finger. (b) Normalized mean reaction times, taking the mean reaction time in the neutrally cued trials as 100%. Adapted from [3].

modified simply by providing non informative visual feedback or orienting the head (and eyes) towards the stimuli. Moreover, the nature of the interaction (performance enhanced or degraded) is critically dependent on the task itself, specifically whether the task calls upon an intrinsic (body-centred) or extrinsic (centred on external coordinates) reference frame.

### Higher Level Processes

#### Single Unit Recordings in Monkeys

In general terms, studies of visual attention indicate that selective attention can modulate the firing rate elicited by sensory stimuli and the times at which spikes fire. Behaviourally relevant, or salient, inputs may be selected and/or amplified, so improving the signal-to-noise ratio; irrelevant signals may be filtered or gated. The extent to which such mechanisms contribute to tactile attention is only now being explored.

Tactile information from the periphery is conveyed to the parietal receiving areas (►primary and secondary somatosensory cortex, S1 and S2) through the dorsal column – medial lemniscal pathway. There is limited

evidence for attentional modulation of neuronal responses at the thalamic relay site for lemniscal inputs, the ventrobasal nucleus, corresponding to the second major relay for peripheral afferent information after the dorsal column nuclei. In contrast, related factors, in particular the level of arousal, can produce large changes in neuronal responses to tactile inputs at the level of the thalamus with neurones being more responsive as arousal increases.

The results of recordings from awake primates trained in tactile discrimination tasks (vibration, tactile roughness, tactile letter recognition) along with diversionary tasks (visual or auditory) indicate that selective attention to tactile stimuli can influence neuronal responses in S1 cortex, but the effects can be up to three times larger in S2 cortex and more than twice as frequent [1,5,6]. As in studies of human psychophysics, sensory stimuli are presented under different conditions of attention. Neuronal responses evoked by attended tactile stimuli are compared with those evoked by the same stimulus while attention is shifted either to another modality and/or to another spatial location.

Sustained selective attention towards tactile stimuli enhances neuronal responses to tactile stimuli, both in S1 and S2 cortex [5,6]. Within the S1 cutaneous hand representation, selective attention particularly modulates discharge during the portion of the trial in which the attended feature, a change in surface texture, might occur. By examining stimulus-response functions under different attentional conditions (relevant versus irrelevant), it has been possible to show that S1 neurones show an *additive increase* in neuronal responsiveness to tactile stimuli with directed attention, i.e., the entire stimulus-response curve is shifted upwards (Fig. 2c) [6].

In the S2 hand representation, the effects are much more generalized, sometimes spanning multiple epochs

within the trials [5,6]. Moreover, some cells show attention-related changes in activity even prior to the start of tactile stimulation, i.e., a shift in baseline activity accompanies the shift in attention towards tactile stimuli. Concentrating on the epoch containing the salient feature (a change in surface texture), examination of the stimulus-response curves indicates that response gain is increased with directed attention, i.e., there is a *multiplicative increase* in S2 responsiveness to tactile inputs [6]. As shown in Fig. 2d, the slope of the stimulus-response curve is increased. These effects are, moreover, selective in that only cells responsive to changes in surface texture, the salient feature, show an increase in response gain. Together, it appears that tactile attention, at least within the context

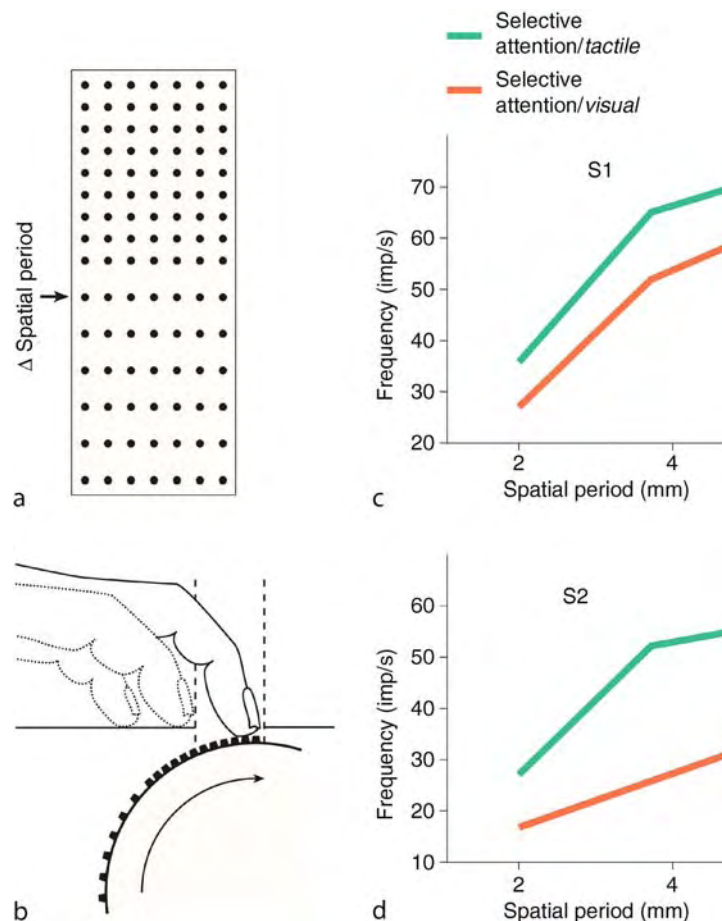

**Tactile Attention. Figure 2** Neuronal mechanisms underlying attentional enhancement of cortical responsiveness to tactile stimuli (cross-modal manipulation of attention, tactile/green or visual/red). Recordings were made from monkeys trained to discriminate either a change in surface texture (a, b) or a change in light intensity (not shown). Textured surfaces (a) were mounted on a drum and scanned under the fingertips (b). (c) When attention is directed to the tactile modality (green), then the stimulus-response curve for texture-sensitive neurones in S1 shows an upward shift (additive mechanism), in comparison to when the animal attended and discriminated visual stimuli. (d) S2 texture-sensitive neurones show evidence for an increase in response gain, as shown by the increased steepness of the slope of the stimulus-response curve (multiplicative mechanism). Adapted from [6].

of a tactile-visual cross-modal manipulation of attention, both selects and amplifies salient inputs in S2. There is likely a second and independent attentional mechanism, operational in both S1 and S2, which produces an additive increase in neuronal responsiveness, evident in the population of cutaneous neurones activated by the tactile stimulation.

Two other mechanisms likely contribute to attentional tuning in S2 cortex. There is evidence for increased synchrony with directed attention to tactile stimuli, and work in the visual system suggests that this can produce a multiplicative increase in stimulus-sensitivity. In addition, many S2 cells show a marked post-reward suppression (in the context of a task requiring the monkey to attend and discriminate changes in tactile roughness), with some cells losing their stimulus-sensitivity. Such a response pattern is not found in S1 [6]. This inhibition may allow neuronal resources to actively disengage from attended inputs, ensuring that attention can be shifted elsewhere. The suppressed discharge may provide a neuronal correlate for the psychophysical phenomenon of “inhibition of return” whereby sensory processing at recently attended locations may be slowed when the stimulus – visual, auditory or tactile – is repeated with a short inter-stimulus interval.

This description of attentional influences is, however, very much dependent on the experimental paradigm used to study attention. There is good evidence that a more complex design, combining spatial and cross-modal attention, elicits an initial suppression of neuronal responses to tactile stimuli [1] in both S1 and S2. Moreover, S2 cells show evidence of subsequent enhancement during a later interval, corresponding to that which contained the salient tactile feature, specifically the presence or absence of an amplitude pulse. Together this pattern of modulation likely enhances the signal-to-noise ratio for the relevant input.

### **Recordings in Humans (Imaging and Evoked Potentials)**

While single unit recordings can provide detailed information about the cellular mechanisms related to attention, the “view” is limited to the regions sampled with a microelectrode. One of the advantages of whole brain imaging (►PET, positron-emitting tomography; ►fMRI, functional magnetic resonance imaging) is that an overview of the entire neuronal network involved in controlling attention can be obtained, although with much less temporal resolution than possible with single unit recordings. The latter is, in part, overcome with more recent methods for recording event-related potentials triggered by tactile stimuli (e.g., ►MEG, magnetoencephalographic recordings).

Regional cerebral blood flow (►rCBF) elicited by tactile stimulation is increased with attention. Even

simple anticipation of light tactile stimulation can increase S1 rCBF. In both S1 and S2, the area of activation (seen using fMRI) is larger with directed attention, but this only reaches significance for S2. Consistent with single unit recordings, rCBF shows larger increases in S2 than S1 when attention is directed to tactile stimuli. In addition, sustained attention to tactile or visual stimuli results in the activation of a cortical network that includes the right dorsolateral frontal cortex and bilateral inferior parietal lobule (possibly corresponding to primate area 7b), and this independent of the laterality of the stimulus. This network may underlie the well known right hemispheric dominance of human attention (see Pathology, below) [7]. Multimodal alerting stimuli – capturing attention involuntarily – also activate preferentially right hemisphere structures, including the temporo-parietal junction and the inferior frontal cortex [8] along with other structures (insula, left anterior cingulate and supplementary motor area).

Evoked potential studies confirm that, as seen in non human primates, attention can enhance responsiveness to tactile inputs, with the effects being significant in S2 but not S1. The latter result may, however, reflect technical limitations with MEG recordings since this only “sees” regions located perpendicular to the surface, picking up responses from area 3b in the central sulcus, but not areas 1 and 2 on the crown of the postcentral gyrus. Somatosensory cortical evoked responses are modulated by cross-modal (tactile/auditory) and spatial manipulations of attention. Attentional effects are evident for relatively short-latency components (70–100 ms post-stimulus). The need to average together many responses, however, means that these experiments are often based on sustained attention to, for example, a single modality during a block of trials (often with short inter-trial intervals). Subject reports may not be made until after the block of trials (e.g., count the number of rare or oddball stimuli perceived). Thus, the link to the attentional processes that likely accompany selective attention to features or spatial locations is not obvious.

### **Lower Level Processes**

Unexpected stimuli can draw attention involuntarily towards the stimulus. As discussed above, both voluntary and involuntary attention activate preferentially, but not exclusively, right hemisphere structures. The extent to which these activations overlap is not known at present. Attentional systems are, moreover, constrained to act in concert with other systems, including controls over sleep and wakefulness. For example, there exists a diffuse and widespread cholinergic innervation of cortex arising from basal forebrain structures which modulates neuronal responsiveness to sensory stimuli, including tactile [9]. The norepinephrine system may also play an important role.

## Function

Attention, as indicated by its definition, acts so as to focus awareness and the processing capacities of the brain on objects and events relevant to one's immediate, behavioural goals.

## Pathology

Unilateral parietal lesions in humans, frequently involving the right posterior parietal regions, often result in spatial neglect (failure to attend to the contralateral side of space) and perceptual extinction (patients are unaware of stimuli applied to the contralesional side of the body when stimuli are presented simultaneously to the ipsi- and contralesional sides) in the absence of major sensory deficits. Perceptual extinction can be seen for tactile stimuli, as well as visual and auditory stimuli, but is not necessarily associated with neglect. When one simultaneously touches two mirror sites on the body, patients with ►tactile extinction do not perceive the contralesional (left) touch, although single contralesional touches can be detected. This phenomenon is thought to involve a disorder in spatial attention. Left tactile extinction may appear or be enhanced when patients look to the right; conversely, looking to the left can improve the perception of contralesional stimuli. In addition, tactile extinction is modulated by the position of the affected hand: extinction can improve when the affected hand is placed in the right rather than the left hemisphere [10].

## References

- Burton H, Sinclair RJ (2000) Tactile-spatial and cross-modal attention effects in the primary somatosensory cortical areas 3b and 1–2 of rhesus monkey. *Somatosens Motor Res* 17:213–228
- Spence C, Nicholls MER, Driver J (2001) The cost of expecting events in the wrong sensory modality. *Percept Psychophys* 63:330–336
- Post LJ, Chapman CE (1991) The influence of cross-modal manipulations of attention on the detection of vibrotactile stimuli in humans. *Somatosens Motor Res* 8:149–157
- Johnson RM, Burton PC, Ro T (2006) Visually induced feelings of touch. *Brain Res* 1073/1074:398–406
- Hsiao SS, O'Shaughnessy DM, Johnson KO (1993) Effects of selective attention on spatial form processing in monkey primary and secondary somatosensory cortex. *J Neurophysiol* 70:444–447
- Chapman CE, Meftah E-M (2005) Independent controls of attentional influences in primary and secondary somatosensory cortex. *J Neurophysiol* 94:4094–4107
- Pardo JV, Fox PT, Raichle ME (1991) Localization of a human system for sustained attention by positron emission tomography. *Nature* 349:61–64
- Downar J, Crawley AP, Mikulis DJ, Davis KD (2000) A multimodal cortical network for the detection of changes in the sensory environment. *Nature Neurosci* 3:277–283
- Sarter M, Hasselmo ME, Bruno JP, Givens B (2005) Unraveling the attentional functions of cortical cholinergic inputs: interactions between signal-driven and cognitive modulation of signal detection. *Brain Res Rev* 48:98–111
- Bartolomeo P, Perri R, Gainotti G (2004) The influence of limb crossing on left tactile extinction. *J Neurol Neurosurg Psychiatr* 75:49–55

## Tactile C Fibers

VAUGHAN G MACEFIELD

School of Medicine, University of Western Sydney, Sydney, NSW, Australia

Prince of Wales Medical Research Institute, Sydney, NSW, Australia

### Synonyms

Low-threshold C fiber mechanoreceptors; CT afferents; CT fibers

### Definition

Tactile C fibers are a class of slowly-conducting (unmyelinated) sensory axon in the skin. Like other unmyelinated afferents, it is believed that the sensory terminals of these fibers are free nerve endings, though there are specializations in their sensory specificity. Whereas the majority of afferent C-fibers in the skin serve nociceptive, thermoceptive or chemoceptive functions, tactile C fibers (CT afferents) are unusual in possessing low mechanical thresholds – they respond to stimuli that are typically in the “light touch” range and hence in the province of the classic ►cutaneous mechanoreceptors – the myelinated tactile afferents. First described in the hairy skin of the cat [1], the first human tactile C fibers were found in the skin of the face, during percutaneous microelectrode recordings (►microneurography) of the infraorbital [2] and supraorbital [3] nerves. More detailed studies documented the properties of these fibers in the hairy skin of the forearm [4–6]. Given that this region is typical of the skin of much of the body, it is reasonable to conclude that tactile C-fibers are distributed widely over the body, though they have not been found in the hand. That they have been found in the hairy skin of the thigh [7] and foot would certainly suggest that they are ubiquitous.

### Characteristics

#### Quantitative Description

Typical of C-fibers recorded by microneurography, tactile C-fibers generate negative-going, triphasic action potentials (Fig. 1). The receptive fields of CT

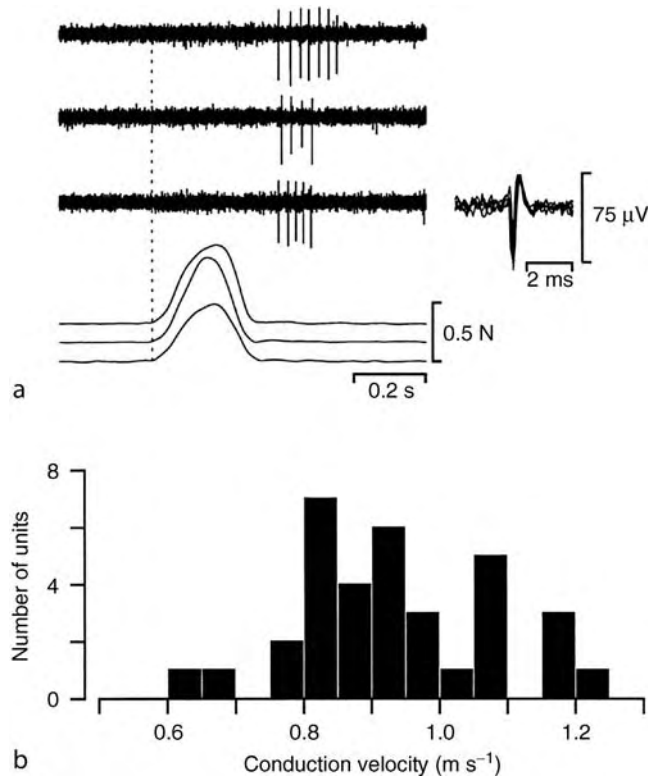

**Tactile C Fibers. Figure 1** Microelectrode recording from a low-threshold mechanosensitive C-fiber afferent in the forearm skin. The mechanoreceptor responded at long latency to brisk taps over its receptive field (a); superimposed spikes in the inset show the typical morphology of an extracellular recording from an unmyelinated axon. Conduction velocities, measured from the onset of the mechanical stimulus, are shown for 34 CT afferents in (b). Figure reproduced from [5].

afferents are similar in shape and size to those of the myelinated tactile afferents with small receptive fields – the ►rapidly-adapting type I mechanoreceptors (FA I) and ►slowly-adapting type I mechanoreceptors (SA I). Indeed, they also share the feature of possessing several (1–9) “hot spots” within the receptive field, as assessed by scanning the area with a 5 mN probe; these zones of maximal sensitivity presumably correspond to the locations of the sensory terminals of the axons [6]. Figure 1 shows the responses of a CT afferent to percussive stimulation of the skin.

Estimation of conduction velocities from the latency to a mechanical or electrical stimulus reveals a mean conduction velocity of  $\sim 0.9$  m/s, i.e., within the range of conduction for unmyelinated axons [4]. CT afferents possess some unusual features: they respond in a slowly-adapting fashion to forces applied normal to the skin but, unlike the slowly-adapting (myelinated) cutaneous afferents, typically generate a sustained “off-discharge” following a brisk percussive stimulus. One can speculate that this after-discharge may contribute to stimulus localization; indeed, there is evidence that – in the absence of large-fiber cutaneous input – CT afferents can provide information on the location of a

punctate stimulus [8]. And while they have a poor capacity to follow high-frequency vibration, stroking the skin is a particularly effective stimulus: peak firing rates of  $\sim 100$  Hz can be achieved by light stroking, the slower the stimulus the greater the response [3]. Peak firing rates of 400 Hz – approaching the absolute refractory period for C fibers – have also been observed. An example, from a CT afferent located on the hairy skin of the foot, is illustrated in Fig. 2. Interestingly, the response to light stroking exceeds the response to indentation; the myelinated ►fast-adapting type I mechanoreceptors (FAI) likewise respond preferentially to stroking.

As stroking with cotton wool can activate CT endings their mechanical thresholds must be very low. Indeed, the indentation (von Frey) thresholds of CT fibers in the face are similar to those of the slowly-adapting type I mechanoreceptors supplying the hand (0.6–2.3 mN; [3]); CT afferents of the forearm have thresholds ranging from 0.3–2.5 mN; [4]. Interestingly, CT afferents demonstrate “fatigue” with repeated stroking stimuli, and with sustained indentation exhibit a biphasic response: an initial excitation that adapts, followed by a slow acceleration in the discharge [5]. The mechanism for the latter is unknown.



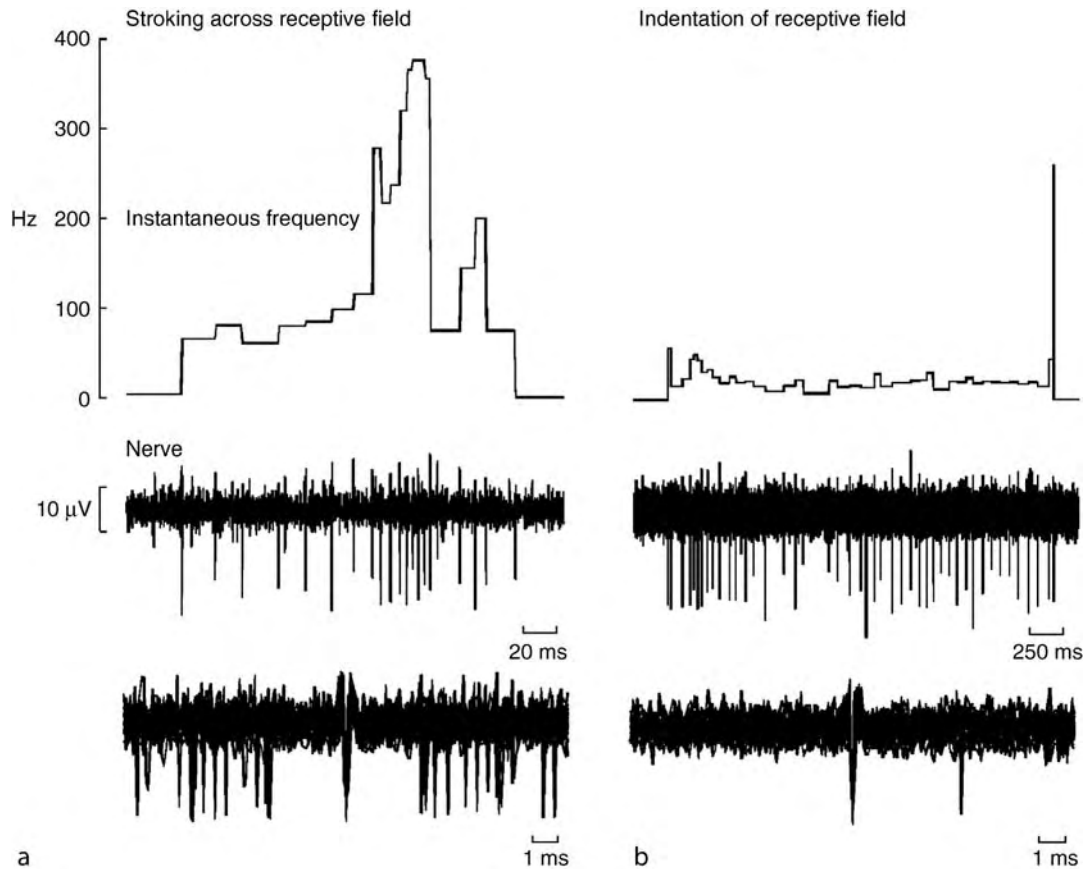

**Tactile C Fibers. Figure 2** Microelectrode recording from a low-threshold mechanosensitive C-fiber afferent located on the dorsum of the foot. The mechanoreceptor responded vigorously to stroking over its receptive field with cotton gauze (a); instantaneous frequencies were higher than those generated by indentation of its receptive field (b). Unpublished data from Macefield.

### Higher Order Processes

Given that CT fibers are sensitive to light stroking of the skin it has been suggested that they subserve an affective component of touch, engaging areas of the brain involved in the processing of emotion – the limbic system – rather than those comprising the discriminative somatosensory system. Studies in patients lacking large-fiber sensory axons yet preserved small-fiber function reveal that their capacity to feel this light touch remains. Moreover, the stroking stimuli feel “pleasant.” Furthermore, brain imaging studies have shown that light stroking of the hairy skin in these patients activates the insular cortex but not the primary somatosensory cortex [9]; the insula is also engaged in feelings of warmth [10].

### Process Regulation

There is no evidence that the sensitivity of CT afferents can be modified by efferent control mechanisms.

### Function

As noted above, the sensitivity of CT afferents to caress-like touch, and their projection to the insular cortex,

suggests that their primary role is in the affective aspects of touch.

### Pathology

It is not known whether the loss of CT afferent input is associated with any specific pathology, though one would expect these afferents to be involved in the small-fiber neuropathies that compromise conduction along unmyelinated axons (e.g., diabetes). However, as noted above, these afferents may provide some significant tactile information in large-fiber sensory neuropathies, in which tactile (and proprioceptive) information provided by myelinated axons is lost.

### References

1. Douglas WW, Ritchie JM (1957) Non-myelinated fibres in the saphenous nerve that signal touch. *J Physiol* 139:385–399
2. Johansson RS, Trulsson M, Olsson KA, Westberg KG (1988) Mechanoreceptor activity from the human face and oral mucosa. *Exp Brain Res* 72:204–208

3. Nordin M (1990) Low-threshold mechanoreceptive and nociceptive units with unmyelinated (C) fibres in the human supraorbital nerve. *J Physiol* 426:229–240
4. Vallbo AB, Olausson H, Wessberg J, Norrsell U (1993) A system of unmyelinated afferents for innocuous mechanoreception in the human skin. *Brain Res* 628:301–304
5. Olausson H, Wessberg J (1999) Unmyelinated afferents constitute a second system coding tactile stimuli of the human hairy skin. *J Neurophysiol* 81:2753–2763
6. Wessberg J, Olausson H, Fernstrom KW, Vallbo AB (2003) Receptive field properties of unmyelinated tactile afferents in the human skin. *J Neurophysiol* 89:1567–1575
7. Edin B (2001) Cutaneous afferents provide information about knee joint movements in humans. *J Physiol* 2001 531:289–297
8. Cole J, Bushnell MC, McGlone F, Elam M, Lamarre Y, Vallbo A, Olausson H (2006) Unmyelinated tactile afferents underpin detection of low-force monofilaments. *Muscle Nerve* 34:105–107
9. Olausson H, Lamarre Y, Backlund H, Morin C, Wallin BG, Starck G, Ekholm S, Strigo I, Worsley K, Vallbo AB, Bushnell MC (2002) Unmyelinated tactile afferents signal touch and project to insular cortex. *Nat Neurosci* 5:900–904
10. Olausson H, Charron J, Marchand S, Villemure C, Strigo IA, Bushnell MC (2005) Feelings of warmth correlate with neural activity in right anterior insular cortex. *Neurosci Lett* 389:1–5

difference in magnitude of the parameter between two stimuli that a subject is able to detect on more than 75% of trials. Like detection thresholds, difference or discrimination thresholds are quantified using a number of different methods. Forced choice methods are commonly used to minimize subjects' biases.

#### ► Processing of Tactile Stimuli

---

## Tactile Extinction

### Definition

When one simultaneously touches two mirror sites on the body, patients with tactile neglect do not perceive the contralesional touch, although single contralesional touches can be detected. Patients can also show extinction in other modalities (vision, audition, olfaction).

#### ► Tactile Attention

---

## Tactile Detection Threshold

### Definition

For any particular stimulus parameter (see “detection of tactile stimuli”), the absolute threshold is the lowest magnitude that the subject is able to detect on more than 50% of trials. Measuring thresholds is complicated by interaction of different stimulus parameters. For example, a commonly used measure is the threshold force (or pressure) of a Von Frey hair applied to the skin. But this depends on the temporal profile of the contact, including contact velocity and acceleration. Thresholds are measured using a range of approaches including the method of limits (ascending or descending), the staircase method, and forced choice paradigms.

#### ► Processing of Tactile Stimuli

---

## Tactile Discrimination Threshold

### Definition

A difference threshold, (or difference limen) for a particular parameter of a tactile stimulus is the smallest

---

## Tactile Form Discrimination

### Definition

The complexity and spectrum of forms which characterize the objects that we encounter in everyday life are many and varied. They range from the simple curve of an apple to the complex shapes encountered during common tasks, for example using eating utensils or operating computer devices such as a keyboard, mouse or track ball. Information about these characteristics is essential for successful task manipulation or identification. For the most part, when manipulating objects, form identification is done at the unconscious level with the success of the task dependent on the ability of the tactile system to extract the precise three-dimensional form of encountered objects. Most of these complex object characteristics can be reduced to a smaller number of elemental components and these have been studied extensively in psychophysics experiments and complementary neural experiments. Experimental stimuli range from bars, gratings and curvatures to complex patterns such as embossed letters and Braille-type characters. These are either scanned across or indented into the skin surface and either human ability is quantified or neural responses are characterized for the specific parameter being studied. Ultimately

these studies of tactile form discrimination address key questions concerned with the spatial resolution within neural populations, i.e., how precise information is represented within neural population responses.

#### ► Processing of Tactile Stimuli

## Tactile Lamellar Corpuscle

#### ► Meissner Corpuscle Regeneration

## Tactile Paralysis

### Definition

Inability to recognize an object by touch despite preserved or minimally impaired somatosensory function. Also called tactile agnosia.

#### ► Haptics

## Tactile Sensation in Oral Region

GREG K. ESSICK<sup>1</sup>, MATS TRULSSON<sup>2</sup>

<sup>1</sup>Department of Prosthodontics and Center for Neurosensory Disorders, School of Dentistry, University of North Carolina, Chapel Hill, NC, USA

<sup>2</sup>Department of Prosthetic Dentistry, Institute of Odontology, Karolinska Institutet, Sweden

### Synonyms

Touch sensation, or mechanosensation, in the mouth and on the lips

### Definition

Oral ►tactile sensation is the conscious sensation, or perceptual experience, evoked by physical contact between an oral tissue (e.g., tip of the tongue) innervated by tactile receptors (►low-threshold mechanoreceptors) and some other entity such as a food particle, a tooth or the lip [1]. The sensation can

occur passively when an object moves into contact with innervated tissue, or actively when the tissue moves into contact with an object.

The ►oral region refers to the oral cavity, bound anteriorly by the oral port, the ►vermillion of the lips, and posteriorly by the anterior pillar of the fauces, the palatoglossal arches [2]. It is bound superiorly by the palate and inferiorly by the floor of the mouth, under the tongue. When the upper and lower teeth are occluded, the oral cavity is subdivided further into a vestibular region external to the teeth (internal portions of lips and cheeks) and oral cavity proper internal to the teeth (tongue and palate).

Oral tissues innervated by tactile receptors include epithelium and teeth [1]. The epithelium is subdivided into the transitional epithelium of the lips (the vermillion); the delicate lining mucosa of the lips, cheeks, alveolus, ventrum of the tongue, soft palate, and floor of the mouth; and the tougher masticatory mucosa of the hard palate, gingiva (gum tissue surrounding the teeth), and ►tongue dorsum less the specialized chemosensory epithelium in the taste buds located therein [2]. The tactile sensory ►innervation of the teeth is located in the ►periodontal ligaments, which attach the roots of the teeth to the surrounding alveolar bone. The oral tissues differ in their roles and the mechanical demands placed on them during function, in their sensory innervations, and thus in their sensitivity to touch.

### Characteristics

#### Psychophysical Approaches

Attributes of oral tactile sensations are assessed using ►psychophysical approaches. The simplest attribute, that of ►tactile detection, is often characterized by the lowest force (e.g., in mN, or more commonly in grams) or the lowest pressure against the innervated tissue, or the smallest vertical skin displacement (e.g., in µM) required for detecting touch on a pre-specified percentage (e.g., 50%) of applications [1,3]. Nylon filaments that buckle to deliver calibrated forces are often used to measure static detection ►thresholds. Mechanical probes that move sinusoidally in and out of the tissue at controlled ►frequencies and displacements are sometimes used to measure dynamic, ►vibrotactile detection thresholds. In both cases, sensitivity is expressed by the inverse of the threshold value.

►Two-point thresholds are measured in the oral region to assess suprathreshold tactile sensation [1,4]. These thresholds are the minimum separations (e.g., in mm) at which two points of physical contact feel like two distinct points (the two-point perception threshold) or can be discriminated from one point of contact (the ►two-point discrimination threshold). These ►differential thresholds depend not only on spatial attributes of tactile sensation (►spatial acuity), but ►intensive and ►temporal attributes as well.

Threshold measures assess tactile sensation indirectly. For example, after injury and ►regeneration of peripheral nerves that supply the oral tissues, the thresholds may be totally normal yet tactile sensations feel qualitatively different than before the injury.

The most complex attributes of suprathreshold tactile sensations are assessed by methods that require subjects to actively manipulate standardized textured stimuli or miniature three-dimensional forms (such as embossed letters of the alphabet) with the tip of the tongue. Psychophysical responses are obtained to quantify how well the subject identifies the stimuli (e.g., a square object or the letter “E”); ►tactile form discrimination) or to characterize evaluative judgments of the stimuli, e.g., in terms of perceived grittiness, oiliness, dryness, or tactile pleasantness. Appreciation of textural attributes is an important component of the enjoyment of food and drink.

### Behavioral Approaches

During eating, forces exerted by the teeth must be regulated to effectively cleave boluses of food while oral soft tissues are kept clear of the ►occlusal table. The same low-threshold mechanoreceptors that underlie tactile sensation underlie the exacting ►motor control required for ►biting, chewing and speaking [1,5,6]. The consequences of loss of ►information from the mechanoreceptors can be evaluated by studying behavior before and after anesthetizing sensory nerves to the tissues under investigation. A second approach is to study patients who have lost sensory innervation as a result of injury to peripheral branches of the ►trigeminal nerve.

## Description of the Condition

### Regional Variations in Tactile Detection Sensitivity (Fig. 1a)

Within the mouth the contact detection threshold is lowest on the tip of the tongue (about 10 mg) [1,7]. Among other oral and facial structures, thresholds are only lower on the perinasal skin (5 mg). Slightly less sensitive than the tongue tip is the vermillion of the upper and lower lips (20 mg), followed by the anterior hard palate (50 mg). Thresholds do not remain constant across individual structures [3]. For example, across the vermillion, sensitivity is highest at the border with the ►hairy perioral ►skin, and lowest at the mucocutaneous junction with the oral labial and ►buccal mucosa. On the tongue dorsum, sensitivity falls at least ten fold antero-posteriorly over the anterior two thirds of the tongue along the midline, and decreases further by a factor of about 2 from the midline to the lateral edges of the tongue. There is no consensus description as to how sensitivity varies over the extent of the hard and soft palates or of threshold values at sites that have been studied. Tactile detection thresholds on

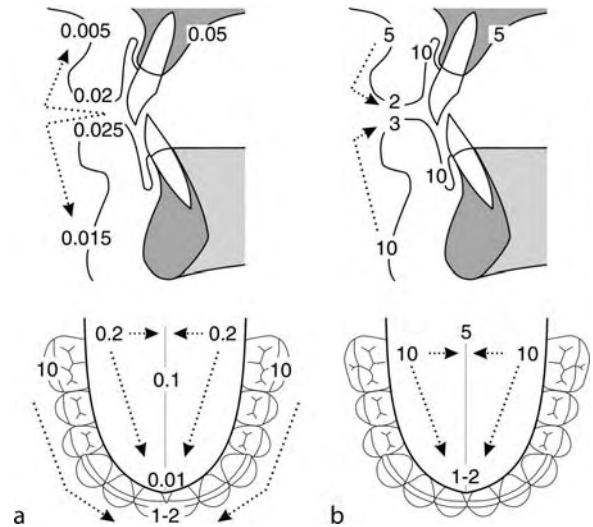

### Tactile Sensation in Oral Region.

**Figure 1** Approximate values of touch detection thresholds in grams (a) and of two-point thresholds in millimeters (b) on perioral (top) and lingual/dental tissues (bottom). Dotted arrows denote directions over which sensitivity increases (see text). Collectively, the tip of the tongue and vermillion of the lips are rivaled only by the fingertips in tactile sensitivity and tactile discrimination acuity. Note that the sensitivity of the teeth to static touch is orders of magnitude less than that of the oral soft tissues.

the gingiva (100s of mg) are substantially higher than those observed on the lips, tongue dorsum, or central portion of the palate. On average, detection sensitivity does not differ on the two sides, right vs. left, of the oral region.

### Dental Tactile Detection Sensitivity

Subjects with natural teeth are able to detect foils only 20  $\mu\text{m}$  in thickness when they are placed between the teeth, demonstrating an extraordinary level of sensitivity. The contact detection threshold is lowest for the anterior teeth, 1–2 g, and increases distally along the arch to about 10 g for the molars. Infiltration of local anaesthesia close to the tooth dramatically increases the threshold value, confirming the role of low-threshold ►periodontal mechanoreceptors in dental tactile sensitivity [8].

### Regional Variations in Tactile Discrimination Capacity (Fig. 1b)

With some noted exceptions, tactile discriminative capacity varies similarly among orofacial structures to tactile detection sensitivity [1,4,7]. The two-point thresholds are lower on the tip of the tongue than any other body location, approximating 1 mm. Slightly less sensitive than the tongue tip is the vermillion of the

upper (2 mm) and lower (3 mm) lips, and the anterior hard palate (5 mm). Notably, values for these diverse structures are all within the normal range for the fingers, attesting to their high acuity. On the tongue dorsum, sensitivity falls 4–5-fold antero-posteriorly over the anterior two thirds of the tongue along the midline, and decreases by a factor of 2–3 from the midline to the lateral edges of the tongue. Positionally matched sites on the ventral side of the tongue are reported to be less discriminative, as well as sites located sublingually. From the upper and lower vermillion of the lips, the two-point thresholds decrease oro-fugally, approximating 8–10 mm on the vestibular mucosa intraorally, as well as on the inferior border of the chin and on the cheeks extraorally. On average, tactile discriminative capacity does not differ on the two sides of the oral region, although right vs. left sided differences have been reported on the tongues of individual subjects.

#### **Anatomical Variation in the Innervation of the Oral Tissues**

Stimulus-evoked activity in the low-threshold mechanoreceptors that innervate the oral region is the peripheral basis for oral tactile sensation. Overall, the density of innervation is highest anteriorly, declines both posteriorly and laterally, and is higher on the pinnacle surfaces of the tissues, e.g., dorsal vs. ventral surface of tongue, vermillion vs. cutaneous or mucosal surfaces of lips, ▶interdental papillae versus other areas of the alveolar ridge, and gyri versus sulci of palatal rugae (horizontal corrugations of tissue behind the upper front teeth) [9]. To a first approximation, tactile discrimination capacity varies in parallel with these variations in innervation density (see sections above). Tactile detection sensitivity depends additionally on the compliance of the tissue, affected by the state of hydration and degree of keratinization [3].

The density of the oral sensory innervation has not been quantitatively estimated, but is thought to be rivaled only by that of the hand [10]. This is evidenced by the relatively large diameters of the terminal branches of the trigeminal nerve in relation to the relatively small surface areas of tissue supplied, the high ▶tactile acuity of the tongue and lips, and the relatively large volume of somatosensory cortical and thalamic grey matter devoted to the oral region.

Compared to the skin of the hand, the corpuscular endings of myelinated afferents terminating in oral tissues are less clearly defined, more variable in morphology, and less numerous. Certain morphologically identifiable receptor endings found ubiquitously in the hand are limited in the oral region. For example, the ▶Pacian corpuscle is notably absent with perhaps the exception of the ventrum of the tongue; ▶Merkel's disk receptors found in most oral tissues are notably absent from the dorsum of the tongue [10].

#### **Low-Threshold Mechanoreceptors in the Lips and Oral Mucosa**

The low-threshold mechanoreceptors found in the lips and ▶oral mucosa have functional properties similar to three of the four types of ▶cutaneous mechanoreceptors described in the glabrous skin of the human hand (FA I, SA I and SA II afferents; See essays entitled “Cutaneous mechanoreceptors, anatomical characteristics” and “Cutaneous mechanoreceptors, functional behavior”) [1,6]. Slowly-adapting mechanoreceptors with a high dynamic sensitivity (i.e., they respond vigorously to the onset of the mechanical stimulus) and an irregular discharge during maintained tissue deformation resemble the SA I afferents (Fig. 2a).

Another group of slowly adapting mechanoreceptors characterized by a regular discharge rate, exquisite sensitivity to lateral skin stretch, and ▶spontaneous activity is similar to SA II afferents (Fig. 2b). Rapidly-adapting mechanoreceptors in the lips and oral mucosa resemble those of the ▶FA I afferents (Fig. 2c). Importantly, no mechanoreceptors encountered in human recording experiments have showed response properties similar to those of ▶FA II afferents (Pacian corpuscles). As such, the oral region, unlike the hand, is notably insensitive to high frequency vibrations and mechanical transients, the stimuli to which FA II mechanoreceptors are most sensitive.

The ▶receptive fields of oral mechanoreceptors are generally small and well defined, with the smallest fields observed at the tip of the tongue (ca. 1 mm in diameter; Fig. 2d). The majority (ca. two thirds) of the mechanoreceptors terminating superficially in the tongue adapt rapidly to maintained tissue deformation [10]. In contrast, most (ca. two thirds) mechanoreceptors in the facial skin, lips and buccal mucosa are slowly adapting [1,6].

#### **Low-Threshold Mechanoreceptors in the Periodontal Ligaments**

The periodontal ligaments are richly innervated with ▶Ruffini-like nerve ▶endings, which signal information about intensive, temporal, and spatial aspects of tooth loads [1,5,8]. These receptors show slowly adapting response properties and possess the capacity to discharge continuously during sustained tooth loads, provided that the force is strong enough and applied in an appropriate direction (Fig. 3a).

The resemblance in response properties to those of SA II mechanoreceptors (Ruffini endings) in the skin is striking: The presence of spontaneous activity, a steady discharge response to steady loads, relatively weak responses to the onset of stimuli, and directional selectivity in the effectiveness of loads.

Recordings from human subjects reveal that the receptive fields of about half of the periodontal mechanoreceptors involve more than one tooth, typically two to

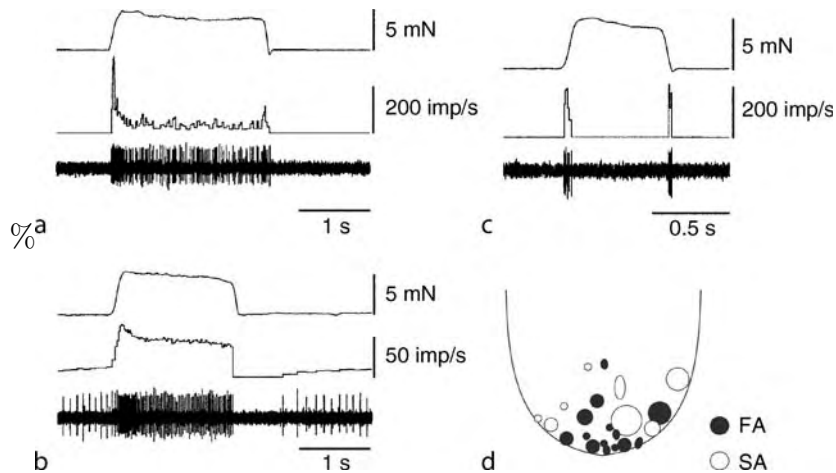

**Tactile Sensation in Oral Region. Figure 2** Recordings from the three different types of low-threshold mechanoreceptors found in the lips and oral mucosa. Response properties are similar to those of tactile receptors in the human hand: SAI (a), SAI (b), and FAI (c). For each panel, the upper trace is the force in mN applied to the receptive field, the middle trace is the instantaneous frequency response in impulses per second, and the lower trace is the electrical afferent nerve recording. (d) Receptive fields of single mechanoreceptive afferents from human lingual nerves. (Modified from [10]).

four teeth [1,5]. Each afferent always exhibits the highest response rates to stimulation of one particular tooth, the receptor-bearing tooth, with a gradual and rather sharp decline in responsiveness to loads applied to the adjacent teeth. Mechanical coupling between neighbouring teeth likely causes the multi-tooth receptive fields.

Human periodontal mechanoreceptors are normally broadly tuned to the direction of tooth loading (Fig. 3). As such, an individual periodontal mechanoreceptor provides ambiguous information about the direction of a force applied to the tooth. However, information about the precise direction of force is represented reliably in the activity from small populations of receptors, which possess preferred directions at which forces evoke the greatest neural responses [1]. The preferred directions of the mechanoreceptors supplying the mandibular anterior teeth and the premolars are quite evenly distributed around the circumference of the tooth, as viewed in the horizontal plane. In contrast, the receptors supplying the molars have a clear preference for the distal-lingual direction, i.e., toward the back of the mouth and toward the tongue. There is also a preference for downward-directed forces, but with fewer receptors responding preferentially in this direction because the number of receptors decreases from front to back along the dental arch [5].

Based on the relationship between the magnitude of tooth load and the steady-state discharge rate of the receptor, human periodontal receptors can be classified into two groups, saturating receptors and non-saturating receptors [5,6]. The saturating receptors constitute about 80% of the population and show a marked

curved relationship between the steady state discharge rate and the amplitude of the tooth load. The receptors at the anterior teeth feature their highest sensitivity to changes in static force at force levels below some 1 N. The corresponding value for the posterior teeth is slightly higher, about 3–4 N. At higher forces, the sensitivity gradually decreases and the receptor discharge attains approximately its highest rate for all force levels above the limit. Moreover, for the saturating receptors the sensitivity to changes in force (dynamic sensitivity) decreases in parallel with the static sensitivity as the force increases. The non-saturating receptors, on the other hand, exhibit nearly linear stimulus-response relationships implying that these receptors efficiently encode force and force changes also at high forces levels.

### Higher Level Structures and Processes

Neural pathways and structures within the central nervous system for the **somatosensory processing** of information signaled by low-threshold mechanoreceptors in the trigeminal nerve are mostly similar to those associated with the spinal nerves (see essay entitled “Central somatosensory projections”). A noted exception is the mesencephalic nucleus, which consists, in part, of cell bodies of periodontal mechanoreceptors that distribute to the apex of the tooth [1]. In the somatosensory (ventrobasal) thalamus, the orofacial region is represented medial to subcorporeal regions; however, in primary somatosensory cortex (postcentral gyrus), it is represented laterally (see essay entitled “Somatosensory cortex I (SI)”).

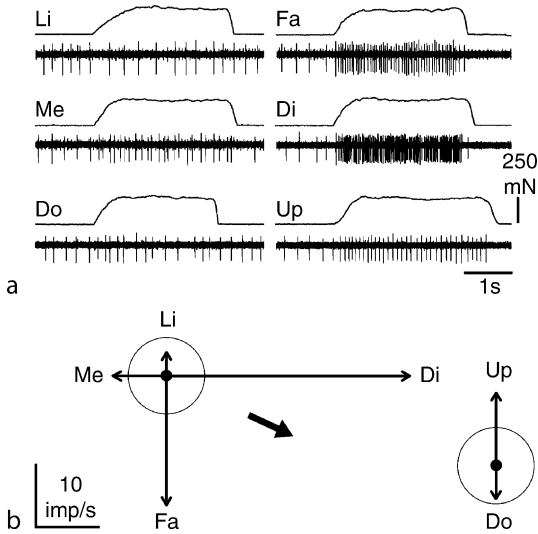

### Tactile Sensation in Oral Region.

**Figure 3a** Recordings from a single periodontal mechanoreceptor to forces applied in six directions to the lower central incisor (the receptor-bearing tooth). For each panel, the upper trace is the force in mN applied to the tooth in the stated direction: lingual (Li), facial (Fa), mesial (Me), distal (Di), downward (Do), and upward (Up). The lower trace is the electrical afferent nerve recording. (b) Vectoral representation of the responses to sustained force application in the horizontal (left) and axial (right) directions. The length of each vector is proportional to the mean discharge rate evoked in each direction. The spontaneous discharge rate is represented by the circle with the radius indicating its intensity. The thick arrow represents an estimate of the most efficient excitatory stimulus direction in the horizontal plane, i.e., the calculated preferred direction. (Modified from Trulsson et al.: *J Physiol* 447:373–389, 1992).

### Regulation of the Process

As similar for the upper and lower limbs, mechanoreceptive information from the orofacial region is selectively **gated** during voluntary movements. As a result, certain aspects of tactile sensation are altered during functional activity.

### Function

#### Low-Threshold Mechanoreceptors in the Face and Oral Mucosa

The exceptionally high innervation densities of the tips of the tongue and digits of the hand support their unique role in manipulation and exploration of objects. In contrast, low-threshold mechanoreceptors supplying the buccal mucosa and face discharge vigorously not only when the tissue is touched (Fig. 2), but also in response to deformations of the tissue that occur during voluntary lip and jaw movements (e.g., during generation of air pressures for speech sounds or during chewing; Fig. 4) [1,6].

The precise nature of the responses indicates that these mechanoreceptors, most often viewed as exteroceptors mediating tactile sensations, also serve a role in **proprioception**, signalling detailed information about the consequences of muscle activation on the soft tissues (see essay entitled “Proprioception: Role of cutaneous receptors”). This function is particularly important for the control of the facial muscles, since these muscles lack receptors that are traditionally considered proprioceptors, i.e., they have no muscle spindles, Golgi tendon organs, or joint receptors.

#### Low-Threshold Periodontal Mechanoreceptors

Dental tactile sensations are secondary to the important role played by periodontal mechanoreceptors in the motor control of the jaw. The anterior teeth are most highly innervated and are involved in the initial stages of food intake, before food is transferred to posterior segments of the dentition. Sometimes the anterior teeth are even used as a “third hand” in manipulative tasks, or as a precision cutting tool. Proper execution of these tasks relies heavily on sensory information as does the execution of comparably exacting manipulative tasks performed by the densely innervated finger tips of the hand. The shift from a high sensitivity of the receptors to most directions at the anterior teeth to the distal-lingual direction at the molars meets the functional demands of the anterior versus posterior teeth. During chewing, the anterior teeth experience forces in all directions, whereas the forces that normally act on the molars are limited more distal-lingually.

Model simulations reveal that periodontal mechanoreceptors possess the capacity to signal information about the mechanical events that occur when humans use their teeth to manipulate, bite and chew food [1,5]. For example, the saturating receptors respond distinctly to small forces similar to those produced by the initial contact with food, and effectively signal small changes in low force levels as occur when subjects manipulate, position and hold food between the teeth. Consistent with model simulations, behavioural experiments have shown that subjects use signals from periodontal receptors in the fine motor control of the jaw for these tasks (Fig. 5).

Human subjects with anesthesia applied to the teeth demonstrate a marked disturbance in the control of precisely directed, low biting forces, but not in generating the higher forces required to bite through food substances.

### Pathology

#### Effects of Loss of Mechanoreceptive Input

Temporary loss of tactile sensory function is common after accidental injuries or injuries to the trigeminal nerve as a result of oral surgical procedures. Patients often report bothersome altered sensations, drooling,

biting the lip, tongue or cheek, and difficulty with speech or kissing. Altered sensation in the lips and tongue can substantially impair the patient's quality of life, particularly if it remains long term. Lack of coordination in chewing has been observed following denervation of intraoral receptors including periodontal receptors.

### Dental Implants and Osseoperception

Unlike natural teeth, **dental implants** are in direct contact with the jawbone without an intervening periodontal ligament. Despite the lack of periodontal mechanoreceptors, tactile-like sensations, via a process called **osseoperception**, are evoked by mechanical stimulation of an implant. These sensations are mediated by mechanoreceptors located in the surrounding tissues (e.g., **periost**, mucosa, muscle or joint). The dynamic, vibrotactile detection threshold tends to be relatively similar for implants and natural teeth. However, the static detection threshold of implants has been reported to be 10–50 times higher than that of natural teeth.

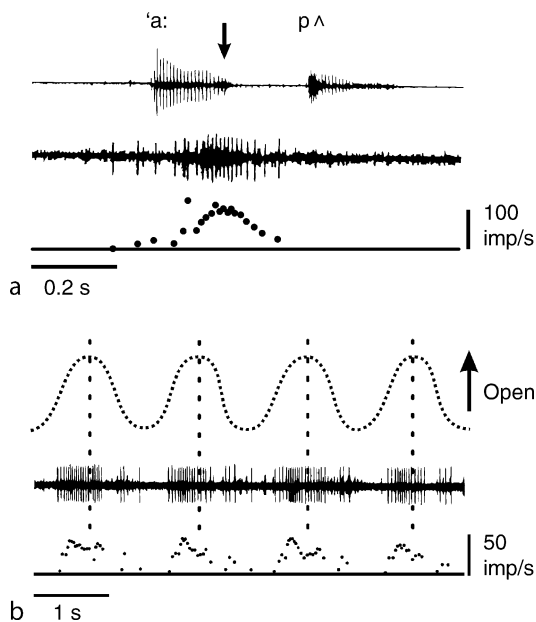

### Tactile Sensation in Oral Region.

**Figure 4** Recordings from an oral mechanoreceptor in the infraorbital nerve during speech gestures and chewing movements. The afferent was slowly adapting with receptive field located in the buccal mucosa about 1 cm lateral to the corner of the mouth. (a) Activity evoked when the subject said [ˈa:pA]. Audio signal, microelectrode record, and instantaneous discharge frequency represented in top, middle and bottom traces, respectively. Arrowhead indicates a moment of rapid lip movements resulting in “pop-puff” sounds in the audio record. (b) Activity evoked by chewing movements. Top trace is of chewing movement; middle trace is as in (a). (Modified from Johansson et al.: *Exp Brain Res* 72:209–214, 1988).

Moreover, similar to subjects with anesthetized teeth, patients with dental implants show a disturbed fine motor control of jaw actions associated with biting and intraoral manipulation of food (**Fig. 5d**).

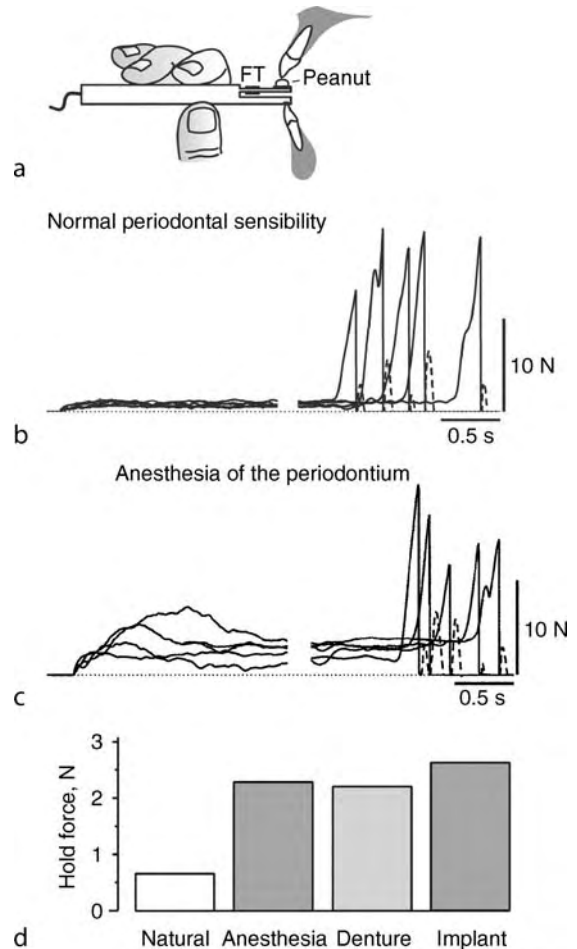

### Tactile Sensation in Oral Region.

**Figure 5** Importance of periodontal mechanoreceptor feedback to fine motor control of the jaw. (a) Subjects were instructed to position the apparatus so that a peanut half, resting on a duraluminum plate equipped with force transducers (FT), could be held and split by a pair of opposing central incisors. b and c, Examples of force profiles (five superimposed trials) obtained during normal periodontal sensibility (b) and during anaesthesia (c) of the periodontium. Note the considerably higher and more variable hold forces produced by the subjects during the anaesthesia. (d), Bars represent the mean hold force of (i) subjects with natural teeth, (ii) subjects with anesthetized natural teeth, (iii) subjects with full removable dentures supported only by the mucosa, and (iv) subjects with dental prostheses (in both jaws) supported only by osseointegrated implants. (Modified from Trulsson and Johansson: *Exp Brain Res* 107:486–496, 1996 and Trulsson and Gunne: *J Dent Res* 77:574–582, 1998).



## References

1. Trulsson M, Essick GK (2004) Chapter 6: Mechanosensation. In: Miles TS, Nauntofte B, Svensson P (eds) *Clinical oral physiology*. Quintessence Books, Copenhagen, pp 65–197
2. Gartner LP (1994) Oral anatomy and tissue types. *Sem Dermatol* 13:68–73
3. Grossman RC (1967) Methods of determining oral tactile experience. In: Bosma JF (ed) *Symposium on oral sensation and perception*. CC Thomas, Springfield, IL, pp 161–181
4. Brill N, Tryde G, Edwards C, Thomas H (1974) Age changes in the two-point discrimination threshold in human oral mucosa. *J Oral Rehab* 1:323–333
5. Trulsson M (2006) Sensory-motor function of human periodontal mechanoreceptors. *J Oral Rehab* 33:262–273
6. Trulsson M, Johansson RS (2002) Orofacial mechanoreceptors in humans: encoding characteristics and responses during natural orofacial behaviors. *Behav Brain Res* 135:27–33
7. Grushka M, Sessle BJ, Howley TP (1987) Psychophysical assessment of tactile, pain and thermal sensory function in burning mouth syndrome. *Pain* 28:169–184
8. Linden RWA, Millar BJ, Scott BJ (1995) The innervation of the periodontal ligament. In: Berkovitz BKB, Moxham BJ, HN (eds) *The periodontal ligament in health and disease*, 2nd edn. Mosby-Wolfe, London, pp 133–159
9. Grossman RC, Hattis BF (1967) Oral mucosal sensory innervation and sensory experience: a review. In: Bosma JF (ed) *Symposium on oral sensation and perception*. CC Thomas, Springfield, IL, pp 5–62
10. Trulsson M, Essick GK (1997) Low-threshold mechanoreceptive afferents in the human lingual nerve. *J Neurophysiol* 77:737–748

## Tactile Senses – Touch

YOSHIAKI IWAMURA

Department of Sensory Science, Kawasaki University of Medical Welfare, Okayama, Japan

### Introduction

Touch is the sensation arising from our own body. We identify our own body parts as well as objects coming into contact with our body through somatosensory receptors on the skin and deep tissues. The definition of touch has been changed in western science history. In ancient Greece, Aristotle defined touch as the sensation through the flesh. It included everything but vision, audition, olfaction, and gustation. Thus, it included even visceral sensation in the current knowledge. The origin of touch sense: where the receptors for touch sense existed was not known. In the end of nineteenth century, touch was defined as the sense evoked by the stimulus imposed on the passive skin surface. The definition made investigation of the touch sensation more prosperous, and several receptor types for touch

were identified morphologically in the skin. The research of touch in the passive sense has dominated the modern psychological and physiological research field since then. In the middle of twentieth century, D. Katz and J. J. Gibson opposed the general attitude of investigators to limit touch to the passive world and stressed the importance of active touch, that is, the only touch sensation in daily life to perceive objects by manipulation. Active touch is a complex sensation based on signals from receptors of both skin and deep tissue, and on unique central mechanisms. The issue is currently one of major subjects of somatosensory research. This chapter deals with the somatosensory system – from the peripheral receptors to the neocortex, which engages in touch sensation in both the passive and active sense.

### Cutaneous Mechanoreceptors, their Anatomical Characteristics

Light mechanical stimulation to the skin causes a tactile, pressure or vibration sensation. Such stimulation activates cutaneous mechanoreceptors. They are located in the epidermis, dermis, or sometimes at subcutaneous tissue, and are innervated by myelinated nerve fibers with a large to medium caliber. Electron-microscopically identified receptors are Merkel cell-neurite complex, Ruffini endorgan, Meissner's corpuscle, hair follicle receptors (lanceolate receptors), sinus hair follicles, and encapsulated corpuscles, such as, Krause ending, Pacinian corpuscle, and others. Details of the morphology of these cutaneous mechanoreceptors have been described (► [Cutaneous mechanoreceptors, anatomical characteristics](#)).

### Mechanosensory Transduction

Mechanoreceptors work as sensory transducers to transform mechanical energy into electrical energy. Receptor potential is generated and then converted into a series of impulses at a spike-generating site, the first Ranvier node of sensory nerve fibers innervating receptors. Different structures of cutaneous mechanoreceptors may be suitable to receive different forms of mechanical energy. Lamella of corpuscles works as mechanical filter. There is still controversy over the functional role of Merkel cells in the Merkel cell-neurite complex.

The application of mechanical forces to mechanoreceptors open mechanosensitive ion channels, increase membrane conductance, and generate receptor potentials. By using techniques of both electrophysiology and molecular biology, mechanosensitive ion channels have been extensively studied in nematode (*Caenorhabditis elegans*) and arthropod (*Drosophila*). However, ion channels gated by low mechanical stimulation have not yet been identified in mammals (► [Mechanosensory transduction](#)).

## Processing of Tactile Stimuli

Low-threshold cutaneous mechanoreceptors are activated by the tactile stimuli, stresses and strains arising from the interaction between the skin and objects when we touch or manipulate objects by hand. Four classes of mechano-sensitive units were recorded in the peripheral nerves, first in cats and then in humans. They are called fast adapting afferent I (FAI), fast adapting afferent II (FAII), slowly adapting afferent I (SAI), and slowly adapting afferent II (SAII). These four receptor types have different response characteristics because of differences in their structure and in their location in the skin. During manipulation, the receptor responses are determined by different features of the manipulated object and by hand movements. Such features include contact or grip force, the presence of shear forces, the area and shape of the contact region, the surface texture, the shape and compliance of the object, and the presence of slip between the object and the skin. A population of mechano-receptive afferents is able to simultaneously encode multiple stimulus parameters because each parameter has a different representation in the spatial and temporal patterns of activity across the afferent population. An overview is presented on how these tactile sensors of the glabrous or hairy skin represent object and task parameters such as simple stimuli, pattern and form, texture, shape, and manipulation. A brief note is also presented on the central mechanisms (► [Processing of tactile stimuli](#)).

## Cutaneous Mechanoreceptors, Functional Behavior

Responses of cutaneous mechanoreceptors to the controlled skin indentation have been assessed in the human skin by the technique of microneurography. Receptive field properties of these receptor units were described in detail. Differences exist in the population of common receptors between the glabrous and hairy skin. There are unique receptor types in the hairy skin, the field units and tactile C units that will be described in a separate essay. There are four types of mechanoreceptors in the human glabrous skin, FAI, FAII, SAI and SAI, and their analogue in the hairy skin. The mode of activation of the glabrous skin mechanoreceptors by the manipulation of objects such as lifting or holding is described in detail. The results of microstimulation of single afferents are also noted (► [Cutaneous mechanoreceptors, functional behavior](#)).

## Tactile C Fibers

These are a class of slowly conducting unmyelinated sensory nerves, found in the hairy skin, and are called as tactile C fibers. Whereas the majority of afferent C fibers in the skin are nociceptive, thermosensitive, or chemosensitive, tactile C fibers are unusual in that they are mechano-sensitive, have a low and respond

better to slowly moving mechanical stimuli. Unlike myelinated low threshold mechanoreceptors, tactile C fibers are limited to the hairy skin. They were found first in the cat hairy skin and then in human forearm skin. They convey information of innocuous touch sense from the hairy skin to the brain not to the primary somatosensory cortex, but possibly to the insular cortex. Their functional role is thus thought to be in the affective aspects of touch (► [Tactile C fibers](#)).

## Vibration Sense

The vibration sense, a subset of the sense of touch, is transduced by the Pacinian receptor channel. It corresponds to Fast adapting type II afferents (FAII). The Pacinian corpuscle is sensitive to sinusoidal vibrations of between 0.4 and 700 Hz. It is able to follow at a 1:1 ratio the individual periodic displacements in a U-shaped sensitivity function with a maximal sensitivity at between 250 and 300 Hz. Exquisitely sensitive, it can be activated by a displacement as small as 0.1  $\mu\text{m}$  (peak) at 250 Hz. Vibration sense is thought to be a highly sensitive “alerting” system to indicate that something is present, on or near the surface of the skin (► [vibration sense](#)).

## Aging of Tactile Sense

The tactile sense (touch) is not exempt from the effects of advancing age. These effects go largely unnoticed by most people because interaction with the environment is much more salient in vision and hearing. Although these effects have been studied for about 80 years, for the most part the early studies used poorly controlled stimulators such as cotton swabs, hairs and primitive electronic devices. Controlled laboratory experiments using modern technologies for measurement have been used to investigate aging of the vibratory sense. Studies of the tactile sense usually fall into two broad categories, namely measurements made at threshold and at suprathreshold levels of stimulation. Research on the effects of aging on the tactile sense has focused on measuring both threshold and suprathreshold responses (► [Aging of tactile sense](#)).

## Tactile Sensation in Oral Region

Oral tactile sensation is a conscious perceptual experience. It is evoked by physical contact between oral tissue innervated by tactile receptors (low-threshold mechanoreceptors) and some other entity such as a food particle, a tooth or the lip. The sensation can occur passively when an object moves into contact with innervated tissue, or actively when the tissue moves into contact with an object. The oral region refers to the oral cavity. When the upper and lower teeth are occluded, the oral cavity is subdivided further into a vestibular region external to the teeth (internal portions of lips and cheeks) and oral cavity proper internal to the teeth (tongue and palate). The oral tissues differ in their roles and the mechanical demands placed on them during function, in their sensory innervations, and thus in their sensitivity to touch.

Attributes of oral tactile sensations are assessed using psychophysical or behavioral approaches. There are regional variations in tactile discrimination capacity, and in the innervation of the oral tissues. The exceptionally high innervation densities of the tips of the tongue support its unique role in manipulation and exploration of objects. Low-threshold mechanoreceptors supplying the buccal mucosa and face discharge vigorously not only when the tissue is touched, but also in response to deformations of the tissue that occur during voluntary lip and jaw movements.

Neural pathways and structures within the central nervous system for the somatosensory processing of information signaled by low-threshold mechanoreceptors in the trigeminal nerve are mostly similar to those associated with the spinal nerves (► [Tactile sensation in oral region](#)).

### Somatosensory Projections to the Central Nervous System

Somatosensory projections arise from sensory receptors and nerve fibers distributed throughout the body. They are concerned with the sensory modalities of touch, pain and thermal sensation, and the kinesthetic sense, the sense of body position and movement. The different modalities of somatic sensation are derived from sensory receptors or nerve endings in the skin or from receptors in muscles and joints.

Somatosensory information is carried from all parts of the body to the central nervous system via vast numbers of nerves that finally enter either the spinal cord or the brainstem. Upon entering the central nervous system, somatosensory nerve fibers may project, as a result of branching in their axons, into more than one target site at which they make synaptic connections with neurons of the central nervous system. Within the spinal cord there are at least three major pathways for conveying somatosensory information to higher centers of the brain for somatic sensation and perception, the dorsal column (DC) system, the spinothalamic tract (STT) system and the spinocervical tract (SCT) system.

Somatosensory information may also be conveyed to higher centers of the brain over less direct pathways, in particular, involving spino-reticular pathways whose functions are not entirely clear, but are probably not of major importance for the signaling of detailed discriminative information for sensory experience (► [Somatosensory projections to the central nervous system](#)).

### The Somatosensory Cortex I (SI)

The cortical area involved in the somatosensory processing in the rostralmost parietal lobe, the postcentral gyrus. The somatosensory cortex was defined earlier as the cortical regions where the cortical stimulation provoked either localized bodily movements in monkeys or subjective somatosensory experiences in

humans. Later, cortical evoked potentials were recorded by electrical stimulation of the body surface in various animals to determine the extent of the somatosensory cortex. At least three areas, the somatosensory cortex I (SI), II (SII), and the supplementary somatosensory cortex have been identified in primates including humans.

Over the surface of the somatosensory cortex I (SI) in the human postcentral gyrus, the somatotopic map of the body representation was drawn, based on evoked subjective somatic sensation. In animals, cortical evoked potentials are recorded with the shortest latency after stimulation of the periphery, and analogous somatotopic maps of the body representation were drawn.

The following subjects were discussed in the light of current knowledge. Anatomical structures of SI, cytoarchitectonic subdivisions of Brodman, thalamic inputs, cortico-cortical association connections, callosal connections, corticofugal connections, somatotopic representation of the body surface, plastic alteration of the somatotopy, representation of pain in SI, columnar structures, diversity of the neuronal receptive field along a perpendicular array, hierarchical processing in the hand region, vertical neuronal arrays representing active touch, bilateral representation of the body in SI, attributes of tactile perception represented in the cortical activity (► [The somatosensory cortex I \(SI\)](#)).

### The Somatosensory Cortex II (SII)

SII is the cortical area involved in the somatosensory processing in the frontoparietal operculum in primates and in the lateral cortical region in the cat. It is defined as a separate cortical region from SI.

The anatomical position of SII and the results of single neuronal recording studies revealed that SII is a higher stage of somatosensory information processing, downstream to SI. SII receives cortico-cortical projections from SI in addition to the thalamic inputs. SII projects to the frontal lobe and insular cortex. In SII the bilateral representation of the body, especially that of hands and feet is more common. The functional role of SII in somatic sensation is not yet clear, but its possible and specific role in tactile object recognition, tactile memory, tactile attention processes, and process of decision making have been discussed in the light of its anatomical connections to other cortical areas, experimental evidence in both animals and humans and clinical observations of human patients (► [The somatosensory cortex II \(SII\)](#)).

### Somatosensory Cortex, Plasticity

The somatosensory cortex is characterized with a somatotopic representation of the contralateral body. Areas depend on inputs from the somatosensory thalamus and other somatosensory areas for activation. The loss of a source of activation, such as afferents from the hand, is followed by neurons developing responsiveness to remaining inputs, such as those from the face or arm.

Sensory experiences can also alter the response properties of neurons, often in ways that they become more selective for the experienced stimuli. These plastic changes in somatosensory cortex are mediated by the growth of axons and the formation of new synapses in the somatosensory system, as well as by cellular changes that influence the sensitivities of neurons to neurotransmitters.

A major loss of sensory inputs results in an extensive reactivation of deactivated portions of the somatosensory cortex by remaining somatosensory inputs in ways that result in misperceptions, such as feeling touch or pain in a missing (phantom) limb. Researchers are trying to understand the mechanisms of neural plasticity so that useful forms of plasticity can be promoted, and harmful types of plasticity can be prevented (► [Somatosensory cortex, plasticity](#)).

### Barrel Cortex

The layer IV of mouse and rat SI cortex is characterized with a unique structure called barrels. When viewed in sections cut parallel to the cortical surface and stained with the cytochrome oxidase (CO) stain, they appear as oval dense zones: one for each of the digits and pads on the feet, and one for each of the large and many of the small whiskers on the face around the nose and mouth.

Rodents have specialized the whiskers on their face into exquisitely sensitive tactile organs with which they explore their environment, by moving the whiskers back and forth (whisking). Each whisker in these species is a complex sensorimotor organ that can move the whiskers precisely to gather the most salient information.

Each whisker follicle is innervated by over 200 sensory fibers that render it extremely sensitive to the direction, magnitude, duration, frequency and velocity of any stimulus that can perturb the whiskers. In the rat's vibrissa (whisker) system, neurons representing whiskers at each level in the pathway are topographically organized into functional "whisker maps". These maps correlate well with the anatomically discrete cell aggregates at each level: "barrelettes" in the brainstem, "barreloids" in the thalamus and "barrels" in layer IV of the primary somatosensory cortex (SI). Each map replicates the spatial arrangement of whiskers on the face (► [Barrel cortex](#)).

### Haptics

Haptics is defined as sensing objects by manipulation or palpation. Haptic sensing is focused on perceiving the physical properties of external objects rather than internal tactile sensations, and the hand is the primary organ through which the external world is explored tactually.

Haptic sensing involves both the tactile and proprioceptive sensory modalities. The tactile inputs come from cutaneous mechanoreceptors in the hand that encode the surface features and shapes of objects as they are explored, whereas the proprioceptive signals provide information about joint angles, the rate of joint

movement and the forces generated on contact, all of which can assist in perceiving the properties of objects held in the hand. It is this active process of manual exploration in which there is a close interplay between finger movements and tactile perception that distinguishes haptics from passive touch.

For some properties, such as the perception of roughness of a surface or the detection of minute surface irregularities, it appears to matter little whether the hand moves over a stationary surface (haptic sensing) or the surface is moved across a stationary hand (tactile sensing), all that is important is that there is relative motion between the skin and the surface.

For other properties, such as the perception of weight, hand movements greatly facilitate perception, as reflected in the increased sensitivity to changes in weight when an object is lifted as compared to when it rests on the passive hand. Peripheral proprioceptive feedback resulting from the active movement provides an additional source of information about the object. A further source of information about force comes from the cortically generated motor command transmitted to the muscles involved in supporting the weight. Copies of these commands, known as corollary discharges, are sent to a number of the sensory areas in the cortex and are involved in the perception of force.

Impairments in haptic object recognition can occur in the absence of primary sensory loss. They are usually associated with lesions in the posterior parietal lobe, sensory thresholds on the hand are normal or only mildly impaired, but there is a profound deficit in recognizing objects haptically. A number of terms are used to describe these impairments in haptic object recognition consequent to cortical damage, including astereognosis, tactile apraxia and tactile paralysis. The deficits appear to result from difficulties in tactile shape perception and inefficient manual exploration strategies. Lesions in the posterior parietal lobe therefore affect the capacity to make precise controlled finger movements and to plan these movements efficiently, both of which are essential to haptic object recognition (► [Haptics](#)).

### Active Touch

Active touch refers to the act of touching, and implies voluntary, self-generated movements. With active touch, the environment is explored using specialized touch organs in order to gather information about the properties of surfaces (texture, hardness, temperature) and/or objects (size, shape, weight, location) located in the nearby peri-personal space. In contrast, passive touch, or the act of being touched, implies that the sensory input is generated by an external agent, and this type of touch is not generally exploratory in nature and experienced only occasionally in daily life.

In humans and other primates, the hand is generally used for active tactile exploration of the surround. The

hand is characterized with a high density of peripheral sensory receptors, a correspondingly large cortical representation and thus high sensory acuity. The hand is not only a touch organ, but also has a highly developed ability to make independent finger movements. The manipulation provokes rich sensory signals of both a cutaneous and proprioceptive nature to be sent to the brain.

Since D. Katz (1925) and J. J. Gibson (1962) emphasized the importance of investigating active touch, there have been many studies to compare various aspects of the two modes of touch experimentally, and whether the perception is equivalent with active and passive touch has been studied. A number of studies have compared perceptual performance using active and passive touch, but these have concentrated almost exclusively on tasks dependent on cutaneous feedback. Their results have shown that perceptual performance with active and passive touch is similar when exploratory conditions are suitably matched. Equivalence for active and passive touch has been shown for a variety of cutaneous tasks, including the detection of minute surface irregularities, texture discrimination, scaling the roughness of various surfaces, and recognition of raised tactile patterns (letters, Braille characters). Occasionally, investigators have shown an advantage for active touch over passive touch, e.g. recognition of Braille characters, but the findings have not been confirmed in other studies using similar types of pattern recognition tasks.

There has been a long-standing debate about the perceptual equivalence of active touch and passive touch. Current evidence indicates that there is perceptual equivalence for active and passive touch in a range of tasks, mostly dependent only on cutaneous inputs. Active touch, on the other hand, likely enjoys an advantage over passive touch in being more efficient: the relevant sensory information is collected, and analyzed, more rapidly. The underlying neuronal mechanisms differ, because only active touch involves voluntary movements. Thus it is conceivable that the motor commands associated with active touch may trigger central mechanisms such as attention that contribute to enhance neuronal responses to salient inputs during active touch. Finally, active touch enjoys a number of advantages over passive touch: digits can be oriented so that the most sensitive skin areas contact the object and; movement speed can decline at critical times during exploration, so minimizing suppressive gating influences (themselves speed-dependent). It thus seems unwise to generalize from results obtained using one form of touch to the other (► [Active touch](#)).

### Tactile Attention

Attention allows one to focus awareness and the processing capacities of the brain on objects and events relevant to one's immediate behavioral goals. Tactile attention specifically refers to attention to somatic

sensory stimuli. While this term can encompass all of the submodalities that contribute to somatic sensation (touch/pressure, position/movement, temperature, pain), most experimental studies have concentrated on characterizing sensory responsiveness to touch during manipulations of attention.

In comparison with the visual system, there is much less information available about the effects of attention on the perception of tactile stimuli. Attentional effects are inferred by measurement of reaction time, response accuracy and also measures of sensory sensitivity (detection or discrimination thresholds). Faster reaction times are presumed to reflect speeded up processing and decision-making. Improved accuracy and reductions in sensory thresholds are likewise considered to reflect enhanced processing of sensory inputs.

Psychophysical studies in humans on (i) spatial attention, (ii) cross-modal attention and (iii) orienting, and the results of experimental studies to examine the neuronal correlate of human psychophysics, single unit recordings from SI and SII in monkeys were described. The neuronal responsiveness to tactile stimuli was enhanced by a vibratory cue. The enhancement was more pronounced in SII than in SI. Possible mechanisms of the attentional tuning in SII were discussed in detail.

There are studies to investigate the effects of attention in humans. Regional cerebral blood flow (rCBF) elicited by tactile stimulation is increased with attention. Even simple anticipation of light tactile stimulation can increase SI rCBF. In both SI and SII, the area of activation (seen using fMRI) is larger with directed attention, but this only reaches significance for SII. Consistent with single unit recordings, rCBF shows larger increases in SII than SI when attention is directed to tactile stimuli. In addition, sustained attention to tactile or visual stimuli results in the activation of a cortical network that includes the right dorsolateral frontal cortex and bilateral inferior parietal lobule (possibly corresponding to primate area 7b), and this is independent of the laterality of the stimulus. This network may underlie the well-known right hemispheric dominance of human attention. Evoked potential studies confirm that, as seen in non human primates, attention can enhance responsiveness to tactile inputs, with the effects being significant in SII but not SI (► [Tactile attention](#)).

## Tactile (Touch) Receptors

► [Cutaneous Mechanoreceptors, Anatomical Characteristics](#)

## Tactile Vocoder

### Definition

Devices designed for use by the deaf and hard-of-hearing in order to display the sounds and patterns of speech upon the surface of the skin by vibrations.

► Aging of Tactile Sense

## Tangle

### Definition

A characteristic feature of the brains of Alzheimer's patients, the intracellular aggregates of paired helical filaments, composed of the protein tau.

► Alzheimer's Disease  
► Neuroinflammation: Chronic Neuroinflammation and Memory Impairments

## Tail Currents

### Definition

Membrane currents measured during ion channel closing. Tail currents are associated to channel de-activation and are typically measured during a voltage-clamp pulse on return to resting membrane potentials. The pulse is preceded by a step depolarization able to open a significant fraction of available ion channels.

## Tailor's Cramp

### Definition

George Vivian Poore (1890) described a case of Tailor's Cramp and other troubles affecting the function of the hand. He described two forms: (i) the spasmodic form, which was like a focal ► [dystonia](#), and a neuritic type, a diffuse form, which had a neuromuscular cause.

## Tanycyte

### Definition

A specialized cell type located in the ventricular ependymal wall. Developmentally related to radial glia, these cells are found in select regions along the third ventricle, the floor of the cerebral aqueduct, and the caudal floor of the fourth ventricle. They express a variety of neuroendocrine marker molecules, and take up various protein tracers from the cerebrospinal fluid. The function of tanycytes remains incompletely understood, but their likely functions include forming diffusion barriers and mediating neuroendocrine communication between the cerebrospinal fluid, portal capillary networks, and neuronal groups in adjacent brain parenchyma. They have been proposed to be involved in providing T3 to the central nervous system (CNS) following T4 uptake from the cerebrospinal fluid (CSF).

► [Hypothalamus-Pituitary-Thyroid Axis](#)

## Tangential Migration

### Definition

Interneurons are produced in subpallium and migrate into the telencephalon parallel to the pial surface.

## Tanycytes

### Definition

Tanycytes are cells lining the third ventricle establishing contacts with blood vessels of the ME.

## Tardive Dyskinesia

### Definition

Refers to dyskinesic movements secondary to longterm use of neuroleptic (antipsychotic) or anti-emetic medications, which have dopamine antagonist activity. Tardive dyskinesia is typical choreatic, dystonic, or a combination of the two. It is best to prevent tardive syndromes by using the lowest dose of an atypical antipsychotic for the shortest possible duration. Once present, treatment of tardive dyskinesia can be challenging. The data supporting the use of Vitamin E and benzodiazepines are weak, although the sedative/ anxiolytic effects of the latter may suppress abnormal movements. There are no large scale head-to-head studies comparing atypical neuroleptics among themselves. Clozapine and quetiapine have the lowest reported cases of tardive dyskinesia. Dopamine depleting agents may also be used in intractable cases of tardive dyskinesia.

- ▶Chorea
- ▶Drugs for Motor Disorders

## Target Organ (Autonomic)

### Definition

Target organs are organs innervated by autonomic nerves, and are also called effector organs. Examples include the pupil, heart, blood vessels, sweat glands, gastrointestinal tract, hormone secretory organs, and urogenital organs.

- ▶Parasympathetic Nervous System
- ▶Sympathetic Nervous System

## Target Selection in Axon Growth

### Definition

The phenomenon by which axons enter and recognize specific zones comprised of their target cells.

- ▶Axon Pathfinding

## Target Specificity

- ▶Synaptic Specificity

## Target Step Saccade Task

### Definition

At the beginning of a trial, a visual target is presented, and the subject (human or monkey) is required to fixate it. At the end of the fixation period, this target is extinguished at the same time that a second target comes on. The subject must then make a gaze shift to fixate the new target. This standard task allows for precise experimental control of the direction and amplitude of gaze shifts.

- ▶Saccade, Saccadic Eye Movement

## Targeting Endothelial Dysfunction Through Treatment of Erectile Dysfunction: Current Pharmacological Treatment and Mechanism of Action

BOBBY D. NOSSAMAN<sup>1,3</sup>,  
SUBRAMANYAM N. MURTHY<sup>1</sup>, SERAP GUR<sup>2</sup>,  
WAYNE G. HELLSTROM, PHILIP J. KADOWITZ<sup>1</sup>

<sup>1</sup>Department of Pharmacology, Tulane University Medical Center, New Orleans, LA, USA

<sup>2</sup>Department of Urology, Tulane University Medical Center, New Orleans, LA, USA

<sup>3</sup>Department of Anesthesiology, Ochsner Health System, New Orleans, LA, USA

### Definition

▶Erectile dysfunction is defined as a persistent medical and/or psychological disorder that refers to the inability to obtain an adequate penile erection for satisfactory sexual activity.

### Characteristics

Erectile dysfunction is a neurovascular disorder modulated by hormonal, local, biochemical and structural

changes of the penis [1]. The incidence of erectile dysfunction increases with age and affects approximately 30 million men with a tripling of the prevalence of complete impotence in men from 40 to 70 years of age [2,3]. Erectile dysfunction, as well as diverse diseases such as hypertension, atherosclerosis, hyperlipidemia, obesity, congestive heart failure, renal failure, and diabetes, is associated with functional and structural changes of the **vascular endothelium** (endothelial dysfunction) with additional aberrations in vessel wall contractility leading to vascular wall remodeling [2,4]. The penile vascular endothelium plays an important role in erection and when dysfunctional, it is involved in the pathogenesis of this medical condition. The vascular endothelium responds to a variety of insults and changes from a healthy functional state to an unhealthy endothelium that promotes vasoconstriction, hypercoagulation, and inflammation. This ability of the vascular endothelium to promote parenchymal dysfunction makes this tissue an important target for medical intervention [3,4].

Three important vasodilators produced by the endothelium, nitric oxide (NO), prostacyclin, and endothelium-derived hyperpolarizing factor, act to maintain normal endothelial function (**endothelial nitric oxide**). However, the endothelium primarily controls local vascular function through the release of NO, which protects the vessel wall against the development of excess wall stiffness, inflammation, thrombosis, and the development of atherosclerosis [3]. There is now emerging evidence to suggest that malfunction of this major pathway plays an important role in the endothelial dysfunction found in erectile dysfunction and in cardiovascular diseases [3]. Current pharmacological therapies that are beneficial in the management of erectile dysfunction, their mechanism of action, and potential side effects are the focus of this chapter.

### Pathogenesis

Endothelial dysfunction is involved in the pathogenesis of erectile dysfunction and may be an early sign of cardiovascular disease as the risk factors for cardiovascular disease; diabetes, hyperlipidemia, hypertension, obesity, and smoking have also been shown to be involved in the development of erectile dysfunction. Moreover, erectile dysfunction could be considered an early manifestation of cardiovascular disease [2,4].

Although cardiovascular disease and erectile dysfunction were thought to be the end result of atherosclerosis, recent studies suggest that erectile dysfunction can develop prior to the development of overt manifestations of vascular damage from atherosclerosis as studies suggest symptoms of erectile dysfunction in patients can precede the onset of symptoms from other cardiovascular diseases, due to the observations that the inflow penile blood vessels are

smaller than found elsewhere in the body [1,3]. Early development of impaired penile blood flow and organ dysfunction, suggest this disease could be used as a barometer of the status of overall cardiovascular health, even if patients have no other cardiovascular symptoms [3]. Earlier detection would facilitate earlier intervention and could offer the potential of providing effective treatment for erectile dysfunction and as well as to improve outcomes from other cardiovascular diseases [3].

### Current Pharmacological Therapy

#### Life Style Changes

Current therapy for erectile dysfunction includes counseling to change life-style. Patients are advised to decrease excessive alcohol use, stop smoking, increase exercise, correct hyperlipidemia, and control all co-morbid medical diseases such as hypertension, obesity, and diabetes [3,5].

#### Androgen Replacement Therapy

Hypoandrogenism may be an important factor in the induction of erectile dysfunction. Androgen replacement therapy is a therapeutic option for erectile dysfunction following clinical investigation that androgen levels are low. Androgen replacement therapy offers additional benefits including increased muscle mass, decreased lethargy, and decreased development of osteoporosis [3,5].

#### Mechanism of Action

Testosterone stimulates endothelial and neuronal production of NO and can improve endothelial repair mechanisms by increasing bone marrow-derived endothelial progenitor cells number in the peripheral circulation [6]. Furthermore, androgens may stimulate the differentiation of progenitor cells into smooth muscle cells and inhibit their differentiation into adipocytes. Androgens also have a direct effect on penile tissue to maintain erectile function and help reverse the metabolic and structural changes in the corpus cavernosum that cause venous leakage [7].

#### Side Effects

The risk of prostate disease should be discussed before implementing hormonal replacement therapy. Although testosterone replacement therapy does not induce the development of prostate cancer, testosterone supplementation can exacerbate existing prostate cancers, and a diagnosis of prostate cancer remains a contraindication [3].

#### Selective Type 5 Phosphodiesterase Inhibitors

Currently, the most effective pharmacological therapy for erectile dysfunction is the selective type 5 phosphodiesterase (PDE5) inhibitor class of drugs



(▶selective type 5 phosphodiesterase inhibitors) [3]. Sildenafil, tadalafil, and vardenafil are effective, safe and reliable oral agents. All three drugs in this class have similar pharmacology and each is effective in patients with erectile dysfunction of all ages, severity and etiology. While there are clear pharmacokinetic and pharmacodynamic differences between these agents, clinical differences are difficult to identify [8].

Testosterone, plus PDE5 inhibitor therapy, may also be beneficial in improving erectile function in hypogonadal men (▶male hypogonadism) who are unresponsive to PDE5 inhibitor therapy [3].

### Mechanism of Action

NO mediates penile erection under normal conditions, with PDE5 the major cGMP-hydrolyzing enzyme in the penis. When this enzyme is blocked with use of the PDE5 inhibitor class of drugs, released NO is sustained causes a greater increase in cGMP with resultant enhancement of corpora cavernosal inflow and improved erection [3].

### Side Effects

There have been concerns about the effects of these agents on the heart and their safety profile in patients with coronary artery disease. The concerns focused on the reported effects of PDE5 inhibitors on blood pressure and heart rate, cardiac electrophysiology, and cardiovascular adverse events in clinical trials. Since there are currently three PDE5 inhibitors, attention has been given to class effects as well as unique individual safety and adverse events. These drugs lower blood pressure as they are mild vasodilators, but these effects are usually mild and produce few symptoms. However, when combined with nitroglycerin, blood pressure drops can be profound and life threatening [3].

There are reports of changes of the QT interval although none of the three agents are dangerously associated with QTc prolongation; although vardenafil has a drug-in-sen a warning for patients at risk for QTc prolongation [3].

There do not appear to be significant cardiovascular safety issues in men with satisfactory cardiac and performance status [3]. It is interesting to note that sildenafil has been shown to have a protective effect in an experimental model of ischemia reperfusion in the heart [9]. Indeed, with the observed vasodilator effect from these drugs, studies point to the improved exercise tolerance and coronary dilation in patients taking PDE5 inhibitors [3].

Patients presenting to the emergency room with a chief complaint of chest pain suggestive of a heart attack need to inform emergency personnel if they are taking a PDE5 inhibitor. Similarly, before administration of, emergency personnel need to ask patients if they have used PDE5 inhibitors. Nitrates should not be given for

at least 24 h after a patient uses sildenafil or vardenafil and at least 48 h after a patient uses tadalafil [3].

Additionally, rare reports of the development of non-arteritic anterior ischemic optic neuropathy in diabetic men using PDE5 inhibitors may reduce the use of these agents [3].

### Conclusion

Erectile dysfunction was once viewed primarily as a psychological issue, but is now understood to represent predominantly organic etiologies and is a highly manageable disorder in most patients. Goal directed assessment and management implies a focus on patient (and partner) preferences regarding various treatment options. Psychosocial interventions also may serve as useful therapeutic adjuncts. Sexual dysfunction is more likely to occur among men in poor physical and emotional health but is also highly associated with negative experiences in sexual relationships and overall mental well-being [10]. Treatment options range from oral pharmacological agents to surgery and may be pursued in a stepwise management approach. In conclusion, Erectile dysfunction has a significant association with cardiovascular disease and this disease could serve as a harbinger of subsequent cardiovascular events [5].

### Acknowledgment

NIH Grant HL62000, HL77421, ES10018, and RR16456

### References

1. Brunner H, Cockcroft JR, Deanfield J, Donald A, Ferrannini E, Halcox J, Kiowski W, Luscher TF, Mancia G, Natali A, Oliver JJ, Pessina AC, Rizzoni D, Rossi GP, Salvetti A, Spieker LE, Taddei S, Webb DJ (2005) Endothelial function and dysfunction. Part II. Association with cardiovascular risk factors and diseases. A statement by the Working Group on Endothelins and Endothelial Factors of the European Society of Hypertension. *J Hypertens* 23:233–246
2. Maas R, Schwedhelm E, Albsmeier J, Boger RH (2002) The pathophysiology of erectile dysfunction related to endothelial dysfunction and mediators of vascular function. *Vasc Med* 7:213–225
3. Nossaman, BD, Gur S, Kadowitz PJ (2007) Gene and stem cell therapy in the treatment of erectile dysfunction and pulmonary hypertension; potential treatments for the common problem of endothelial dysfunction. *Curr Gene Ther* 7:131–153
4. Francavilla S, Bocchio M, Pelliccione F, Necozone S, Francavilla F (2005) Vascular aetiology of erectile dysfunction. *Int J Androl* 28(Suppl 2):35–39
5. Burnett AL (2006) Erectile dysfunction *J Urol* 175: S25–S31
6. Caretta N, Ferlin A, Palego PF, Foresta C (2005) Erectile dysfunction in aging men: testosterone role in therapeutic protocols *J Endocrinol Invest* 28:108–111
7. Traish A, Kim N (2005) The physiological role of androgens in penile erection: regulation of corpus cavernosum structure and function. *J Sex Med* 2:759–770

8. Carson CC (2006) PDE5 inhibitors: are there differences? *Can J Urol* 13(Suppl 1):34–39
9. Kukreja RC, Salloum F, Das A, Ockaili R, Yin C, Bremer YA, Fisher PW, Wittkamp M, Hawkins J, Chou E, Kukreja AK, Wang X, Marwaha VR, Xi L (2005) Pharmacological preconditioning with sildenafil: basic mechanisms and clinical implications. *Vascul Pharmacol* 42:219–232
10. Laumann EO, Paik A, Rosen RC (1999) Sexual dysfunction in the United States: prevalence and predictors. *JAMA* 281:537–544 [erratum appears in *JAMA* 1999 Apr 7; 281(13):1174]

## Tastant

PATRICIA M. DI LORENZO, JEN-YUNG CHEN,  
ANDREW M. ROSEN, ANDRE T. ROUSSIN  
Dept. of Psychology, Binghamton University,  
Binghamton, NY, USA

### Synonyms

Taste stimulus; Sapid Saporous, Saporific stimulus

### Definition

A tastant is a water-soluble chemical that produces a taste sensation by activating ►[taste receptor cells \(TRCs\)](#) and producing activity in taste-related pathways (see ►[Taste](#)) in the nervous system.

### Characteristics

#### Taste Qualities

Taste stimuli encompass a variety of chemical structures, but, some would argue, evoke only a handful of different sensations. A taste quality may therefore encompass a group of ligands that produce a similar sensation in a particular species. In humans and most mammals, there are four commonly known “primary” or “basic” taste qualities: salty, sour, bitter (►[taste-bitter](#)) and sweet. A preponderance of recent evidence points to umami, described as “savory,” as a fifth basic taste quality. Another group of chemicals that have been put forward as potential tastants are fatty acids. Though not exhaustive, [Table 1](#) is a list of tastants and the taste qualities that they evoke in humans. For more detailed information about the chemistry of tastants, see [\[1\]](#).

Taste receptor proteins are embedded in the membranes of ►[taste receptor cells \(TRCs\)](#). TRCs use a variety of mechanisms, including second-messenger cascades utilizing the ►[G-protein gustducin](#) or direct mediation of ion-channel flux, to transduce tastants into biological reactivity. The mechanisms of ►[transduction](#) are specific to the taste receptor.

In mammals, ►[taste information](#) is conveyed by nerves innervating the ►[taste buds](#) of the oral cavity. Most species have evolved a homologous group of taste-specific fiber paths. The activation of these paths by various ligands defines these chemicals as tastants, as opposed to odorants (see ►[olfactory perception](#)). Some sensations that are often labeled as “taste,” such as metallic or alkaline, actually arise from the concurrent stimulation of trigeminal or ►[olfactory pathways](#). “Tastes” or “flavors” in the colloquial sense are actually combinations of taste, olfactory, tactile and thermal sensations; there are very few purely taste sensations. In part, that accounts for the observation that people can lose a large part of their sense of taste and not be aware of any deficit [\[2\]](#).

### Saltiness

Salt intake is essential to maintain osmotic balance in the body and to support nervous transmission. The deletion of salt from the diet, or the removal of the adrenal gland, lead to salt cravings, also known as a “salt appetite.” In mammals this is expressed as an increase in the amount of the highest concentrations of NaCl that is ingested. Salt deprivation early in life can also lead to permanent changes in the development of the gustatory system in rodents.

The sensation of saltiness in its purest form is produced by NaCl. Other salts produce taste qualities e.g. bitter or sour, in addition to saltiness. Some salts (e.g. NaCl or KCl, see below under Sweetness) at low concentrations can be perceived as sweet.

In rodents, the transduction of NaCl is thought to involve the entry of Na<sup>+</sup> ions directly into the TRC through two separate pathways. The first is through epithelial sodium channels (ENaCs) that are reversibly blocked by the diuretic amiloride. These amiloride-sensitive channels are located on the apical portion of the TRC. Na<sup>+</sup> is thought to enter the TRC through these channels, depolarize the TRC membrane, thereby opening Na<sup>+</sup>, K<sup>+</sup> and Ca<sup>++</sup> channels and promoting transmitter release. The second, amiloride-insensitive transduction pathway for NaCl is by Na<sup>+</sup> entry through Na<sup>+</sup> channels located on the basolateral TRC membrane below the tight junctions within the ►[taste bud](#). The degree to which these transduction pathways are utilized in human salt perception is unknown.

There is also a role for the anion in the transduction and subsequent perception of saltiness. Small anions such as Cl<sup>-</sup> act through a paracellular shunt by diffusing past the tight junctions. This produces a negative region at the basal portion of the TRC which further promotes the influx of positive ions. The tight junctions control this diffusion and current flow; they pass small cations more freely than larger ones. This accounts for the observation that salts with larger anions, e.g. Na-gluconate, do not taste as salty as those with smaller ones, e.g. NaCl.

**Tastant. Table 1** Examples of tastants and the taste qualities that they evoke

Salty salts	Notes
NaCl	prototypical salty stimulus, found in table salt; tastes sweet at low concentrations
LiCl	Tastes sweet and sour at low concentrations
Na <sub>2</sub> SO <sub>4</sub>	can evoke sweet, sour, bitter and salty taste
NaNO <sub>3</sub>	a.k.a. saltpeter; found in leafy green vegetables, fertilizer; used as a food preservative in hot dogs
Na-gluconate	product of fermentation of glucose; chelating agent used to clean metal and glass
<b>Bitter Salts</b>	
KCl	Tastes sweet-bitter at low concentrations
CaCl <sub>2</sub>	used to melt ice on roads, in cement and to add saltiness to foods such as pickles
NH <sub>4</sub> Cl	tastes salty-sour; found in volcanic rock; used to slow melting on ski slopes and to flavor vodka
NH <sub>4</sub> Br	used as a flame retardant and in manufacture of photographic chemicals
MgCl <sub>2</sub>	found in seawater; called “nigari” in Japanese; used as a coagulant in making tofu from soy milk
<b>Sour</b>	
HCl	prototypical sour stimulus; inorganic acid
acetic acid	main ingredient of vinegar
citric acid	found in citrus fruits, strawberries and kiwis; part of cellular citric acid cycle
lactic acid	produced by bacteria in fermented foods
malic acid	found in most fruits and some vegetables; also present in wine
HNO <sub>3</sub>	highly caustic; used in explosives and fertilizer
NaOH	a.k.a. lye; used in drain cleaner and food preparation; highly caustic
tartaric acid	Found in fruits, especially grapes; main acid in wine
<b>Sweet</b>	
<i>sugars</i>	
sucrose	prototypical sweet stimulus; main ingredient in table sugar; disaccharide consisting of glucose and fructose
fructose	monsaccharide; found in honey, tree fruits, berries, melons, beets, onions; used in corn syrup
glucose	monsaccharide; main product of photosynthesis; main source of energy in cells
lactose	disaccharide consisting of glucose and galactose; makes up 2–8% of milk solids
maltose	disaccharide consisting of two units of glucose; metabolized by yeast in the fermentation process
<i>amino acids</i>	
<i>d</i> -alanine	a nonessential amino acid; found in meat, poultry, fish and dairy foods
<i>d</i> -histidine	unlike the <i>d</i> - isomer, it is not a part of mammalian protein
<i>d</i> -tryptophan	unlike the <i>d</i> - isomer, it is not a part of mammalian protein
glycine	a nonessential amino acid; an inhibitory neurotransmitter; required along with glutamate to activate NMDA receptors
threonene	an essential amino acid; found in cottage cheese, lentils, sesame seeds, meat, poultry, fish
<i>proteins</i>	
brazzein	500–1000X sweeter than sugar; heat stable; derived from the fruit of West African ballion plant
monellin	1000X sweeter than sugar; degrades with heat; found in fruits of West African serendipity shrub
thaumatin	2000X sweeter than sugar; heat stable; found in seed coating of katemfe fruit of West Africa; taste builds slowly and leaves a licorice-like aftertaste
<b>Intense (artificial) Sweeteners</b>	
Na-saccharin	300X sweeter than sugar; bitter aftertaste; tastes bitter at high concentrations
Acesulfame-K	bitter aftertaste; tastes bitter at high concentrations; 180–200X sweeter than sugar
Aspartame	180X sweeter than sugar; degrades with heat;
cyclamate	30–50X sweeter than sugar; heat stable
dulcin	250X sweeter than sugar; removed from market in 1954 over carcinogenic concerns
neotame	8,000–13,000X sweeter than sugar, structurally related to aspartame, moderately heat stable

**Tasant. Table 1** Examples of tastants and the taste qualities that they evoke (Continued)

Salty salts	Notes
<b>Bitter</b>	
quinine HCl	prototypical bitter stimulus; an alkaloid derived from the bark of the South American cinchona tree; used to treat and prevent malaria
quinine SO <sub>4</sub>	see quinine HCl
urea	a.k.a. carbamide; organic compound used in many industrial applications
sucrose octaacetate	intensely bitter; used as a bitter additive to prevent poisoning; denatures alcohol
cycloheximide	highly toxic; made by bacterium <i>Streptomyces griseus</i> ; used as fungicide in agriculture
denatonium	the most bitter substance known; used as a bitter additive to prevent poisoning; denatures alcohol
caffeine	a.k.a. guaranine, mateine, theine; found in berries and leaves of >60 plants; found in coffee, tea, many soft drinks and chocolate; CNS stimulant
nicotine	alkaloid found in nightshade family of plants, e.g. tobacco; neurotoxin used in pesticides, cigarettes; highly addictive
salacin	derived from bark of white willow; found in aspirin; antipyretic, anti-inflammatory and analgesic
aristolochic acid	derived from Aristolochiaceae family of plants; carcinogenic and nephrotoxic
phenylthiocarbamide (PTC)	a.k.a. phenylthiourea; coded by dominant gene, is tasteless to part of the population
6-n-propylthiouracil (PROP)	coded by dominant gene, is tasteless to part of the population; less toxic than PTC
<b>Umami</b>	
monosodium glutamate (MSG)	Found in meats, cheese, mushrooms and tomatoes
l-aspartate	nonessential amino acid; neurotransmitter and excitotoxin
disodium 5'-inosate (IMP)	enhances umami taste when presented with MSG; used as an additive to instant noodles and potato chips
disodium 5'-guanosinate (GMP)	enhances umami taste when presented with MSG; derived from dried fish and seaweed; used as a food additive
<b>Fatty acids</b>	
linoleic acid	polyunsaturated omega-6 fatty acid; found in sunflower and safflower oil; used in making soap, emulsifiers
oleic acid	monounsaturated omega-9 fatty acid; found in olive and grapeseed oil
stearic acid	saturated form of oleic acid
<b>Other</b>	
Polycose <sup>®</sup>	an easily digestible source of calories used as a nutritional supplement in humans; consists primarily of polysaccharides derived from starch, a.k.a. glucose polymers, maltodextrins, maltooligosaccharides; very attractive to rodents but less so to humans
ethanol	a.k.a. ethyl alcohol, grain alcohol; contained in alcoholic beverages; produced by fermentation; taste is a mixture of sweet and bitter

(Abbreviation: a.k.a., "also known as.")

### Sourness

The sensation of sourness is associated with organic and inorganic acids or other molecules that are acidic in nature. Acids are associated with unripened fruit and are produced by the fermentation process. Bacteria associated with rotting food also produce acids (e.g. lactic acid). Most fruits (e.g. citric acid) and vegetables (e.g. succinic acid) contain acids, as does wine (tartaric and malic acids) and vinegar (acetic acid).

Although it was originally thought that the perception of sourness appears to be directly related to

the concentration of the hydrogen ion, more recent studies suggest that this is not so for organic and dilute inorganic acids [3,4]. A variety of transduction mechanisms have been studied for sourness, and it appears that there are large species differences in the mechanisms that are present. Mechanisms that have been proposed include a proton exchange mechanism, a stimulus-gated Ca<sup>++</sup> channel and the direct entry through a H<sup>+</sup> channel that has yet to be identified. Recently a polycystic-kidney-disease-like ion channel (PKD2L1) has been identified as a candidate sour taste

sensor in mice. This ion channel is located on a subset of taste receptor cells that are distinct from those responsible for sweet, bitter and umami taste. Mice in which PKD2L1-expressing cells have been experimentally ablated have been shown to be devoid of responsiveness to sour stimuli while responses to all other taste qualities remain intact [5].

### Bitterness

Bitterness is thought to signal toxicity and is therefore of utmost importance to the survival of the organism. Many plants that are poisonous taste bitter.

The perception of bitter is mediated by the ▶T2R receptors, a highly divergent group of ▶G-protein-coupled Receptors (GPCRs). These receptor types are expressed on a subset of cells that have been shown to be distinct from those expressing sweet and umami. The wide variety of receptor subtypes dedicated to bitter tastants accounts for the diversity of chemicals that evoke bitter taste sensations. These include some plant alkaloids such as quinine, the prototypical bitter substance, brucine, nicotine, strychnine and caffeine, as well as hydrophilic salts of  $\text{Ca}^{++}$ ,  $\text{Mg}^{++}$ ,  $\text{Ba}^{++}$ ,  $\text{Cs}^+$ ,  $\text{K}^+$  or  $\text{NH}_4$ . Other compounds such as urea, sucrose octaacetate, denatonium chloride and many of the D-isomers of amino acids also taste bitter. Some intense sweeteners such as Na-saccharin and acesulfame-K can taste bitter at high concentrations and have a bitter aftertaste.

Among humans, there is a well-studied genetic variation in the ▶GPCR T2R38 that is correlated with the ability to detect the bitterness of a family of structurally related chemicals containing the N-C = S moiety. Two examples of these compounds are phenylthiocarbamide (PTC) and 6-n-propylthiouracil (PROP). Sensitivity to PTC and PROP is correlated with the number of fungiform papillae on the anterior tongue and can predict preferences for sweet and fatty foods in humans. An association between sensitivity to PROP and alcohol dependence has also been suggested. PTC and PROP sensitivity are controlled by the PTC loci on human chromosome 5p15 7q31 that codes for a member of the T2R bitter receptor family.

### Sweetness

There are a wide variety of compounds that produce a sweet sensation, including mono-, di-, and polysaccharides, polyalcohols (e.g. glycerol, xylitol, mannitol), along with some amino acids, peptides and proteins. The prototypical exemplar of the sweet taste quality is sucrose, a disaccharide. In addition, some salts, including NaCl, KCl, NaOH, KOH, salts of berrylium and lead acetate and carbonate, taste sweet at low concentrations. The sweetness of weak solutions of lead (a toxic substance when ingested) has particularly troubling implications for public health.

Most sweet and umami tastants are transduced by a group of three ▶GPCRs, T1R1, T1R2, and T1R3, collectively termed the ▶T1R receptors. In humans, genes for the ▶T1R receptors have been localized to chromosome 1. Sweet sensing TRCs express a heterodimer of the T1R2 and T1R3 receptors. The result, a T1R2/T1R3 receptor, mediates sensation of sweet tastants. There remains, however the possibility that other receptors for sweet as well as umami tastants exist [6].

Considerable across species differences in sweet perception are related to variation in the T1R sequence and expression. For example, cats lack any sensitivity to sweet tastes due to the absence of T1R2 receptors. Due to mutations of the T1R2 and T1R3 genes sequence, some compounds that are sweet to humans (e.g. aspartame, cyclamate, neohesperidin dihydrochalcone, neotame and the sweet proteins brazzein, monellin and thalmatin) are tasteless to rodents and New World monkeys.

### Umami

Although still controversial to some, there is good evidence that the taste of umami should be considered a fifth “basic” taste quality. Umami was formally described by Ikeda in 1908. The word “umami” means “deliciousness” or “savory” in Japanese; the word “xianwei” is the equivalent of umami in Chinese. Umami-inducing compounds include monosodium glutamate (MSG) and two 5'-ribonucleotides, disodium 5'-inosate (IMP) and disodium 5'-guanosalte (GMP). IMP and GMP have the ability to enhance the taste of MSG when mixed with it. MSG, IMP and GMP are found in meats, cheeses, mushrooms (e.g. *Lentinus edodes*, shiitake), fish (e.g. katsuobushi or bonito, a mackerel-like fish), kelp or sea tangle (*Laminaria japonica*, seaweed or kombu) and tomatoes. Other compounds such as L-aspartate, some higher order peptides and organic acids can also induce an umami sensation.

The receptor for umami is a heterodimer of the T1R1 and T1R3 ▶GPCRs. The T1R1/T1R3 receptor is broadly responsive to L-amino acids in rodents and narrowly tuned to umami in humans [6]. The Taste-mGluR4 (also a ▶GPCR) has also been implicated in the transduction of umami taste.

### Fats (lipids)

The discovery of a transduction mechanisms sensitive to free fatty acids (the hydrolyzed product of triglycerides) in the membrane of TRCs [7] has led to the speculation that “fattiness” may be an additional taste quality. Two transduction mechanisms have been described: the inhibition of the delayed rectifying  $\text{K}^+$  channels and through the fatty acid CD36 transporter. Behavioral evidence suggests that fatty acids (e.g. linoleic acid, oleic acid and stearic acid) may qualify as tastants in both rats and humans and that the taste of fatty acids is detectable without the aid of input from other sensory cues such as texture, viscosity or smell.

### Water as a Tasant

Because water elicits a response in TRCs and in the taste nerves of some species, it can be considered a tasant. Its action is thought to involve an aquaporin, AQP5, a membrane channel that selectively admits water molecules into the cell. Water entry then activates a volume regulated anion channel.

Water can also elicit a sweet aftertaste when it is used to rinse the mouth after application of a sweet taste blocker.

### Taste Modifiers and Mixture Effects

There are several substances that are known to modify the taste quality evoked by some tastants when they are presented just before or along with that tastant. For example, the Na<sup>+</sup> channel blocker amiloride can reduce the saltiness of NaCl when mixed with it. Thaumatin is a sweet-tasting protein found in the West African plant *Thaumatococcus danielli* that can block bitterness, as can adenosine monophosphate. Lactisol (Na-2-(4-methoxyphenoxy) propionate, a synthetic compound found in roasted coffee, is a potent suppressor of sweetness, while chlorogenic acid and cynarin, both found in artichokes, are sweetness enhancers.

Many examples of sweet blockers or modifiers are plant-derivatives [8]. For example, treating the tongue with Miraculin, a glycoprotein derived from the berry fruit of the West African bush *Synespalum dulcifica*, can make sour substances taste sweet even though miraculin itself is tasteless. Similarly, circulin, derived from *Circuligo latefolia* can also make sour substances taste sweet. Two substances derived from the leaves of the plant *Gymnema sylvestre*, gymnemic acid and gurmardin (a peptide) suppress sweetness in humans and rats respectively. Ziziphin, purified from the leaves of *Ziziphus jujuba*, and hodulcin, extracted from the leaves of *Hovenia dulcis*, can both block sweet taste.

When chemicals of different taste qualities are mixed there are often changes in the perceptual properties of the components of the mixtures. The most common effect is that of mixture suppression. For example, NaCl, will suppress bitterness when salt is added to a bitter substance. Sucrose and citric acid will suppress each other, as in lemonade, when mixed. Synergy, though rare, can also occur, as in the enhancement of umami taste by the addition of IMP or GMP to MSG. For a detailed review of taste mixture effects in humans, see [9].

### Function

#### Taste Perception Across Species

The function of taste perception (► [taste – conscious perception of; taste – context dependence](#)) is mainly in the regulation of ingestion of nutrients and avoidance of toxic substances. Through the evolutionary process, the taste system in various species has adapted to its

metabolic and/or dietary requirements. For example, the T1R2/T1R3 receptor that is specialized for sweet perception in mammals, may instead be sensitive to amino acids in lower phyla such as fish (see below). In vertebrates, genes that code for T1R receptors are highly conserved across phyla whereas genes that code for T2R receptors are highly divergent [10].

### Invertebrates

Insects such as drosophila do not have the same complement of T1R and T2R taste receptors as vertebrates have. Instead, a large family of ~60 candidate gustatory receptor genes (*Gr*) provides the receptors for taste. Most research has focused on the perception of sweet and bitter perception, e.g. cells containing GR5a receptors selectively respond to sugars and cells containing GR66a receptors respond to bitter compounds. Perception of sour taste has not been studied in detail in *Drosophila*. However, detection of salt is thought to be mediated by direct influx of sodium ions into TRCs via DEG/EnaC channels such as PPK11 and PPK19 (Amrein and Thorne, 2005). The lack of homology with mammalian taste receptors has suggested that the taste system in insects and mammals has evolved independently. Even so, taste preferences of drosophila and humans are quite similar.

### Fish

Fish have highly developed chemosensory systems and are often the subject of taste research. The taste buds of fish are distributed around the lips and oral cavity, as well as across external body surfaces and fins. Interestingly, there is an overlap between taste and olfactory systems in fish; sugar, salt and quinine activate both taste and olfactory receptors. However, T1R and T2R families of receptors have been identified in the taste, but not the olfactory systems of fish. These receptors serve the same behavioral functions of attraction (T1Rs) and aversion (T2Rs) as they do in mammals, but in fish, T1R2 receptors are responsive to amino acids rather than sugars as in mammals.

### Amphibian (Frog)

Amphibians such as frogs are usually active at night and eat insects and other invertebrates. Early physiological studies found that individual taste cells and fibers can respond to multiple taste stimuli: salts (especially CaCl<sub>2</sub>), amino acids, sour, and bitter. Interestingly, large water responses have also been noted in frog. These responses may serve in osmotic regulation since amphibians have highly permeable skin.

### Reptiles (Lizards and Snakes)

Taste buds are present on the tongue and/or oropharyngeal area in most reptiles, though taste buds have been found in only some species of snakes. Most reptiles are

predators and their sensitivity to tastants of various qualities reflects their diet. The lacertid lizard, *Podarcis lilfordi*, for example, can behaviorally discriminate among sucrose, lipids and proteins and the lizard *Anolis carolinensis* can discriminate between untreated crickets and crickets treated with either dextrose/aspartame powder (sweet sensation for humans) or quinine hydrochloride powder (bitter sensation for humans).

### Birds

The taste buds of birds are similar to those in mammals; most of them are distributed on the posterior part of the tongue and floor of the pharynx. Many birds (e.g. chickens) are unresponsive to sweet tastes. Parrots, hummingbirds, and other nectar and fruit feeders are exceptions. Most birds can detect salt, are more tolerant to sour than humans, and most will reject bitter solutions.

### Mammals

In general, mammals have more taste buds than other animals. Among mammals, the dog's sense of taste is poorly developed compared with that of humans, while the pig has a greater sensitivity to taste. It has been shown that cats lack a sweet receptor and are neither attracted to nor avoid the taste of sweet carbohydrates and intense sweeteners. For most rodents and primates, sweet, salty, sour, bitter and umami tastants are easily identified across a wide range of stimulus intensities.

### References

- Shallenberger RS (1993) Taste chemistry. Chapman and Hall, New York
- Kveton JF, Bartoshuk LM (1994) The effect of unilateral chorda tympani damage on taste. *Laryngoscope* 104(11):25–29
- Breslin PA, Huang L (2006) Human taste: peripheral anatomy, taste transduction, and coding. *Adv Otolaryngol* 63:152–190
- Roper SD (2007) Signal transduction and information processing in mammalian taste buds. *Pflugers Arch* 454(5):759–776
- Huang AL, Chen X, Hoon MA, Chandrashekar J, Guo W, Tränkner D, Ryba NJ, Zuker CS (2006) The cells and logic for mammalian sour taste detection. *Nature* 442(7105):934–938
- Bachmanov AA, Beauchamp GK (2007) Taste receptor genes. *Ann Rev Nutr* 27:389–414
- Gilbertson TA, Fontenot DT, Liu Z, Zhang H, Monroe WT (1997) Fatty acid modulation of K<sup>+</sup> channels in taste receptor cells: gustatory cues for dietary fat. *Am J Physiol Cell Physiol* 272:C1203–C1210
- Kurihara Y (1992) Characteristics of antisweet substances, sweet proteins, and sweetness-inducing proteins. *Crit Rev Food Sci Nutr* 32(3):231–252
- Keast RS, Breslin PA (2002) An overview of binary taste-taste interactions. *Food Qual Pref* 14:111–124
- Shi P, Zhang J (2006) Contrasting modes of evolution between vertebrate sweet/umami receptor genes and bitter receptor genes. *Mol Biol Evol* 23(2):292–300

## Taste

JEAN-PIERRE MONTMAYEUR

Centre des Sciences du Goût, Centre National de la Recherche Scientifique, Rue Hugues Picardet, Dijon, France

### Synonyms

Gustation

### Definition

Of the five senses, taste, along with olfaction, allow the sensing and discrimination of chemicals. In particular, taste enables the analysis of the chemical content of foods present in the oral cavity. This task is performed through the integration of signals emanating from specialized cells capable of detecting sapid stimuli, and transmitted to the brain via the gustatory branches of cranial nerves with which they are connected. The gustatory information collected in the mouth bears direct consequences on the ingestive behavior and digestive events.

### Characteristics

#### Description of the Peripheral Structure

#### *Taste Cells in the Oral Cavity Are the Sensors of Sapid Stimuli*

Foods that enter the oral cavity are subsequently analyzed by chemical sensors. In particular, water-soluble molecules or tastants dissolved in saliva come into contact with specialized chemosensory cells that contain taste receptors. Taste cells are strategically disseminated in the oral cavity on the tongue, the palate, the epiglottis, the pharynx and the larynx. Taste cells are typically found grouped together in a structure called the taste bud. Regions rich in taste buds are often called papillae although ►*filiform papillae* do not contain taste buds. On the tongue there are three types of papillae containing taste buds, which can be distinguished by their location and their morphology from which their names are derived.

On the dorsal surface in the anterior part of the human tongue there are about 200 mushroom-like pegs called ►*fungiform papillae* each containing between one and six taste buds. ►*Two foliate papillae*, each shaped like a leaf are found on the lateral edges towards the back of the tongue, one on each side and each containing between 300 and 3,000 taste buds. Finally, near the back of the tongue between three and 13 ►*circumvallate papillae* protrude from the dorsal surface of the tongue. Each circumvallate papillae is surrounded by a circular invagination (trench) embedded deep in the epithelium and along which between 700 and 3,000 taste buds are distributed. Circumvallate papillae are arranged in a row forming a chevron

shape located in front of the sulcus terminalis at the boundary with the oropharynx.

The taste bud is a structure shaped like an onion containing 30–100 elongated cells (Fig. 1).

The apical region of the taste bud is designed to sense sapid molecules while the baso-lateral region of the taste bud communicates information to the brain through afferent fibers that form synapses with selected cells within the taste bud. At their apical pole, taste cells are in contact with the saliva in the mouth by means of microvilli protruding through the taste pore. Below the pore, are tight junctions that create a selective intercellular barrier separating the functionally distinct apical and basal region of the elongated cells of the taste bud.

Ultrastructural, cellular and molecular studies have distinguished four types of cells composing the taste bud [1]. Type I cells or “dark cells” which act as supporting cells. Type II cells or “light cells” which extend microvilli at their apical pole where taste receptors for sweet, umami and bitter compounds are thought to reside. Type III cells or “intermediate cells” have the distinctive feature to be in contact with afferent sensory nerve fibers through conventional chemical synapses. Types II and III cells are commonly referred to as “taste cells.” Additionally, a population of progenitor cells (type IV) of epithelial origin is found at the base of the taste bud. It is estimated that taste cells are renewed every ten to fifteen days from the progenitor cells. Taste bud innervation is important for taste cell survival in that it provides trophic factors

to the taste bud that in fact will degenerate when the sensory nerve is severed.

#### ***A Variety of Receptors and Transduction Mechanisms Mediate Tastants Detection by Taste Cells***

Some taste cells are equipped at their apical pole with specialized receptors responsible for the detection of sapid molecules. These receptors, also called taste receptors, are involved in the detection of a wide variety of substances with extremely variable chemical structures including but not restricted to: ions, carbohydrates, alkaloids, small proteins and amino acids. The taste sensations evoked by these compounds can be categorized into five basic modalities known as bitter, salty, sour, sweet and umami. Two main types of receptors appear to be involved in the detection of sapid chemicals [2]. Sour and salty stimuli are detected by ion channels, while G protein coupled receptors (GPCRs) are involved in sweet, bitter and umami detection.

In mice, a heteromer composed of two members of the transient receptor potential (TRP) family of ion channels (PKD2L1 and PKD1L3) has emerged recently as one of the main sensors of sour stimuli by taste cells. Salty sensation is thought to be mediated, at least in part by an amiloride sensitive sodium channel (ASSC) which belongs to the epithelial sodium channel (EnaC) family of ion channels.

In humans, two families of GPCRs, namely Tas1Rs and Tas2Rs, are involved in the detection of sweet,

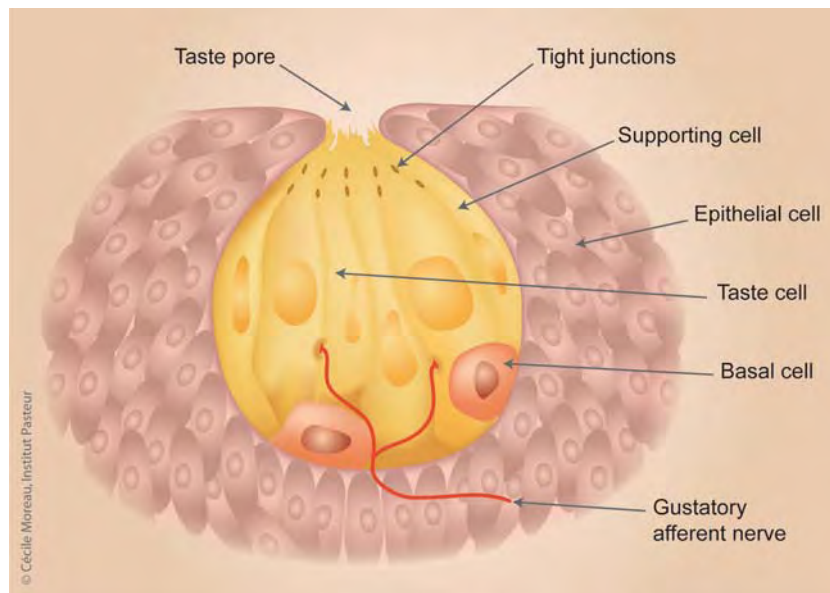

**Taste. Figure 1** Diagram showing the organization and various types of cells composing the taste bud. The taste bud is a structure shaped like an onion composed of elongated as well as rounded basal cells and surrounded by epithelial cells. In the apical region, microvilli from elongated cells (taste cells and supporting cells) protrude through the taste pore (diameter about 20  $\mu\text{m}$ ), where they come into contact with the saliva in the mouth. In the baso-lateral region of the taste bud, taste cells communicate the taste information to afferent nerve fibers through synapses.



umami and bitter tasting chemicals. The Tas1R family comprises three members which assemble as pairs to produce functional receptor for sweet (Tas1R2-Tas1R3) or umami (Tas1R1-Tas1R3) tasting substances. The Tas2R family includes 25 members, four of which have been shown to function as receptors for bitter tasting compounds. Slight genetically inherited modifications in the Tas2R38 receptor protein have been shown to be linked to the sensitivity of some individuals to detect the bitter chemical phenylthiocarbamide (PTC).

When activated by tastants dissolved in the saliva, taste receptors modify the physiological properties of the taste cell in which they are expressed, ultimately leading to neurotransmitter release (Fig. 2).

This process can be mediated by ion channels acting as taste receptors through which cations directly enter the cell. Alternatively, in the case of GPCRs a cascade of intracellular events implicating heterotrimeric G-proteins coupled to the receptor as well as effector proteins producing second messengers is involved. For example, the signaling cascade engaged after stimulation of Tas1R or Tas2R receptor is believed to involve the release of the G $\beta\gamma$  subunits from the taste specific G-protein alpha subunit called gustducin which couples to the receptors as an heterotrimeric complex. This leads to the activation of the phospholipase C beta-2 which hydrolyzes phosphatidylinositol-4,5-bisphosphate (PIP2) into inositol 3-phosphate (IP3) and diacylglycerol (DAG). Then, IP3 activates

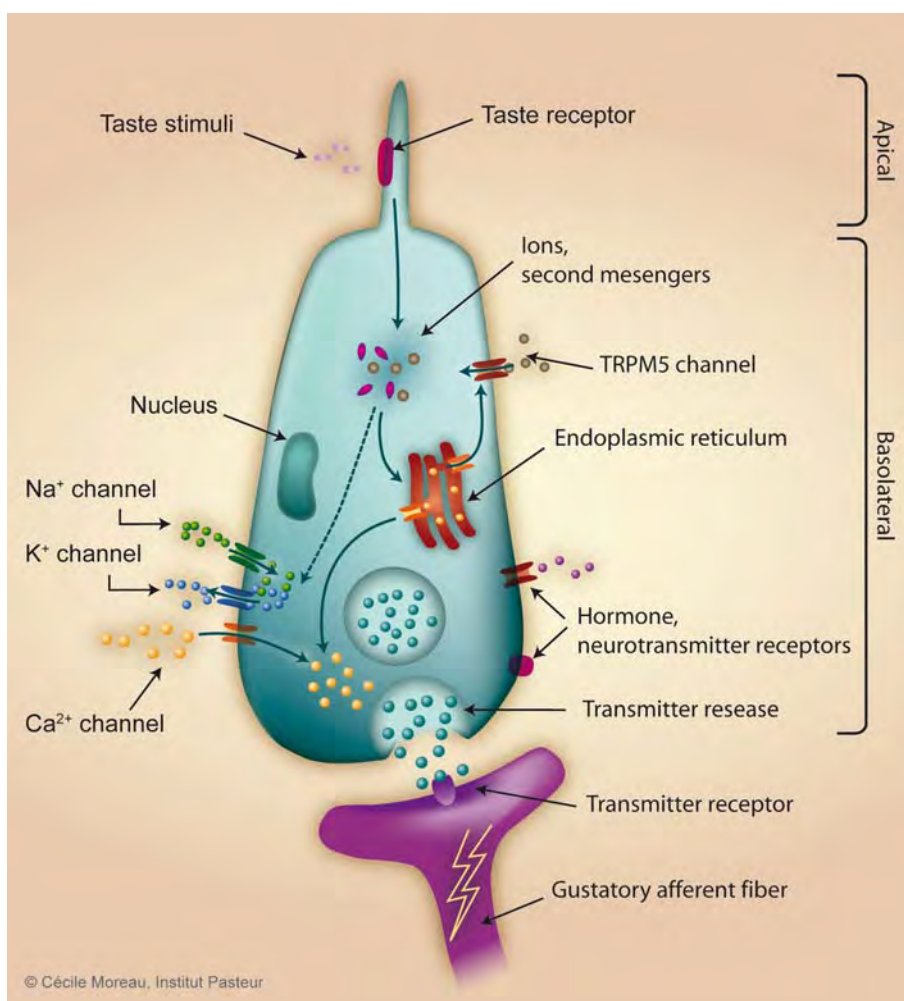

**Taste. Figure 2** Molecular organization of a taste cell. The taste cell is an elongated cell for which the apical and baso-lateral surfaces which are separated by tight junctions are functionally distinct. Tastants dissolved in saliva are recognized by taste receptors located in microvilli extending from the apical membrane of the cell. Upon activation of the receptor which can be a GPCR or an ion channel, an intracellular signal transduction cascade is initiated involving ion channels such as TRPM5 located on the baso-lateral membrane of the cell. This cascade ultimately leads to an increase in intracellular Ca<sup>2+</sup> thereby causing synaptic vesicles to release neurotransmitter at the synapse with primary sensory neurons.

receptors causing the release of  $\text{Ca}^{2+}$  from intracellular stores, which in turn activates TRPM5, a member of the TRP family of ion channels. Gating of TRPM5 by intracellular  $\text{Ca}^{2+}$  allows entry of monovalent cations into the cell and subsequent depolarization [3]. This is followed by the release of neurotransmitter by the activated cell and transmission of the signal produced to the afferent fibers on their way to the central nervous system.

#### **Branches of the Cranial Nerves Carry the Taste Information from the Taste Buds to the Brain**

Primary sensory neurons from three cranial nerves (VIIth, IXth and Xth) make synapses with taste buds. Anatomical studies have shown that single nerve fibers from the taste branches of these cranial nerves contact several taste buds and that each taste bud is in contact with several fibers. The innervation of the taste buds in the oral cavity follows a logic along an antero-posterior axis. Taste buds in the fungiform and anterior part of the **▶foliate papillae** are innervated by the chorda tympani branch of the facial nerve (VIIth). This nerve also contacts taste buds on the palate through its greater superior petrosal branch.

The circumvallate and caudal taste buds of the foliate papillae are innervated by the lingual branch of the glossopharyngeal nerve (IXth). Taste buds in the larynx are innervated by the superior laryngeal branch of the vagus nerve (Xth). These primary sensory neurons travel through the geniculate, petrosal, and nodose ganglia respectively before entering the solitary tract and synapse with neurons in the rostro-lateral part of the nucleus of the solitary tract (rNST) in an area called the gustatory area [4].

In rodents, electrophysiological studies of the responsiveness of single fibers within these nerves following stimulation of the tongue with tastants have shown that single fibers carry the information from several taste qualities, but that their sensitivities vary according to the taste stimulus. Hence fibers have been classified into four different types [5]. In the rat, fibers of the chorda tympani can be classified into NaCl best, quinine best, sucrose best and HCl best based on their relative sensitivity to four types of taste stimuli. The same is true for the glossopharyngeal taste fibers, although the proportion of the relative fibers vary between the two nerves. Fibers of the glossopharyngeal nerve being predominantly responsive to HCl and quinine while fibers of the chorda tympani nerve are mainly responsive to sucrose and NaCl [6]. In the hamster, the greater superior petrosal branch of the chorda tympani is thought to be predominantly responsive to sucrose and the superior laryngeal branch of the vagus nerve present the particularity to be responsive to water [7].

#### **Description of the Central Structure**

##### ***The Taste Information Travels via the Brainstem and the Thalamus en Route to the Cortex***

Afferent fibers from the various peripheral nerves innervating taste buds in the oral cavity converge onto second-order neurons in the rNST, which in turn project to the parvocellular region of the ventroposteromedial nucleus of the thalamus. From there the taste information reaches the gustatory cortex traveling via neurons projecting to the anterior insula in the temporal lobe, as well as to the operculum in the frontal lobe before being further processed in the orbitofrontal cortex [8,9] (Fig. 3).

Clinical observations as well as brain imaging technology have shown that the gustatory information travels on the ipsilateral side.

The segregation of first-order neurons emanating from distinct region of the oral cavity contributes to creating a topographical map of taste inputs from the oral cavity in the brainstem. Gustatory neurons become more broadly tuned as they become central such that neurons from the gustatory cortex are broadly tuned to perceptually distinct stimuli, suggesting that ensemble of neurons operate at that level. Furthermore, cortical neurons are able to integrate stimuli from mechanical, visual and olfactory sensors to provide an image of the food placed in the oral cavity.

##### ***Taste Information Coding***

Over the years, anatomical, electrophysiological, biochemical, cellular and molecular biology studies have allowed tremendous progress in our understanding of the organization of the mammalian gustatory system. The receptors involved in the detection of tastants are being unraveled and it seems pretty clear at this point that taste bud cells specialized in the detection of tastants of the five taste modalities are distinct. Nonetheless, gap junctions and paracrine secretions indicate that cells within the taste bud communicate with each other. Moreover, the nerve fibers contacting a few taste buds and several cells within each taste bud respond to different taste stimuli, suggesting that each fiber receives information from cells with different receptive fields. The implication of such an organization would be that distinct activation patterns in the entire fiber population encode specific taste sensations. This model, also called the “distributed model,” is being challenged by findings putting forward the “labeled line” model according to which nerve fibers are connected to populations of taste bud cells specialized in the detection of a specific stimulus [10]. In the labeled line model, fibers would be dedicated to a single taste modality and thus segregated until at least reaching the gustatory area of the NST. One can envision that a straight feed

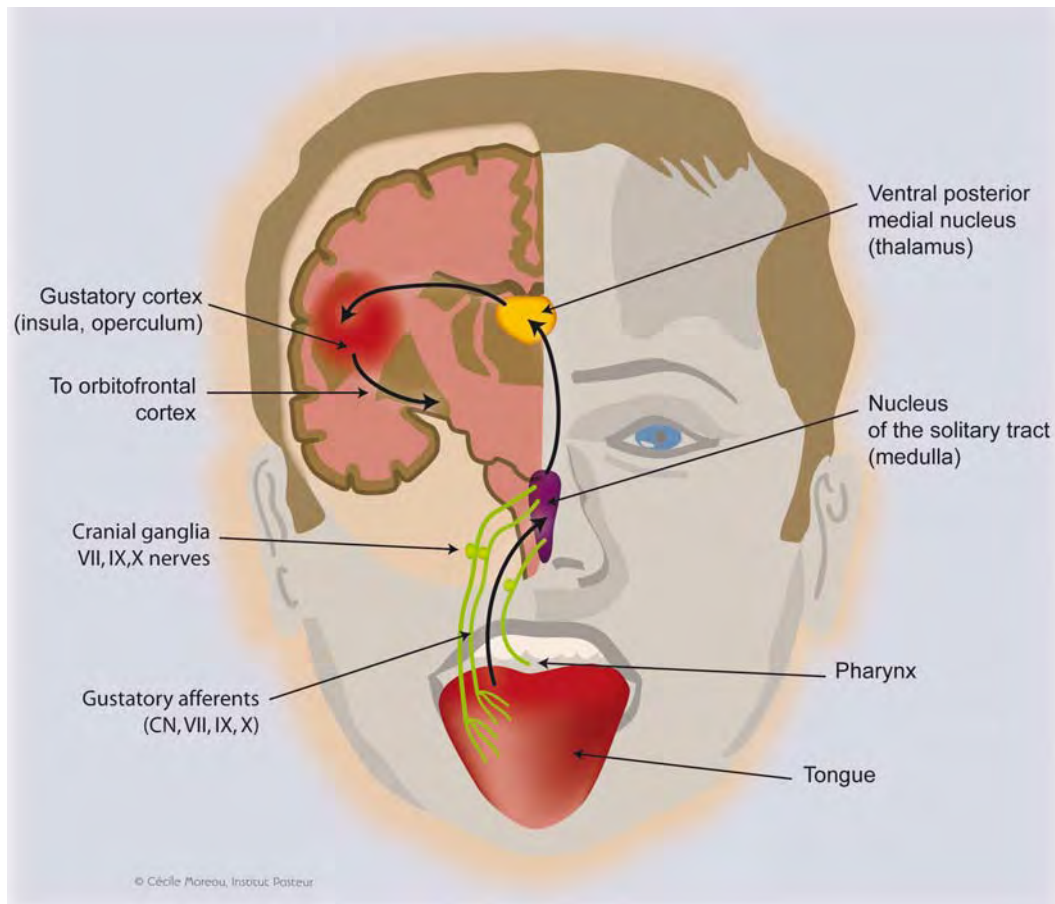

**Taste. Figure 3** Pathways involved in the processing of the taste information in human. The information generated by taste receptors in the oral cavity travels through cranial nerves VII, IX and X to the nucleus of the solitary tract (brain stem). The second relay is in the thalamus where the information is further processed before reaching the frontal operculum and insula, also called primary gustatory cortex, and then the orbitofrontal cortex. In rodents, the taste information travels through the solitary tract and parabrachial nuclei of the brain stem before reaching the gustatory cortex.

forward system like in the labeled line model would be appropriate for the efficient control of the ingestive behavior after sampling while perception of taste stimuli would require further processing as well as integration of multisensory information. Much remains unknown, therefore a better understanding of the functional organization of the taste system will provide valuable insight into the mechanisms underlying taste detection.

## References

- Murray RG (1993) Relations in mouse circumvallate taste buds. *Microsc Res Tech* 26:209–224
- Lindemann B (2001) Receptors and transduction in taste. *Nature* 413:219–225
- Liman ER (2007) TRPM5 and taste transduction. *Handb Exp Pharmacol* 179:287–298
- Hamilton RB, Norgren R (1984) Central projections of gustatory nerves in the rat. *J Comp Neurol* 222:560–577
- Smith DV, Frank ME (1993) Sensory coding by peripheral taste fibers. In: Simon SA, Roper SD (eds) *Mechanisms of taste transduction*. CRC, Boca Raton, FL, pp 295–338
- Frank ME (1991) Taste-responsive neurons of the glosso-pharyngeal nerve of the rat. *J Neurophysiol* 65:1452–1463
- Smith DV, Hanamori T (1991) Organisation of the gustatory sensitivities in hamster superior laryngeal nerve fibers. *J Neurophysiol* 65:1098–1113
- Norgren R (1984) Central neural mechanisms of taste. In: *The handbook of physiology: The nervous system III (section 2)*. Waverly, Baltimore, pp 1087–1128
- Rolls ET (2006) Brain mechanisms underlying flavour and appetite. *Philos Trans R Soc Lond Biol Sci* 361:1123–1136
- Spector A, Travers SP (2005) The representation of taste quality in the mammalian nervous system. *Behav Cogn Neurosci Rev* 4:143–191

## Taste – Bitter

### Definition

Bitterness is a property of a diverse group of chemicals, many of which are toxic. Quinine, found in tonic water, is the prototypical bitter substance. Many bitter tasting chemicals contain alkaloid structures, indicating that the sense of “bitterness” evolved to enable animals to recognize and avoid poisonous plants. Bitter tastes are transduced by a family of G-protein coupled receptors, the T2R receptors. There is a wide variety in the number of T2R receptors in humans and not all of the ligands that bind with them have been identified. There are some bitter substances, e.g. phenylthiocarbamide (PTC) and 6-n-propylthiouracil (PROP) and structurally related compounds, that taste bitter to some people but not others. Sensitivity to PTC and PROP is correlated with the number of fungiform papillae on the anterior tongue and can predict preferences for sweet and fatty foods in humans. An association between sensitivity to PROP and alcohol dependence has also been suggested. PTC and PROP sensitivity are controlled by the PTC loci on human chromosome 5p15 7q31 that codes for a member of the T2R bitter receptor family.

► Tastant

occurs can affect our perceptions and value judgments of that taste. For example, a fruity odor can enhance and lower the threshold for the perception of a sweet stimulus. Also, in solutions containing multiple tastants, sensory thresholds for components of the mixture can be raised. Two additional variables also provide context for taste perception: physiological state, e.g. hunger, hormonal state, and experience, e.g. history of conditioned taste aversions.

► Taste

## Taste – Salt

### Definition

Salt taste is one of our basic taste modalities, also called taste qualities or basic tastes. It is thought to be part of a system that maintains adequate body mineral levels. Salt taste is primarily the taste of sodium chloride, which elicits the “purest” salt taste. However, other compounds, including various potassium, calcium, and ammonium ions also elicit salt taste. Salt taste is linked to pleasantness and is thus associated with intake behavior. It is believed but not proven that salts stimulate a dedicated population of taste receptor cells on the tongue and other parts of the oral cavity. Evidence suggests that two signal transduction pathways mediate salt taste. One is specific for sodium, blocked by amiloride in rodents, and possibly involves the epithelial sodium channel ENaC. The other mediates the taste of sodium and other ions as well. It involves an ion channel that is sensitive to cetylpyridinium chloride. Ion fluxes through these membrane channels of specific taste receptor cells likely lead to receptor potentials, i.e., electrical excitation. The stimulus is eventually propagated to the afferent cranial nerves VII, IX, and X and conveyed to the cerebral cortex where neuronal activities reflect the cognitive perception of salty.

► Gustation

► Tastant

► Taste

## Taste – Conscious Perception of

### Definition

The process by which organisms acquire, select, organize and interpret taste sensations elicited by applying taste stimulus to taste receptor cells. Conscious perception of taste requires the participation of the taste cortex, but our reactivity (swallowing or spitting out) to tastants in the mouth does not.

► Taste

## Taste – Context Dependence

### Definition

Our perception of the flavor of food is a complex combination of taste, olfaction, tactile and thermal senses. So, the context, that is, the simultaneous presence of other types of sensations, in which a taste

## Taste – Sour

### Definition

Sour taste is one of our basic taste modalities, also called taste qualities or basic tastes. It appears to be

involved in water and electrolyte balance and in warning against spoiled food or unripe fruits. Sour taste is initiated by protons. Several transduction mechanisms have been described to underlie sour taste including activation of proton-gating of acid-sensing cation channels (ASICs) or of hyperpolarization and cyclic nucleotide-gated channels (HCN). Sour taste is transduced by a dedicated population of taste receptor cells on the tongue and other parts of the oral cavity. These cells express the polycystic kidney disease 2L1 (PKD2L1) gene that could be part of the sour “receptor.” Cation fluxes through membrane channels of the specific taste receptor cells likely generate receptor potentials, i.e., electrical excitation. The stimulus is eventually propagated to the afferent cranial nerves VII, IX, and X and conveyed to the cerebral cortex where neuronal activities reflect the cognitive perception of sour.

- ▶ Acid-Sensing Ion Channels
- ▶ Gustation
- ▶ HCN Channels
- ▶ Tastant
- ▶ Taste

---

## Taste – Sweet

### Definition

Sweet taste is one of our basic taste modalities, also called taste qualities or basic tastes. It is thought to be a detector of calories, particularly in the form of carbohydrates. It detects mono and disaccharides, but also certain amino acids, sweet tasting proteins of tropical fruits, and artificial sweeteners. Sweet taste is linked to neural networks engaged in attraction, thereby promoting intake behavior. Sweet taste is defined by a specific population of taste receptor cells on the tongue and other parts of the oral cavity that are characterized by the expression of the sweet taste receptor molecule, which is a class C G protein-coupled receptor composed of the two subunits TAS1R2 and TAS1R3. The receptor heteromer is activated in vitro by numerous tested sweet tasting substances that bind to various binding pockets.

Evidence also suggests that homomers of TAS1R3 and TAS1R2 may function as sensors for some sweet tasting compounds. Contacts of sweet tasting molecules with the specific taste receptor cells trigger signal transduction reactions leading to receptor potentials, i.e., electrical excitation. The stimulus is eventually propagated to afferent cranial nerves VII, IX, and X and conveyed to the cerebral cortex where neuronal activities reflect the cognitive perception of sweet.

▶ G-protein Coupled Receptors (GPCRs): Key Players in the Detection of Sensory and Cell-Cell Communication Messages

- ▶ Gustation
- ▶ Tastant
- ▶ Taste

---

## Taste – Umami

### Definition

Umami taste is considered to be one of our basic taste modalities, also called taste qualities or basic tastes. In humans it is the taste of glutamate, in rodents many amino acids contribute to this sensation. Umami taste is therefore considered to be a detector of calories, in the form of protein. A hallmark of umami taste is that 5'-ribonucleotides enhance the perception of glutamate. Umami taste is linked to neural networks engaged in attraction, thereby promoting intake behavior. It is defined by a specific population of taste receptor cells on the tongue and other parts of the oral cavity that are characterized by the expression of the umami taste receptor, a class C G protein-coupled receptor composed of the two subunits TAS1R1 and TAS1R3.

Activation of the TAS1R1–TAS1R3 heteromer through amino acids is enhanced by 5'-ribonucleotides reflecting the characteristic sensory property of umami taste. Evidence also suggests that metabotropic glutamate receptors or taste specific variants thereof contribute to umami taste. Contacts of umami tasting molecules with the aforementioned specific taste receptor cells trigger signal transduction reactions leading to receptor potentials, i.e., electrical excitation. The stimulus is eventually propagated to the afferent cranial nerves VII, IX, and X and conveyed to the cerebral cortex where neuronal activities reflect the cognitive perception of umami.

▶ G-protein Coupled Receptors (GPCRs): Key Players in the Detection of Sensory and Cell-Cell Communication Messages

- ▶ Gustation
- ▶ Tastant
- ▶ Taste

---

## Taste Aversion Learning

- ▶ Aversive Taste Memory

## Taste Bud

MAKOTO SUGITA

Department of Oral Physiology, Graduate School of Biomedical Sciences, Hiroshima University, Hiroshima, Japan

### Synonyms

A cluster of gustatory chemosensory cells

### Definition

Taste buds are onion-shaped aggregates of 50–150 cells embedded in oral and pharyngeal epithelia. They contain proliferative basal cells as well as elongated cells, which span the depth of the epithelium and are oriented perpendicularly to the basal lamina. Taste bud cells arise from local epithelial progenitors. However, they have characteristics of both epithelia and neurons. Taste bud cells are renewed because of a limited life-span, and constantly differentiate from progenitor cells

throughout life, generating heterologous cell populations. Among those, a subset of the elongated cells that express taste receptors is responsible for detecting sweet, bitter, salty, sour, and umami stimuli in foods. Sensing of the chemical signals in the taste receptor cells leads to activation of specific populations of neurons in the brain, which enables us to evaluate nutritious diets and to prevent the ingestion of toxic substances.

### Characteristics

#### Location of Taste Buds

Lingual taste buds reside within three types of papillae in mammals (Fig. 1). (i) Fungiform papillae containing one or a few taste buds are found in the anterior two-thirds of the tongue. Depending on the species, from approximately 100 to several hundred fungiform papillae form in a stereotypical array on the dorsal lingual surface [1]. (ii) Circumvallate papillae are present at the posterior dorsal border between the oral and pharyngeal tongue. Mouse possesses one circumvallate papilla, whereas human possesses 8–12

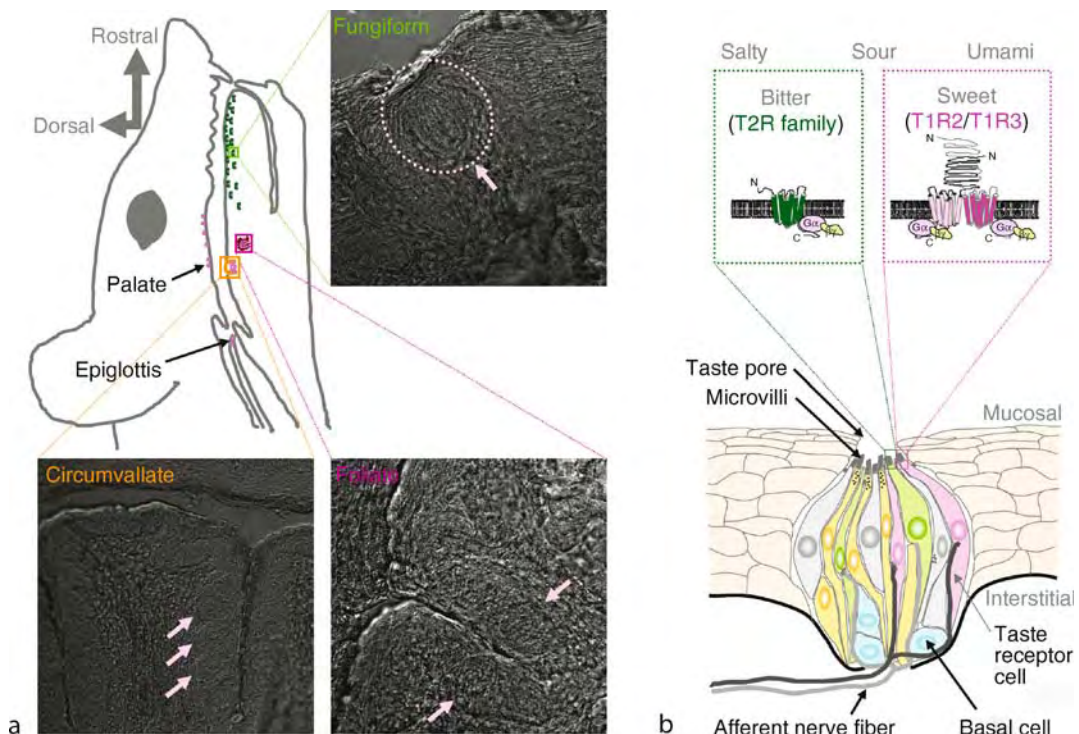

**Taste Bud. Figure 1** Locations and morphological characteristics of taste buds. (a) Schematic representation of the regions containing taste buds in the mouse oral cavity. Differential interference contrast images of the coronal sections of taste buds embedded in fungiform, foliate and circumvallate papillae are also shown. Arrow heads indicate locations of taste buds. (b) Schematic representation of a taste bud and associated structures. The taste receptor cells detect sweet, bitter, salty, sour and umami stimuli, and transmit taste information to afferent nerve fibers. The sensations of bitter and sweet taste are initiated by the interaction of sapid molecules with the T2Rs and the T1R2/T1R3 heteromers, respectively, expressed in the taste receptor cells. The bitter and sweet receptors are expressed in non-overlapping populations of taste receptor cells.

circumvallate papillae in a V-shaped formation [1]. (iii) Foliate papillae are found at the posterior lateral sides of the tongue. There is one foliate papilla composed of a series of clefts on each side of the tongue. In the circumvallate and foliate papillae, taste buds lie in the epithelial linings which grow below the surface of the tongue, facing a cleft [1]. Circumvallate and foliate papillae contain hundreds of taste buds each. In addition to residing in lingual papillae, taste buds are also located in the epithelium of the epiglottis, pharynx, and palate (Fig. 1a).

Taste buds in the fungiform papillae and in the palate are innervated by the ganglion neurons in branches of the facial nerve, the chorda tympani and greater superficial petrosal nerve, respectively. Taste buds in the foliate and circumvallate papillae located at the posterior tongue are innervated by the glossopharyngeal nerve. The superior laryngeal nerve, a branch of the vagus nerve, innervates the taste buds in the epiglottis. Each ganglion neuron contacts multiple taste receptor cells within a taste bud, and relays taste information to the neurons in the solitary tract nuclei of the medulla. From the solitary tract nuclei, taste information is transferred to the neurons in the pontine parabrachial nuclei, then to the thalamus, and then to the gustatory cortex.

### Development and Maintenance of Taste Buds

During mouse development, taste papillae appear first as the epithelial thickenings, described as placodes, at embryonic day (E) 12.5 [1,2]. Then, the placode undergoes series of invaginations and evaginations to form a papilla with a distinctive epithelium over a connective tissue core. Taste buds are first morphologically evident within the papillary epithelium at approximately E18. Nerves reach the basement membrane of developing taste papillae at E14, begin to penetrate into the papillary epithelium by E15, and densely innervate it by E16. Importantly, initiation of papillae morphogenesis does not require innervation. Furthermore, the rodent taste papillae structurally form well before taste bud cells fully differentiate within the papillae.

Wnt- $\beta$ -catenin signaling is activated in developing fungiform placodes and taste bud cells [2]. Enhanced stimulation of Wnt- $\beta$ -catenin signaling in mutant mice causes massive overproduction of enlarged fungiform papillae and taste buds. Conversely, ablation of Wnt- $\beta$ -catenin signaling blocks initiation of fungiform papillae morphogenesis [2]. Thus, Wnt- $\beta$ -catenin signaling confined to the epithelium plays a critical role in initiating fungiform papilla development while regulating expressions of its downstream targets such as Sox2 and Shh and BMP4, and leads to the production of taste buds [2,3]. During the development, taste bud progenitors express brain-derived neurotrophic factor (BDNF)

before innervation, although it remains unclear whether BDNF expression is dependent on Wnt- $\beta$ -catenin signaling and Sox2 at present. BDNF-deficient mice show severely malformed taste-bud bearing papillae and severe reduction of taste buds, a loss of proper innervation of remaining taste buds and a loss of taste discrimination [4]. Ectopic overexpression of BDNF led to the misdirection of gustatory axons into non-gustatory tissue, which resulted in sparsely innervated gustatory papillae with few taste buds [5], although the intrinsic BDNF levels in the gustatory epithelium might not be reduced. On the other hand, afferent nerve transection causes either loss of taste buds or appearance of atrophic taste buds. When denervated taste buds are reinnervated, taste buds are reconstituted. It is controversial whether nerves are necessary to initiate taste bud morphogenesis. However, molecular signals exchanged between afferent nerves and taste buds are important for certain steps of development and maintenance of taste buds.

### Morphologic Characteristics and Molecular Markers of Taste Bud Cells

Based on the ultrastructural features, mammalian taste bud cells have been classified into type I (dark) cells, type II (light) cells, type III (intermediate) cells, and basal cells [6]. Basal cells are likely to be progenitor cells. The type I cell possesses an electron-dense cytoplasm, and is slender with several long microvilli of various lengths extending into the oral cavity. The nucleus of the cell is invaginated. Many electron-dense granules are apically localized in the cell. The type II cell is a more electron-lucent, spindle-shaped cell with a large round nucleus, short thick microvilli, and electron-lucent, swollen cisternae of smooth endoplasmic reticulum. The type III cell is a slender, spindle-shaped cell with intermediate electron-density in the cytoplasm between the type I and type II cells, and with a solitary thick microvillus. The type III cell possesses perinuclear dense-core vesicles, and is characterized by conventional synaptic contacts with nerve processes [6].

The presence of a particular molecular marker is likely to correlate with cell type. Type I cells contain blood group H antigen. Type III cells express neural cell adhesion molecule (NCAM), and synaptic proteins such as SNAP25, syntaxin-1, and synaptobrevin-2 [6]. Subpopulations of type III cells contain either protein gene product 9.5 (PGP 9.5) or serotonin (5-HT). Type II cells express signaling molecules of taste transduction, including G protein-coupled taste receptors,  $\alpha$ -gustducin, phospholipase C  $\beta$ 2 (PLC $\beta$ 2), and type III inositol 1,4,5-trisphosphate (IP $_3$ ) receptor (IP $_3$ R3) [6]. Syntaxin-1 and synaptobrevin-2 are present in type II cells. PGP 9.5 is expressed in a subset of type II cells that do not express  $\alpha$ -gustducin. NCAM and 5-HT are also reported to be present in a small subset of PLC $\beta$ 2- and IP $_3$ R3-expressing cells. Thus, some proteins are expressed in more than one

morphologic taste cell type, especially in both type II and type III cells. It remains unclear whether different types of taste bud cells represent independent cell lineages, whether one cell type (for example, type III) grades into another (for example, type II) as the taste cell matures or differentiates, or whether asymmetric cell division of basal cells underlies production of the lineage-restricted basal cells or the different types of taste bud cells and receptor cells in a nerve-dependent or -independent manner. Nevertheless, their ultrastructural characteristics in combination with molecular expression patterns suggest that the type II and type III cells differentiate to function as the specialized cells that transduce taste stimuli into neural signals, whereas type I cells play a supportive or glia-like role. Of note, BDNF expression persists in adult taste system. BDNF is localized to the synaptically connected type III cells and type II cells, but is absent from basal cells and type I cells, implying its potential role in maintaining synaptic function [7].

### Functions of Taste Receptor Cells in Taste Buds

The cells expressing taste receptors (taste receptor cells) are responsible for detecting sweet, bitter, salty, sour, and umami taste stimuli (Fig. 1b). The sensations of bitter, sweet and umami tastes are initiated by the interaction of sapid molecules with G protein coupled receptors (GPCRs) in the apical membranes of taste receptor cells. Two families of mammalian taste receptors, T1Rs and T2Rs, have been implicated in sweet, umami and bitter detection [8]. There are 36 intact T2R genes in mice and 25 genes in humans. Some of the T2Rs are reported to be functional bitter receptors both *in vivo* and *in vitro*. Most of the members of the T2R receptor family are co-expressed in the same subset of taste cells [8], suggesting that this cell type recognizes a diverse array of structurally distinct bitter compounds without a fine discriminatory power among different bitter compounds. The T1R receptor family (T1R1, T1R2 and T1R3) generates at least two heteromeric receptors. The T1R1/T1R3 and T1R2/T1R3 heteromers function as umami and sweet receptors, respectively [8]. Thus, T1R3 are commonly used as a subunit of both sweet and umami receptors. The human T1R1/T1R3 heteromer selectively senses L-glutamate over other amino acids, whereas the mouse T1R1/T1R3 heteromer appears to act as a sensor for many L-amino acids with similar affinity because of the differences between human and rodent T1R1 subunits. The single T1R2/T1R3 receptor can recognize a large collection of diverse chemical structures of sweeteners such as natural sugars, some amino acids, proteins and synthetic sweeteners, by using different domains of its receptor complex for recognition.

Both T1Rs and T2Rs are partially coexpressed with the  $\alpha$ -subunit of the G protein gustducin, a taste-specific signaling molecule. Mice deficient in  $\alpha$ -gustducin show

markedly reduced behavioral and nerve responses to bitter, sweet and umami compounds [9]. Thus, the gustducin heterotrimer plays substantial roles in bitter, sweet and umami transduction *in vivo*. Binding of those taste compounds to the G protein-coupled receptors leads to dissociation of the heterotrimeric G protein gustducin. Then, the released G $\beta\gamma$  subunits (G $\beta$ 3 and G $\gamma$ 13) activate PLC $\beta$ 2, which hydrolyzes phosphatidylinositol-4,5-bisphosphate into diacylglycerol and IP $_3$ . Subsequently, IP $_3$  activates IP $_3$ R3, which elicits the release of Ca $^{2+}$  from intracellular stores to the cytoplasm. Rapid increases in [Ca $^{2+}$ ] $_i$  open basolaterally located TRPM5 channels. Elevation of [Ca $^{2+}$ ] $_i$  and TRPM5-mediated membrane depolarization might be required for the neurotransmitter release onto afferent nerve fibers, which relay and process taste information. Importantly, T2Rs and T1Rs are not co-expressed in the same taste receptor cells, although T2R-expressing cells and T1R-expressing cells are localized in the same taste buds [8]. Furthermore, there is no coexpression of T1R1 and T1R2, suggesting that sweet, umami and bitter taste modalities are encoded separately by the activation of distinct cell types.

Salty and sour taste transduction appears to be mediated by ion channels belonging to the transient receptor potential (TRP) family, and the epithelial sodium channel (ENaC)/degenerin (DEG) family. NaCl salt taste is initiated by current flowing into the taste receptor cells through amiloride-sensitive epithelial sodium channels (ENaC) located in the apical membrane. Na $^+$  influx through the cation channels elicits membrane depolarization, leading to the production of action potentials that result in the neurotransmitter release onto an afferent nerve fiber. Therefore, amiloride reduces, but not completely eliminates, the responses to NaCl in taste receptor cells and chorda tympani nerves. The member(s) of the TRP family, such as TRPV1, might be also involved in amiloride-insensitive salt taste transduction. Protons are the primary sour taste stimuli since acid-elicited sour taste is proportional to proton concentration. The proton-gated channels, the proton-conducting channels as well as pH-dependent ion exchangers in taste receptor cells are believed to be involved in sour taste transduction. Generally, upon acid stimulation, the proton-gated channel activities elicit membrane depolarization directly via the current flow through the channel, leading to the production of action potentials and the neurotransmitter release. Genetic ablation of the cells expressing PKD2L1, a member of the TRP family, shows complete unresponsiveness to sour tasting stimuli in peripheral nerve recordings [8]. Therefore, the PKD2L1-expressing cells are likely to be acid-sensing cells. PKD2L1 may substantially function as a component of the sour taste receptor, while interacting with the other member of the TRP family, such as



PKD1L3, and forming a pH-regulated cation channel [8]. Alternatively, the other molecules, selectively expressed in a subset of PKD2L1-expressing cells, may play a role in triggering sour taste transduction. The ►acid-sensing ion channels (ASICs) of the ENaC/DEG family are also proposed to be involved in sour taste transduction. Importantly, PKD2L1 was found to be expressed in a subset of taste receptor cells distinct from those responsible for bitter, sweet, and umami taste transduction [8].

It is reported that transmitters such as serotonin, glutamate, acetylcholine, norepinephrine, and several neuropeptides are released from taste bud cells. However, the taste receptor cells appear to transmit information to the primary afferent neurons by releasing ATP, which activates the ionotropic purinergic receptors P2X<sub>2</sub>/P2X<sub>3</sub> on the postsynaptic membrane of the neurons [10]. P2X<sub>2</sub>/P2X<sub>3</sub> double knock-out mice lost all of the sweet, bitter, salty, sour, and umami responses in the chorda tympani and glossopharyngeal nerve recordings [10], implying that the taste receptor cells on the tongue and their associated afferent neurons may commonly employ ATP as a neurotransmitter and P2X<sub>2</sub>/P2X<sub>3</sub> as receptors, respectively.

### Taste Coding in Taste Buds

Identification of taste receptors and their downstream signaling molecules revealed ►taste coding in the periphery. Mice lacking either PLCβ2 or TRPM5 diminish behavioral and nerve responses to sweet, umami and bitter taste stimuli [8]. Thus, the T1R and T2R families converge on a common signaling pathway in the taste receptor cells. Nevertheless, separate populations of taste receptor cells appear to be uniquely tuned to sweet, umami, and bitter taste, since mice engineered to rescue PLCβ2 exclusively in T2R-expressing cells respond normally to multiple bitter compounds, but not to sweet or umami taste [8]. In addition, genetic ablation of either T1R2- or PKD2L1-expressing cells showed specific unresponsiveness to only a single taste quality (sweet and sour, respectively) in the tastant-induced activity of nerves innervating the tongue [8]. Thus, distinct populations of taste receptor cells are uniquely tuned to detect sweet, umami, bitter and sour taste. Furthermore, transgenic mice expressing a RASSL k-opioid receptor in either T1R2-expressing (sweet) or T2R-expressing (bitter) cells display attraction and aversion, respectively, to the synthetic opioid agonist spiradoline, which is a normally tasteless compound [8]. Therefore, activation of a specific type of taste receptor cells and its line of neurons is dedicated to elicit a specific behavior. To constantly maintain the contrastive behavioral responses as taste cells turn over, a newly arising taste cell expressing either T1R2 or T2R might selectively form a synapse with an appropriate afferent nerve carrying specific taste information. Alternatively, the afferent

nerve fibers which transmit specific taste information might contact common progenitor cells, induce the expression of the specific receptor, and thus cause the cells to become specific taste receptor cells. Clarification of the molecular and cellular mechanisms underlying the establishment of connectivity between taste receptor cells and their associated afferent neurons is now of critical relevance to understand taste coding in the central nervous system, and to decipher the neuronal activities responsible for eliciting contrastive behavioral responses.

### References

1. Mistretta CM (1991) Developmental neurobiology of the taste system. In: Getchell T, Doty R, Bartoshuk L, Snow L (eds) Smell and taste in health and disease. Raven, New York, pp 35–64
2. Liu F, Thirumangalathu S, Gallant NM, Yang SH, Stoick-Cooper CL, Reddy ST, Andl T, Taketo MM, Dlugosz AA, Moon RT, Barlow LA, Millar SE (2007) Wnt-β-catenin signaling initiates taste papilla development. *Nat Genet* 39:106–112
3. Zhou Y, Liu H-X, Mistretta CM (2006) Bone morphogenetic proteins and noggin: inhibiting and inducing fungiform taste papilla development. *Dev Biol* 297:198–213
4. Nosrat CA, Blomlof J, ElShamy WM, Ernfors P, Olson L (1997) Lingual deficits in BDNF and NT3 mutant mice leading to gustatory and somatosensory disturbances, respectively. *Development* 124:1333–1342
5. Farbman AI (2003) Neurotrophins and taste buds. *J Comp Neurol* 459:9–14
6. Yang R, Stoick CL, Kinnamon JC (2004) Synaptobrevin-2-like immunoreactivity is associated with vesicles at synapses in rat circumvallate taste buds. *J Comp Neurol* 471:59–71
7. Yee CL, Jones KR, Finger TE (2003) Brain-derived neurotrophic factor is present in adult mouse taste cells with synapses. *J Comp Neurol* 459:15–24
8. Chandrashekar J, Hoon MA, Ryba NJP, Zuker CS (2006) The receptors and cells for mammalian taste. *Nature* 444:288–294
9. Wong GT, Gannon KS, Margolskee RF (1996) Transduction of bitter and sweet taste by gustducin. *Nature* 381:796–800
10. Finger TE, Danilova V, Barrows J, Bartel DL, Vigers AJ, Stone L, Hellekant G, Kinnamon SC (2005) ATP signaling is crucial for communication from taste cells to gustatory nerves. *Science* 310:1495–1499

## Taste Coding

### Definition

Insight into how taste information is processed in taste receptor cells and afferent neurons. The two models, “labeled-line” and “across-fiber pattern,” have been

proposed. In the labeled-line model, information of each taste quality (salty, sour, sweet, umami or bitter) is processed through activation of non-overlapping populations of taste receptor cells and their associated afferent neurons. In the across-fiber pattern model, the afferent neurons are broadly tuned, and the specification of any one taste quality is embedded in a unique combinatorial pattern of activity distributed across populations of neurons.

- ▶ Gustation
- ▶ Neural Coding of Taste
- ▶ Taste
- ▶ Taste Bud

---

## Taste Hedonic Value

### Definition

It refers to palatability. Recordings of orofacial and somatic behavioral patterns are used to measure palatability. As a consequence of conditioned taste aversions, the hedonic value of the conditioned taste becomes aversive, thus, being disliked.

- ▶ Conditioned Taste Aversion

---

## Taste Learning

- ▶ Conditioned Taste Aversion

---

## Taste Neophobia

### Definition

Unconditioned response to novel tastes. It consists in a reduced intake compared with later presentations provided that it was not followed by aversive visceral consequences.

- ▶ Conditioned Taste Aversion

---

## Taste Reactivity Test

### Definition

It refers to a method developed by H.G. Grill and R. Norgren in 1978 for assessing the orofacial and somatic responses induced by a taste stimulus in the rat using videotape recordings. It is applied to the study of the palatability shifts induced by learning. Among other responses, appetitive patterns include paw licking and mouthing while aversive patterns include gaping, chin rubbing, and head shaking.

- ▶ Conditioned Taste Aversion

---

## Taste Stimulus

- ▶ Tastant

---

## Taste-potentiated Odor Aversion

### Definition

The process by which the combined presentation of both an odor and a taste paired with visceral malaise leads to a strong aversion to the odor. Taste-potentiated odor aversion refers to the increase in the strength of odor aversion after odor and taste conditioning, similar to taste aversions induced in one-trial, long-delay conditions.

- ▶ Behavioral Methods in Olfactory Research
- ▶ Conditioned Taste Aversion

---

## Tat Protein

### Definition

The ▶ [human immunodeficiency virus](#) (HIV) Tat protein is a transactivator of viral replication and thus essential for new HIV production. Tat protein released by HIV-infected cells is neurotoxic and induces the

expression numerous pro-inflammatory genes in host cells including immune cells and glia.

- ▶ Central Nervous System Inflammation: Astroglia and Ethanol
- ▶ Human Immunodeficiency Virus (HIV)

## TATA-Box

### Definition

The DNA sequence element recognized by the TATA-box binding factor, a critical component of TFIID. The TATA sequence is usually located 35 bp upstream of the TSS and its presence in a promoter helps to position the pre-initiation complex (PIC) so that transcription fires from one major site. Not all genes, however, contain TATA-boxes.

- ▶ Promoter

## Tau Mutation

### Definition

A missense mutation of the casein kinase 1 $\epsilon$  gene that causes alteration in enzymatic activity of this serine-threonine kinase. Phosphorylation of the PER proteins is altered in mutant animals, leading to early degradation of PER and shortening of circadian periodicity. Originally discovered in a group of hamsters that display a shortened behavioral circadian rhythm, the Tau mutation was the first altered circadian phenotype observed in mammals.

- ▶ Circadian Rhythm
- ▶ Clock

## Taxis

### Definition

Movement by a freely motile simple organism towards or away from a stimulus (such as a light, temperature or chemical gradient).

## Taxon Navigation

### Definition

Behavior relying on an egocentric reference frame and directed by an association between a cue and a goal to get a goal location. Locomotion based on routes; that is locomotion rules based on making a memorized set of paths and turns at particular distances and landmarks. Taxon locomotion is inflexible in that the subject can only traverse previously learned routes.

- ▶ Spatial Learning/Memory
- ▶ Spatial Memory

## Tay-Sachs Disease

### Definition

Fatal genetic lysosomal storage disease due to a defect of  $\beta$ -hexosaminidase, which leads to accumulation of the ganglioside G<sub>M2</sub> in lysosomes. Infants seem to develop normally initially, but after a few months start deteriorating in terms of their physical (developing muscle atrophy and paralysis) and mental abilities (developing blindness, deafness, ▶ dysphagia, ▶ dementia, ▶ seizures and increased startle response to noises). A rarer form involves young adults with unsteady gait, progressive deterioration and cherry-red spots in their eyes.

## TBPII

- ▶ Brain Inflammation: Tumor Necrosis Factor Receptors in Mouse Brain Inflammatory Responses

## Tectobulbar and Tectospinal Tract

### Synonyms

Tractus tectobulbaris + tectospinalis

**Definition**

Deep layers of the superior colliculus project to nuclei of the brainstem (often called bulb). The greatest bundle descends close to the midline on the contralateral side, while one much smaller bundle continues on its ipsilateral course. The tectospinal tract runs parallel over a long distance.

- ▶ Mesencephalon

**Tectobulbospinal Tract****Definition**

One of the names of the fiber tract which originates in the superior colliculus (anterior part of the “tectum mesencephali”), undergoes decussation in the midbrain, descends near the midline through the pons and medulla and terminates in the upper segments of the spinal cord. Its pontomedullary portion, after the decussation in the midbrain and till the entry in the spinal cord, is called “predorsal bundle.”

- ▶ SC-Tectoreticulospinal neurons (TRSNs)
- ▶ Superior Colliculus
- ▶ Tectum

**Tecto-reticulo-spinal Neurons****Definition**

Superior colliculus (SC) efferent neurons whose response properties for orienting movement (synergic eye and head movement) and projections have been extensively documented in the cat. Their axons have been shown to decussate in the midbrain and descend through the contralateral predorsal bundle to project to various preoculomotor structures in the brain stem, including the paramedian pontine reticular formation, where burst neurons are located.

- ▶ Burster-Driving Neurons
- ▶ Paramedian Pontine Reticular Formation (PPRF)
- ▶ Superior Colliculus

**Tectospinal Tract****Synonyms**

- ▶ Tractus tectospinalis

**Definition**

A large projection from the substantia nigra terminates in a very regular pattern of bands in the superior colliculus, middle gray layer. This layer contains the cells giving rise to the predorsal fasciculus, a major descending bundle, which dispatches a large number of fibers to premotor and motor centers in the brainstem and spinal cord. Runs in the medial longitudinal fasciculus.

- ▶ Mesencephalon

**Tectum****Definition**

The dorsal part of the midbrain derived from the alar plate in development.

**Tectum of Mesencephalon****Synonyms**

Tectum mesencephali; Tectum of midbrain

- ▶ Quadrigeminal Plate
- ▶ Mesencephalon

**Tegmental Area (Forel's Field)****Synonyms**

Nuclei campi perizonalis (Forel-Feld); Nuclei of perizonal fields (Forel's field)

**Definition**

Between the thalamus and zona incerta is situated Forel's tegmental field. It belongs to the subthalamus and consists of myelinated axons which belong to the thalamic fasciculus. This is composed of the lenticular fasciculus and ansa lenticularis and is the most important connection between the globus pallidus and ventral lateral thalamic nucleus.

► Diencephalon

**Tegmentum**

► Tegmental Area (Forel's Field)

**Tegmentum (Midbrain, Pontobulbar)****Definition**

A term used in macroscopic anatomy of the brainstem. In the midbrain it includes all structures between the cerebral peduncles and substantia nigra ventrally and the borders of the superior and inferior colliculi dorsally. In the pons it comprises all structures overlying the basilar pontine nuclei and, in the medulla, those overlying the medial lemniscus and the pyramidal tract.

- Inferior Colliculus
- Pyramidal Tract
- Superior Colliculus

**Tegmentum of Mesencephalon****Synonyms**

Tegmentum mesencephali; Tegmentum of midbrain

**Definition**

Quadrigeminal plate. This deep layer of the Mesencephalon stretches between the tectum of Myelencephalon and the cerebral peduncles, arising to the surface only deep in the interpeduncular fossa.

A number of cranial nerve nuclei are encountered here as well as the reticular formation of Myelencephalon with its nuclei, the substantia nigra and parts of the central gray matter of ► **Mesencephalon**.

► **Mesencephalon**

**Tegmentum of Pons****Synonyms**

► Tegmentum pontis

**Definition**

The tegmentum of pons comprises the dorsal part of the pons and contains the nuclei of the cranial nerves: trigeminal nerve (V), abducens nerve (VI), facial nerve (VII) and vestibulocochlear nerve (VIII).

► Pons

**Telencephalic****Definition**

Refers to the telencephalon, which is the rostral (front) part of the forebrain and consists of the pallium and subpallium.

► Evolution of the Wulst

**Telencephalon****Definition**

In most vertebrates, bilateral and dorsal evaginations of the rostral forebrain. In ray-finned fishes, the telencephalon is everted. In all vertebrates, it shows two major divisions: pallium and subpallium. The subpallium includes at least part of the preoptic region, which is neither evaginated nor everted.

At a deep level, it is composed of the commissures, the limbic system and the basal ganglia, on the surface of both hemispheres it is composed of the greatly folded cortex (cerebral cortex). All “higher” brain functions are found here, e.g. voluntary motor control, motor and sensory speech, cognition, visual and auditory systems, surface and proprioceptive sensibility. Also memory as well as affective and emotional mechanisms.

► [Evolution and Embryological Development of the Forebrain](#)

► [Evolution of Hippocampal Formation](#)

The majority of these neurons increase their activity with increases in local temperature. Certain types of nonspecific cation channels are responsible for the thermosensitivity. The spinal cord is another important thermosensitive site. Additionally, warm and cold receptors in the skin detect external temperatures and provide signals for the feed forward control that allows corrective responses to be initiated before a deviation in core temperature occurs. The preoptic area integrates brain and skin temperature signals, and sends efferent signals to the thermoregulatory effector organs. The sympathetic nerves innervate most effectors including skin blood vessels, sweat glands, and brown adipose tissue.

► [Hypothalamus](#)

---

## Teleost Fish

### Definition

The taxonomic class of teleost (“bony”) fish is the largest and most successful group of fishes, representing approximately 95% of all living fish species, and making up approximately half of all living vertebrates.

---

## Temperature Regulation

### Definition

Temperature regulation refers to the maintenance of the temperature or temperatures of a body within a restricted range under conditions involving variable internal and/or external heat loads. The regulated body temperature, however, is not rigidly fixed, and may change under certain conditions, such as time (circadian variation) or fever. Temperature regulation is established by behavioral means in poikilothermic animals, and additionally by autonomic means in homeothermic animals including humans. The temperature of only the central part of the body (core) is well maintained, while the temperature of outer layer of the body (shell) fluctuates to a greater degree. The basic mechanism of regulation involves a negative feedback system. Brain areas important for temperature regulation are distributed throughout the neural axis; the most important reside in the preoptic area of the hypothalamus. About one fifth of the neurons in this region change their activities with changes in local brain temperature, and are called thermosensitive neurons.

---

## Template

### Definition

Manifestation (trace) of memory in the brain that can be use to compare and adapt incoming information.

---

## Template in Birdsong

### Definition

Auditory memory of the song to be produced.

► [Song Learning of Songbirds](#)

---

## Temporal

### Definition

Refers to the timing properties of the speech signal, including sound duration and variations in sound intensity over time.

► [Hearing Aids](#)

## Temporal Coding in Olfactory System

NATHALIE BUONVISO, TRISTAN CENIER,  
FRANÇOIS DAVID  
Neurosciences sensorielles, Comportement,  
Cognition Université Claude Bernard Lyon 1  
CNRS – UMR5020 – INFL LYON, Lyon, France

### Synonyms

Neuronal ensemble; Synchronization; Firing patterns

### Definition

Temporal coding in the olfactory system refers to the fact that some temporal components of the neuronal activity are used as cues for representation of odor quality and/or intensity.

Animals detect and discriminate a large variety of odor molecules in their environment. These molecules are recognized by odorant receptors (nearly 1,000 types of odorant receptors) located on sensory neurons in the olfactory epithelium. Sensory neurons that express a given odorant receptor are widely distributed within a specific zone of the olfactory epithelium. Each odorant can bind to multiple, but specific, odorant receptors so that the quality of an odorant is determined by the combination of a number of odorant receptors, each recognizing a specific molecular feature of the odorant molecule. Moreover, within the olfactory epithelium, odorant molecules migrate differentially according to their relative sorption properties and this migration can be enhanced or slowed down by inhalation rate or duration. Thus, the physico-chemical properties of odorant molecules determine a spatio-temporal representation of odors at the peripheral level. This representation is transferred to the glomeruli of the olfactory bulb (OB) by the axons of sensory neurons.

Anatomical, genetic and functional mapping studies indicate that each odorant is represented at the bulbar level by a spatial map of activated glomeruli. This glomerular organization is highly conserved across species, indicating that such spatial representation is crucial for information coding. However, while this spatial information is probably sufficient when an animal has to discriminate very different odors, it will need a more precise representation for discrimination between very similar odors. Similarly, separation of odorants in a mixture needs more precision than a purely spatial representation. This precision might be provided by a mechanism that exploits the temporal aspects of neuronal activity. The temporal representation of a stimulus in neuronal structures has been evaluated through the observation of electrophysiological signals, mainly: (i) action potentials of individual cells and (ii) local field potentials (LFPs) of the

network, representing the summated activity of a large neuronal population and their interactions.

### Characteristics

What is “time” for olfactory coding? For about two decades, the theory of coding in the olfactory system has evolved according to two main ideas: (i) Information about an odor is carried by patterns of activity across a large population of neurons in the olfactory system, (ii) the absolute time of spikes is not the relevant information in **▶odor coding**; rather, the time has to be considered as relative to a particular clock or time basis. Olfactory information may be represented at various timescales: a slow timescale, depending on odor sampling processes (>100ms), and a faster one imposed by the network oscillatory activity (on the order of 10ms). Whatever the time basis, the coding principle consists in the transfer of reliable information including both odor intensity and odor quality.

### A Slow Time Scale Related to Odor Sampling

Because breathing results in periodic sampling of the olfactory environment in mammals, the respiratory cycle represents a naturally fitted temporal frame. The respiratory frequency, often named theta frequency, may vary from 1–2 Hz in anaesthetized animal to 8–12 Hz in the sniffing bouts of behaving rats. At the moment, there is no direct evidence that respiratory dynamics has a significant functional role in temporal coding; however, it is highly suggested by the fact that temporal coupling between olfactory and respiratory signals depends on chemical features of the odorants. Such coupling appears at multiple levels: receptor neuron input to the OB, OB network activity, OB output neuron activity and cortical cell activity.

### At the Peripheral Level

Temporal dynamics of receptor neuron input to the OB can be visualized by calcium imaging methods [1]. Such an activity is oscillatory at the glomerular level and locked to the respiratory cycle. These odor-evoked **▶glomerular oscillations** differ in amplitude, latency and rise time in an odorant-specific manner (see Fig. 1).

Moreover, the odor-evoked response of each glomerulus is differentially modulated by sniffing parameters such as frequency. When odor concentration increases, response latencies are reduced, response amplitudes are increased, new glomeruli are recruited, but the temporal sequence of glomerular activation is maintained. Thus, each odor is represented by a specific glomerular activation sequence, both within a sniff and across consecutive sniffs, which contains a concentration-invariant information. The temporal patterning of glomerular activity is then partly transmitted to relay neurons, the mitral and tufted cells.

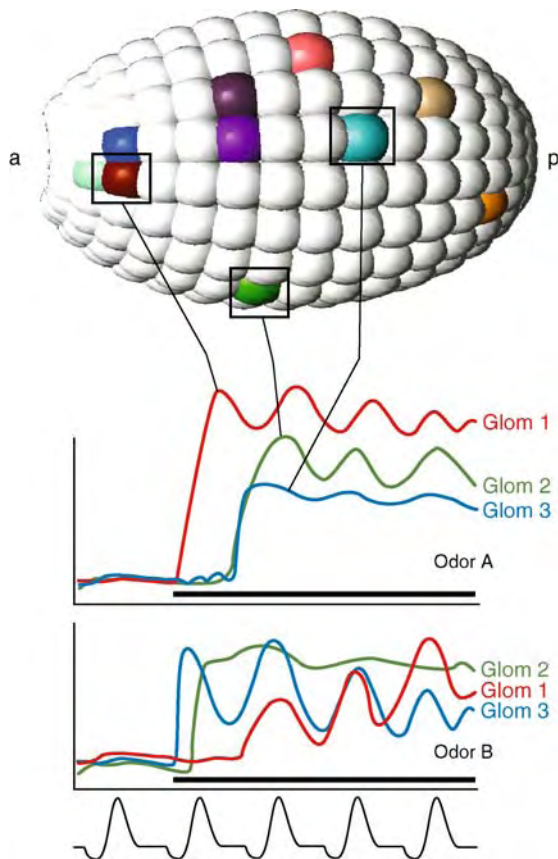

**Temporal Coding in Olfactory System. Figure 1** Temporal patterns of glomerular activation. *Top*: schematic representation of the glomerular layer of the olfactory bulb *a*: anterior, *p*: posterior. *Middle*: Representation of glomerular response intensity for three glomeruli: y-axes indicate the level of activation of the glomeruli (in arbitrary unit) in response to two odors A and B (horizontal bars indicate odor stimulation). *Bottom*: respiratory monitoring, negative deflection: inspiration; positive deflection: expiration. The amplitude, latency and rise time of activation vary across glomeruli and across odors. The fluctuation in the level of activation of the glomeruli is closely related to the respiratory phase. The temporal sequence of activated glomeruli differs between odors.

### At the Bulbar Level

Traditionally, the temporal aspects of coding have been mainly investigated by extracellular unitary recording methods. Most works agree with the observation that periodic sampling of odors influences bulbar activity spiking discharges both in the OB and the piriform cortex. Particularly, mitral cells, OB secondary neurons, show a definite temporal pattern of firing with respect to particular phases of the respiratory cycle [2] (see Fig. 2).

Responses are not static but evolve over the time of a respiratory cycle. An important phase in the respiratory

cycle is the transition epoch between inhalation and exhalation: around this point, spike discharges present the maximum of activation or suppression. This point represents also the maximum of recruitment of sensory neurons. These respiratory related oscillations act by enhancing the temporal precision of spike discharge [3]. Odor representation is relevant when the activity is considered over a population of mitral cells. Indeed, no individual unit is able to reliably discriminate between odorant stimuli. On the contrary, a distinct representation of odorants, even as similar as enantiomers, is possible when considering responses from a population of mitral cells integrated over single respiratory cycle.

Respiratory-phase information seems to be concentration-invariant since the profile of mitral cell responses relative to the respiratory phase is relatively unaffected by changes in odor concentration. Concentration coding rather relies on the latency and number of spikes in a burst relative to the respiratory cycle: mitral cells respond to stronger odorant stimulation with more spikes per burst and a shorter latency to the time of the first spike.

Glomerular and mitral dynamics probably contribute to the representation of odorant information. Firstly, the cortex would recognize the temporal sequence of glomerular activity patterns and/or the temporal characteristics of each glomerulus response within the sequence. This sequence is determined by the chemical nature of odor, the sniffing behavior and the sampling-related mechanisms. Then, within this sequence, odor representation would be refined by the dynamic map of mitral cells respiratory-phased activities which is more related to the intrinsic network connectivity.

Behaviorally, ►odor discrimination can be achieved in a single sniff both in animal (rodent, rabbit) and human, implying that odor can be represented within a single respiratory cycle. In rodents, there is a speed-accuracy trade-off in olfactory discrimination, discrimination being less accurate or longer when odors are very similar. In any case, each sniff can be considered as a complete snapshot of the olfactory environment [4]. Perception can be modified by changes in sniffing frequency. For example, different bulbar maps depending on sniffing frequency can represent the same stimulus. Particularly, rapid sniffing allows the animal to improve detection of a novel odor in the odor landscape [5]. Thus, by regulating its sniffing rate and depth, the behaving animal can influence the representation of odor stimulus and then its perception. This led some authors to the conclusion that the sniff itself is part of the olfactory percept [6].

In non mammalian animals, a slow dynamics exists which also depends on odor sampling process and which could reproduce the slow breathing rhythm: flicking in crustaceans, antenna movements in insects or coughing in fish, all of these sampling mechanisms represent an



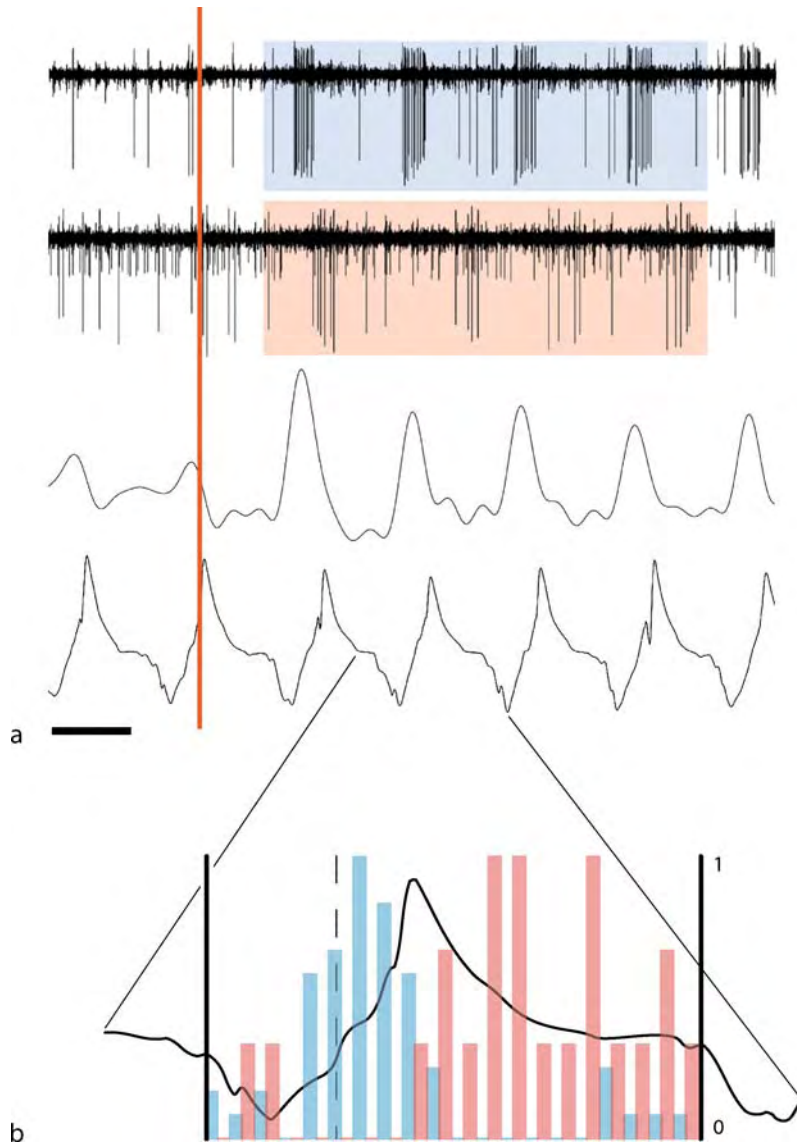

**Temporal Coding in Olfactory System. Figure 2** Respiration-related activity of mitral cells. (a) *Top traces*: unitary extracellular activity from two simultaneously recorded mitral cells (raw signal band-pass filtered: 300–3000 Hz). *Lower trace*: bulbar LFP (raw signal band-pass filtered: 0.5–5 Hz). *Bottom trace*: Respiratory monitoring (negative/positive deflection: inspiration/expiration). Time bar: 500 ms. Vertical red bar: odor stimulation onset. Low frequencies in the LFP signal follow the respiratory rhythm with peak activity occurring at the inspiration/expiration transition point. Both mitral cells emit odor evoked spike bursts at different epochs of the respiratory cycle. (b) Respiration-cycle triggered histogram showing the average spike distribution of both cellular activities relative to the respiratory cycle. Vertical axis: normalized firing rate; a value of 1 corresponds to the maximum rate. Blue/red bars indicate the average firing rate of cells 1 and 2 over the four respiratory cycles included in blue/red boxes on top traces.

analogous to sniffing behavior, both in function and frequency. The representation of odors evolves along the time: early representations are a coarse categorization of the odor while the late representations become sharp images of the odor, allowing for fine discrimination.

The slow timescale related to sampling process can thus be considered as a first temporal cue in odor coding.

#### A Fast Time Scale Related to Network Dynamics

At the bulbar and cortical levels, additionally to this slow temporal reference, the network produces another signal that may be used as time basis: the fast network oscillations of the LFPs. The oscillatory nature of LFPs may be exploited by the system as a common clock, a temporal reference for different cells or diverse areas. Stimulus-evoked oscillatory synchronization of

neurons results in the forming of a neural assembly in which neurons are bound temporally: neurons from a same assembly fire synchronously and in relation with the LFP oscillation phase. In such a coding principle, the relation between LFP oscillations and unitary activities is the relevant parameter for odor encoding.

In locusts, an individual neuron of the antennal lobe (analogous to the mammalian OB) synchronizes with different neurons at different epochs of the oscillatory response. Each odor is thus represented by a specific sequence of activated neurons that synchronize at different cycles of an oscillatory population response [7]. In fishes, the strength of coupling between LFP oscillations and spikes of relay neurons determines the nature of the information conveyed: spikes tightly coupled with the oscillation convey information about odor category whereas the less synchronized spikes from the same population of neurons convey information about precise odor identity [8]. In mammals, such mechanisms have not been described. Even if mitral cell spikes preferentially occur during the troughs of gamma oscillations, no simple rule has been revealed indicating a relation between odorant quality and pattern of LFP/spikes coupling. Bulbar processing in mammals is probably more complex due to the higher complexity of the network and its entries, and to the existence of several oscillatory regimes. Indeed, oscillatory activity is related to respiratory cycle in freely-breathing animals (see Fig. 3).

During odorant stimulation, LFP alternatively oscillates in the gamma range (40–80 Hz) around the inspiration-expiration transition epoch and in the beta range (15–35 Hz) during the other respiratory phases [2]. At least in anesthetized animals, the pattern of beta/gamma alternation depends on odorant quality and/or intensity. The hypothesis can be advanced that

synchrony on gamma and/or beta oscillations would selectively tag the activity of neurons that code for one odor. The subpopulation of synchronized mitral cells could be recognized as an assembly by coincidence detection mechanisms in the olfactory cortex. During gamma regime, the oscillation synchronized neuronal map would represent the perceptual significance of odour (chemical features, concentration...); during beta regime, the oscillation synchronized neuronal map would represent the contextual significance of odor (ecological significance, significance in a learning task...).

Behaviorally, does the system use the oscillations it produces? The best argument today comes from a work in the honeybee, using a behavioral learning paradigm. It has been shown that altering synchronization of neurons impairs the discrimination of molecularly similar odorants. Thus, oscillatory synchronization of neuronal assemblies is essential for fine sensory discrimination [7].

In the mammal, the functional role of oscillatory synchronizations is still hypothetical. In the olfactory bulb and cortex of the behaving rat, odor presentation induces a power decrease in gamma oscillations and an increase in power of beta oscillations. In the trained rat, odorant stimulation evokes a spatial distribution of oscillatory activity which depends on the chemical nature of the stimulus, but also on its behavioral meaning [9]. Indeed, on the one hand, beta LFPs oscillations spatial map is characteristic of the odor; on the other hand, the emergence of a powerful odor-induced beta oscillatory activity is predictive of behavioral odor recognition.

## Conclusions

In summary, odor information is represented in the bulbocortical network by (i) the spatio-temporal sequence of

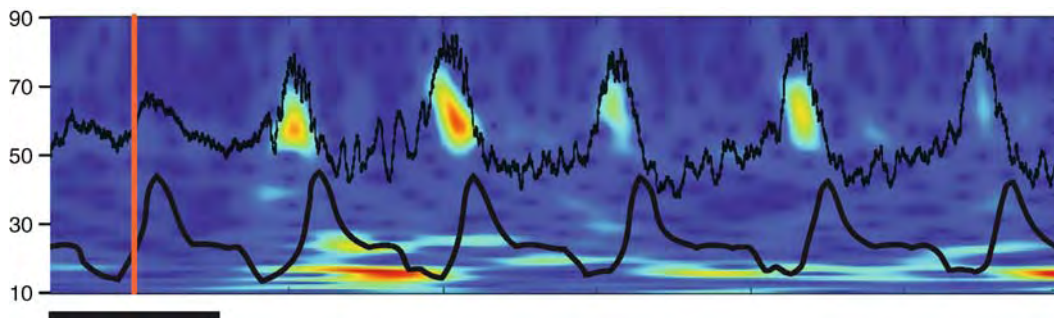

**Temporal Coding in Olfactory System. Figure 3** Odor-evoked LFP oscillatory activity in the olfactory bulb. *Foreground, top:* LFP recording, raw signal (0–5000 Hz); *bottom:* respiratory monitoring. *Background:* Time frequency representation of the raw LFP signal. x-axis = time, y-axis = frequency (in Hz). Time bar: 500 ms. Energy is color coded: the warmer the color the higher the amplitude of the oscillation in the signal. The oscillatory activity occurs in bursts, alternating between the beta range (10–35 Hz) and the gamma range (40–90 Hz) frequencies. The occurrence of oscillatory bursts is patterned by the respiratory cycle, with gamma bursts occurring around the inspiration/expiration transition and beta bursts occurring during the expiration phase.

activated glomeruli, (ii) the spatial combination of active neurons, (iii) the slow temporal sequence of activity patterns imposed by sampling-related process, (iv) the rapid synchronization of neuronal subpopulations relative to the network oscillatory regime. Therefore coding in the olfactory system is not a static phenomenon but a dynamical process with different temporal components, each of them probably readout by an adapted mechanism. This spatio-temporal representation is moreover dynamically reorganized by experience.

Sampling related process and odor characteristics impose the slow temporal dynamics, while intrinsic network dynamics established the fast LFP oscillatory regimes. Thus both dynamics are generated by system functioning. Dynamical representation of odors can nevertheless stand for a code provided that the neural network uses these temporal clues as a computational variable for coding. Firstly, the slow respiration-related rhythm could subserve a filtering function whereby neuronal responses could be selected on the basis of their respiratory phase. Such a functional phase-coding relative to theta cycle (i.e. related to respiratory frequency) has been evidenced in hippocampus place cells [10]. Secondly, the fast network oscillations probably intervene in a second step by refining the pattern of activated neurons through a synchronization binding process. This coding principle is better understood in other systems [10]. In such conditions, temporal dynamics, although epiphenomenal, are used by the system and thus may be considered as supporting temporal coding. The ultimate evidence would be provided in mammals if behavioral experiments could show changes in behavior in relation with a modification of the bulbocortical dynamics.

## References

- Spors H, Wachowiak M, Cohen LB, Friedrich RW (2006) Temporal dynamics and latency patterns of receptor neuron input to the olfactory bulb. *J Neurosci* 26:1247–1259
- Buonviso N, Amat C, Litaudon P (2006) Respiratory modulation of olfactory neurons in the rodent brain. *Chem Senses* 31:145–154
- Schaefer AT, Margrie TW (2007) Spatiotemporal representations in the olfactory system. *Trends Neurosci* 30:92–100
- Kepecs A, Uchida N, Mainen ZF (2006) The sniff as a unit of olfactory processing. *Chem Senses* 31:167–179
- Verhagen JV, Wesson DW, Netoff TI, White JA, Wachowiak M (2007) Sniffing controls an adaptive filter of sensory input to the olfactory bulb. *Nat Neurosci* 10:631–639
- Mainland J, Sobel N (2006) The sniff is part of the olfactory percept. *Chem Senses* 31:181–196
- Laurent G (2002) Olfactory network dynamics and the coding of multidimensional signals. *Nat Rev Neurosci* 3:884–895
- Friedrich RW (2006) Mechanisms of odor discrimination: neurophysiological and behavioral approaches. *Trends Neurosci* 29:40–47
- Martin C, Gervais R, Hugues E, Messaoudi B, Ravel N (2004) Learning modulation of odor-induced oscillatory responses in the rat olfactory bulb: a correlate of odor recognition? *J Neurosci* 24:389–97
- Fries P, Nikolic D, Singer W (2007) The gamma cycle. *Trends Neurosci* doi: 10.1016/j.tins.2007.05.005

## Temporal Coding in Electroreception

BRUCE A. CARLSON

Department of Biology, University of Virginia,  
Charlottesville, VA, USA

### Synonyms

Time coding, electrosensory

### Definition

Confronted with a variable environment, organisms are faced with the task of extracting information to guide their behavior. A massive amount of raw information is encoded by the peripheral nervous system, which is then winnowed down, processed, and analyzed by the central nervous system in order to obtain behaviorally-relevant information. Time is an inherent element of neural coding. The timing of neural activity reflects the timing of stimuli responsible for that activity, and thereby informs the organism of the stimulus time of occurrence. An organism's accuracy in determining when something occurred is thereby limited by the degree of temporal precision achieved by its nervous system.

The nervous system can also use time to encode information beyond the stimulus time of occurrence. For instance, barn owls compare the arrival times of sounds at the two ears to determine the horizontal location of sound sources in space, bats use the delay between their echolocation calls and returning echoes to determine the distance to a target, and many organisms use precise temporal patterns to convey information in their communication signals. Neuroethological studies of the underlying neural mechanisms for such behaviors have revealed a great deal about the specializations that nervous systems have evolved for preserving and representing temporal information. Time plays an especially critical role in electroreception, perhaps more so than for any other sensory system. Weakly electric fish have therefore served as important model systems for studying the neural basis of accurate and precise

► temporal coding.

## Characteristics

### Quantitative Description

Weakly electric fish possess an electromotor system that generates weak **▶electric organ discharges**, or **▶EODs**, from a specialized electric organ, as well as an electrosensory system for receiving and analyzing these EODs. Unlike acoustic signals that propagate as traveling pressure waves, electric signals exist as non-propagating electrostatic fields [1]. This is a behaviorally significant, distinguishing feature of electric signals. The temporal structure of acoustic signals is distorted by factors such as reflection, refraction, absorption, dispersion, and reverberation. This has the effect of smearing the fine temporal structure of the signal, limiting the amount of information that may be transmitted using temporal features. By contrast, electric fields are not subject to these sources of distortion. As a result, the fine temporal structure of electric signals is preserved, and information may be encoded at very minute time scales [1]. For this reason, weakly electric fish are exquisitely sensitive to temporal features of electric signals, with sensitivity in some species extending to the submicrosecond range [2].

### Higher Level Structures

Although the available evidence indicates that electrosensory systems have independently evolved multiple times, the electrosensory pathways of weakly electric fish share a common overall design [3]. Electric signals are first received by specialized electroreceptors located in the skin and distributed throughout the body [4]. Primary afferent fibers, located in the lateral line nerves, transmit electroreceptor input to the hindbrain, where they terminate in a derived brain region termed the **▶electrosensory lateral line lobe (ELL)**. The first steps in electrosensory processing occur within the ELL, where primary afferent input, feedback loops from higher electrosensory regions, and descending input from other modalities and motor pathways converge [3]. ELL neurons project primarily to two distinct areas, the preeminent nucleus between the hindbrain and the midbrain, and the **▶torus semicircularis** in the midbrain [3]. The preeminent nucleus gives rise to a prominent ELL feedback pathway. In the torus semicircularis, additional electrosensory processing occurs. Studies on temporal coding and processing in electrosensory pathways have focused on the preservation of timing by primary afferents and ELL neurons, and on the extraction of information, by comparing differences in timing between different inputs within specialized circuits in the ELL and torus semicircularis.

### Lower Level Components

#### Electroreceptor Organs

In weakly electric fish, the encoding of sensory information within the EOD is achieved by tuberos

**▶electroreceptor organs**, which give rise to two distinct types of afferents: amplitude coders and time coders [4]. Amplitude-coding afferents encode the amplitude of EODs in their firing rate, relative latency to the first action potential, or number of action potentials. Time-coding afferents are much more sensitive than amplitude-coding afferents. In response to each outside positive-going voltage step, they fire a single action potential at a short fixed latency, thereby providing a precise marker of the EOD time of occurrence.

#### Specialized Features of Time-Coding Circuitry

The electrosensory pathways of weakly electric fish are characterized by several unique anatomical specializations, which have been associated with neural circuits in which action potential timing precision is of the utmost importance [5]. The neurons are relatively large, which increases input resistance, thereby rendering the neurons less sensitive to synaptic noise. These large neurons are typically spherical and adendritic, which minimizes differences in the arrival times of multiple synaptic inputs, and shortens the distance between synapses and the action potential initiation zone of the axon, thereby minimizing the attenuation of synaptic current. The axons are correspondingly large and heavily myelinated, which increases conduction velocity, thereby minimizing the effect of jitter on the timing of spike arrival at the synaptic terminal. These axons give rise to large club endings that engulf a large portion of the postsynaptic soma. This large size ensures sufficient synaptic current for overcoming the high input resistance of the postsynaptic cell. In addition, these synapses are often mixed chemical/electrical, which helps ensure rapid activation of the postsynaptic cell.

### Higher Level Processes

#### Species Recognition in Pulse-Type Mormyrids

In mormyrid electric fish from Africa, electric communication appears to be mediated exclusively by time-coding electroreceptors called **▶knollenorgans** [6]. Knollenorgans are much more sensitive than other tuberos electroreceptor organs, making them well-suited to detecting the EODs of distant conspecifics. Perhaps the strongest evidence for their privileged role in communication comes from the fact that every time a fish generates its own EOD, knollenorgan input is blocked by inhibition at the projection site of primary afferents in the nucleus of the electrosensory lateral line lobe (nELL). This inhibitory input comes from an electric organ corollary discharge pathway, which originates in the command center for EOD production, and provides a precise reference of EOD timing. As a result, activity caused by the fish's own EOD production never reaches higher processing centers in the midbrain.

Mormyrids generate a pulse-type EOD, in which the duration of a single EOD pulse is much shorter than

the interval between pulses [7]. The EOD waveform is highly stereotyped and conveys several aspects of the sender's identity, such as its species, sex, dominance, and possibly even its individual identity. The total duration of the EOD is a particularly salient variable across species, ranging from as little as 100  $\mu$ s to over 10 ms, and it may also exhibit sex- and status-related differences, with dominant males having a longer EOD than females [7]. Early playback studies in the field have demonstrated that this temporal variation plays an important role in electrocommunication [6]. Specifically, the relative timing of positive and negative voltage transients in the EOD plays a critical role in sender recognition.

Knollenorgans are able to faithfully encode the timing of these transients. The EOD of a neighboring fish will cause current to flow into one half of the body surface and out the other, meaning that knollenorgans on these two surfaces will be exposed to opposite stimulus polarities (Fig. 1a).

As knollenorgans only respond to positive-going voltage steps, those located where current is entering the skin respond to the EOD onset, while those located where current is exiting the skin respond to the EOD offset (Fig. 1b). Thus, by comparing spike times from opposite sides of the body, a mormyrid can determine the duration of the EOD waveform [6]. A similar mechanism for waveform discrimination in wave-type electric fish has also been proposed [8].

#### The Jamming Avoidance Response in Wave-Type Species

In contrast to pulse-type electric fish, wave-type species generate an EOD in which the duration of each pulse is approximately equal to the intervals between pulses, resulting in a continuous, quasi-sinusoidal waveform. When an object enters the electric field, it causes modulations in the EOD that are used by the fish to extract information about the object, a process called ►active electrolocation (Fig. 2a).

However, when fish encounter another individual with a similar EOD frequency, they experience mutual jamming of their electrolocation systems (Fig. 2b). To avoid this jamming, the fish shift their EOD frequencies away from each other, a behavior termed the ►jamming avoidance response (JAR) [2].

Properly executing the JAR requires that a fish determine whether it has a higher or lower EOD frequency than its neighbor. Extensive studies in a gymnotiform fish, *Eigenmannia*, and a mormyrid fish, *Gymnarchus*, have revealed a common algorithm for making this distinction [2]. The combination of two EODs leads to sinusoidal modulations in amplitude and phase (timing), at a frequency equal to the frequency difference between the two EODs (Fig. 2c). However, the temporal relation between amplitude and phase modulation is reversed, depending on whether the fish

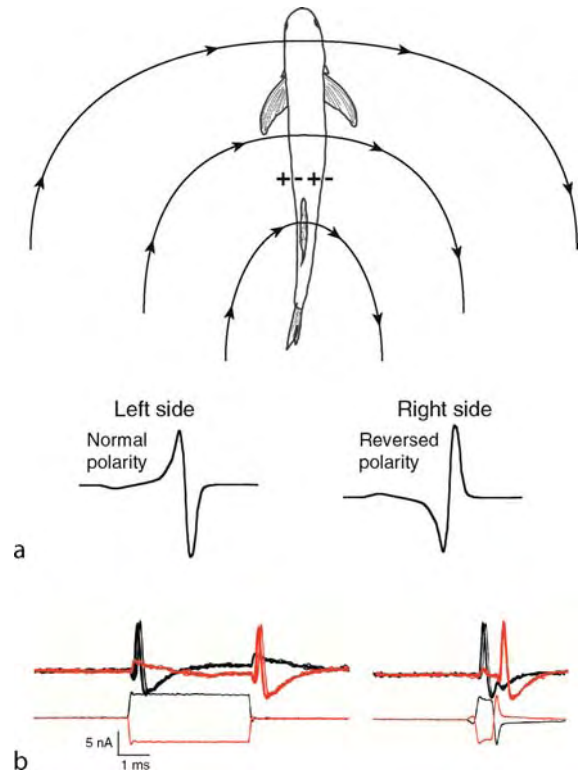

#### Temporal Coding in Electroreception.

**Figure 1** Temporal coding by knollenorgan electroreceptors in mormyrids. (a) Current flow through a fish's body resulting from EOD production by another fish. One side of the body is outside positive/inside negative, while the other half is outside negative/inside positive, meaning that the EODs detected across the two skin surfaces are of opposite polarities. (b) By stimulating a single knollenorgan with both normal and reversed polarity currents, one can emulate the response of knollenorgans located on opposite sides of the body. Action potentials occur on stimulus onset under normal polarity (black), while they occur on stimulus offset under reversed polarity (red). In a natural situation, the difference in action potential times would occur between different knollenorgans, which could then be compared to determine the stimulus duration.

has a higher or lower EOD frequency than its neighbor (Fig. 2d). Thus, by comparing these two features, the fish can make the correct decision to either increase or decrease its EOD frequency [2]. However, detecting phase modulation requires that the fish have a timing reference. As the fish's own EOD and its neighbors EOD have different spatial distributions, different portions of the body surface are subject to different depths of modulation (Fig. 2d). Thus, the fish can extract phase information by comparing inputs from time-coding afferents on two different regions of the body surface, one that is strongly modulated with one that is weakly modulated (Fig. 3).

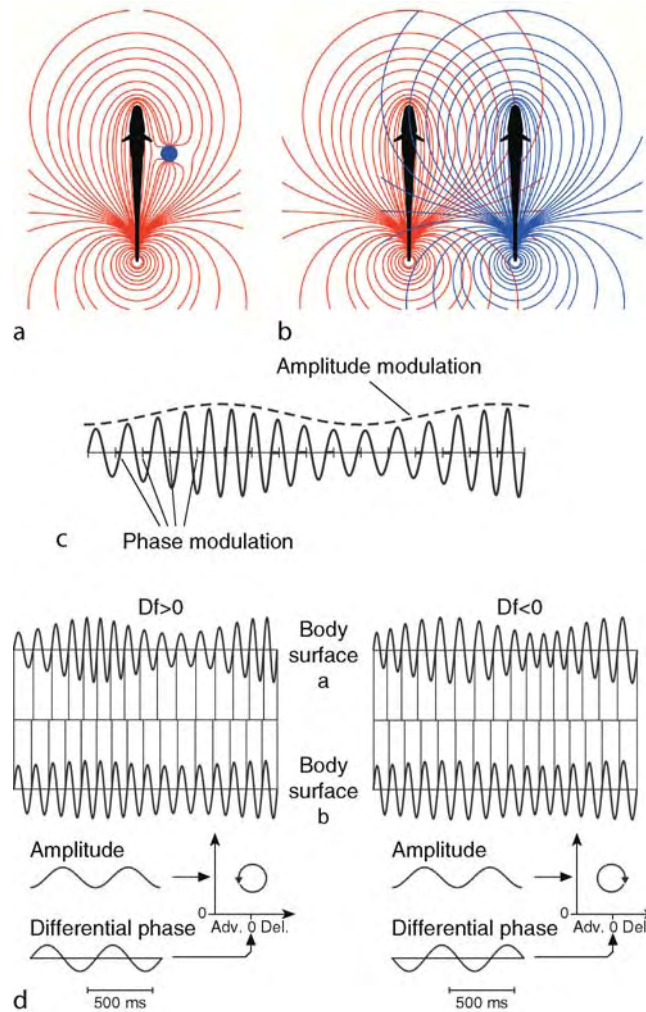

**Temporal Coding in Electroreception. Figure 2** (a) In active electrolocation, the electric field of a weakly electric fish (shown as isopotential lines in *red*) is distorted by the presence of an object (shown in *blue*). (b) The electric field (*red*) may also be distorted by the EOD of another individual (*blue*). (c) To avoid jamming of active electrolocation systems by another individual with a similar EOD frequency, the fish performs the JAR, which relies on comparing modulations in amplitude and phase that result from combining the two EODs. (d) Two different body surfaces are subjected to stronger (a) and weaker (b) interference from a neighbor's EOD, which results in different depths of modulation. The temporal relationship between amplitude and the phase of "body surface a" relative to "body surface b" is reversed when switching the sign of  $Df$ , which results in a different sense of rotation in a Lissajous graph.

A different algorithm for the JAR, one which relies on temporal asymmetries in the natural EOD waveform that are encoded exclusively by time-coding afferents, has also been proposed [8].

#### Mechanisms of Temporal Feature Extraction

The previous sections dealt with the problem of neural encoding, or how precise temporal information can be represented by the timing of action potentials in sensory neurons. We now turn to the problem of how these action potential trains may be used to extract information about specific stimulus features; in this case, how precise spike times may be compared to extract

information about timing differences. Although similar adaptations are in place for preserving timing information in the early stages of sensory processing, these temporal comparisons are achieved by quite different mechanisms in different species.

In mormyrids, the nELL neurons relay phase-locked knollenorgan input to the torus semicircularis, where their axons terminate in a region called the anterior extero-lateral nucleus (ELa). Within ELa, there are two distinct types of neurons, large cells and small cells, both of which receive excitatory input from nELL axons (Fig. 4a). Upon entering ELa, the nELL axons immediately terminate onto one or two large cells, and

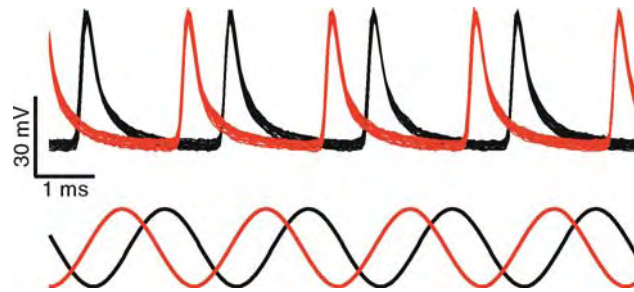

**Temporal Coding in Electroreception. Figure 3** Time-coding afferent activity in the wave-type fish *Gymnarchus*. The *top* traces show action potentials recorded from a single afferent (multiple sweeps are superimposed), while the *bottom* traces show the stimuli that elicited these responses. The *black* traces show the response to an unmodulated sine wave, while the *red* traces show the response to a sine wave advanced in time. The action potential times precisely follow the stimulus cycle. In a natural situation, the difference in action potential times would occur between afferents at different body surfaces that are exposed to different depths of phase modulation. The action potential times could then be compared to extract information about timing differences.

then wind their way throughout the nucleus, twisting and turning over distances of 3–4 mm before branching and terminating onto a large number of small cells [9]. The large cells project exclusively within ELA, terminating on small cells with large inhibitory synapses [9]. Thus, the small cells receive phase-locked input from two different sources: excitatory input from nELL axons responding to EOD onset from one part of the body, and inhibitory input from ELA large cells responding to EOD offset from another part of the body (Fig. 4a).

As the excitatory input is delayed by the time it takes an action potential to propagate down the long, winding path of the nELL axon, a given small cell will only respond to EODs longer than a certain duration, such that the delayed, excitatory response to EOD onset arrives before the inhibitory response to EOD offset [9].

In *Eigenmannia*, temporal comparisons are also made in the torus semicircularis. Large spherical cells within the ELL relay phase-locked afferent input to both giant cells and small cells within the torus in a somatotopic fashion (Fig. 4b). The giant cells then project widely across this somatotopic map onto several small cells, which therefore receive timing information from different portions of the body surface and are sensitive to temporal disparities between those surfaces [2,3]. The giant cells synapse directly onto the soma of the small cells, while the spherical cells synapse on the small cell dendrites, thereby delaying the arrival of the signal at the soma due to the passive propagation of synaptic current along the dendrite (Fig. 4b).

In *Gymnarchus*, temporal comparisons occur within the ELL rather than the torus. Nevertheless, the underlying circuitry for time disparity detection shares several similarities with the circuits in mormyrids and *Eigenmannia* [10]. Time-coding primary afferents synapse onto the dendrites of small ovoidal cells in the ELL and also project to giant cells within the ELL

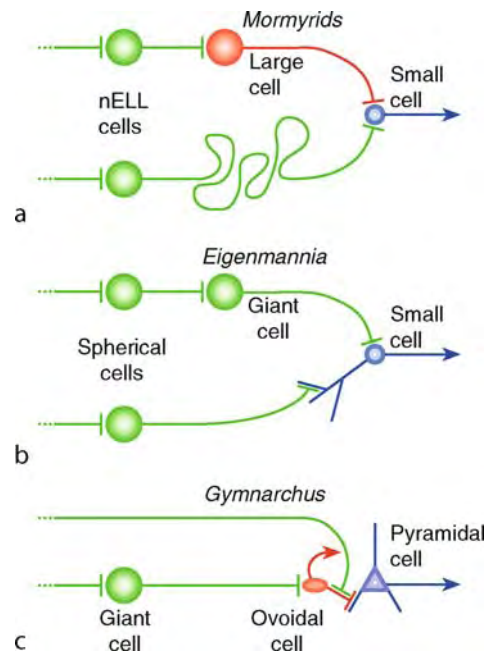

**Temporal Coding in Electroreception. Figure 4** Circuits for making temporal comparisons in weakly electric fish. Neurons known or thought to be inhibitory are shown in red. Based on physiological recordings, neurons that are known to be sensitive to temporal disparities between different body surfaces are shown in blue. The *dashed lines* from the *left* represent incoming primary sensory afferents, while the *arrows* pointing to the *right* represent axonal projections to other regions. (a) Knollenorgan pathway in mormyrids. (b) Time-coding pathway in *Eigenmannia*. (c) Time-coding pathway in *Gymnarchus*.

(Fig. 4c). The giant cells, in turn, project to the soma of ovoidal cells. The ovoidal cells thereby receive convergent timing input from different body surfaces [10]. Although physiological recordings from ovoidal cells have not yet been made, their dendrites make

dendro-dendritic connections with nearby pyramidal cells [10], which are remarkably sensitive to temporal disparities between different body surfaces [2]. This sensitivity appears to be due, at least in part, to a complex adaptation mechanism, and preliminary evidence suggests that inhibition may play a role at the ovoidal cell-pyramidal cell synapse.

Despite the differences among these neural circuits, certain generalizations can be made (Fig. 4). In each pathway, there is an obvious shift in size from large, spherical neurons that are involved in preserving and relaying timing information, to small neurons that make the actual timing comparisons between different inputs. Once the temporal comparison is made, spike times do not need to be as precise, because the presence or absence of some stimulus feature (a particular timing difference) may now be represented by the overall level of neural activity (firing rate). Thus, there is no need for the neurons to be so large at the point of comparison. Furthermore, it may be that the small size of the comparator neurons reduces the attenuation of rapid synaptic currents by minimizing membrane capacitance. Although employing different mechanisms, delaying the arrival of spikes from one input to the comparator neuron seems to be another general feature. By adjusting this neural delay, the circuit can determine the stimulus delay that will result in a simultaneous arrival of inputs from different sources. If both inputs are excitatory, this particular delay will elicit the strongest response. If one input is inhibitory, then this particular delay will elicit the weakest response. Either way, the comparator neuron is tuned to differences in the arrival times of different inputs.

### Function

It is clear that knowledge of precise stimulus timing can be used to obtain a wealth of information from the environment. The three examples discussed come from organisms with disparate evolutionary histories that use timing information for different purposes. Nevertheless, there are strong similarities between their temporal coding pathways, suggesting that the unique features of these pathways represent specialized adaptations. Although the examples discussed in this chapter come from an eclectic group of organisms for which time holds special significance, the unique features of their time coding pathways are also found in other temporal coding systems [5]. This finding underscores the fact that basic principles in neuroscience may best be realized through a comparative, neuroethological approach to neural structure and function.

### References

- Hopkins CD (1986) Temporal structure of non-propagated electric communication signals. *Brain Behav Evol* 28:43–59
- Kawasaki M (1997) Sensory hyperacuity in the jamming avoidance response of weakly electric fish. *Curr Opin Neurobiol* 7:473–479
- Bell C, Maler L (2005) Central neuroanatomy of electro-sensory systems in fish. In: Bullock TH, Hopkins CD, Popper AN, Fay RR (eds) *Electroreception*. Springer, New York, pp 68–111
- Zakon HH (1986) The electroreceptive periphery. In: Bullock TH, Heiligenberg W (eds) *Electroreception*. Wiley, New York, pp 103–156
- Carr CE, Friedman MA (1999) Evolution of time coding systems. *Neural Comput* 11:1–20
- Hopkins CD, Bass AH (1981) Temporal coding of species recognition signals in an electric fish. *Science* 212:85–87
- Carlson BA (2002) Electric signaling behavior and the mechanisms of electric organ discharge production in mormyrid fish. *J Physiol Paris* 96:403–417
- Kramer B (2001) Signal analysis in the communication of a weakly electric fish, *Eigenmannia virescens* (Gymnotiformes). In: Backhaus W (ed) *Neuronal coding of perceptual systems*. World Scientific, New Jersey, pp 314–333
- Xu-Friedman MA, Hopkins CD (1999) Central mechanisms of temporal analysis in the knollenorgan pathway of mormyrid electric fish. *J Exp Biol* 202:1311–1318
- Matsushita A, Kawasaki M (2004) Unitary giant synapses embracing a single neuron at the convergent site of time-coding pathways of an electric fish, *Gymnarchus niloticus*. *J Comp Neurol* 472:140–155

---

## Temporal Coding in Sensation

### Definition

The process by which nervous systems encode the precise timing of stimulus events.

---

## Temporal Integration in Photoreceptors

### Definition

A term referring to the photoreceptor's ability to sum individual photons over time. The period of integration often determines the temporal resolution a photoreceptor. Photoreceptors with short integration time, such as cones, are well adapted to detect rapid changes in the images, while those with longer integration time, such as rods, are well suited for low light vision.

### ► Photoreceptor



## Temporal Lobe

### Synonyms

Lobus temporalis

### Definition

Temporal lobe stretches from the temporal pole to the lateral sulcus.

► Telencephalon

## Temporal Lobectomy

### Definition

Surgical separation of the ► temporal lobe from the rest of the forebrain.

► Ganglion Cells

## Temporal Response of Retinal Ganglion Cells

### Definition

The time course of physiological response. Parasol retinal ganglion cells have a more rapid response and can track more rapid visual changes than midget retinal ganglion cells.

- Retinal Ganglion Cells
- Visual Processing Streams in Primates

## Temporal Rule of Multisensory Integration

### Definition

The principle that multisensory stimuli from will be integrated depending on their relative temporal parameters. Typically, stimuli presented at the same time will result in enhanced multisensory integration, while stimuli presented at different time result in decreased multisensory integration, or multisensory

inhibition. For any given neuron, a “temporal window of multisensory integration” will exist such that stimuli from different sensory modalities will be integrated only if both presented within this window. Different neurons and different brain areas may have different temporal windows for optimal multisensory integration.

► Multimodal Integration

## Temporal Summation in Pain

### Definition

Perceived increase in pain created by repeated administration of brief noxious stimuli. This perceptual phenomenon presumably occurs when high frequency stimulation of group C polymodal nociceptive afferents amplifies second-order neuronal activity in the spinal cord dorsal horn. This series of events has been shown to involve N-methyl-D-aspartate (NMDA) glutamate receptors. Temporal summation is thought to reflect central neural mechanisms similar to those responsible for the hyperalgesia and allodynia that accompany many forms of clinical pain.

- Gender/sex Differences in Pain
- Hyperalgesia and Allodynia
- Glutamate Receptors
- Nociceptors and characteristics

## Temporal-lobe Seizures (Psychomotor Seizures)

### Definition

► Complex Partial Seizures

## Temporally Graded Retrograde Amnesia

### Definition

A type of retrograde amnesia where recently acquired memories are more impaired than remote memories.

► Amnesia

## Tenascin

### Definition

Several members of the tenascin gene family have been described. They represent large multimeric extracellular matrix proteins, each of them consisting of identical subunits built from variable numbers of repeated domains. They have variety of actions including antiadhesive function and promotion of neurite outgrowth.

#### ► Regeneration of Optic Nerve

## Tendon

THOMAS G. SANDERCOCK

Department of Physiology, Northwestern University,  
Feinberg School of Medicine, Chicago, IL, USA

### Synonyms

Series elasticity; Aponeurosis; External tendon; Muscle-tendon unit

### Definition

A fibrous band of tissue, mainly composed of collagen, that connects the muscle fibers to bone.

### Characteristics

#### Introduction

Tendon is a tough band of fibrous connective tissue that links the muscle fibers to the skeleton, allowing efficient force transmission from muscle to skeleton. The function of tendon is analogous to a rope, in that the tendon unit can only pull. Tendons are highly resistant to extension, but they are relatively flexible, and can therefore be angulated around bone surfaces, or deflected beneath retinacula, to change the final direction of pull. Tendon, along with the related aponeurosis, allows complicated muscle architectures, with widely varying muscle shapes, to exert force at the precise location needed for efficient movement. Tendon is very stiff, yet its spring-like properties play an important role in energy storage and hence efficient locomotion and movement.

### Anatomy

Muscles have amazing diversity, and not surprisingly, so do their tendons. Some muscles attach to bone directly, without any visible tendon, but this is the exception. Some tendons connect muscle to muscle. Tendons come in a wide range of sizes and shapes. They usually

take the form of cords or straps. They can be round, oval, or elongate in cross-sectional profile. The total cross-sectional area varies greatly and is generally proportional to muscle strength. The length of the tendon also varies. Length is determined by its location and function in the body, but, as described below, will affect the stiffness of the muscle-tendon unit and therefore its functional properties.

Aponeuroses are broad flat sheets of collagen fibers arising at the muscle fascicle termination and merging into the tendon (see Fig. 1).

The term tendon is sometimes used to describe just the external tendon, but because of their similar composition and continuum of the collagen fibrils, in this essay the term tendon will also include the aponeuroses. However, since the aponeuroses are at the boundary with the muscle fibers, they are subject to different loading conditions. Muscle has a nearly constant volume. Hence, when the fibers shorten they must increase in cross-sectional area. This places additional force on the aponeurosis, compared to the external tendon, which may alter the mechanical properties [1].

Tendon and aponeuroses are composed primarily of the protein collagen. There are numerous types of collagen isoforms, but type I and III predominate in adult tendon. Groups of three collagen molecules polymerize together to form the base unit. These units are then staggered to form a microtendon, and in turn, a fibril. Most of the strength of tendon is due to the parallel densely-packed collagen fibrils. Fibril-associated collagens and proteoglycans are present in small quantities and are critical for tendon structure. Under a light microscope the dominant feature of tendon is the wavy collagen fibers. This waviness disappears as soon as the tendon is loaded. Tenocytes, a specialized fibroblast, are also visible and are responsible for the maintenance of collagen structure. The low density of vascular networks in tendon leads to their characteristic white appearance.

The muscle fibers terminate in specialized processes producing collagen. At the muscle-tendon junction the sarcolemma exhibits finger-like extensions and invaginations that increases the surface area and helps transmit force. The last actin filaments in the muscle terminate in transmembrane proteins that link to the collagen matrix outside. These collagen fibrils fuse

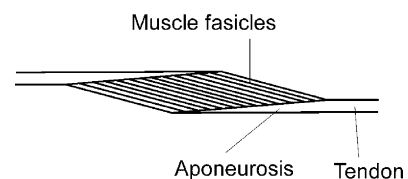

**Tendon. Figure 1** Muscle-tendon unit. A simplified view of muscle fascicles originating and terminating on the aponeuroses, which in turn becomes the tendon.

together to form microtendons and then in turn the aponeurosis and tendon [2].

The direction of force from a tendon is often altered by specialized structures. Retinacula are fibrous bands which bind down the tendons and alter direction much in the way a pulley can redirect force. An example is the retinaculum redirecting force from the extensor digitorum longus muscle along the surface of the foot. Some tendons have bones inserted in them. An extreme example is the patella. It is inserted in the tendon from the quadriceps, and serves to redirect the force to the lower leg. In situations where tendons and other structure move relative to each other and are in tight apposition, synovial sheaths and bursae provide mechanical isolation. An example are synovial sheaths of the digital flexor tendons. Some tendons have no special isolation and partially slide next to synergist tendons. Example are the tendons from the plantaris and gastrocnemius muscles. Where tendons of synergists run next to each other collagen strands often connect the tendons, linking them together. They must slide together or a shear force develops between the tendons.

### Material Properties

Tendon acts like a very rigid spring. The farther it is stretched – the more force it produces. The simplest model treats it like a linear spring.

$$\Delta F = k\Delta l \quad (1)$$

Where  $\Delta F$  is the change in force,  $k$  is the stiffness of the spring, and  $\Delta l$  is the change in length. In general, the greater the cross-sectional area the stiffer the tendon (larger  $k$ ), and the longer the tendon the lower the stiffness. For this reason the material properties are

expressed as normalized values – stress versus strain (see Zajac for greater detail [3]). Force normalized by the cross-sectional area is stress ( $\text{N/m}^2$  or Pa).

$$\sigma = F/A \quad (2)$$

Change in length divided by the original length is strain.

$$\varepsilon = (l - l_0) / l_0 \quad (3)$$

A linear spring is a good first approximation for tendon, but it does not capture its many complexities. Figure 2 shows the behavior of an isolated tendon as it is stretched and shortened. It is immediately apparent that as it is stretched, force increases in a nonlinear fashion. Initially it shows a toe region where force increases slowly with stretch. This has been attributed to the length before the collagen fibrils have straightened out. Next comes a quasi-linear region where force increases more rapidly with stretch. The stretch was stopped when the tendon was stretched to about 3% of its initial length. For most muscles the tendon cross-sectional area is matched to muscle size, so this 3% stretch represents about how far tendon stretches during an isometric contraction when a muscle is fully activated. Next the tendon was shortened. It produced less force than it did on stretch. This is readily apparent in Fig. 3. Here the force-length characteristics from Fig. 2 are normalized and plotted as a stress-strain curve. Substantial hysteresis is seen. The hysteresis is significant because it shows some energy is lost in the stretch shortening cycle.

The slope of the stress-strain curve is the elastic (Young's) modulus, and is a measure of the stiffness of the tendon (see below).

$$E = \sigma/\varepsilon \quad (4)$$

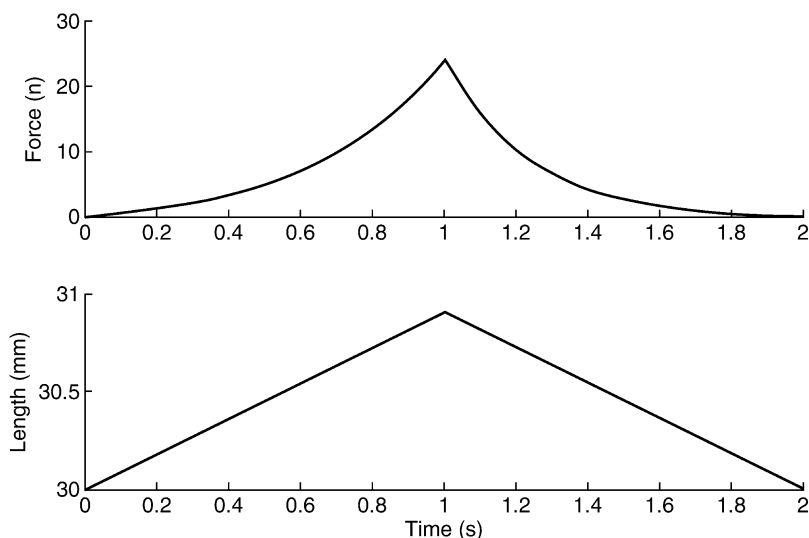

**Tendon. Figure 2** Force from cat soleus external tendon during stretch and shortening. The tendon was about 30 mm in length with a cross-sectional area approximately  $1 \text{ mm}^2$ .

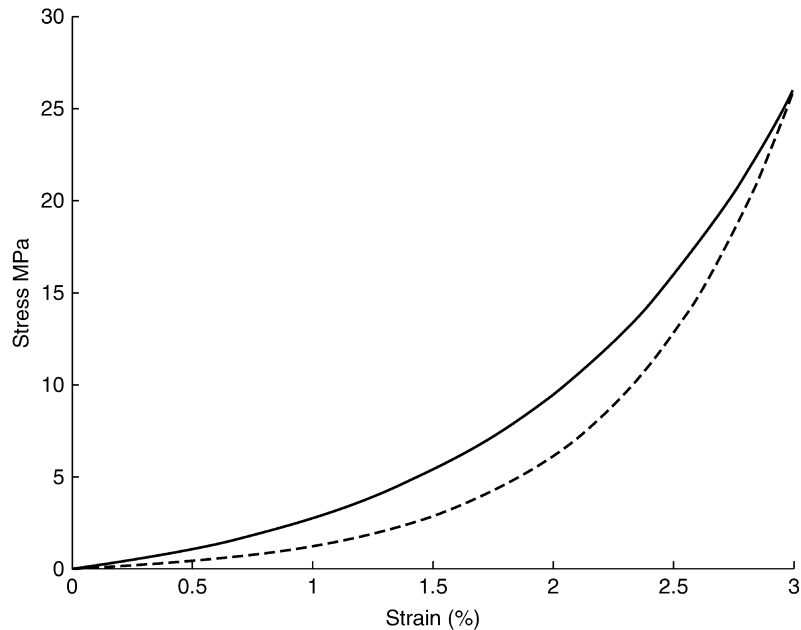

**Tendon. Figure 3** Stress-strain properties for cat external tendon. The *solid line* shows the results during stretch and the *dotted line* during shortening. The difference between them is an example of hysteresis.

At maximal muscle activation, the elastic modulus of tendon is approximately 1.0 GPa. At maximal muscle activation tendon strain is approximately 3%. This will vary if a muscle has a proportionately thicker tendon.

Tendon has many other complex properties. When tendon is stretched, well beyond the 3% strain shown in Fig. 3, it reaches a yield point and the tendon ruptures. The rupture point depends on the tendon history as well as the speed at which the tendon is stretched (strain rate). In general tendon shows many history effects – its material properties change with time. Hence the stress-strain curve, hysteresis, and fatigue all depend on how often and how fast a tendon is loaded. These complex properties generally are generally not considered in musculo-tendon models used for motor control. When a mathematical model is needed to describe tendon it is usually modeled as a linear spring, an exponential spring, or with a piecewise exponential-linear relationship.

Tendon material properties are similar between muscles and between vertebrate animals. The exception is the stiffer ossified tendons of some birds. There is substantial disagreement to what degree the material properties of tendons vary with different muscles, species, and ages [4]. Part of the problem is the experimental error encountered in securing the cut end of excised tendon. Because of this problem the measured stress-strain properties of excised tendon vary by a factor of two. The difference between the material properties of tendon and aponeurosis is also an open question.

Muscle is known to exert force proportional to its cross-sectional area (see physiological-cross-sectional area in muscle). Muscle can exert a maximum of about

200–300 kPa. The cross-sectional area of the tendon will determine how near breaking it is during maximum loads. The length of the tendon and its cross-sectional area will determine how much it will stretch at full loads. A thinner tendon will be more compliant but will have a smaller safety factor for rupture. Different muscles will require tendons with different properties for efficient functioning.

#### Stiffness of the Muscle-Tendon Unit

Stiffness is a measure of the ability of a muscle to resist a length change due to a small perturbation. It is defined as the change in force divided by the change in length. Stiffness is one of muscles most important functional characteristics and plays a key role in stabilizing the joints. Because the muscle fibers are in series with the tendon, the stiffness of the muscle-tendon complex depends on both, with the least stiff element dominating. In general, at activation levels near maximal for the muscle, tendon stiffness plays a significant role in the overall muscle-tendon stiffness [5].

#### Contractile Properties – The Series Elastic

Tendon can be considered to be in series with the muscle fibers (see Fig. 1). Thus, tendon is part of the series elastic in Hill-type muscle models (see essay on modeling). If a muscle-tendon is held at a fixed length and the muscle is stimulated, the muscle fibers shorten and the tendon is stretched, until steady state is reached where the force from the muscle fibers balance the recoil force from the tendon. This is often referred to as an isometric contraction even though the muscle fibers

have shortened. Griffiths [6] used piezoelectric crystals to measure muscle fiber length during contraction of cat medial gastrocnemius. He demonstrated that even during a stretch of the muscle tendon unit there is often some shortening of the muscle fibers. The difference is made up by stretch of the tendon. Ultrasonography (the imaging of muscle tissue with sound) has shown similar effects in humans [7].

### Energy Storage

Tendon can play a significant role in efficient locomotion. When tendon is stretched it stores potential energy that can be recovered as work as the tendon is released. The characteristics of tendon allow 80–95% of this energy to be recovered. Wallabies use elastic storage in the ankle flexors during hopping [8]. When the foot was on the ground the muscle fascicles contracted nearly isometrically. The tendon stretched and recoiled but the muscle fascicles remained at almost the same length and did little work. Thus, energy was stored in the tendon on landing and then returned as kinetic energy on takeoff. Some animals make extreme use of this behavior. The camel has gastrocnemius muscle fascicles only a few millimeters long, hence the length change of the muscle-tendon complex, which occurs with locomotion, must be almost entirely due to elastic recoil of the tendon.

Not all animals make use of the tendon for energy storage. The kangaroo rat showed much lower stress in the gastrocnemius during hopping and this resulting in little stretch of the tendon. These animals are capable of large jumps, involving much larger forces than steady hopping. Because the tendons have to be large enough for jumping, they can't be flexible enough for hopping. Thus they don't save much elastic energy in the tendon.

The muscle tendon unit can be optimized for a particular purpose. The short muscle fascicles and flexible tendon of the wallaby save energy, but have

limited use for other purposes than hopping. Short fascicles are a poor design for animals that climb trees because the uneven footholds forces them to use their limbs in a wide range of positions. Hence, the narrow length-tension properties of the muscle limit the force produced (see essay on length-tension).

### Recruitment of Motor Units – Common Tendon Model

Tendon is an anisotropic material that it is much stiffer along the longitudinal axis (the direction of the collagen fibrils) compared to the transverse axis (across the collagen fibrils). When a single motor unit is active there is a differential strain (shear) of the aponeurosis and tendon near the active motor unit. They are strained more than other parts of the tendon (Fig. 4). During normal activation of a muscle, when multiple motor units are active, nonuniform strain has been reported but it is not clear if it is physiologically significant. This nonuniform strain may alter the apparent stress-strain properties of the tendon seen by motor units. Further complications come from the change in pennation angle of the muscle fibers and the change in cross sectional area of the muscle fibers during shortening. These effects are not fully understood and they can alter the apparent material properties of the aponeurosis.

To determine the effective tendon properties governing the interaction between motor units, muscle was stimulated in two parts using the ventral roots [9]. A simple model was assumed with a linear elastic element representing the tendon. No assumptions were made about the location of the common-elasticity. The parameter was estimated by measuring the interaction between two separate parts of the muscle. The magnitude of the common-tendon was estimated in three ways: (i) the shift in the length-tension relation; (ii) by using the muscle puller to mimic the extra stretch of the elasticity when both parts of the muscle were active; and (iii) as an algebraic calculation based

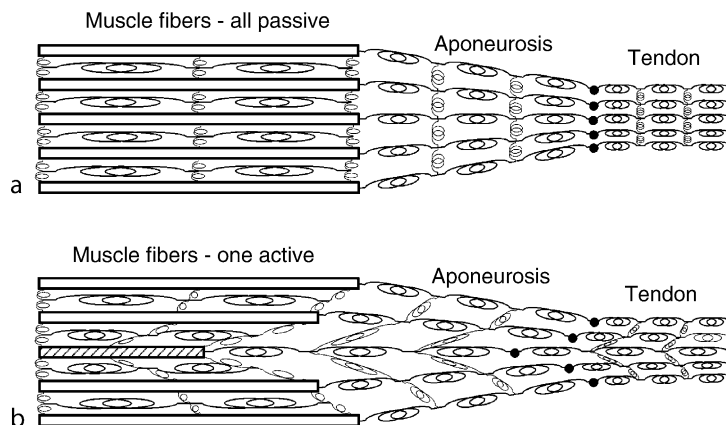

**Tendon. Figure 4** Differential strain in aponeurosis and external tendon when a muscle is partially active. (a) All muscle fibers are inactive. (b) A single muscle fiber is active. This differential strain may complicate the properties of the aponeurosis and tendon when a muscle is partially active and only some motor units are recruited.

on whole muscle stiffness measurements when one or both parts of the muscle were active. When smaller portions of the muscle were activated interaction was consistent with the same common-tendon. Thus, the common-tendon measured by the interaction of the parts is more linear than expected from the isolated tendon with stress-strain properties shown in Fig. 3. The good fit of this simple model suggests it can be used to model motor unit recruitment, where motor units are assumed to be parallel and independent force generators, connected to a common-elasticity.

### Higher Level Structures

Limbs.

### Lower Level Components

Microfilaments.

*Structural Regulation.* The regulation of tendon strength is not fully understood.

*Process Regulation.* It is unknown if it is different from musculo-skeletal control.

### Function

Transmit the force from muscle fibers to the skeleton. The compliance of the tendon helps to protect the muscle from injury during quick stretches. The tendon can also store energy during locomotion.

### References

1. Epstein M, Wong M, Herzog W (2006) Should tendon and aponeurosis be considered in series? *J Biomech* 39:2020–2025
2. Trotter JA (2002) Structure-function considerations of muscle-tendon junctions. *Comp Biochem Physiol A Mol Integr Physiol* 133(4):1127–1133
3. Zajac FE (1989) Muscle and tendon: properties, models, scaling, and application to biomechanics and motor control. *Crit Rev Biomed Eng* 17:359–411
4. Bennett MB, Ker RF, Dimery NJ, Alexander RM (1986) Mechanical properties of various mammalian tendons. *J Zool* 209:537–548
5. Proske U, Morgan DL (1987) Tendon stiffness: methods of measurement and significance for the control of movement. A review. *J Biomech* 20:75–82
6. Griffiths RI (1991) Shortening of muscle fibres during stretch of the active cat medial gastrocnemius muscle: the role of tendon compliance. *J Physiol* 436:219–236
7. Kawakami Y, Fukunaga T (2006) New insights into in vivo human skeletal muscle function. *Exerc Sport Sci Rev* 34(1):16–21
8. Biewener AA, Roberts TJ (2000) Muscle and tendon contributions to force, work, and elastic energy savings: a comparative perspective. *Exerc Sport Sci Rev* 28(3):99–107
9. Sandercock TG (2000) Nonlinear summation of force in cat soleus muscle results primarily from stretch of the common elastic elements. *J Appl Physiol* 89:2206–2214

## Tendon

ALBERT J. BANES<sup>1</sup>, WALTER HERZOG<sup>2</sup>,  
MICHELLE WALL<sup>3</sup>

<sup>1</sup>University of North Carolina, North Carolina State University, North Carolina, USA

<sup>2</sup>University of Calgary, Faculty of Kinesiology, Calgary, Canada

<sup>3</sup>Flexcell International Corp., North Carolina, USA

### Definition

Tendon is a dense fibrous tissue that connects muscle to bone. The primary function of tendon is to transmit force from muscles to bones, thereby producing movement.

### Characteristics

Anatomically, tendons have a hierarchical structure of cell layers and arrangements of extracellular matrix molecules. The tendon has three primary structural zones: the ►myotendinous junction (MTJ), the tendon proper, and ►osseotendinous junction (OTJ). The MTJ at the proximal end focuses muscle force through an ►epimysium to the tendon. The tendon proper is comprised of an outer ►paratenon structure of loose connective tissue comprised of fibroblastic paratenon cells (PC) that is 25% collagen (75% collagen type I, 25% collagen type III), 25% proteoglycan and 50% lipid [1]. The paratenon acts as a conduit for blood vessels, nerves and lymphatics. The ►epitenon is a second circumferential layer surrounding the tendon proper and is comprised of 3–8 biologically distinct surface cells (ESC) that secrete an abundance of fibronectin and promote cell migration and healing [2–4]. The epitenon is continuous with a 3–8 cell-thick ►endotenon layer (ENC), whose cells have not been well characterized. The endotenon acts as a conduit for blood vessels, nerves and lymphatics, and surrounds the tensile load bearing collagen fascicles with linear and circular bundles of collagens. Finally, the tendon fascicles are comprised of linear, millimeters-long collagen ►fibrils having a periodic, zig-zag crimp pattern with elastin fibers attached to allow stretch and return of the non-elastic collagen fibrils [5]. The cells within the fascicles are internal ►fibroblasts (IF) that secrete the fibrillar collagens which are covalently crosslinked at lysines and hydroxylysines to add strength [3]. The distal tendon end attaches to bone at the osseo-tendinous junction (OTJ) where it assumes a fibrocartilagenous phenotype especially where it compresses against bone (e.g., at calcaneus in Achilles tendon) [6]. ►Tenocytes are interconnected by gap junctions that facilitate intercellular communication [7].

Tendons generally have a limited blood supply, more so in the flexor tendons of the hand where the vinculae supply blood to the digital tendon. Tendons are sympathetically innervated and have localized regions that have substance P- and neuropeptide Y-positive nerves [8]. Tenocytes in the paratenon, epitenon and internal compartments express receptors for growth factors such as PDGF, IGF-1, and TGF- $\beta$ 1. Tenocytes also express purinoceptors that react with ATP, UTP, and ADP, cytokine receptors that react with IL-1 $\beta$  and TNF $\alpha$ , and adrenoceptors that react with neurotransmitters such as norepinephrine [9,10]. Results of gene array experiments indicate a complex expression profile, including expression of genes previously thought to be exclusively expressed in muscle (such as titin). However, gene markers enriched in tendon include COMP (cartilage oligomeric protein), tenomodulin, and scleraxis. Mechanosensor organelles including Golgi tendon organs, Pacinian corpuscles and Ruffini endings are present and detect and transmit changes in muscle tension and pressure to the nervous system. There is no anatomically described functional tendon unit or proven markers that can be used to stage normal development or disease progression. These two areas are important to further understanding tendon biology and biomechanics.

Functionally, tendons are either biomechanically strong, power-transferring and energy-returning spring components or biomechanically weak apposing positional organs. The Achilles tendon linking the gastrocnemius and soleus muscles in the lower limb to the foot is an example of a high force-transferring tendon. The flexor digitorum profundus (FDP) tendon in the hand is an example of a low force-transferring and positional tendon. The extensor pollicis longus tendon in the hand is an example of a weak, positional return tendon in the hand. Power transferring flexor tendons, such as the Achilles tendon, have breaking strengths ranging from 80 to 130 MPa. Equine flexor tendons can withstand up to 15% strain; otherwise, tendons usually are subjected to strains of 1–5%. Tendons also act as springs to store and return energy.

## References

1. Tsuzaki M, Yamauchi M, Banes AJ (1993) Tendon collagens: Extracellular matrix composition in shear stress and tensile components of flexor tendons. *Connect Tissue Res* 29:141–152
2. Banes AJ, Link GW, Bevin AG, Peterson HD, Gillespie GY, Bynum D, Watts S, Dahners L (1988) Tendon synovial cells secrete fibronectin in vivo and in vitro. *J Orthoped Res* 6:73–82
3. Banes AJ, Donlon K, Link GW, Gillespie GY, Bevin AG, Peterson HD, Bynum D, Watts S, Dahners LE (1988) A simplified method for isolation of tendon synovial cells

and internal fibroblasts: Conformation of origin and biological properties. *J Orthoped Res* 6:83–94

4. Brigman BE, Yin H, Tsuzaki M, Lawrence WT, Banes AJ (1994) Fibronectin in the tendon-synovial complex: Quantitation in vivo and in vitro by ELISA and relative mRNA levels by polymerase chain reaction and northern blot. *J Orthoped Res* 12(2):253–261
5. Canty EG, Lu Y, Meadows RS, Shaw MK, Holmes DF, Kadler KE (2004) Coalignment of plasma membrane channels and protrusions (fibroprotruders) specifies the parallelism of tendon. *J Cell Biol* 165:553–563
6. Vogel KG, Meyers AB (1999) Proteins in the deep tensile region of adult bovine deep flexor tendon. *Clin Orthoped* 367:S344–S355
7. McNielly C, Benjamin M, Banes AJ, Ralphs J (1996) Immunochemical localization of multiple connexins in flexor tendons. *J Anatomy* 189:593–600
8. Ackermann PW, Li J, Finn A, Ahmed M, Kreicbergs A (2001) Autonomic innervation of tendons, ligaments and joint capsules. A morphologic and quantitative study in the rat. A morphologic and quantitative study in the rat. *J Orthoped Res* 19:372–378
9. Tsuzaki M, Bynum D, Almekinders L, Yang X, Banes AJ (2003) ATP is secreted by human tendon cells and modulates load-induced expression of IL-1b, COX II, and MMP-3. *J Cell Biochem* 89:556–562
10. Tsuzaki M, Guyton G, Garrett W, Archambault J, Herzog W, Almekinders L, Bynum D, Yang X, Banes AJ (2003) IL-1b induces COX2 and MMP-1 in human tendon cells. *J Orthoped Res* 21:256–264

## Tendon Jerk

### ► Tendon Reflex

## Tendon Organ

### Definition

Golgi tendon organs are encapsulated structures 0.2–1 mm long, usually located at musculo-tendinous junctions. Their sensory endings, which become group Ib afferent axons, are entwined amongst the tendinous strands of 10–20 motor units, a given motor unit affecting 1–6 tendon organs. Most tendon organs respond sensitively to force actively generated by the motor units with which they are associated.

### ► Feedback Control of Movement

## Tendon Reflex

### Definition

A tendon reflex (also called “tendon jerk,” “stretch reflex,” or “spinal stretch reflex”) is the earliest response of a muscle to being stretched by a sudden brief deformation of its tendon, which is typically produced by tapping the tendon. For example, the kneejerk reflex is the tendon reflex of the quadriceps muscles that is elicited by tapping the patellar tendon just below the knee. A tendon reflex is produced by an entirely spinal pathway consisting mainly of group Ia afferents from the muscle spindles, their excitatory synapses on the muscle’s motoneurons, and the motoneurons. Oligosynaptic (i.e., di- and tri-synaptic) excitatory and/or inhibitory inputs to the motoneurons from group 1 or 2 afferents may also contribute. Because it is largely monosynaptic, the latency of a tendon reflex depends mainly on the lengths and conduction velocities of the afferent and efferent axons in the peripheral nerve.

► [Conditioned Reflexes](#)

## Tenrec

### Definition

*Echinops telfairi*, a small mammalian species endemic to Madagascar. Also known as the lesser hedgehog tenrec, this species bears a physical resemblance to the better-known European hedgehog. Tenrecs have very little neocortex in comparison to other mammals.

► [Evolution of Association Pallial Areas: Parietal Association Areas in Mammals](#)

## Tension-type Headache

### Definition

A mild to moderate bilateral pressing or squeezing headache not made worse by physical activity and not accompanied by nausea and/or vomiting.

► [Headache](#)

## Tensor Tympani Muscle

### Definition

One of two muscles in the middle ear of mammals that is involved in the middle ear muscle reflex. (The other middle ear muscle is the stapedius muscle.) The tensor tympani muscle arises from the auditory tube and inserts onto the malleus, or hammer, which is the middle ear bone situated closest to the tympanum. The tensor tympani muscle is innervated by the trigeminal nerve. Its contractions dampen sound-induced oscillations of tympanum and middle ear bones and reduce sound amplitude, thus protecting the ear from intense sound signals.

► [Auditory-Motor Interactions](#)

## Teratogen

### Definition

Substance or pharmaca that when taken by a pregnant female, can reach and harm development of the fetus by inducing birth defects or malformations.

► [Endocrine Disorders of Development and Growth](#)

## Terminal Arbor

### Definition

The final pattern made by axonal endings as they terminate on their target neurons.

## Terminal Bouton

### Definition

Terminal bouton is the specialized presynaptic terminal at the end of an axon. Terminal boutons contain necessary organelles, proteins and molecules needed to



transmit chemical/electrical information to the postsynaptic cell. During development, they form from growth cones that undergo a morphogenesis after target selection.

- ▶ Synapse
- ▶ Synaptogenesis

## Terminal Cisternae (Junctional SR, Heavy SR)

### Definition

Compartment of the sarcoplasmic reticulum that makes direct contact with the t-tubule membrane and from which  $\text{Ca}^{2+}$  is released through the ryanodine receptor during excitation-contraction coupling. In skeletal muscle, 2 terminal cisternae border a t-tubule and form a triad.

- ▶ Excitation–Contraction Coupling

## Terrestrial Magnetic Field

- ▶ Geomagnetic Field

## Territorial Motivation

### Definition

Motivational aspects derived from the spatial location of the animal. In territorial species, an individual defends an area against other members of its species. The animal's location in its territory or in a competitor's territory may radically alter the behavioral response to a conspecific, changing from aggressive (when the animal is located within its own territory) to defensive/submissive (when it is located outside its territory).

- ▶ Evolution of Septal Nuclei

## Tertiary Sensory System

### Definition

- ▶ Sensory Systems

## Test and Inducing Stimuli

### Definition

Visual illusions and after-effects are often characterized as the effect of one part of a visual display on another part.

- ▶ Visual Illusions

## Tetanus in Muscle Contraction

### Definition

Mechanical response generated when a train of closely spaced stimuli is applied to muscle. An unfused tetanus occurs when the stimulation rate produces partial summation of individual twitches. A fused tetanus occurs when the stimulation rate produces full summation of individual twitches.

- ▶ Force Potentiation in Skeletal Muscle

## Tetanus (Pathological)

### Definition

Characterized by augmented muscle tone and spasms and caused by *tetanospasmin*, a protein toxin produced by the anaerobic *Clostridium tetani*, which in the form of spores is prevalent in soil and enters the body via badly oxygenized wounds. Here the vegetative cell form produces the toxin that is retrogradely transported in ▶ motoneuron axons to ▶ brainstem and ▶ spinal cord, where it migrates transneurally to presynaptic terminals and blocks the release of inhibitory transmitters

such as glycine and GABA, thereby producing ▶ **spasms**. ▶ **Preganglionic sympathetic neurons** may also be disinhibited resulting in sympathetic hyperactivity and high concentrations of circulating ▶ **catecholamines**. Like ▶ **botulinum toxin**, tetanospasmin may also block the ▶ **neuromuscular junction** and produce muscle weakness and paralysis.

---

## Tetany

### Definition

Tetany manifests itself as contractions of predominantly distal muscles in the hand (carpal ▶ **spasms**) or feet (pedal spasms), and occasionally as ▶ **laryngospasm**. With prolonged contractions, tetany may cause muscle damage with subsequent pain; and severe tetany, when involving the spine musculature, may entail ▶ **opisthotonus**. Tetany usually results from increased excitability of peripheral nerves, occurring during hypocalcemia, hypomagnesemia or severe respiratory alkalosis. ▶ **Spasmophilia** is an idiopathic normocalcemic tetany, which may be hereditary or acquired.

---

## Tetracycline-Regulated Transgenics

▶ **Conditional Transgenics**

---

## Tetraethylammonium Chloride (TEA)

### Definition

Tetraethylammonium chloride (TEA) is a simple ammonium ion. When applied from the cell outside, it blocks some types of voltage-dependent  $K^+$  channels, especially those of the Kv3 and BK family channels.

▶ **Action Potential**  
▶ **Neuronal Potassium Channels**

---

## Tetrahydrocannabinol

### Definition

▶  **$\Delta^1$ -tetrahydrocannabinol**, is the main psychoactive substance found in the Cannabis sativa plant. It was isolated by Raphael Mechoulam's laboratory at the Hebrew University in Jerusalem in 1964. A synthetic version of it – dronabinol, is also available.

▶ **Cannabinoids**

---

## Tetrapod

### Definition

Vertebrates that have four feet, i.e., the amphibians, mammals, reptiles and birds. (Snakes are tetrapods that secondarily have lost this character.)

---

## Tetrodotoxin (TTX)

### Definition

Tetrodotoxin (TTX) is a toxin derived from bacteria. It is concentrated in certain organs of puffer fish (fugu) and fishes of the order Tetraodontiformes and has given rise to the Chinese proverb "To throw away life, eat blowfish" (puffer fish). Its effects are said to have been discovered by the legendary Chinese emperor Shun Nung (2838–2698 B.C.) who, while compiling a pharmacopoeia, personally tasted 365 drugs and yet lived an amazing 140 years to tell the tale. Similar to saxitoxin (STX), tetrodotoxin is a very potent blocker of most voltage-gated  $Na^+$  channels, thereby preventing the conduction of action potentials along nerves and/or muscle membranes.

▶ **Action Potential**  
▶ **Saxitoxin (STX)**

## Texture Discrimination in Touch

### Definition

The most common perceptual descriptor of surface texture is the sensation of roughness. Stimuli employed to measure the resolution of this perceptual feature have ranged from common materials such as sandpaper and fabrics to surfaces which can be manufactured and defined precisely – gratings of alternating grooves and ridges, and embossed dots of differing spatial configuration. Discrimination thresholds range from 5 to 10% variation in the spatial period of the elements depending on whether the surface is scanned across the skin or simply indented into the skin with no lateral movement.

► Processing of Tactile Stimuli

## Texture Processing in Vision

### Definition

Texture processing refers to the brain's ability to respond to the local statistics of textured regions in a scene or picture. Texture processing includes texture segregation, and can generate recognizable percepts of object form (Form perception).

► Form Perception

## Texture Segregation in Vision

### Definition

A visual texture refers to the size, shape, and arrangement of different elements of a scene or picture. Texture segregation refers to the brain's ability to group into distinct regions and objects different parts of a scene that have different texture statistics. Boundary and surface processes in the brain can use texture, as well as edge, shading, depth, and color information to generate percepts of visual form.

► Form Perception

## TGF- $\beta$

► BMP Signaling and Synaptic Development

## Thalamic Pain

► Central Pain

## Thalamic Syndrome (Déjérine-Roussy)

### Definition

The syndrome results from local restricted infarcts in the ventroposterolateral ► **thalamus** and can produce burning pain and other ► **dysesthesias** in body regions whose noxious stimulation normally does not entail pain sensations.

► Central Pain

► Thalamus

## Thalamic Ventrobasal Complex

### Definition

Thalamic ventrobasal complex is composed of the ventral thalamic nuclei named nucleus ventralis postero-lateralis (VPL) and nucleus ventralis postero-medialis (VPM). The former relays somatosensory signals from the limbs and body while the latter relays signals of trigeminal nerve origin from the face and oral cavity.

► Somatosensory Cortex I

## Thalamotomy

### Definition

Surgical procedure where part of thalamus is surgically destroyed to cause a permanent lesion.

► Essential Tremor

## Thalamus

### Definition

The thalamus consists of a large ovoid mass of gray matter forming the larger dorsal subdivision of the diencephalon located medially to the internal capsule and caudate nucleus. It is a complex collection of cell groups (nuclei), through which sensory information (except for olfactory information) is relayed and processed on its ascending path to the cerebral cortex (also thought of as the “gate-keeper” to the cerebral cortex). It also transmits and processes information to the cortex from the basal ganglia and cerebellum.

## Theodicy

### Definition

A “justification of God” in the face of the evils in the actual world.

► Possible World

## Theories on Motor Learning

HIROKAZU TANAKA, MITSUO KAWATO  
ATR Computational Neuroscience Laboratories,  
Kyoto, Japan

### Definition

Motor learning is an assortment of adaptive processes in motor control by which a new movement skill is

being acquired (skill acquisition) or motor performance is being restored even under novel kinematical or dynamical environment (motor adaptation). Computational theories of motor learning often describe motor learning as a relaxation process toward a desirable behavioral goal (i.e., a tradeoff between task performance, body stability, and energy consumption).

### Characteristics

#### Optimality Principles for Motor Control and Learning

Lively movements define what animals are. Control and coordination of body movements have evolutionarily necessitated elaborate central nervous systems, the idea supported by the fact that the brain is a luxury that motionless plants needed not to develop. An important aspect about body movements is that those appear to be purposive for certain behavioral goals and to have invariant features such as straight trajectories in arm reaching and specific rhythms in locomotion, implying underlying optimality goals. Several computational models explain motor control as achieving optimality of behavioral goals, namely a tradeoff between task performance, body stability, and energy consumption. Voluntary arm reaching has offered a test bed for assessing several successful optimization models such as the minimum jerk, minimum torque change, and minimum variance models. Locomotion may be understood as optimization of gait so as to maximize traveling distance using minimal energy. Also, movement control must be adaptive to ever-changing environments, and the process of adaptive motor control is defined as motor learning. Optimality principles regard motor learning as a relaxation process toward optimization goals.

#### Motor Learning as a Composite of Subsystems

The current prevailing view in computational motor control and learning (► [Optimization model for motor control and learning](#)) is that, once an optimization goal is specified, motor control may be solved with a network composed of homogenous units, possibly in the primary motor cortex (Fig. 1a) [1].

This approach has been most successful in explaining quite a few invariant movement properties. This striking success, regrettably however, misguided some neuroscientists to be convinced that a homogeneous optimality computation suffices for motor control and learning. This view, simple and attractive though it appears, overlooks biological concerns in motor learning.

We, here, propose an alternative view that the brain seems to employ several parallel and hierarchical subsystems specialized for their designs so as to achieve overall optimality (Fig. 1b). Although optimality principles furnish a general and conceptual framework, there are several concrete computational problems specific to biological motor control that could not easily be solved in

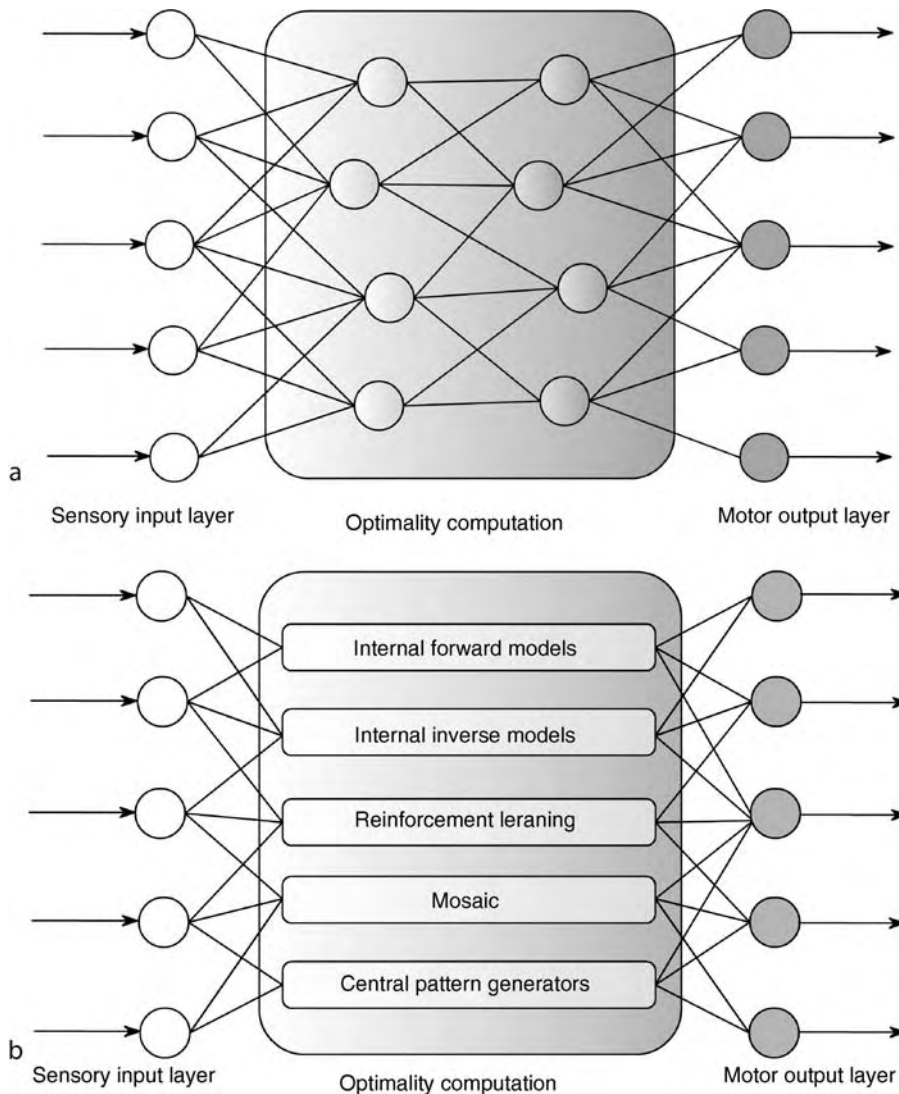

**Theories on Motor Learning. Figure 1** Schematic diagram for optimality computation. The widespread view claims a single, homogenous network (a). We contrariwise propose the computation as a composite of subsystems, each developed for certain computational problems specific to biological motor control and learning (b).

a single, homogeneous network. One may follow the successful approach in science for handling a difficult large-scale problem, namely the “divide-and-conquer” strategy: separate an original problem into multiple, more tractable subproblems, solve those subproblems per se, and then assemble the solutions of subproblems to form the sought solution to the original problem. We will consider three difficulties that the biological motor system must overcome, and how those difficulties are solved by various computational approaches. First of all, the delay time of sensory feedback is significant and makes a naive use of feedback control unstable or oscillatory. Visual signals, for instance, need approximately up to 100 ms to reach higher visual areas mainly due to the sluggishness in retinal photoreceptor reactions

and the hierarchical structure of visual system. Therefore, if dependent only on sensory signals, the motor system sees only past position of an effector (limb or eye ball) and must develop a predictive mechanism that estimates a current effector state for reliable control. Second, sensory signals may not always specify direct information about how movement can be improved, the difficulty known as the distal-teacher problem [2]. Learning based on teacher signals is called supervised learning, and movement errors measured between desired and actual states are often used as a teacher signal in supervised learning. Nevertheless, movement errors perceived in visual coordinates do not readily dictate whether and how much a muscle activity involved in that movement should be potentiated or depressed in such a way as to reduce

the visual errors at later movements. This becomes exacerbated when a movement outcome is evaluated only through a reward or a punishment in so-called reinforcement learning in which the teacher signal is least informative. In addition to sensory delay and insufficient teacher signals, the motor system must control very high degree-of-freedom effectors, making the number of possible motor control commands more than astronomical. Computation seeking optimality in such large systems will be unattainable in practical time frame, so the motor system needs to constrain possible search spaces. We, hereafter, provide an overview on several computational approaches to overcome these difficulties and their connection to biological motor learning.

### Internal Forward and Inverse Models

For a reliable control, the delay in sensory information transmission must somehow be compensated, and a reliable estimate of current effector state must be computed ahead of time. Internal model is proposed as a neural mechanism that mimics an input–output relationship of an environment or a body to be controlled [3]. There are two kinds of internal models: *forward* one for estimating a current state, given current sensory signal reporting previous limb state and efference copy of motor command, and *inverse* one for producing motor commands that realize a desired effector state. The forward model (► **Internal forward model**), on one hand, computes a current state (e.g., position and velocity of eye or limb), essentially by solving equations of motion using current sensory signal and efference copy of motor commands. The computation is called forward because current state is computed in a causal manner. Predictions with forward models have a few advantages: estimation of current effector state, prediction of motor outcome, and comparison with actual sensory signals to produce error necessary for motor learning. The inverse model, on the other hand, maps a desired effector state onto necessary motor commands that accomplish that desired state. The control signal produced by inverse model is called feedforward, in contrast to feedback control that depends purely on sensory signals. Both forward and inverse models must have knowledge about body dynamics that is to be controlled. Fast and reliable body control becomes possible by combining the forward and inverse models; initially, the forward model estimates the current state given most recent sensory signals and efference motor copies, and then the inverse model produces necessary motor commands by comparing the desired state to the estimate of current state by the forward model.

One may then wonder how internal models are to be acquired when there is no direct teacher signal available. Our body and its dynamics are subjected to inevitable modifications caused by development,

fatigue or injury, and internal models must accordingly be adaptive to take those changes in consideration. Also, internal models ought to be retrained when subjected to novel environments, such as those using altered visual field by prisms or feeling no gravitational field in space. If an explicit teacher signal was provided, a supervised learning process would be achieved without great efforts. The problem is, the teacher signals for internal models must be represented in coordinate systems of their outputs (e.g., joint angles or motor commands), whereas errors are usually obtained through visual coordinates (Cartesian positions) or joint-angle space of proprioception. Teacher signals for inverse models are, hence, not obviously given. A possible solution was given by Kawato and coworkers; feedback control signals, though delayed, can approximate teacher signals and afterward be utilized to train inverse models [4]. In the initial phase of motor learning, an ► **internal inverse model** for a certain movement is not suitably trained and thus actual movement is most likely to deviate from a desired one. Feedback control comes into play when sensory signal alerts the deviation of current state from the desired one. That feedback control signal reports how well or badly the inverse model produced feedforward motor command in that movement and can then be used to update the inverse model properly in the next movement. In this ► **feedback error learning** (FEL), in an initial phase of motor learning before the inverse model is well trained, feedback control guides movement and trains the inverse model, and then feedforward control comes to be more dominant as the inverse model becomes trained. Eventually, movement will become feedforward-control dominant and need not rely exclusively on delayed sensory signals.

The next question is to ask where, if any, internal models are located in the brain. Now, there is substantial evidence from anatomy, electrophysiology, and human brain imaging that the cerebellum possesses at least certain form of internal models and that the cerebellar cortical circuit realizes FEL-type learning to train internal inverse models [5]. First, three anatomical observations about cerebellar cortical circuits support this: the circuit is feedforward from the input layer (granular cells) to the output (Purkinje cells) via parallel fibers, Purkinje cells receive tens of thousands of inputs from granular cells, and there is only one teacher signal (climbing fiber) for each Purkinje cell. This circuit structure appears analogous to a multilayered neural network in artificial intelligence, which is known to be able to approximate any nonlinear function, so it is in particular appropriate for learning general input–output relations. Also, electrophysiological studies of behaving animals revealed that simple spikes of Purkinje cells generated by parallel fiber inputs represent inverse models of eye or arm, and that complex spikes

generated by climbing fiber input represent error signal in the motor-command space, both in agreement with the FEL model. In addition, synaptic strengths were shown to have plasticity in conjunction with motor learning. Finally, recent human imaging studies found activations in the cerebellum that correlated well with error signals and with the formation of an internal model while participants were learning novel computer interfaces.

### Reinforcement Learning

Motor learning often encounters situations where teacher signals, either direct or indirect, are not available at all, and movement outcome is evaluated only through a reward or a punishment. Infants learning to walk will be rewarded with a toy if they succeed in traveling to their parents but will be punished by falling down to the floor if they fail. Here, note that there is no explicit teacher signal on how walking could be improved but only evaluation of movement, called (either positive or negative) reinforcers, is given later, so a learner must learn by trial and error so as to discover best control strategies that maximize the reward. Reinforcement learning (RL), initially motivated by the Pavlovian associative learning and later on developed in the field of machine learning, provides an appropriate strategy, or policy, using only reinforcers [6]. In RL, finding an optimal policy is pursued by a tradeoff of exploration among possible search directions and exploitation of current best sources known through previous explorations. RL has become very popular since an efficient algorithm called the temporal difference (TD) error algorithm was proposed, and various problems have been solved by RL methods, including both discrete-time problems such as maze solving and backgammon and continuous-time problems such as cart-pole stand up and pendulum swinging up. On the top of practical use, RL rekindled neuroscientists' attention when dopamine neuron activity in midbrain was found to represent TD error signals [7], and how RL is realized in the basal ganglia circuit has since been argued. RL becomes desperately useless, however, in case that a problem to be solved involves many degrees of freedom. This is because the space of possible states and actions grows exponentially and becomes too gigantic to be explored within reasonable time, and also because most trials will produce no reward or punishment, that makes no information available as to improve a policy. Therefore, a naive application of the standard RL algorithm to a large-scale problem is doomed to fail.

### MOSAIC Model

The difficulty in extending RL to a large-scale problem, also known as curse of dimensionality, can be alleviated by hierarchizing or modularizing the original problem. This approach has been proven to work efficiently within shorter computational time in, for example, composite Q, feudal RL, SMDP learning, and max Q

algorithms. Nevertheless, in those studies, structures of hierarchy and modularity were assigned manually by researchers from problem to problem, so it was needed to develop an algorithm that automatically and correctly decomposes an original problem into smaller, more tractable subproblems. A modular selection and identification control (MOSAIC) model, proposed initially as a model of supervised learning and extended to RL, attempts this automatic problem decomposition naturally by self-organizing multiple parallel modules, each consisting of a predictive forward model and a paired control inverse model [8]. Which controllers will be used depends on how satisfactorily paired predictive models predict movement outcome or an immediate reward. The fitness of prediction to actual sensory signal is termed a responsibility signal, which in turn determines to what extent modules are updated with given error signals. Initially, before motor learning, all modules are set to random initial conditions, and all predictors produce almost equally bad estimates, resulting in similar amount of responsibility signals distributed all over the modules. During learning, predictive models that happen to produce good predictions become updated and specialized for particular tasks or situations. Finally at the end of learning, each unit becomes an expert for its own purpose, and only a small subset of the responsibility signals takes nonzero values at one point of time. In other words, all modules are novices at first, and grow differentiated toward their own specialities. In this way, the **MOSAIC model** automatically self-organizes large-scale problem into small subproblems without direct human assignments. Although the MOSAIC model still suffers when a problem is large, it points a right direction for further investigation.

### Nonlinear Dynamical Approach

Although degrees of freedom (DOFs) are enormous in body dynamics, all muscles and joint angles do not operate independently but cooperate and regulate each other to some extent. Indeed, electromyography measured from a frog hindlimb while kicking, jumping, swimming, or walking, consists of no more than six principal components. Likewise in animal locomotion, hip, knee, and ankle angles are not randomly controlled but are either inphase or antiphase to each other. This effective reduction in DOFs is called movement synergy, and resultant DOFs are referred to as **motor primitives**, collective variables, or order parameters. Self organization of nonlinear, nonequilibrium systems was proposed by Kelso and coworkers as dynamics of those low-dimensional systems, and experimentally well-defined movement patterns were assumed to correspond to nonlinear dynamical attractors [9]. In this framework, a transition from one motor pattern to another when an experimental parameter is modified can be regarded as a bifurcation process from an unstable equilibrium point to

another stable one. Predictions from this approach have been confirmed in a variety of psychophysical experiments including human bimanual finger coordination and animal gait patterns. An important implication here is that the motor system itself should have internal nonlinear dynamics in the synergistic low-dimensional space, consistent with biological rhythmic generators in the brain stem and spinal cords. This phenomenological approach was further extended successfully by Schaal and coworkers to real-time motor learning in humanoid robotics [10]. Although in Kelso's approach the nonlinear dynamics was manually fixed so as to explain observed movement patterns, Schaal incorporated a learning process of dynamics on stable and unstable attractors ("attractor landscape") from human movements monitored by motion capture equipment. Also, ►**motor synergy** was not a priori assumed there but emerged spontaneously as a result of excitatory and inhibitory couplings between DOFs. This dynamical-system-based control is proven to scale up to motor learning of humanoid full-body movements in various tasks such as walking, drum beating, and tennis ball hitting. Whether and how the brain realizes motor synergy and the nonlinear dynamical approaches, however, still remain little investigated.

In this essay, we presented our view that the motor cortex has evolved to recruit computational subunits for motor optimality, and reviewed a few difficulties in biological motor control and learning, their possible computational solutions, and relations to the motor system in the brain. We have fulfilled reasonably the first two stages of the divide-and-conquer strategy. The next challenge will be to integrate individual computational approaches into a coherent, unified theory that fulfills optimality on the whole. Therefore, close collaborations between psychophysical, electrophysiological, computational, and robotics approaches should carry on for further development in motor learning.

## References

1. Todorov E (2004) Optimality principles in sensorimotor control. *Nat Neurosci* 7:907–915
2. Jordan MI, Rumelhart DE (1992) Forward models – supervised learning with a distal teacher. *Cogn Sci* 16:307–354
3. Kawato M (1999) Internal models for motor control and trajectory planning. *Curr Opin Neurobiol* 9:718–727
4. Kawato M, Furukawa K, Suzuki R (1987) A hierarchical neural network model for control and learning of voluntary movement. *Biol Cybernet* 57:169–185
5. Wolpert DM, Kawato M (1998) Internal models in the cerebellum. *Trends Cogn Sci* 2:338–347
6. Sutton RS, Barto AG (1998) *Reinforcement learning: an introduction*. MIT Press, Cambridge, MA
7. Schultz W, Dayan P, Montague PR (1997) A neural substrate of prediction and reward. *Science* 275:1593–1599
8. Haruno M, Wolpert DM, Kawato M (2001) MOSAIC model for sensorimotor learning and control. *Neural Comput* 13:2201–2220
9. Schoener G, Kelso JAS (1988) Dynamic pattern generation in behavioral and neural systems. *Science* 239:1513–1520
10. Ijspeert AJ, Nakanishi J, Schaal S (2003) Learning attractor landscapes for learning motor primitives. *Adv Neural Inf Process Syst* 1523–1530

---

## Theory – Theoretical Expression

### Definition

Theoretical expressions are expressions that occur, in addition to logical and mathematical vocabulary, in the formulation of a theory. In a narrow sense, a theoretical expression refers to theoretically postulated entities (electron) or states (being charged). Many philosophers think that the meaning of, e.g., "being charged" is constituted by the role charged particles play according to physics, which is partly captured by Coulomb's law of electrostatic interaction (State, functional).

► **Argument**

► **Logic**

---

## Theory of Mind

► **Theory Theory (Simulation Theory, Theory of Mind)**

---

## Theory on Classical Conditioning

RUTH M. COLWILL  
Department of Psychology, Brown University,  
Providence, Rhode Island, USA

### Synonyms

Theory on Pavlovian conditioning; Theory on stimulus–outcome learning; Theory on CS-US associations

### Definition

Theory on ► **classical conditioning** seeks to characterize the conditions under which learning about the



relationship between conditioned and unconditioned stimuli occurs, the nature of ►conditioned stimulus (CS) and ►unconditioned stimulus (US) encoding, and the rules for conditioned performance.

## Characteristics

### Conditions for Classical Conditioning

Many of the most important theoretical developments to have occurred in the field of associative learning find their origin in studies of the rules by which one event comes to be treated as a signal for the occurrence or omission of another event. What this work has suggested is that an association will not develop between two events simply because they were delivered contiguously in time. Three lines of research have contributed to dissatisfaction with the classical notion prevalent in philosophy, psychology and neuroscience of temporal contiguity as the principle governing the formation of associations.

### Cue Competition Effects

Studies of cue competition or stimulus selection include ►blocking, ►overshadowing and relative validity effects. The Kamin blocking effect [1] is widely regarded as one of the principal challenges to a simple temporal contiguity learning rule. The original experiments showed that it was possible to prevent or block learning about the relation between a visual cue and shock despite the fact that they bore an adequate temporal relation simply by conducting those pairings in the presence of a previously established signal for the shock. Blocking has been replicated many times, in a variety of conditioning situations and with a range of species. A related phenomenon called overshadowing demonstrates that learning about a stimulus can also be reduced if its pairings with the US are carried out in conjunction with another neutral stimulus [1,2]. These cue competition effects demonstrate that despite perfect temporal contiguity between a CS and an US, learning about their relation may fail to occur.

### Contingency

Another observation that contributed to the demise of a simple temporal contiguity principle was that the strength of an association was a function of the actual ►contingency between the two events and not the number of their pairings [3]. Learning about a stimulus was quite different in rats that experienced the same number of CS-US pairings but that received different rates of the US in the absence of the CS. When USs were presented only during the CS, that CS was treated as a good signal for the US. However, as the rate of USs in the absence of the CS approximated the rate during the CS, conditioning declined. This finding has also been replicated in different species and across a range of

conditioning situations. Subsequent studies have found that signaling the US presentations that occur in the absence of the CS can restore conditioning to the CS further supporting the idea that contingency degradation operates by weakening the predictive value of the CS.

### Inhibitory Learning

Just as important as procedures showing that learning may fail to occur despite temporal contiguity of the stimulus and the outcome is the finding that learning occurs under circumstances where the stimulus and the outcome are never presented at the same time. Such learning is described as inhibitory and is most powerful when a stimulus is presented at a time when an expected outcome is omitted. The Pavlovian ►conditioned inhibition paradigm [2] consists of a mixture of two trial types; on some trials a CS is paired with the US and on other trials, the CS is presented with another stimulus (conditioned inhibitor) and not followed by the US. Under these conditions, the conditioned inhibitor comes to signal that the US will not occur. There have been many replications of Pavlovian conditioned inhibition across a variety of species and conditioning preparations. For example, one study with rabbits found that a tone that had been nonreinforced in the presence of a light that signaled paraorbital shock came to suppress responding to that light. Moreover, the tone stimulus not only transferred its suppressive properties to another stimulus signaling the shock outcome (summation test) but was resistant to being trained as a signal for that outcome (retardation test).

The collective impact of these results was to highlight the inadequacy of the traditional temporal contiguity principle for the formation of associations. For classical conditioning to occur, a CS had to provide otherwise unavailable information about the US. For example, in the blocking paradigm, the added stimulus signaled no new information beyond that given by the previously trained stimulus; consequently it could not become associated with the US. Learning models were developed to incorporate the need for a mechanism superior to one that was only sensitive to the temporal relationship between the events to be associated but they did so by devising ingenious elaborations on the traditional contiguity-driven system.

### Theoretical Perspectives

Initially, two contrasting theories emerged to organize the empirical evidence that CS-US learning was not a straightforward function of CS-US contiguities. The ►Mackintosh model [4] attributed variations in learning about CS-US contiguities to variations in CS processing and the ►Rescorla-Wagner model [5] attributed them to variations in US processing. Revised

models and new theories have since followed to address the shortcomings of these approaches and to incorporate new empirical findings [6–10] but the Rescorla-Wagner model remains arguably the most influential theory of classical conditioning. This is due in part to the similarity between its discrepancy algorithm and the independently derived error-correction (delta) rule of many ►connectionist networks, and to the overall success of this approach to stimulus competition effects.

### The Rescorla-Wagner Model

Although the Rescorla-Wagner model retains the essential notion of CS-US temporal contiguity, it specifies the need for the contiguous US to be surprising, in other words not predicted by any other stimulus. At a casual level, surprise is represented as the discrepancy between what actually happened on a trial and what was expected. The cleverness of the theory lies in the development of a simple but elegant algorithm to determine just how surprising an outcome is.

According to the Rescorla-Wagner model, CS-US learning is represented as the associative strength of the CS ( $V_{CS}$ ). The current associative strength of a CS is the accumulation of changes in its associative strength ( $\Delta V_{CS}$ ) calculated on each trial that the CS was previously presented using the expression:

$$\Delta V_{CS} = \alpha_{CS} \beta_{US} (\lambda - V_T)$$

where  $V_T$  represents the total or sum of the individual associative strengths of all CSs present on that trial;  $\alpha$  and  $\beta$  are fixed rate parameters determined by the salience (physical properties) of the CS and US, respectively;  $\lambda$  is the maximum conditioning that the US can support.

The iterative application of this equation across a series of conditioning trials with a single CS produces a CS-US learning curve that follows a negatively accelerated path towards an asymptote. Increments in associative strength early in training are large relative to those on later trials because  $V_T$  grows over training which reduces the size of the discrepancy ( $\lambda - V_T$ ). The model also predicts that a trained CS will extinguish if it is repeatedly presented without the US. On extinction trials, the discrepancy term ( $0 - V_T$ ) is initially negative and adjustments in associative strength will occur until  $V_T$  is equal to zero. Empirical phenomena (spontaneous recovery and disinhibition) strongly suggest that ►extinction does not involve the erasure of original excitation but rather its masking by the acquisition of inhibition.

The Rescorla-Wagner model accounts for cue competition effects by including the associative strengths of all CSs present on a trial in the calculation of  $V_T$ . Blocking, for example, is attributed to the fact that prior training of one stimulus (A) in the compound (AX) causes  $V_T$  to grow so that the discrepancy term ( $\lambda - V_T$ ) is effectively

zero on the first AX training trial. Consequently, there is no surprising US to condition X when it is paired with the US in the presence of A. Degradation of the CS-US contingency is treated as a special case of blocking by the context or background cues associated with the USs presented in the absence of the CS.

The Rescorla-Wagner model treats conditioned inhibition as the opposite of excitation. Thus, conditioned inhibition is characterized as the acquisition of net negative associative strength by the inhibitor. For example, on trials when the inhibitor is presented with a CS that has been paired with the US but no US is given, the discrepancy is negative ( $0 - V_T$ ). The cumulative effect of these negative changes in associative strength is to drive the associative strength of the inhibitor from zero to a negative value that offsets the associative strength of the excitatory CS.

The Rescorla-Wagner model generated some novel predictions about classical conditioning that were subsequently confirmed by experiments. For example, CS-US learning is superior in the presence of an inhibitor (superconditioning). An inhibitory stimulus will also shelter a CS that is no longer paired with the US in its presence from undergoing a decrement in associative strength (protection from extinction). The model also correctly predicted a condition under which a CS will lose associative strength despite continued pairing with the US (overexpectation).

Subsequent research did not support the prediction by the Rescorla-Wagner model that a conditioned inhibitor would extinguish when repeatedly presented alone. Moreover, conditioned inhibition is no longer regarded as the opposite of excitation. Current research suggests that conditioned inhibition involves a modulatory process and is more properly conceptualized as the opposite of its positive counterpart known as facilitation or positive occasion-setting. There is debate about the locus of action of modulators; some data support the idea that modulators act as a gate on specific CS-US pathways whereas other data suggest that modulators act more generally by altering the threshold for US activation by a CS.

### The Nature of CS and US Encoding

There is general agreement that classical conditioning involves the ►acquisition of an association between internal representations of the CS and the US rather than the ►reinforcement or strengthening of an association between internal representations of the CS and a response. Random and explicitly unpaired control procedures are used to show that the changes in behavior to the CS result from its pairing with the US rather than from experience with the events per se. Other procedures (US devaluation, US inflation, transfer) are used to reveal the presence of a CS-US association and to shed light on the nature of the encoding of the US. Post-conditioning changes in the value of the US have specific and

appropriate effects on responding to the CS that was paired with that US. The transfer procedure demonstrates that a CS trained with one outcome has an effect on an instrumental response trained with that same outcome that is different from its effect on an instrumental response trained with a different outcome. The selectivity of such results reveals detailed learning about the sensory characteristics of the US in classical conditioning. Research has also shown that CS-US temporal arrangements and CS-US similarity relationships can influence which features of the US are selected for association with the CS.

The difference in theoretical approaches to encoding of the CS becomes apparent when the CS is a compound cue consisting of two or more stimuli. Elemental theories like the Rescorla-Wagner model [5] assume that the representation of a compound CS consists of the simultaneous activation of the representations of its constituent components. In contrast, configural theories like the Pearce model [10] assume that there is a single internal representation of the compound CS that is distinct from the representations of its constituent components. Neither approach has been completely satisfactory in predicting the results of the entire set of stimulus summation studies and all discrimination learning studies including negative patterning (the XOR problem) and CS similarity experiments. Further elaboration of the replaced elements model [6], a hybrid approach that blends configural and elemental encoding of the CS, promises to remedy the shortcomings of these elemental and configural models.

### Rules for Conditioned Performance

Expression of a ►conditioned response (CR) has generally been considered a simple direct function of the strength of the CS-US association. The Pearce model [10] departs slightly from this principle by asserting that conditioned responding is determined by the associative strength of the CS together with any generalized strength from other similar stimulus configurations. Other models [8,9] have developed predictive-driven performance rules to explain apparent failures of CS-US contiguities to produce learning. This approach has also been successful in addressing the temporal dynamics of conditioning. Among the regularities that have been observed is the fact that the speed of acquisition of conditioned responding is relatively constant for constant values of the intertrial interval/trial duration (ITI/TD) ratio.

### References

1. Kamin LJ (1969) Selective association and conditioning. In: Mackintosh NJ, Honig WK (eds) *Fundamental issues in associative learning*. Dalhousie University Press, Halifax, Nova Scotia, Canada, pp 42–64

2. Pavlov IP (1927) *Conditioned reflexes* (Anrep GV, Trans.). Oxford University Press, London
3. Rescorla RA (1968) Probability of shock in the presence and absence of CS in fear conditioning. *J Comp Physiol Psychol* 67:504–509
4. Mackintosh NJ (1975) A theory of attention: variations in the associability of stimuli with reinforcement. *Psychol Rev* 82:276–298
5. Rescorla RA, Wagner AR (1972) A theory of Pavlovian conditioning: variations in the effectiveness of reinforcement and nonreinforcement. In: Black AH, Prokasy WF (eds) *Classical conditioning II: Current research and theory*. Appleton-Century-Crofts, New York, pp 64–99
6. Wagner AR, Brandon SE (2001) A componential theory of Pavlovian conditioning. In: Mowrer RR, Klein SB (eds) *Handbook of contemporary learning theories*. Lawrence Erlbaum Associates, Mahwah, NJ, pp 23–64
7. Pearce JM, Hall G (1980) A model for Pavlovian learning: variations in the effectiveness of conditioned but not of unconditioned stimuli. *Psychol Rev* 87:532–552
8. Gallistel CR, Gibbon J (2000) Time, rate and conditioning. *Psychol Rev* 107:289–344
9. Miller RR, Matzel LD (1988) The comparator hypothesis: a response rule for the expression of associations. In: Bower GH (ed) *The psychology of learning and motivation: advances in theory and research*, vol 22. Academic Press, San Diego, CA pp 51–92
10. Pearce JM (1987) A model of stimulus generalization for Pavlovian conditioning. *Psychol Rev* 101:587–607

## Theory on CS-US Associations

- Theory on Classical Conditioning

## Theory on Pavlovian Conditioning

- Theory on Classical Conditioning

## Theory on Stimulus-outcome Learning

- Theory on Classical Conditioning

## Theory Theory (Simulation Theory, Theory of Mind)

LOUISE RÖSKA-HARDY

Kulturwissenschaftliches Institut, Essen, Germany

### Synonyms

Theory of mind; Folk psychology

### Definition

#### *Theory of Mind*

Theory of mind denotes the conceptual system that underlies the ability to understand, predict and interpret the thoughts, feelings and behavior of self and others by reference to specific ►[mental states \(states of mind\)](#). Originally introduced by primatologists, the term “Theory of mind” (ToM) is used to refer to (1) the ability to impute mental states, i.e. to mentalizing or mind-reading (►[Mentalizing, mind-reading](#)), (2) the study of children’s understanding of mind in developmental and cognitive psychology, and (3) the “Theory Theory” account of mental state attribution.

#### *Theory Theory*

Theory theory accounts for the cognitive abilities of humans in terms of a body of implicit knowledge, constituted by a representational system in the form of law-like generalizations or ►[innate](#) mechanisms. The central claim is that this internally represented knowledge is theory-like, because it consists of an abstract, coherent and causal-explanatory framework that enables explanation and prediction.

In the Theory of mind, Theory Theorists claim that psychologically competent humans understand and predict thought and action by inferentially applying a body of implicit knowledge, a folk-psychological Theory of mind. On this view, the attribution of mental states both to self and others is based on knowledge of a theory, which deploys mental state concepts like perception, belief and desire within a network of causal-explanatory generalizations. The theory in question is conceived as a set of generalizations or laws for the deployment of mental concepts, as a theory analogous to any empirical scientific theory or as a special purpose body of knowledge in a mental ►[module](#). However, all versions emphasize the inferential basis of mental state attribution.

#### *Simulation Theory*

Simulation theory maintains that humans understand and predict others’ mental states and behavior not by deploying a body of internally represented knowledge

structured like a theory, but by employing their own cognitive capacities and mechanisms to mentally model others’ cognitive processes. Simulationists claim that mental state attribution does not require theory-mediated inference. Rather, one uses one’s own mental processes to simulate the other’s mental processes, by pretending or imagining oneself to be in the other’s position and then generating the thoughts or actions attributed.

### Description of Theory

#### *Theory Theory in Philosophy*

The Theory Theory, originating in the philosophy of mind, claims that everyday mental state terms like “believe” or “want” denote theoretical concepts whose contents are fixed by the role they play in a substantive theory of the causal structure and functioning of the mind. The idea is that mental state terms and concepts are definable in terms of their connections to other concepts in a coherent theoretical framework, much as theoretical, non-observational terms and concepts are defined in science. On this view, the meaning of a term like “belief” and the content of the concept of belief are given by their role in common sense generalizations, or a collection of laws like “Seeing that  $p$  leads to the belief that  $p$ ” or “A person who wants  $p$  and believes that  $q$  is a means of obtaining  $p$ , will generally do  $q$ .” These generalizations are taken collectively to form a naive theory, a ►[folk psychology \(common sense psychology, mentalistic psychology\)](#), which relates sets of mental states and specifies causal relations between these mental states, inputs from the environment and behavior.

To understand a mental concept like belief is to know a sufficient amount of the folk-psychological theory within which the concept is embedded. Philosophical theory theorists claim that ordinary people predict and explain behavior and mental states by inferentially applying the generalizations or laws of the common sense theory. The theory is conceived either as a set of folk-psychological generalizations or laws for the deployment of mental concepts in ►[common sense functionalism \(Folk Functionalism\)](#), or as an empirical theory like any other scientific theory.

#### *Theory Theory in Psychology*

The Theory Theory approach in developmental and cognitive psychology evolved against the background of philosophical Theory Theory, applied to the question of whether children have a Theory of mind. Theory Theories of cognitive development construe everyday mental concepts as theoretical constructs, but differ from the philosophical Theory Theory in that they propose specific acquisition mechanisms.

Theory Theory in psychology encompasses two different and opposing accounts – the theory-formation

account and the modularity account. The scientific Theory Theory account claims that children construct theories of mental states that resemble scientific theories. Some proponents construe the acquisition process as analogous to theory construction and revision in science, while others take the end-state theory to result from the child's increasingly sophisticated capability to represent mental states. Innate module accounts of development hold that the child's Theory of mind results from the maturation of innate modules and processors which are part of humans' biological endowment, not from theorizing. Although both accounts claim that mental state attribution rests on internally represented knowledge which is theory-like, they disagree over its source, acquisition mechanisms and character.

### Scientific-Theory Theory

Often called the "child-as-scientist view," this version of developmental Theory Theory employs the model of scientific theory change to explain the acquisition of a Theory of mind. The basic claim is that children acquire a Theory of mind by deploying ►**domain-general** learning mechanisms, similar to the general theory-forming capacities employed by adult scientists. On this view, the everyday conception of the mind is an implicit naive theory, and children's conceptions of the mind are also implicit theories which posit mental state concepts as theoretical constructs to provide causal explanations and facilitate predictions. Changes in these conceptions are construed as theory changes, because concepts undergo theoretical revision by processes similar to those employed in scientific theorizing. It is claimed that the child's conceptual system changes in predictable ways when contrary evidence cannot be assimilated to the current conception, or when children acquire a more sophisticated capacity to represent mental states [1].

Infants start with initial innate theories, which are revised and restructured in the light of accumulating evidence. At 2 1/2 years, children are said to have nonrepresentational notions of desire and perception, which exclude the notion of misrepresentation or false belief. This explains their failure on ►**false-belief tasks**. Subsequently, children formulate a succession of implicit naive theories and revise them on the basis of evidence and experience to develop increasingly accurate Theories of mind. By the age of four, when the false-belief tasks are passed, normal children's Theory of mind is said to involve genuinely representational mental concepts like belief just as normal adults' implicit Theory of mind does.

The transitions from one developing Theory of mind to another are understood in analogy to transitions in scientific theorizing, like the development of the heliocentric theory of planetary movement from Copernicus

to Kepler. New theories are inferred from accumulating evidence and change as a result of experience. Advocates of scientific Theory Theory argue that the child's understanding of mind is a theory, because it exhibits the characteristics of theoretical knowledge, e.g. it is coherent, exhibits a complex relation to evidence, postulates mental states as unobservable, explanatory entities, is defeasible and undergoes systematic changes [2]. The widely documented shift in children's ability to attribute false beliefs between two and four years of age is adduced as evidence for the theory-formation account.

### Modularity Theory

Modularity theories of the child's Theory of mind are construed as versions of Theory Theory, because they postulate a representational information base in innate mechanisms which is theory-like. However, they differ from the theory-formation view of development, because the core process is not theorizing, but biological maturation. Modularity theories take cognitive structures like the apparatus of mental state attribution to be the result of innately specified modules and developmental processes, not the product of an acquired theory. The child's Theory of mind is created from pre-determined representations of input, triggered by experience from the environment, not developed from evidence. On this view, the Theory of mind is a ►**domain-specific** ability, supported by an innate, encapsulated and dedicated module, whose functioning is segregated from the other intellectual capacities of the individual.

Proponents of modularity differ in their views on modular mechanisms. The basic claim is that the Theory of mind is a special purpose body of knowledge contained in a mental module, which matures through a process of ►**ontogenetic** development and starts developing in infancy. It develops from the growth and functioning of one or more modules which come on-line as the child matures. The information in these modules is stored as special processing algorithms and/or as a set of mentally represented propositions. Innate processor theories postulate pre-specified processors which come on-line serially until the child arrives at mentalistic understanding of thought and action [3]. These processors take information about other's behavior as input and generate explanations and predictions as output. Another view attributes mentalizing abilities to a modular Theory-of-Mind-Mechanism (ToMM), which operates with innate concepts of pretense, belief and desire and produces domain-specific learning [4]. This mechanism is an information-processing device that computes data structures called ►**metarepresentations**, which relate agents to information. It is hypothesized to form the basis for ToM-acquisition. Mind-reading deficits in autism (►**Autism** (Autistic

Disorder, Childhood Autism)) are cited in support of the modularity account of development [5].

### Simulation Theory

There are different varieties of Simulation Theory, but all maintain that one uses one's own mental processes to attribute mental states to others without deploying theoretical knowledge. The central claim is that people use their own mental mechanisms to generate predictions and explanations of others' thoughts and behavior, drawing on their capacity to mimic or replicate others' reasoning and decision-making; they do not deploy a theory.

#### Simulation Theory in Philosophy

In the philosophy of mind, mental simulation approaches argue that one need not employ a Theory of mind to understand and predict others' behavior. Instead, one uses one's own mind as a model for understanding the minds of others, e.g. by pretending or imagining oneself to be in their situations and using one's own mental mechanisms to generate the thoughts and actions attributed to the other within a simulation. Approaches differ as to whether simulation involves introspective access to one's own mental states, analogical inference, prior possession of mental state concepts or automatic, non-conscious processes. Some proponents do not consider simulation an empirical thesis, but most take empirical findings to be relevant to claims about simulation processes and mechanisms.

On the ►introspection-simulation approach, one attributes mental states to others by using one's own cognitive and inferential mechanisms to match those of the other person [6]. In a simulation, one's cognitive system operates off-line on pretend or surrogate states and does not issue in action. No knowledge of how the system works is required; one must only possess such a mechanism and be able to feed in appropriate inputs and to construe its outputs. To determine what decision someone will take, one feeds pretend beliefs and desires into one's practical-reasoning system, which operates off-line and generates further mental states as outputs. The output of the simulation process provides the basis for attributing a decision to another. The simulation terminates in an inference from oneself to the other, in which one infers the other's mental state from one's recognition of the pretend state which issues from simulating the other. This version of simulation assumes a prior understanding of mental state concepts, and proposes an account in terms of introspection or self-monitoring. The existence of neonate imitation and ►mirror neurons are cited in support.

The non-introspectionist version of simulation claims that one makes other-attributions by re-centering one's cognitive map and imaginatively identifying with the other. The belief or decision generated within the scope of simulation is directly attributed to the other [7].

On this view, an egocentric shift on the part of the attributor lies at the core of simulation, not introspection coupled with analogical inference; one imagines oneself to be the other who is acting in a particular situation. After imaginative transformation, attributing a mental state to another is a case of mental "self"-attribution to oneself-as-the-other within the context of simulation. The notion of an "ascent routine" is introduced to obviate the need for introspection and prior possession of mental state concepts. An ascent routine is a procedure which allows one to get the answer to a question about one's own mental states by answering a question that is not about a mental state, e.g. answering the question "Do you *believe* that Mickey Mouse has a tail?" by answering a question about the world, "*Does* Mickey Mouse have a tail?". Non-introspectionist Simulation Theory claims that embedding an ascent routine within a simulation of another allows one to attribute mental states to the other directly without theorizing.

#### Simulation Theory in Psychology

In developmental psychology, the simulation account of the child's understanding of the mind emphasizes the role of subjective experience and imagination in explaining and predicting thought and action. Proponents argue that children use their first-hand experiences of beliefs, desires and perceptions in imagination to understand the minds of others, not a theory [8]. They propose that children develop an understanding of mental states through their direct, personal experiences of them, i.e. through introspection. Such experiences are of the child's own mental states; they are not theoretical constructs. On this view, children use introspective access to their own mental states and the exercise of the imagination to make mental state attributions; theory and inference are not required.

#### Hybrid Theories

Theory Theory and Simulation Theory were originally conceived as competing empirical accounts of mentalizing abilities, which necessarily exclude each other. It was assumed that either Theory Theory or Simulation Theory would prove correct. In recent years this assumption has been revised in the face of mounting evidence that mentalizing abilities and deficits are complex and multifaceted phenomena. A number of accounts have been proposed, which combine aspects of Theory Theory and Simulation Theory [9,10]. These hybrid theories suggest that humans' ability to understand and predict mental states and behavior are subserved by several different processes. Some aspects of mentalizing may rely on simulation processes, others on bodies of knowledge based on general learning mechanisms or embodied in modules, and still others on neurophysiological mechanisms.

## References

1. Perner J (1991) Understanding the representational mind. MIT Press, Cambridge, MA
2. Gopnik A, Meltzoff A (1997) Words, thoughts and theories. MIT Press, Cambridge, MA
3. Baron-Cohen S (1995) Mindblindness: an essay on autism and theory of mind. MIT Press, Cambridge, MA
4. Leslie AM (2000) "Theory of mind" as a mechanism of selective attention. In: Gazzaniga MS (ed) The new cognitive neurosciences. MIT Press, Cambridge, MA, pp 1235–1247
5. Frith U (2003) Autism: explaining the enigma, 2nd edn. Blackwell, Oxford
6. Goldman A (2006) Simulating minds. Oxford University Press, Oxford
7. Gordon R (1995) Simulation without introspection or inference from me to you. In: Davies M, Stone T (eds) Mental simulation. Blackwell, Oxford
8. Harris P (2000) The work of the imagination. Blackwell, Oxford
9. Currie G, Ravenscroft I (2002) Recreative minds, imagination in philosophy and psychology. Oxford University Press, Oxford
10. Nichols S, Stich S (2003) Mindreading, an integrated account of pretense, self-awareness and understanding other minds. Oxford University Press, Oxford

## Thermophilic

### Definition

A preference for warmer temperatures.

## Theropoda

### Definition

The archosaurian group incorporating bipedal carnivorous dinosaurs include Tyrannosaurus and Velociraptor. These are the stem-group of birds.

- ▶ The Phylogeny and Evolution of Amniotes

## Theta Burst

### Definition

Excitatory activity at around 5 Hz observed in the intact hippocampus. Experimentally, the theta burst

stimulation (several trains of 4 or 5 pulses at 100 Hz given at 200 ms intervals) is used to induce LTP in physiological conditions.

- ▶ Memory, Molecular Mechanisms
- ▶ Associative Long-Term Potentiation (LTP)
- ▶ Long-Term Potentiation (LTP)

## Theta Cell

### Definition

A hippocampal interneuron that increases its firing rate during the theta rhythm and whose firing is highly rhythmic (entrained to the theta rhythm). Theta cells are typically inhibitory.

- ▶ Spatial Learning/Memory
- ▶ Theta Rhythm

## Theta Rhythm

### Definition

A hippocampal oscillation of approximately 5–9 Hz observed during active exploration in rodents and in REM sleep in most mammals (and to a lesser extent, Birds).

- ▶ Brain Rhythms
- ▶ Evolution, of Hippocampal Formation

## Thiamine (Vitamin B1) Deficiency

### Definition

Thiamine deficiency in malnourished and alcoholic patients may lead to chronic ▶neuropathy and degeneration of the anterior lobes of the ▶cerebellum entailing ▶ataxia and ▶tremor of trunk and legs during stance and walking.

- ▶ Wernicke-Korsakoff Syndrome

---

## Thing

### Definition

A paradigm thing is a spatially extended concrete particular that has a temporal history, is subject to change and causation, can be perceived by different senses, and handled by ordinary human action, e.g. a natural material body or a human artifact. Persons, shadows, atoms, and numbers may also be called “things.” Ordinary things have been analyzed as bundles of [→] attributes, as substrata with attributes, or as systems of physical particles.

- ▶ Argument
- ▶ Logic

---

## Third Ventricle

### Synonyms

Ventriculus tertius

### Definition

The third ventricle lies in the center of the diencephalon. Via an interventricular foramen, it is connected in each case with one lateral ventricle and conveys its CSF on to the fourth ventricle via the mesencephalic aqueduct.

---

## Three Neuron Arc

### Definition

The three basic neurons that transmit activity from the semicircular canals to the eye muscle. The reflex arc is composed of a sensory afferent, central neuronal link, and motor neuron.

- ▶ Velocity Storage
- ▶ Vestibulo-ocular Reflex

---

## Threshold Accommodation

### Definition

During slowly rising sub-threshold depolarization, the action potential threshold may rise as well, due to the

Na<sup>+</sup> channel inactivation overtaking the Na<sup>+</sup> channel activation

- ▶ Action Potential

---

## Threshold Control

- ▶ Equilibrium Point Control

---

## Threshold Control in Motor Control

### Definition

Centrally-elicited changes in the threshold configuration of the body or its segments, i.e., the configuration at which activity of muscles is nullified but any deviations from this configuration meet active muscle resistance; underlies posture and movement control; a major empirical observation underlying the  $\lambda$  model for motor control; a solution to the posture-movement problem.

- ▶ Equilibrium Point Control

---

## Threshold in Psychophysics

### Definition

The minimum of stimulus intensity required to elicit a percept (absolute threshold) or to just notice a change of a given percept or between two percepts (difference threshold).

- ▶ Psychophysics

---

## Threshold Tests

### Definition

One way of testing olfaction is to present an odorant in very low concentration which is hardly smelt by the



subject. If the subject is repeatedly able to detect the odor, he is presented an even lower concentration up to the moment when he does not detect the presence of an odor anymore. Then the odorant concentration which is presented is increased again until the subject detects its presence again. This procedure is done several times. This leads to an up and down around a concentration which is called the threshold. The threshold concentration of an odorant is the minimal required concentration at which it can reliably be detected by a subject. The threshold test indicates that thresholds vary among people and are different between different odorants.

► Smell Disorders

## Thrombolysis

### Definition

Intravenous or intraarterial delivery of a clot-busting drug.

► Ischemic Stroke  
► Stroke

## Thrombotic Stroke

► Ischemic Stroke

## Thymocytes – Cells of Thymus

► Nervous, Immune and Hemopoietic Systems: Functional Asymmetry

## Thyroid Axis

► Hypothalamus-Pituitary-Thyroid Axis

## Thyrotoxic Periodic Paralysis

### Definition

Acquired disease secondary to hyperthyroidism (predominantly in Asian populations) and results from a sudden shift of  $K^+$  into the cells, which leads to hypokalemia and muscle weakness. The pathophysiology is not well understood.

## Thyrotropin Releasing Hormone

### Definition

A tripeptide with hormonal and neuromodulatory actions.

## TIA (Transient Ischemic Attack)

### Definition

ATIA is like a temporary ischemic stroke. An artery is temporarily blocked, preventing blood from reaching a part of the brain. This lack of blood flow causes that part of the brain to stop functioning, producing the symptoms. The symptoms of a TIA are the same as symptoms of an ischemic stroke. In a TIA, the blood vessel opens up again, before any permanent injury to the brain occurs and the patient recovers completely. Most TIA symptoms last less than 30 minutes, but by Definition, all deficits must have cleared within 24 hours.

► Ischemic Stroke  
► Stroke

## Tic Douloureux

### Definition

Also known as trigeminal neuralgia, sudden onset stabbing excruciating pain occurs in attacks lasting from less than 1 s to 2 min several times a day. Location is usually in the trigeminal distribution of V2 or V3.

► Headache

---

## Tics

### Definition

Brief coordinated movements that are repetitive though irregular, e.g., winking, shrugging.

capacitance. The time constant determines how rapidly the membrane potential can change in response to a current injection, or to synaptic inputs. The time constant is measured from voltage trajectory in response to a current step from the resting potential.

- ▶ Cable Theory
- ▶ Intracellular Recording
- ▶ Membrane Potential: Basics

---

## Tilt Reaction

### Definition

Activation of body and/or eye muscles induced by whole-body tilt.

- ▶ Vestibulo-Spinal Reflexes

---

## Time Domain

### Definition

The description of a signal as a function of time.

- ▶ Signals and Systems

---

## Time Coding, Electrosensory

- ▶ Temporal Coding in Electroreception

---

## Time Domain in Acoustics

### Definition

Representation of vibration or sound that relates magnitude (e.g., pressure) to time.

- ▶ Acoustics

---

## Time Constant in Eye Movement

### Definition

The time course of changes in eye position or the firing rate of neurons can sometimes be described mathematically by an exponential,  $X = X_0 e^{-(t/T)}$ , where  $X$  is the position or firing rate,  $X_0$  is the initial value of  $X$ ,  $t$  is time, and  $T$  is the “time constant” of the exponential.

The time constant is equivalent to the amount of time required for  $X$  to decay to 36% ( $1/e$ ) of  $X_0$ .

---

## Time/frequency Analysis

- ▶ Measurement Techniques (Electromyography)

---

## Time Constant in Membrane Biophysics

### Definition

The time constant of a cell membrane is determined by the product membrane resistance and membrane

---

## Timegiving Stimulus

### Definition

- ▶ Chronobiology
- ▶ Zeitgeber

## Time-on-Task Effect

### Definition

Progressive decline in performance on a task (longer reaction times, greater number of errors, increased response variability) the longer one is continuously engaged in it. The time-on-task effect is readily observable in vigilance tests. Breaks (with or without sleep) provide recuperation from the effect.

- ▶ Alertness Level

## Time-to-Contact

### Definition

The time at which contact with an approaching object will occur. Time-to-contact can be directly estimated from the visual motion of the object and object size.

- ▶ Optic Flow

## Timeless

### Definition

A gene that is a fundamental component of the molecular mechanism that underlies generation of circadian rhythmicity in animals. Abbreviation: Tim.

- ▶ Circadian Cycle
- ▶ Clock

## Timothy's Syndrome

### Definition

Timothy's syndrome is a childhood disorder that manifests clinical symptoms such as sudden death resulting from abnormal heart beat, immune deficiency, autism, hypoglycemia, syndactyly and long QT

syndrome. Timothy's syndrome is caused by missense mutations in the Cav1.2 CACNA1C calcium channel gene.

- ▶ Calcium Channels – an Overview
- ▶ Ion Channels from Development to Disease

## Tinnitus

### Definition

A personalized, enduring and annoying perception of a sound (often a rather high-pitched tone) that is not audible outside the perceiving person.

## TIRF, TIRFM

- ▶ Evanescent Field Fluorescence Microscopy

## Tissue Engineering

### Definition

The practice of growing cells to form new tissues for use as prosthetic replacement parts.

- ▶ Joints

## Titin

### Definition

Titin, also called connectin, is a giant filamentous polypeptide consisting primarily of about 300 immunoglobulin (Ig) and related fibronectin type III repeats, and a unique proline (P), glutamate (E), valine (V), and lysine (K)-rich (PEVK) domain. Titin spans a half sarcomere in skeletal muscle, from M-band to the Zplate.

Titin is associated with passive stiffness and force production in muscle and preserving structural integrity of the sarcomere.

► [Molecular and Cellular Biomechanics](#)

---

## TLLBs

► [SC – Tectal Long-Lead Burst Neurons](#)

---

## T-Lymphocytes

### Definition

Often called T cells. T cells are divided into CD4<sup>+</sup> and CD8<sup>+</sup> T cells. CD4<sup>+</sup> T cells can be subdivided into T helper (Th) 1 and Th2 cells. Th1 cells produce cytokines, such as interleukin (IL)-2 and interferon- $\gamma$ , and mediate a delayed type hypersensitivity (DTH) response, while Th2 cells produce cytokines, such as IL-4, 5, 6, 10, and 13, and help in humoral immunity. CD8<sup>+</sup> T cells play a role as cytotoxic T lymphocyte (CTL). CD4<sup>+</sup> T cells recognize exogenous antigens presented by major histocompatibility complex (MHC) class II, while CD8<sup>+</sup> T cells recognize endogenous antigen (usually synthesized within cells) presented by MHC class I molecule.

---

## TNF- $\alpha$

### Definition

► [Tumor Necrosis Factor- \$\alpha\$](#)

---

## TNF-receptor 1 (TNFR1)

### Definition

TNFR1 is one of the tumor necrosis factor- $\alpha$  (TNF- $\alpha$ ) cognate receptors that is expressed predominantly in astrocytes and oligodendrocytes and elicits both cell

survival and cell death signals. Upon binding of TNF- $\alpha$  induces activation of intracellular pathways, including NF- $\kappa$ B that is involved in the activation of genes that regulate different cellular processes and MAPKs which are a family of cytoplasmic proteins that form an integrated network controlling cellular functions such as differentiation, proliferation, and cell death.

► [TNF- \$\alpha\$](#)

---

## TNFR2

► [Brain Inflammation: Tumor Necrosis Factor Receptors in Mouse Brain Inflammatory Responses](#)

---

## TNFR55

► [Brain Inflammation: Tumor Necrosis Factor Receptors in Mouse Brain Inflammatory Responses](#)

---

## TNFR60

► [Brain Inflammation: Tumor Necrosis Factor Receptors in Mouse Brain Inflammatory Responses](#)

---

## TNFR75

► [Brain Inflammation: Tumor Necrosis Factor Receptors in Mouse Brain Inflammatory Responses](#)

---

## TNFR80

► [Brain Inflammation: Tumor Necrosis Factor Receptors in Mouse Brain Inflammatory Responses](#)

## Tolerance and Dependence

MACDONALD J. CHRISTIE

Pain Management Research Institute, Kolling Institute,  
The University of Sydney at Royal North Shore  
Hospital, St Leonards, NSW, Australia

### Definition

The clinical utility of many psychoactive drugs is limited by development of tolerance and dependence during chronic use. Tolerance and dependence contribute to the induction and maintenance of ▶[drug addiction](#). ▶[Drug tolerance](#) is defined by a reduced responsiveness of the organism to the drug, usually manifest by the need to use increasing doses to achieve the desired effect. Use of the term drug tolerance usually refers the long-term loss of responsiveness that develops after days to weeks of drug use. “Acute” tolerance, which develops rapidly (seconds to minutes) during the course of a single episode of ▶[drug intoxication](#) is often explained by rapid mechanisms of ▶[receptor desensitization](#) and/or ▶[internalization](#) but other homeostatic processes can also be involved. ▶[Drug dependence](#) often (but not always) develops in parallel with tolerance. Dependence is defined by the emergence of a ▶[withdrawal syndrome](#), usually aversive, upon cessation of chronic drug use. Specific withdrawal syndromes are characteristic of the class of drug used and are known to result from unmasking of neural adaptations that have developed to achieve homeostasis during chronic drug use. For the major drugs of ▶[addiction](#), withdrawal symptoms almost invariably include craving which can be very persistent.

### Characteristics

#### Quantitative Description

Tolerance results from adaptive mechanisms at the level of the drug target (receptor), as well as at the cellular, synaptic and network levels, where adaptive changes occur due to homeostatic mechanisms tending to restore normal function in spite of the continued perturbations produced by the drug. Metabolic tolerance, usually due to hepatic enzyme induction makes a minor contribution to behavioural tolerance for some drugs, eg. ▶[alcohol](#). Associative, or conditioned tolerance, where drug use is always paired with a distinctive environment also plays an important role and is mediated by specific neural systems in behaving animals. While the present discussion is confined to tolerance, it should also be noted that some behavioural responses to drugs are enhanced (▶[sensitization](#)) with chronic use which is thought to contribute to drug addiction [1].

Tolerance can arise from metabolic depletion of ▶[neurotransmitters](#) or neurotoxicity. Some drugs,

most notably 3,4-methylenedioxy ▶[methamphetamine](#) (MDMA or ▶[ecstasy](#)) produce profound tolerance via neural metabolic mechanisms [2] that involve depletion of the target neurochemical and anatomical structures, ▶[serotonin](#) and serotonin containing nerve terminals (see Chapter on Stimulants). MDMA acts principally by releasing serotonin from nerve terminals in the brain. Acute doses of MDMA profoundly deplete serotonin from nerve terminals. Replenishment is thought to be delayed because MDMA also inhibits tryptophan hydroxylase, a key serotonin synthesizing enzyme. In animal models (and probably humans) MDMA damages serotonergic nerve terminals, which partially or fully recover function over periods of weeks to months. The substantial tolerance that develops after single or repeated doses of MDMA persists for weeks and is almost certainly due to these mechanisms. Tolerance to some other drugs that release ▶[brain monoamines](#), such as methamphetamine may, in part, involve similar mechanisms.

Adaptive mechanisms at multiple levels of organisation of the nervous system can contribute to tolerance. These can be roughly divided into the three kinds of adaptive processes outlined in Fig. 1. In panel A of Fig. 1, “receptor tolerance” refers to loss of responsiveness of the target receptor over time. For ▶[G-protein coupled receptors](#) (▶[GPCRs](#)), loss of function of the receptor may be due to reduced receptor expression on the cell surface or loss of functional coupling to effectors, such as ▶[potassium-selective channels](#) in the case of opioid drugs interacting with the  $\mu$  receptor [3]. Loss of cell surface receptor expression over periods of days to weeks, termed ▶[downregulation](#), can arise from multiple cellular mechanisms. Receptor activation of many GPCRs, particularly by high agonist concentrations induces their internalization and recycling (see Fig. 2). A net loss of surface receptors may occur during agonist stimulation because a large proportion of receptors may be in the intracellular stage of the cycle at any one time, particularly when tolerance is already profound and receptor occupancy is high. Disruption of capacity of ▶ [\$\mu\$ -receptors](#) to internalize by germline knockout of a key protein in the pathway,  $\beta$ -arrestin (Arrestin 3), prevents opioid tolerance development [4], suggesting this process is important for behavioural expression of tolerance. A net loss of receptor protein can also develop because a proportion of receptors internalized during each cycle are targeted to lysosomes for degradation. Some GPCR agonists stimulate receptors strongly but do not activate internalization cascades and produce little downregulation. For example, morphine and etorphine are both efficacious  $\mu$ -receptor agonists but morphine only very weakly induces internalization [5]. This difference has been postulated to produce differences in rate or extent of tolerance development [5]. Chronic treatment

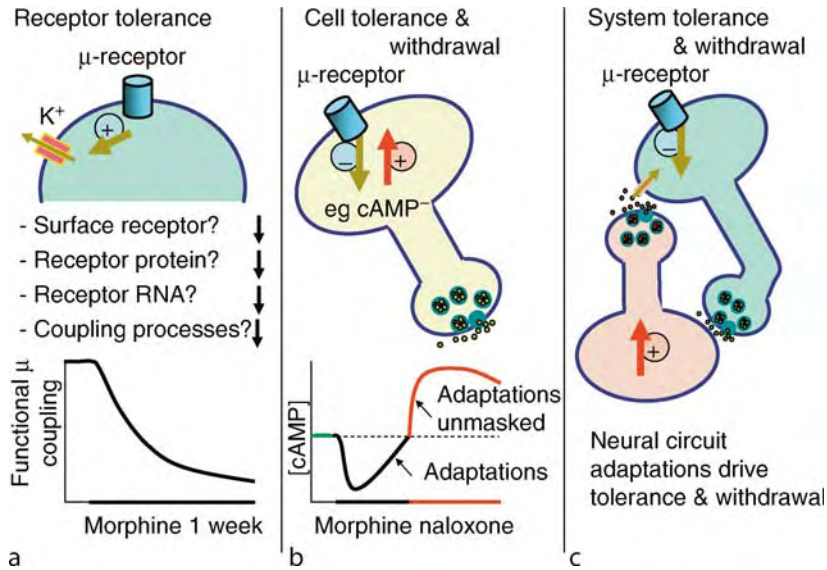

**Tolerance and Dependence. Figure 1** Uses the example of opioid tolerance at  $\mu$ -opioid receptors to show the general levels of neural organization where tolerance develops. In Panel A tolerance can arise from a direct loss of target receptor function, which can be due to any of the mechanisms listed. In Panel B adaptive processes within the cell, either downstream of the receptor or via general cellular homeostatic mechanisms, adapt to chronic perturbation to restore (near) normal function. On removal of drug, or application of receptor antagonists (naloxone for  $\mu$ -receptors) these adaptations rebound to cause cellular withdrawal. In Panel C broader homeostatic adaptations can develop throughout neural networks to produce tolerance and then withdrawal on removal of drug.

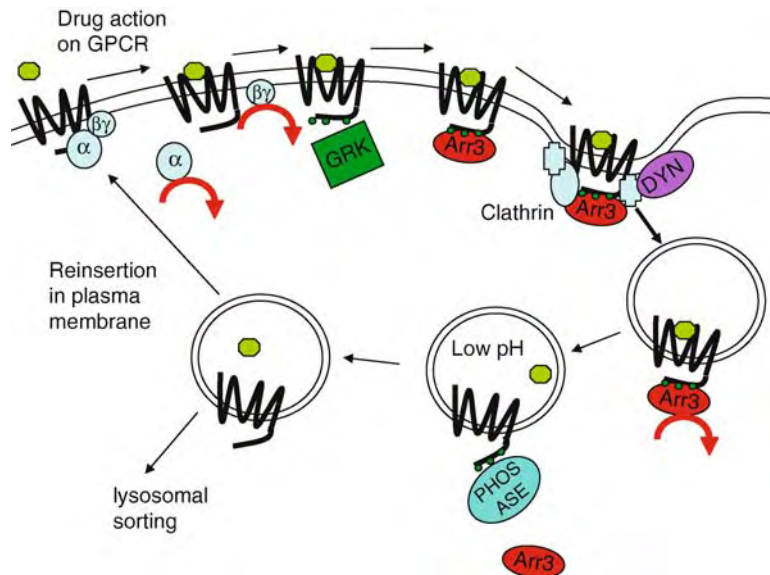

**Tolerance and Dependence. Figure 2** Shows the general cycle of GPCR cycling that can contribute to desensitization and downregulation [4]. Red arrows indicate points in the cycle where active receptor signaling occurs (G protein  $\alpha$  and  $\beta\gamma$  subunits signal to many effectors such as potassium channels, calcium channels and adenylyl cyclase, and the receptor- $\beta$ -arrestin (Arr3) complex signals through other effectors). G-protein receptor kinase (GRK) phosphorylation is thought to initiate desensitization, following which Arr3 associates, driving dynamin (DYN) dependent endocytosis. It should be noted that the details of these signaling processes have not been fully established for all of the GPCRs relevant for addiction or clinically.

with etorphine produces moderate downregulation of  $\mu$ -receptors but morphine does not, possibly because a small proportion of  $\mu$ -receptors are degraded during each internalization cycle driven by etorphine but not by morphine. It should also be noted that alternatively spliced GPCRs, which often vary in the C-terminal domains involved in association with **receptor trafficking** proteins may be cycled at different rates. Tissue specific expression of splice variants could therefore differentially affect tolerance development in different neural systems. Other GPCRs, for example the **cannabinoid receptor** (CB1), are preferentially targeted to lysosomes after internalization. Tolerance to **cannabinoids** may be largely due CB1 receptor degradation by lysosomes and is prevented by blockade of lysosomal targeting the receptor [6] (see Chapter on Cannabinoids). For some GPCRs persistent activation may decrease mRNA synthesis although this has generally been found not to be the case for many receptors including the  $\mu$ -receptor (author to correct).

For **ionotropic** receptor agonists, most notably nicotine, receptor tolerance and its contribution to dependence is very complex [7]. Neuronal **nicotinic receptors** are composed of varying combinations of multiple subunits that are differentially expressed in the nervous system. Different subunit combinations have different rates of rapid receptor desensitization. Paradoxically, chronic nicotine treatment increases cell surface expression of some subunits but this is thought to occur because receptors accumulate at the cell surface in a persistently desensitized state.

Panel B of Fig. 1 illustrates cellular tolerance using cyclic-AMP (**cAMP**) as an example of a specific set of adaptations that develop downstream of receptor activation. Inhibitory GPCRs interacting with the Gi/o class of **G-proteins** that couple to inhibition of **adenylate cyclase** activity thereby reducing cAMP concentrations (e.g. all **opioid receptors**, **dopamine D2** and **cannabinoid receptors**) produce adaptive superactivation of adenylate cyclase with chronic drug exposure [8]. Depressed cAMP concentrations return to normal during continued exposure to the drug because adenylate cyclase is superactivated. Other components of the cAMP and **cAMP-dependent kinase** (protein kinase A; **PKA**) cascade (e.g. phosphodiesterases) also appear to adapt to return cAMP concentrations to normal. Downstream effectors of cAMP therefore develop tolerance. Chronic disturbances of **cAMP-PKA** activity and other protein kinases downstream from receptor activation can produce myriad cellular adaptations. Considerable attention has focussed on transcriptional control via phosphorylation state of the **cAMP response element-binding protein** (CREB), which affects protein synthesis of neurotransmitter receptors, adenylate cyclase isoforms and other signaling proteins [1,8,9]. Cycles of

intoxication and withdrawal may produce different adaptations than persistent drug exposure via these mechanisms. Cellular adaptations are not limited to events downstream of the receptor. Other homeostatic mechanisms, such as altered transmembrane chloride gradients, calcium homeostasis or synaptic structure and strength of synaptic transmission, are activated within neurons by the persistent changes in neural excitability produced by various drugs [10].

System tolerance and withdrawal is shown in Panel C of Fig. 1. Homeostatic adaptations to neural firing, synaptic strength and neurochemical balance can develop throughout neural and neuron-glia networks to compensate for depressed or enhanced activity produced by chronic drug exposure of one component of the network [10]. For some signaling systems quite specific antagonistic or compensatory neural mechanisms have been postulated. For  **$\mu$ -opioids**, various peptide containing neural systems have been proposed to function as “anti-opioid” systems including the **dynorphin- $\kappa$ -opioid system**, **neuropeptide FF**, **orphanin FQ/nociceptin** and **cholecystokinin** [5]. Such systems may develop compensatory or functionally antagonistic actions during morphine tolerance development to mediate tolerance.

Drug dependence and the emergence of a **withdrawal syndrome** on cessation of drug use (or administration of drug antagonists) are believed to result from many of the adaptations described above. Receptor tolerance (Panel A, Fig. 1) is largely passive in terms of development of dependence for receptor systems that exhibit low or subtle basal activity. For example,  $\mu$ -receptor tolerance can be dissociated from dependence under some circumstances because simply reducing sensitivity of the receptor does not produce withdrawal rebound on cessation of drug use. For neural systems where tonic activity of the receptor in question is critical for normal function, eg. **GABA<sub>A</sub>** receptors, loss of receptor sensitivity can contribute substantially to withdrawal. Loss of GABA<sub>A</sub> receptor function associated with alcohol tolerance almost certainly contributes to reduced **seizure threshold** and other signs of the **alcohol withdrawal syndrome**. Partially restoring GABA<sub>A</sub> receptor function during withdrawal using benzodiazepines attenuates many of these signs and symptoms.

Adaptations downstream from receptor activation, or receptor independent homeostatic adaptations in neurons or neural networks produce drug withdrawal signs and symptoms, which can be very persistent. During opioid withdrawal, rebound elevation of cAMP signaling mechanisms drive withdrawal behaviour (See Panel B, Fig. 1, [3]). Similar mechanisms are also likely to occur for other GPCRs that couple to inhibition of adenylate cyclase [3]. Multiple downstream or circuit adaptations may persist for weeks to months or years

after cessation of drug use. Some are of a general structural nature, such as altered neuronal and synaptic architecture, dendritic morphology and axonal branching may be driven by transcriptional effects of phospho-CREB, other phosphorylation-transcriptional cascades or neuron-glia interactions [1,8–10].

## References

1. Lu L, Koya E, Zhai H, Hope BT, Shaham Y (2006) Role of ERK in cocaine addiction. *Trends Neurosci* 29:695–703
2. Parrott AC (2005) Chronic tolerance to recreational MDMA (3,4-methylenedioxymethamphetamine) or ecstasy. *J Psychopharmacol* 19:71–83
3. Williams JT, Christie MJ, Manzoni O (2001) Cellular and synaptic adaptations mediating opioid dependence. *Physiol Rev* 81:299–343
4. Bohn LM, Gainetdinov RR, Lin F-T, Lefkowitz RJ, Caron MG (2000)  $\mu$ -Opioid receptor desensitization by  $\beta$ -arrestin-2 determines morphine tolerance but not dependence. *Nature* 408:720–723
5. Waldhoer M, Bartlett SE, Whistler JL (2004) Opioid receptors. *Annu Rev Biochem* 73:953–990
6. Tappe-Theodor A, Agarwal N, Katona I, Rubino T, Martini L, Swiercz J, Mackie K, Monyer H, Parolaro D, Whistler J, Kuner T, Kuner R (2007) A molecular basis of analgesic tolerance to cannabinoids. *J Neurosci* 27:4165–4177
7. Dani JA, Harris RA (2005) Nicotine addiction and comorbidity with alcohol abuse and mental illness. *Nat Neurosci* 8:1465–1470
8. Watts VJ, Neve KA (2005) Sensitization of adenylate cyclase by Galpha i/o-coupled receptors. *Pharmacol Ther* 106:405–421
9. Carlezon WA Jr, Duman RS, Nestler EJ (2005) The many faces of CREB. *Trends Neurosci* 28:436–445
10. Rich MM, Wenner P (2007) Sensing and expressing homeostatic synaptic plasticity. *Trends Neurosci* 30:119–125

## Toll-like Receptor

### Definition

The Toll-like receptors (TLRs) are transmembrane proteins that recognize pathogens and activate immune cell responses. TLRs are activated following the binding of small, conserved molecular sequences found on pathogens called pathogen-associated molecular patterns or PAMPs.

► **Microglia: Functions in Immune Mechanisms in the Central Nervous System**

## Tongue Dorsum

### Definition

Top surface of tongue, visible when the mouth is open. The tongue dorsum contrast to the tongue ventrum, the underneath side of the tongue.

► **Tactile Sensation in Oral Region**

## Tonic Activity of Sympathetic Nerves

GERARD L. GEBBER

Department of Pharmacology and Toxicology,  
Michigan State University, East Lansing, MI, USA

### Definition

“Tonic” refers to a state of continuous activity that exists in both the sympathetic and parasympathetic divisions of the autonomic nervous systems under a wide variety of conditions. Strictly defined, “autonomic” or “autonomous” signifies independence or freedom from control by external forces. In actuality, this definition should not be applied to pre- and postganglionic autonomic neurons because their tonic discharges are synaptically driven. In the case of the sympathetic division, many of the inputs that are now referred to as “presympathetic” originate in the brainstem.

This essay deals exclusively with the tonic activity of sympathetic nerves with cardiovascular targets.

### Characteristics

#### Quantitative Description

Recordings from pre- and postganglionic sympathetic nerve bundles with cardiovascular targets reveal a complex and variable mixture of rhythmic and aperiodic components. Depending upon experimental conditions, rhythmic discharges with frequencies equal to or less than that of the respiratory rate, and equal to or higher (~10 Hz) than the heart rate have been observed in several species. The rhythmic discharges are superposed on a background of ► **broad-band noise** whose nature will be discussed later in this essay.

Fast Fourier transform is used to decompose sympathetic nerve discharge (SND) into its frequency components. The results are depicted as a ► **power density spectrum**, in which power (watts) of the signal is plotted as a function of frequency. **Figure 1** shows a series of power density spectra of inferior cardiac



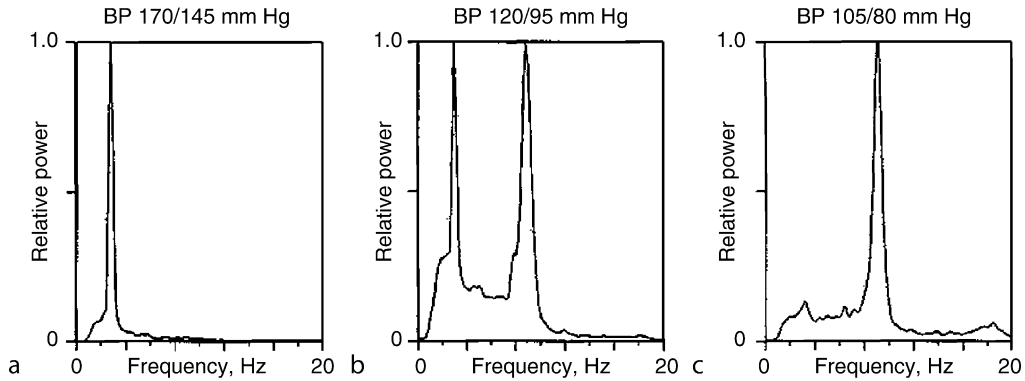

**Tonic Activity of Sympathetic Nerves. Figure 1** Frequency composition of naturally occurring discharges recorded from inferior cardiac postganglionic sympathetic nerve at three different blood pressure levels (in mmHg) in a urethane-anesthetized cat. Each of the power density spectra of inferior cardiac sympathetic nerve discharge (SND) is an average 32 5-s windows with a frequency resolution of 0.2 Hz per bin. Relative power on a scale of 0–1.0 is plotted as a function of frequency.

postganglionic SND obtained at different blood pressure levels in a urethane-anesthetized cat.

The respiratory-related rhythm in SND was purposely filtered from this recording to draw the reader's attention to the two more rapid (cardiac-related and 10 Hz) rhythms. The frequency composition, as well as the absolute power of SND, is highly dependent upon the level of negative feedback from the arterial baroreceptors to the central generators. When negative feedback was very strong at a high blood pressure level (170/145 mmHg), almost all of the power in SND appeared in a peak at the frequency ( $\sim 3$  Hz) of the heart beat (Fig. 1a). When blood pressure was lowered to 120/95 mmHg, thereby reducing the negative feedback, a  $\sim 10$ -Hz rhythm appeared in combination with the cardiac-related rhythm (Fig. 1b). Moreover, these rhythms were superposed on a broad-band of background noise. Total absolute power was increased as expected when baroreceptor-mediated central inhibition of SND is reduced. Further lowering of blood pressure to 105/80 mmHg all but eliminated the cardiac-related rhythm, but led to a further increase in 10-Hz as well as broad-band power (Fig. 1c). The changes in absolute power in these bands are not directly evident because power in each of the spectra is normalized on a scale of 0–1.0.

### Higher Level Structures

As first observed in Ludwig's laboratory in the nineteenth century [1], blood pressure in anesthetized animals is little affected by midbrain transection at the midcollicular level (i.e. decerebration), but is profoundly reduced by transection of the cervical spinal cord. The fall in blood pressure is attributable to the loss of tonic SND generated in the lower brain stem. As reviewed below, the mechanisms involved in generating tonic SND remain controversial. Information on the influences exerted on

SND by peripheral afferents and forebrain regions is beyond the scope of this essay. These subjects have been reviewed by Sato and Schmidt [2] and in the book edited by Loewy and Spyer [3].

### Lower Level Components

The properties and anatomical distribution of pre- and postganglionic sympathetic neurons are described in the book edited by Lopwy and Spyer [3].

### Higher Level processes

Chemical inactivation of an anatomically circumscribed region of the rostral ventrolateral medulla (RVLM) by microinjection of the  $\gamma$ -aminobutyric acid (GABA) agonist, muscimol, leads to reductions in SND and blood pressure to levels approaching those observed after cervical spinal cord transection. Thus, the integrity of the RVLM is essential for maintenance of the normotensive state. Neurons in the RVLM send their axons to the intermediolateral cell column (IML) of the thoracolumbar spinal cord, which contains the somata of the preganglionic sympathetic neurons.

Two contrasting views have been offered on the origin of the discharges of RVLM presympathetic neurons and, thus, tonic SND. The view of Guyenet et al. [4] is based on data from the rat. They found that some RVLM presympathetic neurons exhibit endogenous **pacemaker** properties, leading to clock-like discharges at a frequency near 20 Hz either in slice or after blockade of excitatory synaptic transmission in vivo with kynurenate. On this basis, they attribute tonic SND, at least in part, to RVLM pacemaker neurons, and ascribe the cardiac- and respiratory-related rhythms in SND to resetting of pacemaker discharges by synaptic inputs from baroreceptor circuits and the respiratory oscillator.

In contrast, Barman and Gebber [5] have proposed that the rhythmic components of SND in the cat are generated by networks of anatomically distributed brain stem neurons of different types, none of which necessarily has pacemaker properties. They view the rhythmic components of SND as arising in ►network oscillators that may become entrained to their baroreceptor and respiratory inputs under some conditions and not in others. The neurons comprising the network oscillators are located in at least four distinct regions of the medulla oblongata. These are the RVLM, caudal ventrolateral medulla (CVLM), lateral tegmental field (LTF) and raphe nuclei. Those in the RVLM and raphe send their axons to the IML, whereas LTF and CVLM do not. Antidromic mapping has been used to trace the axons of the LTF neurons to the RVLM and raphe. Barman and Gebber [5] have reviewed the interconnections of the four cell groups and the methodology used to demonstrate correlation of their discharges to the cardiac-related and/or 10-Hz rhythms in SND. Strikingly, none of the medullary neurons in the cat with sympathetic nerve-related activity exhibit the clock-like activity expected of pacemaker neurons. Rather, cat medullary neurons with activity correlated to the cardiac-related and/or 10-Hz rhythms miss firing in a variable number of cycles of postganglionic SND. As a consequence, interspike intervals are quite variable as evidenced by their exponential or  $\gamma$ -like distributions. Thus, the strong rhythms characteristic of SND are not readily apparent at the level of the single neurons comprising the generators of the cardiac-related and 10-Hz rhythms. Rather, the rhythms in SND appear to be ►emergent properties of brain stem networks composed of irregularly firing neurons. Figure 2 illustrates this point.

Bursts of postganglionic inferior cardiac nerve activity were locked 1:1 to the arterial pulse in this baroreceptor-intact cat (Fig. 2a). The cardiac-related rhythm, however, was not readily apparent in the spike train of a LTF neuron whose activity was recorded along with SND. Note that the LTF neuron missed firing in a variable number of cardiac-related bursts of SND (Fig. 2a). As a consequence, the interspike interval histogram for this LTF neuron was  $\gamma$ -like in shape (Fig. 2b). Nonetheless, the LTF spike-triggered average of SND (Fig. 2c) and the ►coherence function relating LTF unit activity to SND (Fig. 2e) demonstrated that the two signals were correlated. When active, the preferred firing time of the LTF neuron was near the beginning of the rising phase of the cardiac-related burst of postganglionic SND (Fig. 2c). It follows that the strong rhythm in SND emerges from the synchronized discharges of a small and continuously changing segment of the total population of such brain stem neurons.

The debate on whether the rhythmic components of SND are generated by cellular pacemakers or network

oscillators likely will continue for some time. Regarding the pacemaker theory of Guyenet et al., Lipski et al. [6] have argued that RVLM presympathetic neurons are normally synaptically driven rather than intrinsically active. Specifically, their intracellular recordings made in vivo from rat RVLM neurons did not show pacemaker potentials in preparations in which their synaptic inputs were left undisturbed. The implication of this finding is that the pacemaker potentials recorded intracellularly from these cells in slice are not normally involved in generating SND.

In the cat, LTF neurons projecting to the RVLM fire earlier during the cardiac-related burst of postganglionic SND than do RVLM-spinal neurons projecting to the IML [5]. Thus, it is unlikely that the cardiac-related rhythm is generated by RVLM pacemaker neurons. Nonetheless, the existence of a pacemaker mechanism has not been absolutely ruled out in the cat. It is possible that the brain stem networks described by Gebber and Barman's group are driven by pacemaker neurons located in an as of yet unexplored region of the cat brain stem.

As already mentioned, the rhythmic components of SND are superposed on a broad frequency band of background noise. The characteristics of the noise in SND have recently come under scrutiny. Two possibilities have been considered to explain the noise. The first is that the noise might be a ►random process comprised of uncorrelated events. The second possibility is that long-term correlations exist among the fluctuations in brain stem unit interspike intervals, population burst intervals and/or burst amplitudes. If the correlations extend over more than one time scale, the fluctuations would be best modeled as a ►fractal process in which the current value of the measured parameter is related to those in the distant past (i.e. long-term memory exists). Gebber and Barman [7] have reviewed the analytical techniques used to distinguish between random and fractal processes. They and their colleagues have provided conclusive evidence that the broad-band components in the SND are fractal rather than random in nature. The physiological implications of this finding are dealt with later in this essay.

### Lower Level Processes

The level of the tonic SND after acute cervical spinal cord transection is only a small fraction of that present in animals with an intact neuraxis. Residual SND in spinal cats is broad-band in frequency and lacks rhythmic components. Whereas the level of residual SND is low, the importance of spinal circuits in mediating changes in SND and blood pressure produced by activation of somatic and visceral afferent nerves is clear [2].

### Function

Because blood pressure is significantly reduced to hypotensive levels after cervical spinal cord transection, the importance of the continuous state of activity in the

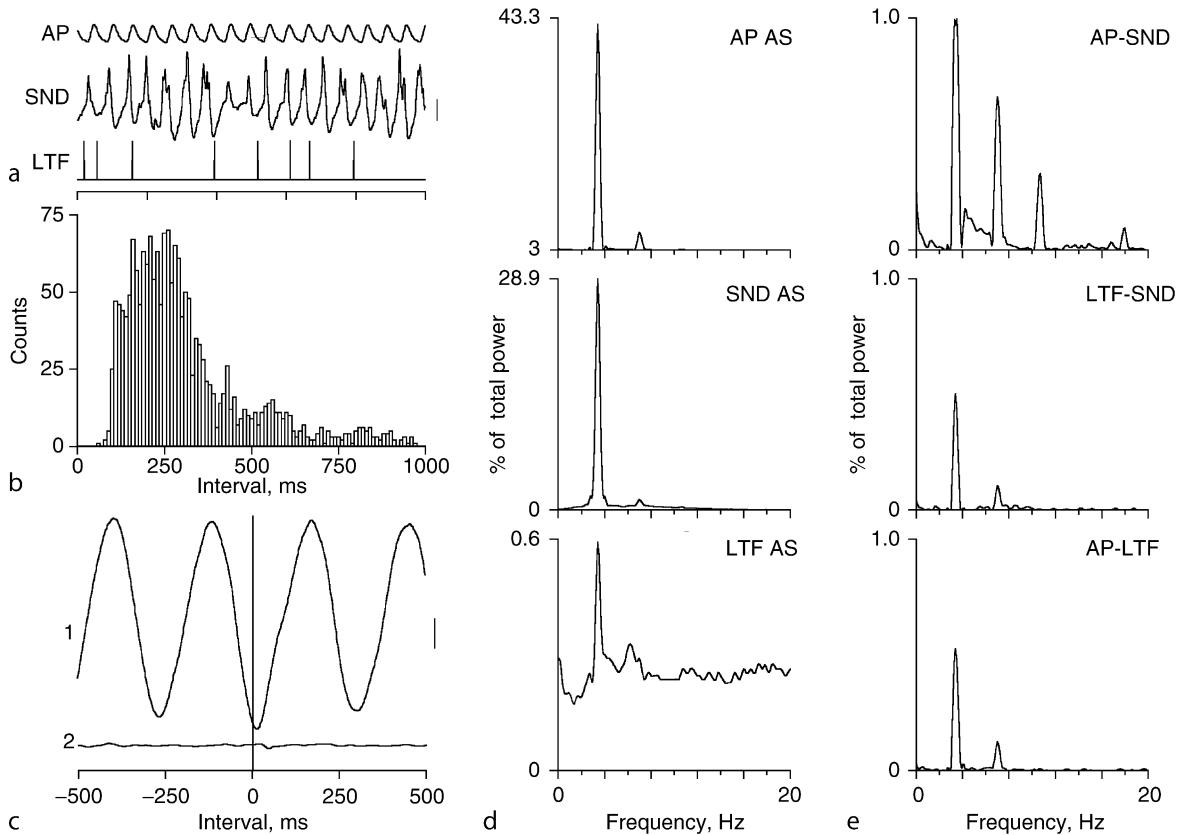

**Tonic Activity of Sympathetic Nerves. Figure 2** Coherence of the discharges of a single neuron in the medullary lateral tegmental field (LTF) to the cardiac-related rhythm in inferior cardiac SND of a barbiturate-anesthetized cat. (a) traces (top to bottom) are oscilloscopic records of the femoral arterial pulse (AP), SND, and standardized pulses representing the action potentials of the LTF neuron. Time marker is 1 s/division; vertical calibration is 40  $\mu$ V. Blood pressure was 145/105 mmHg. (b) interspike-interval histogram for this LTF neuron, bin width is 10 ms. (c) averages of SND triggered by the spikes of the LTF neuron (1) and random pulses (2), each series containing 1,622 events; bin width is 5 ms. (d) power density autospectra (AS) of AP, SND, and LTF unit activity. (e) coherence functions relating pairs of signals. The autospectra and coherence functions are averages of 125 5-s windows with a frequency resolution of 0.2 Hz per bin (reproduced from Ref. [5] with the permission of Sage Publications, Thousand Oaks, CA).

sympathetic nervous system is unquestioned. However, there is no general agreement currently as to whether one or another component (rhythmic or aperiodic) provides additional benefits. Some investigators view the rhythmic components as epiphenomena in the sense that they reflect the fundamental organization of the networks generating SND, but subservise no special role in cardiovascular regulation. However, others have proposed that the networks generating the rhythmic components of SND serve as the substrate for formulation of highly differentiated patterns of spinal sympathetic outflow. One such response pattern is the **defense reaction** whose cardiovascular components include an increase in blood pressure and heart rate, decreased blood flow to viscera due to vasoconstriction and increased blood flow to skeletal muscle due, in part,

to a reduction in vasoconstriction sympathetic outflow to that tissue [8].

The mechanisms responsible for the increases in sympathetic outflows to the heart and vasculature of the viscera in the face of decreased vasoconstrictor outflow to skeletal muscle has been the object of recent investigation. The classic view that this pattern involves activation of a point-to-point hard-wired pathway, which excites some sympathetic outflows while inhibiting others, has been questioned. The model offered by Gebber and Barman [9,10] attributes the defense reaction and perhaps other highly differentiated cardiovascular response patterns to the dynamic reorganization of the strong coupling of multiple brain stem oscillators responsible for the 10-Hz rhythm in SND. The model is briefly described here.

Rather than arising from a single source, the 10-Hz rhythm is generated by a family of dynamically coupled brainstem oscillators, each of which primarily controls a different portion of the spinal sympathetic outflow and, thus, a different cardiovascular target. The defense reaction is viewed as an **emergent property** of the system of strongly coupled 10-Hz oscillators. More specifically, the **phase relations** among the coupled oscillators are considered as an important determinant of relative 10-Hz burst amplitudes in different sympathetic nerves. Switches from one pattern of spinal sympathetic outflow (e.g. defense-like) to another (e.g. generalized increase in sympathetic outflow) is envisioned to occur when the level of some **nonspecific control parameter** (e.g. inputs from the defense region of the midbrain periaqueductal gray (PAG)) reaches a critical point at which the phase relations among the coupled oscillators are abruptly changed. Importantly, increased phase lag of one oscillator relative to another leads to a decrease in the output of the lagging oscillator and, thus, vasodilatation due to reduced vasoconstrictor outflow to its target organ. The basic observations leading to this model are presented in Figs. 3 and 4.

In anesthetized cats, the sympathetic and cardiovascular components of the defense reaction can be simulated by electrical or chemical activation of the midbrain PAG. Strikingly, whether or not electrical activation of the PAG elicits a defense-like reaction is dependent upon the frequency of stimulation relative to that of the free-running (unstimulated state) 10-Hz rhythm. The amplitude of 10-Hz bursts of activity in the sympathetic nerves to the heart (CN) and kidney (RN) was increased when the frequency of electrical stimulation was equal to or greater than that of the free-running 10-Hz rhythm. In contrast, the amplitude of 10-Hz bursts in the vertebral sympathetic nerve (VN) to the vasculature of forelimb skeletal muscle was decreased (Fig. 3a). These changes were accompanied by an increase in the phase lag of VN 10-Hz activity relative to that in the CN and RN (Fig. 4). Importantly, when the same PAG sites were electrically activated using a frequency slightly below that of the free-running rhythm, a generalized increase in the 10-Hz discharges occurred in all three nerves (Fig. 3b). Under these conditions, the phase relations among the 10-Hz discharges of the three nerves were unchanged.

The PAG stimulus frequency at which the switch between the two patterns shown in Fig. 3 occurred was always at the frequency of the free-running rhythm. This is remarkable because the frequency of the free-running rhythm ranged from 8 to 12 Hz. Thus, the same frequency of stimulation could produce either pattern depending upon the momentary frequency of the free-running rhythm. This response characteristic virtually rules out the possibility that the defense-like pattern

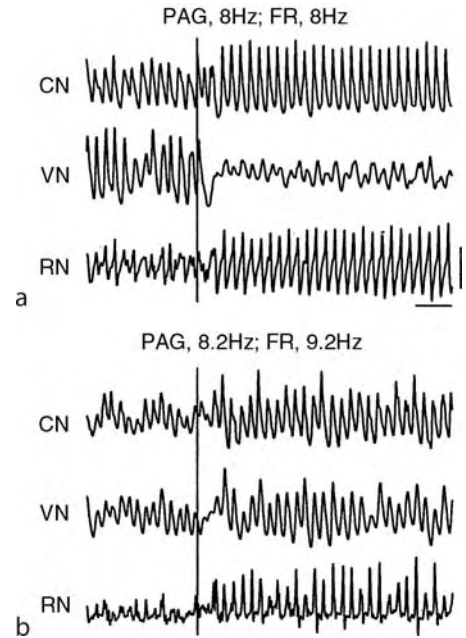

### Tonic Activity of Sympathetic Nerves.

**Figure 3** Patterns of spinal sympathetic outflow elicited by electrical activation of the defense region of the cat midbrain periaqueductal gray (PAG). Traces in (a) and (b) show the discharges of the inferior cardiac (CN), vertebral (VN), and renal (RN) postganglionic sympathetic nerves. (a) PAG stimulation at 8.0 Hz was started at vertical line; the frequency of the free-running rhythm was 8.0 Hz. (b) PAG stimulation at 8.2 Hz; free-running rhythm, 9.2 Hz (reproduced from Ref. [5] with permission of Sage Publications, Thousand Oaks, CA).

of reciprocal changes in VN versus CN and RN 10-Hz discharges arose from activation of point-to-point hard-wired connections that always reduce excitatory drive to some sympathetic nerves while increasing drive to others.

Other than reflecting long-term memory arising from nonlinear linkage of processes occurring on different time scales, the functions of the fractal noise in SND remain to be elucidated. At least two possibilities are open to future investigation. Linkage of processes operating on different timescales may prevent excessive mode-locking, which would restrict the functional responsiveness of the organism to unexpected challenges. For example, in some patients with low output congestive heart failure, there is a breakdown of fractal fluctuations in heart rate that is accompanied by the emergence of a dominant cardiac frequency mode near 0.02 Hz. Such patients are at a high risk for ventricular fibrillation. Whether fractal SND plays a role in promoting fractal fluctuations of heart rate in the healthy heart remains to be determined.

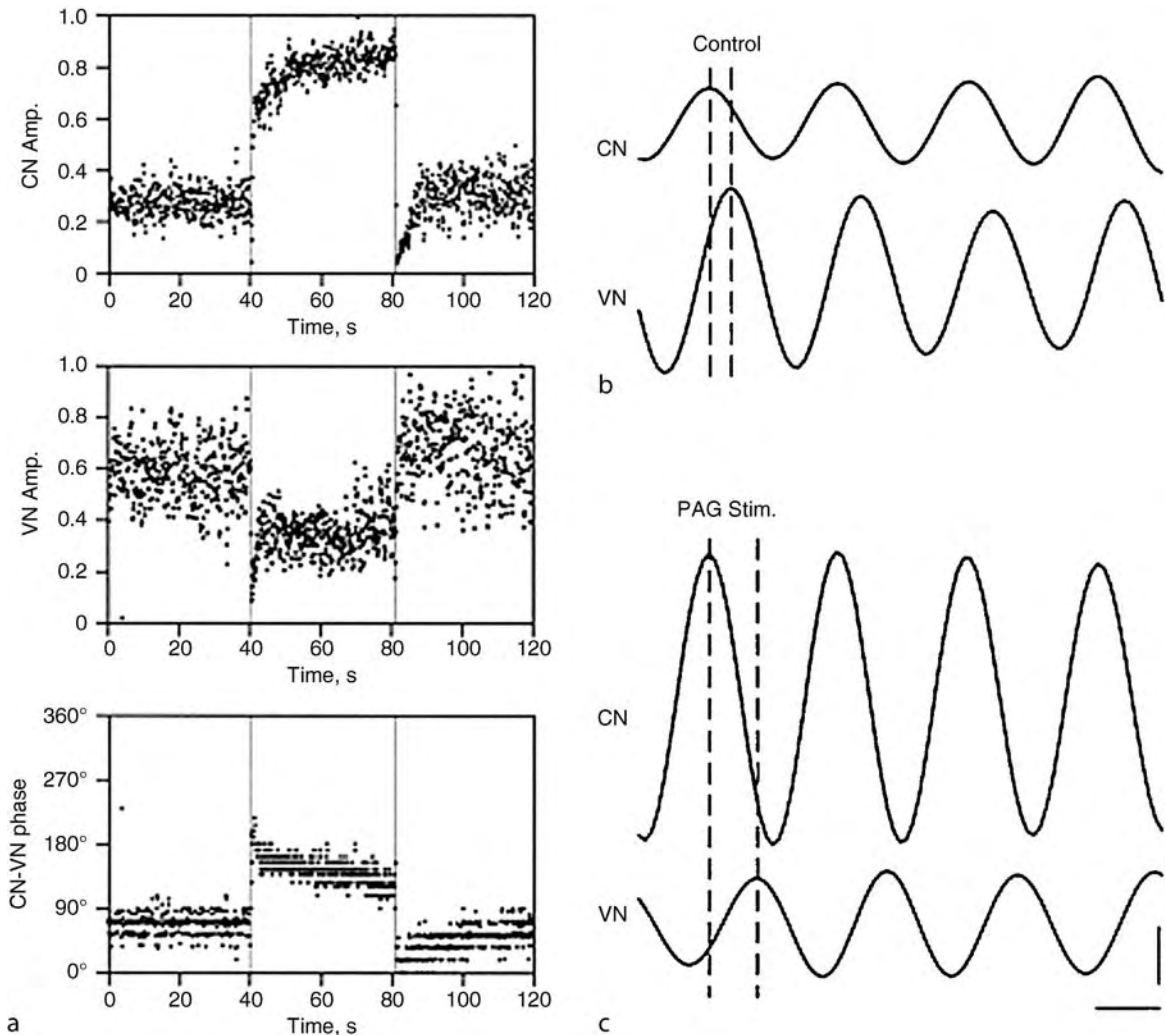

**Tonic Activity of Sympathetic Nerves. Figure 4** Defense-like changes in SND produced by PAG stimulation in a urethane-anesthetized, baroreceptor-denervated cat. (a) Amplitude and relative phase-time series of CN and VN activities. Data points are cycle-by-cycle measurements of peak-to-trough 10-Hz burst amplitude (normalized on scale of 0–1.0) and phase lag of VN 10-Hz activity relative to that in CN. Vertical lines mark start (left) and end (right) of PAG stimulation at a frequency (10-Hz) equal to that of the free-running rhythm. (b) Digitally filtered CN and VN 10-Hz slow waves in absence of PAG stimulation. (c) During PAG stimulation, vertical calibration, 40  $\mu$ V; horizontal calibration, 50 ms in (b) and (c) (reproduced from Gebber et al. (1999) *J Neurophysiol* 82:841–854 with the permission of the American Physiological Society).

Noise is often viewed as detrimental to signal detection. However, in some neuronal circuits, low levels of random or fractal noise actually optimize the response of the system to its weak rhythmic inputs. This phenomenon is referred to as **stochastic resonance**. Whether the fractal noise in SND subserves such a function, thereby promoting the pattern generating capabilities of the system of coupled oscillators generating the 10-Hz rhythm, remains open to investigation.

### Pathology

Hyperactivity of the sympathetic nervous system has been reported for certain animal models of hypertension,

and has been suggested to play a role in congestive heart failure and cardiac arrhythmias. This topic is not within the scope of this essay.

### References

1. Blessing WW (1997) The lower brainstem and bodily homeostasis. Oxford University Press, New York, Chap. 5, pp 165–268
2. Sato A, Schmidt RF (1973) Somatosympathetic reflexes: afferent fibers, central pathways, discharge characteristics. *Physiol Rev* 53:916–947

3. Loewy AD, Spyer KM (1990) Central regulation of autonomic functions. Oxford University Press, New York, pp 390
4. Guyenet PG, Koshiya N, Huangfu D, Baraban SC, Stornetta RL, Li Y-W (1996) Role of medulla oblongata in generation of sympathetic and vagal outflows. In: Holstege G, Bandler R, Saper CB (eds) The emotional motor system. Elsevier, Amsterdam, pp 127–144
5. Barman SM, Gebber GL (2000) “Rapid” rhythmic discharges of sympathetic nerves: sources, mechanisms of generation and physiological relevance. *J Biol Rhythms* 15:365–379
6. Lipski J, Kanjhan R, Kruszezwska B, Rong R (1996) Properties of presympathetic neurons in the rostral ventrolateral medulla in the rat: an intracellular study ‘in vivo.’ *J Physiol (Lond)* 490:729–744
7. Gebber GL, Barman SM (2004) What’s all the noise about? Distinguishing fractal from random processes in the sympathetic nervous system. In: Pandalai SG (ed) Recent research developments in physiology, vol 2, Research Signpost, Kerala, India, pp 167–186
8. Hilton SM (1982) The defense-aroused system and its relevance for circulatory and respiratory control. *J Exp Biol* 100:159–174
9. Gebber GL (2001) A defense-like reaction: An emergent property of a system of coupled non-linear oscillators. *Clin Exp Pharmacol Physiol* 28:125–129
10. Gebber GL, Barman SM (2003) From the top down: an alternative to reductionist views on the central neural control of cardiovascular function. In: Pandalai SG (ed) Recent research developments in physiology, vol 1, Research Signpost, Kerala, India, pp 367–384

---

## Tonic-clonic Seizures

### Definition

Tonic-clonic seizures (formerly referred to as *grand mal epilepsy*) may be preceded by an aura possibly indicating a focal origin. For example, tingling and numbness in a hand suggest involvement of the ►parietal cortex, etc. The seizure then usually starts with a *tonic phase* (of 15–30 sec duration) characterized by the opening of eyes and mouth, flexion and abduction of arms, extension of the legs, followed by jaw closure often leading to tongue laceration, respiratory arrest with cyanosis, urinary or fecal incontinence. The tonic phase is followed by vigorous jerks (cloni), rhythmic contractions of the entire body with continuing apnea, eye movements and grimacing. The seizure mostly terminates within 1–2 minutes and subsides into sleep and then confusion and lethargy. It may be the end-stadium of a primarily generalized seizure or a secondarily generalized partial seizure, and is indicative of

damage or disease of the ►cerebral cortex of various causes (e.g., infectious, vascular and neoplastic lesions, ►metabolic encephalopathy, etc.).

---

## Tonic Discharge in Oculomotor System

### Definition

The steady-state firing rate of a neuron. In the oculomotor system, the term usually refers to steady firing that co-varies monotonically with the angular position of the eyes in the orbit in a preferred direction. For instance, abducens motoneurons on the left have a steady post-saccadic discharge that is proportional to leftward eye position.

►Brainstem Burst Generator

---

## Tonic Neurons Encoding Eye Position

### Definition

Some neurons present a very stable discharge rate (i.e., a very narrow interspike interval distribution) for their physiological range of action potential firing. Two representative examples of tonic neurons are skeletal and extraocular motoneurons. A special type of tonic neuron can be found mainly in the interstitial nucleus of Cajal and in the nucleus prepositus hypoglossi; these neurons seem to encode eye position signals. Their firing is very stable for a given range of discharge rates, in order to maintain a stable eye position in the orbit during observation of a visual target.

►Neuronal Integrator – Horizontal

---

## Tonic Vibration Reflex

### Definition

Muscle contraction elicited by surface vibration, each cycle of which elicits a spike in muscle spindle afferent fibers which normally have a very low resting activity.

Also refers to the postural changes and force generated in the limb controlled by the vibrated muscle.

► **Proprioception Effect of Gravity**

## Tonics

► **Stimulants**

## Tonotopic Organization (Maps)

GÜNTER EHRET

Department of Neurobiology, University of Ulm,  
Ulm, Germany

### Synonyms

Sound representation; Auditory maps

### Definition

Tonotopic organization expresses *gradients in the representation (maps) of sound properties*. Such properties are frequency of tones, frequency ratios between harmonics and the pitch of complex sounds, speed and direction of frequency sweeps, sound intensity and location of sound in space. Scales of these properties cover space of sensory and neural tissues at levels of the ► **auditory system** of animals including humans. In a strict sense, tonotopic organization refers only to *frequency maps* as established by pure tone stimuli. In a wider sense and beyond tonotopic organization, the term “auditory map” includes also *gradients in the representation of neural response properties* to sounds such as neuronal sensitivity or response threshold, response latency, ► **dynamic range** of the response and sharpness of ► **frequency tuning**.

### Characteristics

#### Quantitative Description

Frequency maps arise in the inner ears. The relevant structure in mammals is the ► **cochlea** (Fig. 1) of which the average length varies between about 6 mm in mice and 60 mm in elephants. The cochlear length is one of the factors determining over how many octaves frequency range a given species can hear. Except for some bats (e.g. mustached bat) with specialized cochleae, sound frequency can be transformed to cochlear position by

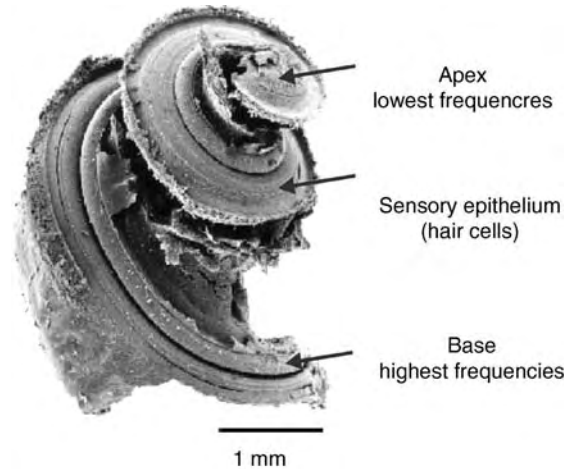

**Tonotopic Organization (Maps).** Figure 1 View of the cochlea of a rat (modified scanning electron microscopic picture by M. Lenoir). Frequency representation along the cochlear spiral starts with high frequencies at the cochlear base and ends with low frequencies at the apex. The number of coils of the cochlea and the frequency range covered are species-specific parameters.

the empirical equation:  $f = A(10^{ax} - k)$  (Eq. 1 where  $f$  = frequency;  $x$  = cochlear position as distance in mm from the apex of the cochlea;  $A$ ,  $a$ ,  $k$  = species-specific constants [1,2]). The applicability of Eq. 1 indicates that the cochleae of most mammals are scale models of each other. Except for the cochlear frequency map, quantitative descriptions of maps exist only for the main nucleus of the auditory midbrain, the central nucleus of the inferior colliculus, with regard to modeling the maps for the representation of frequency, intensity and tonal phase [3].

### Higher Level Structures

For the sense of hearing, frequency is the only sound property mapped at the level of the sensory epithelium. Hence, tonotopy in the strict sense is both the most basic and the highest-level map of all maps in the auditory systems. Tonotopies are found at all levels of the ► **auditory pathways** from the inner ear to the highest auditory centers of vertebrates from fish to mammals [4]. Sensory epithelia for hearing include the sacculus, utriculus and lagena in the inner ear of fish, the sacculus and the amphibian and basilar papillae in amphibians, the basilar papilla in reptiles and birds and the cochlea (elongated and coiled basilar papilla) in mammals. In mammals, the sensory epithelium extends only along one spatial dimension from cochlear base to apex (Fig. 1) resulting in a one-dimensional frequency map, i.e. every audible frequency is optimally transformed to a neural response only at a single spot (see Eq. 1).

Thus, the sensory cells (▶hair cells) at a given spot on the sensory epithelium or neurons at a given location in an auditory brain center are distinguished by their place-specific ▶characteristic frequency.

Frequency maps can also be found in the ears and in centers of the central nervous system of some sound-producing insects such as grasshoppers and crickets [4].

### Lower Level Components

The inner ear tonotopy is reproduced as an unchanged or expanded or compressed scale model in most centers of the auditory pathways of the brain. Studies on the central auditory pathways in mammals report additional *maps of sound properties and maps of neural response properties*. The most complete mappings exist for the auditory midbrain inferior colliculus (Fig. 2) [5–7] and the auditory cortex (Fig. 3) [8–10], especially those of the mustached bat (*Pteronotus parnellii*; (Fig. 4) [11].

### Midbrain Inferior Colliculus

In the central nucleus of the inferior colliculus, the tonotopy consists of two frequency gradients. The first

gradient is represented by ▶frequency-band laminae containing neurons of characteristic frequencies in a small range almost identical with the frequency bandwidth within which the auditory system can resolve frequency components of a complex frequency spectrum such as vowels of human speech. Frequency-band laminae of low frequencies are located dorsally, those of high frequencies ventrally and medially (Fig. 2). Within a given frequency-band lamina, characteristic frequencies of neurons increase going from medial to lateral locations (see double-lined arrow in Fig. 2). Thus, the two frequency gradients together guarantee a continuous frequency representation in a zigzag pattern through the laminae from low (dorsal and medial) to high (ventral and lateral) locations in the three spatial dimensions of this midbrain nucleus. At the same time, the frequency-band laminae map with their frequency ranges the bandwidths of frequency resolution (critical bandwidths) in the hearing of a given species.

Further maps are indicated by gradients of shading in Fig. 2. The shading from light (medial) to dark

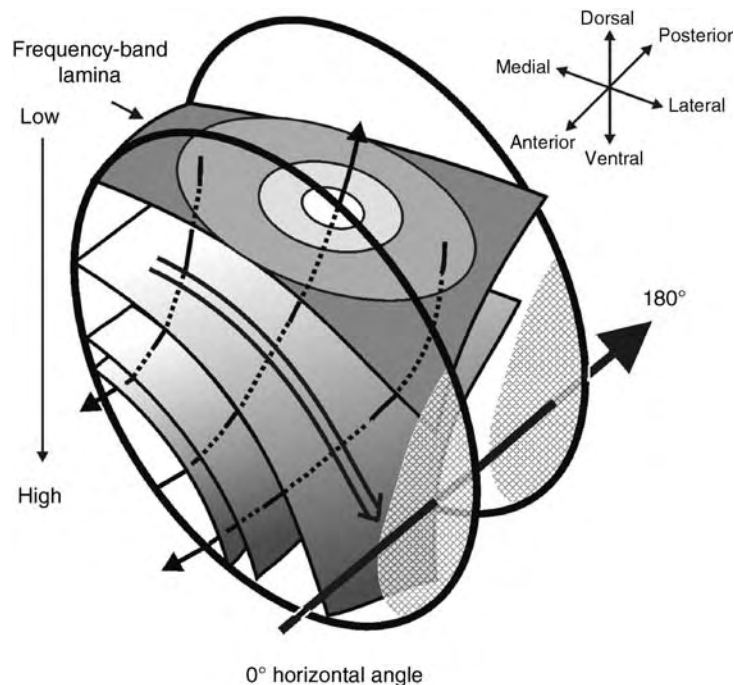

**Tonotopic Organization (Maps). Figure 2** Central part of the inferior colliculus of the midbrain whose anterior and posterior parts have been cut away. The frontal sectioning planes are indicated by the *two thick oval lines*. The remaining inferior colliculus shows the layered structure of the frequency-band laminae. Basically, the represented frequencies of the laminae increase according to the main tonotopical gradient from low (dorsal) to high (ventral). The *double-lined arrow* shows the frequency increase within a lamina from medial to lateral (minor tonotopical gradient). The *three arrows* passing through the laminae indicate the average location of neurons preferring upsweps (lateral and medial positions) or down sweeps (central position) in frequency (from low to high or high to low, respectively). Gradients of the other maps of sound properties and neural response properties are indicated by *arrows and shadings*. They are explained in the text. Modified from figures and data in [5–7].



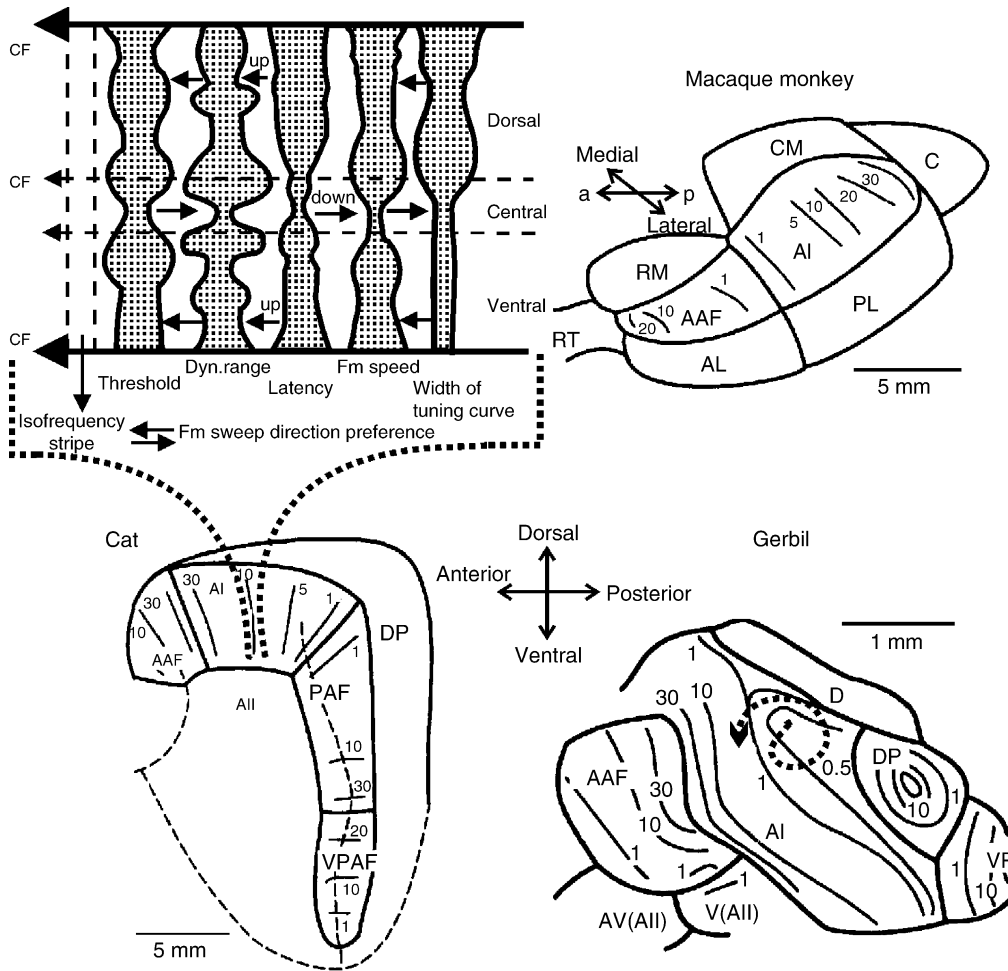

**Tonotopic Organization (Maps). Figure 3** General organization of auditory cortical fields of cats, monkeys and gerbils. Primary (A) and anterior auditory fields (AAF) are always tonotopically organized (*small numerals* indicate the characteristic frequency (CF) of neurons in kHz). Other fields (All, CM, PAF, etc.) may be tonotopically organized or not. The 10 kHz isofrequency stripe of the cat AI is enlarged. Every isofrequency stripe contains rather patchy maps of sound parameters and neural response parameters superimposed on each other (here, for better visibility they are placed side by side). Five are shown: tone response threshold and latency, size of the dynamic range, width of frequency tuning curve and preferred speed (fm speed) of an upsweeping (*up*) or a down sweeping (*down*) tone. The average locations of small values of the parameters are indicated by necks, those of large values by dilations of the patterns [8–10]. The *dotted spiral* in the gerbil AI indicates a pitch map.

(lateral) shown in the high-frequency laminae expresses an increase in the represented tonal pitch from low (medial) to high (lateral) and a decrease of neural tone-response latencies from long (medial) to short (lateral). On average, neurons located medially respond best with a relatively long latency (more than 12 ms) to low-pitched sounds (less than 100 Hz amplitude modulation frequency) while neurons at a lateral position respond best to high-pitched (more than 500 Hz periodicity) sound with a short latency (less than 10 ms). In the low-frequency lamina, a concentric pattern from the center to the periphery of the lamina indicates (i) the increase of average tone-response thresholds of

neurons, (ii) the increase in the average speed of low frequency sweeps of tones to which the neurons can optimally respond and (iii) the decrease in the average sharpness of frequency tuning of neurons. The concentric threshold map may be part of a concentric representation of sound intensity from soft (center) to loud (periphery) [3]. Finally, the bold arrow passing from anterior to posterior through the lateral nucleus of the inferior colliculus (Fig. 2, cross-hatched area) shows a gradient of neurons responding best to a sound source located at a certain horizontal angle in the range of 0–180° in the sound field contralateral to the side of the midbrain shown.

### Auditory Cortex

The auditory cortex is situated in the temporal region of the ►neocortex (Fig. 4). In mammals with non-specialized audition such as the cat, gerbil, macaque monkey and human, the auditory cortex consists of several fields of which at least the two primary fields, the primary auditory field (AI) and the anterior auditory field (AAF) are tonotopically organized (Fig. 3). Other higher-order fields may contain a clear frequency map as in the cat and gerbil or are without such a map. For example, neurons in higher-order fields may respond best to a combination of frequencies such as neurons in most fields of the mustached bat auditory cortex (Fig. 4).

Neurons located in a given ►isofrequency stripe of AI show gradients in the form of patches concerning the representation of the sound properties speed (slow vs. fast speed) and direction (up vs. down sweep direction) of frequency sweeps and the neural tone-response properties threshold, latency, dynamic range and sharpness of frequency tuning (Fig. 3, enlarged 10 kHz isofrequency stripe of the cat AI). Further, a rather spiral-like map of ►periodicity pitch (about

50–1,500 Hz) is shown in the low-frequency region of the gerbil AI tonotopy.

The auditory cortex of the mustached bat has been mapped extensively. The major maps are shown in Fig. 4 [11]. The primary auditory cortical field (AI) is divided into three parts. The frequency range between about 61 and 63 kHz is very much expanded in its representation. This specialized area of AI contains two half-circular maps of sound intensity i.e. neurons responding best to sound pressure levels between about 13–98 dB. Immediately dorsal of AI is a field (B) with a concentric map of locations of a sound source at horizontal angles of about 4–45° in the sound field contralateral to the auditory cortex shown. Also dorsal of AI is a field (C) in which the deviations between the first harmonic of the emitted bat's echolocation call and the second and third harmonic of the perceived echoes of this call are mapped in the best responses of the neurons. Two fields further dorsally in the cortex (D, E) contain maps of the time differences between the emission of the first harmonic of an echolocation call and the perception of the second, third and fourth harmonic of its echo.

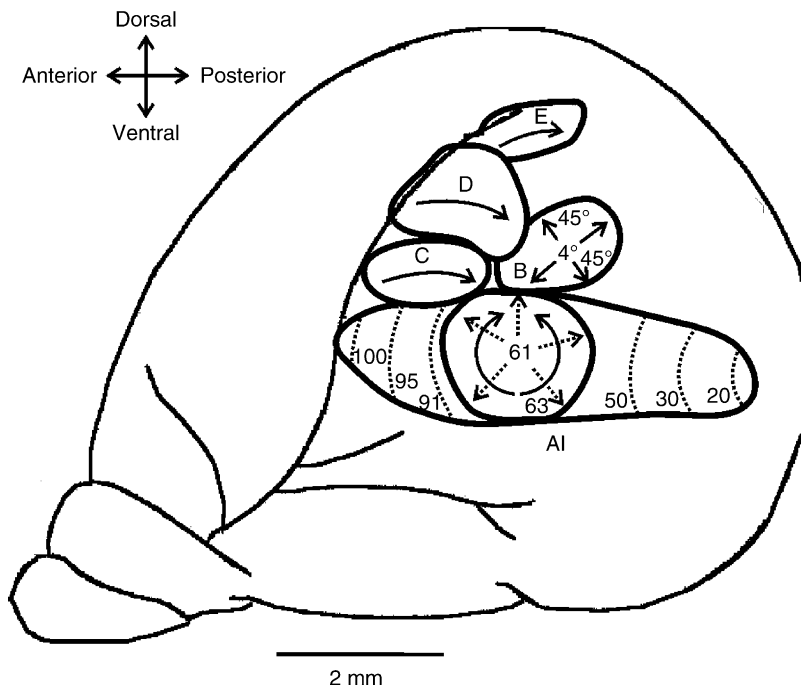

**Tonotopic Organization (Maps).** **Figure 4** Lateral view of the brain of the mustached bat. Five auditory cortical fields are shown on the temporal cortex. In the primary field (AI), the tonotopy extends from about 10 to almost 110 kHz (*small numerals*) with an expansion of the frequency range between about 61 and 63 kHz. Besides this tonotopy in AI, the other fields contain special maps in which combinations of features of the echolocation calls and their echoes are represented in order in the best responses of the neurons along the *arrows* shown. Field B indicates the horizontal position in flight direction (about 4–45°) of the prey or another object, field C contains a map of the relative speed between the bat and its pursued prey, fields D and E both contain maps of the distance between the bat and its prey [11].

### Structural Regulation

Tonotopies are established during the maturation of the inner ear. In mammals, the development starts with the responsiveness of hair cells to rather low frequencies in the middle and upper basal cochlear locations. There, the mapped frequencies increase and the tonotopy expands towards more basal and apical locations during the further development and thus leads to increases in the audible frequency range towards higher and lower frequencies respectively. Because the anatomical connections between the cochlea and the brain and along the auditory pathways of the brain are already established before the start of hearing, the tonotopic maturation of the cochlea is reflected by equivalent developments of frequency maps in the centers of the auditory pathways [12].

### Higher Level Processes

In mammals, the cochlear tonotopy emerges from mechanical properties of hair cell displacement by ►traveling waves along the sensory epithelium proceeding from the base to the apex. The main determinants of local displacement maximums are the stiffness gradient of the basilar membrane and the amplification of the displacement amplitude by the outer hair cells [1,2]. In the other classes of vertebrates, the hair cells are intrinsically tuned to respond best to a small range of frequencies in addition to the mechanical tuning along the sensory epithelium [4].

Tonotopies in higher auditory centers are due to the passing on, via homotopic anatomical connections, the point-like isofrequency information of the inner ear to two-dimensional frequency-band laminae, also called isofrequency planes, in auditory centers having three spatial dimensions (e.g. Fig. 2) or to one-dimensional isofrequency stripes in the two-dimensional auditory cortex (Figs. 3 and 4). Thus frequency maps in higher auditory centers such as midbrain and auditory cortex of the forebrain basically emerge from the patterns of anatomical connections and from the shapes and sizes of the auditory centers.

### Lower Level Processes

Auditory maps other than frequency representations are *computational maps*. They result from processing of the neural code of auditory nerve fibers in brain centers and from neural interactions in and between centers of the auditory pathways. For example, maps of auditory space concerning the horizontal plane (see Figs. 2 and 4) can be established only after inputs from the left and right ear have been compared in nuclei of the brainstem superior olivary complex. There, differences both in the arrival time and the amplitude of the signals from the ears, which are due to the horizontal angle of a

sound source relative to the ears, lead to a differential activation of neurons in such a way that a given horizontal angle is represented as a response optimum of neurons at a certain location in the superior olivary nuclei. This sorting of horizontal angles of sound sources to places in neural tissues in the brainstem is the origin of maps of horizontal space in the midbrain (Fig. 2) and the auditory cortex (Fig. 4).

The various auditory maps on the frequency-band laminae of the inferior colliculus (Fig. 2) and on the isofrequency stripes of the auditory cortex (Fig. 3, expanded 10 kHz stripe of cat AI) are often superimposed on one another. Important consequences arise. (i) Only a few neural representations of sound properties and neural response properties exist independently of each other. The functional geometry of a brain area restricts the maximal number of independent maps to three in a given three-dimensional space (e.g. inferior colliculus) and to two in a given two-dimensional space (e.g. primary auditory cortex). (ii) The interdependence of mapped properties create slocus-specific combination sensitivities in the responses of the neurons. At a given place, combination-sensitive neurons may respond best to sounds of a certain frequency composition, intensity, pitch and location in space, all at the same time.

### Process Regulation

The shapes, even up to the loss, of auditory maps in a given brain center are regulated in several ways. Long-term exposure to a given sound, mainly in young subjects and experience with sounds of importance (learning) strongly influence auditory maps, especially in higher centers of the auditory pathways [11,13,14]. In general, the representations of the prevalent, discriminative or otherwise important sound characteristics are enlarged. This plasticity of auditory maps is mediated by changes in (i) the balance between converging excitatory and inhibitory input to neurons of a map, (ii) the connections between neurons at different levels of the auditory system and between neurons in a given auditory center, (iii) the influence of higher on lower auditory centers often correlating with the attention to and expectation of certain sounds and (iv) the influences of other sensory and modulating (e.g. hormonal, motivational, emotional) systems on the auditory system.

### Function

The formation of auditory maps in the brain answers the question as to how properties of sounds from the external world are transformed into internal neural representations on which the “brain can work”, i.e. that can be used as the basis for sound perception and recognition. In this sense, all auditory maps are functional maps. The mere existence of a map for a

certain sound property indicates the parameter range over which this property can be perceived and discriminated. For example, the frequency range of the tonotopy covers the main frequency range of hearing and indicates that these frequencies can be discriminated. If a certain parameter range of a map is expanded or a map is restricted to a small parameter range only, this overrepresentation or selected representation indicates a special importance of this range in hearing and sound communication of a species. An example is the mustached bat's AI with the enlargement of the 61–63 kHz range (Fig. 4). In this range, the bat expects the main echo frequency of its echolocation call for getting information about the size and location (equivalent to the intensity of the echo) of the pursued prey or of other objects hit by the call.

Since auditory maps are *regulated* structures or processes, their appearances and shapes are dynamic, for example during maturation or due to learning. This plasticity of maps is a significant factor for individuals to be able to adapt to conditions of importance or unimportance of a given acoustic environment or of communication with congeners. Thus, auditory maps, especially in higher brain centers, are not pure sensory maps but rather perceptual maps permanently adjusted to an individual's auditory experience and life style [13–15].

### Pathology

Tonotopies may change in older subjects or subjects having been exposed to very loud sounds (more than about 110 phon) due to cochlear damage. With increasing age, hair cells are often lost at the basal portion of the cochlea with the effect that the high frequency part of the tonotopy is lost in the cochlea and therefore in all higher auditory brain centers. Exposure to a loud tone of a given frequency leads to hair cell damage at the place where this frequency is represented in the cochlea. The tone-frequency related part of the tonotopy is thus lost, i.e. the subject's perceptual threshold for the tone will be permanently increased.

In the course of and after cochlear damage, the phenomenon of ► **tinnitus** may occur. Often a tone that is not physically present in a subject's environment and not even present in the activity of a subject's auditory nerves is heard continuously and may lead to annoying feelings. It seems that by paying attention to sound percepts caused by cochlear disturbances these sounds are learned to be important and thus may cover an increased portion of the frequency maps in the brain [16]. It is not understood in detail how tinnitus-related activities in the tonotopies of the brain become established. Tinnitus appears however, to be a state of misregulation in the balance of excitation and inhibition and of ascending and descending information processing in the auditory maps and pathways respectively of the brain [16].

### References

1. Greenwood DD (1990) A cochlear frequency-position function for several species – 29 years later. *J Acoust Soc Am* 87:2592–2605
2. Dallos P, Pooper AN, Fay RR (eds) (1996) *The cochlea*. Springer-Verlag, New York
3. Herrnberger B, Kempf S, Ehret G (2002) Basic maps in the auditory midbrain. *Biol Cybern* 87:231–240
4. Webster DB, Fay RR, Popper AN (eds) (1992) *The evolutionary biology of hearing*. Springer-Verlag, New York
5. Ehret G (1997) The auditory midbrain, a “shunting yard” of acoustical information processing. In: Ehret G, Romand R (eds) *The central auditory system*. Oxford University Press, New York, pp 259–316
6. Schreiner CE, Langner G (1997) Laminar fine structure of frequency organization in auditory midbrain. *Nature* 388:383–386
7. Ehret G, Hage SR, Egorova M, Müller BA (2004) Auditory maps in the midbrain: the inferior colliculus. In: Pressnitzer D, de Cheveigné A, McAdams S, Collet L (eds) *Auditory signal processing. Physiology, psychoacoustics and models*. Springer-Verlag, New York, pp 162–168
8. Ehret G (1997) The auditory cortex. *J Comp Physiol A* 181:547–557
9. Stiebler I, Neulist R, Fichtel I, Ehret G (1997) The auditory cortex of the house mouse: left-right differences, tonotopic organization and quantitative analysis of frequency representation. *J Comp Physiol A* 181:559–571
10. Schulze H, Hess A, Ohl FW, Scheich H (2002) Superposition of horseshoe-like periodicity and linear tonotopic maps in auditory cortex of the Mongolian gerbil. *Eur J Neurosci* 15:1077–1084
11. Suga N, Yan J, Zhang Y (1997) Cortical maps for hearing and egocentric selection for self-organization. *Trends Cogn Sci* 1:13–20
12. Romand R (1997) Modification of tonotopic representation in the auditory system during development. *Prog Neurobiol* 51:1–17
13. Garraghty PE, Kaas JH (1992) Dynamic features of sensory and motor maps. *Curr Opin Neurobiol* 2:522–527
14. Weinberger N (2004) Specific long-term memory traces in primary auditory cortex. *Nat Rev Neurosci* 5:279–290
15. Scheich H, Ohl FW, Schulze H, Hess A, Brechmann A (2005) What is reflected in auditory cortex activity: properties of sound stimuli or what the brain does with them? In: König R, Heil P, Budinger E, Scheich H (eds) *The auditory cortex. A synthesis of human and animal research*. Lawrence Erlbaum, Mahwah, pp 383–407
16. Eggermont JJ, Roberts LE (2004) The neuroscience of tinnitus. *Trends Neurosci* 27:76–82

---

## Top-Down Approach

### Definition

The analysis of the processing of sensory systems and the meaning of stimuli can, in principle be

accomplished by two different approaches: bottom-up and top-down. Top-down means that the analysis is based on the behavioral relevance of stimuli and that only behaviorally relevant stimuli are used to unravel the processing in the brain. This is the approach taken by ethologists. It is in sharp contrast to the approach often taken by physicists that use theoretically well characterized stimuli (noise, tones, clicks in audition) without knowledge of their relevance. The advantage of the top-down analysis is that always the behavioral relevance is known. The disadvantage is that the stimuli may be so complex and unique that it is not possible to draw general conclusions (see also bottom-up approach).

## Topological Position

### Definition

Location of a division/subdivision or a cell group within the organism or part of the organism according to topological (internal) coordinates. For the basic divisions/subdivisions of the organism or part (such as the radial histogenetic units in the brain), this position (and thus the relation to neighbors) remains the same throughout ontogeny. Further, in organisms (or parts of them) sharing the same configuration and basic organization plan (for example, vertebrates or the brain of vertebrates), the topological position of homologous divisions/subdivisions should be the same across species.

► Evolution and Embryological Development of the Forebrain

## Topology

### Definition

Geometric configuration of any given structure (such as the brain) according to internal coordinates, which remain unaltered independent of deformations or differential growth of subdivisions that occur during development.

► Evolution and Embryological Development of the Forebrain

## Torpor

### Definition

Natural state of animals characterized by inactivity with a low reactivity: suspended animation. Hibernators use torpor to minimize outside exposure. Euthermic hibernators suppress metabolism in torpor, thus reducing energy expenditure.

► Hibernation

## Torsion Dystonia

### Definition

Also known as idiopathic torsion dystonia may begin in childhood or young adulthood. Dystonia (sustained muscle contraction causing twisting or turning around one or multiple joints) usually begins at one limb and then becomes generalized.

► Dystonia

## Torsion in Eye Movement

### Definition

Torsion is the rotation of the eye about the line of sight. The line of sight is thus not displaced by torsional eye movements, in contrast to horizontal or vertical eye movements.

► Eye Orbital Mechanics

## Torus Semicircularis

### Definition

Caudal region of the midbrain roof corresponding to the mammalian inferior colliculus. This region is divided into subnuclei that each receive lemniscal projections from corresponding primary hindbrain nuclei. It is

devoted to processing of acoustic, mechanosensory, and electrosensory information.

► Evolution of Mechanosensory and Electrosensory Lateral Line Systems

---

## Total Internal Fluorescence Microscopy

► Evanescent Field Fluorescence Microscopy

---

## Total Internal Reflection

### Definition

A real-time imaging technique that makes use of an evanescent wave to monitor distances as small as 1 nm; in live cells, used to monitor vesicles at or very near the plasma membrane. Has enabled assessment of physical states thought to represent vesicle targeting and tethering, as well as direct observation of docking and fusion.

► Synaptic Proteins and Regulated Exocytosis

---

## Touch Dome

### Definition

The touch dome is a small part of the skin 150–300  $\mu\text{m}$  in diameter with high mechanical sensitivity. This area of the skin is slightly elevated, and can be visible under a dissecting microscope. This dome-like elevated part contains many Merkel cell-neurite complexes arranged at the basal layer of the epidermis. The epidermis of the touch dome is thicker than the surrounding regular epidermis.

► Cutaneous Mechanoreception, Anatomical Characteristics

► Merkel Cell-Neurite Complex Regeneration

---

## Touch Sensation, or Mechanosensation, in the Mouth and on the Lips

► Tactile Sensation in Oral Region

---

## Touch-evoked Pain

► Hyperalgesia and Allodynia

---

## Tourette's Syndrome

### Definition

Neuro-developmental disorder of pre-pubertal onset, with a higher prevalence in boys than girls. It is characterized by irrepressible motor and vocal ►tics: multiple brief muscular ►spasms (*convulsive tics*) in the face, neck and shoulder; repetitive, stereotyped, strongly emotional gestures or vocalizations (e.g., *vocal tics*, such as grunts and barking sounds); behavioral abnormalities (coprolalia and other obscene utterances). The Tourette syndrome often co-occurs with ►attention-deficit/hyperactivity disorder (ADHD), ►obsessive-compulsive disorder, and a range of other mood and anxiety disorders. Its etiology is not clear yet, but the pathophysiology may involve dysfunctions of the ►basal ganglia, where overactivity of the ►dopaminergic system may entail overactivity of clusters of ►striatal neurons in inappropriate contexts, which would lead to disinhibition of thalamo-cortical circuits and ultimately to the production of tics.

► Basal Ganglia

► Dopamine

---

## Trace Eyeblink Conditioning

### Definition

The eyeblink conditioning paradigm in which the conditioned stimulus (CS) terminates before the onset

of the unconditioned stimulus (US). The time interval separating the CS offset from the US onset is called the trace interval. It is presumed that for the subject to learn the association between the stimuli, a trace of the conditioned stimulus has to be stored in the brain until the unconditioned stimulus is presented. This paradigm is distinct from delay conditioning where the conditioned and unconditioned stimuli partially overlap and co-terminate.

► Motor Learning

## Tracking

### Definition

- Eye-Head Tracking
- SC-Tectoreticulospinal Neurons (TRSNs)

## Tract

### Definition

A tract is a collection of axons projecting from one nuclear group to another in the central nervous system.

## Trafficking

### Definition

Membrane recycling of receptors and synaptic vesicles.

- Membrane Components
- Transport

## Trafficking Adaptors

### Definition

These are generally multi-protein complexes in which one component recognizes and binds to a trafficking

motif within a membrane protein, with other components of the complex mediating interactions with a specific sub-cellular compartment.

► Receptor Trafficking

## Trafficking Motifs

### Definition

These are linear peptide motifs within the cytoplasmic domain of a membrane protein that direct the movement of that protein from one compartment or membrane to another.

► Receptor Trafficking

## Training

### Definition

Training is defined as a process toward acquisition of a skill, memory and knowledge. Learning and memory have been thought to have encoding, retention and retrieval stages. Encoding is thought to occur during training. Generally training has been associated with an act with a goal directed will or intention. However, just exposure to input that leads to learning and memory is also regarded as training.

- Learning Curve
- Sensory Plasticity and Perceptual Learning

## Trajectory Attractors in Neural Networks

### Definition

Paths stored in a recurrent neural network along which the network state (firing pattern of units) moves smoothly and continuously. The network state is changed from a pattern to a slightly different pattern at one time, which characteristic is distinct from that of

a conventional neural network storing a sequence of almost orthogonal patterns whose state is changed from a pattern to a very different pattern at one time.

► Associative Memory

---

## Trajectory in Motor Control

### Definition

Equilibrium trajectory of an effector (e.g., of the hand during reaching movements); comprised of the effector's equilibrium positions at each instance of movement. Referent trajectory of an effector; comprised of the positions of the effector's associated with threshold configurations of the body at each instant of movement.

► Equilibrium Point Control  
► Threshold Control

---

## Trans-acting Factor

► Transcription Factor

---

## Transactional Functionalism

### Definition

A school of psychology which claimed that the retinal image is always ambiguous so that perception is a function of past experience, which is used by the observer to make a "best bet" based upon that experience.

► Visual Illusions

---

## Transcortical Reflex

### Definition

A long-latency EMG response to muscle stretch or cutaneous stimulation that depends on rapid

transmission of the sensory volley and evoked motor volley and involves the cerebral cortex. Also known as a long loop reflex.

► Long Loop Reflexes

---

## Transcranial Magnetic Stimulation

MILOŠ LJUBISAVLJEVIĆ

Department of Neurophysiology, Institute for Medical Research, Belgrade, Serbia and Montenegro

### Synonyms

Magnetic stimulation

### Definition

Transcranial Magnetic Stimulation [1,2] is a non-invasive, nearly painless method of activation of human cortical neurons by applying a magnetic pulse over the scalp. It allows functional mapping of the human brain (► brain mapping) and creation of transient functional lesions. It has proved to be an unparalleled tool in its ability to alter cortical activity in awake, behaving man and has provided considerable advance to studies of brain function in the last decade.

TMS can be applied as:

1. Single-pulse TMS (sTMS) – traditional way of delivering magnetic stimuli in which single pulses are delivered to excitable structures of interest at random intervals and maximum frequency of 0.3 Hz. The corresponding minimal time interval is needed for conventional monophasic TMS machines to charge up between successive stimuli.
2. Paired-pulse TMS (pTMS) – paired-pulse stimulation involves applying two magnetic stimuli, of equal or different intensity, separated in time by a varying interstimulus interval (ISI). Magnetic pulses may be applied through one coil over the same cortical spot, or through two coils, each positioned over a different spot.
3. Repetitive (rapid-rate) TMS (rTMS) – refers to magnetic stimuli given more frequently than the usual 0.3 Hz available with most commercial single-pulse stimulators.

Most of the work elucidating basic mechanisms of TMS has been performed on the ► motor cortex, where the response to stimuli could be easily quantified by measuring the characteristics of the ► motor evoked potential (MEP). It is believed that the principles



derived from these studies would apply when stimulating other ►cortical areas, although demonstrating this has proved to be more difficult in practice.

### Purpose

Developed two decades ago [2], TMS has found a wide range of applications and has had a dramatic impact on studies of the healthy and diseased human brain. TMS is now widely used as a research tool, while in the clinical domain it has found only limited applications, being commonly used to study ►central motor conduction time (CMCT). More recently, it has been developed (rTMS) as a potentially useful therapeutic tool, particularly in ►psychiatry.

TMS produces two main types of responses when applied over brain; it can excite it or it can also induce inhibition (see later: Principles and Methods and measurements). It is by virtue of these two phenomena and their derived responses that TMS produces its effects, which then have to be assessed within the constraints of the experimental paradigm. TMS can be used within two major contextual frameworks: to produce interruption of brain activity, also referred to as ►virtual lesion; or to evaluate different aspects of cortical excitability, allowing the study of changes in cortical physiology in connection with ►cortical plasticity and brain disorders.

### Interruption of Brain Activity: Virtual Lesion

In virtual-lesion methodology, TMS is applied while the subject is trying to perform a task, thus introducing noise into the neural assemblies involved in signal processing of the given task, and disrupting the activity of focal brain regions and the task itself. In this way, it can be established whether a specific brain area plays a causal role in the specific type of processing. The virtual-lesion methodology was first used in studies of the motor system by applying single-pulse TMS over the motor cortex while subjects were instructed to perform flexion and extension movements of the wrist [3]. The “go” command to initiate the movement was coupled with a TMS stimulus delivered 100 ms later, but before the movement was expected to commence. The effect of TMS was to markedly delay the onset of wrist movement without altering its overall form, thus increasing the reaction time. In a similar paradigm, TMS was used to disrupt visual processing. When delivered 80–100 ms after the visual stimulus, TMS impaired subjects in seeing randomly generated letters on a monitor, indicating that the visual processing was disrupted during that interval.

In general, the choice of a dependent variable in TMS experiments will primarily depend on the function under investigation that is to be disrupted. Available experience suggests that reaction time is a more robust and versatile measure than error measurements.

### Cortical Physiology

TMS is generally used to evaluate different aspects of cortical excitability. Parameters such as ►motor threshold (MT) to a single magnetic pulse, or ►intra-cortical inhibition (ICI) and ►intra-cortical facilitation (ICF) evoked by double-pulse stimulation, or the duration of the ►silent period (SP) can be measured (for details on MT and SP see later). When TMS is delivered in a conditioning-test paradigm (pTMS), it can be used to assess cortical inhibitory and excitatory processes reflecting the activity of interneurons in the cortex. In this technique, the first (conditioning) stimulus is sub-threshold, and the test shock that follows after a short time interval is supra-threshold (in the original method, 80% and 120% of motor threshold, respectively [4]). The conditioning stimulus has no effect on the spinal ►motoneuron excitability, but initiates intracortical influences that modulate the amplitude of the MEP response elicited by the test stimulus. In normal subjects, at intervals shorter than 5 ms, the conditioning stimulus produces an inhibition of the test response, while at longer intervals, between 7 and 30 ms, the conditioning stimulus produces facilitation. It is believed that GABA-ergic cortical neurons mediate ICI, so that inhibitory processes tested with the paired-pulse technique and the SP probably reflect different aspects of cortical inhibition.

### Brain Plasticity

Although still loosely defined, brain ►plasticity generally describes the ability of the brain to change. Basically, it refers to processes of ►neural repair, ►learning and ►memory. TMS was successfully added to a battery of non-invasive techniques that are available to study these mechanisms. To study plasticity, TMS could be applied in a multitude of settings and experimental paradigms, the following lines only summarizing techniques and parameters (see also Methods and measurements) available to study ►reorganization in brain function by using TMS.

Mapping is effectively used to produce functional representations of primarily motor areas, but it can be used to map other cortical regions like somatosensory and visual cortex etc. With this technique, the number of excitable scalp positions, the location of the optimal position and several other parameters related to the representation of a particular muscle can be determined. In combination with other techniques (►PET, ►fMRI), these maps can be related to individual brain anatomy, thus enabling the combination of functional data and anatomical structures. Finally, measuring changes in maps under particular acute or chronic conditions allows the identification of changes associated with different forms of plasticity.

►Motor threshold (see later) can be used to provide indirect information on changes in membrane

excitability in motor cortex. Motor-threshold measurements can be complemented with the measurement of recruitment curves (see below), which provide information on another aspect of cortical excitability, the underlying mechanisms of which are still poorly understood, however. As described earlier, ICI and ICF provide sensitive estimates of the functions of inhibitory and excitatory interneuronal circuits in the motor cortex. TMS has also been used to study functional connectivity of different cortical regions and to disrupt task performance (see above).

Applications of these techniques have effectively led to identification of various patterns of neural reorganization in different conditions. For instance, TMS has been used to describe short-term plasticity associated with transient ►deafferentation, ►central fatigue, ►skill acquisition, implicit learning, etc. Lesion-induced plasticity associated with amputations, traumatic root and spinal cord injury, hemispheric lesions and other pathological conditions have also been studied [for review see [5]].

### Magnetic Stimulation in Disease

TMS has been used, with more or less success, to reveal intracortical processes in almost every neurological disorder. Abnormalities revealed by TMS are usually not disease-specific, but rather reflect general changes in cortical excitability. For example, studies with TMS have revealed abnormalities in ►Parkinson's disease and ►dystonia, showing a decrease in ICI and an increase in the slope of the MEP ►recruitment curve, but without significant changes in motor threshold. Similarly, ICI is reduced in ►epilepsy while threshold measurements have revealed conflicting results. Nevertheless, although the abnormalities revealed by TMS are not specific to these diseases, they are intrinsic parts of the underlying pathological processes and can be effectively utilized to guide the treatment strategies, or even to quantify the physiological effects of different drugs in individual patients.

### Therapeutic Use

The delivery of a single TMS pulse does not appear to have any lasting effects. However, ever since the advent of TMS, it has been anticipated that rTMS may produce effects that outlast the stimulation period and may thus be used to treat brain disease or reduce functional deficits. The first report showed that rTMS at frequencies of 5 Hz and higher transiently enhanced the motor excitability [6], to the extent of even evoking an epileptic seizure. Interestingly, slow rTMS at 1 Hz can transiently decrease the excitability, producing inhibition that is relatively long-lasting [7]. Lasting effects of rTMS on clinical symptoms have been demonstrated in Parkinson's disease, in patients with task-specific dystonia and in depression patients. The

exact mechanisms underlying these effects are not known, although it has been suggested that they may be central equivalents of synaptic ►long-term potentiation (LTP) and ►depression (LTD). Although these early studies provided the initial impetus for studies aimed at modulating cortical tone, after a decade of experimentation, TMS has not yet yielded any treatments that effectively alleviate any neurological disorder. For instance, although early observations showed that rTMS affected ►mood in healthy individuals, and could be potentially effective in the treatment of mood disorders, it has failed so far to yield provable, significant therapeutic effects. In part, the problem might be associated with the very large number of possible combinations of magnetic stimulation parameters (frequency, intensity, train duration, inter-train intervals, number of trains, site of stimulation, etc.) or, more importantly, with the issue of safety (see later) that places stringent boundaries on the stimulation parameters that can be potentially used in therapy. Finally, another limitation is related to the depth of penetration of the effective stimulating current.

### Central Motor Conduction Time (CMCT)

Probably the only routinely used clinical application of TMS, CMCT allows neurologist to non-invasively estimate conduction time in the central segment of the motor pathway. CMCT is defined as the latency difference between the MEP evoked by stimulation of motor cortex and spine (motor root). It is usually less than 7 and 15 ms for upper and lower limbs, respectively. When TMS is used for spinal cord stimulation, it excites the nerve roots in the region of inter-vertebral foramina, so that the calculated CMCT will be slightly longer. To overcome this, electrical stimulation of peripheral nerves and calculation of CMCT by the ►F-wave method could be used (see below). However, this is associated with considerable discomfort and may not be optimal, particularly in children. CMCT is slightly faster in women and increases with age. Typically, CMCT is prolonged in ►multiple sclerosis and cervical ►spondylitic myelopathy.

### Principles

#### Mechanisms of Action of TMS

The general principle of operation of a magnetic stimulator is to generate a rapidly changing magnetic field of the magnitude of several Tesla, which would then induce a flow of electric current in adjacent biological tissue, depolarizing excitable structures such as nerve axons. To generate such a magnetic field, a commercial magnetic stimulator consists of a storage capacitor, which allows high-peak current (in the kilo-ampere range) to be delivered with a very short rise time (100–200  $\mu$ s) and an overall duration of less than 1 ms, to a coil of wire, called the magnetic coil. This produces the induction effect, generating a magnetic

field with the lines of flux passing perpendicularly through the plane of coil, which when placed above the scalp induces an electrical field oriented perpendicularly to the magnetic field. The characteristics of the induced electric field in the nervous tissue depend on the rate of change and on the intensity of the magnetic field. The probability of inducing the activation is proportional to the rate of change of the electric field [1]. The activation of axon occurs when the induced electric field generates a difference in the electrical potential between two points along the length of the axon. This occurs at points where the axon crosses the electric field lines by bending across them, which creates a difference in potential at points adjacent to the bend and induce stimulation at this point. Thus, the knowledge of orientation of the induced electric field and of the anatomical orientation of the cortical axons being stimulated may serve to deduce the site of stimulation. The precise extent of activation of cortical neurons is not known, but it has been established that TMS is more likely to stimulate neurons that run parallel to the cortical surface, which leads to the conclusion that corticospinal motor neurons are preferentially activated transsynaptically through other cortical cells, rather than directly. This was recently confirmed by direct observations showing that TMS produces descending corticospinal discharges, containing multiple indirect (I-waves) descending waves with longer latency rather than shorter-latency direct waves (D-waves) [8].

Commercially available magnetic stimulators can either generate monophasic or biphasic magnetic pulses, the biphasic form probably requiring lower field intensities to induce a current in the neural tissue.

Several different shapes of magnetic coils have been developed, which allow the generation of magnetic fields of different shapes and strengths. The three most commonly used types of coils are the standard round coil, the figure-of-eight coil and the double-cone (butterfly) coil. The round coils are powerful and produce the maximal electric field near the circumference and no current at the center of the coil. Assuming that the initial current flow in the coil is in one direction when viewed from above (e.g., clockwise), the induced current flows in the opposite, anti-clockwise direction, thereby preferentially activating neurons in the right motor cortex, and vice versa. Figure-of-eight coils consist of two windings that lie in the same plane, allowing current to flow in opposite directions in the two coils, so that the maximal electric field is induced at the intersection of the two round components. The geometry of the figure-of-eight coil makes it particularly suitable for selective stimulation of specific targets within the cortex. The double-cone coil was specifically developed to improve the stimulation of structures lying deeper in the central sulcus of the brain.

The two windings of this coil are oriented at an angle, typically 100°, thus generating the highest-intensity field right below its center.

In conclusion, a TMS pulse randomly excites neurons that lie within the induced effective electrical field, and evokes both excitatory and inhibitory effects in the cortex. Several studies have shown that, although limited by the type of coil used, the optimal stimulation for the given task is crucially determined by the precise orientation of the coil. Thus, the functional localization of the TMS effects is to a significant degree controlled by the experimenter.

### Methods and Measurements

For routine studies, TMS is coupled with a standard ►**electromyographic (EMG)** recording setup registering surface or needle EMG. The standard parameters of the MEP response include cortical threshold, latency, amplitude of response, and silent period in the active muscle (SP) (see Fig. 1).

### Cortical Threshold

Cortical threshold refers to the minimal intensity of TMS that produces an MEP (see [10]). The threshold for producing an MEP in resting muscles reflects the global excitability of the motor pathway, including all interposed individual neurons along the pathway. At the cortical level, it would reflect the excitability of individual neurons and their density in a central core. The confirmation that it indicates membrane excitability has come from studies showing that drugs affecting sodium and calcium channels can influence the threshold. In addition, even slight voluntary pre-activation of the target muscles reduces the cortical threshold. In general, in adults, the threshold is independent of age, gender and hemisphere but varies with different target muscles. In the same individual, the threshold usually follows a proximal-distal pattern, being lowest for distal arm muscles and highest for leg and axial muscles.

### Latency, Amplitude of Response and Silent period

Latency refers to the time elapsed from the stimulus onset to the beginning of the MEP. It reflects the time needed for the excitation to travel from the brain to the muscle(s). It depends on background voluntary activation of the muscle(s), which – if present – shortens the latency by several milliseconds. It may be prolonged in certain diseases, but in general, TMS does not have substantial diagnostic value in these diseases.

The amplitude of the MEP is usually expressed as peak-to-peak amplitude, between the two peaks of opposite polarity, or as an area under the rectified MEP curve. The MEP amplitude reflects the overall activity in the ►**corticospinal tract** at the moment of stimulation. Thus, it reflects the sum of cortical

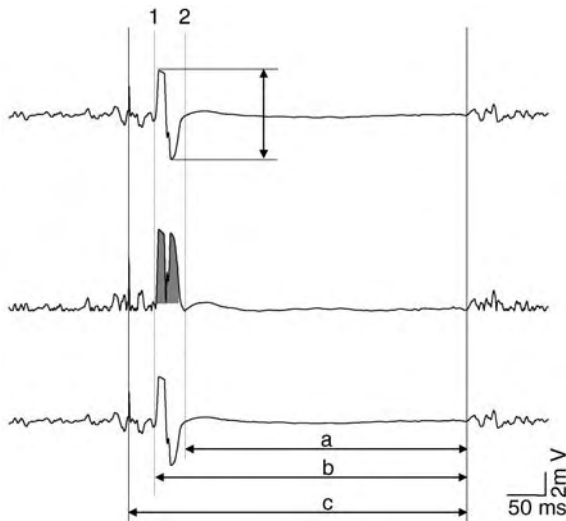

### Transcranial Magnetic Stimulation. Figure 1

Electromyographic responses to cortical magnetic stimulation. *Top and bottom*: Unrectified traces. Motor evoked response (MEP) recorded from the first dorsal interosseus muscle during weak voluntary activation. *Middle*: Full-wave rectified trace. *Vertical continuous line at left*: time of magnetic stimulus; *vertical dashed lines 1 and 2*: beginning and end point of MEP, respectively; *single vertical arrow below bottom trace*: reoccurrence of EMG activity after the silent period (SP). The time from the magnetic stimulus to *vertical line 1* corresponds to the latency of the MEP. The time between two *vertical dashed lines* corresponds to the MEP duration. The *vertical double-arrow* in the top trace indicates the peak-to-peak amplitude of the MEP. The *shaded area* under the rectified curve in the middle trace corresponds to the MEP area. *Horizontal arrows a, b and c* correspond to three different approaches for measuring the time to resumption of the EMG signal following an SP: a, from the end of the MEP; b, from the beginning of the MEP; c, from the magnetic stimulus. (With permission from [9]).

and spinal motoneuron activity. The MEP amplitude increases with increasing stimulus intensity and voluntary activation. The relations between stimulus intensity, voluntary activation and the growth of MEP amplitude are usually referred to as recruitment curves. These curves are not fully understood as they probably reflect the number and excitability of neurons other than those activated at threshold. The MEP amplitude usually shows considerable inter-trial and inter-individual variations, which probably reflects the complex interactions occurring in the corticospinal pathway. The MEP amplitude is also critically influenced by coil position, and even minimal changes in coil/skull alignment can drastically influence the amplitude of subsequent responses. To overcome the variability, a ratio of cortically evoked MEP to the response evoked by

supramaximal stimulation of peripheral nerve (MEP/CMAP ratio) can be calculated. The recently developed triple-stimulation technique [11], which involves TMS of the cortex and electrical stimulation of the peripheral stimulation at two sites provides a better estimate of cortical motor neuron activation, but is at the same time cumbersome and can be uncomfortable.

Finally, TMS produces a period of electrical silence in the EMG recording of the voluntarily activated muscle. This is termed “silent period” (SP) and can be produced with both sub-threshold and supra-threshold stimulus intensities. Thus, the threshold for TMS inhibitory phenomena may be lower than that for the excitatory effects. If induced by supra-threshold stimuli, the SP follows the MEP, so that the duration of the SP can be measured from the stimulus artifact, from the onset latency or from the end point of the MEP, to the restoration of the EMG activity (Fig. 1). The duration of the silent period is usually directly related to stimulus intensity and relatively independent of background contraction. SP’s are generally longer in small hand muscles than in proximal arm and leg muscles. Several factors contribute to SP. Its initial part probably depends on refractoriness of spinal motoneurons, ▶*Renshaw inhibition* and peripheral reflex inputs, while its latter part is mostly due to various cortical inhibitory mechanisms.

### Transcranial Electrical Stimulation (TES)

The only other technique available for transcranial stimulation of the human brain is electrical stimulation. In ▶*transcranial electrical stimulation*, a single high-voltage capacitative discharge that produces a twitch of contralateral body muscles when applied over the motor cortex. As compared with TMS (see before), electrical stimulation in man induces D-waves similar to those seen after electrical stimulation of exposed cortex in monkey. This indicates that TES activates ▶*pyramidal tract* axons directly, probably several internodes away from the neuron body. The biggest disadvantage of electrical stimulation is that only a small portion of the applied current flows into the brain, while much of it flows between the electrodes on the scalp and induces contraction of the scalp muscles and activation of pain receptors, thus producing considerable discomfort to subjects.

### Advantages and Disadvantages

In contrast to electrical stimulation, magnetic stimulation is non-invasive and produces minimal discomfort to subjects, reasons for which it is used almost exclusively today. However, electrical stimulation may still be used when appropriate since it often yields information otherwise not available from either method alone.

The main advantage that TMS adds to other neurophysiological and imaging techniques is its ability

to probe the neural activity within relatively small volumes of neural tissue, in a small amount of time (less than one second). It should not be considered as superior but rather complementary to other methods, each of them allowing questions from a specific perspective to be addressed.

One of the main limitations of TMS pertains to the difficulty to limit the extent of the induced current flow, particularly when using powerful round coils, thus limiting its focus. This problem can partly be overcome by using the figure-of-eight coil and orienting it appropriately to the targeted structures. Current spread also limits the application of TMS for stimulation of peripheral nerves.

Other limitations pertain to safety issues. Single-pulse TMS has proven to be an extremely safe tool with no long-term adverse effects. As to short-term effects, the induction of epileptic seizures and ►**kindling** has caused major concerns. Only three reports on seizures induced with single sTMS have been published so far. However, it has been established that rTMS, as a more powerful stimulation modality with the potential to regionally block or facilitate cortical processes, can induce seizures [12]. Moreover, it should be noted that there is as yet little information on potential rTMS long-term effects. Thus, rTMS should be used with appropriate precautions and strict observation of the guidelines for its safe use (for details see [12] and <http://pni.unibe.ch/maillist.htm>).

## References

1. Barker AT (1999) The history and basic principles of magnetic nerve stimulation. *Electroencephalogr Clin Neurophysiol Suppl* 51:3–21
2. Barker AT, Jalinous R, Freeston IL (1985) Non-invasive magnetic stimulation of human motor cortex. *Lancet* 1:1106–1107
3. Day BL, Rothwell JC, Thompson PD, Maertens dN, Nakashima K, Shannon K, Marsden CD (1989) Delay in the execution of voluntary movement by electrical or magnetic brain stimulation in intact man. Evidence for the storage of motor programs in the brain. *Brain* 112(Pt 3):649–663
4. Kujirai T, Caramia MD, Rothwell JC, Day BL, Thompson PD, Ferbert A, Wroe S, Asselman P, Marsden CD (1993) Corticocortical inhibition in human motor cortex. *J Physiol* 471:501–519
5. Chen R, Cohen LG, Hallett M (2002) Nervous system reorganization following injury. *Neuroscience* 111:761–773
6. Pascual-Leone A, Valls-Sole J, Wassermann EM, Hallett M (1994) Responses to rapid-rate transcranial magnetic stimulation of the human motor cortex. *Brain* 117:847–858
7. Chen R, Classen J, Gerloff C, Celnik P, Wassermann EM, Hallett M, Cohen LG (1997) Depression of motor cortex excitability by low-frequency transcranial magnetic stimulation. *Neurology* 48:1398–1403
8. Di Lazzaro V, Oliviero A, Profice P, Insola A, Mazzone P, Tonali P, Rothwell JC (1999) Direct recordings of descending volleys after transcranial magnetic and electric motor cortex stimulation in conscious humans. *Electroencephalogr Clin Neurophysiol* 51:120–126
9. Ellaway PH, Day NJ, Ljubisavljevic M (1999) Magnetic stimulation of the nervous System. In: Windhorst U, Johansson H (eds) *Modern techniques in neuroscience research*, Chapter 33. Springer, Berlin Heidelberg New York, pp 869–891
10. Rossini PM, Barker AT, Berardelli A, Caramia MD, Caruso G, Cracco RQ, Dimitrijevic MR, Hallett M, Katayama Y, Lucking CH (1994) Non-invasive electrical and magnetic stimulation of the brain, spinal cord and roots: basic principles and procedures for routine clinical application. Report of an IFCN committee. *Electroencephalogr Clin Neurophysiol* 91:79–92
11. Magistris MR, Rosler KM, Truffert A, Myers JP (1998) Transcranial stimulation excites virtually all motor neurons supplying the target muscle – A demonstration and a method improving the study of motor evoked potentials. *Brain* 121:437–450
12. Wassermann EM (1998) Risk and safety of repetitive transcranial magnetic stimulation: report and suggested guidelines from the International Workshop on the Safety of Repetitive Transcranial Magnetic Stimulation, June 5–7, 1996. *Electroencephalogr Clin Neurophysiol* 108:1–16

## Transcription Factor

TETSUICHIRO SAITO

Graduate School of Medicine, Chiba University, Chiba, Japan

### Synonyms

Trans-acting factor

### Definition

Transcription factors control (activate or repress) transcription of genes by regulating the access of RNA polymerase to DNA. Most transcription factors bind to a specific DNA sequence and are grouped into transcriptional activators and repressors. Transcriptional activators bind to an enhancer of the genomic DNA and form a complex containing basal transcription factors and RNA polymerase II, which initiates transcription at a specific site (Fig. 1).

Many transcriptional activators also bind histone acetyltransferases, which activate genes by acetylating histones. Genes are inactivated by transcriptional repressors, which bind to a silencer of the genomic DNA and recruit histone deacetylases.

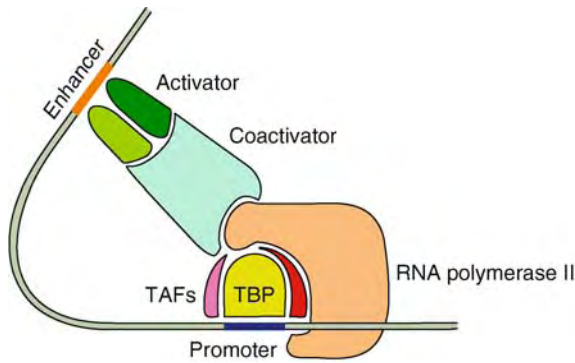

**Transcription Factor. Figure 1** Assembly of the transcription initiation complex on a promoter.

## Characteristics

### Quantitative Description

At least 1,850 genes encode transcription factors in the human genome [1].

### Higher Level Structures

Protein

### Lower Level Components

Transcription factors are classified into three major classes, basal transcription factors, transcriptional activators and repressors. TFIID, which contains the TATA-binding protein (TBP) and TBP-associated factors (TAFs) [2] are basal transcription factors. Transcriptional activators and repressors have DNA-binding and protein-protein interaction domains. They are grouped into several families based on their structural motifs, homeodomain, ►basic helix-loop-helix, zinc finger and leucine zipper, etc. (Table 1).

Homeodomain proteins are further divided into subfamilies by the amino acid sequence similarities of their homeodomains and additional motifs, some of which are crucial for protein-protein interaction [3]. Zinc finger proteins also comprise several subfamilies.

### Structural Regulation

Many transcription factors exert their functions by forming dimers with themselves or another structurally related factor. In some cases, their dimer formation and nuclear entry are regulated by their modification (mainly by phosphorylation).

### Higher Level Processes

Transcription factors control various processes from development to higher order function of the nervous system. At early stages of development, several types of homeodomain proteins, such as Pax6 and Emx2, control regional patterning of the brain [4]. Nkx2.2 and Nkx6.1 are involved in dorso-ventral patterning of the

developing nervous system. Hox-subfamily proteins determine regional identity along the antero-posterior body axis. Then, proneural factors, including Mash1 and Math1, which are among the basic helix-loop-helix (bHLH) proteins, are expressed in distinct regions or populations of cells, specify neuronal progenitors and promote neuronal differentiation [5]. Members of HMG box proteins, Sox2 and Sox10, counteract the activity of proneural factors and inhibit neurogenesis, thereby maintaining progenitors. Proneural factors activate gene expression of another bHLH protein, NeuroD, which controls neuronal differentiation. These bHLH proteins form a heterodimer with a ubiquitous bHLH protein, E2a, to bind to DNA. There are bHLH proteins that inhibit neurogenesis, such as Hes1, by repressing expression of ►proneural factor genes or by preventing proneural factors from binding to DNA. Math1 directly activates the *Mbh1* gene, encoding a Bar-type homeodomain protein, which specifies commissural neuronal identity [6]. Several LIM- and Paired-like-type homeodomain proteins control specification of neuronal subtypes as well. Some of Dlx- and POU-type homeodomain proteins are required for proper differentiation of specific types of neurons. Many transcription factors have multiple functions at different stages. Nkx2.2 and En1 regulate differentiation of oligodendrocytes and axonal projection of postmitotic neurons respectively, as well as early regional patterning.

Axonal projection is also regulated by LIM- and Bar-type homeodomain proteins. When axons of motor and sensory neurons reach the vicinity of target muscles, expression of the ►ETS proteins Pea3 and ER81 is induced by peripheral signals and controls axonal branching.

C<sub>2</sub>H<sub>2</sub>-type zinc finger proteins, which are the largest family of transcription factors, are involved in many processes other than development. Neural restrictive silencer factor (Nrsf/Rest) represses expression of numerous neuronal genes, which encode ion channels and neurotransmitters etc. in non-neuronal cells [7]. Zif268 mediates extracellular signals and is associated with learning and memory [8].

Ubiquitously expressed Smad- and Stat-family proteins regulate proliferation and differentiation of cells in response to extracellular signals. Leucine zipper proteins, c-Fos and CREB, are also mediators of various extracellular signals and implicated in learning and memory [8,9].

### Lower Level Processes

In most cases, gene expression is regulated by multiple enhancers and silencers and the combination of active transcription factors determines which gene is expressed. A list of transcription factors can be obtained from the TRANSFAC database (<http://www.gene-regulation.com>). Potential binding sites of transcription factors in

**Transcription Factor. Table 1** Families of transcription factors in the nervous system

Family (motifs)	Representative members	Function
Homeodomain		
Hox	Hoxa1, Hoxc8	Determination of regional identity
Paired	Pax2, Pax6	Regional patterning
Emx	Emx2	Regional patterning
Nkx	Nkx2.2, Nkx6.1	Regional patterning; oligodendrocytic differentiation
En	En1	Regional patterning; axonal projection
LIM	Islet1, Lhx1	Specification of neuronal subtypes; axonal projection
Bar	Mbh1	Specification of neuronal subtypes; axonal projection
Paired-like	Phox2a, Drg11	Specification of neuronal subtypes
Dlx	Dlx1	Neuronal subtype-specific differentiation
POU	Brn3a	Neuronal subtype-specific differentiation
Winged helix/forkhead	Bf1	Regional patterning
Basic helix-loop-helix	Mash1, Math1	Initiation of neurogenesis
	NeuroD	Neuronal differentiation
	Hes1	Inhibition of neurogenesis
	Per1, Clk	Controller of circadian rhythm
T-box	Tbr1	Neuronal subtype-specific differentiation
HMG box	Sox2, Sox10	Maintenance of progenitors
	Lef1	Mediator of Wnt signaling
ETS	Pea3, Er81	Axonal branching
Zinc finger		
C <sub>2</sub> H <sub>2</sub>	Gli1, Zic1	Regional patterning
	Nrsf/Rest	Silencing of neuronal genes
	Zif268	Mediator of various extracellular signals
Gata	Gata2	Neuronal subtype-specific differentiation
Nuclear hormone receptor	RAR $\alpha$ 1, RXR	Mediator of retinoids and steroid hormones
Rel	RBP-J/CBF1	Mediator of Notch signaling
Smad	Smad2	Mediator of TGF- $\beta$ -family signaling
Stat	Stat3	Mediator through Jak kinases of extracellular signals
Leucine zipper	c- Fos, CREB	Mediator of various extracellular signals
Novel	CaRF	Mediator of calcium influx

a given DNA sequence can be searched using the MatInspector software (<http://www.genomatix.de/index.html>).

### Process Regulation

Extracellular signals regulate the function of transcription factors [10]. The transforming growth factor (TGF)- $\beta$  binds to TGF- $\beta$  receptors, which phosphorylate Smad2 and Smad3. These phosphorylated Smad proteins form heterodimers with Smad4 and enter the nucleus. Similarly, dimerization and nuclear entry of Stat proteins are regulated by JAK kinases, which associate with membrane receptors. CREB becomes active after phosphorylation by several kinases, including the cAMP-dependent protein kinase and Ca<sup>2+</sup>-calmodulin-dependent protein kinases, downstream of various signals. A novel transcription factor, CaRF, is specifically

activated by calcium influx. The binding of Wnt proteins to Frizzled membrane receptors leads to release of  $\beta$ -catenin, which forms a heterodimer with Lef1 and functions as a transcription factor. Gli proteins are downstream effectors of the Patched membrane receptor, which binds to the Hedgehog protein. The RBP-J/CBF1 protein becomes active by interacting with the cytoplasmic domain of the Notch receptor, which is released after binding to its ligand.

### Function

Basal transcription factors support the initiation of transcription. A subunit of TFIID, TBP, binds to a core promoter of the genomic DNA, such as the TATA box. TAFs stabilize TFIID on the promoter and interact with RNA polymerase II to form the transcription initiation complex.

The efficiency and rate of transcription are up-regulated by an enhancer, which is located upstream or downstream of the promoter. Transcriptional activators bind to enhancers and interact with the basal transcription factors through coactivator proteins, thereby stabilizing the transcription initiation complex on the promoter (Fig. 1). A member of the coactivator proteins, p300/CBP, acetylates histones in nucleosomes. Acetylation of histones destabilizes nucleosomes and enhances the binding of transcription factors to DNA.

NRSF/REST binds to neural restrictive silencer elements, which control neuronal genes, and interacts with the corepressors, mSin3 and CoREST. They recruit histone deacetylases and inactivate genes by stabilizing nucleosomes.

### Pathology

Numerous developmental and physiological defects are caused by mutations of transcription factor genes (see the TRANSFAC database).

### References

1. Venter JC et al. (2001) The sequence of the human genome. *Science* 291:1304–1351
2. Carey M, Smale ST (2000) Transcriptional regulation in eukaryotes. Concepts, strategies, and techniques. Cold Spring Laboratory, Cold Spring Harbor, NY
3. Duboule D (1994) Guidebook to the homeobox genes. Oxford University Press, Oxford
4. O'Leary DDM, Nakagawa Y (2002) Patterning centers, regulatory genes and extrinsic mechanisms controlling arealization of the neocortex. *Curr Opin Neurobiol* 12:14–25
5. Bertrand N, Castro DS, Guillemot F (2002) Proneural genes and the specification of neural cell types. *Nat Rev Neurosci* 3:517–530
6. Saba R, Johnson JE, Saito T (2005) Commissural neuron identity is specified by a homeodomain protein, Mbh1, that is directly downstream of Math1. *Development* 132:2147–2155
7. Ballas N, Mandel G (2005) The many faces of REST oversee epigenetic programming of neuronal genes. *Curr Opin Neurobiol* 15:500–506
8. Frankland PW, Bontempi B (2005) The organization of recent and remote memories. *Nat Rev Neurosci* 6:119–130
9. Carlezon WA Jr, Duman RS, Nestler EJ (2005) The many faces of CREB. *Trends Neurosci* 28:436–445
10. West AE, Griffith EC, Greenberg ME (2002) Regulation of transcription factors by neuronal activity. *Nat Rev Neurosci* 3:921–931

## Transcription Factor Codes

► Combinatorial Transcription Factor Codes and Neuron Specification

## Transcriptional Start Site (TSS)

### Definition

The first nucleotide of the major mRNA species for a gene. The TSS is surrounded by a small region of upstream and downstream flanking sequence that makes up the 10 bp Inr of the core promoter region.

► Promoter

## Transcriptome

### Definition

Transcriptome is the set of all mRNA molecules (or transcripts) in a cell or population of cells in a given set of circumstances. This means that unlike the genome, which is fixed for a given organism, barring mutations, the transcriptome can change depending upon the context of the experiment. Recent work has shown that a large portion of the genome is actively transcribed into non-protein-coding RNAs (ncRNA). Therefore the transcriptome could be considered to include both protein coding mRNAs and ncRNAs in the most general sense.

► Serial Analysis of Gene Expression

## Transducer

### Definition

A device that converts variations in a physical quantity such as pressure, to an electrical signal or vice versa.

► Measurement Techniques (Pressure)

► Sensory Systems

## Transduction in Olfactory System

HEINZ BREER, JÖRG STROTMANN  
University of Hohenheim, Institute of Physiology,  
Stuttgart, Germany

### Synonyms

Signal conversion; Stimulus translation



## Definition

Central process for all cells sensing the external environment. Conversion of an adequate stimulus into a signal of the cell, often mediated by cascades of biochemical reaction and second messenger systems. For ►[chemosensation](#), the nature of the primary information that needs to be converted is chemical.

## Characteristics

### Description of the Process

Olfactory sensory neurons (OSNs) translate information about the type and concentration of volatile chemicals in the respiratory air stream into the electrical language of the nervous system. The molecular machinery mediating the chemo-electrical signal transduction process is located in the odor-sensing compartments of olfactory cells, the chemosensory cilia. These long ciliary protrusions of the apical dendritic knob form a complex mat in the mucus layer covering the nasal epithelium; this arrangement greatly increases the sensory surface area and thus raises the probability of odorant/receptor contact. Interaction of appropriate odorant molecules with receptor proteins in the ciliary membrane triggers a cascade of events within the cell that transforms the ligand/receptor binding into an excitation of the neuron. Experimental evidence indicate that this process is mediated via intracellular second messenger pathways and although in the various olfactory subsystems and multiple subpopulations of sensory neurons several mechanisms may be operating, compelling evidence points to a predominant role of the adenylyl cyclase/cyclic-AMP pathway in cells of the main olfactory system [1,2]. Upon an odorant/receptor interaction, the enzymatic cascade is triggered via the trimeric G-protein  $G_{olf}$  which activates adenylyl cyclase III, the most active isoform for catalyzing the conversion of ATP to cyclic AMP, leading to an elevation of the intraciliary cAMP concentration. The basal concentration of cAMP appears to be just below the level that is required for activation of cyclic nucleotide-gated (CNG) cation channels in the ciliary membrane and is probably an equilibrium determined by the activities of adenylyl cyclase III and phosphodiesterase. Opening of the CNG channels allows the influx of  $Na^+$ - and especially  $Ca^{2+}$ -ions which provides the first electrical signal, a slight depolarization of the membrane. The main change of the membrane potential results from the flow of  $Cl^-$ -ions through  $Ca^{2+}$ -activated  $Cl^-$ -channels opened by the raising internal  $Ca^{2+}$ -concentration. Due to the unusually high concentration of intracellular  $Cl^-$  there is an efflux of  $Cl^-$ -ions thus causing a strong depolarization of the olfactory sensory neuron. This is considered as an evolutionary adaptation to the fact that olfactory cilia reside in the mucus, where the ion concentrations are not as well controlled as in the interstitial fluid. In this way, olfactory neurons

have a  $Cl^-$ -battery, which makes their electrical responsiveness independent from the actual  $Na^+$ -concentration in the mucus. Odorants not always elicit excitation but certain odorants induce an inhibitory response in distinct OSNs; in those cells, the cAMP cascade mediates the activation of ciliary  $Ca^{2+}$ -dependent  $K^+$ -currents leading to a hyperpolarisation of the membrane. The electrical response of OSNs to odorant application occurs with a time delay of at least 50 ms [3], this is consistent with the notion that the generation of receptor current is mediated via several biochemical steps and the formation of second messengers. The local change of the transmembrane potential spreads quickly with about  $10^7 \mu m/s$  due to the high input resistance of several  $G\Omega$  [4].

When the membrane potential reaches the threshold at the axon hillock action potentials are generated which propagate along the axon and convey the electrically coded information into the olfactory bulb. Employing ►[second messenger cascades](#) as mechanisms for sensory transduction provides a strong potential for signal amplification since it is generally thought that an activated G-protein-coupled receptor activates multiple G-proteins and effector molecules. However, receptor-odorant complexes are too short-lived to activate several G-proteins, implying that signal amplification in olfactory transduction is rather low and fundamentally different from that of phototransduction [5]. Signal amplification in olfaction may be accomplished by repeated binding of odorant molecules to the same receptor and the high probability of odorant binding due to the high number of receptor proteins in the ciliary membrane of an OSN.

## Functional Elements

### Olfactory Cyclic Nucleotide Gated (CNG) Channels

Central element in the process of converting an odorant stimulus into an electrical response of the olfactory neurons is the ►[cyclic nucleotide gated \(CNG\) channel](#) in the ciliary membrane which allows an influx of cations. The CNG channel of OSNs is composed of three distinct types of subunits: the principle CNGA2-subtype, and the modulatory subunits CNGA4 and CNGB1b; they form a heterotetrameric protein complex composed of two A2, one A4 and one B1b subunits. The principle CNGA2 subunit alone can form a functional channel that is activated by cyclic nucleotides; however, the channel properties differ considerably from that of heteromeric channels. This demonstrates the physiological roles of the modulatory subunits. In addition to fine tuning the functional properties of the channel, the B1b subunit seems also to participate in the correct targeting of the channel proteins to the ciliary compartment of the OSN.

The channel is activated by the direct binding of cyclic nucleotides and is only weakly sensitive to membrane voltage. It contains four binding sites for the cyclic nucleotides and although its activation has long been known to be a highly cooperative process, the mechanism of gating was not well understood until recently. Based on studies using novel caged nucleotides a model with three binding steps has been proposed, of which the first and the third have a high ligand affinity and the second step has a low affinity, but this one switches the channel's open probability from low to high. This model was very recently expanded to a four step model in which the first ligand induces small but noticeable opening, the second ligand switches the still mostly closed to a fully open channel, whereas the third and fourth ligand only stabilize the open conformation.

The native CNG channel conducts mainly  $\text{Ca}^{2+}$ -ions under physiological conditions which has at least two highly relevant consequences: first, the rise in internal  $\text{Ca}^{2+}$  opens  $\text{Ca}^{2+}$  activated  $\text{Cl}^-$  channels which confers an inward current and acts as an efficient amplifier of the primary current (see below). Second,  $\text{Ca}^{2+}$ -ions entering the cell serve as a negative feedback modulator by reducing the sensitivity of the channel to its ligand cAMP which subsequently promotes channel closure. This  $\text{Ca}^{2+}$ -mediated negative feedback on the olfactory CNG channel is a major molecular mechanism responsible for the fast **►sensory adaptation** of OSNs to constant stimuli [6]. The regulatory effect on the olfactory CNG channel appears to be mediated by  $\text{Ca}^{2+}$ -calmodulin (CaM).  $\text{Ca}^{2+}$ -free calmodulin, called apocalmodulin, is already constitutively bound to the heterologously expressed heteromeric olfactory CNG channels even in the absence of  $\text{Ca}^{2+}$ ; when the  $\text{Ca}^{2+}$  concentration rises, it can rapidly modulate the CNG channel sensitivity by directly binding to the pre-associated calmodulin. Since  $\text{Ca}^{2+}$ -ions enter the olfactory cilia through the CNG channel itself, the pre-association of calmodulin clearly contributes to a very fast feedback modulation at the channel level. A mathematical model of adaptation based on direct negative regulation of CNG channels by  $\text{Ca}^{2+}$ -calmodulin in olfactory cilia is well in line with the experimental data.

### Chloride-Channels

The influx of cations through the CNG channel contributes only slightly to cell depolarization; the major contribution is mediated via  $\text{Ca}^{2+}$ -activated  $\text{Cl}^-$  channels. Due to the unusually high concentration of intracellular  $\text{Cl}^-$  in the lumen of the cilia opening of these channels leads to a  $\text{Cl}^-$  efflux and thereby to a depolarization of the membrane [7]. The high intracellular  $\text{Cl}^-$  concentration is a prerequisite for

this mechanism and an uncommon feature of adult neurons which implies that OSNs have unique transport systems for accumulating  $\text{Cl}^-$ -ions. Intracellular chloride concentrations in OSNs may be as high as 40–50 mM. The chloride concentration seems to be higher in the olfactory knob than in the dendrite and the cell body, suggesting that the primary site for  $\text{Cl}^-$ -uptake is at the knob and/or the cilia. The uptake of  $\text{Cl}^-$ -ions is mediated through a  $\text{Na}^+2\text{Cl}^-\text{K}^+$  cotransporter (NKCC1). In contrast, the main transporter for  $\text{Cl}^-$  extrusion operating in other neurons, KCC2, was not expressed in OSNs. NKCC1 is mainly located in the dendrite and soma of OSNs suggesting that these serve as a large  $\text{Cl}^-$  reservoir of the cell, which is utilized to maintain the intralumenal  $\text{Cl}^-$ -concentration of the cilia elevated during the response to odors [8]. Isolated OSNs from NKCC1 knockout (NKCC1-ko) mice show drastically reduced odor-activated currents probably due to a decreased influx of  $\text{Cl}^-$  through  $\text{Ca}^{2+}$ -activated  $\text{Cl}^-$  channels. The intact epithelium of NKCC1-ko mice however shows responses to odor stimuli which are only moderately reduced [9], suggesting that additional, not yet identified,  $\text{Cl}^-$  transport mechanisms exist in OSNs.

The fact that a rise in intracellular  $\text{Ca}^{2+}$  elicits the  $\text{Cl}^-$  efflux has led to the hypothesis that this might be a CaM-mediated process. Transfection of mutant CaM into the Odora cell line which is derived from OSN precursor cells indeed affects the  $\text{Ca}^{2+}$  sensitivity of the  $\text{Cl}^-$  efflux, indicating the involvement of CaM in the gating mechanism. As a candidate gene which might encode the  $\text{Cl}^-$ -channel in mouse OSNs, a member of the bestrophin family of channels has been presented. Major electrophysiological properties of the Best2 channel heterologously expressed in HEK293 cells resemble those of  $\text{Cl}^-$  currents measured from OSN cilia.

## Regulation of the Process

### Role of Calcium

Calcium-ions entering the cilia through the CNG channel play a central role in olfactory transduction not only in activating the  $\text{Cl}^-$  channels and thus eliciting the major part of the receptor potential but in addition, it has profound negative feedback effects on various elements of the signal transduction cascade. Most notably are the contributions of  $\text{Ca}^{2+}$  in mediating adaptation processes occurring after prolonged odor stimuli. On the first level, calcium acts with calmodulin via direct feedback on the CNG channel (see above), thereby mediating a rapid adaptation. In addition, there seem to be further  $\text{Ca}^{2+}$ -CaM dependent adaptation mechanisms. This notion is based on two observations: first, response kinetics after prolonged odor stimulation are substantially different from short repetitive stimuli and secondly, after long odor stimulation the kinetics

differ from those induced by direct activation of the CNG channel, indicating that other elements of the transduction cascade are also affected during longer odor exposure. As a candidate target ACIII emerged; the activity of ACIII and the capacity to generate cAMP is inhibited upon phosphorylation through CaM dependent Kinase II (CaMKII) and blocking of CaMKII activity impairs the adaptation process to long odor stimuli. In contrast, the counterpart of ACIII, the cAMP-hydrolysing phosphodiesterase (PDE1C2), seems not affected by  $\text{Ca}^{2+}$ -calmodulin and not immediately involved in olfactory adaptation. A tight control of the intracellular  $\text{Ca}^{2+}$ -level is thus critical for the response characteristics of OSNs. The transient rise of the  $\text{Ca}^{2+}$  levels subsequent to influx has to be restored to pre-stimulus conditions. The  $\text{Na}^+/\text{Ca}^{2+}$  exchanger mediates efficient  $\text{Ca}^{2+}$  extrusion. Inhibition of the exchanger leads to greatly prolonged responses to odor stimulation, probably due to the persistent elevation of  $\text{Ca}^{2+}$ -levels and  $\text{Cl}^-$ -permeability. During prolonged odor exposures the interplay of influx and extrusion of  $\text{Ca}^{2+}$ -ions generates oscillatory receptor currents [10] allowing the cell to periodically fire burst of action potentials.

## References

1. Schild D, Restrepo D (1998) Transduction mechanisms in vertebrate olfactory receptor cells. *Physiol Rev* 78:429–466
2. Matthews HR, Reisert J (2003) Calcium, the two-faced messenger of olfactory transduction and adaptation. *Curr Opin Neurobiol* 13:469–475
3. Lowe G, Gold GH (1991) The spatial distributions of odorant sensitivity and odorant-induced currents in salamander olfactory receptor cells. *J Physiol* 442:147–168
4. Trotier D (1986) A patch-clamp analysis of membrane currents in salamander olfactory receptor cells. *Pflugers Arch* 407:589–595
5. Bhandawat V, Reisert J, Yau KW (2005) Elementary response of olfactory receptor neurons to odorants. *Science* 308:1931–1934
6. Kurahashi T, Menini A (1997) Mechanism of odorant adaptation in the olfactory receptor cell. *Nature* 385:725–729
7. Kleene SJ, Gesteland RC (1991) Calcium-activated chloride conductance in frog olfactory cilia. *J Neurosci* 11:3624–3629
8. Reisert J, Lai J, Yau KW, Bradley J (2005) Mechanism of the excitatory  $\text{Cl}^-$  response in mouse olfactory receptor neurons. *Neuron* 45:553–561
9. Nickell WT, Kleene NK, Kleene SJ (2007) Mechanisms of neuronal chloride accumulation in intact mouse olfactory epithelium. *J Physiol* 583:1005–1020
10. Reisert J, Matthews HR (2001) Simultaneous recording of receptor current and intraciliary  $\text{Ca}^{2+}$  concentration in salamander olfactory receptor cells. *J Physiol* 535:637–645

## Transfer Function

### Definition

A function, which describes the relation between the output of a system and its input. The transfer function is usually expressed in the frequency domain or using the Laplace transform.

► Signals and Systems

## Transfer Tests

### Definition

Confrontation with novel stimuli or conditions that have not been experienced before to see whether a subject transfers a concept (see conceptualization) to a new situation. Learning wants to be excluded, thus choice behavior is not reinforced.

► Cognitive Elements in Animal Behavior

## Transfer-appropriate Processing

### Definition

The concept that memory performance is a function of the degree to which cognitive operations engaged at encoding are recapitulated at retrieval.

► Episodic Memory

## Transforming Growth Factor Alpha (TGF- $\alpha$ )

### Definition

A 17 kDa mitogenic polypeptide is expressed in the majority of neurons, and in maturing astrocytes, in the developing and adult brain of humans, and different species of animals. It is closely related to epidermal

growth factor (EGF), and can also bind to the EGF receptor with similar effects. TGF- $\alpha$  is expressed in the suprachiasmatic nucleus (SCN) in a circadian fashion, and, when infused into the third ventricle, reversibly inhibits locomotor activity and disrupts circadian sleep-wake cycles. These actions are likely mediated by epidermal growth factor (EGF) receptors on neurons in the hypothalamic subparaventricular zone, a major relay station for SCN efferents. Mice with a hypomorphic EGF receptor mutation exhibit excessive daytime locomotor activity and fail to suppress activity when exposed to light (so-called “masking”).

- ▶ Clock Coupling Factors
- ▶ Sleep-wake Cycle
- ▶ Suprachiasmatic Nucleus

---

## Transgene

### Definition

The (recombinant) gene that is introduced.

- ▶ Gene Therapy for Neurological Diseases

---

## Transgenic Animal

### Definition

An animal that has been engineered to result in a stable, inheritable change in its genome, usually at the level of a single gene.

---

## Transgenic Mouse

### Definition

A mouse in which a hybrid gene is introduced artificially into the genome and is capable of being transmitted to successive generations. Commonly, transgenic mice can be classified as having either a gain of function where a gene of interest is forcefully expressed (commonly referred to as “transgenic”) or a loss of function in which an endogenous target gene is functionally deleted (“knock out”).

---

## Transient Global Amnesia

### Definition

A type of memory disorder characterized by a sudden onset of simultaneous anterograde and retrograde amnesia, without the presence of other cognitive disturbances (e.g., verbal or visuospatial difficulties). The person remains fully conscious and aware, but complains of a noticeable memory impairment. The episode can last for a few to several hours, but usually resolves within a day. Its causes are still unknown, but have been linked to focal ischemic lesions, brain tumors, and migraine headaches.

- ▶ Amnesia

---

## Transient Internal Desynchrony

### Definition

Loss of synchrony between two or more endogenous circadian rhythms, originally defined to describe dissociation between multiple circadian rhythms in humans following transmeridian travel or shiftwork rotation.

- ▶ Internal Desynchrony

---

## Transitions between Electroencephalographic Stages

### Definition

Refers to a switch from one electroencephalogram (EEG) stage to another. Transitions can occur between wakefulness and sleep, between sleep stages and between sleep and wakefulness.

Neuronal cell groups in the brainstem and midbrain actively promote wakefulness and sleep. The switch between wakefulness and sleep states is thought to be controlled by mutual inhibition among these cell groups.

- ▶ EEG in Sleep States
- ▶ Electroencephalography
- ▶ Sleep Stages

## Translational Regulation

- mRNA Targeting: Growth Cone Guidance

## Translational Vestibulo-Ocular Reflex

### Definition

The translational or linear vestibulo-ocular reflex (TVOR, LVOR) is the compensatory eye movement generated in response to a linear displacement of head. The reflex is mediated by the otoliths and semicircular canals and the vestibular nuclei.

- Vestibulo-Ocular Reflexes

## Transmembrane Recording

- Intracellular Recording

## Transmembrane Voltage

- Membrane Potential: Basics

## Transmissible Spongiform Encephalopathies (TSEs)

### Definition

Fatal neurodegenerative disorders associated with an accumulation of abnormal isoforms of prion protein (PrP) in neurons. They include bovine spongiform encephalopathy in cattle (“mad cow” disease), and ► Creutzfeldt-Jakob disease (CJD) and ► Kuru in humans.

## Transmission Channel

### Definition

In communication theory the medium that allows the signal to travel from the sender to the receiver.

## Transneuronal Tracers

### Definition

Transneuronal tracers, such as barley lectin, are molecules that are transported through the axons and/or dendrites of neurons and that can be transferred to other neurons at or near synapses. Transneuronal tracers can be visualized by histochemical techniques, thereby revealing the locations of connected neurons.

## Transplantation of Artificial Materials for Nerve Regeneration

MASAYOSHI OHTA<sup>1,2</sup>, YOSHIHISA SUZUKI<sup>1,2</sup>,  
CHIZUKA IDE<sup>1,3</sup>

<sup>1</sup>Department of Anatomy and Neurobiology, Kyoto University Graduate School of Medicine, Kyoto, Japan

<sup>2</sup>Department of Plastic and Reconstructive Surgery, Kyoto University Graduate School of Medicine, Kyoto, Japan

<sup>3</sup>Department of Occupational Therapy, Aino University Faculty of Nursing and Rehabilitation, Osaka, Japan

### Definition

Artificial materials for nerve regeneration represent manufactured biological and non-biological materials for transplantation: the former includes collagen, polyglycolic acid, polylactic acid, poly- $\epsilon$ -caprolactone, ► alginate, and ► chitosan, while the latter comprises, for example, silicone, rubber, and plastic.

Collagen is one of the most common fibrous components of connective tissue.

► Glycolic acid, lactic acid and  $\epsilon$ -caprolactone ( $\epsilon$ -caproic acid) are naturally occurring hydroxyl acids. These have been utilized to synthesize biodegradable polymers (polyglycolic, polylactic and poly- $\epsilon$ -caprolactone) in medicine. The degradation speed of

poly  $\epsilon$ -caprolactone under physiologic conditions is slower than that of polyglycolic or polylactic acid.

Alginate derived from brown seaweed is a long chain of polysaccharide composed of two monosaccharides,  $\beta$ -D-mannuronic acid and  $\alpha$ -L-guluronic acid.

Chitosan is the deacylated derivative of chitin, a polysaccharide extracted from crustacean exoskeletons or generated via fungal fermentation processes. Chitosan is a  $\beta$ -1,4-linked polymer of 2-amino-2-deoxy-d-glucose. It carries a positive charge from amine groups.

### Characteristics

The peripheral nerve is composed of nerve fibers and surrounding connective tissues called the endoneurium. The endoneurium includes Schwann cell basal laminae and adjacent connective tissue. Schwann cell basal laminae are extracellular matrices synthesized by Schwann cells themselves. It is well known that basal laminae of Schwann cells [1] and muscle fibers serve as an effective conduit for the growth of regenerating axons. This fact provides the biological basis for the use of artificial materials including extracellular matrices as a conduit for regenerating nerves in repairing injured nerves. In clinical cases of peripheral nerve injury, autogeneic nerve grafts have usually been used for bridging a large gap between proximal and distal nerve stumps of injured nerves. However, autogeneic grafts have problems including the sacrificing of healthy nerves, resulting in a non-sensation zone of the relevant area. On the other hand, allogeneic nerve grafts may lead to serious immunological problems throughout the patient's entire life. In this respect, artificial materials have been studied in order to overcome these drawbacks of auto- and allogeneic nerve grafts.

### Silicone

Silicone, a non-biological material, has been used as a tube for bridging the stumps of injured nerves. There is a clinical study involving the transplantation of silicone tube bridging a short nerve gap of 3–5 mm in the human median and ulnar nerves [2]. The silicone tubes were removed because of local discomfort experienced by some patients 1–3 year after surgery. A new nerve structure was formed within the tube bridging the nerve gap. The success of this study might have been due to the tubulization of the short gap between the proximal and distal stumps. A non-biological material exists for a long time without any degradation tendency. Biodegradable material can be removed by degradation from the lesion after a certain period of time around which nerve regeneration has been completed. In this sense, biodegradable materials have extensively been studied as the guiding scaffolds of regenerating nerves.

### Collagen

Collagen, one of the most common components of connective tissue, is considered to be an appropriate material as a guide for growing axons. In clinical peripheral nerve regeneration, regenerating axons should traverse the connective tissue gap between the proximal and distal stumps in which collagen fibers may serve as a guide for the growth of axons. In this respect, collagen fibers can be one of the most suitable biological materials for guiding regenerating axons. However, the result is not necessarily desirable in terms of the efficacy of the collagen fibers. In an experiment in which the nerve gap was short (5 mm long), and the postoperative period was long (3.5 years), there was no difference between the collagen guides, autografts, and direct suture repair surgery in the monkey median and ulnar nerves [3]. Collagen fibers coated with laminin and fibronectin were shown to be an effective conduit in the rat.

### Polyglycolic Acid

A polyglycolic acid conduit was used in a multicenter clinical study, in which nerve stumps were connected by standard repair either end-to-end or with a nerve graft, or repair using polyglycolic acid conduits [4]. There was no difference in two-point discrimination between the control (standard repair by either end-to-end or with a nerve graft) and polyglycolic acid conduit group. The overall results of this study showed no significant difference between the two groups. However, in the case of a short (4 mm) nerve gap, the mean moving two-point discrimination was much shorter in the glycolic acid conduit repair group than in the control group.

### Copolymer of Polyglycolic Acid and Polylactic Acid

A copolymer of polyglycolic acid and polylactic acid has been used as a material to make a tube for bridging nerve stumps in peripheral as well as central nerve regeneration. The mesh tube made of these biodegradable materials is believed to inhibit connective tissue infiltration into the tube. The tube can be filled with the cellular or non-cellular materials as the direct conduits of axons that extend through the tube. Collagen fibers filled in the polyglycolic/polylactic acid copolymers serve as effective guide bridging the 80 mm long gap in the cat sciatic nerve [5]. There is a study in which multiple-channel scaffolds (tubes) were made with the copolymer of polyglycolic acid and polylactic acid, and, used, after the distribution of Schwann cells within the tubes, as a transplant for spinal cord regeneration [6]. Considering that peripheral nerve fibers are bundles of small channels made of basal lamina scaffolds, multi-channel scaffolds can also be effective conduits for peripheral nerve regeneration.

### Poly- $\epsilon$ -Caprolactone

Poly- $\epsilon$ -caprolactone is used alone or in copolymer with polylactic acid as a scaffold for the growth of regenerating axons. The tube is coated with other materials or filled with effective cells such as Schwann cells or effective extracellular matrix such as basal laminae derived from muscle fibers [7]. In denatured muscle segments, basal laminae of muscle fibers remained in the form of a tube after cellular components of muscle fibers had been removed. Regenerating axons extended through muscle fiber-derived basal laminae. A polylactic acid- $\epsilon$ -caprolactone copolymer served to protect muscle fiber basal laminae from early degradation to be used by regenerating axons for several months after grafting.

### Alginate

Alginate is a unique material derived from brown seaweed. Calcium alginate gel has been used as a food additive. However, due to its toxicity, calcium alginate has been limited in terms of its medical application. In our laboratory, a new type of alginate gel was produced by treatment of ethylenediamine and carbodiimide, which covalently cross-links the carboxyl groups of alginate. The resulting alginate gel has a higher transparency and higher water content than calcium alginate gel. This covalently cross-linked new alginate gel has been shown to be useful for skin repair and nerve regeneration [8], and as a bone scaffold.

Bridging the nerve gap by freeze-dried covalently cross-linked alginate gel promoted nerve regeneration in rat sciatic and cat facial nerves. We analyzed nerve regeneration through alginate gel in the early stages within 2 weeks and in the late stages up to 21 months after transplantation. Alginate is not fabricated into the tube, but used in the form of a disc by which the injured nerve is sandwiched bridging the proximal and distal stumps. When put into the lesion, the freeze-dried alginate disc absorbs the body fluid to become softer.

In the very early stage, regenerating axons grow without Schwann cell investment through the partially degraded alginate gel, being in direct contact with the alginate without a basal lamina covering. Numerous mast cells were found infiltrating the alginate. Later, regenerating axons were surrounded in small bundles by common Schwann cells. Some axons at the periphery were partly in direct contact with alginate. At the distal stump, numerous Schwann cells had migrated into the alginate 1–2 weeks after surgery. Though regenerated myelinated fibers were thin (approximately 1  $\mu$ m in diameter) at 8 weeks, they had a distribution pattern similar to that of normal nerves at 21 months after surgery. It can be said that alginate gel has good biocompatibility for axonal outgrowth and Schwann cell migration. Alginate gel served as an effective conduit for the growth of

regenerating axons of the central nervous system including the spinal cord [9].

### Chitosan

Chitosan is another unique material that is a derivative of chitin. Chitosan has a polycationic carbohydrate structure, which provides a suitable scaffold for cell adhesion. Chitosan degrades into saccharides including glucosamines, metabolites normally found in mammals. Chitosan is considered to lead to minimal foreign body reaction. Presently, chitosan is clinically applied to protect burned skin in plastic surgery.

Transplantation of a cell adhesive laminin-conjugated chitosan tube enhanced nerve regeneration. The tube structure is not necessarily required for chitosan or alginate for bridging the nerve gap. In our study, the proximal and distal nerve stumps with 8-mm gap were sandwiched by freeze-dried chitosan gel sponge. By 14 days, regenerating axons had reached and extended through the distal stump. Numerous macrophages accumulated in a dense cell layer on the chitosan and phagocytosed it. Regenerating axons were not in touch with chitosan nor with macrophages, but extended through the loosely woven connective tissue compartment between the chitosan. Two to 4 months after surgery, regenerated myelinated fibers were as thick as normal fibers. Chitosan is considered to be usable as a conduit for peripheral nerve regeneration [10].

### References

1. Ide C, Tohyama K, Yokota R, Nitatori T, Onodera S (1983) Schwann cell basallamina and nerve regeneration. *Brain Res* 288:61–75
2. Dahlin LB, Anagnostaki L, Lundborg G (2001) Tissue response to silicon tubes used to repair human median and ulnar nerves. *Scand J Plast Reconstr Surg Hand Surg* 35:101–108
3. Archibald SJ, Shefner J, Kraup C, Madison RD (1995) Monkey median nerve repaired by nerve graft or collagen nerve guide tube. *J Neurosci* 15:4109–4123
4. Weber RA, Breidenbach WC, Brown RE, Jabaley ME, Mass DP (2000) A randomized prospective study of polyglycolic and conduits for digital nerve reconstruction in humans. *Plast Reconstr Surg* 106:1036–1045
5. Matsumoto K, Ohnishi K, Kiyotani T, Sekine T, Ueda U, Nakamura T, Endo K, Shimizu Y (2000) Peripheral nerve regeneration across an 80-mm gap bridged by a polyglycolic acid (PGA)-collagen tube filled with laminin coated collagen fibers: a histological and electrophysiological evaluation of regenerated nerves. *Brain Res* 868:315–328
6. Moore MJ, Friedman JA, Lewellyn EB, Mantila SM, Krych AJ, Ameenuddin S, Knight AM, Lu L, Currier BL, Spinner RJ, Marsh RW, Windebank AJ, Yaszemski ML (2006) Multiple-channel scaffolds to promote spinal cord axon regeneration. *Biomaterials* 27:419–429
7. Mligiliche NL, Tabata Y, Kitada M, Endoh K, Okamoto K, Fujimoto E, Ide C (2003) Poly lactic acid-caprolactone

copolymer tube with a denatured skeletal muscle segment inside as a guide for peripheral nerve regeneration: a morphological and electrophysiological evaluation of the regenerated nerves. *Anat Sci Int* 78:156–161

8. Suzuki Y, Tanihara M, Ohnishi K, Suzuki K, Endo K, Nishimura Y (1999) Cat peripheral nerve regeneration across 50 mm gap repaired with a novel nerve guide composed of freeze-dried alginate gel. *Neurosci Lett* 259:75–78
9. Kataoka K, Suzuki Y, Kitada M, Hashimoto T, Chou H, Bai H, Ohta M, Wu S, Suzuki K, Ide C (2004) Alginate enhances elongation of early regenerating axons in spinal cord of young rats. *Tissue Eng* 10:493–504
10. Ishikawa N, Suzuki Y, Ohta M, Cho H, Suzuki S, Dezawa M, Ide C (2007) Peripheral nerve regeneration through the space formed by a chitosan gel sponge. *J Biomed Mater Res*

## Transplantation of Bone Marrow Stromal Cells for Spinal Cord Regeneration

MASAYOSHI OHTA<sup>1,2</sup>, YOSHIHISA SUZUKI<sup>1,2</sup>, CHIZUKA IDE<sup>1,3</sup>

<sup>1</sup>Department of Anatomy and Neurobiology, Kyoto University Graduate School of Medicine, Kyoto, Japan

<sup>2</sup>Department of Plastic and Reconstructive Surgery, Kyoto University Graduate School of Medicine, Kyoto, Japan

<sup>3</sup>Department of Occupational Therapy, Aino University Faculty of Nursing and Rehabilitation, Osaka, Japan

### Synonyms

Mesenchymal stem cell

### Definition

Bone marrow stromal cells (BMSCs) are included in the so-called ►mesenchymal stem cells [1] that give rise to various kinds of cells including osteocytes, chondrocytes, tenocytes, adipocytes, and smooth muscle cells [2]. BMSCs were initially referred to as plastic-adherent cells.

### Characteristics

#### Preparation of BMSCs

Usually the femur and tibia of the rat are used as a source of bone marrow. The bones are cut off at both ends, and the marrow is flushed out with  $\alpha$ -MEM using a needle. The collected bone marrow tissue is dissociated, and then filtered. The suspension is centrifuged, and the pellets are suspended with  $\alpha$ -MEM, and cultured in medium. Forty-eight hours later, non-adherent cells are removed by

replacing the medium. Plastic-adherent cells, referred to as stromal cells [3], grow to confluence, and are passaged to maintain the proper conditions.

#### Characterization of Isolated BMSCs

Cell surface markers were assessed using FACS to characterize isolated rat and human BMSCs. BMSCs expressed CD29 ( $\beta$ 1-integrin), CD90 (Thy-1), and CD54 (ICAM-1), but not CD34 (a hematopoietic stem cell marker), CD11b/c (macrophages), or vWF (human endothelial cells), consistent with previous reports [4]. Basically identical results were obtained by immunocytochemical examination. BMSCs were also immunopositive to mesenchymal progenitor markers; 95% of BMSCs showed immunopositivity to PDGF receptor  $\beta$  and 45% to smooth muscle actin. In contrast, vascular (CD31) and hematopoietic (CD45, leukocyte common antigen) lineage markers were negative. As for neuronal markers, only 0.5% of BMSCs showed neurofilament immunoreactivity.

#### Cell Differentiation

BMSCs differentiate into osteocytes, chondrocytes, adipocytes, and other cell types including skeletal muscle fibers, cardiomyocytes, hepatocytes, neural cells and epithelial cells of the lung and intestinal tract in specific experimental conditions [1,2,5]. On the other hand, there are reports that the apparent trans-differentiation might at least in part be due to cell fusion.

#### Cytokines and Trophic Factors

BMSCs secrete cytokines such as macrophage colony-stimulating factor-1 (MCSF-1), interleukins, stem cell factors, and trophic factors including nerve growth factor [NGF], brain-derived neurotrophic factor [BDNF], hepatocyte growth factor [HGF], and vascular endothelial-derived growth factor [VEGF] [6]. It is also reported that BMSCs induce glial cells to produce neurotrophic factors like BDNF and NGF. BMSCs also express receptors for many molecules including interleukin 6 or 7, leukemia inhibitory factor, stem cell factor, granulocyte and macrophage colony-stimulating factors, thrombopoietin, tumor necrosis factor  $\beta$ 1 and  $\beta$ 2, and interferon  $\gamma$ .

#### Cell Transplantation

Transplantation of BMSCs has been studied in CNS injury including spinal cord injury [7–9], and traumatic and ischemic brain injuries [10] of the rat. BMSCs are transplanted by direct injection into the spinal cord lesion [7] or via blood flow.

BMSCs were directly transplanted into the injury site in animal models of traumatic and ischemic brain injuries, Parkinson's disease and spinal cord injury. BMSCs directly transplanted into the injured spinal cord 1 week after injury led to significant recovery.



It was suggested that grafted cells differentiated into neurons and integrated into neuronal networks.

However, the direct injection of transplants might cause secondary damage to the surviving tissues at the lesion site. Therefore, we have proposed that the infusion of BMSCs through ►cerebrospinal fluid is more appropriate and practical than direct cell injection into the lesion [8]. In our experiment, the spinal cord of the rat was contusion-injured at T8–9, and BMSCs (approximately  $1 \times 10^6$  viable cells) derived from the bone marrow of the same strain were infused into the cerebrospinal fluid (CSF) via the fourth ventricle through a hole drilled at a site 3.5 mm caudal to the lambda suture in the midline. The injected cells were conveyed to the subarachnoid space of the spinal cord through the CSF, and some of them invaded the

contusion-injured site, while most were attached to the spinal cord surface (Fig. 1a–d).

There is no finding suggesting the proliferation of BMSCs within the lesion or on the surface of the spinal cord. BMSCs disappeared before 3–4 weeks after infusion from the recipient. BMSCs did not differentiate into any neural cells in the host tissue, as examined by immunohistochemistry. Although BMSCs did not survive for a long time nor differentiate into neuronal cells, the cavity in the spinal cord decreased in volume (Figs. 2 and 3a, b), and the behavior of the rats with transplantation improved compared with the control rats as based on the ►BBB score (Fig. 3c, d).

It is probable that BMSCs release some trophic substances into the CSF effective for the rescue of degenerating tissues, resulting in the volume reduction

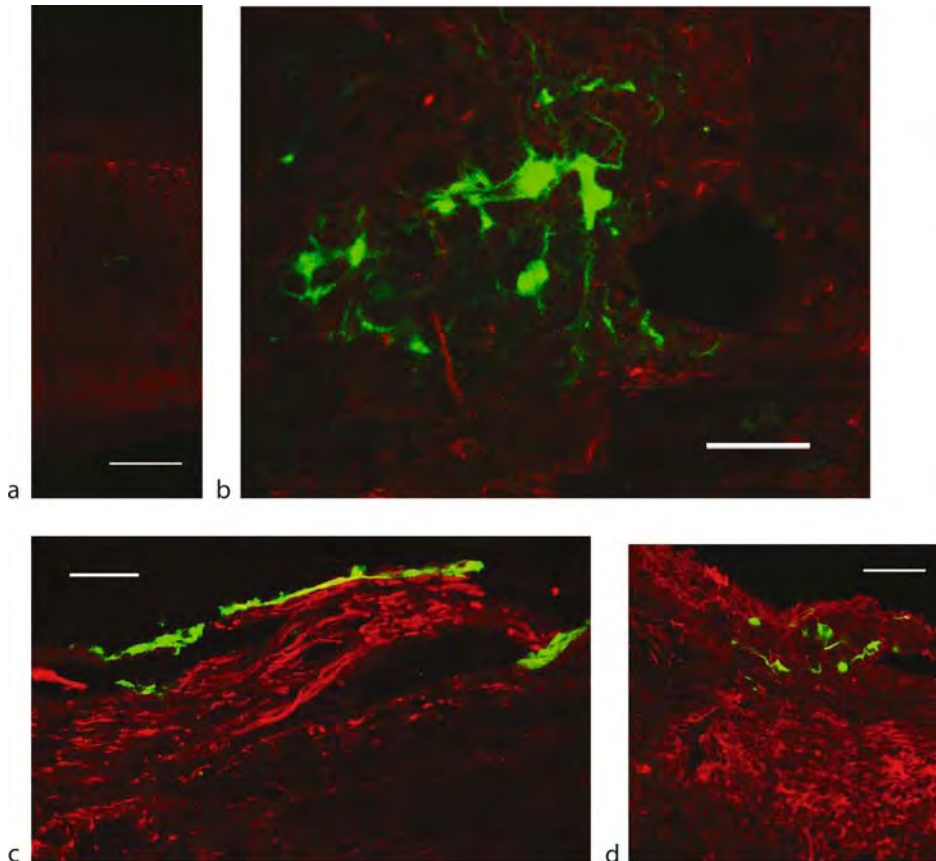

**Transplantation of Bone Marrow Stromal Cells for Spinal Cord Regeneration. Figure 1** These micrographs show the immunohistochemistry of the contusion-injured spinal cord of the rat 2 weeks after cell infusion. BMSCs were infused through the fourth ventricle into the cerebrospinal fluid immediately after contusion. The host spinal cord tissue was stained for GFAP (red) in a–b. (a) Low magnification of the GFP-positive cells (green) located within the lesion. (b) BMSCs in (a) are shown at higher magnification. BMSCs are partly integrated into the host tissue. (c, d) The transplanted BMSCs (green) are also seen attached to the roots (c) and located within the spinal cord near the surface (d). Scale bar; 1 mm in (a), and 240  $\mu$ m in (b–d).

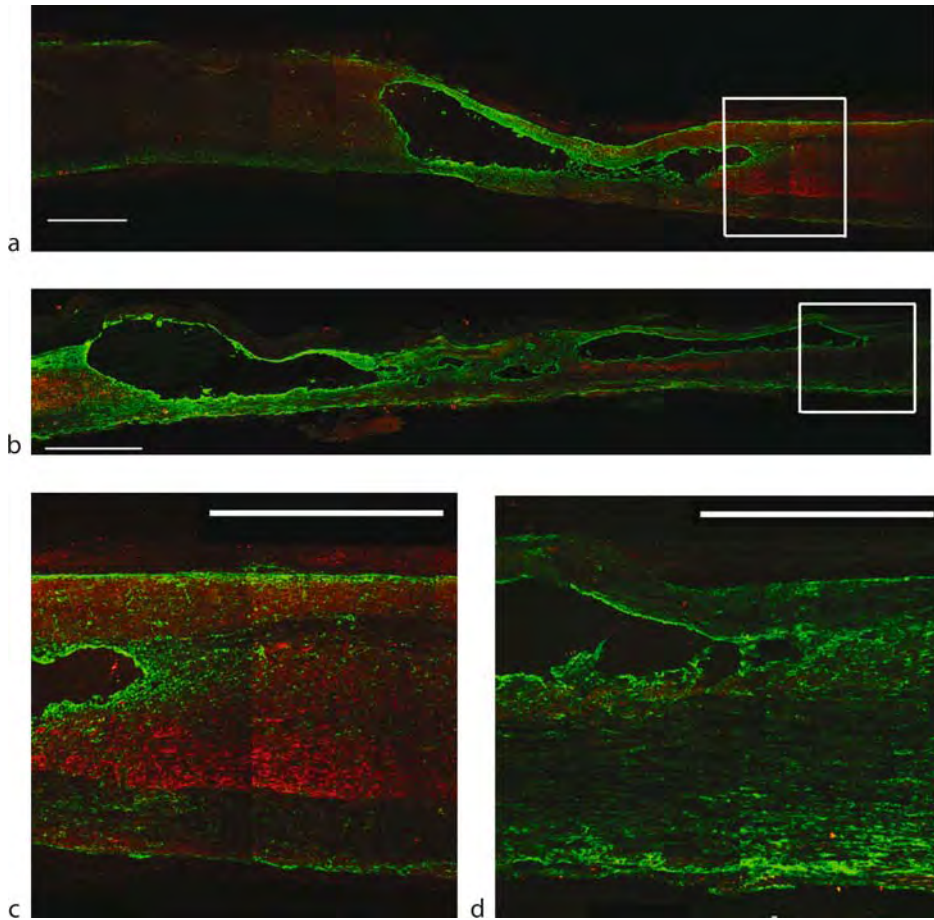

**Transplantation of Bone Marrow Stromal Cells for Spinal Cord Regeneration. Figure 2** Immunohistochemistry of the spinal cord with cavities from the BMSC-infused rats 5 weeks after transplantation. Rats were injured by weight-drop from a height of 25 mm. The spinal cord was double-stained for GFAP (*green*) and  $\beta$ -tubulin (*red*). (a, b) Low magnification of the spinal cord cavities of BMSC-infused rats (a) and control rats (b). The cavity is bordered by GFAP-stained astrocytes both in BMSC-transplanted (a) and control spinal cord (b). (c, d) The boxed parts of the cavities in (a, b) are enlarged in (c, d), respectively. The red-stained neuronal elements are distinct in the BMSC-transplanted spinal cord rats (c) as compared with the control spinal cord (d). The  $\beta$ -tubulin-stained neuronal elements are abundant in areas close to the cavity in the spinal cord from BMSCs-transplanted rats (c), while they are sparse in the spinal cord from the control (d). Scale bar; 1 mm in (a–d).

of cavities and leading to the behavioral improvement of rats (Figs. 2 and 3). The finding that CSF from the rats, into which BMSCs had been injected 2 days prior, enhanced the attachment and differentiation of neurosphere cells *in vitro* suggests that some trophic substances might be released from BMSCs into the CSF.

Considering that BMSCs can be used for autologous transplantation, and that the CSF-infusion of transplants imposes a minimal burden on patients, the above results indicate that the transplantation of BMSCs is a promising clinical treatment of CNS injury.

#### Clinical Application

The clinical application of bone marrow stromal cells is ready to commence based on the work in our laboratory.

After discussion for more than 2 years, the Medical Ethics Committee of Kansai Medical University approved our application on July 1, 2005: the treatment of acute spinal cord injury by infusing autogeneic bone marrow stromal cells through the CSF of patients within 1–2 weeks after injury.

Transplantation of autogeneic bone marrow stromal cells was carried out by lumbar puncture to the first patient with spinal cord injury at C5 on March 23, 2006. There has been no harmful implication with respect to cell transplantation through the cerebrospinal fluid. The patient is now under observation for the evaluation of the sensory as well as motor function improvement by the effect of cell transplantation.

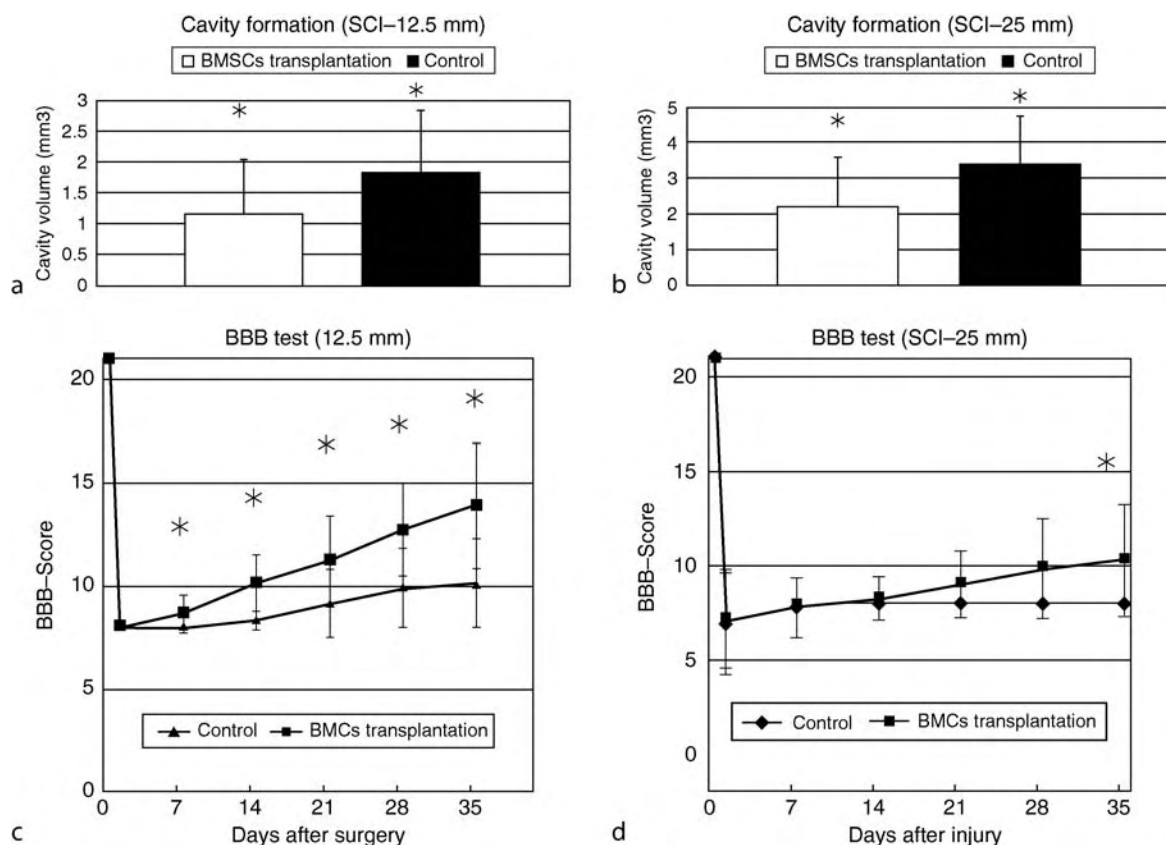

**Transplantation of Bone Marrow Stromal Cells for Spinal Cord Regeneration. Figure 3** (a, b) These graphs show the difference in cavity volume between the BMSC-transplanted and control groups at 5 weeks after cell infusion. The spinal cord was injured by weight-drop from a height of 12.5 mm ( $n = 8$ : control group  $n = 8$ : BMSC injection group) (a) and from the height of 25 mm ( $n = 8$ : control group  $n = 8$ : BMSC injection group) (b). The cavity volume values were significantly different between the BMSC-grafted and control rats ( $*p < 0.05$ ). (c, d) These graphs show the analysis of locomotor recovery as measured by BBB scores. The experimental designs of (c, d) correspond to (a, b), respectively. BBB scores are significantly higher in the BMSC-transplanted rats at all time points in (c), and at 5 weeks after injection in (d) ( $*p < 0.05$ ).

## References

- Pittenger MF, Mackay AM, Beck SC, Jaiswal RK, Douglas R, Mosca JD, Moorman MA, Simonetti DW, Craig S, Marshak DR (1999) Multilineage potential of adult human mesenchymal stem cells. *Science* 284:143–147
- Prockop DJ (1997) Marrow stromal cells as stem cells for nonhematopoietic tissues. *Science* 276:71–74
- Azizi SA, Stokes D, Augelli BJ, DiGirolamo C, Prockop DJ (1998) Engraftment and migration of human bone marrow stromal cells implanted in the brains of albino rats – similarities to astrocyte grafts. *Proc Natl Acad Sci USA* 95:3908–3913
- Dezawa M, Kanno H, Hoshino M, Cho H, Matsumoto N, Itokazu Y, Tajima N, Yamada H, Sawada H, Ishikawa H, Mimura T, Kitada M, Suzuki Y, Ide C (2004) Specific induction of neuronal cells from bone marrow stromal cells and application for autologous transplantation. *J Clin Invest* 113:1701–1710
- Sanchez-Ramos J, Song S, Cardozo-Pelaez F, Hazzi C, Stedeford T, Willing A, Freeman TB, Saporta S, Janssen W, Patel N, Cooper DR, Sanberg PR (2000) Adult bone marrow stromal cells differentiate into neural cells in vitro. *Exp Neurol* 164:247–256
- Chen X, Katakowski M, Li Y, Lu D, Wang L, Zhang L, Chen J, Xu Y, Gautam S, Mahmood A, Chopp M (2002) Human bone marrow stromal cell cultures conditioned by traumatic brain tissue extracts: growth factor production. *J Neurosci Res* 69:687–691
- Chopp M, Zhang XH, Li Y, Wang L, Chen J, Lu D, Lu M, Rosenblum M (2000) Spinal cord injury in rat: treatment with bone marrow stromal cell transplantation. *Neuroreport* 11:3001–3005
- Ohta M, Suzuki Y, Noda T, Ejiri Y, Dezawa M, Kataoka K, Chou H, Ishikawa N, Matsumoto N, Iwashita Y, Mizuta E, Kuno S, Ide C (2004) Bone marrow stromal cells infused into the cerebrospinal fluid promote functional recovery of the injured rat spinal cord with reduced cavity formation. *Exp Neurol* 187:266–278

9. Wu S, Suzuki Y, Ejiri Y, Noda T, Bai H, Kitada M, Kataoka K, Ohta M, Chou H, Ide C (2003) Bone marrow stromal cells enhance differentiation of cocultured neurosphere cells and promote regeneration of injured spinal cord. *J Neurosci Res* 72:343–351
10. Mahmood A, Lu D, Wang L, Chopp M (2002) Intracerebral transplantation of marrow stromal cells cultured with neurotrophic factors promotes functional recovery in adult rats subjected to traumatic brain injury. *J Neurotrauma* 19:1609–1617

## Transplantation of Neural Stem Cells for Spinal Cord Regeneration

HIDEYUKI OKANO

Department of Physiology, School of Medicine, Keio University, Tokyo, Japan

### Definition

Transplantation of in vitro expanded ►neural stem cells into a damaged site of the spinal cord in vitro, aimed at axonal regeneration, replenishment of lost neural cells, and functional restoration.

### Characteristics

#### Background

It has long been believed that the damaged adult central nervous system (CNS) cannot regenerate. However, it is now an important target of study in the field of regenerative medicine. In fact, to *recapitulate* normal neural development has become a vital strategy for ►regeneration of the CNS. During normal CNS development, stem cells or stem-like cells appear at the earliest stage. Based on this knowledge, there is increasing interest in the usefulness of stem cells in the CNS (neural stem cells, NSCs) as a tool to recapitulate normal CNS development and achieve regeneration.

NSCs have multilineage potential and self-renewing capability. Since there are no definitive molecular markers for NSCs, it is practically difficult to distinguish NSCs from neural progenitor cells. In such cases, these cells are collectively referred to as neural stem/progenitor cells (NSPCs).

Establishment of experimental evidence of the existence of NSCs with multilineage potential and self-renewing capability has been aided by one of the major breakthroughs in CNS stem cell biology: clonogenic expansion of NSCs by neurosphere formation in serum-free medium containing EGF and/or FGF-2 [1]. This excellent culture method has enabled the definition of the NSCs experimentally and the quantification of

the multilineage potency and self-renewing capability of these cells. The availability of a method for the expansion of stem cells in vitro is currently limited to the stem cells of the nervous system. Furthermore, using this culture method, NSCs or NSPCs have been shown to proliferate in an undifferentiated state in vitro, allowing mitotic expansion of the cells and cell harvesting in bulk. Taking advantage of the ease with which NSPCs can be harvested from ►neurosphere cultures (or similar methods) in vitro, numerous attempts have been made to transplant NSPCs into animals in an attempt to treat damaged brains and spinal cords [2]. In this study, we shall describe attempts at transplantation of NSPCs into an injured spinal cord with the aim of achieving spinal cord regeneration.

### Traumatic Injury of the Spinal Cord and the Current Standard Clinical Treatments for this Condition

The spinal cord is a part of the CNS and its structure is characterized by full preservation of the primitive segmental arrangement established in the embryonic neural tube. The spinal cord extends from the lower end of the brainstem, down the vertebral canal to the upper margin of the second lumbar vertebra, conducting and modulating impulses back and forth between the brain and the rest of the body. Ascending sensory pathways transfer sensory information from the nerve endings in the skin, muscles, joints and systemic organs to the brain. Descending motor pathways, including the corticospinal tracts (CSTs), control the voluntary movements and reflex functions of the limbs and trunk. Other descending pathways modulate the output of the autonomic nervous system, which controls body homeostasis, as well as the bowel, bladder and sexual functions. Based on this functional structure, traumatic spinal cord injuries can result in severe damage, such as the loss of motor and sensory functions caudal to the level of injury, because of severance of the descending and ascending fiber tracts. Disruption of fibers that control the autonomic nervous system could also lead to impairment of vascular, exocrine and endocrine gland, bowel, bladder, and sexual functions.

The current standard clinical treatment for spinal cord injury consists of surgical stabilization of the vertebral column to prevent posttraumatic instability of this column, and administration of high doses of steroids to decrease the amount of tissue damage. However, these treatments have modest effects at best, and there is a great need for novel “regenerative” treatment strategies that could significantly protect and/or restore the functions of the spinal cord following SCI.

### Experimental Regenerative Treatments for the Injured Spinal Cord

The presumed lack of self-regenerative properties of the adult mammalian spinal cord could be attributable

to a combination of factors, including the inhibitory characteristics of CNS myelin and injury-induced **glial scars**, the apparent inability of endogenous adult NSCs in the spinal cord to initiate de novo neurogenesis after injury, and the lack of sufficient trophic support. However, since the 1980s, numerous studies have reported on the beneficial effects of transplantation of peripheral nerves and the fetal spinal cord for spinal cord injuries. These studies have indicated that the introduction of an appropriate environment into the injured site can induce the injured axons to regenerate. Although researchers first focused on the effectiveness of fetal spinal cord transplantation for spinal cord injuries, donor shortage and ethical problems preclude the practical clinical application of this approach. On the other hand, recent progress in the understanding of the biology of NSCs has made it possible to routinely harvest NSCs from small amounts of fetal CNS tissue in vitro, e.g., by the neurosphere culture method [1]. Therefore, expansion of NSPCs in vitro may, at least be partially of use to overcome the practical and ethical problems associated with fetal tissue transplantation, and such cells may provide a potential source for the graft material needed for attempts aimed at regeneration of the injured spinal cord.

In addition to NSPCs, there have been numerous attempts at regeneration of the spinal cord using transplantation of other cells, including genetically engineered NSPCs, Schwann cells, marrow stromal cells, olfactory ensheathing glia, activated macrophages (reviewed in [3]) and embryonic stem cells-derived oligodendrocyte progenitor cells [4], the effects of which have been described in other essays in this Encyclopedia and elsewhere.

### Possible Obstacles in the Transplantation of NSCs into the Injured Spinal Cord

One of the most important issues that must be addressed with regard to the transplantation of NSPCs into the injured spinal cord is that the adult spinal cord appears to be a non-neurogenic site, i.e., endogenous NSPCs existing in the adult rat spinal cord proliferate and differentiate exclusively into astrocytes, but not into neurons, in situ following injury [5]. However, these observed lacks of neurogenesis are not likely to be an intrinsic characteristic of adult spinal cord-derived NSPCs, since these cells have been shown to be able to differentiate into neurons, both in vitro and following transplantation into neurogenic sites, such as the hippocampal dentate gyrus [6]. Thus, it is likely that the microenvironment plays an important role in the differentiation of NSCs and their progenies. Naturally, these observations raised the possibility of successful treatment of spinal cord injury by transplanting NSCs into the sites of injury of the spinal cord.

### Therapeutic Time Window for NSPC Transplantation in a Model of SCI

Considering the microenvironment within the injured spinal cord, it was shown that in the adult spinal cord, transplanted exogenous NSPCs may not be absolutely non-neurogenic, and that transplantation during a narrow therapeutic time window may allow successful neurogenesis [7]. This window of opportunity may be rather brief, because the microenvironment in the host spinal cord changes rapidly after injury. Recent reports have shown that transient severe inflammation occurs around the injured site of the cord during the acute phase, immediately following the injury. During this time, the levels of many **pro-inflammatory cytokines** that have neurotoxic or astrocyte-inducing effects, such as IL-1, IL-6, and TNF $\alpha$ , increase, to then decline sharply within 24 h [8], indicating that the microenvironment during this acute phase may not be suitable for the survival of grafted cells. Thus, the immediately post-traumatic microenvironment of the spinal cord, which is in an acute inflammatory stage, may not be favorable for the survival and differentiation of NSPC-transplants. On the other hand, in the chronic stage after injury, glial scars form at the injured site in the spinal cord and inhibit the regeneration of neuronal axons. Thus, the optimal timing for transplantation may be 1–2 weeks after the injury (Fig. 1).

Based on this evidence, in this study, in-vitro-expanded rat fetal spinal cord-derived NSPCs were transplanted into an adult rat spinal cord **contusion injury model** [at the C4–C5 level] nine days after the injury, to examine the ability of the transplanted NSPCs to differentiate into neurons in vivo and the consequent improvement of the motor functions [7] (Fig. 2).

Following transplantation at this time point after the injury, it was found that the transplanted neurosphere cells, cultured from the rat embryonic spinal cord on Day 14.5 (E14.5) and pre-labeled with bromodeoxyuridine (BrdU) in culture, could introduce neurons, astrocytes and oligodendrocytes into the injured adult rat spinal cord. Furthermore, the transplantation resulted in mitotic production of new neurons in vivo, and these neurons extended their processes into the host tissue to form synaptic structures. In addition, we observed behavioral improvement in the rats transplanted with neurosphere cells as compared with the control rats.

### Efforts to Enhance the Therapeutic Effects of NSPC-Transplantation

To achieve even better effects of cell therapy using NSPCs in various types of CNS damage, including SCI, efforts have been made to improve the therapeutic actions of NSPCs by genetic engineering (stem cell gene therapy) [9], developing convenient methods

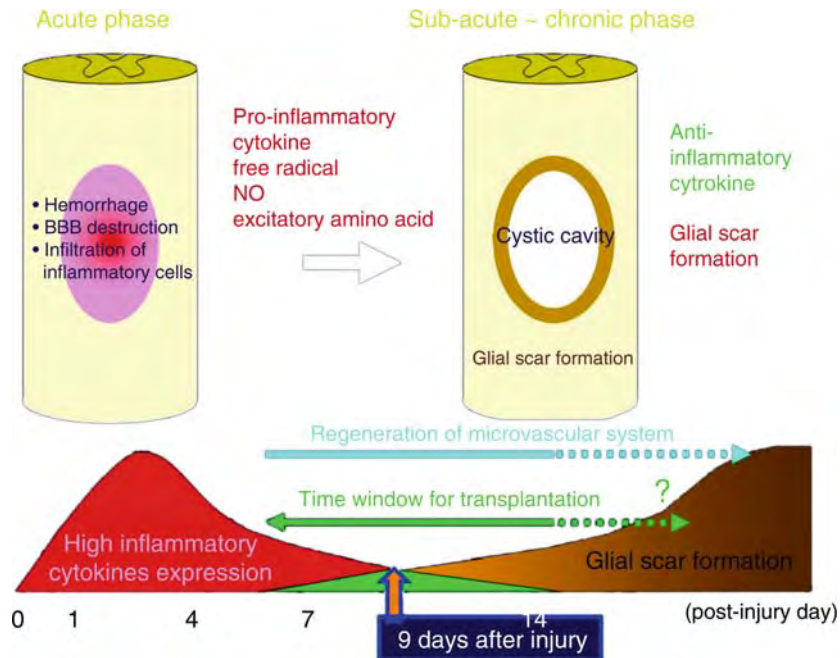

**Transplantation of Neural Stem Cells for Spinal Cord Regeneration. Figure 1** Therapeutic time window for transplantation of NSCs into injured spinal cords (adapted from reference [2]). The time schedule of various events after spinal cord injury. Ogawa et al. [7] found that delaying NSPC transplantation until nine days after rat spinal cord injury resulted in the production of new neurons, oligodendrocytes, and astrocytes, as well as functional recovery. In contrast, the transplantation during the acute phase, that is, within a week of the injury, failed to induce these effects, probably due to the high expression level of inflammatory cytokines, including IL-1 $\alpha$  and  $\beta$ , TNF- $\alpha$  and IL-6. Taking into consideration previous findings concerning the transplantation of fetal neural tissues into the cerebral cortex, which showed the important contribution of micro vascularization to the success of such transplantation, it is suggested that the beneficial effects of delayed NSC transplantation could result from microvascular regeneration in the host. Delaying of the transplantation until the chronic phase is unlikely to lead to functional recovery, due to enlargement of the cystic cavities at the site of injury and glial scar formation.

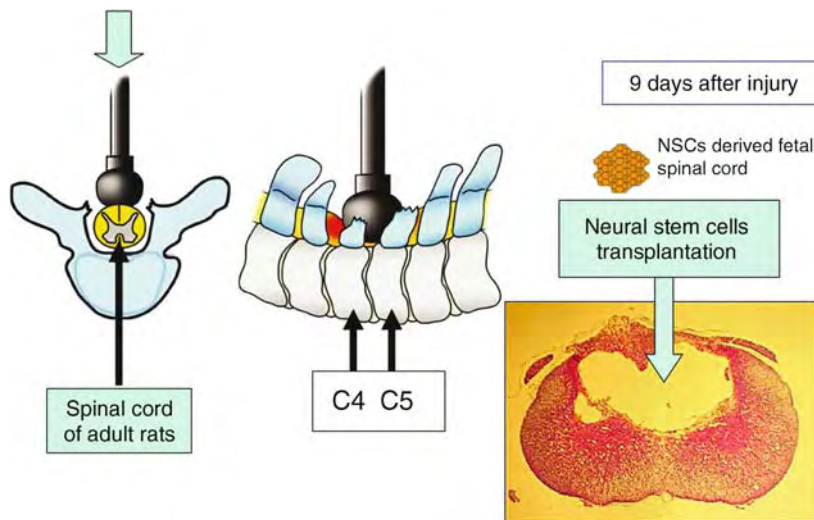

**Transplantation of Neural Stem Cells for Spinal Cord Regeneration. Figure 2** NSPC transplantation into an adult rat model of SCI. Contusive injury was induced at the level of C4/C5 in adult rats. This SCI model showed cavity formation in the dorsal part of the spinal cord. In-vitro-expanded NSPCs were transplanted into the cavity nine days after the induction of the injury.

for administrating NSPCs into injured spinal cord, or using combinations of various other therapeutic interventions (e.g., scaffolds for cell therapy) with NSPC transplantation.

#### **Genetically Engineered NSPCs**

Here, as an example, I would like to introduce a recent development of Neurogenin-2 gene-based stem cell gene therapy in a SCI model. It was reported that transduction of adult NSPCs with Neurogenin-2 (Ngn-2), a neuronal basic Helix-Loop-Helix gene, before transplantation into a rat thoracic spinal cord weight-drop injury model, suppressed astrocytic differentiation of the engrafted cells and prevented graft-induced sprouting and allodynia-like hypersensitivity of the forepaws [9]. On the other hand, transplantation of NSPCs without the Ngn-2 transgene caused aberrant axonal sprouting associated with allodynia. Thus, transduction with Ngn-2 improved the beneficial effects of the engrafted stem cells, including the increase in the amounts of myelin in the injured area, and recovery of hindlimb locomotor functions and hindlimb sensory responses, as confirmed by functional magnetic resonance imaging.

#### **Convenient Methods for Administrating NSPCs into Injured Spinal Cord**

Instead of injecting cell suspension of NSPCs into the intraspinal cavity that resulted from the secondary injury, a recent report suggests a novel and convenient method of supplying cultured neurosphere cells to the injured spinal cord, by injection of cells into the cerebrospinal fluid (CSF) through the fourth ventricle or cisterna magna. GFP-tagged hippocampus-derived NSPCs were transplanted into the CSF of a rat with SCI. Notably, injected cells were extensively transported by CSF within the subarachnoid space, survived as clusters on the pial surface of the spinal cord, migrated into the lesion site and integrated into the injured spinal cord tissues, indicating the efficacy of this new method.

#### **Scaffolds for Cell Therapy**

To better direct repair following spinal cord injury (SCI), an implant modeled after the intact spinal cord consisting of a multicomponent polymer scaffold (including poly(lactic-co-glycolic acid) (PLGA)) seeded with a murine NSPC-line (clone C17.2) was developed [13]. Implantation of the scaffold-C17.2 cells unit into an adult rat hemisection model of SCI promoted long-term improvement in function (persistent for 1 year in some animals) relative to a lesion-control group. Other types of scaffolds, including various types of extracellular matrixes, are also being developed together with NSPC transplantation in order to enhance the tissue-integration and survival of transplanted NSPCs-derived cells within the host tissues.

#### **Primate SCI Model and NSPC Transplantation**

Direct extrapolation of the results obtained in rodent experiments to clinical cases is difficult, because of species differences of the spinal cord between rodents and primates, in terms of the structure and functions. Therefore, preclinical studies using nonhuman primates, are necessary before NSPCs can be applied in clinical trials to treat human patients with spinal cord injury (SCI). Therefore, we conducted a preclinical study on ▶common marmosets (*Callithrix jacchus*), taking advantage of the fact that these animals can be bred in experimental colonies, their supply is stable and reliable, and that adequate genetic and microbiological control is possible to minimize biases. We then established a common marmoset model of graded-contusive SCI, which had characteristics quite similar to those of human SCI, and examined the effectiveness of human NSPC transplantation on the recovery of motor functions in the contusive SCI models of the primates with tetraplegia [10]. Cervical-contusion SCI was induced in ten adult common marmosets using a stereotaxic device. Nine days after the injury, in-vitro-expanded human NSPCs were transplanted into the spinal cord of five randomly selected animals, and the other sham-operated control animals received culture medium alone. Eight weeks after the transplantation, histologic analysis revealed that the grafted human NSPCs survived and differentiated into neurons, astrocytes, and oligodendrocytes, and that the cavities in the spinal cord of the experimental animals were smaller than those in the sham-operated control animals. The motor functions of the transplanted animals were also significantly better than those of the sham-operated control animals. These findings suggest that NSPC transplantation was effective for the restoration of structure and function after SCI even in primates, and that NSPC transplantation might also be feasible in the treatment of SCI in humans.

#### **Mechanisms of Functional Recovery of the Injured Spinal Cord Following NSPC Transplantation**

Based on the recent results of NSPC transplantation into SCI models, the mechanisms underlying the functional improvement in the rat and primate SCI models may be explained as follows:

1. Neurons derived from the grafted cells “relayed” signals from the disrupted fibers in the host, including ascending fibers that existed in the dorsal column. Alternatively, grafted NSPC-derived inhibitory (GABAergic and/or glycinergic) interneurons established synapses with the host neurons and functionally restored the neuronal circuits disrupted by the SCI, to attenuate the spasticity and/or excitotoxicity [15].

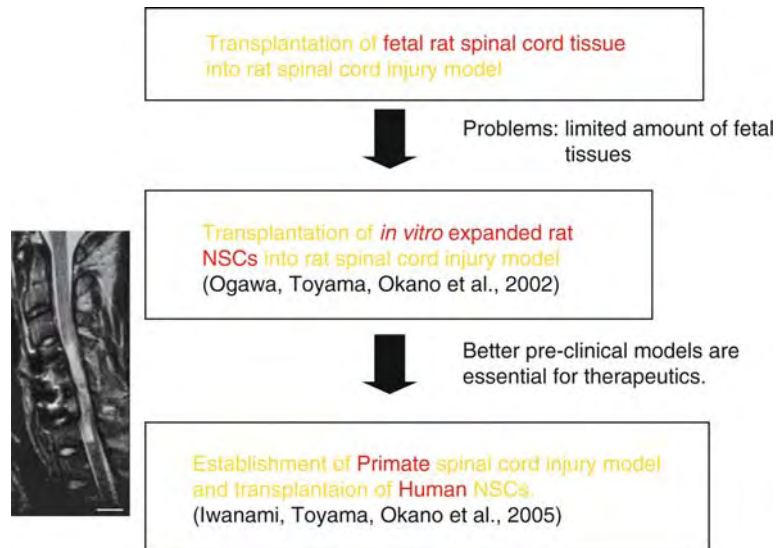

**Transplantation of Neural Stem Cells for Spinal Cord Regeneration. Figure 3** Progresses in cell therapy for SCI. Historically, fetal spinal cord tissues were transplanted into rat SCI models (*upper panel*). Obviously, these studies had the problems of limited availability of fetal tissues and ethical problems, interfering with their clinical application. On the other hand, transplantation of in-vitro-expanded NSPCs nine days after the injury resulted in functional recovery of the injured spinal cord in adult rats (*middle panel*) [4]. As a further step, a primate SCI model was established, in which functional restoration was achieved after transplantation of human NSPCs [6].

- Oligodendrocytes derived from the grafted cells might have remyelinated the fibers that had been demyelinated as a result of injury, and restored the salutatory conduction along the neuronal axons of the long-projection neurons.
- Astrocytes derived from the donor neural progenitor cells might have played active roles in the generation of neuronal cells, axonal regeneration of host neuronal axons, enhancement of axonal extension of donor-derived neurons, synapse formation, and/or physiological maturation of the neuronal cells.
- **Trophic effects** (indicating that the functional improvement may not be dependent on the transplanted human NSPCs becoming functional neurons and making the right connections, but rather on the secretion of trophic factors from the transplanted cells) might also be effective for the survival and differentiation of the host cells in the injured spinal cord, leading to functional recovery.

### Conclusions and Perspectives

The progress of the stem cell therapy for SCI can be summarized in Fig. 3.

However, the underlying mechanisms for functional improvement or other benefits associated with most of the cell-based transplants, including NSPC transplantation, are not currently precisely understood. Elucidation of the mechanisms underlying the possible benefits and

disadvantages of cell-based transplantation may be expected to guide further development of improved therapeutic interventions for patients with SCI patients [4].

### References

- Reynolds BA, Weiss S (1992) Generation of neurons and astrocytes from isolated cells of the adult mammalian central nervous system. *Science* 255:1707–1710
- Okano H (2002) The stem cell biology of the central nervous system. *J Neurosci Res* 69:698–707
- Steeves J, Fawcett J, Tuszynski M (2004) Report of international clinical trials workshop on spinal cord injury. Vancouver, Canada, 20–21 February 2004. *Spinal Cord* 42:591–597
- Keirstead HS, Nistor G, Bernal G, Totoiu M, Cloutier F, Sharp K, Steward O (2005) Human embryonic stem cell-derived oligodendrocyte progenitor cell transplants remyelinate and restore locomotion after spinal cord injury. *J Neurosci* 25:4694–4705
- Johansson CB, Momma S, Clarke DL, Risling M, Lendahl U, Frisen J (1999) Identification of a neural stem cell in the adult mammalian central nervous system. *Cell* 96:25–34
- Shihabuddin LS, Horner PJ, Ray J, Gage FH (2000) Adult spinal cord stem cells generate neurons after transplantation in the adult dentate gyrus. *J Neurosci* 20:8727–8735
- Ogawa Y, Sawamoto K, Miyata T, Miyao S, Watanabe M, Toyama Y, Nakamura M, Bregman BS, Koike M,



- Uchiyama Y, Toyama Y, Okano H (2002) Transplantation of in vitro expanded fetal neural progenitor cells results in neurogenesis and functional recovery after spinal cord contusion injury in rats. *J Neurosci Res* 69:925–933
8. Nakamura M, Houghtling RA, MacArthur L, Bayer BM, Bregman BS (2003) Differences in cytokine gene expression profile between acute and secondary injury in adult rat spinal cord. *Exp Neurol* 184:313–325
  9. Hofstetter CP, Holmstrom NA, Lilja JA, Schweinhardt P, Hao J, Spenger C, Wiesenfeld-Hallin Z, Kurpad SN, Frisen J, Olson L (2005) Allodynia limits the usefulness of intraspinal neural stem cell grafts; directed differentiation improves outcome. *Nat Neurosci* 8:346–353
  10. Iwanami A, Kakneko S, Nakamura M, Kanemura Y, Mori H, Kobayashi S, Yamasaki M, Momoshima S, Ishii H, Ando K, Tanioka Y, Tamaoki N, Nomura T, Toyama Y, Okano H (2005) Transplantation of human neural stem/progenitor cells promotes functional recovery after spinal cord injury in common marmoset. *J Neurosci Res* 80:182–190

## Transplantation of Olfactory Ensheathing Cells

GILES W PLANT

Red's Spinal Cord Research Laboratory, School of Anatomy and Human Biology, The University of Western Australia, Crawley, Perth, WA

### Synonyms

Spinal cord; Glia; Injury

### Definition

Olfactory ensheathing cells: a specialized cell from the nose to support nerve growth within the spinal cord.

Brain and spinal cord injuries have severe consequences for human patients, but these injuries have considerable financial and social consequences, particularly to their families. The field of spinal cord injury (SCI) in particular has provided the scientists and clinicians of today a very challenging problem. To address the problem of SCI, numerous attempts have been developed to treat these injuries in mammalian research models. Axonal regeneration within the central nervous system can be influenced in a number of ways; this review will concentrate on the transplantation of cells isolated from adult tissues only. These cells include a number isolated from both the peripheral and central nervous systems. The main focus of this essay is one cell type isolated from the primary olfactory system (center for smell processing in the brain), called olfactory ensheathing cells, and their potential role in SCI repair.

## Characteristics

### What are Olfactory Ensheathing Cells?

The olfactory ensheathing cells are specialized glial cells found in the olfactory system. They are located specifically within the olfactory epithelium/Lamina propria and olfactory bulb. The ensheathing cell surrounds sensory axons as they leave the olfactory epithelium and accompany these axons from the nose all the way to their targets in the brain. The ensheathing cells share properties of other glia (“glue”) such as astrocytes and Schwann cells, which are the two main glial types found in the central nervous system (CNS) and peripheral nervous system (PNS) respectively. This shared property makes the ensheathing cell quite original, because it can function in both the PNS and CNS well. The primary olfactory system is also unusual in its ability to replace its neurons throughout adult life. This process is known as neurogenesis and the olfactory ensheathing cells are thought to play a very important role in this mechanism. The roles within the olfactory system and their properties have made the olfactory ensheathing cells promising candidates for nervous system repair particularly SCI.

### Olfactory Ensheathing Cell Transplants

Numerous SCI models have been used to test the efficacy of olfactory ensheathing cell transplants. These models have involved dorsal root lesions, partial tract lesions, contusion/compression or complete transections. Additional models involving photochemical damage of the spinal cord have also included the use of ensheathing cell transplants to mediate repair.

Numerous experiments have been carried out over the last 11 years, utilising olfactory ensheathing cell transplants to the injured spinal cord. The first experiment demonstrating that OEC were able to support regenerative growth of lesioned axons within the damaged CNS (particularly spinal cord) was performed by [1] in a model of dorsal root injury. Following the lesioning of the dorsal root and their re-adjointing to the spinal cord, ensheathing cells were injected into the spinal cord close to where a dorsal root had been cut. Sensory axons were able to regenerate into the spinal cord from the peripheral nerve and functional contact was made with target neurons. Two concerns arose from this study, the first being that Hoechst 33342 dye used in the study has a propensity to leak into surrounding tissue giving inaccurate monitoring of transplanted cells and secondly, appropriate functional activity is most accurately measured by physiological and behavioural methods not used in the original study. Other laboratories have supported the original findings, but two recent studies have not been able to confirm the original results. Of particular interest was the lack of physiological active contacts made by any sensory axons in this paradigm [2]. The lack of similarity and outcomes between projects may be due to cell transplantation, cell origin, cell purity and even rat versus mouse models.

This initial work by [1] was closely followed by two publications reporting the regeneration of supraspinal motor axons into grafts of olfactory ensheathing cells and in combination with Schwann cells grafts [3,4]. Li and colleagues [4] described the use of olfactory ensheathing cells isolated from the adult olfactory bulb and reported the return of function of the forelimb after a unilateral lesion of the corticospinal tract at a cervical level of the spinal cord. However, a cell purification protocol was not used, unlike Ramon-Cueto et al. [4] who used a p75 antibody purification protocol used in original publication [1]. These results raise an important question of whether OEC are the true regenerative cell in some experiments. Further published reports using lesions of the CST tract have also had mixed results when using OEC transplants. Studies have utilised OEC transplants from the olfactory bulb, but differ in purity and isolation techniques; this may have influenced the end results. Ruitenbergh and colleagues [5] recently described the use of p75 purified OEC transplants engineered to secrete NT-3 or a reporter gene *LacZ* but showed no return of forepaw function when compared to medium controls when a lesion of the C4 spinal cord was carried out. Although forepaw behaviour was not changed, it was intriguing to observe that axonal regeneration/sparing was seen in the CST projection and axons were found long distances from the lesion (up to 1 cm). Other combinational therapies with OEC have been used to repair the corticospinal tract, including treating the animal with methylprednisolone with some measure of success.

Ramon-Cueto and colleagues [4] showed in a first experiment using a complete transplantation of the spinal cord that OEC could accompany axons descending in the spinal cord to re-innervate the distal spinal cord. This report combined the growth promotional abilities of Schwann cells with OEC transplants at either end of the Schwann cell grafts. Previous reports using Schwann cells had showed that spinal cord axons can enter these grafts, but cannot exit due largely to the expression of inhibitory molecules. OEC transplants in this experimental model enabled 5HT-positive raphe axons in particular to enter the distal spinal cord segments via an unusual and rather unexpected route, the connective fibroblast/OEC tissue surrounding the Schwann cell filled man made polymer tube (▶PAN/PVC tube). This propensity of raphe axons to grow near or through OEC grafts has also been shown in complete transection and contusion injuries of the spinal cord. Further to this initial work combining Schwann cells with OEC, [6] produced a report of the effectiveness of p75 purified OEC transplants on the complete transected spinal cord without Schwann cells added. The authors reported successful behavioural recovery of the transplanted rat's hind limb after a complete spinal cord transection. Interestingly the authors had to wait

8 months for the effect to be seen involving climbing activity of the rat. Another result observed with this novel experiment was the regeneration of a number of other important motor tracts, including the corticospinal tract.

An important advance in OEC transplantation was the use of the New York University contusion device to injure the rat spinal cord, aiming to mimic the injury seen in the majority of human spinal cord cases. OEC transplants were injected into a ▶contusion injury after 30 min or 7 days after the initial impact [7]. An increase in behavioural recovery (using the open field ▶BBB test) was seen in the 7 day transplant group but not the 30 min group, when compared to control medium injected groups. In addition, numerous descending motor populations of axons, in particular rubrospinal and raphespinal, were found to be in larger numbers distal to the contusion injury. Further to this study, a combined use of Schwann cells with OEC did not improve behaviour or increase myelination. However interpreting these results is difficult, because these experiments were relying on the use of immunohistochemical markers not exclusive to OECs. How many OEC had survived transplantation, what roles do they really play in the repair mechanisms and how do they effect Schwann cell invasion into the injury site from the periphery?

This problem of identifying OECs within *in vivo* spinal cord models is acknowledged and has been an experimental concern for many years. However, this was elegantly answered by Ruitenbergh and colleagues [8] by using gene therapy to label the transplanted cells with a reporter gene. Cell labelling was carried out in two ways, either by adenoviral or lentiviral vectors, with the latter being the most stable and successful. Green fluorescent protein (GFP) – positive OECs were seen within transplant sites even after 4 months post transplantation and could be easily identified from the host glia. In addition this labelling technique allows cells to be tracked throughout the CNS neuropil and provide absolute evidence of migration. Other reports have used gene therapy to label OEC, both for *in vivo* identification and for secretion of additional growth factors supplied to a lesion site [9]. OEC have also been identified via xenografting; human, pig or mouse cells and used in conjunction with specific antibodies, metal nanoparticles, and in situ hybridization to locate these transplanted cells or recently transgenic animals with reporter genes (eg GFP mice or rats) have been used (Fig. 1).

### Additional Benefits of OEC Transplantation

The physical and molecular interaction of transplanted cells within the host spinal cord is vital to the overall success of repair. Schwann cells in contrast to OEC cause upregulation of matrix molecules, particularly proteoglycans (PGs) and are physically isolated by the

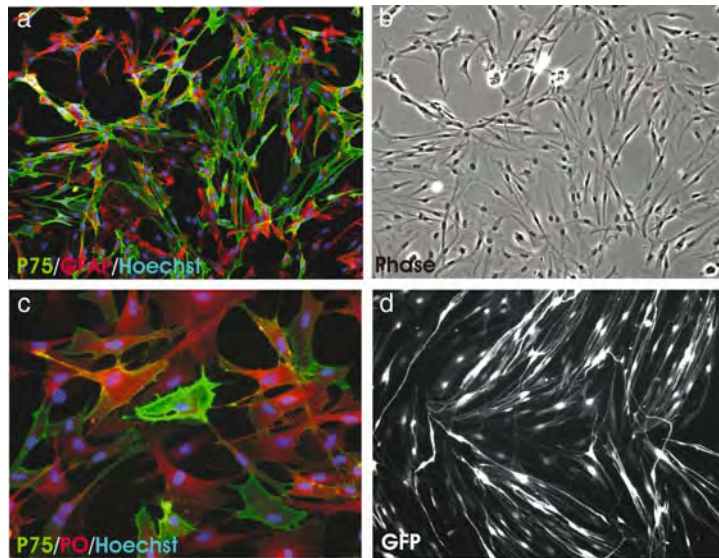

**Transplantation of Olfactory Ensheathing Cells. Figure 1** Olfactory ensheathing cells isolated from the adult olfactory bulbs of rats. (a) Immunocytochemically stained primary olfactory ensheathing cells *in vitro*. Olfactory ensheathing cell cultures are very pure when p75-immunoselected by adhesion. Cells are immunopositive for Glial Fibrillary acidic protein (red) and for the low affinity nerve growth factor receptor (p75) (Green). (b) A phase brightfield picture of the same field as (a). (c) Olfactory ensheathing cells also express large basal amounts of the myelin protein PO (red) and sometimes without a significant downregulation of the receptor p75 (green). This is quite different to the PO expression if primary Schwann cells which has significant downregulation of p75 with upregulation of PO. Olfactory ensheathing cells can also be genetically modified by viral vectors such as Lentiviral vectors. (d) Olfactory ensheathing cells engineered to produce green fluorescent protein (GFP) *in vitro*. These labelled cells can then be transplanted into the injured spinal cord and their function monitored.

host astrocytes. *In vitro* co-culture experiments have showed that OEC interact well with astrocytes and do not increase production of chondroitin sulphate PGs. Further evidence of the unique mechanism by which OEG interact with astrocytes was provided by experiments controlling levels of N-cadherin and showed this molecule to be a key player in OEC cell adhesion/migration while in the presence of astrocytes. Understanding the mechanism of OEC cell interaction in the host spinal cord and the molecules involved will in the future help translational scientists design optimal cell transplants. Indeed, recent publications have suggested combinational approaches to overcome the scar tissue by use of OECs with and the enzyme cocktails to degrade inhibitory molecules. Results obtained from these studies have shown improvement in both axonal regeneration and behavioural outcomes.

Spinal cord injury repair strategies not only will be designed to improve regeneration of axons into the denervated distal spinal cord but scientists also believe that mechanisms of repair are important. A number of reports have suggested that OEC transplants have a tissue sparing effect on spinal tissue and this has been closely correlated with improved behaviour not axonal regeneration [9]. OEC transplants also may increase angiogenesis within the spinal cord and therefore improve function by

preventing cell losses and provide nutrients for injured tissue. Lastly, a new area of interest is the effect OECs may have on inflammatory responses within the CNS tissue after injury. They are hypothesised to play a key role in the olfactory system during neurogenesis but is this via local control of the ►inflammatory cascade when a neuron dies and is replaced? Only time will tell if these roles are true and can be utilised. Further to axonal regeneration and tissue sparing it is also believed that an increase in the number of injured axons being remyelinated by a cell transplant would significantly improve the functional activity of the spinal cord after injury. How remyelination can occur has been a target of many authors over the years and has included the use of OEC transplants to remyelinate denuded axons. Methods have included isolating cells from embryonic [10] and adult animals but direct evidence was inconclusive that OEC can form myelin (Rev 10). However, these results cannot explain the myelination reported when a clonal line has been used isolated from postnatal rats. It may be that OEC obtained from younger animals have a more plastic nature and are able to form myelin around axons, even though in the normal *in situ* environment they cannot. This is a very important area of research and recent documented evidence has indicated the age of the cell may well be a key determinant of the OEC myelination capacity. Recent

advances as mentioned earlier in gene therapy techniques and transgenic rodents has helped the field in tracking the myelinating capacity of OEC *in vivo*. Myelination of spinal cord axons (monitored by protein zero expression and electron microscopy) have been shown, but how pure are the transplanted cells? In addition ►protein zero (P0) is expressed by OEG without the formation of a compact myelin segment, whereas myelin basic protein (MBP) is not. What role does P0 have in the olfactory system? The tantalising possibility is that P0 may be a growth promotive protein? These results indicate an urgent need for standardised protocols in which all laboratories can use. Of particular interest in the future will be the source of the OEC in adult systems, either from the olfactory bulb or lamina propria. The isolation and purification of OECs and the role the supporting cells around them have will give valuable insight into the different cell phenotypes. What role do OEC play in olfactory neurogenesis, axonal growth and guidance of olfactory axons to their appropriate targets. These important details will help us to design better and more appropriate glial transplants in the future. In addition the use of genomic screening techniques will provide unique insights to the genes involved in neurogenesis and axonal growth.

### Summary

OEC cells are one important part of the translational scientist's tools in spinal cord injury research. They have shown immense promise in a number of publications over the last decade in stimulating central nervous system repair. However, little is known of the true mechanisms involved in the OEC transplant results. Are the results truly a direct effect? Are OECs stimulating endogenous repair mechanisms? Can OECs modulate inflammatory cascades within the injured tissue? The answer to these questions may be "all of the above", but what is needed in this field of neural regeneration is correct identification of the OEC within the *in vivo* model and to distinguish these cells from the rest of the host cellular make up. If one can truly do this and one can isolate novel molecules from these cells and mechanisms of repair be ascertained, then the field will truly advance.

### References

1. Ramon-Cueto A, Nieto-Sampedro M (1994) Regeneration into the spinal cord of transected dorsal root axons is promoted by ensheathing glia transplants. *Exp Neurol* 127:232–244
2. Riddell JS, Enriquez-Denton M, Toft A, Fairless R, Barnett SC (2004) Olfactory ensheathing cell grafts have minimal influence on regeneration at the dorsal root entry zone following rhizotomy. *Glia* 47:150–167
3. Li Y, Field PM, Raisman G (1997) Repair of adult rat corticospinal tract by transplants of olfactory ensheathing cells. *Science* 277(5334):2000–2002

4. Ramon-Cueto A, Plant GW, Avila J, Bunge MB (1998) Long-distance axonal regeneration in the transected adult rat spinal cord is promoted by olfactory ensheathing glia transplants. *J Neurosci* 18:3803–3815
5. Ruitenber MJ, Levison DB, Lee SV, Verhaagen J, Harvey AR, Plant GW (2005) NT-3 expression from engineered olfactory ensheathing glia promotes spinal sparing and regeneration. *Brain* 128:839–853
6. Ramon-Cueto A, Cordero MI, Santos-Benito FF, Avila J (2000) Functional recovery of paraplegic rats and motor axon regeneration in their spinal cords by olfactory ensheathing glia. *Neuron* 25:425–435
7. Plant GW, Christensen CL, Oudega M, Bunge MB (2003) Delayed transplantation of olfactory ensheathing glia promotes sparing/regeneration of supraspinal axons in the contused adult rat spinal cord. *J Neurotrauma* 20:1–16
8. Ruitenber MJ, Plant GW, Christensen CL, Blits B, Niclou SP, Harvey AR, Boer GJ, Verhaagen J (2002) Viral vector-mediated gene expression in olfactory ensheathing glia implants in the lesioned rat spinal cord. *Gene Ther* 9:135–146
9. Ruitenber MJ, Plant GW, Hamers FP, Wortel J, Blits B, Dijkhuizen PA, Gispen WH, Boer GJ, Verhaagen J (2003) Ex vivo adenoviral vector-mediated neurotrophin gene transfer to olfactory ensheathing glia: effects on rubrospinal tract regeneration, lesion size, and functional recovery after implantation in the injured rat spinal cord. *J Neurosci* 23:7045–7058
10. Boyd JG, Doucette R, Kawaja MD (2005) Defining the role of olfactory ensheathing cells in facilitating axon remyelination following damage to the spinal cord. *FASEB J* 19:694–703

## Transplantation of Schwann Cells

XIAO-MING XU

Kentucky Spinal Cord Injury Research Center,  
Department of Neurological Surgery, School of  
Medicine, University of Louisville, Louisville,  
KY, USA

### Synonyms

Transplantation

### Definition

The term ►Schwann cell is named after Theodor Schwann (1810–1882), a German physiologist and histologist. Schwann cell is a type of peripheral nerve glial cell that surrounds axons. A Schwann cell can enclose a number of individual axons (ensheathment) or surround a single axon with a compact spiraled sheet of its own plasma membrane (myelination). Axons ensheathed by a single layer of Schwann cell processes are called ►unmyelinated axons. Axons surrounded by a compact spiraled sheet of Schwann cell plasma

membrane are called ►myelinated axons. Schwann cells, harvested from the peripheral nerves of rodents [1], primates [2] or humans [3], can be purified and expanded in culture. Transplantation of Schwann cells has been considered as one of the most promising repair strategies for the regeneration and/or remyelination of damaged axons of the central (CNS) and peripheral (PNS) nervous systems (Fig. 1).

## Characteristics

### Quantitative Description

The ability of Schwann cells to substantially influence axonal regeneration and remyelination in both the CNS and PNS derives, at least in part, from the following three unique properties:

1. *Schwann cells produce a variety of ►neurotrophic factors*: Schwann cells are a source of numerous neurotrophic factors. Many of them are known to play critical roles in the regeneration and remyelination of damaged nerve fibers. The factors produced

by Schwann cells include nerve growth factor (NGF), brain-derived neurotrophic factor (BDNF), neurotrophin-3 (NT-3), ciliary neurotrophic factor (CNTF), insulin-like growth factor (IGF), glial cell-line derived neurotrophic factor (GDNF) and platelet-derived growth factor-BB (PDGF-BB).

2. *Schwann cells express a number of ►cell adhesion molecules*: Schwann cells are known to produce an array of well-characterized cell adhesion molecules (CAM) such as N-cadherin, N-CAM, and L1/Ng-CAM. Schwann cells also produce a number of extracellular molecules (ECM) such as laminin and collagens. Many of these molecules have been shown to promote neurite outgrowth in vitro and axonal regeneration in vivo.
3. *Schwann cells form myelin on regenerated or demyelinated axons*: Myelin, a multi-lamellar membrane sheath elaborately wrapped around axons by Schwann cells, is required for efficient and rapid propagation of action potentials by saltatory conduction. Schwann cells, after being grafted into the CNS, can form myelin on demyelinated [2,4] or regenerated axons [3,5–8]. Successful conduction of remyelinated axons by grafted Schwann cells can be found in the adult CNS [9].

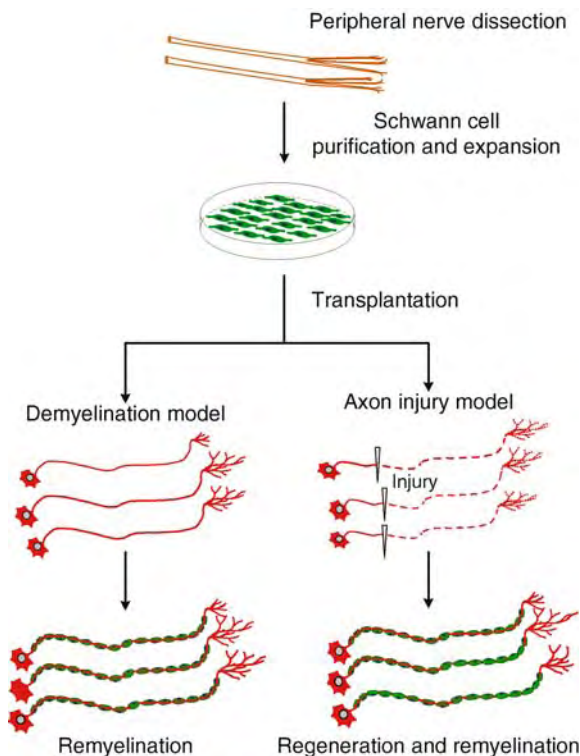

**Transplantation of Schwann Cells. Figure 1** Models of Schwann cell-based remyelination and regeneration therapies. Schwann cells can be harvested from neonatal or adult peripheral nerves, and purified and expanded in culture. Purified populations of Schwann cells can be transplanted into demyelinated or axotomized CNS regions. Grafted Schwann cells can promote remyelination of demyelinated axons or regeneration and remyelination of injured axons.

## Function

Although Schwann cells are not normally present in the CNS, they function normally after being grafted into this location. Transplantation of Schwann cells into the CNS may play the following functional roles:

1. *Promotes remyelination of demyelinated axons*: Demyelination of central axons can occur in a number of diseases, such as multiple sclerosis. Schwann cells can be effective in repairing areas of central demyelination and restore effective conduction. When persistent demyelination was created in the spinal cord, implantation of cultured autologous Schwann cells into the lesion site resulted in Schwann cell remyelination of demyelinated, but not severed, axons [2,4]. Such remyelination by grafted Schwann cells could re-establish normal conduction velocity across the lesion [9]. No remyelination occurred if Schwann cells were not introduced.
2. *Promotes regeneration of injured axons*: It is well accepted that injured axons in the adult mammalian CNS do not regenerate spontaneously. These axons, however, are capable of regeneration if a peripheral nerve graft is provided. It is now clear that the major cellular component of the peripheral nerve that promotes axonal regeneration is the Schwann cell. Schwann cells, after being transplanted into various regions of the injured adult mammalian CNS, survived, promoted axonal regeneration, and ensheathed or myelinated regenerated axons [6].

3. *Bridges the gap of CNS injuries*: CNS injury incurs disconnectional damage to the axons and a successful repair strategy requires reconnection of those disconnected axons to their appropriate functional effectors. Grafts of guidance channels seeded with Schwann cells can provide the necessary cellular alignment and environment to guide and support axonal growth in the bridge across the injury aftermath. In cases where axons were severed, as in the transected [5] or hemisectioned [10] thoracic spinal cord model, grafts of Schwann cell-seeded semi-permeable polymer channels created a bridge between the stumps of the injured cord and promoted axonal regeneration and remyelination (Fig. 2). At one month post-grafting, the cord stumps were united by a tissue cable that contained Schwann cells, axons at different stages of myelination or ensheathment by Schwann cells, blood vessels, and perineurial fibroblasts [3,5,10]. Robust regeneration of host axons occurred from both the rostral and caudal

directions into the Schwann cell graft environment. In addition to the axons that originated from neurons in the spinal cord, those from different brainstem regions also regenerated into the graft [10]. Clear evidence was shown that grafted Schwann cells survived and supported axonal regeneration and remyelination in this model. The absence of Schwann cells in control bridges resulted in scarce axonal growth, indicating that a key role is played by Schwann cells in promoting axonal regeneration in the injured CNS.

### Pathology

Although Schwann cells are not normally present in the mammalian CNS, they can enter the central nervous system under certain pathological conditions. For example, following traumatic CNS injuries, Schwann cells from the host peripheral nerve could migrate into the damaged CNS after the glial limiting membrane between the CNS and PNS has been interrupted. Aberrant

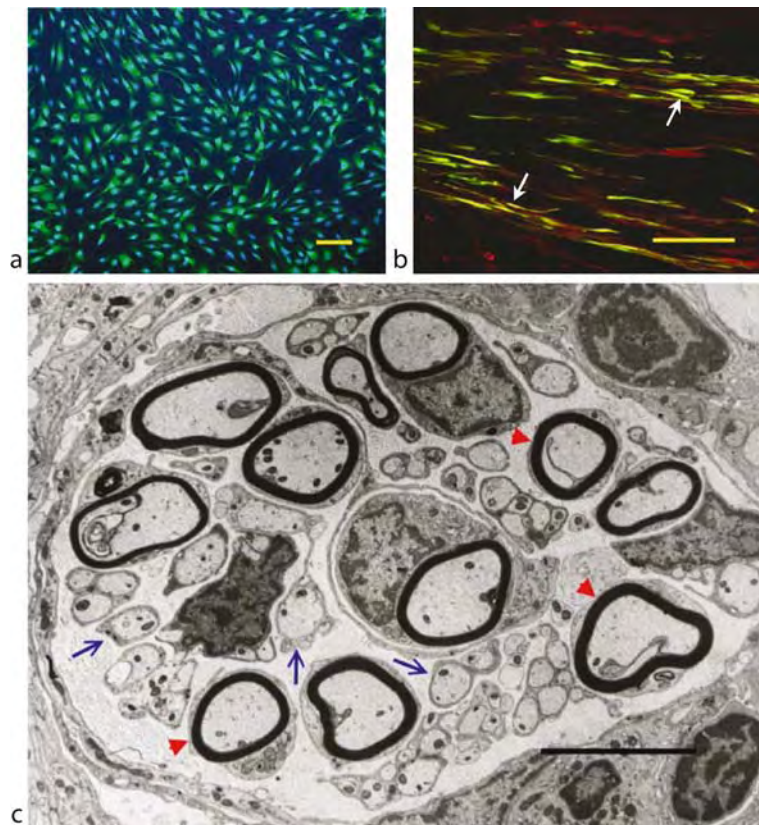

**Transplantation of Schwann Cells. Figure 2** Schwann cell characterization, transplantation and evaluation. (a) Schwann cells, purified from adult rat sciatic nerves, are immunopositive for S100, a marker for Schwann cells (green). The cells are counterstained with Hoechst 33342, a fluorescent nuclear dye (blue). (b) Grafted Schwann cells (arrows), transduced with an adenoviral vector encoding green fluorescence protein (green), are associated with regenerating axons (neurofilament-positive; red) within the guidance channel being grafted into the injured spinal cord. (c) At the ultrastructural level, grafted Schwann cells either ensheath (arrows) or myelinate (arrowheads) regenerated axons.

proliferation of Schwann cells and nerve fibers, namely Schwannosis, occurs frequently in humans with spinal cord injuries. The invading Schwann cells may also contribute to certain degrees of endogenous repair, since these cells can myelinate or ensheath surviving axons at and beyond the lesion cavities. The contribution of migrating Schwann cells in this endogenous repair process reaffirms the strategy of transplanting exogenous Schwann cells, since such a repair strategy may represent a natural feature of the spontaneous recovery.

### Therapy

Schwann cells are a unique cell type that holds promise as a cellular source for the regeneration and remyelination of injured axons in the CNS. These cells have demonstrated several significant advantages for transplantation. For example, Schwann cells can be prepared easily in a purified form and expanded homogeneously in culture in rodents [1], primates [2] and humans [3]. Transplantation of Schwann cells was reported to be safe for both autologous [2,5,10] or xenologous [3] transplants. The longitudinal alignment of Schwann cells within the graft, and the neurotrophic factors, extracellular matrix molecules and cell adhesion molecules that they produce, all contribute to the efficacy of Schwann cells in promoting axonal regeneration and remyelination

in the injured adult CNS. Moreover, Schwann cells can reliably myelinate central axons in the lesioned CNS milieu, which is critical for functional recovery after successful axonal regeneration.

Schwann cells have been implicated as an efficacious therapy for the repair of various CNS degenerative diseases. In demyelination injuries of the CNS, grafted Schwann cells survive, migrate, form myelin and promote function of remyelinated axons. In traumatic CNS injuries, transplantation of Schwann cells provides necessary cellular bridging to guide and support axonal growth across the lesion site. Although Schwann cells have many advantages and are considered a promising cell type for transplantation, limitations also exist. For example, Schwann cell-promoted axonal regeneration is mainly confined within the graft region, and only a limited number of axons are able to exit from the graft and enter the host CNS environment [5,10]. This is because other factors, such as the presence of inhibitory cues associated with the glial scar and CNS myelin, prevent further growth of regenerating axons from the Schwann cell graft back into the host CNS environment. For this reason, a complete therapy for functional regeneration after CNS injury may involve the use of combinatorial strategies, including the Schwann cell bridge transplantation and other efficacious treatments

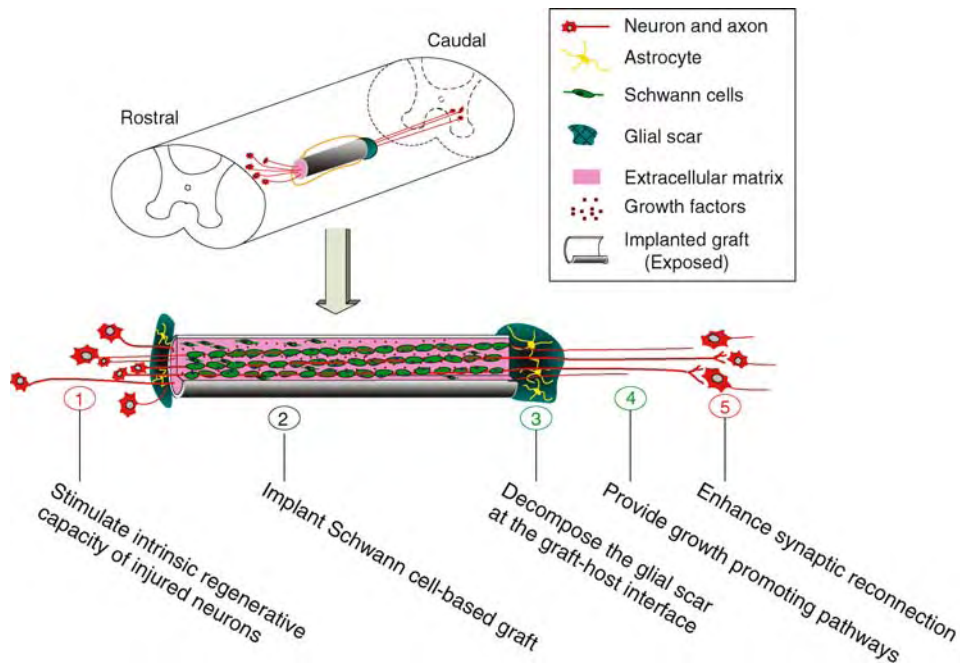

**Transplantation of Schwann Cells. Figure 3** Combinatorial strategies using Schwann cells and other therapies for the repair of CNS injuries. As a promising cell type for transplantation, Schwann cells can be used in combination with other repair strategies such as boosting the intrinsic regenerative capacity of injured neurons, decomposing the glial scar at the graft–host interfaces, generating growth promoting pathways in the host spinal cord, and enhancing synaptic reconnection between regenerating axons and their targets to achieve better anatomical regeneration and functional recovery after various CNS injuries.

such as boosting the intrinsic regenerative capacity of injured CNS neurons [6], decomposing the glial scar [8], generating growth promoting pathways along the course of axonal regeneration [7], and enhancing synaptic reconnection between regenerating axons and their targets (Fig. 3).

## References

1. Morrissey TK, Kleitman N, Bunge RP (1991) Isolation and functional characterization of Schwann cells derived from adult peripheral nerve. *J Neurosci* 11:2433–2442
2. Bachelin CF, Lachapelle C, Girard Moissonnier P, Serguera-Lagache C, Mallet J, Fontaine D, Chojnowski A, Le Guem E, Nait-Oumesmar B, Baron-Van Evercooren A (2005) Efficient myelin repair in the macaque spinal cord by autologous grafts of Schwann cells. *Brain* 128:540–549
3. Guest JD, Rao A, Olson L, Bunge MB, Bunge RP (1997) The ability of human Schwann cell grafts to promote regeneration in the transected nude rat spinal cord. *Exp Neurol* 148:502–522
4. Blakemore WF, Crang AJ (1985) The use of cultured autologous Schwann cells to remyelinate areas of persistent demyelination in the central nervous system. *J Neurol Sci* 70:207–223
5. Xu XM, Chen A, Guenard V, Kleitman N, Bunge MB (1997) Bridging Schwann cell transplants promote axonal regeneration from both the rostral and caudal stumps of transected adult rat spinal cord. *J Neurocytol* 26:1–16
6. Pearse DD, Pereira FC, Marcillo AE, Bates ML, Berrocal YA, Filbin MT, Bunge MB (2004) cAMP and Schwann cells promote axonal growth and functional recovery after spinal cord injury. *Nat Med* 10:610–616
7. Bamber NI, Li H, Lu X, Oudega M, Aebischer P, Xu XM (2001) Neurotrophins BDNF and NT-3 promote axonal re-entry into the distal host spinal cord through Schwann cell-seeded mini-channels. *Eur J Neurosci* 13:257–268
8. Chau CH, Shum DK, Li H, Pei J, Lui YY, Wirthlin L, Chan YS, Xu XM (2004) Chondroitinase ABC enhances axonal regrowth through Schwann cell-seeded guidance channels after spinal cord injury. *FASEB J* 18:194–196
9. Honmou O, Felts PA, Waxman SG, Kocsis JD (1996) Restoration of normal conduction properties in demyelinated spinal cord axons in the adult rat by transplantation of exogenous Schwann cells. *J Neurosci* 16:3199–3208
10. Xu XM, Zhang SX, Li H, Aebischer P, Bunge MB (1999) Regrowth of axons into the distal spinal cord through a Schwann-cell-seeded mini-channel implanted into hemisectioned adult rat spinal cord. *Eur J Neurosci* 11:1723–1740

from synapses and stop signaling among neurons and glial cells. As an example, glutamate transporters have high affinity for the substrate, are sodium-dependent and are expressed in most cell types within the central nervous system.

## Transverse Temporal Gyrus (Heschl)

### Synonyms

Gyrus temporalis transversus

### Definition

The floor of the lateral sulcus is formed by the upper side of the temporal lobe. This almost flat plane is called the temporal plane. It has characteristic, transverse gyri (transverse temporal gyrus (Heschl) which are called Heschl's transverse convolutions. In this cortex area (area 41 and 42) terminates the auditory tract, hence the term auditory cortex or primary auditory cortex. This area is tonotopically organized and has large efferents in the surrounding auditory cortex.

► Telencephalon

## Trapezoid Body

### Synonyms

► Corpus trapezoideum

### Definition

Efferents originating in the ventral cochlear nucleus decussate in a broad fiber band to the contralateral side. As soon as it reaches the contralateral side this band, the trapezoid body, kinks upwards in a 90° angle, and is now called the lateral lemniscus. As such, it passes on to the inferior colliculus.

► Myelencephalon

## Transporter (Biophysics)

### Definition

Denotes many types of transporters or carriers. Neurotransmitter transporters remove neurotransmitters

## Traube–Hering Waves

### Definition

Blood pressure oscillations entrained with respiration. Often grouped with Mayer waves and were described



around the same time historically (1860s), but we consider these to be separately entrained with respiration as is sympathetic nerve activity.

#### ► Pontine Control of Respiration

## Traumatic Brain Injury

### Definition

Acquired open or closed head injury, caused by external physical force and resulting in structural changes in the brain and partial or total functional disability.

#### ► Traumatic Brain Injury: Rat Model of Neuroinflammation and Expression of Matrix Metalloproteinases

## Traumatic Brain Injury: Rat Model of Neuroinflammation and Expression of Matrix Metalloproteinases

EUGENE VLODAVSKY

Department of Pathology, Rambam Medical Center, and Faculty of Medicine, Technion-Israel Institute of Technology, Haifa, Israel

### Definition

Neuroinflammation plays a significant role not only in repair, but also in secondary brain damage after traumatic brain injury (TBI). Hyperbaric oxygen therapy (HBOT) demonstrates anti-inflammatory and neuroprotective properties in our rat model of TBI.

### Characteristics

#### Traumatic Brain Injury (TBI)

► Traumatic brain injury is one of the major medical and socioeconomical problems in the modern world, due to the growing numbers of patients suffering from immediate and remote complications and neurological damage as a result of head trauma.

#### Brain Damage Following TBI

The brain damage following TBI is the result of direct mechanical disruption of brain tissue and indirect (secondary or delayed) mechanisms. The brain tissue surrounding the damaged area (so called “traumatic

penumbra”) is the stage for the reparative process and also of secondary brain damage which may develop after hours or days. Observations of the time-dependent increase in the volume of the cortical lesion in TBI and the presence of degenerating neurons in chronic post-traumatic lesions support the hypothesis that delayed cell death may be a very important component of post-traumatic pathology [1]. The mechanisms of delayed brain damage after TBI are not clearly understood, but recent studies implicate the acute inflammatory response to the destruction of brain tissue as an important factor in secondary brain damage [2].

### Cell Death Mechanisms After TBI

In the past it was believed that the main mechanism of cell death after cerebral stroke and trauma was necrosis. Recently, increasing evidence has been accumulating on the involvement of apoptosis (programmed cell death) in delayed post-traumatic neuronal death [3]. Positive ►TUNEL (►Terminal deoxynucleotidyl transferase biotin-dUTP Nick End Labeling) staining of cells in pathological specimens from cortical contusion lesions, together with obvious activity of caspases (effective enzymes of apoptosis) in human and experimental TBI, were regarded as the evidence of apoptotic death pathway. Today, more and more experimental data reveal the appearance of morphologic features of both necrosis and apoptosis in the same neural cell, and this fact has led to the possibility of a continuum between apoptosis and necrosis in TBI lesions. Because apoptosis is an energy-dependent process, some researchers have suggested that the apoptotic process may be active as long as ATP is present in the damaged cell but, later, when the progressive mitochondrial damage leads to depletion of ATP, the injured cell may shift to necrosis [1].

### Neuroinflammation and its Role in TBI

It is becoming increasingly clear that acute inflammation in traumatic penumbra area, characterized by infiltration of brain tissue by neutrophil leukocytes recruited from the blood flow, has a dual significance: it is essential to the repair process around the irreversibly damaged brain area and, at the same time, it can be harmful for partially damaged brain tissue, playing a role in post-traumatic delayed neuronal death [4,5]. Neutrophils cause tissue damage by the effects of their toxic enzymes, such as myeloperoxidase. They may contribute to secondary injury by causing microvascular occlusion, releasing free oxygen radicals, cytolytic proteases, and proinflammatory cytokines. Generally, acute inflammatory reaction has three major components: (i) alteration of blood caliber – vascular dilatation – that increases blood flow; (ii) structural changes in the blood microvessel wall that permit the plasma proteins and leukocytes to leave the circulation;

(iii) emigration of leukocytes from microcirculation and their accumulation at the focus of injury. The dilatation of microvessels in the area of injury and leakage of proteins, accompanied by increased blood viscosity, cause a decrease in blood flow, thereby increasing the ischemic damage. During inflammatory reaction, there is also early activation and tissue expression of metalloproteinases which facilitate penetration of neutrophils through the blood-brain barrier.

### Matrix Metalloproteinases (MMPs) as Important Players in Secondary Brain Damage after TBI

The natural inhibitors of ►matrix metalloproteinases (MMPs) are tissue inhibitors of metalloproteinases (TIMPs) [6,7]. Leukocytes and macrophages are major sources of MMP production. MMPs released by leukocytes play vital roles in extravasation and migration of leukocytes into tissues – the key event in the inflammatory process. MMPs were shown to be upregulated, especially MMP-2 and -9, in various types of brain injury – ischemia and reperfusion, hemorrhagic injury and TBI [6,7]. It was also established that, after TBI, the influx of inflammatory cells provides the major source of MMP activity, and that MMPs in the damaged brain and in ►neuroinflammation play a deleterious role, directly and indirectly promoting cell death, including apoptosis, through death receptors.

### Hyperbaric Oxygen Therapy (HBOT) After TBI

The search for neuroprotective treatment that will reduce secondary brain damage caused by TBI has become a critical issue, due to the grave medical and socioeconomic consequences of the growing numbers of patients suffering from remote complications and neurological damage as the result of head trauma. One of the promising methods applied in this area is HBOT. In clinical practice, HBOT remains a controversial issue, mainly due to the absence of a large randomized multicenter study. Nevertheless, supportive data have been provided by several authors showing reduced mortality and improved vital brain functions in severely brain injured patients treated by HBOT [7]. Numerous experimental studies have provided evidence supporting the neuroprotective effect of HBOT in various models of brain injury [7,8]. The basic mechanisms of the beneficial effects of HBOT are not clearly understood, but it has been demonstrated that hyperbaric oxygen (►hyperbaric oxygen treatment) reduces the extent of secondary brain damage in models of TBI and ischemia.

### Anti-Inflammatory Effects of HBOT

It has been shown experimentally in tissues other than brain that HBOT has anti-inflammatory properties. It decreases neutrophil adhesion to the endothelium of postcapillary venules, reduces tissue myeloperoxidase activity in experimental colitis, and inhibits

proinflammatory cytokine production. In the model of focal cerebral ischemia, HBOT reduces neutrophil infiltration and local myeloperoxidase activity, improves neurological outcome, and decreases the volume of necrosis [9].

### Anti-Inflammatory and Neuroprotective Role of HBOT in TBI

Taking into account the known anti-inflammatory effects of HBOT, it was suggested that it may reduce secondary neuroinflammation after TBI. The study was performed to evaluate the effects of HBOT on inflammatory infiltration by neutrophils in the traumatic penumbra area in our model of focal brain injury in rats, correlated to the extent of cellular death in brain tissue. Immunohistochemical expression of MMPs (2 and 9) and TIMPs (1 and 2) in untreated and treated animals was examined by computerized image analysis. We used a model of TBI called “dynamic cortical deformation” (DCD) and described by Shreiber et al. [10]. Forty Sprague-Dawley rats were divided into three groups: ten animals underwent DCD only, ten animals were treated by normobaric oxygen following DCD, and 20 animals received HBOT after the injury (for a detailed protocol of the treatment, see [2]).

DCD caused a highly reproducible brain lesion consisting of a necrotic core and a perilesional area. This area was divided virtually into four successive layers at a distance 0.5, 1.0, 1.5 and 2.0 mm from the necrotic core. In each of these layers, we counted the number of neutrophils stained by myeloperoxidase, the percent of TUNEL-positive brain cells (index of cell death), and the intensity of immunohistochemical staining for MMP-2 and -9 and TIMPs (1 and 2), measured by computerized image analysis. Counting the myeloperoxidase-stained neutrophils in the different layers of the traumatic penumbra revealed a significant decrease in neutrophil infiltration in the group of HBO-treated animals, most striking in the inner layers of the perilesional zone (Graph 2). This was accompanied by a significant decrease in the percentage of TUNEL-positive brain cells (index of cell death) in the layers of the perilesional brain tissue (Graph.1). To a significantly lesser extent, normobaric oxygen treatment also proved to reduce neutrophil infiltration, although this effect was limited to the immediate perilesional neighborhood. The index of TUNEL-positive cells did not decrease significantly after normobaric oxygen treatment.

The expression of MMP-2 and MMP-9 was increased around the traumatic necrotic lesion, but MMP-9 showed much higher levels (Figs. 1 and 2). Only weak positivity for TIMP-1 was revealed, and there was no staining for TIMP-2. After treatment with hyperbaric oxygen, there was a substantial decrease in the intensity and extent of staining for MMP-9, but MMP-2 and TIMP-1 expression remained unchanged (or the changes were insignificant).

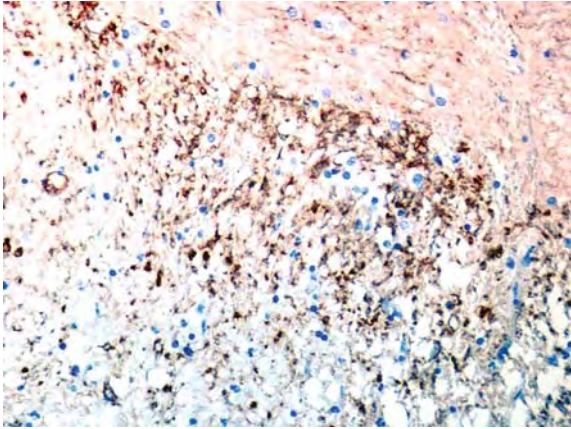

**Traumatic Brain Injury: Rat Model of Neuroinflammation and Expression of Matrix Metalloproteinases. Figure 1** High expression of MMP-9 around the traumatic lesion (traumatic penumbra) in the rat's brain. Immunoperoxidase, x200.

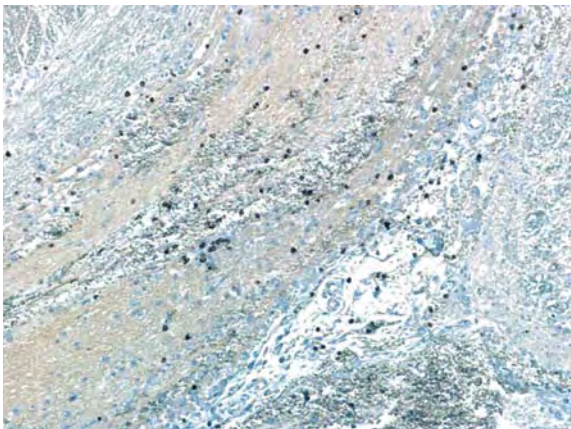

**Traumatic Brain Injury: Rat Model of Neuroinflammation and Expression of Matrix Metalloproteinases. Figure 2** Marked decrease in MMP-9 expression in traumatic penumbra after HBO treatment. Immunoperoxidase, x200.

### Conclusions and Perspectives

The results of this study demonstrate marked parallelism in the decrease of cell death extent, reactive neuroinflammation, and the expression of MMP-9 following HBOT. This proves that, in the acute period after TBI, HBOT substantially decreases the harmful effects of inflammation and MMP-9 overexpression that promotes delayed cell death in the traumatic penumbra.

It remains unclear if the decrease in the number of apoptotic TUNEL-positive cells in traumatic penumbra

is the result of the anti-apoptotic effects of hyperbaric oxygen or the secondary consequence of the reduction of the harmful inflammatory reaction. Both anti-apoptotic and anti-inflammatory effects of HBOT in non-traumatic conditions are well documented in the literature, and further research will eventually disclose the complex mechanism of hyperbaric oxygen effects in the traumatic penumbra area.

It is well established that inflammatory perilesional reaction in TBI and stroke has a dual effect – it not only provides additional damage to the brain tissue, but is also essential for the repair process. A large body of evidence has been collected, showing that the inflammatory response in the ischemic or traumatized brain has detrimental effects in the acute phase and beneficial effects in the chronic phase [4]. This means that early (within hours) and late (days-weeks) post-injury inflammatory response may play different roles and, therefore, the inflammatory reaction must not be suppressed but rather modulated, with special emphasis on the timing and dosage of treatment modalities.

### References

1. Raghupathi R (2004) Cell death mechanisms following traumatic brain injury. *Brain Pathol* 14:215–222
2. Vlodaysky E, Palzur E, Soustiel JF (2006) Hyperbaric oxygen therapy reduces neuroinflammation and expression of matrix metalloproteinase-9 in the rat model of traumatic brain injury. *Neuropath Appl Neurobiol* 32:40–50
3. Keane R, Kraydieh S, Lotocki G et al. (2001) Apoptotic and antiapoptotic mechanisms after traumatic brain injury. *J Cereb Blood Flow Metab* 21:1189–1198
4. Leker RR, Shohami E (2002) Cerebral ischemia and trauma – different etiologies yet similar mechanisms: neuroprotective opportunities. *Brain Res Rev* 39:55–73
5. Bramlett HM, Dietrich WD (2004) Pathophysiology of cerebral ischemia and brain trauma: similarities and differences. *J Cereb Blood Flow Metab* 24:133–150
6. Wang X, Mori T, Jung J-C, Fini E, Lo EH (2002) Secretion of MMP-2 and -9 after mechanical trauma injury in rat cortical cultures and involvement of MAP Kinase. *J Neurotrauma* 19:615–625
7. Crocker S, Pagenstecher A, Campbell I (2004) The TIMPs tango with MMPs and more in the central nervous system. *J Neurosci Res* 69:1–9
8. Palzur E, Vlodaysky E, Mulla H et al. (2004) Hyperbaric oxygen therapy for reduction of secondary brain damage in head injury: an animal model of brain contusion. *J Neurotrauma* 21:41–48
9. Miljkovic-Lolic M, Silbergleit R, Fiskum G, Rosenthal RE (2003). Neuroprotective effects of hyperbaric oxygen treatment in experimental focal cerebral ischemia are associated with reduced brain leukocyte myeloperoxidase activity. *Brain Res* 971:90–94
10. Shreiber DI, Bain AC, Ross DT et al. (1999) Experimental investigation of cerebral contusion: histopathological and immunohistochemical evaluation of dynamic cortical deformation. *J Neuropathol Exper Neurol* 58:153–164

## Traveling Waves

### Definition

The traveling wave is a hydromechanical event in the fluid spaces of the cochlea. The basilar membrane with the sensory hair cells sitting on it is stiff at the cochlear base and very flexible at the cochlear apex. Induced by fluid motions at the cochlear base due to a tonal stimulus, this stiffness gradient leads to displacements of the basilar membrane traveling towards the cochlear apex. At a certain locus between base and apex corresponding to the frequency of the tone, the traveling wave leads to a maximum displacement of the basilar membrane and, by that, to a maximum stimulation of the sensory cells.

- ▶ Cochlea
- ▶ Tonotopic Organization (Maps)

## Tree Shrews

### Definition

A family (*Tupaiaidea*) of mammals belonging to the order Scandentia. These small squirrel-like animals from Southeast Asia are considered the closest living relatives to primates.

- ▶ Evolution of the Visual System: Mammals – Color Vision and the Function of Parallel Visual Pathways in Primates

## T1-Relaxation

### Definition

T1 or equivalently, spin-lattice relaxation, is a phenomenological time constant that describes the how fast the protons in a magnetic resonance imaging experiment after excitation with an electromagnetic pulse return to thermal equilibrium. T1 relaxation is together with the T2 relaxation process the major contributors to image contrast in Magnetic Resonance images.

- ▶ Magnetic Resonance Imaging

## T2-Relaxation

### Definition

T2 or equivalently, spin-spin relaxation, is a phenomenological time constant that describes the exchange of energy between neighboring atomic nuclei in magnetic resonance imaging experiments. T2 relaxation is together with the T1 relaxation process the major contributors to image contrast in MR images.

- ▶ Magnetic Resonance Imaging

## Tremor

### Definition

Rhythmic oscillation of a body part by alternating or synchronous contraction of agonist and antagonist muscles. It usually involves the hands, but the head, jaw, voice, tongue, and the lower limbs may also have tremor. Resting tremor occurs while the limb is not active, such as the asymmetric tremor of the hand while it is resting on the lap in a patient with Parkinson disease. Action tremor can be postural (hands in the outstretched position), intention (finger-nose-finger), or task-specific (seen while performing a specific activity, e.g, writing). Action tremor is typically seen in essential tremor.

- ▶ Essential Tremor
- ▶ Parkinson Disease

## TRH

### Definition

▶ Thyrotropin releasing hormone, a tripeptide with hormonal and neuromodulatory actions.

- ▶ Hypothalamo-pituitary-thyroid Axis

## Triad

### Definition

A membrane compartment in skeletal muscle consisting of intracellular junctions between 2 SR terminal cisternae flanked on either side of a t-tubule.

- ▶ Excitation–Contraction Coupling

## Triadin

### Definition

A 95-kDa transmembrane glycoprotein of the junctional sarcoplasmic reticulum (terminal cisternae) that forms a supramolecular complex with calsequestrin, junctin and RyRI, the sarcoplasmic reticulum  $\text{Ca}^{2+}$  release channel in skeletal muscle, that plays an important role in ensuring rapid  $\text{Ca}^{2+}$  release during excitation-contraction coupling in skeletal muscle.

► Excitation-Contraction Coupling

## Trichromacy

### Definition

Normal human observers possess three independent channels for conveying color information, based upon the outputs of three different retinal cone types, which generate the initial steps in color vision by differentially absorbing long, medium and short wavelengths of light. A single set of three appropriately chosen primaries is sufficient to match the color appearance of any stimulus for a trichromat. To some extent, then, trichromats are color blind but not so color blind as dichromats who lack one cone type and can match the color appearance of any stimulus with only two primaries; and not so color blind as rod monochromats who can match any two lights by adjusting the intensity of one of them.

- Color Processing
- Evolution of the Visual System: Mammals – Color Vision and the Function of Parallel Visual Pathways in Primates
- Photoreceptors
- Retinal Color Vision in Primates

## Trigeminal Autonomic Cephalalgias (TACs)

### Definition

This is a group of cyclical, short-lasting, severe headaches located in the trigeminal nerve distribution and autonomic parasympathetic activation. Cluster headache is the most common of the TACs.

► Headache

## Trigeminal Complex

### Definition

A group of brainstem and spinal cord nuclei that receive inputs from the trigeminal nerve subserving the face and mouth.

► Evolution of the Somatosensory System: in Mammals

## Trigeminal Ganglion (Gasseri)

### Synonyms

Ganglion trigeminale (Gasseri)

### Definition

In the middle of the cranial fossa is situated the ganglion of the trigeminal nerve (V). Here autonomic fibers synapse and here the nerve divides into its three major branches: ophthalmic nerve (V1), maxillary nerve (V2) and mandibular nerve (V3).

► Nerves

## Trigeminal Lemniscus

### Synonyms

Lemniscus trigeminialis

### Definition

Once the afferents have left the principle nucleus of the trigeminal nerve, they cross to the contralateral side as the ventral tegmental fasciculus, and form bundles here called the trigeminal lemniscus. The latter then passes together with the medial lemniscus and the spinothalamic tract to the thalamus.

► Mesencephalon

## Trigeminal Nerve (V)

### Synonyms

N. trigeminus (N.V)

**Definition**

The trigeminal nerve is the largest cranial nerve and has sensory/somatomotor functions. It provides sensory innervation for the entire face as well as for large parts of the cranial meninges and mucosa.

It provides motor innervation for the masticatory muscles. It emerges laterally from the pons, passes to the petrous bone, forming the trigeminal ganglion there in a dural fold. From here, three branches continue further: ophthalmic nerve (V1), maxillary nerve (V2) and mandibular nerve (V3).

## ▶ Nerves

**Trigeminal Neuralgia (Paroxysmal Facial Pain, Tic Douloureux)****Definition**

Characterized by excruciating paroxysmal pain attacks (of seconds up to few minutes duration) in the gums, lips, cheek and skin, occurring mostly in middle-aged and elderly people. They tend to recur all around the clock, often for weeks, and may be triggered by touch or movements of the afflicted body parts, with no sensory loss being apparent. Although a few pathological changes close to the trigeminal nerve can occasionally be identified, the cause often remains undetected.

**Trigeminal Olfactory Function****Definition**

The trigeminal nerve is the fifth cranial nerve. This nerve supplies the entire facial skin as well as the oral and nasal cavity with sensory innervation. The information about touch, temperature, pain and irritation are mediated by this trigeminal nerve. Accordingly, all volatiles reaching the nasal cavities which have stinging, prickling or even irritating properties (e.g., pepper) will stimulate the intranasal trigeminal function. Since most odorants do, to some extent stimulate the trigeminal nerve, this system is often co-stimulated with the olfactory system.

- ▶ Olfactory Perception
- ▶ Smell Disorders

**Trigeminal System****Definition**

The trigeminal system refers to the motor and sensory components of the trigeminal nerve, the fifth cranial nerve (V). The trigeminal nerve has the following functional components: branchial motor (special visceral motor) — muscles of mastication supplied by the motor nucleus of V; and somatic sensory — afferents from the face via the mesencephalic nucleus of V (proprioception), the main sensory nucleus of V (touch), and the spinal nucleus of V (pain and temperature).

**Trigger Neurons****Definition**

Trigger Neurons are a class of neurons that are thought to initiate the burst in the saccadic burst generator and thereby trigger a saccade. Their existence is suggested by the finding that omnipause neurons had to be silenced before saccadic burst neurons could begin discharging. Hence inhibitory “trigger” interneurons are thought to be interposed between higher saccadic command centers (the superior colliculus and frontal eye fields, whose efferents are excitatory) and the omnipause neurons. Indeed, pre-saccadic inhibition of omnipause neurons has been observed, and microstimulation near long-lead burst neurons in the pontine reticular formation can inhibit omnipause neurons, but a precise identification of the hypothetical trigger neurons has not yet occurred.

- ▶ Brainstem Burst Generator
- ▶ Omnipause Neurons
- ▶ Ponto-Pontine Long-Lead Burst Neurons
- ▶ Saccade, Saccadic Eye Movement
- ▶ Superior Colliculus

**Trigger Point****Definition**

Hyperirritable loci of skeletal muscle that are very sensitive to mechanical manipulation.

- ▶ Viscero-Somatic Reflex

## Trinucleotide Repeat Disease

SIMON C. WARBY, ALICIA SEMAKA,  
MICHAEL R. HAYDEN  
Centre for Molecular Medicine and Therapeutics,  
University of British Columbia, Vancouver, Canada

### Synonyms

Triplet Repeat Disorders; Trinucleotide Repeat Expansion Disorder

### Definition

Trinucleotide repeat diseases are a group of heritable disorders that result from an expanded number of tandemly repeated trinucleotides at specific genomic loci. The number of trinucleotide repeats tends to be unstable and can result in disease when it exceeds a specific threshold length.

### Characteristics

#### Clinical and Genetic Features

Collectively, the common clinical features of trinucleotide diseases include neurodegeneration, ataxia, mental retardation, and muscle weakness or wasting [1]. The average age of onset differs for each disorder and ranges from infancy to adulthood. Disease symptoms can vary within a family and reduced ►penetrance or variable ►expressivity is frequently observed. Most trinucleotide disorders are inherited in an autosomal dominant fashion although some follow either an ►autosomal recessive or an ►X-linked inheritance pattern (Table 1).

The trinucleotide repeats can be located throughout the gene in either coding (i.e., exon) or noncoding (i.e., intron, 5'/3' untranslated (UTR)) sequences. Both the type of trinucleotide repeat and the location of the repeated sequence in the gene influence the disease mechanism. A large proportion of trinucleotide repeat disorders are caused by ►CAG repeats which encode the amino acid glutamine. These trinucleotide repeat diseases are often referred to as ►polyglutamine disease or ►polyQ disease because the repeated CAG tract encodes long stretches of glutamine in the protein. Trinucleotide repeat diseases can also be caused by other triplet repeat sequences such as CGG, GAA, and CTG. For each gene, the number of repeats observed in the general population is polymorphic, but for each trinucleotide disease, there is a specific threshold of expansion (i.e., repeat size) that is required to develop the disorder.

Polyalanine repeat disorders are emerging as another class of diseases [2], and differ from other trinucleotide repeat disorders in that polyalanine tracts

are far less polymorphic and dynamic compared to the large repeat expansions seen in other trinucleotide repeat diseases.

### Instability of Trinucleotide Repeats

A defining feature of trinucleotide repeat disorders is the dynamic nature of the genetic mutation [3]. The trinucleotide repeats are a ►microsatellite that can undergo somatic and gametic instability, resulting in changes in the number of tandem trinucleotide repeats in different tissues of the body or when passed to the next generation. Within each disorder, the size of the trinucleotide tract is important clinically, as there is an inverse relationship between the trinucleotide repeat length and age of onset in many trinucleotide diseases, particularly those involving CAG repeats (Fig. 1).

Another characteristic feature of trinucleotide disorders is the phenomenon of anticipation. ►Genetic anticipation refers to an increasing disease severity and a decreasing age of onset as the disease gene is transmitted to the next generation of a family. It is the gametic repeat instability observed in trinucleotide disorders that is the molecular basis of anticipation. The instability bias towards repeat expansion can result in a more severe disease phenotype in the next generation.

There are multiple mechanisms that can lead to repeat instability. Trinucleotide repeat instability is associated with DNA metabolic processes including recombination, repair and replication. In the case of gametic instability, these repeat size changes can occur before, during or after gametogenesis through a combination of these mechanisms [5].

Factors that influence the likelihood of trinucleotide repeat expansion have been identified. Primarily, the degree of repeat instability is dependent on the number of tandem repeats; where larger trinucleotide tracts tend to be unstable and prone to further repeat expansion. "Pure" trinucleotide tracts that are uninterrupted by other sequences or degenerate codons (i.e., codons that differ in sequence but code for the same amino acid) are particularly unstable. The amount of trinucleotide instability may also depend on the sex of the transmitting parent, where expansion preferentially occurs when the gene is inherited from either the maternal or paternal lineage. Other factors, such as paternal age or environmental conditions may also influence repeat instability.

### Premutations of Disease

Another important feature of trinucleotide disorders is the occurrence of *de novo* or sporadic cases of the disease in a family with no previous history of the condition. New mutations are caused by intermediate alleles or genes with repeat numbers in the ►premutation range. Individuals with an intermediate allele or premutation repeat size do not display clinical features of the disease.

**Trinucleotide Repeat Disease. Table 1** At least 19 diseases are caused by unstable trinucleotide repeats

		OMIM	Inherit	Gene	Chromo	Triplet	Normal	Expanded
DRPLA	Dentatorubral-Pallidoluysian Atrophy	125370	D	<i>ATN1</i>	12q	(CAG) <sub>n</sub>	7–34	49–93
HD	Huntington Disease	143100	D	<i>HD</i>	4p16.3	(CAG) <sub>n</sub>	6–34	36–121
SBMA	Spinal and Bulbar Muscular Atrophyb (Kennedy Disease)	313200	Xr	<i>AR</i>	Xq11-12	(CAG) <sub>n</sub>	9–35	36–62
SCA1	Spinocerebellar Ataxia 1	164400	D	<i>ATXN1</i>	6p22-23	(CAG) <sub>n</sub>	6–38	39–91
SCA2	Spinocerebellar Ataxia 2	183090	D	<i>ATXN2</i>	12q23-24	(CAG) <sub>n</sub>	15–24	32–200
SCA3	Spinocerebellar Ataxia 3 (Machado-Joseph disease)	109150	D	<i>MJD</i>	14q24-31	(CAG) <sub>n</sub>	13–47	53–86
SCA6	Spinocerebellar Ataxia 6	183086	D	<i>CACNA1A</i>	19p3	(CAG) <sub>n</sub>	4–18	19–33
SCA7	Spinocerebellar Ataxia 7	164500	D	<i>ATXN7</i>	3p12-21	(CAG) <sub>n</sub>	4–19	34–306
SCA12	Spinocerebellar Ataxia 12	604326	D	<i>PPP2R2B</i>	5q31-33	(CAG) <sub>n</sub>	4–32	40–78
SCA17	Spinocerebellar Ataxia 17	607136	D	<i>TBP</i>	2q13	(CAG) <sub>n</sub>	25–42	43–63
FRAXE	Fragile XE Mental Retardation Syndrome	309548	X	<i>FMR2</i>	Xq28	(CCG) <sub>n</sub>	4–39	>200
FRAXA	Fragile X Mental Retardation Syndrome	300624	XD	<i>FMR1</i>	Xq27.3	(CGG) <sub>n</sub>	6–58	>200
FXTAS	Fragile X Tremor/Ataxia Syndrome	300623	XD	<i>FMR1</i>	Xq27.3	(CGG) <sub>n</sub>	6–58	59–200
HDL2	Huntington Disease-Like 2	606438	D	<i>JPH3</i>	16q24.3	(CTG) <sub>n</sub>	6–28	41–78
DM1	Myotonic Dystrophy 1 (Dystrophia Myotonica 1)	160900	D	<i>DMPK</i>	19q13.3	(CTG) <sub>n</sub>	5–35	50–10,000
DM2	Myotonic Dystrophy 2 (Dystrophia Myotonica 1)	602668	D	<i>ZNF9</i>	3q21	(CCTG) <sub>n</sub>	10–26	75–11,000
SCA8	Spinocerebellar Ataxia 8	608768	D	<i>ATXN8/OS</i>	13q21	(CTG) <sub>n</sub>	15–50	>71
FRDA	Friedreich Ataxia 1	229300	r	<i>FXN</i>	9q13	(GAA) <sub>n</sub>	6–32	66–1700
SCA10	Spinocerebellar Ataxia 10	603516	D	<i>ATXN10</i>	22q13	(ATTCT) <sub>n</sub>	10–29	280–4500

Online Mendelian Inheritance in Man (OMIM) reference number, pattern of inheritance, affected gene, chromosome location, type of trinucleotide repeat and the range of normal and expanded (disease-associated) alleles are listed<sup>1</sup>. Although DM2 and SCA10 are microsatellite repeat disorders with more than three tandemly repeated nucleotides, they are included here because they are hypothesized to have mechanisms of pathogenesis similar to other trinucleotide repeat disorders. Inheritance patterns are dominant (D) or recessive (r) and can be X-linked (X).

However, given the dynamic nature of the repeated sequence, the number of repeats can increase into the disease-associated range upon transmission to the next generation resulting in a sporadic case of the disease.

### Gain of Protein Function Trinucleotide Repeat Diseases

At least nine trinucleotide repeat disorders are the result of elongated CAG repeats leading to expression of a polyglutamine-expanded protein (Table 2). The similarities in CAG disease characteristics and genetic etiology suggest similar mechanisms of pathogenesis involving an acquired “toxic function” in each of the polyglutamine-expanded proteins. Most polyglutamine disorders are inherited in an autosomal dominant fashion. Collectively they show germline repeat size instability leading to anticipation, particularly with

paternal transmission. Each disease usually begins in mid-life and results in death 10–20 years after onset. Early and late onset variants of each disease exist, as there is a strong inverse relationship between CAG length and age of onset.

Notably, each of the polyglutamine expansion disorders result from a mutation in a different gene encoding a protein that is widely expressed, yet lead to degeneration of a unique subset of neurons. This is consistent with a gain-of-function mechanism, although the factors that dictate the specificity of each disease is not yet clear. Aside from the polyglutamine tract, the mutant proteins show little or no sequence or structural similarity to each other, and each disorder results in a unique pattern of neuropathology and clinical symptoms.



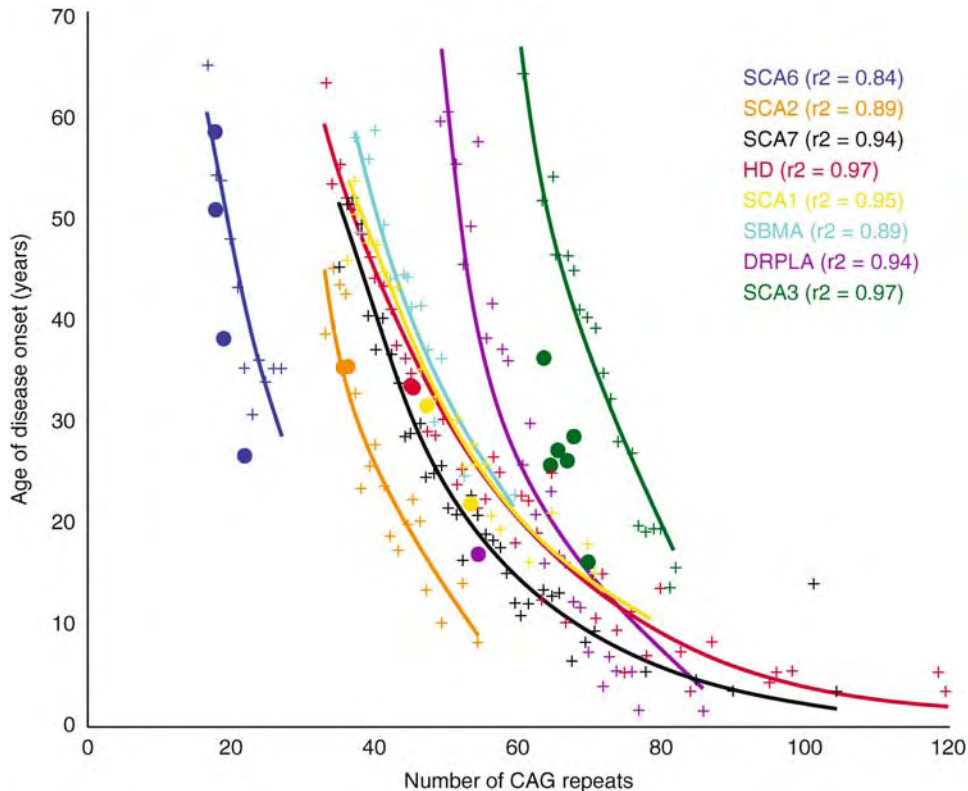

**Trinucleotide Repeat Disease. Figure 1** Inverse relationship between trinucleotide length and age of onset for the CAG disorders. Mean age of onset (+) for different CAG repeat sizes for eight of the CAG disorders. Age of onset of homozygotes (largest CAG allele) is indicated with a filled circle (●). Best fit line is calculated using a simple exponential decay model,  $r^2$  value is indicated. Adapted from Gusella and Macdonald [4].

The prototypical CAG repeat disease is ► **Huntington disease (HD)**, which results from polyglutamine-expansion in the ► **huntingtin** protein. HD is clinically distinguished by progressive motor disability featuring ► **chorea** but may involve both involuntary and voluntary movements, mental disturbances including cognitive decline, and changes in personality and mood. Medium spiny neurons containing  $\gamma$ -amino butyric acid (GABA) in the striatum are most susceptible to neurodegeneration, although there may be atrophy in the cortex and other regions of the brain as the disease progresses.

► **Spinal and Bulbar Muscular Atrophy (SBMA)** is an X-linked progressive neuromuscular disease that affects males. SBMA is caused by polyglutamine-expansion in the androgen receptor (AR) gene product which results in progressive muscle weakness, fasciculations and degeneration of lower motor neurons.

► **Dentatorubral-Pallidoluysian Atrophy (DRPLA)** and numerous ► **Spinocerebellar Ataxias (SCAs)** are also caused by gain-of-function CAG mutations. Ataxia, tremors, and dysarthria are common clinical findings.

Interestingly, there are many other CAG-containing genes in the genome that have not been associated with disease and the genes that cause the majority of clinically-defined SCA disorders remain unknown. In order to rapidly identify new CAG-expansion disorders, the normal distributions of CAG tract size have been established in genes encoding polyglutamine-containing proteins [6].

### Loss of Protein Function Trinucleotide Repeat Diseases

Inhibiting the expression of specific genes is a second mechanism by which expanded trinucleotide repeats can cause disease (Table 3). Since the following disorders result from a loss of specific protein expression, any mutation that results in loss of protein function or expression will produce the disorder; the trinucleotide repeat expansions that are described here are the most frequent of these mutations.

► **Fragile X mental retardation syndrome (FRAXA)** is an X-linked developmental disorder that results in moderate-to-severe mental retardation, characteristic facial features, and autistic behavioral problems. FRAXA

**Trinucleotide Repeat Disease. Table 2** Polyglutamine repeat disorders

	Protein	Mutation location	Clinical phenotype
HD	Huntingtin	Coding	Chorea, dystonia, cognitive deficits, psychiatric problems
SCA1	Ataxin1	Coding	Ataxia, slurred speech, spasticity, cognitive impairments
SCA2	Ataxin2	Coding	Ataxia, polyneuropathy, decreased reflexes, infantile variant with retinopathy
SCA3	Ataxin3	Coding	Ataxia, parkinsonism, spasticity
SCA6	CACNA1A	Coding	Ataxia, dysarthria, nystagmus, tremors
SCA7	Ataxin7	Coding	Ataxia, retinal degeneration, cardiac failure in infantile form
SCA17	TBP	Coding	Ataxia, cognitive decline, seizures, and psychiatric problems
SBMA	Androgen Receptor	Coding	Motor weakness, swallowing, gynecomastia, decreased fertility, proximal muscle atrophy
DRPLA	Atrophin-1	Coding	Ataxia, seizures, choreoathetosis, dementia

**Trinucleotide Repeat Disease. Table 3** Trinucleotide repeat expansions that result in a loss of function disease

	RNA	Mutation location	Clinical phenotype
FRAXA	<i>FRMP</i>	5'YTP	Mental retardation, speech delay, autistic behavior, macroorchidism, connective tissue defects
FRAXE	<i>FMR2</i>	5'YTP	Mental retardation
FRDA	<i>FXN</i>	intron	Ataxia, loss of proprioception, slurred speech, cardiomyopathy, diabetes, scoliosis

occurs most frequently in males but can result in mild mental retardation in females. The gene involved is *FMR1*, which encodes the protein FRMP. Expansions greater than 200 repeats in the unstable CGG tract located

in the 5' UTR of *FMR1* results in increased methylation and decreased histone acetylation and ultimately the loss of FRMP expression. Interestingly, premutations in *FMR1* (59-200 CGG) result in FXTAS (see below) (Fig. 2).

► **Fragile XE Mental Retardation (FRAXE)** is a similar, although less common disorder compared to FRAXA. It is characterized by mild mental retardation and lacks any physical abnormalities. FRAXE results from loss of expression of the *FMR2* protein due to CCG repeat expansion in the 5' UTR of *FMR2*. With greater than 200 CGG repeats, *FMR2* is hypermethylated, resulting in transcriptional silencing and loss of protein function.

► **Friedreich ataxia (FRDA)** is an autosomal recessive disorder with symptoms typically beginning in childhood or adolescence. The phenotype includes progressive ataxia, gait disturbances, severe heart abnormalities, speech and vision problems, scoliosis, and diabetes. The progression of symptoms usually plateaus in early adulthood and death occurs by the fourth or fifth decade. FRDA results from the expansion of an unstable GAA repeat in the first intron of the *FRDA* gene which encodes frataxin. The GAA repeat expansion inhibits the transcriptional elongation of *FRDA* and reduces the expression of frataxin. Frataxin is believed to be involved in mitochondrial iron metabolism and is implicated in oxidative stress. The disease is likely due to a partial loss of frataxin expression.

### RNA-Mediated Dominant Trinucleotide Repeat Diseases

A third category of trinucleotide repeat diseases involve the expanded trinucleotide tract conferring a specific gain-of-function of the RNA transcript [7]. In addition to those diseases mentioned below (Table 4), a similar mechanism may play a role in a growing number of dominantly-inherited noncoding expansion disorders including spinocerebellar ataxia type 8 (SCA8), SCA10, SCA12, and Huntington disease-like 2 (HDL2).

► **Myotonic dystrophy 1 (DM1)** is a progressive, multisystem disorder that most prominently features dysfunction, weakness and degeneration of the skeletal and smooth muscles. The eye, heart, endocrine system, and central nervous system may also be affected. DM1 is an autosomal dominant disorder that demonstrates genetic anticipation due to instability in a CTG tract in the 3' UTR of the *DMPK* gene. Both onset and severity of DM is correlated to the size of the CTG repeat which results in three clinical categories of DM1; mild, classic, and congenital. Notably penetrance and expressivity of the disease are variable within and between families.

How mutations in RNA can result in dominantly inherited disease is not fully resolved. However, the proposed mechanism of pathogenesis in DM1 may serve as a model for the other diseases in this category. The

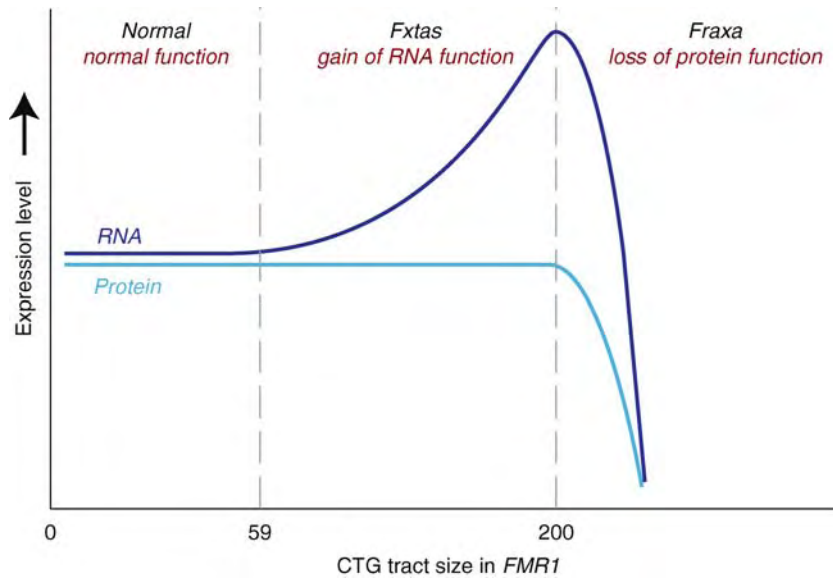

**Trinucleotide Repeat Disease. Figure 2** Expanded *FRMP1* gene alleles can result in disease by two separate disease mechanisms. Alleles with greater than 50 CTG repeats in the 5' UTR of *FMR1* result in increased expression of *FMR1* RNA, are believed to interfere with the processing of other RNA transcripts in a dominant-negative manner, and are associated with FXTAS. Alleles with CTG repeats of greater than 200 repeats result in the loss of *FMR1* expression and are associated with FRAXA.

CTG expansion in *DMPK* is transcribed as CUG repeats in the RNA transcript, and seems to result in abnormal RNA processing. Studies of *DMPK*-overexpressing or *DMPK*-null mice suggest the disease is not a direct result of alterations to *DMPK* protein. Rather, it supports the hypothesis that expanded CUG-repeats alters the activity of specific RNA binding proteins that function to regulate the alternative splicing of RNA transcripts other than *DMPK*. Interestingly, DM1 is the result of a single mutational mechanism; other mutations in *DMPK* (deletions, point mutations, etc.) do not result in DM.

► **Myotonic dystrophy 2 (DM2)** is a clinically similar but genetically distinct disorder that results from CCTG expansion in intron 1 of the *ZNF9* gene. In general, DM2 is milder and most often has a later average onset when compared with DM1. *DMPK* is a protein kinase and does not have functional similarity to *ZNF9*, a zinc finger protein. However, the presence of expanded CUG/CCUG repeats in their respective transcripts suggests a common mechanism of pathogenesis.

► **Fragile X Tremor/Ataxia syndrome (FXTAS)** is the result of “premutation” alleles for FRAXA in *FMR1*. Unlike many other trinucleotide repeat disease where premutation alleles have not been associated with disease, *FMR1* premutation alleles that contain 59-200 CGG repeats are associated with increased risk for FXTAS and ► **premature ovarian failure (POF)**. FXTAS typically occurs in males older than 50 years and

**Trinucleotide Repeat Disease. Table 4** Trinucleotide repeat disorders that result from dominant negative RNA transcripts

	RNA	Mutation location	Clinical phenotype
DM1	<i>DMPK</i>	3'YTP	Muscular weakness and dystrophy, myotonia, cataracts, cardiomyopathy, insulin resistance
DM2	<i>ZNF9</i>	Intron	Similar to DM1 but no congenital form
FXTAS	<i>FRMP</i>	5'YTP	Cerebellar gait ataxia, intention tremor, Parkinsonism, cognitive and psychiatric alterations

clinically features cerebellar gait ataxia and intention tremors. In contrast to the loss of *FRMP* function in FRAXA, the premutation allele of FXTAS seems to confer a gain of toxic RNA function. The mechanism of toxicity is not clearly understood, but supported by the observation that *FRMP* RNA is elevated in FXTAS patients, and that expression of *FMR1* RNA containing 90 CGG repeats is neurotoxic in model systems.

### Genetic Counseling and Testing

Given the inherited nature of trinucleotide repeat disorders, families may benefit from genetic counseling services. Through genetic counseling, families are provided information on the natural history, inheritance, and specific implications of the disease. This is of particular importance given the complexities of trinucleotide repeat disease inheritance and pathogenesis. Genetic counseling is also advisable when individuals are considering undergoing genetic testing [8], which is available for a large proportion of the trinucleotide repeat disorders. Given the later onset of some trinucleotide repeat disorders, genetic testing can be predictive in nature and a discussion of the various psychosocial and ethical issues surrounding predictive testing can assist the patient in making informed decisions.

### Treatment

At this time, medical management of trinucleotide repeat diseases is directed towards controlling disease symptoms. The future remains promising with many researchers around the globe working towards understanding mechanisms and finding treatment for the various trinucleotide repeat disorders. Research efforts utilizing animal models continue to shed light on the molecular pathogenesis of the disease allowing the identification of potential therapeutic targets. Similarities in the pathogenic mechanisms of the gain-of-function trinucleotide repeat diseases suggest similarities in possible treatments. Therapeutic compounds of interest include those that regulate neuronal excitability or neurotransmission, protein misfolding or aggregation, caspase activity and apoptosis, RNA interference, trophic support, oxidative stress, transcriptional dysregulation and histone de-acetylase inhibitors [9]. Cell transplantation studies have also shown promise [10]. For diseases featuring a loss-of-function, focus is on therapeutics that can restore or compensate for lost protein function.

### References

1. Clinical and genetic testing information for each disorder can be found at GeneReviews. (<http://www.ncbi.nlm.nih.gov/books/bv.fcgi?rid= gene.TOC>). Detailed information on each human genetic disorder can also be found at the Online Mendelian Inheritance in Man (OMIM) at the NCBI website (<http://www.ncbi.nlm.nih.gov/sites/entrez?db= OMIM>)
2. Albrecht A, Mundlos S (2005) The other trinucleotide repeat: polyalanine expansion disorders. *Curr Opin Genet Dev* 15:285–293
3. Mirkin SM (2007) Expandable DNA repeats and human disease. *Nature* 447:932–940
4. Gusella JF, MacDonald ME (2000) Molecular genetics: unmasking polyglutamine triggers in neurodegenerative disease. *Nat Rev Neurosci* 1:109–115

5. Pearson CE, Edamura KN, Cleary JD (2005) Repeat instability: mechanisms of dynamic mutations. *Nat Rev Genet* 6:729–742
6. Butland SL, Devon RS, Huang Y, Mead CL, Meynert AM, Neal SJ, Lee SS, Wilkinson A, Yang GS, Yuen MM, Hayden MR, Holt RA, Leavitt BR, Ouellette BF (2007) CAG-encoded polyglutamine length polymorphism in the human genome. *BMC Genomics* 8:126
7. Ranum LP, Cooper TA (2006) RNA-mediated neuromuscular disorders. *Annu Rev Neurosci* 29:259–277
8. Benjamin CM, Adam S, Wiggins S, Theilmann JL, Copley TT, Bloch M, Squitieri F, McKellin W, Cox S, Brown SA (1994) Proceed with care: direct predictive testing for Huntington disease. *Am J Hum Genet* 55:606–617
9. Di Prospero NA, Fischbeck KH (2005) Therapeutics development for triplet repeat expansion diseases. *Nat Rev Genet* 6:756–765
10. Dunnett SB, Rosser AE (2007) Stem cell transplantation for Huntington's disease. *Exp Neurol* 203:279–292

---

## Trinucleotide Repeat Expansion Disorder

- ▶ Trinucleotide Repeat Disease

---

## Tripartite Synapse

- ▶ Neuron–Astrocyte Interactions

---

## Triplet Repeat Disorders

- ▶ Trinucleotide Repeat Disease

---

## Trismus

### Definition

Tonic ▶ spasm of the masticatory muscles, usually as symptom of a general disease (▶ tetanus, ▶ meningitis, ▶ epilepsy etc.).

## Tritanopia

- ▶ Color Blindness

## Trk-A Receptor

### Definition

Tyrosinkinase A receptor, the high affinity receptor for the nerve growth factor (NGF). This receptor molecule is essential for the ontogenesis of a large group of nociceptive afferents and sympathetic efferents. If lacking due to a genetic defect, Congenital Insensitivity to Pain with Anhidrosis (CIPA-syndrome) is a consequence.

- ▶ Nerve Growth Factor
- ▶ Nociceptors and Characteristics

## Trochlear Nerve (IV)

### Synonyms

N. trochlearis (N.IV)

### Definition

The trochlear nerve is the thinnest cranial nerve and is purely somatomotor in nature. It emerges as the sole cranial nerve on the dorsal side of the brainstem, beneath the inferior colliculus, and innervates only one muscle, the superior oblique muscle of the eyeball. By a change in tension, contraction of this muscle generates eye movement, laterally and downwards. The nerve reaches the orbita together with the oculomotor nerve (III) and abducens nerve (VI). Skull: superior orbital fissure.

- ▶ Nerves

## TRP

### Definition

Transient receptor potential

- ▶ TRP Channels

## TRP Channels

CHRISTIAN HARTENECK

Molekulare Pharmakologie & Zellbiologie, Charité  
Universitätsmedizin Berlin, Thielallee, Berlin,  
Germany

### Definition

▶TRP channels are ▶non-selective cation channel proteins with six transmembrane domains and a pore-forming loop between the fifth and the sixth transmembrane domain. The ion-permeating pore is formed by multimerisation of four proteins and allows the permeation of  $\text{Ca}^{2+}$  and  $\text{Na}^{+}$  ions. TRP proteins are assigned to distinct subfamilies based on sequence similarities to *Drosophila* TRP (▶TRPC, ▶TRPM, ▶TRPV, ▶TRPN ▶TRPA channel family) or structural and functional features (▶TRPP and ▶TRPML channel family).

### Characteristics

The mystery of the molecular basis for the hormone-induced  $\text{Ca}^{2+}$  transient in nonexcitable cells in mammals began to be unraveled with the molecular characterization of the *trp* locus in the genome of ▶*Drosophila melanogaster*. Blind flies of the *trp* phenotype have been characterized by recordings of the visual nerve and have been named as ▶transient receptor potential (*trp*) due to the shape of obtained electroretinogram recordings (for review see [1]). The positional cloning of the *trp* gene results in the identification of a protein, TRP, having structural and sequence similarities to voltage-gated calcium channels [2]. The growing number of sequences entries from genome as well as expressed-sequences tag (EST) sequencing approaches enabled the identification of TRP-homologous protein in worm and mammals shortly after the cloning of ▶*Drosophila* TRP. Structural characteristics of the proteins identified by sequence analysis lead to the classification of the new proteins into different subfamilies [3]. According to the unified nomenclature, the term “TRP channels” represents nowadays a collecting term for proteins of the TRP superfamily comprising at least seven different subfamilies (TRPC, TRPM, TRPV, TRPA, TRPN, TRPML, TRPP) [4]. The initial sequence-based classification has meanwhile been supported by functional differences.

### TRP Channels Involved in Hormonal Signaling Cascades

Since the cloning of *Drosophila* TRP as a channel protein involved in the ▶receptor-mediated ▶photo-transduction pathway of flies, it is known that TRP channels play an important role in receptor-induced cellular signaling pathways [1,5–7]. Detailed analysis

of the activation mechanism of TRP channels of the classic TRP channel (TRPC) family showed that the mammalian as well as the fly **TRPC proteins** are activated by different **second messengers** generated by receptor-induced signaling pathways (Fig. 1).

Hormones, **neurotransmitter** and **growth factors** binding to G protein-coupled receptors or receptor tyrosine kinases induce the breakdown of phosphoinositides by the activation of phospholipase C (PLC) isoforms leading to the formation of inositol-1,4,5-trisphosphate (IP<sub>3</sub>) and diacylglycerole (DAG). While IP<sub>3</sub> increases intracellular Ca<sup>2+</sup> concentration by a release mechanism via stimulation of IP<sub>3</sub> receptors, DAG mediates Ca<sup>2+</sup>-entry via channels of the TRPC family (TRPC2, TRPC3, TRPC6, TRPC7). The activation by DAG of TRPC2, TRPC3, TRPC6, TRPC7 is a direct effect of DAG in a ligand-dependent manner independent of enzymes of the proteinkinase C (PKC) family (see Fig. 1 right part). In contrast to the mammalian TRPC channels, the *Drosophila* proteins (TRPL and TRP $\gamma$ ) are activated by polyunsaturated fatty acids resulting from phospholipase A<sub>2</sub>-mediated breakdown of DAG subsequent to PLC activation (see Fig. 1 left part). Like many other TRP channels, TRPC4 and TRPC5 have been discussed to be involved in **capacitative Ca<sup>2+</sup> entry**. Whereas for other TRP channels, detailed analysis revealed Ca<sup>2+</sup>-dependent pathways independent of the filling status of the endoplasmic reticulum as Ca<sup>2+</sup> stores, the situation for TRPC4 and TRPC5 is still unclear.

In addition to the immediate involvement of TRPC channels in hormonal signaling pathways, it became clear that hormonal activation pathways modulate a variety of other TRP channels by indirect mechanisms

like phosphatidylinositol-4,5-bisphosphate (PIP<sub>2</sub>), Ca<sup>2+</sup>, phosphorylation pathways etc. PIP<sub>2</sub> as substrate of PLC and the precursor of DAG inhibit TRPM7, TRPM8 and TRPV1 and sensitize the activity of TRPM4 and TRPM5. Whether this modulation is based on direct lipid-protein interaction or on subsequent enzymatic-triggered pathways is a topic of current scientific discussion. TRP channels as Ca<sup>2+</sup>-permeable non-selective cation channels are dually regulated by Ca<sup>2+</sup>. The role of Ca<sup>2+</sup> is complex and depends on the properties of the analyzed protein. TRPM4 and TRPM5, as Ca<sup>2+</sup>-activated Na<sup>+</sup> channels are stimulated by elevated intracellular Ca<sup>2+</sup> concentrations, whereas TRPV5 and TRPV6 as Ca<sup>2+</sup>-transport proteins with high selectivity for Ca<sup>2+</sup> are stimulated by low intracellular Ca<sup>2+</sup> concentrations. Finally, as auto-regulatory mechanism, Ca<sup>2+</sup> potentiates the activity of TRPC6, TRPC7, TRPM2, TRPM8, TRPV4 and TRPL in a Ca<sup>2+</sup>/calmodulin-dependent manner.

### Trafficking of TRP Channels

TRP channels as **integral plasma membrane proteins** (**Cell Membrane – Components and Functions**) are synthesized at the endoplasmic reticulum and subsequently transported via the *trans*-Golgi network to the plasma membrane. In order to control the ion transport activity across the plasma membrane, cells developed several mechanisms. The concentration of inserted proteins can be regulated either by the control of the insertion mechanism or the control of removal of channel proteins by modulating protein stability (for review see [8]). The insertion of TRPP2, TRPC3, TRPM2 and TRPV4 is controlled by the protein-protein

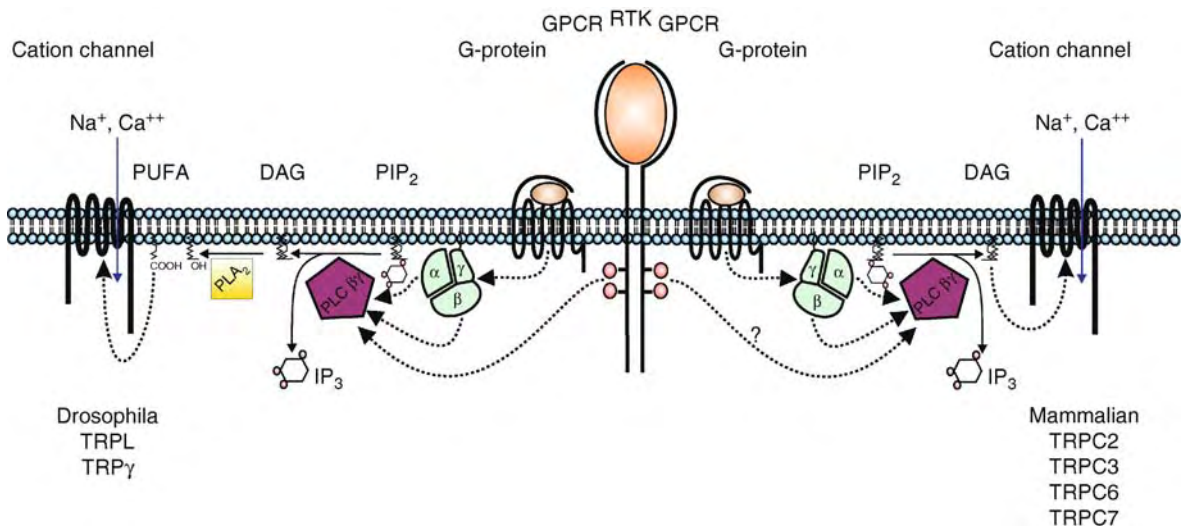

**TRP Channels. Figure 1** Receptor-induced activation mechanisms of TRP channels in fly and mammals. RTK receptor tyrosine kinase; GPCR G protein-coupled receptor; PLC phospholipase C; PLA<sub>2</sub> phospholipase A<sub>2</sub>; PIP<sub>2</sub> phosphatidylinositol-4,5-bisphosphate; IP<sub>3</sub> inositol-1,4,5-trisphosphate; DAG diacylglycerol; PUFA polyunsaturated fatty acid.

interaction of ▶**phosphofurin acidic cluster sorting proteins (PACS)** with a C-terminal domain of the channel proteins characterized by a serine or threonine residue embedded in a cluster of acidic amino acids. The interaction is regulated by protein phosphorylation of TRPP2, TRPC3, TRPM2 and TRPV4 by the protein kinase casein kinase 2 (CK2). The plasma-membrane concentration of TRPV4 is strongly controlled. In addition to control mechanisms for membrane targeting, protein stability is also modulated via posttranslational modification and addition of ▶**ubiquitin** resulting in increased proteolysis of TRPV4. It is likely that this or other mechanisms also tightly regulate the membrane concentration of other TRP channels.

Trafficking or shuttling of TRP channels as regulatory mechanism has not only to be discussed in terms of protein synthesis and degradation, but also in terms of recycling of the TRP channel protein removed from the plasma membrane by vesicular transport mechanism triggered by small GTPases. The activity of *Drosophila* TRPL is changed by such a mechanism in order to enable light-dependent adaptation of fly ▶**photoreceptor** cells. Light stimulation induces the translocation of TRPL from the plasma membrane into rhabdomeric storage compartment by vesicular transport, whereas during darkness and dim light, TRPL is recycled and transported to the plasma membrane. Activation-dependent regulation of plasma membrane concentration has also been shown for TRPC3 and TRPC6.

### Integration of TRP Channels in Macromolecular Protein Complexes

Fly phototransduction as a model system for the structure and function of TRP channels enabled not only the identification of TRP channels but also the understanding that TRP channels are integrated in macromolecular protein complexes [1,7]. In the fly eye, the proteins of the fly phototransduction pathway, TRP, PLC, and PKC, are clustered via INAD, a PDZ domain protein. Via homomultimerisation and binding of ▶**myosin III** protein, INAD forms a sub-membrane network clustering the signal-transduction proteins. A variety of interaction partners have been identified for mammalian TRP channels (for review see [7]). Besides the interaction of TRP channels with cytoplasmic or other membrane proteins, another feature of channel proteins has to be discussed. Based on the fact that four TRP channel proteins are necessary to form an ion-permeating pore, the hetero-multimerisation of TRP channel proteins would allow increasing the variability of TRP channels. Despite the large number of putative possible channel proteins, the experimentally detectable variety is much smaller. In heterologous systems, TRP channels assemble into heteromeric channel complexes within the narrow confines of phylogenetically closely related channels. Furthermore, only for very small numbers, the

heteromerisation is accompanied by detectable changes in electrophysiological parameters. Heteromerisation of TRPC1 and TRPC5 result in a pore-forming channel complex with attenuated ▶**current-voltage relationship**, whereas the TRPM6/TRPM7 complexes form a pore with an increased ▶**conductance**. In all other cases, interaction can be detected in recombinant systems; however, the physiological relevance needs to be shown.

### TRP Channels as Targets of Secondary Plant Compounds

An exciting feature of TRP channels is that many different plant compounds modulate the activity of TRP channels [5–7,9]. Although nearly all synthetic compounds tested so far are not selective in modulating the function of a distinct TRP channel, the naturally occurring structures of plant origin are highly selective for one or two different TRP channel proteins. ▶**Capsaicin** activates selectively TRPV1, camphor TRPV3, menthol TRPM8, hyperforin TRPC6. As active principle of remedies used in different cultures of traditional medicine, the identification of the natural compounds as TRP channel activators enabled to clarify the physiological role of TRP channels involved in ▶**thermosensation** as well as in neuronal differentiation processes. Furthermore, the high selectivity of natural compounds suggests to develop selective synthetic compounds for research as well as for clinic applications.

### TRP Channels in Thermosensation

TRPV1 or capsaicin receptor 1 has been identified by expression cloning based on the knowledge that capsaicin induces the sensation of warmth and modulates pain sensation. Meanwhile, it is clear that the complete spectrum of relevant temperatures for our body is covered by at least six different TRP channels [5–7]. ▶**TRPA1** and TRPM8 are the cold sensors in our body, being activated by temperatures at 0 to 18°C and 8 to 28°C, respectively. Moderate temperatures between 23 and 29°C activate TRPV3, mainly expressed extra-neuronally in keratinocytes. The next temperature window is occupied by TRPV4 modulated by temperatures above 27°C. Temperatures above 42°C activate TRPV1, whereas noxious heat (above 52°C) induces TRPV2-mediated currents.

### TRP Channels in the Brain

Neuronal and glial cells express a variety of TRP channels; however, the physiological role of the expressed TRP channels in the particular context is often unclear [5–7]. For some TRPC channels, the physiological role has been clarified. TRPC5 is discussed to participate in ▶**growth cone** guidance, whereas TRPC3 and TRPC6 mediate cation entry in growth factor-mediated pathways triggering neurite outgrowth. TRPC1 and TRPC5 are involved in synaptic activity. The function of the ADP-ribose activated

TRPM2 in ►microglia physiology is discussed in the context of ►oxidative stress. Oxidative stress via hydrogen peroxide induces the activation of poly-ADP-ribose-polymerase (PARP) and subsequent elevated levels of ADP-ribose via ADP-ribose-glucohydrolase leading to the activation of TRPM2. Elevated intracellular  $\text{Ca}^{2+}$  concentrations mediated by TRPM2 are proposed to regulate microglia activity. As oxidative stress and microglial dysfunction is discussed in the context of ►neurodegenerative diseases, TRPM2 forms a putative therapeutic drug target for the treatment of neurodegenerative diseases like ►Parkinson' disease, ►Alzheimer's disease or ►multiple sclerosis.

### TRP Channels in Volume Regulation and Mechanotransduction

Besides the sensory role of TRP channels in thermosensation, TRP channels function also as mechanosensors and proteins sensing extracellular hypoosmolarity [5–7,10]. In flies, the protein encoded by the *no mechanoreceptor potential C* (►nompC) gene, NOMPC, is involved in the mechanosensory signal transduction pathway of sensory hair cells, and in *C. elegans* loss of function of the *osm-9* gene results in defects in avoidance behavior in response to hyperosmolar solutions. The high sequence similarity of OSM9 to mammalian TRPV4 enabled the discovery of osmolarity-dependent regulation of TRPV4 activity. In addition to TRPV4, TRPV2 and TRPM3 have been shown to respond to hypoosmolar solutions. The assignment of TRPC6 as mechanically or osmotically activated channel is mainly based on the use of a tarantula toxin and is discussed controversially. The underlying mechanism has to be clarified thoroughly in future. Another candidate for mechanotransduction is TRPA1. Based on the structural similarity with NOMPC, both channel proteins encode for a large number of N-terminal ankyrin repeats, TRPA1 was proposed to be the mechanically gated transduction channel mediating the auditory responses in the stereocilia of mammalian hair cells. However, TRPA1<sup>-/-</sup> mice have no defect in auditory function, and therefore the putative mechanosensory function in other physiological contexts remains to be unraveled.

### Conclusion

Within the short period since the description of the first TRP channel, enormous progress has enabled us to get an idea of the multiple functions of TRP channels in physiology. Their role in thermosensation as well as sensor proteins to detect mechanic stress or changes in osmolarity has been identified. Other TRP channels are essential for the  $\text{Ca}^{2+}$  and  $\text{Mg}^{2+}$  homeostasis in our body, whereas another group of TRP channels participates in receptor-induced signaling cascades. Nevertheless, we are still at the beginning of

understanding the role and importance of TRP channels in physiology and pathophysiology.

### References

1. Montell C (2005) Drosophila TRP channels. *Pflügers Arch* 451:19–28
2. Montell C, Rubin GM (1989) Molecular characterization of the Drosophila *trp* locus: a putative integral membrane protein required for phototransduction. *Neuron* 2:1313–1323
3. Harteneck C, Plant TD, Schultz G (2000) From worm to man: three subfamilies of TRP channels. *Trends Neurosci* 23:159–166
4. Montell C, Birbaumer L, Flockerzi V et al. (2002) A unified nomenclature for the superfamily of TRP cation channels. *Mol Cell* 9:229–231
5. Nilius B, Owsianik G, Voets T, Peters JA (2007) Transient receptor potential cation channels in disease. *Physiol Rev* 87:165–217
6. Ramsey IS, Delling M, Clapham DE (2006) An introduction to TRP channels. *Annu Rev Physiol* 68:619–647
7. Venkatachalam K, Montell C (2007) TRP channels. *Annu Rev Biochem* 76:387–417
8. Cayouette S, Boulay G (2007) Intracellular trafficking of TRP channels. *Cell Calcium* 42:225–232
9. Kraft R, Harteneck C (2005) The mammalian melastatin-related transient receptor potential cation channels: an overview. *Pflügers Arch* 451:204–211
10. Christensen AP, Corey DP (2007) TRP channels in mechanosensation: direct or indirect activation? *Nat Rev Neurosci* 8:510–521

## TRP Receptors

### Definition

A family of trans-membrane molecules which form unspecific cation channels, e.g., in nociceptor terminals. Some members of this receptor family play a major role in transduction of noxious stimuli, e.g., the TRPV1 and TRPA1 receptors.

►Nociceptors and Characteristics

►TRP Channels

## TRPA1 Protein

### Definition

The mammalian TRPA1 protein has been named according to the high number of ankyrin repeats in



the N-terminal region of the protein. In mammals, TRPA1 forms a cold sensing channel protein. The question whether or not TRPA1 mediates noxious cold is still in discussion.

► TRP Channels

## TRPC Proteins

### Definition

The members of the classic TRP (TRPC) channel family are activated by intracellular mediators released upon ligand-induced receptor-activation leading to the stimulation of phospholipase C isoforms. The name “classic TRP channels” is based on the high sequence similarity to the founding member, *Drosophila* TRP, and the common function as channel proteins mediating  $\text{Ca}^{2+}$  entry upon receptor activation. The direct activation mechanism of individual TRPC proteins is often unclear and discussed controversially. *Drosophila* TRPL and TRP $\gamma$  are activated by polyunsaturated fatty acids, whereas the activation mechanism of *Drosophila* TRP is still unclear. In contrast to this activation mechanism of the fly TRPCs, the mammalian members TRPC2, TRPC3, TRPC6 and TRPC7 are stimulated by diacylglycerols resulting from the breakdown of phosphoinositides by phospholipase C activation.

► TRP Channels

## TRPM Proteins

### Definition

The eight members of the melastatin-like TRP (TRPM) channel family are named according to their sequence similarity to melastatin. The function of melastatin, TRPM1, is still mysterious. Melastatin or TRPM1 was first cloned in 1998 and since then suggested to function as a tumor suppressor protein in melanocytes. TRPM2 forms an ADP-ribose-activated channel in macrophages, pancreatic  $\beta$ -cells and dopaminergic neurons. ADP-ribose accumulation can be induced by hydrogen peroxide-dependent activation of poly-ADP-ribosepolymerase. TRPM3 is activated by the application of extracellular hypoosmolar solutions or sphingosine. TRPM4 and TRPM5 form  $\text{Ca}^{2+}$ -activated  $\text{Na}^+$  channels, impermeable for  $\text{Ca}^{2+}$ . TRPM6 and

TRPM7 are the  $\text{Mg}^{2+}$ -permeating channels. TRPM6 mediates intestinal absorption and renal reabsorption of  $\text{Mg}^{2+}$ , whereas the ubiquitously expressed TRPM7 is involved in cellular  $\text{Mg}^{2+}$  homeostasis. TRPM8 forms one of the cold receptors in mammals and is activated by cooling compounds like menthol.

► Melanocyte  
► Sodium Channels  
► TRP Channels

## TRPML Proteins

### Definition

The three members of the mucolipidin-like TRP (TRPML) channel family are named according to their participation in mucopolipidosis IV, a hereditary disease caused by mutations in TRPML1. Mucopolipidosis is a disease caused by the intracellular accumulation of carbohydrates and lipids. According to this storage disease, an involvement of mucolipidin-like proteins in intracellular, lysosomal transport processes is discussed.

► TRP Channels

## TRPN Proteins

### Definition

Like TRPA1, TRPN proteins can be characterized by the occurrence of many ankyrin repeats in the N-terminal region. As TRPN proteins have only been identified in *Drosophila*, *C.elegans* and zebra fish, TRPN channels may be the counterparts to the mammalian TRPA1. NOMPC forms a  $\text{Ca}^{2+}$ -permeable channel in *Drosophila* mediating sensory hair cell mechanotransduction.

► TRP Channels

## TRPP Proteins

### Definition

The three members (TRPP2, TRPP3, and TRPP5) of the polycystin-like TRP (TRPP) channel family or

polycystins are named according to their participation in polycystic kidney disease (PKD). PKD results from mutations in proteins of a channel complex. The central components of the complex are a protein with proposed receptor function PKD1 (TRPP1, TRPP4) and a direct interacting channel protein with six transmembrane domains (TRPP2, TRPP3, TRPP5). Loss of function mutations in the channel complex formed by PKD1 and TRPP2 results in alterations in polarization and function of cyst-lining epithelial cells, leading to autosomal dominant PKD. In addition, TRPP3 has been described as sour taste sensor in mammals.

- ▶ Sour Taste
- ▶ TRP Channels

---

## TRPV Proteins

### Definition

The members of the vanilloid receptor-like TRP (TRPV) channel family are named according to the sequence similarity to the vanilloid receptor 1, the channel protein activated by the vanilloid capsaicin. The involvement in thermosensation is the common characteristic of TRPV1 to TRPV4, whereas TRPV 5 and TRPV6 mediate intestinal absorption and renal reabsorption of  $\text{Ca}^{2+}$  in mammals.

- ▶ TRP Channels
- ▶ Ubiquitin

---

## TRPV1 Receptors

### Definition

TRPV1 receptors are members of a subfamily of transient receptor potential (TRP) ion channels that respond to vanilloid agents such as capsaicin, the pungent ingredient in hot peppers. These channels respond to hot temperatures and acid pH as well as certain endogenous substances such as anandamide. The channels were first discovered in nociceptive afferent neurons but were later identified in epithelial cells in the urinary bladder.

- ▶ Micturition, Neurogenic Control Nociceptors and Characteristics
- ▶ TRP Channels

---

## T2Rs

### Definition

▶ G-protein coupled receptor (GPCR) taste receptors detect bitter taste ligands. About 30 genes coding for members of this family are clustered in mice and human genomes at a loci known to be associated with bitter taste defects.

- ▶ Bitter Taste
- ▶ G-protein Coupled Receptors (GPCRs): Key Players in the Detection of Sensory and Cell-Cell Communication Messages

---

## True Memories

### Definition

Memories for experiences that actually occurred.

- ▶ Memory Distortion

---

## True Proposition

- ▶ Information

---

## Truncal Ataxia

### Definition

Ataxia is impaired motor coordination usually related to disorders of the cerebellum or its connections with the brain and spinal cord. Truncal ataxia refers to the unsteadiness of posture and the wide based gait seen as part of the overall ataxic syndrome. Impaired tandem gait is an early feature of truncal ataxia.

---

## Truth Conditions

### Definition

The conditions under which a sentence is true. According to an influential tradition in semantics, the

sense or meaning of an assertive sentence can be identified with its truth conditions.

- ▶ Representation (Mental)

## Truth Value

### Definition

In classical bivalent logic there are exactly two truth values: truth and falsity. Two sentences which are both false therefore share the same truth value. And the sentences “ $1 + 1 = 2$ ” and “London is the capital of Italy” therefore differ in truth value.

- ▶ Representation (Mental)

## Tryptamine

### Definition

A simple molecule that serves as the framework for many biologically-active molecules, including the neurotransmitter serotonin, as well as the tryptamine class of hallucinogens.

- ▶ Hallucinogens
- ▶ Serotonin

## Tryptophan

### Definition

*Tryptophan* (abbreviated as *Trp* or *W*) is one of the 20 standard amino acids essential in the human diet. It is encoded in genetic code as the codon *UGG*. The distinguishing structural characteristic of tryptophan is that it contains an indole functional group. Tryptophan is a biochemical precursor for the compounds such as serotonin (neurotransmitter), melatonin (neurohormone) and niacin (essential for cell survival and DNA repair).

- ▶ Neurodegenerative Diseases: Tryptophan Metabolism

## TTX

### Definition

- ▶ Tetrodotoxin (TTX)

## Tubercle, Olfactory

### Definition

Conspicuous eminence on the ventral surface of the brain of macrosmatic mammals located between the anterior olfactory nucleus and preoptic region which receives inputs from the olfactory bulb and olfactory cortex. Comprising a superficial molecular layer, dense cell layer and superficial and deep polymorph layers, the olfactory tubercle represents the ventral most extent of striatopallidum containing both ventral striatum, in the dense cell and superficial polymorph layers, and ventral pallidum in the deep polymorph layer.

- ▶ Olfactory Bulb
- ▶ Olfactory Cortex
- ▶ Striatopallidum

## Tuberculoventral System

### Definition

An intrinsic fiber tract that reciprocally interconnects the dorsal and ventral cochlear nuclei.

- ▶ Cochlear Nucleus

## Tuberomamillary Nucleus

### Definition

Group of neurons in the hypothalamus, the only neurons that produce histamine as neurotransmitter.

- ▶ Drinking Disorders and Osmoregulation

## Tuberomammillary Nucleus (TMN)

### Definition

Subnucleus of the posterior hypothalamus composed by a cluster of magnocellular neurons that produce the neurotransmitter histamine. Histamine producing neurons project widely throughout the brain and are involved in the control of arousal, attention, appetite and learning.

- ▶ Histamine
- ▶ Hypocretin/Orexin
- ▶ Hypothalamus
- ▶ Ventrolateral Preoptic Nucleus (VLPO)

## Tubulin

### Definition

The basic protein building block of the microtubule. Tubulin is found as a dimer of the structurally similar  $\alpha$ -tubulin and  $\beta$ -tubulin. These tubulin proto-mers then assemble in a linear, end-to-end fashion forming protofilaments, which can then be assembled to form a microtubule. Given the dimeric nature of tubulin, the resultant microtubule has a polarity (one end terminating with  $\alpha$ -tubulin, the other with  $\beta$ -tubulin).

- ▶ Axonal Pathfinding and Network Assembly

## Tuberous Sclerosis Complex (TSC)

### Definition

Severe autosomal-dominant disorder usually diagnosed in childhood and characterized by the development of benign tumors (hamartomas) distributed throughout the body, heart, kidneys, liver, lungs, skin and brain. TSC can thus lead to renal or heart failure, ▶ [epilepsy](#), autism, mental retardation and neurocutaneous syndrome. The classic triad consists of ▶ [seizures](#), mental retardation, and cutaneous angiofibromas. Facial angiofibromas are highly suggestive of TSC. The cause is an inactivating mutation in either of two tumor-suppressor genes – TSC1 gene on chromosome 9 and TSC2 on chromosome 16, with TSC2 mutations accounting for 80–90% of all mutations.

## Tufted Cells in Olfactory Bulb

### Definition

Glutamatergic projection neurons situated in the external plexiform layer and the glomerular layer of the olfactory bulb. There are several subclasses, but those cells that receive sensory input in the glomerulus and project out of the olfactory bulb to other brain areas are often grouped together with mitral cells in studies using extracellular recording in intact mammals. They receive direct input from olfactory sensory neuron terminals, and project directly to olfactory cortex, as well as to intrabulbar targets. Like mitral cells, they also have multiple, complex interactions with periglomerular cells, through conventional and dendrodendritic synapses.

- ▶ Olfactory Bulb
- ▶ Olfactory Cortex
- ▶ Olfactory Nerve

## Tubular Repair of Nerves

### Definition

Repairing nerves by enclosing both the nerve ends in a tubular structure of biological or synthetic nature, leaving a short distance between the nerve ends.

- ▶ Regeneration: Clinical Aspects

## Tumor Necrosis Factor

- ▶ Brain Inflammation: Tumor Necrosis Factor Receptors in Mouse Brain Inflammatory Responses

## Tumor Necrosis Factor- $\alpha$

### Definition

Tumor necrosis factor- $\alpha$  is a potent paracrine and endocrine mediator of inflammatory and immune functions. It is secreted by activated monocytes and macrophages, and many other cells, including B cells, T cells and fibroblasts. It provides a rapid form of host defense against infection but is fatal in excess. Exerts cytotoxic as well as differentiation and growth modulatory activities on many different target cells.

- ▶ Brain Inflammation: Tumor Necrosis Factor Receptors in Mouse Brain Inflammatory Responses
- ▶ TNF: Differential role of TNF receptors in mouse brain inflammatory responses

## Tumor Suppressor Gene

### Definition

Tumor suppressor genes have important roles in normal cellular function, such as cell cycle regulation, DNA repair and apoptosis. Cancer may develop subsequent to inactivation of both alleles (known as the “two-hit” hypothesis), such as through mutation of one allele with loss of heterozygosity of the other allele. Well studied tumor suppressors are encoded by the p53 and retinoblastoma (Rb) genes.

- ▶ Chromatin Immunoprecipitation and the Study of Gene Regulation in the Nervous System

## Tuning Curve of Visual Neurons

### Definition

A tuning curve to some feature of a visual stimulus (e.g., orientation, speed, disparity, etc.) is a curve that shows the average response of a neuron to different feature values. Typically, the curve is bell shaped: the neuron responds maximally to a particular feature value and gradually less and less as the value moves away from the most preferred stimulus, in either direction.

- ▶ Visual Illusions

## Tutor Song

### Definition

The song that is or has been perceived during the sensory period.

## TVOR (Translational VOR)

- ▶ Vestibulo-Ocular Reflex

## Twitch (Muscle)

### Definition

Generation of a single action potential at the sarcolemmal membrane of a skeletal muscle fiber produces the characteristic mechanical response known as twitch. The muscle twitch is characterized by a single rise and fall in force with a rapid time course ( $\sim 100$  ms for rodent muscle at  $35^\circ\text{C}$  and  $\sim 500$  ms for amphibian muscle at  $3^\circ\text{C}$ ). The twitch to tetanus force ratio ranges from 0.10–0.50, increasing with lowered temperature.

- ▶ Force Potentiation in Skeletal Muscle

## Two-Point Discrimination and Threshold in Cutaneous Mechanosensation

### Definition

Two-point discrimination is a term used to describe our ability to perceive two neighboring stimuli contacting the skin as two separate points rather than one. This ability is quantified by determining the minimum distance between two stimuli that are perceived as two distinct stimuli, a measurement referred to as the two-point threshold. Thresholds vary from about 2 mm on the finger tip to around 40–50 mm on the upper arm

and leg. Although commonly used in the clinic, this is a relatively crude and unreliable measure that does not reflect the true spatial resolution of the system.

- ▶ Haptics
- ▶ Processing of Tactile Stimuli

---

## Two-Process Model of Sleep Regulation

### Definition

The two processes of Alexander Borbély's two process model of sleep regulation (Hum Neurobiol 1:195–204, 1982). A propensity for sleep increases during wakefulness and dissipates during sleep. In the model this homeostatic sleep process was referred to as Process S, and its dynamics are derived from the sleep-wake dependent changes in electromyographic (EEG) slow-wave activity. Process S interacts with a circadian process, Process C. Process C defines an upper and a lower threshold between which Process S oscillates. Sleep onset is triggered when Process S reaches the upper threshold and sleep continues until Process S reaches the lower threshold. The thresholds were estimated on the relationship between sleep duration and circadian time at which sleep is initiated and on the dynamics of EEG slow wave activity (see Process S).

- ▶ Electromyography

---

## Two-Third Power Law

### Definition

The two-third power law prescribes that the angular velocity  $\omega$  and curvature  $k$  of curved movements are related by the power law  $\omega = Ck^{2/3}$  with  $C$  a constant. Using tangential velocity  $v$ , this relation can be rewritten as  $v = Ck^{-1/3}$ . This relation has a phenomenological basis but can be derived under the assumption that curved movements are produced by sine and cosine modulated orthogonal components. It can also be derived with the assumption that movements minimize jerk (optimize smoothness).

- ▶ Motor Control Models

---

## Tylotrich Hairs

### Definition

Hairs are classified in terms of stiffness; down hair, guard hair, a Tylotrich hair. Tylotrich hairs are most biggest and strong hairs except vibrissae, and often associated with touch dome. But they are lacking in primates.

- ▶ Cutaneous Mechanoreceptors, Anatomical Characteristics

---

## Tympanal Organ

### Definition

A type of mechanoreceptor used to detect acoustic signals that is normally associated with a thinned region of cuticle – the tympanic membrane – whose motion directly corresponds to the pressure changes of an acoustic stimulus in the surrounding medium.

- ▶ Invertebrate Ears and Hearing

---

## Type 1 and Type 0 Resetting

TILL ROENNEBERG<sup>1</sup>, MARTHA MERROW<sup>2</sup>

<sup>1</sup>The University of Munich, Munich, Germany

<sup>2</sup>The University of Groningen, Haren, The Netherlands

### Synonyms

Weak and strong resetting

### Definition

Type 1 and Type 0 resetting describe two qualitatively different response-types of a ▶circadian rhythm to a ▶zeitgeber stimulus. Circadian rhythms are circa 24-h oscillations in, e.g., sleep-wake behavior, secretion of certain hormones, gene expression and a multitude of other processes; zeitgebers are those signals from the environment which organisms can use to synchronize (entrain) their biological clock to the 24-h day. When circadian rhythms “run free” in constant conditions, their period often deviates from 24 h. Stable ▶entrainment is

achieved when a zeitgeber stimulus can shift the phase of the circadian rhythms each day by the exact amount that compensates the difference between the ►free-running period and that of the zeitgeber (normally 24 h).

### Characteristics

When a free-running period is shorter than 24 h (e.g., 22 h), the circadian rhythm has to be delayed (in this case by 2 h, every day); if it is longer, it has to be advanced. This type of entrainment is called type 1. To achieve a type 1 entrainment, the rhythm has to respond differently to a zeitgeber stimulus (with a given duration and a given strength) depending on its internal phase. In general, circadian clocks are advanced when they receive a light pulse during the second half of their internal night, are relatively unresponsive during their internal day, and respond with a delay in the first half of their internal night. The characteristic which represents this phase-dependent response is called ►phase response curve (►PRC). In type 1 ►resetting, the resulting phase (i.e., where it ends up after having been shifted) depends on when during its cycle it received the light pulse.

Another possibility to synchronise circadian rhythms with their cyclic environment is if every zeitgeber stimulus – no matter when it is received – resets the rhythm to the same internal phase (e.g., to the beginning of the internal day). This type of resetting is called type 0. In type 0 resetting, the resulting phase is independent of the timing of the zeitgeber stimulus. In analogy to a board game, type-1 resetting is like drawing cards that tell you to move  $x$  spaces forward or backward, while type 0 refers to the cards that always send you back to “Go.” Type 1 resetting refers to weak responses where even the maximal advance or delay is less than half a cycle while in type 0 resetting the maximal phase shift is always as long as the entire cycle. Since the response to a zeitgeber stimulus depends on its strength (both intensity and duration), a type 1 resetting characteristic can be transformed into a type 0 by increasing the zeitgeber strength.

### Circadian Clocks are Built for Entrainment

►Circadian rhythms are biological oscillations that occur with a frequency of approximately once per 24 hours when an organism is held in constant conditions (hence, circadian from *circa dies*, Latin, or about a day). These self-sustained rhythms occur in organisms from all phyla, regulating biology from the level of gene expression to behavior (see also ►chronobiology).

Considering that virtually all living things have evolved in a cycling environment, the “constant conditions” often used to investigate circadian clocks are rather artificial. In nature, circadian clocks are virtually always entrained to their cyclic environment [1,2]. In nature ALL zeitgebers are caused directly or

indirectly by the rotation of the Earth around its axis thereby regularly exposing different parts of the globe to sunlight. Thus, all non-photic cyclic parameters, from temperature to the availability of food or the threat of predators, ultimately depend on light. It is, therefore, not surprising that light is the most prominent zeitgeber for circadian clocks although, theoretically all other, light-dependent parameters could also be used as (non-photic) zeitgebers [3]. In addition to the richness of the temporal physical environment, the daily alternations of light and darkness alone have complex characteristics. They can change in amplitude (for example, for organisms that are either exposed to direct sunlight or those living in shaded niches); their duration (►photo-period) can change over the course of the year, or the duration of dawn and dusk periods can be different at higher latitudes compared to the equator. Even their spectral characteristics can be different (for example, for organisms living in the ocean compared to those living on a glacier).

The question of how exactly the alternating exposure to light and darkness entrains circadian clocks remains a topic of debate. Are only the changes (transitions) from light to dark and vice versa important cues for entrainment, or does the cyclic light environment entrain the clock by continuously influencing its progression? The former is called non-parametric entrainment, the latter parametric. These two hypotheses for explaining entrainment had prominent representatives among the pioneers of our field. While Pittendrigh favored the non-parametric hypothesis, Aschoff favored the parametric view [4,5]. While the former heavily relies on the phase response curve, the latter believes that entrainment is achieved by a continuous influence of the changing light levels on the rhythm’s period, thus using a ►velocity or *tau* ►response curve. As always, the truth probably lies in between the two hypotheses. Depending on the niche of an organism or depending on the time of year, a combination of parametric and non-parametric will eventually explain how circadian clocks are entrained. The fact that both parametric and non-parametric entrainment occur in nature is demonstrated by the finding that some organisms entrain perfectly without ever experiencing dawn or dusk [6].

### Phase Response Curves Come in Different Shapes

The non-parametric hypothesis favors the lights-on and -off signals as the key to entrainment. Although natural photoperiods consist of extended blocks of light and darkness, single steps (from light to darkness or from darkness to light) or even light pulses as short as a flash can predictably shift (reset) the phase of a circadian rhythm, and if they occur in regular intervals, they can entrain the clock. A prerequisite for such an entrainment mechanism is that the clock responds differently to the same stimulus (e.g., pulse of light) depending on when it

receives the stimulus during its cycle resulting in a phase response curve (PRC). While entrainment protocols involve a regular repetition of a zeitgeber, PRCs are constructed by measuring the direction and magnitude of phase shift to a single stimulus given at different internal phase in otherwise constant conditions.

Internal phase refers to a time within the **▶circadian cycle** that corresponds to an arbitrarily designated but, nevertheless, identifiable “event” of the rhythm that is being measured. Such an “event” could be, for example, the trough of a circadian temperature rhythm or the onset of activity following the main sleeping bout. For the construction of a PRC, the zeitgeber (e.g., a light pulse) is applied – in separate experiments – at different phases of the cycle (2h, 4h, 6h, etc. after, e.g., the activity onset) and the resulting phase of the rhythm (e.g., of the activity onset) is compared to that of a control experiment where the rhythm ran free without a perturbation. This comparison yields the phase shift which is elicited by a light pulse given at a specific internal time which can be either delayed, advanced or not shifted at all. The resulting phase shifts induced over an entire circadian cycle are then plotted as a phase response curve (PRC, see Fig. 1). A typical type-1 PRC shows phase advances (in the second half of the internal night), phase delays (in the first half of the internal night) and a non-responsive “▶dead zone” (in the

middle of the internal day) [7]. For a collection of most known PRC’s, see [www.cas.vanderbilt.edu/johnsonlab/prcatlas/index.html](http://www.cas.vanderbilt.edu/johnsonlab/prcatlas/index.html).

PRCs can be plotted in two different ways. In most cases, the amount of phase shift elicited (y-axis) is plotted against the internal phase at which the pulse was given (x-axis). By convention, internal phase is either expressed as Circadian Time [8] (CT; anchored at the time at which lights would have been turned on, defined as CT0) or Internal Time [9] (IT, anchored at mid-night, i.e., at the mid-point between the times at which lights would have been turned off and on, defined as IT0). An alternative graphing method, called a Phase Transition Curve (PTC), plots the (new) phase which results from the perturbation of the zeitgeber stimulus (y-axis) against the internal phase at which the pulse was given (x-axis). The labels “type 1” and “type 0” resetting are derived from the slopes of the PTC. If the stimulus always resets the **▶oscillator** to a given phase, the slope of the PTC is zero (“go back to start,” no matter where you are); if, however, the stimulus shifts the phase by a certain amount, which changes depending on the internal time when it was given, the slope will be close to one. The stronger the zeitgeber stimulus, the more it will shift the phase, the more the individual phase shifts within a PRC, the more the PTC will deviate from a slope of 1. With strong resetting, the slope approaches 0 (almost complete resetting).

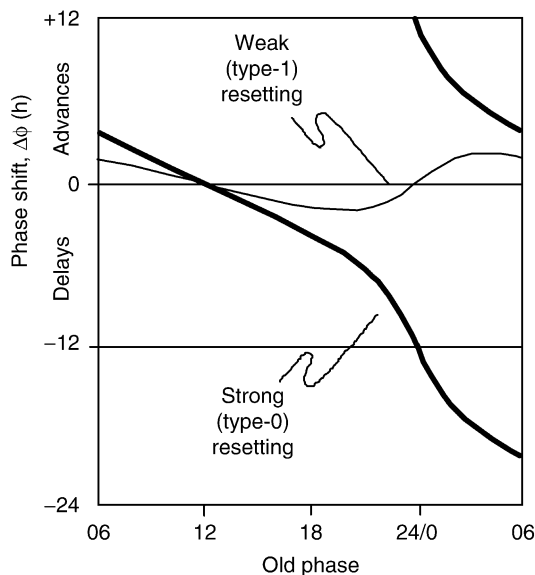

**Type 1 and Type 0 Resetting. Figure 1** Phase response curves can show strong or weak resetting in response to a zeitgeber. The stimulus is delivered at a given circadian time (old phase) and, some days later, the new phase is determined. This phase shift is plotted either as an advance, a delay or no change. Reprinted from [2].

### PRC's and Circadian Entrainment

Experiments probing how a given zeitgeber affects the phase of a free running circadian rhythm have been remarkably successful in providing a theoretical basis for entrainment. To do this, one puts the zeitgeber period ( $T$ ), the free-running period ( $\tau$ ), and the PRC into a systematic relationship. The daily phase shifts ( $\Delta\phi$ ) necessary to ensure stable entrainment must (exactly) compensate for the difference between  $T$  and  $\tau$ :  $\Delta\phi = \tau - T$ . Thus, by definition, delays are negative and advances positive. Stable entrainment can only be achieved if one point on the PRC represents the necessary  $\Delta\phi$ , and this is exactly the phase at which the zeitgeber pulse must be given to the oscillator every day. If entrainment was achieved predominantly non-parametrically, e.g., if it was the signal of dawn which ensures entrainment, then the phase of entrainment (chronotype) is determined by the period of the zeitgeber cycle (in nature 24 h), the shape of the PRC and the free-running rhythm.

### Significance of Type 1 and Type 0 Resetting in the Natural Environment

Entrainment is the basis for the variety in temporal aspects of human behavior (as well as that of most organisms on earth), exemplified by the well known



“early” or “late” type individuals (chronotypes), those who either retire and rise early or late within the day. Both the free-running rhythm and the shape and amplitude of a PRC can vary between species but it can also vary between individuals within a species. It can even change over the lifetime of an individual. Each species and each individual within a species and even an individual at different ages can, therefore, show a different phase of entrainment (be a different chronotype). In real life, the strength of the stimulus (or the sensitivity to the stimulus) will have an impact on the free running period and the PRC, and will thus also contribute to chronotype. For humans, this would relate to people living and working predominantly indoors compared to those working outdoors.

The shape of the PRC which has evolved for a given species generally reflects the relationship between  $T$  and  $\tau$ . If for example, the  $\tau < T$ , the PRC should have a substantial delay portion; if  $\tau > T$ , the PRC will have to show a substantial advance portion. There is yet another parameter that influences the relationship between  $T$ ,  $\tau$  and the PRC – the more robust a rhythm, the larger its amplitude, the less it will be perturbed by a given zeitgeber stimulus. Robust (high amplitude) circadian clocks would, therefore, predictably show rather a type 1 than a type 0 resetting characteristic. Although this can be explained by simple mechanical oscillator theory, it may also make sense in biology, as can be shown by the example of aging. Young animals (including humans) generally have a more robust circadian oscillator, expose themselves to stronger zeitgeber stimuli and their input pathways are more sensitive compared to older animals, yet clocks of all ages need to be entrainable. In this case, the decreased exposure to strong zeitgeber stimuli in the elderly would be compensated for by a decreased robustness (amplitude) of their circadian system.

## References

1. Johnson CH, Elliott JA, Foster R (2003) Entrainment of circadian programs. *Chronobiol Int* 20(5):741–774
2. Roenneberg T, Daan S, Merrow M (2003) The art of entrainment. *J Biol Rhythms* 18(3):183–194
3. Roenneberg T, Foster RG (1997) Twilight times - ight and the circadian system. *Photochem Photobiol* 66:549–561
4. Pittendrigh CS (ed) (1981) Circadian systems: entrainment. In: Aschoff J (ed) *Biological rhythms*, vol. 4. Plenum Publishers, New York, pp 95–124
5. Pittendrigh CS, Daan S (1976) A functional analysis of circadian pacemakers in nocturnal rodents. IV. Entrainment: pacemaker as clock. *J Comp Physiol A* 106:291–331

6. Hut RA, Van Oort BE, Daan S (1999) Natural entrainment without dawn and dusk: the case of the European ground squirrel (*Spermophilus citellus*). *J Biol Rhythms* 14(4):290–299
7. Pittendrigh CS, Minis DH (1964) The entrainment of circadian oscillators by light and their role as photoperiodic clocks. *Am Nat* 158:261–294
8. Pittendrigh CS, Minis DH (1964) The entrainment of circadian oscillations by light and their role as photoperiodic clocks. *Am Nat* 98:261–294
9. Daan S, Merrow M, Roenneberg T (2002) External time - internal time. *J Biol Rhythms* 17(2):107–109

## L-type $\text{Ca}^{2+}$ Channel

### Definition

The L-type calcium channel is the dihydropyridinesensitive Cav1.2 calcium channel, that is essential for smooth muscle contraction and the target for the calcium channel blocker/calcium antagonists.

► Calcium Channels – an Overview

## Type I Position-Vestibular-Pause (PVP) Neuron

### Definition

Neurons in the vestibular nuclei, which constitute most of the intermediate leg of the direct vestibulo-ocular reflex (VOR) pathway.

► Position-Vestibular-Pause Neurons

► Vestibular Nuclei

► Vestibulo-Ocular Reflexes

## Type I Secondary Vestibular Neurons

### Definition

Vestibular nucleus neurons that receive a primary afferent input from the ipsilateral horizontal semicircular canal. They show type I response to head rotation in

the horizontal plane: an increase in their firing rate during head rotations to the ipsilateral side and a decrease during rotations to the contralateral side.

- ▶ Burster-Driving Neurons
- ▶ Semicircular Canals
- ▶ Vestibular Nuclei

---

## Type II Restriction Endonucleases

### Definition

Restriction endonucleases catalyse the hydrolysis of the sugar-phosphate backbone of DNA. Type II Restriction enzymes cut double stranded DNA at a predictable location within or very near the nucleotide recognition sequence making them useful in molecular biology. Most Type II restriction enzymes cut within their palindromic recognition sites. For example EcoRI cuts within its recognition site of 5'-GAATTC-3'. Type II restriction enzymes on the other hand cleave DNA at a considerable offset from the recognition site. For example BmsFI cleaves 10 and 14 nucleotides away from its recognition site.

- ▶ Serial Analysis of Gene Expression

---

## Type II Ca/Calmodulin-dependent Kinase

- ▶ Calcium Binding Proteins

---

## D-type K<sup>+</sup> Current (I<sub>D</sub>)

### Definition

D-type K<sup>+</sup> current (I<sub>D</sub>) is activated by sub-threshold depolarizations, inactivates slowly, contributes to action-potential repolarization and is blocked by 4-aminopyridine, which broadens action potentials.

- ▶ Action Potential
- ▶ Neuronal Potassium Channels

---

## Tyrosine Hydroxylase

### Definition

The enzyme tyrosine hydroxylase (TH) catalyzes the conversion of L-tyrosine to L-dihydroxyphenylalanine (L-DOPA), which is the rate-limiting step in the production of dopamine and noradrenaline (norepinephrine).

- ▶ Dopamine
- ▶ Noradrenaline

---

## Tyrosine Kinase Receptors

### Definition

Large family of membrane spanning proteins that upon activation by ligand binding catalyze the transfer of phosphates from ATP to tyrosine residues on various substrates that act as signal transducers.

---

## Ubiquitin-proteasome System

### Definition

A complex system of degrading unwanted (e.g., misfolded) cellular proteins. Impairment in this system can lead to abnormal aggregation of intracellular proteins.

---

## Uhthoff's Phenomenon

### Definition

Transient worsening of neurological symptoms with elevation of body core temperature is known as Uhthoff's phenomenon. Worsening symptoms, such as visual blurring or leg heaviness can occur in a hot environment or with exercise. These symptoms, sometimes called pseudo-exacerbations, may result from transient nerve conduction block.

- ▶ Multiple Sclerosis

---

## ULT

- ▶ Muscle Imaging Techniques: Ultrasound

---

## Ultradian Rhythm

### Definition

Circadian rhythms are biological rhythms that occur with a periodicity of approximately 24 h. Ultradian

rhythms are biological rhythms that occur with substantially shorter periodicity, such that multiple cycles occur during each 24 h day. Examples of ultradian rhythms include rhythms of parathyroid and insulin secretion, heart rate, blood pressure, and episodes of REM sleep. While circadian rhythms have been demonstrated to be based in all organisms on self-sustaining cellular oscillations, the mechanistic bases for ultradian rhythms – including whether any of them are self-sustaining – have remained obscure.

- ▶ Cellular Clock
- ▶ Circadian Rhythm
- ▶ Morning/Evening Oscillators
- ▶ Rapid Eye Movement (REM) Sleep

---

## Umami Taste

### Definition

- ▶ Taste - Umami

---

## Unconditioned Reflex

### Definition

A reflex is a stereotyped behavior that reliably occurs at a characteristic latency after a specific stimulus. An unconditioned reflex is a reflex that has not been modified by a well-defined conditioning experience, such as a classical or operant conditioning protocol.

Many (and perhaps all) unconditioned reflexes are in reality the products of interactions early in life between genetic endowment and activity-dependent central nervous system plasticity. Thus, the traditional distinction between conditioned and unconditioned reflexes is

meaningful only when defined in terms of a specific experimental protocol.

- ▶ Classical Conditioning (Pavlovian Conditioning)
- ▶ Conditioned Reflexes
- ▶ Operant Conditioning

---

## Unconditioned Response (UR)

### Definition

In classical conditioning, the unconditioned response (UR) is a response evoked by the unconditioned stimulus. The UR includes mostly reflexive autonomic response, such as salivary secretion and vasomotor responses, and muscle movements, such as flexion reflex and eyelid reflex.

- ▶ Classical Conditioning (Pavlovian Conditioning)

---

## Unconditioned Stimulus (US)

### Definition

In classical conditioning, the unconditioned stimulus (US) is a stimulus presented following the conditioned stimulus. The US is chosen to elicit innate reflexive responses (unconditioned response), such as food in the salivary conditioning protocol and airpuff in the eyelid conditioning protocol.

- ▶ Behavioral Methods in Olfactory Research
- ▶ Classical Conditioning (Pavlovian Conditioning)
- ▶ Unconditioned Response (UR)

---

## Uncontrolled Manifold Hypothesis

### Definition

A hypothesis that states that the central nervous system created a subspace (an uncontrolled manifold, UCM) in the space of independent elemental variables and organizes co-variation of elemental variables to restrict much of their variability to the UCM.

- ▶ Coordination

---

## Uncorrelated Broadband Noises

### Definition

Two noises with flat magnitude spectra whose fine structures are uncorrelated. Specifically, noises are said to be uncorrelated if one is given the amplitude (e.g., in volts) of one of the noise bursts at an instant in time, one cannot predict the amplitude of the other noise burst at that instant or any other instant in time. Perfectly correlated noises, by contrast, have identical magnitude and phase spectra.

---

## Under- or Indeterminate System

### Definition

A mathematical system is called under- or indeterminate if it has fewer system equations than unknowns. Indeterminate systems typically have an infinite number of possible solutions.

---

## Uniformity

### Definition

The property of a material body such that all its points are mutually materially isomorphic. In an evolving uniform body (undergoing growth or remodeling) the material isomorphisms are functions of time.

- ▶ Mechanics

---

## Unilateral Labyrinthectomy

### Definition

The surgical or chemical ablation of the sensory receptors of one inner ear.

- ▶ Vestibular Compensation and Plasticity

## Unilateral Neglect

### Definition

- ▶ Hemispatial neglect

## Unipolar depression

- ▶ Major Depressive Disorder

## Unity of Science

### Definition

Unity of Science is the idea that the various empirical sciences form a coherent “unified” system by being connected by reductive relations, and that physics is the ultimate reduction base. An associated idea propounded in the Vienna Circle is that there is a physicalist language common to all sciences in which any observation can be expressed.

- ▶ Behaviorism
- ▶ Information
- ▶ Logical

## Unloading Reflex

### Definition

The unloading reflex, or unloading response, is the automatic and stereotypical dis-facilitation of a homonymous muscle after it has been rapidly shortened/ unloaded. The response is caused by the removal of the afferent feedback component of the reflex control loop.

- ▶ Integration of Spinal Reflexes

## Unmyelinated Axon

### Definition

Axons ensheathed by a single layer of Schwann cell process are called unmyelinated axons.

- ▶ Myelin
- ▶ Schwann Cell

## Unmyelinated Mechanoreceptors

### Definition

A mechanically sensitive sensory ending which conducts slowly ( $\sim 1$  m/s). An afferent C-fiber. In the skin, a subclass known as “tactile C fibers” possess mechanical thresholds similar to those of myelinated cutaneous mechanoreceptors.

- ▶ Electric Fish

## Unreinforced Learning

- ▶ Latent Learning

## Unsharp Mask

### Definition

In digital image processing, an unsharp mask is a simple method used to sharpen an image, effecting contrast enhancement. It does not increase image resolution, but rather improves small-scale [▶acutance](#). A slightly blurred version of the original image is created and then subtracted from the original image, creating a highpass filtered difference image called the unsharp mask that emphasizes regions of transition (edges). This mask is then used to transform the original image to emphasize the contrast along these edges.

The scale of the contrast enhancement in this operation is determined by the blur distance. The more blurred the image that is initially subtracted from the

original, the lower the corner frequency of the resulting unsharp mask, and the larger the scale of the contrast enhancement. The effects of larger-scale contrast enhancement are broader and less restricted to the sharp edges of the original image.

► Contrast Enhancement

---

## Unsharp Masking

► Contrast Enhancement

---

## Unsupervised Learning

### Definition

Unsupervised learning is a form of learning in computational models such as connectionist (artificial neural network) models. In contrast to supervised learning, unsupervised learning algorithms work without providing explicit feedback on the error of the net with respect to its input (i.e., no teaching signal). Learning develops by using internal or statistical structure of data set, so that the responses (output) will be fully characterized statistical properties of inputs. Often, the aim of unsupervised learning algorithms is to cluster the input according to similarity. While this is biologically more plausible than providing an external teaching signal, problematic issues in this context are how many clusters to form, and when to stop training. Often, weights are adjusted until some internal constraint is fulfilled. It has been proposed that unsupervised learning occurs in cortex-based learning.

- Connectionism
- Learning Curve
- Neural Networks
- Supervised Learning

---

## Upper Motor Neuron Syndrome

### Definition

Old-fashioned term meaning a syndrome resulting from lesion of the so-called upper motor neurons, i.e.,

neurons originating at higher levels of the central nervous system and synapsing on the ► [motor neurons](#) proper (lower motor neurons) in brainstem and spinal cord. Such lesions result in ► [spasticity](#), enhanced ► [tendon reflexes](#) (jerks) and ► [Babinski sign](#).

- Babinski Reflex
- Spasticity
- Tendon Reflex

---

## Upper Respiratory Tract Infections (URTIs)

### Definition

The common cold is probably the most frequently occurring illness in humans worldwide. More than 200 different viruses cause colds, and rhinoviruses and coronaviruses are the culprits 25–60% of the time. Rhinoviruses often attack during the fall and spring seasons, while the coronavirus is common during the winter. The average adult has two or three respiratory infections each year. Epidemiological data suggest that endurance athletes are at increased risk for upper respiratory tract infection during periods of heavy training and the 1- to 2-wk period following race events.

- [Hormones and Respiratory Infections](#)

---

## Uptake Carrier

- [Neurotransmitter Transporter](#)

---

## Urbilateria

- [Evolution of the Brain: Urbilateria](#)

## Urbilaterian Ancestor/Urbilateria

### Definition

The last common ancestor of all bilaterian phyla before the split of the protostome and deuterostome lineages.

- Evolution of the Brain: Urbilateria

## Ureter

- Visceral Afferents

## Urethelium

### Definition

Urethelium is the membrane lining the inner surface of the bladder.

## Urethrogenital Reflex

### Definition

Urethrogenital reflexes refer to a rat model that mimics the nerve and muscle responses associated with human sexual climax.

- Sexual Reflexes

## Urination

- Micturition, Neurogenic Control

## Urodeles

### Definition

Urodeles are one of three orders of living amphibians (order Caudata). They are commonly referred to as salamanders and newts depending on the taxonomic group within the order. Urodeles are the most generalized of the amphibians, and in their basic body appearance most similar to known fossil amphibians. A number of urodele species diverge from the hypothesized amphibian ancestral state in interesting ways that have implications for evolutionary changes in the brain, including (in the same or different species) secondary reductions in brain size, large increases in genomic DNA content and subsequent increase in cell size, and the retention of juvenile characteristics in adults (“neoteny”). Others, such as the plethodontid salamanders, have highly specialized visual systems and tongue motor systems used for visually guided prey capture that is very similar to that used in the anurans.

- Evolution of the Brain: Amphibians

## Urogenital Reflexes

### Definition

The neural control of the lower urinary tract and reproductive organs (i.e., the urogenital organs) is dependent on autonomic and somatic nerves arising in the lumbosacral spinal cord. Many of the functions of these organs are regulated involuntarily by reflex mechanisms: the urogenital reflexes. Some reflexes are organized in the spinal cord, e.g., penile erection induced by tactile stimulation of the penis; whereas others require coordination between the brain and spinal cord, e.g., penile erections induced by visual erotic stimuli. Some reflexes are complex, requiring coordination between autonomic and somatic nerves, e.g., seminal emission-ejaculation; whereas others involve interactions between different organs, e.g., inhibition of micturition by stimulation of afferent nerves to the penis or vagina.

- Micturition
- Neurogenic Control
- Sexual Reflexes

## Usher's Syndrome

### Definition

- ▶ Inherited Retinal Degenerations

control, the regulation of blood pressure, and the production of eye movements.

- ▶ Cerebellar Functions
- ▶ Motion Sickness
- ▶ Posture Role of Cerebellum

---

## Utriculus

### Definition

One of two otolith organs that sense gravity and linear acceleration such as from initiation of movement in a straight line. The utricle is oriented horizontally in the head, and registers accelerations acting in the horizontal plane.

- ▶ Peripheral Vestibular Apparatus
- ▶ Vestibulospinal Responses

---

## Uvula Vermis

### Synonyms

- ▶ Uvula of vermis (IX)

### Definition

Segment of vermis cerebelli lying between the tonsil of cerebellum.

Like the entire vermis cerebelli, the uvula vermis also receives its afferents primarily from the spinal cord. It is thus part of the spinocerebellum = palaeocerebellum.

- ▶ Cerebellum

---

## Uvula

### Definition

A region of the caudal cerebellum midline (vermis) that receives vestibular inputs and participates in postural



---

## V1

### Definition

- ▶ Primary Visual Cortex
- ▶ Striate Cortex Functions

---

## V2, Secondary Visual Cortex

- ▶ Evolution of the Visual System, in Mammals – Comparative Evolutionary Aspects across Orders

---

## Vacuolar Myopathy

### Definition

- Spinal cord degeneration in ▶ AIDS patients.
- ▶ Acquired Immunodeficiency Syndrome (AIDS)

---

## Vagal Afferents

- ▶ Visceral Afferents

---

## Vagal Nerve

### Definition

- The tenth cranial nerve.
- ▶ Vagus Nerve

---

## Vagotomy

### Definition

Dissection of vagal nerves.

---

## Vago-Vagal Reflex

### Definition

A vago-vagal reflex is a reflex, for example for neural control of the stomach, that involves vagal sensory afferents that transmit information to the brain stem, integrative circuitry in the brain stem and vagal efferent fibers that transmit back to the target organ.

- ▶ Autonomic/Enteric Reflexes

---

## Vagus Nerve

### Definition

The vagus nerve is the tenth cranial nerve and arises from a number of nuclei in the medulla oblongata and caudal pons. The vagus nerve provides parasympathetic motor innervation to organs throughout the thoracic and abdominal cavities, and so plays a major role in regulating cardiovascular, respiratory and digestive system functions. Importantly, the vagus nerve also provides general sensory innervation of these same organ systems, and carries some information on taste from receptors at the base of the tongue and on the epiglottis. Special visceral efferent fibers of the vagus nerve regulate a number of muscles of the pharynx and larynx, giving the vagus nerve a role in speech and swallowing, and bilateral lesions of the vagus may lead to death by suffocation. Of uncertain significance are general somatic sensory neurons within the vagus nerve projecting to the skin of the external ear.

## Vagus Nerve, Motor Fibers

### Definition

Motor components of the vagus nerve (X). The somatomotor components come from nucleus ambiguus, the visceromotor from the dorsal nucleus of the vagus nerve.

## Vagus Nerve, Sensory Fibers

### Definition

Sensory components of the vagus nerve (X). The somatosensory fibers pass on to the spinal nucleus of the trigeminal nerve, the viscerosensory to the solitary nucleus.

## Value-Based Learning

JOHN PHILIP O'DOHERTY

Computation and Neural Systems Program, Division of Humanities and Social Sciences, California Institute of Technology, Pasadena, CA, USA

### Definition

► **Value-based learning** refers to the process by which an animal learns about the ► **rewards** or ► **punishers** available in its environment, so that behavior can be organized in order to seek out the rewards and avoid the punishers. Value-based learning encompasses two broad categories of associative learning phenomena: Classical or Pavlovian conditioning, by which an animal learns passive associations between an initially affectively neutral stimulus and a rewarding or punishing outcome, and instrumental conditioning by which an animal learns to make responses in order to obtain rewards or avoid punishers.

### Characteristics

In order to survive, both humans and other animals need to be able to learn about the affective value of stimuli in their environment and to predict when and where stimuli of affective significance will occur, so that behavior can be organized prospectively in order to seek

out rewards and avoid punishers. This capacity seems to depend on at least four distinct processes: (i) The ability to encode the value of rewarding or punishing stimuli, (ii) The ability to encode predictions of future rewarding or punishing events, (iii) The ability to learn to predict future rewarding or punishing outcomes, and (iv) The ability to modify action selection in order to choose those actions which lead to a greater probability of obtaining rewards or avoiding punishers.

### Neural Substrates of Stimulus Reward Value Encoding

Single-unit neurophysiology studies in animals and functional neuroimaging studies in humans have revealed a contribution of one brain structure in particular: the orbitofrontal cortex in encoding stimulus-reward value. Neurons in monkey orbitofrontal cortex respond to the taste or odor of a food reward when the animal is hungry, but such responses decrease to the same taste or odor once the animal has been sated on that food [1]. Brain imaging studies in humans have also suggested a key role for this area in encoding stimulus reward-value for a variety of rewards in different modalities, such as odors, tastes, touch, as well as for rewards in the visual or auditory domains. Human orbitofrontal cortex also responds to the receipt of more abstract rewards not tied to a specific sensory modality, such as monetary reward. [2]. Orbitofrontal cortex has been found to respond also to the receipt of aversive or punishing stimuli in different modalities, including unpleasant odors, tastes and monetary loss, suggesting a role for this region in encoding both positive and negative value.

### Neural Responses Related to Prediction of Future Rewards

Reward prediction in its simplest form can be studied through the phenomenon of appetitive classical conditioning whereby an arbitrary affectively neutral stimulus acquires affective value by virtue of being repeatedly paired with the subsequent presentation of reward. Following conditioning, such a stimulus can be said to be predictive of subsequent reward. Single unit studies in rats and monkeys have revealed neural responses in a number of brain regions such as the amygdala in the medial temporal lobes as well as the orbitofrontal cortex in response to stimuli predictive of subsequent reward, or that respond in anticipation of a reward outcome [3,4]. Other neurons have been found in these areas that respond to cues predictive of the subsequent presentation of aversive or punishing stimuli. Human neuroimaging studies have also confirmed a role for the amygdala and orbitofrontal cortex in responding to cues predictive of subsequent rewards as well as punishers [2]. These predictive representations appear to track the current value of the associated reward, such that responses to cues predictive of a particular food outcome decrease if the subject no longer

values that outcome as a result of having previously consumed it to satiety. Another region that has been found to respond in human imaging studies during reward anticipation is the ventral striatum, including the nucleus accumbens as well as ventral parts of the putamen [5].

### Learning of Reward Predictions: the Role of Dopamine

How are predictions of reward learned? A candidate mechanism may be via the phasic activity of dopamine neurons present in the substantia nigra and ventral tegmental area in the midbrain, that project widely to the striatum, amygdala and prefrontal cortex including the orbital surface. Recordings from dopamine neurons in non-human primates reveal that the phasic activity of these neurons seem to encode the difference between expected and actual reward. That is, these neurons increase their firing when a reward is presented unexpectedly but decrease their firing from baseline when a reward is unexpectedly omitted [6]. During reward-learning these neurons have also been found to respond initially at the time of reward presentation, but once learning is complete to respond instead at the time of the presentation of the predictive stimulus. The response profile of these neurons has been suggested to resemble a prediction error signal found in theoretical models of conditioning such as the Rescorla–Wagner learning rule and its real time extension: temporal difference learning. The error signal in such models is used to update expectations of future reward, and thus plays a crucial role in learning. According to this proposal, the phasic activity of dopamine neurons acts to modulate learning of stimulus-reward and/or stimulus-response associations in target regions such as the striatum. Indeed, consistent with this proposal, dopaminergic input has been found to facilitate neuronal plasticity in the striatum. Human neuroimaging studies have also reported activity in target areas of dopamine neurons such as ventral striatum during reward-learning, that resemble the prediction error signals thought to be conveyed by dopamine neurons [2]. Moreover, systemic administration of dopamine antagonists have been found to decrease prediction error related responses in human striatum.

However, the role of dopamine in learning has also been challenged by others. There is some evidence to suggest that mice lacking in dopamine can perform normally on some tasks designed to probe reward-learning. Furthermore, mice with increased tonic dopamine levels do not show any evidence of an enhanced ability to learn to obtain rewards. This suggests that at least some aspects of reward-learning may be dopamine independent. An alternative view is that dopamine is involved not in learning per se, but instead in mediating the degree to which an animal “wants” or is motivated to obtain reward [7]. Another proposal is that dopamine

may play a role in signaling and facilitating learning about salient and/or novel events in general as opposed to playing a specific role in reward-learning [8]. Evidence of a role for dopamine in responding during aversive learning is mixed. Single-unit studies have generally failed to observe strong dopaminergic activity in response to aversive events, and indeed it has been found that dopamine neurons may in fact inhibit responding during aversive stimulation such as tail pinch in rats. On the other hand, a number of studies measuring dopamine release in the striatum in rats have found evidence for increased dopamine levels during aversive as well as ▶[appetitive](#) conditioning. However, as termination of an aversive stimulus can in itself be rewarding, the implications of these studies for understanding the role of dopamine in aversive learning are still debated.

### Action Selection for Reward

Once predictions of future reward are established, the next step is to use these predictions to guide behavior. More specifically, humans or other animals need to be able to bias their action selection so that they choose those actions which in a given context lead to the greatest probability of obtaining future reward or avoiding punishers. The problem of choosing responses in order to obtain reward or avoid punishers is often termed instrumental conditioning. Two distinct mechanisms have been proposed to underlie this form of learning: goal-directed learning whereby responses are associated with the ▶[incentive value](#) of outcomes (response–outcome or stimulus–response outcome learning), and habit learning whereby a particular response comes to be favored in a particular context without any link to the value of the outcome (stimulus–response learning). Behavior under goal-directed control can be flexibly modified following changes in the incentive value of the associated outcome, whereas habit learning is less flexible in that behavior under control of the habit system will persist even after the outcome is no longer valuable to the animal [9]. These two distinct forms of learning have been suggested to control behavior at different times during instrumental conditioning, with goal-directed learning controlling behavior early on in training, while habit learning takes control once an action has been performed extensively. Lesion studies have implicated a part of the dorsal striatum, specifically its dorsolateral aspect in habit learning in rats, whereas a part of the prefrontal cortex (prelimbic area) and dorsomedial striatum have been implicated in goal-directed learning. Less is known about the specific neural systems involved in goal-directed and habit learning in humans and other primates. Neurons in primate dorsal striatum have been found to encode specific response–reward associations, for both saccadic eye-movements and hand movements. Human neuroimaging studies of reward-based action selection have

implicated the dorsal part of the striatum which is activated when a contingency is established between responses and reward or even when such a contingency is merely perceived. Flexible reward-based action selection may also depend on prefrontal cortex, specifically its ventromedial aspect, including the orbitofrontal cortex. Damage to this area in humans impairs the ability to choose advantageously on tasks that probe the ability to choose actions for reward under uncertainty, or to reverse previously learned stimulus-response-reward associations [10]. Furthermore, human imaging studies have revealed activity in this region related to behavioral choice [2]. These findings suggest that a distributed network of regions including the dorsal striatum and ventromedial prefrontal cortex may be particularly involved in guiding reward-based action selection.

## References

1. Rolls ET (2000) The orbitofrontal cortex and reward. *Cereb Cortex* 10:284–294
2. O'Doherty JP (2004) Reward representations and reward-related learning in the human brain: insights from neuroimaging. *Curr Opin Neurobiol* 14:769–776
3. Schoenbaum G, Chiba AA, Gallagher M (1998) Orbitofrontal cortex and basolateral amygdala encode expected outcomes during learning. *Nat Neurosci* 1:155–159
4. Paton JJ, Belova MA, Morrison SE, Salzman CD (2006) The primate amygdala represents the positive and negative value of visual stimuli during learning. *Nature* 439:865–870
5. Knutson B, Cooper JC (2005) Functional magnetic resonance imaging of reward prediction. *Curr Opin Neurol* 18:411–417
6. Schultz W, Dickinson A (2000) Neuronal coding of prediction errors. *Ann Rev Neurosci* 23:473–500
7. Berridge KC, Robinson TE (1998) What is the role of dopamine in reward: hedonic impact, reward learning, or incentive salience? *Brain Res* 28:309–369
8. Horvitz JC (2000) Mesolimbocortical and nigrostriatal dopamine responses to salient non-reward events. *Neuroscience* 96:651–656
9. Balleine BW, Dickinson A (1998) Goal-directed instrumental action: contingency and incentive learning and their cortical substrates. *Neuropharmacology* 37:407–419
10. Bechara A, Tranel D, Damasio H (2000) Characterization of the decision-making deficit of patients with ventromedial prefrontal cortex lesions. *Brain* 123 (Pt 11):2189–2202

## Vanderbergh Effect

### Definition

A female mouse exposed to male urine will enter puberty earlier than those not exposed to male urine.

## Varicosity

### Definition

Varicosities are swellings of about 1–2  $\mu\text{m}$  diameter along a postganglionic sympathetic axon as it branches to innervate a target organ. Varicosities contain accumulations of neurotransmitter vesicles.

- ▶ Autonomic Effects on Skeletal Muscle
- ▶ Postganglionic Neurotransmitter
- ▶ Sympathetic Pathways

## Vascular Endothelium

### Definition

The internal lining of the vascular bed consisting of a continuous layer of cells that maintains the vascular bed in a vasodilatory, anti-thrombotic, and anti-inflammatory state.

## Vasculitis

### Definition

Inflammation of blood vessels, marked by infiltration of inflammatory cells within the blood vessel wall, leading to damage of the blood vessel and of the tissue being supplied by the blood vessel.

## Vasoactive Intestinal Peptide (VIP)

### Definition

Also known as vasoactive intestinal polypeptide, VIP is a potent 28-amino acid vasodilator peptide, originally isolated from intestinal extracts. Widely distributed in the peripheral and central nervous systems, a huge

number of biological effects are attributed to VIP such as smooth muscle relaxation, fluid secretion from the pancreas and inhibition of gastric acid secretion. VIP is the principal transmitter in atropine-resistant parasympathetic vasodilatation within the salivary glands. VIP is also produced in the suprachiasmatic nuclei (SCN) of the hypothalamus. VIP is found in the ventral part of the SCN, while its main neuronal target, the VPAC2 receptor, is expressed throughout the SCN. The SCN coordinates daily timekeeping in the body and VIP, along with gastrin-releasing peptide (GRP), plays a key role in communication among individual SCN oscillator cells. Mice bearing a mutation in VIP or in its receptor, show substantial abnormalities in circadian rhythmicity. VIP is involved in synchronizing the timing of SCN function with the environmental light/dark cycle. After exposure to light, up-regulation of the *Per* clock genes in the SCN is first apparent in the area of ventral GRP/VIP containing cells and later in the rest of the SCN. In contrast to arginine-vasopressin (AVP), it appears that neither VIP nor GRP is rhythmically expressed in the SCN under constant conditions, although in light/dark cycles, VIP is elevated at night and GRP is elevated in the day.

- ▶ Circadian Rhythm
- ▶ Clock Gene
- ▶ Salivary Secretion Control
- ▶ Suprachiasmatic Nucleus

## Vasocongestion

### Definition

Increased blood flow or swelling of, for example, the pelvic organs.

## Vasoconstriction

### Definition

Vasoconstriction is the constriction of blood vessels, i.e. the reduction of their diameter induced by contraction of transversal and longitudinal smooth muscles surrounding them.

## Vasopressin (VP) or Antidiuretic Hormone (ADH)

### Definition

Vasopressin is a peptide hormone found in most mammals including humans, is also known as arginine vasopressin (AVP) and as antidiuretic hormone (ADH). There are two forms of vasopressin, differing in the amino acid at position 8: arginine vasopressin is widespread, while lysine vasopressin is found in pigs. VP has antidiuretic and vasopressor actions, and is used in the treatment of diabetes insipidus. VP is synthesized from a pre-prohormone precursor in neurons of the hypothalamus, and has many actions in the brain. VP is released into the brain in a circadian rhythm by neurons of the suprachiasmatic nuclei (SCN) of the hypothalamus. VP released from these and other centrally-projecting hypothalamic neurons is involved in aggression, blood pressure regulation and temperature regulation. Hypothalamic neurons also transport VP to the posterior pituitary gland where it is stored and from which it can be released into the blood stream of the pituitary portal system.

- ▶ Circadian Rhythm
- ▶ Homeostasis
- ▶ Suprachiasmatic Nucleus
- ▶ The Hypothalamo Neurohypophysial System

## Vasopressinergic Central Pathways

Fibers are involved in blood pressure and temperature regulation, regulation of osmolality and corticosteroid secretion. They influence cognition, aggression, paternal behavior and social attachment.

- ▶ The Hypothalamo Neurohypophysial System
- ▶ Hypothalamo-Pituitary-Adrenal Axis, ▶ Stress and Depression

## Vater-Pacini Corpuscle

- ▶ Pacinian Corpuscle Regeneration

---

## Vection

### Definition

The illusory percept of self-motion that occurs on exposure to visual motion in large parts of the visual field (optic flow).

- ▶ Optic Flow

---

## Vector

### Definition

A quantity described by several numbers, e.g. position in 3-D space is described by three numbers.

- ▶ Neural Networks for Control

---

## Vectorial Burst Neurons

### Definition

A class of cells that discharge a burst of spikes for saccadic eye movements having a narrow range of sizes and directions (their movement field). Neurons may not burst for saccades that are much smaller or larger than the optimum. Superior-colliculus burst neurons typify the latter type.

- ▶ Brainstem Burst Generator
- ▶ Saccade
- ▶ Saccadic Eye Movement
- ▶ Superior Colliculus

---

## Vegetative Nervous Function

- ▶ Ageing of Autonomic/Enteric Function

---

## Velis

### Definition

A protein of the CASK-Mint-Velis complex enriched at presynaptic active zones; probably contributing to the adaptor or scaffolding functions. As known as MALS or Lin-7.

- ▶ Synaptic Proteins and Regulated Exocytosis

---

## Velocity

### Definition

The vector obtained as the derivative of the position vector of a particle with respect to time. For a material body, at each instant of time there exists a velocity field, namely a velocity vector assigned to each particle of the body.

- ▶ Mechanics

---

## Velocity Gradient

### Definition

The spatial (Eulerian) gradient of the velocity field.

- ▶ Mechanics

---

## Velocity Response Curve (VRC)

### Definition

A construct devised to explain why and how the circadian period lengthens when rodents are exposed to constant light (LL). Under LL, all phases of the phase response curve (PRC) are light-stimulated. Assuming no LL-induced change in the shape of the underlying PRC, each momentary effect of light exposure will cause a change in the measured circadian period equal to the amount of added phase delay or subtracted phase

advance. Accordingly, the period will lengthen most rapidly at times with greatest phase delays and shorten most rapidly at times with greatest phase advances. This effect will be compounded as light intensity becomes greater. House mice have a PRC that does not allow large phase advances, but does allow relatively large phase delays; the PRC of the hamster is the opposite.

Thus, the mouse is predicted to lengthen its circadian period dramatically as intensity increases. In contrast, the hamster is predicted to have no net change in period as intensity increases from dim to very bright, but at intermediate intensities, is actually expected to shorten. There are few studies of this phenomenon, but the limited data are generally consistent with expectation, although the intensity-related decrease in period has not been observed in hamsters.

- ▶ Circadian Period
- ▶ Phase Advance
- ▶ Phase Delay
- ▶ Phase Response Curve

## Velocity Storage

THEODORE RAPHAN

Department of Computer and Information Science,  
Institute of Neural and Intelligent Systems,  
Brooklyn College of the City University of New York,  
Brooklyn, NY, USA

### Definition

Conceptually, ▶ **velocity storage** is a central vestibular mechanism that stores incoming velocity information about head and body movement and activates the oculomotor system. Velocity storage has been modeled as an integrator, with inputs from the canals, visual and somatosensory systems and generates a low frequency component of eye velocity that compensates for motions that activate these systems. Initially, it was hypothesized that the major function of velocity storage was to extend the time constant of the cupula and eighth nerve dynamics during continuous rotation in darkness, store information about surround velocity to generate optokinetic after-▶ **nystagmus**, and serve as a focus for visual-vestibular interaction. Further work has shown that it has a three-dimensional mathematical structure that can be modeled as a three-dimensional integrator with orientation properties linked to the spatial vertical and ▶ **gravity**. It has proven useful in explaining a wide range of data on lesions. It also explains data in the vestibular nuclei on visual-vestibular interaction.

The orientation properties of velocity storage now show promise of shedding light on the underlying mechanisms associated with motion sickness.

### Description of the Theory

#### Introduction

The central nervous system stores information over a wide range of modalities including storage of visual and spatial information utilized in subject navigation through the environment. Within the last thirty years, inertial storage of velocity has been shown to be a critical component of the vestibulo-ocular reflex (VOR), which maintains ocular stability during head and body movement in space [1–4]. This storage not only has a profound affect on the time course of compensatory ocular responses, but also on spatial orientation [5,6]. The purpose of this paper is to review the work that has given rise to the concept of velocity storage, and how models of velocity storage have enhanced our understanding of the VOR and spatial orientation.

#### Overview of the Vestibular Ocular Reflex

Early work on the vestibular system established the ▶ **semicircular canals** and otoliths (▶ **Otolith organs**) of the vestibular labyrinth as important elements of vestibular system processing. Somewhat later, Breuer, Crum Brown and Mach discovered, almost simultaneously, that the semicircular canals perceived angular motion (See [7,8] for comprehensive review). Mach further inferred that the canals were transducers of angular acceleration, not angular velocity from experiments in which subjects were rotated in darkness and in light. The subjects sensed angular movement only at the beginning and end of rotation in darkness and felt that they were stationary while rotating at a constant velocity. In contrast, if subjects were rotating in light, they never lost the sensation of motion. This demonstrated that vestibular receptors in the semicircular canals were activated only at the beginning and end of rotation, and that the visual system supplied the activity during the constant velocity portion of the rotation to maintain the sense of motion. Later work by Ter Braak and Mowrer showed that the slow phase eye velocity of post-rotatory nystagmus could be canceled by the previous rotation in light (Reviewed in [1,2]). Thus, the critical relationship between vision and the vestibular system in generating eye velocity arose.

Models of the VOR were initially confined to one dimension and were largely concerned with defining the processing of the ▶ **angular vestibulo-ocular reflex (aVOR)** by the semicircular canals. Early models of the aVOR were based on its input-output behavior in response to sinusoidal angular velocity, and aVOR processing was mainly attributed to the properties of the endolymph and elastic properties of the cupula.

The central processing was attributed to the ►three neuron arc as defined by Lorente de No, which was not assigned any specific dynamic properties (See [7,8]). With the ability to record activity of semicircular canal afferents, it soon became clear that for steps of constant velocity rotation, afferent firing rates decayed more rapidly than the nystagmus that was generated. The time constant of decay of the afferents was about 3–5 s [9], while the nystagmic slow phase velocity had a time constant of 12–20 s [2]. This finding led to the postulate that there was a central neural network that stores velocity information, prolonging the time constant of the nystagmus generated by the semicircular canals [2]. Because it was modeled as an integrator, it has been referred to as “the velocity storage integrator” [2].

In addition to activation by the semicircular canals, velocity storage is also activated by the visual, otolithic and somatosensory systems [1,4]. Optokinetic nystagmus (►Nystagmus – optokinetic (OKN)), induced by continuous full field surround motion, produces an ►optokinetic after nystagmus (OKAN) in darkness, which has a time course similar to that of vestibularly induced nystagmus by a step of rotation. OKN enhances eye velocity when rotating in light, and cancels what would have been a robust post-rotatory eye velocity after stopping in darkness [2]. This has been modeled as visual activation of the same velocity storage integrator as is activated by the semicircular canals [2]. The otoliths activate velocity storage during off-vertical axis rotation (OVAR) (See [8]), and the somatosensory system activates velocity storage during continuous circular locomotion [3,4].

Over the last decade, it has become clear that velocity storage does more than just lengthen the time constant of vestibular responses and act as a focus for visual, otolithic and somatosensory information. Velocity storage has a three dimensional structure that can be characterized by an orientation vector, which tends to align vestibular and optokinetic responses with the ►equivalent acceleration due to gravity, i.e. the spatial vertical [5,6]. That is, regardless of head tilt, this orientation vector tends to align with the spatial vertical or with the acceleration field generated by combinations of linear acceleration from centrifugation and gravity (►Gravito-inertial acceleration (GIA)) (See [7,8] for review). The orientation vector has characteristics that are closely linked to the perception of the spatial vertical in humans [5]. Individual components of the model of the VOR have been found to be represented in the function of various structures in the central or peripheral nervous system, and to predict the effects of lesions or drugs on vestibular and oculomotor function.

### Modeling of Velocity Storage in One Dimension

Velocity storage has been modeled in one dimension by a single integrator, which is characterized by a single

parameter,  $h$  (Fig. 1a). The value  $h$  specifies the “leak” of the integrator and determines its time constant. If  $h$  is negative, it is said to have negative feedback. Thus, when a step input is applied to the integrator (Fig. 1b), its state,  $X$ , rises exponentially (Fig. 1c). Similarly, when the step is dropped to zero (Fig. 1b), the integrator state falls exponentially to zero over the same time course (Fig. 1c). The rise and fall characteristics are determined by its time constant,  $1/h$ . If  $h$  is small, i.e. the integrator time constant is large, the integrator becomes ideal. An ideal integrator charges linearly for a step input and maintains its charge following the cessation of the stimulus (Fig. 1d).

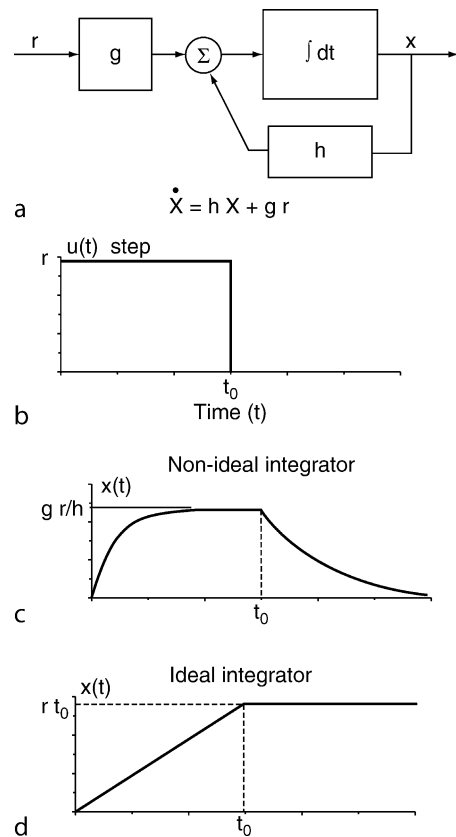

**Velocity Storage. Figure 1** (a) One dimensional integrator and its corresponding dynamic system equation, which determines its temporal response. (b–d) Step response of the integrator. (b) Stimulus, which is a step ( $r$ ) in velocity for  $t_0$  seconds, then falls to zero. (c) Exponential rise of the state ( $X$ ) to a steady state value produced by the step in stimulus in (b). When the stimulus falls to zero, the integrator output decays with a time constant of  $1/h$ . (d) Response of an ideal integrator ( $h = 0$ ) to the same stimulus. The state  $X$  rises linearly during the stimulus and is held constant for all time when the stimulus drops to zero (Adapted from Raphan and Cohen, 1996).



**Fitting the Integrator into Visual-Vestibular Interactions**  
 Figure 2a shows how the integrator would fit into a model of the AVOR and visual-vestibular interaction in one dimension. The model has as one input HEAD VELOCITY relative to space,  $r_h$  which is transduced by

the semicircular canals  $D_{can}$  to generate the eighth nerve signal,  $r_v$  (Fig. 2a). This signal is processed over a direct path,  $g_1$  and activates the velocity storage integrator. The direct pathway and the integrator state sum to generate the signal,  $v_n$  that in part generates the eye

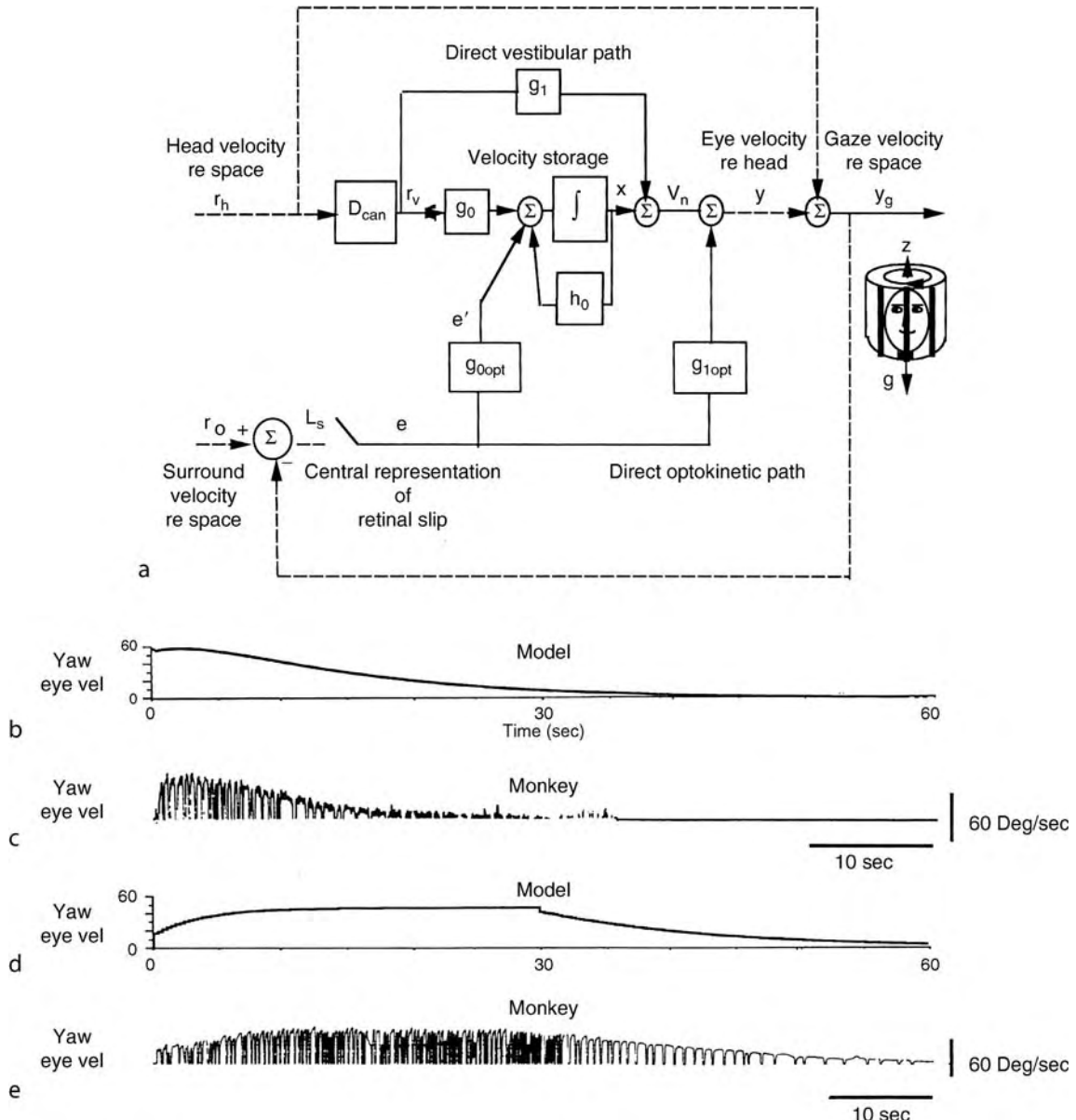

**Velocity Storage. Figure 2** (a) One dimensional model of visual-vestibular interaction with the velocity storage integrator acting as the focus for the interaction (See text for detailed description). Model simulations (b, d), and corresponding data (c, e) from a monkey in response to the same stimulus. (a, b) Per- and postrotatory response to a step in head velocity during darkness. Note the rapid rise at the onset of the stimulus, a slower rise during the plateau phase, and a decay to zero during the constant velocity rotation (Per-rotatory phase) or during the stationary period following stopping after rotation (post-rotatory phase). (d, e). Response to a step in surround velocity that induced optokinetic nystagmus (OKN) for 30 s. Note the initial rise and slower rise to a steady state velocity during OKN. At the end of OKN. There was a decrease in slow phase velocity to zero with the time constant of the velocity storage integrator. The model predicts the dominant aspects of both responses (Adapted from Raphan and Cohen, 1996).

velocity command signal,  $y$ . Head velocity and eye velocity  $y_h$  are mechanical signals that summate to give gaze velocity in space  $y_g$ .

The input,  $r_o$ , represents surround velocity relative to space generated by an optokinetic stimulus. Gaze velocity is subtracted from the stimulus velocity, and together with the switch,  $L_s$ , determine the central representation of retinal slip. In light,  $L_s$  is closed and  $e$  is the difference between surround and gaze velocity. In darkness,  $L_s$  is open, and  $e$  is zero. The retinal slip signal couples to the velocity storage integrator with a coupling parameter,  $g_{opt}$ , and contributes to the activation of the state,  $x$  and to  $v_n$ . There is also a contribution to eye velocity,  $y$ , over a direct optokinetic path,  $g_{1opt}$ .

Simulations can be compared to experimental data to demonstrate how the VOR works for steps of both head and surround velocity (Fig. 2b–e). For a step in head velocity of  $r_o = -60^\circ/s$ , the parameter  $g_1$  determines the initial jump in the direct vestibular path (Fig. 2b), which is also the initial jump in eye velocity. Since the cupula dynamics are fixed, the time constant of the integrator,  $1/h_0$ , and the coupling to the integrator  $g_0$  determine the shape of the integrator response, i.e. how fast it rises to a peak, the value of the peak and the time course of the decay (Fig. 2b). There is a plateau in the response, which is either a flattening or a small overshoot in eye velocity. Saturation of the integrator would flatten the plateau, but this has been neglected here for simplicity. The corresponding data from a monkey (Fig. 2c) show that the per- or post-rotatory response (►Nystagmus – per-rotatory vestibular, ►nystagmus – post-rotatory vestibular) to a step in head velocity is predicted accurately.

The response of the model to a step in surround velocity during OKN is shown in Fig. 2d. Eye velocity jumps to an initial value determined by the surround velocity and the direct pathway gain,  $g_{1opt}$ . A signal related to retinal slip causes the integrator to accumulate activity. The rate at which activity is accumulated is dependent on the time constant of the integrator,  $1/h_0$ , and the feedback from eye velocity. As the activity in the integrator builds up, the retinal slip is reduced and the direct pathway contributes less to the response. Thus, when the lights are extinguished at the beginning of OKAN, there is a small drop in eye velocity, which is much less than the initial jump in eye velocity at the start of OKN. In dark, the integrator decays with its characteristic time constant and is expressed as OKAN. Figure 2e shows the OKN and OKAN response of a monkey in response to a step of surround velocity of  $60^\circ/s$ . All of the essential characteristics, i.e. the initial rapid rise, the slow rise to steady state velocity, and the slow decay during OKAN are inherent in the one dimensional optokinetic response and are predicted by the single integrator model of velocity storage.

Identification of the central neural structures that govern the behavior of these parameters can shed light

on how OKN is mediated and has clinical significance. Thus, the model can be used “diagnostically” by identifying differences in the response with parameter modifications in the model in altered states of the system. For example, adaptation has been associated with the parameter  $g_1$  and habituation with the parameter  $1/h_0$ . Effects of lesions of the flocculus and paraflocculus have been modeled by a simple elimination of  $g_{1opt}$  and by defining the nonlinear properties of  $g_{0opt}$ . Similar associations can be made following occipital lobectomies. Lesions of the nodulus and uvula can be modeled as a modification of  $h_0$ . Effects of administration of baclofen, which are associated mainly with  $h_0$  and  $g_{1opt}$ , have also been simulated. The coupling to the integrator  $g_{0opt}$  is likely to be mediated through the nucleus of the optic tract (NOT). This pathway is also an important input to the flocculus and nodulus, which control the direct visual pathway gain and the integrator time constant (See [7,8] for a review). Thus, the modeling of velocity storage and the pathways that interact with it have consolidated our understanding of visual-vestibular interactions.

### Modeling of Velocity Storage in Three Dimension

The three-dimensional characteristics of velocity storage bring into evidence its spatial orientation properties, suggesting that it might function in maintaining body orientation during natural movement [5,6], although the link between velocity storage and maintenance of orientation during walking has not yet been clearly delineated. The spatial orientation of velocity storage is present during optokinetic or vestibular activation, and is present in all mammalian species that have been tested including man, monkey and rabbit. When subjects are upright, so that their yaw or body axis is aligned with gravity (Fig. 2a), vestibular or visual motion about the long axis of the body produce pure horizontal or yaw eye movements (Fig. 2c and e) [5]. Since eye movements are rotations of a globe in the orbit, these are rotations of the eyes around axes that are about the spatial vertical. If subjects are tilted and the visual surround is rotated around the yaw axis of the head (Fig. 3a and e), however, a small vertical or pitch component of eye velocity appears [5,6], and becomes prominent during the OKAN (Fig. 3c and g Dots). The pitch component builds up and decays in conjunction with the decay in yaw eye velocity (Fig. 3b and f). The eye velocity vector follows a curved trajectory, which asymptotically approaches a vector that is along the ►eigenvector and tends to align with the spatial vertical (Fig. 3d and h). This has been modeled by extending the parameter  $h_0$ , for the one dimensional model to a matrix,  $H(L)$ , which is dependent on the linear acceleration,  $L$ , activating the otoliths, and that couples the yaw component of eye velocity to pitch or roll, depending on head position (Fig. 4a). When the head is

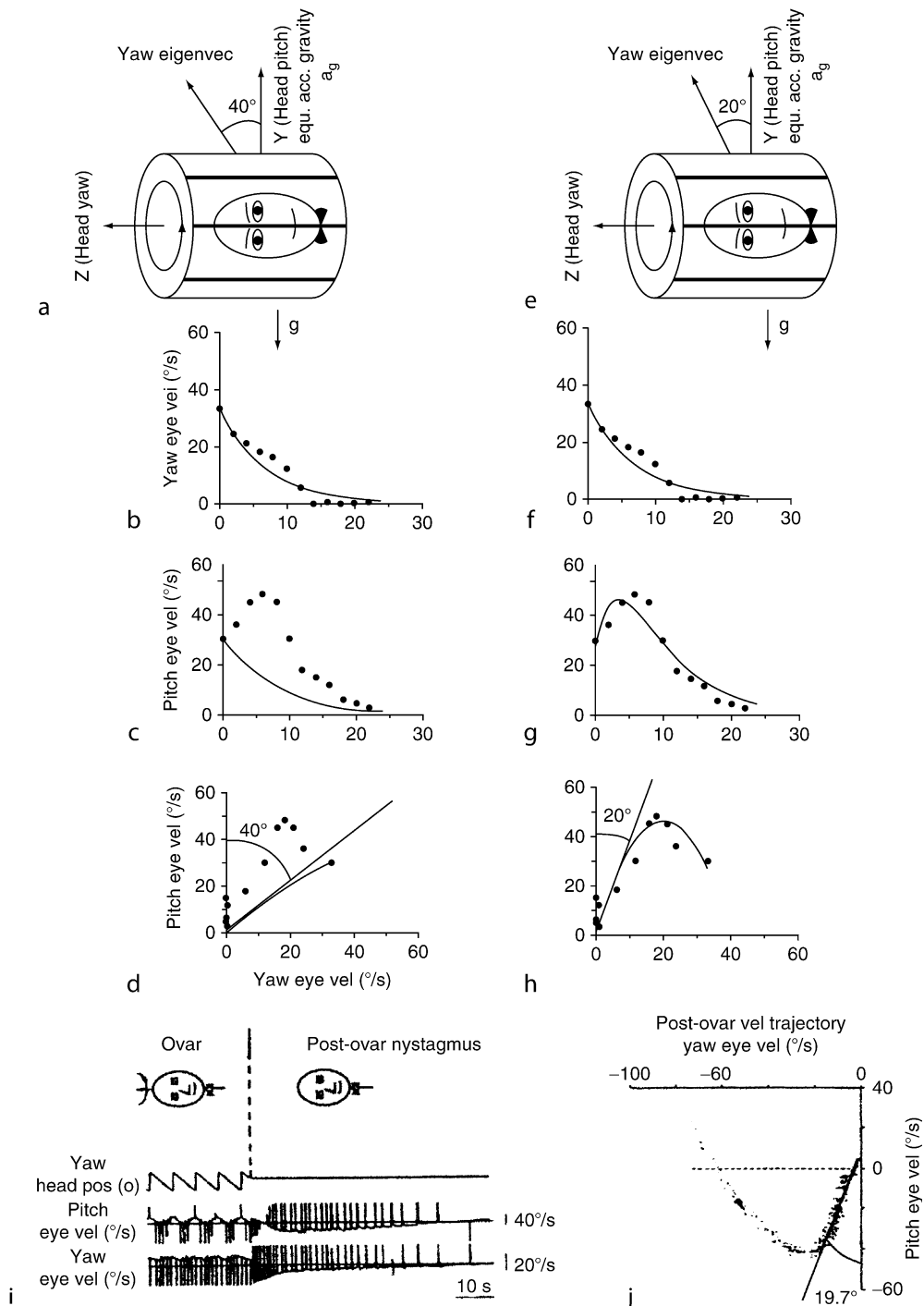

**Velocity Storage. Figure 3** Fits to eye velocity data during OKAN following an OKN stimulus along a monkey's yaw or z axis while tilted right side down. (a) Fit of yaw eye velocity for an eigenvector direction at  $40^\circ$  relative to the spatial vertical (a) and eigenvalues  $h_{22} = -0.2/s$  (Pitch Time Constant = 5 s) and  $h_{33} = -0.133/s$  (Yaw Time Constant = 7.5 s), the yaw velocity vector was fit quite well (b). However, the pitch velocity was fit poorly (c). The trajectory in velocity space also fit the data poorly (d). When the eigenvector direction of the system matrix was changed to  $20^\circ$  (e) and the eigenvalues were kept the same, the data for both horizontal (f) and vertical (g) were fit well. In trajectory space, the data were fit well and asymptotically approached the yaw eigenvector direction. (i) Post OVAR velocity also had cross coupling from yaw to pitch velocity. (j) In trajectory space, the eye velocity had a curved trajectory and asymptotically approached the yaw eigenvector direction (Adapted from Raphan and Sturmfels, 1991; Cohen and Raphan, 2004).

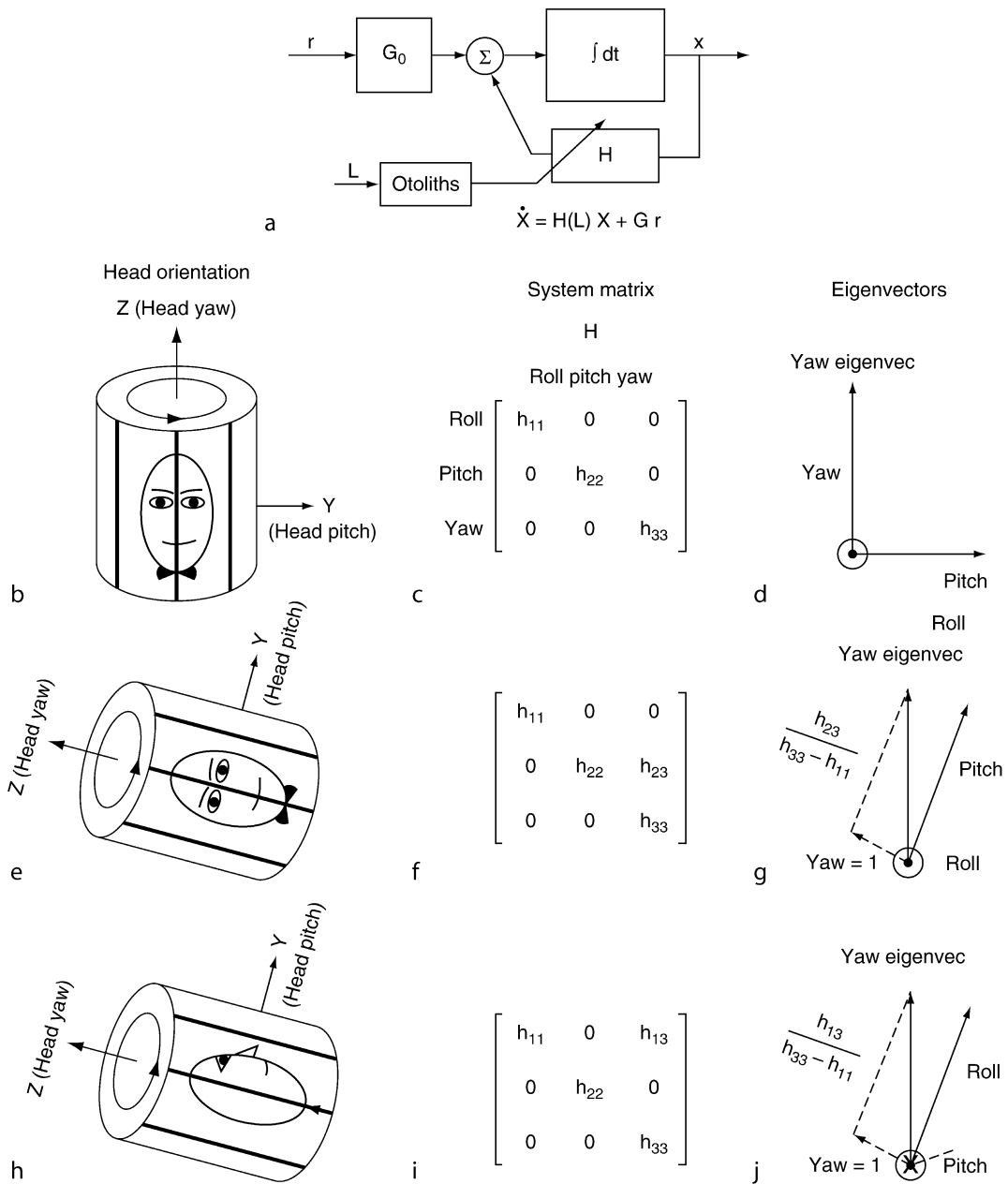

**Velocity Storage. Figure 4** (a) Extension of the integrator model (Fig. 1a) to three dimensions. The inputs ( $r, L$ ) and state ( $X$ ) and the forward gain ( $G_0$ ) and feedback ( $H$ ) are matrices. The state equation is a vector equation and  $H$  is a function of linear acceleration input,  $L$ . For upright orientation (b), the system matrix,  $H$ , is diagonal (c), with no cross-coupling. The yaw eigenvector is along the yaw axis of the head. When the head is tilted side down (e), a yaw-to-pitch cross coupling ( $h_{23}$ ) is introduced that reorients the yaw eigenvector towards the spatial vertical (g). Similarly, when tilted supine (h), a cross-coupling component from yaw to roll,  $h_{13}$ , is introduced into the system matrix that again orients the yaw eigenvector towards the spatial vertical (j) (Adapted from Raphan and Sturm, 1991).

upright (Fig. 4b), there is no coupling from yaw to roll or pitch. The velocity-storage matrix is diagonal (Fig. 4c) and the yaw eigenvector is aligned with the head yaw axis (Fig. 4d). This generates pure yaw OKN-OKAN in response to yaw stimulation. When the head is tilted side down (Fig. 4e), there is coupling from yaw

to pitch, giving rise to the parameter  $h_{23}$  in the system matrix,  $H$  (Fig. 4f), inducing a realignment of the orientation vector with the spatial vertical. When the head is supine (Fig. 4h), the coupling is from yaw to roll, giving rise to the parameter  $h_{13}$  in the system matrix,  $H$  (Fig. 4i) and a concomitant realignment of the

eigenvector towards the spatial vertical (Fig. 4j). An important outcome of this extension of velocity storage to three dimensions was the understanding that velocity storage has an internal representation of the spatial vertical, which governs eye velocity and is represented by the yaw eigenvector or orientation vector. If the surround velocity is along this orientation vector, eye velocity during OKAN decays along it [5,6].

A critical feature of the orientation of the eigenvector is how it contributes to the cross-coupled eye velocity. For example, when the yaw eigenvector is deviated from the spatial vertical by 40° (Fig. 3a), the model predicts the yaw component of eye velocity, but fails to predict the dynamics of the pitch component (Fig. 3c). The trajectory in velocity space is then not fitted accurately (Fig. 4d). On the other hand, when the eigenvector is 20° relative to the spatial vertical (Fig. 4e), the yaw and pitch components of the eye velocity vector are accurately predicted (Fig. 4f and g). The trajectory in velocity space approaches the eigenvector (Fig. 3h). An interesting outcome of this study was that an inverse procedure was developed, whereby the direction of the eigenvector could be estimated from the three-dimensional eye velocity vector [6], and this orientation vector could then be compared to the orientation vector of velocity storage as it is activated from the vestibular system.

As predicted, the same declines along orientation vectors occur during post-rotatory nystagmus (nystagmus – post-rotatory vestibular) when the head is tilted with regard to gravity. Thus, when monkeys are stopped in side down positions after constant velocity rotations during off-vertical axis rotation (OVAR) (Fig. 4i), the post-OVAR eye velocity trajectory approaches the orientation vector established during OKAN (Fig. 4j). This shows that velocity storage is the primary orienting component of velocity in the aVOR. This conclusion is supported by studies utilizing centrifugation as well as by orientation of the eyes to gravity during caloric stimulation in canal-plugged animals (See [7] for review). Thus, the alignment of eye velocity towards the vector sum of the linear accelerations occurs during both vestibular-induced nystagmus and OKN. In both cases, it depends on the spatial orientation of velocity storage.

The spatial orientation of velocity storage is under control of the nodulus and uvula of the vestibulo-cerebellum, and the eyes no longer reorient to the GIA vector when these structures are damaged. Recently, it has been shown that the time constant and orientation properties of velocity storage play a critical role in motion sickness, which is also dependent on the nodulus and uvula [10].

## Conclusion

The work on velocity storage, which was initially conceived to explain OKN and OKAN and the

enhancement of the low frequency characteristics of the aVOR beyond that of the cupula and eighth nerve dynamics, now has the potential of giving us insight into the mechanisms that govern maintenance of spatial orientation during circular walking. Its dynamics and orientation properties and how to control them may also give us insight into the management of motion sickness.

## Acknowledgments

Supported by grants DC05222, EY04148, and Core Center Grant P30 DC05204 from the NIH.

## References

1. Cohen B, Matsuo V, Raphan T (1977) Quantitative analysis of the velocity characteristics of optokinetic nystagmus and optokinetic after-nystagmus. *J Physiol (Lond)* 270:321–344
2. Raphan T, Matsuo V, and Cohen B (1979) Velocity storage in the vestibulo-ocular reflex arc (VOR). *Exp Brain Res* 35:229–248
3. Bles W, Kotaka S (1986) Stepping around: nystagmus, self-motion perception and Coriolis effects. In: Keller EL, Zee DS (eds) *Adaptive processes in visual and oculomotor systems* Pergamon, Oxford, pp 465–471
4. Solomon D, Cohen B (1992) Stabilization of gaze during circular locomotion in darkness; II. Contribution of velocity storage to compensatory eye and head nystagmus in the running monkey. *J Neurophysiol* 67:1158–1170
5. Dai MJ, Raphan T, Cohen B (1991) Spatial orientation of the vestibular system: dependence of optokinetic after nystagmus on gravity. *J Neurophysiol* 66:1422–1438
6. Raphan T, Sturm D (1991) Modelling the spatiotemporal organization of velocity storage in the vestibulo-ocular reflex by optokinetic studies. *J Neurophysiol* 66:1410–1420
7. Raphan T, Cohen B (2002) The vestibulo-ocular reflex (VOR) in three dimensions. *Exp Brain Res* 145:1–27
8. Cohen B, Raphan T (2004) The physiology of the vestibuloocular reflex (VOR). In: Highstein SM, Fay RR, Popper AM (eds) *Springer handbook of auditory research. The Vestibular System*, Springer, pp 235–285
9. Goldberg JM, Fernandez C (1971) Physiology of peripheral neurons innervating semicircular canals of the squirrel monkey. I. Resting discharge and response to angular accelerations. *J Neurophysiol* 34:635–660
10. Dai MJ, Kunin M, Raphan T, Cohen B (2003) The relationship of motion sickness to the spatial-temporal properties of velocity storage. *Exp Brain Res* 151:173–189

## Vent

### Definition

An opening through the hearing aid to allow airflow into the ear.

►Hearing Aids

## Ventral Amygdalofugal Pathway

### Definition

One of the main fiber bundles connecting the amygdala with subcortical brain regions. After leaving the amygdala, these fibers course beneath the globus pallidus to reach the hypothalamus and brainstem.

- ▶ Amygdala

## Ventral Cochlear Nucleus

### Definition

Major division of the cochlear nucleus consisting of the anteroventral cochlear nucleus (AVCN) and the posteroventral cochlear nucleus (PVCN).

- ▶ Cochlear Nucleus

## Ventral Cortical Pathway

### Definition

One of the two prominent components of the retinogeniculo-cortical visual pathway that is dominated by input from midsize retinal ganglion cells, projects through cortical areas including V4 and inferotemporal cortex (IT), and is thought to be crucial for color and form analysis.

- ▶ Color Processing
- ▶ Extrastriate Visual Cortex
- ▶ Form Perception
- ▶ Retinal Ganglion Cells
- ▶ Visual Processing Streams in Primates

## Ventral Plate

- ▶ Floor Plate

## Ventral Respiratory Group

### Definition

A collection of premotor neurons in the region of the nucleus ambiguus that manifest respiratory-related activity and shape the timing and intensity of activation of a variety of respiratory motor neurons.

- ▶ Anatomy and Function in the Respiratory Network

## Ventral Root of the Spinal Nerve

### Synonyms

N. spinalis; Radix ant; Anterior root of the spinal nerve

### Definition

Motor fibers emerge from the spinal cord to the periphery in the ventral root of a spinal nerve.

- ▶ Medulla spinalis

## Ventral Striatopallidum

DANIEL S. ZAHM

Department of Pharmacological and Physiological Science, Saint Louis University School of Medicine, Grand Blvd., Saint Louis, MO, USA

### Synonyms

Ventral striatopallidal system; Ventral parts of the basal ganglia

### Definition

Ventral striatopallidum is a rostroventral extension of the ▶basal ganglia within the ▶basal forebrain that subserves motivational aspects of behavior.

### Characteristics

The concept of ventral striatopallidum emerged during the late 1960s and early 70s when Lennart Heimer, using a combination of superficially limited heat lesions in combination with the Fink–Heimer silver

method for degenerating axon terminals, convincingly demonstrated a ►cortico-basal ganglia-thalamocortical circuit involving the ►piriform (primary olfactory) cortex [1]. Prior to this discovery, the olfactory cortex had been thought to ►project directly to the ►hypothalamus, via terminations in the ►lateral preoptic area and anterolateral hypothalamus. The new findings revealed instead that the olfactory cortex projects to superficial and intermediate layers of the ►olfactory tubercle, which do not return a reciprocal corticocortical projection to the olfactory cortex, as would be expected if the tubercle were a part of the cortical mantle, which at the time was the consensus viewpoint. Rather, the parts of the olfactory tubercle that are densely innervated by the primary olfactory cortex, project to a rostroventral extension of the ►globus pallidus within the basal forebrain and deep parts of the tubercle. Studies of the somatodendritic architecture (size, shape and distinctive characteristics) of neurons in the olfactory tubercle that received inputs from the olfactory cortex revealed that they are identical to those of striatal neurons in the ►caudate nucleus and ►putamen [2]. Likewise, the striatopallidal synaptic relationships established by the ►projections of these olfactory tubercle striatal neurons in what became known as the ►ventral pallidum were identical to those in the globus pallidus [1].

These striatopallidal relations of the olfactory system had been demonstrated so convincingly as to influence thinking on a related structure, the ►nucleus accumbens. Although the intrinsic organization of the nucleus accumbens had for many years been compared favorably to that of the caudate nucleus and putamen [3], the “accumbens” had never been regarded formally as a part of the basal ganglia and indeed was instead lumped with the ►limbic system. However, realization that the massive projection from the nucleus accumbens to the ventral pallidum utilizes synaptic differentiations identical to those of striatopallidal terminations in the globus pallidus [4] cemented the conclusion that the nucleus accumbens and its termination field in the ventral pallidum, like the striatopallidal districts in the olfactory tubercle, are bona fide basal ganglia structures in terms of intrinsic organization and extrinsic connectivity. Together, the accumbens, striatal parts of olfactory tubercle and ventral pallidum substantially expanded the territories within the forebrain that can be regarded as occupied by basal ganglia and, simultaneously, reduced the amount of basal forebrain territory long known as ►substantia innominata due to the undetermined nature of its organization. More significantly, the identification of these functional-neuroanatomical relationships indicated that the entire cerebral cortex, including the olfactory cortex and ►hippocampus, is subserved by basal ganglia mechanisms. Thus, just as the caudate nucleus and putamen, collectively referred to as ►dorsal striatum,

receive massive inputs from the neocortex and a number of subcortical structures, such as ►midline-intralaminar thalamic nuclei and dopaminergic neurons in the ►substantia nigra pars compacta, so the ventral striatum receives massive projections from ►allocortex, including the hippocampus and ►orbitofrontal cortex and subcortical projections from thalamic midline-intralaminar nuclei and dopaminergic neurons in the ►mesencephalic ventral tegmental area. The nuclei of the ►basal complex of the amygdala, which have been widely regarded as cortical-like in terms of their connectional and intrinsic organization, also project massively to ventral striatum. Just as the caudate nucleus and putamen project via massive “striatopallidal” projections to the globus pallidus, so ventral striatum projects massively, via “ventral striatopallidal” projections, to the ventral pallidum.

Furthermore, the dorsal and ventral parts of the basal ganglia exhibit fundamentally similar outputs to [1] the cortex, via the thalamus and [2] motor effector sites in the brainstem. The “reentrant” pathway to the cortex belonging to the dorsal striatopallidum originates in the medial segment of the globus pallidus, which, via a synaptic relay in the rostroventral thalamus, projects to ►premotor and ►supplemental motor cortex [5]. Ventral pallidum projects to frontal association cortex via a synaptic relay in the ►mediodorsal nucleus of the thalamus [6]. Thus, reentrant pathways associated with dorsal and ventral striatopallidum were regarded from their inception [4] as parallel, segregated circuits through the basal ganglia (Fig. 1), a concept that has been further refined and popularized in the ensuing years (see essay on Striatopallidum). Descending outputs from dorsal and ventral striatopallidum terminate in the ventral mesencephalon and ►mesopontine tegmentum [5,7].

Despite the conformance of both dorsal and ventral striatopallidum to a fundamental pattern of organization, these two major divisions or territories of the basal ganglia nonetheless also differ significantly in certain aspects of neurochemical composition, intrinsic structure and extrinsic connections. Generally speaking, such differences relate to the abundance and diversity of classical and peptidergic neurotransmitter/neuromodulators and their receptors and less apparent compartmentalization of ventral striatopallidal organizational features as compared to dorsal striatopallidum.

One example of this involves the chemospecificity and connectional specificity of striatal ►medium spiny neurons (MSNs), which in the dorsal striatum fall into two distinct, approximately equivalently sized categories [9]. The MSNs comprising one of these groups express dopamine D-1 receptors and the neuropeptides ►substance P and ►dynorphin and project prominently to the medial segment of the globus pallidus and substantia nigra reticulata, which, because they emit the characteristic dorsal striatopallidal outputs – to

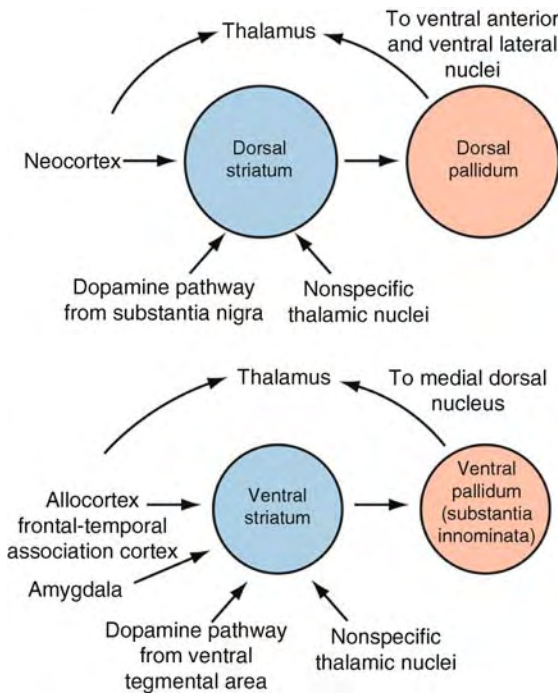

**Ventral Striatopallidum. Figure 1** Modification of figure first published in Heimer and Wilson [4] illustrating the parallel, segregated character of cortico-basal ganglia-thalamocortical pathways traversing dorsal (*above*) and ventral (*below*) striatopallidum (further modified from [8] with permission).

the ►thalamus and ►brainstem as noted above – are recognized as basal ganglia “output nuclei.” These MSNs are said to give rise to a “direct” pathway to the output nuclei. The remaining MSNs express dopamine D-2 receptors and the neuropeptide ►enkephalin and project to the lateral segment of the globus pallidus, which in turn utilizes a synaptic relay in the ►subthalamic nucleus to reach the output nuclei by an “indirect” pathway. Dense accumulations of dynorphin and substance P versus enkephalin characterize the terminations of these pathways in the output nuclei and lateral pallidal segment respectively. In ventral striatum, D-1 and D-2 dopamine receptors and these peptides are not obviously segregated in subpopulations of MSNs and are associated poorly if at all with direct and indirect pathways. Consequently, substance P, dynorphin and enkephalin are distributed coextensively throughout the ventral pallidum [10].

Another form of neurochemical and connective compartmentalization observed in dorsal, but not ventral, striatum involves ►opioid receptor rich, ►acetylcholinesterase poor figures (called patches or striosomes), which in sectioned material are dispersed, island-like, within an acetylcholinesterase rich, mu

opiate receptor poor matrix [9]. A variety of other neurochemical markers, such as a number of neuropeptide and calcium binding protein immunoreactivities, also conform to the patch-matrix pattern, but it is not characterized by obvious structural heterogeneity, such as might involve different sizes or clustering of neurons. In the ventral striatum, the patch-matrix pattern is absent, but heterogeneous clusters of MSNs sometimes associated with elevated expression of opioid receptors or other neurochemical markers are present [9]. In addition to the clustering of MSNs, a variety of other medium and small types of neurons form clusters in ventral, but not dorsal, striatopallidum. The connective relationships and functional significance of these “small celled islands,” which are conspicuous in the olfactory tubercle, are largely unknown.

The accumbens part of the ventral striatum exhibits distinctive subterritories, designated as accumbens core and shell, which are characterized by different patterns of afferent and efferent connections and preferential distributions of various neurochemical markers, such as calcium binding proteins and neuropeptides and neurotransmitters and their receptors and transporters [10]. The core of the accumbens, which is directly continuous with the overlying dorsal striatum, has connections that much resemble those of the dorsal striatum. The shell, which wraps around the medial, ventral and lateral aspects of the core, is characterized by robust connections with the lateral hypothalamus that must be regarded as anomalous by the standard of the rest of the striatal complex.

Ventral striatopallidum appears to be an integral component of the “reward” system of the brain. Its functions are inextricably linked to the actions of dopamine released by the dense “mesolimbic” dopaminergic innervation, which arises from dopaminergic neurons located in the mesencephalic ventral tegmental area. Circumstances associated with increased activation of dopaminergic neurons and elevated extracellular concentrations of dopamine in the ventral striatum, particularly the accumbens, are accompanied by increased locomotion and positive modulation of ►affect, whereas reductions in dopamine neuron activation and decreased extracellular concentrations of ventral striatal dopamine are associated with ►bradykinesia and ►anhedonia. Ventral striatal dopamine release appears to be necessary for ►Pavlovian conditioning and the establishment of learned ►instrumental responses, i.e., actions that lead to the acquisition of ►reinforcement, i.e., ►reward. The capacity of ventral striatal dopamine release to “stamp-in” behavior that culminates in reinforcement leads to the idea that the ventral striatum is involved in processes subserving memory consolidation. Much evidence indicates that the medial parts of the accumbens and olfactory tubercle, including the medial accumbens shell, contribute more to the



affective and drive components of motivated behaviors, while the lateral parts, including the core of the accumbens, are involved in processes through which environmental cues come to guide actions so as to achieve the dictates of such drives.

## References

- 1 Heimer L (1972) The olfactory connections of the diencephalon in the rat. An experimental light- and electron-microscopic study with special emphasis on the problem of terminal degeneration. *Brain Behav Evol* 6:484–523
- 2 Millhouse OE, Heimer L (1984) Cell configurations in the olfactory tubercle of the rat. *J Comp Neurol* 228:571–597
- 3 Chronister RB, DeFrance JF (1980) Nucleus accumbens in historical perspective. In: Chronister RB, DeFrance JF (eds) *The neurobiology of the nucleus accumbens*. Hair Institute for Electrophysiological Research, pp 1–6
- 4 Heimer L, Wilson RD (1975) The subcortical projections of allocortex: similarities in the neuronal associations of the hippocampus, the piriform cortex and the neocortex. In: Santini M (ed) *Golgi centennial symposium proceedings*, Raven, New York, pp 173–193
- 5 Nauta WJH, Mehler WR (1966) Projections of the lentiform nucleus in the monkey. *Brain Res* 1:3–42
- 6 Young WS III, Alheid GF, Heimer L (1984) The ventral pallidal projection to the mediodorsal thalamus: a study with fluorescent retrograde tracers and immunohisto-fluorescence. *J Neurosci* 4:1626–1638
- 7 Groenewegen HJ, Berendse HW, Haber SN (1993) Organization of the output of the ventral striatopallidal system in the rat: ventral pallidal efferents. *Neurosci* 57: 113–142
- 8 Heimer L (2003) A new anatomical framework for neuropsychiatric disorders and drug abuse. *Am J Psychiatry* 160:1726–1739
- 9 Gerfen CR (1992) The neostriatal mosaic: multiple levels of compartmental organization. *Trends Neurosci* 15:133–139
- 10 Heimer L, Zahm DS, Alheid GF (1995) Basal Ganglia. In: Paxinos G (ed) *The rat nervous system*, 2nd edn. Academic, San Diego, pp 579–628

without detectable boundaries with the formations of dopaminergic neurons in the substantia nigra pars compacta and retrorubral field respectively. The dopaminergic neurons in all of these formations are intermingled with other neuronal types, particularly expressing  $\gamma$ -amino butyric acid (GABA) and glutamate as transmitters. The ventral tegmental area gives rise to the mesocorticolimbic system, comprising largely dopaminergic, but also GABAergic and glutamatergic, projections to a number of basal forebrain structures, including ventral striatopallidum, extended amygdala, basal amygdala, septum, the magnocellular basal forebrain system and orbitofrontal cortex.

- ▶ Dopamine
- ▶ Ventral Striatopallidum

## Ventral Thalamic Nuclei

### Synonyms

Nuclei ventrales thalami; Ventral nuclei of thalamus

### Definition

The ventral nuclear group of the thalamus is composed of four nuclei. Whereas the ventral anterior nucleus and ventral lateral nucleus are integrated in the somatomotor control system, the ventral posterior nucleus is the main thoroughfare for all somatosensory information on its way to the cerebral cortex. The ventral posterolateral thalamic nucleus conveys protopathic and epicritic information from the trigeminal complex, the ventral posteromedial nucleus from the spinal cord.

- ▶ Diencephalon

## Ventral Tegmental Area, Mesencephalic

### Definition

The mediobasal part of the ventral mesencephalon which contains a substantial portion of the neurons that give rise to the ascending dopaminergic projection system. The formation of dopaminergic neurons in the ventral tegmental area merges laterally and caudolaterally

## Ventricular System

### Definition

A system of interconnected chambers and channels within the central nervous system that are filled with cerebral spinal fluid.

- ▶ Meninges & Cisterns

## Ventricular Zone

A pseudo-stratified mitotic compartment lining the ventricle. Radial glial cells divide in this region.

► Evolution and Embryological Development of the Cortex in Amniotes

## Ventriculitis

### Definition

Inflammation of a ventricle, especially of a ventricle of the brain.

## Ventriloquist Effect

### Definition

Ventriloquist effect denotes the subjective impression of an observer that the ventriloquist's puppet speaks rather than the ventriloquist, evoked by the strong cross-modal interaction between vision and audition.

► Audition (Hearing)  
► Vision

## Ventrolateral Funiculus

### Definition

In the spinal cord, an area of white matter in which many of the nociceptive ascending pathways travel.

► Ascending Nociceptive Pathways

## Ventrolateral Medullary Reticular Formation

### Definition

The ventrolateral medullary formation is that portion of the medullary reticular formation containing neurons

that control sympathetic vasomotor tone, cardiac function, respiration, and endocrine function. Neurons in the rostral ventrolateral medullary reticular formation provide the major tonic excitatory input to the sympathetic preganglionic vasomotor neurons and mediate most descending and reflex influences controlling arterial pressure.

► Central Regulation of Autonomic Function  
► Sympathetic Pathways

## Ventrolateral Preoptic Nucleus

MATT CARTER, LUIS DE LECEA

Department of Psychiatry and Behavioral Sciences, Stanford University School of Medicine, Palo Alto, CA, USA

### Synonyms

VLPO

### Definition

A region of the mammalian brain thought to play a major role in the promotion of sleep.

The ventrolateral preoptic nucleus (VLPO) is a region of the mammalian hypothalamus thought to play a major role in the promotion of sleep [1–3]. Many studies have used a variety of anatomical, pharmacological, and electrophysiological techniques to demonstrate that the VLPO is mostly active during sleep, is necessary for normal sleep, and works primarily by inhibiting other subcortical areas of the brain that promote arousal. Here, we summarize the current state of knowledge about the VLPO and its role in the regulation of the ► sleep/wake cycle.

### Characteristics

#### Anatomy

The VLPO is a subdivision of the lateral preoptic area (LPOA) located in the anterior hypothalamus. To date, the VLPO has been studied almost exclusively in rats, where the volume of cells is roughly 600  $\mu\text{m}^3$  in diameter [2]. The VLPO can be further anatomically and functionally subdivided into a dense cluster of neurons (VLPOc) and a more diffuse, extended component (VLPOe) [3]. Neurons in the VLPO are multipolar and have a characteristic triangular shape with three primary dendrites [4]. Over 90% of VLPO neurons express the inhibitory ► neuropeptide galanin, as well as the GABA biosynthetic enzymes GAD65 and GAD67 [4]. Thus,

the galaninergic and GABAergic outputs of the VLPO to other brain regions are inhibitory.

### Connectivity

The VLPO forms major reciprocal, inhibitory connections with other regions of the brain that promote the awake state. This includes the monoaminergic nuclei that maintain arousal, such as the histaminergic ▶**tuberomammillary nucleus** (▶**TMN**), the serotonergic dorsal and median ▶**raphe** nuclei, and the noradrenergic ▶**locus coeruleus** (LC) [5–7]. Anatomically, the VLPOc projects most heavily to the TMN, while the VLPOe projects to the raphe nuclei and LC. The VLPO also sends inhibitory projections to the cholinergic pedunculopontine (PPT) and laterodorsal tegmental nuclei (LDT), as well as the ▶**hypocretin**-containing neurons in the lateral hypothalamus (LH). Because all of these brain regions play a major role in promoting and maintaining wakefulness, inhibitory projections from the VLPO are hypothesized to promote sleep by decreasing their excitation of other brain regions.

These wake-promoting brain regions also send inhibitory projections to VLPO neurons [7]. VLPO neurons are inhibited by acetylcholine (ACh) and norepinephrine (NE) outputs from the PPT/LDT and LC, respectively. Although the TMN inhibits VLPO neurons, histamine does not affect VLPO activity. However, the TMN also contains GABA, galanin, and endomorphin, all of which may be inhibitory to VLPO neurons. Interestingly, serotonergic projections from the raphe nuclei have different effects on different VLPO neurons [8]. Roughly half of VLPO neurons are inhibited by ▶**serotonin**, referred to as Type I neurons, while the other half, Type II neurons, are excited. Different serotonin receptors are located on these two distinct cell types, revealing the probable mechanism by which serotonin causes these opposite effects.

The VLPO also receives projections from multiple other brain areas that are involved in the circadian, homeostatic, and metabolic drive for sleep [7]. For example, the VLPO receives projections from the ▶**suprachiasmatic nucleus** (▶**SCN**), the mammalian ▶**circadian pacemaker**. The VLPO also receives substantial GABAergic projections from the dorsomedial hypothalamus (DMH), a region of the body that integrates information about food intake and organismal homeostasis from visceral sensory inputs, cognitive information from the prefrontal cortex, and emotional information from the limbic system.

### Pharmacology

As mentioned above, VLPO neurons are inhibited by ACh, NE, and are differentially excited/inhibited by serotonin. Some wake-promoting drugs work, at least in part, by perturbing inputs to the VLPO [1].

For example, the wake-promoting drug modafinil blocks the reuptake of noradrenaline at noradrenergic terminals on VLPO neurons. The stimulant nicotine also enhances the noradrenergic inhibition of VLPO neurons. VLPO neurons are also affected by endogenous somnogens [1]. For example, adenosine reduces the inhibition of VLPO neurons through the A<sub>1</sub>R receptor and directly excites Type II neurons through the A<sub>2a</sub>R receptor. Prostaglandin D<sub>2</sub>, a well-characterized somnogen, indirectly excites VLPO neurons. Many sleep-promoting drugs, such as barbiturates, benzodiazepines, chloral hydrate, ethanol, and most gaseous anesthetics, may enhance the GABAergic projections of VLPO neurons to arousal-promoting nuclei by enhancing the action of GABA at their receptors. Additionally, the sleep-promoting drug Gaboxadol has been shown to increase expression of the immediate early gene *c-fos* in VLPO neurons.

### Hypothesized Role in Promoting Sleep

Recent studies support the idea of the VLPO as a key sleep-promoting center in the brain. As mentioned above, the VLPO sends inhibitory projections to all of the major nuclei in the ▶**brainstem** and hypothalamus that promote arousal. Thus, activation of the VLPO suppresses the wake-promoting properties of these activating systems. Furthermore, VLPO neurons are primarily active during sleep. Electrophysiological recordings of VLPO neurons across wake- ▶**sleep states** show that these neurons fire twice as much during sleep as during wakefulness [9]. Animals sleeping prior to sacrifice show an increased expression of the immediate early gene *c-fos*, a marker of neural activity, within the VLPO [3]. The intensity of Fos staining in the VLPO correlates with the amount of sleep prior to sacrifice. Little Fos staining occurs in rats prior to sleep, even in sleep-deprived rats, suggesting that VLPO neurons are active during sleep but that this activity does not build up to cause homeostatic pressure to produce sleep. Interestingly, expression of Fos in the VLPOc appears to correlate with the amount of non-REM sleep while expression of Fos in the VLPOe correlates with REM sleep [6].

These correlational studies are further supported by lesion studies in rats in which physical ablation of the VLPOc was found to cause deficits in ▶**non-REM sleep** while ablation of the VLPOe caused deficits in ▶**REM sleep** [5]. Animals with lesions to the entire VLPO region show much more frequent transitions between sleep and wakefulness, with up to 60% loss of total sleep and profound ▶**insomnia** [1,5]. These loss-of-function studies demonstrate that the VLPO is necessary for normal sleep/wake patterns. Future studies in which neural activity in the VLPO is artificially stimulated will demonstrate the sufficiency of the VLPO to cause transitions from the awake state to the sleep state.

The inhibitory, reciprocal connections between the VLPO and other arousal-promoting nuclei establish a model of sleep regulation that seeks to explain why sleep is an all-or-none event (either an organism is asleep or it is not) [1,10]. In the model, when VLPO neurons are active during sleep, they actively inhibit the arousal promoting nuclei. Thus, the VLPO neurons also relieve their own inhibition. When arousal-promoting nuclei are active during waking states, they actively inhibit the VLPO, additionally relieving their inhibition. Thus, activity in one competing side in the sleep circuit decreases inhibitory outputs from the other side, disinhibiting its own action. This “flip/flop” circuit model may explain why there is virtually no intermediate transition state from sleep to wakefulness (and vice versa), and why these transitions are so abrupt. Interestingly, many arousal-promoting nuclei sit at one end of this model circuit (LC, TMN, LH, raphe nuclei, etc.), whereas the VLPO and the median preoptic area are, to date, the only known subcortical sleep-promoting centers.

## References

1. Saper CB, Scammell TE, Lu J (2005) Hypothalamic regulation of sleep and circadian rhythms. *Nature* 437:1257–1264
2. Sherin JE, Shiromani PH, McCarley RW, Saper CB (1996) Activation of ventrolateral preoptic neurons during sleep. *Science* 271:216–219
3. Gaus SE, Strecker RE, Tate BA, Parker RA, Saper CB (2002) Ventrolateral preoptic nucleus contains sleep-active, galaninergic neurons in multiple mammalian species. *Neuroscience* 115:285–294
4. Gallopin T, Fort P, Eggermann E, Cauli B, Luppi PH, Rossier H, Audinat E, Muhlethaler M, Serafin M (2000) Identification of sleep-promoting neurons *in vitro*. *Nature* 404:992–995
5. Lu J, Greco MA, Shiromani P, Saper CB (2000) Effect of lesions of the ventrolateral preoptic nucleus on NREM and REM sleep. *J Neurosci* 20:3830–3842
6. Lu J, Bjorkum AA, Xu M, Gaus SE, Shiromani PH, Saper CB (2002) Selective activation of the extended ventrolateral preoptic nucleus during rapid eye movement sleep. *J Neurosci* 22:4568–4576
7. Chou TC, Bjorkum AA, Gaus SE, Lu J, Scammell TE, Saper CB (2002) Afferents to the ventrolateral preoptic nucleus 22:977–990
8. Gallopin T, Cauli B, Luppi PH, Rossier J, Lambolez B, Fort P (2002) Serotonin modulation reveals two types of sleep-promoting neurons in the ventrolateral preoptic nucleus. *FENS Abstr* 1:024–13
9. Szymusiak R, Alam N, Steininger TL, McGinty D (1998) Sleep-waking discharge patterns of ventrolateral preoptic/ anterior hypothalamic neurons in rats. *Brain Res.* 803:178–188
10. Lu J, Sherman D, Devor M, Saper CB (2006) A putative flip-flop switch for control of REM sleep. *Nature* 441:589–594

## Ventromedial Hypothalamic Syndrome

### Definition

Fits of rage, emotional lability, hyperphagia with obesity and intellectual deterioration due to an hypothalamic tumor.

► Neuroendocrinology of Tumors

## Verbal Memory

ITARU F. TATSUMI<sup>1</sup>, MASUMI WATANABE<sup>2</sup>

<sup>1</sup>LD/Dyslexia Centre, Chiba, Japan

<sup>2</sup>Department of Speech, Language and Hearing Sciences, Niigata University of Health and Welfare, Niigata, Japan

### Definition

Verbal memory is a rather broad concept that refers to memory for verbally presented information. There are a variety of tasks for measuring verbal memory capability, including learning of word lists, story recall (or logical memory), and learning of sequences of paired words. In list learning, the subject is required to recall an auditorily presented word list immediately or several minutes after the list presentation. The former recall condition is referred to as “immediate recall” and the latter as “delayed recall.” With story recall, the subject listens to a short story and is asked to tell anything about the story under immediate and delayed (usually 30 min) recall conditions. In paired word learning, a sequence of word pairs is presented and recall of the second word of each pair is demanded when the tester utters each of the first words. As these tasks suggest, verbal memory primarily indicates acquisition or registration of memory for spoken materials.

### Characteristics

#### Acquisition of Verbal Information

#### Verbal Memory is Classified as Episodic Memory

Current memory theory classifies long-term memory into declarative and non-declarative types [1,2]. Declarative memory is further divided into episodic and semantic memory. Episodic memory is memory of events or personal experiences, so one can identify when and where his or her episodes happened. Verbal memory falls into this category. A brain mechanism that closely associates with episodic memory is the medial

temporal cortex including the hippocampus. The left medial temporal cortex is specialized for memory for verbal information, and the right medial temporal cortex for memory for visuospatial information [3].

The medial temporal region works as a hub for episodic memory, but presumably does not include memory content which is stored elsewhere in the brain. As medial temporal cortices contribute to consolidate episodic memory, damage to these areas results in the severe memory impairment referred to as “amnesia.” People who suffer from amnesia are unable to acquire memory for events that occurred after the onset of amnesia. This is known as “anterograde amnesia.” They also cannot remember events which arose in the period of several years before the onset (partial “retrograde amnesia”), since the medial temporal areas are assumed to participate in retrieval of episodic memory during that period. But they are able to recall older memory before this period. Amnesic patients generally have not only anterograde but also partial retrograde amnesia. Function of other memory (semantic memory, short-term memory and non-declarative memory) and cognitive abilities are preserved in (pure) amnesia.

### **Verbal Memory Reflects Left Hemisphere Function**

As mentioned in its definition, verbal memory is a catch-all concept referring to memory for verbally given information, and more specifically acquisition of episodic memory. There are a wide range of tasks used to evaluate verbal memory ability. In studies that deal with verbal memory, multiple tasks on memory, perception and cognition are generally conducted at the same time: visuospatial perception and memory, short-term memory, procedural memory, verbal fluency, orientation and so on. This enables researchers to find out characteristic profiles of performances on the tasks for, e.g. brain-damaged and normal aged people, and to gain a clue to estimate brain functions. It is well confirmed that the left hemisphere processes verbal information and the right hemisphere visuospatial information. Deficient verbal memory is a sign of anomaly in the left hemisphere or the left medial temporal cortex, and decreased nonverbal visuospatial memory implies damage to the right medial temporal region [3].

### **Retrieval of Semantics and Lexical Information in Word Finding**

What we often observe in daily life concerning memory for verbal information is word-finding difficulty, otherwise known as the “tip of the tongue (TOT) phenomenon.” This may happen in such situations as when you suddenly meet an old friend. You can immediately identify who he or she is, but often cannot remember his/her name quickly. Occasions of encountering this difficulty gradually increase as one gets older. Finding people’s proper names (e.g. Salinger,

Mozart) is more difficult than finding common nouns (e.g. rye, flute) in both young and aged people [4].

The term “word finding” means that, based on word semantics, the mental lexicon is accessed to retrieve word information necessary to utter the word in question. The mental lexicon is assumed to be a memory store for syntactic, morphological, and phonological information of words which was acquired in past years, which contrasts with verbal memory for just-acquired episodes (events, word list, short story, etc.). As such, the mental lexicon is a member of neither verbal memory nor episodic memory. Since, however, access to or retrieval from semantic memory (see below) and the mental lexicon is a topic central to human memory, let us take a brief look at how a word is found in the brain.

### **Word-Finding Difficulty and Semantics**

► **Anomia**, which is synonymous with word-finding difficulty, is widely seen in pathological cases like aphasia, Alzheimer’s disease, semantic dementia, and herpes simplex virus encephalitis (HSVE or HSE). Semantic dementia results from progressive but circumscribed degeneration of the inferolateral anterior temporal lobe bilaterally (left-side atrophy is usually prominent) [5,6], beginning from the anterior temporal cortex and extending posteriorly with the medial region being disproportionately retained [7].

Patients with semantic dementia reveal a profound semantic memory loss. Semantic memory refers to the memory for facts and general knowledge, including word meanings. In picture naming, the concept or meaning represented by the picture is activated in the semantic memory, and the activation, in turn, transmits to the phonological form of the word relevant to the concept. Accordingly, semantic memory loss engenders naming difficulty.

In semantic dementia, episodic memory is disproportionately well preserved. Deficient semantic memory and retained episodic memory in semantic dementia are in sharp contrast with preserved semantic memory with defective episodic memory in amnesia. In neuropsychology such contrast is called “double dissociation.” The dissociation suggests that episodic and semantic memory are independent, and furthermore that the medial temporal region responsible for episodic memory and the inferolateral temporal region responsible for semantic memory have separate functions.

### **Category-Specific Naming Deficits in HSVE**

Patients recovering from HSVE exhibit a special semantic memory impairment known as “category-specific semantic deficits,” in which memory loss is observed for specific semantic categories (e.g. living things, mainly animals) with relatively spared semantics for inanimate objects (e.g. knife, bicycle) [8,9]. Since word finding as in picture naming, or retrieval of word phonology from

the mental lexicon, is based on semantics of the word to be uttered, this particular semantic memory loss results in ► **category-specific naming deficits**, i.e. deficient naming for living things with spared naming for inanimate things. Curiously, the reverse profile of naming or semantic impairments, i.e. better naming for living than for non-living objects, is rare. Brain lesions in patients recovering from HSVE are usually found in the bilateral temporal cortices, including the anterior and medial temporal regions.

### **Anomia in Aphasia**

Aphasia designates language impairment caused by brain damage to language-related areas (usually in the left hemisphere). Several subtypes exist: for example, Broca's aphasia, Wernicke's aphasia, conduction aphasia, transcortical sensory and motor aphasia, and ► **amnesic aphasia**, each showing distinctive speech and language deficits. Anomia is ubiquitous in almost all aphasic patients irrespective of their subtypes. Aphasia whose language disorder is unnoticeable except for anomia is called "amnesic or anomic aphasia."

Anomia refers to a retrieval problem for nouns, but it is also found for other grammatical word classes. Interestingly, there is a tendency that patients with non-fluent aphasia such as Broca's aphasia who may show deficient syntactic ability (agrammatism) have more difficulty with verb recall than noun recall. Contrarily, patients with fluent aphasia such as amnesic and Wernicke's aphasia exhibit the reverse.

Underlying mechanisms of anomia in aphasia are thought to be caused by impairment (i) in word semantics as in semantic dementia, or (ii) in retrieval of word phonology from the mental lexicon due to disconnection between semantics and word phonology [10]. Episodic memory in aphasic patients is well preserved even in "amnesic" aphasia.

### **References**

1. Squire LR (1987) *Memory and brain*. Oxford University Press, New York
2. Tulving E (1983) *Elements of episodic memory*. Clarendon Press, Oxford
3. Scoville WB, Milner B (1957) Loss of recent memory after bilateral hippocampal lesions. *J Neurol Neurosurg Psychiatry* 20(1):11–21
4. Tatsumi IF, Senda M, Ishii K, Mishina M, Oyama M, Toyama H, Oda K, Tanaka M, Gondo Y (2000) Brain regions responsible for word retrieval, speech production and deficient word-fluency in elderly people: A PET activation study. *Proc ICSLP 2000* 2:5–10
5. Snowden JS, Goulding PJ, Neary D (1989) Semantic dementia: a form of circumscribed cerebral atrophy. *Behav Neurol* 2:167–182
6. Hodges JR, Patterson K, Oxbury S, Funnell E (1992) Semantic dementia: Progressive fluent aphasia with temporal lobe atrophy. *Brain* 115:1783–1806

7. Mummery CJ, Patterson K, Price CJ, Ashburner J, Frackowiak RS, Hodges JR (2000) A voxel-based morphometry study of semantic dementia: relationship between temporal lobe atrophy and semantic memory. *Ann Neurol* 47(1):36–45
8. Warrington EK, McCarthy R (1983) Category specific access dysphasia. *Brain* 106:859–878
9. Caramazza A, Mahon BZ (2003) The organization of conceptual knowledge: the evidence from category-specific semantic deficits. *TRENDS Cog Sci* 7(8): 354–361
10. Nickels L (2003) Rehabilitation of Spoken Word Production in Aphasia. *Aphasiology* 16 (10 and 11):935–979

---

## **Vergence Eye Movements**

### **Definition**

Vergence eye movements rotate the lines of sight of the two eyes by the same amount but in opposite directions (mostly horizontal) in order to maintain binocular fusion during changes in viewing distance. They are driven by binocular disparity and by blur from inappropriate accommodation (defocused retinal image). Vergence movements are generally slow but can considerably speed up when occurring in conjunction with saccades.

### ► **Binocular Vision**

---

## **Vergence Neurons**

### ► **Near Response Neurons**

---

## **Verification Criterion**

### ► **Meaning (Verification Theory)**

---

## **Verification Principle**

### ► **Meaning (Verification Theory)**

## Verification Theory of Meaning

### Definition

The view that the meaning of every non-analytic statement consists in the conditions of its verification. Two empirical statements have the same meaning, according to this view, if and only if they can be verified under exactly the same conditions.

- ▶ Behaviorism
- ▶ Logical

## Verificationism

- ▶ Meaning (Verification Theory)

## Verificationist Theory of Meaning

- ▶ Meaning (Verification Theory)

## Vermilion

### Definition

Red portion of the lip, bordered by hairy skin extraorally, and oral mucosa intraorally.

## Vermis Cerebelli

### Synonyms

Vermis of cerebellum (I–X)

### Definition

Vermis cerebelli is the name given to the entire middle region between the two cerebellar hemispheres. It receives its afferents from the spinocerebellar tracts and is thus also called the spinocerebellum. Some of its

efferents (from zone A) course via the fastigial nucleus to the thalamus and to the vestibular nucleus. Another part (from zone B) passes without synapsing to the lateral vestibular nuclei.

- ▶ Cerebellum

## Versican

### Definition

Versican is a chondroitin sulfate proteoglycan (q.v.). It is found as three splice variants, V0, V1, V2. As with many chondroitin sulfate proteoglycans it is inhibitory to axon regeneration. In the adult central nervous system it is found in the general extracellular matrix and in perineuronal nets, the main form being V2 made by oligodendrocyte lineage cells. During development all the splice variants are produced in several parts of the developing embryo.

## Version

### Definition

Conjugate eye movement.

## Vertebra

### Definition

One of the bony rings that makes up the spinal or vertebral column.

- ▶ Evolution of the Spinal Cord

## Vertebrates

### Definition

Animals with a spinal column (back bone), i.e., fish, amphibians, reptiles, birds, mammals.

## Verticality Perception

ADOLFO M. BRONSTEIN

Imperial College London, Charing Cross Hospital,  
London, UK

### Synonyms

Perception of uprightness; Sense of uprightness; Perception of verticality; Feeling or sense of what's up and what's down; Gravity perception; Gravitception

### Definition

The perception of verticality is the multi-sensory mediated sense that allows human beings to accurately ascertain what is up and what is down and deviations thereof, in a gravitational field.

### Description of the Theory

► **Gravity** has provided a formidable evolutionary drive for postural and locomotor mechanisms, as life on earth demands a permanent battle with the gravitational force. How verticality is perceived influences how standing and moving are carried out, but the intimate link between gravitational perception and action has not been fully elucidated yet. Apart from any theoretical interest, this field has practical implications in clinical medicine and aerospace exploration.

Although even the simplest organisms are able to orient with respect to gravity, vertebrates have developed complex sensory systems capable of detecting this ubiquitous force. Since according to the Relativity Theory there is no conceptual distinction between linear acceleration and gravity, the problem that organisms face is how to differentiate the linear acceleration associated with translational movements of the body (e.g. accelerating whilst standing on a train), which may require ocular and body compensatory movements, from body tilt with respect to the gravitational vector, which requires a different set of compensatory movements or none at all. Partly this distinction is possible thanks to the different dynamic properties of the sensory channels involved in gravity perception and partly to complex neural computations [1].

The sensory systems involved in gravitational processing are the *vestibular*, the *somatosensory* and the *visual* systems. The vestibular input arises from two sensory organs in the inner ear labyrinth (the utricle and the sacculus), collectively referred to as the otolith organs. These organs sense both the gravitational pull and linear accelerations with a wide frequency range, that is they can sense slow and prolonged tilts as well as high frequency brief accelerations.

The somatosensory system comprises both tactile superficial cutaneous inputs and information about deep

somatic pressure, stretch and tension in joints, muscles and tendons (proprioception). Simple introspection should allow a person to feel the pressure on their buttocks if they are seated or the tension in their ankles if they are standing; information that they can use to sense if they are seated/standing truly upright or tilted to one side. These receptors (e.g. muscle spindles) also have a wide response range so they are thought to provide accurate input over a broad frequency range. However, tactile and to some extent proprioceptive inputs experience sensory adaptation, so the absolute accuracy of the input may decay over time.

The visual system is also capable of providing information about verticality but its ability is diminished by the inherent ambiguity present in the visual stimulus. Visual processes *per se*, i.e. working in isolation, cannot tell if a person is tilted with respect to the visual world or if the visual world is actually tilted. In practice this ambiguity is resolved by cross-referencing the visual input with respect to the gravito-inertial systems (the vestibulo-proprioceptive input).

Each of these sensory systems can contribute to the perception of verticality or uprightness by two different mechanisms. One is by directly estimating the actual deviation of the body or of an external object from actual (gravitational) vertical, a position based or "tonic" mechanism. A second, indirect mechanism does not necessarily measure position or tilt angle with respect to gravity but senses the dynamic components of movement. Additional CNS processing can then reconstruct position, in this case angle with respect to the gravity vector. An example is obtaining head position information by central mathematical processing of the raw dynamic head acceleration and velocity signals present in the vestibular nerve [1] or by cross-referencing to other sensory signals. By way of example, imagine a person sitting sideways on a car that suddenly accelerates sideways at say 1G. The summation of this lateral (orthogonal to gravity) acceleration with the gravitational vector will lead to a tilt of the resulting gravito-inertial vector of 45°. However, the lack of concurrent visual and semicircular canal input signaling head rotation (which would have occurred if they had tilted away from vertical) would be centrally interpreted as having accelerated sideways rather than tilted sideways. In conditions where additional sensory inputs are absent or impoverished, e.g. flying amidst thick clouds, unusual accelerations can result in pilot disorientation and accidents [2,3].

Numerous experiments have shown that it is possible to assess the perception of verticality within individual sensory modalities. This has led to the concept of SVV, SHV, SPV (subjective visual, haptic, postural vertical respectively). The application of these measurements to neurological patients has been a fruitful area of applied neuroscience.



### Subjective Visual Vertical

The svv is usually measured with subjects seated in the dark facing a luminous rod that can pivot around the line of sight. Subjects are required to bring the rod to upright; usually 5–10 discrete measurements are taken. Several hundred papers have been written using this inexpensive and simple technique. Unilateral lesions to the peripheral (labyrinth) and central vestibular structures induce abnormal tilts of the svv [4]; this was assumed to depend on damage to the graviceptors (otolith organs). By extension, tilts of the svv have been thought to indicate unilateral otolith disease. However, selective stimulation of the vertical semicircular canals also induces tilt of the svv [5]. The conclusion is that the main variable capable of provoking visual (i.e. svv) tilt is ocular tilt (i.e. torsion of the eyes). Since stimulation and lesions of the otolith and the vertical semicircular systems induce torsional eye movements, tilts of the svv alone cannot distinguish between the two.

Whereas svv tilts indicate tilts of the visually mediated perception of verticality, claims that the svv measures an “internal representation of gravity” [6] are questionable. Whilst such a hypothetical internal representation of verticality may well exist, clinical research has failed to prove its existence. Indeed, patients with ▶central vestibular lesions can have severe tilts of the svv (in agreement with the ocular tilt present in such patients) but otherwise normal verticality perception via postural and haptic means [7]. Each sensory channel can sense uprightness independently. When the different sensory estimates do not agree with each other in health or disease, ▶sensory conflict (see this term under “Central Vestibular Disorders”) arises, in turn leading to disorientation and motion sickness-like symptoms.

### The Effect of Postural and Visual Stimuli on the svv Visual Stimuli

A useful development of the basic svv protocol is the so-called “rod and frame test.” The concepts behind this protocol were initially developed by Witkin [8] who observed that individuals differed considerably in the amount of “weight” they placed on vision for verticality orientation. Based on experiments in which subjects faced sensory conflict between visual and gravito-inertial (vestibulo-proprioceptive) cues, Witkin classified subjects as visually dependent, if vision was capable of overriding gravito-inertial cues or visually independent if they preferably relied on gravito-inertial cues (see Fig. 1).

The rod and frame test consists of a luminous rod as for conventional svv surrounded by a larger luminous frame that can be tilted. The svv is then measured in two conditions, without frame in total darkness and with the frame tilted to one side and then the other. The amount of svv tilt induced by the tilted frame therefore allows a measurement of how much peripheral vision influences the perception of visual verticality. Subjects with large frame induced tilts of the svv are thus considered visually dependent.

A disk rotating about the visual axis placed behind the svv line has an even stronger tilt effect on the svv. This “rod and disc” test is particularly useful of assessing the influence of dynamic visual cues on verticality perception, with practical implications for patients with vestibular disorders of balance (see *visual vertigo*) [9].

### Postural Stimuli

If the svv is measured in the upright body position most subjects are extremely accurate, placing the svv line within 1–2° of true gravitational vertical. However, if measurements are taken with subjects lying



**Verticality Perception. Figure 1** Witkin's experimental set up (a) in which the subject and the room could be tilted independently. Below a visually dependent subject is depicted. When the SPV was assessed in the dark (b) the subject was accurate. When, assessed in the tilted room the subject is largely driven by the tilted visual surroundings (c). The arrow indicates true gravitational vertical. Taken from Witkin (1959), reproduced with permission of Scientific American.

sideways, significant biases of svv readings appear. A clear-cut effect is observed when subjects setting the svv line are lying sideways in the region of 60–90°. At these large tilt angles, subjects set the line with a bias of 10–20° in the same direction as the body tilt (this is called the Aubert or “A” effect). This implies that at such body tilt angles, the visual world is not perceived upright but is seen as tilted away from vertical in the opposite direction to body tilt, i.e. the amount of body tilt is underestimated. With small degrees of body tilt (10–30°) there is a smaller, less consistent effect in which the svv settings are biased in the opposite direction of body tilt (the “E” effect). It is thought that the A and E effects are induced by an asymmetric adaptation of somatosensory afferents during body tilt overriding the more veridical otolith signals; in agreement patients with absent vestibular function show a larger A effect [10].

As a footnote, most studies measuring the subjective visual horizontal show similar results to svv measurements but occasional discrepancies are present that are not reviewed here. The subjective visual horizontal should not be confused, however, with the subjective horizon or gravity referenced eye level (grel). This parameter is assessed by asking subjects in the dark to indicate the plane “where the sea meets the ski.” In contrast to the svv, which is an entirely geocentric concept (the concept of verticality is expressed in external, gravitational coordinates), grel is eye level referenced and therefore semi-geocentric [11].

### **The Subjective Postural Vertical (spv)**

Subjects standing or seating in a tilting device in the dark can estimate whether they are “upright” or not within 2–3° of the true gravitational line. If body tilts are delivered in different planes away from the vertical, a “cone” of verticality or uprightness can be defined [12]. Most studies of the spv are conducted with seated and strapped subjects and, in these conditions, contact, pressure and other somatosensory cues are prominent. Accordingly patients with unilateral vestibular lesions do not show a clear bias in their spv as could be expected. However, peripheral and central vestibular lesions provoke a small decrement in the accuracy of the spv (data scatter) indicating that vestibular input is also contributory to some extent. Intra-abdominal receptors also seem to add to the formation of the spv [13]. The assessment of the different sensory modalities of verticality perception may have a practical clinical role in the prognosis and rehabilitation of patients with neurological lesions especially stroke and this topic is actively being investigated at present.

### **References**

1. Angelaki DE, Shaikh AG, Green AM, Dickman JD (2004) Neurons compute internal models of the physical laws of motion. *Nature* 430:560–564
2. Benson AJ (1973) Neurological aspects of disorientation in aircrew. *Proc R Soc Med* 66:519–523
3. Holmes SR, Bunting A, Brown DL, Hiatt KL, Braithwaite MG, Harrigan MJ (2003) Survey of spatial disorientation in military pilots and navigators. *Aviat Space Environ Med* 74(9):957–965
4. Friedmann G (1970) The judgement of the visual vertical and horizontal with peripheral and central vestibular lesions. *Brain* 93:313–328
5. Pavlou M, Wijnberg N, Faldon ME, Bronstein AM (2003) The effect of semicircular canal stimulation on the perception of the visual vertical. *J Neurophysiol* 90:622–630
6. Brandt T, Dieterich M (1994) Vestibular syndromes in the roll plane: topographic diagnosis from brainstem to cortex. *Ann Neurol* 36(3):337–347
7. Bronstein AM, Perennou DA, Guerraz M, Playford D, Rudge P (2003) Dissociation of visual and haptic vertical in two patients with vestibular nuclear lesions. *Neurology* 61:1260–1262
8. Witkin HA (1959) The perception of the upright. *Sci Am* 200:51–56
9. Guerraz M, Yardley L, Bertholon P, Pollak L, Rudge P, Gresty MA, Bronstein AM (2001) Visual vertigo: symptom assessment, spatial orientation and postural control. *Brain* 124:1646–1656
10. Bronstein AM, Yardley L, Moore AP, Cleaves L (1996) Visually and posturally mediated tilt illusion in Parkinson’s disease and in labyrinthine defective subjects. *Neurology* 47:651–656
11. Bringoux L, Tamura K, Faldon M, Gresty MA, Bronstein AM (2004) Influence of whole-body pitch tilt and kinesthetic cues on the perceived gravity-referenced eye level. *Exp Brain Res* 155:385–392
12. Bisdorff AR, Wolsley CJ, Anastasopoulos D, Bronstein AM, Gresty MA (1996) The perception of body verticality (subjective postural vertical) in peripheral and central vestibular disorders. *Brain* 119:1523–1534
13. Mittelstaedt H (1998) Origin and processing of postural information. *Neurosci Biobehav Rev* 22(4):473–478

## **Vertigo**

### **Definition**

An abnormal sensation of motion. The illusion of motion can be rotational such as a spinning sensation or can involve a feeling of being tilted or pulled to one side. Vertigo is most often due to disturbances of ►vestibular function. Vertigo may occur under physiological conditions (mismatch of sensory inputs including somatosensory, vestibular and visual; unfamiliar head movements, e.g. in seasickness; unusual head/neck positions) or in many pathological conditions (e.g., acute vestibular vestibulopathy, ►Menière’s disease,

▶acoustic neuroma, intoxication (e.g., ▶alcohol-induced vertigo), psychogenic vertigo.

- ▶Central Vestibular Disorders
- ▶Disorders of the Vestibular Periphery
- ▶Menière's Disease

## Vesicle Fusion

▶Non-Synaptic Release

## Vesicular Neurotransmitter Transporter

HIROSHI OMOTE, YOSHINORI MORIYAMA  
Department of Biochemistry, Faculty of Pharmaceutical Sciences, Okayama University, Okayama, Japan

### Definition

Many neurotransmitters are secreted from neural and non-neural cells through exocytosis of vesicles. Vesicular neurotransmitter transporters are membrane transporters responsible for the accumulation of neurotransmitters in such secretory vesicles [1–3]. Typical neurotransmitters secreted through exocytosis are acetylcholine, dopamine, histamine, GABA and glutamate. The vesicular neurotransmitter transporters are located in the vesicle membrane, and transport neurotransmitters across the membrane using an electrochemical gradient of protons generated by V-type  $H^+$ -ATPase (Fig. 1).

### Characteristics

#### Quantitative Description

Typical vesicular neurotransmitter transporters consist of 500–600 amino acid residues with molecular weights of 550–650 K.

#### Higher Level Structures

Vesicular neurotransmitter transporters are secondary active transporters that transport substrates across membranes using an electrochemical gradient of ions. Membrane transporters are classified into primary and secondary active transporters based on the energy source for transport. Primary active transporters are directly coupled to metabolism. Typical primary transporters use

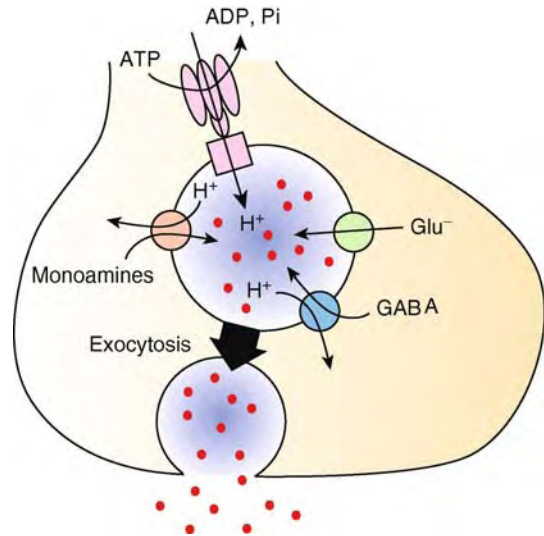

### Vesicular Neurotransmitter Transporter.

**Figure 1** Neurotransmitters are sequestered to vesicles by the vesicular neurotransmitter transporters using an electrochemical gradient of protons established by V-ATPase. Concentrated neurotransmitters are secreted through exocytosis.

the energy of ATP hydrolysis. On the other hand, secondary active transporters use the electrochemical gradient of ions established by primary active transporters. The secondary active transporters include  $Na^+/H^+$  exchanger and  $Na^+$ /glucose co-transporter in the plasma membrane, and are widely distributed from bacteria to human. Most of these transporters in human are classified into solute carrier families (SLC).

### Lower Level Components

Vesicular neurotransmitter transporters comprise of three families including ▶VGAT, ▶VChT/▶VMAT and ▶VGLUT (Table 1).

VGAT, vesicular GABA transporter, transports inhibitory amino acids such as GABA and glycine to vesicles [4]. Although glycine uptake by VGAT needs further demonstration, histochemical and transport experiments with synaptic vesicles have indicated VGAT transports glycine [5]. ▶VIAAT and SLC32 are aliases for VGAT. This family consists of a single member.

VChT and VMAT are members of the SLC18 family [6,7]. VAT, vesicular amine transporter, is a synonym for VMAT. This family of transporters consists of three members, VMAT1, VMAT2 and VChT. Vesicular monoamine transporters VMAT1 and VMAT2 mediate the accumulation of monoamines such as 5-hydroxytryptamine, dopamine, adrenaline, noradrenaline and histamine. These two transporters were identified by expression cloning for organic amines. Biochemical and histochemical studies have indicated that VMAT2

**Vesicular Neurotransmitter Transporter. Table 1** Vesicular neurotransmitter transporters

Family name	Protein name	Substrates	Coupling	Tissue distribution	Inhibitors	Amino acid residues	Sequence accession ID
SLC32	VGAT	GABA, glycine	H <sup>+</sup> antiport	Central nervous system, pituitary, pineal gland, testis		525 (57.4k)	NP_542119
SLC18	VMAT1	Serotonin, dopamine, adrenaline, noradrenaline, histamine	H <sup>+</sup> antiport	Adrenal gland, sympathetic ganglia, skin, carotid body	Reserpine	525 (56.3k)	NP_003044
	VMAT2	Serotonin, dopamine, adrenaline, noradrenaline, histamine	H <sup>+</sup> antiport	Brain, adrenal gland, sympathetic ganglia, carotid body, intestine, stomach, endocrine pancreas, basophils, mast cells, platelets	Reserpine, tetrabenazine	514 (55.7k)	NP_003045
	VACHT	Acetylcholine	H <sup>+</sup> antiport	Brain, intestine, peripheral nervous system	Vesamicol	532 (57.0k)	NP_003046
SLC17	VGLUT1	L-Glutamate	$\Delta\psi$ driven uniport	Brain, pineal gland, islets of Langerhans, bone		582 (64.4k)	NP_065079
	VGLUT2	L-Glutamate	$\Delta\psi$ driven uniport	Brain, pineal gland, islets of Lagerhans, testis		560 (61.6k)	NP_064705
	VGLUT3	L-Glutamate	$\Delta\psi$ driven uniport	Brain, liver, kidney		589 (65.0k)	NP_647480

makes a major contribution to the uptake of these amines to the synaptic vesicles of neurons. VACHT, vesicular acetylcholine transporter, accumulates acetylcholine in synaptic vesicles.

The third family, VGLUT, comprises of vesicular glutamate transporters that mediate glutamate uptake into the vesicles [8,9]. So far, three isoforms of VGLUT have been found, which are named VGLUT1, VGLUT2 and VGLUT3. All of these glutamate transporters belong to the SLC17 family. Other members of the SLC17 family are the type I phosphate transporters and sialic acid transporter. Among the members, only VGLUTs are involved in glutamate accumulation in vesicles. Similar to type I phosphate transporters, VGLUTs are able to transport inorganic phosphate when an artificial Na<sup>+</sup> gradient is applied. In this respect, VGLUTs are multifunctional transporters.

In addition to these transporters, vesicular transporters for ATP and D,L-aspartate are present in secretory vesicles, but have not been identified yet.

### Higher Level Processes

Exocytosis is the principle mechanism of neurotransmitter secretion at the chemical synapses of neurons. In addition to those of the central nervous system, many peripheral neural and non-neural cells secrete neurotransmitters through exocytosis. Such a system needs machinery for the concentration of neurotransmitters in secretory vesicles, exocytosis of vesicles, signal

detection through receptors and signal termination by reabsorption of neurotransmitters in cells. The vesicular neurotransmitter transporters and **V-ATPase** cooperate to concentrate neurotransmitters in vesicles. In some cases, cells contain multiple types of secretory vesicles that contain different neurotransmitters. Therefore, vesicular neurotransmitter transporters must be correctly localized in specific vesicles to release appropriate ligands upon stimulation. Concentrated neurotransmitters are released through exocytosis initiated by stimulation. Vesicles fuse with the plasma membrane and open up into the extracellular space, and neurotransmitters inside of vesicles are released. This process must be tightly controlled to avoid unexpected signal generation. The released neurotransmitters are detected by receptors on the targeted cells and trigger responses to ligands. Vesicular neurotransmitter transporters that appear on the plasma membrane are recycled to vesicles through endocytosis. Plasma membrane transporters reuptake neurotransmitters into the cells to terminate signal response. In the case of acetylcholine, hydrolysis by acetylcholine esterase eliminates signaling.

As vesicular neurotransmitter transporters are an indispensable part of signaling through exocytosis, these transporters are good markers for determining the type of signal transmission. In other words, vesicular neurotransmitter transporters determine the mode of signal transmission. For example, VGAT is responsible

for GABA and glycine accumulation in vesicles. Hence, VGAT is localized in GABAergic and glycinergic neurons. VGAT is also found in the pituitary, pineal gland, pancreas and testis, indicating the presence of GABAergic or glycinergic systems in these organs. In the case of vesicular monoamine transporters, a cell's adrenergic, noradrenergic, serotonergic, dopaminergic or histaminergic function is determined by coexpression of other factors such as plasma membrane transporters of these amines and the enzymes for the synthesis of these amines. VMATs are found in various cells that use monoamines as neurotransmitters. In contrast to VMAT, VACHT only transports acetylcholine. The vesicular acetylcholine transporter is co-expressed with choline acetyl transferase that synthesizes acetylcholine, and that is used as a marker for cholinergic neurons. L-Glutamate is the major excitatory neurotransmitter in the central nervous system. The complimentary localization of VGLUT1 and VGLUT2 in the central nervous system suggests functional differences between these transporters. Recent studies on signaling systems revealed that glutamatergic systems play important roles in the peripheral system [8]. VGLUTs are found in such glutamatergic cells as  $\alpha$  cells of islets of Langerhans and pineal cells of pineal glands.

### Process Regulation

The amino acid sequences of vesicular neurotransmitter transporters include potential phosphorylation sites. Although there have been reports for the phosphorylation of these vesicular neurotransmitter transporters, its function is not currently understood. In addition, gene expression control of VGAT and VMAT has been reported, but further study is required to reveal their roles.

### Function

The vesicular neurotransmitter transporters are responsible for the accumulation of substrates using the energy generated by V-ATPase. V-ATPase uptakes  $H^+$  to vesicles through ATP hydrolysis. The uptake of  $H^+$  by secretory vesicles generates an electrochemical gradient of  $H^+$  across the membrane. This gradient is composed of chemical and electrical gradients, and is used by vesicular neurotransmitter transporters. Depending on the transporter, both or one of these components is used as an energy source for transport. For instance, VGAT is an antiporter that transports GABA into vesicles, and  $H^+$  is translocated to the outside of the vesicles. In this case, VGAT utilizes membrane potential as well as the  $H^+$  gradient for substrate transport. Thus, ionophores that dissipate the electrochemical gradient of  $H^+$  inhibit GABA uptake. Similarly, VMAT and VACHT uptake one substrate molecule and translocate two  $H^+$  in the other direction. The substrate specificity of VMAT is not strict, and thus it transports various biological monoamines

into vesicles. Contrary to these transporters, VGLUTs are uniporters and only use the electrical component. The substrate specificities of VGLUTs are strict and they cannot transport D-glutamate or aspartate. Details of transport mechanism of these transporters are not well understood because of the lack of a good assay system and structural information. However, recent progress in structural biology has indicated that alternate change between inward-facing and outward-facing conformations involve substrate transport by the bacterial homolog [10]. A similar mechanism must be involved for the vesicular neurotransmitter transporters.

As the electrochemical gradient of  $H^+$  generated by V-ATPase drives vesicular neurotransmitter transporters, inhibitors of V-ATPase such as bafilomycin and *N*-ethylmaleimide, ionophores that collapse gradients, diminish neurotransmitter accumulation in vesicles.

### Pathology

Since neurotransmitters are correlated with higher functions of the neural systems, improper functioning of vesicular neurotransmitter transporters may cause neuropsychiatric disorders. Although no disease triggered by mutation of a vesicular transmitter transporter has been reported, future work may reveal a genetic disorder directly related to the function of these transporters.

The vesicular monoamine transporters are able to sequester various amines in vesicles. Such a functionality of VMAT is correlated with vulnerability to addiction, schizophrenia, depression and the neurotoxicity of Parkinsonism-inducing agents such as MPTP (*N*-methyl-1,2,3,6-tetrahydropyridine). Vesicular neurotransmitter transporters are good markers for neural systems like the cholinergic and glutamatergic ones. Thus, high affinity ligands for VMATs and VACHT are good tools for revealing neural damage due to neurodegenerative diseases. Radio labeled ligands, vesamicol and tetrabenazine have been successfully used to visualize VMATs and VACHT in the brain in Parkinson's disease.

### Therapy

The VMATs are the site of reserpine and tetrabenazine actions. Reserpine is used as an antihypertensive reagent to control the heart rate. These reagents shut the dopaminergic system down through inhibition of VMAT activity.

### References

1. Gasnier B (2000) The loading of neurotransmitters into synaptic vesicles. *Biochimie* 82:327–337
2. Moriyama Y, Hayashi M, Yamada H, Yatsushiro S, Shougo I, Yamamoto A (2000) Synaptic-like microvesicles, synaptic vesicle counterparts in endocrine cells, are involved in a novel regulatory mechanism for the synthesis and secretion of hormones. *J Exp Biol* 203:117–125

3. Eiden L (2000) The vesicular neurotransmitter transporters: current perspectives and future prospects. *FASEB J* 14:2396–2400
4. Gasnier B (2004) The SLC32 transporter, a key protein for the synaptic release of inhibitory amino acids. *Eur J Physiol* 447:756–759
5. Sagné C, Mestikawy SE, Isambert MF, Hamon M, Henry JP, Giros B, Gasnier B (1997) Cloning of a functional vesicular GABA and glycine transporter by screening of genome databases. *FEBS Lett* 417:177–183
6. Parsons MS (2000) Transport mechanisms in acetylcholine and monoamine storage. *FASEB J* 14:2423–2434
7. Eiden LE, Schäfer MKH, Weihe E, Schütz B (2004) The vesicular amine transporter family (SLC18): amine/proton antiporters required for vesicular accumulation and regulated exocytotic secretion of monoamines and acetylcholine. *Eur J Physiol* 447:636–640
8. Moriyama Y, Yamamoto A (2004) Glutamatergic chemical transmission: look! Here, there, and anywhere. *J Biochem* 135:155–163
9. Reimer RJ, Edwards RH (2004) Organic anion transport is the primary function of the SLC17/type I phosphate transporter family. *Eur J Physiol* 447:629–635
10. Abramson J, Smirnova I, Kasho V, Verner G, Kaback HR, Iwata S (2003) Structure and mechanism of the lactose permease of *Escherichia coli*. *Science* 301:610–615

---

## Vestibular Apparatus

### Definition

Sensory system in the inner ear for detecting linear and rotational accelerations of the head.

► Peripheral Vestibular Apparatus

---

## Vestibular Commissural Inhibitory System

### Definition

The functionally inhibitory pathways that link the bilateral vestibular nuclei concerned with eye movements (particularly the medial vestibular nuclei and the superior vestibular nuclei). Commissural neurons in each of these nuclei project to the approximately equivalent region of the contralateral nuclei, where they inhibit the contralateral neurons via inhibitory interneurons.

This reciprocal, inhibitory commissural system is functionally important in optimising the responsiveness of the vestibular neurons to slow or small head rotations and also contributes to determining the time-constant of the vestibulo-ocular reflexes.

Neurons in the lateral vestibular nuclei of the two sides, which deal predominantly with otolith (macular) afferent inputs, also participate in a functionally analogous but less well characterized commissural inhibitory system.

- Otolith
- Vestibular Compensation and Plasticity
- Vestibular Primary Afferent Pathways in Mammals
- Vestibular Nuclei
- Vestibulo-ocular Reflex

---

## Vestibular Commissure

### Definition

Axonal projections of central vestibular neurons that cross the midline of the brainstem or the cerebellum and interconnect functionally-related pairs of neuronal populations. Contralateral-projecting vestibular neuronal pathways that carry semicircular canal signals and inhibit functional pairs of coplanar semicircular canal neurons facilitate an increase in the gain of vestibular responses during angular head acceleration.

► Functional and Neurochemical Organization of Vestibulo Pathways

---

## Vestibular Compensation and Plasticity

MAYANK B. DUTIA<sup>1</sup>, HANS STRAKA<sup>2</sup>

<sup>1</sup>Centre for Integrative Physiology, Edinburgh University, Hugh Robson Building, George Square, Edinburgh, UK

<sup>2</sup>L.N.R.S., CNRS UMR 7060 – Université Paris 5, 45 rue des Saints-Pères, 75270 Paris cedex 06, France

### Definition

“► Vestibular compensation” (VC) is a broad term for the overall behavioral and functional recovery that takes place in the control of eye movements and posture

after damage to the vestibular system. In its most widely investigated form, VC refers to the behavioral recovery that follows the permanent loss of the peripheral semicircular canal and macular receptors of one inner ear (e.g. after ►unilateral labyrinthectomy, UL) or their de-afferentation (e.g. after unilateral vestibular neurectomy). Because the loss of afferent input from the vestibular receptors on the lesioned side is permanent, it is accepted that the behavioral recovery in VC must involve extensive synaptic and neuronal plasticity in the brainstem vestibular nuclei, cerebellum and related areas of the brain (for reviews, see [1–8]).

Related forms of VC, which no doubt share common brain plasticity mechanisms, also take place after the partial or incomplete loss of peripheral afferent input from one inner ear. In the clinical context, peripheral vestibular damage may often occur gradually over a prolonged time, in which case VC is also a continuous process, which continuously attempts to normalize oculomotor and postural motor control.

### Characteristics

The vestibular system has a fundamental role in the control of eye movements and stabilization of gaze, the control of posture and locomotion and in cognitive aspects of balance, self-orientation and spatial navigation. Information from the vestibular, visual and proprioceptive systems converges in the first instance on neurons in the brainstem vestibular nuclei. Vestibular nucleus (VN) neurons transform these inputs into motor commands for eye and head movements and also project to higher brain areas including the hippocampus and thalamus, reaching the vestibular cortex. The correct temporal and spatial integration of these input signals by brainstem VN neurons is therefore critical both for oculomotor and postural reflex function, as well as spatial cognition and navigation.

Damage to the peripheral vestibular receptors in the inner ear of one side or to the vestibular nerve precipitates a complex and debilitating syndrome of oculomotor, postural and cognitive deficits. Since there is no regeneration of the damaged vestibular receptors or nerve, the behavioral recovery during vestibular compensation is attributed to neural and synaptic plasticity in the vestibular pathways. Detailed studies of the behavioral deficits that follow UL in animals and humans have emphasized that VC is by no means a single process. There are wide differences in the time course and ultimate level of compensation for the range of oculomotor, postural and cognitive deficits that follow UL. Thus although the term “vestibular compensation” refers to the overall behavioral recovery, it is clear that the underlying physiological mechanisms are diverse, with differences in the signals that initiate and drive them, their time course and end-points.

### Behavioural Consequences of Unilateral Vestibular Deafferentation

The signs and symptoms that follow UL have been characterized in a range of species using a wide range of techniques including ►posturography, video oculography and 3D-search coil recordings of eye movements and X-ray cinematography. Although there are species differences, the nature of the vestibular deafferentation syndrome and the subsequent behavioral recovery are broadly similar in various animals from the goldfish and frog to monkey and man, indicating that the underlying processes share many commonalities.

The deficits observed immediately after UL can be divided into two categories on the basis of their relationship to head movement. “Static” signs are observed in the absence of head movement, affecting head and body posture and eye movements. In addition “dynamic” signs are observed during head movements (that is in response to vestibular stimulation) and result from abnormalities in the amplitude and timing of the vestibulo-ocular, vestibulo-collic and vestibulo-spinal reflexes. In general static symptoms show a rapid recovery following UL, with many of the initial severe static symptoms disappearing within a few days, while compensation of the dynamic symptoms is much slower and incomplete.

In mammals the most prominent static symptom is a high-frequency spontaneous horizontal ocular nystagmus (SN), seen as a slow drift of the eyes towards the lesioned side (slow phase) followed by a fast beat towards the intact side (quick phase). Soon after UL the frequency of SN in rats and guinea pigs is around 80–180 beats per minute. The frequency of SN begins to decrease soon after UL, declining to about half of its initial value within 6 h in the rat and disappearing completely within about 60 h. In the monkey and man SN may persist for up to a week. In amphibians, SN does not occur.

UL also results in disturbances in the position of the eyes, head and body. Ocular torsion and ocular skew deviation cause the eye on the affected side to rotate and deviate downwards in its orbit relative to the eye on the intact side. The deviated position of the eyes causes a systematic error in the perception of horizontal and vertical lines, which are seen as being rotated towards the affected ear in proportion to the ocular torsion. Humans show relatively little head and body rotation after unilateral vestibular loss, but many other species show a tilting of the head towards the lesioned side in the roll plane (“roll head tilt,” RHT) and a turning of the head towards the lesioned side in the yaw plane (“yaw head tilt,” YHT). Other static postural symptoms in animals include a curvature of the upper spine towards the lesioned side, circular walking and barrel rolling and an asymmetric extensor muscle tone in the ipsi- and contra-lesional limbs with a tendency to

fall to the lesioned side. Along with the disappearance of SN after UL, most static signs ameliorate remarkably rapidly. Barrel-rolling and circular walking subside within 4 h in the rat, while ocular torsion, skew deviation and YHT have largely disappeared within a few days.

By contrast the recovery of dynamic symptoms is slow and incomplete. UL results in severe abnormalities in the gain, symmetry and phase of the hVOR. After UL, hVOR gain is significantly lower than its normal value of approximately 1.0 and is severely asymmetric; hVOR gain in response to rotations towards the side of the lesioned ear (the “ipsi-lesional” side) is much lower than that in response to rotations towards the intact side (the “contra-lesional” side). During rotations towards the ipsi-lesional side the hVOR gain falls to approximately 0.3–0.4 in humans and guinea pigs, while during contra-lesional rotations hVOR gain is higher, around 0.7–0.8. These abnormalities in hVOR performance appear to be permanent – they do not significantly compensate in the long term and can be observed months and years following ►[labyrinthectomy](#).

Despite the incomplete recovery of dynamic deficits in vestibular reflex performance, the majority of animals or patients are able to return to a near-normal lifestyle after unilateral vestibular loss. Presumably high-level, cognitive and behavioral strategies are developed in order to minimize the effects of the permanently compromised vestibular reflexes. Thus patients may learn to minimize head turns or to blink or fixate on a visual target during head rotations so as to suppress the VOR or generate compensatory saccades during voluntary head rotations towards the deficient side. Potentially, different subjects may develop individual compensatory strategies and indeed use different strategies in particular circumstances and these strategies may be learnt and refined over varying times during VC. The behavioral compensation of *dynamic* deficits after UL is therefore a complex, multifactorial and potentially individualistic process and the underlying mechanisms are at present largely unexplored.

### Effects of Unilateral Vestibular Deafferentation on Neuronal Activity in the Vestibular Nuclei

Unilateral vestibular loss has profound effects on the activity of neurons in the brainstem vestibular nuclei and the severe behavioral symptoms induced by UL are believed to arise directly from these effects. Of the four main vestibular nuclei in the brainstem, the most extensively studied is the medial vestibular nucleus (MVN). Immediately after UL, the normally high resting discharge rate of the majority of MVN neurons on the ipsi-lesional side is virtually abolished, while the activity of MVN neurons on the contra-lesional side is either normal or increased (Fig. 1).

Furthermore, the amelioration of the static symptoms is broadly correlated with a recovery of the resting activity of the ipsi-lesional MVN neurons to near-normal levels. MVN neurons are the major CNS target of primary vestibular afferents from the semicircular canals; they occupy a central position in the VOR pathway providing a major input to abducens motoneurons and also project to the cervical spinal cord and the forebrain, relaying information to the vestibular cortex. It is therefore generally accepted that the profound loss of resting activity in these neurons immediately after UL is an important factor in generating the initial static symptoms, as well as the behavioral and cognitive deficits that immediately follow UL. Much research has therefore focussed on understanding the causes of the initial silencing of the resting discharge of ipsi-lesional MVN cells after UL and the mechanisms that may bring about the recovery of their resting activity early in VC. However it should be borne in mind that other brain centres may also be important in the early behavioral recovery after UL.

Interestingly, recent experiments have shown that after ►[bilateral labyrinthectomy](#), where the MVN neurons of the two sides are equally disfacilitated by the interruption of the primary vestibular afferents on both sides, the resting activity of MVN cells is not abolished; instead, it decreases to only about 50% of normal on both sides. This implies that after UL, the reason for the silencing of the ipsi-lesional MVN neurons is not the deafferentation itself, since one would then expect the resting activity in both MVNs to be abolished after bilateral deafferentation. Instead, the silencing of the ipsi-lesional MVN neurons after UL is probably because these cells are subjected to not only the loss of excitation from the lesioned primary vestibular afferents, but also a continued and enhanced commissural inhibition from contra-lesional MVN neurons, which tend to become hyperactive because of the collapse of inhibitory drive from the lesioned side (Fig. 1b). Normally, the reciprocal commissural inhibitory pathways that link the MVN of the two sides are important in optimizing the dynamic responsiveness of the MVN neurones to head movements and the time constant of the brainstem neural integrator. After UL however, the commissural inhibitory system is pushed into marked imbalance as a result of the disfacilitation of the ipsi-lesional MVN cells (Fig. 1b). Thus a fundamental cause of the silencing of the deafferented MVN neurons appears to be the commissural inhibitory input to the ipsi-lesional cells. In this light, it is reasonable to hypothesize that cellular mechanisms that may relieve the ipsi-lesional MVN cells from excessive commissural inhibition after UL would promote the recovery of their resting discharge and the restoration of their inhibitory control of the contra-lesional MVN neurons and that this would help



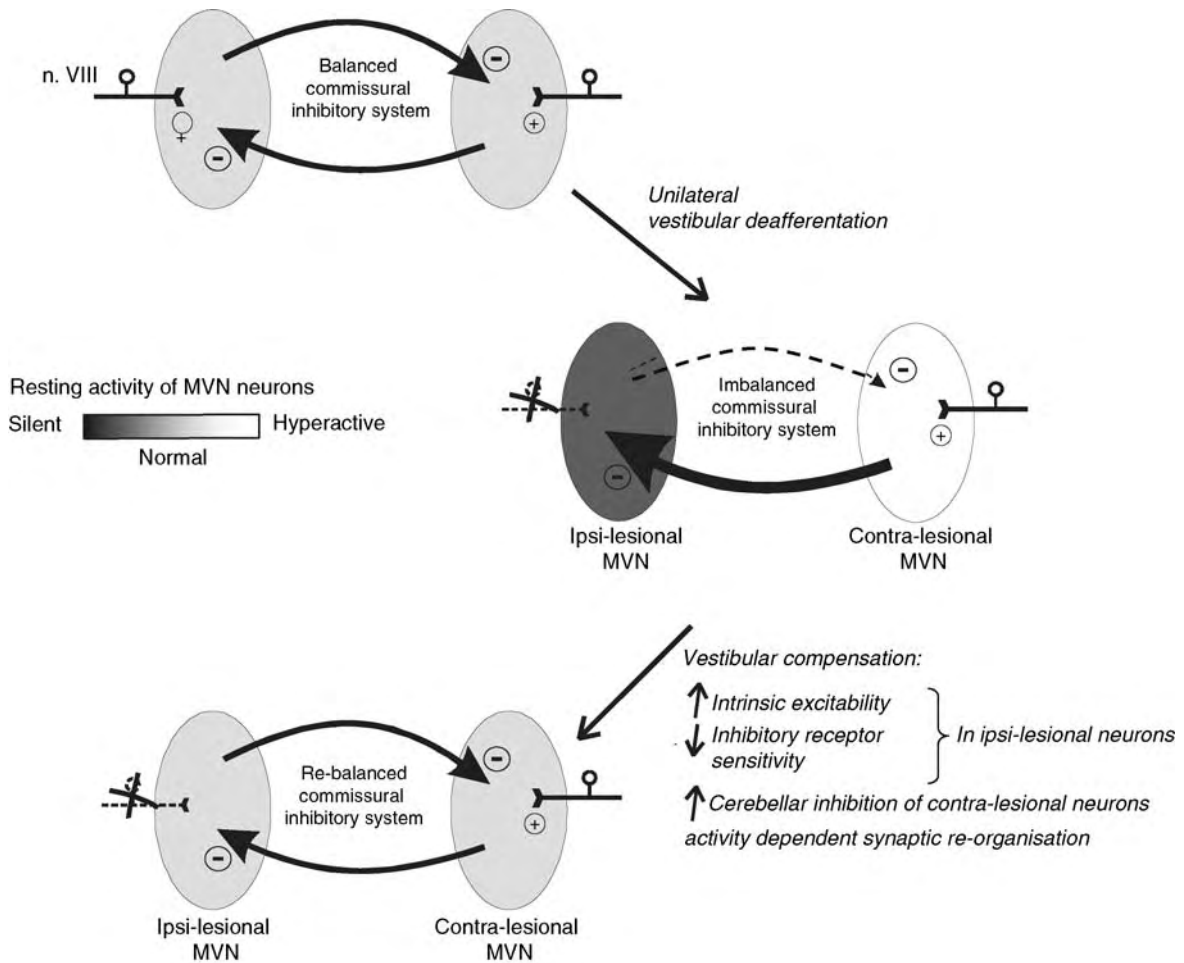

**Vestibular Compensation and Plasticity. Figure 1** Schematic representation of the effects of unilateral vestibular deafferentation on the commissural inhibitory system and the neuronal activity in the medical vestibular nuclei in the brainstem. During vestibular compensation, several cellular processes have been identified which may contribute to the re-balancing of the commissural system and the restoration and maintenance of neural activity in the deafferented vestibular neurons.

to “re-balance” the levels of neuronal activity in the MVN of the two sides.

### Mechanisms Involved in the Recovery of Ipsi-lesional Vestibular Neuronal Activity After UL

Experimental evidence accumulated over the past 10 years has indicated at least four candidate mechanisms, which may operate in parallel and synergistically, to bring about the restoration of resting activity in the deafferented ipsi-lesional MVN neurons after UL.

#### 1. Changes in the Responsiveness of Vestibular Nucleus Neurons to Inhibitory Synaptic Inputs

Evidence for adaptive changes in the intrinsic properties of MVN neurons after UL has come from studies of *in vitro* brain slice preparations of the brainstem. Such studies have significantly increased our understanding

of the electrophysiological characteristics of MVN neurons and the actions of many neurotransmitters that influence vestibular function. Analysis of the responsiveness of MVN neurons to the inhibitory neurotransmitters GABA and glycine (which are the main transmitters involved in the commissural inhibitory system) in slices from normal animals and animals that had compensated for various times after UL showed that the sensitivity of the ipsi-lesional MVN neurons to these inhibitory transmitters is significantly down-regulated after UL. Thus the same doses of GABA and glycine cause a much smaller inhibition of ipsi-lesional MVN neurons from animals after UL than normal MVN neurons. This reduction in the sensitivity to inhibitory inputs is appropriate to counteract the enhanced commissural inhibition to which the ipsi-lesional MVN cells are subjected after UL (Fig. 1b).

This has been proposed as one plausible mechanism that may help to restore their resting discharge early in VC (Fig. 1c).

Interestingly, MVN neurons possess both the muscimol-sensitive GABA-A subtype and the baclofen-sensitive GABA-B subtype of GABA receptors and both subtypes are down-regulated immediately after UL. However, the GABA-A receptor mediated inhibition recovers within a few days, while the responsiveness to GABA-B receptor mediated inhibition remains down-regulated in the long term. The functional importance of the altered function of GABA-B receptors in compensated animals has been confirmed in behavioral experiments, in which the GABA-B receptor agonist baclofen was administered to animals that had partially or fully compensated after UL.

### 2. *Changes in the Electrophysiological Excitability of Vestibular Nucleus Neurons After Deafferentation*

In parallel with the changes in their sensitivity to inhibitory neurotransmitters after UL, after deafferentation the ipsi-lesional MVN cells also up-regulate their intrinsic electrophysiological excitability (Fig. 1c). This was first observed simply as an increase in the mean spontaneous discharge rate of the ipsi-lesional MVN cells in brain slices taken from animals that had compensated for various times after UL. Subsequent studies using intracellular recordings have shown that there are changes in their input resistance and resting membrane potentials, but the responsiveness to synaptic inputs is also potentiated through the up-regulation of appropriate ion channels. In particular there is an increase in the number of cells that show low-threshold calcium spikes (LTS) after UL. This is of interest because it can be strongly activated by small depolarizing inputs when the membrane potential is hyperpolarized. Thus the increased expression of LTS in the ipsi-lesional MVN neurons, which are indeed hyperpolarized and silent immediately after UL may significantly increase their responsiveness to their remaining synaptic inputs from other, non-vestibular sources. In the longer term, these changes in the intrinsic electrophysiology of the ipsi-lesional MVN neurons persist and additional changes also occur in the electrophysiological properties of contra-lesional MVN neurons. The excitability and signal-processing characteristics of the vestibular neurons are therefore modified permanently after deafferentation.

### 3. *Adaptive Changes in Synaptic Connectivity in the Vestibular Reflex Networks*

In addition to the changes in the properties of MVN neurons after deafferentation after UL, the synaptic connectivity of excitatory and inhibitory pathways in the brainstem vestibular nuclei also undergoes gradual, activity-dependent re-organization. Thus 2 months after

unilateral vestibular neurectomy, the strength of excitatory synaptic inputs to the ipsi-lesional MVN neurons from the contra-lesional, intact side was significantly increased. After partial vestibular neurectomy in which only one branch of the vestibular nerve is sectioned leaving the innervation of the remaining end-organs intact, there is an expansion of the excitatory synaptic inputs from the intact afferents to the ipsi-lesional MVN cells. Thus MVN neurons that are deprived of their original synaptic inputs as a result of the sectioning of the vestibular nerve branch that normally supplies them become responsive to excitatory inputs from the other, remaining intact vestibular afferents. This substitution of inputs through the re-organization of synaptic connectivity is similar to that seen in other sensory systems after partial deafferentation, for example the area of the somatosensory cortex concerned with a particular body part gradually becomes responsive to inputs from adjacent regions if its normal input region is deafferented. In the vestibular nuclei, such "re-wiring" of synaptic connectivity has the beneficial effect that the deafferented MVN neurons receive substitute excitatory inputs that may help to restore and maintain their resting discharge. However the re-wired connections may now generate quite inappropriate vestibular reflexes, since the MVN neurons which were previously concerned with for example horizontal canal afferent inputs may now receive synaptic excitation from utricular afferents and so generate horizontal eye movements in response to head movements in the vertical plane. Thus while synaptic re-wiring may help to restore resting activity in the deafferented MVN neurons and contribute to their long-term survival after UL, the generation of new and inappropriate reflexes as a consequence of re-wiring suggests that the suppression of such reflexes, by for example alternative non-vestibular strategies for gaze stabilization, may be an important part of the overall process of VC.

### 4. *Post-lesional Changes in the Control of Vestibular Nucleus Neurons by the Cerebellum*

While the cerebellum and in particular the flocculus has long been known to be important in calibrating the gaze-stabilizing function of the VOR, the role of the flocculus in VC has been unclear. Recent studies by Kitahara and colleagues have demonstrated that the flocculus plays an important role in the early compensation of static symptoms, particularly ocular nystagmus. An important role for the flocculus is also indicated by the finding that in a knock-out mouse lacking the delta-2 subunit of the glutamate receptor, which is selectively localized in cerebellar Purkinje cells and which is essential for cerebellar cortical plasticity, the severity of ocular nystagmus after UL is exaggerated and the time-course of recovery is

prolonged. Consistent with this are the findings that indicate that cerebellar cortical plasticity in the flocculus occurs after UL and is required for compensation. However the flocculus is not essential for VC, as even in flocculectomized animals the ocular nystagmus eventually disappears completely; thus other processes, such as the changes in intrinsic properties of MVN neurons and synaptic re-organization of the brainstem vestibular pathways may be sufficient to achieve compensation, but over a longer recovery time. In the normal development of VC and the relatively rapid subsidence of nystagmus within a few days however, the flocculus appears to play an important but as yet unclear role. As proposed by Kitahara and colleagues, the flocculus may act to inhibit the activity of contralesional MVN neurons (Fig. 1b) and so reduce the commissural inhibition they project to the deafferented ipsi-lesional MVN cells after UL.

### **Interactions Between Stress, the Neuroendocrine System and Brain Plasticity During Vestibular Compensation**

The development of vestibular compensation after UL is significantly affected by stress and stress-related steroids, as well as conditions such as anxiety and depression, where the normal function of the hypothalamo-pituitary-adrenal (HPA) stress axis is altered. Glucocorticoids (GCs) released by the adrenal cortex in response to HPA activation in response to stress have widespread actions throughout the body; in addition they have important modulatory effects on the function of neurons and synapses in the brain. GCs may act directly on membrane ion channels and neurotransmitter receptors to regulate their function or they may alter gene expression in neurons through specific intracellular receptors (glucocorticoid receptors, GRs or mineralocorticoid receptors, MR). GCs may also be rapidly converted by a range of enzymes to active neurosteroids. In addition to stress steroids, neurosteroids derived from the sex steroid progesterone also affect neuronal and synaptic function in the vestibular system and cerebellum.

A number of studies suggest that glucocorticoids and neurosteroids may modulate vestibular system function and compensation. Anxiety and stress in patients with vertigo significantly delays the recovery from vestibular symptoms. Conversely, treatment of patients with the glucocorticoid steroid methylprednisolone has been reported to improve vestibular compensation. Yamanaka and co-workers showed that administration of the synthetic GR agonist dexamethasone facilitated behavioral recovery following UL in rabbit; in contrast, administration of the GR antagonist RU38486 delayed compensation. Glucocorticoids and neurosteroids have direct excitatory actions on MVN neurones. However in a recent study, systemic administration of dexamethasone

was found to have no effect on the rate of compensation of spontaneous nystagmus in the guinea pig.

At the neuronal level, the development of the increase in excitability of MVN neurons after UL (Fig. 1c) is dependent on activation of GRs. Thus the increase in excitability of the ipsi-lesional MVN neurons was prevented by administration of the GR antagonist RU38486 and did not develop in animals that remain anaesthetized after UL. However, in anaesthetized animals that were treated with the synthetic GR agonist dexamethasone simultaneously with UL, the increase in excitability did occur. These findings suggest that the acute stress that normally accompanies the behavioral symptoms immediately after UL may have a role in facilitating the cellular plasticity in MVN neurons. An important site of action of glucocorticoids during VC would appear to be the cerebellar flocculus. However, a critical optimal level of GR activation appears to be required, since additional stress in the form of restraint applied to a compensating animal after UL causes a retardation of the behavioral recovery.

The interactions between the stress axis, glucocorticoids and vestibular plasticity may have potentially important implications for the treatment and management of patients with balance disorders. Perhaps a factor in the known effectiveness of vestibular rehabilitation exercises in promoting VC may be the acute stress that accompanies the performance of initially aversive movements, which may facilitate the plasticity mechanisms in the brain that are necessary for VC. It is also possible that patients who are unable to compensate adequately after UL, may have pre-existing alterations in their stress axis function through depression or anxiety or develop changes in their stress axis as a result of the vestibular dysfunction and the associated symptoms. This may result in too low or too high levels of stress responses to vestibular, visual and postural challenges that may impede the cellular plasticity in the vestibular pathways necessary for VC. Further investigations to reveal the cellular mechanisms of action of stress steroids on VC are necessary in animal models, as well as studies of stress axis function in patients with balance disorders.

### **Studies of Changes in Gene and Protein Expression in the MVN During VC**

In a search for the molecular mechanisms of plasticity in MVN neurons during vestibular compensation, a number of studies have looked for changes in gene and/or protein expression after UL. The changes in amino acid neurotransmitter receptor efficacy, the intrinsic properties of MVN neurons and the re-organization of neural connectivity that are implicated in VC as reviewed above may be brought about by a range of molecular mechanisms. These include changes dependent on alterations in gene expression, e.g. changes in

neurotransmitter receptor subunit expression or composition or the expression of molecules regulating neural growth and axon guidance and changes not necessarily dependent on alterations of gene expression, e.g. involving changes in protein phosphorylation or other post-translational modifications of proteins. A number of studies have reported such changes in the MVN after UL (Table 1), but no clear picture has yet emerged which appears to link many of the individual findings.

In particular, painstaking and detailed analyses by Eleore and co-workers on glycine and GABA receptor gene expression in the MVN after UL have not detected significant changes that might account for the functional down-regulation of these receptors during VC. Similarly no significant changes in voltage-gated Na channels and calcium-activated K channels, which might correlate with the changes in intrinsic excitability of MVN neurons, were detected at the gene level. On the other hand, administration of protein kinase C (PKC) inhibitors has been shown to retard VC, implying that protein phosphorylation in the MVN or related sites is necessary. At present the molecular mechanisms of VC remain intriguing but largely unclear.

### Drugs and Treatment of VC

No single drug treatment for the debilitating symptoms of unilateral vestibular loss and the promotion of vestibular compensation exists, no doubt reflecting its multifactorial and complex nature. Anticholinergics and neuroleptics are often used for their anti-emetic effects, but experimental evidence that these drugs promote vestibular compensation is lacking. Histaminergic drugs have long been used to treat vestibular disorders in man and their mechanisms of action have also been investigated. Vestibular compensation is facilitated by histamine and is associated with increased central histamine release and alterations in histamine H3 receptor expression in the vestibular nuclei. Histamine has widespread actions in brain, affecting alertness and arousal as well as modulating neurotransmitter release and actions at many types of synapses. Antagonists of the H1-receptor that pass the blood brain barrier (typical compounds are diphenhydramine, promethazine and dimenhydrinate) have sedative as well as vestibulo-depressant effects. Their use for motion sickness is well established and the mechanism of action is believed to include anti-emesis via histaminergic effects on emetic

**Vestibular Compensation and Plasticity. Table 1** Summary of studies investigating changes in gene and protein expression in MVN during vestibular compensation

Main finding	References
Asymmetric changes on c-fos expression during VC in rat	Kaufman et al. 1992, Cirelli et al. 1996
Increased phosphorylation of several likely protein kinase C substrates in the MVN+ prepositus hypoglossi 10–53 h post-UVD	Sansom et al. 1997
Intracerebroventricular administration of protein kinase C (PKC) inhibitors retards recovery of spontaneous nystagmus in rat up for to 8 h post-UVD	Balaban et al. 1999
Up-regulation of three unidentified proteins in guinea pig ipsilateral VN 1 week after UVD	Ris et al. 1999
No change in PKC-mediated phosphorylation in guinea pig MVN, but increased phosphorylation in contra-lesional prepositus hypoglossi, 10–53 h post-UVD	Kerr et al. 2000
Increased immunoreactivity for phosphorylated form of cAMP/calcium response element binding protein (pCREB) bilaterally in the rat VN, 1–24 h post-UVD	Kim et al. 2000
Inhibition of protein kinase C (PKC), but not Ca <sup>2+</sup> /calmodulin-dependent kinase II (CaMKII), in the VN affects recovery from spontaneous nystagmus but not postural symptoms in guinea pig	Sansom et al. 2000
No change of GAP-43 protein or mRNA in rat vestibular nuclei after UVD	de Waele et al. 2000
Down-regulation of NR2A, GluR2 and GluR7 mRNA in ipsi-lesional MVN 6 h post-UVD, but not at 50 h post-UVD, in the rat	Horii et al. 2001
Increase in expression of GAD65 mRNA bilaterally, and GABA-A receptor alpha-1 subunit mRNA ipsilaterally, in rat VN 6–50 h post-UVD	Horii et al. 2003, Neuroreport 14, p2359
No change in voltage-gated Na channels or Ca-activated K channels in VN after UVD	Patko et al. 2003
Microarray analysis showed differing gene expression between ipsi- and contra- rat VNC, 6 h after UVD	Horii et al. 2004
Increased asymmetrical expression of pERK1/2 in rat VN 5–90 min post-UVD	Kim et al. 2004
No change in glycine receptors and gephyrin protein in VN after UVD in rat	Eleore et al. 2004
Increase in histamine H3 receptor expression in rat ipsi-lesional VN within 48 h post-UVD	Lozada et al. 2004
No change in GABA-A and GABA-B receptor mRNA after UVD in rat	Eleore et al. 2005

centres in the brain, as well as unspecific sedative effects of the drugs. However it is likely that the overall sedative effect of H1-antagonists retards rather than promotes vestibular compensation, but this issue has not been investigated. The anti-vertigo effects of two calcium channel antagonists, flunarizine and cinnarizine have also been attributed to H1-receptor antagonism. Betahistine, a histamine analogue displaying partial H1 agonism and H3 antagonism, has been widely used for the treatment of Meniere's disease and vestibular disorders. Its mechanism of action may include the modulation of central histamine release and its excitatory actions on H2 receptors.

Effective vestibular rehabilitation after vestibular loss is achieved by exercise and training which involves stimulation of the visual and somatosensory systems, presumably allowing and promoting activity driven sensory substitution in the central vestibular pathways. It may also be relevant that such exercises also stimulate a moderate stress response, which may facilitate brain plasticity. Slow or incomplete compensation in some subjects may also involve altered responses to stress, as in depression or anxiety as discussed above, though this remains to be established.

## References

1. Curthoys IS, Halmagyi GM (1999) Vestibular compensation. *Adv Otorhinolaryngol* 55:82–110
2. Curthoys IS (2000) Vestibular compensation and substitution. *Curr Opin Neurol* 13:27–30
3. Seemungal BM, Gresty MA, Bronstein AM (2001) The endocrine system, vertigo and balance. *Curr Opin Neurol* 14:27–34
4. Balaban CD (2002) Neural substrates linking balance control and anxiety. *Physiol Behav* 77:469–475
5. Darlington CL, Dutia MB, Smith PF (2002) The contribution of the intrinsic excitability of vestibular nucleus neurons to recovery from vestibular damage. *Eur J Neurosci* 15:1719–1727
6. Dieringer N (2003) Activity-related postlesional vestibular reorganization. *Ann NY Acad Sci* 1004:50–60
7. Straka H, Vibert N, Vidal PP, Moore LE, Dutia MB (2005) Intrinsic membrane properties of vertebrate vestibular neurons: Function, development and plasticity. *Prog Neurobiol* 76:349–392
8. Bergquist F, Dutia MB (2006) Central histaminergic modulation of vestibular function – a review. *Acta Physiol Sinica* 58:293–304

## Vestibular Disorders

► Disorders of the Vestibular Periphery

## Vestibular Ganglion

### Synonyms

► Ganglion vestibulare

### Definition

In the vestibular ganglion are situated the somas of the bipolar ganglion cells which receive the signals from the sensory cells and conduct them in the direction of the brainstem. In doing so, they project to the vestibular nuclei (medial, superior, inferior) and to the cerebellum.

## Vestibular Ganglion Cells

### Definition

These cells comprise bipolar vestibular primary afferents. One process of these afferents receives excitatory signals from vestibular hair cells. The other process forms the vestibular nerve that projects to the brainstem. The somas of vestibular ganglion cells are clustered peripherally in Scarpa's ganglion.

► Vestibular Primary Afferent Pathways

## Vestibular Nerve

### Synonyms

N. vestibularis

### Definition

Part of cranial nerve VIII, the vestibulocochlear nerve. Predominantly sensory nerve whose fibers convey information from the vestibular parts of the inner ear (sacculi, utricles and semicircular canals) to the vestibular nuclei (medial, superior and inferior) and the cerebellum. The somas of the bipolar ganglion cells are located in the vestibular ganglion.

► Nerves

## Vestibular Neuritis

### Definition

Disorder of the labyrinth which causes the sudden onset of severe rotatory vertigo often accompanied by nausea and vomiting. The vertigo usually subsides over the course of several days although disequilibrium and unsteadiness may persist for a longer period of time. A viral etiology has been proposed. The differential diagnosis of acute vertigo includes central causes such as cerebellar hemorrhage or infarction.

► Disorders of the Vestibular Periphery

## Vestibular Nuclei

### Definition

Clusters of cells near the dorsal surface of the brainstem (near the entry zone of the vestibular nerve within the cerebellar peduncle) that receive projections from primary vestibular afferents. There are seven such nuclei including: medial, descending, superior and lateral vestibular nuclei (MVN, DVN, SVV, LVN), parasolitary nucleus (Psol), Y-group and nucleus intercalatus.

► Vestibular Primary Afferent Pathways in Mammals  
 ► Vestibular Secondary Afferent Pathways  
 ► Vestibulo-Spinal Reflexes

## Vestibular Nystagmus

### Definition

A physiological nystagmus that occurs generally involuntary when the head is rotated. It consists of two components of eye movements: slow phase, which is compensatory movement to keep the visual image stationary on the retina (called vestibulo-ocular reflex; VOR), and quick phase, which rapidly reset the eye position deviation by slow phase. The proprioceptors of the vestibular system for VOR are the semicircular canals of the inner ear. There is also a pathological form resulting from damage to the vestibular system. The

direction of the slow phase is toward the labyrinth that has sustained damage.

► Burster-Driving Neurons  
 ► Vestibulo-ocular Reflexes  
 ► Semicircular Canals

## Vestibular Primary Afferent Pathways in Mammals

ADEL MAKLAD, FENG FENG, BERND FRITZSCH  
 Department of Biology, University of Iowa, Iowa City, IA, USA

### Synonyms

Vestibular system

### Definition

The primary vestibular and auditory neurons delaminate from the ventromedial aspect of the otocyst and migrate away to the presumptive vestibular (Scarpa's) and auditory (spiral) ganglion connecting the ear with the hindbrain. Primary vestibular afferents, which innervate the ►otolith organ and cristae sense linear and angular accelerations and thus help control a variety of motor and visceral systems. Vestibular primary afferent fibers enter the brainstem at the ponto-medullary junction. These fibers pass below the restiform body and then bifurcate into ascending and descending branches. The bundle containing thicker axons enters the medulla between the ventral aspect of the inferior cerebellar peduncle and the dorsal aspect of the spinal tract of the trigeminal nucleus. It turns caudally and then passes into the vestibular complex. The bundle with thinner axons ascends to the cerebellum by passing through the superior vestibular and lateral ►vestibular nuclei. The thin axons then distribute to several folia within the cerebellum, but primarily to the ipsilateral uvula-nodulus. The vestibular complex and uvula-nodulus are responsible for the initial processing of vestibular information by the central nervous system.

### Characteristics

The ear develops from placodal thickenings of the ectoderm on both sides of the hindbrain into a complex structure of ducts and recesses that contains the five vestibular endorgans (three canal cristae, the saccule and utricle) and the cochlea (Fig. 1).

From the ventromedial aspect of this otocyst, a group of neuroblasts delaminate under the influence

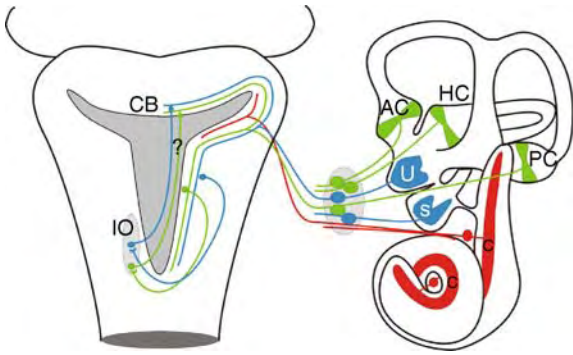

**Vestibular Primary Afferent Pathways in Mammals.** **Figure 1** Schematic of the vestibular pathway connections. Vestibular neurons (green and blue ovals) terminate with their distal processes in a given endorgan (green to angular acceleration sensitive cristae organs, blue to linear acceleration sensitive gravistatic organs). Central projections of these neurons reach the vestibular nuclei of the brainstem and the cerebellum (CB). In contrast, auditory neurons (red circles) project from the cochlea (C) to the auditory nuclei of the brainstem. Vestibular neurons in the vestibular nuclei receive partially overlapping angular and linear information from several canal cristae and otolith organs. Second order vestibular neurons project to distinct subnuclei of the inferior olive (IO), which in turn may project in a partially segregated fashion to the vermis. Abbreviations: AC anterior crista; C cochlea; CB cerebellum; HC horizontal crista; IO inferior olive; PC posterior crista; S saccule; U utricle.

of specific genes [1] and migrate away to form the vestibular ganglion between the ear and the hindbrain. There they differentiate into bipolar neurons, which contact the hair cells of the labyrinth and the second order vestibular neurons of the brainstem, the vestibular nuclei [1]. The vestibular neurons are located in the vestibular ganglion, also called Scarpa's ganglion, which is divided into two parts, the superior and the inferior divisions. The centrally projecting axons from the vestibular ganglion form, together with axons projecting from the auditory (spiral ganglion) neurites, the eighth (stato-acoustic) nerve. The central processes of the primary afferent vestibular neurons divide into an ascending and descending branch after entering the brain stem at the inner aspect of the restiform body (Fig. 1). The primary afferents terminate in the vestibular nuclei. Some primary vestibular neurites pass directly to the cerebellum, in particular the nodulus and uvula of the vermis [1].

### Topology of Vestibular Ganglion

Largely based on older techniques for tracing and on non-mammalian data, a clear-cut segregation of the vestibular ganglion neurons has been proposed based on their endorgans and the sensations they convey [2]. In the last two decades however, several reports have

been published that do not agree with this traditional notion [1]. These reports concluded that the vestibular ganglion neurons of rodents are not exclusively organized in an endorgan specific fashion. They are only partially segregated with some random distribution. Neurons from different endorgans that convey different information show an overlapping distribution (Figs. 1, 2).

Based upon ultrastructural characteristics, vestibular ganglion neurons can be classified into two main types, large neurons and small neurons. ▶ **Vestibular ganglion cells** vary in size with mean diameters ranging between 21 and 15  $\mu\text{m}$  depending on the species. These two size classes correspond to different functions based on their termination in the sensory epithelia [3]. Vestibular neurons are among the largest ganglion cells and can be 50  $\mu\text{m}$  in diameter. Quantification using various counting procedures has revealed numerical differences between studies as well as across development of a given species. For example, total numbers of the vestibular ganglion cells in mouse rise to peak with a mean of 9200 at E19, although there is a subsequent decline to an average of 4600 at P0 in rats, which is maintained through adult life. Whether or not this reported decline in numbers is mediated by the neurotrophic factors that are essential for vestibular ganglion survival [4] remains unclear. Using unbiased counting procedures, others reached different numbers for mice and humans.

A detailed mapping study of vestibular neuron location with respect to endorgans using selective dye applications [1] showed that the distribution of the vestibular ganglion cells for a given endorgan is not entirely random. Most of the ganglion cells labeled from a specific endorgan are tightly packed and surrounded by an area of sparse distribution, shared with other primary neurons that project to other endorgans (Fig. 2).

Having migrated to their definitive location, vestibular ganglion cells send axons to second order neurons in the vestibular nuclei and the cerebellum. Migration seems to depend on a number of factors [5] and the molecular basis of peripheral projection development shows an increasing list of very different molecules that are involved in finding the right endorgan and terminating there [5].

### Vestibular Primary Afferent Projection to Vestibular Nuclei

The primary afferent vestibular neurons project to four nuclei that comprise the vestibular complex. The four nuclei of the vestibular nuclear complex are the lateral vestibular nucleus (also called Deiter's nucleus), the medial vestibular nucleus, the superior vestibular nucleus and the inferior (or descending) vestibular nucleus. Several smaller nuclei not included in the

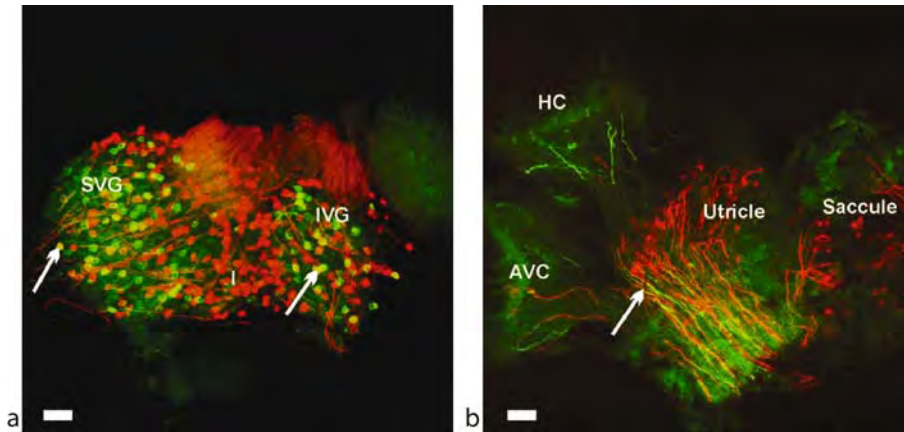

**Vestibular Primary Afferent Pathways in Mammals. Figure 2** Retrograde labeling of vestibular primary afferent projection to cerebellum. Retrograde filling of sensory neurons (a) and of afferents in the vestibular epithelia (b) is shown after a double application in the nodulus (green) and in the uvula (red) of a 10-day-old mouse. Note the few double labeled sensory neurons in the vestibular ganglion (a arrows; yellow cells) that suggests that only few sensory neurons have branches to both folia of the cerebellum. The sensory neurons to the uvula (red, a) show an aggregation in the isthmus region (I). Fibers to the gravistatic maculae derive predominantly from the uvula (red, b) whereas fibers to the cristae are more often labeled from the nodulus (green, b). Bar indicates 100 μm.

classical groups, the parasolitary nucleus, Y-group and X-group also receive vestibular primary afferents [6].

It is generally agreed that, in vestibular central representation, each endorgan has a domain of almost exclusive projection and a domain of sparse projection overlapping with other endorgans (Fig. 2), reproducing the peripheral distribution pattern at the level of the ganglion [7]. Such a partial functional as well as anatomical overlap is best studied in the frog [8]. In rats and mice, anterior and lateral cristae, utricle and saccule maculae are in relation with neurons largely overlapping in the superior ganglion. Neurons localized in the inferior ganglion and connected to the posterior crista and saccular macula show tighter clustering but incomplete segregation [1]. This central overlapping pattern may be a universal functional feature of the vestibular system in which monosynaptic afferent canal and otolith inputs [8] converge. These convergent inputs are capable of responding in a finely graded fashion to signals originating from more than one endorgan [7].

### Superior Vestibular Nucleus

Mice show an extensive overlap of fibers of gravistatic and cristae afferents (Fig. 3).

Despite the overlap of these endorgans throughout the nucleus, saccular terminals tend to be more in the lateral and ventral region of the nucleus, while the posterior canal terminals concentrate in the dorsal and medial regions [9]. In the gerbil, saccular projections are sparse [7] and utricular nerve terminations are seen primarily in the lateral part of the nucleus [7]. The

posterior canal projects to the medial superior vestibular nucleus. Lateral canal afferents project to the larger part of the nucleus, with heavier projections rostrally and medially while anterior canal afferents project most heavily medially, centrally and inferiorly [7]. Anterior afferents project most strongly to the medial portion of the nucleus in the pigeon [7], squirrel monkey and cat [2] though in the latter species anterior canal terminals are present throughout that nucleus. Lateral canal afferents project primarily to the central [2] or medial portion of the nucleus in the pigeon, the medial and ventral portion in the squirrel monkey [7] and ventrally in the cat, though terminals are present through the nucleus [7].

### Lateral Vestibular Nucleus

The lateral vestibular nucleus is classified into two divisions based on cytoarchitecture and afferent and efferent connections. The dorsal division of the lateral vestibular nucleus contains multipolar giant cells [7]. Previous reports stated that the dorsal lateral vestibular nucleus does not receive primary vestibular afferent in birds, gerbils [7], cats and monkeys [7]. Others suggested the existence of a minor primary vestibular input in opossum, chinchilla and guinea pig. The mouse data reported substantial overlapping projection from the saccule and posterior canal [1]. There is still argument about primary vestibular afferent projection to the ventral lateral vestibular nucleus. Some investigators reported exclusive gravistatic projections [7] or exclusive utricular projection. Others reported a projection common to otolith and canals [2].



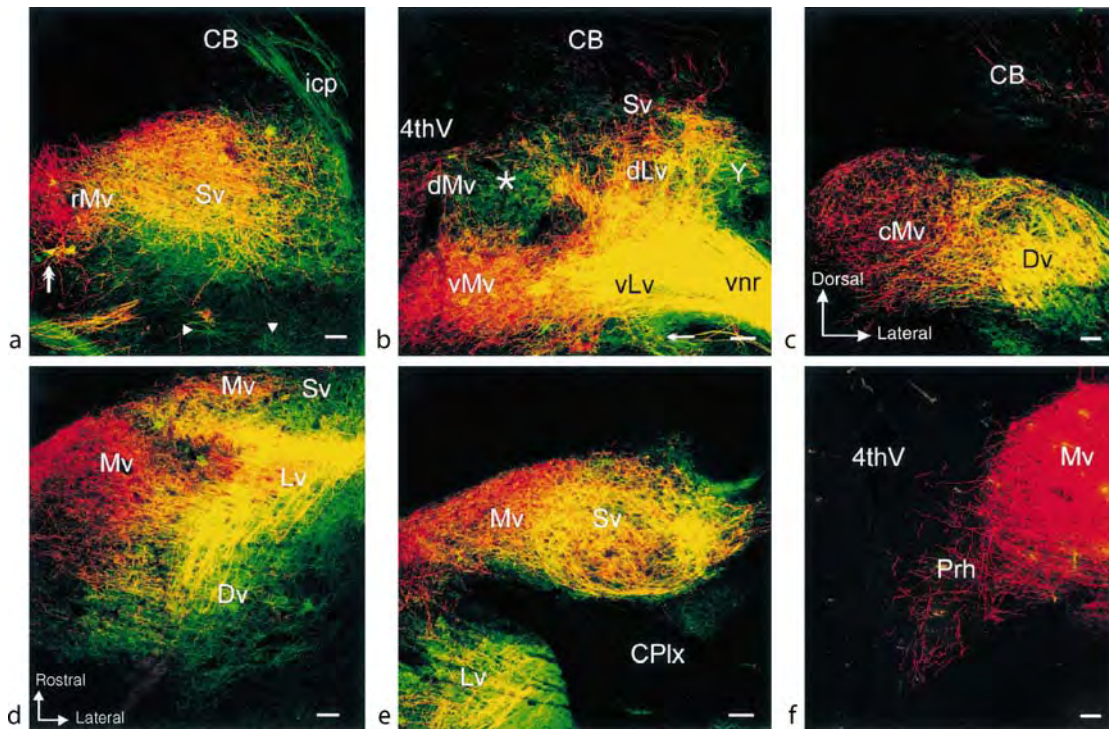

**Vestibular Primary Afferent Pathways in Mammals. Figure 3** Central projection of vestibular endorgans. Central projection of the saccule and posterior crista (PC) at P7 mice as shown in transverse (a-c) and horizontal (d-f) sections. (a) Section of the brainstem at the rostral nuclear level, showing the segregation and overlap of the saccular and PC projections in the superior (Sv) and medial (rMv) vestibular nuclei. Note the single and double-labeled efferent neurons near the rMv (arrow). (b) A section of the brainstem at midnuclear level shows the saccular and PC projections to the various components of the vestibular nuclear complex. Note that there are areas of segregation (indicated by asterisk, Y, vMv, double arrow) as well as areas of overlap. (c) A section of the brainstem at the caudal nuclear level shows the overlapping projection of the saccule and PC projections to the Dv and Mv. (d) This section demonstrates the vertical segregation of the saccule and PC projection. Note that the saccular projection is more prominently to the more lateral parts compared to the medial projection of the PC. (e) This more dorsal section shows the distribution of the saccule and PC fibers in the Sv and rMv. Note the segregation in the Mv and Lv, but overlap in Sv. (f) A more ventral section shows only the PC projection throughout the rostrocaudal extent of the Prh. Abbreviations: CB cerebellum; cMv caudal medial vestibular nucleus; Dv descending vestibular nucleus; icp inferior cerebellar peduncle; Lv lateral vestibular nucleus; Mv medial vestibular nucleus; Prh prepositus hypoglossus; Sv superior vestibular nucleus; vLv ventral lateral vestibular nucleus; vMv ventral medial vestibular nucleus; vnr vestibular nerve root. Orientation of (a-c) is indicated in (c) and (d-f) is indicated in (d). Bar indicates 100  $\mu$ m.

### Medial Vestibular Nucleus

This nucleus has medium to small size neurons and is involved in projections to the extraocular motor nuclei, the medial vestibulospinal tract and the vestibular commissural system [6]. In birds, otolith and canal projections are topographically organized with variable degrees of overlap [2]. In mammals, the anterior and posterior canals project heavily and completely to the medial vestibular nucleus. The densest posterior canal projections were reported rostro-laterally in the cat, while in the gerbil, mouse and guinea pig these projections were more distributed throughout the nucleus [1]. The otolith projection has a circular region in the dorsal lateral quadrant of the medial vestibular nucleus that is surrounded by the posterior canal fibers [1].

### Inferior Vestibular Nucleus

The inferior vestibular nucleus projects to the spinal cord, contralateral vestibular nuclei, cerebellar vermis and ►cerebellar nuclei [6]. In pigeon, overlapping, but more topographically organized projections from the canals and otolith organs were reported [2]. In mice, terminals from both endorgans were obvious in the central and lateral part of the inferior vestibular nucleus where the more numerous saccular terminals overlap with the posterior canal fibers [1]. Similar arrangements were found in the monkey. This nucleus also receives fibers from the vermis of the cerebellum and appears to be a site where vestibular inputs are integrated with inputs from other sensory systems and inputs from the cerebellum [6].

### Cell Group Y and X

Cell group Y is a small cell group positioned dorsal to the restiform body, medial to the dorsal cochlear nucleus and lateral to the lateral vestibular nucleus. Exclusive saccular projection to group Y was described in cat, gerbil and monkey. The most profound saccular input is to the ventral portion of Y [7], while much less is targeted to the dorsal portion. However, more dorsolateral projections from the posterior canal are reported in mice [1]. Cell group X receives spinal input from C1 to C3 dorsal roots and projects to the cerebellum. In macaque, opossum and cat, this nucleus is also reported to receive cerebellar afferents from the fastigial nucleus. More recent data showed a minor input to this nucleus largely from the saccule and posterior canal in the newborn mouse [1].

### Vestibular Primary Afferent Projections to Cerebellum

Although, several cerebellar folia receive scattered projections from vestibular primary afferents, the terminals

of more than 90% are restricted to the ipsilateral uvula-nodulus [6]. Only a fraction of vestibular afferents projects to other cerebellar folia [1]. Vestibular afferent fibers are among the earliest in development to reach the cerebellum [1] and contact the granule cells and the unipolar brush cells as mossy fibers in neonates [10]. Brodal and Hoivik suggested that primary vestibular afferents reach the flocculus, nodulus, ventral and lateral cerebellum nucleus. Subsequent reports suggested different vermal folia as receiving primary vestibular afferent projections.

### Cerebellar Nucleus

The topography of vestibular primary afferent projections to the cerebellar nuclei is still unclear. Carpenter described primary vestibulocerebellar afferent fibers to the medial cerebellar nucleus of cat while others saw fibers passing through but were not able to determine if they were fibers of passage or terminals. In rat, fibers detected by degeneration methods appear

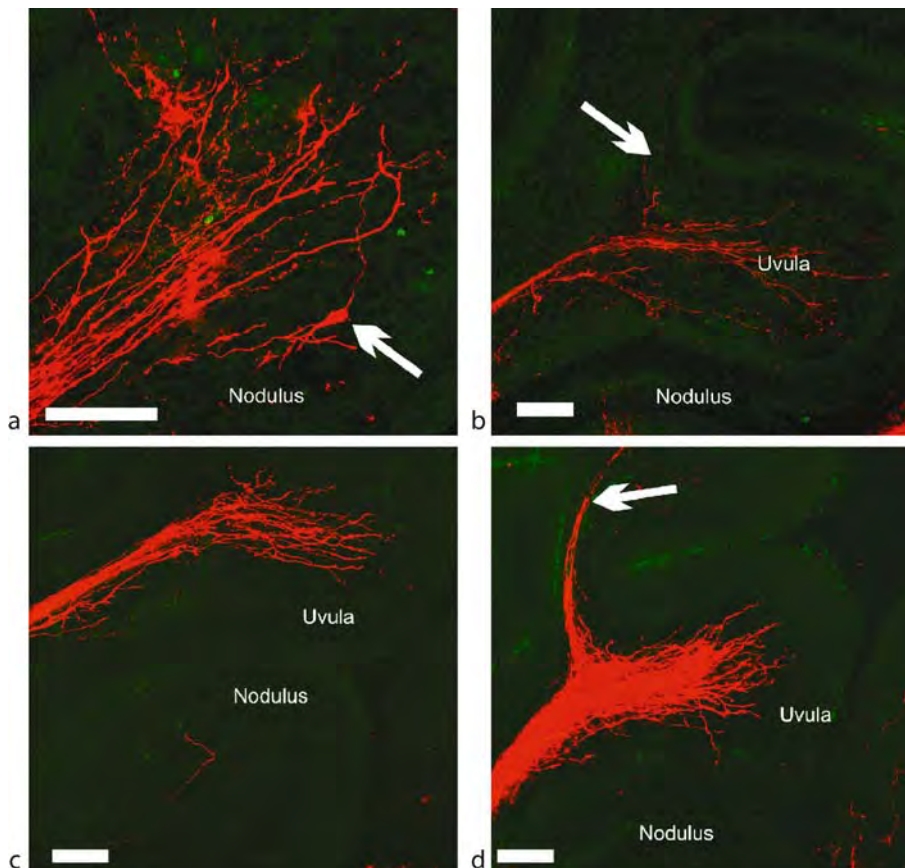

**Vestibular Primary Afferent Pathways in Mammals. Figure 4** Projection of vestibular primary afferents to the cerebellum. The tracer application was restricted to the posterior crista (a and b) or saccular macula (c and d) in P7 mice. Primary afferent projections to the cerebellum from the posterior crista are most prominent to the nodulus (b) with fewer fibers to the uvula (a). In contrast, primary saccular afferents projected mainly to the uvula, with only occasional fibers extending to nodulus (c and d). Fibers terminate in the inner granular layer with a prominent projection to unipolar brush cells shown transcellularly filled in (b). Bar indicates 100  $\mu$ m.

to project only to caudal portions of the medial cerebellar nucleus. Dye tracing studies have demonstrated saccular projections to the lateral and interposed cerebellar nuclei and utricular projections to the medial and anterior interposed cerebellar nuclei [7]. Lateral and anterior canal afferents also terminate in the interposed nucleus [7].

### Vermis

Primary vestibular afferents end in a common and overlapping pattern in the vermis, particularly in the uvula and nodulus [10]. Other data suggested that only 60% of all primary afferents project directly to the cerebellum, almost exclusively to the nodulus and uvula [1]. Physiological data demonstrate that primary vestibular neurons convey angular and linear motion to the vestibulo-cerebellar cortex in specific, partially segregated patterns (Fig. 3).

The nodulus receives a much more prominent input from the canal cristae. In contrast, the uvula receives mixed projections biased toward fibers from the maculae and, to a lesser extent, from the canal cristae [1,2,10]. Some reports mention utricular projections to the dorsal uvula in some species [7], while anterior and lateral canal afferents project primarily to uvula and nodulus [7]. Retrograde tracing studies support the notion of a segregated cerebellar projection [1,6]. The primary afferent vestibular input is largely restricted to the vermis, mainly to the nodulus and uvula, with very sparse projection to other vermal folia [1]. Earlier reports of an extensive and topographic projection of the ear to the flocculus and paraflocculus [6] were not confirmed by others. The vermis also receives vestibular climbing fibers originating from two subnuclei of the contralateral inferior olive, the  $\beta$ -nucleus and dorsomedial cell column (Fig. 4). They cross the midline to synapse on Purkinje neurons in the contralateral uvula-nodulus [6].

### Conclusion

The topology of vestibular afferent inputs to the vestibular nuclei and cerebellum is both segregated and overlapped. The overlap of primary afferent terminals from several endorgans provides opportunities for sensory integration. Overall, the lateral vestibular nucleus receives inputs from the utricle and ►semicircular canals. The medial and superior vestibular nucleus receives inputs primarily from the semicircular canals. The inferior vestibular nucleus receives inputs from semicircular canals, utricle, saccule and cerebellar vermis. Several cerebellar folia receive scattered projections from vestibular primary afferents; the terminals of more than 90% are restricted to the ipsilateral uvula-nodulus. Vestibular ascending fibers originate from two subnuclei of the inferior olive, the  $\beta$ -nucleus and dorsomedial cell column. It is

possible that the differential information processing of angular and linear acceleration information in vestibular nuclei is related to these subnuclei, which in turn project to the cerebellar vermis, which receives a segregated input from primary vestibular afferents (Fig. 4). While some evidence for such a parallel and convergent processing system exists, not all the details have been verified through multicolor tract tracing.

### References

1. Maklad A, Fritsch B (2003) Development of vestibular afferent projections into the hindbrain and their central targets. *Brain Res Bull* 60:497–510
2. Dickman JD, Fang Q (1996) Differential central projections of vestibular afferents in pigeons. *J Comp Neurol* 367:110–131
3. Xiang Z, Bo X, Burnstock G (1999) P2X receptor immunoreactivity in the rat cochlea, vestibular ganglion and cochlear nucleus. *Hear Res* 128:190–196
4. Fritsch B, Tessarollo L, Coppola E, Reichardt LF (2004) Neurotrophins in the ear: their roles in sensory neuron survival and fiber guidance. *Prog Brain Res* 146:265–278
5. Fritsch B, Pauley S, Matei V, Katz DM, Xiang M, Tessarollo L (2005) Mutant mice reveal the molecular and cellular basis for specific sensory connections to inner ear epithelia and primary nuclei of the brain. *Hear Res* 206:52–63
6. Barmack NH (2003) Central vestibular system: vestibular nuclei and posterior cerebellum. *Brain Res Bull* 60:511–541
7. Newlands SD, Purcell IM, Kevetter GA, Perachio AA (2002) Central projections of the utricular nerve in the gerbil. *J Comp Neurol* 452:11–23
8. Straka H, Holler S, Goto F (2002) Patterns of canal and otolith afferent input convergence in frog second-order vestibular neurons. *J Neurophysiol* 88:2287–2301
9. Maklad A, Fritsch B (2002) The developmental segregation of posterior crista and saccular vestibular fibers in mice: a carbocyanine tracer study using confocal microscopy. *Brain Res Dev Brain Res* 135:1–17
10. Dino MR, Perachio AA, Mugnaini E (2001) Cerebellar unipolar brush cells are targets of primary vestibular afferents: an experimental study in the gerbil. *Exp Brain Res* 140:162–170

## Vestibular Secondary Afferent Pathways

V

NEAL H. BARMACK

Neurological Sciences Institute, Oregon Health & Science University, Beaverton, OR, USA

### Synonyms

Vestibular nuclei; Secondary vestibular circuitry

## Definition

Vestibular secondary afferent pathways are neural circuitry that includes the afferent and efferent connections of vestibular nuclear neurons. The vestibular nerve branches as it enters the brain stem into two fiber bundles containing axons of unequal thickness. One branch, containing thicker axons, enters the medulla between the ventral aspect of the inferior cerebellar peduncle and the dorsal aspect of the spinal tract of the trigeminal nucleus. This branch turns caudally and passes into the vestibular complex. The branch with thinner axons ascends to the cerebellum by passing through the superior vestibular and lateral vestibular nuclei (SVN, LVN). This review focuses on secondary vestibular neurons, their afferent and efferent connections and some of the reflex functions of the central nervous system to which this circuitry contributes.

## Characteristics Vestibular Nuclei

The vestibular complex has four “classical” nuclear groups, (i) medial vestibular nucleus, MVN, (ii) descending (or spinal) vestibular nucleus, DVN, (iii) lateral vestibular nucleus (Deiter’s), LVN and (iv) superior vestibular nucleus, SVN. The borders of the individual vestibular nuclei are difficult to distinguish based on cytological characteristics (Fig. 1).

Several smaller nuclei, not included in the “classical” group, nonetheless receive vestibular primary afferents. These include (i) the parasolitary nucleus (PsoI), (ii) Y-group and (iii) the nucleus intercalatus (Staderini). The PsoI lies wedged between the MVN and DVN in the most caudal part of the vestibular complex. It consists of a compact cluster of small GABAergic neurons extending from the tract of the solitary nucleus to the surface of the fourth ventricle (Fig. 2).

The Y-group is divided into dorsal and ventral divisions. The ventral division lies in a crescent that encapsulates the inferior cerebellar peduncle, lateral to the caudal aspect of LVN. The dorsal division lies below the interpositus nucleus, caudal to where the cerebellum joins the brainstem. Rostrally, the dorsal and ventral divisions merge.

Dorsal Y-group neurons receive ipsilateral vestibular primary afferents, as well as bilateral projections from vestibular secondary afferents. The ventral division of the dorsal Y-group projects to the ipsilateral flocculus, nodulus and contralateral oculomotor complex. The dorsal division projects contralaterally to the dorsal cap and beta nucleus of the inferior olive (Fig. 2a,b).

Three nuclei adjacent to the vestibular complex lack primary afferent vestibular projections, but are nonetheless often included in discussions of the vestibular complex. The nucleus prepositus hypoglossi (NPH) receives most of its input from secondary vestibular neurons, as well as projections from cerebellum and

cerebellar nuclei. Cells in the NPH project bilaterally to the vestibular nuclei, most densely to the ipsilateral MVN, DVN and ventrolateral LVN. The NPH also projects to the flocculus, reticular formation, medial rectus subdivision of the ipsilateral oculomotor nucleus (III), contralateral abducens nucleus (VI) and contralateral dorsal cap of the inferior olive (Fig. 2a). The descending projection to the dorsal cap is composed of cells expressing acetylcholine and GABA.

Single unit recording from NPH neurons suggests that the NPH encodes vestibular and eye movement-related information. In the monkey, the activity of NPH neurons is not modulated by either vestibular or optokinetic stimulation when the monkey is trained to maintain fixation. Rather NPH neurons encode eye position exclusively.

Two other nuclei lie adjacent to the vestibular complex. Nucleus x, is a small-celled nucleus lateral to the caudal DVN. Nucleus z consists of a cluster of small cells rostral to the anterior pole of the nucleus gracilis. The functions of these nuclei remain unknown.

## Topography of Primary Afferent Projections to the Vestibular Complex

Topography within the vestibular complex exists, but it does not conform to the cytoarchitecturally defined boundaries. Within the SVN, secondary neurons responsive to stimulation of the ipsilateral anterior semicircular canal are found more laterally than are neurons responsive to stimulation of the ipsilateral horizontal semicircular canal.

A second kind of “negative topography” is indicated by the projection of horizontal semicircular canal afferent terminals to all vestibular nuclei *except* the LVN and PsoI. PsoI neurons are driven exclusively by stimulation of the ipsilateral vertical semicircular canals and otoliths. Secondary neurons within the LVN receive vestibular primary afferents from the ipsilateral sacculus.

## Vestibular Primary Afferent Convergence

While vestibular primary afferents may convey information from single end organs, the discharge of secondary vestibular neurons indicates convergence of information from more than one end organ. This convergence combines information from semicircular canals and otoliths. Some secondary neurons may retain inputs only from single otoliths. Such “private lines” might be useful in discriminating stimuli that fall within the frequency ranges of both semicircular canals and otoliths.

## Vestibular Internuclear Projections

The pattern of interconnections within the vestibular complex has been mapped with microinjections of HRP into the vestibular complex of the rabbit. Interconnections between the SVN–DVN and SVN–MVN are

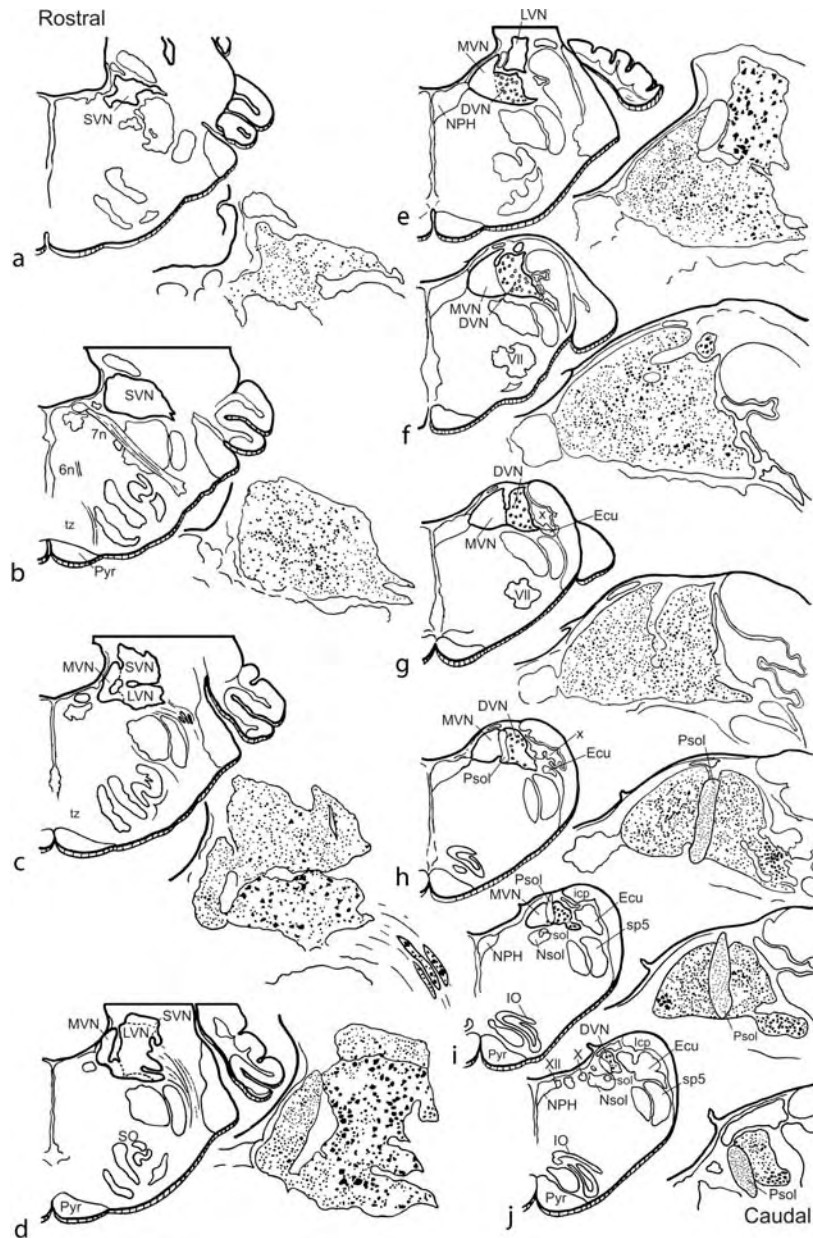

**Vestibular Secondary Afferent Pathways. Figure 1** Vestibular nuclei of the cat. Transverse sections extend from the rostral (a) through the caudal (j) poles of the vestibular complex. Abbreviations: *DVN*, descending vestibular nucleus; *Ecu*, external cuneate nucleus; *icp*, inferior cerebellar peduncle; *IO*, inferior olive; *LVN*, lateral vestibular nucleus; *MVN*, medial vestibular nucleus; *NPH*, nucleus prepositus hypoglossi; *Nsol*, solitary nucleus; *Psol*, parasolitary nucleus; *Pyr*, pyramidal tract; *SO*, superior olive; *sol*, solitary tract; *sp5*, spinal trigeminal nucleus; *SVN*, superior vestibular nucleus; *tz*, trapezoid nucleus; *VII*, facial nucleus; *X*, dorsal motor nucleus of vagus; *XII*, hypoglossal nucleus; *6n*, abducens nerve; *7n*, facial nerve. Modified from [1].

reciprocal. A group of larger neurons in the rostro-ventral MVN, SVN and LVN receive inputs from smaller cell regions of MVN, SVN and DVN, but do not reciprocate. The MVN has a non-reciprocal projection to the DVN. The dorsal Y-group receives projections from both ipsilateral and contralateral SVN.

### Vestibular Commissural Projections

The vestibular nuclei, with the exceptions of the LVN and Psol, are topographically interconnected through the commissural system. However, the commissural connections are not restricted to homologous nuclei (Fig. 3).

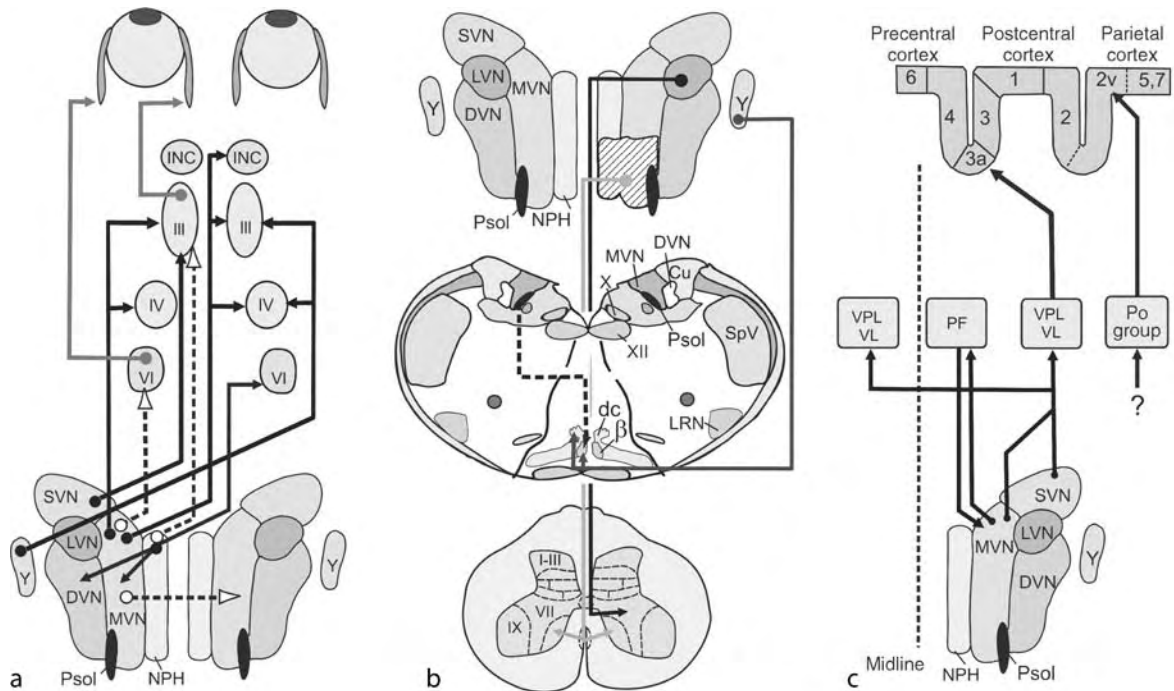

**Vestibular Secondary Afferent Pathways. Figure 2** Ascending and descending connections of the vestibular complex. (a) Projections of vestibular complex onto oculomotor apparatus. (b) Descending projections of vestibular complex to spinal cord and to inferior olive. (c) Ascending projections of vestibular complex to thalamus and cortex. Abbreviations:  $\beta$ ,  $\beta$ -nucleus; *Cu*, cuneate nucleus; *dc*, dorsal cap of Kooy; *DVN*, *MVN*, *LVN*, *SVN*, descending, medial, lateral and superior vestibular nuclei; *INC*, interstitial nucleus of Cajal; *LRN*, lateral reticular nucleus; *NPH*, nucleus prepositus hypoglossi; *PF*, parafascicular nucleus; *PsoI*, parasolitary nucleus; *SpV*, spinal trigeminal nucleus; *PO group*, posterior thalamic nuclear group; *VL*, ventrolateral nucleus; *VPL*, ventral posterior lateral nucleus; *III*, *IV*, *VI*, oculomotor cranial nuclei; *X*, dorsal motor nucleus of vagus; *XII*, hypoglossal nucleus; *Y*, *Y*-group. Modified from [2–4,5].

Rather, cells within a nucleus on one side of the brainstem, say the left *MVN*, project to the contralateral *SVN* and *DVN* as well as the contralateral *MVN*. Electrical stimulation of the utricular macula evokes excitation in ipsilateral secondary vestibular neurons and inhibition in more than 50% of the contralateral secondary vestibular neurons excited by ipsilateral utricular stimulation. Only 10% of ipsilaterally saccular-sensitive secondary vestibular neurons are inhibited by contralateral saccular stimulation.

#### Ascending Projections of Vestibular Nuclei

Targets of secondary vestibular afferents are diverse. The rostral halves of *DVN*, *MVN* and *SVN* provide an ascending input to cranial motor nuclei *III*, *IV* and *VI*, controlling the reciprocal contractions of extraocular muscles. Other brainstem nuclei that receive ascending projections from secondary vestibular neurons include nucleus Darkschewitch, sensory trigeminal nucleus, interstitial nucleus of Cajal and the subparafascicular complex. The subparafascicular complex projects reciprocally back to the ipsilateral *MVN* (Fig. 2c).

Several ascending projections to the thalamus-cortex originate from the rostral part of the vestibular complex to the ventrobasal thalamus (*VPL*, *VPM*, *VPI* and *VPL*) (Fig. 2c). Neurons in the ventrobasal complex are driven by stimulation of deep proprioceptors and joint receptors as well as vestibular inputs.

Vestibular thalamo-cortical projections terminate in areas 3aV and T3 and parietal visual cortex. These cortical areas receive optokinetic and somatosensory as well as vestibular inputs (Fig. 2c). Humans with damage to parietal cortex do not recognize true vertical. Deprived of surrounding visual cues, they cannot correctly align a disk with a line on it so that the line has a true vertical orientation. Cortical vestibular areas project back to the vestibular complex, suggesting that these cortical regions may supersede reflexes evoked by activity in vestibular primary afferents.

The caudal aspect of the *NPH* and *MVN* project to several folia within the cerebellum, including the anterior and posterior vermis and flocculus. Immunohistochemical surveys show that most, if not all of these ascending projections are cholinergic and originate from the caudal *MVN* and *NPH*. Immunohistological

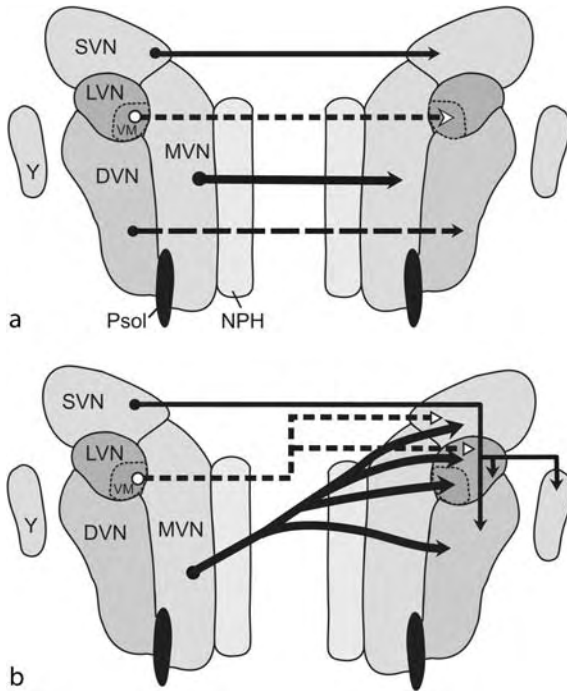

### Vestibular Secondary Afferent Pathways.

**Figure 3** Commissural projections within the vestibular nuclei of the gerbil. (a) Three vestibular nuclei (SVN, MVN and DVN) have homologous and reciprocal connections. The LVN and PsoI do not. (b) The vestibular nuclei also have divergent connections to non-homologous contralateral vestibular nuclei. Abbreviations: *DVN*, *MVN*, *LVN*, *SVN*, descending, medial, lateral and superior vestibular nuclei; *NPH*, nucleus prepositus hypoglossi; *PsoI*, parasolitary nucleus; *Y*, Y-group. Modified from [6].

results are consistent with radiochemical measurements of choline acetyltransferase (ChAT) activity in tissue samples obtained from the vestibular nuclei using the “micropunch” technique. Enzymatic measurements of ChAT activity in the MVN show that activity is higher by at least a factor of 10 than the ChAT activity of the SVN, DVN or LVN. The cholinergic projection to the uvula-nodulus, determined by immunohistochemistry and a regional assay for ChAT activity, is greatest to folia 9d and 10. The ventral paraflocculus also receives a dense cholinergic projection. The flocculus and folia 1 receive less.

### Descending Projections of Vestibular Nuclei

Descending lateral and medial vestibulospinal tracts originate from the LVN and MVN and DVN. The lateral vestibulospinal tract is organized within the LVN topographically. Fibers from the lumbosacral spinal cord originate from the dorsocaudal LVN. Fibers to the cervical cord originate from the rostroventral LVN (Fig. 2b). Axons in the lateral vestibulospinal tract

terminate in the ipsilateral lumbosacral region where they make monosynaptic and polysynaptic connections with motoneurons. Axons in the medial vestibulospinal tract terminate bilaterally in the medial part of the cervical ventral horn. The bilateral representation of vestibulospinal axons is most dense in the cervical enlargements from which motoneurons supplying the suboccipital muscles originate. These motoneurons participate in vestibulocollic reflexes.

Outputs of vestibular nuclei not only evoke reflexes mediated by skeletal muscles, they evoke autonomic reflexes as well. Vestibulo-sympathetic reflexes modulate local changes in blood flow, respiration rate and heart rate. These reflexes are abolished by lesions of the caudal MVN and DVN in cats.

The circuitry by which these vestibular-autonomic effects are induced includes projections from the caudal vestibular nuclei (DVN, MVN and PsoI) to the solitary nucleus (Nsol). The Nsol receives autonomic afferents from the heart, esophagus and stomach, carried chiefly by branches of the IX and X cranial nerves. Neurons in the cerebellar fastigial nucleus respond to changes in blood pressure, heart rate and respiration. Moreover, electrical stimulation of the cerebellar uvula or fastigial nucleus modifies blood pressure, heart rate and respiration.

### Visual Influences on Vestibular Nuclei

Vestibular primary afferents comprise only one of the sensory inputs to the vestibular complex. Most secondary vestibular neurons are driven by visual (optokinetic) as well as vestibular stimulation. Although visual signals to the vestibular nuclei originate from a variety of brainstem and cortical sources, the best-understood pathways by which optokinetic signals reach the vestibular complex comprise the ►accessory optic system (AOS) (Fig. 4).

The AOS includes the medial, dorsal and lateral terminal nuclei, MTN, DTN, LTN and the nucleus of the optic tract, NOT. Each nucleus within the AOS receives projections from direction selective retinal ganglion cells having large receptive fields and preferred stimulus vectors. For example, NOT neurons respond to temporal-to-nasal optokinetic stimulation of the contralateral eye at velocities of  $0.1\text{--}30^\circ\text{s}^{-1}$  and have receptive fields larger than 50.

These receptive field characteristics suggest that AOS neurons detect self-motion rather than the motion of external objects, such as the flight of a bird or a baseball. This information is combined with the spatial information provided by vestibular primary afferents at the level of the vestibular nuclei, NPH, nucleus reticularis tegmenti pontis, dorsolateral pontine nuclei and inferior olive.

While the anatomy and physiology of the AOS have been described most extensively in mammals such as the rabbit, the same fundamental details have been confirmed in primates. In all mammals there is a

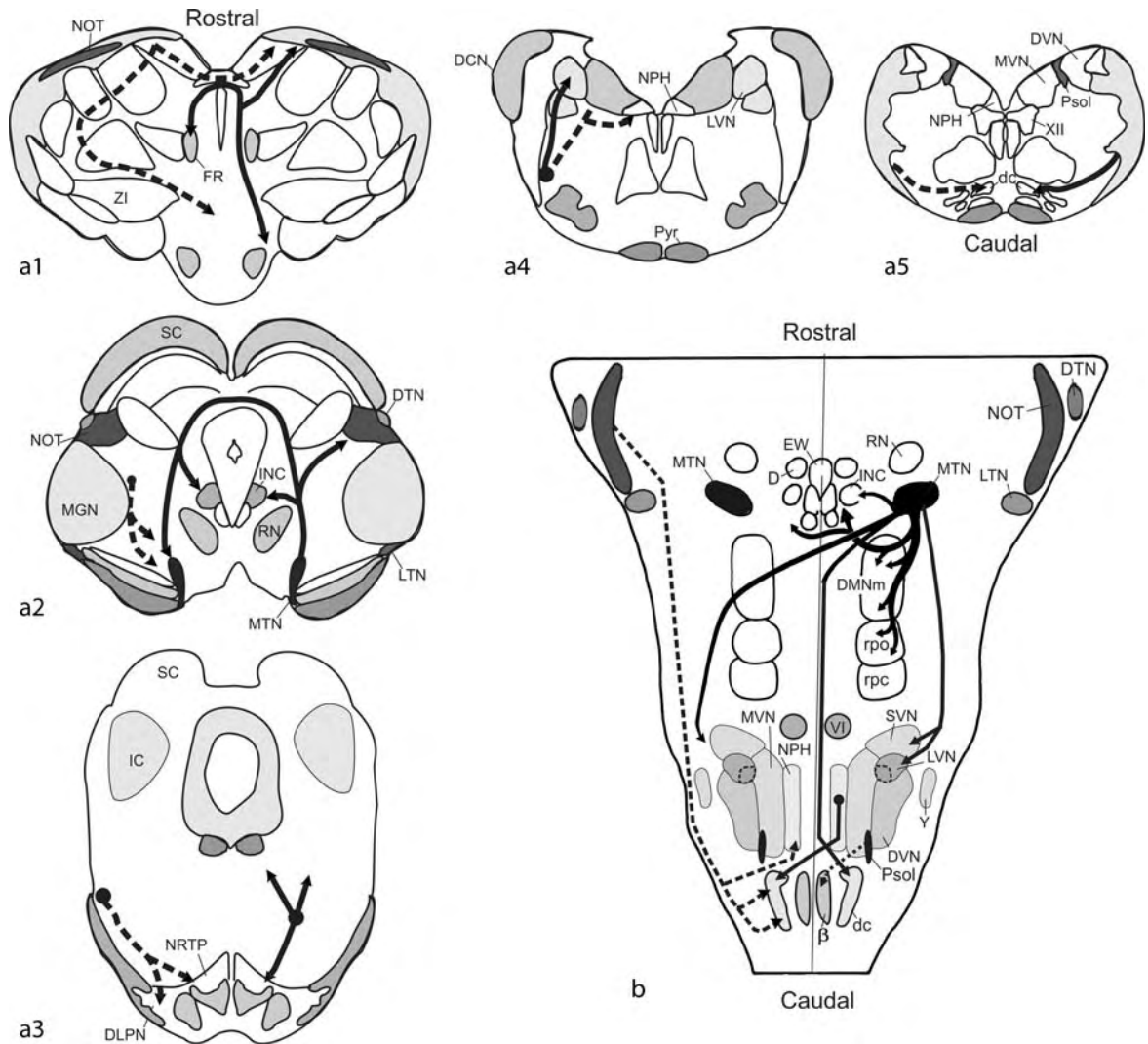

**Vestibular Secondary Afferent Pathways. Figure 4** Pathways by which optokinetic information reaches the vestibular system. (a1–a5) Transverse sections through the brainstem of the rabbit, from rostral (a1) to caudal (a5). Note the descending connections of the nucleus of the optic tract (*NOT*) (*dashed lines*) and ascending and descending connections of the medial terminal nucleus (*MTN*) (*solid black lines*). These transverse sections correspond to different rostral-caudal levels of the brainstem. (b) Horizontal section through the brainstem showing the caudal paths taken by the descending projections originating from the *NOT* (*dashed lines*) and *MTN* (*solid black lines*). Abbreviations:  $\beta$ ,  $\beta$ -nucleus; *D*, nucleus of Darkschewitsch; *dc*, dorsal cap of Kooy; *DCN*, dorsal cochlear nucleus; *DLPN*, dorsolateral pontine nucleus; *DMNm*, deep mesencephalic nucleus; *DTN*, dorsal terminal nucleus; *DVN*, descending vestibular nucleus; *EW*, Edinger–Westphal nucleus; *FR*, fasciculus retroflexus; *IC*, inferior colliculus; *icp*, inferior cerebellar peduncle; *INC*, interstitial nucleus of Cajal; *LTN*, lateral terminal nucleus; *LVN*, lateral vestibular nucleus; *MGN*, medial geniculate nucleus; *MTN*, medial terminal nucleus; *MVN*, medial vestibular nucleus; *NOT*, nucleus of the optic tract; *NPH*, nucleus prepositus hypoglossi; *NRTTP*, nucleus reticularis tegmenti pontis; *OT*, optic tract; *Psol*, parasolitary nucleus; *Pyr*, pyramidal tract; *RN*, red nucleus; *rpc*, nucleus reticularis pontis caudalis; *rpo*, nucleus reticularis pontis oralis; *SC*, superior colliculus; *SVN*, superior vestibular nucleus; *VI*, abducens nucleus; *XII*, hypoglossal nucleus; *ZI*, zona incerta. Modified from [7].

descending projection from the visual cortex to the AOS. In primates this projection originates from the pre-striate cortex (areas OAa and PGa). Selective stimulation or inactivation of this region modifies the directional selectivity of neurons in the AOS.

#### Neck-Proprioceptive Inputs to Vestibular Nuclei

Signals from proprioceptors embedded in the inter-transverse muscles at the base of the cervical vertebrae also activate secondary vestibular neurons. Injection of HRP into the caudal *MVN* and *DVN* retrogradely



labels neurons ipsilaterally in the C<sub>2</sub>–C<sub>3</sub> spinal ganglia, contralaterally in the central cervical nucleus and bilaterally in C<sub>1</sub>–C<sub>6</sub> dorsal horn cells. Cells in the dorsal horn, cervical nucleus and spinal ganglia do not project to the LVN, SVN and most of DVN. Neurons in the vestibular complex also receive secondary cervical afferents relayed through the external cuneate nuclei. Movement of the head with respect to the body stimulates neck proprioceptors and evokes reflexive eye movements as well as postural adjustments of the limbs.

### Cerebellar Projections to the Vestibular Complex

Cerebellar projections to the vestibular complex include, but are not restricted to, nodular efferents. Purkinje cells located within sagittal zones in the uvula, as well as the nodulus project to different regions within the vestibular complex.

While regions of the vestibular complex receiving Purkinje cell projections overlap with the same regions providing bilateral, mossy fiber, cholinergic projections to the uvula-nodulus, the overlap is far from perfect. The dorso-caudal MVN and DVN receive dense projections from uvula-nodular Purkinje cells. This region partially overlaps the areas within the MVN, DVN and ventral LVN from which the medial vestibulo-spinal tract originates. The uvula-nodulus also projects to the SVN.

Within the vestibular complex, only LVN neurons receive a uniformly dense cerebellar projection. This projection arises from the “b zone” of the vermis; a zone defined on the basis of its climbing fiber projections from the forelimbs and hindlimbs of the cat. The non-uniform immunolabeling of the MVN, NPH, SVN, DVN and PsoL suggests a functional specialization within each nucleus that is determined not only by its efferent projections, but also by whether it receives direct cerebellar projections.

### Reflexive Movements Evoked by Activity in Secondary Vestibular Neurons

Natural stimulation of the vestibular, optokinetic and neck proprioceptive systems evokes reflexive movements. These movements include those of the eyes, ears, head and trunk as well as reflexive contractions of gut smooth muscle and reflexive changes in heart rate, blood pressure and respiration. Secondary vestibular neurons participate in several different “field-holding reflexes,” the purpose of which is to maintain a stable spatial environment. These reflexes include the vestibuloocular reflex (VOR), optokinetic reflex (OKR), cervicoocular reflex (COR), vestibulocollic reflex (VCR) and other postural reflexes involving forelimb muscles and axial musculature of the trunk.

Each reflex has a unique gain (response amplitude/stimulus amplitude) and frequency range over which it operates. In rabbits, for stimulus amplitudes of 20, the

VOR evoked by stimulation of the semicircular canals operates over a frequency range of 0.02–5.00 Hz, with a peak gain of 0.90 at a frequency of 0.40 Hz. The otolithic component of the VOR operates over a lower frequency range (0.005–0.10 Hz), with a peak gain of about 0.50 at a frequency of 0.02 Hz. The frequency ranges of the OKR, COR and VCR are comparable to that of the otoliths.

Head movements activate four reflexes synergistically (VOR, OKR, COR, VCR) (Fig. 5).

Movement of the head to the left stimulates the hair cells in the ampulla of the left horizontal semicircular canal. If the eyes are open during the leftward head movement, directionally selective ganglion cells in the left eye are stimulated as the visual field drifts across the left retina in the temporal-nasal direction. Finally, neck proprioceptors embedded in the transversospinal muscles at the base of the right cervical vertebrae are stretched. Each of these signals converges on the vestibular nuclei and acts synergistically, causing a rightward, conjugate eye movement.

### Reflexes Involving the Vestibular Nuclei

The functions of the secondary vestibular neurons are certainly more complicated than the classical “three neuron arc” first described by Lorente [9]. This can be appreciated by observing the effects of gravity on the orientation of post-rotatory nystagmus or optokinetic afternystagmus (OKAN II) in space. In such experiments the slow phase of the nystagmus remains horizontal in space, despite changes in head position about the inter-aural axis. Although the orientation of nystagmus in space remains constant, it is generated by different pairs of extraocular muscles, contingent on head position. When the animal is in a prone orientation, the nystagmus is expressed by the horizontal rectus muscles. When the animal is pitched nose-up or nose-down, the nystagmus is expressed by the vertical rectus muscles. At present, little is understood about the participation of the vestibular nuclei in generating nystagmus. Even less is understood about how an otolithic head position signal can cause an ongoing nystagmus to be completely re-routed to different pairs of extraocular muscles.

Two different aspects of nystagmus may reveal fundamental properties of circuitry in which secondary vestibular neurons are embedded. First, nystagmus may be generated by circuitry that includes secondary vestibular neurons as well as other brain stem neurons. Activity induced in this circuitry may be independent of head position. Second, a topographic conversion must occur, allowing the nystagmic rhythm to be channeled into different circuits controlling horizontal and vertical eye movements. This conversion is under the control of otolithic as well as optokinetic and neck proprioceptive inputs.

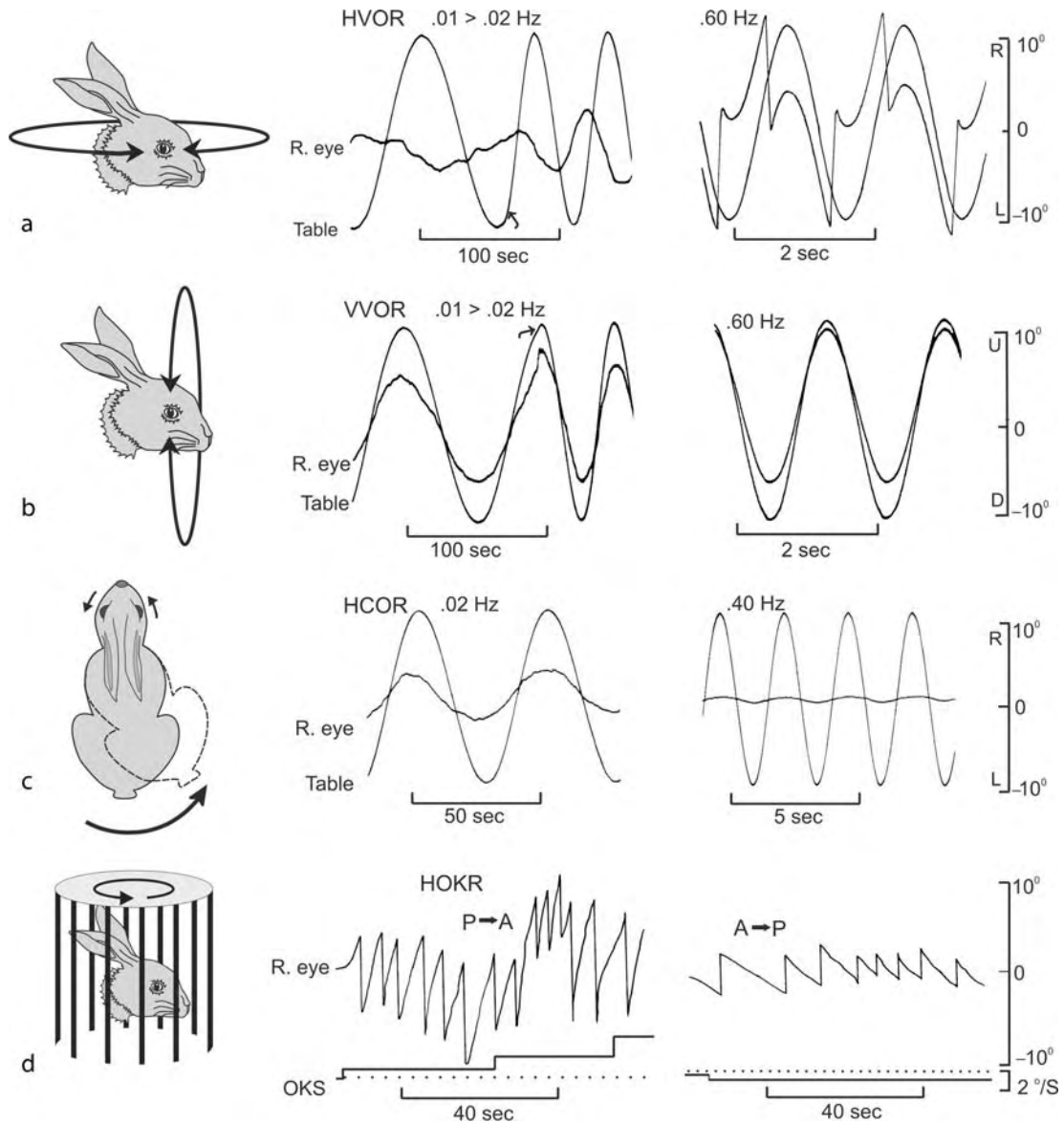

**Vestibular Secondary Afferent Pathways. Figure 5** Reflexive eye movements evoked by vestibular, optokinetic and neck proprioceptive stimulation. (a) Horizontal vestibuloocular reflex (HVOR) is evoked by rotation of the rabbit about the vertical axis (yaw), stimulating the horizontal semicircular canals. Note that the gain of the HVOR increases with stimulus frequency. (b) Vertical vestibuloocular reflex (VVOR) is evoked by rotation of the rabbit about a longitudinal axis (roll). Note that the gain of the VVOR is relatively high even at lower frequencies due to the contribution of the utricular otoliths. At higher frequencies the VVOR can be attributed to stimulation of the posterior and anterior semicircular canals. (c) Horizontal cervico-ocular reflex (HCOR) is evoked by rotation of the body of the rabbit in the horizontal plane about the fixed head. This is done in total darkness. Note that the gain of the HCOR even at the optimal frequency of 0.02 Hz is only about 0.25. (d) Horizontal optokinetic reflex (HOKR) is evoked by unidirectional, constant velocity, movement of a contour-rich stimulus. Only one eye views the rotating optokinetic stimulus (OKS). Eye movements of higher gain are evoked by stimulation in the posterior–anterior direction (P→A) compared to the gain of eye movements evoked by OKS in the anterior–posterior direction (A→P). Modified from [8].

### Central Motor Commands to Vestibular Secondary Neurons

Secondary vestibular neurons not only respond to vestibular, optokinetic and neck proprioceptive signals, they

distinguish between passive and active rotation of the head (Fig. 6).

The ability to suppress information concerning the vestibular consequences of active head and eye

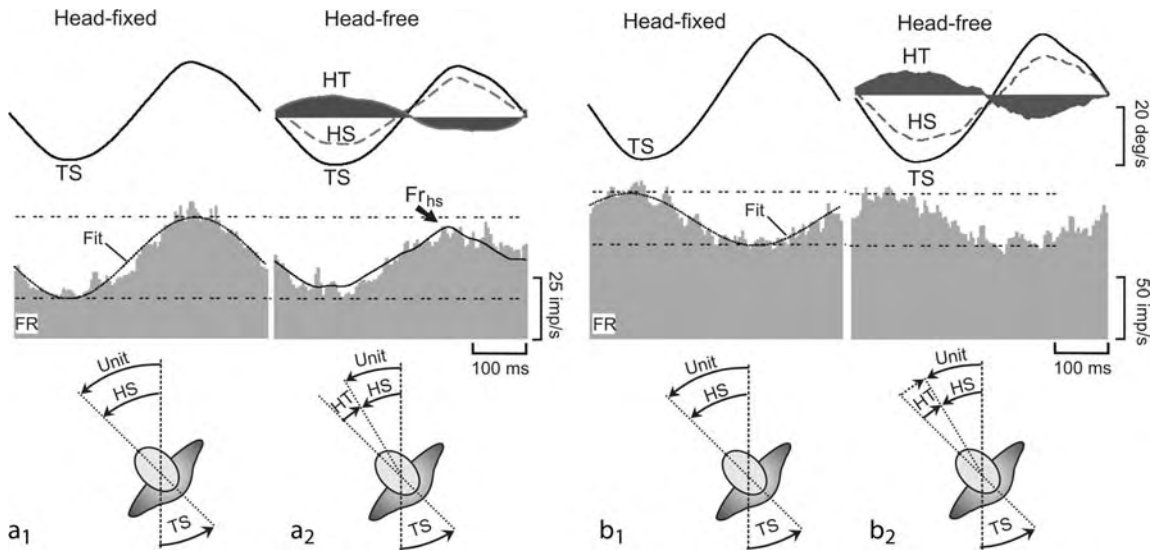

**Vestibular Secondary Afferent Pathways. Figure 6** Discharge differences in a secondary vestibular neuron caused by “active” and “passive” vestibular stimulation. The activity of two secondary vestibular neurons was measured during whole body rotation, with the head restrained ( $a_1$ ,  $b_1$ ) or unrestrained ( $a_2$ ,  $b_2$ ). When the head was unrestrained, horizontal rotation of the body evoked a vestibulocollic reflex (VCR). Responses were averaged during several cycles of horizontal vestibular stimulation. The *dashed lines*, bracketing the averaged responses, show the change in response modulation with respect to the head-fixed condition. The *cartoon* below each panel represents the head movement during each condition. In the head-fixed condition, head on trunk movements were eliminated ( $HT = 0$ ) and the velocity of the head in space ( $HS$ ) was the same as the turntable or trunk velocity ( $TS$ ). In the head-free condition, a compensatory head on trunk movement ( $HT$ ) was evoked by turntable rotation ( $TS$ ), which reduced the head velocity in space ( $HS$ , in this case  $TS$  plus  $HT$ ). The model, superimposed on the unit's firing rate ( $FR_{hs}$ ) during the head-free condition, is the vector product of the unit sensitivity during the head-fixed condition (*dashed line labeled fit*) and the head velocity in space during the head-free condition ( $HS$ ). The modulation of discharge of the secondary vestibular neuron in (a) was reduced when the VCR reduced the velocity of the head in space. The modulation of discharge of the neuron in (b) was unaffected by the reduction in velocity caused by the VCR. This implies the existence of a centrally generated signal capable of altering the gain of the evoked discharge. Modified from [10].

movements implies the central regulation of discharge rather than a mere summation of sensory influences. Similarly, the discharge of a subset of secondary vestibular neurons can be modified by central eye movement commands. In monkeys trained to suppress eye movements, vestibular stimulation evokes reduced discharge of secondary vestibular neurons.

### Functions of Vestibular Nuclei

Although they receive primary vestibular afferents, the vestibular nuclei receive information from other sensory systems as well. The discharge of secondary vestibular neurons is clearly influenced by vision, neck proprioception and centrally generated commands. Secondary vestibular neurons contribute to the control of balance by influencing the discharge of motor and pre-motor neurons. The linkage of the vestibular nuclei and the autonomic nervous system is often overlooked. This linkage is vital for effective support of postural reflexes evoked by changes in regulation of

skeletal muscle. Secondary vestibular neurons have reciprocal connections with cerebral and cerebellar cortices. The vestibular nuclei are at a sensory-motor crossroads. Vestibular compensation may reflect the properties of secondary vestibular neurons within the context of a larger system that uses vestibular, visual, cutaneous and proprioceptive information. This larger system also includes the cerebellum and cerebral cortex.

### References

1. Brodal A, Pompeiano O (1957) The vestibular nuclei in the cat. *J Anat* 91:438–454
2. Büttner U, Lang W (1979) The vestibulocortical pathway: neurophysiological and anatomical studies in the monkey. In: Granit R, Pompeiano O Reflex control of posture and movement. Elsevier/North-Holland, Amsterdam, pp 581–588
3. Büttner-Ennever J (1992) Patterns of connectivity in the vestibular nuclei. In: Cohen B, Tomko DL, Guedry F (eds) Sensing and controlling motion. *Ann NY Acad Sci* 656:363–378

4. Deecke L, Schwarz DWF, Fredrickson JM (1977) Vestibular responses in the rhesus monkey ventroposterior thalamus. II. Vestibulo-proprioceptive convergence at thalamic neurons. *Exp Brain Res* 30:219–232
5. Graf W, McCrea RA, Baker R (1983) Morphology of posterior canal related secondary vestibular neurons in rabbit and cat. *Exp Brain Res* 52:125–138
6. Newlands SD, Kevetter GA, Perachio AA (1989) A quantitative study of the vestibular commissures in the gerbil. *Brain Res* 487:152–157
7. Giolli RA, Blanks RHI, Torigoe Y, Williams DD (1985) Projections of medial terminal accessory optic nucleus, ventral tegmental nuclei, and substantia nigra of rabbit and rat as studied by retrograde axonal transport of horseradish peroxidase. *J Comp Neurol* 232:99–116
8. Barmack NH, Nastos MA, Pettorossi VE (1981) The horizontal and vertical cervico-ocular reflexes of the rabbit. *Brain Res* 224:261–278
9. Lorente de N6 R (1933) Vestibulo-ocular reflex arc. *Arch Neurol Psychiatry (Chic)* 30:245–291
10. Gdowski GT, Boyle R, McCrea RA (2000) Sensory processing in the vestibular nuclei during active head movements. *Arch Ital Biol* 138:15–28

## Vestibular Statokinetic Reflex

### Definition

Activation of body and/or eye muscles due to stimulation of ampullar and macular receptors of the vestibular system induced by head movements in space.

- ▶ Peripheral Vestibular System
- ▶ Vestibulo-Spinal Reflexes

## Vestibular System

NEAL H. BARMACK<sup>1</sup>, VITO E. PETTOROSSO<sup>2</sup>

<sup>1</sup>Neurological Sciences Institute, Oregon Health and Science University, Beaverton, OR, USA

<sup>2</sup>Department of Internal Medicine, Section of Human Physiology, University of Perugia, Perugia, Italy

The vestibular system detects motion and position of the head in space. It uses this information to regulate postural reflexes and control movement.

### Peripheral Vestibular Receptors

Embedded in bone behind the ears, the labyrinth consists of five separate sensors. Three of these

comprise the ▶ **semicircular canals**, a series of three membranous and interconnected “hula hoops” oriented in three different planes, roughly at right angles with respect to one another. Each senses angular acceleration of the head in a different plane. The semicircular canals contain a fluid, endolymph. When the head rotates, the endolymph lags behind, much as a raw egg lags when the egg shell is rotated. The lagging endolymph pushes against a thin gelatinous matrix membrane, the ▶ **cupula** into which ▶ **hair cells** are embedded. These hair cells transduce submicron movements of the cupula and depolarize the hair cells. All hair cells in the cupula have the same anatomical orientation determined by the spatial orientation of the singular ▶ **kinocilium** to the multiple ▶ **stereocilia** in each hair cell (Fig. 1).

▶ **Otoliths** (▶ **Otolithic receptors**) comprise a second class of vestibular sensors. Otoliths have a specialized neuroepithelium, the ▶ **macula**, composed of a polysaccharide membrane surface onto which small crystals of calcium carbonate (▶ **otoconia**) adhere. On the other side of the macular membrane are hair cells. The multiple stereocilia and single kinocilium of hair cells are embedded in the macula. When the head moves a linear acceleration is imparted to the otoconia, deflecting embedded ▶ **cilia** of the hair cells, altering their excitability and modulating the release of transmitter. Hair cells are excited when the stereocilia are bent towards the single kinocilium. Head movements alter the orientation of the macula with respect to the linear acceleration of gravity, displace the embedded cilia and change the membrane potential of the hair cells (Fig. 1). One of the otoliths, the ▶ **utricle**, lies in the horizontal plane. The other, the ▶ **sacculle** lies in a near sagittal plane.

Within the macula of each otolith, hair cells have a range of spatial orientations. Consequently they can detect linear accelerations in several directions. Within the ▶ **crista ampullaris** of each semicircular canal, hair cells have a single orientation. They detect the force exerted by endolymph in only one plane.

Depolarization of hair cells causes increased release of the synaptic transmitter, glutamate. This excites primary afferents at the base of the hair cells. The cell bodies of these primary afferents are located in ▶ **Scarpa’s ganglion**, just outside the caudal brainstem. Axons from the bipolar cells in Scarpa’s ganglion form the superior and inferior branches of the ▶ **vestibular nerve**.

The vestibular nerve enters the brain stem and divides into two fiber bundles containing axons of unequal thickness (Fig. 2a) [1]. The bundle containing thicker axons enters the medulla between the ventral aspect of the inferior cerebellar peduncle and the dorsal aspect of the spinal tract of the ▶ **trigeminal nucleus**. It turns caudally and then passes into the ▶ **vestibular complex** (Fig. 2b).

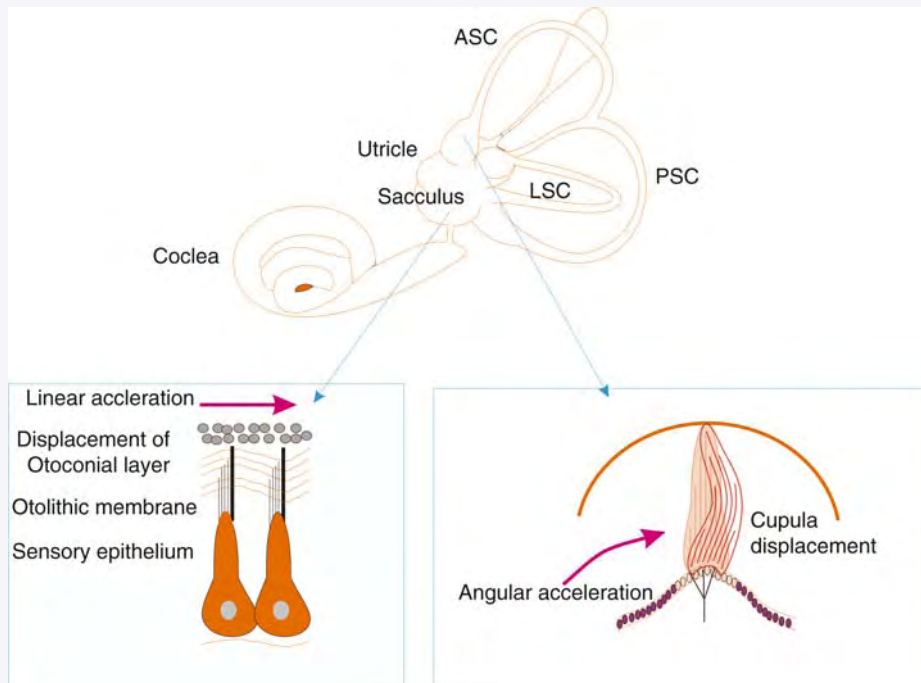

**Vestibular System. Figure 1** Schematic drawing of the labyrinth. Spatial orientation of the semicircular canals, utricle and sacculus. In the left insert, the effect of linear acceleration on macular epithelial cells and overlying structures is shown. In the right insert, the effect of the angular acceleration on the crista ampullaris is shown. The arrows indicate the direction of acceleration. *Abbreviations:* ASC, LSC and PSC, anterior, lateral and posterior semicircular canal.

The bundle with thinner axons ascends to the ►cerebellum by passing through the superior vestibular and lateral ►vestibular nuclei (SVN, LVN). The thin axons then distribute to several folia within the cerebellum, but primarily to the ipsilateral ►uvula-nodulus. The vestibular complex and uvula-nodulus are responsible for the initial processing of vestibular information by the central nervous system.

### Vestibular Nuclei and Vestibular Secondary Afferent Pathways

The vestibular complex has four “classical” nuclear groups: (i) ►Medial vestibular nucleus, MVN, (ii) Descending (or spinal) vestibular nucleus, DVN, (iii) ►Lateral vestibular nucleus (►Deiters), LVN, and (iv) Superior vestibular nucleus, SVN (Fig. 2b).

Several smaller nuclei, not included in the “classical” group, nonetheless receive ►vestibular primary afferents. These include: (i) ►Parasolitary nucleus (Psol), (ii) ►Y-group, (iii) ►Nucleus intercalatus (Staderini) (see Fig. 3). Y-group neurons receive ipsilateral vestibular primary afferents, as well as bilateral projections from vestibular secondary afferents (for review, see [3]).

### Ascending Vestibular Projections

DVN, MVN and SVN project to cranial motor nuclei III, IV and VI. These nuclei control the reciprocal contractions of ►extraocular muscles. Secondary vestibular neurons also project to ►nucleus Darkschewitsch, sensory trigeminal nucleus, ►interstitial nucleus of Cajal and the ►subparafascicular complex.

Secondary vestibular neurons in the rostral part of the vestibular complex project to the ►ventrobasal thalamus (VPL, VPM, VPI and VPL). These thalamic nuclei project to areas 3aV and T3 and parietal visual cortex. Humans with damage to parietal cortex do not recognize true vertical. Deprived of surrounding visual cues, they cannot correctly align a disk with a line on it so that the line has a true vertical orientation. ►Cortical vestibular areas project back to the vestibular complex, suggesting that these cortical regions may supersede reflexes evoked by activity in vestibular primary afferents.

The caudal aspect of the ►nucleus prepositus hypoglossi (NPH) and MVN project to several folia within the cerebellum, including the anterior and posterior ►vermis and ►flocculus. Immunohistochemical surveys show that most, if not all of these ascending projections are cholinergic and originate from the caudal MVN and NPH (for review, see [4]).

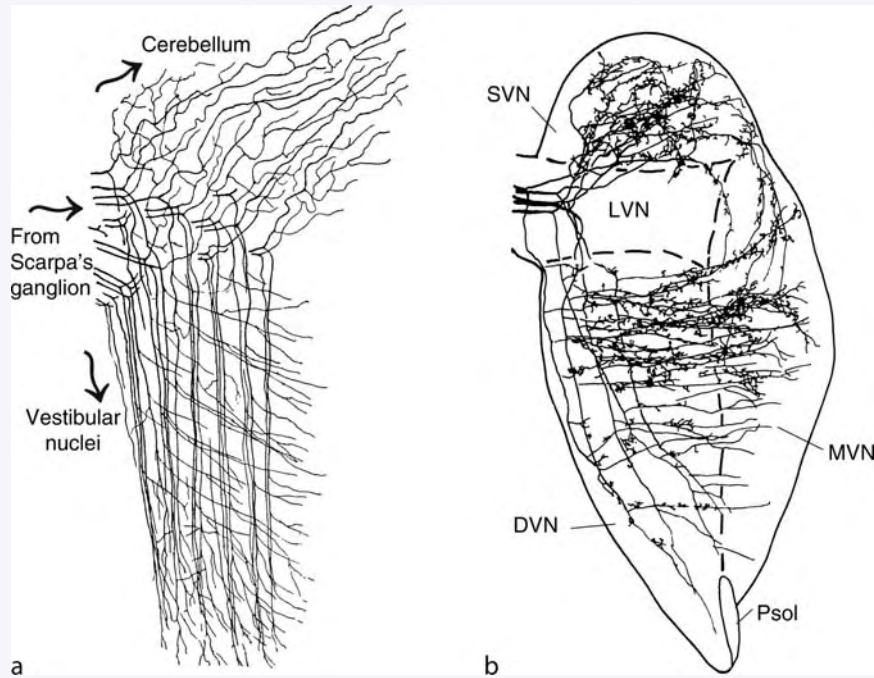

**Vestibular System. Figure 2** Projection of vestibular primary afferents to the vestibular complex and to the cerebellum. (a) Vestibular primary afferents bifurcate as they enter the brainstem. Modified from [1]. (b) The terminal fields within the cat vestibular complex of five horizontal semicircular canal afferents, intra-axonally labeled with HRP, are illustrated. The terminals are mapped onto a schematic that represents a horizontal section through the vestibular complex. *Abbreviations:* DVN, descending vestibular nucleus; LVN, lateral vestibular nucleus; MVN, medial vestibular nucleus; NPH, nucleus prepositus hypoglossi; Psol, parasolitary nucleus; SVN, superior vestibular nucleus. Modified from [2].

### Descending Vestibular Projections

Descending lateral and ▶medial vestibulo-spinal tracts originate from the LVN and MVN and DVN. Fibers to the lumbosacral spinal cord originate from the dorso-caudal LVN. Fibers to the cervical cord originate from the rostroventral LVN. Axons in the lateral vestibulo-spinal tract terminate in the ipsilateral lumbosacral region where they make monosynaptic and polysynaptic connections with motoneurons. Axons in the medial vestibulo-spinal tract terminate bilaterally in the medial part of the cervical ventral horn.

Secondary vestibular neurons also evoke ▶autonomic reflexes. Vestibulo-sympathetic reflexes modulate changes in blood flow to skeletal muscles, respiration, blood pressure and heart rate (for review, see [3]).

### Visual-Vestibular Interactions

Secondary vestibular neurons are driven by visual as well as vestibular stimulation (▶Visual-Vestibular Interaction). Visual input to the vestibular complex originates from both brainstem and cortical sources. Brainstem visual signals come primarily from the ▶accessory optic system (AOS).

The visual cortex provides a descending projection to the AOS. In primates this projection originates from the

▶pre-striate cortex (▶areas OAa and ▶PGa). Selective stimulation or inactivation of this region can modify the directional selectivity of neurons in the AOS (for review, see [5]).

Signals from ▶proprioceptors embedded in the inter-transverse muscles at the base of the cervical vertebrae activate secondary vestibular neurons. The vestibular complex also receives secondary cervical afferents relayed through the external ▶cuneate nuclei. Movement of the head with respect to the body stimulates neck proprioceptors and evokes reflexive ▶eye movements as well as ▶postural adjustments of the limbs.

### Functional and neurochemical organization of vestibulo-motor pathways

Secondary vestibular neurons express several synaptic transmitters, including: acetylcholine, GABA, glycine, aspartate, glutamate and taurine.

### Secondary Vestibular Neurotransmitter Receptors

AMPA receptor (alpha-amino-3-hydroxy-5-methyl-oxazole-4-propionic acid) subunits GluR1, 2, 3 and 4 have been localized to secondary vestibular neurons using both immunohistochemistry and hybridization histochemistry. Subunits NR1, NR2A and NR2C of

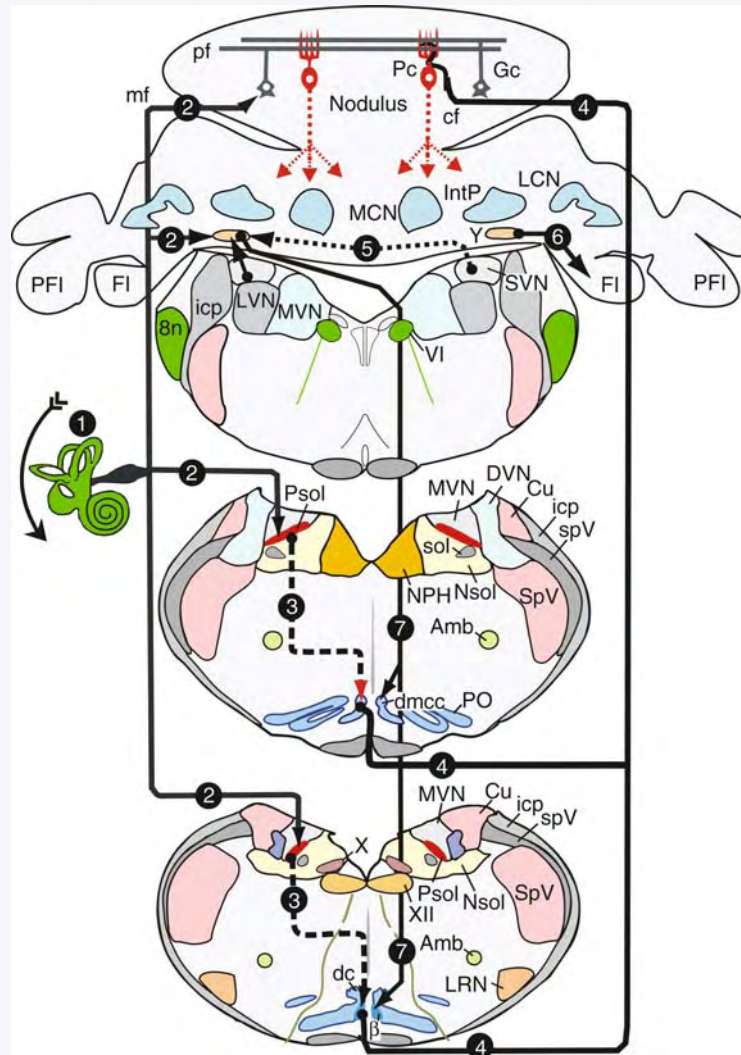

**Vestibular System. Figure 3** Circuitry for activation of vestibular climbing fiber projections to cerebellar ▶ **nodulus**. Sequences in activation are indicated by solid lines for excitatory pathways and dashed lines for inhibitory pathways. Pathways are listed numerically. 1. Roll tilt onto the left side increases vestibular primary afferent discharge. 2. Primary afferents project as mossy fibers to ipsilateral granule cell layer of nodulus, parasolitary nucleus (Psol) and dorsal Y-group. 3. Descending GABAergic projection from Psol inhibits activity of olivary neurons in ipsilateral  $\beta$ -nucleus and dorsomedial cell column (dmcc). 4. Climbing fibers from  $\beta$ -nucleus and dmcc project to contralateral nodulus. 5. Vestibular nuclei bilaterally project to dorsal y-group. 6. Dorsal Y-group projects to ipsilateral flocculus. 7. Dorsal Y-group projects to contralateral dorsal cap,  $\beta$ -nucleus and dmcc. *Abbreviations:* Amb, nucleus ambiguus;  $\beta$ ,  $\beta$ -nucleus; cf, climbing fiber; Cu, cuneate nucleus; dc, ▶ **dorsal cap of Kooy**; dmcc, dorsomedial cell column; DVN, descending vestibular nucleus; FI, flocculus; Gc, granule cell; icp, inferior cerebellar peduncle; IntP, Interpositus nucleus; LRN, lateral reticular nucleus; mf, mossy fiber; LCN, lateral cerebellar nucleus; LVN, lateral vestibular nucleus; MCN, medial cerebellar nucleus; MVN, medial vestibular nucleus; NPH, nucleus prepositus hypoglossi; Nsol, nucleus solitarius; Pc, Purkinje neuron; pf, parallel fiber; PFI, paraflocculus; PO, principal olive; Psol, parasolitary nucleus; sol, tractus solitarius; SpV, spinal trigeminal nucleus; spV, spinal trigeminal tract; SVN, superior vestibular nucleus; X, dorsal motor nucleus of the vagus; XII, hypoglossal nucleus; VI, abducens nucleus; Y, Y-group; 8n, auditory-vestibular nerve.

N-methyl-D-aspartate (NMDA) receptors are widely distributed within the vestibular complex. A subset of GABA-expressing secondary vestibular neurons in the MVN, SVN and DVN comprise the commissural system of the vestibular complex.

### Movements Evoked by Secondary Vestibular Neurons

Natural stimulation of the vestibular, ▶ **optokinetic** and neck proprioceptive systems evokes reflexive movements of the eyes, ears, head and trunk. Secondary

vestibular neurons participate in several “▶field-holding”▶reflexes, the purpose of which is to maintain a stable spatial environment. Reflexes to which the vestibular nuclei contribute include: ▶vestibuloocular reflex (VOR), ▶optokinetic reflex (OKR), ▶cervicoocular reflex (COR), ▶vestibulocollic reflex (VCR) and ▶vestibulospinal reflex (VSR). The VOR represents an important subsystem that contributes to gaze stability during head movement. The basic structure of the VOR reflex arc is simple in the sense that the arc contains only three neurons in series: the primary fibers of the vestibular nerve, the secondary neurons in the vestibular nuclei and the motoneurons of the extraocular muscle. However, it is complex with respect to its multiple parallel arrangements. The activation of the receptors of the semicircular canals elicits eye movements in the same plane, but in directions opposite to head movements. Reflex eye movements are compensatory since they reduce retinal slip of images during head rotation. In addition to VOR, the vestibular system contributes to optokinetic reflexes (OKRs). OKRs stabilizes gaze during slow head displacement. Optokinetic and vestibular responses combine to assure gaze stability in a wide range of head movement (Visual-vestibular Interaction). OKRs are closed-loop reflexes. Compensatory eye movements reduce the retinal slip that evokes them. VORs are open-loop reflexes since head movements are not necessarily reduced by eye movements. Moreover, the optokinetic input through the flocculus causes long-term effects on the vestibular neurons connected with the VOR to increase or decrease the excitability depending upon the functional requirement (Visuo-vestibular calibration).

In some animals vestibular nuclei mediate also the cervicoocular reflex (COR), that contribute to eye position within the orbit. Another important function of the vestibular nuclei is to control posture and body movement. This control is exerted either by direct efferent projections of the vestibular neurons to the spinal cord or by indirect activation of ▶reticulospinal and ▶proprioospinal neurons. The labyrinthine receptors sensitive to angular and linear acceleration detect head movement and position and are connected with a descending network that activate neck muscle for eliciting vestibulocollic reflex (VCR) and vestibulospinal reflex (VSR) involving forelimb muscles and axial musculature of the trunk. The neck and body muscle activation is responsible of head stability and body equilibrium and, in general, tends to oppose the effect on the posture of the gravity force.

Secondary vestibular neurons not only respond to vestibular, optokinetic and neck proprioceptive signals, they distinguish between passive and active rotation of the head. The ability to suppress information concerning the vestibular consequences of active head and eye movements implies the central regulation

of discharge rather than a mere summation of sensory influences. Similarly, the discharge of a subset of secondary vestibular neurons can be modified by central eye movement commands. (For review, see [6]).

### Functional Vestibular tests

To investigate vestibular function a variety of tests have been developed for vestibuloocular reflex (caloric test, Head shaking test, ocular tilt reaction) and for vestibulospinal reflex (Romberg test, posturography, Galvanic test, VEMP).

### Vestibular Compensation and plasticity

Unilateral loss of vestibular function creates an imbalance in both postural and oculomotor control. The oculomotor deficit is characterized by a conjugate ocular ▶nystagmus composed of slow and fast segments. The slow phase is directed towards the side of the damaged labyrinth. The fast phase is directed away from the damaged labyrinth. A unilateral labyrinthectomy also produces head tilt in the roll and yaw planes, spinal cord curvature, circular walking, barrel rolling, asymmetric muscle tone and a reduction in gain of the VOR, VCR and VSR. Several hours, days or weeks after UL, spontaneous ocular nystagmus subsides. This disappearance of nystagmus is termed “compensation.” By contrast loss of reflex gain of the VOR, VCR and VSR recovers slowly if at all (for review, see [7]).

### Vestibular Cerebellum

More than 90% of vestibular primary afferents (▶Vestibular cerebellum) project to the ipsilateral uvula-nodulus where they terminate as ▶mossy fibers in the ipsilateral granule cell layer. Secondary vestibular afferents project bilaterally onto granule cells in the uvula-nodulus and also onto granule cells in the flocculus, paraflocculus and folia 1 of the anterior lobe. In both the cat and the rabbit, the uvula-nodulus sends reciprocal projections to the caudal MVN. In the cat, the rostral and lateral regions of the MVN receive projections from the flocculus.

Vestibular information reaches the uvula-nodulus over ▶climbing fiber as well as mossy fiber afferents (Fig. 3). Vestibular climbing fibers originate from two subnuclei of the ▶inferior olive, the Y-nucleus and ▶dorsomedial cell column (dmcc). They cross the midline to synapse on ▶Purkinje neurons in the contralateral uvula-nodulus. The ▶β-nucleus and dmcc receive secondary vestibular projections from the *ipsilateral* parasolitary nucleus, a small GABAergic nucleus that receives a primary vestibular afferent projection and from the *contralateral* dorsal Y-group (Fig. 3). β-nucleus and dmcc neurons respond to roll-tilt.

Modulation of cerebellar Purkinje cell discharge is contingent on interactions between mossy and climbing



fiber vestibular projections. Climbing fibers directly evoke “complex spikes” (CSs) that discharge at 0.2–8.0 imp/s. The proximate cause of higher frequency “▶simple spikes” ▶(SSs) is less well understood. SSs discharge at ~20–60 imp/s. SSs reflect the summed synaptic actions of ~150,000 parallel fibers on each Purkinje cell. Since parallel fibers have lengths of 3–7 mm, the signal their combined signal to individual Purkinje cells cannot be topographically precise. Rather each Purkinje cell probably receives parallel fiber synaptic signals that reflect the excitatory influence of otoliths and semicircular canals from both labyrinths. Purkinje cell activity is also influenced by inhibitory interneurons such as basket, Golgi and stellate cells (for review, see [6]).

### Motion Sickness and Vestibular System

▶Motion sickness is the autonomic consequence of sensory stimulation that induces spatial disorientation. In humans and many mammals, acute motion sickness reaches a climax with retching. This ballistic event is heralded by subthreshold peristaltic contractions that can be recorded from either the esophagus or the lower intestines. Motion sickness is preceded by increased concentrations (10–20-fold) of arginine ▶vasopressin, possibly secreted by the ▶hypothalamus.

A popular view of motion sickness is that it is produced by sensory conflict between vestibular receptors or between vestibular and non-vestibular receptors. A good example of such conflict is when one is sitting in a train and an adjacent train begins to move. One’s vestibular system informs us that we are not moving, while the optokinetic system informs us that we are. For many people, exposure to just a few minutes of unidirectional optokinetic stimulation is sufficient to induce nausea. Individuals who have bilateral loss of labyrinthine function tend not to experience motion sickness.

Motion sickness is often treated pharmacologically. One modestly effective antimotion sickness agent is the anti-muscarinic compound, ▶scopolamine. Scopolamine increases tolerance for sensory stimulation without inducing nausea. The benefit of reduced sensitivity to nauseogenic stimulation is countered by non-specific muscarinic effects, such as: dry mouth, blurred vision, dizziness, drowsiness and anxiety.

A second strategy for preventing motion sickness blocks at a more central level the sequence of steps leading to an overproduction of vasopressin. Administration of the centrally acting antimuscarinic agent, ▶atropine, reduces the release of vasopressin, which in turn reduces gastric dysrhythmias.

### Peripheral Vestibular Disorders

Normal vestibular function depends on a balanced encoding of head movement by ten different vestibular

endorgans. When these endorgans become impaired, dizziness, ▶ataxia and imbalance occur. Some of the possible causes of peripheral abnormalities include: alcohol intoxication, temporal bone trauma, exposure to certain ototoxic antibiotics, invasive tumors of the vestibular nerve, virally induced damage to the vestibular nerve and pathology of unknown etiology (such as ▶Ménière’s disease). The extent of functional loss can often be accurately estimated and diagnosed based upon careful monitoring of movements of the patient under conditions of controlled vestibular stimulation.

Often unilateral labyrinthine damage can be pinpointed by recording the direction and amplitude of spontaneous ocular nystagmus. Recovery of full vestibular function following traumatic or disease-induced damage often occurs, but it is never complete. Over a period of weeks, nystagmus disappears. This recovery is termed “compensation.” However, vestiges of damage can still be detected in reflex function if the patient is tested with rapid accelerations [8].

### Central Vestibular Disorders

Central vestibular disorders are caused by pathological processes inside the neural axis including pathological states of the vestibular nerve. Their descriptive etiology includes: demyelinating, tumoral, vascular, degenerative, traumatic. Their topography includes: medullary, cerebellar, cortical. Systemic descriptions include: vestibulo-spinal, vestibulo-autonomic, vestibulo-ocular, vestibulo-cortical. Functional symptoms include: ▶vertigo, dizziness, ataxia, ▶oscillopsia and unsteadiness.

### References

1. Cajal SR (1911) *Histologie du système nerveux de l’homme et des vertébrés*. Maloine, Paris
2. Sato F, Sasaki H (1993) Morphological correlations between spontaneously discharging primary vestibular afferents and vestibular nucleus neurons in the cat. *J Comp Neurol* 333:554–556
3. Highstein SM, Holstein GR (2005) The anatomy of the vestibular nuclei. *Prog Brain Res* 151:157–203
4. McCreary RA, Horn AK (2005) Nucleus prepositus. *Prog Brain Res* 151:205–230
5. Giolli RA, Blanks RH, Lui F (2005) The accessory optic system: basic organization with an update on connectivity, neurochemistry, and function. *Prog Brain Res* 151:407–440
6. Barnack NH (2003) Central vestibular system: vestibular nuclei and posterior cerebellum. *Brain Res Bull* 60:511–541
7. Curthoys IS, Halmagyi GM (1995) Vestibular compensation: a review of the oculomotor, neural, and clinical consequences of unilateral vestibular loss. *J Vestib Res* 5:67–107
8. Halmagyi GM, Curthoys IS, Cremer PD, Henderson CJ, Todd MJ, Staples MJ, D’Cruz DM (1990) The human horizontal vestibulo-ocular reflex in response to high-acceleration stimulation before and after unilateral vestibular neurectomy. *Exp Brain Res* 81:479–490

## Vestibular Tests: Caloric Test

CATHERINE DE WAELE  
Laboratoire de Neurobiologie des Réseaux  
Sensori-moteurs, CNRS, Paris, France

### Synonyms

Bithermal tests of inner ear

### Definition

Caloric stimulation is a test, which uses differences in temperature to diagnose uni- or bi-lateral vestibular dysfunction. It allows determination of the function of the horizontal semicircular canals at low frequencies.

### Characteristics

This test is performed in subjects placed in a supine position with the head tilted at 30° from the horizontal to make the lateral canals horizontal. The external ear canal is irrigated with hot (44°C) water for 30 s first on the left and then on the right side with an interval of rest of at least 5 min between the two sides. Then, a similar procedure is performed with cold water (33°C) on both sides with an interval of rest of at least 5 min between the hot water and cold water irrigations. An ocular nystagmus is normally induced, which builds in 30 s and which gradually decreases over 2 min. Patients should avoid eating a heavy meal before the test and avoid caffeine, alcohol, allergy medications and sedatives for at least 24 h, as these can affect the results. In addition, they should have no tympanic membrane perforation. The test is of minimal discomfort. However, some people find cold and hot water in the ear uncomfortable and complain of vertigo and nausea; this always disappears after 2 min.



Caloric test

Eye movements are measured using videonystagmography. In normal patients, the quick phase of the induced-ocular nystagmus beats toward the non-irrigated ear with cold water whereas it beats toward the irrigated ear with hot water. The peak slow-phase velocities of each nystagmus are measured for each condition, warm right, warm left, cold right, cold left. These four numbers are then used to compute three additional numbers:

- *The total response on one side with cold and warm water* is calculated by summing all responses on one side. It should be  $>20^\circ/\text{s}$ . Responses of  $<10$  are suggestive of a canal hypoflexia.
- *Directional preponderance* represents the differences between the two ears: right-beating minus left-beating/total left and right-beating. It should be  $<35\%$ .
- *Unilateral canal paresis*, i.e. responses on the intact side minus responses on the lesioned side/sum of the responses on the intact and the lesioned side. The Jonkee index is considered as normal when less or equal to 20%.

Several authors have tried to model the caloric responses. The response theoretically results from a combination, possibly nonlinear, of convection induced stimulation of the canal, a direct effect of temperature on the nerve, transduction responses in the mechanics of the cupula, adaptation responses in the nerve and brainstem and other central processing effects, mainly including velocity storage. A descriptive curve-fitting approach to the response is exemplified by that of Formby et al. [1,2].

### Characteristics

Although caloric stimulation exhibits considerable inter- and intra-variability responses in the same subject

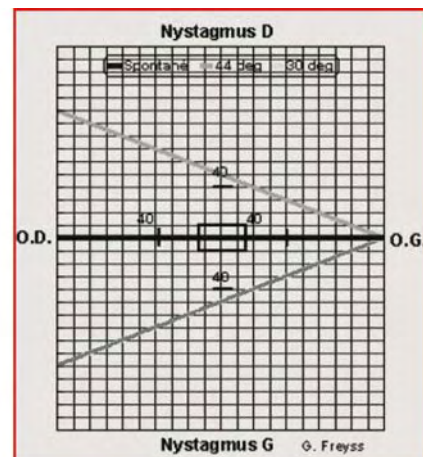

[3], this test is of great value in patients suffering from vertigo or dizziness since it is ~80% accurate in differentiating horizontal canal dysfunction at low frequencies.

## References

1. Formby C, Carter RL, Hansen CA, Kuntz LA (1992) Measurement, analysis and modelling of the caloric response. I. A descriptive mathematical model of the caloric response over time. *Acta Otolaryngol (Stock): Suppl 498*:4–18
2. Formby C, Kuntz LA, Rivera-Taylor IM, Rivera-Mraz N, Weesner DR, Butler-young NE, Ahlers AE (1992) Measurement, analysis and modelling of the caloric response. Evaluation of mental alerting tasks for measurement of caloric-induced nystagmus. *Acta Otolaryngol (Stock):Suppl 498*:19–29
3. Proctor LR (2000) Results of serial vestibular testing in unilateral Meniere's disease. *Am J Otol 21(4)*:552–558

frequency range, the head-shaking test measures the function of the horizontal canal ampulla in a middle frequency band.

## References

1. Perez P, Llorente JL, Gomez JR, Del Campo A, Lopez A, Suarez C (2004) Functional significance of peripheral head-shaking nystagmus. *Laryngoscope 114(6)*:1078–1084

## Vestibular Tests: Myogenic Potentials Induced by Short Duration Galvanic Currents

CATHERINE DE WAELE  
Laboratoire de Neurobiologie des Réseaux  
Sensori-moteurs, CNRS, Paris, France

### Synonyms

Galvanic test

### Definition

This test allows to appreciate the excitability of the spike trigger zone of the primary vestibular neurons [1,2].

### Characteristics

This test allows the appreciation of the excitability of the spike trigger zone of the primary vestibular afferents [1,3]. Vestibular evoked myogenic potentials (VEMPg) are induced by using bilateral short duration and high intensity transmastoid galvanic currents. The galvanic current is delivered through large surface retroauricular electrodes of ~900 mm<sup>2</sup>, individually coated by electro-surgical plating (3 M), generously coated with electrode gel and placed over each mastoid process [3]. Galvanic current duration was of about 1 ms, intensity 8 mAmp and frequency of delivery 5 Hz. VEMPg were then recorded after amplification, low-pass filtered filtering (5 and 1.6 kK) and averaging (200 events) from the sterno-cleido-mastoid (SCM) muscle ipsilateral to the cathode through a surface electrode in the middle of the SCM muscle. The test is performed under two different experimental conditions. In the first condition, the head is laid on a pillow and patients are asked to relax. In this case, only the stimulation artifact can be detected. In the second condition, patients in a supine position are asked to raise their head from the pillow and to rotate their head on the side contralateral to the cathode to maximally contract the studied SCM muscle.

In the first condition, only the stimulation artifact can be detected since the SCM is not contracted. In the

## Vestibular Tests: Head-Shaking Test

CATHERINE DE WAELE  
Laboratoire de Neurobiologie des Réseaux  
Sensori-moteurs, CNRS, Paris, France

### Synonyms

Canalo-ocular test at medium frequency

### Definition

The head-shaking test allows determination of an asymmetry between the two horizontal canals [1]. The head of the patient is shaken in the horizontal plane for 20 s and at the end of the stimulation the induced eye movements are recorded using videonystagmography.

### Characteristics

In case of asymmetry between the two sides, a horizontal ocular nystagmus with the fast phase oriented toward the healthy side appears (first phase), which can reverse after a variable time (3–10 s: secondary phase). It results from both an asymmetry between the two horizontal canal ampullae and the velocity stockage mechanism. This test can be performed easily in young patients but may be more difficult to perform in old patients with cervical arthrosis.

The head-shaking test is easy to perform at the bedside to detect a potential asymmetry between two horizontal semicircular canals. Compared to the caloric test, which detects a potential asymmetry in the low

second condition, both the artifact of stimulation and VEMPg are recorded. A subtraction between these two traces allows detection of VEMPg and decreases the stimulus artifact. VEMPg are composed of two components, first a positivity (P13g) with a latency of about 10 ms followed by a negativity (N23g) with a latency of about 15 ms. The latency of the evoked potentials and of the amplitude of the P13g/N23g peak is then precisely measured. The ratio  $100 \times (\text{amplitude healthy side} - \text{amplitude lesioned side}) / (\text{amplitude healthy side} + \text{amplitude lesioned side})$  can also be calculated to compare galvanic responses on the two sides.

### Summary

VEMPg allow appreciation of the excitability of the vestibular nerve. This test is particularly interesting in the case of uni- or bi-lateral areflexia detected by other vestibular tests. In the follow-up of patients treated by intratympanic gentamycin injections because of intractable Meniere's disease, it can predict the possible reoccurrence of rotatory vertigo [4]. It will be also useful in the near future in bilateral areflexic patients before a potential vestibular implantation.

### References

1. Murofushi T, Takegoshi H, Ohki M, Ozeki H (2002) Galvanic-evoked myogenic responses in patients with an absence of click-evoked vestibulo-colic reflexes. *Clin Neurophysiol* 113:305–309
2. Watson SR, Welgampola MS, Colebatch JG (2003) EMG responses evoked by the termination of galvanic (DC) vestibular stimulation: "off-responses." *Clin Neurophysiol* 114(8):1456–1461
3. Watson SR, Fagan P, Colebatch JG (1998) Galvanic stimulation evokes short-latency EMG responses in sternocleidomastoid which are abolished by selective vestibular nerve section. *Electroencephalogr Clin Neurophysiol* 109(6):471–474
4. de Waele C, Megnenni R, Freyss G, Zamith F, Bellalinet N, Vidal pp, Tran Ba Huy P. Intratympanic gentamicin injections for Meniere disease: vestibular hair cell impairment and regeneration. *Neurology*. 2002 Nov 12;59(9):1442–1444

## Vestibular Tests: Ocular Tilt Reaction

CATHERINE DE WAELE  
Laboratoire de Neurobiologie des  
Réseaux Sensori-moteurs, CNRS, Paris, France

### Synonyms

Headtilt; Skew deviation; Deviation of the perception of the visual vertical and horizontal

### Definition

The ocular tilt reaction (OTR) is a compensatory postural reflex, which arises from the stimulation of the otoliths [1,2].

OTR is a postural synkinesis consisting of:

1. A skew deviation and binocular eye torsion.
2. Head tilt.
3. Deviation of the perception of the visual vertical and horizontal, all to the same side.

### Characteristics

Each deficit could be measured. OTR results from injuries such as stroke, multiple sclerosis or trauma [1] to brainstem vestibular or cerebellar nuclei conveying otolith afferents.

### References

1. Brodsky MC, Donahue SP, Vaphiades M, Brandt T (2006) Skew deviation revisited. *Surv Ophthalmol* 51(2):105–128
2. Halmagyi GM, Curthoys IS, Brandt T, Dieterich M (1991) Ocular tilt reaction: clinical sign of vestibular lesion. *Acta Otolaryngol (Stockh)* 481:47–50

## Vestibular Tests: Romberg Test

CATHERINE DE WAELE  
Laboratoire de Neurobiologie des Réseaux  
Sensori-moteurs, CNRS, Paris, France

### Synonyms

Equilibrium neurological test

### Definition

The Romberg test is a neurological test to detect imbalance. It detects the inability to maintain a steady standing posture with the eyes open or closed. This test consists of standing with the feet together and the index pointed forward with eyes either open or closed.

### Characteristics

A positive Romberg's sign could be the sign of:

1. A dysfunction of organs involved in postural control: inner ear, vestibular nerve, pons region of the brainstem where the CN VIII arises or damage to other central nervous system pathways which connect to the pons, such as cerebellum.
2. A proprioceptive dysfunction. A lesion anywhere along the pathway from the proprioceptive sensors to the cerebellum can give rise to cerebellar ataxia.

The Romberg test gives information about receptors involved in the control of balance. It should always be included in a battery of other vestibular and neurological tests.

### References

1. Lee CT (1998) Sharpening the sharpened Romberg. SPUMS J 28(3):125–132

## Vestibular Tests: Static and Dynamic Posturography

CATHERINE DE WAELE  
Laboratoire de Neurobiologie des Réseaux  
Sensori-Moteurs, CNRS, Paris, France

### Synonyms

Measure of equilibrium

### Definition

Quantification of the postural oscillations when the subject was located on a stable or unstable platform.

### Characteristics

During the last decade, static posturography on stationary platforms or dynamic posturography on moving platforms has become widely used to probe balance in patients suffering from dizziness. The subjects are instructed to stand straight and motionless with arms along the sides of the body and head erect when placed on a static or moving platform. Strain-gauge force transducers provide the displacement of the center of foot pressure (COP) at a 40 Hz sampling frequency.

Dynamic posturography can be performed on different moving platforms with eyes either open or closed. A sea-saw platform moving either in the medio-lateral or in the antero-posterior directions or a motorized platform generating linear horizontal displacements in different directions can be used. A computerized dynamic posturography (Equitest) including both a sensory organization test (SOT) and a motor control test can also be used. The

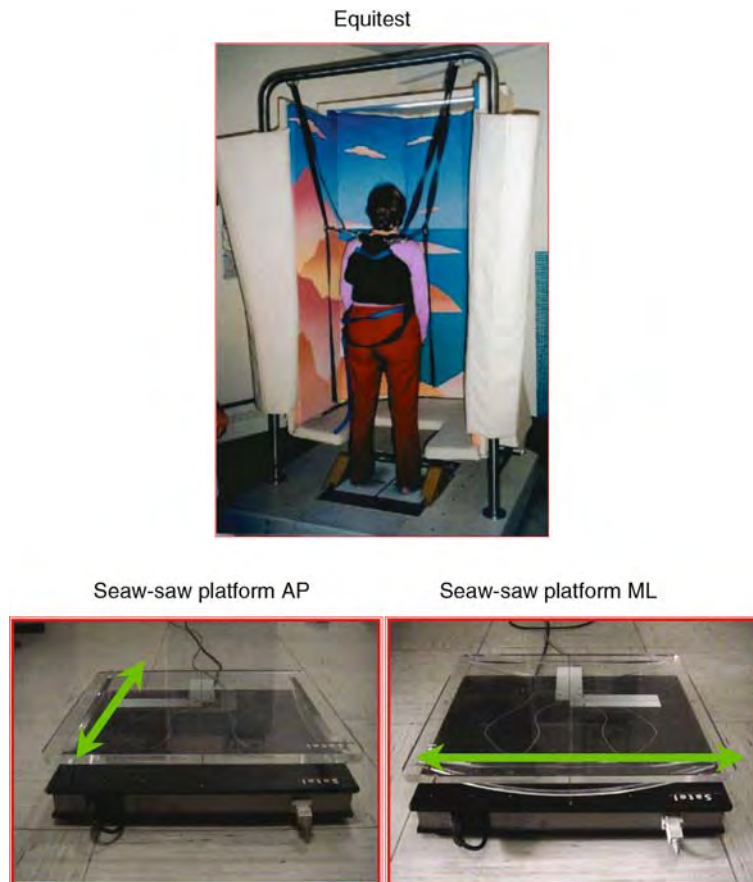

**Vestibular Tests: Static and Dynamic Posturography.** Figure 1 Figure illustrating on the right side the equitest and on the left side the sea-saw platform.

SOT uses six different conditions, (i) eyes open, (ii) eyes closed, (iii) visual-referenced, (iv) sway-referenced with eyes open, (v) sway-referenced with eyes closed and (vi) visual- and sway-referenced with eyes open. It allows testing of the subject's ability to use vestibular, visual and tactile-proprioceptive inputs in motor response coordination appropriate to external conditions (Fig. 1) [1].

### Analysis

Based on the results of Fourier analysis, three principal variables are considered in both static and dynamic conditions.

1. *The total length of the elementary displacements (in mm)*, which is the sum of the distances covered between each point of the stabilogram (static condition) or the absolute value of the sum of "pivot" elementary displacements of the moving platform (dynamic condition).
2. *The sway area (in mm<sup>2</sup>)* Body sway is evaluated by computing the position of the center of force over time and by measuring the sway area of the confidence ellipse that contained 90% of the positions of the center of force sampled.
3. *The total power spectrum of the oscillations (in volts<sup>2</sup>)* which is calculated by fast Fourier transform (FFT) of the total length of the "pivot" displacement.

For all these variables, higher values correspond to more unstable subjects.

For the Equitest, a score was attributed during the sensory test, for each of the six tested conditions.

### Conclusion

Posturography is the only quantified test, which allows assessment of balance in patients suffering from dizziness. In unilateral vestibular loss patients, patients fall in conditions 5 and 6 of the Equitest, when tested at early stages following the lesion. Finally, a recent study [2] showed that investigating dynamic balance using a non-motorized seesaw platform with eyes closed is a useful and robust test for assessing the effects on balance of a unilateral vestibular deficit. Body sway in the medio-lateral direction was found to be greater than in the antero-posterior condition for up to 1 year following the lesion.

### References

1. Nashner LM (1971) A model describing vestibular detection of body sway motion. *Acta Otolaryngol* 72:429–436
2. Mbongo F, Patko T, Vidal PP, Vibert N, Tran Ba Huy P, de Waele C (2005) Postural control in patients with unilateral vestibular lesions is more impaired in the roll than in the pitch plane: a static and dynamic posturography study. *Audiol Neurootol* 10(5):291–302

## Vestibular Tests: Vestibular Evoked Myogenic Potentials Induced by High Level Sounds

CATHERINE DE WAELE

Laboratoire de Neurobiologie des Réseaux  
Sensori-Moteurs, Faculté de Médecine CNRS,  
Paris, France

### Synonyms

Saccular test

### Definition

This test allows appreciation of the function of the sacculus and the sacculo-spinal pathways [1].

### Characteristics

Subjects undergo vestibular evoked myogenic potential (VEMP) testing using a standard protocol with a nerve monitoring system (Nicolet, Madison). Surface electrodes are placed on the midline forehead (ground electrode), on the skin overlying the mid portion of the sternocleidomastoid muscle bilaterally (SCM: active electrode) and on the skin of the sternum (reference electrode). Prior to each test run, impedances are measured from each electrode to ensure adequate electrode contact and symmetrical measures of impedance between sides. During the test, patients are placed in the supine position, with the head raised from the pillow and turned on the side contralateral to the stimulated side in order to maximally contract the SCM muscle ipsilateral to the stimulated side. Air-conducted high level 100 dB short tone bursts (STB: 500 Hz) or 100 dB clicks are presented to the tested ear through a headphone. The analysis time is 100 ms with a stimulation rate of 5 Hz. The EMG signal from the stimulated side is amplified, bandpass-filtered (2–1.6 kHz) and averaged (250 events). In the case of conductive hearing loss, VEMP's cannot be detected since the signal has become too low to stimulate the sacculus. In this case, STB should be delivered using a bone vibrator (Fig. 1).

Two early waves can be detected, a positivity called P13 occurring with a mean latency of 10 ms followed by a negativity called N23, detected with a mean latency of 14 ms. The threshold, the latency and the peak-to-peak amplitude of these two waves are carefully recorded. Since the amplitude of the response is linearly related to the intensity of the SCM activation during the period of averaging, the peak-to-peak amplitudes can be expressed relative to the level of background mean rectified EMG to create a ratio that largely removes the effects of differences in muscle activity. The ratio  $100 \times (\text{amplitude healthy side} / \text{amplitude lesioned side})$

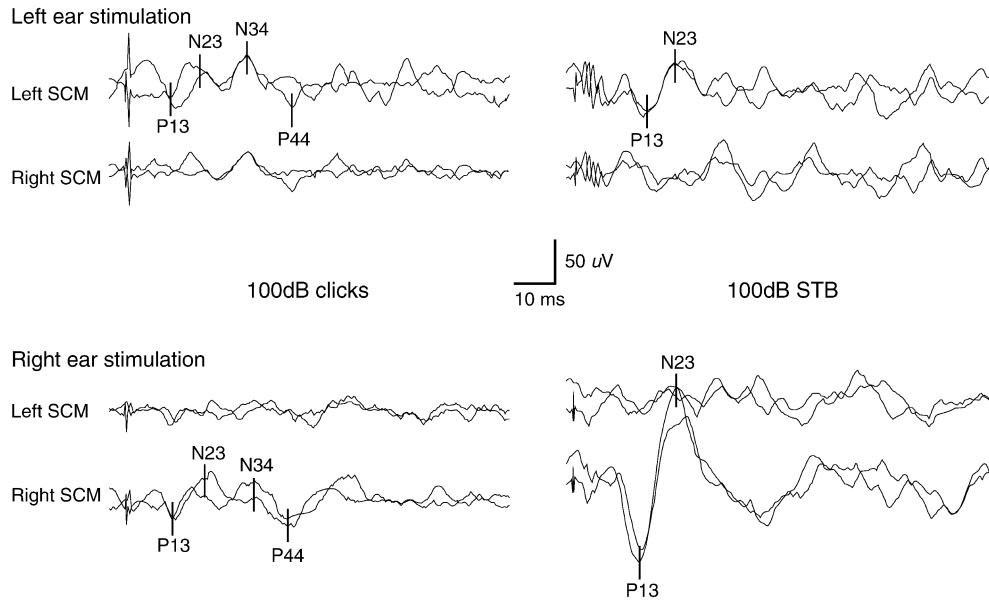

**Vestibular Tests: Vestibular Evoked Myogenic Potentials Induced by High Level Sounds. Figure 1** Illustration of the VEMP's induced by 100 dB high level click or 500 Hz short tone burst. Notice the early waves, P13 and N23 induced by this stimulation at the level of the ipsilateral SCM.

plus amplitude lesioned side) may also be calculated to compare the saccular responses of both sides. The P13/N23 peak-to-peak amplitude also depends on the type of stimulus; it is always bigger when induced by STB than by high level clicks. This could be due to a better recruitment of the saccular cells and/or of the saccular nerve.

The amplitude is the best parameter for indicating a potential dysfunction of the saccular nerve and of the sacculus. In particular, asymmetries of >2.5:1 of P13g/N23g peak amplitudes signal a dysfunction of the sacculus and the sacculospinal pathways on one side. In contrast, the latency is rarely changed in cases of peripheral vestibular dysfunction.

VEMP's are the consequences of the activation of paucisynaptic and inhibitory sacculo-colic pathways with a first synapse at the level of the primary vestibular afferents, a second at the level of the second order vestibular neurons and a third at the level of the spinal motoneurons innervating the SCM muscle.

VEMP's induced by high level sounds (STB or clicks) allow appreciation of the function of the sacculus and the sacculo-colic pathways. This test is important in peripheral vestibular disease such as Meniere's disease, acoustic neurinomas and dizziness. In case of vestibular neuronitis, it allows appreciation of the functioning of the inferior vestibular nerve.

## References

1. Colebatch JG, Halmagyi GM, Skuse NF (1994) Myogenic potentials generated by a click-evoked vestibulocollic reflex. *J Neurol Neurosurg Psychiatr* 57:190-197

## Vestibulocerebellum

### Definition

Several classifications are used to subdivide the cerebellum based on anatomical, phylogenetic and functional (i.e. termination of cerebellar afferents and efferents) findings. The flocculo-nodular lobe and adjoining parts of the caudal vermis have been named vestibulocerebellum because of heavily projecting vestibular afferents. The vestibulocerebellum corresponds to the archicerebellum based on phylogenetic and embryological studies.

► [Cerebellar Functions](#)

► [Cerebellum – Role in Eye Movements](#)

## Vestibulocochlear Nerve (VIII)

### Synonyms

► [N. vestibulocochlear \(N.VIII\)](#)

### Definition

Vestibulocochlear nerve (VIII) is composed of two parts:

- Vestibular nerve: it is responsible for innervation of the vestibular structures of the inner ear (sacculi, utricles and semicircular canals).

Nucleus: vestibular nuclei.

- Cochlear nerve: it innervates the cochlea and is the first element of the auditory tract. Nucleus: cochlear nuclei.

Skull: internal acoustic meatus.

## Vestibulocollic and Cervicocollic Control

EMILY A. KESHNER

Department of Physical Therapy, College of Health Professions and Department of Electrical and Computer Engineering, College of Engineering, Temple University, Philadelphia, PA, USA

### Definition

Control of the neck is exerted primarily by two sensory systems, the vestibular system in response to the signals received by the vestibular end organs (the otoliths and the semicircular canals within the vestibular labyrinths) and the proprioceptors of the cervical spine. Two automatic and stereotypical responses can be elicited by direct stimulation of these receptors. The vestibulocollic reflex (VCR) is a compensatory response of the neck muscles when head motion is sensed by the vestibular organs in the inner ear. The cervicocollic reflex (CCR) is a compensatory response of the neck muscles that is driven by neck proprioceptive inputs during motion of the body.

### Description of the Theory

The function of the VCR is to stabilize the position of the head in space and thereby stabilize gaze in space [1]. The function of the CCR is to stabilize the head on the body and, thereby, provide information about motion of the head with respect to the trunk [2]. These reflexes are unquestionably evoked in decerebrate animals, but their contribution to head stabilization in alert animals and during functional motion are not as clear. In the accompanying essay, the physiological and behavioral data that support the presence of these reflexes in alert animals is presented together with the argument for their contribution to the control of posture and balance.

### Characteristics of the VCR

The VCR is not a simple monosynaptic reflex pathway. The majority of neurons that may produce the VCR

response have disynaptic and trisynaptic connections between the vestibular labyrinths and the neck muscles through the medial and lateral vestibulospinal pathways projecting on to the cervical motoneurons. Other inputs to the motoneurons include the reticulospinal pathways which have been shown to be capable of producing the short latency VCR behaviors when vestibulospinal pathways are interrupted [1]. Inputs from the vestibular afferents (the semicircular canals and the otolith organs) converge on to single vestibular neurons in the vestibular nuclei before descending to the neck motoneurons. More than 30% of vestibular neurons receive convergent inputs from the vertical semicircular canal and the otolith nerves. About 15% of vestibular neurons receive convergent inputs from the horizontal semicircular canals and the otolith nerves. Convergence of canal and otolith inputs will produce an accurate reception of and an appropriate compensatory reaction to complex head movements that are both rotational and linear. Vestibular neurons also receive input from the cerebellum, which has been shown to adjust the gain of the VCR. Monosynaptic inputs from somatosensory afferents in the cervical spine also converge on to the vestibular neurons. This compound convergence indicates an extensive integration of signals at the second order neurons, which will then activate the appropriate set of muscles in order to orient the head in the correct direction. The result is that the central representation of head movement is controlled at the initial stages of sensory processing in the brain stem [3].

The second order vestibulospinal neurons respond to externally applied movements of the head by encoding the angular velocity of the movement which reflects the head velocity in space signaled by the semicircular canal afferents [3]. Typical neck motoneurons receive input from all six of the semicircular canals, which makes them capable of generating reflex movements that are compensatory for three dimensional velocity perturbations. Branches from vestibulospinal fibers may also terminate on motoneurons of more than one muscle [1], suggesting that the reflex head movements support head stabilization about multiple degrees of freedom and implicating vestibulospinal fibers in the formation of neck muscle synergies. The functional result of this convergence of descending inputs with body oriented and head oriented afferent signals is that responses to passive and active head perturbations are differentially organized (Fig. 1).

Dynamic properties of a VCR tested in alert cats [2] are suggestive of a linear second order system that demonstrates an increase in gain (amplitude) and a phase (timing) lead as frequency increases. Open loop dynamics of the VCR have been characterized in healthy young adults by fixing the trunk to a chair that was rotated in a ►pseudorandom fashion in ►yaw [4] or ►pitch [5] (Fig. 2). Very low gains of the VCR



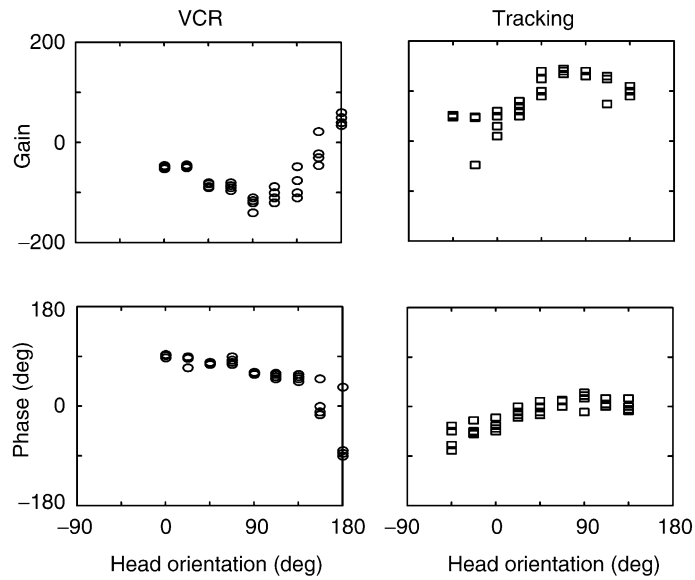

**Vestibulocollic and Cervicocollic Control. Figure 1** Gains and phases of right complexus muscle EMG responses against angle of orientation during a voluntary head tracking task or passive VCR rotations of the whole body ( $0^\circ$  = yaw,  $90^\circ$  = pitch) are plotted for four trials of one animal. A  $90^\circ$  phase advance during the VCR relative to tracking indicates a velocity rather than position related response. Unique patterns of activity can be selected by each animal for active tracking responses, indicating that the CNS can generate movements in the same direction using different muscle patterns.

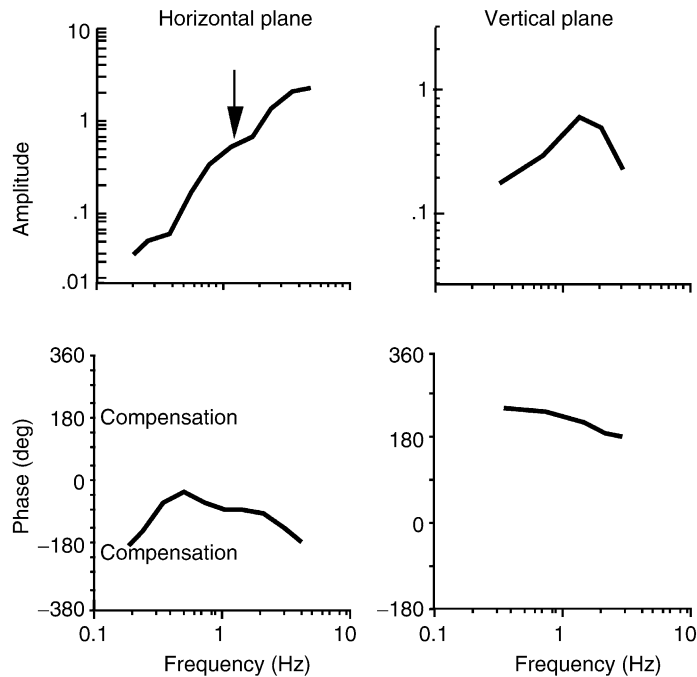

**Vestibulocollic and Cervicocollic Control. Figure 2** Bode plots of the amplitude and phase of the average neck with respect to trunk response to horizontal and vertical plane pseudorandom sum of sine rotations during a mental distraction task in healthy subjects. Phases of  $\pm 180^\circ$  and amplitudes equal to one indicate that the head is perfectly compensating for motion of the trunk to stay stable in space. A phase of  $0^\circ$  indicates that the head is moving with the trunk. Amplitudes greater than one indicate that the head is moving more than the trunk. The vertical arrow indicates the plateau in the horizontal plane dynamics that appeared around 1.5–2.5 Hz.

emerge below 0.5 Hz. At 1–3 Hz, the VCR appears to play a predominant role in stabilizing the head as gains move toward unity and compensatory phases are almost 180° out of phase with the rotational disturbance. This is a functional bandwidth for reflex control, as the preferred frequency for natural gait occurs around 1.8 Hz [6]. Above 3–4 Hz, resonant behaviors indicate that control by head inertia and mechanical properties of the neck are predominant. Human head stability during pitch exceeded that during yaw at the low end of the frequency range, implying a contribution of a static otolith VCR. These findings are supported by dynamical models of the head stabilization system [2,7].

### Characteristics of the CCR

When the neck was rotated while the head was held fixed in space [2], open loop dynamics of the CCR were very similar to those of the VCR in alert cats, but with increased torques which could be attributed to the viscoelastic properties of the neck muscles. Both the dynamic behavior of the CCR and its high sensitivity to small motions of the cervical spine resemble the properties of muscle spindle primary afferents, signifying that these afferents provide the major input responsible for the CCR. In fact, short latency reflexes in the neck muscles of alert cats are attenuated or abolished by partial or complete dorsal **rhizotomy** at the first cervical vertebra. The high density of muscle spindles in the cervical musculature insinuates a high degree of sensitivity into relatively small cervical stimuli so that rapid cervical postural corrections can be made. Evidence of these immediate changes was observed when subject maintained the position of their head in space during simultaneous postural and cognitive tasks with and without a weight placed on top of their heads [8]. Adding weight to the head did not significantly change head or neck position, suggesting that there was an immediate and compensatory response for the added weight. This compensatory response was explored through dynamic models of the head and neck that predicted that the mechanism that controlled the position of the head in space was an alteration in the system mechanics through an increased contribution from the CCR for modulating stiffness and the viscoelastic properties of the head-neck system [7,8].

### Contributions of the VCR and CCR to Behavior

Data from both decerebrate and alert animals indicate that the CCR and VCR behave approximately linearly, both individually and in combination [2]. When the head was driven by a **servomotor** while the body remained stationary, EMG activation by the two reflexes added linearly to produce a large response. When the body was rotated and the head was allowed to counter-rotate about the first and second cervical joints, the two reflexes combined linearly in an antagonistic

fashion; the CCR acted to oppose head rotations produced by the VCR. Acting together, the two reflexes assisted each other in preventing oscillation of the head on a stationary body. But although the characteristics of these two reflexes are well characterized in constrained animals, the contribution of these responses during functional activities is not as clear. It is known that the disynaptic vestibular pathways are not sufficient to produce the dynamics of the VCR. Furthermore, the muscle torques generated by the VCR are not adequate to produce the forces necessary to counteract external disturbances [1]. The simple responses identified in reduced preparations such as decerebrate cats are not as readily elicited in alert animals. Both alert cat and human subjects have the ability to suppress or modulate the appearance of the VCR and it has been demonstrated that the reflex dynamics can be modified by mental set. Even when subjects were fixed firmly to a turntable and rotated with a pseudorandom **sum of sines** while distracted by mental arithmetic, a time domain analysis revealed that the contribution to head stability by the short latency CCR and VCR was negligible. Long latency stabilizing mechanisms with onset times around 140 ms emerged as the primary influence on head stabilization [9]. Thus the concept of the VCR and CCR emerging as short latency stimulus evoked reflexes does not explain the response dynamics during functional behaviors.

Strong behavioral evidence of head instability in both animals and humans with acute loss of vestibular signals however, strongly implicates vestibular input in the process of maintaining head stabilization. During transient free fall of the head or during whole body ascent and descent, the sternocleidomastoid muscle can be activated at about 24–44 ms in healthy subjects compared to about 67–80 ms in labyrinthine deficient subjects. The shorter latency response of the muscle in the healthy subjects might be vestibular in origin, while the longer neck muscle response in the labyrinthine deficient subjects might have been a stretch reflex rather than a response due to activation of vestibular receptors. When subjects were standing on a platform that was linearly translated in the anterior or posterior direction, EMG responses of the neck and upper trunk muscles appeared in the direction that would appropriately compensate for motion of the head [10]. These responses were elicited at the same latencies as the automatic postural reactions in the lower limb (Table 1) suggesting that stabilization of the head and neck was not controlled by ascension of proprioceptive inputs from the lower limb. It is unlikely that these longer latency muscle EMG responses were a startle response because they did not adapt across trials. More probably, stabilization of the head and upper trunk was being independently controlled by vestibular and cervical proprioceptive signals. Cervical afferent signals converge on the vestibular nuclear complex and adjacent reticular

**Vestibulocollic and Cervicocollic Control. Table 1** Means and standard deviations of muscle EMG latencies during platform translations

Muscles	Anterior translations	Posterior translations
<b>*** Short latency responses (ms)</b>		
Soleus		60 ± 6
Neck extensors		54 ± 14
<b>Long latency responses (ms)</b>		
Soleus	149 ± 39	95 ± 11
Neck extensors	103 ± 25	135 ± 25
Tibialis anterior	98 ± 14	117 ± 22
Neck flexors	107 ± 18	95 ± 19

formation and the intimate connections between these inputs and cerebellar pathways may be responsible for transforming vestibular inputs from head centered to body centered coordinates. Vestibulospinal control of the trunk and lower limb has been described in the accompanying essay of this Encyclopedia.

Longer latencies of the response imply that even if the stabilizing responses are of vestibular origin, their influence on head stabilization could be under descending control. Rather than directly producing the muscular forces for direct stabilization of the head in space, the vestibular inputs may be involved in changing the control parameters for stabilization of the head and neck. For example, damping parameters could be altered through changes in both VCR and CCR reflex activation or through changes in the viscoelastic properties of the system [8]. A loss of damping by vestibular inputs would explain the increased magnitudes of the later components of trunk and head angular and linear motion in labyrinthine deficient subjects during seated linear accelerations [6] (Fig. 3). With the trunk fixed so that it moved in phase with the accelerating seat, low response gains in the labyrinthine deficient subjects and phases close to 0° at low frequencies imply that the head is moving with the trunk as would occur with control by the CCR acting alone, whereas a 90° phase advance in healthy subjects indicates that the head is compensating for the motion of the body. With the trunk free to move however, the flattened phase responses at frequencies below 1 Hz in the healthy subjects suggest a neural controller that is damping the system mechanics [8]. In the LD subjects, a steep phase descent was continuous across the frequency range as would be expected if the only controller were system mechanics and there were no neural delays present in the response. Steeply descending phases and gain drops observed above 2 Hz when the trunk was free to move might also be due to increasing time delays in the control system, as would occur if the descending controllers required more processing time than simple reflex mechanisms.

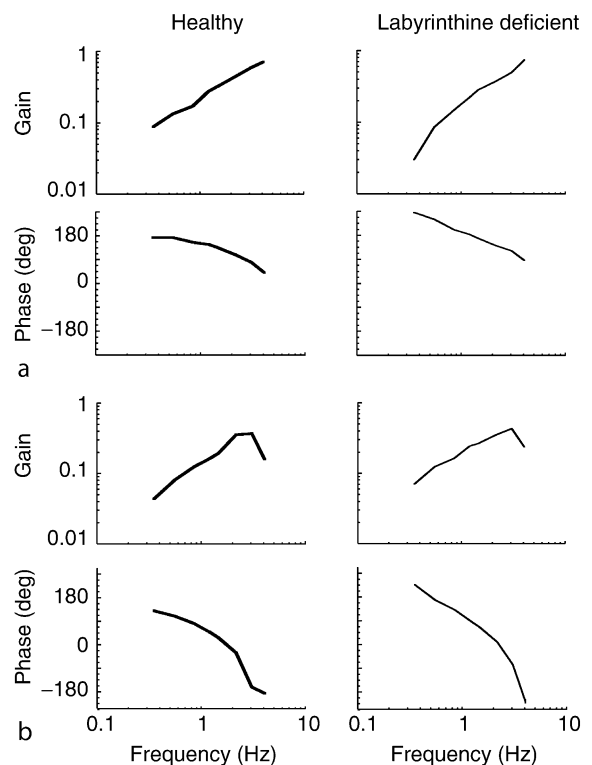

### Vestibulocollic and Cervicocollic Control.

**Figure 3** Bode plots of the average gains and phases of head angular position with respect to sled linear position in healthy and labyrinthine deficient subjects during linear sum of sines translations. Responses in each group are plotted for trunk fixed (a) and trunk free (b). According to the phase conventions, 0° indicates the head rotating in downward pitch as the sled moved forward; ±180° indicates the head rotating in upward pitch as the sled moved forward; ±90° indicates a lag or lead of the head with respect to the sled.

Thus the vestibular system does not appear to be directly implicated in generating the initial head stabilizing response during functional motion. The role of the vestibular system may actually be one of damping

the response to the mechanics of the system and of monitoring the position of the head and trunk in space, secondary to feedback from segmental proprioceptors, in order to minimize the sustained effects of destabilization and maintain orientation in space. Although the response properties of the VCR to linear motions of the body are less well defined than those of rotational motion, suggestive evidence will be addressed in the accompanying essay in this Encyclopedia that the linear vestibular reflexes play a significant role in head and gaze stabilization during locomotion.

## References

1. Wilson VJ, Schor RH (1999) The neural substrate of the vestibulocollic reflex. What needs to be learned. *Exp Brain Res* 129:483–493
2. Goldberg J, Peterson BW (1986) Reflex and mechanical contributions to head stabilization in alert cats. *J Neurophysiol* 56:857–875
3. Boyle R (2001) Vestibulospinal control of reflex and voluntary head movement. *Ann NY Acad Sci* 942:364–380
4. Keshner EA, Peterson BW (1995) Mechanisms controlling human head stabilization. I. Head-neck dynamics during random rotations in the horizontal plane. *J Neurophysiol* 73:2293–2301
5. Keshner EA, Cromwell RL, Peterson BW (1995) Mechanisms controlling human head stabilization. II. Head-neck characteristics during random rotations in the vertical plane. *J Neurophysiol* 73:2302–2312
6. Keshner EA (2003) Head-trunk coordination during linear anterior-posterior translations. *J Neurophysiol* 89:1891–1901
7. Peng GC, Hain TC, Peterson BW (1996) A dynamical model for reflex activated head movements in the horizontal plane. *Biol Cybern* 75:309–319
8. Keshner EA, Hain TC, Chen KJ (1999) Predicting control mechanisms for human head stabilization by altering the passive mechanics. *J Vestib Res* 9:423–434
9. Guitton D, Kearney RE, Wereley N, Peterson BW (1986) Visual, vestibular and voluntary contributions to human head stabilization. *Exp Brain Res* 64:59–69
10. Keshner EA, Woollacott MH, Debu B (1988) Neck, trunk and limb muscle responses during postural perturbations in humans. *Exp Brain Res* 71:455–466

## Vestibulo-colic Reflex

### Definition

Activation of neck muscles induced by labyrinthine (vestibular) stimulation. In general, it is aimed at stabilizing the position of the head in space.

- ▶ Peripheral Vestibular System
- ▶ Vestibulo-Spinal Reflexes

## Vestibulo-Ocular Reflex (VOR)

J. VAN DER STEEN

Department of Neuroscience, Erasmus MC, Rotterdam, The Netherlands

### Synonyms

Vestibulo-ocular reflex; AVOR (angular VOR); RVOR (rotational VOR); LVOR (linear VOR); TVOR (Translational VOR)

### Definition

The vestibulo-ocular reflex (VOR) is a short latency reflex system, which ideally generates a rotation of the eye with an amplitude equal and opposite to the direction of a head movement as a result of vestibular stimulation.

### Characteristics

#### Quantitative Description of the VOR

Angular or linear movements of the head cause an oculomotor response that compensates for the head movement. The eyes make a counter rotation in the head such that the line of sight (gaze) remains stationary. The generated eye movements consist of smooth components (slow phases) interrupted by fast resetting movements (fast phases or saccades).

Based on their function three major forms of vestibulo-ocular reflexes exist.

1. The *rotational* or ▶ *angular vestibulo-ocular reflex* (RVOR or AVOR) provides ocular stability during head rotations. It receives its main input from the semicircular canals.
2. The *ocular counter roll reflex* (tilt reflex) helps to maintain an upright position in relation to the earth's vertical. This reflex invokes ocular counter rolling movements of the eye that are held during a static change in the position of the head with respect to gravity. This reflex is mediated by the otolith organs.
3. The ▶ *translational vestibulo ocular reflex* (TVOR or LVOR) assists in maintaining fixation stability during linear movements of the head. This reflex arises from sensory information from both the semicircular canals and otolith organs.

A typical AVOR response is illustrated in [Fig. 1](#). The figure shows recordings of eye and head movements of a subject who was oscillated about a vertical axis with a frequency of 1 Hz and amplitude of 4 degrees peak-to-peak. Eye movements are in opposite direction to the head movement. When the head rotates to the left, the eye counter-rotates to the right with respect to the head and vice versa. The efficacy of the reflex is determined

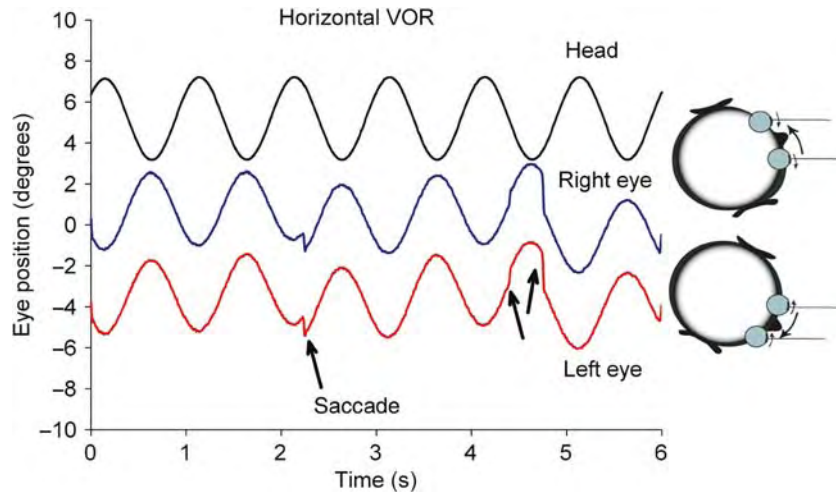

**Vestibulo-Ocular Reflex (VOR).** Figure 1 Horizontal eye movements in response to sinusoidal vestibular stimulation about the vertical axis. Stimulus frequency was 1 Hz, peak-to-peak amplitude  $4^\circ$ . Notice that when the head goes to the right (upward deflection) the eye rotates to the left (downward deflection).

by the **VOR gain** and **VOR phase**, where gain is the ratio between eye and head motion and phase is the delay between head motion and eye movement onset.

### The Vestibular System

The VOR is mediated by the vestibular system. The backbone is the three-neuron reflex arc (see Fig. 2). At the input side the system senses the forces generated by linear and angular accelerations of the head. These sensors are situated in five organs located within the cavities of the vestibular labyrinth hidden in a bone structure (os petrosum) on each side of the skull. The sensory signals are conveyed to the vestibular nuclei located in the brainstem. The vestibular nuclei are the interface between sensory signals from the vestibular organ and motor command signals generated by the oculomotor nuclei. They transform the sensory signals into command signals for the eye muscles. The vestibular nuclei add and process information coming from a variety of additional neuronal sources and send their output to the oculomotor nuclei, which provide the command signals for the eye muscles (see higher level organization).

### What Processing Is Necessary to Generate a VOR?

Angular accelerations of the head cause a displacement of the fluid (endolymph) in the semicircular canals. This causes a bending of the hair cells located in the cupula of each canal. Each canal is only maximally sensitive to angular motion of the head in the plane of that canal because hair cells are unidirectionally selective and all the hair cells in one semicircular canal are oriented in the same direction. Although displacement of the cupula system during natural head movements is an adequate stimulus for the semicircular canals, angular

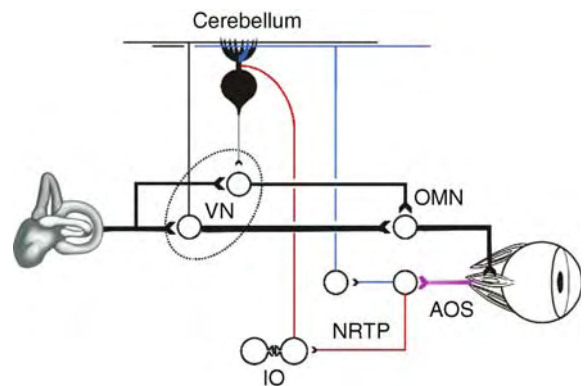

**Vestibulo-Ocular Reflex (VOR).** Figure 2 The connections from the vestibular organ via the vestibular nucleus (VN) to the oculomotor nucleus (OMN) forming the three-neuron reflex arc (bold black lines). This feed forward connection, which is the basis of the VOR receives inhibitory input from the cerebellum at the level of the VN. The amount of cerebellar activity is determined by the retinal slip information coming into the cerebellum via the accessory optic system (AOS) via the nucleus reticularis tegmenti pontis (NRTP) and inferior olive (IO). These two inputs project onto the Purkinje cells via respectively parallel and ascending fiber pathways.

acceleration is proportional to head velocity rather than to head acceleration. This is because the mechanical response of the canal system is determined by its hydrodynamic properties. Angular acceleration in the plane of the canal imposes inertial forces on the mass of the endolymph fluid contained by that canal, resulting in a relative fluid flow in opposite direction [1]. Because the fluid flow is opposed by viscous forces proportional

to the velocity of the flow, each canal effectively integrates the angular acceleration imposed on the head. Thus, within the range of natural head movements (0.1–5 Hz) the semicircular canals act as sensitive speedometers, which send angular velocity information via nerve signals (see higher level organization) to the vestibular nuclei.

An important role in the vestibular system is played by a special circuit called velocity storage. Velocity storage holds or stores the activity from the semicircular canals and releases this activity over a more extended period of time. Both a fast “direct” and a slow “indirect” velocity storage pathway are involved in the generation of the AVOR. The effect is an increase in the time constant of the AVOR to 20–40 s (this is a 4–6 fold increase with respect to the cupula time constant of the canal) [2].

The AVOR eye movement response is thus the result of the combination of peripheral and central information processing. At the periphery, the canal hydrodynamic properties determine that between 0.1 and 5 Hz the AVOR is approximately 180° out of phase with the head movement and has almost unity gain. Outside this frequency band specific gain and phase changes occur, such that there is a phase lead and decrease in gain at very low frequencies, whereas there is a phase lag at very high frequencies.

Central processing in the brainstem in the form of velocity storage effectively integrates velocity signals into position signals, thus providing the necessary information to control the eye muscles. It also lengthens the period that vestibular activity is present in the vestibular system.

### What Processing Is Necessary to Generate a Linear VOR?

*Linear accelerations* of the head (including gravity) are detected by the otolith organs.

These organs have a macula with sensory hair cells placed in multiple orientations. The tips of the hair cells are placed against a heavy load, the otolith. Whenever there is a linear displacement of the head, a shear force is exerted between the macula and otolith, which deflects the hair cells. A static position change with respect to gravity results in a counter roll of the eyes, which is maintained as long as the head is in that position (see Fig. 3). In fish, amphibians and rodents otolith-ocular reflexes compensate for up to 60% of the angle of head tilt [3]. In humans, the gain of static otolith-ocular reflexes is much smaller viz. 0.1–0.2 [4].

Under dynamic conditions the situation is different. Most lateral eyed species have only a very limited response to linear accelerations at higher frequencies. In frontal eyed species (humans and primates) the TVOR has developed in line with foveal vision and stereopsis. This enables us to stabilize the eyes when we drive a car,

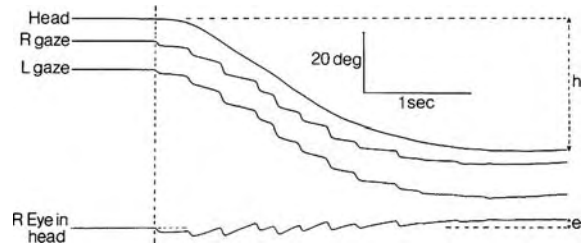

**Vestibulo-Ocular Reflex (VOR).** Figure 3 Torsional eye movements of a human subject who made a large (40°) roll movement to the left. During the rotation there are compensatory torsional eye movements. With the head stationary at 40° roll, there is only a very small residual compensation of the eye, which is maintained as long as the head remains in that position.

run or walk. Under these activities linear accelerations occur all the time. Therefore, the TVOR is regarded as a foveal stabilization mechanism that works in close synergy with foveal visual pathways (smooth pursuit). The goal is to minimize binocular disparities by minimizing the retinal slip in both eyes. The role of the TVOR in foveation also shows from the fact that the TVOR scales with viewing distance [5]. Interestingly the properties of TVOR such as scaling with viewing distance occur particularly at higher stimulus frequencies (>1 Hz). Although recently much progress has been made, the pathways and neuronal processing of LVOR are complex and still only partially known. Both otolith-ocular and canal-ocular pathways are involved. As a result, the linear vestibular system is not only capable of stabilizing the eyes during linear accelerations, but is also capable of distinguishing whether a change in activity is due to tilt or inertia induced by linear motion (for a review see Angelaki [6]).

### Higher Level Organization

#### *The Intrinsic Coordinate System of the Vestibular System*

The anatomical arrangement of the canals is such that two canals on both sides of the head are paired. Each pair works in a push-pull fashion: When one canal is excited, the other canal is inhibited. The VOR is organized in a head centric system allowing three degrees of freedom. Both the anatomical organization of the sensors and that of the eye muscles allow compensation in all three dimensions. Fig. 4 shows a top view of the arrangement of the three canal pairs in relation to the eye muscles that are innervated by each pair. Notice that both the vertical canal planes and the vertical and oblique eye muscles are oriented at approximately 45° angles. Depending on the plane of motion different groups of eye muscles are activated. Rotation about the vertical axis involves the medial and lateral rectus muscles, whereas rotation about a horizontal axis activates the superior recti and oblique muscles.

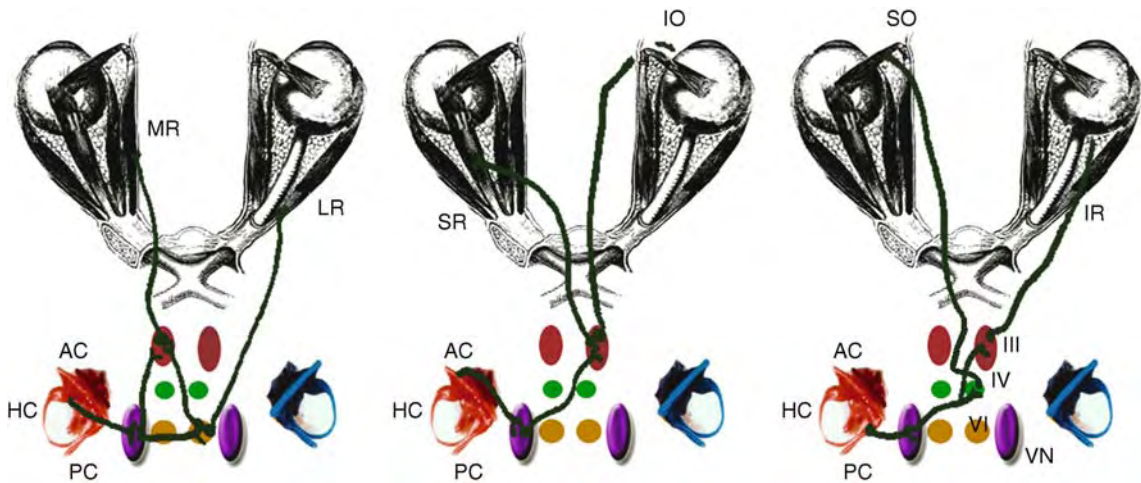

**Vestibulo-Ocular Reflex (VOR).** **Figure 4** Excitatory connections of the individual semicircular canals via the vestibular (VN) and oculomotor nuclei (III, IV and VI) to specific eye muscles. *Left panel:* horizontal canal (HC) connections to medial rectus (MR) and lateral rectus (LR) muscles. Projections run via the VN to contralateral abducens nucleus (VI) and ipsilateral oculomotorius nucleus (III). *Middle panel:* Anterior canal (AC) projects from III to ipsilateral superior rectus (SR) and contralateral inferior oblique (IO) (not visible). *Right panel:* Posterior canal (PC) projects to contralateral inferior rectus (IR) and ipsilateral superior oblique muscle (SO) via the contralateral trochlear nucleus (IV) and oculomotorius (III). Notice that the plane of pulling action of individual muscles lines up with the canals to which they are connected.

Although ideally vestibular eye movements should be fully compensatory during rotations about any axis, gain of the AVOR about the nasal-occipital axis, evoking torsional eye movements has been found to be systematically lower than for yaw and pitch. In lateral eyed species, the situation for roll and pitch is reversed, which relates to the different orientation of the eye and attachment of the ocular muscles relative to the skull.

#### Matching Visual and Vestibulo Ocular Reflexes

An important question is how the VOR is matched within the brain with other sensory modalities such as vision. Although the eye is an object with three rotational degrees of freedom, visual stabilization systems (pursuit, fixation saccades) occur in a single plane i.e. there are only two degrees of freedom for ocular torsion. This behavior is formulated in ►Listing's ►Law and states that any eye position in the orbit can be reached from the primary position by rotation about a single axis in the so called Listing's plane. This is problematic during head motion because an ideal AVOR stabilizes retinal images by rotating the eye about an axis parallel to head motion. But head movements occur in three dimensions and are not confined to Listing's plane. Currently there are different results and opinions about 3D behavior of the AVOR. Some researchers suggest a head centric organization of the AVOR with primary axes that closely follow Listing's plane and which are

optimal for retinal image stabilization [7]. Others have reported that the AVOR employs axes that form a compromise between Listing's Law and the axis of head rotation. It is currently also still debated as to whether specific kinematic behavior is time limited to a specific phase of the VOR response and if it is neurally or more peripherally implemented in the oculomotor plant (for a review see Crane et al. [8]).

#### Plasticity of the VOR

The VOR is a very fast feed forward reflex system with a delay of about  $8 \times 10^{-3}$  s. Because the vestibular organs do not directly receive feedback, information on the accuracy of the response must come from other sources. The most important information comes from the visual system. Retinal slip information projects via a subcortical pathway called the accessory optic system (AOS) and via the inferior olive (IO) to the flocculus, which is part of the cerebellum. The flocculus also receives vestibular information from the semicircular canals via special neurons in the vestibular nucleus.

The two sources of information are compared by the Purkinje cells (the only output cells from the cerebellum), which project back onto the vestibular nuclei. The cerebellar loop thus forms an essential part of the vestibular system, which can modulate the activity of the three-neuron reflex arc system. It is therefore essential for plastic behavior of the VOR. Patients with cerebellar lesions fail to show adaptive behavior.

### Function

The VOR is very important for stabilizing vision particularly during locomotion. Because slight head movements are present all the time, patients whose VOR is impaired cannot read, because they cannot even stabilize the eyes during small head tremors.

The VOR evolved early in evolution and has changed very little since its origin. The same basic design found in humans has been found in fossils of dinosaurs.

Vestibular eye movements are generated with much smaller latencies than visually generated eye movements. This is due to the much larger time needed for the visual system to detect and process motion. So the dinosaurs already relied on vestibular input to compensate for linear and angular accelerations during locomotion.

Although the VOR reflex does not depend on visual input and works even in total darkness or when the eyes are closed, in daily life situations the VOR works in close synergy with visual stabilization systems. Visual information is continuously monitored by the brain to assure retinal image stability. If vision gets blurred during head movements, the VOR undergoes plastic changes that restore visuomotor performance via cerebellar loops.

The vestibular system responds to movements that have angular or linear acceleration components. In healthy persons all parts of the vestibular organ are in balance and work together to give the appropriate VOR response. However, when unilateral damage occurs to the vestibular organ or even to one canal, the balance is disturbed. This is reflected in spontaneous eye movements (nystagmus, drift).

### References

1. Jones GM, Milsum JH (1965) Spatial and dynamic aspects of visual fixation. *IEEE Trans Biomed Engl* 12(2):54–62
2. Jones GM (1991) The vestibular contribution. In: Carpenter RHS (ed) *Vision and visual dysfunction*, vol 8. London, Macmillan, p 339
3. Baarsma EA, Collewijn H (1975) Eye movements due to linear accelerations in the rabbit. *J Physiol* 245(1):227–247
4. Collewijn H, Van der Steen J, Ferman L, Jansen TC (1985) Human ocular counterroll: assessment of static and dynamic properties from electromagnetic scleral coil recordings. *Exp Brain Res* 59(1):185–196
5. Paige GD, Telford L, Seidman SH, Barnes GR (1998) Human vestibuloocular reflex and its interactions with vision and fixation distance during linear and angular head movement. *J Neurophysiol* 80(5):2391–2404
6. Angelaki DE (2004) Eyes on target: what neurons must do for the vestibuloocular reflex during linear motion. *J Neurophysiol* 92(1):20–35
7. Crawford JD, Vilis T (1991) Axes of eye rotation and Listing's law during rotations of the head. *J Neurophysiol* 65(3):407–423
8. Crane BT, Tian JR, Demer JL (2005) Human angular vestibulo-ocular reflex initiation: relationship to Listing's law. *Ann NY Acad Sci* 1039:26–35

## Vestibulo-Oculomotor Connections

WERNER M. GRAF

Department of Physiology and Biophysics, Howard University College of Medicine, Washington, DC, USA

### Synonyms

Elementary vestibulo-ocular reflex arc – three-neuron arc

### Definition

Compensatory eye movements are embedded in a system of three-dimensional geometry that characterizes both the sensory periphery (semicircular canal orientations) and the motor effectors (extraocular muscle pulling directions). This framework organization is also reflected in the anatomical networks mediating compensatory eye movements, linking each of the semicircular canals to a particular set of extraocular muscles (so-called principal vestibulo-ocular reflex connections to ►*yoked muscles*). These connections are identical across species throughout evolution. These short latency connections consist of three neurons, i.e., primary vestibular neurons of the vestibular nerve, second-order vestibular neurons in the vestibular nuclei, and the respective extraocular motor neurons.

### Characteristics

The production of eye movements requires precise space-time coordination of all moving elements, i.e., head, body and two eye balls. This function is subserved by a neuronal network that is conserved across species and possesses a high degree of adaptability, or motor learning. In the case of the vestibular-oculomotor connectivity, very precise sensory-motor relationships are established, that are only matched to some degree by vestibulo-spinal connections. While we have intricate maps of the visual, auditory and somatosensory spaces, the corresponding sensory-motor relationships have not been elaborated to the same degree of exactness. Clearly, vestibulo-motor projections must have played a primordial role in spatial orientation and postural control throughout vertebrate history, while other sensory systems subserved accessory functions (e.g., visual input eliciting the dorsal light reflex in fishes). One important phylogenetic requirement must have been to ensure a rapid response: vestibular reflexes can be as fast as 16 ms from stimulus to motor reaction. One way to ensure such rapid responses is to employ hard-wired connections, and we see such a system in operation in vestibulo-motor relationships. The fast response time of this system allows precise motor action to keep visual images constantly unblurred or prevent injuries by fast reflexes, e.g., when breaking a fall or preventing a fall



altogether. Nevertheless, the system retained a remarkable adaptability to cope with internally and externally imposed changes. Once the spatial components of this system were put in place during vertebrate evolution, fundamental changes were no longer possible, only modifications of the original blue print.

### Vestibulo-Ocular Connectivity

The conservation of similar spatial geometries of semicircular canals and eye muscle pulling directions is also reflected in a stereotypical innervation pattern of the principal neuronal connections for the production of compensatory eye movements across vertebrates. This innervation scheme has been termed the “elementary vestibulo-ocular reflex arc” [1], or the “three-neuron arc” [2] (principal vestibulo-ocular reflex connections to yoked muscles). The three neurons involved in this reflex arc are the primary vestibular neurons, the second-order vestibular neurons in the vestibular nuclei in the brain stem, and the respective extraocular motoneurons.

As we have already mentioned in the chapter devoted to “Vestibulo-oculomotor System: Functional Aspects”, the ipsilateral superior rectus and the contralateral inferior oblique muscles are activated from the anterior semicircular canal, the ipsilateral superior oblique and the contralateral inferior rectus muscles from the posterior canal, and the ipsilateral medial rectus and the contralateral lateral rectus muscles from the horizontal canal. The antagonists of these muscles are inhibited by the same semicircular canals. The entire three-neuron arc connections of the vestibulo-ocular reflexes are summarized in Fig. 1a–c.

The innervation pattern of the vestibulo-ocular three-neuron-arcs together with the stereotypical three-dimensional geometry of the sensory and motor periphery (Fig. 1d) is the basis of space-time coordinated compensatory eye movements.

While the reflex arcs from the semicircular canals to extraocular motoneurons pools indeed are fairly stereotypical, otolith projections usually are more heterogeneous in nature. In particular, such projections do not seem to follow the classical three-neuron arc scheme. In general, otolith-ocular input is weak by contrast to, for instance, vestibulo-spinal projections. Nevertheless, otolith pathways seem to be embedded in the spatial reference frame of the semicircular canals.

### Primary Neurons

The first leg of the three-neuron-arc is composed of the primary vestibular neurons linking the receptor ▶hair cells of the semicircular canals and the otoliths to vestibular nucleus neurons (Fig. 2).

In general, semicircular canal units terminate in the superior, medial and descending (inferior) vestibular nuclei. There are no terminals in the lateral vestibular

nucleus (Deiters) (Fig. 2a). Canal afferents also project directly to the cerebellum, namely the nodulus, uvula and the anterior vermis, but, interestingly enough, not to the flocculus. Otolith-related primary neurons send few collaterals into the superior vestibular nucleus and almost none to the medial vestibular nucleus. Their major projections reach the lateral (Deiters) and the descending vestibular nucleus (Fig. 2b). Some terminations are also found outside the vestibular complex proper. Saccular afferents target neurons in the reticular formation near the abducens nucleus and the spinal trigeminal nucleus. Utricular afferents also project to the area adjacent to the abducens nucleus and even contact abducens motoneurons directly [3]. All in all, otolith afferents seem to display more caudal vestibular termination sites than semicircular canal afferents. Thus, there is a clear qualitative difference between the canal and otolith systems. Functionally, excitatory vestibulo-ocular relay neurons are principally found in the medial vestibular nucleus, inhibitory ones in the superior vestibular nucleus, and canal afferents project largely to these areas. Otolith inputs, by contrast, seem to have reduced direct vestibulo-ocular relevance, except for the monosynaptic utriculo-abducens projections. Their major targets regions largely contain vestibulo-spinal neurons, in particular the lateral vestibular (Deiters) nucleus, the origin of the lateral vestibulo-spinal tract. The otolith projection pattern therefore is in keeping with the weak direct otolith influences on extraocular motoneurons.

### Spatial Coordination of Compensatory Eye Movements

Conjugate eye movements including those about the optic axis i.e., torsion, are subserved by the “classical” vestibulo-ocular innervation pattern (see Fig. 5 in the previous chapter “Vestibulo-Oculomotor System: Functional Aspects”). Primary vestibular neurons typically transmit semicircular canal-specific information to second-order neurons in the vestibular nuclei. In the ▶vertical systems, these latter neurons project either to two principal ▶contralateral extraocular muscle motoneurons for excitatory innervation (see Fig. 5a and b in the previous chapter “Vestibulo-Oculomotor System: Functional Aspects”), or to two ▶ipsilateral motoneurons pools for inhibitory innervation (the principal vestibulo-ocular reflex connections to yoked muscles) (Fig. 1a and b). One of these motoneuron pools projects to a muscle in the ipsilateral eye, the other one to a muscle in the contralateral eye. This particular crossed and yoked innervation pattern assures conjugacy in the vertical eye movement systems. The specific excitatory and inhibitory connectivity exemplifies the reciprocal excitatory/inhibitory (or push-pull) organizational nature of the VOR system.

Specifically, neurons of the anterior semicircular canal system contact the contralateral superior rectus

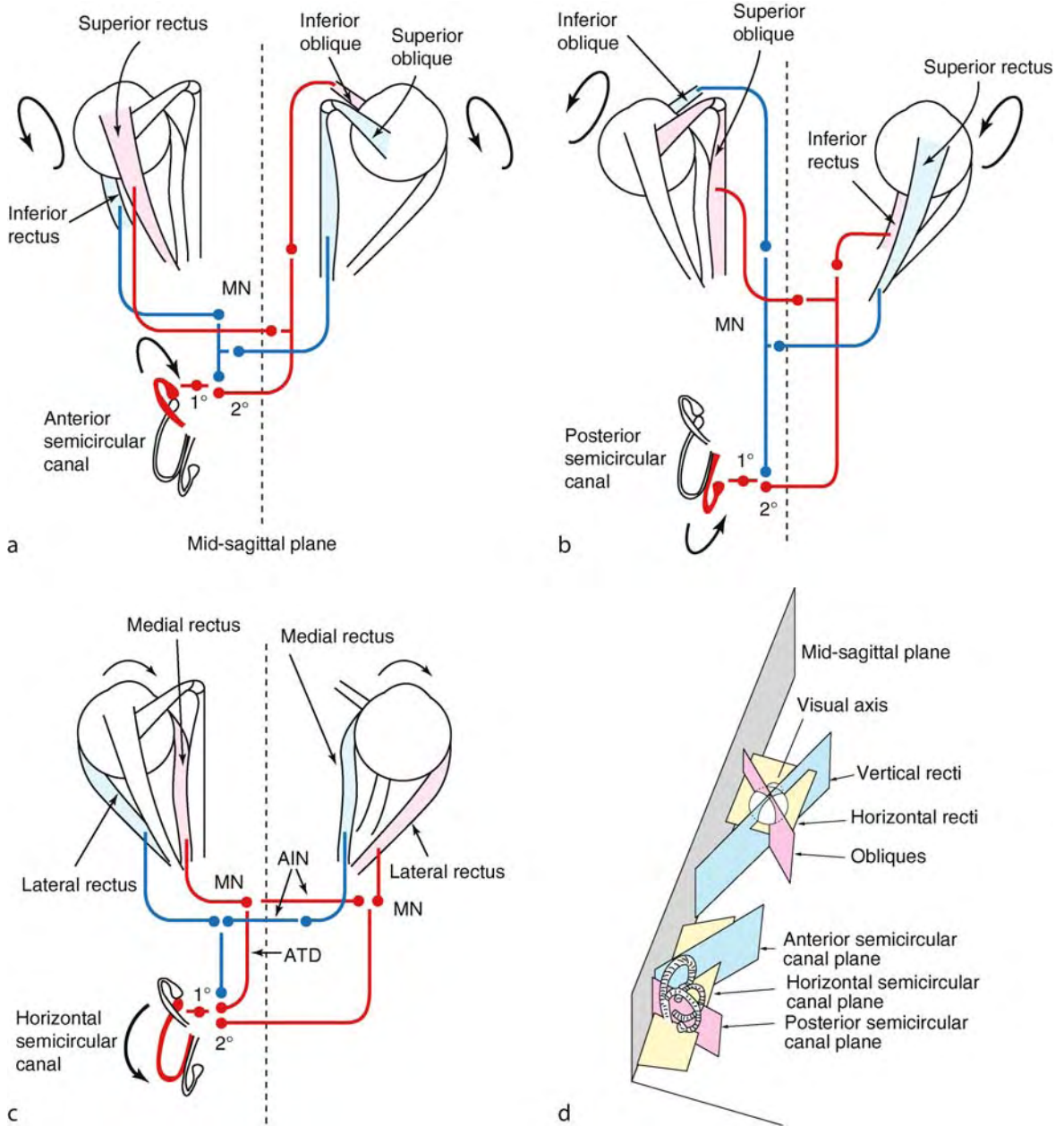

**Vestibulo-Oculomotor Connections. Figure 1** The neural and geometrical basis for spatial coordination of compensatory eye movements. The reflex arc between individual semicircular canals and four extraocular muscles typically consists of three neurons, the primary neuron (1°, vestibular nerve), the second-order vestibular neuron (2°, vestibular nucleus neurons), and the oculomotor neuron (MN, in oculomotor, trochlear and abducens nuclei). Excitatory connections are shown in red, inhibitory connections are shown in blue. Contralaterally projecting vestibular neurons are in general excitatory, ipsilaterally projecting ones inhibitory. The respective semicircular canals ((a) anterior canal; (b) posterior canal; (c) horizontal canal) and their primary nerve pathways are marked in red. The on-directions of the semicircular canals are illustrated by thick black arrows. The connectivity of the horizontal system has a few peculiarities, such as an ipsilaterally projecting excitatory connection, the “Ascending Tract of Deiters” (ATD), and the abducens internuclear neuron pathway (AIN). (d) Semicircular canals and extraocular muscles form a three-dimensional intrinsic reference frame system for the production of vestibulo-ocular reflexes. This ensemble and the particular VOR connectivity constitute the basis for compensatory eye movement coordination in physical space.

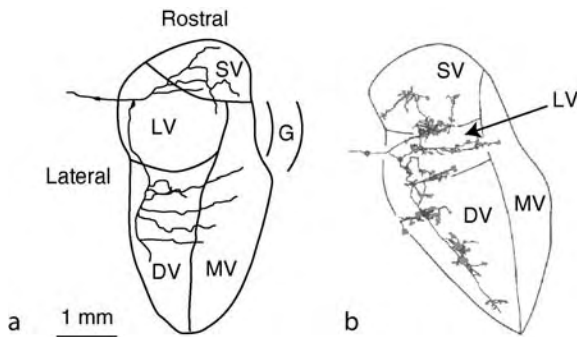

**Vestibulo-Oculomotor Connections. Figure 2** Axonal arborization of individual primary vestibular neurons. (a) Horizontal semicircular canal unit. Terminations are found in the superior (SV), descending (inferior) (DV) and medial (MV) vestibular nuclei. The lateral (LV) vestibular nucleus does not receive semicircular canal projections. The axonal arborization of this neuron is typical for all semicircular canal-related units. G: genu of the facial nerve (modified after Mannen H, Sasaki S-I, Ishizuka N (1982) Trajectory of primary vestibular fibers originating from the lateral, anterior and posterior semicircular canal in the cat. *Proc Jpn Acad Ser B* 58:237–277). (b) Sacculus unit. Terminations are found in the superior, descending (inferior) and lateral (Deiters) vestibular nuclei. The medial vestibular nucleus does not receive otolith projections. The axonal arborization of this neuron is typical for all otolith-related units (modified after Imagawa M, Graf W, Sato H, Suwa H, Isu N, Izumi R, Uchino Y (1998) Morphology of single afferents of the saccular macula in cats. *Neurosci Lett* 240:127–130).

and inferior oblique motoneurons via an excitatory projection, and the ipsilateral superior oblique and inferior rectus motoneurons via an inhibitory projection (Figs. 1a and 3a). For instance, left anterior semicircular canal stimulation produces a contraction of the left superior rectus and of the right inferior oblique muscle. In such case, excitatory input reaches the right-side oculomotor nucleus, specifically the superior rectus and inferior oblique motoneuron pools, via a second-order neuron in the left vestibular nucleus whose axon crosses the midline to the right side of the brain (Figs. 1a and 3a).

Conjugacy of anterior canal elicited eye movements is assured by the contralateral projection of superior rectus motoneurons (see Fig. 4 in the previous chapter “Vestibulo-Oculomotor System: Functional Aspects”), and the ipsilateral projection of inferior oblique motoneurons. Inhibition of the antagonists of above muscles, right superior oblique and left inferior rectus, is mediated by an inhibitory second-order vestibular neuron in the left nucleus that contacts superior oblique motoneurons in the left trochlear nucleus and inferior rectus motoneurons in the left oculomotor nucleus (Figs. 1a and 3a). For conjugacy, left-side superior oblique motoneurons project across the midline to the right-side

superior oblique muscle. Left-side inferior rectus motoneurons innervate the left inferior rectus muscle.

A similar scenario holds for projections originating with the posterior semicircular canal (Fig. 1b). In such case, left posterior semicircular canal stimulation elicits a contraction of the left superior oblique and of the right inferior rectus muscle. Excitatory input reaches the right-side trochlear and oculomotor nuclei, specifically the superior oblique and inferior rectus motoneuron pools via second-order neurons in the left vestibular complex whose axons project across the midline to the right side (Figs. 1b and 3b). Again, inhibition of the antagonists of the above muscles, right superior rectus and left inferior oblique, is mediated by an inhibitory second-order vestibular neuron in the left nucleus. This neuron contacts superior rectus and inferior oblique motoneurons in the left oculomotor neurons (Figs. 1b and 3b). Again, conjugacy is ensured by the contralateral and ipsilateral projections of superior oblique and inferior rectus motoneurons, respectively in the excitatory sensory-motor link. In the inhibitory link, left-side superior rectus motoneurons project across the midline to the right-side superior rectus muscle, left-side inferior oblique motoneurons innervate the left inferior oblique muscle.

### The Horizontal Canal Pathways

► **Horizontal** conjugate eye movements are produced by the simultaneous contraction of the lateral rectus muscle in one eye and the medial rectus muscle in the other eye. The neuronal networks underlying horizontal conjugate eye movements are the exception to the rule introduced above for vertical canal pathways. The fundamental difference between the two is the ipsilateral placement of medial rectus motoneurons (Fig. 4).

We have seen that in the vertical systems, two motoneuron pools, superior rectus and superior oblique always address their respective contralateral extraocular muscles (Fig. 4 in the previous chapter “Vestibulo-Oculomotor System: Functional Aspects”). Such an innervation scheme subserves conjugacy of eye movements, and is also in agreement with Hering’s Law of equal innervation of yoked muscles. In the horizontal eye movement pathways, the same functional relationship applies (see Fig. 5c in the previous chapter “Vestibulo-Oculomotor System: Functional Aspects”). However, we find the two associated motoneuron pools, lateral rectus and medial rectus on opposite sides of the brain. Both of them innervate ipsilaterally located muscles. Vestibular information from the horizontal semicircular canal reaches the ipsilateral and the contralateral abducens nucleus, contralaterally projecting vestibular nucleus neurons being excitatory, ipsilaterally projecting ones being inhibitory (Fig. 1c). Thus, only abducens motoneurons, innervating the lateral rectus muscles receive direct vestibular input.



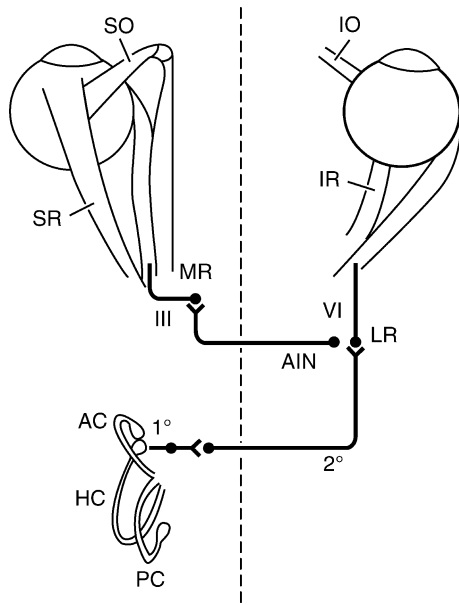

### Vestibulo-Oculomotor Connections.

**Figure 4** Horizontal vestibulo-ocular reflex circuitry. Medial rectus motoneurons are found ipsilaterally to their respective muscle, unlike superior rectus and superior oblique motoneurons. Therefore, eye movement signals to assure conjugacy of horizontal eye movements need to be transmitted via a surrogate neuron. The link between the yoked lateral rectus and medial rectus is assured by the abducens internuclear pathway. SR, superior rectus; SO, superior oblique; MR, medial rectus; IR, inferior rectus; IO, inferior oblique; LR, lateral rectus; AIN, abducens internuclear neuron; 1°, vestibular nerve; 2°, second-order vestibular neuron; III, oculomotor nucleus; VI, abducens nucleus.

### The Fine-Tuning of Compensatory Eye Movements

When examining the exact spatial arrangement between extraocular muscle and semicircular canal planes, we observe slight but noticeable deviations from strict coplanarity (Fig. 1d). Therefore, some compensatory mechanisms need to be enlisted to assure spatially correct compensatory eye movements. In general terms, other connections, the so-called accessory connections between semicircular canals and extraocular muscles in addition to the classical principal three-neuron arc have to be considered, and several modeling approaches have relied on this idea [5,6]. When we look again at the examples of frontal- and lateral-eyed animals, the different geometrical arrangements and kinematic actions of the extraocular muscles in these species must be taken into account. While the neuronal machinery of the compensatory eye movement system of humans is not open to immediate experimental exploration that in cats and rabbits can be used to test these models. In general, there is good agreement of theoretical conclusions and experimental results in cats [6], but less so

in rabbits [5,6]. For instance, anterior-canal related excitatory vestibular neurons not only send axons to contralateral superior rectus motoneurons, but some neurons also have re-crossing collaterals to ipsilateral superior rectus motoneurons. In a similar fashion, posterior canal-related neurons elicit accessory excitatory input to ipsilateral lateral rectus and contralateral medial rectus motoneurons, as well as inhibitory input to ipsilateral medial rectus motoneurons. While the same modeling analysis has not been performed to the same extent in monkeys, the pertinent literature also suggests that accessory connections play an important role in the spatial coordination of their vestibulo-ocular reflexes [7]. For instance, anterior-canal related excitatory vestibular neurons also project not only to contralateral superior rectus motoneurons, one of their principal targets, but also to the ipsilateral homonymous motoneurons as an accessory connection [8]. Such a projection is similar to that of the VOR system in cats, another frontal-eye species.

Some vestibular nucleus neurons may also not subserve the same functional role as others. For instance, regarding projection targets, at least four different types have been identified. There are neurons which project only to spinal cord areas, so-called vestibulo-spinal only types, and neurons which only project to extraocular motoneuron targets, so-called vestibulo-ocular only types. These neurons are thought to subserve only either vestibulo-spinal or vestibulo-ocular functions. A number of vestibular neurons project to both oculomotor and spinal cord areas, and are termed vestibulo-ocular-spinal neurons, and a role in eye-head coordination has been postulated for them. Finally, there are vestibular only neurons, for which no motoneuron projection area has been identified. Such neurons have been shown to project to the cerebellum and the pontine reticular formation. It should be noted that all the above described neurons contact multiple targets some of which are related to motor control while others subserve other functions (Fig. 3).

### Trajectories of Vestibulo-Ocular Neurons

Neurons related to eye movement functions are typically found in the medial (magnocellular), ventro-lateral (so-called ventral Deiters), descending and superior vestibular nuclei (Fig. 2a). Typically, the population in the superior vestibular nucleus is composed of inhibitory neurons, whose axons ascend ipsilaterally. An exception is the so-called extra-MLF anterior canal pathway, which is excitatory, and crosses the midline (see below).

Excitatory vestibular nucleus neurons making contact with trochlear or oculomotor nucleus neurons, i.e., anterior or posterior-canal related, typically ascend in the contralateral medial longitudinal fasciculus (MLF) after the midline crossing (Fig. 3a and b). In addition, the extra-MLF pathway of the anterior canal system

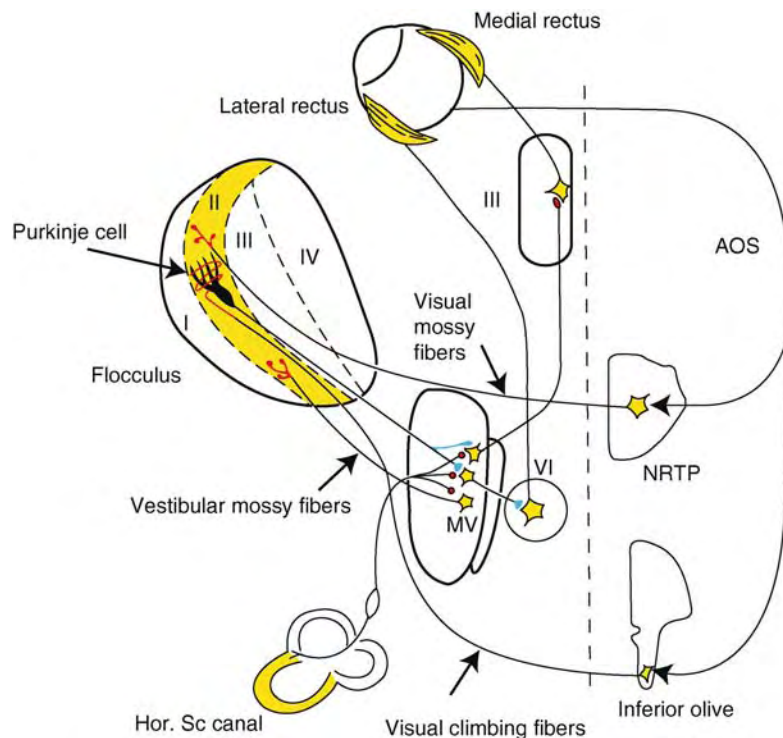

**Vestibulo-Oculomotor Connections. Figure 5** Modular organization of vestibulo-ocular processing loops (yellow). Elements involved in horizontal eye movements comprise the horizontal semicircular canal (hor. sc canal) and its projection neurons in the vestibular nuclei, notably the medial vestibular nucleus (MV), the accessory optic system (AOS) for horizontal visual feed-back projecting to the nucleus reticularis tegmenti pontis (NRTP) and the inferior olive, and the co-called “horizontal” processing zone in the flocculus of the cerebellum. Cerebellar horizontal zone out-put, in turn, is involved in adaptive learning and calibration (illustrated by the blue synapse symbols) of horizontal eye movements produced by reciprocal excitation/inhibition of lateral rectus motoneurons in the abducens nucleus (VI) and medial rectus motoneurons in the oculomotor nucleus (III) (after Ito (1971) *Brain Res* 40:81–85).

whose cell bodies are found in the superior vestibular nucleus, ascends initially through the reticular formation, crosses the midline at the level of the nucleus reticularis tegmenti pontis towards the red nucleus, and then addresses superior rectus and inferior oblique motoneurons. Inhibitory vestibular neurons ascend for some distance through the reticular formation to join the ipsilateral MLF further rostrally.

Horizontal canal vestibular neurons take a direct route to the contralateral (excitatory), or ipsilateral (inhibitory) abducens nucleus. The horizontal-canal related ATD (excitatory) joins the ipsilateral MLF to reach ipsilateral medial rectus motoneurons [9].

### Neuronal Signals in the Vestibular Nuclei encoding Eye Movements

Regarding the actual neuronal signals transmitted to oculomotor neurons by vestibular neurons, only limited structure-function data, i.e., linking the morphology and projection pattern of a given cell to its signal content, are available to date (see e.g., [8,9]). Regarding eye movements, several response types have been

reported. So-called ▶**Position-Vestibular-Pause cells** (PVP) carry signals related to head velocity and eye position in the head. In addition these cells pause for all saccades or fast phases of nystagmus. ▶**Position-burst cells** code eye position, but burst for saccades in one direction and pause during saccades in the opposite direction. Position cells fire according to a given eye position in the head, but show no saccade relatedness, i.e., neither burst nor pause during a saccade. The so-called ▶**gaze velocity cells** encode eye velocity. ▶**Vestibular pause cells** carry a signal which is similar to that transmitted to the brainstem by the vestibular nerve, except that they pause for all saccades. While the above five response types seem to be clearly related to eye movement processing, a sixth cell type, so-called ▶**vestibular-only cells**, carry a copy of the signals transmitted by the vestibular nerve without any eye movement relatedness.

### Modules of Visual-Vestibular Interaction

Clearly, there is a progression across species in terms of the importance of the neuronal pathways involved in

optokinetic reflex processing. Detection of visual movement of low velocities in fishes, amphibians and rabbits takes place in the retina and is transmitted via the pretectum and accessory optic system. In cats, non-human primates, and humans, in particular, cortical areas play an increasingly important role, notably for processing high-speed visual stimuli. In any case, the pretectum and the accessory optic system constitute a major pathway of visual input to the vestibular nuclei and the cerebellum. Visual movement information from the retina reaches the pretectum (nucleus of the optic tract) and the accessory optic system (medial, dorsal and lateral terminal nuclei in mammals; nucleus of the basal optic root in birds). Different components of the three-dimensional visual space are anatomically segregated and represented in these nuclei and sub-nuclei). From there, this information is relayed to the vestibular nuclei via the nucleus prepositus hypoglossi and/or the VTRZ (ventral tegmental relay zone) and to the cerebellum via the nucleus reticularis tegmenti pontis and the inferior olive.

Furthermore, the different coordinate axes of this intrinsic coordinate system seem to have given rise to a modular organization of certain motor processing functions. For instance, in the flocculus of the cerebellum, several modular zones were distinguished on the basis of electrical stimulation and visual coordinate axes analysis, i.e., one horizontal zone and two “vertical” ones (see e.g., [10]) (Fig. 5).

Visual input also plays an important role for the adaptation and calibration of the eye movement reflexes, and the cerebellum seems to play a basic role in this function. This function can readily be appreciated when receiving a new prescription of eye glasses. Initially, we often see blurred images, because our compensatory eye movements do not exactly match our head movements. However, after a few days, our eye movements have adapted to the new movement conditions.

### Conclusions

The generation of compensatory eye movements is subserved by an extremely conserved neuronal circuitry from fishes to humans. Vestibular innervation of eye muscles follows the stereotypical principal three-neuron-arc connectivity in a reciprocal excitatory-inhibitory innervation pattern. Fine-tuning of spatially coordinated VOR movements is assured by accessory connections other than the principal projections. These accessory connections are species specific and seem to depend on the placement of the eyes in the head of a given animal. The three-dimensional vestibulo-ocular reference frame also provides a blue print for a modular organization of sensory-motor transformations related to at least eye- and head-movement reflexes including motor learning. The latter is exemplified by its zonal expression in the cerebellum.

### Acknowledgement

This work was supported by grants from the European Union (QLK6-CT-2002-00151: EUROKINESIS) and NIH/NINDS (5 U54 NS039407-07: Specialized Neuroscience Research Program HU-SNRP2). The author wishes to thank France Maloumian for help with the illustrations.

### References

1. Lorente de Nó R (1933) Vestibulo-ocular reflex arc. *Arch Neurol Psychiatr* 30:245–291
2. Szentágothai J (1950) The elementary vestibulo-ocular reflex arc. *J Neurophysiol* 13:395–407
3. Uchino Y, Ikegami H, Sasaki M, Endo K, Imagawa M, Isu N (1994) Monosynaptic and disynaptic connections in the utriculo-ocular reflex arc of the cat. *J Neurophysiol* 71:950–958
4. Highstein SM, Baker R (1978) Excitatory termination of abducens internuclear neurons on medial rectus motoneurons: relationship to syndrome of internuclear ophthalmoplegia. *J Neurophysiol* 41:1647–1661
5. Robinson DA (1982) The use of matrices in analyzing the three-dimensional behavior of the vestibulo-ocular reflex. *Biol Cybern* 46:53–66
6. Ezure K, Graf W (1984b) A quantitative analysis of the spatial organization of the vestibulo-ocular reflexes in lateral- and frontal-eyed animals. II. Neuronal networks underlying vestibulo-oculomotor coordination. *Neuroscience* 12:95–109
7. Suzuki Y, Straumann D, Simpson JI, Hepp K, Hess BJM, Henn V (1999) Three-dimensional extraocular motoneurons innervation in the rhesus monkey. I. Muscle rotation axes and on-directions during fixation. *Exp Brain Res* 126:187–199
8. McCrea RA, Strassman A, Highstein SM (1987b) Anatomical and physiological characteristics of vestibular neurons mediating the vertical vestibulo-ocular reflexes of the squirrel monkey. *J Comp Neurol* 264:571–594
9. McCrea RA, Strassman A, May E, Highstein SM (1987a) Anatomical and physiological characteristics of vestibular neurons mediating the horizontal vestibulo-ocular reflex of the squirrel monkey. *J Comp Neurol* 264:547–570
10. Voogt J, Wylie (2004) Functional and anatomical organization of floccular zones: a preserved feature in vertebrates. *J Comp Neurol* 470:107–112

## Vestibulo-Oculomotor System: Functional Aspects

V

WERNER M. GRAF

Department of Physiology and Biophysics, Howard University College of Medicine, Washington, DC, USA

### Synonyms

Vestibulo-ocular reflex; VOR – Compensatory eye movements

## Definition

The ► **vestibulo-ocular reflex** produces eye movements via a sensory-motor transformation which originates in the vestibular system, our sense of balance. This reflex stabilizes the visual world during either self-induced movements or during that resulting from passive displacements of the head and/or the body.

## Characteristics

Eye movements are an essential prerequisite for many animals, including humans to survive and navigate in all life situations. A most important function of the oculomotor system is the stabilization of the visual image on the retinae during movement, and we are customarily unaware of such a function. This function, compensatory eye movements, or the vestibulo-ocular reflex (VOR) is an extremely fast sensory-motor transformation taking place within 16 ms from stimulation to motor execution (the corresponding reflex via the visual system, the ► **optokinetic reflex**, takes 80–150 ms). VOR deficits impair gaze stabilization and lead to the clinical sign of oscillopsia, a sensation that the world is moving about when walking or riding in a car (Fig. 1).

Such a sensation can be visualized by recording with a video camera while walking, mounting and descending stairs or performing fast panning movements. When

playing back the film, only jerky and blurred images are seen. Our compensatory eye movement system prevents such occurrences, and typically we observe a stable world, even when running or jumping over an obstacle. The VOR is a function of the vestibular system, i.e., the labyrinth, and is mediated via short pathways to the effectors, the extraocular muscles.

## The Labyrinthine Receptors

The vestibular organ is part of the inner ear and consists of the ► **semicircular canals** and the ► **otoliths** (Fig. 2a). Semicircular canals and otoliths detect movement accelerations, the semicircular canals angular accelerations (rotations) the otoliths linear accelerations (translations). The otoliths function by signaling head or body displacements with reference to earth gravity (gravity vector).

The entire labyrinth is filled with a fluid, the endolymph. In the semicircular canals, the endolymph causes a so-called endolymph current, which, during a given head movement, displaces receptor cell sensors, the ► **cilia** of ► **hair cells** inside a specialized area of the canal lumen, the ► **ampulla** [1]. The operation of this system can be visualized when rotating a glass filled with liquid: the glass will rotate around the liquid, which remains more or less stationary. By a similar mechanism, the receptor organs inside the semicircular canals will be pushed against the temporarily stationary



**Vestibulo-Oculomotor System: Functional Aspects. Figure 1** Illustration of head movement during normal walking. Note vertical and lateral displacements of head trajectories as part of compensatory mechanisms to keep a stable gaze during locomotion. Without vestibulo-ocular and vestibulo-colic reflexes, unblurred vision would not be possible (photo courtesy of Ian Spooner – Photographer, The University of Sheffield, Student Recruitment, Admissions & Marketing, 1 Palmerston Road, Sheffield S10 2TE – UK/Professor Paul Dean, Dept. Psychology, The University of Sheffield, Western Bank, Sheffield S10 2TP – UK).



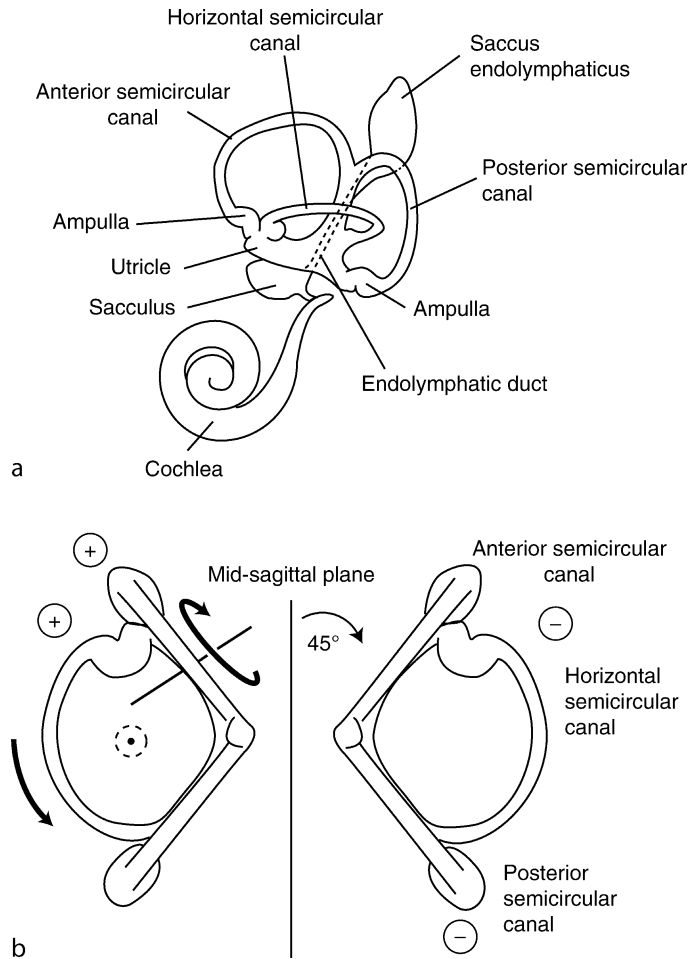

**Vestibulo-Oculomotor System: Functional Aspects. Figure 2** Anatomy of the vestibular system. (a) Lateral view of the left human labyrinth with semicircular canals and otoliths, and the hearing portion (cochlea). (b) Spatial orientation of an idealized semicircular canal system (*top view*) with vertically oriented anterior and posterior canals, and horizontally oriented horizontal canals. In this case, an idealized orthogonal system is depicted: the vertical canals are oriented  $45^\circ$  off the mid-sagittal axis (“diagonal” orientation), and the angle between ipsilateral vertical and horizontal canals is also shown orthogonal similar to a corner in a room. Three organizational principles characterize this arrangement: bilateral symmetry, mutual orthogonality between canals, and the push-pull operational mode illustrated here for the right posterior and the left anterior canals, and the right and left horizontal canals, i.e., when one canal becomes excited (+), its coplanar counterpart becomes inhibited (-). Canal on-directions are indicated by the directions of the arrows about the canal rotation axes (modified after Werner, Cl. Das Gehörorgan der Wirbeltiere und des Menschen. VEB Georg Thieme, Leipzig, 1960).

endolymph and thus the occurrence of movement is detected and signaled to the brain. An important characteristic of the macroscopic anatomy of the semicircular canals is their three-dimensional orientation. The ensemble of the six canals, three on each side forms a physical coordinate system to detect angular accelerations in three-dimensional space. This particular orientation provides a blueprint for the spatial coordination of a number of reflex functions and sensory interactions [2].

The semicircular canal system on each side of the head consists of a horizontal (lateral) canal and two

vertical canals (one anterior and one posterior canal) (Fig. 2a). The vertical canals are oriented about  $45^\circ$  off the mid-sagittal plane of the head (Fig. 2b). The functional planes of the canals form angles of  $90^\circ$ , or close to that value, to ensure so-called mutual orthogonality (Fig. 2b). The arrangement of the three semicircular canals of one side can be compared to the walls and floor forming the corner of a room.

By contrast to the semicircular canals, the otoliths are receptors that depend on the presence of gravity (“graviceptors”). They detect linear accelerations, and do not function in microgravity. Most ►vertebrates,

including humans, possess two otoliths on each side, the horizontal utricle and the vertical saccule. At normal resting posture of the head, the utricle is oriented earth horizontally [3]. The receptor cells of the otoliths are embedded in the so-called otolith membrane, which contains the ►otoconia. During a displacement of the head from normal upright position, the otoconia will slide across the hair cells and produce a shear force upon the cell cilia. The result will be righting reflexes, and static displacements of the eyes.

### The Extraocular Muscle Apparatus

The eye ball is rotated by six extraocular muscles, two horizontal ones and four vertical ones (see also the chapter on “Extraocular Motoneurons”). The vertical eye muscles are superior rectus (SR), inferior rectus (IR), superior oblique (SO) and inferior oblique (IO); the horizontal eye muscles are lateral rectus (LR) and medial rectus (MR) (Fig. 3).

The motoneurons of the lateral rectus are found in the abducens nucleus (sixth cranial nerve), of the superior oblique in the trochlear nucleus (fourth cranial nerve), and for superior rectus, inferior rectus, inferior oblique and medial rectus muscles in the oculomotor nucleus (third cranial nerve). The central innervation of these muscles is quite conserved throughout vertebrate phylogeny with four motoneuron populations typically projecting ipsilaterally (IR, IO, MR, LR) and two projecting contralaterally (SR, SO) (Fig. 4).

The geometric arrangement of the six extraocular muscles and their innervation is also quite stereotypical across vertebrate species. The three-dimensional arrangement follows the spatial geometry of the vestibular semicircular canals, i.e., the typical diagonal, 45° off the mid-sagittal plane orientation of vertical canals (Fig. 3) is reflected in the pulling direction of the vertical eye muscles, the horizontal eye muscles are aligned with the horizontal semicircular canals (see also Fig. 1d in the chapter “Vestibulo-Oculomotor Connections”).

### Vestibulo-Oculomotor Geometry

The conservation of similar spatial geometries of semicircular canals and eye muscle pulling directions is also reflected in a stereotypical innervation pattern of the principal neuronal connections for the production of compensatory eye movements across vertebrates. Since we have two eyes, their movements need to be space-time coordinated, i.e., they have to move in the same direction at the same time. This type of eye movement is called “conjugate” eye movement. It is important to emphasize that the vestibular system and its contextual motor effectors, the oculomotor and spinal-motor systems are bilaterally organized, i.e., their proper function can only be fully appreciated if both sides of the brain are considered for their operations.

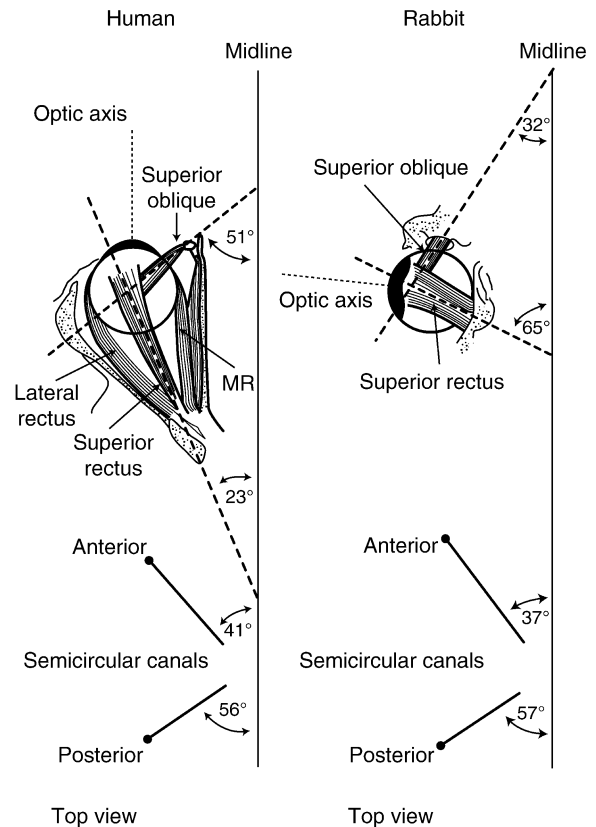

### Vestibulo-Oculomotor System: Functional Aspects.

**Figure 3** Spatial relationship between vertical semicircular canals and vertical extraocular muscles in frontal-eyed (human) and lateral-eyed vertebrates (rabbit). In all species, the superior rectus remains closely aligned with the ipsilateral anterior canal plane, the superior oblique with the ipsilateral posterior canal plane. Note, in particular, the differential insertion of the superior oblique muscle in humans versus rabbits, i.e., in front and behind the eye equator, respectively. MR, medial rectus (modified after 4).

Within this framework, excitatory connections are formed between the anterior canal and the ipsilateral superior rectus and the contralateral inferior oblique muscle (Fig. 5a), between the posterior canal and the ipsilateral superior oblique and the contralateral inferior rectus muscle (Fig. 5b), and between the horizontal canal and the ipsilateral medial rectus and the contralateral lateral rectus muscle (Fig. 5c).

Since the antagonists to these muscles will have to relax at the same time, we observe the existence of inhibitory connections to these antagonists arriving from the same semicircular canals. These stereotypical excitatory/inhibitory relationships form the basis of spatial coordination of compensatory eye movements. Stimulation of single canal nerves, therefore, readily elicits eye, even head movements in the plane of this particular semicircular canal [5]. Strictly speaking,



#### Vestibulo-Oculomotor System: Functional Aspects.

**Figure 4** Photomicrographs of superior rectus (bright field) and superior oblique (dark field) motoneurons in goldfish following injection of the respective individual muscles with horseradish peroxidase (HRP). Note midline crossing of motoneuron axons in both cases. Superior rectus motoneuron axons travel directly across the midline to enter the contralateral oculomotor nerve, superior oblique motoneuron axons arch through the cerebellum and the anterior medullary velum to exit dorsally through the contralateral trochlear nerve.

however, this innervation scheme applies only to angular compensatory movements.

While the reflex relationships from the semicircular canals to eye muscles are fairly stereotypical, otolith influences are usually less clearly defined. Utricular nerve stimulation may elicit ipsilaterally directed horizontal eye movements, and some vertical ones. Saccular stimulation usually causes bilateral or unilateral upward movements of the eyes, but also downward movements can be observed. In general, direct otolith-ocular input to the eyes is weak by comparison with canal-ocular or otolith-spinal influences.

#### Lateral- and Frontal-Eyed Animals

Head movements in animals with different interocular angles, e.g., the extreme examples of rabbits and humans (Fig. 3), seemingly require different compensatory eye movements. For instance, a head movement about

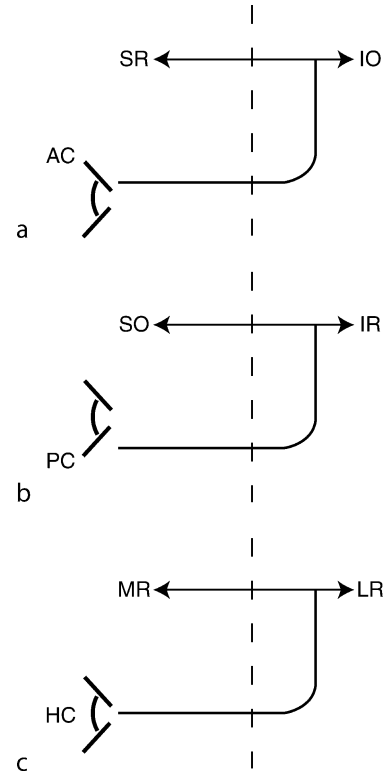

#### Vestibulo-Oculomotor System: Functional Aspects.

**Figure 5** Principal excitatory vestibulo-ocular reflex relationships of the three semicircular canals (a) Anterior canal (AC). (b) Posterior canal (PC). (c) Horizontal canal (HC). Each canal influences principally one ipsilateral and one contralateral eye muscle: the anterior canal the ipsilateral superior rectus (SR) and the contralateral inferior oblique (IO); the posterior canal the ipsilateral superior oblique (SO) and the contralateral inferior rectus (IR); the horizontal canal the ipsilateral medial rectus (MR) and the contralateral lateral rectus (LR). The dashed vertical lines represent the midline.

the naso-occipital axis in a rabbit results in vertical eye movements, and **torsional** ones in a human (Fig. 6).

In fact, if the reference frame is tied to the **optic axis** this difference is observed, but if the reference frame is linked to the head, it is not. In all cases, such movements occur about the naso-occipital axis, i.e., in the transverse plane of the head, because all eye movements are just rotations of the eye ball in the head irrespective of a frontally or laterally directed optic axis.

The necessary requirements for compensatory eye movements in lateral and frontal-eyed animals have been elaborated in some detail [4,2]. Since there is no difference in the principal central reflex relationships as concerns the vestibulo-ocular reflexes, spatially correct compensatory eye movements occur because of subtle changes in eye muscle **kinematics** resulting from small changes in the insertions and pulling directions of

vertical eye muscles during the course of evolution and the process of eye frontalization (Fig. 3) [4]. In this context, we have to appreciate that the extraocular muscles can have more than one action, especially the

vertical ones. In such case, we distinguish one primary and two secondary actions (Fig. 7). As a general principle, the primary actions of all extraocular muscles remain identical in all vertebrates. For instance, the

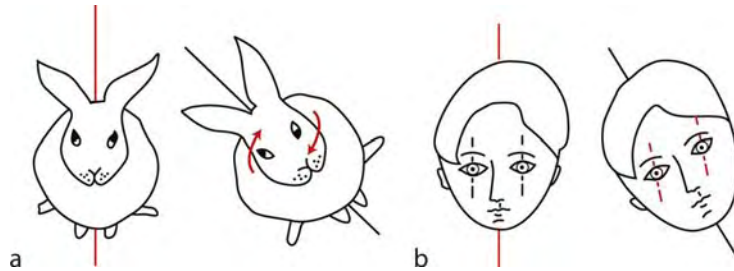

**Vestibulo-Oculomotor System: Functional Aspects. Figure 6** Compensatory eye positions in a rabbit (a) and a human (b) following a head tilt to the right. In the lateral-eye rabbit, the respective compensatory eye movements appear as vertical upward and downward movements of the right and left eyes, respectively (red arrows) to attain reorientation with the original upright head posture (solid red line). In the frontal-eyed human, the appropriate compensatory eye movements are torsions (rotations about the optic axes) to the left of both eyes (red dashed lines). In both cases, the compensatory rotations are identical, although they appear different because of the different placement of the eyes in the head in rabbits and humans (see also Fig. 3) (modified after Duke-Elder S, Wybar K (1973) In: Sir Stewart Duke-Elder (ed) Ocular motility and strabismus. System of ophthalmology, vol 6. Kimpton, London).

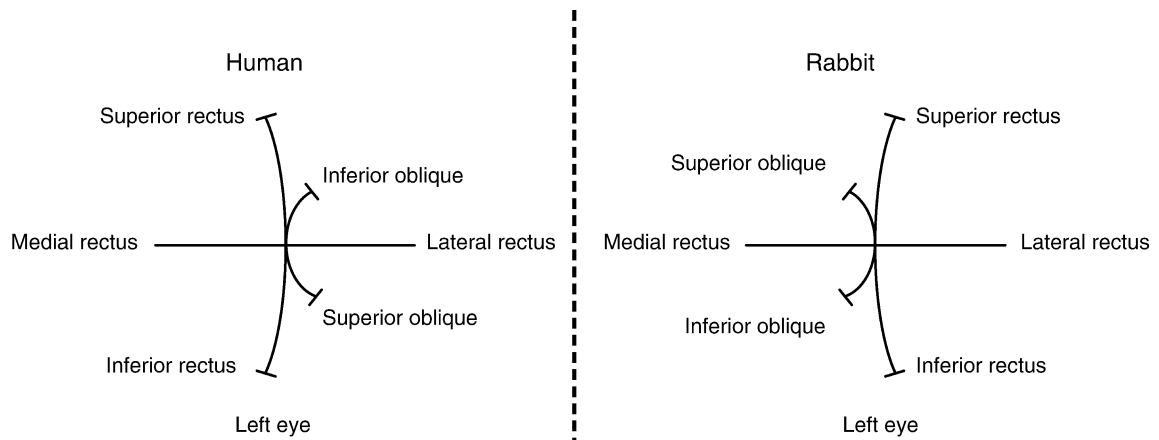

	Human		Rabbit	
	Primary action	Secondary actions	Primary action	Secondary actions
Superior rectus	Elevation	Intorsion, adduction	Elevation	Extorsion, abduction
Inferior rectus	Depression	Extorsion, adduction	Depression	Intorsion, abduction
Superior oblique	Intorsion	Depression, abduction	Intorsion	Elevation, adduction
Inferior oblique	Extorsion	Elevation, abduction	Extorsion	Depression, adduction
Medial rectus	Adduction		Adduction	
Lateral rectus	Abduction		Abduction	

**Vestibulo-Oculomotor System: Functional Aspects. Figure 7** Kinematic actions of individual extraocular muscles in humans and rabbits. In the upper half of the figure, the kinematic actions are presented in the form of Hering diagrams, in the lower half in tables. The lines in the Hering diagram illustrate the relative magnitudes of vertical, horizontal and torsional components. Note similarity in primary actions between humans and rabbits, and complete difference in secondary actions (modified after 4).

primary action of the superior rectus is always an elevation of the eye ball, that of the superior oblique is always ►intorsion (i.e., a rotation of the upper aspect of the eye ball towards the nose). However, the secondary actions of the superior rectus in humans are intorsion and adduction (horizontal rotation towards the nose); in rabbits they are extorsion (rotation towards the ear) and abduction (horizontal rotation towards the ear). Likewise, the superior oblique produces depression and abduction in humans, but elevation and adduction in rabbits as secondary action. It is really the latter actions that account for the all-important correct spatial performance of the vestibulo-ocular reflex. The differences in secondary actions of these muscles result from differences in insertion and pulling directions. In case of the superior rectus, the change between extorsion and intorsion occurs because in rabbits the optic axis is oriented laterally, and in humans frontally (Fig. 3). As a consequence, the muscle's

pulling direction changes across the optic axis from the extorsion side in rabbits to the intorsion side in humans. The change in the superior oblique kinematics is due to a change in the insertion of the muscles either in front of the eye's equator, as in rabbits, or behind, as in humans (Fig. 3). As a consequence, the superior oblique causes elevation in rabbits, and depression in humans, as a secondary action.

Let us consider an example of a particular compensatory eye movement following a head movement about its naso-occipital axis (Fig. 8). Since we rarely perform head or body movements in exactly semicircular canal coordinates, compensatory eye movements in any other plane are produced by a combination of inputs arising from all six semicircular canals. The actual spatial direction of these movements depends on the relative stimulation of these six canals by a given head/body movement. In our specific example of a head movement about the naso-occipital axis towards the right, the

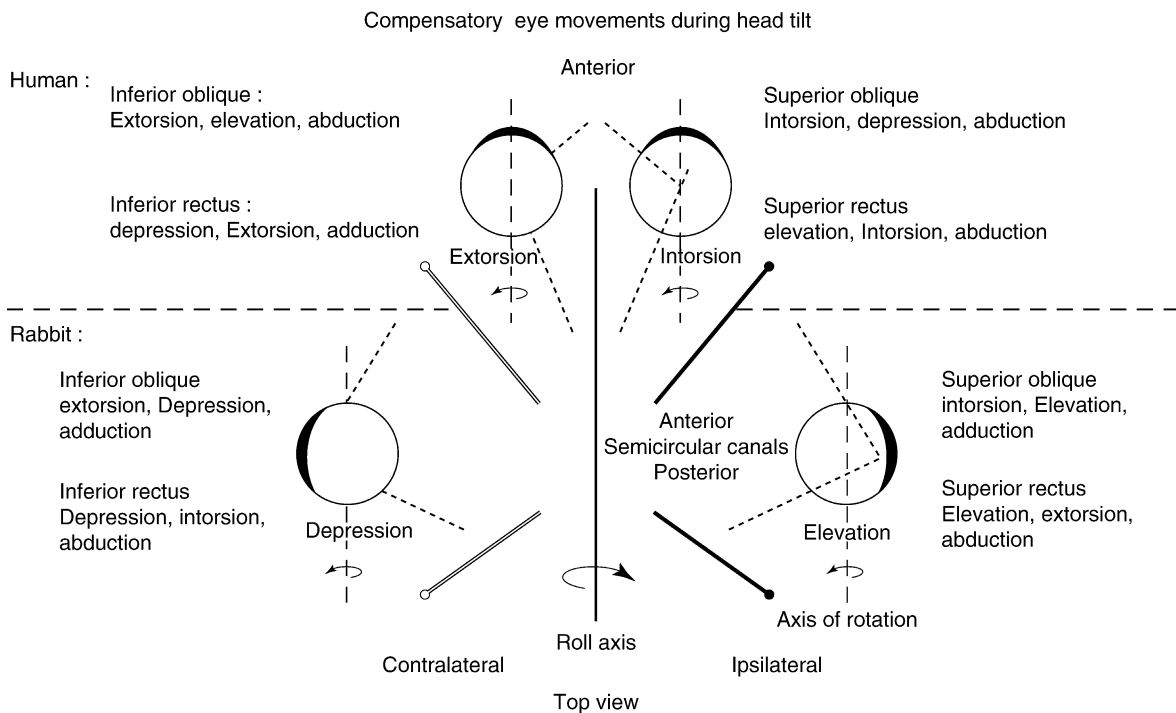

**Vestibulo-Oculomotor System: Functional Aspects. Figure 8** Extraocular muscle co-contractions for the production of compensatory eye movements in humans and rabbits during a head tilt to the right (symbolized by solid canal representations) (compare to Fig. 6). In both cases, the right-side semicircular canals will be excited, the left ones inhibited. Thus, in both cases the ipsilateral superior rectus and superior oblique, and the contralateral inferior rectus and inferior oblique will contract (muscles are symbolized by thick dashed lines). Although stimulation and vestibulo-oculomotor connectivity are the same in the two species, the ensuing eye movements are seemingly different because of frontal- or lateral-eyed nature. The different requirements are subserved by different kinematic actions of extraocular muscles in the two examples: in humans, the required bilateral torsional eye movements are produced by reinforcement of intorsion in the right eye, and extorsion in the left eye; in rabbits, the required vertical eye movements are produced by reinforcing the elevation components of the co-contracting muscles in the right eye, and the depression components in the left eye. Synergistic components are indicated in capital letters, components that will cancel out in small letters (modified after 4).

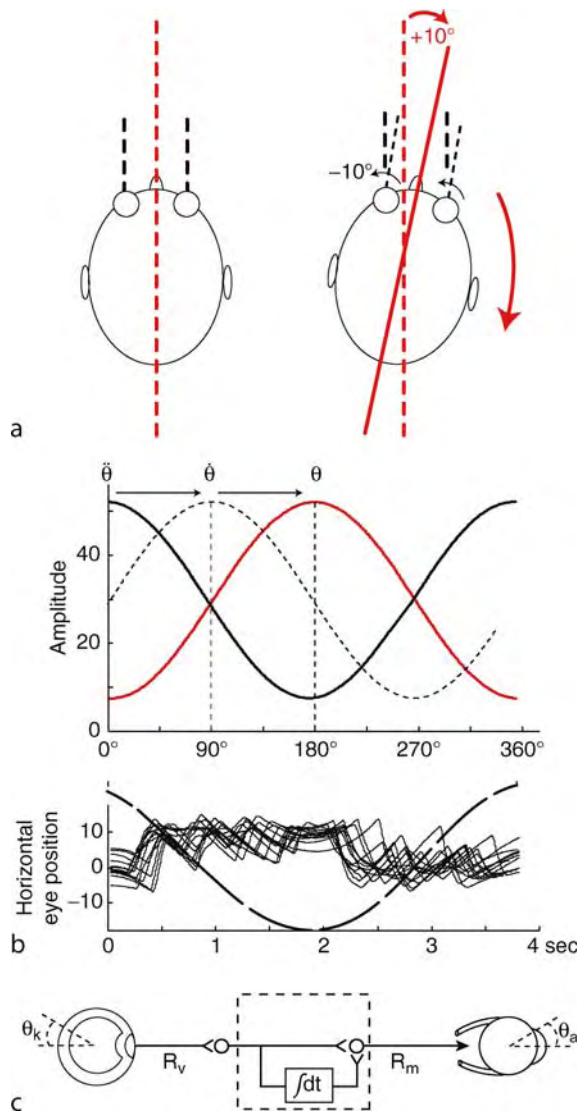

### Vestibulo-Oculomotor System: Functional Aspects.

**Figure 9** Dynamics and functional organization of the vestibulo-ocular reflex (horizontal plane). (a) Illustration of the principle of reflex operation: a head displacement to the right over  $10^\circ$  (red) will elicit an equal and opposite eye movement, i.e.,  $-10^\circ$  to the left (black). (b) Gain and phase plot of a sinusoidal head movement. The upper graph represents idealized sinusoidal phase shifts of movement parameters encountered in the vestibulo-oculomotor system: head acceleration ( $\ddot{\theta}$ ) is integrated by mechanical means into head velocity signal ( $\dot{\theta}$ ) that is integrated a second time into a position signal ( $\theta$ ). In the lower graph, the slow phases of vestibular nystagmus are serially apposed to show eye position in space (thick black dashed curve) and to illustrate its compensatory nature vis-à-vis the eliciting head movement (head position curve in red in the upper graph). Head position and eye position in space are opposite to each other. (c) Conceptual representation of the neuronal integrator necessary to produce

right-side anterior and posterior semicircular canals would be stimulated in an excitatory fashion, while the left-side anterior and posterior canals would be inhibited. The ensuing compensatory eye movements in a human would be conjugate torsional eye movements to the left (Fig. 8; see also Fig. 6b). Taking the innervation examples of the above introduced pathways (Fig. 5) and extraocular muscle kinematics into account (Fig. 7), the combined excitatory input from the two right-side canals would elicit contraction of the right-side superior rectus and superior oblique, and the left-side inferior rectus and inferior oblique.

In the right eye, the kinematic actions of the involved muscles, superior rectus (elevation, intorsion, adduction) and superior oblique (intorsion, depression, abduction) would be combined with elevation/depression and adduction/abduction cancelling one another, while the intorsion components would be reinforced to produce the required compensatory movement (Fig. 8). A mirror-action would occur in the left eye, producing pure extorsion. While the same vestibulo-ocular connections would be present in a rabbit, the compensatory eye movements for the same head movement would require elevation of the right eye and depression of the left eye (see Fig. 6a). As in the case of the human example, a combination of kinematic actions will take place. Because of the different kinematics of extraocular muscles in rabbits, the elevation components of superior rectus and superior oblique would be reinforced, while the extorsion/intorsion and abduction/adduction components of these muscles would cancel one another (Fig. 8). Again, a mirror-image scenario would hold for the left eye.

### Dynamic Aspects

The vestibulo-ocular reflex is defined as eye movements over the same angle (or distance), but opposite in direction as the eliciting head or body movement (Figs. 9a and b). Vestibulo-ocular reflexes may occur during angular movements of the head, i.e., rotations, or during linear movements, i.e., translations.

Semicircular canal receptors only detect angular accelerations, but because of the inertial characteristics of the **cupula**-endolymph system (so-called overdamped torsion pendulum), a mechanical integration of the acceleration stimulus takes place [1]. Thus, vestibular nerve fibers transmit a head velocity signal to their target neurons in the vestibular nuclei. However, when recording from oculomotor motoneurons, their

an eye position signal equal and opposite in direction as a head movement ( $\theta_n$  vs.  $\theta_e$ ). A head velocity signal coming from the vestibular nerve ( $R_v$ ) undergoes a second integration ( $dt$ ) to arrive at the required eye position signal ( $R_m$ ) (modified after 1).

firing rates show an almost linear relationship between eye position and eye velocity. This observation subsequently led to the idea that a second integration from velocity to position had to take place centrally after the first mechanical integration from acceleration to velocity in the sensory periphery (Fig. 9b). This second integration is a function of neuronal computation (so-called neuronal integrator) (Fig. 9c), and is thought to consist of the nucleus prepositus hypoglossi/ vestibular nuclei for horizontal eye movements, and of the interstitial nucleus of Cajal/ vestibular nuclei for vertical eye movements (see also Chapters on Neural Integrators).

### Neurotransmitters

The neurotransmitters for excitatory vestibular neurons seem to be glutamate and aspartate, and the peripheral nerve input to vestibular nucleus neurons also seems to be mediated via glutamate. Within the inhibitory vestibulo-ocular projections, two neurotransmitters have been reported. Neurons involved in vertical vestibulo-ocular reflexes have been shown to express GABA, whereas neurons mediating the horizontal vestibulo-ocular reflex express glycine. This dichotomy may have an explanation in the evolution of the vestibular system. Horizontal canals were not present in agnathan species of the Devonian period (400–350 million years ago), but were added to the two vertical canals when gnathostomes appeared, possibly as a result of the expression of the *Otx1* gene [6].

### Reflex Versus Voluntary Eye Movements

It should be noted here that vestibulo-ocular eye movements are reflex eye movements and cover all three dimensions of physical space, whereas voluntary eye movements, such as ►saccades (fast and jerky eye movements) and smooth pursuit eye movements (slow following movements) obey ►Listing's Law, and are therefore two-dimensional, i.e., Listing's Law removes the torsion components from a given eye movement. Listing's Law stipulates that all eye movements are performed about axes confined to Listing's plane, which coincides roughly with the equatorial plane of the eye ball (a plane bisecting the eye ball in the frontal plane). Indeed all eye positions can be attained by confining the ocular rotation axes to this one plane, but no true torsion movements, i.e., about the visual axis are possible. What can be observed are so-called "false" torsions (see also Chapters "Eye orbital mechanics" and "Listing's law").

### Active Versus Passive Movement

Clearly, each time we perform a head movement, vestibular receptors become activated, and central processing between commands and reflexes takes place. Vestibular receptors *per se* do not distinguish between

active and passive movements, however second-order vestibular neurons, i.e., two synapses away from the receptor cells already react differentially to active and passive head movements. Thus, vestibular signals are strongly attenuated by self-generated movements as early as the first central projection neurons. For instance, neurons could stop firing during active head movements, while during passive movements, they would transmit a head velocity signal. The purpose of such attenuation is clearly related to suppressing unwanted reflex movements. Without suppression of reflexes, we could not move, since reflex action would always bring us back to our point of origin.

Furthermore, in the vestibular nuclei, neurons carrying eye and head movement-related signals have been found in a similar proportion as neurons that only signal head velocity, with no eye movement signals present. The latter are thought to be part of the vestibulo-cortical relay. Vestibular thalamic and cortical units have been reported not to carry eye movement signals.

Since the introduction of the concept of the reafference principle [7] to control and calibrate self-generated movements, numerous studies have sought to uncover the actual underlying neuronal elements and control signals for efference copy expressions and corollary discharges. This question was addressed by testing the responses of vestibular neurons to active movement, passive whole body rotation, and various combinations of head-in-space and/or head-on-trunk movements. Because neurons were suppressed only when the intended active movement and the actual displacement of the head in space were matched, the signal subserving active-passive differences in the vestibular nuclei must be of central origin, arising from a comparison of an efference copy – or an internal prediction – and the actual movement of the head. Posterior parietal cortex neurons may perform this function, or at least play an important role in it [8,9].

### Visual-Vestibular Interaction

Under normal every-day living conditions, we move about with our eyes open. In circumstances such as these we perform visuo-vestibulo-ocular reflexes rather than vestibulo-ocular reflexes. The importance of vision, during slow and constant velocity movements, e.g., during human car driving, or bird soaring, when vestibular input becomes deficient, cannot be overestimated. The reason is that, as remarked earlier, vestibular receptors can only detect accelerations, i.e., changes in velocity, but not constant velocities. Therefore, during longer periods of constant velocity head movements (>8 s), vestibular information is reduced to nothing.

Visual information about movement reaches the vestibular nuclei, and ultimately no distinction between visual or vestibular derived information is possible [10]. Purely visual, i.e., optokinetic stimulation has to be in a

direction opposite to that of a corresponding head/body movement to be congruent with the perceived movement direction and to avoid eventual visual-vestibular conflicts. A number of studies have now also analyzed the three-dimensional characteristics of visual inputs to eye movement and postural control circuits in several species. The spatial coordinates of the visual signal closely match the sensory and motor coordinates of the VOR, i.e., of the semicircular canals and the extraocular muscles (Fig. 10). While none of the three geometries are completely

identical with one another, the spatial orientation of semicircular canal, oculomotor and optokinetic stimulation axes are obviously quite similar.

### Conclusions

Vestibulo-oculomotor geometry in vertebrates is highly conserved and the almost congruent geometries on which it relies provide an organization principle for space-time coordinated movements. Self-motion detection and subsequent movement execution in the

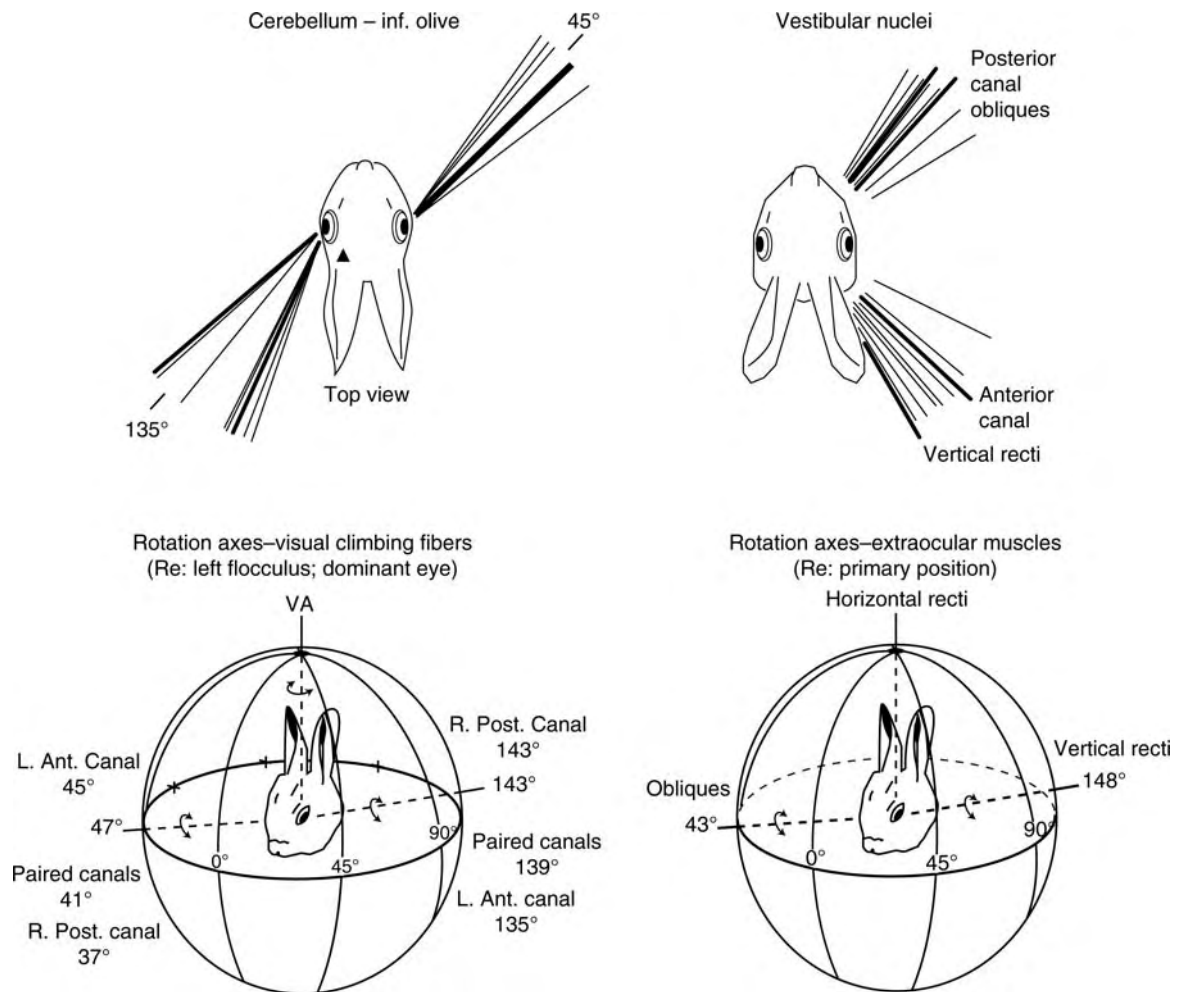

**Vestibulo-Oculomotor System: Functional Aspects. Figure 10** Visual coordinate axes for global self-motion detection and compensatory eye movements. The upper graphs show a two-dimensional rendering of the visual response axes (thin lines) related to vertical movements in the inferior olive/cerebellum system and in the vestibular nuclei. Corresponding canal and extraocular muscle axes are symbolized by thick lines (modified after Graf W, Wilson VJ Afferents and efferents of the vestibular nuclei. The necessity of context-specific interpretation. *Prog Brain Res* 80. Eds.: J.H.J. Allum and M. Hulliger. Elsevier Science Publishers B.V. (Biomedical Division): Amsterdam – New York – Oxford, 1989; pp 149–157). In the lower half a three-dimensional view of the visual coordinate axes in the inferior olive/cerebellum is presented including the corresponding vestibular sensory and oculomotor motor axes. In all instances a close geometrical relationship is noticeable between the three interrelated systems (modified after Graf W, Simpson JI, Leonard CS (1988) Spatial organization of visual messages of the rabbit's cerebellar flocculus. II. Complex and simple spike responses of Purkinje cells. *J Neurophysiol* 60:2091–2121).



oculomotor system of vertebrates constitutes an ideal physical solution with optimal signal-to-noise ratio. The almost machine-like operational mode of the visuo-vestibulo-oculomotor system suggests that peripheral mechanisms are largely employed to simplify central nervous operations. This operational principle has been ideally demonstrated in the common reference frames of the vestibulo-oculomotor system, including its central nervous connectivity. As a consequence, the workload of the brain is decreased in favor of animal economy and presumably higher order operations (learning, perceptive functions, etc).

### Acknowledgements

This work was supported by a grant from the European Union (QLK6-CT-2002-00151: EUROKINESIS) and NIH/NINDS (5 U54 NS039407-07: Specialized Neuroscience Research Program HU-SNRP2). The author wishes to thank France Maloumian for help with the illustrations.

### References

1. Wilson VJ, Melvill Jones G (1979) Mammalian vestibular physiology. Plenum Press, New York
2. Simpson JI, Graf W (1985) The selection of reference frames by nature and its investigators. In: Berthoz A, Melvill Jones G (eds) Adaptive mechanisms in gaze control. Reviews in oculomotor research, vol 1. Elsevier, Amsterdam, pp 3–16
3. Graf W, Wang DH, de Waele C, Vidal PP (1992) The role of otoliths in maintaining the upright posture of the head-neck system in the guinea pig. In: Shimazu H, Shinoda Y (eds) Vestibular and brain stem control of eye, head and body movements. Japan Scientific Societies Press, Tokyo/S. Karger, Basel, pp 79–90
4. Simpson JI, Graf W (1981) Eye muscle geometry and compensatory eye movements in lateral-eyed and frontal-eyed animals. *Ann N Y Acad Sci* 374:20–30
5. Suzuki J-I, Cohen B (1964) Head, eye, body and limb movements from semicircular canal nerves. *Exp Neurol* 10:393–405
6. Fritsch B, Beisel KW (2003) Molecular conservation and novelties in vertebrate ear development. *Curr Top Dev Biol* 57:1–44
7. v. Holst E, Mittelstaedt H (1950) Das Reafferenzprinzip. *Naturwissenschaften* 37:464–476
8. Gabel SF, Misslich H, Gielen CCAM, Duysens J (2002) Responses of neurons in area VIP to self-induced and external visual motion. *Exp Brain Res* 147:520–528
9. Klam F, Graf W (2006) Discrimination between active and passive head movements by macaque ventral and medial intraparietal cortex neurons. *J Physiol* 574:367–386
10. Dichgans J, Brandt Th (1978) Visual-vestibular interactions: effects of self-motion perception and postural control. In: Held R, Leibowitz und H, Teuber H-L (eds) Handbook of sensory physiology, vol 8: Springer Verlag, Berlin, pp 755–804

## Vestibulo-positional Reflex

### Definition

Activation of body and/or eye muscles induced by changes of head position in space. They are exclusively due to stimulation of macular receptors of the vestibular system.

- ▶ Peripheral Vestibular System
- ▶ Vestibulo-Spinal Reflexes

## Vestibulo-spinal Neuron

### Definition

Neuron with its cell body in the vestibular nuclei of the brain stem and its axon terminating in the spinal cord.

- ▶ Vestibular Nuclei

## Vestibulo-spinal Reflexes

DIEGO MANZONI

Dipartimento di Fisiologia e Biochimica, Università degli Studi di Pisa, Pisa, Italy

### Definition

The vestibulospinal (VS) reflexes are changes in the activity of body muscles induced by movements of the head in space that stimulate ▶labyrinthine receptors and aimed at stabilizing ▶posture.

### Characteristics

#### Functions

The VS reflexes contribute to the control of postural orientation. In this task, they continuously collaborate with reflexes elicited by stimulation of visual and somatosensory receptors. Labyrinthine receptors are sensitive to modifications (i) of the head position with respect to the earth vertical or (ii) of the angular/linear velocity of head motion in space. This information can be used to monitor deviations from the maintained body position. Two functional categories of VS reflexes can be distinguished, those acting on the limb muscles that stabilize the position of the trunk in space and those

acting on the neck muscles (vestibulo-colic reflexes) that stabilize the position of head in space [1]. Trunk and head stabilization are two postural tasks that are pursued simultaneously, although not necessarily with the same efficacy [2]. For instance, when a stable base of support is lacking, it appears that the position of the head with respect to the vertical is very stable, while body orientation is more variable. This is the case in a monkey jumping from one branch to another or in a man standing upon an unstable surface [2]. VS reflexes are tightly coupled to ▶cervicospinal reflexes [1], activations of body muscles elicited by stimulation of neck receptors following rotation of the head with respect to the trunk. This coupling can be expected, because movements of the head are likely to stimulate both neck and vestibular receptors and activity of vestibular afferents cannot be directly related to the position of the trunk in space. Vestibulospinal (VS) and cervicospinal (CS) reflexes acting on the limbs interact so as to modify the ▶postural tone only when the position of the trunk in space is changed [1]. The goal of trunk stabilization could be also achieved by information that arises from (body) receptors directly activated by trunk displacement; it is currently matter of debate whether this process is actually occurring.

### Description of the Process

VS and CS reflexes can be studied in both animals and humans by observing the changes in limb posture or in ▶electromyographic (EMG) activity induced following passive displacement of the head and/or of the body. These postural modifications are characterized by tonic and/or phasic components. The former, due to stimulation of macular afferents are sustained changes in muscle activity lasting as long as a new position is maintained, while the latter, due to ampullar afferents [1] and to a population of macular dynamic afferents are transient modifications related to the movement period. The CS are elicited by stimulation of neck spindle afferents, particularly those located in the deep perivertebral muscles, which show tonic or tonic-phasic responses to neck displacement. Simultaneous coplanar rotation of the head and trunk (whole body) in the same direction can be considered a selective stimulus for the labyrinth (Fig. 1a).

Rotation of the body with respect to a stationary head activates only neck receptors (Fig. 1b). Rotation of the head with respect to the body leads to costimulation of both receptorial systems (Fig. 1c). Information on VS and CS reflexes has been also obtained by comparing the limb posture to that of the head and body during spontaneous behavior. A fundamental property of VS (and CS) reflexes is their high degree of spatial organization; each muscle is maximally activated for a given direction of the stimulus, so that a head-in-space (or head-to-body) displacement will induce a pattern of

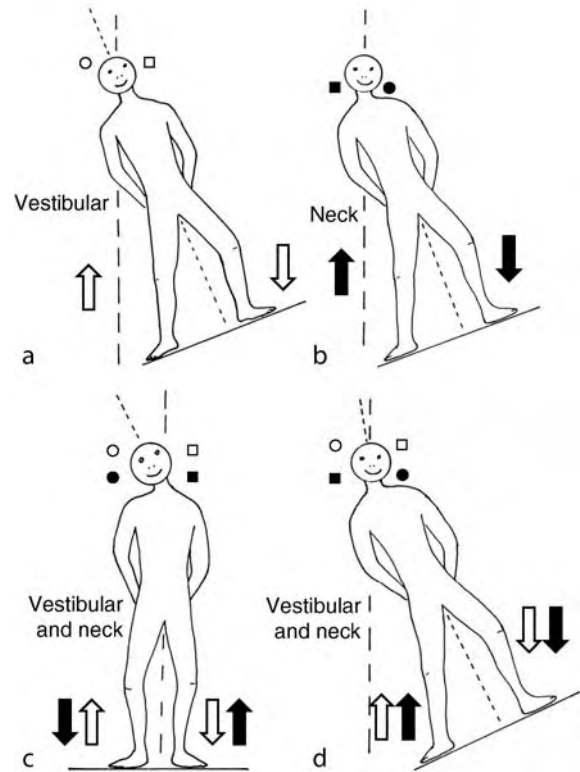

**Vestibulo-spinal Reflexes.** Figure 1 Vestibulospinal and cervicospinal reflexes elicited by rotational stimuli in the frontal plane. Arrows represent increases (upward arrows) and decreases (downward arrows) in the limbs' extensor tone induced by stimulation of labyrinthine (white arrows) and neck (black arrows) receptors. The long- and short-dashed lines represent earth vertical and longitudinal head/body axes, respectively. (a) Labyrinthine reflexes induced by whole-body tilt. The extensor tone increases during side-down (white circle) and decreases during side-up tilt (white square). (b) Neck reflexes induced by the displacement of the body with respect to a fixed head. The extensor tone increases during side-up (black square) and decreases during side-down (black circle) neck rotation. (c) Vestibular and neck reflexes elicited by rotation of the head over the fixed body are opposite in action and leave the extensor tone symmetrical on both sides. (d) Vestibular and neck reflexes elicited by simultaneous rotation of the head and body in the same direction, but with a larger amplitude of body tilt, exert the same action on the limbs extensor tone.

muscle activation that depends critically upon the plane of rotation [3,4].

When VS reflexes acting at the level of limb muscles are taken into account, it appears that they increase the extensor tone of the limb(s) loaded by the displacement of the body in space [1]. For instance, whole-body rotation within the frontal plane increases the extensor tone of the side-down limbs, while decreasing

that of the side-up limbs (Fig. 1a). On the other hand, side-down and side-up rotations of the neck, elicited by rotation of the body with respect to a stationary head, decrease and increase the extensor activity, respectively (Fig. 1b). So, due to stimulation of vestibular and neck receptors, rotation of the head on a stationary body, which does not affect the loading condition of the limbs, leaves the postural tone unmodified. When the directions of head rotation in space and with respect to the trunk are opposite, the two reflexes act synergistically. This may occur when head and body are tilted in the same direction, but due to a partial righting of the head, the angle of body tilt is larger than that of head tilt (Fig. 1e). VS reflexes, particularly those elicited by stimulation of the sacculus, are involved in the landing reaction, i.e. in the increase in the activity of the plantar flexors of the foot which is induced by the linear acceleration associated with a fall [5]. This reflex response is aimed at increasing the stiffness of these muscles, thus allowing the absorption of a part of the energy of the impact on the ground.

The vestibulo-colic reflexes elicited by a whole body rotation in a given direction, will induce a contraction of the neck that will oppose the displacement of the head in space [3,1]. For instance, a rotation around the vertical axis towards the right side will activate the left neck muscles, displacing the head in the corresponding direction (Fig. 2a).

It is worth mentioning that vestibulo-colic reflexes elicited by vertical acceleration escape this general rule. For instance, an upward acceleration imposed on the whole animal will induce a contraction of the dorsal neck muscle, thus stabilizing the position of the head with respect to the trunk. Vestibulo-colic reflexes interact with cervico-colic reflexes, elicited by stimulation of neck receptors, that give rise to the contraction of the stretched muscles (Fig. 2b). So, during a passive displacement of the head on the trunk to the right side, vestibulo- and cervico-spinal reflexes will act synergistically to activate the left neck muscles, thus resulting in a strong stabilizing action on the position of the head in space and with respect to the trunk (Fig. 2c). On the other

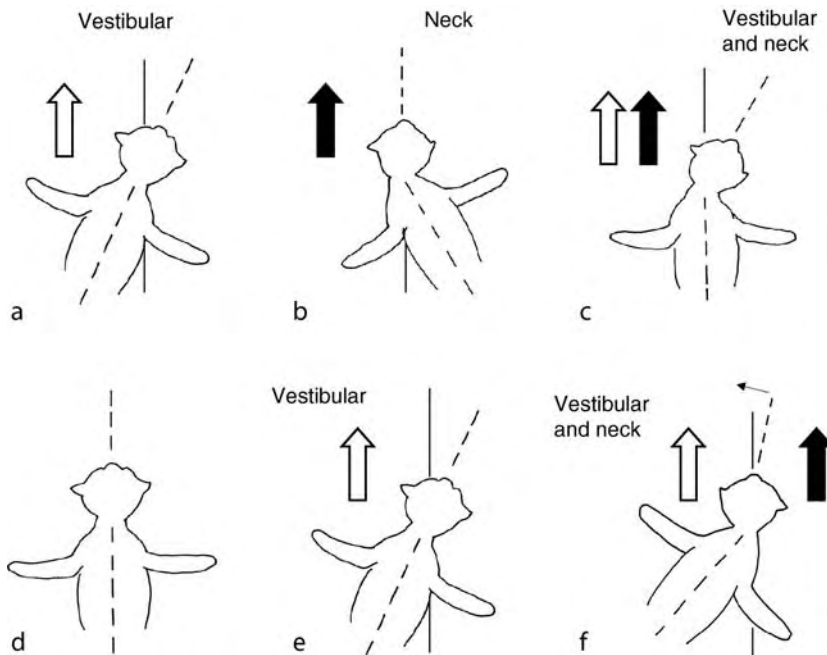

**Vestibulo-spinal Reflexes. Figure 2** ▶ **Vestibulocollic reflex** and ▶ **cervicocollic reflex** elicited by rotations in the horizontal plane. Upward arrows represent increases in the neck muscle activity induced by stimulation of labyrinthine (white arrows) and neck receptors (black arrows). Dashed and continuous lines represent the head/body longitudinal axes and the medial sagittal plane, respectively. (a) Whole body rotation to the right side stimulates vestibular receptors and induces an increase in the activity of the left neck muscles. (b) Rotation of the body with respect to a stationary head towards the right side stimulates neck receptors and increases the activity of the stretched muscles on the left side. (c) Rotation of the head to the right over a stationary body elicits vestibular and cervical reflexes that act synergistically on the neck muscles and induces their contraction on the left side. (d–f) Starting from the initial resting position (d), whole-body rotation to the right activates the neck muscles of the left side (e, white arrow) and induces a rotation of the head to the left (f, dotted arrow). This movement activates neck receptors that induce the contraction of the stretched neck muscles on the right side (f, black arrow).

hand, following whole-body rotation to the right (Fig. 2e), the left neck muscles will be activated by the vestibulo-collic reflex, turning the head to the left side. The cervico-collic reflex elicited by the latter movement, will induce the contraction of right side neck muscles (Fig. 2f), leading to an increase in the stiffness of the head-neck system. The characteristics of muscle activation observed during VS reflexes change with the stimulus frequency, due to the corresponding modification in the relative contribution of the tonic and phasic components of the reflex to the overall response. When low frequency sinusoidal rotational stimuli in vertical planes are considered, it appears that, due to stimulation of otolith receptors, the peak of muscle activity is close to (forelimb muscles) or leads, (neck muscles) the extreme angular position of the animal. By increasing the stimulus frequency there is a growth in the input from ►semicircular canals, which increases the amplitude of the muscle response and shifts the peak of EMG activity towards that of the angular velocity, thus increasing the phase lead with respect to position, particularly in the neck muscles. It is of interest that increasing the frequency of tilt produces little change in the preferred direction of individual limb muscles while those of neck muscles may show quite large variations. This finding has been attributed to the occurrence within vestibulo-collic pathways of a large convergence of labyrinthine signals endowed with different spatial and temporal properties. When rotational stimuli are applied in the horizontal plane, the responses are exclusively due to stimulation of canal receptors and their dynamic characteristics differ from those above described.

In standing human subjects, VS reflexes can be elicited by electrical stimulation of the labyrinth applied to the mastoid bone [6]. Cathodic current applied on one side increases the discharge of the corresponding labyrinthine afferents and when the subject is facing forward induces a body sway in the frontal plane (Fig. 3a), directed away from the stimulated labyrinth [6].

Direct measurements of the positions of the head and scapular and pelvic girdles indicate the recruitment of neck, trunk and limb muscles. It is of interest that when the subject is kept still, the same stimulus induces the perception of sway towards the activated labyrinth.

The neurophysiological mechanisms of neck and vestibular reflexes have been extensively investigated. They are due to changes in the activity of brainstem and cerebellar neurons, induced by stimulation of vestibular and/or neck receptors. Vestibular and/or neck signals reach the ►vestibular nuclei, the ponto-medullary reticular formation, the cerebellar nuclei and vermal/paravermal cortical regions and finally the monoaminergic neurons located in the ►locus coeruleus (LC) and in the ►raphe nuclei [7,8,9]. Within the above-mentioned structures, most of the recorded neurons are maximally activated for animal tilt and/or neck rotation

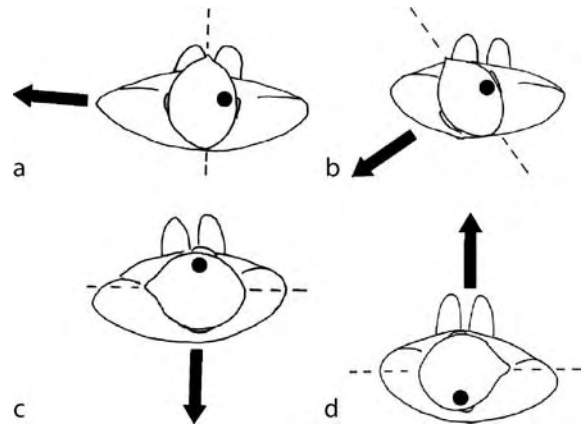

**Vestibulo-spinal Reflexes.** Figure 3 The direction of the body sway induced by electrical ►cathodic stimulation of the labyrinth rotates by the same angle and in the same direction as the head over the body. The dotted line represents the naso-occipital head axis. The (right) labyrinth stimulated with cathodic current is marked by a black dot. The arrows show the direction of the body sway elicited by stimulation of the right labyrinth in different head positions (a–d).

occurring in a particular, “preferred” direction [7]. In addition, the majority of the recorded units are affected by both vestibular and cervical input. The VS neurons that allow a fast transfer of information from the labyrinth to the spinal circuits are an important element of the reflex network [1]. Those located in the ►lateral vestibular nucleus of Deiters, which exert an excitatory action on limb extensor motoneurons and project to the whole extent of the spinal cord, are particularly involved in the development of VS spinal reflexes acting on the limb muscles. VS neurons located within the ►medial vestibular nucleus project only up to the upper levels of the spinal cord, where they inhibit ipsilateral neck motoneurons, while exciting the contralateral ones. They seem therefore well suited to eliciting the vestibulo-collic reflexes [1]. Their pattern of activity during whole-body rotation cannot however account for the dynamic characteristics of these reflexes. Moreover, since vestibulo-collic responses are not abolished by sectioning the medial VS tract, other descending systems must be involved in this reflex response.

### Regulation of the Process

VS reflexes are submitted to several regulatory processes. Their amplitude is dependent upon behavioral conditions, increasing when the amplitude of the support base is reduced and when visual and/or somatosensory information cannot be utilized for postural control. There is evidence that the vestibulo-collic reflex, which would oppose any voluntary head movement, can be depressed in the latter case. In

addition, VS reflexes interest a given muscle only when the latter is involved in a postural function [6]. In addition, modifications in VS reflexes are induced by changing the postural orientation. Accordingly, identical stimuli to the labyrinth may give rise to different postural responses. For instance, the postural sway elicited by ▶galvanic stimulation of the labyrinth is modified according to the position of the head with respect to the body, signaled by neck afferents [6]. In particular, the direction of sway, which occurs in the frontal plane when the subject is facing forward, rotates by the same angle and in the same direction as the head over the body (Fig. 4 b–d).

So, different muscle synergies are induced by an identical stimulus to the labyrinth [6]. A corresponding phenomenon occurs in the decerebrate cat, where the preferred response direction of the forelimb extensors is modified by body-to-head displacement and rotates in the same direction and by the same amplitude as the body [8] (Fig. 4a). In both examples, neck information modifies the VS reflexes, making them appropriate to counteract the effects of the direction of sway signaled by vestibular receptors. We may therefore conclude that neck afferents exert not only a direct effect on postural tone (CS reflexes), but also modulate VS reflexes. Similar actions are also exerted by proprioceptive afferents signaling wrist position; it is known in fact that dorsal and ventral flexion of the forepaw not only increase and decrease respectively the firing of ipsilateral limb extensor motoneurons but also the gain of the VS reflexes acting at this level. Finally, proprioceptive afferents signaling the postural orientation may induce plastic changes of adaptive nature in the amplitude of VS reflexes. For instance, in decerebrate cats, a three hour period of continuous and simultaneous whole animal tilt and forepaw oscillation [10] may lead to a progressive increase in the amplitude of the VS reflex acting at the level of the forelimb extensors that persist for hours after the end of the adaptive stimulation. These changes manifest only when side-down animal tilt occurs simultaneously with dorsal flexion of the forepaw, as would be the case in a leg flexing under the body weight, thus requiring a strengthening of the VS reflexes in order to stabilize posture. Similar phenomena can be also elicited by appropriate costimulation of vestibular and neck receptors. The neurophysiological mechanisms underlying gain regulation, proprioceptive tuning and adaptive properties of VS reflexes are poorly understood. An important role in gain regulation could be exerted by those structures that modify the postural tone during the sleep-waking cycle. During waking, the reticulospinal inhibitory system fires at low level, while the noradrenergic LC neurons that support the postural tone are tonically active. During sleep, reticulospinal neurons are excited by descending influence from the pons,

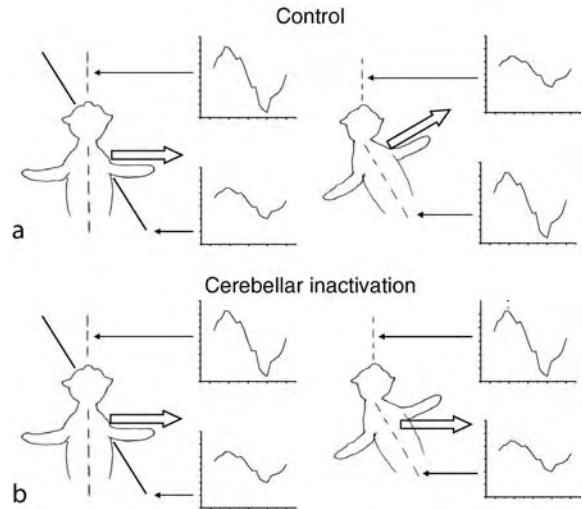

**Vestibulo-spinal Reflexes. Figure 4** Proprioceptive tuning of vestibulospinal reflexes and its cerebellar control. The *dotted line* represents the longitudinal body and head axes. The *white arrows* represent the directions of whole animal tilt giving rise to the maximal response of a forelimb extensor muscles. The graphs show the modulation of activity of a forelimb extensor muscle elicited by a sinusoidal tilt around the axis indicated by the thin arrows. (a) When head and body axes are aligned (*left figure*) the forelimb muscle shows the maximal modulation of its activity (*upper graph*) during a side-down, whole-animal tilt around the longitudinal head axis. When the tilt occurs around an axis oblique with respect to the longitudinal one (*continuous line*), the modulation is smaller (*lower graph*). The preferred ▶*direction of stimulation* is perpendicular to the head (and body) longitudinal axis. Rotation of the body around the stationary head (*right figure*) modifies the muscle responses to labyrinthine stimulation. The best responses are no longer obtained for tilt around the head longitudinal axis but rather around the body axis (*lower graph*). The preferred direction of stimulation is now perpendicular to the body (not head) longitudinal axis. (b) Following inactivation of the cerebellar anterior vermis, body-to-head displacement does not modify the orientation of the axis of rotation leading to the maximal response. The preferred direction of stimulation is always perpendicular to the head longitudinal axis.

while the LC discharge is depressed, leading to a reduction in postural tone, which disappears completely during REM sleep together with the LC discharge (see [9]). It has been shown that an increase in the activity of the reticulospinal inhibitory system or else a depression in the LC discharge (obtained by local microinjections of appropriate neurotransmitter agonists and antagonists) greatly enhanced the gain of VS reflexes acting on forelimb extensors [9]. It may well be that small changes in the activity of these neuronal systems may also occur during waking, thus leading to the appropriate

modification of the reflex response. Another structure possibly involved in the gain regulation of VS reflexes is the cerebellar vermal cortex of the anterior lobe, which keeps under its direct inhibitory control both lateral VS and fastigial neurons. The latter in turn excite lateral VS and reticulospinal neurons. It has been shown that the functional inactivation of this cortico-cerebellar region by a local injection of a GABA-A agonist greatly depresses the gain of VS reflexes (see [10]). The cerebellum is also involved in the tuning of VS reflexes exerted by proprioceptive neck afferents. In fact, functional inactivation of the cerebellar anterior lobe may abolish the changes induced, by rotating of the neck over the body, in the preferred response direction of the limb extensors to labyrinthine stimulation [8] (Fig. 4b). Moreover this procedure prevents the induction of plastic changes in VSR gain induced by costimulation of labyrinthine and proprioceptive afferents and, when performed after the adaptation process, abolishes the already established gain modification (see [10]). A suppression of the induction of VS reflex adaptation is also induced by blockade of noradrenergic beta-receptors within the same cerebellar region. In conclusion there is evidence that, acting through the cerebellum, proprioceptive afferents may (i) tune the VS reflexes according to body posture and (ii) induce plastic changes that adapt their gain to the behavioral condition

## References

1. Wilson VJ, Melvill Jones G (1979) Mammalian vestibular physiology. Plenum Press, New York
2. Horak FB, Macpherson JM (1996) Postural orientation and equilibrium. In: Rowell L, Shepherd J (eds) Handbook of physiology, section 1, exercise: regulation and integration of multiple systems. Oxford University Press, New York. pp 255–292
3. Baker J, Goldberg J, Peterson B (1985) Spatial and temporal response properties of the vestibulocollic reflex in decerebrate cats. *J Neurophysiol* 54:735–756
4. Wilson VJ, Schor RH, Suzuki I, Parks B (1986) Spatial organization of neck and vestibular reflexes acting on the forelimbs of the decerebrate cat. *J Neurophysiol* 55:514–526
5. Lacour M, Xerri C, Hugon M (1978) Muscle responses and monosynaptic reflexes in falling monkey. Role of the vestibular system. *J Physiol* 74:427–438
6. Britton TC, Day BL, Brown P, Rothwell JC, Thompson PD, Marsden CD (1993) Postural electromyographic responses in the arm and leg following galvanic vestibular stimulation in man. *Exp Brain Res* 94:143–151
7. Kasper J, Schor RH, Wilson VJ (1988) Response of vestibular neurons to head rotations in vertical planes. II. Response to neck stimulation and vestibular-neck interaction. *J Neurophysiol* 60:1765–1778
8. Manzoni D (2005) The cerebellum may implement the appropriate coupling of sensory inputs and motor responses: evidence from vestibular physiology. *Cerebellum* 4:178–188
9. Pompeiano O, Horn E, d’Ascanio P (1991) Locus coeruleus and dorsal pontine reticular influences on the gain of vestibulospinal reflexes. In: Barnes CD, Pompeiano O (eds) Progress in brain research, vol 88. Neurobiology of the locus coeruleus. Elsevier, Amsterdam, pp 435–462
10. Andre P, Pompeiano O, Manzoni D (2005) Adaptive modification of the cats vestibulospinal reflex during sustained and combined roll tilt whole animal and forepaw rotation: cerebellar mechanisms. *Neuroscience* 132:811–822

## Vestibulospinal Responses

EMILY A. KESHNER

Department of Physical Therapy, College of Health Professions and Department of Electrical and Computer Engineering, College of Engineering, Temple University, Philadelphia, PA, USA

### Definition

The vestibular system operates as an integrator of multiple lines of feedback (e.g., visual, proprioceptive and labyrinthine) prior to signaling segmental mechanisms, through the medial and lateral vestibulospinal tracts to adjust the position of the trunk and lower limbs in order to keep the position of the head stable in space.

### Description of the Theory

Whereas vestibular control of motion at the head and neck can be isolated through the vestibulocollic reflex, vestibular control of postural responses of the whole body are not as clearly delineated. It is too restrictive to define the vestibulospinal system as controlled by only the vestibular afferents. The lateral nucleus of the vestibular nuclei is the primary origin of the lateral vestibulospinal tract (LVST), which projects to the lumbosacral cord. The medial vestibulospinal tract (MVST) descends bilaterally through the medial longitudinal fasciculus as far as the upper thoracic enlargements. But primary afferent input to the LVST and MVST pathways includes the utricle of the vestibular otoliths, the fastigial nucleus and vermal cortex of cerebellum and the same spinal motoneurons to which the vestibulospinal pathways project. Thus the vestibular signals are modulated both by descending (cerebellar) and ascending (spino-vestibular) pathways before acting on spinal segmental motoneurons [1]. Cervical proprioceptive inputs provide a feedback signal about trunk velocity, so that the vestibular neurons could remain sensitive to perturbations of the body even as vestibular drive is reduced by a reduction of head

motion in space. A physiological correlate for the participation of the vestibular system in this process has been observed in secondary horizontal canal neurons that were specifically related to neck velocity [2].

Precise descriptions of the anatomy and neurophysiology of the pathways involved in these actions are comprehensively described elsewhere [3]. But descriptions of isolated pathways' locations and actions cannot convey how all of these control pathways operate through the biomechanics of the system to produce functional postural dynamics (Fig. 1). In the accompanying essay, the physiological and behavioral data that signify contributions of the vestibulospinal system to the control of posture and gait are presented.

### Characteristics of the Vestibulospinal Responses

The principal role of the vestibulospinal system is to stabilize the head in space and it does this during both transient and stationary disturbances to the body by changing the arrangement of the limbs. The vestibular system measures the head's angular velocity and linear acceleration and detects head position relative to the gravitational axis. Head angular velocity is measured by the cristae of the semicircular canals, while the maculae of the labyrinths (utricle and saccule) register linear acceleration and changes in gravitational force. Electrical

stimulation studies on decerebrate animals have presented evidence that descending impulses from the vestibular nuclei were primarily excitatory to proximal forelimb extensor muscle via monosynaptic pathways. Distal muscles of the forelimbs received excitatory and inhibitory influences via polysynaptic connections [3].

In order to keep the head stable in space, the vestibular system will combine the labyrinthine signals with those of the segmental proprioceptors to invoke changes in the limbs that will keep the head oriented in space. For example, in response to sustained tilts of the body, otolith signals generate limb flexion and extension patterns in cats, monkeys and humans, which would correctly restore the head to a stable vertical position. Vestibulospinal limb reflexes have also been shown to be responsible for counteracting dynamic tilts of the body. Numerous studies of postural sway following linear and rotational disturbances of the base of support have been performed with subjects having unilateral or bilateral labyrinthine deficit. The results of these studies have demonstrated impaired control of whole body sway and delayed and diminished responses of the muscles in the lower limb when labyrinthine inputs were absent [4].

Because the vestibular system primarily senses head motion, it is less sensitive to body sway than are the

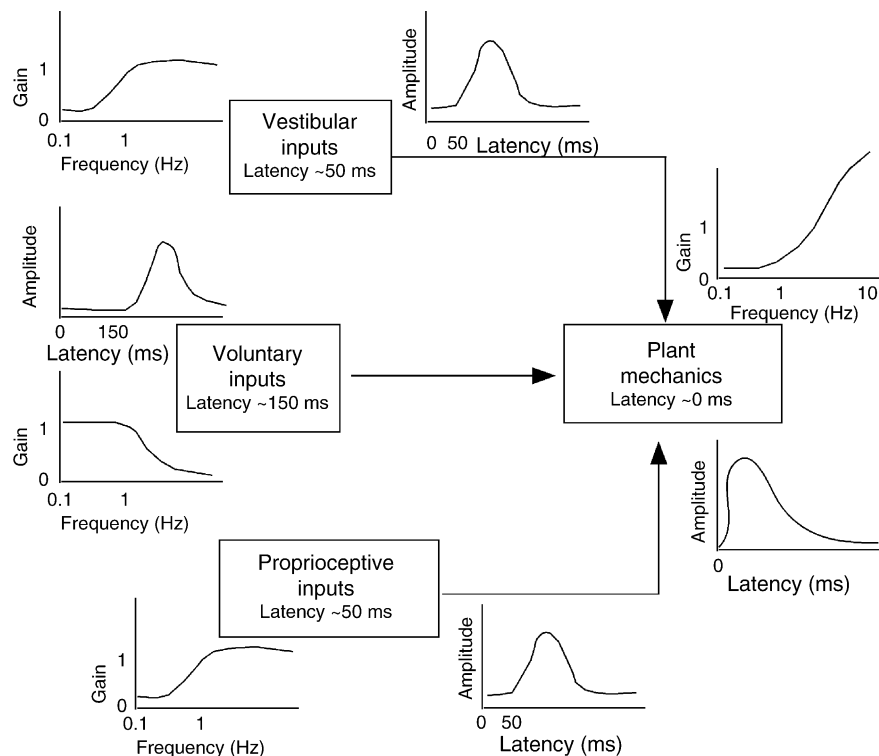

**Vestibulospinal Responses. Figure 1** Flow diagram depicting the pathways that can influence vestibulospinal control of posture. Graphs surrounding each control box illustrate the expected activation of each control mechanism in the time (latency) and frequency domains.

visual or the somatosensory systems. It is a common belief that the vestibular system becomes the dominant controller of posture when there is a conflict between or impairment of visual and somatosensory information. But subjects with vestibular loss do not necessarily utilize somatosensory cues to a greater extent than do normal subjects to attenuate sway. Thus, the disorientation exhibited by patients with labyrinthine loss when visual or somatosensory information is unreliable might be explained by the fact that neither signal can adequately specify the orientation of the body in all situations. Although different sensory pathways often provide congruent information, each sensory modality is only partially redundant with another because each transduces different stimulus parameters (e.g., velocity or position) and each is effective within a specific frequency domain. For example, control mechanisms for head stabilization have been clearly delineated as acting within well defined frequency bandwidths [5]. Voluntary mechanisms are the predominant controller at low frequencies (<1 Hz), vestibulocollic and cervicocollic reflexes predominate up to 2 Hz and head inertia and other mechanical factors predominantly control the head at higher frequencies. Thus vestibulospinal control of dynamic postures can only succeed with a convergence of sensory information from the vestibular, somatosensory and visual systems.

In alert animals and humans it is difficult to isolate the influences of the vestibular end organs on postural responses of the whole body. The otoliths have been implicated in providing the early muscle responses in the lower limb necessary to oppose a fall. Early responses (75–90 ms) in the gastrocnemius muscle have been recorded during a linear acceleration stimulus when alert animals and humans were unexpectedly dropped from some height. These responses disappeared when the animal was labyrinthectomized but remained intact with canal plugging, thereby supporting the assertion that these short latency responses were of otolith (most likely, saccular) origin [3]. These conclusions have been replicated in humans using galvanic vestibular stimulation (GVS), which delivers a pure disturbance at the vestibular receptor level uncomplicated by inputs to other sensory channels. Externally applied galvanic currents have been shown to act upon the most distal part of the vestibular nerve and produce direction specific body sway and a characteristic modulation of EMG activity in postural muscles in standing humans that requires the integrity of the vestibular nerve. When standing, GVS produces a sustained tilt in the direction of the anode, but immobilized subjects experience illusions of movement in the direction opposite to the sway response. GVS produces a vestibular signal similar to that produced by tilt of the whole body and evokes a corrective

response to maintain the position of the head in space. The perception of roll and tilt is maximized when subjects received a long stimulus with the head at a specific pitch angle. Responses to GVS applied to the eighth nerve were recorded when the head was oriented in an upward or downward position while turned to the right so that stimulation of the canals would vary but stimulation of the otoliths remained constant. Results of this stimulation suggest that short latency (60–70 ms) responses in the leg muscles are most probably driven by the otolith organs and medium latency responses (120 ms) are most probably driven by the semicircular canals [6].

As mentioned in the accompanying essay on vestibulocollic and cervicocollic control in this Encyclopedia, forces generated by the vestibulospinal responses may not be adequate to counteract external disturbances. Similarly, responses to vestibulospinal stimulation during complex behaviors suggest that the vestibulospinal influences modulate rather than generate lower limb postural responses. When standing upright, the gravity sensors of the inner ear constantly monitor the position of the head and body and send any information about tilting movement to the vestibular nuclei. It can then be relayed down the spinal cord to the areas controlling limb muscles. It will usually tend to relax groups of muscles on one side of the body and contract similar groups on the other, which allows a person to resist a fall. But in patients with labyrinthine deficit, the magnitude of the lower limb muscle responses is significantly reduced and these individuals often cannot sustain a stable position following repeated disturbances to the base of support [4]. Studies of the H-reflex response in lower limb muscles that were not being used to maintain balance because the subjects were lying prone demonstrate that stimulating the vestibulospinal system, either with GVS or by changing the orientation of the body in space, affects the excitability of the lower limb motoneuron pool [7,8]. Electrophysiological evidence from intact cats indicates that lesions compromising the vestibulospinal and reticulospinal tracts lead to a loss of muscle tonus and these animals have problems in adapting their gait to walk on an inclined plane [9]. Thus the primary role of the vestibulospinal system may be to modify muscle tone rather than to elicit postural reflexes.

There is also evidence that the vestibulospinal pathways have modulating influences on gait in humans. For example, it has been observed that walking with the head tilted back modifies the lower limb EMG responses, which could imply an influence of otolith inputs on gait. In muscle, torques generated by the VCR are not adequate to produce the forces necessary to counteract external disturbances. In subjects walking on a treadmill, the head stayed stable in space relative to the trunk for speeds up to 1.2 m/sec. As walking velocity increased, a



significant head translation developed. The predominant frequency of head movement was restricted to a narrow range from 1.4 Hz at 0.6 m/s to 2.5 Hz at 2.2 m/s. The coordination of head and trunk movement was most coherent at walking velocities between 1.2 and 1.8 m/s and at frequencies between 1.4 and 2.5 Hz. Within the range of 0.8–1.8 m/s, subjects tended to increase their stride length rather than step frequency to walk faster, thereby maintaining the predominant frequency of head movement at close to 2.0 Hz [10]. These results suggest an intimate connection between the CNS mechanisms controlling a stable head and those that control walking velocity.

## References

1. Boyle R (2000) Morphology of lumbar-projecting lateral vestibulospinal neurons in the brainstem and cervical spinal cord in the squirrel monkey. *Arch Ital Biol* 138:107–122
2. Gdowski GT, McCrea RA (2000) Neck proprioceptive inputs to primate vestibular nucleus neurons. *Exp Brain Res* 135:511–526
3. Wilson VJ, Melvill-Jones G (1979) *Mammalian vestibular physiology*. Plenum, New York
4. Keshner EA, Allum JH, Pfaltz CR (1987) Postural coactivation and adaptation in the sway stabilizing responses of normals and patients with bilateral vestibular deficit. *Exp Brain Res* 69:77–92
5. Keshner EA, Peterson BW (1995) Mechanisms controlling human head stabilization. I. Head-neck dynamics during random rotations in the horizontal plane. *J Neurophysiol* 73:2293–2301
6. Cathers I, Day BL, Fitzpatrick RC (2005) Otolith and canal reflexes in human standing. *J Physiol* 563:229–234
7. Kennedy PM, Cresswell AG, Chua R, Inglis JT (2004) Vestibulospinal influences on lower limb motoneurons. *Can J Physiol Pharmacol* 82:675–681
8. Knikou M, Rymer WZ (2003) Static and dynamic changes in body orientation modulate spinal reflex excitability in humans. *Exp Brain Res* 152:466–475
9. Matsuyama K, Drew T (2000) Vestibulospinal and reticulospinal neuronal activity during locomotion in the intact cat. II. Walking on an inclined plane. *J Neurophysiol* 84:2257–2276
10. Hirasaki E, Moore ST, Raphan T, Cohen B (1999) Effects of walking velocity on vertical head and body movements during locomotion. *Exp Brain Res* 127:117–130

## Vibration Receptors

► **Cutaneous Mechanoreceptors, Anatomical Characteristics**

## Vibration Sense

RONALD T. VERRILLO

Institute for Sensory Research, Syracuse University, Syracuse, NY, USA

### Definition

### Characteristics

The skin is by far the largest sensory surface of the human body. It is approximately 1.75 m<sup>2</sup> in area and comprises about 6% of the total body weight. In addition to providing a protective barrier against hazardous agents in the environment (mechanical and chemical) and in assisting with the preservation of core body temperature through sweating, it is host to a number of sensory systems. These include mechanoreception (touch), temperature [1], and pain. Vibrotaction, the vibration sense, is a subset of the sense of touch which also included light touch, brushing and steady pressure. In addition to its function as a defensive mechanism, the sense of touch also plays a major role in sexual arousal and thereby is important to the procreative process and the preservation of the species. It is also capable of signaling complex blends of sensation such as itch and tickle.

When the skin is displaced mechanically the disturbance is transmitted through its outer layers (► **epidermis**) to the deeper layers (► **dermis**) where a number of different mechanoreceptors are located at various depths. In hairless skin (glabrous), located on the palms of the hands and soles of the feet, there are four principle receptors. These are the ► **Pacinian corpuscles (PC)**, which are the largest mechanoreceptors in the body, ► **Meissner corpuscles**, ► **Merkel cell neurite processes** and ► **paciniform endings** (formerly Ruffini endings).

A fifth type of neural process found in skin is the ► **free nerve endings**, which has no organized end-organ structure. These nerve endings, ubiquitous throughout the interior and on the surface of the body, are considered primarily as pain receptors or high-intensity mechanoreceptors and will not be considered further in the current discussion.

► **Hairy skin** contains PCs, Merkel disc neurite processes, paciniform endings and hair follicle “basket” endings. All of these receptors respond to various configurations of mechanical disturbances imposed upon the surface of the skin.

Measurements of tactile sensitivity are made at two levels of stimulus intensities. Threshold measurements are made to determine the minimal amplitude of displacement that the observer is able to detect 50%

of the time. Suprathreshold measurements are made to determine the subjective judgments of intensity that the observer makes when the physical amplitudes of displacement are greater than the minimal-detectable level.

### Threshold Measurements

One of the basic operating characteristics of both the auditory and vibrotactile sense modalities is the response to different frequencies at the threshold of detection.

The methods used in making measurements of the human response to stimulation is called ►**psychophysics**. Measurements are conducted with the subject located inside a sound and vibration proofed booth, comfortably seated with the arm and hand resting upon a firm surface. The vibrator is located beneath; a circular contactor mounted on the moving element of the vibrator protrudes through a hole in the surface which has a diameter 2.0 mm larger than that of the contractor so there is a 1.0 mm gap between the contactor and the rigid surface. This prevents the vibration from spreading across the surface of the skin beyond the immediate location of the contactor. This allows an exact specification of the size of the skin that is being stimulated. It is also necessary to control the temperature at the surface of the skin because temperature can have a profound effect on vibrotactile sensations; at low temperatures the skin is less sensitive. Typically, the subject wears headphones with narrow-band noise to mask the sounds of the vibrator. The subject responds by pressing buttons to indicate when the stimulus is felt, the responses are recorded by the investigator sitting outside of the booth.

The Pacinian corpuscle is sensitive to sinusoidal vibrations of between 0.4 and 700 Hz. It is able to follow at a 1:1 ratio the individual periodic displacements in a U-shaped sensitivity function with a maximal sensitivity at between 250 and 300 Hz. Exquisitely sensitive, it can be activated by a displacement as small as 0.1  $\mu\text{m}$  (peak) at 250 Hz. The Meissner corpuscle is less sensitive to variations in frequency. Its curve of sensitivity is relatively flat, and it is most sensitive in the region around 30 Hz, able to detect displacement amplitudes of about 15  $\mu\text{m}$ . The Merkel cell complex is also unresponsive to frequency changes, having a sensitivity curve that is relatively flat and most sensitive to frequencies around approximately 10 Hz. The frequency response of the paciniform receptors is similar to that of the PC, but very much less sensitive, having a maximal sensitivity in the region of 250–300 Hz. However, its threshold curve is about 25 dB higher (10  $\mu\text{m}$ ) than that of the PC. The psychophysical threshold measurements of the four principle cutaneous receptor channels are shown in Fig. 1.

The curves shown in Fig. 1 are based on measurements made on ►**glabrous skin** located over the thenar eminence (palm of the right hand). Measurements made on hairy skin of the volar forearm have the same configuration, but are displaced upward (less sensitive) by about 15 dB. Although the Meissner corpuscle is not found in hairy skin, it is thought that the hair follicle endings subserve the same function.

Only the PC channel is capable of integrating energy over both time and space. In the spatial domain, if the area of stimulation is increased, the threshold of

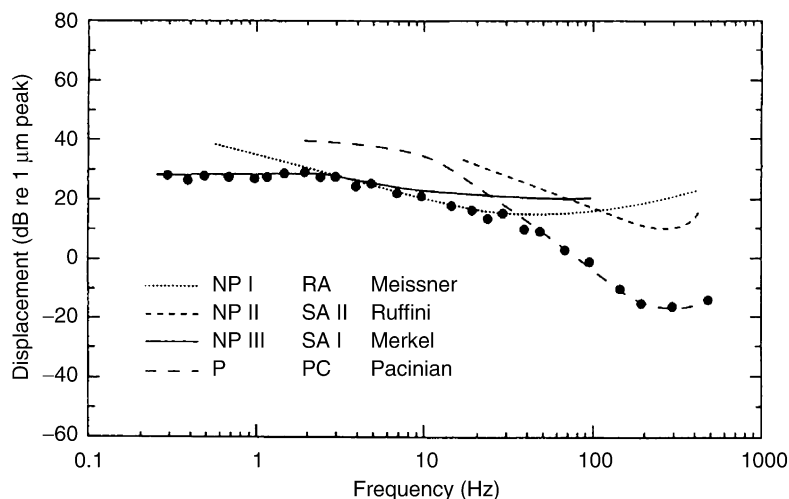

**Vibration Sense. Figure 1** Thresholds of detection in dB re 1.0  $\mu\text{m}$  of peak displacement plotted as a function of sinusoidal frequency in Hz, measured at the thenar eminence (palm). Decreasing thresholds (increased sensitivity) as the area of the contactor increases is indicative of spatial summation in the higher frequencies, which activates the Pacinian channel. From [2].

detection decreases in a direct, orderly fashion (increased sensitivity). When plotted as a function of contactor area the threshold curves obtained on both glabrous and ► **hairy skin** decrease by 3 dB per doubling of area. This indicates that there is a perfect integration of the energy imposed upon the surface of the skin [2]. Similarly, in the temporal domain, if the duration of the stimulus is increased, the threshold decreases in an orderly fashion in accordance with an excepted theory of temporal summation in sensory systems [3]. None of the non-Pacinian receptor channels is capable of either spatial or temporal summation [4]. The function of the Pacinian receptor channel is thought to be that of a highly sensitive “alerting” system to indicate that something is present on or near the surface of the skin. The non-Pacinian receptor channels are thought to signal the sight of stimulation and to enable the appreciation of surface textures and the roughness of objects touching or being touched by the surface of the skin; they are essentially feature detectors [5,6].

A four-channel model of cutaneous receptors has been proposed that is based on empirical data obtained from anatomical, electrophysiological and psychophysical experiments [7]. First proposed as a duplex model of vibrotaction [8,9], it was later expanded to a triplex form and finally to its current four-channel format [9]. Perceptions of the environment ultimately will be a blend of inputs from all of the cutaneous receptor systems as the signals from the periphery converge at higher levels of the central nervous system, probably within the somatosensory regions of the cortex.

### Suprathreshold Measurements

Interactions between humans and the environment occur primarily at supra-threshold levels of stimulation; that is, at intensities of the physical stimulus that are above the minimum displacements needed to elicit a response. These interactions are important for survival as well as for communication. Responses to suprathreshold stimuli have been studied by a number of methods, but the most useful has been the method of Absolute Magnitude Estimation (AME) in which subjects are asked to assign numbers whose subjective magnitude matches their impression of how intense the sensations feel. No standard or modulus is given. The numbers given by the subject are plotted as a function of the physical intensity of the stimulus. The resultant best-fit curve describes a power function with a slope that is different from one sense modality to another but is typically consistent within each modality. Figure 2 shows the results obtained at four frequencies [10], plotted as subjective magnitude in assigned numbers as a function of the amplitude of displacement in decibels. The measure of central tendency of a group of subjects is obtained by computing the geometric means of the group. The best-fit curves are drawn through the

untransformed, raw judgments given by the subjects. In the mid-to high range of physical intensities the curves describe power functions with an exponent (slope) of about 1.0. It might be added that in vision, hearing and touch the results of AME experiments have always yielded power functions along a multitude of physical dimensions. Exponents vary from modality to modality, but within each modality the results are consistent.

### Subject Variables

Because humans vary in a number of important ways, including age, gender, hand preference, etc., studies have been performed to ascertain the effects of these variables on responses to vibratory stimulation. These experiments have determined that there is no difference between males and females in ► **absolute threshold** values in vibrotaction, but at suprathreshold levels women perceive the same physical intensity of stimulation as being more intense than men. That is, women typically assign higher numbers to the same amplitudes of displacement than do men. The detection thresholds of women also vary systematically over the duration of the menstrual cycle. The sensitivity to a 250 Hz sinusoidal vibration increased up to the onset of menstruation. Then the women became less sensitive for 12–13 days when they reached a nadir of insensitivity. These changes were not observed in women taking birth-control pills. It is apparent that vibrotactile sensitivity is influenced by hormonal balance. Hand preference has no effect on the absolute threshold of detectability, but suprathreshold stimuli delivered to homologous sites on opposite sides of the body, the stimuli have an interactive effect on right-and left-handed subjects. That is, a stimulus delivered to one side of the body can affect the sensation resulting from a stimulus delivered to the opposite side. However, in ambidextrous persons there was no cross-body effect; it appeared that the two contralateral sites were functioning quite independently of each other. There is no difference in threshold values of the two hands nor is there a difference between right and left-handed individuals. The effects of aging are detrimental to the vibration sense throughout the life span, but these effects are considered in detail in another entry of this encyclopedia.

### Epilogue

It is legitimate to ask the question: “Why study the sense of vibration?” After all, in this sense humans are not afflicted with sensory deficits such as blindness or deafness that take an enormous toll in society, economically and on the quality of life of the individual. There are several answers to this question. First, to understand the functioning of any aspect of the body is a legitimate pursuit of any scientific endeavor. Improvements in the “way of life” are often made by the endeavors of individuals driven not by goals of practical

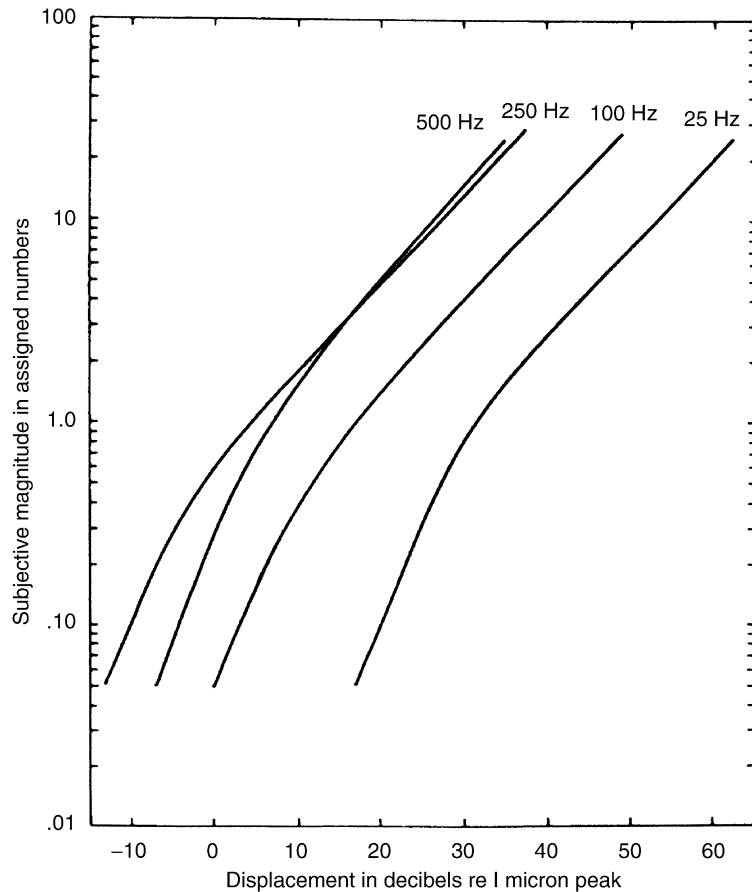

**Vibration Sense. Figure 2** Subjective magnitude of vibration of five frequencies is assigned numbers plotted as a function of displacement in dB re 1.0  $\mu\text{m}$  peak. In the mid-to upper range of displacement the curves describe power functions with a slope (exponent) of about 1.0. From [10].

application but rather by insatiable curiosity. The more we understand about how the body works, the better our position to cure its ills and improve the general welfare.

Second, there are many practical applications for our knowledge about the vibration sense. Deficits in sensitivity, at threshold and at suprathreshold levels, are often precursors of neurological and metabolic disorders. The study of tolerance levels often leads to improvements in the safety and acceptability of the workplace environment. A very important application of knowledge about the vibration sense has been for the use of vibrotaction as a substitute or surrogate of the senses of vision and hearing. Time-honored systems for aiding the blind in reading the printed word are found in the use of Braille and more recently in the development of electronic reading devices. Aids to mobility for the blind that utilize the sense of touch have also been developed. For the deaf, alerting systems for potential hazards are in use and, of great importance, devices to aid the deaf in understanding the spoken word (Tactile Vocoders) are now commercially available. Tactile

signals are also used to supplement the eyes and ears in environments in which they are overtaxed with information, such as in aircraft and space vehicles. The military applications include communication with personnel who would be exposed to danger should conventional channels be used. In the field of robotics, substitutes for the eyes and ears have for the most part successfully achieved, but the effort continues to enable robots to tactually feel the environment as do humans.

At the theoretical, basic and applied levels, there are a multitude of reasons for efforts to study and understand the vibration sense.

## References

1. Bolanowski SJ Jr, Verrillo RT (1982) Temperature and criterion effects in the somatosensory system: a neurophysiological study. *J Neurophysiol* 48:837–856
2. Verrillo RT (1963) Effect of contactor area on the vibrotactile threshold. *J Acoust Soc Am* 35:1962–1966

3. Zwislocki J (1960) Theory of temporal summation. *J Acoust Soc Am* 32:1046–1060
4. Verrillo RT (1965) Temporal summation in vibrotactile sensitivity. *Sens Proc* 37:843–846
5. Verrillo RT (1979) The effect of surface gradients on vibrotactile thresholds. *Sens Proc* 3:27–36
6. Verrillo RT, Bolanowski SJ, McGlone FP (1999) Subjective magnitude of tactile roughness. *Somatosens Mot Res* 16:32–36
7. Bowlanowski SJ, Gescheider GA, Verrillo RT, Checkosky CM (1988) Four receptor channels mediate the mechanical aspects of touch. *J Acoust Soc Am* 84:168–169
8. Verrillo RT (1966) Specificity of a cutaneous receptor. *Percep Psychophys* 1:149–153
9. Verrillo RT (1968) A duplex mechanism of mechanoreception. In: Kenshalo DR (ed) *The skin senses*. CC Thomas, pp 139–159
10. Verrillo RT, Fraioli AJ, Smith RL (1969) Sensation magnitude of vibrotactile stimuli. *Percep Psychophys* 6:366–372

## Vibrotactile

### Definition

The sensation that is the result of applying vibrations to the surface of the skin.

► [Vibration Sense](#)

## Vigilance

### Definition

The ability to maintain the necessary amount of attention to perform a task at a specified level. Vigilance tests are typically monotonous, and aim to test the overall level and duration of sustained attention.

► [Alertness Level](#)

## Vigilance States

► [Sleep States](#)

## Viral Central Nervous System Infection

### Definition

Virus infection in the central nervous system (CNS). Virus can spread to the CNS via the neural (using peripheral nerves), olfactory, or hematogenous routes. Most viruses, such as poliovirus and herpes virus, cause acute pathology, while some viruses, such as measles virus and lymphocytic choriomeningitis virus (LCMV), can persistently infect the brain, leading to chronic disease. Cell types that are infected by viruses in the CNS differ depending on the virus. For example, poliovirus infects neurons, JC virus infects oligodendrocytes, and HIV infects monocyte/macrophage lineage cells. Although some viruses can latently infect host cells without causing CNS damage, other viruses cause lytic infection or apoptosis of cells in the CNS. Antivirus immune responses in the CNS can be a double-edged sword; immune responses can eradicate virus from the CNS, while severe immune responses can damage CNS tissue (immunopathology), whose regeneration ability is limited.

## Viral Myelinopathy

### Definition

Any virus disease of the myelin; degeneration of the white matter of the brain of viral etiology.

## Viral Vector

### Definition

A virus that is genetically modified in such a way that it is still able to deliver its genetic contents to the cell nucleus but has lost its capacity to divide.

► [Gene Therapy for Neurological Diseases](#)

## Virotoxin

### Definition

Viral proteins with toxic or inflammatory properties.

► [Neuronal Cell Death and Inflammation](#)

## Virtue Epistemology

### Definition

According to these approaches, in order to count as knowledge, a person's true belief has to be the result of the person's intellectual virtue.

► Knowledge

## Viruses for Transneuron Tracing

### Definition

Neurotropic viruses reproduce inside living neurons and cross that neuron's synapses to the neurons connected to it. This property allows tracing of a pathway across one or more synapses. A solution containing a virus is injected into a target structure. After a survival time appropriate for the number of synapses in the pathway (1 day/synapse is typical) the animal is sacrificed and its brain histology treated with antibodies to reveal the presence of the virus. Some viruses travel in the retro grade direction and others in the anterograde direction.

## Viscera

### Definition

A general term that refers to the internal organs of the body. The contents of the four great body cavities: the cranium (skull), the thorax (chest), the abdomen, and the pelvis.

► Evolution of the Spinal Cord

## Visceral Afferents

JOHN F. B. MORRISON

Department of Physiology, Faculty of Medicine and Health Sciences, UAE University, Al Ain, UAE

### Synonyms

Vagal afferents; Splanchnic afferents; Pelvic afferents; Afferent innervation of the heart; Lungs; Airways;

Gastrointestinal tract; Kidney; Ureter; Bladder; Reproductive organs; Mesenteries; Visceral sensation; Visceral reflexes

### Definition

Visceral Afferents are neurons that sense events occurring within internal organs, the membranes that cover them or their attachments to the body wall. The information carried by visceral afferents is concerned with the physiological regulation of viscera such as the heart, lungs, gastrointestinal or urogenital organs, or may occasionally appear as a conscious sensation, often, but not necessarily, painful in nature.

### Characteristics

#### Higher Level Structures

The thoracic, abdominal and pelvic viscera are the main sources of visceral afferent information, and nerve endings may be found in muscular walls, the inner lining, the surrounding membranes of these organs or in the ►mesenteries and ►omentum. Afferent information includes the movements or stretch of visceral walls, the composition of the visceral contents, events that occur within the external coverings of the organs, and stretch of the mesenteries. The pathways to the central nervous system (CNS) are twofold: the vagus (Xth cranial) nerve, which carries information from the thoracic and upper abdominal viscera to the brainstem, and the spinal afferent pathway, which innervates all abdominal and thoracic organs and enters the spinal cord via the dorsal roots. These pathways have cell bodies in the nodose and dorsal root ►ganglia (DRGs), respectively. The vagal neurones are particularly concerned with the physiological regulation of thoracic and upper abdominal organs and sensations such as satiety, breathlessness and stimuli that elicit cough; whereas the spinal innervation is concerned with pain and other normal sensations as well as some reflex activities; sensations and reflex activities arising within the pelvis are largely dependent upon the ►pelvic nerve. In addition to the visceral afferents with cell bodies in the DRGs or nodose ganglia, the enteric nervous system has sensory neurons with cell bodies embedded within the walls of viscera, and project to efferent neurons in the prevertebral sympathetic ganglia [1,2] (See Fig. 1).

Many events that occur inside the body, such as the beating of the heart or movements of the intestines, occur without any conscious knowledge of their existence. Exceptionally, individuals may become aware of irregularities of their heartbeat (palpitations) or of intestinal activity (colic); many people thankfully go through most of their lives without experiencing visceral pain, because that can be particularly intense and unpleasant. Other common visceral sensations, such as that of a full stomach, a full bladder or the desire to defecate depend on the activity of neurons

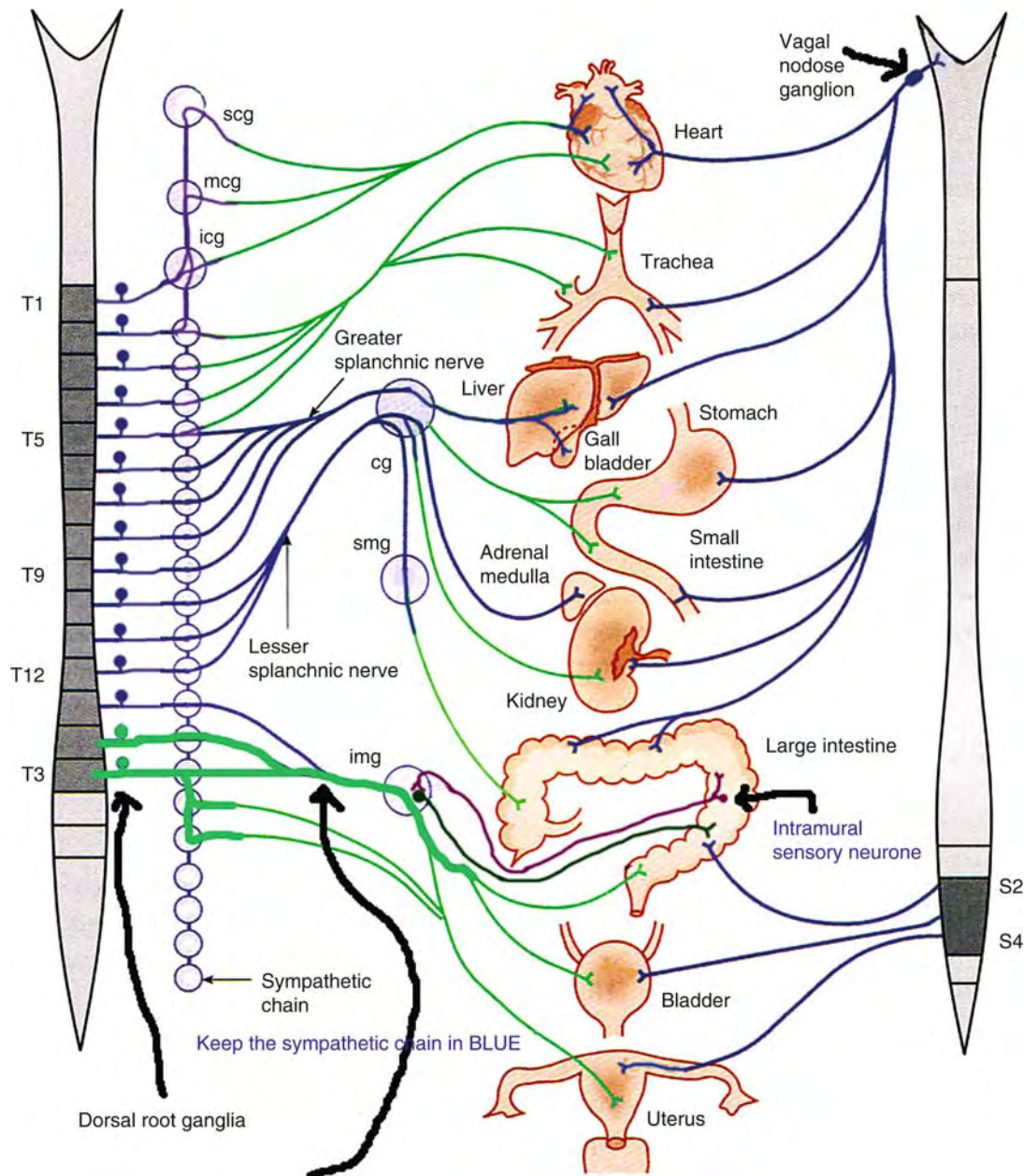

**Visceral Afferents. Figure 1** Diagram of the vagal, spinal and enteric afferent pathways.

that monitor distension or stretch of the walls of the stomach, bladder or rectum. While these may be regarded as warning signs that viscera are nearing a danger limit of distension, some sensations, such as satiety, also depend on afferent signals related to stomach volume and the hormonal changes associated with digestion. Some sensations are pathognomic of particular disorders, and arise from viscera in which there are inflammatory or other physical changes; for example, the substernal burning sensation of heartburn is

associated with gastric acid secretion following food intake, but may indicate the presence of inflammatory or ulcerative changes within the affected tissues. The association between sensations of this type and inflammatory change may be related to sensitization of visceral afferents (see below).

Contractions of the walls of the intestine, ureter, biliary tract or uterus may give rise to spasmodic pains that wax and wane; this colicky pain is most marked when the contractions occur against some obstruction.

Contractions of viscera, however, are not always associated with noxious sensations - entirely the opposite is true during contractions of pelvic organs during an orgasm.

### Lower Level Processes

The vast majority of visceral afferent axons are unmyelinated C-fibers; virtually all the afferents in the abdominal vagus nerve are of this type; a small percentage of spinal visceral afferents are finely myelinated (A $\delta$  fibers). Large myelinated axons are uncommon in visceral nerves, but in some species a few A $\beta$  myelinated axons innervate Pacinian corpuscles in the mesenteries. The spinal visceral afferents innervate the serosal surface and mesenteric or omental attachments of viscera as well as the smooth muscle and mucosal lining of some organs, whereas the vagal afferents innervate mainly the muscle layers and the lining. The spinal visceral system divides into medial and lateral pathways around the dorsal horn to reach the autonomic preganglionic neurons and the area around the central canal. Transmission at these synapses is achieved by glutamate, tachykinins and other mediators e.g., ATP. The vagal afferents terminate in the medulla, in nuclei such as the tractus solitarius.

Neuropeptides are present in the majority of spinal C- and (to a lesser extent) A $\delta$ - afferents, and have an important role to play at both their central and peripheral terminals in neurotransmission and neurogenic edema formation, respectively. The peripheral terminals release tachykinins, Calcitonin Gene-Related Peptide (CGRP) and other mediators, which cause vasodilatation, and increase capillary permeability. In some tissues, e.g., the stomach, the release of neuropeptides (e.g., CGRP) is believed to protect the mucosa against acid attack. The dual function of sensory transducer and neurotransmitter release at these peripheral terminals has sometimes been called a sensory-motor function. This process seems to be associated particularly with capsaicin sensitive C-afferents; capsaicin is a ligand for the TRPV1 receptor, which is also sensitive to protons and to heat. The TRPV1 receptor is present in a subgroup of visceral afferents and appears to be associated with visceral pain pathways (e.g., in the [urothelium](#) and the gastric mucosa); however, knockouts for TRPV1 not only interfere with sensation, but can also show modified physiological reflex responses [3]. A variety of other ligand binding sites can be identified in visceral afferent neurons [4,5].

The electrical properties of visceral afferents determine the impulse traffic in visceral afferents and depend largely on the properties of specific ion channels within their membranes; recent studies in this area focus mainly on the properties of the DRGs of afferents from bladder, colon, heart and stomach. The cell bodies of unmyelinated neurons commonly show TTX-resistant

sodium channels and slow inactivating A-type K<sup>+</sup> channels. The larger neurons of A $\delta$  fibers have lower thresholds to electrical stimulation and have TTX-sensitive sodium channels and fast inactivating A-type K<sup>+</sup> channels. It has been shown that the state of the A-type K<sup>+</sup> channels regulates afferent neuron excitability and the firing properties of the afferents (e.g., the phasic or tonic nature of the excitation during stimulation). High-voltage-activated calcium channels also exist in dorsal root ganglion neurons that innervate the bladder or the colon, and these channels, as well as the A-type K<sup>+</sup> channels, are potential targets in the development of drugs that can modify afferent input in order to control pain or overactive visceral reflexes.

### Process Regulation

Sensitization means that the gain of the mechanosensory transducer is increased following the application of a sensitizing stimulus, and it is one mechanism by which painful states may be exacerbated, and reflex activity increased. Sensitizing stimuli include inflammation of the viscera and the presence of chemical mediators including ATP, nitric oxide and nerve growth factor (NGF; [neurotrophin 1](#)) [6–8]. During chronic inflammation, spinal afferents innervating the bladder or stomach and vagal afferents from the stomach increase the expression of in the Na(v)1.8 TTX-resistant channels; these changes may account for the resting activity and hypersensitivity associated with inflammation or ulceration. Following spinal cord injury (SCI), bladder afferents are also sensitized, a process which is dependent on production of NGF (and other neurotrophins) by these neurons. There is now good evidence that blockade of NGF production or release can reduce the sensitization and prevent the expression of the additional TTX-resistant sodium channels.

Certain mechano-transducer functions, e.g., stretch of the urothelium (the lining of the bladder), appear to be dependent upon a chemical mechanism. ATP may be released by stretching urothelial cells, and can act on P2X2/3 receptors within local nerve endings; it is the latter that determines the intensity of the response. Blockade of the P2X2/3 receptors (or their removal by gene knockout) can reduce considerably the mechanical sensitivity of these afferents, while P2X agonists have the opposite effect; ATP is now recognized as an important mediator in the normal transduction process at this site.

### Functions

The functions for visceral afferents arising from different organs may have specific functions with respect to visceral regulation, or may promote more generalized responses.



The vagus nerve contains afferent fibers that sense physiological changes within the heart, blood vessels, lungs, airways, and the upper gastrointestinal tract. Some vagal (and glossopharyngeal nerve) afferents monitor arterial blood pressure (baroreceptors) and the gaseous elements in the arterial blood (arterial chemoreceptors). The heart has atrial as well as ventricular receptors - the latter occur in the endocardium, muscle and epicardium. Within the lung, different receptors sense the presence of irritants in the airway, the lung volume, the distension of pulmonary capillaries or the presence of inflammatory mediators. Cough and breathlessness (dyspnoea, e.g., in cardiac failure) are subserved by pulmonary vagal afferents, and indicate that some noxious events may be signaled by this route.

Within the upper GI tract, the vagal afferent endings are situated largely within the smooth muscle or the mucosal lining of the viscera. There are several types of mucosal receptor which respond to mechanical stimuli, changes in luminal pH or fatty acid content. Others are excited by the local release of 5-HT or of cholecystikinin (►CCK): there is evidence in humans and animals that some of these intestinal receptors may have a role to play in satiety, possibly because of this relationship of afferent nerve endings with hormone-secreting cells [8].

In ruminants, the sequence of contractions in various parts of the stomach is signaled and regulated by vagal afferents, and normal rumination depends on the integrity of this innervation.

The spinal visceral afferents travel within the sympathetic and pelvic parasympathetic nerves and have their cell bodies in the DRGs. Many of these afferents are excited by mechanical changes in the viscera such as distensions or movements; tension on mesenteries causes intense pain, and many splanchnic nerve afferents innervate the serosal surface of the viscera and the mesenteries or omenta, and are excited by tension on these tissues. There are also reports of intra-abdominal thermoreceptors. The mechanoreceptors often show ongoing activity at rest that can be correlated with visceral movements. Low threshold afferents signal physiological changes within certain viscera, e.g., the bladder, and are also excited by the high pressures within the viscus. In addition, there are high threshold mechanoreceptors that are sometimes regarded as nociceptors; however, injury to viscera is not necessarily an adequate stimulus for visceral pain, and there are a number of well recognized conditions where injury to viscera does not result in pain. There remains some controversy over the nature of the signals that initiate visceral pain, and these may differ between different organs. Some authors have concluded that the encoding of visceral nociceptive events may occur by an intensity mechanism rather than a specificity mechanism (as in the skin), it may be that this is a key difference between viscerosensory and somatosensory processing [9,10].

A third group of spinal visceral afferents are the “silent” afferents, which do not respond to the intensities of stimuli that excite the low or high threshold afferents. However, they develop mechanosensitivity during inflammation. This sensitization is associated with changes in ion channel expression within the neuronal cell membranes (see above).

There are reports that the properties of afferents may be altered by ageing [11].

### Pathology

**Referred Pain.** The pain of gall bladder inflammation is often felt in the right upper quadrant of the abdomen and at the tip of the right shoulder, and this combination of symptoms is of some importance in coming to the correct diagnosis. The underlying mechanism that gives

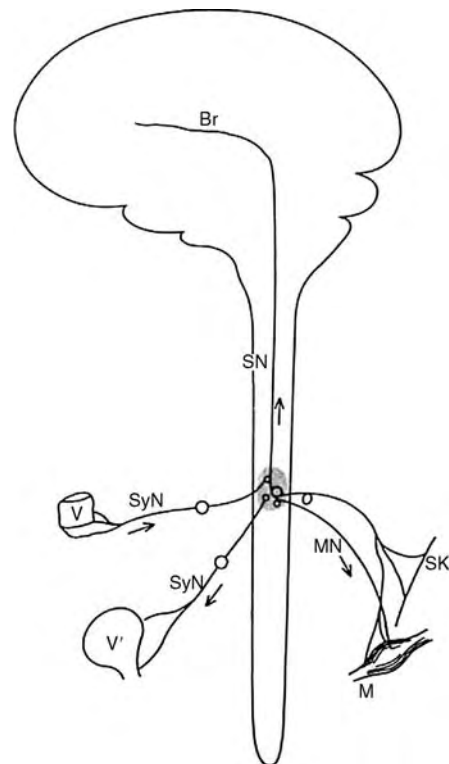

**Visceral Afferents. Figure 2** Mackenzie's concept of the causal relationship between visceral afferent stimulation and referred pain, viscerosomatic and viscerovisceral reflexes (V-V'). Afferent discharge from a viscus (V) is carried by sympathetic nerve trunks (SyN), and then activates a pathway (SN) to the brain (Br) that initiates visceral pain; the pain is located in the somatic areas innervated by this pathway and may be associated with a segmental 'irritable focus' that gives rise to cutaneous hyperalgesia (SK) and changes in somatic muscle tone (M) mediated by motoneurons (MN).

rise to this diverse distribution of symptoms can be understood if one considers the segments of the spinal cord that innervate these areas of the body. The biliary tract is innervated by segments of the spinal cord that also supply the skin and muscle of the right upper quadrant of the abdominal wall, but when inflammation of the gall bladder impinges on the diaphragm it causes afferent input via the phrenic nerve, which arises within areas of the cervical segments that innervate the right shoulder. This idea of the common segmental origin of sensory nerves to all of the regions involved in this inflammatory process is stated in Ruch's Convergence-Projection Theory of Referred Pain. There appear to be no specific visceral sensory pathways in the central nervous system; rather, information concerning events in the viscera is carried from the spinal cord to the brain by neurones that also carry information about events affecting areas of the skin and body musculature innervated by the same segments of spinal cord. A potential confusion of the exact origin of sensation may therefore arise, because sensory inputs received by the brain may have arisen from viscera or skin or muscle, and the origin of these messages may be misinterpreted. Events in the biliary tract give rise to sensation in the right shoulder because the same central neurones transmit messages from both sites. This concept can be extended to sensory inputs from many viscera [12] (see Fig. 2).

Information provided by patients about the location and nature of their visceral pains may be subject to misinterpretation when it is transmitted along spinal pathways normally involved in some other sensory activity.

### Therapy

Most potential new therapies are experimental in nature; however, capsaicin and its analogs have been used in humans to modify afferent sensitivity.

### References

1. Cervero F, Morrison JFB (1986) Visceral sensation. Elsevier, Oxford, pp 1–324
2. Janig W, Morrison JF (1986) Functional properties of spinal visceral afferents supplying abdominal and pelvic organs, with special emphasis on visceral nociception. *Prog Brain Res* 67:87–114
3. Birder LA, Nakamura Y, Kiss S et al. (2002) Altered urinary bladder function in mice lacking the vanilloid receptor TRPV1. *Nat Neurosci* 5:856–860
4. Burdya G, Lal S, Spiller D et al. (2003) Localization of orexin-1 receptors to vagal afferent neurons in the rat and humans. *Gastroenterology* 124:129–139
5. Cockayne DA, Hamilton SG, Zhu QM et al. (2000) Urinary bladder hyporeflexia and reduced pain-related behaviour in P2X3-deficient mice. *Nature* 407:1011–1015
6. Dmitrieva N, McMahon SB (1996) Sensitisation of visceral afferents by nerve growth factor in the adult rat. *Pain* 66:87–97

7. Rong W, Spyer KM, Burnstock G (2002) Activation and sensitisation of low and high threshold afferent fibres mediated by P2X receptors in the mouse urinary bladder. *J Physiol* 541:591–600
8. Feinle C, Grundy D, Fried M (2001) Modulation of gastric distension-induced sensations by small intestinal receptors. *Am J Physiol Gastrointest Liver Physiol*. 280: G51–G57
9. McMahon SB (1997) Are there fundamental differences in the peripheral mechanisms of visceral and somatic pain? *Behav Brain Sci* 20:381–391
10. Habler HJ, Janig W, Koltzenburg M (1990) Activation of unmyelinated afferent fibres by mechanical stimuli and inflammation of the urinary bladder in the cat. *J Physiol* 425:545–562
11. Hotta H, Morrison JF, Sato A et al. (1995) The effects of aging on the rat bladder and its innervation. *Jpn J Physiol* 45:823–836
12. MacKenzie J (1909) Symptoms and their interpretation. Shaw, London, pp 1–297

## Visceral Nervous Function

### ► Ageing of Autonomic/Enteric Function

## Visceral Pain

KLAUS BIELEFELDT

University of Pittsburgh, Department of Medicine, Pittsburgh, PA, USA

### Definition

Visceral pain defines the complex sensory experience of pain arising from viscera within the thoracic, abdominal or pelvic cavity.

### Characteristics

#### Epidemiology

Visceral pain is a common and often chronic problem. Within the United States, it accounts for more than 12 million physician consultations annually. Epidemiologic studies suggest that about up to 50% of surveyed adults complain about pain at the time of the interview, with about one-fifth suffering from some type of visceral pain. In contrast to the documented age-dependent rise in most other types of pain, the prevalence of visceral pain decreases in persons over 60 years of age. Acute pain, such as chest tightness or pressure during cardiac ischemia, generally serves a

physiologically meaningful role, alerting the organism about a potential injury. In contrast, chronic pain is less clearly related to potentially noxious stimuli, does not trigger reactions to avoid harm to the organism, and is, therefore, often considered pathologic. Chronic pain syndromes involving visceral structures are common. In the majority of cases, no structural or biochemical abnormalities can be identified, leading to the diagnosis of a functional disorder, such as irritable bowel syndrome and non-ulcer dyspepsia, which have an estimated prevalence of up to 10% in the general population. As is true for several other chronic pain syndromes, women more commonly report chronic visceral pain than men [see Shinal and Fillingim essay]. While few prospective studies determined the natural history of such disorders, current data suggest that more than 60% of affected individuals will continue experiencing at least intermittent pain or discomfort for more than one year.

### Characteristics of Visceral Pain

Visceral pain is typically poorly localized and referred to distant cutaneous sites. This pattern of pain referral (►referred pain) often helps identifying the underlying problem. For example, upper abdominal pain radiating to the right shoulder blade suggests cholecystitis, while a belt-like radiation to the back points at a potential pancreatic origin. However, as is true for the vague localization of visceral pain, referral patterns overlap between different structures: patients with cardiac or esophageal problems can both experience pain radiating to neck or left shoulder. Visceral sensations and pain also poorly discriminate between different stimulus modalities, as shown in studies examining responses to esophageal distension, which is reported as heartburn by up to one third of healthy volunteers.

In addition to its discriminative power (localization, stimulus modality and intensity), sensory input, especially pain, generally carries an emotional dimension (valence) (see Gracely essay: Emotional Affective Aspects of Pain) Comparison between painful cutaneous and visceral stimuli of similar intensity reveal that visceral pain triggers stronger emotional reactions. Finally, the autonomic responses that characterize pain, such as changes in heart rate or blood pressure, are more pronounced in response to visceral pain and can secondarily affect organ function (e.g. vomiting, diarrhea, fecal urgency), which may further worsen the experience of discomfort and pain.

### Triggers of Visceral Pain

The currently accepted definition of pain refers to a complex sensory experience triggered by injurious or potentially injurious stimuli. This definition is based on its physiological role as an alarming experience that assures survival by leading to appropriate

defensive or withdrawal reactions. Typical triggers of visceral pain are distension of hollow organs (stretch), strong contraction of visceral smooth muscle (tension), stretch or torsion of the mesenteric attachments of abdominal viscera, inflammation or ischemia. In contrast to cutaneous pain, the most common causes of visceral pain, stretch or tension, do not result in damage. Conversely, burning, pinching or cutting of internal organs – all obviously linked to injury or tissue damage – are not painful or not even perceived at all. While varying from organ to organ, the most common causes of visceral pain are stretch, tension or chemical signals generated during inflammation or ischemia (Table 1).

Most experimental approaches investigating mechanisms of visceral pain in humans or animals rely on distension of hollow organs as a reproducible stimulus. Distending pressures exceeding 30 mmHg typically elicit a sensation of pain and/or aversive responses. Human studies have demonstrated enhanced responses to mechanical stimulation in patients with visceral pain syndromes, thus providing evidence that they represent manifestations of visceral hyperalgesia. However, the invasive and time-consuming nature of these tests and their poor correlation with symptoms limit their utility as a diagnostic tool in clinical medicine. Chemical stimuli are less frequently used as experimental triggers of discomfort of pain because repeated stimulus applications and the identification of distinct sensory thresholds can not be performed. In addition, some chemical noxae (e.g. protons) may lead to injury, further arguing against their use as a stimulus in experimental pain research.

### Peripheral Pathways of Visceral Sensation and Pain

The organization of visceral sensory innervation differs from that of other structures in the body insofar as two anatomically distinct sensory pathways convey afferent input to the central nervous system. Most

**Visceral Pain. Table 1** Triggers of visceral pain

Stimulus modality	Physiological correlate	Organ-specific examples
Stretch	Distension	Gastric fullness and bloating
		Pain during ectopic pregnancy
Tension	Muscle contractions	Labor contractions
		Renal colic
Chemical	Tissue acidosis	Ischemic pain (myocardial infarction)
Chemical	Inflammatory mediators	Cystitis, cholecystitis

viscera receive a dual innervation (►[dual visceral innervation](#)) with vagal and spinal afferents extending to thoracic and abdominal organs except for the distal colon and pelvic viscera (e.g. urinary bladder). Two sensory nerves also convey information from the distal colon and pelvic viscera, with thoracolumbar and lumbosacral afferents, respectively. While these distinct sensory pathways share many important properties, important anatomical and physiological differences exist, suggesting differential contribution to conscious perception and pain.

Vagal afferents project via the nodose ganglion directly to the brain stem, where they terminate in the nucleus of the solitary tract. From there, fibers project rostrally to brain structures involved in autonomic regulation, such as the hypothalamus, supraoptic nucleus, and – via the parabrachial nucleus and ventro-medial thalamus – the insular cortex, anterior cingulate cortex and amygdala, areas that regulate arousal and the affective responses to different stimuli including pain. Spinal afferents traverse the prevertebral ganglia, where they may branch and provide afferent input to postganglionic sympathetic neurons. The cell bodies of spinal afferents are located within dorsal root ganglia, where visceral sensory neurons account for less than 10% of the neurons. The central terminations project to superficial and deeper layers of the dorsal horn. Second and higher order neurons send their axons through several ascending pathways (spinomedullary, spinopontine, spinomesencephalic, spinohypothalamic and spinothalamic tracts) (see Giesler essay: Ascending nociceptive pathways) to medullary and higher brain structures, including hypothalamus, thalamus and cortical areas. While most sensory input contributes to autonomic regulation, changes in affect and arousal as described above, spinal afferents – via spinothalamic projections to the dorsolateral part of the thalamus – also provide discriminative input about visceral stimuli to the primary and secondary sensory cortex (see below). In addition to the spinothalamic tract, a post-synaptic dorsal column ascending pathway plays a role in visceral nociception (see Giesler essay: Ascending nociceptive pathways). Surgical or experimental interruption of this pathway results in significant improvement of intractable pain due to pelvic malignancies and abolishes aversive responses to noxious visceral stimuli in experimental models of visceral pain. Current evidence suggests that the dorsal column and spinothalamic tract pathways may differentially contribute to visceral nociception with a more significant role for spinothalamic projections in the autonomic and affective responses triggered by visceral pain.

The properties of the distinct afferent pathways have been investigated *in vivo* and *in vitro*. Using hollow organ distension as the stimulus, most studies have focused on acute responses to mechanical

stimulation. Experiments demonstrated that animals rapidly learned to modify their behavior to avoid gastric distensions to a pressure that typically triggers an aversive response. While vagotomy did not affect these results, transection of spinal afferents through splanchnic nerve resection abolished this effect, suggesting that spinal rather than vagal afferents convey information about acute painful gastric mechanical stimuli. Recordings from teased nerve fibers further supported the role of spinal afferents in visceral pain. Vagal mechanosensory fibers form a relatively homogeneous group with essentially all having a low threshold for activation. While the majority of mechanosensitive visceral afferents projecting to the spinal cord have response profiles similar to vagal afferents, about 20–30% of spinal afferents only respond to high intensity stimuli. The activation threshold falls within the range of stimulus intensities that are perceived as painful and/or trigger aversive responses. Thus, behavioral and physiological data indicate that a specific pathway and perhaps even specific fibers play an important role in visceral nociception (specificity coding). However, most low threshold mechanosensitive fibers encode stimulus intensity well into the noxious range. Thus, it is possible that they contribute to the sensation of pain, if stimulus intensity (i.e. summation of input) rather than the activation of specific “nociceptors” (intensity coding) elicits pain perception.

The two distinct afferent pathways innervating pelvic organs also differ functionally. The majority of colonic afferents within the pelvic nerve respond to low intensity stimulation, particularly stretch, consistent with a role in defecation, which requires input about filling of distal colon and rectum. In contrast, most of the thoracolumbar colonic afferents appear to be located in the mesentery or serosa and only respond to high intensity stimuli, suggesting a potential role in nociception. Similarly, thoracolumbar afferents do not play a significant role in the regulation of micturition under physiologic conditions, but are strongly activated during bladder inflammation.

As already mentioned, the functional distinction of visceral afferents as low or high threshold is based on responses to mechanical stimulation. However, the frequently changing composition of luminal contents and the importance of ischemia and inflammation as triggers of visceral pain clearly highlight the importance of chemical stimuli in visceral sensation and pain. Yet, relatively little is known about the differential contribution of visceral afferent pathways to chemonociception. Considering the acidic environment of the stomach, protons play a potentially important role as triggers of discomfort and pain in gastroesophageal reflux and dyspepsia. Acidic solutions can activate vagal and spinal sensory neurons. Consistent with

these results, obtained in dissociated cells, vagal afferents respond to luminal acidification of esophagus or stomach (Fig. 1).

Using *c-fos* expression as a surrogate marker for neuronal activation, intragastric administration of noxious acidic solutions appeared to selectively activate vagal rather than spinal afferent pathways. Consistent with these findings, vagotomy, but not splanchnic nerve resection blunted responses to infusion of acid into the stomach in rats. These findings suggest that, different from responses to mechanical stimulation, vagal afferents may contribute to chemonociception.

Finally, “silent” nociceptors have been proposed to play a role in triggering painful sensations. By definition, such silent nociceptors are not activated by typical experimental paradigms used to examine sensory neurons. However, exposure to inflammatory mediators or noxious chemicals can acutely alter their properties, making them responsive to mechanical stimuli. Very little is known about the presence and functional relevance of such silent afferents in the gastrointestinal tract. Interestingly, activation of previously silent afferents have been described in the vagus after luminal exposure to bile, again raising questions about a possible role of vagal input in

nociception. However, the paucity of studies does not allow conclusions about the relative contribution of this class of afferents to visceral pain.

### Structure of Primary Sensory Nerve Endings

Visceral afferents often dichotomize extensively in the periphery with several sensory terminations that can span a wide region within a target organ. Anatomical and physiological experiments have demonstrated that a single neuron can project to several receptive fields within the target organ (Fig. 2).

Experiments with retrograde tracers injected into different organs even suggest that a single neuron may innervate two anatomically distinct structures, such as urinary bladder and distal colon or esophagus and heart. However, functional evidence of the existence of neurons projecting to two organs is still lacking. Nonetheless, these findings provide a potential explanation for the poor spatial discrimination of visceral afferent input.

Relatively little is known about structure-function relationship of visceral afferent terminals. Free nerve endings extend toward the epithelium, where they may form some varicosities and can be found in close proximity with specialized epithelial cells that can

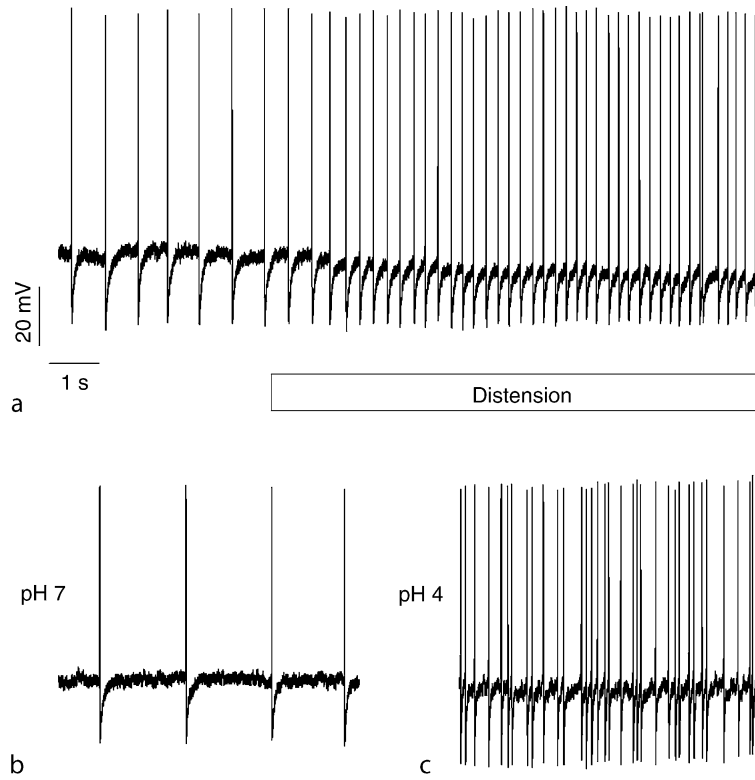

**Visceral Pain. Figure 1** The tracings show intracellular recordings from a nodose neuron innervating the stomach. Gastric distension (a) identified the neuron as mechanosensitive. The baseline activity of this neuron (b) increases significantly after lowering the luminal pH to 4 (c).

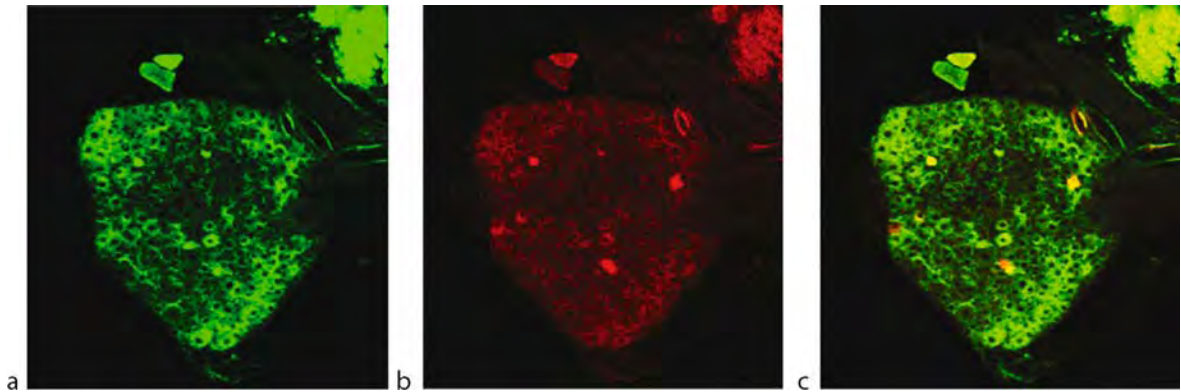

**Visceral Pain. Figure 2** Gastric sensory neurons in the nodose ganglion were identified by injection of different retrograde labels into the fundus and pylorus of the mouse stomach. The differential uptake of labels identifies neurons projecting to fundus (a) or pylorus (b). The merged image (c) shows neurons innervating both areas.

release chemical mediators upon stimulation. These neuro-epithelial interactions have been best characterized in the gastrointestinal tract and urinary bladder. Within the gut, enteroendocrine cells store vesicles containing serotonin and/or a variety of neuropeptides. Luminal stimuli trigger the release of these signaling molecules, which in turn activate nerve endings within the vicinity. Similarly specialized cells have also been documented in the airways and may contribute to chemosensation. In the urinary bladder, distension or chemical stimuli cause release of ATP from epithelial cells, activating primary afferents through interaction with purinergic receptors. In areas covered by squamous epithelium, free nerve endings even project into the epithelial layer itself. Considering the role of such free endings as cutaneous nociceptors, it is likely that these fibers contribute to pain sensation.

In addition to such free endings, some structural specializations of visceral sensory nerve terminals have been identified. Vagal afferents innervating the gastrointestinal tract form intraganglionic laminar endings (IGLE), a branching network of nerve fibers surrounding enteric neurons within the myenteric ganglia, a component of the enteric nervous system. Based on their structure and proximity to punctate receptive fields of mechanosensitive vagal afferents, these IGLEs likely function as mechanosensitive endings and are activated by stretch. Similar structures have recently been described in the distal rectum, which is innervated by spinal afferents. A second structural specialization, intramuscular arrays (IMA), has been described in vagal afferents projecting to the proximal gastrointestinal tract. These branching fibers run parallel to smooth muscle cells. They are more restricted in their distribution and appear to cluster close to sphincteric regions in the foregut, suggesting a role as tension receptors. Currently available information suggests that these receptors are activated by low intensity

stimuli. Thus, it is unclear whether they contribute to the sensation of pain. Recently, varicose branch points or endings have been described in mesenteric and serosal afferents that are only activated by high intensity punctate stimuli. While these results suggest a potential contribution to nociception, additional studies with more physiological stimuli are needed to determine the relevance of these findings.

#### Functional Characterization of Primary Afferents

Different receptor types have been described based on functional characteristics. Within the gastrointestinal tract, some afferent fibers respond to low intensity mucosal stimulation, another group is activated by stretch, and a third group only responds to intense punctate stimuli. Considering these physiologic properties and the preferential location of their receptive fields, these afferents are often referred to as mucosal, muscular and serosal, respectively, although anatomical confirmation of such a restricted localization is still missing. The very low threshold of mucosal afferents argues against a role nociception. While muscular afferents also have low thresholds for activation, they encode stretch over a wide range of stimulus intensities and may thus contribute to pain or discomfort. The high threshold of serosal afferents has been interpreted as an indication of their role as nociceptors. However, the lack of responses to stretch, an important trigger for pain in hollow viscera, argues against such serosal afferents as the sole or even primary source of nociceptive input. Perhaps more importantly, it is difficult to relate the response to high intensity punctate stimuli used experimentally to physiologically meaningful events in the hollow viscera.

Independent of their different responses to different mechanical stimuli, most visceral afferents can also be activated by chemical and/or mechanical stimuli (Fig. 1). Thus, visceral afferents are polymodal

(► **polymodal afferents**), a characteristic they share with a subset of cutaneous nociceptors. This property may explain the poor discriminatory power of visceral input. For example, distension of the distal esophagus may trigger a sensation of heartburn. Similarly, while most individuals describe gastric distension with terms such as fullness, it may lead to epigastric burning or nausea in some persons.

### Neurochemical Properties of Visceral Sensory Neurons

Studies of cutaneous innervation suggest that neurons can be differentiated based on the expression of surface markers, ion channels or neuropeptides by using immunohistochemical techniques. Based on their neurochemical properties, many investigators distinguish two classes of neurons with presumed nociceptive function. Small peptidergic neurons, characterized by the presence of calcitonin gene related peptide (CGRP) or substance P as neurotransmitters, typically express the high affinity receptor for nerve growth factor (NGF) and the non-selective vanilloid receptor TRPV1. Hereditary disorders affecting this population of neurons or experimental destruction of these cells significantly alters responses to noxious stimuli. A second group of cells does not contain neuropeptides, but typically releases ATP as their transmitter and binds the plant lectin isolectin B4 (IB4). All of these ► **neurochemical markers** can be found in visceral sensory neurons. Yet, the utility of CGRP, TRPV1, IB4 or other surrogate markers used to identify nociceptive neurons is questionable for the innervation of the viscera. About 70–80% of spinal neurons projecting to the viscera are peptidergic. However, physiologic experiments reveal that only 20–30% of visceral afferents have high thresholds for mechanical stimuli. Similarly, TRPV1 and IB4 labels the majority of vagal afferents, which do not play a role in pain responses to acute mechanical stimulation (Fig. 3).

Additional studies are needed to identify neurochemical characteristics that distinguish different subgroups of visceral sensory neurons and aid in the detection of nociceptive neurons.

### Physiological Properties of Visceral Sensory Neurons

Electrophysiological studies performed *in vivo* and *in vitro* demonstrate that most visceral afferent neurons exhibit little or no spontaneous activity. Most visceral sensory neurons possess unmyelinated (C-fibers) or thinly myelinated axons (A $\delta$  fibers) with slow conduction velocities. Thus, based on conduction velocity, visceral afferents resemble cutaneous nociceptors. About 50–60% of vagal and spinal sensory neurons projecting to the viscera generate action potentials with a distinct hump during the falling phase – a property often attributed to the expression of tetrodotoxin (TTX) resistant voltage-dependent sodium channels (Fig. 4) (see Gold essay: Voltage-gated channels and pain).

This interpretation is consistent with the presence of TTX-resistant spikes in more than half of the visceral sensory neurons studied *in vitro*, which again is similar to findings obtained in recordings from cutaneous nociceptors. However, the majority of visceral afferent fibers can be activated by low intensity stimuli, which do not trigger aversive responses or pain, demonstrating again the limited utility of applying commonly used criteria defining nociceptive neurons to the visceral innervation.

A series of studies has demonstrated the importance of purinergic receptors in normal visceral function. As mentioned above, bladder distension triggers ATP release from the epithelium and triggers micturition through activation of P2X receptors. While initially thought to be important in regulating visceral function, the P2X family of ligand-gated ion channels play an important role in pain. Considering the role of P2X receptors in urinary bladder function, several studies have examined the contribution of purinergic signaling in visceral sensation and pain. While only a small fraction of cutaneous neurons express P2X receptors, the majority of bladder afferents and about one third of gastrointestinal afferents innervating stomach, small intestine or colon respond to P2X receptor agonists. Visceral inflammation is associated with an increased ATP release from the epithelium, suggesting a potential contribution of enhanced purinergic signaling in

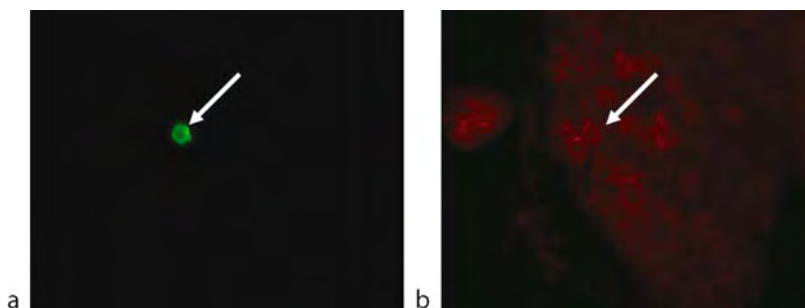

**Visceral Pain. Figure 3** Gastric mechanosensory neuron was directly labeled by intracellular injection of neurobiotin (a). The same neuron (arrow) also expresses TRPV1 immunoreactivity (b).

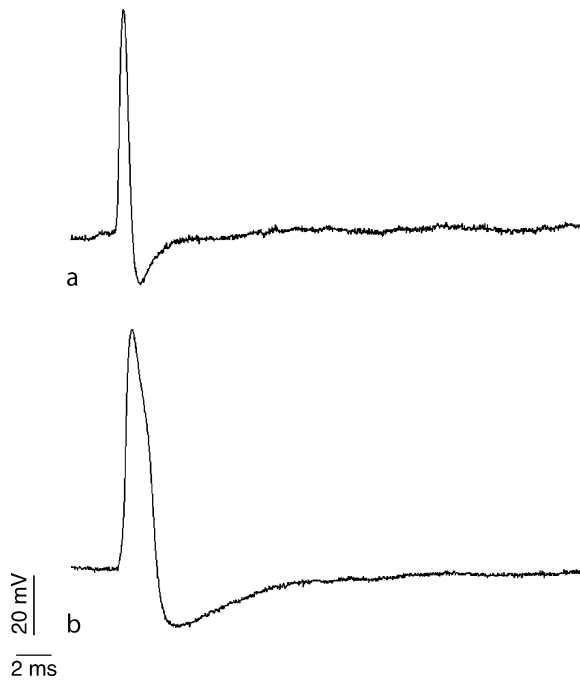

**Visceral Pain. Figure 4** The tracings show action potentials from nodose neurons innervating the stomach. The action potential shape differs significantly between the two tracings with panel B showing a broader spike with distinct hump during the falling phase.

visceral hypersensitivity. Finally, a selective P2X receptor antagonist blunted the behavioral changes in response to intraperitoneal injection of acetic acid. Thus, current evidence supports the importance of purinergic signaling in normal visceral function and a potential role in the development of visceral pain.

Considering the role of protons during ischemia, inflammation and the high proton concentration within the proximal gastrointestinal tract, many studies investigated mechanisms of acid-sensation in visceral sensory neurons. Essentially all visceral sensory neurons studied respond to protons through activation of different acid sensitive ion channels. The fraction of responsive neurons and the properties of acid-sensitive ion currents recorded in visceral sensory neurons differs from unlabeled dorsal root ganglion neurons, most of which likely innervate skin, muscle or joint structures. Several different ion channels have been proposed to contribute to these proton-gated currents. Considering their homology with mechanosensory channels in helminthes, members of the family of acid sensitive ion channels (ASICs) may function as molecular sensors for chemical (acid) and mechanical stimuli. Functional and immunohistochemical studies demonstrate that most visceral sensory neurons express different ASICs. The properties of acid-sensitive

currents differ significantly between groups of visceral sensory neurons, pointing at distinct physiological roles. For example, higher proton concentrations are required to activate transient inward currents in nodose ganglion (vagal) compared to dorsal root ganglion neurons innervating the stomach. Data on the importance of these channels in visceral sensation are just emerging and show a complex picture: Loss of ASIC1 is associated with an increase in responses to mechanical stimulation of gastro-esophageal and colonic afferents. Within the gastrointestinal tract, loss of ASIC2 increased responses of gastric mucosal, but decreased those of muscular afferents. ASIC3 knockout mice showed an impaired visceromotor response to colonic distension and decreased activation of tension receptors in stomach and colon. As ASICs form heteromultimers, changes in the molecular makeup of these channel complexes may explain the disparate effects of selective gene knockouts. Thus, current data support an important role for ASICs in visceral mechanosensation.

Members of the TRP (transient receptor potential) family of ion channels, a group of non-selective cation channels first identified in drosophila, play a role in osmosensory and mechanosensory function in *C. elegans* neurons. Several members of this family have been identified in mammalian neurons, where they are activated by temperature, protons and/or a variety of algogenic substances, such as capsaicin or mustard oil. Most studies addressing the role of these channels in visceral sensation focused on TRPV1, the capsaicin receptor. However, other members of this channel family are also expressed in visceral sensory neurons. About 70–80% of neurons projecting to stomach, small bowel or colon respond to capsaicin, a pungent vanilloid that activates the TRPV1 receptor, which can also be activated by protons. These data are in line with results using immunohistochemical techniques to examine the expression of TRPV1 in visceral sensory neurons described above. Several recent studies suggest that TRPV1 channels are involved in visceral mechanosensation with knockout mice showing blunted responses to mechanical stimulation of bladder, jejunum and colon. Interestingly, the satiety factor oleoylethanolamide activates TRPV1 channels in vagal neurons and decreases food intake in mice.

TRPV1 and other members of the TRP family may play an important role in the plasticity of primary afferent neurons. Chemicals released during inflammatory processes, such as serotonin, bradykinin, nerve growth factor, proteases or ATP, alter the function of TRPV1 receptors. In colon sensory neurons, serotonin shifts the temperature-activation function of TRPV1 to lower temperatures, leading to inward currents and action potential activation around the normal body temperature, a mechanism that may contribute to sensitization of visceral afferents during inflammation.



In addition, inflammation alters the expression of this ion channel, thereby further increasing excitability.

### Peripheral Sensitization and Visceral Pain

Similar to nociceptors, primary afferents innervating the viscera exhibit significant functional plasticity. Different stimulus modalities may interact and acutely sensitize neurons to concomitant or subsequent stimulation. For example, prior administration of heated or acidic solution into esophagus or stomach sensitizes these organs to subsequent distending stimuli. In addition, inflammation or exogenous application of inflammatory mediators or cytokines can alter the physiological properties of visceral sensory neurons, increasing responses to different stimuli. These enhanced responses are due to changes in the expression and/or function of ion channels involved in signal transduction (e.g. TRPV1, members of the ASIC family and purinergic receptors described above) and channels determining excitability (e.g. voltage-sensitive sodium channels, transient potassium current). Mediators and mechanisms of [▶peripheral sensitization](#) largely resemble those described for skin or other organs. Considering the role of growth factors in neuronal development and function, many studies have investigated their potential contribution to visceral hypersensitivity. Nerve growth factor (NGF) has been studied most extensively. NGF levels increase during visceral inflammation associated with enhanced responses to visceral stimulation. Neutralization of NGF through antibodies blunts the development of visceral hypersensitivity while transient NGF overexpression through viral gene transfer mimics the effect of inflammation.

Despite these similarities, differences exist between cutaneous and visceral afferents. Prior studies demonstrate that only the subgroup of cutaneous afferents thought to contribute to nociception sensitize in response to inflammatory mediators. In contrast, essentially all visceral afferents can sensitize, thus suggesting that they all may contribute to enhanced input to the central nervous system in pathologic states that may result in the sensation of pain. Consistent with these considerations, patients with dyspeptic symptoms due to hypersensitivity not only complain about increased pain intensity during gastric distension, but also report greater sensations of bloating, nausea or fullness during stimulation, arguing against a selective modulation of nociceptors alone in human disease.

Studies of patients with chronic pancreatitis provide important support for the clinical significance of peripheral sensitization in visceral pain. Pain is a typical characteristic of this often debilitating disease and at times leads to surgical interventions, including total resection of the organ. Detailed investigations of tissue samples obtained during such operations demonstrate significant alterations of peripheral nerves. In

patients with pancreatitis, large neuroma-like nerve bundles surrounded by inflammatory cells are seen. In addition, the expression of neuropeptides, their receptors and growth factors and their receptors is increased in chronic pancreatitis. Thus, pain correlates with structural and functional changes of peripheral nerves that are consistent with findings obtained in animal experiments of human disease.

### Central Pathways of Visceral Sensory Input

Central terminations of primary afferents arborize extensively within the central nervous system and may synapse with many second order neurons. Within the spinal cord, these central processes may extend over several segments in the rostro-caudal axis and even cross the midline. The wide distribution of visceral afferent input is yet another factor for the poor spatial discrimination of visceral sensation. Visceral afferents primarily project to the superficial spinal laminae (laminae I and II), the area around the central canal (lamina X) and the deeper lateral spinal grey (lamina V). Stimulation of primary afferents leads to excitatory synaptic input in all second and most higher order spinal neurons. Vagal afferents project directly into the brain stem with most central terminations ending in the nucleus of the solitary tract, which shows some organotypic organization. Most second order neurons within the central nervous system encode visceral input over a wide range of intensities (wide dynamic range neurons). A small number of spinal neurons is only activated by mechanical stimulation in the noxious range, suggesting a potential role in nociception.

Essentially all second order neurons within the spinal cord also receive converging input from other viscera as well as somatic structures. This viscerosomatic and viscerovisceral convergence explains the referral of painful visceral sensation to other, often distant body regions. Typical examples are the pain in the left shoulder and left arm during myocardial ischemia and the right-sided back and shoulder pain in biliary disorders. Such referral due to convergent input appears to be unidirectional in humans, meaning visceral stimuli trigger a somatic sensation rather than somatic stimuli causing a perception of visceral changes. While no correlate has been described in humans, recent studies using experimental models of human disease suggest that skin or muscle injury can indeed trigger visceral hypersensitivity in animals.

Glutamate is the primary fast transmitter released from afferent neurons in spinal cord and brain stem. Several ionotropic and metabotropic glutamate receptors have been identified in the spinal cord and the nucleus of the solitary tract, where they play an important role in mediating excitatory synaptic potentials and modulating synaptic signal transmission through pre- and postsynaptic mechanisms. Experiments in animals and human

volunteers clearly demonstrated the importance of glutamate receptors, as inhibitors of NMDA and non-NMDA receptors block visceral sensation and pain. The high fraction of peptidergic neurons innervating the viscera suggests a special role of peptide release in visceral sensation and pain. Most studies have focused on substance P and neurokinin (NK) receptors, which are activated by substance P. Consistent with a role for substance P, noxious colorectal distension triggered internalization of NK1 receptors, which is increased in animals with colonic hypersensitivity. Neurokinin receptor antagonists and substance P or neurokinin receptor knockout mice show altered responses to visceral or cutaneous pain. However, despite these encouraging preclinical findings, testing neurokinin 1 receptor antagonists in humans has not shown convincing analgesic effects.

### Cortical Representation of Visceral Pain

The development of non-invasive techniques such as positron emission tomography or functional magnetic resonance imaging (see Tracey essay: Pain Imaging) allows detailed investigations of human brain activity in response to different visceral stimuli. Most studies focused on hollow organ distension as a mechanical stimulus that may be perceived as painful but does not cause injury. Consistent with bilateral organ innervation, stimulation of esophagus, stomach, colon or bladder activate both cerebral hemispheres. Painful stimuli typically activate several cortical and cerebellar structures, often referred to as the pain matrix. These include the insula, the cingulate cortex and, in many studies, the prefrontal cortices. In contrast to cutaneous pain, visceral pain does not consistently activate the primary sensory cortex. In addition, visceral stimulation preferentially activates the perigenual portion of the anterior cingulate cortex, which is not as clearly associated with other experimental pain states. This region has been implicated in the regulation of affect, thus providing a possible structural basis for the observation that visceral pain elicits stronger emotional response compared to noxious cutaneous stimulation.

### Descending Modulation of Visceral Pain

Cortical and lower centers within the brain do not only receive and process input, they also modulate signaling in the spinal cord through descending pathways, which can facilitate or inhibit transmission (see Mason essay: Descending modulation of nociception). Cortical structures, primarily the anterior cingulate cortex, project via the periaqueductal grey to brainstem structures, primarily the rostralateral ventral medulla, which sends processes to the spinal dorsal horn. In experimental animals, electrical or chemical stimulation of these areas significantly alters responses to noxious stimulation. Current evidence suggests that this inhibitory influence, mediated

in part by opioid receptors, predominates under physiological conditions and may contribute to the development of chronic pain in several disorders, including functional visceral pain syndromes.

### Central Sensitization and Visceral Pain

Increased sensitivity to noxious stimuli (hyperalgesia) is a hallmark of many structural and functional disorders affecting the viscera. Repetitive stimulation using a single stimulus modality (e.g. distension) or sequential administration of two different stimulus modalities (e.g. luminal acid administration followed by electrical stimulation of the esophagus) leads to a decrease in pain threshold and a parallel increase in the area of cutaneous pain referral, clearly proving involvement of central rather than peripheral mechanisms. Most experiments focus on the effects of visceral hyperalgesia on cutaneous referral patterns. However, several recent studies suggest that at least in animals, cross-sensitization can be bidirectional with sensitization of cutaneous or muscular afferents triggering visceral hypersensitivity in organs with sensory innervation converging to the same segment of the spinal cord. Administration of ketamine blocks the development of hyperalgesia, suggesting a role for NMDA receptors in the development of **central sensitization**, which is consistent with the known importance of NMDA receptors in synaptic plasticity (see Sandkühler essay: Synaptic long-term potentiation (LTP) in pain pathways).

Interestingly, acute sensitization through luminal acid exposure of the duodenum also lowers thresholds to esophageal stimulation. This effect on two distant organs with limited overlap in sensory innervation cannot be explained through spinal mechanisms. Additional evidence supports the importance of supraspinal sites in regulating visceral sensory function. Epidemiological studies have demonstrated the frequent coexistence of disorders characterized by chronic pain. For example, the majority of patients with irritable bowel syndrome suffer from other disorders characterized by chronic pain or discomfort without underlying structural or biochemical changes. The common association with mood disorders and a high prevalence of early childhood abuse or stressful life events in this patient population indicate that psychological factors contribute to the pathogenesis of these disorders. Such situations have been mimicked experimentally through maternal separation, water avoidance stress or neonatal colonic injury, which trigger visceral hypersensitivity in susceptible rodent strains. Current evidence suggests that decreased inhibitory modulation of afferent input plays an important role in mediating visceral hypersensitivity. Using heterotopic stimulation, several groups have shown differences in processing of painful stimuli between healthy controls and patients suffering from chronic pain syndromes. This paradigm

relies on intermittent application of painful stimuli during ongoing presence of an unpleasant stimulus at a second, distant site (hence heterotopic stimulation). While normal volunteers rate the intensity of visceral stimuli lower in the presence of the heterotopic stimulus, patients with irritable bowel syndrome rank the visceral stimulus similarly under the two experimental conditions. As the intensity of the visceral stimulus is equal for both groups and both conditions, differences in perception have been attributed to differences in descending modulation.

### Clinical Manifestations of Visceral Pain

Pain is a complex sensory and emotional experience that typically triggers responses to protect the organism from impending harm. While visceral pain clearly meets this definition, it nonetheless is distinct from pain caused by a noxious cutaneous stimulus. The source is not visible, and withdrawal from or removal of the source of potential injury are not possible. Under normal conditions, visceral sensory input rarely reaches the level of conscious perception. However, the ascending sensory information reaches brain structures and contributes to the regulation of organ function. Thus, visceral input that triggers pain also triggers changes in autonomic function, which further exacerbate its unpleasant or subjectively threatening impact. For example, dyspnea often accompanies cardiac pain; nausea is commonly associated with gastrointestinal pain; patients with cystitis typically complain about significant urgency. Verbal descriptors reflect this difference as healthy volunteers use more terms of unpleasantness in response to visceral compared to similarly intense cutaneous stimuli.

While acute visceral pain correlates quite well with abnormal function or potential injury, most chronic visceral pain syndromes are characterized by the defining pain and an association with other symptoms, indicating altered visceral function, but no identifiable structural or biochemical abnormalities. They are characterized by discomfort or pain in response to innocuous stimuli and as such represent a state of visceral hypersensitivity (Table 2). They often coexist in one individual or are associated with other chronic pain states, such as headaches, low back pain or fibromyalgia and/or mood disorders. Finally, brain imaging studies all show increased comparable activation of areas associated with processing of visceral pain and affect, consistent with patient reports about discomfort and pain.

Many different mechanisms have been implicated in their pathophysiology. Current evidence suggests that both peripheral and central sensitization contribute to the pathogenesis of these disorders. Up to one third of individuals suffering from irritable bowel syndrome or functional dyspepsia recall an acute illness, such as infectious gastroenteritis, prior to the onset of their

**Visceral Pain. Table 2** Common visceral pain syndromes

Syndrome	Pain location	Associated symptoms
Functional dyspepsia	Epigastrium	Postprandial fullness Bloating Nausea
Irritable bowel syndrome	Lower abdomen	Diarrhea and/or constipation Bloating
Interstitial cystitis	Suprapubic area	Dysuria Increase micturition frequency
Chronic Pelvic Pain	Sacral/pelvic	Sexual dysfunction

chronic disorder. Current evidence suggests that an acute episode of gastroenteritis increases the relative risk about sevenfold for development of irritable bowel syndrome. Thus, acute inflammation presumably sensitizes primary afferents, which has been shown repeatedly in animal experiments, and likely causes central sensitization as well, with both processes contributing to the development of hypersensitivity that persists after resolution of the initial injury/inflammation. While conventional investigations do not show overt inflammation, several subtle changes have been identified. Interestingly, increased mast cell numbers have been found in the mucosa of patients with irritable bowel syndrome and interstitial cystitis. These mast cells are often seen in close proximity to nerves. Mast cell stimulation can activate the release of several mediators, such as histamine or tryptase, which may directly activate primary afferent neurons. The potential importance of such a mechanism is supported by experiments that measured mediator release from colonic biopsies, showing higher levels for prostaglandin, tryptase and histamine release in patients with irritable bowel syndrome compared to healthy controls.

Yet, peripheral mechanisms are clearly not sufficient to explain the chronic course that characterizes many of these visceral pain syndromes. Preexisting psychiatric disorders, primarily anxiety, are an important predictor for the development of functional dyspepsia or irritable bowel syndrome after an episode of acute gastroenteritis, suggesting an important role of psychological mechanisms. Several conceptual models have been proposed to explain the development and frequent coexistence of these functional pain syndromes. Biological models are based on the assumption that an inciting peripheral event, such as an acute gastroenteritis, sensitizes peripheral afferent pathways which secondarily alter central processing, leading to persistent symptoms after apparently complete

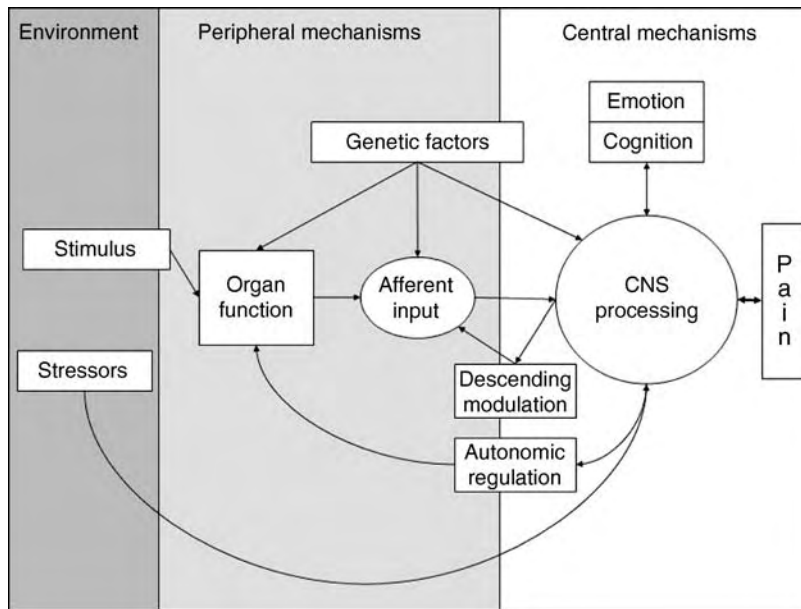

**Visceral Pain. Figure 5** Conceptual model summarizing factors contributing to the development of visceral pain syndromes.

resolution of the initially triggering event. This model integrates psychological and environmental factors as important modulators that affect sensory processing in the brain (Fig. 5).

An alternative, exclusively psychological model invokes a primarily central mechanism, hypervigilance, with focused attention on visceral input. Stress and cognitive factors clearly play a key role in both models, which is consistent with reported exacerbations during or after stressful life events. Activation of the hypothalamic-pituitary adrenal axis with increased cortisol levels have been identified in patients with chronic visceral pain syndromes. Psychological or pharmacological interventions have successfully targeted these modulating or triggering factors. For example, antagonists of the corticotropin releasing factor receptor 1 alleviate symptoms in patients with irritable bowel syndrome.

### Summary

Experimental and clinical data clearly demonstrate that visceral pain has unique characteristics. Generally, visceral pain is triggered by stimuli that do not cause tissue injury. Conversely, truly noxious stimuli may not be perceived as painful. Despite their complex innervation with two anatomically and functionally distinct afferent pathways, the innervation density of visceral structures is low. This relatively sparse innervation and the polymodal nature of visceral afferent neurons likely contribute to the limited ability to accurately identify visceral stimuli. While vague and poorly localized at the site of origin, visceral pain

is typically referred to distant structures (referral pain). Most visceral input is not consciously perceived, but provides feedback for autonomic regulation of organ function. However, essentially all visceral afferents can sensitize in response to injury or inflammation. Thus, the enhanced activity of such low threshold visceral afferents may directly or indirectly (i.e. through secondary changes in organ function) contribute to unpleasantness or even pain perceived during disease states. Central processing of visceral input and pain involves structures that are important in affective responses, providing a basis for the higher emotional valence of visceral sensation and pain. The perception of painful stimuli is altered by stressors, affective and cognitive factors all of which are important causes for the development and potential targets for the treatment of chronic visceral pain syndromes.

### References

1. Blackshaw LA, Brookes SJH, Grundy D, Schemann M (2007) Sensory transmission in the gastrointestinal tract. *Neurogastroenterol Motil*:19:S1–S19; Summary of peripheral mechanisms contributing to visceral sensation and pain
2. Jones RCW III, Xu L, Gebhart GF (2005) The mechanosensitivity of mouse Colon afferent fibers and their sensitization by inflammatory mediators require Transient receptor potential vanilloid 1 and acid-sensing ion channel 3. *J Neurosci* 25:10981–10989; Experimental evidence supporting a role of two distinct ion channels in mechanosensation and development of peripheral sensitization within the gastrointestinal tract

3. Spiller RC (2003) Postinfectious irritable bowel syndrome. *Gastroenterology* 124:1662–1671; Analysis of clinical evidence linking transient visceral inflammation to the onset of functional disorders associated with pain.
4. Ness TJ, Gebhart GF (1987) Characterization of neuronal responses to noxious visceral and somatic stimuli in the medial lumbosacral spinal cord of the rat. *J Neurophysiol* 57:1867–1892; Detailed physiological characterization of second order visceral afferents and convergent somatic input in the spinal cord
5. Willert R, Wolf CJ, Hobson A, Delaney C, Thompson D, Aziz Q (2004) The development and maintenance of human visceral pain hypersensitivity is dependent on the *N*-methyl-D-aspartate receptor. *Gastroenterology* 126:683–692; Psychophysical experiments in humans examining mechanisms of central sensitization.
6. Strigo IA, Bushnell MC, Boivin M, Duncan GH (2002) Psychophysical analysis of visceral and cutaneous pain in human subjects. *Pain* 97:235–246; Experimental data obtained in human volunteers demonstrating unique characteristics of visceral sensation and pain
7. Vandenbergh J, Vos R, Persoons P, Demyttenaere K, Janssens J, Tack J (2005) Dyspeptic patients with visceral hypersensitivity: sensitisation of pain specific or multimodal pathways? *Gut* 54:914–919; Detailed physiologic characterization of patients with functional visceral pain arguing against selective changes of nociceptive signaling (specificity theory) in the pathogenesis of chronic visceral pain syndromes
8. Zhuo M, Gebhart G (2002) Facilitation and attenuation of a visceral nociceptive reflex from the rostroventral medulla in the rat. *Gastroenterology* 122:1007–1019; Experimental studies examining spinal modulation of visceral input through descending pathways
9. Whitehead W, Palsson O, Jones K (2002) Systematic review of the comorbidity of irritable bowel syndrome with other disorders: what are the causes and implications? *Gastroenterology* 122:1140–1156; Summary of our current understanding related to prevalence of different pain syndromes in patients with functional pain disorders and the potential implications on underlying mechanisms
10. Hobson AR, Aziz Q (2004) Brain imaging and functional gastrointestinal disorders: has it helped our understanding? *Gut* 53:1198–1206; Review of our current understanding of central processes of visceral pain including description of investigational methods

## Visceral Referred Pain

### Definition

Pain resulting from noxious stimulation of a visceral organ that is referred to somatic structures innervated by the same spinal segments as the diseased organ, is referred to proximal and axial body areas but generally not distal limbs, and is generally felt as a deep, but not superficial or cutaneous pain.

- ▶ Referred Pain
- ▶ Viscero-Somatic Reflex

## Visceral Reflexes

- ▶ Visceral Afferents

## Visceral Sensation

- ▶ Visceral Afferents

## Visceral Stimuli

### Definition

Stimuli applied to the gastrointestinal track including mechanical pressure, chemical and thermal stimuli. They are characterized by poor localization, tonic increases in muscle tone and autonomic responses including alterations in respiration, heart rate and blood pressure.

## Viscero-cardiovascular Reflexes

- ▶ Cardiovascular Reflexes

## Viscero-Somatic Reflex

ROBERT D. FOREMAN

Department of Physiology, University of Oklahoma Health Sciences Center, Oklahoma City, OK, USA

### Definition

Viscero-somatic reflex or reflexes usually occur when a diseased visceral organ initiates the transmission of information in afferent nerves (Fig. 1).

This information is relayed and expressed in somatic structures after making synaptic connections

in the spinal cord. The status of neuronal activity within the spinal cord, depending on a variety of stressors, may contribute to the somatic symptoms. These viscerosomatic reflexes commonly affect somatic structures, particularly muscle, in the same segment that receives afferent input from the diseased visceral structure, but can affect somatic areas that are distant from the diseased structure. “Referred pain” is a form of a viscerosomatic reflex. The cardiac-somatic motor reflex will be used in this essay as a prototype of a viscerosomatic reflex.

## Characteristics

### Quantitative Description

Referred pain is a classic symptom of diseased visceral organs. Angina pectoris resulting from cardiac disease will be used to describe the role of a viscerosomatic reflex. Muscle contractions produced during activation of cardiac afferent fibers by injecting noxious chemicals into the pericardial sac can be another source of cardiac pain [1,2]. In this model of muscle-related referred pain (►Visceral referred pain), visceral evoked muscle contractions increase muscle afferent activity, which converges on neurons also receiving input from cardiac afferent fibers, to generate angina-like referred pain. Episodes of angina pectoris resulting from ischemic episodes often cause a deep, muscular-like, incapacitating pain [3] in patients with infarcted hearts. In addition to the muscle pain, patients also exhibit increased tone of the upper thoracic ►paraspinal muscle [4].

### Lower Level Processes

Noxious chemical stimulation of the heart (►Noxious (Allogenic) Chemical Stimulation of the Heart) activated cardiac afferent fibers. A description of the visceral afferent fibers is given in an accompanying essay of this Encyclopedia.

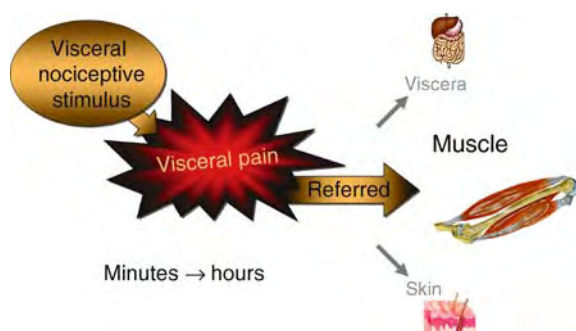

**Viscero-Somatic Reflex. Figure 1** A schematic figure describing the events that occur when a visceral nociceptive stimulus elicits referred pain to the somatic structures, particularly muscle. The events can occur from minutes to hours. This figure represents a form of viscerosomatic reflexes or motor reflexes.

Single unit potentials and compound motor action potentials were the most common motor unit discharge patterns identified from EMG records that were evoked by noxious chemical stimulation of cardiac afferent fibers. Most of the single-unit patterns lasted >75 s, with amplitudes that were <150  $\mu\text{V}$  in response to noxious stimulation of the heart (Fig. 2a and c).

The EMG records also contained many compound motor action potentials; each compound potential is the sum of multiple single-unit potentials. These discharges represent the process of motor recruitment, and are described as the complex pattern (Fig. 2b). Most of the complex patterns lasted <75 s, and the amplitudes of the potentials were >150  $\mu\text{V}$ .

### Process Regulation

The prototype for the process regulation of the viscerosomatic reflex was to examine muscle responses to noxious chemical stimulation of the heart. The regulation was determined by generating ►spasm-like electromyography (EMG) activities in response to noxious

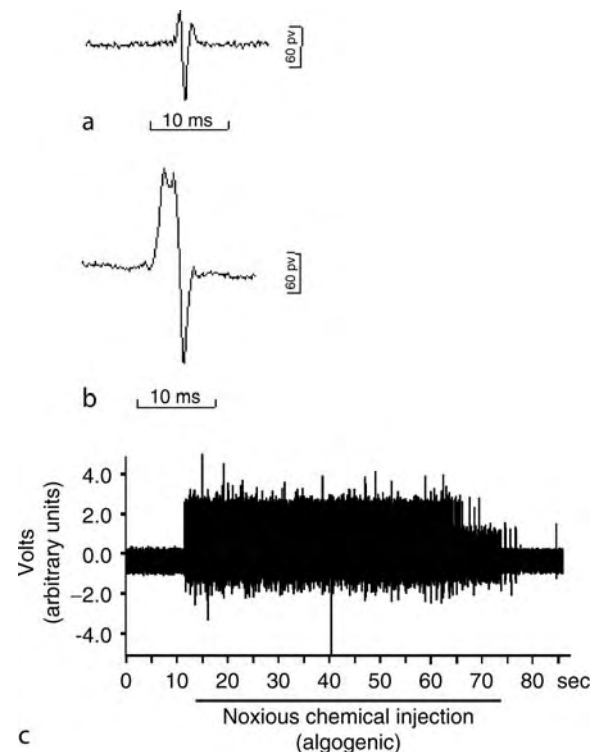

**Viscero-Somatic Reflex. Figure 2** Chemical-evoked EMG waveforms and discharge patterns. (a) Waveform of a single-unit potential. (b) Waveform of a compound motor action potential from a complex pattern. (c) Raw tracing of EMG activities when algogenic chemicals were injected into the pericardial sac to activate cardiac afferent fibers. The bar underneath the seconds indicates the time that the chemicals remained in the pericardial sac (Adapted from [1,2]).

chemical activation of afferent fibers innervating the heart [1,2]. The afferent pathways of the cardiac-motor reflexes were identified, and their functions were described as they related to cardiac **nociception**. The paraspinal muscles (spinotrapezius) were chosen to

measure EMG activities because of the increased tonicity of the upper cervical and thoracic paraspinal muscles that have been palpated in cardiac patients [4]. Information transmitted via the sympathetic and the vagal afferent fibers contributed to changes in EMG activities (Figs. 3 and 4).

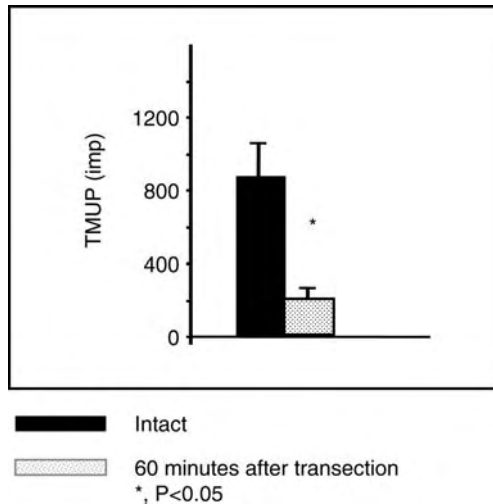

**Viscero-Somatic Reflex. Figure 3** Effects of left sympathetic chain transection on algogenic mixture-evoked EMG activities. The solid bar is the total motor unit potentials (TUMP) that were generated when algogenic chemicals were injected in the pericardial sac for 60 sec. The hatched bar represents the TUMP that were produced by the intrapericardial injections of the chemicals 60 minutes after transecting the left thoracic sympathetic chain (Adapted from [2]).

### Differentiation of the Afferent Pathways Sympathetic Cardiac Afferent Fibers

Injections of noxious chemicals into the pericardial sac activated cardiac sympathetic afferent fibers that significantly increased the total motor unit potentials, latency of response, peak rate of discharge and duration of the response of the paraspinal (spinotrapezius) EMG activities (Fig. 3). However, transections of sympathetic afferent fibers in the sympathetic chain significantly reduced the total motor unit potentials (Fig. 3). In addition, electrical stimulation of the left sympathetic chain excited afferent fibers that always evoked EMG activities.

### Vagal Cardiac Afferent Fibers

Electrical stimulation of either the left or right vagal afferent fibers did not generate any EMG activities; however, stimulation with the same parameters of either of these vagus nerves suppressed the EMG activities, when they were evoked by injecting the noxious chemicals into the pericardial sac. However, noxious chemical stimulation of the cardiac afferent fibers significantly increased the total motor unit potentials, the peak response and the duration of the response of the evoked EMG activities after performing bilateral vagal transection (Fig. 4).

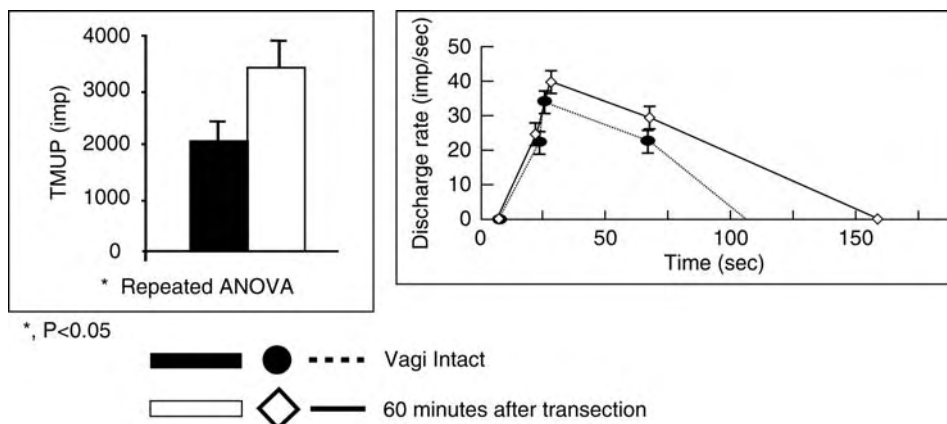

**Viscero-Somatic Reflex. Figure 4** Algogenic mixture-evoked EMG activities before and after bilateral cervical vagal transection. Left Panel: The solid bar represents the total motor unit potentials (TUMP) produced by the intrapericardial injections of algogenic chemicals for 60 sec. The open bar is the TUMP to intrapericardial injections after bilateral vagotomy. Right Panel: The discharge rate of the EMG activities in response to intrapericardial injections of algogenic chemicals for 60 sec. before vagotomy is represented by the dashed line and filled circles. The discharge rate after vagotomy is represented by the solid line and open diamonds. (Adapted from [2]).

### Persistence of the Evoked Response of EMG Activities

The EMG activities often persisted even after the noxious chemicals were withdrawn and the heart was repeatedly flushed with saline. Sensitization of peripheral and central mechanisms might play a role that contributes to protracted motor discharges.

### Function

Muscle contractions generated by noxious chemical stimulation of cardiac receptors have characteristics resembling muscle spasms. The amplitude of motor unit potentials and duration of the motor recruitment of the cardiac-evoked EMG activities have many similarities to EMG activities recorded from ischemic, fatigued, and painful muscles [5]. The similarities lead to the suggestion that the increased EMG activity evoked by algogenic chemicals is a type of reflexive muscle spasm. Clinical studies also provide evidence that support the transition from muscle contraction to muscle pain. The intensity and duration of the pain is dependent on the activity being transmitted in sympathetic and vagal afferent fibers during noxious chemical stimulation of their receptors in the heart (Fig. 5).

### Sympathetic Cardiac Afferent Fibers in Cardiac-Motor Reflexes

The functional relevance resulting from activation of sympathetic cardiac afferent fibers to evoke spinothoracic contractions might be a type of primitive reflex. This reflex is similar to contractions of the rectus abdominus activated by electrical stimulation of lower thoracic sympathetic afferent fibers [6], which was suggested as a type of protective reflex. Therefore, the heart may be protected when the chest wall tightens around the cardiac region during a cardiac insult.

Sympathetic cardiac afferent fibers might also play a critical role in the generation of ► **muscle hyperalgesia**; since sympathectomies in humans result in pain relief (see [7]). Evoked muscle contractions during ischemic episodes would provide the necessary nociceptive input to muscle afferents to induce angina-like referred pain.

### Vagal Cardiac Afferent Fibers in the Cardiac-Motor Reflexes

Activation of vagal cardiac afferent fibers could modulate the intensity of cardiac pain. Intense excitation of sympathetic cardiac afferent fibers and/or decreased activity in the vagal cardiac afferent fibers can generate spasm-like muscle contractions. Inhibition of spasm-like muscle contractions by vagal afferent stimulation indicated that information transmitted by vagal cardiac afferent fibers could play an important anti-nociceptive role in muscle hyperalgesia. During an ischemic episode, pain of muscle spasms could function as a warning about a dysfunctional heart. However, if vagal attenuation (modulation) of muscle contractions were not present in

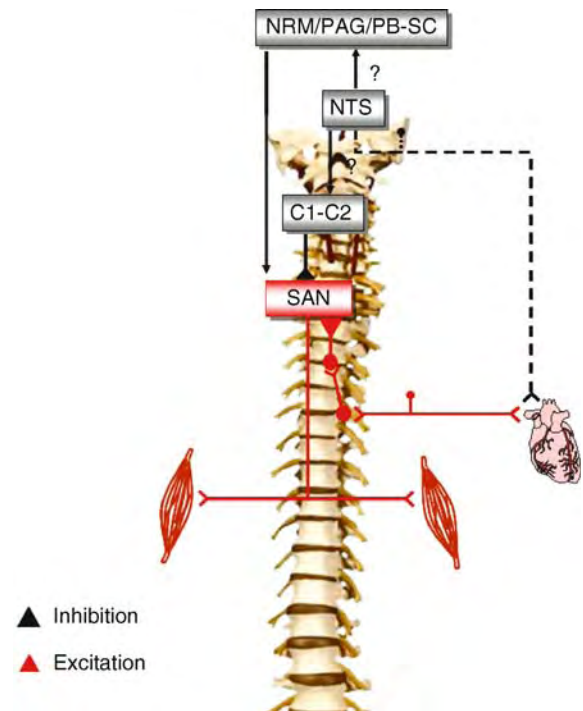

**Viscero-Somatic Reflex. Figure 5** Summary diagram of the functional pathways of the cardiac-spinothoracic motor reflexes. The solid red line represents the excitation of the sympathetic afferent fibers from the heart. These afferents synapse on interneurons in the spinal cord that excite the motoneurons of the spinal accessory nerve (SAN). The black dashed line represents the vagal afferent fibers that originate from the heart and terminate in the nucleus tractus solitarius (NTS). The information from the NTS may inhibit the activity of the motoneurons in the SAN via descending modulation from the nucleus raphe magnus (NRM) and/or the parabrachial-subcoeruleus (PB-SC) nuclei. The output from the NTS may also activate neurons in the upper cervical spinal segments (C1-C2) that, in turn, inhibit the activity of motoneurons in the SAN. The question marks in the circuits are included because the details of these pathways and their effects have not been described.

the cardiac-motor reflexes, patients might experience intense pain. Thus, instead of a warning signal, the intense pain could exacerbate symptoms, thereby creating a vicious cycle that might result in chronic muscle pain. Consequently, excitation of vagal afferents might be a means to treat clinical pain with a muscular origin.

The interaction of these two afferent pathways, in addition to the convergence-projection theory onto the ► **spinothalamic tract** cells [7], could potentially explain cardiac referred pain. Furthermore, this mechanism might also be responsible for the increased paraspinal muscle tone found in patients with chronic cardiac diseases [4].



Ultimately, maintenance of cardiac afferent balance between the information transmitted in the sympathetic and in the vagal afferent fibers could be a useful strategy for treating the muscular component of cardiac pain. Thus, another benefit gained from the inhibition of the muscle spasms by vagal afferent stimulation might be maintenance of homeostasis. It is possible that vagal inhibition of motor reflexes might prevent excessive metabolic demand by the skeletal muscles. Consequently, the workload to the heart is decreased, thereby improving cardiac function and achieving homeostasis. In fact, therapeutic successes of vagal afferent stimulation for attenuation of cardiac pain and prevention of ischemia episodes [8] has been documented. The insights into the muscular mechanism of cardiac pain might improve efficacy of treatments in cardiac patients.

### Pathology

The myofascial ►trigger point is a pathological condition that is proposed to be the result of reflexive muscle spasms [9]. Trigger points are hyperirritable loci of skeletal muscle that are very sensitive to mechanical manipulation. Clinically, mechanical pressure applied to these regions can lead to referred pain and tenderness. EMG recording of the trigger points at rest reveal intermittent, variable high-amplitude (>100  $\mu$ V) spike potentials and consistently present, lower-amplitude (<60  $\mu$ V) spike potentials (see [9]). The EMG recordings from trigger points at rest are similar to the single-unit and complex patterns elicited by noxious chemical stimulation of the cardiac afferent fibers, leading to the suggestion that EMG activation in the paraspinal muscle evoked by noxious stimulation of the heart might have a hyperalgesic component.

There is also the proposition that muscle hyperalgesia is generated by noxious stimulation of visceral afferent fibers. Clinically, muscle pain and rigidity accompany many non-cardiac cases of visceral-evoked contractions. In addition, many patients also report severe non-localized tenderness in the abdominal area. Also, several animal studies also demonstrate visceral-evoked responses showing concurrence between EMG activities and muscle hyperalgesia in other regions of the body, resulting from stimulation of visceral organs such as the esophagus, uterus, ureter, urinary bladder and colon.

### Therapy

Patients with refractory angina pectoris are unresponsive to conventional treatments such as optimal anti-anginal pharmacological therapy and are not candidates for revascularization. However, human studies have shown that ►spinal cord stimulation can be used effectively to treat this pain [10]. The Gate-control theory is the most commonly accepted explanation for describing the pain relief experienced in these patients. The basis of this theory is that spinal cord stimulation activates large fibers

in the dorsal column, which in turn activate inhibitory interneurons that modulate the processing of spinothalamic tract cells activated by the small fiber input resulting from noxious stimulation of the heart [7]. However, based on the viscerosomatic reflex that produces muscle contraction and leads to muscle pain and hyperalgesia, an alternative or additional explanation is that spinal cord stimulation activates spinal inhibitory interneurons that suppress visceromotor reflexes. Thus, spinal cord stimulation may provide a “calming” influence on noxious sympathetic afferent input at the spinal cord level, and reestablish the balance between the sympathetic and parasympathetic cardiac afferents fibers. This rebalancing would alleviate the skeletal muscle component of refractory angina pectoris.

### References

1. Jou CJ, Farber JP, Qin C, Foreman RD (2001) Intra-pericardial algogenic chemicals evoke cardiac-somatic motor reflexes in rats. *Auton Neurosci Basic Clin* 94:52–61
2. Jou CJ, Farber JP, Qin C, Foreman RD (2001) Afferent pathways for cardiac-somatic motor reflexes in rats. *Am J Physiol Regulat Integrative Comp Physiol* 281: R2096–R2102
3. Laucevicius L, Kaunaite D (1978) Electromyographic investigation of skeletal muscles of patients with angina pectoris. *Electromyogr Clin Neurophysiol* 18:397–415
4. Beal MC (1985) Viscerosomatic reflexes: a review. *J Am Osteopath Assoc* 85:786–801
5. Newham DJ, Edwards RHT, Mills KR (1994) Skeletal muscle pain. In: Wall PD, Melzack R (eds) *Textbook of pain*. Churchill Livingstone, London, pp 423–440
6. Downman CB, McSwiney BA (1946) Reflexes elicited by visceral stimulation in the acute spinal animal. *J Physiol* 105:80–94
7. Foreman RD (1999) Mechanisms of cardiac pain. *Annu Rev Physiol* 61:143–167
8. Zamotrinsky A, Afanasiev S, Karpov RS, Cherniavsky A (1997) Effects of electrostimulation of the vagus afferent endings in patients with coronary artery disease. *Coron Artery Dis* 8:551–557
9. Simons DG, Travell JG, Simons LS (1999) Travell & Simons’ myofascial pain and dysfunction. Williams & Wilkins, Baltimore, p 1–93
10. Linderoth B, Foreman RD (1999) Physiology of spinal cord stimulation: review and update. *Neuromodulation* 2:150–164

## Viscero-Visceral Reflex

### Definition

A viscero-visceral reflex is a reflex in which stimulation of visceral receptors results in activation of visceral

motor phenomena. It is convenient to think of such reflexes as purely neurological phenomena, analogous to somatic reflexes such as the so-called “deep tendon reflexes.” However, in normal homeostasis, humoral factors may also contribute to the afferent and efferent limbs of the reflex. Viscero-visceral reflexes play an important role in coordinating the activities of the various organs of the digestive system. For example, with stomach emptying, humoral and neural reflexes stimulate emptying of the gall bladder in order to assist digestion and absorption in the small intestine. Viscero-visceral reflexes also occur between different organ systems, for example, between the urogenital and digestive systems. Otherwise inconspicuous viscerovisceral reflexes may become pronounced when freed from descending inhibition, as for example in spinalized animals, and may become pathological in some situations, an example of which would be hypertensive incidents induced by bladder filling in patients with high spinal cord injuries.

## Vision

UWE. WINDHORST  
Göttingen, Germany

### Synonyms

Seeing

### Definition

Vision encompasses a range of organismic capabilities from the primordial detection of electromagnetic radiation to the sensation of the dynamic structure of the external world by means of such radiation within a limited bandwidth. In highly developed animals and humans that live in a complex environment, vision involves representational, attentional and memory processes as well as motor actions performed by large parts of the central nervous system.

### Introduction

Early on in evolution, organisms – even unicellular organisms – have developed a sense for light [1], maybe as early as for chemical stimuli. This attests not only to the significance of vision for the orientation and action of living beings in their specific environmental niche, but also to the long time span that evolution has had to develop visual systems, based on only eight known types of optical systems [2] and a larger variety of neural systems.

What is the purpose of vision? A rash answer might be to provide a description of the external world as faithful as could possibly be. This answer would go astray. Unicellular organisms do not need such a description, quite apart from the fact that they would be unable to produce it. They should be content with the possibility of discriminating brightness from darkness to synchronize biochemical processes with the ► [circadian cycle](#). This capacity has been preserved throughout evolution up to the most sophisticated organisms including humans. Other organisms have developed specialized visual capacities adjusted to specific environmental requirements. To cope with, and move in, the complex niche of tree canopies, primates and man’s ancestors had to develop a visual system with exquisite spatio-temporal information-processing capacities: excellent object Computational vision, depth (Binocular vision) and motion processing perception at high resolution, perfected by ► [color perception](#) (Color processing; Retinal color vision in primates).

Vision enables not only perception of the world (Visual perception), but also provides part of the sensory control of movement. Many visual sub-systems controlling motor outputs have evolved as partially independent input–output modules. Thus, many behaviors of vertebrates, from catching prey to avoiding obstacles, depend on specialized pathways from the visual receptors (Photoreceptors) to the motor nuclei (Visual pathways for perception and action; Visuomotor integration).

What is it that the primate visual system must achieve? In order to arrive at an answer, imagine a monkey moving through the tree canopies, jumping from one tree branch to the next. The requirements to be fulfilled can be briefly summarized as follows:

- *Representation of the three-dimensional (3D) external world in space and time*; this requires:
  - *Figure-ground discrimination*: isolation, identification and recognition of objects. Objects may be characterized in terms of *intrinsic properties* (attributes of each object per se) and *relational properties* (properties that objects possess due to their relation to other objects). Objects must thus be characterized as to:
    - *Form (shape), texture*, etc., involving discrimination of boundaries (Form perception; Visual object representation).
    - *Color* (Color processing; Retinal color vision in primates).
    - *Spatial arrangement* (direction and distance (depth); Binocular vision).
    - *Motion* (Visual motion processing).
  - *Memory*: Recognition is impossible without attending to the object (Visual attention), associating it

with previous instances of its occurrence or that of similar objects stored in memory.

- *Perception of self-motion* through the 3D world, which creates image shifts across the retina and must be distinguished from object motion (Optic flow).
- *Integration of visual information* with that of other ►sensory systems (e.g., ►audition, ►tactile sensation, ►proprioception; Multimodal integration).
- *Provision of inputs for evaluation and decision systems*; evaluation involves labeling the object(s) with affective and emotional cues, which greatly influence decisions for action.
- *Provision of inputs for visually guided motor actions including ►eye movements* (Active vision; ►Eye-hand coordination; Visuo-motor integration; Visual space representation for action; Visual space representation for reaching).
- *Provision of inputs for fast motor responses*: Some actions cannot await the outcome of long evaluation and decision processes, but must be initiated fast for escape or defense.
- *Selection by attention*: The recognition of complex spatio-temporal patterns is computationally very demanding and cannot, therefore, be performed with maximal resolution across the entire ►visual field. Parts of the visual world and specific objects of immediate interest must be selected by directed attention (Visual attention).

This synopsis will concentrate on visual processes in primates.

## Statistics of Visual Images

The problems involved in perceiving a plastic, moving, and potentially colorful external world are immense. On the other hand, the task is aided by the world's regularity. The world to be represented is not like a noisy random-dot display as generated by a computer. Rather, it is ordered and structured due to the evolutionary processes creating long-range spatial and temporal correlations among its parts. This structure corresponds to information that – if available to a seeing organism – could help it reduce the uncertainty about the world. Neural representations of such regularities thus correspond to some “pre-knowledge” about the world contained in its statistical structures. This pre-knowledge may be acquired by evolutionary and ontogenetic experience and learning and should be embodied in the dynamic structures and behaviors of nerve cells and their connections [3] (Experience with natural images as a basis for vision). Indeed, all learning may be said to be an internalization of environmental regularities, driven by the statistically regular occurrence of reinforcement following particular sensory stimuli or self-initiated actions. In this sense, environmental redundancy is exploited rather than suppressed [4]

(►Retinal lateral interactions; Visual cortical and subcortical receptive fields; Sensory systems).

## Optical Projection, Adjustment to Target Distance, and Pupil Control

The very first representation serving as the input to central visual information processing is the 2D image on the retina, which is an inverse projection of the 3D external world through the eye's optical apparatus. Already here, the mapping is influenced and modulated by eye movements, adjustment to target distance (Accommodation of the lens; ►Vergence eye movements; Accommodation-vergence interactions) and changes in pupil width (Neural regulation of the pupil ►pupillary light reflexes), which are results of CNS actions.

## Neuroanatomical Overview

Before indulging in a deeper discussion of functions, a gross overview of primate visual structures and pathways is here given.

### Anatomy of the Early Visual System

A schematic section through the pathway from the retinas to the primary visual cortex (striate cortex, area V1, ►Brodmann's area 17 [5] and brainstem structures is presented in Fig. 1.

### Retina

Rather than a simple visual projection screen, the retina is a protrusion of the brain and an information-processing device of the same complexity as the cerebral neocortex [6–8], which makes the retina similarly susceptible to degenerative processes (Inherited retinal degenerations). While the post-retinal anatomy differs substantially among vertebrates, retinal anatomy does not, but is remarkably conserved from fish to primates [9]. The mammalian retina contains of the order of 80 cell types, distinct in terms of morphology, physiology, spatial distribution and synaptic organization [6–8].

There are three (nuclear) layers of cells: outer photoreceptors, intermediate cells and inner ganglion cells (Inherited retinal degenerations). Rod photoreceptors and multiple cone photoreceptors (Photoreceptors; Retinal color vision in primates) connect to at least ten types of ►retinal bipolar cells (Photoreceptors; Retinal bipolar cells) that in turn connect to more than a dozen types of ganglion cell (Retinal ganglion cells) and a greater number of amacrine cell types (Retinal direction selectivity and starburst amacrine cells). Connections are in part characterized by specialized, structurally complex “ribbon” synapses releasing glutamate (Retinal ribbon synapses). This vertical connectivity establishes parallel functional channels, between which extensive and varied lateral interactions

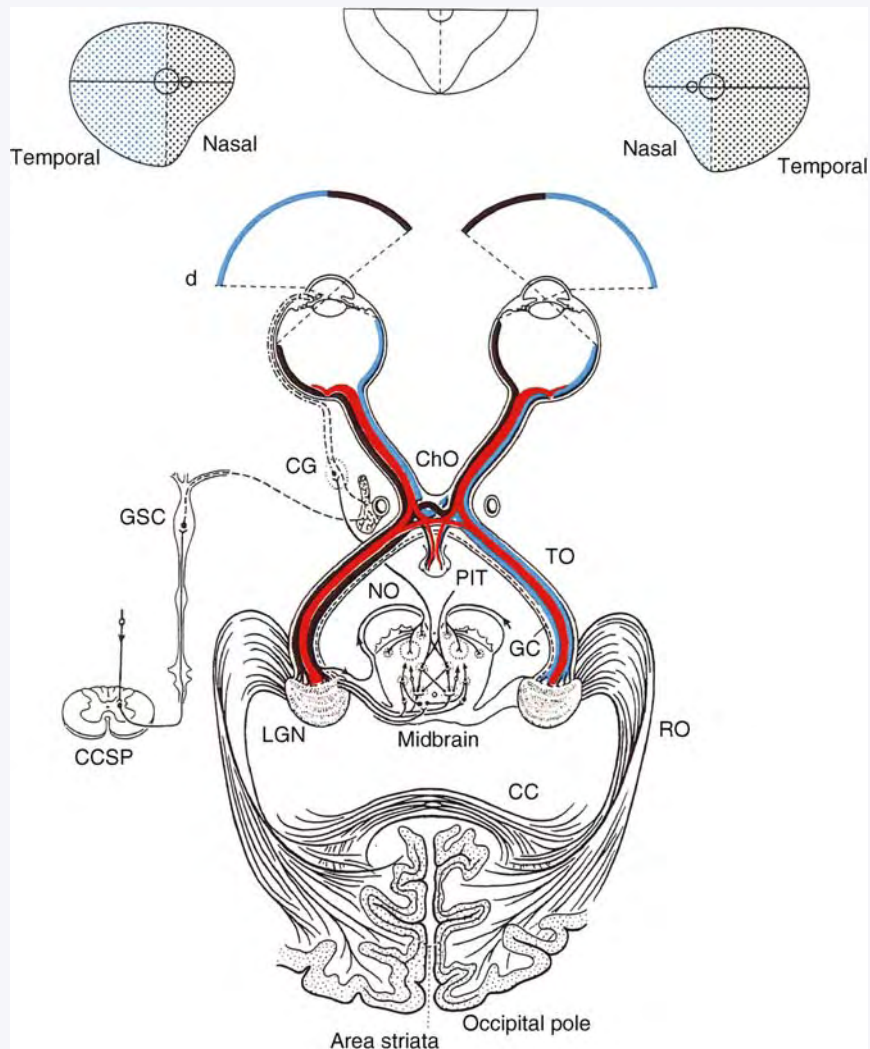

**Vision. Figure 1** Visual pathways from the retina, looked at from above, in humans. (a) Binocular visual field. (b) and (c) Visual fields of the left and right eye, respectively. (d) Visual pathways from the retina via the lateral geniculate nucleus to the primary visual cortex (also called striate cortex because of the stripe of [Gennari](#)). Note that the retina also projects to the brainstem, particularly via the K and, to some extent, via the M system, whereas in the primate P retinal ganglion cells do not project to the superior colliculus, which is therefore color-blind. Abbreviations: CC, corpus callosum; CCSP, centrum cervico-spinale (C8-Th2, involved in pupillary regulation); CG, ganglion ciliare; ChO, optic chiasm; GSC, ganglion cervicale superius; LGN, lateral geniculate nucleus; NO, nervus oculomotorius; PIT, pituitary gland; RO, radiatio optica (Gratiolet); TO, tractus opticus (Modified from Windhorst U (1996) Central processing of vision. In: Greger R, Windhorst U (Eds) *Comprehensive Human Physiology. From Cellular Mechanisms to Integration*. Springer, Berlin Heidelberg New York, pp 789–828).

take place, however ([Retinal lateral interactions](#); Retinal direction selectivity and starburst amacrine cells), providing for complex network processing. The complexity is also evidenced by the fact that, whereas each human eye contains of the order of 100 million photoreceptors, only about 1.5 million retinal ganglion cells project to the higher centers. This convergence necessitates profound data compression, which to accomplish poses problems as to an efficient code ([Retinal lateral interactions](#); Sensory systems).

### Ganglion Cell Projections

Retinal ganglion cells of each eye send their axons to the [blind spot](#) (a natural [scotoma](#)) where they form the optic nerve ([Fig. 1](#)). The two optic nerves merge to form the optic chiasm that in turn gives rise to the two optic tracts. In the optic chiasm, the ganglion cell axons from both eyes re-arrange as shown in [Fig. 1](#). This ensures that information from the left visual hemi-fields separated by the vertical meridians is conveyed to the right hemisphere, and vice versa.

As seen in Fig. 1, ganglion cells also project to the midbrain ►superior colliculus and other brainstem structures, which are involved in accommodation of the pupils and control of eye movements. In addition, the superior colliculus projects to the ►pontine nuclei, which in turn project to the cerebellum; this pathway may be involved in the visual guidance of movements [10].

### Lateral Geniculate Nucleus

The lateral geniculate nucleus (LGN) of the ►thalamus is the first synaptic station for ganglion cell axons in the pathway toward the primary visual cortex (Geniculostriate pathways). Optic nerve fibers from the ipsilateral eye terminate in layers 2, 3 and 5, and fibers from the contralateral eye in layers 1, 4 and 6. These layers are organized in topographical register (►retinotopy) with the retina and are stacked upon each other so that overlying cells in different layers receive ganglion cell inputs from corresponding retinal loci. Moreover, the LGN is differentiated as to the size of the principal (projection) cells (Geniculostriate pathway; Visual processing streams in primates):

- Large neurons (*magnocellular: M*) lie in the lower two layers.
- Small cells (*parvocellular: P*) occupy the upper four layers.
- Very small neurons (*koniocellular: K*) lie in three pairs of specialized layers.

These different classes of geniculate cell are fed differentially by inputs from distinct sets of retinal ganglion cells and in turn project differentially to specific layers of the primary visual cortex (Geniculostriate pathway; ►Striate cortex functions).

*Modulation of Lateral Geniculate Nucleus Neurons.* Retinal inputs provide a minority of the synapses on LGN neurons, the majority coming from the ►hypothalamus, brainstem ►parabrachial nuclei, the ►raphé nuclei, ►thalamus and the visual cortex (Geniculostriate pathway; Striate cortex functions). The inputs from brainstem regions might modulate signal transmission through the LGN during different states of wakefulness and sleep [11].

*Geniculo-Cortical Projections* (Geniculostriate pathway; Striate cortex functions). The axons of LGN cells travel through the radiatio optica (Fig. 1) to the primary visual cortex. Beside this major target, a small projection also targets visual areas other than area V1, so-called pre-striate or extra-striate areas (Extrastriate visual areas), including cortical areas V2, V3/V3a, V4, MT (V5). This might account for phenomena such as ►blindsight and residual motion perception after destruction of area V1. These areas receive visual information also via another pathway circumventing the LGN and involving the pulvinar (Visual role of the pulvinar) and/or the superior colliculus (cf. Fig. 1).

The geniculate projection to area V1 is ordered topographically (retinotopically), as is the retinogeniculate one, creating a retinotopic map of the visual field on the primary visual cortex (Striate cortex functions). Similar retinotopic maps are seen in higher visual areas, but with decreasing precision, due in part to the increasing ►receptive field size [12].

### Primary and Secondary Visual Cortices

Although there are direct projections from LGN to ►extrastriate visual cortex bypassing the primary visual cortex [13], the latter receives the major LGN input, such that the different LGN cell classes project differentially to the six different layers and ►blob and interblob regions (Geniculostriate pathway; Striate cortex functions), which in turn project differentially to further visual areas (areas V2 to V5 (MT) and the superior colliculus; Extrastriate visual areas).

As outlined above (see Fig. 1), each primary visual cortex receives inputs from both eyes. These two topographical projections must somehow be put in register, which on a large scale indeed occurs. Nonetheless, the geniculo-cortical fibers originating from different eyespecific LGN layers are kept fairly separate in area V1, with afferents related to the two eyes ending in different, interdigitating, vertical slabs of cortex called *ocular dominance columns* (Geniculostriate pathway; Striate cortex functions).

An important link between area V1 and temporal and parietal areas is area V2. Unlike area V1, area V2 is not organized according to ocular dominance. But like area V1, area V2 is neurochemically differentiated into regions of different cytochrome-oxidase (CO) staining: thin and thick stripes of rich CO staining separated by pale “interstripes” of low CO density (Striate cortex functions; Extrastriate visual areas).

### Further Visual Areas and Cortico-Cortical Projections

Visual cortex of primates is parceled into a large number of distinct cortical areas [12,14] (Extrastriate visual areas), whose neuron populations are selective for various stimulus features [15]. While many of these areas are primarily involved in visual functions, others are also implicated in functions like multisensory integration (Multimodal integration) and visually guided ►motor control (Visuomotor integration; Visual space representation for action; Visual space representation for reaching). The connectivity within and between these areas is immensely complex, including many reciprocal connections (►Visual cortex – neurons and local circuits; Extrastriate visual areas, Neocortical circuits: Computation in 3D).

### Initiating Analysis in the Retina

The principal task of visual processing is to make inferences about the 3D world from its 2D projection

onto the two retinas [16]. The retinal image can be described as an intensity distribution that is a function of several physical variables: 2D position, wavelength, and time. Since the mosaic of photoreceptors samples the image as a collection of pixels, this initial fragmented representation must be integrated again into coherent neural representations. This process starts right in the retina, followed by other transformations at subsequent processing stages.

### Photoreceptors

The *duplicity theory of vision* is based on the existence of two broad classes of light receptors, rods and cones, accounting for colorless scotopic (night) vision and photopic (day) vision (Photoreceptors). These two systems are not completely independent, however, since signals generated in rods are also fed, via ►[gap junctions](#) and other pathways, into cone pathways, thus establishing 2–3 different rod pathways to ganglion cells (Retinal ganglion cells).

At the very start, vision requires the transduction of electromagnetic radiation into an electrical membrane potential change (Membrane biophysics). This transduction is initiated by ►[photopigments](#), rhodopsin in rods and slightly different pigments in cones. Vertebrate photoreceptors hyperpolarize in response to light absorption, involving a cascade of intermediate steps (Photo-transduction). This hyperpolarizing response to adequate sensory stimulation is unusual (Sensory systems) and creates a problem because the output of retinal ganglion cells must be in the form of sequences of ►[action potentials](#). The hyperpolarizing response to light must therefore be converted into depolarization somewhere in the retinal network.

*Spectral Sensitivity of Cones.* Color perception is found throughout the animal kingdom, from insects to mammals, and may therefore be rightly assumed to convey a large evolutionary advantage to its possessors. But the mechanisms involved vary widely among species. Animals of some phyla can express as many as four ►[opsins](#). Other animals seem to have lost this richness. Some nocturnal animals, such as the owl monkey, have only one cone photoreceptor. Most non-primate mammals, New-World monkeys and some humans have two types of cone. Old-World monkeys and normal humans are trichromatic having three types of cone, a long-wavelength (L-) cone, a middle-wavelength (M-) and a short-wavelength (S-) cone. The spectral sensitivity functions of the different cones are broad and overlap widely, having the far-reaching implication that a particular wavelength cannot be determined by an individual cone, but only by comparison between signals from cones of different sensitivity [6,17] (Retinal color vision in primates; Color processing).

*Intrinsically Photosensitive Ganglion Cells.* Some specialized ganglion cells in mammals also operate as

photoreceptors, project to the ►[suprachiasmatic nucleus](#) and ►[pretectum](#), help synchronize the ►[circadian rhythm](#), and contribute to the ►[pupillary light reflex](#) and other reactions (Retinal ganglion cells). But they also project to the LGN and may thus contribute to perception; since they do not adapt to ambient light, they could assist in perception of absolute brightness [17].

### Ganglion Cell Outputs

The complex connections between retinal neurons create new representations of the visual image as evident from responses of ganglion cells. Primates possess more than a dozen types of ganglion cell that receive different patterns of inputs from cones and intercalated interneurons and project to different cells in the lateral geniculate nucleus (Retinal ganglion cells; Visual processing streams in primates). In primates, *midget ganglion cells* (also called *P cells* because they project to the small cells in LGN) and *small bistratified ganglion cells* have antagonistic ►[center-surround](#) organization of their receptive fields (Visual cortical and subcortical receptive fields) and are involved in the red-green and blue-yellow chromatic channels, respectively (Color processing). Midget ganglion cells are also sensitive to non-chromatic stimuli and responsible for *contrast* and *high spatial acuity*. Another important feature of spatio-temporal retinal processing is the sensitivity of some ganglion cell types to moving stimuli. Primate *parasol cells* (also called *M cells* because they project to large cells in the LGN) are sensitive to fast moving or low-contrast stimuli and are thought to serve as “novelty detectors” underlying an alarm system and to contribute to global form perception and depth perception. *Direction-selective ganglion cells* may contribute to the discrimination between object and self-motion (Retinal ganglion cells; Visual processing streams in primates). Direction-selectivity may result from several mechanisms including network properties involving amacrine cells and individual intrinsic cell properties (Retinal direction selectivity and starburst amacrine cells). There are other unusual cells, in particular in non-primate mammals, such as cells “suppressed-by-contrast” and “local edge detectors.” Correlations between morphology and response patterns suggest that there may be around a dozen afferent signal channels [13,17].

### Lateral Geniculate Nucleus

Cells in the LGN have response properties similar to retinal ganglion cells. Thus, M cells generally exhibit high contrast-sensitivity, with little, albeit existent, sensitivity to different isoluminant colors without specificity. By contrast, most P cells are very sensitive to differences in wavelength and little to luminance contrast [16,18]. LGN cells are subject to modulating effects of feedback connections and afferents from the

brainstem that are not yet well understood (see above). As for retinal ganglion cells, the receptive fields of most LGN cells are mostly organized in circular center-surround arrangements (Geniculostriate pathway; Visual cortical and subcortical receptive fields), which also applies to their responses to color.

### Form, Color, Motion, Depth and Distance

The information coded in the discharges of LGN cells is about tiny aspects of the outer world rather than more global issues of importance. What happens with this pre-processed information?

#### “What”, “Where” and “How”

An influential hypothesis propounds that different aspects of the external visual world are processed through different processing streams, in non-human primates (Extrastriate visual cortex; Visual processing streams in primates) and humans [12]. The so-called *ventral processing stream* extends from area V1 into inferior temporal areas, with further connections to ►prefrontal cortex and ►limbic areas. It is mainly concerned with *intrinsic object qualities* such as shape (form), size, brightness, texture, and color, whereby it is also called “what” channel. Its major function is assumed to be the identification and recognition of objects, with short- to long-term memory being of utmost importance. The *dorsal processing stream* extends from area V1 into superior temporal and parietal areas, with connections into the frontal cortex (below). It has been assumed to be mainly concerned with *relational object properties*, such as location, depth and motion (the “where” or “spatial vision” channel). A somewhat different, albeit not incompatible, view has emphasized the role of the dorsal stream in visually guided motor actions (whence it is also called the “how” pathway [19]; Visual pathways for perception and action). This strict functional segregation has been disputed, however (Extrastriate visual cortex). In fact, shape is also processed in the dorsal stream and needs to be since motor actions on objects require information on the latter’s shape [12,15] (Visual space representation for action). In any case, if different aspects of the world are processed in different areas, they must be bound together in some way (Binding problem). These major processing streams are complemented by sub-cortical visual pathways involving the pulvinar and/or the inferior and superior colliculus (Visual role of the pulvinar).

#### Human Brain Lesions

In humans, the concepts of different processing streams involving functionally specialized cortical areas are in part based on functional brain imaging studies [12] and in part on clinical deficits following localized brain lesions (Visual neuropsychology). Impressive syndromes include blindsight, ►agnosia of form and object, ►prosopagnosia, ►achromatopsia and ►color

agnosia, ►asynthesia, ►Balint’s syndrome, ►hemispatial neglect, ►visuospatial disorientation, ►depth perception disorders, and motion perception disorders (►akinetopsia). Although these syndromes generally favor the idea of functional specialization (Visual perception), the interdependence of object properties requires communication between the pathways. Consequently, there are many anatomical connections between temporal and parietal areas, and neurons in these areas show intermixed sensitivities to object features (Extrastriate visual cortex).

#### Form

When we intend to reach for and grasp a cup of tea, obviously we first need to recognize and identify the cup as a distinct and known entity. Humans are astonishingly good and fast at recognizing objects. There are several hypotheses as to how objects might be represented neurally (Visual object representation) and how the nervous system might accomplish this feat [12]. Generally, the identification and recognition of objects requires the visual system to solve the following problems (cf. Form perception):

- *Figure-ground separation*. The first problem is to distinguish objects from the background, thereby isolating and individualizing them. This in turn requires:
  - *Contour detection*: Object borders must be detected as localized and oriented features. Border contours are defined by discontinuities not only in luminance and color, but also in texture, disparity, and motion.
  - *Feature classification* as to whether they arise from an individual object or the interaction between different objects.
  - *Feature grouping*: The features intrinsic to an object must be grouped together to define the object’s outline.
- *Discrimination of invariant and changeable object properties*: Neural object representations must be such as to allow object recognition independent of [20] (Face processing in different brain areas; Computational vision):
  - *Variations in size* due to varying distance.
  - *Variations in lighting conditions and contrast* due, e.g., to changing illumination.
  - *Variations in spatial frequency* due, e.g., to blurring (changes in spatial resolution).
  - *Variations in position* on the retina (translation of non-fixated objects).
  - *Variations in angle of view* due to object rotations.
- *Association with memory representations of objects*: *Per definitionem*, “re-cognition” implies linking perceived objects with memorized objects.

One influential hypothesis posits that object recognition is performed in the ventral processing stream in a

hierarchical series of steps involving several functionally specialized cortical areas. Object recognition would start in the primary visual cortex with the detection and representation of local stimulus features and thence proceed into the inferotemporal (IT) cortex by a succession of integrative processes putting the simple features together into more abstract holistic representations [12,15,16] (computational vision). In the following brief overview, we shall concentrate on primate research.

### Form Processing in the Primary Visual Cortex

Neurons in the monkey primary visual cortex are characteristically sensitive to simple features [15].

#### Contour Detection

Most cortical cells in primary visual cortex (area V1) respond weakly or not at all to diffuse light, but strongly to stationary or moving lines, contrast borders, slits of light etc., of various orientations and forms, which provides the main basis for the detection of object shape [1,15] (Striate cortex functions). In addition to tiny center-surround cells in layer IV C, area V1 has neurons with new types of receptive fields, some important ones being (Visual cortical and subcortical receptive fields):

- ▶ *Simple cells* with non-circular receptive fields, whose main characteristic is a specific spatial orientation. Clusters of cells with about the same orientation are concentrated within *orientation columns*, and the orientations change systematically along the length of ocular dominance slabs (Striate cortex functions).
- ▶ *Complex cells* are the commonest cells and share orientation-specificity with simple cells.
- ▶ *End-stopped cells*. For the simple cells discussed above, it does not matter whether the optimally oriented light bar or edge exceeds the limits of their receptive field, but there are others for which it does. That is, if the bar or edge exceeds a certain limit in one or both directions, the cell's response declines from its optimum. These so-called "end-stopped" simple cells would allow for the detection of corners, sudden breaks in lines or curvatures, and are also sensitive to the direction of motion in two dimensions [1,15].

#### Classical Receptive Fields and their Surrounds

The area V1 cells described above appear well suited to detect stationary or moving edges and contrasts. However, this is not enough because objects have extended borders and surfaces captured therein. The visual system must therefore integrate the information on local features over larger spatial expanses so as to define boundaries and surfaces belonging to distinct objects (Form perception; Perceptual filling-in). A first indication of such integrative processes is the modulation of receptive fields by their surrounds.

Receptive fields in area V1 are neither rigid nor time-invariant. Rather, their properties change over largely varying time scales, depending on spatial and temporal context (Contextual influences in visual processing), state of arousal and attention (Visual attention), on expectations (below) and on previous experiences [21,22]. The receptive fields defined above are therefore now referred to as ▶ *classical receptive fields* ('CRF'). Modulations by the surround may be exerted on [22]:

- *Orientation specificity*. The responses of area V1 neurons to oriented line segments placed in their CRF can be suppressed by a texture of line segments surrounding the CRF. These effects have been interpreted as providing possible substrates for perceptual "pop-out," the segregation of borders between textures and the detection of the location and direction of changes in contour orientation, such as junctions or corners [21].
- *Directional motion selectivity*. Perception of motion (Visual motion processing) and certain ▶ *motion aftereffects* possibly result from contextual surround effects [22].
- *Receptive field size* may change depending on events in the surround [22].

The responses of cells in area V1 are modulated by brightness of surfaces well outside the CRF [21]. Such effects may contribute to perceptual phenomena such as ▶ *lightness constancy* [23] and ▶ *color constancy* (below; Color processing). Also, the perception of *relative depth* of objects and their 3D shape requires integration of signals from cortical areas representing disparate points on the retina (below).

#### Form Processing in the Ventral Processing Stream

Still, local contour elements must be put together into more or less coherent lines that delineate at least larger parts of objects (Form perception). Some of these processes follow, at a psychophysical level, Gestalt laws (Gestalt psychology).

*Contour Saliency*. In natural scenes, short contour segments do not occur at random, but are correlated to define elongated lines of object borders that are often nearly straight over limited ranges. One way of representing these lines could be to interconnect neurons that represent frequently occurring short contour elements of appropriate location and orientation. Contours composed of similarly oriented, collinear features are more readily visible than ones made up of segments with large orientation differences, giving rise to *contour saliency* [21].

*Illusory (Anomalous or Subjective) Contours*. In addition to real contours based on, e.g., luminance gradients, we are able to perceive illusory contours. Neurons that respond to illusory contours have been



found in areas V1 and V2 of the macaque monkey. Since many of such illusory contours are produced as if by occlusion by an interposed object, these neurons could contribute to [▶figure-ground organization](#) [15] (Form perception; Contextual influences in visual processing).

▶*Contour (or Boundary) Completion*. If near objects partially occlude far objects, these are segmented into image fragments. However, these fragments can be grouped together to create a representation of the partially occluded object (Form perception; Contextual influences in visual processing).

▶*Border Ownership* (Form perception). To recognize partial occlusion requires that the visual system, firstly, distinguish between the “true” boundaries of a surface and those created by an intervening surface and, secondly, determine whether separate image patches should be grouped together into a single surface. An essential step here appears to be the determination of border ownership, and that may be helped by the illusory contours. Border ownership is coded by subsets of neurons in areas V2 and V4. They encode not only local contrast borders, but also the side (object) to which the border belongs [15].

*Kinetic contours* emerge from the differences in direction or speed of motion of two abutting textures; neurons in areas V2 and V4 might contribute to their detection [15].

*Surface Filling-In*. Objects are not just defined by the boundaries delineating them, but also by the surfaces within the boundaries. How are these surfaces *filled* in terms of brightness, color, depth etc.? When a portion of the visual field is masked by a gray area, with the boundaries kept constant, the pattern and color of the surrounding area spills into the mask (Form perception; Perceptual filling-in). Neurons in area V1 respond when their CRFs are positioned in the mask. In area V3, the cell responses develop with a time course corresponding to the perceptual fill-in phenomenon. Again, long-range intracortical connections and their dynamic modulation may underlie these phenomena [21].

### Neurons Responsive to Complex Features

Proceeding from area V4 into infero-temporal (IT) cortex, neurons become increasingly selective for complex stimulus characteristics [15,24] (for cortical areas named below see [▶Extrastriate visual cortex](#)). In area V4 and [▶PIT](#), they may be selective for single characteristics, such as stimulus size, orientation in the plane and color, and for moderately complex patterns, such as line intersections, e.g., an “X” or T junctions, and curvatures. Populations of curvature-selective V4 neurons may encode complete shapes as aggregates of curved boundary fragments. In posterior IT, neurons appear to integrate multiple contour elements as coded

in area V4. In areas [▶CIT](#) and [▶AIT](#), “elaborate” cells respond to ever more complex features, such as star-shaped stimuli or combinations of features, such as a circular brown stippled area with a bar extending to the right. These features are not complex enough to completely specify natural objects. This implies that any individual object (shape with texture and color, often moving at some spatial depth) can only be represented by the coordinated activity of several to many cell populations, except in the case of faces (below). Far out in [▶area TE](#) of the ventral pathway, neurons are selective for 2D shape defining the external contour of an object, irrespective of the cues (motion, texture, luminance or disparity differences) [15].

Three-dimensional object shape may be inferred or derived from a number of cues, including two-dimensional ones, but stereoscopic vision based on the slightly different aspects delivered by the two eyes would be much more powerful for 3D shape description (Binocular vision; see below). In fact, a large proportion of macaque IT neurons are selective for 3D shape. Thus, IT cortex processes not only 2D but also 3D shape information and may thus complete shape representation by a stereoscopic mechanism [25]. 3D-selective cells are concentrated in the lower bank of the [▶superior temporal sulcus \(STS\)](#) [26]. This area receives input from the [▶intraparietal cortex \(IPS\)](#) of the dorsal processing stream, containing neurons responsive to disparity-defined orientation in depth.

Increasingly complex object representations and invariances have been modeled successfully (Computational vision).

### Invariances

Objects known to a viewer are identified by reproducible, invariant constellations of features, which may still appear differently under varying circumstances, i.e., change with size, position (retinal place), orientation, viewing angle, illumination etc. The task of the perceptual system is to recognize the object despite its changing appearance. This requires the capability to extract the invariant features from the changeable ones. Thus, if the IT pathway is involved in object recognition and identification, it should contain neurons that can abstract from certain properties such as size, orientation, retinal position, color and viewing angle (Face processing in different brain areas; Computational vision).

- *Invariance to object translation*. Neurons in IT have large receptive fields and might thus fulfill the prerequisite for invariance to object translation in the visual field.
- *Orientation constancy*. Only about 3% of elaborate cells display *orientation constancy* (responding equally to presentations of effective stimuli at all angles) or *size constancy* over a quite a large range [24].

- *Size constancy* denotes the capacity of monkeys and humans to accurately judge the size of objects up to a distance of 30 m. It requires that object size be scaled with distance, for which an estimate of distance is required (see below). A constancy intimately associated with size constancy is *speed constancy* (constancy of the distance traveled by a moving object per unit time), which must also take into account distance. In fact, viewing distance modulates neuronal responses also in the ventral processing stream leading up to inferotemporal cortex [27].
- *View invariance*. There are also neurons responding selectively to one or more familiar objects irrespective of the viewing angle (Face processing in different brain regions).

These invariances resemble those seen in some face- and hand-specific cells (Face processing in different brain areas; Computational vision). An intriguing instance of invariance, namely *color constancy* (Color processing), is mentioned below.

### Object Categorization

Object recognition (Visual object representation) is not enough to deal with the world. Different objects have different implications for the observer. This has put an evolutionary pressure on being capable to perceptually categorize objects [28]. For example, it is of paramount importance to distinguish between edible and non-edible objects, living and non-living objects, dangerous and harmless objects, etc. In advanced animals, most categories are learned. Characteristic of perceptual categorization is that objects in different categories are regarded as distinct despite their potential similarity (apple vs. billiard ball), while dissimilar objects in the same category (apple vs. banana) are treated alike. In macaque monkeys trained to categorize cats and dogs, neuronal activity in the lateral prefrontal cortex reflects these categories and category boundaries [29]. In human patients, category-specific cell responses occur in the ►hippocampus, ►amygdala and ►entorhinal cortex, all of which receive convergent input from temporal neocortical regions specialized for processing complex visual stimuli (Face processing in different brain areas).

### Recognition of Biologically Important Objects

Recognition of complex visual patterns such as biological bodies, faces, hands, limbs and other known objects is an essential, and perhaps the most highly developed, skill of the visual system, and is of obvious evolutionary significance.

Quite a proportion of cells in the monkey IT cortex, in particular in areas AIT and ►STPa, are selectively responsive to objects, biological bodies, heads, faces, hands, and limbs [20,24]. However, face-sensitive cells (Face processing in different brain areas; Computational

vision), and probably also neurons that “learn” to become acquainted with specific objects, are distributed more widely over cortical and limbic structures.

### Color

Color sensitivity is not absolutely necessary for object recognition, as evidenced by color-deficient animals and humans who manage quite well in the world. Nonetheless, color helps to discriminate objects from each other (Color processing; Striate cortex functions). For all its usefulness, however, color perception comes along with a number of problems. The foremost are:

- *Color constancy*: Invariance of color perception against changes in ambient illumination [30]. While changes in ambient illumination change the spectrum of wavelength reflected from a surface, the perceived color associated with that surface should not change. This is a context-dependent phenomenon (Color processing).
- *Color contrast*. In contrast to color constancy, which generates similar percepts despite dissimilar spectral returns from the target, similar spectral returns may generate dissimilar color percepts, again as a function of context.
- *Color assimilation*. While in color constancy and contrast the color percepts generated by the targets are shifted away from those of their surrounds, highly repetitive spatial patterns make the apparent colors of the patterned elements assimilate with each other.

These well-known psychophysical phenomena have been explained by the idea that they are generated by past experience with the statistical organization of spectral returns from the natural visual environment [31] (Experience with natural images as a basis for vision).

### Color Coding in Subcortical Pathways

As mentioned above, a single cone photoreceptor cannot distinguish between a change in wavelength and intensity of light [6,17] (Retinal color vision in primates; Color processing). This implies that the signals from different cones need to be recoded, as in fact occurs in the antagonistic center-surround organization of the receptive fields of *midget ganglion cells* (also called *P cells* because they project to the small cells in LGN) and *small bistratified ganglion cells*, which are involved in the red-green and blue-yellow chromatic channels, respectively. But there are more cells and channels carrying chromatic signals [17]. Recoding continues in the primary visual cortex and beyond.

### Color Coding in Visual Cortex

While LGN receptive fields show some similarity to those of retinal ganglion cells, those of area V1 cells are

rather dissimilar and indicate another major recoding [17] (Color processing:). Color appears to be a quality altogether different from shape. However, color coding and edge and orientation coding are multiplexed rather than separated in monkey visual areas V1 and V2, indicating that cortical processing does not separate form and color information in different feature maps [32]. Area V1 cells show a variety of color preferences with varying receptive field structures. Area 2 contains color-sensitive neurons with their sensitivity depending on surrounding context [17]. In area V4 (an important gateway to the inferotemporal cortex involved in form processing), color can be combined with texture and other shape information to facilitate object recognition. Area 4 thus contains many color-processing neurons, among which neurons exhibiting color constancy are of great importance. While some area V4 cells are selective for the stimulus form independent of color, others show conjoint sensitivity to both form and color. As well, cells in infero-temporal cortex appear to code conjointly for both color and shape.

### Depth and Distance

Acting in a 3D world requires an excellent representation of the spatio-temporal arrangement of objects and their relations to the body. Arms and hands, working under close visual guidance (Eye-hand coordination; Active vision), have been of paramount importance for the rise of the human intellect and culture, especially for the production and use of tools (Visual space representation for action). The hand and binocular stereopsis have developed together. Depth perception is based on monocular and binocular cues.

### Monocular Vision

Even in monocular vision, a number of cues enable some guess as to the distance of objects [1]:

- *Static (pictorial) cues*
  - *Relative size* of objects known from experience.
  - *Perspective*. Roads and railway tracks narrow into the distance.
  - *Texture gradient*. Texture elements of a regularly textured pattern narrow down with increasing distance.
  - *Shadows*.
  - *Brightness*. Brighter objects appear closer.
  - *Color (chromostereopsis)*. Highly saturated red and blue patches in a plane may appear to have different distances.
  - *Haziness*. Far objects appear hazier and less clear than near objects.
  - *Occlusion (interposition)* (see above).
- *Motion cues*
  - ▶ *Motion parallax*.
  - *Optic flow*.

### Stereopsis

Depth perception based on binocular vision is much more vivid than that derived from monocular cues [33] (Binocular vision). The two retinal images of 3D objects differ in both horizontal and vertical dimensions, giving rise to *horizontal and vertical disparities*. Vertical disparity occurs because objects on either side of the vertical meridian are closer to one eye than the other and thus span different angles in the two eyes. The patterns of these disparities across the visual field depend on the 3D world structure, gaze angle, viewing distance and eye alignment. Disparity-based stereopsis poses a number of new problems [34]:

- *Binocular matching*: In order to compute disparities, corresponding features in the two retinal images must be selected and identified correctly.
- *Disparity detection*: The retinal disparities must be detected by neural mechanisms based on signals from both eyes.
- *Binocular fusion*: The two images of the two eyes must be *fused* into a single percept.
- *Depth constancy*: Since the magnitude of horizontal disparity depends on viewing distance and alone is insufficient to compute stereopsis reliably, additional information about distance and angle of gaze is required.

### The Binocular Correspondence Problem

In order to compute disparity, corresponding features in the two images must be selected and identified correctly (Binocular vision). How this is done, is one of the fundamental problems in stereoptic research.

### Disparity-Selective Cells

Required for disparity detection and evaluation are binocular cells with receptive fields in both retinæ. In monkey cortex, cells with non-circular receptive fields, simple and complex cells, receive inputs from both eyes. In fact, nearly all cells in the foveal region of areas V1 and V2, and most cells in higher-order areas are binocular. Disparity detectors have been found in areas V1, V2, V3, V3A, VP, V5 (MT), ▶MST and IT of monkeys and in the superior colliculus of cats and opossums [33–37].

In foveal cortex, there are several categories of cells responding in various ways to horizontal disparities, each class responding to stimuli appearing in depth farther, at, or nearer than the binocular fixation point (Binocular vision). Exactly how disparity-sensitivity comes about is not yet completely understood [34].

In humans, the dorsal processing stream contains areas responsive to 3D cues [12]. In monkeys, the caudal part of the lateral bank of the intraparietal sulcus (▶area CIP) contains neurons that are responsive to binocular disparity and tuned to the *axis orientation* of

long and thin stimuli in 3D space. Other neurons prefer broad and flat stimuli and are tuned to the *surface orientation* in depth. Such neuron sensitivities may be functionally important for grasping and object manipulation (Visual space representation for action).

Disparity-sensitive neurons are also found in the inferotemporal (IT) cortex of the ventral processing stream. A proportion of neurons concentrated in area TEs is sensitive to 3D shape defined by disparity (e.g., curved surfaces) with properties suggesting that at this level the ‘stereo correspondence problem’ is solved. These representations are also invariant to fronto-parallel position and size [15].

### **Binocular Rivalry**

When two different images are presented to the two eyes, they are not perceived superimposed, but compete for perceptual dominance so that perception is disintegrated into complex sequences of patchworks from the two images. It is not clear yet where in the brain rivalry occurs and how it is organized (► **Binocular rivalry**).

### **Motion**

Objects move relative to each other and to an observer, and the observer himself moves his eyes or the head or the entire body in the environment (self-motion). To detect, analyze, categorize and evaluate these various motions is of utmost survival value (Visual motion processing). Motion analysis is a complex biological process. For higher animals, such as many mammals including primates, a number of problems must be solved:

- *Detection of motions of retinal image elements* (Retinal direction selectivity and starburst amacrine cells).
- *Deduction of object motion from image-element motions* despite the restricted size of receptive fields, which causes the ► **aperture problem** (Visual motion processing).
- *Integration of object and motion information*, requiring the convergence of signals from the ventral and dorsal processing streams.
- *Distinction of retinal image changes resulting from object motions or from movements of the eyes, head and/or whole body movements (self-motion)*, or both; this may require integrating information from other (non-retinal) signals about eye, head and/or body movements.
- *Provision of appropriate outputs to:*
  - *Evaluation systems* (dangerous or not?).
  - *Decision systems*.
  - *Motor systems* (oculomotor and somato-motor).

### **The Motion Correspondence Problem**

At the origin of motion perception must be mechanisms for motion detection (Visual motion processing). Here

appears a problem similar to the correspondence problem in binocular depth estimation, translated into the temporal domain. The visual system must identify and determine the spatio-temporal displacements of those features in the dynamic retinal image, which originate from the same moving objects. This is known as the ► **motion correspondence problem**. For help in a solution, the human visual system exploits local, cross-cue matching constraints [38].

### **Motion and Direction Sensitivity**

Motion and direction sensitivity is particularly prevalent in areas and neurons in the dorsal processing stream from primary visual cortex through area V5 (MT) and ► **area MST** [12,15]. Area MT (V5) – by also being sensitive to pattern direction, speed gradients and disparity and having large antagonistic surrounds – appears to play a prominent role in segmenting motion from its background and possibly in computing structure from motion and depth cues [15,35] (Visual motion processing). Signals from area MT (V5) are transmitted to ► **area MSTd** (dorsal MST) involved in assessment of self-motion via optic flow analysis, to ► **area MSTv** (ventral MST) involved in the analysis of visual trajectories, smooth ► **pursuit eye movements** and arm trajectories, and to ► **area FST** (floor of the superior temporal visual area), from which might originate an action-related pathway [15]. Many neurons in area MSTd respond to movement in depth, rotary movement in space and optic flow (Visual space representation for action).

### **Object Motion**

The problem of recovering coherent object motion from the motion of retinal image features has no unique solution. For example, when two objects move past each other, some moving retinal features belong to one or the other object, but other features arise from changing overlap (corners at points of overlap). The distinction requires, firstly, the classification of the moving features as arising from one or the other source and, secondly, the grouping of those features belonging to any individual object. Interpretation of object motion is thus secondary to *feature classification* [39,40]. Another principal problem for the visual system is to deduce the direction of object motion from the direction of object contours (Visual motion processing). There is evidence that area MT contains neurons performing this integration. The ► **anterior superior temporal polysensory area** (STPa) contains motion-sensitive neurons that selectively respond to movements of external objects, but not to retinal motion resulting from the observer’s own motion. These cells then compute object motion relative to the observer, which suggests that some (retinal, vestibular, somatosensory) reference signals are used to discriminate between object and self-motion [41].

### Biological Motion Recognition

Human subjects are extremely good at perceiving and interpreting ►biological motion from impoverished displays of small light sources attached to points of articulations, e.g., shoulders, elbows, wrists, knees, ankles etc. They can even distinguish movement patterns such as dancing, running, walking, as well as identity, gender, facial expression etc. And they are fast at it, responding to exposure durations of 100–200 ms [12,42].

The biological correlates of these perceptual capabilities may be found in neurons in the macaque temporal cortex, which are selectively sensitive to particular body movements, e.g., walking. The infero-temporal (IT) cortex and the anterior superior temporal polysensory area (STPa) contain form-sensitive cells that respond preferentially to four characteristic views: the face (Face processing in different brain areas), the left, the right and the back view of head and body. Also, in area STPa, form-independent neurons discriminate between motions in Cartesian directions: toward, away, left, right, up and down. There are, then, neurons that conjointly react to specific body motions, such as a left-profile view walking to the observer's left, etc. Whole-brain functional MRI of *humans* suggests that, whereas face and form stimuli activate primarily the ventral processing system and motion stimuli primarily the dorsal processing system, recognition of biological motion stimuli may activate both systems as well as their confluence in the superior temporal sulcus (STS) [43].

### Perception of Self-Motion

Eye or head movements and self-motion induce changes in retinal image. The image changes resulting from self-motion are briefly referred to as *optic flow*. Due to the motion parallax, self-motion and depth perception are intimately related. The analysis of optic flow is important for stabilizing stance and locomotion (walking speed), for perceiving the 3D scene and object motion, for computation of the time to contact in impending collision, for stabilizing the visual world by eye movements, for orientation, for visually guided navigation in the 3D world and path integration. A predominant role in optic flow analysis has the dorsal processing stream leading up to area MT and medial superior temporal area (MST) (Optic flow).

### Attention and Expectation

The recognition of complex spatio-temporal displays is very demanding and surpasses the computational capacities of the brain. The many objects in a visual scene thus compete for neural representation (Visual attention). Moreover, much of the sensory, especially visual, information impinging on the nervous system is not immediately relevant behaviorally. These problems require mechanisms ensuring

- *Selection of relevant pieces of information*; involving
  - *Facilitation* of needed information.
  - *Suppression* of unneeded information.
- *Localization of this information and directional processes* toward this locus.
- *Eye movements* toward selected objects (if needed) to focus and regard them at high spatial resolution.

These processes require complex and flexible mechanisms engaging widely distributed networks at cortical and sub-cortical levels, which have also been modeled by ►neural network approaches (Computational vision). Attention thus modulates visual signal processing by way of ►top-down influences as distinct from stimulus-driven ►bottom-up processes (Visual attention).

The biological significance of a visual (or other) sensory stimulus is greatly influenced by whether it is novel or expected. There are many examples of cell responses to stimuli being modulated by expectation. For instance, cells in macaque area V3a respond strongly to the motion of an oriented bar when the monkey is maintaining steady fixation, but they respond much more weakly when the monkey induces the same retinal stimulus by moving his eyes with the bar fixed in space [44]. Also, there are neurons in area STPa that respond to any moving object except when the object is the monkey's own hand moving into the cell's receptive field [45]. This indicates that, for some neurons, a stimulus can produce a response when the motion is unpredictable or unexpected, but fails to do so when the motion is predictable from the monkey's own behavior. Such anticipatory influences on sensory processing may be generated by an ►internal model of the motor system (Motor control) and explain why you cannot tickle yourself [46].

### Toward Action

Adaptive goal-directed behavior depends on the successful integration of multifarious sub-functions, sensory and motor. In visually highly developed animals such as primates, vision plays a predominant role in guiding many motor activities. To do so, eye movements must be closely coordinated with other body movements (Active vision), which involves some partially specialized areas in posterior parietal cortex and connected areas in the frontal lobe. Similarly, visually guided goal-directed arm and hand movements such as reaching, grasping and object manipulation involve specific parietal and frontal areas (Visual space representation for action; Visual space representation for reaching). Conversely, movements change visual inputs, closing the loop (Visuo-motor integration).

In order to direct a movement toward a visual and/or other sensorily defined target, visual spatial information must be combined with auditory, tactile and proprioceptive spatial information. For example, for directing

gaze (eye plus head) toward a visible target, it is necessary to determine the location of the target relative to the body, which in turn requires the combination of information on retinal image location and eye and head position. Hence, multimodal information from different senses must be combined (Multimodal integration). What is more, the different types of information are encoded in different frames of references, necessitating coordinate transformations (Sensory systems; Motor control).

### Concluding Remarks

In the history of philosophy and science, vision has always occupied a preeminent stand, not only since Plato's cave allegory. Over the past several centuries, wide strides have been made in unraveling the mysteries of vision by the use of a huge number of approaches. While considerable advances have been achieved in our understanding of the neuroanatomical and neurophysiological bases of the visual system in many organism, the major challenge of bridging the gaps toward comprehending the nature and generation of visual perception remains and will do so for some time to come.

### Acknowledgment

Dedicated to the outstanding scientist, academic teacher and friend Rainer F. Greger (3.1.1946–16.12.2007).

### References

- Hubel DH (1988) Eye, brain, and vision. Scientific American Library, New York
- Fernald RD (2004) Eyes: variety, development and evolution. *Brain Behav Evol* 64:141–147
- Simoncelli EP, Olshausen BA (2001) Natural image statistics and neural representation. *Annu Rev Neurosci* 24:1193–1216
- Barlow HB (2001) The exploitation of regularities in the environment by the brain. *Behav Brain Sci* 24:602–607
- Brodmann K (1909) Vergleichende Lokalisationslehre der Großhirnrinde in ihren Prinzipien, dargestellt auf Grund des Zellenbaues. Barth, Leipzig
- Dacey DM (2000) Parallel pathways for spectral coding in primate retina. *Annu Rev Neurosci* 23:743
- Field GD, Chichilnisky EJ (2007) Information processing in the primate retina: circuitry and coding. *Annu Rev Neurosci* 30:1–30
- Masland RH, Raviola E (2000) Confronting complexity: strategies for understanding the microcircuitry of the retina. *Annu Rev Neurosci* 23:249–284
- Meister M, Berry II MJ (1999) The neural code of the retina. *Neuron* 22:435–450
- Glickstein M (2000) How are visual areas of the brain connected to motor areas for the sensory guidance of movement? *Trends Neurosci* 23:613–617
- Sherman SM (1996) Dual response modes in lateral geniculate neurons: mechanisms and functions. *Vis Neurosci* 13:205–213
- Grill-Spector K, Malach R (2004) The human visual cortex. *Annu Rev Neurosci* 27:649–677
- Masland RH, Martin PR (2007) The unsolved mystery of vision. *Curr Biol* 17:R577–R582
- Felleman DJ, van Essen DC (1991) Distributed hierarchical processing in the primate cerebral cortex. *Cerebral Cortex* 1:1–47
- Orban GA (2008) Higher order visual processing in macaque extrastriate cortex. *Physiol Rev* 88:59–89
- DeYoe EA, van Essen DC (1988) Concurrent processing streams in monkey visual cortex. *Trends Neurosci* 11:219–226
- Solomon SG, Lennie P (2007) The machinery of colour vision. *Nat Rev Neurosci* 8:276–286
- Merigan WH, Maunsell JHR (1993) How parallel are the primate visual pathways? *Annu Rev Neurosci* 16:369–402
- Goodale MA, Westwood DA (2004) An evolving view of duplex vision: separate but interacting cortical pathways for perception and action. *Curr Opin Neurobiol* 14:203–211
- Wallis G, Rolls ET (1997) Invariant face and object recognition in the visual system. *Prog Neurobiol* 51:167–194
- Gilbert CD (1998) Adult cortical dynamics. *Physiol Rev* 78:467–485
- Wörgötter F, Suder K, Zhao Y, Kerscher N, Eysel UT, Funke K (1998) State-dependent receptive field restructuring in the visual cortex. *Nature* 396:165–168
- MacEvoy SP, Paradiso MA (2001) Lightness constancy in primary visual cortex. *Proc Natl Acad Sci USA* 98:8827–8831
- Tanaka K (1997) Mechanisms of visual object recognition: monkey and human studies. *Curr Opin Neurobiol* 7:523–529
- Janssen P, Vogels R, Orban GA (1999) Macaque inferior temporal neurons are selective for disparity-defined three-dimensional shapes. *Proc Natl Acad Sci USA* 96:8217–8222
- Janssen P, Vogels R, Orban GA (2000) Selectivity for 3D shape that reveals distinct areas within macaque inferior temporal cortex. *Science* 288:2054–2056
- Dobbins AC, Jeo RM, Fiser J, Allman JM (1998) Distance modulation of neural activity in the visual cortex. *Science* 281:552–555
- Logothetis N, Sheinberg DL (1996) Visual object recognition. *Annu Rev Neurosci* 19:577–621
- Freedman DJ, Riesenhuber M, Poggio T, Miller EK (2001) Categorical representation of visual stimuli in the primate prefrontal cortex. *Science* 291:312–316
- Smithson HE (2005) Sensory, computational and cognitive components of human colour constancy. *Phil Trans R Soc* 360:1329–1346
- Long F, Yang Z, Purves D (2006) Spectral statistics in natural scenes predict hue, saturation, and brightness. *Proc Natl Acad Sci USA* 103:6013–6018
- Friedman HS, Zhou H, von der Heydt R (2003) The coding of uniform colour figures in monkey visual cortex. *J Physiol (London)* 548:593–613
- Parker AJ (2007) Binocular depth perception and the cerebral cortex. *Nat Rev Neurosci* 8:379–391
- Gonzalez F, Perez R (1998) Neural mechanisms underlying stereoscopic vision. *Prog Neurobiol* 55:191–224
- Born RT, Bradley DC (2005) Structure and function of visual area MT. *Annu Rev Neurosci* 28:157–189
- Cumming BG, DeAngelis GC (2001) The physiology of stereopsis. *Annu Rev Neurosci* 24:203–238

37. Poggio GF (1995) Mechanisms of stereopsis in monkey visual cortex. *Cerebr Cortex* 5:193–204
38. Hibbard PB, Bradshaw MF, Eagle RA (2000) Cue combination in the motion correspondence problem. *Proc R Soc Lond B Biol Sci* 267:1369–1374
39. Croner LJ, Albright TD (1999) Seeing the big picture: integration of image cues in the primate visual system. *Neuron* 24:777–789
40. Duncan RO, Albright TD, Stoner GR (2000) Occlusion and the interpretation of visual motion: perceptual and neuronal effects of context. *J Neurosci* 20:5885–5897
41. Hietanen JK, Perrett DI (1996) A comparison of visual responses to object- and ego-motion in the macaque superior temporal polysensory area. *Exp Brain Res* 108:341–345
42. Neri P, Morrone MC, Burr DC (1998) Seeing biological motion. *Nature* 395:894–896
43. Vaina LM, Solomon J, Chowdhury S, Sinha P, Belliveau JW (2001) Functional neuroanatomy of biological motion perception in humans. *Proc Natl Acad Sci USA* 98:11656–11661
44. Galletti C, Battaglini PP, Fattori P (1990) ‘Real-motion’ cells in area V3a of macaque visual cortex. *Exp Brain Res* 82:67–76
45. Hietanen JK, Perrett DI (1993) Motion sensitive cells in the macaque superior temporal polysensory area: I. Lack of response to the sight of the monkey’s own hand. *Exp Brain Res* 93:117–128
46. Blakemore SJ, Wolpert D, Frith C (2000) Why can’t you tickle yourself? *Neuroreport* 11:R11–R16

(see Fig. 1). Such zones of convergence would overlap continuously with each other. This connectivity would be part of the architecture by which translation-invariant representations are computed.

Each layer is considered to act partly as a set of local self-organizing competitive neuronal networks with overlapping inputs as shown in Fig. 1b. These competitive nets operate by a single set of forward inputs leading to (typically non-linear, e.g. sigmoid) activation of output neurons; of competition between the output neurons mediated by a set of feedback inhibitory interneurons which receive from many of the principal (in the cortex, pyramidal) cells in the net and project back (via inhibitory interneurons) to many of the principal cells which serves to decrease the firing rates of the less active neurons relative to the rates of the more active neurons; and then of synaptic modification by a modified **Hebb rule**, such that synapses to strongly activated output neurons from active input axons strengthen, and from inactive input axons weaken [1].

Translation-, size- and view-invariance could be computed in such a system by utilizing competitive learning operating across short time scales to detect regularities in inputs when real objects are transforming in the physical world [1–3]. The hypothesis is that because objects have continuous properties in space and time in the world, an object at one place on the retina might activate feature analyzers at the next stage of cortical processing, and when the object was translated to a nearby position, because this would occur in a short period (e.g. 0.5 s), the membrane of the postsynaptic neuron would still be in its “Hebb-modifiable” state (caused for example by  $\text{Ca}^{2+}$  entry as a result of the voltage-dependent activation of **NMDA receptors**, or by continuing firing of the neuron implemented by recurrent collateral connections forming a short-term memory), and the presynaptic afferents activated with the object in its new position would thus become strengthened on the still-activated postsynaptic neuron. Other invariances, for example size, spatial frequency, rotation, and view invariance, could be learned by similar mechanisms to those just described [1–3]. It is suggested that the process takes place at each stage of the multiple-layer cortical processing hierarchy, so that invariances are learned first over small regions of space, and then over successively larger regions. This limits the size of the connection space within which correlations must be sought.

Increasing complexity of representations could also be built in such a multiple layer feature hierarchy by similar competitive learning mechanisms. Evidence consistent with this suggestion that neurons are responding to combinations of a few variables represented at the preceding stage of cortical processing is that some neurons in areas V2 and V4 respond to end-stopped lines, to combinations of lines, or to more complex

## Vision – Computational Approaches

GUSTAVO DECO<sup>1</sup>, EDMUND T ROLLS<sup>2</sup>

<sup>1</sup>Department of Technology, Computational Neuroscience, Universitat Pompeu Fabra, Barcelona, Spain

<sup>2</sup>Department of Experimental Psychology, University of Oxford, Oxford, UK

### Definition

Brain mechanisms for object and face recognition

### Characteristics

Cortical visual processing for object recognition is considered to be organized as a set of hierarchically connected cortical regions consisting at least of areas V1, areasV2, areasV4, **posterior inferior temporal cortex (TEO)**, and **anterior inferior temporal cortex (TE)** as shown in Fig. 1 [1].

There is convergence from each small part of a region to the succeeding region (or layer in the hierarchy) in such a way that the **receptive field** sizes of neurons (e.g. 1° near the fovea in area V1) become larger by a factor of approximately 2.5 with each succeeding stage

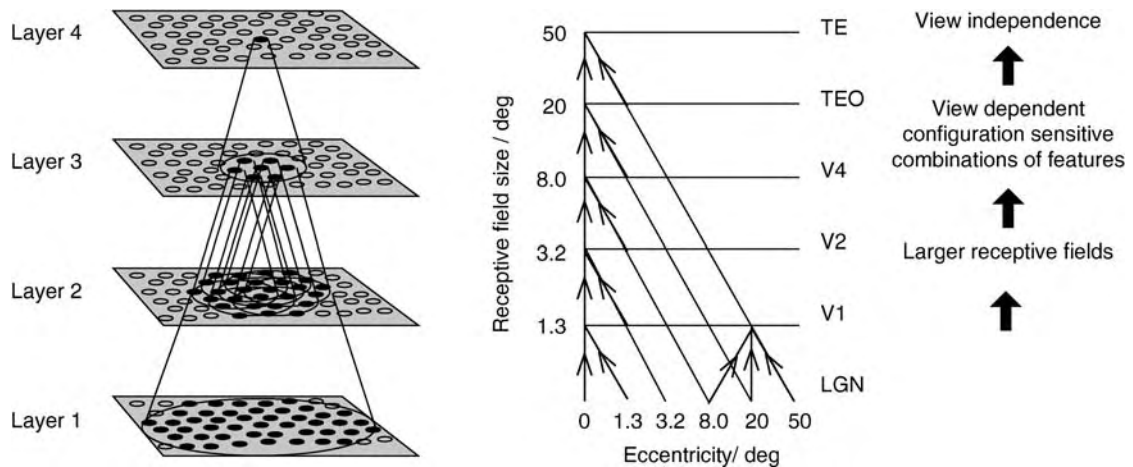

**Vision – Computational Approaches. Figure 1** Schematic diagram showing convergence achieved by the forward projections in the visual system, and the types of representation that may be built by competitive networks operating at each stage of the system from the primary visual cortex (area V1), through the secondary visual cortex (area V2), to area V4, then to the posterior inferior temporal cortex (TEO), and then to the anterior inferior temporal visual cortex (area TE) (see text). LGN - lateral geniculate nucleus. *Right*: as it occurs in the brain. *Left*: as implemented in VisNet. Convergence through the network is designed to provide fourth layer neurons with information from across the entire input retina.

features; in posterior inferior temporal cortex to stimuli which may require two or more simple features to be present; and in the temporal cortical face processing areas to images that require the presence of several features in a face (such as eyes, hair, and mouth) in order to respond [1]. It is an important part of this suggestion that the relative spatial location of the features would be inherent in the features which were being combined [3]. For example, cells might not respond to the combination of an edge and a small circle unless they were in the correct spatial relation to each other. Further combinations of such neurons at the next stage would include sufficient local spatial information so that an arbitrary spatial arrangement of the same features would not activate the same neuron, and this is the proposed, and limited, solution which this mechanism would provide for the feature-**binding problem**. It is suggested that view-independent representations could be formed by the same type of computation, operating to combine a limited set of views of objects [3].

In this biologically plausible scheme, the representation would be suitable for recognition of an object, and for linking associative memories to objects, but would be less good for making actions in 3D-space to particular parts of, or inside, objects, as the 3D coordinates of each part of the object would not be explicitly available. It is therefore proposed that visual fixation is used to locate in foveal vision part of an object to which movements must be made, and that local disparity and other measurements of depth then provide sufficient information for the motor system to make actions relative to the small part of space in which

a local, view-dependent, representation of depth would be provided [1,3].

To test and clarify these hypotheses, a network (VisNet) with the architecture shown in Fig. 1b has been simulated. It can perform object, including face, recognition in a biologically plausible way, and after training shows for example translation- and view-invariance [1–3].

The synaptic learning rule used can be summarized as follows:

$$\delta w_{ij} = k \cdot m_i \cdot r_j'$$

and

$$m_i^t = (1 - \eta)r_i^{(t)} + \eta m_i^{(t-1)}$$

where  $r_j'$  is the  $j$ th input to the neuron,  $r_i$  is the output of the  $i$ th neuron,  $w_{ij}$  is the  $j$ th weight on the  $i$ th neuron,  $\eta$  governs the relative influence of the trace and the new input (typically 0.4–0.6), and  $m_i^{(t)}$  represents the value of the  $i$ th cell's memory trace at time  $t$ . In the simulation the neuronal learning was bounded by normalization of each cell's dendritic weight vector, as in standard competitive learning [1].

To train the network to produce a translation-invariant representation, one stimulus was placed successively in a sequence of nine positions across the input, then the next stimulus was placed successively in the same sequence of nine positions across the input, and so on through the set of stimuli. The idea was to enable the network to learn whatever was common at each stage of the network about



a stimulus shown in different positions. To train on view-invariance, different views of the same object were shown in succession, then different views of the next object were shown in succession, and so on. It has been shown that the network can learn to form neurons in the last layer of the network that respond to one of a set of simple shapes (such as “T, L and +”) with translation-invariance, or to a set of 5–8 faces with translation-, view-, or size-invariance, provided that the trace learning rule (and not a simple Hebb rule) is used.

Further developments include analysis of more powerful learning rules; a solution to the feature-binding problem by the use of neurons that self-organize to represent feature combinations with the relative positions of the features part of what is required for a neuron to respond; operation of the system in a cluttered environment; generalization from trained to untrained views of objects; a new training algorithm named continuous transformation learning [3]; the incorporation of top-down connections so that attentional effects can be simulated [4] (see Fig. 2); and a unifying theory of how invariant representations of optic flow produced by rotating or looming objects could be produced in the dorsal visual system [3].

Related feature hierarchy approaches to invariant object recognition include investigations of Fukushima in 1991 and Riesenhuber, Poggio and colleagues [5] (though they did not have self-organizing learning rules), and investigations that performed function optimization to generate neurons in the later layers that were orthogonal and showed temporal continuity when trained on visual scenes [6].

### A Biased Competition Model of Object and Spatial Attentional Effects on the Representations in the Visual System

Visual attention (► Visual attention) exerts ► top-down influences on the processing of sensory information in the visual cortex, and therefore is intrinsically associated with inter-cortical neural interactions. Thus, elucidating the neural basis of visual attention is an excellent paradigm for understanding the basic mechanisms of inter-cortical neurodynamics. Recent cognitive neuroscience developments allow a more direct study of the neural mechanisms underlying attention in humans and primates. In particular, the work of Chelazzi, Miller, Duncan and Desimone in 1993 has led to a promising account of attention termed the biased competition hypothesis [7]. According to this hypothesis, ► attentional selection operates in parallel by biasing an underlying competitive interaction between multiple stimuli in the visual field toward one stimulus or another, so that behaviorally relevant stimuli are processed in the cortex while irrelevant stimuli are filtered out. Thus, attending to a stimulus at a particular location or with a particular feature biases the

underlying neural competition in a certain brain area in favour of neurons that respond to the location, or the features, of the attended stimulus.

Neurodynamical models for biased competition have been proposed and successfully applied in the context of attention and ► working memory. In the context of attention, Usher and Niebur introduced in 1996 an early model of biased competition. Deco and Zihl in 2001 extended Usher and Niebur’s model to simulate the psychophysics of visual attention by ► visual search experiments in humans. Their neurodynamical formulation is a large-scale hierarchical model of the visual cortex whose global dynamics is based on biased competition mechanisms at the neural level. Attention then appears as an emergent effect related to the dynamical evolution of the whole network. This large-scale formulation has been able to simulate and explain in a unifying framework visual attention in a variety of tasks and at different cognitive neuroscience experimental measurement levels, including single-cells, ► fMRI, psychophysics, and neuropsychology [1,8].

For example, Deco and Rolls [9] extended previous concepts of the role of biased competition in attention by providing the first analysis at the integrate-and-fire neuronal level, which allows the neuronal non-linearities in the system to be explicitly modeled, in order to investigate realistically the processes that underlie the apparent gain modulation effect of top-down attentional control. In the ► integrate-and-fire model, the competition is implemented realistically by the effects of the excitatory neurons on the inhibitory neurons, and their return inhibitory synaptic connections. This was also the first integrate-and-fire analysis of top-down attentional influences in vision that explicitly models the interaction of several different brain areas. Part of the originality of the model is that in the form in which it can account for attentional effects in areas V2 and V4 in the context of biased competition, the model with the same parameters effectively makes predictions which show that the “contrast gain” effects in area MT can be accounted for by the same model (see [9] and references therein). These detailed and quantitative analyses of neuronal dynamical systems are an important step towards understanding the operation of complex processes such as top-down attention, which necessarily involve the interaction of several brain areas.

### Extending Perceptual Models to Cognitive Processing

In addition to biased competition, there is also ► cooperation between neurons, where global representations find their neural correlate in assemblies of co-activated neurons. Co-activation is achieved by stronger than average mutual connections between the members of each assembly. Reverberatory communication between the members of the assembly then leads to persistent activation of the member neurons and gives

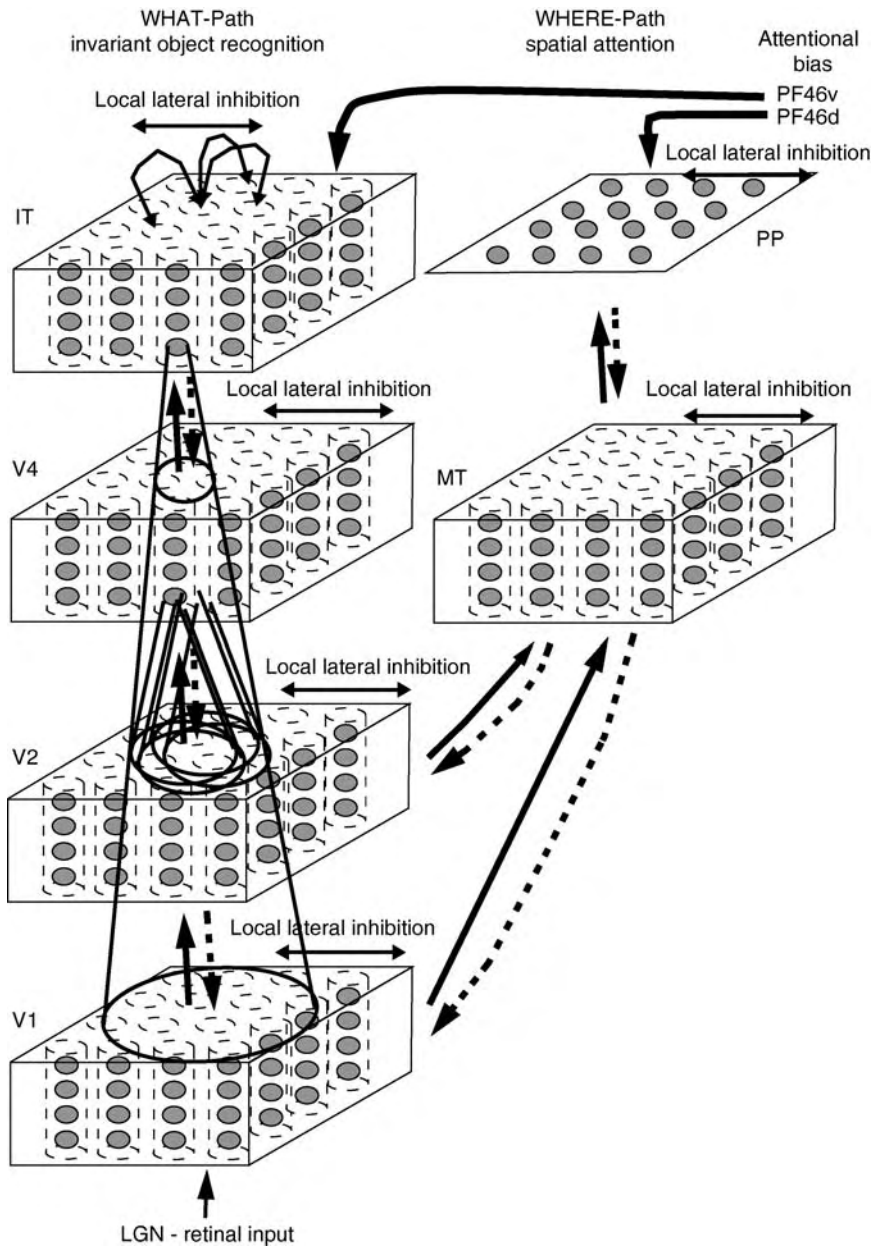

**Vision – Computational Approaches. Figure 2** Cortical architecture for hierarchical and attention-based visual perception. The system is essentially composed of five modules structured such that they resemble the two known main visual paths of the mammalian visual cortex. Information from the retino-geniculo-striate pathway enters the visual cortex through area V1 in the occipital lobe and proceeds into two processing streams. The occipital-temporal stream leads ventrally through areas V2-V4 and IT (inferior temporal visual cortex), and is mainly concerned with object recognition. The occipito-parietal stream leads dorsally into PP (posterior parietal complex), and is responsible for maintaining a spatial map of an object's location. The solid lines with arrows between levels show the forward connections, and the dashed lines the top-down back-projections. Short-term memory systems in the prefrontal cortex (PF46) apply top-down attentional bias to the object or spatial processing streams (after [4]).

rise to a representation extended in time. In this way, the theoretical and computational framework of *biased competition and cooperation* offers a unifying principle for neurocognitive modeling of higher neocortical functions [8]. Cognitive behavior requires complex

context-dependent processing of information that emerges from the links between attentional perceptual processes, working memory and reward-based evaluation of the performed actions. Indeed, *cognitive flexibility* requires coordination between associative

cortical areas that implement working memory, attention, expected rewards, and the alteration of behavior if reinforcers are not obtained as expected.

In this framework one can show how an attentional state held in short-term memory in the prefrontal cortex can by top-down processing influence ventral and dorsal stream cortical visual areas (► [Extrastriate visual cortex](#)); using biased competition to account for many aspects of visual attention. Furthermore, in the context of *working memory and reward processing*, one can model in a unifying form attentional and memory effects in the prefrontal cortex, integrating single-cell and fMRI data, and different paradigms in the framework of biased competition, including the following. (i) Visual Working memory, in the context of the “What” and “Where” paradigm and the Context-Dependent Delayed Match to Sample task (including modeling of single neuron responses, of fMRI signals, and of the effects of pharmacological manipulations which are relevant for clinical diagnosis) [8,9]. (ii) ► [Attentional Filtering](#), which represents a particularly strong attentional effect, in which the context gates sensory input in an all-or-none fashion. Moreover, attentional filtering might be part of a neural correlate of ► [inattention blindness](#), which is the inability of humans to recover any information from unattended sensory stimuli. Inattention blindness is thought to be part of an important cognitive mechanism, namely that of focusing or “concentrating” on a task to be performed [10]. (iii) ► [Selective Working Memory](#), which allows the formation of working memory, where task-relevant information is maintained in mind over a delay period while task-irrelevant information is filtered out through an attentional mechanism. (iv) Task-Switching in the Wisconsin card-sorting task. Earlier models involving semi-realistic neural networks focused on the existence of “rule coding clusters” and on perseverative errors. The current model improves the biophysical realism in order to generate predictions for functional MRI studies, and for lesion effects. The fMRI signal during task-switching was predicted in an implicit condition (where subjects had to detect a change in task by trial and error), and in an explicit condition (where subjects were informed about the change). Comparison with the actual fMRI data showed a close almost quantitative agreement with experimental data (Stemme, Deco, Busch and Schneider, 2005).

The models also directly address how ► [bottom-up processes](#) and top-down processes interact in visual cognition, and show how some apparently serial processes reflect the operation of interacting parallel distributed systems. It is also possible to show how within the prefrontal cortex attentional bias can influence the mapping of sensory inputs to motor outputs, and thus play an important role in decision making [8]. Furthermore, the absence of expected *rewards* can

switch the attentional bias signal, and thus rapidly and flexibly alter cognitive performance [8].

## References

1. Rolls ET, Deco G (2002) Computational Neuroscience of Vision. Oxford: Oxford University Press
2. Wallis G, Rolls ET (1997) Invariant face and object recognition in the visual system. *Prog Neurobiol* 51:167–194
3. Rolls ET, Stringer SM (2006) Invariant visual object recognition: a model, with lighting invariance. *J Physiol* 100:43–62
4. Deco G, Rolls ET (2004) A neurodynamical cortical model of visual attention and invariant object recognition. *Vis Res* 44:621–644
5. Serre T, Wolf L, Bileschi S, Riesenhuber M, Poggio T (2007) Robust object recognition with cortex-like mechanisms. *IEEE Trans Pattern Anal Mach Intell* 29:411–426
6. Wyss R, Konig P, Verschure PF (2006) A model of the ventral visual system based on temporal stability and local memory. *PLoS Biol* 4:e120
7. Desimone R, Duncan J (1995) Neural mechanisms of selective visual attention. *Annu Rev Neurosci* 18:193–222
8. Deco G, Rolls ET (2005a) Attention, short-term memory, and action selection: a unifying theory. *Prog Neurobiol* 76:236–256
9. Deco G, Rolls ET (2005b) Neurodynamics of biased competition and co-operation for attention: a model with spiking neurons. *J Neurophysiol* 94:295–313
10. Szabo M, Almeida R, Deco G, Stetter M (2004) Cooperation and biased competition model can explain attentional filtering in the prefrontal cortex. *Eur J Neurosci* 19:1969–1977

## Visual Action Space

- [Visual Space Representation for Reaching](#)

## Visual Acuity, Hyperacuity

### Definition

Visual acuity is the ability to perceive fine detail, usually measured as the minimal size and distance of two points, or of a set of alternating black and white lines (grating), required to see them separately. Visual acuity is commonly given in minutes of visual angle, e. g. human grating acuity is 1', cat grating acuity is

~10'. Acuity depends on the peak density and receptive field size of the smallest ganglion cell type in the area centralis/fovea. Hyperacuity refers to conditions where performance is better than at the two-point separation. Examples are Vernier acuity = the detection of an alignment offset between two lines (10" in man, 1' in cat), and stereo acuity = depth discrimination by the use of the two eyes

- ▶ Binocular Vision
- ▶ Retinal Ganglion Cells
- ▶ Visual Receptive Field

---

## Visual Association Cortex

- ▶ Extrastriate Visual Cortex

---

## Visual Attention

STEPHANIE A. McMAINS, SABINE KASTNER  
Department of Psychology, Princeton Neuroscience  
Institute, Center for the Study of Brain, Mind and  
Behavior, Princeton University, Princeton, NJ, USA

### Definition

The term “visual attention” refers to a set of cognitive operations that mediate the selection of relevant and the filtering out of irrelevant information from cluttered visual scenes.

### Characteristics

In everyday life, visual scenes typically contain more items than can be processed at any one time due to the limited processing capacity of the visual system. “Visual attention” refers to the cognitive operations that allow us to efficiently deal with this capacity problem by selecting relevant information and by filtering out irrelevant information. Attention is a highly flexible mechanism that can operate on regions of space, particular features of an object, or on entire objects. Attention can also be directed either overtly or covertly. For instance, if a barking dog ran up to you, you would not only direct your attention towards it, but would also look directly at it, deploying overt attention. On the other hand, if you are driving a car,

you might need to attend to an approaching pedestrian while still looking at the road, thereby deploying covert attention. In most laboratory settings, experiments investigate one particular type of attention, such as covert attention to a spatial location, but in everyday life, all forms of attention interact dynamically.

The two most common behavioral paradigms employed to study visual attention are the ▶ **spatial cueing paradigm** that probes attention to a single location or stimulus, and the ▶ **visual search** task that probes attention in the presence of distracters. In this chapter, we will outline the neural basis that underlies attentional operations in these two tasks, as they have been studied in humans using functional brain imaging and in non-human primates using electrophysiological techniques.

### Neural Basis of Single Stimulus Detection

The spatial cueing paradigm was invented by Michael Posner and is often simply referred to as the “▶ **Posner paradigm**.” In this paradigm, subjects look at a central fixation point and are given a brief cue instructing them to attend to a particular peripheral location. The cue can either be symbolic such as an arrow at fixation pointing to the target location, thereby indicating it abstractly, or physical such as a brief stimulus flashed at the target location. A symbolic cue requires subjects to deploy their attention endogenously, based on internal representations, while physical cues at the target location draw exogenous attention, a quick stimulus-driven orienting of attention to a salient stimulus. After a variable delay, a visual stimulus is presented briefly, which subjects are required to detect. On most trials, known as valid trials, the target appears at the cued (i.e. attended) location. On the rest of the trials, known as invalid trials, the target appears at an uncued (i.e. unattended) location. The typically observed response difference in detecting stimuli on valid and invalid trials is thought to reflect the effects of attention on selected locations in space. Attending to a location improves the accuracy and speed of reporting a target at that location and can increase perceptual sensitivity for target discrimination.

Attentional effects during Posner type cueing tasks have been investigated both in single-cell recording studies in monkeys and in neuroimaging studies in humans. In a typical physiology experiment, a stimulus is presented within a neuron’s receptive field (RF; ▶ **Visual cortical and subcortical receptive fields**), while the animal is either cued to covertly attend to the stimulus in the RF or to a different location in the visual field. Neural responses are enhanced when the animal attends to the stimulus in the RF as compared to when it attends away from the RF [1]. In general, attention effects are larger on “effective” stimuli that elicit a strong response when placed in the RF compared

to “non-effective” stimuli that elicit a small response. Attentional response enhancement has been observed in several areas in the macaque visual system including ► areas V1, V2, V4, MT, ► inferior temporal (IT) cortex and the ► lateral intraparietal (LIP) area (► Extrastriate visual cortex). Interestingly, attentional modulation of more advanced processing stages occurs earlier (after about 150 ms in IT cortex relative to stimulus onset) than that of early stages (after about 230 ms in area V1).

In a typical human experiment, instead of placing a single stimulus within a RF, identical stimuli are placed at corresponding locations to the right and left of a central fixation point, with one stimulus in each visual hemifield. Subjects are then cued to covertly attend to either the right or left visual field. When subjects attend to the cued stimulus, responses in visual cortex are enhanced (as early as 80–130 ms after stimulus onset) in the ► retinotopic representation of the attended stimulus compared to when subjects are cued to attend elsewhere in the visual field [2] (Fig. 1a). These results indicate that attention biases processing in favor of stimuli at the attended location at the expense of those at unattended locations (Fig. 1b). Such attentional response enhancement has been observed throughout the visual system, including subcortical processing stages such as the ► lateral geniculate nucleus (LGN) and cortical stages such as ► areas V1, V2, V3, V4, V3A, and MT (Fig. 1a). In cortex, the magnitude of attentional modulation increases from ► primary visual cortex (Brodmann’s area 17, striate cortex, area V1) to more advanced processing stages. Together with the latency differences of attention effects observed in monkey physiology this finding supports the idea that attention operates through top-down signals that are transmitted via corticocortical feedback connections, thereby reversing the visual processing hierarchy. However, this notion has recently been challenged by findings of larger attentional modulation in the LGN than in area V1 (Fig. 1). The greater LGN modulation may be due to additional feedback input from sources other than area V1 such as the ► reticular nucleus of the thalamus (TRN). Importantly, these findings suggest that attentional modulation in the visual system may be organized in more complex ways than by simply reversing the visual processing hierarchy.

Attentional enhancement has also been investigated during the cue period, when subjects are covertly attending to a spatial location prior to the onset of the target stimulus, in the absence of visual stimulation. Physiology and functional brain imaging studies [3] have revealed increased neural signals at the cued location (Fig. 1c). This attentional modulation in the absence of visual stimuli is termed a baseline increase and is thought to reflect a top-down bias of neural signals in favor of the attended location.

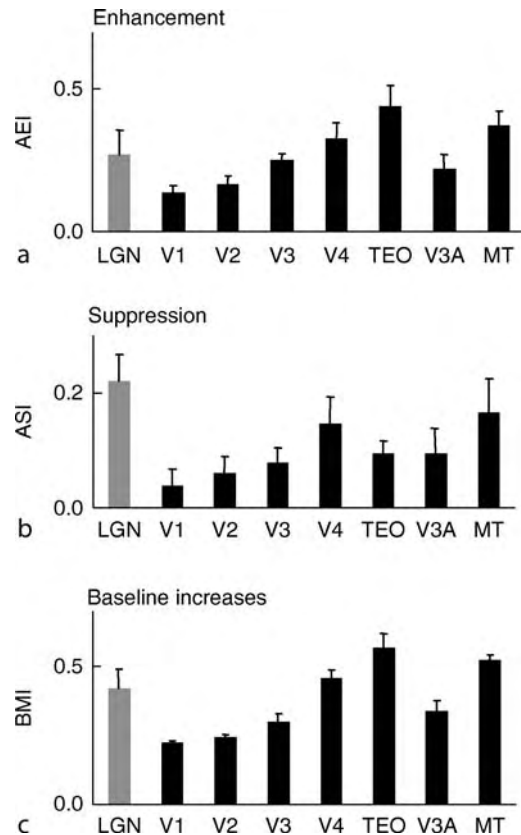

**Visual Attention. Figure 1** Attentional response modulation in the lateral geniculate nucleus (LGN) and in visual cortex. Checkerboard stimuli that reversed contrast at 7.5 Hz were presented in alternation either to the left or right visual hemifield. Subjects either detected luminance changes within the checkerboard stimuli or ignored the peripheral stimuli and performed a letter counting task at fixation. Attention effects were quantified by defining several indices: (a) attentional enhancement index (AEI), which reflects the amount of attentional enhancement observed when subjects attended to the peripheral stimuli, (b) attentional suppression index (ASI), which reflects the amount of suppression observed for the peripheral stimuli when subjects performed an attention task at fixation, and (c) baseline modulation index (BMI), which reflects cue period activity observed when subjects were attending to a peripheral target location in expectation of the stimulus onset (for index definitions, see O’Connor et al., 2002). For all indices, larger values indicate larger effects of attention. In visual cortex, attention effects increased from early to later processing stages. Attention effects in the LGN were larger than in area V1. Averaged index values from four subjects. Vertical bars indicate S.E.M. across subjects. (From O’Connor et al., 2002.)

In addition to biasing processing in favor of a spatial location, attention can also bias processing in favor of a particular stimulus attribute (► Feature-based attention) or in favor of an entire object (► Object-based attention).

In experiments investigating feature-based attention, stimuli are typically composed of multiple stimulus features (e.g. colored shapes moving in different directions), and subjects are cued to attend to a particular feature dimension (e.g. the color red) while ignoring the other dimensions. In monkey studies, neural responses increased, when the feature in the RF matched the cued feature regardless of where the animal was attending. Feature-based attention effects have been observed in area V4 for several feature dimensions including color, luminance, orientation, and direction of motion [4]. In human neuroimaging studies, where activity is measured at the level of entire areas within neural networks, researchers have taken advantage of the functional specialization of visual cortex (► [Visual perception](#)) in studying feature-based attention. In one such study, Corbetta and colleagues investigated attention to shape, color, or speed and observed enhanced activity in visual regions specialized for processing the attended feature, including enhanced activity in the posterior ► [fusiform gyrus](#) for attention to shape, area V4 for attention to color, and area MT for attention to motion.

Object-based attention signals have been investigated in human studies, in which subjects attend to a particular feature of an object, while signals evoked by the unattended features of the attended object are measured. In one such study, Kanwisher and colleagues used stimuli that consisted of overlapping images of houses and faces [5]. On any given trial, one of those images moved. Subjects attended to and performed a task on either the house, the face, or the motion, resulting in increased activity in regions specialized for processing the attended feature or object, that is, the ► [fusiform face area](#), ► [parahippocampal place area](#), or MT, respectively. Interestingly, activity also spread to the unattended feature of the attended stimulus. For instance, when the face stimuli were moving, and subjects attended to the faces, increased activity was observed in MT as compared to when subjects attended to stationary house stimuli. Thus, attentional biasing signals appear to spread to the unattended features of the attended object, resulting in enhanced signals in regions specialized for processing the unattended feature. These studies demonstrate that processing can be biased in favor of an attended object, with all features of the attended object receiving some amount of enhanced processing.

Taken together, the studies reviewed thus far provide converging evidence that attention biases processing in visual cortex towards a particular location, feature, or object by increasing the activity of neural populations that represent the attended aspect of the visual scene. However, many of the studies summarized thus far have only considered attention effects on a single stimulus or object while typical scenes contain several

objects, of which one is chosen for further processing. The attentional operations involved in such a selection process are studied in the visual search paradigm.

### Neural Basis of Visual Search

In a typical visual search task, subjects are given an array of stimuli (e.g. circles of different colors) and asked to report if a particular target stimulus (e.g. a red circle) is present in the array. Many factors affect the difficulty of this task. Anne Treisman and her colleagues have suggested that one important factor is how many features the target shares with other elements in the array. If the target (e.g. red circle) has a unique feature, such as being a different color from the distracters (e.g. green circles), the search is completed relatively quickly regardless of the number of elements in the array. This phenomenon is known as “pop-out” or efficient search. For other search arrays, where the target is defined by a conjunction of features (e.g. red horizontal line) that are shared by the distracters (e.g. red and green horizontal and vertical lines), search time increases as a function of the number of elements in the array. This is known as inefficient search, and each additional element in the array is thought to add about 50 ms to the time required to identify the target. Visual search type tasks are more similar to our everyday experience, where we typically face cluttered scenes with many objects that exceed our processing capacity. Due to limited processing capacity, multiple stimuli compete for processing resources in the nervous system. For instance, imagine you are watching your favorite TV program. This is much easier to do when alone in a room than when in a room full of rowdy children. The addition of sensory input interferes with your processing of the TV program. The neural substrate of competitive interactions among multiple sensory inputs in the visual domain is a mutual suppression of activity evoked by stimuli in nearby locations. In physiology studies, such suppressive interactions have been observed by comparing neural responses to stimuli presented alone in a neuron’s RF to those evoked by the same stimulus when presented together with a second stimulus within the RF [1]. The response to the two stimuli presented together has been shown to be a weighted average of the responses to each individual stimulus. For instance, if a single effective stimulus elicits a high firing rate and a single non-effective stimulus elicits a low firing rate, the response to the two stimuli presented together will be somewhere in between the firing rates of the individual stimuli. Competitive interactions among multiple stimuli have been found in several areas of macaque visual cortex including areas V2, V4, MT, ► [Cerebro-Cortical Area \(MST\)](#), and IT.

Competitive interactions have also been reported in human visual cortex using a design in which four

stimuli were presented in nearby locations in the periphery of the visual field, while subjects performed a task at fixation [3]. The peripheral stimuli were either presented simultaneously, allowing neural competition to occur, or sequentially, resulting in less competition for neural resources as the stimuli were not present in the visual field at the same time. Activity was reduced in the simultaneous relative to the sequential condition, suggesting that the stimuli interacted in a mutually suppressive way (Fig. 2a). These suppressive interactions were smallest in area V1 and increased in magnitude toward ventral extrastriate areas V4 and ►Cerebro-Cortical Area (TEO) (Fig. 2a). This increase in magnitude of suppression effects across visual areas suggests that competitive interactions were scaled to the RF size of the neurons, given that only neurons in area V4 and TEO have large enough RFs to encompass all four stimuli. This idea was tested directly in a second study in which the separation among the stimuli was increased. When the stimuli were moved further apart, suppressive effects weakened in areas V2 and V4 while remaining unchanged in TEO. Taken together, these monkey and human studies have begun to provide a neural basis for competition among multiple stimuli in cluttered visual displays.

According to the ►biased competition theory of attention, competition among multiple stimuli can

be biased by both bottom-up (stimulus-driven) and top-down (cognitive) factors. To probe bottom-up factors the four stimuli in the sequential/simultaneous paradigm described above were presented in a “pop-out” array, in which one stimulus differed in color and orientation from the others. Such an array results in an efficient search when probed in a visual search task. Competitive interactions among the four stimuli in the pop out array were eliminated, suggesting that competition was biased in favor of the salient “pop-out” stimulus.

Top-down attentional influences on competition have been studied in physiology studies, in which monkeys were instructed to attend to one of two stimuli present in the RF. Remarkably, neural responses to the attended stimulus were as large as if the stimulus was presented alone suggesting that attention operates by counteracting the suppressive influences of the second (distracter) stimulus [1]. Similarly, in humans, activity has been found to be greater for simultaneously presented (i.e. competing) stimuli when subjects attend to a stimulus in the presence of distracters (Fig. 2b). Taken together, these monkey and human studies suggest that attention may enhance processing of attended stimuli and counteract suppressive influences of distracters at intermediate stages of visual cortex. This may be an important mechanism by which unwanted information is filtered out effectively from cluttered visual scenes.

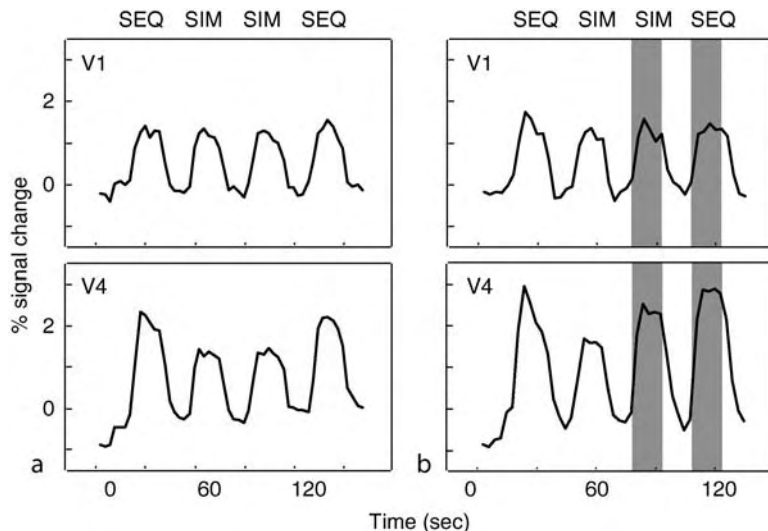

**Visual Attention. Figure 2** Competitive interactions and attentional modulation in visual cortex. (a) Suppressive interactions in areas V1 and V4. Simultaneously presented stimuli evoked less activity than sequentially presented stimuli in area V4, but not in area V1, suggesting that suppressive interactions were scaled to the RF size of neurons in visual cortex. (b) Attentional modulation of suppressive interactions. The suppression effect in area V4 was replicated in the unattended condition of this experiment, when the subjects’ attention was directed away from the stimulus display (*unshaded time series*). Spatially directed attention (*shaded time series*) increased responses to simultaneously presented stimuli to a larger degree than to sequentially presented ones in area V4. (Adapted from Kastner et al., 1998.)

Feature-based attention mechanisms have also been investigated in the presence of distracters. The observation that neural responses to a selected feature increases regardless of where the animal attends has led to the hypothesis that feature-based attention may operate globally throughout the visual field. If one considers a visual search task where subjects are looking for a red circle in an array of colored shapes, it will certainly be advantageous from a computational point of view to increase neural responses to any red items, thereby marking the candidate target stimuli and restricting the remaining search to the subset of red shapes to ultimately find the circle. This is opposed to space- and object-based attention, which are both inherently tied to a spatial location. This hypothesis has been tested in physiology studies, in which the effects of feature-based attention on unattended stimuli were systematically investigated [6]. Two moving dot patterns were presented in different locations of the visual field. The direction of motion of each stimulus was varied independently while one stimulus was attended and the other one was ignored. Neural responses to the ignored stimulus were investigated while two factors were varied, the similarity of the attended motion direction in relation to the unattended neuron's directional tuning function (i.e. whether the attended direction constitutes an effective or non-effective stimulus for the unattended RF), and the similarity between the attended direction of motion and the direction of motion presented to the unattended RF. Enhancement of responses evoked by the unattended stimulus depended on both factors. Feature-based attentional enhancement was greatest when the motion direction of the stimulus in the unattended RF was effective and also when it matched the attended direction.

A similar effect has been observed in humans in an experimental design with two stimuli, one presented in each visual hemifield [7]. The attended stimulus consisted of two overlapping dot patterns, one moving upward and the other moving downward. The stimulus in the unattended hemifield always moved in the same direction (e.g. downward). ▶fMRI signals were measured in the retinotopic representation of the unattended stimulus while subjects alternated between attending to the same direction as the distracter (i.e. downward) or to the opposite direction (i.e. upward). As in the physiology studies, signals evoked by the distracter stimulus were greater in areas V1, V2, V3, V3A, V4, and MT when it matched the attended direction. Taken together, these results suggest a feature-based attention mechanism that operates globally and biases processing throughout the visual field by enhancing the population response to attended features. This type of global attention mechanism might be important in guiding spatial attention to regions of the visual field that contain behaviorally relevant stimuli.

### Attentional Control Mechanisms in Frontal and Parietal Cortex

Converging evidence from patient, functional brain imaging, and physiology studies suggests that there is a distributed network of brain regions crucial for the control of attentional biasing signals that operate in visual cortex, as reviewed in the previous sections. It has long been known from the patient literature that unilateral brain lesions to regions of the ▶parietal lobe, ▶frontal lobe, ▶anterior cingulate gyrus, ▶basal ganglia, or pulvinar (▶Visual role of the pulvinar) can result in an impairment in spatially directing attention to the contralateral hemifield, often referred to as ▶visuospatial hemineglect. Patients suffering from neglect will ignore the visual hemifield contralateral to the side of the lesion, often failing to read from one side of a book, or ignoring food on one side of a plate. In less severe cases the deficit only becomes apparent when the patient is confronted with competing stimuli, such as in ▶visual extinction. When visual extinction occurs, patients are able to orient attention to an object presented to their impaired visual hemifield in isolation, but not when a competing object is presented simultaneously in the normal hemifield. When two stimuli are presented simultaneously, one in each hemifield, patients will only detect the one presented to the intact side.

In human neuroimaging studies, a network consisting of the ▶superior parietal lobe (SPL), ▶frontal eye fields (FEF), and ▶supplementary eye fields (SEF) (extending into the anterior cingulate cortex) has been found to be activated in tasks that involve spatial-, feature-, and object-based attention suggesting that it constitutes a general attention network (Fig. 3a) [8]. This network of brain areas heavily overlaps with that involved in oculomotor processing and thus appears to be recruited for both overt and covert attention [9].

Researchers have attempted to disambiguate regions involved with attentional operations, or “sources” that generate attentional biasing signals (i.e. the fronto-parietal network), from “sites” that receive the biasing signals via feedback connections resulting in modulation of ongoing processing in visual cortex. One such study in humans contrasted activations observed while subjects directed attention to a blank peripheral location in anticipation of the onset of a visual stimulus (expectation period) with activations following the onset of the peripheral stimulus while subjects detected the occurrence of a target stimulus [3]. During the expectation period, the same fronto-parietal network was activated as during the selection of relevant information, consisting of the SPL, FEF, and SEF (Fig. 3b). Importantly, there was no further increase in activity evoked by the attended stimulus presentations, rather there was sustained activity throughout the expectation period and the attended stimulus presentation (Fig. 3d). This is different from the activity in visual cortex, which increased during the



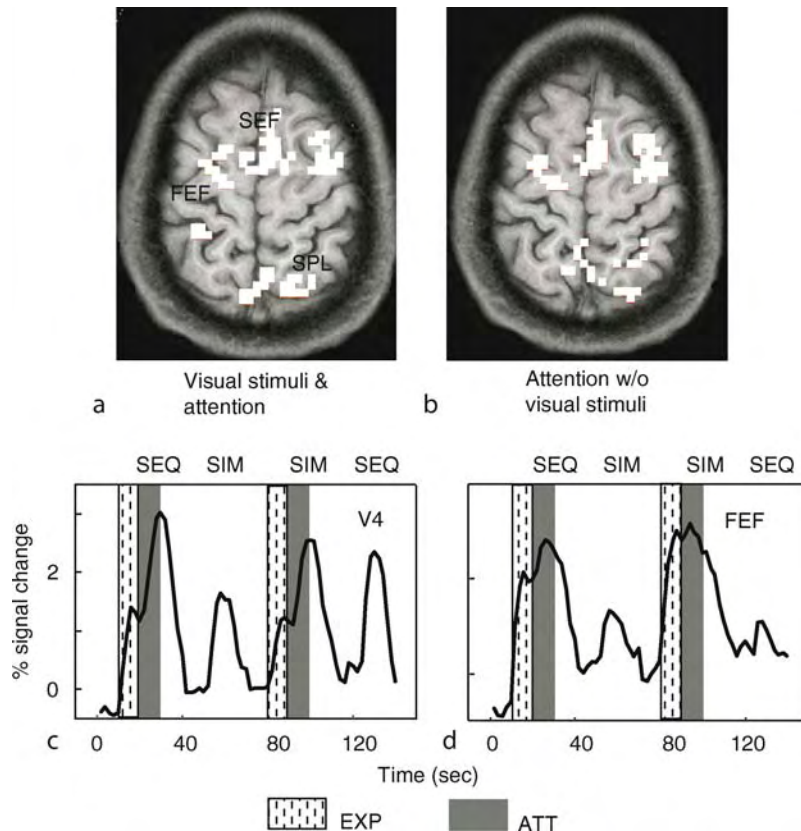

**Visual Attention. Figure 3** A fronto-parietal network for spatial attention. Axial slice through frontal and parietal cortex. (a) When the subject directed attention to a peripheral target location and performed a discrimination task, a distributed fronto-parietal network was activated including the SEF, the FEF and the SPL. (b) The same network of frontal and parietal areas was activated when the subject directed attention to the peripheral target location in expectation of the stimulus onset. (c) Time series of fMRI signals in area V4. Directing attention to a peripheral target location in the absence of visual stimulation led to an increase of baseline activity (*textured blocks*), which was followed by a further increase after the onset of the stimuli (*gray shaded blocks*). Baseline increases were found in both striate and extrastriate visual cortex. (d) Time series of fMRI signals in FEF. Directing attention to the peripheral target location in the absence of visual stimulation led to a stronger increase in baseline activity than in visual cortex; the further increase of activity after the onset of the stimuli was not significant. (Adapted from Kastner et al., 1999.)

expectation period but was also followed by an additional increase in activity during stimulus presentation (Fig. 3c). These findings suggest that activity in fronto-parietal cortex reflects the attentional operations of the task itself and not visual processing, implying that these regions are the sources of top-down biasing signals. This notion has been strongly supported by physiology studies in monkeys, in which subthreshold stimulation of eye movement representations within FEF resulted in spatial attention-like modulation of activity in retinotopically corresponding sites in area V4 [10]. Together, these studies indicate that the fronto-parietal network is the source of top-down attention signals that bias competition by facilitating neural processing of selected information and by filtering out suppressive influences of distracting information.

As reviewed in this chapter, visual attention comprises complex and flexible mechanisms that

engage a widely distributed network of brain regions ranging from subcortical nuclei to high-level regions in frontal cortex. All of these areas cooperate to mediate the selection of relevant stimuli from the environment for further processing based on the cognitive demands of the behavioral context.

## References

1. Reynolds JH, Chelazzi L, Desimone R (1999) Competitive mechanisms subserve attention in macaque areas V2 and V4. *J Neurosci* 19:1736–1753
2. O'Connor DH, Fukui MM, Pinsk MA, Kastner S (2002) Attention modulates responses in the human lateral geniculate nucleus. *Nat Neurosci* 5:1203–1209
3. Kastner S, Pinsk MA, De Weerd P, Desimone R, Ungerleider LG (1999) Increased activity in human visual cortex during directed attention in the absence of visual stimulation. *Neuron* 22:751–761

4. Motter BC (1994) Neural correlates of attentive selection for color or luminance in extrastriate area V4. *J Neurosci* 14:2178–2189
5. O’Craven KM, Downing PE, Kanwisher N (1999) fMRI evidence for objects as the units of attentional selection. *Nature* 401:584–587
6. Martinez-Trujillo JC, Treue S (2004) Feature-based attention increases the selectivity of population responses in primate visual cortex. *Curr Biol* 14:744–751
7. Saenz M, Buracas GT, Boynton GM (2002) Global effects of feature-based attention in human visual cortex. *Nat Neurosci* 5:631–632
8. Serences JT, Yantis S (2006) Selective visual attention and perceptual coherence. *Trends Cogn Sci* 10:38–45
9. Corbetta M, Shulman GL (2002) Control of goal-directed and stimulus-driven attention in the brain. *Nat Rev Neurosci* 3:201–215
10. Moore T, Armstrong KM (2003) Selective gating of visual signals by microstimulation of frontal cortex. *Nature* 421:370–373

---

## Visual Categories

### Definition

- ▶ Visual Object Representation
- ▶ Visual Perception

---

## Visual Cognition

- ▶ Visual Neuropsychology

---

## Visual Cortex: Neurons and Local Circuits

RODNEY J. DOUGLAS<sup>1</sup>, HENRY KENNEDY<sup>2</sup>,  
KEVAN A. C. MARTIN<sup>1</sup>

<sup>1</sup>Institute of Neuroinformatics UZH/ETH  
Winterthurerstrasse, Zurich, Switzerland

<sup>2</sup>INSERM u846, Stem Cell and Brain Research  
Institute, Department of Integrative Neuroscience, Bron  
cedex, France

### Definition

This essay describes the neuronal elements and the basic circuits they form in the ▶primary visual cortex. The

primary visual cortex is a clearly defined area of the ▶neocortex that receives input from the ▶retina relayed by the visual ▶thalamus and contains a complete representation of visual space. It has served as the key example for studies of the circuits and functions of neocortex.

### Characteristics

#### The Structure of Visual Cortex

The visual cortex is one of numerous areas of the neocortex that contribute to high-level perceptual, motor, and cognitive functions. There are about  $10^{11}$  neurons in the Central Nervous System (CNS), of which  $10^{10}$  comprise the neocortex. Over 50% of the non-human primate neocortex is involved in visual processing, compared to about 11% for somatosensory, 8% for motor, and 3% for auditory processing. The visual processing takes place in many different areas of neocortex and they are connected together in a hierarchy. The primary visual cortex, which receives the earliest visual input, comprises less than 10% of the cortex ( $10^8$  neurons in primates, and  $10^{(6-7)}$  neurons in rat and cat). The primary visual cortex, also called ▶visual area 1 (V1), ▶striate cortex, or ▶area 17, is the best-studied cortical area and so has been the primary source of knowledge of cortical neurons and circuits. As with the rest of the neocortex, the visual cortex is composed of six distinct layers. Its overall thickness is about 1.5 mm, which is about the average thickness of the neocortex across all mammals despite the wide range of brain size across species. The density of synapses ( $\sim 10^8$  synapses/mm<sup>3</sup>) is also remarkably constant across species. On the other hand, the density of neurons varies with cortical region, and histological layer. Sensory cortical areas, such as the visual cortex, have the densest neuronal packing (100,000 neurons/mm<sup>3</sup> in cat visual cortex, for example). On average, neurons receive the same number of synapses as they give, which is about 5,000 synapses. The axons that interlink cortical neurons in their local circuits extend only a few millimeters, but they are highly branched. If joined together, the nerve fibers contained within one cubic millimeter of neocortex would form a 4-km long thread. This is a vivid indication of the extreme degree of connectivity amongst the local cortical neurons.

Based on regional histological differences of the cortical layers, the primate neocortex can be divided into about 100 different areas, some of which correspond to functionally distinct areas. The cell densities in these various areas may differ significantly from the averages referred to above, with primary visual cortex. All regions of cortex are composed of the same basic types of neurons, which are found in approximately the same proportions throughout the neocortex.

### Synaptic Types

As in many other regions of the brain, the neocortex has two basic functional types of ▶synapses, excitatory and

inhibitory. These functional types correlate with distinct morphological types: asymmetric and symmetric. There is a very useful correlation between the morphology of the synapses, and their function. The asymmetric synapses excite their postsynaptic targets, while the symmetric synapses inhibit their targets. The two types of synapse are named for the presence of electron dense specializations on their ►postsynaptic membrane, but their ►neurotransmitter-containing vesicles also have distinctive morphologies. The most obvious distinction is that the electron dense structures lining the pre- and postsynaptic membranes are of equal thickness for inhibitory synapses (“symmetric” synapses), but for excitatory synapses the thicknesses are “asymmetric,” being much thicker on the postsynaptic side than the presynaptic. Symmetric synapses also usually have pleomorphic synaptic vesicles, while for asymmetric synapses the vesicles are spherical.

### Neuronal Types

There are no universally agreed criteria for classifying cortical neurons, but like synapses they come in two basic types, with many subdivisions (Fig. 1).

These two classes have physiological correlates: the spiny neurons of neocortex are excitatory, while the smooth neurons are inhibitory. The “spiny” cells are so-named, because their dendrites bear thousand of

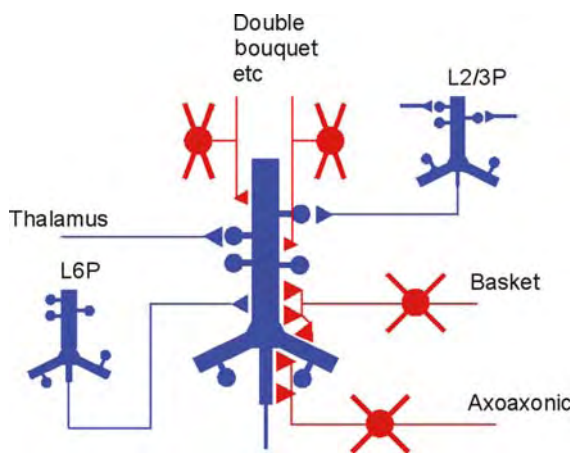

**Visual Cortex: Neurons and Local Circuits. Figure 1** Schematic of excitatory and inhibitory cortical neurons and their synaptic targets. In the center is a pyramidal cell (blue) with typical club-like spines, which form excitatory synapses with thalamic axons arising from the dorsal lateral geniculate nucleus (dLGN) and other pyramidal cells of layers 2/3 (L2/3P). The layer 6 pyramidal cells (L6P) form excitatory synapses. The pyramidal cell shown to be inhibited by axo-axonic or “chandelier” cells, by basket cells and by double-bouquets cells, each of which forms synapses on different parts of the pyramidal cell, including the initial segment of the pyramidal cell’s axon.

club-like protrusions called “►spine”, which are a few microns in length. The smooth neurons are so-named, because they lack dendritic spines. Different types of spiny neurons are classified according to their shape of their dendritic tree and the layer in which their cell body is located, while the smooth neurons are classified, not on the basis of dendritic morphology, but on the basis of their axonal morphology. Spiny neurons have about  $10^3$ – $10^4$  spines per neuron. Spines are the major location where synapses are formed and each spine receives only one excitatory synapse. In addition to the excitatory synapse, about 8% of spines receive also an inhibitory synapse. Why some cells have spines and others do not, is not known. The role of the spine itself remains mysterious. One possibility is that spines offer some electrical advantage in controlling the effect of the spine synapse on the input to the post-synaptic neuron. Another possibility is that spines provide a local chemical environment that is isolated from the trunk dendrite and able to support specific metabolically mediated long-term changes in synaptic efficacy. Yet another is that the spines provide a motile “leash” that enables the postsynaptic neuron to select actively amongst the possible presynaptic input synapses in the vicinity of the spine.

### Spiny Neurons

Spiny neurons can be broadly subdivided into two groups: the ►spiny stellate cells, named for their radially symmetrical dendrites that give them a star-like appearance, and the ►pyramidal cells, which are characterized by one apical dendrite, which is much thicker than the basal dendrites (4–8  $\mu\text{m}$  diameter, compared to 1–1.5  $\mu\text{m}$  for the basal dendrites) and extends upward to the surface of the cortex. In the primary sensory areas such as the primary visual cortex, spiny stellate cells are the main cell type in layer 4, which is the major target layer of input from the thalamus. The axons of spiny stellate cells project horizontally within layer 4 and upward into the more superficial layers. Only rarely do they project out of their own cortical area. However, in the remaining layers the spiny neurons are represented exclusively by the pyramidal cells, which comprise 70–80% of all cortical neurons.

Pyramidal cells each have about 8 basal dendrites, dispersed radially about the soma and one apical dendrite, which gives rise to oblique branch dendrites close to the soma. Although the apical dendrite is a very prominent feature, it contributes only about 10% of the total dendritic length of the pyramidal cell. The overall length of basal dendrites, measured from soma to their tips, is 150–200  $\mu\text{m}$ . The length of the apical dendrite depends on the cortical depth of the soma. Some layer 5 (L5) pyramidal cells have apical dendrites of over 1.0 mm. The pyramidal cells found in the superficial

layers of cortex (layers 2 and 3) have apical dendrites that ramify in the top of layer 2 and in layer 1. The local arborization of their axon is either in the superficial layers, or in layer 5 and 6.

In general the axons of the deep pyramidal cells arborize in the superficial layers or in the deep layers, only rarely in both. Many have axons that project out of the cortical area. The pyramidal cells of layer 5 can also be divided into two classes on the basis of the morphology of their dendrites. One class has thick apical dendrites that branch in top layer 2 and layer 1, and the others have thin apical dendrites that end in the superficial layers without further branching. Layer 5 is the only layer of visual cortex that projects to nuclei involved in motor control. A major target of the layer 5 cells is the ►superior colliculus, which is part of the system that drives ►saccadic eye movements. The apical dendrites of L6 pyramidal neurons ramify in layer 4, and the single thin apical trunk ends in the superficial layers. Their axons mainly in layer 4, but unusually, the majority of synapses made by layer 6 pyramidal cells are with dendritic shafts of other spiny neurons, not with their spines. Many layer 6 pyramidal cells also project back to the dorsal ►lateral geniculate nucleus (dLGN).

Spiny neurons make most of their synapses onto the spines and shafts of other spiny cells. 85% of the contacts are onto spines, and 14% onto shafts. Less than 50% of the postsynaptic shafts are ►GABA-ergic. 1% of the synapses are made with the cell bodies of GABA-ergic neurons. Overall, 80–90% of pyramidal cell synapses are made onto spiny cells, which are usually other pyramidal cells, and the remainder are made with smooth cells. Each pyramidal neuron usually forms only 1–5 synapses with a single target cell.

### Smooth Neurons

The smooth neurons comprise between 15–20% of cortical neurons. They are called “smooth” merely to indicate that they have very few, if any, spines. The smooth neurons have varicose, multipolar dendrites and are rather irregular in appearance. Smooth cells contain GABA and they make symmetrical synapses with their targets. Not all the symmetrical synapses of the cortex are made by synaptic boutons that contain GABA. Immunocytochemical studies have shown that some symmetrical synapses are formed by boutons that contain ►acetylcholine, ►noradrenalin, ►dopamine, ►serotonin, or ►neuroactive peptides. However, the vast majority (99%) of symmetrical synapses are formed by GABA-ergic synaptic boutons. The symmetrical synapses account for 16% of all synapses in the primary visual cortex.

Although smooth neurons only constitute a minority of cortical neurons, they seem to have more variety in their morphological appearance. The total number of

different varieties is not certain, but each layer seems to possess its characteristic types. Layer 1, which is sparsely populated with neurons, contains only GABA-ergic neurons, which include the large horizontal ►Cajal-Retzius cell, which contain the protein “reelin,” which is important for the control of neuronal migration. Many other types are found in all the other layers and include ►basket cells, ►chandelier cells (or “axo-axonic” cells), ►double-bouquet cells, ►neurogliaform cells and ►Martinotti cells. The exact proportions and connectivity of each cell type is not known. Each GABA-ergic neuron contains one of three different  $\text{Ca}^{2+}$ -binding proteins. The basket cells and chandelier cells contain a  $\text{Ca}^{2+}$ -binding protein called parvalbumin, while the double-bouquet cells contain calretinin, or calbindin. The parvalbumin-containing neurons form synapses on the proximal portions of their target neurons (cell body, axon initial segment, and proximal dendrites), while the calbindin- and calretinin-containing neurons form synapses on the distal parts of the dendritic tree of their targets. Experimentally, the basket cells are encountered most frequently, so most is known about them. Their axons ramify within the layer of its cell body. The superficial and deep basket cell axons may extend 1–1.5 mm, but the clutch cell axonal arborization is restricted to only about 0.3–0.5 mm. Each basket cell contacts about 300 target cells, making roughly ten synapses with each target. Each pyramidal cell receives input from about 10–30 basket cells.

We suspect that the different smooth cell types and the different distributions of synapses on their target neurons reflect different functions, but this has not yet been established. It is possible, for example, that different types of smooth cells effect either local, or inter-areal operations; or that some mediate different dynamics of inhibition. One celebrated case that begs a linkage between connectivity and function is that of the chandelier (axo-axonic) cell. These cells are located mainly in superficial layers and their axons terminate exclusively on the initial segment of pyramidal cells, mainly in the superficial layers. The initial segment is a thickening at the beginning of the axon that is thought to be the locus of action potential initiation, and is an attractive site for possible inhibitory control. However, the action of such inhibition is unknown.

### Inputs to Visual Cortex

#### Subcortical Inputs

The local circuits in visual cortex receive their input from the dorsal lateral geniculate nucleus (dLGN) of the thalamus, which is the major nucleus for processing retinal information before passing it on to the primary visual cortex. In primates there are about  $10^6$  neurons in the dLGN that project to the  $10^8$ – $10^9$  cells of V1. The input ratio of 1:1,000 gives some indication of the active role that the cortical circuitry must play in the

interpretation of the input data. Layer 4 is the principal target layer of the dLGN input (Fig. 2), but all other layers also receive an input from the dLGN. The dLGN is divided into eye-specific sublayers and this segregation of left and right eye is maintained in the distribution of dLGN axon terminals in layers 4 and 6, where they form patchy domains of terminals about 0.5 mm wide.

The left and right eye columns are reminiscent of zebra stripes when looked at from above and this pattern is known as “▶ocular dominance columns.”

The dLGN synapses are excitatory (glutamate is the neurotransmitter) and they activate both spiny and smooth cells. However, even in layer 4 the dLGN provides less than 10% of the total number of excitatory synapses. The arbor of a single dLGN terminal forms 1,000–10,000 boutons and each bouton forms on

average more than one synapse. However, any particular cortical cell receives only a few synapses from a single dLGN relay cell, so each relay cell may form synapses with several thousand cortical cells. Thus, the contribution from one relay cell to a particular cortical cell is very small, and provides only a fraction of a percent of its total excitatory synaptic input.

In addition to the dLGN, which provides the major sensory input, about 20 other subcortical structures project to the neocortex. The monoaminergic systems are the best studied of these and include the dopamine-positive fibers arising from the rostral mesencephalon, the noradrenalin fibers originating from the ▶locus coeruleus, and the serotonin fibers that originate from the mesencephalic ▶raphé nuclei. The monoaminergic projections are thought to be facultative in the processes

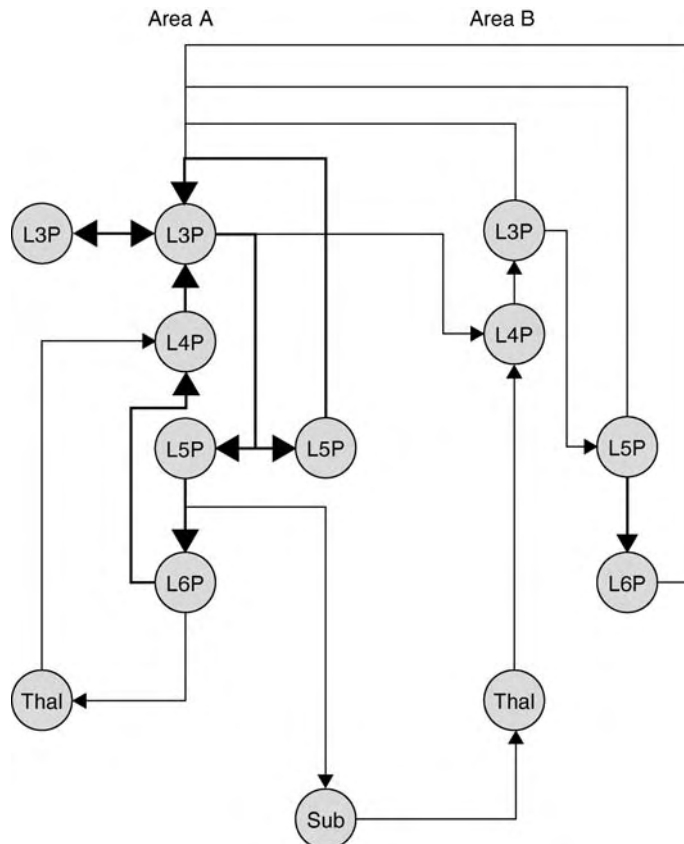

**Visual Cortex: Neurons and Local Circuits. Figure 2** Graph showing the dominant interactions between significant excitatory cell types in neocortex, and their sub-cortical and interareal relations. The nodes of the graph are organized approximately spatially; vertical corresponds to the layers of cortex, and horizontal to the lateral extent. *Linking arrows* show the direction of excitatory transmission. *Lines in bold* indicate the relations between excitatory neurons in a local patch of neocortex. *Thin lines* indicate excitatory connections to and from subcortical structures and other cortical areas. Each node is labeled for its cell type. For cortical cells the number after “L” refers to the layer in which the cell body is located and P indicates that it is an excitatory neuron (generally of pyramidal morphology). “Thal” denotes the dorsal lateral geniculate nucleus of the thalamus, and “Sub” indicates target structures such as the superior colliculus.

of **cortical plasticity**. However, the dopaminergic neurons, which are thought to provide an error signal during **trial-and-error learning**, project mainly to the prefrontal cortex and not to the primary visual cortex.

### Outputs from Visual Cortex

Of the  $10^{10}$  cells in cortex, only about  $10^{(7-8)}$  project to extra-cortical targets. This means that over 99% of cortical cells are involved only in intracortical circuits. The inter-areal projections are exclusively axons of spiny cells. The targets of these projections are always both spiny and smooth cells. None of the projections in cortex that have been studied so far terminate exclusively on excitatory or inhibitory targets. However, the ratio of excitatory to inhibitory terminations may vary and so the balance of excitation and inhibition could be an important aspect of each projection.

Superficial pyramidal cells tend to project to other cortical areas, whereas deep pyramidal cells tend to project both to other cortical areas and subcortically (Fig. 2). The extent of the subcortical projections is quite large in some contexts. For example, the projections from the L6 pyramidal cells to the LGN are ten times more numerous than the geniculocortical projections themselves. The purpose of this arrangement is still not known.

Although most pyramidal cells project outside their cortical area, they have extensive collaterals that project within their local area and they make about 80% of their synaptic contacts within a few dendritic diameters (1–2 mm) of their cell body. Thus, the major component of cortical processing seems to be local. Where projections between cortical areas occur, they are usually associated with a reciprocal connection from their target area. Usually the forward projections arise from the pyramidal cells of the superficial layers and terminate in the middle layers of the target area, whereas the backward projections arise in layers 3 and 5 of the target area and terminate outside the middle layers – in layer 1 and 2 and layer 5 and 6 of the target area.

### Organization of Neuronal Types in Circuits

There are two features of cortical neurons that simplify the analysis of cortical circuits. One is that the dendritic and axonal projections of the different types of neurons are laminar specific. The second is that the different types of neurons make stereotyped synaptic connections with each other. For example, all spiny cells make 85% of their connections with other spiny cells. When a layer 5 pyramidal cell axon is observed to form most of its synaptic boutons in layer 6, then it is safe to assume that its major connection is to the pyramidal cells of layer 6. By defining the principal layers to which the different spiny cell axons project and assuming that they connect mainly to the neurons located in the target layers, a possible basic circuit of the cortex emerges (Fig. 2).

In this basic circuit, the thalamic input arrives in layer 4. The excitatory cells in layer 4 project to the superficial layers. The superficial pyramidal neurons project to layer 5, which in turn project to layer 6, and the loop is closed by a projection from layer 6 to the input layer 4 (Fig. 2). This circuit infers only the connections of the spiny, excitatory neurons. The spiny neurons as a class provide most of the inter-laminar connections within a cortical area, whereas the axons of smooth neurons principally arborize locally within their layer of origin. The cardinal feature of the circuits of the neocortex is that they form rich excitatory and inhibitory connections with each other. These are referred to as “recurrent” circuits.

Overall, the spiny cells provide the basic framework of long distance excitation in both the vertical and lateral dimensions, which is then shaped by local inhibitory neurons. In the visual cortex this sequence of processing was thought to be the mechanism by which the **receptive fields** are elaborated from simple to complex. The interlaminar connections are also the means whereby common properties are transmitted to a radial “column” of cells. This “columnar” organization of functional properties is the means whereby common functional attributes can be represented by all the neurons in a given patch of cortex. In the visual cortex there are many common properties shared by all the neurons in a radial column that extends from layer 1 to layer 6, including common position in their representation of visual space, orientation of the stimulus, and their eye preference. These local circuits between and within the 6 layers of the visual cortex provide the major processing required to correctly interpret the enormous amount of information relayed from the retina by the dLGN every second. While we understand more about the elements that make up the visual cortex than any other area, we are still some way from understanding the general principles by which visual cortex processes its inputs.

### Acknowledgements

This work was supported by EU FP6–2005 IST-1583. ANR-05-NEUR-088(HK); SNF NCCR NEURAL PLASTICITY AND REPAIR (KM).

### Reference

1. Binzegger T, Douglas R, Martin K (2004) A quantitative map of the circuit of cat primary visual cortex. *Journal of Neuroscience*, 24:8441–8453
2. Douglas RJ, Markram H, Martin KAC (2003) Neocortex in the Synaptic Organization of the Brain, GM shepherd (ed), 499–558, Oxford university Press
3. Douglas RJ, Martin KAC (2004) Neuronal circuits of the neocortex. *Annual Review of Neuroscience* 27:419–451
4. Douglas RJ, Martin KAC (2007) Recurrent neuronal circuits in the neocortex. *Current Biology* 17:R496–R500

## Visual Cortical and Subcortical Receptive Fields

JUDITH A. HIRSCH<sup>1</sup>, LUIS M. MARTINEZ<sup>2</sup>

<sup>1</sup>Department of Biological Sciences, University of Southern California, Los Angeles, CA, USA

<sup>2</sup>Instituto de Neurociencias, CSIC – Universidad Miguel Hernández, Alicante, Spain

### Synonyms

Center-surround receptive fields; Simple receptive fields; Complex receptive fields

### Definition

The term ►receptive field refers to the region of visual space where changes in luminance influence the activity of a single neuron. Receptive fields of different types of cells in the visual pathway have different substructures. For example, receptive fields with a center-surround structure are common in the ►retina and ►lateral geniculate nucleus of the ►thalamus whereas most cells in the ►primary visual cortex have either simple or ►complex receptive fields.

### Characteristics

#### Subcortical Receptive Fields

##### The Retinal Receptive Field

Although we see the world as a seamless whole, our perception is based on the contribution of many cells, each encoding only a small area of visual space. An individual neuron's window on the world is called its "receptive field." This term was coined by Hartline to explain his observations of how single retinal ganglion cells (►Retinal ganglion cell) in the frog's retina

respond to light [1]. Hartline described the receptive field as the retinal region where a change in luminance either reduced or increased a neuron's activity. Later, Kuffler, recorded from ganglion cells in the mammalian retina and found that their receptive fields had a stereotyped substructure [2]. The entire field covered a roughly circular patch that was divided into two concentric subregions; a disk shaped "center" and an annular "surround" (Fig. 1a). The border between the center and surround was defined by preference for stimulus ►contrast. A spot of light shone in an On subregion evoked excitation at short latency (Fig. 1b). If the dark spot was flashed in same place, however, firing rate increased only after the stimulus was removed (Fig. 1c). Thus, On responses are driven by increases in luminance and Off responses by decreases in luminance. Based on such response patterns, Kuffler divided ganglion cells into two classes, ►On center cells and ►Off center cells.

#### Antagonism Between the Center and Surround Retinal Receptive Field

Kuffler also found that the center and surround had an antagonistic influence on each other (►Center-surround antagonism). This mutual suppression results from push-pull responses to stimuli of the reverse contrast within each subregion; that is, where bright stimuli excite, dark stimuli inhibit. How does the geometry of the receptive field combine with push-pull to influence neural responses? As mentioned above, a small bright spot confined to an On center evokes robust excitation. If that bright spot is presented along with a dark annulus in the surround, then that bull's-eye stimulus elicits even greater excitation. But, if the both the On center and Off surround are filled by a large bright stimulus, the level of excitation induced is less than that driven by illumination of the center alone, (Fig. 1d). Ganglion

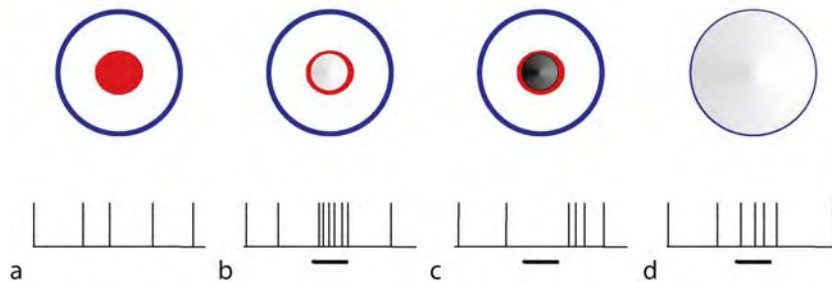

**Visual Cortical and Subcortical Receptive Fields. Figure 1** Neural responses of cells with center-surround receptive fields. Panels (a–d) represent responses of a single On center retinal ganglion cell or thalamic relay cell to different types of visual stimulation; the On center is represented by a red disk and the surround by a blue circle. In ambient lighting, the cell fires spontaneously (a). A bright spot falling in the center is excitatory; stimulus position is indicated by the shaded disk in the receptive field and stimulus duration is symbolized by the horizontal bar at bottom (b). A dark stimulus at the same position suppresses firing (c). Stimulation of the center and surround with bright light evokes weaker excitation than illumination of the center alone (d).

cells with Off centers and On surrounds behave in a commensurate fashion.

### **Functions of the Retinal Receptive Field**

Not long after Kuffler's work was published, it became clear that structure of the retinal receptive field was well suited to perform specific tasks in visual processing. The concentric placement of On and Off subregions made single cells sensitive to local changes in stimulus ►contrast (as if each cell were a spot detector). The antagonistic relationship between subregions enhanced this sensitivity and served another function too. Specifically, Barlow and colleagues suggested that subfield antagonism reduces redundancy in the visual signal transmitted downstream to the thalamus and cortex [3] (►Sensory senses). This reduction is analogous to image compression in computer vision. The importance of this concept has gained importance over time as it has become clear that natural images, like those of the landscapes or social gatherings we see daily, are themselves highly redundant (►Experience with natural images as a basis for vision). That is, natural images contain significant spatial correlations – neighboring points in the image often have similar luminance values [4] (►Vision). Subfield antagonism reduces the number of spikes that are required to convey information about redundant segments of the visual scene. Last, apart from its role in visual processing *per se*, subfield antagonism helps to conserve energy by limiting the number of spikes required to encode images – spikes, after all, are metabolically expensive.

### **Similarities and Differences in the Receptive Fields of Different Retinal Ganglion Cells**

There are many types of ganglion cells, with the greatest diversity found in primates (►Retinal ganglion cells; ►Visual processing streams in primates). Cells in each class form a layer in the retina and are arranged as an anatomical mosaic such that their receptive fields tile all of visual space. Even though ganglion cells all have receptive fields with a center-surround structure, for some the border between center and surround is defined by sensitivity to different wavelengths rather than intensities of light. In other words, some types of ganglion cells have subregions divided by preference for stimulus color rather than contrast. Another difference among the receptive fields of different ganglion cells is size. Some classes of ganglion cells have receptive fields that are relatively small (e.g. X cells in the cat or P cells in the monkey) or large (e.g. Y cells in the cat or M cells in the monkey) at any given position in the retina. Cells with the smallest fields confer the finest degree of spatial acuity; that is, they are tuned to the highest spatial frequencies [5]. Despite such differences among classes of ganglion cells, the structure of the retinal receptive field can be

generalized. It is often characterized mathematically as the difference of two Gaussians, one a narrow function representing the center and the other a wide function symbolizing the surround [5].

### **The Structure of Receptive Fields in the Lateral Geniculate Nucleus of the Thalamus**

Retinal ganglion cells project to the lateral geniculate neurons of the thalamus. Relay cells in the lateral geniculate nucleus reprise the center-surround structure of their presynaptic partners [6]. Yet, this does not mean that the thalamic fields are direct copies of those in retina. A single relay cell might receive inputs from multiple ganglion cells, hence remixing the spatial information sent from retina. The subregions that build thalamic receptive fields also are mutually antagonistic and have a push-pull arrangement of excitation and suppression. This pattern is not simply fed forward from the eye, however; it is generated *de novo* by local inhibitory circuits.

### **Receptive Fields in the Primary Visual Cortex** **Simple Receptive Fields**

Hubel and Wiesel joined the Kuffler laboratory and made the first recordings from the primary visual cortex. They found a population of cortical neurons that they named ►simple cells because of striking similarities with relay cells [6]. Like receptive fields in the thalamus, simple receptive fields were divided into On and Off subregions that had an antagonistic influence on each other. Unlike the subcortical concentric pattern, however, the On and Off subregions were elongated and lay side by side. What made this discovery so exciting was that the new geometric arrangement correlated with the emergence of neural sensitivity to stimulus ►orientation. In the thalamus, a ►contour of any orientation drives cells vigorously, provided the stimulus covers a much larger fraction of the center than the surround. This is not the case for simple cells. These neurons respond briskly to a stimulus aligned with the long axis of a sign-matched subregion; for example, a bright bar flashed over an On subfield elicits a strong discharge. But as the bar is tilted farther and farther away from the preferred angle, it evokes fewer and fewer spikes.

Thus, as in the retina and thalamus, the structure of this new type of cortical receptive field has the potential to explain how neural response properties are generated. In the retina and thalamus, neural receptive fields confer sensitivity to highly localized boundaries in light intensity. This local selectivity is pooled by cortical neurons for the detection of spatially extended contrast borders, e.g. edges, of various orientations. The ability to detect oriented contours is widely viewed as an essential step in parsing the visual scene into its meaningful components. Moreover, in the spirit of Barlow, theoretical studies show that the simple



receptive field is ideal for efficiently encoding natural images [4].

### Circuits Build the Simple Receptive Fields

By marking recording sites with electrolytic lesions, Hubel and Wiesel linked the simple receptive field to cortical layers 4 and 6, the regions where thalamic afferents terminate. Combining this anatomical result with their physiological observations, they proposed a model of how cortical receptive fields were built. The essence of the idea is that convergent input from On and Off center relay cells, whose receptive fields are aligned in visual space, build the On and Off subregions of the cortical fields (Fig. 2a, left) (see also ► [Geniculostriate pathway](#); ► [Striate cortex functions](#)). This feed-forward circuit for the simple receptive field has received substantial experimental support [7]. Also, the circuit has been expanded to include inhibitory simple cells that complete a push-pull profile within subregions [7] (Fig. 2a, right). Although simple receptive fields vary in terms of the number, length and width of component subregions, they have a stereotyped shape and are often represented in computational models as 2D Gabor functions (sinusoidally modulated Gaussian functions) [8].

### Complex Receptive Fields

A second type of cortical receptive field is called complex. This category was originally defined by exclusion to encompass all receptive fields that lacked spatially opponent and mutually antagonistic subregions [6]. Most ► [complex cells](#) that Hubel and Wiesel reported were tuned for stimulus angle and were excited

by bright or dark bars placed anywhere within the receptive field (there are exception to these rules; a fraction of complex cells respond only to stimuli of one contrast while others are not oriented). Hubel and Wiesel originally believed that all complex receptive fields were generated hierarchically by convergent input from simple cells that had the same orientation preference but different arrangements of On and Off subregions (Fig. 2b, left). It later became clear that a minority of complex cells receive direct input from lateral geniculate relay cells (Fig. 2b, right). Presumably there are also complex receptive fields that are constructed by input from other complex cells. Complex cells are found in all six cortical laminae, with stereotypic differences in response properties in each layer [7].

The idea of the hierarchically constructed complex receptive field was formalized with the “energy model” [9]. The model builds complex receptive fields by squaring and summing the responses of Gabor filters that represent simple cells. These Gabor filters have similar spatial frequencies (the simulated subfields are of equal width) and orientation but are arranged in quadrature so that the “On” and “Off” subregions overlap.

### Mapping Cortical Receptive Fields

Different techniques are required to map simple vs. complex receptive fields [10]. Simple receptive fields can be mapped easily with stimuli like visual noise. One of the first noise patterns used was sparse noise – small, dark or bright rectangles flashed individually in random order [8]. The power of modern computers has made the use of complicated noise patterns, like those with a Gaussian distribution of luminances, common as well.

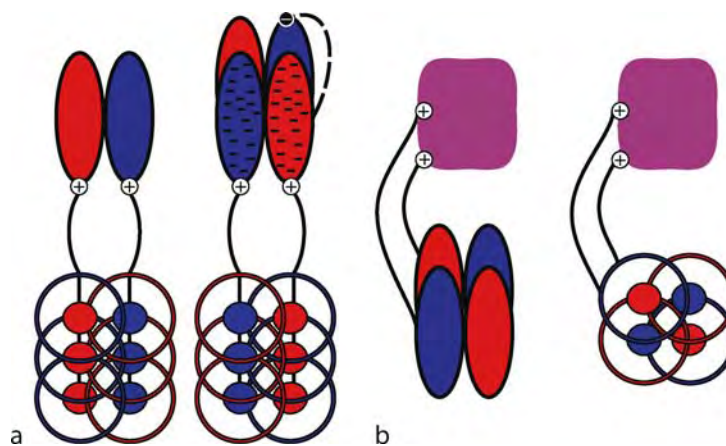

**Visual Cortical and Subcortical Receptive Fields. Figure 2** Hypothesized wiring diagrams for cortical receptive fields. Convergent input from thalamic relay cells with aligned On (red) and Off centers (blue) provide excitation to On and Off subregions of the simple receptive field; conventions as in Fig. 1 (a, left). Local inhibitory simple cells, labeled with minus signs, mediate suppression evoked by stimuli the non-preferred contrast (a, right). Complex receptive fields built by convergent input from co-oriented simple cells whose receptive fields overlap and have similar shapes but the reverse placement of On and Off subregions (b, left). Convergent input from On and Off relay cells with overlapping receptive fields form some complex fields (b, right).

Simple receptive fields can easily be reconstructed from the responses to such stimuli with the method of ► [spike-triggered averaging](#). This technique defines the receptive field as the average of all stimuli that appear a short time before each spike occurs. Spike-triggered averaging, however, is not appropriate for characterizing complex receptive fields. For example, the average of all stimuli that evoke spikes for cells in which On and Off responses spatially overlap would approach zero. Thus, sophisticated methods such as spike-triggered covariance, which recover second- and higher-order aspects of the stimuli that drive spikes, are required [10].

An important message to take home from the description of complex cells is that their receptive fields alone do not provide sufficient information to predict the neural response to a given stimulus. Nor does the structure of the complex receptive field necessarily provide information about underlying circuitry. Thus, the idea of the receptive field as defined by Hartline becomes less powerful at higher levels of cortical integration. At these later stages of processing, the term receptive field is often stretched to include the best mathematical model that can be made to predict a given cell's response to visual signals. Last, Hartline defined the receptive field as spatial construct, but most modern descriptions include a temporal dimension as well.

#### **Alternative Definitions of Simple and Complex Cells and Consideration of Species Differences**

There is a separate criterion used to separate simple from complex cells that is not based on receptive field structure *per se*, but on the linearity of response to sinusoidal gratings. The test for linearity comes from an important approach to visual processing based on spatial and temporal frequency analyses [5]. Linear responses were once thought to be restricted to cells whose receptive fields had separate On and Off subregions, i.e. simple cells. But complex cells that respond exclusively, or much more strongly, to dark stimuli than to bright ones also respond to gratings in a roughly linear manner. Indeed linear responses are found in all cortical layers, suggesting that different types of circuit operate in this fashion. Understanding how such circuits are built might help explain ► [orientation selectivity](#) in higher species, which develops fully at intracortical stages of processing rather than at the thalamocortical level as in cat. In particular, it is not clear if simple cells provide the sole route to orientation selectivity in primates. Along this line of thought, the circuitry underlying the receptive fields described here has been delineated in the cat, whose cortex has been studied more intensively than that of any other animal. Future research is required to understand the circuits that build receptive fields in primates.

Last, not all authors classify simple and complex cells based on the types of receptive fields that Hubel

and Wiesel described, nor on measurements of the linearity of response. Thus, when reading the literature, it is useful to read each group of authors' own criteria for categorizing receptive fields.

## **References**

1. Hartline HK (1941–1942) The neural mechanisms of vision. The Harvey Lectures. XXXVII:39–68
2. Kuffler SW (1953) Discharge patterns and functional organization of mammalian retina. *J Neurophysiol* 16:37–68
3. Barlow HB (1961) The coding of sensory messages. In: Thorpe WH, and Zangwill OL (eds) *Current problems in animal behaviour*. Cambridge University Press, Cambridge
4. Field DJ (1987) Relations between the statistics of natural images and the response properties of cortical cells. *J Opt Soc Am A* 4:2379–2394
5. Shapley R, Lennie P (1985) Spatial frequency analysis in the visual system. *Ann Rev Neurosci* 8:547–583
6. Hubel DH, Wiesel TN (1962) Receptive fields, binocular interaction and functional architecture in the cat's visual cortex. *J Physiol* 160:106–154
7. Hirsch JA, Martinez LM (2006) Circuits that build visual cortical receptive fields. *Trends Neurosci* 29:30–39
8. Jones JP, Palmer LA (1987) The two-dimensional spatial structure of simple receptive fields in cat striate cortex. *J Neurophysiol* 58:1187–1211
9. Adelson EH, Bergen JR (1985) Spatiotemporal energy models for the perception of motion. *J Opt Soc Am A* 2:284–299
10. Schwartz O et al. (2006) Spike-triggered neural characterization. *J Vis* 6:484–507

## **Visual Cortical Processing Streams**

### **Definition**

Visual cortical processing streams denote sequences of cortical visual areas involved in processing different aspects of the environment. The dorsal cortical pathway is dominated by input from parasol retinal ganglion cells, projects through cortical areas including MT, MST, LIP and VIP, and is thought to be crucial for motion and localization analysis. The ventral cortical pathway is dominated by input from midget retinal ganglion cells, projects through cortical areas including V4 and inferotemporal cortex (IT), and is thought to be crucial for color and form analysis.

- [Extrastriate Visual Cortex](#)
- [Retinal Ganglion Cells](#)
- [Visual Processing Streams in Primates](#)

## Visual Dependence/Independence

### Definition

Subjects whose verticality perception (and spatial orientation) is/is not influenced by background visual stimuli (e.g. static frames or rotating disks).

► Verticality Perception

## Visual Fixation

### Definition

► Fixation

► Fixation System

## Visual Extinction

### Definition

► Visual Attention

## Visual Form Representation

► Visual Object Representation

## Visual Field

### Definition

The visual field (synonym for field of view) is the total area in which objects can be seen. Visual fields are typically measured in terms of angular co-ordinates centered on the direction of gaze. One might therefore characterize a normal visual field (in humans) for one eye as extending about 60° upward, 75° downward, 60° laterally toward the nose and 100° laterally toward the temple. Visual fields are measured using a device called a perimeter.

## Visual Field Defects

### Definition

Various pathologies can cause visual field defects, that is, areas of blindness. These pathologies can affect the retina, areas of the brain involved in visual processing or the neural tracts that link these areas.

## Visual Illusions

PETER WENDEROTH

Department of Psychology, Macquarie University,  
North Ryde, Sydney, NSW, Australia

### Synonyms

Optical illusions

### Definition

Unfortunately, there is no generally agreed definition of visual illusions [1] and, as a result, some visual phenomena are classed as illusions by some authors but not by others. For example, similar effects often occur both when all parts of a stimulus are displayed simultaneously (often called “►illusion”) and also when certain parts are presented successively (often called “►aftereffect”). In Fig. 1a, the surrounding grating tilted down on the right makes the surrounded horizontal grating appear tilted up on the right (the “tilt illusion”). The same tilt misperception occurs in Fig. 1b if one adapts to (stares steadily at) the grating on the left for 30 s and then looks at the horizontal grating on the right (the “tilt aftereffect”). Some authors classify aftereffects as illusions.

The definition of illusion adopted here is: A visual illusion occurs when there is a discrepancy between a physical stimulus and the perception of that stimulus, despite the normal functioning of the visual system. With this definition, an aftereffect is not an illusion because ►adaptation causes the visual system to be modified temporarily so that it is not functioning normally. So the effect in Fig. 1b is not strictly an

illusion but the effect in Fig. 1a is an illusion, because it occurs without adaptation.

Several authors [e.g., 2] regard Penrose's impossible triangle (Fig. 2a) and the Necker cube (Fig. 2b) as illusions but with my definition of illusions they are not.

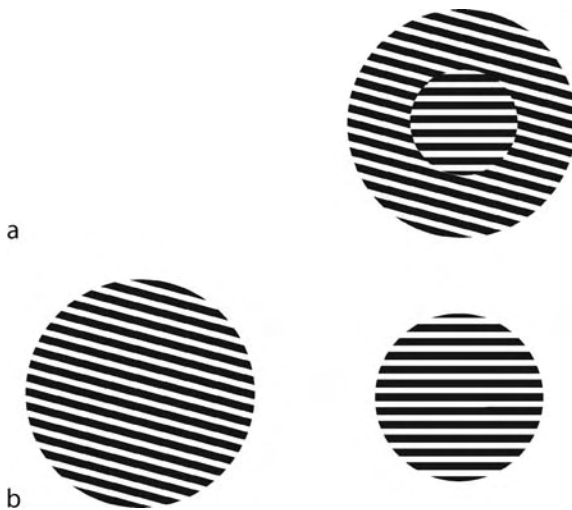

**Visual Illusions. Figure 1** Tilt illusion (a) and tilt aftereffect (b). For details see text.

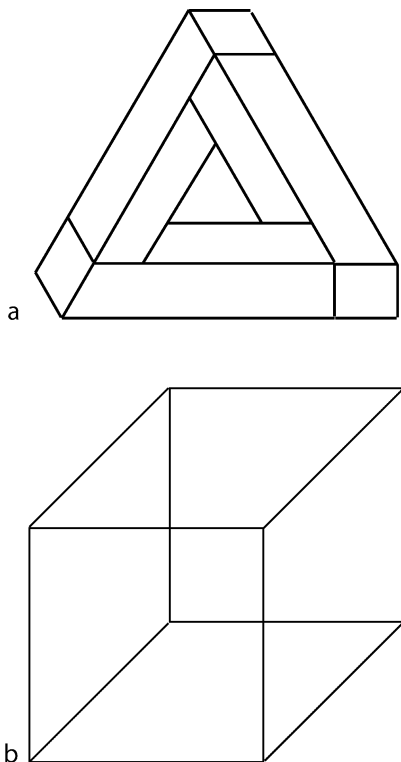

**Visual Illusions. Figure 2** Penrose's impossible triangle (a) and Necker cube (b). For details see text.

Each corner of the triangle looks like a proper corner in depth when viewed locally but no such three-cornered global triangle could exist in depth. However, there is no sense in which there is a discrepancy between the physical display and the perception. Similarly, the Necker cube perceptually fluctuates in depth so that it appears sometimes as being viewed from above, sometimes from below, but neither of these bistable percepts is a discrepancy between the stimulus and the percept. It is simply that the minimal depth information in the drawing is consistent – not discrepant – with either view.

## Characteristics

### A functional Approach to Illusions

It is clear from the above that the term “illusion” is a difficult one and it has even been suggested that the term is no longer useful [1]. One reason for this is that there is often “a discrepancy between a physical stimulus and the perception of that stimulus, despite the normal functioning of the visual system” due to nothing other than the design limits of the visual system. For example, metamerism, the fact that a mixture of three primary spectral lights can be used to match a monochromatic light is a mistaken perception because the two stimuli are physically different yet look the same. However, this “discrepancy” is more usefully viewed as the result of normal human ▶trichromacy. Although human observers would make fewer mistakes in the domain of color vision if they had more than three cone types, it is likely that having just three types provides sufficient disambiguation of sensory signals to achieve most of what needs to be achieved in operating in the world, most of the time.

Beginning with Helmholtz, there is a strong tradition of viewing the visual system as sets of mechanisms that are designed to interpret incoming sensory data and that use inference, knowledge of constraints and other “tricks” to compensate for the limitations in the sensory input so as to optimally recover properties of the world [2]. Recently, there has been a strong revival of this conceptual approach using Bayesian theory (see below).

### Illusions in the History of Psychology

In his book entitled *The Psychology of Visual Illusion* [3], Robinson notes that “a large proportion of all that is in this book was described by Helmholtz (1856) in his *Handbuch*” [4]. Between 1856 and the present it is possible to identify four broad phases in the scientific study of illusions: the early approach to ▶geometrical illusions; illusions used as exemplars to promote general theories of perception (“Schools” of Psychology); the “feature detector” approach based upon the explosion of knowledge of visual neurophysiology; and current modelling approaches.

### The Early Approach to Geometrical Illusions

First, for many years around the turn of the twentieth century, illusions were studied by many as curiosities and as primary targets for explanation in their own right. Emphasis was on how many different illusions, mainly those evident in geometrical drawings, could be explained in terms of the same principles. A favorite way of attacking this question was to attempt to show that one illusion could be explained in terms of another and a master of this method was Judd [5]. Fig. 3 demonstrates a Euclidean *tour de force* that actually reveals nothing at all about the mechanisms underlying the illusions and also tells us nothing about visual processes. Thus, in Fig. 3a, the acute angle arm, YZ, looks shorter than the obtuse angle arm, XY. Therefore, in Fig. 3b, the true distance between the acute angle arms,  $d_1$ , appears to lie closer to the vertex, at  $d^2$ . Because  $d^1$  is a longer distance than  $d^2$  acute angles look larger than they are. This in turn accounts for the Zöllner illusion (Fig. 3c) in which the long parallel lines appear to diverge at the top, because the acute angle segments (dotted) appear expanded.

However, the dotted oblique lines in Fig. 3d are shorter than the solid oblique segments so the distance

between vertical parallels will be underestimated. This “explains” the Poggendorff illusion in which oblique and truly collinear transverse test segments appear noncollinear (Fig. 3e): because the parallels appear (dashed parallels) closer than they really are the perceived transversals must appear misaligned and, in addition, Judd predicted and found (Fig. 3f) that the distance, Y, between oblique parallels appears shorter than that, X, between vertical parallels. It should be noted that many of Judd’s “explanations” have been shown to be false.

### Schools of Thought in Psychology

The second phase of the study of illusions, in the first half of the twentieth century, saw the rise of the “schools” of perception psychology: the ►Gestalt movement, ►Transactional Functionalism and the ►Direct Perception movement, propagated by James Gibson. In all three of these movements, the initial question was “Why do things look as they do?” and as has been pointed out, to ask such a general question of all perceptual phenomena simply guarantees an answer so broad as to be meaningless, because the answer cannot contain principles or processes that apply to

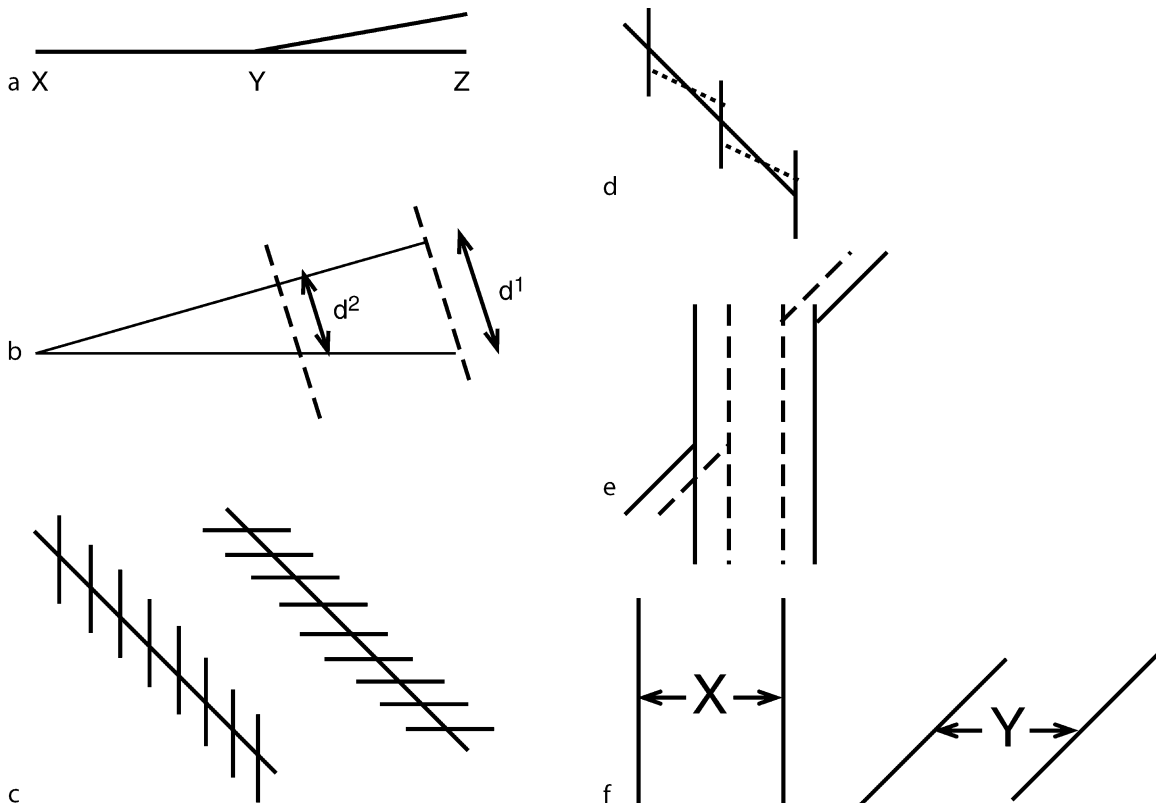

**Visual Illusions. Figure 3** (a–f) Various geometrical illusions. (c) Zöllner illusion. (d) Poggendorff illusion. For more details see text.

only a subset of perceptual phenomena [6]. Nevertheless, illusions were used by the Gestaltists to argue that all perception is due to innate brain organizing processes so that, for example, a coin that is tilted and so is elliptical on the retina appears circular, as it really is, because innate brain processes make shapes as “good” as possible. The Transactionalists built a distorted, nonrectangular room that looked like a normal room through a peephole. Consequently, although two people in the room looked equidistant from the observer, the one who was actually much closer looked huge and the other, much further away, looked like a dwarf. The Transactionalists wanted to assert that all perception is determined by past experience and argued that experience dictates the normal room percept and also allows the illusory percept of different sized people. Interestingly, although these theorists never addressed the illusions presented by the other group, it is clear that past experience could “explain” the circular appearance of the coin; and brain forces that made objects as “good” as possible could “explain” the room’s looking normal and rectangular. Gibson ignored illusions altogether, arguing that perception is a “function of stimulation” and, since illusions are by definition not a function of stimulation they are not perception either.

### **The “Feature Detector” Approach to Illusions**

In the third phase of the study of illusions, interest in the classic geometrical illusions (e.g., Fig. 3) waned; rarely were illusions studied for their own sake; and illusions were not (usually) used to bolster general theories of perception. Rather, with the explosion of knowledge of neurophysiology and new imaging methods such as ▶fMRI, researchers have used the knowledge of visual mechanisms in nonhumans to predict visual illusions that would be expected to occur if humans had the same machinery; and they use newly discovered illusions to infer the presence of underlying neural mechanisms that can be searched for in the brains of non-human animals. This more modern approach to the study of illusions dates back to at least 1963, when a study of adaptation in rabbit retina by Barlow and Hill [see 2] led to this comment regarding the ▶motion aftereffect (but the comment equally applies to illusions): “Finally, it is interesting to ask if the argument can be used in reverse. If after-effects are due to the imbalance of maintained activity of units [i.e., neurones] specifically excited by features of the inspection [i.e., inducing] figures, *can one deduce the nature of the units which analyse sensory data from the nature of the after-effects which are so readily produced?*” [my italics] (p. 1374). Although many physically different stimuli can produce the same output from a single unit or neuron so that no one such cell can literally be a “detector” of anything, the fact that visual neurones exhibited narrow ▶tuning curves to various parameters of a stimulus

(e.g., orientation, motion direction, color, etc.) often led to the misleading use of the term “feature detectors” to describe these neurones. Explanations of illusions (and aftereffects) were then sought in terms of interactions between populations of neurones that are selectively tuned to the features of the ▶inducing and test stimuli. The general notion was that illusions were perceptual mistakes that arose as unfortunate by-products of normal perceptual processes.

### **Modeling Mechanisms and Processes in Vision**

Vision scientists often use conceptual models to help explain and understand the mechanisms of vision. This entails explicit mathematical descriptions of brain processes that are hypothesized to occur under particular experimental conditions, using the constraints of known neurophysiology and ▶psychophysics: ▶computational modelling. This contemporary approach often tends not to regard illusions as regrettable side effects of normal vision but rather as manifestations of the visual system’s “best guess” as to the state of the world, given the available noisy sensory data. This more functional approach, which has its origin in Helmholtz’s notion of “unconscious inference” [4], has recently been revived in Bayesian models of visual perception. Proponents of this approach consider that the visual system performs some form of Bayesian inference to derive a perception from sensory data, using prior probabilities and likelihood calculations. Models based on this idea have been used to describe various visual subsystems, including motion perception, with very impressive fits to a variety of data sets [7].

Whether an illusion is experienced or not or what kind of illusion occurs with a particular visual stimulus can depend entirely upon the task given to the observer [8]. The Bayesian idea that perception, including perceptual error, does not arise from direct experience of sensory events but rather from likelihoods calculated from those sensory events, has been shown to predict that exactly the same visual stimulus may induce an illusion or may not, depending upon the task [9]. When observers are asked to judge whether dots are drifting to the left or right of a marker, neurones tuned to the marker direction are not very helpful because their response to the marker direction and slightly different directions is almost the same. Neurones tuned to directions somewhat different from the marker direction are more useful, because the slope of their tuning curve means that differences in their responses to the marker direction and a slightly different direction are much larger. Hence, the optimum strategy is to more heavily weight responses of neurones tuned to directions away from the marker direction and this results in a repulsion illusion for such a fine discrimination. But when the task is to judge whether the dots are moving toward or away from the marker, a very coarse discrimination, the

best strategy is to weight most heavily the responses of neurones tuned precisely to the marker direction and in that case an attraction illusion occurs. The occurrence of illusions has sometimes been taken to indicate that there are two spaces, the physical and the psychological. But as Morgan (1979) noted, there is only one physical space on which we perform operations or tasks, and it is no surprise that physically different operations can produce physically different outcomes [see 8].

### Why Study Visual Illusions?

Neuropsychologists often learn about the normal working of the brain from case studies of patients with localized brain damage that causes the brain to behave abnormally. In the same way, in order to understand the mechanisms that underlie normal, and usually correct, perception, it is often helpful to investigate instances in which erroneous perceptions occur. It is particularly theoretically useful when one factor, A, (whether an experimental manipulation or neural damage) affects process 1 but not process 2 while another factor, B, affects process 2 but not process 1. This ►**double dissociation** allows the conclusion that 1 and 2 are different processes and have different determinants. By way of example, the tilt illusion can be measured as a function of the angle between the central, horizontal test stimulus in Fig. 1a and the surrounding inducing stimulus. When the angle is small (e.g., 15°) the test appears repelled in orientation from the inducer. When the angle is large (e.g., 75°) the test is perceptually attracted to the inducing orientation. It has been shown that one set of experimental manipulations reduces repulsion effects without any effect on attraction effects; whereas other manipulanda eradicate attraction effects without affecting repulsion effects, a double dissociation indicative of different mechanisms [10]. Indeed, the evidence suggests that repulsion effects occur early in the visual system in ►**striate cortex** (area V1) but that attraction effects occur in ►**extrastriate cortex**, in V2 or higher [10,11]. Illusions such as the tilt illusion can be used to probe normal visual mechanisms in another way, by probing levels of processing in the human visual system. For example, oriented stimuli can be defined by ►**first-order cues** (luminance and color) or ►**second-order cues** (disparity, texture, motion, etc.). Because the tilt illusion occurs when the inducing and test stimuli are defined by the same or by different cues [11], the illusion can be said to be cue invariant to some extent, which in turn implies that it may occur at a cue invariant level of the visual system. More recently, it has been shown that the repulsion tilt illusion is reduced significantly when the inducing stimulus is second-order while the test stimulus is first-order; but that the attraction tilt illusion is unaffected by that manipulation [12]. This is consistent with the idea that first- and second-order processing mechanisms are initially

separate but combine after a nonlinearity, with repulsion effects generated prior to the nonlinearity but attraction effects generated after the nonlinearity [12]. These results are also consistent with other evidence for separate mechanisms underlying repulsion and attraction tilt illusions [10,11,13]. For excellent demonstrations and explanations of optical illusions go to <http://www.michaelbach.de/ot/>.

### References

1. Wenderoth P (1992) Perceptual illusions. *Aust J Psychol* 44:147–151
2. Gregory RL (1997) Visual illusions classified. *Trends Cogn Sci* 1:190–194
3. Robinson JO (1972) *The Psychology of visual illusion*. Hutchinson, London
4. Southall JPC (ed) (1962) *Helmholtz's treatise on physiological optics*, vol 3. Dover, New York
5. Judd CH (1899) The study of geometric illusions. *Psychol Rev* 6:241–261
6. Hamlyn DW (1961) *The psychology of perception*. Routledge & Kegan Paul, London
7. Weiss Y, Simoncelli EP, Adelson EH (2002) Motion illusions as optimal percepts. *Nat Neurosci* 5:598–604
8. Wenderoth P (1983) Identical stimuli are judged differently in the orientation and position domains. *Percept Psychophys* 33:399–402
9. Jazayeri M, Movshon JA (2007) A new perceptual illusion reveals mechanisms of sensory decoding. *Nature* 446:912–915
10. Wenderoth P, Johnstone S (1988) The different mechanisms of the direct and indirect tilt illusions. *Vision Res* 28:301–312
11. Poom L (2000) Inter-attribute tilt effects and orientation analysis in the visual brain. *Vision Res* 40:2711–2722
12. Smith S, Clifford CWG, Wenderoth P (2001) Interaction between first- and second-order orientation channels revealed by the tilt illusion: psychophysics and computational modelling. *Vision Res* 41:1057–1071
13. Wenderoth P, Clifford CWG, Wyatt AM (2001) A hierarchy of spatial interactions in the processing of contrast-defined contours. *J Opt Soc Am A* 18:2190–2196

## Visual Memory

### Definition

Visual memory refers to the ability to recall pictures, scenes, words, or other information that is presented visually. Visual memories can last for a short amount of time, as in visual iconic memories or afterimages, or for many years, as in the type of learned long-term memory that enables us to visually imagine and recognize events that have occurred years or even decades ago.

## Visual Motion Processing

COLIN W. G. CLIFFORD

School of Psychology, University of Sydney, Sydney, NSW, Australia

### Synonyms

Motion processing; Motion vision

### Definition

Various factors contribute to changes in the pattern of light incident on our retinas, such as our movement through the world, our eye and head movements, and the motion of objects in the world around us. Visual motion processing refers to the sensory analysis of retinal image motion and its interpretation in terms of these factors.

### Characteristics Motion Detection

Physically, motion is change in position over time. Computationally, a processing scheme for detecting the direction of image motion must satisfy several requirements [1]. Temporal change in the image signal at a single location on the retina contains no information about the direction of image motion. Instead, the dynamic image signal must be sampled at multiple locations or spatial phases. These samples must then be processed asymmetrically in time and combined. Consider, for example, the delay-and-compare scheme for motion processing [2] illustrated in Fig. 1.

Two samples of the retinal image are taken from nearby spatial locations. Temporal asymmetry is implemented in the form of a delay between samples, introducing ►direction selectivity into the scheme. The resulting signals are then multiplied together (a quadratic non-linearity). In a final stage of ►motion opponency, signals from motion detectors selective for opposite directions of motion are subtracted to produce a signal whose sign conveys the direction of image motion.

### Direction Processing

Elementary motion detectors are sensitive to motion between the spatial locations at which they sample the retinal image but not to motion along the perpendicular axis. In other words, each elementary motion detector is only sensitive to motion along one spatial dimension in the two-dimensional retinal image. Recovery of two-dimensional retinal motion requires the combination of responses from a population of detectors sensitive to different axes of motion. Even then, the structure of the retinal image may be such that two-dimensional motion cannot be recovered unambiguously. Specifically, if the

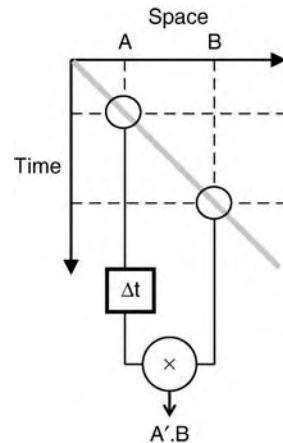

**Visual Motion Processing. Figure 1** Schematic of elementary motion detector. The trajectory of an object moving at a constant velocity is oriented in space-time (*grey line*). To detect this motion we need to take signals from at least two points in space and combine them asymmetrically in time. The simplest “delay and compare” mechanism is a direct multiplication of two signals: the correlation detector [2]. When the stimulus moves from Position A to Position B at the appropriate speed, signals from the two receptors reach the comparison stage at the same time. When the stimulus moves in the opposite direction, from Position B to Position A, the non-delayed signal from one receptor reaches the comparison stage long before the delayed signal from the other receptor.

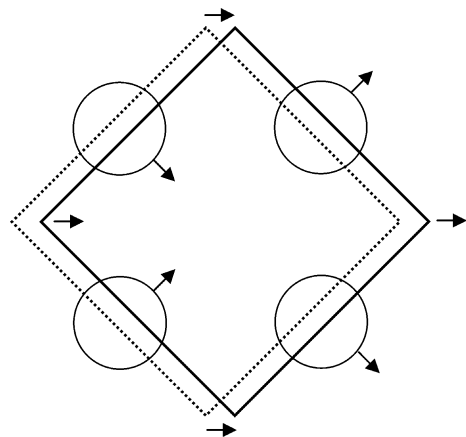

**Visual Motion Processing. Figure 2** The aperture problem. Neurons early in the visual processing hierarchy have small receptive fields. It is as though each neuron is “viewing” the world through a small aperture. Consequently, the region of the retinal image which they sample can often be essentially one-dimensional in structure (e.g. an edge). In this case, only the component of motion perpendicular to the edge can be recovered unambiguously. Only in regions of the image with two-dimensional structure (e.g. corners) can motion be recovered locally.



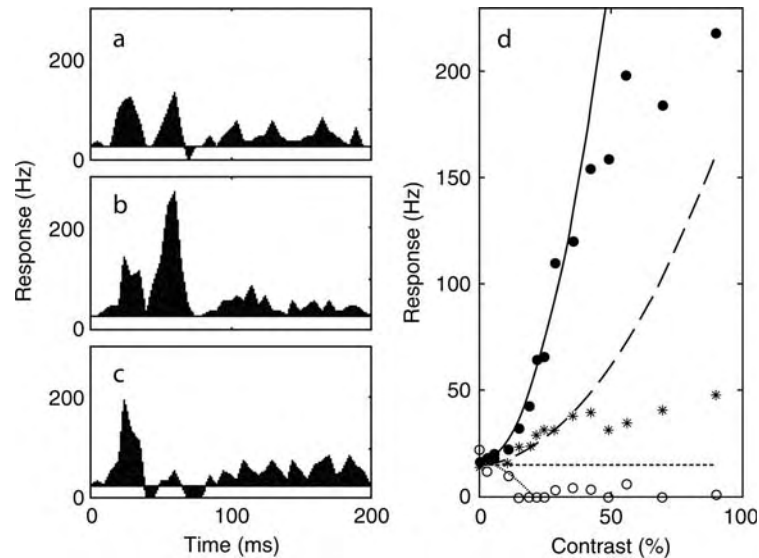

**Visual Motion Processing. Figure 3** Response to motion of neurons in the nucleus of the optic tract. (a) Two flashes of a wide-field sinusoidal grating with no phase shift between presentations produce responses similar in size. (b) When phase shifts by quarter of a cycle between presentations, corresponding to [▶apparent motion](#) in the preferred direction, the magnitude of the second response is increased. (c) When apparent motion is in the anti-preferred direction, the second response is smaller than the first (motion opponency) [4]. (d) Response of a different neuron to no motion (*stars*); apparent motion in the preferred direction (*filled circles*); apparent motion in the anti-preferred direction (*open circles*) as a function of grating contrast. The curves are the best-fitting quadratic functions for contrasts up to 25% [3].

region of the image sampled by the population of detectors is spatially one-dimensional (e.g. an edge) then only the component of motion perpendicular to the spatial structure can be recovered locally. This is the essence of the [▶aperture problem](#) (Fig. 2), whose solution requires integration of motion information from disparate regions of an object.

### Sub-Cortical Motion Processing

In the sub-cortical mammalian brain, direction selectivity is most clearly evident in the [▶nucleus of the optic tract](#) (NOT) and the [▶accessory optic system](#) (AOS). The NOT and AOS are connected to the motor system that controls stabilizing eye movements such as [▶optokinetic nystagmus](#). Most cells respond in a highly direction-selective and motion-opponent manner to movement across large regions of the visual field such as the [▶optic flow](#) produced by self-motion. Their directional properties probably originate in the retina but in certain species there is an additional cortical input. The essential non-linearity in the motion detectors is quadratic [3], characteristic of a multiplication of signals (Fig. 3).

### Cortical Motion Processing

In the primate brain, significant direction selectivity is evident in [▶primary visual cortex](#) (V1) but motion opponency does not emerge until the [▶MT complex](#) [5]. Ascending the visual motion processing hierarchy from

V1 to the MT complex reveals an increase in receptive field size and the emergence of neurons able to integrate local motions into a coherent interpretation of object motion or patterns of optic flow [6,7]. Patterns of activity in the MT complex and in other extrastriate visual areas have also been shown to correlate with the perception of three-dimensional [▶structure-from-motion](#) [8]. Microstimulation of MT has been shown to bias reports of perceived direction [9], indicating that the processing of motion in the MT complex is causally linked to motion perception and not simply involved in oculomotor control. Indeed, bilateral damage to the MT complex in a human subject has been reported to produce a selective deficit in motion perception while leaving other aspects of vision largely unimpaired [10].

### References

1. Borst A, Egelhaaf M (1989) Principles of visual motion detection. *Trends Neurosci* 12:297–306
2. Reichardt W (1961) Autocorrelation, a principle for the evaluation of sensory information by the central nervous system. In: Rosenblith WA (ed) *Sensory communication*. Wiley, New York, pp 303–317
3. Clifford CWG, Ibbotson MR (2003) Fundamental mechanisms of visual motion detection: models, cells and functions. *Prog Neurobiol* 68:409–437
4. Ibbotson MR, Clifford CWG (2001) Characterising the temporal delay filters of biological motion detectors. *Vision Res* 41:2311–2323

5. Heeger DJ, Boynton GM, Demb JB, Seidemann E, Newsome WT (1999) Motion opponency in visual cortex. *J Neurosci* 19:7162–7174
6. Movshon JA, Adelson EH, Gizzi MS, Newsome WT (1985) The analysis of moving visual patterns. In: Chagas C, Gattass R, Gross C (eds) *Pattern recognition mechanisms*. Pontificia Academia Scientiarum, Vatican City, pp 117–151
7. Snowden RJ (1994) Motion processing in the primate cerebral cortex. In: Smith AT, Snowden RJ (eds) *Visual detection of motion*. Academic Press, London, pp 51–83
8. Brouwer GJ, van Ee R (2007) Visual cortex allows prediction of perceptual states during ambiguous structure-from-motion. *J Neurosci* 27:1015–1023
9. Salzman CD, Britten KH, Newsome WT (1990) Cortical microstimulation influences perceptual judgements of motion direction. *Nature* 346:174–177
10. Zihl J, von Cramon D, Mai N (1983) Selective disturbance of movement vision after bilateral brain damage. *Brain* 106:313–340

## Visual Neuropsychology

ANNA BROOKS<sup>1</sup>, RICKY VAN DER ZWAN<sup>1</sup>,  
MANUEL MERCIER<sup>2</sup>, OLAF BLANKE<sup>2,3</sup>

<sup>1</sup>Laboratory of Perceptual Processing, Southern Cross University, Lismore, NSW, Australia

<sup>2</sup>Laboratory of Cognitive Neuroscience, Brain-Mind Institute, École Polytechnique Fédérale de Lausanne, Switzerland

<sup>3</sup>Department of Neurology, University Hospital, Geneva, Switzerland

### Synonyms

Visual cognition; Visual neuroscience; Perceptual processing; Perceptual correlates; Vision science

### Definition

Visual neuropsychology is the field of enquiry devoted to elucidating links between the anatomy and physiological functioning of cerebro-cortical structures and the ►visual perception and cognition as well as visually-mediated behaviors to which they give rise through experimentation in healthy and brain damaged humans.

### Characteristics

Visual neuropsychology is the sub-discipline of neuropsychology dedicated to understanding how visual information is processed by cerebro-cortical and sub-cortical mechanisms and how that information gives rise to perception, cognition, and other behaviors. The discipline has grown in conjunction with knowledge of the anatomical connections and tuning properties of

visual cortical neurons in ►occipital cortex and extra-occipital cortex. In particular, the discovery of streams of processing arising within the ►primary visual cortex (Brodmann's area 17; striate cortex; ►area V1) and extending into other cortical areas (see Fig. 1) (►Visual processing streams in primates; Extrastriate visual cortex), and the elucidation of the contribution of those processing streams to visual behaviors through scientific and clinical observations forms the basis of visual neuropsychology. Thus, visual neuropsychologists explore cortical functioning using psychophysical and neuroimaging techniques in healthy and brain-damaged humans to understand the nature of visually mediated behaviors.

Interestingly, while visual perceptions seem coherent and unitary, striking clinical dissociations illustrate that each stream can to some extent operate independently of the other (►Visual perception). Behavioral dissociations manifest as processing difficulties in one domain in the relative absence of difficulties in another, so suggesting independence of the two domains. An example of a single-dissociation within visual neuropsychology has been the observation of a patient who has impaired motion perception (►Motion blindness or

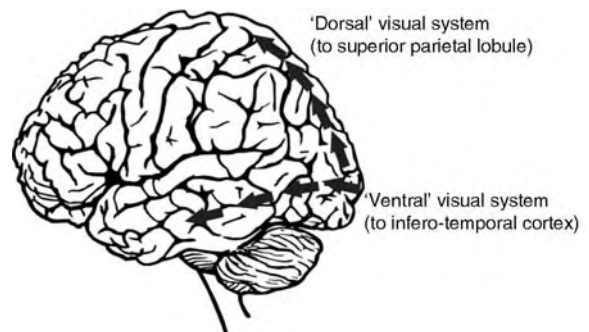

**Visual Neuropsychology. Figure 1** The so-called “where” pathway runs dorso-medially from visual area V1 through visual cortical ►areas V2, the ►V3/V3a complex, the ►superior temporal sulcus (►STS) or ►middle temporal sulcus (MT) to ►posterior parietal cortex (►PPC). It encodes primarily spatial- and timing-related information, and is also heavily implicated in visuo-motor processing. Damage along this pathway can result in a number of deficits, the most striking of which is ►spatial neglect, akinetopsia, or optic ataxia (see below). The second pathway runs from area V1 ventro-laterally through areas V2, V3, V4 and to the ►inferior temporal cortex (►IT). It processes information relating to the color and shape of objects within the visual array and for that reason commonly is referred to as the “what” pathway (see for example [1]). Damage along this pathway can result in a number of deficits; the best studied are ►visual agnosia and prosopagnosia (see below).

► **akinetopsia**) but almost normal form perception (see for example [2]). Double dissociations occur when two single dissociations with complementary deficit/ability profiles due to comparable size of brain damage are observed. Thus, while clinical participants are more heterogeneous in terms of their neural functioning than healthy participants, case studies illuminate sometimes unpredicted relationships between visual processes. Indeed neuropsychological case observations have often provided first clues on functional specialization within the human brain. It now seems clear, then, that visual perception and cognition as well as visually-mediated behaviors arise from simultaneous and largely parallel processing in both streams (► **Visual perception**).

### Akinetopsia

Akinetopsia or motion blindness is defined as a selective impairment in perceiving the direction and speed of visual motion stimuli (► **Visual motion processing**), while other aspects of the visual scene such as color and form are perceived normally. The most clear and comprehensive demonstration of akinetopsia has been provided by Zihl and colleagues [2] who described a patient suffering from extensive and bilateral brain damage at the occipito-temporo-parietal junction. While the patient was unable to discriminate objects in motion the ability to perceive static form and color was normal. Interestingly, auditory motion perception and the perception of static and biological forms defined by visual motion stimuli are normal or much less impaired. Patients with severe motion blindness may also suffer from illusory visual motion perceptions suggesting that ► **area MT±/V5** is also relevant for conscious motion perception.

Brain damage, from tumors, trauma, or stroke, may lead also to more complex forms of motion blindness such as a selective deficit in the detection and discrimination of forms defined by visual motion stimuli (► **Form-from-motion (FfM) blindness**). Double dissociations between motion blindness and FfM blindness also have been observed [3]. FfM blindness seems to arise due to damage to at least three distinct posterior processing areas: Severe FfM blindness without akinetopsia is due to damage in, usually, the right hemisphere ventral occipito-temporal cortex, whereas FfM blindness with akinetopsia is due to damage to either or both area MT+/V5 and the ► **lateral occipital complex (► LOC)**, an area that is highly active during object perception and object recognition [4] (► **Visual object representation**).

Finally, the perception of ► **biological motion (BM)** (► **Biological motion processing**) stimuli may also be impaired by focal brain damage. BM blindness seems to be associated with parietal and temporal lobe damage. Patients with BM blindness often have normal visual motion perception but often suffer also FfM blindness.

Neuroimaging work in healthy subjects has shown that a distributed network of brain areas is involved in BM perception including the superior temporal sulcus, the lateral occipital complex, MT+/V5, and the ► **fusiform gyrus**. A remarkable aspect of BM is that, along with motion direction and speed information, it conveys also a large range of socially relevant information. Accordingly, it seems that left frontal brain damage may impair the perception of personality traits and that damage to right ► **somatosensory cortex** may impair the perception of emotions as conveyed by BM stimuli.

### Balint's Syndrome

Named after Hungarian physician Rudolf Balint and sometimes referred to as ► **Balint-Holmes syndrome** in honor of the later contributor Gordon Holmes, the syndrome is classically defined as an acquired, triple-symptom complex. The original patient described by Balint exhibited a range of symptoms including firstly ► **optic ataxia** or misreaching for objects under conditions of visual guidance. Behaviors associated with this symptom include, for example, lighting the middle rather than the end of one's cigarette, or misreaching for a door-handle. Based on Balint's observations that when assessed independently his patient's elementary visual and motor capabilities appeared intact, the deficit was defined as being specific to visuo-motor integration (► **Visuomotor integration**). The second symptom, termed psychic paralysis of gaze by Balint but now more commonly known as ► **optic apraxia**, relates to the occurrence of sticky visual fixations. Such ► **spasms** occur in spite of intact extraocular function (and thus unrestricted eye rotations), and manifest as an inability to voluntarily shift one's gaze from one object within the visual scene to another. The third and final symptom reported by Balint was spatial disorder of attention (► **Visual attention**), now more commonly referred to as ► **simultanagnosia**. In this case, a patient's ability to recognize individual objects is compromised when those objects are presented simultaneously within the visual scene.

In the case of Balint's original patient and those reported subsequently, attempts have been made to map the neuroanatomical underpinnings of the triple-symptom complex. Whilst some lack of consensus remains about the neural structures giving rise to the syndrome, most reports implicate involvement of bilateral posterior parietal cortex: post-mortem results of Balint's and others' patients, and more recent neuroimaging studies support the contention that damage to bilateral occipito-parietal cortex underlies the syndrome. Certainly that analysis is consistent with the role in visually guided behaviors of the so-called visual dorsal processing stream (which includes occipito-parietal cortex). Indeed, convergent evidence related to visuo-temporal processing capabilities – attributed directly to

dorsal stream processing - has recently been reported. As predicted by models of normal dorsal stream processing, such capabilities are disrupted in patients exhibiting ► **Balint's syndrome**.

The cortical damage on which Balint's syndrome onset appears to be based arises via a number of etiological mechanisms. These include trauma through accident, stroke, and the development of cortical tumors. High levels of co-occurrence have also been observed in patients exhibiting posterior cortical atrophy (► **Posterior cortical atrophy**) and degenerative diseases such as Alzheimers (► **Alzheimer's**). Perhaps unsurprisingly those same diseases lead also to akinetopsia. Consistent with the aetiology of those diseases, incidence of the syndrome is observed almost exclusively in adults, although at least one case study involving a child has been reported [5]. The most effective treatment strategies are multi-contextual and involve first raising awareness of their functional deficits in sufferers, and then teaching them to anticipate conditions under which deficits manifest. That process usually depends upon patients being taught functionally adaptive and compensatory techniques.

Problems disambiguating Balint's syndrome from disorders such as visual ► **neglect** (see below), along with the scarcity of classical triple-symptom presentations has led to recent re-conceptualizations of the syndrome. That is, the symptoms may not be sufficiently autonomous to satisfy Benton's criteria for an independent syndrome. Rather, attention is now focused on understanding the three symptoms individually rather than considering them as a consistent constellation of signs.

### Optic Ataxia

Considered the typical visuo-motor deficit, optic ataxia (OA) was first described by Rudolf Balint as one of a constellation of symptoms associated with what later came to be known as Balint's syndrome (see above). Classic definitions of the disorder focus on pronounced deficits reaching for objects under conditions of visual guidance. That is, patients are deficient in their capacity both to reach for and grasp objects represented in visual space despite preservation of visual, motor, and musculo-skeletal processing capacity. For example, and as originally described by Balint, patients can search with their knife outside a plate for food positioned in plain view on the plate. Based on its frequent occurrence in the absence of the other symptoms of Balint's syndrome, OA has emerged as an independent neuropsychological disorder.

More recent reviews of the disorder cite three key characteristics. The first is the pronounced deficit in the control of direction of arm and hand movements made under visual guidance, particularly for objects

located in *peripheral* visual space. The second is the specifically *visuo*-motor aspect of the disorder: equivalent motor tasks performed under ► **proprioceptive** guidance, for example, can be performed without deficit. The third characteristic is the specificity of the deficit for *immediate* visuo-motor functions. Tasks involving delayed behavioral responses are performed with higher levels of accuracy than those performed "online".

Neural accounts of the disorder emphasize the key role played by the action-oriented visual dorsal processing stream: Patients typically exhibit symptoms after extensive damage to posterior parietal cortex. Specific sub-areas involved likely include the ► **superior parietal lobule**, ► **intraparietal sulcus**, and ► **occipitoparietal sulcus** in various combinations. OA manifests as a consequence of both bilateral and unilateral parietal damage. In the latter cases, hemispheric asymmetries are observed: damage to unilateral cortex results in misreaching via both hands to objects presented in contralesional visual space (the so-called *field* effect), or misreaching to either visual field of the contralesional hand (the so-called *hand* effect).

### Prosopagnosia

Also known as *face blindness* or *facial agnosia*, ► **prosopagnosia** is a disorder in which sufferers are unable to recognize previously familiar human faces (► **Face processing in different brain areas**). This is the case in spite of preserved ability to recognize objects (► **Visual object representation**) more generally and to make fine visual discriminations.

Historically multiple examples of patients presenting with such patterns of impairment were reported in the eighteenth Century (for an historical overview see [6]). However the term prosopagnosia itself was not coined until 1947. At that time, German neurologist Joachim Bodamer published a report identifying the existence of a number of patients deficient in the ability to discriminate between familiar individuals on the basis of visual inspection of their facial features. For example, Bodamer described one of his patients as manifesting a severe deficit in ability to discriminate friends, family or himself on that basis, whilst the ability to perform the same task on the basis of cues such as individual speech or gait patterns was retained.

Neural correlates of prosopagnosia have been identified primarily on the basis of lesion analysis. Such analyses most commonly implicate bilateral damage to the inferomedial part of the temporo-occipital region, specifically the fusiform gyrus and ► **lingual gyrus**. Less commonly unilateral, right-hemisphere damage to the same region gives rise to the disorder [7]. Based on those findings and in acknowledgement of its key role in vision-based face recognition, the right mid-fusiform gyrus is now commonly referred to as the ► **fusiform face area** or FFA [8].

Acquired prosopagnosia arises usually from stroke damage, brain injury, or from diseases such as Alzheimer's and Parkinson's disease (▶**Parkinson's disease**). However, less common congenital presentations have also been reported. The patterns of cortical disruption on which the disorder is based also commonly give rise to additional vision-based deficits including bilateral upper visual field deficits, ▶**achromatopsia** or left ▶**hemiachromatopsia** and ▶**topographagnosia** (for a review see [6]).

Neurocognitive accounts of the disorder vary. The co-occurrence of prosopagnosia with deficits in performing general object recognition (▶**Visual object agnosia**) has been presented as evidence that the disorder is domain-general. That is, prosopagnosia represents one specific manifestation of more general object recognition deficits. That account is weakened by the existence of facial/object recognition double dissociations: Complementary to face-specific deficits of the type described by Bodamer and others, the existence of patients with deficits in object recognition but not in face-recognition have been reported. In an example reported by Moscovitch and colleagues [9] patient CK was shown to be poor at recognizing non-face objects and at reading, but not deficient in terms of his capacity to recognize faces.

Initial diagnosis of the disorder is commonly based upon self-report and a simple clinical test in which one familiar individual, dressed in a similar fashion to several others amongst whom he or she stands, must be identified on the basis solely of visual inspection. An inability to perform that task, combined with tests demonstrating the face-specificity of the deficit while excluding the existence of general intellectual impairment or poor visual processing, form the basis for confirmation of the initial diagnosis. Once diagnosed, treatment options are limited. Most commonly, the debilitating social and functional aspects of the disorder are addressed through training in the implementation of compensatory strategies. These include using alternative perceptual cues such as the gait, speech patterns, and isolated (rather than global) facial features to identify individuals, and cognitive strategies such as keeping lists of the individuals likely to be present at particular times of day and in particular locations.

### Spatial Neglect

▶**Neglect** (also known as spatial, unilateral or hemispatial neglect) is a syndrome characterized by the tendency to act as if half of the world does not exist. Typically it manifests across sensory domains (vision, touch, audition, even smell) despite normal processing, at least peripherally, in each. Neglect arises typically from unilateral damage to inferior parietal or superior temporal cortex, often as a result of an infarction of the right middle cerebral artery. Involvement of

▶**prefrontal and premotor cortex**, along with ▶**thalamus** and ▶**basal ganglia**, has also been implicated. While the syndrome occasionally manifests as a function of damage to left hemisphere, it arises more commonly, and with more severe and enduring symptoms from damage to right hemisphere.

The behavioral correlates of neglect can be mapped across three conceptual, patient-referent spatial areas: personal, peri-personal (within reaching distance), and extra-personal space (within sensory processing distance). Examples of behaviors related to personal space include the application of make-up only to the ipsi-lesional side of one's face, and the dressing of only the ipsi-lesional side of one's body. Symptomatic behaviors in peri-personal space include inattention to contra-lesional text and pictures presented in books, and lack of awareness of the presence of food positioned contra-lesionally on one's plate. Finally, behaviors associated with extra-personal space include a tendency to ignore people and objects in the contra-lesional hemifield and a failure to navigate routes or spaces that require contra-lesional turns or deviations.

Contemporary theories of the cognitive correlates of neglect focus on disruption to processes mediating mechanisms of spatial attention (▶**Visual attention**). Such disruptions can occur in the absence of patient awareness (▶**Anosognosia**) and can temporarily be ameliorated by the deliberate re-focusing of attention to a target within the neglected space. Similarly, the severity of neglect is spatially heterogeneous, becoming more severe as a function of distance into contra-lesional space. Thus, neglect must be differentiated from functional deficits associated with sensory (e.g. ▶**Hemianopia**) or motor impairment, both of which are less influenced by attentional strategies. Interestingly, and in a further contrast to sensory and motor deficits, neglect can manifest in tasks requiring recall (▶**memory**) and ▶**mental imagery**. Memory deficits particularly are interesting: Patients may be unable to describe, from memory, that part of a familiar scene corresponding to neglected space. However, if asked to adopt a different perspective, one that moves features that previously fell into neglected space into ipsi-lesional space, those features can be recalled.

Diagnostically the most reliable tools are simple pencil-and-paper tests. On drawing-from-memory or copying tasks neglect patients will omit details from the neglected side of the object to be recalled or copied. On line-bisection tasks requiring participants to mark the mid-point of a horizontal line neglect patients typically indicate their perceived midpoint far to the right of the actual midpoint (and normal subjects on the same task typically mark a little to the left of the actual midpoint, so-called ▶**pseudo-neglect**). Similarly, on line- and other types of cancellation tasks neglect

patients will delete only targets in their non-neglected hemi-field.

Amelioration of neglect can be achieved by ▶[optokinetic stimulation](#) and ▶[caloric stimulation](#), but improvements are temporary. Similarly transient improvements are associated with the application of vibration to the neck. The only reliable and medium-to-long-term treatment for neglect seems to be achieved by using ▶[prism adaptation](#) [10]. In the absence of an effective treatment for neglect most patients undergo rehabilitative therapies that focus on the development of cognitive strategies to overcome inattention to objects within the neglected hemifield.

## References

1. Milner AD, Goodale MA (1995) *The visual brain in action*. Oxford University Press, Oxford
2. Zihl J, von Cramon D, Mai N (1983) Selective disturbance of movement vision after bilateral brain damage. *Brain* 106(Pt 2):313–340
3. Cowey A, Vaina LM (2000) Blindness to form from motion despite intact static form perception and motion detection. *Neuropsychologia* 38(5):566–578
4. Blanke O, Brooks A, Mercier M, Spinelli L, Adriani M, Lavanchy L, Safran AB, Landis T (2007) Distinct mechanisms of form-from-motion perception in human extrastriate cortex. *Neuropsychologia* 45(4):644–653
5. Gillen JA, Dutton GN (2003) Balint's syndrome in a 10-year-old male. *Dev Med Child Neurol* 45:349–332
6. Grüsser OJ, Landis T (1991) *Faces Lost: prosopagnosia*. In: *Visual agnosias and other disturbances of visual perception and cognition: vision and visual dysfunction*, 12. MacMillan, Amsterdam, pp 259–286
7. Mayer E, Rossion B. *Prosopagnosia*. In: Godefroy O, Bogousslavsky J (eds) *The cognitive neurology of stroke*, Cambridge University Press (in press)
8. Kanwisher NG, McDermott J, Chun MM (1997) The fusiform face area: a module in human extrastriate cortex specialized for face perception. *J Neurosci* 17:4302–4311
9. Moscovitch M, Winocur G, Behrmann M (1997) What is special about face recognition? Nineteen experiments on a person with visual object agnosia and dyslexia but normal face recognition. *J Cogn Neurosci* 9:555
10. Rossetti Y, Rode G, Pisella L, Farnè A, Li L, Boisson D, Perenin MT (1998) Prism adaptation to rightward optical deviation rehabilitates left hemispatial neglect. *Nature* 395:166–168

## Visual Object Recognition

### ▶ Visual Object Representation

## Visual Object Representation

CHARLES E. CONNOR

Krieger Mind/Brain Institute and Department of Neuroscience, Johns Hopkins University, Baltimore, MD, USA

### Synonyms

Visual shape representation; Visual form representation; Visual object recognition

### Definition

Visual object representation is the process of encoding object information in ▶[visual cortex](#) for purposes of object identification, discrimination, evaluation, and ▶[memory storage](#).

### Characteristics

#### Computational Difficulty

Object vision is so computationally difficult that even the best computer vision systems achieve only rudimentary performance compared to humans. The difficulty lies in the enormous complexity and variability of visual object information. The representation of an object on a ▶[retina](#) or camera is an isomorphic pattern of response rates or pixel values. This pattern is extremely complex (on the order of a million pixel-like signals for human vision) and hopelessly variable – the same object can produce a virtual infinity of retinal images depending on its position, orientation, lighting, partial occlusion, and plastic deformation. Object information at this level is therefore highly implicit, i.e., extensive analysis would be required to extract useful information such as object identity. The visual system must transform this complex, implicit, variable input into an explicit, compact, stable representation of useful object information. This transformed representation is then accessible to other brain structures for storage and association in memory, decision-making, behavioral guidance, and conscious awareness.

The brain is so adept at this transformation process that it is transparent to us – it seems trivial to look around a room and recognize all the objects in it. Yet, this is one of the most computationally intensive tasks the brain performs, and it depends on continuous processing in a dedicated series of brain regions that make up the ventral visual pathway (see the entry on ▶[Visual Processing Streams in Primates](#)). The final stages of this pathway in ventral occipitotemporal cortex carry the transformed neural representation underlying our remarkable abilities to recognize and understand objects. The nature of this representation is unknown, but experimental results support several theoretical ideas that could help explain the extraordinary power of human object vision.

## Structural Representation

One dominant theory is that visual objects are represented as spatial configurations of common geometric parts. This representation would be carried by the ensemble activity of neurons tuned for various part shapes and positions [1]. A ►[structural representation](#) of this kind could be relatively simple and compact, facilitating transmission, storage, and association of object information. It could also be relatively stable across changes in object position, size, and orientation, if the spatial ►[reference frame](#) were defined by the object itself. It would provide explicit geometric information useful for evaluating the properties and functionalities of objects and guiding physical interactions with objects (►[Visual space representation for action](#)). Perhaps most importantly, structural representation has the combinatorial power to encode the limitless space of real-world objects, in a way somewhat analogous to encoding millions of words with different combinations of just 26 letters. Structural representation may be reflected in the way we verbally describe objects as spatial arrangements of parts. (“A teapot is round, with a C-shaped handle on one side, an S-shaped spout on the other side, and a disc-shaped lid on top.”)

The theory of structural representation is supported by psychophysical studies showing human perceptual sensitivity to part information and neurophysiological studies of visual responses in ventral pathway cortex of nonhuman primates. Neurons in higher level ventral pathway cortex of macaque monkeys respond selectively to simple object components and neurons with similar component sensitivity are grouped into columns [2]. Component shape is encoded in terms of geometric derivatives. Neurons are tuned for contour orientation (a first-order derivative), contour curvature (second order), contour spirality (third-order) and surface curvature [3–5]. Derivative coding is much more compact than the original retinal representation, because real-world object boundaries are relatively smooth, and thus large shape fragments encompassing many retinal receptors can be summarized by a few neurons signaling overall orientation and curvature.

Component position is represented in an object-centered reference frame. Higher level ventral pathway neurons are finely tuned for position relative to object center-of-mass, and only broadly tuned for retinotopic position [6]. This makes for a representation that is much more stable across changes in object position on the retina. Tuning for component shape and component position is simultaneous – a given neuron might respond to concave boundary fragments, oriented toward the right, positioned above object center. At intermediate processing stages, neurons represent individual, local shape components. At higher processing stages, neurons represent combinations of components [6], a trend that

may lead to neurons selective for global shapes of familiar, ecologically important objects.

## Exemplar-based Representation

A very different coding scheme may be necessary for extremely complex shape patterns, especially faces (►[Face processing](#)), which are processed in specialized brain regions (see entries on ►[Extrastriate Visual Cortex](#) and ►[Visual Cortical Areas](#)). Humans are remarkably sensitive to the fine structural differences that distinguish individual faces. The highly composite nature of facial shape might make a structural description unwieldy. Instead, composite shape differences can be efficiently represented in terms of similarities to exemplars. Detailed local shape correspondences with exemplars can be implicitly summed across entire objects to generate an explicit signal for overall similarity. The pattern of similarities to multiple exemplars can uniquely define an individual object [7]. In the case of faces, exemplar coding may be organized around the “average” face, learned across a lifetime of exposure. Psychophysical, imaging, and neurophysiological evidence suggests that neurons are tuned along similarity dimensions with an origin (lowest response point) near the morphological average across large numbers of human face photographs. Neural coding with respect to the average face would explain why caricatures are easier to recognize than veridical photographs. ►[Exemplar-based representation](#) may be reflected in the way we verbally describe faces in terms of well-known individuals (“He looks like a cross between Al Pacino and Dustin Hoffman”) and averages across groups (“She looks Asian, female, middle-aged”).

## Categorical Representation

Structural and exemplar-based coding depend directly on object geometry inferred from retinal images. However, much of our knowledge about object identity and meaning transcends geometry and depends instead on learned categorical relationships between geometrically dissimilar shapes. Representation of such relationships is bound to depend on ►[medial temporal lobe](#) structures like the ►[hippocampus](#), which make extensive reciprocal connections with higher level visual cortex. Neurons in human hippocampus have been shown to respond selectively to both photographs and typewritten names of the same celebrities [8], clearly reflecting learned associations between geometrically unrelated objects. Animal experiments indicate that such arbitrary neural response relationships can be established by repeated exposure to stimulus pairs in close spatiotemporal proximity and by learning task-related associations between stimuli [9]. Categorical associations can also be important for making fine distinctions between geometrically similar objects, and neurons in ►[prefrontal cortex](#) have been shown to represent sharp task-defined boundaries

between highly similar images of quadrupedal animals [10]. Finally, categorical learning provides an alternative to explicit processing of object geometry for achieving stability across image changes, especially changes in orientation or viewpoint. The relationship between different views of the same object could be learned from their close spatiotemporal proximity during normal experience.

## References

1. Marr D, Nishihara HK (1978) Representation and recognition of the spatial organization of three-dimensional shapes. *Proc R Soc Lond B Biol Sci* 200:269–294
3. Fujita I, Tanaka K, Ito M, Cheng K (1992) Columns for visual features of objects in monkey inferotemporal cortex [see comments]. *Nature* 360:343–346
3. Pasupathy A, Connor CE (2002) Population coding of shape in area V4. *Nat Neurosci* 5:1332–1338
4. Gallant JL, Braun J, Van Essen DC (1993) Selectivity for polar, hyperbolic, and Cartesian gratings in macaque visual cortex. *Science* 259:100–103
5. Janssen P, Vogels R, Orban GA (2000) Three-dimensional shape coding in inferior temporal cortex. *Neuron* 27:385–397
6. Brincat SL, Connor CE (2004) Underlying principles of visual shape selectivity in posterior inferotemporal cortex. *Nat Neurosci* 7:880–886
7. Edelman S (1999) Representation and recognition in vision. MIT, Cambridge, MA
8. Quiroga RQ, Reddy L, Kreiman G, Koch C, Fried I (2005) Invariant visual representation by single neurons in the human brain. *Nature* 435:1102–1107
9. Sakai K, Miyashita Y (1991) Neural organization for the long-term memory of paired associates. *Nature* 354:152–155
10. Freedman DJ, Riesenhuber M, Kreiman G, Poggio T, Miller EK (2001) Categorical representation of visual stimuli in the primate prefrontal cortex. *Science* 291:312–316

## Visual Pathways for Perception and Action

DAVID A. WESTWOOD

School of Health and Human Performance, Dalhousie University, Halifax, NS, Canada

### Definition

The study of vision has traditionally been guided by the goal of understanding the representations – neural or otherwise – that underlie one’s perception of the visual world. Of course, vision is not merely a system for generating a representation of the surrounding

environment; it also plays a key role in guiding the organism’s interactions with that environment. In other words, vision must be considered as both a perceptual and a sensorimotor system. Many models of human cognition assume that the sensorimotor aspects of visual function are intrinsically linked to the representational aspects of vision. According to this perspective, the visual control of movement proceeds from visual afference to perceptual representation to response selection and execution. In contrast to this intuitively appealing idea, however, considerable evidence has amassed in recent years which suggests that the situation is not quite so simple. This evidence comes from a number of converging methodologies, including ►neuroanatomy, ►neuropsychology, ►psychophysics, and a variety of neurophysiological techniques including non-human primate electrophysiology, functional magnetic resonance imaging (►fMRI), and ►transcranial magnetic stimulation (TMS). One broad interpretation of the existing evidence is that there are separate systems in the central nervous system for the visual control of action, and for visual ►perception [1]. These systems have different operating characteristics, and work together in the control of goal-directed behavior. Although the action and perception systems may map onto the ►dorsal and ventral streams of cortical vision, respectively, there is likely not a simple relationship between structure and function.

### Characteristics

#### Neuroanatomy of the Visual System

The visual system is in fact many distinct systems. The ►retinal ganglion cells leaving the ►retina are organized into subcortical (tectopulvinar; ►Visual Role of the Pulvinar) and cortical (geniculostriate; ►The geniculo-Striate Pathway) pathways. Afferent fibers in the tectopulvinar pathway make connections in the ►optic tectum of the midbrain, including the ►superior colliculus, before projecting to the pulvinar nucleus of the ►thalamus and then the ►parietal cortex. The superior colliculus and parietal cortex are known to play important roles in the visual control of eye, head, and limb movements, leading to the conclusion that the tectopulvinar pathway is primarily a sensorimotor system. Afferent fibers in the geniculostriate system project to the ►lateral geniculate nucleus of the thalamus before terminating in the ►striate cortex of the ►occipital lobe (area ►V1). From V1, neurons project to the adjacent extrastriate region (area ►V2), which then gives rise to two streams of projections. The so-called ►dorsal stream includes ►V5 (also known as the motion-sensitive region, ►MT), ►V3a, ►PO, and a variety of distinct regions in the parietal cortex [e.g., ►VIP, ►LIP, ►MIP, AIP (►Area AIP)]. The so-called ►ventral stream consists of areas ►V3 and ►V4, and various regions of the ►inferior temporal cortex. It has



been suggested that the dorsal stream is actually two distinct streams, one consisting of neurons in the ►superior parietal lobule and the second consisting of neurons in the ►inferior parietal lobule. Whereas the tectopulvinar pathway is primarily a sensorimotor system, the geniculostriate pathway and the subsequent cortical streams mediate a variety of high-level visual functions such as conscious awareness, object recognition (►Visual object representation), spatial orientation, form perception, and sensorimotor integration.

Considerable efforts have been made to understand the functions of the dorsal and ►ventral visual streams, given their prominence in the cortical visual system. Based on a series of elegant lesion studies with macaque monkeys, Ungerleider and Mishkin [2] proposed that the dorsal stream is responsible for spatial perception, whereas the ventral stream is responsible for object perception. A more recent interpretation advanced by Goodale and Milner suggests that the dorsal stream is a sensorimotor system that is responsible for the visual transformations necessary for the control of skilled movement, whereas the ventral stream is a perceptual system that is responsible for interpreting current visual input using long-term representations stored in memory. A complete exposition of this model and its supporting evidence can be found in [1]. Some of the key evidence will be reviewed here.

### Evidence from Human Neuropsychology

#### Cortical Blindness (“Blindsight”)

►Blindsight is a disorder occurring from damage to the ►primary visual cortex, in which phenomenal visual awareness is lost but some visual functions are spared. Some of the earliest reports of blindsight indicated that patients could point to targets in the affected region of space with reasonable accuracy despite reporting no awareness of the target’s location. Although it is not entirely clear which visual pathways underlie the preserved visual functions in blindsight, it has been suggested that the tectopulvinar (i.e., subcortical) pathway, with its projections to the superior colliculus and ►posterior parietal cortex, may mediate some of the residual sensorimotor abilities. Independent of the neural substrates associated with blindsight, the fact that patients can point with reasonable accuracy to targets they claim not to perceive argues strongly for some independence between the visual pathways for perception and action.

#### Visual Form Agnosia

In 1991, David Milner, Melvyn Goodale and their colleagues published two papers describing the case of a woman, known as D.F., who presented with a ►visual agnosia subsequent to an anoxic episode. At the time of these initial reports, CT images indicated extensive damage to brain regions near the junction of the occipital

and temporal lobes. More recent high-resolution MR images confirmed that the primary site of injury was a region of cortex called the lateral occipital complex (►LOC), which resides at the junction of the occipital and temporal lobes. As reported by Milner and Goodale, D.F. was quite unable to identify common objects depicted by black and white line drawings, although her performance improved with grey-scale and colored drawings in which diagnostic color and/or texture cues were available. Thus, D.F.’s visual agnosia was relatively selective for the form, or shape, of objects. Indeed, D.F. performed poorly when asked to indicate the orientation of a high-contrast slot either by rotating a hand-held manipulandum or by comparing the orientations of two slots. Despite her inability to perceive the orientation of the slot, however, D.F. was quite good at orienting a small wooden card when she reached out and attempted to insert the card into the slot as though mailing a letter. The card was oriented appropriately early in the unfolding movement, well before physical contact with the slot could have provided feedback. Clearly, D.F.’s lack of form perception had no impact on her ability to use form information to control her action, suggesting a separation between the visual pathways mediating perception and action. Goodale et al. proposed that D.F.’s preserved visuomotor abilities are attributable to her intact dorsal stream, whereas her poor form perception is likely due to the lesion in the ventral stream.

#### Optic Ataxia

►Optic ataxia is a visuomotor disorder characterized by an inability to transform visual information into appropriate actions despite relatively intact visual and motor abilities. Because optic ataxia is typically associated with bilateral damage to the posterior parietal cortex, a major constituent of the ►dorsal visual stream, this disorder has often been held up as a counterpoint to D.F.’s ►visual form agnosia, which occurred following a lesion in the ventral stream. Indeed, Goodale and colleagues directly compared D.F., a visual form agnostic, and R.V., an optic ataxic, in a motor task and a perceptual task using irregular shaped, unfamiliar objects. In the perceptual task, the patients were asked to make same-different judgments about pairs of shapes, and in the motor task, the patients were asked to reach out and grasp the objects. In the judgment task, R.V. performed on par with age-matched controls, whereas D.F. performed well below chance. In the ►grasping task, D.F. showed good grip placement on the object’s surfaces, aligning her index finger and thumb such that they spanned the object’s geometric centre of mass, whereas R.V. often selected unstable grip points. The results of the study thus provide a compelling ►double dissociation suggesting that the dorsal stream is responsible for the visual control of

action whereas the ventral stream is responsible for visual perception. In recent years, the notion that optic ataxia is a global disorder of visuomotor control or integration has been challenged, since the observed deficits are typically only seen for targets located in the peripheral visual fields, or when target information must be updated in response to a change in eye position. Nevertheless, the observed visuomotor deficits in optic ataxia are not accompanied by similar deficits in visual perception, supporting the independence of the pathways mediating perception and action.

### Evidence from Psychophysics

#### *Pictorial Illusions Affect Perception More Than Action*

Although the evidence from human neuropsychology provides compelling support for the distinction between the visual pathways for perception and action, it is wise to question the external validity of a model of visual function that is based heavily on evidence gleaned from patients with brain lesions. In 1995, Salvatore Aglioti and colleagues published a paper on participants with no visual or neurological conditions, in which they claimed to find different effects of a ►pictorial illusion (the well-known ►Ebbinghaus illusion or ►Tichener Circles figure) in perceptual and motor tasks. The perceptual effects of the illusion were measured by having participants choose to pick up one of two target disks depending on which one was judged to be larger. One disk was surrounded by an annulus of much smaller circles and the other was surrounded by an annulus of much larger circles. In trials where the two disks were physically identical, participants' decisions confirmed the existence of a perceptual illusion: the disk surrounded by smaller circles was judged to be larger than the disk surrounded by larger circles. In contrast to this perceptual judgment, however, the size of the maximum grip aperture (i.e., the separation between the index finger and thumb) used to pick up the chosen disk was unaffected by the sizes of the circles in the surrounding annulus. The sizes of the target disks were then adjusted within the small- and large-circle annuli so that participants consistently judged them to be of similar sizes. In this case, the physical difference in disk sizes was accurately reflected in the size of the grip aperture used for grasping. Aglioti et al.'s observations are broadly consistent with the notion that perception and action are mediated by distinct visual systems that have different operating characteristics. This study generated a tremendous amount of interest in pictorial illusions and their effects on a variety of perceptual and motor tasks [3].

Although there is some disagreement about whether or not the visual illusion paradigm provides convincing support for the independence of visual perception and visually guided action, there are some consistent themes that have emerged from the paradigm that mirror similar

themes in the neuropsychological literature [3]. For example, the apparent independence of action and perception disappears when the tasks are performed after the target stimulus has been removed from view and thus require memory. In the illusion paradigm, one finds that grasping actions, for example, are much more sensitive to a pictorial illusion when the target is removed from view as compared to when it remains visible. In a similar vein, one finds that the visual form agnostic patient, D.F., performs very poorly when grasping a target object that has been removed from view, as compared to her quite good performance when the target remains visible. Together, these observations converge on the idea that there is a dedicated visuomotor system that operates separately from visual perception, but only when current vision of the target stimulus is available. When interacting with remembered objects, it appears that visual perception is in fact used to guide the action.

#### *Rapid updating of Limb Movements in Response to Undetected Changes in the Visual Array*

In 1986, Goodale and colleagues carried out a study in which participants reached out to touch a small visual target that occasionally changed position during the course of a concurrent saccadic eye movement. During a ►saccade, there is a transient reduction in perceptual sensitivity to changes in the visual array. This phenomenon is known as ►saccadic suppression. Consistent with this phenomenon, participants in the study were unaware that the target had changed position. Nevertheless, the ending points of the reaching movements reflected the updated position of the target, indicating that information about the perturbation was available to the sensorimotor system. Recent studies on the updating of reaching movements in response to changes in target features suggest that this form of on-line visuomotor control is analogous to an "automatic pilot", in the sense that the updating is rapid and resistant to countermanding intentions. The on-line control system appears to be located in the posterior parietal cortex, since the system breaks down in cases of damage to the posterior parietal cortex, or when brief magnetic pulses are used to temporarily interfere with neural activity in posterior parietal cortex [4]. Using ►PET imaging, Desmurget and colleagues [5] found increased metabolic activity in posterior parietal cortex when participants reached to a target that changed position during the movement as compared to trials where the target remained stationary, providing support for a parietal locus of on-line visuomotor control.

### Evidence from Neurophysiology

The evidence presented above arguably represents the strongest support for the hypothesis that separate systems exist in the human visual system for perception

and the control of action. However, a large body of evidence has accumulated in the past decade that provides indirect support for this hypothesis, by localizing the neural substrates associated with a variety of sensorimotor and perceptual functions and by characterizing the neural processing that places in those regions.

In the extensive non-human primate literature, ►single-unit recording (►Extracellular recording) studies have identified distinct neural populations in parietal cortex where neural activity is correlated with the performance of specific sensorimotor tasks like saccadic eye movements, head movements, reaching movements, and grasping movements (for a recent review, see [6]). The causal connection between these brain areas and the implicated sensorimotor task has been probed in some cases in permanent or reversible inactivation studies. This literature supports the notion that there are distinct populations of neurons in the dorsal stream that contribute to the visuomotor transformations that underlie control of body movements. In a similar vein, single-unit recording studies implicate a variety of distinct neural populations in extrastriate regions in the processing of various low-level visual features associated with perceptual analysis, such as color, shape, depth, orientation, and motion (for a recent review, see [7]). There are also populations of neurons in the inferior temporal cortex where complex visual stimuli, involving conjunctions of a variety of low-level visual features, elicit preferential responding (for a recent review, see [8]). This line of evidence points to a role for neurons in the ventral stream in perceptual analysis of the surrounding environment.

In humans, there has been an explosion of interest in generating functional maps of ►cerebral cortex using functional MRI. Although a comprehensive review of this literature is not possible here, the human fMRI data tends to be broadly supportive of the work described above from non-human primates. That is, distinct neural regions appear to be preferentially activated in posterior parietal cortex for various sensorimotor tasks, such as saccades, head movements, reaching movements, and grasping movements (for a recent review, see [9]). Likewise, regions in the occipital and temporal cortices are preferentially activated by low-level visual features, and conjunctions of visual features (for a recent review, see [8]). In a very recent study, [10] present fMRI evidence suggesting a double-dissociation between the analysis of 3D object shape for action and perception, with the anterior intraparietal region (AIP) showing selective activation for grasping, and the lateral occipital complex (LOC) showing selectivity for shape discrimination.

With the advent of transcranial magnetic stimulation (TMS), the causal connection between brain regions and task performance can now be explored. A few

studies have used TMS to disrupt activity in regions of posterior parietal cortex, and have found significant disruptions to the on-line control of reaching movements [4], and a break-down in the temporal coordination between the ►kinematics of hand and eye movements. In the future, TMS studies will surely provide important insights into the functional organization of the cortical visual pathways, and will contribute to the understanding of how perceptual and sensorimotor systems interact.

### Concluding Remarks

Vision is used for perceptual and ►sensorimotor functions, so that organisms can both understand and interact with their environment. Despite the intuitive notion that perception guides action, converging evidence from diverse methodologies suggests that perception and action are mediated by distinct visual systems that have different operating characteristics. This organizational structure reflects the different ways that afferent information needs to be organized and transformed for guiding movements versus interpreting objects and their spatial relationships.

### References

1. Milner AD, Goodale MA (1995) *The Visual Brain in Action*. Oxford University Press, Oxford
2. Ungerleider LG, Mishkin M (1982) Two cortical visual systems. In: Ingle DJ, Goodale MA, Mansfield RJW (eds) *Analysis of visual behavior*. MIT Press, Cambridge, MA, pp 549–586
3. Goodale MA, Westwood DA (2004) An evolving view of duplex vision: separate but interacting cortical pathways for perception and action. *Curr Opin Neurobiol* 14:203–211
4. Desmurget M, Epstein CM, Turner RS, Prablanc C, Alexander GE, Grafton ST (1999) Role of the posterior parietal cortex in updating reaching movements to a visual target. *Nature Neurosci* 2:563–567
5. Desmurget M, Grea H, Grethe JS, Prablanc C, Alexander GE, Grafton ST (2001) Functional anatomy of nonvisual feedback loops during reaching: a positron emission tomography study. *J Neurosci* 21:2919–2928
6. Buneo CA, Andersen RA (2006) The posterior parietal cortex: sensorimotor interface for the planning and online control of visually guided movements. *Neuropsychologia* 44:2594–2606
7. Sincich LC, Horton JC (2005) The circuitry of V1 and V2: integration of color, form, and motion. *Ann Rev Neurosci* 28:303–326
8. Reddy L, Kanwisher N (2006) Coding of visual objects in the ventral stream. *Curr Opin Neurobiol* 16:408–414
9. Culham JC, Cavina-Pratesi C, Singhal A (2006) The role of parietal cortex in visuomotor control: what have we learned from neuroimaging? *Neuropsychologia* 44:2668–2684
10. Cavina-Pratesi C, Goodale MA, Culham JC (2007) fMRI reveals a dissociation between grasping and perceiving the size of real 3D objects. *PLoS ONE* 2:e424

## Visual Perception

SEMIR ZEKI

Department of Imaging Neuroscience,  
University College London, London, UK

### Definition

General neural strategies for constructing the perceived visual world.

### Characteristics

#### The Primary Visual Cortex and the Hierarchical Processing of the Visual Scene

One simple fact of enormous significance separates our present-day view of the visual brain and of vision as a process from the view held until the 1960s. That fact lies in the extent of the visual cortex as it was conceived in the 1960s and as we know it today. Up to the 1960s, it was commonly believed that there is a single visual area, ►cerebro-cortical area V1 (Brodmann's area 17; primary visual cortex), co-localized with a cortical zone of distinct architecture – the ►striate cortex – which occupies a fraction of the cerebral cortex. Connected with the ►retinas through a subcortical station (the ►lateral geniculate nucleus, LGN), area V1 was long imagined to be the sole visual perceptive centre, with cells in its different layers analyzing the features of the visual environment in increasingly complex ways, in hierarchical fashion. There might, to be sure, be other areas somehow involved with vision, but their involvement was thought to be of an associative kind – involving activities such as ►learning and memory. Since the late 1960s, the extent of cerebral cortex recognized to be devoted directly to vision has increased dramatically, so that we now consider something perhaps in the region of one fifth of the entire cortex to be directly visual. This dramatic upward revision of the extent of visual cortex is not the result of redefining the boundaries of area V1, but rather the realization that there are many more visual areas besides it. The actual number remains uncertain, some putting it as high as 36 while others considering a dozen or so to be more realistic. Whatever the actual number, the principle of the multiplicity of visual areas is now beyond doubt.

#### The Principle of Parallelism

But what do all these visual areas do? Do they continue the process of hierarchical analysis previously thought to reside in area V1? A simple anatomical finding that was later confirmed by functional studies suggested that visual processing is organized in an entirely different way than thought previously. The visual

areas are not connected serially, starting from area V1. Instead area V1 has several reciprocal, parallel connections with the other visual areas, although serial connections incorporating hierarchical stages are a feature of each of the parallel pathways. In these parallel pathways emanating from it, area V1 sends different types of signals to each of the other visual areas, e.g. color information to area V4 (►Color Processing), and motion information to area V5 (MT) (►Visual Motion Processing). This anatomical fact alone ushers in the important principle of parallelism or parallel processing in vision, as indeed in other cortical operations.

#### Functional Specialization in the Visual Brain

The consequence of this parallelism is of enormous interest. For it suggests that different visual areas outside area V1 receive signals in parallel and process them simultaneously and independently. It would be difficult to suppose that they process the same signals. In fact, direct physiological recordings from single cells in the macaque monkey brain supplemented later by human brain imaging experiments, and fortified by the results of clinical studies, show that there is a functional specialization in the visual brain, with different visual areas processing different visual attributes. Perhaps the easiest way to demonstrate this is to show the difference in the processing of color and motion. The former is processed in area V4 (►Cerebro-cortical area V4) while the latter in area V5 (►Cerebro-cortical area V5). These are not the only two specializations in the visual brain, far from it. But, for the purposes of this article, consideration of these two attributes helps to illustrate admirably a cardinal factor in the operations of the visual brain, namely the principle of functional specialization.

#### Feature Independence in the Visual Scene

Why there should be a functional specialization in the visual brain is a moot point. There are two major candidates. The first is inherent in our visual world. Different visual attributes, such as color, or motion or depth (►Binocular Vision), or a particular expression on a face (►Face Processing in Different Brain Areas), occur haphazardly and unpredictably and with temporal independence of one another. If, for example, a bus moving to the right was always red, then the presence of a bus could be determined from its color, or form (►Form Perception), or direction of motion alone; there would be no need for these different attributes to be registered independently. But a bus can be stationary or move to the left, and could be any color. Equally red could be a property of many different objects. We refer to the unpredictable and independent occurrence of attributes as the principle of feature independence.

### The Temporal Requirements for Processing Form and Color

Another factor that may be important is that the temporal requirements for generating different visual attributes are themselves different. To determine the color of a surface, the brain has to compare the wavelength composition of the light coming from it and from surrounding points simultaneously in time, whereas to determine the presence, direction and speed of motion, it has to integrate signals from at least two points successively in time. Thus, the functional processing requirements as well as the temporal requirements of the two are different. Immanuel Kant had argued that time is a given a priori, a sort of inherited organizing principle that categorizes (visual) experiences. If this is indeed so, then the conclusion seems inescapable that the same temporal a priori cannot be applied to the generation of different visual experiences. Implied in this is the belief that the two different, specialized areas, have inherently different inherited wiring mechanisms and temporal dynamics.

### The Asynchronous Perception of the Visual World

That the generation of different visual experiences entails different temporal requirements and therefore that activity in different, specialized, visual areas reaches a perceptual endpoint at different times is exemplified by the principle of temporal asynchrony, which simply states that different visual attributes are perceived at different times. The basis for this lies in psychophysical observations in which subjects are asked to pair two different attributes, for example two colors with two directions of motion. These experiments have shown that we perceive color about 80–100 ms before we perceive motion. Nor is the temporal asynchrony confined to color and motion alone. For example, we also perceive color and orientation with a difference of about 40 ms. Many variations of these experiments leave little doubt that different attributes of the visual world are not perceived in precise temporal registration. There have been different interpretations of why this should be so. But the one that is to date the more compelling, because backed-up by the more convincing experiments, is that it is due to differences in processing time for the different attributes of the visual scene.

### The Mis-Binding of Attributes Over Brief Periods of Time

One consequence is that, because we see different attributes at different times, we mis-bind them over brief time windows (<100 ms), in the sense that we pair the color presented at time  $t$  with the motion that occurred at time  $\delta t-1$ . The strong implication of this finding is that the brain does not have a centre that waits for the results of processing in different areas to reach an end-point before binding them (► [Binding Problem](#)).

Instead, it binds what has been processed and is therefore perceptually available. This in turn implies that, up to a significant degree, processing sites such as areas V4 and V5 are also perceptual sites, activity in them becoming perceptually explicit without the mandatory involvement of higher areas such as the ► [frontal lobe](#) or ► [parietal lobe](#). It is however unlikely that they can act in complete isolation, but which other areas or cortical systems may be involved in bringing their processings to perceptual fruition remains unknown.

### Processing Sites may Also be Perceptual Sites

That a processing site is also a perceptual site is shown by experiments, which have used combined psychophysical and imaging approaches. In these, stimuli belonging to distinct ► [visual categories](#) (for example, faces and houses) are presented in such a way that they are either consciously perceived or not. Imaging experiments show that, whether perceived or not, a house stimulus activates the area of the brain specialized for object detection (► [Visual Object Representation](#)), while a face stimulus activates the part of the brain specialized for detection of faces (► [Face Processing in Different Brain Areas](#)). The difference is that, when consciously perceived, the activity in the respective areas is more intense. It is still not clear whether the change from the processing to the perceptual stage involves an increase in the activity of cells that are already engaged or whether new cells are recruited to render what has been processed perceptually, and therefore consciously, explicit. Similar experiments lead to a generally accepted principle that the conversion from a processing stage to a perceptual state depends upon a change in strength of activation.

### Conscious Visual Perception without V1

The picture that has emerged therefore is that each of these areas has considerable autonomy, in the sense that activity in one of the specialized areas is independent of that in others to a surprising extent. This of course should have become evident from an examination of the clinical literature, which shows that damage to distinct visual centers can lead to distinct forms of perceptual loss, confined to the attribute for which the area is specialized, without affecting other attributes. Prominent among these syndromes are those of ► [achromatopsia](#) (color imperception resulting from damage to area V4), ► [akinetopsia](#) (motion imperception resulting from damage to area V5) and ► [prosopagnosia](#) (failure to identify faces, resulting from damage to another specialized area, lying in front of area V4). It also becomes evident from examining clinical evidence which shows that when visual area V5 is disconnected

from area V1 (with which it is reciprocally connected and from which it normally receives its visual input) but has a secondary visual input that reaches it without passing through area V1, the subject can still experience visual motion consciously though crudely (► [Riddoch Syndrome](#)). The relative autonomy of these areas is also shown by experiments that study brain activity in more natural settings. It turns out that each area has a highly characteristic activity time course. This is the logical consequence of each area's distinct processing architecture, and the specialization in distinct features such as color and motion that can vary independently over time in our environment. It is thus possible to delineate cortical areas simply based on their distinct temporal activity fingerprint. Modern methods can thus reveal the brain's organization based on its chronoarchitecture.

### The Distribution of Visual Consciousness in Space and in Time

There is a relentless and ineluctable logic to this succession of findings, leading to conclusions that seem also inescapable. If we become aware of different attributes of the visual world because of activity in different specialized areas, it follows that visual consciousness is distributed in space. If we become aware of different attributes at different times, it follows that visual consciousness is distributed in time. From this it follows that there is no unified visual consciousness, but instead that there are many visual consciousnesses that are distributed in time and space (theory of micro-consciousness). Actual experiments lead ineluctably to this conclusion, even if the conclusion itself is not radically different from what Kant, after his philosophical speculations, enunciated in his book, *The Critique of Pure Reason*: "All presentations have a necessary reference to a possible empirical consciousness [micro-consciousness]. For if they did not have this reference, and becoming conscious of them were entirely impossible, then this would be tantamount to saying that they do not exist at all. But all empirical consciousness has a necessary reference to a transcendental consciousness (a consciousness that precedes all particular experience), viz., the consciousness of myself as original apperception" (original emphasis).

### References

1. Zeki S (2005) The Ferrier lecture 1995. Behind the seen: the functional specialization of the brain in space and time. *Phil Trans R Soc Lond B Biol Sci* 360:1145–1183
2. Hubel DH, Wiesel TN (1977) The Ferrier lecture: functional architecture of macaque monkey visual cortex. *Proc R Soc Lond B* 198:1–59
3. Kant I (1783) *Kritik der reinen Vernunft*, 1st edn (trans: Pluhar WS as *Critique of pure reason*). Hackett, Indianapolis

## Visual Pigments

### ► Photopigments

## Visual Probe Trials

### Definition

At the beginning of a trial, a visual target is presented, and the subject (human or monkey) is required to fixate it. After a delay period, a second target is presented, but the fixation target remains on. To perform the trial correctly, the subject must maintain fixation on the original target. This task is commonly used with monkeys, to allow the experimenter to measure visual receptive fields.

### ► Visual Receptive Field

## Visual Processing Streams in Primates

WILLIAM H. MERIGAN

University of Rochester Eye Institute and Center for Visual Sciences, University of Rochester, Rochester, NY, USA

### Synonyms

Primate visual pathway; Parallel visual processing streams

### Definition

Like all known ► [visual systems](#), the primate (human and monkey) visual system consists of several parallel visual pathways, each originating in the ► [retina](#) and projecting to a variety of brain locations, and each covering the entire visual field. The separate pathways originate in the approximately 14 ► [retinal ganglion cell types](#) in the primate.

### Characteristics

#### Organization of the Retinal Ganglion Cell Classes

All visual systems contain numerous specialized ganglion cell types, in the primate visual system there are at least 14 ganglion cell types [1] ([Fig. 1](#)).

Each of these cell types has unique anatomy and physiology suggesting specialized roles in visual processing. Individual retinal ganglion cells have irregularly shaped ▶dendritic fields (▶Dendritic field of retinal ganglion cell) and ▶receptive fields (▶Receptive field of retinal ganglion cell), whose size is inversely proportional to the number of cells, but for each class of ganglion cell all of the dendritic/receptive fields are juxtaposed such that they cover the entire visual field. This is illustrated

in Fig. 1 for two retinal ganglion cell classes in the cat (On and Off alpha cells) [2] (Fig. 2).

**Does Each Retinal Ganglion Cell Class Have an Independent Role in Visual Processing?**

Independence is suggested both by the unique anatomy and physiology of ganglion cell types described above and the fact that each cell type covers the entire retina. Thus, it is conceivable that each could function independently

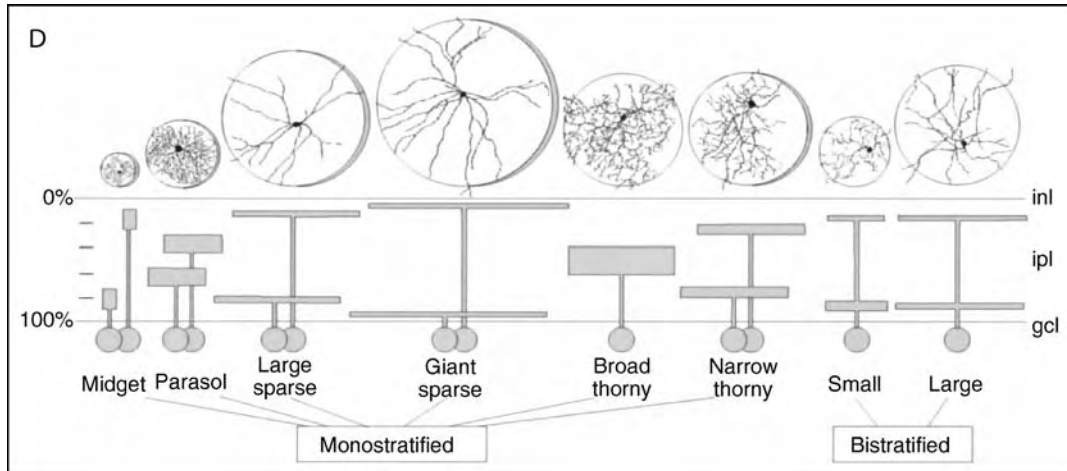

**Visual Processing Streams in Primates. Figure 1** Illustration of 13 retinal ganglion cell types in the macaque retina. Dendritic fields are illustrated at the top and the branching level of dendrites in the inner plexiform layer are shown by the horizontal bars that are placed in the correct depth (0–100%). From Dacey et al. [1].

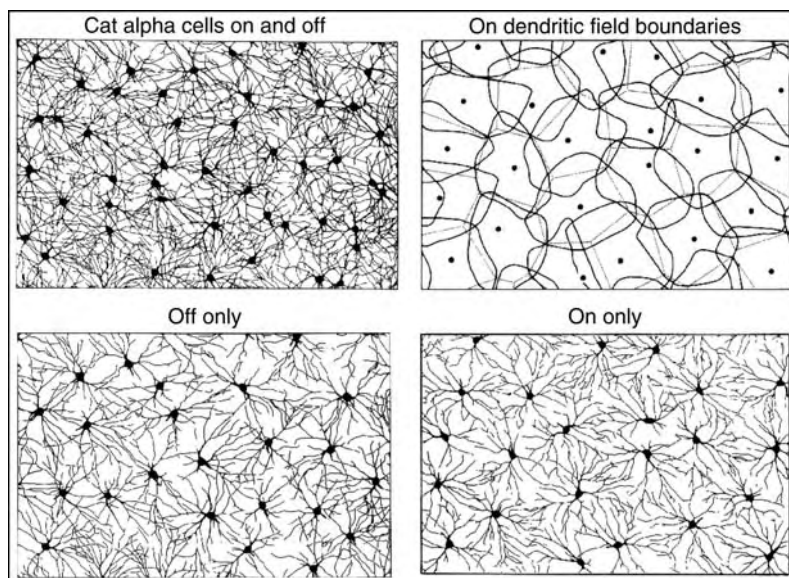

**Visual Processing Streams in Primates. Figure 2** Illustration of ganglion cell coverage of the retina from the cat. Two types of retinal ganglion cells, On and Off Alpha cell, each provide complete coverage of the retina. From Peichl and Wässle [2].

to mediate some aspects of visual processing. However, it is more likely that most aspects of visual processing involve multiple ganglion cell types.

### What is Known About the Most Prominent Retinal Ganglion Cell Types?

#### Midget Ganglion Cells

These are the most numerous retinal ganglion cells, constituting approximately 80% of total ganglion cells. As described above, dendritic/receptive field size is inversely proportional to the number of cells, thus these cells have the smallest dendritic/receptive fields. This is also the most studied type of ganglion cell having been shown to mediate ►visual acuity, ►color vision and many aspects of ►contrast sensitivity [3]. In some publications these cells are labeled ►P cells, because they project to the ►parvocellular layers of the ►lateral geniculate nucleus [4].

#### Parasol Ganglion Cells

These are the second most numerous retinal ganglion cells, making up approximately 10% of all retinal ganglion cells. Dendritic/receptive fields of these cells are larger than those of midget cells, but smaller than those of most other retinal ganglion cell classes, which are less numerous. The function of these cells are also well studied, and they have been found critical to visual sensitivity for fast moving or low contrast stimuli [5]. These cells have been termed ►M cells because they project to ►magnocellular layer of the lateral geniculate nucleus.

#### Blue-Yellow Cells

Blue-yellow cells are the third most numerous retinal ganglion cell type, making up about 5% of all retinal ganglion cells. Receptive/dendritic field sizes are approximately the same size as those of parasol cells. These cells, also called small bistratified, receive input from ►blue cones and appear to mediate blue-yellow visual perception.

#### Melanopsin-Containing Cells

Relatively recently discovered, there appear to be two classes of these cells, each of which seems to cover the entire retina. One class projects to ►suprachiasmatic nucleus and mediates ►diurnal rhythms and the other projects to the ►pretectum and plays a role in pupillary control. In addition, both types also project to the lateral geniculate nucleus, suggesting additional roles in vision [6].

### Other Sparse, Large Dendritic/Receptive Field Cell Classes

The anatomy, physiology and visual function of the other classes of retinal ganglion cells including broad

and narrow thorny cells, large bistratified cells and other cells are not well understood at present.

### Dorsal and Ventral Visual Processing Streams

It has been proposed (cite Ungerleider and Mishkin) that the different retinal ganglion cell types give rise to two functionally specialized ►retino-geniculo-cortical pathways.

The ►ventral cortical pathway is dominated by input from midget retinal ganglion cells, projects through cortical areas including area ►V4 and ►inferotemporal cortex (IT), and is thought to be crucial for color and form analysis.

The ►dorsal cortical pathway is dominated by input from parasol retinal ganglion cells, projects through areas including ►MT, ►MST, ►LIP and ►VIP, and is thought to be crucial for motion and localization analysis.

### Summary of the Known Role of the Different Retinal Ganglion Cell Classes

Although particular ganglion cell types appear to mediate the visual functions they are specialized for (e.g. midget cells mediate acuity; blue-yellow cells mediate blue-yellow color perception) it is likely that the visual system combines information from individual cell types when possible.

### References

1. Dacey DM, Peterson BB et al. (2003) Fireworks in the primate retina: in vitro photodynamics reveals diverse LGN-projecting ganglion cell types. *Neuron* 37(1):15–27
2. Peichl L, Wässle H (1979) Size, scatter and coverage of ganglion cell receptive field centres in the cat retina. *J Physiol* 291:117–141
3. Merigan WH, Katz LM et al. (1991) The effects of parvocellular lateral geniculate lesions on the acuity and contrast sensitivity of macaque monkeys. *J Neurosci* 11:994–1001
4. Shapley R, Reid RC et al. (1991) Receptive fields of P and M cells in the monkey retina and their photoreceptor inputs. *Neurosci Res – Suppl* 15:S199–S211
5. Merigan WH, Maunsell JHR (1993) How parallel are the primate visual pathways. *Annu Rev Neurosci* 16:369–402
6. Dacey DM, Liao HW et al. (2005) Melanopsin-expressing ganglion cells in primate retina signal colour and irradiance and project to the LGN. *Nature* 433:749–754

## Visual Psychic Cortex

►Extrastriate Visual Cortex



## Visual Purple

► Photopigments

## Visual Receptive Field

### Definition

The term receptive field refers to the region of visual space where changes in luminance influence the activity of a single neuron. Also known as the classical receptive field (CRF). For structures such as the retina, lateral geniculate nucleus (LGN) and primary visual cortex, visual receptive fields (RFs) are measured in degrees of visual angle, and organized by their position on the retina (retinotopic). Receptive fields of different types of cells in the visual pathway have different substructures. For example, receptive fields with a center-surround structure are common in the retina and lateral geniculate nucleus of the thalamus whereas most cells in the primary visual cortex have either simple or complex receptive fields. The term may also be used to cover other restrictive properties of the response of a cell, i.e., a direction-selective receptive field, which responds only to motion within the receptive field in some particular direction. Similar concepts exist for other sensory modalities.

- Lateral Geniculate Nucleus
- Retinal Ganglion Cells
- Striate Cortex Functions
- Geniculo-striate Pathway
- Visual Cortical and Subcortical Receptive Fields

## Visual Role of the Pulvinar

KENNETH L. GRIEVE<sup>1,2</sup>, CASTO RIVADULLA<sup>2</sup>,  
JAVIER CUDEIRO<sup>2</sup>

<sup>1</sup>Faculty of Life Sciences, University of Manchester, Manchester, UK

<sup>2</sup>Neurosciences and Motor Control Group (Neurocom), Department of Medicine-INEF-Galicia, University de A Coruña, Campus de Oza, A Coruña, Spain

### Synonyms

Higher thalamic sensory processing; Cortico-thalamic interactions in higher thalamus

### Definition

The “Visual Role of the ►Pulvinar” refers to the dominant sensory input to the largest thalamic nucleus in the primate. However, the structure of the Pulvinar comprises several sub-nuclei and reciprocally links lower brain structures, such as the ►superior colliculus, to almost the entire ►cerebral cortex. It is involved with many ►sensory systems, particularly in the phenomena of ►arousal, ►attention and salience.

### Characteristics

#### Connections of the Pulvinar Nuclei

The Pulvinar is a large dorsal thalamic cellular mass comprising four major sub-nuclei which occupy ~25% of the ►thalamus in higher primates (reviewed in [1]). On anatomical grounds the Pulvinar was traditionally divided into Inferior, Lateral, Medial and Oral (or Anterior) nuclei; see Fig. 1. Of these the Oral Pulvinar is considered mainly somatosensory in function and will not be dealt with in detail here. Much as its better known cousin, the ►dorsal Lateral Geniculate Nucleus (dLGN), nestles over its input from the optic tract, the Pulvinar nucleus forms a cushion-like structure over the fibers forming the brachium of the Superior Colliculus (SC, which provides a significant input, see below). Unlike the dLGN, the Pulvinar nucleus is less cell dense and does not appear obviously internally structured or laminated. It required anatomical studies, coupled with histochemistry (for substances as diverse as ►calbindin, ►AChE and ►SMI32; recently reviewed in [2]) to reveal the internal organization of the nucleus.

In terms of “vision,” the Pulvinar receives a small input directly from the ►retina, and from the superficial layers of the SC – these are focused on the Inferior and Lateral divisions, located laterally in the nucleus.

The Pulvinar is typical of a 2° sensory thalamic structure – it receives input from sub-cortical structures and is reciprocally connected to the cerebral cortex (a 1° structure would be dLGN, with major input from the periphery). In the case of the Pulvinar this connectivity with cerebral cortex is extremely widespread, from ►primary visual cortex (V1) on the ►occipital pole, up to and including ►parietal, ►temporal, ►frontal and even ►cingulate cortices, as well as the amygdala. These connections are organized within the Pulvinar in a lateral to medial direction, with those areas dealing with “lower” sensory function, primary visual cortex and near extra-striate (V2 to MT (V5)) being more medially located than the “higher” sensory areas (temporal, parietal and above). These therefore associate directly with visual inputs from the retina and SC – see Fig. 1.

Indeed, the sub-cortical connections themselves also mirror this organization, such that the deeper layers of the SC (more motor than the superficial

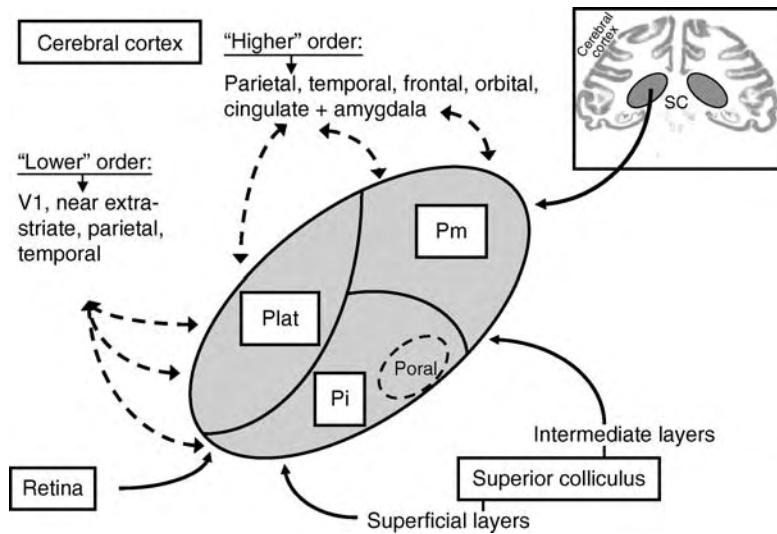

**Visual Role of the Pulvinar.** **Figure 1** Inset shows the relative position of the Pulvinar in the posterior thalamus – note that at this relatively posterior level the Pulvinar occupies almost the whole of thalamic space (modified from an image from BrainMaps.org). Main figure: of the four Pulvinar nuclei, the Oral, or Anterior Pulvinar is not visual, but deals with somatosensation, and would not normally be found at the same AP level as the main mass. The structure is divided roughly equally into three subnuclei – Inferior, Lateral and Medial. The homologous structure in lower animals is the Lateral Posterior thalamic group. *Arrows* indicate anatomical connections known to exist between structures listed, showing the topography of these connections across the Pulvinar from lateral to medial: from “early” visual structures to “higher-order” cortical and associated structures. *Pi* Inferior Pulvinar; *Plat* Lateral Pulvinar; *Pm* Medial Pulvinar. Near-extrastriate include these cortical fields like V2, V4 etc, which surround V1, but whose names may vary from species to species. Note that this is an over simplification – there may be as many as 8–10 possible subdivisions of the Pulvinar and nomenclature is not fixed but varies from publication to publication.

visual layers) contact the more medial regions of the Pulvinar [3].

Like other thalamic nuclei, the Pulvinar also receives powerful modulatory inputs from the ►brainstem and other brain regions involved in arousal and ►sleep/wake.

Divisions within the Pulvinar have been defined anatomically. However, they are also identifiable by virtue of the maps of visual space which are represented by the ►visual receptive fields of the individual cells within the nucleus. Thus contralateral visual space is represented several times across the medio-lateral extent of the nucleus.

Cells within the Pulvinar are of two major types – the more common “relay” cells, which are excitatory and project to the cerebral cortex, and intrinsic inhibitory interneurons, which project locally within the nucleus, and may be restricted within sub-nuclei – this is a common feature of thalamic processing in most (but not all) thalamic nuclei.

Thus the Pulvinar has the capacity to carry out significant, possibly high level, visual processing and sits in a unique position, whereby information from very diverse cortical sources may be processed in a central location, prior to “redistribution” to a wide cortical receiving network.

### “Higher” Thalamus

The Pulvinar is often regarded as a higher thalamic nucleus – basic visual functions are first carried out by the network which includes the dLGN and cortical area V1, before higher cortical regions (and associated thalamic nuclei) then add subsequent processing (the hierarchical model, but see below). Visual cortical areas send axons to the pulvinar regions with which they communicate in ►retinotopic order and, as noted above, this is reflected in the physiological organization of the pulvinar. Cortical cells providing input to thalamus (this is a general statement which applies to the pulvinar) come in two different types – driver and modulators – these appear to sub-serve different functions – driver provide a main source of activation, while modulators alter on-going activity [4]. Anatomically, driver activity appears to come from ►cortical layer V cells, and modulator from layer VI. While specific sensory nuclei, like the dLGN, receive only modulatory inputs, higher nuclei, like the pulvinar receive both types from each of the cortical areas with which it communicates (with the possible exception of V1 which sends only driver type). The nature of the visual inputs to Pulvinar nuclei has not been studied in depth at the single cell level.

Visual Pulvinar cells have visual receptive fields – these can range from simple concentric types to oriented

or binocular, or even color specific, but these are mixed throughout the region, perhaps signaling the diversity of inputs, or some level of organization as yet not known. It is known that some cells in Inferior and Lateral Pulvinar have responses which include modulation from “non-visual” sources such as eye-position – responses typical of some higher cortical areas e.g. parietal/frontal [5]. Key to an understanding of pulvinar function, visual responses are modulated by attention, or ►visual salience – which can result in increased activity – selecting a salient cue – or decreased – for the suppression of non-salient cues [1]. At the “higher” end, in the medial pulvinar, receptive fields are even more diverse and difficult to quantify, again representing the more abstract nature of their inputs. We may regard these as non-visual, in the sense that processing has gone beyond the strictly sensory.

Cells projecting from pulvinar to cortex may be organized at a finer level than the main subdivisions suggest – for example, cells projecting to neighboring, but separate, parietal cortical areas are found in sheets (laminae?) within lateral and medial pulvinar [6]. However, the influence of pulvinar cells on recipient cortical cells is largely unknown.

### Sensory Integration for Attention and Arousal

The visual pulvinar cannot be properly described without placing it in the context of the nucleus as a whole, and the organization of the visual primate brain. Separation of visual information through the primate

brain into two functionally distinct streams has been widely accepted for many years – the ►Dorsal Stream carries information about spatial location, and motion, from V1 to parietal cortex and beyond, and the ►Ventral Stream carries information about form and color, etc, from V1 to the temporal cortices (including, for example, face recognition cells). Very recently, Kaas and co-workers [2] have suggested that the Pulvinar may also be organized in this way, such that the more lateral component (parts of the Inferior and Lateral divisions, as defined before) form part of Ventral stream, and the more medial Inferior and part of the Lateral form part of the Dorsal pathway, in particular related to the motion sensitive areas such as MT and MST – see Fig. 2. However, this appealing suggestion falls short of a complete picture, as these authors have not accounted for the major part of the Dorsal stream which involves parietal areas encoding eye-position etc. It is tempting to speculate that the more medial components of the Lateral and parts of the Medial Pulvinar may form this other component, as these are the very areas containing cells with eye position information (see above, and Fig. 2).

Information from other senses are clearly utilized by the higher regions of the pulvinar; for example it is notable that cells may respond not only to vision, but eye movements, and, further, head or even arm movements. Although not strictly “visual,” it is important to note that these movements (actions) are based upon the visual knowledge of the relative positions of the objects

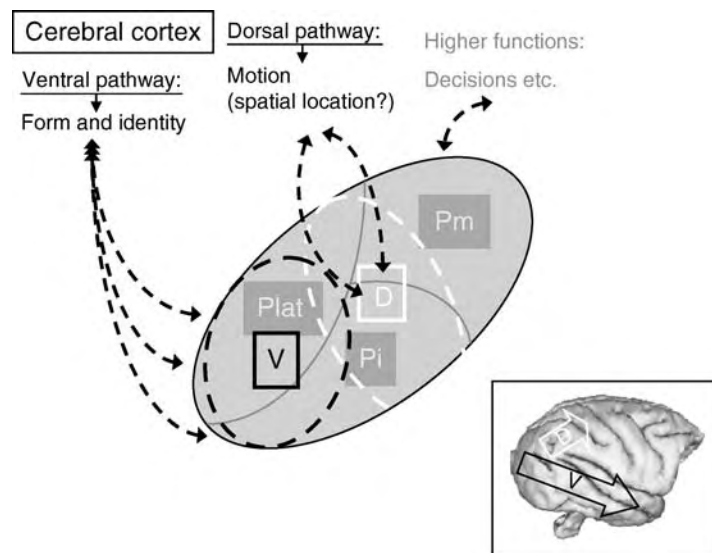

**Visual Role of the Pulvinar. Figure 2** As for Fig. 1, the Pulvinar nucleus is shown as a coronal section. Here we illustrate current thoughts on the relationship of Pulvinar with basic visual function: regions of pulvinar, which cross traditional anatomical/connectional borders, are “associated” with the two main cortical processing streams, which are illustrated in the inset (modified from an image from BrainMaps.org). Thus, parts of Inferior and Lateral Pulvinar contribute to the Ventral “What” pathway, while the remainder of the inferior and parts of the Lateral and Medial Pulvinar contribute to the Dorsal “Where” pathway – see text for more detail.

of interest and this combination of vision and action is key to our interaction with the space around us [3].

Whether or not we regard the pulvinar as “following” the now accepted two visual pathway model, the key element in its function is the major descending cortical input (driver and modulator), with reciprocating connections back to cortex. These loops may constitute a mechanism as important for central processing, (here for vision, but in more medial pulvinar involving other senses), as the loops created between directly linked cortical areas (for example the massive reciprocal connections between V1 and V2, or V1 and MT(V5)). They provide a part of the alternative view to the traditional hierarchical model of cortical function, in which activity may ascend and descend cortical areas with equal strength, acting continuously. Thus pulvinar may act as a component in a series of integrated loops-within-loops allowing cortico-cortical interactions to achieve appropriate levels of excitation to “pick” sensory stimuli of relevance, without producing saturating or damaging levels of excitation, or uncontrolled oscillation, a hypothesis first put forward by Crick and Koch (the “No-strong-loops” hypothesis [7]).

### Clinical Note

Much of our current understanding of the overall role of the Pulvinar has come from clinical studies of brain damage in humans. While animal lesion studies can give significant insight in many cases, work on the Pulvinar is sparse and not very revealing, particularly because of the ability of animals to recover function soon after lesioning. In humans, damage to thalamic areas following ►stroke is quite common. However, the exact region of damage is less easy to ascertain than in precise animal lesion studies, and may often include several sub-regions. Nevertheless, human studies support the view that the Pulvinar (as a whole) is involved with attention and, for example, the selection of appropriate targets from within a field of distractors (picking a face from the crowd!) [8]. At a higher, perhaps more abstract level, damage to the most medial components of the Pulvinar can alter our visual recognition of fear-inducing stimuli [9]. However, most excitingly very recent imaging studies have utilized strategies to reveal internal organization of the human Pulvinar which confirms that the visual organization can be examined on a level equivalent that of animal studies, and promises that future studies may complete the link between the single cell-level studies in monkeys and cognitive studies in humans [10].

### References

1. Robinson DL, Cowie RJ (1997) The primate pulvinar: structural, functional and behavioural components of visual saliency. In: Steriade M et al. (eds) *Thalamus*, vol 2. Elsevier BV, Amsterdam, The Netherlands, pp 53–92
2. Kaas JH, Lyon DC (2007) Pulvinar contributions to the dorsal and ventral streams of visual processing in primates. *Brain Res Rev* 55:285–296
3. Grieve KL, Acuña C, Cudeiro J (2000) The primate pulvinar: vision and action. *TINS* 23:35–39
4. Sherman SM, Guillery RW (2002) The role of the thalamus in the flow of information to the cortex. *Philos Trans R Soc Lond B* 357:1695–1708
5. Robinson DL, McClurkin JW, Kertzman C (1990) Orbital position and eye movement influences on visual responses in the pulvinar nuclei of the behaving macaque. *Exp Brain Res* 82:235–246
6. Hardy SGP, Lynch JC (1992) The spatial distribution of pulvinar neurons that project to two subregions of the inferior parietal lobule in the macaque. *Cereb Cortex* 2:217–230
7. Crick F, Koch C (1998) Constraints on cortical and thalamic projections: the no-strong-loops hypothesis. *Nature* 391:245–250
8. Michael GA, Desmedt S (2004) The human pulvinar and attentional processing of visual distractors. *Neurosci Lett* 362:176–181
9. Ward R, Calder AJ, Parker M, Arend I (2007) Emotion recognition following human pulvinar damage. *Neuropsychologia* 45:1973–1978
10. Cotton PL, Smith AT (2007) Contralateral visual hemifield representations in the human pulvinar nucleus. *J Neurophysiol* 98:1600–1609

---

## Visual Saliency

### Definition

The nature or quality of an object viewed which gives it relevance or importance to the viewer. The more salient an object, the more easily visually identified it is – the more separable from other objects or background. Saliency may refer also to other sensory modalities.

---

## Visual Search

### Definition

► Visual Attention

---

## Visual Shape Representation

► Visual Object Representation

## Visual Space Representation for Action

HIDEO SAKATA<sup>1</sup>, AKIRA MURATA<sup>2</sup>,  
KEN-ICHIRO TSUTSUI<sup>3</sup>

<sup>1</sup>Department of Administrative Nutrition, Faculty of Health and Nutrition, Tokyo, Japan

<sup>2</sup>Department of Physiology, Kinki University School of Medicine, Osaka-sayama, Japan

<sup>3</sup>Division of Systems Neuroscience, Graduate School of Life Sciences, Tohoku University, Sendai, Japan

### Synonyms

Visual space perception for action

### Definition

Visual space representation refers to the perception of position, movement and orientation in 3D space as well as 3D shape of visual objects.

### Characteristics

#### Introduction

We live in a three-dimensional world. In order to act in the real world, we need an internal representation of the 3D space around us. Where in the brain do we have the neural representation of the 3D world? Since Ungerleider and Mishkin proposed the idea of “two visual pathways” in 1982, it has been generally accepted that the dorsal cortical visual pathway projecting into the posterior **▶parietal cortex** is concerned with “space vision,” i.e., perception of the position and movement of visual objects in space, whereas the ventral cortical visual pathway projecting into the **▶inferotemporal cortex** is concerned with “object vision,” i.e., identification of objects by their shape and color (**▶Visual processing streams in primates**). There are two important areas for the early processing of space vision in the dorsal pathways [1]. One is **▶V5/MT** for visual motion, and the other is **▶V3A** for **▶binocular disparity** or **▶stereopsis**. Area V5/MT projects to area **▶MST** [2] and area V3A projects to area **▶CIP** [3,4] (LOP defined by Van Essen’s group) of the **▶parietal association cortex**. MST represents movement of objects in space and CIP represents 3D orientation of axis and surface of visual objects.

In early studies of single unit activity of the posterior parietal association cortex in conscious behaving monkeys, V.B. Mountcastle’s group found several classes of neurons related to **▶eye movements** of **▶smooth pursuit**, **▶saccade**, and fixation as well as those related to the hand movements of reaching and grasping. Initially, they were considered to be related to the motor command or visual attention (**▶Visual attention**). Later, it became clear that many of them were related to the perception of

spatial positions or movements of visual targets [5,6]. Moreover, in the anterior bank of caudal **▶STS** (MST and its vicinity), purely visual neurons sensitive to visual motion in space such as the **▶depth-movement-sensitive (DMS) neurons** [6] and the **▶rotation-sensitive (RS) neurons** [7] were recorded. In area CIP in the lateral bank of the caudal intraparietal sulcus, a group of disparity-sensitive neurons that represent the axis orientation [6] and surface orientation [3,4] of objects in space were recorded. Sakata et al. [6] proposed that the parietal association cortex is primarily concerned with the visual space perception, by representing motion, position, and orientation of visual objects in space. In recent studies of area **▶AIP** of the inferior parietal lobule (**▶IPL**), Murata et al. [8] found a group of **▶hand manipulation task-related neurons** that were visual dominant and selective for the 3D shape and orientation of the target object. Motor dominant and visual-motor neurons were also recorded in AIP, which may play an important role in the visual guidance of hand actions.

In this essay, we briefly describe a variety of parietal visual neurons that represent various aspects of space vision. The parietal association cortex is primarily concerned with the perception of the physical environment, representing three-dimensional movement, position, orientation, and structure in the egocentric frame of reference. Space vision is action-oriented, and its information is used to guide hand actions through the parieto-frontal interconnections.

### Representation of Visual Movement in Space by MST Neurons

MST (medial superior temporal) area in macaque monkeys is anatomically defined as a forward cortico-cortical projection from the neighboring V5/MT area [2]. Two distinct areas of projection from V5/MT were demonstrated by tritium-labeled proline injection [2], and these may correspond to the MSTl and MSTd areas defined by R. H. Wurtz’s group in relation to pursuit eye movement. Unlike V5/MT, MST neurons have large receptive fields and no retinotopic organization. The appropriate stimulus for MST neurons is not a simple linear movement of the retinal image. Many MST neurons respond to more complicated stimuli such as movement in depth [6], rotary movement in space [7], and optical flow (**▶Optic Flow**), as studied in the MSTd by Wurtz’s group.

*Depth-movement-sensitive neurons:* A group of MST neurons that respond to approaching or receding movement of the visual stimulus better than to the fronto-parallel movement were designated as depth-movement-sensitive (DMS) neurons [6]. Most DMS neurons respond to size changes as well as to disparity changes of the stimulus. The majority of DMS neurons respond to a combination of these two stimuli better than to either one of these stimuli alone.

*Rotation sensitive (RS) neurons:* RS neurons respond significantly better to rotary movement than to linear translational movement of the same stimulus. These neurons were found in the anterior bank of the caudal superior temporal sulcus that turned out to be MST and its vicinity. An extensive study of these neurons was published later [7]. RS neurons respond well to the rotation of a luminous bar or a spot and are likely related to the perception of rotations of individual objects. Moreover, the majority of RS neurons respond better to depth rotation than to rotation in the fronto-parallel plane [5]. An example of a depth RS neuron responding to the Ames window is shown in Fig. 1. RS neurons may play an important role in guiding turning, swinging, and revolving actions.

#### Neural Representation of Spatial Position in Area LIP and 7a

The posterior parietal cortex is the most likely area of the brain involved in the perception of position in

egocentric space, as lesions in this area in humans cause visual disorientation in which the judgment of distance is severely disturbed.

*Visual fixation neurons of ▶LIP and 7A:* In early studies of parietal neurons in alert monkeys, visual fixation (VF) neurons were found to be activated during fixation on a static target in a certain position [5]. Most of the VF neurons are selective for the fixation direction (gaze direction) and increase their activity monotonically with increasing orbital eccentricity. Many are also selective for the distance of the fixation point. The majority of depth-selective VF neurons prefer a nearby target, and their activity increases gradually as the distance of the target from the eye decreases with increasing angle of convergence and degree of accommodation. There is psychophysical evidence by C. Hofsten to indicate that a change in the angle of convergence changes the distance estimation. It was found that the visual stimulus in the fovea was necessary to activate at least some of the VF neurons

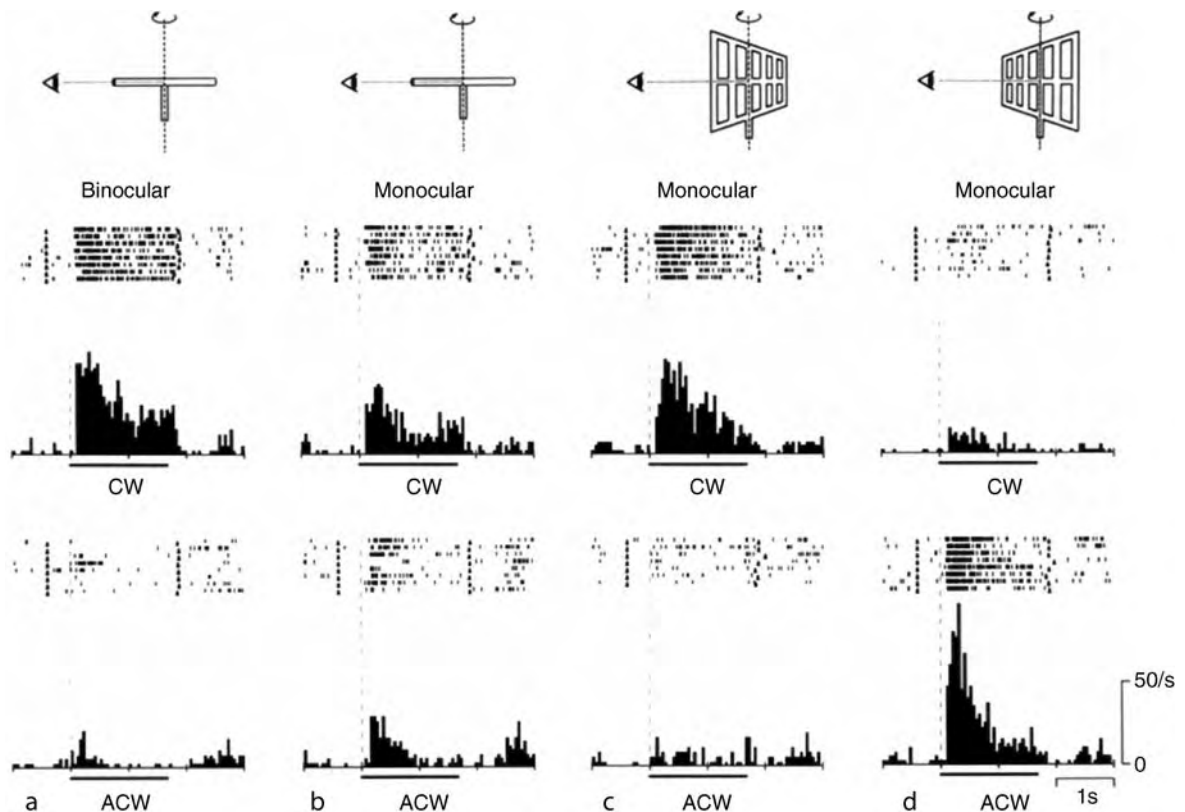

**Visual Space Representation for Action. Figure 1** Responses of depth RS neuron to rotation of Ames window (a trapezoid 21 cm in height, with a long edge of 25 cm and short edge of 14 cm), compared with those to a regular bar. (a) Response to rotation of a bar under binocular viewing conditions. (b) Response to rotation of a bar under monocular viewing conditions. (c), (d) Response to rotation of a trapezoidal (window-shaped) plate (around the axis parallel to the base) under monocular viewing conditions, with the longer edge moving in front of (c) or behind (d) the axis. The range of rotation was half a turn ( $180^\circ$ ), and the viewing distance was 150 cm for all conditions. Note a reversal of preferred direction of rotation in D. Stimuli were rotated in the sagitto-horizontal plane, although diagrams are drawn on the horizontal plane for simplicity (Adapted from [7]).

[5]. Since many VF neurons stopped their discharges when the LED spot for fixation was turned off, they likely represent the spatial position of the visual target in the egocentric frame of reference.

Recent discovery of eye position neurons in the ▶**somatosensory cortex (SI)** by M. E. Goldberg's group support the view that VF neurons receive ▶**proprioceptive** signals from the extraocular muscles via SI to represent the eye position to be combined with the visual signal of the target in the fovea. This position signal is necessary to guide reaching of the hand to the target.

### **Area CIP and the Representation of 3D Surface Orientation by the Integration of Multiple Depth Cues**

In the caudal part of the lateral bank of the intraparietal sulcus, we identified a distinct visual area that contains neurons selective to the orientation of an object in depth [6], which was later designated as area CIP (caudal intraparietal) [3,4]. This area appears to be included in the dorsal visual pathway, as it receives strong input from the neighboring V3A, which has been reported by S. M. Zeki's group to contain neurons sensitive to binocular disparity and its neurons are organized in a columnar fashion according to binocular disparity (near/far). The majority of CIP neurons are sensitive to binocular disparity, and the receptive field size of the neurons is normally more than 15° in diameter, often extending to quarter or half of the visual field. The visual properties of these neurons are tested using real objects as well as binocular computer graphics. Many CIP neurons show rough selectivity to the shape of the visual object, either to an elongated object or a flat plate-like object, and show strong selectivity to the 3D orientation of the preferred object. Orientation-selective neurons with selectivity to the elongated object were designated as ▶**axis-orientation-selective (AOS) neurons**, and those selective to the flat plate-like object were designated as ▶**surface-orientation-selective (SOS) neurons**.

In further experiments, the properties of the SOS neurons were extensively tested using binocular computer graphics. First, their preference to the 3D surface orientation was tested for depth invariance, by changing the depth of the object from "in front of" to "behind" the fixation spot [3]. Most of the SOS neurons tested showed strong depth invariance, preserving the 3D orientation-selectivity regardless of the change in depth of the object relative to the fixation spot. In contrast, the disparity-sensitive neurons in the occipital cortex are known to be tuned to a specific disparity (near, far or zero) as studied by G. F. Poggio's group. It is likely that the disparity gradients across a cluster of V3A neurons are integrated in the SOS neurons in order to represent depth-invariant 3D orientation. Second, the SOS neurons were tested for their sensitivity to monocular depth cues, such as linear perspective and texture

gradients [4]. The majority of SOS neurons show a selective response to the surface orientation defined by a monocular depth cue alone. In almost all the SOS neurons showing sensitivity to both binocular and monocular depth cues, the selectivity is the same for the surface orientation defined by the binocular cue alone in the random-dot stereogram (RDS) and that defined by the monocular cue alone (Fig. 2). This result suggests that the binocular and monocular depth cues are integrated in the SOS neurons in order to construct a cue-invariant general representation of surface orientation. SOS and AOS neurons are necessary to adjust the orientation of the hand to the orientation of the object to be grasped or the slot to be inserted.

### **Linking Space Vision to the Control of Hand Actions**

The parietal association cortex and ▶**premotor areas** have several parallel inter-connections with each other that may play an important role in linking space perception to the control of hand and arm movements. The dorsal visual pathway is separated into two channels: the dorso-dorsal pathway and the ventro-dorsal pathway as suggested by G. Rizzolatti's group. In the dorso-dorsal pathway, ▶**V6A** defined by Galletti et al. [9] in the ▶**superior parietal lobule (SPL)** on the anterior bank of the parieto-occipital sulcus has strong reciprocal connections with the dorsal premotor cortex (▶**F2** and ▶**F7**). V6A neurons are mainly related to reaching [9], although they may also be related to grasping. They may also be related to eye-hand coordination, as indicated by R. Caminiti's group. V6A and ▶**MIP** overlap the ▶**parietal reach region (PRR)**, as defined by R.A. Andersen's group. Some of the visual neurons in V6A encode the craniotopic (head-centered) frame of reference that is suitable for controlling reaching movements [4]. There is an intense anatomical connection between V6A and LIP as demonstrated by G. Rizzolatti's group. This connection may provide a spatial position signal from VF neurons to V6A for the control of reaching.

The ventro-dorsal pathway projects to the anterior intraparietal (AIP) area and area ▶**PFG/PF** of the inferior parietal lobule (IPL). These areas have reciprocal connections with the ▶**ventral premotor cortex (F5)**, as studied by G. Rizzolatti's group. They found ▶**mirror neurons** in the PFG/PF, similar to the ones they found in F5, whereas AIP was related to visual guidance of grasping [8].

### **Hand Manipulation Task-Related Neurons in AIP**

AIP neurons are activated during a hand-manipulation task in which monkeys are required to grasp and pull various objects [8]. In order to separate the visual response from the movement-related activity, the activity of AIP neurons was compared under three conditions: movement in light and in darkness, and fixation on an object in light. Thus, the task-related

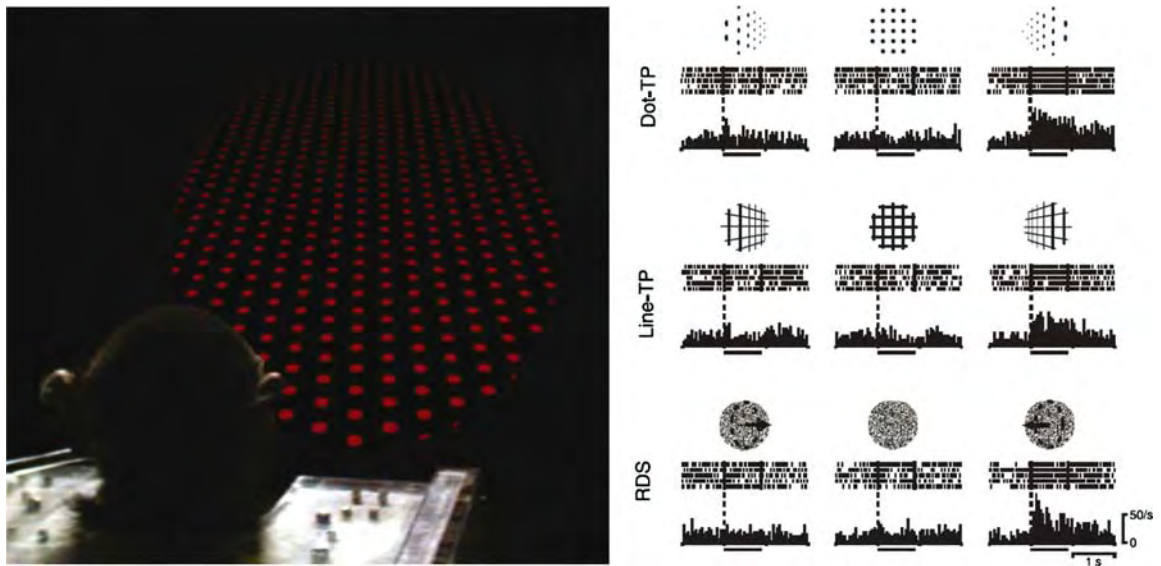

**Visual Space Representation for Action. Figure 2** *Left*: photograph of a monkey facing a computer display showing a surface orientation defined by texture gradients. *Right*: activity of a representative SOS neuron showing sensitivity to both monocular and binocular cues. This neuron showed selectivity to a surface tilted  $45^\circ$  clockwise around the Y-axis regardless of the type of the depth cue, such as texture gradients in a dot texture pattern (Dot-TP, *top row*), those in a line texture pattern (Line-TP, *middle row*), or binocular disparity gradients in a random-dot stereogram (RDS, *bottom row*) (Adapted from [4]).

neurons could be classified into three different types; motor-dominant, visual-motor, and visual-dominant neurons. Motor-dominant neurons fire during manipulation both in light and in darkness with the same intensity. Visual-dominant neurons respond only in the light. Some of them (object type) are activated during object fixation. Visual-motor neurons reduce their responses during manipulation in darkness and some of them (object type) respond during object fixation. **Figure 3** shows an example of object-type visual-dominant neurons. This typical neuron showed a highly selective response to the view of a ring among six 3D objects with elementary shapes, suggesting that it represented the 3D shape of the objects. Motor-dominant neurons are likely to be activated by the efference copy of the motor command. Since AIP has a strong reciprocal connection with F5, the efference copy most likely comes from F5.

#### **Role of F5 Neurons in Visual Guidance of Grasping**

In the ventral premotor cortex (F5), neuron activity shows selectivity for the type of hand movement, such as precision grip, finger prehension, and whole hand grasping [10]. The functional properties of F5 neurons were studied in collaboration with Rizzolatti's group using the same hand manipulation task apparatus as used for the AIP neurons. A group of hand-manipulation-related neurons in F5 is activated partially when the monkey fixated on the objects to be grasped, just as in the visual-motor neurons in area AIP. The other group of grasping

neurons does not show any visual response, just like the motor-dominant neurons in AIP. The major difference is that no neurons similar to the visual dominant neurons of AIP were found in F5. These results suggest that F5 is closer to the output motor system than the AIP is. Indeed it is well known that the premotor areas including F5 send projections to the **primary motor cortex (F1)**. F5 likely receives visual information about objects, such as 3D-shape, orientation and size from AIP.

#### **Conclusion**

The parietal association cortex is the site of visual space perception. In MST, (i) depth-movement-sensitive (DMS) neurons integrate size changes and disparity changes in order to represent movements in depth; and (ii) rotation-sensitive (RS) neurons, including depth RS neurons, represent rotary movements in space. In CIP, (i) axis-orientation-selective (AOS) neurons and (ii) surface-orientation-selective (SOS) neurons represent the 3D orientation of elongated and flat objects in space, respectively. The early finding that **visual fixation (VF) neurons** in LIP and 7A represent spatial positions of objects in a head-centered frame of reference was supported by a more recent finding of eye position neurons in S1. VF neurons may contribute to the control of reaching through the reciprocal connection of LIP to V6A. In AIP, hand-manipulation task-related neurons are categorized into motor-dominant, visual-motor, and object-type visual-dominant neurons representing the



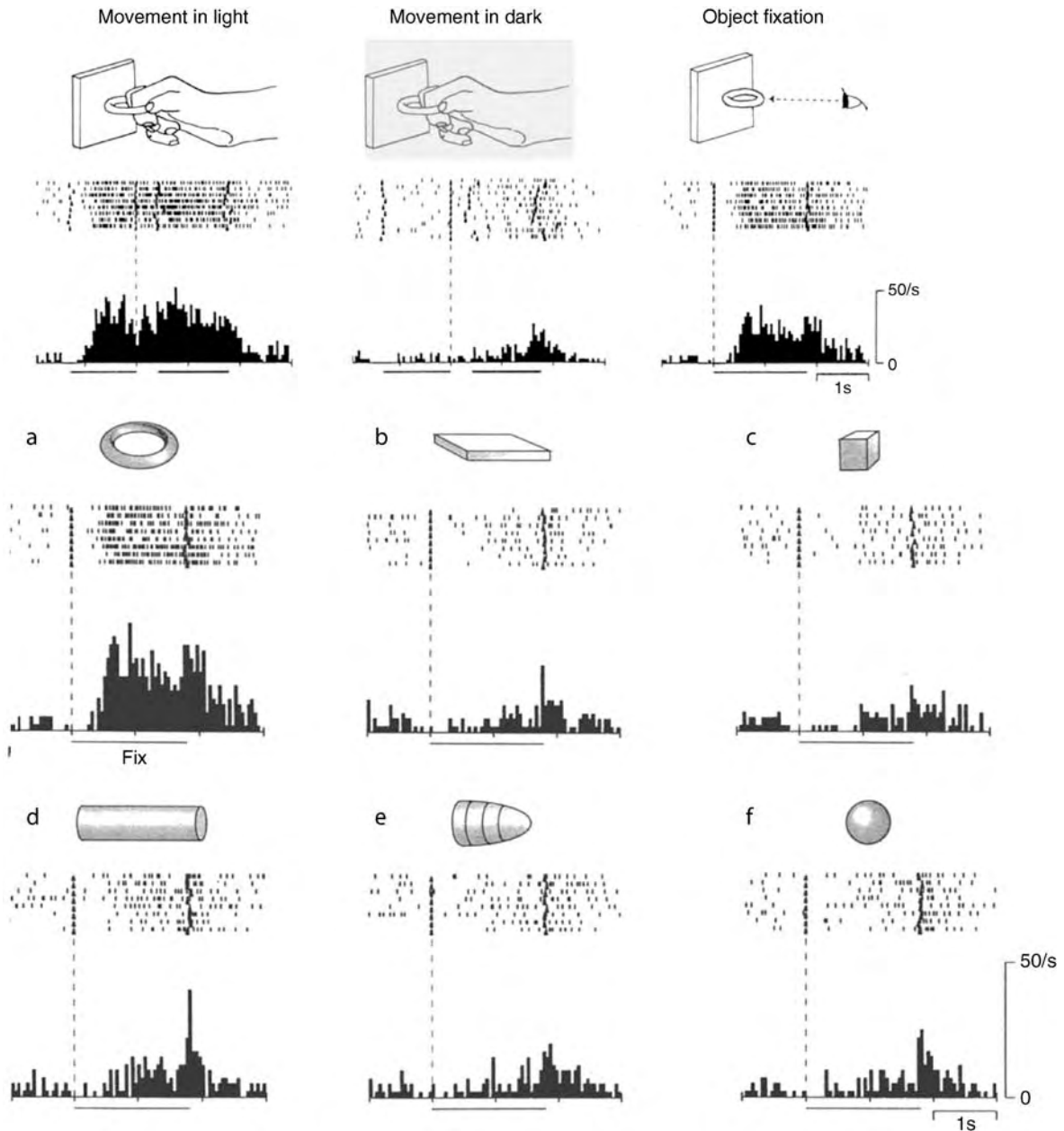

**Visual Space Representation for Action. Figure 3** Example of visual-dominant neuron which responded very selectively to the ring. The *upper panel* shows activity during manipulation of the object in light and in darkness, and during fixation on the objects. The *lower panel* shows the selectivity of the neuron during fixation on six different objects (Adapted from [8]).

3D shapes of objects for grasping. AIP neurons likely contribute to the [preshaping](#) of the hand through the reciprocal connection of the AIP and F5.

## References

1. Zeki SM, Shipp S (1988) The functional logic of cortical connections. *Nature* 335:311–317
2. Maunsell JH, van Essen DC (1983) The connections of the middle temporal visual area (MT) and their relationship to a cortical hierarchy in the macaque monkey. *J Neurosci* 3:2563–2586
3. Taira M, Tsutsui KI, Jiang M, Yara K, Sakata H (2000) Parietal neurons represent surface orientation from the gradient of binocular disparity. *J Neurophysiol* 83:3140–3146
4. Tsutsui KI, Sakata H, Naganuma T, Taira M (2002) Neural correlates for perception of 3D surface orientation from texture gradient. *Science* 298:409–412

5. Sakata H, Shibutani H, Kawano K (1980) Spatial properties of visual fixation neurons in posterior parietal association cortex of the monkey. *J Neurophysiol* 43:1654–1672
6. Sakata H, Taira M, Kusunoki M, Murata A, Tanaka Y (1997) The TINS Lecture. The parietal association cortex in depth perception and visual control of hand action. *Trends Neurosci* 20:350–357
7. Sakata H, Shibutani H, Ito Y, Tsurugai K, Mine S, Kusunoki M (1994) Functional properties of rotation-sensitive neurons in the posterior parietal association cortex of the monkey. *Exp Brain Res* 101:183–202
8. Murata A, Gallese V, Luppino G, Kaseda M, Sakata H (2000) Selectivity for the shape, size, and orientation of objects for grasping in neurons of monkey parietal area AIP. *J Neurophysiol* 83:2580–2601
9. Galletti C, Kutz DF, Gamberini M, Breveglieri R, Fattori P (2003) Role of the medial parieto-occipital cortex in the control of reaching and grasping movements. *Exp Brain Res* 153:158–170
10. Rizzolatti G, Camarda R, Fogassi L, Gentilucci M, Luppino G, Matelli M (1988) Functional organization of inferior area 6 in the macaque monkey. II. Area F5 and the control of distal movements. *Exp Brain Res* 71:491–507

## Visual Space Representation for Reaching

ALEXANDRA BATTAGLIA-MAYER,  
ROBERTO CAMINITI  
Department of Human Physiology and Pharmacology,  
SAPIENZA, University of Rome, Rome, Italy

### Synonyms

Visuo-motor space; Visual action space

### Definition

Visual space for ►reaching refers to the ►peri-personal space within which arm movement is made to bring the hand on objects that have been localized by using visual information.

### Characteristics

#### Behavioral Characteristics of Arm Reaching to Visual Targets

Visually-guided reaching consists of a coordinated eye-hand action, often also accompanied by a movement of the head, toward objects identified through visual information (for a review, see [1]). When the visual target to reach is in the periphery of the ►visual field, the hand movement is usually preceded by a fast (800°/s) ►saccade that brings the target onto the ►fovea. If target eccentricity exceeds 10° of visual angle, eye movement is

accompanied by concomitant head movement. The command to move the head, the eye, and the arm is addressed almost simultaneously to these different effectors, as indicated by the onset of their respective ►electromyographic activity. However, the different inertia allows the eye to move first, followed by the head and then by the arm. Since the speed of the saccade brings the eye to the target before the hand moves from its starting position, the initial motor command is composed by using peripheral visual information, while foveal vision might be used for control of hand movement in its final stage. Accuracy of reaching is maximal when vision of hand is allowed and it is deteriorated whenever eye or head movements are prevented.

### Coordinate Transformations

In the visual space for reaching, the direction of the target is mapped in ►retinotopic coordinates, whereas its distance is derived by combining ►retinal disparity and fixation distance information, such as the ►vergence angle of the two eyes, ►accommodation, and ►vertical disparity. The vergence angle has a crucial importance, since in the peri-personal space its range of maximal efficiency roughly coincides with the arm length. This view is supported by the observation that in early postnatal development arm reaching develops at the same time as binocular control. It is believed that this information, together with that about hand position in space, is used to specify the desired movement trajectory, which is based on the computation of the difference between the target and the hand location, an entity referred to as “►motor error.” In the field of view, the position of the hand can be encoded in visual coordinates, while outside the visual field or in the dark, ►proprioceptive information and corollary signal of the motor command contribute to its determination. The combination of information concerning target and hand position requires the transformation of the end-point of reaching from retinal to ►egocentric coordinates, a process to which eye position can contribute essential information, provided that target depth is recovered mainly from binocular (►vergence) cues. Therefore, a combination between eye and hand information is believed to occur into a common egocentric (binocular) frame of reference. Various psychophysical studies have outlined the cascade of sensorimotor transformations necessary to remap target location from initial retinotopic coordinates into binocular viewer-centered frame, to body- and hand-centered frames. A modern view is that the ►coordinate frame used to encode arm reaching to visual targets is hybrid and context-dependent, since it can vary depending on the current sensory information, task demands, geometry of the visual space, and cognitive context (for a review, see [1]). Forward models of movement control state that an estimate of

the sensory consequence of an upcoming or planned movement is used to compute the difference between the motor command and its state, thus contributing essential information to the computation of the “motor error.”

### Central Representation of the Visual Space for Reaching

The visual space for reaching is represented in a variety of parieto-frontal cortical areas, which form the so-called ▶*visual dorsal stream* [2], a cortical pathway that originates from visual cortical areas and through ▶*Posterior Parietal Cortex* (▶*PPC*) processes information about spatial properties of objects and of the visual scene where they are located (“where” information). This type of information is then conveyed, through cortico-cortical projections, to ▶*premotor* and ▶*motor cortex* that are the output-regions of the parieto-frontal network to address messages to the spinal cord. From this perspective the dorsal stream can be considered a distributed system essential for composition of motor commands of eye-hand signals necessary for the visuomotor operations of daily life. The cortical areas of the parieto-occipital (PO) junctions are believed to play a crucial role, since they receive visual inputs from different ▶*extrastriate cortical areas* and project to ▶*premotor cortex* in the ▶*frontal lobe* [1–4].

▶*Parieto-occipital (PO) cortex* contains a coarse representation of the visual field, with a wider representation of visual periphery, as compared to other

visual areas. PO neurons have large and often bilateral ▶*receptive fields*, and are sensitive to the orientation and direction of motion of visual stimuli (Fig. 1).

These neurons are also influenced by optic flow fields (▶*Optic flow*), and this property is an important source of optic flow information to motor cortex, via frontal premotor areas. In fact, optic flow modulates also the activity of motor cortical cells that, among the different flow motions, are particularly sensitive to expansion-like flow fields. In fact, “expansion” is the type of motion that influences the retina when a subject moves toward an object (or when the object approaches the subject), therefore this type of optic flow provides information about the subject-object relative movement direction, in other words about the interaction between ego-motion and object motion (see chapter on ▶*Vestibular-Visual Interaction*). Posterior parietal cells sensitive to optic flow do not display “opponent vector organization,” a feature of parietal visual neurons that can be important in processing the radial motion of objects moving toward or away from the fovea [5]. Thus, encoding object motion in the visual space representation of parietal cortex might reside on separate parallel mechanisms, segregated in different populations of neurons, one based on optic flow information and related to global motion, another on opponent vector organization, mostly devoted to local motion analysis.

As with the majority of parietal neurons, the activity of PO cells is often influenced by the angle of ▶*gaze*

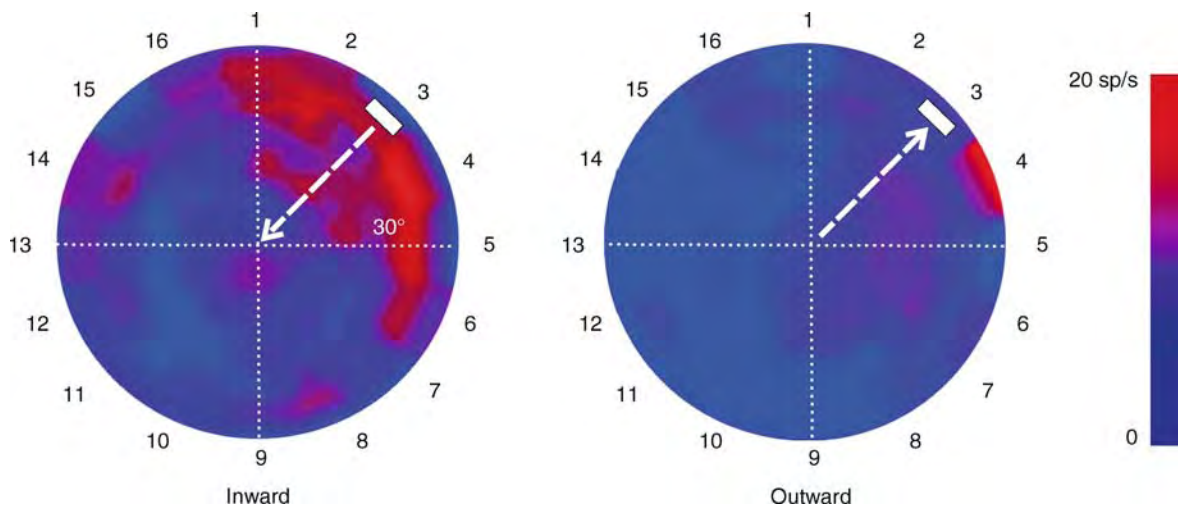

**Visual Space Representation for Reaching. Figure 1** Visual response features of a parietal cell in the form of color contour maps of the visual field, observed during a visual stimulation task during which the monkey was fixating in the center of the workspace and a white bar was moved in 16 directions inward (IN) and outward from the fovea ( $0^\circ$ ). Notice the difference of the cell response for different stimulus motion direction. Horizontal and vertical meridians of the visual fields are shown by white dotted lines, the numbers indicate the direction of stimulus motion. The color calibration bar is in spikes/s.

[6], a signal that is essential for the transformation of the position of a visual target from retinal to head-centered coordinates.

Neurophysiological studies have shown a gain modulation of eye vergence on the disparity-tuning of neurons in the ►Lateral intraparietal area (LIP, area 7) of monkeys performing saccadic eye movement to targets in 3D space [7]. This study provides evidence for an egocentric coding of 3D target distance in parietal cortex. Interestingly, LIP projects to the ►anterior intraparietal area (AIP), a region cortico-cortically connected to ventral premotor (►Area F5) cortex, and involved in the control of visually-guided hand movement (for reviews, see [8]). Therefore, information about target distance and its update is available to the network controlling not only eye, but also hand movement.

### General Properties of Reach-related Neurons in the Parieto-Frontal System

The activity of reach neurons in both frontal and parietal cortex varies in a broad fashion with arm movement direction and position (Fig. 2a and b), and encoding of movement direction resides in a ►population code (for a review, see [1]). In addition, reaching neurons across the parieto-frontal system are influenced by the visuo-spatial signal concerning target location, as well as by the eye position and movement direction (Fig. 2c). In both frontal and parietal cortices, neural modulation occurs at all stages of reaching, i.e. during preparation, execution of eye-hand movements, as well as during static holding of hand and/or eye in space [1,9,10]. In conclusion, the essential characteristic of parietal reach neurons consists in their combinatorial nature,

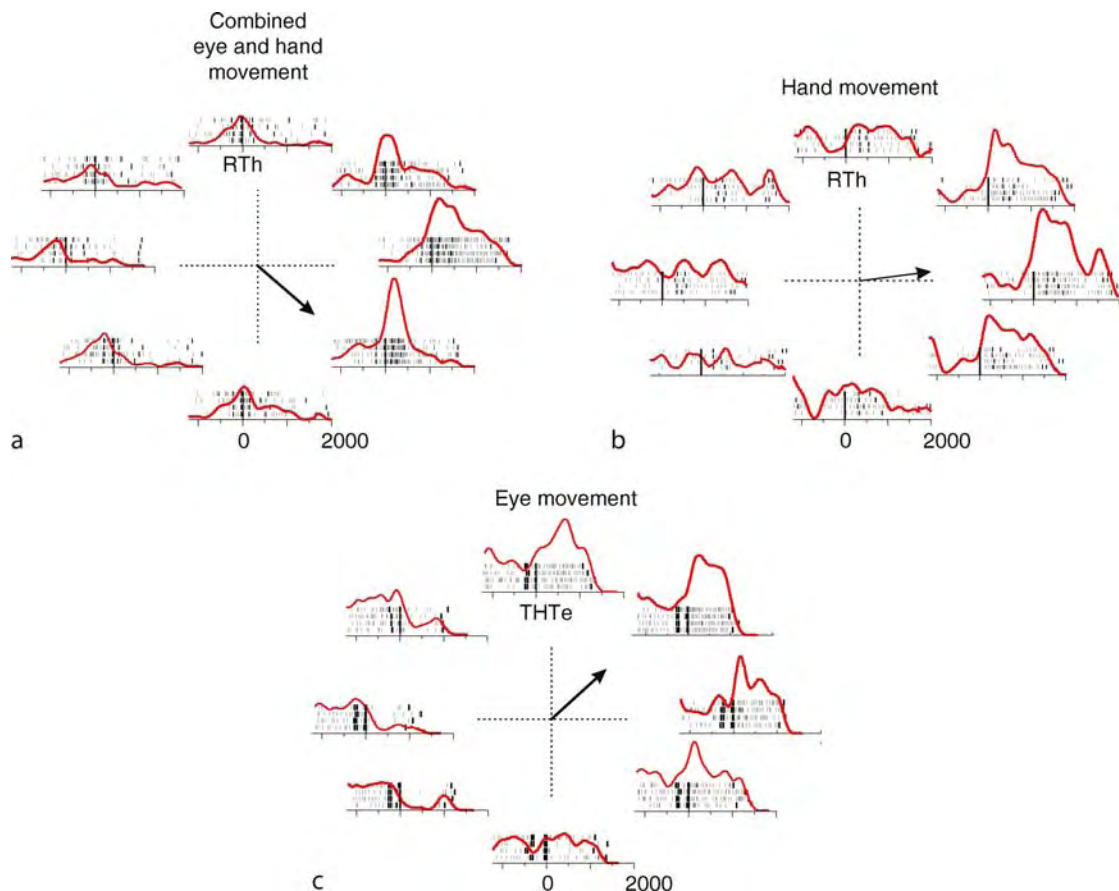

**Visual Space Representation for Reaching. Figure 2** Neural activity in the form of raster displays and spike density functions (red curve) of three parietal cells studied in the *Reaching Task* (a), where both eye and hand moved toward a peripheral target, the *Reaching-Fixation Task* (b), where only the hand moved to the target, while the eyes were fixating the center of the workspace, and the *Eye Movement Task* (c), where only the eye moved toward the visual target. For each movement direction four replications are displayed. Action potentials are indicated by grey strokes, while thick black markers define behavioral epochs. The neural activity is aligned (black vertical line) to the hand reaction-time (RTh) epoch (a, b), and to the end of eye movement when the eye stays on the peripheral target (THTe; c). In the centre of each panel, the black arrow indicates the preferred direction. (modified from Battaglia-Mayer et al. (2005) *Cereb Cortex* 15:514–525).

with different eye and hand signals influencing neural activity with different strength, depending on the task demands.

The coexistence of a variety of signals is not specific to the parietal cortex, but might be regarded as a general feature of all nodes of the parieto-frontal system, where different signals are combined and distributed all over the network in a gradient-like fashion. However, the different cortical regions might be functionally distinguished on the basis of the strength with which a given signal influences neuronal activity, together with their cortico-cortical connections.

This graded influence takes different forms and can be shown both at single cell level, as well as by the overall distribution of reaching-related signals across parietal and frontal cortex. This distribution, together with the pattern of reciprocal association connections among these areas, determines the architecture of the parieto-frontal network.

In the ►superior parietal lobule (SPL) cells, the ►preferred directions of individual eye and hand signals obtained from different epochs of different visuomotor tasks, cluster within a restricted part of space, the *global tuning field* [1,4] (GTF; Fig. 3), an ideal visuomotor frame to dynamically combine eye and hand signals on the basis of their spatial tuning,

therefore a possible substrate for eye-hand coordination, in its different forms (for a review, see [4]).

In the ►inferior parietal lobule (IPL) (►Area 7a), three main classes of combinatorial reach neurons have been identified: hand-dominant, whose neural activity is mostly correlated to hand signals, eye-dominant, whose activity is mostly modulated by eye signals, and eye-hand cells, with neural activity equally determined by eye and hand information. At the population level, the distribution of the eye-hand preferred directions computed during different epochs of different tasks is highly skewed (Fig. 4) toward the contralateral space [4]. IPL neuronal activity is more intensely modulated during the hand movement to the fixation point, therefore in an ecologically relevant form of visuomotor behavior.

### The Functional Architecture of the Parieto-Frontal Network Underlying Reaching

When the distribution of hand and eye information in the parietal and frontal cortex is confronted with the organization of cortico-cortical connections, a distributed system emerges, characterized by a gradient-like architecture ([9]; for a recent review, see [4]), where parietal and frontal areas are reciprocally connected (Fig. 5). At the caudal and rostral nodes of the network, respectively in the parieto-occipital cortex (►Area

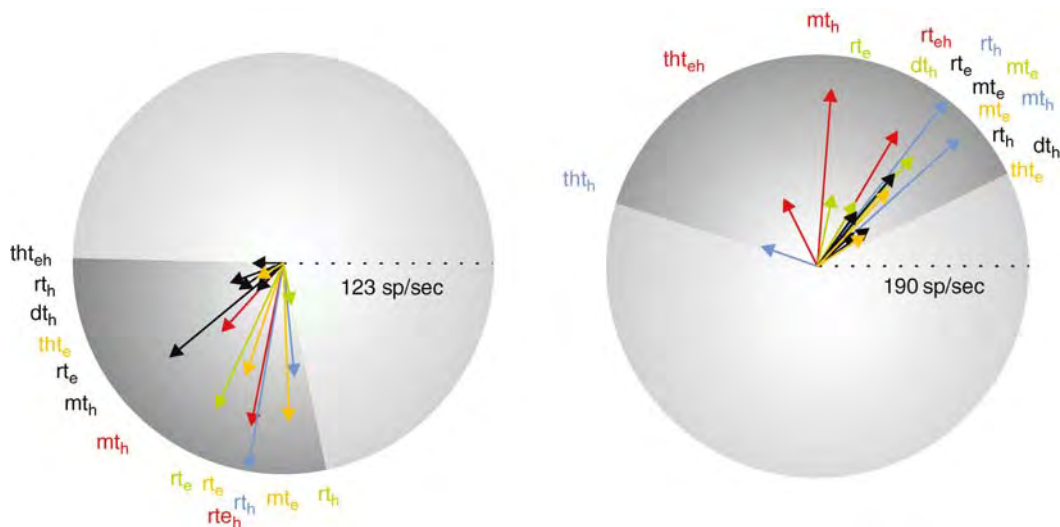

**Visual Space Representation for Reaching. Figure 3** The two circles refer to two typical parietal cells, displaying the orientation of their preferred direction (PD) vectors in different task epochs. Macaque monkeys made arm and/or eye movements from a central origin in eight different directions. PDs (*colored arrows*) of cell activity were computed during different epochs of different tasks: a Reaching task to foveal (*red*), or to extrafoveal targets (*blue*) targets, an eye movement task (*yellow*), and a Delay Reaching task, performed both under light conditions (*light green*) and in total darkness (*black*). The length of each PD vector is proportional to the mean cell's firing rate (sp/s) in a particular epoch, and the radius of the circle is normalized to the maximum discharge rate. For each cell, PD vectors cluster within a restricted part of the workspace, referred to *global tuning field*. The acronyms *rt*, *mt*, *dt*, *tht* indicate reaction-time, movement-time, delay-time, target holding time, respectively; subscripts *e* and *h* stand for eye and hand, respectively. Each acronym is color-coded (see above), depending on the behavioral task (modified from Battaglia-Mayer et al., 2006).

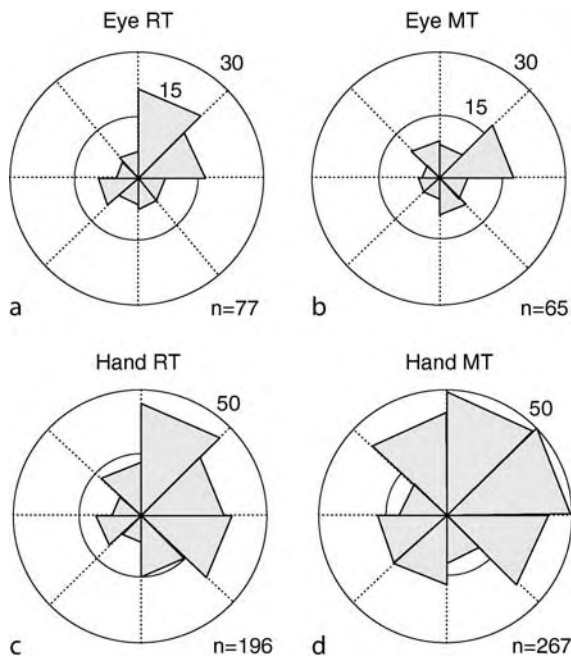

#### Visual Space Representation for Reaching.

**Figure 4** Rose diagrams indicating the distribution of preferred directions across the population of directionally-tuned cells recorded in the Inferior Parietal Lobule (*left hemisphere*), obtained during eye reaction time (RT, a) and eye movement time (MT, b) of visually guided saccades and hand reaction time (c) and hand movement time (d) of reaching movement to visual targets. The number (n) of preferred directions included in each distribution is displayed in each plot. Numbers on the circle indicate the scale of the rose diagrams. All distributions show a significantly difference from uniformity and are clearly skewed toward the right hemifield, that is contralateral to the recording hemisphere (modified from Battaglia-Mayer et al. (2005) *Cereb Cortex* 15:514–525).

V6A, ▶Area 7m, ▶Area PEc) and in the rostral part of dorsal premotor cortex (▶PMdr; ▶Area 6), eye signals predominate on hand information (Fig. 5a, green shaded regions). At intermediate parietal (▶Area MIP, Area PEc, ▶Area PEa, ▶Area 5) and frontal (border between rostral, PMdr, and caudal, ▶PMdc, premotor cortex) levels, eye and hand signals coexist, although their strength relationships may differ depending on the specific sub-region considered (Fig. 5a, yellow shaded regions). Finally, in the rostralmost part of the parietal cortex (▶Area PE) and in the caudalmost part of the frontal cortex (PMdc; ▶primary motor cortex, MI), hand information dominates on eye signals (Fig. 5a, red shaded regions). The gradient-architecture also characterizes the functional organization of other cortical networks, such as that including motor cortex (▶Area 4); ▶pre-supplementary motor cortex (▶pre-SMA,

antero-mesial part of area 6), and ▶SMA (postero-mesial part of area 6). Frontal and parietal regions displaying a similar activity-type are cortico-cortically connected (Fig. 5b and c). Throughout the network, all these reach-related signals are directional in nature.

Another gradient concerns the type of information treated in the network. Moving from caudal to rostral in SPL, a transition from signals concerning preparation to those about movement execution and sensory feedback occurs; the opposite has been described in the frontal cortex. Eye and/or hand position information are to a large extent ubiquitous at most rostro-caudal locations of parietal and frontal cortex. This is an essential feature of the network, since the gain modulation exerted by eye position on visual parietal neurons (for a review, see [10]) favors the transformation of target location from retinal to ▶body-centered coordinates, while hand position signals are essential for computing hand movement trajectory [1] across the network.

Concerning the temporal relationships between neural activity and reaching movement in the parieto-frontal system, in both the SPL and IPL, neural activity in most cells leads arm movement onset (Fig. 6), while other cells discharge around or during movement. The same is true in dorsal premotor and motor cortex, to which SPL projects via cortico-cortical connections. In posterior parietal cortex, most SPL cells fire before the saccade that brings the eye to the target, while in IPL they mainly fire at the end of the saccade, thus encoding an eye-position signal. The comparison of the onset time of cell activity relative to different behavioral events leading to arm reach in parietal (SPL) and frontal (dorsal premotor and motor) cortex shows a simultaneous recruitment of cells relative to the presentation of the visual target [9]. Instead, at the visual go-signal and at the beginning of arm movement, frontal cortical activity leads parietal activity, suggesting that the latter is mostly related to ▶coordinate transformation and control of reach, the former to planning and execution of movement. Therefore, the same visual signal can recruit different populations of cells at different times, depending on whether it instructs the animal on the future direction of arm movement, or to make such a movement.

#### The Visuomotor Disorders after Lesion of Posterior Parietal Cortex in Humans

*Superior parietal lesions.* A common consequence of lesion of PPC (in particular right SPL) is ▶optic ataxia (OA) [4]. This deficit consists of a failure to properly reach targets under visual guidance. In addition, OA patients are unable to make fast on-line corrections of hand movement trajectory. Optic ataxia occurs during reaching or grasping for real targets, but not when pantomiming hand grasping movement of memorized objects, thus showing its context-dependency.

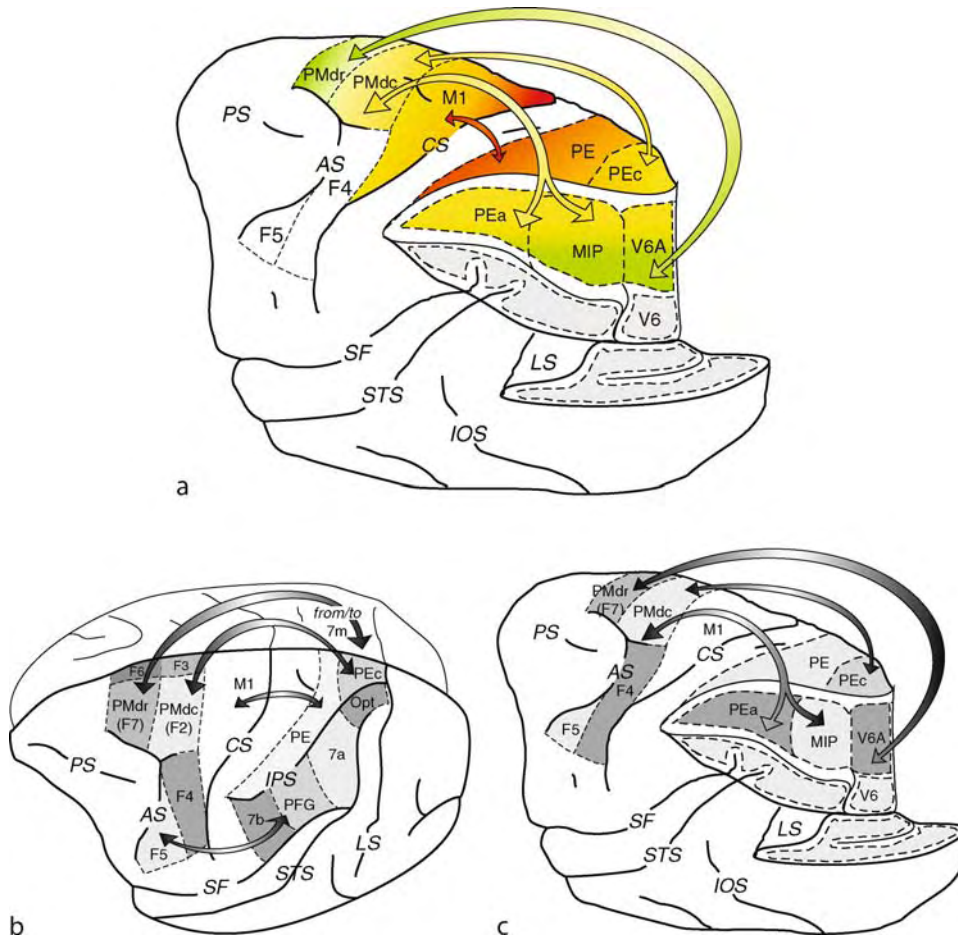

**Visual Space Representation for Reaching. Figure 5** (a) Gradient-like architecture of the fronto-parietal system. Lateral view of the monkey's brain (left hemisphere) where parts of the parietal and occipital lobes have been removed to show the location of the areas buried in the medial bank of the intraparietal sulcus and in the rostral bank of the parieto-occipital sulcus. The color code indicates the distribution of the main types of visuomotor signals processed in the network. Green areas refer to regions where eye signals predominate, red areas depict the predominance of hand related signals, while the yellow areas indicate the regions where eye and hand signals coexist in rather uniform fashion (see text for details). The arrows indicate the main cortico-cortical connections and are color coded (same as above) according to the type of information flow. (b,c) Main ipsilateral connections (arrows) between the parietal and the frontal areas involved in reaching.

The functional properties of neurons in PPC and their connections with premotor and motor cortex via association fibers offer the basis for an interpretation of OA from a neurophysiological perspective: (i) SPL neurons are influenced by different signals concerning localization of visual target, eye and hand position and movement direction; the key feature of SPL neurons is the *global tuning field*, characterized by the invariance of the cell's preferred directions across different eye-hand visuo-motor tasks; (ii) parietal neurons encode both hand movement direction and tangential velocity and modulate their activity in a way that predicts changes of hand movement trajectory; (iii) SPL neurons project to and receive from premotor and motor

cortices, thus forming a parieto-frontal network with recurrent dynamics.

In conclusion, the disorders of reaching and of its on-line control in OA patients can be interpreted as a consequence of the breakdown of the combinatorial mechanisms of SPL neurons, and of the collapse of the parietal frontal cross-talk, therefore as a cortico-cortical **disconnection syndrome**.

**Inferior parietal lesions.** Parietal patients with lesion in the right IPL suffer from **hemispatial neglect**, which, beyond the well-known attention and spatial disorders, also includes movement disorders, such as **directional hypokinesia (DH)**. This is characterized by a lengthening of the hand reaction-time for leftward

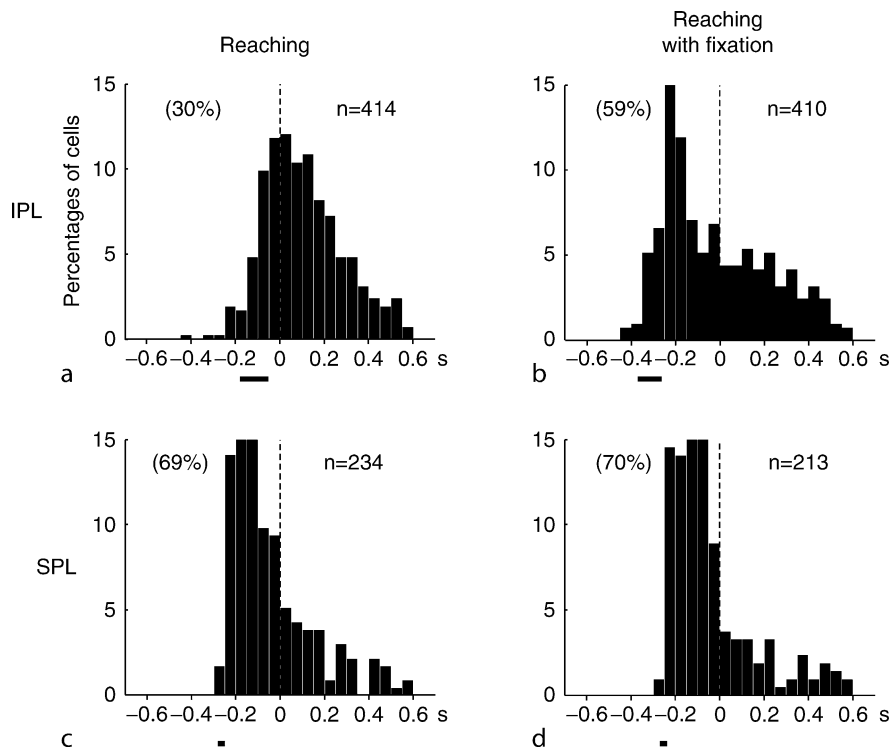

**Visual Space Representation for Reaching. Figure 6** Frequency distributions of onset-time of cell activity relative to hand movement to visual targets with (*Reaching*) and without (*Reaching with Fixation*) prior eye movement. (a–b) Data from area 7a (IPL). (c–d) Data from areas V6A and PEc (SPL). Vertical interrupted lines indicate the beginning of hand movement. Percent in brackets indicate the proportion of cells firing before the onset of hand movement. Thick horizontal bars below the x-axes refer to the mean of the begin of reaction time  $\pm$  SD (from Battaglia-Mayer A, Mascaro M, Caminiti R (2007) *Cereb Cortex* 17:1350–1363).

movement to targets mainly, but not exclusively, located in the contralateral space (for a review, see [4]). In visual search tasks, probably because of a failure in updating the motor command on the basis of past movements, the hand recursively moves among the same targets, all located in the right part of space, and so does the eye. Saccade reaction-time is elongated, and saccades tend to be ▶*hypometric*, while the eye trajectory displays a “staircase” shape. In this context it is worth stressing that a main spatial property of IPL reach-related neurons is the anisotropy of the representation of the motor space, since the distribution of these cells’ preferred directions during reaction and movement-time mostly points toward the contralateral space (see above). The loss of this representation after IPL lesion can explain the difficulty of movement toward the contralateral space, typical of DH in patients with hemispatial neglect.

### Conclusions

The modern analysis of the dynamic properties of population neurons and of their emergent properties in the parietal-frontal network, together with the study of

their cortico-cortical connections, represents a powerful tool to understand the eye-hand visuomotor operations underlying reaching, as well as their disorders in patients suffering from PPC lesions.

### References

1. Battaglia-Mayer A, Caminiti R, Lacquaniti F, Zago M (2003) Multiple levels of representation of reaching in the parieto-frontal network. *Cereb Cortex* 13:1009–1022
2. Goodale MA, Milner DA (1992) Separate visual pathways for perception and action. *Trends Neurosci* 15:20–25
3. Caminiti R, Ferraina S, Johnson PB (1996) The sources of visual information to the primate frontal lobe: a novel role for the superior parietal lobule. *Cerebral Cortex* 6 (3):319–328
4. Battaglia-Mayer A, Archambault P, Caminiti R (2006) The cortical network for eye–hand coordination and its relevance to understanding motor disorders of parietal patients. *Neuropsychologia* 44:2607–2620
5. Motter BC, Mountcastle VB (1981) The functional properties of the lightsensitive neurons of the posterior parietal cortex studied in waking monkeys: foveal sparing and opponent vector organization. *J Neurosci* 1(1):3–26



6. Andersen RA, Mountcastle VB (1983) The influence of the angle of gaze upon the excitability of the light-sensitive neurons of the posterior parietal cortex. *J Neurosci* 3:532–548
7. Genovesio A, Ferraina S (2004) Integration of retinal disparity and fixation distance-related signals toward an egocentric coding of distance in the posterior parietal cortex of primates. *J Neurophysiol* 91:2670–2684
8. Sakata H, Taira M, Kusunoki M, Murata A, Tanaka Y (1997) The TINS lecture. The parietal association cortex in depth perception and visual control of hand action. *Trends Neurosci* 20(8):350–357
9. Johnson PB, Ferraina S, Bianchi L, Caminiti R (1996) Cortical networks for visual reaching: physiological and anatomical organization of frontal and parietal lobe arm regions. *Cereb Cortex* 6:102–119
10. Andersen RA, Buneo CA (2002) Intentional maps in posterior parietal cortex. *Ann Rev Neurosci* 25:189–220

---

## Visual System

### Definition

All the parts of the nervous system whose operation generates visual percepts; includes the retina, the lateral geniculate nucleus of the thalamus, the primary and higher order visual cortices and the interconnections of these major stations.

- ▶ Extrastriate Visual Cortex
- ▶ Lateral Geniculate Nucleus
- ▶ Primary Visual Cortex
- ▶ Retina
- ▶ Vision

---

## Visual Thalamo-cortical Pathway

- ▶ Geniculo-Striate Pathway

---

## Visual Transduction Cascade

- ▶ Phototransduction

---

## Visual-vestibular Integration

- ▶ Visual-Vestibular Interaction

---

## Visual-Vestibular Interaction

DOUGLAS R. W. WYLIE

University Centre for Neuroscience and Department of Psychology, University of Alberta, Edmonton, AB, Canada

### Synonyms

Visual-vestibular integration

### Definition

Visual-vestibular interaction refers to the combining of sensory signals from the vestibular apparatus with visual information from the retina to assist in the control of posture, locomotion and eye movements.

### Characteristics

#### Optic Flow During Self-Motion

The vestibular system responds to motion of the head in space, but other sensory systems also provide information about self-motion, including the visual system. Because the world consists of stationary objects and surfaces, self-motion through the environment induces patterns of motion across the entire retina, known as ▶ optic flow [1]. Optic flow provides a rich source of proprioceptive information and can be used for several behaviors including determination of heading, control of posture and locomotion, perception of self-motion and navigation [2]. [Figure 1](#) shows an illustration of the optic flow resulting from forward translation (*left*) and rotation about the vertical axis (*right*).

The arrows represent local image motion in the optic flowfield, as projected onto a sphere surrounding an observer. From self-translation, the optic flowfield consists of a radial focus of expansion in the direction of self-motion. During self-rotation, there is circular flow about the axis of rotation, but opposite to the direction of head rotation. These examples are very much-simplified versions of the optic flowfield. This is especially the case for self-translation, as there is also a velocity gradient, from zero at the focus of expansion to maximal along the equator of the sphere. Moreover, during self-translation near objects move faster in

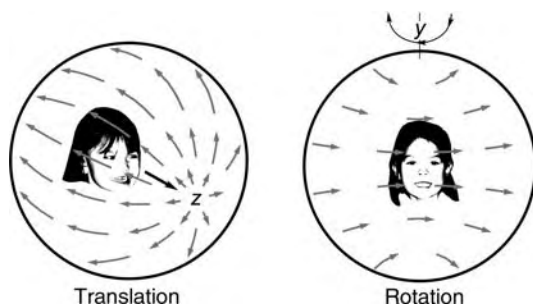

**Visual-Vestibular Interaction. Figure 1** Schematic illustrations of optic flow that occurs during self-translation (*left*) and self-rotation (*right*). The *grey arrows* indicate the direction of local motion within the flowfield as projected onto a sphere surrounding the observer. For forward self-translation, out of the page along the vector indicated by the *black arrow* toward point *z*, there is a radial focus of expansion in the direction of translation, and backward planar motion along the equator of this sphere. For rightward rotation about the vertical axis (*y*), there is circular motion along the axis of rotation (i.e. directly above and below the head) and leftward planar motion along the equator.

the flowfield than do far objects. Finally, the structure of local motion in the flowfield during self-translation changes depending on the point of fixation [3].

### Optokinetic Responses

The use of visual information for postural stabilization is easily demonstrated by observing two people standing on one foot, one individual with eyes open and the other with eyes closed; the latter will begin to stumble whereas the former can maintain posture. The individual with eyes open can maintain posture by minimizing optic flow, a process referred to as an optomotor or ▶**optokinetic response**. Optokinetic responses work with spinal and vestibular reflexes to maintain posture and gaze. The easiest way to demonstrate optokinetic responses is with an optokinetic drum (Fig. 2).

This device consists of vertical black and white stripes on the inside of a rotating cylinder. If an animal is placed inside the center of the cylinder, but with the head fixed, an oscillating horizontal eye movement known as ▶**optokinetic nystagmus** (OKN) will result. OKN consists of two phases, a slow phase in which the eyes move slowly in the direction of visual motion and a fast phase in which saccades bring the eyes back to a central position. If the head is free but the trunk is fixed, a nystagmic head movement results; this is known as the optocollic response (OCR). During the slow phase of OKN, the attempt is to match eye velocity with the velocity of the visual motion, i.e. the optokinetic responses function to stabilize the retinal image and

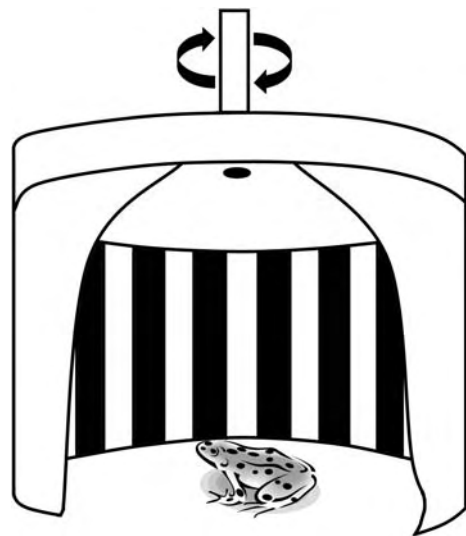

**Visual-Vestibular Interaction. Figure 2** An optokinetic drum. The cylinder is enclosed, but the front has been cut away to reveal the stripes inside.

work with the vestibuloocular reflex (VOR) in this regard. In fact, the OKN can support gaze stabilization when the VOR is non-optimal. The gain of the VOR is low for slow head movement, but increases with faster stimulation. In contrast, the gain of the OKN is very high for slow visual motion, but declines with increasing speed. Moreover, the VOR starts at movement onset, but the vestibular signal habituates exponentially during a head movement and is absent during constant velocity. The OKN builds up rather slowly (see below) and continues to respond even during constant velocity. Thus, the OKN and VOR have somewhat complementary roles to contribute to gaze stabilization throughout the head movement.

The slow phase of OKN builds up slowly until it reaches a steady state and if the lights are turned off, the eye movements persist, decaying over the course of a few seconds. This is known as optokinetic after-nystagmus (OKAN). The build-up to the steady state and OKAN is accomplished by the “velocity-storage mechanism” and is reflected in the activity of vestibular nucleus neurons (see Fig. 4 below).

In frontally eyed mammals, the build-up to the steady state is quicker and the slow phase of OKN is said to consist of “direct” and “indirect” components. These are also known as the “early” and “delayed” components of OKN and the early/direct component is also referred to as the ocular following response [3]. The indirect component refers to the gradual build-up of slow phase due to the velocity storage mechanism. The “direct” component occurs soon after the onset of visual motion and allows for a quicker build-up to a steady state. OKN persists at high velocities (100–200°/s).

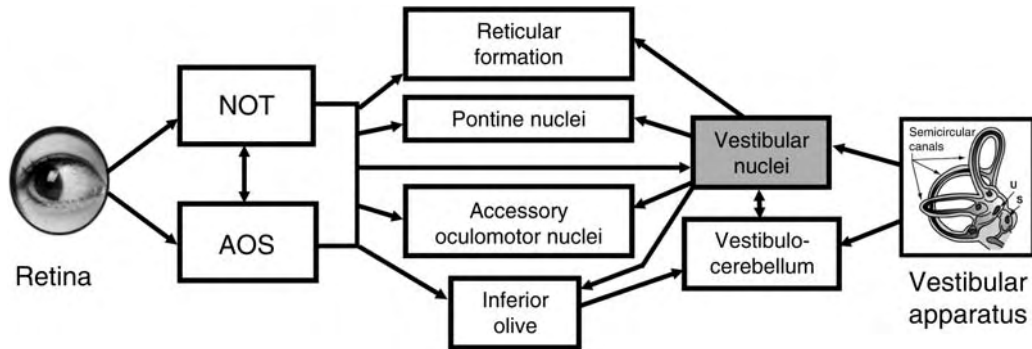

**Visual-Vestibular Interaction. Figure 3** A simplified schematic of the projections of the nucleus of the optic tract (NOT), the accessory optic system (AOS) and the vestibular apparatus. Although the projections are much more extensive [5], sites of visual-vestibular interaction in the brainstem are indicated. The primary vestibular projection is to the vestibular nuclei and vestibulocerebellum, which also receive input from the AOS and NOT. When considering secondary vestibular targets, the sites of visual-vestibular interaction are numerous.

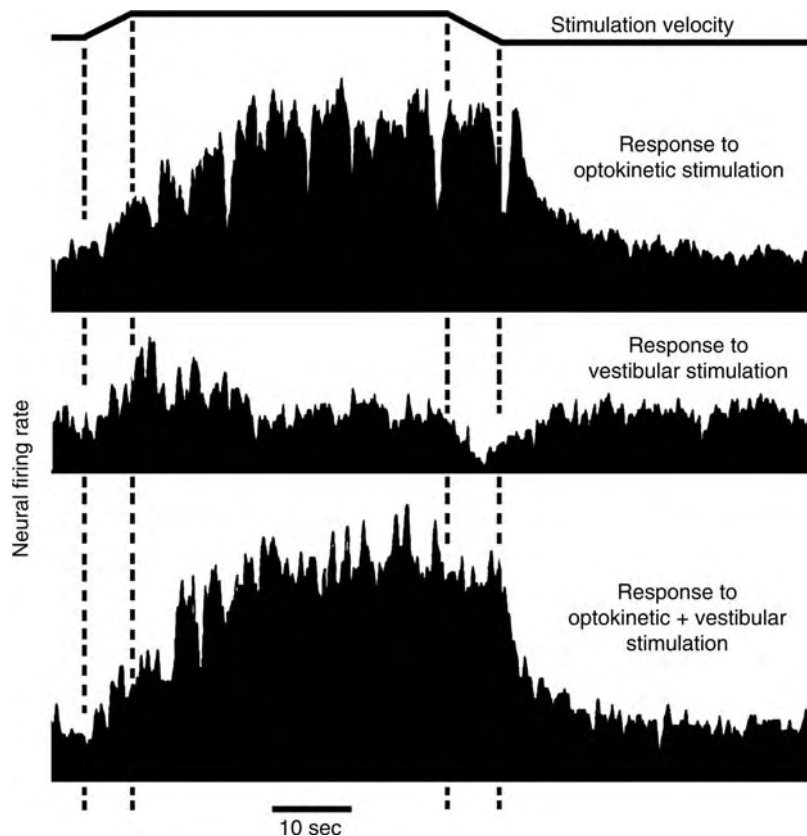

**Visual-Vestibular Interaction. Figure 4** Responses of a neuron from the vestibular nucleus of the goldfish to visual and vestibular stimulation. The stimulus velocity profile is shown at the top. The top peri-stimulus time histogram shows the response of the neuron to leftward rotation of the optokinetic drum. The middle histogram shows the response to rotation of the animal to the right in darkness. The bottom trace shows the response of the neuron to rotation of the animal to the right in the light. Adapted from [6].

### Vection

In addition to eliciting optokinetic responses, optic flow also elicits the perceptual state known as ►vection [4]. Vection is the illusory percept of self-motion that results

when one is presented with optic flow stimuli. This is often exploited by the entertainment industry. For example, in the original *Star Wars* movie, the character Luke Skywalker is in the cockpit of a spacecraft, which

descends into a trench along the surface of the Deathstar. When the point of view is from the cockpit, the audience is exposed to a flowfield resulting from forward translation (Fig. 1). Members of the audience may then experience the feeling that the visual stimuli are stationary, but they themselves are in the spacecraft moving forward across the surface of the Deathstar. The illusory percept of self-translation is known as linear vection. In the laboratory, vection can be easily demonstrated and quantitatively measured using an optokinetic drum. If placed inside the drum depicted in Fig. 2, an observer initially reports that the drum is spinning around them. However, as the drum continues to spin, after a period of about 30 s, they report that the drum is stationary, but they are rotating in the direction opposite that of the drum. The illusory percept of self-rotation is known as circular vection. Generally, larger stimuli are more effective in eliciting vection. When the visual stimuli consist of foreground and background, it is the perceived background that drives vection. Radial motion is most effective for eliciting linear vection, but laminar flow with kinetic occlusion will support linear vection.

### Neural Substrates

In mammals, retinal-recipient subcortical nuclei that convey visual information related to self-motion include the nuclei of the ►accessory optic system (AOS) and the nucleus of the optic tract (NOT) in the pretectum [5]. In most mammals, the AOS consists of four nuclei, the medial, lateral and dorsal terminal nuclei (MTN, LTN, DTN) and the interstitial nucleus of

the superior fasciculus. Critically, lesions to the AOS and NOT abolish optokinetic responses and stimulation elicits nystagmic eye movements. Neurons in these pathways have large receptive fields (see Fig. 5, left) and respond best to large moving stimuli that are rich in visual texture (e.g. checkerboards or random dot patterns). Generally speaking, the MTN and LTN are associated with vertical motion whereas the NOT and DTN are associated with horizontal motion. The AOS and pretectum project to many structures that are involved in motor and oculomotor control, including structures that receive vestibular input (Fig. 3). Efferents of the AOS and the pretectum include the accessory oculomotor nuclei, several pontine nuclei, the vestibular nuclei and parts of the inferior olive that project to the vestibulocerebellum. In some species there are direct projections from the AOS and pretectum to the vestibulocerebellum.

Visual-vestibular integration at the neural level was first shown in recordings from vestibular nucleus neurons [6]. Figure 4 shows the response of a neuron in the vestibular nuclei of an anesthetized goldfish to optokinetic and vestibular stimulation.

The top trace shows the response to rotation of the visual surround in the leftward direction. Note the slow build-up of the response, which mirrors the gradual build-up of the indirect OKN. Also the response of the neuron decays slowly after the cessation of visual stimulation, which mirrors OKAN. The middle trace shows the response of the same neuron to body rotation to the right, in darkness. Note the relatively quick response at the onset of the vestibular stimulation, but

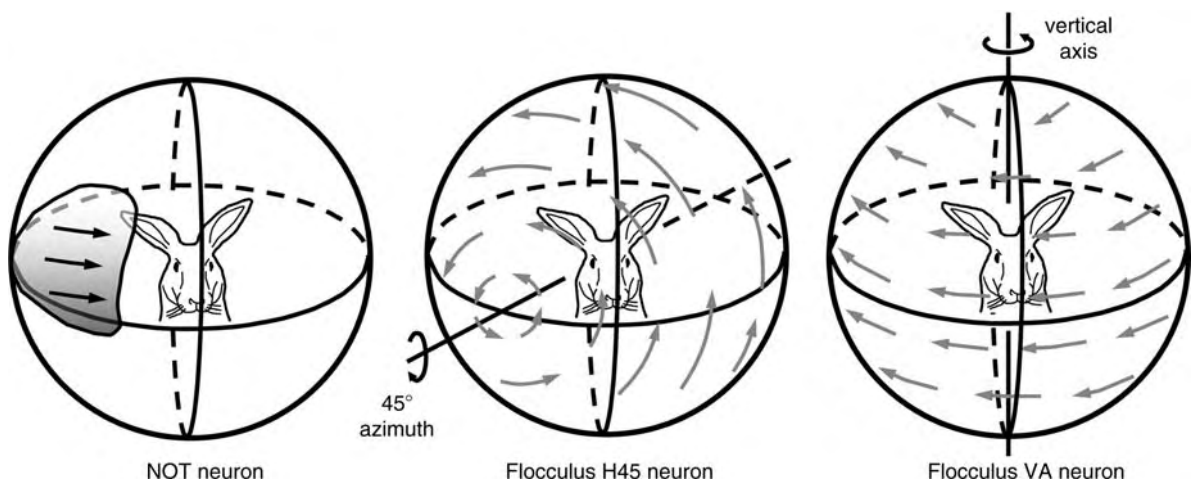

**Visual-Vestibular Interaction. Figure 5** Optokinetic receptive fields. On the left, the receptive field of a neuron from the nucleus of the optic tract (NOT) is shown. They are large (average  $60^\circ$ ) and most prefer forward (i.e. temporal-to-nasal) motion. In the flocculus, Purkinje cells have panoramic visual receptive field and prefer rotational optic flow about either the vertical axis (VA neurons; middle) or a horizontal axis oriented  $45^\circ$  from the midline (H45 neurons).

the decline during the constant velocity portion of the stimulation. This neuron responded more to visual than to vestibular stimulation, but the relative magnitude of the responses to visual vs. vestibular stimulation is quite variable. The bottom trace shows the response of the neuron to rightward rotation of the animal in the light, which provides concomitant visual and vestibular stimulation. The response appears as a linear combination of the responses to the two inputs. Neurons responsive to patterns of optic flow and vestibular stimulation have also been found in parietal and occipito-temporal areas of the cerebral cortex. For example, in primates, neurons in the medial superior temporal area respond to patterns of translational and rotational optic flow, and vestibular stimulation [1].

The efferent pathway of the AOS and pretectum that has been most thoroughly studied is that from the inferior olive to the vestibulocerebellum [7]. The vestibulocerebellum consists of the flocculus, nodulus and ventral uvula. The congruence of visual and vestibular processing is best demonstrated with reference to the responses of flocculus Purkinje cells. In the inferior olive and the vestibulocerebellum, the visual information from the AOS and pretectum is integrated so that the Purkinje cells have panoramic receptive fields and respond best to patterns of optic flow resulting from either self-translation or self-rotation [8,9]. As shown in Fig. 5, flocculus Purkinje cells respond best to rotational optokinetic stimulation about one of two axes, either the vertical axis (VA neurons) or a horizontal axis oriented 45° to the midline (H45 neurons).

This means that floccular Purkinje cells respond best to optic flow resulting from a head rotation that maximally stimulates either the horizontal semicircular canals (VA neurons) or the ipsilateral anterior/contralateral posterior canal pair (H45 neurons). The system is evolutionarily highly conserved as demonstrated by essentially identical response properties in rabbits and pigeons [8,9].

The flocculus has been shown to be critical for the adaptation of the VOR. The gain of the VOR can be changed by rotating an animal inside an optokinetic drum that is not stationary, but moving at the same speed in the opposite direction. The compensatory eye movement required for this circumstance is twice that of normal conditions. After prolonged adaptation with this stimulation, subsequent rotation of the animal in the dark will reveal that the gain of VOR has increased, i.e. the aberrant optokinetic information given is somehow responsible for adjusting the gain of the VOR so that effective gaze stabilization can be maintained. Lesions to the flocculus prevent the adaptive change in the VOR. The synaptic mechanism of adaptive recalibration of the VOR involves long-term depression (LTD) but the site(s) of this learning is a topic of debate [10].

Visual-vestibular integration also occurs in the nodulus and ventral uvula of the vestibulocerebellum. In mammals, some Purkinje cells respond to optic flow patterns, whereas others respond best to vestibular stimulation originating in the otolith organs [7]. In birds it has been shown that Purkinje cells respond best to patterns of optic flow resulting from self-translation along either the vertical axis or a horizontal axis oriented 45° to the midline, i.e. a common reference frame is used for processing optic flow resulting from self-translation and self-rotation [8]. A precise role for the ventral uvula and nodulus has yet to be determined, although they are involved in controlling posture and eye movements.

## References

1. Duffy CJ (2000) Optic flow analysis for self-movement perception. *Int Rev Neurobiol* 44:199–218
2. Gibson JJ (1966) *The senses considered as perceptual systems*. Houghton Mifflin, Boston
3. Miles FA (1998) The neural processing of 3-D visual information: evidence from eye movements. *Eur J Neurosci* 10:811–822
4. Nakamura S (2006) Effects of depth, eccentricity and size of additional static stimulus on visually induced self-motion perception. *Vision Res* 46:2344–2353
5. Giolli RA, Blanks RH, Lui F (2005) The accessory optic system: basic organization with an update on connectivity, neurochemistry, and function. *Prog Brain Res* 151:407–440
6. Allum JH, Graf W, Dichgans J, Schmidt CL (1976) Visual-vestibular interactions in the vestibular nuclei of the goldfish. *Exp Brain Res* 26:463–485
7. Barmack NH (2005) Inferior olive and oculomotor system. *Prog Brain Res* 151:269–291
8. Frost BJ, Wylie DR (2000) A common frame of reference for the analysis of optic flow and vestibular information. *Int Rev Neurobiol* 44:121–140
9. Simpson JI, Graf W (1985) The selection of reference frames by nature and its investigators. *Rev Oculomot Res* 1:3–16
10. Du Lac S, Raymond JL, Sejnowski TJ, Lisberger SG (1995) Learning and memory in the vestibulo-ocular reflex. *Annu Rev Neurosci* 18:409–441

## Visually Guided Saccades

### Definition

A type of saccadic eye movement that is directed to a visible target.

► Saccade, Saccadic Eye Movement

## Visuo-manual Coordination

### ► Eye-Hand Coordination

## Visuomotor

### Definition

Refers to transformations between vision and motor processes involving the eyes and or the limbs.

### ► Eye-Hand Coordination

## Visuomotor Integration

SOOYOON SHIN, TRINITY B. CRAPSE,  
J. PATRICK MAYO, MARC A. SOMMER

Department of Neuroscience, The Center for the Neural Basis of Cognition, and the Center for Neuroscience at the University of Pittsburgh, University of Pittsburgh, Pittsburgh, PA, USA

### Synonyms

Visuomotor transformation; Visuomotor interaction

### Definition

Visuomotor integration is the coordination of neuronal activity between visual-related and motor-related parts of the brain in order to influence behavior and perception.

### Characteristics

#### Vision and Movement

Vision guides movement, and movement affects vision. To facilitate the coordination between vision and movement, reciprocal interactions are needed between brain areas involved in visual and motor processing. The use of visual information to influence movement processing, and movement information to influence visual processing, is termed visuomotor integration.

For primates, vision is the primary sense. It drives behaviors as diverse as looking around a scene and moving through the world. Visual information arrives from the ►retina, is interpreted by a network of ►visual processing areas in the brain (Fig. 1, yellow arrows), and is sent to subcortical areas that cause movement

generation (red arrows). In turn, movements may influence visual input, and so information about actions is fed back to visual processing areas to close the loop (Fig. 1, grey arrows).

Visuomotor integration varies in its details depending on the behavioral context and the effector used, e.g., eye or hand. There are four general aspects of visuomotor integration, however. First, visuomotor integration is relatively slow. Vision is useful for planning movements but sluggish for online control, and the time from visual input to motor output is surprisingly long and variable. Second, visuomotor integration is spatially organized. The retina is a finely grained two-dimensional map, and central brain regions recapitulate this map. Third, visuomotor integration is adaptive. The relationship between visual input and motor output is continuously monitored and adjusted as necessary. Fourth, visuomotor integration is bidirectional. Not only are visual signals transformed to motor commands, but motor commands are fed back to aid visual processing. Here we review these four components of visuomotor integration.

### Visuomotor Integration is Relatively Slow

A good way to begin analyzing a system is to consider its input. Characteristics of the input limit the possible ways that the system may produce an output. Visual information is the input to visuomotor transformations, and vision is one of our slower senses. Vision helps to initiate movements but may be too slow for the real-time control of movements.

After visual information is transduced by ►photo-receptors, approximately 70 ms elapses before it reaches central areas for visuomotor integration. Added to this afferent lag are further delays related to planning. The final reaction times of visuomotor acts are typically around 200 ms. These afferent lags and reaction times are about 50 ms longer than analogous delays for auditory inputs and 20 ms longer than for skin receptor inputs.

At the output of visuomotor transformation, many movements take less than 70 ms to complete. Hence the movements terminate before visual feedback can provide information about movement progress. Brief movements, therefore, can be triggered but not continuously controlled by visual signals. Such movements must be ►ballistic (open-loop) or controlled by non-visual feedback.

An example of a short-duration movement that is triggered but not controlled by vision is the ►saccade, a rapid eye movement that relocates the fovea to a new part of the scene. To minimize time in flight (when vision is blurred on the retina), and maximize time during fixation (when vision is optimal), saccades have high velocity and short duration. For most naturally occurring saccades (<15° amplitude), the duration is

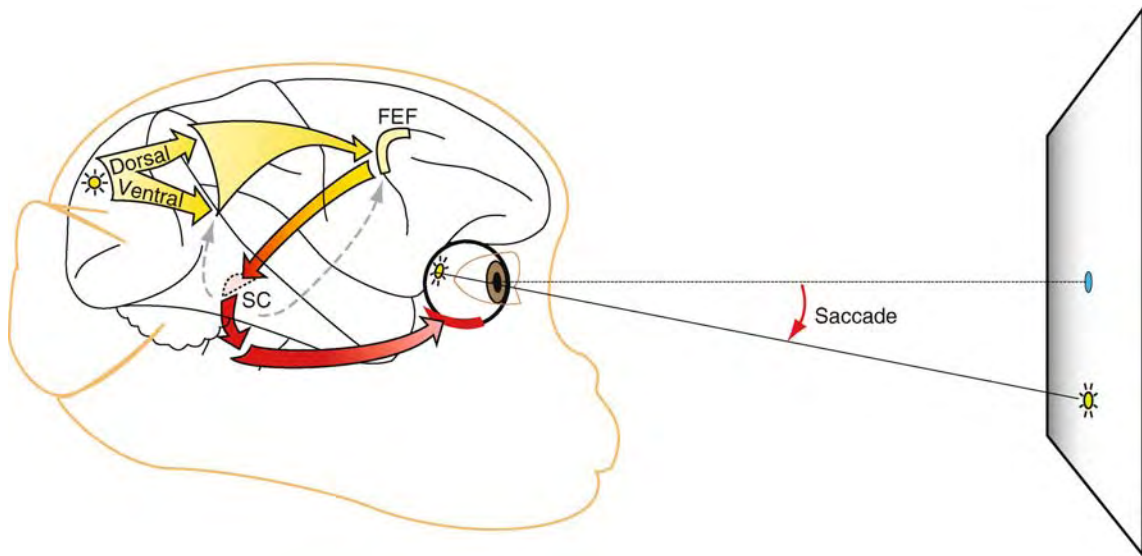

**Visuomotor Integration. Figure 1** Neuronal circuits for visuomotor integration in the primate brain. Illustrated as an example circuit is the core network for ►saccade generation. While a monkey foveates one stimulus (*blue dot*), another suddenly appears (*yellow dot*). The goal is to make a saccade to the new stimulus. An image of the yellow stimulus is projected onto the retina and encoded in ►primary visual cortex (*far left*; the pathway from retina to visual cortex is omitted for clarity). The location of the visual stimulus is processed by a ►dorsal pathway, the identity of the stimulus by a ►ventral pathway, and the processed information is sent to visuomotor areas such as the ►FEF (*yellow arrows*). From there, signals are sent to the ►SC and other brainstem areas to cause eye muscle contraction (*red arrows*). Feedback information about saccades is sent to cerebral cortex to close the loop (*grey arrows*). Modified from [1].

less than 50 ms. Such movements, therefore, are too fast for visual feedback. Even for large, long duration saccades, visual feedback is blurred by the fast eye motion. The low-level saccade generating circuitry (in the ►pons and ►midbrain) controls saccadic progress not with visual feedback, but with internal estimates of the eye's instantaneous state [2].

Certain eye movements, such as ►smooth pursuit, are slower and may use vision for control. The function of smooth pursuit is to keep the eyes foveated on a moving object such as a bird in flight. Smooth pursuit can persist for several seconds, so visual feedback is able to influence the ongoing movement. Continual visual input is compared with predictions of the input, and if there is a mismatch, pursuit velocity is adjusted.

As note above, visual sluggishness has two main components: initial, afferent lag and subsequent planning-related lags. The planning stage seems to begin in ►parietal and frontal cortex, after basic visual scene analyses are performed by ►occipital cortex. Cortex is only a few synapses above the oculomotor muscles. It is intriguing, therefore, that the time from the start of parietal/frontal cortex activation to the start of the movement is long (~100 ms) and variable. The delay is used for cortical computations that select the next movement as a function of past, present, and predicted future visual inputs [3,4].

### Visuomotor Integration is Spatially Organized

Visual information reaches about one third of the primate ►cerebral cortex and much of the brainstem. Many of these brain areas are laid out in a visually ordered ►topographic manner. We focus on two of the areas as examples of the spatial aspects of visuomotor integration. These are the ►frontal eye field (FEF) in frontal cortex, and the intermediate layers of the ►superior colliculus (SC), in the midbrain (Fig. 1). Both the FEF and intermediate SC contain neurons that are active for incoming visual stimuli as well as outgoing eye movement commands; moreover, electrical stimulation of each area evokes saccades and inactivation of each area impairs saccades. Thus, the FEF and the SC are implicated in using visual information to guide the execution of saccades. Visually guided skeletal movements, such as moving one's hand, depend on comparable areas of the cortex and brainstem, as well as the spinal cord.

Spatial orderliness begins in the two-dimensional sheet of the retina. Visual stimuli produce a pattern of activity on the retina that reflects the layout of stimuli in the real world. The pattern is recapitulated throughout the visual system with high fidelity. This maintenance of spatial relationships is due to connections that form repeated topographies. For the purpose of visual analysis, ►topographic maps facilitate form discrimination and other

spatial evaluations. For the purpose of visuomotor integration, the maps offer an efficient link between the ► visual field and the motor workspace.

The FEF and SC contain neurons that are active for visual input (so-called visual neurons), saccade generation (movement neurons), or both (visuomovement neurons) [5,6]. Neurons with visual responses fire for stimuli falling within a certain retinal zone called the receptive field. Neurons with saccade-related activity fire for saccades having a certain range of vectors (amplitudes and directions) that delimits the movement field. Visual and movement neurons are arrayed together such that neighboring neurons have similar receptive fields and movement fields. For visuomovement neurons, which have both a receptive field and a movement field, the two fields are coincident. Across the FEF and SC, receptive fields and movement fields vary systematically. In an elegant fashion, therefore, evolution and development have interlinked the visual and motor maps. This spatial organization plays a vital role in transforming visual input to eye movement output.

To see why the overlap of visual and motor maps is beneficial, consider a simple example. Imagine you are looking straight ahead and see something in the upper-right portion of your peripheral vision, for example a yellow dot (Fig. 2, left). The dot will activate a discrete portion of your retinas and then a corresponding location on the FEF and SC visual maps (for the SC map, the location is shown with a yellow dot in Fig. 2, middle). Each visual map is spatially integrated with a

coincident movement map, and therefore locations on each map encode not only a visual stimulus but also the vector of saccade needed to foveate the stimulus (Fig. 2, right, yellow arrow). All locations in contralateral space are represented in each FEF and SC map (other colored dots and arrows in Fig. 2).

Although visuomotor maps in FEF and SC are similar, there are some notable differences between them. Pure visual-related neurons are common in the FEF but rare in the SC intermediate layers. Overall, FEF neurons seem to play more of a role in representing visual targets for saccades, while SC neurons seem more related to saccadic dynamics such as instantaneous motor error and velocity. Also, the SC map is more finely elaborated in terms of movement vectors. In both the SC and FEF, saccadic amplitude is well organized, but in the SC saccadic direction is laid out explicitly too, in a mapping orthogonal to amplitude (Fig. 2). In the FEF there may be some directional organization, but it seems patchy [5].

The differences between the FEF and SC maps suggest that the former is more visual and the latter more motor in nature. This is not to say, however, that visuomotor transformations proceed in a leap from visual FEF to motor SC, or between any two structures. The differences between FEF and SC are a matter of degree, and visuomotor transformations are best characterized as gradual [7]. Neuronal activity slowly loses its dependence on vision and gains a tight relation to movement as it proceeds from area to area. Below the SC, spatial codes of saccadic vectors are transformed into temporal codes that

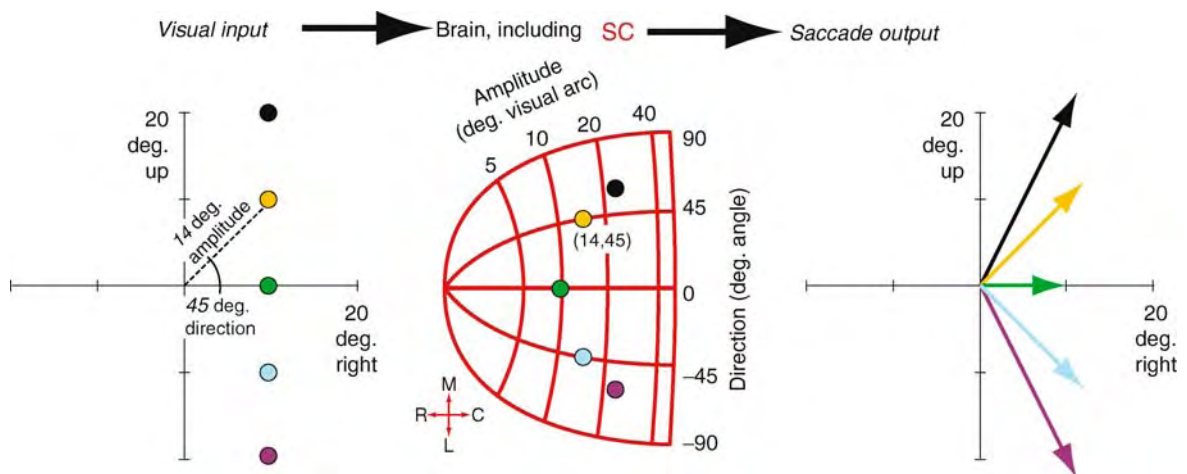

**Visuomotor Integration. Figure 2** Visuomotor transformation using a ► topographic map. *Left:* Visual stimuli (dots) in the right visual field. The yellow dot appears ~14° from the fovea at an angle of 45° up from horizontal. *Middle:* Stimuli in the right visual field are encoded on the left SC visuomotor map, shown schematically. The rostral (R) to caudal (C) dimension represents increasing amplitudes of distance from the fovea. The lateral (L) to medial (M) dimension represents increasing angles relative to horizontal. The yellow dot in the visual field is encoded by neurons at site (14, 45) on the SC map. Other visual stimuli are encoded by corresponding sites. *Right:* The neuronal output of the SC map causes saccades. Neurons driven by the yellow dot cause a saccade of 14° amplitude angled 45° up from horizontal (yellow arrow). Neurons elsewhere on the map generate other saccadic vectors (other arrows). Modified from [6].



precisely coordinate the contractions of oculomotor muscles.

In the skeletal motor system, movement topographies are present as well. However, the spatial relations between visual input and skeletal movements (e.g., arm movements) are more complex and variable than those between vision and eye movements. The ultimate control region for skeletal motor execution seems to be ►primary motor cortex, which contains neurons with visual (and other sensory) inputs arranged in a body map. How the spatiotemporal transformation occurs from this map to the alpha-►motoneurons of the spinal cord is the focus of much physiology and modeling.

### Visuomotor Integration is Adaptive

Visuomotor integration must be able to change as our body and surroundings change. From infancy to adulthood the relation of the retinas to the rest of the body is altered extensively, and yet visually guided movements must stay accurate. Even in adults, injury can alter visual input, motor output, or the relation between the two. The environment changes too, requiring behaviors to adapt accordingly.

►Adaptation can be quick, as shown by donning prism glasses; within only a few dozen trials, eye and reaching movements are re-calibrated to adjust for the altered visual input. Once a visuomotor relation is adapted, the new behavior can persist for life.

While steady-state visuomotor integration mostly involves the cerebral cortex, brainstem, and spinal cord, plasticity in visuomotor integration relies on two extensive subcortical networks: the ►cerebellum and the ►basal ganglia [8,9]. The cerebellum (Fig. 3, left) is most critical for short-term adaptation as in the prism glasses example. Error signals that represent unexpected differences between visual input and motor output reach the cerebellum via ►climbing fibers from the ►inferior olive. These error signals have a strong, long-lasting effect on cerebellar activity. This altered cerebellar activity is relayed through ►thalamus to modify visuomotor transformations in the cerebral cortex.

The basal ganglia play a broader role in adaptation. Rather than micro-managing movements on a millisecond time scale as the cerebellum, the basal ganglia seem to help select which movement is appropriate given the context of the situation. This context may change to require a different motor response for the same visual input. Context-dependent adaptation in basal ganglia depends on occurrence of reward (Fig. 3, upper right). Reward is reported by dopaminergic neurons in the substantia nigra and other brainstem regions that feed back to the input nodes of the basal ganglia. The feedback alters basal ganglia activity, and as with the cerebellum, the altered neuronal activity is relayed by thalamus to influence visuomotor transformation in the cerebral cortex.

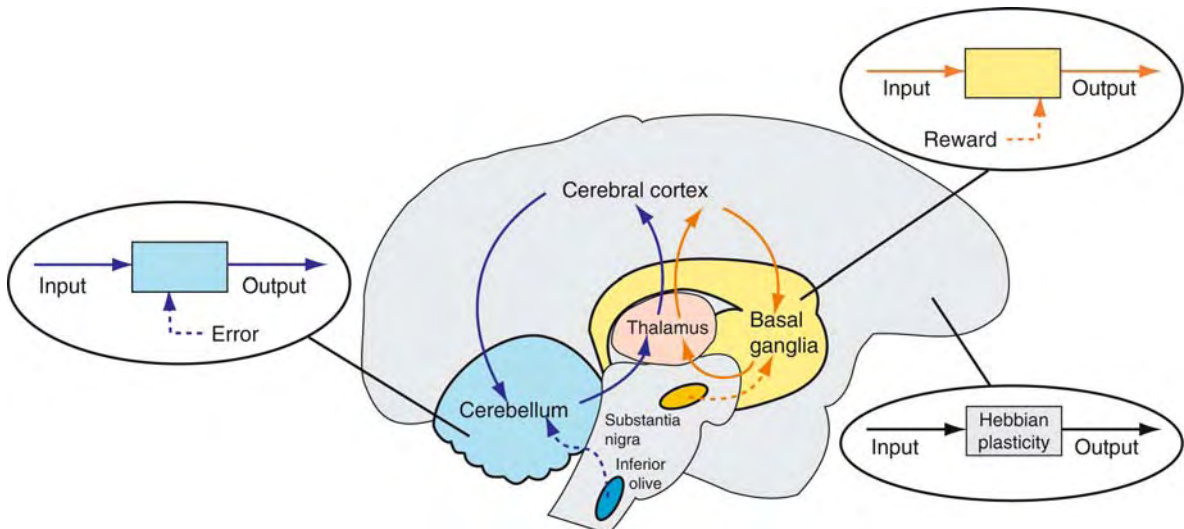

**Visuomotor Integration. Figure 3** Circuits for visuomotor adaptation. A silhouette of the monkey brain is shown with the critical subcortical networks for adaptation superimposed. *Left:* The cerebellar loop receives visual information from cerebral cortex and other areas and relays the information back to cortex through ►thalamus. The feedback to cortex is modified, however, by error signals provided by the inferior olive. *Upper right:* The basal ganglia loop is similar, but its signals are modified by reward, for example from the ►substantia nigra (pars compacta). *Lower right:* Many neurons in the cerebral cortex also have the capacity to adapt through intrinsic, Hebbian, processes, so that input-output (visual-saccade) relationships may change with ►long-term potentiation or depression. Modified from [8].

Finally, it should be noted that many neurons have an intrinsic capacity for input-output plasticity. Any neuron may be involved in adaptation as long as its action potential output can be modified for a given pattern of afferent input, for example via **▶Hebbian synaptic plasticity**. Some adaptation mechanisms may be resident in cerebral cortex, therefore, and independent of basal ganglia and cerebellum (Fig. 3, lower right).

### Visuomotor Integration is Bidirectional

Every movement that we make causes spurious changes to our sensory input. A major problem for the brain is to disregard the sensory artifacts of self-movement while maintaining sensitivity to sensory changes caused by external objects. One way that the brain solves this problem is by copying the outgoing motor command and sending this copy back to visual areas to provide information about the upcoming movement. Such copies of motor commands are called **▶corollary discharge** or **▶efference copy** [1].

Just as saccades have proven a good model for studying visual-to-motor processes, they have been equally important for understanding motor-to-visual processes. Saccades permit rapid relocation of the fovea, but an attendant visual artifact is the sudden displacement of the entire scene across the retina. If we were to perceive the visual world as actually detected by the retinas, we would see the world jumping from place to place every time we make a saccade. Yet we enjoy a percept of visual stability. To complicate things further, some objects in the visual scene move on their own, and the brain must distinguish those movements from the saccade-induced visual artifacts. Corollary discharge is crucial for the joint processes of stabilizing our visual percept across saccades and distinguishing real object motion from saccade-induced motion.

Where does the corollary discharge originate, and where does it travel to influence vision? One corollary discharge pathway ascends from the SC to the FEF via a thalamic relay node (Fig. 4). When the SC issues a movement command to lower saccade-generating circuits, it sends a corollary discharge of the command to the FEF (blue arrows). The corollary discharge encodes information about saccadic timing, size, and direction, allowing the FEF to prepare for the imminent eye movement and its visual consequences.

Within the FEF, corollary discharge interacts with visual input arriving from earlier visual areas (Fig. 4, yellow arrow). One result is that some visual neurons suddenly sample a new part of the visual field just before the eyes begin to move [10]. Such shifting receptive fields allow neurons to analyze the same region of absolute visual space (in **▶world-centered coordinates**) before and after each saccade. Hence this mechanism may help to stabilize our percept of the visual scene across saccades.

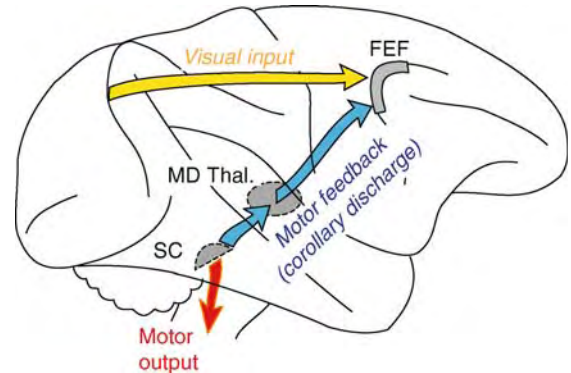

**Visuomotor Integration. Figure 4** Example circuit for motor-to-visual feedback. As in Fig. 1, visual input is sent to the FEF (yellow arrow) and motor output descends from the SC (red arrow). In addition, a copy of the motor output ascends as feedback through mediodorsal thalamus (MD Thal.) to the FEF (blue arrow). Such feedback is known as corollary discharge. As discussed in the text, corollary discharge interacts with visual input at single FEF neurons to cause shifting receptive fields. The general function of corollary discharge is to help the visual system interpret whether changes in visual input represent trivial artifacts of self-movement or real changes in the external environment. Modified from [1].

Smooth pursuit is another example of a behavior that requires an ongoing, internal estimate of movement progress. As noted above, visual feedback is used by the smooth pursuit system to monitor accuracy and control the movement in real time. But the actual control process requires the visual input to be compared with a prediction, and that prediction requires an internal estimate of the ongoing eye movement. This estimate could be provided by corollary discharge or by **▶proprioception**, i.e., the sense of muscle position.

### Summary

Visuomotor integration is the coordination of sensation with action. Distributed cortical-subcortical circuits transform visual input to motor output in a manner that is spatially precise but relatively slow. The circuits, and their attendant visuomotor processes, change as needed. Because movements influence visual input, corollary discharge of movements closes the loop. The basic principles of visuomotor integration as established for eye movements are likely to hold for skeletomotor movements as well.

### References

1. Sommer MA, Wurtz RH (2008) Brain circuits for the internal monitoring of movements. *Annu Rev Neurosci* 31:317–338

2. Girard B, Berthoz A (2005) From brainstem to cortex: computational models of saccade generation circuitry. *Prog Neurobiol* 77:215–251
3. Gold JI, Shadlen MN (2007) The neural basis of decision making. *Annu Rev Neurosci* 30:535–574
4. Schall JD (2001) Neural basis of deciding, choosing and acting. *Nat Rev Neurosci* 2:33–42
5. Bruce CJ, Goldberg ME (1985) Primate frontal eye fields. I. Single neurons discharging before saccades. *J Neurophysiol* 53:603–635
6. Sparks DL, Mays LE (1990) Signal transformations required for the generation of saccadic eye movements. *Annu Rev Neurosci* 13:309–336
7. Wurtz RH, Sommer MA, Paré M, Ferraina S (2001) Signal transformations from cerebral cortex to superior colliculus for the generation of saccades. *Vision Res* 41:3399–3412
8. Doya K (2000) Complementary roles of basal ganglia and cerebellum in learning and motor control. *Curr Opin Neurobiol* 10:732–739
9. Graybiel AM (2005) The basal ganglia: learning new tricks and loving it. *Curr Opin Neurobiol* 15:638–644
10. Duhamel JR, Colby CL, Goldberg ME (1992) The updating of the representation of visual space in parietal cortex by intended eye movements. *Science* 255:90–92

---

## Visuomotor Space

- ▶ Visual Space Representation for Reaching

---

## Visuomotor Transformation

### Definition

Refers to transformations between vision and motor processes involving the eyes and or the limbs.

- ▶ Visuomotor Integration

---

## Visuospatial Attention

### Definition

Visuospatial attention refers to mechanisms by which a particular spatial location in the visual field is selected for further processing. The processing of stimuli appearing at the attended spatial location will be enhanced, while stimuli appearing at neighboring

regions will be suppressed. Visuospatial attention can be directed either overtly or covertly. During overt attention, attention is linked to the eye gaze direction. During covert attention, the oculomotor and attention systems operate independently, allowing attention to be deployed throughout the visual field while the eye gaze remains fixed. Visuospatial attention can be deployed prior to stimulus onset, biasing processing in favor of any upcoming stimuli presented at the attended location.

- ▶ Visual Attention

---

## Visuospatial Disorientation

### Definition

Some brain-damaged patients can identify objects, but have problems in visually locating them or their distance. These patients also cannot look at named objects or cannot navigate correctly so as to avoid bumping into them. The damage is typically in the occipital-parietal area on both sides. Visuo-spatial disorientation occasionally concurs with ▶ *simultanagnosia*, both of which are components of ▶ *Balint's syndrome*. Focal parietal lesions may lead to impairment of the perception of horizontal and vertical axes, of length and distance estimation, orientation discrimination and position matching.

- ▶ Visual Neuropsychology

---

## Visuospatial Hemineglect

### Definition

- ▶ Visual Neuropsychology

---

## Vitalism

### Definition

The idea, associated with Pasteur in the nineteenth century and with Driesch in the early twentieth century,

that characteristic functions of life such as growth, reproduction, and evolution are due to a special principle of life – like an entelechy or an élan vital – and can thus not be explained mechanistically in terms of physical and chemical properties alone, nor are they capable of being produced artificially.

- ▶ Epiphenomenalism
- ▶ Reductionism (Anti-Reductionism Reductive Explanation)

---

## Vitamin B12 Deficiency

### Definition

Vitamin B12 deficiency in pernicious anemia may give rise to chronic ▶ [neuropathy](#) and to degeneration of the spinal cord affecting the ▶ [dorsal columns](#) and ▶ [corticospinal tracts](#) (combined degeneration), leading to loss of position and vibration sense and consequent gait disorder (▶ [sensory ataxia](#)).

- ▶ Corticospinal Tract
- ▶ Dorsal Column

---

## VMLBs

- ▶ Burst Cells – Medium Lead – Vertical

---

## Vocalization Afterdischarges (VADs)

### Definition

Animal vocalizations that occur after a noxious stimulus that are considered to be a direct index of the unpleasantness associated with the sensations evoked by the noxious stimulus. VADs are mediated by brain structures involved in mediating pain unpleasantness in humans (medial thalamus, anterior cingulate cortex, amygdala) and suppressed by drug treatments that reduce pain unpleasantness in humans. VADs are distinguished from vocalizations that occur during noxious stimulation. These latter vocalizations are

mediated by brainstem mechanisms and exhibit different spectrographic characteristics than VADs.

- ▶ [Emotional/Affective Aspects of Pain](#)

---

## Voigt Element

### Definition

Voigt element is a spring in parallel with a dashpot. The spring exhibits linear elastic behavior (the force required to extend it is proportional to the extension), and the dashpot exhibits linear viscous behavior (the force required to extend it is proportional to the speed of the extension). Used to model the viscoelastic behavior of inorganic and organic materials, including for example eye muscles and orbital tissue.

- ▶ [Eye Orbital Mechanics](#)

---

## Volition

### Definition

The power to will to do something or the willing of something. Willing is sometimes understood as the mental action of deciding or choosing to do something, sometimes as trying to do something, and sometimes as the combination of deciding or choosing to do something and trying to do it. Wishing and wanting to do something are less closely connected to action. We do not always decide, choose, or try to do things that we wish or want to do. When we recognize that we wish or want to do something, we may reflect on whether to do it and decide not to do it. We may even try to prevent ourselves from doing it.

- ▶ [Freedom of Will](#)

---

## Voltage

### Definition

Denotes the difference between electrical potentials measured at two points.

- ▶ [Membrane Potential: Basics](#)

## Voltage Clamp

- ▶ Action Potential
- ▶ Intracellular Recording

## Voltage Sensor

### Definition

The voltage sensor is that part of a voltage-dependent (or –gated or -sensitive) ion channel protein responsible for the detection of the membrane potential. Positively charged amino acid residues in S<sub>4</sub> of each repeat play an essential role as a voltage sensor.

- ▶ Action Potential

## Voltage-activated Na<sup>+</sup> Channel

- ▶ Sodium Channels

## Voltage-dependent Calcium Release

- ▶ Excitation-Contraction Coupling

## Voltage-dependent Inactivation

### Definition

Voltage-dependent inactivation denotes the inactivation of ion channels with membrane depolarization.

- ▶ Action Potential

## Voltage-dependent (or –gated or -sensitive) Calcium Channels

- ▶ Calcium Channels – an Overview

## Voltage-dependent (or –gated or -sensitive) Cation Channels

### Definition

Members of this superfamily of transmembrane proteins bearing highly selective aqueous pores are activated and inactivated by changes in the plasma membrane potential. The family comprises several subclasses of channels (e.g., Na<sup>+</sup>, K<sup>+</sup>, Ca<sup>2+</sup>, cyclic nucleotide-regulated channels). The channels display a conserved core structure consisting of six transmembrane segments and an ion-conducting pore loop between S<sub>5</sub> and S<sub>6</sub>. In most channels the S<sub>4</sub> segment is positively charged and serves as voltage sensor. All members of the family are tetrameric.

- ▶ Calcium Channels – an Overview
- ▶ Cyclic Nucleotide-Regulated Cation Channels
- ▶ Neuronal Potassium Channels
- ▶ Sodium Channels

## Voltage-dependent (or –gated or -sensitive) Chloride Channels

### Definition

- ▶ Chloride Channels and Transporters

## Voltage-dependent (or –gated or -sensitive) Potassium Channels

- ▶ Neuronal Potassium Channels

## Voltage-dependent (or -gated or -sensitive) Sodium Channels

### ► Sodium Channels

## Voltage-Gated Ion Channels and Pain

MICHAEL S. GOLD

Department of Medicine, Division of Gastroenterology, Hepatology and Nutrition, University of Pittsburgh School of Medicine, Pittsburgh, PA, USA

### Synonyms

Voltage-dependent ion channels; Voltage-sensitive ion channels; Pain and voltage-gated ion channels

### Definition

► **Voltage-gated** ion channels are channels in cell membranes that when open are permeable to ions in solution where the opening and closing of the channel, referred to as gating, is controlled by membrane potential [1]. These channels are generally described in reference to the ion(s) ( $\text{Na}^+$ ,  $\text{K}^+$ ,  $\text{Ca}^{2+}$ , etc.) for which they are most permeable. Voltage-gated ion channels involved in the perception of pain are located on neurons critical for the transmission and modulation of noxious, or potentially tissue damaging stimuli.

### Characteristics

#### Structure of Voltage-Gated Ion Channels

The focus of this section is on channels with intrinsic voltage sensitivity. Ion channels with intrinsic voltage sensitivity encompass large and diverse protein families, but all members share several common features [2]. These include a protein structure composed of four repeat domains of six membrane-spanning regions (S1-S6). The voltage-sensor is composed of specific amino acid residues in S4 [1]. The channel pore with residues that serve as a “► **selectivity filter**” for specific ions is lined by the linker between S5 and S6. Additional membrane-spanning regions are present on some channels, such as the voltage- and  $\text{Ca}^{2+}$ -gated big conductance  $\text{K}^+$  (BK) channel. The  $\alpha$ -subunit of voltage-gated  $\text{Na}^+$  and  $\text{Ca}^{2+}$  channels constitutes a single protein encompassing all 4 domains. Therefore, diversity in the properties of these channels reflects, in part, diversity in  $\alpha$ -subunits [3]. Voltage-gated

$\text{K}^+$ , BK and hyperpolarization and cyclic nucleotide (HCN) gated channels are composed of four distinct subunits that may be from the same gene (homomers) or from different genes (heteromers). Therefore, the diversity of these channels not only reflects properties of the  $\alpha$  subunit, but the combination of  $\alpha$  subunits that comprise the channel.

The superfamily of voltage-gated ion channels includes family members such as the ► **inward rectifying  $\text{K}^+$  channels** ( $\text{K}_{ir}$ ) and the ► **two-pore  $\text{K}^+$  channels** ( $\text{K}_{2p}$ ) composed of segments with homology to the S5-pore loop-S6 sequence of the prototypical voltage-gated ion channel, but lack intrinsic voltage-sensitivity conferred by the S4 segment [2]. The superfamily also includes transient receptor potential (► **TRP**) channels and ► **cyclic nucleotide gated** (CNG) ion channels with subunit homology that encompasses the entire S1-S6 segments of the prototypical voltage-gated ion channel, although the “voltage-sensor” has been largely uncoupled from the channel gating process, resulting in channels that are gated by stimuli other than voltage [2]. Finally, there are ion channels such as members of the  $\text{K}_{ir}$  family and *N*-methyl-D-aspartate (► **NMDA**)-type glutamate gated channels that do not have intrinsic voltage sensitivity, but have voltage-dependent properties. The voltage-dependence of these channels is conferred by a voltage-dependent block of the channel by other molecules such as polyamines or  $\text{Mg}^{2+}$  and are relieved with the appropriate change in membrane potential. None of these channels will be discussed further here.

#### Gating of Voltage-Gated Ion Channels

The state (open, closed and/or inactivated) of a voltage-gated ion channel is controlled by membrane potential, or voltage. “Steady-state” is often used to describe the fraction of channels residing in any given state at a specific membrane potential. The rate at which channels transition between states, referred to as a channel’s kinetic properties, may or may not be voltage-dependent [2]. Furthermore, for any given channel, some transitions, such as those associated with ► **activation** or the ► **recovery from inactivation**, may be voltage-dependent, while other transitions, such as those associated with ► **inactivation** and ► **deactivation**, may not be. At a single channel level, voltage-dependent transitions between states are not absolute, but rather reflect changes in channel open probability such that the probability of the channel being open is very low when it is in the “closed” state and considerably higher, but rarely equal to one, when it is in the “open” state. The voltage-dependence and rates at which channels transition between states, referred to as channel biophysical properties, are determined by intrinsic properties of the  $\alpha$ -subunits, the interaction between  $\alpha$ -subunits and accessory subunits or other proteins, the phosphorylation state of the channel

and, in the case of BK channels, the concentration of intracellular  $\text{Ca}^{2+}$  [2]. The biophysical properties of a channel, in addition to the channel density and relative distribution in a membrane, determine its function. The biophysical properties, density and relative distribution of channels are dynamically regulated [4].

### Transmission of Noxious Stimuli

A series of events are necessary for noxious or potential tissue damaging stimuli to ultimately result in the perception of pain. The stimulus energy must be ►transduced (►sensory transduction) into an electrical signal in a nociceptor, usually its terminal, resulting in a ►generator potential. The generator potential must be of sufficient magnitude to produce an ►action potential. The action potential must be successfully propagated to the central terminals of nociceptive afferents. Depolarization of central terminals must be of sufficient magnitude and duration to enable the  $\text{Ca}^{2+}$  influx necessary for transmitter release [4]. The ►synaptic potential (postsynaptic potential) evoked in the second order dorsal horn neuron must of sufficient magnitude to generate an action potential in that dorsal horn neuron. This series of processes must be repeated to enable the dorsal horn neuron to transmit the neural signal to, for example, the thalamus and neurons in the thalamus to subsequently transmit the neural signal to a number of critical sites in the cerebral cortex.

### Voltage Gated ion Channels Critical for the Transmission of Noxious Stimuli

Different classes and types of voltage-gated channels are critical for action potential initiation, propagation and transmitter release [5]. ►Voltage-gated  $\text{Na}^+$  channels underlie the rapid membrane depolarization associated with the upstroke of the action potential. ►Voltage-gated  $\text{K}^+$  channels contribute to the repolarization of the membrane during the falling phase of the action potential. These channels also contribute to the increase in membrane conductance that occurs following an action potential (►after-hyperpolarization), and therefore may influence the timing between action potentials. ►Voltage-gated  $\text{Ca}^{2+}$  channels mediate  $\text{Ca}^{2+}$  influx in neuron terminals that is necessary for transmitter release. The relative density of channel types, their distribution and biophysical properties determine critical aspects of neuronal excitability, including ►action potential threshold, maximum firing frequency, action potential burst duration (also known as ►adaptation or ►accommodation), and action potential ►conduction velocity.

### Channels Mediating Pain in Response to Tissue Injury

Following tissue injury, there are changes in the biophysical properties, density and distribution of voltage-gated ion channels that contribute to on-going

pain and increased sensitivity of the injured tissue [5]. These changes reflect rapid events that involve protein-protein interactions, such as those underlying channel phosphorylation, as well as slower events that may reflect changes in channel ►trafficking (transport and membrane localization similar to ►receptor trafficking) and/or gene ►transcription and ►translation (RNA). Inflammatory mediators and ►trophic factors such as prostaglandin E2, tumor necrosis factor  $\alpha$  and nerve growth factor (NGF) play important roles in the acute regulation of ion channels (see ►Inflammatory pain). Appropriate access to trophic factors such as NGF and glial-derived neurotrophic factor (GDNF) play important roles in the regulation of ion channel expression [5]. The specific pattern of changes in voltage-gated ion channels depends on a number of factors including: (i) type of injury (i.e. neuropathic versus inflammatory), (ii) time following injury (i.e. acute versus chronic), (iii) site of injury (i.e. cutaneous versus visceral), (iv) past history of the injured subject and injured tissue, (v) sex and (vi) age [4]. In general, an increase in inward current (i.e.  $\text{Na}^+$  and  $\text{Ca}^{2+}$  channels) and/or a decrease in outward current (i.e.  $\text{K}^+$  channels) will result in an increase in nociceptor excitability and therefore pain.

*Voltage-gated  $\text{Na}^+$  channels ( $\text{Na}_V$ ):* Of the nine voltage-gated  $\text{Na}^+$  channel  $\alpha$ -subunits known to generate functional channels [6], four may play particularly important roles in pain:  $\text{Na}_V1.3$ ,  $\text{Na}_V1.7$ ,  $\text{Na}_V1.8$  and  $\text{Na}_V1.9$  [7].

$\text{Na}_V1.3$  expression is increased in peripheral neurons following peripheral nerve injury or inflammation. This channel may contribute to an increase in the rate of ►recovery from inactivation, and inhibiting its expression (knock-down) may attenuate nerve injury-induced hypersensitivity [7].  $\text{Na}_V1.3$  in the spinal cord and thalamus may also contribute to ongoing pain following spinal cord injury [8].

Expression of  $\text{Na}_V1.7$  is restricted to the peripheral nervous system and neuroendocrine tissue and is preferentially expressed in nociceptive afferents. Channel expression is increased following peripheral inflammation. Mutant (knockout) mice deficient in  $\text{Na}_V1.7$  fail to develop an appropriate level of inflammatory hypersensitivity. Humans with a loss of function mutation in  $\text{Na}_V1.7$  are insensitive to noxious stimulation. Two gain-of-function mutations have been associated with two distinct human pain syndromes [9].

Expression of  $\text{Na}_V1.8$  is generally restricted to sensory neurons where it is preferentially expressed in nociceptive afferents. A host of inflammatory mediators that produce hypersensitivity increase channel function while mediators that attenuate inflammatory hypersensitivity attenuate channel function. Knock-down or selective block of the channel attenuates both inflammation and nerve injury-induced hypersensitivity.

While the Na<sub>v</sub>1.8 knockout mouse only demonstrates a decrease in mechanical sensitivity with little decrease in hypersensitivity associated with inflammation or nerve injury, compensatory changes have been documented [5].

Na<sub>v</sub>1.9 is present in nociceptive afferents and inflammatory mediators increase channel function. The Na<sub>v</sub>1.9 knockout mouse has an attenuated response to inflammation [5].

**Voltage-gated Ca<sup>2+</sup> channels (Ca<sub>v</sub>):** Voltage-gated Ca<sup>2+</sup> channels are described in terms of their threshold for activation (high threshold versus low threshold) or what was originally thought to be their function: ► **L-type** (Ca<sub>v</sub>1.1–Ca<sub>v</sub>1.4) in heart, ► **N-type** (Ca<sub>v</sub>2.2) in neurons, ► **P/Q-type** (Ca<sub>v</sub>2.1) in purkinje neurons [10]. High threshold channels are critical for transmitter release and are, therefore, a primary target for both endogenous (i.e. enkephalins) and exogenous (i.e. morphine) analgesic drugs (e.g. opioids). The N-type channels appear to be particularly important for transmitter release in the spinal cord because of the analgesic efficacy of selective N-type channel blockers after spinal administration. High threshold channels may be inhibited by the inflammatory mediator prostaglandin E<sub>2</sub>, although the functional consequences of this inhibition remain to be determined. Similarly, nerve injury is associated with a decrease in both high threshold and low threshold voltage-gated Ca<sup>2+</sup> currents, but it is also unclear whether these changes contribute to the hypersensitivity associated with nerve injury [5]. Peripheral nerve injury is associated with a dramatic increase in the α<sub>2δ</sub>-Ca<sup>2+</sup> channel subunit complex. This subunit is a binding site for drugs such as gabapentin, and may confer therapeutic efficacy by enabling block of Ca<sup>2+</sup> channels. Low threshold (► **T-type**, Ca<sub>v</sub>3.1–Ca<sub>v</sub>3.3) channels may play an important role in establishing the excitability of peripheral nerve terminals, and manipulations that produce an increase in channel function may be associated with an increase in nociceptive sensitivity [5].

**Voltage-gated K<sup>+</sup> channels (K<sub>v</sub>):** Voltage-gated K<sup>+</sup> channels are generally described in terms of properties of the current (i.e. inactivating versus non-inactivating) or their pharmacological sensitivity (i.e. 4-aminopyridine (4-AP)-versus tetraethylammonium (TEA)-sensitive). These channels play a critical role in regulating the excitability of sensory neurons as pharmacological block of these channels results in a dramatic increase in excitability [5]. Tissue injury-induced increases in afferent excitability have been shown to be associated with decreases in 4-AP-sensitive and/or TEA-sensitive K<sup>+</sup> currents. Because of the complexity of this channel family, the specific subunits responsible for the changes in excitability have yet to be identified in most cases. However, K<sub>v</sub>4.2 does appear to play a major role in regulating the excitability of dorsal horn neurons and block of this

channel suggests a significant role in inflammatory hyperalgesia.

**HCN channels:** The contribution of HCN channels to pain associated with tissue injury has not been studied extensively. However, there is evidence that following nerve injury there is an increase in HCN channel function that may contribute to spontaneous activity in nociceptive afferents and therefore on-going pain [5].

## References

1. Tombola F, Pathak MM, Isacoff EY (2006) How does voltage open an ion channel? *Annu Rev Cell Dev Biol* 22:23–52
2. Yu FH, Yarov-Yarovoy V, Gutman GA, Catterall WA (2005) Overview of molecular relationships in the voltage-gated ion channel superfamily. *Pharmacol Rev* 57:387–395
3. Gutman GA, Chandy KG, Grissmer S, Lazdunski M, McKinnon D, Pardo LA, Robertson GA, Rudy B, Sanguinetti MC, Stuhmer W, Wang X (2005) International Union of Pharmacology. LIII. Nomenclature and molecular relationships of voltage-gated potassium channels. *Pharmacol Rev* 57:473–508
4. Caterina MJ, Gold MS, Meyer RA (2005) Molecular biology of nociceptors. In: Hunt S, Koltzenburg M (eds) *The neurobiology of pain*. Oxford University Press, Oxford, pp 1–33
5. Gold MS (2006) Ion channels: recent advances and clinical applications. In: Flor H, Kaslo E, Dostrovsky JO (eds) *Proceedings of the 11th World Congress on Pain*. IASP Press, Seattle, pp 73–92
6. Catterall WA, Goldin AL, Waxman SG (2005) International Union of Pharmacology. XLVII. Nomenclature and structure-function relationships of voltage-gated sodium channels. *Pharmacol Rev* 57:397–409
7. Rush AM, Cummins TR, Waxman SG (2007) Multiple sodium channels and their roles in electrogenesis within dorsal root ganglion neurons. *J Physiol* 579:1–14
8. Waxman SG, Hains BC (2006) Fire and phantoms after spinal cord injury: Na<sup>+</sup> channels and central pain. *Trends Neurosci* 29:207–215
9. Waxman SG (2007) Channel, neuronal and clinical function in sodium channelopathies: from genotype to phenotype. *Nat Neurosci* 10:405–409
10. Catterall WA, Perez-Reyes E, Snutch TP, Striessnig J (2005) International Union of Pharmacology. XLVIII. Nomenclature and structure-function relationships of voltage-gated calcium channels. *Pharmacol Rev* 57:411–425

## Voltage-gated Na<sup>+</sup> Channel

### ► Sodium Channels



## Voltage-gated Sodium Channels: Multiple Roles in the Pathophysiology of Pain

SULAYMAN D. DIB-HAJJ<sup>1</sup>, STEPHEN G. WAXMAN<sup>2</sup>

<sup>1</sup>Department of Neurology and Center for Neuroscience and Regeneration Research, Yale University School of Medicine, New Haven, CT, USA

<sup>2</sup>Rehabilitation Research Center, VA Connecticut, USA Healthcare System, West Haven, CT, USA

### Synonyms

Neuropathic pain; Inflammatory pain; Painful neuropathies

### Definition

Normal pain or nociception is an adaptive process that is necessary for the survival of the species because it alerts the individual to harmful conditions which can be life-threatening. Signals for painful or noxious stimuli, for example hot surfaces, are first detected by specialized high-threshold sensory neurons called nociceptors. Pathological pain, for example ►**neuropathic pain**, is caused by lesion or disease of the somatosensory system and which persists even after the physical aspects of injury have healed.

### Characteristics

#### General Features of Voltage-Gated Sodium (Na<sup>+</sup>) Channels

►**Voltage-gated sodium (Na<sup>+</sup>) channels** underlie the generation and propagation of electric impulses along excitable membranes of cells such as neurons and myocytes (►**Action potential**; ►**Action potential propagation**), and ►**sodium (Na<sup>+</sup>) channelopathies** underlie several inherited human disorders that affect neuronal function, skeletal and cardiac muscle contraction [1–4]. We will review in this essay recent data from human patients with gain-of-function or loss-of-function mutations in Na<sub>v</sub>1.7, which confirm this channel's key role in pain states and identify it as a novel target for drug development to treat pain.

Sodium (Na<sup>+</sup>) channels are heteromultimeric structures containing a single large pore-forming  $\alpha$ -subunit and smaller auxiliary  $\beta$ -subunits [5]. While the  $\alpha$ -subunit alone is necessary and sufficient to form a functional channel,  $\beta$ -subunits and an array of cytosolic molecules regulate trafficking and channel density at the cell membrane [3] (►**Cell membrane – components and functions**). Nine  $\alpha$ -subunits (Na<sub>v</sub>1.1–Na<sub>v</sub>1.9) and four  $\beta$ -subunits ( $\beta$ 1– $\beta$ 4) have been identified in mammals with specific spatial and temporal expression

patterns, and several of their cognates have been found in lower vertebrates [5].

The  $\alpha$ -subunits of Na<sup>+</sup> channels are large polypeptides (200–260 kDa), which are organized into four domains (DI–DIV), each consisting of six transmembrane segments connected by intra- and extra-cellular linkers (Fig. 1) [5].

The  $\beta$ -subunits are much smaller (33–36 kDa) and belong to the immunoglobulin superfamily of proteins (►**Immunoglobulin**), each with a single transmembrane segment and a larger extra-cellular domain that has the characteristic immunoglobulin fold [5]. Many of the Na<sup>+</sup> channels produce currents with distinct biophysical and pharmacological features [6] that invariably impact the electrogenic profile of neurons or muscle cells in which they are present (►**Action potential**).

Among the neuronal channels, recent studies indicate that a mutant phenotype depends on the complement of Na<sup>+</sup> channels in the neuron in which the mutant channel is expressed (as will be discussed in a later section). Gain-of-function mutations in ►**voltage-gated Na<sup>+</sup> channels** are often dominantly inherited [2,4] whereas loss-of-function mutations are either dominant as in ►**epilepsy** [4], or recessive as in ►**congenital indifference to pain** [2]. Recently, Na<sub>v</sub>1.7 has become the focus of intense investigation for its role in acquired and inherited ►**neuropathic pain** symptoms.

#### Tissue Distribution of Na<sub>v</sub>1.7

Robust Na<sub>v</sub>1.7 expression has been reported in a majority of functionally identified ►**nociceptive neurons** and in ►**sympathetic** neurons of the peripheral nervous system (PNS) (Fig. 2) [2]. Evidence for the expression of Na<sub>v</sub>1.7 in central nervous system (CNS) neurons has been controversial because of inconsistent findings. A global knock out of Na<sub>v</sub>1.7 has been shown to be lethal in new-born mice [7]. Surprisingly, however, humans with ►**nonsense mutations** of Na<sub>v</sub>1.7 survive with no apparent cognitive or motor deficits but with impaired smell and complete indifference to pain [2]. One explanation for the lethality in transgenic mice is that the inability to smell due to the loss of Na<sub>v</sub>1.7 leads to starvation in affected mice.

Immunohistochemical studies (Fig. 2) have shown that Na<sub>v</sub>1.7 is uniformly distributed within the cell bodies of small-diameter ►**dorsal-root ganglion (DRG) neurons** and along the unmyelinated ►**C-fibers** within the sciatic nerve. Na<sub>v</sub>1.7 has also been found within nerve endings of DRG neurons in culture [2], an observation that suggests a similar accumulation at nerve endings *in vivo*. The presence of Na<sub>v</sub>1.7 at nerve endings and its enabling biophysical properties would be consistent with a role of amplifying the typically weak ►**generator potentials** [6]. Since the reagents used in these immunohistochemical studies cannot distinguish between cytoplasmic and plasma membrane-bound channels, future

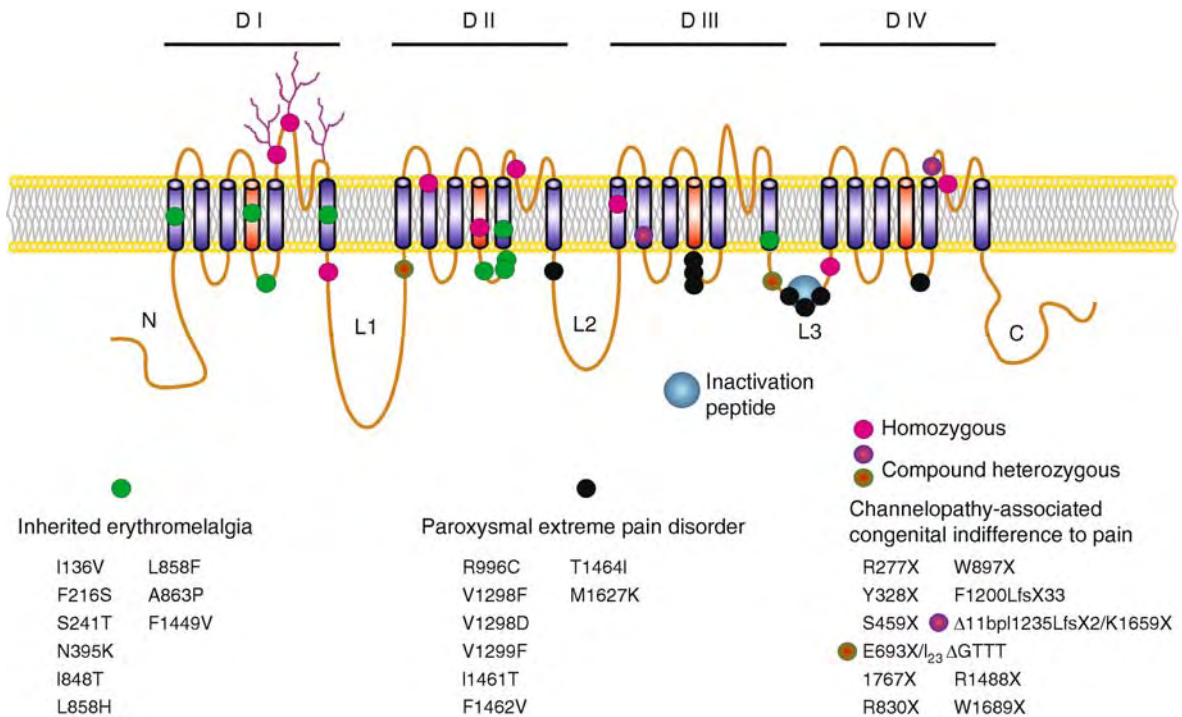

**Voltage-gated Sodium Channels: Multiple Roles in the Pathophysiology of Pain.** Figure 1 Schematic of voltage-gated sodium channel showing locations of the known mutations in Nav1.7-related inherited pain disorders. Inherited erythromelalgia (green symbols) and paroxysmal extreme pain disorder (PEPD, black symbols) mutations are gain-of-function and inherited as a dominant trait. Channelopathy-associated congenital indifference to pain (CIP) is caused by loss-of-function mutations which are inherited as a recessive trait. Homozygous channelopathy-associated CIP mutations carry the same nonsense mutation on both alleles of *SCN9A* (solid magenta), whereas two pairs of compound heterozygous mutations (blue-magenta and red-green) carry different mutations which produce non-functional channels on the two alleles. Reproduced with permission from [2].

studies using  $\text{Na}_v1.7$ -specific reagents that can bind to the extra-cellular regions of the channel are needed for unequivocal demonstration of the presence of this channel at the plasma membrane.

### Role of $\text{Na}_v1.7$ in Painful Neuropathies

There is substantial evidence for a critical role of  $\text{Na}^+$  channels in acquired and inherited painful **neuropathies**, and clinical evidence that  $\text{Na}^+$  channel blockers produce partial relief from neuropathic pain. A direct and central role of  $\text{Na}_v1.7$  in painful disorders in humans has been confirmed by the identification and analysis of gain-of-function and loss-of-function mutations in this channel [1,2]. Genetic studies have identified gain-of-function **missense mutations** within ***SCN9A***, the  $\text{Na}^+$  channel gene that encodes  $\text{Na}_v1.7$ , in patients with inherited **erythromelalgia (IEM)** (see below). A different set of gain-of-function missense mutations has been identified in  $\text{Na}_v1.7$  in patients with **paroxysmal extreme pain disorder (PEPD)** (see below), previously referred to as familial rectal pain [8]. Recently, loss-of-function mutations in  $\text{Na}_v1.7$  have been identified in individuals with congenital and

complete inability to experience pain [9]. These studies provide a complementary picture for the role of this channel in pain signaling.

### Inherited Erythromelalgia

Erythromelalgia or “burning feet syndrome,” first described by S. Weir Mitchel in the late nineteenth century, is characterized by episodes of excruciating pain in the extremities and associated skin redness. Inherited erythromelalgia (IEM) (also known as **erythromelalgia**) can start early in life with a mean age of onset of 3 years and typically affect feet and hands, whereas symptoms of adult-onset IEM typically start in mid-life [2]. While early- and juvenile-onset IEM have been linked to mutations in  $\text{Na}_v1.7$  (Fig. 1), the genetic cause for adult-onset IEM remains to be identified [2].

Pain episodes in  $\text{Na}_v1.7$ -related, early-onset IEM are triggered by mild warmth or exercise, and are accompanied by erythema and mild swelling in the hands and feet, and sometimes in the ears or face [2]. The frequency and severity of symptoms increase with age. Patients with  $\text{Na}_v1.7$ -related IEM do not suffer

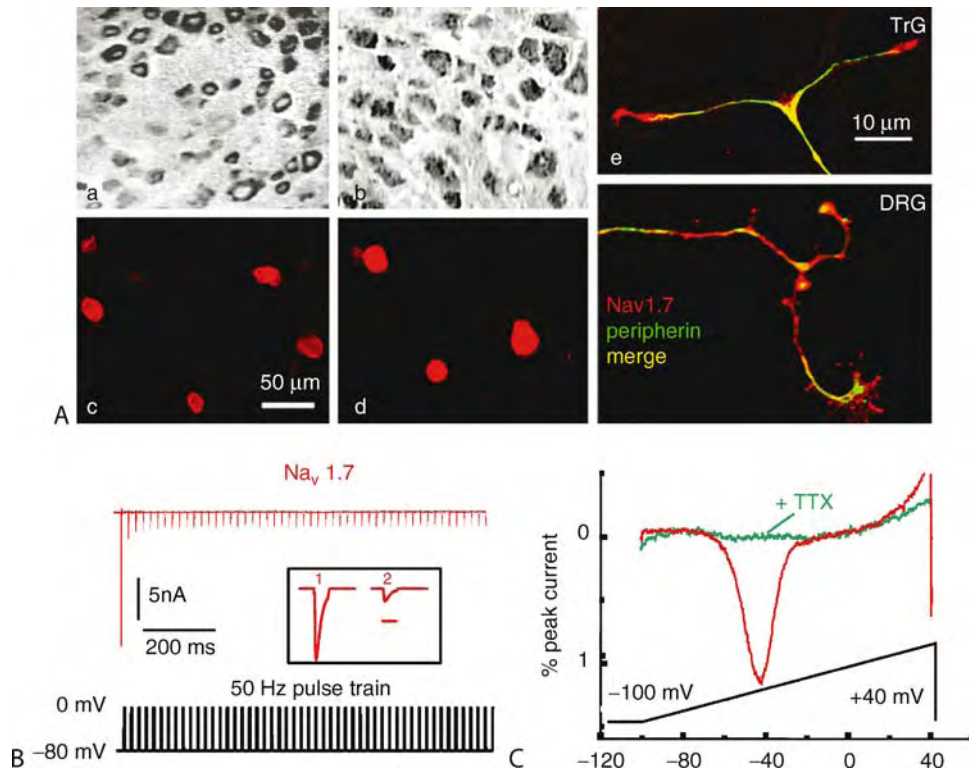

**Voltage-gated Sodium Channels: Multiple Roles in the Pathophysiology of Pain.** **Figure 2** Na<sub>v</sub>1.7 is expressed in DRG and SCG neurons, accumulates at neurite tips, and possesses distinct biophysical characteristics consistent with its role in nociception. (a) Immunostaining of Na<sub>v</sub>1.7 channels in DRG and SCG neurons *in vivo* and in cultured neurons. (Aa,Ab) Na<sub>v</sub>1.7 channels are present in adult rat DRG and SCG neurons *in vivo*, and (Ac, Ad) in cultured DRG and SCG neurons from P2 rat pups. (Ae, Af) Na<sub>v</sub>1.7 protein is present in neuritic extensions of small trigeminal (TrG) and dorsal root ganglion (DRG) which give rise to peripherin-positive unmyelinated C-fibers, and accumulates at the tips of these neurites. (b) Trains of 50 Hz stimulation show that sodium channel Na<sub>v</sub>1.7, expressed in HEK 293 cells, recovers slowly from fast-inactivation and is unable to follow and sustain high frequency firing. (f) Using ramp stimulation to mimic small graded subthreshold potentials, Na<sub>v</sub>1.7 produces a TTX-sensitive ramp current. Aa–Ad are adapted from [Rush AM, Dib-Hajj SD, Liu S, Cummins TR, Black JA, Waxman SG (2006) Proc Natl Acad Sci U S A 103:8245–8250]; Ae–Af, are adapted with permission from [2]; B and C are adapted from [Cummins TR, Howe JR, Waxman SG (1998) J Neurosci 18:9607–9619].

from sensory (other than somatosensory pain), motor or cognitive abnormalities. However, their degraded quality of life and lack of effective drugs for treatment has led to several cases of suicide. Except for skin redness in the affected extremities, patients with early-onset IEM do not report other ►autonomic abnormalities such as orthostatic hypotension or gastrointestinal symptoms. The erythema in affected areas might be caused by a combination of the release of vasodilating peptides, ►substance P and ►calcitonin-gene related peptide, by hyperactive C-fibers, and impaired cutaneous vasoconstriction caused by hypoexcitable sympathetic neurons [2]. In the absence of effective drugs for all forms of erythromelalgia, patients find partial relief from cooling their affected extremities while avoiding environmental conditions that can precipitate attacks.

### Paroxysmal Extreme Pain Disorder

Several cases of paroxysmal extreme pain disorder (PEPD) have been linked to mutations in Na<sub>v</sub>1.7 [8] that are distinct from those in IEM (Fig. 1); however, almost half of the reported cases of PEPD do not carry mutations in this channel. The severe pain in PEPD patients along with redness in the lower body can start in infancy (and possibly *in utero*), and is induced by defecation or probing of the perianal areas, and, unlike cases of IEM, is accompanied sometimes by tonic non-epileptic seizures, syncope, bradycardia and occasionally asystole [10]. It remains to be determined if the non-epileptic seizures, syncope, bradycardia and asystole are caused by autonomic neuron dysfunction which might be induced by Na<sub>v</sub>1.7 mutant channels in sympathetic neurons. Pain progresses with age to

ocular and maxillary/mandibular areas and is triggered by cold, eating or emotional state [10]. Pain episodes can last seconds to minutes (and hours in extreme cases), and gradually subside over minutes. When tolerated, the anti-convulsant  $\text{Na}^+$  channel blocker carbamazepine has been effective in relieving the symptoms, while other drugs including other anti-epileptics are not effective [10]. It is remarkable that these patients do not complain from pain in their extremities or show reddened feet as in patients with IEM, nor do patients with IEM suffer from rectal, ocular or mandibular pain as in PEPD patients.

### Congenital Indifference to Pain

$\text{Na}_v1.7$ -related congenital inability to experience pain is a very rare, autosomal recessive trait [9]. These patients do not produce functional  $\text{Na}_v1.7$  channels and do not experience pain from normally painful acts such as inserting sharp objects in their hands or after bone fracture, tongue and lip biting, or walking on hot surfaces (burning coal). However, except for deficits in their ability to smell and feel pain, these patients suffer no other sensory, motor or cognitive deficits. Heterozygous parents are asymptomatic suggesting that loss of functional  $\text{Na}_v1.7$  on one allele does not lead to **▶haploinsufficiency**. Because many of the patients in these studies are young or adolescent, it remains to be seen what changes in pain perception might come with age, and if these changes represent learned behavior or physiological changes along the pain information axis.

### Molecular Pathophysiology

The role of  $\text{Na}_v1.7$  in pathophysiology of pain in inherited neuropathies has been inferred from the effect of individual mutations on the **▶gating** properties of mutant channels, and in specific cases by studying the effect of mutant channel expression on firing properties of DRG neurons. The ability to study the biophysical properties of  $\text{Na}_v1.7$  in a mammalian cell line [2] has facilitated the characterization of almost a dozen mutations by whole-cell patch clamp (see **▶Intracellular recording**) analysis to determine changes in intrinsic channel properties, for example **▶activation** and **▶steady-state inactivation**. Importantly, the establishment of transfection of primary neurons by **▶electroporation** has enabled the elucidation of physiological aspects of neuronal hyperexcitability of sensory neurons, which underlies neuropathic pain.

$\text{Na}_v1.7$  produces a fast activating and inactivating current, which is sensitive to nanomolar concentrations of **▶tetrodotoxin** (TTX-S), but unlike other TTX-S channels,  $\text{Na}_v1.7$  channels are slow to recover from fast inactivation (**▶reprime**) and produce a current in response to small slow depolarizations (ramp stimulus) (Fig. 2) [2,6]. The ability of  $\text{Na}_v1.7$  to produce a ramp current close to the resting membrane potential

(**▶Membrane potential – basics**) of DRG neurons suggests that it might act at earlier stages of electrogenesis as a “threshold” channel, amplifying weak stimuli such as generator potentials, and thus setting the gain in nociceptors [6]. While experimental evidence has begun to explain how gain-of-function mutations of  $\text{Na}_v1.7$  render DRG neurons hyperexcitable in painful neuropathies (see below), it is less understood why the lack of functional  $\text{Na}_v1.7$  in patients with congenital indifference to pain completely abrogates the pain response [9].

To date, eight IEM mutations [2] and three PEPD mutations [8] in  $\text{Na}_v1.7$  have been characterized by whole-cell voltage-clamp (see **▶Intracellular recording**) studies. All of the IEM mutations lower the threshold for activation of  $\text{Na}_v1.7$ , thus allowing the channel to open in response to a weaker stimulus compared to wild-type channels. The three PEPD mutations do not affect the voltage-dependence of activation, but shift the voltage-dependence of fast-inactivation in a positive direction ensuring that more channels will be available to open at more depolarized potentials compared to normal DRG neurons [8]. Changes in threshold of channel activation (**▶Sodium ( $\text{Na}^+$ ) Channel Activation**) or the fraction of the total channels available to open at depolarized potentials can contribute to DRG neuron hyperexcitability by lowering the threshold for single action potentials or sustaining repetitive firing (as will be discussed below) (see **▶Action potential**).

The location of PEPD mutations in  $\text{Na}_v1.7$  (Fig. 1) [8] within the fast-inactivation peptide in L3 and its putative receptor site in the S4-S5 linkers in domains III and IV, is consistent with the impaired channel fast-inactivation (**▶Sodium ( $\text{Na}^+$ ) channel fast-inactivation**) [5].

The structure-function effect of the mutations in  $\text{Na}_v1.7$  from IEM patients is less clear. Except for the mutation in the S4 of domain I (DI/S4) where an effect on activation might be expected *a priori* because S4 segments act as the **▶voltage-sensors** of the channel, the other mutations clearly bias the open state of the channel through unknown mechanism(s).

The expression of three mutant  $\text{Na}_v1.7$  mutations A863P, L858H and F1449V but not wild-type channels in DRG neurons lowers the threshold for single action potential and increases the number of spikes produced by a sustained stimulus (Fig. 3) [2], both hallmarks of neuronal hyperexcitability.

The majority of current underlying the depolarizing phase of action potential in nociceptive DRG neurons is carried by the  $\text{Na}^+$  channel  $\text{Na}_v1.8$ , a tetrodotoxin-resistant (TTX-R) channel which is present in sensory but not sympathetic neurons, and the biophysical properties of  $\text{Na}_v1.7$  suggest that it might not contribute significantly to this current [6]. Thus, the activation of mutant  $\text{Na}_v1.7$  channels at more hyperpolarized

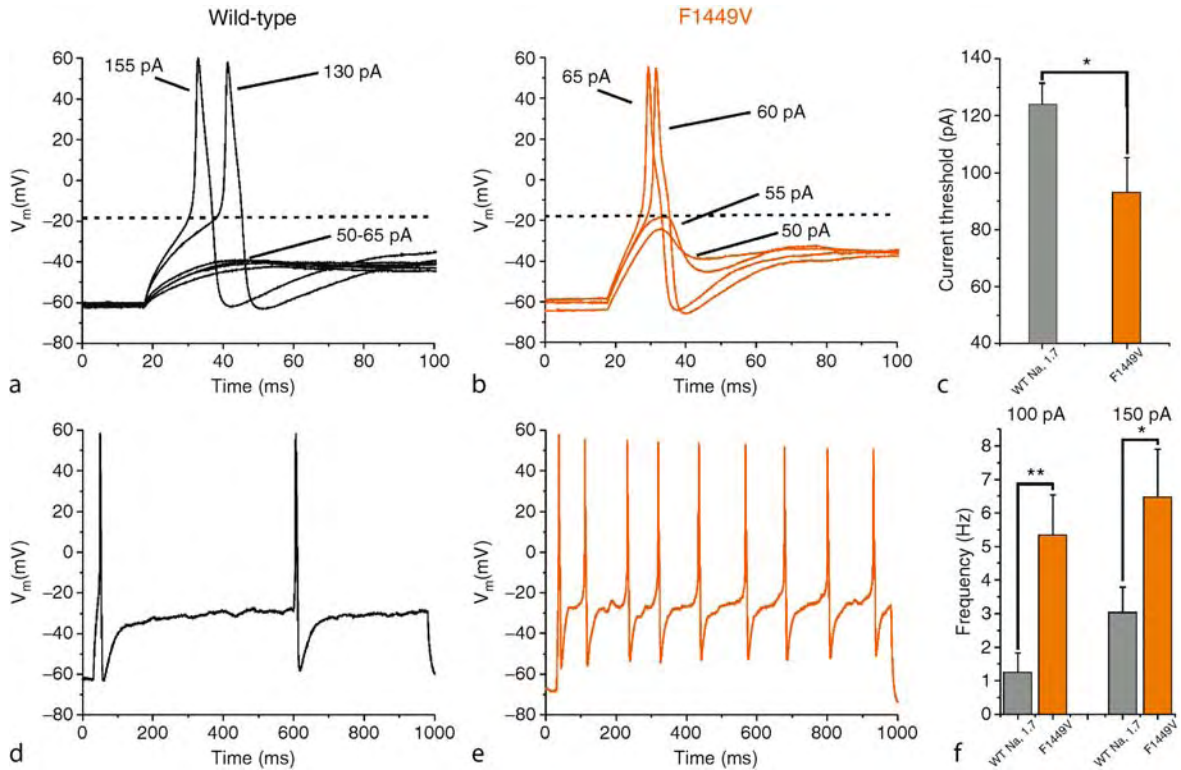

**Voltage-gated Sodium Channels: Multiple Roles in the Pathophysiology of Pain. Figure 3** Effect of the F1449V mutation on electrogenesis in small DRG neurons. (a): Representative traces from a small (<30 mm) DRG neuron expressing wild-type Na<sub>v</sub>1.7, showing subthreshold responses to 50–65 pA current injections and subsequent all-or-none action potentials evoked by injections of 130 pA (current threshold for this neuron) and 155 pA. (b): In contrast, in a cell expressing the F1449V erythromelalgia mutation, action potentials were evoked by a 60 pA current injection, demonstrating a lower current threshold for action potential generation. The voltage for takeoff of the all-or-none action potential (dotted line) was similar for the neurons in panels a and b. (c): There is a significant (\**p* < 0.05) reduction in current threshold in cells expressing F1449V compared to cells expressing wild-type Na<sub>v</sub>1.7. (d) Shows the firing of a neuron expressing wild type Na<sub>v</sub>1.7 (same neuron as in A), which responded to a 950 ms stimulation of 150 pA with two action potentials. In contrast, (e) shows that, in a neuron expressing the mutant channel F1449V (same cell as in b), an identical 150 pA depolarizing stimulus evoked high-frequency firing. (f) There is a significant increase in the frequency of firing in response to 100 pA and 150 pA stimuli (950 ms) following expression of F1449V in comparison to wild-type Na<sub>v</sub>1.7. Reproduced with permission from [Dib-Hajj SD, Rush AM, Cummins TR, Hisama FM, Novella S, Tyrrell L, Marshall L, Waxman SG (2005) *Brain* 128:1847–1854].

voltages compared to wild-type channels would be expected to reduce the threshold stimulus required to generate an all-or-none action potential without altering the voltage at which the action potential is elicited, presumably the voltage at which Na<sub>v</sub>1.8 channels are activated. Indeed, the threshold voltage for a single action potentials in DRG neurons transfected with wild-type or mutant Na<sub>v</sub>1.7 channels is around -20 mV, the voltage at which Na<sub>v</sub>1.8 activates [6].

The shift in voltage-dependence of activation as in the case of all known IEM mutations, steady-state inactivation as in the case of PEPD mutations, or both as in the case of IEM mutations A863P and F1449V, are predicted to increase the number of channels that are constitutively “open” within the voltage range that

is defined by the overlap between activation and inactivation curves (window current). The larger window current is predicted to cause a depolarizing shift in the resting membrane potential of neurons. Indeed, both L858H and A863P mutant Na<sub>v</sub>1.7 channels have been shown to cause a 5 mV depolarizing shift in resting membrane potential of DRG neurons [2]. Depolarization of the resting membrane potential brings DRG neurons closer to activation threshold for Na<sub>v</sub>1.8 channels and thus enhances the chances that these neurons will fire in response to a stimulus.

The depolarization of the resting membrane potential of neurons expressing mutant Na<sub>v</sub>1.7 could also cause a resting inhibition of the other TTX-S channels, including the mutant channel itself, which have a

hyperpolarized activation and inactivation compared to  $\text{Na}_v1.8$  [6]. Thus, it is predicted that neurons, which do not normally produce  $\text{Na}_v1.8$  channels, will become hyperexcitable. Indeed, the L858H  $\text{Na}_v1.7$  mutant channels, which render DRG neurons hyperexcitable, cause SCG neurons to become hypoexcitable (Fig. 4) [2]. The role of  $\text{Na}_v1.8$  channels in neuronal hyperexcitability is supported by its ability to rescue firing properties of SCG neurons when it is co-expressed with the L858H mutant  $\text{Na}_v1.7$  channel (Fig. 4).

#### Dysregulation of $\text{Na}_v1.7$ in Acquired Pain States

$\text{Na}_v1.7$  has been shown to be a major contributor to inflammation-induced pain (►Inflammatory pain) in

animal models. Following inflammation of the hind paw in rats,  $\text{Na}_v1.7$  levels in DRG neurons are elevated, with a concomitant increase in the amplitude of TTX-S current in these neurons [2]. A contribution of  $\text{Na}_v1.7$  to inflammatory pain is further supported by the finding that antisense-mediated knock-down of  $\text{Na}_v1.7$  levels in primary afferents reduces inflammation-induced thermal hyperalgesia (►Hyperalgesia and allodynia) in mice. Importantly, a direct role of  $\text{Na}_v1.7$  in inflammatory pain has been confirmed in studies using  $\text{Na}_v1.7$  knock-out mice, which show almost no signs of inflammation-induced pain [7]. Thus,  $\text{Na}_v1.7$  appears to play an important role in inflammation-induced pain.

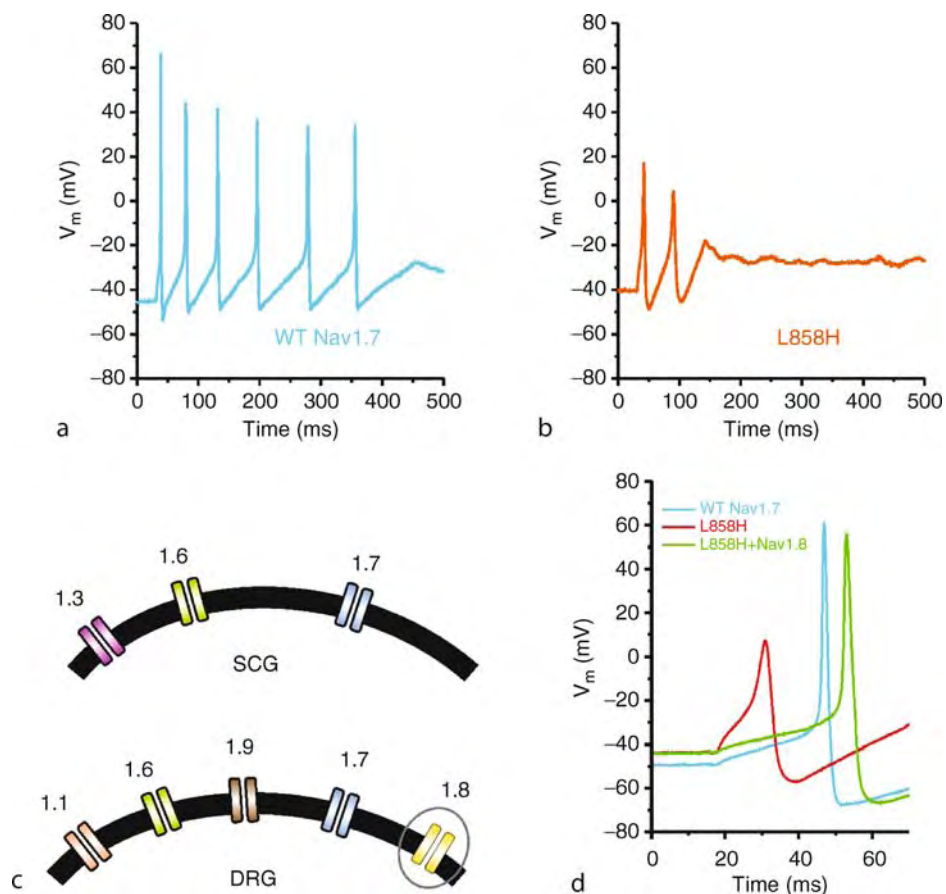

**Voltage-gated Sodium Channels: Multiple Roles in the Pathophysiology of Pain. Figure 4** L858H mutation decreases firing frequency in SCG neurons and phenotype is rescued by the co-expression of  $\text{Na}_v1.8$ . (a) Representative SCG neuron expressing WT  $\text{Na}_v1.7$  fires 6 action potentials in response to a 950 ms input of 40 pA from RMP (~ -45 mV). (b) Representative SCG neuron expressing L858H fires only 2 action potentials, with reduced overshoot, in response to a 100 pA current injection from RMP (~ -40 mV). (c) Schematic representation of the cell membrane of SCG and DRG neurons showing the different complement of voltage-gated sodium channels that are present in the two different neurons. (d) Action potential overshoot in SCG neurons transfected with the L858H erythromelalgia mutant channel (red trace) was significantly reduced compared to that in neurons transfected with wild type  $\text{Na}_v1.7$  (blue trace). The action potential overshoot was restored to wild type levels when  $\text{Na}_v1.8$  was co-expressed with L858H (green trace). Adapted with permission from [Rush AM, Dib-Hajj SD, Liu S, Cummins TR, Black JA, Waxman SG (2006) Proc Natl Acad Sci USA 103:8245–8250].

### Summary

The elucidation of the role of  $\text{Na}_v1.7$  in different forms of inherited painful neuropathies has not only identified a potential target for treatment but also provides hope for future mechanism-based diagnosis of such disorders. The lack of cognitive, motor and sensory deficits in humans lacking functional  $\text{Na}_v1.7$  suggests that  $\text{Na}_v1.7$ -specific blockers might be free from significant side effects. While generic  $\text{Na}^+$  channel blockers have been effective in treatment of some cases of neuropathic pain, their usefulness in a clinical setting is tempered by their undesirable side effects. While the contribution of  $\text{Na}_v1.7$  channels to pain states in acquired and inherited neuropathies is only now beginning to be revealed, the pursuit of small molecule blockers of  $\text{Na}_v1.7$  for pharmaceutical applications is in full vigor.

### Acknowledgement

This work was supported in part by grants from the National Multiple Sclerosis Society and the Rehabilitation Research Service and Medical Research Service, Department of Veterans Affairs, and the Erythromelalgia Association. The Center for Neuroscience and Regeneration Research is a Collaboration of the Paralyzed Veterans of America and the United Spinal Association with Yale University.

### References

1. Waxman SG (2007) Channel, neuronal and clinical function in sodium channelopathies: from genotype to phenotype. *Nat Neurosci* 10(4):405–409
2. Dib-Hajj SD et al. (2007) From genes to pain:  $\text{Na}_v1.7$  and human pain disorders. *Trends Neurosci* 30(11):555–563
3. Wood JN et al. (2004) Voltage-gated sodium channels and pain pathways. *J Neurobiol* 61(1):55–71
4. George AL (2005) Inherited disorders of voltage-gated sodium channels. *J Clin Invest* 115(8):1990–1999
5. Catterall WA et al. (2005) International union of pharmacology. XLVII. Nomenclature and structure-function relationships of voltage-gated sodium channels. *Pharmacol Rev* 57(4):397–409
6. Rush AM et al. (2007) Multiple sodium channels and their roles in electrogenesis within dorsal root ganglion neurons. *J Physiol (Lond)* 579(Pt 1):1–14
7. Nassar MA et al. (2004) Nociceptor-specific gene deletion reveals a major role for  $\text{Nav}1.7$  (PN1) in acute and inflammatory pain. *Proc Natl Acad Sci USA* 101(34):12706–12711
8. Fertleman CR et al. (2006)  $\text{SCN9A}$  mutations in paroxysmal extreme pain disorder: allelic variants underlie distinct channel defects and phenotypes. *Neuron* 52(5):767–774
9. Cox JJ et al. (2006) An  $\text{SCN9A}$  channelopathy causes congenital inability to experience pain. *Nature* 444(7121):894–898
10. Fertleman CR et al. (2007) Paroxysmal extreme pain disorder (previously familial rectal pain syndrome). *Neurology* 69(6):586–595

## Voltammetry

### Definition

Technique to record the extracellular concentrations of certain substances, in particular biogenic monoamines and related compounds, applicable in vivo.

► [Extracellular Recording](#)

## Volume-regulated Anion Conductance

### Definition

► [Chloride Channels and Transporters](#)

## Voluntary Memory

### Definition

Conscious memory.

► [The Proust Effect](#)

## Voluntary Movement

MARTHA FLANDERS

Department of Neuroscience, University of Minnesota, Minneapolis, MN, USA

### Introduction

Voluntary movement is the expression of thought through action. Virtually all areas of the central nervous system are involved in this process. The main flow of information may begin in cognitive cortical areas in the frontal lobe, or in sensory cortical areas in the occipital, parietal and temporal lobes. Ultimately, information flows from motor areas in the frontal lobe through the brainstem and spinal cord to the motoneurons. The ► [basal ganglia](#) and ► [cerebellum](#) have reciprocal connections with most of the structures listed above, and therefore play a supporting role.

One approach to understanding the neural control of voluntary movement is to consider the function of each of the structures involved (Fig. 1a).

For example, the primary motor cortex is generally regarded as the main cortical area for providing descending motor command signals to motoneurons. However, the exact functions of other brain structures remain open for debate. Since diseases of the basal ganglia and cerebellum are relatively common, numerous functions have been proposed for these structures (e.g., movement initiation, error correction, etc.). One

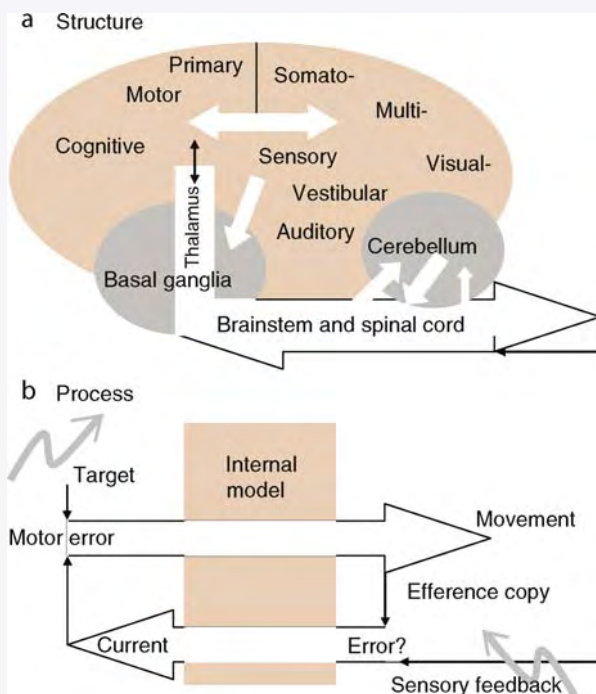

**Voluntary Movement. Figure 1** (a) Schematic diagram of the main central nervous system structures involved in voluntary movement. Cognitive and motor cortical areas are in the frontal lobe; sensory and association areas are in the occipital, parietal and temporal lobes. The basal ganglia and cerebellum get input from the brainstem and spinal cord, and are interconnected with the cerebral cortex through the thalamus. (b) Schematic flow chart of the types of processing that must occur in the control of voluntary movement. Information about target location is combined with information about current location to form a motor error input command to the internal model. The output is the motor command to produce a movement. An efference copy of this command, representing the expected result of the movement, can be compared to sensory feedback, representing the actual result. The efference copy can also be used to update the representation of the current location. If the central nervous system can extrapolate in time, the information in the sensory input (gray, smoothly curved arrows), it would make up for delays due to synaptic transmission and axonal conduction.

emerging perspective is that the basal ganglia and cerebellum do not have discrete roles in motor control and instead work via their interconnections with other subcortical and cerebral cortical structures (see 1–3).

A different approach to the study of voluntary movement is to consider the movement goals, strategies and algorithms for implementation, without direct reference to the neuroanatomy. Theoretical and computational studies have been aimed at providing a quantitative description of movement characteristics in order to gain insight to the neural code. Furthermore, flow chart models like the one shown in Fig. 1b have become increasingly sophisticated by incorporating hypothetical processes such as the use of efference copy.

Hopefully, future studies will merge this functional approach with the more anatomical approach by establishing the exact neural mechanisms for implementing the key algorithms that are essential to sensorimotor integration.

### Structures Involved in Voluntary Movement

The ultimate output of the motor system is the activation of a **motor unit** (defined as a single motoneuron and the group of the muscle fibers contacted by its axon). Researchers have documented several consistent aspects to the patterns of motor unit activation used for voluntary hand and arm movement:

1. As muscle force is increased, small motor units tend to be recruited prior to large motor units (the **size principle**, 4).
2. Neighboring motor units within the same muscle can be preferentially selected for different movements (such as arm movements in different directions, 5).
3. The motor system does not exert independent control of each motor unit or of each muscle, instead groups of motor units across different muscles show covariation in their recruitment patterns (see **muscle synergies**).
4. There is often inhibition of motor units with a mechanical action antagonistic to that of the excited motor units (a classical phenomenon in motor control physiology known as **reciprocal inhibition**).

The brain controls voluntary arm and hand movements by sending descending motor commands to the pattern generating circuitry in the spinal cord. The primary motor cortex is the cerebral cortical structure most directly responsible for activating this circuitry and thereby controlling motor unit selection and recruitment. Although premotor cortical areas also provide direct projections to motoneurons (see **motor cortex – output properties and organization**), and somatosensory cortical areas also contribute to the corticospinal tract, the primary motor cortex provides the most powerful projection to the spinal cord for the control of voluntary



hand and arm movements. There is a complex mapping of hand and arm representations across the surface of the cerebral cortex; it has been characterized as patchy and redundant (see ►[motor cortex – hand movements and plasticity](#)). This pattern may be consonant with the number of different types of voluntary movements that are possible and the inherent plasticity of the hand motor control system [6].

The basal ganglia play a modulatory role in shaping the output of the cerebral cortex. Because the basal ganglia are organized into loops that run from cortex through striatum through pallidum through thalamus back to cortex, they are positioned to assist with the facilitation, shaping, and learning of movement. While modern investigations have revealed that the basal ganglia also influence cognition and emotion, their participation in motor control has received the greatest attention and may be their most important function (see ►[basal ganglia – motor function of](#)). Deficits seen in humans with ►[Parkinson’s disease](#) (degeneration of dopamine pathways from substantia nigra to striatum) suggest that in healthy humans, the basal ganglia have a role in integrating the activities of the many, diverse cortical and sub-cortical regions that are engaged in implementing and adapting ongoing motor behavior.

The cerebellum is an intriguing and somewhat mysterious structure (see ►[cerebellum – motor function of](#)). It is a key structure for processing sensory information from the ►[vestibular system](#), and for the control of ►[eye movement](#). It is also important for voluntary limb movement. An exquisite feature of voluntary movement is its flexibility and adaptability, and the cerebellum, in conjunction with other sensory and motor structures, is thought to play an important role in ►[motor learning](#). Due to its interconnections with the cerebral cortex and its involvement in motor learning, theorists have speculated that the cerebellum is the site of (or at least an important part of) the so-called ►[internal model](#), a functional construct which will be described in detail in the following section.

### Processing Algorithms for Voluntary Movement

Due to the complexity of the sensorimotor system, it may be useful to analyze its function without direct consideration of the specific anatomical structures involved. A class of voluntary movements that has been used extensively for this purpose is point-to-point ►[reaching movements](#). In a reaching movement, the arm begins at rest with the hand in a specific initial location. A visual target appears and the hand must then be moved, in one simple motion, to stop at the specified final location. Observations about the characteristics of such movements have given rise to various ►[motor control models](#), which generally provide a description of the sensorimotor transformation by proposing that

the goal is to optimize a particular characteristic, like the smoothness of the hand trajectory or the amount of muscle activation [7–10]. These models have provided valuable accounts of the types of kinematic (position and movement-based) and kinetic (force-based) parameters that are used by the control system.

Studies of reaching movements have also provided solid evidence for the simplest aspect of the flow chart shown in Fig. 1b. The simplest part of this model is the transformation from a visually presented goal (labeled “target”), through the “INTERNAL MODEL,” to the output command to contract arm motor units (labeled “movement”). This aspect of the internal model is called the inverse model because the visual target is specified in terms of its position or velocity (kinematic parameters) and the output is in terms of muscle force or change in force (kinetic parameters). Because the laws of physics generally describe the cause and effect transformation of force to movement (i.e., force equals mass times acceleration), the sensorimotor transformation of a kinematic goal to a muscle force is considered to be backwards or “inverse.” This neural mapping must take into account the mechanical characteristics of the arm and any object held in the hand, or else the reaching movement would miss its target. Numerous investigations (e.g., 11) have provided evidence that the brain can learn a new internal model within a few trials, even when the model must account for unusual patterns of elastic or viscous resistance to arm movement (rather than the more common situation where one learns to interact with a new object with unexpected inertial characteristics).

The goal of moving the hand from an initial location to a final location can be called a “motor error,” defined as the difference between the current and the target locations. Electrophysiological studies have shown that frontal and parietal cortical areas represent this motor error in terms of the direction or velocity of a reaching movement, not just the final target position (e.g., 12,13). Furthermore, the proper pattern of motor unit recruitment depends on both the initial and the final arm positions, as well as the other mechanical aspects of the arm and hand held object. Therefore the internal model must take into account the arm’s initial position as well as its final target position.

In studies of reaching from a stationary hand, head and body position to a stationary target, it is possible to regard the sensorimotor transformation as open-loop or feedforward (i.e., occurring without additional information about the hand or target location). However if the body moves (as in stepping while reaching) or the target moves (as in tracking or drawing), the hand and target locations must be updated (see ►[movement sequences](#)). Models to describe such processes are more speculative than the initial proposal of a feedforward transformation through the inverse model.

Several lines of indirect evidence indicate that the sensorimotor system may contain a real-time estimate of the current arm and hand position during the course of a reaching, tracking, or drawing movement [14,15]. This may be accomplished by creating an “efference copy” (Fig. 1b) within the cerebral cortex, of the motor commands sent to the spinal cord (see also 16). It has been hypothesized that the efference copy information, which is in terms of muscle forces, goes back through the internal model in the opposite (forward) direction (right to left in Fig. 1b) in order to quickly produce an estimate of current hand position (the expected result of the current motor command).

If this is true, it is possible for the sensorimotor system to make an ongoing comparison of the target location and the current hand location (the “motor error” in Fig. 1b) during the course of a fast reaching movement. However, to use this mechanism for tracking a moving target, the representation of current hand position should be compared with a representation of current target location, which would need to be extrapolated from previously sensed target motion to make up for visual sensory processing delays. This hypothetical predictive extrapolation is indicated by a gray, smoothly curved arrow in Fig. 1b.

The initial motivation for proposing a quick efference copy feedback loop was the fact that sensory feedback may be subject to processing delays of as much as 100–200 ms. This is due to the numerous synaptic delays in the visual pathway, and also due to long axonal conduction times in the somatosensory system. If the current hand location was simply sensed using visual or somatosensory input, this sensory feedback information would arrive at the internal model too late to be used during an ongoing movement. However, as mentioned above, recent research on [smooth pursuit eye movement](#) has begun to provide evidence that smooth, natural target trajectories can be extrapolated (see [eye-hand coordination](#)). For example, a target velocity sensed on the retina could potentially be transformed to a representation of the most likely future target location via processing in motion sensitive cortical areas [17].

It is not known whether the somatosensory cortical areas can perform a similar function, i.e., extrapolating a smoothly changing, familiar input to make up for the sensory delay. If so, it could make up for the time delay in tactile and proprioceptive feedback (as suggested by the gray smoothly curved feedback arrow in Fig. 1b). This would serve to produce an additional, somatosensory-based input to the forward model, which, along with the efference copy, would update current arm position (see Fig. 1b). Furthermore, it would provide the basis for a haptic comparison of the expected and actual somatosensory consequences of a hand movement (“error?” in Fig. 1b). This may be the mechanism that forms the basis of haptic perception.

## Conclusions and Future Directions

In voluntary movement, collections of motor units are selected and recruited based on an ongoing evaluation of neural representations of current and target states. The transformation from goal to motor command must be processed using memories: the internal model and hypothetical mechanisms for sensory extrapolation are essentially memories developed through experience. Most prior research on this process has employed arm movements to visual targets, but one can think of more general examples as well:

Imagine a woman driving while singing along with the singer of a familiar song on the car radio. The driver’s voice is the immediate result of a complex sequence of motor unit activations and aspects of these patterns have become “hard wired,” genetically and through prior use of the pattern generating circuitry. The driver’s song does not lag the radio’s song by the amount of time that it takes to process the radio’s auditory information. This suggests that the radio’s auditory cues are filtered through the memories ingrained in the driver’s brain, to make up for the sensory delay. The driver is constantly listening to the radio but she can lead the voice on the radio and she can even finish the song after the radio goes off.

Common experiences such as this indicate the types of processes that must occur in sensory and motor areas (e.g., flexible patterns of motor unit recruitment and sensory extrapolation based on learning). The structures involved in some of these functions have been revealed mainly through cases of human brain lesions and disease, and studies using functional brain imaging in humans and electrophysiological recordings in animals. However, few studies have specified the neurophysiological basis of complex algorithms such as the use of efference copy and the recollection of memories. Thus there are many open questions for future research.

## References

1. Alexander GE, DeLong MR, Strick PL (1986) Parallel organization of functionally segregated circuits linking basal ganglia and cortex. *Annu Rev Neurosci* 9:357–381
2. Kelly RM, Strick PL (2003) Cerebellar loops with motor cortex and prefrontal cortex of a nonhuman primate. *J Neurosci* 23:8432–8444
3. Hoshi E, Tremblay L, Feger J, Carras PL, Strick PL (2005) The cerebellum communicates with the basal ganglia. *Nat Neurosci* 8:1491–1493
4. Henneman E, Somjen G, Carpenter DO (1965) Functional significance of the size in spinal motor neurons. *J Neurophysiol* 28:560–580
5. Herrmann U, Flanders M (1998) Directional tuning of single motor units. *J Neurosci* 18:8402–8416
6. Fetz EE (1969) Operant conditioning of cortical unit activity. *Science* 163:955–958
7. Flash T, Hogan N (1985) The coordination of arm movements: an experimentally confirmed mathematical model. *J Neurosci* 5:1688–1703

8. Uno Y, Kawato M, Suzuki R (1989) Formation and control of optimal trajectory in human multijoint arm movement. Minimum torque change model. *Biol Cybern* 61:89–101
9. Soechting JF, Buneo CA, Herrmann U, Flanders M (1995) Moving effortlessly in three-dimensions: does Donders' law apply to arm movement? *J Neurosci* 15:6271–6280
10. Harris CM, Wolpert DM (1998) Signal dependent noise determines motor planning. *Nature* 394:780–784
11. Shadmehr R, Mussa Ivaldi FA (1994) Adaptive representation of dynamics during learning of a motor task. *J Neurosci* 14:3208–3224
12. Moran DW, Schwartz AB (1999) Motor cortical representation of speed and direction during reaching. *J Neurophysiol* 82:2676–269
13. Buneo CA, Jarvis MR, Batista AP, Andersen RA (2002) Direct visuomotor transformations for reaching. *Nature* 416:632–636
14. Wolpert DM, Ghahramani Z, Jordan MI (1995) An internal model for sensorimotor integration. *Science* 29:1880–1882
15. Dassonville P (1995) Haptic localization and the internal representation of the hand in space. *Exp Brain Res* 106:434–448
16. Shergill SS, Bays PM, Frith CD, Wolpert DM (2003) Two eyes for an eye: the neuroscience of force escalation. *Science* 301:187
17. Shibata T, Tabata H, Schaal S, Kawato M (2005) A model of smooth pursuit based on learning target dynamics. *Neural Netw* 18:213–224

that in turn contain vomeronasal receptor proteins on their surfaces.

- ▶ Evolution of Olfactory and Vomeronasal Systems
- ▶ Vomeronasal Organ (Jacobson's Organ)

## Vomeronasal Organ (Jacobson's Organ)

### Definition

The nose of most vertebrates contains an additional anatomically distinct chemosensory system, the accessory olfactory system or vomeronasal organ (VNO) or Jacobson's organ. The peripheral organ is a cigar-shaped, blind-ended sac or tube located in the most ventral part of the nasal septum. It contains the vomeronasal epithelium where vomeronasal receptor neurons are located. The sensory neurons within the VNO detect distinct scents containing chemical compounds which are often, but not always, large non-volatile molecules. The VNO is used in the detection of pheromones and detects other odorous compounds in addition. The VNO has been postulated to be involved in responses to pheromones, molecules produced and emitted by members of the same species. Pheromones have been defined to elicit a reproducible reaction and implicated in mating, courtship, sexual and other behaviors. They can also interact with the endocrine system. Pheromones are mostly present in bodily secretions such as urine, sweat and seminal fluid. The axons of pheromone sensory neurons in the VNO project to the accessory olfactory bulb, from which they relay to the amygdala and hypothalamus, structures associated with reproductive behavior, mood, memory and neuroendocrine responses. In mammals, two additional families of G-protein coupled receptors V1R and V2R receptors, unrelated to the family of olfactory receptors, have been identified in the vomeronasal organ and they are differentially expressed in two different populations of vomeronasal sensory neurons. In the apical part of the VNO, neurons express receptors of the V1R family which couple to a Gi-type of G-protein, whereas those in the basal part of the VNO express the V2R receptors which couple to Go-proteins. V1R receptors number about 140 and are of the same general type of proteins as the olfactory receptors. V2R receptors on the other hand possess a long extracellular N-terminal loop. They are estimated to be about hundred in rodents. The signal transduction mechanism in the vomeronasal neurons is not completely understood, but recent physiological and biochemical

## Vomeronasal Amygdala

### Definition

Group of nuclei of the amygdaloid complex involved in the processing, integration and relay of the vomeronasal information received directly from the accessory olfactory bulb.

- ▶ Accessory Olfactory System
- ▶ Vomeronasal Projection Pathway
- ▶ Vomeronasal System

## Vomeronasal Epithelium

### Definition

Chemosensory epithelium located within the vomeronasal organ. It contains vomeronasal receptor neurons

evidence implicates phospholipase  $C\beta_2$ ,  $IP_3$  and DAG as important second messenger components which induce a calcium increase and the activation of a transient receptor potential (TRPC2) channel. So far, none of the V2R class of receptors could be functionally expressed and characterized. In the case of the V1R receptor, for one of the family member in mouse activating ligands have been identified.

- ▶ Accessory Olfactory System
- ▶ Evolution of Olfactory and Vomeronasal Systems
- ▶ G-protein Coupled Receptors (GPCRs): Key Players in the Detection of Sensory and Cell-Cell Communication Messages
- ▶ Olfactory Sense
- ▶ Pheromone

---

## Vomeronasal Pathway

- ▶ Accessory Olfactory System

---

## Vomeronasal Pit

### Definition

Vestigial –and probably non-functional - vomeronasal organ found in some human adults. So far, a connection of the vomeronasal pit to the brain has not been found.

- ▶ Accessory Olfactory System
- ▶ Vomeronasal Organ (Jacobson's Organ)

---

## Vomeronasal System

### Definition

Also called accessory olfactory system. A chemosensory system present in tetrapods composed of a vomeronasal epithelium, located into the vomeronasal organ, an accessory olfactory bulb and vomeronasal- recipient

areas of the telencephalon. It is able to detect biologically relevant substances such as prey odors and pheromones.

- ▶ Accessory Olfactory Bulb/Vomeronasal Organ
- ▶ Accessory Olfactory System
- ▶ Evolution of Olfactory and Vomeronasal Systems
- ▶ Odor
- ▶ Pheromone
- ▶ Vomeronasal Epithelium
- ▶ Vomeronasal Organ (Jacobson's Organ)

---

## Vomeronasal System (Accessory Olfactory System)

- ▶ Evolution of Olfactory and Vomeronasal Systems

---

## Vomiting Center

### Definition

Complex involving various visceral pathways and actual vomiting reflex. Brain stem nuclei including parvicellular reticular formation, nucleus tractus solitarii, the dorsal motor nucleus of vagus, and the nucleus ambiguus constitute the vomiting center.

- ▶ Anti-Motion Sickness Drugs

---

## VOR Adaptation

STEPHEN M. HIGHSTEIN

Department of Otolaryngology, Anatomy and Neurobiology, Washington University Medical School, St. Louis, MO, USA

### Synonyms

VOR motor learning

## Definition

The vestibulo-ocular reflex or VOR is a feed forward, short limb reflex to compensate head movement with an equal, but opposite eye movement, thus stabilizing the eyes within the orbits to ensure ocular fixation upon a visual target. There are also visually driven eye movements to keep the visual target on the fovea of the retina, the region with the highest visual acuity. Visually driven reflexes require the image of the visual target to travel via the retina to the visual cortex for processing before a motor command can be sent to the brainstem to move the eyes. Due to this long pathway and concomitant processing time, these visually driven processes are by nature relatively slow. By contrast, the VOR is a three-neuron arc in its shortest pathway and thus produces motor commands relatively rapidly. Visually driven and vestibularly driven oculomotor reflexes work in concert to ensure that the eyes always accurately track the visual target within the bandwidth of naturally occurring head and target motion. In analogy to VOR control, the eyes are akin to a gyroscope in the orbit always remaining stable, focused upon the viewed target despite head movement. The gain of this VOR reflex, defined as eye velocity/head velocity, is nominally one in the light, i.e. the eyes are always stable within the orbit during head movement.

The VOR is a plastic or adaptive reflex. Change due to aging, disease or other causes that might reduce the magnitude of the input signal concerning head velocity arising within the vestibular labyrinth, or reduce the magnitude of the output or eye velocity caused by the extra ocular eye muscles, can reduce the VOR gain. If gain reduction occurs, the visual image will no longer be stable upon the fovea during head movement. By a process called motor learning, the VOR gain can be again recalibrated to a value of one. Although the VOR is recalibrated in the light, the actual eye movements produced by the vestibular system are measured in the dark in the absence of vision. Gain of the reflex in the dark is generally slightly less than one.

## Characteristics

### Quantitative Description

In the laboratory, VOR gain change or motor learning can be achieved by prolonged, conflicting visual-vestibular stimulation to increase or decrease the output of the reflex. Motor learning causes changes in the efficacy of synaptic transmission through multiple, specific information pathways, and these can be quantified as changes in neuronal sensitivity to specific stimuli [1–5]. Physiological recording shows that synaptic plasticity is likely to occur in many elements of the circuitry and in many

pathways; e.g. a plastic site located at the GABAergic synapses between Purkinje cells and ►flocculus target neurons (FTNs) in the vestibular nuclei has been identified [1]. The effect of VOR motor learning upon the sensitivities of FTNs can also be compared with results taken from floccular Purkinje cells [1,5–11]. Model simulations indicate that VOR motor memories are stored as plastic changes at multiple synapses carrying both sensory and motor information located both in the cerebellum and brainstem. Thus, changes at a single site (e.g. FTN or cerebellum) are not sufficient to account for the learned behavior. This hypothesis is further supported by studies showing that behavior in lesioned animals results from different mechanisms than those observed in the intact animal (►Flocculus hypothesis). Thus, simple measurement of VOR gain following cerebellar lesion does not adequately evaluate the role of the lesioned structure in VOR memory storage.

## Structural Regulation

In the laboratory, the VOR gain can be artificially recalibrated by the wearing of magnifying lenses such as reading glasses to raise the gain, or telescopes to lower the gain. In primates, including humans, the gain can thus be changed from values of about 0.2 to 2. Importantly, removal of the cerebellar flocculus precludes further change in VOR gain. Thus, an intact flocculus is necessary for adaptive VOR gain modification.

## References

- Blazquez PM, Hirata Y, Heiney SA, Green AM, Highstein SM (2003) Cerebellar signatures of vestibulo-ocular reflex motor learning. *J Neurosci* 23:9742–9751
- Ito M (2005) Bases and implications of learning in the cerebellum – adaptive control and internal model mechanism. *Prog Brain Res* 148:95–109
- Ito M (1987) Signal processing in cerebellar Purkinje cells. *Physiol Bohemoslov* 36:203–216
- Lisberger SG, Pavelko TA (1988) Brain stem neurons in modified pathways for motor learning in the primate vestibulo-ocular reflex. *Science* 242:771–773
- Lisberger SG, Pavelko TA, Bronte-Stewart HM, Stone LS (1994a) Neural basis for motor learning in the vestibuloocular reflex of primates. II. Changes in the responses of horizontal gaze velocity Purkinje cells in the cerebellar flocculus and ventral paraflocculus. *J Neurophysiol* 72:954–973
- Blazquez P, Partsalis A, Gerrits NM, Highstein SM (2000) Input of anterior and posterior semicircular canal interneurons encoding head-velocity to the dorsal Y group of the vestibular nuclei. *J Neurophysiol* 83:2891–2904

7. Blazquez PM, Hirata Y, Highstein SM (2004) The vestibulo-ocular reflex as a model system for motor learning: what is the role of the cerebellum? *Cerebellum* 3:188–192
8. Hirata Y, Highstein SM (2001) Acute adaptation of the vestibuloocular reflex: signal processing by floccular and ventral parafloccular Purkinje cells. *J Neurophysiol* 85:2267–2288
9. Hirata Y, Highstein SM (2000) Analysis of the discharge pattern of floccular Purkinje cells in relation to vertical head and eye movement in the squirrel monkey. *Prog Brain Res* 124:221–232
10. Hirata Y, Highstein SM (2002) Plasticity of the vertical VOR: a system identification approach to localizing the adaptive sites. *Ann N Y Acad Sci* 978:480–495
11. Lisberger SG, Pavelko TA, Broussard DM (1994b) Neural basis for motor learning in the vestibuloocular reflex of primates. I. Changes in the responses of brain stem neurons. *J Neurophysiol* 72:928–953

---

## VOR Gain

### Definition

The gain of the vestibuloocular reflex (VOR) is used in experimental and clinical settings to give a quantitative measure of the effectiveness of the VOR. It is defined as the ratio of the amplitude of slow phase eye and head movement.

► Vestibulo-ocular Reflexes

---

## VOR Phase

### Definition

The phase of the vestibulo-ocular reflex (VOR) is used in experimental and clinical settings to quantify the time delay between eye and head movement onset of the VOR. Phase values are often expressed in degrees or radians. This is because sine wave stimulation is often used to test the VOR.

► Vestibulo-ocular Reflexes

---

## VOR Suppression

KATHLEEN E. CULLEN

Department of Physiology, Aerospace Medical Research Unit, McGill University, Montreal, QC, Canada

### Definition

The vestibulo-ocular reflex (VOR) is classically associated with stabilizing the visual world on the retina by producing an eye movement of equal and opposite amplitude to the motion of the head. Indeed, the VOR effectively stabilizes the visual axis in space for the wide range of head motions that are generated during daily activities such as walking and running. The most direct pathway that mediates the VOR consists of only three neurons; vestibular afferents, which project to interneurons in the vestibular nuclei, which in turn project to extraocular motoneurons. The efficiency of this direct three neuron arc is reflected in its fast response time (Fig. 1a). Compensatory eye movements lag head movements by as little as 5–6 ms in the primate [1].

While a fully operational VOR is crucial for minimizing retinal slip during our every day activities, it is counterproductive during natural orienting behaviors in which the head movements are made to redirect our fovea or axis of visual gaze to a particular object in our visual field. Specifically, when the head is immobilized, saccadic and smooth pursuit eye movements are made to voluntarily redirect the axis of gaze in space. Saccadic eye movements function to rapidly redirect the fovea to a new object of interest (Fig. 1b, *left panel*). Smooth pursuit eye movements function to keep a slowly moving visual object on the fovea (Fig. 1c, *left panel*). Under natural conditions, where the head is not restrained, head movements are commonly generated in combination with saccadic and smooth pursuit eye movements to redirect gaze. These coordinated eye-head movements are termed rapid ►gaze shifts (Fig. 1b, *right panel*) and eye-head pursuit (Fig. 1c, *right panel*), respectively. A fully operational VOR would be counterproductive during both behaviors, because a fully functional VOR would produce an eye movement command in a direction opposite to that of the intended shift of the axis of gaze. This essay considers the results of behavioral and neurophysiological investigations that have advanced our understanding of how the VOR is suppressed during gaze shifts, when the behavioral goal is to redirect rather than stabilize gaze.

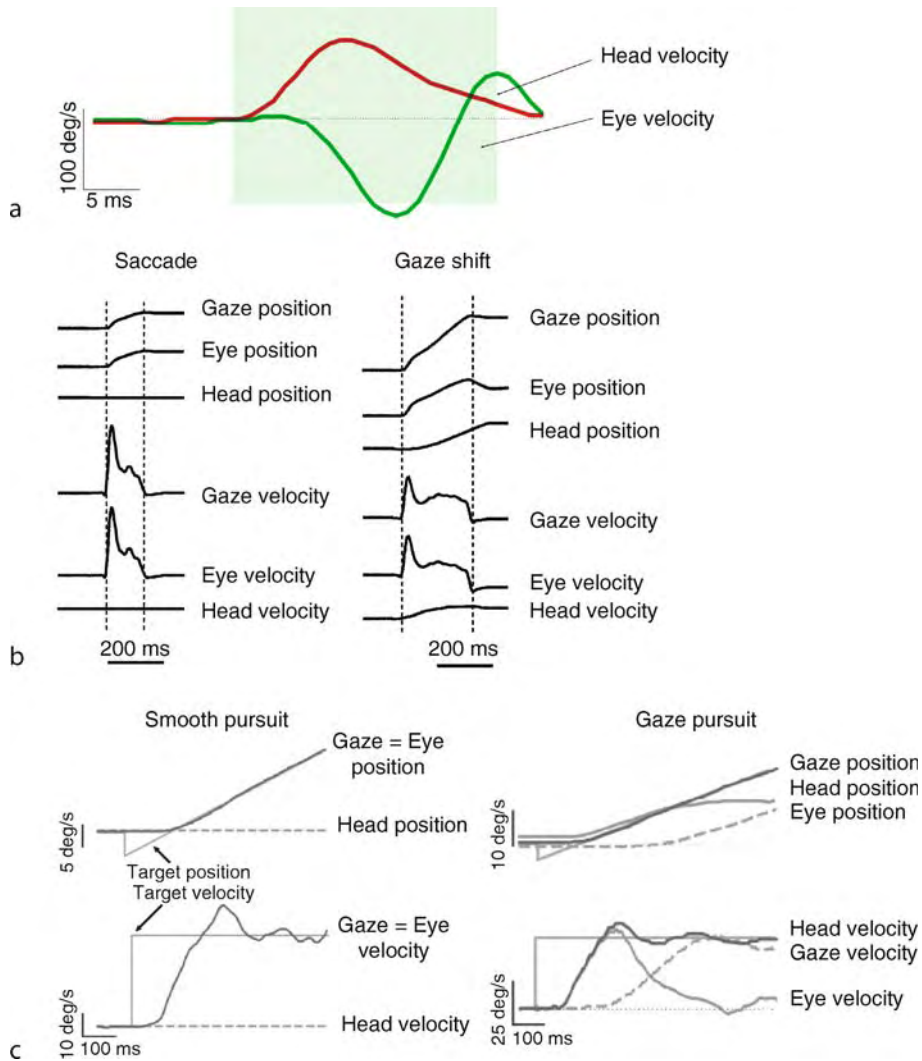

**VOR Suppression. Figure 1** (a) The minimal latency of the VOR is  $\sim 5$  ms. (b) Gaze shifts made with the head-restrained (*left panel*) and head unrestrained (*right panel*). (c) Pursuit response to a step-ramp target trajectory made with the head-restrained (*left panel*) and head unrestrained (*right panel*).

## Characteristics

### The VOR During Gaze Shifts

#### Behavioral Studies

When the head is not restrained, a combination of rapid eye and head movements (gaze shift) is commonly used to redirect the visual axis to a new target in space. Bizzi and colleagues [2] originally proposed that the VOR remains functional during gaze shifts, such that it eliminates the head's contribution to the change in gaze. In this schema, termed “the **linear summation hypothesis**”, the actual eye movement generated at the level of the extraocular motoneurons reflects the summation of two signals: an intact VOR from vestibular pathways (i.e. a compensatory eye movement

signal (Fig. 2a)), and a separate oculocentric saccadic eye movement signal from the brainstem ‘burst generator’ (Fig. 2b), which counters the VOR and redirects the axis of gaze. The conceptual simplicity of this proposal (Fig. 2c) has made it an attractive model of gaze shift generation.

Over the past three decades, substantial evidence has accumulated indicating that the linear summation hypothesis is generally not valid during gaze shifts (see discussion in [3]). In order to probe the status of the VOR during gaze shifts, perturbations as diverse as electromagnetic clutches to brake the head, torque motors or hammers to “bump” the head, as well as whole-body rotations have been employed. The

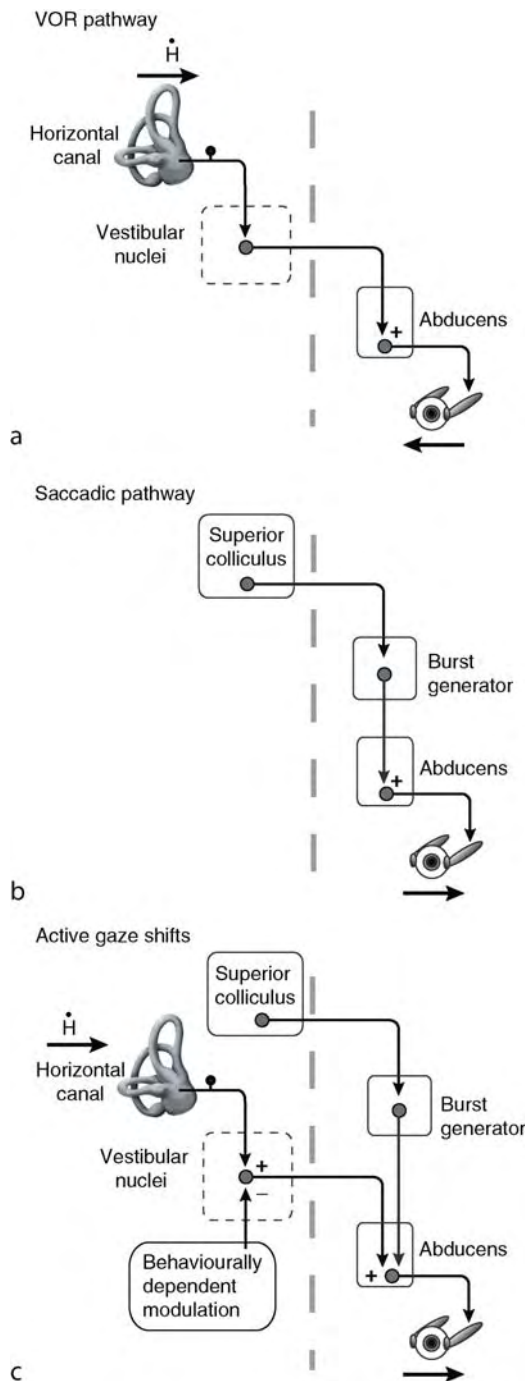

**VOR Suppression. Figure 2** The primary inputs to the abducens motor nucleus that mediate (a) the VOR and (b) Saccadic eye movements. (c) Interactions between these pathways during a rightward gaze shift.

results of most studies have shown that transmission through the VOR pathways is modulated in a behaviorally dependent manner during gaze shifts (Fig. 2c). There is common agreement that the VOR

is completely turned off during large gaze shifts and is significantly suppressed during smaller gaze shifts. For gaze shifts less than 50 degrees, VOR gain (defined as: change in eye velocity/change in head velocity caused by a perturbation) decreases as a function of increasing gaze shift amplitude. Thus, the head movements generated during gaze shifts contribute to changing the axis of gaze in space, since the contribution of the head movement to gaze is not completely cancelled out (i.e. VOR gain  $\neq -1$ ). As a result, several models have been proposed to explain how eye and head movements are coordinated to produce accurate gaze shifts.

Until recently, the exact time course of the suppression during gaze shifts had been a matter of controversy (see discussion in [3]). It was initially proposed that the VOR was rapidly switched from an “on” to an “off” state during gaze shifts and then back on at gaze shift end. This was furthered by the suggestion that VOR gain decreases exponentially ( $T_c = \sim 50$  ms) from the onset of the gaze shift, and returns to a value greater than unity immediately after a gaze shift. However, the temporal resolution of the method used in this latter study was limited. More recently, discrete transient perturbations have been used to more directly probe the time course of VOR attenuation during gaze shifts (Fig. 3a; [3]). This approach has shown that VOR suppression is maximal early in the gaze shift and progressively recovers to reach normal values near gaze shift end (Fig. 3b). High variability across subjects, however, precludes establishing a unifying description of the absolute level and time course of VOR suppression during gaze shifts.

### Neural Correlates

A neural correlate for the suppression of the VOR during gaze shifts has recently been identified (reviewed in [4]). Prior investigations in head-restrained monkeys have revealed that there are several classes of vestibular nuclei neurons, which discharge in relation to horizontal passive whole-body rotation and/or eye movements. ▶ **Type I position-vestibular-pause (PVP) neurons** are thought to constitute most of the intermediate leg of the direct VOR pathway; PVP neurons receive a strong monosynaptic connection from the ipsilateral vestibular afferents and, in turn, project directly to contralateral extraocular motoneurons (Fig. 4a).

Type I PVP neurons derive their name from the signals they carry during head-restrained oculomotor and vestibular paradigms: (i) their firing rates increase when the eyes move to more contralaterally directed ▶ **positions**, (ii) during slow phase ▶ **vestibular** nystagmus, these neurons are sensitive to ipsilateral head rotations (i.e. a type I response), and (iii) their discharges cease (▶ **pause**) for ipsilaterally directed



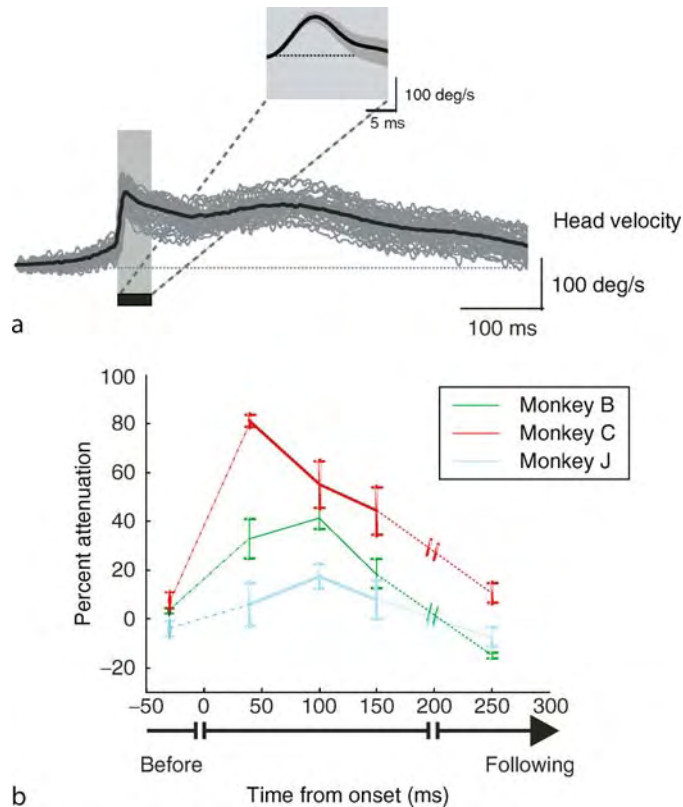

**VOR Suppression. Figure 3** (a) Head trajectories that were experimentally perturbed (vertical shaded grey bar and inset) during gaze shifts. (b) VOR gain in response increases over time from gaze shift onset ultimately reaching unity at gaze shift end. Error bars represent standard errors.

saccades and vestibular quick phases (for more detail see Essay on PVP Neurons). While these neurons are robustly modulated in response to passive head rotations, their responses to head velocity are dramatically attenuated during gaze shifts. As shown in the inset of Fig. 4a, neuronal responses are much less than those predicted by the same neuron's response during passive whole body rotation (pVOR model; heavy line). Note, that the gaze shift interval is denoted by the two vertical dashed lines.

The head-velocity information encoded by type I PVP neurons is increasingly attenuated as a function of gaze shift amplitude. This neurophysiological trend (Fig. 4b) mirrors the results of the prior behavioral studies which were discussed above. In Fig. 4b, results from two of these prior studies have been superimposed on PVP neuron data for comparison (see [5]). These findings provide strong support for the proposal that the amplitude-dependent reduction of the responses of PVP neurons underlies the amplitude-dependent decrease in behavioral VOR gain observed during gaze shifts (see: [5]).

The attenuation of PVP responses during gaze shifts can be accounted for by a known mechanism, namely

projections from the brainstem saccade generator to the vestibular nuclei (Fig. 5; reviewed in [5]). During saccades, vestibular quick phases and gaze shifts, brainstem burst neurons (BNs) become active as denoted by the “gate”. As a result, BNs provide an inhibitory input related to eye velocity ( $E'$ ) and head velocity ( $H'_{BN}$ ) to type I PVP neurons during gaze shifts via their projections to type II neurons in the vestibular nuclei. (Note: type II vestibular nuclei neurons are activated in response to contralateral head rotations). In contrast, the head velocity sensitivity of PVP neurons recovers immediately following the end of a gaze shift once gaze is stable, even when the head is still moving (see inset: Fig. 4a). This observation is also consistent with the mechanism illustrated in Fig. 5, since the brainstem saccade generator is not active during this interval.

### The VOR During Eye-Head Pursuit

#### Behavioral Studies

Head-restrained primates generate continuous eye movements, termed smooth pursuit, to shift gaze to follow a moving visual target of interest. When the head

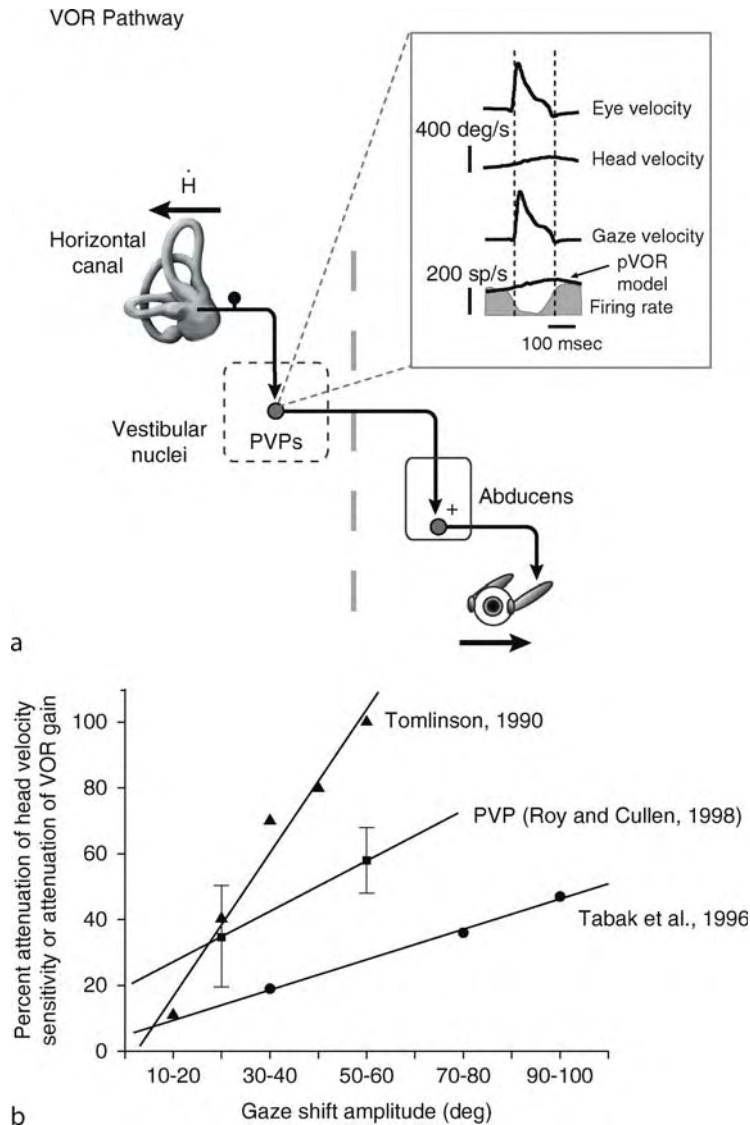

**VOR Suppression. Figure 4** (a) The three-neuron arc that mediates the horizontal VOR and responses of PVP neurons during gaze shifts (inset). (b) Comparison of the percent attenuation of PVP (*filled square*) head velocity sensitivity during gaze shifts and the percent attenuation of the VOR gain as measured in behavioral experiments.

is not restrained, a combination of head and eye motion (eye-head pursuit) is commonly used. Bizzi and colleagues proposed that the linear summation hypothesis could also be applied to eye-head pursuit see discussion in [4]. In this schema, the eye movements generated reflect the summation of two opposing signals (Fig. 6c): a VOR (Fig. 6a), which cancels out the contribution of head motion to gaze and an ocular pursuit signal of cerebellar origin (Fig. 6b). In support of linear summation, several subsequent studies demonstrated that the frequency response of head-restrained smooth pursuit

and head-unrestrained eye-head pursuit are generally comparable.

An intact VOR would be counterproductive during eye-head pursuit for the same reason it would be counterproductive during gaze shifts. As shown in Fig. 6c, a fully functional VOR would generate an eye movement command in the direction opposite to that of the ongoing tracking. To date there is much accumulated evidence indicating that the VOR is not only cancelled by a smooth pursuit signal (i.e. the schema proposed in Fig. 6c), but that the gain of the

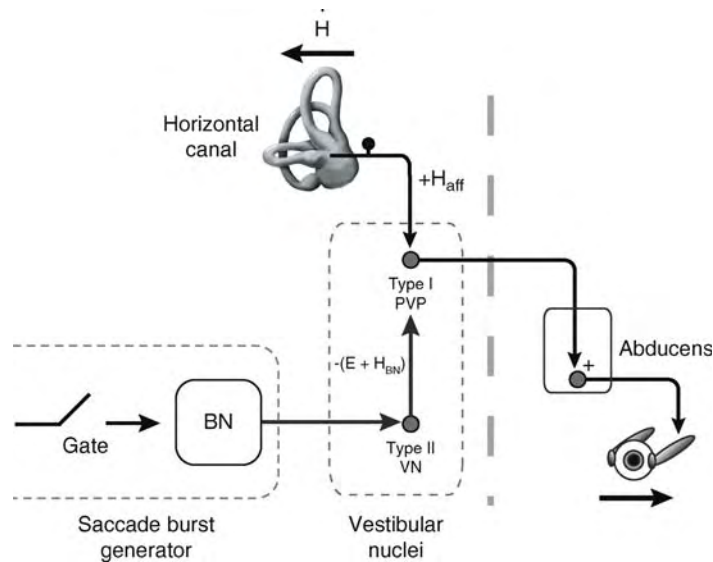

**VOR Suppression. Figure 5** The brainstem mechanism that underlies the reduction in VOR gain during gaze shifts.

VOR pathway itself is partially suppressed during combined eye-head tracking [6]. Firm evidence for this non-visual or parametric adjustment of VOR gain was found by applying transient perturbations to the head while subjects voluntarily cancelled their VOR by tracking a head stationary target. In monkeys and humans, suppression of the evoked VOR is observed at very short (i.e.  $< 30$  ms) latencies (Fig. 7b) in this condition versus when the same perturbation is applied while the animal is stationary ( $>90$  ms Fig. 7a; [7,8]). This indicates that during VOR cancellation, the efficacy of the VOR is suppressed by a mechanism that does not depend on visual feedback or smooth pursuit (Fig. 7c).

The idea that a parametric adjustment of transmission in the VOR pathways contributes to VOR cancellation is consistent with the findings of many investigations (reviewed in [7]). First, it has long been known that humans can decrease the gain of their VOR by simply imagining a target that moved with their heads (e.g. [6]). This result shows that the VOR can be suppressed by non-visual inputs. Moreover, humans are better able to suppress their VOR during passive, pseudorandom vestibular stimulation than they are able to pursue a visual target that is moved pseudorandomly at similar velocities, and their ability to cancel torsional VOR is better than their ability to generate torsional smooth pursuit. Finally, there is some clinical evidence showing that the ability to generate smooth pursuit eye movements and to cancel the VOR are not always equally affected by CNS lesions.

The question then arises: what is the advantage of having a non-pursuit related mechanism to negate the VOR during eye-head tracking? It appears that parametric suppression of the VOR operates to extend the accuracy of eye-head tracking movements beyond what would be possible by the pursuit system alone. Although gaze accuracy is comparable during eye-head pursuit and pursuit in the head-restrained condition when target motion is predictable, pursuit of faster unpredictable moving targets can be improved when primates are free to move their heads.

#### Neural Correlates

Electrophysiological studies have provided insights into the mechanisms that suppress the VOR during eye-head pursuit. The attenuation of the head-velocity sensitivity of PVP neurons underlies parametric (i.e. non-visual) suppression of the VOR during eye-head tracking. The head velocity modulation of the direct VOR pathways (i.e. PVP neurons) is attenuated by 30% during cancellation of the VOR. This reduction in head-velocity sensitivity occurs at latencies that are too short to be mediated by smooth pursuit pathways (Fig. 8a; [9]). The relative attenuation of the response of PVP neurons is directly comparable to the amount of suppression of VOR that can be attributed to the non-visual mechanism (bottom: Fig. 7b; [9]). During combined eye-head pursuit, the velocity modulation of the direct VOR pathways is likewise attenuated by 30%. Thus, parametric adjustments of

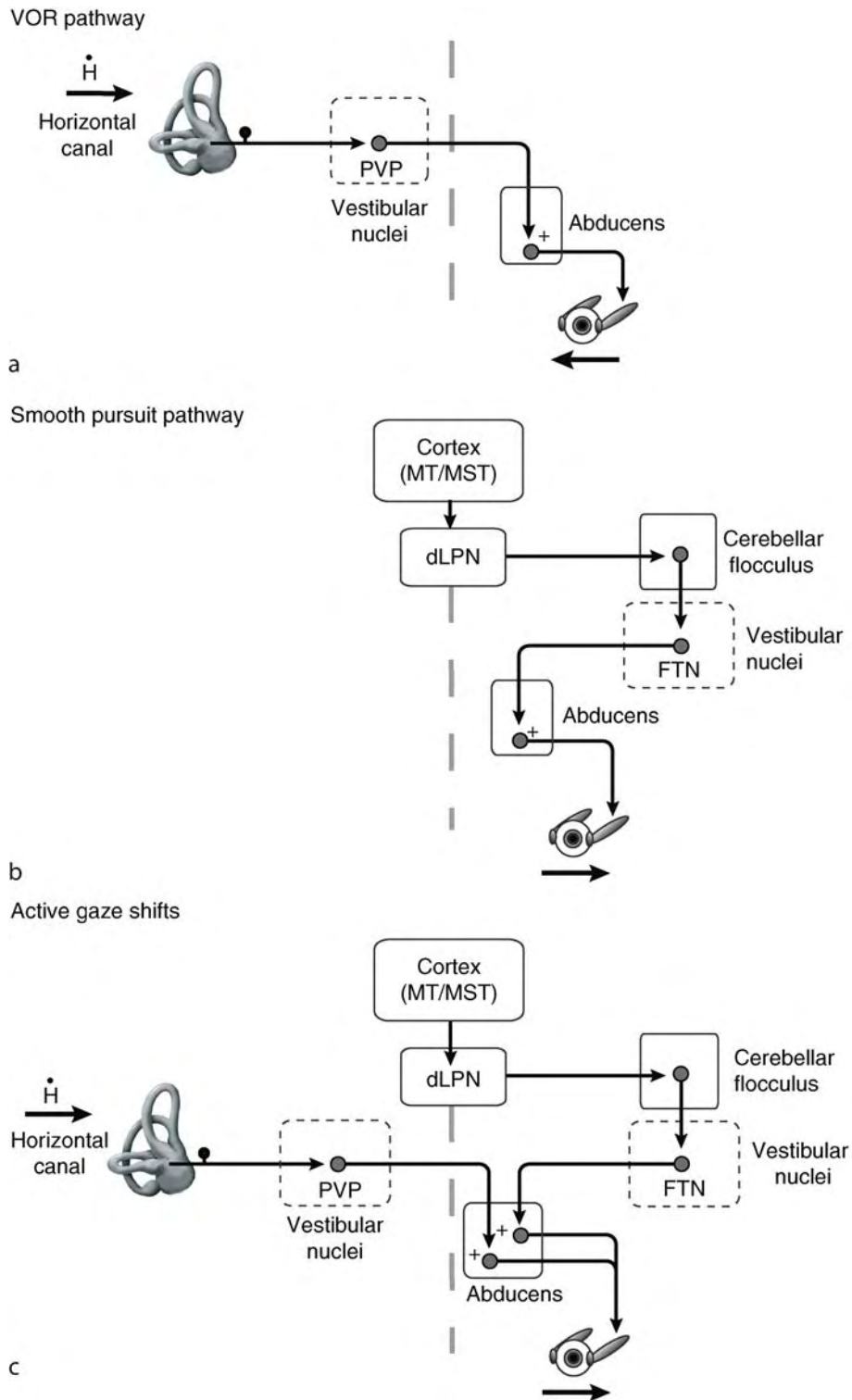

**VOR Suppression. Figure 6** The primary premotor inputs to the abducens motor nucleus that mediate the (a) VOR and (b) smooth pursuit eye movements. (c) Interactions between these pathways during combined eye-head tracking. Abbreviations: dLPN: (▶Dorsal lateral pontine nuclei), MT/MST, (▶Middle temporal area and middle superior temporal area (MT/MST)).

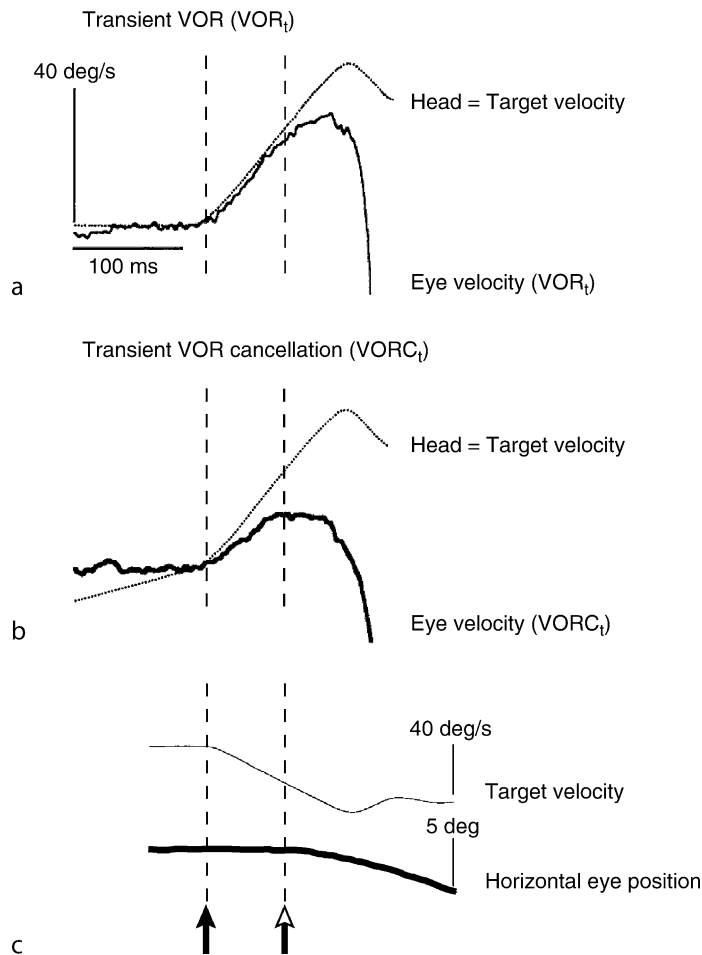

**VOR Suppression. Figure 7** (a, b) An unpredictable step in head acceleration was applied in two conditions: (a) the subject was initially stationary and fixating a stationary target (VOR<sub>t</sub>) and (b) the subject was initially canceling its VOR (VORC<sub>t</sub>). (c) When the visual target is accelerated in a similar manner, the latency of the smooth pursuit eye movement (dotted line) is comparable to latency of VOR suppression in b.

transmission in the direct VOR pathway are observed during cancellation of the VOR as well as during the active head movements made during coordinated eye-head pursuit.

In contrast, pursuit related cancellation of the VOR is mediated by a different group of premotor neurons in the vestibular nuclei and nucleus prepositus. These neurons receive a pursuit-related command from the cerebellar flocculus, and also project to the abducens nucleus. During head-restrained pursuit and eye-head pursuit, these cells carry a gaze velocity signal (reviewed in [8]). Moreover, when the head is perturbed during eye-head tracking, the longer latency responses of these cells are consistent with smooth pursuit delays [10]. Thus, during eye-head tracking, the smooth pursuit inputs mediated via these neurons function in parallel with the attenuation in the gain of the direct VOR

pathways (i.e. PVP neurons) to cancel the VOR at the level of abducens motor neurons. The specific premotor pathways that mediate parametric and pursuit-dependent cancellation are shown schematically in Fig. 8b.

## References

1. Huterer M, Cullen KE (2002) Vestibuloocular reflex dynamics during high-frequency and high-acceleration rotations of the head on body in rhesus monkey. *J Neurophysiol* 88:13–28
2. Bizzi E, Kalil RE, Togliasso V (1971) Eye-head coordination in monkeys: evidence for centrally patterned organization. *Science* 173:452–454
3. Cullen KE, Huterer M, Braidwood DA, Sylvestre PA (2004) Time course of vestibuloocular reflex suppression during gaze shifts. *J Neurophysiol* 92:3408–3422



---

## VOR - Tilt VOR

### Definition

Compensatory eye movements subsequent to head or body rotations about the naso-occipital axis, i.e., lateral tilt, mediated by the vestibulo-ocular reflex (VOR). The reflex can be dynamic, i.e., during oscillatory movements, or sustained, i.e., during static tilt. In the latter case, eye position is maintained by otolith input.

- ▶ Vestibulo-ocular Reflexes
- ▶ Vestibulo-oculomotor Connections
- ▶ Vestibulo-oculomotor System: Functional Aspects

---

## VOR - Translational

### Definition

Compensatory eye movements subsequent to head or body translations, i.e., linear displacements.

- ▶ Vestibulo-oculomotor Connections
- ▶ Vestibulo-oculomotor System: Functional Aspects

---

## VRAC

### Definition

Volume-Regulated Anion Conductance

- ▶ Chloride Channels and Transporters

---

## Wagner's Corpuscle

- ▶ Meissner Corpuscle Regeneration

---

## Wake-on Cells

### Definition

This group of neurons begins to discharge seconds before the onset of wakefulness and remains very active until 5–8 s before the end of wakefulness. During wakefulness, discharge rates of these cells (8–20 spikes/s) are much higher than those of REM-off cells. The neurotransmitter identity of these neurons is not definitive but based on their location it is most likely that these cells contain the neurotransmitter acetylcholine (ACh) and/or glutamate.

- ▶ Acetylcholine
- ▶ Cholinergic Brainstem
- ▶ Glutamate
- ▶ Rapid Eye Movement (REM) Sleep
- ▶ REM-off Cells
- ▶ Sleep-Wake Cycle

---

## Wake-REM-on Cells

### Definition

This group of neurons displays higher discharge rates during REM sleep and waking than during NREM sleep. The majority of this type of cell is located within the pedunculopontine tegmentum (PPT) and laterodorsal tegmentum (LDT). The neurotransmitter identity of

these neurons is not definitive but based on their location it is most likely that these cells contain the neurotransmitter acetylcholine (ACh).

- ▶ Acetylcholine
- ▶ Cholinergic Brainstem
- ▶ Non-REM Sleep
- ▶ Rapid Eye Movement (REM) Sleep

---

## Wake-sleep Cycle

- ▶ Sleep-Wake Cycle

---

## Waking

### Definition

Waking is the physiological state that alternates with sleep, with the periodicity of the alternating rhythm being controlled by the circadian clock located in the suprachiasmatic nucleus of the hypothalamus. Wakefulness is maintained by the reticular activating system, and the electroencephalogram (EEG) is characterized by low-voltage, fast frequency activity, with alpha rhythm (8–12 Hz) emerging during relaxed wakefulness and eyes closed.

Wakefulness features mental activation associated with muscle tone, maintenance of posture, and full capability for behavioral, perceptual, cognitive, and emotional interaction with the environment.

- ▶ Circadian Clock
- ▶ Electroencephalography
- ▶ Suprachiasmatic Nucleus
- ▶ Sleep Walking



---

## Walking

### Definition

Mode of movement by using the legs.

surface of the water. The animal has to swim in the pool and to learn the location of the hidden platform. In this model, learning- or memory-disruptive effects of drugs can be evaluated.

---

## Wallenberg's Syndrome

### Definition

(aka lateral medullary syndrome, PICA syndrome). Although the area involved is the area supplied by the PICA, Wallenberg's syndrome is usually caused by occlusion of the VA at the level of the PICA. Symptoms are: ipsilateral facial numbness, ataxia and Horner's syndrome; contralateral arm/leg numbness, dysarthria, dysphagia, dysphonia.

- ▶ Horner's Syndrome
- ▶ Stroke

---

## Wavelength ( $\lambda$ )

### Definition

The distance between two wave fronts of a pressure wave traveling in a medium.

- ▶ Acoustics

---

## Wavelet Analysis

- ▶ Measurement Techniques (Electromyography)

---

## Wallerian Degeneration

### Definition

The active process of axonal dissolution, myelin breakdown, Schwann cell proliferation, macrophage invasion and phagocytosis of axonal material and myelin. This process which occurs in the nerve distal to injury provides the structural and cellular milieu which is exploited by regenerating axons subsequently.

- ▶ Axon Degeneration and Regeneration of Peripheral Neurons
- ▶ Myelin
- ▶ Peripheral Nerve Regeneration and Nerve Repair
- ▶ Schwann Cell

---

## Way Finding

- ▶ Spatial Memory

---

## Weak and Strong Resetting

- ▶ Type 1 and Type 0 Resetting

---

## Water Maze

### Definition

Experimental paradigm to study orientation. A circular pool filled with opaque liquid (water). At one location in the pool, an escape platform is hidden under the

---

## Weber Syndrome

### Definition

The Weber syndrome results from unilateral ventral lesion (infarction) of the midbrain and is characterized

by ipsilateral ►**pareisis** of adductive and vertical eye movements and of pupillary dilation, and by paresis of contralateral face, arm and leg.

---

## Weigert Stain

### Definition

The Weigert stain involves the treatment of nervous tissue with potassium dichromate to preserve myelin lipids. The lipids are then stained with the use of hematoxylin, providing a useful technique for visualizing fiber pathways. The pathways appear black due to the staining of myelin sheaths.

---

## Werdnig-Hoffmann Disease (Spinal Muscular Atrophy, SMA)

### Definition

Common recessive autosomal disease characterized by degeneration of lower ►**motoneurons** caused by mutations of the “Survival of Motor Neuron 1” (SMN1) gene. Patients present with muscle ►**paralysis** and ►**muscle atrophy**, greater in the proximal muscles, leading to scoliosis and limited upper extremity function. Spinal Muscular Atrophy Type I (SMA I) is a frequent disorder and without treatment death occurs by 2 years. Death is caused by severe and progressive restrictive lung disease.

---

## Wernicke-Korsakoff Syndrome/Encephalopathy

### Definition

Serious consequence of alcoholism and ►**thiamine (vitamin B1) deficiency**. Certain characteristic signs of this disease, notably ►**ophthalmoplegia**, ►**nystagmus**, and ►**ataxia**, respond rapidly to the administration of thiamine but to no other vitamin. Wernicke's syndrome may be accompanied by an acute global confusional state that may also respond to thiamine. Left untreated, Wernicke's syndrome frequently leads to a chronic

disorder in which ►**learning** and ►**memory** are strongly impaired. This so-called Korsakoff's psychosis is characterized by ►**confabulation**, and is less likely to be reversible once established.

- Ataxia
- Confabulations
- Nystagmus

---

## Wernicke's Aphasia

### Definition

Wernicke's aphasia is primarily a deficit in language comprehension resulting from lesions of Wernicke's area (Brodmann's area 22: posterior part of the left temporal lobe) and often of left superior temporal areas (Brodmann's areas 39 and 40) and area 37. With extensive lesions, auditory and visual inputs are disturbed. Patients may speak at normal rate and melody, but excessively (logorrhea) and without meaning (empty speech), and may use the wrong words (paraphasia) or produce new words (neologisms). They also are disabled as to reading and writing.

---

## Wernicke's Area

### Definition

Auditory comprehension center

- Wernicke's Aphasia

---

## Western Blot

### Definition

Western Blot is a technique used to identify proteins in a sample. Gel electrophoresis separates the proteins in the sample on the basis of size. Proteins are transferred to a membrane where they are probed with a primary antibody specific to the target protein, followed by secondary antibody detection of the primary antibody.

## Wheatgerm Agglutinin Conjugated with Horseradish Peroxidase (WGA-HRP)

### Definition

Wheatgerm-agglutinin conjugated with horseradish peroxidase is a neural tracer that is transported both from the cell body to axon terminals (the orthograde directions) and axon terminals to the cell body (retrograde directions). Wheatgerm agglutinin is much more strongly transported than HRP so that WGA-HRP can be used in much lower concentrations than HRP (1% vs 20% is typical). HRP is conjugated to the wheatgerm agglutinin so that WGA-HRP can be visualized with the wide variety of familiar chemical reaction for revealing HRP.

## Whiplash-associated Disorders (WAD)

### Definition

WADs result from fast whip-like neck movements induced mainly by rear- and front-end or lateral impacts during motor vehicle collisions, producing abrupt accelerations and decelerations of the head relative to the body with compressions or torsions of the cervical spine. These cause bone or soft-tissue injuries, which may lead to acute and chronic pain and dysfunctions of various sorts, such as local mechanical ► [hyperalgesia](#), sensory and motor deficits, muscle fatigue, stiffness, temporo-mandibular dysfunctions, cognitive impairments of memory and concentration, distress, depression, anxiety and sleep disturbances.

## Whitten Effect

### Definition

The presence of a male will induce estrous in females made anestrous by injections of estradiol, group housing or constant light.

► Accessory Olfactory System

## Wilson's Disease

### Definition

Wilson's disease is a rare autosomal recessive disease of copper excretion with neurological features, including abnormalities of speech, tremor, incoordination and dystonia.

► Drugs for Motor Disorders

## Windowed Fourier Analysis

► Measurement Techniques (Electromyography)

## Wing Fanning (Insects)

► Odor-Sampling Behavior

## Wiping Reflex

### Definition

The term is used to describe scratching in frog. An acid-soaked piece of filter paper is placed upon a site on the cutaneous surface; the nearby hindlimb reaches towards and "wipes" the filter paper off the site.

► Scratching

## Word-taste Synesthesia

► Lexical-Gustatory Synesthesia

---

## Work

### Definition

A quantity of energy passed from one system to another. Usually refers, when used without qualification, to mechanical work. Mechanical work is calculated as the time integral of force in the mechanical linkage between the systems with respect to distance moved by the linkage. The common formulation force x distance only applies when the force is constant. Also work can describe the transfer of electrical or osmotic work.

- ▶ Energy/Energetics

---

## Working Memory

### Definition

A capacity of short-term storage of information used in complex cognitive activities such as reasoning, problem solving and language by maintaining information in an active state during processing.

- ▶ Emotional Learning/Memory
- ▶ Memory and Dementia

---

## Worm

- ▶ Serial Analysis of Gene Expression

---

## Writer's Cramp

### Definition

Writer's cramp is a task-specific focal upper limb dystonia characterized by abnormally contracting muscles causing cramping in the hand and fingers while writing. The dystonia causes abnormal posturing of the wrist and fingers while writing. The most common posture is flexion and ulnar deviation of the wrist, and a tight grip of the pen with the thumb and index finger. The first line of treatment is botulinum toxin injection into target muscles which are thought to be overactive.

- ▶ Botulinum Toxin

---

## Wulst

### Definition

German for "bulge" Refers to a bulge-like structure in the anterior forebrain, demarcated by the vallicula, which houses a large blood vessel.

- ▶ Evolution of the Brain: in Birds

---

## X Neurons, TRSNs

- ▶ SC – Tectoreticulospinal Neurons

---

## X, Y and W Cells

### Definition

Physiologically defined retinal ganglion cell and lateral geniculate nucleus cell classes originally defined in cats.

- ▶ Evolution of the Visual System in Mammals — Comparative Evolutionary Aspects across Orders
- ▶ Lateral Geniculate Nucleus (LGN)
- ▶ Retinal Ganglion Cells

---

## Xenografting

### Definition

Synonym: xenotransplantation. Transplantation of tissues and organ pieces from an animal to a person, or to another animal of a different species.

---

## Xerostomia

### Definition

Xerostomia is sensation of dryness; with or without hyposalivation (usually defined as measured resting secretion  $\leq 0.1$  ml/min or stimulated secretion  $\leq 0.7$  ml/min of whole saliva).

- ▶ Salivary Secretion Control

---

## X-Linked Disease

### Definition

The two sex chromosomes are X and Y. Males are characterized by an XY pair, and females are characterized by an XX pair. X-linked disease is a genetic disease caused by a mutation of a gene on the X-chromosome. Males will be affected, because they have only the one X-chromosome located mutant allele. Females show much less prevalence of disease, because to be affected they would need to receive a mutant allele from both parents.

For example, a disease such as Duchenne muscular dystrophy (DMD) is inherited, because the responsible mutated dystrophin gene is carried on the X chromosome. As males have only one X chromosome, the characteristics represented by its genes are typically expressed, whereas in females with two X chromosomes they are not. DMD is therefore considered an X-linked recessive genetic disease.

- ▶ Duchenne Muscular Dystrophy

---

## Yaw

### Definition

Turn about the vertical axis.

---

## Yeast 2-Hybrid

### Definition

Yeast 2-hybrid is a technique used to identify protein-protein interactions, based on the idea that if two proteins interact a reporter gene is activated. This approach is often used to identify unknown interactors (prey) of a known protein (bait). The yeast GAL-4 gene is split into DNA binding and activating domains, and each used separately to tag the bait protein and the prey proteins. The GAL-4 protein is only functional when the split domains come in close contact with one another, because the proteins they tag interact. These DNA sequences are subcloned into vectors and used to

transform yeast, which contain the reporter gene. Yeast that turn color are then isolated and used to identify the prey protein that interacts with the bait.

---

## Yoked Muscles

### Definition

Muscles that always contract together, i.e., are “yoked.”

---

## Young's Modulus

### Definition

The Young's Modulus of a material is defined by the slope of the stress-strain curve.

► [Measurement Techniques](#)

---

## Zeitgeber

### Definition

The word “zeitgeber” is derived from the German words for time (Zeit) and giver (Geber). It refers to a stimulus that conveys environmental time information to a biological clock. An environmental signal is said to be a zeitgeber when it can be shown to re-set the timing of a biological rhythm. In the case of a circadian (daily) rhythm, the strongest zeitgeber is typically light, which is detected primarily via specialized non-visual photoreceptors.

In addition to light, any signal that is structured with a reliable 24 h periodicity could, in theory, be utilized by biological systems to gather time information concerning the environment. Even the low amplitude oscillations in temperature that occur in vertebrates will synchronize daily cellular rhythms and social cues can act as (weak) zeitgebers.

- ▶ Chronobiology
- ▶ Circadian Rhythm

---

## Zeitgeber Time

### Definition

Zeitgeber time (ZT) refers to experimental time, specifically within an experiment concerning chronobiology.

In such an experiment, a zeitgeber is delivered at least once per cycle to synchronize a free-running circadian rhythm to the cycle. Under the formalism of ZT, each full cycle is divided into 24 equal “hours” (even if an experimental day of more or less than 24 actual hours is used). The 0 and 24 h time points correspond to lightson or experimental dawn. This means that, in an experiment with a cycle of 12 h of light and 12 h of darkness, ZT0 corresponds to lightson, or 6 h after the mid-point of the dark period. An alternative convention, External Time (ExT), is the same as ZT except that the

0 and 24 h time points correspond to midnight, as for our local clock time.

- ▶ Chronobiology
- ▶ Circadian Rhythm

---

## Zeroes

### Definition

The roots of the nominator of a transfer function.

- ▶ Signals and Systems
- ▶ Transfer Function

---

## Zinc-Finger

### Definition

A distinct class of transcription factors in which a DNA-binding polypeptide loop or “finger” forms through a coordination complex of zinc with cysteine and histidine residues at the base of the loop.

- ▶ Hox Gene-Related Respiratory Control Disturbance

---

## Zip Code

### Definition

Nucleotide sequences in an mRNA, of which the secondary and tertiary structure determine the subcellular localization of a given transcript.

- ▶ Extrasomal Protein Synthesis in Neurons